

IM R19

MOBILE ELEVATING WORK PLATFORM
USE AND MAINTENANCE MANUAL

MUM MEWP IM R19 USA R00 01/2019

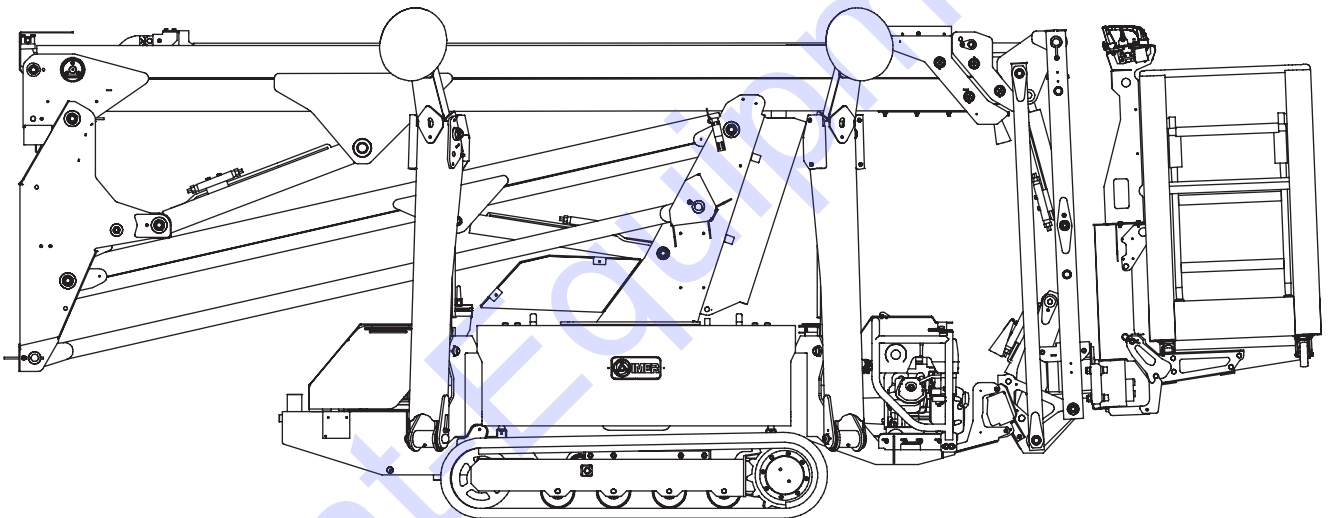

TRANSLATION OF THE ORIGINAL INSTRUCTIONS



www.Discount-Equipment.com

TO PURCHASE THIS PRODUCT PLEASE CONTACT US



**Equipment Financing and
Extended Warranties Available**



**Discount-Equipment.com is your online resource for
commercial and industrial quality parts and equipment sales.**

561-964-4949

visit us on line @ www.discount-equipment.com

Select an option below to find your Equipment

Search by Manufacturer

Search by Product Type

Request a Quote

We sell worldwide for the brands: Genie, Terex, JLG, MultiQuip, Mikasa, Essick, Whiteman, Mayco, Toro Stone, Diamond Products, Generac Magnum, Airman, Haulotte, Barreto, Power Blanket, Nifty Lift, Atlas Copco, Chicago Pneumatic, Allmand, Miller Curber, Skyjack, Lull, Skytrak, Tsurumi, Husquvarna Target, Stow, Wacker, Sakai, Mi-T-M, Sullair, Basic, Dynapac, MBW, Weber, Bartell, Bennar Newman, Haulotte, Ditch Runner, Menegotti, Morrison, Contec, Buddy, Crown, Edco, Wyco, Bomag, Laymor, EZ Trench, Bil-Jax, F.S. Curtis, Gehl Pavers, Heli, Honda, ICS/PowerGrit, IHI, Partner, Imer, Clipper, MMD, Koshin, Rice, CH&E, General Equipment, Amida, Coleman, NAC, Gradall, Square Shooter, Kent, Stanley, Tamco, Toku, Hatz, Kohler, Robin, Wisconsin, Northrock, Oztec, Toker TK, Rol-Air, APT, Wylie, Ingersoll Rand / Doosan, Innovatech, Con X, Ammann, Mecalac, Makinex, Smith Surface Prep, Small Line, Wanco, Yanmar

Table of contents

Presentation	8
Static and dynamic tests	9
After-sale service	9
Spare-parts service	9
Liability	9
General instructions - safety	10
Manual	10
Safety systems.....	10
Labels and plates	10
Operator's requirements	11
Distance from the electric lines	13
Not allowed operations.....	14
To minimize hazards	16
Risk of folding	16
Risk of falling.....	17
Electric hazards	17
Explosion or burn hazards	17
Residual risks.....	18
Description of the machine	19
Main components.....	21
Control and power instruments	22
Electronic circuit	24
Electric circuitry	24
Control proportionality	24
Radio control and remote control	25
Radio control.....	25
Remote control.....	26
The platform panel	26
Dead-Man Button.....	27
Receiver	27
Platform panel battery for radio control.....	28
Battery charger	28
Charging the battery	29
Technical specifications.....	30
Overall dimensions.....	31
Diagram work	33
Plates and labels	34

Identification	39
Standard equipment.....	40
Optional.....	40
Machine operations.....	41
Ground movements - Aerial movements.....	41
Ground movements	42
Drive and steering.....	42
Widening the span of the crawling tracks	42
Stabilisation.....	42
Automatic stabilisation	42
Manual stabilisation	42
Aerial movements	43
Lifting/lowering of the lifting boom.....	43
Lifting/lowering of the pantograph.....	43
Turret rotation.....	43
Telescopic boom extension/retraction.....	43
Jib lifting/lowering.....	43
Cage rotation	43
Cage levelling	43
Machine status	44
Machine stowed away.....	44
Machine in the safety transport mode	45
Stabilised and stowed away machine	46
Machine open.....	47
Safety systems	48
Operating irregularities	49
Audible alarms	49
Safety belts attachment points	49
Overload sensor.....	50
Temperature relay	51
Overturning moment limiter	52
Clogged up oil filter sensor.....	52
Inclinometer and a spirit level.....	53
Micro switches.....	54
Micro switches SQ1A-B	55
Micro switch SQ8 (lifting boom)	55
Micro switch SQ9 (pantograph)	55
Micro switch SQ10 (control panel in the cage)	56
Micro switches SQ3-4-5-6.....	56
Emergency devices	57
Emergency stop	57

Battery switch	57
Electric valves for emergency operations	57
Manual pump	58
Electric pump 12V (optional)	58
Control stations	59
Control panel	60
Ground control panel	60
Turret rotation	62
Pantograph lifting/lowering	62
Boom lifting/lowering	62
Telescopic boom extension/retraction	62
Jib lifting/lowering	62
Cage rotation	62
Cage balancing	62
Platform control panel	64
Selector keys	65
Switches	67
Joystick controls	69
LED bar	70
Display unit	71
Engine status	71
Machine status	72
Use of the machine	76
Checking before using	77
Operation of the machine	78
Setting the machine into the working position	80
Starting the machine up	80
Motor start-up	81
Drive and Steering	82
Driving along the inclined terrain	82
Machine stabilisation	84
Automatic stabilisation	85
Manual stabilisation	86
Moving the aerial part	87
Returning to the stowed away mode	89
Retraction of the aerial part	89
Retraction of the stabilisers	90
Motor switch-off	91
Switching the machine off	92
End of works	92
Emergency procedures	93
Emergency manual procedures	94

Using manual pump	95
EXAMPLE 1	97
EXAMPLE 2	98
Manual Emergency Lowering Procedure.....	99
With the electric 12V pump (optional).....	102
The machine is blocked without any alert signals.....	102
From the ground	102
From the platform control panel.....	103
The machine is blocked in the alert mode	104
EXAMPLE 1	106
EXAMPLE 2.....	107
Manual start-up of the diesel/petrol engine	108
Petrol engine.....	108
Battery recharging.....	110
Battery charges characteristics; 120 V line	110
Transport.....	111
Loading and unloading of the machine	111
Using the loading platform	111
When lifting	112
How to uncouple the cage	113
Fastening the machine.....	114
Storage	115
Disposal and scrapping.....	115
Maintenance.....	116
Machine cleaning	116
Maintenance Summary Table.....	117
Maintenance of petrol/diesel engine	118
Petrol engine.....	118
Maintenance of the electric motor	119
Temperature relay	119
Checking the oil level; periodic oil replacement	120
Changing the oil	120
How to replace the oil filter cartridge.....	121
Greasing the machine movements controlling mechanisms.....	121
Batteries	122
Electrolyte level check	122
Check the battery charge.....	122
Check of screws tightening	123
Check the wear of the telescopic boom guides.....	123
Safety devices check	124

Red emergency stop button.....	124
Engine speed	124
Load limiter	125
Load sensor	125
Moment limiter	125
Micro switches	126
SQ1A-B.....	126
SQ8.....	126
SQ9.....	126
SQ10 (for the radio-controlled models).....	126
Manual emergency movements check.....	127
Brakes check.....	127
Good grip	127
Braking distances.....	127
Structure check	128
Checking the hydraulic tubes	129
Checking performance	129
Safety speed.....	129
Pantograph lifting/lowering.....	129
Boom lifting/lowering.....	129
Telescopic boom extension/retraction.....	130
Turret rotation	130
Jib lifting/lowering.....	130
Cage rotation	130
Maintenance of rubber crawling tracks	131
Checking the tension of the crawling tracks.....	131
How to loosen up or stretch the crawling track	132
How to replace the crawling tracks	133
Machine Logbook.....	135

This edition comprises the use and maintenance manual for a tracked, self-propelled, hydraulic scissor lift platform:

IM R19

Designed and manufactured to be:

- Powered by Diesel fuel or petrol;
- Hydraulically operated and with proportional controls;
- Remote-controlled by radio control or remote control.

IM R19 reaches a working height of 16.60 m and can be used outdoors.

Only qualified and skilled operators can use these machines.

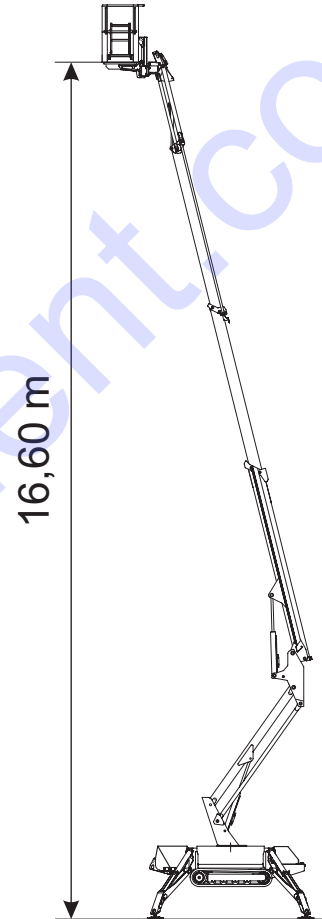

This manual was compiled in order to furnish the user with all the necessary instructions for a correct and safe use of the machine, so as to preclude heavy damages to the user and to any third parties.

All information and instructions comprised in this manual are fully binding, and must be read carefully and properly understood prior to the initial operation of the machine.

The manual is to be construed as an integral part of the machine, and therefore should always remain within reach on the platform for any future reference.

**All framed parts of the text are meant to furnish you with important safety instructions,
and should therefore be read with particular attention**

Static and dynamic tests

Before commissioning, the static and dynamic tests have been performed in full compliance with the harmonised industrial standard EN 280 Art. 6.3.

After-sale service

For any mechanical interventions, repairs and alterations/modifications, please refer to the authorised workshops only. For any specific information please contact our Technical After-Sale Assistance.

Spare-parts service

Good working performance of the unit, as well as its long life may be ensured by using the original spare parts only. Please make use of the "SPARE PARTS CATALOGUE" for this purpose.

Please always quote the information/data provided on the identification plates placed on the chassis and the cage, should you require any spare parts or technical assistance.

Liability

La IMER International S.p.A. shall be released from any liability or any obligations for any damage to persons or objects caused by any of the reasons listed further below:

- Non-observance of the instructions comprised in this MANUAL referring to driving, use and maintenance of the machine.
- Erroneous actions in regarding the use and maintenance of the machine.
- Modifications introduced either to the structure, and/or parts of the machine without prior authorisation of IMER International S.p.A., and/or making use of any inappropriate equipment for the task.
- Non-standard and/or incorrect use of the machine, in contravention of the specific instructions comprised in the present MANUAL.
- Use of any non-original spare parts not specifically authorised by the Manufacturer.

General instructions - safety

Manual



A suitable working safety is very important in order to avoid serious injuries for the operator himself and for the other persons, therefore it is compulsory to carefully read and well-understand this manual to know the exact and essential instructions for the use of the machine and the maintenance operations.

This manual is to be considered as an integral part of the machine and it should always remain on the platform for future reference.

This use manual must be carefully preserved by the user for the whole machine life, even if the machine is lent, rent or sold

The figures described in this manual DON'T always exactly reproduce the model described but these are used for a better and easier understanding of the text.

Safety systems

The safety systems applied to the machine are inevitably subject to wear and to go out of tune. Therefore, they must be controlled and kept in perfect efficiency; also, it is not advisable to evaluate their operational and safety conditions only on the basis of their functioning.

Such systems do not relieve the operator of the responsibility of carrying out an informed and appropriate use of the machine.

It is absolutely forbidden to remove, modify or tamper with parts of the self-propelled aerial platform, which are important for safety and stability.

Any tampering whatsoever with the main members of the self-propelled aerial platform and associated safety devices immediately nullifies guarantee conditions.

Labels and plates



Potential dangers and instructions regarding the machine are given on labels and plates; these should therefore be kept in a clearly legible, good condition.

Operator's requirements

Only qualified and skilled operators can use these machines



The operator shall:

- Read and well understand all the documentation enclosed to the machine, be properly trained and instructed in the correct use of the machine and know the safety rules and devices.
 - Be physically in good conditions and not make use of dope, alcohol or drugs that could affect the attention, the reaction, the sight and the hearing.
 - Give a great importance to safety and refuse to work if you think you are not working under safe conditions.
 - Well-know the maximum working load.
- Use suitable accident prevention equipment accordingly with the working conditions and the local rules in force.
 - When you are on the cage keep all the parts of the body inside the guard rails and both feet have to be firmly rest on the floor surface.
 - Make always use of an assistant in areas where the sight is obstructed.
 - Always work under highest safe conditions, tidiness and cleaning.
 - Before using the machine check daily the controls and safety devices and make sure they are in perfect working order.
 - Check that the working area is free from persons, animals or obstacles before making any movement of the machine.
 - Check that the ground where the machine has to operate is free from holes, bumps, drops, uneven level, obstructions, debris and coverings which could hide possible potholes or others dangers.
 - Clean the ladder, the floor surface of the platform and the handrails from oil and grease.
 - Once the work has been finished and when the machine remains unattended, take the key off to avoid that unauthorized persons can use it.
 - Commuting platform control panel, always remove the key to avoid an unauthorized use from the ground control panel while personnel is present on the platform. The safety manager must hold a spare key enabling to use the ground control panel as emergency place. (In case of failure it is possible to lower the machine).

In particular



- Be aware that the tracked platforms with remote control can be used by qualified personnel only.
 - Do not give the platform panel to people who have not been thoroughly trained.
 - Familiarize yourself with the symbols and the positions of the levers for the operation of functions and handling.
- Always check before starting work, the functionality of the button for the emergency stop of the platform panel.
 - Whenever the machine is moving along on the ground, make use of the platform control panel while staying at a safe distance from the machine at all times. No unauthorised persons may remain within the working area of the machine when it is in operation.
 - Release all the levers if the movement of the machine becomes uncontrollable and immediately press the emergency stop button of the platform panel.
 - Always press the emergency button of the platform panel when the unit is not in use. This also applies for short breaks, for example, if the driver wants to move the machine.
 - Always press the emergency button of the platform panel at the end of the work. The platform panel must be kept out of reach of unauthorized persons.

Distance from the electric lines



The machine is not electrically insulated and does not offer any protection against active parts, electrical lines and plants which are not protected or not sufficiently protected.

Here below you can find a table concerning the safety distances to be compulsory observed according to the Italian law.

In other countries the operator may have different limitations to be observed

Un (kV)	Minimum allowed distance (m)	
da 0 a 300V	avoid contact	
da 300V a 50kV	10ft	3.05m
da 50kV a 200kV	15ft	4.60m
da 200kV a 350kV	20ft	6.10m
da 350kV a 500kV	25ft	7.62m
da 500kV a 750kV	35ft	10.67m
da 750kV a 1000kV	45ft	13.72m

Un = nominal voltage

Not allowed operations



It is strictly forbidden to use the machine:

- On public roads.
 - Without an adequate environmental lighting to work or to move under safety conditions.
 - Work in case of strong storm, with or without rain, or with wind with speed higher than 12,5 m/s, 6 grade of the Beaufort scale described below.
- Without making sure that the platform gate bar is closed.
 - without using the safety belts.
 - While moving, with boxes opened.
 - If the working area is not free from obstacles which could cause dangerous conditions.
 - While entering in contact with fixed or mobile objects.
 - Under bad working conditions.
 - In a different way from what it has been described in the instruction manual.
 - After modifying or removing the safety devices.
 - After fastening it to adjacent structures.

In addition, it is forbidden to:

- Operate or lift the platform when it is placed on the truck loading platform or other vehicle.
- To throw some objects and tools from the top to down and vice versa.
- Use the boom for purposes other than setting the staff, their tools and equipment to work position.
- Control the machine from the ground control panel with a second operator on the cage.

Beaufort Wind Scale

	Description	Wind speed (km/h)	Wind speed (km/h)	Sea conditions	Land conditions
0	Calm	0	0	Flat	Calm. Smoke rises vertically.
1	Light air	1-6	0.3-1.5	Ripples without crests.	Wind motion visible in smoke.
2	Light Breeze	7-11	1.6-3.4	Small wavelets. Crests of glassy appearance, not breaking.	Wind felt on exposed skin. Leaves rustle.
3	Gentle breeze	12-19	3.4-5.4	Large wavelets. Crests begin to break; scattered whitecaps.	Leaves and smaller twigs in constant motion.
4	Moderate breeze	20-29	5.5-7.9	Small waves.	Dust and loose paper raised. Small branches begin to move.
5	Fresh breeze	30-39	8.0-10.7	Moderate (1.2 m) longer waves. Some foam and spray.	Smaller trees sway.
6	Strong breeze	40-50	10.8-13.8	Large waves with foam crests and some spray.	Large branches in motion. Whistling heard in overhead wires. Umbrella use becomes difficult.
7	Near gale / Moderate gale	51-62	13.9-17.1	Sea heaps up and foam begins to streak.	Whole trees in motion. Effort needed to walk against the wind.
8	Fresh gale	63-75	17.2-20.7	Moderately high waves with breaking crests forming spindrift. Streaks of foam.	Some twigs broken from trees. Cars veer on road.
9	Strong gale	76-87	20.8-24.4	High waves (6-7 m) with dense foam. Wave crests start to roll over. Considerable spray.	Larger branches break off trees, construction/temporary signs and barricades blown over, damage to circus tents and canopies.
10	Whole gale / Storm	88-102	24.5-28.4	Very high waves. The sea surface is white and there is considerable tumbling. Visibility is reduced.	Trees broken off or uprooted, saplings bent and/or deformed, poorly attached asphalt shingles and shingles in poor condition peel off roofs.
11	Violent storm	103-117	28.5-32.6	Exceptionally high waves.	Widespread vegetation damage, minor damage to most roof shingles/surfaces, gravel may be blown from flat roofs.
12	Hurricane	> 117	> 32.5	Huge waves. Air filled with foam and spray. Sea completely white with driving spray. Visibility greatly reduced.	Considerable and widespread damage to vegetation, a few windows broken, structural damage to mobile homes and poorly constructed sheds and barns.

To minimize hazards

Follow the instructions below:

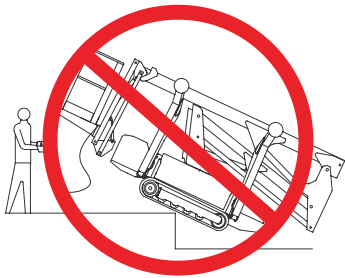

Risk of folding

- Check the ground is firm and even.
- Do not use the machine on slippery, icy, muddy ground and with holes, which has a slope higher than the allowed limit.
- Keep a distance of at least 2 m from steep unevenness (ditches, steep terrain, etc...).
- Check that the ground where the machine has to operate is free from holes, bumps, drops, uneven level, obstructions, debris and coverings which could hide possible potholes or others dangers.
- Comply with the maximum load and the allowable number of persons.
- Distribute the load on the entire platform surface uniformly.
- Avoid the machine knocks against fixed or mobile obstacles.

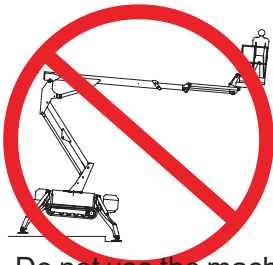

- Do not use the machine as a crane with materials suspended to the lifting structures or to the basket.
- Do not increase the maximum available working height by putting ladders or scaffolds on the platform or climbing onto the guard rails.
- Do not place materials on the guard rails.
- Give the best attention during movements with mobile travelling platform.
- Carry out the movements only if the working area visibility is complete.
- Do not use an horizontal force above 400N.
- Do not equip the machine with elements (ex. panels) which increase the wind exposure.

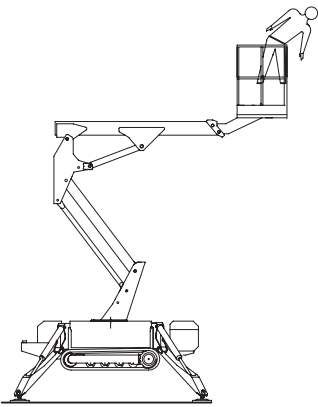

Risk of falling

- The use of safety belts is compulsory.
- Do not lean out of the safety perimetric guard rails of the platform.
- Do not use guard rails as admittance means to get on or get down from the platform.
- Do not get on or get down from the platform when it is lifted.

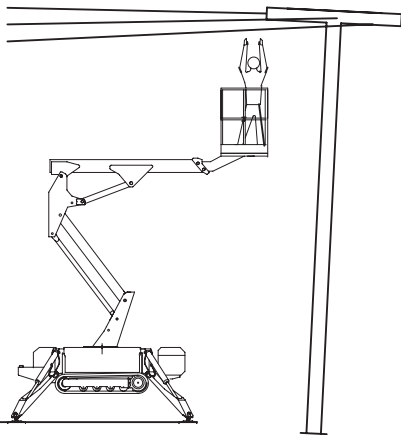

Electric hazards

- As the machine is not electrically insulated, the operator has to pay a particular attention to avoid any contact with probably energized parts.
- Do not carry out works near electrical lines at a distance lower than the one indicated in the table page 15.

Explosion or burn hazards

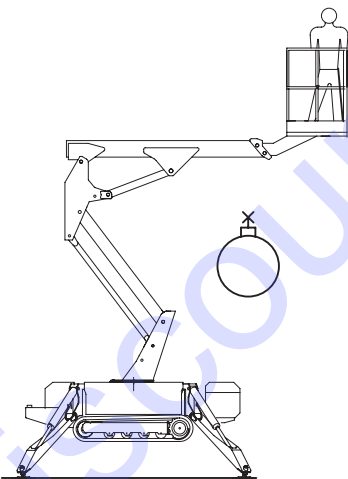

- Do not use the machine near open flames or heat sources.
- Charge batteries in ventilated environment, far from heat sources or explosive fluids.
- Do not use the machine if there are oil leakage.
- Do not use the machine in environments with explosive atmosphere.
- Shut the engine down during refuelling.
- Make refueling in a well-ventilated area.
- Dry fuel in case it is poured out .
- Do not smoke during refueling.

Residual risks

The plates and labels listed below indicate the residual risks that remain despite there being protective measures incorporated into the machine’s design and regardless of the safety devices adopted.



Description of the machine

The remote-controlled aerial platform IM R19 is used to lift persons, materials and equipment to enable works to be performed at certain heights (indoor and outdoor).

It is intended to be used accordingly with the foreseen technical data described in the suitable sheet, on solid and strong grounds and not before a Qualified Operator has checked the operational safety.

It is equipped with:

- A. Chassis
- B. Stabilizers
- C. Turret
- D. Lifting structure
- E. Bearing structure or basket

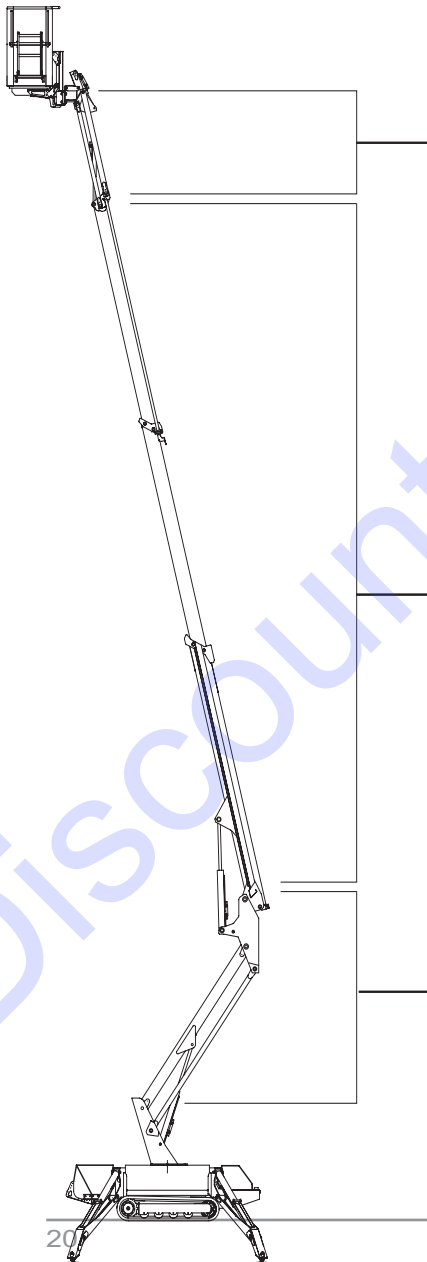

The lifting system consists of 3 main structures operated by hydraulic cylinders:

- Jib
- Telescopic boom
- Pantograph

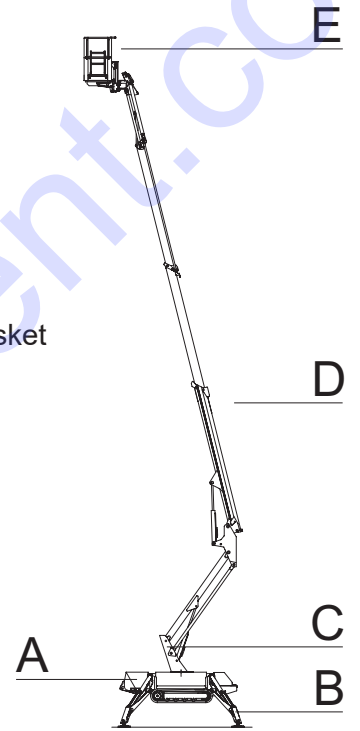

Main components

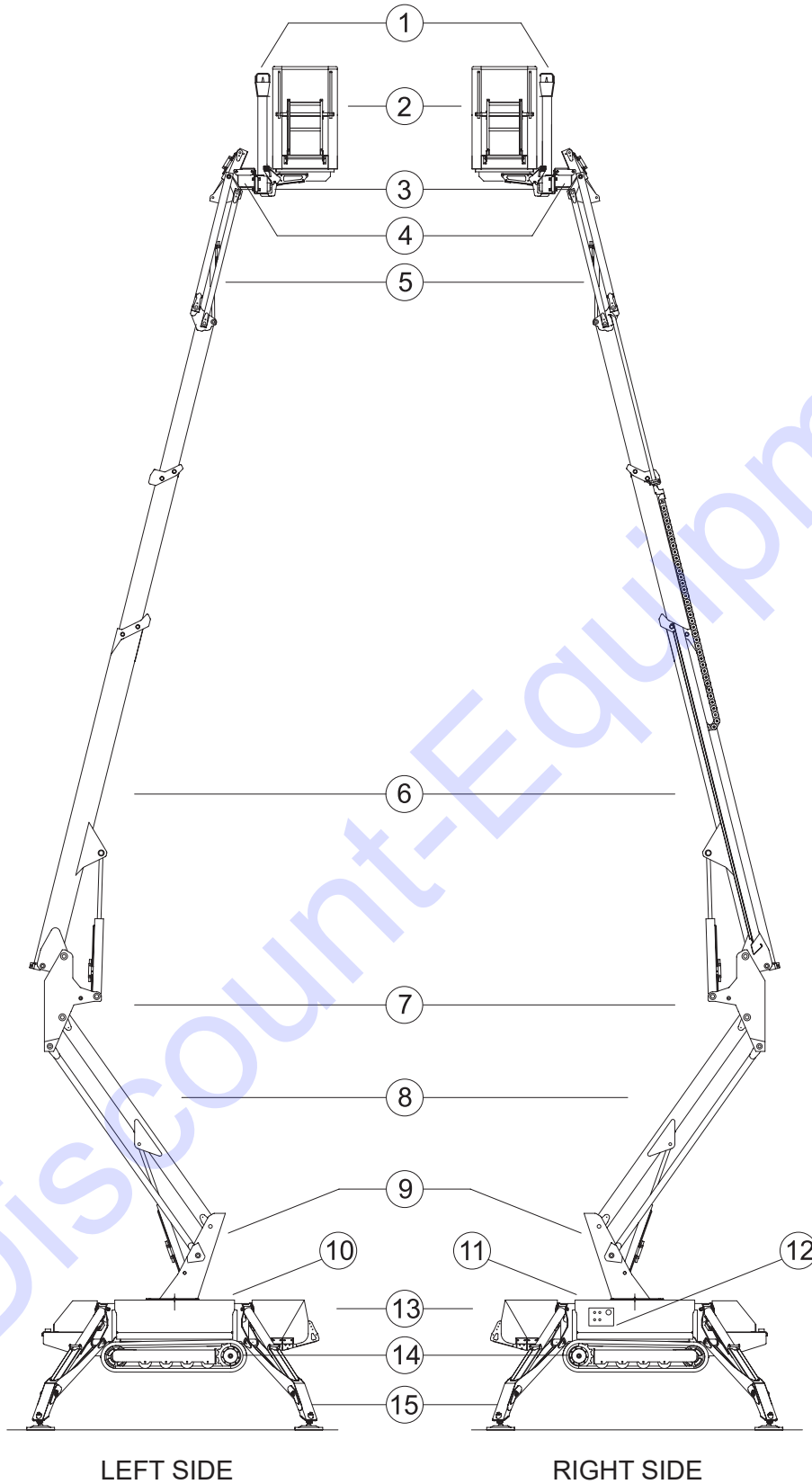

- 1. Platform panel
- 2. Platform - basket
- 3. Actuator rotation
- 4. Load cell
- 5. Jib
- 6. Telescopic booms
- 7. Knee
- 8. Rods Pantograph
- 9. Turret
- 10. Left box
- 11. Right box
- 12. Ground control panel
- 1. Chassis
- 2. Driving wheels
- 3. Stabilizers

Control and power instruments

RIGHT SIDE

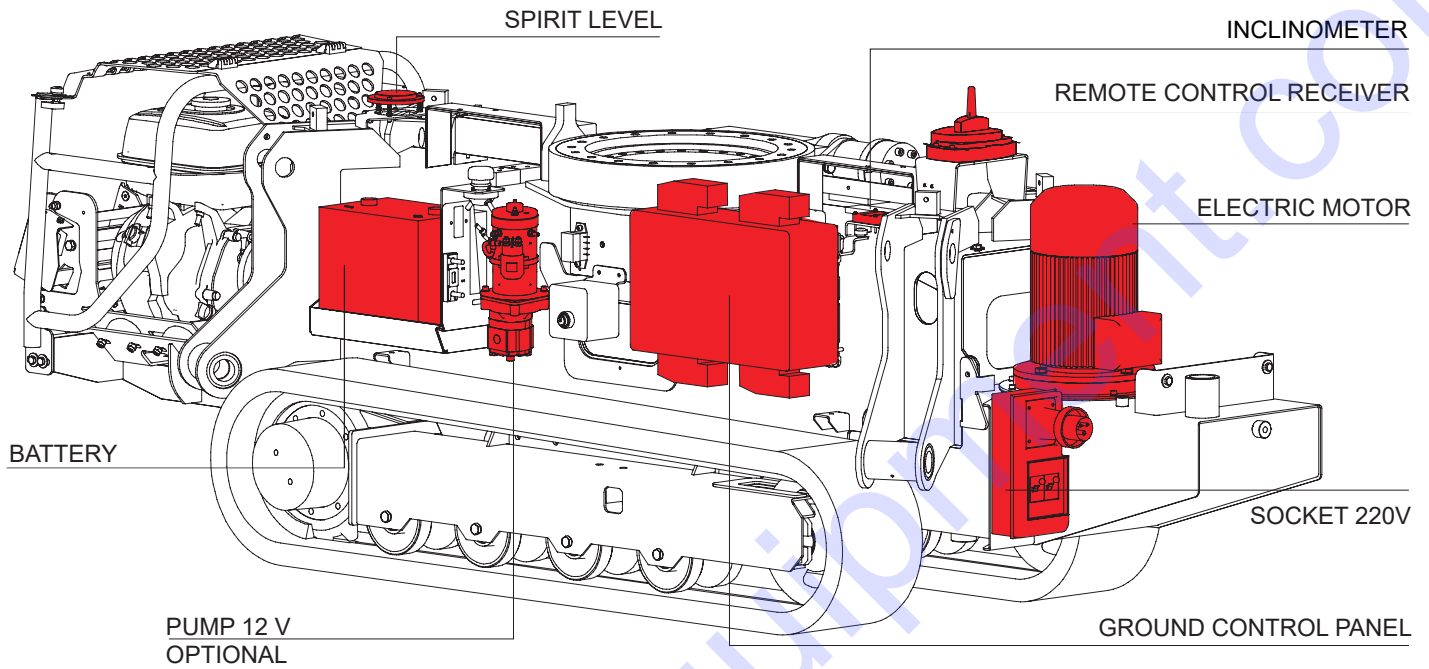

LIFT SIDE

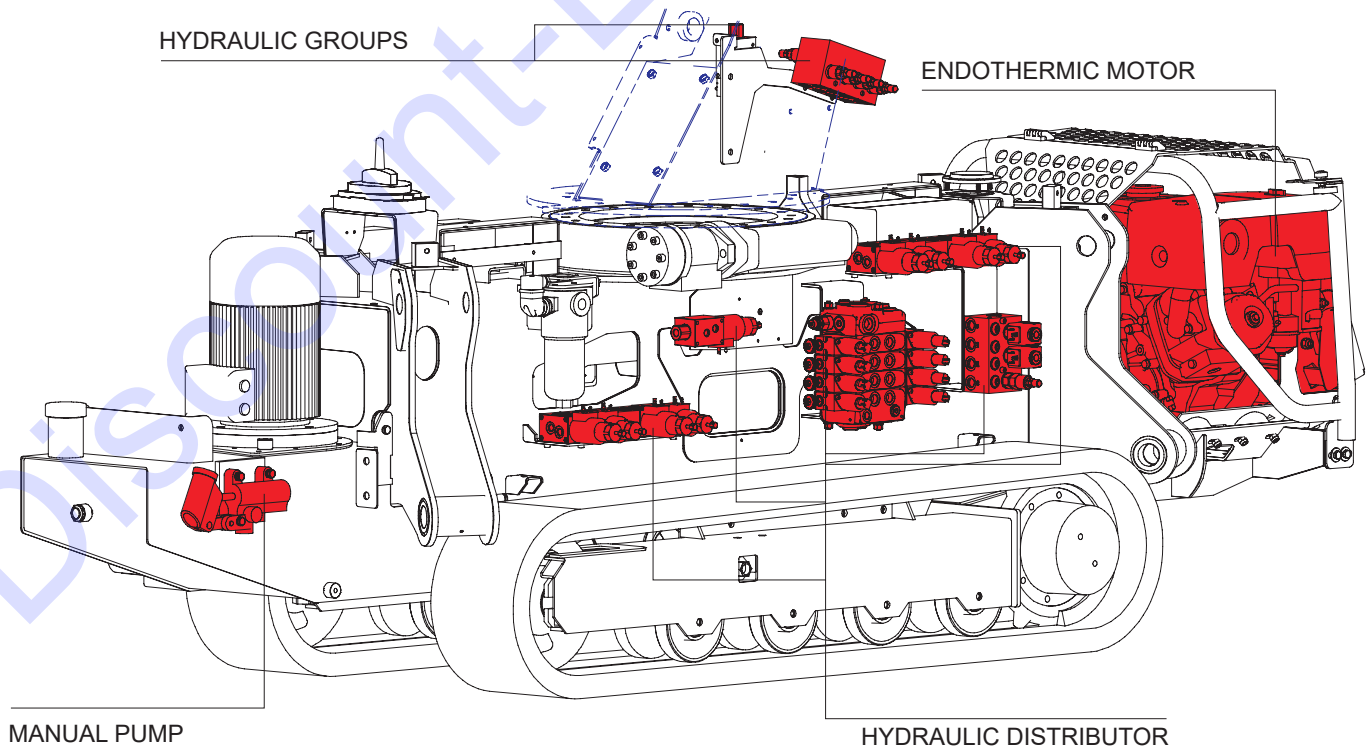

CAGE

Platform PANEL

The platform panel is removable and may be used by the operator also from the ground.

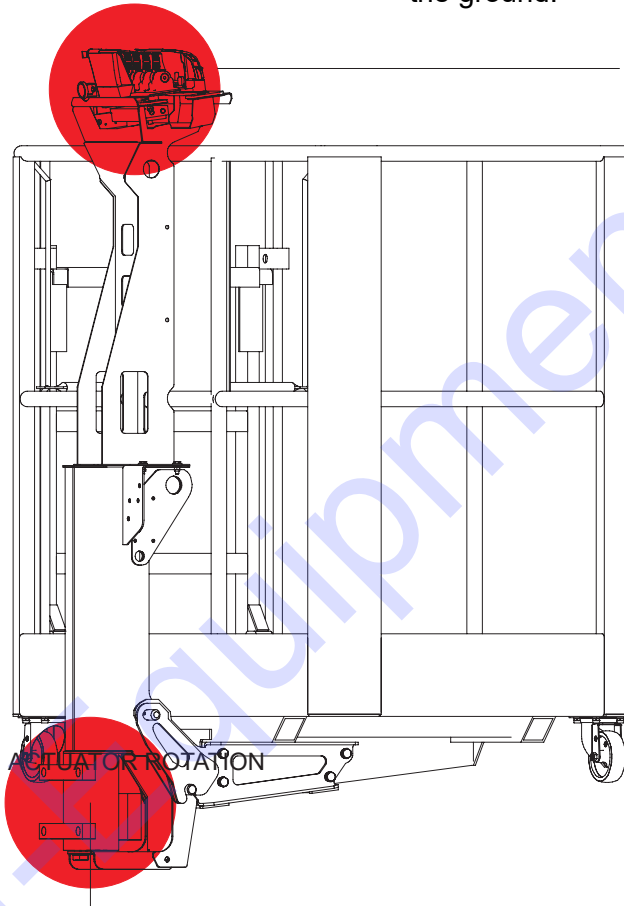

Electronic circuit

The electronic equipment consists of electronic microprocessor devices for the machine operation:

- two main control units located behind the ground control panel
- receiver for the platform panel (communicating via the CAN Bus transmission protocol with the two main boards)
- platform panel with display (communicating with the receiver by wire or radio)
- overload controller on the platform located near the cage

Electric circuitry

Voltage of the power supply should comply with the data referenced on the label of the electric motor. At full load, it must be between 205 V and 240 V.

To start up the machine it is necessary to make use of a 2-pole cable + earth to plug it into the mains socket.

Dimensions of the power supply cable

The electric power supply cable should be appropriately designed to avoid any voltage drops. Use of automatic winders should be avoided. The diameter of the power supply cable must comply with the nominal current value and the actual length of the cable in order to avoid excessive voltage drops.

Section of the cable (mm ²)			Length of the cable (m)
1.5	2.5	4.0	
0 - 8	9 - 13	14 - 22	

Power supply cables used in the yard should have an appropriate outer coating resistant to squeezing and wear, as well as to any adverse weather conditions.

In order to ensure full conformity with the power supply unit, consult the provisions of the CEI-64-8 industrial standard (document of harmonisation CENELEC HD384).

Control proportionality

Drive and all lifting system movements are proportionally controlled: depending on the movements of the joystick controls an electronic system provides more or less energy to the electro-hydraulic valves that regulate the oil flow to the hydraulic actuators.

Radio control and remote control

Radio control

The radio control is a digital remote control system, based on microprocessor technology, protected against electromagnetic and radio interference.

The radio control consists of:

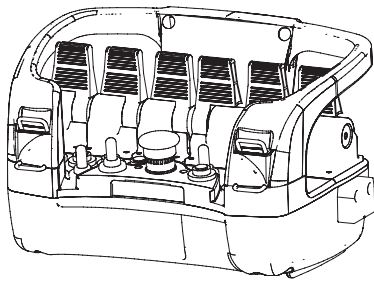

- a **PORTABLE CONTROL UNIT (Platform PANEL)** with joystick controls for proportional control of movements (switches and buttons for ON/OFF functions, warning lights, graphic LCD).

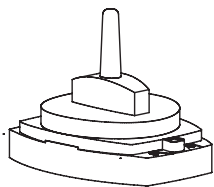

- a **UNIT RECEIVER**

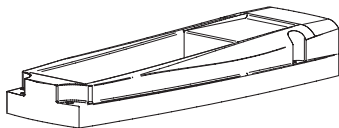

- a **BATTERY CHARGER**

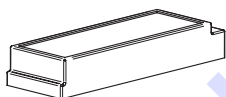

- two **BATTERIES** for platform panel

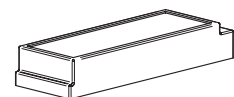

- a **SERIAL CABLE**

The platform panel and the receiver are combined so that a radio control operates only the machine for which it is intended.

Where you can't use the radio control (for example in airports) you can connect to the platform panel:

- on the cage by the especially provided control cable;
- on the ground through the serial control cable connected to the central unit (the cable is contained within the document holder box).

Remote control

The remote control is a wire control system with the same functionality as the radio system, but without the remote control.

The remote control consists of:

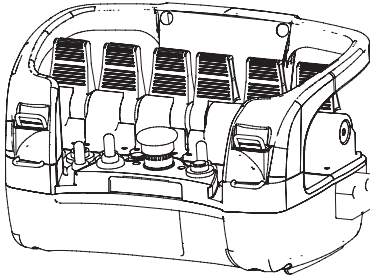

- a **PORTABLE CONTROL UNIT (Platform PANEL)** with joystick controls for proportional control of movements (switches and buttons for ON/OFF functions, warning lights, graphic LCD).

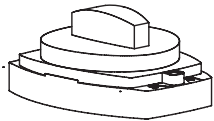

- a **UNIT RECEIVER**



- a **SERIAL CABLE**

The platform control panel is powered by the serial control cable connected to the central unit. The remote control model has no batteries for the platform control panel.

The platform panel

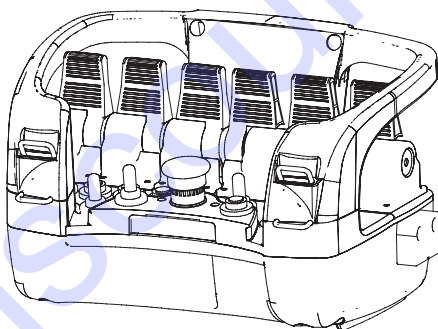

The portable control unit is sturdy, weather resistant, light and compact.

The levers and the joystick controls are proportional with spring return to the center. The platform panel is equipped with an emergency stop button to stop immediately all the movements.

The joystick controls are surrounded by a frame to protect against any accidental activation and mechanical damage.

A LED and an audible alarm are used to indicate the normal operation, the battery charge status and as a diagnostic tool for the detection of any malfunction.

For the models with a radio control unit, the platform control panel functions with a battery inserted in its lower part (see "Battery for platform control panel").

Dead Man Button

Dead Man Button is located on the right side of the platform panel, on the basket

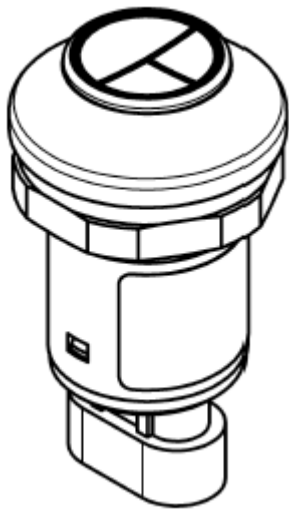

It is an additional security for operator, because it allows movements only if it is pressed

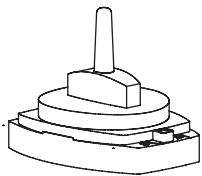

Receiver

The electronic control unit is contained in a sturdy plastic box and is provided with connectors that connect the platform panel.

The electronic control unit of the radio control mount the antenna and the radio receiver, the remote control no.

Status and alarm indications are reported by the central unit through a 7-segment display placed on the receiver.

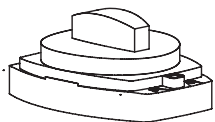

In the event of a malfunction the display unit will show “Er” followed by four characters divided into two blocks corresponding to the allocated error code.

If the problem is regarded as “temporary” only, the error code will be repeated 3 times and then the radio control will return to stand-by, just as in the switched-on mode.

If the malfunction is regarded as “blocking”, the display will show the error code continuously until the radio control is turned off.

The error code may be displayed upon the activation of the receiver, or upon the activation of the platform control panel (thus enabling the operating mode).

Platform panel battery for radio control

The battery inserted into the lower part of the platform panel, allows for the use by radio. Another battery is supplied to be always placed in the battery charger.

The replacement is quick and very simple to perform.. The operation of a fully charged battery is about 8 hours.

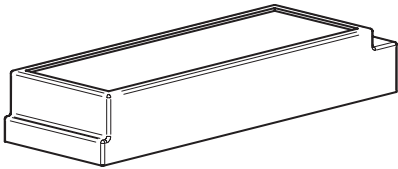

When the battery is low, the platform panel beeps three times as a warning and the red LED ON begins to flash (led on the left of the emergency stop button). When a battery is fully charged the red LED ON is activated.

The battery must be used until the red LED turns off, after which it must be changed. If the capacity of the battery is too low, the platform panel may not turn on.

The battery capacity and operational performance are reduced in conditions of extreme cold. The battery recharges automatically during the use of the platform panel with the serial cable.

In order to minimize the consumption of the battery, and, for safety reasons, the platform panel turns off automatically after a period of inactivity of 30 minutes.

Battery charger

Battery charger is placed in a box of the left-hand side of the turret.

It is supplied from a 12 V battery for the motor start-up and it is designed to prevent damage to the battery even if it is subjected to the long cycles of continuous charging.

There are two LED indicators on the upper part of battery charger:

- **Red LED** (power) - Indicates the presence of the supply voltage.
- **Green LED** (status of charge)
 - **Flashing**, the battery is charging (the battery charger is in fast charge mode)
 - **Lit up steady**, the battery is charging (the battery charger is in charge maintenance mode).

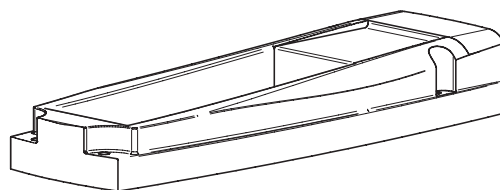

Charging the battery

The battery charger starts a charge cycle when a battery is inserted (the green LED starts blinking). The battery charging of the radio control takes place in two consecutive steps:

- first step with a high current, to reach the level of nominal charge in short time;
- second step, with a low current, to maintain the charge reached until the battery is removed.

The time normally used to recharge a dead battery is about 3 hours (the green LED is lit up steady).

If the voltage at the device is lost, the battery charger, recalls the last work mode and resumes charging in “fast” or “maintenance” mode when power is restored.

As a precaution the battery charger stops always to charge after 3 hours, even if the battery has not reached full charge. When charge is finished, the green LED will remain on at all times.

Battery charge with serial cable

If the operator is using the platform panel with the serial cable connected, the battery in the battery compartment is automatically recharged.

In case of need the platform panel can be used as alternative instrument for the charge of the batteries even when the system is not used.

Insert the battery into the appropriate compartment (emergency stop button of the platform panel pressed) and connect the serial cable between platform panel and central unit. The charging time is approximately 12-14 hours.

Technical specifications

Description	Petrol
Max. working load (including 2 person)	230 kg 510 lb
Drive speed	0 - 2 km/h 1.24 mph
Max. slope	32%
Max. allowed side force	400N 90 lbf
Max. allowed side inclination for the chassis	1°
Turret rotation	355°
Basket rotation	124°
Endothermic motor	8,2 / 3600 kW/giri
Electric pump	220 / 2,2 V/kW
Battery	12 / 95 C5 V/Ah
Battery charger	12 / 12 V/A
Stabilizers load	1750 daN 3930 lbf
Machine weight	2435 kg 5370 lb
Oil tank	30 l 8 gal
Measured sound power level	102 db
Guaranteed sounding power level	104 db
Level of acoustic pressure weighed at operator's place	82 db
Max. hydraulic pressure	220 bar 3190 psi
Working temperature	da -20 a +40 °C da -4 a 104 °F

Vibrations

As regards vibrations, according to the measurements carried out in the most unfavourable conditions of use, it has been established that:

- the average weighted quadratic value in frequency of the acceleration relevant to the upper limbs is lower than 2.5 m/sec²;
- the average weighted quadratic value in frequency of the acceleration relevant to the body is lower than 0.5 m/sec².

Overall dimensions

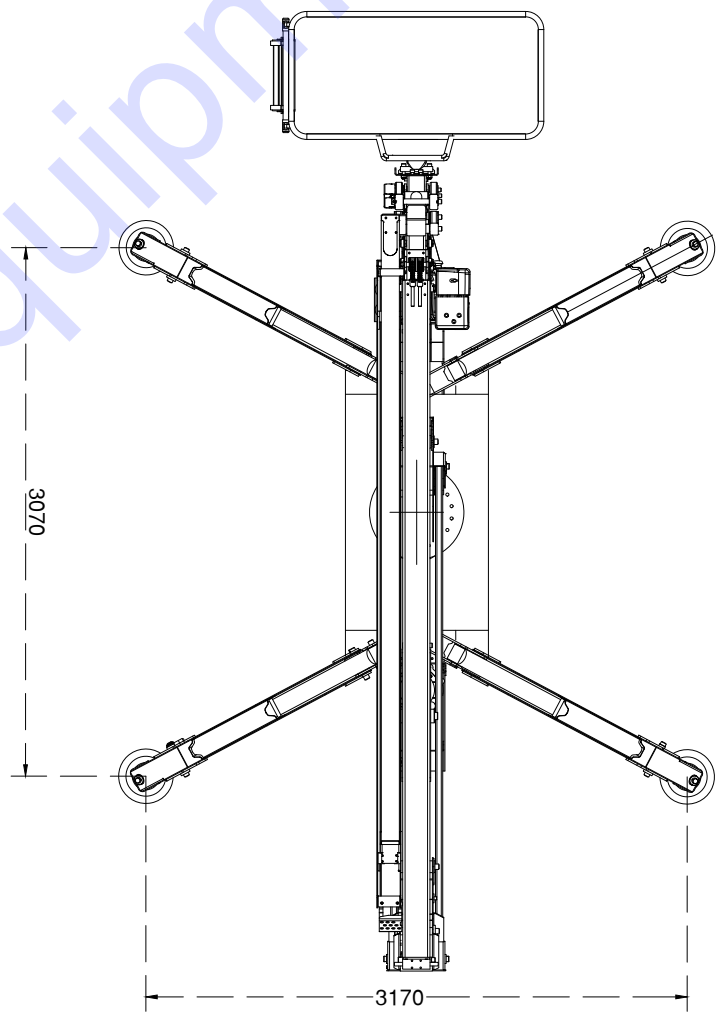
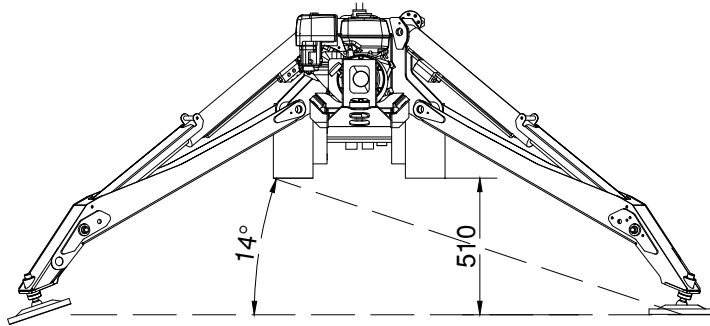

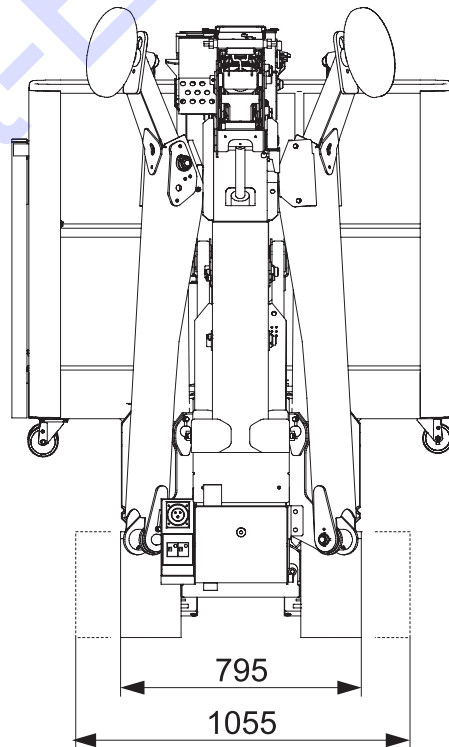
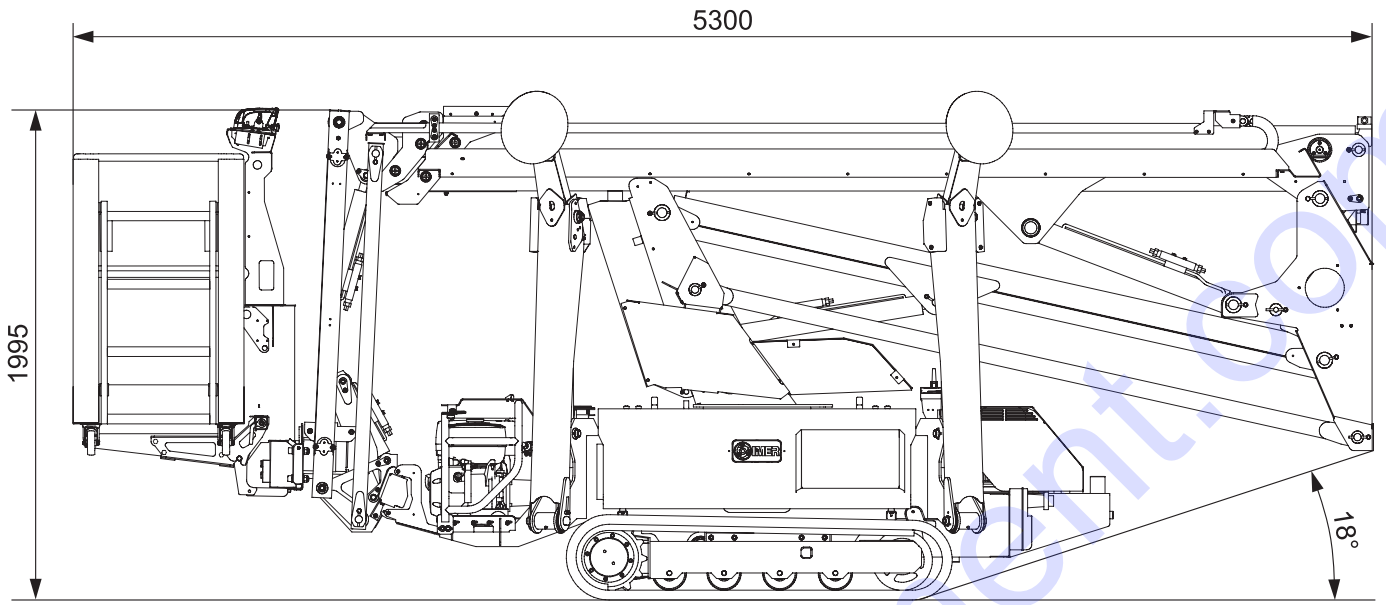
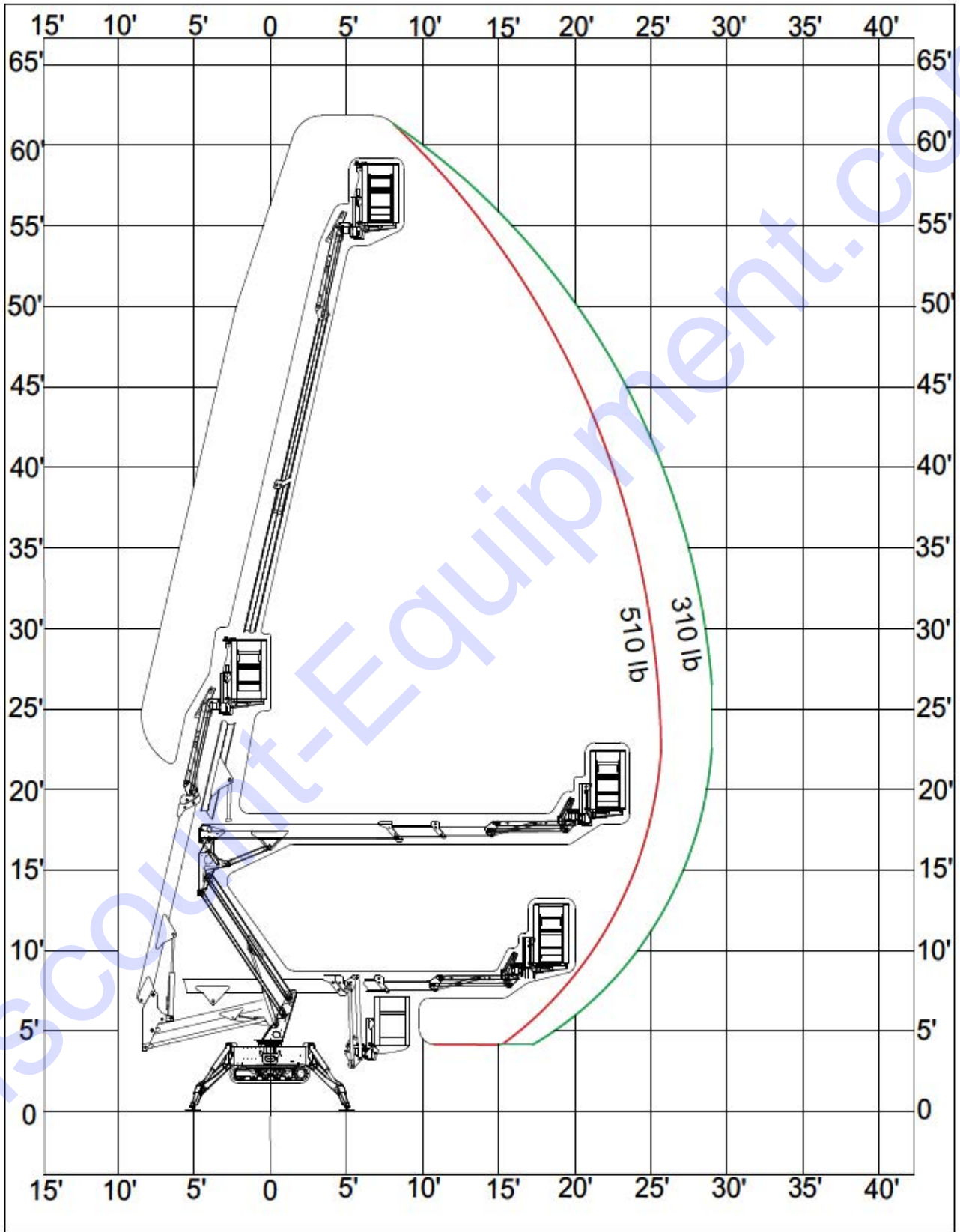

Diagram work



Plates and labels

Using the illustrations, check that all the plates and labels are in place.

Plates and labels that contain no text will have an 8-digit numbering or an alphanumeric code ending with XX.

Plates and labels that contain text will have an alphanumeric code ending with the relevant country code for the machine's destination country.

79421033	Y/B BANDS	1	A00358XX	110V SUPPLY	1
82521034	Y/B BANDS	4	A00445USA	MANUAL EMERGENCY MOVEMENTS	1
A00356USA	WORK DIAGRAM	1	A00442USA	PROHIBITION MODIFY COMPONENTS	1
82021098	Y/B BANDS	4	A00443USA	EMERGENCY SEQUENCE	1
A00405USA	SAFETY ELECTRIC DISTANCE	1	A00449USA	MANUAL DESCENT INSTRUCTION	1
A00145XX	DOCUMENT BOX	1	A00451XX	PROHIBITION CLIMBED ON RAILINGS	6
A00411USA	MAX. STAB. LOAD	4	A00457XX	MANUAL READING	1
A00448USA	CRUSHING HAZARD	4	A00369XX	OIL SYMBOL	1
A00174XX	OIL TYPE ISO 46	1			
A00444USA	BASKET ROTATION	2			
A00454USA	FALL ARREST POINT	1			
A00450USA	SAFETY ELECTRIC DISTANCE	1			
A00302XX	LOGO	4			
A00304XX	LOGO	1			
A00322XX	LOGO	1			
A00352XX	IM R19	3			
A00447USA	CRUSHING HANDS HAZARDI	4			
A00406USA	FALLING HAZARD	1			
A00357XX	TURRET ALIGNMENT	1			
A00190XX	LIFTING HOOKS	4			
A00033GB	EMERGENCY	1			
A00361XX	LABEL HYDRAULIC BLOCKS	1			
A00362XX	SERIAL CABLE	1			
A00363XX	ROPES FOR TRANSPORT	4			
A00364XX	BREAKER	1			
A00380XX	DIRECTIONAL ARROW	1			
3231792	MADE IN ITALY MADE IN EU	1			
A00407USA	TIP OVER HAZARD	2			
A00408USA	CRUSHING HAZARD	1			
A00409USA	IMPROPER USE HAZARD	1			
A00410USA	ANNUAL INSPECTION	1			
A00458USA	EMERGENCY PUMP	1			
A00103USA	NO STOPPING	4			
A00462USA	MAX PLATFORM LOAD 230KG-510LB	1			
A00354USA	INSTRUCTION PLATE	1			
A00383USA	REMOVE KEY	2			

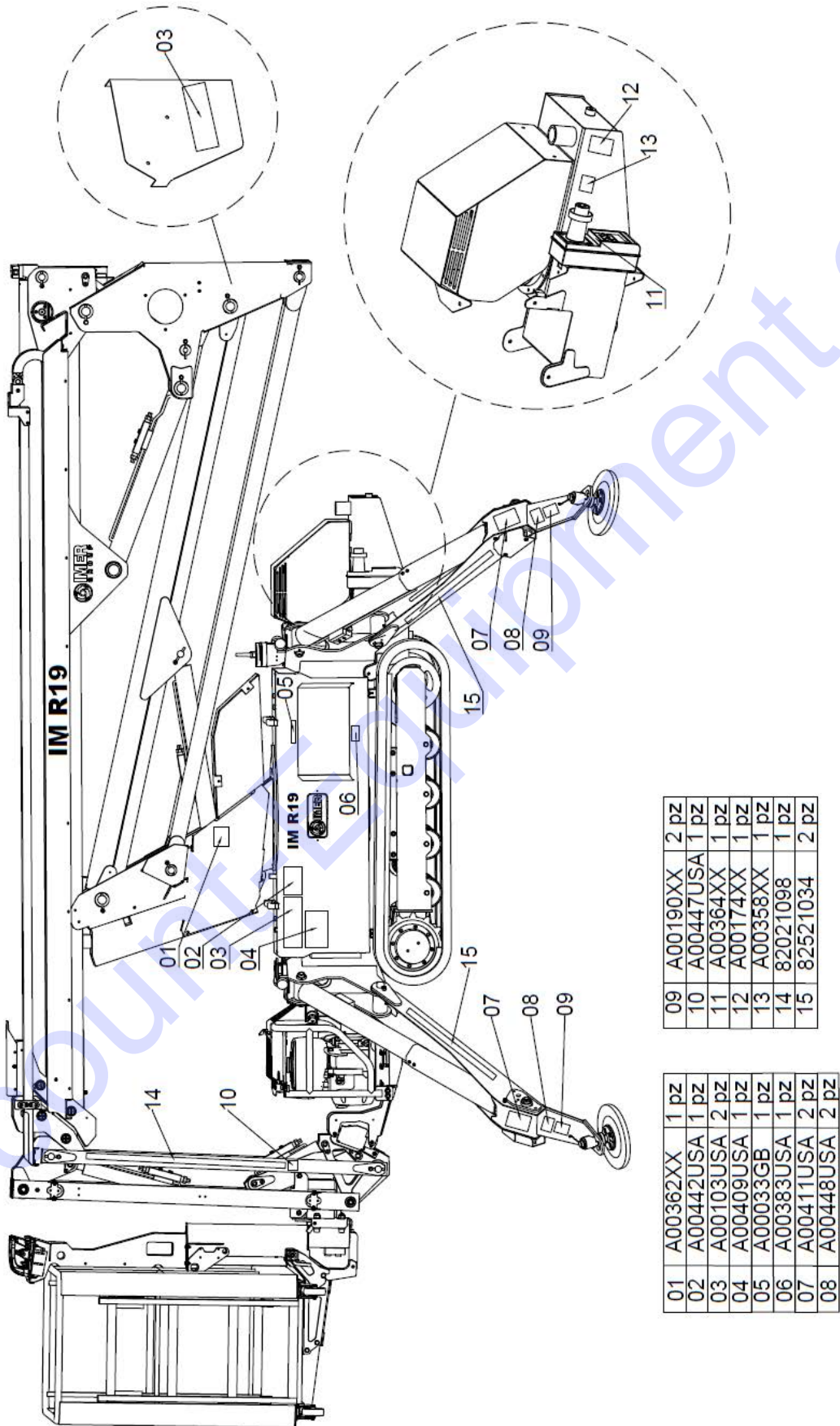

09	A00190XX	2 pz
10	A00447USA	1 pz
11	A00364XX	1 pz
12	A00174XX	1 pz
13	A00358XX	1 pz
14	82021098	1 pz
15	82521034	2 pz

01	A00362XX	1 pz
02	A00442USA	1 pz
03	A00103USA	2 pz
04	A00409USA	1 pz
05	A00033GB	1 pz
06	A00383USA	1 pz
07	A00411USA	2 pz
08	A00448USA	2 pz

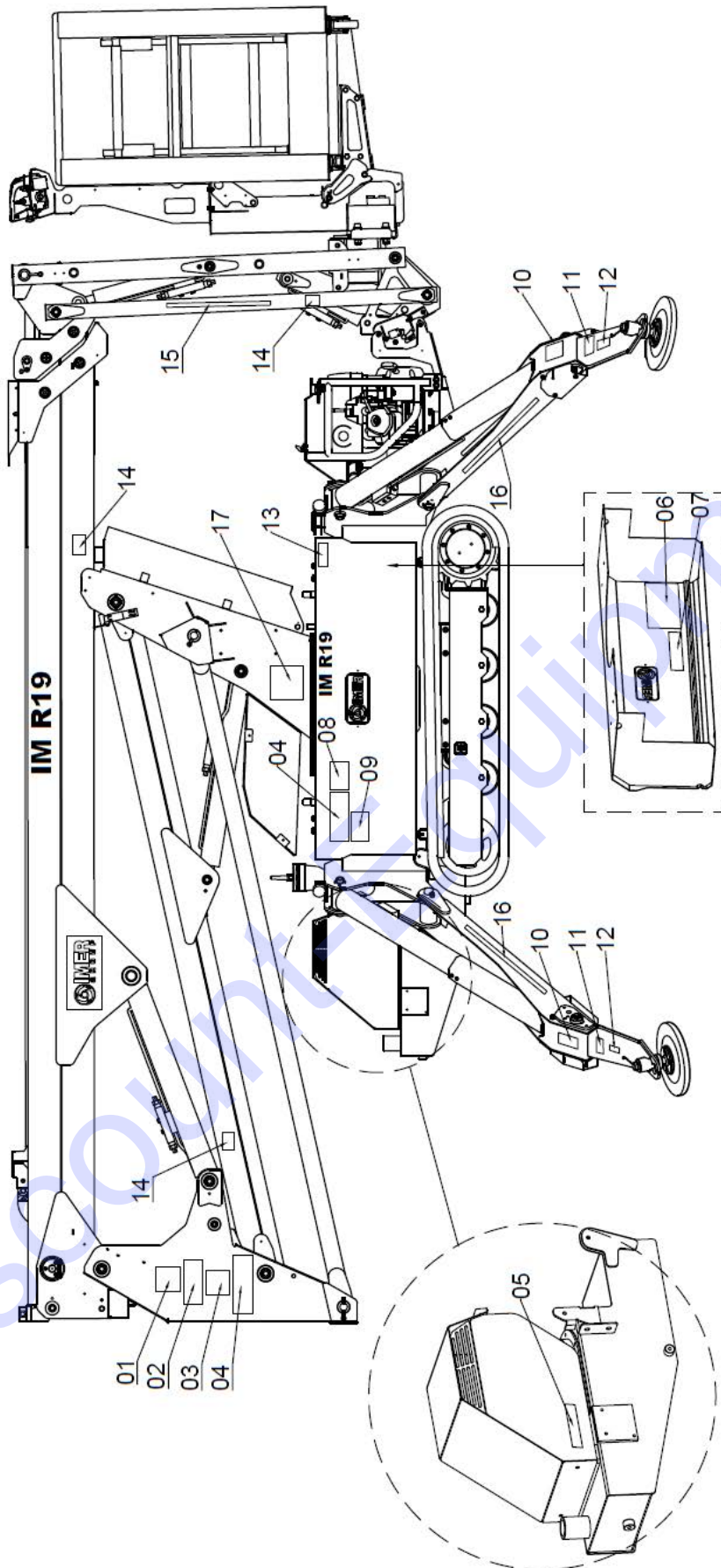

17 A00031USA 1 pz

09	A00409USA	1 pz
10	A00411USA	2 pz
11	A00448USA	2 pz
12	A00190XX	2 pz
13	A00449USA	1 pz
14	A00447USA	3 pz
15	82021098	1 pz
16	82521034	2 pz

01	A00405USA	1 pz
02	A00407USA	1 pz
03	A00410USA	1 pz
04	A00103USA	2 pz
05	A00458USA	1 pz
06	A00445USA	1 pz
07	A00443USA	1 pz
08	A00442USA	1 pz

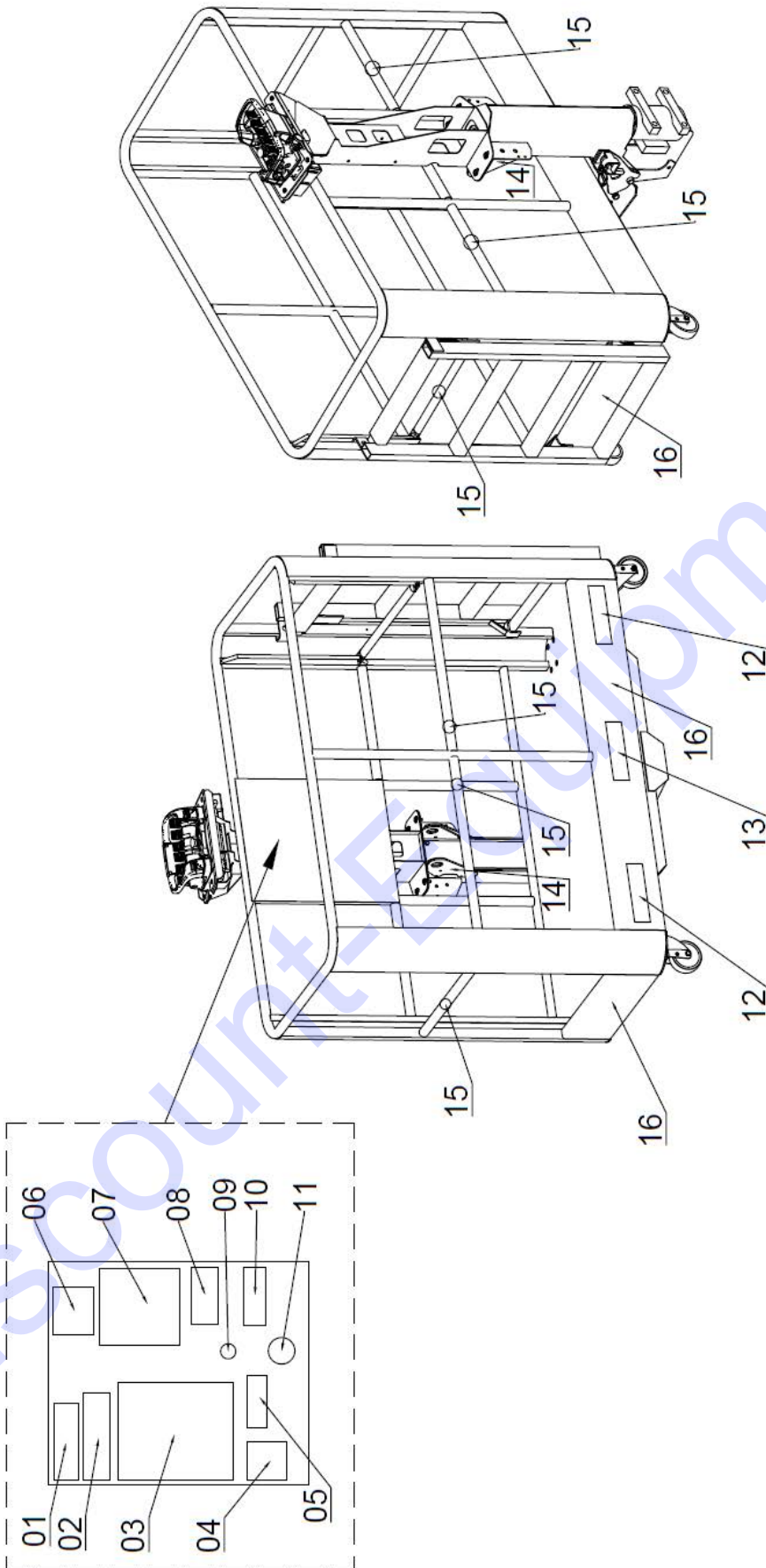

09	A00457USA	1 pz
10	A00408USA	1 pz
11	3231792	1 pz
12	A00444USA	2 pz
13	A00462USA	1 pz
14	A00454USA	2 pz
15	A00451XX	6 pz
16	79421033	3 pz

01	A00450USA	1 pz
02	A00406USA	1 pz
03	A00356USA	1 pz
04	A00289XX	1 pz
05	A00383USA	1 pz
06	A00405USA	1 pz
07	A00354USA	1 pz
08	A00407USA	1 pz

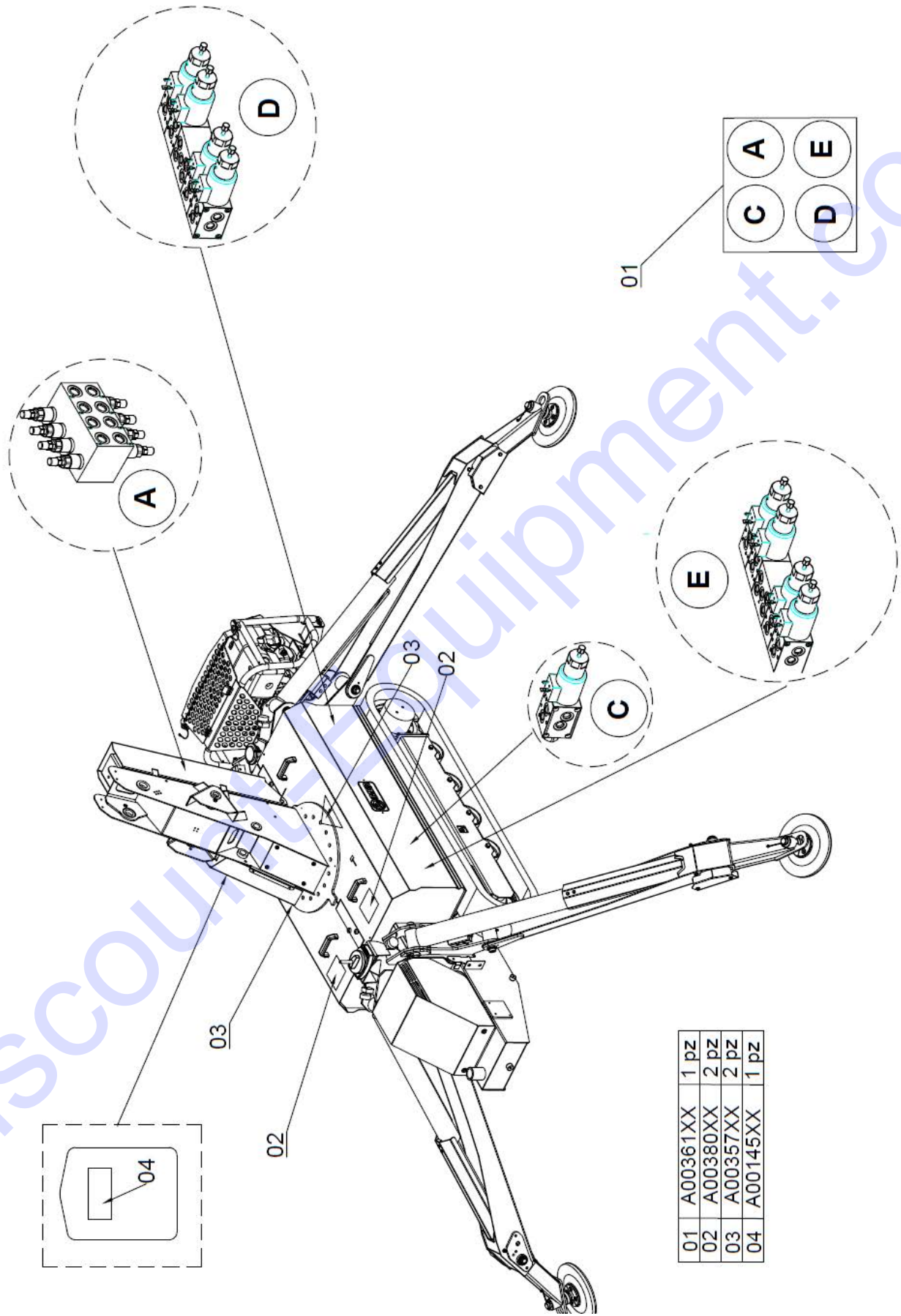

01	A00361XX	1 pz
02	A00380XX	2 pz
03	A00357XX	2 pz
04	A00145XX	1 pz

Identification

Two metal plates fixed to the chassis and the cage specify all data necessary to identify the model of the machine.

 IMER International SpA Via Salceto, 53-55 53036 Poggibonsi (SI) ITALY			
DENOMINATION	MOBILE ELEVATING WORK PLATFORM		
MODEL	IM R 19		
MEWP CLASSIFICATION	TYPE 1	GROUP	B
SERIAL N.		POWER	8.2+2.2 kW
MANUFACTURING YEAR		BATTERY	12/95 C5 V/Ah
MASS	2435 - 5370 kg-lbs	MAX PRESSURE	220 - 3190 bar-psi
MAX WORKING HEIGHT	16.6 - 54.5 m-ft	WIND SPEED ALLOWED	12.5 - 28 m/s-mph
MAXIMUM ALLOWABLE OPERATING INCLINATION		1°	
RATED LOAD	230 - 510 kg-lbs		140 - 310 kg-lbs
n.PERSONS	2		1
MASS OF EQUIPMENT	70 - 154 kg-lbs		60 - 132 kg-lbs
MANUAL FORCE	400 - 90 N-lbf		400 - 90 N-lbf

The data refers to the standard model

Standard equipment

- Proportional and simultaneous movements
- Wireless radio control
- Parking brakes
- Rubber crawling tracks
- Hydraulically widened span of the crawling tracks
- Rotation of the turret: 355°
- Hydraulic balancing of the cage
- Hydraulic rotation of the cage
- Automatic stabilisation
- Moment limiter
- Load limiter
- Blocking valves on the cylinders
- Manually operated emergency platform lowering
- Double controls, i.e. from the ground and from the cage
- Electric timer
- Machine movements acoustic signalling
- Battery isolator
- Socket, plug and safeguard for the 120 V power supply cable
- Air/water line in the cage
- Dead-man Button

Optional

- Wire control kit
- Cage beacon kit
- No marking tracks kit
- Emergency electric pump 12 V
- Preheating kit for the diesel engines

Ground movements - Aerial movements

The operations refer to the two parts of the machine: the lower (ground) part and the aerial part that extends upward into the air.

The lower (ground) part of the machine is made up of the carriage (with crawling tracks and stabilisers).

The operations performed by the lower part:

- Driving and steering of the machine
- Widening and narrowing of the crawling tracks span
- Stabilisation

The aerial part comprises the lifting system.

The operations performed by the aerial part:

- Lifting/lowering the lifting boom
- Lifting/lowering of the pantograph
- Turret rotation
- Extension/retraction of the telescopic boom
- Lifting/lowering of the jib
- Cage rotation
- Cage levelling

Depending on the actual position of the machine, the operations can be performed either on the ground or in the air.

Ground movements

Drive and steering

For driving purposes the chassis is equipped with two hydraulic motors which drive the rubber crawling tracks. The steering is facilitated by driving the tracks at different speeds.

Widening the span of the crawling tracks

Track widening makes it possible to obtain greater stability during any repositioning of the machine on worksites or hazardous terrain.

The movement is facilitated by a hydraulic cylinder placed in the internal part of the chassis.

Stabilisation

Overall stabilisation of the machine is ensured with the aid of 4 hydraulic cylinders. It may be obtained either automatically or manually.

Automatic stabilisation

Apart from a simultaneous lowering of 4 stabilizers, automatic stabilisation also comprises the levelling out of the machine with a tolerance lesser than 1°.

Manual stabilisation

Every stabiliser is lowered or lifted separately.

In the case the machine should have to be stabilised in difficult conditions, in the areas full of obstacles or characterised by a very strong inclination, manual stabilisation function should be used to compensate adequately for the inclination of the terrain.

Aerial movements

Lifting/lowering of the lifting boom

A hydraulic cylinder situated between the upper joint of the pantograph and the lifting boom facilitates this operation.

Lifting/lowering of the pantograph

A hydraulic cylinder situated between the lower and superior bar of the pantograph facilitates this operation.

Turret rotation

The operation is facilitated by a hydraulic motor, which moves a turntable on the chassis. The turret rotates by 355°.

Telescopic boom extension/retraction

A hydraulic cylinder located between the boom and the telescopic boom facilitates this operation.

Jib lifting/lowering

A hydraulic cylinder located between the frame and the jib arms facilitates this operation.

Cage rotation

A hydraulic rotor placed between the jib and the cage facilitates this operation.

Cage levelling

In order to recover horizontal position of the cage that might be lost during various manoeuvres of lifting and lowering of the lifting boom, the automatic levelling is facilitated by two cylinders, master – slave, coupled up with the boom and the jib.

It is also possible to adjust the levelling of the cage manually by using the hydraulic cylinder placed between the jib support and the cage.

Machine status

Various terms indicating the status or position of the machine are often referenced throughout this Manual.

Every status of the machine is shown on the display unit of the platform control panel.

Machine stowed away

The machine is deemed stowed away when the cage is in its shelter position and no stabilisers are under pressure.

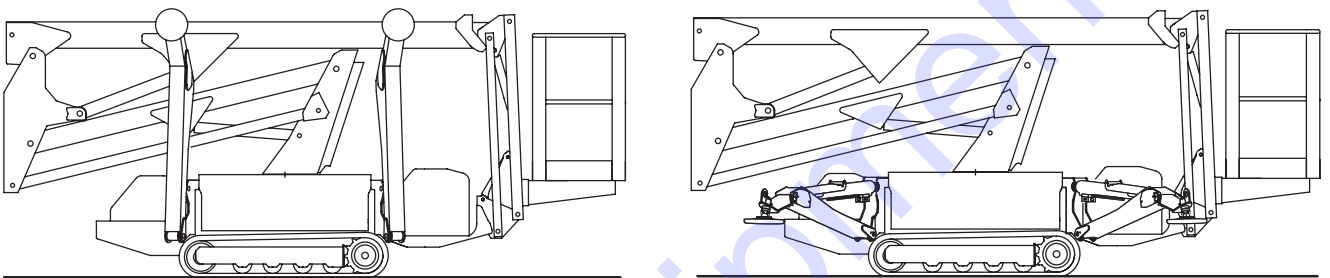

The stowed away mode of the machine facilitates:

- MOVING the machine with the aid of the drive and steering
- STABILISATION of the machine

A stowed away mode of the machine is the only position permitting the movement of the stabilisers

PICTOGRAMS DISPLAYED ON THE PLATFORM CONTROL PANEL

When the machine is in a stowed away mode, a  pictogram will appear on the platform display unit.

The stowed away mode of the machine is the position that should be assumed by the machine at the commencement and at the end of work.

Machine in the safety transport mode

The machine is in the **SAFETY TRANSPORT MODE** when the lifting boom is lifted up to 5° angle and none of the stabilisers is under pressure.

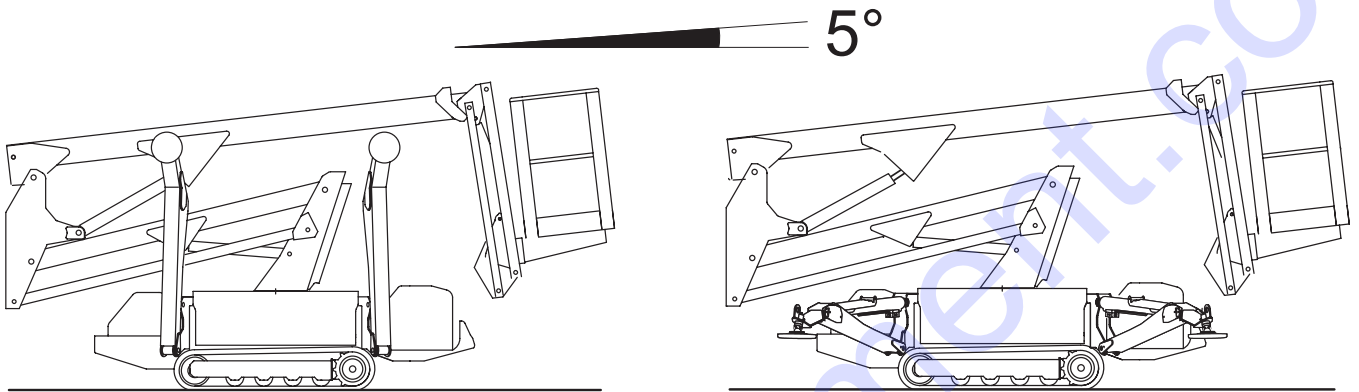

The safety transport mode facilitates:

- MOVING the machine with the aid of the drive and steering

PICTOGRAMS DISPLAYED ON THE PLATFORM CONTROL PANEL

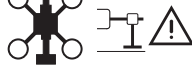
When the machine is in the SAFETY TRANSPORT MODE, a  pictogram will appear on the platform display unit.

When the machine is in the SAFETY TRANSPORT MODE it may be safely loaded/unloaded on a carrying vehicle with no accidental impact on the cage.

Stabilised and stowed away machine

The machine is **STABILISED AND STOWED AWAY** when all 4 stabilisers are under pressure and the cage is in a stowed away position.

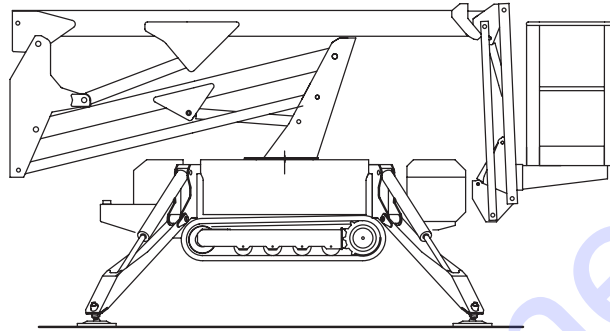

The **STABILISED AND STOWED AWAY MODE** facilitates:

- opening of the lifting system by raising the lifting boom upon the commencement of work
- returning to the stowed away mode of the machine by lifting the stabilisers upon the end of work.

PICTOGRAMS DISPLAYED ON THE PLATFORM CONTROL PANEL



STABILISED AND STOWED AWAY MACHINE

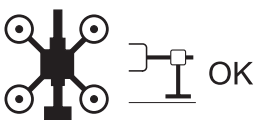

STABILISED, LEVELLED OUT and STOWED AWAY MACHINE

Machine open

The machine is deemed **OPEN** when it is stabilised and the boom raised over 5° angle and/or the pantograph raised over 6° angle.

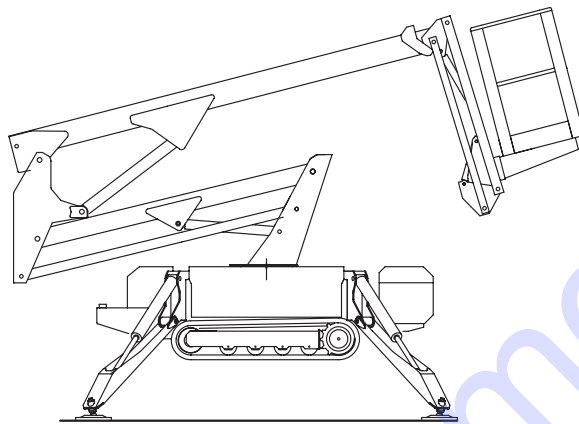



When the MACHINE is STABILISED AND STOWED AWAY:

- By raising the **LIFTING BOOM UP TO 5° ANGLE** THE LIFTING OF THE PANTOGRAPH is activated.
- By raising the **LIFTING BOOM ABOVE 5° ANGLE** all the movements of the aerial part are activated.
- By raising the **PANTOGRAPH ABOVE 6° ANGLE** all the movements of the aerial part are activated.

The machine mode becomes now the MACHINE OPEN MODE.

In this position all the movements of the aerial part of the machine can be executed, excluding the cage balancing.

PICTOGRAMS DISPLAYED ON THE PLATFORM CONTROL PANEL

When the lifting boom is raised, a   pictogram will appear on the platform display unit. Moment control is now activated.

Safety systems

The machine is provided with several safety devices safeguarding its normal operation in order to preclude any accidental injuries (accidents).

Adequate command of the characteristics of the safety devices on the machine is crucial. The machine is not to be put into operation unless the following sections of the manual have been read carefully and understood.

Depending of the position of the machine, its safety devices may be optionally activated. It is important to be well appraised of the CONFIGURATION and the actual significance of the respective MACHINE MODES, as referenced on the preceding pages.

Any damaged safety device, be that resultant from failure or improper use, may cause serious damage to the machine, and consequently prove hazardous to an operator's life and safety

Check periodically all the safety devices, as per the instructions comprised in this Manual

All safety devices should be intact. The Manufacturer shall not be held liable for any accidents resultant from any unauthorised modifications made to the machine that might potentially cause damage to its safety devices

Operating irregularities

In the case of any malfunction detected by the self-diagnostics of the main control units, the display unit on the platform control panel will show an error code.

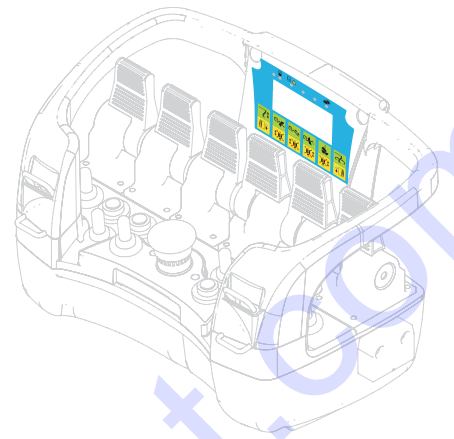

Safety belts attachment points

The machine is fitted with suitable anchorage points for the safety belts.

Audible alarms

In the case of any operating irregularities: they are signalled by a high frequency intermittent sound. Machine's movements are then either entirely or partly blocked until the machine is effectively returned under the safety operating conditions.

Normal functioning: any movement of the machine is signalled by a low frequency intermittent sound.

Overload sensor

The overload sensor consists of a load cell placed between the cage and the jib and checks for a potential overload.

Overload is a load exceeding the maximum admissible working load

If there is an overload:

Raising the lifting boom:



- warning lights on the ground control panel are lit up
- the alert sounds out
- all the movements are blocked

In order to re-activate the movements any such an excessive load must be removed.

Load cell warning lights

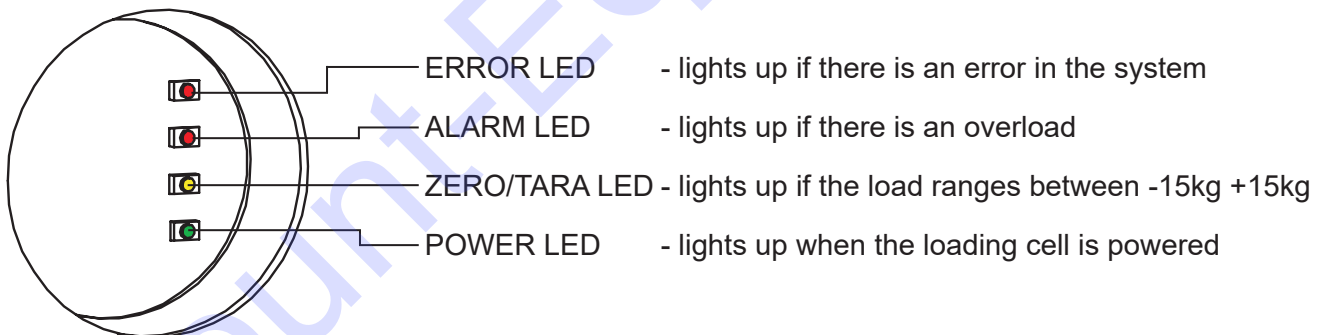

Temperature relay

Temperature relay protects the electric motor against potential overload.

It is installed in the anterior part of the chassis, inside the protection box.

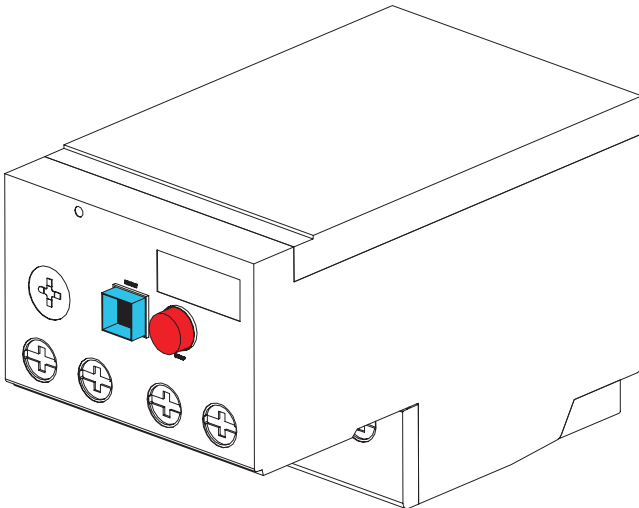

If an overload occurs, the temperature relay interrupts the power supply to the motor.

After having identified and eliminated the cause of an overload, in order to restart the motor press down the blue key on the relay reset.

The red key is used to carry out a relay test (see “Maintenance of an electric motor”)

Overturning moment limiter

The overturning moment limiter consists of a strain pivot placed on the pin at the boom of the lift cylinder and checks whether the overturning moment has exceeded its maximum value

Maximum overturning moment is the maximum moment that a machine can support while remaining in the safety use mode.

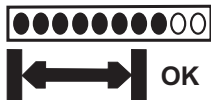

When the lifting boom is raised, the moment control is activated.

The machine is stabilised, not stowed away, and the aerial system is fully operational.

Full spots indicate the percentage of the actually reached moment.

- When the 80% - 100% range of the maximum permissible moment has been reached, the **movements will slow down**.
- With the moment equal to 100% of the permissible value, **every movement causing the increase of the moment itself will be blocked**: extension pull up, lowering the lifting boom, jib movement and pantograph movement. Alert will sound out and the following pictogram will appear on the display unit:

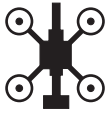

The only movements remaining fully operational will be: the movements that reduce the moment itself: raising of the lifting boom, extension retraction, cage rotation and turret rotation.

In order to have all the movements activated one should introduce the moment value of at least 85% of the maximum permissible value. The following pictogram will appear on the display unit:



If the moment exceeds 110% of the permissible value, all machine movements will be blocked, and the machine could be reset into the safety mode only with the aid of the emergency movements

Clogged up oil filter sensor

It consists of a sensor placed in the oil filter within the hydraulic installation.

If the filter is clogged up, all the movements are slowed down to 40% of the maximum value allowed.

Inclinometer and a spirit level

Please note that the maximum inclination of the chassis is set at 1 grade.

There are two devices to control the inclination of the machine: the **inclinometer** and the **spirit level**.

The inclinometer is integrated into the self-levelling system and is made up of an angle sensor mounted in the anterior part of the chassis controlling its inclination. The following pictograms will appear on the display unit:

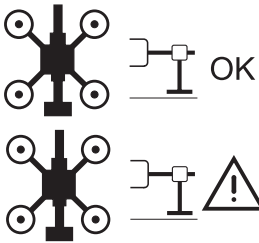
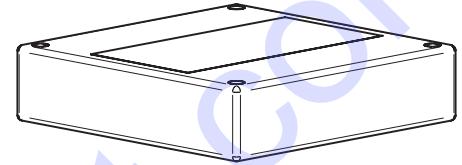

- the chassis is levelled out (with respect to zero) with an error of $\pm 0,1^\circ$
- the chassis is inclined over 1°

The automatic levelling is electronically supported, thus increasing an easy and comfortable use of the machine. It is mandatory to ALWAYS CHECK during and after the levelling out procedure the correct inclination of the machine by using the spirit level

The spirit level is placed in the posterior part of the chassis, visible both from the cage and from the ground.

During the levelling out procedures, make sure to use the spirit level to check if the permissible level of inclination of 1° is maintained.

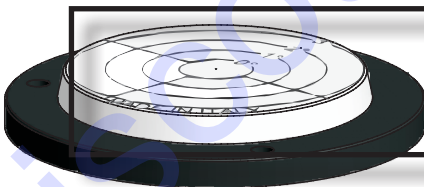

After every levelling out operation, make sure to always check the correct inclination of the machine

If the machine is not correctly levelled out, and its stability is then compromised, it poses a hazard both for the operator and any other persons working in close proximity

Micro switches

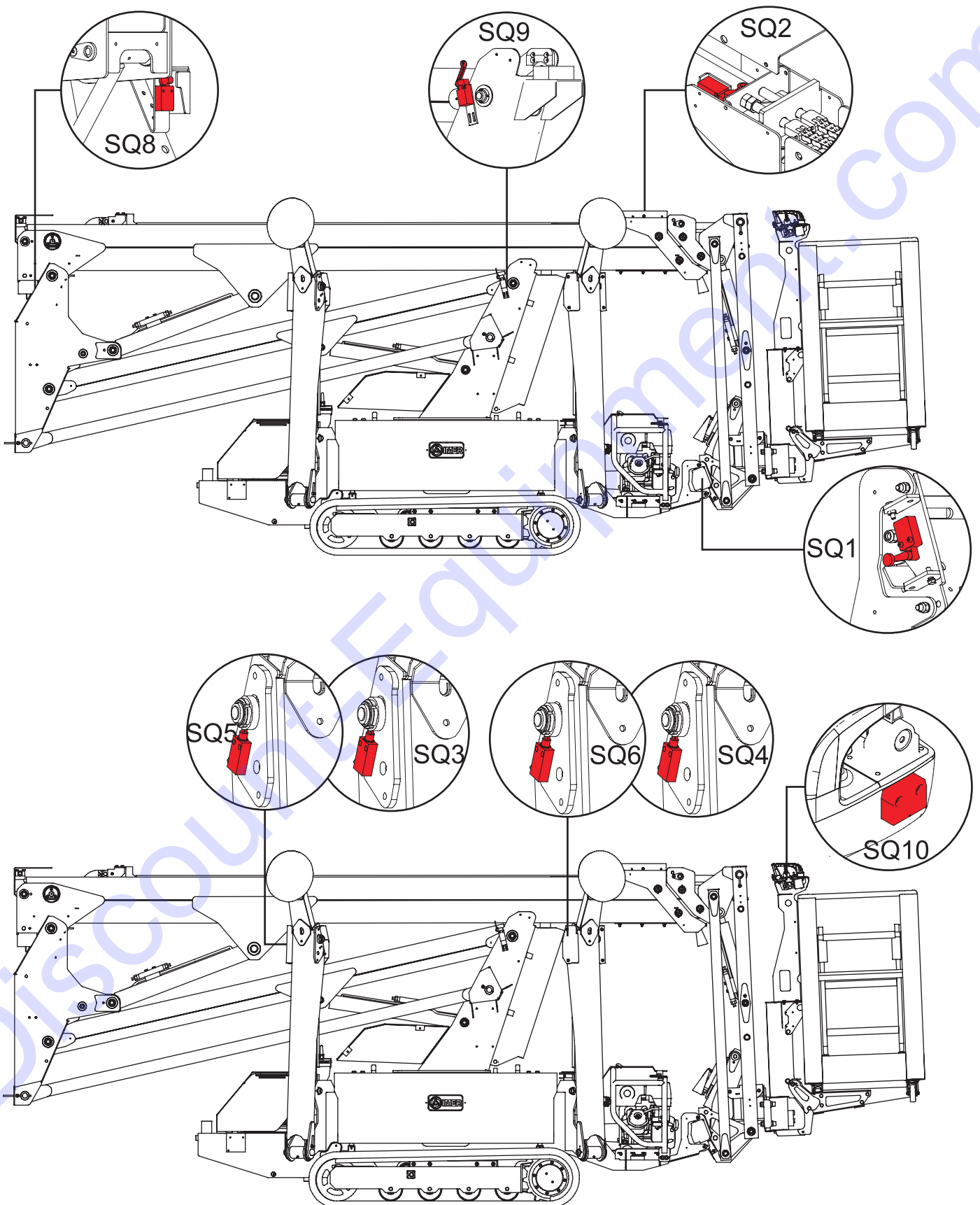

Micro switches SQ1A-B

SQ1A E SQ1B micro switch is located in the stowing seat of the cage indicating its presence there.

With a MACHINE STOWED AWAY (cage housed in its seat) **it is possible to:**

- Drive at any speed (using the diesel/petrol engine)
- Lower and/or lift the stabilisers

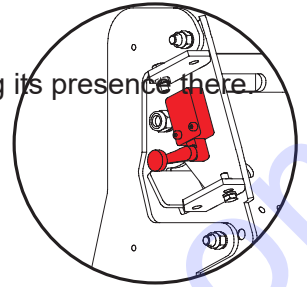

With MACHINE IN THE SAFETY TRANSPORT MODE (cage out of its seat) **it is possible to:**

- Driving at any speed (using the IC engine)

With MACHINE STABILISED STOWED (cage in its seat) **it is possible to:**

- Lift the boom
- Lower and/or lift the stabilisers

With the machine STABILISED and the cage OUT of its stowing seat **it is possible to:**

- Raise the lifting boom
- Raise the pantograph

Micro switch SQ8 (lifting boom)

SQ8 micro switch is located on the knee of the lifting boom and it indicates its angulation.

With the machine STABILISED, raising the lifting boom at an angle exceeding 5° all the movements of the aerial part will be activated, excluding the cage balancing.

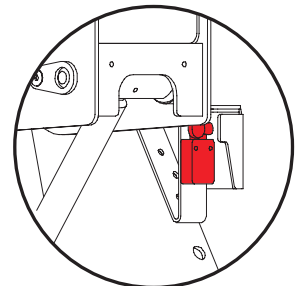

Micro switch SQ9 (pantograph)

SQ9 micro switch is situated on the left-hand side of the turret in the proximity of the pantograph arm, and it checks its inclination.

With the machine STABILISED, raising the pantograph at an angle exceeding 6° all the movements of the aerial part of the machine will be activated, excluding the cage balancing.

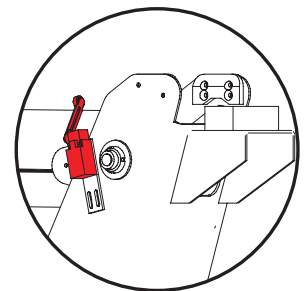

Micro switch SQ2 (chain break)

SQ2 micro switch is located over the boom and it controls the chain.

When the chain is broken, it blocks the movement of the boom.

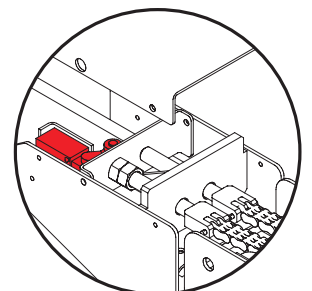

Micro switch SQ10 (control panel in the cage)

SQ10 - micro switch is located on the platform control panel and it indicates its presence.

If the platform control panel is in its seat on the machine and the machine is stabilised, all the movements of the aerial part of the machine may be activated from the platform control panel.

If the platform control panel is not in its seat and the machine is stabilised:

- Machine with radio control: it is not possible to activate the movements of the aerial part.
- Machine with a guiding cable: it is possible to activate the movements of the aerial part.

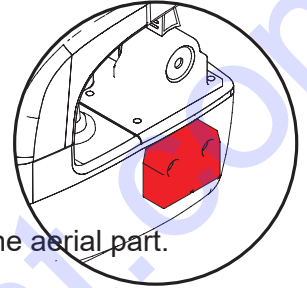

Micro switches SQ3-4-5-6

SQ3 SQ4 SQ5 SQ6 - micro switches are located in the proximity of the locating pin on the stem of the stabiliser cylinders.

They control the pressure of the stabilisers.

- If only one of the stabilisers is under pressure, the drive is blocked.
- If all 4 stabilisers are under pressure, it is possible to move the aerial part.

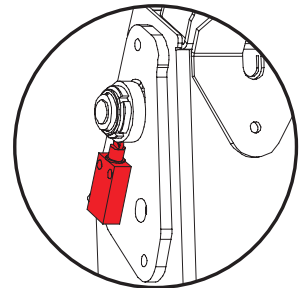

Emergency devices

Emergency devices are fitted onto the machine.

It is fundamental to know the characteristics and the functioning of all the emergency devices; it is recommended not to operate the machine before reading and understanding well the following section.

Emergency stop

Emergency stop is situated on the platform control panel of the ground, as well as on the platform control panel located in the cage.

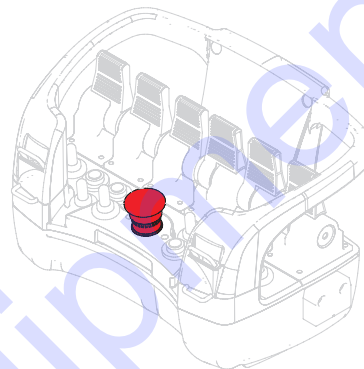
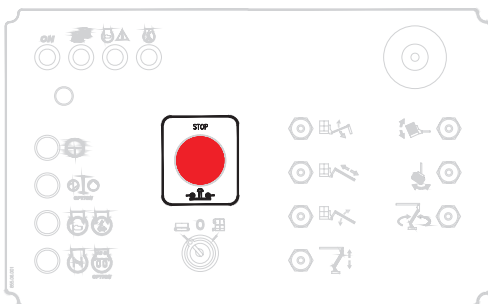

When pressing down one or both emergency stops, all the movements are blocked, thus facilitating an immediate arrest of every machine function at an emergency.

In order to restart the normal functions of the machine, rotate the emergency stop in the clockwise direction.

Battery switch

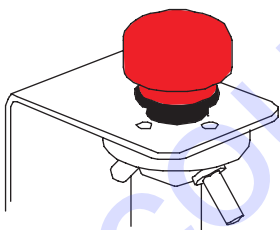

The battery switch is located in the right-hand side box.

This security device isolates all power supply circuits and the battery control, effectively blocking all machine functions.

It should be used in the case of extended shut downs, or during any maintenance procedures on the electrical systems.

Electric valves for emergency operations

Hydraulic blocs mounted onto the machine are fitted with the electric valves to be used in the case of any emergency operations.

In order to gain an insight into their functioning please see the section on “Manual emergency procedures” in the Manual.

Manual pump

The manual pump is located on the left-hand side of the oil tank, while its operating lever is located at the base of the turret.

The manual pump is used to supply oil under pressure in any emergency situations.

See the section on “Manual Emergency Procedures” in the Manual.

Electric pump 12V (optional)

The electric pump is located in the right-hand side box.

The electric pump is used to supply oil under pressure in any emergency situations.

See the section on “Manual Emergency Procedures” in the Manual.

Control stations

The operators control stations are:

- Platform control station located on the ground
- Platform control station located on the cage support
- Ground control station located on the frame base

When one of the control station is operated, the other one is disabled.

During routine operations **all the functions are executed from the control station located in its proper seat in the cage.**

The platform control panel is extractable and may be used by the operator also from the ground. In this case in the radio-controlled versions, the following movements are available: **driving, stabilisation and lifting of the boom up to an angle of 5°**; in the radio-controlled version all the movements are available.

The ground control panel is used mostly in emergency situations or during any maintenance procedures. It is not possible to control driving, steering and the stabilisation of the machine from the control panel on the ground.

In the radio-controlled models the platform control panel must always be activated, even if the machine is controlled from the control panel on the ground

Types of machine operations:

- Drive (backward and forward)
- Steering
- Widening of the crawling tracks span
- Stabilisation
- Lifting/lowering of the lifting boom
- Lifting/lowering of the pantograph
- Turret rotation
- Extension/retraction of the telescopic boom
- Lifting/lowering of the jib
- Cage rotation
- Cage levelling

The following movements may be performed simultaneously:

- Lifting/lowering of the lifting boom
- Extension/retraction of the telescopic boom
- Lifting/lowering of the pantograph
- Turret rotation

Ground control panel

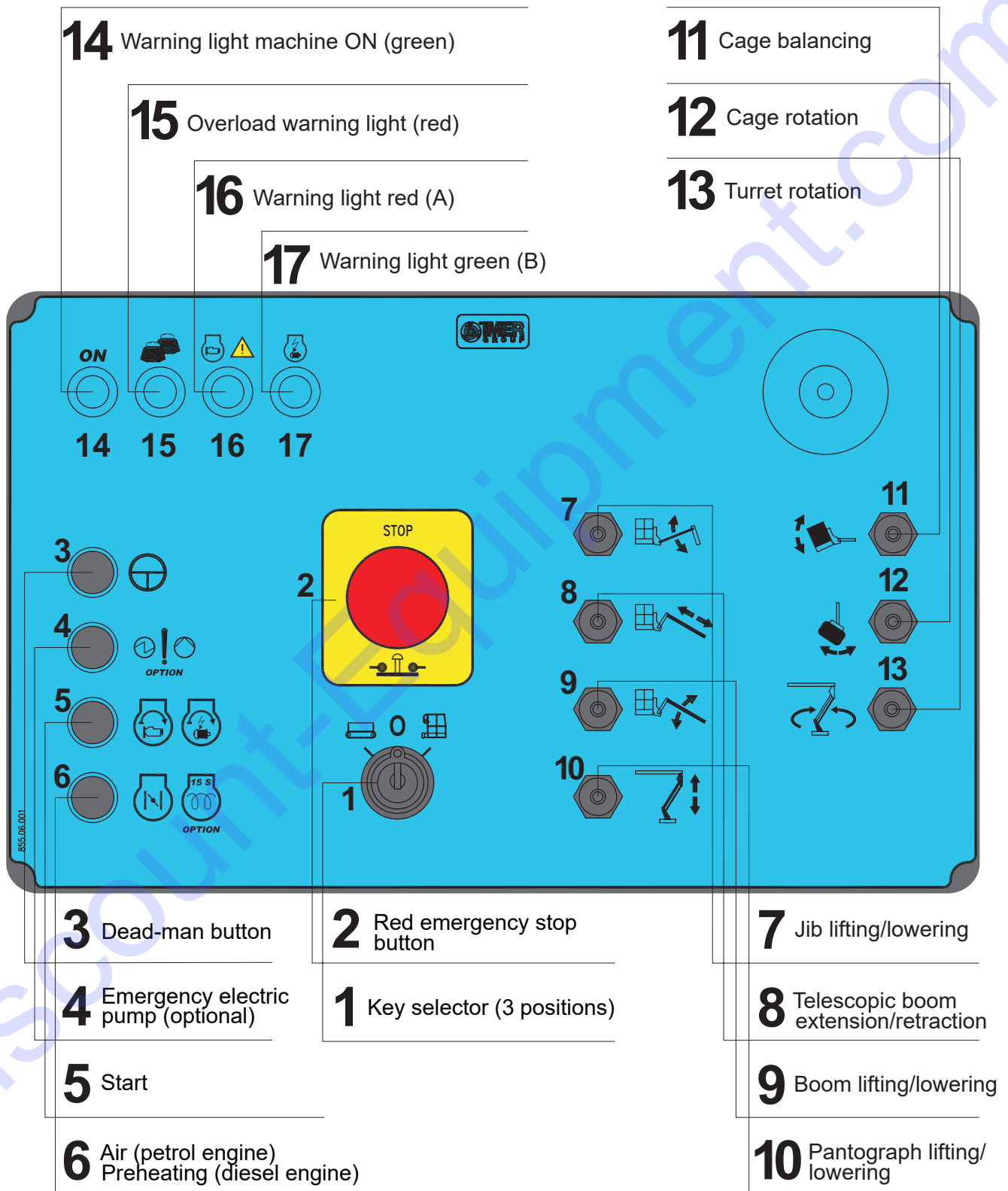

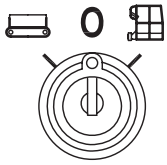

1 - Key selector (3 positions)

- Central position: the machine is powered off
- Right-hand position: controls in the platform control panel are active
- Left-hand position: controls in the ground control panel are active

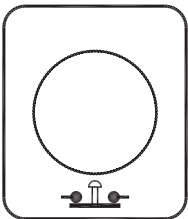

2 - Red emergency stop button

- When pressed - it arrests all the functions of the machine
- When released - it allows the operation of the machine

Once it has been pressed, rotate it clockwise to have it released.



3 - Dead-man button

Control of every movement of the aerial part of the machine is possible by using the selector keys from 7 to 13 and pressing down Button 3 equipped with a dead-man function (operator's presence is required).



4 - Emergency electric pump

Starting emergency electric pump (optional)



5 - Start

Starting of the motor (diesel or petrol). If the machine is connected to the mains voltage, the electric motor will be started.



6 - Air (petrol engine) Preheating (diesel engine)

It helps firing off the engine in cold weather.

- Petrol engine: simultaneously press down and hold the key selector no 5 to activate the air supply to the engine.
- Diesel engine: press down and hold for a few seconds before starting off the fuel preheating*.

* Air preheating in the diesel engine is optional.

7....13 - Movement selectors - aerial part

Movements of the aerial part are facilitated with the selector keys no: 7 - 8 - 9 - 10 - 11 - 12 - 13 and button 3 with a dead-man's function.

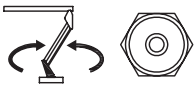

Turret rotation

- Turn the key selector 13 to the right to turn the turret anti-clockwise
- Turn the key selector 13 to the left to turn the turret clockwise



Pantograph lifting/lowering

- Move the key selector 10 upwards to lift the pantograph
- Move the key selector 10 downwards to lower the pantograph



Boom lifting/lowering

- Move the selector key 9 upwards to lift the boom
- Move the selector key 9 downwards to lower the boom

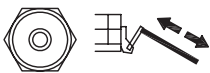

Telescopic boom extension/retraction

- Move the selector key 8 to the right to extend the telescopic boom
- Move the selector key 8 to the left to retract the telescopic boom



Jib lifting/lowering

- Move the selector key 7 upwards to lift the jib
- Move the selector key 7 downwards to lower the jib



Cage rotation

- Turn the selector key 12 to the right to turn the cage anti-clockwise
- Turn the selector key 12 to the left to turn the cage clockwise



Cage balancing

- Move the selector key 11 upwards to lift the cage
- Move the selector key 11 downwards to lower the cage

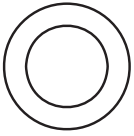
ON

14 - Machine ON warning light

The green warning light 14 lights up when the selector key 1 is not in its central position.

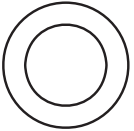

15 - Overload warning light

The red warning light 15 lights up when the machine is disconnected, it blinks when the machine is open, or when there is an overload.

In the starting-up phase selector key the light 15 lights up for a few seconds.

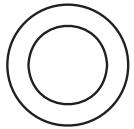

16 - Disconnected mains warning light

If the red warning light 16 lights up, the mains is disconnected. When the diesel engine is started, the warning light goes out.

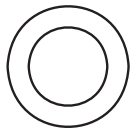

17 - Connected mains warning light



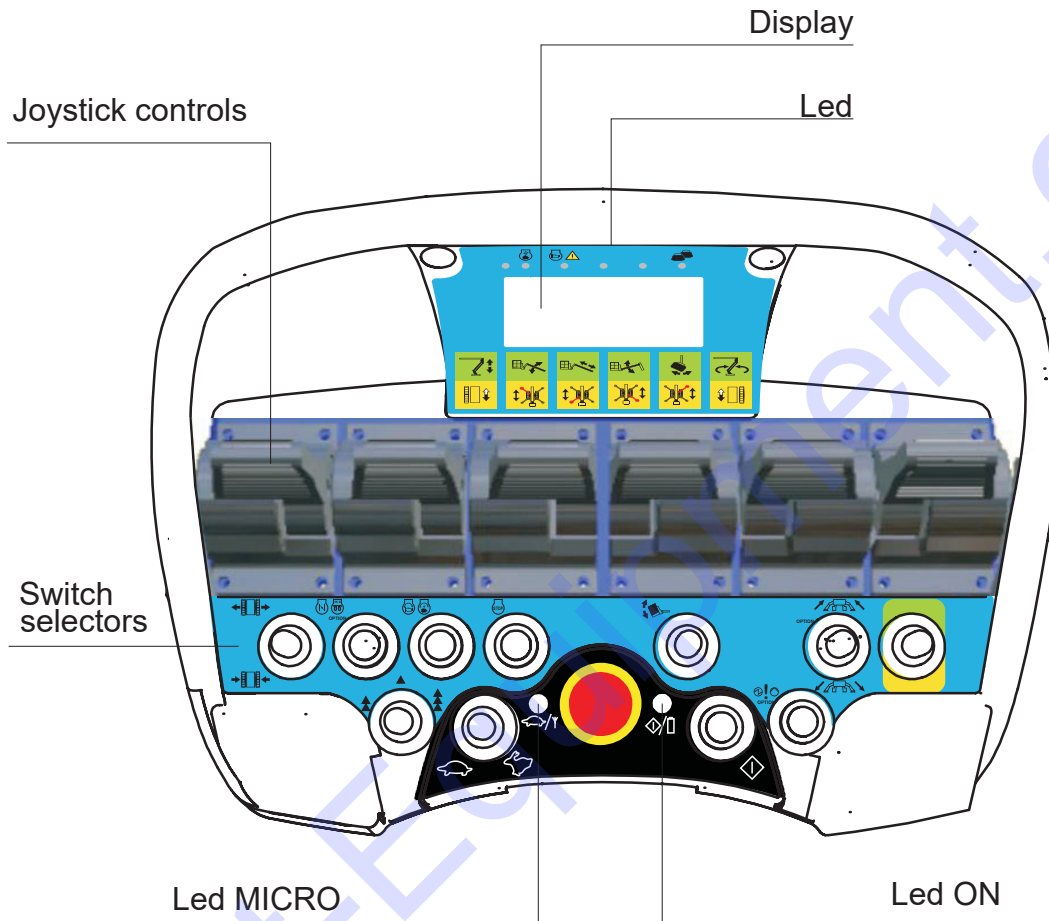

If the red warning light 17 lights up, the mains is connected and the electric motor can be used.

Platform control panel

Switch the platform control panel on with the switch and wait until red LED ON is on .



The LED ON and LED MICRO indicate the functioning status and any potential alerts.

-  **RED LED ON lit up:** platform control panel is active and transmitting via cable or via radio.
-  **RED LED ON flashing once every second:** the battery is running low. This indication is preceded by three beeps from the internal buzzer.
-  **RED LED MICRO lit up:** radio communication signal is lost
-  **GREEN LED MICRO lit up flashing once every second:** it indicates the currently active operating speed

Error code

The radio control performs a check on its own parts at each start-up and in the event of any faults it shows an error code by causing the LED ON to flash and the internal buzzer to beep a number of times, depending on the actual type of error found.

Selector keys

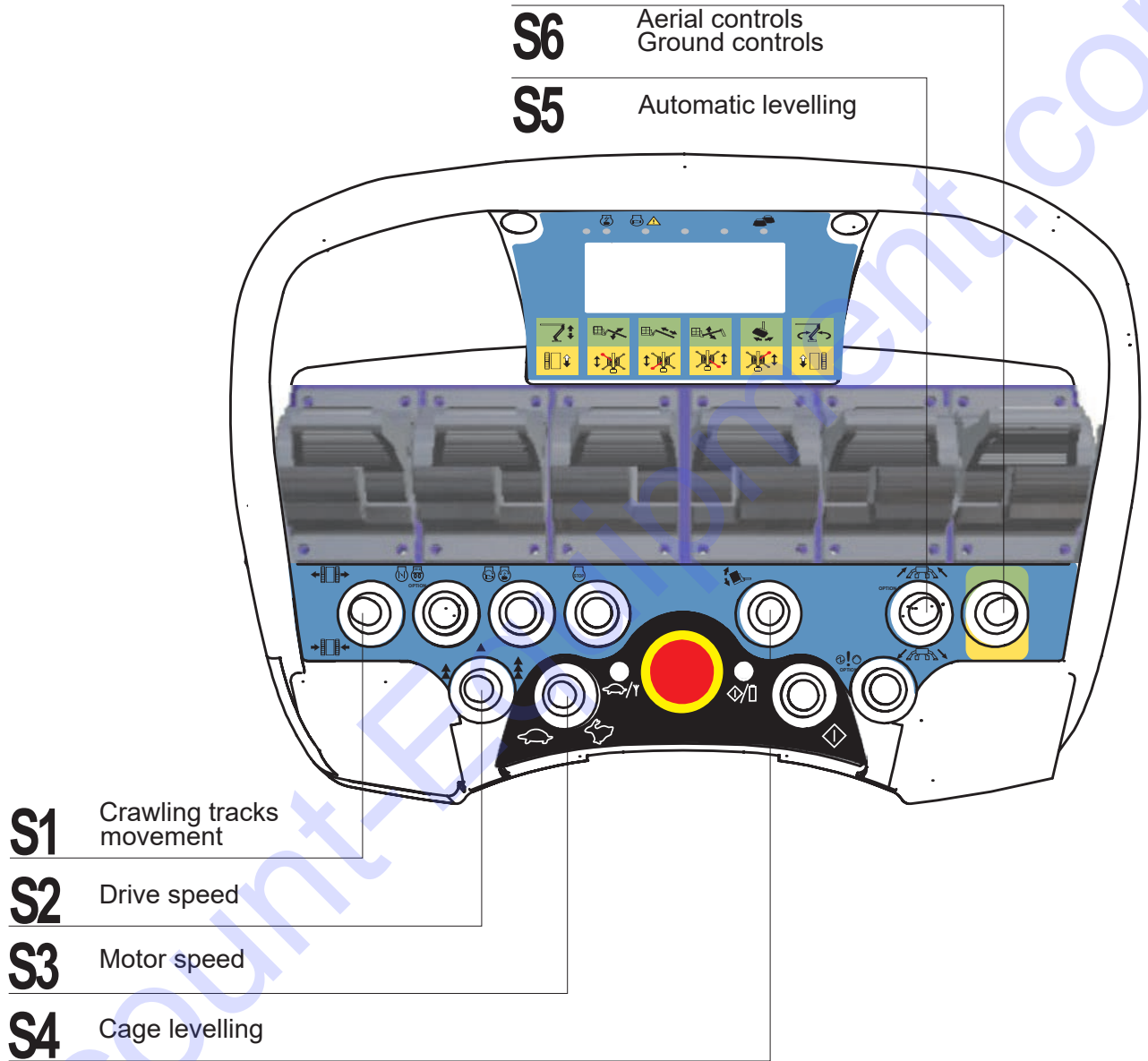

S1 - Crawling tracks movement

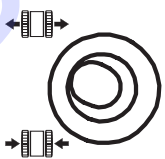

- forward - it widens the span of the crawling tracks
- backward - it reduces the span of the crawling tracks

Tracks widening function is permitted only when the machine is stabilised and stowed away.

S2 - Driving speed



- to the right - maximum speed
- to the left - average speed
- at the centre - minimum speed

Diesel or petrol engine

The speed can only be selected when the machine is stowed away and in the safety transport mode.

Electric motor

The speed selection function is not active. Driving may be attempted in the safety mode only.

S3 - Diesel engine speed



- to the right - "hare" - higher revolutions
- to the left - "turtle" - lower revolutions

In certain operations, e.g. driving the machine in a safety transport mode, the motor runs in lower revolutions, irrespective of the actual position of the S3 key selector.

S4 - Cage balancing

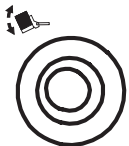

- forward - cage lifting
- backward - cage lowering

A prerequisite condition for executing this operation: LIFTING BOOM MAY NOT BE LIFTED OVER 5° and THE PANTOGRAPH MAY NOT BE LEFT OPEN.

S5 - Automatic stabilisation

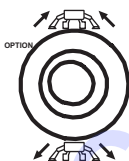

- forward - feet lifting automatic destabilisation
- backward - feet lowering automatic stabilisation

A prerequisite condition for executing this movement: THE CAGE MUST BE HOUSED IN ITS STOWED AWAY SEAT.

The machine is levelled out with a maximum error of 0.1° with respect to 0.

S6 - Selection of movements



- forward - joysticks move the aerial part
- backward - joysticks facilitate driving, steering (M1-M6), lifting/lowering of every cylinder or the stabiliser (M2-M3-M4-M5) for the manual stabilisation.

Switches

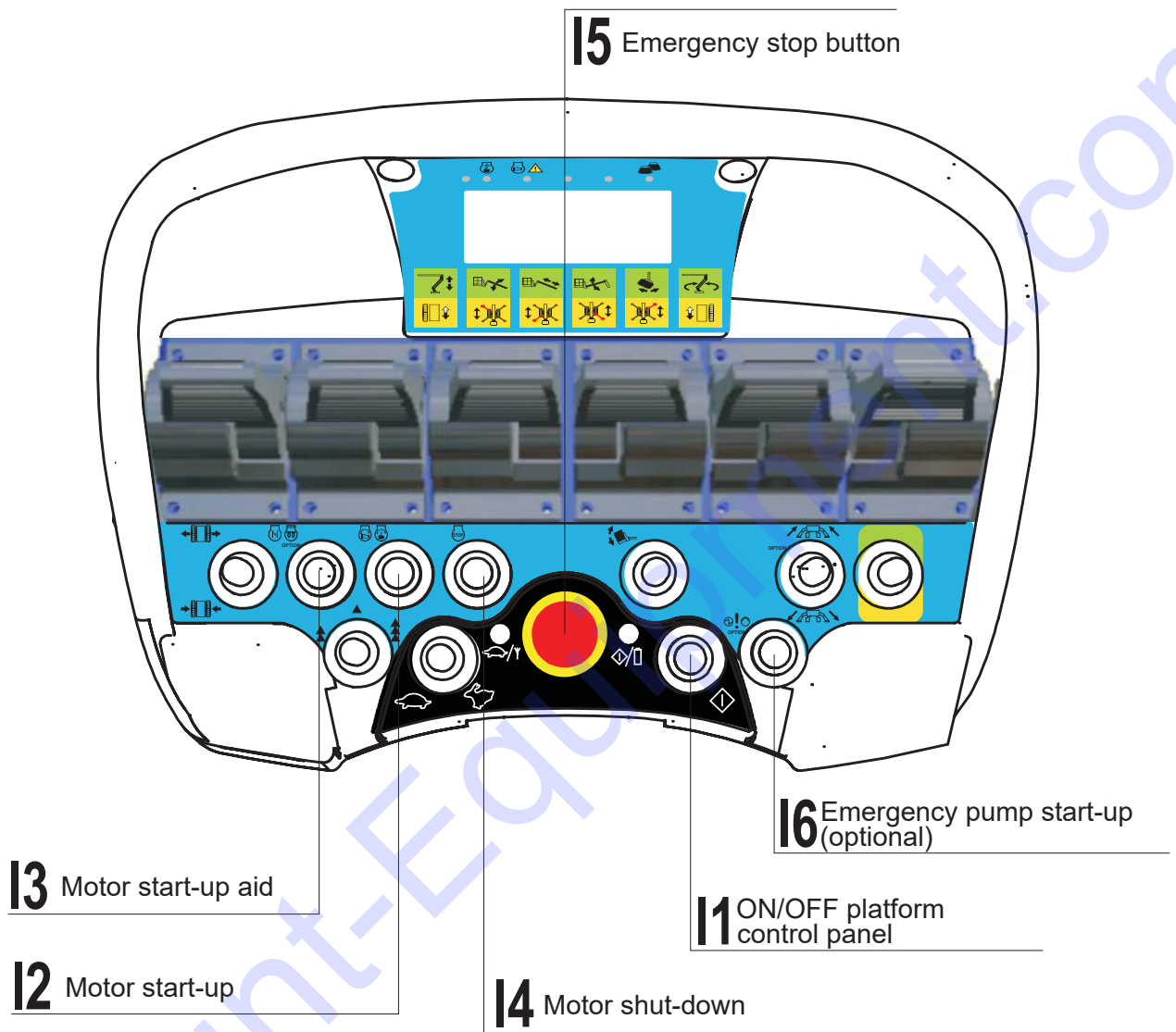

11 - Platform control panel switching on



The I1 switch must be used to switch the platform control panel on.
To switch the platform control panel off, the I5 switch is used.

12 - Starting-up the electric motor or a diesel/petrol engine



To start-up the electric motor the machine must be connected to the electric mains. If it is not connected up to the mains, the diesel/petrol engine will be started-up instead. In order to start-up the diesel/petrol engine in cold weather, use the I3 switch.

I3 - Engine start-up aid

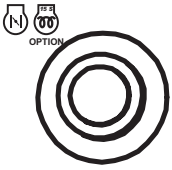

Helps to start-up the engine in cold weather.

- **Petrol engine:** press down simultaneously the I2 key to activate the air supply into the engine
- **Diesel engine:** keep pressed down for a few seconds before starting-up, using the I2 key for activation of the engine preheating*

* Preheating of the diesel engine is optional.

I4 - Engine shutdown



It shuts down the electric motor or a diesel engine.

I5 - Emergency stop button

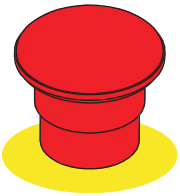

When pressed down it arrests all operations in the machine and also shuts down the platform control panel. To release, turn it clockwise.

The platform control panel will be reactivated with the use of the I1 key.

I6 - Activating the emergency pump (optional)



Activates the electric emergency pump (optional).

Joystick controls

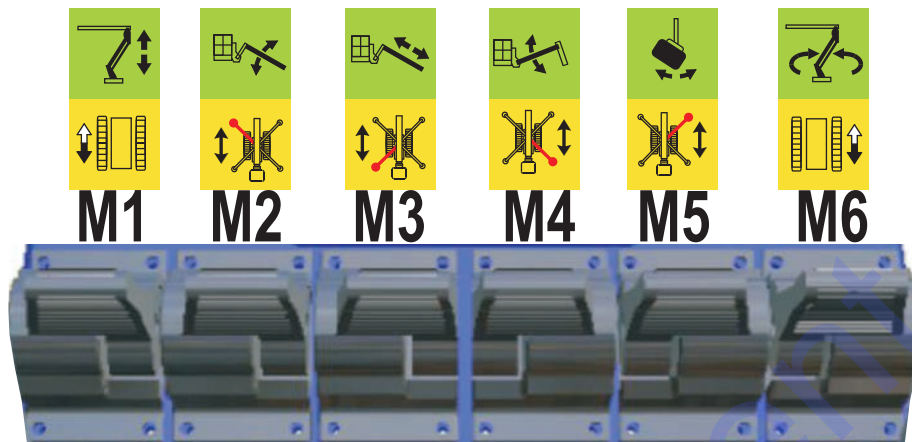

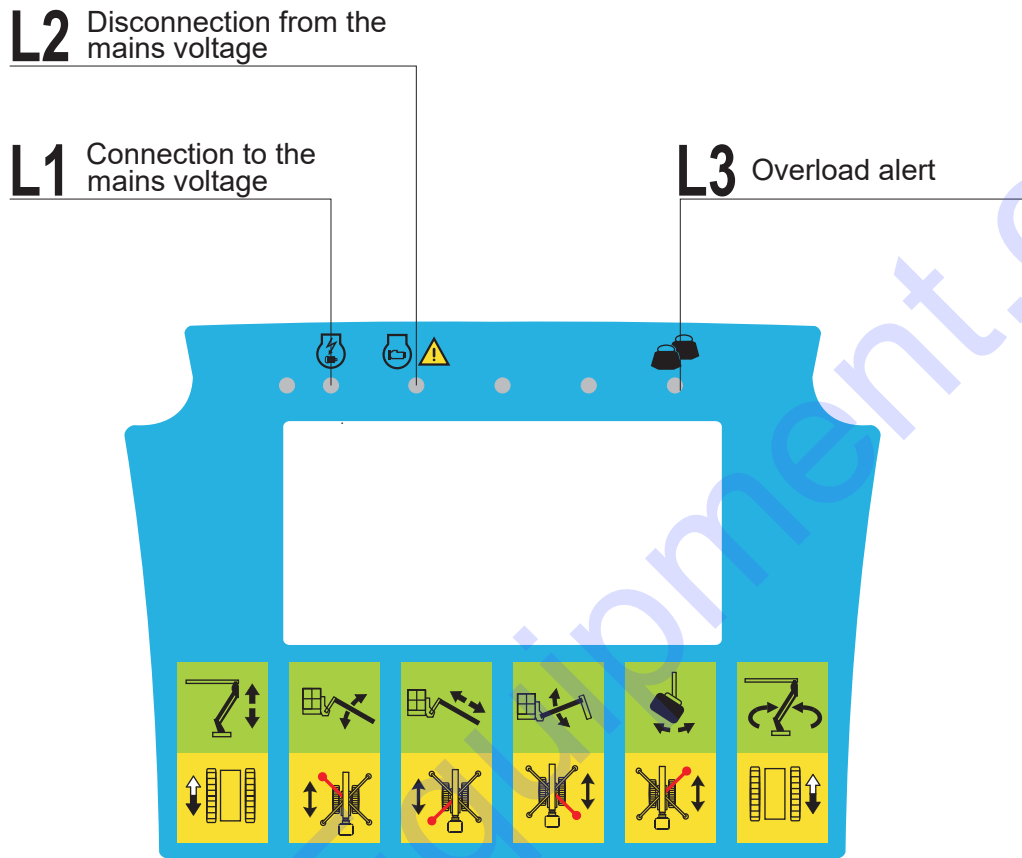

Table of operations controlled by the joystick controls, depending on the actual position of the S6 selector key

 S6 forward Aerial part operations		
M1 - PANTOGRAPH	Forward	Pantograph lifting
	Backward	Pantograph lowering
M2 - BOOM	Forward	Boom lifting
	Backward	Boom lowering
M3 - TELESCOPIC BOOM	Forward	Telescopic boom extension
	Backward	Telescopic boom retraction
M4 - JIB	Forward	Jib lifting
	Backward	Jib lowering
M5 - CAGE ROTATION	Forward	Cage rotation clockwise
	Backward	Cage rotation anti-clockwise
M6 - TURRET ROTATION	Forward	Turret rotation clockwise
	Backward	Turret rotation anti-clockwise

 S6 backwards Ground part operations		
M1 - LEFT-HAND CRAWLING TRACK	Forward	Forward
	Backward	Backward
M2 - FRONT LEFT-HAND STABILISER	Forward	Lifting
	Backward	Lowering
M3 - REAR LEFT-HAND STABILISER	Forward	Lifting
	Backward	Lowering
M4 - REAR RIGHT-HAND STABILISER	Forward	Lifting
	Backward	Lowering
M5 - FRONT RIGHT- HAND STABILISER	Forward	Lifting
	Backward	Lowering
M6 - RIGHT-HAND CRAWLING TRACK	Forward	Forward
	Backward	Backward

LED bar



L1 - Connection to the mains voltage

Green warning light; when it lights up the machine is connected up to the mains



L2 - Disconnection from the mains voltage

Orange warning light; when it the mains is disconnected, and when the diesel/petrol engine is started up, the warning light goes out.



L3 - Overload alert

Red warning light; it lights up when the boom is being lifted with the machine in a stabilised mode. The alert means there is an overload, so the load within the cage should be decreased.

Display unit

The display unit shows:

- Engine (motor) status
- Machine status
- Alerts

Engine status



The engine status is visualised by 4 pictograms



Diesel or petrol engine is started up



Oil in the engines

- diesel engine: too high oil pressure
- petrol engine: too low oil pressure



Alternator and starter battery status

- Off after start-up: the alternator is working
- Lit up steadily: the alternator is not working
- If it flashes with the engine switched off, it indicates that the starter battery is drained (flat)



Oil filter clogged-up

- The oil filter in the hydraulic circuit is clogged-up and needs to be replaced as soon as possible. All machine operations are slowed down by 40% of the maximum speed allowed.

Machine status

Machine status is shown by the symbols on the display unit and described in detail in the “Machine Status” section.

MACHINE STOWED AWAY

The machine is stowed away when the cage is in its stowed away seat and none of the stabilisers are under pressure.

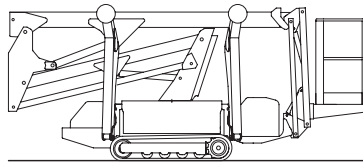

When the machine is stowed away the following actions may be executed:

- driving at all speeds (when a diesel engine is used)
- driving at a reduced speed (when an electric motor is used)
- span of the crawling tracks may be widened
- stabilisers may be repositioned
- lifting the boom up to the angle of 5° (**in this case the machine is not stowed away any more but moves right into the safety driving mode**)
- cage balancing

MACHINE IN THE SAFETY TRANSPORT MODE

The machine is in the safety transport mode when the boom is lifted below 5° angle and none of the stabilisers are under pressure.

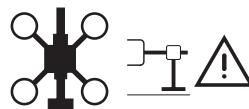

The machine in the safety driving mode may perform the following operations:

- drive at all speeds and with minimum rotations of the engine (when a diesel engine is used)
- drive at a reduced speed (when an electric motor is used)
- lift the boom up to 5° angle
- lower the boom
- balance out the cage

STABILISED AND STOWED AWAY MACHINE

The machine is **STABILISED AND STOWED AWAY** when all 4 stabilisers are under pressure and the cage is in its stowed away seat.



With the machine in the stabilised and stowed away mode the following operations may be performed:

- repositioning of the stabilisers
- lifting of the boom (in this case the machine is not stowed away any more)
- widening of the crawling tracks span
- cage balancing
- cage rotation

STABILISED, LEVELLED OUT AND STOWED AWAY MACHINE

The machine is **STABILISED, LEVELLED OUT AND STOWED AWAY** when all 4 stabilisers are under pressure, the machine is levelled out and the cage is in its stowed away seat.

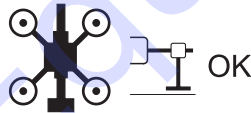

Check visually the levelling out of the machine with the spirit level.

With the machine in the stabilised, levelled out and stowed away mode, the following operations may be performed:

- repositioning of the stabilisers
- lifting of the boom (in this case the machine is not stowed away any more)
- widening of the crawling tracks span
- cage balancing
- cage rotation

If one of these pictograms appears on the display, it means that one or more stabilisers feet lost touch with the ground.

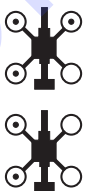

The machine is not stabilised any more.



The stabilisation phase should be repeated.

By lifting the boom and taking the cage out of its stowed away seat, the pictogram of moment control will appear on the display unit. By taking in consideration other pictograms more information on the machine status may thus be obtained.

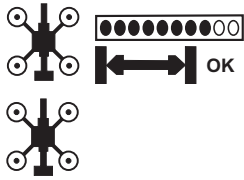

The machine is STABILISED and no longer STOWED AWAY.

The stabilisers movement is blocked.

By lifting the boom over the 5° angle and/or the pantograph over the 6° angle all the movements of the aerial part become activated.

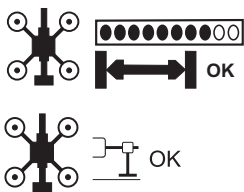

The machine is STABILISED, LEVELLED OUT and no longer STOWED AWAY.

The stabilisers movement is blocked.

By lifting the boom over the 5° angle and/or the pantograph over the 6° angle all the movements of the aerial part become activated.

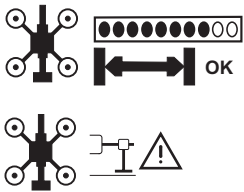

The machine is INCLINED over 1° angle

The loss of levelling is not the best condition for operating the machine. Nevertheless, the machine's electronic system does not actuate any blocking of its operations as the conditions are still deemed safe. It is up to the operator to decide either to continue using the machine, or to close its aerial part and restore its stability.

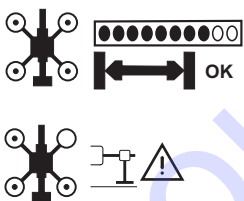

The machine LOST ITS TOUCH WITH THE GROUND WITH REGARD TO ONE OF ITS STABILISER FEET

The machine's electronic system does not actuate any blocking of its operations as the conditions are still deemed safe. It is up to the operator to decide either to continue using the machine, or to close its aerial part and restore its stability.

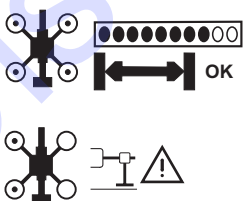

The machine LOST ITS TOUCH WITH THE GROUND WITH REGARD TO TWO OF ITS STABILISER FEET

The loss of touch with the ground by two stabiliser feet is deemed a hazardous condition for continuing any operations.

The movements of the aerial part will be blocked, except for the following cases:

- lowering of the pantograph
- retraction of the extension part
- lowering of the jib

MOMENT ALERT



This pictogram will appear when the moment is equal to or higher than 100% of the allowed value, and the operation still increasing it is being executed:

- rising of the extension
- lowering of the boom
- jib movement
- pantograph lifting

The movement will be blocked and the alarm will sound out.

It will be possible to perform only those operations that actually reduce the moment:

- lifting of the boom
- retraction of the extension
- cage rotation
- turret rotation

Use of the machine

Before carrying out any operations, it is necessary to read and well understand the contents of the present Manual, as well as all the instructions on the plates and labels

Checking before using

Before the machine is put into operation and any operation is executed, it must be thoroughly checked visually in the way described further below.

It is also vital to carry out all the checks on the machine's safety systems/devices prior to putting it into any operation.

Make sure that the following malfunctions DO NOT occur:

- oil leakage from the pipes and other components of the hydraulic system
- cut or disconnected electric wires
- cuts on or irregular wear of the crawling rubber tracks
- damaged, deformed, loosened up or missing screws and bolts, or cracked up welds

Make sure to check that:

- terrain where the platform is to operate is solid (compact) and actually able to support the maximum allowable load per each crawling track and stabiliser feet
- present Manual is on board
- all plates and labels are well visible and have not been removed
- both the handrails and the platform itself are free from any grease and oil residue
- working area remains totally unobstructed, without any potholes, and the ground is even

Other checks to be completed:

- Check the hydraulic oil level
- Make sure there is fuel in the tank
- Make sure the tension of the rubber crawling tracks is correct
- First switch on the ground control panel and then the platform control panel and wait for about ten seconds for the switching-on sequence to be completed.
- Make sure no errors are reported on the display unit on the platform control panel, or on the light indicators of the ground control panel.

Operation of the machine

In order to lift up persons, materials and/or equipment to facilitate the works at some height, it is necessary to do the following:

1. Put the machine into the working position using the drive and the steering
2. Have the machine effectively stabilised
3. Keep on extending the machine's aerial part until the required position has been reached

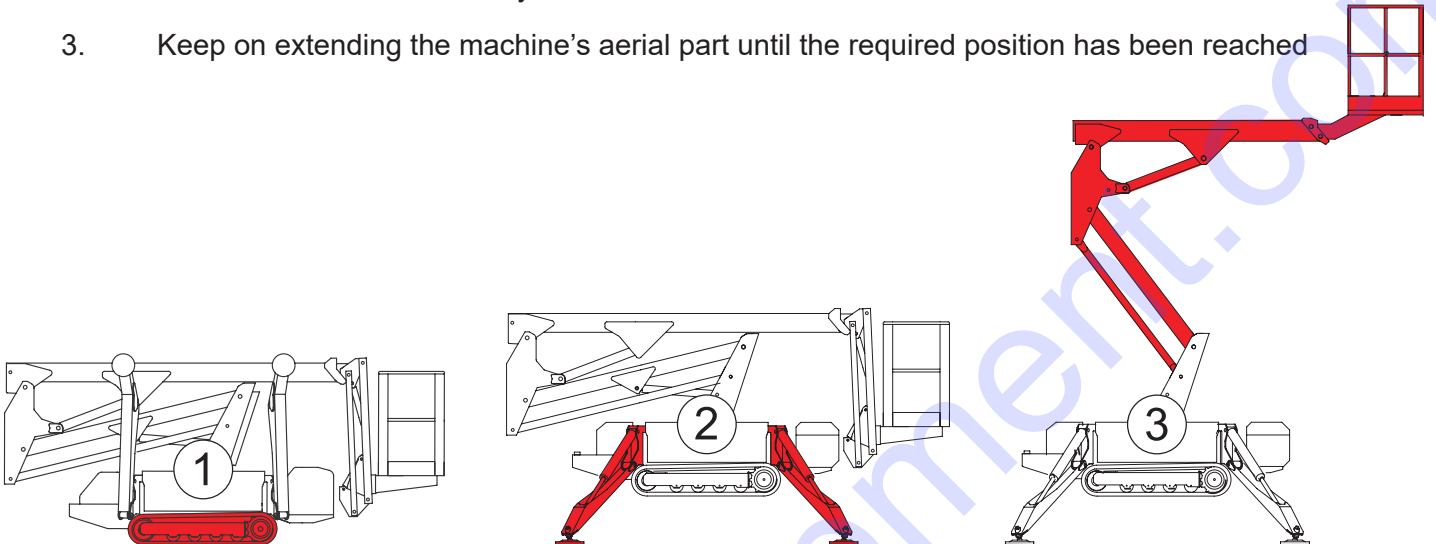

To execute these operations it is necessary to:

- Control the drive and machine stabilisation from the ground control panel
- Climb onto the cage
- Have the aerial part extended upwards

Or

- Climb onto the cage
- Control the drive and machine stabilisation
- Have the aerial part extended upwards

***Make sure the red emergency stop button is not pressed down,
neither on the ground control panel, nor on the platform control panel***

Setting the machine into the working position

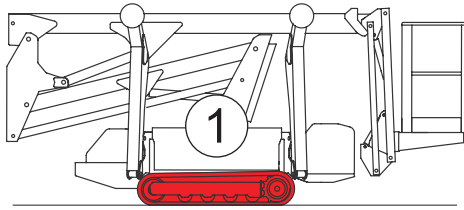

Starting the machine up

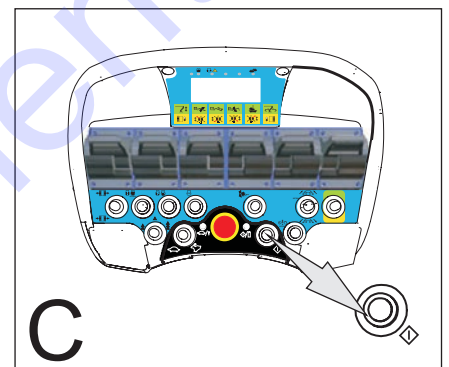
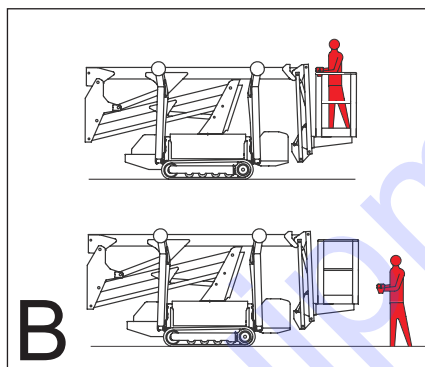
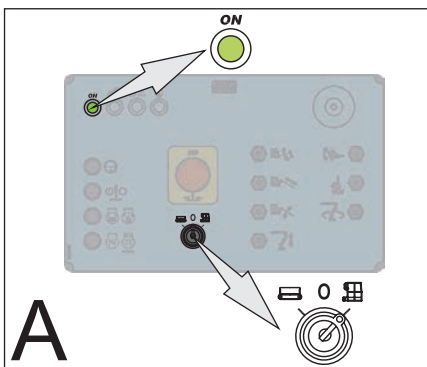

- A. Insert the selector key 1 into the ground control panel and turn it to the right; warning light 14 is lit up. Each time the machine is started up, audible alarms (buzzer) and warning lights light up to confirm their correct operation. Before putting the machine into operation, wait until they are all switched off.
- B. Get onto the cage or take the platform control panel to the ground.
- C. Turn the platform control panel on with the I1 selector key.

Motor start-up

- D. Start up the diesel/petrol engine or electric motor by pressing down the I2 selector key

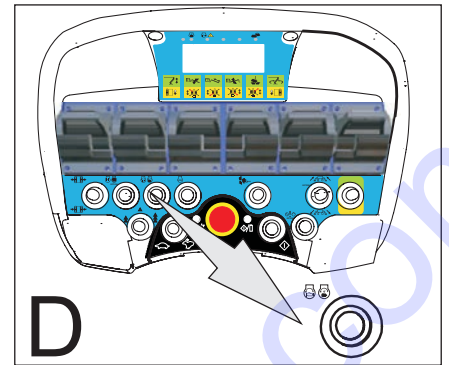

When the yellow warning light is lit up, the machine is disconnected from the mains and the diesel/petrol engine will start up.



When the green warning light is lit up, the machine is connected to the mains and the electric motor will start up. Differential magneto-thermal switch must be activated.

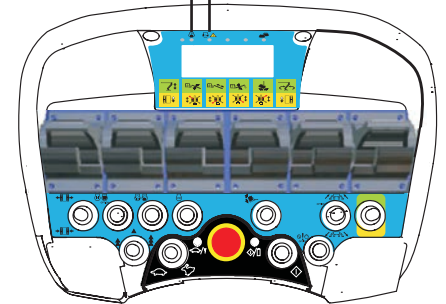

Drive and Steering

To make use of the machine's drive, the machine must be stowed away, or in the safety transport mode

When making use of the machine's drive from the ground with the aid of the platform control panel, the distance of at least 2 meters from the machine should be maintained

Before performing any operations, check if the working area around is free from any persons, animals or obstacles

For driving the machine along, the terrain must be free from any potholes, obstacles, debris, and/or anything that might cover up any potholes or other hazards

If the terrain proves suitable, widen the span of the crawling tracks to its maximum width in order to increase the machine's stability

Driving along the inclined terrain

- Never attempt to drive the machine along the terrain of an inclination exceeding 18° (32%)
- When driving the machine across any laterally sloping terrain, widen the span of the crawling tracks to its maximum width to increase the machine's stability; also lower the stabilisers down to the position almost reaching the ground level. Do not drive the machine on lateral slopes above 11° .

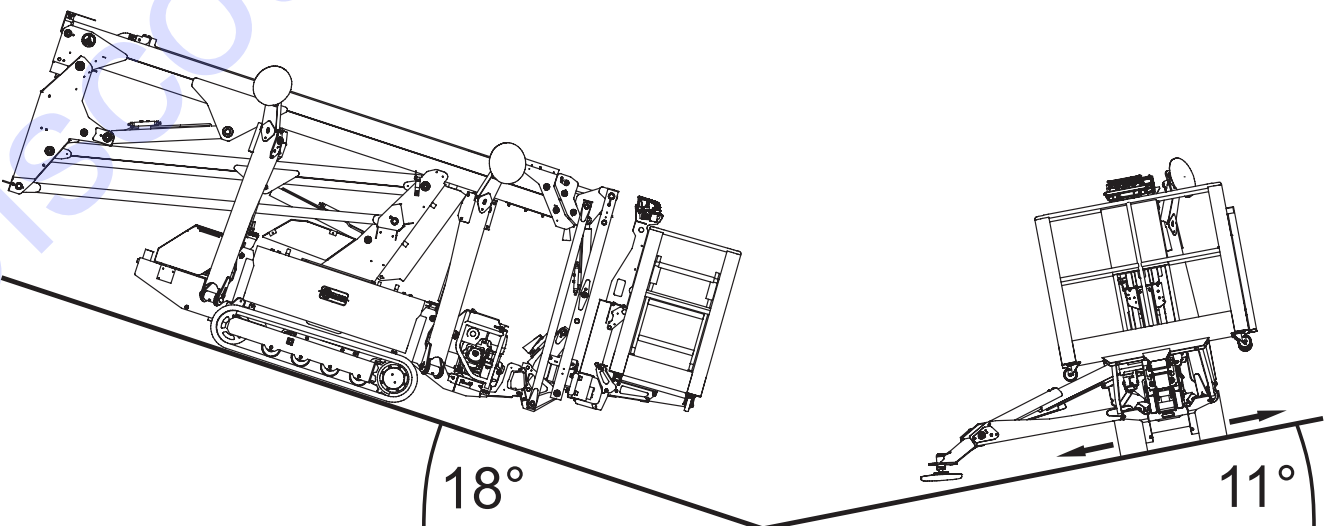

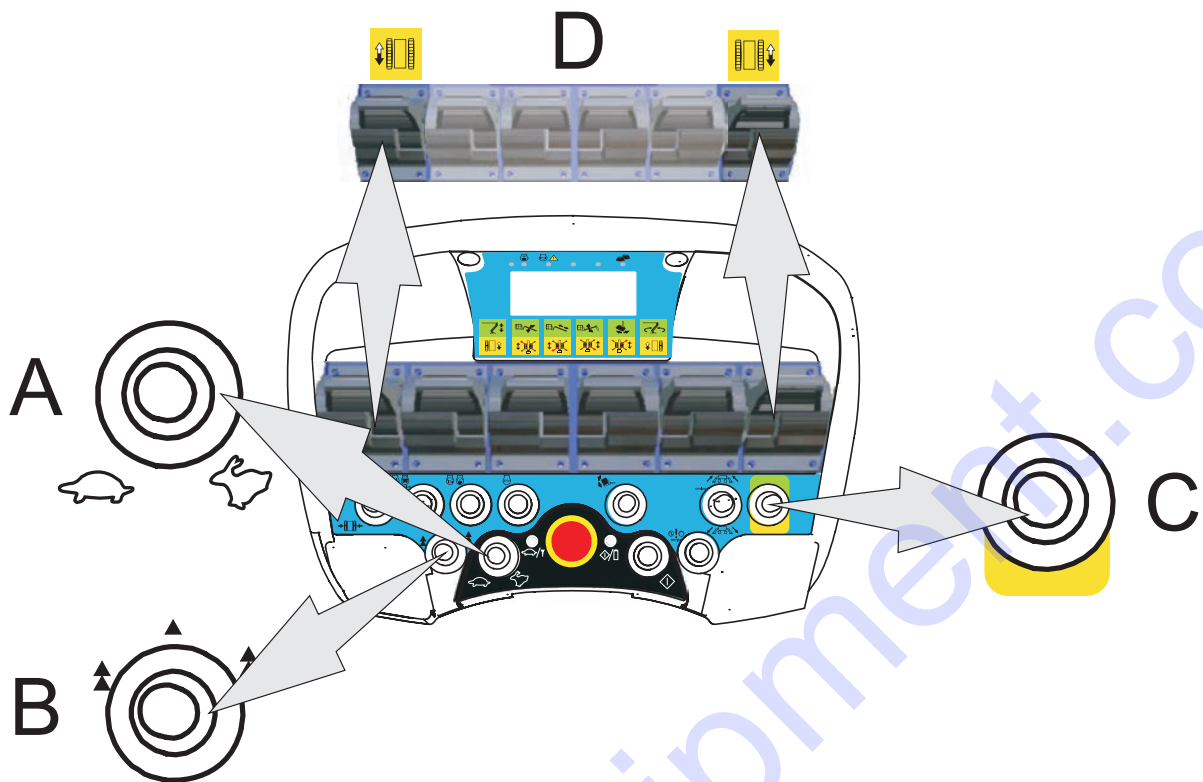

- A Using the S3 selector key **set the desired speed of the engine** (when using the diesel engine)
- B With the S2 selector key **select the desired speed** (when using the diesel engine)
- C Move backward S6 to **activate the movements of the two tracks** along the ground
- D Move forward the two joystick controls M1 – M6 for the tracks

If necessary, widen or close the span of the crawling tracks with the S1 selector key . Change of the tracks span should best be done during the actual driving.

In order to steer the machine the speed of the respective crawling tracks must be different.

- **Steering to the right:** will require the **M1** joystick to be inclined more
- **Steering to the left:** will require the **M6** joystick to be inclined more

Machine stabilisation

Once the machine is properly positioned, the procedures of stabilisation and levelling out may be commenced.

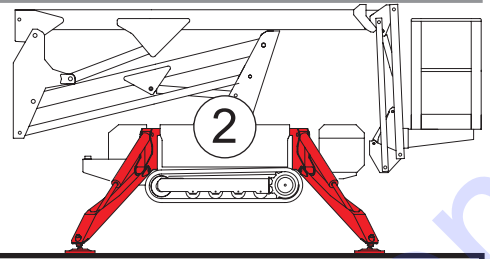

Stabilisers may be repositioned only when the machine is stowed away

As automatic levelling out is merely an electronic aid for a significantly simplified use of the machine, great attention must also be paid to the instructions given below

Before commencing any machine stabilisation operations, make sure there are no persons in the proximity of the plates and stabiliser cylinders

Before commencing any machine stabilisation operations, make sure the terrain is flat (without any potholes or depressions), with a good adhesion and able to support the maximum load transferred onto the ground by the stabilisers, that is described on the rating plate placed on the machine

If necessary place some strong weight distribution plates under the stabiliser small plates

Make sure the stabilisers do not rest on any underground pipes or road drainage wells

Machine stabilisation is achieved when the machine is in a horizontal position with tolerance below 1°

Attempting to have the machine stabilised on a terrain of a higher inclination than the permitted one may result in compromising its overall stability and consequently cause serious damage to people and property.

It is absolutely mandatory to work with the machine stabilised well within the limit

Automatic stabilisation

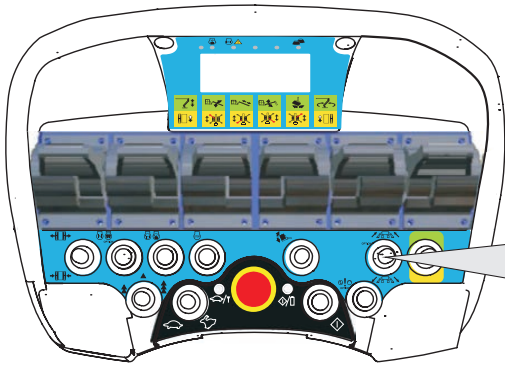

Turn **S5** backward and keep it pressed for the duration of the operation; the stabilisers are lowered down and the machine is now stabilised and levelled out.

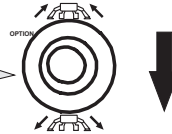

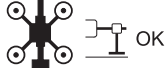
When the pictogram  appears on the display unit on the platform control panel, the levelling out is completed and the operation is automatically stopped.

- Reset the selector into a neutral position.
- When another operation has raised the chassis out of the ground, another automatic stabilisation operation should be carried out.
- Always check visually the effective levelling out of the machine by making use of the special spirit level.

With the cage in its stowed away seat:

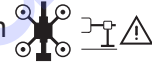
- If the machine is inclined above 1° , the pictogram  on the display unit will signal the loss of levelling.
- If one or more stabiliser feet should lose touch with the ground, the pictogram will appear on the display unit and all the movements of the aerial part will be blocked.

The stabilisation operation should be repeated in every one of the above referenced cases,

With the aerial part of the machine open:

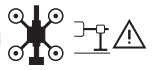
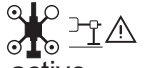
- If the machine is inclined above 1° the pictogram  on the display unit will signal the imminent hazard of overturning.
- If one of the stabiliser feet should lose touch with the ground, the pictogram  will appear on the display unit, whereas all the movements of the aerial part will remain active.

In none of the above referenced cases the electronic system of the machine will block any operations. It is the operator's prerogative to decide whether to continue operating the machine, or to close down the aerial part of the machine and have it reset in a stabilised mode.

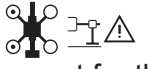
- If two stabiliser feet should lose touch with the ground, the pictogram  will appear on the display unit and all the movements of the aerial part will be blocked, except for the following ones:
 - lowering of the pantograph
 - retraction of the extension
 - lowering of the jib

Manual stabilisation

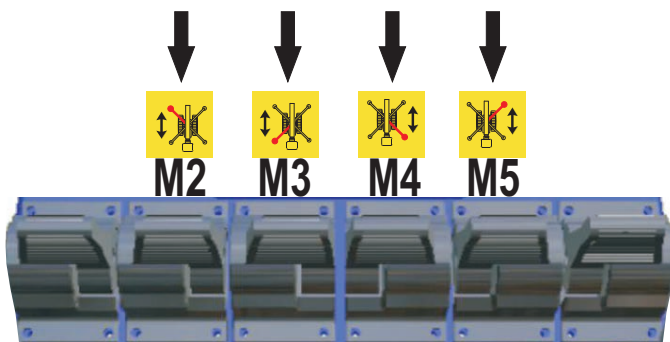

Using the 4 joysticks: **M2 – M3 – M4 – M5** push them backward to have the machine effectively stabilised.

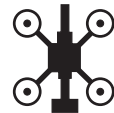

The pictogram will appear on the display unit on the platform control panel.

***A single stabiliser foot that touches the ground
may not be lowered until all four feet have contact with the ground***

After the stabilisation has been completed, please check the following:

- the crawling tracks are **lifted from the ground**
- visually check how the **stabilising cylinders are in contact with the ground**
- visually check the **actual levelling-out of the machine** by making use of the special spirit level.

After the completion of the positioning and the stabilisation phases have the platform control panel inserted back into its docking station in the cage.

In close proximity of the radio control unit make sure that micro-magnetic switch placed on the side of the platform control panel is securely pushed into its socket.

Moving the aerial part

- Make sure that the load conforms to the originally set limits and is well distributed around
- Make sure that the bar closing access to the platform is properly secured
- Make sure that the red emergency stop button is not pressed down neither on the ground control panel nor on the platform control panel
- Always check that the warning emergency lights are not lit up indicating some sort of emergency situation

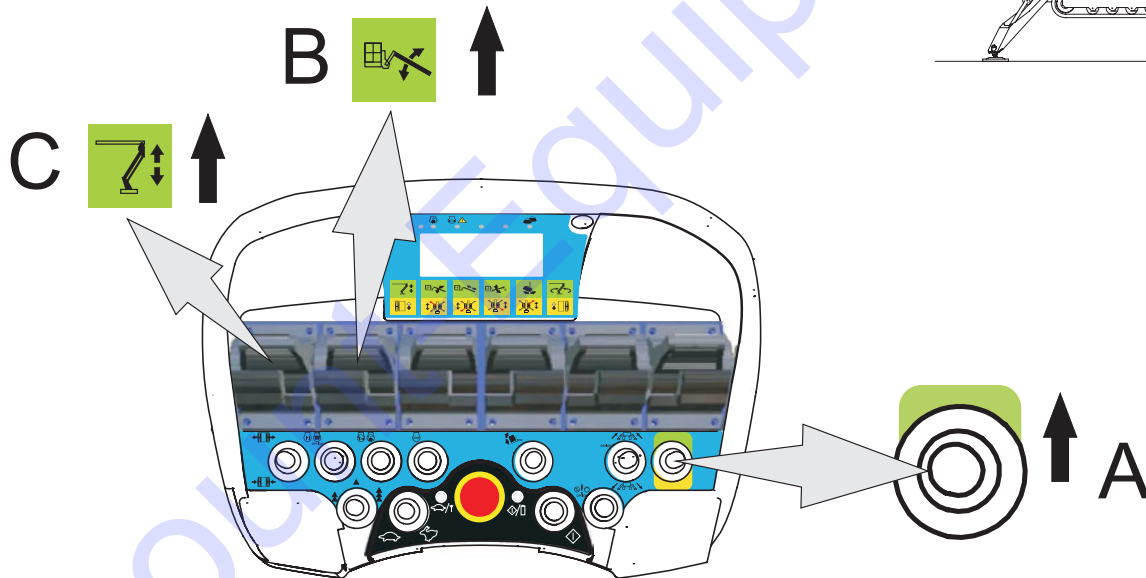
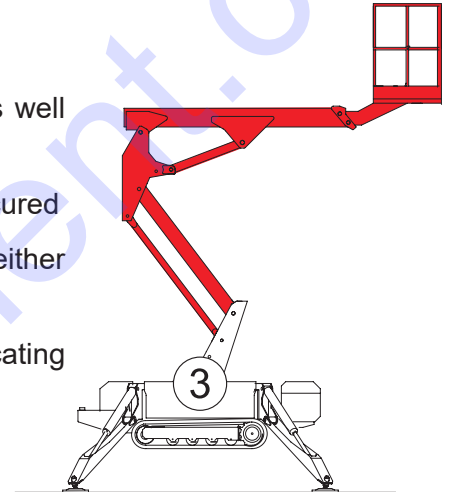





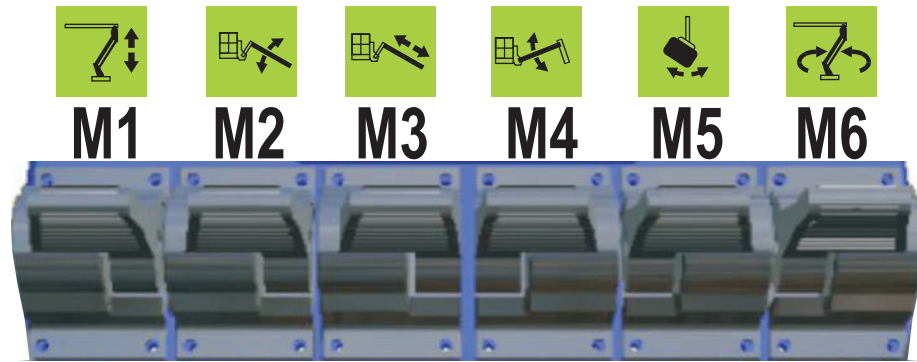

A Push forward the **S6**

B Lift the boom by pushing forward the **M2** joystick.
Lifting of the boom is the first operation to be executed in order to commence the activation of the lifting system.

C Lift the pantograph by pushing forward the **M1** joystick.

Through the lifting of the boom over 5° and/or the pantograph over 6° all the movements of the aerial part controlled by the joysticks become activated.



JOYSTICK		AERIAL MOVEMENT
 M1 Pantograph	Forward	Lifting
	Backward	Lowering
 M2 Boom	Forward	Lifting
	Backward	Lowering
 M3 Boom retraction	Forward	Extension
	Backward	Retraction
 M4 Jib	Forward	Lifting
	Backward	Lowering
 M5 Cage rotation	Forward	Clockwise rotation
	Backward	Anticlockwise rotation
 M6 Turret rotation	Forward	Clockwise rotation
	Backward	Anticlockwise rotation

Returning to the stowed away mode

After completing the works at height return to the stowed away mode.

Retraction of the aerial part

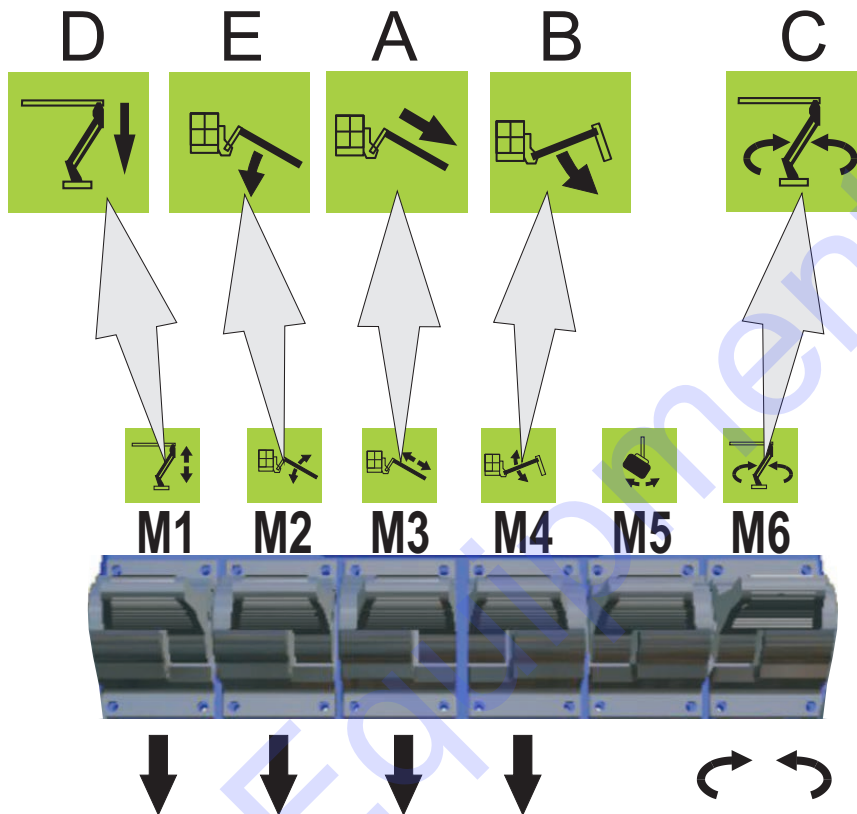

- A Retract completely the extension by pulling the **M3** joystick backward
- B Lower completely the jib by pulling the **M4** joystick backward
- C Rotate the turret with **M6** for as long as it becomes perfectly aligned with the chassis
- D Close the pantograph completely by pulling the **M1** joystick backward
- E Close the boom completely by pulling the **M2** joystick backward

Retraction of the stabilisers

The retraction of the stabilisers is possible only with the cage in its stowed away seat.

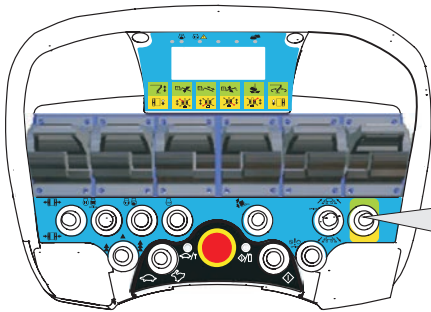

Push S6 backwards to **activate the ground movements**.

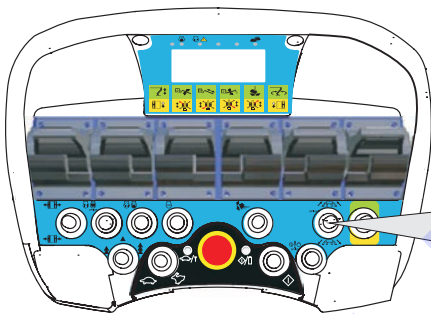

Automatic procedure

Push S5 forward to stop the movements.

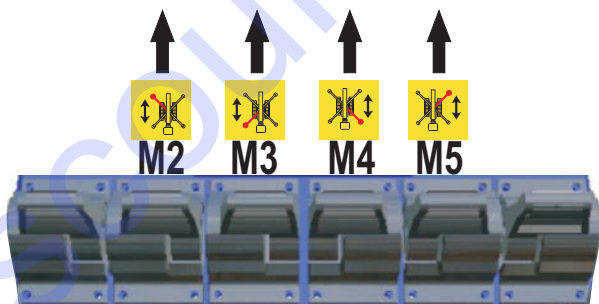

Manual procedure

Using the 4 joystick controls M2 – M3 – M4 – M5 push them forward to lift the feet.

At this stage there is no possibility to check out the movement sequence of the stabilisers, so be very careful when trying to lower the platform down, and always make sure to keep the machine as much levelled out as possible

Motor switch-off

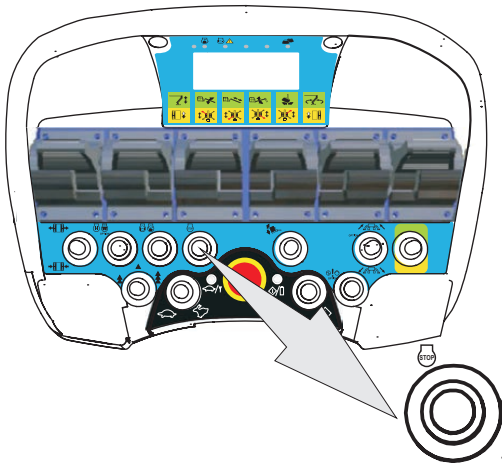

From the platform control panel

- Switch the diesel/petrol engine /electric motor off using the **I4** button

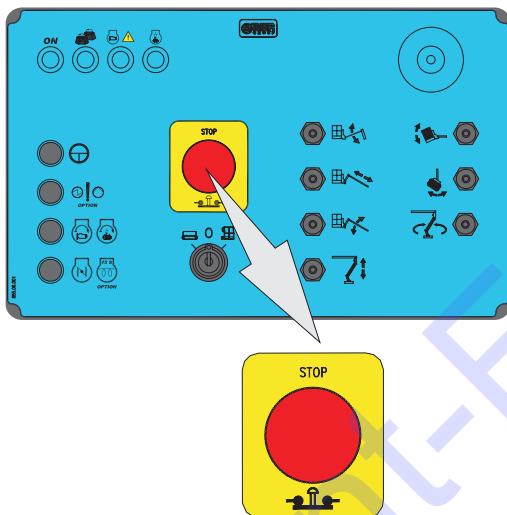

From the ground control panel

- Press down the emergency button 2

Switching the machine off

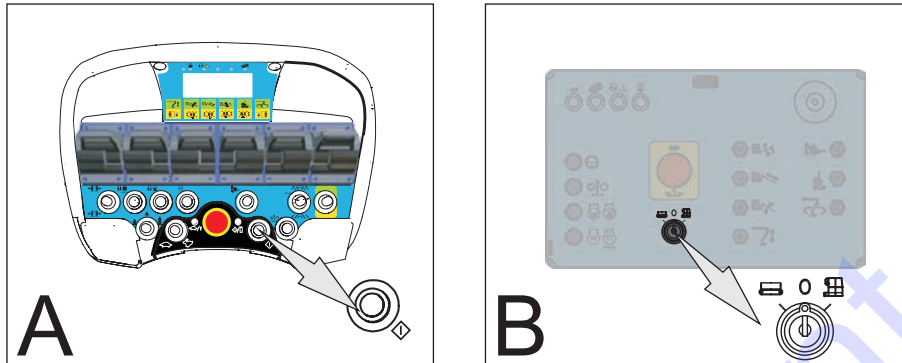

- A** . Switch off the platform control panel with the I1 button
- B** . Turn the key into the central position in the ground control panel

End of works

- Always make sure to remove the key from the selector.

Emergency procedures

Emergency manual procedures

If the machine is blocked due to mechanical or electrical fault, or due to the operator's fault, it is possible to put it into the transport configuration which can be facilitated by the operator from the ground.

The standard procedure consists in using the electric valves of the hydraulic blocks located in the left-hand box (P - E - D - C), on the right-hand side of the turret (A) and the manual pump on the left-hand side of the tank.

Other procedures apply to the machine fitted with the electric 12 V pump.

Any manually executed procedures may cause the machine to accidentally tip over, so make sure you always perform them very carefully

Before carrying out any emergency operations, press down the red emergency stop button

Before carrying out any emergency operations, make sure there are no obstacles of any kind around the machine

Using manual pump

The hydraulic blocks are located in the left-hand side box (P - E - D - C) and on the right-hand side of the turret (A).

The manual pump is located on the left-hand side of the tank.

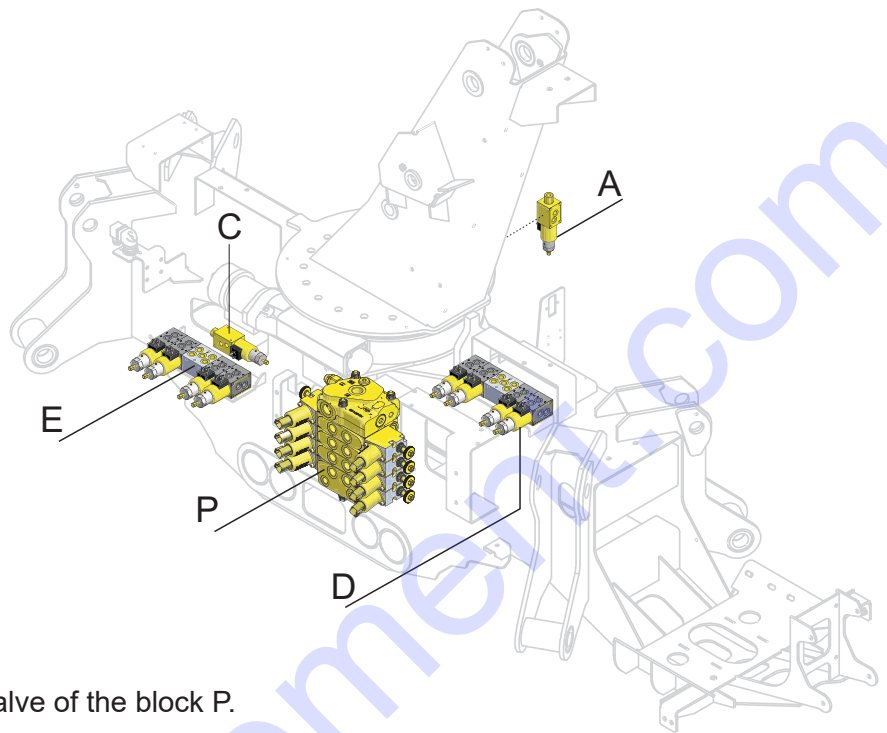

Every operation is controlled by the electric valve of the block P.

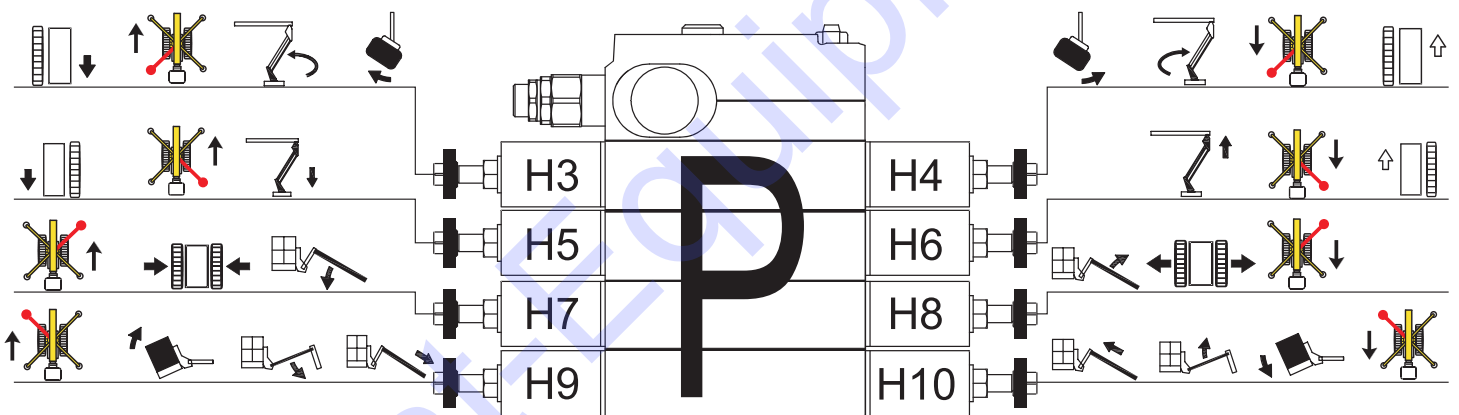

One or two electric valves of the blocks D - C - E - A also control certain operations.

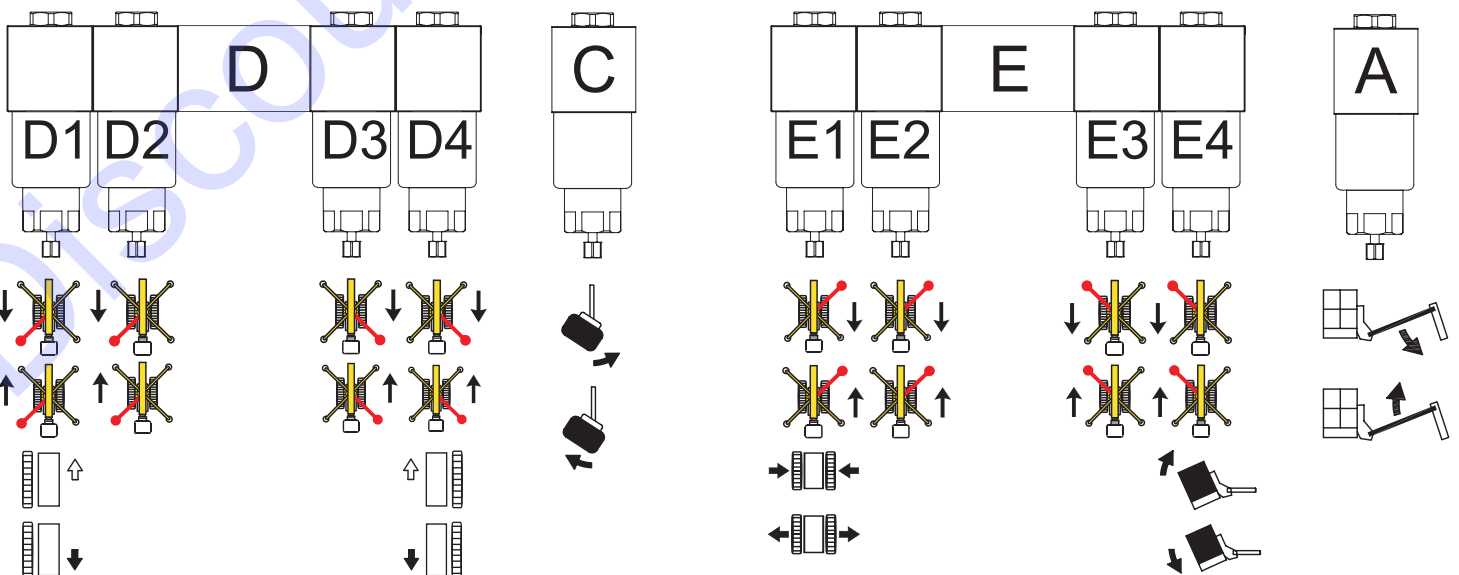

To carry out a manually-controlled operation:

1. Identify the electric valve responsible for the activation of the main block P.
2. Unscrew the protective nut on the electric valve (using adjustable wrench No. 13).
3. Screw the pawl of the electric valve to the end.
4. Screw the protective nut on the electric valve back on (using adjustable wrench No. 13).
5. Check if the movement is associated with one or two electric valves on the switch block.
6. Having identified it/them, screw the pawl.

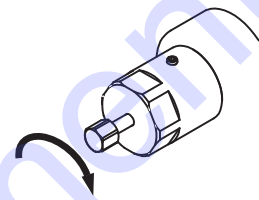
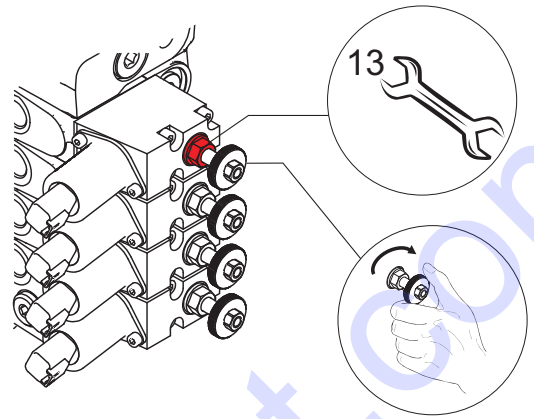

7. After having set the hydraulic blocks, start up the hydraulic pump using the proper lever to activate the operation.

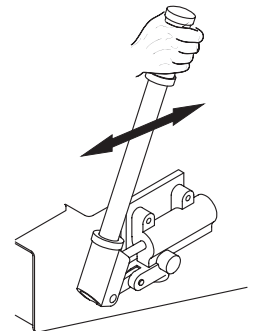

At the end of this operation, check the emergency electric valves, which must resume their initial setting, as indicated below:

In the MAIN BLOCK P

1. Unscrew the protective nut on the electric valve (using adjustable wrench No. 13)
2. Screw the pawl of the electric valve to the end
3. Screw the protective nut on the electric valve back on (using adjustable wrench No. 13)

In the BLOCS: D - C - E - A

1. Screw the pawl of the electric valve to the end

EXAMPLE 1

If necessary, carry out the **pantograph lowering** operation:

1. This operation is associated with the electric valve H5 of the main block P

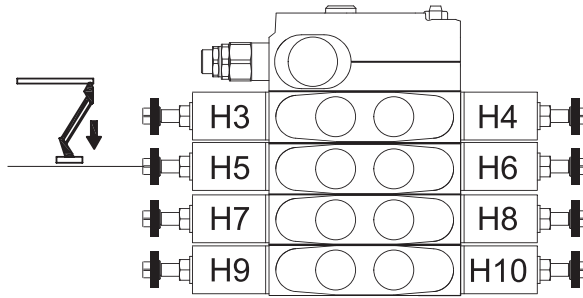

2. Unscrew the protective nut on the electric valve H5 (using adjustable wrench No. 13)
3. Screw the emergency pawl to the end
4. Screw the emergency pawl of the electric valve H5 (using adjustable wrench No. 13)
5. Start the hydraulic pump up by using the appropriate lever until the pantograph is completely lowered
6. Unscrew the protective nut on the electric valve H5 (using adjustable wrench No. 13)
7. Unscrew the pawl of the electric valve H5
8. Screw the protective nut on the electric valve H5 back on (using adjustable wrench No. 13)

EXAMPLE 2

If necessary, carry out the **lowering of the rear left stabiliser** operation:

1. The operation is associated with the electric valve H4 of the main block P and with the electric valves D1 - D2 of the block D

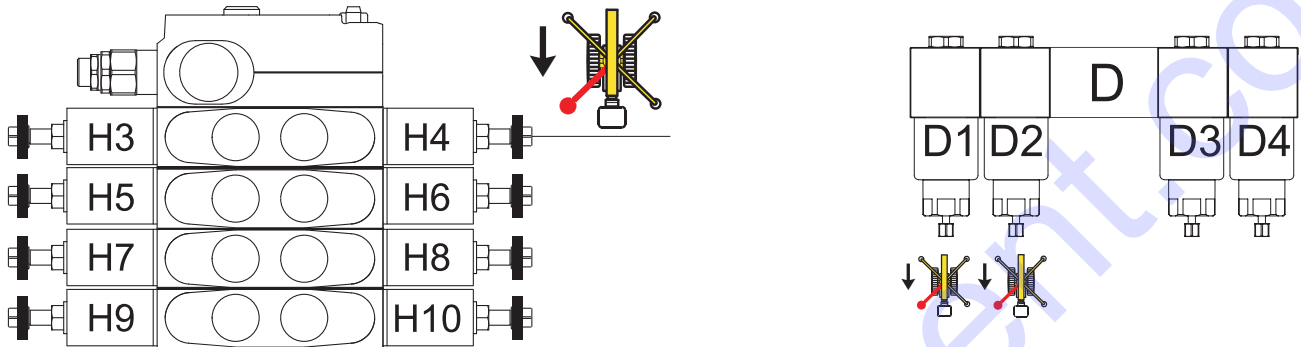

2. Unscrew the protective nut on the electric valve H4 (using adjustable wrench No. 13)
3. Screw the emergency pawl to the end
4. Screw the emergency pawl of the electric valve H4 back on (using adjustable wrench No. 13)
5. Screw the pawl on the electric valves D1 - D2
6. Start the hydraulic pump up by using the appropriate lever until the stabiliser is completely lowered
7. Unscrew the protective nut on the electric valve H4 (using adjustable wrench No. 13)
8. Unscrew the pawl of the electric valve H4
9. Screw the protective nut on the electric valve H4 (using adjustable wrench No. 13)
10. Unscrew the pawl on the electric valves D1 - D2

Emergency Manual Lowering Procedure

In case manual pump needs to be used, it is recommended to follow the following procedure in order to avoid destabilizing movements and risks a more dangerous situation.

The following procedure is also shown inside the hood of the machine in the form of an label

1. **Phase 1:** Retracting Telescopic Boom

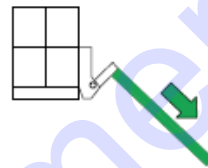

2. **Phase 2:** Lowering Jib

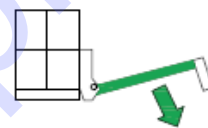



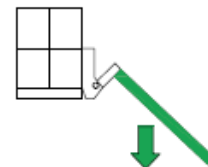











3. **Phase 3:** Lowering Telescopic Boom













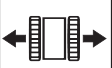
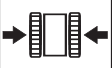

4. **Phase 4:** Lowering Pantograph



On this page and in the following 2 tables there is a summary of the electric valves and the operations controlled by them.

	H3	H4	H5	H6	D1	D2	D3	D4	C
									
									
									
									
									
									
									
									
									
									
									
									
									
									

	H7	H8	H9	H10	E1	E2	E3	E4	A
									
									
									
									
									
									
									
									
									
									
									
									
									
									

With the electric 12V pump (optional)

The electric 12V pump is located in the right-hand box.

There are two emergency procedures requiring the use of electric 12V pump depending on the problem to be addressed:

- The machine is blocked and no alert is signalled (e.g. no fuel)
- The machine is blocked with the alert activated

As the electric 12V pump is connected up to the starting battery, its prolonged use will cause its rapid discharge

The machine is blocked without any alert signals

Check if the machine is connected to the 220 V mains and the differential magneto-thermal switch is not activated

In the radio-controlled models, the platform control panel must be switched on

From the ground

Execute the following operations from the ground control panel.

1. Move the selector key to the left.
2. Press down the button 4 to activate the electric 12V pump.
3. Keeping pressed down the button 3 simultaneously move the selector of the operation to be executed.

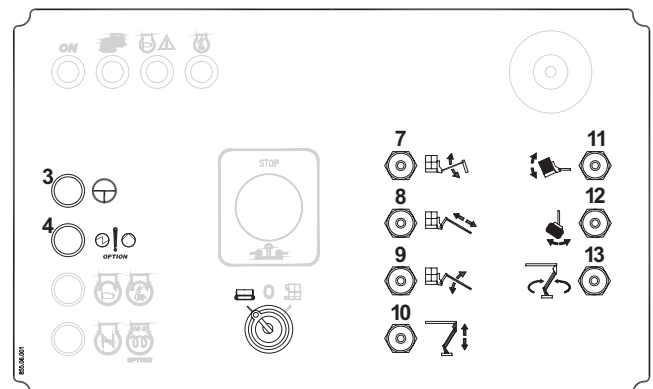

From the platform control panel

1. Turn the selector key to the right on the ground control panel
2. Switch on the platform control panel with the I1 switch
3. Press the I6 switch to switch the electric 12V pump on
4. Move the joystick and choose the required operation

The machine is blocked in the alert mode

The hydraulic blocks situated in the left-hand box (P - E - D - C) and on the right-hand side of the turret (A).

The starting up switch of the electric 12 V pump is situated in the right-hand box.

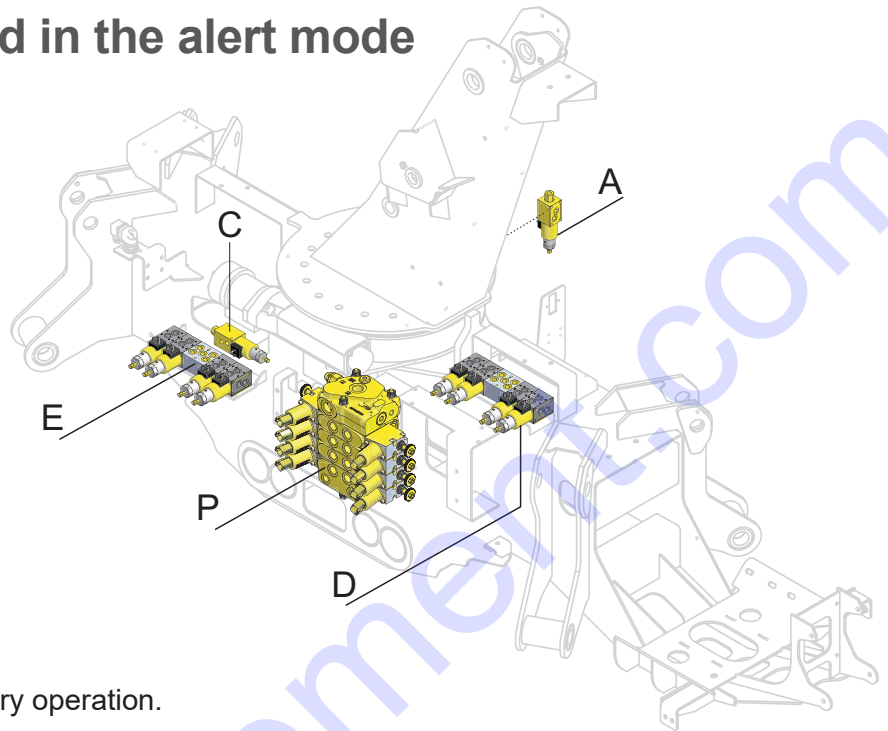

The electric valve of the P block controls every operation.

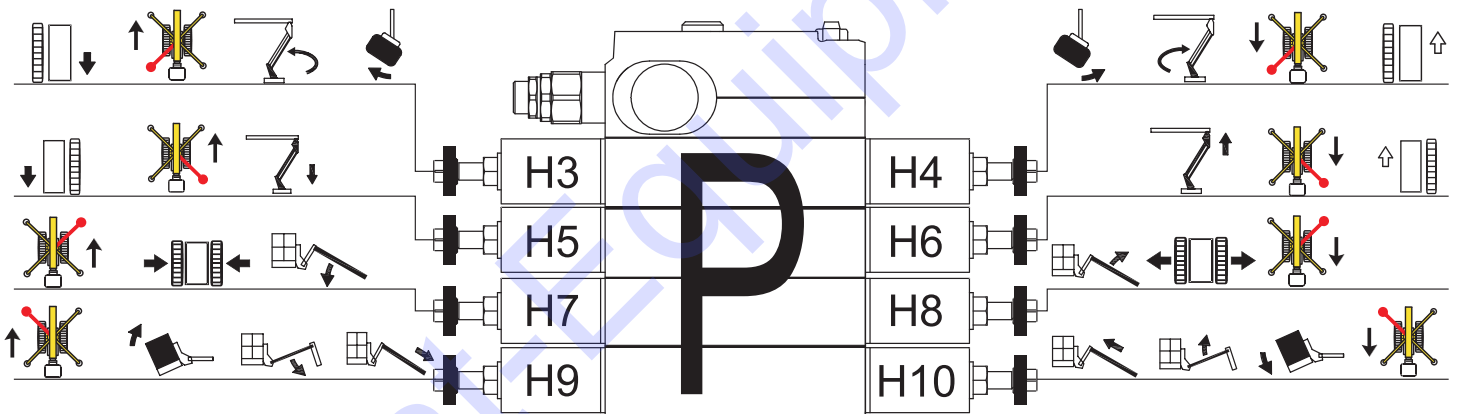

Certain operations are controlled from one or two electric valves of the D - C - E - A blocks.

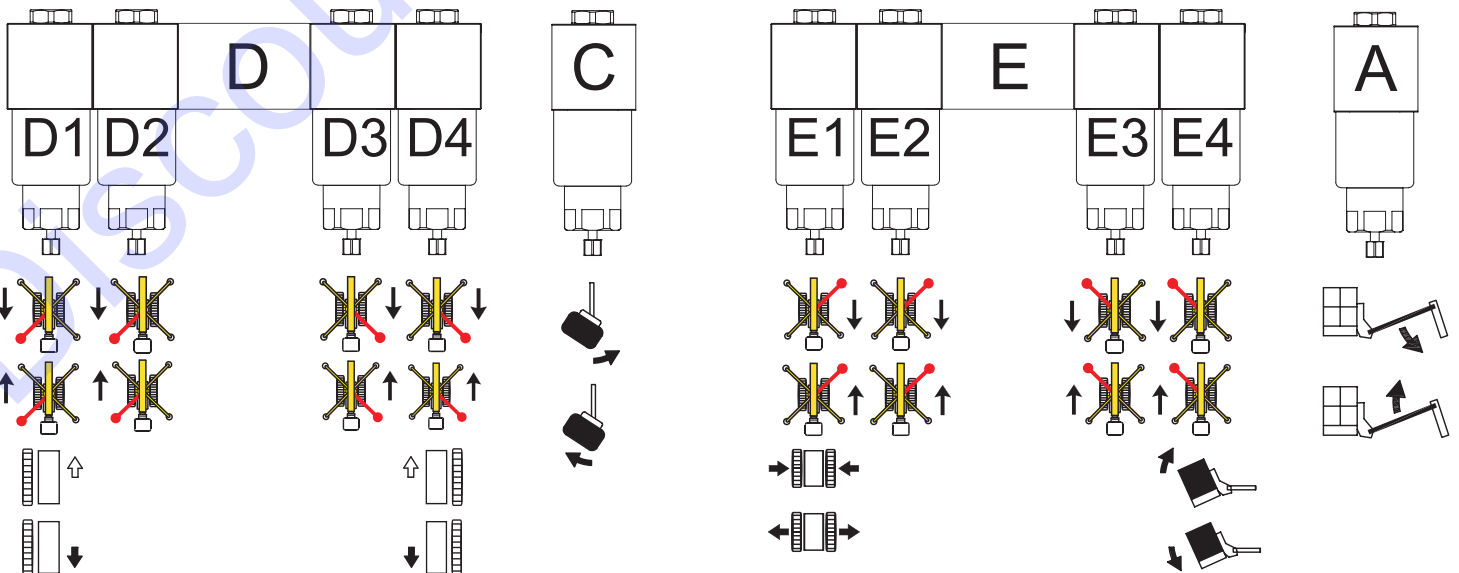

To perform the operation manually:

1. Identify on the main block P the electric valve associated with the operation
2. Unscrew the protective nut on the electric valve (using adjustable wrench No. 13)
3. Screw the electric valve pawl to the end
4. Screw the protective nut on the electric valve (using adjustable wrench No. 13)
5. Check if the movement is associated with one or two electric valves on the switch block
6. Unscrew the protective nut on the electric valve H5 (using adjustable wrench No. 13)

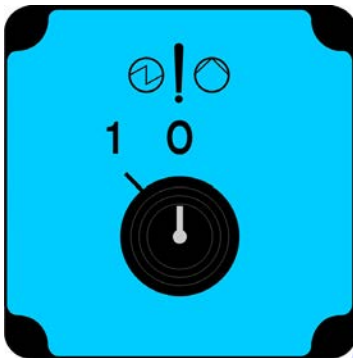
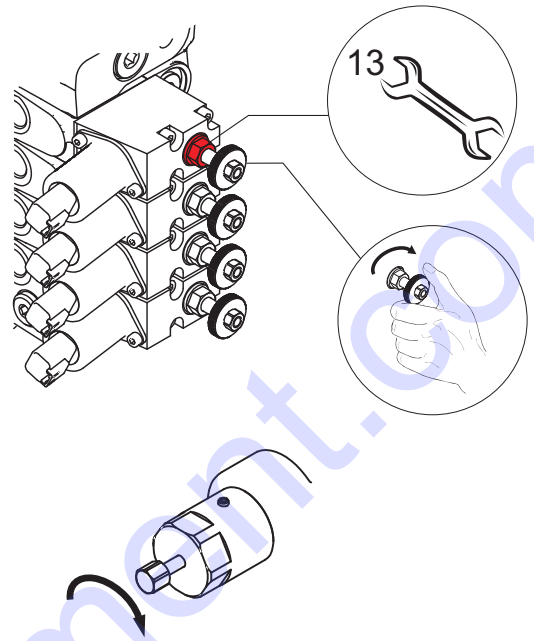

After having set the hydraulic blocks, activate the electric 12V pump by turning the switch to 1 and keeping it in this position until the operation is completed.

At the end of this operation, check if the emergency electrical valves are set in their initial position, as indicated below:

In the MAIN BLOCK P

1. Unscrew the protective nut on the electrical valve (using the adjusting wrench No. 13)
2. Unscrew the pawl of the electric valve to the end
3. Screw the protection nut of the electric valve back on (using the adjusting wrench No. 13)

In the D - C - E - A BLOCKS

1. Unscrew the pawl of the electric valve to the end

On pages 104/105 there are 2 tables comprising a summary of the electric valves and the operations controlled by them.

EXAMPLE 1

If necessary, carry out the **pantograph lowering** operation:

1. This operation is associated with the electric valve H5 of the main block P

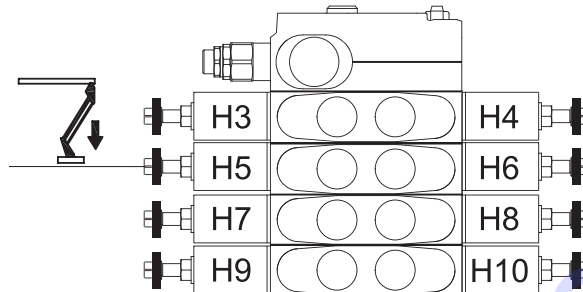

2. Unscrew the protective nut on the electric valve H5 (using adjustable wrench No. 13)
3. Screw the emergency pawl to the end
4. Screw the emergency pawl of the electric valve H5 (using adjustable wrench No. 13)
5. Start the hydraulic pump up by using the appropriate lever until the pantograph is completely lowered
6. Unscrew the protective nut on the electric valve H5 (using adjustable wrench No. 13)



7. Unscrew the pawl of the electric valve H5
8. Screw the protective nut on the electric valve H5 back on (using adjustable wrench No. 13)

EXAMPLE 2

If necessary, carry out the **lowering of the rear left stabiliser** operation:

1. The operation is associated with the electric valve H4 of the main block P and with the electric valves D1 - D2 of the block D

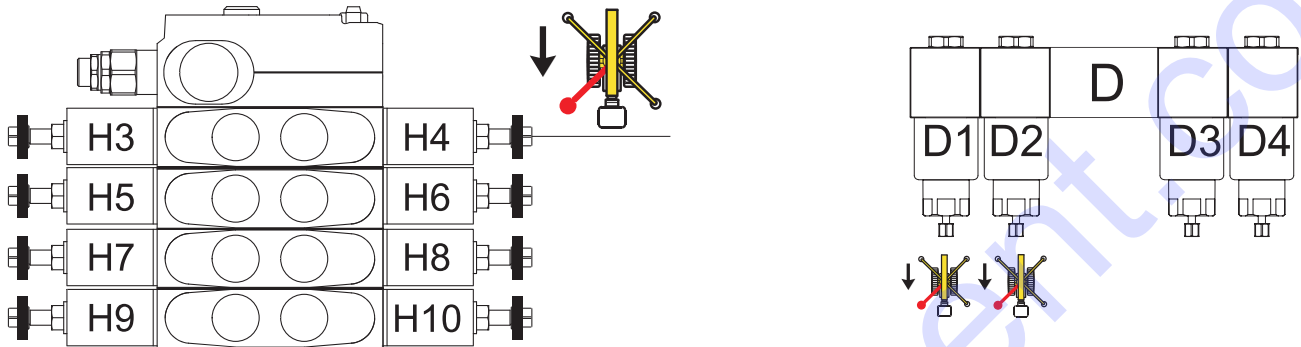

2. Unscrew the protective nut on the electric valve H4 (using adjustable wrench No. 13)
3. Screw the emergency pawl to the end
4. Screw the emergency pawl of the electric valve H4 back on (using adjustable wrench No. 13)
5. Screw the pawl on the electric valves D1 - D2
6. Start the hydraulic pump up by using the appropriate lever until the stabiliser is completely lowered
7. Unscrew the protective nut on the electric valve H4 (using adjustable wrench No. 13)

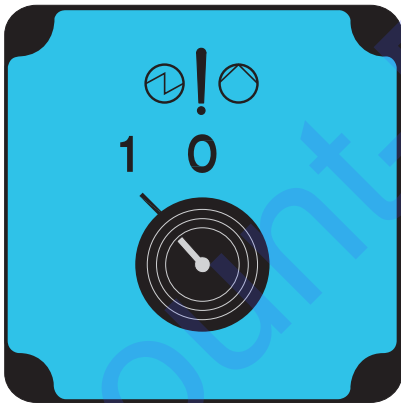

8. Unscrew the pawl of the electric valve H4
9. Screw the protective nut on the electric valve H4 (using adjustable wrench No. 13)
10. Unscrew the pawl on the electric valves D1 - D2

Petrol engine

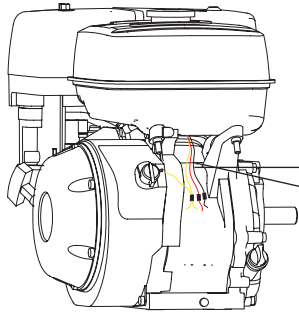

1. Find the 4 wires, as shown in the figure, on the right-hand side of the engine, (2 yellow ones, 1 red and 1 black)

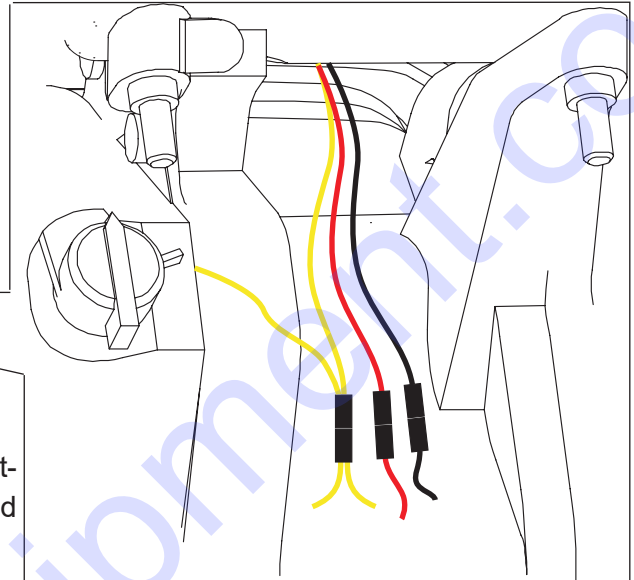

2. Remove the red and black wires from the respective connectors

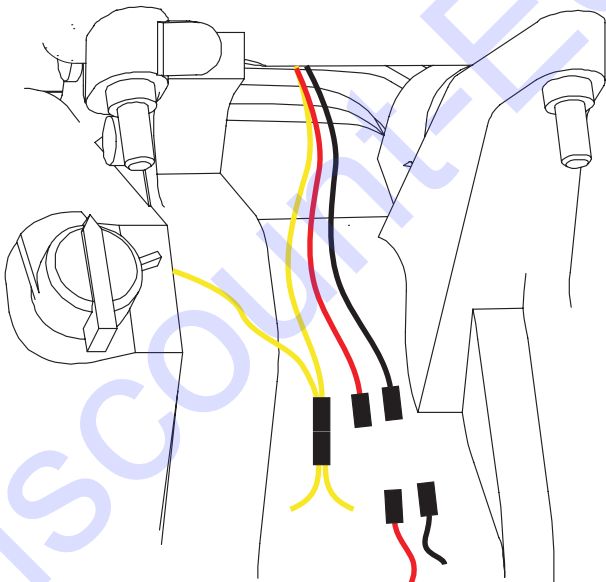

3. Connect up both terminals

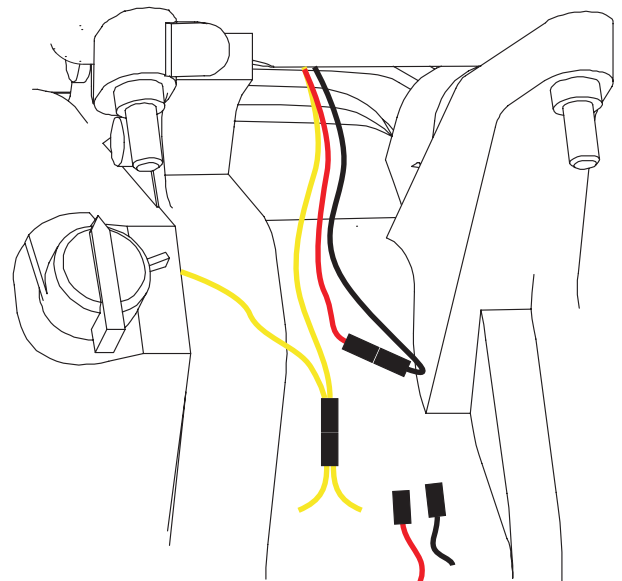

4. Pull the engine start-up lever until resistance is felt and then release it

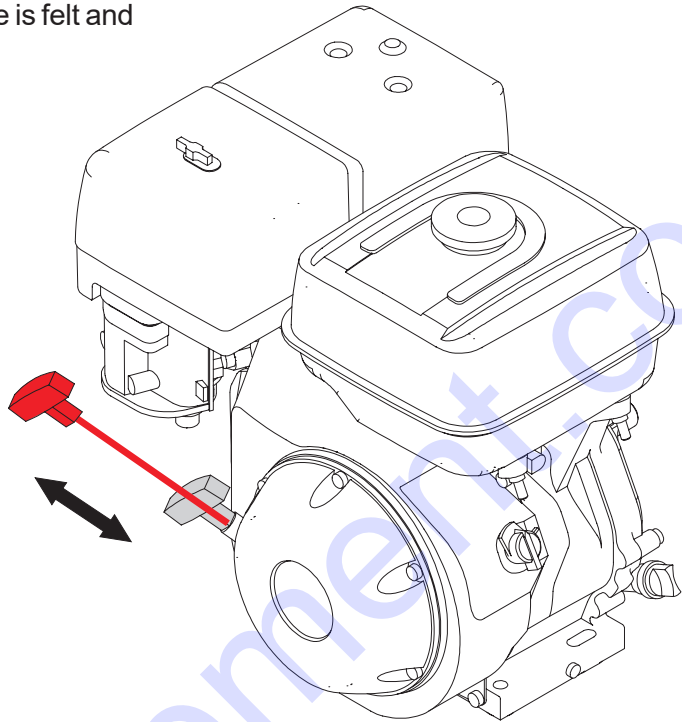

5. Pull the air lever to the outside

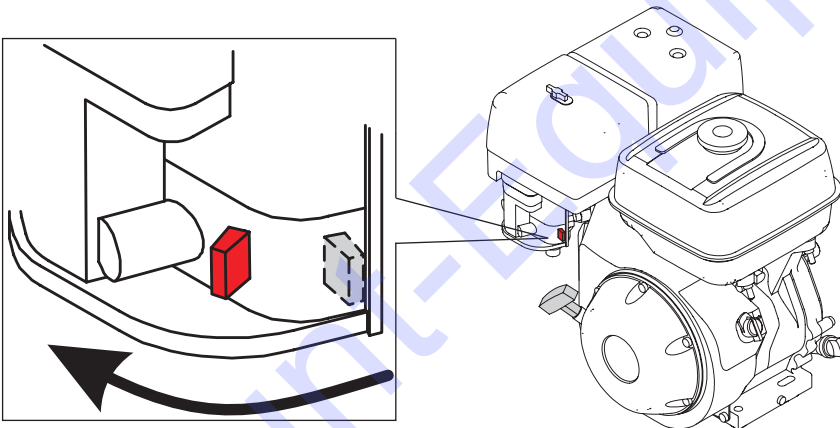

6. Pull the lever decisively

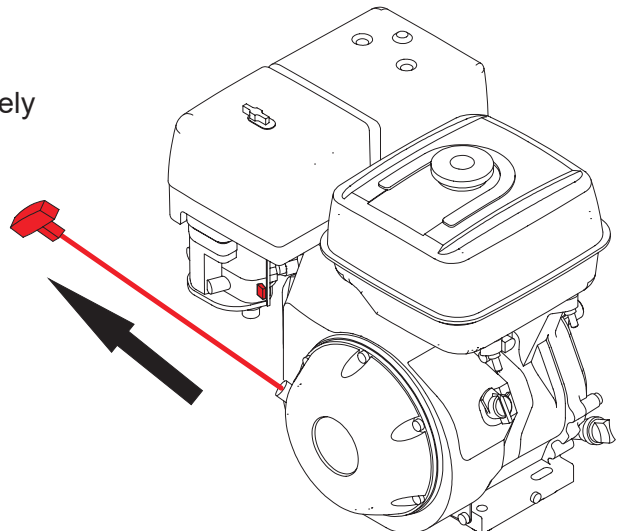

Battery recharging



The following pictogram on the display unit on the platform control panel will appear, in addition to indicating the fault of the alternator (lit up steadily); it indicates the status of the starter battery:

- Flashing: the starter battery is below the warning level and must promptly be recharged.

To have it recharged the machine needs to be connected to the 220 V mains (or 110 V) and the circuit breaker on the electric pump battery charger needs to be switched on.

Il caricabatterie accenderà una spia verde mentre sta effettuando la carica della batterie e una spia rossa quando avrà raggiunto la carica completa.

Battery charges characteristics; 120 V line

- Battery charger 12 V 12 A
- Power supply 85/264 V – 50/60 Hz
- Operating temperature from -10°C to +45°C
- Charging curve IUoU
- Protection against output short circuit
- Protection against polarity reversal
- Weight: 1.5 Kg

Transport

Make sure the vehicle used for the transport and/or lifting of the machine can support its weight

Loading and unloading of the machine

Loading and unloading of the machine onto the platform of the carrying vehicle may be done as follows:

- with the aid of a loading platform
- by having it lifted directly

If necessary, detach the cage to reduce the length of the machine, as illustrated in the next paragraph

Using the loading platform

- Park the carrying vehicle on a flat surface.
- Position the loading platforms in a parallel position to each other at a distance equal to that of the crawling tracks, and at the inclination lower than 18° .
- Lift the boom setting the machine into a safety transport mode. This way the cage is safe from any impacts.
- Always carry out all the loading/unloading operations, as well as lift the machine off the ground maintaining a safe distance.
- Proceed with caution, with a minimum speed, to avoid shaking up the machine.
- Place the machine in such a position on the loading platform that none of its parts protrudes outside it.

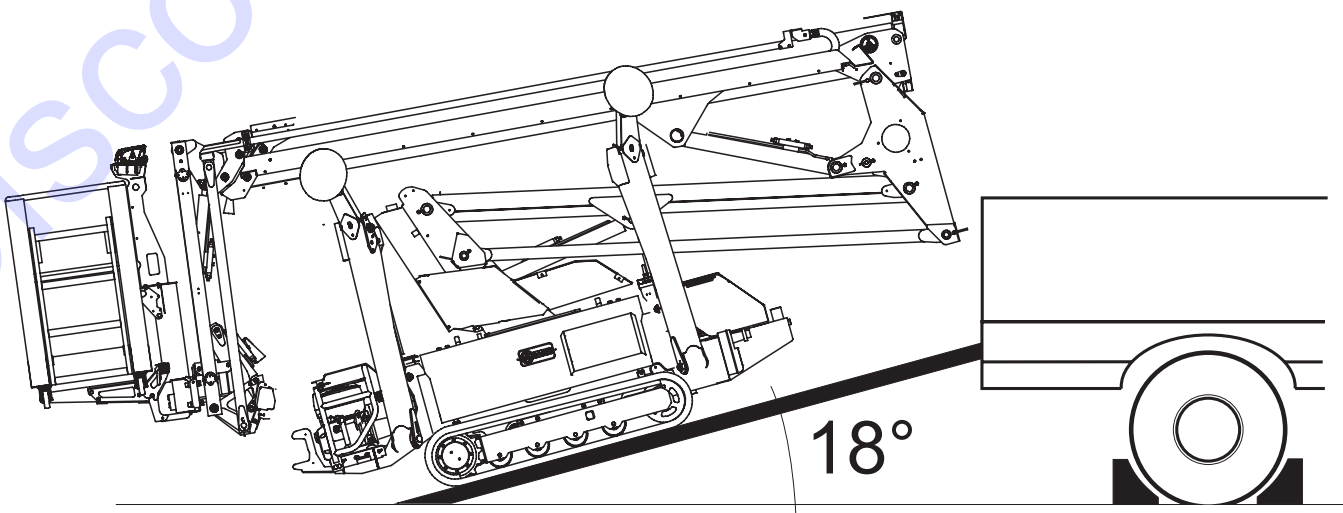

When lifting

The lifting may be carried out with a crane or a bridge crane.

Use the tape, chains and hooks in perfect operating condition only.

- The machine may be lifted up in a stowed away mode only.
- No operator may be in the cage at the time.
- The entire area of the lifting operation must be free from personnel and/or any objects.
- Do not move the machine over the heads of any persons.

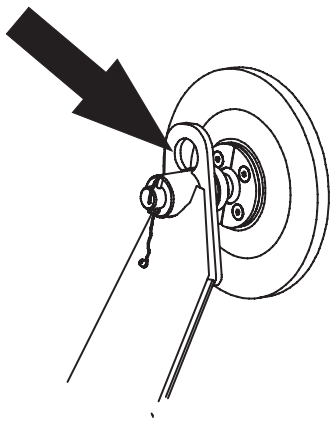

Attach the machine with the ropes and chains through the 4 attachment points, as indicated in the labels.

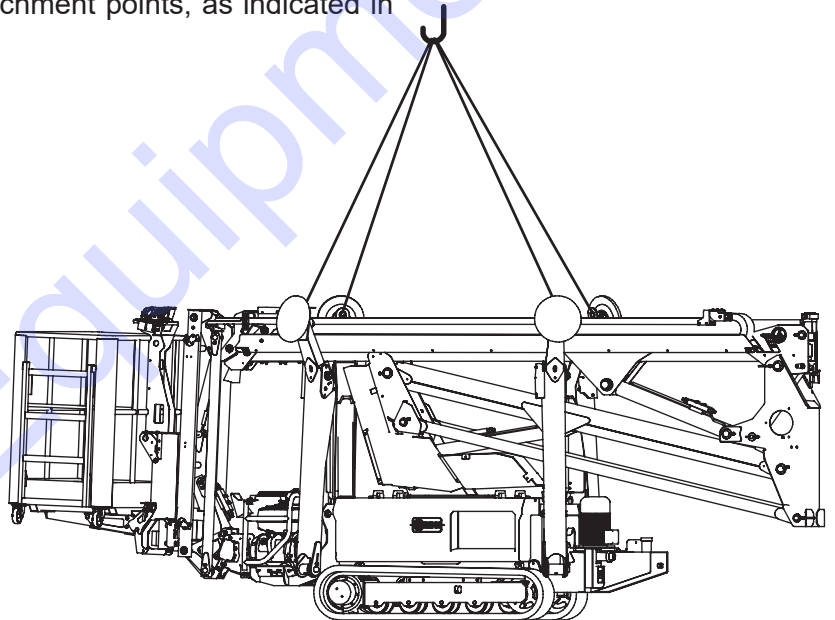

Do not hang the machine on the ropes differently than recommended as otherwise it might be exposed to structural damage

In the figure the machine is positioned within its own centre of gravity.

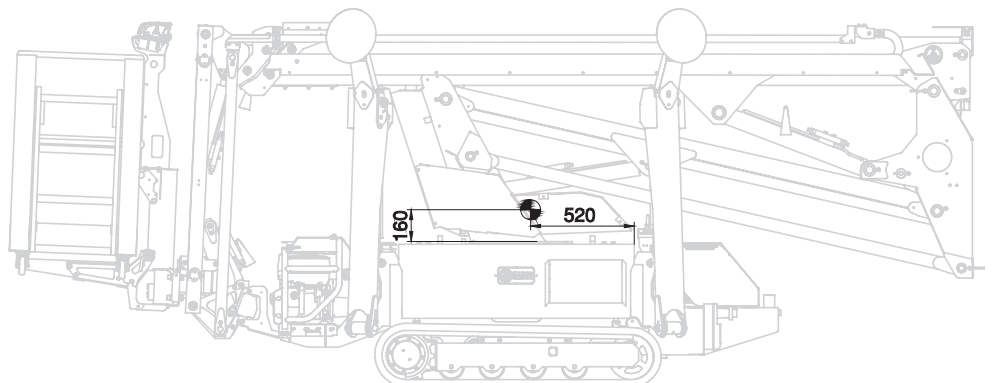

How to uncouple the cage

- Park the carrying vehicle on a flat surface
- Keep on lowering the cage, using the balancing control, until it touches the ground

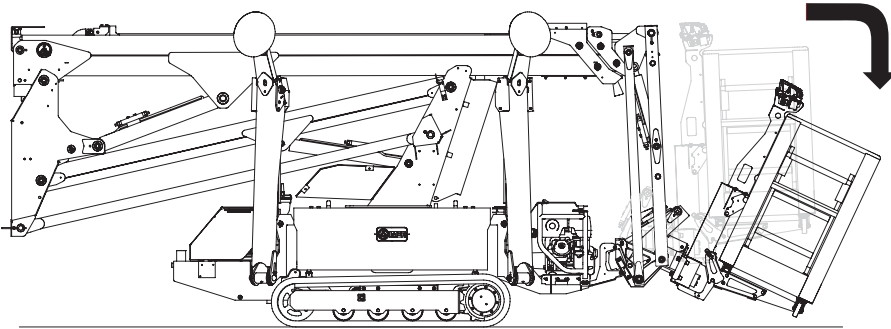

- Remove the flexible plug out of the pin

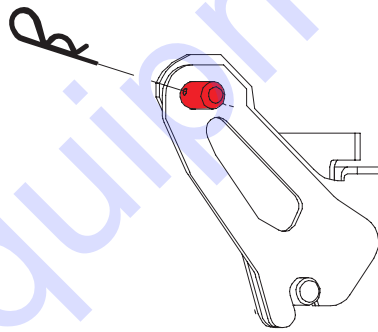

Trough the following operation the cage will be uncoupled from the machine; it requires at least two operators to have it executed

- Rotate the pin and then pull it out

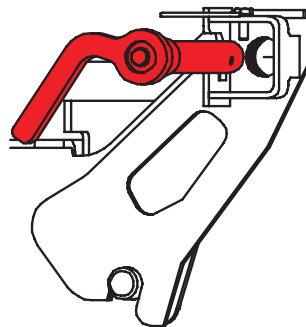

- Place the cage onto the ground

Fastening the machine

Prior to shipment make sure the machine is properly secured on the carrying vehicle platform with tapes threaded through the 4 attachment points; 2 anterior and 2 posterior ones, as indicated on the appropriate labels.

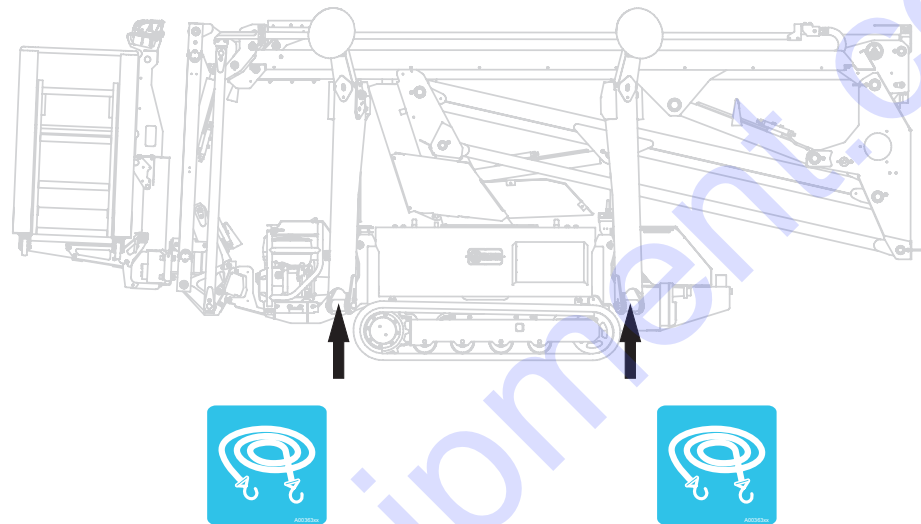

Do not secure the machine at any different points than those specifically indicated on the labels

Secure the cage on the vehicle platform to preclude any lateral movements of the rotating part

It is strictly prohibited to start the machine up when on the carrying vehicle platform

Storage

In the event of long storage periods, shelter the machine in a dry and ventilated place, with fully loaded batteries. Charge the batteries every 2 months regularly.

Storage temperature: -20/+50°C

Before using the machine after a storage period exceeding 30 days, carry out the inspections described in the Maintenance Summary Table, item “after long periods of inactivity”

Disposal and scrapping

The machine consists mainly of steel, aluminium, plastic, synthetic rubber and copper.

Special attention must be paid to disposal of electric batteries (Italian legislation: D.Lgs. 188/08) and of the hydraulic oil contained in the tank of the hydraulic circuit (Italian legislation: DPR 691/82).

The main components of the machine are listed below:

- Cast iron
- Nylon
- Steel
- Teflon
- Copper
- Polycarbonate
- PVC
- Ertalyte

Maintenance

Long life and maximum safety during machine operation can only be assured by careful and regular maintenance.

The schedule stipulated in the maintenance summary table refers to normal use conditions, whereas in the case of any heavy duty working conditions (extreme temperature, polluted atmosphere, high humidity, high elevation, etc.) those intervals must be shorter.

Frequency and scope of periodical maintenance and inspections may depend on applicable national regulations.

Machine cleaning

Once each working-shift has been finished, or when you feel it is necessary, have the machine cleaned:

- Clean all the surfaces by means of a compressed air blow, preventing undue accumulation of grime and dirt.
- Spray a normal degreasing product and eliminate the residual dirt using of cotton clothes.

Never use diluents, scrapers and steel brushes to prevent any damage to the painted surfaces

Do not clean the machine with a high-pressure water jet. Humidity or water penetration into the electric components could cause failures and/or damage to the electric/electronic control modules

Maintenance Summary Table

OPERATIONS TO BE CARRIED OUT	AFTER THE FIRST 50 HOURS	EVERY DAY	EVERY MONTH	EVERY 100 HOURS OR EVERY 6 MONTHS	EVERY 250 HOURS OR ONCE A YEAR	AFTER LONG PERIODS OF INACTIVITY (30 DAYS)
Check the oil level			X			X
Change the oil		X				X
Check the electrolyte level		X				X
Check the batteries charge		X				X
Change the oil filter cartridge				X		X
Check the tightening of all the screws	X			X		X
Grease the mechanisms	X			X		X
Check the safety devices	X				X	X
Check emergency manual operations				X		X
Check the brakes				X		X
Carry out structural check	X		X			X
Check the hydraulic tubes					X	X
Check the performance					X	X
Check power and auxiliary cables					X	X

Maintenance of petrol/diesel engine

Please find further below the tables stipulating the maintenance schedule of the petrol and diesel engines. For more detailed instructions consult the Manual enclosed with the machine documentation.

Petrol engine OPERATIONS TO BE CARRIED OUT	AFTER EVERY USE	EVERY 20 HOURS OR EVERY MONTH	EVERY 50 HOURS OR EVERY 3 MONTHS	EVERY 100 HOURS OR EVERY 6 MONTHS	EVERY 300 HOURS OR ONCE A YEAR
Check the oil level	X				
Change the oil in the engine		X		X	
Check the air filter	X				
Clean the air filter			X		
Replace the air filter					X
Clean the filter bowl				X	
Check/adjust the ignition plug				X	
Replace the ignition plug					X

Maintenance of the electric motor

Periodically check:

- engine functions for any vibrations or irregular noise
- air inlet on the rotor cover for any obstructions
- for dust, oil leakage or other undue grime on the motor

Temperature relay

The temperature relay fitted on the machine serves to protect the electric motor against any possible overload.

Perform the following test to check a correct functioning of the relay.

1. Open the protection box of the temperature relay.
2. Start the electric motor up.
3. Press down the red STOP key on the relay.
4. Check if the motor switches off.
5. Reset the motor using the blue RESET key.

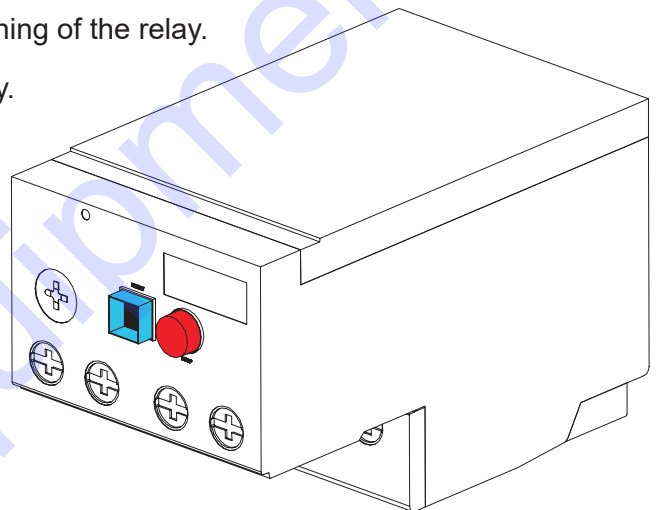

Checking the oil level; periodic oil replacement

The checking of the oil level and its topping up should always be done with the platform fully lowered

Check that the oil level remains above the minimum value; the oil level readout must be in the middle. Whenever necessary, top up the oil level with the oil of the same viscosity as indicated on the tank.

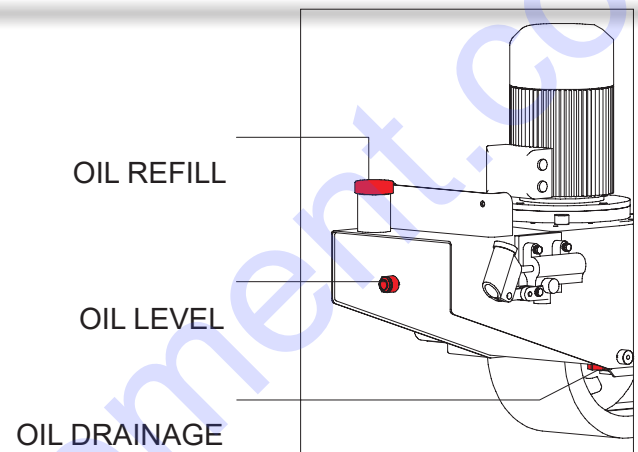

Changing the oil

The complete change of oil must be done with the machine in the stowed away mode

The tap placed under the tank facilitates a total oil drainage.

- The oil should be drained out of the tank to an appropriate container.
- Close the drainage tap.
- Refill with the new oil through the inlet tap.

Hydraulic oil is a pollutant

Avoid any spillage of the hydraulic fluid. Should this accidentally happen, make sure to use the appropriate containers and control the spillage with the appropriate oil

Any used-up oil must be collected and never disposed of into the sewerage system. Specialised companies may take care of its disposal or eventual recycling, in full conformity with applicable national legislation

How to replace the oil filter cartridge

The cartridge must be replaced when:

- upon every oil replacement
- in compliance with the schedule stipulated in the Table of Maintenance
- when the error code 556 is displayed on the platform control panel display and all the machine operations have been slowed down.

The first replacement of the cartridge must be carried out after the first 50 working hours in order to effectively purge the machine's hydraulic system components of any undue operational residues

Greasing the machine movements controlling mechanisms

Thrust block:

- 3 greasers on the worm
- 2 greasers on the sides of the chassis to distribute the grease over the teeth

Stabilisers:

- 1 on the cylinder
- 1 on the pin

Housing:

- All the cylinder pins (excluding the strain pivot of the moment control)

Batteries

The battery contains sulphuric acid - it is a highly health hazardous substance

In the event of the acid coming into an accidental contact with the skin or the eyes, have them rinsed immediately with copious amount of water and consult a doctor

It is recommended to always wear protective gloves and glasses when carrying out any maintenance on the batteries

Electrolyte level check

- Open the right cowling
- Check the level, and fill it up with distilled water, if necessary
- If some battery fluid has accidentally been spilled up, mop it up immediately

Check the battery charge

The battery charge level can be read out on the platform control panel

For the battery recharge, please see section on "Battery recharge"

Battery replacement

- Open the right-hand box
- Set the battery isolator in the OFF position
- Disconnect the battery terminals, always starting off with the negative (-) pole.
- Reconnect the electric cables always starting off with the positive (+) pole.

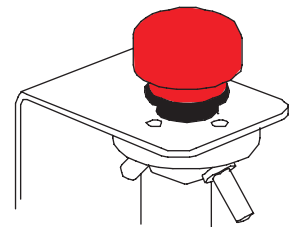

Replace the battery with the one of equivalent characteristics

Check of screws tightening

DESCRIPTION	TYPE	Qty	Tightening	
			N x m	Lb x ft
Screws fastening the thrust block to the base-truck	M16×70 UNI 5931	18	250	184
	M16×70 UNI 5739	6	250	184
Screws fastening the thrust block to the turret	M16×70 UNI 5931	18	250	184
Screws fastening the wheel reduction gear to the base tracks	M10×30 UNI 5931	16	50	37
Screws fastening the motor to the drive wheel	M10x30 UNI 5931	16	50	37

Check the wear of the telescopic boom guides

Check if the extended boom is sufficiently rigid and without any clearance between the extension and the guides.

Safety devices check

The following test facilitates checking that all the safety devices on the machine are fully operational.

The safety systems installed on the machine are inevitably subject to wear and loss of calibration, therefore they must be periodically checked and maintained in perfect service condition. It is not recommended to have their efficacy verified on the basis of their performance only.

No such systems may in any way relieve the operator of his individual responsibility of operating the machine with all due diligence.

Red emergency stop button

- Press down the emergency stop button on the ground control panel and check that no operation is possible, either from the ground or from the platform. Reset the button into the ON position.
- Press down the emergency stop button on the platform control panel and check that no operation is possible, either from the ground or from the platform. Reset the button into the ON position.

Engine speed

Make sure there are no obstacles in close proximity of the platform, either above or below it, before carrying out the check

None of the 4 stabilisers (levelling outriggers) should be left under pressure and the petrol/diesel engine is to be used for the task.

Start the test on the machine in the stowed away mode.

- Switch on the engine using the platform control panel, carry out the boom lifting until it stops. Make sure that the engine drive is steady revolutions.
- Lower the boom until reaching the stowed away position and make sure that all the speeds settings are operational, so the engine can be accelerated, if required.

Load limiter

- Load the platform with the load equal to 110% of the nominal value.
- During the lifting of the boom, check that:
 1. Overload warning light on the platform control panel is switched on
 2. Alert from the platform control panel sounds out
 3. Overload warning light on the ground control panel is switched on
 4. Alert from the ground control panel sounds out
 5. All the operations are blocked
 6. Excessive load is removed
 7. All operations are fully restored

Load sensor

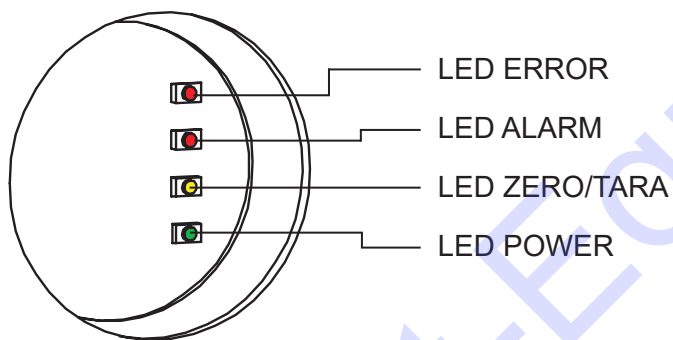

With the machine powered up check that:

- green POWER LED lights up and when there is no load, yellow ZERO/TARA LED is on
- load a weight of about 30-40 kg and check that the yellow LED is out.

Moment limiter

- Put a load of 120 kg onto the cage
- Position the boom and the jib horizontally
- Fully lift the pantograph
- Keep the cage in alignment
- Extend the boom until the moment control blocks the operation
- Make sure that the distance between the anterior edge of the cage and the centre of the thrust block is between 7800 ± 250 mm.

Micro switches

SQ1A-B

Set the machine into the stowed away position, and check if the following pictogram is displayed on the platform control panel:

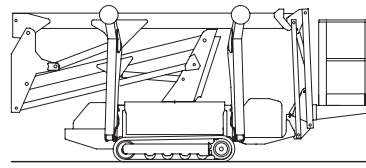

SQ8

- **Set the machine in the safety transport mode**
- Check if the boom lifting over 5° is blocked
- Make sure that the drive is not accelerated
- **Reset the machine into a stowed away position**
- Stabilise the machine
- Lift the boom over 5° angle and check if all aerial movements are released, except the cage balancing

SQ9

- **When the machine is in a stabilised position, lift the boom and take the machine out of the stowed away position**
- Lift the pantograph over 6° angle
- Check if the cage balancing operation is blocked

SQ10 (for the radio-controlled models)

With the machine STABILISED and STOWED AWAY:

- Get onto the cage and insert the platform panel into its proper seat
- Check if the boom may be lifted over 5° angle and all the movements of the aerial part may be activated from the platform control panel
- Take the platform control panel out of its seat
- Make sure that all operations are arrested

Manual emergency movements check

See paragraph “Manual emergency operations”

Brakes check

Good grip

Parking brakes must be capable of stopping the machine on a maximum slope, as indicated in the “Technical Data” Table.

Make sure that brakes immobilise the machine in both directions on the slope, as indicated in the above referenced table.

Braking distances

*All tests must be done with the machine on a flat surface,
with the engine switched on at the highest revolutions*

FAST SPEED

- Select fast speed on the platform control panel
- Set the crawling tracks joysticks to maximum forward position
- Release the joystick and check that the braking distance is less than 60 cm

SLOW SPEED

- Select slow speed on the platform control panel
- Set the crawling tracks joysticks to maximum forward position
- Release the joystick and check that the braking distance is less than 10 cm

Structure check

General

- Check that mechanical structures are protected against oxidation and, if necessary, retouch the oxidised areas.

Chassis

- Check the most important welds visually or by means of penetrating fluids:
 - Bearing structure
 - Wheel supports
 - Trunnions on the spindles
 - Bushing; replace them by using lubricating grease, if necessary
 - Status of the crawling tracks

Turret

- Check the most important welds visually or by means of penetrating fluids (pantograph hinge support, etc.)
- Check the good positioning and fixing of various components (turntable, pantograph hinge pins, etc.)
- Check the correct positioning and fixing of the ballasts
- Check the condition of the turntable and the rotation pinion

Pantograph and Booms

- Check the most important welds visually or by means of penetrating fluids (pantograph booms, intermediate support, boom, telescopic boom, hinge of various cylinders and jib boom)
- Check the cage levelling system, welding of various parts
- Check the correct positioning and fixing of various components (hinge pins, etc.)

Cage and Cage Support

- Check the most important welds visually or by means of penetrating fluids
- Make sure that metal sheet flooring in the cage is in good condition, as well as the side railings
- Check the tightening of the screws and nuts fixing the cage to its support
- Check the correct positioning and fixing of the hinge pins of the cage support to the jib boom

Checking the hydraulic tubes

Hydraulic oil is a pollutant

Avoid any spillage of the hydraulic fluid. Should this accidentally happen, make sure to use the appropriate containers and control the spillage with

- Control visually all hydraulic joints and tighten the junctions, if necessary.
- Check all flexible hydraulic tubes; replace them, if necessary.

Checking performance

Use a chronometer for performing the following checks:

Run the tests with the machine on a flat surface, with the engine running and engine speed on high revolutions

Safety speed

- Select safety speed on the platform control panel.
- Set the crawling tracks joysticks to maximum forward position.
- Check that the machine covers a 10 m distance in more than 65 sec.

Pantograph lifting/lowering

- Select the pantograph lifting function from the ground control panel and check that it takes about 25 sec. for a complete lift.
- Lower the pantograph and check that it takes about 26 sec

Boom lifting/lowering

- Select the boom lifting function from the ground control panel and check that it takes about 48 sec. for a complete lift.
- Lower the boom and check that it takes about 52 sec.

Telescopic boom extension/retraction

- Select the extension of the telescopic boom from the ground control panel and check that it takes about 58 sec. for a complete extension.
- Retract the boom and check that it takes about 40 sec.

Turret rotation

- Select the turret rotation function from the ground control panel and check that it takes:
 - 100 sec. approx. for a complete rotation to the right.
 - 100 sec. approx. for a complete rotation to the left.

Jib lifting/lowering

- Select the jib lifting function from the ground control panel and check that it takes 17 sec. approx. for a complete lift.
- Lower the jib and check that it takes about 15 sec.

Cage rotation

- Select the cage rotation function from the ground control panel and check that it takes:
 - 11 sec. approx. for a complete rotation to the right.
 - 11 sec. approx. for a complete rotation to the left.

Maintenance of rubber crawling tracks

Checking the tension of the crawling tracks

- Position the machine onto a compact and flat surface
- Have the machine stabilised
- Measure the distance A between the outer and inner part of the rubber track in relation to 2 central rolls

The correct tension is the distance spanning 10 - 15 mm

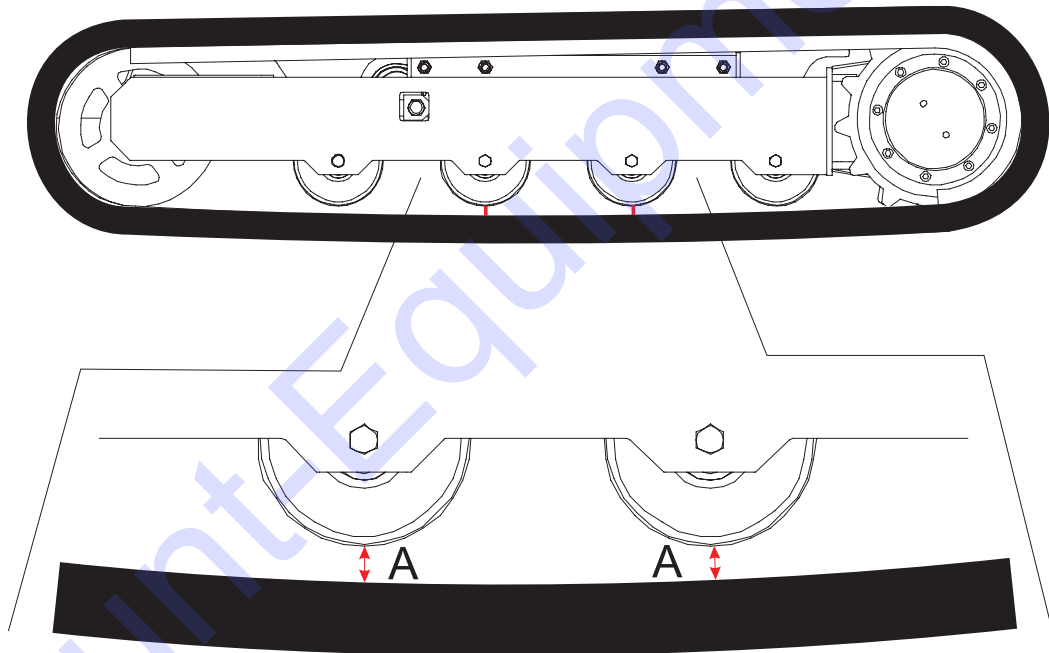

If the value A does not correspond to the indicated values, the crawling track is loosened up or overstretched; see the following paragraph: "How to loosen up - stretch the crawling track".

How to loosen up or stretch the crawling track

The following operations should be completed with the machine stabilised

*The grease contained in the hydraulic system is under pressure.
Do not open the valve more than one turn; if the valve is too much loosened up,
the pressure of the grease may eject it. The greaser may never be left open.*

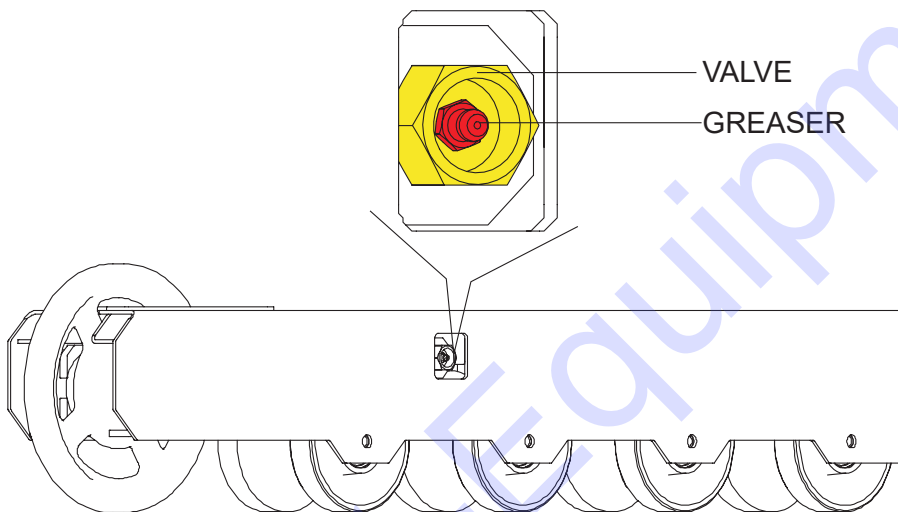

To loosen up the crawling track:

- Slowly open the valve in the anticlockwise direction, not more than half a turn, to drain the grease. If the grease does not come out turn the crawling track slightly.
- Once the correct tension of the crawling track is obtained, close and tighten the valve in the clockwise direction.
- Clean any grease residues outside the mechanism.

To tense up the crawling track:

- Connect the grease gun to the greaser
- Fill the track with the grease until the track tension reaches the correct value.

How to replace the crawling tracks

The following operations should be completed with the machine stabilised

*The grease contained in the hydraulic system is under pressure.
Do not open the valve more than one turn; if the valve is too much loosened up,
the pressure of the grease may eject it. The greaser may never be left open*

- Widen the span of the crawling tracks.
- Complete the following operation to loosen up the crawling track due for replacement:
 - Slowly open the valve in the anticlockwise direction, not more than half a turn, to drain the grease. If the grease does not come out turn the crawling track slightly.
- Take the crawling track out.
- Before fixing a new crawling track, make sure that the direction of the drive is correct.
- Match the track links with the toothed wheel and then place the track of the tension wheel.
- Rotate the driving wheel in the reverse gear.
- Make sure that the links of the crawling track are correctly matched with the toothed wheel and the tension wheel.
- Adjust the tension of the crawling track.

This page is left out empty intentionally

Machine Logbook

Reference to legislation

This Machine Logbook is issued to the aerial platform users, in compliance with the provisions of the Enclosure No. I do the Directive 2006/42/CE.

Instructions for keeping the Machine Logbook

This Machine Logbook must be considered as an integral part of the aerial platform and must be stored on the platform for the duration of its service life, until it is finally dismantled.

Forms for filling in

These instructions were originally supplied when the machine was first marketed. Should the amended/modified instructions be introduced, the user's obligations might change accordingly.

This Machine Logbook is intended to keep a record of following events related to the machine's service life:

- Delivery of the machine to the first buyer
- Transfer of ownership
- Replacement of components in the hydraulic system
- Replacement of components in the electric system
- Replacement of mechanisms or structural components
- Replacement of safety devices and their components
- Periodical maintenance checks except daily inspections indicated in the maintenance summary table
- Major failures and their repairs

***The MONTHLY checks and inspections may be recorded in the Machine Logbook every
6 months***