

IM 47

IM 4746 - IM 4752

MOBILE ELEVATING WORK PLATFORM USE AND MAINTENANCE MANUAL

MUM IM 47 EN R00 06/2019

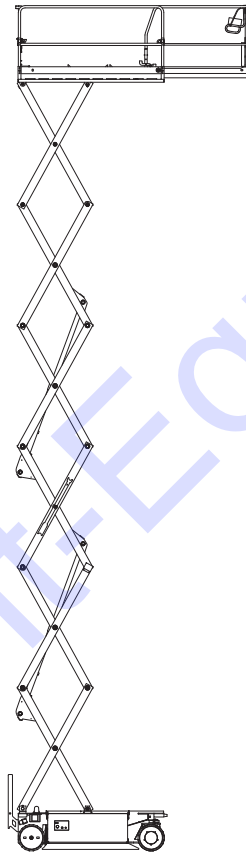

IM 4746

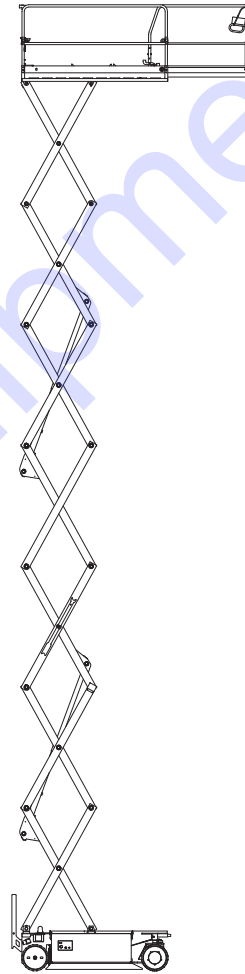

IM 4752

TRANSLATION OF THE ORIGINAL INSTRUCTIONS



www.Discount-Equipment.com

TO PURCHASE THIS PRODUCT PLEASE CONTACT US



**Equipment Financing and
Extended Warranties Available**



**Discount-Equipment.com is your online resource for
commercial and industrial quality parts and equipment sales.**

561-964-4949

visit us on line @ www.discount-equipment.com

Select an option below to find your Equipment

Search by Manufacturer

Search by Product Type

Request a Quote

We sell worldwide for the brands: Genie, Terex, JLG, MultiQuip, Mikasa, Essick, Whiteman, Mayco, Toro Stone, Diamond Products, Generac Magnum, Airman, Haulotte, Barreto, Power Blanket, Nifty Lift, Atlas Copco, Chicago Pneumatic, Allmand, Miller Curber, Skyjack, Lull, Skytrak, Tsurumi, Husquvarna Target, Stow, Wacker, Sakai, Mi-T-M, Sullair, Basic, Dynapac, MBW, Weber, Bartell, Bennar Newman, Haulotte, Ditch Runner, Menegotti, Morrison, Contec, Buddy, Crown, Edco, Wyco, Bomag, Laymor, EZ Trench, Bil-Jax, F.S. Curtis, Gehl Pavers, Heli, Honda, ICS/PowerGrit, IHI, Partner, Imer, Clipper, MMD, Koshin, Rice, CH&E, General Equipment, Amida, Coleman, NAC, Gradall, Square Shooter, Kent, Stanley, Tamco, Toku, Hatz, Kohler, Robin, Wisconsin, Northrock, Oztec, Toker TK, Rol-Air, APT, Wylie, Ingersoll Rand / Doosan, Innovatech, Con X, Ammann, Mecalac, Makinex, Smith Surface Prep, Small Line, Wanco, Yanmar

Table of contents

Presentation	7
Static and dynamic tests	8
After-sale service	8
Spare-part service	8
Responsibility	8
General instructions - safety	9
Manual	9
Safety systems.....	9
Labels and plates	9
Operator's requirements	10
Distance from the electric lines	11
Load distribution.....	12
Not allowed operations.....	13
To minimize hazards	15
Risk of folding	15
Risk of falling.....	16
Electric hazards	16
Explosion or burn hazards	16
Residual risks.....	17
Description of the machine	18
Standard equipment.....	19
Optional.....	19
Presentation	20
List of movements	21
Drive and Steering	21
Lifting/lowering the platform.....	21
Control proportionality	21
Identification	22
Main components.....	23
Control and power instruments position.....	24
Electronic circuit	25
Technical specifications.....	26
Overall dimensions.....	27
Ground pressure	28
Plates and labels.....	29
Safety systems	35

Machine closed - Machine opened	36
Safety speed	37
Anti-shearing operations	37
Pot-hole guard control	37
Inclination control	38
Load limiter	39
Safety belt attachments	39
Battery control	40
Battery connection plug	40
Emergency stop	40
Auto shut-off	40
Audible alarms	40
Safety devices summary	41
Warning lights summary	42
Use of the machine	43
Checking before use	43
Visual checking	43
Operating check	44
From ground	44
From platform	45
Control panels	46
Control panels	47
Ground control panel	47
Platform control panel	49
How to use	55
Operations from ground	56
Starting and enabling the ground control panel	56
Platform lifting/lowering	56
Starting and enabling the platform control panel	57
Emergency stop	57
Turn off the machine	57
Platform access	58
Operations from platform	59
Drive	60
Steering	60
Driving on slopes	61
Drive controlled from ground	62
Platform lifting/lowering	63
Emergency stop	64
Platform extension	65
Guard rails folding	66
Emergency manual procedures	68

Manual lowering	69
Emergency towing	70
Battery recharge	71
Battery charge indicator	72
Before the charge	72
Charge start	73
Charge end	74
Battery disposal	74
Transport	75
Loading and unloading of the machine	75
Through ramps	75
By means of lifting	76
With forklift truck	76
With crane or overhead crane	77
Machine fastening	78
Storage	79
Disposal and scrapping	79
Optional	80
AGM battery kit	81
Beacon kit	81
Compressed air kit	81
Maintenance	82
Machine cleaning	82
Wheels replacement	83
Front wheels	83
Rear wheels	83
Maintenance devices	84
Safety rest	84
Battery connection plug	84
Maintenance summary table	85
Check oil level	86
Oil filter replacement	87
Check of wheel reduction gear oil	88
Grease the mechanisms	88
Battery inspection and cleaning	89
Electrolyte level check	90
Check of battery charge	90
Plate and sticker check	90
Check of screw tightening	91

Safety devices check	92
Red emergency stop button.....	92
Safety speed	92
Anti-overturn protections.....	92
Emergency lowering control.....	93
Anti-shearing operations	93
Check of engine brushes	94
Check brakes on ramp	94
Braking spaces	94
Load Limiter	94
Inclination	95
Structure check	97
Check of hydraulic tubes.....	98
Checking performance	98
Safety speed.....	98
Steering speed.....	98
Power cable and auxiliary check.....	98
Check register	100

This edition contains the use and maintenance of the self-propelled aerial platforms:

IM 4746 - IM 4752

Designed and manufactured to be:

- Electrically operated and with proportional controls.

Only qualified and skilled operators can use these machines.

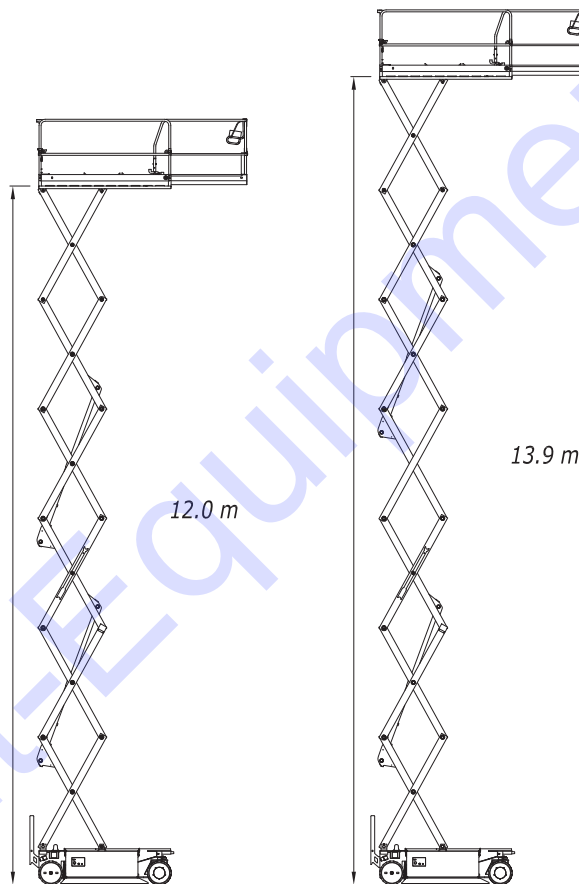

This manual was compiled in order to furnish the user with all the necessary instructions for a correct and safe use of the machine, so as to preclude heavy damages to the user and to any third parties.

All information and instructions comprised in this manual are fully binding, and must be read carefully and properly understood prior to the initial operation of the machine.

The manual is to be construed as an integral part of the machine, and therefore should always remain within reach on the platform for any future reference.

All framed parts of the text are meant to furnish you with important safety instructions, and should therefore be read with particular attention

Static and dynamic tests

Before commissioning, the static and dynamic tests have been performed according to the harmonised standard EN 280 section 6.3.

After-sale service

For interventions, repairs and revisions, address to authorized workshops. For information contact our Technical After-Sale Assistance.

Spare-part service

A good and lasting working guarantee is assured by using original spare parts only; make reference to the "SPARE PARTS CATALOGUE".

Always state the data described on the identification plate placed on the chassis if you need spare parts or assistance.

Responsibility

IMER International s.p.a. will be exempted from any responsibility and obligation for any damage caused to persons or things due to one of the reasons listed below:

- Failure to comply with the instructions in the USE AND MAINTENANCE MANUAL as regards the control, use and maintenance of the machine;
- Incorrect use and maintenance of the machine;
- Changes to the structure or components of the machine without the authorisation of IMER International s.p.a. and/or without the use of appropriate equipment;
- Circumstances unrelated with the normal and correct use of the machine as described in this USE AND MAINTENANCE MANUAL.
- Use of non-original spare parts not authorised by the manufacturer.

General instructions - safety

Manual



A suitable working safety is very important in order to avoid serious injuries for the operator himself and for the other persons, therefore it is compulsory to carefully read and well-understand this manual to know the exact and essential instructions for the use of the machine and the maintenance operations.

This manual is to be considered as an integral part of the machine and it should always remain on the platform for future reference.

This use manual must be carefully preserved by the user for the whole machine life, even if the machine is lent, rent or sold

The figures described in this manual DON'T always exactly reproduce the model described but these are used for a better and easier understanding of the text

Safety systems

The safety systems applied to the machine are inevitably subject to wear and to go out of tune. Therefore, they must be controlled and kept in perfect efficiency; also, it is not advisable to evaluate their operational and safety conditions only on the basis of their functioning.

Such systems do not relieve the operator of the responsibility of carrying out an informed and appropriate use of the machine.

It is absolutely forbidden to remove, modify or tamper with parts of the self-propelled aerial platform, which are important for safety and stability.

In particular as batteries have also a stabilizing function, in case of replacement, check that their weight is not lower than the one indicated in the technical data table of the machine.

Any tampering whatsoever with the main members of the self-propelled aerial platform and associated safety devices immediately nullifies guarantee conditions.



Labels and plates

Potential dangers and instructions regarding the machine are given on labels and plates; these should therefore be kept in a clearly legible, good condition.

Operator's requirements



The operator shall:

1. Read and well understand all the documentation enclosed to the machine, be properly trained and instructed in the correct use of the machine and know the safety rules and devices.
2. Be physically in good conditions and not make use of dope, alcohol or drugs that could affect the attention, the reaction, the sight and the hearing.
3. Give a great importance to safety and refuse to work if you think you are not working under safe conditions.
4. Well-know the maximum working load.
5. Use suitable accident prevention equipment accordingly with the working conditions and the local rules in force.
6. During the working keep all the parts of the body inside the guard rails and both feet have to be firmly rest on the floor surface.
7. Make always use of an assistant in areas where the sight is obstructed.
8. Always work under highest safe conditions, tidiness and cleaning.
9. Before using the machine check daily the controls and safety devices and make sure they are in perfect working order.
10. Check that the working area is free from persons, animals or obstacles before making any movement of the machine.
11. Check that the ground where the machine has to operate is free from holes, bumps, drops, uneven level, obstructions, debris and coverings which could hide possible potholes or others dangers.
12. Clean the ladder, the floor surface of the platform and the handrails from oil and grease.
13. Once the work has been finished and when the machine remains unattended, take the key off to avoid that unauthorized persons can use it.
14. Commuting platform control panel, always remove the key to avoid an unauthorized use from the ground control panel while personnel is present on the platform. The safety manager must hold a spare key enabling to use the ground control panel as emergency place. (In case of failure it is possible to lower the machine).

Distance from the electric lines



The machine is not electrically insulated and does not offer any protection against active parts, electrical lines and plants which are not protected or not sufficiently protected.

Here below you can find a table concerning the safety distances to be compulsory observed according to the Italian law.

In other countries the operator may have different limitations to be observed

Un (V)	Minimum Allowed Distance	
0 – 300 V	<i>Avoid contact</i>	
300 V – 50kV	10ft	3,05m
50kV – 200kV	15ft	4,80m
200kV – 350kV	20ft	6,10m
350kV – 500kV	25ft	7,80m
500kV – 750kV	35ft	10,70m
750kV – 1000kV	45ft	13,70m

Un = nominal voltage

Load distribution

Distribute the load on the entire platform surface uniformly (figure 1)

Do not load on surfaces that are lower than those indicated in figures 2-3-4-5.

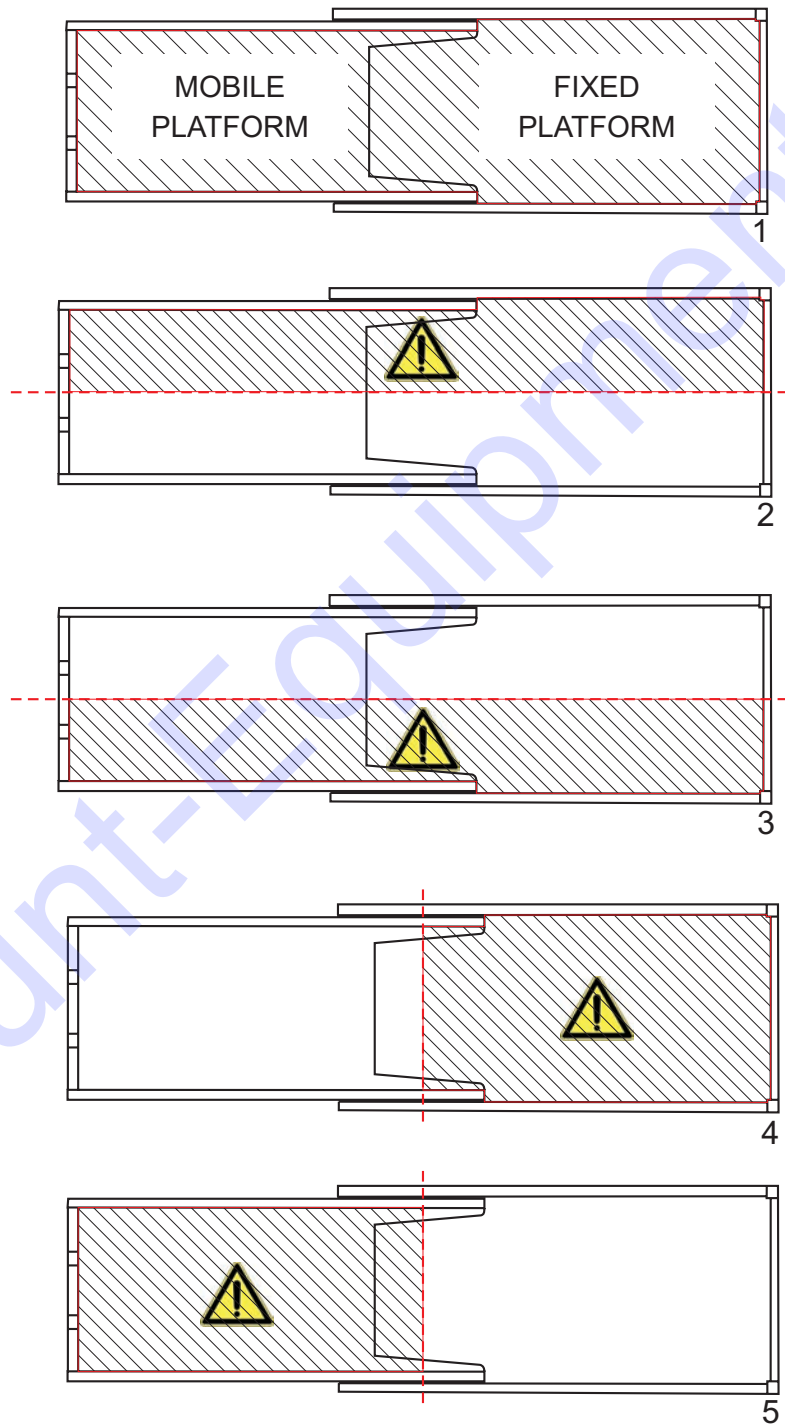

Not allowed operations



It is strictly forbidden to use the machine:

- Out of closed places (machines for internal use).
- On public roads.
- Without an adequate environmental lighting to work or to move under safety conditions.
- Work in case of strong storm, with or without rain, or with wind with speed higher than 12,5 m/s, 6 grade of the Beaufort scale described below (machines for external use).
- Without making sure that the platform gate bar is closed.
- While moving, with boxes opened.
- If the working area is not free from obstacles which could cause dangerous conditions.
- While entering in contact with fixed or mobile objects.
- Under bad working conditions.
- In a different way from what it has been described in the instruction manual.
- After modifying or removing the safety devices.
- After fastening it to adjacent structures.

In addition, it is forbidden to:

- Operate or lift the platform when it is placed on the truck loading platform or other vehicle.
- To throw some objects and tools from the top to down and vice versa.
- Go up and down the ladder when the back box is not completely closed.

Beaufort Wind Scale

	Description	Wind speed (km/h)	Wind speed (km/h)	Sea conditions	Land conditions
0	Calm	0	0	Flat	Calm. Smoke rises vertically.
1	Light air	1-6	0.3-1.5	Ripples without crests.	Wind motion visible in smoke.
2	Light Breeze	7-11	1.6-3.4	Small wavelets. Crests of glassy appearance, not breaking.	Wind felt on exposed skin. Leaves rustle.
3	Gentle breeze	12-19	3.4-5.4	Large wavelets. Crests begin to break; scattered whitecaps.	Leaves and smaller twigs in constant motion.
4	Moderate breeze	20-29	5.5-7.9	Small waves.	Dust and loose paper raised. Small branches begin to move.
5	Fresh breeze	30-39	8.0-10.7	Moderate (1.2 m) longer waves. Some foam and spray.	Smaller trees sway.
6	Strong breeze	40-50	10.8-13.8	Large waves with foam crests and some spray.	Large branches in motion. Whistling heard in overhead wires. Umbrella use becomes difficult.
7	Near gale / Moderate gale	51-62	13.9-17.1	Sea heaps up and foam begins to streak.	Whole trees in motion. Effort needed to walk against the wind.
8	Fresh gale	63-75	17.2-20.7	Moderately high waves with breaking crests forming spindrift. Streaks of foam.	Some twigs broken from trees. Cars veer on road.
9	Strong gale	76-87	20.8-24.4	High waves (6-7 m) with dense foam. Wave crests start to roll over. Considerable spray.	Larger branches break off trees, construction/ temporary signs and barricades blown over, damage to circus tents and canopies.
10	Whole gale / Storm	88-102	24.5-28.4	Very high waves. The sea surface is white and there is considerable tumbling. Visibility is reduced.	Trees broken off or uprooted, saplings bent and/ or deformed, poorly attached asphalt shingles and shingles in poor condition peel off roofs.
11	Violent storm	103-117	28.5-32.6	Exceptionally high waves.	Widespread vegetation damage, minor damage to most roof shingles/surfaces, gravel may be blown from flat roofs.
12	Hurricane	> 117	> 32.5	Huge waves. Air filled with foam and spray. Sea completely white with driving spray. Visibility greatly reduced.	Considerable and widespread damage to vegetation, a few windows broken, structural damage to mobile homes and poorly constructed sheds and barns.

To minimize hazards

Follow the instructions below:

Risk of folding



1. Check the ground is firm and even.
2. Do not use the machine on slippery, icy, muddy ground and with holes, which has a slope higher than the allowed limit.
3. Make sure that the ground suitably supports the maximum load of each wheel.
4. Check that the ground where the machine has to operate is free from holes, bumps, drops, uneven level, obstructions, debris and coverings which could hide possible potholes or others dangers.
5. Comply with the maximum load and the allowable number of persons.
6. Distribute the loads and place them as indicated on page 18.
7. Avoid the machine knocks against fixed or mobile obstacles.
8. Do not use the machine as a crane with materials suspended to the guard rails or to the scissor.
9. Do not increase the maximum available working height by putting ladders or scaffolds on the platform or climbing onto the guard rails.
10. Do not place materials on the guard rails.
11. Give the best attention during movements with mobile travelling platform.
12. During movements, lifting and lowering of the platform, check that there are not obstructions around, above and below the machine.
13. Carry out the movements only if the working area visibility is complete.
14. During movements on slopes or when loading/unloading from the truck through ramps only use the second (medium) speed.
15. Do not use an horizontal force above the maximum allowed value.
16. Do not equip the machine with elements (ex. panels) which increase the wind exposure.

Risk of falling

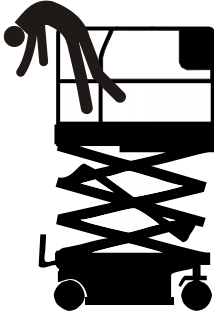

- Do not lean out of the safety perimeter guard rails of the platform.
- Do not use guard rails as admittance means to get on or get down from the platform.
- Do not get on or get down from the platform when it is lifted.

Electric hazards

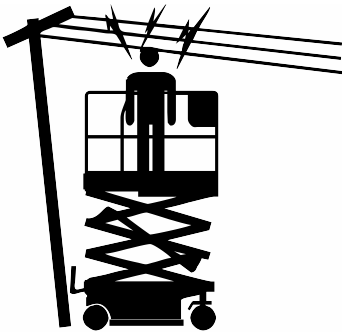

- As the machine is not electrically insulated, the operator has to pay a particular attention to avoid any contact with probably energized parts.
- Do not carry out works near electrical lines at a distance lower than the one indicated in the table page 17.
- To assure the earth-leakage of the electrostatic charges, the front partition of the machine is equipped with a conductive strip. **Always check the wear of this strip and its contact with the earth.**

Explosion or burn hazards

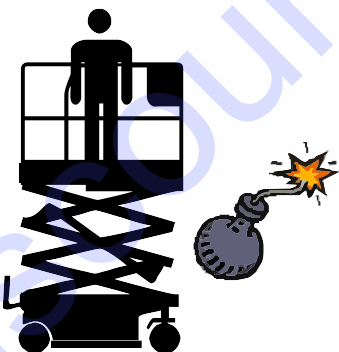

- Do not use the machine near open flames or heat sources.
- Charge batteries in ventilated environment, far from heat sources or explosive fluids.
- Do not use the machine if there are oil leakage.
- Do not use the machine in environments with explosive atmosphere.

Residual risks

The plates and labels listed below indicate the residual risks that remain despite there being protective measures incorporated into the machine's design and regardless of the safety devices adopted.

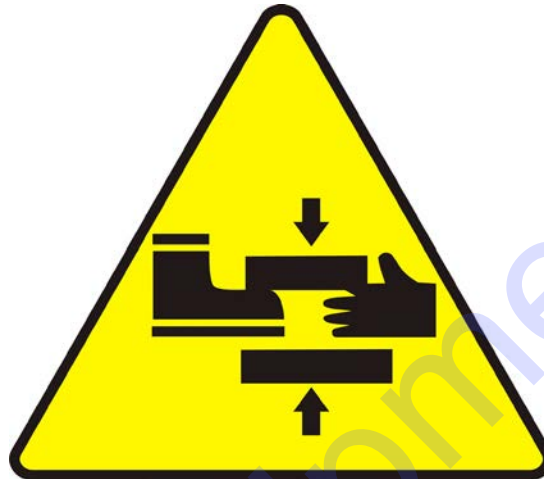

Description of the machine

Standard equipment

- Electric drive on front wheels
- Proportional controls with diagnostics
- Parking brakes with electric disengagement
- Hydraulic steering at 90°
- Manually-operated platform extension
- Emergency manual lowering
- Lock valve on lifting cylinders
- Drive batteries
- Automatic disengagement battery charger
- Movement alarms, Horn
- Display for: battery charge status, hour-meter and diagnostics
- Flatness indicator with motion locking device
- Mechanical wheel drive unlock for emergency towing
- Battery isolator
- Non-marking cushion tyres
- Electric shearing-proof protection
- Battery control system with low-voltage protection
- Overload sensor
- Folding rails
- Anti-overturn protections
- Rotating beacon
- Cable pre-set for 120V line

Optional

- AGM battery kit
- Second beacon kit
- Compressed air kit

Presentation

The aerial platforms **are used to lift persons, materials and equipment to enable works to be performed at certain heights.**

Must to be used accordingly with the foreseen technical data described in the suitable sheet, on solid and strong grounds and not before a Qualified Operator has checked the operational safety.

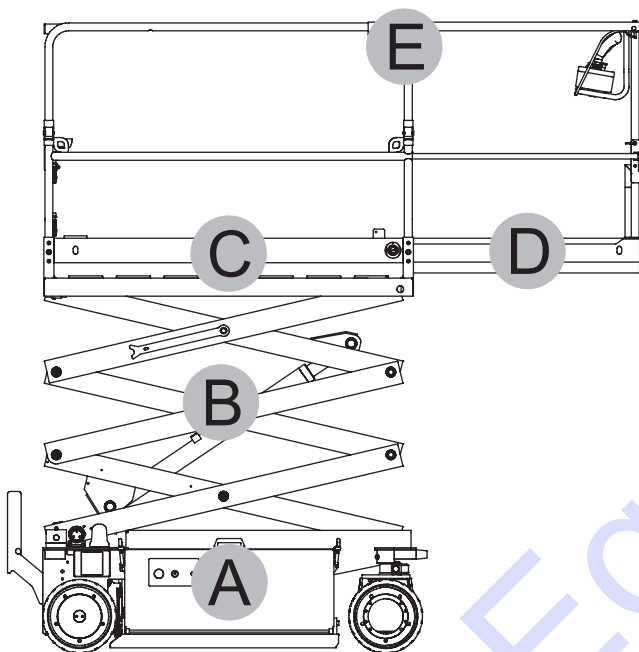

It is equipped with:

- Chassis (A)
- Scissor (B)
- Platform (C)
- Platform extension (D)
- Guard rails (E)

The **railings are folding** to minimise when the machine is completely closed, the maximum height thus allowing the passage through openings of reduced height.

List of movements

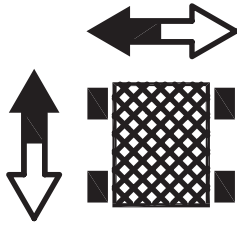

Drive and Steering

The chassis is equipped with two front driving and steering wheels to drive the machine; the two rear wheels are idler.

Electromagnetic brakes act on the front wheels.

The steering is operated by an hydraulic cylinders.

Drive and steering can be carried out also with lifted platform and/or extended.

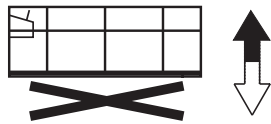

Lifting/lowering the platform

The movement is operated by hydraulic cylinders that work on the scissors.

The lifting/lowering the platform can be carried out also with extended platform.

Control proportionality

Drive and lifting are controlled by proportional control.

The movement graduality is obtained by means of the electronic control; depending on the movements of the joystick on the platform control panel, more or less energy is supplied to the electric motors and electric pump.

Identification

A metallic plate fixed to the chassis contains all data necessary to identify the machine.

 IMER International SpA Via Salceto, 53-55 53036 Poggibonsi (SI) ITALY			
DENOMINATION	MOBILE ELEVATING WORK PLATFORM		
MODEL	IM 4752		
MEWP CLASSIFICATION	TYPE 3	GROUP	A
SERIAL N.		POWER	3 + 4 kW
MANUFACTURING YEAR		BATTERY	24/300 C5 V/Ah
MASS	kg-lbs	MAX PRESSURE	bar-psi
MAX WORKING HEIGHT	m-ft	WIND SPEED ALLOWED	m/s-mpg
MAXIMUM ALLOWABLE OPERATING INCLINATION			
RATED LOAD	kg-lbs	kg-lbs	
n.PERSONS			
MASS OF EQUIPMENT	kg-lbs	kg-lbs	
MANUAL FORCE	N-lbf	N-lbf	
A00031USA			

The data refers to the standard model

Main components

RIGHT SIDE

LEFT SIDE

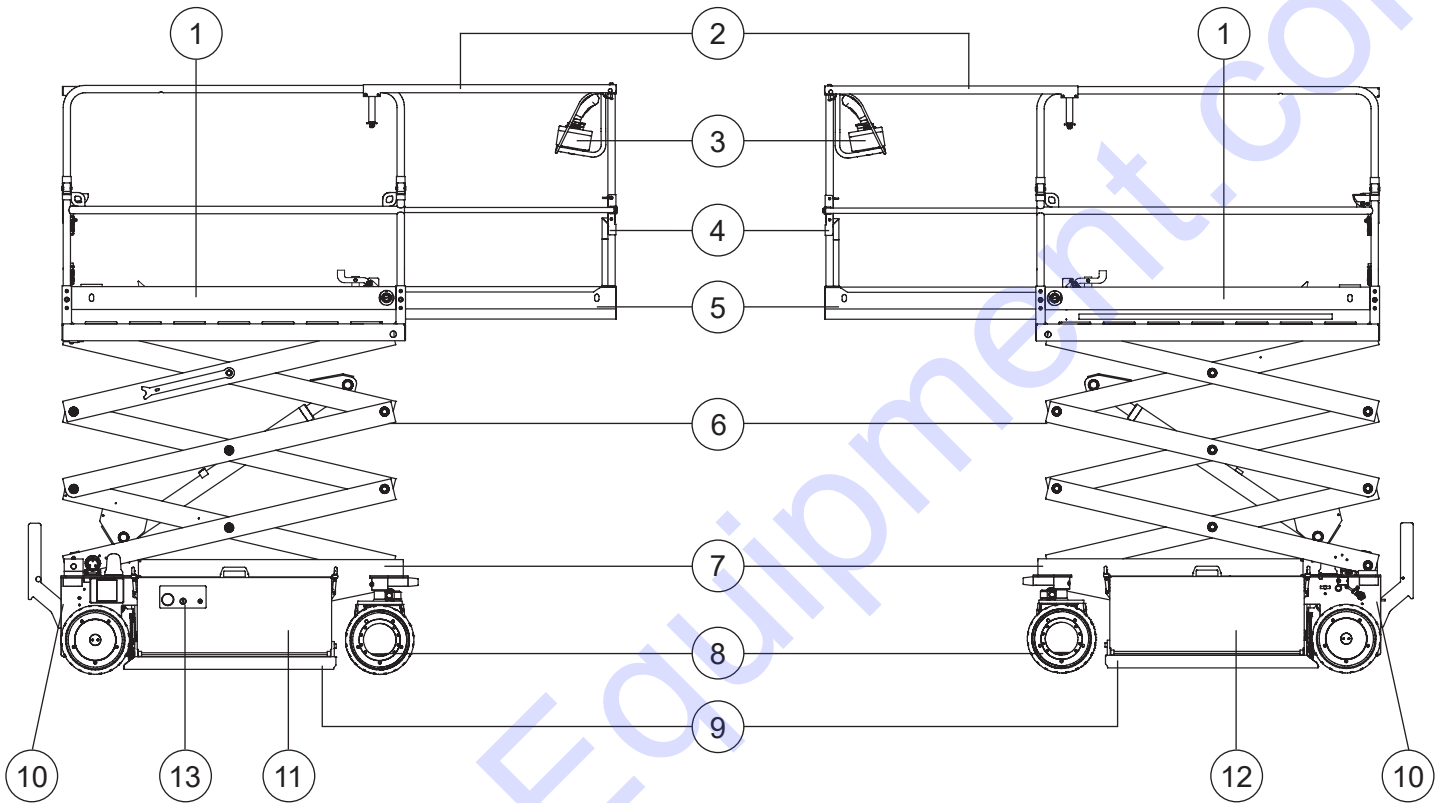

- 1. Fixed platform
- 2. Guard rails
- 3. Control panel
- 4. Document holder
- 5. Platform extension
- 6. Lifting structure
- 7. Chassis

- 8. Driving wheels
- 9. Pot-hole guards
- 10. Back box
- 11. Right box
- 12. Left box
- 13. Ground control panel

Control and power instruments position

RIGHT BOX

The ground control panel is installed on a swivel rest.

The main control unit is behind the ground control panel.

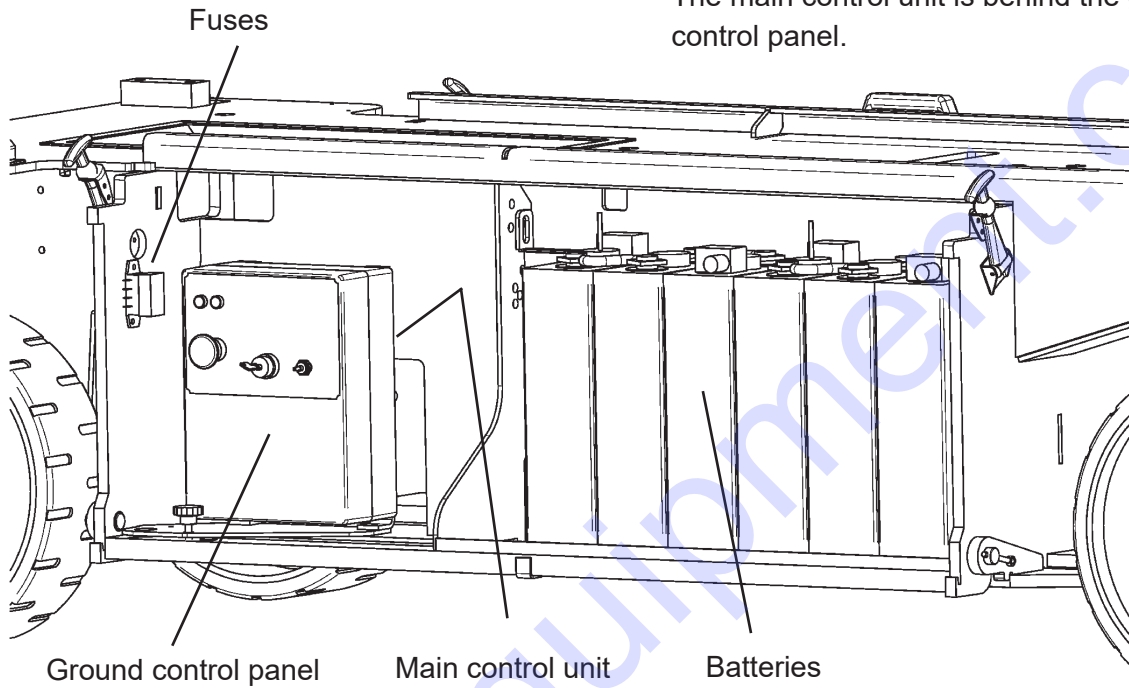

LEFT BOX

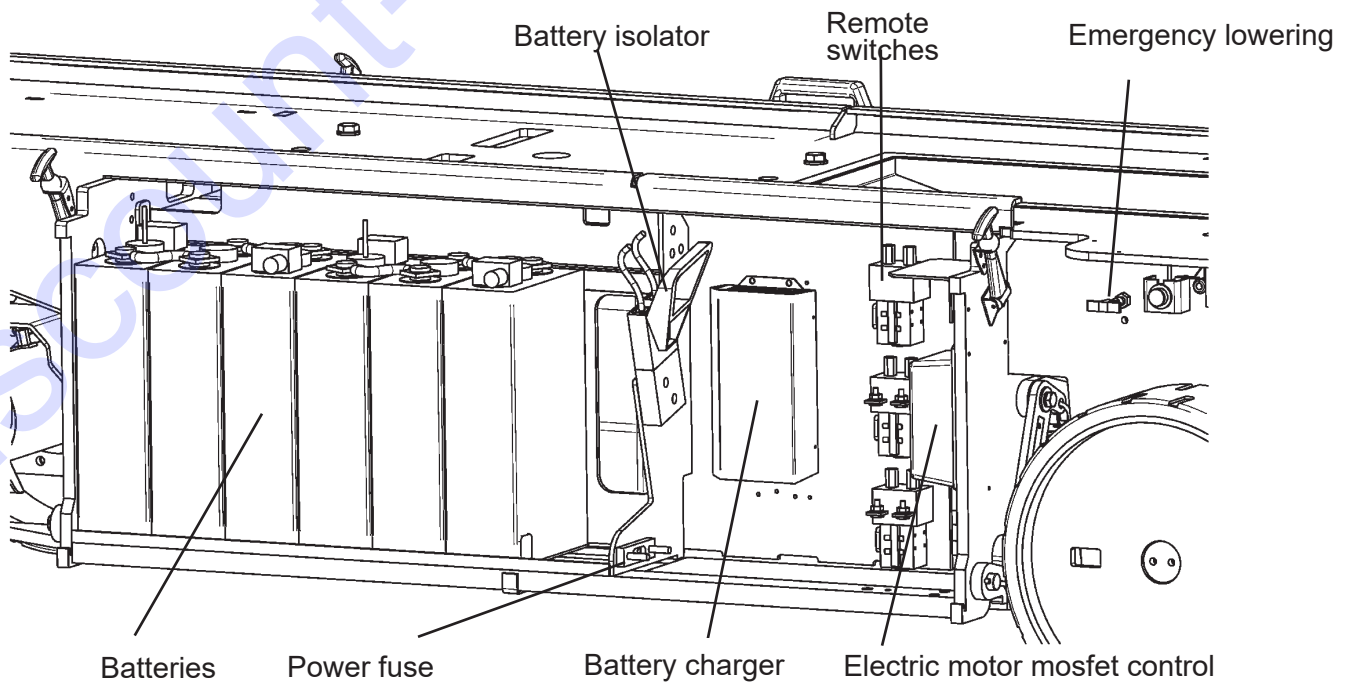

BACK BOX

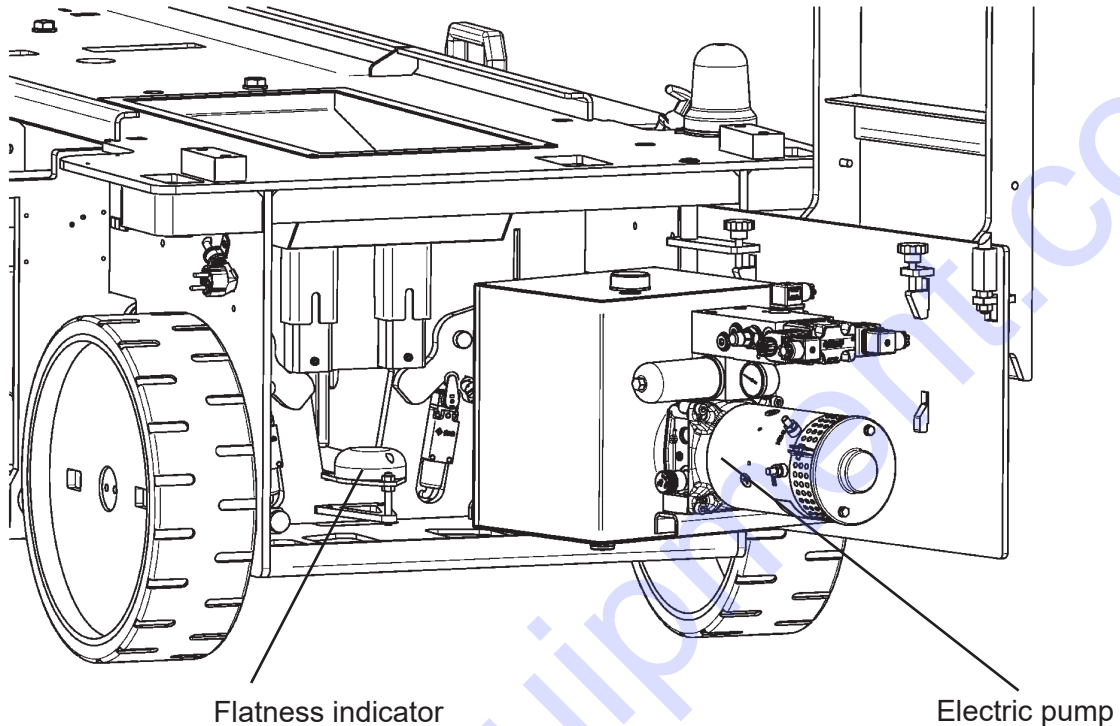

Electronic circuit

The electronic equipment is composed of two microprocessor control units for the machine operation: one main control unit is placed inside the chassis and the other on the platform control panel. These control units are connected through a CAN Bus transmission protocol.

The machine control and commands panel are performed by the main control unit, which has also the following functions:

- monitoring of the battery discharge level;
- platform load control.

The electronic equipment is also composed of further electronic microprocessor devices with the following functions:

- machine inclination control.

The control panel display shows:

- the working hours;
- the battery charge level;
- the fault and error codes detected by the main board self-diagnostic.

Description	Unit of measurement	IM 4746	IM 4752
Number of scissors / cylinders	nr	6 / 2	7 / 2
Rated load / persons	internal use lbs	770 / 3	550 / 2
Lifting / Lowering time (loaded)	s	68 / 55	68 / 67
Drive speed (high / safety)	mph - km/h	2,5/0,4-4 / 0,6	2,5/0,4-4 / 0,6
Max. slope	%	25	25
Max. allowed side force	internal use lbf	90	90
Max. allowed side inclination for the chassis	°	2,0	1,2
Max. allowed longitudinal inclination for the chassis	°	3,0	2,0
Drive batteries	V / Ah	24 / 300	24 / 300
	weight lbs	117 x 4	117 x 4
Amount of acid solution contained in the batteries	gal - L	37	37
Battery charger	V / A	24 / 30	24 / 30
Drive electric motors	V / kW	24 / 3	24 / 3
Hydraulic control unit	V / kW	24 / 3	24 / 4
Machine weight	lbs - kg	6440	6610
Oil tank	gal - L	4,5 - 17	4,5 - 17
Inside / Outside turning radius	ft	0 / 7,8	0 / 7,8
Cushion wheels dimensions	in	16 x 5	16 x 5
Wheels load	lbf - daN	245 - 1090	245 - 1090
Level of acoustic pressure weighed at operator's place	dB	<70	<70
Lifting pressure	psi - bar	2610 - 180	2900 - 200
Working temperature	°F	+14 ÷ +104	+14 ÷ +104

Vibrations

As regards vibrations, according to the measurings carried out in the most unfavourable conditions of use, it has been established that:

- the average weighted quadratic value in frequency of the acceleration relevant to the upper limbs is lower than 2.5 m/sec²;
- the average weighted quadratic value in frequency of the acceleration relevant to the body is lower than 0.5 m/sec².

Overall dimensions

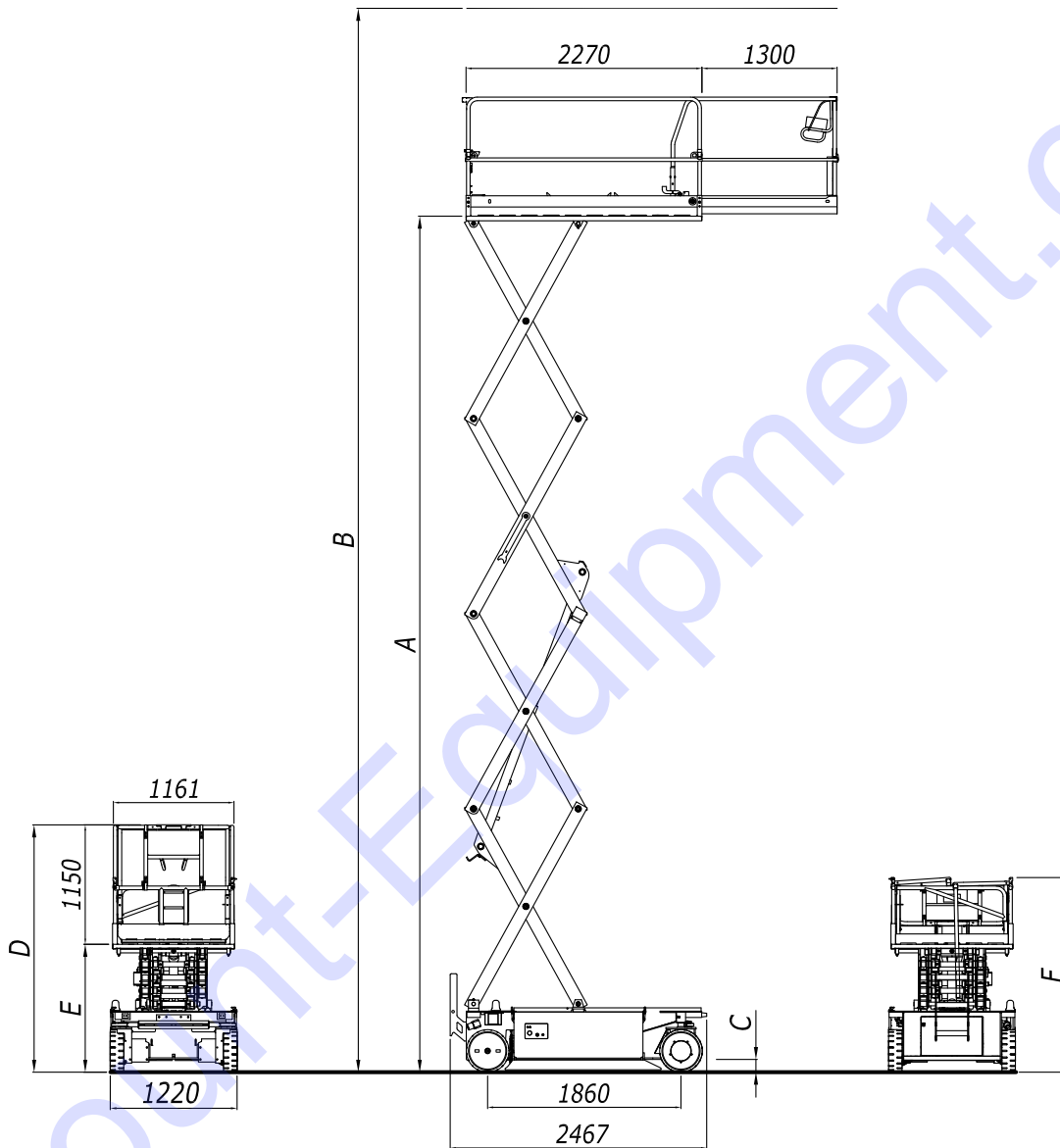

	A (mm)	B (mm)	C (mm)	D (mm)	E (mm)	F (mm)
IM 4746	12 000	14 000	120/22*	2 619	1 489	2 112
IM 4752	13 900	15 900	120/22*	2 746	1 616	2 239

* Pot-hole guard lifted / lowered

Ground pressure

Localized pressure (per wheel)

MODEL	Pressure (kg/cm ²)
IM 4746	14,5
IM 4752	14,5

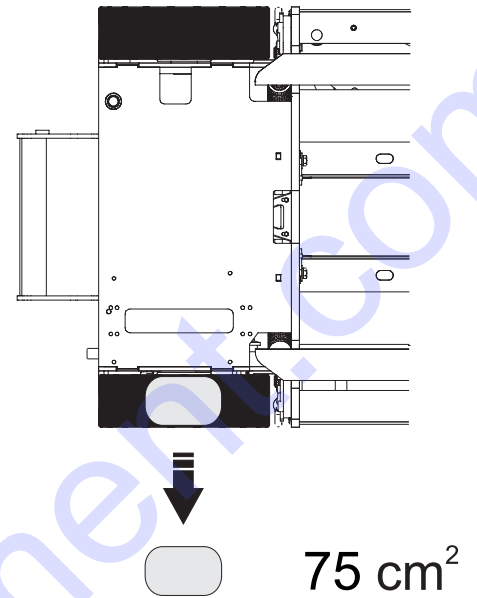

The full load pressure referring to the occupied surface space is the following:

Model	Pressure (kg/m ²)
IM 4746	1 163
IM 4752	1 152

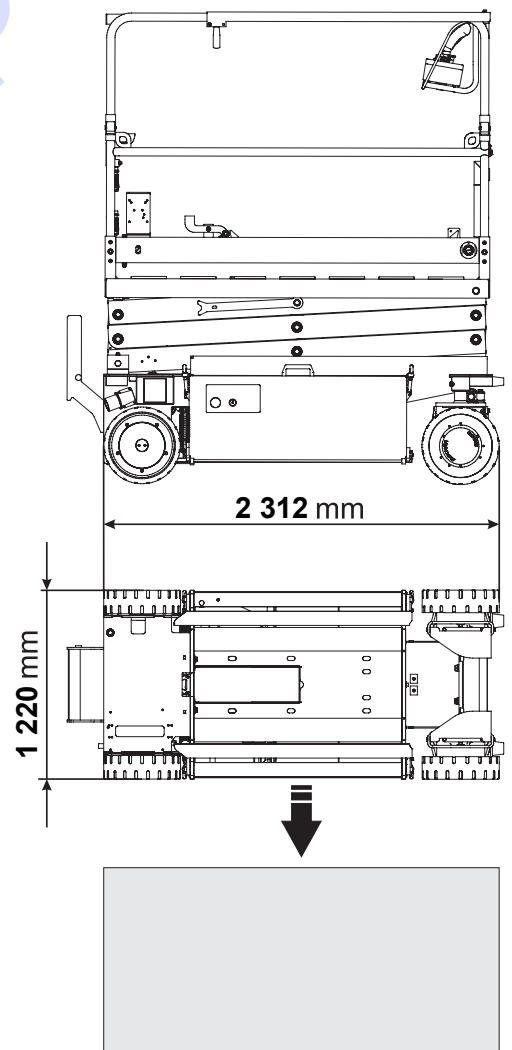

Plates and labels

Using the illustrations, check that all the plates and labels are present.

Plates and labels that contain no text will have 8-digit numbering or an alphanumeric code ending with XX.

Plates and labels that contain text will have an alphanumeric code ending with the relevant country code for the machine's destination country.

Discount-Equipment.com

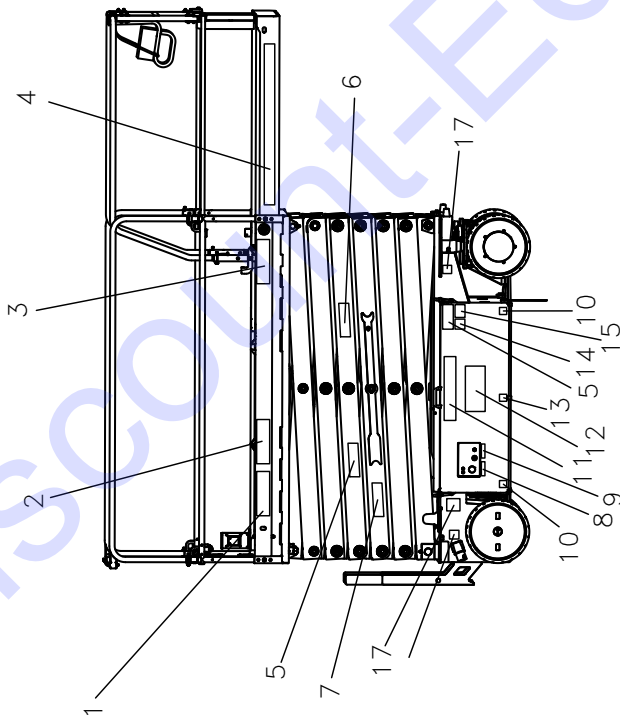
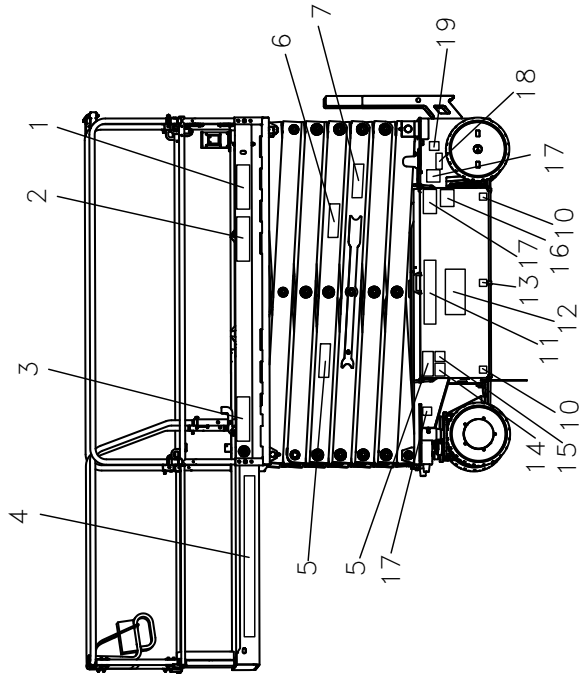

- 1 A00322XX 2pz
- 2 A00456USA 2pz
- 3 Max Load Label
- 4 A00258XX 2pz
- 5 A00103USA 4pz
- 6 A00435USA 2pz
- 7 A00441USA 2pz
- 8 A00033GB 1pz
- 9 A00383USA 1pz
- 10 A00172XX 4pz
- 11 NAME MODEL
- 12 A00322XX 2pz
- 13 A00448USA 2pz
- 14 A00463USA 2pz
- 15 A00442USA 2pz
- 16 A00105USA 1pz
- 17 A00434USA 1pz
- 18 A00436USA 1pz
- 19 A00359XX 1pz

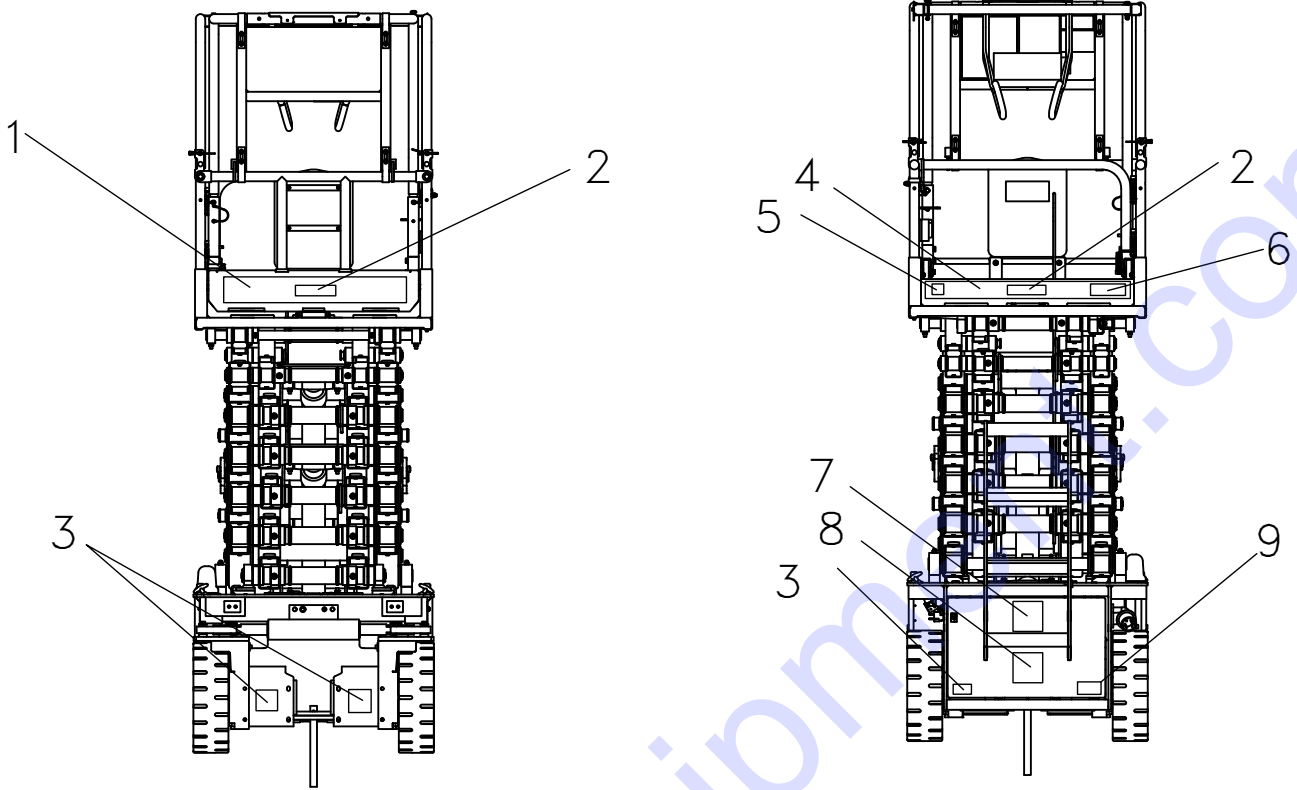

1	82521034	1pz
2	A00438USA	2pz
3	A00463USA	3pz
4	82021098	1pz
5	A00483XX	1pz
6	Max Load Label	
7	A00031USA	1pz
8	A00410USA	1pz
9	A00437USA	1pz

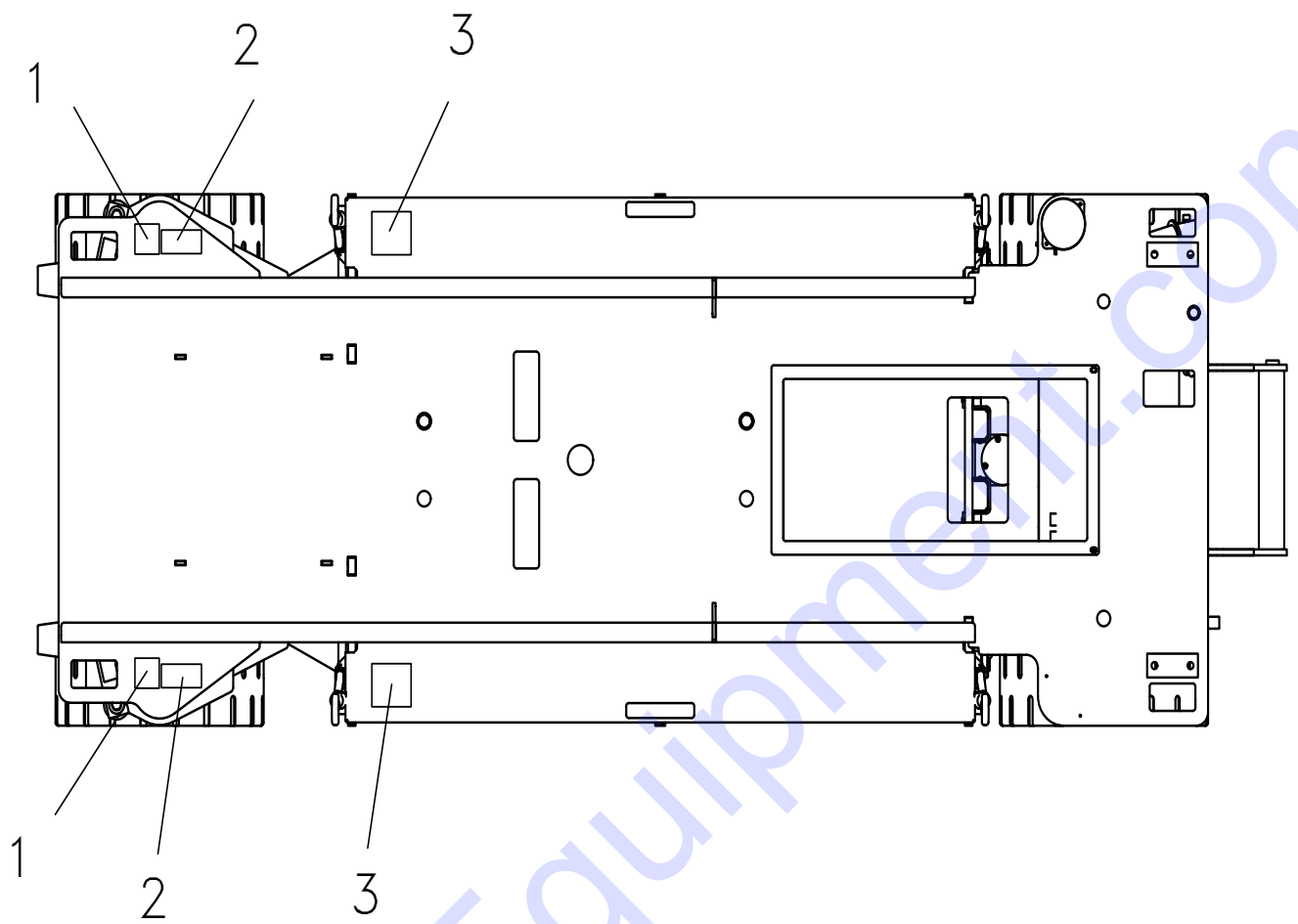

- 1 A00190XX 2pz
- 2 A00453USA 2pz
- 3 A00239XX 2pz

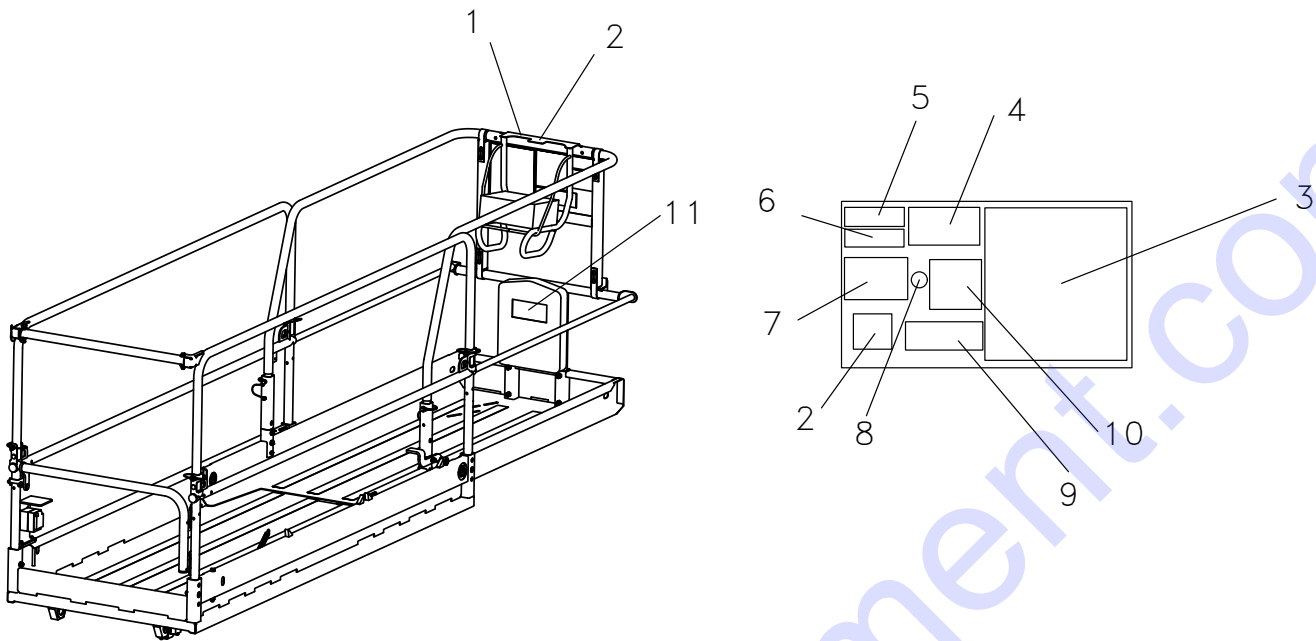

- 1 A00383USA 1pz
- 2 A00216XX 2pz
- 3 A00005USA 1pz
- 4 A00401USA 1pz
- 5 A00450USA 1pz
- 6 A00153GB 1pz
- 7 A00455USA 1pz
- 8 A00457XX 1pz
- 9 Max Load Label
- 10 A00464USA 1pz
- 11 A00145XX 1pz

Safety systems

The machine is provided with safety devices locking the normal operation in order to avoid injuries.

Knowledge of the characteristics and safety operations is crucial: do not operate the machine unless the following section has been read and understood.

Some safety systems work in a different way, depending on the machine position, it is therefore important to be aware of the meaning of CLOSED MACHINE and OPEN MACHINE shown below.

A safety device malfunction caused by fault or tampering, may cause severe damage to the machine and consequently endanger the operator's life.

Check periodically the safety devices according to the manual.

Safety devices should never be tampered with. The manufacturer declines any liability for accidents caused by interventions and tampering of the safety devices.

Machine closed - Machine opened

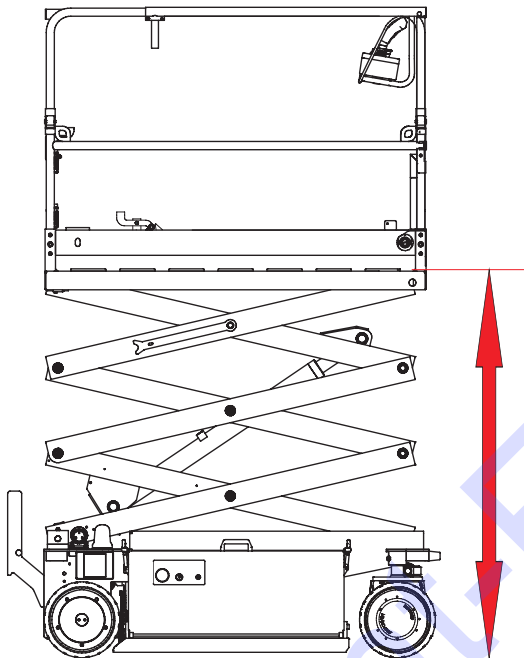

The machine is **CLOSED** when the height between the platform floor surface and the ground is **LESS** than:

- 7 ft (IM 4746)
- 7,5 ft (IM 4752)

The machine is **OPEN** when the height between the platform floor surface and the ground is **GREATER** or **EQUAL** to:

- 7 ft (IM 4746)
- 7,5 ft (IM 4752)

Safety speed

When the machine is open, the drive speed switches automatically to safety reduced speed.

Anti-shearing operations

An electronic control unit locks the lowering for 3 seconds, when the distance between the boom and frame ends is 50 mm approx. (anti-shearing safety).

When lowering is locked:

- Move the joystick to rest position.
- Wait for 3 seconds checking that the persons being side the platform do not risk to be trapped or crushed between scissors.
- Command again the lowering movement which is warned by the audible and visual alarm for 1.5 seconds previously.

In the section between the lowering limit and the totally closed scissors, the movement after a stop is resumed under the same a.m. delay conditions and warnings.

Pot-hole guard control

The pot-hole guards reduce the clear height of the machine and increase its stability.

With closed machine, they are raised.

They lower during platform lifting and with open machine they reach complete lowering.

Pot hole guards opening and closing are controlled by SQ6A -SQ6B microswitches.

If the pot-hole guards are not entirely lowered, **drive and steering are locked.**

Inclination control

The inclination is controlled by the flatness indicator; device located in the rear box which detects the truck inclination.



	Max. allowed inclination	
	side	longitudinal
IM 4746	2,0 °	3,0 °
IM 4752	1,2 °	2,0 °

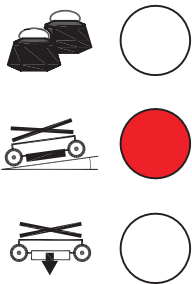

If **inclination is higher** than the maximum allowed values:

With machine closed:

- warning light flashes;
- lifting is enabled with OPEN MACHINE.

Before lifting the platform set the machine back into the stability conditions.

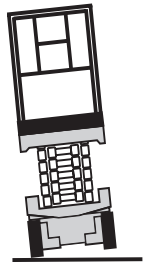

With machine opened:

- warning light turns on;
- the alarm sounds;
- **drive, steering and lifting are locked.**

To restore movements , **lower the platform completely and set the machine back into stability conditions.**

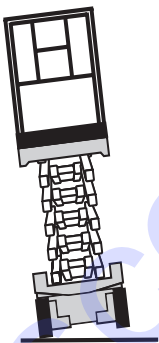

Make sure that no obstacles are present below the platform before lowering it.

Load limiter

Overloads, if any, are checked by the load limiter both with the machine at a standstill position and during platform lifting.



Overload is a load between the nominal one and value up to 120% of the latter.

Load limiter activation

The load limiter is not activated with closed scissors; it is activated during the first meter of lifting when the scissors are completely closed.

With overload:



ON









- warning light on the ground control panel flashes;
- warning light on the platform control panel flashes;
- the alarm sounds;
- **all the movements are locked.** To restore movements, remove the overload.

With overload:

The load limiter consists of:

- The electronic control unit is placed in the right box,
- An angular sensor (positioned below the platform),
- Analogue pressure sensors, set on the lifting cylinders.

Safety belt attachments

The machine is equipped with suitable anchorage points for the safety belts.



If there is more than one person on the platform, use different anchorage points: don't hook more safety belts to the same point.

Battery control

If batteries are exhausted, lifting is locked.

If the battery charger is connected, **all movements are locked**.

Battery connection plug

The battery connection plug is placed in the right box.

This safety device disconnects the power and control circuits of batteries and the battery charger solely remains connected.



Emergency stop

Press one or both the emergency stop buttons, placed on the ground control panel and on the platform control panel to **lock all movements**.

Warning lights and audible alarms remain active.

In order to restore normal functions, pull the button upwards.

If the emergency stop button remains pressed for 2 hours, the machine will automatically shut off, and the warning lights and audible alarm will be deactivated; to switch it back on, pull the button upwards.

Auto shut-off

If the machine remains on and inactive for 6 hours, without either of the emergency buttons being pressed, the electronic system will automatically shut it off.

To turn the machine back on:

- Press one of the emergency buttons and then pull it upwards again;
- Turn the key in the ground panel to the centre position then turn it to the right.





Audible alarms





Fault condition: signalled by a high frequency intermittent sound. Machine movements are entirely or partly locked until the machine is again under safety operating conditions.

Normal operation: any machine movement is signalled by a high frequency intermittent sound.





The frequency of the sound increases during lowering, when the platform is below the lowering limit controlled by the electric anti-shearing device.



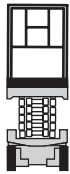

Safety devices summary

 <p>MACHINE CLOSED</p>			
EXCEEDING INCLINATION			
EMERGENCY STOP BUTTON PRESSED	X	X	X
BATTERY CHARGER ACTIVATED	X	X	X
EXHAUSTED BATTERIES		X	

 <p>MACHINE OPENED</p>				SAFETY
DRIVE				X
OVERLOAD	X	X	X	
EXCEEDING INCLINATION	X	X		
POT-HOLE GUARDS NOT LOWERED	X			
EMERGENCY STOP BUTTON PRESSED	X	X	X	
BATTERY CHARGER ACTIVATED	X	X	X	
EXHAUSTED BATTERIES		X		

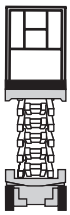
Warning lights summary

 MACHINE CLOSED				
NORMAL OPERATION	○	○	○	
EXCEEDING INCLINATION	☀			
GENERAL PROBLEM (SEE DIAGNOSTIC DISPLAY CODE)				🔊

 MACHINE OPENED				
NORMAL OPERATION	○	○	○	
OVERLOAD		☀		🔊
EXCEEDING INCLINATION	●			🔊
POT-HOLE GUARDS NOT LOWERED			●	
GENERAL PROBLEM (SEE DIAGNOSTIC DISPLAY CODE)				🔊

○ OFF

☀ RED FLASHING

● RED ON

🔊 AUDIBLE ALARM

Use of the machine

Before carrying out any operation it is necessary to read and well-understand this manual along with the instructions described on plates and labels.

Checking before use

Before setting at work the machine and carrying out any operation, the machine itself is to be subjected to a visual and operating check described here below.

During the setting at work it is also necessary to carry out the safety device checking.

Visual checking

Make sure that the following failures are NOT occurred:

- Oil leakage from pipes and other hydraulic components.
- Cut or disconnected electric wires.
- Unloosed or missing nuts in the wheels.
- Irregular worn or cuts in the wheels.
- Damages, deformations, loosen or missing screws and bolts, cracked welding on chassis, wheel supports, steering systems, lifting systems, platforms and guard rails.

Check that:

- The soil where the platform should operate is solid and able to support the maximum load per each wheel.
- The use manual is on board and plates and labels well visible.
- The ladder, the handrails and the platform are free from grease and oil traces.
- The working area is free, without holes and uneven grounds.

Operating check

Once the visual inspection has been finished it is also necessary to carry out an operating check.

- Check the hydraulic oil level.
- Check the electrolyte level in the batteries.
- Check that all the foreseen plates and labels have been suitably positioned and are legible.

From ground

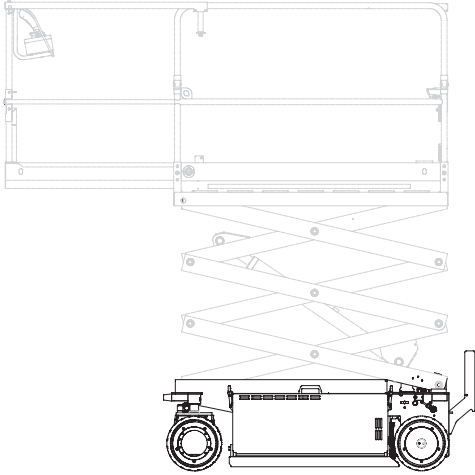

- Press emergency STOP button and check that no operation can be enabled both from ground and from platform. Put button to ON position again.
 - Lift and lower the platform more times and check that no obstacle can occur during these operations.
 - Make sure that the anti-overturn protections are lowered during the platform lifting.
 - Make sure that the electric anti-shearing device well work during the platform lowering.
 - Carry out the operations described in the “Emergency lowering” section and check that everything works well.
- Lift the platform till the anti-overturn protections are completely lowered, push each protection inwards the chassis and check they keep still.
 - Be sure that every movement is advised by the audible and light alarm.

From platform

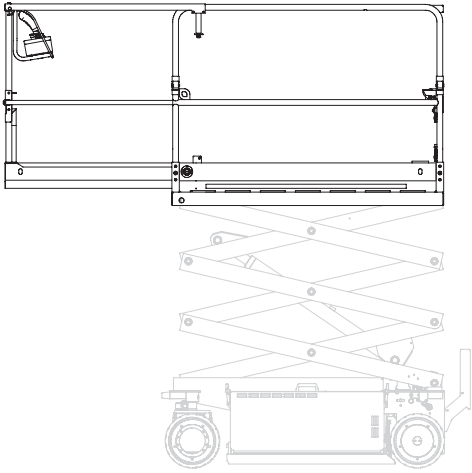

- Make sure that batteries are well charged.
 - Press emergency STOP button and check that no operation can be enabled both from ground and from platform. Put button to ON position again.
 - Lift and lower the platform more times and check that no obstacle could occur during these operations.
 - Make sure that the electric anti-shearing device will work during the platform lowering.
 - Drive forward and back and check that the operation is correct.
 - Check that during drive only steering movement is enabled.
-
- Right and left steer and check that the operation is correct.
 - Press horn and check if it works correctly.
 - During drive release the joystick to check the brakes work correctly: the machine must block in a narrow space.
 - Lift the platform and try the drive forward and back, making sure that the drive speed is made under safety conditions.
 - Be sure that every movement is advised by the audible and light alarm.

Control panels

The foreseen control panels for the operator are two:

- On platform
- On the ground, on the right side of the truck.

Using one control panel doesn't allow the other panel to come into operation.

For normal operating condition **all movements are carried out by the platform control panel or control box**, which is **the main control panel**.

Platform lifting and lowering can be also carried out from the **ground control panel**.

The ground control panel is also used in emergency situations or for maintenance.

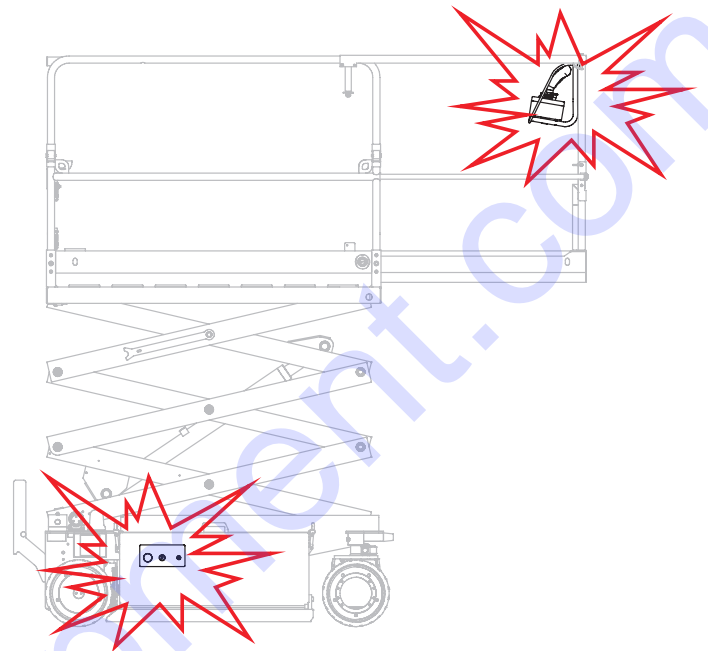

The machine movements are:

- Drive (backward and forward),
- Steering,
- Platform lowering and lifting,
- Manually-operated translation of the mobile platform.

Every time the machine carries out a movement, the rotating beacon installed on the chassis turns on.

The energy required to movements is supplied by electric batteries that feed:

- two electric motors for the machine drive,
- an electric pump for lifting and steering.

Control panels

Ground control panel

4 Warning light machine ON (green)

5 Overload warning light (red)

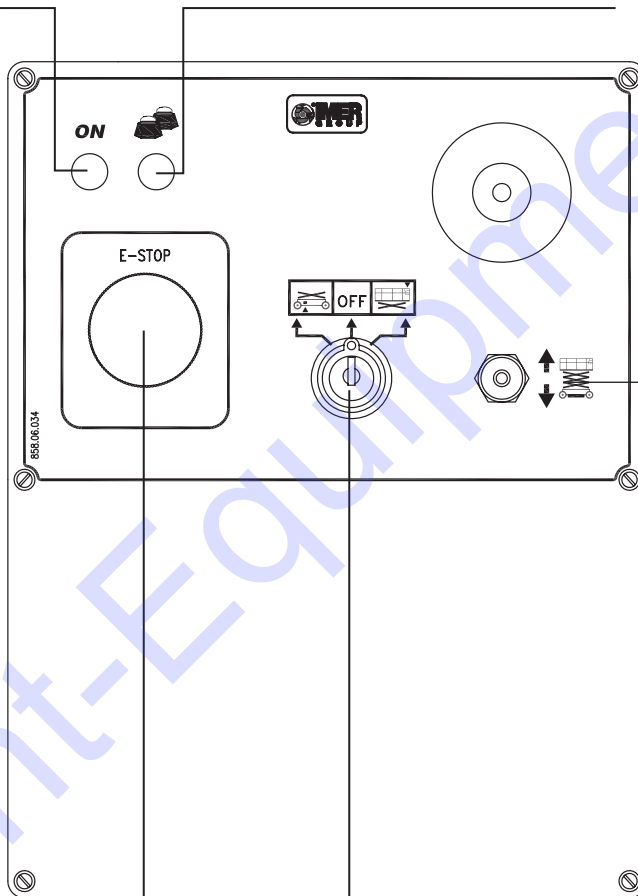

3 Platform lifting/lowering selector

2 Red emergency stop button

1 Key selector (3 positions)

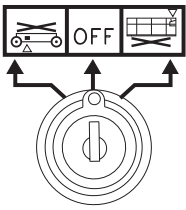

1 - Key selector (3 positions)

- **Central position:** the machine is off. It is possible to extract the key.
- **Right position:** the platform controls are enabled. It is possible to extract the key.
- **Left position:** controls from ground control panel are active. The key must be kept in position and is not removable. If the key is released, it returns automatically to central position (OFF) and the machine is turned off.

E-STOP

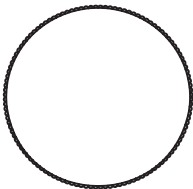

2 - Red emergency stop button

- **Pressed** it locks all the functions of the machine.
- **Released** (pull the button upwards) restore normal functions of the machine.



3 - Platform lifting/lowering selector

- Upwards to lift the platform.
- Downwards to lower the platform.

4 - Warning light machine ON (green)

ON

Light goes on when selector 1 is not in a central position.

5 - Overload warning light (red)

It flashes on when an overload is present.



Platform control panel

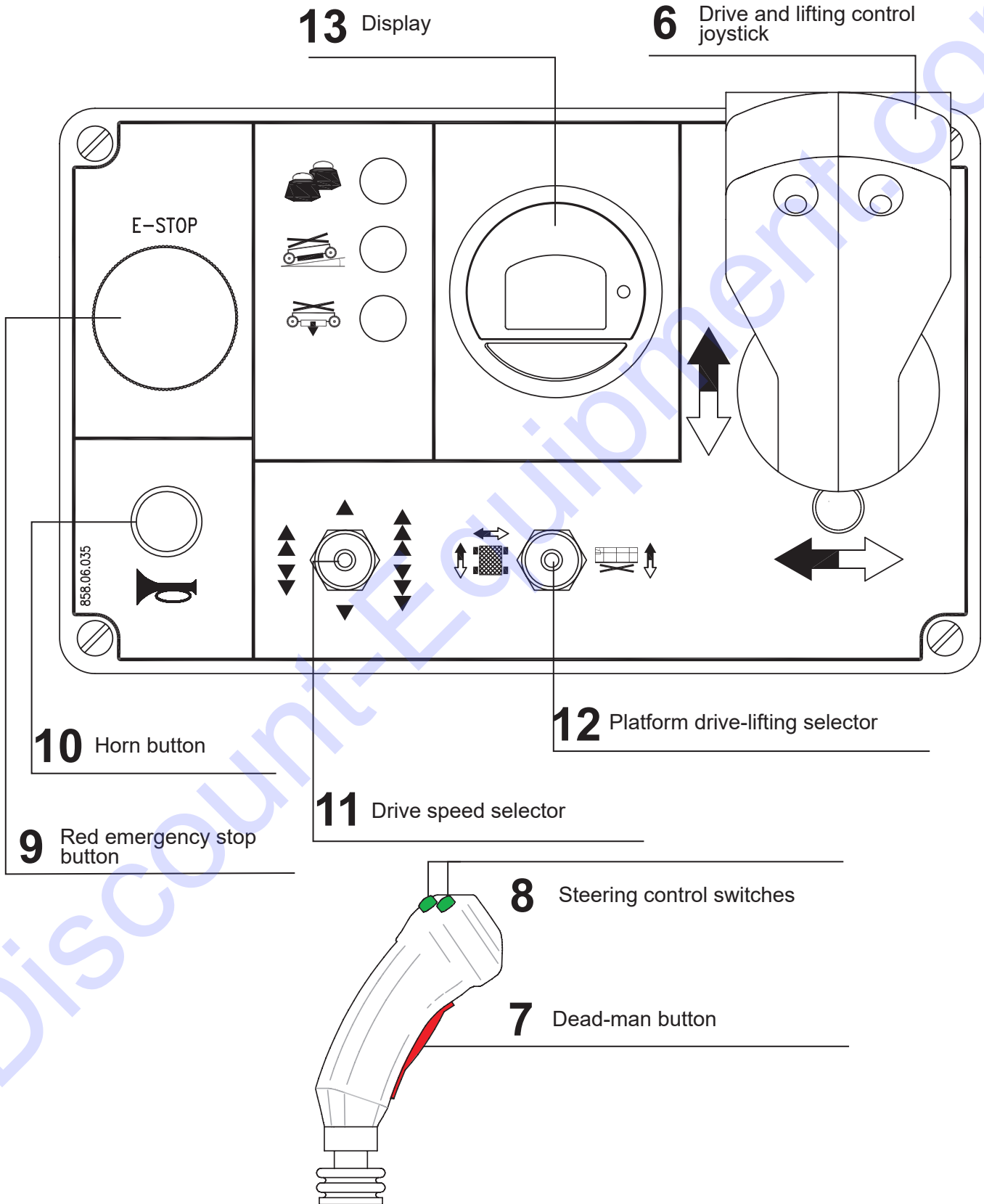

Warning lights

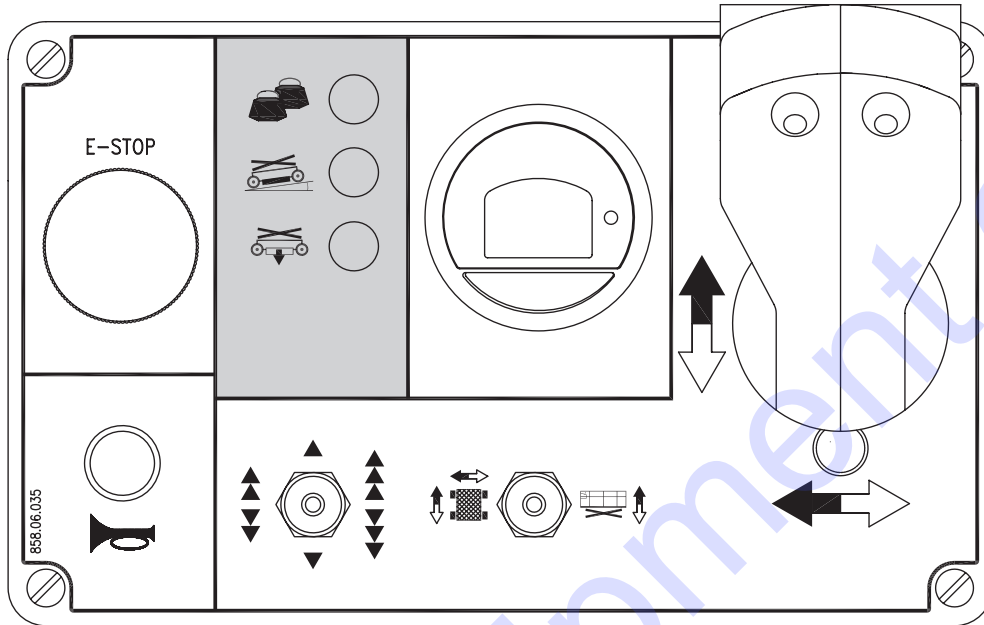

14 Overload warning light (red)



15 Unstable machine warning light (red)

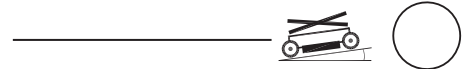

16 Anti-overturn protections warning light (red)



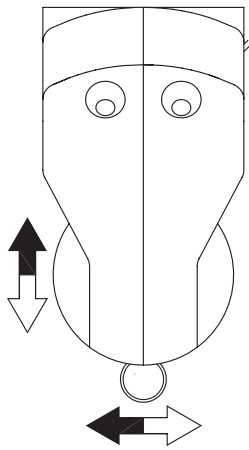

6 - Drive and lifting control joystick

7 - Dead-man button

8 - Steering control switches

Machine movements are carried out by moving joystick-6 and holding down the dead-man button 7

The joystick works on the drive or on the scissor movement depending on the position of selector 12.

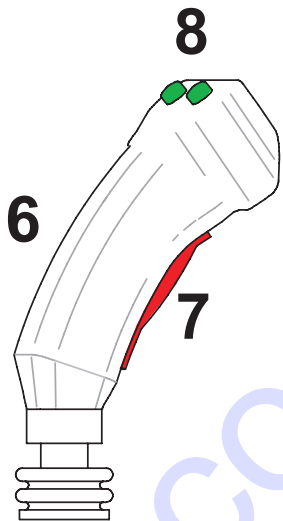

Selector 12 left		
JOYSTICK 6	SWITCHES 8	MOVEMENT
Forward		Drive forward
Back		Drive backward
	right	Steering to the right
	left	Steering to the left
Selector 12 right		
JOYSTICK 6	SWITCHES 8	MOVEMENT
Forward		Platform lifting
Back		Platform lowering

E-STOP

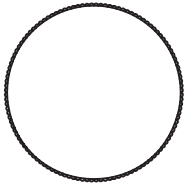

9 - Red emergency stop button

- **Pressed** it locks all the functions of the machine.
- **Released** (pull the button upwards) restore normal functions of the machine.



10 - Horn button

- Press the button to beep the horn.

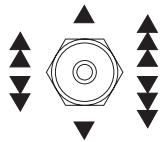

11 - Drive speed selector

- To the **right** maximum speed;
- To the **left** average speed;
- At the **center** minimum speed.



12 - Platform drive-lifting selector

- To the **right**: use joystick 6 to carry out **platform lifting and lowering**;
- To the **left**: use joystick 6 to carry out **drive and steering**.

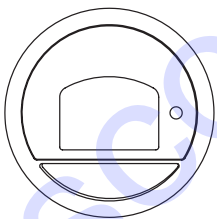

13 - Display

- It shows the working hours of the machine;
- It reports the battery charge status;
- It displays the fault and error codes detected by the self-diagnostic;

For further information, read the following page.

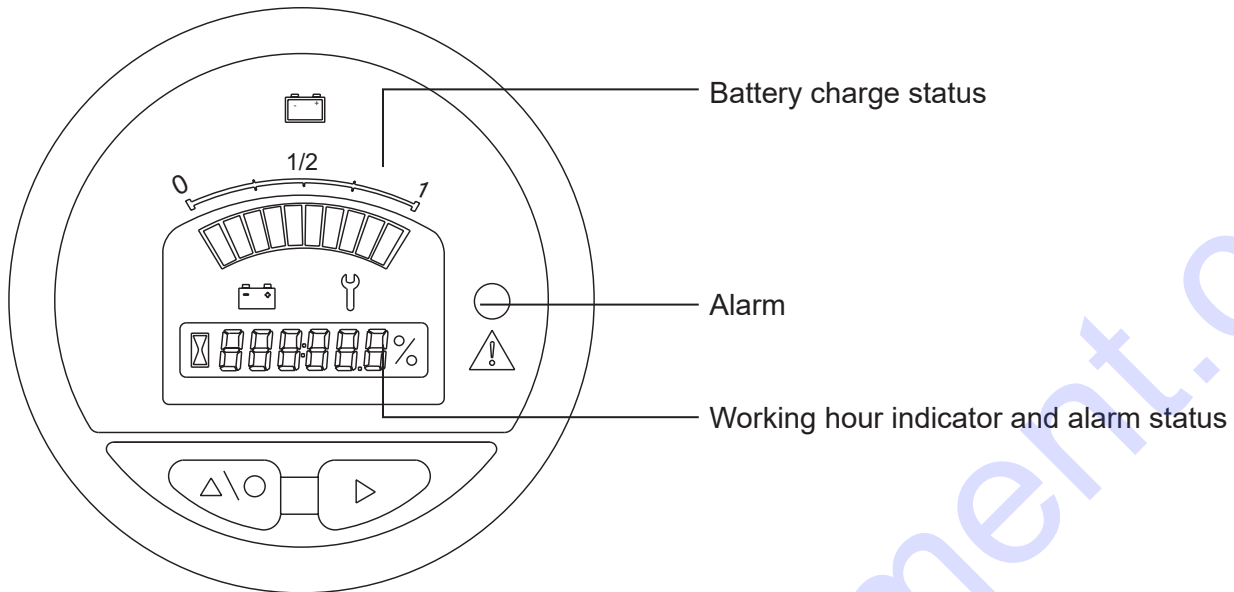

Battery charge status

The battery charge status is indicated by ten bars. Each bar represents 10% of battery charge. The bars turn off in sequence, one after the other, according to the value of the remaining battery charge. When the battery is low no bar is ON the battery symbol flashes.

Alarm

Normally off; when it turns on, it indicates the alarm status which requires assistance.

Working hour indicator and alarm status

Alphanumeric LED display which informs the operator on the working hours. It also indicates the alarm status providing a code relevant to the type of alarm signalled.



14 - Overload warning light (red)

Normally off.

With open machine It flashes when there is an overload.



15 - Unstable machine warning light (red)

Normally off.

It goes on if an inclination that exceeds the allowed limits is present.

With closed machine it flashes.

With open machine it lights up steady.



16 - Anti-overturn protections warning light (red)

Normally off.

It goes on when raising the platform the pot-hole guards cannot be lowered.

Discount-Equipment.com

How to use

Operations from ground

Make sure that the red emergency stop button is not pressed on ground and platform control panel

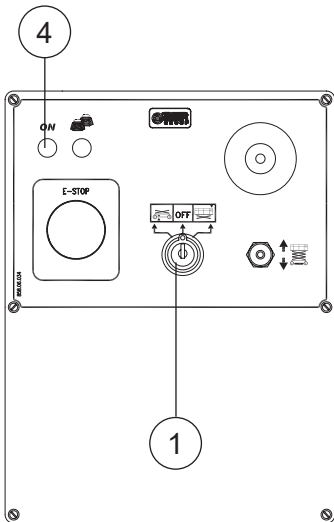

Starting and enabling the ground control panel

- Insert key in selector 1.
- Turn it **left**, keeping it in position.
- Warning light 4 will turn on.

Each time the machine is started up, audible alarms (buzzer) and warning lights turn on to verify their correct operation. Before using the machine, wait they are switched off.

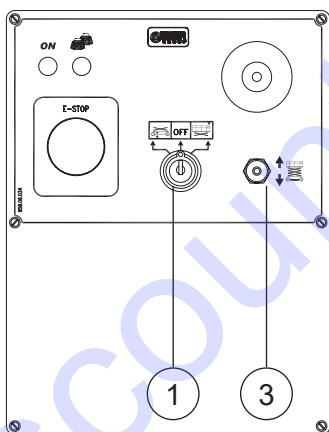

Platform lifting/lowering

- Insert key in selector 1.
- Turn it **left**, keeping the position.
- Move selector 3 **upwards to lift the platform**.
- Move selector 3 **downwards to lower the platform**.

Before lifting or lowering platform, make sure that there are no obstacles above or below it

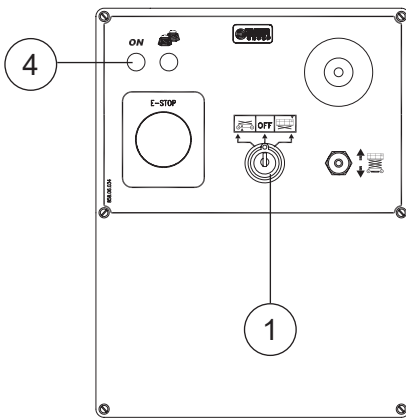

Starting and enabling the platform control panel

- Insert key in selector 1.
- Turn it to the **right**.
- Warning light 4 will turn on.

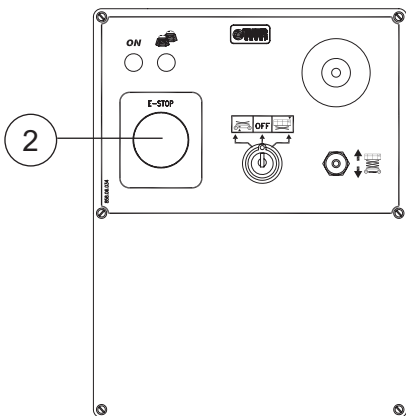

Emergency stop

- Press button 2.

All machine movements and controls are stopped both from ground and platform, except for safety indicators (warning lights and audible alarm).

To restore the normal functions pull button 2 upwards.

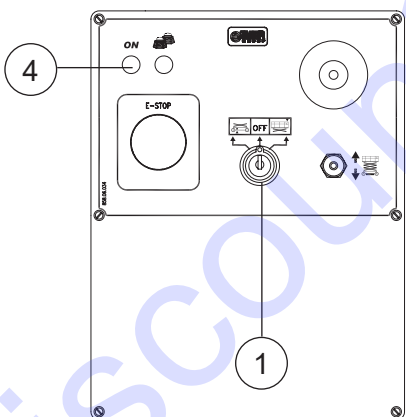

Turn off the machine

It is required turn off the machine once the work has been finished or when the machine remains unattended.

- From the ground control panel, set key selector 1 to central position: warning light 4 will turn off.
- Remove the key and keep it in a guarded place.

Platform access

The “access position” to the platform is possible when the scissor is completely lowered.

The “access position” is the only one from which loading or unloading of persons and/or materials is allowed.

- Get on the platform using the ladder and hanging on to the side rails;
- Open the protection bar and get onto the platform;
- Close the protection bar.

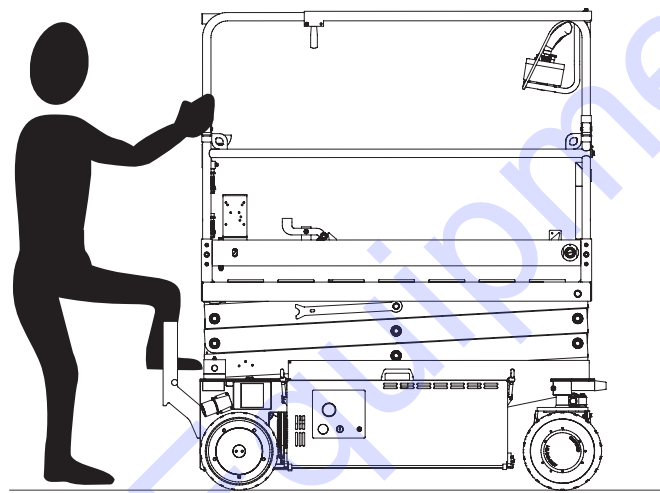

Before getting on the ladder check that the rear box is completely closed.

Operations from platform

- Make sure that the load respects the limits and is well distributed.
- Make sure that the platform gate is perfectly closed.
- Make sure that the red emergency stop button is not pressed on ground and platform control panel.
- Always check the state of the emergency warning lights.
- All platform movements described in the following pages depend on the correct position of the control panel, signalled by a plate placed on the front guard rail. If control panel is moved, use the coloured direction arrows on control panel support and on the front side of the platform, in order to identify the movement direction of the machine.

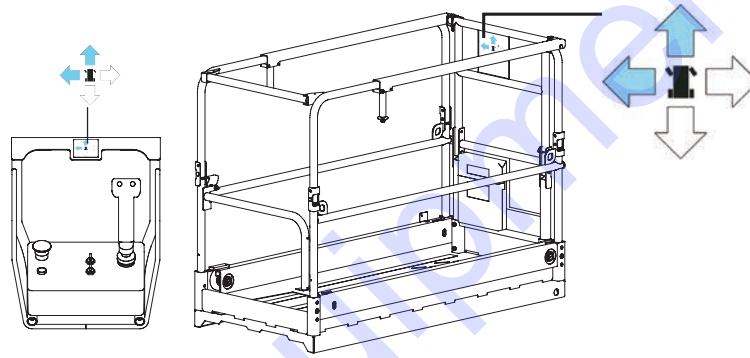

Before moving the machine, make sure that the way is free from obstacles. Check that the way is free from holes, bumps, unevenness, obstructions or debris and coverings which can hide holes or other dangers

Always check the state of the emergency warning lights

Do not move the machine, when the platform is extended, without having checked that there are no obstacles even where there is poor visibility

During movement, do not move selector 12 from drive to lifting position and vice versa. In this case the machine stops. Release joystick 6 and give the command again to restore the movement

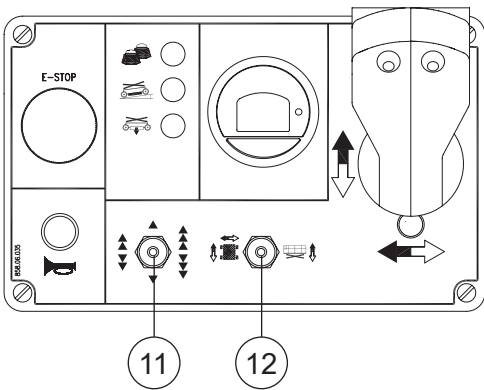

Drive

- With machine **at a standstill position**, move selector **12** left.
- With selector **11** select the drive speed.

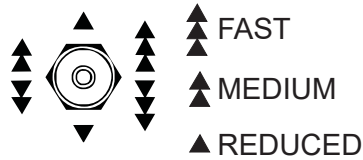

- Hold joystick **6**.
- Press dead-man button **7** and keep it pressed.
- Move joystick forward and back, keeping button **9** always pressed.

It is also possible to move joystick 6 first and then press button 7 to begin the operation.

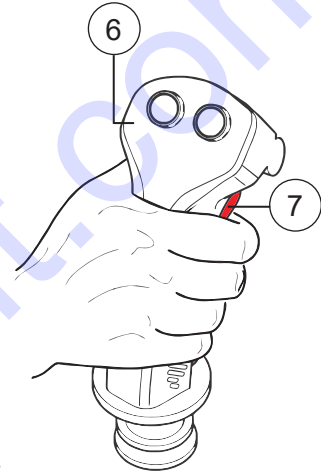

The movement speed depends on the joystick inclination and the selected speed.

The drive is signalled by an audible alarm.

Drive stop

- Gradual stop: set joystick 6 back into starting position, keeping button 7 pressed.
- Quick stop: release button 7.

Steering

During drive press switches 8 right or left, keeping button 7 always pressed.

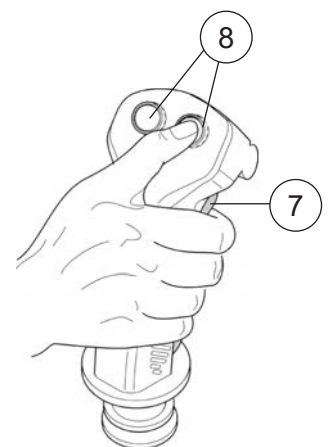

Driving on slopes

- Be sure the platform is completely lowered.
- Do not drive the machine upward or downward on slopes that are higher than 14° (25 %).
- Do not drive the machine on side slopes that exceed the 5° (9 %).

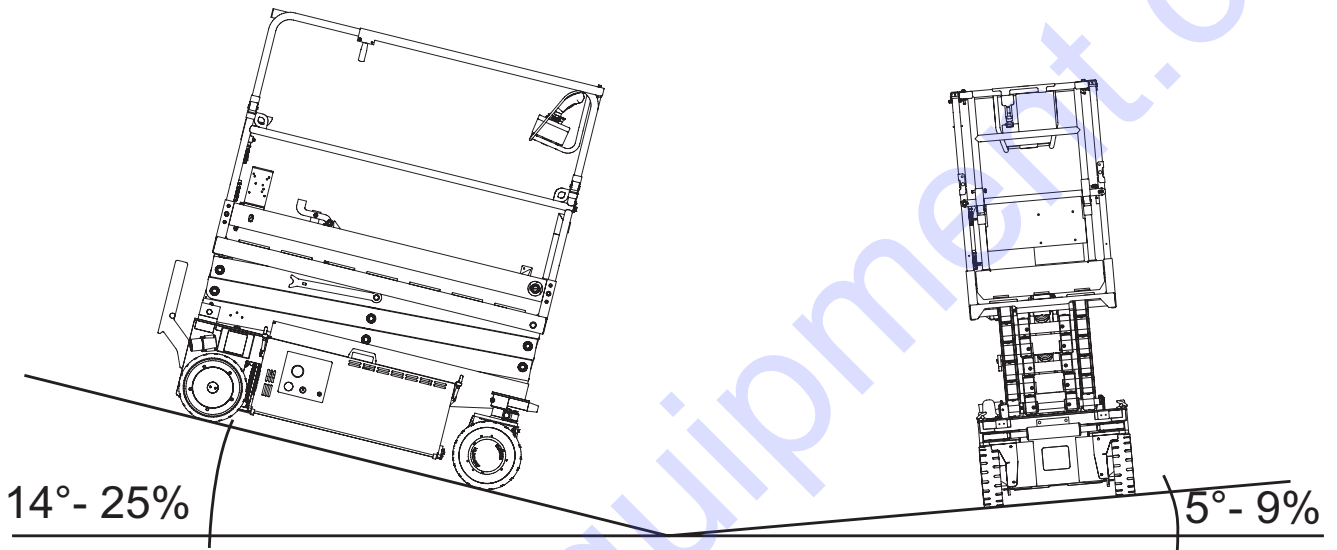

When driving on slopes or when loading/unloading from the truck through ramps only use the second (medium) speed.

Drive controlled from ground

To pass through openings having limited height, it is possible to drive the machine from ground using the platform control panel.

Making sure that:

- Guard rails are folded down;
- The operator keeps a minimum distance of 1 m from the machine;
- The selected speed is the slower one;
- The platform is entirely lowered;
- Use the direction arrows applied on the control box support and on the cowling to identify the running and steering direction.

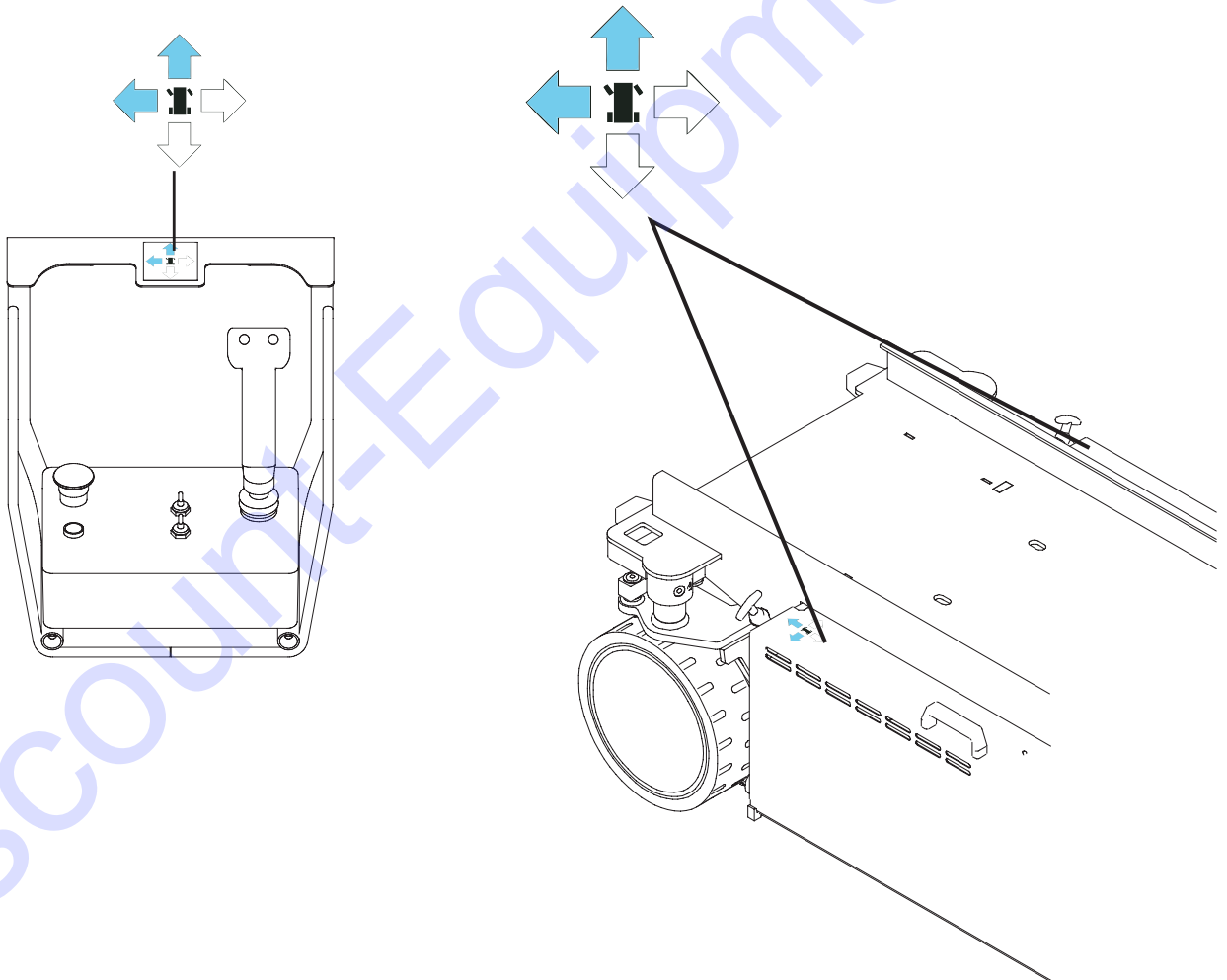

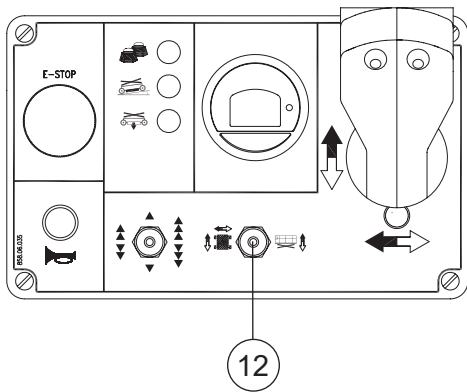

Platform lifting/lowering

- With machine at a standstill position, move selector **12** to the right.
- Hold joystick **6**.
- Press dead-man button **7** and keep it pressed.
- Move the joystick forward to lift the platform or backward to lower it.

The **lifting speed** is adjusted by the inclination given to joystick **6**.

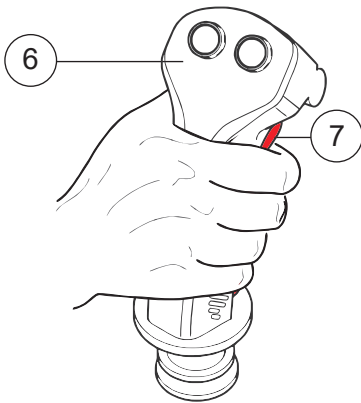

Lifting stop

Slow: Set gradually joystick **6** back into starting position, keeping pressed dead-man button **7**. The electronic control device assures a soft stop.

Quick: release dead-man switch **7**. The electronic control device assures a quick stop.

Lowering stop

Set joystick **6** back to starting position or release dead-man button **7**: stop is immediate.

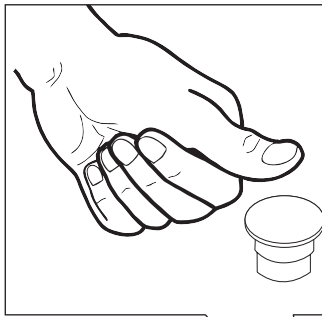

Emergency stop

Press the red emergency stop button **9**:

- In any emergency situation.

By pressing the emergency stop button all machine movements and controls are stopped both from ground and platform, except for safety indicators (warning lights and audible alarm).

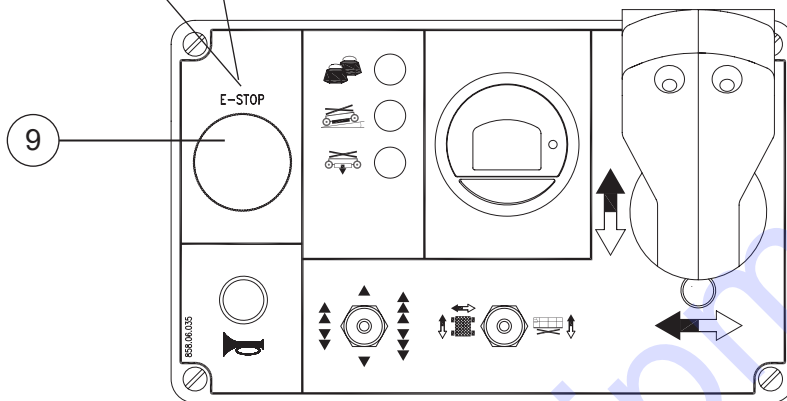

To restore the normal functions pull button **9** upwards.

Platform extension

The platform is equipped with a manually-operated extension.

To extend the platform:

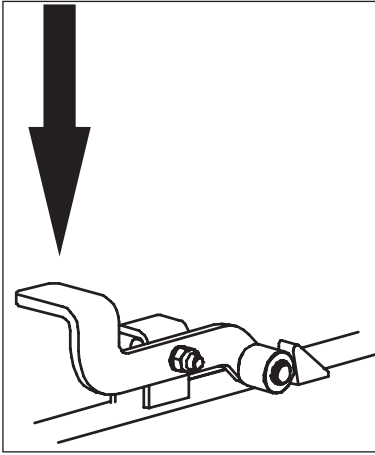

- Be positioned on the fixed platform;
- Press the pedal on the platform with your right foot;
- Hold the mobile guard rails.

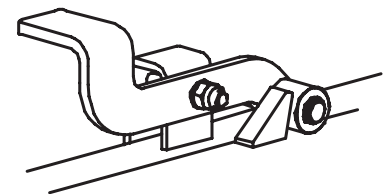
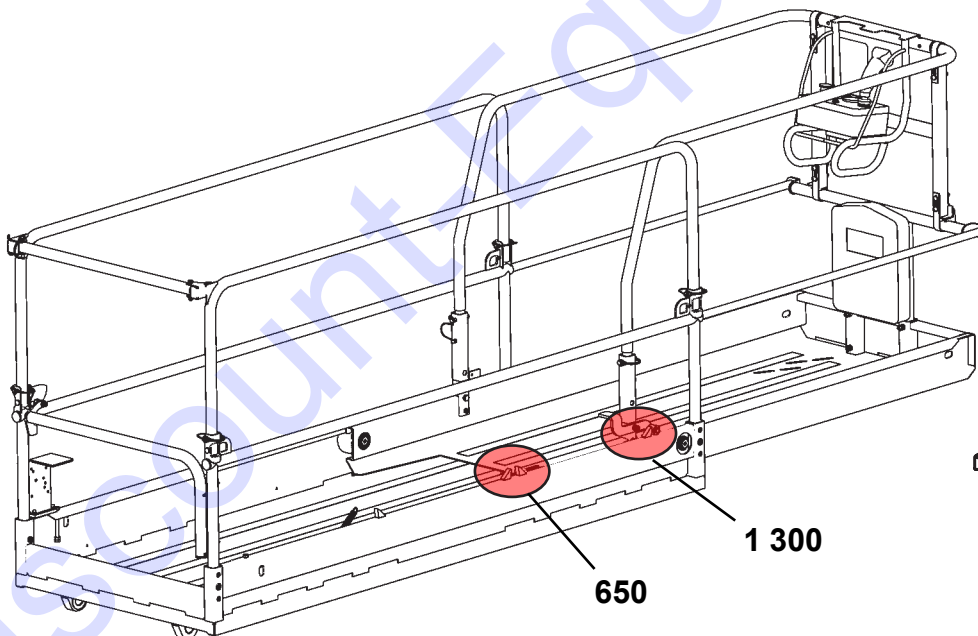
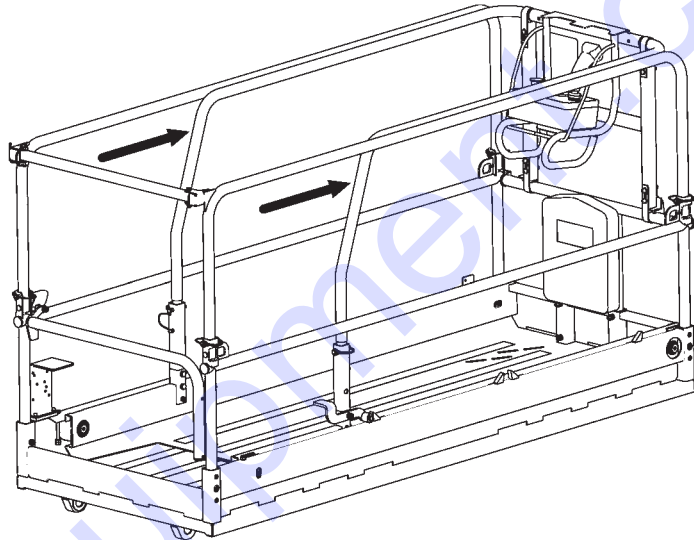

- Push the platform until the pedal pivot arrives above the lock;
 - intermediate position 650 mm
 - fully extended position 1300 mm
- Release the pedal making sure that the suitable lock stops the pivot.

Guard rails folding

We suggest to fold down the guard rails with extended platform.

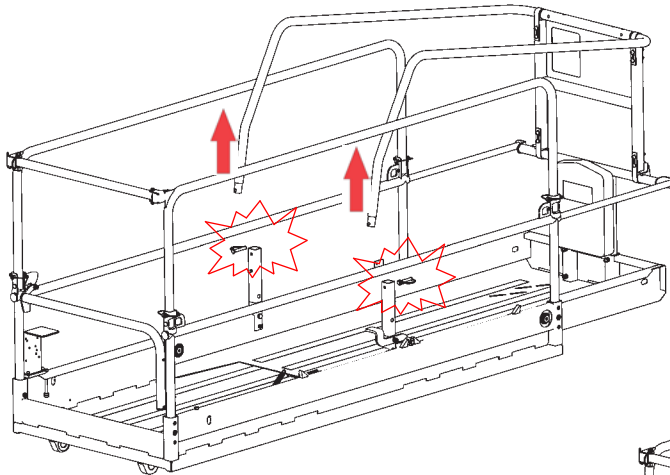

- Position the control panel with relevant support on the platform extension.
- Remove the spring plungers from the 2 extension masts and lift the mobile guard rail.

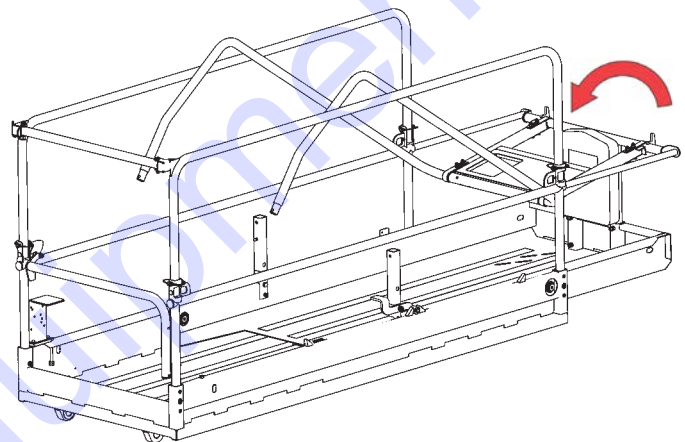

- Fold down the front side until the guard rail is placed on the platform.

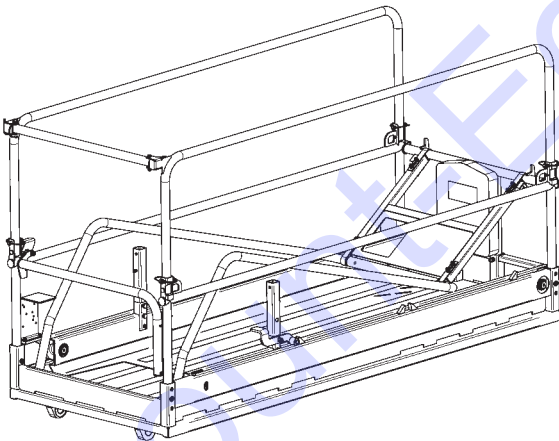

- Retract the platform.

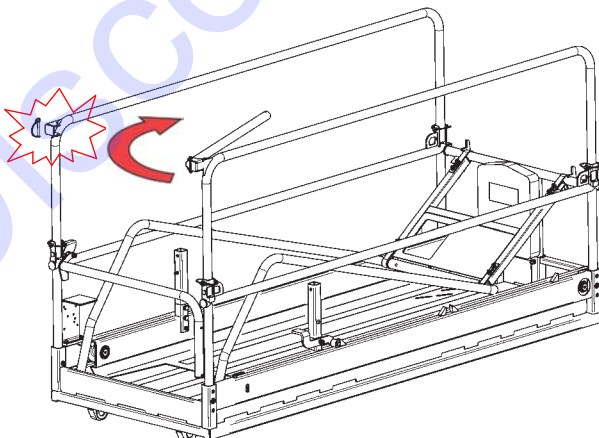

- Bend the platform gate bar by extracting the spring plungers.

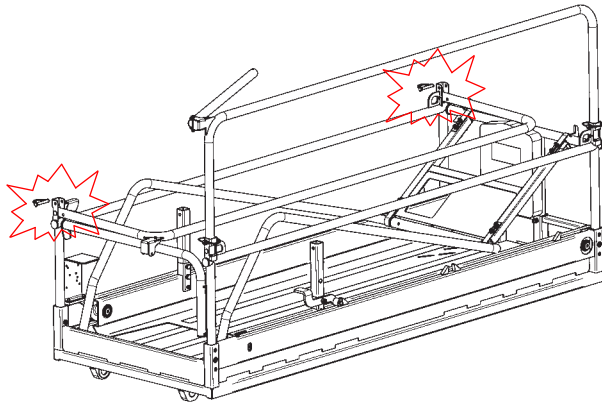

- Remove the spring plungers from hinged points and overturn the left protection.

- Turn the gate bar in the normal position.

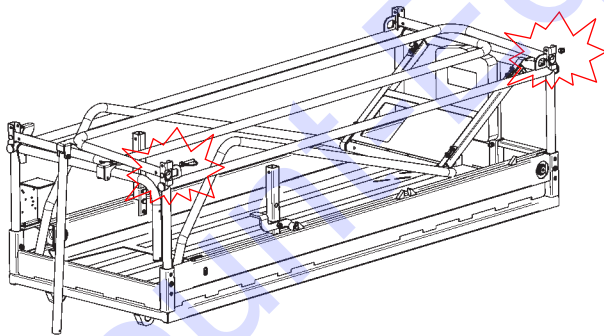
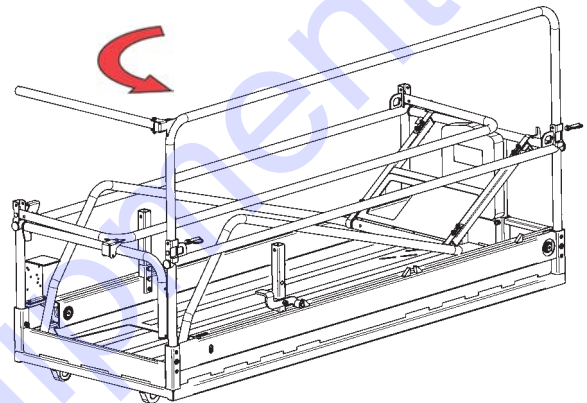

- Remove the spring plungers from hinged points and overturn the right protection.

Do not use the machine resting on board when guard rails are folded down

Do not use the machine if the guard rails and gates are not correctly positioned and perfectly fixed

Emergency manual procedures

Manual lowering

If the machine blocks in lifted position due to a failure, an operator on the ground can lower the platform by pulling the handle on the rear left side.

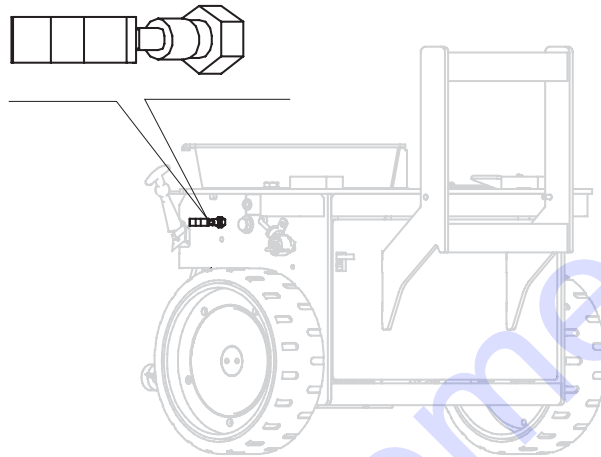

Before carrying out the emergency lowering, press the red emergency stop button

Before carrying out the emergency lowering, make sure that there are no obstacles below the platform

Emergency towing

It is forbidden to tow the machine unless an emergency, such as a malfunctioning or a complete breakdown, occurs

Move the machine for short distances without rubbing the wheels

Make sure that:

- The scissor is completely closed.

Complete the following operations:

- Connect the machine with a rigid towing bar.
- Unscrew the central cap of driving wheels
- Completely remove the central pinion using tweezers and put it in a sheltered and clean place.
- Screw the central cap again and carry out towing.

In this configuration the machine is not braked; do not exceed 4 km/h

- Once towing has been completed, remove the central cap, reposition the pinion till its complete engaging and screw the cap again.
- • Check oil level in the reduction gear and, if necessary, fill up.

Battery recharge

Batteries are the energy source of the machine. To use their capacities in the best way without the risk of a premature decay, always carry out the recharge after every use, independently of what the charge indicator signals.

If the battery recharge is not carried out immediately, the battery might be permanently damaged

Leaving even only one night the batteries exhausted may result in a permanent damage

The batteries have to be charged with the special battery charger placed on the machine.

Battery charger features IIM 4746 - IM 4752 (standard equipment)

Battery charger	24V – 30A
Power supply	90/135V -185/265V - 47/62Hz
Voltage	24V
Charge time	about 11 hours
Operating temperature	from 0°C to +40°C
Protection against output short circuit	
Protection against polarity reversal (fuse)	
Weight	2.35 kg
Connection to the supply mains	standard 3 pole 230V socket
Maintenance mode function	

Battery charge indicator

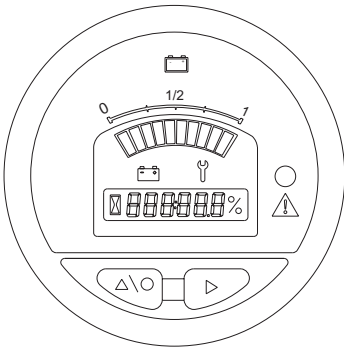

The current charge indicator on the control panel display reports the battery charge status by means of ten bars which turn off one after the other, proportionally to the value of the remaining battery charge. When the battery is low, no bar is ON, and the battery symbol flashes.

Before the charge

Before starting the battery charge it is necessary to check the electrolyte level and, if necessary, fill up till all elements are completely covered:

- Remove the cowlings.
- Open the electrolyte filler caps.
- Check the level and if necessary fill up with distilled water.
- Close caps and dry if some liquid has poured out.

The sulphuric acid contained in the solution can cause serious injuries; if it is unintentionally poured, wash immediately the objects or the surfaces with abundant water

If the acid comes into contact with the skin, wash immediately with abundant water and consult a doctor

It is recommended to always wear gloves and protective glasses during the maintenance operations of batteries.

Charge start

The recharge is to be carried out in a suitable room, well ventilated and separate from the working room, because batteries generates inflammable gases, which can cause explosions if they come into contact with flames or sparks

The recharge is to be carried out with open cowlings

When battery charger is operating the machine is locked

The charge indicator is placed on the rear left part and it has 3 LEDS.

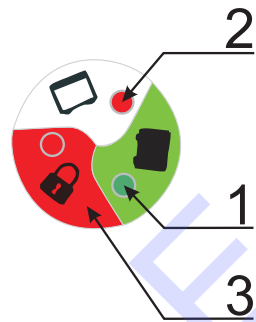
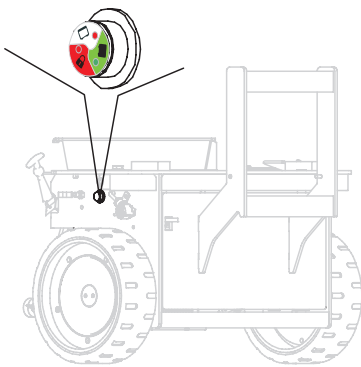

When the machine is locked for low battery LED 3 turns on.

By connecting a power cable to the back socket, the battery charger is automatically started after a few seconds; The CHARGE LED turns on (2). If this operation is not carried out, check the connection to the battery and to the supply mains.

If the above operation is carried out regularly, the battery charger completes the charge and then lights the LED 1.

The electric system where the connection takes place should be made in conformity with IEC 64.8 (CENELEC HD 384, IEC 364-4 -41) regulation; the ground system must be well built and properly maintained.

The power cords used at the work site must have a suitable outer coating resistant to crushing, wear and climate.

Charge break

The power supply failure stops the charge and it causes the switching off of all leds; when the supply voltage is restored, the charge restarts from where it was broken. If you need to stop the charge, disconnect the supply mains cable and use the vehicle.

Maintenance

If the battery charger is fed and connected even during long inactivity periods, it is possible to always keep the battery in charge at 100%. If it is not possible to keep it fed, disconnect the Anderson plug and the battery connectors.

Special signals

When the microprocessor detects a problem it stops the charge and signals it by making the 1 and 2 leds flashing or keeping them lighted and fixed. Follow the operations described below:

1. Disconnect the power supply from the supply mains,
2. Disconnect the battery charger from the battery through the provided grey connector.
3. Reconnect the battery charger to the battery.

If the fault is still present, contact the technical service.

Charge end

When the green led goes on, disconnect battery charger from outlet.

Battery disposal

Run-down lead batteries can not be dumped with ordinary solid waste; being composed of noxious materials, they must be collected, disposed of and/or recycled under the legislation prevailing in each state.

Transport

Make sure that the means of transport supports the machine mass

Loading and unloading of the machine

The loading and unloading of the machine on the vehicle platform takes place:

- Through ramps;
- By means of lifting.

Through ramps

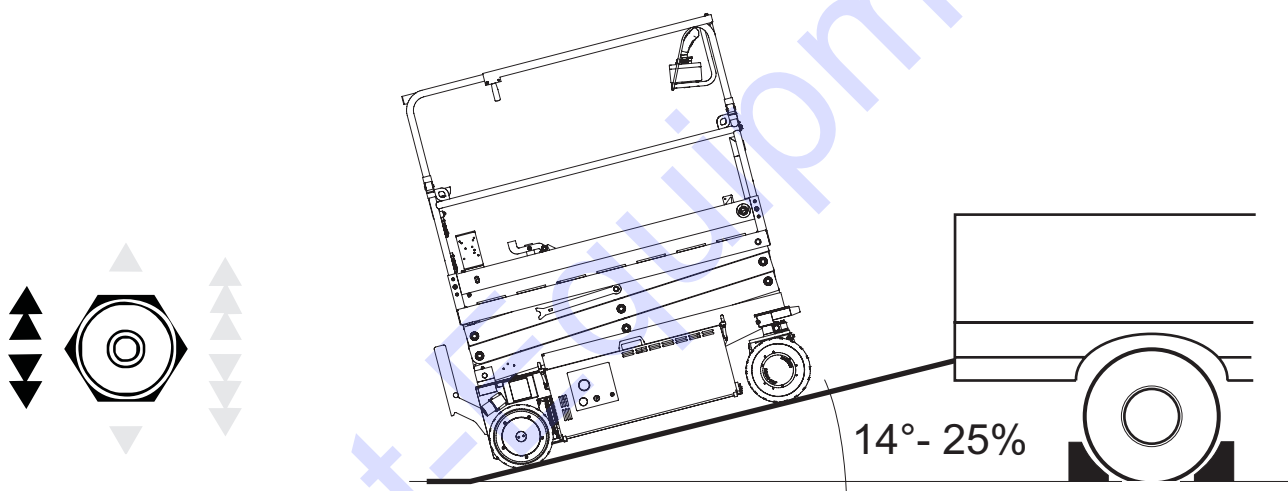

Move the machine only with the second (medium) speed. Using different speeds there is the risk of machine overturning.

- Park the means of transport on a flat surface.
- Place the ramps parallel to each other, at a distance equal to that between the wheels and with an inclination that does not exceed 14°.
- Always perform the loading and unloading operations with closed scissors and retracted platform.
- Proceed with caution.
- Place the machine so that no part of it protrudes from the floor area.

By means of lifting

Facelift may be carried out with a fork chassis or a crane or overhead crane.

Make sure that:

- The scissor is completely closed.
- The platform is not extended.
- The machine is off.

With forklift truck

For forklift lifting, use the areas shown on the labels provided on right and left sides of the chassis.

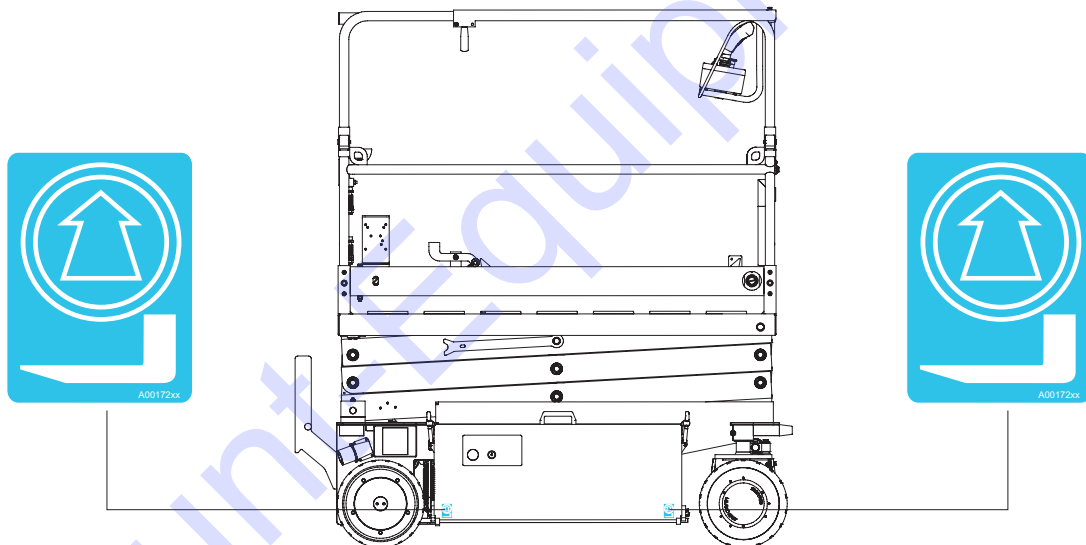

With crane or overhead crane

Use bands, chains and hooks in a perfect state of conservation.

- No operator should be on the platform;
- The area involved in the lifting must be free;
- Do not transit with the machine suspended above people.

Use bands or chains passing through the 4 points of attachment indicated by the labels provided.

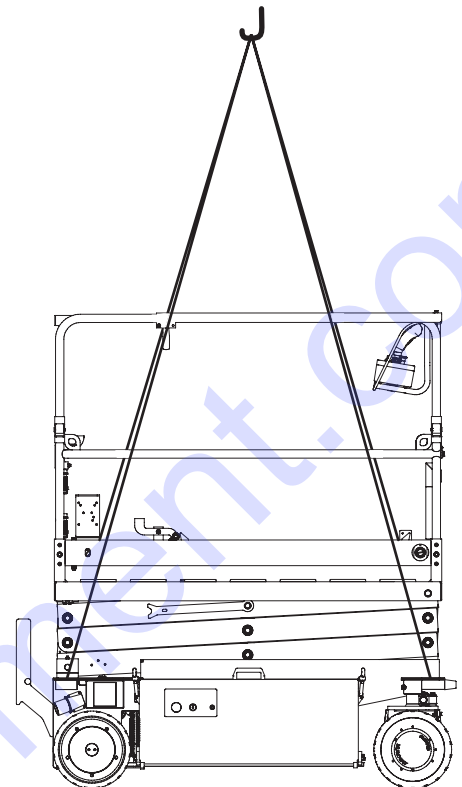

Make sure that the ropes do not come into contact with any machine parts that they might damage

Do not sling the machine in a manner other than the previously indicated, this may cause structural damage

The picture below shows the barycentre position G.

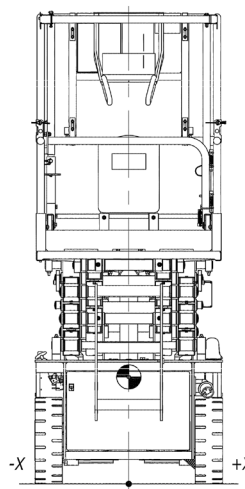
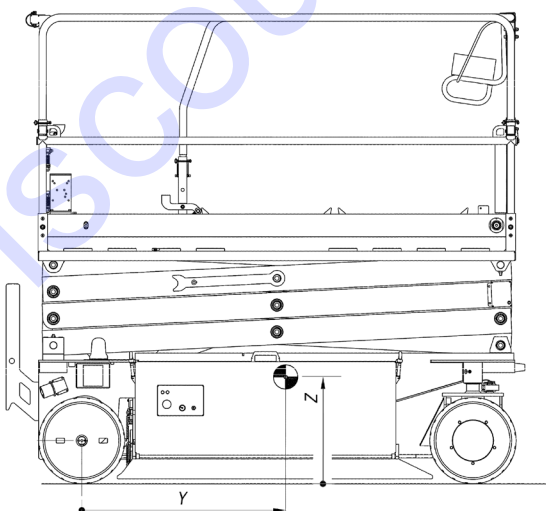

G	X	Y	Z
	mm	mm	mm
IM 4746	0	1014	716
IM 4752	0	1 002	785

Machine fastening

During its transport, fasten the machine to the vehicle platform by means of bands passing through the 4 points of attachment indicated by the labels provided.

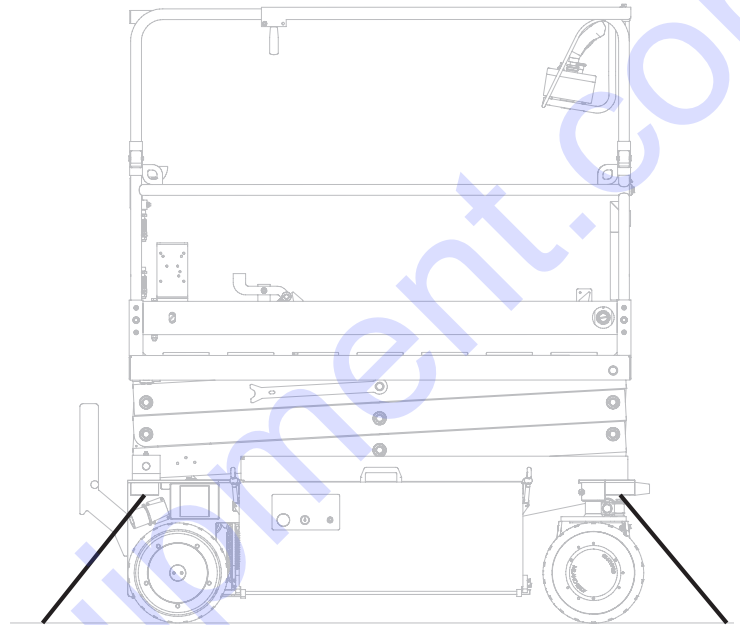

It is forbidden to raise the platform when the machine is placed on the platform of the transport vehicle

Storage

In case of long storage periods, shelter the machine in a dry and ventilated place, with completely loaded batteries. If possible leave the battery charger connected and fed in order to allow the maintenance of the batteries, otherwise recharge the batteries every 2 months regularly.

Storage temperature: -20/+50°C

Before using the machine after a storage period exceeding 90 days, carry out the inspections described in the Maintenance summary table, item "After long periods of inactivity of the machine"

Disposal and scrapping

The machine consists mainly of steel, aluminium, plastic, synthetic gum and copper.

Special attention must be paid to disposing of electric batteries (D.Lgs. 188/08) and of the hydraulic oil contained in the tank and in the hydraulic circuit (DPR 691/82).

The main components of the machine are listed hereunder.

- Cast iron
- Nylon
- Steel
- Teflon
- Copper
- Polycarbonate
- PVC
- Ertalyte

Discount-Equipment.com

Optional

AGM battery kit

As an alternative to standard batteries are provided AGM batteries (gel) of different capacities

Beacon kit

It adds a further beacon to the machine equipment.

Compressed air kit

It allows for the use of compressed air tools on the platform.

Maintenance

Long life and maximum safety during ,machine operation can only be assured by careful and constant maintenance.

The schedule reported in the maintenance summary table refers to normal use conditions; in case of heavy working conditions (extreme temperature, polluting atmosphere, high humidity, elevation) intervals must be shorter.

Frequency and scope of periodical maintenance and inspections may depend on national rules.

We suggest at least one annual check by an authorized service centre.

Machine cleaning

Once each work-shift has been finished or when you think it is necessary, clean the machine:

- Clean all surfaces by means of an air compressed blow, avoiding the formation of dirt heaps.
- Spray a normal degreasing product and eliminate the residual dirt by means of cotton clothes.

Never use diluents, scrapers and steel brushes to avoid damages to the painted surfaces

Do not clean the machine using a jet of high-pressure water. Humidity or water penetration inside electric elements could cause failures and/or damages to the electric/electronic control elements.

Wheels replacement

The wheels must be replaced if:

- The wheel overall diameter is lower than the diameter shown in the technical data table;
- There are traces of irregular wear such as cuts, tears, or missing fragments;
- The metal part is visible through the tread.

Front wheels

To remove the wheels:

- Raise the machine.
- Unscrew the five screws that secure the wheels.

To install the wheels:

- Center the wheel holes with those of the reduction gear
- Screw the five screws until they exert a resistance and check that the wheel is parallel to the
- At the end tighten the five screws with a torque of no more than 11 - 12 daNm.

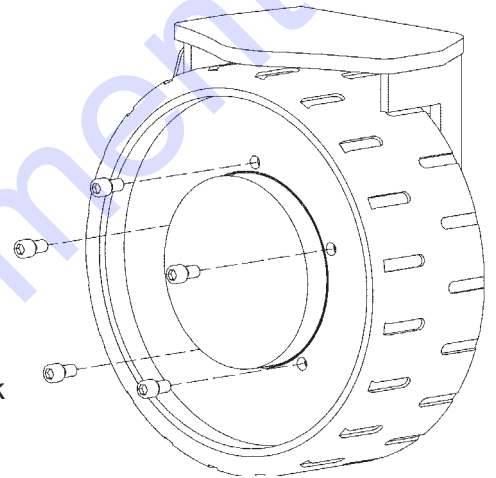

Rear wheels

To remove the wheels:

- Raise the machine.
- Remove the central disk unscrewing the two screws.
- Extract the wheel from the hub using an extractor: the wheel is provided with two slots for the extractor arms.

To install the wheels:

- Insert the new wheel, already equipped with bearings, on the pin using a rubber mallet.
- When the wheel stops, screw the disk on the pin.

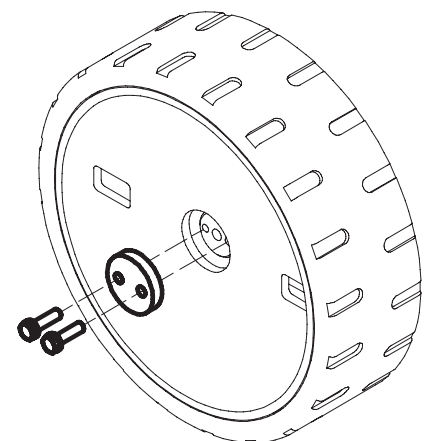

Maintenance devices

Safety rest

If the platform is subjected to maintenance while lifted, lock the lifting system on both machine sides by means of the suitable rests supplied with the machine.

Use the safety rests only when platform is unloaded

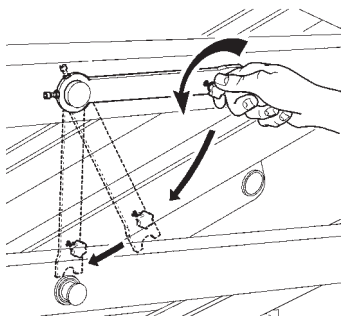

To lock the lifting system:

- Lift platform.
- Unscrew knobs which lock the rests to its boom.
- Lower the platform making sure that the lower fork of each rest fits in the housing obtained in the central pivot end.

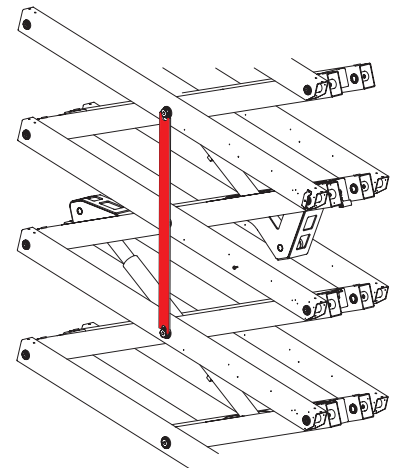
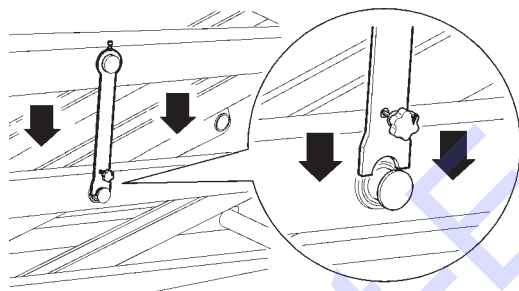

Once works have been finished, lift a little the platform to release the rests, and fix them again to the boom.

Battery connection plug

The battery connection plug is placed in the left box.

This safety device disconnects the power and control circuits of batteries and the battery charger solely remains connected.



Make sure that batteries are disconnected before carrying out the electric equipment maintenance

Maintenance summary table

We suggest at least one annual check by an authorized service centre.

OPERATION TO BE CARRIED OUT	AFTER THE FIRST 100 HOURS	EVERY DAY	EVERY MONTH	200 HOURS OR 6 MONTHS	400 HOURS OR YEARLY	AFTER LONG PERIODS OF INACTIVITY (90 days)
Check oil level			o			o
Oil filter replacement	o				o	
Check of wheel reduction gear oil					o	
Grease the mechanisms				o		
Battery inspection and cleaning			o			o
Check electrolyte level		o				o
Check battery charge		o				o
Plate and sticker check		o				o
Check of screw tightening	o				o	
Safety devices check		o				o
Motor brushes check (drive and control unit)					o	
Check brakes on ramp					o	
Check load limiter					o	
Check inclination device					o	
Structure check	o			o		o
Check of hydraulic tubes				o		o
Checking performance				o		
Power cable and auxiliary check				o		o

The above mentioned operations are described in the following pages.

Check oil level

The oil level checking and the possible topping up should be made when the platform is entirely lowered

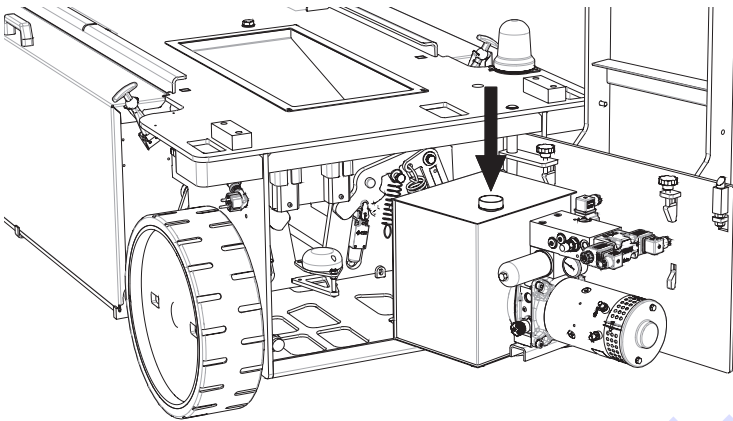

- Open the back box;
- Remove oil tank cap of the hydraulic control unit;
- Check that oil level is about 2 cm from the cap;
- Should it be necessary top up with oil of the same viscosity as indicated on the tank.

The use conditions of the machine and quality of the hydraulic oil prevent the oil from being replaced at regular intervals. During checks, verify that oil keeps its clarity, colour and viscosity characteristics; replace, if necessary.

IMER suggests anyway to replace the oil completely every 3 years.

A cap is located under the tank for total oil drain.

- Open the back box;
- Discharge all oil in a suitable container;
- Close discharge cap;
- Fill in new oil through the filling cap.

The air filter, which is placed in the oil tank cap, should be replaced once a year or every 400 hours (depending on the deadline which occurs first).

Oil filter replacement

Before carrying out this operation, make sure the machine is turned off and completely lowered

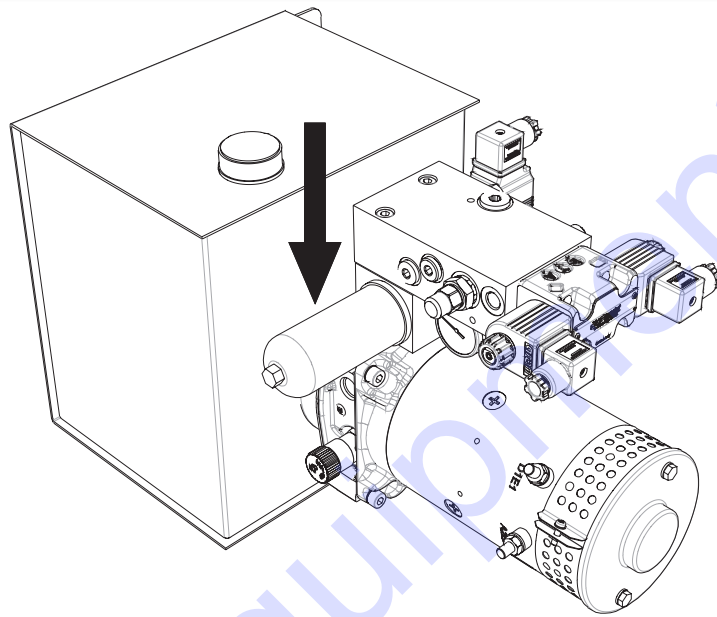

- Unscrew the filter cartridge using a suitable tool, do not use the nut at the bottom of the cartridge.
- Mount the new filter, tightening it by hand.
- Restart the machine for a few minutes.
- Make sure that there are no leaks.

Hydraulic oil is a polluting product

Avoid fluid leakages by using collection tanks and take precautions against accidental leakages by resorting to oil-absorbing products

Exhausted oil must be collected and not disposed of into normal discharge lines; specialized firms attend to dispose of or possibly recycle industrial oils, under the laws prevailing in each individual state

Check of wheel reduction gear oil

- Move the front wheel on the horizontal surface having the two level caps aligned.
- Unscrew one of the two caps: oil must be flush with the hole.
- If necessary, top up with oil type SAE 80 W - 90.
- Total capacity 0,4 litres.

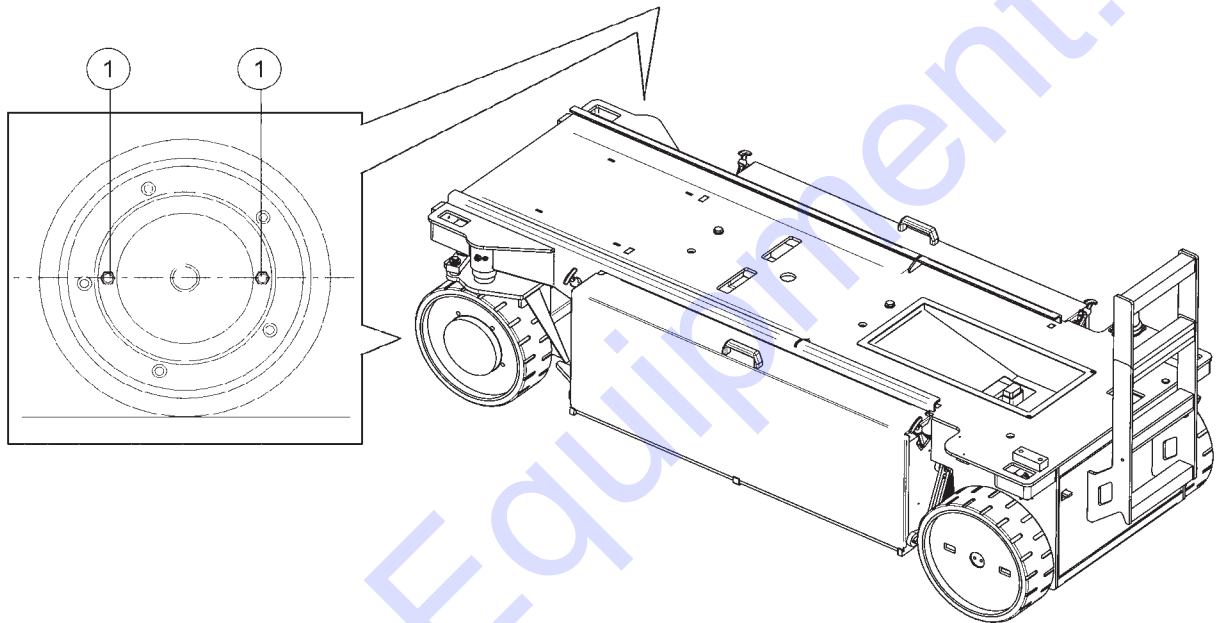

Grease the mechanisms

- Use the lubricators located on both sides of the truck (as shown in figure) to grease the steering wheels spindles.
- Clean and grease the higher and lower sliding guides of the scissors sliding blocks.

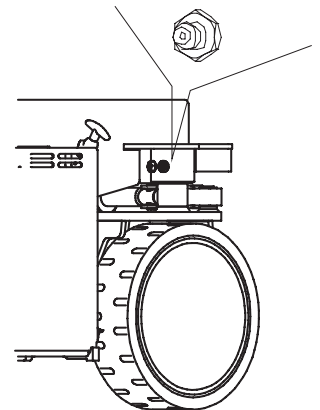

Battery inspection and cleaning

Batteries must be periodically inspected for checking that there are no damages, breakages, fluid leakages or terminal corrosion. Also inspect cables looking for breakages, cuts or fraying.

Disconnect battery connecting plug before carrying out the checks

Always clean batteries that show signs of corrosion on terminals or onto which electrolytic fluid has fallen during filling.

Always clean terminal contact surfaces, lubricate with anti-acid grease or vaseline.

The battery fluid is highly corrosive and can cause severe injuries; if it is poured unintentionally, wash objects or surfaces with abundant water.

If the acid comes into contact with the skin, wash immediately with abundant water and consult a doctor.

Always wear gloves and goggles during battery maintenance.

Keep open flames, cigarettes, sparks or any other flammable source away from batteries

Electrolyte level check

- Remove the cowlings.
- Remove the electrolyte filler caps.
- Check the level and if necessary top up with distilled water.
- Close caps and dry if some liquid has poured out.

The sulphuric acid contained in the solution can cause serious injuries; if it is unintentionally poured, wash immediately the objects or the surfaces with abundant water

If the acid comes into contact with the skin, wash immediately with abundant water and consult a doctor

It is recommended to always wear gloves and protective glasses during the maintenance operations of batteries

Check of battery charge

The battery charge level is displayed on the platform control panel.

For the battery recharge see section "Battery recharge".

Plate and sticker check

Check that all the foreseen plates and labels have been suitably positioned and are legible.

Check of screw tightening

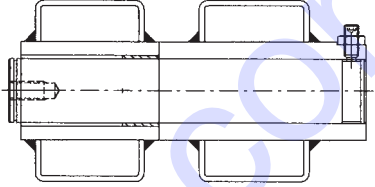
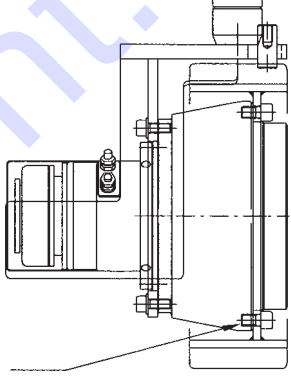
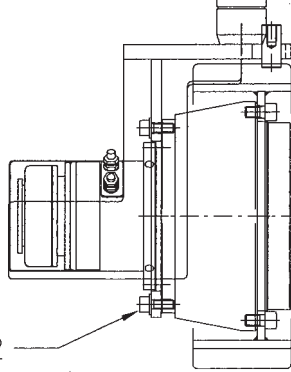
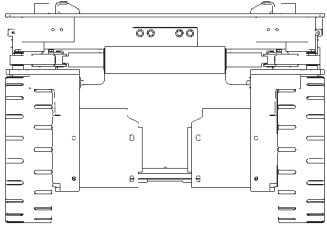
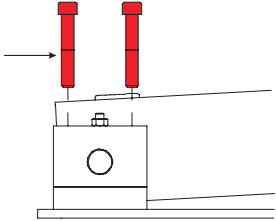
<p>Pin fixing screws on frame</p>	<p>M10X35 DIN 916 DE M10 UNI 5588</p>	<p>2 daNm</p>	
<p>Drive unit fixing screws (1)</p>	<p>TCCE M12x20 UNI 5931 12.9</p>	<p>11 – 12 daNm</p>	
<p>Drive unit fixing screws (2)</p>	<p>TCCE M10X25 8.8 DIN 912</p>	<p>4 – 5 daNm</p>	
<p>Steering cylinder fixing screws</p>	<p>TCCE M14X60 DIN 912</p>	<p>14 daNm</p>	
<p>Frame shells fixing screws</p>	<p>TCCE M14x100 UNI5931 8.8</p>	<p>14 daNm</p>	

Safety devices check

The following test enables to check that all safety devices of the machine work properly.

The safety systems applied to the machine are inevitably subject to wear and decalibration. Therefore, they must be controlled and kept in perfect efficiency; also, it is not advisable to evaluate their operational and safety conditions only on the basis of their functioning.

Such systems do not relieve the operator of the responsibility of carrying out an informed and appropriate use of the machine.

Red emergency stop button

- Press emergency stop button on ground control panel and check that no operation is possible, either from ground or platform. Put button to ON position again.
- Press emergency stop button on platform control panel and check that no operation is possible, either from ground or platform. Put button to ON position again.

Safety speed

Make sure that there are no obstacles above or below platform before carrying out the check

- From the platform control panel, perform the lifting above the height of CLOSED MACHINE.
- Check that drive is possible at safety speed only.

Anti-overflow protections

With the normal machine operation the pot-hole guards lower automatically when the platform is lifted and lower totally above the height of MACHINE CLOSED; on the contrary, drive and steering are disabled.

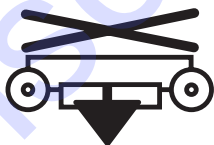

- Entirely lower the platform.
 - Place an obstacle of 30 mm under one of the anti-overflow protections to avoid its lowering.
 - Lift the platform above the height of MACHINE CLOSED.
- Check that drive and steering movements are locked.
 - Check that the anti-overflow protections warning light on the platform control panel and audible alarm turn on.
 - Lower the platform and remove the obstacle.

Emergency lowering control

Make sure that there are no obstacles below the platform before carrying out the control

- Lift platform.
- Pull the handle placed on the rear left part checking the correct operation of the emergency lowering.

Anti-shearing operations

Make sure that there are no obstacles above or below platform before carrying out the check

- Lift platform by 3 meters approximately.
- Lower platform and check that lowering is locked when the distance between the ends of the arms and frames exceeds 50 mm approx. After a time interval of 3 seconds, put the joystick in standstill position and continue the lowering.
- Check that lowering is inhibited if the joystick is activated before the indicated time interval has passed.
- Check that the lowering movement is previously warned by an audible and visual alarm for at least 1.5 s.

Check of engine brushes

Check brush wear of drive electric motors and electrical pump motor; replace them if necessary.

Check brakes on ramp

Parking brakes must be capable to stop the machine on max. slope indicated in the "Technical data" table.

Check that brakes stop on a slope indicated in the above mentioned table.

Braking spaces

All tests must be executed with the machine flat

FAST SPEED

- Select fast speed on platform control panel.
- Push joystick to max forward position.
- Release joystick and check that the braking space is lower than 60 cm.

Load Limiter



- Load platform with a load equal to 120% the nominal load.
- Check that by operating platform lifting:
 - the overload warning light flashes on the platform control panel;
 - the overload warning light flashes on the ground panel.
 - the alarm sounds;
 - all movements are locked.
- Remove overload.
- Check that all movements are restored.

Inclination

Starting with the machine in a perfectly level condition so as to avoid altering the angle values, carry out the following tests

Carry out the following tests from ground by using platform control panel

Do not stop on platform

Make sure that there are no obstacles above or below platform before carrying out the check

The tests are to be carried out in 4 different positions of the machine, using 2 different wedges.

H 	H [mm]
A	85
B	40

IM 8122 - IM 8122 EX - IM 10122

H 	H [mm]
A	100
B	35

IM 10122 EX.

H 	H [mm]
A	100
B	40

IM 4746

H 	H [mm]
A	70
B	25

IM 4752

Below are listed the positions and the tests to be carried out.

- Lower platform completely.



POSITION 1

- Place wedge A under each wheel **of front axle** and move the machine on it.
- Carry out the tests reported on the following page.



POSITION 2

- Place wedge A under each wheel **of rear axle** and move the machine on it.
- Carry out the tests reported on the following page.

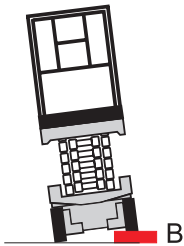

POSITION 3

- Place wedge B under each front and rear left wheel and move the machine on it.
- Carry out the tests reported on following.

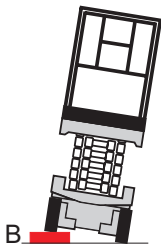

POSITION 4

- Place wedges B under each front and rear right wheel.
- Carry out the tests reported on following.

For each position check that:

- With closed machine:
 1. The inclination warning light flashes.
- With machine open:
 1. Inclination warning light is on.
 2. The alarm sounds.
 3. All movements, lowering excluded, are locked.
 4. By lowering the platform the movements are restored.

Lower the platform completely, lower the wedges and remove them.

Structure check

General

- Check that mechanical structures are protected against oxidation and, if necessary, retouch oxidized area.

Chassis

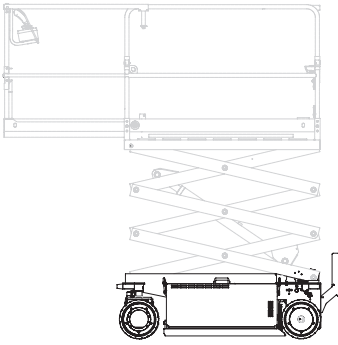

- Check the most important welds visually or by means of penetrating fluids:
 - Bearing structure.
 - Spindles of steering wheels.
 - Wheel supports.
 - Scissor hinging supports.
- Check the shape of the guide profiles for the sliding blocks.
- Check trunnions on spindles.
- Check bushings; replace them by using lubricating grease if necessary.
- Check wheel conditions.

Machine frame

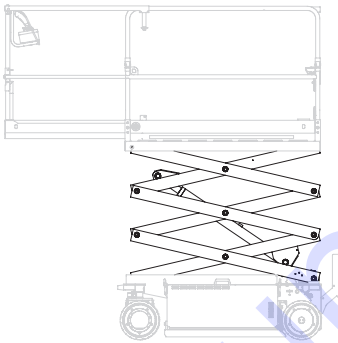

- Visual inspection of its integrity and of the shape of booms and frames.
- Check, visually or by means of penetrating fluids, all welds of articulation bushes, lifting cylinder attachments, and welds on cylinder.
- Check fastening of trunnions and hinging pins of lifting cylinder.
- Check surface conditions of trunnions and bushes; replace if necessary, by utilizing lubricating grease.

Platform

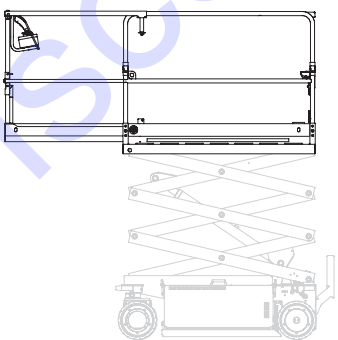

- Check the most important welds visually or by means of penetrating fluids:
 - Tubular structures.
 - Hinging supports.
- Visually check work surface conditions of both fixed and mobile platform.
- Check the shape of guide profile for sliding blocks.
- Check sliding blocks.
- Visually check guard rails and their fastening.

Check of hydraulic tubes

Hydraulic oil is a polluting product. Avoid fluid leakages by using collection tanks and take precautions against accidental leakages by resorting to oil-absorbing products.

- Visual control of all hydraulic joints and tighten junctions, if necessary.
- Check conditions of flexible hydraulic tubes; replace if necessary.

Checking performance

Use a chronometer for executing the following controls.

All tests must be executed with the machine flat

Safety speed

- Select safety speed on platform control panel.
- Push joystick to max forward position.
- Check that machine covers 10 m in a time greater than 55 sec.

Steering speed

- Select safety speed.
- Steer wheels rightwards completely.
- Execute drive and steer leftward completely.
- Check that time necessary to steer from right to left is 6 ÷ 8 sec.

Power cable and auxiliary check

Check electric terminal tightening, correct cable positioning, absence of corrosion and abrasion.

This page has purposely been left blank

Discount-Equipment.com

Check register

Reference to legislation

This check register is issued for aerial work platform users, as envisaged by Enclosure I of 2006/42/EC guideline.

Instructions for keeping this register

This check register must be considered as an integral part of the work aerial platform and must be kept with the platform for its whole life, until it is finally dismantled.

Instructions for compilation

These instructions are supplied based on provisions that are already known at the date the aerial work platform is first marketed. New provisions might be issued which could change the user's obligations.

This register is prearranged for recording the following events related to the useful life of the aerial work platform, based on proposed diagrams::

- Delivery of aerial work platform to the first owner.
- Changes of ownership.
- Replacement of components in the hydraulic system.
- Replacement of components in the electric system.
- Replacement of mechanisms or structural elements.
- Replacement of safety devices and their components.
- Periodical maintenance verification except daily inspections indicated in the maintenance summary table.
- Remarkable failures and their repair.

The MONTHLY checks and controls may be recorded on the check Register every 6 months