

MENEGOTTI TECHNICAL MANUAL

TAMPING RAMMER RAM 65H

Attention:

Before operating the **Menegotti** equipment, read this **technical manual**, it will inform and instruct the operator about the operation of the product. This way, you avoid possible work accidents and premature equipment maintenance.



Congratulations on purchasing a Menegotti product!

With the highest quality, designed and built especially to serve you with technology to suit your needs.

This manual was written to provide you with the information and instructions necessary for the use and maintenance of our equipment, as well as to present you with data relating to its technical characteristics.

Before you put your equipment into operation for the first time, carefully read the information contained herein.

The durability of your equipment depends only on the way it is treated during service (operation) and its satisfactory performance is the result of your careful work, carried out regularly.

Menegotti is prepared to offer you all the necessary technical assistance, as well as to meet your needs for spare parts.

Welcome, you are now a part of the great Menegotti "client family".

MENEGOTTI After Sales and
Technical Assistance departments.

Caution: For best convenience, keep this manual in a appropriate place where it can be consulted when necessary.

Summary

The Company	03
The Product	03
Safety	03
Technical Specifications	05
Components	05
Working Operation	06
Starting up for Equipment	07
Turning the Equipment Off	07
Transportation	08
Storage	08
Cleaning	08
Equipment Maintenance	09
Product Warranty	11
Warranty Term	11

The Company

Reference of quality in the construction machinery segment. Leading brand on sales of Concrete Mixers. Present in over 40 countries in the world. Recognized for having a complete range of products, providing greater productivity and profitability to the business. We are Menegotti North America, a Company from Menegotti Group, and we want to bring you the best we've got!



The Product

Tamping Rammer is a compacting machine, capable of quickly working by applying consecutive impacts to the surface of soil in order to level the uneven soil surface, to compact the soil uniformly so that the void among soil particles are minimized and to increase its dry density with moisture in the soil removed. Rammers are designed to compact loose soils and gravel to prevent settling and to provide a firm, solid base for the placement of footings, concrete slabs, foundations, gas piping works, water pipe works and cable backfill works, etc.

Safety

OBS.: Anyone who performs any type of operation with this equipment must read this manual and the safety instructions.



- NEVER allow improperly trained personnel to operate rammer.
- ALWAYS read, understand, and follow procedures in Operator's Manual before attempting to operate equipment.
- ALWAYS be sure operator is familiar with proper safety precautions and operation techniques before using rammer.
- NEVER operate rammer in applications for which it is not intended.
- NEVER tamper with or disable the function of operating controls.
- NEVER use accessories or attachments which are not recommended by Menegotti for rammer. Damage to rammer and/or injury to user may result.
- ALWAYS use common sense and caution when operating rammer.
- In case of damage or missing parts, contact MGT North America on our telephone number 770 9107450 for replacement.
- With the machine turned off, conduct a daily inspection of the machine's parts. In case of problems, immediately contact Menegotti's authorized service.



- ALWAYS be sure that all other persons are at a safe distance from the rammer. Stop the machine if people step into the working area of the machine.
- ALWAYS guide the rammer in such a way that the operator is not squeezed between the rammer and solid objects. Special care is required when working on uneven ground or when compacting coarse material. Make sure to stand firmly when operating the machine under such conditions.
- NEVER leave a running machine unattended.
- ALWAYS operate the rammer in such a way that there is no danger of it turning over or falling in, when working near the edges of breaks, pits, slopes, trenches and platforms.
- NEVER run machine indoors or in an enclosed area such as a deep trench unless adequate ventilation is provided. Exhaust gas from the engine contains poisonous carbon monoxide gas, exposure to carbon monoxide can cause loss of consciousness and may lead to death.
- NEVER ingest fuel or inhale your vapors, and avoid contact with the skin. In case of contact with skin, wash affected surface immediately. If the fuel comes into contact with the operator's eyes, wash immediately with water and seek medical attention as soon as possible.
- ALWAYS wear protective clothing when operating rammer. Wear goggles or safety glasses, hearing protection, and safety shoes.
- ALWAYS keep hands, feet, and loose clothing away from moving parts of rammer.
- ALWAYS use mask during compaction operations, fuel tank replenishment and cleaning.
- Before starting compaction of trenches, ensure that the walls will not collapse due to vibration.
- Check that the area to be compacted does not contain live electrical lines or gas, water or communication services that may suffer damage due to vibration.
- NEVER touch hot muffler, engine cylinders, or cooling fins. Burns will result.
- Before performing any operation or maintenance, wait for the engine to cool.
- DO NOT refuel the engine when it is hot or running.
- DO NOT refuel near a confined area, areas with sparks, flames, smoke or any restricted area.
- DO NOT spill fuel when filling the engine. Always clean up any fuel spills.
- DO NOT smoke while operating rammer and/or when refueling engine.
- DO NOT smoke near a confined area, areas with sparks, flames, smoke or any restricted area.
- ALWAYS replace fuel tank cap after refueling.
- ALWAYS check fuel lines, fuel cap, and fuel tank for leaks and cracks before starting engine. Do not run machine if fuel leaks are present, or fuel cap or fuel lines are loose.
- ALWAYS turn engine OFF when rammer is not being operated.
- NEVER use choke to stop engine.

- ALWAYS remove or disconnect engine spark plug before servicing rammer, to avoid accidental start-up.
- DO NOT attempt to clean or service rammer while it is running.
- DO NOT operate rammer with safety devices or guards removed or not in working order.
- DO NOT operate rammer without air cleaner.
- DO NOT remove air cleaner paper element, precleaner, or air cleaner cover while operating rammer.
- DO NOT alter engine speeds. Run engine only at speeds specified in Technical Data Section.
- ALWAYS replace safety devices and guards after repairs and maintenance.
- ALWAYS keep area around muffler free of debris in order to reduce to chance of an accidental fire.
- ALWAYS clean debris from engine cooling fins.
- ALWAYS do Periodic Maintenance as recommended in Operator's Manual.
- ALWAYS replace worn or damaged components with spare parts designed and recommended by Menegotti for servicing this rammer.

Technical Specifications

TECHNICAL DATA	RAM 65H
Weight (Lb)	143,3
Base Dimensions - WxL (inch)	11x12,5
Fuel	Gasoline
Fuel Consumption (l/h)	1,0
Tank Capacity (gal)	0,79
Engine brand	Honda GXR120
Power (hp)	4,0
Forward Speed	16m-50ft / min
Stroke (p/min)	up to 680
Impact Force (lbs)	3,800
Compaction Depth (inch)	up to 23,6
Compaction Area	280m ² /3,000sqft / h

Components

COMPONENTS	
1	Fuel Tank Cap
2	Emergency Switch
3	Fuel Tank
4	Digital Hour Meter
5	Honda Engine 4HP
6	Air Filter
7	Roller
8	Air Filter System - 04 Cycles
9	Engine protection
10	Foot

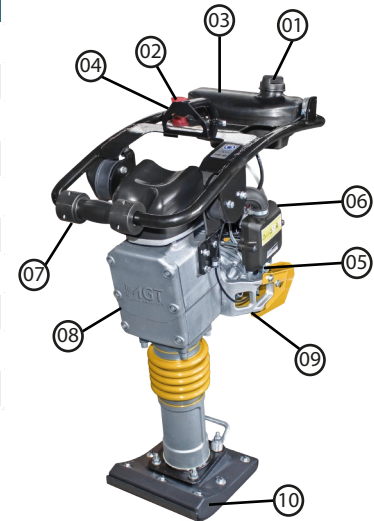

Working Operation

- This equipment can only be used for its proper application and by trained operators.
- Owners of this equipment must train and recommend safety instructions in accordance with local laws.
- Use suitable equipment to lift the product.
- Keep people and animals away from the equipment during use.
- Never allow a person to be used as a weight for this equipment.
- This equipment has been designed to eliminate any risk of accident. However, risks will always exist and could cause accidents and even death from improper use. If the operator is at risk, the equipment must be shut down immediately and the supervisor or responsible person takes steps to eliminate these risks. It is necessary to inform the manufacturer of any risk event or accident with the equipment.

Before starting the operation:

- 1 - Analyze if there are signs or defects present in the equipment.
- 2 - Inspect hoses, openings, drains and other areas for leaks.
- 3 - Check the oil levels and all lubrication systems on the machine.
- 4 - Fill the fuel tank with regular gasoline (unleaded). Simultaneously, check engine oil and make it a habit to replenish on the earlier side. Low lubrication oil level may result in engine seizure due to consumption during operation. Nevertheless, oil level should be checked prior to start up without fail. For lubrication, use automobile engine oil of 10W-30 SE, SF or better grade.
- 5 - Check that the air filter is clean. Excessive dust in the filter will prevent the engine from operating under normal conditions and will damage the engine.

6 - Check every bolt, nut or screwed area for tightness. Loosened due to vibration may result in unexpectedly serious trouble. Be sure to tighten any screwed area.

7 - Remove dirt and dust. Particularly clean the vicinity of recoil starter and foot.

Starting the engine:

- 1 - Open the fuel shut-off valve by moving the fuel cock level to the open position.
- 2 - Set the engine ON/OFF switch to the "ON" position.
- 3 - Grip the recoil starter handle and pull it until you feel slight resistance. Then pull sharply and quickly. Return the recoil starter handle to the starter case before releasing. To release the handle do not release it at the position where it has been pulled to, but release it after returning closely to the starter case.
- 4 - If the engine has started, while listening to explosion sounds, return the choke lever slowly to full-open position. Be sure to perform a warm-up run for the period 3 to 5 minutes at low speed, while paying careful attention to gas leakage or abnormal sound.
- 5 - If it is difficult to start the engine by repeatedly pulling the starter rope, remove ignition plug and check the sparking performance. If the plug is wet due to excessive fuel intake or soiled, replace the coil or clean sufficiently to its internals. With the ignition plug removed, pull the recoil starter handle 2-3 times to discharge excessive blended gas.

Starting up for Equipment

- 1 - Turning the choke level to open the choke. Running the engine for 5 minutes at low speed to warm the engine.
 - 2 - Move the throttle level quickly to the “FULL OPEN” position. DO NOT move the throttle level slowly as this may cause damage to the clutch or spring.
- CAUTION:** Operating the rammer at less than full speeds can result in damage to the clutch springs or foot.
- 3 - After starting to tamping action, adjusts the jumping motion to suit particular soil condition by lightly controlling the throttle lever. When the engine speed falls between the set values shown on the engine, your work can be carried out at the best efficiently. Increasing the engine speed unnecessarily, does not cause the compaction force to increase. On the contrary, a resultant resonance causes the compaction force to decrease, damaging the machine.
 - 4 - Under cold weather, the oil in the machine being viscous, resistance at reciprocating part is greater causing the tamping rammer to perform somewhat irregular movement. Therefore, it is recommended to perform warm-up run while moving the throttle lever repeatedly between ON and OFF positions, before entering the work.
 - 5 - Soil contacting surface of the foot is lined with heat-treated metal sheet for extra strength. However, for compacting cobblestone, use the filling-up soil for example so that the foot hits the soil uniformly.
 - 6 - The tamping rammer has been designed to advance while jumping. For quicker advance, erect the machine by pushing its handle down slightly so that flat surface of the foot at its rear-end contacts the ground.

Turning the Equipment Off

1. With the throttle lever closed from ON to OFF, run the engine for 3-5 minutes at low speed, and after temperature is lowered, turn the switch to the “OFF” position.
2. Close the fuel shut-off valve by moving the fuel cock lever to the CLOSED position.

Emergency shutdown:

- 1 - Move the throttle lever quickly to the IDLE position, and turn the engine ON/OFF switch to the “OFF” position.

Transportation

- 1 - Shutdown engine for transportation.
- 2 - For transportation, tighten fuel tank cap securely and close fuel cock to prevent fuel from spilling.
3. Drain fuel for transportation over long distance or bad road.
4. Secure machine firmly to prevent it from moving or tipping.
5. Rammer should be transported in such position as it is placed on level ground.
6. Make sure lifting device has enough capacity to hold machine (see identification plate on machine for weight). Use central lifting point when lifting machine.

Storage

Rammer should be stored in such position as it is placed on level, after engine and machine have been cooled down. Be sure to secure the rammer as necessary to avoid falling down. If the rammer has to be laid down inevitably, tighten fuel tank cap and engine oil plug securely and wait until engine and machine are cooled down. After laying it down, make sure that there is no leak of fuel or oil. (If fuel leaks, drain the tank).

Long-Term Storage

- Drain fuel from fuel tank, fuel line and carburetor.
- Remove spark plug and pour a few drops of motor oil into cylinder. Crank engine 3 to 4 times so that oil reaches all internal parts.
- Clean exterior with a cloth soaked in clean oil.
- Store unit covered with plastic sheet in moisture free and dust free location out of direct sunlight.

Cleaning

Cleaning the RAM 65H engine air filter (Honda GXR120 engine)

- 1 - Remove the two screws and the air filter cover. Then, remove the air filter element (foam).
- 2 - Remove the paper air filter from the engine.
- 3 - Inspect the element and the paper air filter and inspect if necessary. Replace the filters regularly according to the engine manufacturer's specification (as per the engine instruction manual).
- 4 - Cleaning the air filters:
 - a) Air filter element: Clean with soap and water. Rinse and allow to dry completely. Or, clean with non-flammable solvent and let it dry. Do not put oil on that air filter element.
 - b) Air filter (paper): Tap the filter on a hard surface until all the dust comes out. Or, use compressed air at a maximum pressure of 207kPa (2.1 kgf/cm or 30psi). Never brush the filter.
- 5 - Clean the dirt from the inside of the air filter box and cover it with a damp cloth. Be careful to prevent dirt from entering the air duct leading to the carburetor. After that, reassemble the air filter.

Equipment Maintenance

Periodicity: Perform at each indicated operating interval (h)					
Items	Daily	After 5h	Every 25h	Every 100h	Every 300h
Check fuel level	x				
Check oil level of machine	x				
Check fuel line and fittings for cracks or leaks	x				
Tighten ramming shoe hardware.		x	x		
Check and tighten engine cylinder screws		x	x		
Check and tighten external hardware		x	x		
Clean engine cooling fins			x		
Clean and check spark plug gap			x		
Replace spark plug				x	
Clean recoil starter					x
Change ramming system oil*					x
Clean engine muffler and exhaust port					x

*Change ramming system oil after first 50 hours of operation.

NOTE: If engine performance is poor, check, clean, and replace air filter elements as needed.

Troubleshooting Guide

RAMMER TROUBLESHOOTING		
SYMPTOM	POSSIBLE PROBLEM	SOLUTION
Engine rotates but amplitude not uniform or does not strike	Operating speed of throttle lever is incorrectly set?	Set throttle lever to correct position.
	Oil in excess?	Drain excess oil. Bring to correct level.
	Spring Failure?	Replace spiral spring.
	Speed of engine improper?	Adjust engine speed to correct operating RPM setting.

Difficult to start

ENGINE TROUBLESHOOTING		
SYMPTOM	POSSIBLE PROBLEM	SOLUTION
Fuel is available but spark plug will not ignite (power available at high tension code)	Ignition plug being bridging?	Check ignition system.
	Carbon deposit at ignition?	Clean or replace ignition.
	Short circuit due to deficient insulator?	Replace insulators.
Fuel is available but spark plug will not ignite (power NOT available at high tension code)	Improper spark gap?	Set spark plug gap to the correct gap.
	Short circuit at stop switch?	Check stop switch circuit. Replace stop switch if defective.
Fuel is available and spark plug ignites (compression normal)	Ignition coil defective?	Replace ignition coil.
	Muffler clogged with carbon deposits?	Clean or replace muffler.
	Mixed fuel quality is inadequate?	Check fuel to oil mixture.
	Fuel in use inadequate (water, dust)?	Flush fuel system and replace with fresh fuel.
	Air cleaner clogged?	Clean or replace air cleaner.
	Defective cylinder head gasket?	Tighten cylinder head bolts or replace head gasket.
	Cylinder worn?	Replace cylinder.
Spark plug loose?	Tighten spark plug.	

Operation not satisfactory

ENGINE TROUBLESHOOTING		
SYMPTOM	POSSIBLE PROBLEM	SOLUTION
Not enough power available (compression normal, no misfiring)	Air cleaner clogged?	Clean or replace air cleaner.
	Air in fuel line?	Bleed (remove air) from fuel line.
	Fuel level in carburetor float chamber improper?	Adjust carburetor float.
	Carbon deposit in cylinder?	Clean or replace cylinder.
	Ignition coil defective?	Flush fuel system and replace with fresh fuel.
	Ignition plug often shorts?	Replace ignition wires, clean ignition.
Engine overheats	Fuel in use inadequate (water, dust)?	Flush fuel system and replace with fresh fuel.
	Mixed fuel quality is inadequate?	Check fuel to oil mixture.
	Excessive carbon deposition in combustion chamber?	Clean or replace crankcase.
	Exhaust or muffler clogged with carbon?	Clean or replace muffler.
Rotational speed fluctuates	Spark plug heat value incorrect?	Replace spark plug with correct type spark plug.
	Governor adjustment improper?	Adjust governor to correct lever.
	Governor spring defective?	Clean or replace ignition.
	Fuel flow erratic?	Check fuel line.
Recoil starter not working properly	Air taken in through suction line?	Check suction line.
	Dust in rotating part?	Clean recoil starter assembly.
	Spring spring failure?	Replace sprial spring.

Product Warranty

The warranty is not transferable under the conditions and within the prescribed period and will be valid from the date of purchase of the equipment, through presentation of the sales invoice to the first end consumer. At the time of delivery of the equipment, the customer must receive the information and technical guidelines for the equipment as per the content of this manual.

Therefore, defects caused by mistreatment, carelessness, negligence, recklessness or malpractice, are not covered by this warranty, nor are any repairs or alterations of any part and/or piece of equipment. Also not covered is any assembly of the parts by any party other than the factory itself or Technical Assistant, application outside the specification, mechanical or electrical overloads or phase failure, use in an environment for which it was not designed, incorrect voltages of frequencies, incorrect lubrication, damage caused by accidents of any kind, such as floods, strong winds, fires, landslides or resulting from transportation.

The removal or alteration of the serial numbers originally placed on the product void the warranty, which must be presented on the sales invoice and the Warranty Certificate for the equipment in question.

The warranty assumed is limited to the repair, spare parts or parts assembly of the set of parts, in which the review is conducted by an Authorized Menegotti Technical Assistant and authorized in advance by the Factory, to double check the existence of the manufacturing defect. This repair or exchange will be made by an Authorized Technical Assistant, with the buyer bearing the risks or costs of transportation to and from the Technical Assistant, with the labor and replaced parts being free, under the terms of this warranty.

This supersedes any other warranty, express or implied as well as any and all liability or responsibility of our company concerning the above product.

MENEGOTTI After Sales and Technical Assistance departments.

Warranty Term

By the present CERTIFICATE provided from original purchaser, Menegotti guarantees this product against manufacturing defects, for a period of 12 (twelve) months, being: the first 3 (three) months of legal guarantee, and the last 9 (nine) months a special warranty guaranteed by Menegotti, counted from the invoice issue date of the first final consumer. The components of daily use such as: bearings, clutch disc, gears, tires, brake shoes, etc. are not included in the warranty.

This warranty includes spare parts and repair against manufacturing defects duly verified by the factory or Authorized Technical Assistance. The warranty for this product will be void if it suffers damage caused by accidents, natural events, application outside the specification, or in the case of alterations or repairs by a person or workshop not authorized by Menegotti. The product freight charges, including the technical assistant or factory, are borne by the consumer. Menegotti has a wide network of Technical Assistants throughout the country.

If the equipment is purchased with the electric engine warranty covers defects arising from the internal engine manufacture. Not covered by warranty defects of: broken or crushed shell due to carelessness in transporting/or storage, energization of the motor coupling or out specification defects, general misuse and /or incorrect installation, overcharging due to lack or excess of phase and use of voltage out of the specification.

Aware of this term,

Customer: _____
Model: _____ **Serial Number:** _____
City: _____ **Date:** _____

Customer

Menegotti Authorized Service

MGT
NORTH AMERICA 

**Discount
Equipment**

www.Discount-Equipment.com

To order go to Discount-Equipment.com