

CEMENT MIXER

This equipment is designed for varied production capacity, handling small and large works.

Ideal for use of self-employed professionals and cement artifact companies.



Ideal for professional use.



High speed Towable



Segmented ring gear in 6 pieces.



Steering wheel with strength reduction system.



Heavy duty 2" wheels axle, with high speed hubs and wheels.

12 MONTHS WARRANTY

- Quick and easy maintenance. Segmented ring gear in six interchangeable pieces, allowing better adjustment against the pinion and economy on the replacement of the gear.
- Gravity center balanced with the chassis, assuring more efficiency and less engine efforts.
- Reinforcements on the chassis and yoke arm, increasing the resistance for impacts and allowing the operation on uneven grounds.
- Reinforced drum base, with 1/4" thick steel plate.

LAUNCH

TECHNICAL SPECIFICATIONS	11 Cu Ft	7 Cu Ft
Total Drum Volume	14 Cu Ft	9 Cu Ft
Output Capacity (Mixed)	11 Cu Ft	7 Cu Ft
Weight without Engine	485 Lbs	458 Lbs
Drum Thickness	12g 5/64"	12g 5/64"
Flywheel Protection	Steel Plate	Steel Plate
Wheels	Pneumatic Rim 13"	Pneumatic Rim 12"
Towing	Tow bar for Transport and Towing, with 2" ball Tow Hitch.	Tow bar for Transport and Towing, with 2" ball Tow Hitch.
Motor (optional)	Gasoline - 6.5 HP or 8.0 HP	Gasoline - 6.5 HP or 8.0 HP

- Better design of drum, allowing higher production capacity (1½ bags of cement)
- Efficient paddles design, improving the quality of the mix.

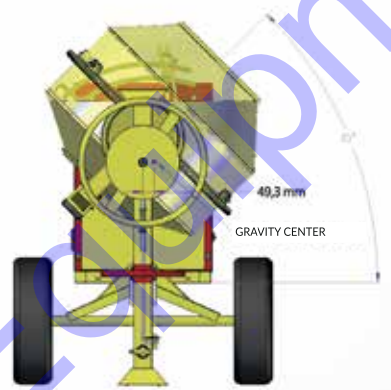

SOLID VALUES, SUSTAINABLE FUTURE.

It is great to reach our 80th year this strong and renewed. Standing on ethic an humanitarian values and always prioritizing quality in everything we do, the Menegotti Group - with all its companies and brands - is prepared to contribute for the construction of a better and more sustainable future to the world.

Thankyou so much!
You're partof this history.



MENEGOTTI
NORTH AMERICA



www.Discount-Equipment.com