

A97

APEX SERIES SHOT BLASTER

SERVICE MANUAL

Go to Discount-Equipment.com to order your parts

A97 230V

A97 400V CE



Read Manual Before Servicing Machine

PARTS FINDER

**Search Website
by Part Number**



**Search Manual
Library For Parts
Manual & Lookup Part
Numbers – Purchase
or Request Quote**

A screenshot of the "Search Manuals" form. It includes fields for "Brand", "Model", "Serial", "Part Number", and "Quantity". There are also dropdown menus for "Year" and "Type". A "Search" button is located at the bottom of the form.

**Can't Find Part or
Manual? Request Help
by Manufacturer,
Model & Description**

A screenshot of the "Parts Order Form". It includes fields for "Manufacturer", "Model", "Serial", "Part Number", and "Quantity". There are also dropdown menus for "Year" and "Type". A "Submit" button is located at the bottom of the form.

Discount-Equipment.com is your online resource for quality parts & equipment.

Florida: **561-964-4949** Outside Florida TOLL FREE: **877-690-3101**

Need parts?

Click on this link: <http://www.discount-equipment.com/category/5443-parts/> and choose one of the options to help get the right parts and equipment you are looking for. Please have the machine model and serial number available in order to help us get you the correct parts. If you don't find the part on the website or on once of the online manuals, please fill out the request form and one of our experienced staff members will get back to you with a quote for the right part that your machine needs.

We sell worldwide for the brands: Genie, Terex, JLG, MultiQuip, Mikasa, Essick, Whiteman, Mayco, Toro Stone, Diamond Products, Generac Magnum, Airman, Haulotte, Barreto, Power Blanket, Nifty Lift, Atlas Copco, Chicago Pneumatic, Allmand, Miller Curber, Skyjack, Lull, Skytrak, Tsurumi, Husquvarna Target, , Stow, Wacker, Sakai, Mi-T- M, Sullair, Basic, Dynapac, MBW, Weber, Bartell, Bennar Newman, Haulotte, Ditch Runner, Menegotti, Morrison, Contec, Buddy, Crown, Edco, Wyco, Bomag, Laymor, Barreto, EZ Trench, Bil-Jax, F.S. Curtis, Gehl Pavers, Heli, Honda, ICS/PowerGrit, IHI, Partner, Imer, Clipper, MMD, Koshin, Rice, CH&E, General Equipment, ,AMida, Coleman, NAC, Gradall, Square Shooter, Kent, Stanley, Tamco, Toku, Hatz, Kohler, Robin, Wisconsin, Northrock, Oztec, Toker TK, Rol-Air, Small Line, Wanco, Yanmar

Table of Contents

Table of Contents	2
Specifications	3
Safety	4
Safety Warnings Used in Manual	4
Safety Labels Placed on Machine	4
General Rules for Safe Operation	5
Shot Blaster Safety Guidelines	6
Electrical Practices	7
Maintenance Schedule	9
Maintenance and Inspection List	9
Maintenance Intervals	9
Troubleshooting Guide	10
General	10
Electrical	11
Maintenance	12
Adjusting the Blast Pattern	12
Adjusting the Height of Magnets and Brushes	14
Removing the Blast Wheel	15
Replacing the Blast Wheel	15
Removing the Liners	16
Replacing the Liners	16
Belt Drive	18
Chain Drive	20
Filter Maintenance	21
Replacing Work Lights	22
Replacing Fuse	22
Removing the Shot Valve Control Cable	23
Replacing the Shot Valve Control Cable	23
Recommended Spare Parts List	24
Parts List and Diagrams	25
Overall	25
Blast Wheel Drive and Cord Manager	26
Separator and Shot Valve	28
Liners	30
Plenums	31
Magnets, Brushes and Rear Seal	32
Handle and Joystick	34
Front Wheel Drive	36
Rear Wheels	38
Edge Blast Plate Assembly - 405118	39
230V Control Box - 404827	40
230V Sub-Panel Assembly - 404946	41
230V Power Cord - 405157	42
230V Cords and Harnesses	42
230V Wiring Diagrams	43
400V Control Box - 405766	47
400V Sub-Panel Assembly - 405765	48
400V Power Cord - 405615	49
400V Cords and Harnesses	49
400V Wiring Diagrams	50
Warranty	54

Specifications

Product Specifications						
Width	Length	Height	Weight	Working Width	Blasting Capacity	Power
15.3" (38.7 cm)	64.5" (163.8 cm)	44" (111.8 cm)	438 lbs (198.7 kg)	10" (25.4 cm)	Up to 1300 ft ² /hr	10 HP (7.5 kW)

Machine Variants			
Region	Serial Number	Max. Operating Amps*	Input Power**
Domestic (North America)	A97-10XXXX	25A	230V, 3 Phase, 60 Hz, 30A
International	A97-11XXXX	13A	400V, 3 Phase, 50 Hz, 32A

*Indicates the maximum amp draw under typical conditions.

**Indicates the expected source/supply connection rating.

Power Cord (Included):

- 405157 (A97 230V)
- 405615 (A97 400V)

Recommended Dust Collector: DL7000

Safety

SAFETY WARNINGS USED IN MANUAL

Look for the safety hazard warning symbol.



This symbol is used to alert the operator of safety hazards. It is used along with the words DANGER, WARNING and CAUTION.



"DANGER" identifies immediate hazards which will result in serious injury or death.



"WARNING" identifies potential hazards which could result in serious injury or death.



"CAUTION" identifies hazardous situations which may result in minor injury and/or could result in damage or destruction of equipment.

SAFETY LABELS PLACED ON MACHINE



Pinch Point Hazard



Shock Hazard



Burn Hazard



Ear Protection Warning



Eye Protection Warning



Silica Dust Warning
Possible Asbestos Exposure
Warning

GENERAL RULES FOR SAFE OPERATION

Before use, anyone operating or performing maintenance on this equipment must read and understand this manual, as well as any labels packaged with or attached to the machine and its components. Read the manual carefully to learn equipment applications and limitations, as well as potential hazards associated with this type of equipment. Keep manual near machine at all times. If your manual is lost or damaged, contact National Flooring Equipment (NFE) for a replacement.

Personal

Dress properly and use safety gear.

Anyone in the work area is required to wear eye protection, hearing protection, a dust mask and safety shoes. Hard hats, face shields, etc. should be worn when specified or necessary. Do not wear loose clothing; it may be caught in moving parts.

Maintain control; stay alert.

Keep proper footing and balance, and maintain a firm grip. Observe surroundings at all times. Do not use when tired, distracted, or under the influence of drugs, alcohol, or any medication that may cause decreased control.

Keep hands away from all moving parts and tooling.

Wear gloves when changing tooling.

Do not force equipment.

Equipment will perform best at the rate for which it was designed. Excessive force only causes operator fatigue, increased wear, and reduced control.

Environment

Avoid use in dangerous environments.

Do not use in rain, damp or wet locations, or in the presence of explosive atmospheres (gaseous fumes, dust, or flammable materials). Remove materials or debris that may be ignited by sparks. Keep work area tidy and well-lit - a cluttered or dark work area may lead to accidents.

Protect others in the work area and be aware of surroundings.

Provide barriers or shields as needed to protect others from debris and machine operation. Children and other bystanders should be kept at a safe distance from the work area to avoid distracting the operator and/or coming into contact with the machine. Operator should be aware of who is around them and their proximity. Support personnel should never stand next to, in front of, or behind the machine while the machine is running. Operator should look behind them before backing up.

Guard against electric shock.

Ensure that machine is connected to a properly grounded outlet. Prevent bodily contact with grounded surfaces, e.g. pipes, radiators, ranges, and refrigerators.

Maintenance & Repairs

Begin maintenance work only when the machine is shut down, unplugged, and cooled down. Maintenance work should only be performed by qualified personnel.

Use proper cleaning agents.

Ensure that all cleaning rags are fiber-free; do not use any aggressive cleaning products.

Schedule regular maintenance check-ups.

Ensure machine is properly cleaned and serviced. Remove all traces of oil, combustible fuel, or cleaning fluids from the machine and its connections and fittings. Retighten all loose fittings found during maintenance and repair work. Loose or damaged parts should be replaced immediately; use only NFE parts.

Do not weld or flame-cut on the machine during repairs, or make changes to machine without authorization from NFE.

Equipment

Use proper parts and accessories.

Only use NFE-approved or recommended parts and accessories. Using any that are not recommended may be hazardous.

Ensure accessories are properly installed and maintained.

Do not permanently remove a guard or other safety device when installing an accessory or attachment.

Inspect for damaged parts.

Check for misalignment, binding of moving parts, loose fasteners, improper mounting, broken parts, and any other conditions that may affect operation. If abnormal noise or vibration occurs, turn the machine off immediately. Do not use damaged equipment until repaired. Do not use if power switch does not turn machine on and off. For all repairs, insist on only identical NFE replacement parts.

Maintain equipment and labels.

Keep handles dry, clean, and free from oil and grease. Keep cutting edges sharp and clean. Follow instructions for lubricating and changing accessories. Motor and switches should be completely enclosed at all times with no exposed wiring. Inspect cord regularly. Labels carry important information; if unreadable or missing, contact NFE for a free replacement.

Avoid accidental starting; store idle equipment.

When not in use, ensure that the machine is unplugged; do not turn on before plugging in. Store in a dry, secured place. Remove tooling when storing, and keep away from children.

Safety

SHOT BLASTER SAFETY GUIDELINES

Before use, anyone operating this equipment must read and understand these safety instructions.

Shot Blasting

Beware of hidden protrusions.

Watch out for hidden dangers and protrusions in flooring. Do not use on largely uneven surfaces.

Provide barriers, shields, or safety glasses as needed to protect others from debris.

Use for correct applications.

Do not force equipment to do heavier duty work than it was made for.

Use a magnetic sweep immediately after blasting.

Steel shot that is left on the walking surfaces creates a slipping hazard which could cause unexpected falls.

Dust Collection

Turn off machine before working with dust collector.

Do not switch off or remove the dust collector while the machine is running.

Use with appropriate dust collecting system.

Do not operate machine designed for use with a dust collector without the dust collector. Ensure dust collector is on and operating properly while grinding.

Dispose of collected waste.

Do not leave the dust collector bag full of waste. Handle and dispose of bag and waste in accordance with all applicable local, state, and federal regulations. The dust bin of a connected dust collector must be emptied before transportation.



WARNING: AVOID CONTACT WITH THE HOT PLENUMS. DO NOT TOUCH PLENUMS WITHOUT PROPER HAND PROTECTION. THE PLENUMS BECOME HOT DURING OPERATION AND REMAIN HOT AFTER STOPPING THE MACHINE.

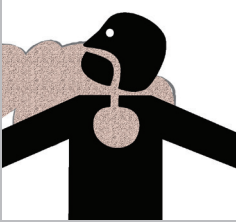

WARNING: GRINDING/CUTTING/DRILLING OF MASONRY, CONCRETE, METAL AND OTHER MATERIALS CAN GENERATE DUST, MISTS AND FUMES CONTAINING CHEMICALS KNOWN TO CAUSE SERIOUS FATAL INJURY OR ILLNESS, SUCH AS RESPIRATORY DISEASE, CANCER, BIRTH DEFECTS OR OTHER REPRODUCTIVE HARM. IF YOU ARE UNFAMILIAR WITH THE RISKS ASSOCIATED WITH THE PARTICULAR MATERIAL BEING CUT, REVIEW THE MATERIAL SAFETY DATA SHEET AND/OR CONSULT YOU EMPLOYER, THE MATERIAL MANUFACTURER/SUPPLIER, GOVERNMENTAL AGENCIES SUCH AS OSHA AND NIOSH AND OTHER AUTHORITIES ON HAZARDOUS MATERIALS. CALIFORNIA AND SOME OTHER AUTHORITIES, FOR INSTANCE, HAVE PUBLISHED LISTS OF SUBSTANCES KNOWN TO CAUSE CANCER, REPRODUCTIVE TOXICITY, OR OTHER HARMFUL EFFECTS. CONTROL DUST, MIST AND FUMES AT THE SOURCE WHERE POSSIBLE. IN THIS REGARD USE GOOD WORK PRACTICES AND FOLLOW THE RECOMMENDATIONS OF THE MANUFACTURER/SUPPLIER, OSHA/NIOSH, AND OCCUPATIONAL AND TRADE ASSOCIATIONS. WHEN THE HAZARDS FROM INHALATION OF DUST, MISTS AND FUMES CANNOT BE ELIMINATED, THE OPERATOR AND ANY BYSTANDERS SHOULD ALWAYS WEAR A RESPIRATOR APPROVED BY OSHA/MSHA FOR THE MATERIAL BEING CUT.

ELECTRICAL PRACTICES



WARNING: ELECTRICAL CORDS CAN BE HAZARDOUS. MISUSE CAN RESULT IN FIRE OR DEATH BY ELECTRICAL SHOCK. READ CAREFULLY AND FOLLOW ALL DIRECTIONS.



CAUTION: ALWAYS FOLLOW APPLICABLE ELECTRICAL CODES, STANDARDS AND/OR REGULATIONS. CONSULT YOUR LOCAL ELECTRICAL AUTHORITY OR A LICENSED ELECTRICIAN BEFORE ATTEMPTING TO MODIFY AN ELECTRICAL INSTALLATION. ENSURE THAT CIRCUIT AND GROUND FAULT PROTECTION DEVICES AND ALL OTHER ELECTRICAL SAFETY EQUIPMENT ARE FUNCTIONING PROPERLY.

Extension Cord Requirements

- Ensure the cord type is suitable for the application and location. If you are unsure about your cord type, consult a qualified electrical professional or electrician.
- Ground your equipment. The equipment must be plugged into an appropriate outlet, one which is properly installed and grounded in accordance with all codes and ordinances. Do NOT modify the plug provided with the equipment. Never remove the grounding prong from the plug.
- Do not remove, bend or modify any metal prongs or pins of the plug. Modifications to power cords and/or plugs may result injury and/or equipment damage.
- FULLY INSERT plug into outlet.
- Do not use excessive force to make connections.
- Never unplug by pulling the cord from the outlet. Pull plug rather than cord to reduce the risk of damage.
- Regularly examine your extension cord and ensure it is in good electrical condition. Never use a damaged cord—either replace it or have it repaired by a qualified person.
- Protect your extension cords from sharp objects, excessive heat and damp or wet areas. Keep the cord away from oil, cutting edges and moving parts.
- Do not drive, drag or place objects over cord.
- Avoid overheating. Uncoil cord and do not cover it with any material.
- Avoid accidental starting. Be sure equipment is turned off before plugging in. Do not use equipment if the power switch does not turn the equipment on and off.
- Make sure equipment is not running before disconnecting cord.
- Unplug equipment. When not in use and before changing accessories or performing maintenance, unplug the machine.

Extension Cord Selection

All cords should be sized appropriately to reduce the risk of damage, fire or reduced performance. Reference the table in this section for cord sizes.

Safety

ELECTRICAL PRACTICES—CONTINUED

How to Use This Table

1. Determine your supply voltage.
2. Determine the total length of your cord including all extension cords.
3. Determine the maximum amp draw for your machine.
4. Trace your voltage across the top of the table to the first length that is greater than or equal to your cord length.
5. Follow the column down to the first row that contains a maximum amp draw greater than or equal to yours.
6. This cell contains the minimum wire size for your application.

Example

Application: Max Amps = 35A, Length = 80ft, Voltage = 480V

Solution: 80ft is between the 50ft and 100ft columns, so the larger of the two columns is chosen. Likewise, 35A is between the 30A and 40A rows, so the larger of the two rows is chosen. 6 AWG (16mm²) is the minimum wire size for this example.

		3 Phase Equipment			
Max Length	230V Supply	25ft (7.5m)	50ft (15m)	75ft (22.5m)	100ft (30m)
	400V Supply	40ft (12m)	80ft (25m)	120ft (36.5m)	160ft (48.5m)
	480V Supply	50ft (15m)	100ft (30m)	150ft (45m)	200ft (60m)
Max Amps		Minimum Wire Size			
20	10 AWG (6mm ²)	10 AWG (6mm ²)	10 AWG (6mm ²)	10 AWG (6mm ²)	10 AWG (6mm ²)
30	8 AWG (10mm ²)	8 AWG (10mm ²)	8 AWG (10mm ²)	8 AWG (10mm ²)	8 AWG (10mm ²)
40	6 AWG (16mm ²)	6 AWG (16mm ²)	6 AWG (16mm ²)	6 AWG (16mm ²)	6 AWG (16mm ²)
50	4 AWG (25mm ²)	4 AWG (25mm ²)	4 AWG (25mm ²)	4 AWG (25mm ²)	4 AWG (25mm ²)

Extension Cord Sizes

		3 Phase Equipment					
Max Length	230V Supply	25ft (7.5m)	50ft (15m)	75ft (25m)	100ft (30m)	150ft (45m)	200ft (60m)
	400V Supply	40ft (12m)	80ft (25m)	120ft (35m)	160ft (50m)	250ft (75m)	325ft (100m)
	480V Supply	50ft (15m)	100ft (30m)	150ft (45m)	200ft (60m)	300ft (90m)	400ft (120m)
Max Amps		Minimum Wire Size					
20	10 AWG (6mm ²)	10 AWG (6mm ²)	10 AWG (6mm ²)	10 AWG (6mm ²)	10 AWG (6mm ²)	10 AWG (6mm ²)	10 AWG (6mm ²)
30	8 AWG (10mm ²)	8 AWG (10mm ²)	8 AWG (10mm ²)	8 AWG (10mm ²)	8 AWG (10mm ²)	8 AWG (10mm ²)	8 AWG (10mm ²)
40	6 AWG (16mm ²)	6 AWG (16mm ²)	6 AWG (16mm ²)	6 AWG (16mm ²)	6 AWG (16mm ²)	6 AWG (16mm ²)	6 AWG (16mm ²)
50	4 AWG (25mm ²)	4 AWG (25mm ²)	4 AWG (25mm ²)	4 AWG (25mm ²)	4 AWG (25mm ²)	4 AWG (25mm ²)	4 AWG (25mm ²)
60	4 AWG (25mm ²)	4 AWG (25mm ²)	4 AWG (25mm ²)	4 AWG (25mm ²)	4 AWG (25mm ²)	4 AWG (25mm ²)	4 AWG (25mm ²)
70*	6 AWG (16mm ²)*	6 AWG (16mm ²)*	6 AWG (16mm ²)*	6 AWG (16mm ²)*	6 AWG (16mm ²)*	6 AWG (16mm ²)*	6 AWG (16mm ²)*
80*	4 AWG (25mm ²)*	4 AWG (25mm ²)*	4 AWG (25mm ²)*	4 AWG (25mm ²)*	4 AWG (25mm ²)*	4 AWG (25mm ²)*	4 AWG (25mm ²)*
90*	4 AWG (25mm ²)*	4 AWG (25mm ²)*	4 AWG (25mm ²)*	4 AWG (25mm ²)*	4 AWG (25mm ²)*	4 AWG (25mm ²)*	4 AWG (25mm ²)*
100*	4 AWG (25mm ²)*	4 AWG (25mm ²)*	4 AWG (25mm ²)*	4 AWG (25mm ²)*	4 AWG (25mm ²)*	4 AWG (25mm ²)*	4 AWG (25mm ²)*

* 75°C TYPE W CORD OR EQUIVALENT

Note: The table is based on a <10% voltage loss, data from the U.S. National Electrical Code Tables 400.5(A) & 400.5(B) and typical resistances for copper wire.

Maintenance Schedule



WARNING: BEFORE PERFORMING MAINTENANCE, ALWAYS DISCONNECT THE MACHINE FROM POWER TO PREVENT ACCIDENTAL STARTUP. DO NOT OPEN THE CONTROL BOX OR TOUCH MOTOR WIRING UNTIL THE MACHINE HAS BEEN TURNED OFF, UNPLUGGED AND AT A STANDSTILL FOR APPROXIMATELY FIVE MINUTES TO PREVENT THE POSSIBILITY OF ELECTRIC SHOCK.

MAINTENANCE AND INSPECTION LIST

Operating Hours/Time Period	Inspection Points and Maintenance Instructions
After repairing	<ul style="list-style-type: none"> • Ensure all safety devices are functioning properly. • Check that all accessible fasteners are tight.
Before, during, and after operation	<ul style="list-style-type: none"> • Check for any foreign matter in the hopper, feed spout or the blast wheel. • Check the amount of shot in the hopper. Refill if necessary.
Daily and prior to starting work	<ul style="list-style-type: none"> • Check the hose connection for tightness and fixed seals. • Check dust hose and filter for damage. • Ensure dust collector has been emptied. • Check blast wheel, feed spout, liners, and fasteners for wear and damage. • Check the separator parts for wear and damage. • Remove foreign parts and dust deposits. • Check magnets and brushes for wear. • Check the electrical connections for dirt and contaminants. • Check the electrical motor for dirt and other contaminants. • Verify direction of blast wheel motor is correct.
Annually	<ul style="list-style-type: none"> • Full overhaul and cleaning of the machine.

MAINTENANCE INTERVALS

Inspections Interval	Part	Sign of Wear	Repairing Action
10-20 hours	Brushes	Wear at the lower end	Readjust brushes flush with floor or replace if needed.
30-40 hours	Blast wheel and control cage	Blades of the blast wheel are worn 1/3, deep grooves	Replace blast wheel and control cage.
50 hours	Liners	Liner thickness less than .12" (3 mm) thick	Replace liners.
	Control box air filters	Dirty or clogged filters	Clean or replace filters.
100 hours	Deflector in the separator	Significant wear of the deflector or inside components	Replace deflector.
	Check belt tension	Tension too loose, slipping belt	Tighten belt.
200 hours	Feed spout	Cracked or worn out feed spout	Replace feed spout.
	Clean front wheel drive chain	Dirty chain	Clean chain.

Troubleshooting Guide



WARNING: BEFORE PERFORMING MAINTENANCE, ALWAYS DISCONNECT THE MACHINE FROM POWER TO PREVENT ACCIDENTAL STARTUP. DO NOT OPEN THE CONTROL BOX OR TOUCH MOTOR WIRING UNTIL THE MACHINE HAS BEEN TURNED OFF, UNPLUGGED AND AT A STANDSTILL FOR APPROXIMATELY FIVE MINUTES TO PREVENT THE POSSIBILITY OF ELECTRIC SHOCK.

GENERAL

Problem	Cause	Solution
Unusual vibrations or noise	Control cage not centered.	Center control cage.
	Blast wheel installed incorrectly.	Check pin on wheel hub.
	Loose blast wheel bolt.	Replace and/or tighten bolt.
	Wheel hub worn out.	Replace wheel hub.
	Unbalance due to broken blast wheel blade.	Replace blast wheel. Check inside of machine and remove broken blade.
	Worn motor bearings or shaft.	Replace motor and/or load adaptor.
	Uneven wear of blast wheel.	Replace blast wheel.
Reduced or no performance	Uneven blast pattern.	Adjust control cage.
	Not enough shot in hopper.	Add shot.
	Insufficient shot fed to blast wheel.	Clean mesh tray. Check valve for blockage.
	Loose shaft clamp.	Tighten set screw to secure clamp to shaft.
	Broken belt.	Replace belt.
	Valve out of adjustment.	Inspect valve for proper opening and closing.
	Too much dust in hopper.	Check dust collector filters and replace if needed. Purge more frequently. Verify CFM rating of dust collector is sufficient.
	Blast wheel or control cage is worn out.	Replace worn parts.
	Valve does not close properly.	Clear valve of debris.
	Too much shot fed when turned on.	Ensure motor reaches a steady state before opening the valve.
	Travel speed is too fast.	Reduce travel speed to achieve desired profile.
	Blast motor rotating in wrong direction.	See Electrical section.
	Belt is slipping.	Check belt tension.
Dropping shot	Too much dust in shot hopper.	Check filters and size of dust collector (CFM).
		Concrete is too soft, building up too much dust in hopper.
	Separator cover is not sealed.	Check cover seal for air leaks. Adjust cover position or replace seal.
	Shot hopper is over-filled.	Remove excess shot to level just below the mesh tray.
	Magnet height out of adjustment.	Verify the magnet height is not above .38" (10 mm).
	Control cage not rotated correctly.	Adjust control cage to achieve even blast pattern.
	Blast wheel worn.	Replace blast wheel.
	Liners worn.	Replace liners.
	Magnets lost field.	Replace magnets.
Blast motor rotating in wrong direction.	See Electrical section.	

Troubleshooting Guide

GENERAL—CONTINUED

Problem	Cause	Solution
Losing shot	Shot being sucked out of vacuum port.	Use a smaller dust collector or reduce suction and flow.
Too much dust present	Insufficient air flow towards dust collector.	Verify CFM rating of the dust collector is sufficient.
		Check all seals and dust hoses.
		Check dust collector filters and replace if needed. Purge more frequently.
Machine won't move	Quick release pin not inserted.	Insert pin.
	Broken chain.	Replace chain.

ELECTRICAL

Problem	Cause	Solution
Blast wheel motor does not start. Blast wheel motor stops during operation.	Emergency stop is depressed.	Release emergency stop button.
	Motor power cable damaged.	Check cable, replace if needed.
	Internal circuit breaker tripped.	Check for blast wheel obstruction. Ensure control box air filters are clean. Reset circuit breaker.
	Faulty switch or relays.	Contact NFE customer support for service.
	Motor damaged.	Contact NFE customer support for service.
Blast motor rotating in wrong direction.	Power supply phases mismatched.	Contact a licensed electrician to repair supply wiring.
	Improper motor wiring.	Contact NFE customer support for service.
Control box does not power on.	Ground fault related failure.	Ensure ground fault protection device is functioning properly.
	Cord unplugged.	Plug in cord.
	Branch circuit breaker tripped.	Make sure you are using an appropriately sized circuit for the amperage requirements.
	Internal circuit breaker tripped.	Reset breaker. If breaker trips again, contact NFE customer support.
	Internal fuse blown (230V machine only).	Replace fuse. If fuse blows again, contact NFE customer support.
	Faulty switch or relays.	Contact NFE customer support for service.
	Internal electrical fault.	Contact NFE customer support for service.
Front wheel drive motor stops during operation.	Motor power cable damaged.	Check cable, replace if needed.
	Variable frequency drive (VFD) fault.	Reset main power switch. If problem persists, contact NFE customer support.
	Speed control damaged.	Replace speed control.
	Joystick damaged.	Replace joystick.
	Motor damaged.	Contact NFE customer support for service.

Maintenance



WARNING: BEFORE PERFORMING MAINTENANCE, ALWAYS DISCONNECT THE MACHINE FROM POWER TO PREVENT ACCIDENTAL STARTUP.

ADJUSTING THE BLAST PATTERN

Factors That Affect the Blast Pattern

- **Position of the control cage:** The correct adjustment of the control cage is the most important factor in achieving an even blast pattern and optimum machine performance. The position of the control cage determines the direction shot is thrown to the surface and the evenness of the blast pattern. Incorrect adjustment of the control cage results in premature wear and reduced blasting performance.
- **Changing blast wheel and control cage:** After changing the blast wheel and control cage, the blast pattern must be checked and readjusted.
- **Worn blast wheel and control cage:** The blast pattern changes with increased wear of the blast wheel and control cage.
- **Shot size:** The size of shot affects the blast pattern. Check the blast pattern whenever the shot is changed and readjust if needed.

Adjusting the Control Cage (Figures 1-4)

When blasting the surface, material should be removed within the whole width of the blast opening and the blast pattern should be even. Evenness of the blast pattern is determined by the position of the control cage. The control cage grooves indicate the position of the opening through which the shot is fed onto the blast wheel. As a starting point, the control cage grooves should be aligned with the corresponding grooves in the cage support plate as shown in Figure 2. If the machine produces a one-sided, uneven blast pattern, adjust the control cage as follows:

1. Loosen the cage clamps (1). Remove the feed spout (2) for easier adjustment of the control cage.
2. Observe the evenness of the blast pattern to determine the direction of adjustment. View from the front of machine—this is the view from the operator's position facing backwards. Make adjustments in fine increments.
 - If the blast pattern is too heavy to the left, adjust control cage (3) counterclockwise to achieve an even pattern.
 - If the blast pattern is too heavy to the right, adjust control cage (3) clockwise to achieve an even pattern.
3. Tighten the cage clamps. Create a blast pattern to check the adjustment.
4. If blast pattern is even, proceed with blasting. If blast pattern is still uneven, repeat the process.

Note: The control cage must be centered with the blast wheel to reduce wear and avoid grinding shot. If a grinding noise can be heard after the control cage has been adjusted, it must be centered: loosen the cage clamps; move the control cage within the opening to understand the play in the system; center the control cage; tighten the cage clamps; start the machine. Repeat process until the grinding noise can no longer be heard—this may take several attempts. (If the grinding noise is still present, remove the control cage and inspect for wear marks to help determine the adjustment direction.)

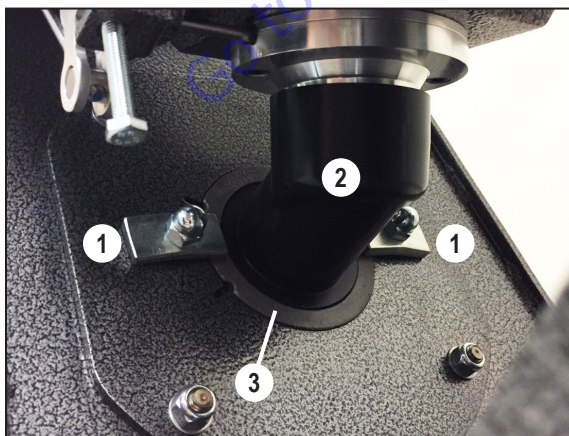

FIG. 1

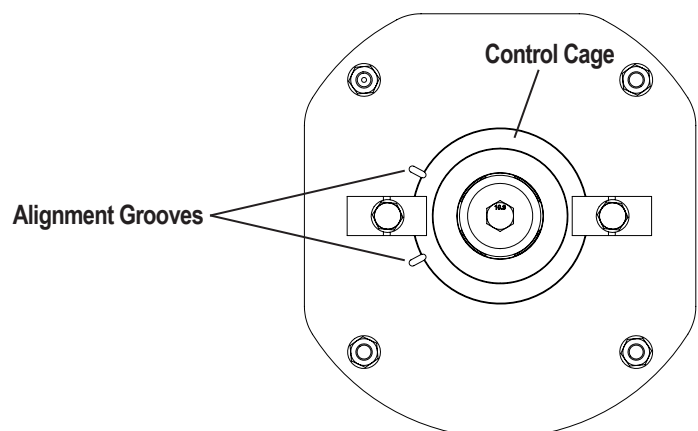

FIG. 2

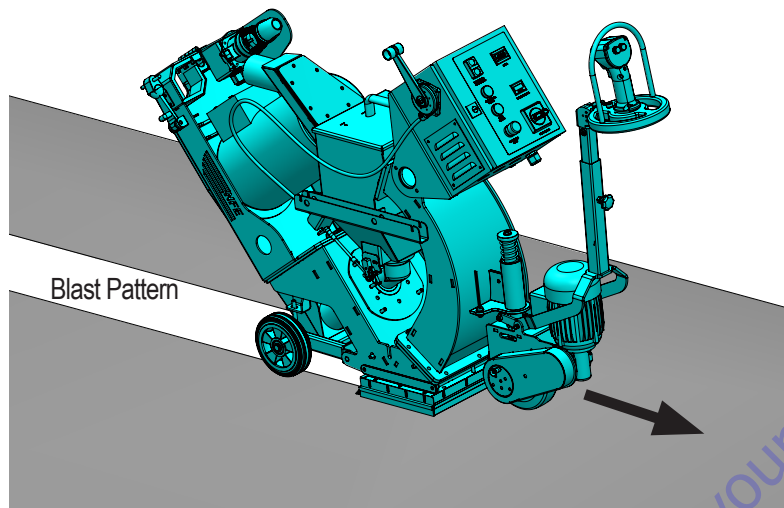

FIG. 3

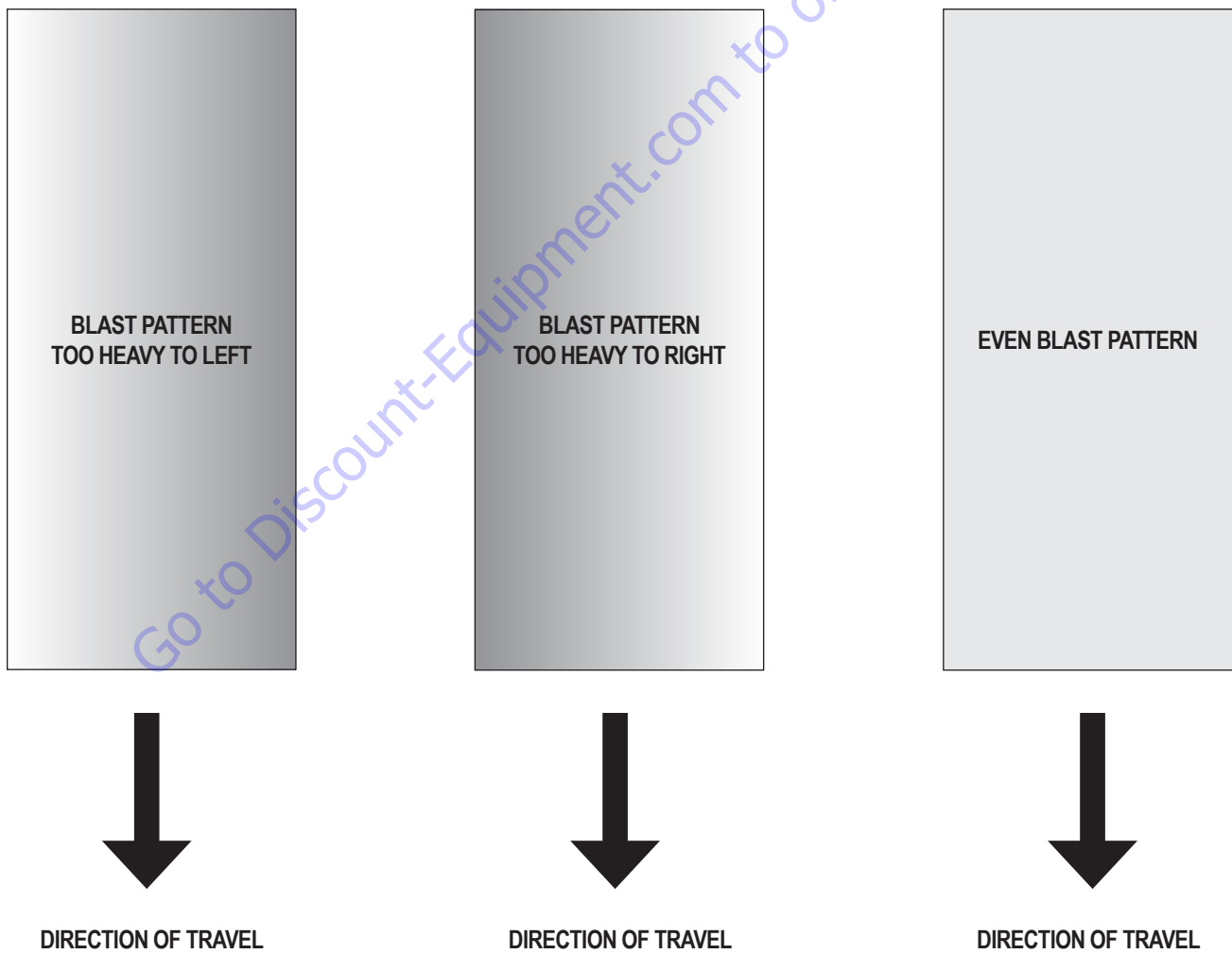

FIG. 4

Maintenance



WARNING: BEFORE PERFORMING MAINTENANCE, ALWAYS DISCONNECT THE MACHINE FROM POWER TO PREVENT ACCIDENTAL STARTUP.

ADJUSTING THE HEIGHT OF MAGNETS AND BRUSHES (FIGURE 5)

The correct height adjustment of the magnets is .13-.38" (3-10 mm) and is important for regulating airflow through the machine and creating a good seal. The magnets should be set at the maximum height of .38" (10 mm) for very rough surfaces. For very smooth surfaces the magnets should be set at the minimum height of .13" (3 mm).

1. Loosen the front and side brushes.
2. Adjust the adjuster bolts on the rear wheels and steering column so the bottom of the magnets are .13-.38" (3-10 mm) above the floor.
3. Tighten the front and side brushes flush with the floor.

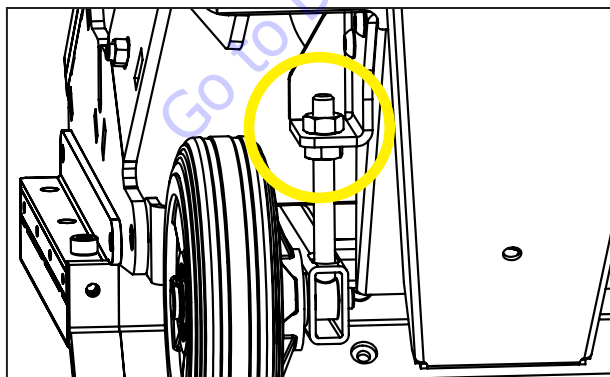
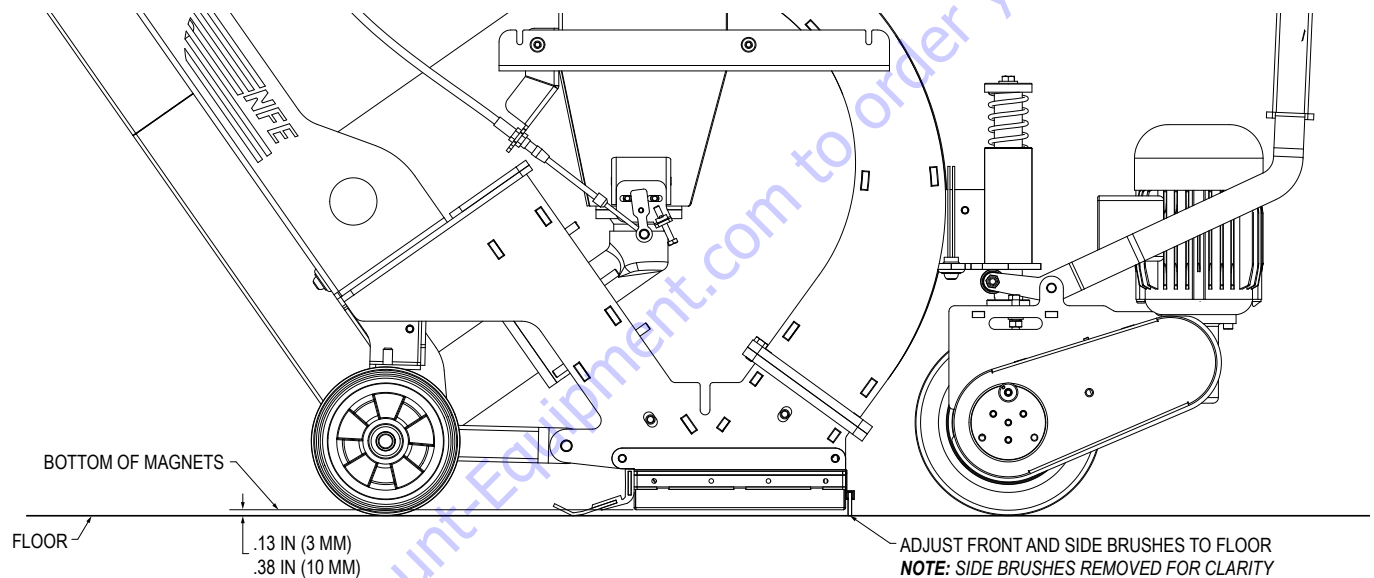

REAR WHEEL ADJUSTER BOLTS

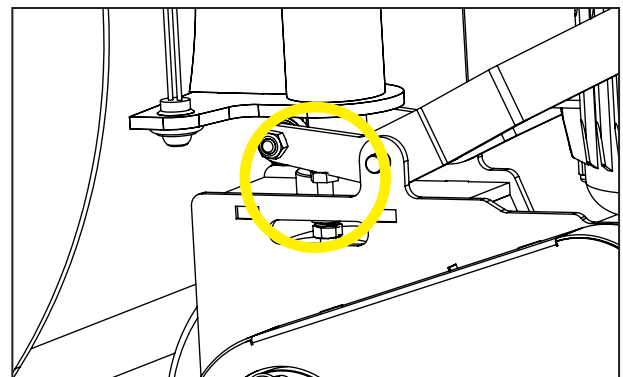

STEERING COLUMN ADJUSTER BOLTS

FIG. 5



WARNING: BEFORE PERFORMING MAINTENANCE, ALWAYS DISCONNECT THE MACHINE FROM POWER TO PREVENT ACCIDENTAL STARTUP.

REMOVING THE BLAST WHEEL (FIGURE 6)

1. Remove the feed spout (1) from the housing.
2. Loosen the control cage clamps (2) and remove the control cage (3).
3. Remove the four nuts (4) of the cage support plate (5) and remove the plate.
4. Prevent the blast wheel (8) from turning. Remove the blast wheel bolt (6) and adapter (7).
5. Remove the blast wheel (8).

REPLACING THE BLAST WHEEL (FIGURE 6)

1. Place the blast wheel (8) through the housing opening and onto the wheel hub (9) aligning it with the pins of the hub. Spin wheel to ensure it is properly seated on the pins and doesn't wobble.
2. Clean the threads of the motor shaft and blast wheel bolt (6) removing any shot.
3. Prevent the blast wheel (8) from turning. Install the blast wheel bolt (6) and adapter (7) and tighten the bolt. Spin the blast wheel to ensure it doesn't wobble.
4. Reattach the front cage support plate (5) with the four nuts (4). Spin blast wheel to ensure it doesn't wobble.
5. Install the control cage (3) aligning the control cage grooves with the corresponding grooves in the cage support plate (5). Spin blast wheel and listen for any grinding noises.
6. Tighten the cage clamps to secure the control cage (3). Make sure the blast wheel can rotate freely.
7. Replace the feed spout (1).
8. Adjust the control cage to achieve an even blast pattern. See Adjusting the Control Cage procedure.

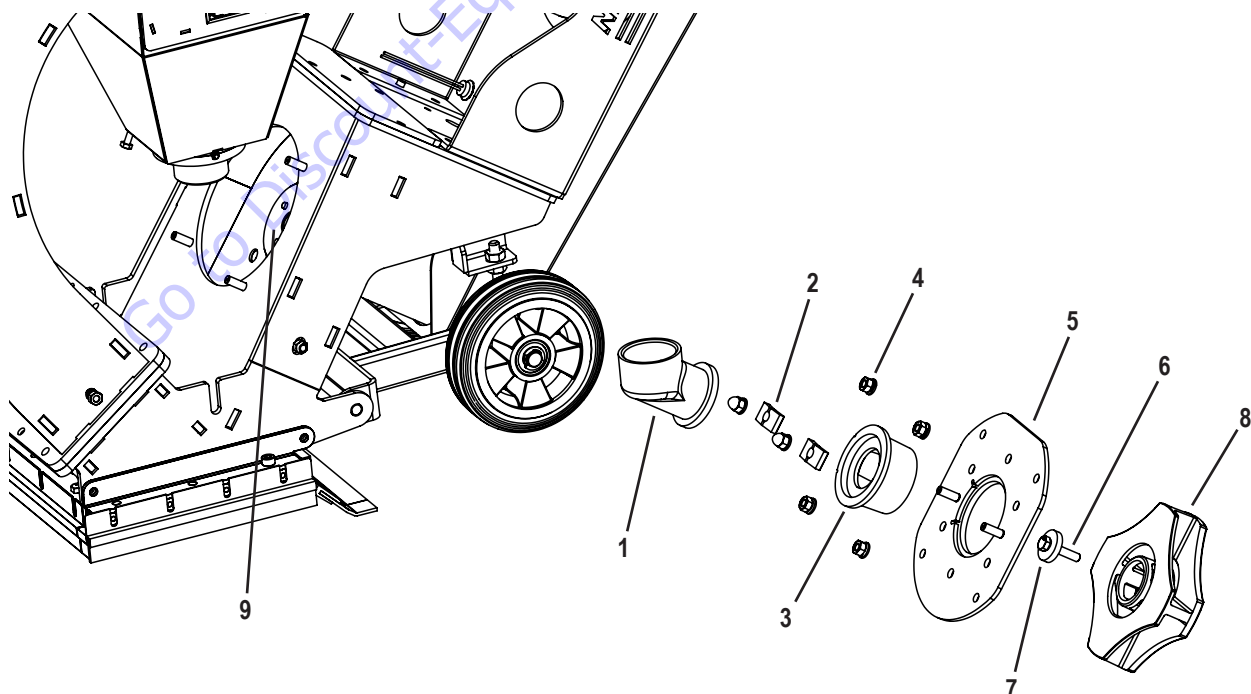

FIG. 6

Maintenance



WARNING: BEFORE PERFORMING MAINTENANCE, ALWAYS DISCONNECT THE MACHINE FROM POWER TO PREVENT ACCIDENTAL STARTUP.



WARNING: THE MACHINE IS VERY HEAVY. WEIGHT OF MACHINE IS SHOWN IN SPECIFICATIONS SECTION OR ON SERIAL NUMBER PLATE. WHEN LIFTING MACHINE, FOLLOW YOUR COMPANY'S SAFETY GUIDELINES TO AVOID INJURY. SEE HOISTING THE MACHINE SECTION IN OPERATING MANUAL.



WARNING: WHEN LAYING THE MACHINE DOWN OR LIFTING UPRIGHT, PREVENT HANDLE FROM SWINGING TO AVOID INJURY AND DAMAGE TO MACHINE. BEWARE OF PINCH POINTS.



WARNING: USE GLOVES WHEN HANDLING THE LINERS AS THE SHARP EDGES COULD CAUSE INJURY TO BARE HANDS.

REMOVING THE LINERS (FIGURE 7)

1. Before removing the liners, remove the blast wheel for easier liner removal and replacement. See Removing the Blast Wheel procedure.
2. Loosen the jam nut and pressure screw (1). Then remove the cover (2) by removing the four screws.
3. Remove the fasteners of the side liners, small liners and bottom liner.
4. Lay the machine down on the right side exposing the underside of the machine.
5. Turn the side liners (3 and 4) toward the inside of the blast housing and remove them through the bottom opening of the housing.
6. Remove the small liners (6 and 7) through the bottom opening.
7. Remove the bottom liner (5) through the bottom opening.
8. Rotate the top liner (8) around the wheel hub and remove it through the bottom opening.

REPLACING THE LINERS (FIGURE 7)

Note: When replacing the liners, a hammer may be needed.

1. Before installing the new liners, check the wheel housing and its corners for wear.
2. Insert the top liner (8) through the bottom opening and rotate it around the wheel hub into the upper part of the housing.
3. Replace the bottom liner (5) through the bottom opening, pushing the studs through the side of the housing. Hand tighten the nuts.
4. Replace the side liners (3 and 4) through the bottom opening, pushing the studs through the side of the housing. Hand tighten the nuts.
5. Replace the small liners (6 and 7) through the bottom opening, pushing the studs through the side of the housing. Hand tighten the nuts. Ensure the small liners are flush against the side liners (3 and 4) so that there is no gap.
6. Lift the machine upright onto its wheels.
7. Tighten the nuts to secure the liners.

Note: Do not overtighten the nuts, as the threaded studs can be damaged.

8. Replace the cover (2) and reinstall the four screws.
9. Tighten the pressure screw (1) until the edges of the top liner are in contact with the upper edges of the side liners. Lock with jam nut.
10. Replace the blast wheel following the Replacing the Blast Wheel procedure.
11. Adjust the control cage to achieve an even blast pattern. See Adjusting the Control Cage procedure.

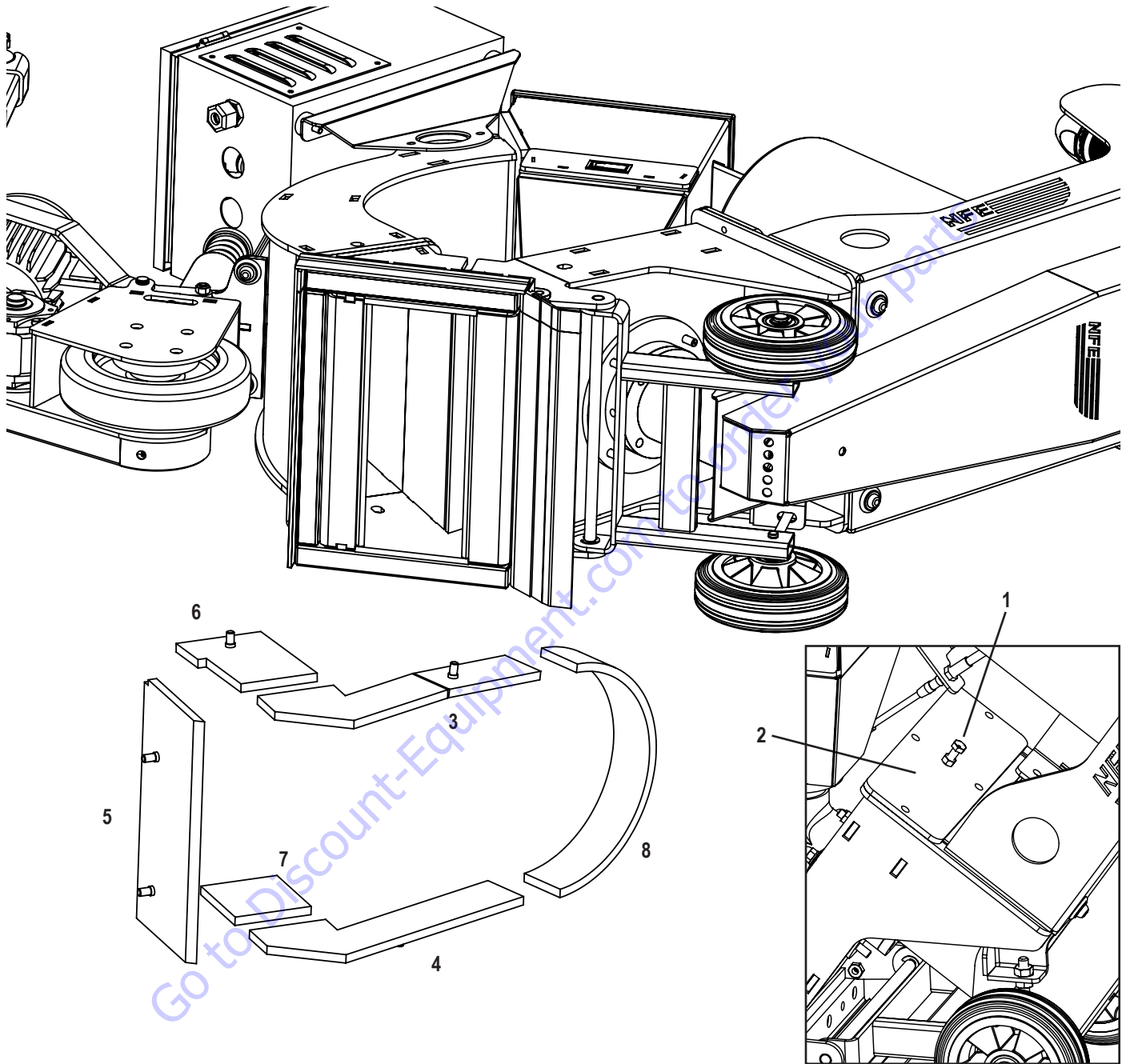

FIG. 7

Maintenance

BELT DRIVE

Key Points

The belt drive transfers power from the blast wheel motor to the blast wheel. The correct belt tension is essential to achieving maximum power transfer and service life. The following points are key to the belt drive running efficiently:

- Too little tension results in slippage, increased belt temperature and shortened belt life.
- Too much tension can result in belt breaks, bearing damage and lower efficiency.
- Temperatures exceeding 158°F (70°C) for a long period of time reduce the service life and performance of the V-belt.
- The grooves of the V-belt pulleys must be free from rust, grease, dirt and damage.
- The use of belt wax or similar substances to increase the friction coefficient is unnecessary and can damage the V-belts. Avoid contamination by oil, grease or chemicals.



WARNING: BEFORE PERFORMING MAINTENANCE, ALWAYS DISCONNECT THE MACHINE FROM POWER TO PREVENT ACCIDENTAL STARTUP.



WARNING: NEVER OPERATE THE MACHINE WITHOUT THE BELT GUARD IN PLACE AS SERIOUS INJURY COULD OCCUR.

Adjusting Belt Tension (Figures 8 and 9)

Check for proper belt tension by measuring the belt deflection in the middle of the belt span. Belt deflection should be .16-.24" (4-6 mm).

To adjust the belt tension:

1. Remove the belt guard.
2. Loosen the four motor mounting bolts. Do not remove.
3. Loosen the jam nuts on the adjustment bolts.
4. Adjust the belt tension by turning the two adjuster bolts in the appropriate direction. Make sure to adjust each bolt the same amount.
5. Retighten the jam nuts on the adjuster bolts.
6. Retighten the motor mounting bolts.
7. Replace the belt guard.

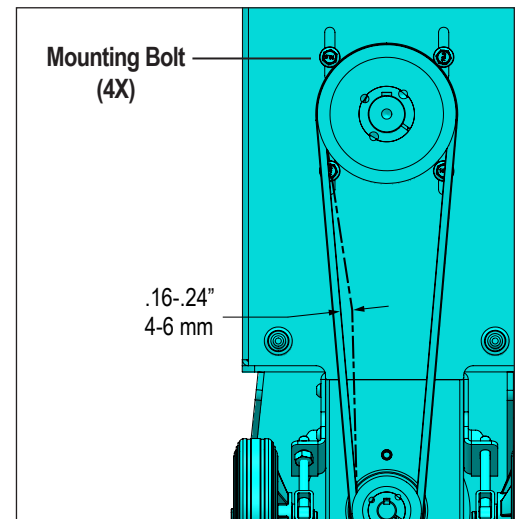

FIG. 8

Removing/Replacing the Belt (Figures 8 and 9)

1. Remove the belt guard.
2. Reduce the distance between the pulleys following the above procedure.
3. Remove the worn belt.
4. Insert the new belt into the pulley grooves. Do not force the belt.
5. Tighten the belt by increasing the distance between the pulleys following the above procedure.
6. Check for proper belt tension.
7. Reinstall the belt guard.

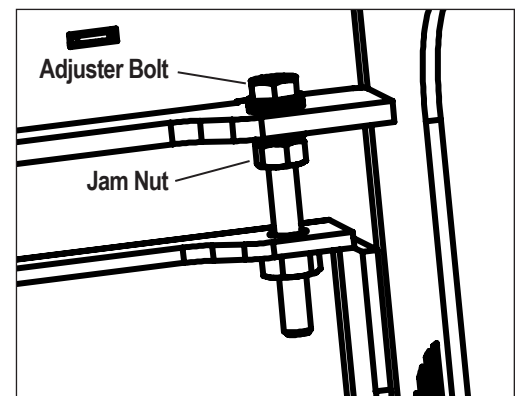

FIG. 9

Taper-Lock Bushings (Figure 10)

Taper-lock bushings are tapered non-flanged split bushings that utilize set screws to mount the pulleys onto the shafts of the blast wheel motor and bearing unit. The same set screws used for installation are used for removal. A hex key wrench is required for tightening and loosening the set screws.

Removing Pulleys

1. Remove the drive belt.
2. Using the hex key wrench, remove the two set screws from the installation holes (1).
3. Thread a set screw into the removal hole (2), tightening in small increments until the pulley is loosened from the bushing.

Note: Each installation and removal hole is only threaded on one side. Installation holes (1) have the pulley side threaded, the bushing side is not threaded. The removal hole (2) has the bushing side threaded, the pulley side is not threaded.

Replacing Pulleys

1. Clean dirt, oil and other contaminants from all contact surfaces. Do NOT use any lubricants on the contact surfaces!
2. Insert the taper-lock bushing into the pulley, matching the hole pattern.
3. Using the hex key wrench, lightly thread the two set screws into the installation holes (1).
4. Mount the assembly onto the shaft, lining up the shaft key with the keyway in the taper-lock bushing.
5. Make sure the pulleys are aligned.
6. Alternately tighten the set screws to secure the pulley to the bushing.

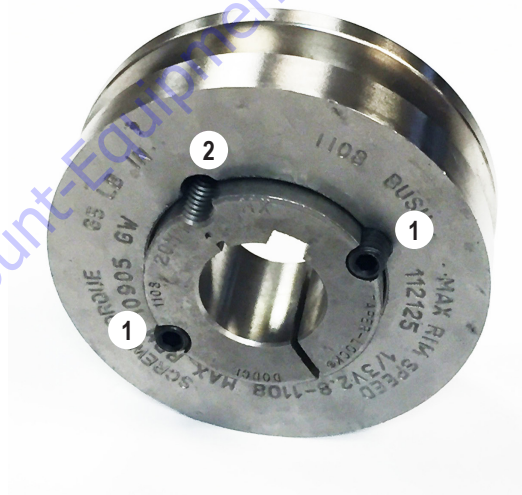

FIG. 10

Maintenance

CHAIN DRIVE

The chain drive transfers power from the front wheel drive motor to the drive sprocket. Proper installation and maintenance of the chain and sprockets contribute to a long service life, while incorrect mounting and insufficient maintenance cause premature wear.



WARNING: BEFORE PERFORMING MAINTENANCE, ALWAYS DISCONNECT THE MACHINE FROM POWER TO PREVENT ACCIDENTAL STARTUP.



WARNING: NEVER OPERATE THE MACHINE WITHOUT THE CHAIN GUARD IN PLACE AS SERIOUS INJURY COULD OCCUR.

Adjusting Chain Tension (Figure 11)

The correct chain tension is set when the chain can be deflected about .39-59" (10-15 mm) in the middle of the chain sprockets.

Note: Do not adjust chain tension tight otherwise sprocket could be damaged.

To adjust the chain tension:

1. Remove the chain guard.
2. Loosen the four mounting bolts of the front wheel drive motor.
3. Shift the motor in the direction needed to achieve proper tension.
4. Tighten the mounting bolts.
5. Replace the chain guard.

Replacing the Chain (Figure 11-12)

The chain is supplied as a string and must be installed as follows:

1. Degrease the chain to prevent any abrasive particles from adhering.
2. Remove the chain guard.
3. Place the chain string on the chain sprockets.
4. Close the chain using the master link. Install the master link assembly (1), then install the master link plate (2). Install the spring clip (3) by placing it over the grooves in the pins, then using a screwdriver or pliers to push the clip into place. The closed end of the clip should point in the forward direction of the chain.

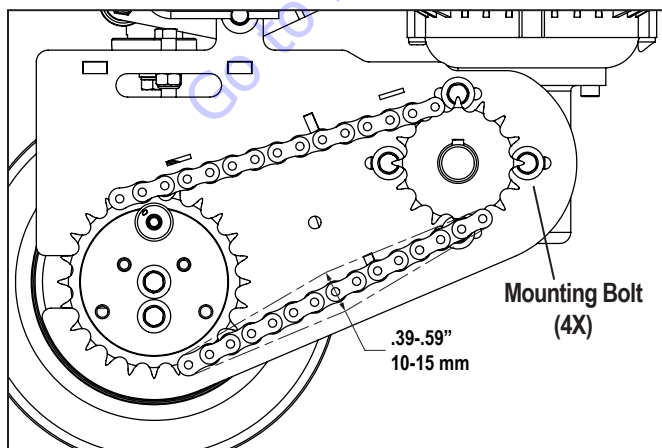

FIG. 11

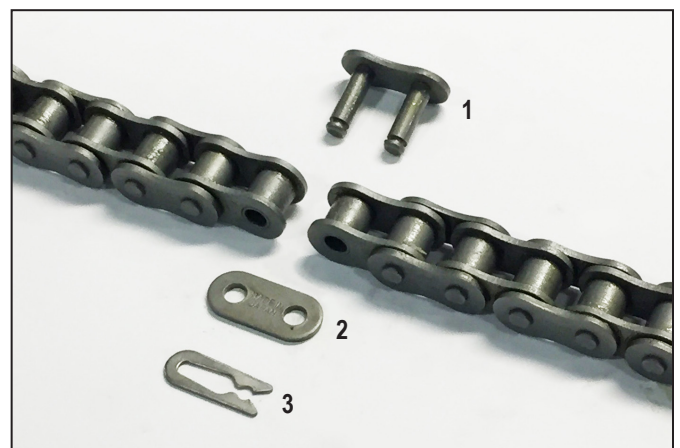

FIG. 12

5. Check for proper chain tension.
6. Replace the chain guard.

Sprocket Alignment

The shafts and chain sprockets must be aligned for optimal drive performance and chain life. If the smaller sprocket is replaced, make sure to install the sprocket completely onto the shaft until it hits the retaining ring. Incorrect mounting causes premature wear of the drive chain.

Chain Drive Maintenance

Always make sure the chain guard is installed before beginning operation. The chain guard protects the drive chain, prevents excessive contamination and prevents injury.

The chain drive needs little maintenance if mounted correctly and not lubricated with grease. The chain drive should be cleaned every three months. Check chain tension at this time.

In order to clean thoroughly:

- Remove the dirt on the outside of the chain drive using a wire brush.
- Wash the chain in petroleum ether or similar.
- Clean the dirt from the internal parts of the chain by putting the chain in petroleum ether, diesel or another solvent for approximately 24 hours. This will soften the dirt in the chain joints and the hardened lubricant remnants. Move the chain several times back and forward in the bath to clean the joints.

FILTER MAINTENANCE (FIGURE 13)



WARNING: BEFORE PERFORMING MAINTENANCE, ALWAYS DISCONNECT THE MACHINE FROM POWER TO PREVENT ACCIDENTAL STARTUP. DO NOT OPEN THE CONTROL BOX OR TOUCH MOTOR WIRING UNTIL THE MACHINE HAS BEEN TURNED OFF, UNPLUGGED AND AT A STANDSTILL FOR APPROXIMATELY FIVE MINUTES TO PREVENT THE POSSIBILITY OF ELECTRIC SHOCK.

Cleaning Control Box Air Filters

The machine has two air filters (one per side). The filters are located inside the control box. To check the filters and clean if necessary, complete the following steps:

1. Use a screwdriver or coin to open the control box door.
2. Remove filters.
3. To clean filters, rinse with water and allow to air dry.
4. Replace filters.



FIG. 13

Maintenance

REPLACING WORK LIGHTS (FIGURE 14)



WARNING: BEFORE PERFORMING MAINTENANCE, ALWAYS DISCONNECT THE MACHINE FROM POWER TO PREVENT ACCIDENTAL STARTUP.

To replace a front or rear work light, complete the following steps:

1. Unplug the connector.
2. Push the LED out of the grommet.
3. Push the grommet out of the hole.
4. Feed the plug through the hole.
5. Reverse the process to install the new light.

Part#	Description
404919	Light, Work, 24VDC, Deutsch Connector



FIG. 14

REPLACING FUSE – 230V MACHINE ONLY (FIGURE 15)



WARNING: BEFORE PERFORMING MAINTENANCE, ALWAYS DISCONNECT THE MACHINE FROM POWER TO PREVENT ACCIDENTAL STARTUP. DO NOT OPEN THE CONTROL BOX UNTIL THE MACHINE HAS BEEN TURNED OFF, UNPLUGGED AND AT A STANDSTILL FOR APPROXIMATELY FIVE MINUTES TO PREVENT THE POSSIBILITY OF ELECTRIC SHOCK.

The fuse is located inside the control box. To check the fuse, and change if necessary, complete the following steps:

1. Use a slotted screwdriver to open the control box door.
2. Flip open the fuse holder and remove fuse.
3. Use a continuity tester to test the fuse.
4. Install new fuse.

Position	Part#	Description	Rated Current
F1	405130	Fuse, 5x20mm, 2A, Time Lag	2A



FIG. 15



WARNING: BEFORE PERFORMING MAINTENANCE, ALWAYS DISCONNECT THE MACHINE FROM POWER TO PREVENT ACCIDENTAL STARTUP. DO NOT OPEN THE CONTROL BOX OR TOUCH MOTOR WIRING UNTIL THE MACHINE HAS BEEN TURNED OFF, UNPLUGGED AND AT A STANDSTILL FOR APPROXIMATELY FIVE MINUTES TO PREVENT THE POSSIBILITY OF ELECTRIC SHOCK.

REMOVING THE SHOT VALVE CONTROL CABLE (FIGURE 16)

1. Remove shot from hopper.
2. Loosen the two adjustment nuts (1) to loosen cable from bracket.
3. Loosen set screw on linkage (2) and slide linkage from shaft.
4. Unscrew swivel (3) from cable (4).
5. Remove shot control lever from side of control box.

REPLACING THE SHOT VALVE CONTROL CABLE (FIGURE 16)

1. Replace shot control lever onto side of control box.
2. With swivel (3) inserted into linkage (2), thread the swivel (3) onto cable (4) until threads protrude from swivel.
3. Slide cable into bracket. Do not tighten the adjustment nuts (1) at this time.
4. Slide linkage (2) onto shaft and tighten set screw on flat of shaft. Linkage should be flush with end of shaft.
5. Pull shot control lever back completely so shot valve is closed.
6. Hand tighten the adjustment nuts (1) making sure that the shot valve flap (5) is horizontal (fully closed position).
7. Move shot control lever back and forth several times verifying the shot valve opens and closes.
8. Tighten the adjustment nuts (1) so the cable is secured to bracket.

Note: Shot valve stop (6) limits the maximum opening of the shot valve if needed.

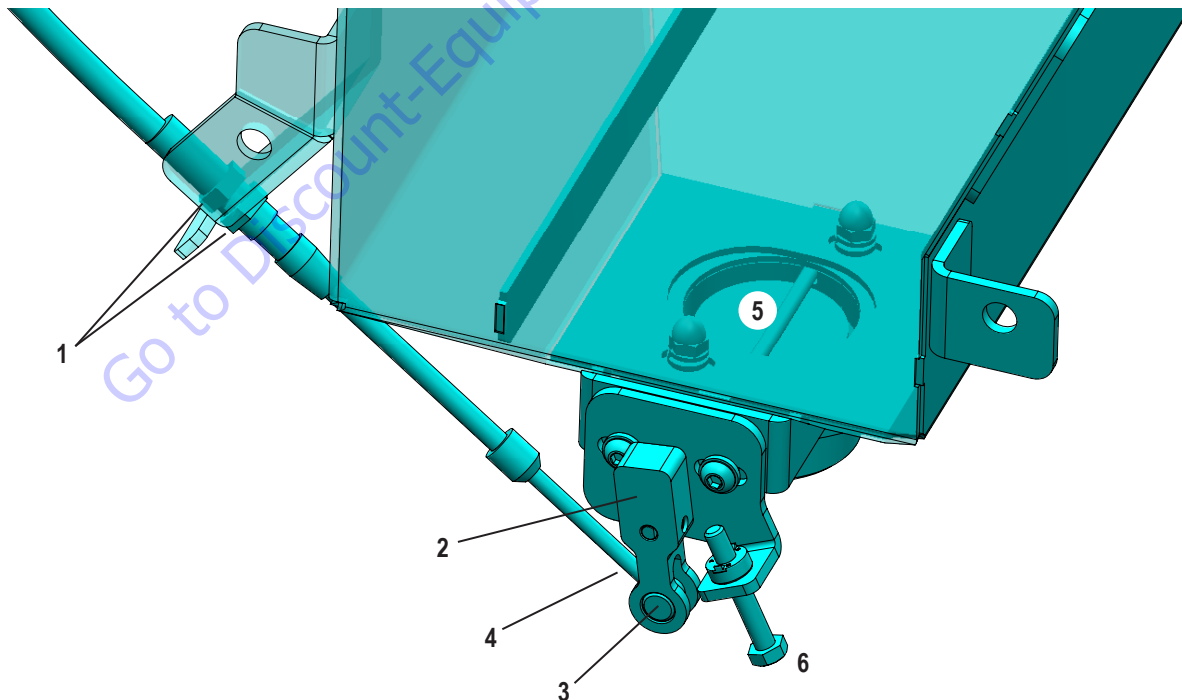

FIG. 16

Maintenance

RECOMMENDED SPARE PARTS LIST

To avoid downtime, NFE recommends keeping the following spare parts in stock.

NFE offers a maintenance kit (Part# A97KIT) which contains the indicated parts as well as tools needed for some maintenance work.

Part Number	Description	Quantity	Included In Kit?
404330	Service Kit, Blast Wheel, 20mm x 165mm, NFE	1	Yes
404361	Liner, Top, 10 inch	1	Yes
404645	Liner, Side LH, w Stud, 10 inch	1	Yes
404646	Liner, Side RH, w Stud, 10 inch	1	Yes
404647	Liner, Bottom, w Stud, 10 inch	1	Yes
404648	Liner, Small LH, w Stud, 10 inch	1	Yes
404649	Liner, Small RH, w Stud, 10 inch	1	Yes
404603	Assy Brush, Side, 10 inch	2	Yes
404604	Assy Brush, Front, 10 inch	1	Yes
404870	Adapter, Blast Wheel	1	Yes
405003	Bolt, Hex, M8x1.25 x 40mm Long, Class 10.9	1	Yes
404380	Seal, Hub, Blast Wheel	1	No
404540	Belt, V, 3VX Style, 45 inch Long	2	No
404844	Assy Cable, Feed Valve, w Lever	1	No

Go to Discount-Equipment.com to order your parts

Parts List and Diagrams

OVERALL

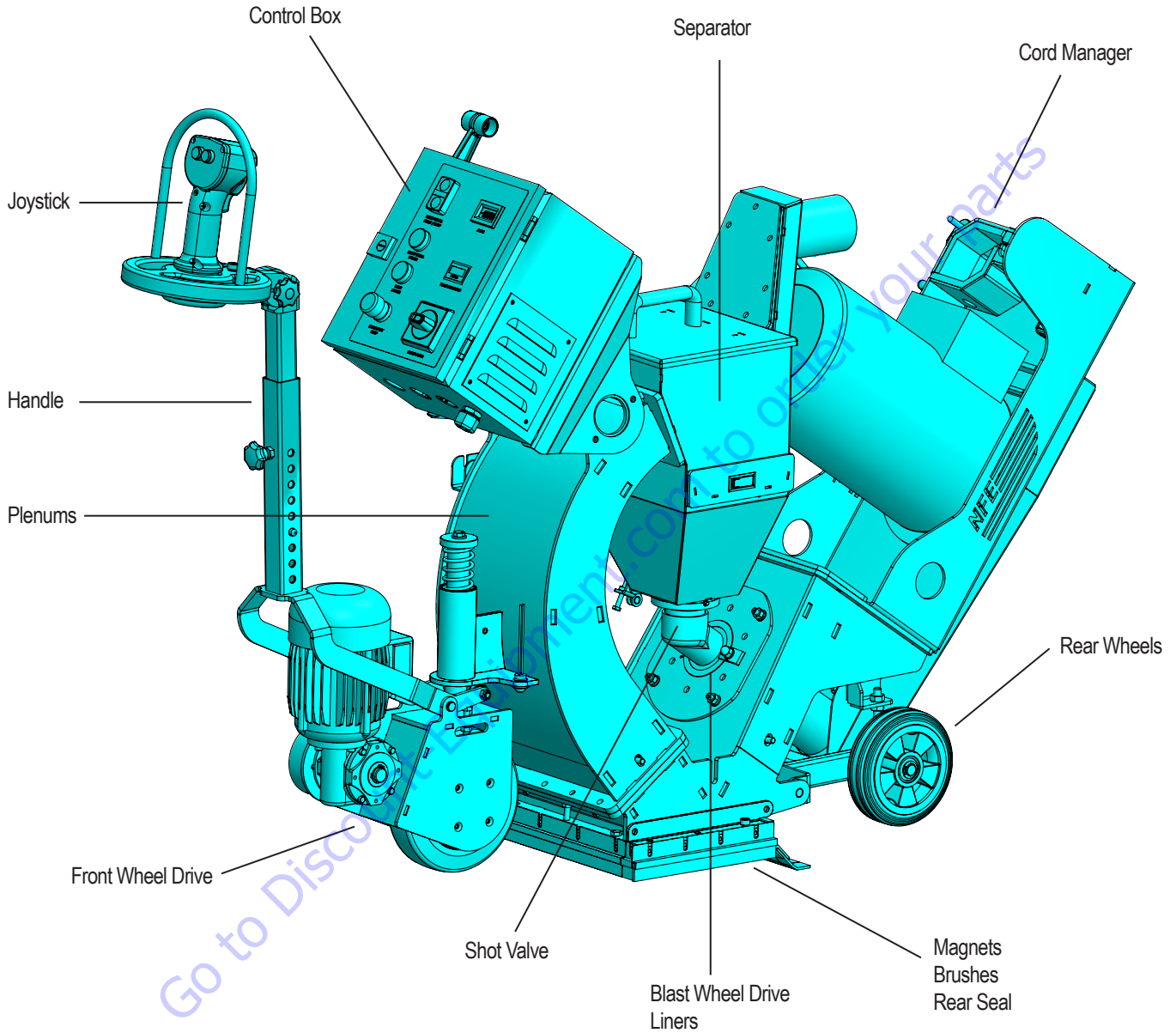

A97 230V machine shown

Parts List and Diagrams

BLAST WHEEL DRIVE AND CORD MANAGER

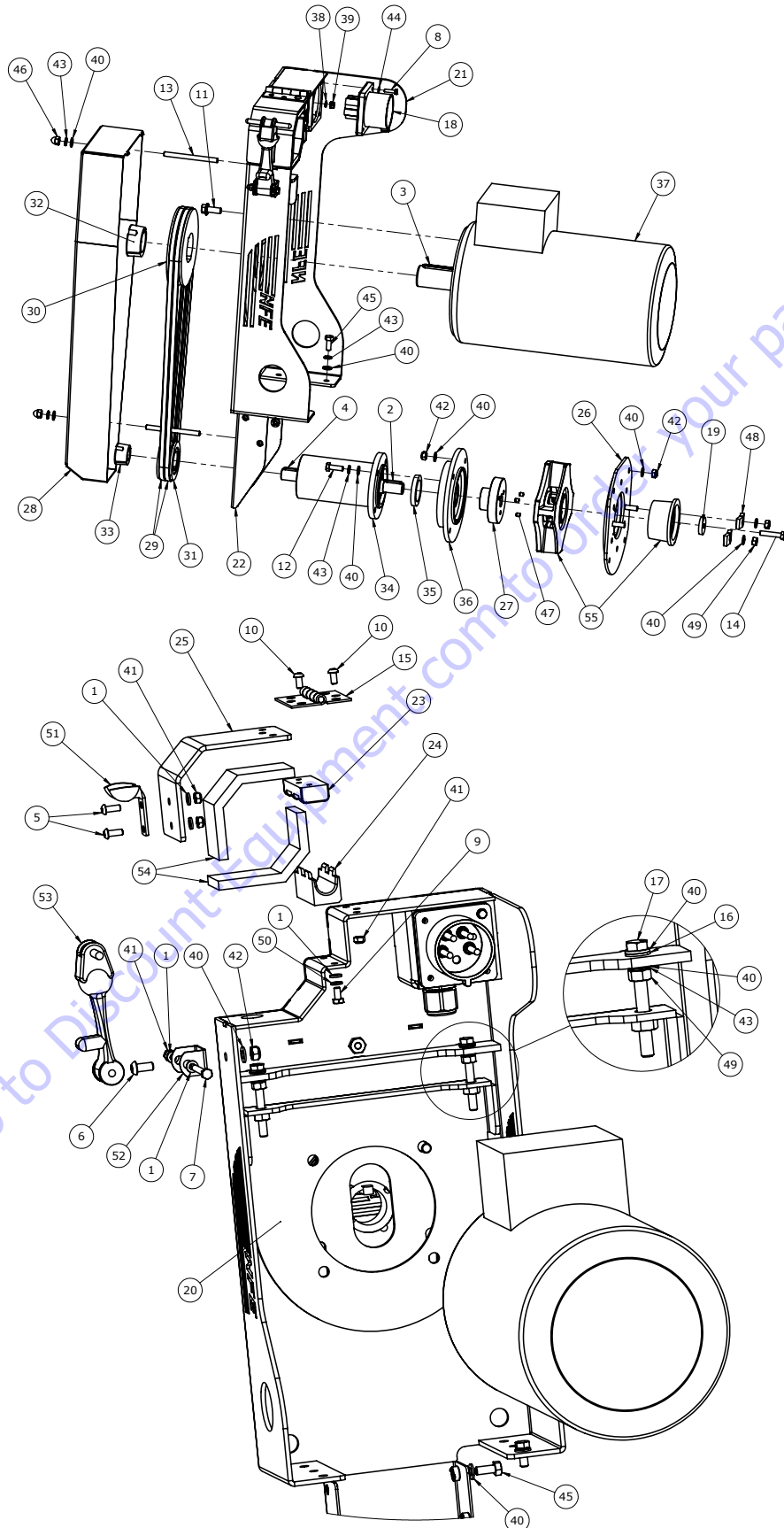

Parts List and Diagrams

BLAST WHEEL DRIVE AND CORD MANAGER—CONTINUED

Item#	Part#	Description	QTY
1	405486	Washer, Flat, M6, Clear Zinc	7
2	405265	Key, Metric, Rounded, 6 W x 6 H x .30 L, Steel	1
3	405264	Key, Metric, Rounded, 10 W x 8 H x 60 L, Steel	1
4	405263	Key, Metric, Rounded, 6 W x 6 H x 25 L, Steel	1
5	405262	Screw, Button Head Cap, M6x1.0 x 16, Clear Zinc	2
6	405261	Screw, Button Head Cap, M8x1.25 x 18, Clear Zinc	1
7	405260	Screw, Hex Head Cap, M6x1.0 x55, Partial Thrd, Clear Zinc	1
8	405259	Screw, Hex Head Cap, M5-0.8 x 20, Clear Zinc	4
9	405258	Screw, Hex Head Cap, M6x1.0 x12, Clear Zinc	2
10	405257	Screw, Button Head Cap, M6x1.0 x12, Black Oxide	6
11	405256	Screw, Hex Flange, M10x1.5 x 25, Clear Zinc	4
12	405254	Screw, Hex Head Cap, M8x1.25 x 25, Clear Zinc	4
13	405012	Rod, Threaded, M8-1.25 x 100, Steel, Clear Zinc	2
14	405003	Screw, Hex Head Bolt, M8x1.25 x 40, Class 10.9	1
15	404957	Hinge, Surface Mount, 3 in x 2.5 in, Black	1
16	404954	Washer, Thrust 8x16x1.5mm, Oil Embedded	2
17	404953	Screw, Hex Head Cap, M8x1.25 x 70, Clear Zinc	2
18	404913	Inlet, IEC 309, 3P4W, 230V, 32A	1
19	404870	Adapter, Blast Wheel	1
20	404858	Assy Plate, Tensioner, Blast Motor, 10 inch	1
21	404857-SV	Assy Weldment Brkt, Motor Mount 10 Inch-SV	1
22	404854-SV	Assy Guard, Lower, Motor Belt, 10 inch-SV	1
23	404639	Clamp, Upper, Power Cord	1
24	404638	Clamp, Lower, Power Cord, 10 Inch	1
25	404637-SV	Clamp, Dust Tube-SV	1
26	404619-SV	Assy Weldment Plate, Cage Support-SV	1
27	404616	Hub, Blast Wheel, 10 inch	1
28	404545-SV	Guard, Motor Belt, 10 inch-SV	1
29	404540	Belt, V, 3VX Style, 45" Long	2
30	404538	Pulley, 5.5" PD, Sheave, Double, 3V Style, Taper Lock	1
31	404536	Pulley, 2.75" PD, Sheave, Double, 3V Style, Taper Lock	1
32	404535	Bushing, Taper Lock, 1610, 38mm Bore, 10mm Key	1
33	404533	Bushing, Taper Lock, 1108, 20mm Bore, 6mm Key	1
34	404446	OverHung Load Adapter, 10 inch	1
35	404380	Seal, Hub, Blast Wheel	1
36	404379	Plate, Support, OHLA	1
37	404359	Motor, 10HP, 230V/400V, 50/60Hz, 3 phase	1
38	403917	Washer, External Tooth, M6, Clear Zinc	1
39	403235	Nut, Keps, M6-1.0, Clear Zinc	1
40	401803	Washer, Flat, M8, Clear Zinc	29
41	401516	Nut, Hex, Nylon Insert, M6-1.0, Clear Zinc	6
42	401509	Nut, Hex, Nylon Insert, M8-1.25, Clear Zinc	9
43	401332	Washer, Lock, M8, Clear Zinc	12
44	401327	Washer, Flat, M5, Clear Zinc	4
45	401315	Screw, Hex Head Cap, M8-1.25 x 20, Clear Zinc	8
46	401301	Nut, Acorn, M8x1.25, Clear Zinc	2
47	400579	Pin, Hub Wheel	3
48	400536	Clamp, Control Cage	2
49	74635	Nut, Hex, M8-1.25	4
50	74619	Washer, Lock, M6	2
51	5200QL-34	Bracket, Reverse Catch	1
52	5200QL-32	Bracket, Hood Lever	1
53	5200QL-31	Lever, Hood	1
54	5200QL-28A	Foam, 3/8 thick x 2 x 6	2
55	404330	Service Kit, Blast Wheel, 20mm x 165mm, NFE	1

Parts List and Diagrams

SEPARATOR AND SHOT VALVE

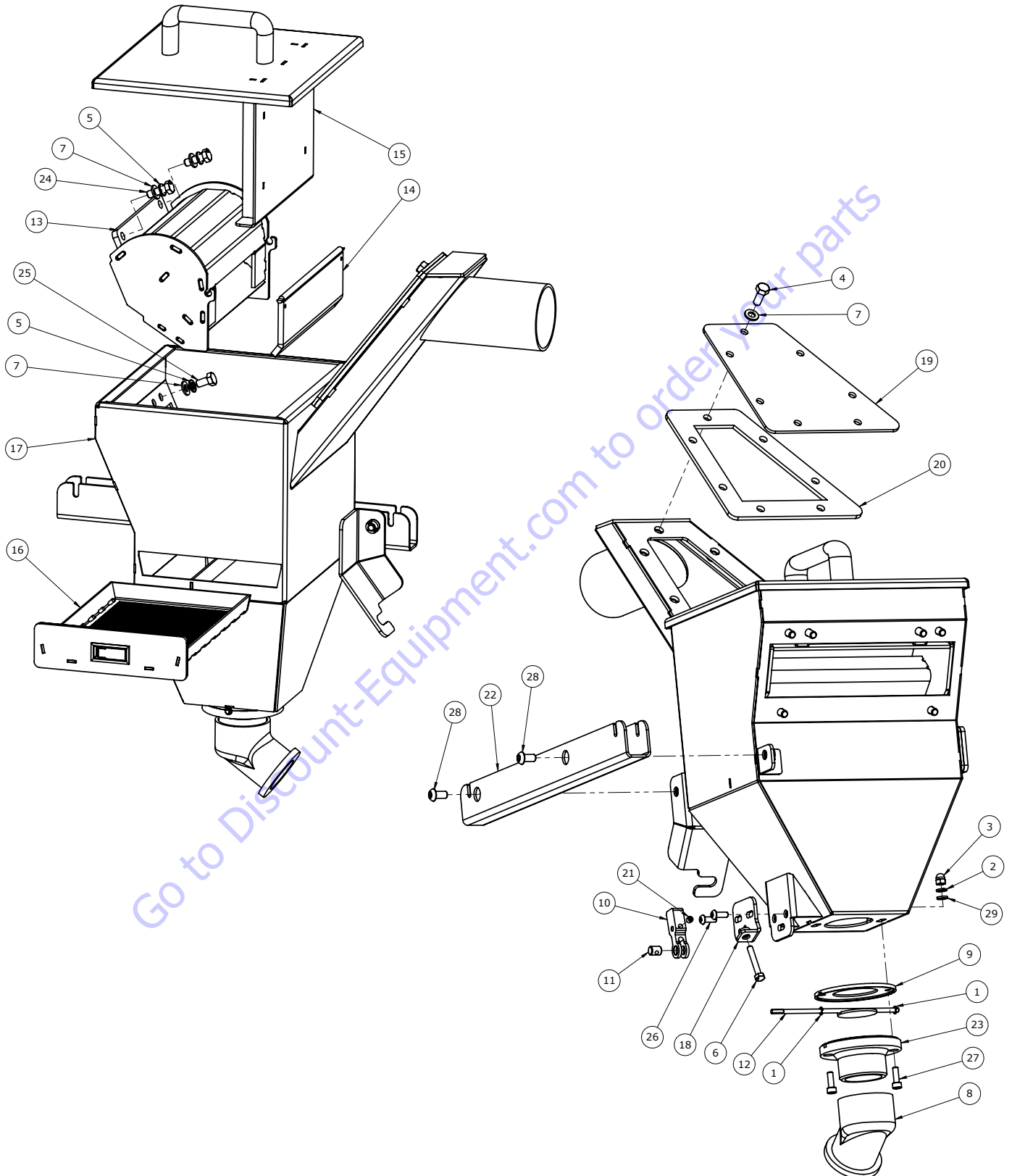

Parts List and Diagrams

SEPARATOR AND SHOT VALVE—CONTINUED

Item#	Part#	Description	QTY
1	73910	E-Clip, 3/16	2
2	74619	Washer, Lock, M6	2
3	401300	Nut, Acorn, M6X1	2
4	401315	Screw, Hex Head Cap, M8-1.25 x 20, Clear Zinc	7
5	401332	Washer, Lock, M8, Clear Zinc	6
6	401654	Bolt, Hex Head M6x1.0 x 40mm Long	1
7	401803	Washer, Flat, M8, Clear Zinc	13
8	404423	Spout, Feed Valve	1
9	404426	Plate, Feed Valve	1
10	404427	Linkage, Shaft, Feed Valve	1
11	404430	Swivel, Feed Valve	1
12	404431	Assy Weldment Butterfly, Feed Valve	1
13	404491	Assy Weldment Deflector	1
14	404497	Assy Weldment Flap, Deflector	1
15	404510-SV	Assy Lid, Hopper-SV	1
16	404511-SV	Assy Tray, Hopper-SV	1
17	404549-SV	Assy Weldment Hopper, 10 inch-SV	1
18	404831-SV	Assy Plate, Adjust, Feed Valve-SV	1
19	404848-SV	Panel, Access, Hopper-SV	1
20	404849	Seal, Access Panel, Hopper	1
21	404850	Screw, Set, Flat, M6x1.0 x 6mm Long	1
22	404874-SV	Tray, Electrical Wires-SV	1
23	405124	Assy Housing w/Magnet, Feed Valve	1
24	405254	Screw, Hex Head Cap, M8x1.25 x 25, Clear Zinc	2
25	405255	Screw, Hex Head Cap, M8x1.25 x 16, Clear Zinc	4
26	405262	Screw, Button Head Cap, M6x1.0 x 16, Clear Zinc	2
27	405280	Screw, Socket Head Cap, M6x1.0 x 18, Clear Zinc	2
28	405281	Screw, Button Head Cap, M8x1.25 x 16, Clear Zinc	2
29	405486	Washer, Flat, M6, Clear Zinc	2

Parts List and Diagrams

LINERS

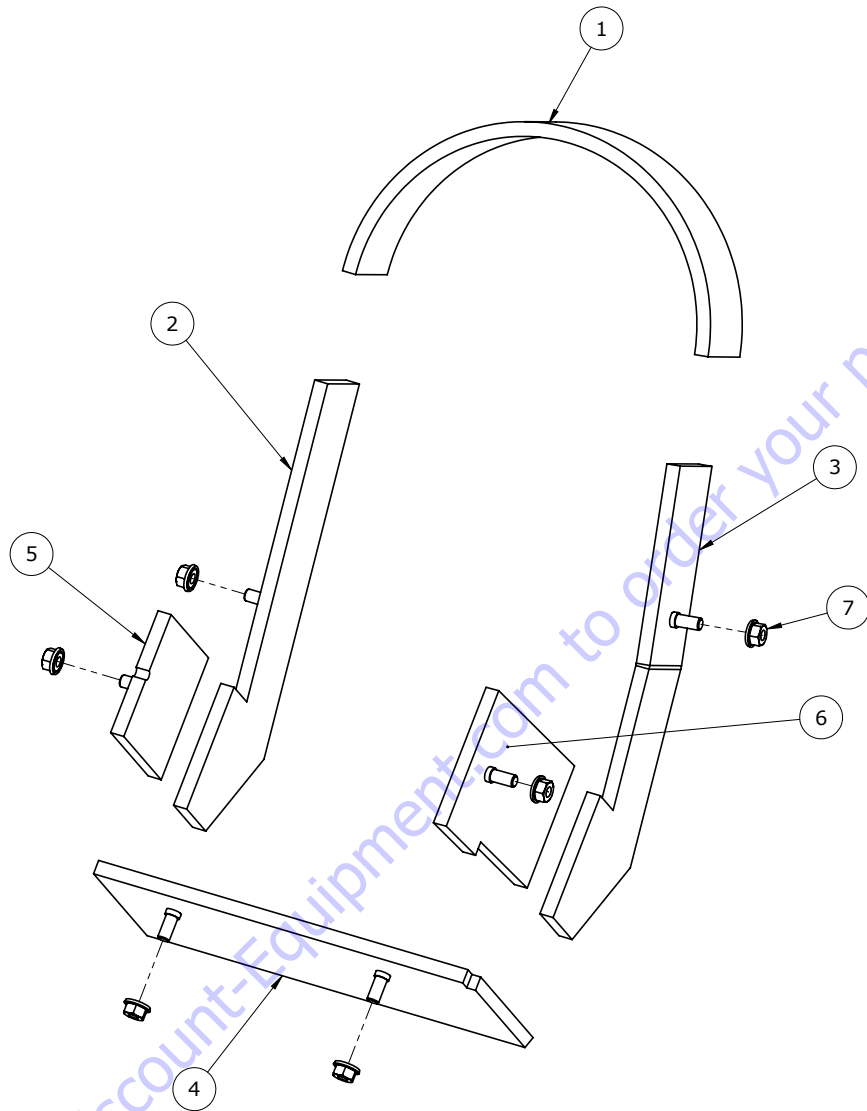

Item#	Part#	Description	QTY
1	404361	Liner, Top, 10 inch	1
2	404645	Liner, Side LH w Stud, 10 inch	1
3	404646	Liner, Side RH, w Stud, 10 inch	1
4	404647	Liner, Bottom, w Stud, 10 inch	1
5	404648	Liner, Small LH, w Stud, 10 inch	1
6	404649	Liner, Small RH, w Stud, 10 inch	1
7	405286	Nut, Hex, w Spring Lock Washer, M8x1.25, Clear Zinc	6

Parts List and Diagrams

PLENUMS

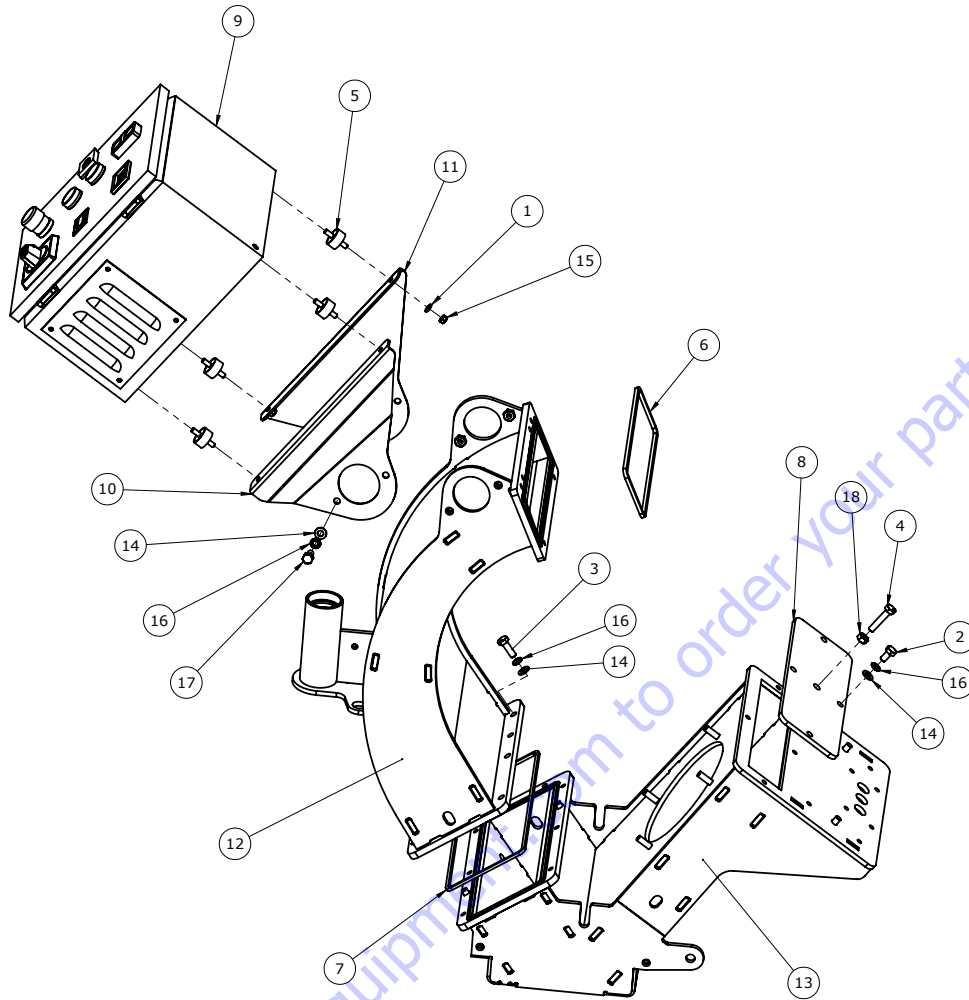

Item#	Part#	Description	QTY
1	405486	Washer, Flat, M6, Clear Zinc	4
2	405255	Screw, Hex Head Cap, M8x1.25 x 16, Clear Zinc	4
3	405254	Screw, Hex Head Cap, M8x1.25 x 25, Clear Zinc	8
4	405003	Screw, Hex Head Bolt, M8x1.25 x 40, Class 10.9	1
5	404893	Mount, Vibration, M6x1, 1 Dia x 500 Long	4
6	404880	Seal, Hopper-Return Plenum	1
7	404879	Seal, Return-Rebound Plenum, 10 inch	1
8	404875-SV	Assy Retainer, Top Liner, 10 inch-SV	1
9	404827	Assembly, Control Box, 230V, A97	1
	405766	Assembly, Control Box, 400V, A97	
10	404629-SV	Mount RH, Elec Encl, 10 inch-SV	1
11	404628-SV	Mount LH, Elec Encl, 10 inch-SV	1
12	404433-SV	Assy Weldment Return Plenum, 10 inch-SV	1
13	404411-SV	Assy Weldment Rebound Plenum, 10 inch-SV	1
14	401803	Washer, Flat, M8, Clear Zinc	16
15	401516	Nut, Hex, Nylon Insert, M6-1.0, Clear Zinc	4
16	401332	Washer, Lock, M8, Clear Zinc	16
17	401315	Screw, Hex Head Cap, M8-1.25 x 20, Clear Zinc	4
18	74635	Nut, Hex, M8-1.25	1

Parts List and Diagrams

MAGNETS, BRUSHES AND REAR SEAL

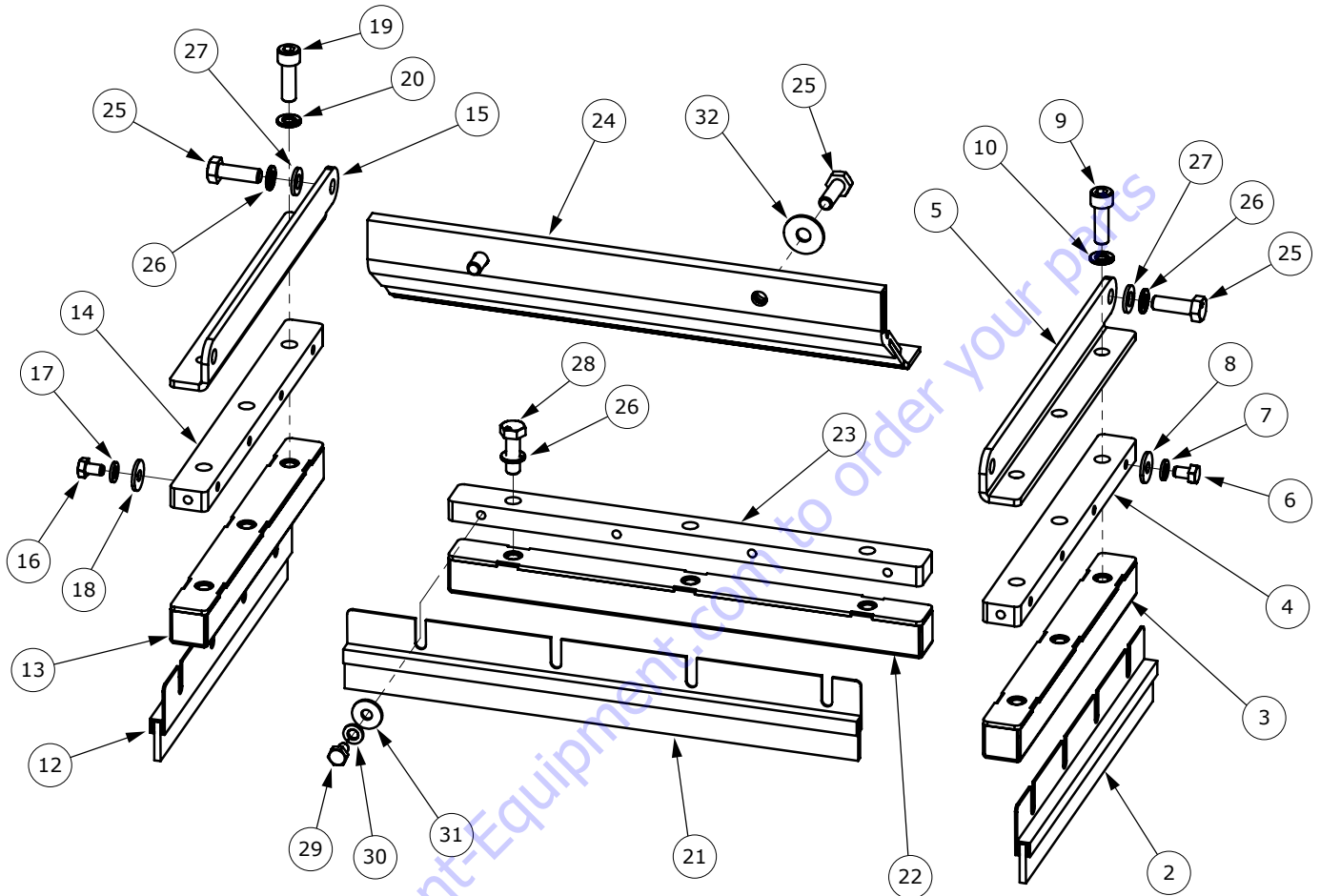

Parts List and Diagrams

MAGNETS, BRUSHES AND REAR SEAL—CONTINUED

Item#	Part#	Description	QTY
1*	404461	Assy Magnet, Removable RH, 10 inch	1
2	404603	Assy Brush, Side, 10 inch	1
3	404449	Assy Magnet, Side, 10 inch	1
4	404457	Mount, Side Magnet, 10 inch	1
5	404460	Bracket RH, Removable Magnet, 10 inch	1
6	405277	Screw, Hex Head Cap, M6x1.0 x 16, Stainless Steel	4
7	405279	Washer, Lock, M6, Stainless Steel	4
8	405278	Washer, Flat, Fender, M6, Stainless Steel	4
9	405276	Screw, Socket Head Cap, M8x1.25 x 25, Stainless Steel	3
10	401332	Washer, Lock, M8, Clear Zinc	3
11*	404852	Assy Magnet, Removable LH, 10 inch	1
12	404603	Assy Brush, Side, 10 inch	1
13	404449	Assy Magnet, Side, 10 inch	1
14	404457	Mount, Side Magnet, 10 inch	1
15	404851	Bracket, LH, Removable Magnet, 10 inch	1
16	405277	Screw, Hex Head Cap, M6x1.0 x 16, Stainless Steel	4
17	405279	Washer, Lock, M6, Stainless Steel	4
18	405278	Washer, Flat, Fender, M6, Stainless Steel	4
19	405276	Screw, Socket Head Cap, M8x1.25 x 25, Stainless Steel	3
20	401332	Washer, Lock, M8, Clear Zinc	3
21	404604	Assy Brush, Front, 10 inch	1
22	404453	Assy Magnet Front, 10 inch	1
23	404605	Mount, Front Magnet, 10 inch	1
24	404390	Flap, Rear Seal, 10 Inch	1
25	405254	Screw, Hex Head Cap, M8x1.25 x 25, Clear Zinc	6
26	401332	Washer, Lock, M8, Clear Zinc	7
27	401803	Washer, Flat, M8, Clear Zinc	4
28	405274	Screw, Hex Head Cap, M8x1.25 x 25, Stainless Steel	3
29	405277	Screw, Hex Head Cap, M6x1.0 x 16, Stainless Steel	4
30	405279	Washer, Lock, M6, Stainless Steel	4
31	405278	Washer, Flat, Fender, M6, Stainless Steel	4
32	401349	Washer, Fender, M8, Clear Zinc	2

*Item 1 includes Items 2-10. Item 11 includes Items 12-20.

Parts List and Diagrams

HANDLE AND JOYSTICK

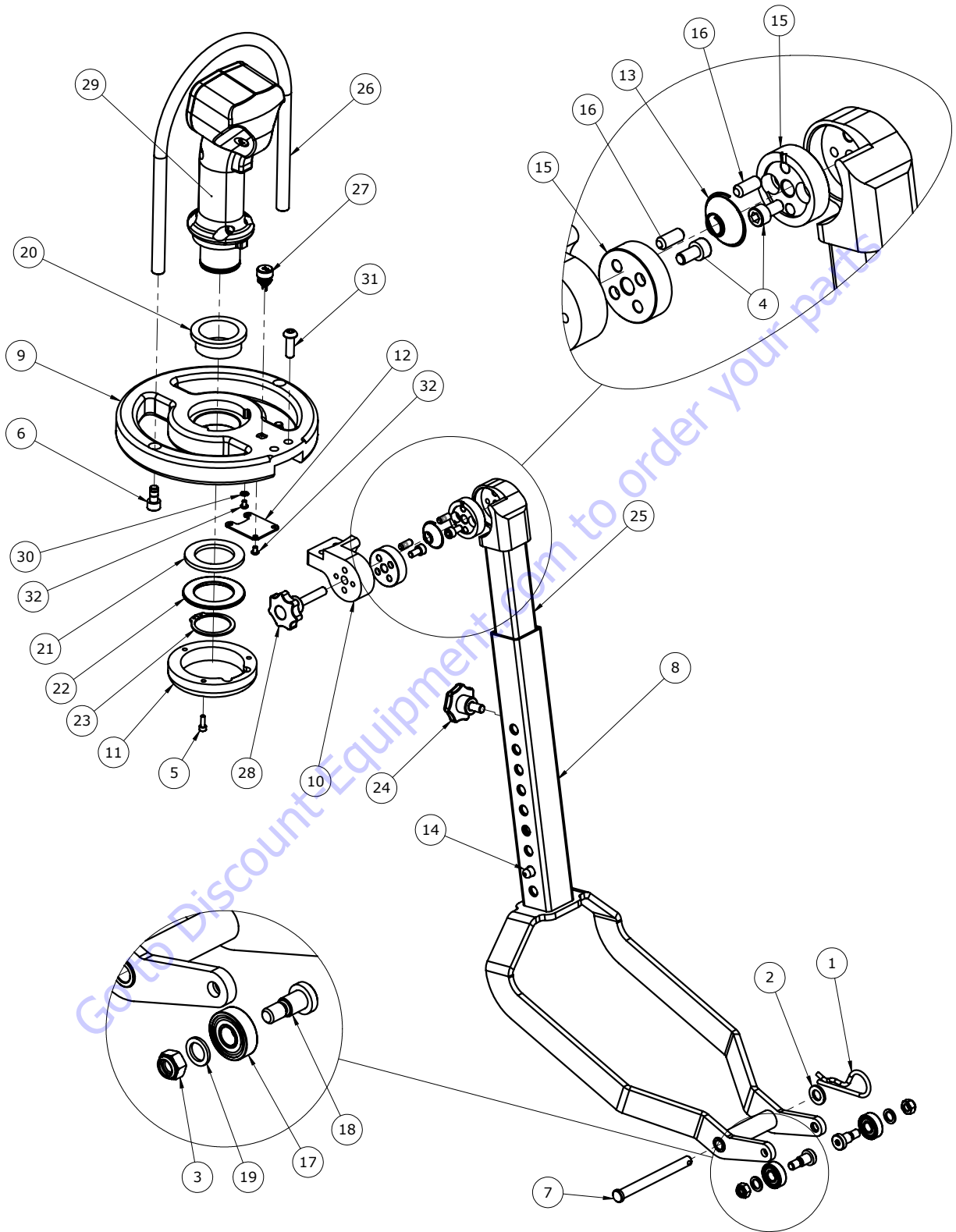

Parts List and Diagrams

HANDLE AND JOYSTICK—CONTINUED

Item#	Part#	Description	QTY
1	73536	5/8 Hitch Pin Clip	1
2	74655	Washer, Flat, M10	1
3	401509	Nut, Hex, Nylon Insert, M8-1.25, Clear Zinc	2
4	401652	Screw, Socket Head Cap, M6-1.0 x 12mm	4
5	401653	Screw, Socket Head Cap, M4-0.7 x 12	3
6	403384	Screw, Socket Head Cap, M8x1.25 - 16mm, Adhesive Patch	2
7	404369	Pin, Clevis, 3/8 Dia x 3.75 Long	1
8	404513-SV	Assy Weldment Handle, Main-SV	1
9	404521	Brace, Joystick, Upper Handle	1
10	404522	Mount, Pivot, Joystick Brace	1
11	404882	Cover, Joystick Wires	1
12	404886	Cap, Joystick, Upper Handle	1
13	404958	Spring, Compression, Conical, .43/1.14" OD x .39 x .034, Stainless Steel	1
14	404968	Button, Push, Height Adjust, Ø.365x.500	1
15	404969	Plate, Serrated, Locking, 40mm OD x 11.5 Thck	2
16	404970	Pin, Spring, 6x16mm, Steel	4
17	404971	Bearing, Ball, 10x26x8mm, 6000-2RSH	2
18	404972	Bolt, Shoulder, Low Profile, 10x12mm, M8x1.25, Stainless Steel	2
19	404974	Washer, Shim, 10 x 15m x .062", Stainless Steel	2
20	405032	Bearing, Flange, 40 x 46 x 20mm, Bronze	1
21	405033	Washer, Thrust 40x60x4mm, Oil Embedded	1
22	405034	Spacer, Round, Joystick	1
23	405035	Ring, Retaining, External, Axial, 40mm, Phosphate	1
24	405039	Knob, 7 Lobe w stud, M8x1.25 x 15mm long	1
25	405040	Assy Weldment Handle, Upper Handle	1
26	405041	Guard, Joystick, Upper Handle	1
27	405088	Potentiometer, 10K, 20%, 300° Turn	1
28	405115	Knob, Plastic, M8 x 40 mm Long Stud	1
29	405158	Assy, Joystick, Wired	1
30	405206	Washer, External Tooth, M4, Clear Zinc	1
31	405272	Screw, Button Head Cap, M8x1.25 x 25, Clear Zinc	2
32	405273	Screw, Button Head Cap, M4x0.7 x 6, Clear Zinc	5
33*	404966	Strain Relief, 90°, Black Nylon, .5" Mount, .25" ID	1

*NOT SHOWN

Parts List and Diagrams

FRONT WHEEL DRIVE

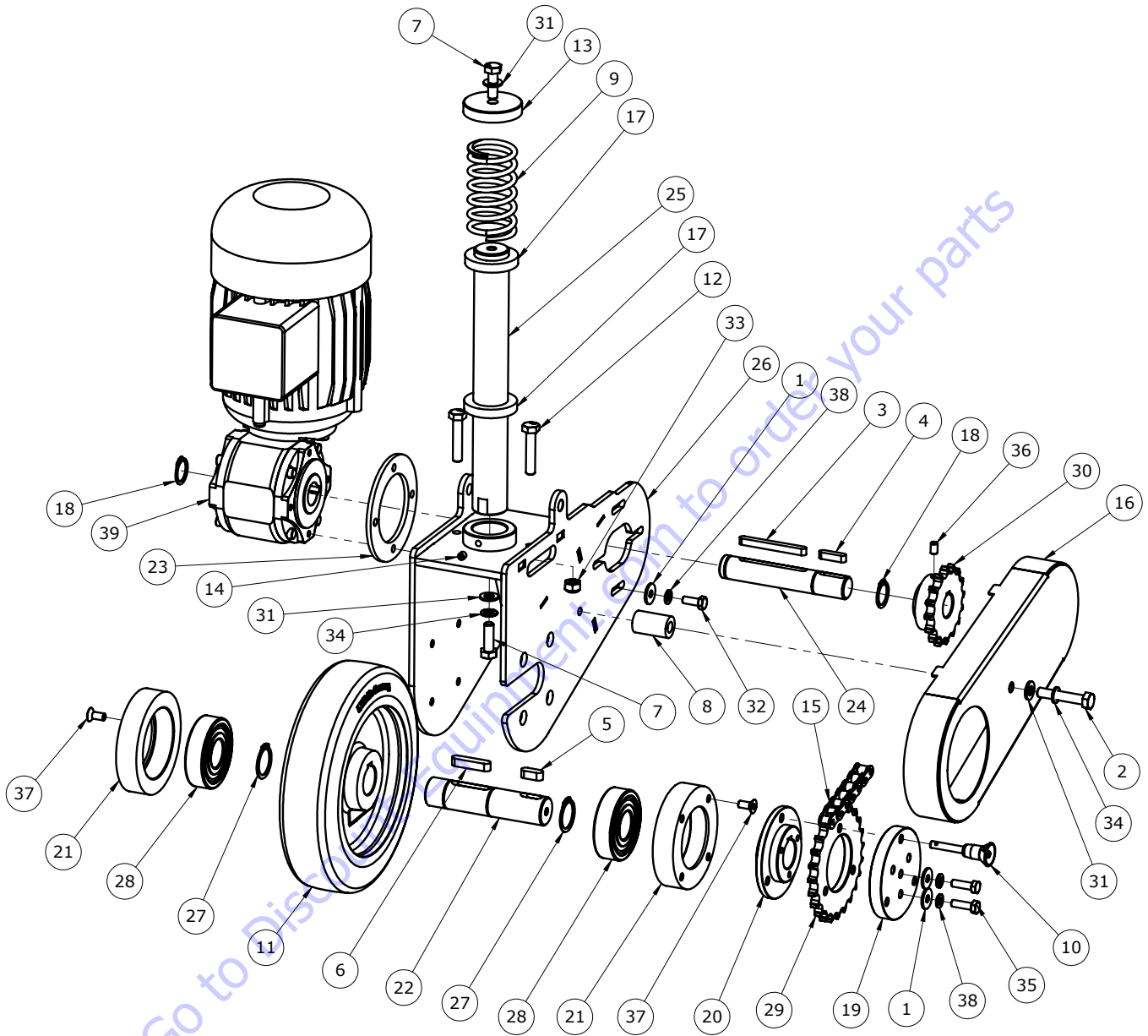

Parts List and Diagrams

FRONT WHEEL DRIVE—CONTINUED

Item#	Part#	Description	QTY
1	405278	Washer, Flat, Fender, M6, Stainless Steel	8
2	405271	Screw, Hex Head Cap, M8x1.25 x 45, Clear Zinc	1
3	405270	Key, Metric, Rounded, 6 W x 6 H x 63 L, Steel	1
4	405269	Key, Metric, Rounded, 6 W x 6 H x 25 L, Steel	1
5	405268	Key, Metric, Rounded, 8 W x 7 H x 20 L, Steel	1
6	405267	Key, Metric, Rounded, 8 W x 7 H x 36 L, Steel	1
7	405254	Screw, Hex Head Cap, M8x1.25 x 25, Clear Zinc	2
8	405114	Spacer, Round, .38 x .75 x 1.25", Aluminum	1
9	405027	Spring, Compression, 1.68 x 3.50 x .177, Stainless Steel	1
10	405023	Pin, Quick Release, 6 x 25mm	1
11	405022	Wheel, Modified, 200mm OD x50 W x 25 Bore, w /Keyway	1
12	405003	Screw, Hex Head Bolt, M8x1.25 x 40, Class 10.9	2
13	404873	Cap, Lift Shaft	1
14	404850	Screw, Set, Flat, M6x1.0 x 6mm Long	1
15	404609	Chain, Roller ISO 08B	1
16	404530-SV	Assy Weldment Chain Guard-SV	1
17	404481	Seal, Lower, Lift Shaft	2
18	404479	Ring, Retaining, External, 20mm Shaft	2
19	404475	Plate, Adapter, Front Wheel	1
20	404474	Adapter, Front Wheel	1
21	404473	Housing, Bearing, Front Wheel	2
22	404472	Shaft, Front Wheel	1
23	404469	Spacer, Gearmotor, Front Wheel	1
24	404468	Shaft, Gearmotor, Front Wheel	1
25	404467	Shaft, Lift, Front Wheel	1
26	404463-SV	Assy Weldment Bracket, Front Wheel-SV	1
27	404377	Ring, Retaining, External, Axial, 25mm, Phosphate	2
28	404376	Bearing, Ball, 25mm IDx 62 ODx 17 W, 6305-2RS1	2
29	404368	Sprocket, Modified, 24T, 08B Roller Chain	1
30	404367	Sprocket, Modified, 16T, 08B Roller Chain	1
31	401803	Washer, Flat, M8, Clear Zinc	3
32	401657	Screw, Hex Head Cap, M6-1.0 x16.0, Clear Zinc	4
33	401509	Nut, Hex, Nylon Insert, M8-1.25, Clear Zinc	2
34	401332	Washer, Lock, M8, Clear Zinc	2
35	401313	Screw, Hex Head Cap, M6-1.0 x 20, Clear Zinc	4
36	74633	Screw, Cup Point Socket Set M6-1.0x10MM	1
37	74620	Screw, Flat Head Socket Cap, M6-1.0 x 14	8
38	74619	Washer, Lock, M6	8
39	404370	Gearmotor, 0.5HP, 230V/400V, 50Hz, 40:1, 3 Phase	1

Parts List and Diagrams

REAR WHEELS

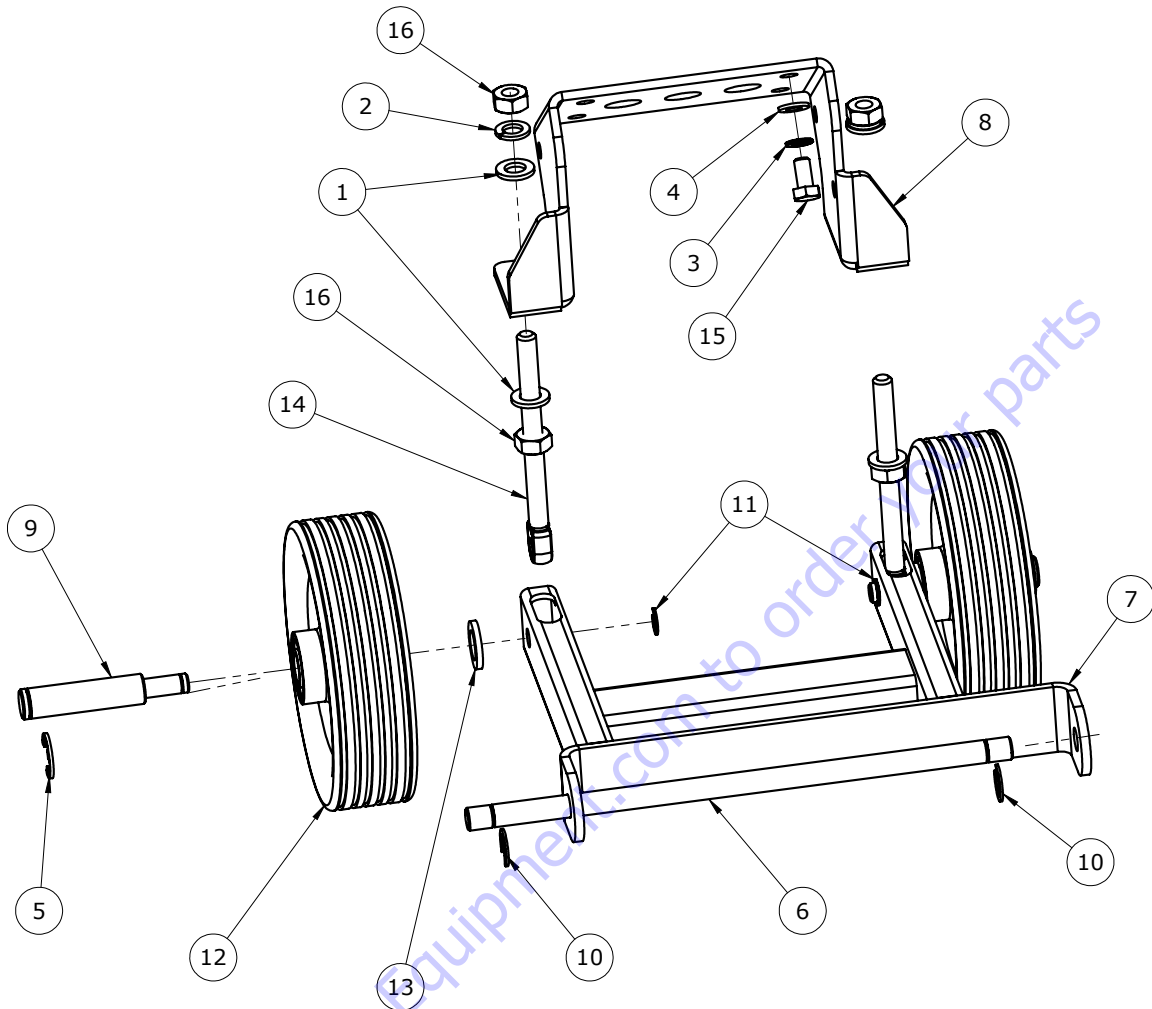

Item#	Part#	Description	QTY
1	74655	Washer, Flat, M10	4
2	74657	Washer, Lock, M10	2
3	401332	Washer, Lock, M8, Clear Zinc	4
4	401803	Washer, Flat, M8, Clear Zinc	4
5	402200	E-Clip, Shaft, .625	2
6	404526	Shaft, Pivot, Rear, 10"	1
7	404622-SV	Assy Weldment Bracket, Rear Wheels, 10 inch-SV	1
8	404624-SV	Mount, Height Adj, Rear, 10 inch-SV	1
9	404837	Shaft, Rear Wheels	2
10	404842	Ring, Retaining, External, E-Clip, 12mm, Phosphate	2
11	404843	Ring, Retaining, External, E-Clip, 10mm, Phosphate	2
12	405120	Wheel, 6 in Dia x 5/8 Bore x 2.25 Hub, Ball Bearing, Black	2
13	405125	Washer, Shim, .625 x 1.00 x .125, Steel	2
14	405129	Rod End, 10 x 125mm, Steel	2
15	405255	Screw, Hex Head Cap, M8x1.25 x 16, Clear Zinc	4
16	405266	Nut, Hex, M10x1.5, Clear Zinc	4

Parts List and Diagrams

EDGE BLAST PLATE ASSEMBLY – 405118

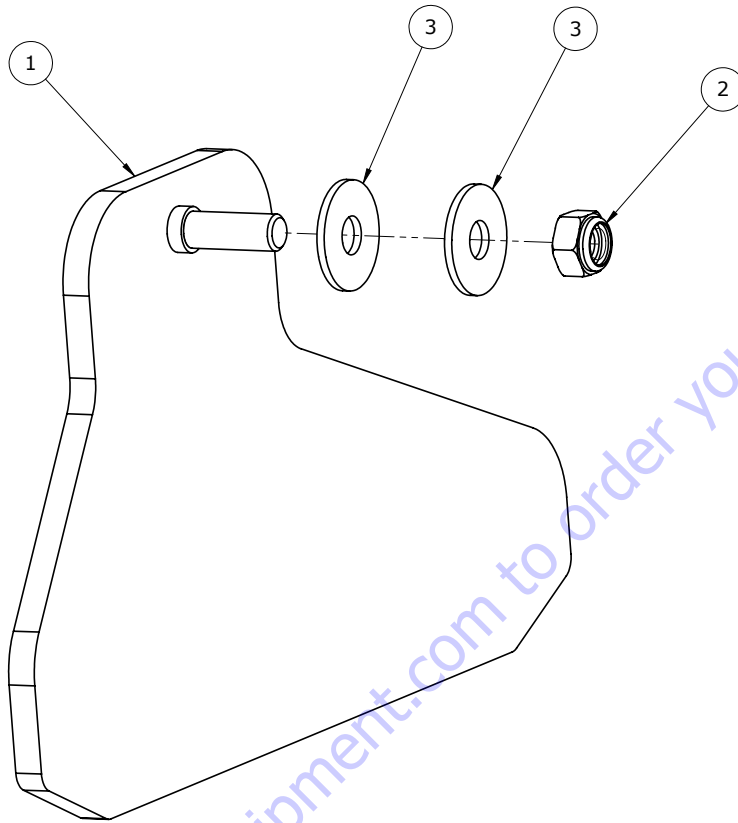

Item#	Part#	Description	QTY
1	405117	Plate, Edge Blast, w Stud, 10 inch	1
2	401509	Nut, Hex, Nylon Insert, M8-1.25, Clear Zinc	1
3	401349	Washer, Fender, M8, Clear Zinc	2

Parts List and Diagrams

230V CONTROL BOX – 404827

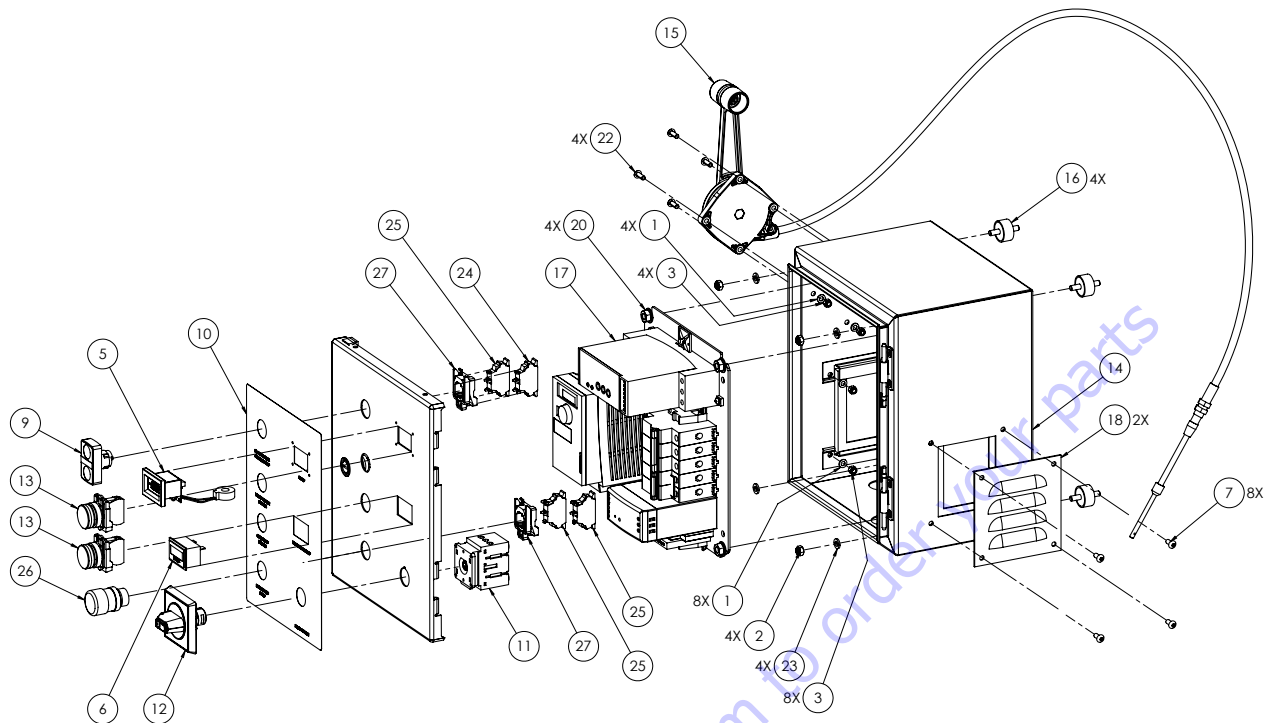

Item#	Part#	Description	QTY
1	401327	Washer, Flat, M5, Clear Zinc	12
2	401516	Nut, Hex, Nylon Insert, M6-1.0, Clear Zinc	4
3	401517	Nut, Hex, Nylon Insert, M5-.80, Clear Zinc	12
4*	403235	Nut, Keps, M6-1.0, Clear Zinc	3
5	403252	Ammeter, AC, Digital, 30A, 85-264VAC Supply	1
6	403253	Meter, Hour, Digital, 20-300VAC, 10-300VDC, Snap-on	1
7	403279	Screw, Button Head Cap, M5-0.8 x 12, Clear Zinc	8
8*	403917	Washer, External Tooth, M6, Clear Zinc	2
9	404773	Switch, 22mm, Pushbutton, Start/Stop, ZB4 Series	1
10	404778	Label, Control Panel, A97	1
11	404820	Switch, Disconnect, 3P, 40A, Door Mount	1
12	404821	Handle, Disconnect Switch, Door Mount	1
13	404822	Indicator, 22mm, Green, 24VDC	2
14	404826	Enclosure, 12x10x8, Custom	1
15	404844	Cable, 45" Long, w/ Lever	1
16	404893	Mount, Vibration, M6x1, 1 Dia x 500 Long	4
17	404946	Assy, Sub-Panel, A97	1
18	405154	Kit, Louver, Steel, Black, 121mm x 114mm	2
19*	405162	Kit, Wire, Control Panel, A97	1
20	405198	Nut, Flanged, M8-1.25mm, Zinc Plated	4
21*	405238	Anchor, Cable Tie, Black Nylon, High Bond Adhesive, 1"x1"	4
22	405301	Screw, Button Head Cap, M5x0.8x14, Clear Zinc	4
23	405486	Washer, Flat, M6, Clear Zinc	4
24	72451	Contact Block, NO, 10A, Spring Clamp, ZB4 Series	1
25	72452	Contact Block, NC, 10A, Spring Clamp, ZB4 Series	3
26	72453	Switch, 22mm, E-Stop, ZB4 Series	1
27	72456	Collar, Mounting, 22mm, ZB4 Series	2
28*	72840	Tie, Cable, Black Nylon, 18lbs, 4"	As Req'd
29*	72842	Tie, Cable, Black Nylon, 40lbs, 6"	As Req'd

*NOT SHOWN

Parts List and Diagrams

230V SUB-PANEL ASSEMBLY – 404946

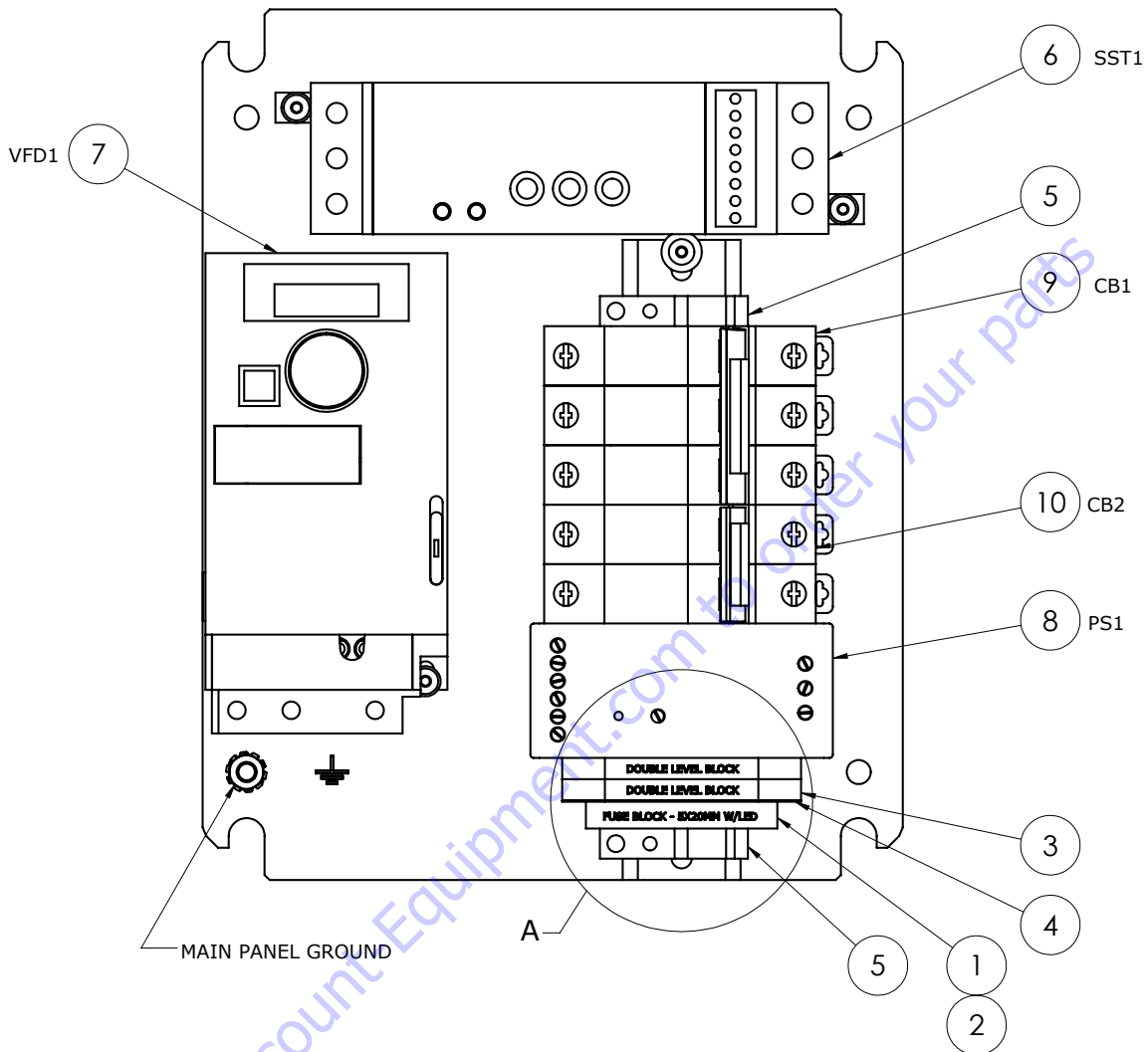

Item#	Part#	Description	QTY
1	404680	Fuse Block, 1P, LED, 90-240V, 5x20mm, DIN	1
2*	405130	Fuse, 5x20mm, 2A, Time Lag	1
3	404685	Terminal Block, Double Level, Feed-Through, Spring	2
4	404698	End Plate, Terminal Block, DIN Rail, CXDL Series	1
5	404718	End Stop, Terminal Block, DIN Rail, 35mm	2
6	404775	Soft Starter, 32A, 200-240V	1
7	404776	VFD, 1/2HP, 1Φ, 200V/240V	1
8	404798	Power Supply, 24V, 60W, DIN Rail	1
9	404799	MCB, 3P, 25A, D Trip, DIN Rail	1
10	404800	MCB, UL1077, 2P, 5A, D Trip	1

*NOT SHOWN

Parts List and Diagrams

230V POWER CORD – 405157

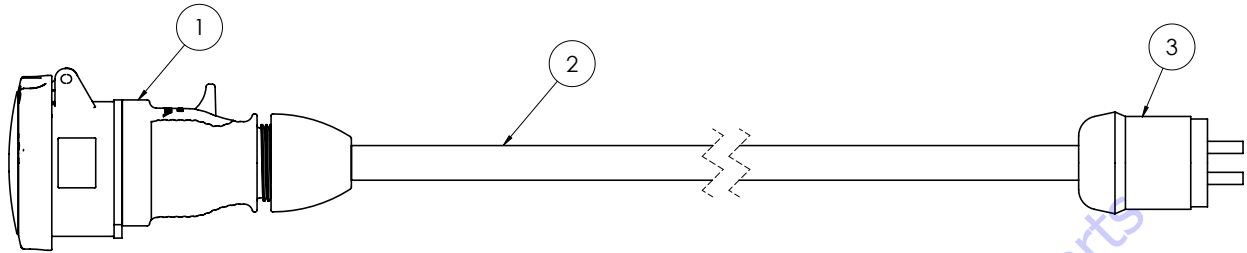

Item#	Part#	Description	QTY
1	404916	Connector, IEC 309, 3P4W, 230V, 32A	1
2	400356	Cord, Power, SOOW, 8/4, Black	51FT
3	402335	Plug, Male, L15-30P, 250V, 30A	1

230V CORDS AND HARNESES (NOT SHOWN)

Part#	Description	QTY
404945	Assembly, Grounding Wire, 10AWG, Green	1
405156	Assembly, Cord, Handle Controls, 22/8	1
405165	Assembly, Cord, Travel Motor, 18/4, A97	1
405163	Assembly, Cord, Power, Control Panel, 8/4, A97	1
405164	Assembly, Cord, Blast Motor, 10/4, A97	1
406060	Assembly, Lighting Harness	1

Parts List and Diagrams

230V MAIN WIRING DIAGRAM

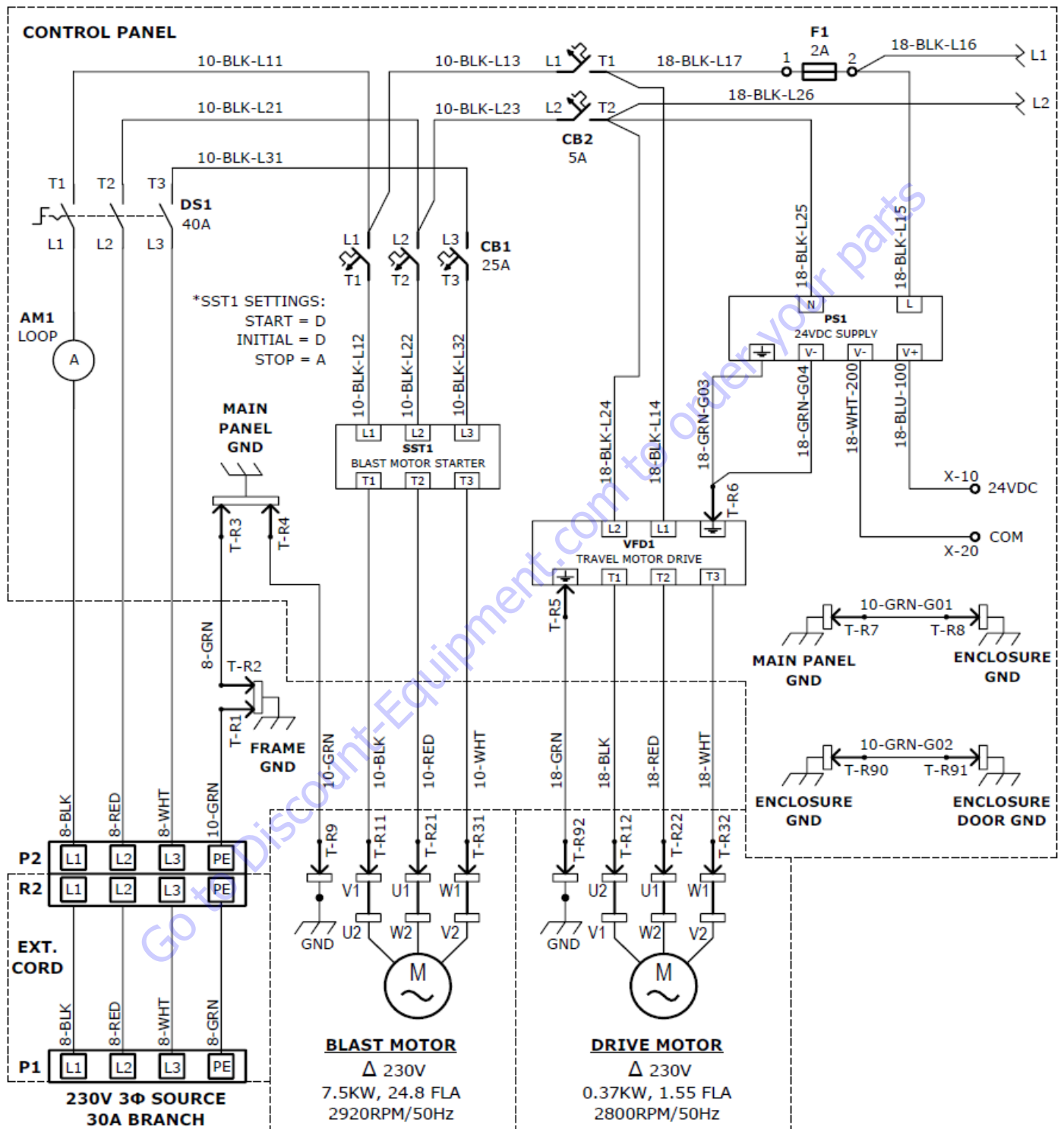

Parts List and Diagrams

230V CONTROLS WIRING DIAGRAM 1

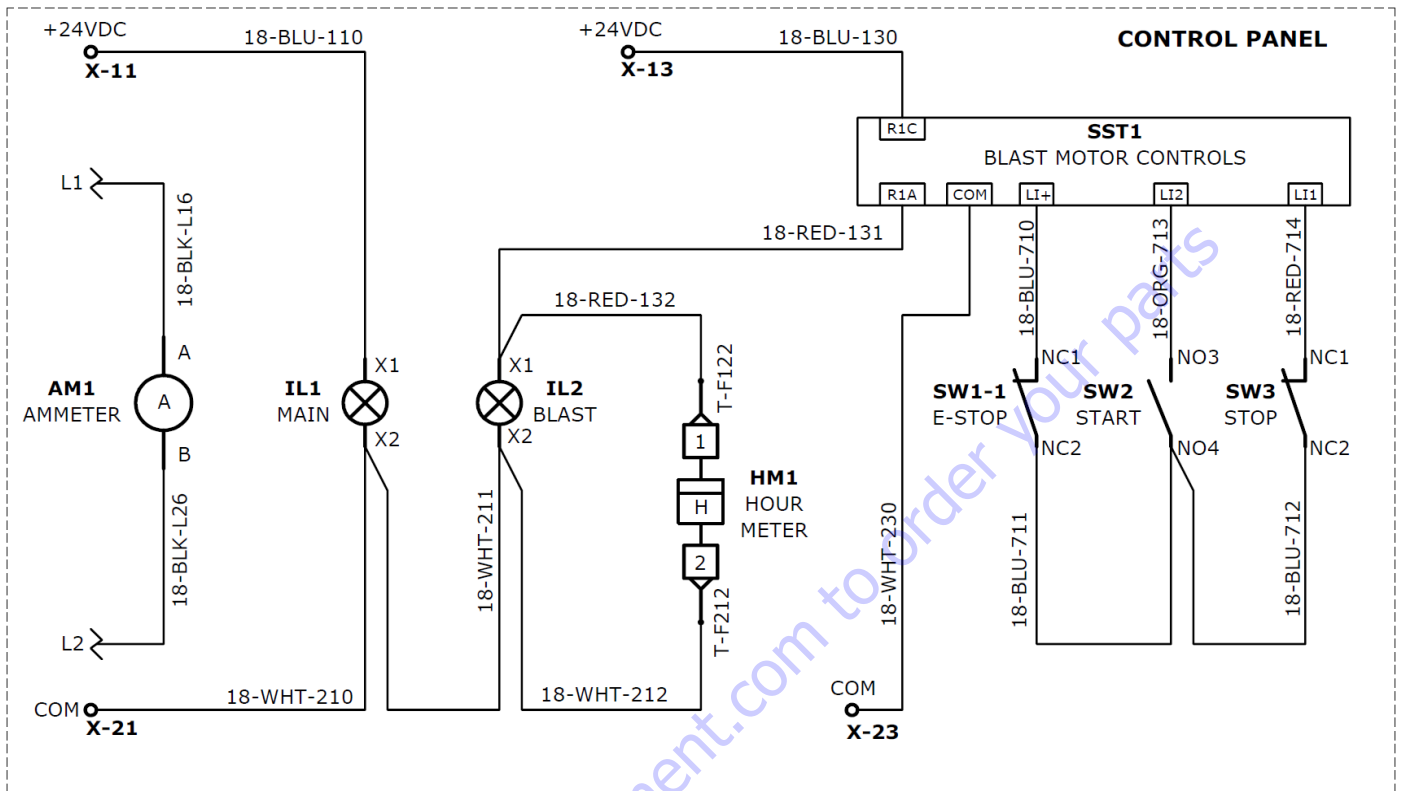

Parts List and Diagrams

230V CONTROLS WIRING DIAGRAM 2

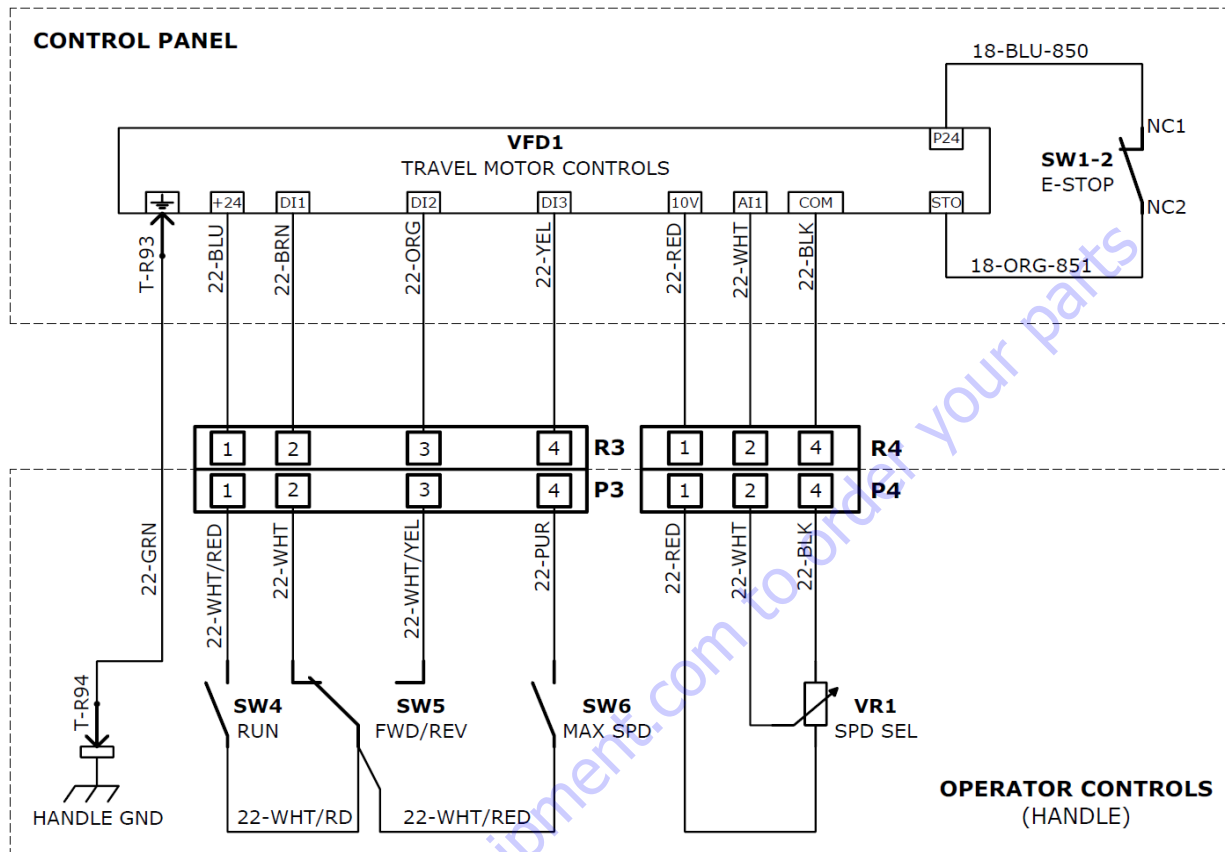

Parts List and Diagrams

230V ACCESSORIES WIRING DIAGRAM

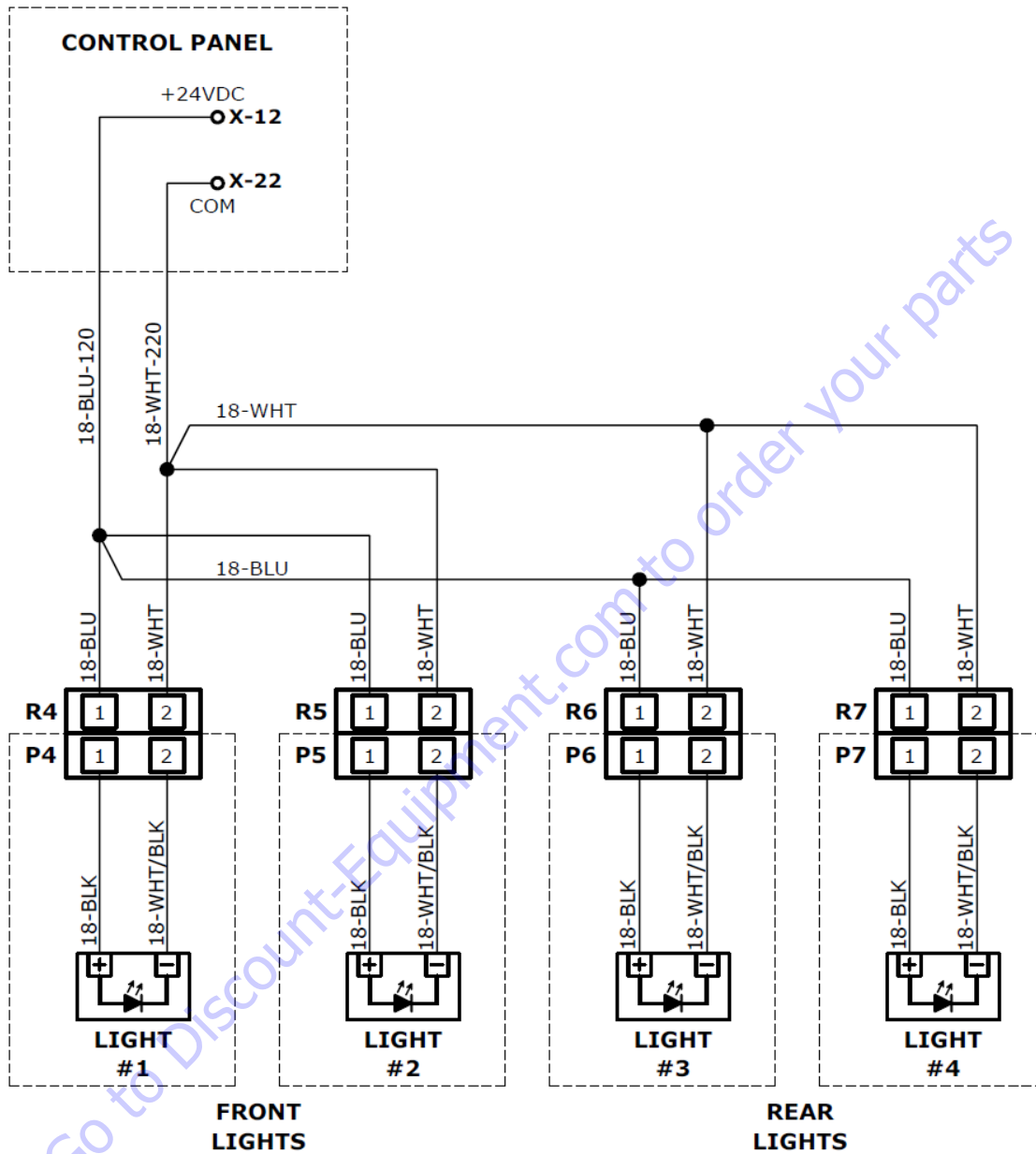

Parts List and Diagrams

400V CONTROL BOX – 405766

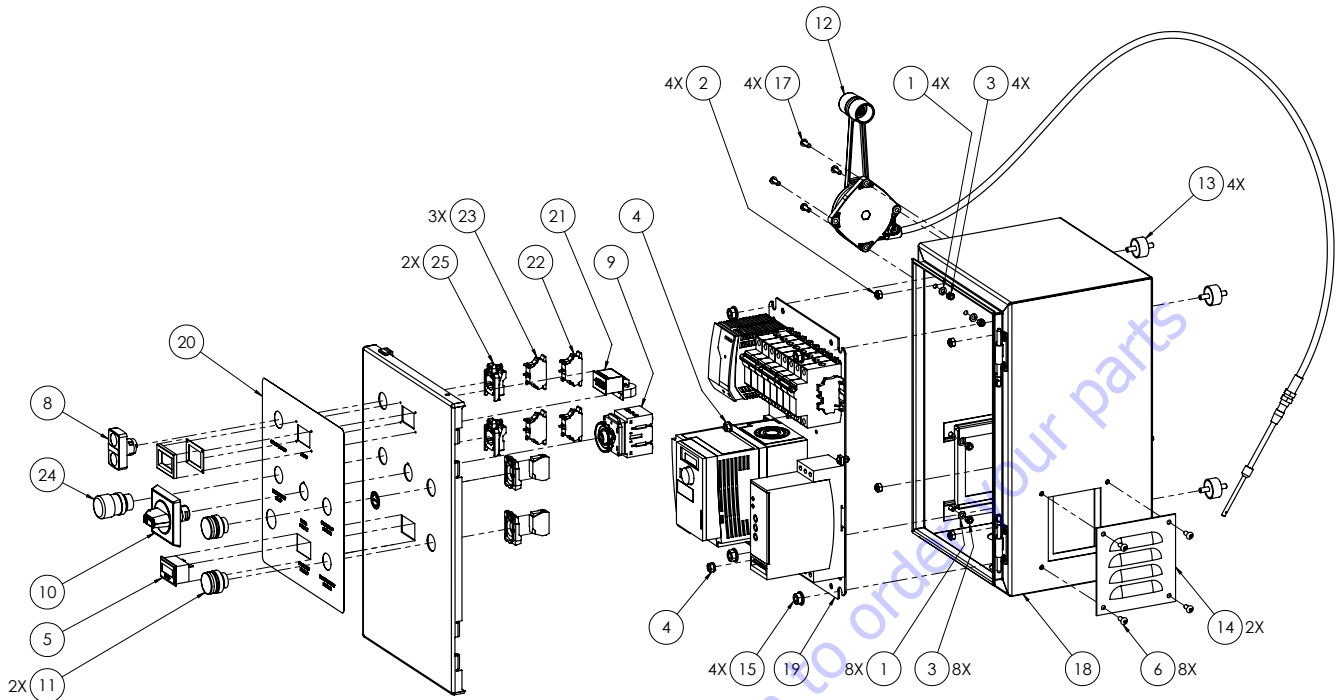

Item#	Part#	Description	QTY
1	401327	Washer, Flat, M5, Clear Zinc	12
2	401516	Nut, Hex, Nylon Insert, M6-1.0, Clear Zinc	4
3	401517	Nut, Hex, Nylon Insert, M5-.80, Clear Zinc	12
4*	403235	Nut, Keps, M6-1.0, Clear Zinc	4
5	403253	Meter, Hour, Digital, 20-300VAC, 10-300VDC, Snap-on	1
6	403279	Screw, Button Head Cap, M5-0.8 x 12, Clear Zinc	8
7*	403917	Washer, External Tooth, M6, Clear Zinc	2
8	404773	Switch, 22mm, Pushbutton, Start/Stop, ZB4 Series	1
9	404820	Switch, Disconnect, 3P, 40A, Door Mount	1
10	404821	Handle, Disconnect Switch, Door Mount	1
11	404822	Indicator, 22mm, Green, 24VDC	2
12	404844	Cable, 45" Long, w/ Lever	1
13	404893	Mount, Vibration, M6x1, 1 Dia x 500 Long	4
14	405154	Kit, Louver, Steel, Black, 121mm x 114mm	2
15	405198	Nut, Flanged, M8-1.25mm, Zinc Plated	4
16*	405238	Anchor, Cable Tie, Black Nylon, High Bond Adhesive, 1"x1"	1
17	405301	Screw, Button Head Cap, M5x0.8x14, Clear Zinc	4
18	405760	Enclosure, 16x10x9, 400V	1
19	405765	Assembly, Sub-Panel, 400V	1
20	405768	Label, Door, 16"x10", 400V	1
21	405784	Ammeter, Digital, 20A, 5-40VDC	1
22	72451	Contact Block, NO, 10A, Spring Clamp, ZB4 Series	1
23	72452	Contact Block, NC, 10A, Spring Clamp, ZB4 Series	3
24	72453	Switch, 22mm, E-Stop, ZB4 Series	1
25	72456	Collar, Mounting, 22mm, ZB4 Series	2
26*	72840	Tie, Cable, Black Nylon, 18lbs, 4"	1
27*	72842	Tie, Cable, Black Nylon, 40lbs, 6"	1

*NOT SHOWN

Parts List and Diagrams

400V SUB-PANEL ASSEMBLY – 405765

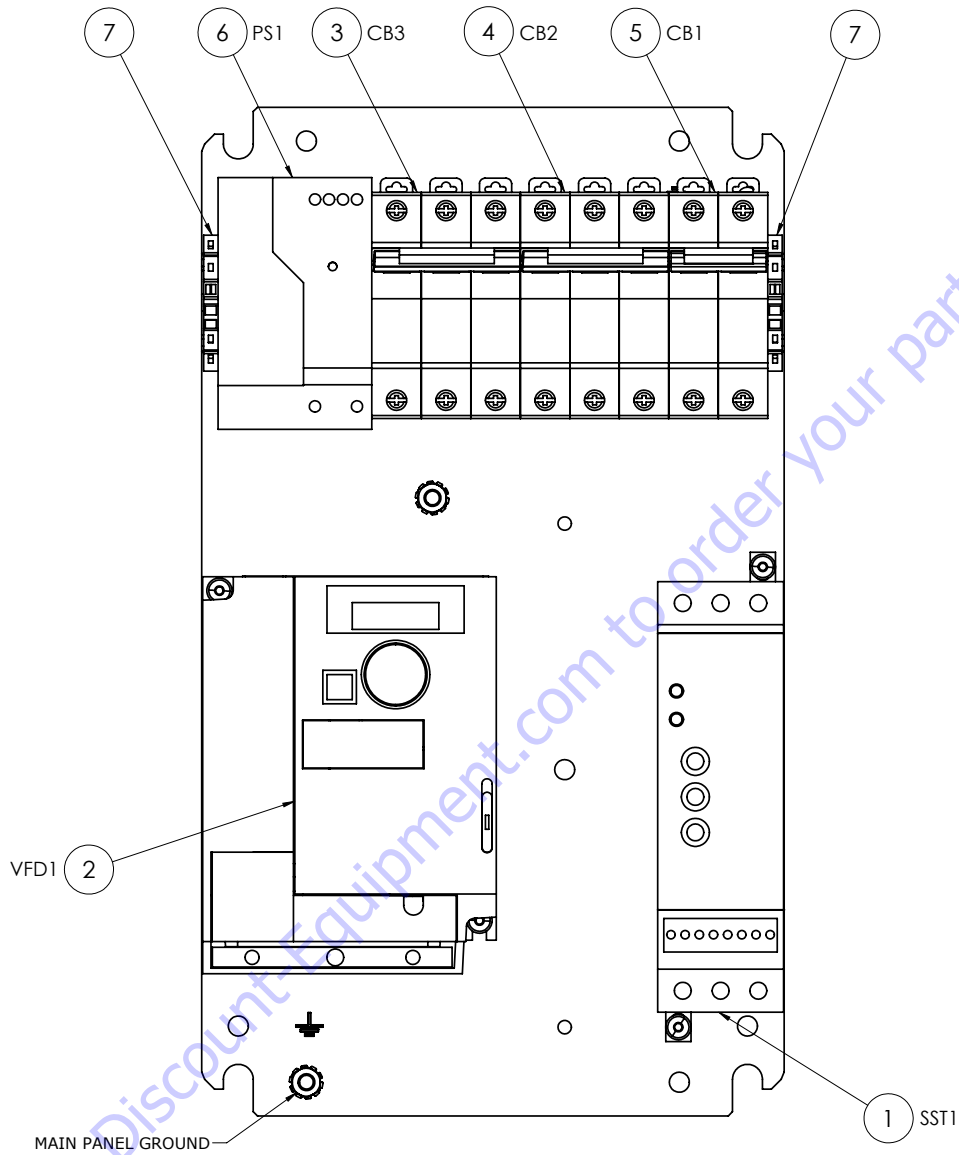

Item#	Part#	Description	QTY
1	405776	Soft Starter, 22A, 400V	1
2	405777	VFD, 1/2HP, 3 ϕ , 400V	1
3	405779	Circuit Breaker, MCB, UL1077, 3P, 20A, D Trip	1
4	405780	Circuit Breaker, MCB, UL1077, 3P, 2A, D Trip	1
5	405781	Circuit Breaker, MCB, UL1077, 2P, 1A, D Trip	1
6	405782	Power Supply, 24VDC, 264-575VAC, 90W, DIN Rail	1
7	405783	End Stop, DIN Rail, 35mm, Slim	2

Parts List and Diagrams

400V POWER CORD – 405615

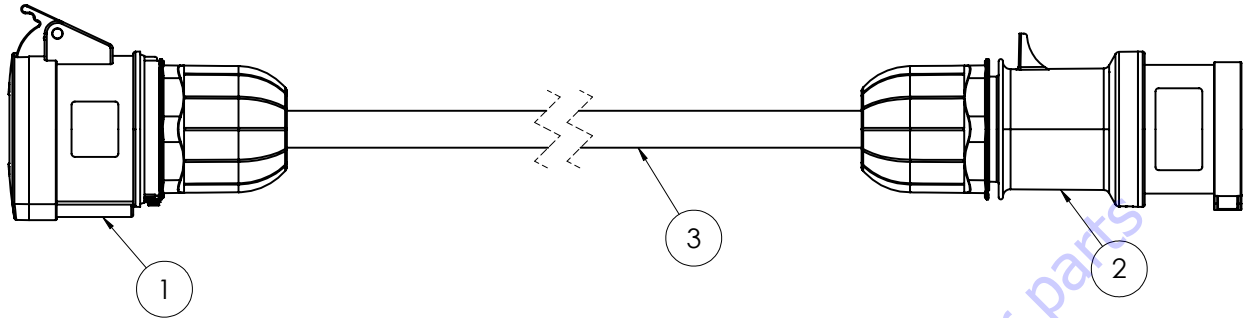

Item#	Part#	Description	QTY
1	405522	Connector, IEC 309, 4P5W, 400V, 32A	1
2	405523	Plug, IEC 309, 4P5W, 400V, 32A	1
3	405949	Cord, Power, H07RN-F, 4mm ² /5, Black CPE	50FT

400V CORDS AND HARNESSSES (NOT SHOWN)

Part#	Description	QTY
404945	Assembly, Grounding Wire, 10AWG, Green	1
405156	Assembly, Cord, Handle Controls, 22/8	1
405774	Assembly, Cord, Travel Motor, 20/4, 400V	1
405772	Assembly, Cord, Power, Control Box	1
405773	Assembly, Cord, Blast Motor, 12/4	1
406060	Assembly, Lighting Harness	1

Parts List and Diagrams

400V MAIN WIRING DIAGRAM

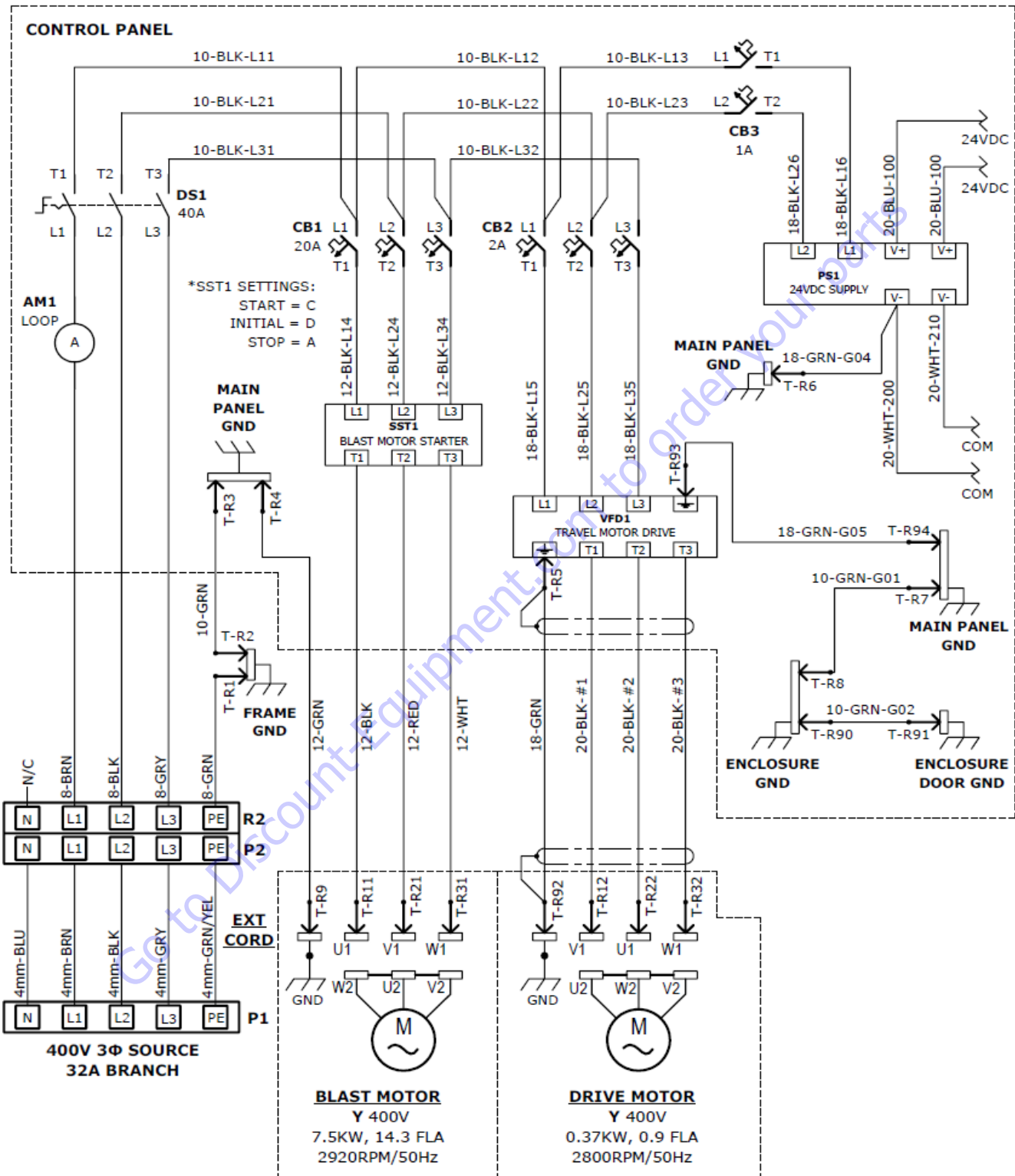

Parts List and Diagrams

400V CONTROLS WIRING DIAGRAM 1

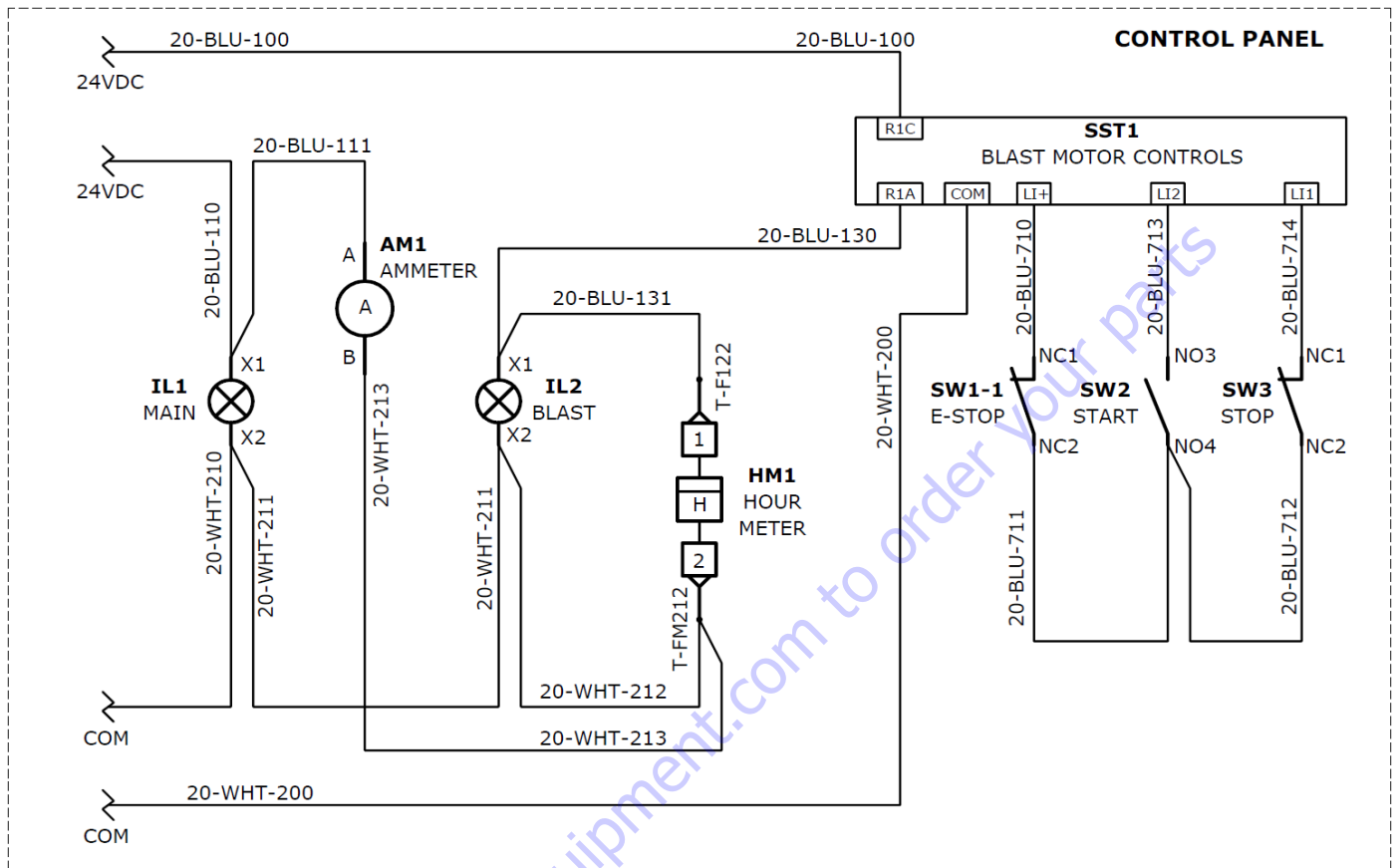

Parts List and Diagrams

400V CONTROLS WIRING DIAGRAM 2

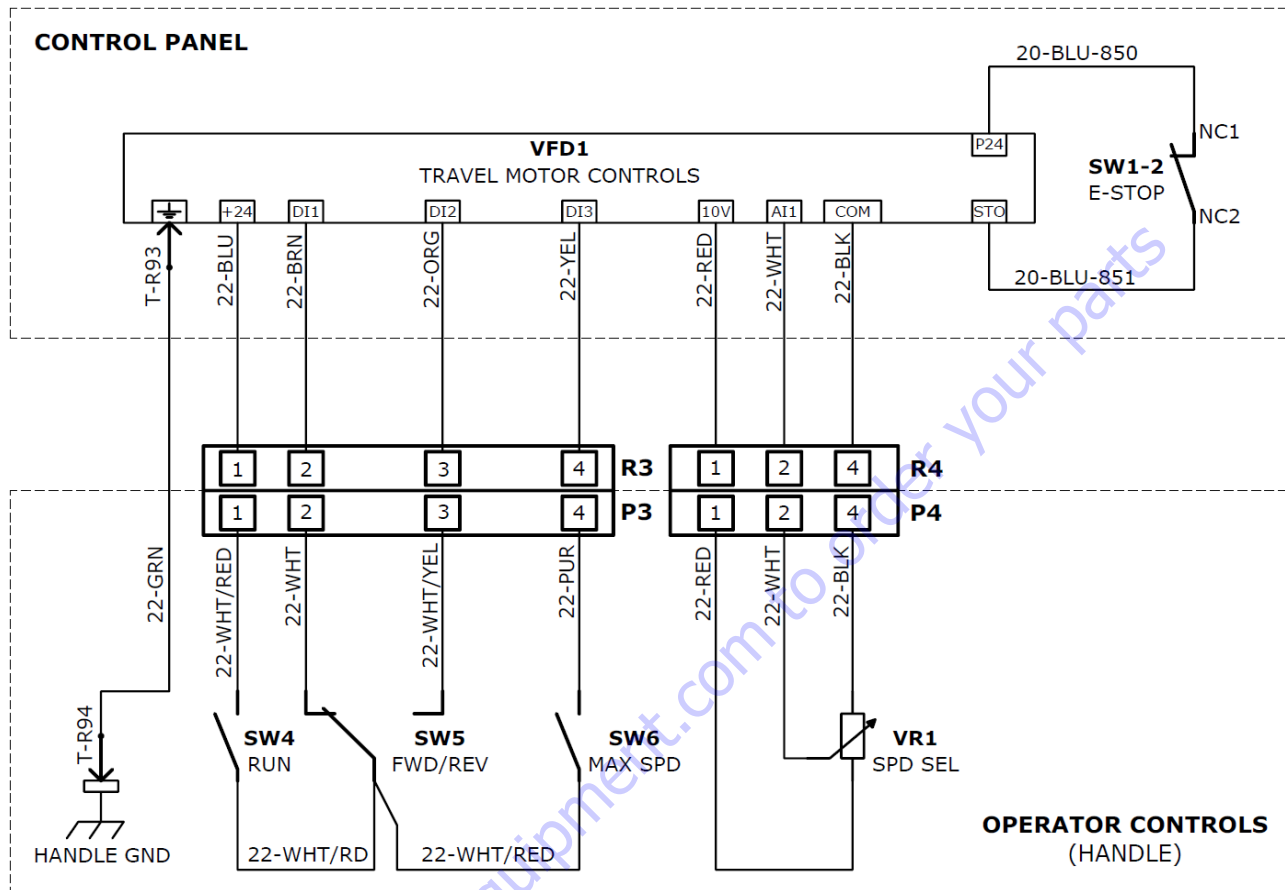

Parts List and Diagrams

400V ACCESSORIES WIRING DIAGRAM

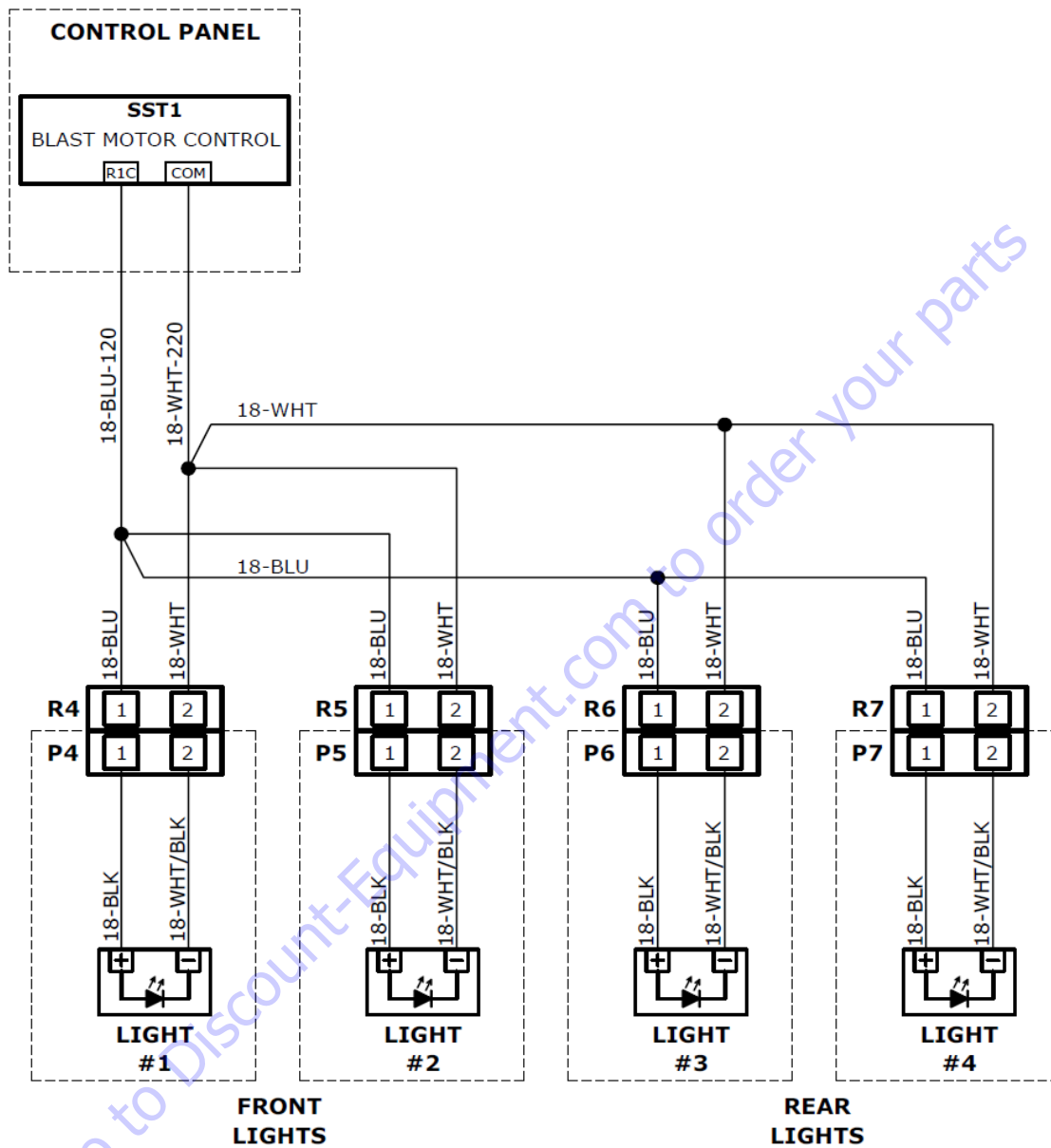

PARTS FINDER

**Search Website
by Part Number**



**Search Manual
Library For Parts
Manual & Lookup Part
Numbers – Purchase
or Request Quote**

Search Manuals

Enter your information to search for parts manuals and lookup part numbers.

* Brand:

* Model:

* Serial:

* Part Number:

* Quantity:

SEARCH

**Can't Find Part or
Manual? Request Help
by Manufacturer,
Model & Description**

Parts Order Form

Please fill in the following information to request help finding a part or manual.

Manufacturer:

Model:

Description:

Quantity:

Submit

Discount-Equipment.com is your online resource for quality parts & equipment.

Florida: **561-964-4949** Outside Florida TOLL FREE: **877-690-3101**

Need parts?

Click on this link: <http://www.discount-equipment.com/category/5443-parts/> and choose one of the options to help get the right parts and equipment you are looking for. Please have the machine model and serial number available in order to help us get you the correct parts. If you don't find the part on the website or on one of the online manuals, please fill out the request form and one of our experienced staff members will get back to you with a quote for the right part that your machine needs.

We sell worldwide for the brands: Genie, Terex, JLG, MultiQuip, Mikasa, Essick, Whiteman, Mayco, Toro Stone, Diamond Products, Generac Magnum, Airman, Haulotte, Barreto, Power Blanket, Nifty Lift, Atlas Copco, Chicago Pneumatic, Allmand, Miller Curber, Skyjack, Lull, Skytrak, Tsurumi, Husquvarna Target, , Stow, Wacker, Sakai, Mi-T- M, Sullair, Basic, Dynapac, MBW, Weber, Bartell, Bennar Newman, Haulotte, Ditch Runner, Menegotti, Morrison, Contec, Buddy, Crown, Edco, Wyco, Bomag, Laymor, Barreto, EZ Trench, Bil-Jax, F.S. Curtis, Gehl Pavers, Heli, Honda, ICS/PowerGrit, IHI, Partner, Imer, Clipper, MMD, Koshin, Rice, CH&E, General Equipment, ,AMida, Coleman, NAC, Gradall, Square Shooter, Kent, Stanley, Tamco, Toku, Hatz, Kohler, Robin, Wisconsin, Northrock, Oztec, Toker TK, Rol-Air, Small Line, Wanco, Yanmar

Go to DiscountEquipment.com to order your parts



www.Discount-Equipment.com



Made in America Since 1968