



Count on it.

Operator's Manual

MB TX 2500S Tracked Mud Buggy

Model No. 68141—Serial No. 40000000 and Up

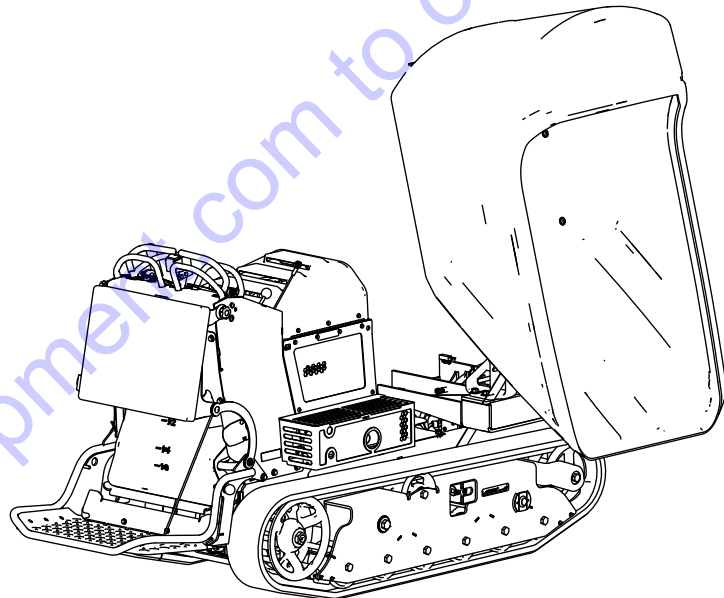

www.discount-equipment.com



PARTS FINDER

**Search Website
by Part Number**



**Search Manual
Library For Parts
Manual & Lookup Part
Numbers – Purchase
or Request Quote**

Search Manuals

Enter your information to help us find the right parts manual for your machine.

* Brand:

* Model:

* Serial:

* Part Number:

SEARCH

**Can't Find Part or
Manual? Request Help
by Manufacturer,
Model & Description**

Parts Order Form

Please fill in the following information to help us find the right part for your machine.

MANUFACTURER:

MODEL:

DESCRIPTION:

DATE:

TIME:

PHONE:

EMAIL:

ADDRESS:

CITY:

STATE:

ZIP:

SEARCH

Discount-Equipment.com is your online resource for quality parts & equipment.

Florida: **561-964-4949** Outside Florida TOLL FREE: **877-690-3101**

Need parts?

Click on this link: <http://www.discount-equipment.com/category/5443-parts/> and choose one of the options to help get the right parts and equipment you are looking for. Please have the machine model and serial number available in order to help us get you the correct parts. If you don't find the part on the website or on one of the online manuals, please fill out the request form and one of our experienced staff members will get back to you with a quote for the right part that your machine needs.

We sell worldwide for the brands: Genie, Terex, JLG, MultiQuip, Mikasa, Essick, Whiteman, Mayco, Toro Stone, Diamond Products, Generac Magnum, Airman, Haulotte, Barreto, Power Blanket, Nifty Lift, Atlas Copco, Chicago Pneumatic, Allmand, Miller Curber, Skyjack, Lull, Skytrak, Tsurumi, Husquvarna Target, Stow, Wacker, Sakai, Mi-T-M, Sullair, Basic, Dynapac, MBW, Weber, Bartell, Bennar Newman, Haulotte, Ditch Runner, Menegotti, Morrison, Contec, Buddy, Crown, Edco, Wyco, Bomag, Laymor, EZ Trench, Bil-Jax, F.S. Curtis, Gehl Pavers, Heli, Honda, ICS/PowerGrit, IHI, Partner, Imer, Clipper, MMD, Koshin, Rice, CH&E, General Equipment, Amida, Coleman, NAC, Gradall, Square Shooter, Kent, Stanley, Tamco, Toku, Hatz, Kohler, Robin, Wisconsin, Northrock, Oztec, Toker TK, Rol-Air, APT, Wylie, Ingersoll Rand / Doosan, Innovatech, Con X, Ammann, Mecalac, Makinex, Smith Surface Prep, Small Line, Wanco, Yanmar

It is a violation of California Public Resource Code Section 4442 or 4443 to use or operate the engine on any forest-covered, brush-covered, or grass-covered land unless the engine is equipped with a spark arrester, as defined in Section 4442, maintained in effective working order or the engine is constructed, equipped, and maintained for the prevention of fire.

Because in some areas there are local, state, or federal regulations requiring that a spark arrester be used on the engine of this machine, a spark arrester is available as an option. If you require a spark arrester, contact your Authorized Service Dealer. Genuine Toro spark arresters are approved by the USDA Forestry Service.

The enclosed engine owner's manual is supplied for information regarding the US Environmental Protection Agency (EPA) and the California Emission Control Regulation of emission systems, maintenance, and warranty. Replacements may be ordered through the engine manufacturer.

▲ WARNING

CALIFORNIA Proposition 65 Warning

The engine exhaust from this product contains chemicals known to the State of California to cause cancer, birth defects, or other reproductive harm.

Battery posts, terminals, and related accessories contain lead and lead compounds, chemicals known to the State of California to cause cancer and reproductive harm. Wash hands after handling.

Use of this product may cause exposure to chemicals known to the State of California to cause cancer, birth defects, or other reproductive harm.

Introduction

This machine is intended to be used by professional, hired operators in commercial applications. It is primarily designed to move concrete, mortar, gravel, dirt, or debris around job sites. Using this product for purposes other than its intended use could prove dangerous to you and bystanders.

Read this information carefully to learn how to operate and maintain your product properly and to avoid injury and product damage. You are responsible for operating the product properly and safely.

Visit www.Toro.com for product safety and operation training materials, accessory information, help finding a dealer, or to register your product.

Whenever you need service, genuine Toro parts, or additional information, contact an Authorized Service Dealer or Toro Customer Service and have the model and serial numbers of your product ready. **Figure 1** identifies the location of the model and serial numbers on the product. Write the numbers in the space provided.

Important: With your mobile device, you can scan the QR code on the serial number decal (if equipped) to access warranty, parts, and other product information.

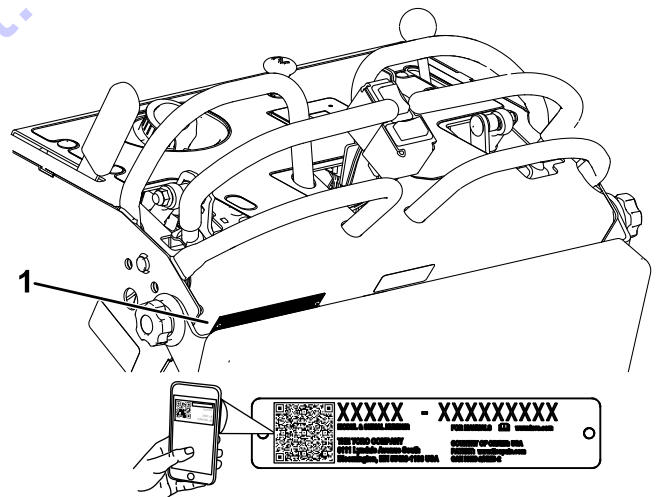

Figure 1

1. Model and serial number location

Model No. _____
Serial No. _____

This manual identifies potential hazards and has safety messages identified by the safety-alert symbol (**Figure 2**), which signals a hazard that may cause

serious injury or death if you do not follow the recommended precautions.



Figure 2

g000502

1. Safety-alert symbol

This manual uses 2 words to highlight information. **Important** calls attention to special mechanical information and **Note** emphasizes general information worthy of special attention.

Contents

Safety	4
General Safety	4
Safety and Instructional Decals	4
Product Overview	8
Controls	8
Specifications	9
Attachments/Accessories	9
Before Operation	9
Before Operation Safety	9
Adding Fuel	10
Performing Daily Maintenance	11
During Operation	12
During Operation Safety	12
Operating the Parking Brake	13
Operating the Throttle	13
Operating the Choke	13
Starting the Engine	14
Shutting Off the Engine	14
Operating the Hopper	14
After Operation	15
After Operation Safety	15
Removing Debris from the Machine	15
Lowering the Hopper without Power	15
Raising the Hopper without Power	16
Moving a Non-Functional Machine	16
Transporting the Machine	17
Lifting the Machine	17
Maintenance	18
Recommended Maintenance Schedule(s)	18
Pre-Maintenance Procedures	19
Maintenance Safety	19
Releasing the Cushion for Rear Access	19
Using the Cylinder Lock	20
Lubrication	21
Greasing the Machine	21
Engine Maintenance	21
Servicing the Air Cleaner	21
Checking the Engine-Oil Level	22
Changing the Engine Oil and Filter	23
Servicing the Spark Plugs	24

Cleaning the Blower Housing	25
Fuel System Maintenance	26
Replacing the Fuel Filter	26
Draining the Fuel Tank	26
Removing the Fuel Tank	27
Electrical System Maintenance	27
Servicing the Battery	27
Servicing the Fuses	29
Drive System Maintenance	29
Servicing the Tracks	29
Servicing the Drive Belt	31
Controls System Maintenance	32
Adjusting the Motion-Control Levers	32
Brake Maintenance	33
Hydraulic System Maintenance	34
Servicing the Hydraulic Drive System	34
Servicing the Hydraulic Lift and Slew System	36
Checking the Hydraulic Lines	38
Cleaning	39
Removing Debris from the Machine	39
Storage	40
Storage Safety	40
Storing the Machine	40
Troubleshooting	41

Safety

General Safety

- Read and understand the contents of this Operator's Manual before starting the engine.
- Do not operate the machine without all guards and other safety protective devices in place and functioning properly on the machine.
- Park the machine on a level surface, lower the hopper, shut off the engine, and remove the key before leaving the operating position.
- Keep your hands and feet away from moving parts. If possible, do not make adjustments with the engine running.

Improperly using or maintaining the machine can result in injury. To reduce the potential for injury, comply with these safety instructions and always pay attention to the safety-alert symbol (Figure 2), which means **Caution, Warning, or Danger**—personal safety instruction. Failure to comply with the instruction may result in personal injury or death.

Safety and Instructional Decals



Safety decals and instructions are easily visible to the operator and are located near any area of potential danger. Replace any decal that is damaged or missing.



115-4858

decal115-4858

1. Crushing hazard of hands or feet—install the cylinder lock.

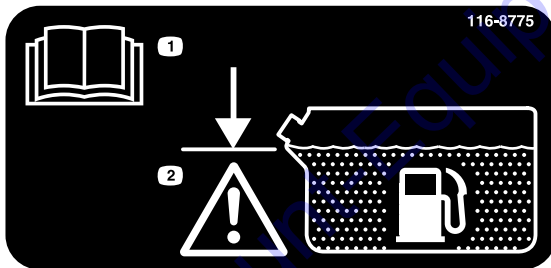

116-8775

decal116-8775

1. Read the *Operator's Manual*.
2. Warning—fill to the bottom of the filler neck; do not overfill the tank.

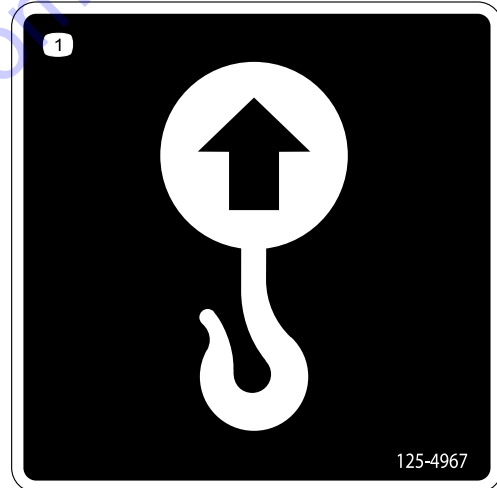

125-4967

decal125-4967

1. Lift point

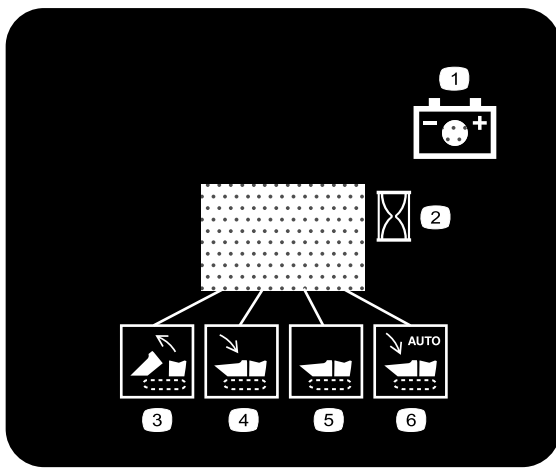

132-8961

decal132-8961

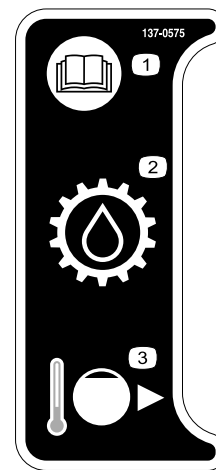

137-0575

decal137-0575

1. Battery charging condition
2. Hour meter
3. Hopper is raising.
4. Hopper is lowering.
5. Hopper is down.
6. Hopper is lowering automatically.

1. Read the *Operator's Manual*.
2. Transmission fluid
3. Cold-fill line



133-8062

decal133-8062

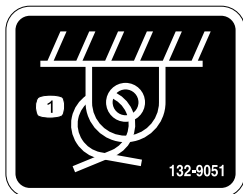

132-9051

decal132-9051

1. Tie-down point

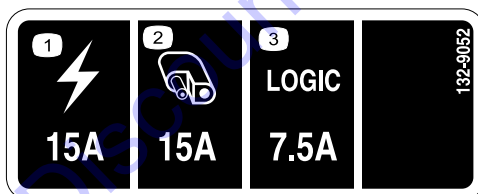

132-9052

decal132-9052

1. Main (15 A)
2. Auxiliary (15 A)
3. Logic (7.5 A)

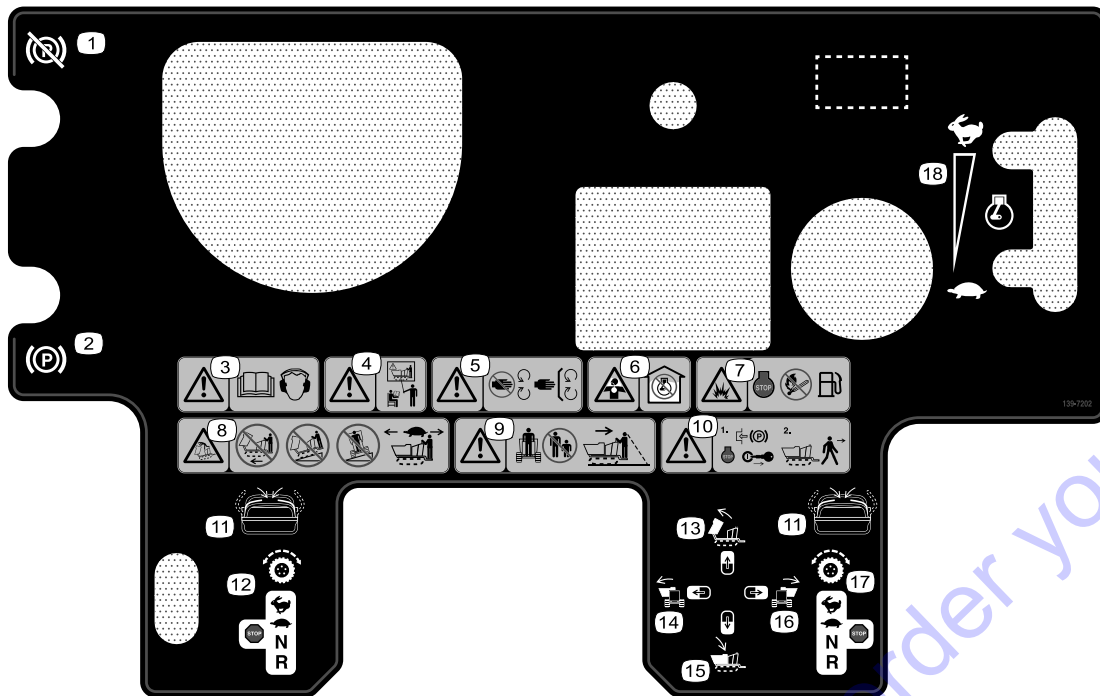

decal139-7202

139-7202

1. Parking—brake release
2. Parking brake
3. Warning—read the *Operator's Manual*; wear hearing protection.
4. Warning—all operators should read the *Operator's Manual* and be trained before operating the machine.
5. Warning—stay away from moving parts; keep all guards and shields in place.
6. asphyxiation hazard, poisonous fumes or toxic gases—do not run the engine in an enclosed space.
7. Explosion hazard—shut off the engine; no fire or open flames while fueling.
8. Tipping hazard—do not drive forward with the hopper raised; do not drive down slopes with the hopper raised; do not drive across slopes with the hopper raised; drive slowly with the hopper lowered.
9. Warning—keep bystanders away; look behind and down when moving in reverse.
10. Warning—engage the parking brake, shut off the engine, and remove the key before leaving the operators position.
11. Move the handles in to operate.
12. Left traction controls
13. Raise hopper
14. Swivel the hopper to the left.
15. Lower hopper
16. Swivel the hopper to the right.
17. Right traction controls
18. Engine-speed control

MBTX-2500S QUICK REFERENCE AID

CHECK/SERVICE DAILY

1. OIL LEVEL, DAILY
2. AIR FILTER
3. GREASE CYLINDER
4. CHECK TRACK
5. CLEAN MACHINE

SERVICE MONTHLY

1. GREASE SLEW DRIVE

(4)

FLUID SPECIFICATION / CHANGE INTERVALS

SEE OPERATOR'S MANUAL FOR INITIAL CHANGE	FLUID TYPE	CAPACITY	CHANGE INTERVALS		PART NO.
			FLUID	FILTER	
ENGINE OIL	10W30	2 QTS.	100 HRS.	100 HRS.	
HYDRAULIC OIL (CYLINDER CIRCUIT)	TORO PREMIUM HYD-OIL	285 OZ.	300 HRS.	300 HRS.	1-633750
HYDRAULIC OIL (TRANSMISSIONS)	TORO HYPR-OIL 500	208 OZ.	300 HRS.	300 HRS.	137-3772
FUEL SYSTEM	97 OIL FRIE MAX 10% ETHANOL				
AIR FILTER				100 HRS.	

SERVICE PARTS

PART #	PART	QTY	LOCATION	PART #	TRACK	QTY	LOCATION
125-0339	HUB SHAFT	2	A	132-8812	TRACK	2	G
140-3558	CYLINDER HYDRAULIC	1	B	136-5231	ROAD WHEEL ASM	14	H
137-1813	CYLINDER HYDRAULIC SEAL KIT	1	C	132-8893	WHEEL DRIVE, MUD BUGGY	2	I
132-8938	PULLEY-ENGINE (WELDED)	1	D	104-4657	BATTERY	1	J
116-3828	PULLEY IDLER	1	E	AU113864	SWITCH, ROCKER	2	K
104-5745	TENSIONER WHEEL ASM	2	F	ST47182	LATCH-RUBBER	1	L
				139-1295	BELT	1	M

139-7223

decal139-7223

1. Read the Operator's Manual.

Product Overview

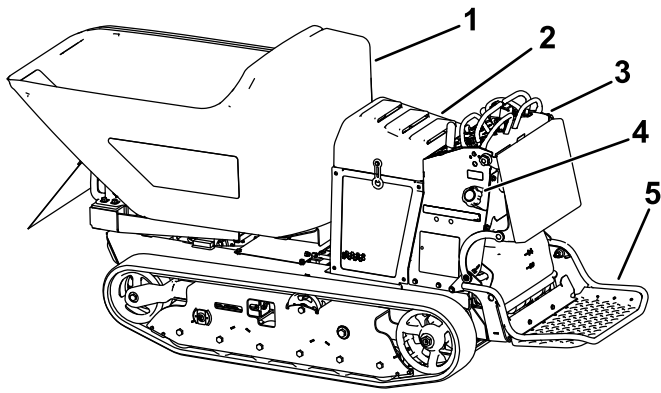

g322676

Figure 3

- | | |
|------------------|----------------------|
| 1. Hopper | 4. Fuel-tank cap |
| 2. Hood | 5. Operator platform |
| 3. Control panel | |

Controls

Become familiar with all the controls (Figure 4) before you start the engine and operate the machine.

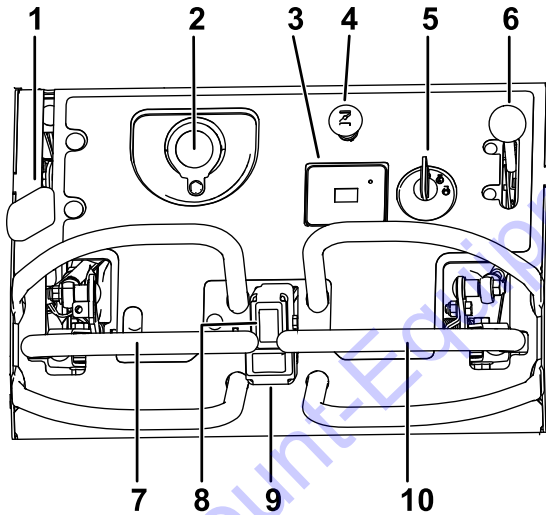

g322670

Figure 4

- | | |
|------------------------|--------------------------------|
| 1. Parking-brake lever | 6. Throttle lever |
| 2. Hydraulic-tank cap | 7. Left motion-control lever |
| 3. Hour meter | 8. Dump switch |
| 4. Choke control | 9. Swivel switch |
| 5. Key switch | 10. Right motion-control lever |

Parking Brake Lever

To engage the parking brake, pull back the lever. (Figure 4).

To disengage the parking brake, push the lever forward.

Hour Meter

The hour meter records the number of hours the engine has operated. It operates when the engine is running. Use these times for scheduling regular maintenance (Figure 4).

Choke Control

Use the choke to start a cold engine. Pull the choke knob up to engage it. Push the choke knob down to disengage it (Figure 4).

Key Switch

Use the key switch to start the engine (Figure 4). The switch has 3 positions: OFF, RUN, and START.

Throttle Lever

The throttle lever is variable between the FAST and SLOW positions (Figure 4).

Motion-Control Levers

Use the motion-control levers to drive the machine forward and reverse and to turn either direction (Figure 4).

Dump Switch

Use the vertical switch to dump and lower the hopper. If you hold the switch down 0.2 to 1.3 seconds, the hopper fully lowers automatically.

Swivel Switch

Use the horizontal switch to swivel the hopper to the left and right.

Specifications

Note: Specifications and design are subject to change without notice.

Width	90.2 cm (35-1/2 inches)
Length	268.0 cm (105-1/2 inches)
Height	130.18 cm (51.25 inches)
Weight	855.5 kg (1,886 lb)
Hopper capacity	0.45 m ³ (16 ft ³)
Maximum load	1,134 kg (2,500 lb)
Discharge Height	38.1 cm (15 inches)

Attachments/Accessories

A selection of Toro approved attachments and accessories is available for use with the machine to enhance and expand its capabilities. Contact your Authorized Service Dealer or authorized Toro distributor or go to www.Toro.com for a list of all approved attachments and accessories.

To ensure optimum performance and continued safety certification of the machine, use only genuine Toro replacement parts and accessories. Replacement parts and accessories made by other manufacturers could be dangerous, and such use could void the product warranty.

Operation

Note: Determine the left and right sides of the machine from the normal operating position.

Before Operation

Important: Before operating, check the fuel and oil level, and remove debris from the machine. Also, ensure that the area is clear of people and debris.

Before Operation Safety

General Safety

- Never allow children or untrained people to operate the machine. Local regulations may restrict the age of the operator. The owner is responsible for training all operators and mechanics.
- Become familiar with the safe operation of the equipment, operator controls, and safety signs.
- Inspect the area where you will use the machine and remove all objects that could interfere with the operation of the machine.
- Know and mark the locations of all utility lines.
- Check that the operator's presence controls, safety switches, and shields are attached and functioning properly. Do not operate the machine unless they are functioning properly.
- Locate the pinch point areas marked on the machine and keep hands and feet away from these areas.
- Do not carry passengers on the machine and keep bystanders and children out of the operating area.
- Ensure that the area is clear of bystanders before operating the machine. Shut off the machine if a bystander enters the area.
- Park the machine on a level surface, engage the parking brake, and shut off the engine. Wait for all movement to stop and allow the machine to cool before adjusting, servicing, cleaning, or storing the machine.

Fuel Safety

- Use extreme care in handling fuel. It is flammable and its vapors are explosive.
- Extinguish all cigarettes, cigars, pipes, and other sources of ignition.
- Use only an approved container.
- Do not remove the fuel cap or fill the fuel tank while the engine is running or hot.
- Do not add or drain fuel in an enclosed space.

- Do not store the machine or fuel container where there is an open flame, spark, or pilot light, such as on a water heater or other appliance.
- If you spill fuel, do not attempt to start the engine; avoid creating any source of ignition until the fuel vapors have dissipated.
- Do not fill containers inside a vehicle or on a truck or trailer bed with a plastic liner. Always place containers on the ground, away from your vehicle before filling.
- Remove the equipment from the truck or trailer and refuel it while it is on the ground. If this is not possible, then refuel from a portable container rather than a fuel-dispenser nozzle.
- Keep the fuel-dispenser nozzle in contact with the rim of the fuel tank or container opening at all times until fueling is complete. Do not use a nozzle-lock-open device.

Adding Fuel

- For best results, use only clean, fresh (less than 30 days old), unleaded gasoline with an octane rating of 87 or higher ((R+M)/2 rating method).
- Gasoline with up to 10% ethanol (gasohol) or 15% MTBE (methyl tertiary butyl ether) by volume is acceptable. Ethanol and MTBE are not the same. Gasoline with 15% ethanol (E15) by volume is not approved for use. Never use gasoline that contains more than 10% ethanol by volume, such as E15 (contains 15% ethanol), E20 (contains 20% ethanol), or E85 (contains up to 85% ethanol). Using unapproved gasoline may cause performance problems and/or engine damage which may not be covered under warranty.
- **Do not** use gasoline containing methanol.
- **Do not** store fuel either in the fuel tank or fuel containers over the winter unless you use a fuel stabilizer.
- **Do not** add oil to gasoline.

⚠ DANGER

In certain conditions, fuel is extremely flammable and highly explosive. A fire or explosion from fuel can burn you and others and can damage property.

- **Fill the fuel tank outdoors, in an open area, when the engine is cold. Wipe up any fuel that spills.**
- **Never fill the fuel tank inside an enclosed trailer.**
- **Do not fill the fuel tank completely full. Add fuel to the fuel tank until the level is 6 to 13 mm (1/4 to 1/2 inch) below the bottom of the filler neck. This empty space in the tank allows fuel to expand.**
- **Never smoke when handling fuel and stay away from an open flame or where fuel fumes may be ignited by a spark.**
- **Store fuel in an approved container and keep it out of the reach of children. Never buy more than a 30-day supply of fuel.**
- **Do not operate without entire exhaust system in place and in proper working condition.**

⚠ DANGER

In certain conditions during fueling, static electricity can be released causing a spark, which can ignite the fuel vapors. A fire or explosion from fuel can burn you and others and can damage property.

- Always place fuel containers on the ground away from your vehicle before filling.
- Do not fill fuel containers inside a vehicle or on a truck or trailer bed because interior carpets or plastic truck bed liners may insulate the container and slow the loss of any static charge.
- When practical, remove fuel-powered equipment from the truck or trailer and refuel the equipment with its wheels on the ground.
- If this is not possible, then refuel such equipment on a truck or trailer from a portable container rather than from a fuel-dispenser nozzle.
- If you must use a fuel-dispenser nozzle, keep the nozzle in contact with the rim of the fuel tank or container opening at all times until fueling is complete.

⚠ WARNING

Fuel is harmful or fatal if swallowed. Long-term exposure to vapors can cause serious injury and illness.

- Avoid prolonged breathing of vapors.
- Keep your face away from nozzle and fuel tank or conditioner opening.
- Keep fuel away from eyes and skin.

Using Stabilizer/Conditioner

Use fuel stabilizer/conditioner in the machine to keep the fuel fresh longer when used as directed by the fuel-stabilizer manufacturer.

Important: Do not use fuel additives containing methanol or ethanol.

Add the amount of fuel stabilizer/conditioner to fresh fuel as directed by the fuel-stabilizer manufacturer.

Filling the Fuel Tank

Fuel-tank capacity: 40.1 L (10.6 US gallons)

1. Clean the area around the fuel-tank cap.
2. Remove the cap.
3. Add fuel until it is at the bottom of the filler neck.

Note: Do not fill the fuel tank completely full. The empty space in the tank allows the fuel to expand.

4. Install the cap.

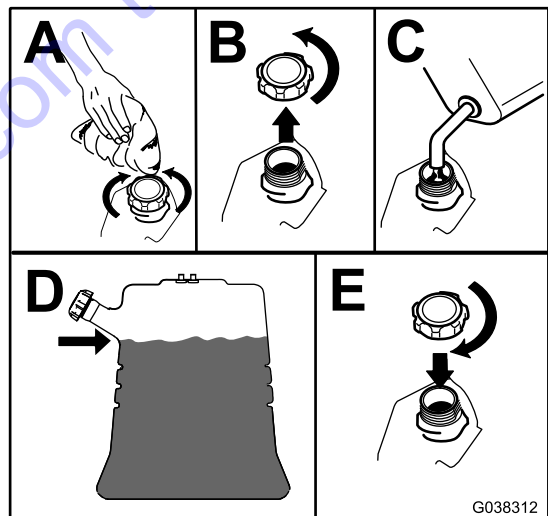

Figure 5

g038312

Performing Daily Maintenance

Before starting the machine each day, perform the Each Use/Daily procedures listed in [Maintenance \(page 18\)](#).

During Operation

During Operation Safety

General Safety

- The owner/user can prevent and is responsible for accidents that may cause personal injury or property damage.
- Do not exceed the rated operating capacity, as the machine may become unstable, which may result in loss of control.
- Wear appropriate clothing including eye protection, long pants, substantial slip-resistant footwear, and hearing protection. Tie back long hair and do not wear loose clothing or loose jewelry.
- Use your full attention while operating the machine. Do not engage in any activity that causes distractions; otherwise, injury or property damage may occur.
- Do not operate the machine while ill, tired, or under the influence of alcohol or drugs.
- Operate the machine only in good light, keeping away from holes and hidden hazards.
- Ensure that all drives are in the Neutral position before starting the engine. Start the engine only from the operating position.
- Keep your hands and feet away from moving parts. If possible, do not make adjustments with the engine running.
- Never jerk the controls; use a steady motion.
- Use care when approaching blind corners, shrubs, trees, or other objects that may obscure your vision.
- Slow down and use caution when making turns and crossing roads and sidewalks with the machine. Always yield the right-of-way.
- Operate the engine only in well-ventilated areas. Exhaust gases contain carbon monoxide, which is lethal if inhaled.
- Never leave a running machine unattended.
- Operate the machine only in good visibility and appropriate weather conditions. Do not operate the machine when there is the risk of lightning.
- Be aware of obstacles in close proximity to you. Failure to maintain adequate distance from trees, walls, and other barriers may result in injury as the machine backs up during operation if you are not attentive to the surroundings.

- Check for overhead clearance (i.e., electrical wires, branches, and doorways) before driving under any objects and do not contact them.
- Do not overload the hopper and always keep the load level when operating the machine.

Slope Safety

- Slopes are a major factor related to loss-of-control and tip-over accidents, which can result in severe injury or death. You are responsible for safe slope operation. Operating the machine on any slope requires extra caution. Before using the machine on a slope, do the following:
 - Review and understand the slope instructions in the manual and on the machine.
 - Evaluate the site conditions of the day to determine if the slope is safe for machine operation. Always use common sense and good judgment when performing this evaluation. Changes in the terrain, such as moisture, can quickly affect the operation of the machine on a slope.
- Raising the hopper on a slope affects the stability of the machine. Keep the hopper in the lowered and straight position when on slopes.
- When operating on a slope, fold the platform up and walk behind the machine until it is on flat ground.
- **Operate up and down slopes with the heavy end of the machine uphill.** Weight distribution changes with a full hopper. A full hopper makes the front of the machine the heavy end, so when traveling up or down slopes with a full hopper, walk behind the machine with the full hopper uphill.
- Identify hazards at the base of the slope. Do not operate the machine near drop-offs, ditches, embankments, water or other hazards. The machine could suddenly roll over if a wheel or track goes over the edge or the edge collapses. Keep a safe distance (twice the width of the machine) between the machine and any hazard.
- Avoid starting, stopping, or turning the machine on a slope. Avoid making sudden changes in speed or direction; turn slowly and gradually.
- Keep all movements on slopes slow and gradual. Do not make sudden changes in speed or direction.
- Do not operate the machine under any conditions where traction, steering, or stability is in question. Be aware that operating the machine on wet grass, across slopes or downhill may cause the machine

to lose traction. Loss of traction to the wheels or tracks may result in sliding and a loss of braking and steering. The machine can slide even if the wheels or tracks are stopped.

- Remove or mark obstacles such as ditches, holes, ruts, bumps, rocks or other hidden hazards. Tall grass can hide obstacles. Uneven terrain could overturn the machine.
- If you lose control of the machine, step off and away from the direction of travel of the machine.

Operating the Parking Brake

Always engage the parking brake when you stop the machine or leave it unattended. Before each use, check the parking brake for proper operation.

⚠ CAUTION

Children or bystanders may be injured if they move or attempt to operate the machine while it is unattended.

Remove the ignition key and engage the parking brake whenever you leave the machine unattended.

Engaging the Parking Brake

Pull the parking-brake lever rearward into the ENGAGED position (Figure 6).

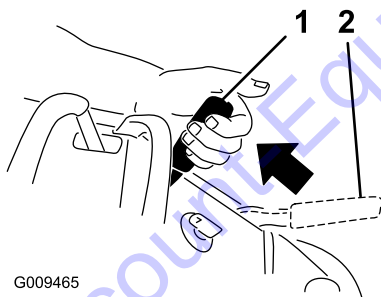

Figure 6

1. Parking brake—ENGAGED position
2. Parking brake—RELEASED position

Releasing the Parking Brake

Push the parking-brake lever forward (Figure 6).

Operating the Throttle

The throttle control moves between FAST and SLOW positions (Figure 7).

Always use the FAST position when moving the machine.

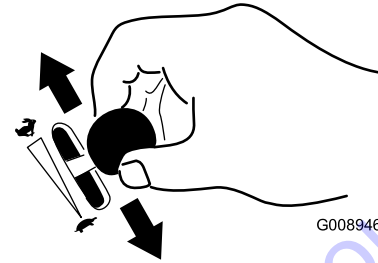

Figure 7

Operating the Choke

Use the choke to start a cold engine.

1. Pull up the choke knob to engage the choke before using the key switch (Figure 8).

Note: Ensure that you fully engage the choke. You may need to hold the knob up when you use the key switch.

2. Push down the choke to disengage the choke after the engine has started (Figure 8).

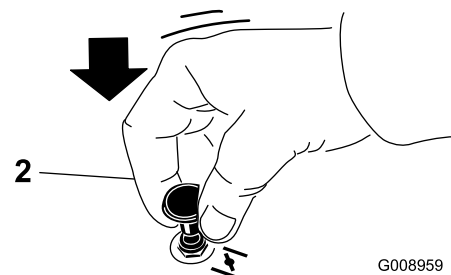
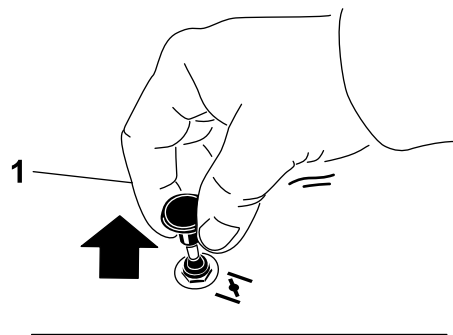

Figure 8

1. ON position
2. OFF position

Starting the Engine

1. Engage the parking brake.
2. Engage the choke.

Note: A warm or hot engine may not require choking. You may need to repeat the starting cycle when you start the engine for the first time after you have filled a completely empty fuel system with fuel.

Note: Let the machine stay at low idle for 3 minutes when starting the machine in a temperature below 30°F.

3. Move the throttle between the FAST and SLOW positions.
4. Turn the key switch to the START position.
5. When the engine starts, disengage the choke.

Important: Do not engage the starter for more than 5 seconds at a time. If the engine fails to start, allow a 15-second cool-down period between attempts. Failure to follow these instructions can burn out the starter.

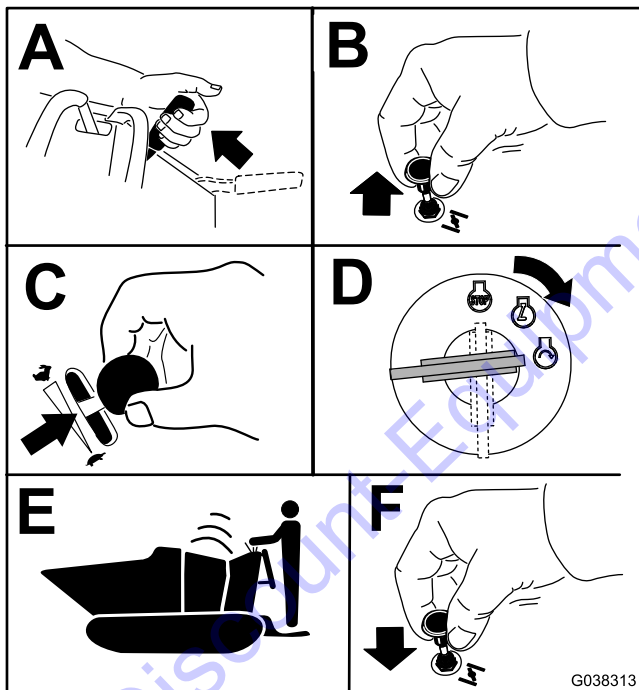

Figure 9

Shutting Off the Engine

1. Move the throttle between the FAST and SLOW positions.
2. Engage the parking brake.
3. Turn the key switch to the OFF position and remove the key.

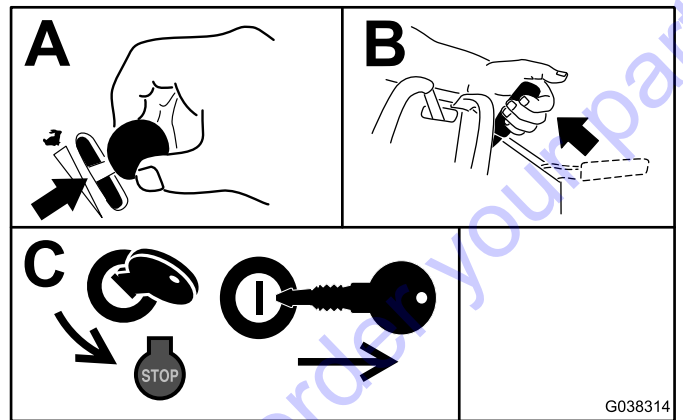

Figure 10

Operating the Hopper

Hopper capacity: 1134 kg (2,500 lb)

Know the load capacity of the machine and never exceed it. This machine normally operates on uneven, unpaved, bumpy, and/or inclined surfaces—adjust the load accordingly.

1. Position the machine where you intend to dump the load.
2. Turn the hopper left or right by pushing the left or right side of the swivel switch.
3. Dump the hopper by pushing the top of the dump switch.
4. Lower the hopper by pushing the bottom of the dump switch.

Note: If you hold the bottom of the switch 0.2 to 1.3 seconds, the hopper fully lowers automatically.

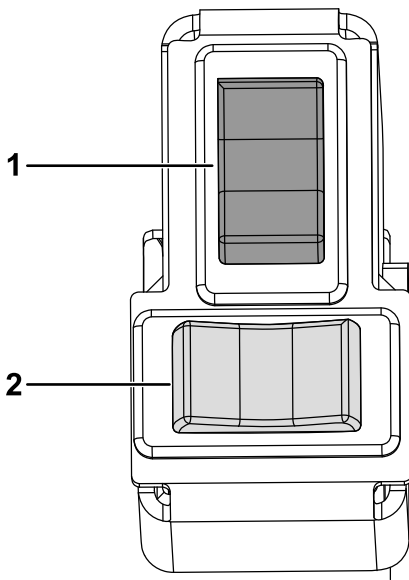

Figure 11

g322672

1. Dump switch—raise and lower the hopper.
2. Swivel switch—turn the hopper left and right.

After Operation

After Operation Safety

General Safety

- Engage the parking brake, shut off the engine, remove the key, and wait for all movement to stop before adjusting, cleaning, or repairing the machine.
- Do not touch parts that may be hot from operation. Allow them to cool before attempting to maintain, adjust, or service the machine.
- Clean debris from drives, mufflers, and the engine to help prevent fires. Clean up oil or fuel spills.
- Use care when loading or unloading the machine into a trailer or truck.

Removing Debris from the Machine

1. Park the machine on a level surface, move the motion-control levers to the NEUTRAL-LOCK position, engage the parking brake, and lower the hopper.
2. Shut off the engine and remove the key. Allow the engine to cool.
3. Clean the inside of the hopper using a hose.

Important: Do not use a hammer to remove material from the inside of the hopper; this may cause damage to the machine.

4. Clean any debris from under the hopper.
5. Wipe away debris from the air cleaner.
6. Clean any debris buildup on the engine and in the transmission with a brush or blower.

Important: Blow out dirt rather than wash it out. If you use water, keep it away from electrical parts and hydraulic valves. Do not use a high-pressure washer. High-pressure washing can damage the electrical system and hydraulic valves or deplete grease.

Lowering the Hopper without Power

1. Install the cylinder lock; refer to [Using the Cylinder Lock](#) (page 20).
2. Ensure that the tub is empty.
3. Place a large drain pan under the hydraulic-manifold block (Figure 12).

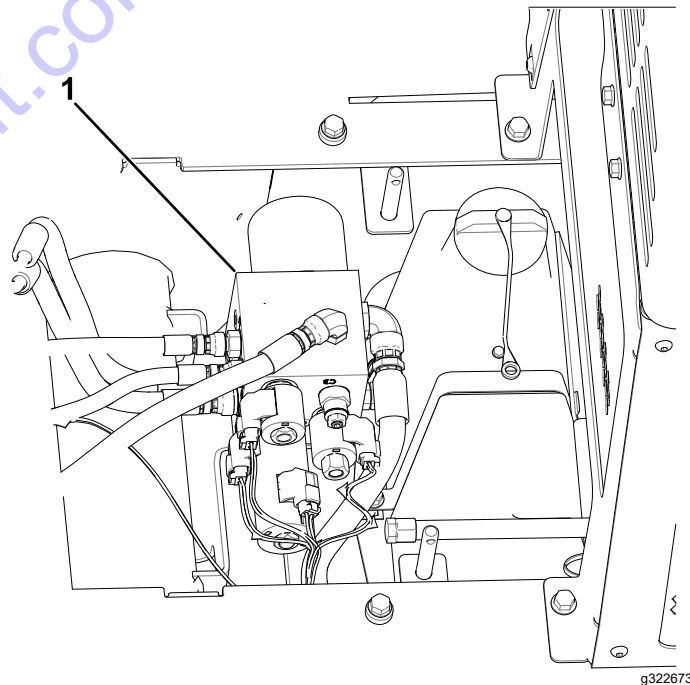

Figure 12

g322673

1. Hydraulic-manifold block
4. Disconnect the hose fittings in the manifold block and allow the fluid to drain into the pan.

Note: Dispose of the used fluid at a certified recycling center.

5. Connect the hose fittings.
6. Use a hoist or have 2 people hold up the hopper and remove the cylinder lock.
7. Carefully lower the hopper to the machine frame.

Raising the Hopper without Power

1. Raise the machine and support it using jack stands rated for the weight of the machine; refer to [Specifications \(page 9\)](#).
2. Place a large drain pan under the hopper lift cylinder ([Figure 13](#)).

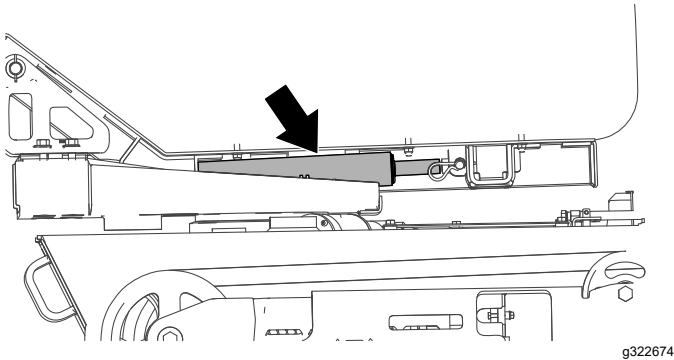

Figure 13
Hopper lift cylinder

3. Remove the hydraulic hose from the barrel end of the lift cylinder and allow the fluid to drain into the pan.
4. Use a hoist or have 2 people hold up the hopper and install the cylinder lock.
5. After making repairs, install the hose to the cylinder, then check the hydraulic-fluid level; add fluid if necessary. Refer to [Checking the Hydraulic-Fluid Level for the Lift and Slew System \(page 36\)](#).

Moving a Non-Functional Machine

Important: Do not tow or pull the machine without first opening the bypass valves in this procedure, or you will damage the hydraulic system.

Note: Opening the bypass valves will ease moving the machine, but the tracks may still skid due to their length and resistance.

1. If possible, raise the hopper and install the cylinder lock; refer to [Using the Cylinder Lock \(page 20\)](#).
2. Shut off the engine and remove the key.
3. Using a wrench, turn the bypass valve on the left and right transaxles so that the flat sides of the valve face left and right (Tow position) as shown in [Figure 14](#) and [Figure 15](#).

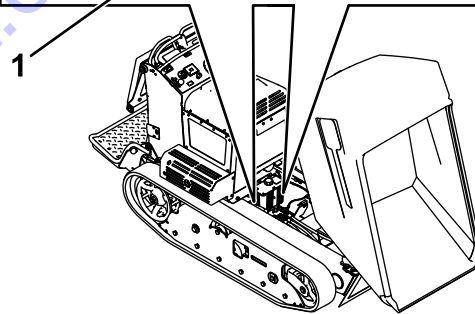
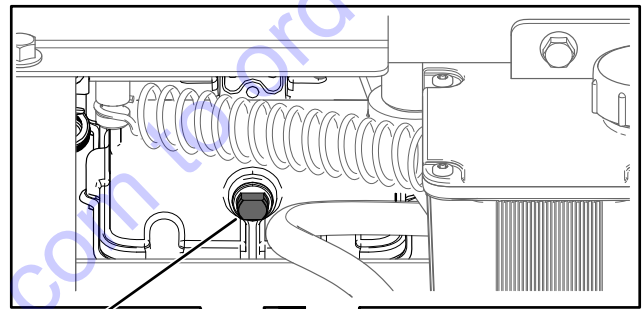

Figure 14

1. Bypass valve

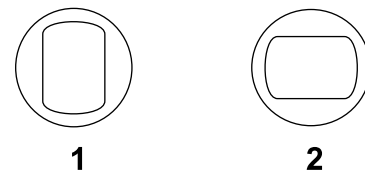

Figure 15

1. Tow position
2. Drive position

4. Tow the machine as required.
5. After repairing the machine, turn the bypass valves so that the flat sides face up and down (Drive position) as shown in [Figure 15](#).
6. Remove the cylinder lock and lower the hopper.

Transporting the Machine

Use a heavy-duty trailer or truck with full-width ramps to transport the machine. Ensure that the trailer or truck has all the necessary brakes, lighting, and marking as required by law. Please carefully read all the safety instructions. Knowing this information could help you, your family, pets or bystanders avoid injury. Refer to your local ordinances for trailer and tie-down requirements.

Important: Do not operate or drive the machine on roadways.

1. Lower the hopper.
2. If using a trailer, connect it to the towing vehicle and connect the safety chains.
3. If applicable, connect the trailer brakes.
4. Carefully load the machine onto the trailer or truck.
5. Shut off the engine, remove the key, and set the brake.
6. Use the metal tie-down loops on the machine to securely fasten the machine to the trailer or truck with straps, chains, cable, or ropes (Figure 16).

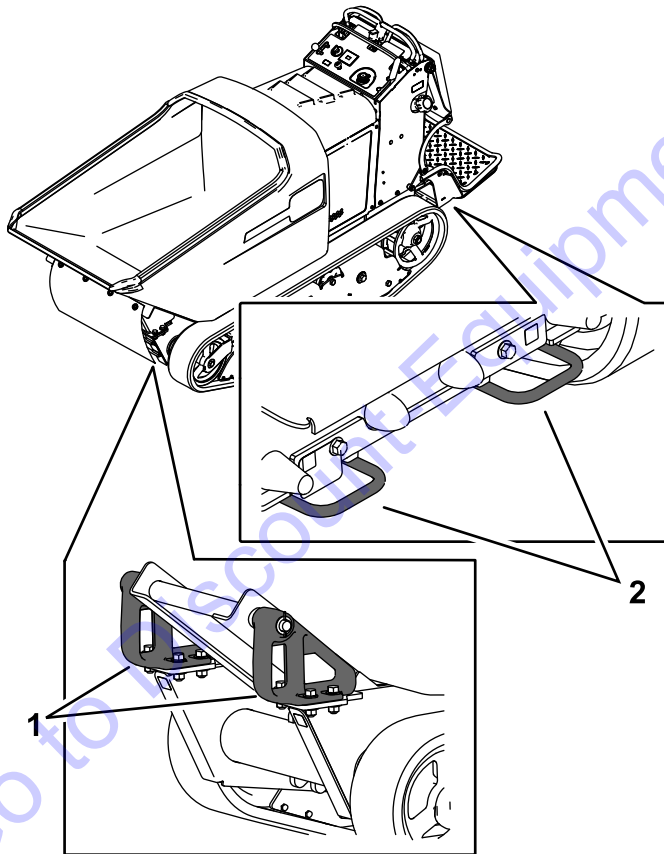

Figure 16

g185890

1. Front tie-down loops
2. Rear tie-down loops

Lifting the Machine

Rotate the hopper and hoist the machine using the lifting points as shown in Figure 17

Note: Take up the slack in the chain or straps to properly balance the unit.

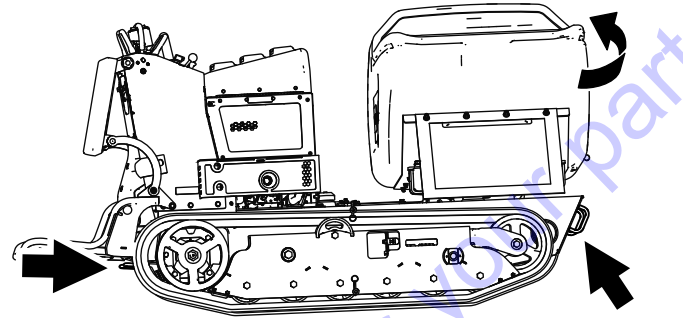

Figure 17

g324717

Maintenance

Note: Determine the left and right sides of the machine from the normal operating position.

Recommended Maintenance Schedule(s)

Maintenance Service Interval	Maintenance Procedure
After the first 10 hours	<ul style="list-style-type: none"> • Check and adjust the track tension (every 10 hours until 50 hours).
Before each use or daily	<ul style="list-style-type: none"> • Check the engine-oil level. • Clean the blower housing (more often under extremely dusty, dirty conditions). • Check the condition of the track. • Check the parking brake operation. • Check the hydraulic-fluid level for the drive system. • Check the hydraulic-fluid level for the lift and slew system. • Remove debris from the machine. • Check for loose fasteners.
Every 25 hours	<ul style="list-style-type: none"> • Service or replace the air-cleaner foam element (more often under extremely dusty, dirty conditions).
Every 40 hours	<ul style="list-style-type: none"> • Check the hydraulic lines for leaks, loose fittings, kinked lines, loose mounting supports, wear, and deterioration.
Every 50 hours	<ul style="list-style-type: none"> • Grease the machine (grease immediately after every washing). • Check the battery. • Check and adjust the track tension.
Every 100 hours	<ul style="list-style-type: none"> • Replace the air-cleaner paper element (more often under extremely dusty, dirty conditions). • Change the engine oil and the engine-oil filter. • Check the spark plug. • Remove the cooling shrouds and clean the cooling areas (more often under extremely dusty, dirty conditions). • Replace the fuel filter (more often under dusty, dirty conditions). • Inspect the drive belt. • Clean dirt buildup in the chassis.
Every 300 hours	<ul style="list-style-type: none"> • Replace the spark plug. • Check the road wheels. • Replace the drive belt. • Change the hydraulic fluid and filter for the drive system. • Change the hydraulic fluid for the lift and slew system. • Replace the hydraulic filter for the lift and slew system.

Important: Refer to your engine owner's manual for additional maintenance procedures.

▲ CAUTION

If you leave the key in the switch, someone could accidentally start the engine and seriously injure you or bystanders.

Remove the key from the switch before you perform any maintenance.

Pre-Maintenance Procedures

Maintenance Safety

- Park the machine on a level surface, engage the parking brake, and shut off the engine. Wait for all movement to stop and allow the machine to cool before adjusting, servicing, cleaning, or storing the machine.
- Disconnect the battery or remove the spark-plug wire before making any repairs. Disconnect the negative terminal first and the positive terminal last. Connect the positive terminal first and negative last.
- Charge the batteries in an open, well-ventilated area, away from spark and flames. Unplug the charger before connecting or disconnecting it from the battery. Wear protective clothing and use insulated tools.
- Battery acid is poisonous and can cause burns. Avoid contact with skin, eyes, and clothing. Protect your face, eyes, and clothing when working with a battery.
- Battery gasses can explode. Keep cigarettes, sparks, and flames away from the battery.
- Do not change the engine governor setting or overspeed the engine.
- Support the machine with jack stands whenever you work under the machine.
- Carefully release pressure from components with stored energy.
- Keep all parts in good working condition and all hardware tightened. Replace all worn or damaged decals.
- Use the cylinder lock to secure the hopper in the raised position.
- Never tamper with safety devices.
- To ensure safe, optimal performance of the machine, use only genuine Toro replacement parts. Replacement parts made by other manufacturers could be dangerous, and such use could void the product warranty.
- Seek immediate medical attention if fluid is injected into skin. Injected fluid must be surgically removed within a few hours by a doctor.
- Ensure that all hydraulic-fluid hoses and lines are in good condition and all hydraulic connections and fittings are tight before applying pressure to the hydraulic system. Keep your body and hands away from pinhole leaks or nozzles that eject high-pressure hydraulic fluid.

- Use cardboard or paper to find hydraulic leaks.
- Safely relieve all pressure in the hydraulic system before performing any work on the hydraulic system.

Releasing the Cushion for Rear Access

You can release the cushion for rear access to the machine for maintenance or adjustment.

1. Lower the platform.
2. Loosen the twist knobs on each side of the machine (Figure 18).

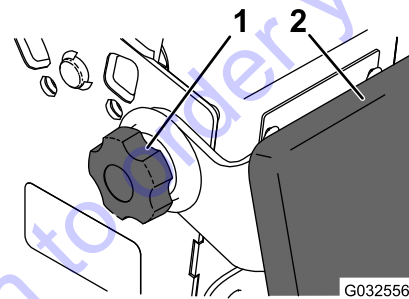

Figure 18

1. Twist knob
 2. Cushion
3. Remove the cushion and lower it to the platform.
 4. Perform any maintenance or adjustment on the machine.
 5. Raise the cushion, and slide it onto the pins on both sides of the machine.
 6. Tighten the twist knobs.

Using the Cylinder Lock

Installing the Cylinder Lock

1. Park the machine on a level surface, move the motion-control levers to the NEUTRAL-LOCK position, engage the parking brake, and fully raise the hopper.
2. Remove the 2 cotterless pins securing the cylinder lock to the machine.

2. Fully raise the hopper.
3. Shut off the engine.
4. Remove the cotterless pins securing the cylinder lock.
5. Place the cylinder lock on the posts inside the machine frame and secure with the cotterless pins.
6. Lower the hopper.

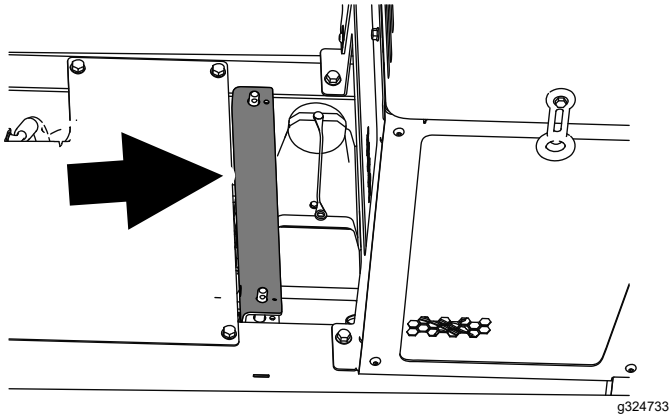

Figure 19

3. Slide the cylinder lock over the lift-cylinder rod and secure with the cotterless pins.

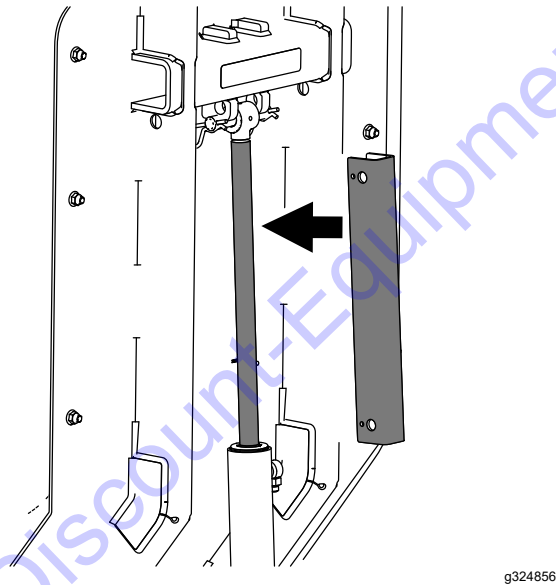

Figure 20

Removing and Storing the Cylinder Lock

Important: Remove the cylinder lock from the lift-cylinder rod and fully secure it in the storage position before operating the machine.

1. Start the machine.

Lubrication

Greasing the Machine

Service Interval: Every 50 hours

When operating the machine under normal conditions, lubricate all grease fittings for the bearings and bushings with No. 2 lithium grease. Lubricate the bearings and bushings immediately after every washing, regardless of the interval listed. Apply a light coating of oil onto the control cables.

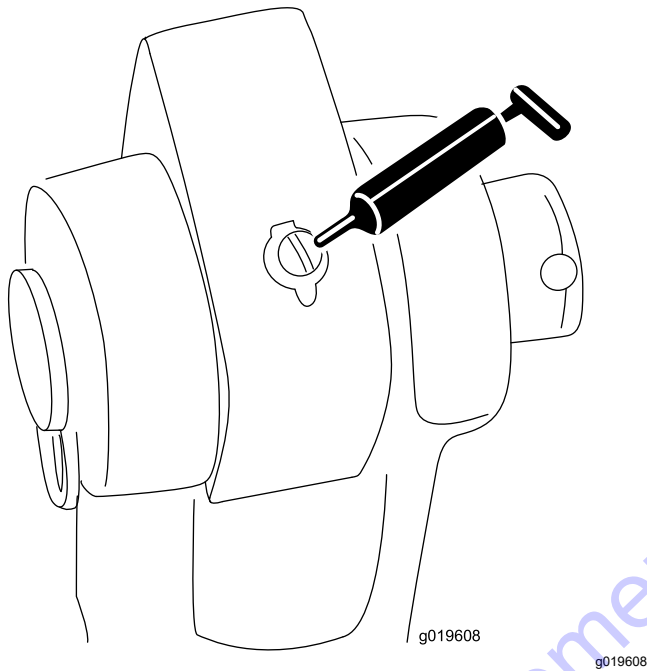

Figure 21
Cylinder pivots (2)

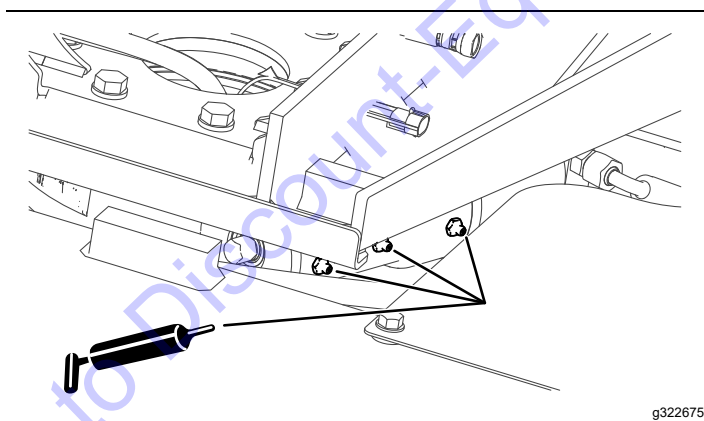

Figure 22
Hydraulic slew motor (3)

Engine Maintenance

Servicing the Air Cleaner

Service Interval: Every 25 hours—Service or replace the air-cleaner foam element (more often under extremely dusty, dirty conditions).

Every 100 hours—Replace the air-cleaner paper element (more often under extremely dusty, dirty conditions).

Note: Operating the engine with loose or damaged air-cleaner components could allow unfiltered air into the engine, causing premature wear and failure.

Note: Service the air cleaner more often under extremely dusty, dirty conditions.

Removing the Elements

1. Rotate the latches outward.
2. Remove the cover to access the air-cleaner elements (Figure 23).

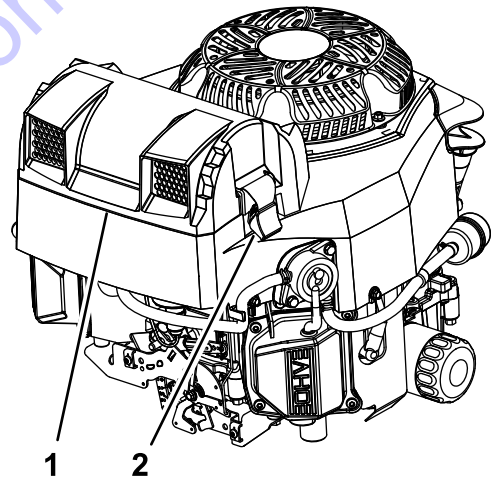

Figure 23

1. Air-cleaner cover
2. Air-cleaner latch

3. Remove the foam and paper elements (Figure 24).
4. Remove the foam element from the paper element (Figure 24).

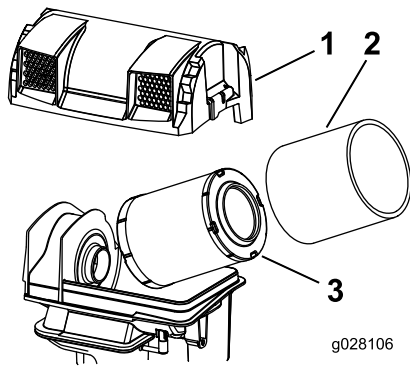

Figure 24

1. Air-cleaner cover
2. Foam element
3. Paper element

Servicing the Foam Element

1. Wash the foam element in warm water and detergent.
2. Rinse and allow it to air dry.
3. Lightly oil the foam element with new oil and squeeze out excess oil.

Servicing the Paper Element

1. Gently tap the paper element to dislodge dirt.

Note: Do not wash the paper element or use pressurized air, as this damages the element.

Note: Replace a dirty, bent, or damaged element. Handle the new element carefully; do not use if the sealing surfaces are bent or damaged.

2. Clean the air-cleaner base as required, and check the condition.

Installing the Elements

1. Install the foam element onto the paper element.
2. Install the elements onto the air-cleaner base (Figure 24).
3. Install the cover, and secure it with the latches (Figure 23).

Checking the Engine-Oil Level

Service Interval: Before each use or daily

Important: Remember to add 80% of the oil, and then gradually fill it to the Full mark on the dipstick.

Important: Do not run the engine with the oil level above the Full mark or below the low mark. Otherwise, you may damage the engine.

1. Park the machine on a level surface, move the motion-control levers to the NEUTRAL-LOCK position, engage the parking brake, and lower the hopper.
2. Shut off the engine, and remove the key. Allow the engine to cool.
3. Open the cowl.
4. Check the engine-oil level as shown in Figure 25.

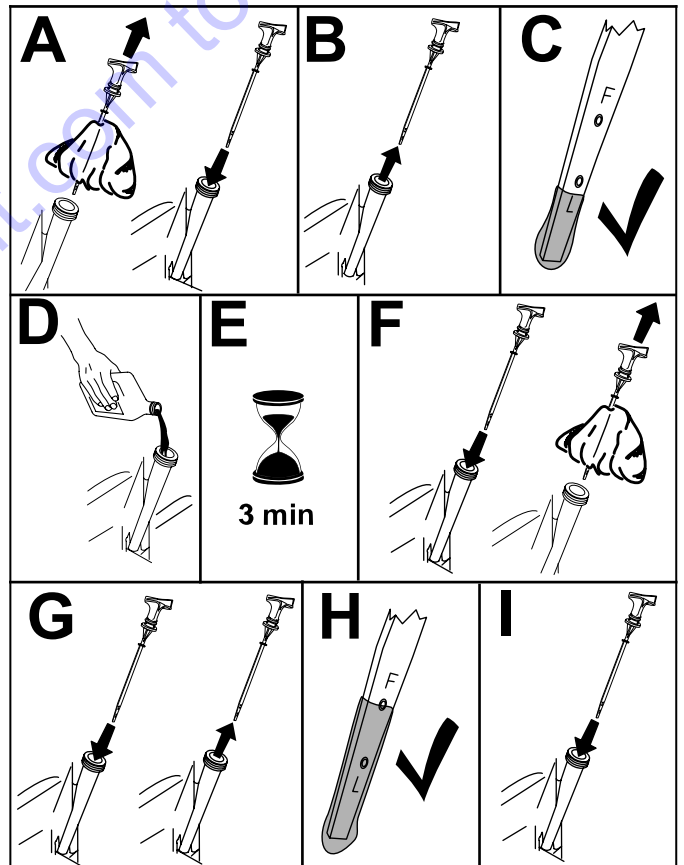

Figure 25

g243578

Changing the Engine Oil and Filter

Service Interval: Every 100 hours

Oil Type: Detergent oil (API service SJ or higher)

Engine Oil Capacity: 1.9 L (64 fl oz)

Viscosity: Refer to the table below.

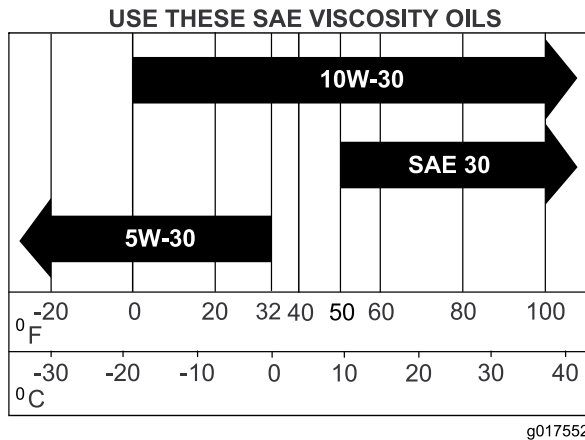
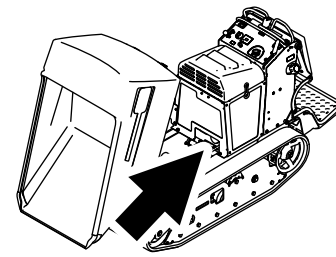

Figure 26



g185888

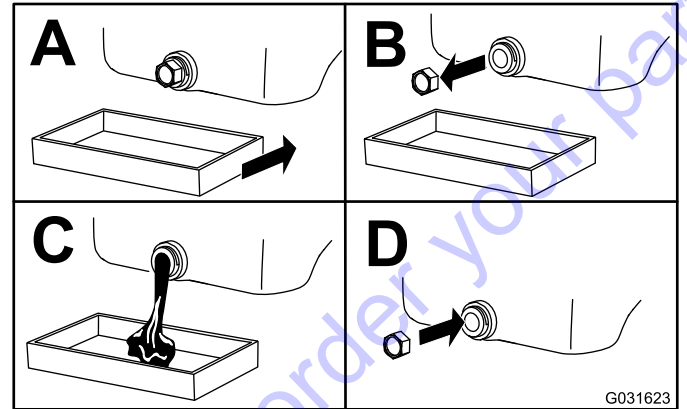

Figure 27

g031623

Change the engine oil while the engine is warm.

Note: Dispose of the used oil at a recycling center.

1. Park the machine on a level surface, move the motion-control levers to the NEUTRAL-LOCK position, engage the parking brake, raise the hopper, and install the cylinder lock.
2. Shut off the engine and remove the key.
3. Perform the following steps to change the engine oil:
 - A. Remove the drain plug and allow all of the existing oil to drain out of the engine (Figure 27).

B. Install the drain plug (Figure 27). Torque the plug to 13.6 N·m (10 ft-lb).

4. Change the engine-oil filter as shown in Figure 28.

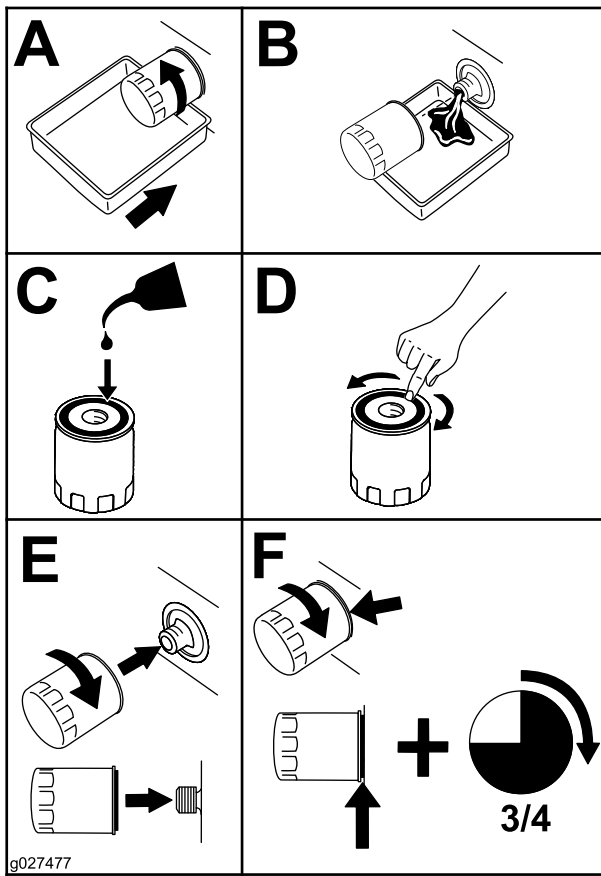

Figure 28

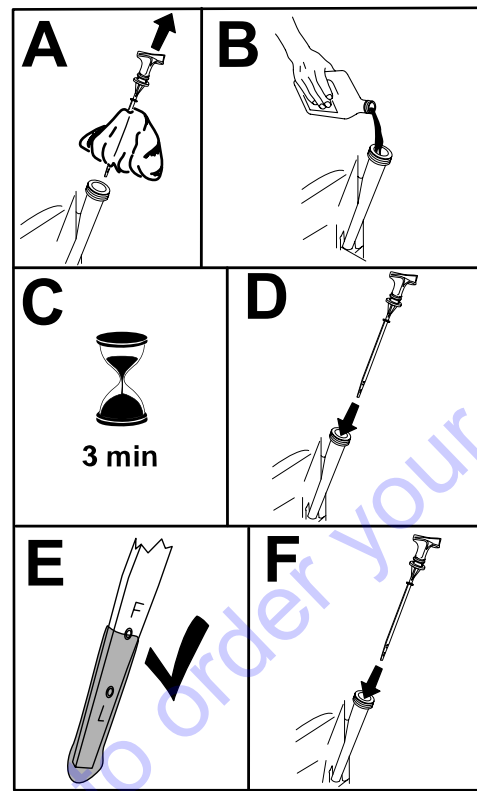

Figure 29

g243623

5. Slowly pour approximately 80% of the specified oil into the filler tube (Figure 29).

Servicing the Spark Plugs

Service Interval: Every 100 hours—Check the spark plug.

Every 300 hours—Replace the spark plug.

The spark plugs are RFI compliant. Equivalent alternate brand plugs can also be used.

Type: Champion XC12YC

Air Gap: 0.76 mm (0.03 inch)

Removing the Spark Plug

1. Park the machine on a level surface, move the motion-control levers to the NEUTRAL-LOCK position, engage the parking brake, and lower the hopper.
2. Shut off the engine and remove the key. Allow the engine to cool.
3. Before removing the spark plug(s), clean the area around the base of the plug to keep dirt and debris out of the engine.
4. Remove the spark plug (Figure 30).

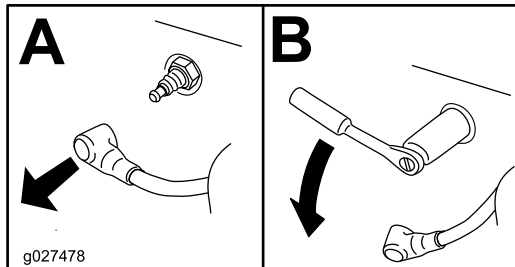

Figure 30

g027478

Installing the Spark Plug

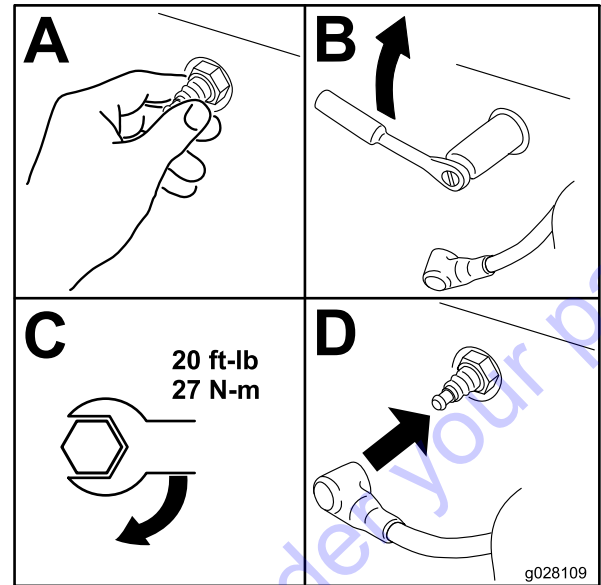

Figure 32

g028109

Checking the Spark Plug

Important: Do not clean the spark plug(s). Always replace the spark plug(s) when it has: a black coating, worn electrodes, an oily film, or cracks.

Note: If you see light brown or gray on the insulator, the engine is operating properly. A black coating on the insulator usually means the air cleaner is dirty.

Set the gap to 0.76 mm (0.03 inch).

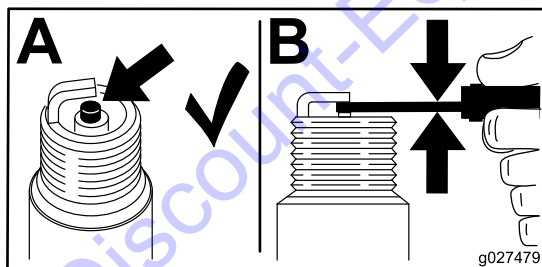

Figure 31

g027479

Important: Ensure that the spark plug is tightened to the correct torque specification. A loose spark plug may cause the cylinder head to overheat, while an overtightened spark plug may cause damage to the threads in the cylinder head.

Cleaning the Blower Housing

Every 100 hours/Yearly (whichever comes first)

To ensure proper cooling, ensure that the grass screen, cooling fins, and other external surfaces of the engine are kept clean at all times.

Ensure that the cooling shrouds are installed.

Important: Operating the engine with a blocked grass screen, dirty or plugged cooling fins, and/or cooling shrouds removed causes engine damage due to overheating.

Fuel System Maintenance

Replacing the Fuel Filter

Service Interval: Every 100 hours/Yearly (whichever comes first) (more often under dusty, dirty conditions).

1. Park the machine on a level surface, move the motion-control levers to the NEUTRAL-LOCK position, engage the parking brake, and lower the hopper.
2. Shut off the engine, and remove the key. Allow the engine to cool.
3. Replace the fuel filter as shown in [Figure 33](#).

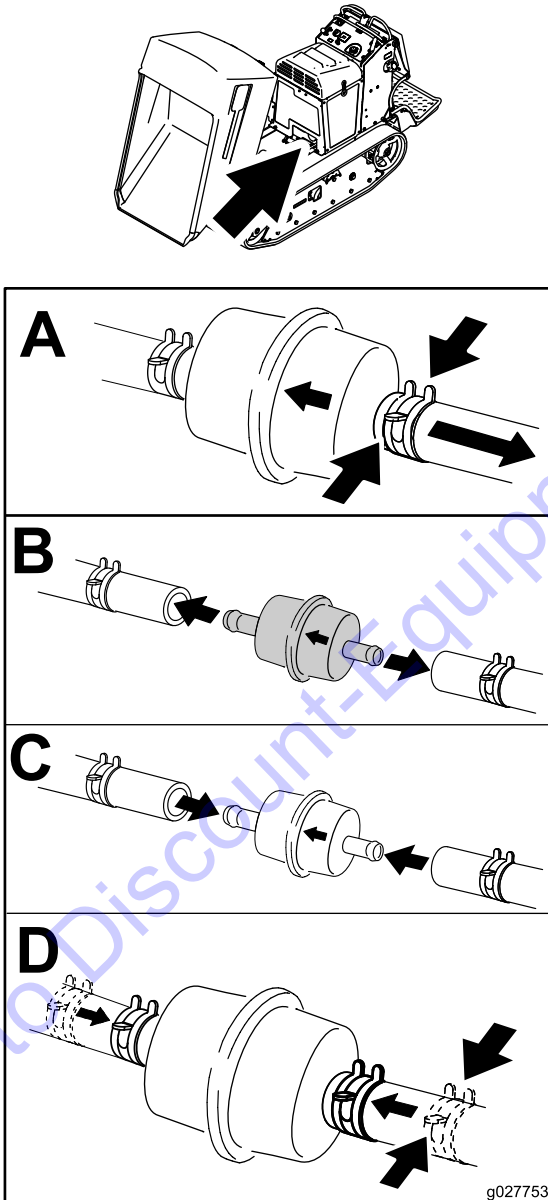

Figure 33

Draining the Fuel Tank

You can drain the fuel tank by removing it and pouring the fuel out of the fill neck; refer to [Removing the Fuel Tank \(page 27\)](#). You can also drain the fuel tank by using a siphon in the following procedure.

⚠ DANGER

In certain conditions, fuel is extremely flammable and highly explosive. A fire or explosion from fuel can burn you and others and can damage property.

- Drain fuel from the fuel tank when the engine is cold. Do this outdoors in an open area. Wipe up any fuel that spills.
- Never smoke when draining fuel and stay away from an open flame, or where a spark may ignite the fuel fumes.

1. Park the machine on a level surface, move the motion-control levers to the NEUTRAL-LOCK position, engage the parking brake, and lower the hopper.
2. Shut off the engine, and remove the key. Allow the engine to cool.
3. Clean around the fuel cap to prevent debris from getting into the fuel tank ([Figure 34](#)).
4. Remove the fuel cap.
5. Insert a syphon pump into the fuel tank.
6. Using the syphon pump, drain the fuel into a clean fuel can ([Figure 34](#)).
7. Wipe up any spilled fuel.

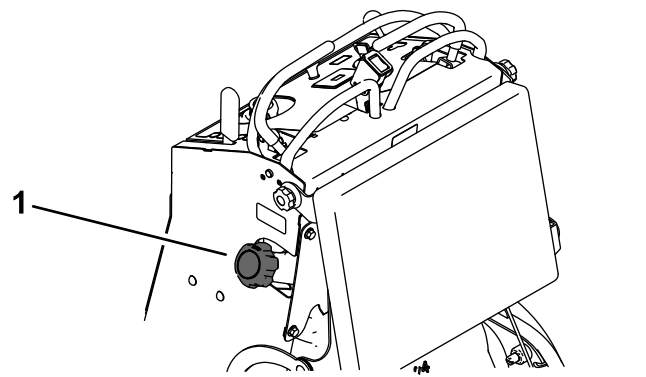

Figure 34

1. Fuel cap

Removing the Fuel Tank

1. Lower the platform.
2. Release the cushion; refer to [Releasing the Cushion for Rear Access](#) (page 19).
3. Remove the cross bracket ([Figure 35](#)).

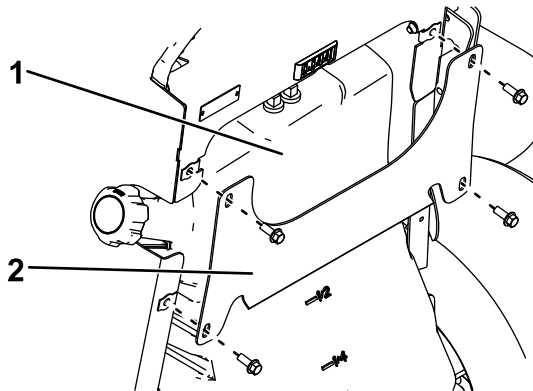

Figure 35

g186223

1. Fuel tank
2. Cross bracket

4. Remove the fuel tank and set it on the operator platform.

Note: If you want to move the fuel tank further from the machine, remove the fuel and vent lines from the top of the tank.

Electrical System Maintenance

Servicing the Battery

Service Interval: Every 50 hours

⚠ DANGER

Battery electrolyte contains sulfuric acid, which is fatal if consumed and causes severe burns.

Do not drink electrolyte and avoid contact with skin, eyes or clothing. Wear safety glasses to shield your eyes and rubber gloves to protect your hands.

Removing the Battery

⚠ WARNING

Battery terminals or metal tools could short against metal machine components, causing sparks. Sparks can cause the battery gasses to explode, resulting in personal injury.

- When removing or installing the battery, do not allow the battery terminals to touch any metal parts of the machine.
- Do not allow metal tools to short between the battery terminals and metal parts of the machine.

⚠ WARNING

Incorrect battery-cable routing could damage the machine and cables, causing sparks. Sparks can cause the battery gasses to explode, resulting in personal injury.

- Always disconnect the negative (black) battery cable before disconnecting the positive (red) cable.
- Always connect the positive (red) battery cable before connecting the negative (black) cable.

1. Park the machine on a level surface, move the motion-control levers to the NEUTRAL-LOCK position, engage the parking brake, and lower the hopper.
2. Shut off the engine, and remove the key. Allow the engine to cool.
3. Remove the negative battery cable from the battery ([Figure 36](#)).

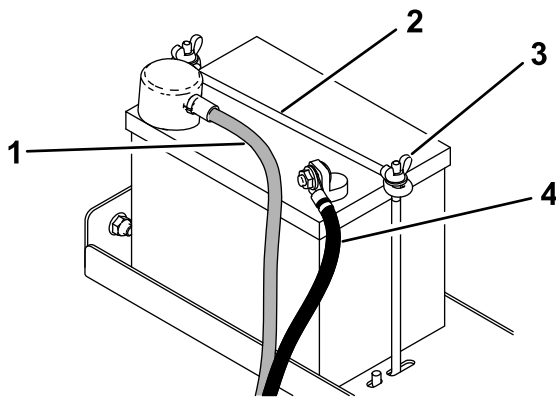

Figure 36

g185906

- | | |
|---------------------------|---------------------------|
| 1. Positive battery cable | 3. Wing nut (2) |
| 2. Securing rod | 4. Negative battery cable |

- Remove the positive battery cable from the battery (Figure 36).
- Remove the 2 wing nuts, securing rod, and the battery (Figure 36).

Installing the Battery

- Place the battery on the platform and secure it using the 2 wing nuts and the securing rod (Figure 36).
- Install the positive battery cable to the battery (Figure 36).
- Install the negative battery cable to the battery (Figure 36).

Charging the Battery

⚠ WARNING

Charging the battery produces gasses that can explode.

Never smoke near the battery and keep sparks and flames away from battery.

Important: Always keep the battery fully charged (1.265 specific gravity) to prevent battery damage when the temperature is below 0°C (32°F).

- Remove the battery from the chassis; refer to [Removing the Battery \(page 27\)](#).
- Perform the following steps to check the electrolyte level:
 - Ensure that the cell covers are free from dirt and debris.

Important: Dirt and debris that enters the battery cells causes damage to the battery.
 - Remove the covers from the top of the cells.
 - Ensure that the electrolyte solution covers the lead plates. Use distilled water to top off the solution level, if needed.
- Ensure that the filler caps are installed on the battery.
- Charge the battery for 1 hour at 25 to 30 A or 6 hours at 4 to 6 A.
- When the battery is fully charged, unplug the charger from the electrical outlet, and disconnect the charger leads from the battery posts (Figure 37).
- Install the battery onto the machine and connect the battery cables; refer to [Installing the Battery \(page 28\)](#).

Note: Do not run the machine with the battery disconnected; electrical damage may occur.

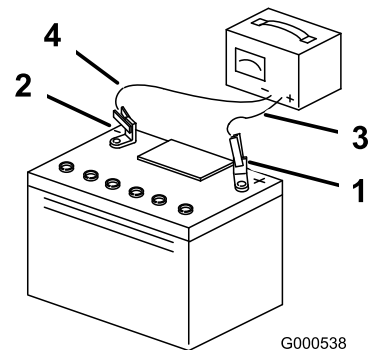

G000538

g000538

Figure 37

- | | |
|--------------------------|---------------------------|
| 1. Positive battery post | 3. Red (+) charger lead |
| 2. Negative battery post | 4. Black (-) charger lead |

Servicing the Fuses

The electrical system is protected by fuses and requires no maintenance. If a fuse blows, check the component or circuit for a malfunction or short.

1. Release the cushion from the rear of the machine.
2. Pull out the fuse to remove or replace it (Figure 38).
3. Install the cushion to the rear of the machine.

Note: Ensure that the correct-size fuse is installed (Figure 38).

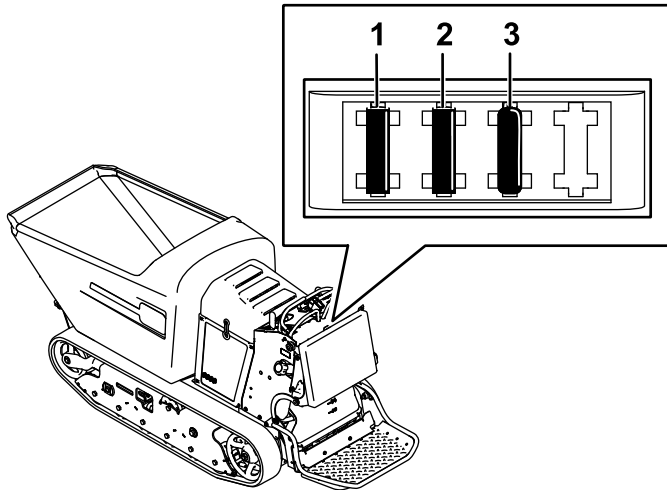

Figure 38

1. Main power fuse (15 A)
2. Auxiliary power fuse (15 A)
3. Logic fuse (7.5 A)

Drive System Maintenance

Servicing the Tracks

Service Interval: Before each use or daily—Check the condition of the track.

After the first 10 hours—Check and adjust the track tension (every 10 hours until 50 hours).

Every 50 hours—Check and adjust the track tension.

Every 300 hours—Check the road wheels.

Cleaning the Tracks

1. Park the machine on a level surface, move the motion-control levers to the NEUTRAL-LOCK position, engage the parking brake, and lower the hopper.
2. Shut off the engine, and remove the key. Allow the engine to cool.
3. Lift/support the side of the machine to be worked on so that the track is 7.6 to 10 cm (3 to 4 inches) off the ground.
4. Using a water hose or pressure washer, remove dirt from each track system.

Important: Ensure that you use high-pressure water to wash only the track area. Do not use a high-pressure washer to clean the rest of the machine. Do not use high-pressure water between the drive sprocket and the machine or you may damage the motor seals. High-pressure washing can damage the electrical system and hydraulic valves or deplete grease.

Important: Ensure that you fully clean the road wheels, the front wheel, and the drive sprocket (Figure 39). The road wheels should rotate freely when clean.

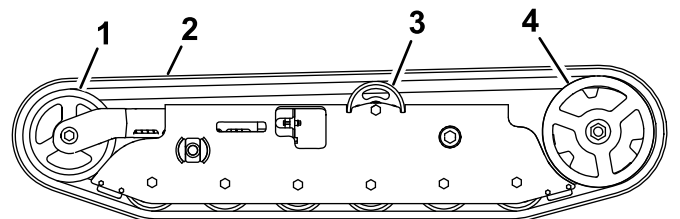

Figure 39

1. Front wheel
2. Track
3. Road wheel
4. Drive sprocket

Adjusting the Track Tension

If you place the tab of the tensioning tool along the rear edge of the tension nut, the other end of the tensioning tool should align with the edge of the tension arm as shown in [Figure 40](#). If the distance is not correct, adjust the track tension using the following procedure:

Note: If the tensioning tool is not available, the distance between the nut and edge of the tension arm should be 7.1 cm (2-13/16 inches).

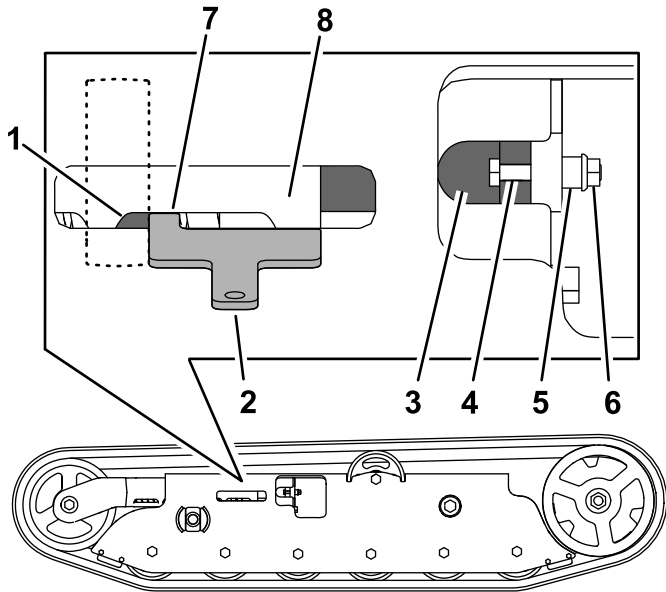

Figure 40
Left Track Shown

- | | |
|--|----------------|
| 1. Tension nut | 5. Spacer |
| 2. Tensioning tool (equal to 7.1 cm or 2-13/16 inches) | 6. Nut |
| 3. Tensioning bolt | 7. Tab |
| 4. Bolt (1/4 x 1-5/8 inches) | 8. Tension arm |

1. Park the machine on a level surface, move the motion-control levers to the NEUTRAL-LOCK position, engage the parking brake, and lower the hopper.
2. Shut off the engine, and remove the key. Allow the engine to cool.
3. Clean the tracks with high-pressure water.

Important: Ensure that you use high-pressure water to wash only the track area. Do not use a high-pressure washer to clean the rest of the machine. Do not use high pressure water between the drive sprocket and the machine or you may damage the motor seals. High-pressure washing can damage the electrical system and hydraulic valves or deplete grease.

4. Raise the machine so that the tracks are off the ground.
5. Clean the drive sprocket, the front wheel, and the road wheels. The road wheels should spin freely when clean.
6. Remove the bolt (1/4 x 1-5/8 inches), spacer, and nut ([Figure 40](#)).
7. Turn the tensioning bolt to adjust the distance between the tension nut and the end tangent of the tension tube until the distance is correct, as shown in [Figure 40](#).
8. Align the closest notch in the tensioning bolt to the bolt hole and secure the tensioning bolt with the bolt (1/4 x 1-5/8 inches), spacer, and nut ([Figure 40](#)).

Replacing the Tracks

Replace the tracks when they are badly worn.

1. Park the machine on a level surface, move the motion-control levers to the NEUTRAL-LOCK position, engage the parking brake, and lower the hopper.
2. Shut off the engine, and remove the key. Allow the engine to cool.
3. Lift/support the side of the machine to be worked on so that the track is 7.6 to 10 cm (3 to 4 inches) off the ground.
4. Remove the retaining bolt for the tensioning screw.
5. Release the drive tension by turning the tensioning screw clockwise ([Figure 40](#) and [Figure 41](#)).

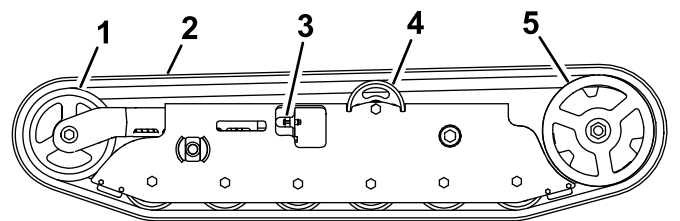

Figure 41

- | | |
|--|-------------------|
| 1. Front wheel | 4. Road wheel |
| 2. Track | 5. Drive sprocket |
| 3. Tensioning screw and retaining bolt | |

6. Remove the track at the top of the front wheel, peeling it off the wheel while rotating the track forward.
7. When the track is off the front wheel, remove it from the drive sprocket and road wheels ([Figure 41](#)).

8. Inspect the condition of the wheels. If the wheels show signs of wear, replace them at this time.
9. Beginning at the drive sprocket, coil the new track around the sprocket, ensuring that the lugs on the track fit between the spacers on the sprocket (Figure 41).
10. Push the track under the lugs and between the road wheels (Figure 41).
11. Starting at the bottom of the front wheel, install the track around the wheel by rotating the track rearward while pushing the lugs into the wheel.
12. Tension the track; refer to [Adjusting the Track Tension \(page 30\)](#).
13. Lower the machine to the ground.
14. Repeat steps 3 through 13 to replace the other track.

Servicing the Drive Belt

Inspecting the Drive Belt

Service Interval: Every 100 hours

1. Park the machine on a level surface, move the motion-control levers to the NEUTRAL-LOCK position, engage the parking brake, and lower the hopper.
2. Shut off the engine, and remove the key. Allow the engine to cool.
3. Release the cushion and remove the fuel tank; refer to [Releasing the Cushion for Rear Access \(page 19\)](#).
4. Inspect the belt (Figure 42). Replace the belt if it is worn; refer to [Replacing the Drive Belt \(page 31\)](#).

Note: The signs of a worn belt include squealing while the belt is rotating, frayed edges, burn marks, and cracks on the belt.

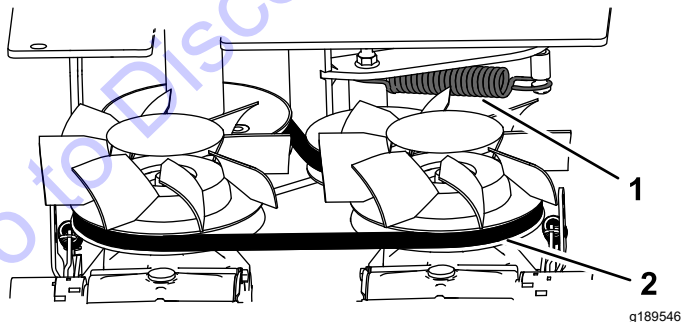

Figure 42

1. Extension spring
2. Belt

Replacing the Drive Belt

Service Interval: Every 300 hours

1. Park the machine on a level surface, move the motion-control levers to the NEUTRAL-LOCK position, engage the parking brake, and lower the hopper.
2. Shut off the engine, and remove the key. Allow the engine to cool.
3. Release the cushion and remove the fuel tank; refer to [Removing the Fuel Tank \(page 27\)](#).
4. Raise the rear of the machine and support the machine on jack stands.
5. Remove the skid plate (Figure 43).

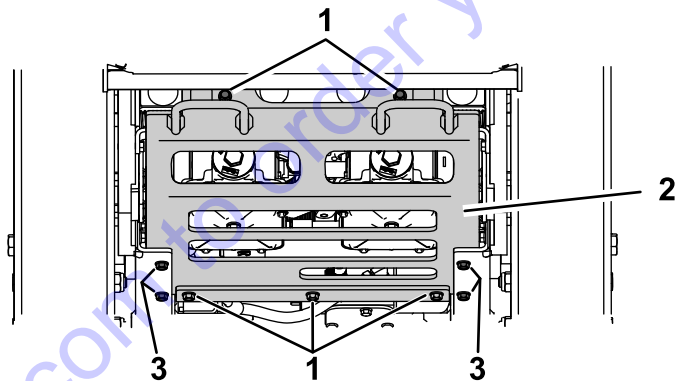

Figure 43

1. Rear bolt (2)
2. Skid plate
3. Side bolt (4)

6. Remove the extension spring (Figure 42).
7. Remove the 2 bolts and 2 nuts and loosen the 2 set screws on the coupler. Remove the gear pump from the pump mount (Figure 44).

Note: You do not need to remove the fittings from the pump.

Controls System Maintenance

Adjusting the Motion-Control Levers

If the motion-control levers do not align horizontally, adjust the right side motion-control lever.

1. Park the machine on a level surface, lower the hopper, engage the parking brake, shut off the engine, and remove the key.
2. Push the motion-control levers down out of the NEUTRAL-LOCK position (Figure 46).
3. Check if the right motion-control lever aligns horizontally with the left motion-control lever (Figure 46).

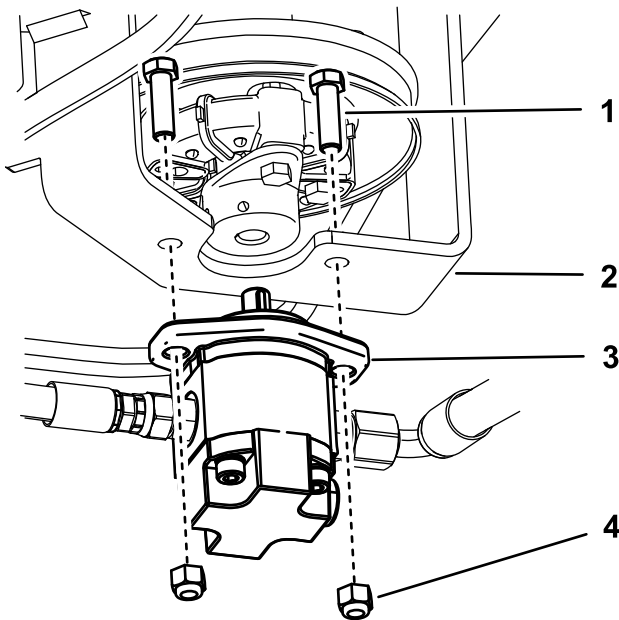

Figure 44

g189559

- | | |
|---------------|--------------|
| 1. Bolt (2) | 3. Gear pump |
| 2. Pump mount | 4. Nut (2) |

8. Remove the drive belt from the engine pulley and 2 transmission pulleys.

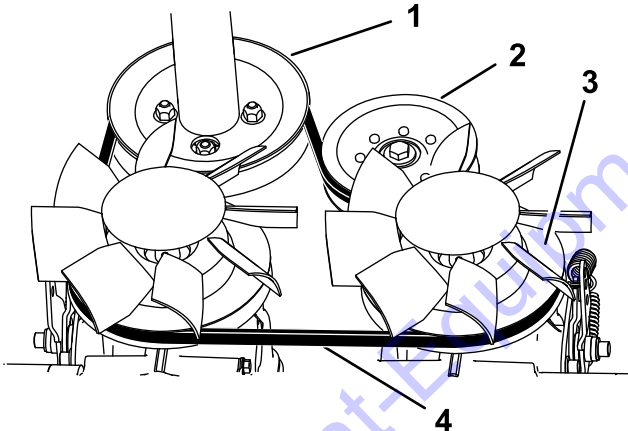

Figure 45

g189571

- | | |
|------------------|----------------------------|
| 1. Engine pulley | 3. Transmission pulley (2) |
| 2. Idler pulley | 4. Belt |

9. Route the new belt around the engine pulley and 2 transmission pulleys (Figure 45).

10. Install the gear pump (Figure 44).

11. Install the extension spring (Figure 42).

12. Install the fuel tank; refer to [Removing the Fuel Tank \(page 27\)](#).

13. Raise the cushion.

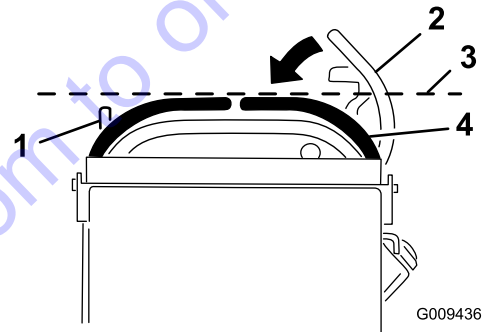

Figure 46

G009436

g009436

- | | |
|-------------------------------|--|
| 1. Left motion-control lever | 3. Check the horizontal alignment here |
| 2. Right motion-control lever | 4. Right motion-control lever in the Neutral-lock position |

4. To adjust the motion-control levers horizontally, you must adjust the cam.

5. Release the cushion from the rear of the machine.

6. Loosen the nut holding the cam (Figure 47).

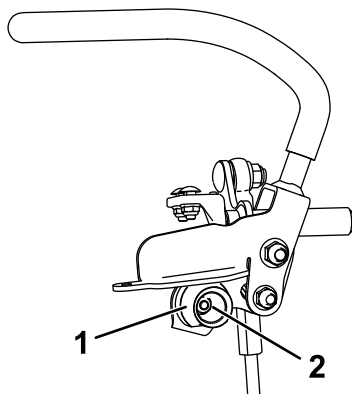

Figure 47

g189389

1. Cam 2. Nut

7. Adjust the cam until it aligns with the left motion-control lever and tighten the nut for the cam.

Note: Moving the cam clockwise (in the vertical position) lowers the handle; moving the cam counterclockwise (in the vertical position) raises the handle.

Important: Ensure that the flat portion of the cam does not go above a vertical position (right or left); otherwise you may damage the switch.

8. Repeat steps 2 through 7 for the left motion-control lever.

4. Release the parking brake.

5. Move the motion-control levers forward.

Note: The machine should move forward.

Note: If the machine does not move forward, refer to [Adjusting the Parking Brake \(page 33\)](#).

6. Engage the parking brake and shut off the machine.

Adjusting the Parking Brake

1. Remove the fuel tank; refer to [Removing the Fuel Tank \(page 27\)](#).
2. Inside the left side of the control tower, adjust the nuts until the cables are taut ([Figure 48](#)).

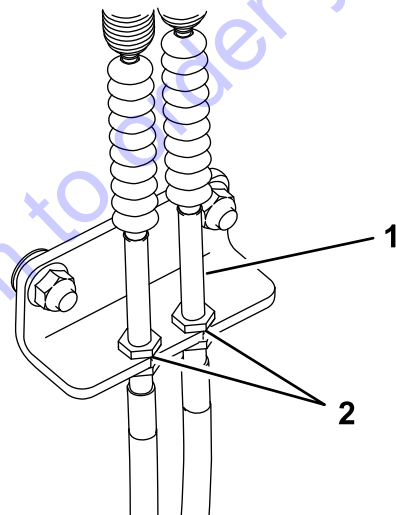

Figure 48

g186011

1. Cable 2. Nuts

3. Install the fuel tank, cross bracket, and cushion.

Brake Maintenance

⚠ WARNING

If the brakes are not properly adjusted, serious injury, or death, may occur.

Check your brakes daily. If you encounter any problems with the brakes while operating the machine, stop the machine immediately and bring it to an Authorized Service Dealer for repair.

Checking the Parking Brake

Service Interval: Before each use or daily

1. Park the machine on a level surface, lower the hopper, and engage the parking brake.
2. Start the engine and move the throttle lever to the FAST position.
3. Move the motion-control levers forward.

Note: The machine should not move forward.

Note: If the machine moves forward, refer to [Adjusting the Parking Brake \(page 33\)](#).

Hydraulic System Maintenance

⚠ WARNING

Hydraulic fluid escaping under pressure can penetrate skin and cause injury. Fluid injected into the skin must be surgically removed within a few hours by a doctor familiar with this form of injury; otherwise gangrene may result.

- Keep your body and hands away from pinhole leaks or nozzles that eject high-pressure hydraulic fluid.
- Use cardboard or paper to find hydraulic leaks; never use your hands.

Servicing the Hydraulic Drive System

Hydraulic-Fluid Specifications

Expansion-tank capacity: 1.4 L (1.5 US qt)

Hydraulic-fluid type: Toro® HYPR-OIL™ 500

Important: Always use the correct hydraulic fluid. Unspecified fluids will damage the hydraulic system.

Note: Many hydraulic fluids are almost colorless, making it difficult to spot leaks. A red dye additive for the hydraulic system oil is available in 0.67 fl oz (20 ml) bottles. One bottle is sufficient for 15 to 22 L (4 to 6 US gallons) of hydraulic fluid. Order Part No. 44-2500 from your authorized Toro distributor.

Checking the Hydraulic-Fluid Level for the Drive System

Service Interval: Before each use or daily

1. Park the machine on a level surface, move the motion-control levers to the NEUTRAL-LOCK position, engage the parking brake, and lower the hopper.
2. Shut off the engine, and remove the key. Allow the engine to cool.
3. Open the cowl.
4. Use the sight window to check the fluid level in the expansion tank (Figure 49).

Note: The fluid level should be at the fill line on the decal.

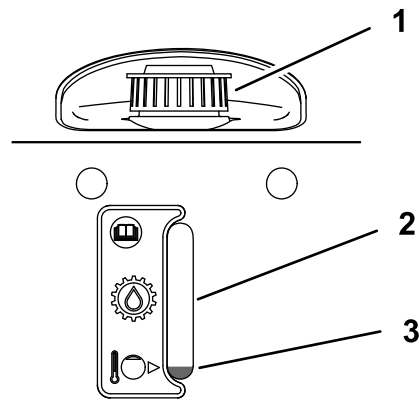

Figure 49

1. Expansion-tank cap
2. Sight window
3. Fluid at fill line

5. If the oil level is low, remove the cap lock and cap from the top of the expansion tank (Figure 50), and add enough of the specified hydraulic fluid to raise it to the proper level.

Important: Ensure that the expansion-tank fluid level is at the proper level. Overfilling the tank may cause fluid to purge out of the breather hole.

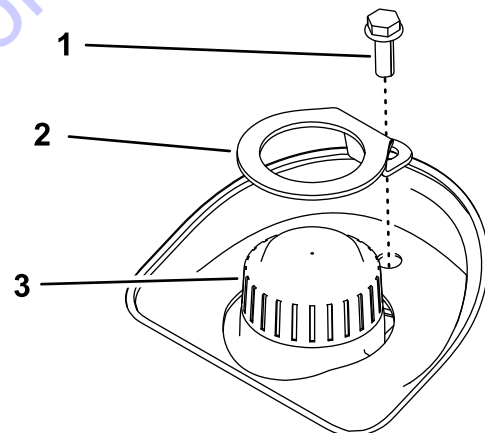

Figure 50

1. Bolt
2. Cap lock
3. Cap

6. Install the cap and cap lock. Wipe up any spilled hydraulic fluid.

Changing the Hydraulic Fluid and Filter for the Drive System

Service Interval: Every 300 hours

1. Park the machine on a level surface, move the motion-control levers to the NEUTRAL-LOCK position, engage the parking brake, and lower the hopper.

2. Shut off the engine, and remove the key. Allow the engine to cool.
3. Lower the cushion and remove the fuel tank; refer to [Removing the Fuel Tank \(page 27\)](#).
4. Remove the 9 bolts (5 rear, 4 side) from the skid plate and remove the skid plate ([Figure 51](#)).

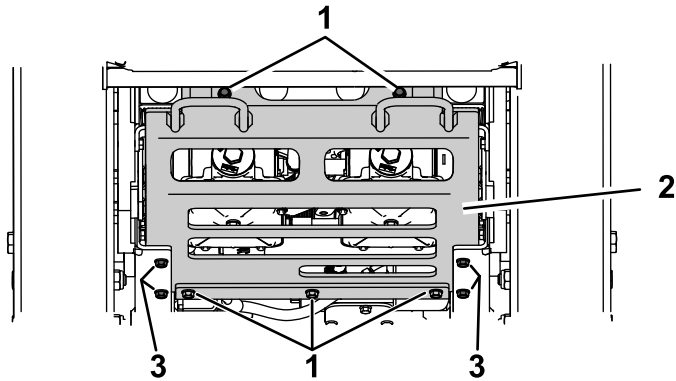

Figure 51

1. Rear bolts (5)
2. Skid plate
3. Side bolts (4)

5. Locate the drain plug in the bottom of each transmission, then place a drain pan under the plugs ([Figure 52](#)).

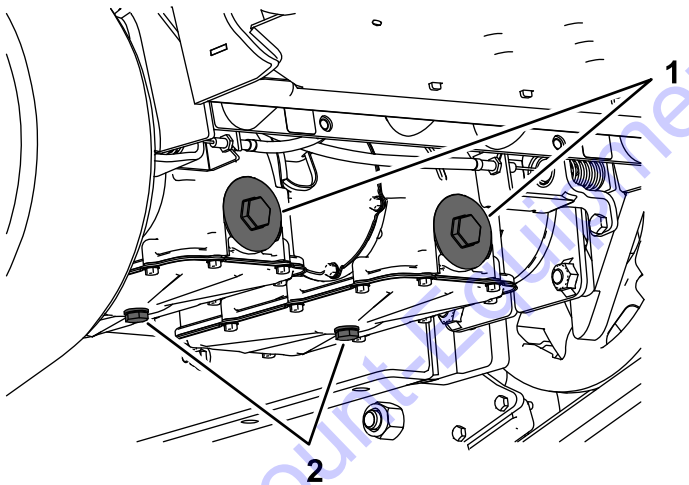

Figure 52

1. Hydraulic filters
2. Drain plugs

6. Remove the drain plugs and allow the hydraulic fluid to fully drain from the machine.
7. Remove the hydraulic-filter cap and hydraulic filter from each transmission ([Figure 52](#)).
8. Install a new hydraulic filter with the spring side facing out and the hydraulic-filter cap for each transmission. Torque to 13 to 15 N·m (115 to 135 in-lb).
9. Install the drain plugs.

10. Loosen the vent plug in each transmission until loose ([Figure 53](#)).

Note: This allows air to escape the hydraulic system as you add hydraulic fluid.

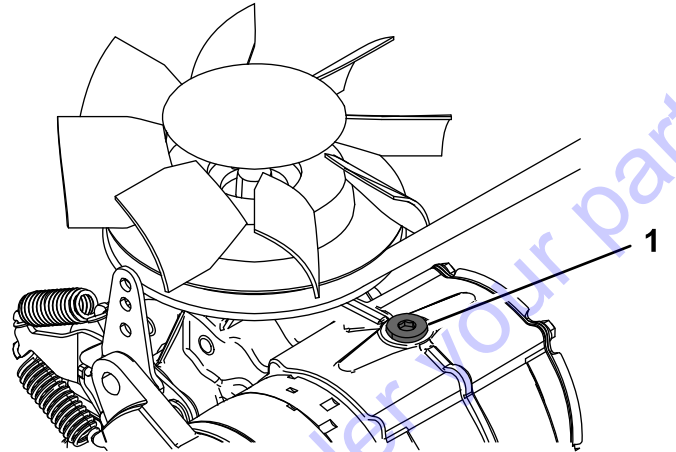

Figure 53

1. Vent plug

11. Slowly add approximately 6.2 L (208 fl oz) fluid to the expansion tank until it starts to come out of the vent plugs.

Important: Use the fluid specified in [Hydraulic-Fluid Specifications \(page 34\)](#) or equivalent. Other fluids could cause system damage.

Important: Monitor the level of fluid in the expansion tank so that you do not overfill it.

12. Tighten the vent plugs.
13. Add hydraulic fluid to the expansion tank until it reaches the fluid line ([Figure 49](#)).

Important: Do not overfill.

14. Install the expansion-tank cap.
15. Install the skid plate ([Figure 51](#)).
16. Install the fuel tank; refer to [Removing the Fuel Tank \(page 27\)](#).
17. Start the engine and let it run for about 2 minutes to purge air from the system.
18. Shut off the engine and check for leaks.

Bleeding the Hydraulic Drive System

Bleed the traction hydraulic system whenever you perform maintenance on the hydrostatic transmission or add hydraulic fluid to the expansion tank.

1. Park the machine on a level surface, move the motion-control levers to the NEUTRAL-LOCK position, engage the parking brake, and lower the hopper.
2. Shut off the engine, and remove the key. Allow the engine to cool.
3. Check the hydraulic fluid level and add hydraulic fluid as necessary; refer to [Servicing the Hydraulic Drive System \(page 34\)](#).
4. Support the machine on jack stands, high enough to raise the tracks off the ground.
5. Start the machine. Slowly move the motion-control levers forward and reverse 5 to 6 times.
6. Check the hydraulic fluid level and add hydraulic fluid as necessary.
7. Repeat steps 5 and 6 as necessary until all the air is completely purged from the system.

Note: Purging is complete when you obtain normal forward and reverse speed.

8. Lower the machine and repeat the procedure with the tracks on the ground.

Servicing the Hydraulic Lift and Slew System

Hydraulic-Fluid Specifications

Reservoir-tank capacity: 6.6 L (1.75 US gallons)

Hydraulic-fluid type: Toro Premium All Season Hydraulic Fluid or Mobil® 424 Hydraulic Fluid

Important: Always use the correct hydraulic fluid. Unspecified fluids will damage the hydraulic system.

Note: Many hydraulic fluids are almost colorless, making it difficult to spot leaks. A red dye additive for the hydraulic system oil is available in 0.67 fl oz (20 ml) bottles. One bottle is sufficient for 15 to 22 L (4 to 6 US gallons) of hydraulic fluid. Order Part No. 44-2500 from your authorized Toro distributor.

Checking the Hydraulic-Fluid Level for the Lift and Slew System

Service Interval: Before each use or daily

1. Park the machine on a level surface, move the motion-control levers to the NEUTRAL-LOCK position, engage the parking brake, rotate and raise the hopper, and install the cylinder lock.
2. Shut off the machine and remove the key. Allow the machine to cool completely.
3. Remove the filler cap from the reservoir tank ([Figure 54](#)).

⚠ CAUTION

The hydraulic breather/filler cap is designed to pressurize the reservoir to 34 kPa (5 psi).

Loosen the cap slowly to avoid injury whenever adding fluid or working on the hydraulic system. Use a wrench on the hex directly under the cap.

Changing the Hydraulic Fluid for the Lift and Slew System

Service Interval: Every 300 hours

1. Park the machine on a level surface, move the motion-control levers to the NEUTRAL-LOCK position, engage the parking brake, raise the hopper, and install the cylinder lock.
2. Shut off the machine and remove the key. Allow the machine to cool completely.
3. Remove the filler cap from the reservoir tank (Figure 54).

⚠ CAUTION

The hydraulic breather/filler cap is designed to pressurize the reservoir to 34 kPa (5 psi).

Loosen the cap slowly to avoid injury whenever adding oil or working on the hydraulic system. Use a wrench on the hex directly under the cap.

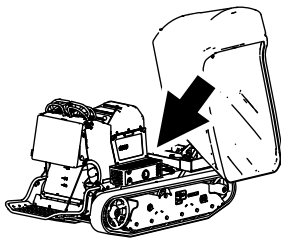

g325619

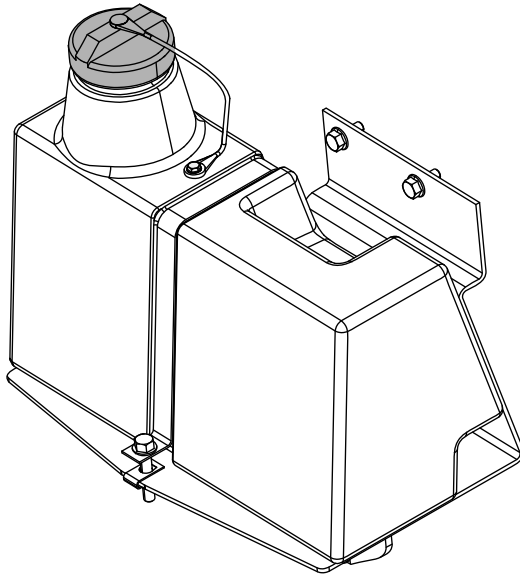

g323276

Figure 54

1. Hex
2. Filler cap

4. Remove the dipstick from the filler neck and wipe it with a clean rag. Insert the dipstick into the filler neck; then remove it and check the level of the fluid. The fluid level should be up to the mark on the dipstick.

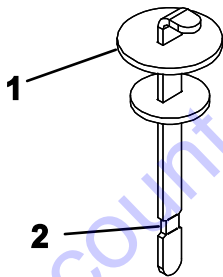

G010029

g010029

Figure 55

1. Dipstick
2. Full mark

5. If the level is low, add the specified hydraulic fluid to raise the level to the full mark.
6. Install the dipstick and cap onto the filler neck.
7. Wipe up any spilled hydraulic fluid.
8. Remove the cylinder lock and lower the hopper.

4. Place a large drain pan under the fittings at the bottom of the reservoir tank.
5. Disconnect a hose fitting and allow the fluid to drain into the pan.
6. When finished, install and tighten the fitting.

Note: Dispose of the used fluid at a certified recycling center.

7. Fill the reservoir tank with approximately 5.9 L (200 fl oz) and install the filler cap.
8. Remove the cylinder lock.
9. Start the engine. Raise and lower the hopper 3 times to fill the cylinder and hoses with fluid.
10. Raise the hopper and install the cylinder lock.
11. Shut off the engine.
12. Add 0.73 L (25 fl oz) of hydraulic fluid and install the filler cap.

Note: The fluid level should be at the Full Mark (Figure 55). Do not fill past this line.

13. Remove the cylinder lock.
14. Start the engine. Raise and lower the hopper several times to remove air from the system.

Replacing the Hydraulic Filter for the Lift and Slew System

Service Interval: Every 300 hours

Important: Do not substitute an automotive oil filter or severe hydraulic system damage may result.

1. Park the machine on a level surface, move the motion-control levers to the NEUTRAL-LOCK position, engage the parking brake, raise the hopper, and install the cylinder lock.
2. Shut off the engine, and remove the key. Allow the engine to cool.
3. Replace the filter as shown in [Figure 56](#).

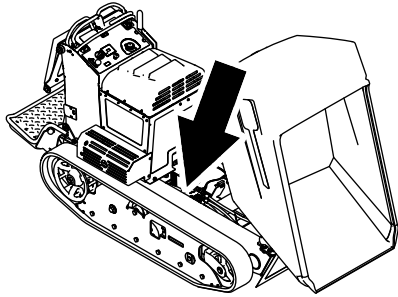

g186042

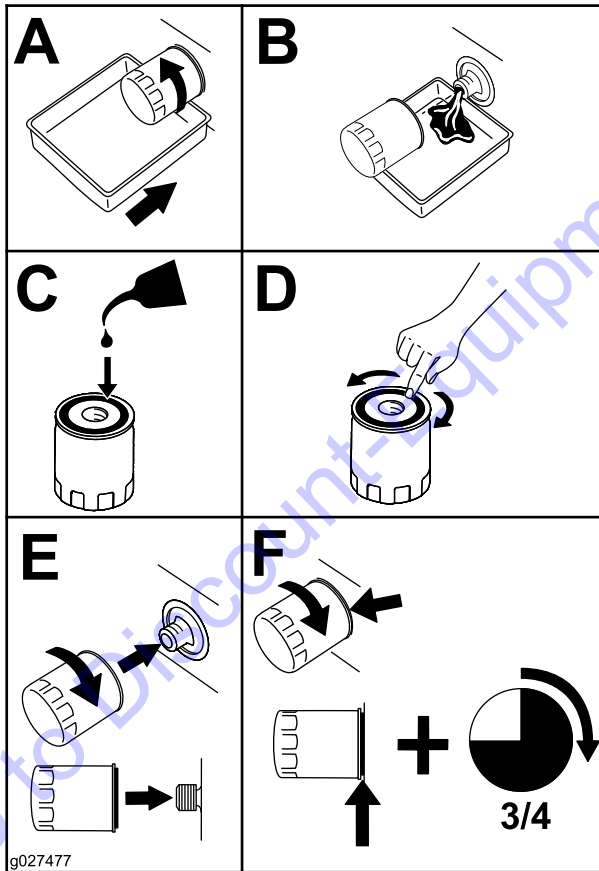

Figure 56

g027477

5. Shut off the engine and check for leaks.
6. Check the fluid level in the reservoir tank, refer to [Checking the Hydraulic-Fluid Level for the Lift and Slew System \(page 36\)](#).

Note: Do not overfill the reservoir tank.

7. Remove the cylinder lock and lower the hopper.

Checking the Hydraulic Lines

Service Interval: Every 40 hours—Check the hydraulic lines for leaks, loose fittings, kinked lines, loose mounting supports, wear, and deterioration. (Make necessary repairs before operating.)

⚠ WARNING

Hydraulic fluid escaping under pressure can penetrate skin and cause injury. Fluid injected into the skin must be surgically removed within a few hours by a doctor familiar with this form of injury; otherwise, gangrene may result.

- Keep your body and hands away from pinhole leaks or nozzles that eject high-pressure hydraulic fluid.
- Use cardboard or paper to find hydraulic leaks; never use your hands.

4. Start the engine and let it run for about 2 minutes to purge air from the system.

Cleaning

Removing Debris from the Machine

Service Interval: Before each use or daily

Every 100 hours

1. Park the machine on a level surface, move the motion-control levers to the NEUTRAL-LOCK position, engage the parking brake, and lower the hopper.
2. Shut off the engine, and remove the key. Allow the engine to cool.
3. Clean the inside of the hopper using a hose.
4. Clean any debris from under the hopper.
5. Wipe away debris from the air cleaner.
6. Clean any debris buildup on the engine and in the transmission with a brush or blower.

Important: It is preferable to blow dirt out, rather than washing it out. If you use water, keep it away from electrical parts and hydraulic valves. Do not use a high-pressure washer. High-pressure washing can damage the electrical system and hydraulic valves or deplete grease.

Go to Discount-Equipment.com to order your parts

Storage

Storage Safety

- Let the engine cool before storing the machine.
- Do not store the machine or fuel near flames or drain the fuel indoors.

Storing the Machine

Service Interval: Before each use or daily

1. Engage the parking brake, shut off the engine, and remove the key.
2. Remove dirt and grime from the external parts of the entire machine, especially the engine. Clean dirt and chaff from the outside of the engine cylinder head fins and blower housing.
3. Service the air cleaner; refer to [Servicing the Air Cleaner \(page 21\)](#).
4. Grease the machine; refer to [Greasing the Machine \(page 21\)](#).
5. Change the engine crankcase oil; refer to [Changing the Engine Oil and Filter \(page 23\)](#).
6. For storage over 30 days, prepare the machine as follows:
 - A. Add a petroleum-based fuel stabilizer/conditioner to the fuel in the tank. **Do not use an alcohol-based stabilizer (ethanol or methanol).**
 - B. Run the engine to distribute conditioned fuel through the fuel system for 5 minutes.
 - C. Shut off the engine, allow it to cool, and drain the fuel tank using a pump-type syphon.
 - D. Start the engine and run it until it shuts off.
 - E. Choke the engine.
 - F. Start and run the engine until it does not start again.
 - G. Dispose of fuel properly. Recycle as per local codes.

Important: Do not store fuel containing stabilizer/conditioner longer than the duration recommended by the fuel-stabilizer manufacturer.

7. Remove the spark plugs and check the condition of them; refer to [Checking the Spark Plug \(page 25\)](#).
8. Prepare the engine as follows:
 - A. With the spark plugs removed from the engine, pour 2 tablespoons of engine oil into the spark plug holes.

- B. Place a rag over the spark plug holes to catch any oil spray, then turn the key to crank the engine and distribute the oil inside the cylinder.
- C. Install the spark plugs.

Note: Do not install the wire on the spark plugs.

9. Check and tighten all bolts, nuts, and screws. Repair or replace any part that is damaged.
10. Paint all scratched or bare metal surfaces. Paint is available from your Authorized Service Dealer.
11. Store the machine in a clean, dry garage or storage area.
12. Cover the machine to protect it and keep it clean.

Troubleshooting

Problem	Possible Cause	Corrective Action
The engine does not start, starts hard, or fails to keep running.	<ol style="list-style-type: none"> 1. The fuel tank is empty or the shutoff valve is closed. 2. A spark-plug wire is loose or disconnected. 3. A spark plug is pitted, fouled, or the gap is incorrect. 4. The air cleaner is dirty. 5. Dirt is in the fuel filter. 6. Dirt, water, or stale fuel is in the fuel system. 	<ol style="list-style-type: none"> 1. Fill the fuel tank with fuel and open the valve 2. Install the wire on spark plug. 3. Install a new, correctly gapped spark plug. 4. Service the air-cleaner element. 5. Replace the fuel filter. 6. Contact an Authorized Service Dealer.
The engine loses power.	<ol style="list-style-type: none"> 1. The engine load is excessive. 2. The air cleaner is dirty. 3. The oil level in the crankcase is low. 4. The cooling fins and air passages under the engine blower housing are plugged. 5. A spark plug is pitted, fouled, or the gap is incorrect. 6. The vent hole in the fuel cap is plugged. 7. Dirt is in the fuel filter. 8. Dirt, water, or stale fuel is in the fuel system. 	<ol style="list-style-type: none"> 1. Reduce the ground speed. 2. Service the air-cleaner element. 3. Add oil to the crankcase. 4. Remove the obstruction from the cooling fins and air passages. 5. Install a new, correctly gapped spark plug. 6. Clean or replace the fuel cap. 7. Replace the fuel filter. 8. Contact an Authorized Service Dealer.
The engine overheats.	<ol style="list-style-type: none"> 1. The engine load is excessive. 2. The oil level in the crankcase is low. 3. The cooling fins and air passages under the engine blower housing are plugged. 	<ol style="list-style-type: none"> 1. Reduce the ground speed. 2. Add oil to the crankcase. 3. Remove the obstruction from the cooling fins and air passages.
The machine does not drive.	<ol style="list-style-type: none"> 1. The hydraulic-fluid in the transmission is low. 2. Air is in the hydraulic system. 3. A drive belt slipped. 4. A drive belt idler spring is missing. 5. The bypass valves are in the tow position. 	<ol style="list-style-type: none"> 1. Add hydraulic fluid to the hydraulic fluid expansion tank in the tower. 2. Bleed the air out the hydraulic system. 3. Replace the pump-drive belt. 4. Replace the pump-drive belt idler spring. 5. Turn the bypass valves to the drive position.

California Proposition 65 Warning Information

What is this warning?

You may see a product for sale that has a warning label like the following:



WARNING: Cancer and Reproductive Harm—www.p65Warnings.ca.gov.

What is Prop 65?

Prop 65 applies to any company operating in California, selling products in California, or manufacturing products that may be sold in or brought into California. It mandates that the Governor of California maintain and publish a list of chemicals known to cause cancer, birth defects, and/or other reproductive harm. The list, which is updated annually, includes hundreds of chemicals found in many everyday items. The purpose of Prop 65 is to inform the public about exposure to these chemicals.

Prop 65 does not ban the sale of products containing these chemicals but instead requires warnings on any product, product packaging, or literature with the product. Moreover, a Prop 65 warning does not mean that a product is in violation of any product safety standards or requirements. In fact, the California government has clarified that a Prop 65 warning "is not the same as a regulatory decision that a product is 'safe' or 'unsafe.'" Many of these chemicals have been used in everyday products for years without documented harm. For more information, go to <https://oag.ca.gov/prop65/faqs-view-all>.

A Prop 65 warning means that a company has either (1) evaluated the exposure and has concluded that it exceeds the "no significant risk level"; or (2) has chosen to provide a warning based on its understanding about the presence of a listed chemical without attempting to evaluate the exposure.

Does this law apply everywhere?

Prop 65 warnings are required under California law only. These warnings are seen throughout California in a wide range of settings, including but not limited to restaurants, grocery stores, hotels, schools, and hospitals, and on a wide variety of products. Additionally, some online and mail order retailers provide Prop 65 warnings on their websites or in catalogs.

How do the California warnings compare to federal limits?

Prop 65 standards are often more stringent than federal and international standards. There are various substances that require a Prop 65 warning at levels that are far lower than federal action limits. For example, the Prop 65 standard for warnings for lead is 0.5 µg/day, which is well below the federal and international standards.

Why don't all similar products carry the warning?

- Products sold in California require Prop 65 labelling while similar products sold elsewhere do not.
- A company involved in a Prop 65 lawsuit reaching a settlement may be required to use Prop 65 warnings for its products, but other companies making similar products may have no such requirement.
- The enforcement of Prop 65 is inconsistent.
- Companies may elect not to provide warnings because they conclude that they are not required to do so under Prop 65; a lack of warnings for a product does not mean that the product is free of listed chemicals at similar levels.

Why does Toro include this warning?

Toro has chosen to provide consumers with as much information as possible so that they can make informed decisions about the products they buy and use. Toro provides warnings in certain cases based on its knowledge of the presence of one or more listed chemicals without evaluating the level of exposure, as not all the listed chemicals provide exposure limit requirements. While the exposure from Toro products may be negligible or well within the "no significant risk" range, out of an abundance of caution, Toro has elected to provide the Prop 65 warnings. Moreover, if Toro does not provide these warnings, it could be sued by the State of California or by private parties seeking to enforce Prop 65 and subject to substantial penalties.

PARTS FINDER

**Search Website
by Part Number**



**Search Manual
Library For Parts
Manual & Lookup Part
Numbers – Purchase
or Request Quote**

Search Manuals

Enter your information to help us find the right parts manual for your machine.

* Brand:

* Model:

* Serial:

* Part Number:

SEARCH

**Can't Find Part or
Manual? Request Help
by Manufacturer,
Model & Description**

Parts Order Form

Please fill in the following information to help us find the right part for your machine.

Manufacturer:	<input type="text"/>
Model:	<input type="text"/>
Description:	<input type="text"/>
Part Number:	<input type="text"/>
Quantity:	<input type="text"/>
Notes:	<input type="text"/>

Submit

Discount-Equipment.com is your online resource for quality parts & equipment.

Florida: **561-964-4949** Outside Florida TOLL FREE: **877-690-3101**

Need parts?

Click on this link: <http://www.discount-equipment.com/category/5443-parts/> and choose one of the options to help get the right parts and equipment you are looking for. Please have the machine model and serial number available in order to help us get you the correct parts. If you don't find the part on the website or on one of the online manuals, please fill out the request form and one of our experienced staff members will get back to you with a quote for the right part that your machine needs.

We sell worldwide for the brands: Genie, Terex, JLG, MultiQuip, Mikasa, Essick, Whiteman, Mayco, Toro Stone, Diamond Products, Generac Magnum, Airman, Haulotte, Barreto, Power Blanket, Nifty Lift, Atlas Copco, Chicago Pneumatic, Allmand, Miller Curber, Skyjack, Lull, Skytrak, Tsurumi, Husquvarna Target, Stow, Wacker, Sakai, Mi-T-M, Sullair, Basic, Dynapac, MBW, Weber, Bartell, Bennar Newman, Haulotte, Ditch Runner, Menegotti, Morrison, Contec, Buddy, Crown, Edco, Wyco, Bomag, Laymor, EZ Trench, Bil-Jax, F.S. Curtis, Gehl Pavers, Heli, Honda, ICS/PowerGrit, IHI, Partner, Imer, Clipper, MMD, Koshin, Rice, CH&E, General Equipment, Amida, Coleman, NAC, Gradall, Square Shooter, Kent, Stanley, Tamco, Toku, Hatz, Kohler, Robin, Wisconsin, Northrock, Oztec, Toker TK, Rol-Air, APT, Wylie, Ingersoll Rand / Doosan, Innovatech, Con X, Ammann, Mecalac, Makinex, Smith Surface Prep, Small Line, Wanco, Yanmar