

TELEHANDLER

MODELS

**634, 642,
842 and 844**



SHOWN WITH
OPTIONAL EQUIPMENT



	Mustang 634	Mustang 642	Mustang 842	Mustang 844
Capacities				
Lift				
Lift Capacity (kg)	6000 lbs. (2722)	6600 lbs. (2994)	8000 lbs. (3629)	8000 lbs. (3629)
Lift Height (m)	34' 3" (10.4)	42' (12.8)	42' (12.8)	44' (13.4)
Lift Capacity at Max. Lift Height (kg)	4000 lbs. (1814)	6600 lbs. (2994)	7000 lbs. (3175)	7000 lbs. (3175)
Max. Forward Reach (m)	23' 3" (7.0)	28' 3" (8.6)	28' 3" (8.6)	30' 5" (9.3)
Lift Capacity at Max. Forward Reach (kg)	900 lbs. (408)	1000 lbs. (453)	1000 lbs. (453)	1000 lbs. (453)
Max. Reach Below Ground (mm)	2' (610)	1' 2" (356)	1' 2" (356)	1' 4" (406)
Engine				
Manufacturer	John Deere	John Deere	John Deere	John Deere
Power (kW)	Std. 99 hp (74)	Std. 99 hp (74)	Std. 115 hp (86)	Std. 115 hp (86)
Optional Power (kW)	Opt. 115 hp (86)	Opt. 115 hp (86)	N/A	N/A
Aspiration	Turbo	Turbo	Turbo	Turbo
Model	4045T	4045T	4045T	4045T
Components				
Transmission -				
Power Shift	Clark 3-Speed	Clark 3-Speed	Clark 3-Speed	Clark 3-Speed
Drive (Full-Time)	4-Wheel	4-Wheel	4-Wheel	4-Wheel
Steering	4-Wheel, 2-Wheel, Crab	4-Wheel, 2-Wheel, Crab	4-Wheel, 2-Wheel, Crab	4-Wheel, 2-Wheel, Crab
Brakes (4-wheel)				
Hydraulic	Internal Wet Disc	Internal Wet Disc	Internal Wet Disc	Internal Wet Disc
Parking Brake	SAHR (Spring Applied, Hydraulic Release)	SAHR (Spring Applied, Hydraulic Release)	SAHR (Spring Applied, Hydraulic Release)	SAHR (Spring Applied, Hydraulic Release)
Axle Manufacturer				
Hydraulic System				
Pump Type	Gear	Gear	Gear	Gear
Total Capacity (L/min)	29 gpm (110)	40 gpm (151)	40 gpm (151)	40 gpm (151)
System Pressure (bar)	3000 psi (207)	3000 psi (207)	3000 psi (207)	3000 psi (207)
Hydraulic Tank Capacity	35 gal. (133)	47 gal. (178)	47 gal. (178)	47 gal. (178)
Specifications				
Approx. Weight (kg)	15,100 lbs. (6850)	22,000 lbs. (9979)	23,350 lbs. (10,591)	23,500 lbs. (10,660)
Length - Less forks (m)	16' (4.9)	19' 1" (5.82)	19' 1" (5.82)	19' 10" (6.05)
Width (m)	7' 10" (2.4)	8' 2.4" (2.5)	8' 2.4" (2.5)	8' 2.4" (2.5)
Ground Clearance (mm)	1' 2" (355)	1' 4" (406)	1' 4" (406)	1' 4" (406)
Wheel Base (m)	9' 2" (2.8)	10' (3)	10' (3)	10' (3)
Turning Radius (m)	12' 6" (3.8)	13' 8" (4.2)	13' 8" (4.2)	13' 8" (4.2)
Overall Height (m)	7' 10" (2.4)	7' 8" (2.3)	7' 8" (2.3)	7' 8" (2.3)
Frame Leveling	±10°	±10°	±10°	±10°
Fuel Capacity (L)	29 gal. (110)	47 gal. (178)	47 gal. (178)	47 gal. (178)
Work Platform System (WPS):				
	Optional	Optional	Optional	Optional
Radio Remote Boom Control				
	Optional	Optional	Optional	Optional
Additional Options:				
	All-Weather Cab, Air Conditioning, Lights, Tire Options, Cold Start Kit, Clutch Cut-Out, Special Paint, Aux. Hydraulics, Centrifugal Pre-cleaner Package	All-Weather Cab, Lights, Tire Options, Cold Start Kit, Clutch Cut-Out, Special Paint, Aux. Hydraulics, Special Paint, Outrigger Package and Centrifugal Pre-cleaner Package	All-Weather Cab, Lights, Tire Options, Cold Start Kit, Clutch Cut-Out, Special Paint, Aux. Hydraulics, Special Paint, Outrigger Package and Centrifugal Pre-cleaner Package	All-Weather Cab, Lights, Tire Options, Cold Start Kit, Clutch Cut-Out, Special Paint, Aux. Hydraulics, Special Paint, Outrigger Package and Centrifugal Pre-cleaner Package
Tire Options:				
	15.00 x 19.5/12 PR 15.00 x 19.5/12 PR (Foam-Filled) 405/70 R20 (14.5 x R20) Radial Traction 405/70 R20 (14.5 x R20) Radial - Foam-Filled	13.00 x 24/12 PR 13.00 x 24/12 PR (Foam-Filled) 13.00 x 24/12 PR - Rock	13.00 x 24/12 PR 13.00 x 24/12 PR (Foam-Filled) 13.00 x 24/12 PR - Rock	13.00 x 24/12 PR 13.00 x 24/12 PR (Foam-Filled) 13.00 x 24/12 PR - Rock

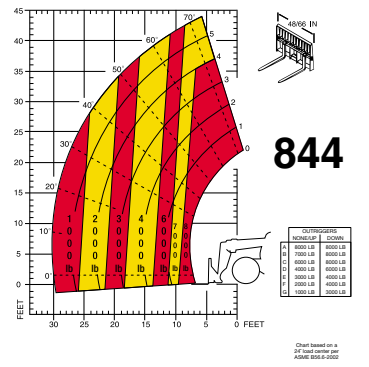
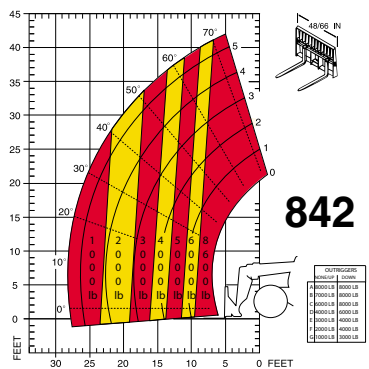
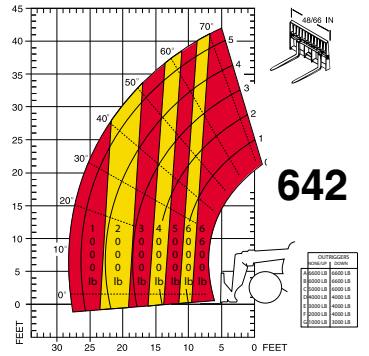
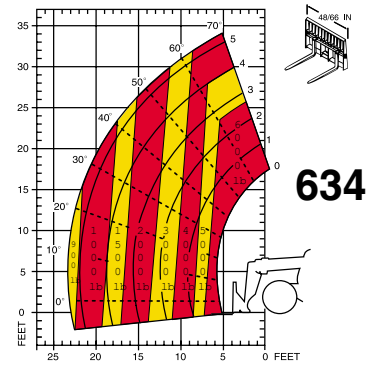

CONTACT YOUR MUSTANG DEALER TODAY!

SAFETY IS NO ACCIDENT. Mustang Manufacturing Company reminds you that before operating any piece of equipment, be sure to read and understand the operator's manual. U.S. OSHA regulations require that forklift operators be trained and certified. Additionally, be sure all safety devices and shields are securely in place and functioning properly. Mustang Manufacturing Company reserves the right to make changes in specifications and add improvements at any time without notice or obligation.



MUSTANG
www.mustangmfg.com
1880 Austin Road

Owatonna, MN 55060-0547
507-451-7112 Fax: 507-451-8209

© 2006 Mustang Manufacturing Company, Inc.
All Rights Reserved.

TEL 634/642/842/844
Rev. 8/2006 Printed in the U.S.A.