



An Oshkosh Corporation Company



www.Discount-Equipment.com

Operation and Safety Manual

Original Instructions - Keep this manual with the machine at all times.

Model
R4045
PVC 1910

ANSI   **AS/NZS GB**

31215804
October 4, 2019 - Rev B

TO PURCHASE THIS PRODUCT PLEASE CONTACT US



**Equipment Financing and
Extended Warranties Available**



**Discount-Equipment.com is your online resource for
commercial and industrial quality parts and equipment sales.**

561-964-4949

visit us on line @ www.discount-equipment.com

Select an option below to find your Equipment

Search by Manufacturer

Search by Product Type

Request a Quote

We sell worldwide for the brands: Genie, Terex, JLG, MultiQuip, Mikasa, Essick, Whiteman, Mayco, Toro Stone, Diamond Products, Generac Magnum, Airman, Haulotte, Barreto, Power Blanket, Nifty Lift, Atlas Copco, Chicago Pneumatic, Allmand, Miller Curber, Skyjack, Lull, Skytrak, Tsurumi, Husquvarna Target, Stow, Wacker, Sakai, Mi-T-M, Sullair, Basic, Dynapac, MBW, Weber, Bartell, Bennar Newman, Haulotte, Ditch Runner, Menegotti, Morrison, Contec, Buddy, Crown, Edco, Wyco, Bomag, Laymor, EZ Trench, Bil-Jax, F.S. Curtis, Gehl Pavers, Heli, Honda, ICS/PowerGrit, IHI, Partner, Imer, Clipper, MMD, Koshin, Rice, CH&E, General Equipment, Amida, Coleman, NAC, Gradall, Square Shooter, Kent, Stanley, Tamco, Toku, Hatz, Kohler, Robin, Wisconsin, Northrock, Oztec, Toker TK, Rol-Air, APT, Wylie, Ingersoll Rand / Doosan, Innovatech, Con X, Ammann, Mecalac, Makinex, Smith Surface Prep, Small Line, Wanco, Yanmar



WARNING

Operating, servicing and maintaining this vehicle or equipment can expose you to chemicals including engine exhaust, carbon monoxide, phthalates, and lead, which are known to the State of California to cause cancer and birth defects or other reproductive harm. To minimize exposure, avoid breathing exhaust, do not idle the engine except as necessary, service your vehicle or equipment in a well-ventilated area and wear gloves or wash your hands frequently when servicing. For more information go to www.P65Warnings.ca.gov.

FOREWORD

The Mobile Elevating Work Platform (MEWP) models covered in this manual are designed and tested to meet or exceed various compliance standards. Please refer to the manufacturer's nameplate affixed to the subject MEWP for specific standard compliance information.

This manual is a very important tool! Keep it with the machine at all times.

The purpose of this manual is to provide owners, users, operators, lessors, and lessees with the precautions and operating procedures essential for the safe and proper machine operation for its intended purpose.

Due to continuous product improvements, JLG Industries, Inc. reserves the right to make specification changes without prior notification. Contact JLG Industries, Inc. for updated information.

Refer to www.JLG.com for Warranty, Product Registration, and other machine-related documentation.

SAFETY ALERT SYMBOLS AND SAFETY SIGNAL WORDS



THIS IS THE SAFETY ALERT SYMBOL. IT IS USED TO ALERT YOU TO THE POTENTIAL PERSONAL INJURY HAZARDS. OBEY ALL SAFETY MESSAGES THAT FOLLOW THIS SYMBOL TO AVOID POSSIBLE INJURY OR DEATH.

⚠ DANGER

INDICATES AN IMMINENTLY HAZARDOUS SITUATION. IF NOT AVOIDED, WILL RESULT IN SERIOUS INJURY OR DEATH. THIS DECAL WILL HAVE A RED BACKGROUND.

⚠ WARNING

INDICATES A POTENTIALITY HAZARDOUS SITUATION. IF NOT AVOIDED, COULD RESULT IN SERIOUS INJURY OR DEATH. THIS DECAL WILL HAVE AN ORANGE BACKGROUND.

⚠ CAUTION

INDICATES A POTENTIALITY HAZARDOUS SITUATION. IF NOT AVOIDED, MAY RESULT IN MINOR OR MODERATE INJURY. IT MAY ALSO ALERT AGAINST UNSAFE PRACTICES. THIS DECAL WILL HAVE A YELLOW BACKGROUND.

NOTICE

INDICATES INFORMATION OR A COMPANY POLICY THAT RELATES DIRECTLY OR INDIRECTLY TO THE SAFETY OF PERSONNEL OR PROTECTION OF PROPERTY.

REVISION LOG

REVISION LOG

Original Issue	A - August 9, 2019
Revised	B - October 4, 2019

To order go to Discount-Equipment.com

SECTION - 1 - SAFETY PRECAUTIONS

1.1 GENERAL1-1

1.2 PRE-OPERATION1-1

 Operator Training and Knowledge.....1-1

 Workplace Inspection1-2

 Machine Inspection1-2

1.3 OPERATION.....1-3

 General.....1-3

 Trip and Fall Hazards1-4

 Electrocution Hazards.....1-5

 Tipping Hazards1-6

 Crushing and Collision Hazards.....1-9

1.4 TOWING, LIFTING, AND HAULING..... 1-10

1.5 MAINTENANCE 1-10

 Maintenance Hazards1-10

 Battery Hazards 1-11

SECTION - 2 - USER RESPONSIBILITIES, MACHINE PREPARATION AND INSPECTION

2.1 PERSONNEL TRAINING2-1

 Operator Training.....2-1

 Training Supervision2-1

 Operator Responsibility2-1

 Machine Familiarization.....2-2

2.2 PREPARATION, INSPECTION, AND MAINTENANCE2-2

 Inspection and Maintenance Table2-3

2.3 PRE-START INSPECTION2-4

2.4 WALK-AROUND INSPECTION2-7

 Inspection Diagram2-8

2.5 FUNCTION CHECK2-9

SECTION - 3 - MACHINE CONTROLS, INDICATORS AND OPERATION

3.1 GENERAL3-1

3.2 DESCRIPTION3-1

3.3 OPERATING CHARACTERISTICS AND LIMITATIONS3-2

 Placards3-2

 Capacities3-2

 Stability3-2

3.4 PLATFORM LOADING3-2

3.5 MACHINE CONTROL LOCATIONS3-3

3.6 BATTERY CHARGING3-4

3.7 GROUND CONTROL STATION.....3-5

 Ground/Platform/OFF Key Selector Switch.....3-6

 Platform Lift/Lower Switch3-6

 Inverter ON/OFF Switch (If Equipped).....3-6

 Ground Emergency Stop Switch3-7

 Hourmeter.....3-7

 Overload Indicator (LSS).....3-7

 MDI Indicator (If Equipped).....3-8

3.8 PLATFORM CONTROL STATION.....3-9

 Platform Emergency Stop Switch 3-10

TABLE OF CONTENTS

Lift/Drive Select Switch	3-10
Forward/Reverse/Lift/Lower Direction Arrow	3-10
Drive/Lift/Steer Joystick Control	3-11
Steering And Traveling	3-11
Steering	3-12
Traveling Forward and Reverse	3-12
Raising And Lowering Platform	3-12
Arm Guards (If Equipped)	3-13
Overload Indicator (LSS)	3-13
Tilt Indicator Warning Light and Alarm	3-13
Variable Tilt - Platform Restricted Height Indicator	3-13
Horn	3-13
Battery Charge Indicator	3-14
System Fault Indicator	3-14
Alarm	3-14
Indoor/Outdoor Operation Indicator	3-14
Indoor/Outdoor Operation Mode Switch	3-14
Low/High Drive Speed	3-14
3.9 PLATFORM MANUAL DESCENT CONTROL	3-15
3.10 GRADE AND SIDESLOPE DEFINITION	3-16
3.11 PLATFORM EXTENSION	3-17
3.12 PLATFORM RAILS FOLD-DOWN PROCEDURE (IF EQUIPPED)	3-18
Platform with Dual Rail Extension Deck	3-18
Platform with Rail In Rail Extension Deck	3-20
3.13 PARKING AND STOWING MACHINE	3-22

3.14 MACHINE LIFTING AND TIE DOWN	3-23
Lifting	3-23
Tie Down	3-24
3.15 TOWING	3-26
Hydraulic Brake Release	3-26

SECTION - 4 - EMERGENCY PROCEDURES

4.1 GENERAL INFORMATION	4-1
4.2 EMERGENCY OPERATION	4-1
Operator Unable to Control Machine	4-1
Righting of Tipped Machine	4-1
Platform Caught Overhead	4-1
4.3 PLATFORM MANUAL DESCENT	4-2
4.4 INCIDENT NOTIFICATION	4-3

SECTION - 5 - ACCESSORIES

5.1 AVAILABLE ACCESSORIES	5-1
5.2 OPTIONS/ACCESSORIES RELATIONSHIP TABLE	5-2
5.3 DC/AC POWER INVERTER	5-4
Safety Precautions	5-4
Preparation and Inspection	5-5
Operation	5-5
5.4 QUIKWELDER™	5-5
Safety Precautions	5-7
Preparation and Inspection	5-7

Operation 5-7

5.5 WORKSTATION 5-8

 Safety Precautions 5-8

 Preparation and Inspection..... 5-8

 Operation 5-8

5.6 ELECTRICIAN'S TREE..... 5-9

 Safety Precautions 5-9

 Preparation and Inspection..... 5-10

 Operation 5-10

5.7 PIPE RACKS 5-10

 Safety Precautions 5-11

 Preparation and Inspection..... 5-11

 Operation 5-11

5.8 PANEL CARRIER..... 5-12

 Safety Precautions 5-13

 Preparation and Inspection..... 5-13

 Operation 5-13

5.9 VISE 5-14

 Safety Precautions 5-14

 Preparation and Inspection..... 5-14

 Operation 5-14

5.10 PLATFORM WORK LIGHTS 5-15

 Operation 5-15

5.11 PLATFORM RAIL PADDING 5-16

5.12 ANTI-VANDALISM PACKAGE..... 5-17

5.13 RAIL MOUNTED PLATFORM EXTENSION HANDLES 5-18

 Operation 5-18

5.14 FOOTSWITCH 5-19

 Operation 5-19

5.15 MAGNETIC GATE LATCH 5-20

 Operation 5-20

5.16 JLG™ MOBILE CONTROL..... 5-21

 Download 5-21

 Operation 5-22

 Document Resources 5-22

SECTION - 6 - GENERAL SPECIFICATIONS AND MAINTENANCE

6.1 INTRODUCTION..... 6-1

 Other Publications Available Specific to this Machine ... 6-1

 Serial Number Identification..... 6-1

6.2 OPERATING SPECIFICATIONS 6-2

 Platform Capacities 6-4

 Machine Dimensions..... 6-5

 Tires..... 6-5

 Batteries..... 6-6

 Battery Charger Specifications..... 6-7

6.3 LUBRICATION..... 6-8

 Lubrication Capacities 6-8

 Lubrication Specifications..... 6-8

 Hydraulic Oil Operating Temperature Chart..... 6-9

6.4 OPERATOR MAINTENANCE..... 6-10

TABLE OF CONTENTS

Scissor Arm - Safety Props	6-10
Hydraulic Oil Check Procedure	6-11
Delta-Q	6-13
Green Power (China (GB) Only)	6-13
Eagle Performance - Battery Charger	6-14
Battery Maintenance and Safety Practices	6-14
Battery Quick-Disconnect (If Equipped)	6-15
Tire Wear and Damage	6-15
Wheel and Tire Replacement	6-16
Wheel Installation	6-16
6.5 SUPPLEMENTAL INFORMATION	6-17
6.6 DECAL INSTALLATION	6-18
Diagram	6-18
Chart	6-19
6.7 DIAGNOSTIC TROUBLE CODES (DTC)	6-21

SECTION - 7 - INSPECTION AND REPAIR LOG

LIST OF FIGURES

3-1. Platform with Dual Rail Extension - Fold Down Sequence	3-19
3-2. Platform with Rail in Rail Extension - Fold Down Sequence	3-21
3-3. Fork Lift Pockets - Location	3-23
3-4. Lifting Machine Using Spreader Bar and Lift Lug Locations	3-24
3-5. Tie Down and Lift Lug Locations	3-25

LIST OF TABLES

1-1 Minimum Approach Distances (M.A.D.)..... 1-6
1-2 Beaufort Scale (For Reference Only) 1-7
2-1 High Drive Cutout Height..... 2-10
2-2 Tilt Activation Setting..... 2-10

To order go to Discount-Equipment.com

SECTION 1. SAFETY PRECAUTIONS

1.1 GENERAL

This section outlines the necessary precautions for proper and safe machine usage and maintenance. In order to promote proper machine usage, it is mandatory that a daily routine is established based on the content of this manual. A maintenance program, using the information provided in this manual and the Service and Maintenance Manual, must also be established by a qualified person and must be followed to ensure that the machine is safe to operate.

The owner/user/operator/lessor/lessee of the machine must not accept operating responsibility until this manual has been read, training is accomplished, and operation of the machine has been completed under the supervision of an experienced and qualified operator.

These sections contain the responsibilities of the owner, user, operator, lessor, and lessee concerning safety, training, inspection, maintenance, application, and operation. If there are any questions with regard to safety, training, inspection, maintenance, application, and operation, please contact JLG Industries, Inc. ("JLG").

WARNING

FAILURE TO COMPLY WITH THE SAFETY PRECAUTIONS LISTED IN THIS MANUAL COULD RESULT IN MACHINE DAMAGE, PROPERTY DAMAGE, PERSONAL INJURY OR DEATH.

1.2 PRE-OPERATION

Operator Training and Knowledge

- Read, understand, and study the Operation and Safety Manual in its entirety before operating the machine. For clarification, questions, or additional information regarding any portions of this manual, contact JLG Industries, Inc.

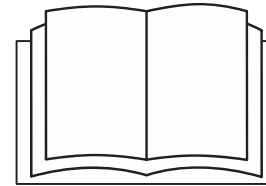

- Only personnel who have received proper training regarding the inspection, application and operation of MEWPs (including recognition and avoiding hazards associated with their operation) shall be authorized to operate a MEWP.
- Only properly trained personnel who have received unit-specific familiarization shall operate a MEWP. The user shall determine if personnel are qualified to operate the MEWP prior to operation.
- Read, understand, and obey all DANGERS, WARNINGS, CAUTIONS, and operating instructions on the machine and in this manual.
- Ensure that the machine is to be used in a manner which is within the scope of its intended application as determined by JLG.

SECTION 1 - SAFETY PRECAUTIONS

- All operating personnel must have a thorough understanding of the intended purpose and function of the MEWP controls, including platform, ground and emergency descent controls.
- Read, understand, and obey all applicable employer, local, and governmental regulations as they pertain to your utilization and application of the machine.

Workplace Inspection

- Precautions to avoid all hazards in the work area must be taken by the user before and during operation of the machine.
- Do not operate or raise the platform from a position on trucks, trailers, railway cars, floating vessels, scaffolds or other equipment unless the application is approved in writing by JLG.
- Before operation, check work area for overhead hazards such as electric lines, bridge cranes, and other potential overhead obstructions.
- Check operating surfaces for holes, bumps, drop-offs, obstructions, debris, concealed holes, and other potential hazards.
- Check the work area for hazardous locations. Do not operate the machine in hazardous environments unless approved for that purpose by JLG.
- Ensure that the ground conditions are adequate to support the maximum tire load indicated on the tire load decals located on the chassis adjacent to each wheel.
- This machine can be operated in nominal ambient temperatures of 0° F to 104° F (-20° C to 40° C). Consult JLG to optimize operation outside of this temperature range.

Machine Inspection

- Do not operate this machine until the inspections and functional checks have been performed as specified in Section 2 of this manual.
- Do not operate this machine until it has been serviced and maintained according to the maintenance and inspection requirements as specified in the machine's Service and Maintenance Manual.
- Ensure all safety devices are operating properly. Modification of these devices is a safety violation.

WARNING

MODIFICATION OR ALTERATION OF A MEWP SHALL BE MADE ONLY WITH PRIOR WRITTEN PERMISSION FROM THE MANUFACTURER.

- Do not operate any machine on which the safety or instruction placards or decals are missing or illegible.
- Check the machine for modifications to original components. Ensure that any modifications have been approved by JLG.
- Avoid accumulation of debris on platform floor. Keep mud, oil, grease, and other slippery substances from footwear and platform floor.

1.3 OPERATION

General

- Machine operation requires your full attention. Bring the machine to a full stop before using any device, i.e. cell phones, two-way radios, etc. that will distract your attention from safely operating the machine.
- Do not use the machine for any purpose other than positioning personnel, their tools, and equipment.
- Before operation, the user must be familiar with the machine capabilities and operating characteristics of all functions.
- Never operate a malfunctioning machine. If a malfunction occurs, shut down the machine. Remove the unit from service and notify the proper authorities.
- Do not remove, modify, or disable any safety devices.
- Never slam a control switch or lever through neutral to an opposite direction. Always return switch to neutral and stop before moving the switch to the next function. Operate controls with slow and even pressure.
- Do not allow personnel to tamper with or operate the machine from the ground with personnel in the platform, except in an emergency.
- Do not carry materials directly on platform railing unless approved by JLG.
- When two or more persons are in the platform, the operator shall be responsible for all machine operations.
- Always ensure that power tools are properly stowed and never left hanging by their cord from the platform work area.
- Do not assist a stuck or disabled machine by pushing or pulling except by pulling at the chassis tie-down lugs.
- Fully lower platform and shut off all power before leaving machine.
- Remove all rings, watches, and jewelry when operating machine. Do not wear loose fitting clothing or long hair unrestrained which may become caught or entangled in equipment.
- Persons under the influence of drugs or alcohol or who are subject to seizures, dizziness or loss of physical control must not operate this machine.
- Hydraulic cylinders are subject to thermal expansion and contraction. This may result in changes to the platform position while the machine is stationary. Factors affecting thermal movement can include the length of time the machine will remain stationary, hydraulic oil temperature, ambient air temperature and platform position.

SECTION 1 - SAFETY PRECAUTIONS

Trip and Fall Hazards

- Prior to operation, ensure all gates and rails are fastened and secured in their proper position.

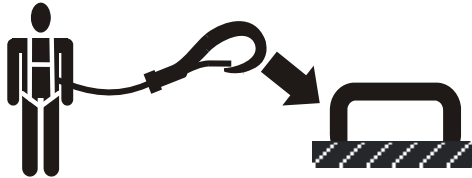

- JLG Industries, Inc. recommends that all persons in the platform wear a full body harness with a lanyard attached to an authorized lanyard anchorage point while operating this machine. For further information regarding fall protection requirements on JLG products, contact JLG Industries, Inc.
- Identify the designated lanyard anchorage point(s) at the platform and securely attach the lanyard. Attach only one (1) lanyard per lanyard anchorage point.
- Enter and exit only through gate area. Use extreme caution when entering or leaving platform. Ensure that the platform assembly is fully lowered. Face the platform when entering or leaving the platform. Always maintain “three point contact” with the machine, using two hands and one foot or two feet and one hand at all times during entry and exit.

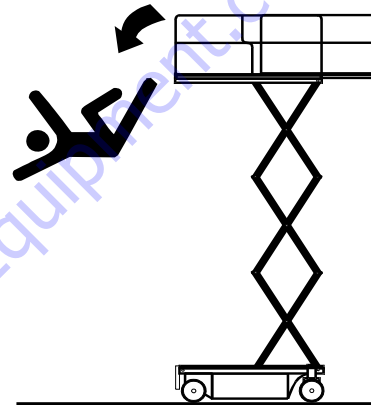

- Keep both feet firmly positioned on the platform floor at all times. Never position ladders, boxes, steps, planks, or similar items on unit to provide additional reach for any purpose.
- Never use the scissor arm assembly to gain access to or leave the platform.
- Keep oil, mud, and slippery substances cleaned from footwear and the platform floor.

Electrocution Hazards

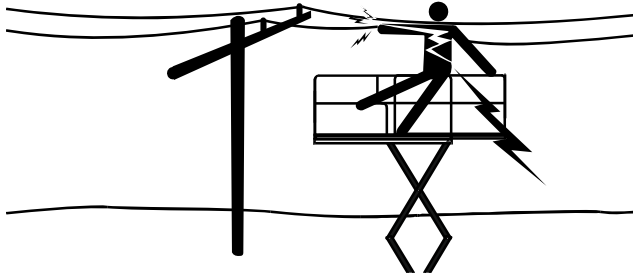

- This machine is not insulated and does not provide protection from contact or proximity to electrical current.
- Maintain distance from electrical lines, apparatus, or any energized (exposed or insulated) parts according to the Minimum Approach Distance (MAD) as shown in Table 1-1.
- Allow for machine movement and electrical line swaying.
- Maintain a clearance of at least 10 ft (3 m) between any part of the machine and its occupants, their tools, and their equipment from any electrical line or apparatus carrying up to 50,000 volts. One foot additional clearance is required for every additional 30,000 volts or less.

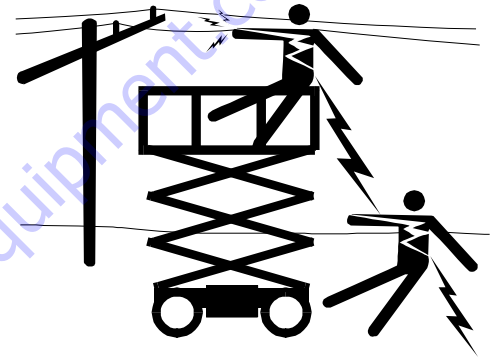

- The minimum approach distance may be reduced if insulating barriers are installed to prevent contact, and the barriers are rated for the voltage of the line being guarded. These barriers shall not be part of (or attached to) the machine. The minimum approach distance shall be reduced to a distance within the designed working dimensions of the insulating barrier. This determination shall be made by a qualified person in accordance with the employer, local, or governmental requirements for work practices near energized equipment.

⚠ DANGER

DO NOT MANEUVER MACHINE OR PERSONNEL INSIDE PROHIBITED ZONE (MAD). ASSUME ALL ELECTRICAL PARTS AND WIRING ARE ENERGIZED UNLESS KNOWN OTHERWISE.

SECTION 1 - SAFETY PRECAUTIONS

Table 1-1. Minimum Approach Distances (M.A.D.)

VOLTAGE RANGE (Phase to Phase)	MINIMUM APPROACH DISTANCE in Feet (Meters)
0 to 50 KV	10 (3)
Over 50KV to 200 KV	15 (5)
Over 200 KV to 350 KV	20 (6)
Over 350 KV to 500 KV	25 (8)
Over 500 KV to 750 KV	35 (11)
Over 750 KV to 1000 KV	45 (14)
NOTE: <i>This requirement shall apply except where employer, local or governmental regulations are more stringent.</i>	

Tipping Hazards

- Ensure that the ground conditions are adequate to support the maximum tire load indicated on the tire load decals located on the chassis adjacent to each wheel. Do not travel on unsupported surfaces.
- The user must be familiar with the operating surface before driving. Do not exceed the allowable sideslope and grade while driving.
- Do not elevate platform or drive with platform elevated while on or near a sloping, uneven, or soft surface. Ensure machine is positioned on a smooth, firm surface within the limits of the maximum operating slope before elevating platform or driving with the platform in the elevated position.

- Before driving on floors, bridges, trucks, and other surfaces, check allowable capacity of the surfaces.
- Never exceed the maximum platform capacity as specified on the platform. Keep all loads within the confines of the platform, unless authorized by JLG.
- Keep the chassis of the machine a minimum of 2 ft (0.6 m) from holes, bumps, drop-offs, obstructions, debris, concealed holes, and other potential hazards at the ground level.
- Do not operate the machine when wind conditions exceed specifications shown in Section 6.2 or as shown on the capacity placard on the platform billboard. Factors affecting wind speed are; platform elevation, surrounding structures, local weather events, and approaching storms.
- Wind speed can be significantly greater at height than at ground level.
- Wind speed can change rapidly. Always consider approaching weather events, the time required to lower the platform, and methods to monitor current and potential wind conditions.
- Do not cover or increase surface area of the platform or the load. Do not carry large surface area items in the platform when operating outdoors. The addition of such items increases the exposed wind area of the machine. Increased areas exposed to wind will decrease stability.
- Do not increase the platform size with unauthorized modifications, deck extensions, or attachments.

⚠ WARNING

DO NOT OPERATE THE MACHINE WHEN WIND CONDITIONS EXCEED SPECIFICATIONS SHOWN IN SECTION 6.2 OR AS SHOWN ON THE CAPACITY PLACARD ON THE PLATFORM BILLBOARD.

Table 1-2. Beaufort Scale (For Reference Only)

BEAUFORT NUMBER	WIND SPEED		DESCRIPTION	LAND CONDITIONS
	mph	m/s		
0	0	0-0.2	Calm	Calm. Smoke rises vertically.
1	1-3	0.3-1.5	Light air	Wind motion visible in smoke.
2	4-7	1.6-3.3	Light breeze	Wind felt on exposed skin. Leaves rustle.
3	8-12	3.4-5.4	Gentle breeze	Leaves and smaller twigs in constant motion.
4	13-18	5.5-7.9	Moderate breeze	Dust and loose paper raised. Small branches begin to move.
5	19-24	8.0-10.7	Fresh breeze	Smaller trees sway.
6	25-31	10.8-13.8	Strong breeze	Large branches in motion. Flags waving near horizontal. Umbrella use becomes difficult.
7	32-38	13.9-17.1	Near Gale/Moderate Gale	Whole trees in motion. Effort needed to walk against the wind.
8	39-46	17.2-20.7	Fresh Gale	Twigs broken from trees. Cars veer on road.
9	47-54	20.8-24.4	Strong Gale	Light structure damage.

SECTION 1 - SAFETY PRECAUTIONS

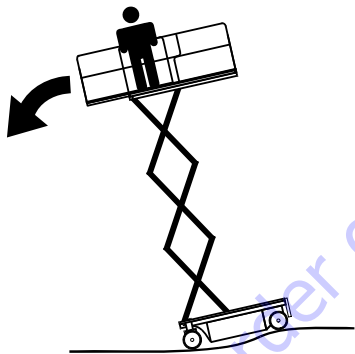
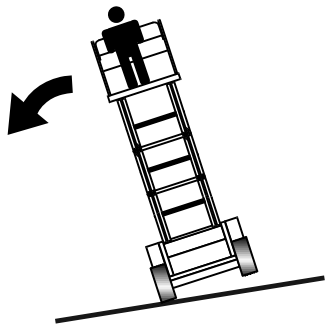

- Never attempt to use the machine as a crane. Do not tie-off machine to any adjacent structure. Never attach wire, cable, or any similar items to platform.
- If the scissor arm assembly or platform is caught so that one or more wheels are off the ground, all persons must be removed before attempting to free the machine. Use cranes, forklift trucks, or other appropriate equipment to stabilize machine.

Crushing and Collision Hazards

- Approved head gear must be worn by all operating and ground personnel.
- Keep hands and limbs out of the scissor arm assembly during operation and when elevated without safety prop engaged.
- Watch for obstructions around machine and overhead when driving. Check clearances above, on sides, and bottom of platform when lifting or lowering platform.
- During operation, keep all body parts inside platform railing.

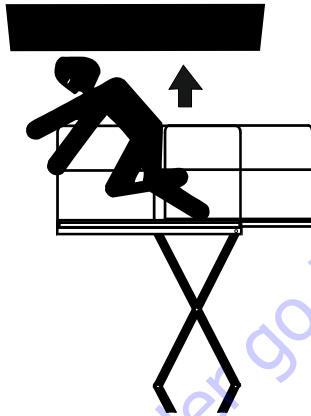

- Always post a lookout when driving in areas where vision is obstructed.

- Keep non-operating personnel at least 6 ft (1.8 m) away from machine during all operations.
- Under all travel conditions, the operator must limit travel speed according to conditions of ground surface, congestion, visibility, slope, location of personnel, and other factors.
- Be aware of stopping distances in all drive speeds. When driving in high speed, reduce drive speed before stopping. Travel grades in low speed only.
- Do not use high speed drive in restricted or close quarters or when driving in reverse.
- Exercise extreme caution at all times to prevent obstacles from striking or interfering with operating controls and persons in the platform.
- Ensure that operators of other overhead and floor level machines are aware of the MEWP's presence. Disconnect power to overhead cranes. Barricade floor area if necessary.
- Do not operate over ground personnel. Warn personnel not to work, stand, or walk under a raised platform. Position barricades on floor as necessary.

⚠ WARNING

IF DRIVING MACHINE WITH THE PLATFORM CONTROL STATION FROM GROUND, DO NOT HANG THE CONTROL BOX ON ANY PART OF THE MACHINE WHILE DRIVING. HOLD THE CONTROL BOX AND KEEP AT LEAST 3 FT (1 M) DISTANCE FROM MACHINE.

SECTION 1 - SAFETY PRECAUTIONS

1.4 TOWING, LIFTING, AND HAULING

- Never allow personnel in platform while towing, lifting, or hauling.
- This machine should not be towed, except in the event of emergency, malfunction, power failure, or loading/unloading. Refer to emergency towing procedures.
- Ensure platform is fully retracted and completely empty of tools prior to towing, lifting or hauling.
- When lifting machine with a forklift, position forks only at designated areas of the machine. Lift with a forklift of adequate capacity.
- Refer to Section 3 for lifting information.

1.5 MAINTENANCE

This sub-section contains general safety precautions which must be observed during maintenance of this machine. Additional precautions to be observed during machine maintenance are inserted at the appropriate points in this manual and in the Service and Maintenance Manual. It is of utmost importance that maintenance personnel pay strict attention to these precautions to avoid possible injury to personnel or damage to the machine or property. A maintenance program must be established by a qualified person and must be followed to ensure that the machine is safe.

Maintenance Hazards

- Shut off power to all controls and ensure that all moving parts are secured from inadvertent motion prior to performing any adjustments or repairs.
- Never work under an elevated platform until it has been fully lowered to the full down position, if possible, or otherwise supported and restrained from movement with appropriate safety props, blocking, or overhead supports.
- DO NOT attempt to repair or tighten any hydraulic hoses or fittings while the machine is powered on or when the hydraulic system is under pressure.

- Always relieve hydraulic pressure from all hydraulic circuits before loosening or removing hydraulic components.
- DO NOT use your hand to check for leaks. Use a piece of cardboard or paper to search for leaks. Wear gloves to help protect hands from spraying fluid.
- Use only replacement parts or components that are approved by JLG. To be considered approved, replacement parts or components must be identical or equivalent to original parts or components.
- Never attempt to move heavy parts without the aid of a mechanical device. Do not allow heavy objects to rest in an unstable position. Ensure adequate support is provided when raising components of the machine.
- Use only approved non-flammable cleaning solvents.
- Do not replace items critical to stability, such as batteries or tires, with items of different weight or specification. Do not modify the MEWP in any way to affect stability.
- Reference the Service and Maintenance Manual for the weights of critical stability items.



⚠ WARNING

MODIFICATION OR ALTERATION OF A MEWP SHALL BE MADE ONLY WITH PRIOR WRITTEN PERMISSION FROM THE MANUFACTURER.

Battery Hazards

- Always disconnect batteries when servicing electrical components or when performing welding on the machine.
- Do not allow smoking, open flame, or sparks near battery during charging or servicing.
- Do not contact tools or other metal objects across the battery terminals.
- Always wear hand, eye, and face protection when servicing batteries. Ensure that battery acid does not come in contact with skin or clothing.

⚠ CAUTION

BATTERY FLUID IS HIGHLY CORROSIVE. AVOID CONTACT WITH SKIN AND CLOTHING AT ALL TIMES. IMMEDIATELY RINSE ANY CONTACTED AREA WITH CLEAN WATER AND SEEK MEDICAL ATTENTION.

- Charge batteries only in a well-ventilated area.
- Avoid overfilling the battery fluid level. Add distilled water to batteries only after the batteries are fully charged.

SECTION 2. USER RESPONSIBILITIES, MACHINE PREPARATION AND INSPECTION

2.1 PERSONNEL TRAINING

The Mobile Elevating Work Platform (MEWP) is a personnel handling device, so it is necessary that it be operated and maintained only by trained personnel.

Operator Training

1. Reading and understanding the Operation and Safety Manual.
2. Thorough understanding of the intended purpose and function of the MEWP controls, including platform, ground, and emergency descent controls.
3. Control labels, instructions, and warnings on the machine.
4. Applicable regulations, standards, and safety rules.
5. Use of approved fall protection equipment.
6. Enough knowledge of the mechanical operation of the machine to recognize a malfunction or potential malfunction.
7. The safest means to operate the machine where overhead obstructions, other moving equipment, and obstacles, depressions, holes, and drop-offs exist.

8. Means to avoid the hazards of unprotected electrical conductors.
9. Selection of the appropriate MEWPs and available options for the work to be performed considering specific job requirements, with involvement from the MEWP owner, user, and/or supervisor.
10. The responsibility of the operator to ensure all platform occupants have a basic level of knowledge to work safely on the MEWP, and to inform them of applicable regulations, standards, and safety rules.
11. The requirement for familiarization in addition to training.

Training Supervision

Training must be done under the supervision of a qualified person in an open area free of obstructions until the trainee has developed the ability to safely control and operate the machine.

Operator Responsibility

The operator must be instructed that they have the responsibility and authority to shut down the machine in case of a malfunction or other unsafe condition of either the machine or the job site.

Machine Familiarization

NOTE: Responsibilities for familiarization may vary by region.

Only properly trained personnel who have received unit-specific familiarization shall operate a MEWP. The user shall determine if personnel are qualified to operate the MEWP prior to operation. The user shall ensure that after familiarization, the operator operates the MEWP for a sufficient period of time to achieve proficiency. When authorized by the user, self-familiarization can be achieved, if authorized, by a properly trained operator reading, understanding and following the manufacturer's operator's manual.

Prior to users authorization of an operator to use a specific model of MEWP, the user shall ensure the operator is familiarized on the following:

1. Location of the manual storage compartment and the requirement to ensure the required manual(s) are present on the MEWP;
2. Purpose and function of the machine controls and indicators at the platform and ground control stations;
3. Purpose, location, and function of the emergency controls;
4. Operating characteristics and limitations;
5. Features and devices;
6. Accessories and optional equipment.

2.2 PREPARATION, INSPECTION, AND MAINTENANCE

The Inspection and Maintenance Table explains the machine inspections and maintenance recommended by JLG Industries, Inc. Consult local regulations for further requirements for MEWPs. The frequency of inspections and maintenance must be increased as necessary when the machine is used in a harsh or hostile environment, if the machine is used with increased frequency, or if the machine is used in a severe manner.

SECTION 2 - USER RESPONSIBILITIES, MACHINE PREPARATION AND INSPECTION

Inspection and Maintenance Table

TYPE	FREQUENCY	PRIMARY RESPONSIBILITY	SERVICE QUALIFICATION	REFERENCE
Pre-Start Inspection	Before using each day; or whenever there's an Operator change.	User or Operator	User or Operator	Operation and Safety Manual
Pre-Delivery Inspection <i>(see note below)</i>	Before each sale, lease, or rental delivery.	Owner, Dealer, or User	Qualified JLG Mechanic	Service and Maintenance Manual and applicable JLG inspection form
Frequent Inspection	In service for 3 months or 150 hours, whichever comes first; or Out of service for a period of more than 3 months; or Purchased used.	Owner, Dealer, or User	Qualified JLG Mechanic	Service and Maintenance Manual and applicable JLG inspection form
Annual Machine Inspection <i>(see note below)</i>	Annually, no later than 13 months from the date of prior inspection.	Owner, Dealer, or User	Factory-Trained Service Technician (Recommended)	Service and Maintenance Manual and applicable JLG inspection form
Preventative Maintenance	At intervals as specified in the Service and Maintenance Manual.	Owner, Dealer, or User	Qualified JLG Mechanic	Service and Maintenance Manual

NOTE: Inspection forms are available from JLG. Use the Service and Maintenance Manual to perform inspections.

NOTICE

JLG INDUSTRIES, INC. RECOGNIZES A FACTORY-TRAINED SERVICE TECHNICIAN AS A PERSON WHO HAS SUCCESSFULLY COMPLETED THE JLG SERVICE TRAINING SCHOOL FOR THE SPECIFIC JLG PRODUCT MODEL.

SECTION 2 - USER RESPONSIBILITIES, MACHINE PREPARATION AND INSPECTION

2.3 PRE-START INSPECTION

The Pre-Start Inspection should include each of the following:

1. **Cleanliness** – Check all surfaces for leakage (oil or battery fluid) or foreign objects. Report this to the proper maintenance personnel.
2. **Structure** – Inspect the machine structure for dents, damage, weld or parent metal cracks or other discrepancies. Report this to the proper maintenance personnel.

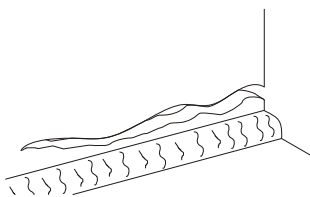

Parent Metal Crack

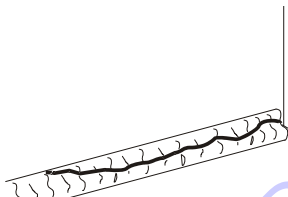

Weld Crack

3. **Decals and Placards** – Check all for cleanliness and legibility. Ensure none of the decals and placards are missing. Ensure all illegible decals and placards are cleaned or replaced (refer to Section 6.6).
4. **Operation and Safety Manuals** – Ensure that a copy of the Operation and Safety Manual, AEM Safety Manual (ANSI markets only), and ANSI Manual of Responsibilities (ANSI markets only) is enclosed in the weather resistant storage container.

5. **Walk-Around Inspection** – Refer to Section 2.4.
6. **Battery** – Charge as required.
7. **Hydraulic Oil Level** – Check the hydraulic oil level in the pump reservoir, add as required (refer to Section 6.4).
8. **Accessories/Attachments** – Refer to the Accessories section in this manual or accessory installed upon the machine for specific inspection, operation, and maintenance instructions.
9. **Function Check** – Once the Walk-Around Inspection is complete, perform a functional check of all systems in an area free of overhead and ground level obstructions. Refer to Section 3 for more specific instructions on the operation of each function.
10. **Platform Gate** – Keep gate and surrounding area clean and unobstructed. Check that gate closes properly and is not bent or damaged. Keep gate closed at all times except when entering/exiting the platform and loading/unloading materials.
11. **Lanyard Anchorage Points** – JLG Industries, Inc. recommends personnel in the platform wear a full body harness with a lanyard attached to an authorized lanyard anchorage point.

⚠ WARNING

IF THE MACHINE DOES NOT OPERATE PROPERLY, TURN OFF THE MACHINE IMMEDIATELY! REPORT THE PROBLEM TO THE PROPER MAINTENANCE PERSONNEL. DO NOT OPERATE THE MACHINE UNTIL IT IS DECLARED SAFE FOR OPERATION.

SECTION 2 - USER RESPONSIBILITIES, MACHINE PREPARATION AND INSPECTION

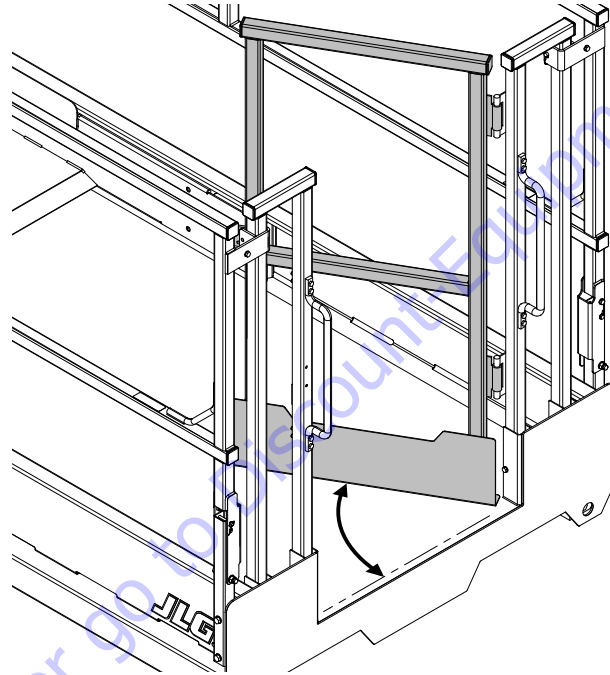

Self-Closing Swing Gate

SECTION 2 - USER RESPONSIBILITIES, MACHINE PREPARATION AND INSPECTION

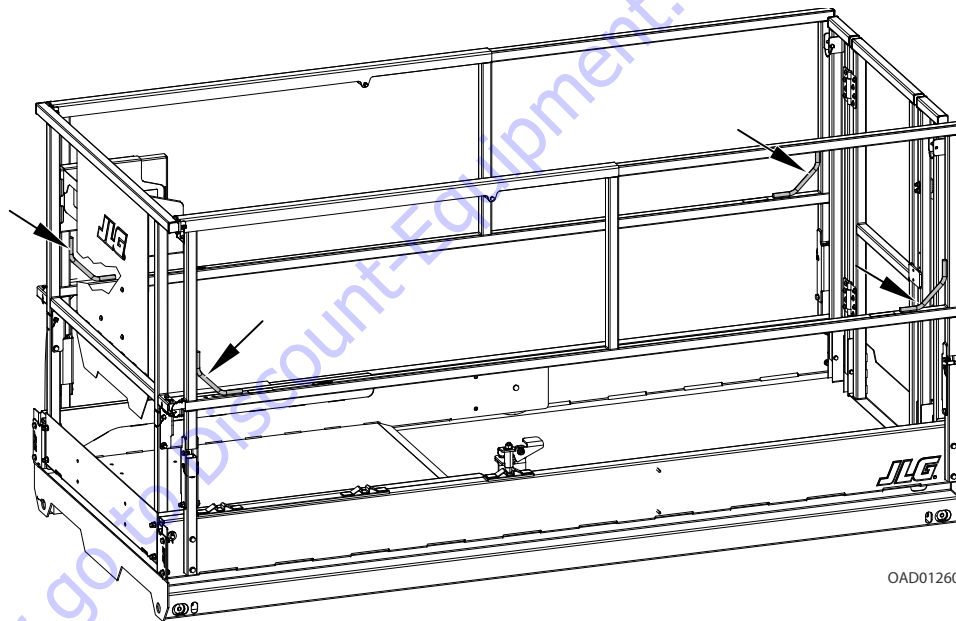
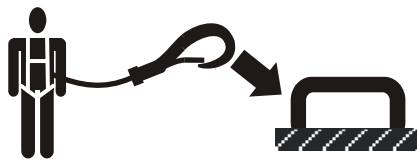

OAD01260

Lanyard Attach Points

2.4 WALK-AROUND INSPECTION

Begin the Walk-Around Inspection at item 1 as noted on the Inspection Diagram. Continue checking each item in sequence for the conditions listed in the following checklist.

⚠ WARNING

TO AVOID POSSIBLE INJURY, BE SURE MACHINE POWER IS "OFF". DO NOT OPERATE UNTIL ALL MALFUNCTIONS HAVE BEEN CORRECTED.

NOTICE

DO NOT OVERLOOK VISUAL INSPECTION OF CHASSIS UNDERSIDE. CHECKING THIS AREA MAY RESULT IN DISCOVERY OF CONDITIONS WHICH COULD CAUSE EXTENSIVE MACHINE DAMAGE.

INSPECTION NOTE: *On all components, make sure there are no loose or missing parts, that they are securely fastened, and that no visible damage, leaks or excessive wear exists in addition to any other criteria mentioned.*

1. **Frame/Chassis/Ladder** – Ensure that pothole protection (PHP) components on frame are in place, undamaged, not bent or worn. Side compartment doors open and close properly. Refer to Inspection Note.
2. **Ground Controls** – Placard secure and legible, control switches return to neutral position when activated and released, emergency stop switch functions properly. Control markings legible.
3. **Hydraulic Pump/Motor, Control Valve Installation** – No unsupported wires or hoses; no damaged or broken wires. Refer to Inspection Note.

4. **Front Wheels, Tires and Drive Motors** – Wheel nut properly secured. Refer to Section 6.4 Inspect wheels for damage and corrosion, Steer linkage, and Steer Cylinder. Refer to Inspection Note.
5. **Battery Compartment** – Refer to Inspection Note.
6. **Rear Wheels, Tires and Hydraulic Brake** – Wheel nut properly secured. Refer to Section 6.4. Inspect wheels for damage and corrosion, check hydraulic brake hoses for damage or leakage. Refer to Inspection Note.
7. **Manual Descent Control** – Refer to Inspection Note.
8. **Beacon(s) (If Equipped)** – Refer to Inspection Note.
9. **Scissor Arms, Pivot Pins and Sliding Wear Pads, Lift Cylinder** – Refer to Inspection Note.
10. **Platform/Handrail/Gate Installation** – Deck extension slides in and out and locks in place properly. Gate closes properly. All fold-down rail pins (if equipped) in place and secure - Refer to Inspection Note.
11. **Platform Control Console** – Ensure that the control console is firmly secured in the proper location. Placards secure and legible, control lever and switches return to neutral when activated and released, and emergency stop switch function properly, required manual(s) in storage box.
12. **Static Strap (Underneath Machine)** – Refer to Inspection Note.

SECTION 2 - USER RESPONSIBILITIES, MACHINE PREPARATION AND INSPECTION

Inspection Diagram

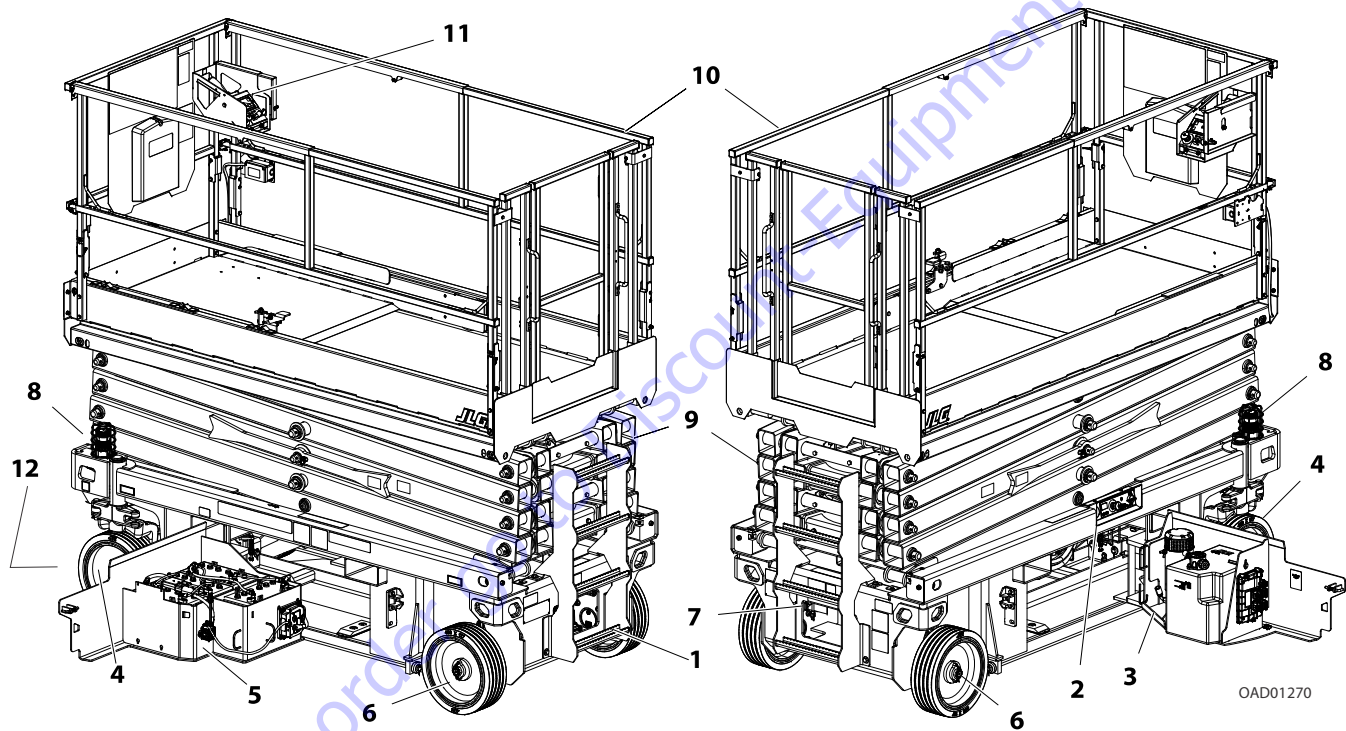

2.5 FUNCTION CHECK

Perform the Function Check as follows:

1. From the **Ground Control Panel** with no load in the platform (refer to Section 3.5):
 - a. Ensure that the key selector switch and the platform lift switch operates properly.
 - b. Ensure that all machine functions are disabled when the Emergency Stop Button is depressed.
 - c. With platform raised a few feet (1 m), ensure that the manual descent control (T-handle located at the left rear of the machine, next to the battery charger) lowers the platform (refer to Section 3.8).
 - d. Verify the Pothole Protection bars are fully lowered when the platform is raised.
2. From the **Platform Control Console**:
 - a. Ensure that the control console is firmly secured in the proper location.
 - b. Ensure that all guards protecting switches are in place.
 - c. Operate all switch functions, drive/lift mode select switch, and horn button.
 - d. Operate all platform joystick functions to ensure proper operation of drive, lift, steer, and enable trigger switch operation.
 - e. Ensure all machine functions stop when function control is released or when joystick trigger is released.
 - f. Ensure that all machine functions are disabled when the platform Emergency Stop Button is depressed.

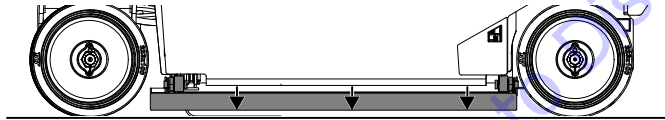

Platform Elevated - Pothole Bars Fully Lowered



Platform Fully Lowered - Pothole Bars Raised

SECTION 2 - USER RESPONSIBILITIES, MACHINE PREPARATION AND INSPECTION

- g. With the platform elevated on a smooth, firm, level surface with no overhead obstructions, drive the machine to check if the high drive cutback speed limit is engaged at the height indicated in Table 2-1. Ensure drive speed is reduced from a top speed to a slower speed.

Table 2-1. High Drive Cutout Height

MODEL	HIGH DRIVE SPEED CUTBACK HEIGHT	DRIVE SPEED REDUCTION
R4045	75 in (190.5cm)	2.0 mph (3.2 kph) to 0.5 mph (0.8 kph)

3. With the platform in the transport (stowed) position.
- Drive the machine on a grade, not to exceed the rated gradeability, and stop to ensure the drive motor brakes hold.
 - Check the tilt indicator light to ensure proper operation. The light should be illuminated if tilted beyond allowed settings in Table 2-2.

NOTE: When the tilt indicator warning is activated the following functions are affected; drive and lift up functions are disabled, platform must be fully lowered (stowed) to drive.

Table 2-2. Tilt Activation Setting

MODEL	TILT SETTING (front to back)	TILT SETTING (side to side)	Maximum Deck Elevation	
R4045	3.50°	1.50° - outdoor 1.50° - indoor	25 - 28.7 ft	7.6 - 8.7 m
			31 ft - max.	9.4 - max.
		2.00° - outdoor 2.00° - indoor	23 - 25 ft	7 - 7.6 m
			27 - 31 ft	8.2 - 9.4 m
		2.50° - outdoor 2.50° - indoor	0 - 23 ft	0 - 7 m
			0 - 27 ft	0 - 8.2 m

SECTION 3. MACHINE CONTROLS, INDICATORS AND OPERATION

3.1 GENERAL

NOTICE

THE MANUFACTURER HAS NO DIRECT CONTROL OVER MACHINE APPLICATION AND OPERATION, THE USER AND OPERATOR ARE RESPONSIBLE FOR CONFORMING WITH GOOD SAFETY PRACTICES.

This section provides the necessary information needed to understand controls and their functions.

⚠ WARNING

DO NOT RAISE PLATFORM EXCEPT ON A SMOOTH, FIRM SURFACE, WITHIN THE LIMITS OF THE MAXIMUM OPERATING SLOPE, FREE OF OBSTRUCTIONS AND HOLES.

TO AVOID SERIOUS INJURY, DO NOT OPERATE MACHINE IF ANY CONTROL LEVERS OR TOGGLE SWITCHES CONTROLLING PLATFORM MOVEMENT DO NOT RETURN TO THE OFF OR NEUTRAL POSITION WHEN RELEASED.

IF THE PLATFORM DOES NOT STOP WHEN A CONTROL SWITCH OR LEVER IS RELEASED, USE THE EMERGENCY STOP SWITCH TO STOP THE MACHINE.

3.2 DESCRIPTION

This machine is a Mobile Elevating Work Platform (MEWP) used to position personnel, along with their necessary tools and materials at work locations.

This MEWP has a primary operator control station in the platform. From this control station, the operator can drive and steer the machine in both forward and reverse directions, raise and lower the platform.

The machine can be driven on a smooth, firm surface, within the limits of the maximum operating slope, from an elevated platform position - Reference Steering And Traveling of this manual for specific requirements.

The machine also has a ground control station which can override the platform control station. Ground controls operate lift up and down. Except for performing inspections and function checks, ground controls are to be used only in an emergency to lower the platform to the ground should the operator in the platform be unable to do so.

3.3 OPERATING CHARACTERISTICS AND LIMITATIONS

Placards

Important points to remember during operation are provided at the control stations by DANGER, WARNING, CAUTION, NOTICE, and INSTRUCTION placards. This information is placed at various locations for the express purpose of alerting personnel of potential hazards constituted by the operating characteristics and limitations of the machine. See foreword for definitions of placard safety signal words.

Capacities

Raising platform above horizontal with or without any load in platform, is based on the following criteria:

1. Machine is positioned on a smooth, firm surface, within the limits of the maximum operating slope,
2. Load is within manufacturer's rated capacity.
3. All machine systems are functioning properly.

Stability

This machine, as originally manufactured by JLG and operated within its rated capacity on a smooth, firm surface, within the limits of the maximum operating slope, provides a stable aerial platform for all platform positions.

3.4 PLATFORM LOADING

The platform maximum rated load capacity is shown on a placard located on the platform billboard and is based upon the machine positioned on a smooth, firm surface, within the limits of the maximum operating slope. Refer to Section 6.2, for the maximum platform capacity.

The platform is entered through an entry gate at the rear of the platform. Keep gate closed at all times except when entering/exiting the platform and loading/unloading materials.

NOTE: *It is important to remember that the load should be evenly distributed on the platform. The load should be placed near the center of the platform when possible.*

3.5 MACHINE CONTROL LOCATIONS

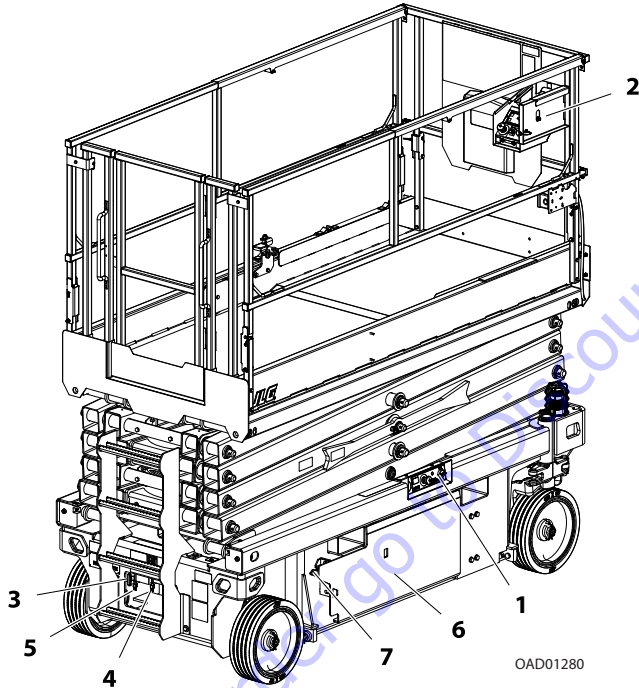

1. Ground Control Station
2. Platform Control Station
3. Platform Manual Descent Control (T-Handle)
4. AC Plug (for Platform AC Receptacle Outlet Box)
5. AC Plug - Battery Charger Input
6. Side Compartment Doors (Both Sides)
7. Side Compartment Door Latch Location (Both Sides)

SECTION 3 - MACHINE CONTROLS, INDICATORS AND OPERATION

3.6 BATTERY CHARGING

The battery charger AC input plug is located inside the frame at the rear of the machine. Refer to Section 6.2 for battery charger specifications.

1. Connect the charger AC input plug to a grounded outlet using a 3 wire heavy duty extension cord.

NOTE: Park the machine in a well-ventilated area before charging.

CAUTION

ONLY PLUG THE CHARGER INTO A PROPERLY INSTALLED AND GROUNDED OUTLET. DO NOT USE GROUND ADAPTERS OR MODIFY PLUG. DO NOT TOUCH NON-INSULATED PORTION OF OUTPUT CONNECTOR OR NON-INSULATED BATTERY TERMINAL.

DO NOT OPERATE CHARGER IF AC SUPPLY CORD IS DAMAGED OR IF THE CHARGER HAS RECEIVED A SHARP BLOW, BEEN DROPPED, OR OTHERWISE DAMAGED IN ANY WAY.

ALWAYS DISCONNECT THE CHARGER AC SUPPLY BEFORE MAKING OR BREAKING THE (POSITIVE/NEGATIVE) CONNECTIONS TO THE BATTERY.

DO NOT OPEN OR DISASSEMBLE CHARGER.

2. After connecting the charger to an AC outlet at the start of the charging cycle, verify normal operation of the LED indicators on the charger (refer to Section 6.4).

NOTE: Current battery charge state can also be seen on the platform control station panel LEDs or the MDI Indicator (if equipped) on the ground control station when machine is powered up.

3. The batteries are fully charged when all three green LED indicators on the platform control station or MDI battery charger status panel are illuminated.

NOTE: If the charger is left plugged in, the charger will automatically restart a complete charge cycle if the batteries voltage drops below a minimum voltage, or if 30 days have elapsed.

3.7 GROUND CONTROL STATION

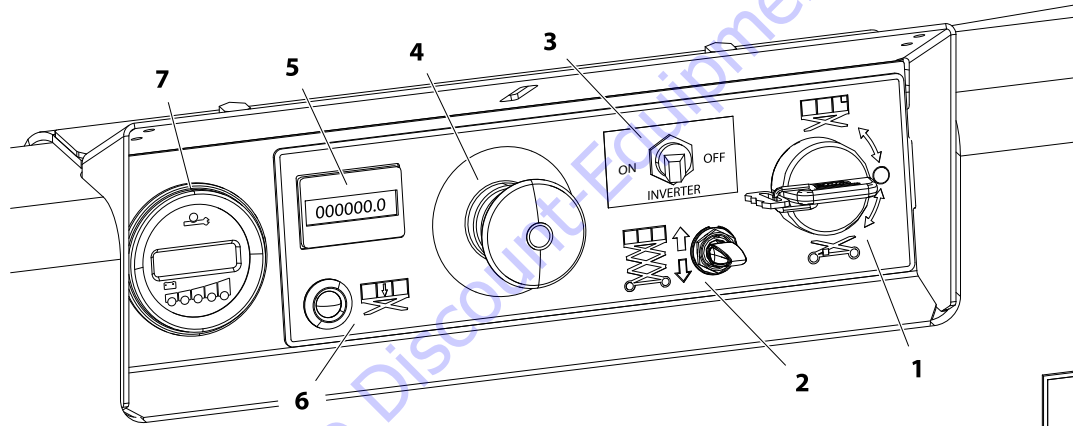

- 1. Ground/Platform/OFF Key Selector Switch
- 2. Platform Lift/Lower Switch
- 3. Inverter ON/OFF Switch (If Equipped)
- 4. Ground Emergency Stop Button
- 5. Hourmeter
- 6. Overload Indicator
- 7. MDI Indicator (If Equipped)

⚠ WARNING

DO NOT OPERATE FROM GROUND CONTROL STATION WITH PERSONNEL IN THE PLATFORM EXCEPT IN AN EMERGENCY.

Ground/Platform/OFF Key Selector Switch

The key selector switch on the Ground Control Station functions to direct electrical power to the desired control station. With the switch turned to the **ground position (1)**, power is supplied to the controls at the ground control station. When the switch is turned to the **platform position (2)**, power is supplied to the controls at the platform control station. The switch should be set to the **OFF position (3)** when not using machine or parking the machine overnight.

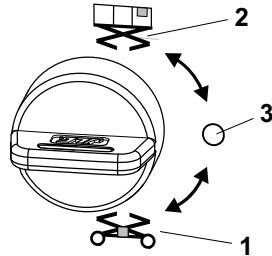

Platform Lift/Lower Switch

A three position, momentary contact lift control switch provides raising and lowering of the platform from the Ground Control Station.

NOTE: *There will be a brief delay between switch activation and movement of the platform.*

When operating platform from the ground controls, activate the lift/lower switch to up position and hold to raise platform, or down position and hold to lower an elevated platform. Release to stop all movement.

Inverter ON/OFF Switch (If Equipped)

When switched on the inverter converts the DC voltage stored in the on-board batteries to AC voltage for use at the AC receptacle outlet mounted on the platform rail.

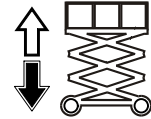

Ground Emergency Stop Switch

Power is turned on by pulling the switch out, and is turned off by depressing switch. A two-position, red, mushroom-shaped emergency stop switch, when positioned to ON with the key selector switch positioned to ground, furnishes operating power to the ground control station key switch. In addition, the switch can be used to turn off power to the function controls in the event of an emergency.

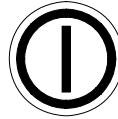

Hourmeter

The machine is equipped with an hour meter to indicate the number of hours the machine has been operated.

000000
HOURS

Overload Indicator (LSS)

The Overload Indicator indicates when the platform has been overloaded. An audible alarm will also signal when the platform is overloaded.

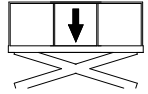

NOTE: If the Overload Indicator is illuminated, further elevation will be prevented. Reduce the weight in the platform to not exceed the rated workload indicated on the capacity decal, then the controls will work again.

NOTE: When ambient temperatures are below freezing, the LSS will have a reduction in available capacity. This will trigger the LSS before achieving the maximum allowable capacity.

SECTION 3 - MACHINE CONTROLS, INDICATORS AND OPERATION

MDI Indicator (If Equipped)

The Multifunction Digital Indicator (MDI) displays a Battery Discharge Indicator (BDI), a LCD display showing the current hourmeter reading, a system distress LED, and Diagnostic Trouble Codes (DTC) when a functional problem occurs with the machine.

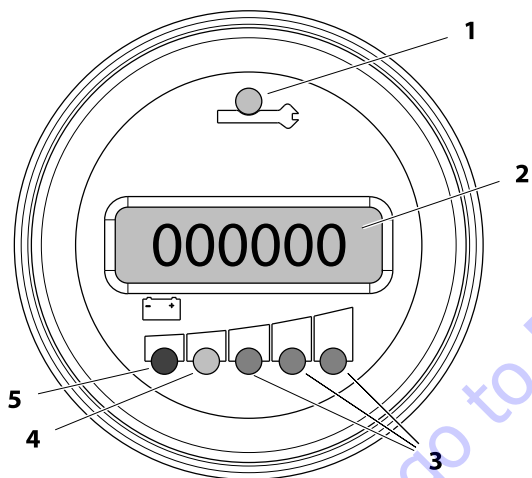

- | | |
|---|---|
| 1. System Fault LED Indicator (RED LED) | 4. Battery Charge LOW Indicator (YELLOW AREA) |
| 2. Hour-meter/DTC Code Display | 5. Battery Re-Charge Indicator (RED AREA) |
| 3. 100% Battery Charge Indicator (GREEN AREA) | |

When a problem occurs and a DTC Code displayed:

- A LED wrench icon (1) LED illuminates.
- A three to five digit DTC code will display on the DTC LCD display (2) below the wrench icon.

NOTE: When more than one DTC exists, each DTC will be displayed on the LCD for three seconds before changing to the next DTC. Once the last active DTC is displayed, the display will recycle indefinitely until the DTCs are corrected. For DTCs and descriptions, refer to Section 6.7.

Also located on the MDI are Battery Discharge Indicators (BDI) (3, 4, 5). The three green LEDs indicate the level of charge (voltage) remaining in the batteries.

NOTE: When the battery voltage is low and will need a charge soon, the yellow LED (4) begin to flash.

BDIs and the hourmeter display under normal operating conditions. When a DTC exists other than 00x DTCs, the BDI LEDs and hourmeter are not be displayed. Additionally, when the platform is elevated and the machine is driving in creep mode, the turtle icon is displayed.

3.8 PLATFORM CONTROL STATION

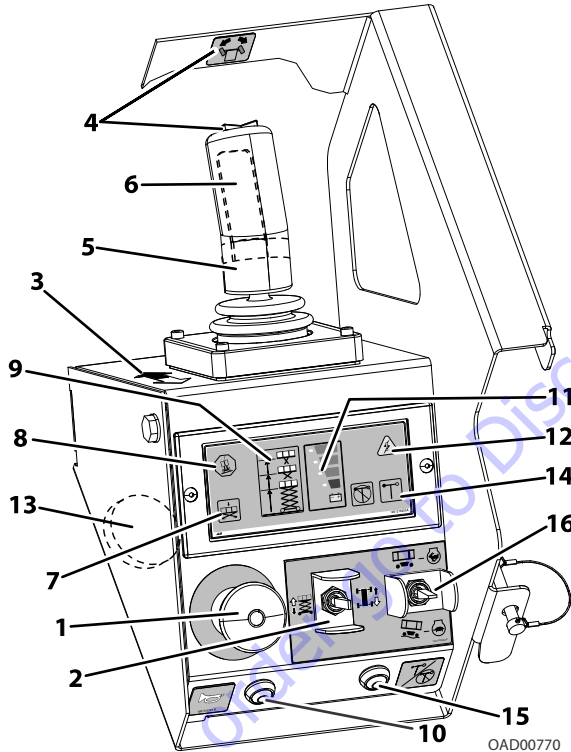

1. Emergency Stop Switch
2. Lift/Drive Select Switch
3. Black/White Directional Arrow
4. Steer Control Switch and Decal
5. Joystick Controller
6. Trigger Enable Switch
7. Overload Indicator (LSS)
8. Tilt Indicator
9. Variable Tilt - Platform Restricted Height Indicator
10. Horn Button
11. Battery Discharge Indicator
12. System Fault Indicator
13. Alarm
14. Indoor/Outdoor - Capacity Indicators
15. Indoor/Outdoor - Capacity Select Switch
16. Drive Speed Select Switch

SECTION 3 - MACHINE CONTROLS, INDICATORS AND OPERATION

Platform Emergency Stop Switch

NOTE: Both the ground and platform emergency stop buttons must be set to ON in order to operate the machine.

When power is directed to the platform from the ground control station, the platform emergency stop switch is turned on by pulling the switch out (on), and is turned off by pushing the switch in (off). The two-position, red, mushroom-shaped emergency stop switch functions to provide power to the platform control station and also to turn off power to machine functions in the event of an emergency.

NOTICE

ALWAYS POSITION EMERGENCY STOP SWITCH TO "OFF" POSITION (PUSHED IN) WHEN MACHINE IS NOT IN USE.

Lift/Drive Select Switch

NOTE: When selecting between the Lift and Drive functions the joystick control must be returned to the neutral position for approximately 1/2 second before the function change is operable.

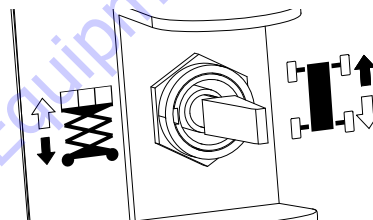

This toggle switch is used to select operation of either the drive or lift function. After selecting a function, the joystick controller must be used in order to activate that function. Only change the function selected, with the joystick in the neutral position. Otherwise, the function selected will not change until the joystick is returned to the neutral position.

Forward/Reverse/Lift/Lower Direction

Arrow

This decal indicates the proper direction to mount the platform control box, with the black arrow pointing to the front of the machine. The black/white arrow also indicates the direction to move the joystick control per the lift/drive selector switch decal for the lift and the drive select functions.

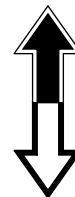

Drive/Lift/Steer Joystick Control

Trigger (Enable) Switch - This trigger switch is located on the front of the joystick controller. It acts as an enable and must be depressed before operating the drive, steer, and lift functions. When released, the function in operation will stop.

The speed on all selected functions is proportionally controlled by the distance from the neutral (center) position of the joystick controller.

NOTE: *Once the trigger switch is pressed, the operator has (5) seconds to begin operating a function. After 5 seconds, the trigger switch must be released and pressed again to operate a joystick function.*

NOTE: *If the machine is also equipped with a footswitch, depress the footswitch in conjunction with the trigger (enable) switch located on the joystick controller. Power is removed from the platform controls when the footswitch is released.*

Steer Switch - The steer switch is a thumb-operated switch located at the top of the joystick controller handle. Depressing the switch to the right will steer the wheels to the right. Depressing the switch to the left will steer the wheels to the left.

Joystick Controller - This controls drive and lift.

Steering And Traveling

WARNING

DO NOT DRIVE WITH PLATFORM RAISED EXCEPT ON A SMOOTH, FIRM SURFACE, WITHIN THE LIMITS OF THE MAXIMUM OPERATING SLOPE, FREE OF OBSTRUCTIONS AND HOLES.

TO AVOID LOSS OF TRAVEL CONTROL OR UPSET ON GRADES AND SIDESLOPES, DO NOT DRIVE MACHINE ON GRADES OR SIDESLOPES EXCEEDING THOSE SPECIFIED IN SECTION 6.2.

BEFORE DRIVING, LOCATE THE DECALS WITH THE BLACK/WHITE ORIENTATION ARROWS ON THE CHASSIS AND THE PLATFORM CONTROLS. MOVE THE JOYSTICK IN THE DIRECTION OF THE BLACK OR WHITE ARROW THAT MATCHES THE COLOR OF THE ARROW ON THE CHASSIS FOR THE INTENDED DIRECTION OF TRAVEL.

IF THE TILT INDICATOR WARNING LIGHT/ALARM IS ACTIVATED WHILE DRIVING WITH PLATFORM RAISED, LOWER PLATFORM COMPLETELY AND DRIVE TO A SMOOTH, FIRM SURFACE, WITHIN THE LIMITS OF THE MAXIMUM OPERATING SLOPE.

1. Place key selector switch at the ground control station to platform operation.
2. Position emergency stop switches, one at the platform and one at the ground control station to the ON position.

SECTION 3 - MACHINE CONTROLS, INDICATORS AND OPERATION

Steering

On the platform control station, position the lift/drive select switch to the drive position.

To steer the machine, engage trigger switch and the thumb operated steer rocker-switch on the joystick handle. Press to the right for steering right, or to the left for steering left. When released, the switch will return to the center-off position and the wheels will remain in the previously selected position. To return the wheels to the center position, the switch must be activated in the opposite direction until the wheels are centered.

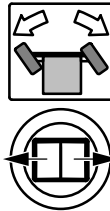

Traveling Forward and Reverse

Position the platform lift/drive select switch to drive/steer position. Squeeze the trigger switch on front of the joystick and move the joystick forward to drive forward, or backward to drive in reverse.

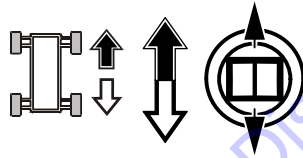

The drive system is proportional: for additional drive speed, push the joystick further from the neutral position in the direction of travel. Releasing the trigger switch or returning the joystick to center will stop machine movement.

NOTE: To ensure proper operation of the desired platform function, move the joystick in the direction of the black or white arrow that matches the color of the arrow on the chassis for the intended direction of travel.

Raising And Lowering Platform

1. If the machine was shut down, place the key selector switch to the platform position.
2. Position both emergency stop switches, to the ON position.
3. Position the lift/drive select switch to lift.
4. Squeeze and hold the trigger switch, and move the joystick back (platform up - white arrow direction) or move the joystick forward (platform down - black arrow direction) and hold until desired elevation is reached. Releasing the trigger switch or moving the joystick back to its center position will stop the function being operated.

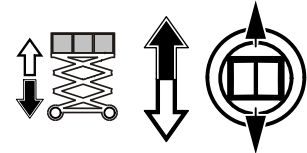

Arm Guards (If Equipped)

If the machine is equipped with electronic arm guards, the platform will stop lowering at a predetermined height and the machine's beacons will flash at a different rate to warn ground personnel. The machine can continue lowering after a three (3) second delay and re-engaging the lowering function. Once the lowering function is re-engaged an audible alarm will sound. After a three second delay, the platform will continue lowering.

Overload Indicator (LSS)

The Overload Indicator indicates when the platform has been overloaded. An audible alarm will also signal when the platform is overloaded.

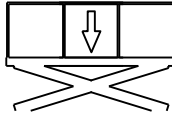

NOTE: If the Overload Indicator is illuminated, further elevation will be prevented. Reduce the weight in the platform to not exceed the rated workload indicated on the capacity decal, then the controls will work again.

NOTE: When ambient temperatures are below freezing, the LSS will have a reduction in available capacity. This will trigger the LSS before achieving the maximum allowable capacity.

Tilt Indicator Warning Light and Alarm

A red warning light on the control panel illuminates and an audible alarm sounds when the chassis is at or beyond the tilt cutout settings.



WARNING

IF THE TILT INDICATOR WARNING LIGHT/ALARM IS ACTIVATED WHEN PLATFORM IS RAISED LOWER PLATFORM AND DRIVE TO A SMOOTH, FIRM SURFACE, WITHIN THE LIMITS OF THE MAXIMUM OPERATING SLOPE.

Variable Tilt - Platform Restricted Height Indicator

This indicator shows the maximum allowable platform elevation when the machine is within the limits of the variable tilt envelope. When activated, allowable platform height will be shown in one of three height ranges, depending on the amount of tilt detected by the machine's tilt sensor. See Table 2-2 on page 2-10 for tilt angle - platform operating height restrictions.

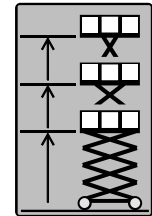

Horn

This push-button switch, when pressed, permits the operator to warn job site personnel when the machine is operating in the area.

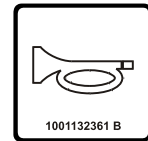

SECTION 3 - MACHINE CONTROLS, INDICATORS AND OPERATION

Battery Charge Indicator

The battery charge indicator displays the current charge status of the onboard batteries. RED LED flashing = batteries depleted, RED LED ON solid = batteries low, RED LED ON and GREEN LEDs ON = batteries FULL charge.

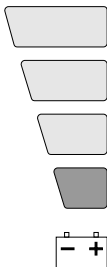

System Fault Indicator

When this indicator light is flashing, a system fault has occurred, possibly stopping machine operation.

Check the MDI Indicator (if equipped) on the Ground Control Station to see if a DTC is displayed.

If the code cannot be cleared by the operator, the machine will require service by a qualified JLG mechanic.



Alarm

This alarm mounted on the front of the platform control station will sound for various machine conditions or warnings such as, system ready chirp or if the machine tilt warning is activated.

Indoor/Outdoor Operation Indicator

The Indoor (GREEN) indicator and the Outdoor (YELLOW) indicator displays which mode the machine is currently set to operate in.

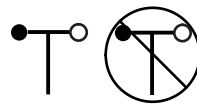

Indoor/Outdoor Operation Mode Switch

This button will toggle between the indoor/outdoor operation modes.

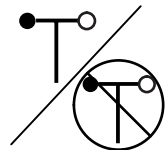

Low/High Drive Speed

The two position speed switch controls high or low range drive speed. High speed would be used in unobstructed open, flat, and level work areas. Low speed would be used in close work areas with obstacles, other machinery or personnel to avoid.

NOTE: Drive speed will automatically be reduced to low drive when the platform is raised above the stowed position, regardless of speed switch position.

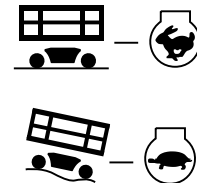

3.9 PLATFORM MANUAL DESCENT CONTROL

The platform manual descent control is used in the event of total power failure to lower the platform using gravity. The manual descent control T-handle is located on the left rear of the machine, just below the platform ladder. Look for the instruction decal located beside the release handle.

The lowering procedure is as follows:

1. Locate the manual descent control red T-handle.

⚠ WARNING

KEEP HANDS AND ARMS OUT OF THE PATH OF THE SCISSOR ARMS AND PLATFORM WHILE LOWERING.

2. Grasp the T-handle and slowly pull out to lower the scissor arms/platform. When the platform is lowered to desired level, allow the T-handle to return to its closed position.

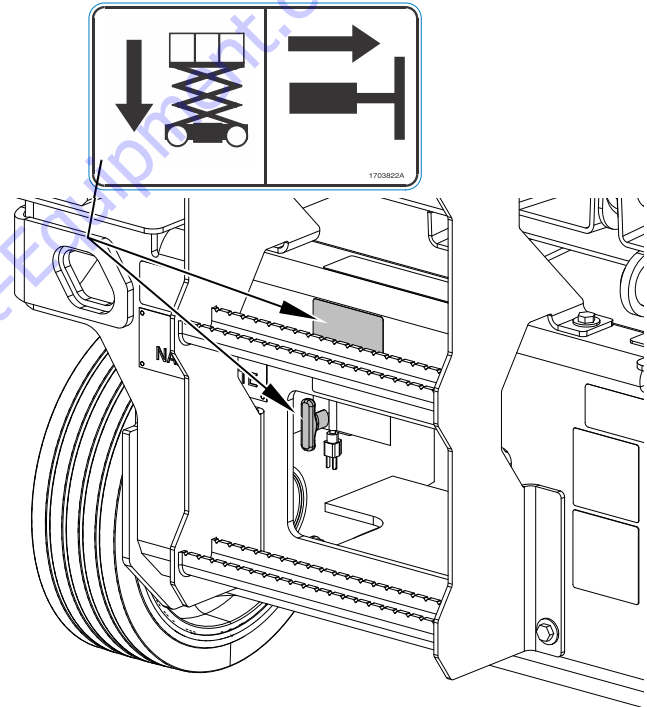

3.10 GRADE AND SIDESLOPE DEFINITION

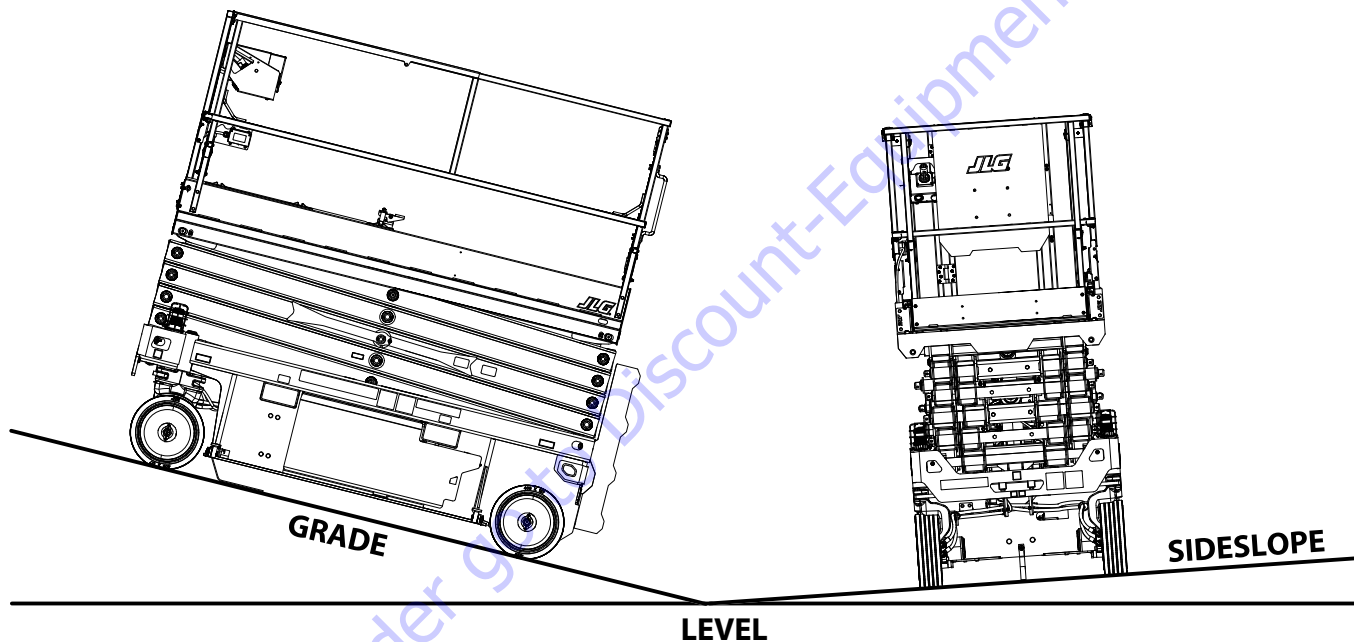

3.11 PLATFORM EXTENSION

This machine is equipped with an extension deck that allows the operator better access to certain work areas. The deck extension adds length to the front of the platform.

⚠ WARNING

FOR MAXIMUM CAPACITY OF THE DECK EXTENSION SEE SECTION 6.2 OR REFER TO THE CAPACITY PLACARD ON THE PLATFORM BILLBOARD.

⚠ CAUTION

DO NOT LOWER WITHOUT COMPLETELY RETRACTING THE PLATFORM EXTENSION.

To extend the deck:

1. Press foot down on locking mechanism lever (1) until it clears the rear platform extension lock (3).
2. While holding the lever, grasp the top handrails (2) and push forward until the locking mechanism pin locks into the forward platform extension lock (4 or 5).

To retract the deck:

1. Press foot down on locking mechanism lever (1) until it clears the forward platform extension lock (4 or 5).
2. Grasp the top handrails (2) and pull back until the locking mechanism pin locks into the rear platform extension lock (3).

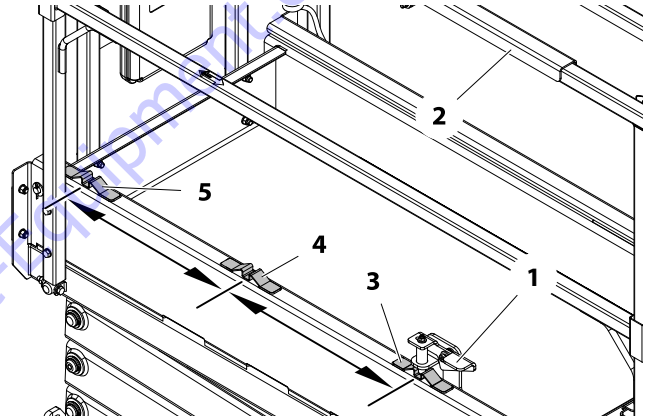

3.12 PLATFORM RAILS FOLD-DOWN PROCEDURE (If Equipped)

See Figure 3-1.

WARNING

ONLY FOLD DOWN THE RAILS WHEN THE MACHINE IS IN THE STOWED (PLATFORM FULLY LOWERED) POSITION. DO NOT RAISE THE PLATFORM WITH THE RAILS FOLDED DOWN. THE RAILS MUST BE IN THE UPRIGHT POSITION AND PROPERLY PINNED WHEN RAISING THE PLATFORM.

The platform rails fold down from the mid rail only, except for the rear gate rail.

Platform with Dual Rail Extension Deck

See Figure 3-1.

The platform end rails fold-down first, then both the extension platform side rails and the main platform side rails will be folded down together.

The platform rails fold down in the following sequence;
(See Figure 3-1.)

Remove the platform control box and place it on the platform deck.

1. Remove platform top rail pins (four total - two front, two rear) and fold the FRONT and REAR GATE platform rails down onto the platform deck.
2. Fold down both platform extension side rails next.
3. Fold down main platform left side rail.
4. Fold down main platform right side rail.

To raise the rails back to the upright position, unfold the rails in the reverse sequence they were folded and replace the rail pins into the rails.

NOTE: *When setting platform side rails back to upright position be certain the extension platform rail guide is interlocked with the main platform rail once both rails are completely upright.*

WARNING

AFTER THE RAILS HAVE BEEN FOLDED DOWN, USE EXTREME CAUTION WHEN EXITING AND ENTERING THE PLATFORM. ENTER AND EXIT PLATFORM ONLY AT THE GATE AREA AND LADDER PROVIDED.

WARNING

IF DRIVING MACHINE WITH THE PLATFORM CONTROL STATION FROM GROUND, DO NOT HANG THE CONTROL BOX ON ANY PART OF THE MACHINE WHILE DRIVING. HOLD THE CONTROL BOX AND KEEP AT LEAST 3 FT (1 M) DISTANCE FROM MACHINE.

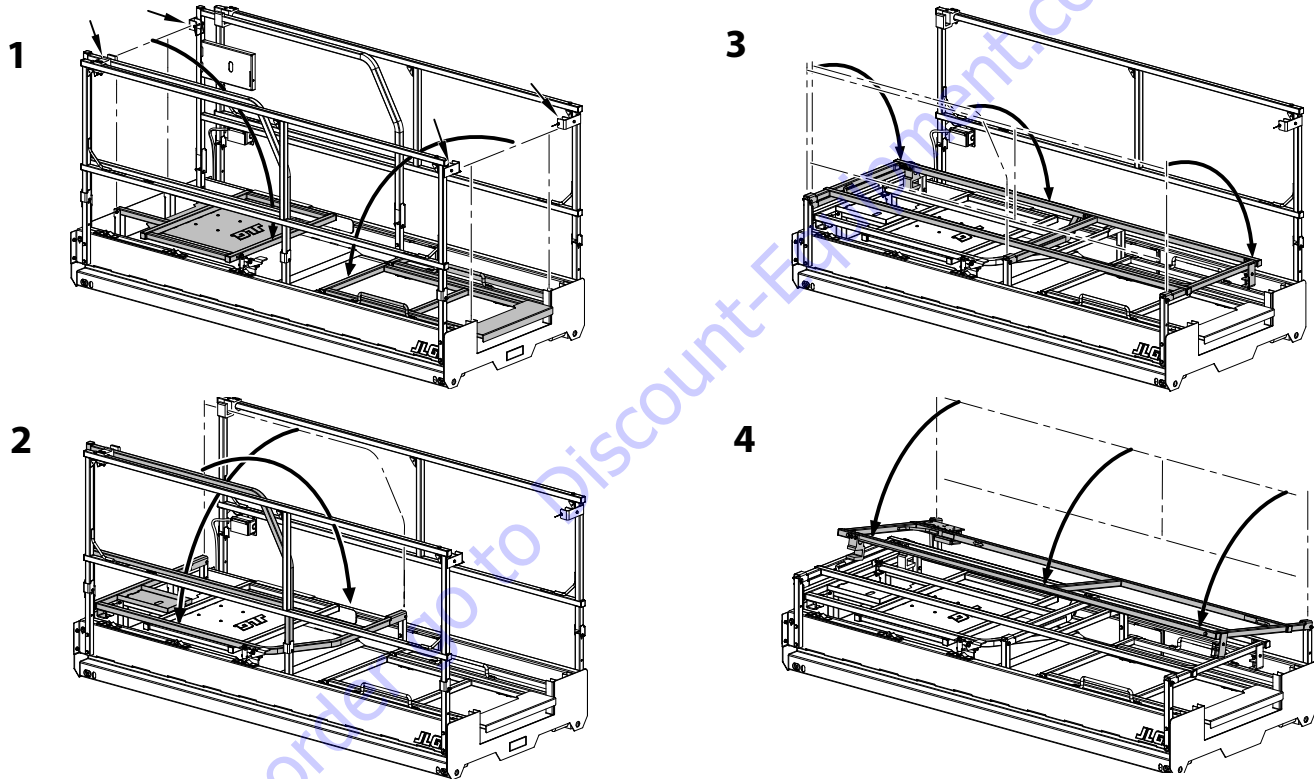

Figure 3-1. Platform with Dual Rail Extension - Fold Down Sequence

Platform with Rail In Rail Extension Deck

(See Figure 3-2.)

⚠ WARNING

ONLY FOLD DOWN THE RAILS WHEN THE MACHINE IS IN THE STOWED (PLATFORM FULLY LOWERED) POSITION. DO NOT RAISE THE PLATFORM WITH THE RAILS FOLDED DOWN. THE RAILS MUST BE IN THE UPRIGHT POSITION AND PROPERLY PINNED WHEN RAISING THE PLATFORM.

The platform rails fold down in the following sequence;

1. At the rear gate rail, pull the pins at the top rail corners one (1) each side and fold the rear gate rail down onto the platform deck.
2. Before lowering side rails, the front deck extension sliding top and mid rail pins, one (1) each rail - four (4) total, must be removed and sliding rails slid towards rear of machine and re-pinned to top and mid side rails. *(Both Sides)*
A - Reuse the top sliding rail pin hole to re-pin to the top side rail.
B - The mid sliding rail is provided a pinning hole under the lanyard attach lug, on the mid rail.
3. Remove the two (2) lower side rail pins and fold down RIGHT side rail.
Remove the two (2) lower side rail pins and fold down LEFT side rail.
4. Remove the two (2) lower front rail pins and fold down FRONT platform extension rail.

To raise the rails back to the upright position, unfold the rails in the reverse sequence they were folded and replace the bail pins to secure rails.

⚠ WARNING

AFTER THE RAILS HAVE BEEN FOLDED DOWN, USE EXTREME CAUTION WHEN EXITING AND ENTERING THE PLATFORM. ENTER AND EXIT PLATFORM ONLY AT THE GATE AREA AND LADDER PROVIDED.

⚠ WARNING

IF DRIVING MACHINE WITH THE PLATFORM CONTROL STATION FROM GROUND, DO NOT HANG THE CONTROL BOX ON ANY PART OF THE MACHINE WHILE DRIVING. HOLD THE CONTROL BOX AND KEEP AT LEAST 3 FT (1 M) DISTANCE FROM MACHINE

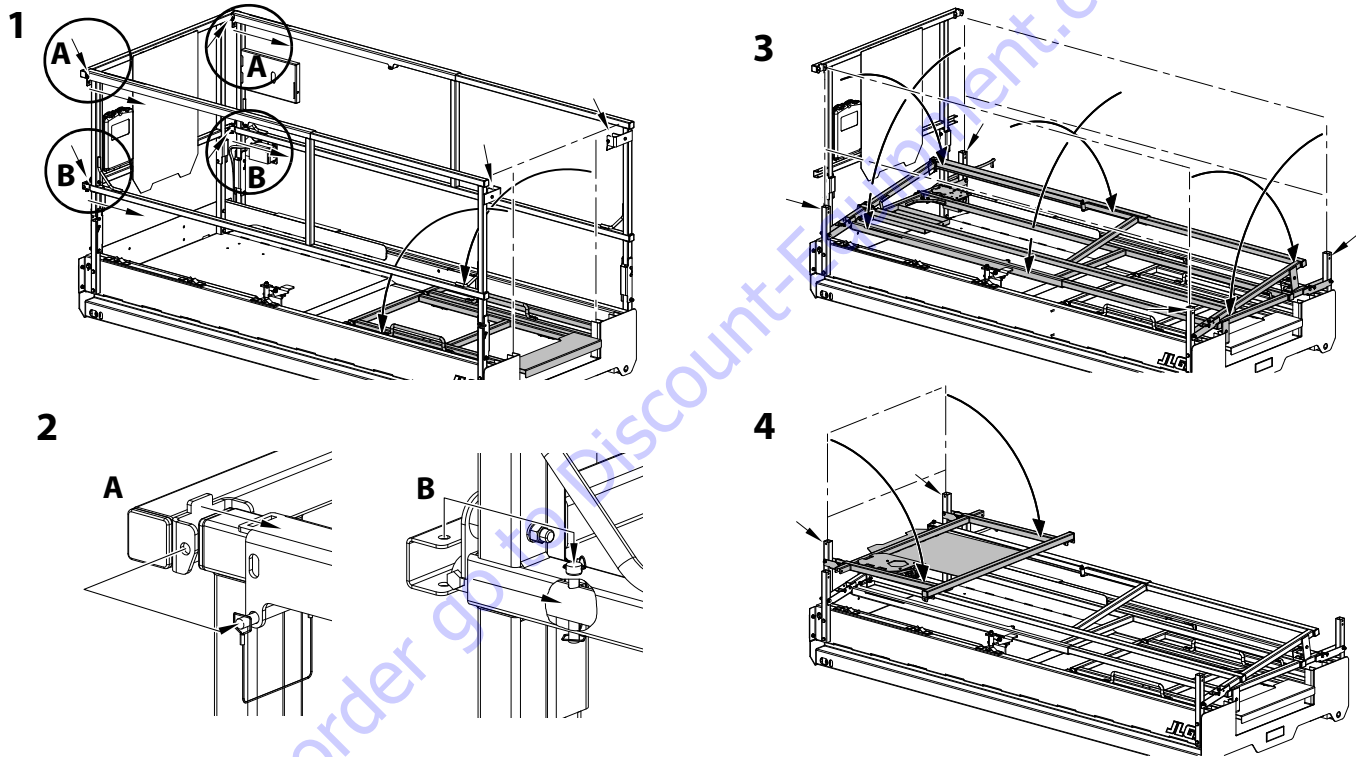

Figure 3-2. Platform with Rail in Rail Extension - Fold Down Sequence

3.13 PARKING AND STOWING MACHINE

1. Drive the machine to a well-protected and well-ventilated area.
2. Ensure the platform is fully lowered.

NOTICE

WHEN THE MACHINE IS SHUT DOWN FOR OVERNIGHT PARKING OR BATTERY CHARGING, THE EMERGENCY STOP AND POWER SELECT SWITCHES MUST BE POSITIONED TO OFF TO PREVENT DRAINING THE BATTERIES.

3. At the ground control station, turn the platform - ground selector key switch to OFF and remove the key to disable the machine and prevent unauthorized use.

NOTE: For added protection, the platform control station can be secured to its mounting plate. Also the side compartment doors can be secured by placing a padlock through the holes provided just below the door latch on each door.

4. At the ground control station, depress emergency stop switch to the off position.
5. If necessary, cover the platform control box, instruction placards, caution and warning decals so that they will be protected from hostile environment.
6. Chock at least two wheels when parking the machine for an extended period of time.

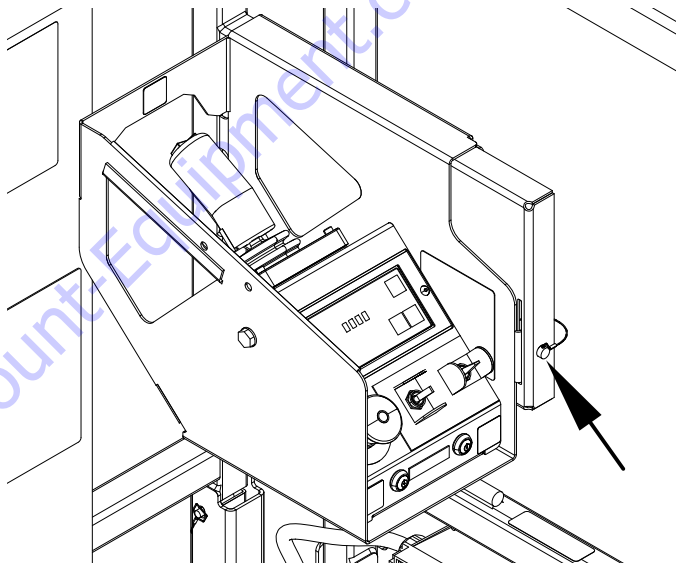

To prevent unauthorized removal, the platform control station can be secured to its mount by replacing the lock pin located on it's mounting tab with a keyed or combination lock.

3.14 MACHINE LIFTING AND TIE DOWN

Lifting

The machine may be lifted using a fork lift truck. Lift only using the built-in fork lift pockets on the side of the machine, and only with the platform in the stowed position. Adjust the width of the **forklift truck, lifting tines** to properly fit the machine forklift pockets (refer to Figure 3-3.) Slide the forklift tines into the forklift pockets and carefully lift machine.

The machine can also be lifted using a spreader bar and four equal length straps or chains capable of supporting the full gross weight of the machine (refer to Figure 3-4.) Lift only using the lifting lugs provided at the four corners of the machine. (See Section 6, *Machine Specifications for machine gross weight*).

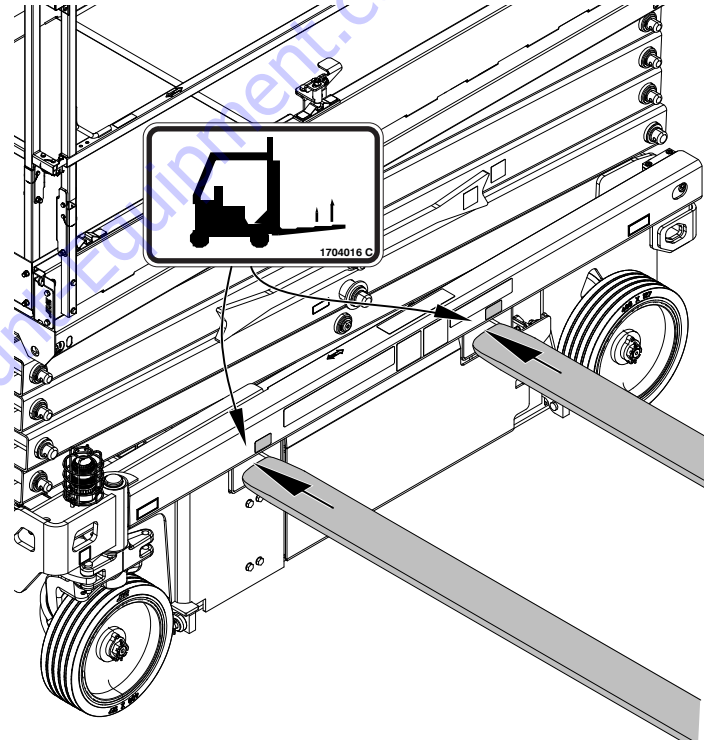
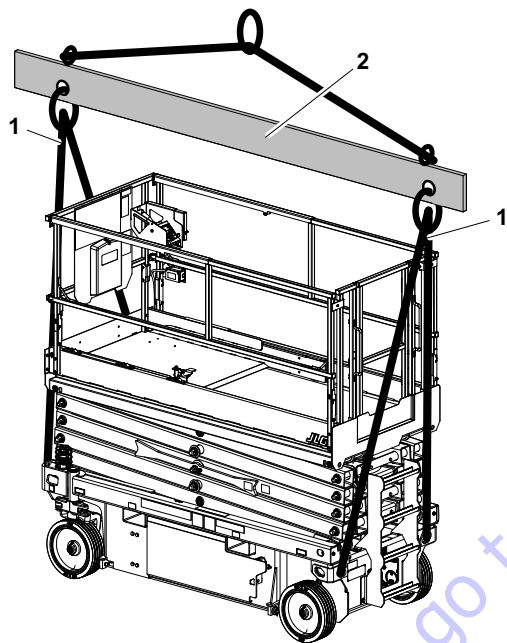

Figure 3-3. Fork Lift Pockets - Location



Tie Down

When transporting the machine, the platform must be fully lowered in the stowed position with the machine securely tied down to the truck or trailer deck. There are two tie-down and one lift lugs located at the front and two tie-down/lift lugs on the rear of the machine. (See Figure 3-5.)

Figure 3-4. Lifting Machine Using Spreader Bar and Lift Lug Locations

1. Four equal length chains or lifting straps.
2. Spreader Bar Assembly.

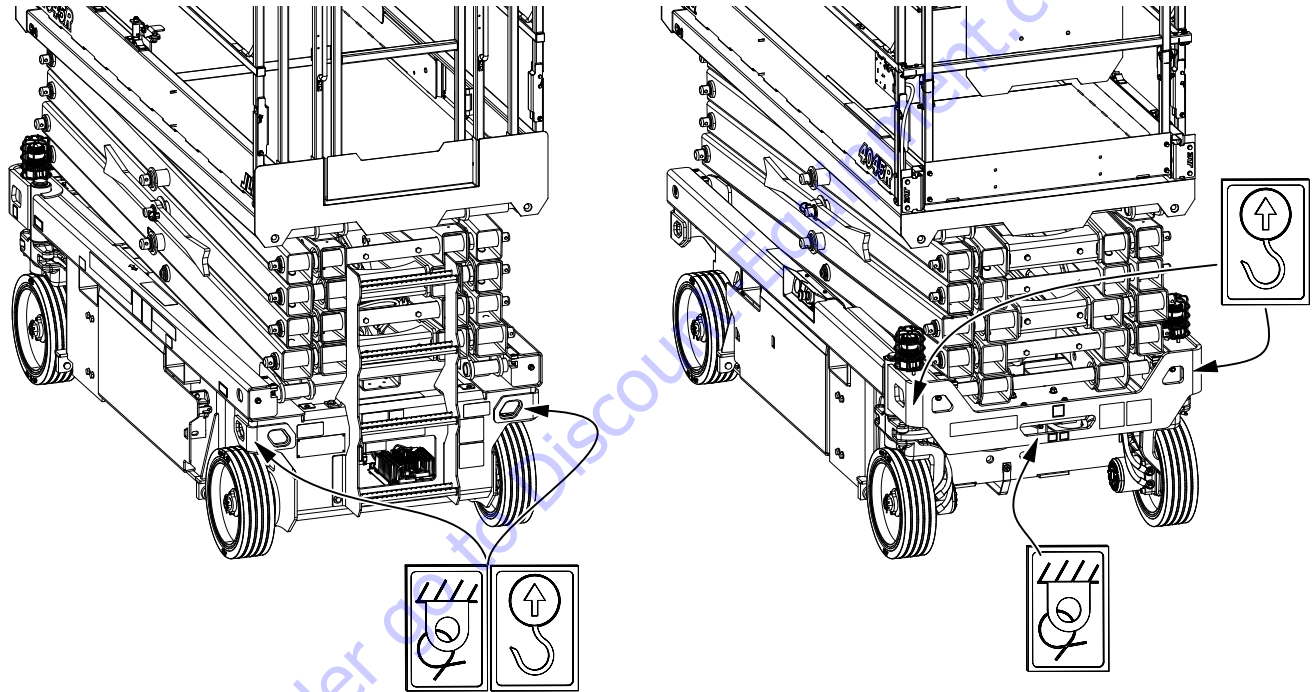

Figure 3-5. Tie Down and Lift Lug Locations

SECTION 3 - MACHINE CONTROLS, INDICATORS AND OPERATION

3.15 TOWING

It is not recommended that this machine be towed, except in the event of an emergency such as a machine malfunction or a total machine power failure.

NOTE: *If machine is disabled to a point where the hydraulic system cannot be operated, the steer circuit will also not be operational. Then the machine will only track in the direction the front wheels are currently positioned.*

Hydraulic Brake Release

1. Chock wheels or secure machine with tow vehicle.
2. At the ground control station turn power off by pressing the Emergency Stop switch in.
3. Open the right side compartment door and locate the main hydraulic control valve.
4. Perform the following to set the drive motor control valve to tow mode. On the drive control valve locate the **tow mode needle valve knob (1)**, screw the valve out until it stops.
5. On the main valve body, to release the brakes, push the **BLACK brake override button (2)** in, (there is a detent which will hold the valve in place).
6. Pump the **RED knob (3)** until pressure builds, approximately 5 to 10 strokes. The brakes should now be released.
7. After towing is complete, chock the machine wheels. Release the **BLACK brake override button (2)** and screw the **tow mode needle valve knob (1)** all the way in to reset the hydraulic brake.

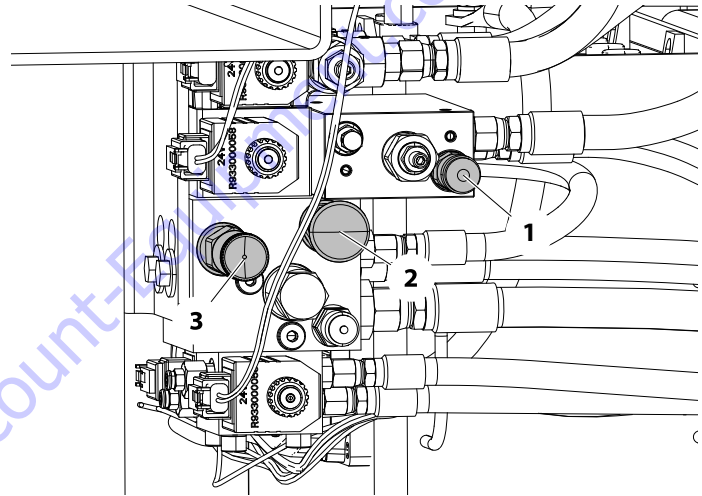

TO PURCHASE THIS PRODUCT PLEASE CONTACT US



**Equipment Financing and
Extended Warranties Available**



**Discount-Equipment.com is your online resource for
commercial and industrial quality parts and equipment sales.**

561-964-4949

visit us on line @ www.discount-equipment.com

Select an option below to find your Equipment

Search by Manufacturer

Search by Product Type

Request a Quote

We sell worldwide for the brands: Genie, Terex, JLG, MultiQuip, Mikasa, Essick, Whiteman, Mayco, Toro Stone, Diamond Products, Generac Magnum, Airman, Haulotte, Barreto, Power Blanket, Nifty Lift, Atlas Copco, Chicago Pneumatic, Allmand, Miller Curber, Skyjack, Lull, Skytrak, Tsurumi, Husquvarna Target, Stow, Wacker, Sakai, Mi-T-M, Sullair, Basic, Dynapac, MBW, Weber, Bartell, Bennar Newman, Haulotte, Ditch Runner, Menegotti, Morrison, Contec, Buddy, Crown, Edco, Wyco, Bomag, Laymor, EZ Trench, Bil-Jax, F.S. Curtis, Gehl Pavers, Heli, Honda, ICS/PowerGrit, IHI, Partner, Imer, Clipper, MMD, Koshin, Rice, CH&E, General Equipment, Amida, Coleman, NAC, Gradall, Square Shooter, Kent, Stanley, Tamco, Toku, Hatz, Kohler, Robin, Wisconsin, Northrock, Oztec, Toker TK, Rol-Air, APT, Wylie, Ingersoll Rand / Doosan, Innovatech, Con X, Ammann, Mecalac, Makinex, Smith Surface Prep, Small Line, Wanco, Yanmar

SECTION 4. EMERGENCY PROCEDURES

4.1 GENERAL INFORMATION

This section explains the steps to be taken in case of an emergency situation during operation.

4.2 EMERGENCY OPERATION

Operator Unable to Control Machine

IF THE PLATFORM OPERATOR IS UNABLE TO OPERATE OR CONTROL THE MACHINE:

1. Other personnel should operate the machine from ground controls only as required.
2. Only qualified personnel in the platform may use the platform controls. **DO NOT CONTINUE OPERATION IF CONTROLS DO NOT FUNCTION PROPERLY.**
3. Rescue equipment can be used to remove the platform occupant(s). Cranes and forklifts can be used to stabilize motion of the machine.

Righting of Tipped Machine

A fork truck of suitable capacity or equivalent equipment should be placed under the elevated side of the chassis, with a crane or other suitable lifting equipment used to lift the platform while the chassis is lowered by the forklift or other equipment.

Platform Caught Overhead

If the platform becomes jammed or snagged in overhead structures or equipment, do the following:

1. Shut off the machine.
2. Rescue all people in the platform before freeing the machine. Personnel must be out of the platform before operating any controls on the machine.
3. Use cranes, forklifts or other equipment to stabilize motion of the machine to prevent a tip over as required.
4. From the ground controls, carefully free the platform from the object.
5. Once clear, restart the machine and return the platform to a safe position.
6. Inspect the machine for damage. If the machine is damaged or does not operate properly, turn off the machine immediately. Report the problem to the proper maintenance personnel. Do not operate the machine until it is declared safe for operation.

SECTION 4 - EMERGENCY PROCEDURES

4.3 PLATFORM MANUAL DESCENT

The platform manual descent control is used in the event of total power failure to lower the platform using gravity. The manual descent control T-handle is located on the left rear of the machine, just below the platform ladder. The lowering procedure is as follows:

1. Locate the manual descent control red T-handle.

⚠ WARNING

KEEP HANDS AND ARMS OUT OF THE PATH OF THE SCISSOR ARMS AND PLATFORM WHILE LOWERING.

2. Grasp the T-handle and slowly pull out to lower the scissor arms/platform. When the platform is lowered to desired level, allow the T-handle to return to its closed position.

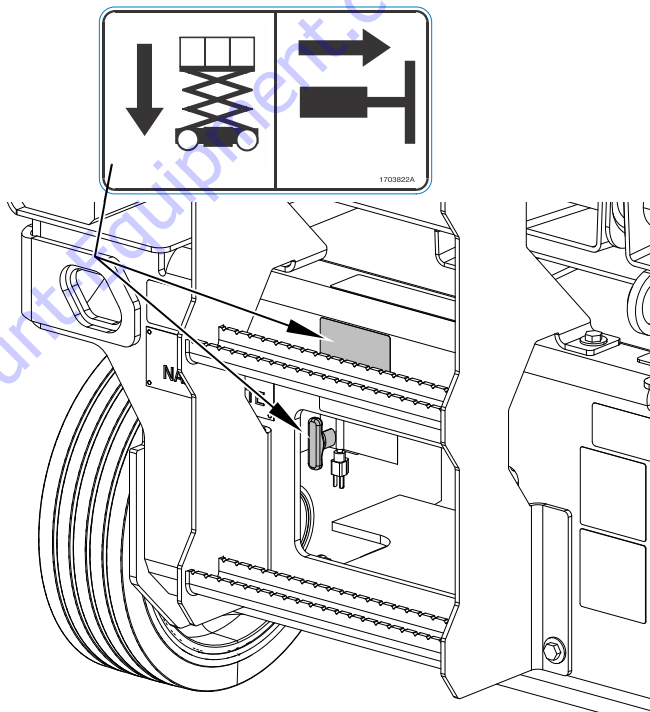

4.4 INCIDENT NOTIFICATION

JLG Industries, Inc. must be notified immediately of any incident involving a JLG product. Even if no injury or property damage is evident, JLG must be contacted by telephone and provided with all necessary details.

- USA: 877-JLG-SAFE (554-7233)
- EUROPE: (32) 0 89 84 82 20
- AUSTRALIA: (61) 2 65 811111
- E-mail: productsafety@jlg.com

Failure to notify the manufacturer of an incident involving a JLG Industries product within 48 hours of such an occurrence may void any warranty consideration on that particular machine.

NOTICE

FOLLOWING ANY INCIDENT, THOROUGHLY INSPECT THE MACHINE. DO NOT ELEVATE PLATFORM UNTIL YOU ARE SURE THAT ALL DAMAGE HAS BEEN REPAIRED, AND THAT ALL CONTROLS ARE OPERATING CORRECTLY. TEST ALL FUNCTIONS FIRST FROM THE GROUND CONTROL STATION, THEN FROM THE PLATFORM CONTROL CONSOLE.

SECTION 5. ACCESSORIES

5.1 AVAILABLE ACCESSORIES

ACCESSORY	MARKET				
	ANSI	CSA	CE	AUS	China
DC/AC Power Inverter	✓				
Quick Welder	✓	✓	✓	✓	✓
Workstation (Unpowered)	✓	✓	✓	✓	✓
Electrician's Tree	✓	✓	✓	✓	✓
Pipe Racks	✓	✓	✓	✓	✓
Panel Carrier	✓	✓	✓	✓	✓
Machinist's Vise	✓	✓	✓	✓	✓
Platform Work Lights	✓	✓	✓	✓	✓
Platform Rail Padding	✓	✓	✓	✓	✓
Anti-Vandalism Package	✓	✓	✓	✓	✓
Rail Mounted Extension Deployment Handles	✓	✓	✓	✓	✓
Footswitch	✓	✓	✓	✓	✓
Magnetic Gate Switch	✓	✓	✓	✓	✓
JLG™ Mobile Control	✓	✓	✓		

5.2 OPTIONS/ACCESSORIES RELATIONSHIP TABLE

ACCESSORY	REQUIRED ITEM	COMPATIBLE WITH (Note 1)	INCOMPATIBLE WITH	INTERCHANGABLE WITH (Note 2)
DC/AC Power Inverter	—	ALL	—	—
Quick Welder	Fire Extinguisher	Inverter, Workstation, Pipe Racks, Panel Carrier, Platform Work Lights, Anti-Vandal Package, Fire Extinguisher, Machinist's Vise, Extension Handles, OH Protection, Footswitch, Dual Rails, Magnetic Gate Latch	Electrician's Tree, Rail Padding	—
Workstation (Unpowered)	—	Inverter, Quik Welder, Electrician's Tree, Pipe Racks, Panel Carrier, Anti-Vandal Package, Fire Extinguisher, Machinist's Vise, OH Protection, Footswitch, Magnetic Gate Latch	Platform Work Lights, Rail Padding, Extension Handles, Dual Rails	—
Electrician's Tree	—	Inverter, Workstation, Pipe Racks, Panel Carrier, Anti-Vandal Package, Fire Extinguisher, Machinist's Vise, Extension Handles, OH Protection, Footswitch, Dual Rails, Magnetic Gate Latch	Quik Welder, Platform Work Lights, Rail Padding	—
Pipe Racks	—	Inverter, Quik Welder, Workstation, Electrician's Tree, Panel Carrier, Anti-Vandal Package, Fire Extinguisher, Machinist's Vise, Extension Handles, OH Protection, Footswitch, Dual Rails, Magnetic Gate Latch	Platform Work Lights, Rail Padding	—
Panel Carrier	—	Inverter, Quik Welder, Workstation, Electrician's Tree, Pipe Racks, Anti-Vandal Package, Fire Extinguisher, Machinist's Vise, Extension Handles, OH Protection, Footswitch, Dual Rails, Magnetic Gate Latch	Platform Work Lights, Rail Padding	—
Machinist's Vise	—	Inverter, Quik Welder, Workstation, Electrician's Tree, Pipe Racks, Panel Carrier, Platform Work Lights, Anti-Vandal Package, Fire Extinguisher, Extension Handles, OH Protection, Footswitch, Dual Rails, Magnetic Gate Latch	Rail Padding	—
Platform Work Lights	—	Inverter, Quik Welder, Anti-Vandal Package, Fire Extinguisher, Machinist's Vise, Extension Handles, OH Protection, Footswitch, Dual Rails, Magnetic Gate Latch	Workstation, Electrician's Tree, Pipe Racks, Panel Carrier, Rail Padding	—
Platform Rail Padding	—	Inverter, Anti-Vandalism Package, Fire Extinguisher, Extension Handles, Footswitch, OH Protection, Dual Rails, Magnetic Gate Latch	Quik Welder, Workstation, Electrician's Tree, Pipe Racks, Panel Carrier, Work Lights, Machinist's Vise	—

SECTION 5 - ACCESSORIES

ACCESSORY	REQUIRED ITEM	COMPATIBLE WITH (Note 1)	INCOMPATIBLE WITH	INTERCHANGABLE WITH (Note 2)
Anti-Vandalism Package	—	Inverter, Quik Welder, Workstation, Electrician's Tree, Pipe Racks, Panel Carrier, Platform Work Lights, Rail Padding, Fire Extinguisher, Machinist's Vise, Extension Handles, OH Protection, Footswitch, Dual Rails, Magnetic Gate Latch	—	—
Rail Mounted Extension Deployment Handles	—	Quik Welder, Electrician's Tree, Pipe Racks, Panel Carrier, Platform Work Lights, Anti-Vandal Package, Rail Padding, Fire Extinguisher, Machinist's Vise, Inverter, Footswitch, OH Protection, Dual Rails, Magnetic Gate Latch	—	—
Footswitch	—	ALL	—	—
Magnetic Gate Switch	—	ALL	—	—
JLG Mobile Control	—	ALL	—	—

Note 1: Any accessory not listed under "COMPATIBLE WITH" is assumed to be incompatible.

Note 2: Can be used on same unit but not simultaneously.

1001218523-H

5.3 DC/AC POWER INVERTER

The DC to AC Power Inverter is used to convert DC voltage from the onboard system batteries to AC voltage for use at the platform AC output receptacle.

The inverter module is mounted on the battery compartment door, battery carrier on the left side of the machine.

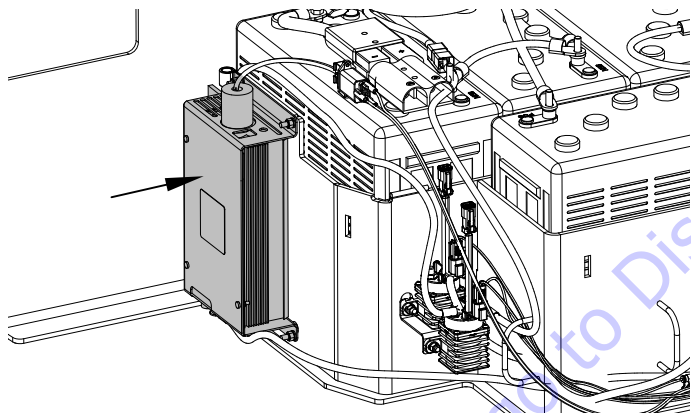

DESCRIPTION	SPECIFICATION
Electrical System Voltage (DC)	24V
Power Inverter: DC Input:	Power Bright
DC Input Voltage:	20 to 30 VDC
Operating Temperature:	-4° F (-20° C) to 113° F (+45° C)
AC Output:	
Output Power (Continuous):	900W
Output Power (Surge):	1800W
Output Power (AC):	7.5A
Output Voltage (AC):	117V +/- 10%
Output Frequency:	60 Hz
Type:	Modified Sine Wave
Protection:	
Out put Reverse DC Polarity:	3X25A Replaceable Fuse

Safety Precautions

- This inverter will only operate from a 24V power source. Do not attempt to connect the inverter to any other power source, including any AC power source.
- Danger of shock or electrocution - treat inverter output the same as commercial AC power.
- Do not allow water or other liquids to contact the inverter.

Preparation and Inspection

- Do not use appliances with damaged or wet cords.
- Route appliance cords and extension cords to prevent accidental pinching, crushing, abrading and tripping people.
- Do not use the inverter near flammable materials or in any locations that may accumulate flammable fumes or gases. This is an electrical device that can briefly spark when electrical connections are made or broken.

Operation

1. Set the inverter ON/OFF switch to the ON position at the ground control station.
2. Only plug in tools or appliances rated within the maximum output wattage at the platform AC receptacle mounted on the platform.

5.4 QUIKWELDER™

The JLG QuikWelder™ is a self-contained Miller wire-feed welder. It is able to weld light to heavy gauge steel with a single welder and has twice the power of a 110-volt plug-in welder (200 amps of power). A gas flow control valve and built-in stitch mode are included for thin metal operations. A fire extinguisher is mounted to the platform's front post.

This accessory requires the QuikWelder™ Ready, a cable of varying length according to model that plugs into the machine's battery and provides power to the station.

NOTE: *QuikWelder can be installed simultaneously with either the Panel Carrier or Pipe Racks; however, the two accessories must be mounted on opposite sides of the platform.*

NOTE: *If the WorkStation is installed, QuikWelder must be installed on the opposite side of the platform.*

SECTION 5 - ACCESSORIES

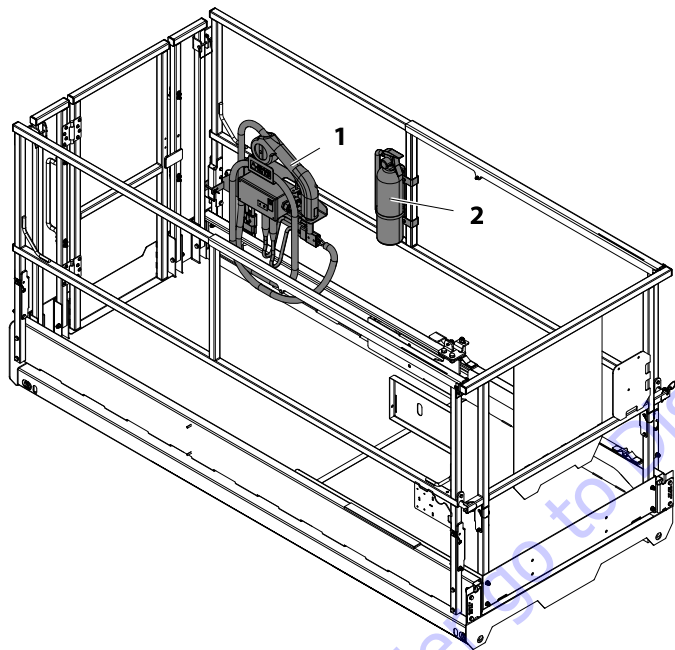

1. QuikWelder Assembly 2. Fire Extinguisher

JLG QuikWelder Installation

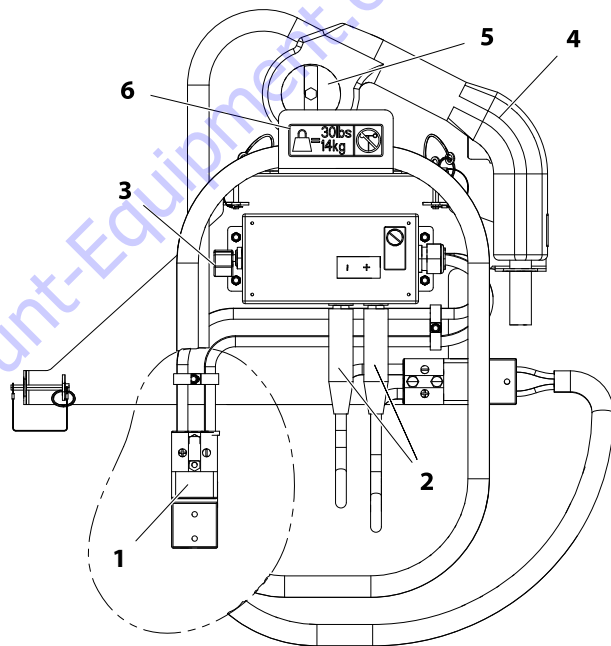

1. Power Input Cable 4. Welder
2. Welder Leads 5. Wire Rod Spool
3. ON/OFF Switch 6. Decal (Weight)

JLG QuikWelder Components

Safety Precautions

WARNING

THIS ACCESSORY AFFECTS THE OVERALL PLATFORM CAPACITY. REFER TO THE CAPACITY DECAL AND ADJUST ACCORDINGLY.

- Ensure correct polarity of leads.
- Wear proper welding apparel.
- Use correct rod size and current settings.
- Do not use electrical cords without ground.
- Do not use electrical tools in water.
- Do not weld to platform.
- Do not ground through the platform.

Preparation and Inspection

- Ensure all components are secured to the platform.
- Check for any missing or damaged components. Replace if necessary.
- Check for loose nuts and bolts. If necessary, torque according to the Torque Chart specifications in Section 1 of the Service Manual.
- Replace any missing or illegible decals.
- Ensure the fire extinguisher is fully charged, operational, and installed nearby on the platform rail.
- Ensure the power cable is connected to the battery and routed through the arm-stack with the platform cable.

Operation

1. Clamp the ground wire onto the material to be welded.
2. Ensure the leads are plugged into the QuikWelder™ box.
3. Remove the welder from the stowed position.
4. Turn on the master switch.
5. Position the welder to material to be welded. Squeeze the trigger to feed the wire to the material.
6. Adjust speed of wire feed with the speed selector knob located on the gun.
7. Turn off the master switch and return to the stowed position when not in use.

5.5 WORKSTATION

The WorkStation offers additional space for storage of tools and objects as well as an adjustable work surface.

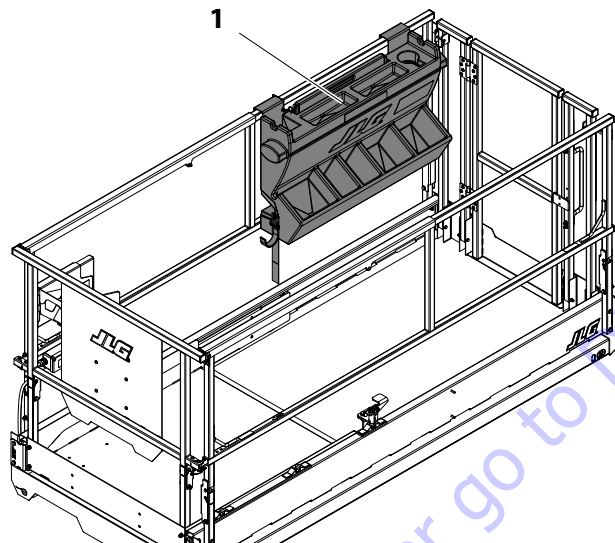

1. Workstation Assembly

NOTE: *The WorkStation can be attached anywhere in the platform unless the machine is equipped with another accessory, at which point the WorkStation must be attached on the opposite side.*

Safety Precautions

⚠ WARNING

THIS ACCESSORY WILL AFFECT THE PLATFORM CAPACITY. REFER TO THE CAPACITY DECAL AND ADJUST ACCORDINGLY.

- Return the adjustable work surface to the stowed position when finished working.
- Do not drive the machine unless materials are properly secured or stored.

Preparation and Inspection

- Ensure the WorkStation is secured to the platform.
- Check for any missing or damaged components. Replace if necessary.
- Check for loose nuts and bolts. If necessary, torque according to the Torque Chart specifications in Section 1 of the Service Manual.
- Replace any missing or illegible decals.

Operation

To use the adjustable work surface, lift the handle and position across the WorkStation.

5.6 ELECTRICIAN'S TREE

The Electrician's Tree provides a stable rack on which to hang spools of wire. Its design is ideal for pulling wire and reducing friction associated with ground-based wire spools.

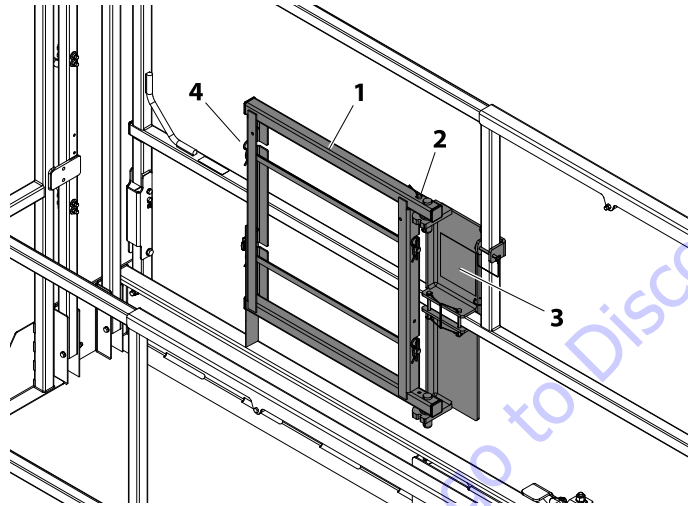

- | | |
|--------------------------------|-------------------|
| 1. Electrician's Tree Assembly | 3. Decal (Weight) |
| 2. Release Pin | 4. Hitch Pins |

NOTE: The Electrician's Tree may be simultaneously installed with Panel Carrier, Pipe Racks, QuikWelder, or WorkStation as long as it is mounted on the opposite side of the platform.

Safety Precautions

⚠ WARNING

THIS ACCESSORY AFFECTS THE OVERALL PLATFORM CAPACITY. REFER TO THE CAPACITY DECAL ON THE ACCESSORY AND ADJUST ACCORDINGLY.

- Ensure no personnel are beneath the platform.
- Do not exit the platform over the rails, or stand on the rails.
- Do not pull wire by driving the machine.
- Only pull wire along the long axis of the machine with the rack in the working position.
- Ensure wire spools rotate freely.
- Return to the stowed position when not in use.

Preparation and Inspection

- Ensure the rack is secured to the platform.
- Check for missing or damaged components. Replace if necessary.
- Check for loose nuts and bolts. If necessary, torque according to the Torque Chart specifications in Section 1 of the Service Manual.
- Replace any missing or illegible decals.
- Ensure release pins are intact and function properly.

Operation

1. Remove release pins and rotate the rack from the stowed position.
2. Pull the hitch pin for the spool rod to be loaded.
3. Load the spools onto the rod and replace the hitch pin.
4. Swing the rack into working position and lock into place by replacing the release pin.
5. When not in use, remove spools and return the rack to the stowed position.

5.7 PIPE RACKS

The Pipe Racks provide a way to store pipe or conduit inside the platform in order to prevent rail damage and optimize platform utility when transporting material to an elevated site. It consists of two racks, attached to the platform handrails, with adjustable straps that secure the load in place.

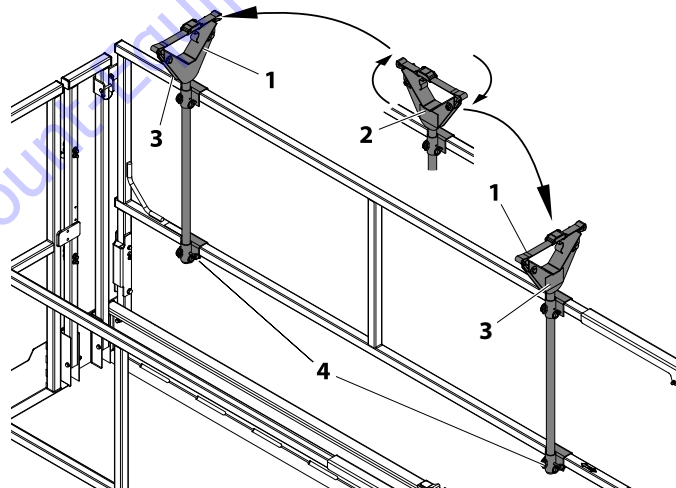

1. Pipe Rack - Work Position
2. Pipe Rack - Stow Position
3. Decal (Weight)
4. Work or Stow Position Pin

NOTE: Panel Carrier and Pipe Racks cannot be installed simultaneously if WorkStation is installed, although they are interchangeable.

Safety Precautions

WARNING

MULTIPLE MATERIAL-HANDLING ACCESSORIES CAN BE INSTALLED BUT ONLY ONE MAY BE LOADED AT A TIME UNLESS APPROVED BY JLG INDUSTRIES, INC.

WARNING

THIS ACCESSORY AFFECTS THE OVERALL PLATFORM CAPACITY. REFER TO THE CAPACITY DECAL AND ADJUST ACCORDINGLY. DO NOT OVERLOAD THE PIPE RACKS.

- Ensure no personnel are beneath the platform.
- Do not exit the platform over the rails, or stand on the rails.
- Do not drive the machine without material secured.
- Return the racks to the stowed position when not in use.

Preparation and Inspection

- Ensure all components are secured to the platform.
- Check for any missing or damaged components. Replace if necessary.
- Check for loose nuts and bolts. If necessary, torque according to the Torque Chart specifications in Section 1 of the Service Manual.
- Replace missing or illegible decals.
- Replace any torn or frayed straps.

Operation

1. To prepare racks for loading, remove work/stow locking pins, rotate each rack 90 degrees from stowed to working position, and secure with the locking pins.
2. Place material onto racks with weight evenly distributed between both racks. Do not exceed the rated capacity stated on the decal.
3. Route the tie-down straps at each end across loaded material and tighten.
4. To remove material, loosen and remove tie-down straps, then carefully remove material from racks.

NOTE: Reinstall tie-down straps across any remaining material before continuing machine operations.

5. When not in use, remove locking pins, rotate racks 90 degrees to the stowed position, and reinstall locking pins.

5.8 PANEL CARRIER

The Panel Carrier can transport flat sheets or panels to an elevated site by positioning them in a channel on the outside of the platform. It consists of a carrier tray that runs parallel to the length of the platform and an adjustable bracket mounted to the handrail to hold material in place.

The panels can measure up to 4ft x 8ft (1.22 m x 2.4 m), or approximately 32 ft sq. (3m sq.).

NOTE: *Panel Carrier and Pipe Racks cannot be installed simultaneously if WorkStation is installed, although they are interchangeable.*

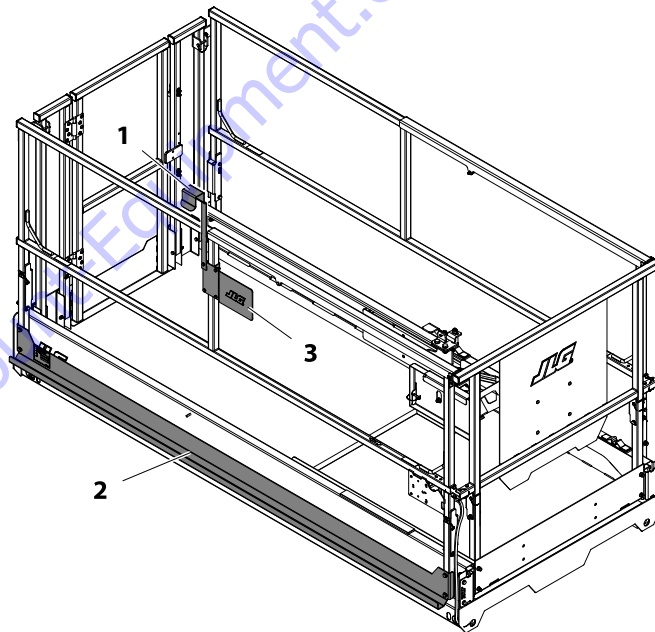

1. Adjustable Bracket
2. Carrier Tray

3. Capacity Decal (On Back)

Safety Precautions

WARNING

MULTIPLE MATERIAL-HANDLING ACCESSORIES CAN BE INSTALLED BUT ONLY ONE MAY BE LOADED AT A TIME UNLESS APPROVED BY JLG INDUSTRIES, INC.

THIS ACCESSORY AFFECTS THE OVERALL PLATFORM CAPACITY. REFER TO THE CAPACITY DECAL AND ADJUST ACCORDINGLY.

WHEN THE CARRIER TRAY IS LOADED, THE INCREASE OF AREA EXPOSED TO WIND WILL DECREASE STABILITY. REFER TO THE DECAL FOR MAXIMUM PANEL SIZE AND WIND SPEED.

- Ensure no personnel are beneath the platform.
- Do not exit the platform over the rails, or stand on the rails.
- Remove the tray when not in use.

Preparation and Inspection

- Ensure all components are secured to the platform.
- Check for any missing or damaged components. Replace if necessary.
- Check for loose nuts and bolts. If necessary, torque according to the Torque Chart specifications in Section 1 of the Service Manual.
- Replace any missing or illegible decals.
- Replace any torn or frayed straps.

Operation

1. Attach the carrier tray to the outside of the platform.
2. Load the Panel Carrier with material and secure with the adjustable bracket.
3. Position the panel to its desired location.
4. Remove the carrier tray when finished.

5.9 VISE

The Vise allows the operator to secure material for assembling, disassembling, drilling, etc., while working from the platform.

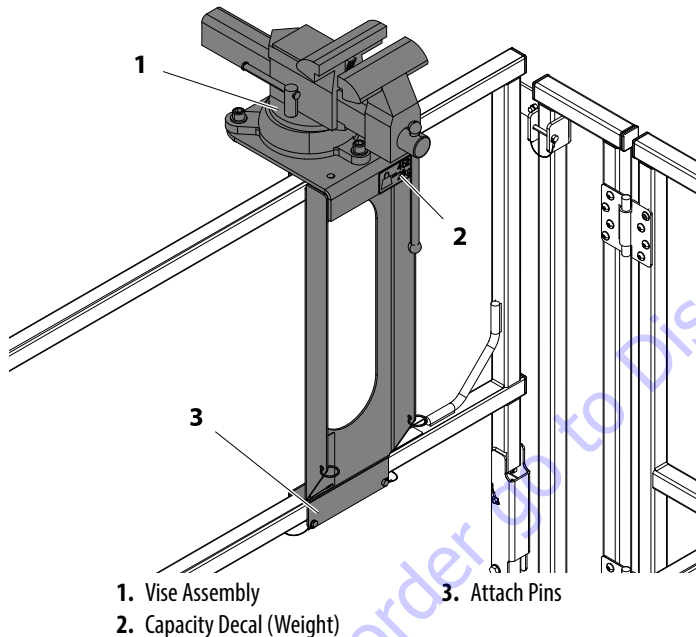

NOTE: If the WorkStation is installed, it must be mounted to the opposite side of the platform from the Vise.

Safety Precautions

⚠ WARNING

THIS ACCESSORY AFFECTS THE OVERALL CAPACITY OF THE PLATFORM. REFER TO THE CAPACITY DECAL AND ADJUST ACCORDINGLY.

- Do not drive machine with material in the Vise.

Preparation and Inspection

- Ensure the Vise is secured to the platform.
- Check for any missing or damaged components. Replace if necessary.
- Check for loose nuts and bolts. If necessary, torque according to the Torque Chart specifications in Section 1 of the Service Manual.
- Replace any missing or illegible decals.
- Remove when not in use.

Operation

1. Load material into the Vise.
2. Tighten the handle until secure.
3. Begin working.

5.10 PLATFORM WORK LIGHTS

The Platform Work Lights accessory consists of two 24V lights that mount to the platform railings.

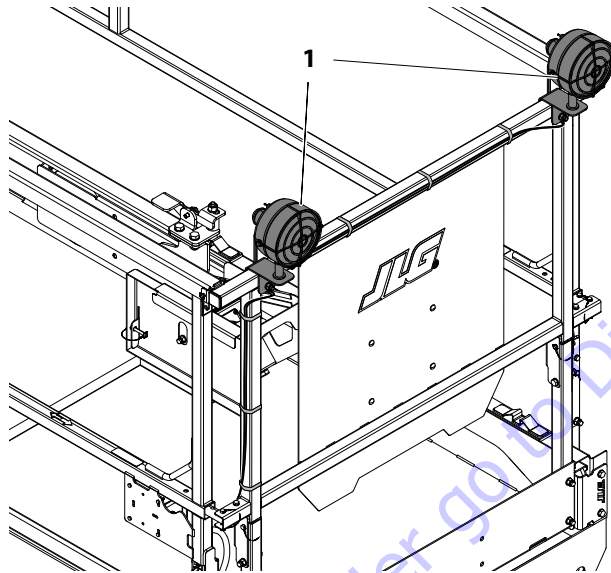

1. 24V Work Lights

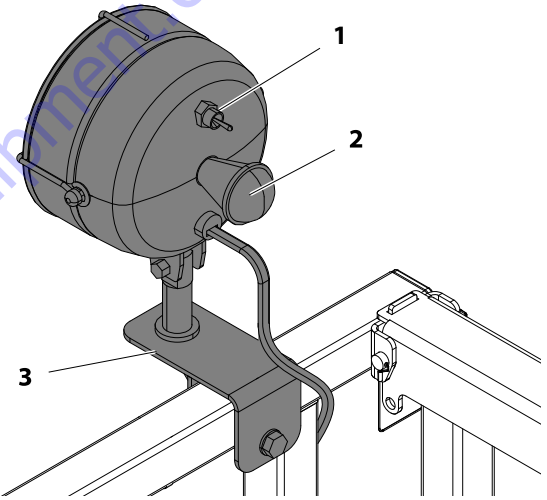

1. ON/OFF Switch
2. Handle

3. Mounting Bracket

Operation

Flip the On/Off switch to operate. Use the handle on the back to direct the light in the desired direction.

5.11 PLATFORM RAIL PADDING

The Platform Rail Padding provides bumpers to the platform rails in order to prevent damage to the platform itself as well as objects it may come in contact with during operation.

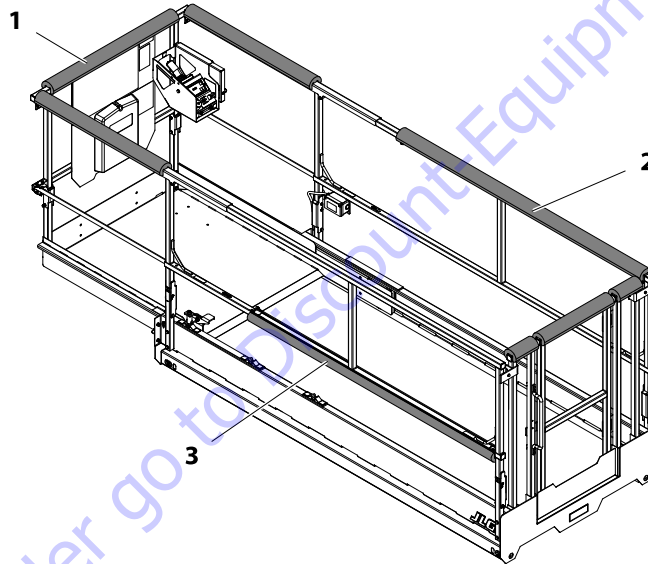

1. Extension Platform - Rail Padding

2. Main Platform Top Side Rail Padding when Extension Platform is Extended.

3. Storage Position of Main Platform Top Side Rail Padding When Platform Extension Is Retracted.

5.12 ANTI-VANDALISM PACKAGE

The Anti-Vandalism Package consists of two lockable covers for the Platform and Ground Control Stations that prevent unauthorized use of the machine. Locks are not provided with this kit.

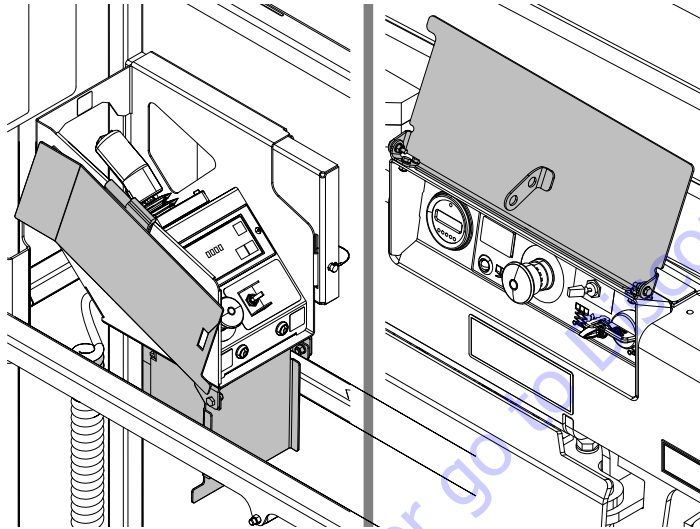

1. Platform Covers Open

2. Ground Station Cover Open

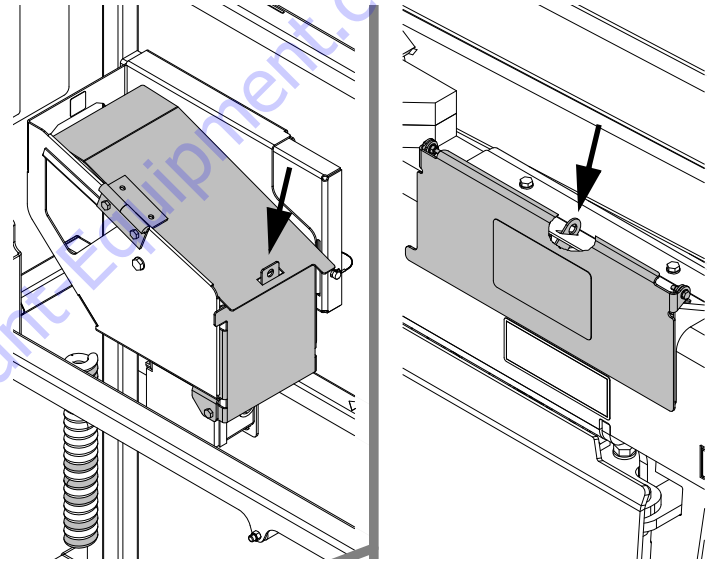

1. Platform Covers Closed

2. Ground Station Cover Closed

5.13 RAIL MOUNTED PLATFORM EXTENSION HANDLES

The platform extension handles accessory are mounted to the top rails of the extension platform at the roller tabs. When rotated up 90° the handles provide the operator an optional grip to push the extension platform out from its stowed position.

Operation

1. Swing both extension handles up 90° to the extend position.
2. While standing on the main platform, release the extension platform lock mechanism with one foot.
3. Grasp both handles and push platform extension out until locked in either of the two other locked extension positions.

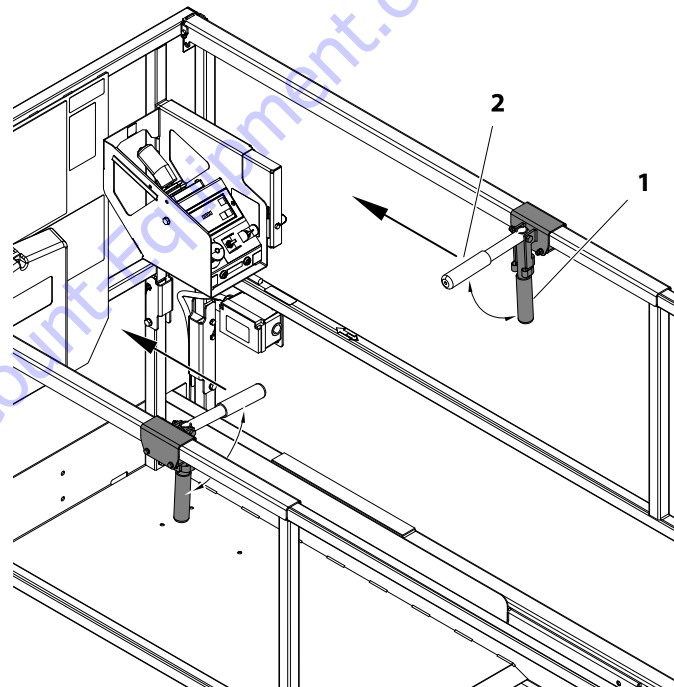

1. Extension Handle Shown in its Stowed Position 2. Extension Handle Rotated Up in the Extension Position

5.14 FOOTSWITCH

The footswitch accessory when installed in the platform acts as another enable switch in the function control circuit.

Operation

The footswitch must be depressed in sequence with the platform control trigger switch to enable operation of machine functions when using the platform controls.

To operate a function depress controls in the following sequence.

1. Footswitch
2. Joystick Trigger
3. Operate Function

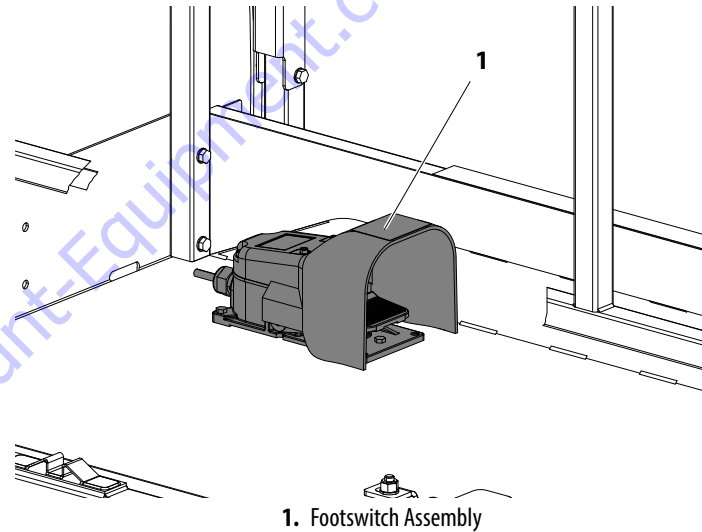

5.15 MAGNETIC GATE LATCH

The platform magnetic gate latch accessory if installed helps ensure the platform gate is securely latched when closed.

Operation

Grasp handle and swing gate open.

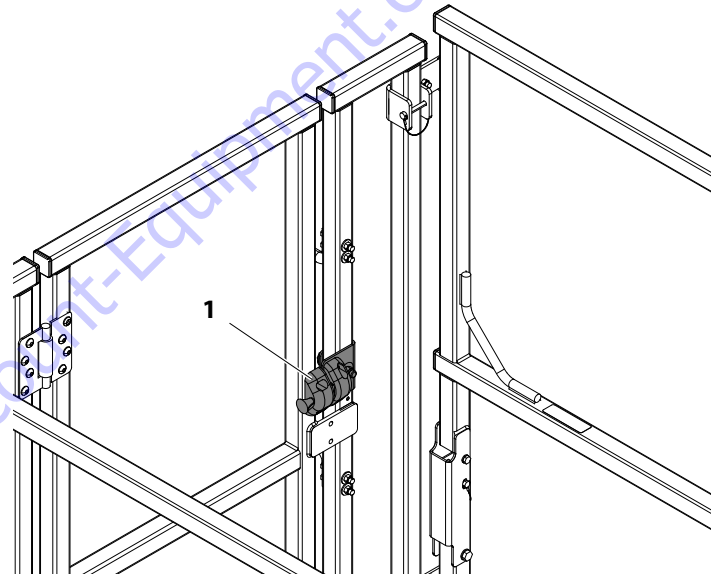

1. Magnetic Gate Latch Assembly

5.16 JLG™ MOBILE CONTROL

The JLG Mobile Control application allows machine operators to drive remotely from a Bluetooth® equipped hand-held mobile device.

Prior to operation, the operator must scan the QR code on the machine with a mobile device equipped with the JLG Mobile Control application. This pairs the Mobile Control module on the machine with the mobile device to allow remote operation.

NOTE: *The Bluetooth word mark and logos are registered trademarks owned by Bluetooth SIG, Inc. and any use of such marks by JLG is under license. Other trademarks and trade names are those of their respective owners.*

Download

Visit the Apple Store®, Google Play®, or <https://www.JLG.com/mobilecontrol> in order to download the JLG Mobile Control application.



OAD00850

Operation

Download, read, and understand the JLG Mobile Control Supplement Manual from <https://www.JLG.com/mobilecontrol> prior to using the JLG Mobile Control.

⚠ WARNING

NEVER DRIVE THE MACHINE USING JLG MOBILE CONTROL WHILE STANDING IN THE PLATFORM, OR WITHOUT CLEAR LINE-OF-SIGHT BETWEEN THE MACHINE AND ITS TRAVEL PATH, AS SERIOUS INJURY COULD OCCUR TO OPERATOR OR BYSTANDER.

Document Resources

Access to application related documentation.

1. Select Settings (a) from the Home Screen
2. Select either:
 - b. JLG Mobile Control Supplement manual
 - c. Legal Statements (FCC, ISED)
 - d. Regulatory Statements (EULAs, DoC)

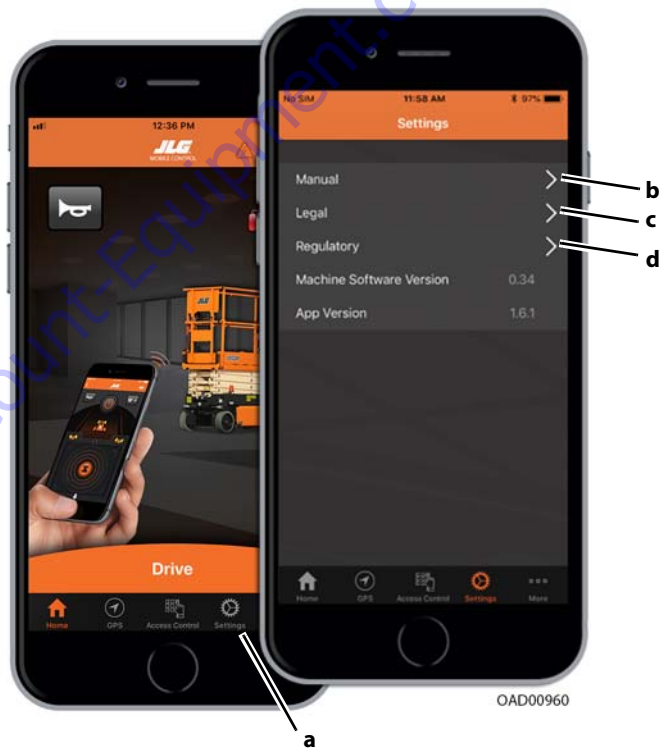

SECTION 6. GENERAL SPECIFICATIONS AND MAINTENANCE

6.1 INTRODUCTION

This section of the manual provides additional necessary information to the operator for proper operation and maintenance of this machine.

The maintenance portion of this section is intended as information to assist the machine operator to perform daily maintenance tasks only, and does not replace the more thorough Preventive Maintenance and Inspection Schedule included in the Service and Maintenance Manual.

Other Publications Available Specific to this Machine

Service and Maintenance Manual 31215805

Illustrated Parts Manual 31215806

Serial Number Identification

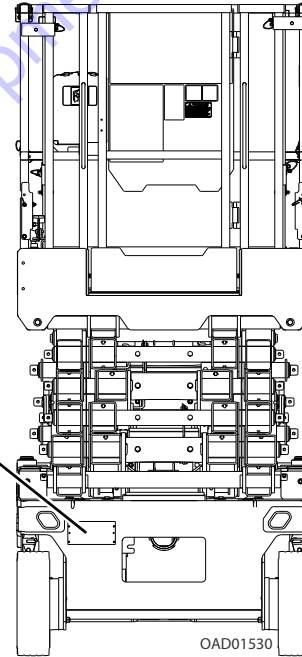

NOTE: Ladder removed for illustrative purposes.

SECTION 6 - GENERAL SPECIFICATIONS AND MAINTENANCE

6.2 OPERATING SPECIFICATIONS

DESCRIPTION	R4045
PLATFORM	ANSI/CSA/CE/AUS/GB
Maximum Platform Height (Ground to Platform Floor - Elevated)	39.3 ft (11.9 m)
Machine Height (Ground to Top of Rails)	8 ft 4 in (2.549 m)
Machine Height - Rails Folded (Ground to Top of Folded Rails)	6 ft 3 in (1.903 m)
Platform Lift Time (No Load)	Lift Up: 63-73 seconds Lift Down: 38-44 seconds
Platform Lift Time (Rated Load)	Lift Up: 70-80 seconds Lift Down: 35-41 seconds
Electronic Arm Guards (Activation Height)	75 in (190.5 cm)
DRIVING	
Maximum Allowable Operating Slope (Platform Fully Elevated)	Front to Back: 3.5° Side to Side: 1.5°
Maximum Stowed Travel Side Slope	2.5°
Maximum Drive Speed (FWD/REV) (Seconds to Drive 25 ft (7.62 m))	Stowed: 8 seconds (2.0 mph (3.4 kph)) Elevated: 34 seconds - (0.5 mph (0.8 kph))

SECTION 6 - GENERAL SPECIFICATIONS AND MAINTENANCE

DESCRIPTION	R4045
Maximum Stowed Travel Grade (Gradeability) (Refer to Section 3.10)	25% (14°)
Elevated Drive Height	Indoor: 39 ft (11.9 m) 28.7 ft (8.75 m) - ANSI/CE/CSA/GB Outdoor: 39 ft (11.9 m) - AUS
Turning Radius	Inside: 0 in (0 cm) (Curb to Curb) Outside: 92 in (233.3 cm)
CHASSIS	
Approximate Gross Machine Weight	ANSI/CE/CSA/GB: 7,000 lb (3175 kg) AUS: 7,525 lb (3413 kg)
Wheelbase	80 in (2.032 m)
Machine Overall Width	45 in (1.143 m)
Maximum Tire Load (per wheel)	2,680 lb (1216 kg)
Ground Bearing Pressure	137 psi (943 kPa)
Ground Clearance	PHP Retracted: 5 in (126 mm) PHP Deployed: 1.26 in (32 mm)

SECTION 6 - GENERAL SPECIFICATIONS AND MAINTENANCE

DESCRIPTION	R4045
Break Over Angle (Grade)	14.5° (26%)
Maximum Hydraulic Pressure	Main Relief: 3000 psi (207 bar) Steer Relief: 1250 psi (86 bar) Lift Relief: 2500 psi (172 bar)

Platform Capacities

MARKET	MAXIMUM OPERATING HEIGHT	MAXIMUM PLATFORM CAPACITY ⁽¹⁾	MAXIMUM CAPACITY ALLOWED ON PLATFORM EXTENSION	MAXIMUM PERSONS ALLOWED IN PLATFORM	MAX. SIDE FORCE (Platform Fully Extended @ Max. Capacity)	MAXIMUM OPERATING WIND SPEED	ENVIRONMENT ⁽²⁾
ANSI/CSA/CE/AUS/GB	FULL	770 lb (350 kg)	250 lb (113 kg)	3 Persons + 242 lb (110 kg)	90 lb (400 N)	0 mph (0 m/s)	INDOOR
ANSI/CSA/CE/AUS/GB	29 ft (8.8 m)	550 lb (249 kg)		1 Person + 371 lb (169 kg)	45 lb (200 N)	28 mph (12.5 m/s)	OUTDOOR
AUS	FULL	300 lb (136 kg)		1 Person + 124 lb (56 kg)			
NOTE: (1) Maximum Platform Capacity includes platform and platform extension. (2) INDOOR USE is use of a MEWP in areas shielded from wind so that there is no wind. OUTDOOR USE is use of a MEWP in an environment that can be exposed to wind.							

1001220378_C, 1001229804_B, 1001231228_A

Machine Dimensions

DESCRIPTION	R4045
Platform Height - Elevated (Ground to Platform Floor)	39.3 ft (12 m)
Platform Height - Stowed (Ground to Platform Floor)	55 in (140 cm)
Rail Height (Platform Floor to Top of Rail)	44 in (113.2 cm) - Folding Rail
Overall Height - (Ground to Top of Rail): (Rails Folded Down):	100 in (254 cm) 75 in (190.3 cm)
Overall Machine Width	45 in (114.3 cm)
Overall Machine Length (w/ladder)	106 in (271.1 cm)
Platform Size - Length (Inside)	96 in (243.4 cm)
Platform Size - Width (Inside)	41 in (104.3 cm)
Wheelbase	80 in (203.2 cm)

Tires

DESCRIPTION	R4045
Size	16 in x 5 in (40.6 cm x 12.7 cm)
Wheel Nut Torque (1-1/8 inch - Slotted Nut with Cotter Pin)	150 ft.lb. (203 Nm)

SECTION 6 - GENERAL SPECIFICATIONS AND MAINTENANCE

Batteries

DESCRIPTION	R4045		
	Lead Acid		AGM
Voltage (24V System - Series)	12V per battery		
Amp Hour Rating	150 Amp Hour @ 20 Hr. Rate	185 Amp Hour @ 20 Hr. Rate	150 Amp Hour @ 20 Hr. Rate
Reserve Capacity	280 Minutes @ 25 Amps	324 Minutes @ 25 Amps	320 Minutes @ 25 Amps
Weight (each battery)	82 lb (37 kg)	106 lb (48 kg)	88 lb (40 kg)

Battery Charger Specifications

DESCRIPTION	R4045		
Electrical System Voltage (DC)	24V		
Battery Charger: Input: AC Input Voltage: Nominal AC Input Voltage: Input Frequency: Max. AC Input Current: Ingress Protection: Operating Temperature: Output: Nominal DC Output Voltage: Max. DC Output Voltage: Max DC Output Current: Max. Interlock Current: Protection: Output Reverse Polarity: Output Short Circuit: AC Overload: DC Overload:	Delta-Q 85-270V AC 100VAC / 240VAC RMS 50 - 60Hz 7.5A IP66 NEMA4 Type 4 -40°F (-40°C) to 149°F (+65°C) 24V 36V 27.1A 1A @ 24V Electronic Protection-Auto Reset Current Limited Current Limited Current Limited	PRO - Eagle Perf. Series 108-132V AC 120VAC 45 - 65Hz 12A IP35 -22°F (-30°C) to 122°F (+50°C) 24V 31.92V 25A 1A @ 24V Electronic Protection-Auto Reset Electronic Protection-Auto Reset Branch Circuit Protection Current Limited	Green Power - Pylon International 100-240V AC — — 45 - 65Hz 8.5A IP66 -4°F (-20°C) to 122°F (+50°C) 24V 34V 30A 1A @ 24V Electronic Protection-Auto Reset Electronic Protection-Auto Reset Current Limited Current Limited

SECTION 6 - GENERAL SPECIFICATIONS AND MAINTENANCE

6.3 LUBRICATION

Lubrication Capacities

COMPONENT	R4045
Hydraulic Reservoir (at Full mark)	6.6 gal (25L)
Hydraulic System (Including Reservoir)	7.9 gal (30L)

Lubrication Specifications

KEY	SPECIFICATIONS
MPG	Multipurpose Grease having a minimum dripping point of 350° F. Excellent water resistance and adhesive qualities, and being of extreme pressure type. (Timken OK 40 pounds minimum.)
EPGL	Extreme Pressure Gear Lube (oil) meeting API service classification GL-5 or MIL-Spec MIL-L-2105.
HO	JLG Recommends - Mobil - Mobilfluid 424 Mobil EAL ENVIRONSYN H 32 Mobil SHC HYDRAULIC EAL 32 EAL and SHC are compatible with each other.

Hydraulic Oil Operating Temperature Chart

 IN THIS REGION FUNCTION SPEEDS & BATTERY LIFE MAY BE SIGNIFICANTLY REDUCED

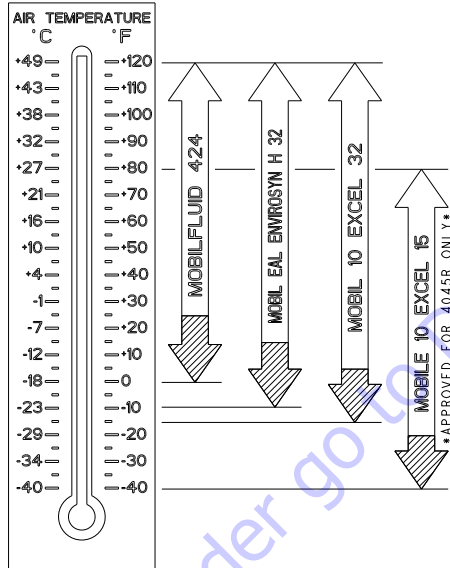

Fluid Description	Properties		Base			Classification		
	Viscosity @ 40°C (Cst, Typical)	Visc Index	Mineral Oils	Vegetable Oils	Synthetic Polyol Esters	Readily Biodegradable	Virtually Non-toxic**	Fire Resistant***
MobilFluid 424	55	145	X					
Mobil EAL EnviroSyn H 32	33	147		X		X		
Mobil 10 Excel 32	32	164	X				X	
Mobil 10 Excel 15	15	168	X				X	

- * Readily biodegradable classification indicates one of the following:
 CO2 Conversion>60% per EPA 560/6-82-003
 CO2 Conversion>80% per CEC-L-33-A-93
- ** Virtually Non-toxic classification indicates an LC50>5000 ppm per OECD 203
- *** Fire Resistant classification indicates Factory Mutual Research Corp. (FMRC) Approval

NOTICE:
 MACHINE OPERATION USING NON-JLG APPROVED HYDRAULIC FLUIDS OR OPERATION OUTSIDE OF THE TEMPERATURE BOUNDARIES OUTLINED IN THE "HYDRAULIC FLUID OPERATION CHART" MAY RESULT IN PREMATURE WEAR OR DAMAGE TO COMPONENTS OF THE HYDRAULIC SYSTEM.

SOME FLUIDS MAY NOT BE AVAILABLE FROM THE FACTORY

6.4 OPERATOR MAINTENANCE

Scissor Arm - Safety Props

⚠ WARNING

NEVER WORK UNDER AN ELEVATED PLATFORM UNTIL IT HAS BEEN RESTRAINED FROM MOVEMENT WITH THE SAFETY PROPS, BLOCKING OR OVERHEAD SLING.

⚠ CAUTION

BOTH SAFETY PROPS MUST BE USED WHENEVER MAINTENANCE PERFORMED ON THE MACHINE REQUIRES THE SCISSOR ARMS TO BE RAISED AND ONLY WITH NO LOAD IN THE PLATFORM.

The safety props are located, one each side of the machine on the scissor arms. To engage the safety props:

1. From the Ground Control Station, raise the platform far enough to allow the safety props to be engaged.
2. Release the locking pin and rotate the prop on each side of machine. **Always set both when engaging.**
3. Lower the platform until the safety props rest against the safety prop stops on the arm set below it, stopping all downward movement of the platform/scissor arm assembly.

To disengage the safety props:

1. Raise the platform enough to release the safety props off the safety prop stops.
2. Rotate the prop assemblies until they align with the scissor arm and the release pin locks into the detent disk behind the arm.

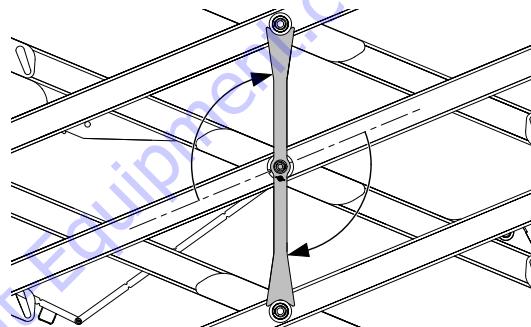

Prop Engaged

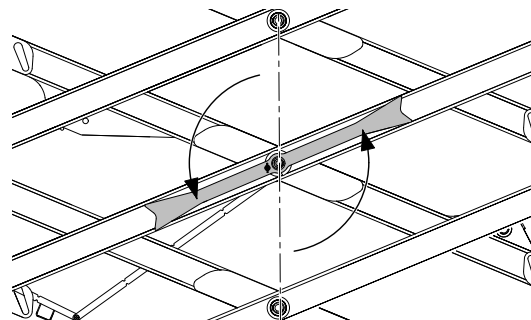

Prop Disengaged

Hydraulic Oil Check Procedure

Lube Point(s) - Hydraulic Reservoir

Reservoir Capacity - Refer to Section 6.3.

Lube - Hydraulic Oil

Interval - Check Daily

NOTE: Check the hydraulic oil level with the platform in the stowed position *ONLY*. Be certain the hydraulic oil has warmed to operating temperature before checking the oil level in the reservoir.

1. On the right side of the machine on the hydraulic compartment door there is a **cutout (1)** which allows viewing of the hydraulic oil tank **marking (2)**. The reservoir is marked with a **MAX (maximum) marking (2)**. The **MIN marking (3)** is the bottom edge of the cutout on the door. The oil level must be kept within these markings for the hydraulic system to operate properly.
2. If additional oil is required, swing compartment door open and wipe all dirt and debris from the **filler/filter cap (4)** area. Remove filler cap and add proper grade of oil. Fill until oil level is close to the **MAX marking (3)**, but not over the **MAX marking**.

NOTE: Care should be taken not to introduce any impurities (dirt, water, etc.) while cap is removed.

NOTE: Recommended lubricating intervals are based on machine operations under normal conditions. For machines used in multi-shift operations and/or exposed to hostile environments or conditions, lubrication frequencies must be increased accordingly.

SECTION 6 - GENERAL SPECIFICATIONS AND MAINTENANCE

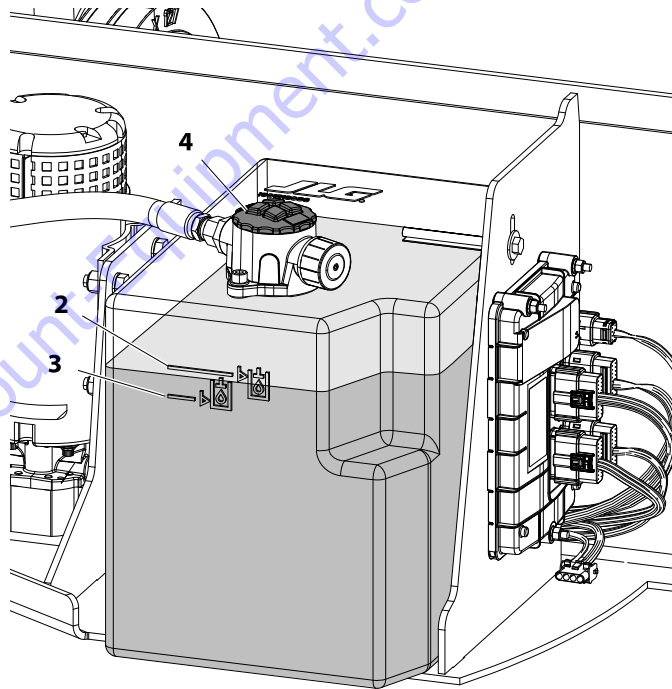
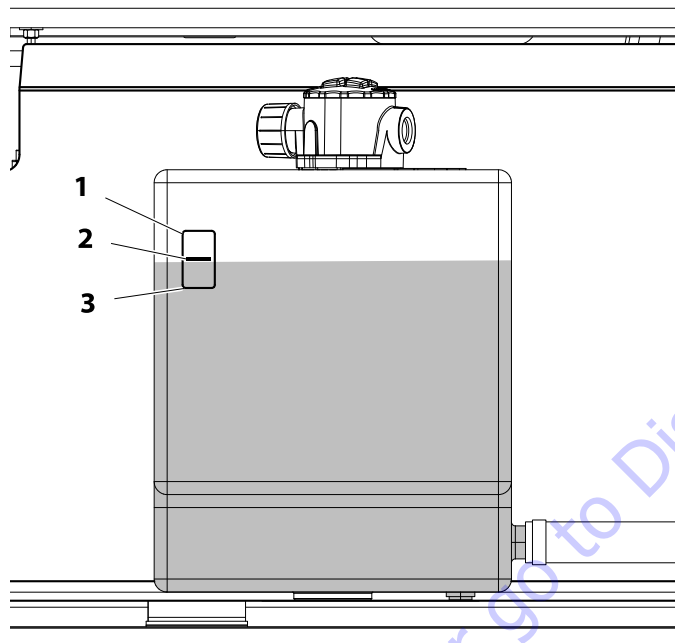

Delta-Q

All chargers are located at rear of machine inside chassis.

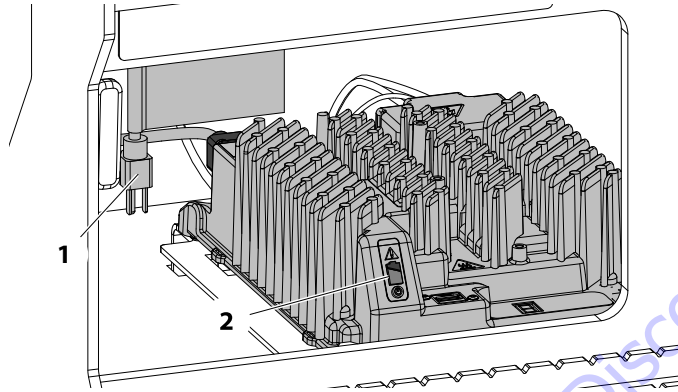

1. AC Voltage Input Plug 2. Charge Indicator LEDs

- **AC Power On:** Blue LED on
- **Low State of Charge:** Bottom Panel - Green LED flashing; Top Panel - Green LED off
- **High State of Charge:** Bottom Panel - Green LED on; Top Panel - Green LED flashing
- **Charge Complete:** Bottom Panel - Green LED on; Top Panel - Green LED on
- **Fault Indicator:** Red LED on
- **External Error Condition Caution:** Amber LED flashing

Green Power (China (GB) Only)

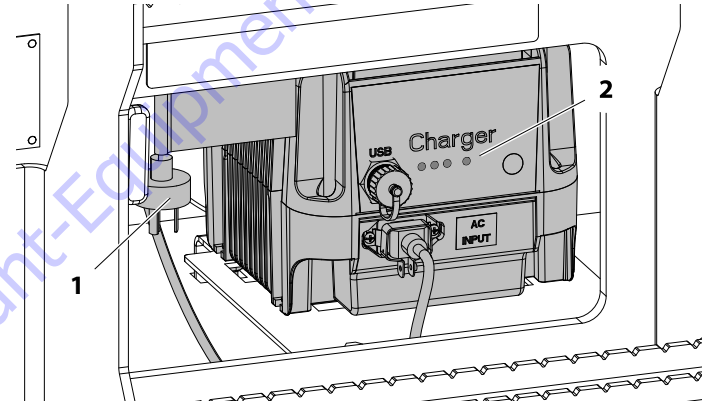

1. AC Voltage Input Cable 2. Charge Indicator LEDs

- **Battery Charging:** Yellow LED - AGM - flashes quickly; Flooded - remains on / AGM flooded - flashes slowly
- **Charge Complete:** Green LED on
- **Fault Indicator:** Red LED on
- **Performing Self-Diagnostic:** Yellow and green LEDs flashing simultaneously

Eagle Performance - Battery Charger

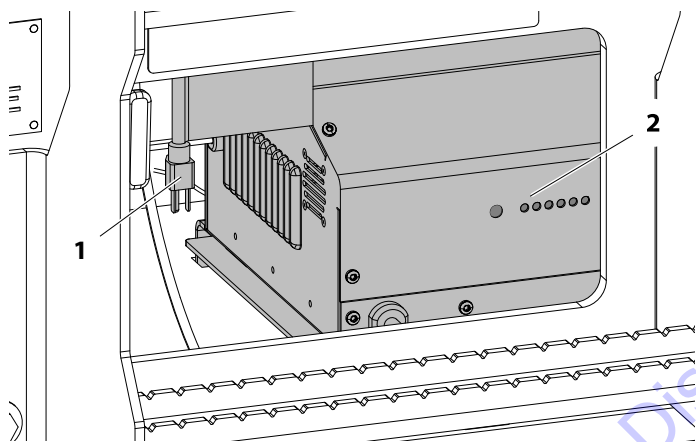

1. AC Voltage Input Cable 2. Charge Indicator LEDs

- **Battery Type Indicator:** Yellow LED on
- **Battery Charging:** 30%-60%-90% Red LED on
- **Charge Complete:** Green LED on
- **No Battery Detected:** 30% Red LED blinking
- **Overall Timer Shutdown:** 30-60-90% Red LEDs blinking
- **Internal OverTemp Shutdown:** 30 - 90% Red LEDs blinking

Battery Maintenance and Safety Practices

NOTE: These instructions are for unsealed (wet) batteries only. If machine is equipped with sealed batteries, no maintenance other than cleaning corroded battery terminals is required.

⚠ CAUTION

ENSURE THAT BATTERY ACID DOES NOT COME INTO CONTACT WITH SKIN OR CLOTHING. WEAR PROTECTIVE CLOTHING AND EYEWEAR WHEN WORKING WITH BATTERIES. NEUTRALIZE ANY BATTERY ACID SPILLS WITH BAKING SODA AND WATER.

BATTERY ACID RELEASES AN EXPLOSIVE GAS WHILE CHARGING, ALLOW NO OPEN FLAMES, SPARKS OR LIGHTED TOBACCO PRODUCTS IN THE AREA WHILE CHARGING BATTERIES. CHARGE BATTERIES ONLY IN A WELL VENTILATED AREA.

ADD ONLY DISTILLED WATER TO BATTERIES. WHEN ADDING DISTILLED WATER TO THE BATTERIES, A NON-METALLIC CONTAINER AND/OR FUNNEL MUST BE USED.

Check the electrolyte level of the batteries often, adding only distilled water when required. When fully charged, battery fluid level should be 1/8" below vent tubes.

- DO NOT fill to bottom of vent tubes.
- DO NOT allow fluid level to go below the top of the plates when charging or operating.

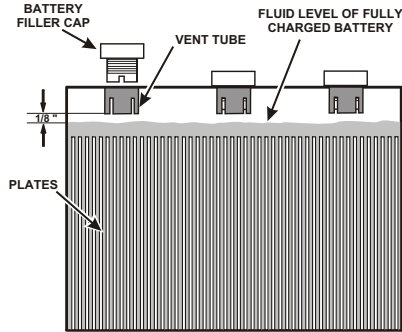

Battery Quick-Disconnect (If Equipped)

Machines equipped with the battery quick-disconnect allow all machine power to be easily disconnected at the batteries without removing battery cables from the battery posts. To disconnect power, locate the RED quick-disconnect connector on top of the batteries inside the battery compartment and pull halves apart.



Tire Wear and Damage

The tire and rim assemblies installed on machines have been approved by the tire manufacturer for applications in which those products are intended to be used. The tire and rims installed on each product model have been designed for stability requirements, which consist of track width, tire compound, and load capacity. Tire changes such as rim width, centerpiece location, larger or smaller diameter, tire compound, etc., without written manufacturers approval, could result in an unsafe condition regarding stability.

The tires and rims installed on machines are to be inspected daily as part of the daily walk-around inspection. JLG requires that the daily walk-around inspection be performed at each operator change during a shift and at each shift change.

Wheel and Tire Replacement

JLG recommends that any replacement tire be the same size and brand as originally installed on the machine or offered by JLG as an approved replacement. Please refer to the JLG Parts Manual for the part number of the approved tires for a particular machine model.

If any of the following is discovered during tire inspection, measures must be taken to remove the JLG product from service immediately. Arrangements must be made for replacement of the tire(s) or tire assembly(s). Both tires/wheels on the same axle must be replaced:

- If the overall diameter of the tire is less than one of the following:
 - 406 x 127 Tire – 15.55 in. (395mm) minimum
- If any uneven wear is discovered.
 - A tire with significant damage in the tread area or sidewall requires immediate evaluation before placing the machine into service. If a cut, tear, chunk, or other discrepancy exceeds any one or more of the following dimensions, the tire must be replaced:
 - 3.0 in. (76 mm) long
 - 0.75 in. (19 mm) wide
 - 0.75 in. (19 mm) deep
- If the metal wheel is visible at any point through the tread area of the tire.
- If more than one discrepancy exists in any quadrant of the wheel (within 90 degrees of one another).

Wheel Installation

It is extremely important to apply and maintain proper wheel mounting torque.

WARNING

WHEEL SLOTTED NUTS MUST BE INSTALLED AND MAINTAINED AT THE PROPER TORQUE TO PREVENT LOOSE WHEELS, A BROKEN NUT, AND POSSIBLE SEPARATION OF WHEEL FROM THE AXLE.

Tighten the slotted nuts to the proper torque to prevent wheels from coming loose. Use a torque wrench to tighten the slotted nuts. The proper procedure for attaching wheels is as follows:

1. If not already installed, install shaft key **(5)** to shaft and align with wheel keyway, install wheel and hub **(3)** onto tapered shaft **(4)**.
2. Start slotted nut **(1)** by hand to prevent cross threading. DO NOT use a lubricant on threads or nut.
3. Torque the slotted nut to 150 ft. lb. (203 Nm).
4. Install cotter pin **(2)**, if hole in slots do not align with cotter pin hole on the tapered shaft, continue to turn nut clockwise to align nut with hole. Do not loosen to align hole.

6.5 SUPPLEMENTAL INFORMATION

The following information is provided in accordance with the requirements of the European Machinery Directive 2006/42/EC and is only applicable to CE machines.

For electric powered machines, the equivalent continuous A-Weighted sound pressure level at the work platform is less than 70dB(A).

For combustion engine powered machines, guaranteed Sound Power Level (LWA) per European Directive 2000/14/EC (Noise Emission in the Environment by Equipment for Use Outdoors) based on test methods in accordance with Annex III, Part B, Method 1 and 0 of the directive, is 109 dB.

The vibration total value to which the hand-arm system is subjected does not exceed 2,5 m/s². The highest root mean square value of weighted acceleration to which the whole body is subjected does not exceed 0,5 m/s².

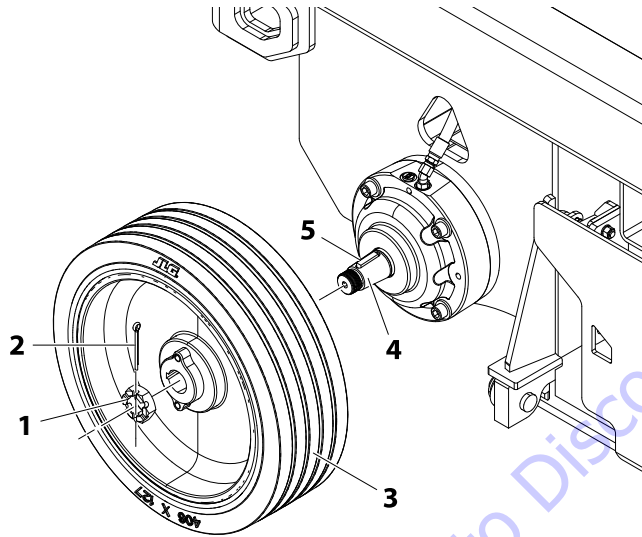

1. Slotted Nut
2. Cotter Pin
3. Wheel and Hub Assembly
4. Tapered Shaft
5. Shaft Key

6.6 DECAL INSTALLATION

Diagram

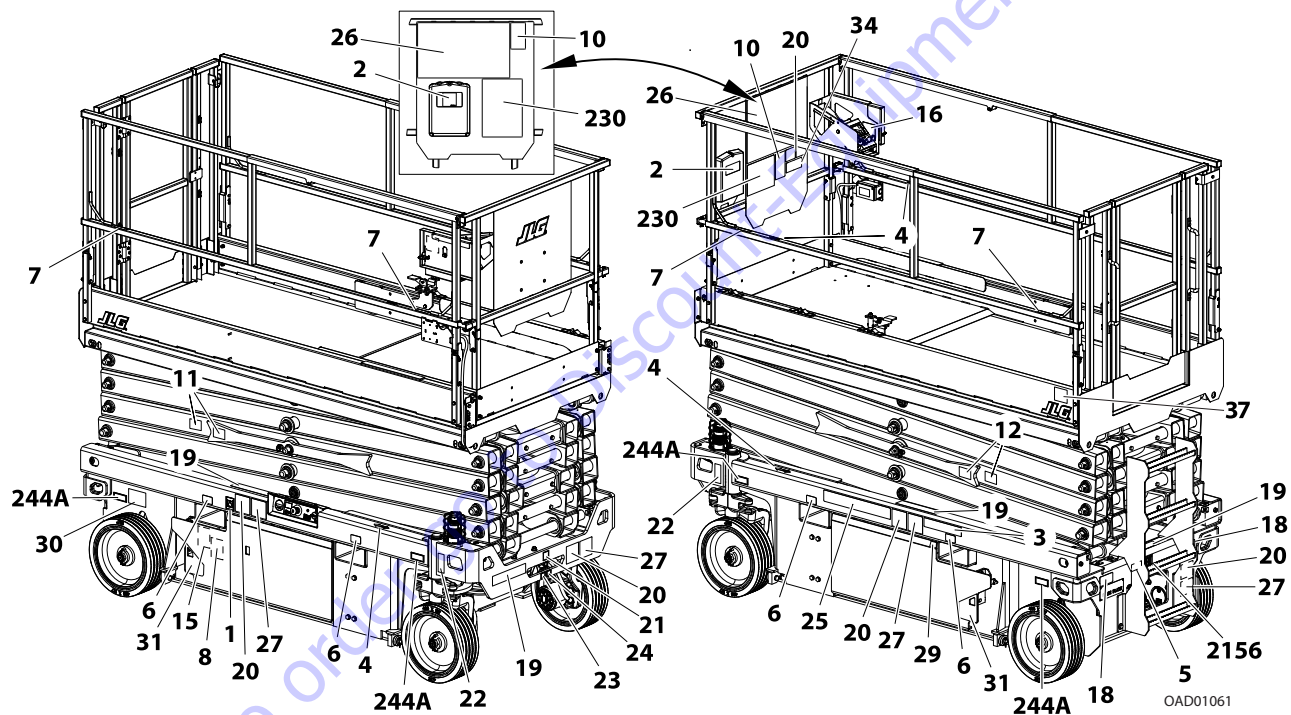

SECTION 6 - GENERAL SPECIFICATIONS AND MAINTENANCE

Chart

ITEM	ENGLISH (1001222124)	ENG/KOR (1001222125)	ENG/CHI (1001222126)	SPA/POR (1001222127)	ENG/SPA (1001222128)	ENG/FRE (1001222129)	CE (1001222130)	AUS (1001222131)
1	1701504	1701504	1701504	1701504	1701504	1701504	1701504	1701504
2	1701640	1701640	1701640	1701640	1701640	1701640	1701640	1701640
3	1703813	1707022	1704344	1704341	1704339	1704339	1705670	1705670
4	1703819	1703819	1703819	1703819	1703819	1703819	1703819	1703819
5	1703822	1703822	1703822	1703822	1703822	1703822	1703822	1703822
6	1704016	1704016	1704016	1704016	1704016	1704016	1704016	1704016
7	1704277	1704277	1704277	1704277	1704277	1704277	1704277	1704277
8	1704412	1704412	1704412	1704412	1704412	1704412	1704412	1704412
9	—	—	—	—	—	—	—	—
10	1705686	1706057	1705946	1705726	1705720	1705723	—	—
11	1001228641	1001228641	1001228641	1001228641	1001228641	1001228641	1001228641	1001228641
12	1001228642	1001228642	1001228642	1001228642	1001228642	1001228642	1001228642	1001228642
13	—	—	—	—	—	—	—	—
14	—	—	—	—	—	—	—	—
15	1001131270	—	—	—	—	1001131270	—	—
16	1001132359	1001132359	1001132359	1001132359	1001132359	1001132359	1001132359	1001132359
17	—	—	—	—	—	—	—	—
18	1001162864	1001162864	1001162864	1001162864	1001162864	1001162864	1001162864	1001162864
19	1001211777	1001215751	1001215752	1001216650	1001215754	1001215755	1705673	1705673
20	1001211779	1001211779	1001211779	1001215748	1001211779	1001211779	1705671	1705671

SECTION 6 - GENERAL SPECIFICATIONS AND MAINTENANCE

ITEM	ENGLISH (1001222124)	ENG/KOR (1001222125)	ENG/CHI (1001222126)	SPA/POR (1001222127)	ENG/SPA (1001222128)	ENG/FRE (1001222129)	CE (1001222130)	AUS (1001222131)
21	1001212290	1001212290	1001212290	1001212290	1001212290	1001212290	1001212290	1001212290
22	1001213442	1001213442	1001213442	1001213442	1001213442	1001213442	1001213442	1001212291
23	1001212292	1001212292	1001212292	1001212292	1001212292	1001212292	1001212292	1001212292
24	1001212293	1001212293	1001212293	1001212293	1001212293	1001212293	1001212293	1001212293
25	1001146794	1001146794	1001146794	1001146794	1001146794	1001146794	1001146795	1001146794
26	1703816	1001162115	1705195	1704699	1704691	1704684	—	—
27	—	1001215750	1001215747	1001216648	1001215748	1001215749	—	—
28	—	—	—	—	—	—	—	—
29	1702155	1702155	1702155	1702155	1702155	1702155	1702155	—
30	1001223055	1001224048	1001224051	1001224052	1001224049	1001223971	—	—
31	1001225620	1001225620	1001225620	1001225620	1001225620	1001225620	1001225620	1001225620
32	1001225621	1001225621	1001225621	1001225621	1001225621	1001225621	1001225621	1001225621
33	1001225622	1001225622	1001225622	1001225622	1001225622	1001225622	1001225622	1001225622
34	1001231801	—	—	—	—	—	—	—
37	—	—	1001244298	—	—	—	—	—
230	1001220378	1001220378	1001220378	1001220378	1001220378	1001220378	1001220378	1001229804
244A	1001224553	1001224553	1001224553	1001224553	1001224553	1001224553	1001224553	1001224553
2156	—	—	—	—	—	—	1001173703	—

NOTE: Reference applicable Illustrated Parts Manual for decal description.

6.7 DIAGNOSTIC TROUBLE CODES (DTC)

NOTICE

THE DTC CODES LISTED IN THE FOLLOWING TABLE IS NOT A COMPLETE LISTING OF MACHINE DTC CODES. THIS LISTING SHOWS ONLY THOSE DTC'S WHICH AN OPERATOR MAY BE ABLE TO CORRECT DUE TO OPERATING ERROR.

The DTC table following is sorted in groups by the first two digits, these digits represent the number of flashes the system distress indicator lamp will flash on the platform indicator panel when a fault occurs.

The more detailed three to five digit code numbers in the DTC column of the following tables are only indicated on a JLG handheld diagnostic analyzer connected to the machine, or on the Ground Control Station - MDI indicator, if equipped.

To troubleshoot multiple DTCs, start with the DTC with the higher first two digits.

If a correction is made during a check, conclude the check by cycling the machine power off then back on, using the emergency stop switch.

NOTICE

SHOULD A FAULT OCCUR WHICH CANNOT BE CORRECTED BY THE OPERATOR, THE PROBLEM MUST BE REFERRED TO A QUALIFIED JLG MECHANIC.

SECTION 6 - GENERAL SPECIFICATIONS AND MAINTENANCE

DTC	Help Message	Alarm	Flash Code	Action	Trigger
001	EVERYTHING OK	None	None	· No Motion restrictions	• Platform Mode and no Faults are active.
002	GROUND MODE OK	None	None	· No Motion restrictions	• Ground Mode and no Faults are active.
003	ALARM SOUNDING – TILTED & ABOVE ELEVATION	PF: Continuous	None	· No Motion restrictions	• Platform is elevated and chassis is not level
004	DRIVING AT CUTBACK – ABOVE ELEVATION	None	None	· DriveState = CREEP	• Platform is elevated and the machine is in the drive mode of operation
005	DRIVE & LIFT UP PREVENTED TILTED & ELEVATED	PF: Continuous	None	• DriveState = PREVENTED • LiftUpState = PREVENTED	• Driving and lift up are not possible since the platform is elevated and the chassis is not level.
006	LIFT UP PREVENTED – MAX HEIGHT ZONE A	None	None	• LiftUpState = PREVENTED	• The vehicle has reached the maximum height allowed by the Indoor/Outdoor selection and further lift up motion is not possible.
007	DRIVING AT CUTBACK – POT-HOLE STILL ENGAGED	None	None	• DriveState = CREEP	<ul style="list-style-type: none"> • While stowed, drive speed is reduced (due to lower ground clearance) since the control system detected that the pot-hole protection mechanism is deployed (failed to retract). • Clear the obstacle blocking the pot-hole protection mechanism, repair the mechanical problem, re-adjust the pot-hole limit switches, or repair the wiring to correct the problem. • Alternately, there may be difficulty with the Elevation Angle Sensor that causes the Control System to improperly believe the platform is stowed.

SECTION 6 - GENERAL SPECIFICATIONS AND MAINTENANCE

DTC	Help Message	Alarm	Flash Code	Action	Trigger
008	FUNCTIONS LOCKED OUT – SYSTEM POWERED DOWN	None	None	<ul style="list-style-type: none"> • Enter SafeMode • LiftDownState = PREVENTED 	<ul style="list-style-type: none"> • A period of time elapsed without activity and the Control System entered a low-power state to preserve battery charge (2 hours). Cycle the Ground EMS in GroundMode or the Platform EMS in PlatformMode to re-enable the vehicle. • Two hours (10 minutes if GroundMode) without Drive Forward, Drive Reverse, Lift Up, Lift Down, Steer Left, or Steer Right. • Timer resets if user changes PlatformMode/GroundMode
009	DRIVE PREVENTED – ELEVATED ABOVE DRIVE CUTOUT HEIGHT	None	None	• DriveState = PREVENTED	<ul style="list-style-type: none"> • The Drive Cutout functionality is enabled, and the Platform is Elevated above the Calibrated Cutout Height.
211	POWER CYCLE	None	2_1	• No Motion restrictions	<ul style="list-style-type: none"> • This Help Message is issued at each power-up. This serves to indicate which messages have been recorded in the failure log since the last power-up event.
212	KEYSWITCH FAULTY	None	2_1	• Force to GroundMode	<ul style="list-style-type: none"> • Both the Ground Select and Platform Select signals are energized, which means there is an issue with the keyswitch or one of the lines are shorted to battery.
221	FUNCTION PROBLEM – HORN PERMANENTLY SELECTED	None	2_2	• Horn Prevented	<ul style="list-style-type: none"> • Horn Switch in the Platform Control Box was closed during power-up. Release or repair the switch to clear the message.
2210	TRIGGER CLOSED TOO LONG WHILE IN NEUTRAL	None	2_2	<ul style="list-style-type: none"> • TriggerState = FALSE therefore • DriveState = PREVENTED • LiftUpState = PREVENTED • LiftDownState = PREVENTED 	<ul style="list-style-type: none"> • Trigger Switch on the Platform Control Box was closed for more than five seconds while the Joystick (accelerator) was in the neutral position (centered). Release switch or repair the switch / wiring to clear the difficulty.
222	FUNCTION PROBLEM – INDOOR / OUTDOOR PERMANENTLY SELECTED	None	2_2	• Previously selected Indoor / Outdoor Mode maintained	<ul style="list-style-type: none"> • Indoor / Outdoor Switch in the Platform Control Box was closed during power-up. Release or repair the switch to clear the message.

SECTION 6 - GENERAL SPECIFICATIONS AND MAINTENANCE

DTC	Help Message	Alarm	Flash Code	Action	Trigger
223	FUNCTION PROBLEM – DRIVE & LIFT ACTIVE TOGETHER	None	2_2	<ul style="list-style-type: none"> • MoveState = LIFT • DriveState = PREVENTED • LiftUpState = PREVENTED • LiftDownState = PREVENTED 	<ul style="list-style-type: none"> • The Drive - Lift Selector Switch indicates that both functions are selected simultaneously. Repair the wiring or switch to clear the message.
2232	FUNCTION PROBLEM – DRIVE & LIFT BOTH OPEN	None	2_2	<ul style="list-style-type: none"> • MoveState = LIFT • DriveState = PREVENTED • LiftUpState = PREVENTED • LiftDownState = PREVENTED 	<ul style="list-style-type: none"> • In PlatformMode, the Drive - Lift Selector Switch indicates that neither function is selected. Repair the wiring or switch to clear the message.
224	FUNCTION PROBLEM – STEER LEFT PERMANENTLY SELECTED	None	2_2	<ul style="list-style-type: none"> • DriveState = PREVENTED 	<ul style="list-style-type: none"> • Steer Left Switch in the Platform Control Box was closed during power-up. Release or repair the switch to clear the message.
225	FUNCTION PROBLEM – STEER RIGHT PERMANENTLY SELECTED	None	2_2	<ul style="list-style-type: none"> • DriveState = PREVENTED 	<ul style="list-style-type: none"> • Steer Right Switch in the Platform Control Box was closed during power-up. Release or repair the switch to clear the message.
228	FUNCTION LOCKED OUT – ACCELERATOR NOT CENTERED	None	2_2	<ul style="list-style-type: none"> • DriveState = PREVENTED • LiftUpState = PREVENTED • LiftDownState = PREVENTED 	<ul style="list-style-type: none"> • Selected function (Drive or Lift) is not allowed because the joystick (accelerator) was not centered at power-up. Return joystick to center momentarily.
229	FUNCTION PROBLEM – TRIGGER PERMANENTLY CLOSED	None	2_2	<ul style="list-style-type: none"> • DriveState = PREVENTED • LiftUpState = PREVENTED • LiftDownState = PREVENTED 	<ul style="list-style-type: none"> • Trigger Switch in the Platform Control Box was closed at power-up. Release switch or repair the switch / wiring to clear the difficulty.

SECTION 6 - GENERAL SPECIFICATIONS AND MAINTENANCE

DTC	Help Message	Alarm	Flash Code	Action	Trigger
231	FUNCTION PROBLEM – LIFT PERMANENTLY SELECTED	None	2_3	In GroundMode then • LiftUpState = PREVENTED • LiftDownState = PREVENTED	• Lift Switch (Up or Down) in the Ground Control Box was closed during power-up. Release or repair the switch to clear the message.
232	GROUND LIFT UP/DOWN ACTIVE TOGETHER	None	2_3	In GroundMode then • LiftUpState = PREVENTED • LiftDownState = PREVENTED	• In GroundMode, the control system has detected the Lift Up and Down are active simultaneously. Check the Lift Switch and associated wiring in the Ground Control Box.
242	AMBIENT TEMPERATURE SENSOR – OUT OF RANGE HIGH	PF: Continuous	2_4	• Drive and Lift Restrictions	• The temperature as communicated by the temperature/tilt sensor is greater than 185° F (85° C).
253	DRIVE PREVENTED – CHARGER CONNECTED	None	2_5	• DriveState = PREVENTED	• Driving is not possible since the vehicle is charging.
254	DRIVE & LIFT UP PREVENTED – CHARGER CONNECTED	None	2_5	• DriveState = PREVENTED • LiftUpState = PREVENTED	• Driving and Lifting are not possible since the vehicle is charging and it is configured to prevent all motion.
255	PLATFORM OVERLOADED	PF: 5000ms ON/ 2000ms OFF GND: 5000ms ON/2000ms OFF	2_5	• Drive and Lift Restrictions	• While the Load Sensing System is enabled, the Platform Load measured by the Load Sensing System is excessive. Functions from Platform Control Station are prevented, and functions from Ground Control may be prevented, depending on machine configuration. • Refer to LSS functionality for Lift and Drive restrictions.

SECTION 6 - GENERAL SPECIFICATIONS AND MAINTENANCE

DTC	Help Message	Alarm	Flash Code	Action	Trigger
256	DRIVE PREVENTED – POT HOLE NOT ENGAGED	PF: 500ms On/ 500ms Off GND: 500ms On/ 500ms Off	2_5	• DriveState = PREVENTED	<ul style="list-style-type: none"> While elevated, driving is not possible since the control system detected that the pot-hole protection mechanism failed to deploy. Clear the obstacle blocking the pot-hole protection mechanism, repair the mechanical problem, re-adjust the pot-hole limit switches, or repair the wiring to correct the problem. Alternately, there may be difficulty with the Elevation Angle Sensor that causes the Control System to improperly believe the platform is elevated.
2568	TEMPERATURE CUTOUT ACTIVE - AMBIENT TEMPERATURE TOO LOW	IfTransportMode = TRUE PF: Continuous IfTransportMode = FALSE PF: OFF	2_5	• Drive and Lift Restrictions	<ul style="list-style-type: none"> The temperature as communicated by the temperature sensor located on the temperature/tilt sensor is less than or equal to {PERSONALITIES->TEMP CUTOUT->CUTOUT SET} (See Low Temperature Cutout Functionality) This DTC shall not be displayed in GroundMode, and no restrictions shall be implemented.
421	POWER MODULE TOO HOT - PLEASE WAIT	None	4_2	• DriveState = PREVENTED • LiftUpState = PREVENTED	<ul style="list-style-type: none"> Heatsink temperature above 203°F (95° C). Possible Cause: Controller is operating in an extreme environment. Excessive load on vehicle. Improper mounting of controller
4235	POWER MODULE TOO HOT - REDUCED OPERATION	None	4_2	• DriveState = CREEP • LiftUpState = CREEP	<ul style="list-style-type: none"> Heatsink temperature exceeded 185° F (85° C). Effect: Reduced drive and brake torque. Possible Cause: Controller is performance-limited at this temperature. Controller is operating in an extreme environment. Excessive load on vehicle Improper mounting of controller.

SECTION 6 - GENERAL SPECIFICATIONS AND MAINTENANCE

DTC	Help Message	Alarm	Flash Code	Action	Trigger
4236	POWER MODULE TOO COLD - MODULE SHUTDOWN	None	4_2	<ul style="list-style-type: none"> • DriveState = PREVENTED • LiftUpState = PREVENTED 	<ul style="list-style-type: none"> • Heatsink temperature below -40° F (-40°C). • Possible Cause: • Controller is operating in an extreme environment.
426	MASTER MODULE TEMPERATURE – OUT OF RANGE	None	4_2	<ul style="list-style-type: none"> • Normal operation 	<ul style="list-style-type: none"> • The Ground Module's internal temperature sensor is out of range. (< 104° F (40° C) or > 302° F (150° C)
441	BATTERY VOLTAGE TOO LOW – SYSTEM SHUTDOWN	None	4_4	<ul style="list-style-type: none"> • SafeMode • LiftDownState = PREVENTED 	<ul style="list-style-type: none"> • Battery Voltage (VBAT) momentarily dropped below 14.5V when using flooded lead-acid batteries, or 16.0V when using AGM batteries. With a low battery charge, this can occur during heavy current demand due to Drive, Steer, or Lift Up. Recharge batteries or check for damaged batteries, sulfated batteries, or poor power connections.
442	BATTERY VOLTAGE TOO HIGH – SYSTEM SHUTDOWN	None	4_4	<ul style="list-style-type: none"> • Enter SafeMode • LiftDownState = MAX 	<ul style="list-style-type: none"> • The Ground Module measured excessively high battery voltage (VBAT) (>32.0V) and de-energized the Main Line Contactor and Battery Relay to protect system devices and was unable to bring voltage down to normal operating range. This may be due to improper battery charging or incorrect voltage batteries being used.
4421	LOGIC SUPPLY VOLTAGE OUT OF RANGE HIGH	None	4_4	<ul style="list-style-type: none"> • Enter SafeMode • LiftDownState = MAX 	<ul style="list-style-type: none"> • The Ground Module's VSW voltage was measured to be more than 32V. This may be caused by loose battery terminal, severely discharge batteries, a damaged battery, or an improper wire harness connection.

SECTION 6 - GENERAL SPECIFICATIONS AND MAINTENANCE

DTC	Help Message	Alarm	Flash Code	Action	Trigger
4424	POWER MODULE VOLTAGE TOO LOW - MODULE SHUTDOWN	None	4_4	<ul style="list-style-type: none"> • DriveState = PREVENTED • LiftUpState = PREVENTED 	<ul style="list-style-type: none"> • Severe B+ Undervoltage Set: Capacitor bank voltage dropped below Severe Undervoltage limit with FET bridge enabled. • Effect: Reduced Drive Torque • Possible Cause: <ul style="list-style-type: none"> • Battery menu parameters are misadjusted • Non-controller system drain on battery • Battery resistance too high • Battery disconnected while driving • Blown B+ fuse or main contactor not closed
4475	POWER MODULE - BDI FAULT	None	4_4	<ul style="list-style-type: none"> • DriveState = PREVENTED • LiftUpState = PREVENTED 	<ul style="list-style-type: none"> • Pump BDI Fault Set: BDI Percentage charge at 0% when the pump was activated. • Effect: ShutdownPump • Possible Cause: <ul style="list-style-type: none"> • Battery is fully discharged • BDI parameters are mis-tuned
4476	BATTERY VOLTAGE TOO HIGH – UNPLUG CHARGER	None	4_4	<ul style="list-style-type: none"> • Enter SafeMode • LiftDownState = MAX 	<ul style="list-style-type: none"> • The Ground Module momentarily measured excessively high battery voltage (VBAT) (>32.0V) and entered SafeMode to protect system devices. This may be due to improper battery charging or incorrect voltage batteries being used.
4477	BATTERY VOLTAGE TOO HIGH – FORCING DISCHARGE	None	4_4	<ul style="list-style-type: none"> • LiftDown = PREVENTED • LiftUp = PREVENTED • Drive = PREVENTED 	<ul style="list-style-type: none"> • The Ground Module momentarily measured excessively high battery voltage (VBAT) (>32.0V) and entered SafeMode. This may be due to improper battery charging or incorrect voltage batteries being used.

TO PURCHASE THIS PRODUCT PLEASE CONTACT US



**Equipment Financing and
Extended Warranties Available**



**Discount-Equipment.com is your online resource for
commercial and industrial quality parts and equipment sales.**

561-964-4949

visit us on line @ www.discount-equipment.com

Select an option below to find your Equipment

Search by Manufacturer

Search by Product Type

Request a Quote

We sell worldwide for the brands: Genie, Terex, JLG, MultiQuip, Mikasa, Essick, Whiteman, Mayco, Toro Stone, Diamond Products, Generac Magnum, Airman, Haulotte, Barreto, Power Blanket, Nifty Lift, Atlas Copco, Chicago Pneumatic, Allmand, Miller Curber, Skyjack, Lull, Skytrak, Tsurumi, Husquvarna Target, Stow, Wacker, Sakai, Mi-T-M, Sullair, Basic, Dynapac, MBW, Weber, Bartell, Bennar Newman, Haulotte, Ditch Runner, Menegotti, Morrison, Contec, Buddy, Crown, Edco, Wyco, Bomag, Laymor, EZ Trench, Bil-Jax, F.S. Curtis, Gehl Pavers, Heli, Honda, ICS/PowerGrit, IHI, Partner, Imer, Clipper, MMD, Koshin, Rice, CH&E, General Equipment, Amida, Coleman, NAC, Gradall, Square Shooter, Kent, Stanley, Tamco, Toku, Hatz, Kohler, Robin, Wisconsin, Northrock, Oztec, Toker TK, Rol-Air, APT, Wylie, Ingersoll Rand / Doosan, Innovatech, Con X, Ammann, Mecalac, Makinex, Smith Surface Prep, Small Line, Wanco, Yanmar

JLG[®]

An Oshkosh Corporation Company



www.Discount-Equipment.com

To order go to www.Discount-Equipment.com