



An Oshkosh Corporation Company



www.Discount-Equipment.com

Operation and Safety Manual

Original Instructions - Keep this manual with the machine at all times.

Models

1532R

1932R

ANSI   **AS/NZS**

3121744

October 4, 2019 - Rev I

TO PURCHASE THIS PRODUCT PLEASE CONTACT US



**Equipment Financing and
Extended Warranties Available**



**Discount-Equipment.com is your online resource for
commercial and industrial quality parts and equipment sales.**

561-964-4949

visit us on line @ www.discount-equipment.com

Select an option below to find your Equipment

Search by Manufacturer

Search by Product Type

Request a Quote

We sell worldwide for the brands: Genie, Terex, JLG, MultiQuip, Mikasa, Essick, Whiteman, Mayco, Toro Stone, Diamond Products, Generac Magnum, Airman, Haulotte, Barreto, Power Blanket, Nifty Lift, Atlas Copco, Chicago Pneumatic, Allmand, Miller Curber, Skyjack, Lull, Skytrak, Tsurumi, Husquvarna Target, Stow, Wacker, Sakai, Mi-T-M, Sullair, Basic, Dynapac, MBW, Weber, Bartell, Bennar Newman, Haulotte, Ditch Runner, Menegotti, Morrison, Contec, Buddy, Crown, Edco, Wyco, Bomag, Laymor, EZ Trench, Bil-Jax, F.S. Curtis, Gehl Pavers, Heli, Honda, ICS/PowerGrit, IHI, Partner, Imer, Clipper, MMD, Koshin, Rice, CH&E, General Equipment, Amida, Coleman, NAC, Gradall, Square Shooter, Kent, Stanley, Tamco, Toku, Hatz, Kohler, Robin, Wisconsin, Northrock, Oztec, Toker TK, Rol-Air, APT, Wylie, Ingersoll Rand / Doosan, Innovatech, Con X, Ammann, Mecalac, Makinex, Smith Surface Prep, Small Line, Wanco, Yanmar



WARNING

Operating, servicing and maintaining this vehicle or equipment can expose you to chemicals including engine exhaust, carbon monoxide, phthalates, and lead, which are known to the State of California to cause cancer and birth defects or other reproductive harm. To minimize exposure, avoid breathing exhaust, do not idle the engine except as necessary, service your vehicle or equipment in a well-ventilated area and wear gloves or wash your hands frequently when servicing. For more information go to www.P65Warnings.ca.gov.

To order go to www.P65Warnings.ca.gov

FOREWORD

This manual is a very important tool! Keep it with the machine at all times.

The purpose of this manual is to provide owners, users, operators, lessors, and lessees with the precautions and operating procedures essential for the safe and proper machine operation for its intended purpose.

Due to continuous product improvements, JLG Industries, Inc. reserves the right to make specification changes without prior notification. Contact JLG Industries, Inc. for updated information.

Refer to www.JLG.com for Warranty, Product Registration, and other machine-related documentation.

SAFETY ALERT SYMBOLS AND SAFETY SIGNAL WORDS



This is the Safety Alert Symbol. It is used to alert you to the potential personal injury hazards. Obey all safety messages that follow this symbol to avoid possible injury or death.

⚠ DANGER

INDICATES AN IMMINENTLY HAZARDOUS SITUATION. IF NOT AVOIDED, WILL RESULT IN SERIOUS INJURY OR DEATH. THIS DECAL WILL HAVE A RED BACKGROUND.

⚠ WARNING

INDICATES A POTENTIALITY HAZARDOUS SITUATION. IF NOT AVOIDED, COULD RESULT IN SERIOUS INJURY OR DEATH. THIS DECAL WILL HAVE AN ORANGE BACKGROUND.

⚠ CAUTION

INDICATES A POTENTIALITY HAZARDOUS SITUATION. IF NOT AVOIDED, MAY RESULT IN MINOR OR MODERATE INJURY. IT MAY ALSO ALERT AGAINST UNSAFE PRACTICES. THIS DECAL WILL HAVE A YELLOW BACKGROUND.

NOTICE

INDICATES INFORMATION OR A COMPANY POLICY THAT RELATES DIRECTLY OR INDIRECTLY TO THE SAFETY OF PERSONNEL OR PROTECTION OF PROPERTY.

REVISION LOG

Original Issue	A - July 14, 2016
Revised	B - August 18, 2016
Revised	C - September 27, 2016
Revised	D - January 30, 2017
Revised	E - February 21, 2017
Revised	F - October 20, 2017
Revised	G - April 20, 2018
Revised	H - June 29, 2018 - Revised Covers, Prop 65
Revised	I - October 4, 2019

To order go to Discount-Equipment.com

SECTION - PARAGRAPH, SUBJECT	PAGE	SECTION - PARAGRAPH, SUBJECT	PAGE
SECTION - 1 - SAFETY PRECAUTIONS			
1.1 GENERAL	1-1	2.4 DAILY WALK-AROUND INSPECTION	2-7
1.2 PRE-OPERATION	1-2	2.5 FUNCTION CHECK	2-9
Operator Training and Knowledge.....	1-2		
Workplace Inspection	1-2	SECTION - 3 - MACHINE CONTROLS, INDICATORS AND OPERATION	
Machine Inspection	1-3	3.1 GENERAL	3-1
1.3 OPERATION.....	1-4	3.2 DESCRIPTION	3-1
General.....	1-4	3.3 OPERATING CHARACTERISTICS AND LIMITATIONS	3-2
Trip and Fall Hazards	1-5	General.....	3-2
Electrocution Hazards.....	1-6	Placards	3-2
Tipping Hazards	1-7	3.4 PLATFORM LOADING	3-2
Crushing and Collision Hazards.....	1-9	3.5 MACHINE CONTROL LOCATIONS	3-3
1.4 TOWING, LIFTING, AND HAULING.....	1-11	3.6 BATTERY CHARGING	3-4
1.5 MAINTENANCE	1-11	3.7 GROUND CONTROL STATION.....	3-5
Maintenance Hazards	1-11	Ground/Platform/OFF Key Selector Switch.....	3-6
Battery Hazards	1-12	Platform Lift/Lower Switch	3-6
		Inverter ON/OFF Switch (If Equipped).....	3-6
SECTION - 2 - USER RESPONSIBILITIES, MACHINE PREPARATION AND INSPECTION		Ground Emergency Stop Switch	3-6
2.1 PERSONNEL TRAINING	2-1	Hourmeter.....	3-7
Operator Training.....	2-1	Overload Indicator (If LSS Equipped).....	3-7
Training Supervision	2-2	MDI Indicator (If Equipped).....	3-7
Operator Responsibility	2-2	3.8 PLATFORM MANUAL DESCENT CONTROL.....	3-9
2.2 PREPARATION, INSPECTION, AND MAINTENANCE	2-2	3.9 PLATFORM CONTROL STATION.....	3-10
2.3 PRE-START INSPECTION	2-4	Platform Emergency Stop Switch	3-12
		Lift/Drive Select.....	3-12
		Forward/Reverse/Lift/Lower Direction Decal.....	3-12

TABLE OF CONTENTS

SECTION - PARAGRAPH, SUBJECT	PAGE	SECTION - PARAGRAPH, SUBJECT	PAGE
Drive/Lift/Steer Joystick Control	3-13	3.14 TOWING.....	3-25
Steering And Traveling.....	3-13	Hydraulic Brake Release.....	3-25
Steering	3-14		
Traveling Forward and Reverse.....	3-14	SECTION - 4 - EMERGENCY PROCEDURES	
Raising And Lowering Platform.....	3-14	4.1 GENERAL INFORMATION.....	4-1
Arm Guards (If Equipped)	3-16	4.2 EMERGENCY OPERATION	4-1
Overload Indicator (LSS) (If Equipped)	3-16	Operator Unable to Control Machine.....	4-1
Tilt Indicator Warning Light and Alarm	3-16	Platform Caught Overhead.....	4-1
Horn	3-16	Righting of Tipped Machine.....	4-1
Battery Charge Indicator	3-16	4.3 PLATFORM MANUAL DESCENT.....	4-2
System Fault Indicator	3-17	4.4 INCIDENT NOTIFICATION	4-3
Alarm	3-17		
Indoor-Zone A/Outdoor-Zone B Operation Indicator... 3-17		SECTION - 5 - ACCESSORIES	
Indoor-Zone A/Outdoor-Zone B Operation Mode		5.1 DC/AC POWER INVERTER	5-4
Switch.....	3-17	Specifications	5-4
Outdoor/Indoor Operation Indicator	3-17	Safety Precautions.....	5-4
Outdoor/Indoor Operation Mode Switch	3-17	Operation	5-5
3.10 PLATFORM EXTENSION	3-18	5.2 MAGNETIC GATE LATCH	5-5
3.11 PARKING AND STOWING MACHINE.....	3-19	Operation	5-5
3.12 PLATFORM RAILS FOLD-DOWN PROCEDURE		5.3 ANTI-VANDALISM PACKAGE	5-6
(IF EQUIPPED)	3-20	5.4 PLATFORM EXTENSION HANDLES.....	5-7
Platform with Rail-in-Rail Extension Deck	3-20	Operation	5-7
3.13 MACHINE LIFTING AND TIE DOWN	3-22	5.5 PIPE RACKS.....	5-8
Lifting.....	3-22	Safety Precautions.....	5-9
Tie Down.....	3-23	Preparation and Inspection	5-9

TABLE OF CONTENTS

SECTION - PARAGRAPH, SUBJECT	PAGE	SECTION - PARAGRAPH, SUBJECT	PAGE
Operation	5-9	Lubrication Specifications	6-8
5.6 FOOTSWITCH	5-10	6.5 OPERATOR MAINTENANCE	6-10
Operation	5-10	Scissor Arm - Safety Prop	6-10
5.7 PANEL CARRIER	5-11	Hydraulic Oil Check Procedure	6-11
Safety Precautions	5-12	Delta-Q - Battery Charger	6-13
Preparation and Inspection	5-12	Green Power - Battery Charger (China Only)	6-13
Operation	5-12	Eagle Performance - Battery Charger	6-14
5.8 JLG™ MOBILE CONTROL	5-13	Battery Maintenance and Safety Practices	6-15
Download	5-13	Battery Quick-Disconnect	
Operation	5-14	(If Equipped)6-15	
Document Resources	5-14	Tire Wear and Damage	6-16
		Wheel and Tire Replacement	6-16
SECTION - 6 - GENERAL SPECIFICATIONS AND MAINTENANCE		Wheel Installation	6-17
6.1 INTRODUCTION	6-1	6.6 SUPPLEMENTAL INFORMATION	6-18
Other Publications Available Specific to this Machine	6-1	6.7 DECAL INSTALLATION	6-19
6.2 OPERATING SPECIFICATIONS	6-2	6.8 DIAGNOSTIC TROUBLE CODES (DTC)	6-22
Platform Capacities	6-4		
Machine Dimensional Data	6-5	SECTION - 7 - INSPECTION AND REPAIR LOG	
Tires	6-5		
Batteries	6-5		
Electrical System	6-6		
6.3 CRITICAL STABILITY WEIGHTS	6-7		
6.4 LUBRICATION	6-7		
Lubrication Capacities	6-7		
Hydraulic Oil	6-7		

TABLE OF CONTENTS

SECTION - PARAGRAPH, SUBJECT

PAGE

LIST OF FIGURES

2-1.	Daily Walk-Around Inspection	2-8
3-1.	Location of Machine Controls.....	3-3
3-2.	Ground Control Station.....	3-5
3-3.	MDI Indicator	3-8
3-4.	Location of Manual Descent Control	3-9
3-5.	Platform Control Station.....	3-10
3-6.	Platform Control Station.....	3-11
3-7.	Grade and Sideslope Definition.....	3-15
3-8.	Platform Deck Extension	3-18
3-9.	Securing Control Station to Platform.....	3-19
3-10.	Rail-in-Rail Fold-Down Sequence	3-21
3-11.	Fork Lift Pockets - Location	3-22
3-12.	Lifting Machine Using Spreader Bar and Lift Lug Locations	3-23
3-13.	Tie Down and Lift Lug Locations	3-24
3-14.	Hydraulic Brakes - Manual Disengage.....	3-25
4-1.	Location of Manual Descent Control	4-2
6-1.	Hydraulic Oil Operating Temperature Chart	6-9
6-2.	Scissor Arm - Safety Prop	6-11
6-3.	Hydraulic Oil Check Procedure.....	6-12
6-4.	Hydraulic Oil Fill Procedure.....	6-12
6-5.	Battery Fluid Level.....	6-15
6-6.	Wheel Installation.....	6-17
6-7.	1532R/1932R - Machine Decal Installation.....	6-19

SECTION - PARAGRAPH, SUBJECT

PAGE

LIST OF TABLES

1-1	Minimum Approach Distances (M.A.D.)	1-7
1-2	Beaufort Scale (For Reference Only).....	1-8
2-1	Inspection and Maintenance Table.....	2-3
2-2	High Drive Cutout Height.....	2-10
2-3	Tilt Activation Setting	2-10
5-1	1532R/1932R - Available Accessories.....	5-1
5-2	1932R Only - Available Accessories.....	5-1
5-3	1532R - Options/Accessories Relationship Table.....	5-2
5-4	1932R - Options/Accessories Relationship Table.....	5-3
6-1	Operating Specifications	6-2
6-2	Platform Capacities.....	6-4
6-3	Dimensions	6-5
6-4	Tire Specifications.....	6-5
6-5	OEM Battery Specifications	6-5
6-6	Battery Charger Specifications.....	6-6
6-7	Critical Stability Weights.....	6-7
6-8	Capacities.....	6-7
6-9	Hydraulic Oil	6-7
6-10	Lubrication Specifications	6-8
6-11	Hydraulic Oil Specifications.....	6-8
6-12	1532R/1932R - Machine Decal Installation Chart.....	6-20
6-13	Diagnostic Trouble Codes (DTC)	6-23
7-1	Inspection and Repair Log.....	7-1

SECTION 1. SAFETY PRECAUTIONS

1.1 GENERAL

This section outlines the necessary precautions for proper and safe machine usage and maintenance. In order to promote proper machine usage, it is mandatory that a daily routine is established based on the content of this manual. A maintenance program, using the information provided in this manual and the Service and Maintenance Manual, must also be established by a qualified person and must be followed to ensure that the machine is safe to operate.

The owner/user/operator/lessor/lessee of the machine must not accept operating responsibility until this manual has been read, training is accomplished, and operation of the machine has been completed under the supervision of an experienced and qualified operator.

These sections contain the responsibilities of the owner, user, operator, lessor, and lessee concerning safety, training, inspection, maintenance, application, and operation. If there are any questions with regard to safety, training, inspection, maintenance, application, and operation, please contact JLG Industries, Inc. ("JLG").

WARNING

FAILURE TO COMPLY WITH THE SAFETY PRECAUTIONS LISTED IN THIS MANUAL COULD RESULT IN MACHINE DAMAGE, PROPERTY DAMAGE, PERSONAL INJURY OR DEATH.

SECTION 1 - SAFETY PRECAUTIONS

1.2 PRE-OPERATION

Operator Training and Knowledge

- The Operation and Safety Manual must be read and understood in its entirety before operating the machine. For clarification, questions, or additional information regarding any portions of this manual, contact JLG Industries, Inc.

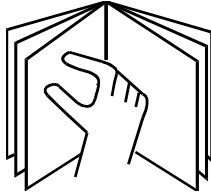

- An operator must not accept operating responsibilities until adequate training has been given by competent and authorized persons.
- Allow only those authorized and qualified personnel to operate the machine who have demonstrated that they understand the safe and proper operation and maintenance of the unit.
- Read, understand, and obey all DANGERS, WARNINGS, CAUTIONS, and operating instructions on the machine and in this manual.

- Ensure that the machine is to be used in a manner which is within the scope of its intended application as determined by JLG.
- All operating personnel must be familiar with the emergency controls and emergency operation of the machine as specified in this manual.
- Read, understand, and obey all applicable employer, local, and governmental regulations as they pertain to your utilization and application of the machine.

Workplace Inspection

- Precautions to avoid all hazards in the work area must be taken by the user before and during operation of the machine.
- Do not operate or raise the platform from a position on trucks, trailers, railway cars, floating vessels, scaffolds or other equipment unless the application is approved in writing by JLG.
- Before operation, check work area for overhead hazards such as electric lines, bridge cranes, and other potential overhead obstructions.
- Check floor surfaces for holes, bumps, drop-offs, obstructions, debris, concealed holes, and other potential hazards.

- Check the work area for hazardous locations. Do not operate the machine in hazardous environments unless approved for that purpose by JLG.
- Ensure that the ground conditions are adequate to support the maximum tire load indicated on the tire load decals located on the chassis adjacent to each wheel.
- This machine can be operated in nominal ambient temperatures of 0° F to 104° F (-20° C to 40° C). Consult JLG to optimize operation outside of this temperature range.
- Do not operate any machine on which the safety or instruction placards or decals are missing or illegible.
- Check the machine for modifications to original components. Ensure that any modifications have been approved by JLG.
- Avoid accumulation of debris on platform deck. Keep mud, oil, grease, and other slippery substances from footwear and platform deck.

Machine Inspection

- Do not operate this machine until the inspections and functional checks have been performed as specified in Section 2 of this manual.
- Do not operate this machine until it has been serviced and maintained according to the maintenance and inspection requirements as specified in the machine's Service and Maintenance Manual.
- Ensure all safety devices are operating properly. Modification of these devices is a safety violation.

WARNING

MODIFICATION OR ALTERATION OF AN AERIAL WORK PLATFORM SHALL BE MADE ONLY WITH PRIOR WRITTEN PERMISSION FROM THE MANUFACTURER.

SECTION 1 - SAFETY PRECAUTIONS

1.3 OPERATION

General

- Machine operation requires your full attention. Bring the machine to a full stop before using any device, i.e. cell phones, two-way radios, etc. that will distract your attention from safely operating the machine.
- Do not use the machine for any purpose other than positioning personnel, their tools, and equipment.
- Before operation, the user must be familiar with the machine capabilities and operating characteristics of all functions.
- Never operate a malfunctioning machine. If a malfunction occurs, shut down the machine. Remove the unit from service and notify the proper authorities.
- Do not remove, modify, or disable any safety devices.
- Never slam a control switch or lever through neutral to an opposite direction. Always return switch to neutral and stop before moving the switch to the next function. Operate controls with slow and even pressure.
- Do not allow personnel to tamper with or operate the machine from the ground with personnel in the platform, except in an emergency.
- Do not carry materials directly on platform railing unless approved by JLG.
- When two or more persons are in the platform, the operator shall be responsible for all machine operations.
- Always ensure that power tools are properly stowed and never left hanging by their cord from the platform work area.
- Do not assist a stuck or disabled machine by pushing or pulling except by pulling at the chassis tie-down lugs.
- Fully lower platform and shut off all power before leaving machine.
- Remove all rings, watches, and jewelry when operating machine. Do not wear loose fitting clothing or long hair unrestrained which may become caught or entangled in equipment.
- Persons under the influence of drugs or alcohol or who are subject to seizures, dizziness or loss of physical control must not operate this machine.

Trip and Fall Hazards

- Prior to operation, ensure all gates and rails are fastened and secured in their proper position.

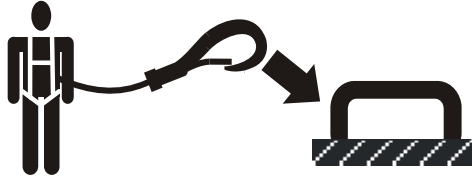

- JLG Industries, Inc. recommends that all persons in the platform wear a full body harness with a lanyard attached to an authorized lanyard anchorage point while operating this machine. For further information regarding fall protection requirements on JLG products, contact JLG Industries, Inc.
- Identify the designated lanyard anchorage point(s) at the platform and securely attach the lanyard. Attach only one (1) lanyard per lanyard anchorage point.
- Enter and exit only through gate area. Use extreme caution when entering or leaving platform. Ensure that the platform assembly is fully lowered. Face the machine when entering or leaving the platform. Always maintain “three point contact” with the machine, using two hands and one foot or two feet and one hand at all times during entry and exit.

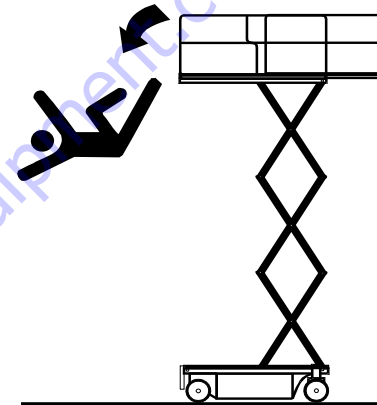

- Keep both feet firmly positioned on the platform floor at all times. Never position ladders, boxes, steps, planks, or similar items on unit to provide additional reach for any purpose.
- Never use the scissor arm assembly to gain access to or leave the platform.
- Keep oil, mud, and slippery substances cleaned from footwear and the platform floor.

SECTION 1 - SAFETY PRECAUTIONS

Electrocution Hazards

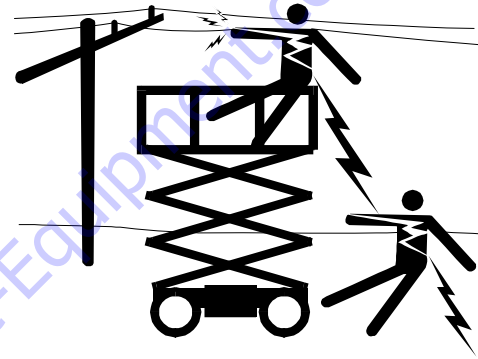
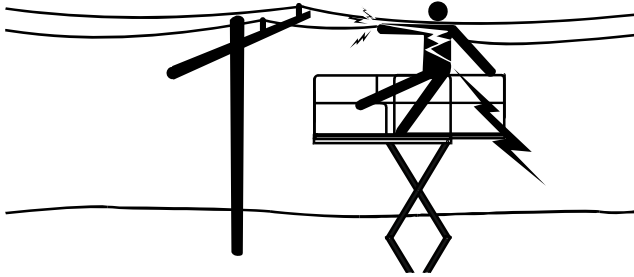

- This machine is not insulated and does not provide protection from contact or proximity to electrical current.
- Maintain distance from electrical lines, apparatus, or any energized (exposed or insulated) parts according to the Minimum Approach Distance (MAD) as shown in Table 1-1.
- Allow for machine movement and electrical line swaying.
- Maintain a clearance of at least 10 ft. (3m) between any part of the machine and its occupants, their tools, and their equipment from any electrical line or apparatus carrying up to 50,000 volts. One foot additional clearance is required for every additional 30,000 volts or less.
- The minimum approach distance may be reduced if insulating barriers are installed to prevent contact, and the barriers are rated for the voltage of the line being guarded. These barriers shall not be part of (or attached to) the machine. The minimum approach distance shall be reduced to a distance within the designed working dimensions of the insulating barrier. This determination shall be made by a qualified person in accordance with the employer, local, or governmental requirements for work practices near energized equipment.

 **DANGER**

DO NOT MANEUVER MACHINE OR PERSONNEL INSIDE PROHIBITED ZONE (MAD). ASSUME ALL ELECTRICAL PARTS AND WIRING ARE ENERGIZED UNLESS KNOWN OTHERWISE.

Table 1-1. Minimum Approach Distances (M.A.D.)

VOLTAGE RANGE (Phase to Phase)	MINIMUM APPROACH DISTANCE in Feet (Meters)
0 to 50 KV	10 (3)
Over 50KV to 200 KV	15 (5)
Over 200 KV to 350 KV	20 (6)
Over 350 KV to 500 KV	25 (8)
Over 500 KV to 750 KV	35 (11)
Over 750 KV to 1000 KV	45 (14)
NOTE: <i>This requirement shall apply except where employer, local or governmental regulations are more stringent.</i>	

Tipping Hazards

- Ensure that the ground conditions are adequate to support the maximum tire load indicated on the tire load decals located on the chassis adjacent to each wheel. Do not travel on unsupported surfaces.
- The user must be familiar with the driving surface before driving. Do not exceed the allowable sideslope and grade while driving.
- Do not elevate platform or drive with platform elevated while on or near a sloping, uneven, or soft surface. Ensure machine is positioned on a firm, level and smooth surface before elevating platform or driving with the platform in the elevated position.
- Before driving on floors, bridges, trucks, and other surfaces, check allowable capacity of the surfaces.
- Never exceed the maximum work load as specified on the platform. Keep all loads within the confines of the platform, unless authorized by JLG.
- Keep the chassis of the machine a minimum of 2 ft. (0.6m) from holes, bumps, drop-offs, obstructions, debris, concealed holes, and other potential hazards at the ground level.
- Do not operate the machine when wind conditions exceed specifications shown in Section 5, Table 6-2 or as shown on the capacity placard on the platform billboard.

SECTION 1 - SAFETY PRECAUTIONS

WARNING

DO NOT OPERATE THE MACHINE WHEN WIND CONDITIONS EXCEED SPECIFICATIONS SHOWN IN SECTION 5, TABLE 5-2 OR AS SHOWN ON THE CAPACITY PLACARD ON THE PLATFORM BILLBOARD.

Table 1-2. Beaufort Scale (For Reference Only)

BEAUFORT NUMBER	WIND SPEED		DESCRIPTION	LAND CONDITIONS
	mph	m/s		
0	0	0-0.2	Calm	Calm. Smoke rises vertically.
1	1-3	0.3-1.5	Light air	Wind motion visible in smoke.
2	4-7	1.6-3.3	Light breeze	Wind felt on exposed skin. Leaves rustle.
3	8-12	3.4-5.4	Gentle breeze	Leaves and smaller twigs in constant motion.
4	13-18	5.5-7.9	Moderate breeze	Dust and loose paper raised. Small branches begin to move.
5	19-24	8.0-10.7	Fresh breeze	Smaller trees sway.
6	25-31	10.8-13.8	Strong breeze	Large branches in motion. Flags waving near horizontal. Umbrella use becomes difficult.
7	32-38	13.9-17.1	Near Gale/Moderate Gale	Whole trees in motion. Effort needed to walk against the wind.
8	39-46	17.2-20.7	Fresh Gale	Twigs broken from trees. Cars veer on road.
9	47-54	20.8-24.4	Strong Gale	Light structure damage.

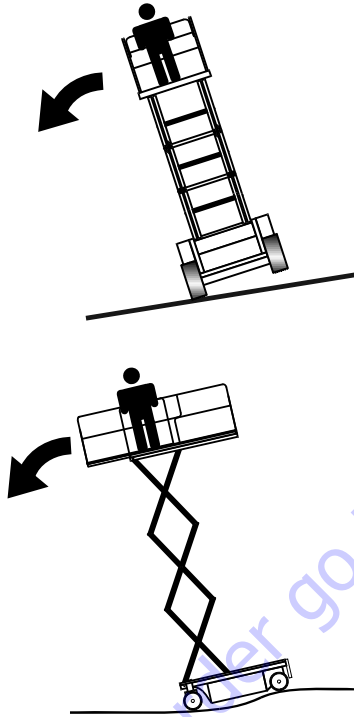

- Never attempt to use the machine as a crane. Do not tie-off machine to any adjacent structure. Never attach wire, cable, or any similar items to platform.
- Do not cover the platform sides or carry large surface-area items in the platform when operating outdoors. The addition of such items increases the exposed wind area of the machine.
- Do not increase the platform size with unauthorized deck extensions or attachments.
- If the scissor arm assembly or platform is caught so that one or more wheels are off the ground, all persons must be removed before attempting to free the machine. Use cranes, forklift trucks, or other appropriate equipment to stabilize machine and remove personnel.

Crushing and Collision Hazards

- Approved head gear must be worn by all operating and ground personnel.
- Keep hands and limbs out of the scissor arm assembly during operation and when elevated without safety prop engaged.
- Watch for obstructions around machine and overhead when driving. Check clearances above, on sides, and bottom of platform when lifting or lowering platform.

SECTION 1 - SAFETY PRECAUTIONS

- During operation, keep all body parts inside platform railing.

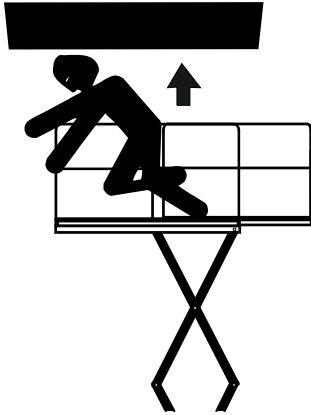

- Always post a lookout when driving in areas where vision is obstructed.
- Keep non-operating personnel at least 6 ft. (1.8m) away from machine during all operations.
- Under all travel conditions, the operator must limit travel speed according to conditions of ground surface, congestion, visibility, slope, location of personnel, and other factors.

- Be aware of stopping distances in all drive speeds. When driving in high speed, switch to low speed before stopping. Travel grades in low speed only.
- Do not use high speed drive in restricted or close quarters or when driving in reverse.
- Exercise extreme caution at all times to prevent obstacles from striking or interfering with operating controls and persons in the platform.
- Ensure that operators of other overhead and floor level machines are aware of the aerial work platform's presence. Disconnect power to overhead cranes. Barricade floor area if necessary.
- Do not operate over ground personnel. Warn personnel not to work, stand, or walk under a raised platform. Position barricades on floor as necessary.

1.4 TOWING, LIFTING, AND HAULING

- Never allow personnel in platform while towing, lifting, or hauling.
- This machine should not be towed, except in the event of emergency, malfunction, power failure, or loading/unloading. Refer to emergency towing procedures.
- Ensure platform is fully retracted and completely empty of tools prior to towing, lifting or hauling.
- When lifting machine with a forklift, position forks only at designated areas of the machine. Lift with a forklift of adequate capacity.
- Refer to Section 3 for lifting information.

1.5 MAINTENANCE

This sub-section contains general safety precautions which must be observed during maintenance of this machine. Additional precautions to be observed during machine maintenance are inserted at the appropriate points in this manual and in the Service and Maintenance Manual. It is of utmost importance that maintenance personnel pay strict attention to these precautions to avoid possible injury to personnel or damage to the machine or property. A maintenance program must be established by a qualified person and must be followed to ensure that the machine is safe.

Maintenance Hazards

- Shut off power to all controls and ensure that all moving parts are secured from inadvertent motion prior to performing any adjustments or repairs.
- Never work under an elevated platform until it has been fully lowered to the full down position, if possible, or otherwise supported and restrained from movement with appropriate safety props, blocking, or overhead supports.
- DO NOT attempt to repair or tighten any hydraulic hoses or fittings while the machine is powered on or when the hydraulic system is under pressure.

SECTION 1 - SAFETY PRECAUTIONS

- Always relieve hydraulic pressure from all hydraulic circuits before loosening or removing hydraulic components.
- DO NOT use your hand to check for leaks. Use a piece of cardboard or paper to search for leaks. Wear gloves to help protect hands from spraying fluid.
- Ensure replacement parts or components are identical or equivalent to original parts or components.
- Never attempt to move heavy parts without the aid of a mechanical device. Do not allow heavy objects to rest in an unstable position. Ensure adequate support is provided when raising components of the machine.
- Use only approved non-flammable cleaning solvents.
- Do not replace items critical to stability, such as batteries or solid tires, with items of different weight or specification. Do not modify unit in any way to affect stability.
- Reference the Service and Maintenance Manual for the weights of critical stability items.



⚠ WARNING

MODIFICATION OR ALTERATION OF AN AERIAL WORK PLATFORM SHALL BE MADE ONLY WITH PRIOR WRITTEN PERMISSION FROM THE MANUFACTURER.

Battery Hazards

- Always disconnect batteries when servicing electrical components or when performing welding on the machine.
- Do not allow smoking, open flame, or sparks near battery during charging or servicing.
- Do not contact tools or other metal objects across the battery terminals.
- Always wear hand, eye, and face protection when servicing batteries. Ensure that battery acid does not come in contact with skin or clothing.

⚠ CAUTION

BATTERY FLUID IS HIGHLY CORROSIVE. AVOID CONTACT WITH SKIN AND CLOTHING AT ALL TIMES. IMMEDIATELY RINSE ANY CONTACTED AREA WITH CLEAN WATER AND SEEK MEDICAL ATTENTION.

- Charge batteries only in a well ventilated area.
- Avoid overfilling the battery fluid level. Add distilled water to batteries only after the batteries are fully charged.

SECTION 2. USER RESPONSIBILITIES, MACHINE PREPARATION AND INSPECTION

2.1 PERSONNEL TRAINING

The aerial platform is a personnel handling device; so it is necessary that it be operated and maintained only by trained personnel.

Operator Training

Operator training must cover:

- Use and limitations of the controls in the platform and at the ground, emergency controls and safety features.
- Control labels, instructions, and warnings on the machine.
- Rules of the employer and government regulations.
- Use of approved fall protection equipment.
- Enough knowledge of the mechanical operation of the machine to recognize a malfunction or potential malfunction.
- The safest means to operate the machine where overhead obstructions, other moving equipment, and obstacles, depressions, holes, and drop-offs exist.
- Means to avoid the hazards of unprotected electrical conductors.
- Specific job requirements or machine application.
- Reading and understanding the Operation and Safety Manual.

Training Supervision

Training must be done under the supervision of a qualified person in an open area free of obstructions until the trainee has developed the ability to safely control and operate the machine.

Operator Responsibility

The operator must be instructed that he/she has the responsibility and authority to shut down the machine in case of a malfunction or other unsafe condition of either the machine or the job site.

NOTE: *The Manufacturer or Distributor will provide qualified people for training assistance with the first unit(s) delivered and from that time forward as requested by the user or his/her personnel.*

2.2 PREPARATION, INSPECTION, AND MAINTENANCE

Table 2-1 explains the periodic machine inspections and maintenance recommended by JLG Industries, Inc. Consult local regulations for further requirements for aerial work platforms. The frequency of inspections and maintenance must be increased as necessary when the machine is used in a harsh or hostile environment, if the machine is used with increased frequency, or if the machine is used in a severe manner.

SECTION 2 - USER RESPONSIBILITIES, MACHINE PREPARATION AND INSPECTION

Table 2-1. Inspection and Maintenance Table

TYPE	FREQUENCY	PRIMARY RESPONSIBILITY	SERVICE QUALIFICATION	REFERENCE
Pre-Start Inspection	Before using each day; or whenever there's an Operator change.	User or Operator	User or Operator	Operation and Safety Manual
Pre-Delivery Inspection <i>(see note below)</i>	Before each sale, lease, or rental delivery.	Owner, Dealer, or User	Qualified JLG Mechanic	Service and Maintenance Manual and applicable JLG inspection form
Frequent Inspection	In service for 3 months or 150 hours, whichever comes first; or Out of service for a period of more than 3 months; or Purchased used.	Owner, Dealer, or User	Qualified JLG Mechanic	Service and Maintenance Manual and applicable JLG inspection form
Annual Machine Inspection <i>(see note below)</i>	Annually, no later than 13 months from the date of prior inspection.	Owner, Dealer, or User	Factory Trained Service Technician (Recommended)	Service and Maintenance Manual and applicable JLG inspection form
Preventative Maintenance	At intervals as specified in the Service and Maintenance Manual.	Owner, Dealer, or User	Qualified JLG Mechanic	Service and Maintenance Manual

NOTE: Inspection forms are available from JLG. Use the Service and Maintenance Manual to perform inspections.

NOTICE

JLG INDUSTRIES, INC. RECOGNIZES A FACTORY-TRAINED SERVICE TECHNICIAN AS A PERSON WHO HAS SUCCESSFULLY COMPLETED THE JLG SERVICE TRAINING SCHOOL FOR THE SPECIFIC JLG PRODUCT MODEL.

2.3 PRE-START INSPECTION

The Pre-Start Inspection should include each of the following:

1. **Cleanliness** – Check all surfaces for leakage (oil or battery fluid) or foreign objects. Report this to the proper maintenance personnel.
2. **Structure** – Inspect the machine structure for dents, damage, weld or parent metal cracks or other discrepancies. Report this to the proper maintenance personnel.

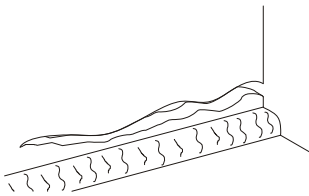

Parent Metal Crack

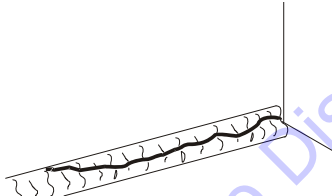

Weld Crack

3. **Decals and Placards** – Check all for cleanliness and legibility. Ensure none of the decals and placards are missing. Ensure all illegible decals and placards are cleaned or replaced. (See Section 6.7, DECAL INSTALLATION)
4. **Operation and Safety Manuals** – Ensure that a copy of the Operation and Safety Manual, AEM Safety Manual (ANSI markets only), and ANSI Manual of Responsibilities (ANSI markets only) is enclosed in the weather resistant storage container.
5. **“Walk-Around” Inspection** – Refer to Figure 2-1. on page 2-8.
6. **Battery** – Charge as required.
7. **Hydraulic Oil Level** – Check the hydraulic oil level in the pump reservoir, add as required. (See Section 6.5)
8. **Accessories/Attachments** – Refer to the Accessories section in this manual or the accessory installed upon the machine for specific inspection, operation, and maintenance instructions.
9. **Function Check** – Once the “Walk-Around” Inspection is complete, perform a functional check of all systems in an area free of overhead and ground level obstructions. Refer to Section 3 for more specific instructions on the operation of each function.

SECTION 2 - USER RESPONSIBILITIES, MACHINE PREPARATION AND INSPECTION

- 10. Platform Gate** – Keep gate and surrounding area clean and unobstructed. Check that gate closes properly and is not bent or damaged. During operation keep gate closed.

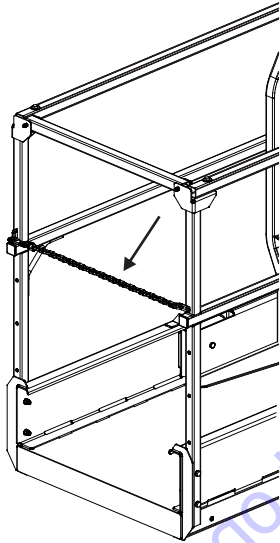

Chain Gate

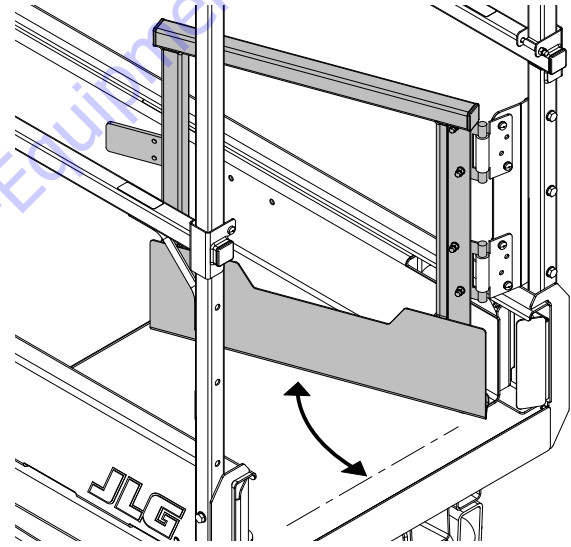

Self-Closing Swing Gate

SECTION 2 - USER RESPONSIBILITIES, MACHINE PREPARATION AND INSPECTION

- Lanyard Anchorage Points** – JLG Industries, Inc. recommends personnel in the platform wear a full body harness with a lanyard attached to an authorized lanyard anchorage point (1).

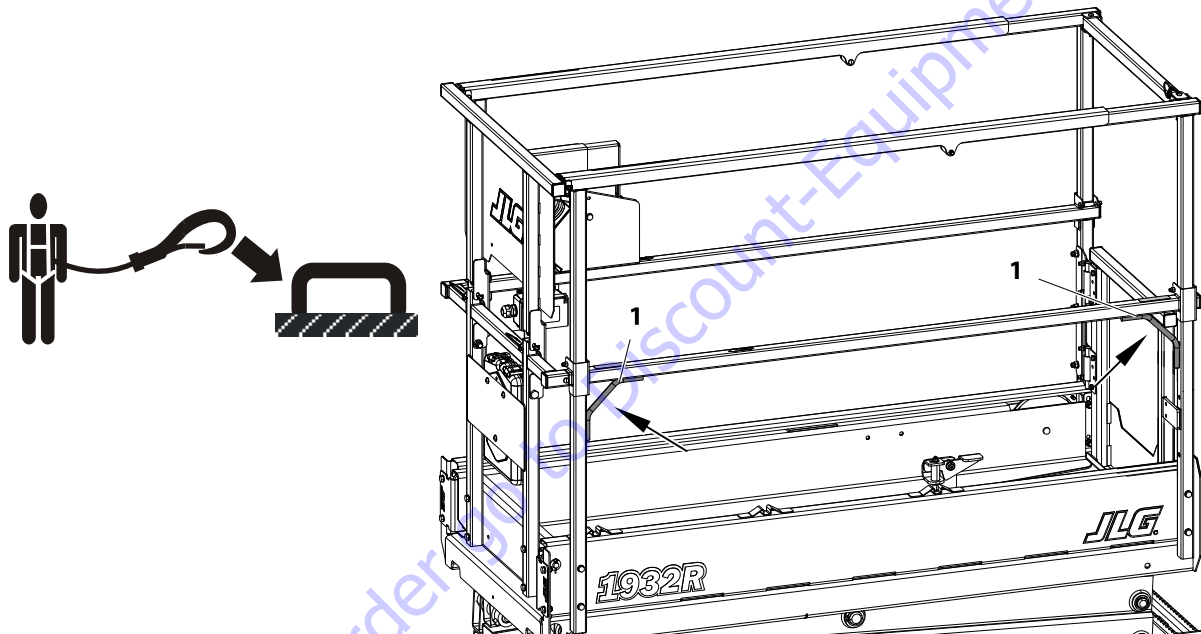

Lanyard Attach Points

2.4 DAILY WALK-AROUND INSPECTION

Begin the “Walk-Around Inspection” at item 1 (refer to Figure 2-1.). Continue checking each item in sequence for the conditions listed in the following checklist.

⚠ WARNING

TO AVOID POSSIBLE INJURY, BE SURE MACHINE POWER IS “OFF”. DO NOT OPERATE UNTIL ALL MALFUNCTIONS HAVE BEEN CORRECTED.

NOTICE

DO NOT OVERLOOK VISUAL INSPECTION OF CHASSIS UNDERSIDE. CHECKING THIS AREA MAY RESULT IN DISCOVERY OF CONDITIONS WHICH COULD CAUSE EXTENSIVE MACHINE DAMAGE.

INSPECTION NOTE: On all components, make sure there are no loose or missing parts, that they are securely fastened, and that no visible damage, leaks or excessive wear exists in addition to any other criteria mentioned.

- 1. Frame/Chassis/Ladder** – See Inspection Note. Ensure that pothole protection (PHP) components on frame are in place, undamaged, not bent or worn. Side compartment doors open and close properly.
- 2. Ground Controls** – Placard secure and legible, control switches return to neutral position, emergency stop switch functions properly. Control markings legible.
- 3. Hydraulic Pump/Motor, Control Valve Installation** – No unsupported wires or hoses; no damaged or broken wires. See Inspection Note.
- 4. Front Wheels, Tires and Drive Motors - Steer linkage, and Steer Cylinder** – See Inspection Note.
- 5. Battery Compartment** – See Inspection Note.
- 6. Rear Wheels, Tires and Hydraulic Brake** – Wheel nut properly secured. Refer to “Tire Wear and Damage” on page 6-16. Inspect wheels for damage and corrosion, check hydraulic brake hoses for damage or leakage. See Inspection Note.
- 7. Manual Descent Control** – See Inspection Note.
- 8. Beacon(s) (If Equipped)** – See Inspection Note.
- 9. Scissor Arms, Pivot Pins and Sliding Wear Pads, Lift Cylinder** – See Inspection Note.
- 10. Platform/Handrail/Gate/Chain Installation** – Deck extension slides in and out and locks in place properly. Gate closes properly. All fold-down rail pins (if equipped) in place and secure. See Inspection Note.
- 11. Platform Control Console** - Ensure that the control console is firmly secured in the proper location. Placards secure and legible, control lever and switches return to neutral, and emergency stop switch function properly, required manuals in storage box.

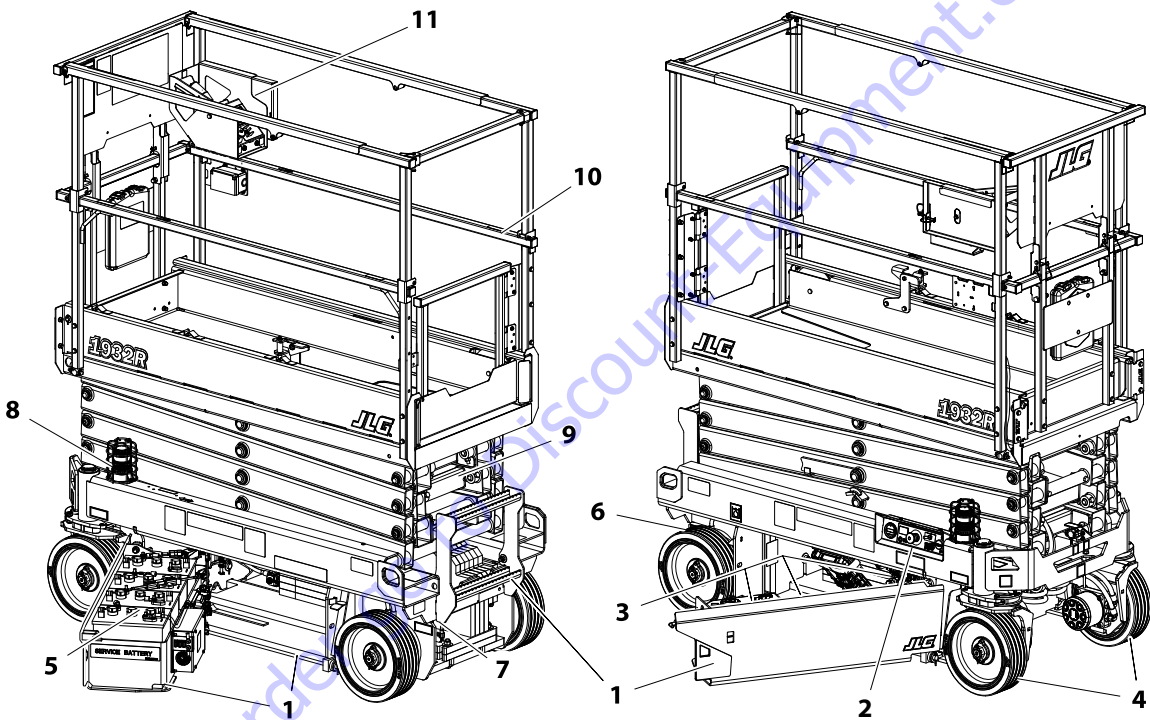
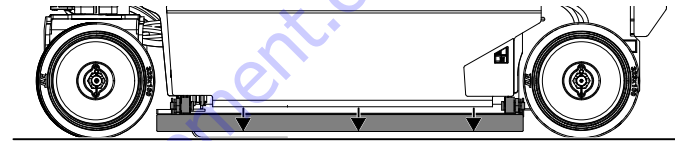

Figure 2-1. Daily Walk-Around Inspection

2.5 FUNCTION CHECK

Perform the Function Check as follows:

1. From the **Ground Control Panel** with no load in the platform: (See Figure 3-2. on page 3-5)
 - a. Ensure that the key selector switch and the platform lift switch operates properly.
 - b. Ensure that all machine functions are disabled when the Emergency Stop Button is depressed.
 - c. With platform raised a few feet (1 m), ensure that the manual descent control (T-handle located at the left rear of the machine, next to the battery charger) lowers the platform properly.
 - d. Check that pot-hole-protection system bars are fully lowered when the platform is raised.



Platform Elevated - Pot-Hole Bars Fully Lowered

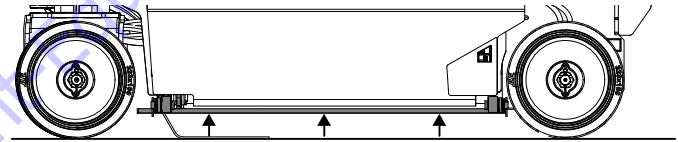

Platform Fully Lowered - Pot-Hole Bars Raised

Pot-Hole-Protection System - Operation

2. From the **Platform Control Console**:
 - a. Ensure that the control console is firmly secured in the proper location.
 - b. Ensure that all guards protecting switches are in place.
 - c. Operate all switch functions, drive/lift mode select switch, and horn button.
 - d. Operate all platform joystick functions to ensure proper operation of drive, lift, steer, and enable trigger switch operation.

SECTION 2 - USER RESPONSIBILITIES, MACHINE PREPARATION AND INSPECTION

- e. Ensure that all machine functions are disabled when the platform Emergency Stop Button is depressed.
- f. With the platform elevated on a smooth, firm, level surface with no overhead obstructions, drive the machine to check if the high drive cutback speed-limit is engaged at the height indicated in Table 2-2. Ensure drive speed is reduced from a top speed to a slower speed.

Table 2-2. High Drive Cutout Height

MODEL	HIGH DRIVE SPEED CUTOUT HEIGHT	DRIVE SPEED REDUCTION
1532R	58 in. (1.5 m)	2.0 mph (3.2 kph)
1932R	67 in. (1.7 m)	to 0.5 mph (0.8 kph)

3. With the platform in the transport (stowed) position.
 - a. Drive the machine on a grade, not to exceed the rated gradeability, and stop to ensure the drive motor brakes hold.
 - b. Check the tilt indicator light to ensure proper operation. The light should be illuminated if tilted beyond allowed settings in Table 2-3.

NOTE: When the tilt indicator warning is activated the following functions are affected; drive and lift up functions are disabled, platform must be fully lowered (stowed) to drive

Table 2-3. Tilt Activation Setting

MODEL	TILT SETTING (front to back)	TILT SETTING (side to side)	Maximum Deck Elevation	
1532R (ANSI/JPN/ CSA)	4°	2.25°	4 - 4.6m (Full)	13 - 15ft.
		2.75°	3.4-4 m	11 - 13ft.
		3.25°	0-3.4 m	0 - 11ft.
1532R (CE/CHN/ AUS)	3.75°	1.50° - outdoor 1.75° - indoor	4 - 4.6m (Full)	13 - 15ft.
		2.00° - outdoor 2.25° - indoor	3.4-4 m	11 - 13ft.
		3.00° - outdoor 3.00° - indoor	0-3.4 m	0 - 11ft.
1932R (ANSI/JPN/ CSA)	3.25°	1.50°	5.2-5.8m (Full)	17 - 19ft.
		2.00°	4.6-5.2m	15 - 17ft.
		2.75°	0-4.6 m	0 - 15ft.
1932R (CE/CHN/ AUS)	3.75°	1.50° - outdoor 1.75° - indoor	5.2-5.8m (Full)	17 - 19ft.
		2.00° - outdoor 2.25° - indoor	4.6-5.2m	15 - 17ft.
		3.00° - outdoor 3.00° - indoor	0-4.6 m	0 - 15ft.

SECTION 3. MACHINE CONTROLS, INDICATORS AND OPERATION

3.1 GENERAL

NOTICE

THE MANUFACTURER HAS NO DIRECT CONTROL OVER MACHINE APPLICATION AND OPERATION, THE USER AND OPERATOR ARE RESPONSIBLE FOR CONFORMING WITH GOOD SAFETY PRACTICES.

This section provides the necessary information needed to understand controls and their functions.

⚠ WARNING

DO NOT RAISE PLATFORM EXCEPT ON A SMOOTH, FIRM AND LEVEL SURFACE FREE OF OBSTRUCTIONS AND HOLES.

TO AVOID SERIOUS INJURY, DO NOT OPERATE MACHINE IF ANY CONTROL LEVERS OR TOGGLE SWITCHES CONTROLLING PLATFORM MOVEMENT DO NOT RETURN TO THE OFF OR NEUTRAL POSITION WHEN RELEASED.

IF THE PLATFORM DOES NOT STOP WHEN A CONTROL SWITCH OR LEVER IS RELEASED, USE THE EMERGENCY STOP SWITCH TO STOP THE MACHINE.

3.2 DESCRIPTION

This machine is a self-propelled aerial work platform on top of an elevating scissor arm mechanism. The Lift's intended purpose is to position personnel with their tools and supplies at positions above ground level. The machine can be used to reach work areas located above machinery or equipment positioned at ground level.

This JLG Lift has a primary operator control station in the platform. From this control station, the operator can drive and steer the machine in both forward and reverse directions, raise and lower the platform.

The machine can be driven on a smooth, firm, and level surface from an elevated platform position - Reference "Steering And Traveling" on page 3-13. of this manual for specific requirements.

The machine also has a ground control station which can override the platform control station. Ground controls operate lift up and down. Ground controls are to be used only in an emergency to lower the platform to the ground should the operator in the platform be unable to do so.

3.3 OPERATING CHARACTERISTICS AND LIMITATIONS

General

A thorough knowledge of the operating characteristics and limitations of the machine is always the first requirement for any user, regardless of user's experience with similar types of equipment.

Placards

Important points to remember during operation are provided at the control stations by DANGER, WARNING, CAUTION, NOTICE, and INSTRUCTION placards. This information is placed at various locations for the express purpose of alerting personnel of potential hazards constituted by the operating characteristics and limitations of the machine. See foreword for definitions of placard safety signal words.

3.4 PLATFORM LOADING

The platform maximum rated load capacity is shown on a placard located on the platform billboard and ground control station and is based upon the machine positioned on a smooth, firm, and level surface. Refer to Section 5, Table 6-2 on page 6-4, for the maximum platform capacity.

The platform is entered through an entry gate at the rear of the platform. Keep entry gate closed during machine operation.

NOTE: *It is important to remember that the load should be evenly distributed on the platform. The load should be placed near the center of the platform when possible.*

3.5 MACHINE CONTROL LOCATIONS

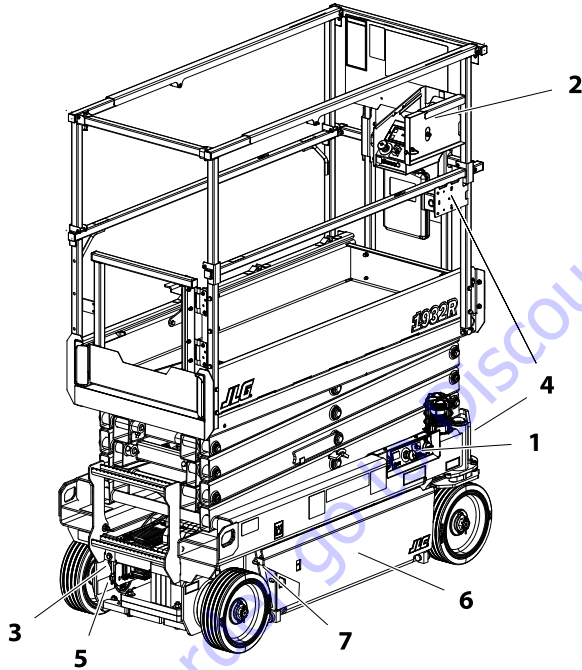

1. Ground Control Station
2. Platform Control Station
3. Platform Manual Descent Control (T-Handle)
4. AC Plug - At Front of Machine - For Platform AC Receptacle Outlet Box
5. AC Plug - Battery Charger Input
6. Side Compartment Doors (Both Sides)
7. Side Compartment Door Latch Location (Both Sides)

Figure 3-1. Location of Machine Controls

3.6 BATTERY CHARGING

NOTE: *Be sure that machine is parked in a well ventilated area before charging begins.*

⚠ CAUTION

ONLY PLUG THE CHARGER INTO A PROPERLY INSTALLED AND GROUNDED OUTLET. DO NOT USE GROUND ADAPTORS OR MODIFY PLUG. DO NOT TOUCH NON-INSULATED PORTION OF OUTPUT CONNECTOR OR NON-INSULATED BATTERY TERMINAL.

DO NOT OPERATE CHARGER IF THE AC SUPPLY CORD IS DAMAGED OR IF THE CHARGER HAS RECEIVED A SHARP BLOW, BEEN DROPPED, OR OTHERWISE DAMAGED IN ANY WAY.

ALWAYS DISCONNECT THE CHARGER AC SUPPLY BEFORE MAKING OR BREAKING THE (POS/NEG) CONNECTIONS TO THE BATTERY.

DO NOT OPEN OR DISASSEMBLE CHARGER.

1. The battery charger AC input plug is located inside the frame at the left rear of the machine next to the battery charger.
See charger specific information in Section 5 starting on page 6-13.
2. Connect the charger AC input plug to a grounded outlet using a 3 wire heavy duty extension cord.
(See Table 6-6, "Battery Charger Specifications," on page 6-6, for battery charger AC input specifications.)

3. After connecting the charger to an AC outlet at the start of the charging cycle, check the LED indicators on the charger for normal operation or if a fault has occurred.
See LED indicator status of each charger in Section 5, starting on page 6-13.
4. Current battery charge state can also be seen on the platform control station panel LEDs, or the MDI indicator (if equipped) on the ground control station, when machine is powered up.
5. The batteries are fully charged when all three GREEN LED indicators on the platform control station or MDI battery charger status panel are illuminated.
(See "MDI Indicator (If Equipped)" on page 3-7 for MDI indicator information.

NOTE: *If the charger is left plugged in, the charger will automatically restart a complete charge cycle if the batteries voltage drops below a minimum voltage or 30 days has elapsed.*

3.7 GROUND CONTROL STATION

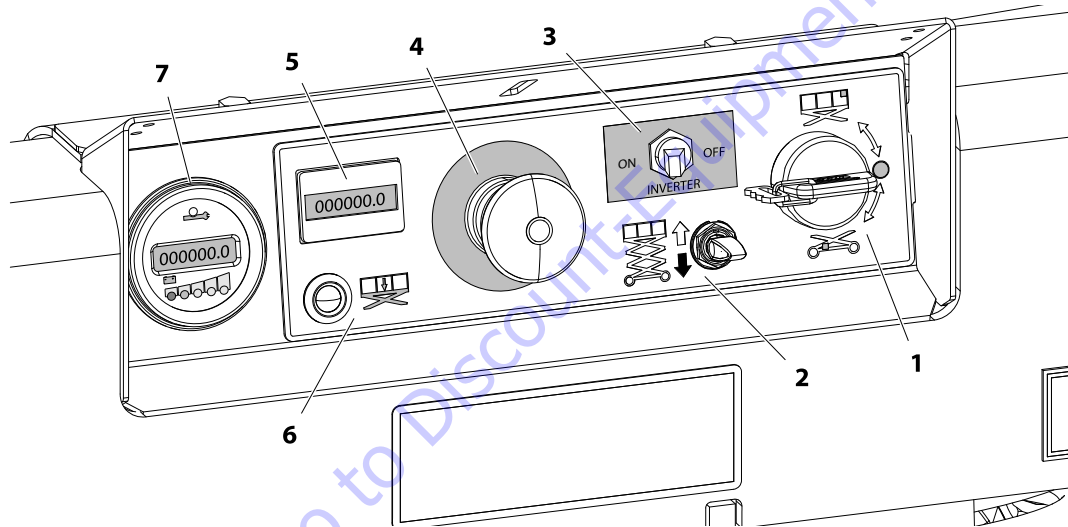

Figure 3-2. Ground Control Station

- | | |
|--|---|
| 1. Ground/Platform/OFF Key Selector Switch | 5. Hourmeter |
| 2. Platform Lift/Lower Switch | 6. Overload Indicator (If LSS Equipped) |
| 3. Inverter ON/OFF Switch (If Equipped) | 7. MDI - Indicator (If Equipped) |
| 4. Ground Emergency Stop Button | |

⚠ WARNING

DO NOT OPERATE FROM GROUND CONTROL STATION WITH PERSONNEL IN THE PLATFORM EXCEPT IN AN EMERGENCY. PERFORM AS MANY PRE-OPERATIONAL CHECKS AND INSPECTIONS FROM THE GROUND CONTROL STATION AS POSSIBLE.

Ground/Platform/OFF Key Selector Switch

(Item 1 - Figure 3-2.)

The key selector switch on the Ground Control Station functions to direct electrical power to the desired control station. With the switch turned to the **ground position (1)**, power is supplied to the controls at the ground control station. When the switch is turned to the **platform position (2)**, power is supplied to the controls at the platform control station. The switch should be set to the **OFF position (3)** when not using machine or parking the machine overnight.

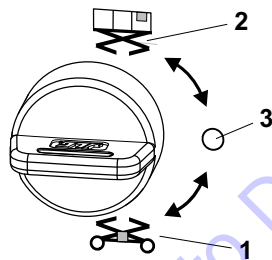

Platform Lift/Lower Switch

(Item 2 - Figure 3-2.)

A three position, momentary contact lift control switch provides raising and lowering of the platform from the Ground Control Station.

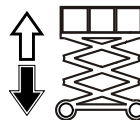

When operating platform from the ground controls -

Toggle the lift/lower switch to up position and hold to raise platform, or down position and hold to lower an elevated platform. Release to center position to stop all movement.

Inverter ON/OFF Switch (If Equipped)

(Item 3 - Figure 3-2.)

When switched on the inverter converts the DC voltage stored in the on-board batteries to AC voltage for use at the AC receptacle outlet mounted on the platform rail.

Ground Emergency Stop Switch

(Item 4 - Figure 3-2.)

Power is turned on by pulling the switch out, and is turned off by depressing switch. A two-position, red, mushroom-shaped emergency stop switch, when positioned to ON with the key selector switch positioned to ground, furnishes operating power to the ground control station



key switch. In addition, the switch can be used to turn off power to the function controls in the event of an emergency.

Hourmeter

(Item 5 - Figure 3-2.)

The machine is equipped with an hour meter to indicate the number of hours the machine has been operated.

000000
HOURS

Overload Indicator (If LSS Equipped)

(Item 6 - Figure 3-2.)

Overload Indicator - Indicates the platform has been overloaded. An audible alarm will also signal when the platform is overloaded.

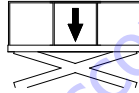

NOTE: If the Overload Indicator is illuminated;

CE: All functions will be prevented from the platform and ground controls. Lower platform using the machine manual descent control.

ANSI Export/Australia/Japan: All platform functions will be prevented. Fully lower the platform from the ground controls or using the machine manual descent control. Reduce the weight in the platform to not exceed the rated workload indicated on the capacity decal.

MDI Indicator (If Equipped)

(Item 7 - Figure 3-2.)

The MDI indicator or Multifunction Digital Indicator displays a Battery Discharge Indicator (BDI), an LCD display which shows the current hour-meter reading or Diagnostic Trouble Code(s) (DTC) when a functional problem occurs with the machine, and a system distress LED.

When a problem occurs (DTC Code displayed):

- A **wrench icon (item 1)** LED will illuminate. (See Figure 3-3.)
- A three to five digit DTC code will display on the **Diagnostic Trouble Code LCD display (item 2)**, below the wrench icon.

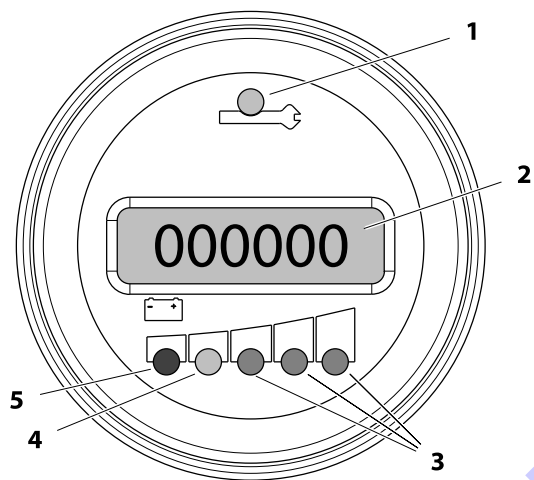

Figure 3-3. MDI Indicator

- | | |
|---|---|
| 1. System Fault LED Indicator (RED LED) | 4. Battery Charge LOW Indicator (YELLOW AREA) |
| 2. Hour-meter/DTC Code Display | 5. Battery Re-Charge Indicator (RED AREA) |
| 3. 100% Battery Charge Indicator (GREEN AREA) | |

NOTE: When more than one DTC exists, each DTC will be displayed on the LCD for 3 seconds before changing to the next DTC. Once the last active DTC is displayed, the display will recycle indefinitely until the DTC's are corrected. For DTC's and descriptions, refer to Section 6.8.

Also located on the MDI are **Battery Discharge Indicators (BDI) (items 3, 4 and 5)**. The (3) GREEN LEDs indicate the level of charge (voltage) remaining in the batteries.

NOTE: When the battery voltage is low and will need a charge soon, the **YELLOW LED (item 4)** begin to flash.

Under normal operating conditions the BDI's and hour-meter will be displayed. When a DTC exists (other than 00x DTC's) the BDI LEDs and hour-meter will not be displayed. Also when platform is elevated and the machine is being driven the creep mode (turtle) is displayed.

3.8 PLATFORM MANUAL DESCENT CONTROL

The platform manual descent control is used in the event of total power failure to lower the platform using gravity. The manual descent control T-handle is located on the left rear of the machine, just below the platform ladder. Look for the instruction decal located beside the release handle.

The lowering procedure is as follows:

1. Locate the **manual descent control T-handle**.
(See Figure 3-4.)

⚠ WARNING

KEEP HANDS AND ARMS OUT OF THE PATH OF THE SCISSOR ARMS AND PLATFORM WHILE LOWERING.

2. Grasp the T-handle and slowly pull out to lower the scissor arms/platform, when the platform is lowered to desired level, allow the T-handle to return to its closed position.

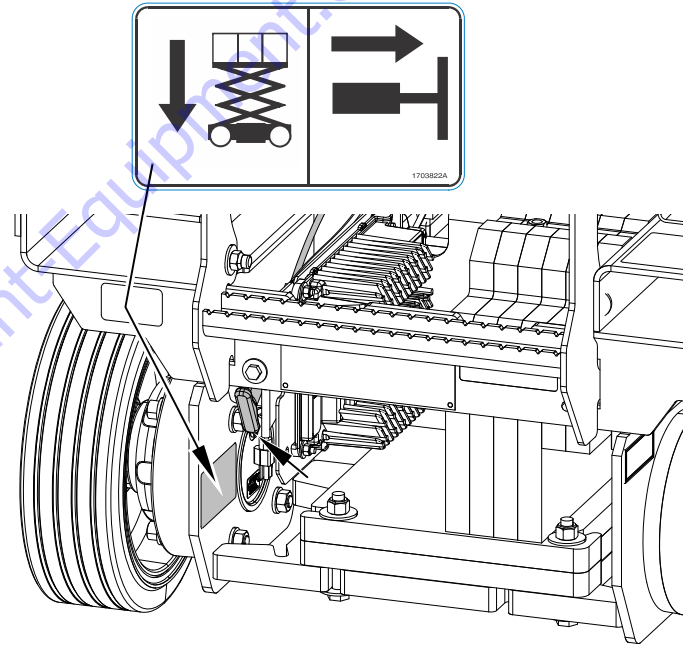
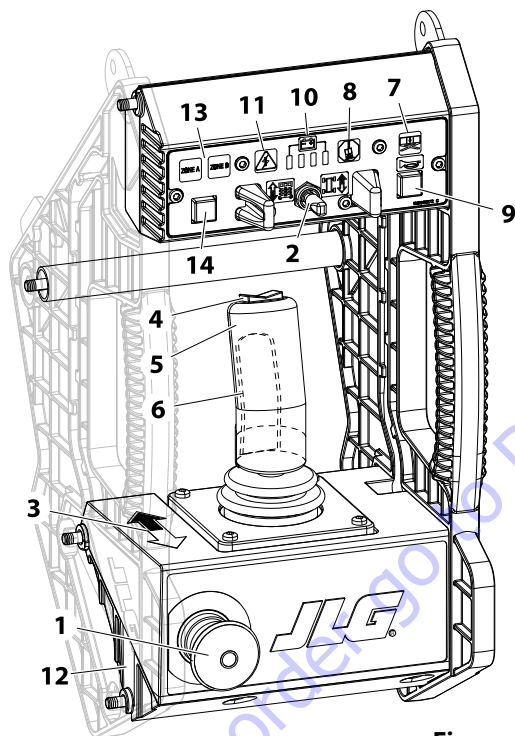

Figure 3-4. Location of Manual Descent Control
(Left Rear of Machine)

3.9 PLATFORM CONTROL STATION



NOTE: 1932R machines are equipped with a platform control station shown in either Figure 3-5. or Figure 3-6.

1. Emergency Stop Switch
2. Lift/Drive Select Switch
3. Black/White Directional Arrow
4. Steer Switch
5. Controller
6. Trigger Switch (*on front of controller*)
7. Overload Indicator (*LSS - if equipped*)
8. Tilt Indicator
9. Horn Button
10. Battery Discharge Indicator
11. System Fault Indicator
12. Alarm (*not shown, located on bottom of box*)
13. Indoor-Zone A (CE)/Outdoor-Zone B (CE) Indicators
14. Indoor-Zone A/Outdoor-Zone B - Select Switch (CE)

Figure 3-5. Platform Control Station

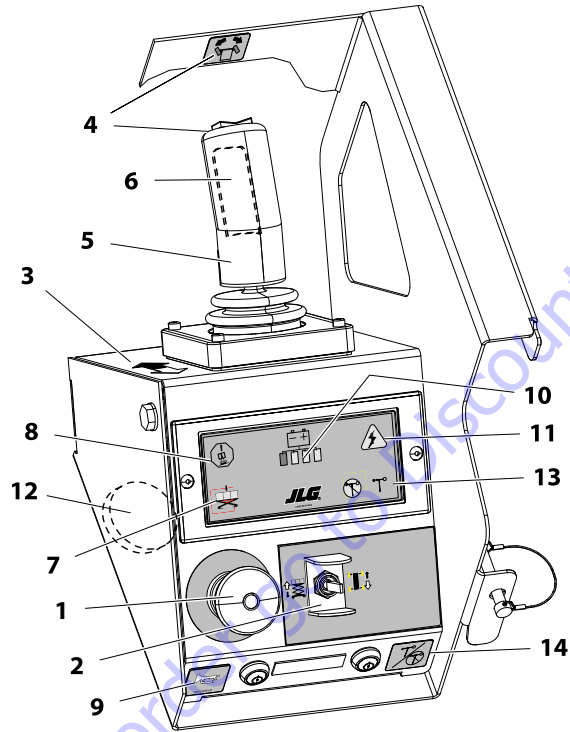

1. Emergency Stop Switch
2. Lift/Drive Select Switch
3. Black/White Directional Arrow
4. Steer Control Switch and Direction Decal
5. Controller
6. Trigger (Enable) Switch
7. Overload Indicator (*LSS - if equipped*)
8. Tilt Indicator
9. Horn Button
10. Battery Discharge Indicator
11. System Fault Indicator
12. Alarm
13. Indoor/Outdoor Operation Indicator (CE/AUS ONLY)
14. Indoor/Outdoor Operation Mode Switch (CE/AUS ONLY)

Figure 3-6. Platform Control Station

SECTION 3 - MACHINE CONTROLS, INDICATORS AND OPERATION

NOTE: (Reference either Figure 3-5. or Figure 3-6.)

Platform Emergency Stop Switch

(Item 1)

NOTE: Both the ground and platform emergency stop buttons must be set to ON in order to operate the machine.

When power is directed to the platform from the ground control station, the platform emergency stop switch is turned on by pulling the switch out (on), and is turned off by pushing the switch in (off). The two-position, red, mushroom-shaped emergency stop switch functions to provide power to the platform control station and also to turn off power to machine functions in the event of an emergency.

Lift/Drive Select

(Item 2)

NOTE: When selecting between the Lift and Drive functions the joystick control must be returned to the neutral position for approximately 1/2 second before the function change is operable.

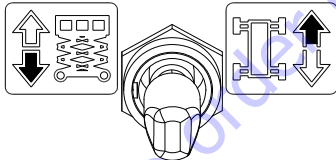

This toggle switch is used to select operation of either the drive or lift function. After selecting a function, the joystick controller must be moved in the proper direction in order to activate that function. Only change the function selected, with the joystick in the neutral position. Otherwise, the function selected will not change until the joystick is returned to the neutral position.

Forward/Reverse/Lift/Lower Direction Decal

(Item 3)

This decal indicates the proper direction to mount the platform control box, the black arrow must point to the front of the machine. The black/white arrow also indicates the direction to move the joystick control per the lift/drive selector switch decal for the lift and drive select functions.

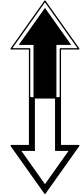

Drive/Lift/Steer Joystick Control

(Items 4, 5, and 6)

Trigger (Enable) Switch - This switch is located on the front of the joystick controller. The trigger switch acts as an enable and must be depressed before operating the drive, steer and lift functions. When released, the function being operated will stop.

NOTE: *Once the trigger switch is pressed, the operator has five seconds to begin operating a function. After five seconds, release the trigger switch and press it again to operate a joystick function.*

The speed on all selected functions is proportionally controlled by the distance from the neutral (center) position of the joystick controller.

NOTE: *If the machine is also equipped with a footswitch (Japanese or Korean Specification only), the footswitch must be depressed in conjunction with the trigger (enable) switch located on the controller. Power is removed from the platform controls when the footswitch is released.*

Steer Switch - The steer switch is a thumb operated switch located at the top of the control handle. Depressing the switch to the right will steer the wheels to the right. Depressing the switch to the left will steer the wheels to the left.

Joystick Controller - The control handle controls two functions: drive and lift.

Steering And Traveling

WARNING

DO NOT DRIVE WITH PLATFORM RAISED EXCEPT ON A SMOOTH, FIRM AND LEVEL SURFACE FREE OF OBSTRUCTIONS AND HOLES.

TO AVOID LOSS OF TRAVEL CONTROL OR UPSET ON GRADES AND SIDESLOPES, DO NOT DRIVE MACHINE ON GRADES OR SIDESLOPES EXCEEDING THOSE SPECIFIED IN TABLE 6-1 ON PAGE 6-2.

BEFORE DRIVING, LOCATE THE DECALS WITH THE BLACK/WHITE ORIENTATION ARROWS ON THE CHASSIS AND THE PLATFORM CONTROLS. MOVE THE JOYSTICK IN THE DIRECTION OF THE BLACK OR WHITE ARROW THAT MATCHES THE COLOR OF THE ARROW ON THE CHASSIS FOR THE INTENDED DIRECTION OF TRAVEL.

IF THE TILT INDICATOR WARNING LIGHT/ALARM IS ACTIVATED WHILE DRIVING WITH PLATFORM RAISED, LOWER PLATFORM COMPLETELY AND DRIVE TO A FIRM LEVEL SURFACE.

1. Place key selector switch at the ground control station to platform operation.
2. Position emergency stop switches, one at the platform and one at the ground control station to the ON position.

Steering

(Item 4)

On the platform control station, position the lift/drive select switch to the drive position.

To steer the machine, engage trigger switch and the thumb operated steer rocker-switch on the joystick handle. Press to the right for steering right, or to the left for steering left. When released, the switch will return to the center-off position and the wheels will remain in the previously selected position. To return the wheels to the center position, the switch must be activated in the opposite direction until the wheels are centered.

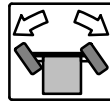

Traveling Forward and Reverse

(Item 5 and 3)

Position the platform lift/drive select switch to drive/steer position. Squeeze the trigger switch on front of the joystick, and move the joystick forward to drive forward or backward to drive in reverse. The drive system is proportional, for additional drive speed push the joystick further from the neutral position in the direction of travel. Releasing the trigger switch or returning the joystick to center will stop machine movement.

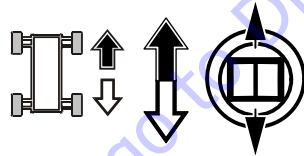

Raising And Lowering Platform

1. If the machine was shut down, place the key selector switch to the platform position.
2. Position emergency stop switches, one at the platform and one at the ground control station to the ON position.
3. Position the lift/drive select switch to lift.
(Item 2)
4. Squeeze and hold the trigger switch, and move the joystick back (platform up - white arrow direction) or move the joystick forward (platform down - black arrow direction) and hold until desired elevation is reached. Releasing the trigger switch or moving the joystick back to its center position will stop the function being operated.

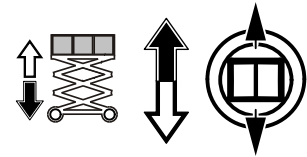

NOTE: To ensure proper operation of the desired platform function, move the joystick in the direction of the black or white arrow that matches the color of the arrow on the chassis for the intended direction of travel.

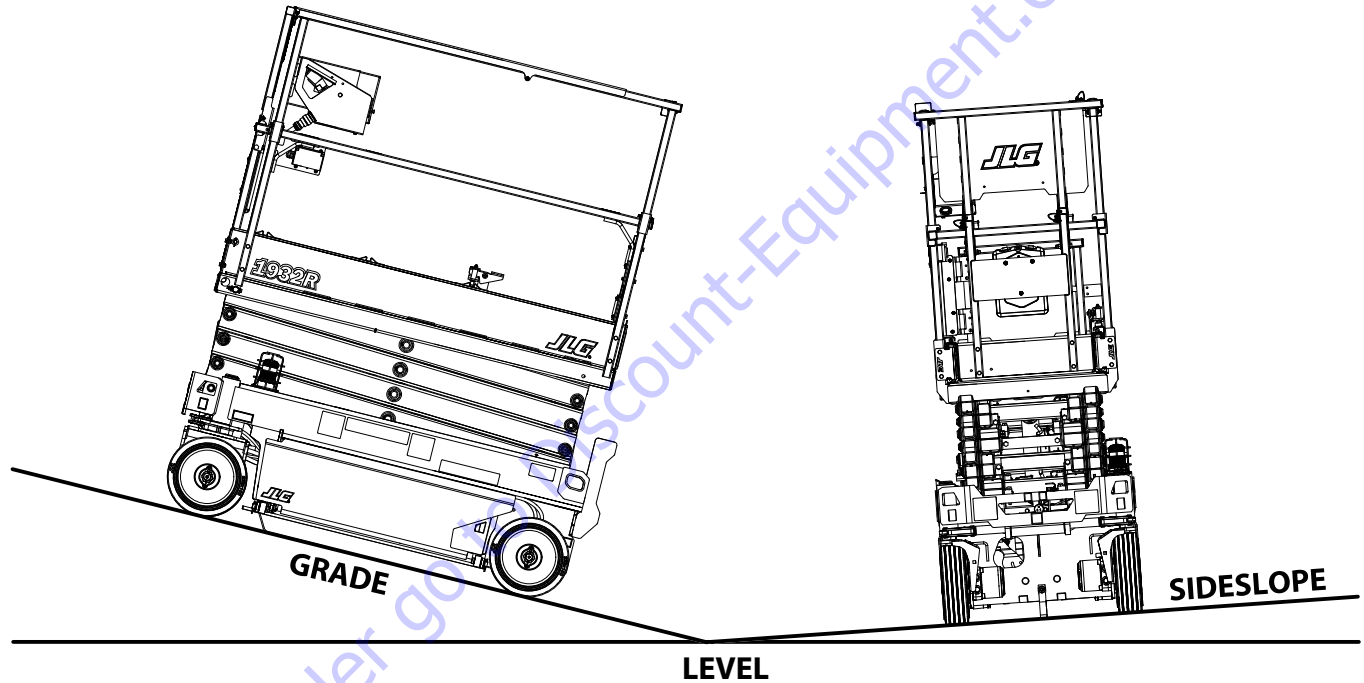

Figure 3-7. Grade and Sideslope Definition

Arm Guards (If Equipped)

If the machine is equipped with electronic arm guards, the platform will stop lowering at a predetermined height and the machine's beacons will flash at a different rate to warn ground personnel, machine lowering can continue after a three (3) second delay. Once the lowering function is re-engaged an audible alarm will sound. After a one and a half (1.5) second delay the platform will continue lowering.

Overload Indicator (LSS) (If Equipped)

(Item 7)

Indicates the platform has been overloaded. An audible alarm will also signal when the platform is overloaded.

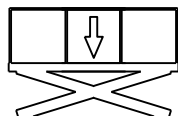

NOTE: If the Overload Indicator is illuminated:

CE: All functions will be prevented from the platform and ground controls. Lower platform using the machine manual descent control.

ANSI Export/Australia/Japan: All platform functions will be prevented. Fully lower the platform from the ground controls or using the machine manual descent control. Reduce the weight in the platform to not exceed the rated workload indicated on the capacity decal.

Tilt Indicator Warning Light and Alarm

(Item 8)

A red warning light on the control panel illuminates and an audible alarm sounds when the chassis is at or beyond the tilt cutout settings.

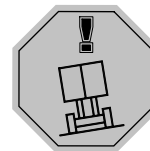

! WARNING

IF THE TILT INDICATOR WARNING LIGHT/ALARM IS ACTIVATED WHEN PLATFORM IS RAISED LOWER PLATFORM AND DRIVE TO A SMOOTH FIRM LEVEL SURFACE.

Horn

(Item 9)

This push-button switch, when pressed, permits the operator to warn job site personnel when the machine is operating in the area.

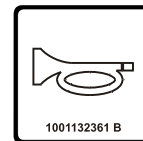

Battery Charge Indicator

(Item 10)

The battery charge indicator displays the current charge status of the onboard batteries. RED LED flashing = batteries depleted, RED LED ON solid = batteries low, RED LED ON and GREEN LEDs ON = batteries FULL charge.

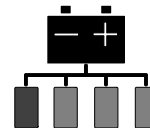

System Fault Indicator

(Item 11)

When this indicator light **is flashing a system fault has occurred**, possibly stopping machine operation. Check the MDI indicator (if equipped) on the Ground Control Station to see if a (DTC) Diagnostic Trouble Code(s) is displayed. An explanation of DTC codes is shown in Section 6.8.

If the code cannot be cleared by the operator, the machine will require service by a qualified JLG mechanic.



Alarm

(Item 12)

This alarm mounted on the front of the platform control station will sound for various machine conditions or warnings such as, system ready chirp or if the machine tilt warning is activated.

Indoor-Zone A/Outdoor-Zone B Operation Indicator

CE/AUS ONLY (Item 13 - Figure 3-5.)

The Indoor/Zone A (GREEN) indicator and the Outdoor/Zone B (YELLOW) indicator, displays which mode the machine is currently set to operate in.

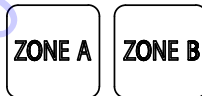

Indoor-Zone A/Outdoor-Zone B Operation Mode Switch

CE/AUS ONLY (Item 14 - Figure 3-5.)

This button will toggle between the outdoor/indoor operation modes. Outdoor mode (Zone B) will restrict platform operations if operating machine outside rated wind speed specifications.

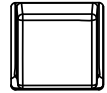

Outdoor/Indoor Operation Indicator

CE/AUS ONLY (Item 13 - Figure 3-6.)

The Indoor (green) indicator and the Outdoor (yellow) indicator displays which mode the machine is currently set to operate in.

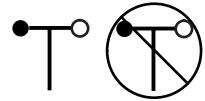

Outdoor/Indoor Operation Mode Switch

CE/AUS ONLY (Item 14 - Figure 3-6.)

This button will toggle between the indoor/outdoor operation modes. Outdoor mode will restrict platform operations if operating machine outside rated wind speed specifications.

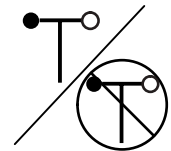

3.10 PLATFORM EXTENSION

(See Figure 3-8.)

This machine is equipped with an extension deck, giving the operator better access to certain work areas. The deck extension adds length to the front of the platform.

⚠ WARNING

FOR MAXIMUM CAPACITY OF THE DECK EXTENSION SEE SECTION 5, TABLE 6-2 OR REFER TO THE CAPACITY PLACARD ON THE PLATFORM BILLBOARD.

⚠ CAUTION

DO NOT "LOWER" WITHOUT COMPLETELY RETRACTING THE PLATFORM EXTENSION.

To extend the deck:

1. Push down on the locking mechanism lever (1) using your foot, while holding down on the lever, slide the top handrails (2) until the locking mechanism pin clears the rear platform extension lock (3).
2. Grasp the top handrails (2) of the extendible deck and push the extension out until it hits the stops and the locking mechanism pin is locked into one of the forward platform extension locks (4) or (5).

To retract the deck:

1. Push down on the locking mechanism lever (1) using your foot, hold down on the lever and slide the top handrails (2) rearward until the locking mechanism pin clears the forward platform extension locks (4) and (5).
2. Grasp the top handrails (2) of the extendible deck and pull the extension back until it hits the stops and the locking mechanism pin is locked into the rear platform extension lock (3).

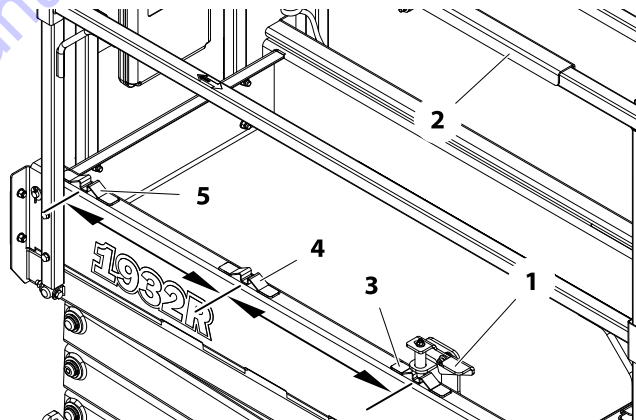

Figure 3-8. Platform Deck Extension

3.11 PARKING AND STOWING MACHINE

1. Drive the machine to a well-protected and well-ventilated area.
2. Ensure the platform is fully lowered.

NOTICE

WHEN THE MACHINE IS SHUT DOWN FOR OVERNIGHT PARKING OR BATTERY CHARGING, THE EMERGENCY STOP AND POWER SELECT SWITCHES MUST BE POSITIONED TO OFF TO PREVENT DRAINING THE BATTERIES.

3. At the ground control station, turn the platform - ground selector key switch to OFF and remove the key to disable the machine and prevent unauthorized use.

NOTE: For added protection, the platform control station can be secured to its mounting plate see Figure 3-9. Also the side compartment doors can be secured by placing a padlock through the holes provided just below the door latch on each door.

4. At the ground control station, depress emergency stop switch to the off position.
5. If necessary, cover the platform control box, instruction placards, caution and warning decals so that they will be protected from hostile environment.

6. Chock at least two wheels when parking the machine for an extended period of time.

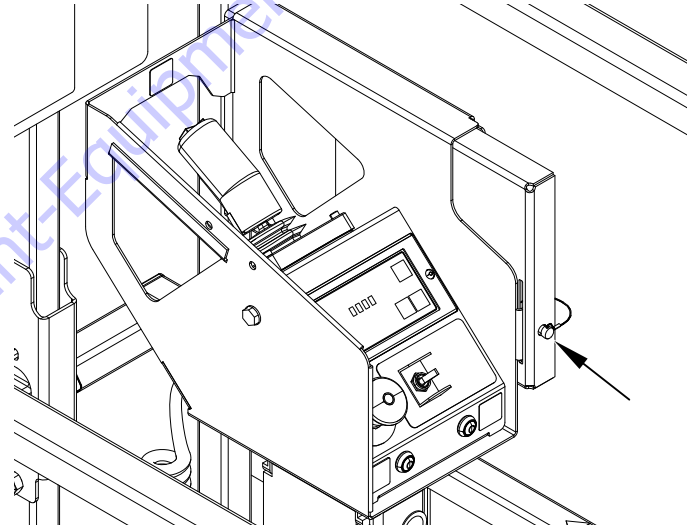

To prevent unauthorized removal, the platform control station can be secured to its mount by replacing the lock pin located on its mounting tab with a keyed or combination lock.

Figure 3-9. Securing Control Station to Platform

3.12 PLATFORM RAILS FOLD-DOWN PROCEDURE (IF EQUIPPED)

⚠ WARNING

DO NOT RAISE PLATFORM WITH RAILS FOLDED DOWN. THE RAILS MUST BE IN THE UPRIGHT POSITION AND PROPERLY PINNED WHEN RAISING THE PLATFORM.

NOTE: *The rails must only be folded down when the machine is in the stowed (platform fully lowered) position.*

The platform rails fold down from the mid-rail only, except for the rear gate rail.

Platform with Rail-in-Rail Extension Deck

The platform rails fold down in the following sequence (refer to Figure 3-10.):

1. Pull pin and fold REAR gate top rail in against RIGHT side rail. Remove the platform control station and place on the floor of the platform.

NOTE: *Front deck extension top rail pins must be removed and deck extension top side rails slid towards rear of machine before lowering side rails. Place pins in the lower holes of the extension side top rails before folding main platform side rails down.*

2. Fully open the swing gate and hold while folding down the RIGHT side rail.
3. Fold down LEFT side rail.
4. Fold down FRONT platform extension rail.

To raise the rails back to the upright position, unfold the rails in the reverse sequence they were folded. Firmly pull the rails back up into position and replace the bail pins into the rails.

⚠ WARNING

AFTER THE RAILS HAVE BEEN FOLDED DOWN, USE EXTREME CAUTION WHEN EXITING AND ENTERING THE PLATFORM. ENTER AND EXIT PLATFORM ONLY AT THE GATE AREA AND LADDER PROVIDED.

⚠ WARNING

IF OPERATING (DRIVING) MACHINE WITH PLATFORM CONTROL STATION FROM GROUND, WITH RAILS FOLDED, KEEP AT LEAST 3 FT. (1 M) DISTANCE FROM MACHINE.

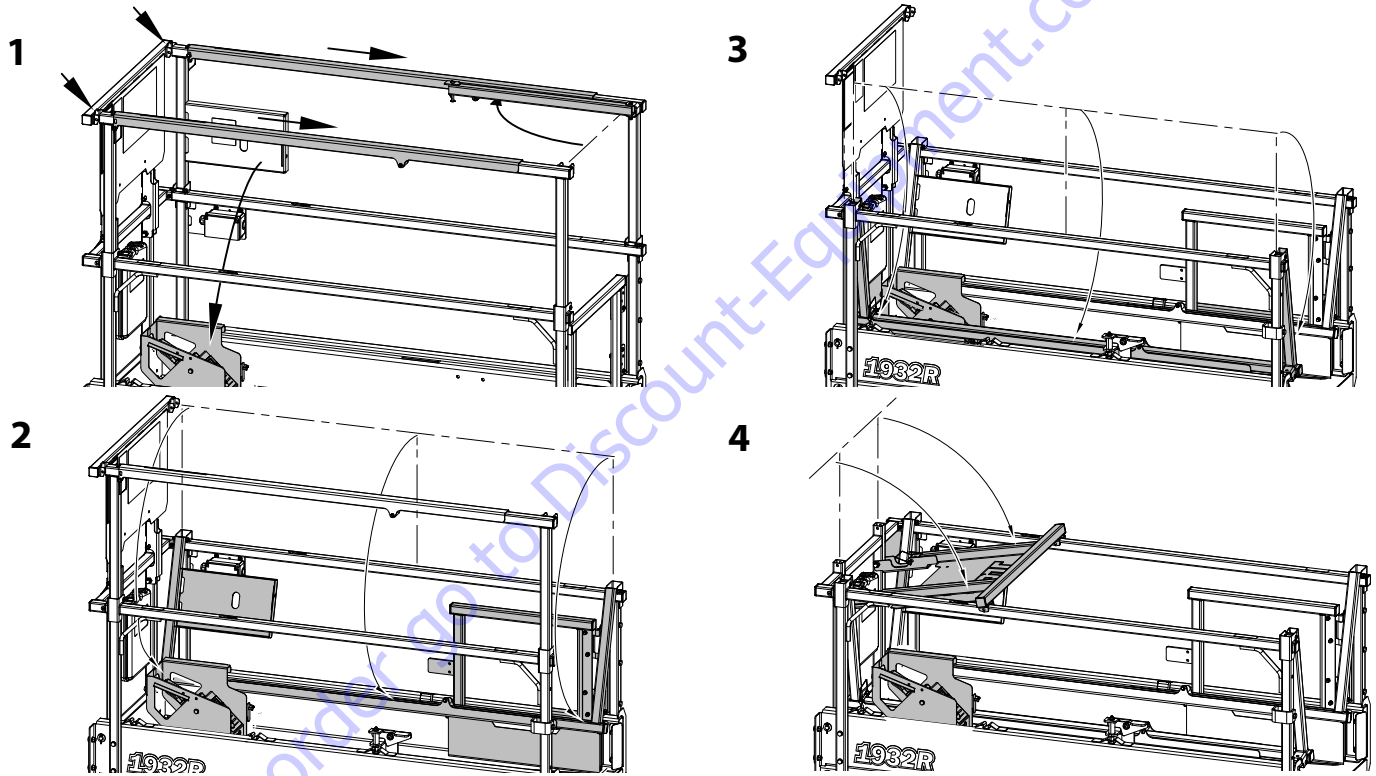

Figure 3-10. Rail-in-Rail Fold-Down Sequence

3.13 MACHINE LIFTING AND TIE DOWN

Lifting

The machine may be lifted using a fork lift truck. Lift only from the rear of the machine and only with the platform in the stowed position. Adjust the width of the **forklift truck, lifting tines (1)** to properly fit the machine forklift pockets, *see Figure 3-11*. Slide the forklift tines into the forklift pockets and carefully lift machine.

The machine can also be lifted using a spreader bar and four equal length straps or chains capable of supporting the full gross weight of the machine, *see Figure 3-12*. Lift only using the lifting lugs provided at the four corners of the machine. (*See Section 6, Machine Specifications for machine gross weight*).

⚠ WARNING

LIFTING THE MACHINE FROM THE SIDES USING A FORK TRUCK IS NOT RECOMMENDED BY JLG. IN THE EVENT THAT THE MACHINE NEEDS TO BE LIFTED FROM THE SIDES CAUTION MUST BE USED TO AVOID JAMMING THE POT HOLE PROTECTION BARS UP AGAINST THE FRAME. EVERY TIME THE MACHINE IS LIFTED FROM THE SIDE, BE SURE AND TEST THE POT HOLE PROTECTION SYSTEM BEFORE THE MACHINE IS PUT BACK INTO OPERATION.

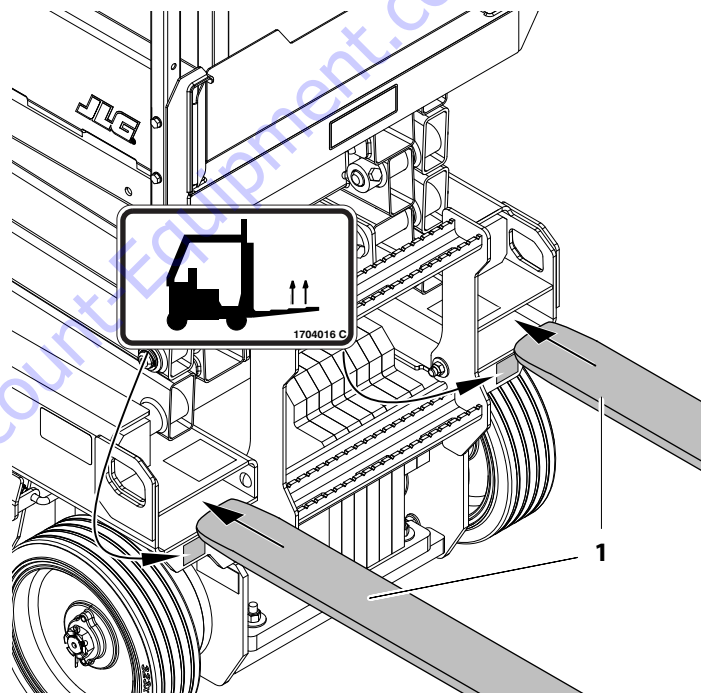
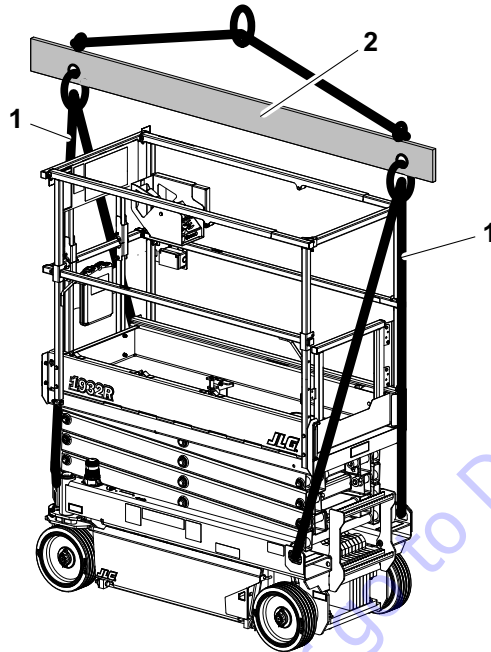

Figure 3-11. Fork Lift Pockets - Location



Tie Down

When transporting the machine, the platform must be fully lowered in the stowed position with the machine securely tied down to the truck or trailer deck. There are two tie-down and one lift lugs located at the front and two tie-down/lift lugs at the rear of the machine. (See Figure 3-13.)

Figure 3-12. Lifting Machine Using Spreader Bar and Lift Lug Locations

- 1. Four equal length chains or lifting straps
- 2. Spreader Bar Assembly

SECTION 3 - MACHINE CONTROLS, INDICATORS AND OPERATION

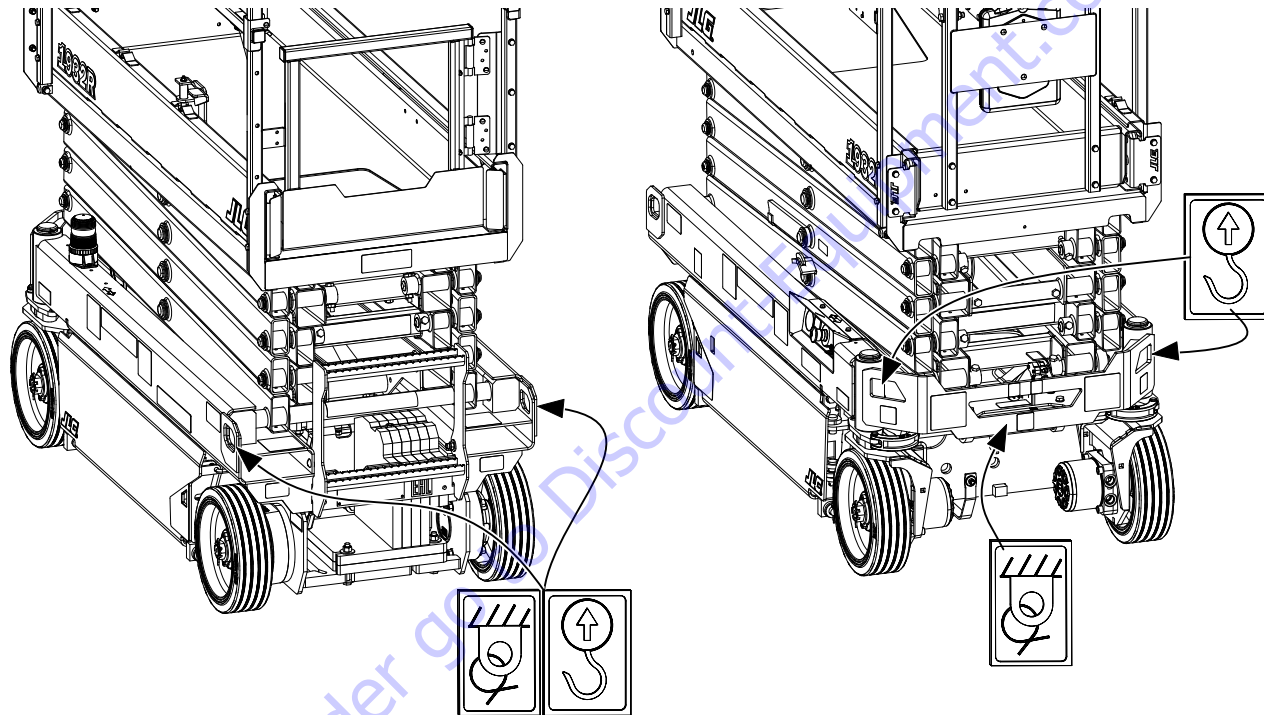

Figure 3-13. Tie Down and Lift Lug Locations

3.14 TOWING

It is not recommended that this machine be towed, except in the event of an emergency such as a machine malfunction or a total machine power failure.

NOTE: *If machine is disabled to a point where the hydraulic system cannot be operated, the steer circuit will also not be operational. Then the machine will only track in the direction the front wheels are currently set.*

Hydraulic Brake Release (See Figure 3-14.)

CAUTION

CHOCK WHEELS OR SECURE MACHINE WITH TOW VEHICLE.

1. At the ground control station turn power off by pressing the Emergency Stop switch in.
2. Open the right side compartment door and locate the main hydraulic control valve.
3. Perform the following to set the drive motor control valve to tow mode. On the drive control valve locate the **tow mode needle valve knob (1)**, screw the valve out till it stops.
4. On the main valve body, to release the brakes, push the **BLACK brake override button (2)** in, (there is a detent which will hold the valve in place).

5. Pump the **RED Knob (3)** until pressure builds, approximately 5 to 10 strokes. The brakes should now be released.
6. After towing is complete, release the **BLACK brake override button (2)** and screw the **tow mode needle valve knob (1)** all the way in to reset the hydraulic brake. Chock the machine wheels.

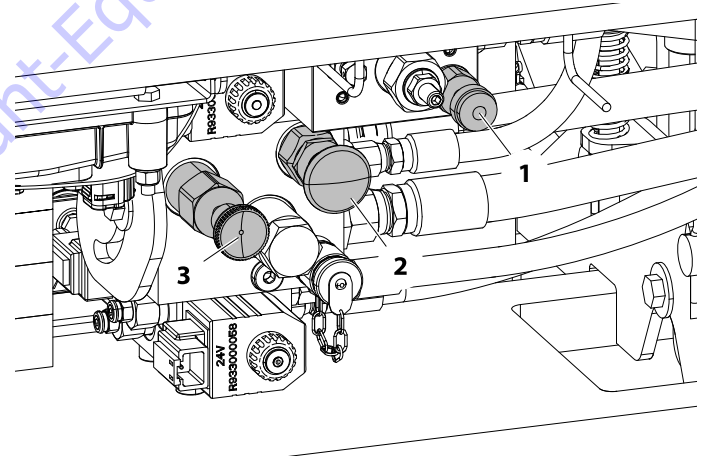

Figure 3-14. Hydraulic Brakes - Manual Disengage.
(Inside Right Side Compartment Door)

TO PURCHASE THIS PRODUCT PLEASE CONTACT US



**Equipment Financing and
Extended Warranties Available**



**Discount-Equipment.com is your online resource for
commercial and industrial quality parts and equipment sales.**

561-964-4949

visit us on line @ www.discount-equipment.com

Select an option below to find your Equipment

Search by Manufacturer

Search by Product Type

Request a Quote

We sell worldwide for the brands: Genie, Terex, JLG, MultiQuip, Mikasa, Essick, Whiteman, Mayco, Toro Stone, Diamond Products, Generac Magnum, Airman, Haulotte, Barreto, Power Blanket, Nifty Lift, Atlas Copco, Chicago Pneumatic, Allmand, Miller Curber, Skyjack, Lull, Skytrak, Tsurumi, Husquvarna Target, Stow, Wacker, Sakai, Mi-T-M, Sullair, Basic, Dynapac, MBW, Weber, Bartell, Bennar Newman, Haulotte, Ditch Runner, Menegotti, Morrison, Contec, Buddy, Crown, Edco, Wyco, Bomag, Laymor, EZ Trench, Bil-Jax, F.S. Curtis, Gehl Pavers, Heli, Honda, ICS/PowerGrit, IHI, Partner, Imer, Clipper, MMD, Koshin, Rice, CH&E, General Equipment, Amida, Coleman, NAC, Gradall, Square Shooter, Kent, Stanley, Tamco, Toku, Hatz, Kohler, Robin, Wisconsin, Northrock, Oztec, Toker TK, Rol-Air, APT, Wylie, Ingersoll Rand / Doosan, Innovatech, Con X, Ammann, Mecalac, Makinex, Smith Surface Prep, Small Line, Wanco, Yanmar

SECTION 4. EMERGENCY PROCEDURES

4.1 GENERAL INFORMATION

This section explains the steps to be taken in case of an emergency situation during operation.

4.2 EMERGENCY OPERATION

Operator Unable to Control Machine

IF THE PLATFORM OPERATOR IS UNABLE TO OPERATE OR CONTROL THE MACHINE:

1. Other personnel should operate the machine from ground controls only as required.
2. Only qualified personnel in the platform may use the platform controls. **DO NOT CONTINUE OPERATION IF CONTROLS DO NOT FUNCTION PROPERLY.**
3. Rescue equipment can be used to remove the platform occupant(s). Cranes and forklifts can be used to stabilize motion of the machine.

Platform Caught Overhead

If the platform becomes jammed or snagged in overhead structures or equipment, do the following:

1. Shut off the machine.
2. Rescue all people in the platform before freeing the machine. Personnel must be out of the platform before operating any controls on the machine.
3. Use cranes, forklifts or other equipment to stabilize motion of the machine to prevent a tip over as required.
4. From the ground controls, carefully free the platform from the object.
5. Once clear, restart the machine and return the platform to a safe position.
6. Inspect the machine for damage. If the machine is damaged or does not operate properly, turn off the machine immediately. Report the problem to the proper maintenance personnel. Do not operate the machine until it is declared safe for operation.

Righting of Tipped Machine

A fork truck of suitable capacity or equivalent equipment should be placed under the elevated side of the chassis, with a crane or other suitable lifting equipment used to lift the platform while the chassis is lowered by the forklift or other equipment.

SECTION 4 - EMERGENCY PROCEDURES

4.3 PLATFORM MANUAL DESCENT

The platform manual descent control is used in the event of total power failure to lower the platform using gravity. The manual descent control T-handle is located on the left rear of the machine, just below the platform ladder. Look for the instruction decal located beside the release handle.

The lowering procedure is as follows:

1. Locate the **manual descent control T-handle**.
(See Figure 4-1.)

⚠ WARNING

KEEP HANDS AND ARMS OUT OF THE PATH OF THE SCISSOR ARMS AND PLATFORM WHILE LOWERING.

2. Grasp the T-handle and slowly pull out to lower the scissor arms/platform, when the platform is lowered to desired level, allow the T-handle to return to its closed position.

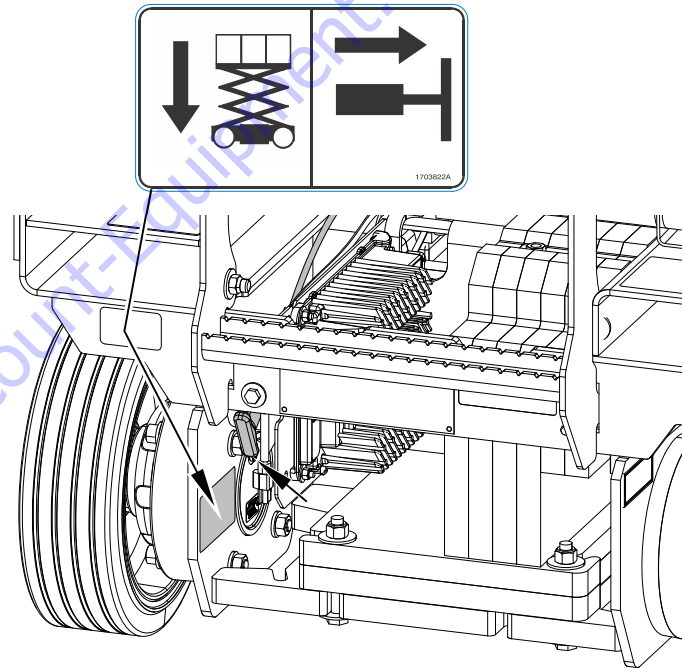

Figure 4-1. Location of Manual Descent Control
(Left Rear of Machine)

4.4 INCIDENT NOTIFICATION

JLG Industries, Inc. must be notified immediately of any incident involving a JLG product. Even if no injury or property damage is evident, JLG must be contacted by telephone and provided with all necessary details.

- USA: 877-JLG-SAFE (554-7233)
- EUROPE: (44) 1 698 811005
- AUSTRALIA: (61) 2 65 811111
- E-mail: productsafety@jlg.com

Failure to notify the manufacturer of an incident involving a JLG Industries product within 48 hours of such an occurrence may void any warranty consideration on that particular machine.

NOTICE

FOLLOWING ANY INCIDENT, THOROUGHLY INSPECT THE MACHINE. DO NOT ELEVATE PLATFORM UNTIL YOU ARE SURE THAT ALL DAMAGE HAS BEEN REPAIRED, AND THAT ALL CONTROLS ARE OPERATING CORRECTLY. TEST ALL FUNCTIONS FIRST FROM THE GROUND CONTROL STATION, THEN FROM THE PLATFORM CONTROL CONSOLE.

SECTION 5. ACCESSORIES

Table 5-1. 1532R/1932R - Available Accessories

ACCESSORY	Market						
	ANSI	ANSI Exp	CSA	CE	AUS	Japan	China (GB)
DC/AC Power Inverter	✓						
Magnetic Gate Latch	✓	✓	✓	✓	✓	✓	✓
Anti-Vandalism Package	✓	✓	✓	✓	✓	✓	✓
Platform Extension Handles	✓	✓	✓	✓	✓	✓	✓
Footswitch		✓				✓	
JLG™ Mobile Control	✓		✓	✓			

Table 5-2. 1932R Only - Available Accessories

ACCESSORY	Market						
	ANSI	ANSI Exp	CSA	CE	AUS	Japan	China (GB)
Pipe Racks				✓	✓		
Panel Carrier				✓	✓		

SECTION 5 - ACCESSORIES

Table 5-3. 1532R - Options/Accessories Relationship Table

ACCESSORY	COMPATIBLE WITH (Note 1)	INCOMPATIBLE WITH	INTERCHANGEABLE WITH (Note 2)
DC/AC Power Inverter	Anti-Vandalism Package, Fire Extinguisher, Platform Extension Handles, Footswitch, Dual Rails, Magnetic Gate Latch	—	—
Magnetic Gate Latch	Inverter, Anti-Vandalism Package, Fire Extinguisher, Platform Extension Handles, Footswitch, Dual Rails	—	—
Anti-Vandalism Package	Inverter, Fire Extinguisher, Platform Extension Handles, Footswitch, Dual Rails, Magnetic Gate Latch	—	—
Platform Extension Handles	Inverter, Anti-Vandalism Package, Fire Extinguisher, Footswitch, Magnetic Gate Latch	Dual Rails	—
Footswitch	Inverter, Anti-Vandalism Package, Fire Extinguisher, Platform Extension Handles, Dual Rails, Magnetic Gate Latch	—	—
JLG Mobile Control	All	—	—
Note 1: Any accessory not listed under "COMPATIBLE WITH" is assumed to be incompatible.			
Note 2: Can be used on same unit but not simultaneously.			
1001218523-H			

Table 5-4. 1932R - Options/Accessories Relationship Table

ACCESSORY	COMPATIBLE WITH (Note 1)	INCOMPATIBLE WITH	INTERCHANGEABLE WITH (Note 2)
DC/AC Power Inverter	Pipe Racks, Anti-Vandalism Package, Fire Extinguisher, Platform Extension Handles, Footswitch, Dual Rails, Magnetic Gate Latch, Panel Carrier, Mobile Control	—	—
Magnetic Gate Latch	Inverter, Pipe Racks, Anti-Vandalism Package, Fire Extinguisher, Platform Extension Handles, Footswitch, Dual Rails, Panel Carrier, Mobile Control	—	—
Anti-Vandalism Package (ANSI, ANSI Exp., CSA, JPN)	Inverter, Pipe Racks, Fire Extinguisher, Platform Extension Handles, Footswitch, Dual Rails, Magnetic Gate Latch, Panel Carrier, Mobile Control	—	—
Anti-Vandalism Package (CE, AUS, GB)	Inverter, Pipe Racks, Platform Extension Handles, Footswitch, Dual Rails, Magnetic Gate Latch, Panel Carrier, Mobile Control	Fire Extinguisher	—
Platform Extension Handles (ANSI, ANSI Exp., CSA, JPN)	Pipe Racks, Anti-Vandalism Package, Rail Padding, Fire Extinguisher, Inverter, Footswitch, Magnetic Gate Latch, Panel Carrier, Mobile Control	Dual Rails	—
Platform Extension Handles (CE, AUS, GB)	Inverter, Anti-Vandalism Package, Footswitch, Magnetic Gate Latch, Panel Carrier, Mobile Control	Fire Extinguisher, Dual Rails	—
Panel Carrier	Inverter, Anti-Vandalism Package, Footswitch, Dual Rails, Magnetic Gate Latch, Mobile Control	Pipe Racks, Extension Handles	—
Pipe Racks	Inverter, Anti-Vandalism Package, Fire Extinguisher, Platform Extension Handles, Footswitch, Dual Rails, Magnetic Gate Latch, Mobile Control	Panel Carrier, Dual Rails	—
Footswitch	Pipe Racks, Anti-Vandalism Package, Fire Extinguisher, Platform Extension Handles, Dual Rails, Magnetic Gate Latch, Panel Carrier, Mobile Control	—	—
JLG™ Mobile Control	All	—	—
Note 1: Any accessory not listed under "COMPATIBLE WITH" is assumed to be incompatible.			
Note 2: Can be used on same unit but not simultaneously.			

1001218523-H

5.1 DC/AC POWER INVERTER

The DC to AC Power Inverter converts DC voltage from the onboard system batteries to AC voltage for use at the platform AC output receptacle.

The inverter module is mounted on the inside of the battery compartment door.

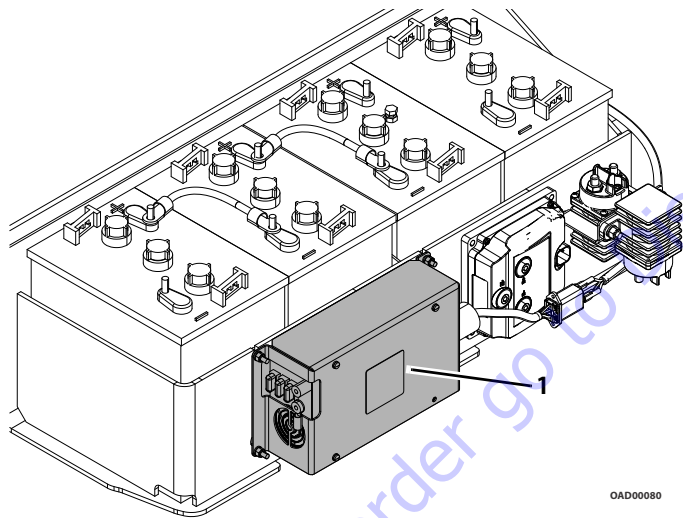

1. Inverter Module

OAD00080

Specifications

DESCRIPTION	SPECIFICATION
Electrical System Voltage (DC)	24V
Power Inverter:	Power Bright
DC Input:	
DC Input Voltage:	20 to 30VDC
Operating Temperature:	-4° F (-20° C) to 113° F (+45° C)
AC Output:	
Output Power (Continuous):	900W
Output Power (Surge):	1800W
Output Power (AC):	7.5A
Output Voltage (AC):	117V +/- 10%
Output Frequency:	60 Hz
Type:	Modified Sine Wave
Protection:	
Output Reverse DC Polarity:	3 X 25A Replaceable Fuse

Safety Precautions

⚠ DANGER

THIS ACCESSORY MAY CAUSE SHOCK OR ELECTROCUTION IF USED IMPROPERLY. TREAT INVERTER OUTPUT THE SAME AS COMMERCIAL AC POWER.

- This inverter will only operate from a 24V power source. Do not attempt to connect the inverter to any other power source, including any AC power source.
- Do not allow water or other liquids to contact the inverter.
- Do not use appliances with damaged or wet cords.
- Route appliance cords and extension cords to prevent accidental pinching, crushing, abrading, and tripping hazards.
- Do not use the inverter near flammable materials or in any locations that may accumulate flammable fumes or gases. This is an electrical device that can briefly spark when electrical connections are made or broken.

Operation

1. Set the inverter ON/OFF switch to the ON position at the ground control station.
2. Only plug in tools or appliances rated within the maximum output wattage at the platform AC receptacle mounted on the platform.

5.2 MAGNETIC GATE LATCH

The Magnetic Gate Latch ensures the platform gate latches securely when closed.

Operation

Grasp handle and swing gate open.

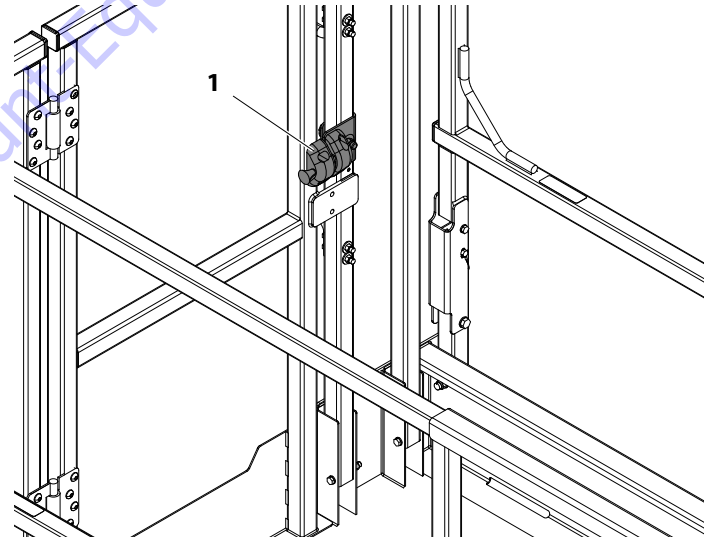

1. Magnetic Gate Latch Assembly

5.3 ANTI-VANDALISM PACKAGE

The Anti-Vandalism Package consists of two lockable covers for the Platform and Ground Control Stations that prevent unauthorized use of the machine. Locks are not provided with this kit.

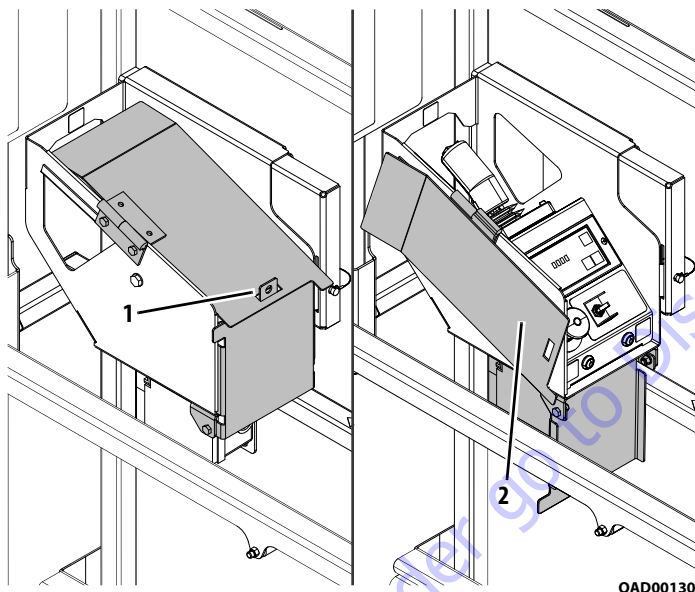

Platform Control Station

1. Lock Position (Covers Closed)

2. Covers Open

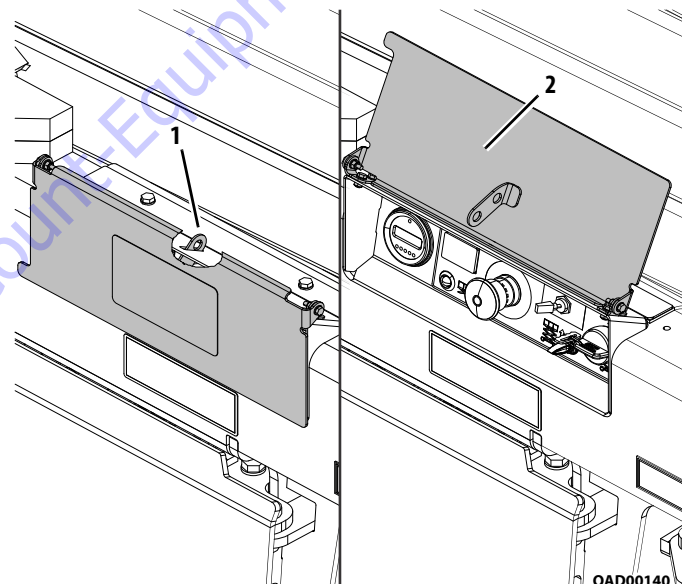

Ground Control Station

1. Lock Position (Cover Closed)

2. Cover Open

5.4 PLATFORM EXTENSION HANDLES

The Platform Extension Handles are mounted to the top rails of the extension platform at the roller tabs. When rotated up 90°, the handles provide the operator an optional grip to push the extension platform out from its stowed position.

Operation

1. Swing both extension handles up 90° to the extend position.
2. While standing on the main platform, release the extension platform lock mechanism with one foot.
3. Grasp both handles and push platform extension out until locked in either of the two other locked extension positions.

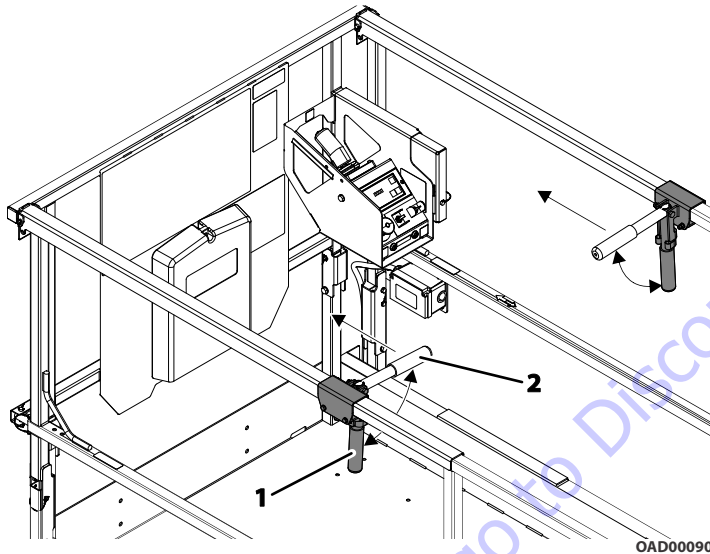

1. Extension Handle in the Stowed Position

2. Extension Handle in the Extension Position

5.5 PIPE RACKS

Pipe Racks store pipe or conduit inside the platform in order to prevent rail damage and optimize platform utility. The accessory consists of two racks attached to the lower platform handrail with adjustable straps that secure the load in place.

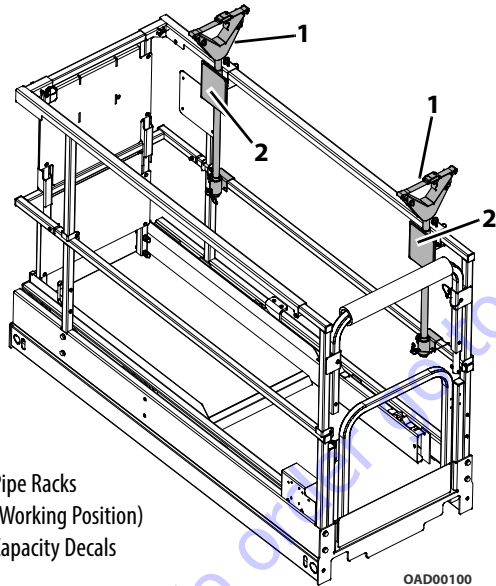

- 1. Pipe Racks
(Working Position)
- 2. Capacity Decals

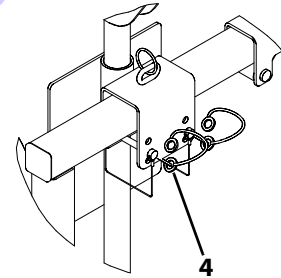
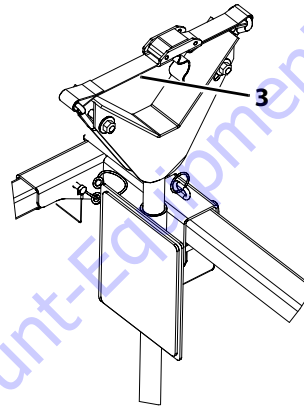

OAD00110

- 3. Tie-Down Strap
- 4. Locking Pins

NOTE: This accessory is available for the 1932R in CE and Australian markets only.

Safety Precautions

WARNING

THIS ACCESSORY AFFECTS OVERALL PLATFORM CAPACITY. REFER TO CAPACITY DECALS AND ADJUST ACCORDINGLY. WEIGHT IN RACKS PLUS WEIGHT IN PLATFORM MUST NOT EXCEED RATED CAPACITY.

NOTICE

RETRACT PLATFORM EXTENSION BEFORE ATTACHING PIPE RACKS AND LOADING MATERIAL.

NOTICE

MAXIMUM WEIGHT IN RACKS IS 45 KG (100 LB) EVENLY DISTRIBUTED BETWEEN RACKS. MAX LENGTH IS 6 M (20 FT). MAX CIRCUMFERENCE OF MATERIAL IS 180 MM PER PIPE.

- Do not exit platform over rails or stand on rails.
- Do not drive the machine without material secured.
- Use this accessory on approved models only.
- Return racks to the stowed position when not in use.

Preparation and Inspection

- Ensure both racks are mounted and securely fastened to inside of platform rails.
- Check for missing or damaged components. Replace if necessary.

Operation

1. To prepare racks for loading, remove locking pins, rotate each rack 90 degrees from stowed to working position, then secure with locking pins.
 2. Place material onto racks with weight evenly distributed between both racks. Do not exceed the rated capacity stated on the decal.
 3. Route the tie-down straps at each end across loaded material and tighten.
 4. To remove material, loosen and remove tie-down straps, then carefully remove material from racks.
- NOTE:** *Reinstall tie-down straps across any remaining material before continuing machine operations.*
5. When not in use, remove locking pins, rotate racks 90 degrees to the stowed position, then secure locking pins.

5.6 FOOTSWITCH

The Footswitch serves as another enable switch in the function control circuit. It must be depressed in sequence with the platform control joystick trigger switch to enable operation of machine functions when using the platform controls. Power is removed from the platform controls when the footswitch is released.

NOTE: This accessory is only available in Japanese and Korean markets.

Operation

To operate a function, engage the footswitch and joystick trigger in any sequence before operating a function.

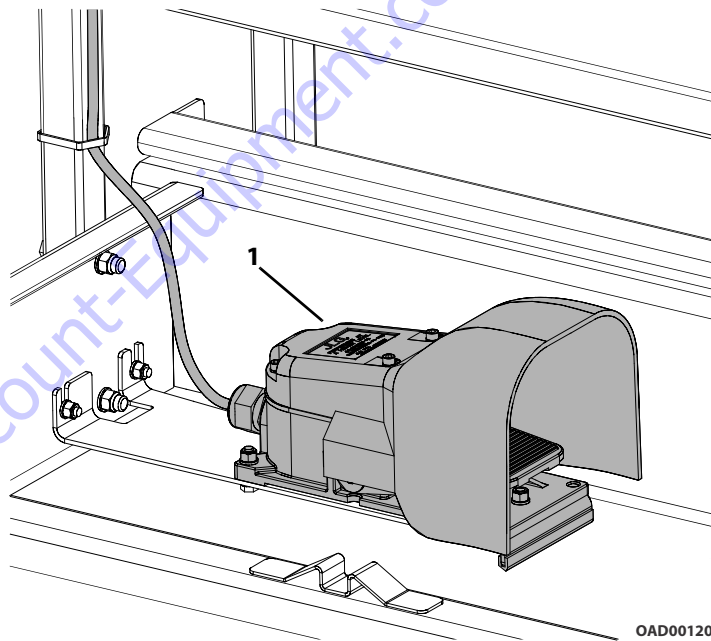

1.Footswitch Assembly

5.7 PANEL CARRIER

The Panel Carrier can transport flat sheets or panels to an elevated site by positioning them in a channel on the outside of the platform. It consists of a carrier tray that runs parallel to the length of the platform and an adjustable bracket mounted to the handrail to hold material in place.

The panels can measure up to 4 ft x 8 ft (1.22 m x 2.4 m), or approximately 32 ft sq. (3 m sq.).

This accessory is available for the 1932R in CE and Australian markets only.

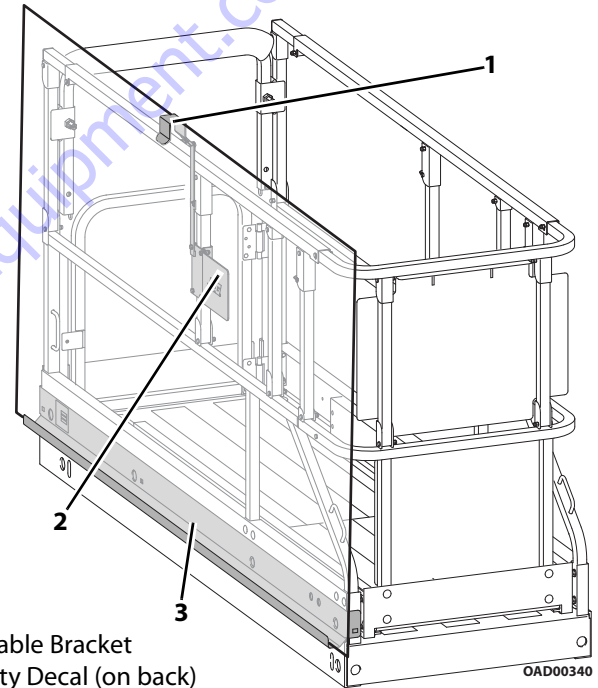

1. Adjustable Bracket
2. Capacity Decal (on back)
3. Carrier Tray

Safety Precautions

⚠ WARNING

MULTIPLE MATERIAL-HANDLING ACCESSORIES CAN BE INSTALLED BUT ONLY ONE MAY BE LOADED AT A TIME UNLESS APPROVED BY JLG INDUSTRIES, INC.

⚠ WARNING

THIS ACCESSORY AFFECTS THE OVERALL PLATFORM CAPACITY. REFER TO THE CAPACITY DECAL AND ADJUST ACCORDINGLY.

⚠ WARNING

WHEN THE CARRIER TRAY IS LOADED, THE INCREASE OF AREA EXPOSED TO WIND WILL DECREASE STABILITY. REFER TO THE DECAL FOR MAXIMUM PANEL SIZE AND WIND SPEED.

- Ensure no personnel are beneath the platform.
- Do not exit the platform over the rails, or stand on the rails.
- Remove the tray when not in use.

Preparation and Inspection

- Ensure all components are secured to the platform.
- Check for any missing or damaged components. Replace if necessary.
- Check for loose nuts and bolts. If necessary, torque according to the Torque Chart specifications in the Service Manual.
- Replace any missing or illegible decals.
- Replace any torn or frayed straps.

Operation

1. Attach the carrier tray to the outside of the platform.
2. Load the Panel Carrier with material and secure with the adjustable bracket.
3. Position the panel to its desired location.
4. Remove the carrier tray when finished.

5.8 JLG™ MOBILE CONTROL

The JLG Mobile Control application allows machine operators to drive remotely from a Bluetooth® equipped hand-held mobile device.

Prior to operation, the operator must scan the QR code on the machine with a mobile device equipped with the JLG Mobile Control application. This pairs the Mobile Control module on the machine with the mobile device to allow remote operation.

NOTE: *The Bluetooth word mark and logos are registered trademarks owned by Bluetooth SIG, Inc. and any use of such marks by JLG is under license. Other trademarks and trade names are those of their respective owners.*

Download

Visit the Apple Store®, Google Play®, or <https://www.JLG.com/mobilecontrol> in order to download the JLG Mobile Control application.



OAD00850

Operation

Download, read, and understand the JLG Mobile Control Supplement Manual from <https://www.JLG.com/mobilecontrol> prior to using the JLG Mobile Control.

⚠ WARNING

NEVER DRIVE THE MACHINE USING JLG MOBILE CONTROL WHILE STANDING IN THE PLATFORM, OR WITHOUT CLEAR LINE-OF-SIGHT BETWEEN THE MACHINE AND ITS TRAVEL PATH, AS SERIOUS INJURY COULD OCCUR TO OPERATOR OR BYSTANDER.

Document Resources

Access to application related documentation.

1. Select Settings (a) from the Home Screen
2. Select either:
 - b. JLG Mobile Control Supplement manual
 - c. Legal Statements (FCC, ISED)
 - d. Regulatory Statements (EULAs, DoC)

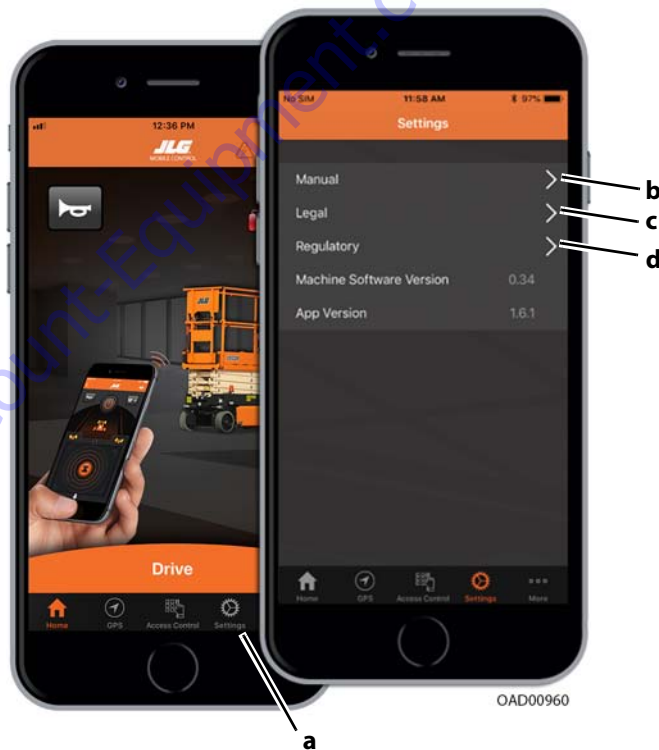

SECTION 6. GENERAL SPECIFICATIONS AND MAINTENANCE

6.1 INTRODUCTION

This section of the manual provides additional necessary information to the operator for proper operation and maintenance of this machine.

The maintenance portion of this section is intended as information to assist the machine operator to perform daily maintenance tasks only, and does not replace the more thorough Preventive Maintenance and Inspection Schedule included in the Service and Maintenance Manual.

Other Publications Available Specific to this Machine

Service and Maintenance Manual.....	3121745
Illustrated Parts Manual.....	3121746

SECTION 6 - GENERAL SPECIFICATIONS AND MAINTENANCE

6.2 OPERATING SPECIFICATIONS

Table 6-1. Operating Specifications

DESCRIPTION	1532R			1932R	
	ANSI/JPN/CSA	CE/AUS	Korean Spec Only	ANSI/JPN/CSA	CE/AUS
Platform					
Maximum Platform Height (Elevated) (Ground to Platform Floor)	15 ft. (4.57m)			19 ft. (5.8 m)	
Platform Lift Time (seconds/no load)	Lift Up:	13 - 16 seconds		17 - 22 seconds	
	Lift Down:	18 - 23 seconds		24 - 29 seconds	
Electronic Arm Guards (Pause Height)	Range:	4.5 ft (1.38 m) 6-15 seconds	—	—	4.5 ft (1.38 m) 6-15 seconds
DRIVING					
Maximum Operating Tilt Angle (platform fully elevated)	(Grade) Front to Back: (Sideslope) Side to Side:	0° 0°	3.75° 1.50° - Outdoor / 1.75° - Indoor	0° 0°	3.75° 1.50° - Outdoor / 1.75° - Indoor
Maximum Drive Speed (FWD/REV) (Seconds to Drive 25 ft (7.62m)	Stowed: Elevated:	8.1 - 9.5 seconds - (2.0 mph (3.2 kph) 32 - 38 seconds - (0.5 mph (0.8 kph)		8.1 - 9.5 seconds - (2.0 mph (3.2 kph) 32 - 38 seconds - (0.5 mph (0.8 kph)	
Maximum Stowed Travel Grade (Gradeability) (Reference Figure 3-7. on page 3-15)		25% (14°)		25% (14°)	
Turning Radius	Inside: (Curb to Curb) Outside:	0 in. (0 cm) 62.93 in. (159.8 cm)		0 in. (0 cm) 62.93 in. (159.8 cm)	
CHASSIS					
Approximate Gross Machine Weight		2,422-2,600 lb. (1099-1179 kg)	2,842-3,142 lb. (1,289-1,425 kg)	2,380 lb (1090 kg)	2,622-2,800 lb. (1189- 1270 kg)
					3,300-3,600 lb. (1497 - 1633 kg)

SECTION 6 - GENERAL SPECIFICATIONS AND MAINTENANCE

Table 6-1. Operating Specifications (Continued)

DESCRIPTION	1532R			1932R	
	ANSI/JPN/CSA	CE/AUS	Korean Spec Only	ANSI/JPN/CSA	CE/AUS
CHASSIS (continued)					
Maximum Tire Load (per wheel)	1,250 lb. (567 kg)	1,365 lb. (620 kg)	1,250 lb. (567 kg)	1,365 lb. (620 kg)	1,540 lb. (699 kg)
Ground Bearing Pressure	115 psi (8.09 kg/cm ²)			100 psi (7.03 kg/cm ²)	125 psi (8.79 kg/cm ²)
Ground Clearance	PHP Retracted:	2.76 in. (7 cm)		2.76 in. (7 cm)	
	PHP Deployed:	0.65 in. (1.65 cm)		0.65 in. (1.65 cm)	
Break Over Angle (Grade)	11.3° (20%)			10.8° (20%)	
Maximum Hydraulic Pressure	Main Relief:	3000 psi (207 bar)		3000 psi (207 bar)	
	Steer Relief:	800 psi (55 bar)		800 psi (55 bar)	
	Lift Relief:	2550 psi (176 bar)		2550 psi (176 bar)	

SECTION 6 - GENERAL SPECIFICATIONS AND MAINTENANCE

Platform Capacities

Table 6-2. Platform Capacities

SPECIFICATION	MACHINE MODEL	MAXIMUM PLATFORM CAPACITY ⁽¹⁾	MAXIMUM CAPACITY ALLOWED ON PLATFORM EXTENSION	MAXIMUM PERSONS ALLOWED IN PLATFORM	MAX. SIDE FORCE (Platform Fully Extended @ Max. Capacity)	MAXIMUM OPERATING WIND SPEED
ANSI/JPN /CSA	1532R	600lb. (272 Kg)	250lb. (113 Kg)	2	100lb. (445 N)	28mph (12.5 m/s)
CE/AUS		275 Kg	120 Kg	Indoor - 2 Persons + 115 Kg	400 N	0 m/s
		125 Kg		Outdoor - 1 Person + 45 Kg	200 N	12.5 m/s
ANSI/JPN /CSA	1932R	550lb. (250 Kg)	250lb. (113 Kg)	2	100lb. (445 N)	28mph (12.5 m/s)
CE/AUS		230 Kg	120 Kg	Indoor - 2 Persons + 70 Kg	400 N	0 m/s
		125 Kg		Outdoor - 1 Person + 45 Kg	200 N	12.5 m/s

NOTE: (1) Maximum Platform Capacity includes platform and platform extension.

Machine Dimensional Data

Table 6-3. Dimensions

DESCRIPTION	1532R	1932R
Platform Height - Elevated (Ground to Platform Floor)	15 ft. (4.57 m)	19 ft. (5.8 m)
Platform Height - Stowed (Ground to Platform Floor)	37.53 in. (95.3 cm) 35.4 (0.905 m) - Korean Spec Only	38.62 in. (98.1 cm)
Rail Height (Platform Floor to Top of Rail)	39.94 in (101.5 cm) Fixed 43.88 in (111.5 cm) Folding 39.4 in (1 m) Fixed - Korean Spec Only	39.94 in (101.5 cm) Fixed 43.88 in (111.5 cm) Folding
Overall Height - Fixed Rails (Ground to Top Rail)	77.7 in. (197 cm) 75 in (1.905 m) - Korean Spec Only	78.78 in. (200.1 cm)
Overall Height - Folding Rails (Ground to Mid Rail) (Rails Down)	63.53 in. (161.4 cm)	64.61 in. (164.11 cm)
Overall Machine Width	32 in. (81.3 cm)	
Overall Machine Length	68.67 in. (174.4 cm)	
Platform Size - Length (Inside)	62.62 in. (159.1 cm)	
Platform Size - Width (Inside)	21.71 in. (55.2 cm)	
Wheelbase	53.03 in. (134.7 m)	

Tires

Table 6-4. Tire Specifications

DESCRIPTION	1532R/1932R
Size	12.72 in. x 3.9 in. (32.3 cm x 10.0 cm)
Wheel Nut Torque (42 mm Slotted Nut with Cotter Pin)	150 ft lb. (203 Nm)

Batteries

Table 6-5. OEM Battery Specifications

DESCRIPTION	Lead Acid	AGM
Voltage (24V System - Series)	6 V per battery	
Amp Hour Rating	225 Amp Hour @ 20 HR. Rate	213 Amp Hour @ 20 HR. Rate
Reserve Capacity	447 Minutes	492 Minutes
Weight	63 lb. (28.6 Kg) (US Battery) 62 lb (28.12 kg) (Trojan)	66 lb. (30 Kg)

Electrical System

Table 6-6. Battery Charger Specifications

DESCRIPTION	ALL MACHINES		
Electrical System Voltage (DC)	24V		
Battery Charger: Input: AC Input Voltage: Nominal AC Input Voltage: Input Frequency: Max. AC Input Current: Ingress Protection: Operating Temperature: Output: Nominal DC Output Voltage: Max. DC Output Voltage: Max DC Output Current: Max. Interlock Current: Protection: Output Reverse Polarity: Output Short Circuit: AC Overload: DC Overload:	Delta-Q 85-270V AC 100VAC / 240VAC RMS 50 - 60Hz 7.5A IP66 NEMA4 Type 4 -40°F (-40°C) to 149°F (+65°C) 24V 36V 27.1A 1A @ 24V Electronic Protection-Auto Reset Current Limited Current Limited Current Limited	PRO - Eagle Perf. Series 108-132V AC 120VAC 45 - 65Hz 12A IP35 -22°F (-30°C) to 122°F (+50°C) 24V 30.92V 25A 1A @ 24V Electronic Protection-Auto Reset Electronic Protection-Auto Reset Branch Circuit Protection Current Limited	Green Power - Pylon International 100-240V AC — — 45 - 65Hz 8.5A IP66 -4°F (-20°C) to 122°F (+50°C) 24V 34V 30A 1A @ 24V Electronic Protection-Auto Reset Electronic Protection-Auto Reset Current Limited Current Limited

6.3 CRITICAL STABILITY WEIGHTS

⚠ WARNING

DO NOT REPLACE ITEMS CRITICAL TO STABILITY, SUCH AS BATTERIES OR SOLID TIRES, WITH ITEMS OF DIFFERENT WEIGHT OR SPECIFICATION. DO NOT MODIFY UNIT IN ANY WAY TO AFFECT STABILITY.

Table 6-7. Critical Stability Weights

COMPONENT		1532R/1932R
Wheel and Tire Assembly (each)		26.9 lb. (12.2 kg)
Wheel/Tire and Drive Assembly (each)		53 lb. (24 kg)
Batteries (each)	Standard:	63 lb. (28.6 kg) (US Battery) 62 lb (28.12 kg) (Trojan)
	AGM:	66 lb. (30 kg)
Batteries (combined)	Standard:	252 lb. (114.3 kg) (US Battery) 248 lb (112.5 kg) (Trojan)
	AGM:	264 lb. (119.8 kg)

6.4 LUBRICATION

Lubrication Capacities

Table 6-8. Capacities

COMPONENT	1532R/1932R
Hydraulic Reservoir (at Full mark)	4 Gal. (15.1 L)
Hydraulic System (Including Reservoir)	4.6 Gal. (17.5 L)

Hydraulic Oil

Table 6-9. Hydraulic Oil

HYDRAULIC SYSTEM OPERATING TEMPERATURE RANGE	SAE VISCOSITY GRADE
0° F to +23° F (-18° C to -5° C)	10W
0° F to 210° F (-18° C to +99° C)	10W-20, 10W-30
50° F to 210° F (+10° C to +99° C)	20W-20

NOTE: Aside from JLG recommendations, it is not advisable to mix oils of different brands or types, as they may not contain the same required additives or be of comparable viscosities.

Lubrication Specifications

Table 6-10. Lubrication Specifications

KEY	SPECIFICATIONS
MPG	Multipurpose Grease having a minimum dripping point of 350° F. Excellent water resistance and adhesive qualities, and being of extreme pressure type. (Timken OK 40 pounds minimum.)
EPGL	Extreme Pressure Gear Lube (oil) meeting API service classification GL-5 or MIL-Spec MIL-L-2105.
HO	JLG Recommends - Mobil - Mobilfluid 424 Mobil EAL ENVIRONSYN H 32 Mobil SHC HYDRAULIC EAL 32 NOTE: EAL and SHC are compatible with each other.

Table 6-11. Hydraulic Oil Specifications

SPECIFICATION	MOBIL MOBILFLUID 424	MOBIL EAL ENVIRONSYN H 32
ISO Viscosity Grade	10W-30	#32
Spec Gravity API	29.0	0.950
Pour Point, Max	-65° F (-54° C)	-38° F (-39° C)
Flash Point, Min.	442° F (228° C)	514° F (268° C)
VISCOSITY SPECIFICATIONS		
at 40° C	55 cSt	33.1 cSt
at 100° C	9.3 cSt	6.36 cSt
at 100° F	80 SUS	—
at 210° F	43 SUS	—
cp at -18° C	2700	—
Viscosity Index	152	147
Operating Temp	—	-20° F (-29° C) to 200° F (93° C)

SECTION 6 - GENERAL SPECIFICATIONS AND MAINTENANCE

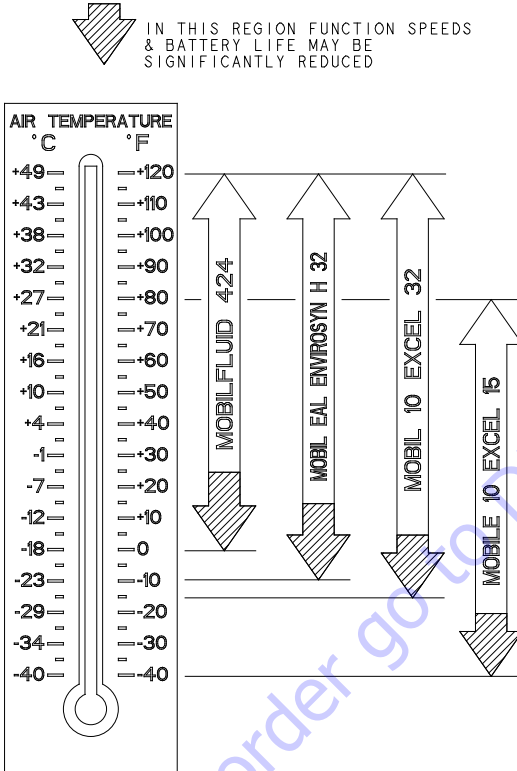

Fluid	Properties		Base			Classification				
	Description	Viscosity @ 40°C (Cst, Typical)	Visc Index	Mineral Oils	Vegetable Oils	Synthetic	Synthetic Polyol Esters	Readily Biodegradable*	Virtually Non-toxic**	Fire Resistant***
Mobilfluid 424		55	145	X						
Mobil EAL Envirosyn H 32		33	147			X		X		
Mobil 10 Excel 32		32	164	X					X	
Mobil 10 Excel 15		15	168	X					X	

- * Readily biodegradable classification indicates one of the following:
 CO2 Conversion > 60% per EPA 560/6-82-003
 CO2 Conversion > 80% per CEC-L-33-A-93
- ** Virtually Non-toxic classification indicates an LC50 > 5000 ppm per OECD 203
- *** Fire Resistant classification indicates Factory Mutual Research Corp. (FMRC) Approval

NOTICE:
 MACHINE OPERATION USING NON-JLG APPROVED HYDRAULIC FLUIDS OR OPERATION OUTSIDE OF THE TEMPERATURE BOUNDARIES OUTLINED IN THE "HYDRAULIC FLUID OPERATION CHART" MAY RESULT IN PREMATURE WEAR OR DAMAGE TO COMPONENTS OF THE HYDRAULIC SYSTEM.

SOME FLUIDS MAY NOT BE AVAILABLE FROM THE FACTORY

1001219909-C

Figure 6-1. Hydraulic Oil Operating Temperature Chart

6.5 OPERATOR MAINTENANCE

Scissor Arm - Safety Prop *(See Figure 6-2.)*

⚠ WARNING

NEVER WORK UNDER AN ELEVATED PLATFORM UNTIL IT HAS BEEN RESTRAINED FROM MOVEMENT WITH THE SAFETY PROP, BLOCKING OR OVERHEAD SLING.

⚠ CAUTION

THE SAFETY PROP MUST BE USED WHENEVER MAINTENANCE PERFORMED ON THE MACHINE REQUIRES THE SCISSOR ARMS TO BE RAISED AND ONLY WITH NO LOAD IN THE PLATFORM

The safety prop is located on the side of the scissor arms on the right side of the machine.

To engage the safety prop:

1. From the Ground Control Station, raise the platform far enough to allow the safety prop to be engaged.
2. Rotate the prop assembly clockwise until it hangs vertically on the side of the scissor arms.
3. Lower the platform until the safety prop rests against the safety prop stop on the arm set below it, stopping all downward movement of the platform/scissor arm assembly.

To disengage the safety prop:

1. Raise the platform enough to release the safety prop off the safety prop stop.
2. Rotate the prop assembly counterclockwise until it is resting on the arm prop holder plate on the side of the scissor arm assembly.

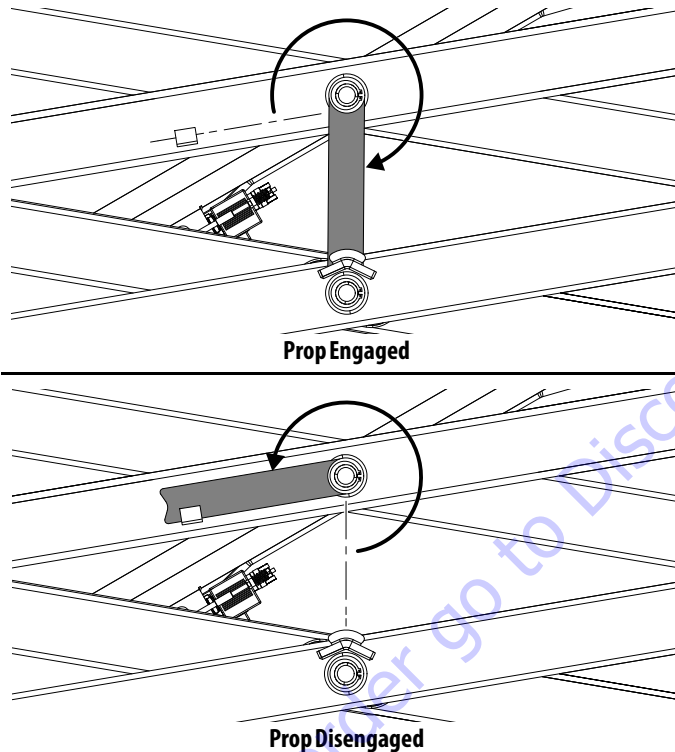

Figure 6-2. Scissor Arm - Safety Prop

Hydraulic Oil Check Procedure (See Figure 6-3. and Figure 6-4.)

Lube Point(s) - Hydraulic Reservoir

Reservoir Capacity - See Table 6-8 on page 6-7.

Lube - Hydraulic Oil

Interval - Check Daily

NOTE: Check the hydraulic oil level with the platform in the stowed position *ONLY*. Be certain the hydraulic oil has warmed to operating temperature before checking the oil level in the reservoir.

1. On the right side of the machine on the hydraulic compartment door there is a **cutout (1)** which allows viewing of the hydraulic oil tank **marking (2)**. The reservoir is marked with a **MAX (maximum) marking (2)**. The **MIN marking (3)** is the bottom edge of the cutout on the door. The oil level must be kept within these markings for the hydraulic system to operate properly.
2. If additional oil is required, swing compartment door open and wipe all dirt and debris from the **filler/filter cap (4)** area. Remove filler cap and add proper grade of oil. Fill until oil level is close to the **MAX marking (3)**, but not over the **MAX marking**.

NOTE: Care should be taken not to introduce any impurities (dirt, water, etc.) while cap is removed.

SECTION 6 - GENERAL SPECIFICATIONS AND MAINTENANCE

to hostile environments or conditions, lubrication frequencies must be increased accordingly.

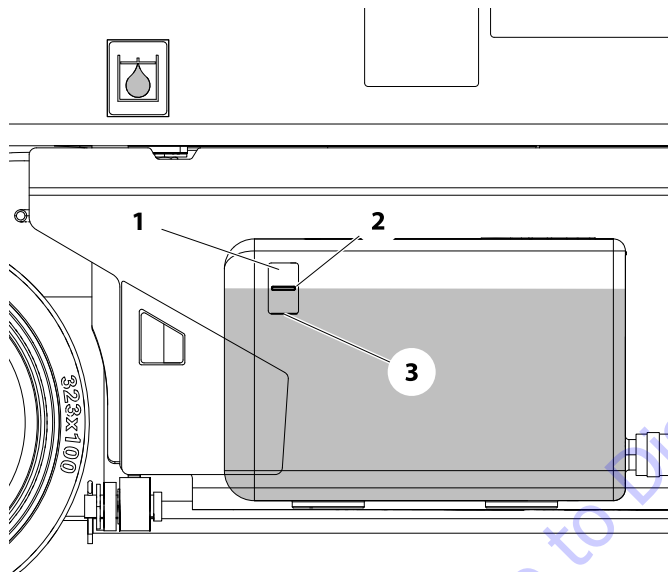

Figure 6-3. Hydraulic Oil Check Procedure

NOTE: Recommended lubricating intervals are based on machine operations under normal conditions. For machines used in multi-shift operations and/or exposed

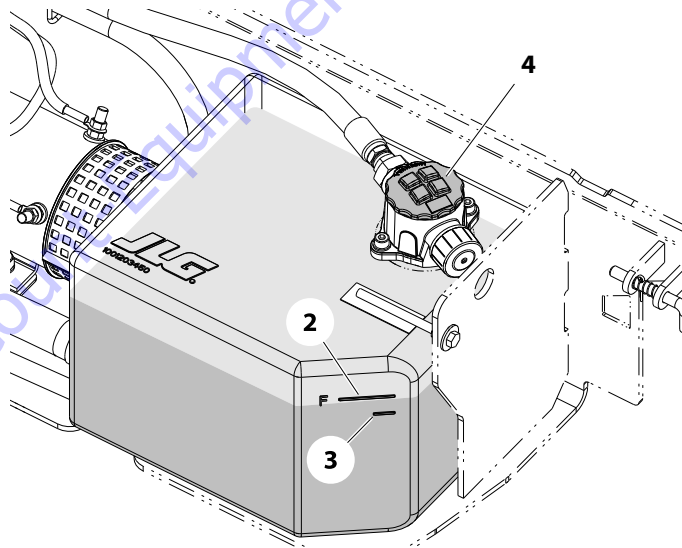
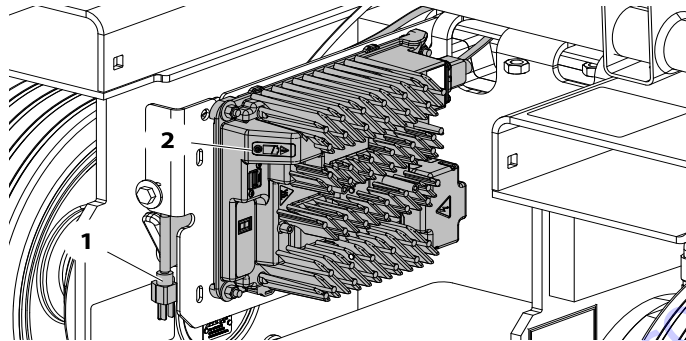

Figure 6-4. Hydraulic Oil Fill Procedure

Delta-Q - Battery Charger



1. AC Voltage Input Plug

2. Charge Indicator LEDs

NOTE: Rear crossmember and ladder shown removed for illustration purposes only.
For Specifications, See Table 6-6 on page 6-6.

- **AC Power On** - BLUE LED ON
- **Low State of Charge** - (Bottom Panel - GREEN LED Flashing)
- (Top Panel - GREEN LED OFF)
- **High State of Charge** - (Bottom Panel - GREEN LED ON) -
(Top Panel - GREEN LED Flashing)
- **Charge Complete** - (Bottom Panel - GREEN LED ON) - (Top
Panel - GREEN LED ON)
- **Fault Indicator** - (RED LED ON)
- **External Error Condition Caution** - (AMBER LED Flashing)

Green Power - Battery Charger (China Only)

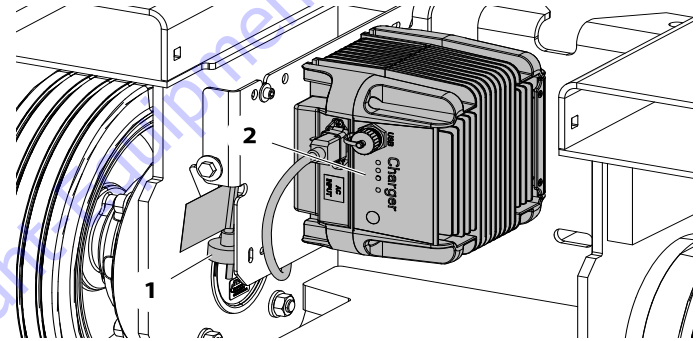

1. AC Voltage Input Cable

2. Charge Indicator LEDs

NOTE: Rear crossmember and ladder shown removed for illustration purposes only.
For Specifications, See Table 6-6 on page 6-6.

- **Battery Charging** - (YELLOW LED - AGM - Flashes Quickly
/FLOODED - Remains ON/ AGM-FLOODED - Flashes Slowly)
- **Charge Complete** - (GREEN LED ON)
- **Fault Indicator** - (RED LED ON)
- **Performing Self-Diagnostic** - (YELLOW and GREEN LEDs
Flashing Simultaneously)

Eagle Performance - Battery Charger

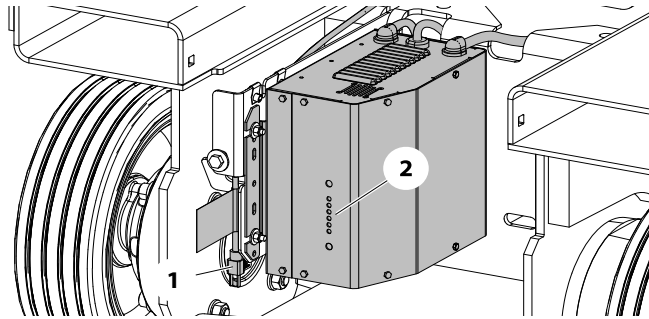

1. AC Voltage Input Cable

2. Charge Indicator LEDs

NOTE: Rear crossmember and ladder shown removed for illustration purposes only.
For Specifications, See Table 6-6 on page 6-6.

- **Battery Type Indicator** - (YELLOW LED ON)
- **Battery Charging** - (30%-60%-90% RED LED ON)
- **Charge Complete** - (GREEN LED ON)
- **No Battery Detected** - (30% RED Blinking)
- **Overall Timer Shutdown** - (30-60-90% RED LEDs Blinking)
- **Internal OverTemp Shutdown** - (30 - 90% RED LEDs Blinking)

Battery Maintenance and Safety Practices

NOTE: These instructions are for unsealed (wet) batteries only. If machine is equipped with sealed batteries, no maintenance other than cleaning corroded battery terminals is required.

CAUTION

ENSURE THAT BATTERY ACID DOES NOT COME INTO CONTACT WITH SKIN OR CLOTHING. WEAR PROTECTIVE CLOTHING AND EYEWEAR WHEN WORKING WITH BATTERIES. NEUTRALIZE ANY BATTERY ACID SPILLS WITH BAKING SODA AND WATER.

BATTERY ACID RELEASES AN EXPLOSIVE GAS WHILE CHARGING, ALLOW NO OPEN FLAMES, SPARKS OR LIGHTED TOBACCO PRODUCTS IN THE AREA WHILE CHARGING BATTERIES. CHARGE BATTERIES ONLY IN A WELL VENTILATED AREA.

ADD ONLY DISTILLED WATER TO BATTERIES. WHEN ADDING DISTILLED WATER TO THE BATTERIES, A NON-METALLIC CONTAINER AND/OR FUNNEL MUST BE USED.

Check the electrolyte level of the batteries often, adding only distilled water when required. When fully charged, battery fluid level should be 1/8" below vent tubes. (See Figure 6-5.).

- DO NOT fill to bottom of vent tubes.
- DO NOT allow fluid level to go below the top of the plates when charging or operating.

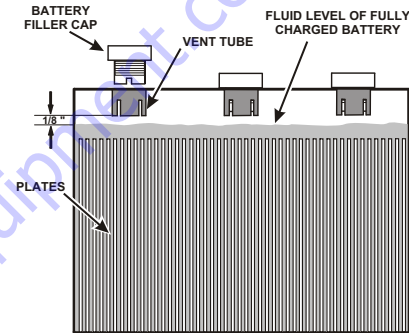
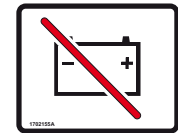

Figure 6-5. Battery Fluid Level.

Battery Quick-Disconnect (If Equipped)

Machines equipped with the battery quick-disconnect allow all machine power to be easily disconnected at the batteries without removing battery cables from the battery posts. To disconnect power, locate the RED quick-disconnect connector on top of the batteries inside the battery compartment and pull halves apart.



Tire Wear and Damage

The tire and rim assemblies installed on machines have been approved by the tire manufacturer for applications in which those products are intended to be used. The tire and rims installed on each product model have been designed for stability requirements, which consist of track width, tire compound, and load capacity. Tire changes such as rim width, centerpiece location, larger or smaller diameter, tire compound, etc., without written manufacturers approval, could result in an unsafe condition regarding stability.

The tires and rims installed on machines are to be inspected daily as part of the daily walk-around inspection. JLG requires that the daily walk-around inspection be performed at each operator change during a shift and at each shift change.

Wheel and Tire Replacement

JLG recommends that any replacement tire be the same size and brand as originally installed on the machine or offered by JLG as an approved replacement. Please refer to the JLG Parts Manual for the part number of the approved tires for a particular machine model.

If any of the following is discovered during tire inspection, measures must be taken to remove the JLG product from service immediately. Arrangements must be made for replace-

ment of the tire(s) or tire assembly(s). Both tires/wheels on the same axle must be replaced:

- If the overall diameter of the tire is less than one of the following:

100 x 323 Tire – 12.25 in. (311mm) minimum

- If any uneven wear is discovered.

A tire with significant damage in the tread area or sidewall requires immediate evaluation before placing the machine into service. If a cut, tear, chunk, or other discrepancy exceeds any one or more of the following dimensions, the tire must be replaced:

3.0 in. (76 mm) long

0.75 in. (19 mm) wide

0.75 in. (19 mm) deep

- If the metal wheel is visible at any point through the tread area of the tire.
- If more than one discrepancy exists in any quadrant of the wheel (within 90 degrees of one another).

Wheel Installation

It is extremely important to apply and maintain proper wheel mounting torque.

⚠ WARNING

WHEEL SLOTTED NUTS MUST BE INSTALLED AND MAINTAINED AT THE PROPER TORQUE TO PREVENT LOOSE WHEELS, A BROKEN NUT, AND POSSIBLE SEPARATION OF WHEEL FROM THE AXLE.

Tighten the slotted nuts to the proper torque to prevent wheels from coming loose. Use a torque wrench to tighten the slotted nuts. The proper procedure for attaching wheels is as follows:

1. If not already installed, install shaft key (5) to shaft and align with wheel keyway, install wheel and hub (3) onto tapered shaft (4).
2. Start slotted nut (1) by hand to prevent cross threading. DO NOT use a lubricant on threads or nut.
3. Torque the slotted nut to 150 ft. lb. (203 Nm).
4. Install cotter pin (2), if hole in slots do not align with cotter pin hole on the tapered shaft, continue to turn nut clockwise to align nut with hole. Do not loosen to align hole.

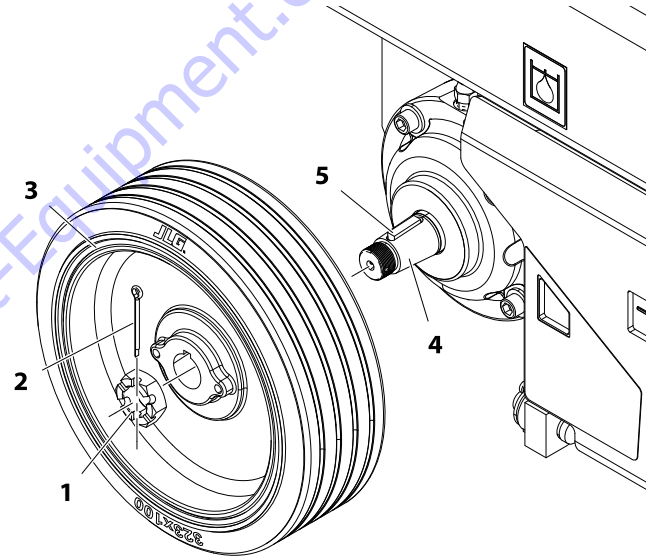

- | | |
|---------------------------|------------------|
| 1. Slotted Nut | 4. Tapered Shaft |
| 2. Cotter Pin | 5. Shaft Key |
| 3. Wheel and Hub Assembly | |

Figure 6-6. Wheel Installation

6.6 SUPPLEMENTAL INFORMATION

The following information is provided in accordance with the requirements of the European Machinery Directive 2006/42/EC and is only applicable to CE machines.

For electric powered machines, the equivalent continuous A-Weighted sound pressure level at the work platform is less than 70dB(A).

For combustion engine powered machines, guaranteed Sound Power Level (LWA) per European Directive 2000/ 14/EC (Noise Emission in the Environment by Equipment for Use Outdoors) based on test methods in accordance with Annex III, Part B, Method 1 and 0 of the directive, is 109 dB.

The vibration total value to which the hand-arm system is subjected does not exceed 2,5 m/s². The highest root mean square value of weighted acceleration to which the whole body is subjected does not exceed 0,5 m/s².

6.7 DECAL INSTALLATION

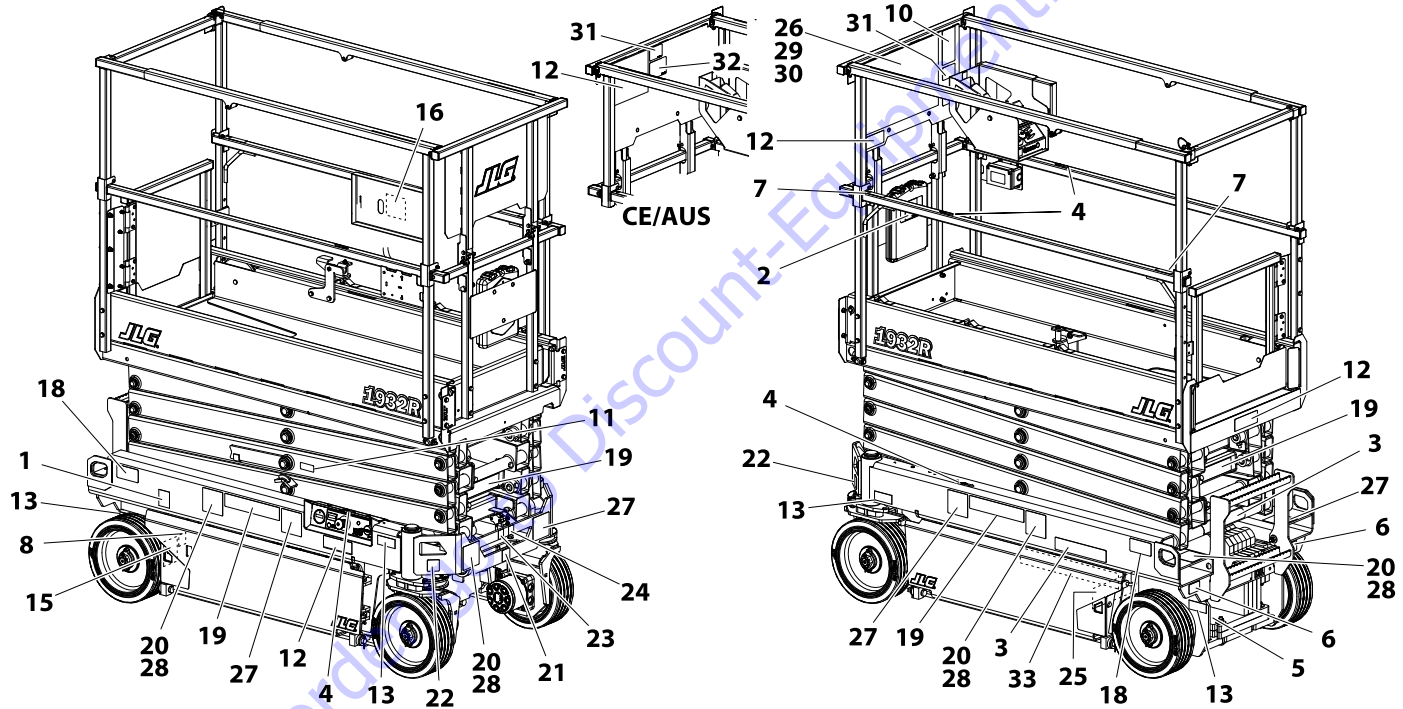

Figure 6-7. 1532R/1932R - Machine Decal Installation (See Table 6-12.)

SECTION 6 - GENERAL SPECIFICATIONS AND MAINTENANCE

Table 6-12. 1532R/1932R - Machine Decal Installation Chart

ITEM	ENGLISH (1001209907-C)	ENG/KOR (1001209908-B)	ENG/CHI (GB) (1001209909-C)	SPA/POR (1001209910-B)	ENG/SPA (1001209911-B)	ENG/FRE (1001209912-A)	CE/JAPAN (1001209913-C)	AUS (1001209914-C)	ENG/CHI (1001222745-A)
1	1701504	1701504	1701504	1701504	1701504	1701504	1701504	1701504	1701504
2	1701640	1701640	1701640	1701640	1701640	1701640	1701640	1701640	1701640
3	1703813	1707022	1704344	1704341	1704339	1704339	1705670	1705670	1704344
4	1703819	1703819	1703819	1703819	1703819	1703819	1703819	1703819	1703819
5	1703822	1703822	1703822	1703822	1703822	1703822	1703822	1703822	1703822
6	1704016	1704016	1704016	1704016	1704016	1704016	1704016	1704016	1704016
7	1704277	1704277	1704277	1704277	1704277	1704277	1704277	1704277	1704277
8	1704412	1704412	1704412	1704412	1704412	1704412	1704412	1704412	1704412
9	—	—	1705679	—	—	1705720	—	—	1705679
10	1705686	1706057	1705946	1705726	1705720	1705693	—	—	1705946
11	1001220430	1001220430	1001220430	1001220430	1001220430	—	1001220430	1001220430	1001220430
12	1001225494 - 1532R 1001209915 - 1932R	1001225494 - 1532R 1001209915 - 1932R	1001225496 - 1532R 1001215746 - 1932R	1001225494 - 1532R 1001209915 - 1932R	1001225494 - 1532R 1001209915 - 1932R	1001225495 - 1532R 1001209916 - 1932R	1001225496 - 1532R 1001215746 - 1932R	1001225496 - 1532R 1001215746 - 1932R	1001225494 - 1532R 10012109915 - 1932R
13	1001227703 - 1532R 1705647 - 1932R	1001227703 - 1532R 1705647 - 1932R	1705647 - 1532R 1705648 - 1932R	1001227703 - 1532R 1705647 - 1932R	1001227703 - 1532R 1705647 - 1932R	1705647 - 1532R 1705648 - 1932R	1705648 - CE 1705647 - JPN	1705647 - 1532R 1705648 - 1932R	1001227703 - 1532R 1705647 - 1932R
14	—	—	—	—	—	1701504	—	—	—
15	1001131270	—	—	—	—	—	—	—	—
16	1001132359	1001132359	1001132359	1001132359	1001132359	1001132359	1001132359	1001132359	1001132359
17	—	—	1705943	—	—	—	—	—	1705943

SECTION 6 - GENERAL SPECIFICATIONS AND MAINTENANCE

Table 6-12. 1532R/1932R - Machine Decal Installation Chart

ITEM		ENGLISH (1001209907-C)	ENG/KOR (1001209908-B)	ENG/CHI (GB) (1001209909-C)	SPA/POR (1001209910-B)	ENG/SPA (1001209911-B)	ENG/FRE (1001209912-A)	CE/JAPAN (1001209913-C)	AUS (1001209914-C)	ENG/CHI (1001222745-A)
18		1001162864	1001162864	1001162864	1001162864	1001162864	1001162864	1001162864	1001162864	1001162864
19		1001211777	1001215751	1001215752	1001216650	1001215754	1001215754	1001219172	1001219172	1001215752
20		1001211779	1001211779	1001211779	1001215748	1001211779	1001211779	1001219171	1001219171	1001211779
21		1001212290	1001212290	1001212290	1001212290	1001212290	1001212290	1001212290	1001212290	1001212290
22		1001212291	1001212291	1001212291	1001212291	1001212291	1001212291	1001212291	1001212291	1001212291
23		1001212292	1001212292	1001212292	1001212292	1001212292	1001212292	1001212292	1001212292	1001212292
24		1001212293	1001212293	1001212293	1001212293	1001212293	1001212293	1001212293	1001212293	1001212293
25		1001146794	1001146794	1001146794	1001146794	1001146794	1001146794	1001146795	1001146794	1001146794
26		1703816	1001162115	1705195	1704699	1704691	1704691	—	—	1705195
27		—	1001215750	1001215747	1001216648	1001215748	1001215748	—	—	1001215747
28		—	—	1705944	—	—	—	—	—	1705944
29		—	—	1705945	—	—	—	—	—	1705945
30		—	—	1001132376	—	—	—	—	—	1001132376
31		1001092071	1001120621	1001120622	1001120623	1001120629	1001092580	1001092497	1001092497	1001120622
32		—	—	—	—	—	—	1001219171	1001219171	—
33		—	—	—	—	—	—	1001146795	—	—
34	prop 65	1001231801								
	y.i.	1001223055								
	ICES	1001228370								

NOTE: Refer to the applicable Illustrated Parts Manual for decal description.

6.8 DIAGNOSTIC TROUBLE CODES (DTC)

NOTICE

THE DTC CODES LISTED IN THE FOLLOWING TABLE IS NOT A COMPLETE LISTING OF MACHINE DTC CODES. THIS LISTING SHOWS ONLY THOSE DTC'S WHICH AN OPERATOR MAY BE ABLE TO CORRECT DUE TO OPERATING ERROR.

The DTC table following is sorted in groups by the first two digits, these digits represent the number of flashes the system distress indicator lamp will flash on the platform indicator panel when a fault occurs.

The more detailed three to five digit code numbers in the DTC column of the following tables are only indicated on a JLG handheld diagnostic analyzer connected to the machine, or on the Ground Control Station - MDI indicator, if equipped.

To troubleshoot multiple DTCs, start with the DTC with the higher first two digits.

If a correction is made during a check, conclude the check by cycling the machine power off then back on, using the emergency stop switch.

NOTICE

SHOULD A FAULT OCCUR WHICH CANNOT BE CORRECTED BY THE OPERATOR, THE PROBLEM MUST BE REFERRED TO A MECHANIC QUALIFIED TO REPAIR THIS MODEL OF JLG LIFT.

Table 6-13. Diagnostic Trouble Codes (DTC)

DTC	Help Message	Alarm	Flash Code	Action	Trigger
001	EVERYTHING OK	None	None	· No Motion restrictions	• Platform Mode and no Faults are active.
002	GROUND MODE OK	None	None	· No Motion restrictions	• Ground Mode and no Faults are active.
003	ALARM SOUNDING – TILTED & ABOVE ELEVATION	PF: Continuous	None	· No Motion restrictions	• Platform is elevated and chassis is not level
004	DRIVING AT CUTBACK – ABOVE ELEVATION	None	None	· DriveState = CREEP	• Platform is elevated and the machine is in the drive mode of operation
005	DRIVE & LIFT UP PREVENTED TILTED & ELEVATED	PF: Continuous	None	• DriveState = PREVENTED • LiftUpState = PREVENTED	• Driving and lift up are not possible since the platform is elevated and the chassis is not level.
006	LIFT UP PREVENTED – MAX HEIGHT ZONE A	None	None	• LiftUpState = PREVENTED	• The vehicle has reached the maximum height allowed by the Indoor/Outdoor selection and further lift up motion is not possible.
007	DRIVING AT CUTBACK – POTHOLE STILL ENGAGED	None	None	• DriveState = CREEP	<ul style="list-style-type: none"> • While stowed, drive speed is reduced (due to lower ground clearance) since the control system detected that the pot-hole protection mechanism is deployed (failed to retract). • Clear the obstacle blocking the pot-hole protection mechanism, repair the mechanical problem, re-adjust the pot-hole limit switches, or repair the wiring to correct the problem. • Alternately, there may be difficulty with the Elevation Angle Sensor that causes the Control System to improperly believe the platform is stowed.

SECTION 6 - GENERAL SPECIFICATIONS AND MAINTENANCE

Table 6-13. Diagnostic Trouble Codes (DTC)

DTC	Help Message	Alarm	Flash Code	Action	Trigger
008	FUNCTIONS LOCKED OUT – SYSTEM POWERED DOWN	None	None	<ul style="list-style-type: none"> • Enter SafeMode • LiftDownState = PREVENTED 	<ul style="list-style-type: none"> • A period of time elapsed without activity and the Control System entered a low-power state to preserve battery charge (2 hours). Cycle the Ground EMS in GroundMode or the Platform EMS in PlatformMode to re-enable the vehicle. • Two hours without Drive Forward, Drive Reverse, Lift Up, Lift Down, Steer Left, or Steer Right. • Timer resets if user changes PlatformMode/GroundMode
009	DRIVE PREVENTED – ELEVATED ABOVE DRIVE CUTOFF HEIGHT	None	None	<ul style="list-style-type: none"> • DriveState = PREVENTED 	<ul style="list-style-type: none"> • The Drive Cutout functionality is enabled, and the Platform is Elevated above the Calibrated Cutout Height.
211	POWER CYCLE	None	2_1	<ul style="list-style-type: none"> • No Motion restrictions 	<ul style="list-style-type: none"> • This Help Message is issued at each power-up. This serves to indicate which messages have been recorded in the failure log since the last power-up event.
212	KEYSWITCH FAULTY	None	2_1	<ul style="list-style-type: none"> • Force to GroundMode 	<ul style="list-style-type: none"> • Both the Ground Select and Platform Select signals are energized, which means there is an issue with the keyswitch or one of the lines are shorted to battery.
221	FUNCTION PROBLEM – HORN PERMANENTLY SELECTED	None	2_2	<ul style="list-style-type: none"> • Horn Prevented 	<ul style="list-style-type: none"> • Horn Switch in the Platform Control Box was closed during power-up. Release or repair the switch to clear the message.

SECTION 6 - GENERAL SPECIFICATIONS AND MAINTENANCE

Table 6-13. Diagnostic Trouble Codes (DTC)

DTC	Help Message	Alarm	Flash Code	Action	Trigger
2210	TRIGGER CLOSED TOO LONG WHILE IN NEUTRAL	None	2_2	<ul style="list-style-type: none"> • TriggerState = FALSE there-fore • DriveState = PREVENTED • LiftUpState = PREVENTED • LiftDownState = PREVENTED 	<ul style="list-style-type: none"> • Trigger Switch on the Platform Control Box was closed for more than five seconds while the Joystick (accelerator) was in the neutral position (centered). Release switch or repair the switch / wiring to clear the difficulty.
222	FUNCTION PROBLEM – INDOOR / OUT-DOOR PERMANENTLY SELECTED	None	2_2	<ul style="list-style-type: none"> • Previously selected Indoor / Outdoor Mode maintained 	<ul style="list-style-type: none"> • Indoor / Outdoor Switch in the Platform Control Box was closed during power-up. Release or repair the switch to clear the message.
223	FUNCTION PROBLEM – DRIVE & LIFT ACTIVE TOGETHER	None	2_2	<ul style="list-style-type: none"> • MoveState = LIFT • DriveState = PREVENTED • LiftUpState = PREVENTED • LiftDownState = PREVENTED 	<ul style="list-style-type: none"> • The Drive - Lift Selector Switch indicates that both functions are selected simultaneously. Repair the wiring or switch to clear the message.
2232	FUNCTION PROBLEM – DRIVE & LIFT BOTH OPEN	None	2_2	<ul style="list-style-type: none"> • MoveState = LIFT • DriveState = PREVENTED • LiftUpState = PREVENTED • LiftDownState = PREVENTED 	<ul style="list-style-type: none"> • In PlatformMode, the Drive - Lift Selector Switch indicates that neither function is selected. Repair the wiring or switch to clear the message.
224	FUNCTION PROBLEM – STEER LEFT PERMANENTLY SELECTED	None	2_2	<ul style="list-style-type: none"> • DriveState = PREVENTED 	<ul style="list-style-type: none"> • Steer Left Switch in the Platform Control Box was closed during power-up. Release or repair the switch to clear the message.

SECTION 6 - GENERAL SPECIFICATIONS AND MAINTENANCE

Table 6-13. Diagnostic Trouble Codes (DTC)

DTC	Help Message	Alarm	Flash Code	Action	Trigger
225	FUNCTION PROBLEM – STEER RIGHT PERMANENTLY SELECTED	None	2_2	• DriveState = PREVENTED	• Steer Right Switch in the Platform Control Box was closed during power-up. Release or repair the switch to clear the message.
228	FUNCTION LOCKED OUT – ACCELERATOR NOT CENTERED	None	2_2	• DriveState = PREVENTED • LiftUpState = PREVENTED • LiftDownState = PREVENTED	• Selected function (Drive or Lift) is not allowed because the joystick (accelerator) was not centered at power-up. Return joystick to center momentarily.
229	FUNCTION PROBLEM – TRIGGER PERMANENTLY CLOSED	None	2_2	• DriveState = PREVENTED • LiftUpState = PREVENTED • LiftDownState = PREVENTED	• Trigger Switch in the Platform Control Box was closed at power-up. Release switch or repair the switch / wiring to clear the difficulty.
231	FUNCTION PROBLEM – LIFT PERMANENTLY SELECTED	None	2_3	In GroundMode then • LiftUpState = PREVENTED • LiftDownState = PREVENTED	• Lift Switch (Up or Down) in the Ground Control Box was closed during power-up. Release or repair the switch to clear the message.
232	GROUND LIFT UP/DOWN ACTIVE TOGETHER	None	2_3	In GroundMode then • LiftUpState = PREVENTED • LiftDownState = PREVENTED	• In GroundMode, the control system has detected the Lift Up and Down are active simultaneously. Check the Lift Switch and associated wiring in the Ground Control Box.
242	AMBIENT TEMPERATURE SENSOR – OUT OF RANGE HIGH	PF: Continuous	2_4	• Drive and Lift Restrictions	• The temperature as communicated by the temperature/tilt sensor is greater than 185° F (85° C).
253	DRIVE PREVENTED – CHARGER CONNECTED	None	2_5	• DriveState = PREVENTED	• Driving is not possible since the vehicle is charging.
254	DRIVE & LIFT UP PREVENTED – CHARGER CONNECTED	None	2_5	• DriveState = PREVENTED • LiftUpState = PREVENTED	• Driving and Lifting are not possible since the vehicle is charging and it is configured to prevent all motion.

Table 6-13. Diagnostic Trouble Codes (DTC)

DTC	Help Message	Alarm	Flash Code	Action	Trigger
255	PLATFORM OVERLOADED	PF: 5000ms ON/2000ms OFF GND: 5000ms ON/2000ms OFF	2_5	• Drive and Lift Restrictions	<ul style="list-style-type: none"> • While the Load Sensing System is enabled, the Platform Load measured by the Load Sensing System is excessive. Functions from Platform Control Station are prevented, and functions from Ground Control may be prevented, depending on machine configuration (Markets other than Japan). • For the Japanese Market, only Lift Up is prevented and Drive (at creep speed) is allowed in the stowed position . • Refer to LSS functionality for Lift and Drive restrictions.
256	DRIVE PREVENTED – POTHOLE NOT ENGAGED	PF: 500ms On/ 500ms Off GND: 500ms On/500ms Off	2_5	• DriveState = PREVENTED	<ul style="list-style-type: none"> • While elevated, driving is not possible since the control system detected that the pot-hole protection mechanism failed to deploy. Clear the obstacle blocking the pot-hole protection mechanism, repair the mechanical problem, re-adjust the pot-hole limit switches, or repair the wiring to correct the problem. • Alternately, there may be difficulty with the Elevation Angle Sensor that causes the Control System to improperly believe the platform is elevated.

SECTION 6 - GENERAL SPECIFICATIONS AND MAINTENANCE

Table 6-13. Diagnostic Trouble Codes (DTC)

DTC	Help Message	Alarm	Flash Code	Action	Trigger
2568	TEMPERATURE CUTOUT ACTIVE - AMBIENT TEMPERATURE TOO LOW	If Transport-Mode = TRUE PF: Continuous If Transport-Mode = FALSE PF: OFF	2_5	<ul style="list-style-type: none"> • Drive and Lift Restrictions 	<ul style="list-style-type: none"> • The temperature as communicated by the temperature sensor located on the temperature/tilt sensor is less than or equal to {PERSONALITIES->TEMP CUTOUT->CUTOUT SET} • (See Low Temperature Cutout Functionality) • This DTC shall not be displayed in GroundMode, and no restrictions shall be implemented.
421	POWER MODULE TOO HOT - PLEASE WAIT	None	4_2	<ul style="list-style-type: none"> • DriveState = PREVENTED • LiftUpState = PREVENTED 	<ul style="list-style-type: none"> • Heatsink temperature above 203°F (95° C). • Possible Cause: • Controller is operating in an extreme environment. • Excessive load on vehicle. • Improper mounting of controller
4235	POWER MODULE TOO HOT - REDUCED OPERATION	None	4_2	<ul style="list-style-type: none"> • DriveState = CREEP • LiftUpState = CREEP 	<ul style="list-style-type: none"> • Heatsink temperature exceeded 185° F (85° C). • Effect: Reduced drive and brake torque. • Possible Cause: • Controller is performance-limited at this temperature. • Controller is operating in an extreme environment. • Excessive load on vehicle • Improper mounting of controller.
4236	POWER MODULE TOO COLD - MODULE SHUTDOWN	None	4_2	<ul style="list-style-type: none"> • DriveState = PREVENTED • LiftUpState = PREVENTED 	<ul style="list-style-type: none"> • Heatsink temperature below -40° F(-40°C). • Possible Cause: • Controller is operating in an extreme environment.

SECTION 6 - GENERAL SPECIFICATIONS AND MAINTENANCE

Table 6-13. Diagnostic Trouble Codes (DTC)

DTC	Help Message	Alarm	Flash Code	Action	Trigger
426	MASTER MODULE TEMPERATURE – OUT OF RANGE	None	4_2	• Normal operation	• The Ground Module's internal temperature sensor is out of range. (< 104° F (40° C) or > 302° F (150° C)
441	BATTERY VOLTAGE TOO LOW – SYSTEM SHUTDOWN	None	4_4	• SafeMode • LiftDownState = PREVENTED	• Battery Voltage(VBAT) momentarily dropped below 14.5V when using flooded lead-acid batteries, or 16.0V when using AGM batteries. With a low battery charge, this can occur during heavy current demand due to Drive, Steer, or Lift Up. Recharge batteries or check for damaged batteries, sulfated batteries, or poor power connections.
442	BATTERY VOLTAGE TOO HIGH – SYSTEM SHUTDOWN	None	4_4	• Enter SafeMode • LiftDownState = MAX	• The Ground Module measured excessively high battery voltage (VBAT) (>32.0V) and de-energized the Main Line Contactor and Battery Relay to protect system devices and was unable to bring voltage down to normal operating range. This may be due to improper battery charging or incorrect voltage batteries being used.
4421	LOGIC SUPPLY VOLTAGE OUT OF RANGE HIGH	None	4_4	• Enter SafeMode • LiftDownState = MAX	• The Ground Module's VSW voltage was measured to be more than 32V. This may be caused by loose battery terminal, severely discharge batteries, a damaged battery, or an improper wire harness connection.

SECTION 6 - GENERAL SPECIFICATIONS AND MAINTENANCE

Table 6-13. Diagnostic Trouble Codes (DTC)

DTC	Help Message	Alarm	Flash Code	Action	Trigger
4424	POWER MODULE VOLTAGE TOO LOW - MODULE SHUTDOWN	None	4_4	<ul style="list-style-type: none"> • DriveState = PREVENTED • LiftUpState = PREVENTED 	<ul style="list-style-type: none"> • Severe B+ Undervoltage Set: Capacitor bank voltage dropped below Severe Undervoltage limit with FET bridge enabled. • Effect: Reduced Drive Torque • Possible Cause: <ul style="list-style-type: none"> • Battery menu parameters are misadjusted • Non-controller system drain on battery • Battery resistance too high • Battery disconnected while driving • Blown B+ fuse or main contactor not closed
4475	POWER MODULE - BDI FAULT	None	4_4	<ul style="list-style-type: none"> • DriveState = PREVENTED • LiftUpState = PREVENTED 	<ul style="list-style-type: none"> • Pump BDI Fault Set: BDI Percentage charge at 0% when the pump was activated. • Effect: ShutdownPump • Possible Cause: <ul style="list-style-type: none"> • Battery is fully discharged • BDI parameters are mis-tuned
4476	BATTERY VOLTAGE TOO HIGH – UNPLUG CHARGER	None	4_4	<ul style="list-style-type: none"> • Enter SafeMode • LiftDownState = MAX 	<ul style="list-style-type: none"> • The Ground Module momentarily measured excessively high battery voltage (VBAT) (>32.0V) and entered SafeMode to protect system devices. This may be due to improper battery charging or incorrect voltage batteries being used.

Table 6-13. Diagnostic Trouble Codes (DTC)

DTC	Help Message	Alarm	Flash Code	Action	Trigger
4477	BATTERY VOLTAGE TOO HIGH – FORCING DISCHARGE	None	4_4	Lift Down = PREVENTED Lift Up = PREVENTED Drive = PREVENTED	<ul style="list-style-type: none"> The Ground Module momentarily measured excessively high battery voltage (VBAT) (>32.0V) and entered SafeMode. This may be due to improper battery charging or incorrect voltage batteries being used.

TO PURCHASE THIS PRODUCT PLEASE CONTACT US



**Equipment Financing and
Extended Warranties Available**



**Discount-Equipment.com is your online resource for
commercial and industrial quality parts and equipment sales.**

561-964-4949

visit us on line @ www.discount-equipment.com

Select an option below to find your Equipment

Search by Manufacturer

Search by Product Type

Request a Quote

We sell worldwide for the brands: Genie, Terex, JLG, MultiQuip, Mikasa, Essick, Whiteman, Mayco, Toro Stone, Diamond Products, Generac Magnum, Airman, Haulotte, Barreto, Power Blanket, Nifty Lift, Atlas Copco, Chicago Pneumatic, Allmand, Miller Curber, Skyjack, Lull, Skytrak, Tsurumi, Husquvarna Target, Stow, Wacker, Sakai, Mi-T-M, Sullair, Basic, Dynapac, MBW, Weber, Bartell, Bennar Newman, Haulotte, Ditch Runner, Menegotti, Morrison, Contec, Buddy, Crown, Edco, Wyco, Bomag, Laymor, EZ Trench, Bil-Jax, F.S. Curtis, Gehl Pavers, Heli, Honda, ICS/PowerGrit, IHI, Partner, Imer, Clipper, MMD, Koshin, Rice, CH&E, General Equipment, Amida, Coleman, NAC, Gradall, Square Shooter, Kent, Stanley, Tamco, Toku, Hatz, Kohler, Robin, Wisconsin, Northrock, Oztec, Toker TK, Rol-Air, APT, Wylie, Ingersoll Rand / Doosan, Innovatech, Con X, Ammann, Mecalac, Makinex, Smith Surface Prep, Small Line, Wanco, Yanmar

JLG[®]

An Oshkosh Corporation Company

**Discount
Equipment**

www.Discount-Equipment.com

To order go to www.Discount-Equipment.com