

OPERATION & MAINTENANCE MANUAL

EXCAVATOR

Vi035-6A (US)

(S/N AH590 & Above)



www.discount-equipment.com

YANMAR

PARTS FINDER

**Search Website
by Part Number**



**Search Manual
Library For Parts
Manual & Lookup Part
Numbers – Purchase
or Request Quote**

Search Manuals

Enter your information to help us find the right parts manual for your machine.

* Brand:

* Model:

* Serial:

* Part Number:

SEARCH

**Can't Find Part or
Manual? Request Help
by Manufacturer,
Model & Description**

Parts Order Form

Please fill in the following information to help us find the right part for your machine.

Manufacturer:	<input type="text"/>
Model:	<input type="text"/>
Description:	<input type="text"/>
Part Number:	<input type="text"/>
Quantity:	<input type="text"/>
Notes:	<input type="text"/>

Submit

Discount-Equipment.com is your online resource for quality parts & equipment.

Florida: **561-964-4949** Outside Florida TOLL FREE: **877-690-3101**

Need parts?

Click on this link: <http://www.discount-equipment.com/category/5443-parts/> and choose one of the options to help get the right parts and equipment you are looking for. Please have the machine model and serial number available in order to help us get you the correct parts. If you don't find the part on the website or on one of the online manuals, please fill out the request form and one of our experienced staff members will get back to you with a quote for the right part that your machine needs.

We sell worldwide for the brands: Genie, Terex, JLG, MultiQuip, Mikasa, Essick, Whiteman, Mayco, Toro Stone, Diamond Products, Generac Magnum, Airman, Haulotte, Barreto, Power Blanket, Nifty Lift, Atlas Copco, Chicago Pneumatic, Allmand, Miller Curber, Skyjack, Lull, Skytrak, Tsurumi, Husquvarna Target, Stow, Wacker, Sakai, Mi-T-M, Sullair, Basic, Dynapac, MBW, Weber, Bartell, Bennar Newman, Haulotte, Ditch Runner, Menegotti, Morrison, Contec, Buddy, Crown, Edco, Wyco, Bomag, Laymor, EZ Trench, Bil-Jax, F.S. Curtis, Gehl Pavers, Heli, Honda, ICS/PowerGrit, IHI, Partner, Imer, Clipper, MMD, Koshin, Rice, CH&E, General Equipment, Amida, Coleman, NAC, Gradall, Square Shooter, Kent, Stanley, Tamco, Toku, Hatz, Kohler, Robin, Wisconsin, Northrock, Oztec, Toker TK, Rol-Air, APT, Wylie, Ingersoll Rand / Doosan, Innovatech, Con X, Ammann, Mecalac, Makinex, Smith Surface Prep, Small Line, Wanco, Yanmar

Read this manual carefully to learn how to operate and service your machine correctly. Failure to do so could result in personal injury or machine trouble.

This manual is the permanent part of your machine, when you sell your machine, hand it together with machine.

This machine had been designed by metric. Accordingly, dimensions mentioned in this manual are metric.

Discrimination of right side and left side for the machine are determined based on the machine posture, in where the blade is in front. i.e. Right side of the operator is machine's right side when the operator seats toward the blade.

The machine operated and serviced correctly has the warranty that is the YANMAR product support program. However, in case of the abuse or modification without permission of YANMAR, the warranty does not become the subject and also product improvement program may not become the subject.

All information, illustrations and specifications in this manual are based on the latest product information available at the time of publication. The right is reserved to make changes at any time without notice.

REFERENCE INFORMATION

Write the correct information for your YANMAR Excavator in the spaces bellow.

Always use these numbers when referring to your YANMAR Excavator.

Model name : _____
Serial Number : _____
Engine Serial Number : _____
Your YANMAR Excavator Dealer : _____
Address : _____
Phone : _____

CALIFORNIA Proposition 65 WARNING

Diesel engine exhaust and some of its constituents are known to the State of California to cause cancer, birth defects, and other reproductive harm.

1. Introduction

This Operation and Maintenance Manual for the YANMAR ViO35-6A Excavator is designed to provide you with important information and suggestions necessary for using the machine with safety and efficiency. Please be sure to read through the manual before using the machine, to make yourself familiar with the procedures and instructions for operating, inspecting and servicing. Keep in mind that failure to observe the precautions given in the manual or using any procedures not prescribed in the manual may cause a serious accident.

⚠ WARNING

Improper use of the machine may lead to hazards which can result in death or serious injury.

Personnel engaged in operating and maintaining the machine are required to familiarize themselves with the contents of the manual before setting about their job.

- **Do not attempt to operate the machine before making yourself familiar with the contents of the manual.**
- **Personnel responsible for using the machine must keep the manual at hand and review it periodically.**
- **If the manual should be lost or damaged, promptly order a new copy from the dealer.**
- **When you transfer the machine to another user, always transfer the manual as well.**
- **We at YANMAR provide customers with products in compliance with applicable your country's regulations and industrial standards. If you are using a YANMAR machine purchased abroad, the machine may lack some safety devices. Please consult your dealer to confirm whether or not that machine is in compliance with applicable your country's regulations and industrial standards.**
- **Some machine specifications may differ from those which are described in this manual because of improvements in its design and performance. If you have any questions about the contents of the manual, don't hesitate to contact your dealer.**
- **Important safety instructions have been presented throughout this manual, and have been summarized in PART ONE : SAFETY. Be sure to review these pages and pay heed to those safety instructions before proceeding to operate the machine.**

2. Safety Information

The following Signal Words have been used in this Manual and on the Safety Signs to indicate the seriousness of the hazards that could be encountered by failing to comply with the applicable Product Warnings, as follows:

⚠ DANGER

The word "DANGER" indicates an imminently hazardous situation which, if not avoided, will result in death or serious injury. "DANGER" is limited to the most extreme situations.

⚠ WARNING

The word "WARNING" indicates a potentially hazardous situation which, if not avoided, could result in death or serious injury.

⚠ CAUTION

The word "CAUTION" indicates a potentially hazardous situation which, if not avoided, may result in minor or moderate injury.

IMPORTANT

The signal Word "IMPORTANT" has been utilized in this Manual to denote those User Directions that must be followed to assure the safe operation and maintenance of the Excavator.

- **WARNING** : Never attempt to operate or service this Excavator until you have first read and understood all of the applicable Product Warnings and User Directions that are set forth in this Manual and on the Safety Signs that are affixed to this Excavator.
The failure to comply with all relevant Safety Instructions could result in bodily injury.
- **WARNING** : Never modify the design of this Excavator or its engine; never remove or disable any of the installed safety guards or devices; and never use any unauthorized attachments in the operation of this equipment.

The implementation of any unauthorized design modifications or the use of unauthorized attachments could result in bodily injury.

Furthermore, since those actions would expressly violate the terms of Yanmar's Product Warranty, the applicable Warranty would also be voided.

In this Manual, the major sections of the product are designated as follows:

Machine.....refers to the entire product.

Machine base.....refers to the section consisting of the upper-structure and the undercarriage.

Implement.....refers to the section consisting of the arm, boom and bucket or other attachment.

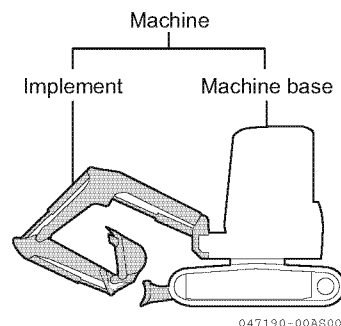

047190-00AS00

3. Product Overview

3.1 Intended uses

The ViO35-6A Excavator is intended to perform the following tasks:

- Digging
- Leveling of ground
- Shoveling
- Ditching and Guttering
- Loading

The machine should not be used for unintended tasks

For the details of how to work with the machine, refer to OPERATION Section "3. Operations using the bucket" on page 176.

3.2 Break in period

The machine should not be subjected to severe stresses and loads during the initial break in period although it has been prepared well and stringently inspected before shipping. Otherwise the machine's performance may be affected and its service life shortened. Thus it is essential to break in the machine for the first approx. 100 service hours (reading of the hour meter).

In breaking in the machine:

- You should warm up the engine by idling for 5 minutes before starting operations.
- You should not operate the machine under heavy loads or at high speed.
- You should not start and accelerate the engine too abruptly, or stop it too abruptly.
- You should not change travel direction too abruptly.

The safety instructions for operation and maintenance that are presented in this Manual are applicable to each of the intended tasks. Never misuse this machine by violating the applicable safety instructions or by attempting to perform unintended tasks, because of the danger of serious bodily injury.

3.3 Conditions to insure compliance with EPA emission standards

Conditions de conformité avec les standards d'émission EPA

An EPA approved engine has been mounted on this machine. The following are the conditions that must be met in order to insure that the emission during operation meets the EPA standards. Be sure to follow these.

The surrounding conditions should be as follows.

(1) Ambient temperature : -4 to 104°F (-20 to 40°C)

(2) Relative humidity : 80% or lower

The fuel and lube oil used should be as follows.

(1) Fuel : Diesel light oil ASTM D975 No.1D S15, S500 or No.2D S15, S500 (ISO 8217 DMX)

- The fuel cetane number should be equal to 45 or higher.
- The sulfur content must not exceed 0.5% by volume. Less than 0.05% is preferred.

In general, using a high sulfur fuel may possible result in corrosion inside the cylinder.

Especially in U.S.A. and Canada, Ultra Low Sulfur fuel should be used.

- The water and sediment in the fuel should not exceed 0.05% by volume.

(2) Lube oil : Type API, class CF

- Do not remove the seals limiting the amount of fuel injected and the speed.
- Be sure to carry out inspections.

Follow the basic guidelines outlined in Section "7. Maintenance Table" on page 252 of this manual, and keep a record of the results. Pay particular attention to these important points: replacing the lube oil and lube oil filter, cleaning the air cleaning the air cleaner element and the radiator fins.

Un moteur thermique agréé EPA est installé sur cette machine. A la suite figurent les conditions d'utilisation permettant de satisfaire au standard EPA; il est impératif de les respecter.

Environnement extérieur:

(1) Température ambiante : -4 à 104°F (-20 à 40°C)

(2) Humidité relative : 80 % au moins

Carburant et huiles à utiliser

(1) Carburant : Diesel léger ASTM D975 N° 1D S15, S500 ou N° 2D S15, S500 (ISO 8217 DMX)

- *L'indice de cétane du carburant doit être égal ou supérieur à 45.*
- *La teneur en soufre ne doit pas dépasser 0,5% par volume. Moins de 0,05% est préférable.*

En général, l'utilisation d'un carburant à teneur élevée en soufre peut entraîner une corrosion à l'intérieur du vérin.

Aux U.S.A. et au Canada notamment, l'utilisation d'un carburant à très basse teneur en soufre est recommandée.

- *L'eau et les sédiments présents dans le carburant ne doivent pas dépasser 0,05% par volume.*

(2) Huiles : type API, classe CF

- *Ne pas retirer les joints limitant la quantité de carburant injecté et la vitesse*
- *Respecter les inspections périodiques*

Suivre les indications figurant dans ce manuel (Table de maintenance 252) et garder une trace des résultats. Faire très attention aux points importants suivant: remplacer l'huile et le filtre à huile, nettoyer l'élément de filtre à air et le radiateur.

Go to Discount-Equipment.com to order your parts

3.4 Emission system warranty

Garantie du système antipollution

YANMAR CO., LTD. Emission Control System Warranty - USA Only

■ Your warranty rights and obligations

- California

The California Air Resources Board (CARB), the United State Environmental Protection Agency (EPA) and YANMAR CO., LTD. hereafter referred to as YANMAR, are pleased to explain the **emission control system warranty** on your 2016, 2017, or 2018 model year industrial compression-ignition engine.

California-certified, new off-road compression-ignition engines must be designed, built and equipped to meet the State's stringent anti-smog standards. In the remaining forty nine (49) states, new non-road compression-ignition engines must be designed, built and equipped to meet the United States EPA emissions standards. YANMAR must warrant the emission control system on your engine for the periods of time listed below provided there has been no abuse, neglect or improper maintenance of your engine.

Your emission control system may include parts such as the fuel injection system, the air induction system, the electronic control system, EGR (Exhaust Gas Recirculation) system and the diesel particulate filter system. Also included may be hoses, belts, connectors and other emission-related assemblies.

Where a warrantable condition exists, YANMAR will repair your off-road compression-ignition engine at no charge to you including diagnosis, parts and labor.

Go to Discount-Equipment.com to Order your parts

■ Manufacturer's Warranty Period

2016, 2017, or 2018 model year off-road compression-ignition engines are warranted for the periods listed below. If any emission-related part on your engine is found to be defective during the applicable warranty period, the part will be repaired or replaced by YANMAR.

If your engine is certified as	And its maximum power is	And its rated speed is	Then its warranty period is
Variable speed or constant speed	$\text{kW} < 19$	Any speed	1,500 hours or two (2) years whichever comes first. In the absence of a device to measure the hours of use, the engine has a warranty period of two (2) years.
Constant speed	$19 \leq \text{kW} < 37$	3,000 rpm or higher	1,500 hours or two (2) years whichever comes first. In the absence of a device to measure the hours of use, the engine has a warranty period of two (2) years.
Constant speed	$19 \leq \text{kW} < 37$	Less than 3,000 rpm	3,000 hours or five (5) years whichever comes first. In the absence of a device to measure the hours of use, the engine has a warranty period of five (5) years.
Variable speed	$19 \leq \text{kW} < 37$	Any speed	3,000 hours or five (5) years whichever comes first. In the absence of a device to measure the hours of use, the engine has a warranty period of five (5) years.
Variable speed or constant speed	$\text{kW} \geq 37$	Any speed	3,000 hours or five (5) years whichever comes first. In the absence of a device to measure the hours of use, the engine has a warranty period of five (5) years.

■ Warranty Coverage

This warranty is transferable to each subsequent purchaser for the duration of the warranty period. Repair or replacement of any warranted part will be performed at an authorized YANMAR dealer.

Warranted parts not scheduled for replacement as required maintenance in the owner's manual shall be warranted for the warranty period. Warranted parts scheduled for replacement as required maintenance in the owner's manual are warranted for the period of time prior to the first scheduled replacement. Any warranted parts scheduled for replacement as required maintenance that are repaired or replaced under warranty shall be warranted for the remaining period of time prior to the first scheduled replacement. Any part not scheduled for replacement that is repaired or replaced under warranty shall be warranted for the remaining warranty period.

During the warranty period, YANMAR is liable for damages to other engine components caused by the failure of any warranted part during the warranty period.

Any replacement part which is functionally identical to the original equipment part in all respects may be used in the maintenance or repair of your engine, and shall not reduce YANMAR's warranty obligations. Add-on or modified parts that are not exempted may not be used. The use of any non-exempted add-on or modified parts shall be grounds for disallowing a warranty.

■ Warranted Parts

This warranty covers engine components that are a part of the emission control system of the engine as delivered by YANMAR to the original retail purchaser. Such components may include the following:

- Fuel injection system (including Altitude compensation system)
- Cold start enrichment system
- Intake manifold and Air intake throttle valve
- Turbocharger systems
- Exhaust manifold and exhaust throttle valve
- Positive crankcase ventilation system
- Charge Air Cooling systems (only 4TNV94CHT)
- Exhaust Gas Recirculation (EGR) systems
- Exhaust gas after treatment (diesel particulate filter system)
- Electronic Control units, sensors, solenoids and wiring harnesses used in above systems
- Hoses, belts, connectors and assemblies used in above systems
- Emission Control Information Labels

Since emissions related parts may vary slightly between models, certain models may not contain all of these parts and other models may contain the functional equivalents.

■ Exclusions

Failures other than those arising from defects in material or workmanship are not covered by this warranty. The warranty does not extend to the following: malfunctions caused by abuse, misuse, improper adjustment, modification, alteration, tampering, disconnection, improper or inadequate maintenance, or use of non-recommended fuels and lubricating oils; accident-caused damage and replacement of expendable items made in connection with scheduled maintenance. YANMAR disclaims any responsibility for incidental or consequential such as loss of time, inconvenience, loss of use of equipment/engine or commercial loss.

■ Owner's Warranty Responsibilities

As the off-road compression-ignition engine owner, you are responsible for the performance of the required maintenance listed in your owner's manual. YANMAR recommends that you retain all documentation, including receipts, covering maintenance on your off-road compression-ignition engine, but YANMAR cannot deny warranty solely for the lack of receipts, or for your failure to ensure the performance of all scheduled maintenance.

YANMAR may deny your warranty coverage if your off-road compression-ignition engine or a part has failed due to abuse, neglect, improper maintenance or unapproved modifications.

Your engine is designed to operate on diesel fuel only. Use of any other fuel may result in your engine no longer operating in compliance with CARB and EPA emissions requirements.

You are responsible for initiating the warranty process. You must present your engine to a YANMAR dealer as soon as a problem exists. The warranty repairs should be completed by the dealer as expeditiously as possible. If you have any questions regarding your warranty rights and responsibil-

ities, or would like information on the nearest YANMAR dealer or authorized service center, you should contact YANMAR America Corporation.

YANMAR Co., Ltd. Garantie de conformité du système de contrôle des émissions - États-Unis seulement

■ *Votre garantie : vos droits et vos obligations*

• *Californie*

*Le California Air Resources Board (CARB), l'Agence américaine de protection de l'environnement (EPA) et YANMAR CO., LTD. ci-après appelée YANMAR, se font un plaisir de vous expliquer les conditions de la **garantie de conformité du système antipollution** de votre moteur industriel à allumage par compression des années-modèles 2016, 2017 ou 2018.*

Les nouveaux moteurs non routiers à allumage par compression certifiés en Californie doivent être conçus, construits et équipés de façon à satisfaire les normes antipollution strictes en vigueur dans cet État. Dans les quarante-neuf (49) autres États, les nouveaux moteurs non routiers à allumage par compression doivent être conçus, construits et équipés afin de respecter les normes strictes de réglementation antipollution de l'EPA. YANMAR doit garantir le système de contrôle des émissions de votre moteur pour les périodes indiquées ci-dessous, à la condition qu'ils n'aient pas fait l'objet d'un usage abusif, d'une négligence ou d'un manque d'entretien.

Le système de contrôle des émissions peut inclure des composantes telles que le système d'injection de carburant, le système d'admission d'air, le système de commande électronique, le système de recirculation des gaz d'échappement et le système de filtres à particules pour le diesel. Des flexibles, courroies, connecteurs et autres unités associées au contrôle des émissions peuvent également être inclus.

Dans l'éventualité d'un problème couvert par la garantie, YANMAR réparera gratuitement le moteur non routier à allumage par compression, ce qui inclut les frais pour le diagnostic, les pièces et la main-d'œuvre.

■ Période de garantie par le fabricant

Les moteurs non routiers à allumage par compression des années-modèles 2016, 2017 ou 2018 sont garantis pendant les périodes indiquées ci-dessous. Si toute composante de votre moteur en lien avec les émissions est jugée défectueuse pendant la période de garantie applicable, cette pièce sera réparée ou remplacée par YANMAR.

<i>Si votre moteur est certifié</i>	<i>A une vitesse maximale de</i>	<i>Une vitesse nominale de</i>	<i>La période de garantie est de</i>
<i>Vitesse variable ou constante</i>	$kW < 19$	<i>Toutes les vitesses</i>	<i>1500 heures ou deux (2) ans, selon l'éventualité qui survient en premier. S'il est impossible de déterminer le nombre d'heures d'utilisation du moteur, sa période de garantie est de deux (2) ans.</i>
<i>Vitesse constante</i>	$19 \leq kW < 37$	<i>3000 t/m et plus</i>	<i>1500 heures ou deux (2) ans, selon l'éventualité qui survient en premier. S'il est impossible de déterminer le nombre d'heures d'utilisation du moteur, sa période de garantie est de deux (2) ans.</i>
<i>Vitesse constante</i>	$19 \leq kW < 37$	<i>Moins de 3000 t/m</i>	<i>3000 heures ou cinq (5) ans, selon l'éventualité qui survient en premier. S'il est impossible de déterminer le nombre d'heures d'utilisation du moteur, sa période de garantie est de cinq (5) ans.</i>
<i>Vitesse variable</i>	$19 \leq kW < 37$	<i>Toutes les vitesses</i>	<i>3000 heures ou cinq (5) ans, selon l'éventualité qui survient en premier. S'il est impossible de déterminer le nombre d'heures d'utilisation du moteur, sa période de garantie est de cinq (5) ans.</i>
<i>Vitesse variable ou constante</i>	$kW \geq 37$	<i>Toutes les vitesses</i>	<i>3000 heures ou cinq (5) ans, selon l'éventualité qui survient en premier. S'il est impossible de déterminer le nombre d'heures d'utilisation du moteur, sa période de garantie est de cinq (5) ans.</i>

■ Couverture de la garantie

Cette garantie est transférable à tout acquéreur subséquent pour la durée de la garantie. La réparation ou le remplacement de toute pièce sous garantie sera effectuée chez un concessionnaire YANMAR autorisé.

Toute pièce garantie, pour laquelle le guide du propriétaire ne prévoit aucun remplacement dans le calendrier des entretiens requis, est garantie pour la période de garantie précisée. Toute pièce garantie, pour laquelle le guide du propriétaire prévoit le remplacement dans le cadre d'un entretien requis, est garantie pour la période précédant le premier remplacement prévu. Toute pièce garantie, pour laquelle un remplacement est prévu dans le cadre d'un entretien requis, qui est réparée ou remplacée pendant la période de garantie, sera garantie pour la période de garantie restante avant le premier remplacement prévu. Toute pièce garantie, pour laquelle aucun remplacement n'est prévu et qui est réparée ou remplacée pendant la période de garantie, sera garantie pour la période de garantie restante.

Pendant la période de garantie, YANMAR est responsable des dommages causés aux autres éléments du moteur par le bris d'une pièce toujours garantie.

Toute pièce de remplacement dont la fonction est identique à la pièce originale peut être utilisée pour l'entretien ou la réparation de votre moteur sans réduire les obligations de YANMAR en fonction de la garantie. Les pièces ajoutées ou modifiées peuvent être utilisées à moins qu'il y ait contre-indication. L'utilisation de toute pièce ajoutée ou modifiée contre-indiquée sera un motif de révocation de la garantie.

■ **Pièces garanties**

Cette garantie couvre les composantes du moteur qui font partie du système antipollution du moteur tel que livré par YANMAR à l'acheteur original. Ces composantes peuvent comprendre les éléments suivants :

- *Système d'injection de carburant (y compris le système de compensation d'altitude)*
- *Système d'enrichissement pour démarrage à froid*
- *Tubulure d'admission et papillon de la soupape d'admission d'air*
- *Système de turbochargement*
- *Collecteur d'échappement et papillon d'échappement*
- *Système de ventilation positive du carter*
- *Systèmes de refroidissement de l'air de suralimentation (4TNV94CHT uniquement)*
- *Système de recirculation des gaz d'échappement*
- *Système de traitement des gaz d'échappement (système de filtres à particules pour le diesel)*
- *Boîtiers, capteurs, solénoïdes et faisceaux de câblage du boîtier de commande utilisés dans les systèmes indiqués ci-dessus*
- *Flexibles, courroies, connecteurs et autres ensembles utilisés dans les systèmes indiqués ci-dessus*
- *Étiquettes d'information sur le contrôle des émissions*

Comme les pièces du système antipollution peuvent varier légèrement d'un modèle à l'autre, elles peuvent avoir une fonction équivalente ou ne pas être présentes sur certains modèles.

■ **Exclusions**

Les défauts autres que celles qui résultent d'un vice de matière ou de fabrication ne sont pas couvertes par la présente garantie. La garantie ne couvre pas les mauvais fonctionnements découlant de tout usage abusif, mauvaise utilisation, ajustement inapproprié, modification, altération, trafiquage, déconnexion, entretien inapproprié ou inadéquat ou utilisation de carburants et d'huiles de graissage non recommandés, ainsi que tout accident ayant causé des dommages et exigé le remplacement d'articles de consommation en lien avec l'entretien prévu. YANMAR n'assume aucune responsabilité pour tout dommage incident ou consécutif, comme une perte de temps, des inconvénients, l'impossibilité d'utiliser l'équipement ou le moteur ou toute perte commerciale.

■ Obligations du propriétaire

En tant que propriétaire d'un moteur non routier à allumage par compression, vous êtes responsable d'effectuer l'entretien requis indiqué dans votre guide de propriétaire. YANMAR recommande que vous conserviez toute documentation, y compris les reçus, couvrant l'entretien de votre moteur non routier à allumage par compression, mais YANMAR ne pourra refuser d'effectuer les réparations couvertes par la garantie simplement du fait que vous n'avez pas conservé ces reçus ou en raison de votre manquement à effectuer tous les entretiens prévus.

YANMAR peut refuser d'effectuer les réparations couvertes par la garantie si votre moteur non routier à allumage par compression ou une pièce de celui-ci a arrêté de fonctionner en raison d'un usage abusif, d'une négligence, d'un entretien inapproprié ou de modifications non approuvées.

Votre moteur est conçu pour ne fonctionner qu'avec du carburant diesel. L'utilisation de tout autre carburant dans le moteur pourra entraîner un fonctionnement non conforme aux exigences émises par le CARB et l'EPA.

En tant que propriétaire, vous devez mettre en marche le processus de garantie. Votre moteur doit être confié à un concessionnaire YANMAR dès que le problème survient. Les réparations couvertes par la garantie seront effectuées par le concessionnaire aussi rapidement que possible. Pour toute question relative à vos droits et à vos obligations en fonction de la garantie, ou pour toute information relative au concessionnaire ou au centre d'entretien autorisé YANMAR le plus proche, contactez YANMAR America Corporation.

3.5 Acquisition of Information on Machines in Operation and Handling of Acquired Information

The controller of this machine stores main data on the operational status of the machine. For the engine, for example, the controller stores information of a purely mechanical nature including the cumulative engine operating time and does not record customer-related data such as audio clips or video footage of conversations or positional information.

Data stored can be acquired using Yanmar's failure diagnosis tool. Yanmar may acquire and use the data acquired for technical diagnosis or research and development aimed at the provision of better services.

With the exception of the cases listed below, neither Yanmar nor entities to which it outsources work will disclose stored data to third parties.

- Cases where the customer (the machine owner) has consented to the provision of data to third parties
- Cases where the provision of such data is required by an enforceable order such as a court order.
- Cases of the provision to public agencies of data that has been processed so that users of said data cannot identify the machine concerned for purposes such as statistical processing.

4. Operation License

Before you operate this machine, confirm the licensing requirements that are applicable to the operation of this machine.

Comply with all applicable laws.

Ask your dealer about licensing requirements.

Go to Discount-Equipment.com to order your parts

5. Ordering Replacement Parts and Service Call

5.1 Location of machine serial number plate

The machine serial number plate is located on the turning frame as illustrated at right. Never remove the plate for any reason.

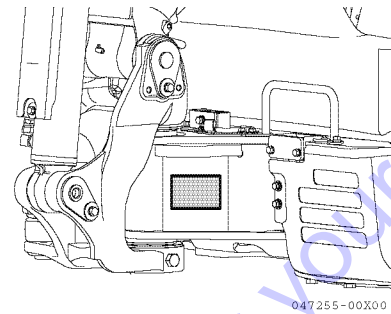

5.2 Location of engine serial number plate

The engine serial number plate is located on the top of the cylinder head cover. Never remove the plate for any reason.

For procedures for opening and closing the operator's seat bottom cover, refer to page 126.

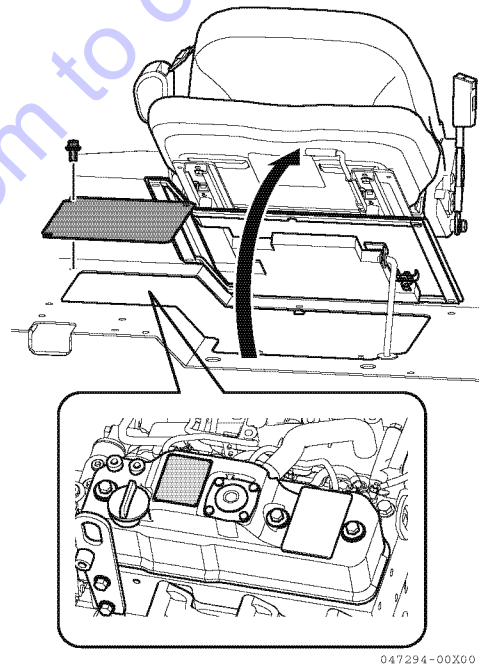

5.3 Location of EPA emission control plate

Localisation de la plaque signalétique EPA

The EPA emission control plate are located on the engine and engine hood as illustrated at right.
Never remove the plate for any reason.

La plaque signalétique est fixée sur le moteur (voir illustration à droite).

En aucun cas ne retirer cette plaque.

Viewed from top

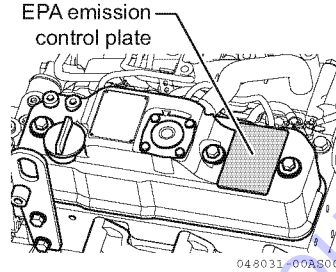

EC emission control plate EPA emission control plate

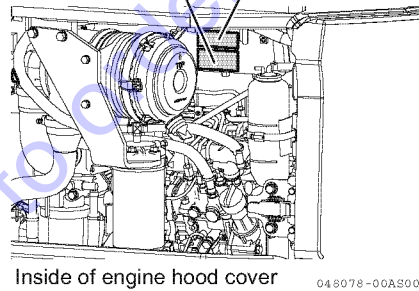

5.4 Ordering replacement parts and service calls

When ordering replacement parts or calling for service, let your dealer know the model designation, the machine serial number, and the engine serial number on the machine serial number plate as well as the reading of the hour meter.

- Machine serial number plate

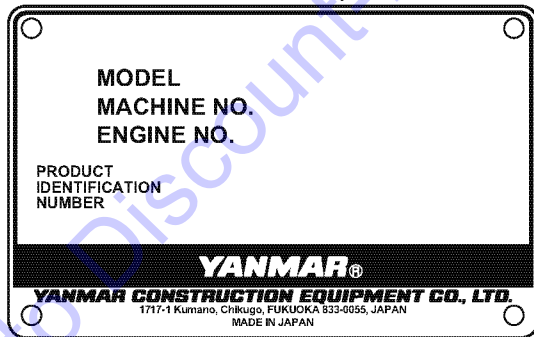

- Hour meter

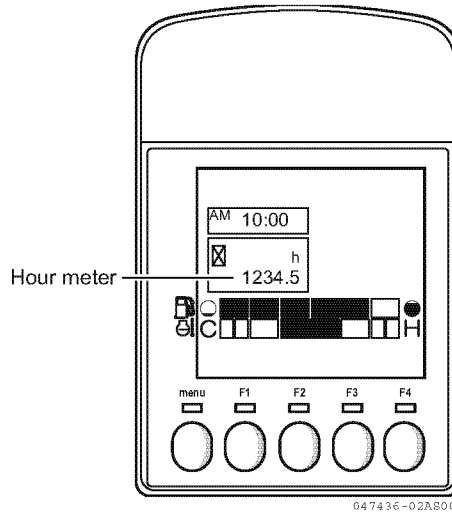

QUICK GUIDE

Identification of Important Parts

Safety

Operation

Maintenance

Optional Parts and Attachments

Troubleshooting

This Quick Guide is intended to provide you with an understanding of the operational flow of this machine to help you find things you need to know when the need arises.

Reference pages of the main text of this manual indicated in this guide must be read to gain detailed information you need and use the machine correctly.

Go to Discount-Equipment.com to order your parts

Identification of Important Parts

Overview

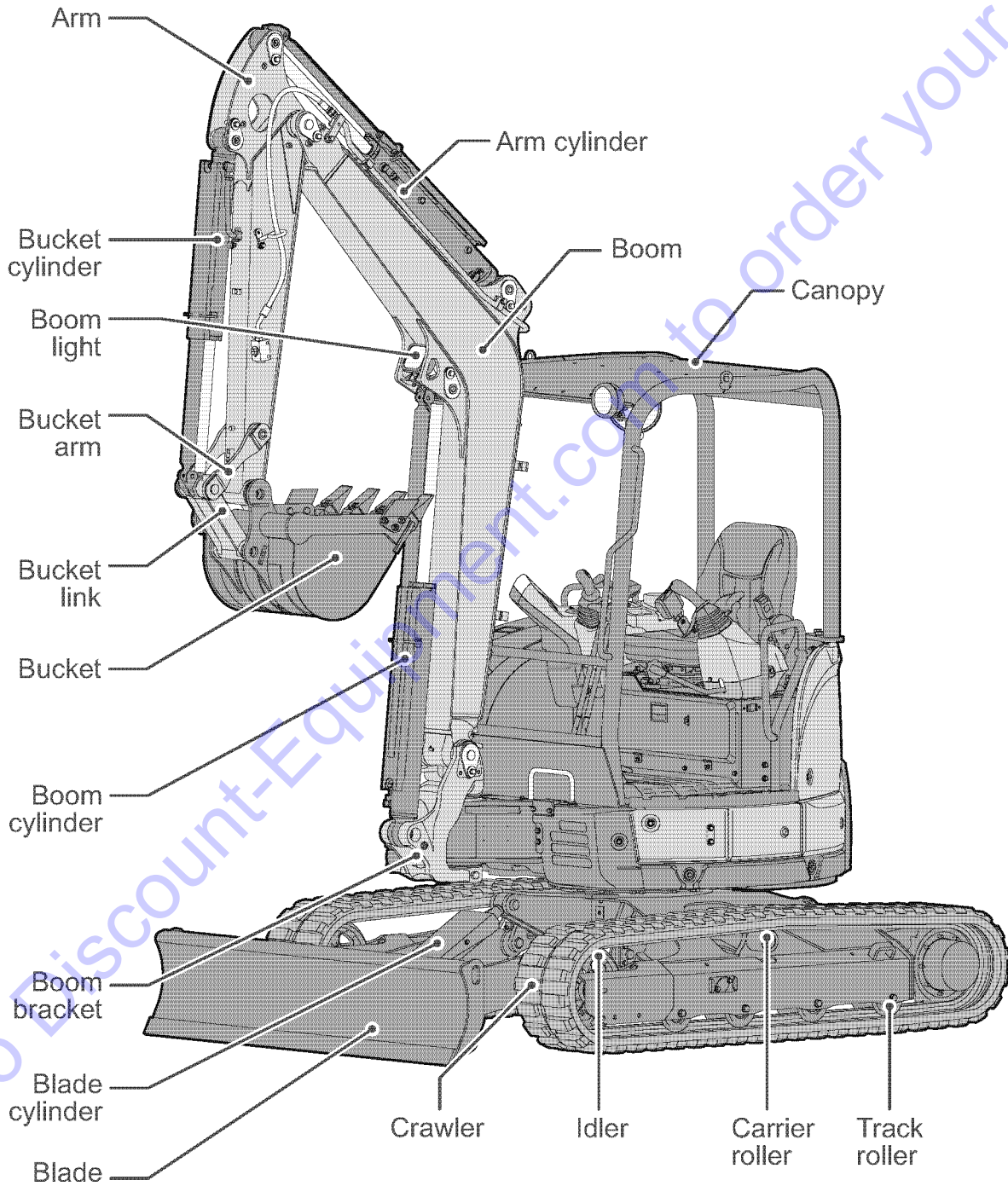

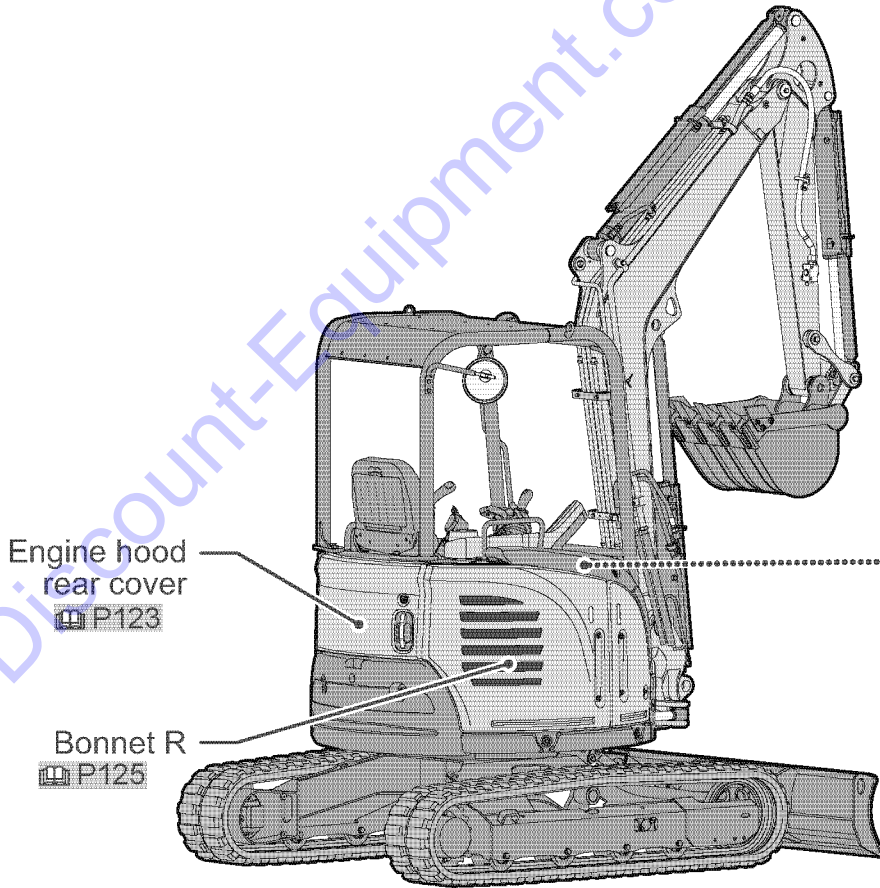
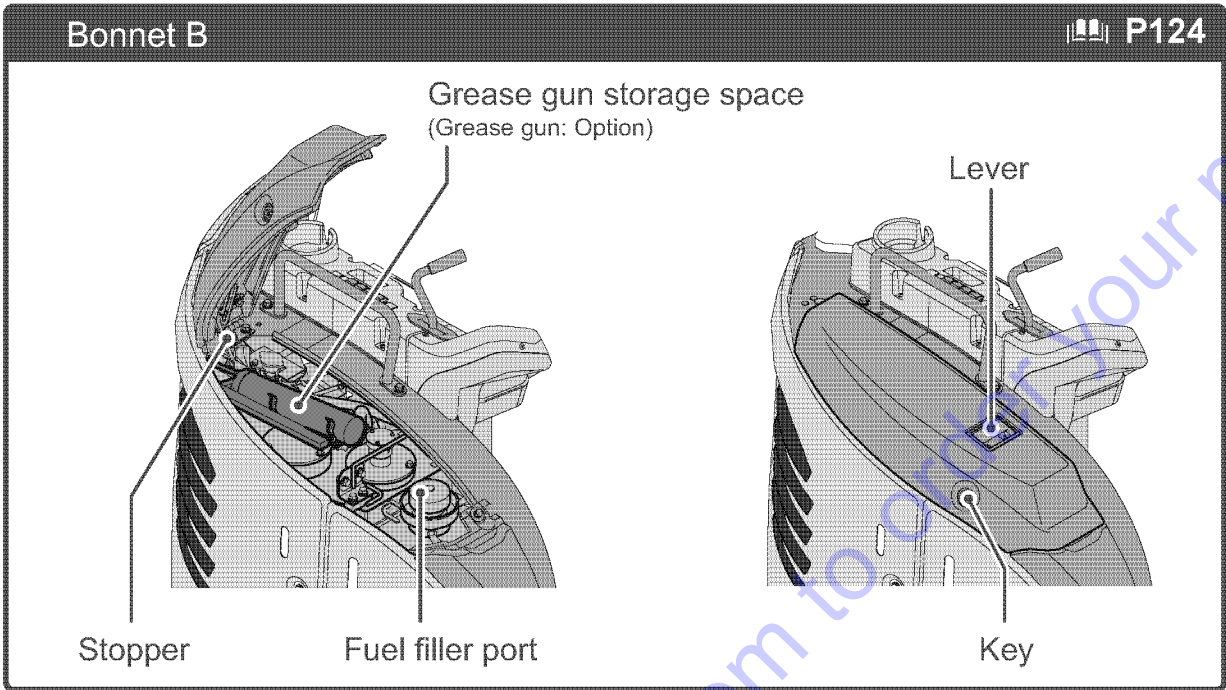

Identification of Important Parts

Controls and switches

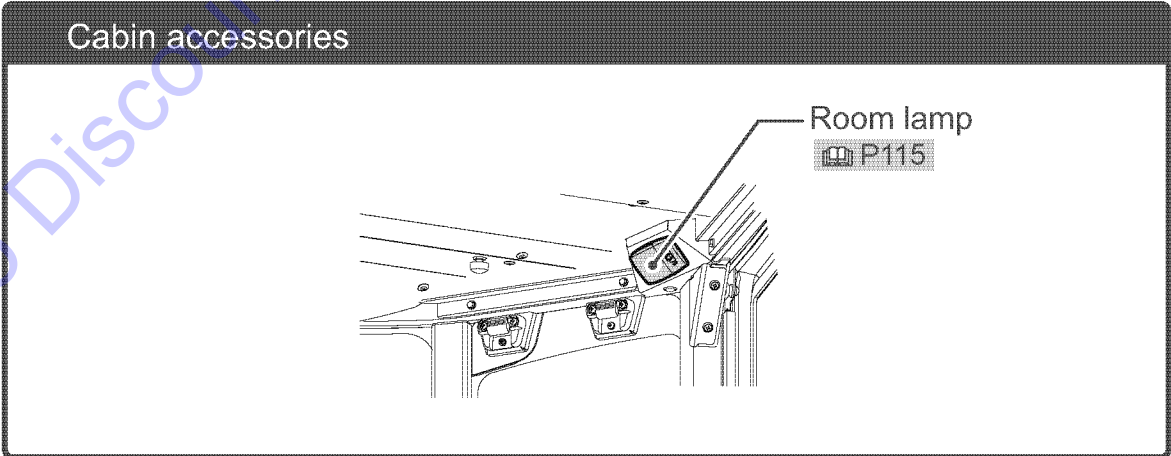
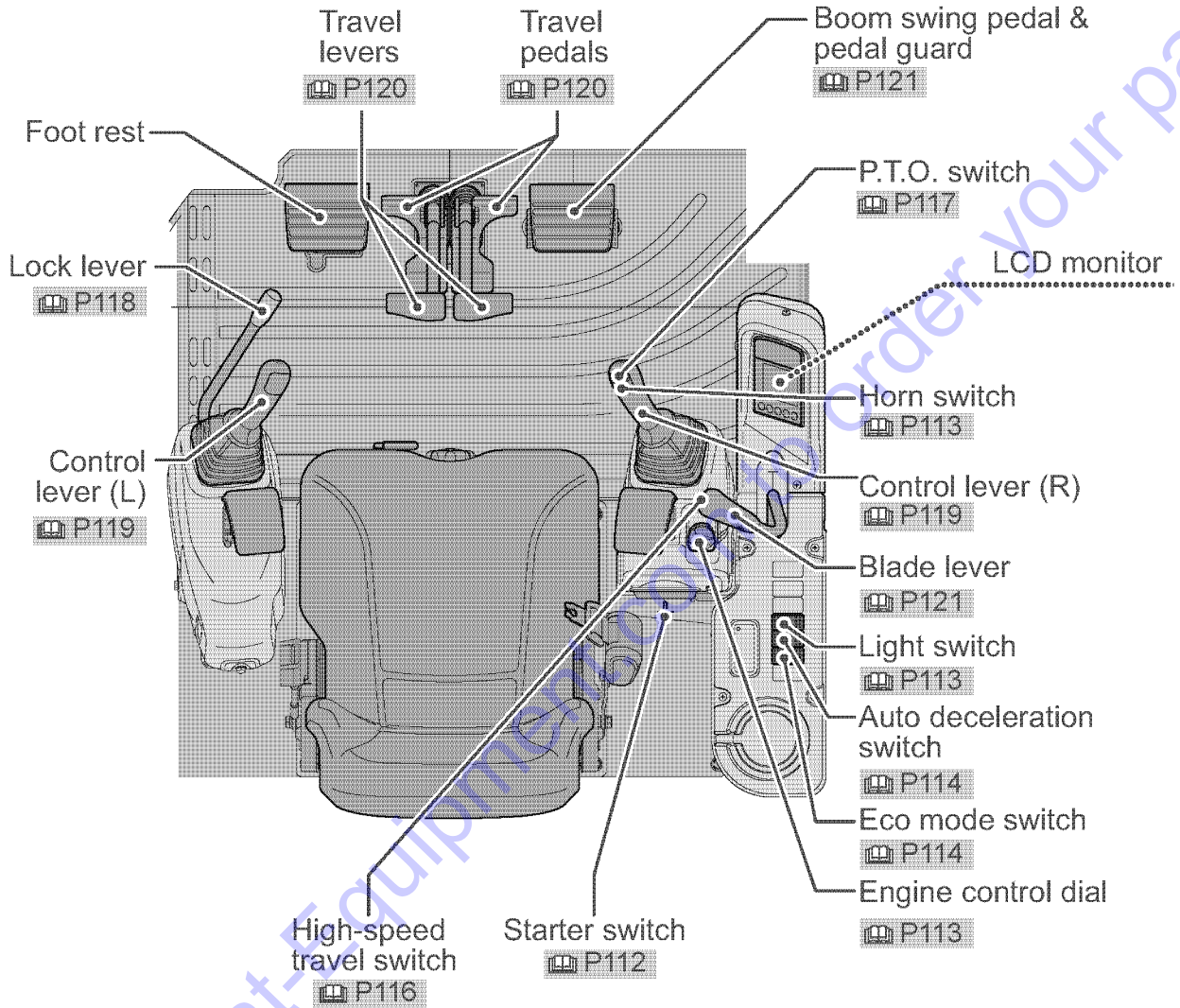

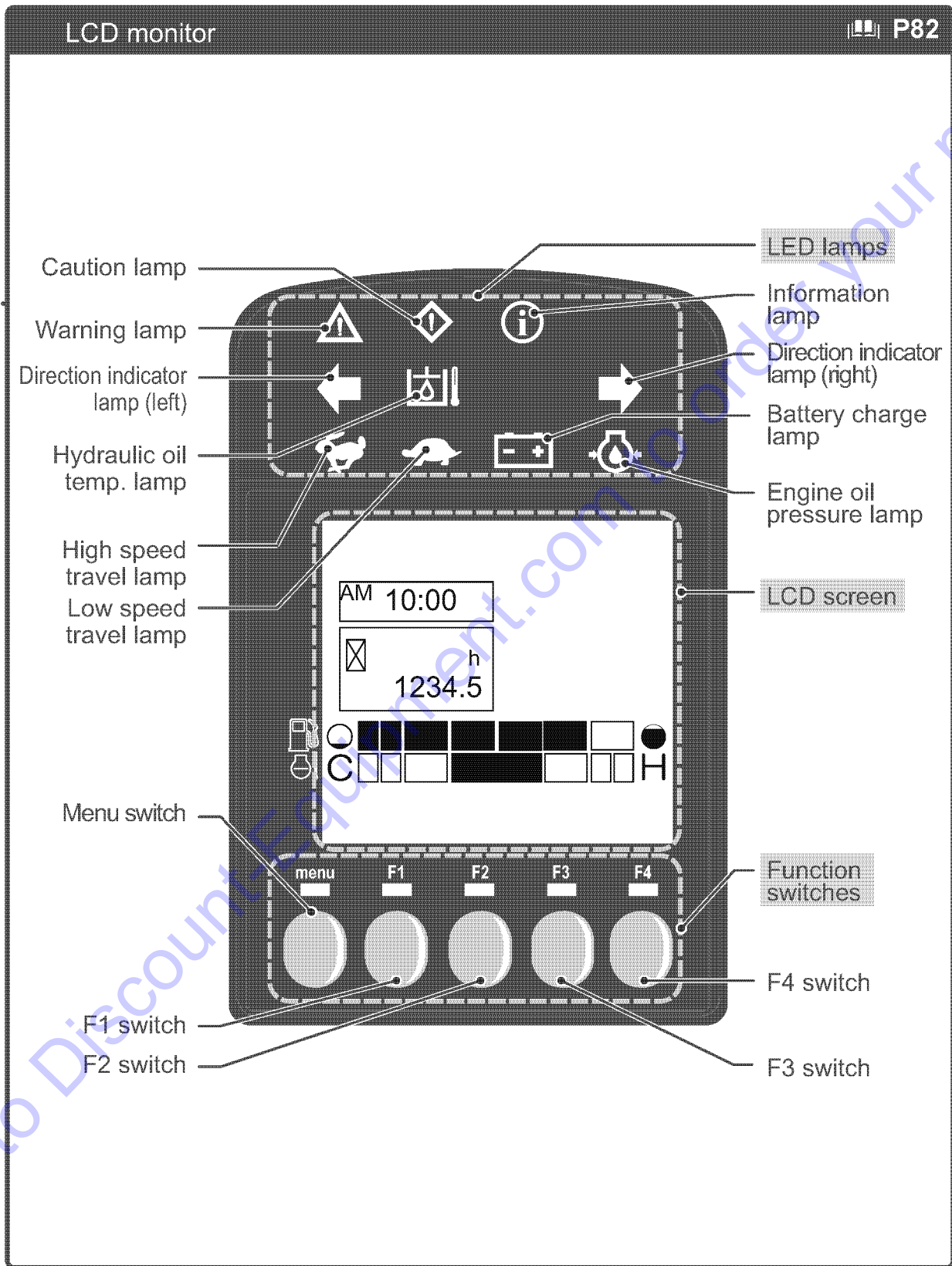

Identification of Important Parts

LCD Monitor Displays

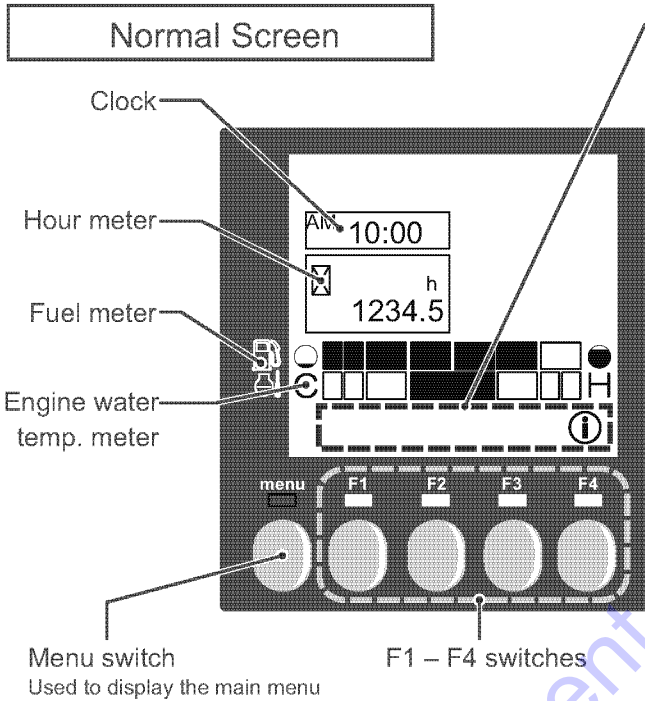

Function switch guidance
Indicates the current functions of the F1 – F4 switches.

	Goes back to the previous screen
	Moves to the item left of the one currently selected
	Moves to the item right of the one currently selected
	Moves to the item above the one currently selected
	Moves to the item below of the one currently selected
	Selects an item or complete a setting
	Increases the selected value by one
	Resets the selected value
	Displays details of information such as maintenance notices

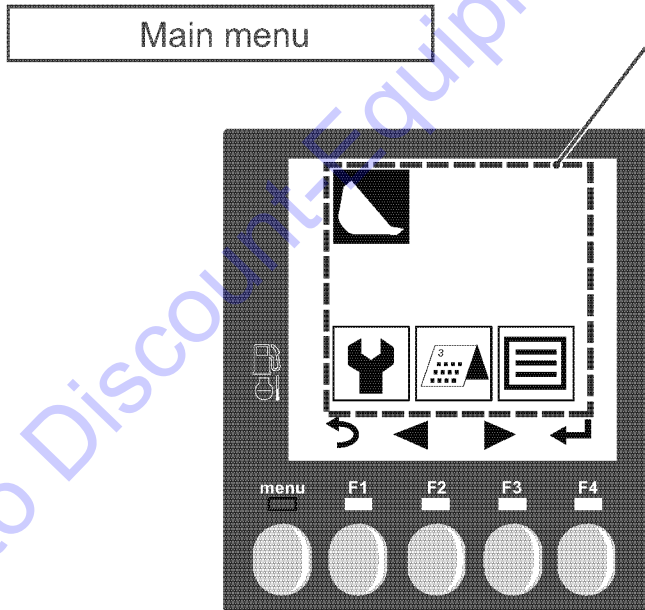

	Displays the normal screen.
	Displays the maintenance screen.
	Displays the Machine Operation Management screen.
	Displays the Settings screen.

In case machine trouble occurs

LED lamps

The lamp corresponding to the error flashes or lights up.



Warning lamp

If the warning lamp flashes and the buzzer sounds, immediately stop operation and take necessary corrective measures.



Caution lamp

If the caution lamp flashes, take necessary corrective measures as soon as possible.

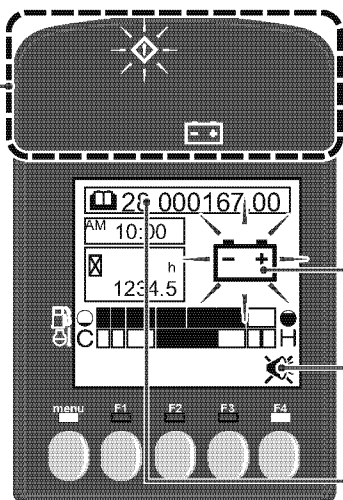

Error icons

Icons representing the corresponding errors are displayed.

Icon	Error description	Warning/caution lamp	Corrective measures
	Abnormal engine cooling water temperature	Warning lamp flashing	Stop the engine startup process and inspect the engine according to "Troubleshooting" on page 29.
	Abnormal engine oil pressure	Warning lamp flashing	Stop the engine startup process and inspect the engine according to "Troubleshooting" on page 29.
	Insufficient battery charge	Caution lamp flashing	Stop the engine startup process and inspect the engine according to "Troubleshooting" on page 29.
	Insufficient amount of fuel	Caution lamp flashing	Refill the fuel tank
	Other errors	Warning or caution lamp flashing	Check the error code and contact the nearest dealer.

Buzzer stop icon

When this icon is displayed, pressing the F4 switch will stop the buzzer.

Error code : Refer to page 333

Information display

Information lamp

This lamp flashes to indicate the existence of information.

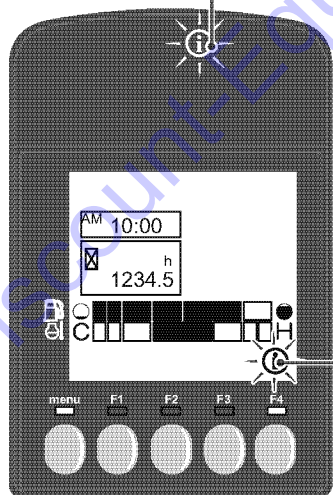



Information icon







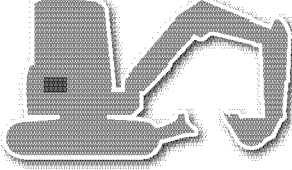



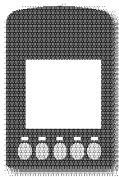

This icon is displayed to indicate the existence of information. Pressing the F4 switch allows checking of information details.

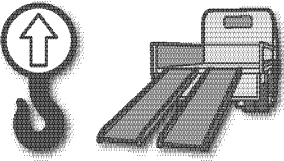
Icon	Description	Reference
	Notice of date and time settings	Procedure for setting the date and time - page 108
	Maintenance notice: Engine oil	Procedure for replacing the engine oil and the engine oil filter - page 282
	Maintenance notice: Engine oil filter	Procedure for replacing the engine oil and the engine oil filter - page 282
	Maintenance notice: Hydraulic oil	Procedure for checking and replenishing the hydraulic oil in the hydraulic oil tank - page 146
	Maintenance notice: Hydraulic oil return filter	Procedure for replacing the hydraulic oil return filter - page 286
	Maintenance notice: Air cleaner element	Procedure for replacing the air cleaner element - page 285
	Maintenance notice: Fuel filter element	Procedure for replacing the fuel filter element - page 280
	Maintenance notice: Travel reduction gear oil	Procedure for replacing the travel reduction gear oil - page 287





Safety

	<p>Basic Precautions P37</p> <p>Safety devices/ Proper clothing/ Prohibit modification/ Source of ignition</p>
	<p>Operating Precautions P42</p> <p>Before starting engine/ Starting engine, working and parking/ Transportation/ Battery/ Towing/ Hooked bucket</p>
	<p>Precautions for Servicing P57</p> <p>Before servicing/ During servicing</p>
	<p>Safety Messages (Warning Labels) P63</p> <p>Location of warning label</p>

Operation

	<p>Description of Control Devices  P82</p> <p>LCD monitor/ Switches/ Control levers and pedals/ Bonnets/ Storage/ Cabin/ Operator's seat/ Work lights/ Fuse/ External power socket</p>
	<p>Operating Instructions  P141</p> <p>Starting and stopping engine/ Traveling, steering and stopping/ Operating implement/ Quick coupler/ P.T.O./ Parking/ Replacing bucket</p>
	<p>Transportation  P209</p> <p>Loading and unloading/ Transporting/ Suspending</p>
	<p>Care and Service in Cold Weather  P215</p> <p>Preparing for cold weather/ Precautions after day's work/ After cold weather ends</p>
	<p>Long-term Storage  P219</p> <p>Before storing/ Storing/ Using machine again</p>
	<p>Troubleshooting  P221</p> <p>Phenomena that are not breakdowns/ Towing/ If the battery is overdischarged/ Troubleshooting</p>



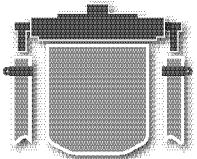

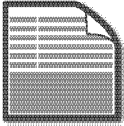
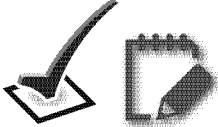
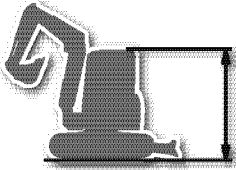
Maintenance

	<p>Precautions for Servicing P235</p> <p>Hour meter/ Genuine parts/ Oil and grease/ Cleaning machine/ High water and oil temperatures/ Replenishing oil/ Welding/ Fire/ Before and after working</p>
	<p>Basic Servicing Practices P238</p> <p>Oils, fuel, and cooling water/ Electrical equipment/ Hydraulic system</p>
	<p>Consumables P246</p> <p>Engine oil filter/ Hydraulic oil tank return filter/ Fuel filter/ Air cleaner/ Bucket</p>
	<p>Fueling, Oiling and Greasing Based on Temperature Range P247</p> <p>Fuel and oil/ Cooling water</p>
	<p>Standard Tightening Torque for Bolts and Nuts P248</p> <p>Required tools/ Torque table</p>
	<p>Replacing Essential Parts Periodically P250</p> <p>List of safety parts</p>

	Maintenance Table P252 Table of service time intervals/ Service intervals when using hydraulic breaker
	Procedures for Maintenance P257 First services/ Nonperiodic services/ Every 50, 100, 250, 500, 1000, 1500 and 2000 service hours
	Specifications and Dimensional Diagrams P301 Weight/ Working range and performance/ Engine/ Dimensions

Go to Discount-Equipment.com to order your parts

Optional Parts and Attachments

	General Precautions P313 Safety precautions/ Precautions for mounting attachment (implement)
	Handling the Hooked Bucket P316 Checking the hooked bucket for damage/ Prohibitions/ Precautions
	Optional Parts and Attachments P317 Optional parts and attachments
	Handling Air Conditioner P318 Description of lever and switches/ How to use air conditioner/ Maintenance, inspection and servicing

Troubleshooting







Contact your dealer about the measures shown in **Service** in the list below.

If there is any abnormality or trouble whose cause is unknown other than those shown below, ask your dealer for repair.

Engine

Problem	Cause	Measure
Engine oil pressure lamp lights up.	Shortage of engine oil	Replenish engine oil. P144
	Clogged engine oil filter	Replace engine oil filter. P282
Steam comes out of top of radiator.	Shortage of cooling water	Check cooling water level. Refill, if necessary. P143 Check cooling water for leak from water port. Service
	Loose fan belt	Adjust belt tension. P147
	Buildup of dust and water scale on cooling system	Replace cooling water. Clean inside of cooling water system. P292
Engine cooling water temp. error is displayed.	Defective thermostat	Replace thermostat. Service
	Clogged radiator fin or inclined fin	Clean or repair fin. P284
	Defective electrical system	Check or replace electrical system. Service
Battery charge lamp lights up.	Loose or broken fan belt	Adjust fan belt tension or replace. P147
	Defective battery	Check battery electrolyte level. Replenish or replace if necessary. P148
	Insufficient power generation of alternator	Check and repair. Service
Turning on starter motor does not start engine.	Shortage of fuel	Refill fuel tank. P145
	Air mixed in fuel system	Repair air leak. Release air from fuel system. P281
	Defective fuel injection pump or deteriorated nozzle performance	Replace pump or nozzle. Service
	Improper compression	Check and repair. Service
	Damaged key stop solenoid.	Check and repair. Service

Troubleshooting

Problem	Cause	Measure
Dark fumes come out of machine.	Clogged air cleaner element	Clean or repair element.  P277
	Deteriorated nozzle performance	Check and repair.  Service
	Improper compression	Check and repair.  Service
Exhaust color is white or bluish white.	Too much oil in oil pan	Drain oil from oil pan to specified level.  P144
	Improper fuel	Replace fuel with recommended one.  P238,P247
	Worn cylinder or piston ring	Repair.  Service

Electrical equipment

Problem	Cause	Measure
Turning starter switch to "START" dose not start starter motor.	Defective wiring system	Check and repair wiring system. Service
	Defective starter switch	Replace starter switch. Service
	Insufficiently charged battery	Recharge battery. P223
	Blown out slow blow fuse	Replace slow blow fuse P138
	Defective starter motor	Check and repair. Service
Maximum engine speed does not provide enough brightness of lamps.	Defective wiring system	Check terminals for looseness and disconnection. Repair terminal, if necessary. Service
	Defective generator or regulator	Check and repair. Service
During engine operation, lamp is extremely bright, and frequently burns out. ----- Electrolyte leaks from battery.	Defective regulator	Replace regulator. Service Repair. Service
Speed of starter motor is too low.	Defective wiring system	Check and repair wiring system. Service
	Insufficiently charged battery	Recharge battery. P223
	Defective starter motor	Check and repair. Service

Troubleshooting

Machine performance

Problem	Cause	Measure
Power or speed of moving part is low.	Deteriorated function caused by worn hydraulic pump	Replace hydraulic pump. Service
	Pressures of main relief valve, or port relief valve of control valve are dropped below set value.	Check and repair valves. Service
	Damaged hydraulic cylinder	Check and repair. Service
	Insufficient amount of hydraulic oil	Replenish hydraulic oil up to specified level. P146
	Clogged filter	Clean or replace filter. P246
Upperstructure does not swing or does not swing smoothly.	Swing brake is not released	Check and repair. Service
	Insufficient amount of grease	Check and grease. P149
	Defective swing brake valve	Check and repair. Service
	Defective swing motor	Check and repair. Service
Temperature of hydraulic oil is too high.	Insufficient amount of hydraulic oil	Replenish hydraulic oil up to specified level. P146
	Overload	Lower load.
Machine does not move straight.	Improperly adjusted track or trapped foreign material	Adjust or clean. P260
	Damaged hydraulic motor.	Check and repair. Service
	Defective hydraulic pump	Check and repair. Service
	Defective control valve	Check and repair. Service
	Damaged sprocket, idler or track roller.	Check and repair. Service

CONTENTS

1 Introduction	1
2 Safety Information	2
3 Product Overview	3
4 Operation License	14
5 Ordering Replacement Parts and Service Call	15
QUICK GUIDE	17
SAFETY.....	35
1 Basic Precautions	37
2 Operating Precautions	42
3 Precautions for Servicing	57
4 Safety Messages (Warning Labels).....	63
OPERATION.....	77
1 Identification of Important Parts	79
2 Description of Control Devices	82
3 Operating Instructions	141
4 Transportation	209
5 Care and Service in Cold Weather	215
6 Long-term Storage	219
7 Troubleshooting	221
MAINTENANCE	233
1 Precautions for Servicing	235
2 Basic Servicing Practices	238
3 Consumables	246
4 Fueling, Oiling and Greasing Based on Temperature Range	247
5 Standard Tightening Torque for Bolts and Nuts.....	248
6 Replacing Essential Parts Periodically	250
7 Maintenance Table	252
8 Procedures for Maintenance.....	257
SPECIFICATIONS AND DIMENSIONAL DIAGRAMS	299
1 Specifications and Dimensional Diagrams	301
OPTIONAL PARTS AND ATTACHMENTS	311
1 General Precautions	313
2 Handling the Hooked Bucket.....	316
3 Optional Parts and Attachments	317
4 Handling Air Conditioner	318

SAFETY

Basic Precautions

Operating Precautions

Precautions for Servicing

Safety Messages (Warning Labels)

WARNING

Never attempt to operate or service this Excavator until you have first read and understood all of the applicable Safety Instructions that are set forth in this Manual.

The failure to comply with all relevant Safety Instructions could result in bodily injury.

This “SAFETY” Part includes safety instructions for optional parts and attachments.

1. Basic Precautions

Follow safety rules at your workplace

- The operation and servicing of this machine is restricted to qualified persons.
- When operating or servicing the machine, follow all the safety rules, precautions and procedures.
- Any work performed by a team or with a signal person should be conducted in accordance with signals agreed on beforehand.

Install safety devices

- Make sure that all guards and covers are installed in their correct position. If any of them are damaged, repair them immediately.
- The proper use of all safety devices, such as lock lever, should be well understood by the machine operator.
- Never remove the safety devices. Always make sure that they operate properly.
For lock lever, refer to Section "2.3 Control levers and pedals" on page 118.
- Incorrect operation of the safety devices could cause serious bodily injury.

Wear proper clothing and safety items

- Do not wear loose clothing or jewelry that can be caught on the control levers and other machine parts. Also avoid wearing working clothes stained with oil as they can ignite.
- Be sure to wear a helmet, safety goggles, safety shoes, a mask, gloves and other protective items, as appropriate. Take particular precautions when generating metal debris, when striking metal objects with a hammer or when cleaning components with compressed air.

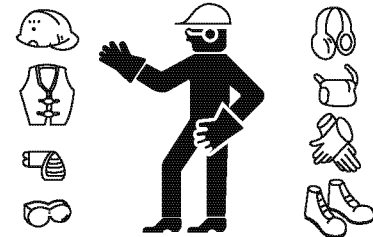

Also make sure there are no persons near the machine.

For driving the pins, refer to Section "3.24 Replacing the bucket without the quick coupler" on page 207.

For cleaning the elements, refer to Section "8.2 Nonperiodic services" on page 258.

Alcohol

- Never operate the machine while you are under the influence of alcohol or when you are ill or feel unwell as this results in accidents.

**Avoid unauthorized modifications**

- Modifications not recommended by YANMAR may cause safety hazards.
- When you wish to modify your machine, contact your dealer. The implementation of unauthorized modifications or the use of unauthorized attachments could result in bodily injury, since those actions would also violate, the terms of YANMAR's Warranty, it would be voided

Always lock up your machine when leaving the operator's seat

- When leaving the operator's seat, be sure to place the lock lever in the lock position, to prevent accidental machine movement which could result in bodily injury.
- When you leave the machine:
 - (1) Lower the bucket to the ground.
 - (2) Place the lock lever in the lock position.
 - (3) Stop the engine.
 - (4) Set all the locks in to the lock position.
 - (5) Be sure to take the key out of the starter switch.
- Be sure to store the key in a designated place so that unauthorized personnel cannot operate the machine.

For information on parking the machine, refer to Section "3.15 Parking the machine" on page 187.

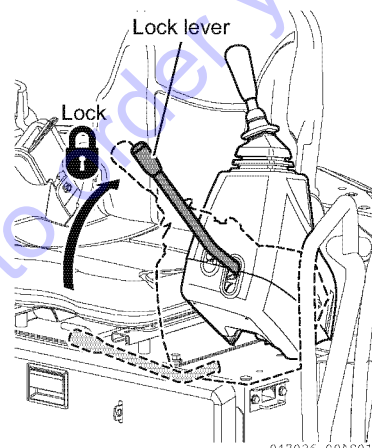

Use handrails and steps when getting on and off

- Do not jump on or off the machine. Never get on or off a machine in motion as it may result in bodily injury.
- When getting on and off the machine, face the machine and use the handrails and steps.
- Do not grab the control levers or the front windshield opening and closing knobs when getting on and off the machine.
- Make sure that you maintain three point contact with the handrails or the steps.
- If the handrails and the steps are soiled with oil or dirt, clean them off immediately. Repair any damaged parts and retighten any loose bolts.
- When opening or closing the cabin side door from the outside, do not do so standing on the part of the machine; for example, on the crawler or the step. Be sure to open or close the door standing on the ground.

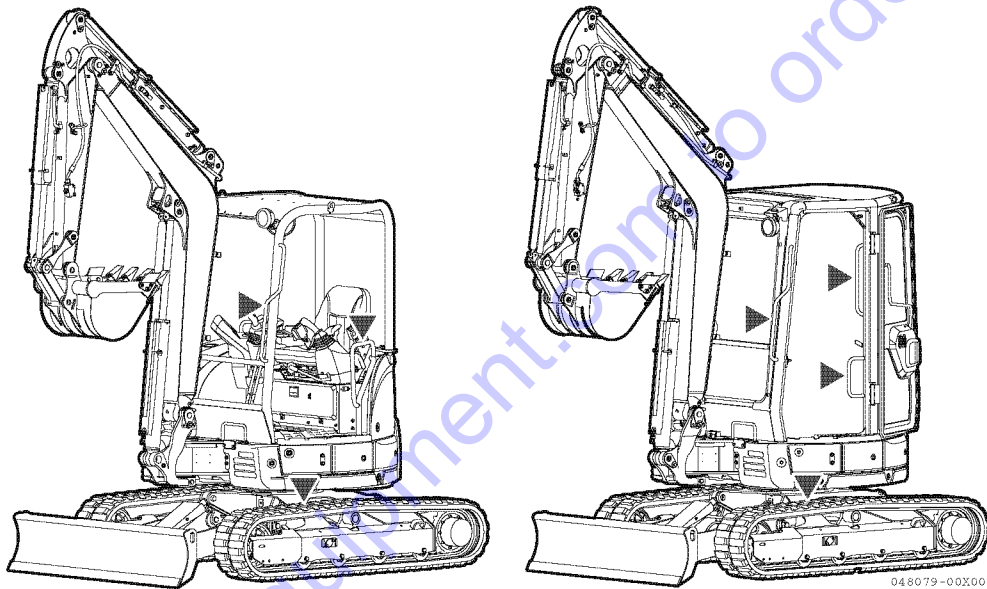

Keep fuel and oil away from sources of ignition

- Open flames can ignite fuel, oil, hydraulic oil or antifreeze solutions, which are flammable and dangerous.

Special attention must be paid to the following matters.

- Keep flammable materials away from lighted cigarettes or matches, or any other sources of ignition.
- Never refuel while the engine is running. Smoking during refueling must be strictly prohibited.
- Firmly tighten the caps on the fuel and oil tanks.
- Store fuel and oil in a cool and well-ventilated place where they are not subjected to direct sunlight.
- Fuel and oil must be stored in a place which meets all applicable safety regulations. Unauthorized persons should not be allowed entry.

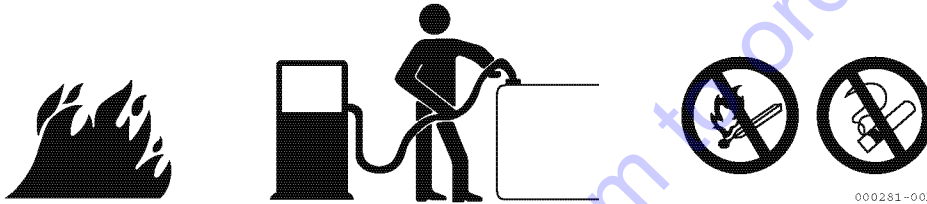

Avoid removing filler caps while temperatures are high

- The engine coolant, engine oil and hydraulic oil are hot and under pressure immediately after the machine stops operation. Removing caps, draining coolant or oil, or replacing a filter at such a time may cause burns. Allow temperatures to cool down and follow the procedures in this manual.

- When removing the radiator cap, stop the engine and allow the coolant to cool down, then turn the cap slowly to relieve all pressures.

- Before removing the cap from the hydraulic oil tank, stop the engine and turn the cap slowly to relieve all pressure to prevent oil from spouting out.

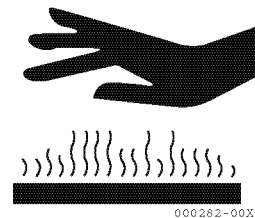

Avoid harmful asbestos dust

- Air containing asbestos dust is carcinogenic and is hazardous to humans. Inhalation of the air may cause lung cancer. When handling materials that may contain asbestos, keep in mind that:
 - Compressed air must not be used for cleaning.
 - Water must be used to clean the machine to prevent asbestos from scattering in the air.
 - You must work on the windward side when operating the machine in a place where there may be asbestos dust.
 - You should wear breathing apparatus as necessary.

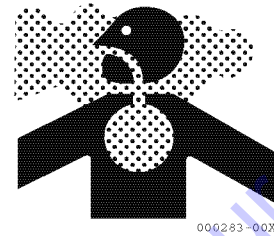

Prevent crush injuries by the implements

- Keep hands, arms and all other parts of your body away from all the moving parts, particularly between the implements and the machine and between the hydraulic cylinder and the implements, as pinch points are created in those areas.

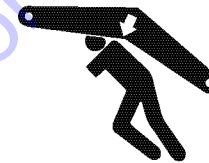

Keep a fire extinguisher and first aid kit handy

- The workplace must be provided with a fire extinguisher. Read instructions on the label to familiarize yourself with how to use it.
- Keep a first aid kit in a prescribed place.
- Advise what to do in the event of fire or accidents.
- Indicate who to contact in an emergency and keep their telephone number in a prominent place.

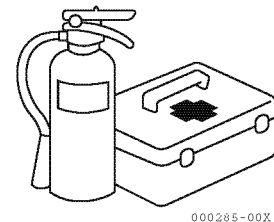

Precautions for installing optional parts and attachments

- When installing or using optional attachments, read the operating instructions for the attachments and the Manual Sections relating to the installation of attachments.
- Use only attachments authorized by YANMAR. The use of unauthorized attachments may affect not only the safety of the machine but also the proper operation and life of the machine.
- The use of unauthorized attachments would also violate the terms of YANMAR's Warranty, so that it would be voided.

Caution for cabin glass

- If the glass of the cabin should be broken by accident, it is very dangerous since the operator's body might contact the implement directly. Immediately stop working to replace the broken glass with a new one.

2. Operating Precautions

2.1 Precautions before starting the engine

Ensure the safety of your workplace

- Before starting the machine, check to see if there are any hazards in your working area.
- Examine the terrain and soil, and decide the best way to do the work.
- When working on the street, provide a signal person or fence for the safety of vehicles and pedestrians.
- If there are underground utilities at the work site, such as water pipes, gas pipes, high-voltage conduits or others, contact the responsible companies to locate them exactly, so as not to damage them.
- Before operating the machine in water, or crossing a creek, confirm the condition of the submerged ground, the water depth and the water flow speed, and make sure that the depth is within the allowable level.

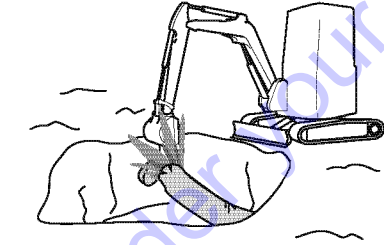

047191-00X00

For allowable water depth, refer to Section "3.10 Precautions for working" on page 172.

Prevent fire

- Wood chips, dead leaves, trash and other flammable materials in proximity to the engine are hazardous as they may cause fire. Always check and keep your machine clear of these flammable materials.
- Check for any leaks from fuel, lube oil or hydraulic oil lines. Repair faults and clean spilled oil as necessary.

For additional information, refer to Section "3.1 Checking before starting the engine" on page 141.

- Check to see where fire extinguishers are located and know how to use them.



000287-00X

Inspect around the operator's seat

Dirt, oil and snow on the floor, levers, handrails or steps are slippery and hazardous. Remove them all completely.

Keep parts and tools away from the operator's seat as they may damage the control levers or switches or create any other hazards.

Provide adequate ventilation when working in an enclosed area

Engine exhaust fumes are harmful to the human body and their inhalation is extremely hazardous. When starting the engine in an enclosed area, open the windows and doors for ventilation. Also do not idle the engine unnecessarily or leave the engine running while the machine is not in use.

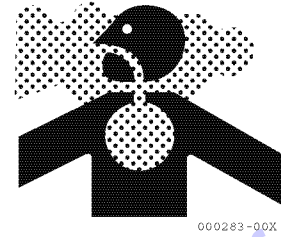

Keep the cabin window clean

- Keep the surface of the cabin windows and the headlights clean for clear view.
- Make sure that your machine is equipped with headlights and all required working lamps, and that they work properly.

Fasten the seat belt

- For your safety, ROPS (Roll-Over Protective Structure)/FOPS (Falling Objects Protective Structures) with a seat belt is installed.
- Always fasten the seat belt across the pelvic region and adjust snugly before you operate the machine.
Never fasten a seat belt across the abdomen.
- The seat belt must be replaced after an accident.
- In addition the seat and seat mounting must be checked by your dealer after an accident has occurred.
- If the seat and seat mounting are damaged, they must be replaced.

ROPS/FOPS

- Never modify the structural member of ROPS/FOPS.
- If ROPS/FOPS is damaged, replace it immediately to prevent bodily injury.
Never repair or modify it.

Caution for the protection of plants from hot wind

The hot wind of the high temperature is exhausted from the muffler and the radiator. If this hot wind hits plants directly, they will die.

Give a cover board to protect plants from the hot wind when working near the arranging fence or plant.

2.2 Precautions for starting the engine, working and parking

Signal before starting the engine

- Check the machine carefully before initial start up for the day.
- Make sure there are no persons near the machine before getting on it.
- Never start the engine when the "SERVICING IN PROGRESS" tag is attached to the control system.
- Sound the horn to alert people nearby before starting the engine.
- Be sure to start the engine and operate the machine from the operator's seat only.
- Do not allow any other persons to get on the machine.

Check the position of the blade before operating the machine

- Check the position of the blade before operating the travel levers. When the blade is located in the back, the operation of the travel levers is reversed.

For instructions on How the machine travels, refer to Section "3.4 Traveling" on page 160.

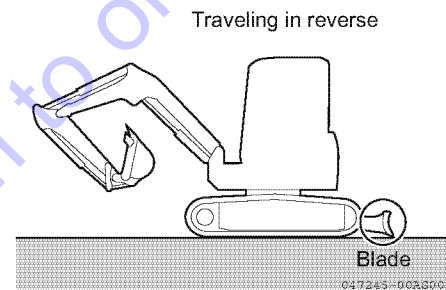

Make sure there are no persons nearby when turning or reversing the machine

- A signal person should be provided for safety when the work site is hazardous or when visibility is poor.
- Keep all other persons away from the work site or the traveling path of the machine.
- Alert persons nearby with a horn or other signal before starting the machine.
- The machine permits a limited range of vision toward the rear. Make sure there are no persons behind the machine before reversing.

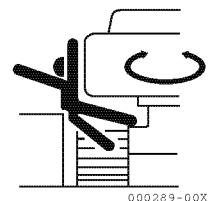
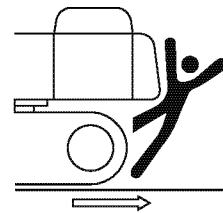

Precautions for traveling

- When traveling with the machine, keep the bucket 16 to 20 in. (40 to 50 cm) above the ground with boom and arm folded as illustrated below.
- If you need to operate the control levers while traveling, never move them abruptly.
- Travel the machine at a low speed and slow down when turning on rough terrain.
- Avoid running over obstacles if possible. If unavoidable, run the machine at a low speed while keeping the implement close to the ground. Never run over obstacles that may cause the machine to tilt more than 10 degrees.

Orientation in travel

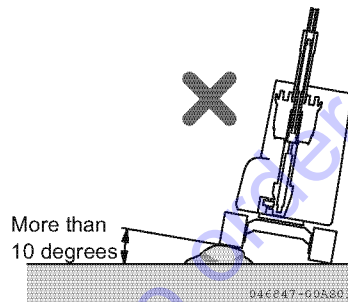
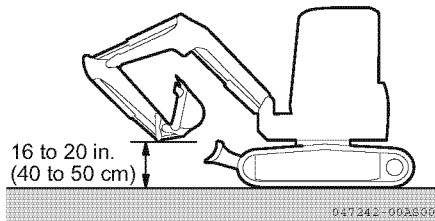

Running the machine on a slope

- Run the machine carefully on a slope to avoid overturning or skidding sideways.
- When running the machine on a slope, keep the bucket 8 to 12 in. (20 to 30 cm) above the ground so that you can immediately lower it to the ground and stop the machine in an emergency.
- Never turn the machine on a slope or run it across the slope.

Move down to flat ground and then make a turn.

For instructions on how to run the machine on a slope, refer to Section "3.11 Precautions for going up and down a slope" on page 173.

- On grasses, dead leaves or a wet metal plate, even with a slight gradient, the machine will easily slip. Under those circumstances, run the machine carefully at low speed to prevent it from skidding.

Going down a slope

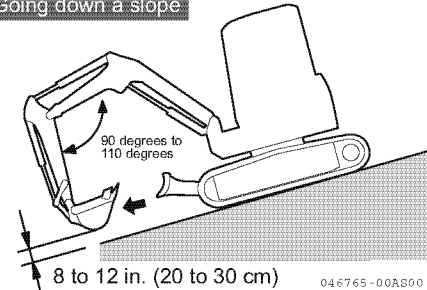

Going up a slope

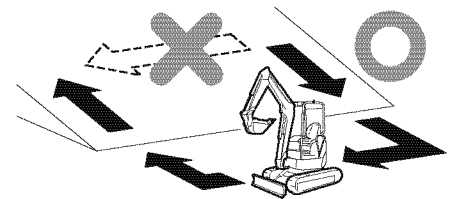
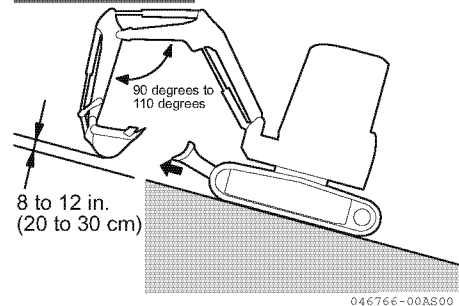

Avoid hazardous work

- Undermining a cliff is dangerous as it may cause a rockslide or landslide.
- Undercutting the machine is dangerous as it may cause a cave-in, resulting in the machine overturning and falling into the excavation.

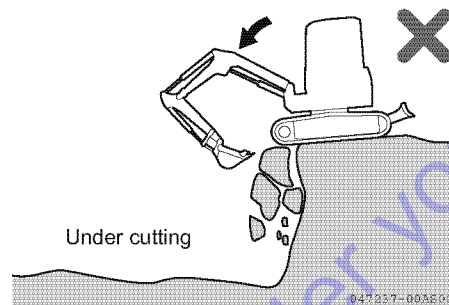
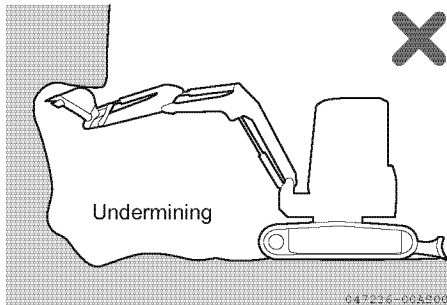

Never suspend loads without a hooked bucket

- Suspending loads without a hooked bucket is extremely hazardous.
- To suspend loads, the machine must be equipped with a hooked bucket specifically designed for the purpose.

For information on suspending loads, refer to Section "3.9 Precautions for operating the implement" on page 169.

⚠️ DANGER

Keep away from electric power lines

- Working in the vicinity of overhead electric power lines presents a very serious hazard and special precautions must be taken. For purposes of this manual you are considered to be working in the vicinity of overhead power lines when the attachment or load of your excavator, in any position, can reach to within the minimum distances shown below.
- The following procedures are effective in preventing accidents or injuries.
 - 1) Wear shoes with rubber or leather soles.
 - 2) Use a signal person to warn the operator when the machine is getting too close to a power line.
- If the machine should contact a wire, the operator must not leave the seat.
- When working near power lines, caution all ground personnel to stand clear of the machine.
- To determine the transmission voltage at the working site, contact the electric utility concerned.

	Transmission voltage (V)	Minimum safe distance [ft. (mm)]
Power distribution	100/200 or less	6.6 (2000) or more
	6600 or less	6.6 (2000) or more
Transmission line	22000 or less	9.8 (3000) or more
	66000 or less	13.1 (4000) or more
	154000 or less	16.4 (5000) or more
	275000 or less	23.0 (7000) or more

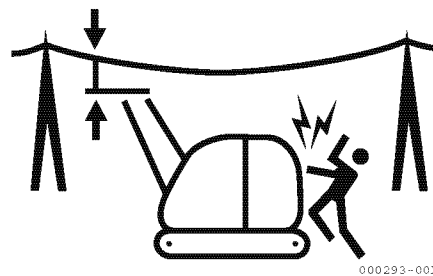

Prevent bumping the implements

- When traveling through tunnels or under bridges, or working at a site near other overhead obstacles, operate the machine carefully so as not to bump the boom, arm, or the implement against those overhead obstacles.

Work only where visibility is good

- When working in a dark place, light up the area with the work lights and head lights, and prepare extra lighting equipment as necessary.
- Stop working when fog, snow or rain impedes your view.

Work carefully in a snow-covered areas

- A snow-covered ground and icy roads are dangerous as they may cause the machine to skid even on a slight slope. Run the machine at low speed, and never start, stop or turn abruptly on such ground or under such road conditions.
- Be careful removing snow as road shoulders or other hazards may be buried under snow.

Unstable ground creates a high possibility of overturn

- Keep away from cliffs, road shoulders or trenches if possible as the ground near them is unstable. The ground may crumble due to the weight or vibrations of the machine, resulting in an overturn or fall of the machine. Be particularly careful when working immediately after rain-storm or after blasting as the ground may be unstable.
- Ground-fills or ground near a ditch may be unstable and may crumble due to the weight or vibrations of the machine, causing the machine to tilt. Much caution must be taken in working in these areas.
- When working in an area where is a high possibility of falling rocks, wear a hard-hat and stay under the canopy.

Using the quick coupler

- Observe the procedures of mounting and dismounting the bucket.
- Always securely and correctly install the lock pin when the bucket is mounted on the quick coupler.
- Replace the lock pin whenever it is damaged or lost.

For information of handling the quick coupler, refer to Section "3.14 Handling quick coupler (option)" on page 177.

Working on a slope

- Be aware that the machine may tip over when swinging the upperstructure or swinging the implement on a slope.
- Never swing the upperstructure toward the downward side of the slope with earth loaded in the bucket.
- If swinging is unavoidable, level off a work area to maintain the machine as horizontal as possible, then swing.

For leveling off a work area, refer to Section "3.11 Precautions for going up and down a slope" on page 173.

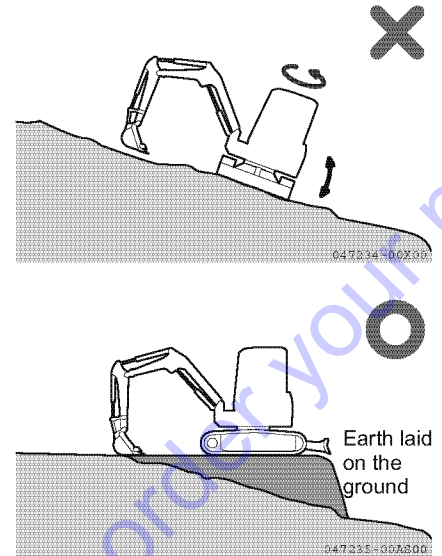

Parking the machine

- Park on level ground. If park on a slope is unavoidable, block the tracks with solid pieces of wood and dig the bucket into the ground. (See the illustration at right.)
- If necessary to park the machine on the side of a road, set up a warning flag, fence, or lamp that can be easily recognized by passing cars and pedestrians but does not impede them.

For parking procedures, refer to Section "3.15 Parking the machine" on page 187.

- When leaving the operator's seat, do the following:

- (1) Be sure to place the bucket on the ground.
- (2) Set the lock lever to the lock position.
- (3) Stop the engine.
- (4) Set all the locks to the lock position.
- (5) Be sure to take the key out of the starter switch.

For information about parking procedures, refer to Section "3.15 Parking the machine" on page 187.

For information about the parts to be locked, refer to Section "3.19 Locking" on page 190.

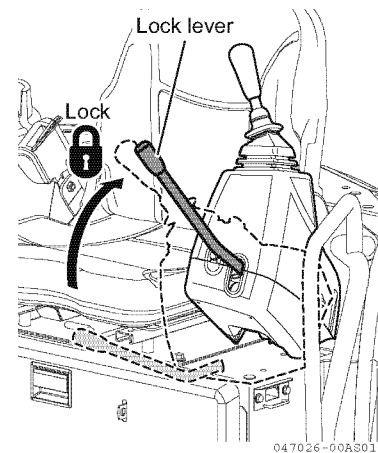
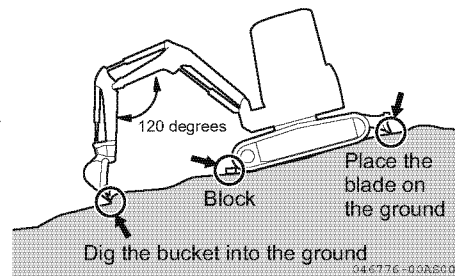

Precautions for the angle blade operation

Precautions for digging, lifting and suspending the machine

- When digging the ground by lowering the blade, lifting up the machine with the blade and suspending the machine, place the angle of blade in the neutral position (refer to the below-mentioned "Neutral position of the angle blade" for the neutral position). The machine may lose balance, which poses a danger, as well as cause excessive force to be imposed on the angle blade, resulting in failures.
- NEVER put the blade lever in the float position, when digging the ground by lowering the blade or lifting up the machine with the blade. NEVER go under the machine, as it may get down suddenly and cause a serious accident.

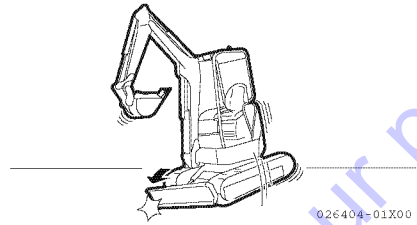

Neutral position of the angle blade

- The neutral position of the angle blade is marked as shown in the figure. Align the marks **1** and **2** in the figure to place the angle blade in the neutral position.

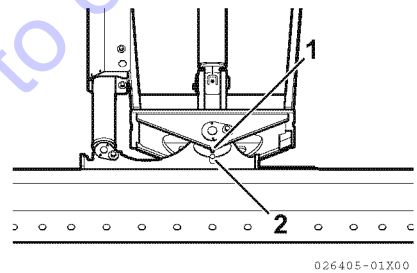

Preventing the angle blade from bumping

NEVER bump the blade. The excessive force may be imposed on the angle blade, resulting in failures.

For the angle lever operation, refer to "Blade angling switch (with angle blade)" on page 117 and "Blade lever" on page 121.



2.3 Precautions for transportation

Precautions for loading and unloading the machine

- Be careful in loading and unloading the machine, because it is a job of high hazard potential.
- Load or unload the machine at a low engine speed, and low travel speed.
- Load or unload the machine on the level, solid ground away from the shoulder of the road.
- Use ramp plates of adequate strength with hooks on their ends.

Check to see that the ramp plates are wide, long, and thick enough to sustain the load so that you can load or unload the machine safely. Support the ramp plates with blocks, to provide additional strength.

- Securely hook the ramp plates to the deck of the truck so that they will not come off.
- Remove grease, oil, and other slippery deposits from the ramp plates, and remove mud from the tracks to prevent the machine from skidding on the ramp plates.
- Do not load or unload the machine if the ramp plates are slippery because of rain, snow or ice.
- Never change travel direction while on the ramp plates. If you need to change travel direction, go down the ramp plates, and change direction on the ground.
- After loading the machine, block it with lumber and secure the machine with a chain or a wire rope so that the machine will not move during transit.

For instructions on loading and unloading the machine, refer to Section "4. Transportation" on page 209.

For instructions on securing the machine, refer to Section "4. Transportation" on page 209.

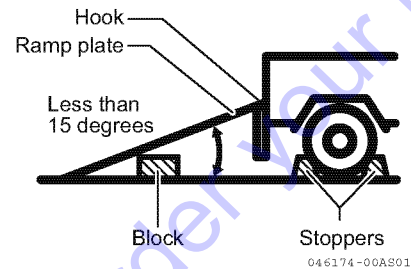

Precautions for transporting

- Transport the machine safely in accordance with the laws associated with applicable law.
- Select a travel route consistent with the width, height and weight of the machine loaded on the truck.

2.4 Precautions for the battery

⚠ DANGER

Be careful in handling the battery

- The battery electrolyte contains dilute sulfuric acid, which can severely burn the eyes or skin. Always wear safety goggles and protective clothing when servicing the battery. If contact with the eyes or skin should occur, flush with a large amount of water and obtain prompt medical treatment.
- Because flammable hydrogen gas is produced by the battery, ignition and explosion may occur. Keep flames and sparks away from the battery.
- Do not use or charge the battery if the battery electrolyte level is below the lower limit. Doing so may cause the battery to explode. Always check the battery electrolyte level before starting the engine. If the electrolyte level is low, add distilled water to the upper limit.
- If you swallow battery electrolyte by mistake, drink a large amount of water, milk, or fresh eggs, and obtain medical treatment immediately.
- Before checking or handling the battery, be sure to stop the engine and turn the starter switch to the "OFF" position.
- Be careful not to cause a short circuit by placing a tool across the terminals of the battery.
- If a terminal connection is loose, sparks may be generated due to contact failure, causing possible ignition and explosion. Be sure to connect the terminals securely.

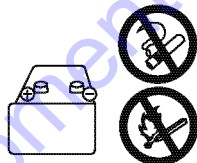

000297-00X

⚠ WARNING

Observe the procedures for starting the engine using booster cables

- When you start the engine using booster cables, wear safety goggles.
- If you start the engine by taking electric power from another machine, do not allow your machine to contact the other machine.
- To connect the booster cables, begin with the positive terminal, and to disconnect them, begin with the negative terminal (ground side).
- If a tool simultaneously touches the positive terminal and the machine, potentially hazardous sparks may be generated.
- Do not connect the booster cables to the terminals in reverse polarity. In other words, never connect the negative terminal on one machine to the positive terminal on the other machine.
- As the last step, connect the negative booster cable terminal to the upper structure frame. At that time, sparks will be generated. Consequently, connect the terminal to a point as far away from the battery as possible.

For information about starting the engine using booster cables, refer to Section "7.3 If the battery is overdischarged" on page 223.

2.5 Precautions for towing

Hook the wire rope on the frame when towing

- Improper towing procedures can cause death or serious injury.
- When towing a machine with another machine, use a wire rope strong enough to sustain the machine weight.
- Never tow a machine on a slope.
- Do not use a towing rope that is kinked, distorted or damaged.
- Do not ride on the towing cable or on the wire rope.
- When connecting an object to be towed, make sure that no person enters the space between the machine and the object.
- To connect an object to be towed, hook the sling belt as illustrated at right.
- The hook provided on the machine is intended for stabilizing the machine during transporting. Never use it for towing.

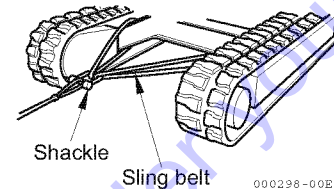

For information about towing the machine, refer to Section "7.2 Towing" on page 222.

Go to Discount-Equipment.com to order your parts

2.6 Precautions for hooked bucket

General precautions

Special hook

- A dedicated hook is required for suspending a load.
- The following procedures are extremely dangerous and must never be attempted:
 - Suspending a load with a wire rope hooked on the bucket teeth
 - Suspending a load with the wire rope directly hooked on the boom or the arm

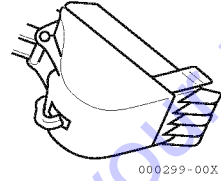

Checking the hook

- Check for abnormalities before suspending a load, as follows:
 - No cracks or deformations in the suspension sling belt and fittings
 - No abnormalities in the locking devices
- Every time you make a voluntary monthly check or a specified annual check, check all suspension gear for abnormalities and enter the results in the inspection records.

Securely attach a wire rope to the hook

- To suspend a load, securely attach a wire rope to the dedicated suspension hook.

Precautions for selecting a place to park the machine

- Survey the terrain and soil and select a solid, level spot for parking the machine, for maximum stability.

Do not use the machine for other than the specified purpose

- Never suspend a person together with the load, under any circumstances, because of the extreme danger.

Keep out of the radius of the work area

- Never permit anyone to enter the work area because of the danger of spilling or swinging the load.

Designate a leader to supervise suspension work

- When suspending a load, designate a leader to supervise the work and follow the leader's instructions.
- Follow the leader's instructions for the handling methods and procedures.
- Define hand signals in advance for communicating, and respond to the leader's signals.

Handling the wire rope

- When handling the wire rope, use leather gloves.
- For additional information about the hooked bucket, refer to Section "2. Handling the Hooked Bucket" on page 316.**

Go to Discount-Equipment.com to order your parts

Precautions for suspending a load

Move a suspended load slowly

- Raise and swing a suspended load slowly.
- Do not operate the control levers or the accelerator lever abruptly.
- The swing speed is three to four times higher than that of a truck crane. Swing the upper structure slowly.

Do not leave the operator's seat

- Never leave the operator's seat with a load suspended.

Do not operate the machine unsafely

- Working beyond the machine's capacity can cause accidents or failures. Suspend loads within the machine's capacity.
- Do not suspend a load greater than the specified maximum, or subject to a sharp impact. Those actions may damage the machine.
- Do not move the suspended load sideways or toward the machine, or haul it. Those actions are extremely dangerous.

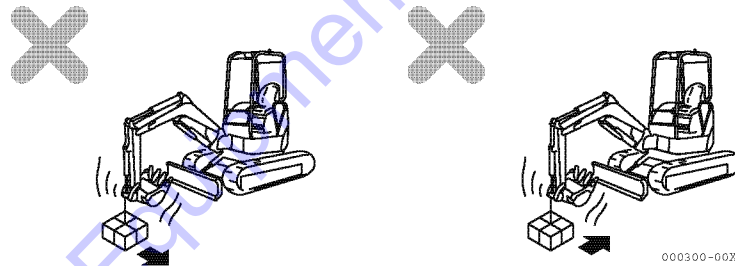

Do not travel while suspending a load

- Do not travel while suspending a load.

Make sure of the posture of the machine

- If the bucket hook is not maintained in a vertical position, the wire rope or the shackle may slip off the hook. Be careful to maintain a vertical hook angle, so that the wire rope or the shackle will not come off.

3. Precautions for Servicing

3.1 Precautions before servicing

Attach the "SERVICING IN PROGRESS" tag to an implement control lever

- If another person should start the engine or operate the control levers while service is in progress, the service personnel can sustain serious bodily injury.

Attach the "SERVICING IN PROGRESS" tag indicating "Servicing in Progress" to one of the implement control levers.

The "SERVICING IN PROGRESS" tag is enclosed with the Operation Manual.

Article number : 172437-03250

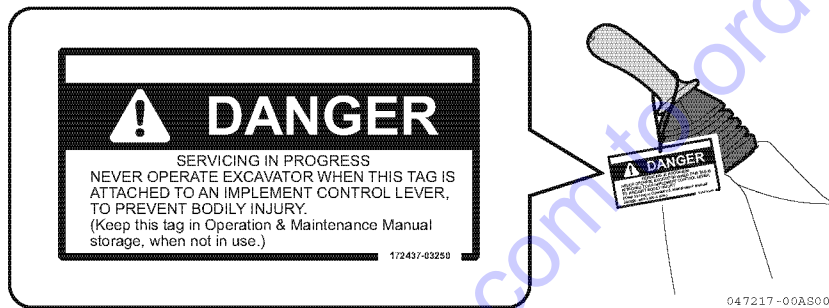

Use appropriate tools

- Using damaged or worn tools or using tools inappropriate for the required application is very dangerous, and may also cause damage to the machine. Make sure to use the tools that are appropriate for the specific job.

For information about tools, refer to Section "5.1 Required tools" on page 248.

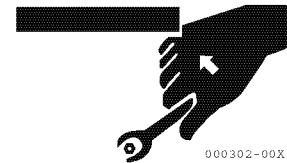

Periodically replace the parts essential to safety

- Aging or damage to the parts listed below can cause a fire. Make sure that they are replaced periodically.
 - Fuel system : Fuel hose and fuel tube cap
 - Hydraulic system : Outlet hose of main pump
- The parts listed above must be replaced periodically even if no abnormality is found in them. (They age with time.)
- If any abnormality is found in them, replace or repair the parts even though the suggested replacement time has not been reached.

For information about replacing essential safety parts, refer to Section "6. Replacing Essential Parts Periodically" on page 250.

Stop the engine before beginning the inspection and servicing

- Be sure to stop the engine before performing inspection and servicing.
- If necessary to perform service while running the engine, as when cleaning the inside of the radiator, be sure to set the lock lever to the lock position and do the job together with a partner.
(One should take the operator's seat so that he or she can stop the engine at any time.)
That person must be careful not to touch any levers in the cabin.
- Be extremely careful not to contact the moving fan or fan or fan belt, or any hot surfaces.

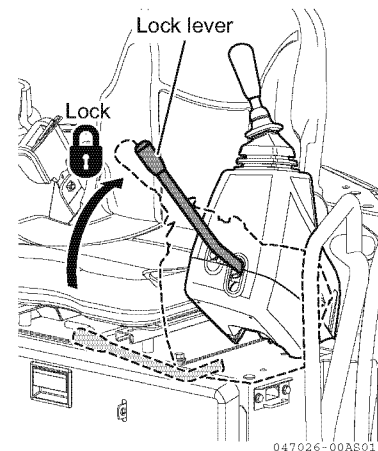
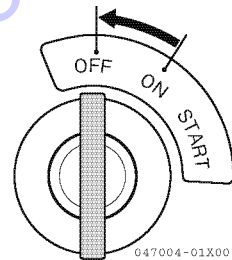

3.2 Precautions during servicing

Keep unauthorized persons away

- Never admit any persons into the work area who are not taking part in the work. Be conscious of the safety of other persons.
Be especially careful when grinding, welding, or using a large hammer.

Removed attachments

- When an attachment is placed on the ground or against a wall after removing it or prior to reinstalling it, be sure that it is stable to prevent it from falling down.



Working under the machine

- Before performing service or repairs underneath the machine, place the implement on the ground in its lowest position.
- Be sure to apply blocks to the tracks to lock the tracks securely.
- Never perform service underneath the machine if it is not completely stable.



Keep the machine clean

- Spilled oil or grease, or scattered parts are dangerous and can cause falls. Keep the machine clean.
- Getting water into the electrical system may cause it to malfunction, resulting in faulty operation of the machine. Also it may permit electrical leaks that could cause a fire or electric shocks.
- Never clean the sensors, connectors or the operator's seat with water or steam.

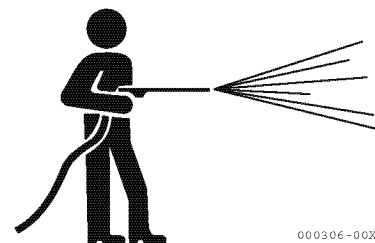

Precautions for fueling and oiling

- Spilled fuel and oil could cause a fire and they are dangerously slippery. Wipe up spills immediately.
- Close the fuel cap and oil cap securely.
- Never use fuel for cleaning.
- Provide good ventilation when replenishing fuel or oil.



000281-00X

Radiator cooling water level

- Before checking the radiator cooling water level, stop the engine and wait until the engine and the radiator have cooled down.
- Slowly loosen the cap to release the inner pressure before removing the cap.

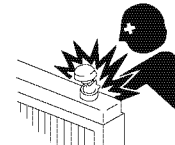

000307-00X

Use an explosion-proof lighting source

- Use an explosion-proof lighting source when checking the fuel, the oil, the cooling water, or the battery electrolyte. Failure to use an explosion-proof lighting source may cause ignition to occur, inducing an explosion.



000308-00X

Precautions for handling battery

- When welding or repairing the electrical system, disconnect the negative terminal of the battery to interrupt the electric circuit.



000309-00X

Handling high-pressure hoses

- Leaks of fuel and oil could cause a fire.
- Do not bend a high-pressure hose forcibly, or strike it with a hard object. Because abnormally bent or damaged piping, tubes, and hoses easily burst under high pressure, never use them.

Be careful of hot oil under high-pressure

- The hydraulic system for the implement operates under high pressure. When replenishing or draining hydraulic oil, be sure to first relieve the high pressure.
- The emission of hot oil under high-pressure from a small leak could result in serious bodily injury. Wear safety goggles and thick gloves when checking for leaks. Use a piece of cardboard or a plywood block to detect emissions of hot oil. If the hot oil should contact your body, obtain prompt medical treatment.

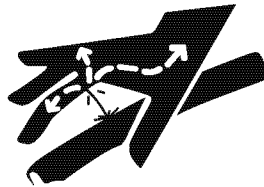

000310-00X

Be careful when servicing systems under high temperature and high pressure

- The engine cooling water and each lube oil system are still under high temperature and pressure immediately after the engine has stopped. Removing caps, draining oil and water, or replacing filter elements at that time may cause a burn. Wait until the temperature drops, then begin servicing in accordance with the procedures described in this manual.

For cleaning the inside of the cooling system, refer to Section "8.2 Nonperiodic services" on page 258.

For checking the level of the cooling water and the hydraulic oil, refer to Section "8.3 Checking before start-up" on page 272.

For checking the oil levels in various systems and replenishing the oil, refer to Section "8.3 to 8.5 Periodic services".

For replacing the oils in various systems and replacing the filter elements, refer to Section "8.6 to 8.8 Periodic services".

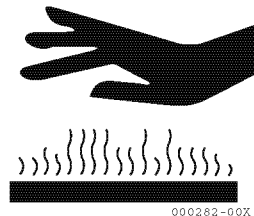

000282-00X

Hazards from the high-pressure grease when adjusting the track tension

High-pressure grease is enclosed in the track adjuster. Failure to use the specified procedures for adjusting the track tension, could cause grease plugs or nipples to eject, which could result in bodily injury.

- Do not loosen the grease draining plug more than one turn.
- Never position your face, hands, legs, or body in line with the grease draining plug and valve.

For information about adjusting track tension, refer to Section "8.2 Nonperiodic services" on page 258.



Rotating radiator fan and fan belt

- Never contact the rotating radiator fan or fan belt with any object.
- Contacting the rotating radiator fan or fan belt with any object can result in serious bodily injury.



Processing wastes

- Do not dispose of waste oil in the sanitary sewer system.
- Always drain the oil from the machine into a secure container, and never directly to the ground.
- When disposing of toxic wastes such as fuel, oil, cooling water, solvent, filters, and spent batteries, comply with all applicable disposal regulation.

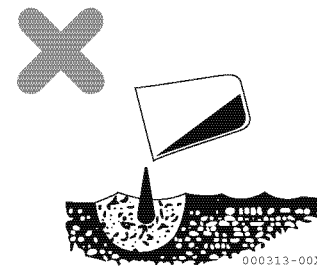

4. Safety Messages (Warning Labels)

There are a number of Warning Labels on the machine. Full descriptions of all Warning Labels and their locations are reviewed in this section. Periodically confirm whether all Warning Labels are still mounted in their correct locations and can be easily read.

If a warning label is missing, damaged or cannot be read, it must be promptly replaced. Also, if a warning label was mounted on a part which is replaced, a new warning label must be installed on the replaced part.

Contact your dealer to obtain new labels. The part code number is shown on each warning label as well as on the reproductions in this manual.

4.1 Location of warning labels

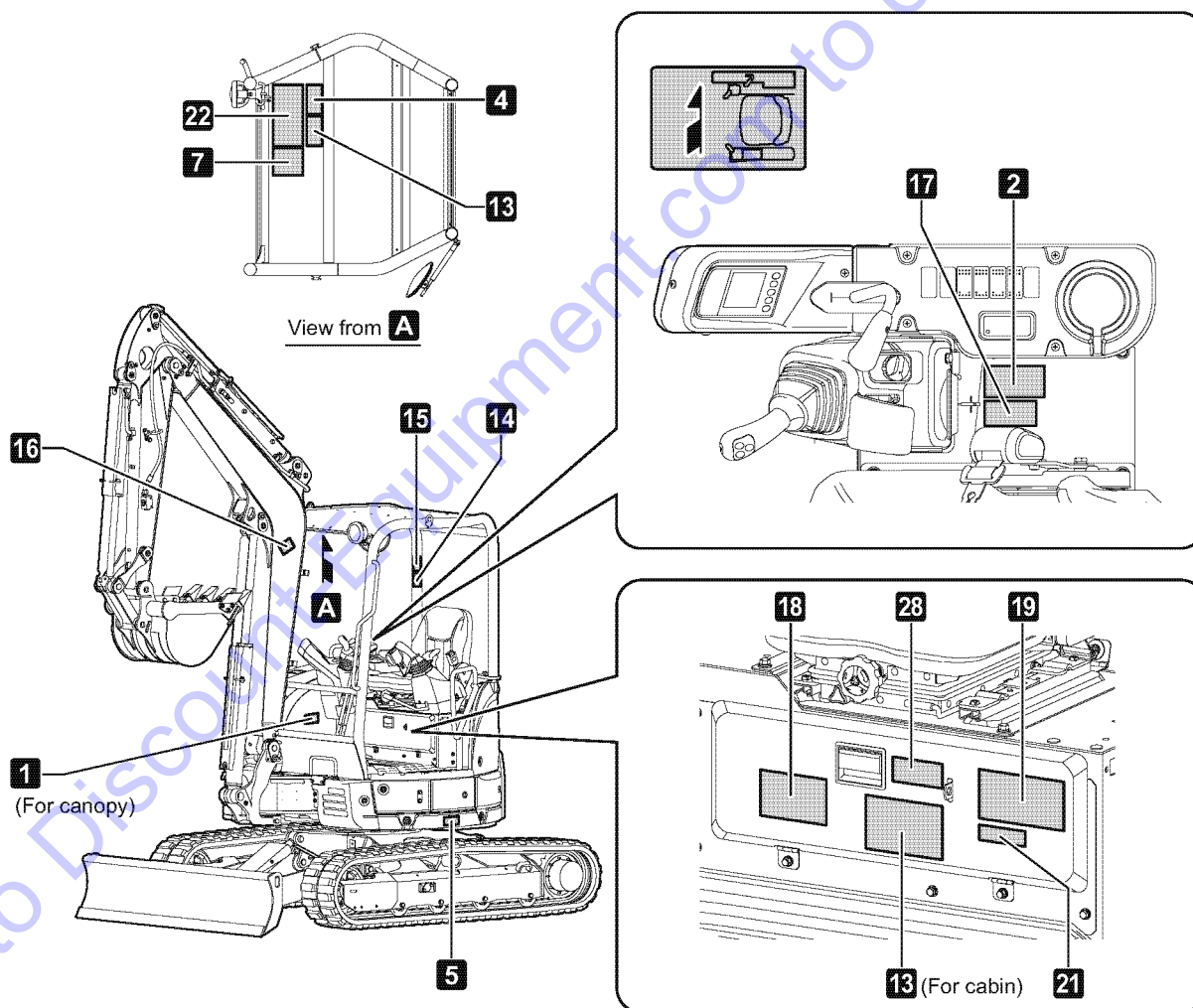

048080-01A501

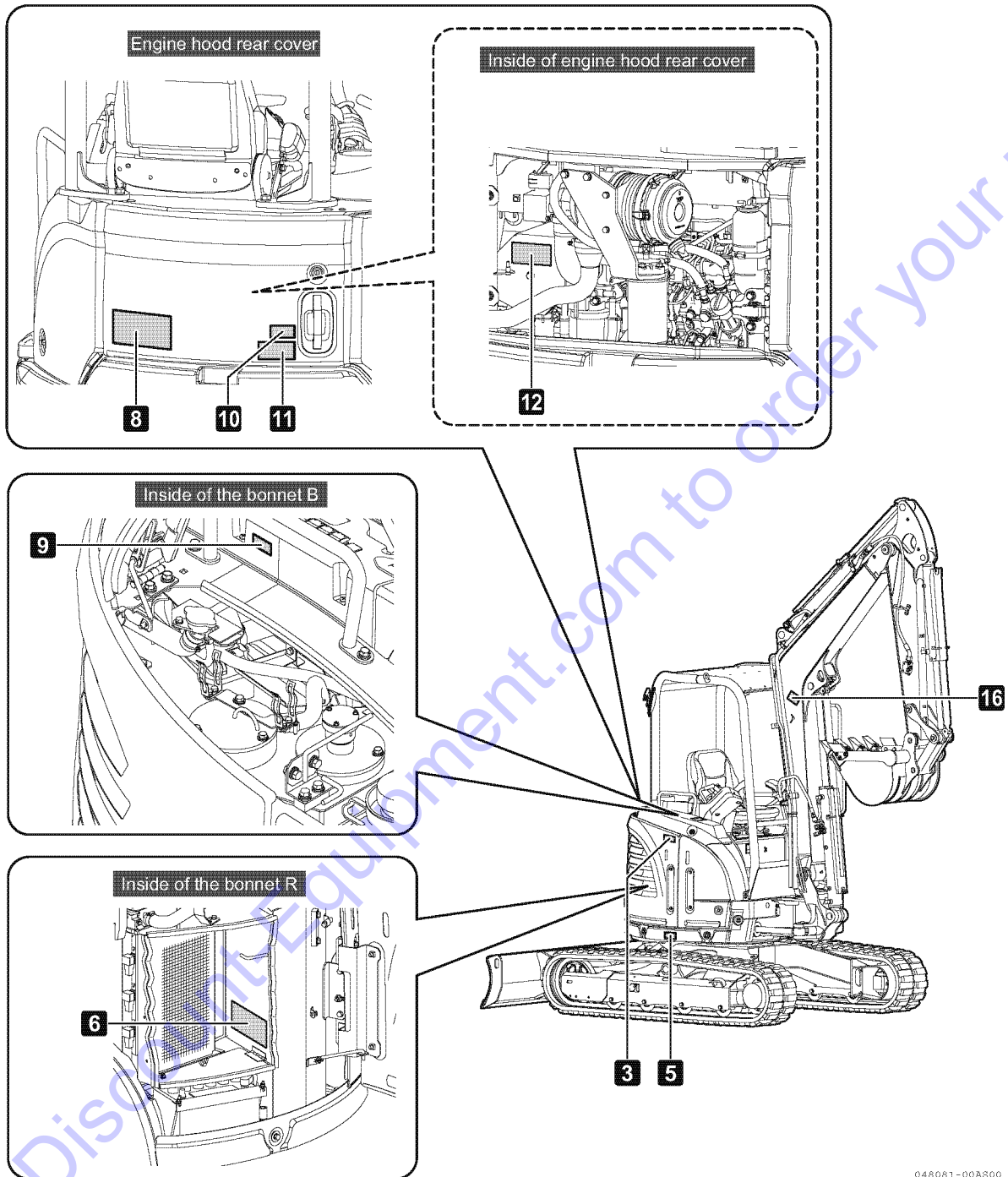

048081-00AS00

For cabin

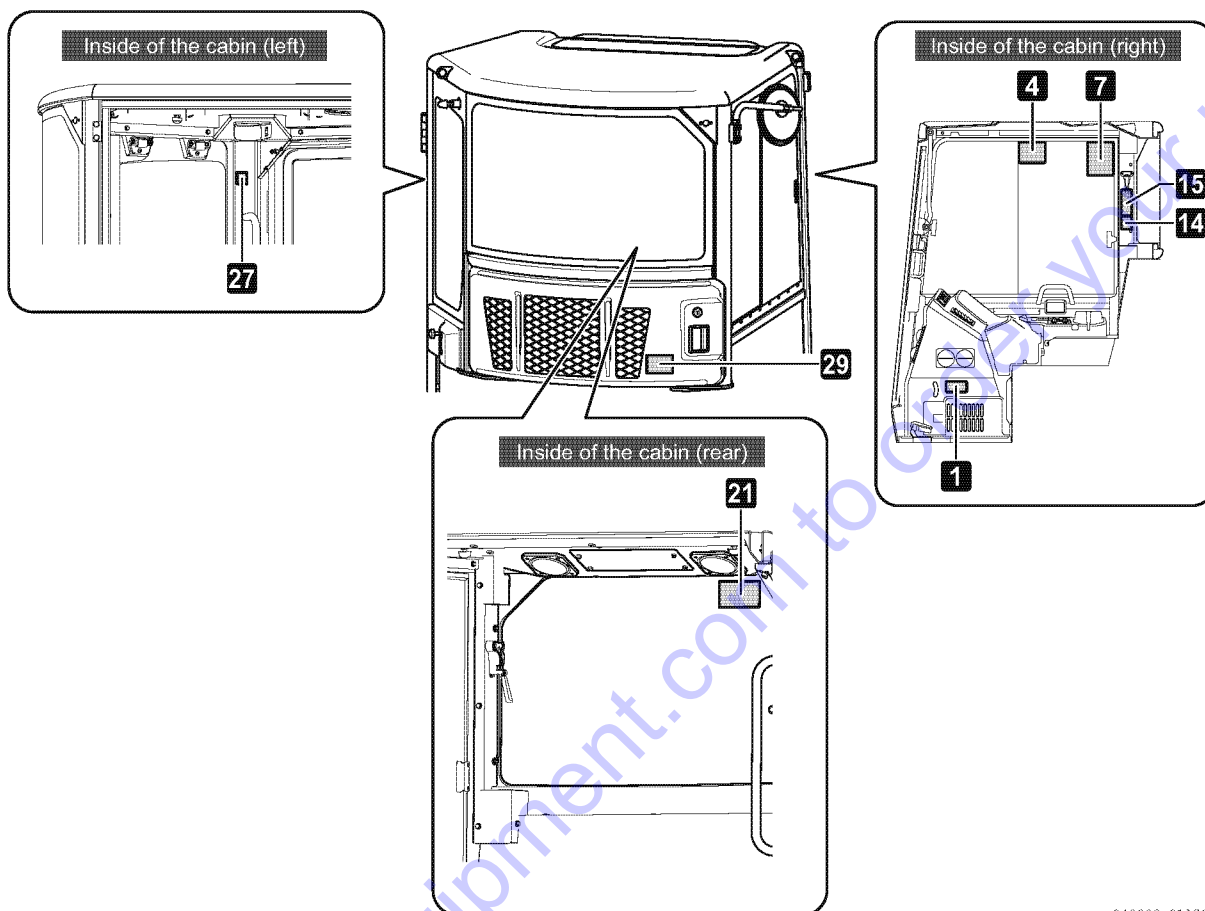

048082-01A501

Go to Discount-Equipment.com to get your parts

Quick coupler spec.

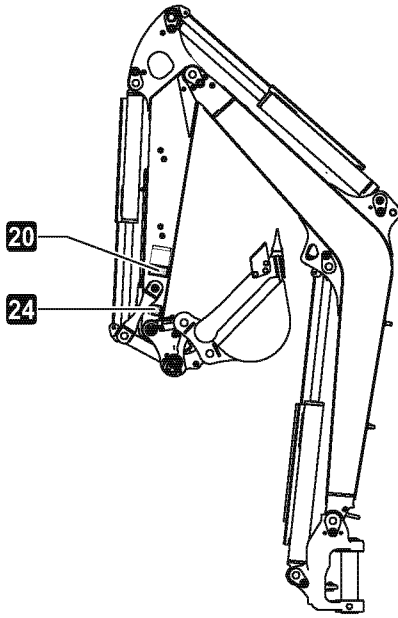

For canopy

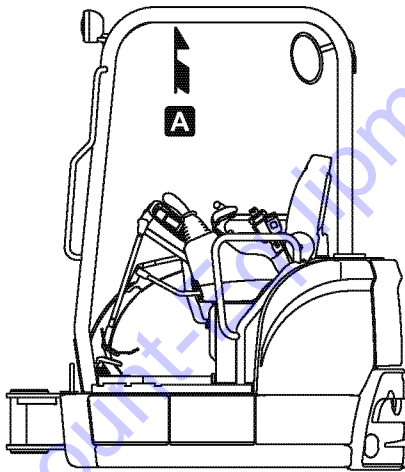

For cabin

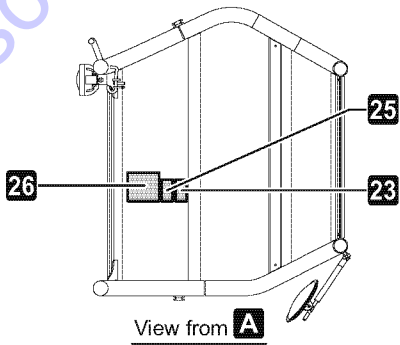
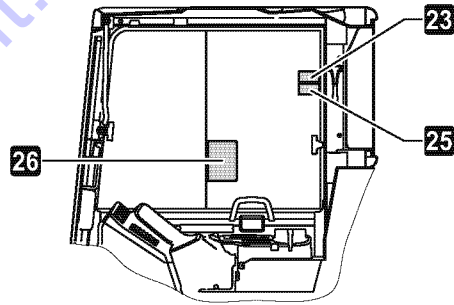

047322-02A801

1 172437-03302

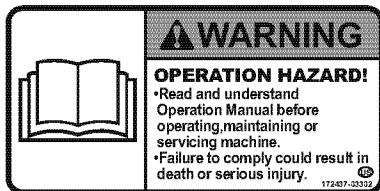

2 172437-03312

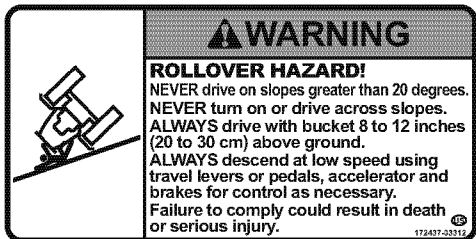

3 172437-03322

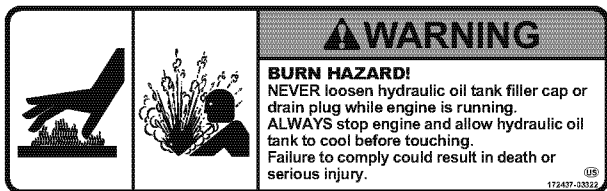

4 172437-03343

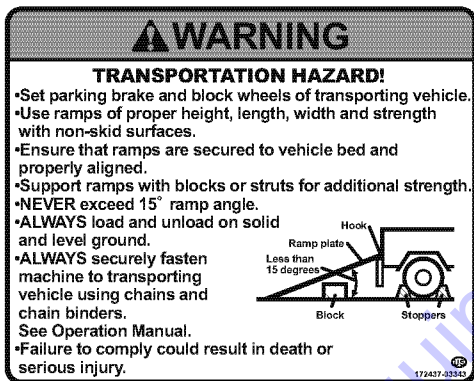

5 172437-03352

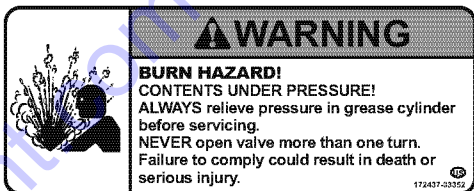

Go to Discount-Equipment.com to order your parts

6 172437-03361

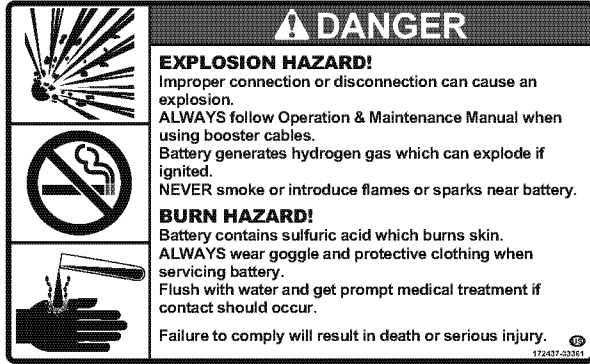

7 172437-03372

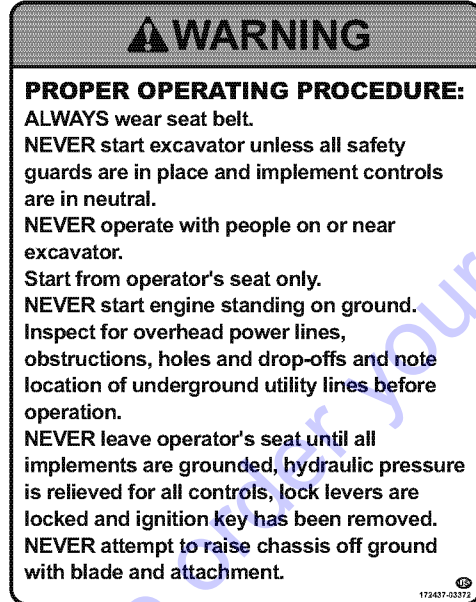

8 172437-03381



9 172437-03391

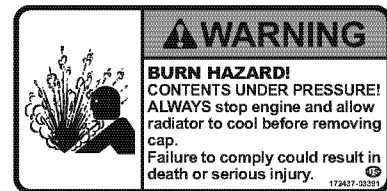

10 172437-03402

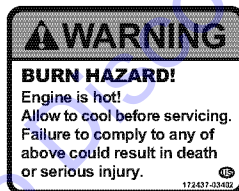

11 172A36-03411

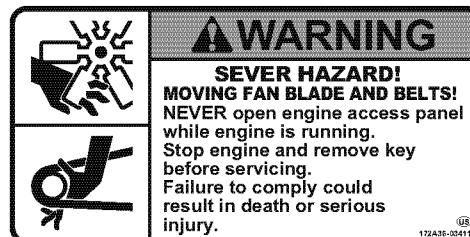

12 172B03-03390

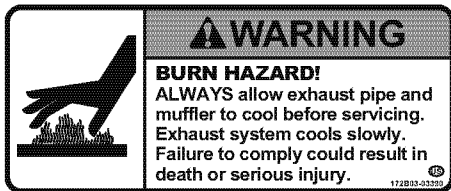

13 172437-03432

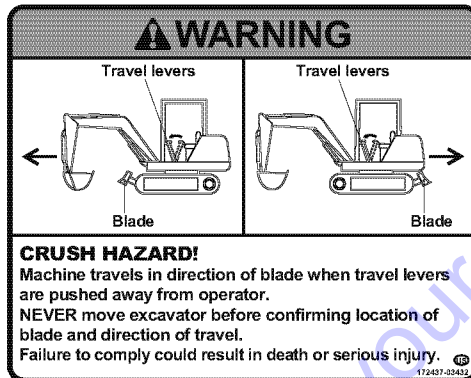

14 172437-03441

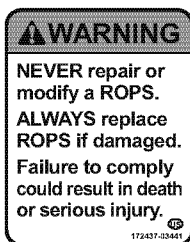

15 172437-03451

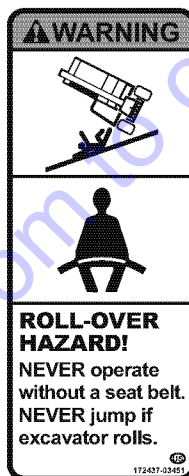

16 172437-03461



17 172437-03471

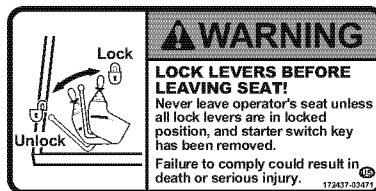

18 172437-03601

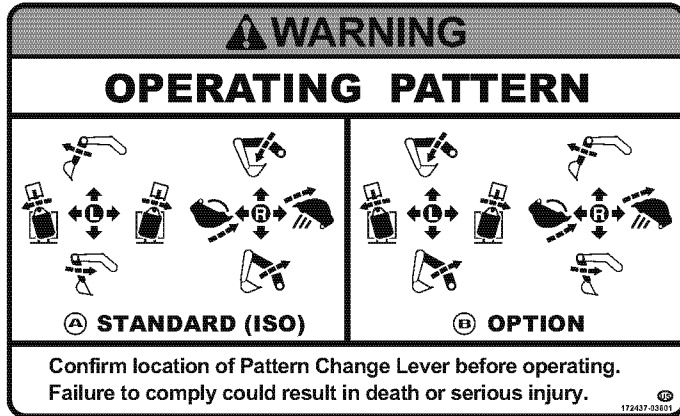

19 172472-03141

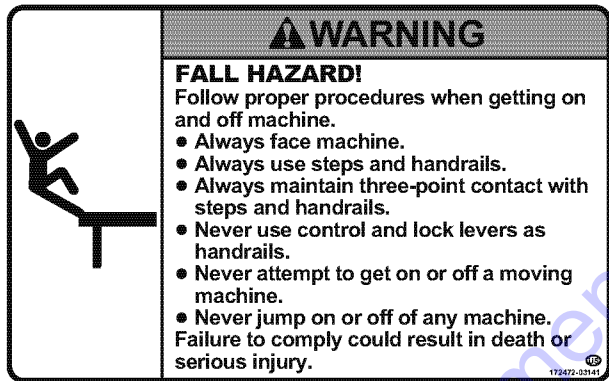

20 172472-03330 (For quick coupler)

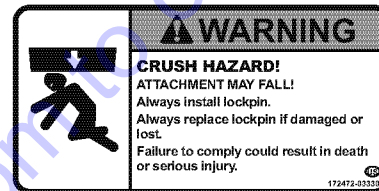

21 172B03-03800



22 172B03-03481

▲ WARNING

TIP-OVER HAZARD!
Never allow total lifting weight to exceed excavator lift capacity.

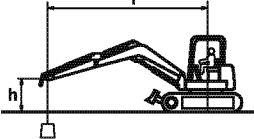

MODEL VIO35-6 EXCAVATOR

Note where application specifications conform to ISO standards.
The weight of all lifting devices, including quick coupler, must be deducted from the value shown in the table to determine the net load that can be lifted.
Genuine quick coupler (110lbs [50kg]).
Standard bucket (196lbs [89kg]).
Lift point is at the bucket hinge point.
Specifications subject to change without notice.
*Rated Hydraulic lift capacity

LIFT POINT HEIGHT h in. (mm)	(r) LIFT RADIUS · in. (mm)				(r) LIFT RADIUS · in. (mm)				(r) LIFT RADIUS · in. (mm)			
	MAX	137.8 (3500)	118.1 (3000)	98.5 (2500)	MAX	137.8 (3500)	118.1 (3000)	98.5 (2500)	MAX	137.8 (3500)	118.1 (3000)	98.5 (2500)
118.1 (3000)	*1719 (780)	*1631 (740)	*1609 (730)		1058 (480)	1322 (600)	*1565 (710)		992 (450)	1278 (580)	*1565 (710)	
78.7 (2000)	*1763 (800)	*1918 (870)	*2138 (970)	*2491 (1130)	903 (410)	1278 (580)	1653 (750)	*2447 (1110)	815 (370)	1256 (570)	1543 (700)	*2447 (1110)
39.4 (1000)	*1807 (820)	*2336 (1060)	*2888 (1310)	*3813 (1730)	793 (360)	1190 (540)	1521 (690)	1984 (900)	749 (340)	1124 (510)	1410 (640)	1807 (820)
Ground (0)	*1873 (850)	*2601 (1180)	*3218 (1460)	*4012 (1820)	815 (370)	1124 (510)	1410 (640)	1873 (850)	793 (360)	1058 (480)	1322 (600)	1719 (780)
-39.4 (-1000)	*1940 (880)	*2403 (1090)	*2954 (1340)	*3703 (1680)	925 (420)	1080 (490)	1388 (630)	1851 (840)	881 (400)	1014 (460)	1322 (600)	1675 (760)
-59.1 (-1500)	*1918 (870)	*2050 (930)	*2579 (1170)	*3130 (1420)	1124 (510)	1080 (490)	1410 (640)	1851 (840)	1058 (480)	1058 (480)	1344 (610)	1675 (760)
-78.7 (-2000)	*1851 (840)				1477 (670)				1410 (640)			

172B03-03481

23 172472-03241 (For quick coupler)



CAUTION

DO NOT DAMAGE LOCK PIN!

Pull lock pin out when changing attachment.

172472-03241

24 172472-03261 (For quick coupler)

▲ WARNING

SEVERE HAZARD!
NEVER insert fingers into pin hole.
Failure to comply could result in death or serious injury.



172472-03261

25 172B03-04410 (For quick coupler)

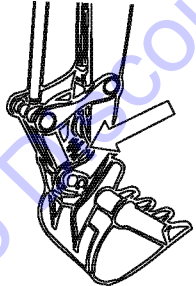

CAUTION

Be sure to remove earth and sand piled in quick coupler.
This may damage hydraulic hoses.

(US) 172B03-04410

26 172B03-04400 (For quick coupler)

⚠️ WARNING	
CRUSH HAZARD!	
	
<p>ALWAYS park on solid, level ground and place attachment on ground before operating quick coupler. Failure to comply could result in death or serious injury.</p>	
	<p>ATTACHMENT COULD FALL! ALWAYS install lock pin to prevent attachment from falling off. Ensure quick coupler securely holds attachment. <u>Lock pin</u></p>
	<p>TIP-OVER HAZARD! Never suspend load with quick coupler hook. Load could fall.</p>
<p>To prevent breakdown or sudden operation of attachment, never open switch box cover except to dismount or mount attachment. Failure to comply could result in death or serious injury.</p>	
<small>US 172B03-04400</small>	

27 172437-03551 (For cabin)

⚠️ WARNING
<p>WINDOW CAN FALL! Always lock window securely. Failure to comply could result in death or serious injury.</p>
<small>US 172437-03551</small>

28 172B03-03410

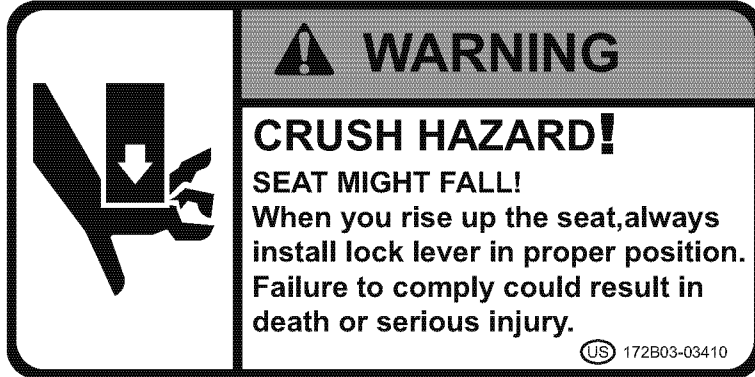

29 172B03-03420 (For air conditioner)



Go to Discount-Equipment.com to order your parts

■ Safety messages (Warning labels) for only ViO35-6A with angle blade

With angle blade

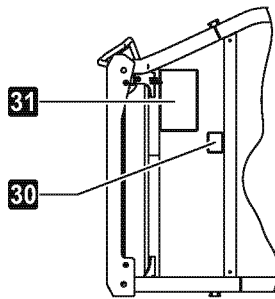
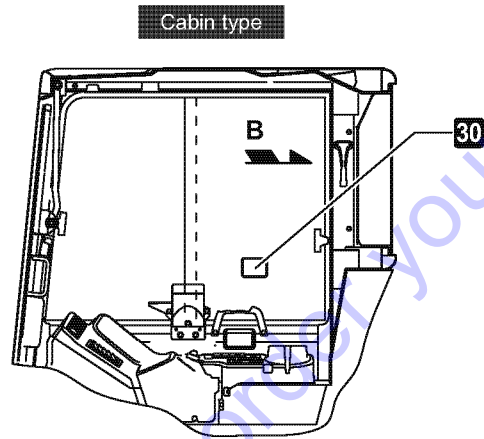
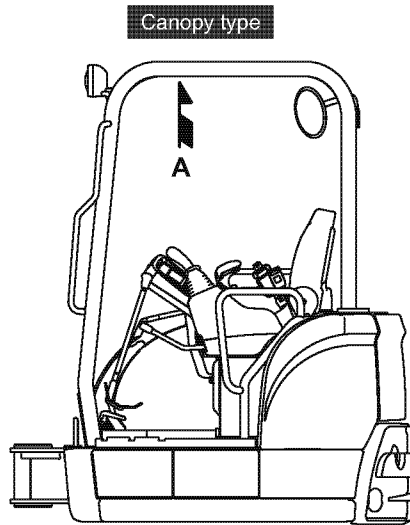

View from **A**

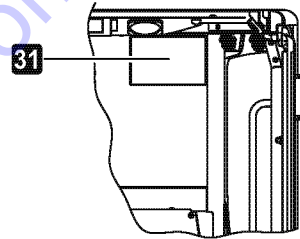

View from **B**

062050-00EN02

30 172A79-03220

▲ WARNING

PERSONAL INJURY HAZARD!

Do not push the blade control lever to the float position while jacking up the machine. Failure to comply could result in death or serious injury.

172A79-03220

31 172B03-03681

▲ WARNING

TIP-OVER HAZARD!
Never allow total lifting weight to exceed excavator lift capacity.

MODEL VIO35-6 EXCAVATOR Angle Blade Spec.

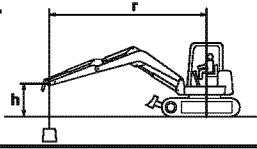

Note where application specifications conform to ISO standards.
The weight of all lifting devices, including quick coupler, must be deducted from the value shown in the table to determine the net load that can be lifted.
Genuine quick coupler (110 lbs [50 kg]).
Standard bucket (196 lbs [89 kg]).
Lift point is at the bucket hinge point.
Specifications subject to change without notice.
* Rated Hydraulic lift capacity

LIFT POINT HEIGHT h in. (mm)	(r) LIFT RADIUS · in. (mm)				(r) LIFT RADIUS · in. (mm)				(r) LIFT RADIUS · in. (mm)			
	MAX	137.8 (3500)	118.1 (3000)	98.5 (2500)	MAX	137.8 (3500)	118.1 (3000)	98.5 (2500)	MAX	137.8 (3500)	118.1 (3000)	98.5 (2500)
118.1 (3000)	*1719 (780)	*1631 (740)	*1609 (730)		1014 (460)	1256 (570)	*1565 (710)		1036 (470)	1344 (610)	*1565 (710)	
78.7 (2000)	*1763 (800)	*1918 (870)	*2138 (970)	*2491 (1130)	859 (390)	1234 (560)	1587 (720)	*2447 (1110)	859 (390)	1322 (600)	1631 (740)	*2447 (1110)
39.4 (1000)	*1807 (820)	*2336 (1060)	*2888 (1310)	*3813 (1730)	749 (340)	1124 (510)	1455 (660)	1895 (860)	793 (360)	1190 (540)	1499 (680)	1918 (870)
Ground (0)	*1873 (850)	*2601 (1180)	*3218 (1460)	*4012 (1820)	771 (350)	1058 (480)	1344 (610)	1785 (810)	837 (380)	1124 (510)	1388 (630)	1829 (830)
-39.4 (-1000)	*1940 (880)	*2403 (1090)	*2954 (1340)	*3703 (1680)	881 (400)	1036 (470)	1322 (600)	1763 (800)	925 (420)	1080 (490)	1388 (630)	1785 (810)
-59.1 (-1500)	*1918 (870)	*2050 (930)	*2579 (1170)	*3130 (1420)	1080 (490)	1036 (470)	1344 (610)	1763 (800)	1102 (500)	1124 (510)	1433 (650)	1785 (810)
-78.7 (-2000)	*1851 (840)				1433 (650)				1455 (660)			

©172B03-03681

Go to Discount-Equipment.com for your parts

OPERATION

1. Identification of Important Parts	79	2.22 External power outlet.....	140
1.1 Overview of the machine	79	3. Operating Instructions	141
1.2 Controls and switches	81	3.1 Checking before starting the engine	141
2. Description of Control Devices...	82	3.2 Starting up the engine	154
2.1 LCD Monitor	82	3.3 Operating and checking instructions after starting the engine	158
2.2 Switches	112	3.4 Traveling	160
2.3 Control levers and pedals	118	3.5 Steering	164
2.4 Engine hood rear cover	123	3.6 Stopping the machine	166
2.5 Bonnet B	124	3.7 Swinging the upperstructure	167
2.6 Bonnet R	125	3.8 Operating the implements	168
2.7 Operator's seat bottom cover.....	126	3.9 Precautions for operating the implement.....	169
2.8 Storage space for the operation & maintenance manual	127	3.10 Precautions for working	172
2.9 Tool storage	127	3.11 Precautions for going up and down a slope	173
2.10 Drink holder	128	3.12 Escaping from the mud.....	175
2.11 Utility box (for the canopy type only) 128		3.13 Operations using the bucket	176
2.12 Windshield (for cabin)	129	3.14 Handling quick coupler (option) ...	177
2.13 Emergency escape hammer (for the cabin type only)	132	3.15 Parking the machine	187
2.14 Operator's seat.....	133	3.16 Inspection requirements after completing operation	188
2.15 Ash tray (for cabin)	134	3.17 Stopping the engine	189
2.16 Work Lights	135	3.18 Inspection requirements after stopping the engine	190
2.17 Air outlet (for cabin)	136	3.19 Locking	190
2.18 Right window glass (for cabin)	136	3.20 Handling the rubber track (for rubber track type)	191
2.19 Cabin side door	137	3.21 Handling hydraulic P.T.O.....	196
2.20 Replenishment of windshield washer fluid	137		
2.21 Fuse	138		

3.22	Handling the thumb bracket	204
3.23	Releasing the internal pressure of the hydraulic circuit by accumulator.....	205
3.24	Replacing the bucket without the quick coupler	207
4.	Transportation	209
4.1	Loading and unloading the machine	209
4.2	Precautions for loading the machine	211
4.3	Precautions for transporting the machine	212
4.4	Suspending the machine	213
5.	Care and Service in Cold Weather	215
5.1	Preparing for cold weather	215
5.2	Precautions after a day's work	218
5.3	After cold weather ends	218
6.	Long-term Storage	219
6.1	Before storing	219
6.2	Storing	220
6.3	Using the machine again	220
7.	Troubleshooting	221
7.1	Phenomena that are not breakdowns	221
7.2	Towing	222
7.3	If the battery is overdischarged	223
7.4	Troubleshooting	228

1. Identification of Important Parts

1.1 Overview of the machine

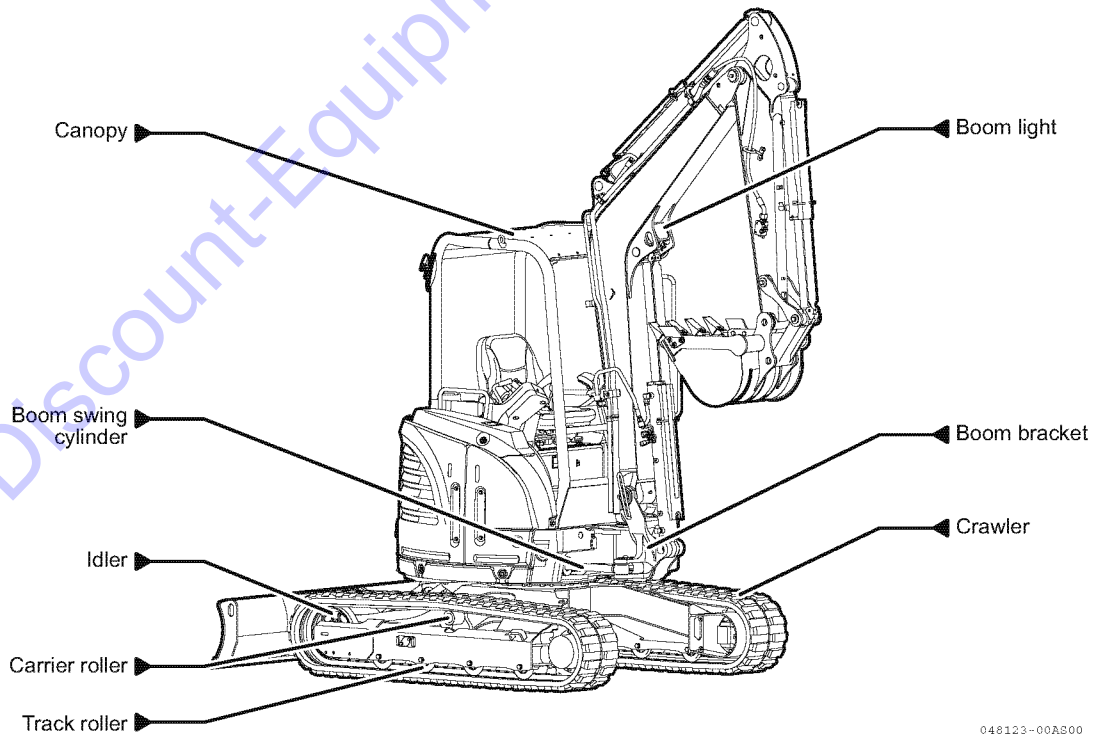
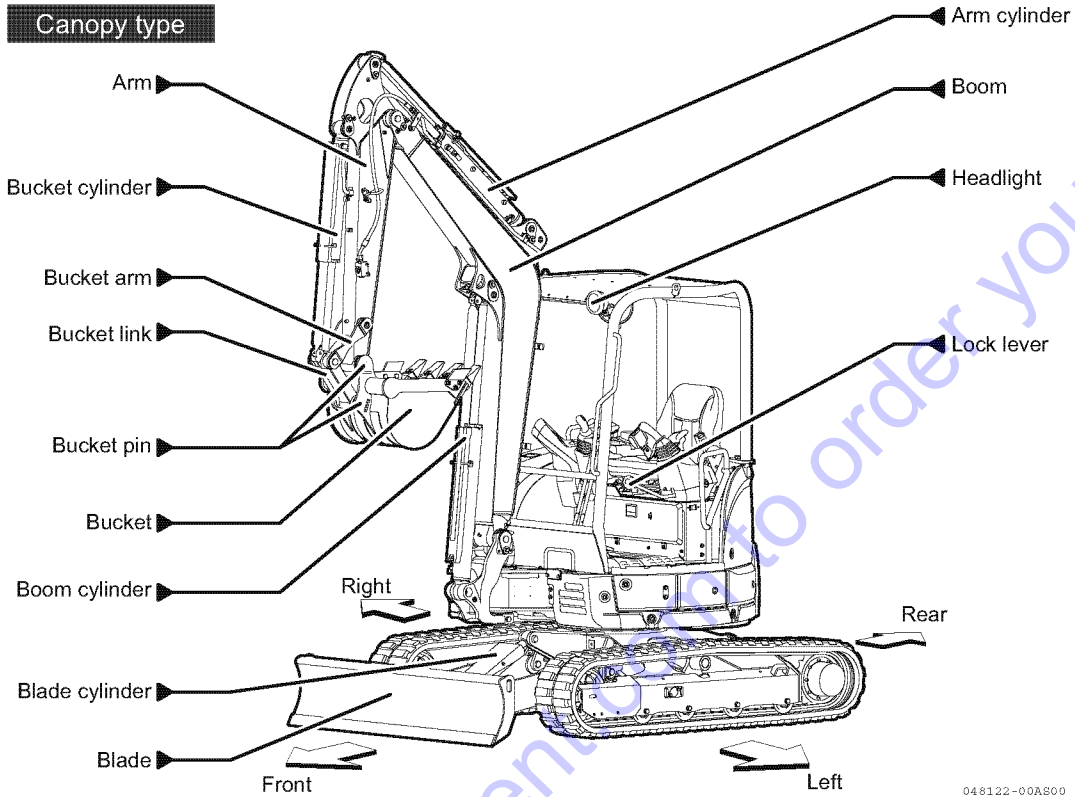

Cabin type

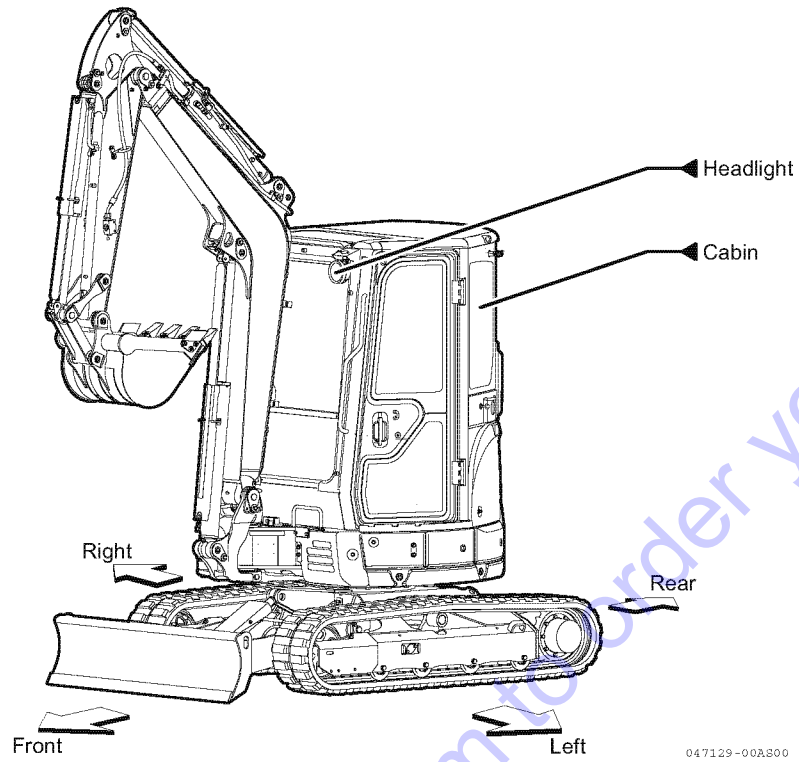

Inside of the cabin

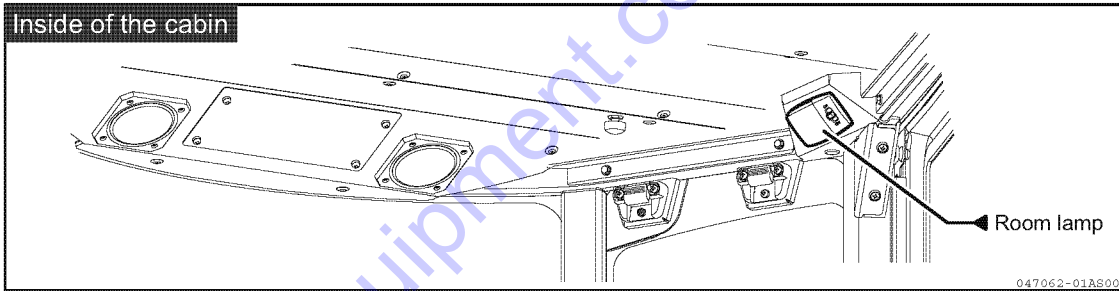

Detail of angle blade

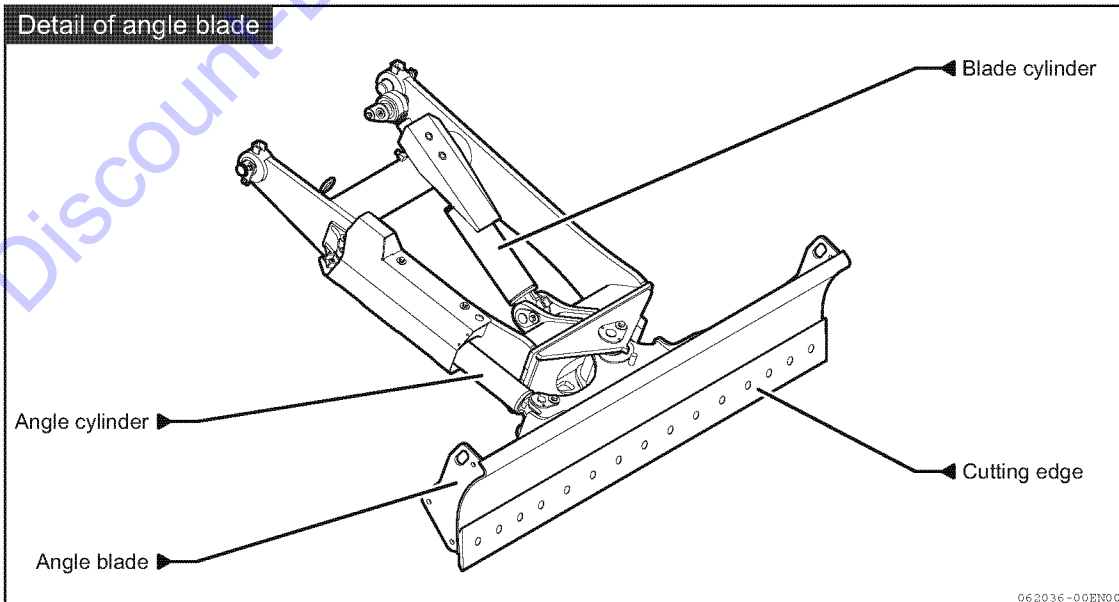

1.2 Controls and switches

For VIO35-6A with the standard blade

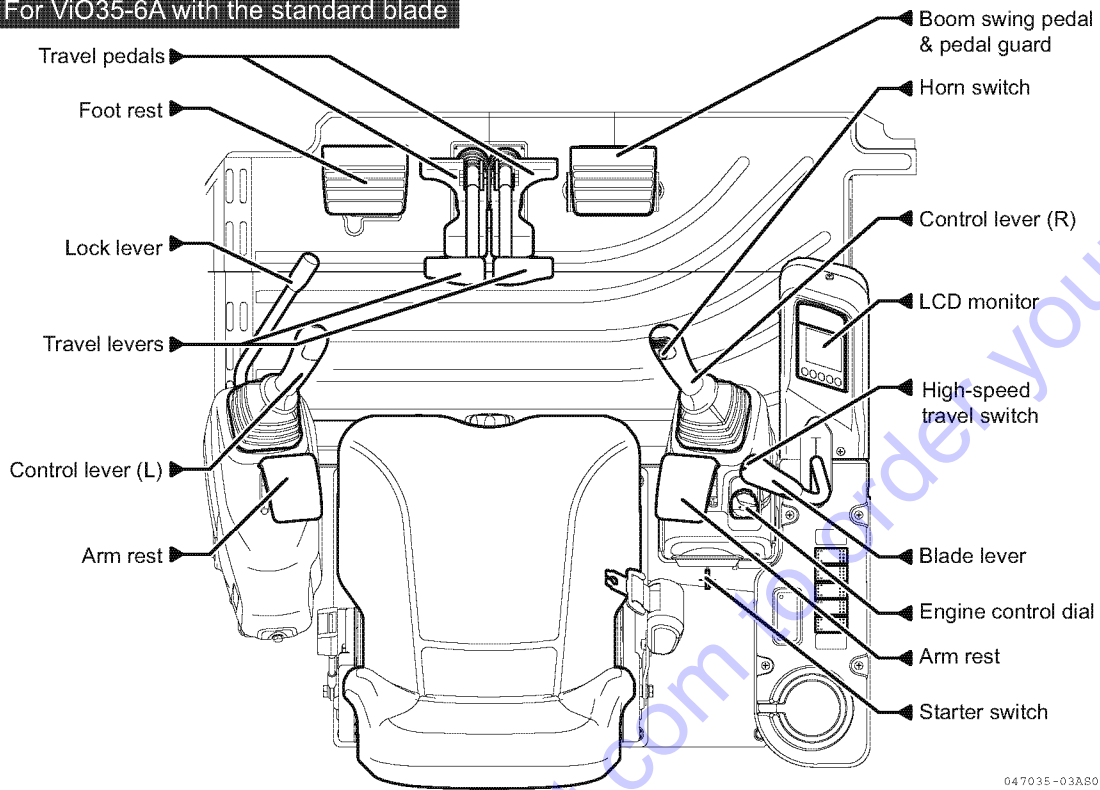

047035-03A802

For VIO35-6A with the angle blade

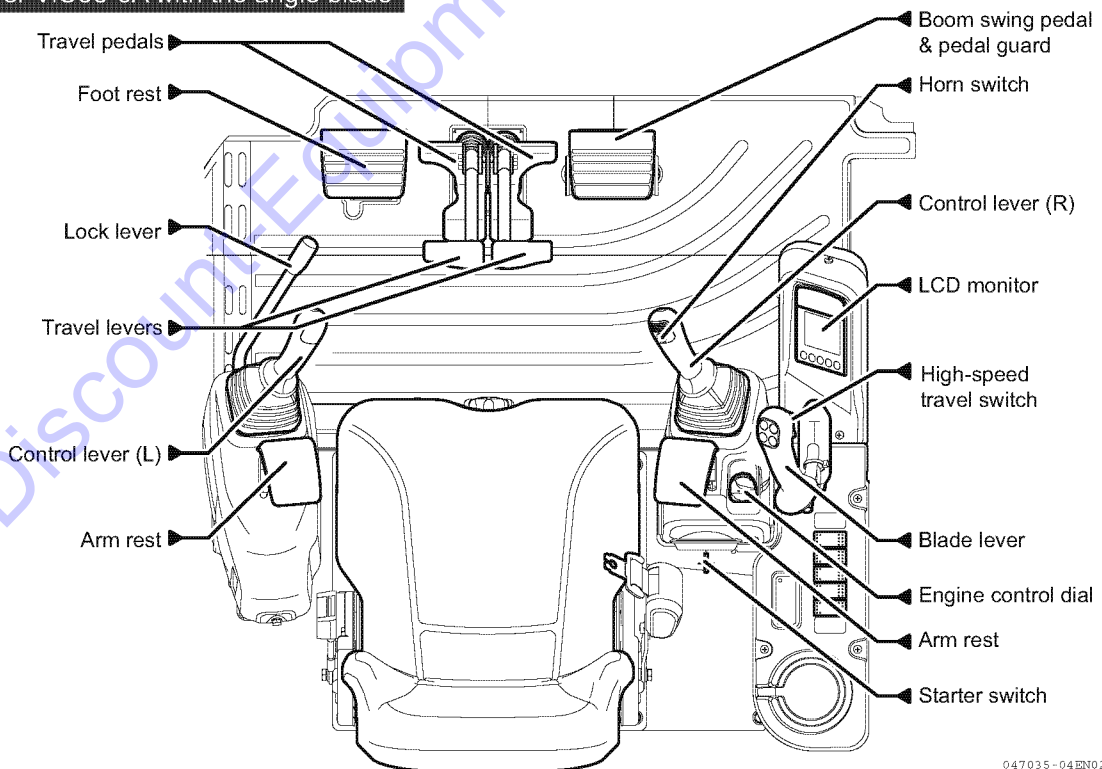

047035-04EN02

2. Description of Control Devices

This section describes several of the control devices necessary to operate the machine. In order to ensure safety and comfort in working with the machine, it is imperative for you to fully understand how to operate and interact with these devices.

2.1 LCD Monitor

Identification of Important Parts and Function

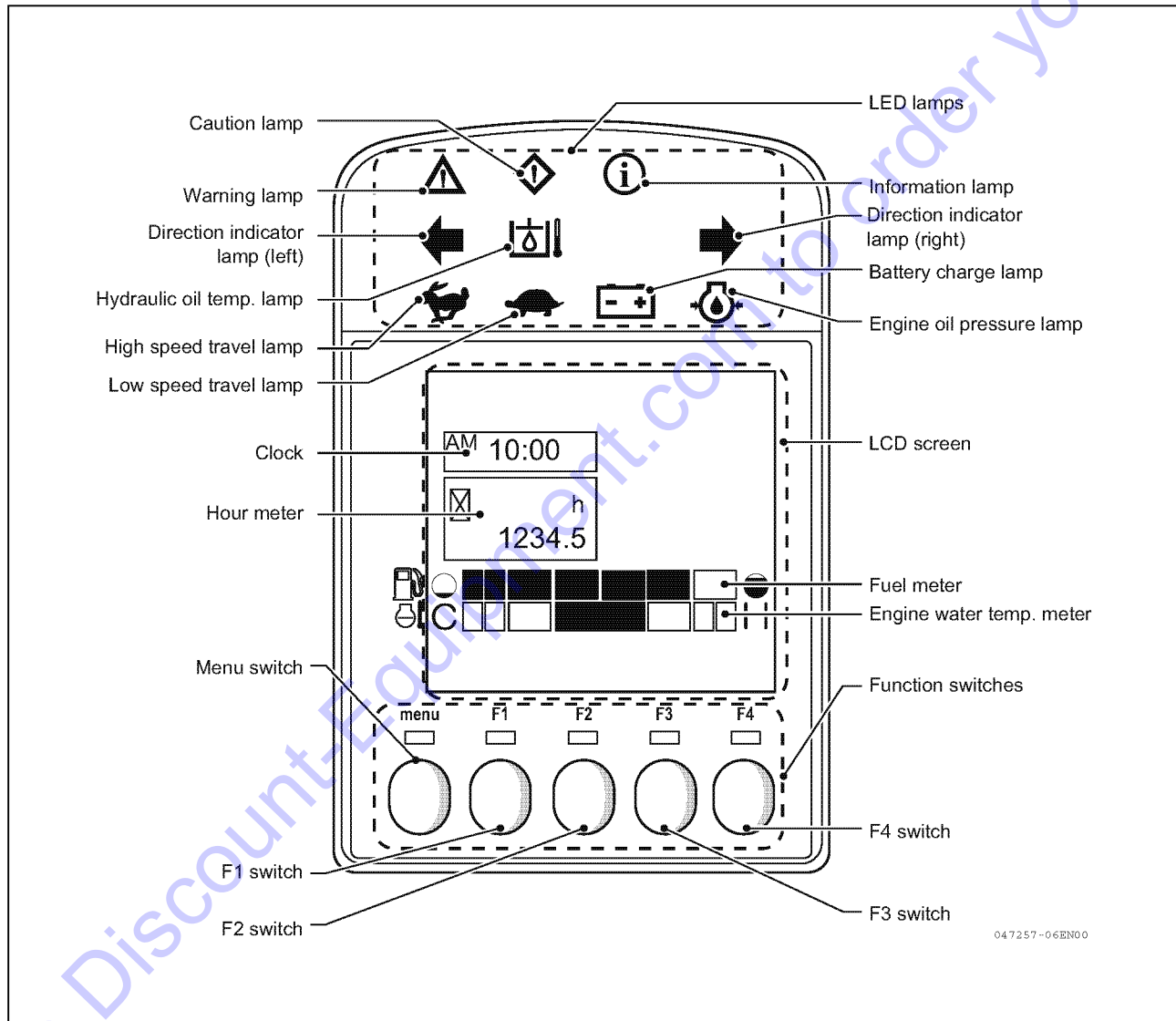

■ LED lamps

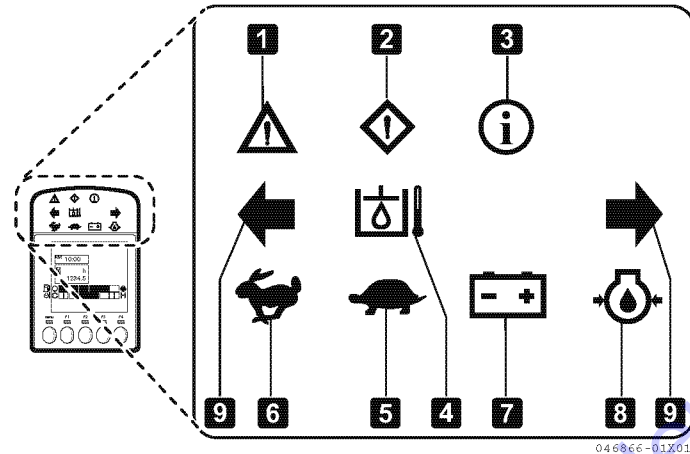

1 Warning lamp

This lamp flashes and the buzzer sounds when operation must be stopped immediately due to machine trouble.

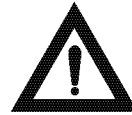

2 Caution lamp

This lamp flashes and the buzzer sounds when corrective measures need to be taken as soon as possible to deal with machine trouble.



3 Information lamp

This lamp flashes to indicate the existence of information that needs to be given to the operator.



4 Hydraulic oil temp. lamp

The function of this lamp is not used in this machine. However, the lamp is illuminated for 2 seconds only when the starter switch has been turned to the “ON” position.



5 Low speed travel lamp

The function of this lamp is not used in this machine. However, the lamp is illuminated for 2 seconds only when the starter switch has been turned to the “ON” position.



6 High speed travel lamp

This lamp is illuminated when the high speed travel switch is in the high-speed position.



7 Battery charge lamp

This lamp lights up and the buzzer sounds when the battery is not being charged properly while the engine is running; at the same time, the caution lamp also flashes.

If this lamp lights up and the buzzer sounds, inspect the battery charge circuit and, if any problems are found, take the necessary corrective measures according to Section "7.4 Troubleshooting" on page 221.



8 Engine oil pressure lamp

This lamp lights up and the buzzer sounds when the engine oil pressure falls outside the normal range; at the same time, the warning lamp also flashes.

If this lamp lights up and the buzzer sounds, immediately stop the engine and carry out inspections according to Section "7.4 Troubleshooting" on page 221.



9 Direction indicator lamp (left, right)

The lamp is illuminated for 2 seconds only when the starter switch has been turned to the "ON" position.

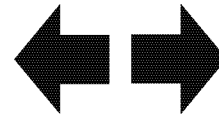

■ LCD screen (Normal screen)

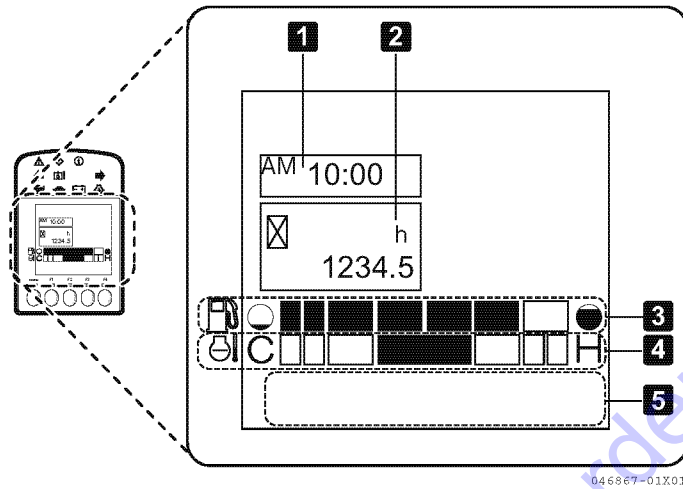

1 Clock

The clock displays the current time.

For the time setting method, refer to the procedure for setting the date and time on page 108.

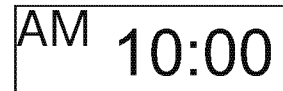

046873-00X00

Note:

Date and time settings are reset each time the battery is removed.

2 Hour meter

The hour meter indicates the total accumulated hours of the machine operation.

The reading of the hour meter helps you set time intervals for periodic servicing of the machine. While the starter switch is turned to the "ON" position, the hour meter will continue registering even if the engine is not running.

The hour meter reading increases by "1" per hour regardless of engine speed.

The digit at the far right registers "1" per 0.1 hour (6 minutes).

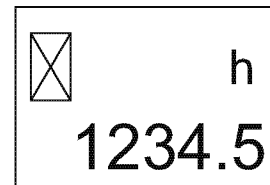

046874-00X00

3 Fuel meter

The fuel meter displays the amount of fuel remaining in the fuel tank.

The fuel meter and caution lamp flash when the fuel level in the tank falls below a prescribed level. When the indicator shows levels close to empty , the tank should be refueled as soon as possible.

The fuel level indicated by the fuel meter may vary depending on the orientation the machine; for example, when the machine is tilted.

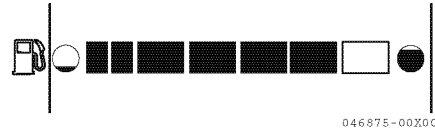

4 Engine water temp. meter

This meter indicates the temperature of the engine cooling water.

The meter and warning lamp flash when the cooling water temperature rises abnormally while the machine is operating; at the same time, an error code and an icon indicating that the cooling water temperature is abnormal are displayed on the screen and the buzzer sounds.

If the meter flashes and the buzzer sounds, immediately stop operation and reduce the engine speed to low idle. After the meter indicates low temperatures, stop the engine and carry out inspections according to Section "7.4 Troubleshooting" on page 221.

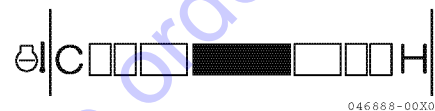

5 Function switch guidance

This guidance uses icons to indicate the current functions of the function switches.

The functions of the individual function switches change depending on the status of the machine or the screen currently displayed.

The current function of each switch can be checked on the icon displayed above its corresponding switch.

Touching the icon with a finger does not activate its corresponding function. Press the switch located under the icon to activate the function.

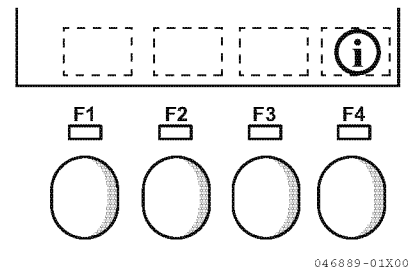

■ Function switches

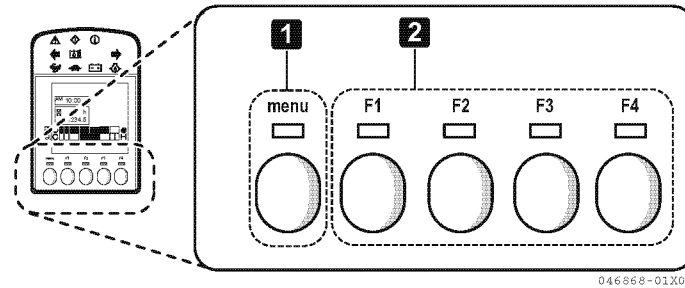

The function switches in the bottom part of the LCD monitor comprise 5 switches (a menu switch and F1 - F4 switches) and their functions change depending on the status of the machine or the screen currently displayed. The switches can be used when the LED lamps located just above the individual switches are illuminated green.

1 Menu switch

Pressing this switch brings up the main menu on the screen.

For details of the menu screen, refer to the description of "Main menu" on page 99.

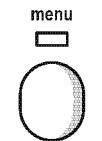

046891-00X00

2 F1 - F4 switches

The functions of the individual switches change depending on the screen currently displayed.

For switch operations on each screen, refer to "LCD Monitor Operation Method" on page 99.

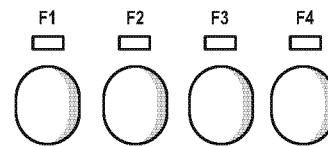

046892-00X00

Operation of LCD Monitor during Start-up

IMPORTANT

Be sure to carry out start-up inspection by referring to the instructions in PART: "MAINTENANCE" or Section "3. Operating Instructions" on page 141 of this manual as well as messages displayed on the LCD monitor.

1. When the starter switch is turned to the "ON" position, the Start screen (Welcome!) appears and the LED lamps located just above the function switches and the following LED lamps light up and the buzzer sounds.

- 1 Warning lamp
- 2 Caution lamp
- 3 Information lamp
- 4 Hydraulic oil temp. lamp
- 5 Low speed travel lamp
- 6 High speed travel lamp
- 7 Battery charge lamp
- 8 Engine oil pressure lamp
- 9 Direction indicator lamp

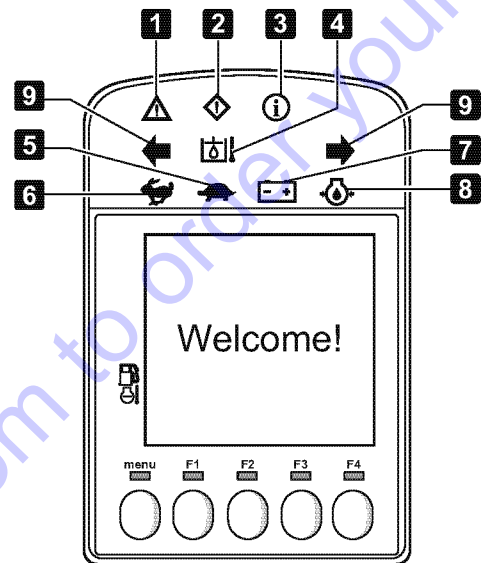

046693-03X01

If any of the LED lamps does not light up or the buzzer does not sound, the LCD monitor may malfunction. Immediately contact the nearest dealer for service.

The LED lamps go out, the buzzer stops sounding and the LCD moves to the next screen 2 seconds after the starter switch is turned to the "ON" position.

Note:

The battery charge lamp and engine oil pressure lamp normally remain illuminated until the engine is started, even after 2 seconds have passed.

The buzzer stops sounding after 2 seconds. However, if the starter switch is left in the "ON" position without the engine being started, current continues to flow.

Leaving the machine in such a state for a prolonged period of time will cause the battery to run down. Whenever the machine is not in use, make sure that the starter switch is in the “OFF” position.

2. If there are problems with the machine or if there is some information such as maintenance notices, problem or information details are displayed.

When there are problems with the machine:





Icons and error codes representing error details are displayed on the LCD screen and the warning or caution lamp flashes depending on the error.

If an error is displayed, do not start the engine and immediately check the error for details to take necessary corrective measures.

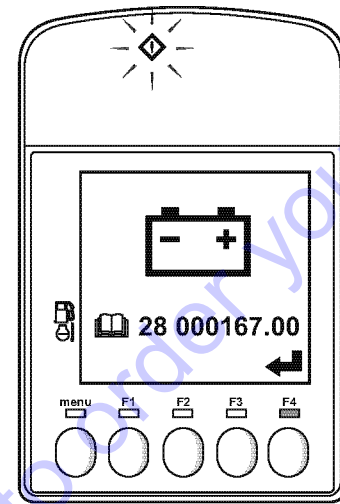
Icons displayed on the screen are listed in the table below.

If an error other than the following is displayed, contact the nearest dealer.



Icon	Error description	Warning/caution lamp	Corrective measures
	Abnormal engine cooling water temperature	Warning lamp flashing	Stop the engine startup process and inspect the engine according to Section "7.4 Troubleshooting" on page 228.
	Abnormal engine oil pressure	Warning lamp flashing	Stop the engine startup process and inspect the engine according to Section "7.4 Troubleshooting" on page 228.
	Insufficient battery charge	Caution lamp flashing	Stop the engine startup process and inspect the engine according to Section "7.4 Troubleshooting" on page 228.
	Insufficient amount of fuel	Caution lamp flashing	Refill the fuel tank.
	Other errors	Warning or caution lamp flashing	Check the error code and contact the nearest dealer.

Note:

For details of error codes, refer to Appendix Table "List of error codes displayed on LCD monitor" on page 333.

When there is more than one machine problem, icons and error codes are alternately displayed on the screen every 5 seconds. Pressing the F4 switch  allows display of the next screen.

When there is some information such as maintenance notices:

When there is some information such as maintenance notices, details of information are displayed on the LCD screen and the information lamp flashes.

Check the information details and take necessary measures.

Icons displayed on the screen are listed in the table below.

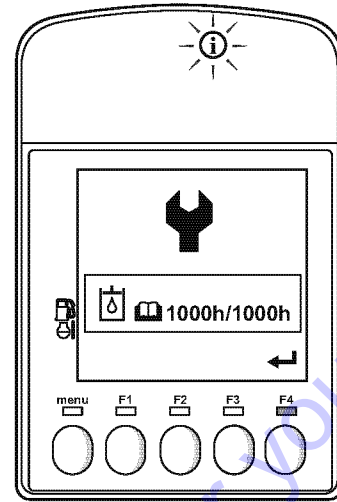

Go to Discount-Equipment.com to order your parts

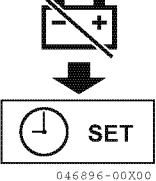
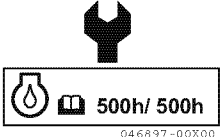
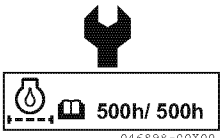
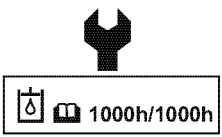
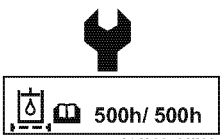
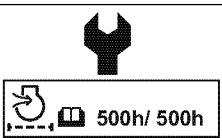
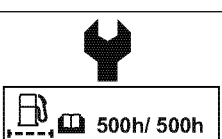
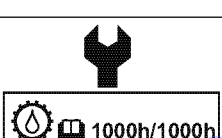
Icon	Description	Measures	Reference
	Notice of date and time settings	Set the date and time.	Procedure for setting the date and time - page 108
	Maintenance notice: Engine oil	Replace the engine oil.	Procedure for replacing the engine oil and the engine oil filter - page 282
	Maintenance notice: Engine oil filter	Replace the engine oil filter.	Procedure for replacing the engine oil and the engine oil filter - page 282
	Maintenance notice: Hydraulic oil	Replace the hydraulic oil.	Procedure for checking and replenishing the hydraulic oil in the hydraulic oil tank - page 146
	Maintenance notice: Hydraulic oil return filter	Replace the hydraulic oil return filter.	Procedure for replacing the hydraulic oil return filter - page 286
	Maintenance notice: Air cleaner element	Replace the air cleaner element.	Procedure for replacing the air cleaner element - page 285
	Maintenance notice: Fuel filter element	Replace the fuel filter element.	Procedure for replacing the fuel filter element - page 280
	Maintenance notice: Travel reduction gear oil	Replace the travel reduction gear oil.	Procedure for replacing the travel reduction gear oil - page 287

Note:

When there is more than one information item, icons are alternately displayed on the screen every 2 seconds. Pressing the F4 switch  allows display of the next screen.

3. After the error or information screen disappears, the display returns to the normal screen.
The normal screen is also displayed when there is no machine problem or information.

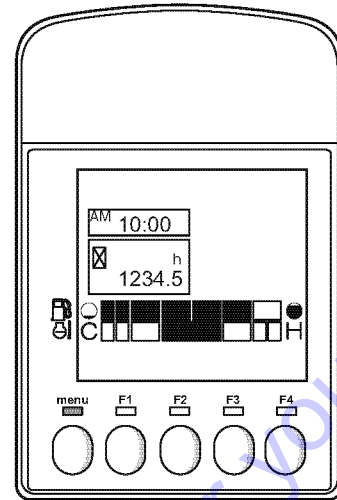

046893-00X01

Note:

In cases where the engine is cold in cold weather, the screen showing that the engine glow plug is operating appears prior to the normal screen appearing. After completion of the engine glow plug operation, the normal screen appears.

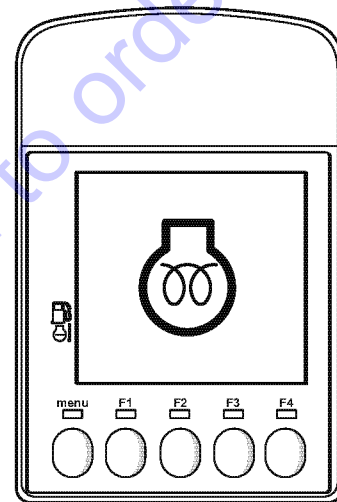

046904-00X00

Go to Discount-Equipment.com to order your parts

Operation of LCD Monitor during Machine Operation

■ Operation of LCD monitor when problems occur during machine operation

Display of machine problems

If problems occur on the machine in operation, corresponding LED lamps light up or flash and details of problems are displayed on the LCD screen.

Note:

When more than one problem occurs, error codes and icons are alternately displayed on the screen every 2 seconds.

Display of warnings

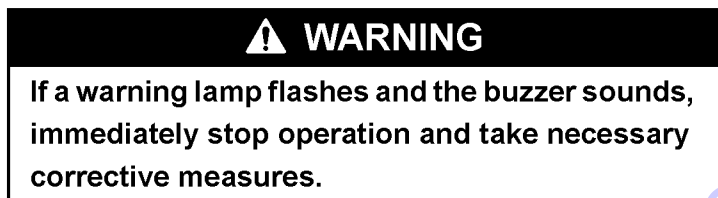

If serious problems requiring immediate stoppage of operation occur during the operation of the machine, the warning lamp flashes and the buzzer sounds continuously.

Icons and error codes showing problem details are displayed on the LCD screen.

When the warning lamp flashes, immediately stop operation and check the error for details to take necessary corrective measures.



If the warning lamp flashes and an error screen appears due to any error other than those described below, immediately stop operation and contact the nearest dealer.

Note:

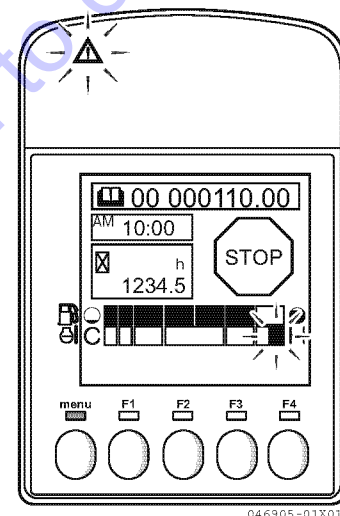
For details of error codes, refer to Appendix Table "List of error codes displayed on LCD monitor" on page 333.





- **Engine water temp. alarm**

If the engine cooling water temperature rises excessively during the operation of the machine, the warning lamp and engine water temp. meter flash, the buzzer sounds continuously and the high temperature icon  and the stop icon  are displayed alternately on the LCD screen.

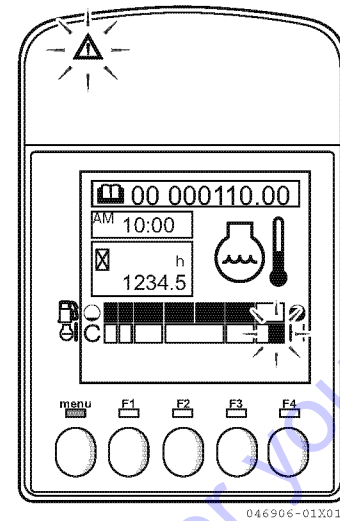
Because this indicates the first signs of engine overheating, immediately stop operation and reduce the engine speed to low idle. After the engine cooling water temperature drops sufficiently, take appropriate corrective measures.



- **Engine oil pressure alarm**

If the engine oil pressure falls outside the normal range, the warning lamp flashes, the engine oil pressure lamp lights up, the buzzer sounds continuously and the engine oil pressure icon  and the stop icon  are displayed alternately on the LCD screen.

In such cases, immediately stop the engine and carry out inspections according to Section "7.4 Troubleshooting" on page 228.

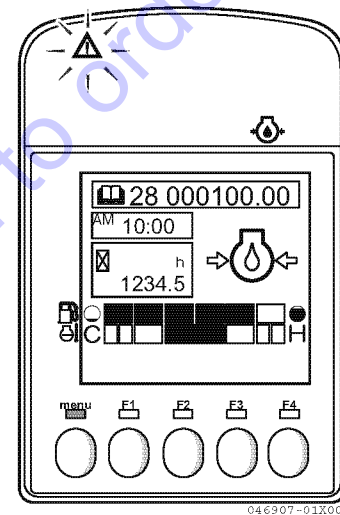

Display of cautions

CAUTION

If a caution lamp flashes, take necessary corrective measures as soon as possible.

If problems requiring the earliest possible implementation of corrective measures occur during the operation of the machine, the caution lamp flashes and the buzzer sounds intermittently.

Pictorial symbols and error codes showing problem details are displayed on the LCD screen.

When the stop buzzer icon  is displayed on the LCD screen, press the F4 switch to stop the buzzer.

The buzzer may not sound for some errors.

When the caution lamp flashes, check the error for details and take necessary corrective measures as soon as possible.

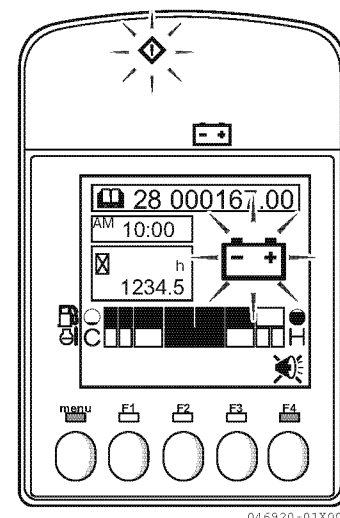

If the caution lamp flashes and an error screen appears due to any error other than those described below, contact the nearest dealer as soon as possible.

Note:

For details of error codes, refer to Appendix Table "List of error codes displayed on LCD monitor" on page 333.

• **Battery charge alarm**

If the battery is not being charged properly while the engine is running, the caution lamp flashes, the battery charge lamp lights up, the buzzer sounds intermittently and the battery icon  is displayed flashing on the LCD screen.

In such cases, carry out inspections according to Section "7.4 Troubleshooting" on page 228 as soon as possible.

Note:

Press the F4 switch  to stop the buzzer.

• **Fuel shortage alarm**

When the amount of the fuel remaining in the fuel tank becomes low, the caution lamp and fuel meter flash and the fuel icon  is displayed flashing on the LCD screen.

In such cases, refill the fuel tank soon.

Note:

This alarm is not accompanied by a buzzer tone or display of an error code.

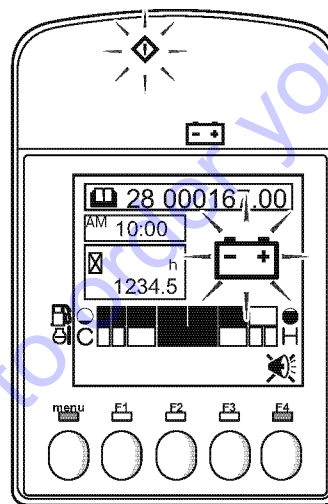

046920-01X00

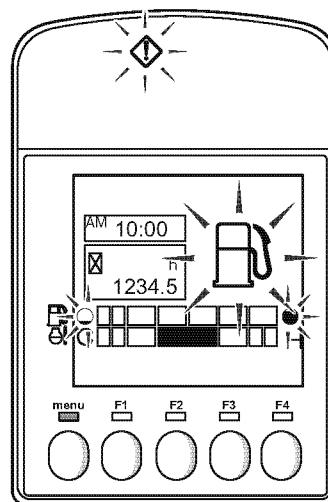

046921-01X00

- **Sensor failure alarm**

If problems occur with the sensor that measures the amount of fuel in the tank or one that measures the engine cooling water temperature, the caution lamp and relevant meter flash and the caution icon  is displayed flashing on the LCD screen.

In such cases, contact the nearest dealer for service as soon as possible.

Note:

This alarm is not accompanied by a buzzer tone.

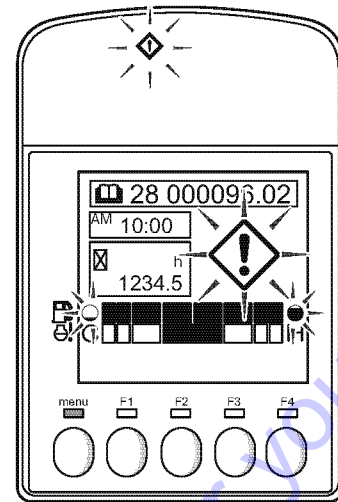

046923-01X00

- **Display of information**

If there is some information such as maintenance notices, the information lamp flashes.

The information icon  is displayed on the LCD screen above the F4 switch.

Pressing the F4 switch will display details of the information.

Check the details and take necessary measures.

Note:

When there is more than one information item, information details are alternately displayed on the screen every 2 seconds.

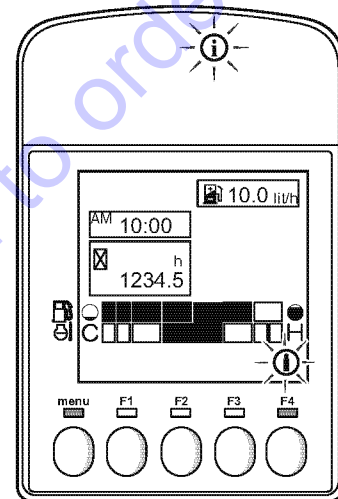

046924-01X00

- **Maintenance notices**

These notices inform the operator that, based on accumulated hours of operation, maintenance items have reached the point where they require maintenance.

Pressing the F4 switch under the information icon  will display items that have reached their maintenance intervals.

Check the items and carry out inspections and maintenance according to the instructions in PART: "MAINTENANCE". After completion of the work, reset the accumulated time for the maintenance item according to the procedure for resetting the accumulated maintenance time on page 102.

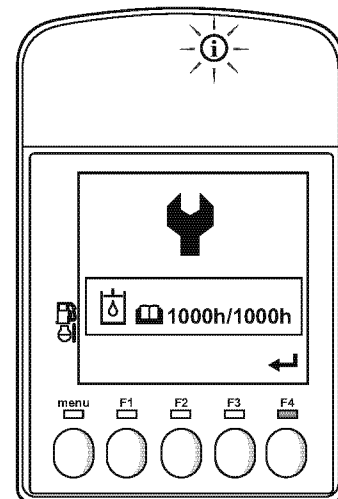

046869-01X00

• **Date and time settings notice**

This notice informs the operator that the date and time need to be set, for example, when the battery has been disconnected and then reconnected.

Pressing the F4 switch under the information icon ⓘ will display an icon indicating that the date and time need to be set after battery reconnection.

Set the date and time according to the procedure for setting the date and time on page 108.

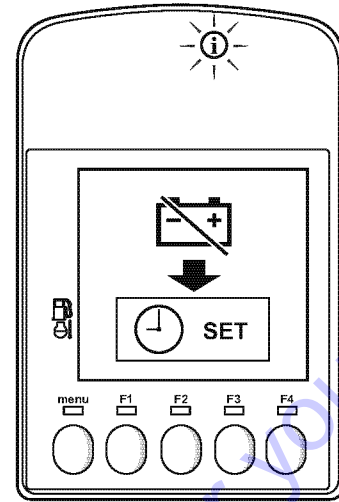

Go to Discount-Equipment.com to order your parts

LCD Monitor Operation Method









When the starter switch is in the “ON” position, the LCD monitor can be operated using the function switches in the bottom part of the monitor.

The switches are available when the LED lamps located just above the individual switches are illuminated green.

Menu switch: Used to display the main menu screen.

F1 - F4 switches: The functions of the individual switches change depending on the screen currently displayed and currently available functions are displayed with their corresponding icons in the function switch guidance part of the LCD screen just above the switches.

Icons used for function switch guidance serve as follows:



	Goes back to the previous screen
	Moves to the item left of the one currently selected
	Moves to the item right of the one currently selected
	Moves to the item above the one currently selected
	Moves to the item below of the one currently selected
	Selects an item or complete a setting
	Increases the selected value by one
	Resets the selected value
	Displays details of information such as maintenance notices





■ Main menu

Pressing the menu switch with the starter switch in the “ON” position brings up the main menu screen.

Selecting an icon from the main menu allows display of its corresponding screen.

The icon currently selected is highlighted.

Select the desired icon by pressing the F2 switch  or F3 switch  based on the function switch guidance displayed on the screen. Press the F4 switch  to display its corresponding screen.

	Displays the normal screen.
	Displays the maintenance screen.
	Displays the Machine Operation Management screen.
	Displays the Settings screen.

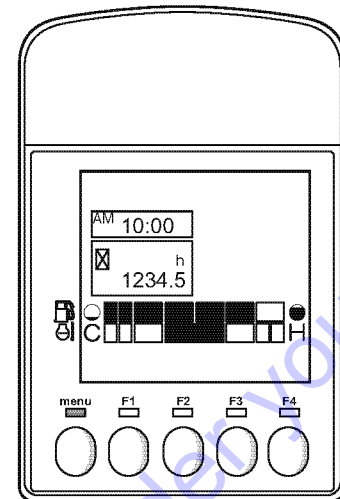

046893-00X01

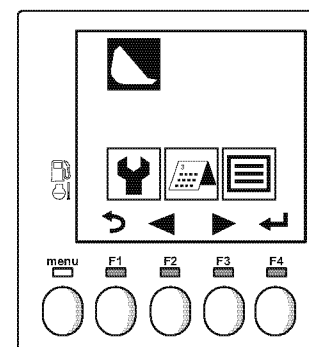

046927-00X01

■ Maintenance screen

Selecting the maintenance icon  with the F2 switch ◀ or F3 switch ▶ from the main menu and then pressing the F4 switch ← brings up the Maintenance screen. The Maintenance Time screen or Maintenance History screen may be displayed from the Maintenance screen.

Selecting the desired icon with the F2 switch ▲ or F3 switch ▼ and then pressing the F4 switch ← brings up its corresponding screen.

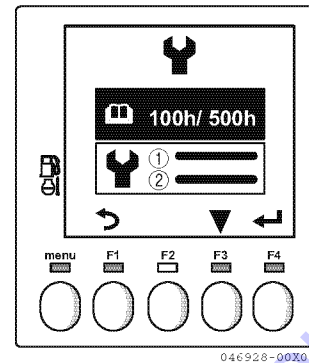

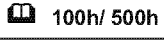
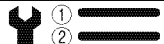





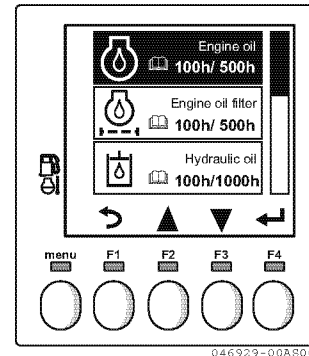

	Displays the Maintenance Time screen.
	Displays the Maintenance History screen.

Pressing the menu switch or the F1 switch → will return to the main menu.

Maintenance Time screen

This screen displays maintenance intervals and accumulated maintenance times since the last maintenance. The initial settings for maintenance items and maintenance intervals displayed are listed in the table below.



Icon	Maintenance item name	Maintenance intervals	Description
	Engine oil	500 hrs	Replacement of engine oil
	Engine oil filter	500 hrs	Replacement of engine oil filter
	Hydraulic oil	1000 hrs	Replacement of hydraulic oil
	Return filter	1st time: 250 hrs 2nd and later times: 500 hrs	Replacement of hydraulic oil return filter
	Air filter	500 hrs	Replacement of air cleaner element
	Fuel filter	500 hrs	Replacement of fuel filter element
	Travel reduction gear oil	1st time: 100 hrs 2nd and later times: 1000 hrs	Replacement of travel reduction gear oil

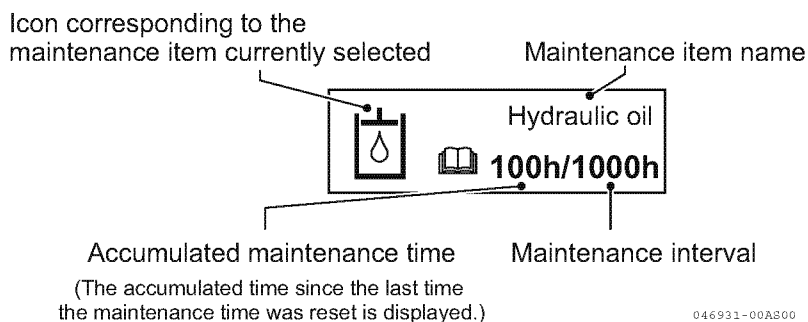

Maintenance items are displayed in vertical alignment on the LCD screen.

Items that are not currently shown on the screen can be displayed by scrolling the list up or down using the F2 switch ▲ or F3 switch ▼ .

Pressing the F4 switch ◀ brings up a screen that allows resetting or changing of the accumulated maintenance time for the currently selected item.

Pressing the F1 switch ▶ will return to the Maintenance screen.

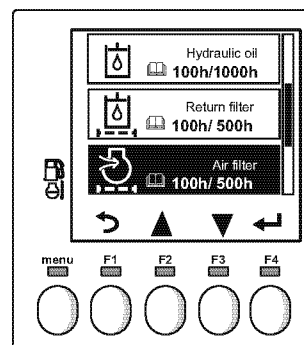
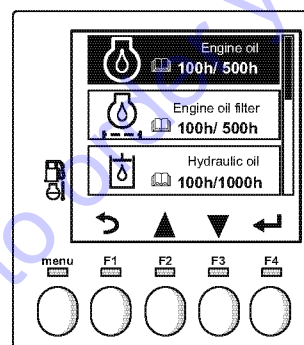

Resetting the accumulated maintenance time

After completion of maintenance work, reset the accumulated maintenance time to zero according to the procedure below.

1. Select the item to be reset on the Maintenance Time screen and press the F4 switch  to highlight the accumulated time of the selected item.
2. Press the F3 switch above which (R) is displayed to reset the accumulated time to zero.

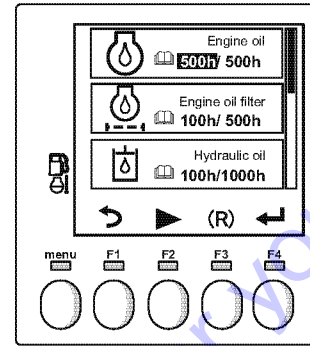

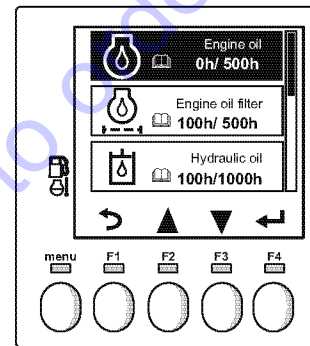

046934-00AS00

3. After "0" is displayed, pressing the F4 switch  to complete the reset procedure will produce a bleep, indicating completion of the setting, and the display will return to the Maintenance Time screen. The date and time and the number of hours indicated on the hour meter are recorded in the maintenance history.



046936-00AS00

Note:



To cancel the reset made by pressing the F3 switch (R) to change the value of accumulated time to zero, press the F1 switch  before pressing the F4 switch  to return the value to the previous accumulated time value. Once the F4 switch  has been pressed, return to the previous accumulated time value is not possible.

Changing the maintenance intervals

To change maintenance intervals, follow the procedure below.

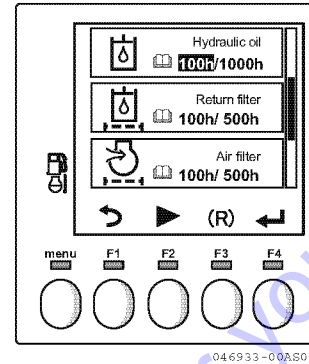
1. Select the item to be changed on the Maintenance Time screen and press the F4 switch  to highlight the accumulated time of the selected item.



2. Pressing the F2 switch  will highlight the digit in the thousands place. Likewise, each time the F2 switch  is pressed, the digits in the hundreds, tens and ones, the accumulated maintenance time and again the digit in the thousands will be highlighted in sequence.

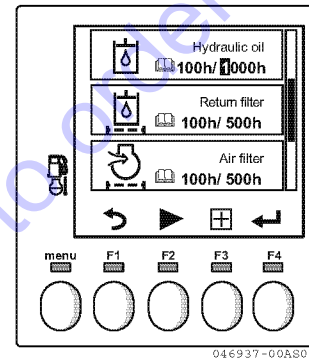

3. After highlighting the digit to be changed, press the F3 switch  repeatedly to increase the value by one until the desired value is reached.

Note:

Pressing and holding the F3 switch  will increase the value continuously until the switch is released.

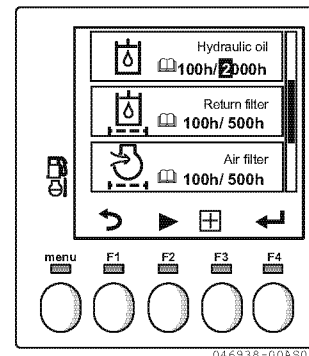

4. After completion of the change of maintenance intervals by repeating Steps 2 and 3, pressing the F4 switch  to execute the change will produce a bleep, indicating completion of the setting, and the display will return to the Maintenance Time screen.

Note:

For recommended maintenance intervals, refer to Section "7. Maintenance Table" on page 252.

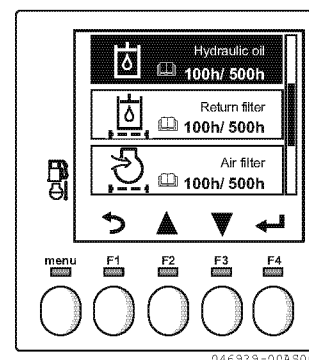

Maintenance History screen

This screen shows data on the past two maintenance sessions. The data includes the date and time of maintenance and the number of hours indicated on the hour meter.

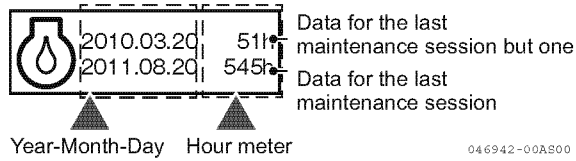

Maintenance items are displayed in vertical alignment on the LCD screen.

Items that are not currently shown on the screen can be displayed by scrolling the list up or down with the F2 switch ▲ or F3 switch ▼.

Pressing the F1 switch ↶ will return to the Maintenance screen.

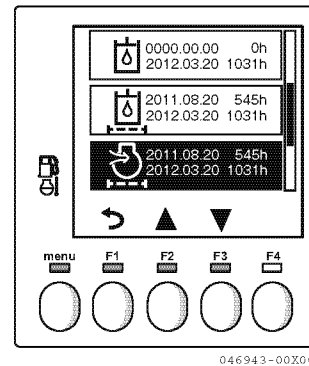
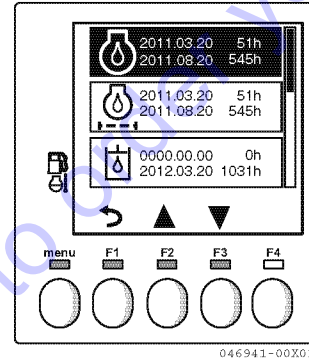
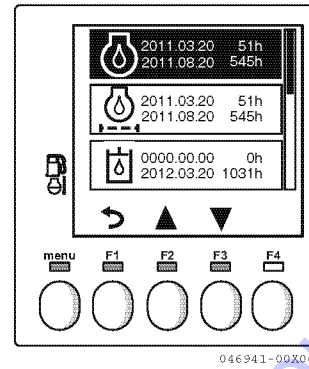

Go to Discount-Equipment.com to buy your parts

Machine Operation Management screen

Selecting the calendar icon  with the F2 switch ◀ or F3 switch ▶ from the main menu and then pressing the F4 switch ⇐ brings up the Machine Operation Management screen.

This screen allows checking of the operating hours of the machine in the past 90 days.

The current month calendar will appear with the current date highlighted.

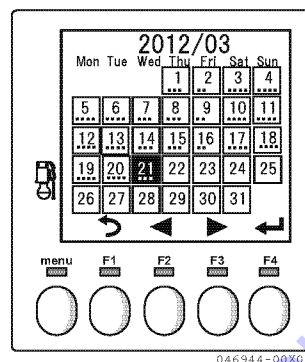

The machine operating hours for each day are displayed roughly with the corresponding numbers of dots under the date number.

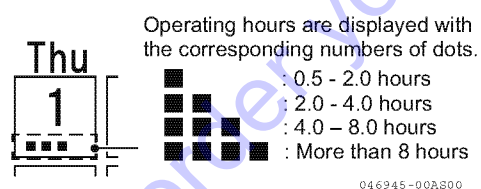

Pressing the F2 switch ◀ or F3 switch ▶ will change a selected date to another, allowing checking of the operational status of the machine in the past 90 days.

Note:

Pressing and holding the F2 switch ◀ or F3 switch ▶ will quickly change selected dates continuously until the switch is released.

Selecting the desired date and then pressing the F4 switch ⇐ will display the machine operating hours for the selected date.

Pressing and holding the F2 switch ◀ or F3 switch ▶ allows changing of the displayed date.

Note:

If the date and time settings are incorrect, the correct date and time cannot be displayed.





Because the clock on the LCD monitor stops when the battery is removed, if the date changes with the battery removed, the date displayed on the Machine Operation Management screen will be different from the actual date.

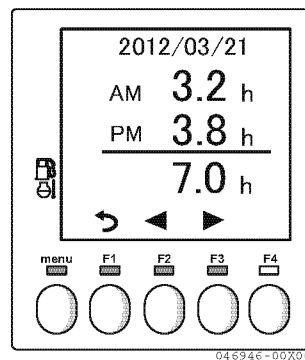

Data recorded on incorrect dates cannot be corrected.

Data recorded prior to the 90 days before the current date are automatically deleted.





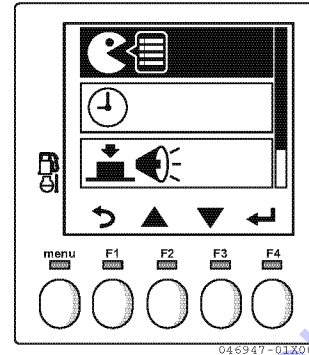

■ Settings screen

Selecting the settings icon  with the F2 switch  or F3 switch  from the main menu and then pressing the F4 switch  brings up the Settings screen.

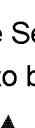

Selecting the desired item to be set on the Settings screen with the F2 switch  or F3 switch  and then pressing the F4 switch  allows changing of the settings listed in the table below.





	Language setting: Changes the language used on the various screens such as the Maintenance Time screen.
	Date and time settings: Sets the current date and time.
	Switch confirmation sound setting: Sets whether to emit a confirmation sound when a switch is pressed.
	Brightness setting: Sets the brightness level of the LED lamps and LCD screen while the work lamp is on.

Go to Discount-Equipment.com to order your parts

Setting the language

Selecting the language setting icon  and then pressing the F4 switch  brings up the Language Setting screen.

The currently set language is highlighted when this screen appears.

Selecting the desired language with the F2 switch  or F3 switch  and then pressing the F4 switch  will produce a bleep, indicating completion of the setting, and the selected language will be displayed in the center of the screen for 2 seconds. This completes the change of language settings. After completion of the language setting, the screen will return to the main menu.

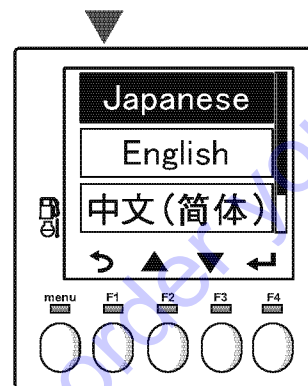
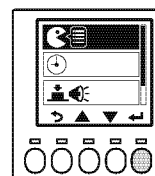

Available languages are listed in the table below.

Indication	Language
Japanese	Japanese
English	English
中文 (简体)	Chinese (Simplified)
中文 (繁体)	Chinese (Traditional)
한글어	Korean
Español	Spanish
Italiano	Italian
Français	French
Deutsch	German
Português	Portuguese
Suomi	Finnish
Svenska	Swedish
Русский	Russian
Symbol	(Icons only)





046948-01X00

Setting the date and time

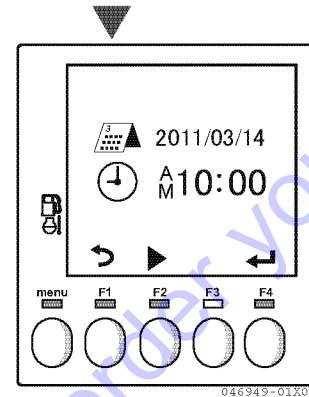
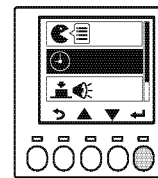
Selecting the clock icon  and then pressing the F4 switch  brings up the Date and Time Settings screen. On this screen, the date and time currently set is displayed.





Pressing the F2 switch  will highlight the year displayed on the screen. Press the F3 switch  repeatedly to increase the value by one until the desired value is reached.

Note:

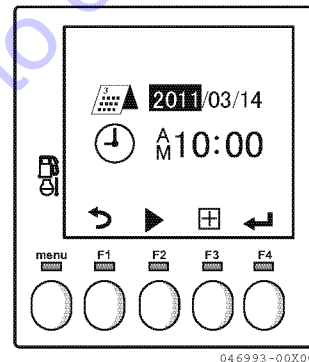

Pressing and holding the F3 switch  will increase the value continuously until the switch is released.





Each time the F2 switch  is pressed, "Year," "Month," "Day," "AM/PM," "Hour," "Minute" and again "Year" will be highlighted in sequence. The currently highlighted item can be changed.

Pressing the F4 switch  to execute the change will produce a bleep, indicating completion of the setting, and the set date and time will be displayed on the screen.



Pressing the F1 switch  will return to the Settings screen.

To return to the Settings screen without executing changes in date and time settings, press the F1 switch  before pressing the F4 switch .

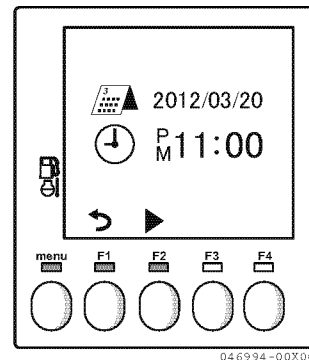
 before pressing the F4 switch .





Setting the switch confirmation sound

Selecting the confirmation sound icon  and then pressing the F4 switch  brings up the Switch Confirmation Sound Setting screen.

A check mark is displayed on the right of the currently selected item.

- ON : A switch confirmation sound is emitted each time a function switch is pressed.
- OFF : No switch confirmation sound is emitted even when a function switch is pressed.



Selecting the desired item with the F2 switch  or F3 switch  and then pressing the F4 switch  will move the check mark to the selected item and produce a bleep, indicating the completion of the setting. This completes the setting change.

Note:

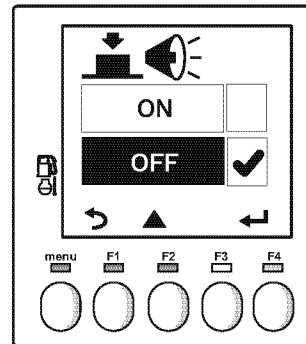
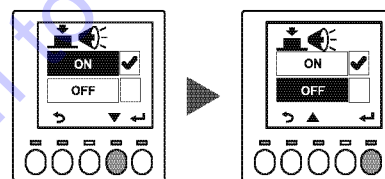
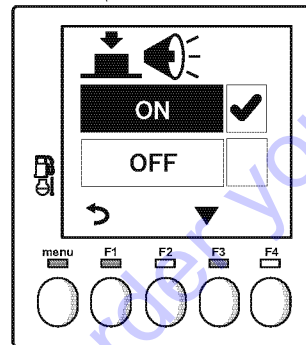
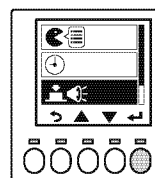

Except for switch confirmation sounds, buzzer sounds emitted when settings are completed or when a failure occurs, for example, cannot be turned off.



Setting the brightness

Selecting the brightness icon  and then pressing the F4 switch  brings up the Brightness Setting screen. This screen allows selecting the brightness level in 5 steps for the LED lamps and LCD screen while the working lamps are on.

The ▼ mark is displayed just above the graduation mark representing the currently selected brightness level and the corresponding number is highlighted.

Move the ▼ mark on the scale to the left or right using the F2 switch  or F3 switch  to select the desired brightness level. The brightness of the LED lamps and LCD screen will change according to the selected level. Selecting the appropriate level of brightness and then pressing the F4 switch  will highlight the number corresponding to the selected brightness level and produce a bleep, indicating completion of the setting. This completes the brightness setting.

Pressing the F1 switch  will return to the Settings screen.

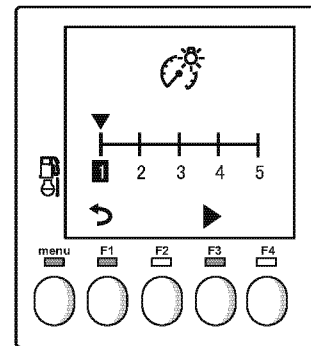
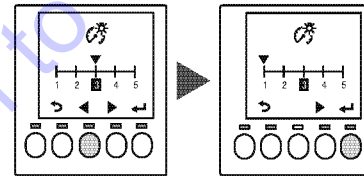
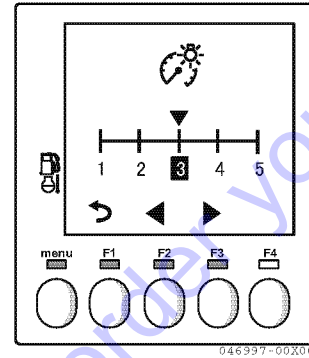
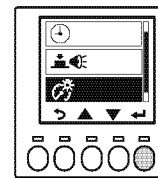



■ Operations of the LCD monitor with the starter switch in the “OFF” position

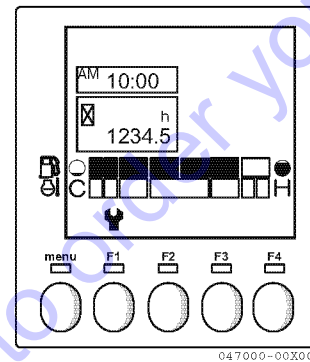
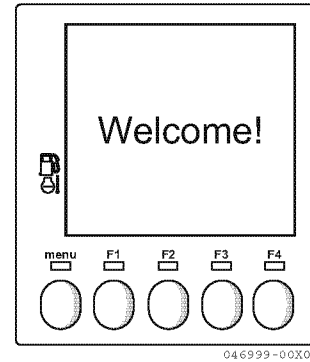

Even when the starter switch is in the “OFF” position, pressing and holding the menu switch allows checking of the hour meter and maintenance time.

Holding the menu switch down will display the Start screen for 2 seconds and then the hour meter.

This screen allows checking of the hours of operation on the hour meter without starting the engine.



Pressing the F1 switch  while holding the menu switch down will display a screen showing the maintenance time.

Select the desired maintenance item with the F2 switch  or F3 switch .

Pressing the F1 switch  will display the screen showing the hour meter

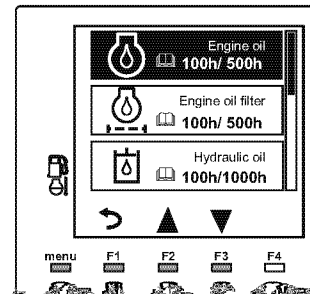

2.2 Switches

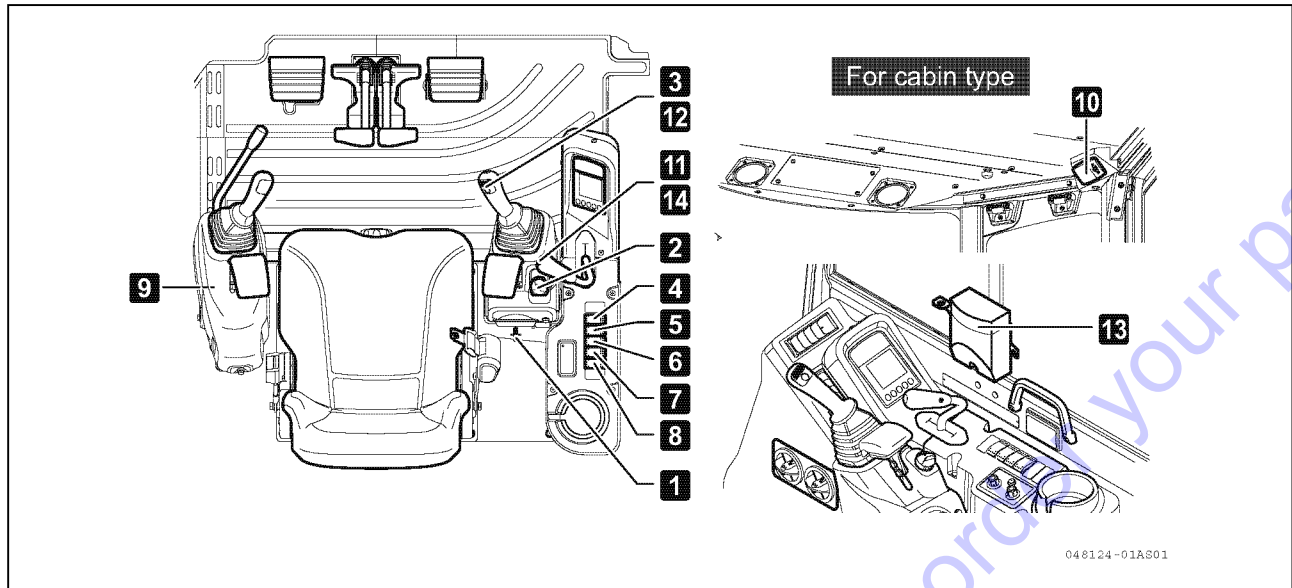

1 Starter switch

Use this switch to start and stop the engine.

- OFF position

Turn the starter switch key to "OFF" to stop the engine and disconnect the electrical circuit or remove the starter switch key.

- ON position

When the starter switch key is in this position, electricity flows in the charging circuit and electrical switches. The starter switch key must be held in the "ON" position while the engine is running.

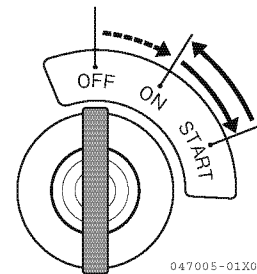

IMPORTANT

In cold weather, operate the heater for several seconds after the starter switch is turned to the "ON" position to facilitate engine starting. During heater operation, an icon indicating that the heater is operating is displayed on the LCD monitor, as shown at the right.

When the engine has been warmed up, the icon disappears. Start the engine only after confirming that the icon has disappeared.

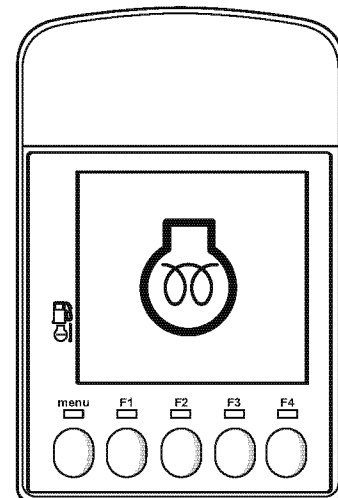

- START position

Turn the starter switch key to this position to start the engine. Hold the key in this position until the engine starts and release the key as soon as the engine starts. The key returns automatically to the "ON" position.

2 Engine control dial

The dial controls the engine speed (output).

IDLING : Turn the dial fully to the left (counterclockwise).

RUN : Turn the dial fully to the right (clockwise).

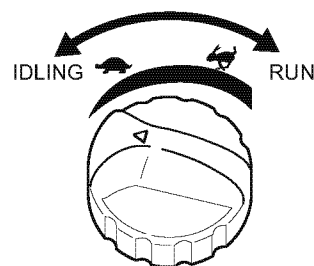

047114-00AS00

3 Horn switch

Press the switch on the top of the right control lever to sound the horn.

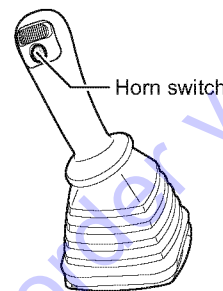

048125-01AS04

4 Wiper switch (for cabin)

The wiper on the windshield is activated.

- Position 1 : The wiper is activated.
- Position 2 : With the switch in Position 1, press it further to spray the washer fluid.
- Position OFF: The wiper is off.

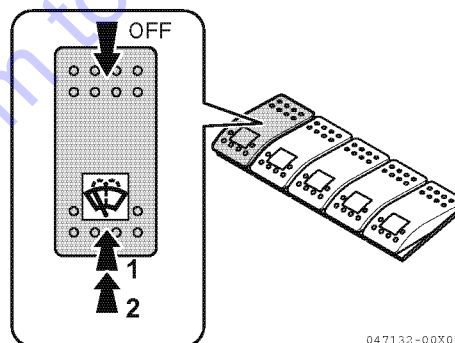

047132-00X01

5 Light switch

The working lamps and inner instrument lamps go on when the starter switch is in the "ON" position.

- ON : The working lamps and inner instrument lamps are turned on.
- OFF : The lamps are turned off.

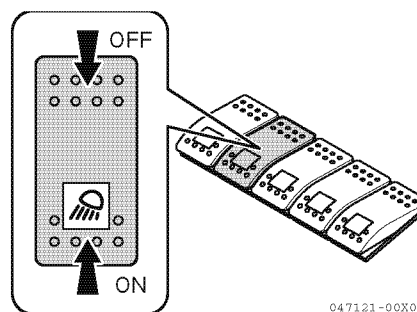

047121-00X00

Go to Discount-Equipment.com to order your parts

6 Auto deceleration switch

This switch is used to activate the equipment that reduces the engine speed and fuel consumption when the engine power is not required, for example, when the travel levers and control levers are in neutral.

- ON : The auto deceleration function is activated.
- OFF : The auto deceleration function is deactivated.

When the auto deceleration switch is switched to the "ON" position and all the control levers and pedals are placed in their neutral position, about 4 seconds later the engine speed is reduced to low idle. If any of the control levers or pedals is operated, the engine speed returns to the speed originally set by the engine control dial.

When the auto deceleration switch is switched to the "OFF" position, whether or not the control levers or pedals are operated, the engine speed returns to the speed originally set by the engine control dial.

Note:

The auto deceleration function may not work until the hydraulic oil warms up. This phenomenon does not constitute a failure.

7 Eco mode switch

This is a switch for drastically reducing the fuel consumption, as the engine speed is reduced to the dial "9" or equivalent even when the engine control dial is in the maximum "10".

- ON : The eco mode is activated.
- OFF : The eco mode is deactivated.

Note:

The eco mode is not activated when the engine speed is at or below the dial "8" of the engine control dial.

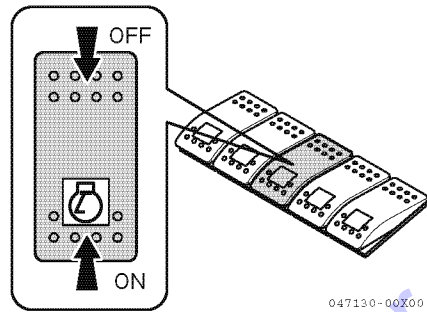

047130-00X00

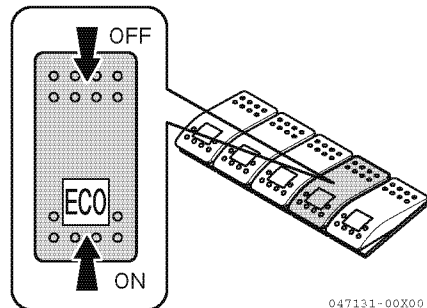

047131-00X00

8 Heater switch**(for cabins without an air conditioner)**

Use this switch to warm up the air in the cabin.

Press the switch to select the fan speed.

- Position 1: Low fan speed
- Position 2: High fan speed (with the switch in Position 1, press it further to select high fan speed)
- OFF : off

Operate the heater switch after the cooling water has warmed up.

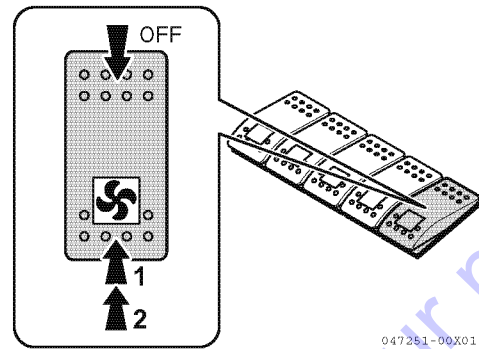

047251-00X01

9 Engine stop switch

If the engine is not stopped by turning the starter switch to the "OFF" position, set is switch to the "STOP" position.

After stopping the engine, always be sure to return the engine stop switch to the "NORMAL" position. When the switch is in "STOP" position, engine cannot be started.

In addition, be sure to return the key switch to "OFF" position to avoid running the battery down.

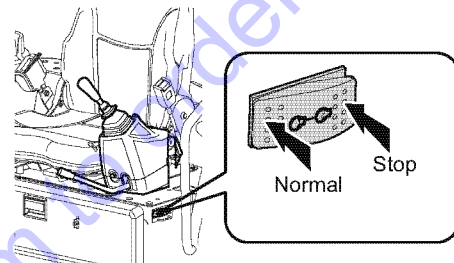

047122-00AS00

10 Room lamp switch (for the cabin type)

- ON : The lamp is illuminated.
- OFF : The lamp is not illuminated.
- Intermediate position: The lamp turns on when the door is opened and goes out automatically after about 15 seconds. The lamp goes out immediately after the door is closed.

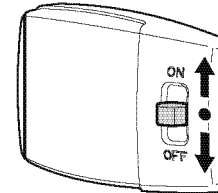

047133-00X00

11 High-speed travel switch

Press this switch on the top of the standard blade lever (on the reverse of the angle blade lever grip) to increase the travel speed. The high speed travel lamp on the LCD monitor lights up when this switch is in the high-speed position. To return the travel speed to low, press the switch again. The high speed travel lamp goes out when the switch is set to the low-speed position.

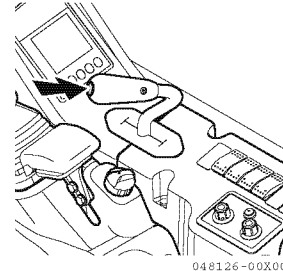

(For the standard blade)

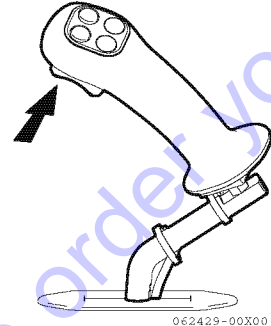

(For the angle blade)

IMPORTANT

Do not run the machine at high speed continuously for prolonged periods of time.

Do not set this switch to the high-speed position while the blade is being operated.

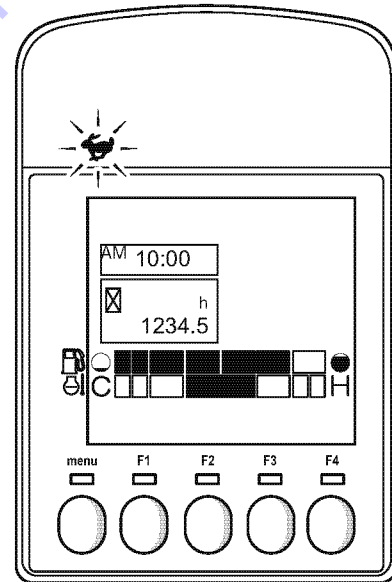

047435-01X00

Go to Discount-Equipment.com to order your parts

12 P.T.O. switch

Move the switch on the top of the right control lever to the right and the left to control the P.T.O.

For handling P.T.O., refer to Section "3.21 Handling hydraulic P.T.O." on page 196.

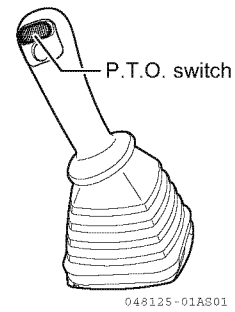
**13 Quick coupler switch box (for quick coupler spec.)**

Refer to Section "3.14 Handling quick coupler (option)" on page 177.

14 Blade angling switch (with angle blade)

Press either switch to angle the blade to right or left.

A : Press the switch to angle the blade to left.

B : Press the switch to angle the blade to right.

When no switch is pressed the blade angle is held as it is.

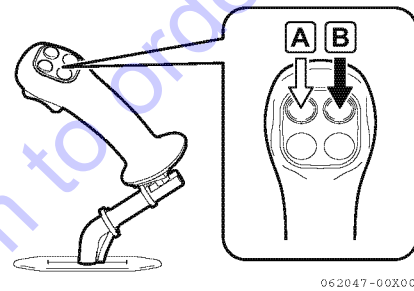

Go to Discount-Equipment.com to order your parts

2.3 Control levers and pedals

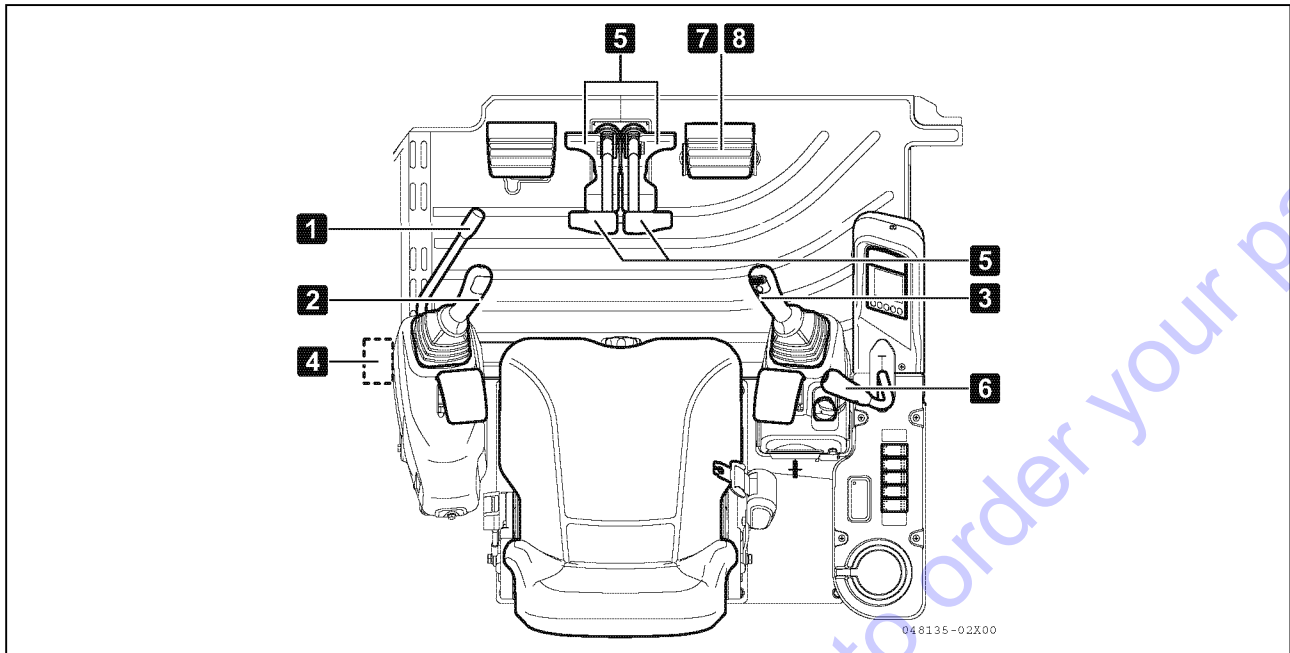

1 Lock lever (for implement control levers on both sides, boom swing pedal and travel lever)

The lock levers lock the implement control levers, boom swing pedal and travel levers.

⚠ WARNING

- When leaving the operator's seat, be sure to put the bucket on the ground and move the lock levers to the lock positions. Keep in mind that if you should touch the unlocked lever inadvertently, a serious accident could occur.
- Be sure to place the lock levers securely in position. If not, they could come out of the lock position. Thus always make sure that the lock levers are in position as illustrated in the right figure.
- When pulling the lock levers back, be careful not to touch the implement control lever.
- Remember that if the lock levers are not pulled back fully, the implement will not be locked.

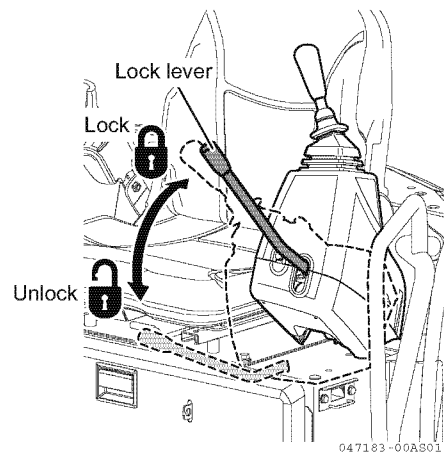

IMPORTANT

The machine uses a hydraulic lock system. If the lock levers are in the lock position, all the hydraulic cylinders for the boom, arm, bucket, boom swing, blade and an actuator in the P.T.O. circuit as well as the swing and travel motors will not activate although the control levers and pedals, and the P.T.O. switches are free to move.

⚠ WARNING

When pushing the lock levers down forward, be careful not to touch the implement control lever.

⚠ WARNING

The relationship between the control lever shift configuration and the implement movement is detailed in this manual. To prevent an accident due to operational error, therefore, the hydraulic system must not be modified by reconnecting the hydraulic hoses and valves.

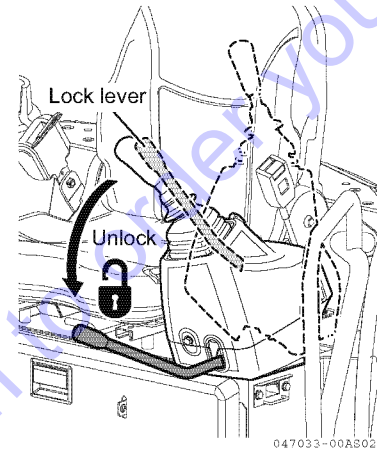

2 Control lever (L)

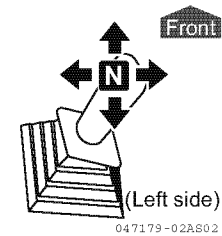

3 Control lever (R)

Use these levers to control the implements and swinging of upperstructure.
Refer to Section "3.8 Operating the implements" on page 168.

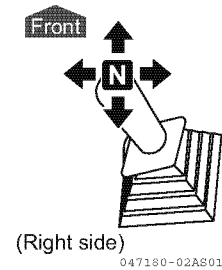

Go to Discount-Equipment.com to buy your parts

4 Operating pattern change valve

Refer to Section "3.8 Operating the implements" on page 168.

1. Stop the engine and make sure the lock lever is in lock position.
2. Open the cover.
3. Unlock the selector handle to move it to suitable position.
4. Securely lock the selector handle.
5. Close the cover.

STD: ISO pattern

OPT: OPT pattern

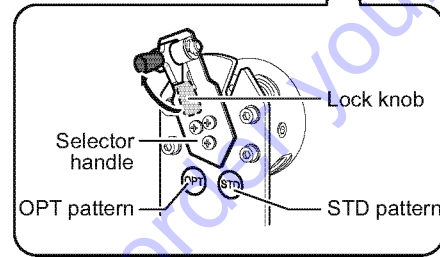
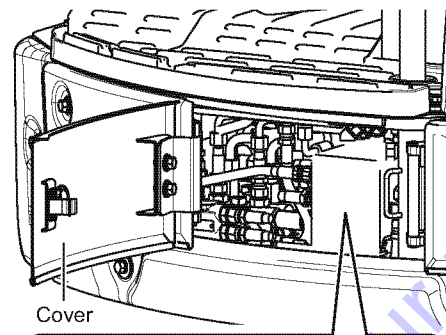

047421-01EN01

5 Travel levers and pedals

The travel levers and pedals control the traveling of the machine.

⚠ WARNING

- If the blade is in the reverse direction, the travel levers and pedals should also be operated in reverse for forward and backward travel.
- When operating the travel levers and pedals, you must check to see if the blade is in the normal position or in the reverse position. Note that the blade is in the normal position when the sprocket is in the rear.

Refer to Section "1.1 Overview of the machine" on page 79.

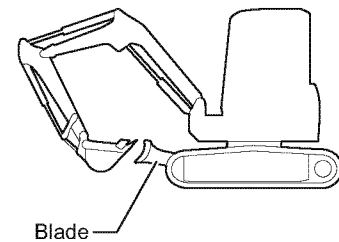

046752-00A800

When using the travel pedals, operate the machine after unfolding the extension plates 1.

When the blade is in the normal position:

- A** : Forward : Push the travel levers forward.
Step on the front of the pedals.
- B** : Reverse : Pull the travel levers backward.
Step on the rear of the pedals.
- N** : Neutral : The machine stops.

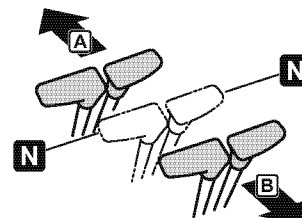

046114-02X00

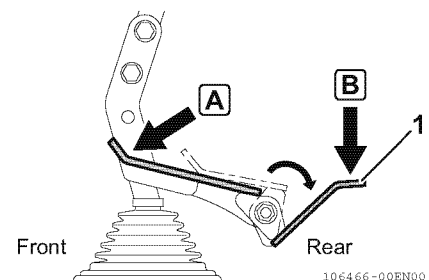

106466-00EN00

6 Blade lever

Use this lever to control the blade.

IMPORTANT

The blade lever is not locked by setting the lock lever to the lock position. Do not touch the blade lever when not operating the blade.

- For the standard blade

- A** : Down : Push the lever forward.
B : Up : Pull the lever backward.
N : Neutral: When released, the lever will return to the neutral position and the blade is held as it is.

- For the angle blade

- A** : Blade down: Push the lever forward.
B : Blade up : Pull the lever backward.
N : Neutral : When released, the lever will return to the neutral position and the blade is held as it is.
C : Blade float: Push the lever forward to its detent position. The blade will be in the float condition and the lever is held as it is. The blade will drop to the ground by gravity and will stop. If this mode is used for operation on a concrete-covered ground or land-leveling operation, the bucket will follow the contour of the ground by using the weight of the blade, so the work can be performed efficiently.

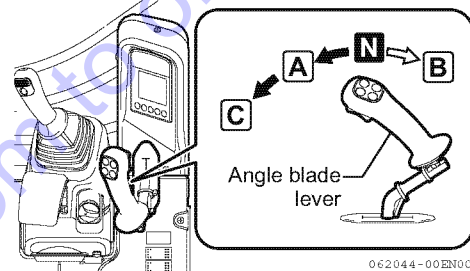
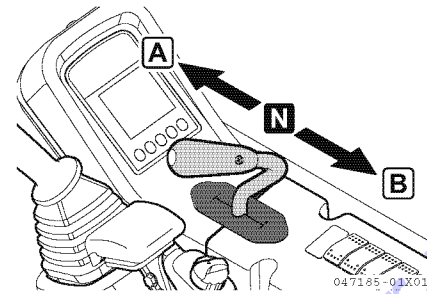
**7 Boom swing pedal**

Use this pedal to swing the boom to right and left after unfolding it flat.

- A** : Swing right: move to the right
B : Swing left : move to the left
N : Neutral : When released, the pedal will return to the neutral position and the boom is held as it is.

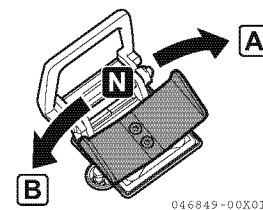

8 Pedal guard (foot rest)

The boom swing pedal has a pedal guard.

⚠ WARNING
To avoid bodily injury, securely place the pedal guard in the lock position whenever the boom swing pedal is not being operated.

Placing the pedal guard in the lock position completely covers the boom swing pedal.

To prevent misuse, always set the pedal guard in the lock position whenever the boom swing pedal is not being operated. The pedal guard can be used as a foot rest.

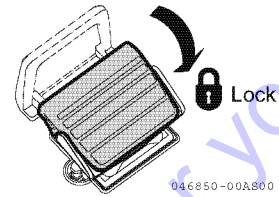
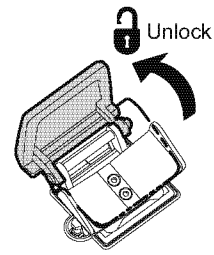

Go to Discount-Equipment.com to order your parts

2.4 Engine hood rear cover

⚠ WARNING

Do not open the engine hood while the engine is running. Rotating fan and fan belt and high temperature components can cause personal injury. Check and service the inside of the engine hood after the engine stops.

■ Opening the engine hood rear cover

1. Insert the starter switch key 1 and turn counterclockwise to unlock.
2. Pull the engine hood rear cover lever 2 to release the lock, and then the engine hood rear cover 3 opens.
3. The engine hood rear cover 3 fully opens to be locked with the stopper 4.

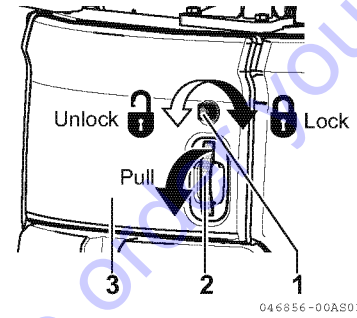

■ Closing the engine hood rear cover

1. Lift up the stopper 4 to disengage the lock.
2. Close the engine hood rear cover 3 and press it fully until it clicks.
3. Turn the starter switch key 1 clockwise and engage the lock.

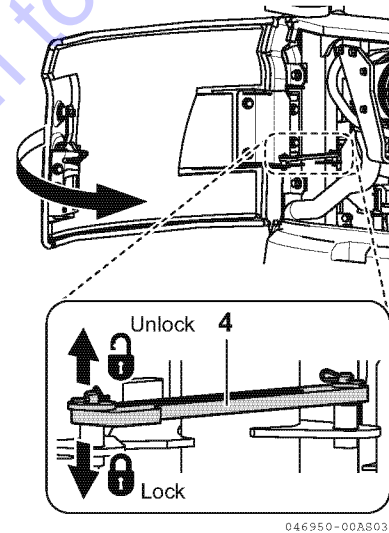

Go to Discount-Equipment.com to order your parts

2.5 Bonnet B

■ Opening the bonnet B

1. Insert the starter switch key 2 and turn counterclockwise to unlock.
2. Pull the bonnet B lever 3 to release the lock, and then the bonnet B 1 opens.
3. The bonnet B 1 fully opens to be locked with the stopper.

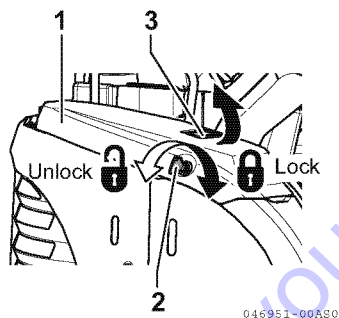

■ Closing the bonnet B

1. Lift the bonnet B 1 slightly and pull the stopper rod 4 to disengage it.
2. Close the bonnet B 1 and press it down fully until it clicks.
3. Turn the starter switch key clockwise and lock the lock.

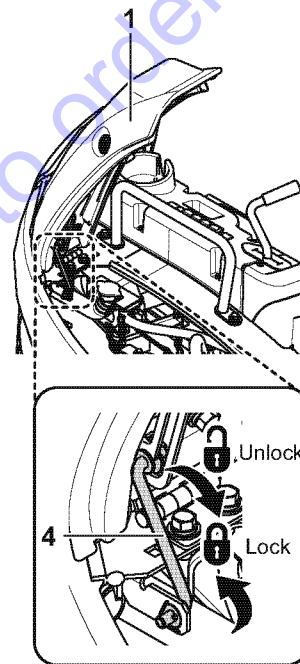

2.6 Bonnet R

■ Opening the bonnet R

1. Open the engine hood rear cover **1**.
2. Pull the lock lever **2** back and open the bonnet R **3**.
3. Hold the bonnet R **3** with the stopper rod **4**.

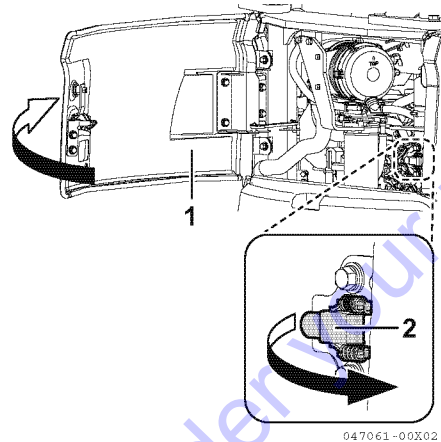

■ Closing the bonnet R

1. Disengage the stopper rod **4** from the bonnet R **3** and put it back in the unlock position.
2. Close the bonnet R **3** and lock it with the lock lever **2**.
3. Close the engine hood rear cover **1**.

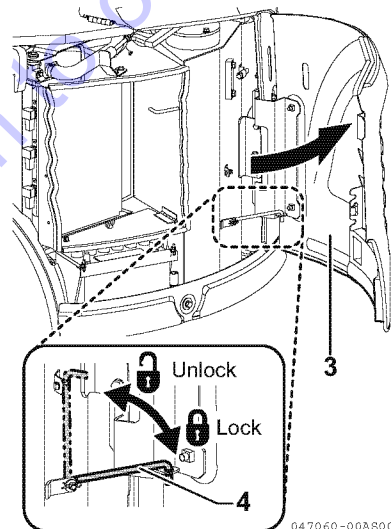

Go to Discount-Equipment.com to order your parts

2.7 Operator's seat bottom cover

■ Opening the operator's seat bottom cover

1. Remove the five bolts 1 around the seat.
2. Pull the lever 2 up and fold the seat backrest forward.
3. Move the seat forward with the slide lever 3.
4. Raise the front of the seat and hold it with the stopper rod 4.

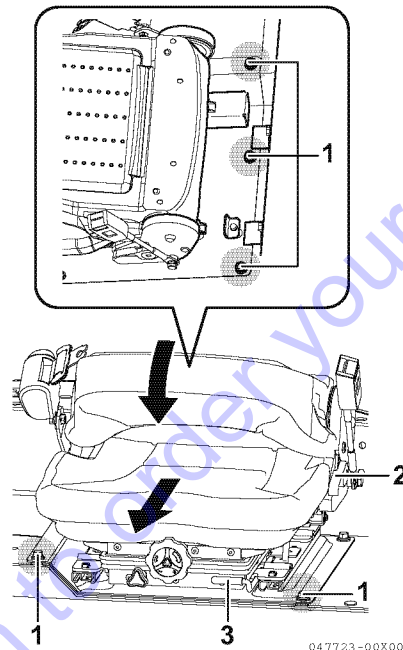

■ Closing the operator's seat bottom cover

1. Lift the seat up slightly and disengage the stopper rod 4.
2. Put the seat down and then install and tighten the bolts 1 around the seat.

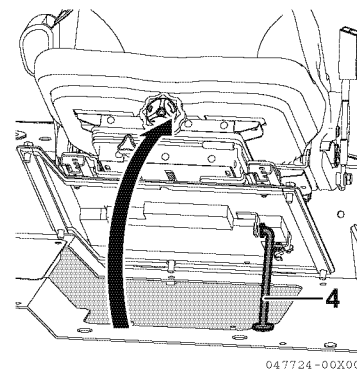

⚠ WARNING

Be sure to engage the stopper rod securely to hold the seat in its raised position.

2.8 Storage space for the operation & maintenance manual

Storage space for the operation and maintenance manual **2** is under the operator's seat.

Pull the lever and open the cover **1**.

Press the cover until it clicks when closing.

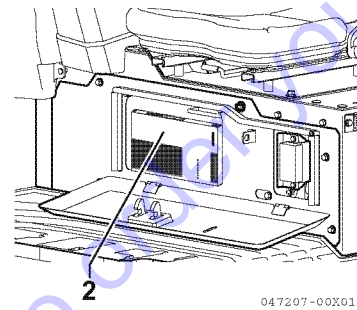
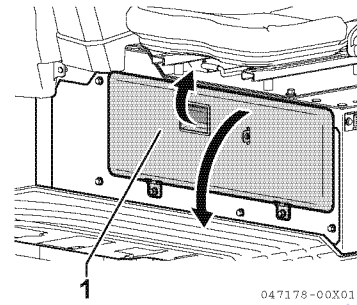

2.9 Tool storage

The storage space **1** for tools (option) is provided inside the tool storage cover on the left side of the machine.

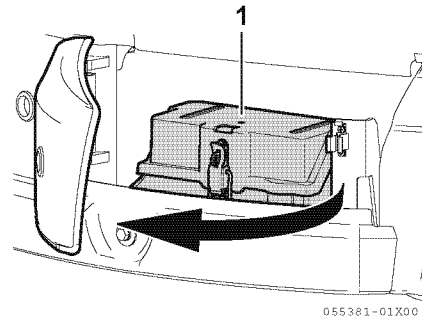

Go to Discount-Equipment.com to buy your parts

2.10 Drink holder

The drink holder 1 is located to the right of the operator's seat.

This holder can be used to put a drink bottle or cup in.

2.11 Utility box (for the canopy type only)

The utility box 2 is located to the right of the operator's seat.

This box can be used to put small articles in.

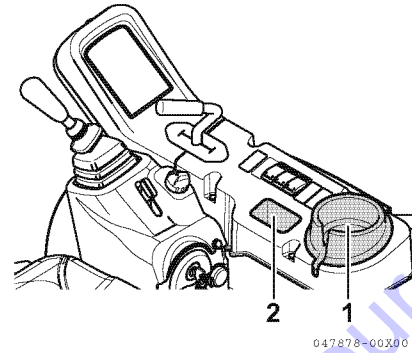

Go to Discount-Equipment.com to order your parts

2.12 Windshield (for cabin)

⚠ WARNING

- To avoid bodily injury while operating the machine, make sure the door and windshield are locked in either the open or shut position.
- When the side door or the windshield is opened and it is not securely locked, it may be closed suddenly on impact during operation. It may cause bodily injury : for example, your hands are put between the door or the windshield and the cabin frame or your head is hit against them.
- Do not put your hand or head out of the opened side door or windshield. When opening the side door or the windshield, lock it securely.

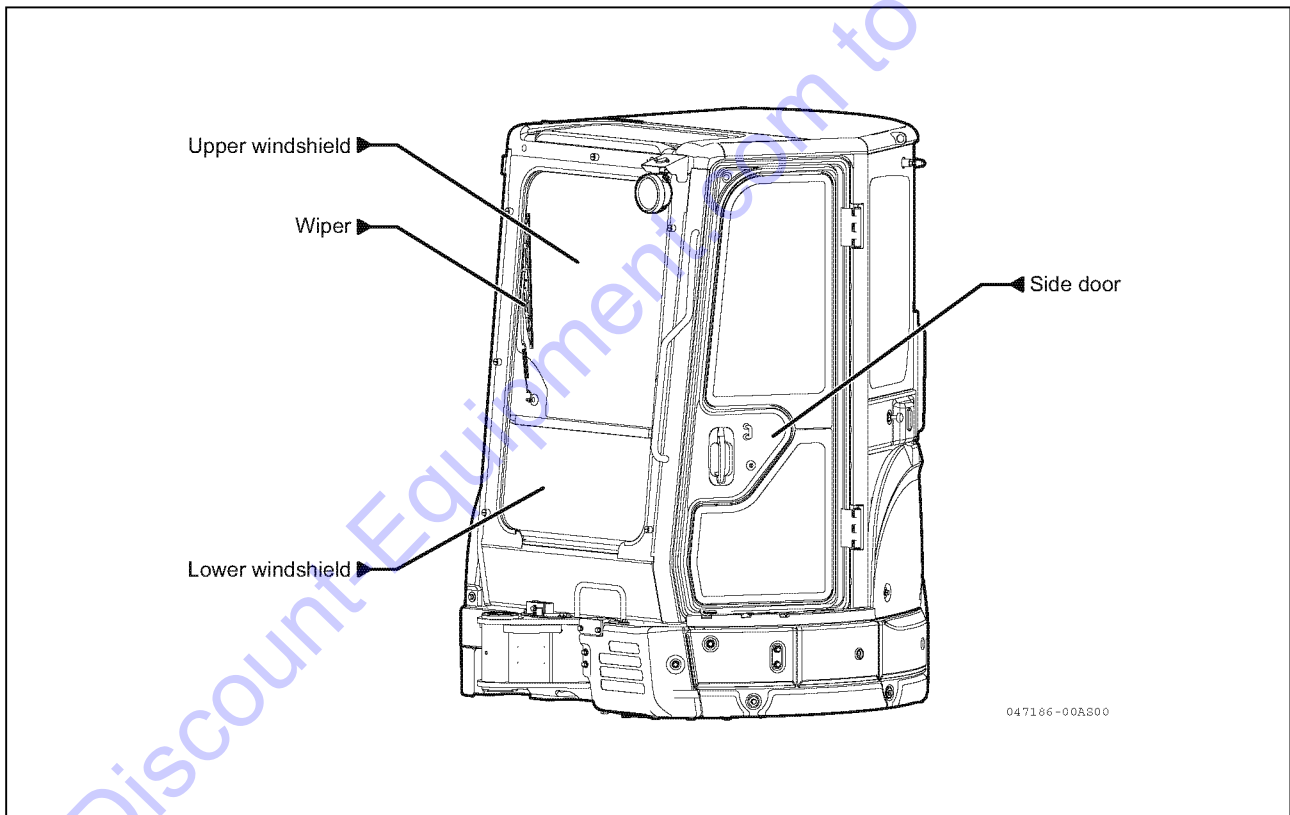

⚠ WARNING

Both the upper and lower windshields can be opened and closed. When housing or closing the upper and / or lower windshields, they may get down suddenly. To prevent this, lock them securely with the lock levers.

⚠ WARNING

- To avoid bodily injury, securely grasp the handles with both hands when opening and closing the windshield.
- Securely lock the windshield using the lock levers and the window locks when storing or closing the upper and lower front windshields.
- When opening or closing the front windshield, be sure to place the lock levers securely in the lock position.

■ Opening the upper windshield

1. Hold the handles with your hands and turn the right and left lock levers to the arrowed direction to release the lock.
2. Slide the windshield to the upper rear side while pulling it to this side.

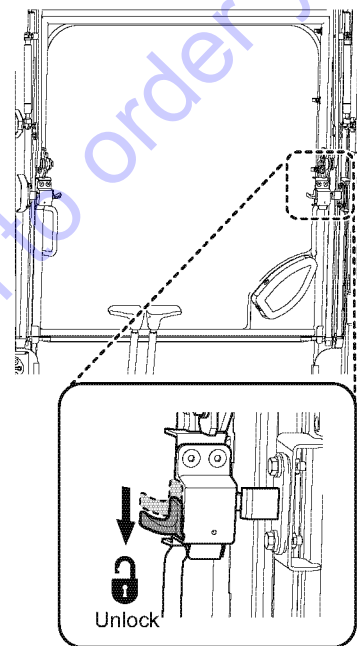

047623-00A800

3. Lock the upper windshield housed under the ceiling securely with the right and left lock levers.

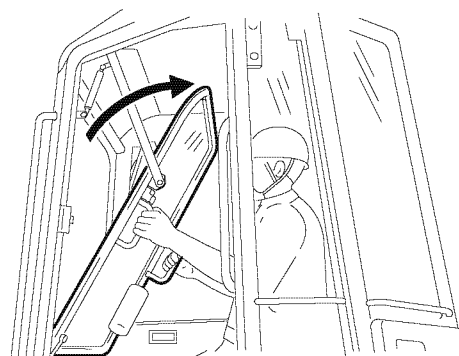

047624-00X00

Go to DiscountEquipment.com to order your parts

■ Closing the upper windshield

1. Hold the handles with your hands and release the right and left lock levers.
2. Holding the handles, lower the upper windshield slowly.
3. Lock the upper windshield securely with the right and left lock levers.

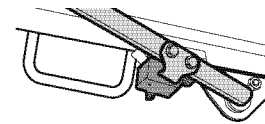
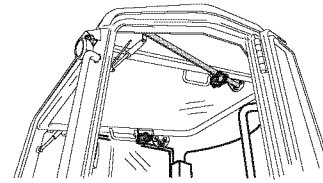

Locked securely

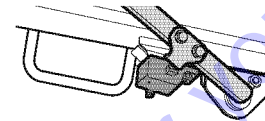

Locked insecurely

047625-00A800

■ Opening and closing the lower windshield

⚠ WARNING

Open and close the lower windshield after housing the upper windshield.

1. Hold the lower windshield with both hands to lift it up.
2. Put the lower windshield in the storage area on the rear left of the cabin.
3. Lock the lower windshield securely by pressing it against the window locks.
4. Push the upper side of each window lock to remove the windshield put in storage.

Lower windshield

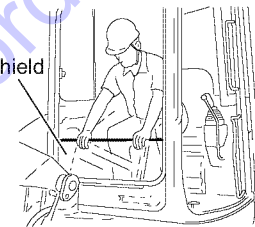

047259-00A800

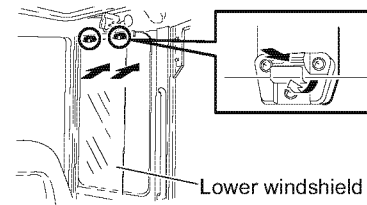

Lower windshield

047260-00A800

2.13 Emergency escape hammer (for the cabin type only)

The emergency escape hammer 1 is provided inside the cabin to escape from the cabin when the door of the cabin cannot be opened.

Break the window glass with the hammer 1 to escape from the cabin when the door cannot be opened.

IMPORTANT

- Remove the broken pieces of glass from the window frame to prevent injuries from broken glass.
- Be careful not to slip on the pieces of broken glass.

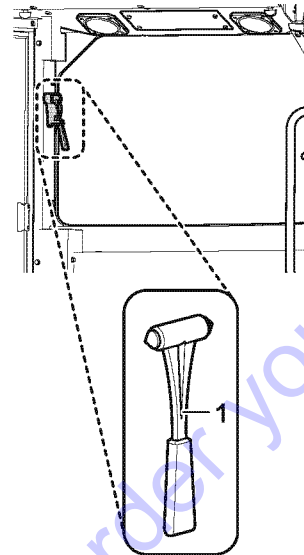

047209-01X01

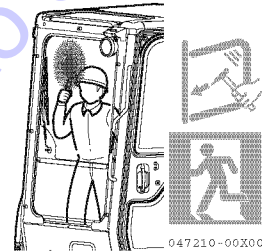

047210-00X00

2.14 Operator's seat

⚠ WARNING

- Be sure to adjust the seat slide to obtain the best operating position whenever you start operation or a new operator begins to operate the machine.
- Do not place any objects with in the moving area of the operator's seat.
- Do not adjust the operator's seat while operating the machine.

Adjust the seat so that the operator can easily operate the control levers in good posture.

■ **Seat position control adjustment (forward and backward)**

Pull the slide lever **A** under the seat upward to slide the seat forward or backward.

The adjustable amount of seat for forward and backward sliding is 4.25 (108 mm). And the seat can be adjusted at any of the 9 levels within 4.25 in. (108 mm).

■ **Seat backrest control adjustment**

Pull the lever **B** upward to adjust the backrest the desired position.

Adjust the backrest, keeping your back in contact with the backrest or pushing the backrest with your hand, to prevent the backrest from returning suddenly.

■ **Weight adjustment**

The weight adjustment dial **C** is turned and it can adjust to the hardness of the bearing surface cushion with the operator's weight.

- Turn the weight adjuster dial **C** clockwise the setting weight is increased.
- Turn the weight adjuster dial **C** counterclockwise, the setting weight is decreased.

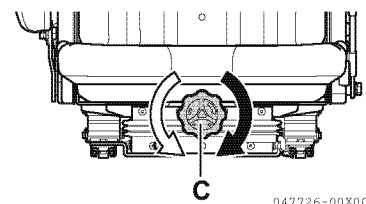
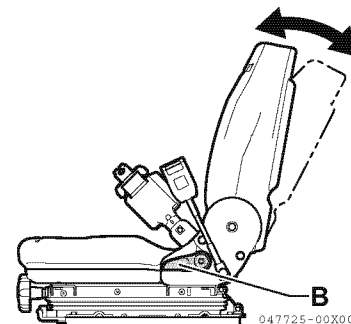
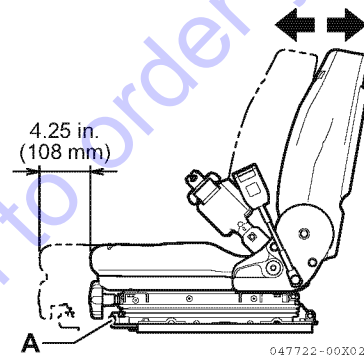

■ Height of seat adjustment

The height of the seat can be adjusted by turning height adjustment dial **D**. Adjust the seat pushing it with your hand when you lower the seat.

- Turn the height adjustment dial **D** clockwise, the seat lowers.
- Turn the height adjustment dial **D** counterclockwise, the seat goes up.

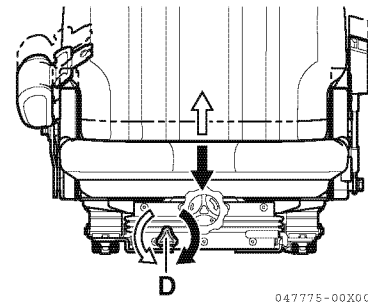

2.15 Ash tray (for cabin)

⚠ WARNING

Do not place any combustible matter in the ash tray.

Open the ash tray **1** by pulling the lid to use it. Be sure to close the ash tray lid when it is not in use.

To empty and clean the ash tray **1**, lift it up by holding both ends.

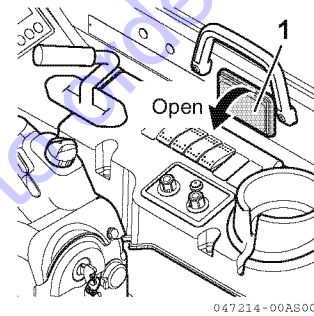

2.16 Work Lights

⚠ WARNING
The work lights gets hot when it is turned on. Do not touch it carelessly with your bare hand to prevent burns.

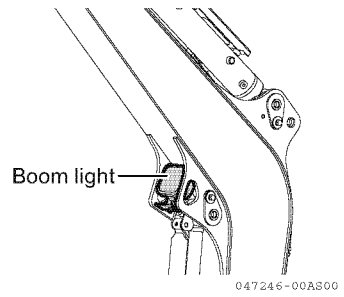

For canopy type

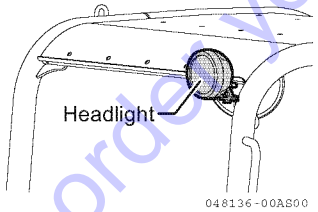

For cabin type

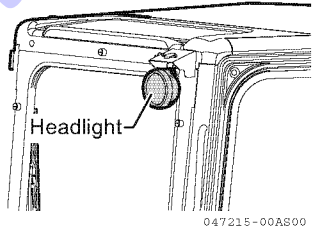

Go to Discount-Equipment.com to order your parts

2.17 Air outlet (for cabin)

The wind direction is adjusted by changing the grille direction.

Move the grille to the desired position with a knob in the center of the grille.

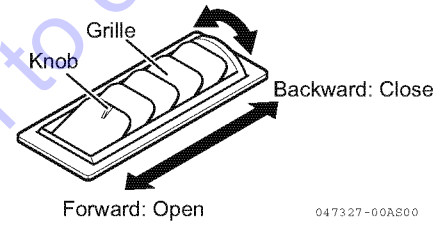
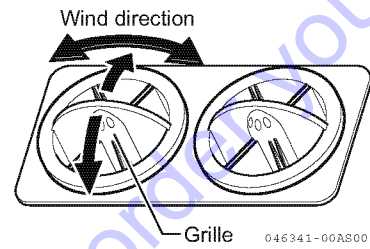
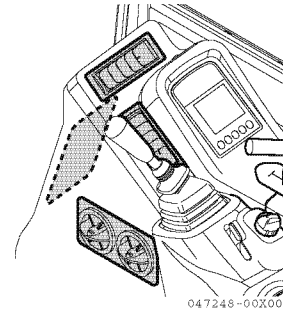

2.18 Right window glass (for cabin)

Open the right window glass in the arrowed direction.

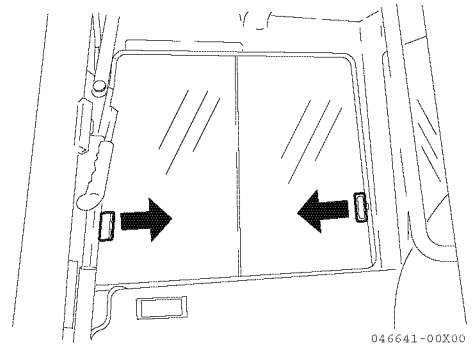

2.19 Cabin side door

Opening and closing the cabin side door

■ From outside.

1. Turn the starter switch key counterclockwise to unlock the side door.
2. Pull the outer handle 1 to this side to open the side door.
3. Close the side door and turn the key clockwise to lock to door.

■ From the inside.

1. Pull the inner handle 2 to this side to open the side door.

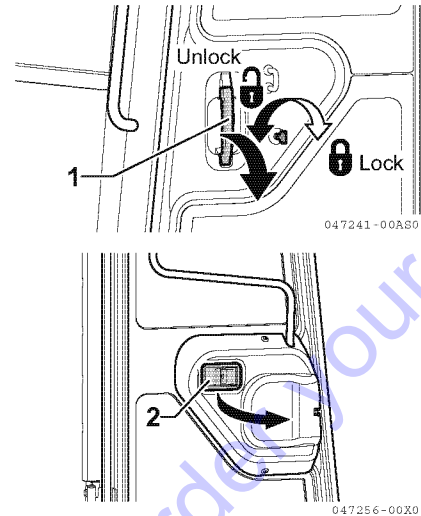

Door lock

The door lock is used to hold the side door open.

1. Press the side door into the lock section to hold it open.
2. Press the lever 3 on the left side of the seat down to release the locked side door.

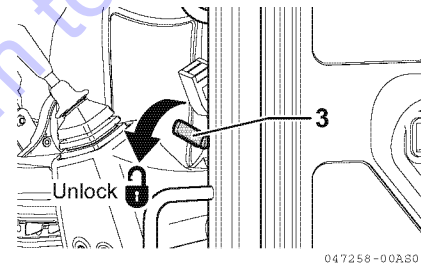

2.20 Replenishment of windshield washer fluid

Add windshield washer fluid, if necessary, to the reservoir

1.

⚠ WARNING

- When you add the reservoir with windshield washer fluid, take care not to enter dust into the reservoir.
- Determine the mixing ratio of the windshield washer fluid to water on the basis of the lowest past temperature

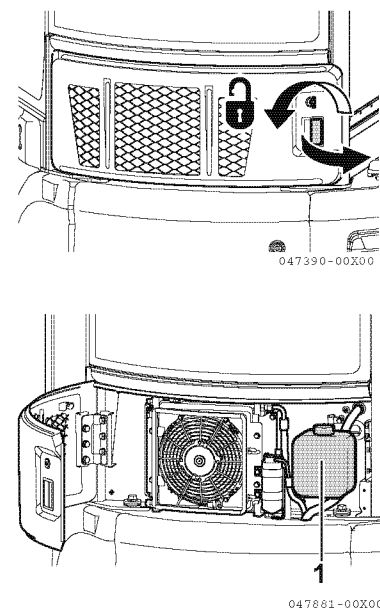

2.21 Fuse

⚠ CAUTION

- When replacing the fuse, be sure to turn off the power by setting the starter switch at the OFF position.
- Using a wire, aluminum foil or the like instead of the fuse could cause burnouts of the gauges, the electrical equipment and the wiring due to overheating.
- If a new fuse is blown out immediately after replacement, there may be a problem with the electrical system. Ask the nearest dealer for check and service.

The fuse protects the electrical equipment and wiring from becoming overheated. If the fuse is corroded with white deposits or if the fuse is loose in the holder, the fuse must be replaced with a new one.

■ Position of the fuse box

Blade fuse

It is installed on the front left of the seat mount.

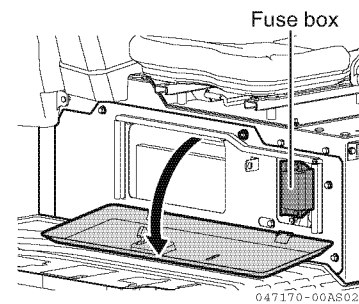

Slow-blow fuse

It is installed on the upper left of the battery inside the bonnet R.

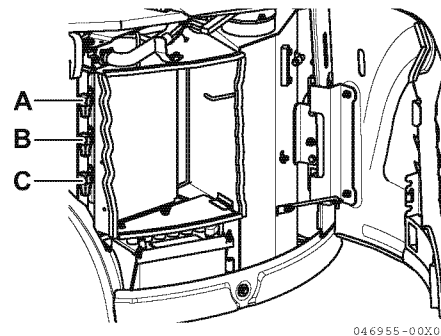

■ Replacing the fuses

If the electrical equipment does not operate, the fuse may have been blown out. Follow the procedure below:

1. Set the starter switch at the “OFF” position.
2. Remove the fuse box cover.
3. If the fuse is blown out, replace it with a spare fuse of rated capacity.

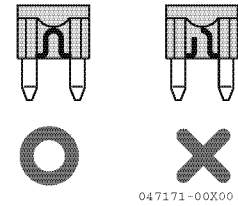

Symbol	Fuse capacity (A)	Circuit name
A	5	LCD monitor 1
B	10	Controller
C	5	Option 2
D	30	Power relay
E	15	Cabin
F	15	Wiper
G	30	Air conditioner
H	5	Back up
I	10	Implement control
J	5	LCD monitor 2
K	5	Option 1
L	5	Immobilizer
M	5	Engine
N	5	Alarm / Traveling devices
O	15	Quick coupler
P	15	External power outlet
Q	30	Light
R	10	Safety
S	15	Spare
T	30	
U	5	
V	10	

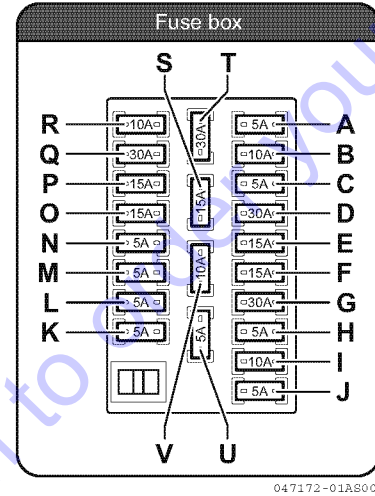

The oblique character parts:

Applicable to models with the relevant equipment.

■ Slow blow fuse

If the starter does not operate even when the starter switch is set to the “START” position, the slow blow fuse may have been blown.

Symbol	Fuse capacity (A)	Circuit name
A	40	Glow
B	50	Starter (for engine)
C	60	Main

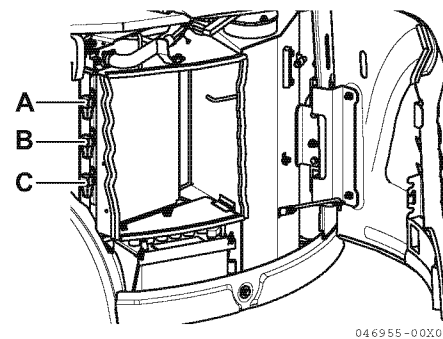

046955-00X01

2.22 External power outlet

The socket type outlet for appliances is available when the key switch is in "ON" position.

The appliances for DC12V-120W (10A) or less are available.

IMPORTANT

- Always close the cover when the outlet is not used for dust-proof.
- Long use without the engine running may cause damage to the battery.

Note:

For cabin type machines, the wiring can be taken out through the rubber hole of the cabin to supply power to appliances outside the machine.

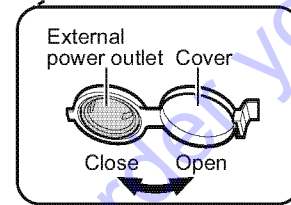
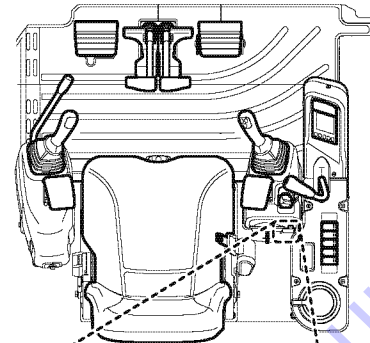

047710-01A801

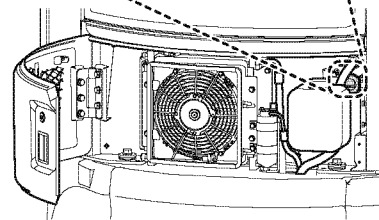
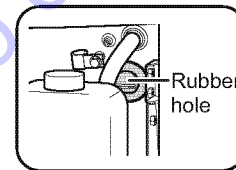

047858-00A800

Go to Discount-Equipment.com to order your parts

3. Operating Instructions

3.1 Checking before starting the engine

⚠ WARNING

- If there are any combustibles in any heat build-up areas, or if there are any fuel and/or oil leaks, a fire can result.
- Check for possible fire causes carefully. If there is anything abnormal, be sure to take corrective action or contact your dealer.

Before starting the engine, visually check the outside and underside of the machine as follows: Check bolts and nuts for loose connections; check the fuel, oil, and water for leaks; and also check the implement and the hydraulic system to see that they are operating properly. In addition, check the electrical wiring for loose connections and for dust deposits in the heat build-up areas. Check the following points before initial start-up for the day.

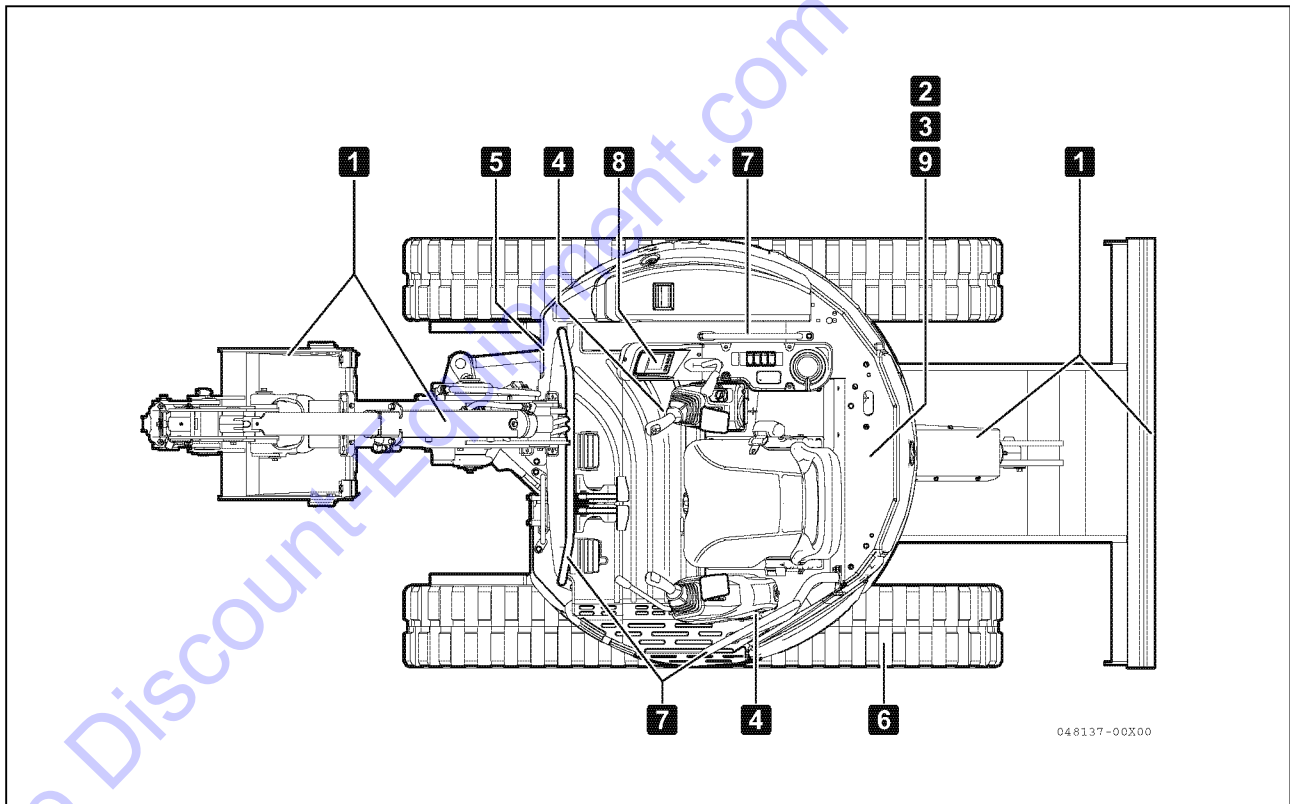

1 Checking the implement, hydraulic cylinders, linkages, and hoses for damage, wear and loose connections

Check the implement, hydraulic cylinders, linkages, and hoses for damage, wear and loose connections. If any abnormality is found, take corrective action.

2 Removing dust deposits from around the engine, battery, and radiator

Check that there are no dust deposits around the engine or on the radiator, and that there are no combustibles (dead leaves, twigs, etc.) in the heat build-up areas, such as the engine muffler, or around the battery. If there are any, remove them.

3 Checking the engine and its accessories for oil or water leakage

Check the engine for oil leakage and the cooling water system for water leakage. If oil or water leakage is found, take a corrective action.

4 Checking the hydraulic system, hydraulic oil tank, hoses, and joints for oil leakage

Check for oil leakage. If oil leakage is found, take corrective action.

5 Checking the grease piping for grease leakage

Check for grease leakage or ooze. If grease leakage or ooze is found, take corrective action.

6 Checking the undercarriage (tracks, sprockets, and idlers) for breakage, wear, loose bolts, and oil leakage around the rollers

If any breakage or wear is found, correct it. Retighten the bolts if necessary. If oil leakage is found, take corrective action.

7 Checking the handrails and steps for breakage and loose bolts.

If any breakage is found, take corrective action. Retighten the bolts if necessary.

8 Checking the gauges and the monitor for breakage and loose bolts

Check the gauges and the monitor for breakage and loose bolts. If any abnormality is found, replace the gauge or the monitor with a new one, or retighten the bolts if necessary. Clean the surfaces of the gauges and monitor.

9 Checking the fuel filter to see whether the red ring has sunk down at the cup bottom

If the red ring has sunk down at the cup bottom, no water has mixed into the oil; if the red ring is floating in the cup, water is mixed into the oil under the red ring. In this case, take out the cup to remove the water.

Checking before start-up

Check the following points before initial start-up for the day.

■ Checking and replenishing the cooling water

⚠ WARNING

- Do not remove the fill cap from the radiator unless refilling the coolant.
- Check the coolant water level in the sub-tank when the engine is cool.

1. Open the engine hood rear cover. Then check that the cooling water level in the sub-tank **1** (illustrated in the right figure) is between the FULL and LOW marks. If the water level is below the LOW mark, refill the sub-tank up to the FULL mark through the water supply port of the sub-tank **1**.

For the quality of cooling water to be used, refer to Section "4. Fueling, Oiling and Greasing Based on Temperature Range" on page 247.

2. After replenishing, securely tighten the radiator cap.
3. If the sub-tank is empty, check it for water leakage, and then, check the water level in the radiator. If the water level is low, refill the radiator first, then refill the sub-tank.
4. If the cooling water level is appropriate, close the engine hood rear cover.

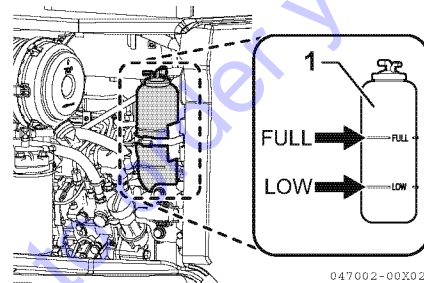

047002-00X02

■ Checking and replenishing the engine oil

⚠ WARNING

- At operating temperature, oil and dipstick areas are hot.
Do not allow hot oil or components to contact skin to prevent bodily injury.
- Check oil level and refill oil after engine has cooled down.

1. Open the engine hood rear cover and securely lock it with the stopper.
2. Pick up the dipstick 1 and wipe it with a rag to remove oil deposits.
3. Insert the dipstick 1 into the dipstick tube fully, then draw it out.
4. If the dipstick 1 is wet above the midpoint between the H and L marks, the engine oil level is appropriate. If the oil level is below the midpoint between the H and L marks, supply engine oil through the oil supply port 2. For the quality of the engine oil to be used, refer to Section "4. Fueling, Oiling and Greasing Based on Temperature Range" on page 247.
5. If the engine oil level is above the H mark, remove the cover 3 under the drain plug 4. Remove the excessive amount of oil through the drain plug 4, then recheck the engine oil level.
6. After verifying that the amount of engine oil is appropriate, securely retighten the oil supply port cap and close the engine hood rear cover.

Note :

When checking the engine oil level after starting up the engine, stop the engine and allow more than 15 minutes for the engine to cool down.

If the machine is slanted, reposition the machine to ensure it is level before checking the engine oil level.

Keep in mind that the excess engine oil must not be disposed of on the ground or the road.

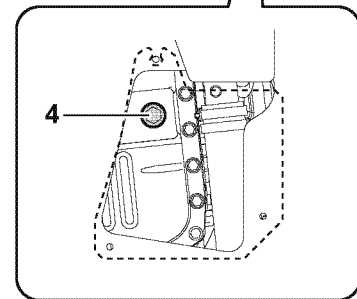
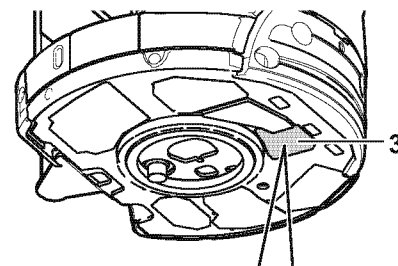
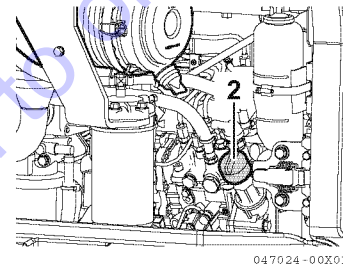
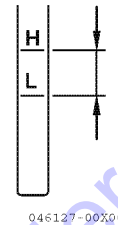
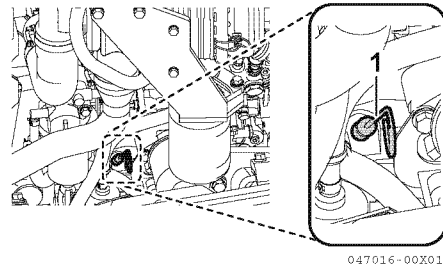

■ Checking the fuel level in the fuel tank and refueling

⚠ WARNING

Be careful not to overfill the fuel tank because it could cause a fire. If the tank is overfilled, completely wipe off the spilled fuel.

⚠ CAUTION

- Do not remove the strainer from the fuel supply port of the fuel tank to refill the tank.
- Be careful not to allow water settled at the bottom of the fuel container or dirt on refueling equipment to enter into the fuel tank.

1. Turn the starter switch to the "ON" position, and check the fuel level with the fuel meter 2. Open the bonnet B 4, and supply fuel from the fuel supply port 5 while checking the level gauge 6.

When the fuel meter 2 and caution lamp 3 flash, approximately 2.4 Gals. (9 L) of fuel is left in the tank.

Capacity : 10.8 Gals. (41 L)

For the quality of the fuel to be used, refer to Section "4. Fueling, Oiling and Greasing Based on Temperature Range" on page 247.

2. After refueling, securely retighten the fuel supply port cap, and close the engine hood B 4.

Note :

If the breather hole 1 in the cap is clogged, the pressure in the tank may decrease and the fuel may not be supplied adequately to the engine. Clean the engine breather hole from time to time.

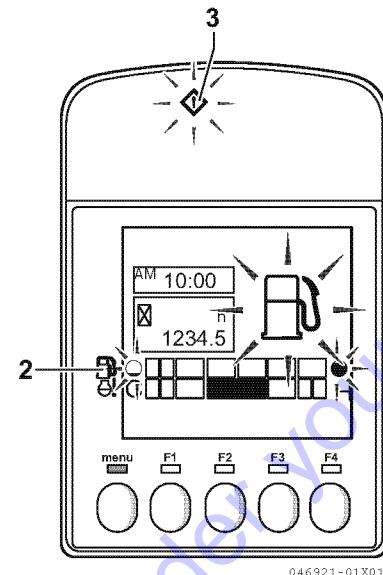

046921-01X01

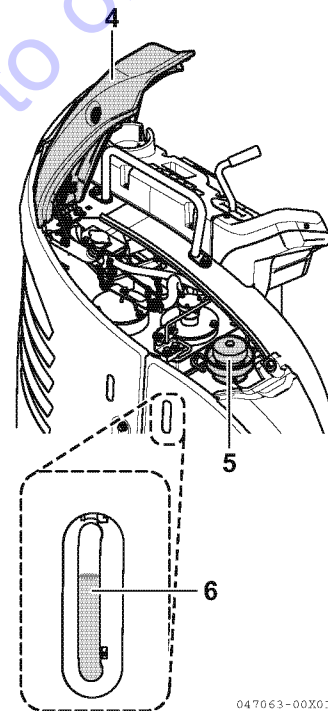

047063-00X01

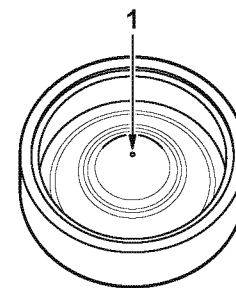

047206-00X00

■ Checking and replenishing the hydraulic oil tank

⚠ WARNING

When removing the plug of the oil supply port, slowly loosen it to release the pressure in the tank to prevent a dangerous high-pressure leak.

1. Park the machine as illustrated in the right figure.

When the machine is not in the posture in the right figure, start the engine, retract the bucket and arm cylinders to their stroke ends at low speed, lower the boom until the bucket teeth is placed on the ground, lower the blade to the ground, and stop the engine.

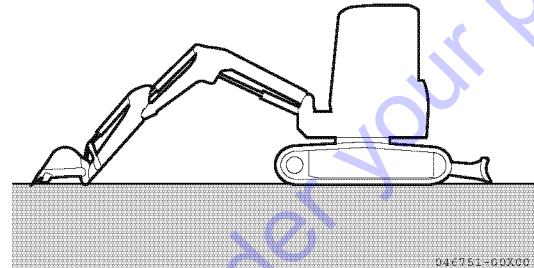

2. Check the oil level with the oil level gauge 1 on the right side of the machine. The oil level must be between the upper and lower limit marks on the gauge.

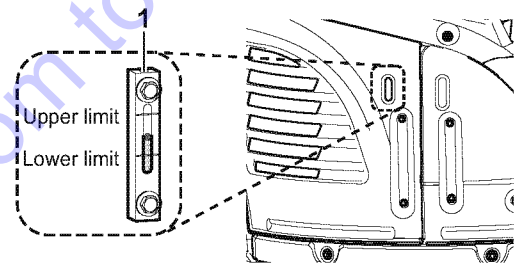

IMPORTANT

Do not replenish hydraulic oil above the upper limit mark on the oil level gauge. An excessive amount of hydraulic oil may damage the hydraulic system by placing stress on its components, causing a dangerous high-pressure leak.

3. Open the bonnet 2 and lock it with the stopper 3. Replenish oil from the oil supply port 4 if the oil level is below the lower limit.

For the quality of the oil to be used, refer to Section "4. Fueling, Oiling and Greasing Based on Temperature Range" on page 247.

4. Disengage the stopper 3 and close the bonnet B 2.

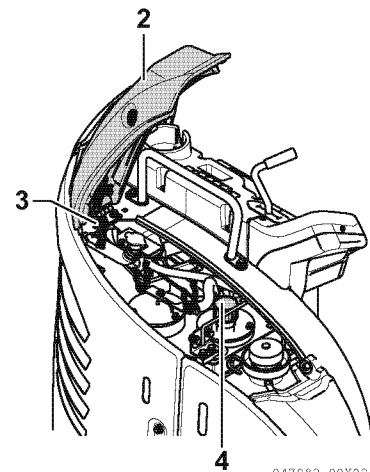

Note :

Note that the oil level varies with the oil temperature.

When reading the oil level, follow these guidelines:

- Before start-up, the oil level gauge should read the level around the midpoint of the gauge scale [oil temperature: 50 to 86°F (10 to 30°C)].
- During normal operation, the oil level gauge should read the level around the upper limit mark of the gauge scale [oil temperature: 122 to 176°F (50 to 80°C)].

■ Checking the fan belt tension

1. Open the engine hood rear cover.
2. Press down the fan belt between the fan pulley **1** and the generator **2** with a finger to check the fan belt tension.
Pressing load : Approximately 22.1 lbs. (10 kgf)
Adequate slack : 0.4 to 0.6 in. (10 to 15 mm)

3. Adjust the tension if necessary.
Refer to Section "8.6 Maintenance every 250 service hours" on page 275 for the adjustment procedure.

4. When the tension is proper, close the engine hood rear cover.

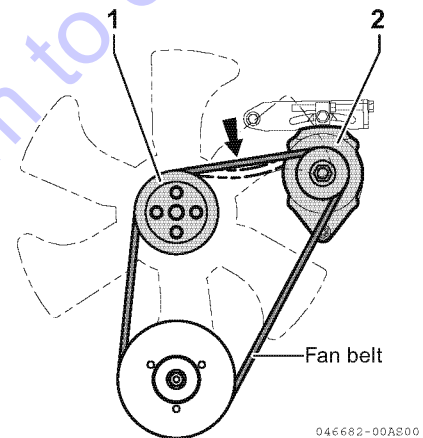
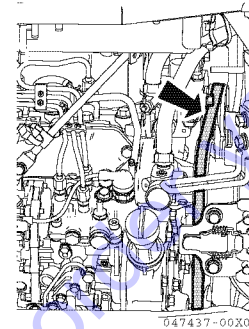
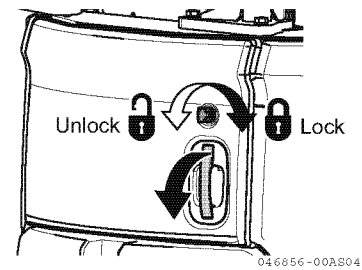

Go to Discount-Equipment.com to buy your parts

■ Checking and replenishing the battery electrolyte

⚠ DANGER

- The battery generates flammable gas and can cause a fire and an explosion. Keep sparks, flames and lit cigarettes away from the battery.
- Battery electrolyte is strong acid. To avoid serious injury, do not allow the electrolyte to contact your skin or splash into your eyes.
- Always wear safety goggles and protective clothing, when adding electrolyte.
- Do not use the machine with the battery which is short of battery electrolyte. The shortage of battery electrolyte not only will reduce the life of the battery but also could cause an explosion.

1. Open the bonnet R 2 and lock it with the stopper 6.

2. Check the electrolyte level of the battery 1.

The level must be between the upper and lower limit marks.

If the level is lower than the lower limit mark, loosen the bolt 3, open the cover 4 and fix it with stopper 5. Then, replenish the electrolyte.

3. Disengage the stopper 6 and close the bonnet R 2.

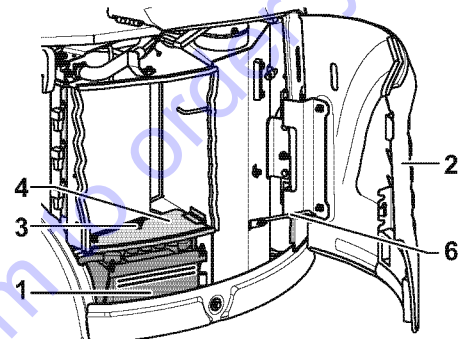

046956-00X00

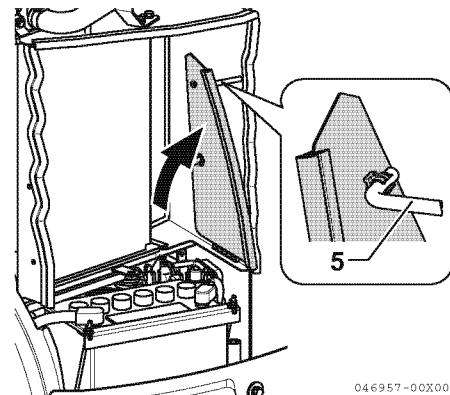

046957-00X00

■ Greasing

IMPORTANT

- Grease the fittings thoroughly after washing the machine or after operation in rain, on soft ground, or in muddy water.
- Be sure to perform the greasing daily before startup.

1. Put the bucket and the blade on the ground and stop the engine.

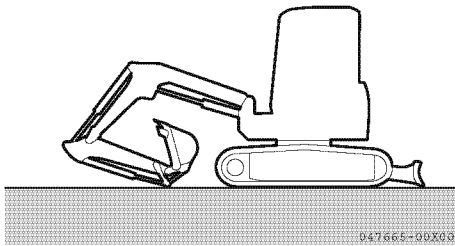

2. Clean the grease nipples indicated in the right figures and grease them using a grease gun.
3. After greasing, wipe off the excessive grease with waste cloth or the like.

Refer to Section " Maintenance" on page 185 for the quick coupler.

Standard blade

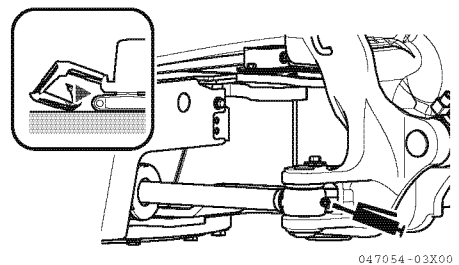
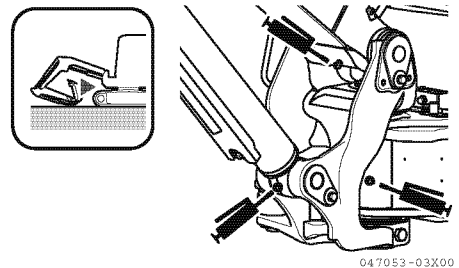
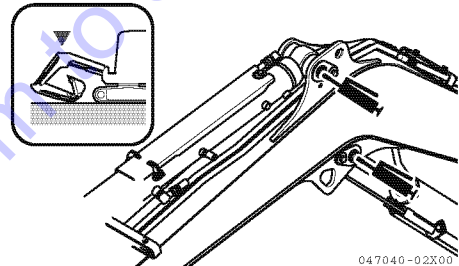
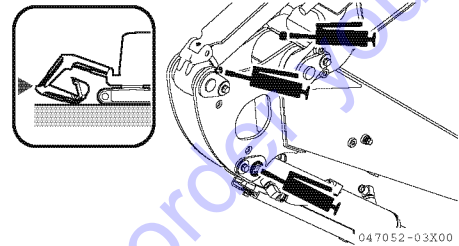
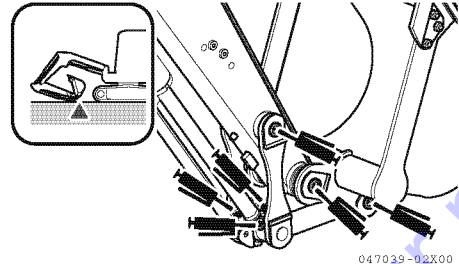

Standard blade

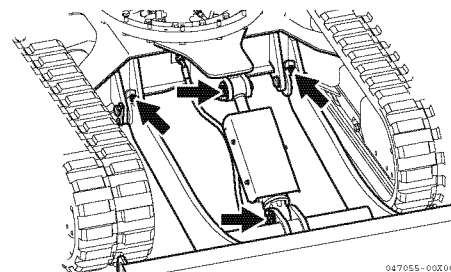

Angle blade

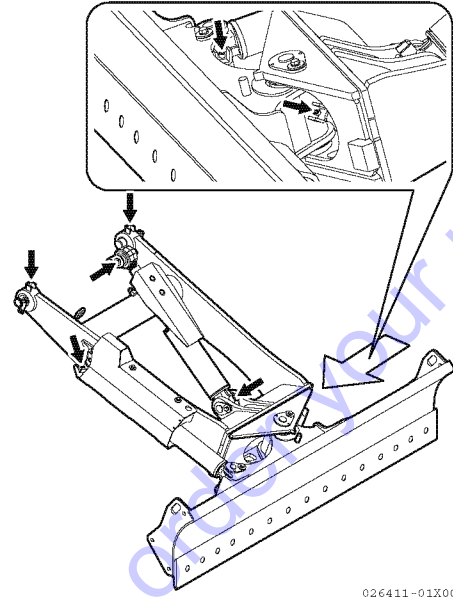

026411-01X00

Go to Discount-Equipment.com to order your parts

■ Checking the electrical equipment

⚠ CAUTION

If a fuse blows out frequently, contact your dealer for assistance.

Check fuses for damage, wiring for poor connections or short circuits, and battery terminals for corrosion or loose fits. Take corrective action.

Check the following items after the starter switch is turned to the "ON" position.

● Check the monitor functions

- Check the functions of LCD monitor (hour meter, water temp. meter and fuel meter).
- Check LED lamps on the LCD monitor.

● Check that all switches function correctly and lamps light correctly.

- Check the work lights.
- Check the horn.
- Check the auto deceleration function.
- Check the eco mode function.
- Check the wiper function. (for cabin)
- Check the room lamp for lighting. (for cabin)
- Check the heater function. (for cabin)
- Check the air conditioner function (option)

● Check the travel alarm function.

- To check the travel alarm function, push or pull the travel levers after the lock levers are unlocked.

Operating and checking instructions before starting up the engine

⚠ WARNING

- Accidentally operating a control lever can cause the machine to move suddenly, possibly causing a serious accident.
- When leaving the operator's seat, be sure to place the lock levers securely in the lock position.

1. Check that the lock lever 1 are in the lock position.

Note :

When both the lock lever are in the unlock position, the engine cannot be started. Pull either lock lever up to start the engine.

2. Check that all other levers are in their appropriate positions.

3. Fasten the seat belt 3 snugly.

4. Insert the key into the starter switch 2 and set it to the "ON" position. Then check the following points:

1- The buzzer will sound, and LED lamps 4 on the LCD monitor will go on.

After 2 seconds, the buzzer and LED lamps except for the following lamps will turn off.

- Engine oil pressure lamp
- Battery charge lamp

If any of the alarm lamps does not go on or the buzzer does not sound, it may mean that the alarm lamp has blown out or the wire is broken. In this event, ask the dealer for repair.

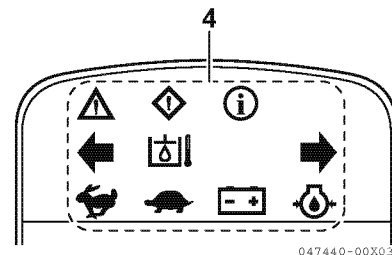
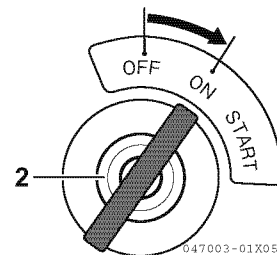
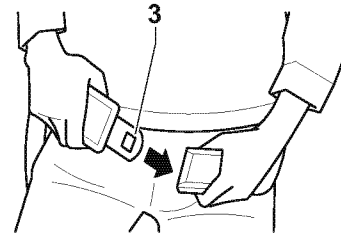
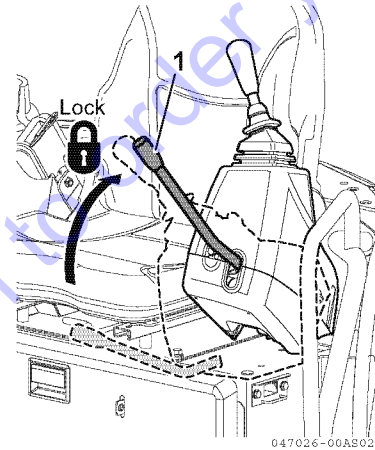
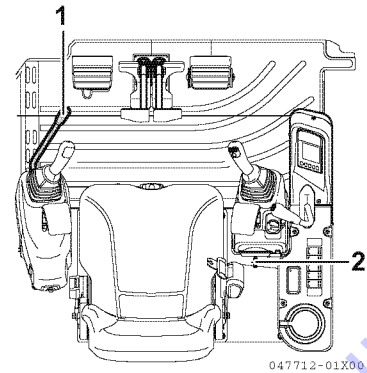

2- Position the light switch to "ON" whether the work lights will go on. If they do not go on, the lamp might have blown out or the wire might be broken. In this event, ask the dealer for repair.

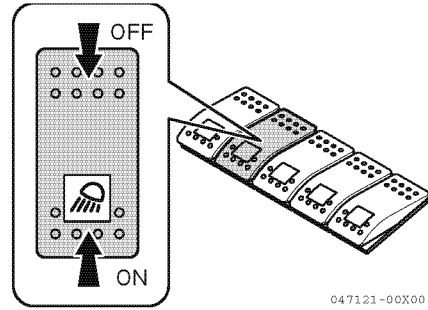

Go to Discount-Equipment.com to order your parts

3.2 Starting up the engine

Normal start-up

⚠ WARNING

- First check that there are no people or obstacles around the machine.
Then sound the horn and start the engine.
- Be sure that you are seated in the operator's seat when starting the engine.
- When starting the engine in an enclosed place, be sure that there is adequate ventilation so that the exhaust gases can escape.

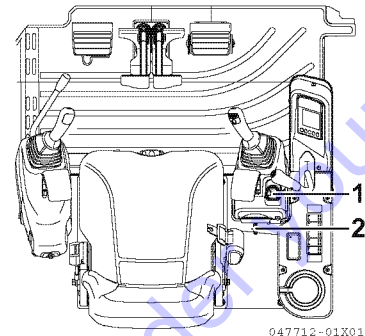

1. Turn the engine control dial 1 to the "RUN" direction.

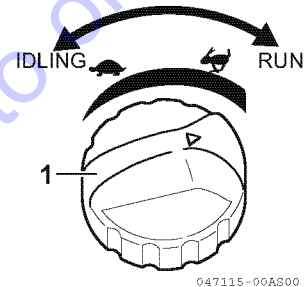

2. Set the key in the starter switch 2 to the "START" position. The engine will start.

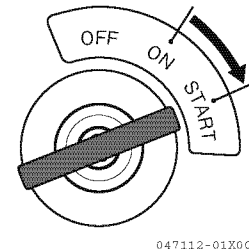

3. After the engine has started, let go of the starter switch key.
The starter switch key will return to the "ON" position by itself.

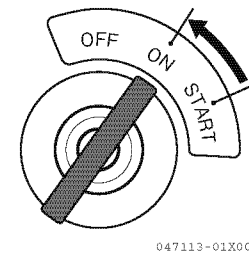

Note :

When the engine is warm, the engine can start up even if the accelerator lever is left in the "IDLING" position.

IMPORTANT

To protect the starter motor and the battery:

- Do not keep the key in the "START" position for more than 10 seconds.
- If the engine fails to start, do not attempt to start the engine immediately again, but set the switch to the "OFF" position and wait for approximately 30 seconds, then start the engine again.

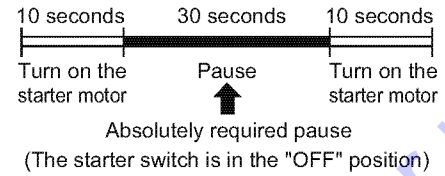

The swing motor with a brake is used. The brake of the swing motor is released when the engine starts.

Go to Discount-Equipment.com to order your parts

Starting the engine in cold weather

⚠ WARNING

- First check to see that there are no people or obstacles around the machine.
Then sound the horn and start the engine.
- Be sure that you are seated in the operator's seat when starting the engine.
- When starting the engine in an enclosed place, be sure that there is adequate ventilation so that the exhaust gases can escape.

To start the engine at a low outside air temperature, follow the steps below:

1. Turn the engine control dial 1 to the "RUN" direction.

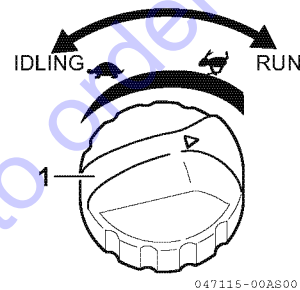
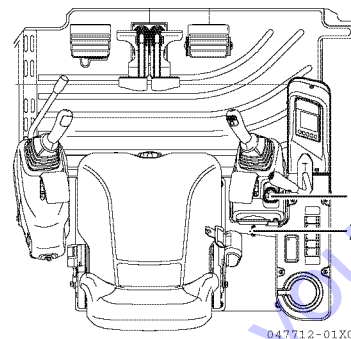

2. Turn the key in the starter switch 2 to the "ON" position and hold it in the position. An icon indicating that the engine glow plug is operating appears on the LCD monitor and disappears when the engine has been warmed up.

Be sure to confirm that the icon has disappeared before starting the engine.

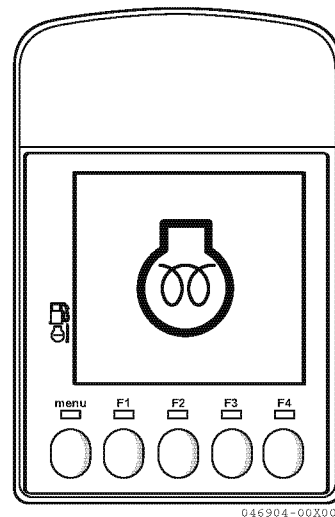
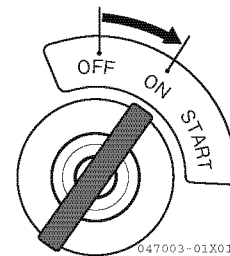

3. Turn the key in the starter switch **2** to the "START" position to start the engine.

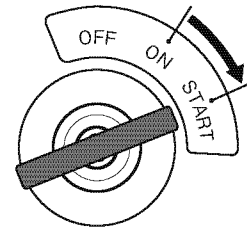

047112-01X00

4. After the engine has started, let go of the starter switch key.
The starter switch key will return to the "ON" position by itself.

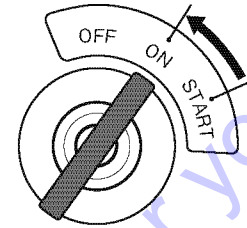

047113-01X00

5. When the engine speed has increased, turn the engine control dial **1** to the "IDLING" position immediately.

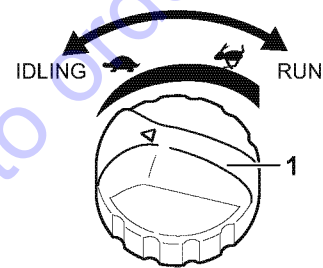

047114-00A802

IMPORTANT

To protect the starter motor and the battery:

- Do not keep the key in the "START" position for more than 10 seconds.
- If the engine fails to start, do not start the engine immediately again, but set the switch to the "OFF" position and wait for approximately 30 seconds, then start the engine again.
- Traveling or operating the machine without adequate warming up in cold weather may adversely affect the machine performance, which causes low operating speed or traveling with deviation.

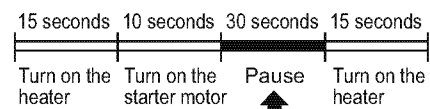

Absolutely required pause

046135-00A800

3.3 Operating and checking instructions after starting the engine

⚠ WARNING

- **Emergency stop.**
If abnormal operation occurs, turn the starter switch key to the "OFF" position, to stop the electrical system and the engine. Then ask your dealer to check the machine.
- **Be sure to warm up the engine.** If you operate the implement without full warm-up, the machine may not respond or operate properly. Especially in cold weather, fully warm up the engine.

IMPORTANT

- The proper hydraulic oil temperature is between 122°F and 176°F (50°C and 80°C).
- If you have to operate the machine at a low hydraulic oil temperature, increase the hydraulic oil temperature to about 68°F (20°C) before operating the implement.
- In the event that you have to operate any control lever at a temperature of lower than 68°F (20°C), operate it gently.
- Do not accelerate the engine rapidly until the engine warms up.

After starting the engine, do not start operating the machine immediately but follow this procedure:

1. Idle the engine to check that LED lamps on the LCD monitor **1** is off.

2. Turn the engine control dial **2** to the midpoint between the "IDLING" and "RUN" positions, and run the engine with no load at medium speed for approximately five minutes.

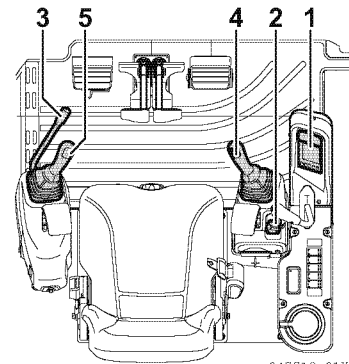

047712-01X02

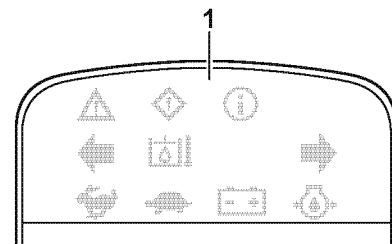

047441-00X01

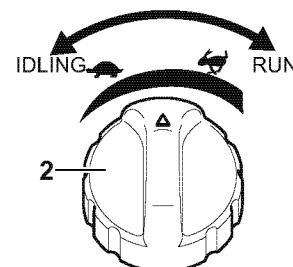

047184-00AS00

3. Unlock the lock lever 3, and lift the bucket from the ground.
4. Operate the bucket and arm control levers slowly to move the bucket and arm cylinders to their stroke ends.
Operate the bucket for thirty seconds and the arm for thirty seconds alternately for approximately five minutes to increase the hydraulic oil temperature to 70°F (20°C) or more.

IMPORTANT

When moving the implement, be careful not to bump it against the machine or the ground.

5. After warming up the engine, check that the LED lamps on the LCD monitor have turned off and no errors are displayed on the LCD screen. If there are any problems, take necessary corrective action.
6. Check the exhaust gas color, the machine noise, and the vibration level for abnormality. If something is abnormal, take corrective action.

7. Set the lock lever 3 to the "LOCK" position to check that the implement cannot be operated and the upperstructure cannot be swung with the left and right control levers.
8. Unlock the lock lever 3 and operate the control levers to check that the implement can be operated and the upperstructure can be swung normally with the control levers. If something is abnormal, take corrective action.
9. Check to see that the swing brake valve operates normally. If something is abnormal, take corrective action.
10. Check that no abnormal noise is heard from the hydraulic system. If any abnormal noise is heard, take corrective action.

Ask your dealer to resolve the problems described in the steps 1 to 10 above.

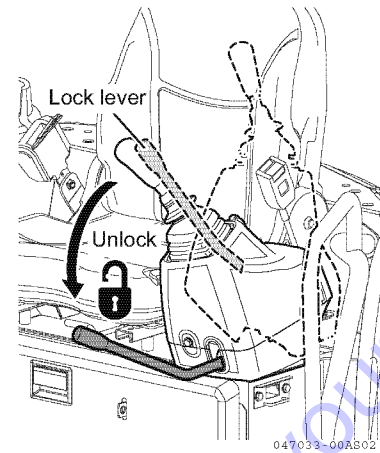

■ Operating the arm

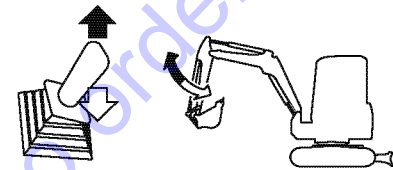

Control lever (L)

■ Operating the bucket

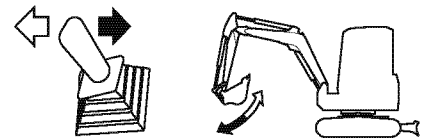

Control lever (R)

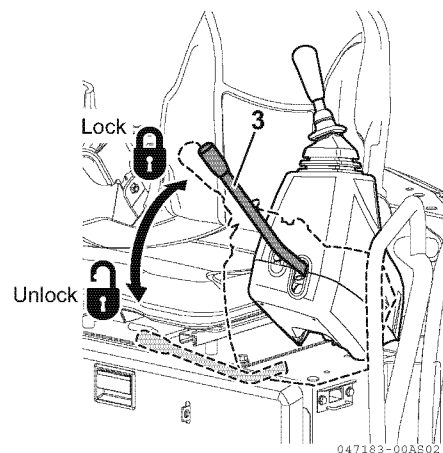

3.4 Traveling

Traveling forward

⚠ WARNING

- Always check the position of the blade before operating the travel levers and pedals. When the blade is in the rear, the travel levers and pedals operate in the reverse of the normal operation.
- A signal person should be in attendance to give signals at sites which are dangerous or not clearly in view of the operator.
- Clear all people from the working area.
- Sound the horn before beginning travel, to alert the people near the machine.
- Clear obstacles from the path of the machine.
- Do not operate the travel levers and pedals rapidly while the engine is running at high speed. Otherwise, the machine may move unexpectedly, causing a serious accident.

1. Turn the engine control dial 1 to the "RUN" position to increase the engine speed.

2. Unlock the lock lever 2, and retract the implement to lift it 16 to 20 in. (40 to 50 cm) above the ground.

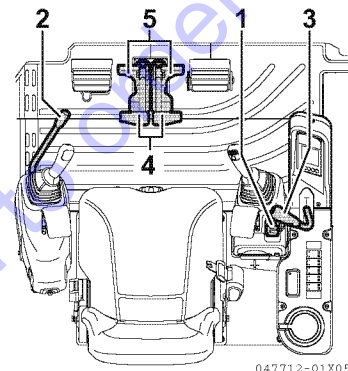

047712-01X05

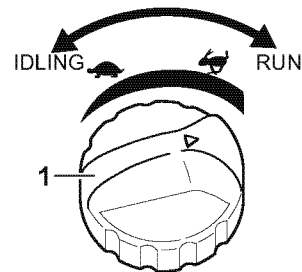

047115-00A800

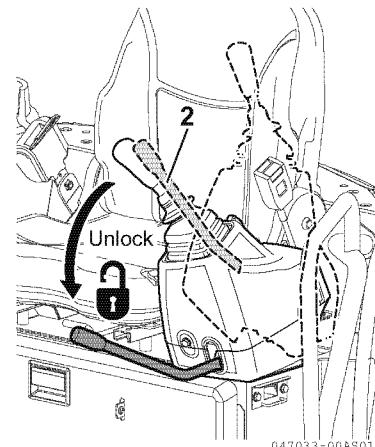

047033-00A801

3. Pull back the blade lever **3** to lift the blade.

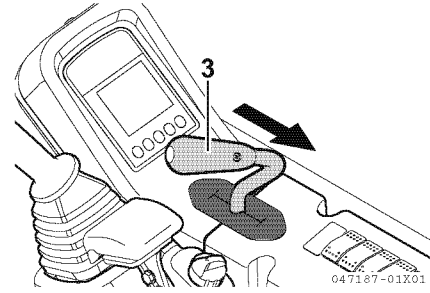

4. Operate the left and right travel levers **4** or pedals **5** as follows:

- When the blade is in the front of the machine; Slowly push the travel levers **4** forward or step on the front of the pedals **5** to move the machine forward.

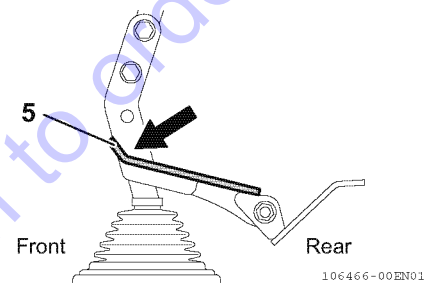
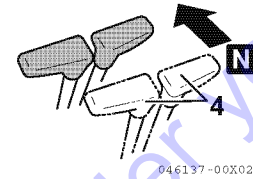

- When the blade is in the rear of the machine; Slowly pull the travel levers **4** back or step on the rear of the pedals in order to move the machine forward.

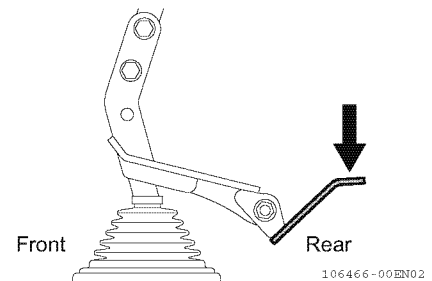
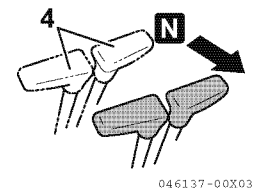

Go to Discount-Equipment.com to order your parts

Traveling in reverse

⚠ WARNING

- Always check the position of the blade before operating the travel levers and pedals.
- When the blade is in the rear, the travel levers and pedals operate in the reverse of the normal operation.
- A signal person should be in attendance to give signals at sites which are dangerous or not clearly in view of the operator.
- Clear all people from the working area.
- Sound the horn before beginning travel, to alert the people near the machine.
- Clear obstacles from the path of the machine.
- There is a blind spot behind the machine. Make sure that no people are in the blind spot before traveling backwards.
- Do not operate the travel levers and pedals rapidly while the engine is running at high speed. Otherwise, the machine may move unexpectedly, causing a serious accident.

1. Turn the engine control dial 1 to the "RUN" position to increase the engine speed.

2. Unlock the lock lever 2, and retract the implement to lift it 16 to 20 in. (40 to 50 cm) above the ground.

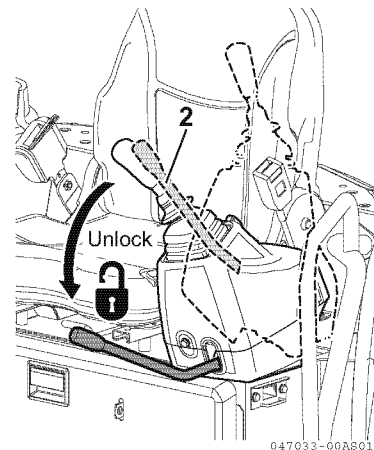
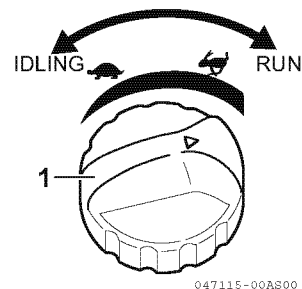
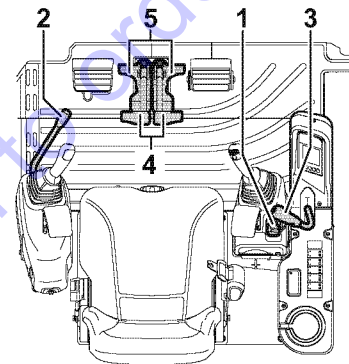

3. Pull back the blade lever **3** to lift the blade.

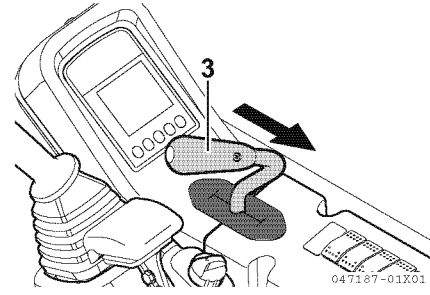

4. Operate the left and right travel levers **4** or pedals **5** as follows:

- When the blade is in the front of the machine; Slowly pull the travel levers **4** back or step on the rear of the pedals in order to move the machine backward.

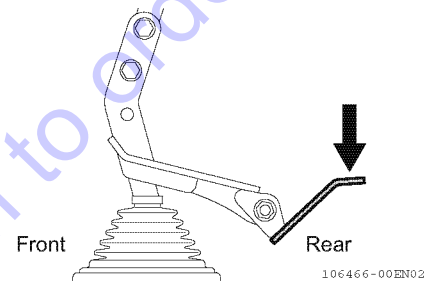
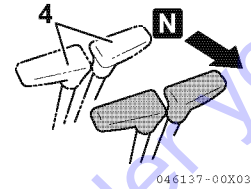

- When the blade is in the rear of the machine; Slowly push the travel levers **4** forward or step on the front of the pedals **5** to move the machine backward.

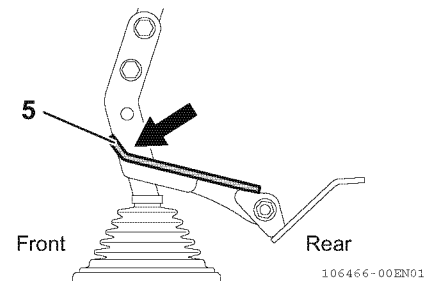
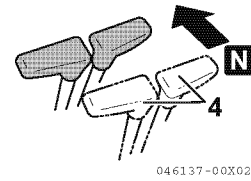

Go to Discount-Equipment.com to order your parts

3.5 Steering

Steering (Turning the machine)

⚠ WARNING

Always check the position of the blade before operating the travel levers.

When the blade is in the rear, the travel levers operate in the reverse of the normal operation.

Do not use the travel pedals to steer the machine, or the machine may not be controlled expectedly, causing a serious accident.

To steer the machine, operate the travel levers only. Do not turn the machine too sharply. Before spin-turning, stop the machine. Operate the two travel levers 1 as follows:

■ Steering the machine when it is not traveling

To turn left, push the right travel lever forward and start traveling forward on the left. Pull the right travel lever back and start traveling in reverse on the left.

Note :

To turn right, operate the left travel lever in the same manner as above.

■ Steering the machine while traveling (the left and right travel levers are both tilted in the same direction)

To turn left, return the left travel lever to the neutral position.

Note :

To turn right, operate the right travel lever in the same manner as above.

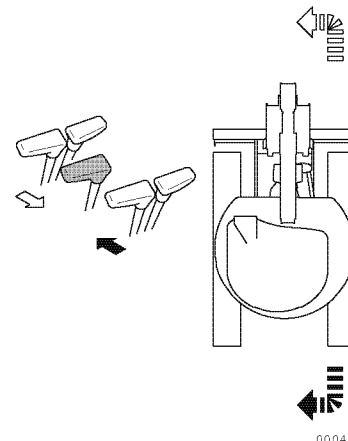
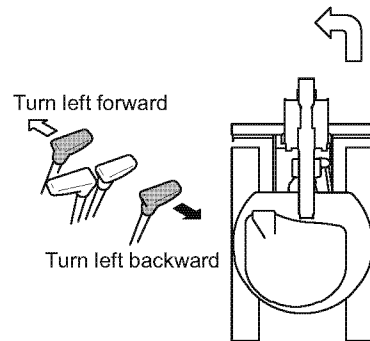
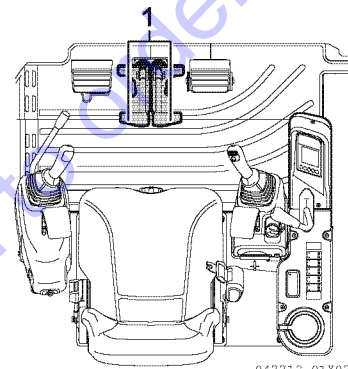

■ Spin-turning the machine when it is not traveling

To spin-turn left, push the right travel lever forward while pulling the left travel lever back.

Note :

To spin-turn right, push the left travel lever forward while pulling the right travel lever back.

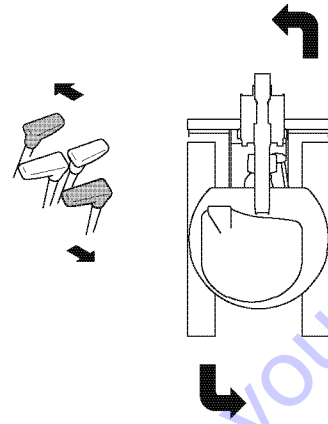

000415-00X01

Go to Discount-Equipment.com to order your parts

3.6 Stopping the machine

⚠ CAUTION
 Do not stop the machine suddenly but provide a safety margin.

⚠ WARNING

- Park on solid, level ground.
- Do not park on a slope. If it is unavoidable to park on a slope, put solid pieces of wood under the track as blocks, place the blade on the ground, and dig the bucket into the ground.

⚠ WARNING

- Do not touch the control levers and pedals accidentally. Otherwise, the implement or the machine may move unexpectedly, causing serious bodily injury.
- Whenever leaving the operator's seat, be sure to place the lock lever securely in the lock position and remove the starter switch key.

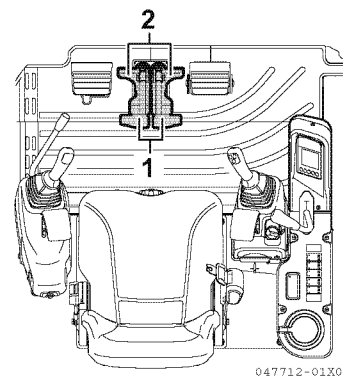
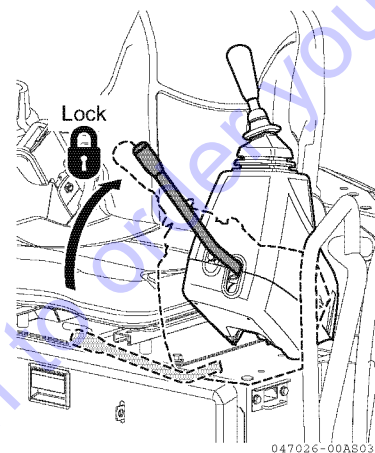
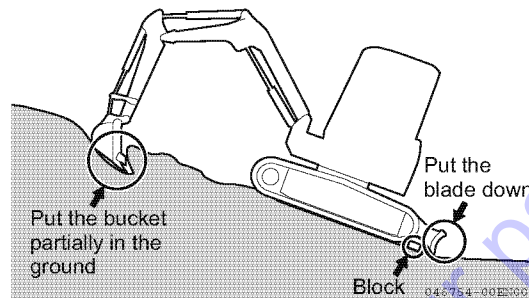

Set the right and left travel levers 1 or pedals 2 to the neutral position to stop the machine.

N : Neutral position

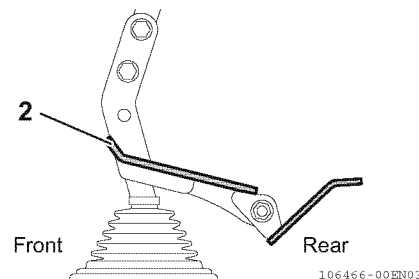
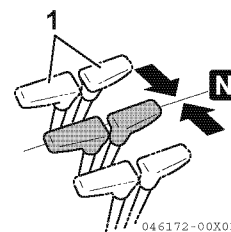

3.7 Swinging the upperstructure

⚠ WARNING

Before swinging, make sure that there are no people or obstacles within the swing range of the implement or the machine tail.

To swing the upperstructure, operate the left control lever as illustrated in the right figure.

A : Swing right

B : Swing left

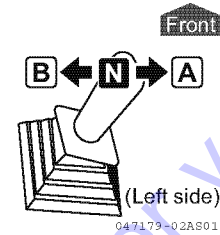

Go to Discount-Equipment.com to order your parts

3.8 Operating the implements

⚠ WARNING

- Check the area around the machine for safety and sound the horn before beginning to operate the machine.
- According to the switching of pattern change lever, control lever operation can be chosen in two patterns.
- To prevent accidental injury, never operate Excavator before confirming location of pattern change lever.

Operate the machine using the right and left control levers, the boom swing pedal and the blade lever.

<STD Pattern>

- Control lever (L) : Operates arm and upperstructure swing.
- Control lever (R) : Operates boom and bucket.

<OPT Pattern>

- Control lever (L) : Operates boom and upperstructure swing.
- Control lever (R) : Operates arm and bucket.

- Boom swing pedal : Operates boom swing.
- Blade lever : Operates blade.

The relation between the operation of the levers and the boom swing pedal, and the movement of the implement are shown in the illustrations on the right.

On releasing the levers and the boom swing pedal, they return to the neutral position and the implement will stop as they are.

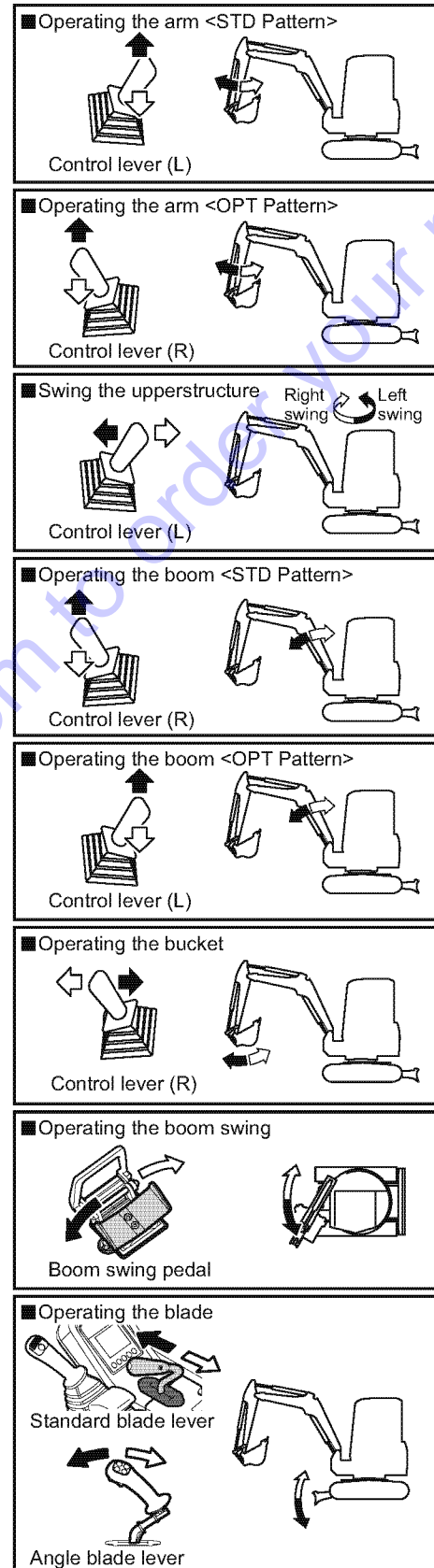

048138-02AS00

3.9 Precautions for operating the implement

⚠ WARNING

- Do not operate the implement control levers while traveling. Stop traveling first and then operate the implement.
- Do not operate the implement on a rocky surface (on hard and soft rocks).

■ Do not use the implement's swing force

Do not level the ground or break down a wall by the use of swing force, and do not dig the bucket teeth into the ground while swinging. Doing these may cause the implement to be damaged.

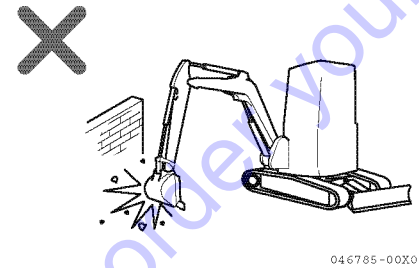

■ Do not use the implement's travel force

Do not excavate the ground by the use of travel force with the bucket teeth in contact with the ground. Doing this may cause excessive force to be imposed on the rear of the machine, shortening the machine life.

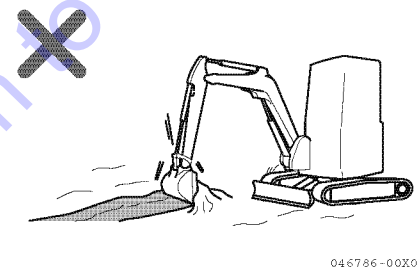

■ Take care not to operate the hydraulic cylinder to the stroke end.

Operating the hydraulic cylinder to the stroke end may impose an undue force on the stopper in the hydraulic cylinder, shortening the implement life. Operate with a small safety margin.

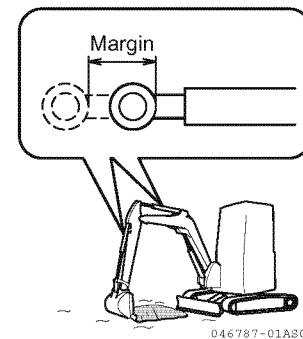

■ Do not operate the implement by the using the dropping force of the bucket

Do not excavate the ground by using the dropping force of the bucket as a pickaxe or pile driver. Doing this may cause excessive force to be imposed on the rear of the machine, shortening the machine life and possibly causing a serious accident.

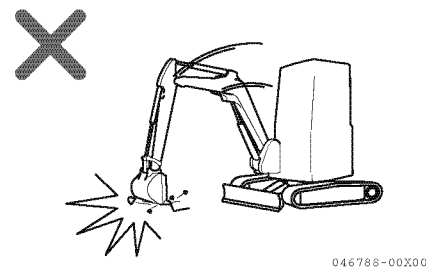

■ **Do not operate the implement by using the dropping force of the machine**

Do not excavate the ground by using the dropping force of the machine.

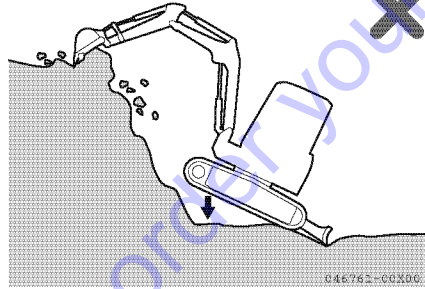
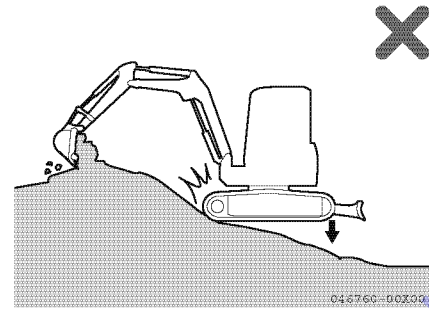

■ **Excavating a hard rock**

It is recommended that a hard rock first be broken into small pieces by other means. Doing so will prevent damage to the machine and will increase economy.

■ **Do not suspend a load unless you use a hooked bucket**

Suspending a load safely requires the use of a hooked bucket. Refer to Section "2. Handling the Hooked Bucket" on page 316.

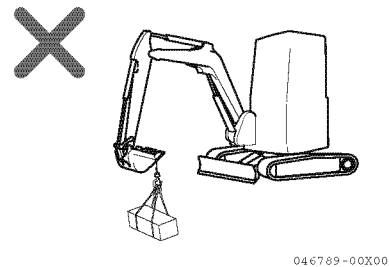

■ **Do not bump the blade against a large rock or boulder**

Do not bump the blade against a large rock or boulder. Doing so may cause the blade or the hydraulic cylinder to be damaged.

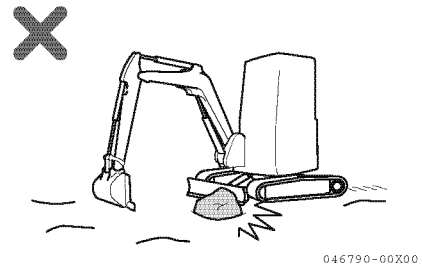

■ **Be careful when retracting the implement**

When retracting the implement for travel or transport, be careful that the bucket and the blade never bump against each other.

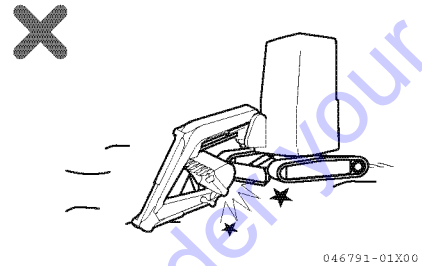

■ **Support the blade on both sides**

When you use the blade as an outrigger, support the blade on both sides.

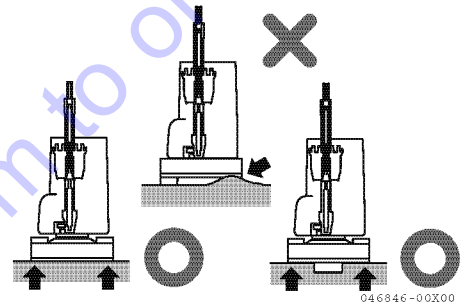

■ **Be careful not to bump the blade when excavating**

When excavating the ground with the blade in front, never let the blade bump against the boom cylinder. Place the blade in rear, if it is not being used.

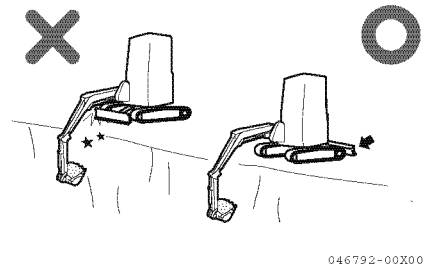

3.10 Precautions for working

■ Precautions for traveling

Driving over a stone or a stump subjects the machine (especially undercarriage) to a shock, which may cause damage to the machine.

Avoid such obstacles by driving around them, or removing them.

If driving over them is unavoidable, reduce speed, hold the implement close to the ground, and drive over the obstacles with the center of the track shoes.

■ Allowable water depth

IMPORTANT

When driving out of water, if the machine climbs a slope at an angle of more than 15 degrees, the rear of the upperstructure may submerge too deeply in the water, which may damage the radiator fan since the radiator fan paddles the water. Avoid this if possible when driving out of water.

The limit of the water depth in which the machine can be used in is up to the center of the carrier roller.

Apply a generous amount of grease to the moving parts (especially bucket pin) that have been submerged in the water for a long time until the used grease is extruded out of the bearings.

Wipe the extruded used grease off with a waste cloth.

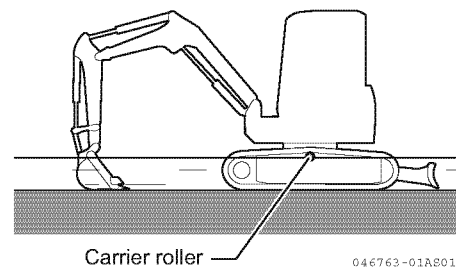
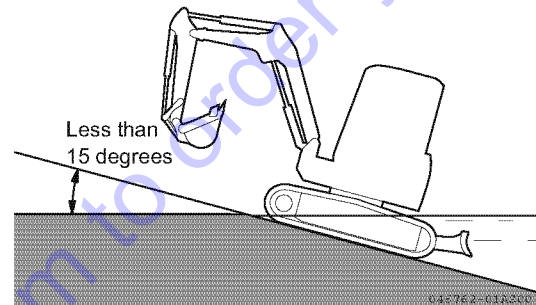
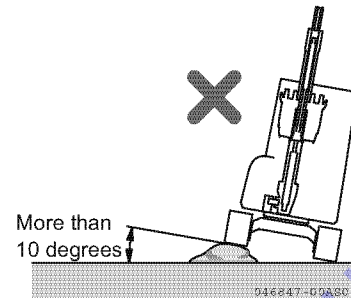

3.11 Precautions for going up and down a slope

⚠ WARNING

- When traveling on a slope, place the implement in the direction of travel and raise the bucket 8 to 12 in. (20 to 30 cm) above the ground.
- When driving over obstacles such as foot paths, hold the implement close to the ground and drive the machine slowly.
- Never turn on or traverse a slope.
- Descend to flat ground to make a course change.
- If the machine is starting to slip or you feel that the machine is unstable, place the bucket on the ground and stop the machine at once.
- Recognize that the machine may roll over when swinging the upperstructure or operating the implement on a slope.
- Do not swing the upperstructure toward the downward side of the slope with a load in the bucket.
- If swinging is unavoidable, first lay earth on the slope to maintain the machine as horizontal as possible, then swing the upperstructure.
- Do not travel on a slope of 20 degrees or more, as the machine may upset.

1. Go down slopes at low speed, using the travel levers and accelerator lever to control your speed.

When going down a slope, drive the machine at low engine speed and position the implement as shown in the right figure.

2. When climbing a slope, drive the machine with the implement positioned as shown in the right figure.

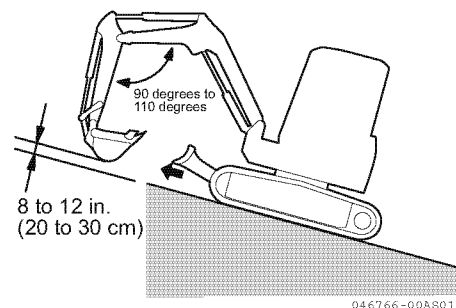
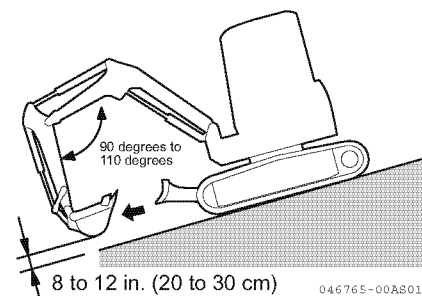
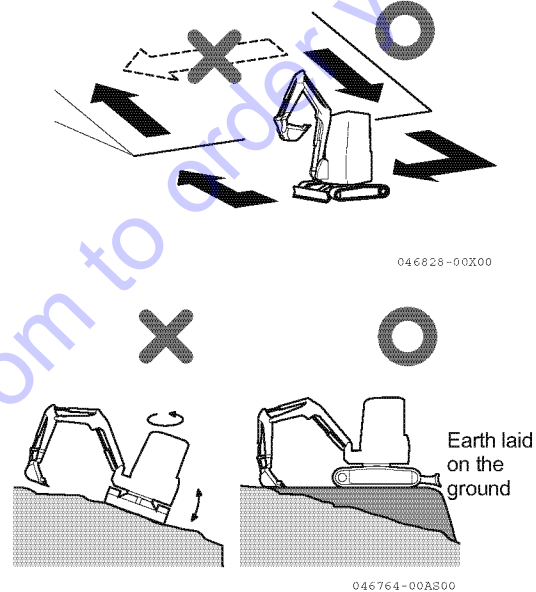

■ **Braking when going down a slope**

When going down a slope, you can automatically brake the machine by setting the travel levers to the neutral position.

■ **When the tracks are slipping**

If you cannot climb a slope by operating the travel levers because the tracks are slipping, retract the arm and make use of the pull-back power of the implement to climb the slope.

■ **When the engine stops**

If the engine stops while climbing a slope, set the travel levers to the neutral position, stop the machine, and restart the engine.

■ **Precautions for traveling on a slope**

Do not open or close the cabin side door on a slope. Doing this may cause the door to swing open or closed very rapidly.

Be sure to lock the cabin side door in either the open or closed position.

Go to Discount-Equipment.com to order your parts

3.12 Escaping from the mud

Carefully operate the machine not to allow it to get mired in mud. If the machine is mired in mud, the machine can escape as follows:

If only one track is mired in the mud

If only one track is mired in the mud, place the bucket on the muddy side, lift the track above the ground, lay a log or a wood block under the track shoe, and raise the bucket to escape.

IMPORTANT

When lifting the machine above the ground with the boom or the arm, press on the ground with the bottom of the bucket. (Do not press on the ground with the bucket teeth.)

In doing this, the angle between the boom and the arm should be 90 degrees to 110 degrees.

The same manner as above should be applied when the bucket is in the reverse position.

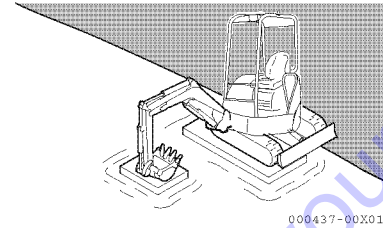

If both tracks are mired in the mud

If both tracks are mired in the mud, lay a log or a wood block under the track shoes in the same manner as mentioned above, dig the bucket into the solid ground, retract the arm just as when excavating, and set the travel lever to the "FORWARD" position to escape from the mud.

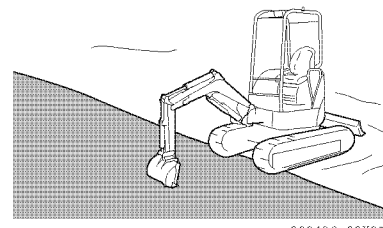

3.13 Operations using the bucket

You can greatly widen the range of work described here by using optional attachments.

Backhoe operation

Backhoe operation is suitable for digging the ground below the machine.

Suppose that the machine is operating as illustrated in the right figure : a maximum digging force of each cylinder can be obtained when the angle between the bucket cylinder and the bucket arm as well as between the arm cylinder and the arm is maintained at 90 degrees.

When digging, make good use of this angle to increase the operating efficiency.

To excavate the ground efficiently by manipulating the arm, the arm needs to be operated within a range of angles between 45 degrees forward and 30 degrees backwards, as illustrated in the right figure. Though the range differs according to the depth of the work, do not move the implement to the cylinder stroke end.

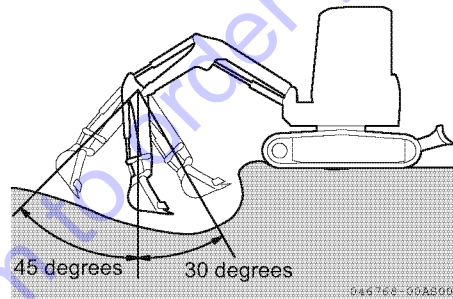
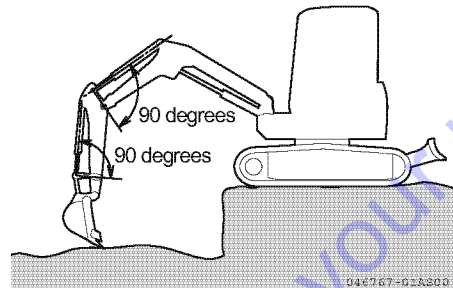

Ditching

To increase work efficiency, install a suitable bucket for ditching and position the tracks in parallel with the ditch to be made.

To make a wide ditch, first dig the two sides, and then dig the center.

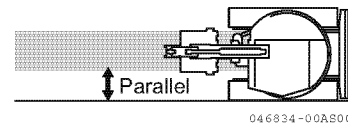

Loading

To increase work efficiency, locate the dump truck at a position where the swing angle of the machine will be minimized and the operator can clearly view the dump truck.

Load earth from the rear of the dump truck, because it can be loaded more easily and in larger amount than from the side.

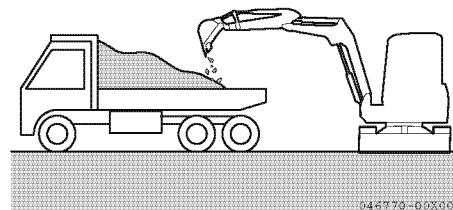

3.14 Handling quick coupler (option)

Features of quick coupler

The quick coupler is the device to simplify the replacement of a variety of attachments for hydraulic implement. The distance between pins is adjustable so that the attachments with different distances between pins are available.

Description of switches

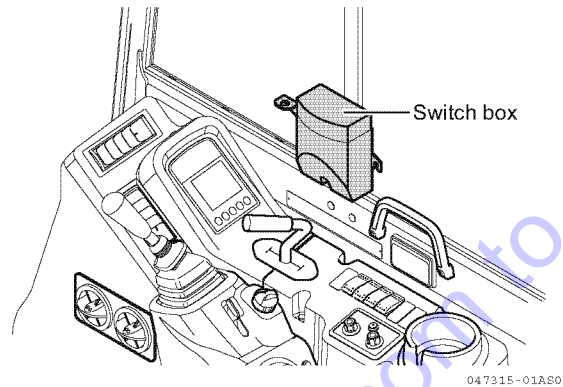

⚠ WARNING

Never open the Switch Box cover except when mounting or dismounting the Attachment to prevent accidental activation of the Quick Coupler. This may cause breakdown or sudden operation of the Attachment, causing serious accident.

● **Control switch of quick coupler**

Use this switch to dismount or mount the attachment.

Operating control switch to dismount or mount the attachment	
Dismounting of attachment	Mounting of attachment
<p>(1) Press (2) Turn to the left</p> <p>Power supply switch goes on, and beeps sound. Lamp goes on.</p> <p style="text-align: right;">000483-00E</p>	<p>(1) Turn to the right (2) Press</p> <p style="text-align: right;">000484-00E</p>

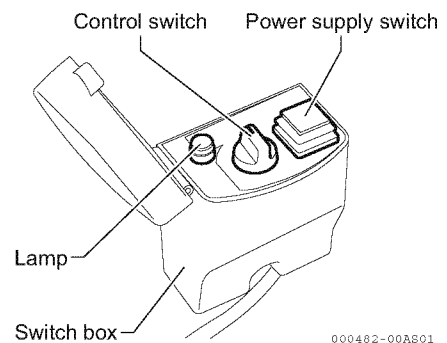

000482-00AS01

Structure of quick coupler

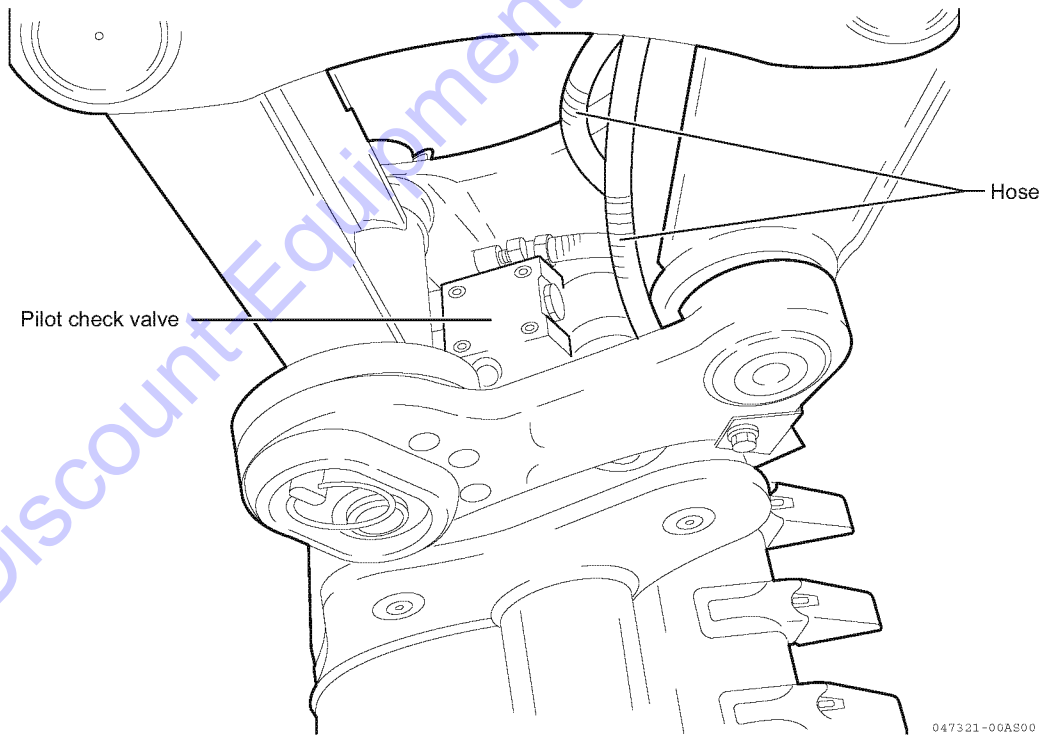
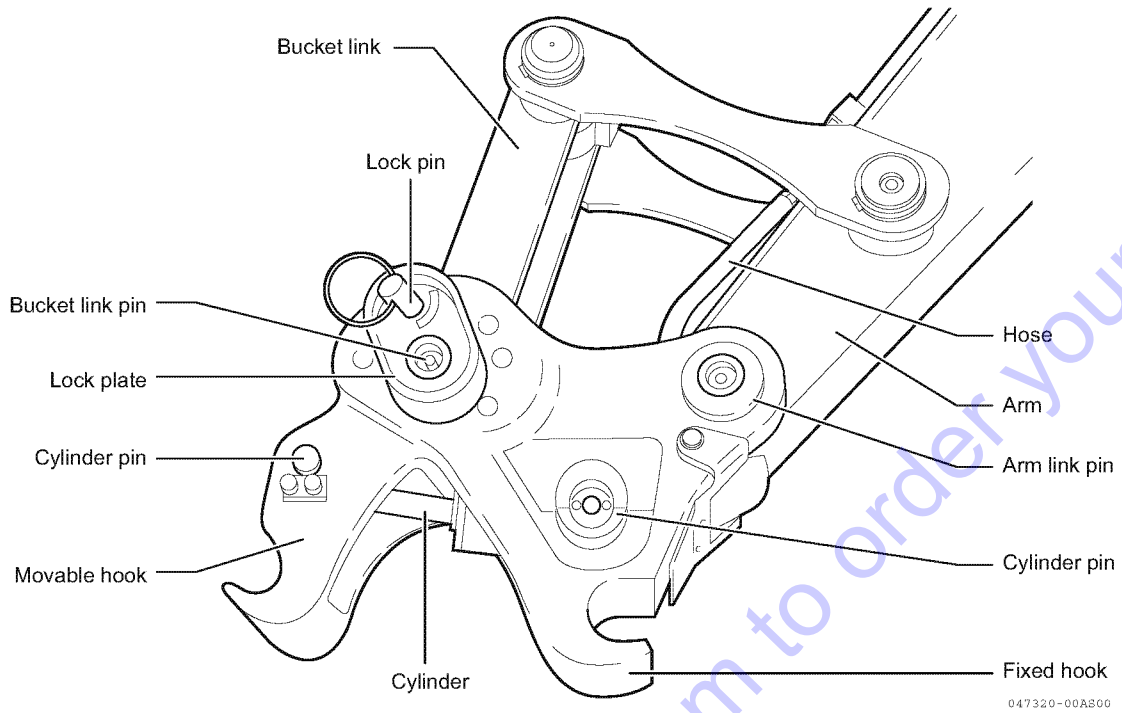

Attachment types

1. The attachments, which can be mounted on the machine with quick coupler, are only the same 2-pin type as the bucket. The 1-pin type such as clamshell cannot be mounted in the quick coupler.
2. The following 2-pin type of attachments exceptionally cannot be mounted in the quick coupler.
 - 1-Attachments much different from the standard bucket in shape of mounting part
 - 2-Attachments with excessively long or short pin pitch
3. Do not use any attachments improper for the machine with the quick coupler.

Allowable size of bucket

Allowable size of bucket to be mounted in the quick coupler

Unit : in. (mm)

Mark	Part	ViO35-6A	
A	Attachment width	4.72 (120) or more	
B	Distance between pins	Pin diameter Ø1.38 (35)	6.22 to 10.5 (158 to 266)
		Pin diameter Ø1.50 (38)	6.50 to 10.9 (165 to 276)
		Pin diameter Ø1.57 (40)	6.61 to 11.1 (168 to 282)
C	Operating radius of bucket	29.5 (750) or less	
D	Pin diameter	Ø1.38 to 1.57 (35 to 40)	

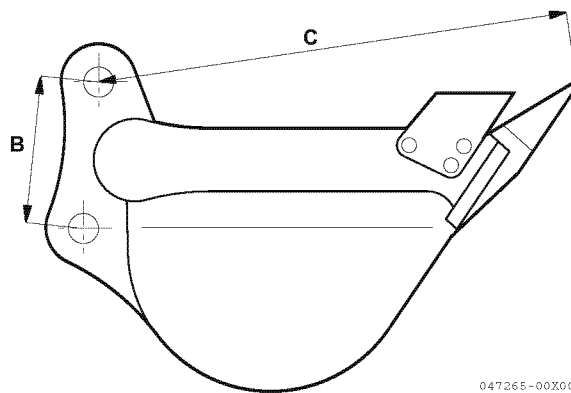
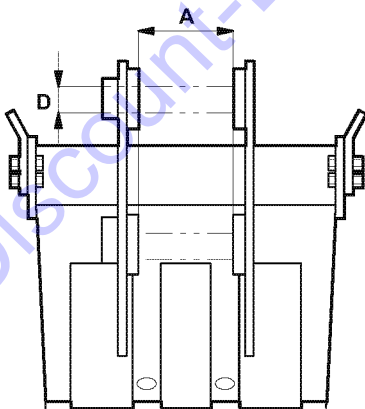

047265-00X00

Phenomena that are not breakdowns

While setting the control switch of the quick coupler in the dismantling mode, stop the engine and then restart it to open the hook of the quick coupler.

Posture for storing the machine without attachment

Place the quick coupler on the ground as illustrated in the right figure for a long-term storage.

If the quick coupler is placed on the ground when the control switch is in the dismantling mode, the hook will open when the engine is restarted, causing the floor surface scratches or the machine breakdown.

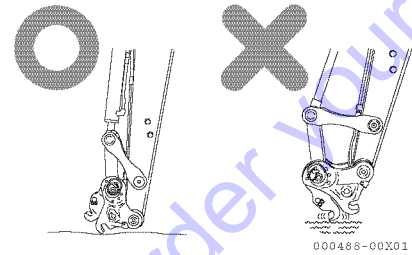

Go to Discount-Equipment.com to order your parts

Dismounting attachment

⚠ WARNING

- Never dismount the Attachment while it is still elevated, as it will drop to the ground and could cause bodily injury.
- Never dismount the Attachment unless it is resting on stable level ground, as it could otherwise fall over.

1. Park the machine on stable level ground.

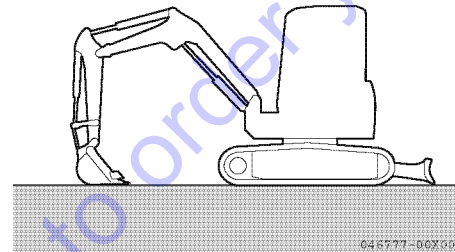

2. Lower the attachment onto the ground.

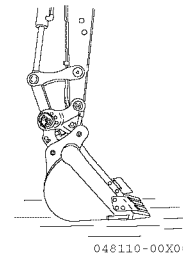

3. Set up the handle of the lock pin.

4. Turn the arrow on the head of the lock pin from the lock position to the unlock position, and then pull it up.

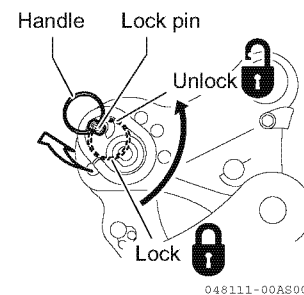

IMPORTANT

The lock pin cannot be removed from the body.

5. Open the switch box cover.

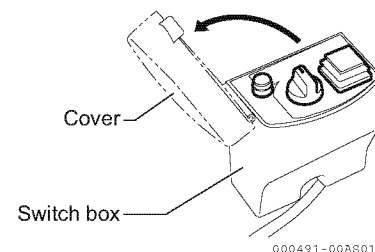

6. Press the power supply switch.

Then, beeps sound and the power supply switch blinks.

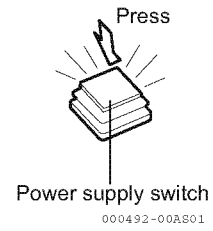

7. Turn the control switch to the dismounting position on the left side, and the attachment is dismounted.

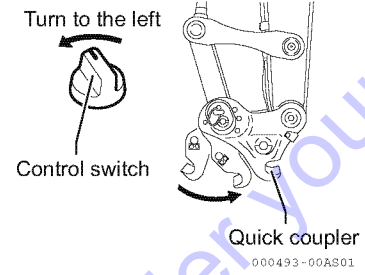

8. Remove the quick coupler from the attachment.

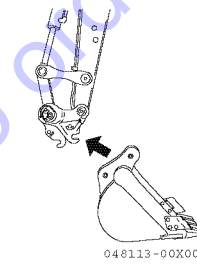

Go to Discount-Equipment.com to order your parts

Mounting attachment

⚠ WARNING

- Never place your hands or any other part of your body between the Quick Coupler and the Attachment to prevent bodily injury.
- Never stand near the Attachment unless it is resting on stable level ground to avoid bodily injury.
- Never use a newly mounted Attachment before confirming that it has been properly secured to the Quick Coupler, and that the Lock Pin has been correctly installed, as accidental detachment could otherwise result.
- Always replace the Lock Pin if damaged or lost. Failure to do so could result in death or serious injury.

1. Place the attachment on stable level ground.
Be sure to install the pins into the attachment.

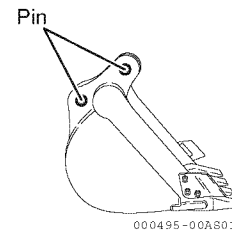

2. Close the movable hook.
3. Put the fixed hook onto the pin of the attachment on the arm side and set the quick hitch level with the ground as illustrated in the right figure.

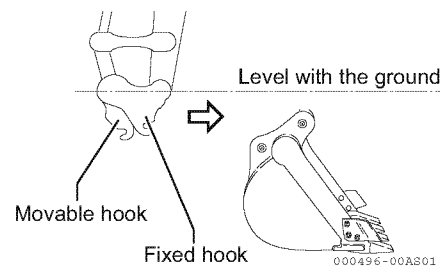

4. Lift the attachment up in that state.

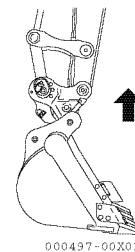

5. Curl the attachment so that it is level.

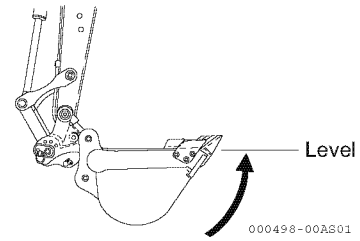

6. Turn the control switch to the mounting position on the right side, and the attachment is mounted.

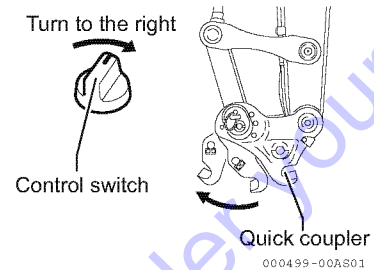

7. Only one of the bores allows the whole lock pin. Install the lock pin to that bore.

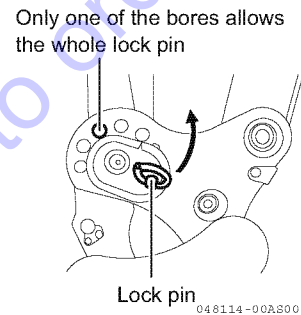

8. Turn the arrow on the lock pin to the lock side.

9. Put the handle of the lock pin down to the arrowed side.

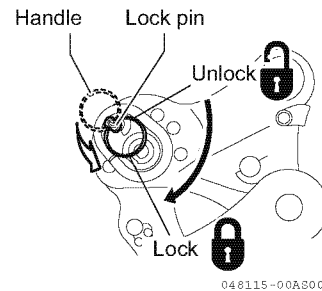

10. Make sure the attachment is securely mounted in the quick coupler before pressing the power supply switch on. The beeps stop sounding and the red lamp goes off.

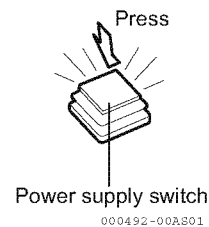

11. Close the switch box cover.

Maintenance

■ Checking specifications

- Check there are no cracks and plays.
- Check the bolts and nuts for looseness.
- Check the hydraulic piping for oil leak.

■ Installation instruction of the Lock Pin

1. Remove the damaged lock pin if any, and clean the bore of the lock plate.

Note:

Replace the lock plate with a new one if it is damaged.

2. Put a new lock pin into the bore of the lock plate.
3. Install the washer and nut onto the lock pin from the back side of the lock plate.

Note:

Apply a lock agent ThreeBond 1324 on the thread.

4. Tighten the nut (M6, Hex 10 mm) to 7.5 to 8.5 ft·lb.
5. Confirm if the new lock pin can smoothly move to the lock and unlock positions.

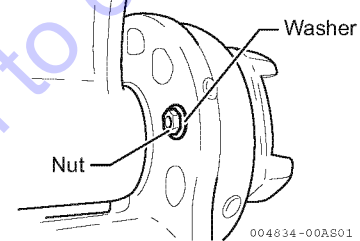
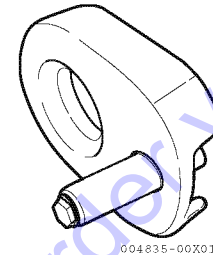

Go to Discount-Equipment.com to order your parts

■ Greasing

IMPORTANT

<p>Grease the fittings thoroughly after washing the machine or after operation in rain, on soft ground, or in muddy water.</p>

1. Put the bucket and the blade on the ground and stop the engine.
2. Clean the grease nipples indicated with the arrows in the right figures and grease them using a grease gun.
3. After greasing, wipe off the excessive grease with waste cloth or the like.

■ Nonperiodic inspection

The pins in the attachment are free from rotation and cannot be worn.

Apply antirust solvent or grease to them to prevent rust.

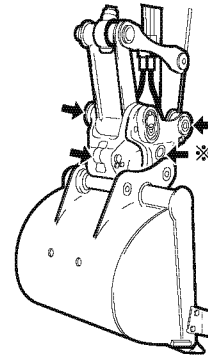

(※: There is another greasing point on the other side.)

047311-00R300

Go to Discount-Equipment.com to order your parts

3.15 Parking the machine

⚠ CAUTION

Do not stop the machine suddenly, but try to stop with a safety margin.

⚠ WARNING

- Park on solid, level ground.
- Do not park on a slope. If parking on a slope is unavoidable, block the tracks with solid pieces of wood, place the blade on the ground, and dig the bucket into the ground.

⚠ WARNING

- Do not touch the control levers and pedals accidentally. Otherwise, the implement or the machine may move unexpectedly, causing a serious accident.
- When leaving the operator's seat, be sure to place the lock levers securely in the lock position and remove the starter switch key.

1. Set the left and right travel levers 1 or pedals 2 to the neutral position to stop the machine.

N : Neutral position

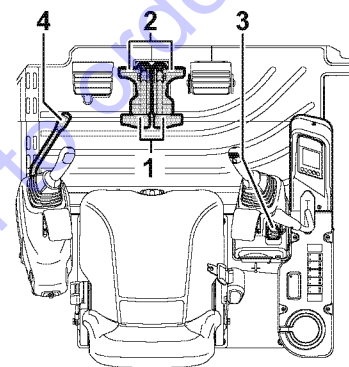
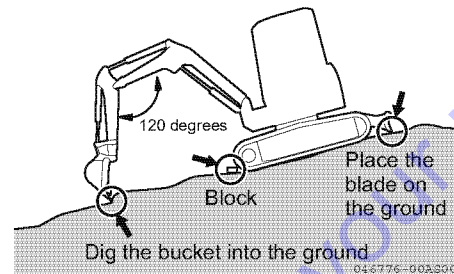

047712-01X06

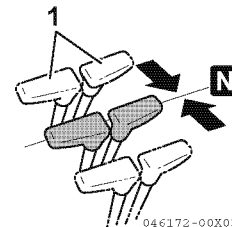

046172-00X03

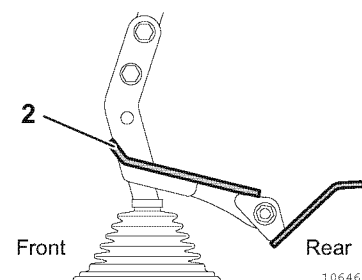

106466-00EN03

2. Turn the engine control dial 3 to the IDLING direction.

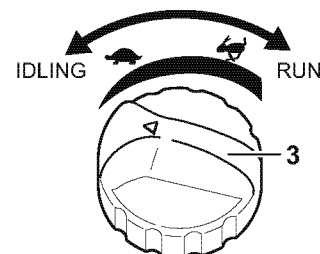

047114-00AS03

3. Place the bucket on the ground with its bottom surface in contact with the ground.
4. Place the blade on the ground.

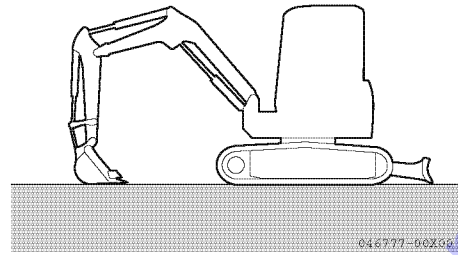

5. Set the lock lever 4 to the "LOCK" position.

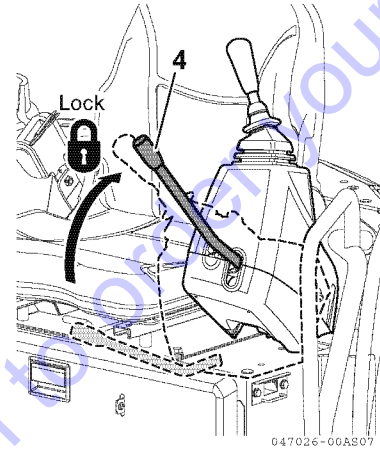

3.16 Inspection requirements after completing operation

Check the water temp. meter 1 and LED lamps on the LCD monitor, and also check the residual quantity of fuel with the fuel meter 2.

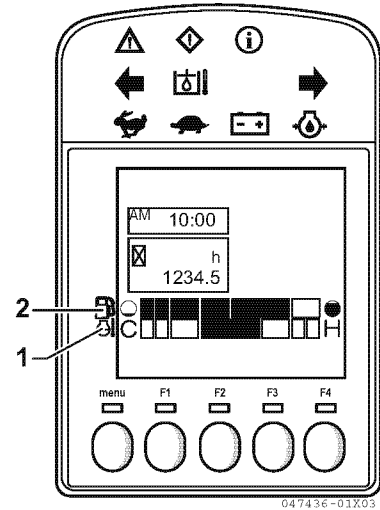

3.17 Stopping the engine

IMPORTANT

- Stopping the engine after rotation at high speed may shorten the engine life. Do not stop the engine suddenly except in case of emergency.
- If the engine is overheated, do not stop the engine immediately. Gradually lower the engine temperature by rotating the engine at medium rotational speed before stopping the engine.

1. Idle the engine for approximately five minutes with no load.

(The engine temperature gradually lowers.)

2. To stop the engine, turn the starter switch key **2** to the "OFF" position.

3. Take the key out of the starter switch **2**.

Note :

As long as the starter switch key is in "ON" position and the lock lever(s) is(are) in unlock position, each implement can be moved by its own weight when respective control levers are operated soon after the engine is stopped.

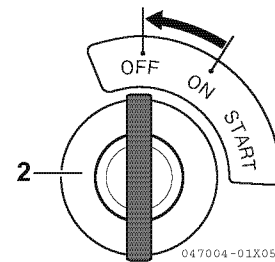
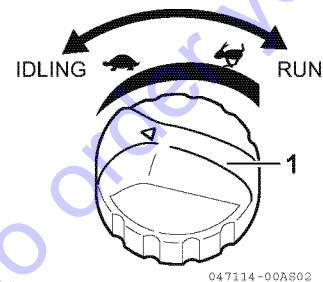

3.18 Inspection requirements after stopping the engine

1. Check oil and water for leaks, and visually inspect the implement, the machine, and the undercarriage by walking around them.

If there are any leaks of oil or water, or any observed abnormality, take corrective action.

2. Completely fill the fuel oil tank.

3. Confirm that the engine room compartment is free of any foreign matter.

Paper or dust in the engine room may cause fire.

Remove them if any.

4. Remove mud adhering to the undercarriage of the machine.

3.19 Locking

Make sure to lock up the following parts :

1. Bonnet B

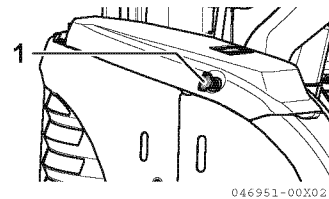

2. Engine hood rear cover

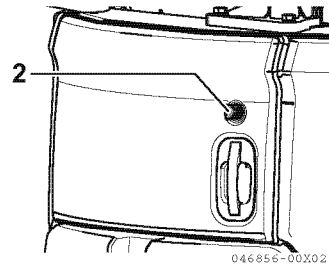

3. Side door (for cabin)

Note :

The starter switch key **1** is used to lock all of the parts mentioned above.

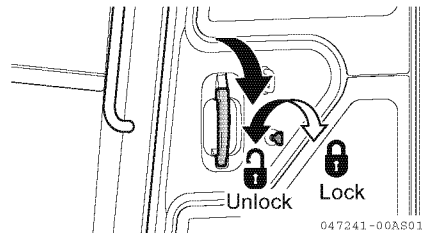

3.20 Handling the rubber track (for rubber track type)

Using the rubber track properly

The rubber track has some advantages over the steel track.

However, you cannot take full advantage of it if you use it in the same manner as for the steel one. Take care in operating with the rubber track according to the conditions of the work site and the type of work.

Comparison Table of Rubber and Steel Tracks

	Rubber	Steel
Low vibration	◇	□
Smooth travel (with no creak)	◇	○
Silent travel	◇	□
Less damage to paved roads	◇	□
Simple handling	◇	□
Susceptibility to damage (strength)	□	◇
Tractive force	◇	◇

◇ : Excellent

○ : Good

□ : Ordinary

Rubber track has many advantages inherent in the unique properties of the material. On the other hand, however, it is low in strength. It is essential that you fully understand the properties of rubber track, and observe the precautions for operating and handling it to prolong its life and get the most out of it. Sure to read Section " Precautions for using the rubber track" before using it.

Warranty for rubber track

The rubber track is not warranted for free repair or replacement if it is damaged because of careless misuse by the customer, including the failure to comply with the prohibitions and the instructions for safe operation; for example, failure to check the tension of the rubber track or service the rubber track properly, or "operation of the rubber track on the edge of a steel plate, a U groove, a block or sharp rubbles and rocks, or on reinforcing bars or iron scraps, which could physically damage the rubber track".

Precautions for using the rubber track

■ Prohibitions

Observe the following prohibitions:

- Do not operate or swing on sharp stones, a hard, uneven rock base, or around steel rods, scrap iron, or edges of iron plates. Failure to observe these prohibitions may damage the rubber track.
- Do not operate the machine on a stony surface like a riverbed. Doing this may damage the rubber track by catching gravel in the track or may cause the track to come off. Forcibly pushing obstacles with the track slipped will shorten the life of the rubber track.
- Prevent the rubber from getting exposed to oil, fuel, or chemical solvents. If it is exposed, immediately wipe it. Also, do not travel on a road which has an oil pool.
- When storing the rubber track for a long time period (more than three months), avoid placing it in a place subject to direct exposure to sunlight or rain.
- Do not operate the machine on heated places such as in an open-air fire, on a steel plate exposed to the blazing sun, or on a hot asphalt road.
- Never run on one rubber track while the other is held above the ground with the implement. Doing this may damage the rubber track or cause it to come off.

Other precautions for using the rubber track

Observe the following precautions when operating the machine:

- Never spin-turn on concrete or asphalt roads.
- Do not change course suddenly. Doing this will cause the rubber track to wear early or be damaged.
- Do not swing on the ground over a large level gap. Remember that running over a level gap at a right angle will prevent the track from coming off.
- Slowly lower the machine after it has been lifted above the ground with the implement.
- It is not recommended that the machine be used to handle any materials that become oily after being crushed (e.g., soybeans, corn, rapeseed oil seeds, etc.). After unavoidably using the machine to handle such materials, fully clean the machine with water.
- It is not recommended that the machine is used to handle materials such as salt, ammonium sulfate, potassium chloride, potassium sulfate, or superphosphate of lime. Handling these materials may affect the core metal adversely. After using the machine to handle such materials, fully clean with water.
- Do not operate the machine at the seashore. Doing this may affect the core metal adversely due to the salt content.
- If the rubber track is cracked, it could be easily damaged when handling salt, sugar, wheat, or soybeans. Be sure to repair any cracks in the rubber track to prevent rubber chips from getting into the materials being handled.
- Do not allow the rubber track to rub against a concrete wall.
- The rubber track is prone to slipping on snow or on a frozen road. Be careful of skidding when traveling or operating on a slope in cold weather.
- Operating the machine in extremely cold weather will deteriorate the rubber track, shortening its life.
- Use the rubber track between -13°F to +131°F (-25°C to +55°C) because of the physical characteristics of rubber.
- Be careful not to damage the rubber track with the bucket while operating the machine.

- Keep the track in appropriate tension to prevent it from coming off.

If the tension is too low, the rubber track may come off under the following conditions.

Even if the tension is adequate, take care when operating the track.

- Do not steer the machine on a large level gap created by a curbstone or a rock [approximately more than 7.87 in. (20 cm)]. Run over a level gap at a right angle to prevent the track from coming off.

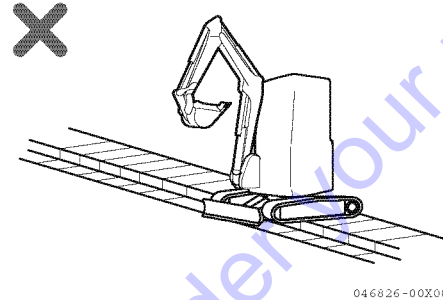

- Do not steer the machine to a boundary between the flat ground and a slope while moving backward. If such steering is not avoidable, slow down the speed.

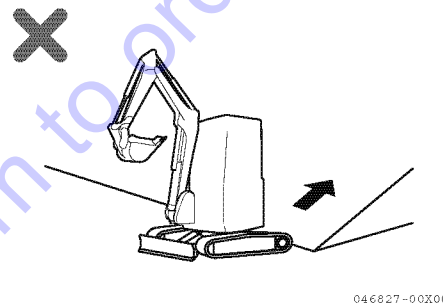

- Do not travel with the track at one end on a slope or on convex ground (at a machine inclination angle of approximately more than 10 degrees), with the track at the other end on flat ground, to prevent the rubber track from being damaged. Be sure to travel with the track at both ends on the same level surface.

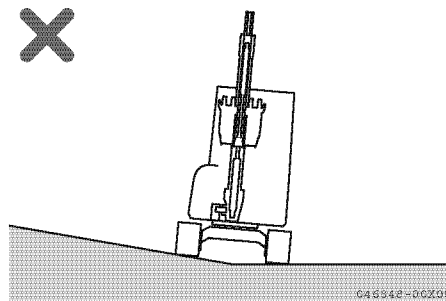

- The three cases illustrated above are those which could cause the rubber track to loosen. In addition, do not steer the machine under such ground conditions as illustrated in the right figure.

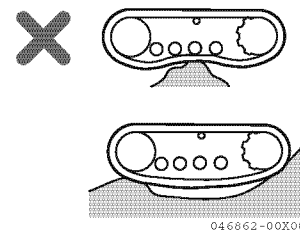

[How the rubber track comes off]

- When running over a level gap, a clearance is created between the track and the track rollers. At this point, the track tends to come off.

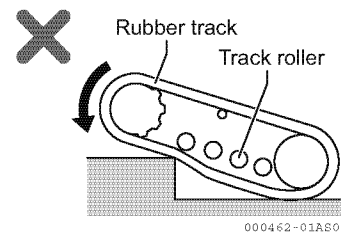

- If the machine further travels in reverse, clearance may also be created between the track rollers and the idler and, the rubber track, causing the rubber track to easily come off.

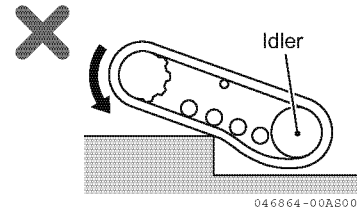

- When the machine is steered while the rubber track is blocked in the transverse direction by an obstacle or the like.
- When the idler and the track rollers are misaligned from the core metal due to rubber track misalignment.

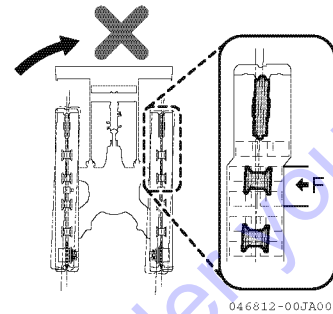

- Traveling in reverse under this condition will cause the rubber track to come off.

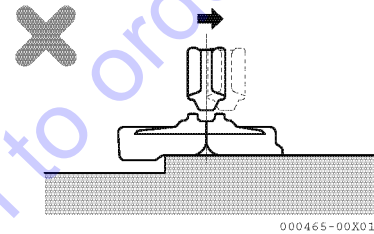

- Steering the machine under this condition will cause the rubber track to come off.

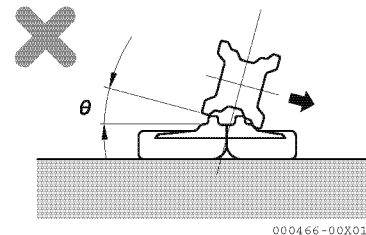

Checking and servicing the machine with rubber track

To check and service the machine with rubber track, refer to and follow Section "7.1 Table of service time intervals" on page 252.

3.21 Handling hydraulic P.T.O.

This machine is provided with one P.T.O. (P.T.O. 1) as standard equipment and a second P.T.O. (P.T.O. 2) is available as an option.

Description of devices

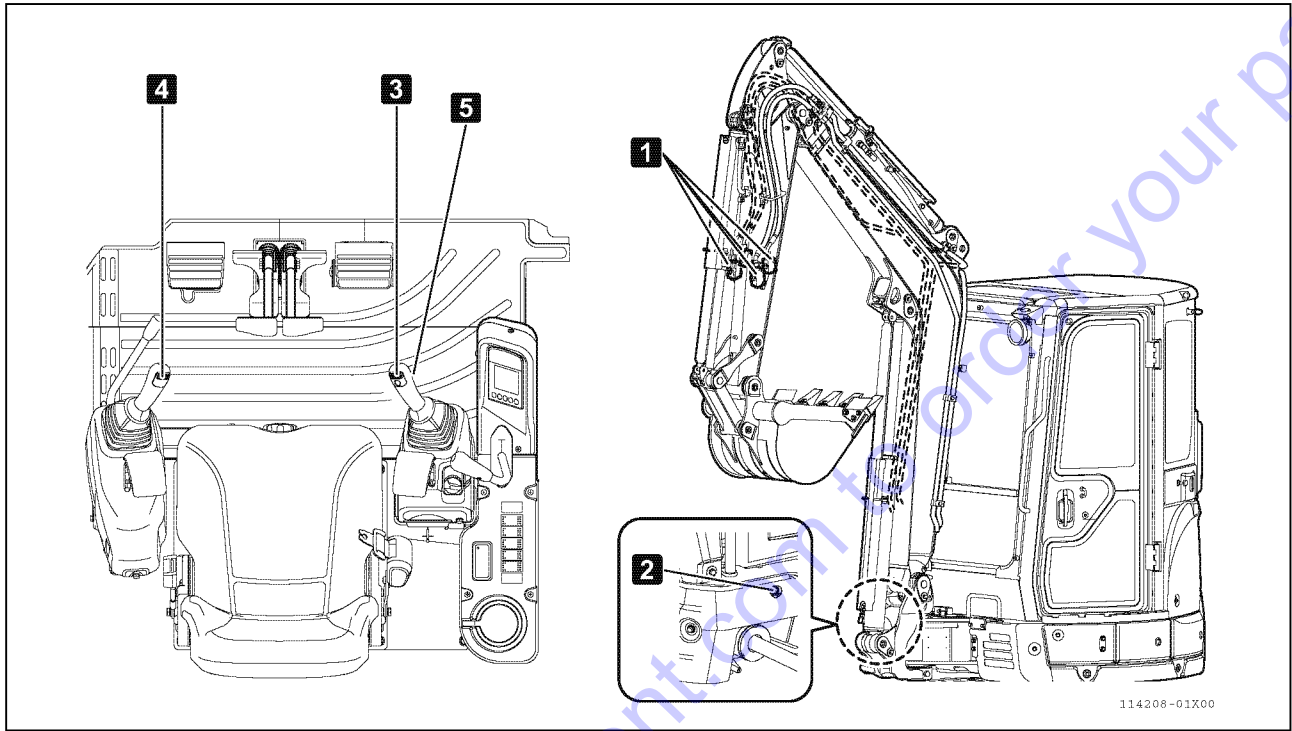

Note:

The machine shown in the figure above is mounted with all components including all available options.

1 Stop valve

This valve can stop the flow of the hydraulic oil.

Open: Hydraulic oil flows.

Closed: Hydraulic oil flow is stopped.

Set this valve at the closed position when removing and installing an attachment.

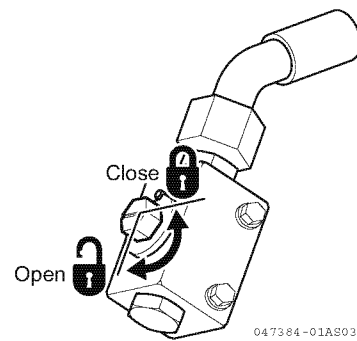

2 P.T.O. selector valve

This valve is used to select either single acting or double acting operation for P.T.O. 1.

Note:

For the P.T.O. 2, switching between single acting and double acting operation is not available and P.T.O. 2 is available only with double acting operation.

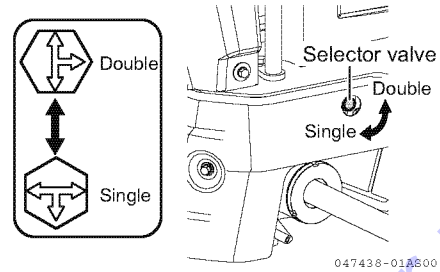
**3 P.T.O. switch for P.T.O. 1**

This switch is located on top of the right control lever and used to operate an attachment connected to the P.T.O. 1.

- To operate an attachment of the single acting type, move the P.T.O. switch to the left with the P.T.O. selector valve in the single acting position.

[Example: Breaker]

- To operate an attachment of the double acting type, move the P.T.O. switch to the right or the left, whichever is desired, with the P.T.O. selector valve in the double acting position.

[Examples: Tilt bucket, Clamshell, etc.]

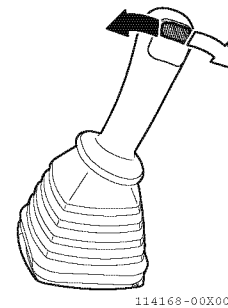
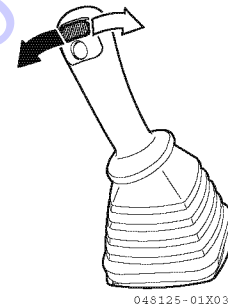
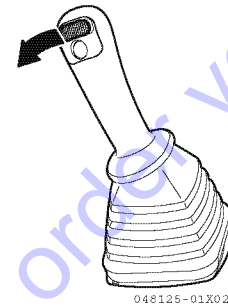
**4 P.T.O. switch for P.T.O. 2 (Option)**

This switch is located on top of the left control lever and moved to the right or the left, whichever is desired, to operate an attachment connected to the P.T.O. 2.

5 P.T.O. hold switch

This switch is used to continuously operate an attachment connected to the P.T.O. 1.

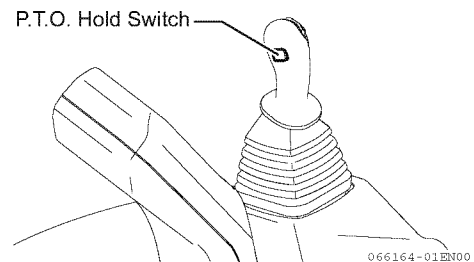

Hydraulic circuit

⚠ WARNING

Always loosen plugs or connectors slowly after depressurizing the P.T.O. pipes when connecting or changing a hydraulic hose.

To install an attachment, connect the attachment hoses to the hydraulic circuit following the procedure below.

■ Depressurizing P.T.O. circuit

1. Stop the engine and then turn the starter switch to the ON position. (Do not start the engine.)
2. Release the lock lever.
3. Move each of the P.T.O. switches on top of the right and left control levers alternately to the right and the left two or three times.

Note:

The P.T.O. switch on top of the left control lever is provided as an option.

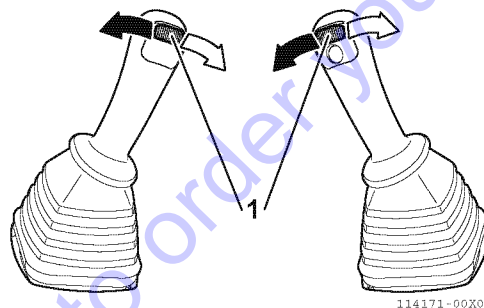

114171-00X00

■ Connecting the hydraulic circuit

1. Make sure that the stop valves are in the closed position and remove the hexagon plugs. Take care not to lose or damage the removed parts.
2. Install the connectors supplied by the manufacturer of the attachment and connect the hoses.

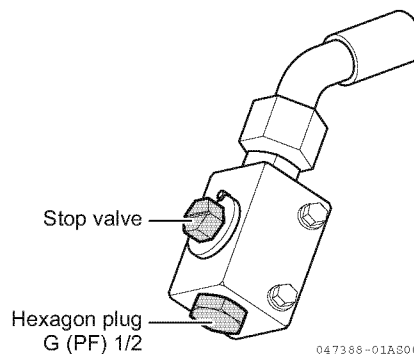

047388-01A800

Oil flow system

The directions of switch operation and the oil flow routes are shown in the figures below.

P.T.O.1

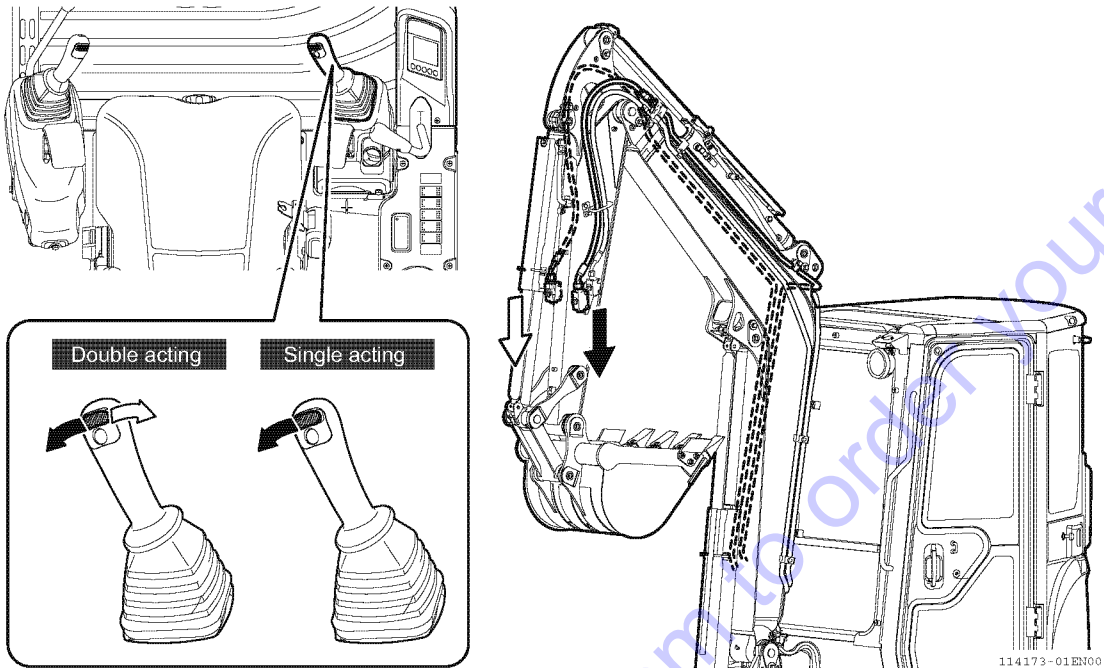

P.T.O.2 (Option)

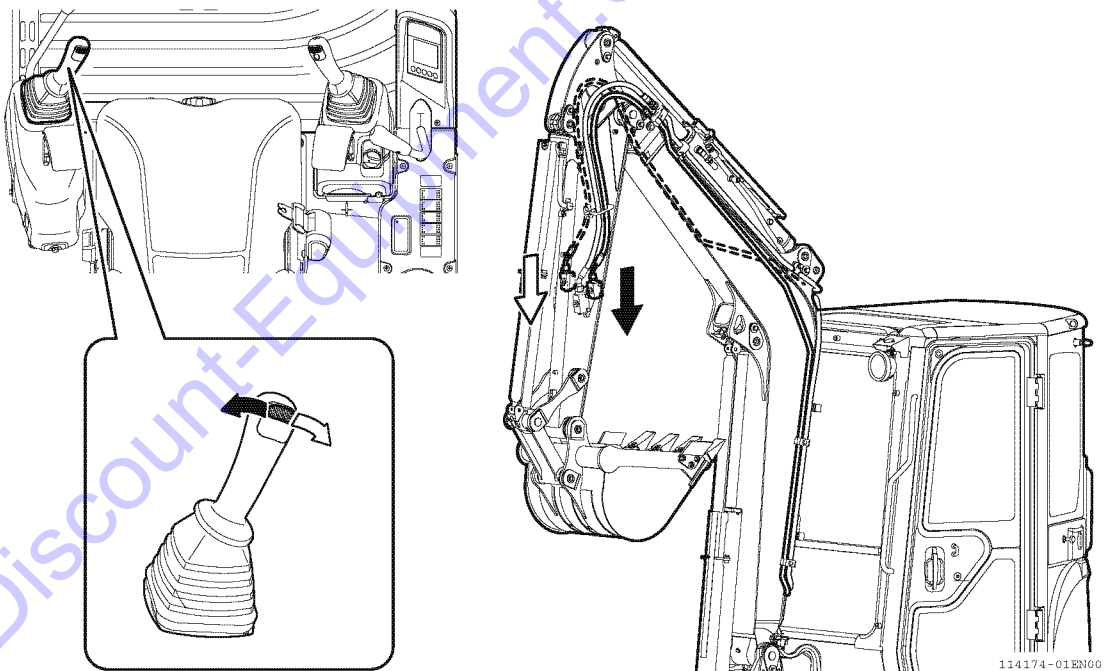

Operating attachment

⚠ WARNING

- **Emergency stop**
In cases where the attachment exhibits abnormal movements unintendedly, turn the starter switch to the OFF position to stop the engine or set the lock lever to the lock position, so that the hydraulic power source is shut off and the attachment is stopped. Then, contact your nearest dealer or distributor for inspection.
- For handling of the attachment, follow the operating instructions supplied by the attachment manufacturer to ensure correct use.

IMPORTANT

- Do not operate an attachment such as a breaker continuously for more than 1 minute. Doing so may cause overheating or damage to the attachment.
- In cases where P.T.O. is used as a hydraulic power source for a hydraulic hand tool such as a hand breaker, reduce the engine speed. Operating a hand tool with the engine running at high speed may cause overheating or damage to the hand tool.

To operate attachments, follow the procedure below.

■ P.T.O. 1 operation

Use P.T.O. switch 1 and hold switch 2 on top of the right control lever to operate an attachment connected to the P.T.O. 1.

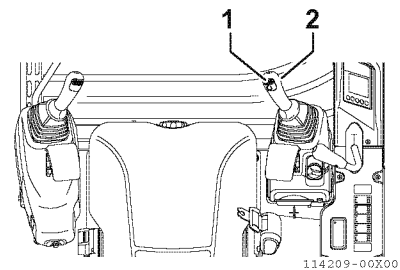

1. Make sure that the stop valves are in the open position.

For oil flow routes, refer to the oil flow system described in Section "Hydraulic circuit" on page 198.

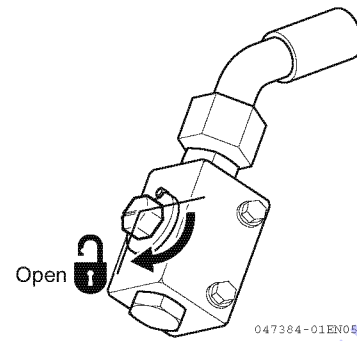
**2. To use a breaker**

- Make sure that the P.T.O. selector valve is in the single acting position.

For the operation of the P.T.O. selector valve, refer to Section "Description of devices" on page 196.

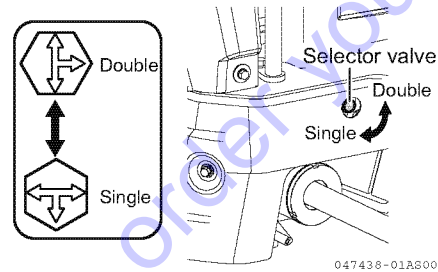

Move P.T.O. switch **1** to the left to operate the breaker.

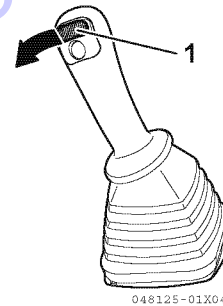
**3. To use a general attachment such as a tilt bucket.**

- Make sure that the P.T.O. selector valve is in the double acting position.

For the operation of the P.T.O. selector valve, refer to Section "Description of devices" on page 196.

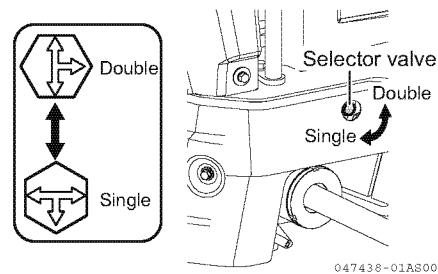

Move P.T.O. switch **1** to the right or the left, whichever is desired, to operate the attachment.

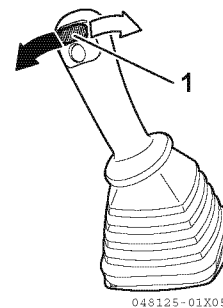

4. Hold function

Hold switch **2** allows continuous operation of an attachment connected to the P.T.O. **1**.

- Activation method

With P.T.O. switch **1** moved to the right end or the left end press hold switch **2** to activate the hold function.

The attachment operates continuously even if the operator releases his/her finger from P.T.O. switch **1** while the hold function is activated.

- Deactivation method

Press hold switch **2** again or move P.T.O. switch **1** while the attachment is operating continuously to deactivate the hold function and stop the attachment.

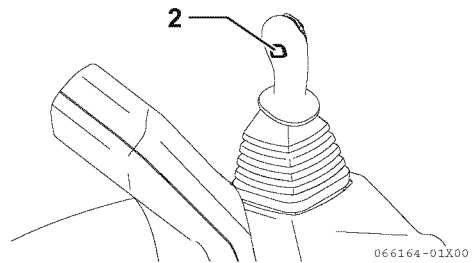

Note:

- Unless P. T. O. switch is moved to the right end or the left end, the hold function is not activated.

■ P.T.O. 2 operation (Option)

Use P.T.O. switch **3** on top of the left control lever to operate an attachment connected to the P.T.O. **2**.

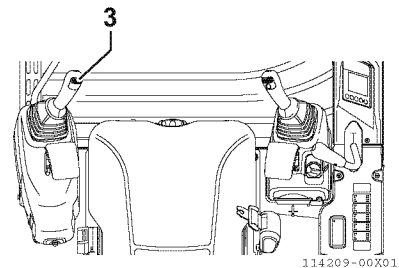

1. Make sure that the stop valves are in the open position.

For oil flow routes, refer to the oil flow system described in Section "Hydraulic circuit" on page 198.

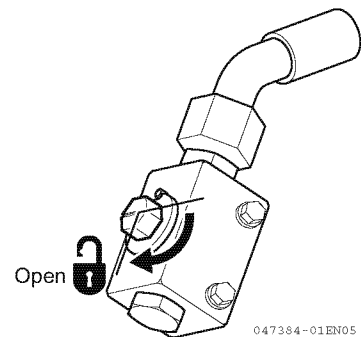

2. Move P.T.O. switch **3** to the right or the left, whichever is desired, to operate the attachment.

Note:

The P.T.O. 2 is available only for attachments of the double acting type. Use the P.T.O. 1 for an attachment of the single acting type such as a breaker.

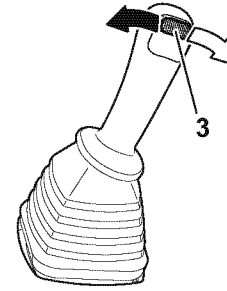

114168-00X01

Long-term storage

If the P.T.O.1 and 2 are not used for a long period of time, do the following:

- Close the stop valves.
- Disconnect the hoses for the hydraulic tool. Tighten the hexagon plug (with O-ring) to the stop valve.

⚠ CAUTION

Operating the P.T.O. switch when the breaker or general attachment is not mounted may cause overheating.

Specifications

- Maximum flow rate for P.T.O. 1 (without load):
16.7 GPM (63.2 L/min)
- Maximum flow rate for P.T.O. 2 (without load):
9.8 GPM (37.0 L/min)

Note:

P.T.O. 2 is available as an option.

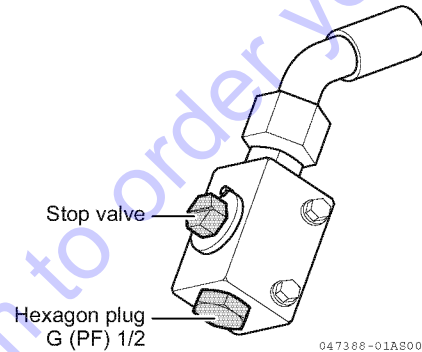

047388-01A800

Go to Discount-Equipment.com to order your parts

3.22 Handling the thumb bracket

Description of thumb bracket

The thumb bracket is a bracket for attaching a thumb cylinder.

IMPORTANT
<ul style="list-style-type: none">• Do not use the thumb bracket for unintended uses.• For selecting and attaching a thumb cylinder, consult your dealer.

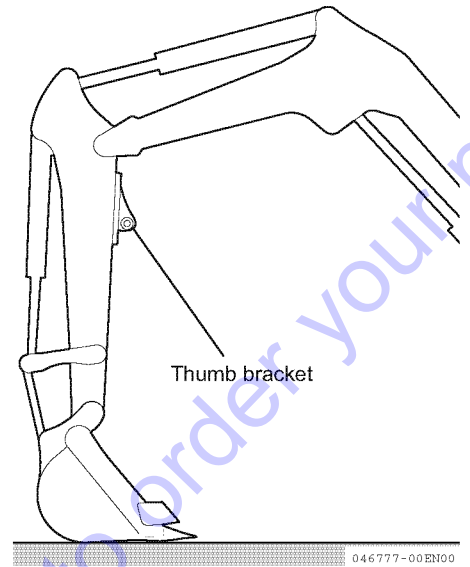

046777-00 EN100

Go to Discount-Equipment.com to order your parts

3.23 Releasing the internal pressure of the hydraulic circuit by accumulator

■ Function of accumulator

The accumulator 1 accumulates the pressure of the operating circuit. As the operating circuit is activated for awhile even after stopping the engine, the following can be done:

- By moving the control levers to the direction of lowering the implement, it can go down on the ground with its self-weight.
- The pressure of the hydraulic circuit can be released.

Note:

The function can be used when the starter switch is "ON" and the lock lever is in the "Unlock" position.

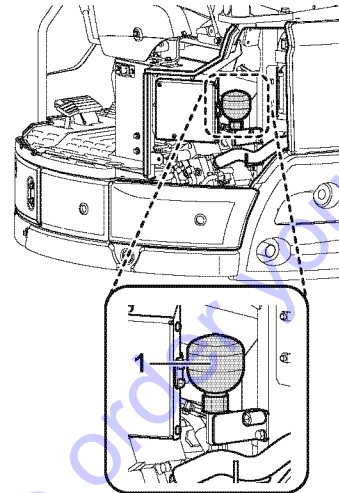

047301-01X00

■ Releasing the internal pressure of the hydraulic circuit

IMPORTANT

The procedures from stopping the engine to moving the control levers and pedals back and forth and around at full stroke must be performed within 15 seconds in the following procedures.

As the accumulator pressure is gradually reduced after stopping the engine, the pressure can only be released right after stopping the engine.

1. Place the implement down on the ground and stop the engine.
2. Set the starter switch to the "ON" position.

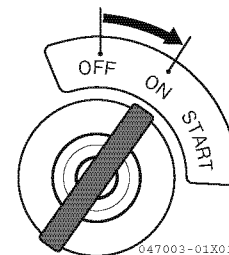

047003-01X01

3. Set the lock lever 2 to the "Unlock" position and move the control levers and pedals back and forth and around at full stroke to relieve the pressure of the hydraulic circuit.

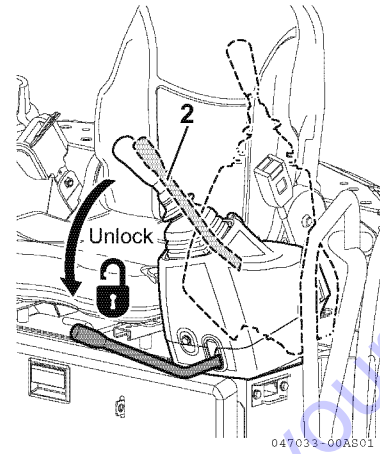

4. Set the lock lever 2 to the "LOCK" position to lock the control levers and pedals.

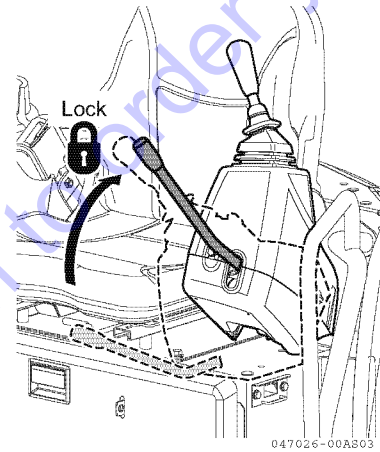

Go to Discount-Equipment.com to order your parts

3.24 Replacing the bucket without the quick coupler

⚠ WARNING

- When driving pins into the bucket with a hammer, metal chips may fly. If metal chips should get into your eyes, they can cause serious injury. Use goggles, a hard hat, and gloves for safety when replacing the bucket.
- After removing the bucket, place it on solid ground in a stable position.
- When aligning the holes for pin A and pin B, be careful not to insert your fingers into those holes to prevent serious injury to your fingers. Visually check the alignment of the holes.

Work on level ground with good footing. If two or more persons work together, communicate with signals selected beforehand for safety.

■ Replacement procedure

Replace the bucket according to the following procedure:

1. Park the machine on level, flat ground, and lower the bucket onto the ground.
2. Stop the engine.
3. Clean around the bucket pin to prevent foreign material from entering the pin holes.
4. Remove pins A and B.

IMPORTANT

- Keep the pins away from dirt or mud.
- The machines have dust seals on either end of the bushing. Be careful not to damage them.

5. Clean the bucket boss section and install the O-ring.

IMPORTANT

- Check that the O-ring is not damaged. If it is damaged, replace it.
- We recommend that you replace the O-ring when you replace the bucket.

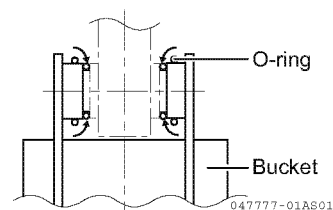
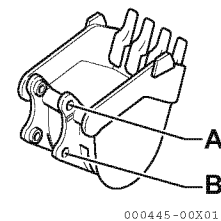
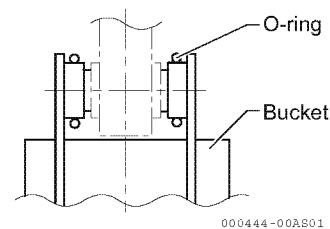
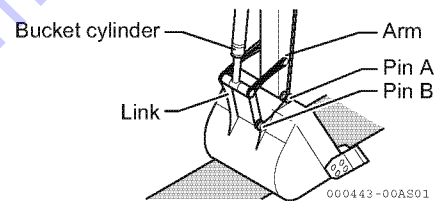

6. Connect the arm to hole (A), and then connect the link to hole (B).

7. Install the O-ring in position.

IMPORTANT
Before mounting the bucket, clean the arm pin hole and grease it.

8. Install the bolt into the bucket pins **A** and **B**.

9. Grease the connecting parts.

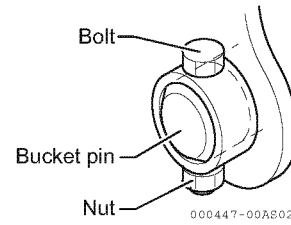

Go to Discount-Equipment.com to order your parts

4. Transportation

4.1 Loading and unloading the machine

For safety in transporting the machine, comply with all applicable regulations and laws.

⚠ WARNING

- Be careful when loading and unloading the machine, because it is a job of high hazard potential.
- Load or unload the machine on level, solid ground far away from the shoulder of the road.
- Load or unload the machine at a low engine speed.
- Use ramp plates of adequate strength having hooks. Check to see that the ramp plates are wide, long, and thick enough to safely sustain the machine so that you can load or unload safely. To prevent the ramp plates from bending too much, support them with blocks.
- Securely hook the ramp plates to the deck of the truck so that they will not come off.
- Remove mud, grease, and other slippery deposits from the track shoes, and grease, oil, and ice deposits from the ramp plates to prevent the machine from skidding.
- Never change the travel direction on the ramp plates. If you need to change the travel direction, go back down on the ramp plates, then do this.
- Swing slowly on the truck bed if necessary since the foothold is unstable.
- Make sure that the side door of the cabin is locked, whether in the open or closed position. Never open or close the side door on the ramp plates, to prevent it from swinging violently.

To load or unload the machine, be sure to use the ramp plates and follow the procedure below:

1. Firmly brake the truck and apply wheel stoppers to the tires. Securely install the ramp plates on the bed of the truck in a position where the center of the truck aligns with the center of the machine. Make sure that the left and right ramp plates are at the same level.

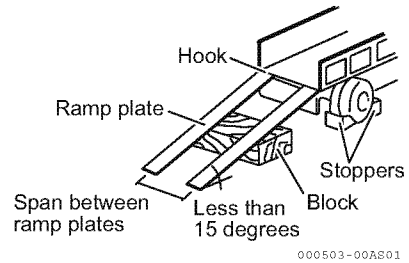

The ramp plates should be set at an angle of less than 15 degrees.

Determine the span between the ramp plates on the basis of the centers of the track shoes.

Do not operate the high-speed switch.

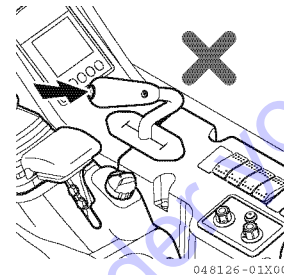

2. Turn the engine control dial to IDLING direction.

3. Travel toward the ramp plates at a low speed, and load or unload the machine with the implement lowered as close as possible to the deck of the truck.

Do not operate any levers other than the travel levers while driving on the ramp plates.

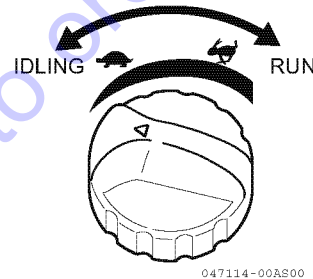

4. Load the machine in a safe position on the truck.

4.2 Precautions for loading the machine

⚠ WARNING

Load or unload the machine on level, solid ground far away from the shoulder of the road.

After loading the machine in a safe position on the truck, secure the machine as follows:

1. Place the blade down on the ground.
2. Extend the bucket and arm cylinders to the maximum limit, and slowly lower the boom down on a block of wood.
3. Stop the engine to take the key out of the starter switch.
(The brake works to lock the swing motor.)
4. Be sure to lock the control levers with the lock levers 1.
5. Lock the bonnet, covers and cabin door with the starter switch key to prevent them from opening during transportation.
6. Provide wood blocks in the front and back of the track and secure the machine with a chain or a wire rope so that the machine will not move during shipping. In particular, be sure to secure it to prevent skidding.

IMPORTANT

To protect the bucket cylinder from being damaged during shipping, place a wooden block under one end of the bucket to prevent it from directly touching the deck of the truck.

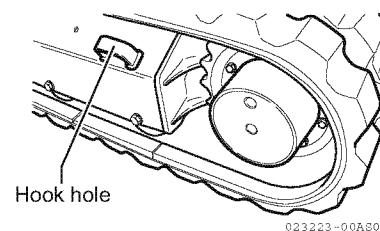
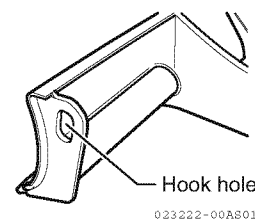
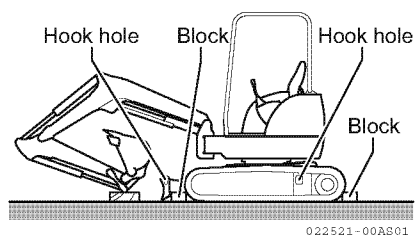
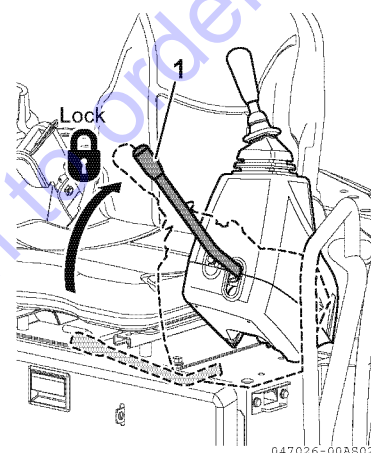
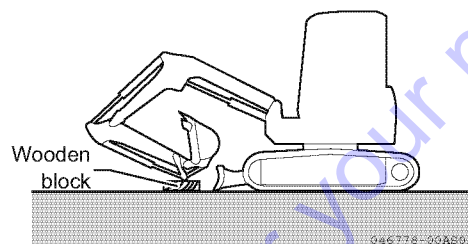

4.3 Precautions for transporting the machine

⚠ WARNING

- Select a route for transporting the machine based on the road width and clearance, and the height and weight of the machine.
- Make sure that the side door of the cabin is closed and locked before shipping.

For safer transportation, comply with all local regulations and laws.

Go to Discount-Equipment.com to order your parts

4.4 Suspending the machine

⚠ WARNING

- Never suspend the machine if any person is on the machine or the implement.
- Use wire ropes strong enough for the weight of the machine.
- Do not suspend the machine in any way other than that explained on the following page.
- Failure to suspend the machine as prescribed will throw the machine off balance.
- Do not swing the machine being suspended.
- When suspending the machine, keep the machine in balance taking care on the center of gravity of the machine.
- Never stand near or under the suspended machine.

For safety in suspending the machine, comply with all applicable regulations.

Go to Discount-Equipment.com to order your parts

Suspend the machine on the level ground as follows:

1. Swing the upperstructure so that the blade is behind the operator's seat.
2. Raise the blade to the highest limit.
3. Extend the hydraulic cylinders of the front implement (except for the swing cylinder) to the maximum.
4. Stop the engine, and make sure that nothing is left around the operator's seat before leaving the machine.
5. Fit the shackles to the suspending hooks on the front side (one point) and the rear side (two points), and securely fasten a sling belt (or a wire rope) to the shackles.
6. Suspend the machine above the ground, wait until the machine is stable and then suspend it slowly.

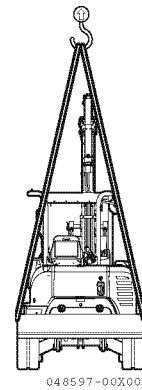
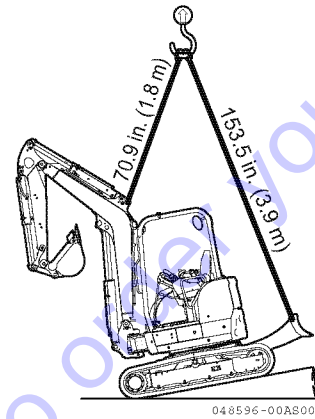
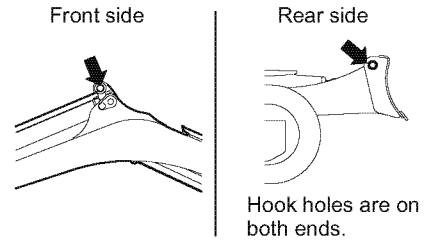

IMPORTANT
<ul style="list-style-type: none"> • For a machine with a cabin, be sure to close the side door and the windshield. • Set each lock lever at the lock position.

Approximate shipping weight:

Unit: lbs. (kg)

			ViO35-6A
Quick coupler	Canopy	Rubber track	7740 (3510)
		Steel track	7960 (3610)
	Cabin	Rubber track	8048 (3650)
		Steel track	8269 (3750)
Without quick coupler	Canopy	Rubber track	7629 (3460)
		Steel track	7850 (3560)
	Cabin	Rubber track	7938 (3600)
		Steel track	8159 (3700)

5. Care and Service in Cold Weather

5.1 Preparing for cold weather

In cold weather, you may have difficulty in starting the engine or the cooling water may freeze. So take measures as follows:

Fuel and lube oil

Use low viscosity fuel and lube oil. For the specified viscosities, refer to Section "4. Fueling, Oiling and Greasing Based on Temperature Range" on page 247.

Cooling water

⚠ WARNING

Anti-freeze is flammable. When handling anti-freeze, keep away from any sources of ignition and do not smoke.

IMPORTANT

Never use an anti-freeze containing methanol, ethanol, or propanol.

For the timing of cooling water change and the mixing ratio of the anti-freeze, refer to Section "Cleaning the inside of the cooling system" on page 292.

Note :

Because a YANMAR genuine long-life coolant (LLC) is added to the cooling water, you need not change it unless the temperature below -31°F (-35°C).

If the temperature falls below -31°F (-35°C), refer to Section "Cleaning the inside of the cooling system" on page 292 to control the density of the cooling water.

Battery

⚠ WARNING

- The battery generates flammable gas and it can cause a fire and an explosion. Keep sparks or flames away from the battery.
- Battery electrolyte contains dilute sulfuric acid which is a strong acid. To avoid serious injury, do not allow the electrolyte to contact skin or splash into eyes.

If the electrolyte contacts your skin or gets in your eyes, flush immediately with large amounts of water, and obtain medical treatment at once.

Battery performance deteriorates as the temperature goes down. When the battery voltage is low, battery electrolyte will easily freeze. Keep the charging rate close to 100% (full charging) and keep the battery warm for easy start the next day.

Note :

Measure the specific gravity of the electrolyte to determine the charge ratio using the conversion table given below.

Charging rate \ Electrolyte temperature	68°F	32°F	14°F	-4°F
	(20°C)	(0°C)	(-10°C)	(-20°C)
100%	1.28	1.29	1.30	1.31
90%	1.26	1.27	1.28	1.29
80%	1.24	1.25	1.26	1.27
75%	1.23	1.24	1.25	1.26

The specific gravity of the electrolyte varies with its temperature and recharged condition.

Preparing heater (for cabin without an conditioner)

Use the heater in cold weather, if equipped.

1. To use the heater, turn the handle **1** on the thermostat case of the engine section counterclockwise to open the valve.
2. Operate the heater switch in the cabin and send warm air into the operator's cabin.
 - When you do not use the heater for a long time during the off season, turn the handle **1** clockwise to close the valve.

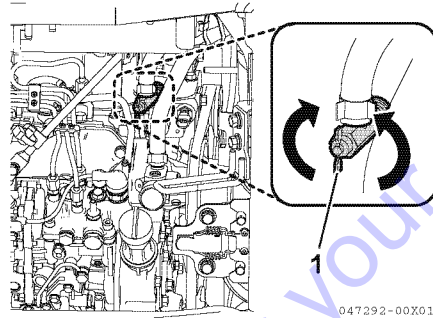

Go to Discount-Equipment.com to order your parts

5.2 Precautions after a day's work

To prevent the machine from getting stuck in the morning due to the mud or water and frozen deposits on the undercarriage, be sure to observe the following precautions.

- Remove mud or water adhering to the machine. If mud or water droplets adhering to the hydraulic cylinder rods get into the seals, the seals could be damaged. So do this to prevent it.
- Park the machine on solid, dry ground.
If no solid, dry ground is available, lay plates on the ground and park the machine on the plates to prevent the frozen tracks from sticking to the ground.
- Drain the water accumulated in the fuel system by turning on the drain plug to prevent freezing.
- As battery performance is deteriorated in low temperatures, cover the battery or move it to a warm place, and reinstall it in the machine on the next morning.
If the level of the battery electrolyte is low, add distilled water before starting operation on the next morning. To prevent the battery from freezing at night, do not add distilled water after completing operation.

5.3 After cold weather ends

When the temperature rises, do the following:

- Replace the lube oil and fuel with the specified viscosities according to Section "4. Fueling, Oiling and Greasing Based on Temperature Range" on page 247.
- If you have added an AF-PT anti-freeze (for one winter season only), fully drain the cooling system, flush the inside of the cooling system well, and fill the cooling water tank with tap water.

6. Long-term Storage

6.1 Before storing

IMPORTANT

When storing the machine, set up the machine as illustrated in the right figure to protect the hydraulic cylinder rods from being corroded.

When storing the machine for a long period, do the following:

- Clean all parts and store the machine indoors. If you have to store the machine outdoors, park the machine on level ground and cover it with a protective sheet.
- Apply lube oil and grease to the machine and replace the engine oil.
- Apply a little amount of antirust to exposed parts of the hydraulic cylinder rods.
- Fill the battery with distilled water up to the upper level mark. After the battery has fully recharged, disconnect the negative terminal, and cover the battery or remove the battery from the machine to store it.
- Add an anti-freeze to the cooling water if the air temperature can fall below 32°F (0°C).
Because a YANMAR genuine long-life coolant (LLC) is added to the cooling water, you need not change it until the temperature falls down to -31°F (-35°C).
If the temperature falls below -31°F (-35°C), refer to Section "Cleaning the inside of the cooling system" on page 292 to control the density of the cooling water.
- Lock the control levers and pedals with the lock levers and pedal guards respectively.

Retract the bucket and arm cylinders to place the bucket on the ground.

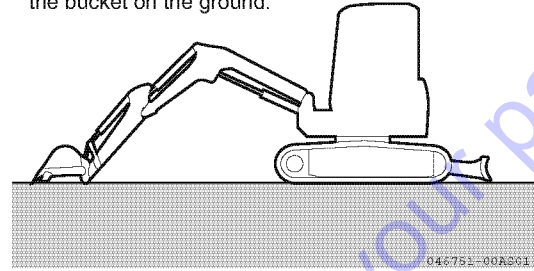

046753-00A301

Go to DiscountEquipment.com to order your parts

- Antirust

When stored near the sea or in a place exposed to sea breezes, the machine easily becomes rusty. Carefully apply an antirust to all exposed parts of the piston rods and cover the machine with a polyethylene sheet or oil paper.

Recommended antirust	Manufacturer
P-1300 (Solvent cutback rust preventive oil)	JX Nippon Oil & Energy corporation
P-3 (Solvent cutback rust preventive oil)	
P-300 (Solvent cutback rust preventive oil)	Cosmo Oil

Some antirust solvent damages rubber materials. Be sure to use the recommended antirust or its equivalent.

- To prevent condensation inside the fuel tank, either drain off the fuel tank or fill the tank.

6.2 Storing

⚠ WARNING

When you have to operate the machine indoors for the antirust procedure, be sure to ventilate the area well by opening windows and doors to prevent asphyxiation.

Move the machine at least once a month to form new oil films on all the moving parts during long-term storage, and recharge the battery at the same time.

6.3 Using the machine again

IMPORTANT

When reusing a machine stored for a long time without antirust treatment once a month, consult your dealer.

To use the machine again after a long period of storage, follow the procedure below:

- Wipe antirust off the hydraulic cylinder rod.
- Apply a generous amount of grease or oil on the moving part.
- Drain water from the fuel tank, the engine oil pan and the hydraulic oil tank by removing the drain plugs.
- After starting the engine, warm-up the machine.

7. Troubleshooting

7.1 Phenomena that are not breakdowns

The following phenomena are not breakdowns:

- Shaking of the bucket

When the boom is raised immediately after extending the arm while curling the bucket, the bucket may shake. This phenomenon is not a breakdown.

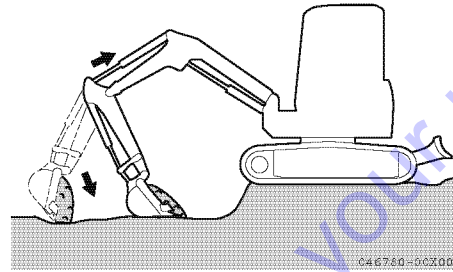

- Discontinuous arm movement

When digging the ground with the arm, the arm may slow down at the almost vertical position momentarily. This phenomenon is not a breakdown. Especially, this phenomenon will occur when the engine speed is low.

- Shift in upperstructure position

When turning the machine sharply such as spin-turning or pivot-turning, the upperstructure may be slightly shifted.

This phenomenon is not a breakdown.

- Thermal shock of the travel motor

If, in cold weather, the temperature of the hydraulic oil is raised 140°F (60°C) higher than the outside temperature by relief operation without traveling after the engine has started, sometimes the machine cannot pivot-turn because of thermal shock. This phenomenon is not a breakdown.

- The swing cylinder is extended when digging

The swing cylinder may be extended in some digging situations or postures. This phenomenon is not a breakdown.

- Time lag in travel speed change response

At low engine speed, a time lag in response may occur when the travel speed is changed from high-speed to low-speed. This phenomenon is not a breakdown.

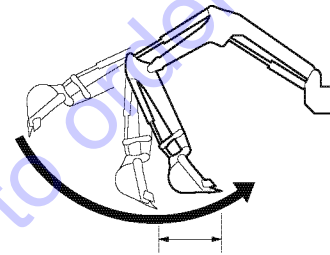

Slow-down is remarkable over this range

046781-00A800

7.2 Towing

⚠ WARNING

Always safely tow a disabled machine by using the proper equipment and procedures.

The use of incorrect methods or improper procedures could result in bodily injury.

Follow the recommendations below to properly perform the towing procedure.

If the machine becomes mired in the muddy ground and cannot come out by itself, or when it is necessary to tow a heavy object with the machine tractive force, tie the sling belt as illustrated on the right.

IMPORTANT

- Check to see that the wire ropes, sling belts, and shackles to be used are of sufficient strength and are free from cracks and damage. Never tow the machine with the wire rope attached only to the hook.
- The hook is only intended for stabilizing the machine during shipping.

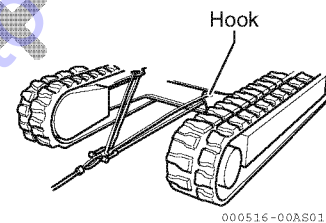
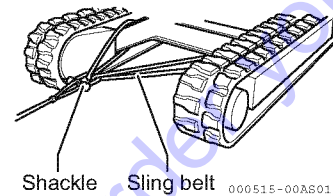

7.3 If the battery is overdischarged

⚠ WARNING

- Stop the engine and turn the starter switch key to the "OFF" position before checking or servicing the battery.
- Flammable hydrogen gas is produced by the battery, which may cause ignition. Keep flames, sparks and lit cigarettes away from the battery.
- The battery electrolyte contains dilute sulfuric acid, which is a strong acid.
If the battery electrolyte contacts your clothes, they may be damaged.
If the battery electrolyte gets into your eyes or contacts your skin, flush immediately with large amounts of water, and obtain medical treatment at once.
- Be sure to wear safety goggles when handling a battery.
- To disconnect the terminals, begin with the negative terminal (ground side); to connect the terminals, begin with the positive terminal.
If a tool touches both the positive terminal and the machine, hazardous sparks may be generated.
- If a terminal is loose, hazardous sparks may be generated due to poor contact, which could cause ignition and explosion.
Be sure to securely connect the terminals.

To disconnect, begin with the negative terminal (ground side)

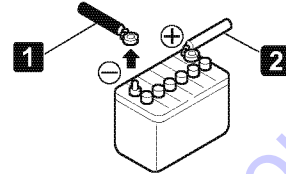

To connect, begin with the positive terminal

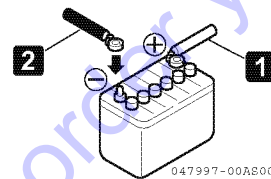

047997-00A800

Starting the engine using booster cables

To start the engine using booster battery cables, do the following.

■ Precautions for connecting and disconnecting the booster cables

⚠ WARNING

- When you start the engine using booster cables, wear safety goggles.
- If you start the engine by taking electric power from another machine, do not allow contact between your machine and the other machine.
- To connect the booster cables, begin with the positive terminal, and to disconnect them, begin with the negative terminal (ground side).
- If a tool touches the positive terminal and the machine at the same time, hazardous sparks may be generated.
- Do not connect the booster cables to terminals of reverse polarity. That is, never connect a negative terminal on one machine to the positive terminal on the other machine.
- As the last step, connect the negative booster cable to the upperstructure. At this time, sparks will be generated. Connect the terminal to a point as far away from the battery as possible.

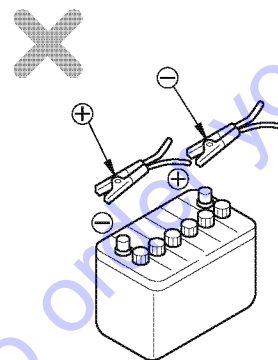

000518-00X01

IMPORTANT

- The booster battery cables capacity and the clip size should be suitable for the battery size.
- The battery of the normal machine should be the same capacity as that of the machine in trouble.
- Check the booster battery cables and clips for an absence of damage, cracks, and corrosion.
- Securely connect the clips.

■ Charging with the battery mounted on the machine

- Remove the battery cables from the positive and negative terminals of the battery before charging it. If this is not done, abnormal voltage may be applied to the generator which could damage it.
- While charging the battery, remove all plugs to release the gases generated by charging.
- If the battery overheats [the temperature of the electrolyte exceeds 113°F (45°C)], interrupt charging.
- Stop charging as soon as the process has been completed.

Overcharging could cause the following troubles:

- Overheating of the battery
 - Decrease in battery electrolyte
 - Battery failure
- Do not reverse polarity of the battery cable connected to the battery (i.e., the negative to the positive, or the positive to the negative).
Reversing the polarity in the connection will cause the generator to be damaged.
 - Handling the battery (except for checking the electrolyte level and measuring the specific gravity of the electrolyte) should be performed after disconnecting the battery cables.

Go to Discount-Equipment.com to order your parts

■ Connecting the booster battery cables

Turn the starter switch to the "OFF" position, and connect the booster battery cables as follows:

1. Turn the starter switches on the normal machine and the machine in trouble to the "OFF" position.
2. Connect the clip of the booster battery cables **A** (normally red) to the positive terminal on the machine in trouble.
3. Connect the other clip of the booster battery cables **A** to the positive terminal on the normal machine.
4. Connect the clip of the booster battery cables **B** (normally black) to the negative terminal on the normal machine.
5. Connect the other clip of the booster battery cables **B** to the engine block of the machine in trouble.

■ Starting the engine

1. Make sure that the clips are securely connected to the battery terminals.
2. Start the engine on the normal machine, and increase the engine speed to the maximum.
3. Turn the starter switch on the machine in trouble to the "START" position to start the engine.
If the engine does not start, wait for more than two minutes and retry starting. (At this point, do not stop the engine on the normal machine and keep engine speed at full.)

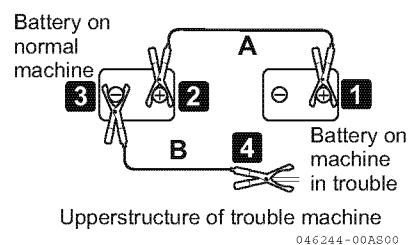

■ Disconnecting the booster battery cables

After the engine on the machine in trouble has started, disconnect the booster battery cables in the reverse order of the connecting procedure.

1. Remove the clip of the booster battery cables **B** from the engine block on the machine in trouble.
2. Remove the clip of the booster battery cables **B** from the negative terminal on the normal machine.
3. Remove the clip of the booster battery cables **A** from the positive terminal on the normal machine.
4. Remove the clip of the booster battery cables **A** from the positive terminal on the machine in trouble.

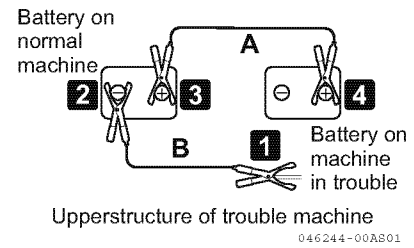

Go to Discount-Equipment.com to order your parts

7.4 Troubleshooting

Engine and electrical equipment

- Contact your dealer about the measures shown in parentheses in the list below.
- If there is any abnormality or trouble whose cause is unknown other than those shown below, ask your dealer for repair.

Problem		Cause	Measure
Engine	Engine oil pressure lamp lights up.	<ul style="list-style-type: none"> • Shortage of engine oil • Clogged engine oil filter 	<ul style="list-style-type: none"> • Replenish engine oil. • Replace engine oil filter.
	Steam comes out of top of radiator.	<ul style="list-style-type: none"> • Shortage of cooling water 	<ul style="list-style-type: none"> • Check cooling water level. Refill, if necessary. (Check cooling water for leak from water port.)
	Engine cooling water temp. error is displayed.	<ul style="list-style-type: none"> • Loose fan belt • Buildup of dust and water scale on cooling system • Defective thermostat • Clogged radiator fin or inclined fin • Defective electrical system 	<ul style="list-style-type: none"> • Adjust belt tension. • Replace cooling water. Clean inside of cooling water system. • Replace thermostat. • Clean or repair fin. • Check or replace electrical system.
	Battery charge lamp lights up.	<ul style="list-style-type: none"> • Loose or broken fan belt • Defective battery • Insufficient power generation of alternator 	<ul style="list-style-type: none"> • Adjust fan belt tension or replace. • Check battery electrolyte level. Replenish or replace if necessary. (•Check and repair.)
	Turning on starter motor does not start engine.	<ul style="list-style-type: none"> • Shortage of fuel • Air mixed in fuel system • Defective fuel injection pump or deteriorated nozzle performance • Improper compression • Damaged key stop solenoid. 	<ul style="list-style-type: none"> • Refill fuel tank. • Repair air leak. Release air from fuel system. (•Replace pump or nozzle.) (•Check and repair.) (•Check and repair.)
	Dark fumes come out of machine.	<ul style="list-style-type: none"> • Clogged air cleaner element • Deteriorated nozzle performance • Improper compression 	<ul style="list-style-type: none"> • Clean or repair element. (•Check and repair.) (•Check and repair.)
	Exhaust color is white or bluish white.	<ul style="list-style-type: none"> • Too much oil in oil pan • Improper fuel • Worn cylinder or piston ring 	<ul style="list-style-type: none"> • Drain oil from oil pan to specified level. • Replace fuel with recommended one. (•Repair.)

Problem		Cause	Measure
Electrical equipment	Turning starter switch to "START" dose not start starter motor.	<ul style="list-style-type: none"> • Defective wiring system • Defective starter switch • Insufficiently charged battery • Blown out slow blow fuse • Defective starter motor 	<ul style="list-style-type: none"> • Check and repair wiring system. • Replace starter switch. • Recharge battery. • Replace slow blow fuse (•Check and repair.)
	Maximum engine speed does not provide enough brightness of lamps.	<ul style="list-style-type: none"> • Defective wiring system • Defective generator or regulator 	<ul style="list-style-type: none"> • Check terminals for looseness and disconnection. Repair terminal, if necessary. (•Check and repair.)
	During engine operation, lamp is extremely bright, and frequently burns out.	<ul style="list-style-type: none"> • Defective regulator 	<ul style="list-style-type: none"> (•Replace regulator.) (•Repair.)
	Electrolyte leaks from battery.		
	Speed of starter motor is too low.	<ul style="list-style-type: none"> • Defective wiring system • Insufficiently charged battery • Defective starter motor 	<ul style="list-style-type: none"> • Check and repair wiring system. • Recharge battery. (•Check and repair.)

Go to Discount-Equipment.com to order your parts

Machine performance

- Contact your dealer about the measures shown in parentheses in the list below.
- If there is any abnormality or trouble whose cause is unknown other than those shown below, ask your dealer for repair.

Problem		Cause	Measure
Machine performance	Power or speed of moving part is low.	<ul style="list-style-type: none"> • Deteriorated function caused by worn hydraulic pump • Pressures of main relief valve, or port relief valve of control valve are dropped below set value. • Damaged hydraulic cylinder • Insufficient amount of hydraulic oil • Clogged filter 	<ul style="list-style-type: none"> (•Replace hydraulic pump.) (•Check and repair valves.) (•Check and repair.) • Replenish hydraulic oil up to specified level. • Clean or replace filter.
	Upperstructure does not swing or does not swing smoothly.	<ul style="list-style-type: none"> • Swing brake is not released • Insufficient amount of grease • Defective swing brake valve • Defective swing motor 	<ul style="list-style-type: none"> (•Check and repair.) • Check and grease. (•Check and repair.) (•Check and repair.)
	Temperature of hydraulic oil is too high.	<ul style="list-style-type: none"> • Insufficient amount of hydraulic oil • Overload 	<ul style="list-style-type: none"> • Replenish hydraulic oil up to specified level. • Lower load.
	Machine does not move straight.	<ul style="list-style-type: none"> • Improperly adjusted track or trapped foreign material • Damaged hydraulic motor. • Defective hydraulic pump • Defective control valve • Damaged sprocket, idler or track roller. 	<ul style="list-style-type: none"> • Adjust or clean. (•Check and repair.) (•Check and repair.) (•Check and repair.) (•Check and repair.)

Angle blade

- Contact your dealer about the measures shown in parentheses in the list below.
- If there is any abnormally or trouble whose cause is unknown other than those shown below, ask your dealer for repair.

Condition	Cause	Check item	Action
Angle speed is slow or it does not work	• Dust being caught in relief valve or malfunction	• Measure set pressure	• Adjust pressure after disassembly and washing or replace
	• Hydraulic oil leakage in the swivel joint	• Inspect swivel joint seal	• Replace seals after disassembly
	• Malfunction of control valve (solenoid valve)	• Inspect fuse • Inspect connection of couplers • Inspect solenoid operation • Inspect spool • Inspect control switch • Inspect solenoid valve-related harness	• Replace faulty parts • Wash spool
	• Hydraulic oil leakage in the cylinder	• Inspect seal in the cylinder	• Replace seals after disassembly
When the angle is operated while traveling, it does not work	• Dust being caught in shuttle valve or malfunction	• Overhaul shuttle valve	• Disassemble and wash • Replace faulty parts
Not floating in the float position	• Dust being caught in blade remote control valve or malfunction	• Inspect pilot pressure • Inspect blade remote control valve	• Disassemble and wash • Replace faulty parts
	• Dust being caught in control valve or malfunction	• Inspect control valve, blade, and spool	• Disassemble and wash • Replace faulty parts

MAINTENANCE

1. Precautions for Servicing	235		
2. Basic Servicing Practices	238		
2.1 Oils, fuel, and cooling water	239		
2.2 Electrical equipment	243		
2.3 Hydraulic system	244		
3. Consumables	246		
4. Fueling, Oiling and Greasing Based on Temperature Range	247		
4.1 Fuel and oil	247		
4.2 Cooling water	247		
5. Standard Tightening Torque for Bolts and Nuts	248		
5.1 Required tools	248		
5.2 Torque table	249		
6. Replacing Essential Parts Periodically	250		
7. Maintenance Table	252		
7.1 Table of service time intervals	252		
7.2 Service intervals when using the hydraulic breaker	256		
8. Procedures for Maintenance ...	257		
8.1 First services	257	8.5 Maintenance every	
8.2 Nonperiodic services	258	100 service hours	274
8.3 Checking before start-up	272	8.6 Maintenance every	
8.4 Maintenance every		250 service hours	275
50 service hours	273	8.7 Maintenance every	
		500 service hours	280
		8.8 Maintenance every	
		1000 service hours	287
		8.9 Maintenance every	
		1500 service hours	291
		8.10 Maintenance every	
		2000 service hours	292
		8.11 Maintenance every	
		3000 service hours	298

1. Precautions for Servicing

Do not use any inspection or servicing procedures that are not described and recommended in this manual.

Park the machine on solid, level ground to inspect and service it.

■ Check the hour meter

Read the hour meter every day to check if any service item has reached the time prescribed for implementation.

Use YANMAR genuine replacement parts

■ Use YANMAR genuine parts specified in the parts catalog

Use YANMAR genuine lube oil and grease

Use YANMAR genuine lube oil and grease of specified viscosity with regard to the temperature.

■ Use clean lube oil and grease

Use clean lube oil, grease and containers to prevent dust from mixing into them.

■ Clean the machine

Clean the machine for easy isolation of faulty parts.

Particularly clean the grease nipple, breather, and the oil level gauge glass to prevent dust from entering into them.

■ Be careful of high water and oil temperatures

It is dangerous to replace the oil, the cooling water and the filter immediately after stopping the engine. Wait until their temperatures drop. When the engine oil is too cool, heat the oil to adequate temperature [approximately 68°F to 104°F (20°C to 40°C)] before draining oil to improve draining efficiency.

■ Check the drained oil and the old filter element

When replacing the engine oil, the hydraulic oil, or the filter element, check the drained oil and the old filter element for metallic dust and foreign solid deposits.

■ Observe precautions for replenishing oil

If a strainer is mounted on the oil port, do not remove the strainer to replenish oil.

■ Be careful of dust

When checking or replacing the oil, do this in the place with no dust or other particles to prevent dust contamination.

■ Attach the warning tag

When the oil or the cooling water is drained, attach the "SERVICING IN PROGRESS" tag to the operator's seat so that other persons will not start the engine.

■ Observe the warning labels

Observe the warning labels affixed to the machine.

■ Observe the precautions for welding

- Make sure to disconnect the battery cables (positive and negative terminals).
- Do not apply more than 200 V continuously.
- Ground the machine within 39.37 in. (1000 mm) from the welded part.
- Make sure that there is no seal or bearing between the welded part and the grounded part.
- Do not ground around the pins on the implement or the hydraulic cylinder.

■ Be careful of fire

Clean parts with noncombustible detergent.

■ Relieve the internal pressure

Before checking or servicing the hydraulic system, relieve the hydraulic oil pressure in the circuit according to the following procedure.

1. Stop the engine.
2. Turn the starter key to "ON" position.
3. Push the lock lever forward to set it in unlock position.
4. Alternatively press the right and left sides of the lever switch several times for the P.T.O. circuit and move levers or pedals to full stroke ends several times for the other actuator circuits.

■ Clean mating surfaces before assembly

When you have removed a part with an O-ring or a gasket seal, clean the mating surfaces before installing the new part.

At this point, do not fail to refit the O-ring or the gasket

■ Do not drop anything from your breast pocket

When you open the cover and attempt to look down into the inside of the machine, remove loose items from your breast pocket to eliminate the risk that they may drop into the machine.

■ Check the undercarriage

After the machine is used at a rocky place, check the undercarriage for damage. Check for loose bolts and nuts, cracks, wear, and other damage. Loosen the tension of the track more than usual.

■ Observe the precautions for cleaning the machine

- Do not spray steam directly at the connectors.
- Do not splash water on the monitors in the cabin.
- Do not spray high-pressure water directly at the radiator and the oil cooler.

■ Check before and after working

If the machine is to be used in mud, rain, snow, or on a beach, check for loose plugs and cocks before working. After working, clean the machine and check each part for cracks and damage and check for loose or missing bolts and nuts. Apply grease earlier than usual. Particularly apply grease every day to the pins on the implement which are submerged in mud.

■ Observe the precautions for working in a dusty place

If you use the machine in a dusty place, be careful of the following:

- Check the air cleaner for clogging.
Clean the air cleaner element earlier than scheduled.
- Clean the radiator fin earlier to prevent it from clogging.
- Clean or replace the fuel filter element earlier than scheduled.
- Clean the electric equipment, especially the starter motor and the generator, to avoid dust deposits.

■ Do not mix oils

Never mix oils of different makes or types. If you have to replenish an oil with a different make or type than the one already in the tank, remove the remaining oil completely.

Go to Discount-Equipment.com to order your parts

2. Basic Servicing Practices

- Use YANMAR genuine replacement parts.
- Do not mix oils of different makes and types when replacing or replenishing oil.
- The following types of oil and cooling water are used in the factory for shipping unless otherwise specified:

Item	Type
Engine oil	Engine oil SAE10W30, CF class
Travel reduction gear	SAE90 (GL-4)
Hydraulic oil	YANMAR SUPER HYDRO. OIL (ISO VG46)
Fuel	Diesel light oil (Ultra low sulfur)
Engine cooling water	YANMAR genuine long-life coolant (LLC) 50% added

2.1 Oils, fuel, and cooling water

Oils

- Because the oil is used in the engine and implement under extreme conditions (high temperature and pressure), it deteriorates as time elapses.

Be sure to use oils of the grades which are specified in the Operation & Maintenance Manual and suitable for the operating temperature range.

Even if the oil is not contaminated, be sure to replace the oil within the specified service hours.

- Oil is equivalent to blood in a human body. Be careful in handling it so that impurities (water, metallic dust, and foreign solids) will not be mixed into it.

Most machine failures are caused by impurities in the oils.

Be careful not to mix impurities into the oils especially after storing the machine and replenishing oils.

- Do not mix oils of different makes and types.
- Use the specified amount of oil.
Larger or smaller amounts of oil than specified may cause machine problems.
- If the oil becomes cloudy, it may suggest that water or air could have been mixed into the hydraulic system. If this event happens, ask your dealer.
- Be sure to replace the oil filter element with a new one when changing the oil.
- To know what condition the machine is in, it is recommended that you analyze the properties of the oil periodically.
Ask your dealer for more information on this issue.

Fuel

- Because the fuel injection pump is a precision device, using a fuel containing water or dust will cause problems.
- Be careful that impurities will not be mixed into the fuel especially after storing the machine and refueling.
- Be sure to use a fuel recommended in the Operation & Maintenance Manual.
In addition, keep in mind that you should use a fuel appropriate for the operating temperature range because it will freeze at temperatures lower than -13°F (-25°C).
- Fully refuel every day after finishing the work so that the moisture in the fuel tank will not condense and water will not mix with the fuel.
- Before starting the engine, or ten minutes after refueling, drain any deposits and water through the drain plug on the fuel tank.
- If the fuel level becomes low or the filter element is replaced, the air should be released from the fuel system.

Cooling water

- Because unpotable water may contain much calcium and impurities, using it will cause water scale to build up in the engine or the radiator, causing poor heat exchange and overheating.
Never use water which is not potable for cooling purposes.
- When using an anti-freeze, observe the precautions described in the Operation & Maintenance Manual.
- The YANMAR machine is shipped with YANMAR genuine anti-freeze. The anti-freeze is anticorrosive to protect the cooling system.
Because the anti-freeze can be used continuously over two years, you need not remove it in hot weather.

DANGER

Keep sources of ignition away from the anti-freeze because it is flammable.

- The mixing ratio of the anti-freeze to the water differs based on air temperature.
For the mixing ratio, refer to Section "Cleaning the inside of the cooling system" on page 292.
- If the engine is overheated, replenish the cooling water after the engine has cooled down.
- Shortage of cooling water will cause the cooling system not only to overheat but also to corrode due to air which comes in the system.

Grease

- Grease ensures smooth operation of moving parts such as connectors and prevent operating noises.
- The nipples not listed on the pages for periodic service are those for overhaul. Normally it is not necessary to refill them.
Grease them if any abnormal condition arises after long term use.
- Wipe the extruded old grease off with a rag after greasing.
Carefully wipe the old grease off completely from all moving parts which are easily worn by adhered sand or dust.

Storing the oil and fuel

- Store the oil and fuel indoors so that they will not be contaminated by impurities such as water or dust.
- When you store oil or fuel in drums for a long period, position them so that their outlets align in a straight line (to prevent moisture absorption).
When storing the oil or the fuel outdoors, cover the drums with a waterproof sheet.
- To avoid deterioration caused by long-term storage, use the oil on a first-in first-out basis.

Filter

- The filters are very important parts which prevent impurities from getting into critical devices through the lube oil, fuel and air systems.

Replace the filter elements periodically according to the instructions of the Operation & Maintenance Manual.

Under difficult conditions, you need to replace the filter elements earlier than suggested in the Operation & Maintenance Manual depending on the type of oil and fuel (sulfur content).

- Never reuse the filter elements (cartridge type) by cleaning them.
- When replacing an oil filter element, check that no metallic dust or foreign solids are present on the old filter. If they are found to be present, contact the nearest dealer.
- Do not unpack the filter element before use.
- Use YANMAR genuine filter elements.

2.2 Electrical equipment

- If electrical equipment gets wet or wiring insulation is broken, electric leaks may occur and the machine may malfunction which is very dangerous.
- Check the fan belt for tension and damage, and also check the battery for electrolyte level.
- Never disconnect or disassemble the electrical equipment mounted on the machine.
- Do not mount any electrical equipment other than those items provided by YANMAR.
- Be careful not to spray water on the electrical equipment when washing the machine or operating in the rain.
- After working near the sea, take necessary precautions to protect the electrical equipment from corrosion.

2.3 Hydraulic system

- The hydraulic system is hot during and immediately after operation. It is also given high pressure during operation. Therefore, check and service the hydraulic system carefully as follows:
 - Put the bucket on the level ground so that no pressure is applied to the hydraulic cylinder circuits.
 - Be sure to stop the engine.
 - Wait until the temperature drops sufficiently and then start maintenance since the hydraulic oil and the lube oil are at high temperature and high pressure immediately after operation.

Do not suddenly remove any plugs, screws or connecting parts of the hoses. Otherwise oil may spout out due to residual internal pressure even when the oil temperature has lowered. Be careful not to face them when loosening them to prevent injury, and loosen them little by little to remove the internal pressure.
- Always relieve the internal pressure before checking and servicing the hydraulic system according to the following procedure.
 1. Stop the engine.
 2. Turn the starter key to "ON" position.
 3. Push the lock lever forward to set it in unlock position.
 4. Alternatively press the right and left sides of the lever switch several times for the P.T.O. circuit and move levers or pedals to full stroke ends several times for the other actuator circuits.
- Check the hydraulic oil level, replace the filter element, and replace the hydraulic oil when necessary.
- When removing the hydraulic hoses and pipings, check the O-ring and the packing for damage before reinstalling them. Replace them if they are damaged.
- Release air after replacing or cleaning the hydraulic oil filter element or strainer, repairing or replacing the hydraulic equipment, or removing the hydraulic cylinder or piping.

Retract the bucket and arm cylinders to place the bucket on the ground.

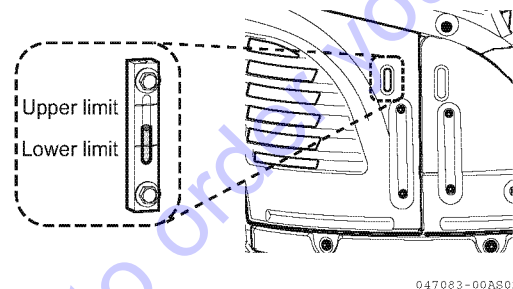
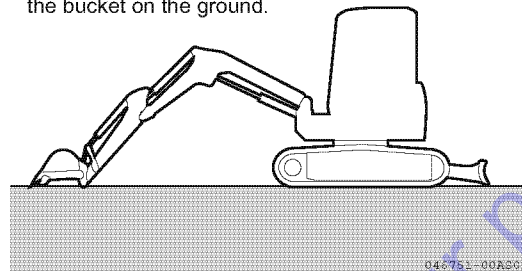

Release air according to the following procedure:

1. Set the engine rotation to medium. That is, set the lever in the middle of the stroke.
2. Slowly operate each cylinder 4 to 5 times to approximately 3.9 in. (100 mm) before both stroke ends.
3. Operate the cylinder 4 to 5 times at full stroke.
 - Failure to release air from the hydraulic cylinder and operating it suddenly to the stroke ends could cause piston seal damage.
 - If air is left in the hydraulic circuit, air is compressed and swollen by the load and the hydraulic equipment does not operate smoothly.
Air in the hydraulic circuit may shorten the service life of the hydraulic pump.
4. Check the hydraulic oil level and replenish to the specified level if necessary.

Go to Discount-Equipment.com to order your parts

3. Consumables

Periodically replace consumable parts such as filter element and bucket teeth.

Periodic replacement prevents malfunction of the machine. When you replace a part, be sure to use a Yanmar genuine part.

When ordering consumables, let us know the parts numbers given in the parts catalog.

■ List of consumables

The parts in () represent those which must be replaced at the same time.

Item	Name	Q'ty	Replacing time interval
Engine oil filter	Oil filter 80×80 L	1	Every 500 service hours
Hydraulic oil tank return filter	Filter element	1	Every 500 service hours (At first 250 service hours)
Fuel filter	Fuel filter element	1	Every 500 service hours
Air cleaner	Cleaner element	1	Every 500 service hours
Bucket	Point teeth	4	-
	(Lock pin)	(4)	
	(Rubber pin)	(4)	
	Side cutter (left)	1	
	Side cutter (right)	1	
	(Bolt 14×35)	(6)	
	(Nut 14)	(6)	

4. Fueling, Oiling and Greasing Based on Temperature Range

4.1 Fuel and oil

Select fuel and oil based on to the air temperature range.

The prescribed amount of oil means the total amount of oil included in the piping and equipment.

The amount of oil to be changed means the amount of oil replaced in checking and servicing.

If you start the engine at air temperatures lower than 32°F (0°C), use SAE10W, SAE10W-30, or SAE15W-40 even if the temperature in the daytime rises to 50°F (10°C) or so.

4.2 Cooling water

Because a YANMAR genuine long-life coolant (LLC) is added to the cooling water, you need not change it unless the temperature falls below -31°F (-35°C).

If the temperature falls below -31°F (-35°C), refer to Section "Cleaning the inside of the cooling system" on page 292 to control the density of the cooling water

Part be refilled	Oil type	Recommendations with regard to temperature ranges						Prescribed amount of oil	Amount of oil to be changed
		(°F) (°C)	-4 (-20)	-14 (-10)	32 (0)	50 (10)	68 (20)		
Engine oil pan	Engine oil	SAE 10W CF						7.7 Qts. (7.3 L)	7.7 Qts. (7.3 L)
		SAE 10W-30 CF							
		SAE 15W-40 CF							
Travel reduction gear	Gear oil	SAE 90 (GL-4)						0.5 Qts. (0.5 L) (For right and left each)	0.5 Qts. (0.5 L) (For right and left each)
Hydraulic oil system	Hydraulic oil	ISO VG46						In the tank 10.6 Gals. (40 L) Other parts 5.8 Gals. (22 L)	10.6 Gals. (40 L)
Fuel tank	Light oil	No. 1-D or No. 2-D diesel fuel						10.8 Gals. (41 L)	-
Cooling system	Water	YANMAR genuine long-life coolant (LLC) added						Radiator	-
								4.0 Qts. (3.8 L)	
								Subtank	
								0.4 Qts. (0.4 L)	

5. Standard Tightening Torque for Bolts and Nuts

5.1 Required tools

The following tools are required for servicing:

No.	Name	Part number	Q'ty
1	Screw driver (universal system)	104200-92350	1
2	Filter wrench 68	119332-92751	1
3	Filter wrench 80	119640-92750	1
4	Filter wrench LO	171301-92750	1
5	Pressuring nozzle	172122-05101	1
6	Wrench 8×10	28110-080100	1
7	Wrench 12×14	28110-120140	2
8	Wrench 17×19	28110-170190	1
9	Wrench 22×24	28110-220240	2
10	Wrench 27×30	28110-270300	1
11	Wrench 32×36	28110-320360	1
12	Hexagon bar wrench 4	28150-040000	1
13	Hexagon bar wrench 5	28150-050000	1
14	Hexagon bar wrench 8	28150-080000	1
15	Box wrench 27×140	28227-271400	1
16	Turning handle 12×250	28230-120250	1
17	Grease hose	933110-09701	1
18	Grease injector 800	933110-09802	1
19	Pliers 200	933171-00470	1

5.2 Torque table

Bolts or nuts in the metric system should be tightened at the torque described below unless specified otherwise.

Item		Thread size × pitch	Tightening torque ft·lbf (N·m)	Remarks
Hexagon bolt (7T) Nut	Coarse threads	M6 × 1	7.23 to 8.68 (9.8 to 11.8)	<ul style="list-style-type: none"> • Apply 80% tightening torque when tightened to aluminum. • Apply 60% tightening torque for 4T bolt and lock nut. • Use fine thread screws for engine only.
		M8 × 1.25	16.6 to 21.0 (22.6 to 28.4)	
		M10 × 1.5	32.6 to 43.4 (44.1 to 58.8)	
		M12 × 1.75	57.9 to 72.3 (78.5 to 98.1)	
		M14 × 2	86.8 to 108.5 (117.7 to 147.1)	
		M16 × 2	123.0 to 151.9 (166.7 to 206.0)	
		M18 × 2.5	173.6 to 209.8 (235.4 to 284.4)	
	M20 × 2.5	238.7 to 296.6 (323.6 to 402.1)		
	Fine threads	M14 × 1.5	94.0 to 108.5 (127.5 to 147.1)	
M16 × 1.5		155.5 to 177.2 (210.8 to 240.3)		
PT plug		1/8	7.2 (9.8)	
		1/4	14.5 (19.6)	
		3/8	21.7 (29.4)	
		1/2	43.4 (58.8)	
Pipe joint bolt		M8	9.4 to 12.3 (12.7 to 16.7)	
		M12	18.1 to 25.3 (24.5 to 34.3)	
		M14	28.9 to 36.2 (39.2 to 49.0)	
		M16	36.2 to 43.4 (49.0 to 58.8)	

IMPORTANT

If a part to be tightened is made of resin like a panel board, excessive tightening torque may damage the tightened part. Be careful when tightening.

6. Replacing Essential Parts Periodically

For safe operation, the machine must be serviced periodically. To increase safety, be sure to periodically replace the parts listed in the table of safety parts on the next page. A fire could result if they deteriorate or are damaged.

These parts are vulnerable to age and wear or deterioration and it is difficult to determine the degree to which they have deteriorated on the occasion of periodic service. To maintain their proper function at all times, therefore, replace them with new ones after using them for a specific period of time even if no abnormality is found with the parts.

If you find abnormalities in these parts before their scheduled replacement time is reached, repair or replace them immediately.

If a hose clamp is deformed or cracked, replace it immediately.

Check the hydraulic hoses (which are not periodic replacement parts). If any abnormality is found in them, retighten them or replace them immediately.

When replacing the hydraulic hoses, replace the O-rings and seals at the same time.

For further information about replacing the safety parts, ask your dealer.

Check the fuel and hydraulic hoses according to the periodic schedule described below.

Check categories	Check points
Start-up check	Oil leak from the connections or bodies of the fuel and hydraulic hoses
Voluntary monthly check	Oil leak from the connections or bodies of the fuel and hydraulic hoses Damage (crack, wear, or peeling) of the fuel and hydraulic hoses
Prescribed annual check	Oil leak from the connections or bodies of the fuel and hydraulic hoses Interference, crushing, aging, torsion, or damage (crack, wear, or peeling) of the fuel and hydraulic hoses

■ List of safety parts

No.	Safety parts to be replaced periodically	Q'ty	Replacement time intervals
1	Fuel hose (fuel tank to water separator)	1	Earlier of either every 2 years or every 4000 service hours
2	Fuel hose (water separator to feed pump)	1	
3	Fuel hose (feed pump to fuel filter)	1	
4	Fuel hose (fuel filter to fuel injection pump)	1	
5	Fuel hose (fuel filter to fuel tank)	1	
6	Fuel hose (fuel injection pump to fuel filter)	1	
7	Fuel hose (fuel injection valve to fuel injection valve)	2	
8	Fuel hose (fuel injection valve to fuel injection pump)	1	
9	Fuel tube cap	1	
10	Main pump outlet hose (P1, P2, P3 to C/V)	3	

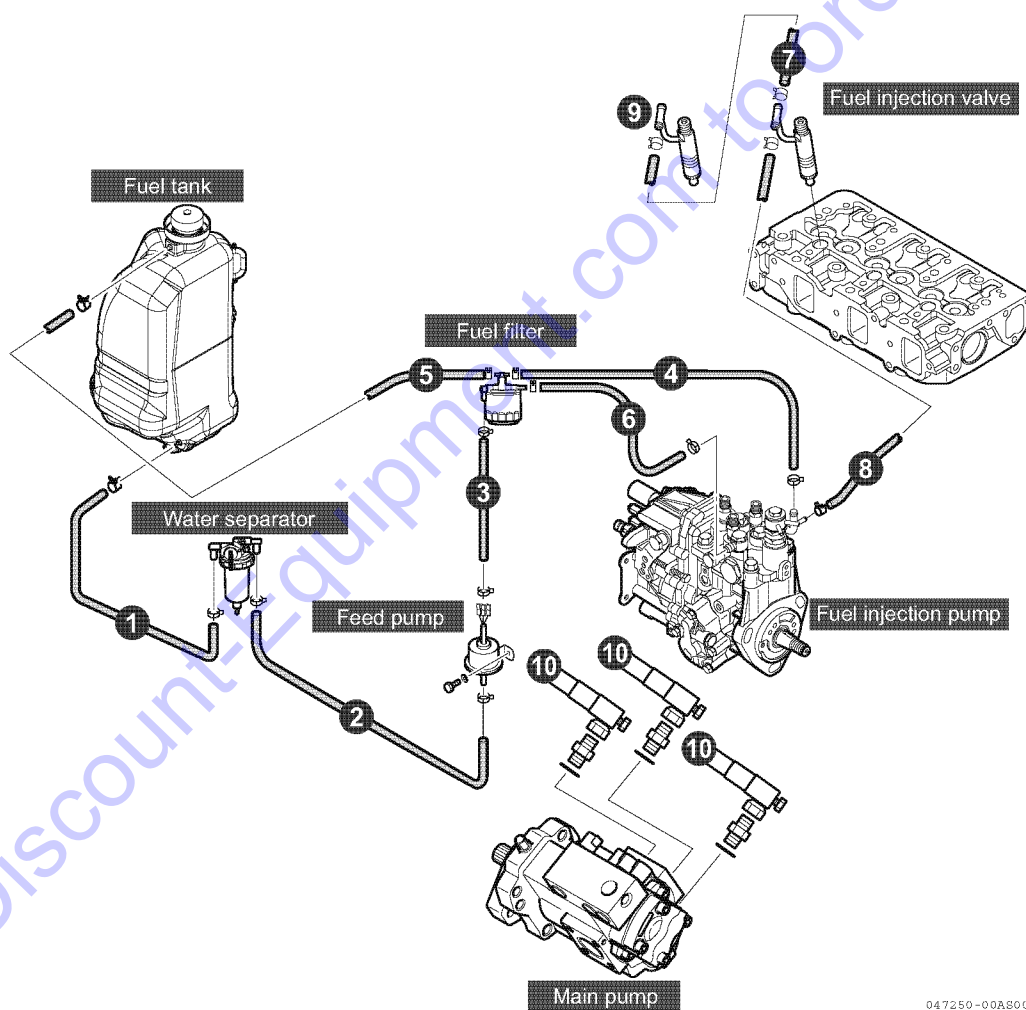

7. Maintenance Table

Daily and periodic inspection are important to keep the machine in its best condition. The following is a summary of inspection and servicing items by inspection interval. Periodic inspection intervals vary depending on the use, loads, fuels and lube oils used and handling conditions, and are hard to establish definitively. The following should be treated only as a general standard.

When the time for an inspection approaches, study the relevant pages in the Operation & Maintenance Manual. Keep a record of daily operation and the results of maintenance work.

7.1 Table of service time intervals

Check and service points	Page
--------------------------	------

■ At first 100 hours (only once after the new machine has started to be used)

Replacing the lube oil for the travel reduction gearbox	287
---	-----

■ At first 250 hours (only once after the new machine has started to be used)

Replacing the hydraulic oil return filter element	257
Cleaning the suction filter element in the hydraulic oil tank	257

■ Nonperiodic servicing

Checking the rubber track (for rubber track type)	258
Checking and adjusting the rubber track tension (for rubber track type)	260
Replacing the rubber track (for rubber track type)	263
Checking and adjusting the steel track tension (for steel track type)	266
Replacing the bucket teeth and the side cutter	269
Replacing the blade cutting edge (with the angle blade)	271

■ Checking before start-up

Checking and replenishing the cooling water	143
Checking and replenishing the engine oil	144
Checking the fuel level in the fuel tank and refueling	145
Checking and replenishing the hydraulic oil tank	146
Checking and adjusting the fan belt tension	275
Checking and replenishing the battery electrolyte	148
Greasing	149
Checking the electrical equipment	151

Check and service points	Page
--------------------------	------

■ Every 50 hours

Greasing the swing gear and the swing bearing	273
Draining the water and deposits in the fuel tank	273

■ Every 100 hours

Cleaning the water separator element	274
--------------------------------------	-----

■ Every 250 hours

Checking and adjusting the fan belt tension	275
Checking and cleaning the air cleaner	277
Checking and replenishing the lube oil for the travel reduction gearbox	279

■ Every 500 hours

Replacing the fuel filter	280
Replacing the engine oil and the engine oil filter element	282
Checking and cleaning the radiator and oil cooler fin	284
Replacing the air cleaner element	285
Replacing the hydraulic oil return filter element	286

■ Every 1000 hours

Replacing the lube oil for the travel reduction gearbox	287
Replacing the hydraulic oil and cleaning the suction filter element	289
Checking and adjusting the intake/exhaust valve clearances	Ask your dealer

■ Every 1500 hours

Checking and adjusting the fuel injection pump.	Ask your dealer
Checking, cleaning and testing the fuel injection valve.	Ask your dealer
Checking the crankcase breather system	Ask your dealer

■ Every 2000 hours

Cleaning the inside of the cooling system	292
Checking the accumulator	296

■ Every 3000 hours

Checking, clean and testing EGR valve	Ask your dealer
Cleaning EGR lead valve	Ask your dealer

■ List of periodic inspection and servicing

◇ : Check ○ : Supply ● : Replace □ : Adjust (clean) ■ : Oil & grease

Check & service items		Daily	Every 50 hrs	Every 100 hrs	Every 250 hrs	Every 500 hrs	Every 1000 hrs	Every 1500 hrs	Every 2000 hrs	Every 3000 hrs	
General	Check falling off, breakage of parts	◇									
	Check loosened bolts & nuts, retighten	◇									
	Check engine condition	◇									
	Clean	□									
Fuel oil	Check & supply of oil to the tank	◇(○)									
	Drain the fuel tank		□								
	Water separator	Check, drain	◇								
		Clean			□						
	Replace the fuel filter element					●					
Lube oil	Engine oil	Check, resupply	◇								
		Replace				●					
	Replace the engine oil filter element					●					
	Travel reduction gear oil	Check, resupply				○					
		Replace			● 1st time		●				
Cooling water	Check & supply of cooling water	◇									
	Check cooling water leakage	◇									
	Check & clean radiator fins					□					
	Check & adjust the fan-belt tension	◇			□						
	Replace the cooling water								● within two years		
	Clean & check the cooling water system								● within two years		
Rubber hose	Check & replace fuel oil pipe, cooling water pipe	◇							●		
Air cleaner	Clean air cleaner				□						
	Replace air cleaner element					●					
Hydraulic system	Hydraulic oil	Check, resupply	◇								
		Replace					●				
	Clean suction filter				□ 1st time		□				
	Replace return filter				● 1st time	●					
	Check for abnormality of hydraulic pump	◇									
	Check function of accumulator								◇		
Grease	Check grease-up positions, grease	■									
	Greasing the swing gears and the swing bearings		■								

◇ : Check ○ : Supply ● : Replace □ : Adjust (clean) ■ : Oil & grease

Check & service items		Daily	Every 50 hrs	Every 100 hrs	Every 250 hrs	Every 500 hrs	Every 1000 hrs	Every 1500 hrs	Every 2000 hrs	Every 3000 hrs
Undercarriage	Check, adjust track tension	◇								
Control equipment	Check performance, play of travel levers (pedals)	◇								
	Check performance, play of control levers	◇								
	Check performance, play of blade lever	◇								
	Check performance, play of boom swing pedal	◇								
	Check performance of engine control dial	◇								
Electric equipment	Check work lights, horn	◇								
	Check hour meter function	◇								
	Check function of LCD monitor	◇								
	Check LED lamps	◇								
	Check wire breakage, short-circuits, loosened terminals retighten	◇								
	Check, resupply battery fluid	◇								
	Check specific gravity of electrolyte							□ As required		
Engine	Check & adjust the intake and exhaust valve clearance						□			
	Check & adjust fuel injection pump							◇		
	Check, clean and test fuel injection valve							◇ As required		
	Check crankcase breather system							◇		
	Check, clean and test EGR valve									□
	Clean EGR lead valve									□

Note :

- When machine is used at dusty worksites clean and replace filter element twice or more frequently than specified in the table.
- Execution of periodic inspection and servicing is indispensable to conform the EPA emission control regulations.

Keep a record of the results.

7.2 Service intervals when using the hydraulic breaker

When a hydraulic breaker is used, the hydraulic oil deteriorates earlier than in usual bucket excavating work. Set up the service time intervals as follows:

- Replacing the hydraulic oil return filter element
Replace the hydraulic oil return filter element on the new machine once after the first 100 to 150 hours. After that ; replace it referring to the chart at right.
- Replacing the hydraulic oil in the hydraulic oil tank
Replace the hydraulic oil according to the chart at right.

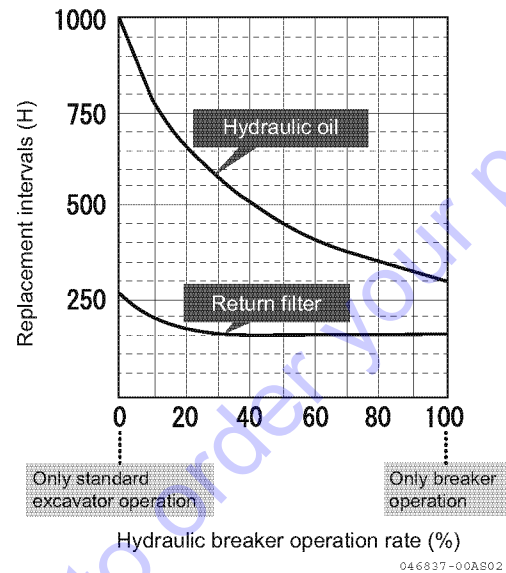

8. Procedures for Maintenance

8.1 First services

Service only once after the new machine has started to be used, as follows.

■ At first 100 hours

- Replacing the lube oil for the travel reduction gearbox.
For this procedure, refer to Section "8.8 Maintenance every 1000 service hours".

■ At first 250 hours

- Replacing the hydraulic oil return filter element.
For this procedure, refer to Section "8.7 Maintenance every 500 service hours".
- Cleaning the suction filter element in the hydraulic oil tank.
For this procedure, refer to Section "8.8 Maintenance every 1000 service hours".

Go to Discount-Equipment.com to order your parts

8.2 Nonperiodic services

Checking the rubber track (for rubber track type)

The rubber track in the following condition requires repair or replacement. Ask your dealer to repair or replace it.

■ Height of lugs

- As the lug height "a" is reduced by wear, the tractive force decreases.
If "a" becomes 0.2 in. (5 mm) or less, replace the track with a new one.
- If two links or more of the steel cord inside the track are exposed due to wear of the lugs, replace the track with a new one.

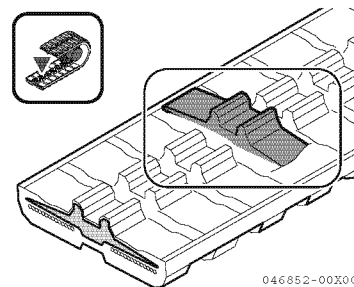
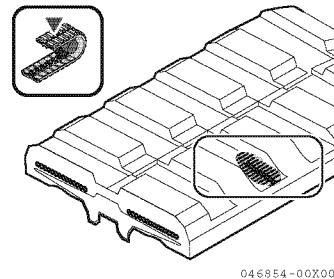
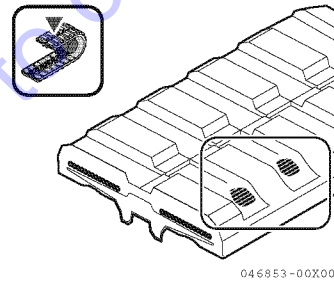
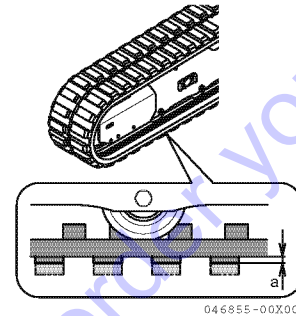

■ Rubber track steel cord breakage

If half or more of either of the steel cords is broken, replace the rubber track with a new one.

■ Coming off of the core metal of the rubber track

If the core metal of the rubber track comes off even at one place, replace the rubber track with a new one.

■ Rubber track tension

If the rubber track tension is loose even after grease is put in, the grease adjuster may be defective internally. Ask your dealer to repair the grease adjuster.

■ Crack in the rubber track

If a crack occurs between any lugs of the rubber track, repair if the crack length reaches approximately 2.4 in. (60 mm). If the inside steel cord is exposed even though the crack is small, repair the rubber track immediately. If the crack length is less than 1.2 in. (30 mm) or the crack depth is less than 0.4 in. (10 mm), you do not need to repair the rubber track.

For a decision on whether the rubber track should be replaced, repaired or should continue to be used, ask your dealer.

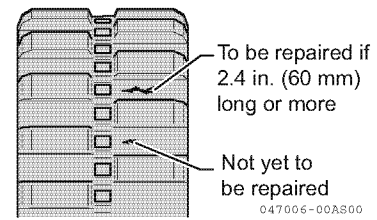

Go to Discount-Equipment.com to order your parts

Checking and adjusting the rubber track tension (for rubber track type)

⚠ WARNING

- When adjusting the rubber track tension while raising the machine, do not support the machine with the implement only.
- The control levers could move or the hydraulic oil could flow out accidentally so that the machine would fall.
- When raising the machine, support it with safety blocks of sufficient strength.
- When the machine is being checked or adjusted by two persons, one must operate the machine in response to signs from the other.

How the rubber track wears out depends on the working conditions and the nature of the ground. Be sure to check the rubber track for wear and tension from time to time. When a new rubber track is mounted, perform the first check after 30 hours operation.

■ Checking the rubber track tension

1. Move the machine so that the joint ( mark) on the inside surface of the rubber track should be positioned at the upper center of the track frame.
2. Lift the machine with the implement.
To do this, operate the control lever slowly.

3. The tension is proper if the clearance (H in the right figure) between the outside rolling surface of the second track roller from the idler side and the inside surface of the rubber track is within the following range :
 - H=0.3 to 0.5 in. (8 to 13 mm)

Working with the rubber track loosened will cause the rubber track to come off or the core metal to wear out earlier.

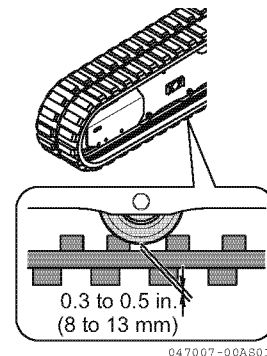
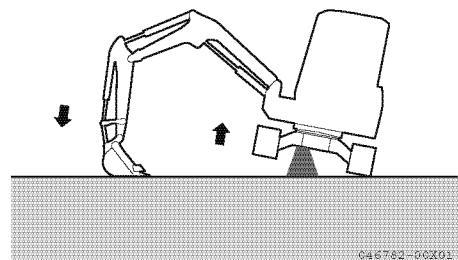
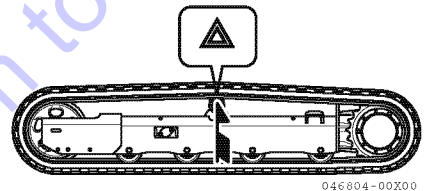

If the tension is improper, adjust it as follows:

■ Adjusting the rubber track tension

• To increase the tension

Prepare a grease gun.

1. Remove the cover 1.

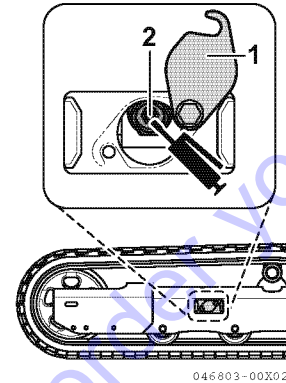

2. Raise the machine using the implement and inject grease through the greasing valve 2 using a grease gun until the rubber track tension is within the specified value of 0.3 to 0.5 in. (8 to 13 mm).

3. To check that the tension is proper, put down the machine and move the machine back and forth slightly.

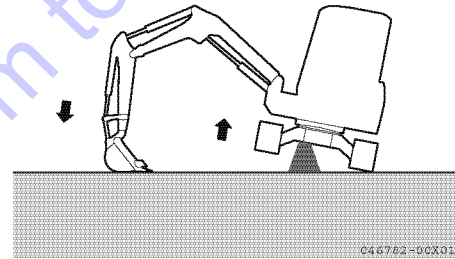

4. Check the rubber track tension again. If the tension is improper, adjust it again.

5. Install the cover 1.

6. The tension is adjustable until the clearance "a" is reduced to 0 in. (0 mm). If the tension is still loose, the rubber track needs repairing due to excessive wear. Contact your dealer and ask for repair.

7. If the tension is loose even after grease injection, it is necessary to replace the rubber track or the grease adjuster. Contact your dealer and ask for replacement.

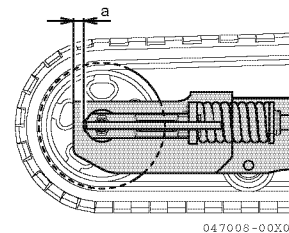

- Loosening the tension

⚠ WARNING

- Grease is under high pressure. If the greasing valve (2) is opened suddenly, grease could be ejected or the valve could blow, which could cause bodily injury.
- Do not rely on valve appearance alone to determine whether or not grease has been discharged, but check that by measuring the tension of the rubber track.
- Do not open the greasing valve (2) more than one turn.
- It is very dangerous to discharge the grease by any procedure other than that described below. If the tension of the rubber track cannot be loosened, contact your dealer and ask for repair.

1. Remove the cover 1.
2. Raise the machine with the implement and slowly loosen the greasing valve 2 and discharge the grease to adjust the rubber track tension to the specified value of 0.3 to 0.5 in. (8 to 13 mm).
3. Never loosen the greasing valve more than one turn. (If the grease is not discharged completely, put down the machine and move the machine back and forth slightly.)
4. Tighten the greasing valve 2.
Tightening torque : 36.2 ft•lbf (49.0 N•m)
5. To check that the tension is proper, put down the machine and move the machine back and forth slightly.
6. Recheck the rubber track tension and readjust it if necessary.
7. Completely wipe off the discharged grease with a waste cloth.

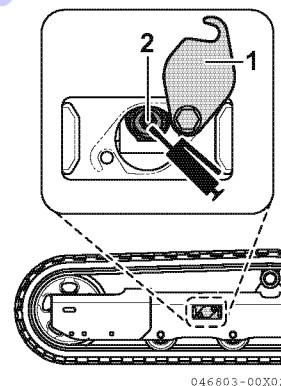

046603-00X02

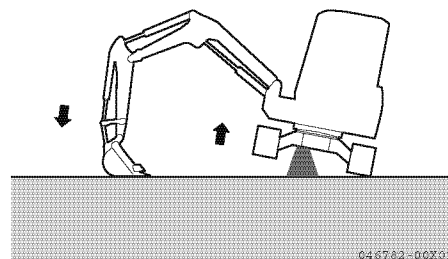

046783-00X01

IMPORTANT

The rubber track is not grease-resistant. Completely wipe off the grease because grease will shorten its service life.

8. Install the cover 1.

Replacing the rubber track (for rubber track type)

⚠ WARNING

- To replace the rubber track with a new one, work with a partner. You must operate the machine in response to signs from your partner.
- Because the rubber track is replaced with the machine in a raised position, there is a danger that the machine may accidentally fall. Do not move any parts other than the rubber track to be replaced in doing the job.
- The high internal pressure of the grease can cause the greasing valve to eject.
When you loosen the greasing valve, do not loosen it more than one turn.
At this point, do not loosen any parts other than the greasing valve. Also, do not turn your face toward the greasing valve.
- If the tension of the rubber track cannot be loosened by the procedure described here, ask your dealer to repair the rubber track.

■ Replacing the rubber track

- Prepare a grease gun and steel pipes.

■ Removing the rubber track

⚠ WARNING

- It is very dangerous to discharge the grease by any procedure other than that described below.
- If the tension of the rubber track cannot be properly adjusted, ask your dealer to repair or replace the rubber track.
- When removing the rubber track, make sure that all of the grease has been completely discharged before turning the sprocket.

1. Raise the machine with the implement.
To do this, slowly operate the control lever.

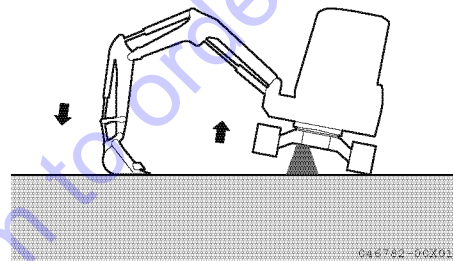

2. Loosen the greasing valve 2 little by little to discharge the grease.
3. Do not loosen the greasing valve 2 more than one turn.

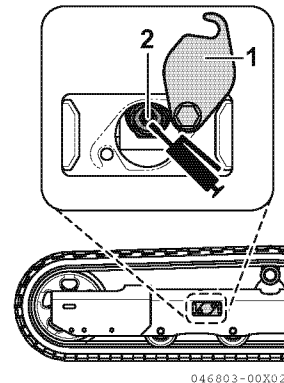

4. Insert the steel pipes into the rubber track and turn the sprocket in the reverse direction. When the rubber track is separated from the idler by the steel pipes, slide the rubber track off.

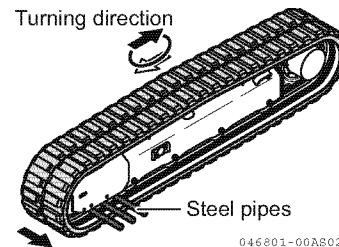

■ Installing the rubber track

1. Raise the machine with the implement.
To do this, slowly operate the control lever.
2. Engage the rubber track with the sprocket, and put the rubber track on the idler.
3. Rotate the sprocket in the reverse direction to push the rubber track in and stop rotating it.
4. Insert a steel pipe into the rubber track, and rotate the sprocket again to put the rubber track on the idler securely.
5. Stop rotating the sprocket, and check that the rubber track is securely put on both the sprocket and the idler.
6. Adjust the rubber track tension, referring to Section "Checking and adjusting the rubber track tension (for rubber track type)" on page 260.
7. Check that the rubber track is fully engaged with both the sprocket and the idler and that the rubber track tension is sufficient, then place the machine down on the ground.

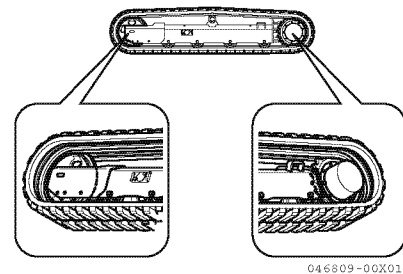
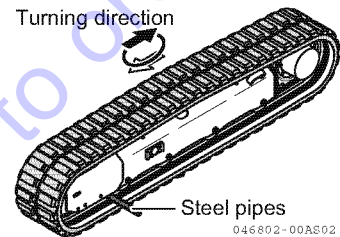
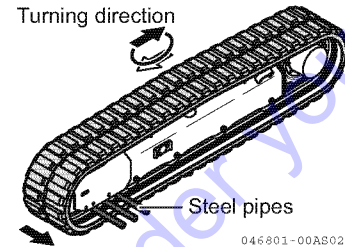
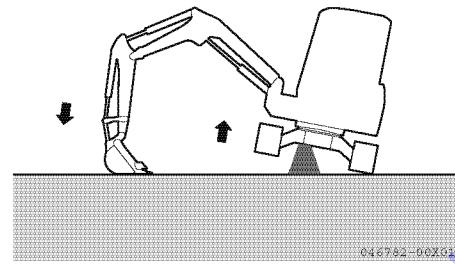

Go to Discount-Equipment.com to order your parts

Checking and adjusting the steel track tension (for steel track type)

⚠ WARNING

- When adjusting the steel track tension while raising the machine, do not support the machine with the implement only. If the control levers should move or the hydraulic oil should flow out, the machine could fall.
- When raising the machine, support it with safety blocks of sufficient strength.
- When the machine is being checked or adjusted by two persons, one must operate the machine in response the signs from the other.

How the pins and bushes on the undercarriage will wear down depends on the working conditions and the ground conditions. Check the steel track tension from time to time to keep proper tension.

Check and adjust the steel track tension under the same conditions as in operation (for example, mud clogged condition in case of working in muddy ground.)

■ Checking the steel track

1. Raise the machine with the implement. To do this, operate the control lever slowly.

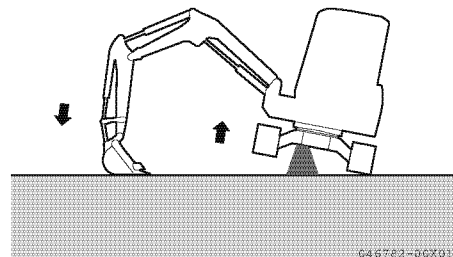

2. At a position that will be safe even if the machine should fall, measure the clearance between the bottom of the track frame and the upper surface of the shoe plate.

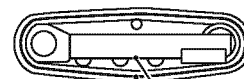

From the bottom of the track frame to the upper surface of the shoe plate.

046245-00A500

The tension is proper if the clearance is 4.9 to 5.3 in. (125 to 135 mm).

If the tension is improper, adjust it as follows:

■ Adjusting the steel track tension

• To increase the tension

Prepare a grease gun.

1. Remove the cover 2.
2. Raise the machine using the implement and inject grease through the greasing valve 1 using a grease gun until the steel track tension is within the specified value of 4.9 to 5.3 in. (125 to 135 mm).
3. To check that the tension is proper, put down the machine and move the machine back and forth slightly.

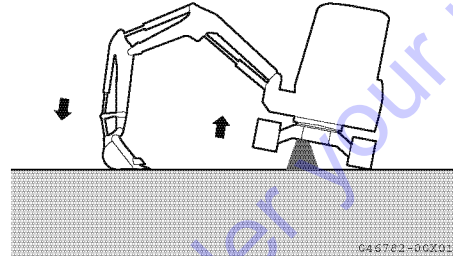

4. Check the steel track tension again. If the tension is improper, adjust it again.
5. Install the cover 2.

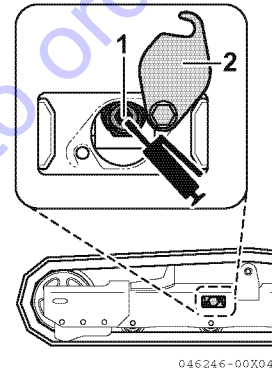

6. The tension can be adjusted until the clearance "a" is reduced to 0 in. (0 mm). If the tension is still loose after adjustment, the pin and the bush should be reversed or replaced because they are worn excessively. Ask your dealer to repair the track.

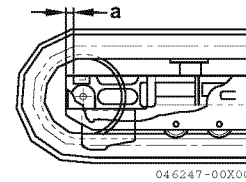

- Loosening the tension

⚠ WARNING

- Grease is under high pressure. If the greasing valve (1) is opened suddenly, grease could be ejected or the valve could blow, which could cause bodily injury.
- Do not rely on valve appearance alone to determine whether or not grease has been discharged, but check that by measuring the tension of the rubber track.
- Do not open the greasing valve (1) more than one turn.
- It is very dangerous to discharge the grease by any procedure other than that described below. If the tension of the rubber track cannot be loosened, contact your dealer and ask for repair.

1. Remove the cover 2.
2. Raise the machine with the implement and slowly loosen the greasing valve 1 and discharge the grease to adjust the steel track tension to the specified value of 4.9 to 5.3 in. (125 to 135 mm).
3. Never loosen the greasing valve more than one turn. (If the grease is not discharged completely, put down the machine and move the machine back and forth slightly.)
4. Tighten the greasing valve 1.
Tightening torque : 36.2 ft•lbf (49.0 N•m)
5. To check that the tension is proper, put down the machine and move the machine back and forth slightly.
6. Recheck the steel track tension and readjust it if necessary.
7. Completely wipe off the discharged grease with a waste cloth.
8. Install the cover 2.

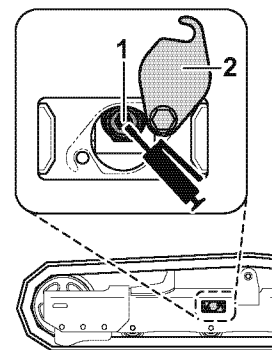
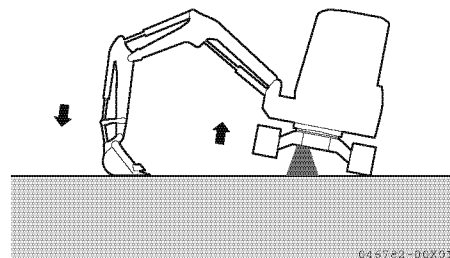

Replacing the bucket teeth and the side cutter

■ Replacing the bucket teeth

When the bucket teeth are worn, replace them in accordance with the following procedure:

⚠ WARNING

When replacing the bucket teeth, be careful not to move the implement by mistake for safety. Place the implement in a stable position, stop the engine, and securely lock the lock levers.

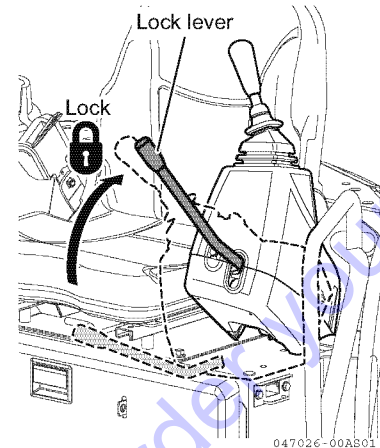

Replace the point type teeth before they are worn to the adapter.

- Place the bucket so that the bottom is level.
- Removing a point:

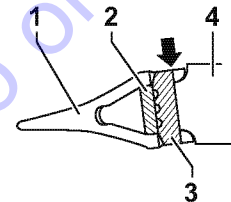

1. Strike out the locking pin 3, which connects the point type tooth 1 to the adapter 4, with a hammer and a tool applied to the pin for removal of it.

IMPORTANT

Do not strike the tool toward the rubber pin lock (2). Otherwise the rubber pin lock may be damaged. Strike the tool toward the back of locking pin (3).

2. Remove the rubber pin lock 2.
3. Check the removed rubber pin lock 2 and locking pin 3.

Replace the damaged rubber pin lock and locking pin. Using the following rubber pin lock and locking pin may cause the points to come off during operation. So, replace them with new ones.

- There is a crack in the rubber of the pin lock and the roller may come off.
- When the roller is pressed with a finger, it sinks in the rubber.
- The locking pin is too short.

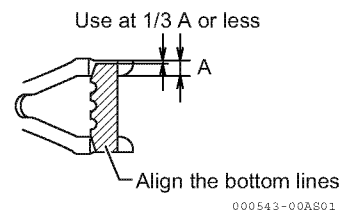
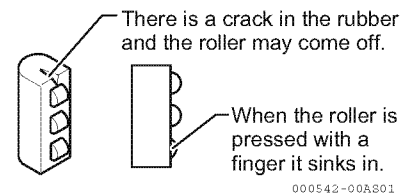

4. Clean the surface of adapter 4 with a putty knife to remove the hard mud on it.
5. Press-fit the rubber pin lock 2 into the hole in adapter 4 by hand or by a hammer.

IMPORTANT

Do not let the rubber pin lock come out of the adapter surface.

6. Fit the point 1 onto adapter 4 and check that the rear surface of the pin bore in the point is aligned with the rear surface of the pin bore in the adapter when the point is pressed strongly.

IMPORTANT

If the rear surface of the pin (3) in the pin bore in the point (1) is in front of the rear surface of the pin bore in the adapter (4), do not strike the locking pin (3) in the bores.

7. Press fit the locking pin 3 in the pin bore in the point 1 and strike the pin so that the upper end of the locking pin should be aligned with the surface of the point.
 - Replace the rubber pin lock and the locking pin with new ones when replacing the point to prevent it from coming off.

■ Replacing the side cutter

Delay in replacing the side cutter could damage the bucket.

Replace the side cutter before the bucket is damaged.

Tightening torque :

110 to 130 ft•lbf (147 to 176 N•m)

Adhesive : Loctite 262

- Replace the bolts, nuts and spring washers when replacing the side cutter.

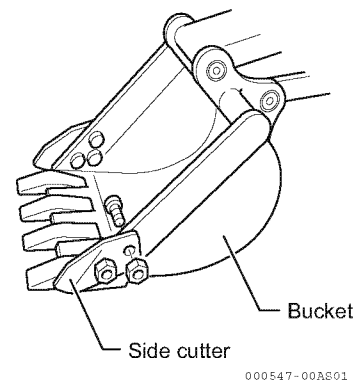
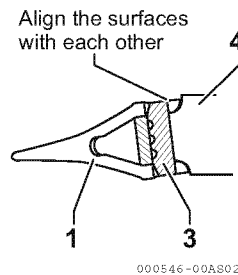
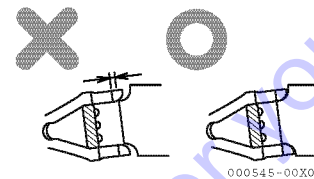
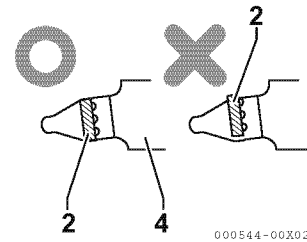

Replacing the blade cutting edge (with the angle blade)

⚠ WARNING

When replacing the cutting edge, be careful not to move the blade by mistake for safety.

Place the blade in a stable position, stop the engine, and securely lock the lock levers.

When the cutting edge is worn, loosen the nuts as shown in the figure and replace the cutting edge.

When installing the cutting edge, apply adhesive to the bolts and tighten the nuts with the following tightening torque.

Tightening torque:

151.8 to 173.5 ft•lbf (205.8 to 235.2 N•m)

Adhesive: Loctite 262

- Replace the bolts, nuts and spring washers when replacing the cutting edge.

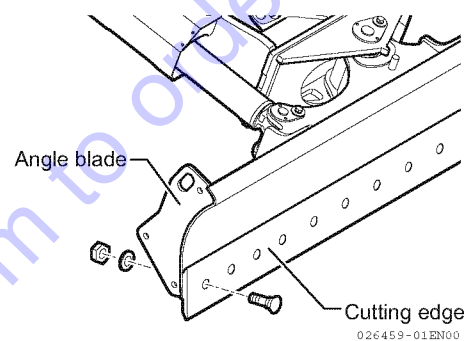
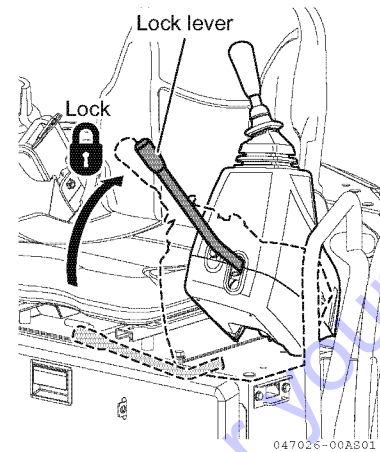

8.3 Checking before start-up

Check the items described below before starting the engine first in a day.

For details of the following items, refer to Section “Checking before start-up” on page 143 of “OPERATION” PART.

- Checking and replenishing the cooling water
- Checking and replenishing the engine oil
- Checking and replenishing the fuel in the fuel tank
- Checking and replenishing the hydraulic oil in the hydraulic oil tank
- Checking the fan belt tension
- Checking and replenishing the battery electrolyte
- Greasing
- Checking the electrical equipment

Go to Discount-Equipment.com to order your parts

8.4 Maintenance every 50 service hours

Greasing the swing gear and the swing bearing

⚠ WARNING

Do not swing the upperstructure while greasing. Swing the upperstructure after each stage of greasing is completed to avoid serious bodily injury.

1. Grease the swing gear and bearing through the grease nipples indicated in the right figure, using a grease gun.
2. Swing the upperstructure little by little to grease them until the upperstructure makes a full turn.

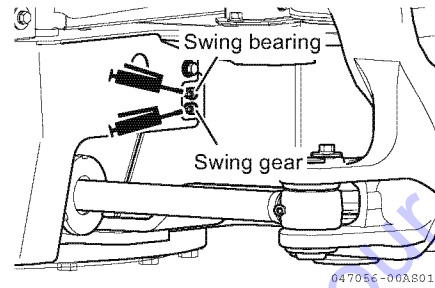

Draining the water and deposits in the fuel tank

⚠ WARNING

Keep sparks, flames and lit cigarettes away.

■ Things to prepare

- Container for fuel waste
1. Swing the upperstructure so that the drain cock 1 under the fuel tank is positioned in the middle of the right and left tracks.
 2. Put the container for fuel waste under the hose of drain cock 1.
 3. Open the drain cock 1 to drain the water and dirt deposits in the fuel tank.
Take care that the fuel does not splash your body.
 4. When clean fuel starts coming out, close the drain cock 1.

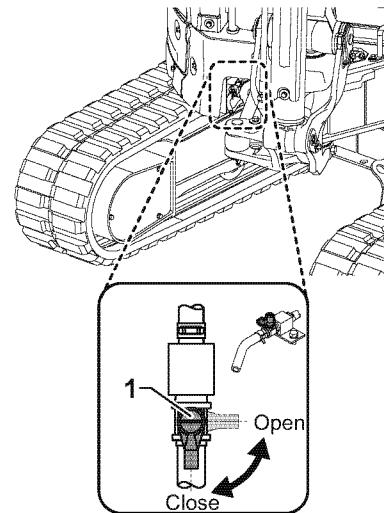

047057-01A800

8.5 Maintenance every 100 service hours

Perform the same maintenance every 50 service hours.

Cleaning the water separator element

⚠ WARNING

- Keep sparks, flames and lit cigarettes away.
- At the operating temperature, the engine components are hot and can cause a burn.
- Disconnect the ground of the battery and clean the element after the engine has cooled sufficiently.
- Fuel oil leaked or spilled onto hot surfaces or electrical components could cause a fire.
- Drain the fuel from the water separator into a container before removing the water separator retainer ring.

■ Things to prepare

- Container for fuel waste
1. Open the engine hood rear cover.
 2. Place the container for fuel waste under the water separator.
 3. After setting the water separator cock to the closed position, loosen the retainer ring to remove the cup and drain the water from the cup. Do not lose the red ring in the cup.
 4. Remove the element and clean it and the inside of the cup, using light oil or a washing agent.
 5. Check the O-ring and if it is damaged or deformed, replace it with a new one.
 6. Install the element and the cup and turn the cock to the open position.
 7. Release air after cleaning of the water separator element.
 8. After air releasing, start the engine to check for leaking and other problems. Then, stop the engine and close the engine hood rear cover.

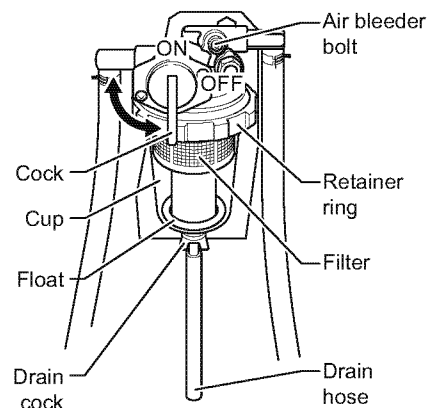

000556-00A801

8.6 Maintenance every 250 service hours

Also perform the maintenance every 50 service hours.

Checking and adjusting the fan belt tension

⚠ WARNING

- Stop the engine, take out the starter switch key, and attach the "SERVICING IN PROGRESS" tag to a control lever.
- The fan belt is hot immediately after the engine is stopped.
Do not adjust the fan belt tension immediately after stopping the engine.
- Adjust the fan belt tension after all parts of the engine have fully cooled down.

■ Checking the fan belt tension

1. Open the engine hood rear cover 1 fully to be locked with the stopper.
2. Press down fan belt between the fan pulley 2 and the generator pulley 3 with a finger to check the generator belt tension.
Pressing load : Approximately 22.1 lbs. (10 kgf)
Adequate slack : 0.39 to 0.59 in. (10 to 15 mm)
3. Adjust the tension if necessary.
4. When the tension is proper, close the engine hood rear cover 1.

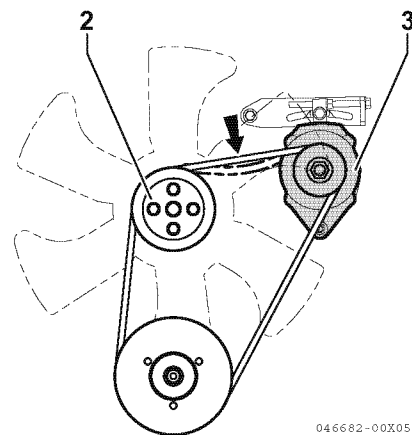
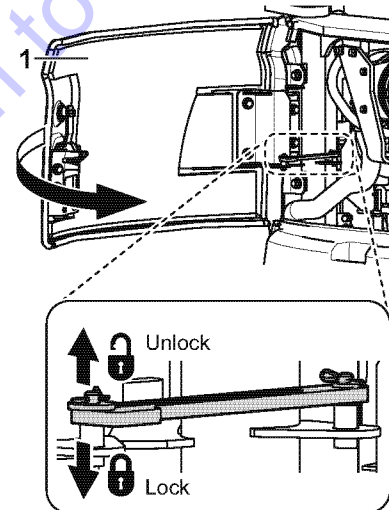

■ Adjustment

1. Open the cover of the seat mount, remove bolts 5 and the cover 4.
2. Loosen mounting bolts 6 of the generator 3.
3. Loosen the lock nut 7 of the adjuster.
4. Turn the adjuster bolt 8 clockwise and move the generator 3 so that the fan belt 9 tension will be slacked approximately 0.4 to 0.6 in. (10 to 15 mm) 72.3 ft-lbf (98.1 N-m).
5. Retighten the mounting bolts 6 to secure the generator.
6. Retighten the lock nut 7 of the adjuster bolt 8.
7. Check the pulleys, the V-groove, and the fan belt 9 for damage, and check to see that the fan belt 9 does not touch the bottom of the V-groove.
8. If the fan belt 9 cannot be adjusted since it has lost its elasticity or if it is damaged or cracked, replace the fan belt 9 with a new one.

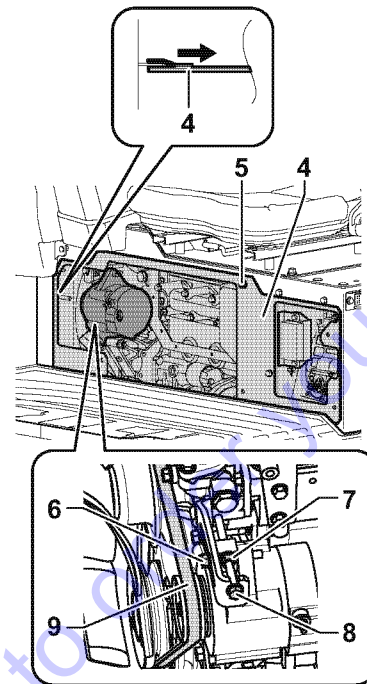

047059-02X00

[Fan belt size] (Inch)

	Size
Fan belt	A38

Checking and cleaning the air cleaner

⚠ WARNING

- Never attempt to clean and replace the air cleaner while the engine is running. Be sure to stop the engine when checking and cleaning it.
- Compressed air is used to clean the element. At that time, be sure to wear safety goggles to prevent scattered dust from coming into your eyes.
- The maximum air pressure should be less than 100 PSI (0.7 MPa) for cleaning purposes.

■ Cleaning procedure for element

1. Open the engine hood rear cover.
2. Remove the clip 1 and remove the dust cup 2.
3. Remove the element 3.
Cover the connector side in the back of the air cleaner body with a waste cloth and tape to prevent dirt from entering.
4. Clean the dust cup 2 and the inside of the body.
5. Blow dry compressed air [100 PSI (0.7 MPa) or less] from inside the element 3 along the pleats to initially remove the dirt. Then blow compressed air from outside the element 3 along the pleats to remove dirt. The blow compressed air again from inside the element 3.

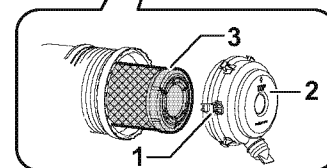
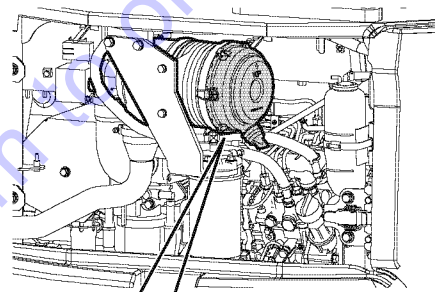

046838-00X01

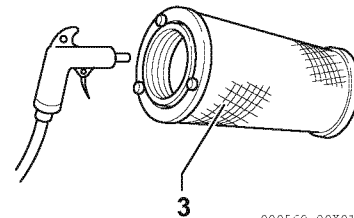

000560-00X01

6. After cleaning, illuminate the element from inside with a light bulb to check it. If there are any small holes or thinner parts, replace the element with a new one.

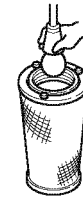

000561-00X01

IMPORTANT

- When cleaning the element, do not tap it or strike it against other objects. Otherwise the element may be damaged.
- Do not reuse the element if the pleat, gasket or seal is damaged.
- Wrap an unused element with paper and store it in a dry place.

7. Remove the clean cloth and the tape used to cover the connector in the back of the body.
8. Mount the cleaned element.
9. Install the dust cup while checking the arrow on it.
10. Close the engine hood rear cover.

Go to Discount-Equipment.com to order your parts

Checking and replenishing the lube oil for the travel reduction gearbox

⚠ WARNING

- The gear oil and casing of the reduction gearbox are hot immediately after ceasing machine operation and can cause bodily injury such as a burn.
Do not allow hot oil or the gearbox to contact your skin.
Replace the oil after the oil and the gearbox have cooled enough to permit touching the surface of the gearbox casing with your bare hand.
- At operating temperature, the reduction gearbox is hot and its contents are under pressure.
In such condition, the oil or a plug may be ejected violently, causing bodily injury. Loosen a plug slowly to gradually relieve the residual pressure.

■ Things to prepare

- Container for oil
 - Oil jug
1. Place the machine so that the oil supply port (common to the drain port) 1 will be in the highest position, as illustrated in the right figure.
 2. Place the container for oil under the level port 2.
 3. Remove the level port 2 plug using a hexagon socket screw key and check that the oil level reaches the lower end of the plug port.
 4. When the oil quantity is insufficient, replenish gear oil through the oil supply port until gear oil overflows from the level port 2.
See Section "4. Fueling, Oiling and Greasing Based on Temperature Range" on page 247 for the oil to be used.
 5. Install the plug.
Tightening torque : 15.9 to 17.4 ft•lbf (21.6 to 23.5 N•m)

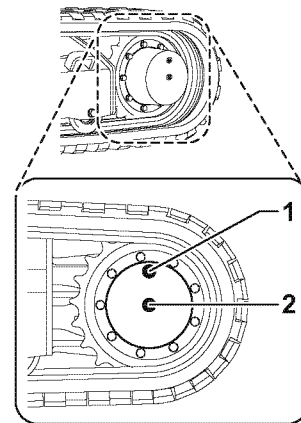

8.7 Maintenance every 500 service hours

Also perform the maintenance every 50, 100, and 250 service hours.

Replacing the fuel filter

⚠ WARNING

- Keep sparks, flames and lit cigarettes away.
 - At the operating temperature, the engine components are hot and can cause a burn. Replace the element after the engine has cooled sufficiently.
- The fuel leaked or spilled onto hot surfaces or electrical components may cause a fire.

■ Things to prepare

- Container for fuel
1. Open the engine hood rear cover.
 2. Place the container for fuel under the fuel filter 1.
 3. Turn the fuel filter counterclockwise with the filter wrench to remove it.
 4. Wipe the dirt from the filter mount.
 5. Fill up the new filter with fuel and apply engine oil to the seal surface of it, then mount it.

IMPORTANT

Be careful not to tighten the filter too much. Screw it in until its packing contacts the bracket and tighten it 2/3 turns more.

6. Release air after the replacement of filter is completed. (Refer to page 281).
7. After air releasing, start the engine to check for leaking and other problems.
8. Then, stop the engine and close the engine hood rear cover.

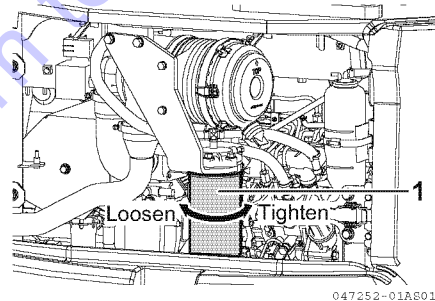

■ How to release air:

1. Fill up the fuel tank.
2. Set the lock lever 1 to the "LOCK" position and the engine control dial to the "RUN" position.
3. Turn the starter switch to the "START" position to crank the engine for approximately 10 seconds.
Air is automatically released and the engine starts.

IMPORTANT

If the engine is not started after this procedure, turn the starter switch to the "OFF" position after 10 seconds and at least a minute later turn it to the "START" position again to restart the engine.

When you refuel, release air in the same way; that is, crank the engine for 10 seconds four or five times. After the engine starts, sometimes it revolves irregularly and stops approximately 20 to 30 seconds later. In this case, turn the starter switch to the "OFF" position, wait for one minute or more and turn the starter switch to the "START" position again.

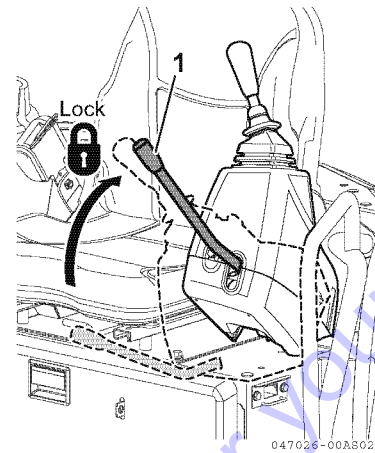

Go to Discount-Equipment.com to order your parts

Replacing the engine oil and the engine oil filter element

⚠ WARNING

- Do not replace the oil immediately after the engine stops to prevent bodily injury, because all the components are hot.
- Do not allow hot oil or components to contact skin.
- Replace the oil and the filter element after the oil and the components have cooled sufficiently.

■ Things to prepare

- Replacement new oil and container for waste oil

Model	Amount of oil	Container
ViO35-6A	7.7 Qts. (7.3 L)	2 Gals. (8 L) or more

- Filter wrench for engine oil filter cartridge

1. Swing the upperstructure so that the drain plug **P** on the bottom of the engine is positioned in the middle of the right and left tracks.
2. Remove the bolts **1** to remove the cover **2** under the machine body. Put the container for waste oil under the drain plug **P**.
3. Slowly remove the drain plug **P** so that the oil should not splash your body and drain the waste oil.
4. Check the waste oil, and contact your dealer if a lot of metallic particles or foreign objects are mixed in it.
5. Reinstall the drain plug **P**.
6. Turn the oil filter cartridge **3** counterclockwise with the filter wrench to remove it.
After removing the oil filter, wait for 10 to 15 minutes.
7. Wipe the dirt and oil from the filter mount and apply engine oil (or apply grease lightly) to the seal surface of a new oil filter and mount the filter.

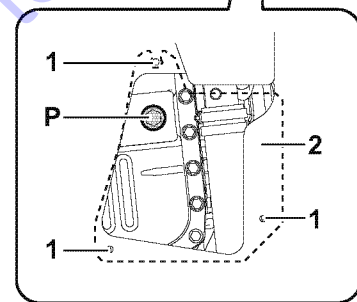
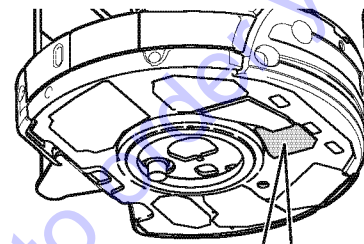

047023-00X03

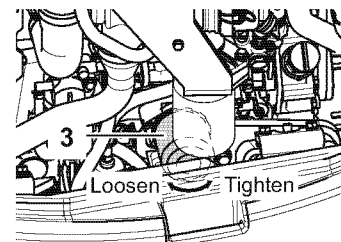

047088-00AS02

8. When mounting the filter, turn it 2/3 of a turn after the seal surface has contacted with the filter mount.

9. After replacing the oil filter cartridge **3**, supply engine oil to the upper limit mark on the oil dipstick **5** through the oil supply port **4**.

Refer to Section "4. Fueling, Oiling and Greasing Based on Temperature Range" for the oil to be used.

10. Idle the engine for several minutes and then stop the engine. Then check that the oil level exceeds the mid-point between the upper and lower limit marks on the oil dipstick.

Refer to Section "8.3 Checking before start-up".

11. Install and tighten the oil supply port cap securely.

12. Mount the cover **2** under the body.

Replace the engine oil and the oil filter element 1 year after the previous replacement, even if the service hours have not reached 500 hours.

Also replace them at 500 service hours, even if 1 year has not elapsed since the previous replacement.

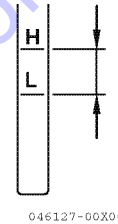
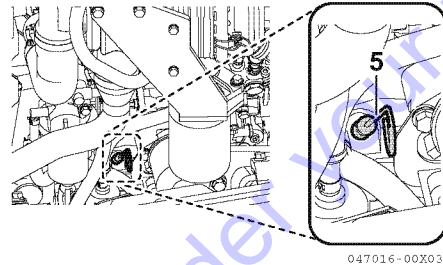
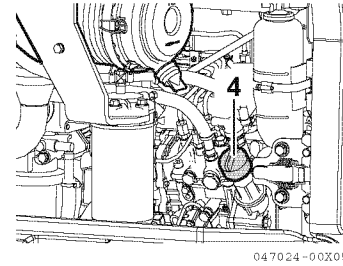

Go to Discount-Equipment.com to order your parts

Checking and cleaning the radiator and oil cooler fin

⚠ WARNING

- Never attempt to check and clean the radiator fin while the engine is running.
Always stop the engine and allow it to cool first, before checking and cleaning it.
- Compressed air can cause bodily injury since the objects around the radiator fin may scatter.
- Whenever using compressed air for cleaning, check that there are no other persons nearby, and always wear safety goggles and protective clothing and shoes.
- The maximum compressed air pressure should be less than 100 PSI (0.7 MPa) for cleaning purposes.

1. Open the engine hood rear cover and open the bonnet R 1.
2. Clean off any mud, dirt or leaves clogged in the radiator fins 2 and the oil cooler fins 3 by blowing compressed air or by flushing with steam.

IMPORTANT

- Always blow the compressed air a little away from the fin to prevent damage to the fin.
- The damaged fin will cause water and oil leakage and overheating.

3. Check that the radiator fins 2 and oil cooler fins 3 are straight and all the dirt is removed completely.
4. Close the engine hood R 1 and close the engine hood rear cover.

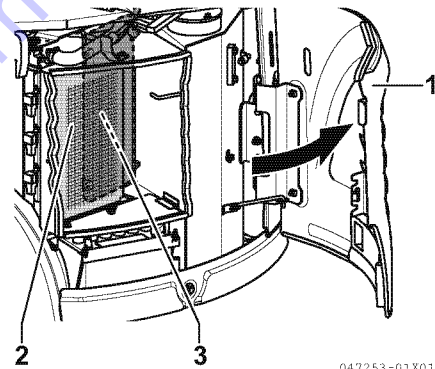

047253-01X01

Replacing the air cleaner element

⚠ WARNING

Never attempt to replace the air cleaner element while the engine is running.

Replace the air cleaner element after the engine has been stopped and cooled sufficiently.

1. Open the engine hood rear cover.
2. Remove the clip 1 to remove the dust cup 2.
3. Remove the element 3.
Cover the connector side in the back of the air cleaner body with a clean cloth and tape to prevent dirt from entering.
4. Clean the dust cup 2 and the inside of the body.
Remove the clean cloth and the tape used to cover the connector in the back side of the body.
5. Install a new element 3.
6. Install the dust cup 2, while checking the arrow on it.
7. Close the engine hood rear cover.

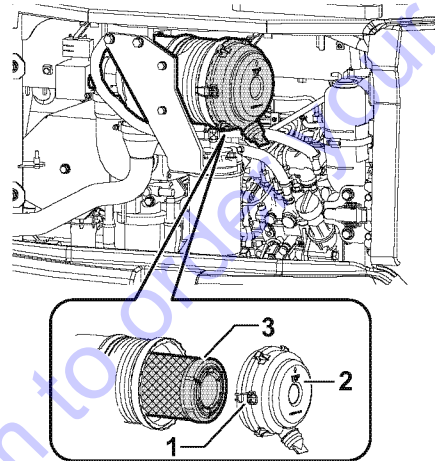

046638-00X01

Go to Discount-Equipment.com to buy your parts

Replacing the hydraulic oil return filter element

⚠ WARNING

- The hydraulic oil and the tank are hot and under pressure at operating temperature. Never replace the oil immediately after operation is stopped.
- Wait until the tank has cooled enough to permit you to touch its surface with your bare hand.
- When removing the oil supply port cap, slowly loosen it to relieve the internal pressure, then remove the cap carefully.
- If the cover of the tank is removed too quickly, the cover may pop out due to the spring force applied to the filter. Also, the hydraulic oil may spout out if the pressure inside the tank has not been gradually relieved.
- Slowly loosen the bolts to remove the cap.

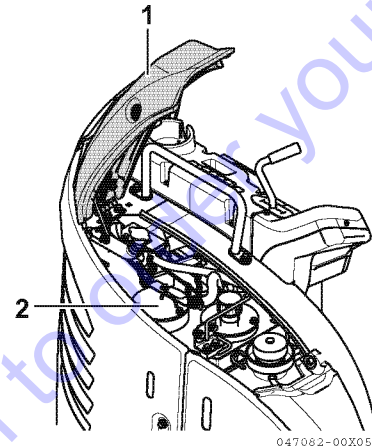

1. Open the bonnet B 1 and clean the area around the tank cover 2 on top of the hydraulic oil tank, using a cloth.
2. Slowly loosen the bolts to relieve the internal pressure, and remove the tank cover 2.
3. Remove the old filter 3 and install the valve to a new filter 3, then install the new filter 3 into the tank.

IMPORTANT

Do not allow any dirt to enter the tank when installing the return filter (3).

4. Clean the contact face of the cover 2 with a cloth and check the O-ring 5. If the O-ring 5 is damaged, replace the O-ring 5 with a new one and then reinstall the tank cover 2.
5. Close the bonnet B 1.

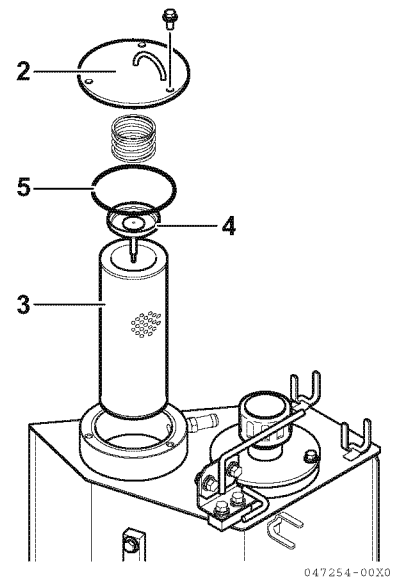

8.8 Maintenance every 1000 service hours

Also perform the maintenance every 50, 100, 250 and 500 service hours.

Replacing the lube oil for the travel reduction gearbox

⚠ WARNING

- The gear oil and casing of the reduction gearbox are hot immediately after ceasing machine operation and can cause bodily injury such as a burn.
Do not allow hot oil or the gearbox to contact your skin.
Replace the oil after the oil and the gearbox have cooled enough to permit touching the surface of the gearbox casing with your bare hand.
- At operating temperature, the reduction gearbox is hot and its contents are under pressure.
In such condition, the oil or a plug may be ejected violently, causing bodily injury. Loosen a plug slowly to gradually relieve the residual pressure.

■ Things to prepare

- Container for waste oil : Capacity of 0.53 Qts. (0.5 L) or more
 - New oil : 0.53 Qts. (0.5 L) for right and left each
 - Oil jug : Capacity of 0.53 Qts. (0.5 L) or more
1. Place the machine so that the oil supply port (common to the drain port) 1 will be in the lowest position, as illustrated in the right figure.
 2. Put the container for the waste oil under the oil supply port 1.
 3. Remove the oil supply port 1, and level port 2 plugs with a hexagon socket screw key to drain the waste oil.

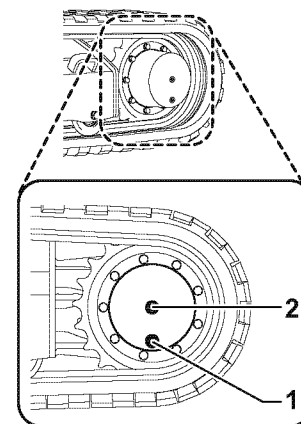

4. After draining the waste oil, reinstall the plug to the oil supply port 1.

[Tightening torque : 15.9 to 17.4 ft•lbf (21.6 to 23.5 N•m)]

5. Rotate the travel reduction gearbox and place the oil supply port 1 in the highest position as illustrated in the right figure.

6. Replenish gear oil to the specified level through the oil supply port 1. Refer to Section "4. Fueling, Oiling and Greasing Based on Temperature Range" on page 247 for the oil to be used.

7. When the oil overflows from the level port 2, reinstall the oil supply port 1 and level port 2 plugs.

[Tightening torque : 15.9 to 17.4 ft•lbf (21.6 to 23.5 N•m)]

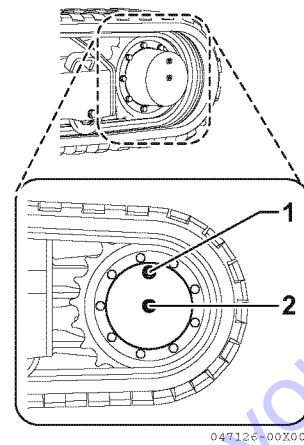

Go to Discount-Equipment.com to order your parts

Replacing the hydraulic oil and cleaning the suction filter element

⚠ WARNING

- The hydraulic oil and the tank are hot and under pressure at operating temperature. Never replace the oil immediately after operation is stopped.
Wait until the tank has cooled enough to permit you to touch its surface with your bare hand.
- When removing the oil supply port cap, slowly loosen it to relieve the internal pressure, then remove the cap carefully.
- If the cover of the tank is removed too quickly, the cover may pop out due to the spring force applied to the filter. Also, the hydraulic oil may spout out if the pressure inside the tank has not been gradually relieved.
Slowly loosen the bolts to remove the cap.

■ Things to prepare

- Container for waste oil : Capacity of 10.6 Gals. (40 L) or more
 - New hydraulic oil : 10.6 Gals. (40 L)
[When all oil is drained from all of the hydraulic equipment, pipes and hoses, the required new oil amount is 16.4 Gals. (62 L)].
 - O-ring
1. Swing the upperstructure so that the drain plug **P** at the bottom of the hydraulic oil tank is positioned in the middle of the right and left tracks.
 2. Retract the bucket and arm cylinders to their stroke ends, lower the boom and put the bucket teeth on the ground.
 3. Put the blade on the ground and stop the engine.

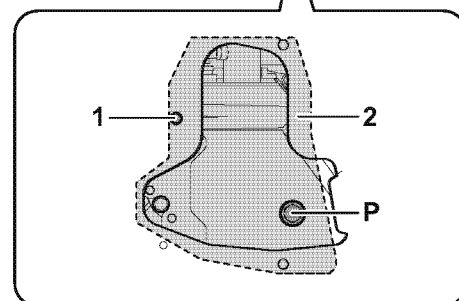
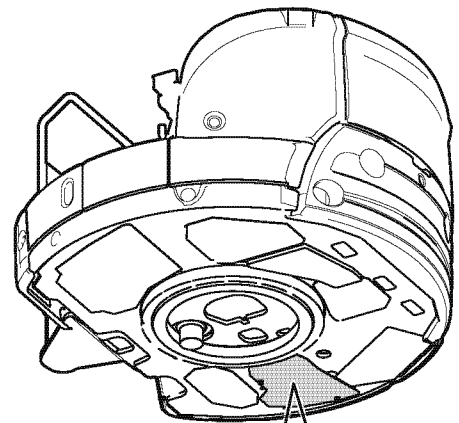
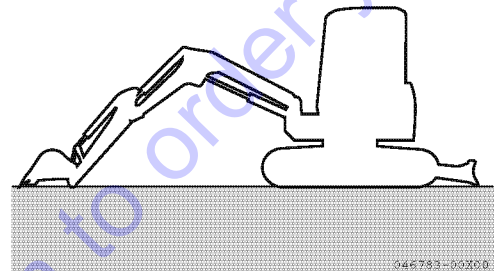

4. Open the bonnet B 3 and clean the area around the tank cover 4 on the top of the hydraulic oil tank with a cloth.

Slowly loosen the cap 5 to relieve the internal pressure.

5. Remove bolts 1 to remove the bottom cover 2. Put the container for waste oil under the drain plug P.

6. Remove the drain plug P and drain the waste oil.
When removing the drain plug, take care that the oil does not splash your body.

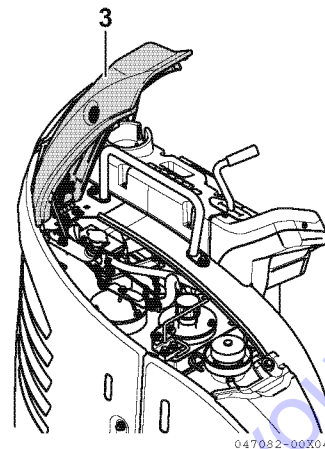

7. Degrease and wash the threads of the plug P, and replace the O-ring 6 installed onto the plug P with a new one.

8. After draining the waste oil, reinstall install and tighten the drain plug P.

Tightening torque : 80 ft•lbf (108 N•m)

9. Remove the tank cover 4 and take out the filter 7 to remove the dirt from it and wash it with clean wash oil or light oil.

10. Check the filter and the O-ring 6 installed onto it. If the filter 7 or the O-ring 6 is damaged or cracked, replace the filter 7 with a new one and install it in the tank.

IMPORTANT

Do not allow any dirt to enter the tank when installing the filter.

11. Wipe off the tank cover 4 mounting surface with a cloth and check the O-ring 6. If the O-ring 6 is damaged, replace it with a new one and then install the tank cover 4.

12. Put oil to the specified level through the oil supply port.
Check the oil level with the oil level gauge on the side of the tank and do not put oil beyond the midpoint between the upper and lower limit marks on the oil level gauge.

See Section "4. Fueling, Oiling and Greasing Based on Temperature Range" for the oil to be used.

13. After replacing the oil, set all control levers to the neutral position and idle the engine for approximately 2 to 3 minutes and then control each implement to check their operation.

14. Close the bonnet B 3.

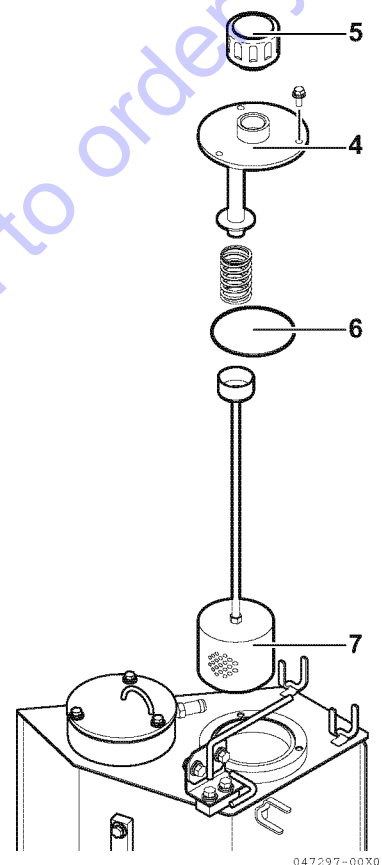

Checking and adjusting the intake/exhaust valve clearances

Ask your dealer for checking and adjusting.

8.9 Maintenance every 1500 service hours

Also perform the maintenance every 50, 100, 250 and 500 service hours.

Checking and adjusting the fuel injection pump.

Ask your dealer for checking and adjusting.

Checking, cleaning and testing the fuel injection valve.

Ask your dealer for checking, cleaning and testing.

Checking the crankcase breather system

Ask your dealer for checking.

Go to Discount-Equipment.com to order your parts

8.10 Maintenance every 2000 service hours

Also perform the maintenance every 50, 100, 250, 500 and 1000 service hours.

Cleaning the inside of the cooling system

⚠ WARNING

- The cooling water is very hot immediately after the engine has stopped. Discharging the cooling water immediately after the engine has stopped may cause burns. Start cleaning the inside of the cooling system after the engine has cooled down sufficiently.
- Stepping into the area behind the machine to clean the inside of the cooling system while the engine is running is very dangerous, because you may not be visible from the operator's seat and the machine could start moving. Also, with the engine hood being opened, contacting the radiator fan or fan belt could result in serious bodily injury. Never step into the area behind the machine while the engine is running.
- Do not remove the radiator cap while the water temperature in the radiator is high. Hot water may spout from the radiator. When you do remove the radiator cap after the water has cooled down, slowly turn the radiator cap to release the internal pressure before removing it.

Clean the inside of the cooling system and replace the anti-freeze for every 2000 service hours or within 2 years, whichever first occurs.

Park the machine on level ground to clean or replace the cooling water.

The YANMAR Long-Life Coolant has anticorrosive effect as well as anti-freeze effect.

Though the mixing ratio of an anti-freeze to water differs with air temperature, at least 30% of anti-freeze by volume is required to obtain anticorrosive effect.

Determine the mixing ratio of the anti-freeze to water on the basis of the lowest past temperature, referring to the ratio table below.

Actually set the temperature 18°F (10°C) lower than the lowest temperature.

■ **Table of mixing ratio of anti-freeze to water**

Lowest temperature	°F (°C)	23 (-5)	14 (-10)	5 (-15)	-4 (-20)	-13 (-25)	-22 (-30)	-31 (-35)	-40 (-40)
Amount of anti-freeze	Qts. (L)	0.66 (0.6)	1.10 (1.1)	1.32 (1.3)	1.54 (1.5)	1.76 (1.7)	1.98 (1.9)	2.20 (2.1)	2.42 (2.3)
Amount of water	Qts. (L)	3.74 (3.6)	3.3 (3.1)	3.08 (2.9)	2.86 (2.7)	2.64 (2.5)	2.42 (2.3)	2.20 (2.1)	1.98 (1.9)

Note :

At the delivery from the factory, water and anti-freeze are mixed in the ratio shown above for the -31°F (-35°C) temperature.

⚠ WARNING

Keep sources of ignition away from the anti-freeze because it is flammable.

Use soft water or distilled water. If you obtain water from a river, a well or a small water-supply system, consult your dealer.

Use a densitometer to control the mixing ratio.

⚠ WARNING

When removing the drain plug, be careful that the anti-freeze does not contact your eyes or skin.

How to clean the inside of the cooling water system

- Container for cooling water
Capacity : 5.3 Qts. (5 L) or more
 - Hose for supplying the water
1. Swing the upper structure so that the drain plug **P** is positioned in the middle of the right and left tracks.
 2. Remove bolts **1** and remove the bottom cover **2**. Put the container for cooling water under the drain plug.
 3. Open the bonnet **B 3**, slowly remove the radiator cap **4**, pour in the washing agent and mount the cap **4**.

IMPORTANT

Washing methods vary depending on the manufacturer of the washing agent.
Follow the instructions of the manufacturer.

4. Start the engine until the water temperature rises to 176 °F (80°C) or more and idle the engine for 10 to 15 minutes. Then stop the engine.
5. After the engine has cooled down, slowly loosen the drain plug **P** to drain the cooling water and remove the radiator cap **4**.
When the drain plug **P** is removed, the cooling water in the radiator is completely drained.
6. After the water is completely drained, reinstall the drain plug **P** and pour tap water through the water supply port of the radiator.
7. When the system is filled with water, remove the drain plug **P**, idle the engine and wash the cooling water system with running water until clean water comes out.
While washing with running water, always keep the water system filled with water by adjusting the amount of water to be drained out and poured in.
Hold the water supply hose securely during washing with running water so that the hose should not come off from the water supply port of the radiator.

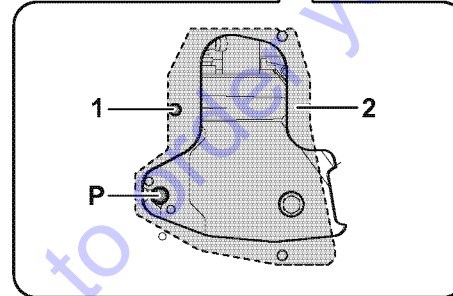
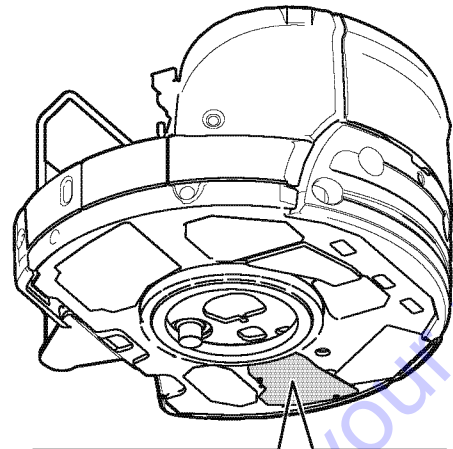

047424-00X00

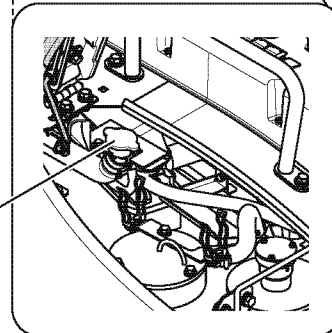
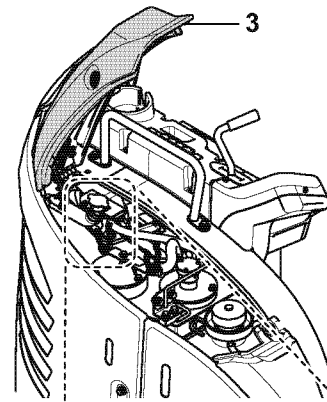

047015-00X01

8. After washing with running water, stop the engine, stop pouring water, drain water completely and then securely reinstall the drain plug **P** and the bottom cover **2**.
9. Pour water mixed with anti-freeze through the water supply port of the radiator to fill it up.
10. To release air, idle the engine for 5 to 6 minutes and then run the engine without load at high speed for 5 to 6 minutes. (While running the engine, keep the radiator cap **4** removed.)
11. Approximately 5 minutes after stopping the engine, pour water mixed with anti-freeze up to the water supply port of the radiator, and install and tighten the cap **4**.
12. Open the engine hood rear cover, drain the cooling water from the sub-tank **5**, wash the inside of the sub-tank **5** and pour water mixed with anti-freeze up to the "FULL" level.

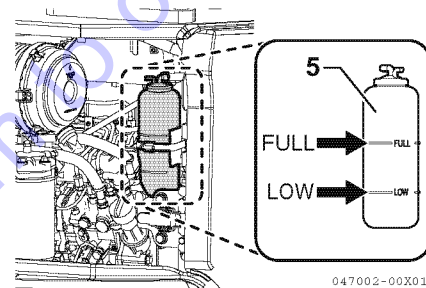

Go to Discount-Equipment.com to order your parts

Checking the accumulator

⚠ WARNING

High pressure nitrogen gas is enclosed in the accumulator. Incorrect handling of the accumulator could cause bodily injury due to an explosion. When handling the accumulator, the following precautions shall be observed:

- Do not disassemble.
- Keep sparks or flames away.
- Do not drill, weld or melt.
- Do not give an impact such as hitting and rolling over.
- The pressure of the hydraulic circuit cannot be relieved completely. When removing the hydraulic equipment, do not work in the direction of oil injection. Loosen the screws slowly.
- As it is necessary to relieve the enclosed gas at the time of disposal, ask your dealer.

IMPORTANT

Continuing to operate the accumulator with the reduced enclosed nitrogen gas pressure will result in failure to relieve the pressure of the hydraulic circuit at the time of machine failures.

■ Function of accumulator

The accumulator 1 accumulates the pressure of the operating circuit. As the operating circuit is activated for awhile even after stopping the engine, the following can be done:

- By moving the control levers to the direction of lowering the implement, it can go down on the ground with its self-weight.
- The pressure of the hydraulic circuit can be released.

Note:

The function can be used when the starter switch is "ON" and the lock lever is in the "Unlock" position.

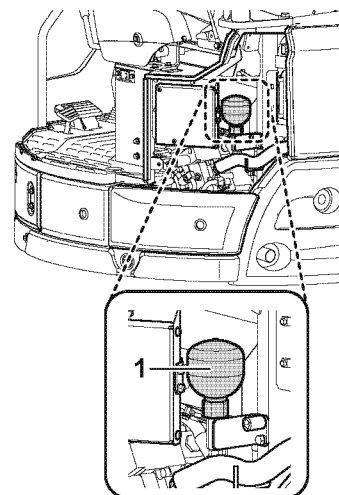

047301-01X00

■ Checking the accumulator function

⚠ CAUTION

Check to see that there are no people or obstacles around the machine before operating the engine.

Check the nitrogen gas enclosed pressure according to the following procedures:

Perform the steps 1-2 while the engine is starting.

1. Stop the machine on level ground with good footing.
2. Keep the implement at maximum reach posture and keep the bucket pivot pin and the boom pivot pin at the same height.

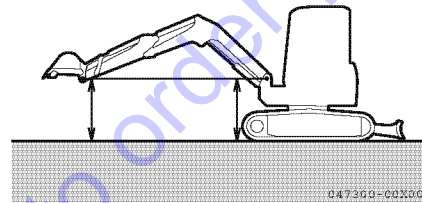

Perform the steps 3-5 within 15 seconds.

As the accumulator pressure is gradually reduced after stopping the engine, checking can only be done right after stopping the engine.

3. While keeping the implement at maximum reach posture, set the starter switch to the "OFF" position to stop the engine.

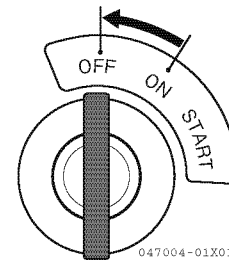

4. Set the starter switch to the "ON" position.

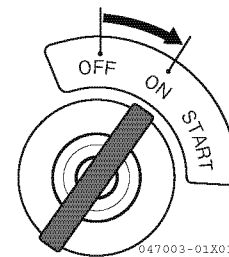

5. Set the lock lever 2 to the "Unlock" position and move the control levers to the boom lower direction at full stroke to check if the implement can go down on the ground.

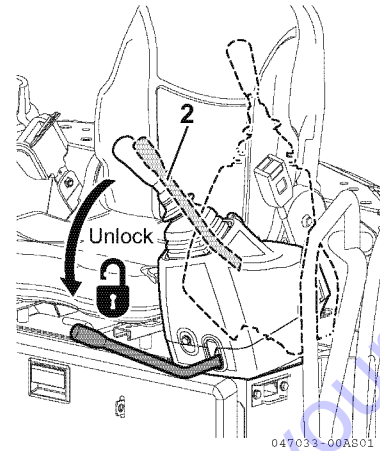

6. If the implement can go down on the ground with its self-weight, the accumulator is normal.
If the implement cannot be lowered or stops along the way, the gas enclosed pressure of the accumulator for operation circuit could be reduced.
Ask your dealer to check the machine.

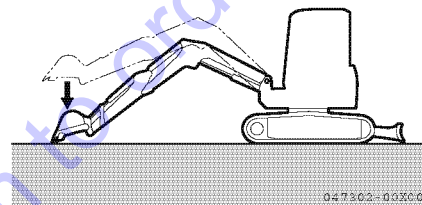

7. Set the lock lever to the "LOCK" position and turn the starter switch "OFF" after the completion of checking.

8.11 Maintenance every 3000 service hours

Also perform the maintenance every 50, 100, 250, 500, 1000 and 1500 service hours.

Checking, cleaning and testing EGR valve

Ask your dealer for checking, cleaning and testing.

Cleaning EGR lead valve

Ask your dealer for cleaning.

SPECIFICATIONS AND DIMENSIONAL DIAGRAMS

1. **Specifications and Dimensional Diagrams** 301

Go to Discount-Equipment.com to order your parts

1. Specifications and Dimensional Diagrams

■ Specifications

Items	Type	VIO35-6A with standard blade			
		Quick coupler		Without quick coupler	
		Canopy	Cabin	Canopy	Cabin

- Weight

Operating mass	Rubber track	lbs. (kg)	7905 (3585)	8214 (3725)	7795 (3535)	8013 (3675)
	Steel track	lbs. (kg)	8125 (3685)	8434 (3825)	8015 (3635)	8324 (3775)

- Working range and performance

Bucket capacity, standard	cu.ft (cu.m)	3.88 (0.11)				
Bucket width, standard	in. (mm)	23.2 (590)				
Maximum digging depth <at down the blade>	in. (mm)	128.0 (3250) <135.4 (3440)>	122.0 (3100) <129.5 (3290)>			
Maximum vertical wall digging depth	in. (mm)	94.9 (2410)	100.8 (2560)			
Maximum cutting height	in. (mm)	201.2 (5110)	195.3 (4960)			
Maximum dumping height	in. (mm)	134.3 (3410)	140.2 (3560)			
Maximum digging radius of the ground	in. (mm)	207.5 (5270)	201.2 (5110)			
Front minimum swing radius <at swinging the boom>	in. (mm)	85.4 (2170) <76.8 (1950)>	79.5 (2020) <71.3 (1810)>			
Boom swing angle: left / right	degrees	43 / 65				
Maximum digging force (bucket)	lbf (kN)	5643 (25.1)	7216 (32.1)			
Travel speed: high / low	MPH (km / h)	2.7 (4.5) / 1.6 (2.7)				
Swing speed	rpm	9.5				
Average ground pressure, standard track	Rubber track	PSI (kPa)	4.80 (33.1)	4.97 (34.3)	4.74 (32.7)	4.92 (33.9)
	Steel track	PSI (kPa)	4.93 (34.0)	5.11 (35.2)	4.87 (33.6)	5.05 (34.8)
Hydraulic pump displacement	GPM (L / min)	9.8 (37.0)×2 <Variable displacement pump> 6.9 (26.2)×1, 2.9 (10.8)×1 <Gear pump>				
System relief set pressure	PSI (MPa)	3205 (22.1)×2, 3060 (21.1)×1				

- Engine

Type	-	Vertical three cylinder water-cooled direct injection diesel engine
Model	-	3TNV88F-ESBV
Rated output, gross / revs	HP (kW) / rpm	24.4 (18.2) / 2200
Displacement	cu.in. (cu.cm)	100.2 (1642)
Compression pressure	PSI (MPa)	493.1 (3.4) at 250 rpm
Nozzle injection pressure	PSI (MPa)	2843 to 2988 (19.6 to 20.6)
Fan belt (V-belt) size	-	A38
Generator capacity	V / A	12 / 55

- **Battery type and capacity.....90D26R, 55Ah (5 hours rate capacity)**

Items	Type		ViO35-6A with angle blade			
			Quick coupler		Without quick coupler	
			Canopy	Cabin	Canopy	Cabin

• Weight

Operating mass	Rubber track	lbs. (kg)	8223 (3730)	8532 (3870)	8113 (3680)	8422 (3820)
	Steel track	lbs. (kg)	8443 (3830)	8752 (3970)	8333 (3780)	8642 (3920)

• Working range and performance

Bucket capacity, standard	cu.ft (cu.m)	3.88 (0.11)				
Bucket width, standard	in. (mm)	23.2 (590)				
Maximum digging depth <at down the blade>	in. (mm)	128.0 (3250) <135.0 (3430)>		122.0 (3100) <129.1 (3280)>		
Maximum vertical wall digging depth	in. (mm)	94.9 (2410)		100.8 (2560)		
Maximum cutting height	in. (mm)	201.2 (5110)		195.3 (4960)		
Maximum dumping height	in. (mm)	134.3 (3410)		140.2 (3560)		
Maximum digging radius of the ground	in. (mm)	207.5 (5270)		201.2 (5110)		
Front minimum swing radius <at swinging the boom>	in. (mm)	85.4 (2170) <76.8 (1950)>		79.5 (2020) <71.3 (1810)>		
Boom swing angle: left / right	degrees	43 / 65				
Maximum digging force (bucket)	lbf (kN)	5643 (25.1)		7216 (32.1)		
Travel speed: high / low	MPH (km / h)	2.7 (4.5) / 1.6 (2.7)				
Swing speed	rpm	9.5				
Average ground pressure, standard track	Rubber track	PSI (kPa)	4.99 (34.4)	5.17 (35.6)	4.92 (34.0)	5.10 (35.2)
	Steel track	PSI (kPa)	5.11 (35.3)	5.29 (36.5)	5.05 (34.8)	5.23 (36.1)
Hydraulic pump displacement	GPM (L / min)	9.8 (37.0)×2 <Variable displacement pump> 6.9 (26.2)×1, 2.9 (10.8)×1 <Gear pump>				
System relief set pressure	PSI (MPa)	3205 (22.1)×2, 3060 (21.1)×1				
Blade angle: left / right	degrees	25 / 25				

• Engine

Type	-	Vertical three cylinder water-cooled direct injection diesel engine
Model	-	3TNV88F-ESBV
Rated output, gross / revs	HP (kW) / rpm	24.4 (18.2) / 2200
Displacement	cu.in. (cu.cm)	100.2 (1642)
Compression pressure	PSI (MPa)	493.1 (3.4) at 250 rpm
Nozzle injection pressure	PSI (MPa)	2843 to 2988 (19.6 to 20.6)
Fan belt (V-belt) size	-	A38
Generator capacity	V / A	12 / 55

• Battery type and capacity.....90D26R, 55Ah (5 hours rate capacity)

■ Model view and working range

Unit: in. (mm)

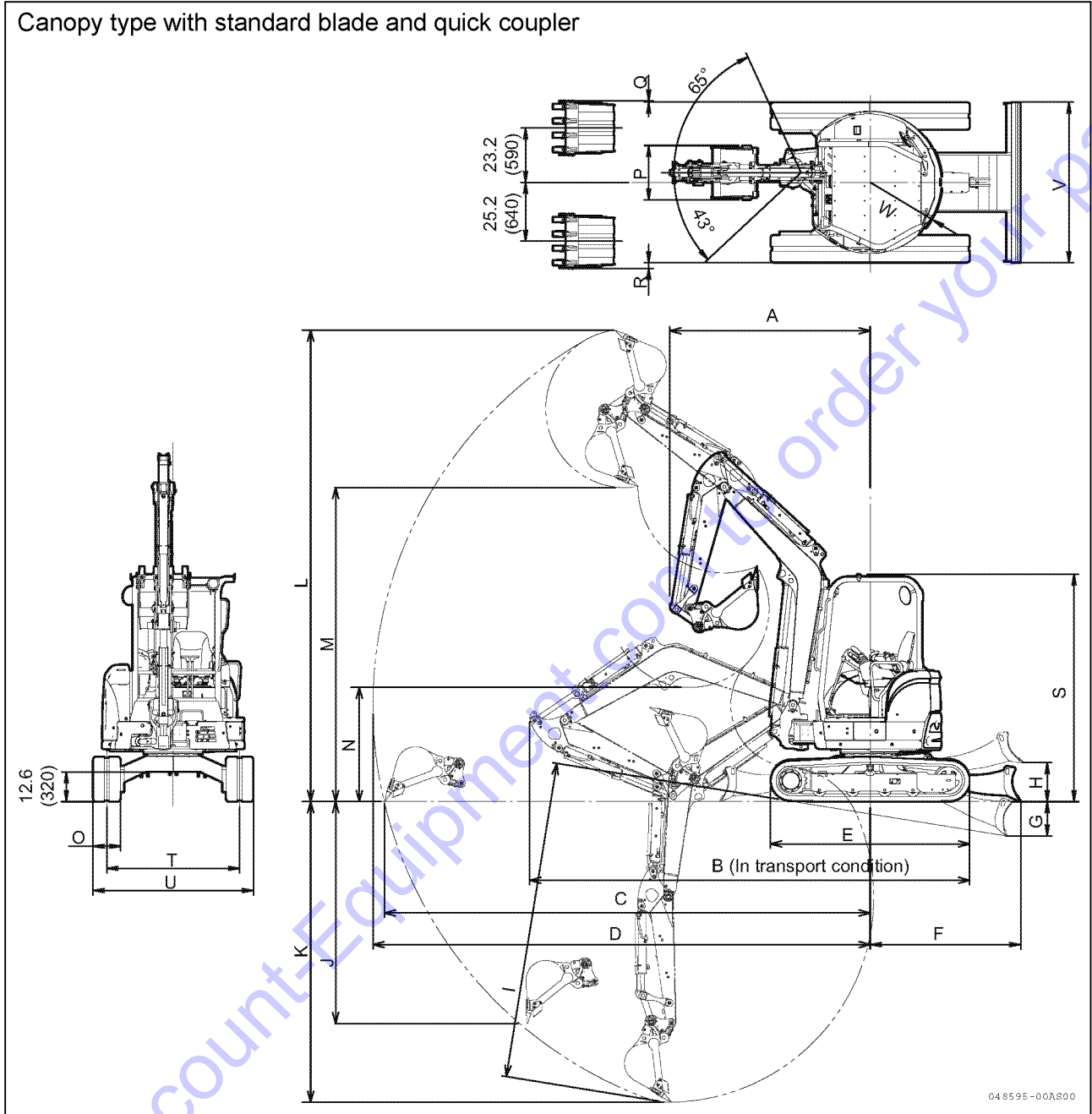

	A <at boom swing>	B	C	D	E	F	G	H	I	J	K
ViO35-6A	85.4 <76.8> (2170 <1950>)	187.8 (4770)	207.5 (5270)	212.2 (5390)	85.0 (2160)	64.2 (1630)	14.6 (370)	16.7 (425)	135.4 (3440)	94.9 (2410)	128.0 (3250)

	L	M	N	O	P	Q	R	S	T	U	V	W
ViO35-6A	201.2 (5110)	134.3 (3410)	48.8 (1240)	11.8 (300)	23.2 (590)	0.6 (15)	2.6 (65)	97.2 (2470)	56.7 (1440)	68.5 (1740)	68.5 (1740)	30.5 (775)

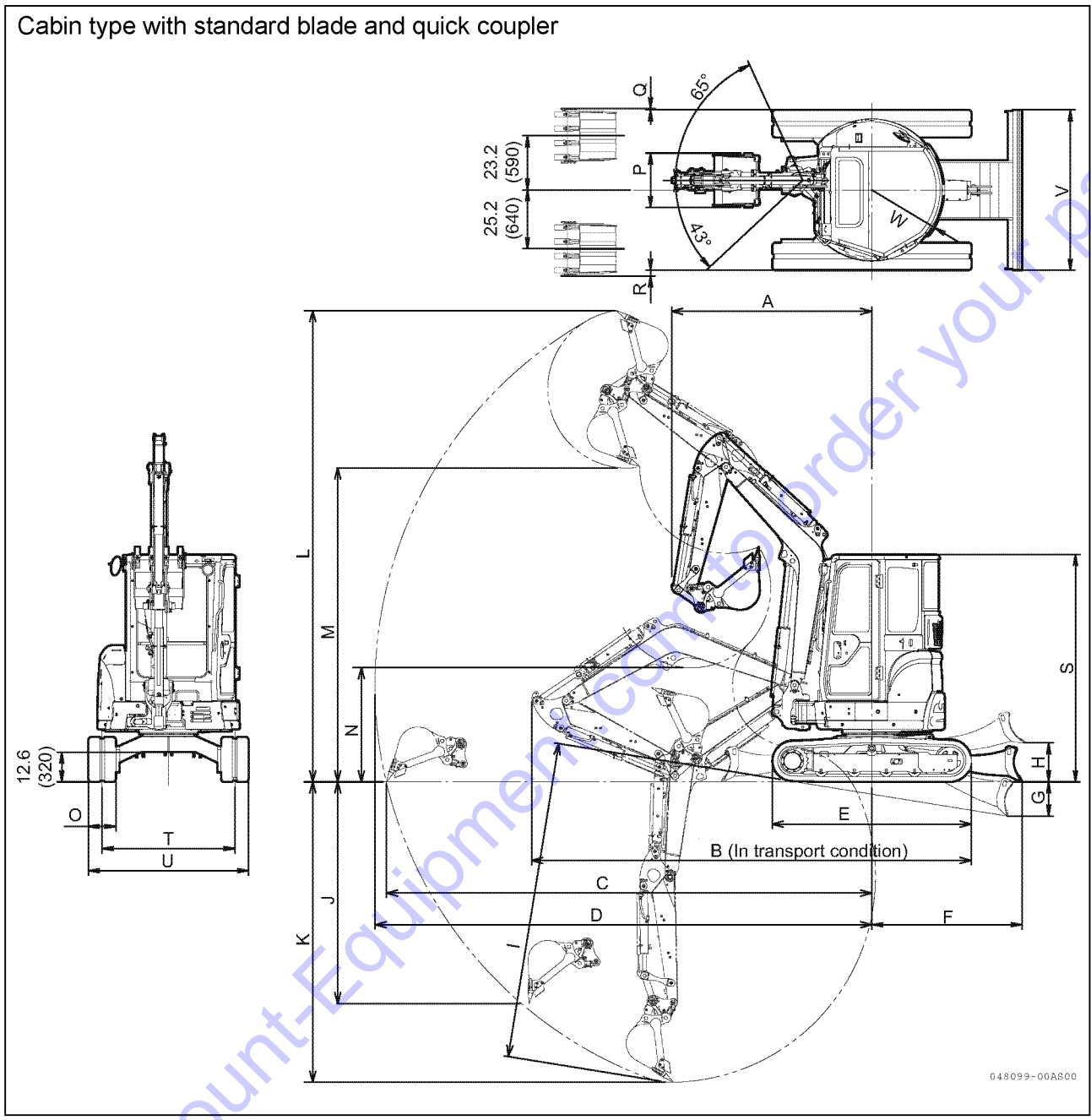

	A <at boom swing>	B	C	D	E	F	G	H	I	J	K
VI035-6A	85.4 <76.8> (2170 <1950>)	187.8 (4770)	207.5 (5270)	212.2 (5390)	85.0 (2160)	64.2 (1630)	14.6 (370)	16.7 (425)	135.4 (3440)	94.9 (2410)	128.0 (3250)

	L	M	N	O	P	Q	R	S	T	U	V	W
VI035-6A	201.2 (5110)	134.3 (3410)	48.8 (1240)	11.8 (300)	23.2 (590)	0.6 (15)	2.6 (65)	97.2 (2470)	56.7 (1440)	68.5 (1740)	68.5 (1740)	30.5 (775)

Unit: in. (mm)

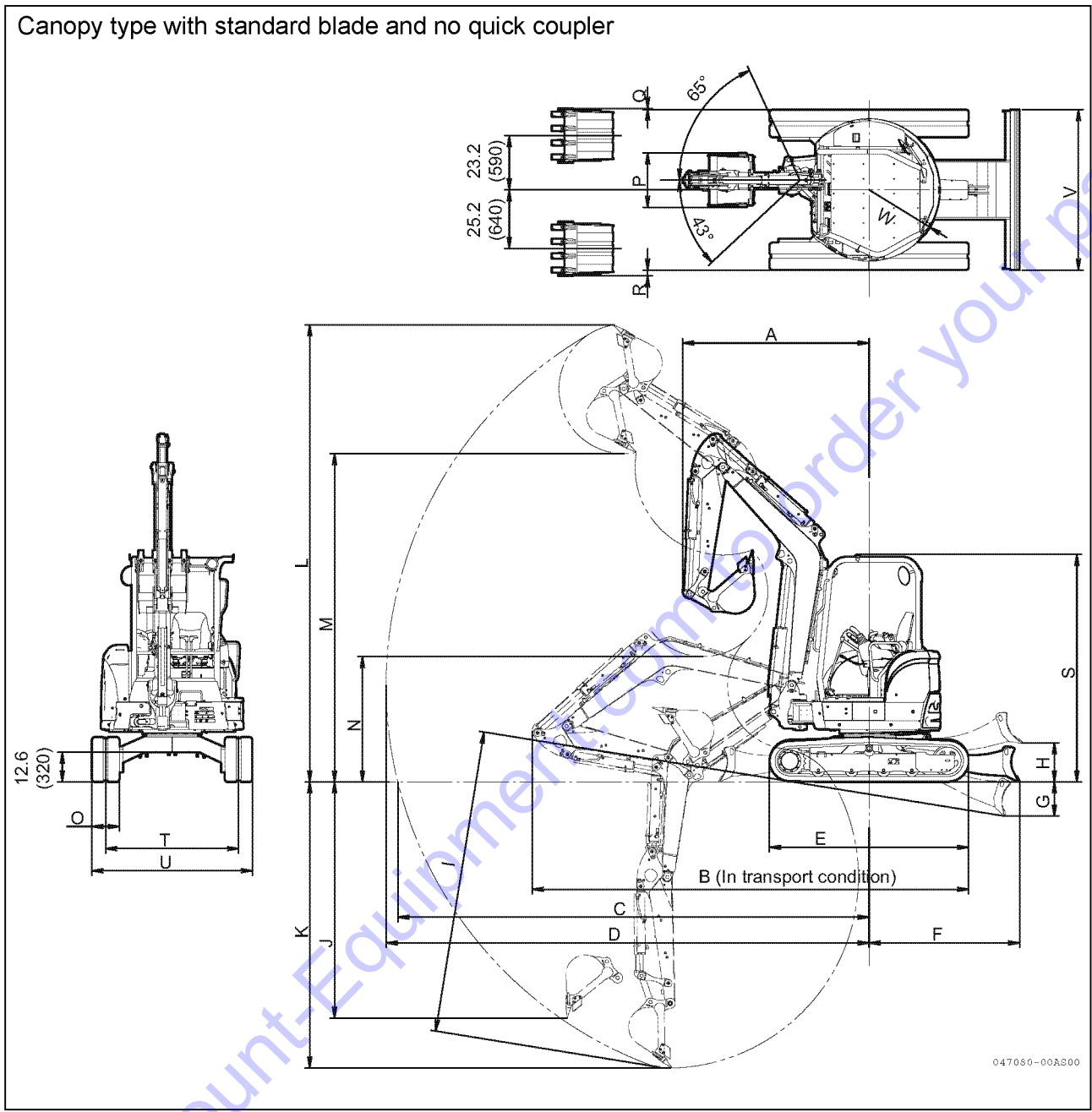

	A <at boom swing>	B	C	D	E	F	G	H	I	J	K
ViO35-6A	79.5 <71.3> (2020 <1810>)	186.2 (4730)	201.2 (5110)	205.9 (5230)	85.0 (2160)	64.2 (1630)	14.6 (370)	16.7 (425)	129.5 (3290)	100.8 (2560)	122.0 (3100)

	L	M	N	O	P	Q	R	S	T	U	V	W
ViO35-6A	195.3 (4960)	140.2 (3560)	53.5 (1360)	11.8 (300)	23.2 (590)	0.6 (15)	2.6 (65)	97.2 (2470)	56.7 (1440)	68.5 (1740)	68.5 (1740)	30.5 (775)

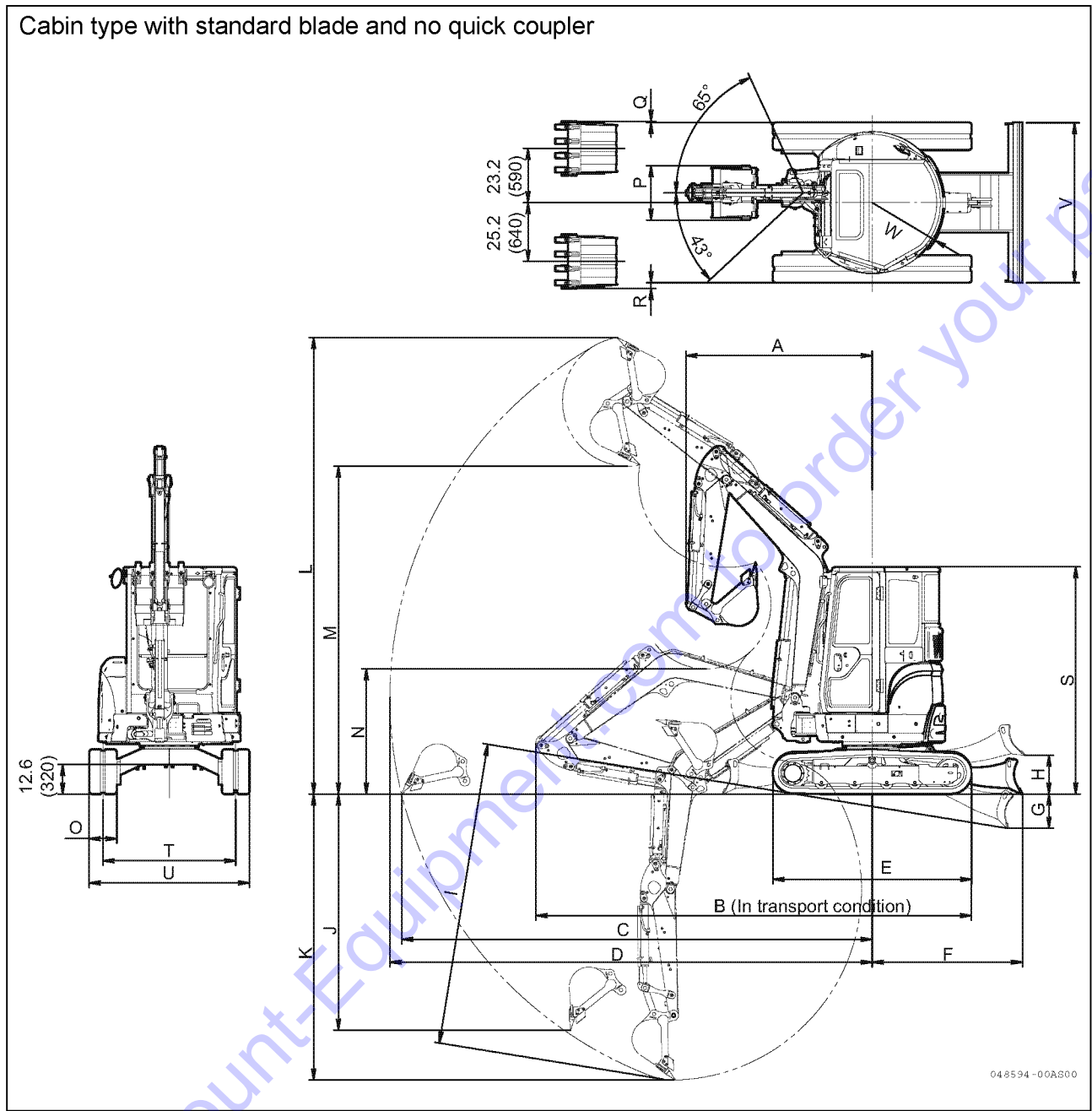

048594-00A800

	A <at boom swing>	B	C	D	E	F	G	H	I	J	K
ViO35-6A	79.5 <71.3> (2020 <1810>)	186.2 (4730)	201.2 (5110)	205.9 (5230)	85.0 (2160)	64.2 (1630)	14.6 (370)	16.7 (425)	129.5 (3290)	100.8 (2560)	122.0 (3100)

	L	M	N	O	P	Q	R	S	T	U	V	W
ViO35-6A	195.3 (4960)	140.2 (3560)	53.5 (1360)	11.8 (300)	23.2 (590)	0.6 (15)	2.6 (65)	97.2 (2470)	56.7 (1440)	68.5 (1740)	68.5 (1740)	30.5 (775)

Unit: in. (mm)

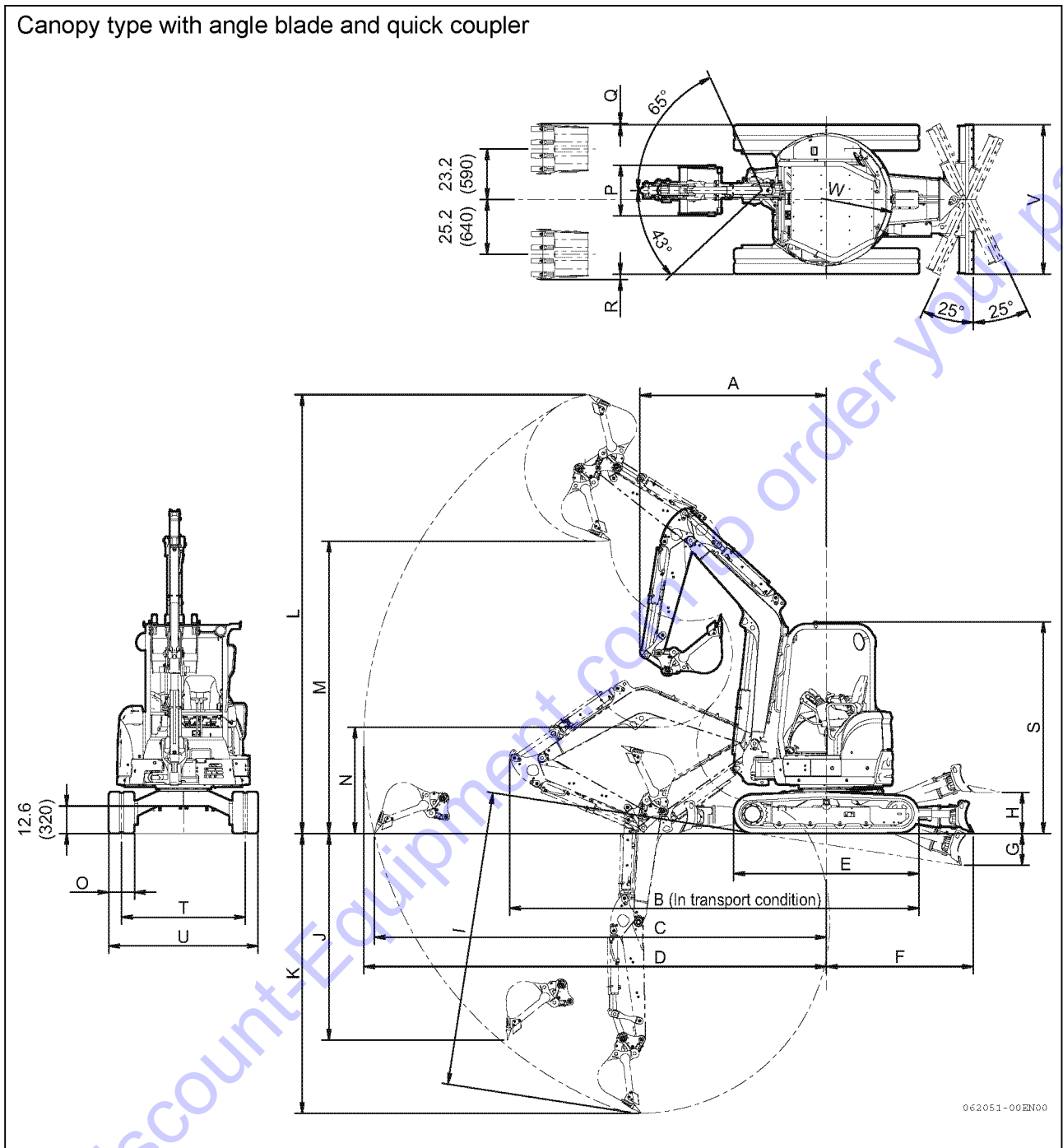

	A <at boom swing>	B	C	D	E	F	G	H	I	J	K
ViO35-6A	85.4 <76.8> (2170 <1950>)	187.8 (4770)	207.5 (5270)	212.2 (5390)	85.0 (2160)	67.3 (1710)	14.6 (370)	18.9 (480)	135.0 (3430)	94.9 (2410)	128.0 (3250)

	L	M	N	O	P	Q	R	S	T	U	V	W
ViO35-6A	201.2 (5110)	134.3 (3410)	48.8 (1240)	11.8 (300)	23.2 (590)	0.6 (15)	2.6 (65)	97.2 (2470)	56.7 (1440)	68.5 (1740)	68.5 (1740)	30.5 (775)

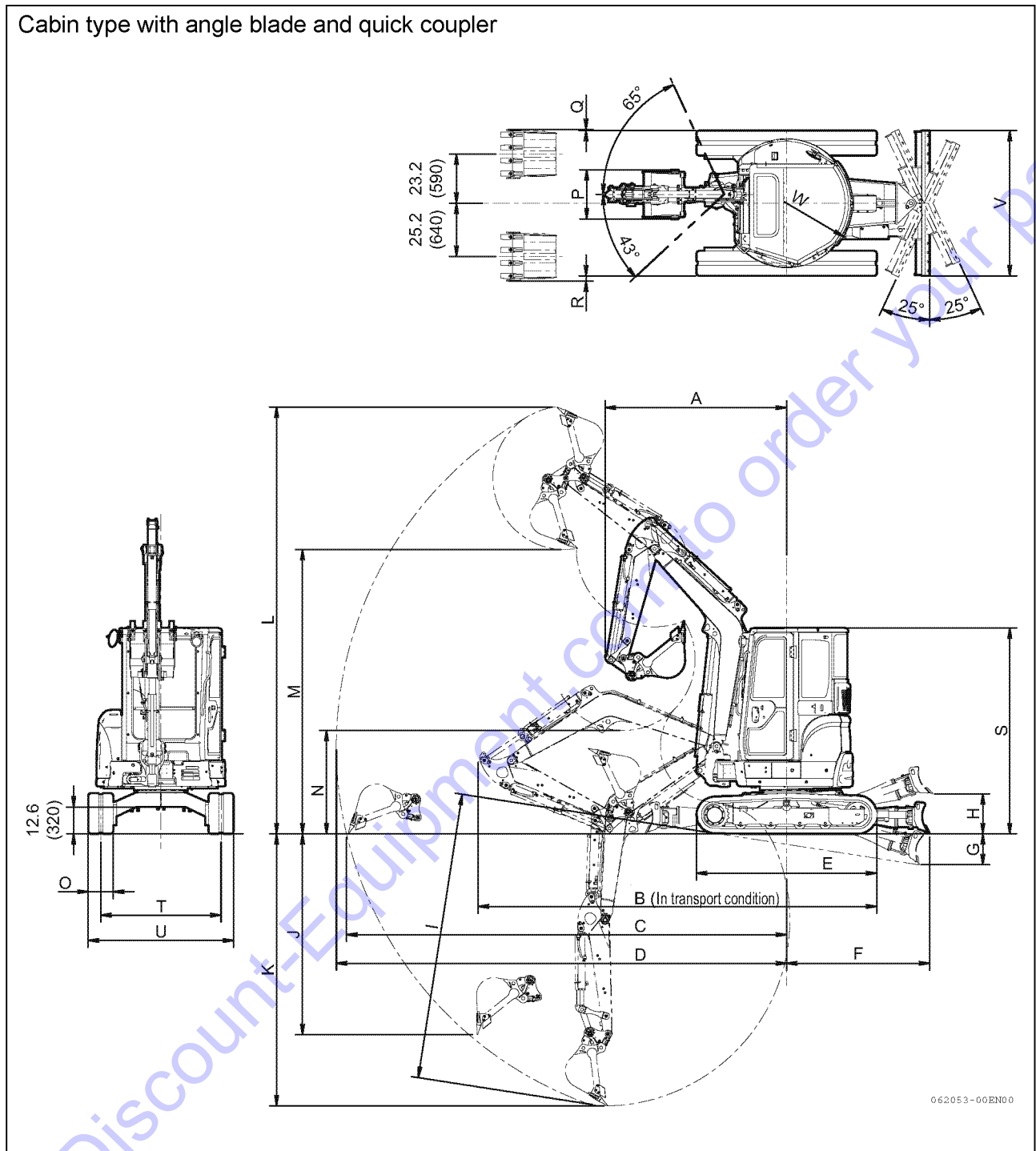

	A <at boom swing>	B	C	D	E	F	G	H	I	J	K
VIO35-6A	85.4 <76.8> (2170 <1950>)	187.8 (4770)	207.5 (5270)	212.2 (5390)	85.0 (2160)	67.3 (1710)	14.6 (370)	18.9 (480)	135.0 (3430)	94.9 (2410)	128.0 (3250)

	L	M	N	O	P	Q	R	S	T	U	V	W
VIO35-6A	201.2 (5110)	134.3 (3410)	48.8 (1240)	11.8 (300)	23.2 (590)	0.6 (15)	2.6 (65)	97.2 (2470)	56.7 (1440)	68.5 (1740)	68.5 (1740)	30.5 (775)

Unit: in. (mm)

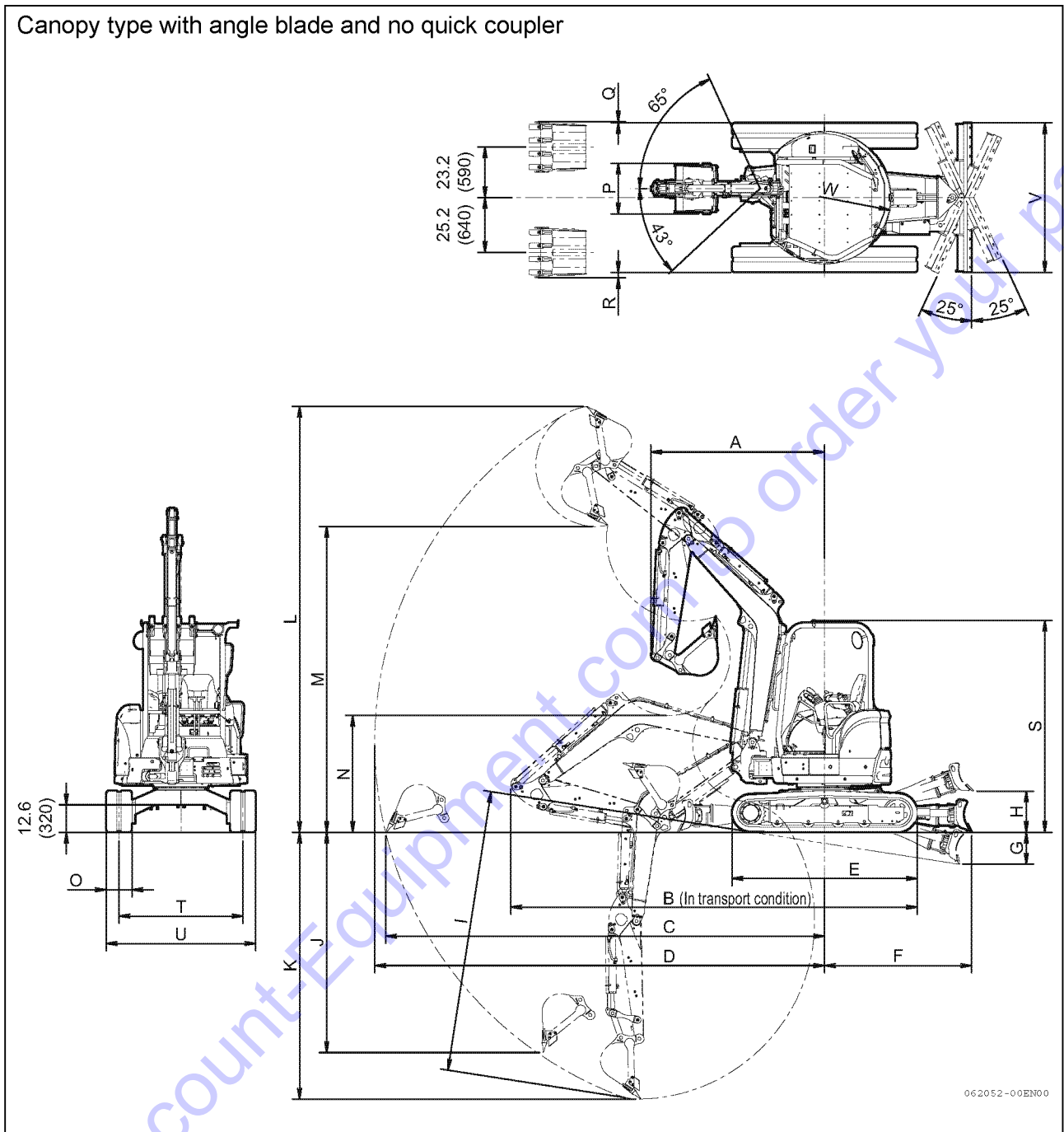

	A <at boom swing>	B	C	D	E	F	G	H	I	J	K
ViO35-6A	79.5 <71.3> (2020 <1810>)	186.2 (4730)	201.2 (5110)	205.9 (5230)	85.0 (2160)	67.3 (1710)	14.6 (370)	18.9 (480)	129.1 (3280)	100.8 (2560)	122.0 (3100)

	L	M	N	O	P	Q	R	S	T	U	V	W
ViO35-6A	195.3 (4960)	140.2 (3560)	53.5 (1360)	11.8 (300)	23.2 (590)	0.6 (15)	2.6 (65)	97.2 (2470)	56.7 (1440)	68.5 (1740)	68.5 (1740)	30.5 (775)

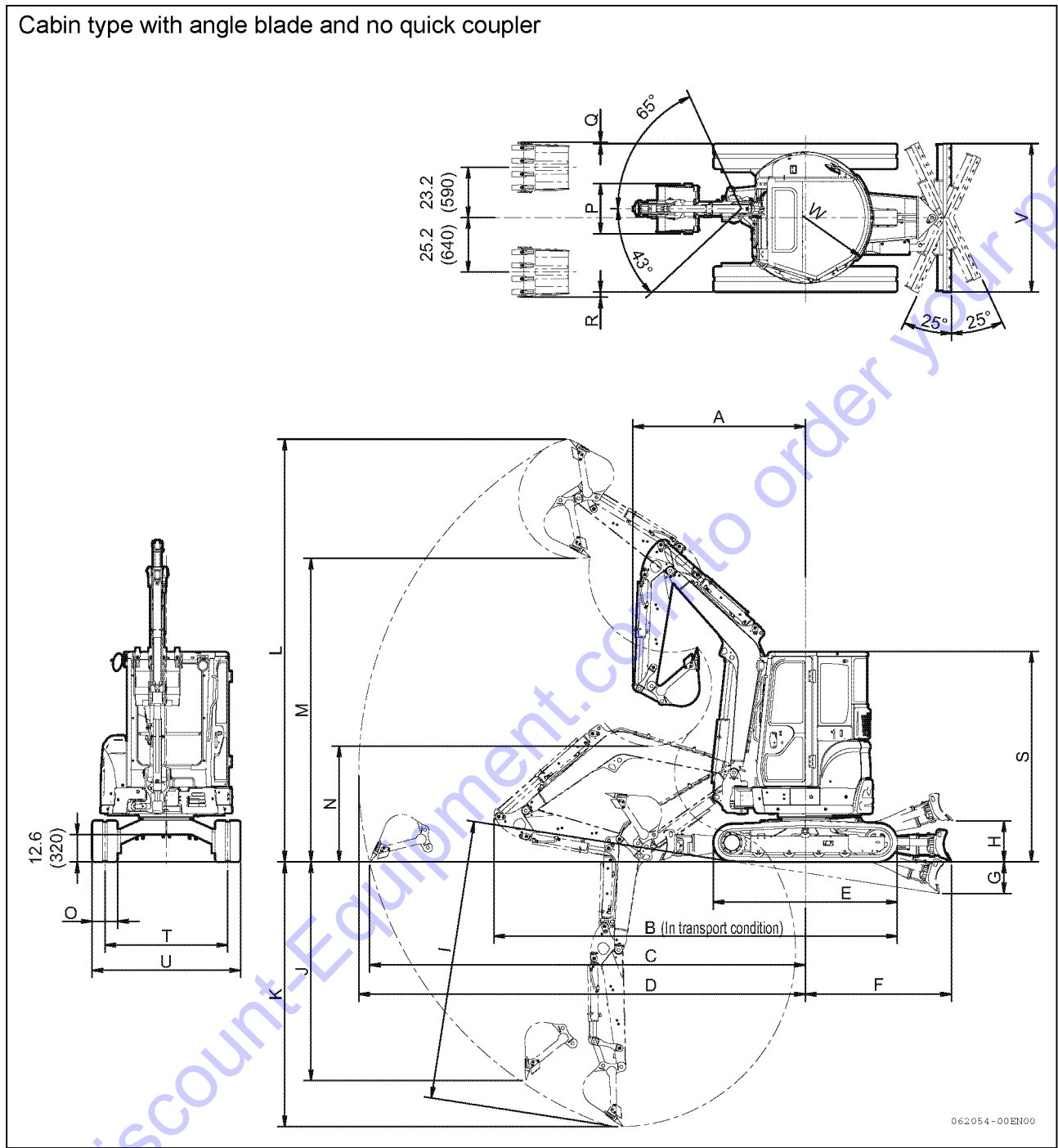

	A <at boom swing>	B	C	D	E	F	G	H	I	J	K
ViO35-6A	79.5 <71.3> (2020 <1810>)	186.2 (4730)	201.2 (5110)	205.9 (5230)	85.0 (2160)	67.3 (1710)	14.6 (370)	18.9 (480)	129.1 (3280)	100.8 (2560)	122.0 (3100)

	L	M	N	O	P	Q	R	S	T	U	V	W
ViO35-6A	195.3 (4960)	140.2 (3560)	53.5 (1360)	11.8 (300)	23.2 (590)	0.6 (15)	2.6 (65)	97.2 (2470)	56.7 (1440)	68.5 (1740)	68.5 (1740)	30.5 (775)

OPTIONAL PARTS AND ATTACHMENTS

- 1. General Precautions 313**
 - 1.1 Safety precautions 313
 - 1.2 Precautions for mounting
an attachment (implement) 315
- 2. Handling the Hooked Bucket ... 316**
 - 2.1 Checking the hooked
bucket for damage 316
 - 2.2 Prohibitions 316
 - 2.3 Precautions 316
- 3. Optional Parts and
Attachments 317**
 - 3.1 Optional parts and attachments 317
- 4. Handling Air Conditioner 318**
 - 4.1 Description of lever and switches
for air conditioner 318
 - 4.2 How to use air conditioner 320
 - 4.3 Maintenance, inspection and
servicing of air conditioner 322

1. General Precautions

1.1 Safety precautions

The mounting of attachments and optional parts that are not authorized by YANMAR may cause accidents as well as shorten the machine life.

If you need to mount any attachments other than those described in this manual, contact your dealer. If you fail to do so, the installation and use of unauthorized attachments and parts may void your Warranty.

⚠ WARNING

Precautions for mounting and dismantling an attachment

When mounting or dismantling an attachment, observe the following precautions for safety.

- **When mounting or dismantling a heavy implement or attachment, place the machine on level, solid ground.**
- **When you work together with a partner, define hand signals and communicate in accordance with those signals.**
- **When moving a heavy load [more than 55.1 lbs. (25 kg)], use a crane.**
- **When removing a heavy part, be sure to support it adequately.**

When lifting such a part with a crane, be aware of its center of gravity.

- **Do not mount or dismantle a heavy part while suspending it with a crane. Be sure to support it securely on a stable base.**
- **Securely support any attachment that has been removed or is to be installed, and take adequate precautions not to let it fall down.**
- **Never stand directly under a load suspended by a crane.**

Stand far enough away to be safe if the load should fall.

IMPORTANT

Comply with all licensing requirements before operating a crane.

Do not permit an unauthorized person to operate a crane.

For more information about the procedures for mounting and dismounting attachments, ask your dealer.

Go to Discount-Equipment.com to order your parts

1.2 Precautions for mounting an attachment (implement)

⚠ WARNING

A long implement may throw a machine off balance, and may cause the machine to roll over when the machine descends or swings on a slope.

The following operations are especially dangerous, and must never be done.

- Descending a slope with the implement raised
 - Traversing across a slope
 - Swinging on a slope
 - If you mount an unusually heavy implement (attachment) on the machine, the inertia of the upperstructure will increase so that the upperstructure will continue to turn over a longer distance after it has been deactivated. This can mislead the operator about the safe distance between the swinging implement and an object nearby and could cause the implement to bump against the object. To avoid this type of accident, deactivate the upperstructure a little earlier than usual. Because of increased inertia, the implement will also drop a greater distance after it has been stopped in mid-air. (The unintentional drifting of the implement will be greater).
 - Be sure that the boom and the arm have been mounted correctly. Otherwise, serious accidents or damage may occur. If you do not know how to mount the boom or the arm correctly, ask your dealer.
 - If you mount a long implement, you may misjudge the distance between the implement and a nearby object, and cause the implement to bump against the object.
- Be sure to provide adequate clearance between long implements and nearby objects.

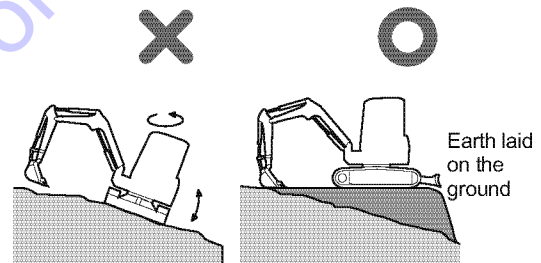
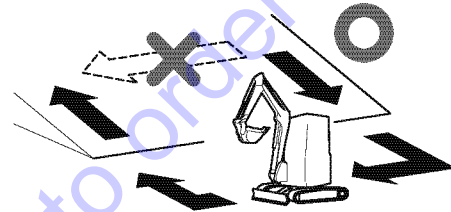
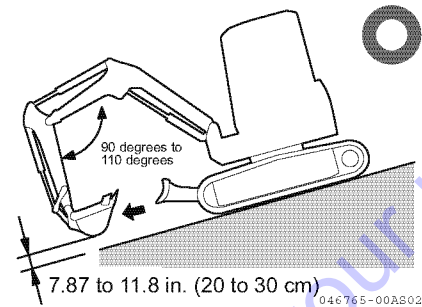

2. Handling the Hooked Bucket

2.1 Checking the hooked bucket for damage

Check the hook, the lock, and the hook mounting base for damage.

If any damage is found, ask your dealer to repair the bucket.

2.2 Prohibitions

■ Do not suspend a load without the dedicated hook

A dedicated hook is required to suspend a load with the machine.

For the details, ask your dealer.

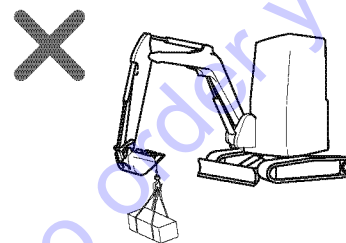

046789-00X00

2.3 Precautions

■ Precautions for suspending a load

- Reduce the engine speed when suspending a load.
- The wire rope or the suspending ring may slip off the bucket hook if the hook is not maintained in a vertical position due to the working posture of the machine. Be careful to maintain a vertical hook position, so that the wire rope or the suspending ring will not slip off.
- When the hooked bucket is used in a reverse position, take care that the bucket hook should not interfere with the arm when dumping the bucket.
- The weight of a load to be suspended must not exceed 308.7 lbs. (140 kg) for ViO35-6A.
- Ask your dealer to mount a hook on the bucket.

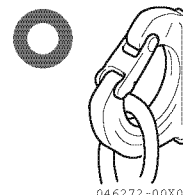

046272-00X00

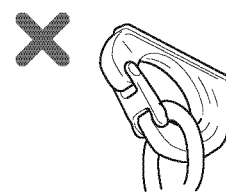

046273-00X00

3. Optional Parts and Attachments

3.1 Optional parts and attachments

The following options are available. Select options useful for your work.

If you need an option, contact your dealer.

- **Bucket (Teeth...Point type)**

Width in. (mm)	Capacity cu.ft (cu.m)	Remarks
19.3 (490)	2.82 (0.08)	-
21.3 (540)	3.53 (0.10)	-
23.2 (590)	3.88 (0.11)	ViO35-6A Standard
25.2 (640)	4.24 (0.12)	-

Go to Discount-Equipment.com to order your parts

4. Handling Air Conditioner

4.1 Description of lever and switches for air conditioner

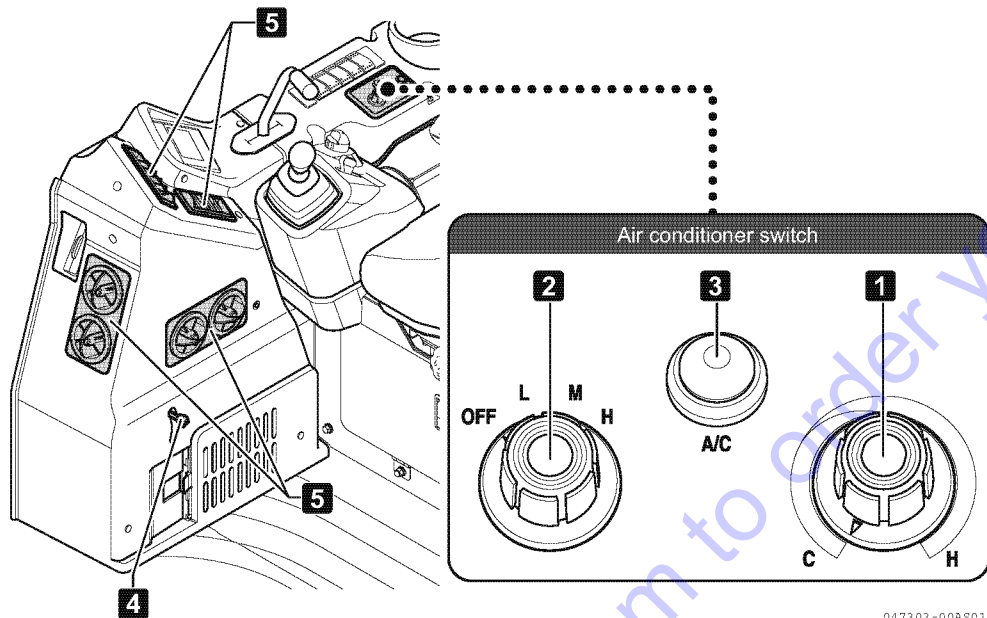

1 Temperature control dial

It is used to control the temperature of the air blown by the air conditioner.

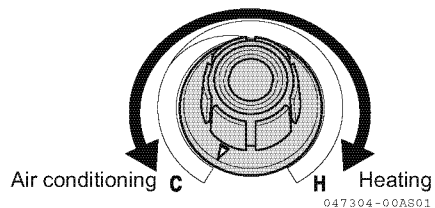

2 Fan switch :

It is used to set the air volume at one of the three levels.

- L : Low
- M : Medium
- H : High
- OFF : Stop

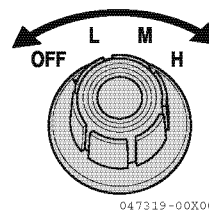

3 Air conditioner switch :

It is used to turn the compressor ON or OFF.

- The compressor is turned OFF. (The lamp goes off.)
- The compressor is turned ON. (The lamp goes on.)

Press the switch in the OFF state to turn the compressor ON, and press it again to turn the compressor OFF. When the fan switch is in the OFF position, the lamp does not go on and the compressor does not work even if the air conditioner switch is turned ON.

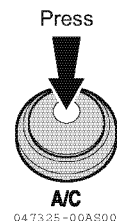

4 Inner and outer air switching lever :

• Outer air induction

Move the lever to the outer air induction mark position to induce the outer air to the cab for cooling and heating. It is used when inducing the clean air from outside the cab or defogging the cab window.

• Inner air circulation

Move the lever to the inner air circulation mark position to circulate the air only in the cab. It is used when rapidly cooling or heating the cab or the outer air is polluted.

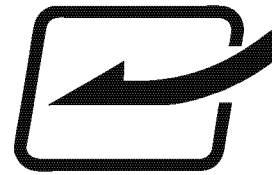
**5 Air outlet**

The wind direction is adjusted by changing the grille direction.

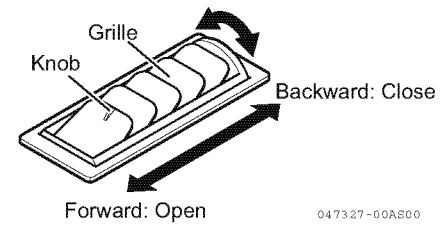
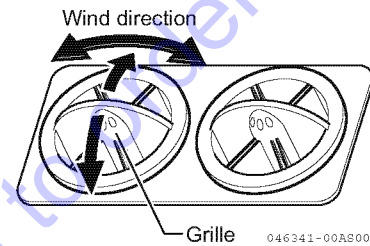

4.2 How to use air conditioner

⚠ CAUTION

- The eyes might get sore from smoking when the air conditioner is being used in the cabin. Ventilate the cabin by opening the window slightly when smoking.
- Some mist might blow off with cooled air when the air conditioner is being used in the cabin. This occurs because the water particles in the wet air are frozen and blown out. It is not abnormal.
- When using the air conditioner after parking the machine in the hot weather, ventilate the cabin by opening the door and windows to let the hot air inside go out of the cabin so that the air-conditioning can work efficiently.
- Take care not to cool the inside of the cabin too long because it is not good for the operator's health. Control the air temperature properly.
- If the air conditioner blows no air, the air volume is too low or the cabin is not air conditioned well when the air conditioner is turned on, ask your dealer to check the air conditioner. If you keep using the air conditioner in such an abnormal state, it will cause damage to the fan motor or the compressor.
- Even in the seasons when the air conditioner is not used, operate the air conditioner for a few minutes once or twice every two or three weeks. That prevents the rotating parts such as the compressor from running out of oil, which prevents malfunction of the parts in turn.

Air conditioning

1. Set the fan switch 1 at any of the three levels (Low, Medium or High).
2. Set the temperature control dial 2 to the C position (counterclockwise position).
3. Turn the air conditioner switch 3 ON. (The lamp goes on.)
4. Control the temperature inside the cabin properly with the temperature control dial 2 and the fan switch 1 after the inside of the cabin has been cooled off.
5. Adjust the air direction with the air outlet grille.
 - Set the fan switch for ventilation to apply preload to the inside of the cabin when the air conditioner is not used, so that no dust can come into the cabin easily during operation.

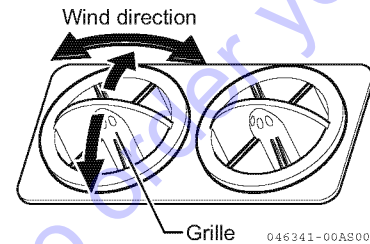
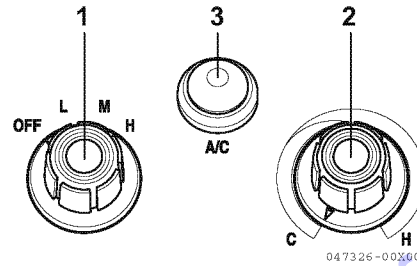

IMPORTANT

Be sure to turn on the air conditioner after starting the engine to prevent excessive force to the compressor etc.

Heating

1. Set the fan switch 1 at any of the three levels (Low, Medium or High).
2. Set the temperature control dial 2 to the H position (clockwise position).
3. Turn the air conditioner switch 3 OFF. (The lamp goes off.)

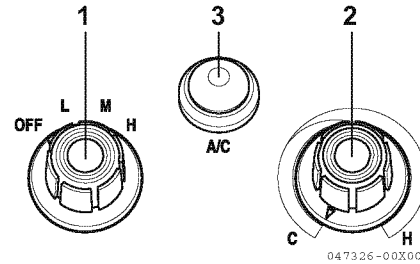

Heating for dehumidification

(In the case that the window glass tends to get fogged in rainy weather in spring or autumn.)

With the heating turned on, turn the air conditioner switch 3 ON. (The lamp goes on.)

- If the temperature inside the cabin is low, dehumidification might not work because the compressor does not operate even if the air conditioner switch 3 is turned ON.

Stop

1. Turn the air conditioner switch 3 OFF. (The lamp goes off.)
2. Turn the fan switch 1 OFF.
 - The air conditioner also stops only by turning the fan switch 1 OFF.

4.3 Maintenance, inspection and servicing of air conditioner

Daily maintenance and periodic inspection and servicing are required for the air conditioner to use it comfortably in the best condition.

Proper maintenance allows reduction in trouble and longer life of the air conditioner.

Exact inspection and servicing prevent trouble and reduce the cost for repair.

The air conditioner should also be checked and serviced at the time of a voluntary monthly inspection and a prescribed annual inspection of the machine.

It is recommended that the rubber hoses and electrical wires should be replaced every two years to use the air conditioner in the best condition.

List of inspection items for air conditioner

	Part	Check item	Servicing
Daily inspection	Filter	Check the filter for clogging.	Clean
	Condenser	Check the cover and the fin for contamination and clogging.	Clean
	Compressor driving belt	Check the belt for tension and damage.	Repair or replace
	Sight glass	Check the refrigerant quantity.	-

Replacing the inner and outer air filters

1. Grab the knobs of the filter and pull it out to this side.
2. Blow off the clogged dirt or the like with compressed air.
Inner air filter can be washed off with water.
Outer air filter can NOT be washed off with water.
3. Reinstall the cleaned filter.

Note:

When washing the cabin floor or other parts with water, be sure to cover the inner air filter to protect it from muddy water splashes.

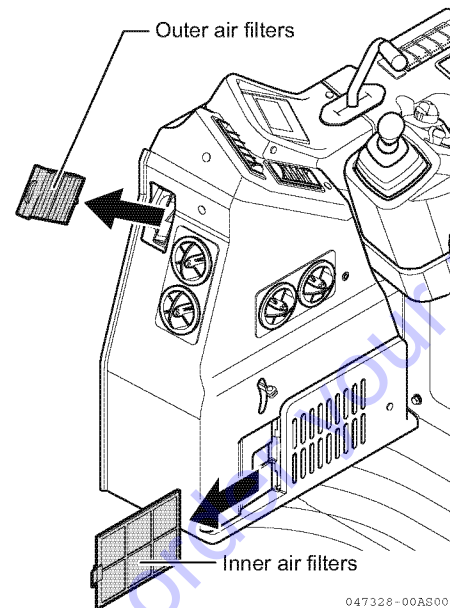

Checking and cleaning condenser

⚠ WARNING

- Be sure to stop the engine and remove the starter switch key before checking and servicing the condenser.
- Be sure to reinstall the cover and other parts, which have been removed for checking and servicing, to their original positions after completion of the work.

1. Open the cabin rear cover.
2. Check the condenser cover 1. If there is any mud or dirt on the condenser 1 wash it off with water.
 - If there is some mud or dirt on the condenser fin, it will cause degradation of the air conditioner performance. Wash it off from the fin with water, using a soft brush.
 - If the condenser fin is crushed or deformed, it will also cause degradation of the air conditioner performance. Repair it with a screwdriver or the like, taking care not to damage the condenser fin.

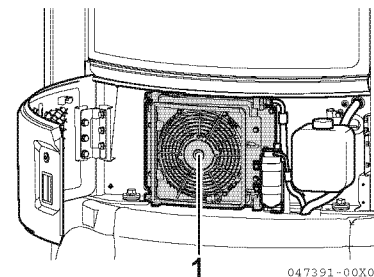
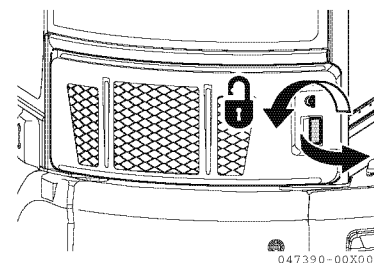

Checking and servicing compressor driving belt

⚠ WARNING

Stop the engine and remove the starter switch key before checking and servicing the compressor driving belt.

Press the compressor driving belt in the middle to check the slack of the compressor driving belt.

Driving belt

Pressing force : Approximately 22.05 lbs. (98.1 N)

Correct slack : 0.31 to 0.35 in. (8 to 9 mm)

If the slack of the belt is not correct, adjust it according to the following procedure :

1. Open the engine hood rear cover and press the belt in the middle with a force of approximately 22.05 lbs. (98.1 N). Adjust the belt tension by loosening the tension pulley bolt and applying a wrench or the like to the protruding portion of bracket so that the slack of the belt will be correct.
 - If the belt tension cannot be adjusted to the specified slack because the belt has lost its elasticity, replace the belt with a new one.
2. Tighten the tension pulley bolt.
3. Check whether each pulley or the belt is damaged, especially whether the belt is in contact with the bottom of the pulley groove.
 - If there are any cuts on the belt or cracks in it, replace it with a new one.

Compressor driving belt :

Mitsuboshi Rawedge moulded cogged V-belt

MPMF-6370 or its equivalent

Yanmar part number : 172460-18120

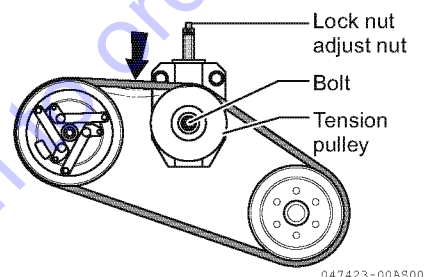
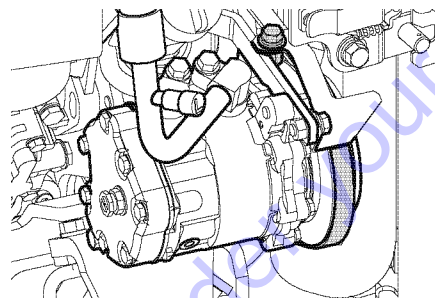

Checking the refrigerant quantity

Open the cabin rear cover and observe the flow of the refrigerant air bubble from the sight glass (inspection window) of the liquid tank according to the following procedure to check the refrigerant quantity.

1. Start the engine and run it at the maximum speed.
2. Set the fan switch 1 at the H level.
3. Set the temperature control dial 2 to the C position.
(Full counterclockwise position.)
4. Turn the air conditioner switch 3 ON. (The lamp goes on.)
5. Check the refrigerant condition from the sight glass and compare it with the check list shown below.

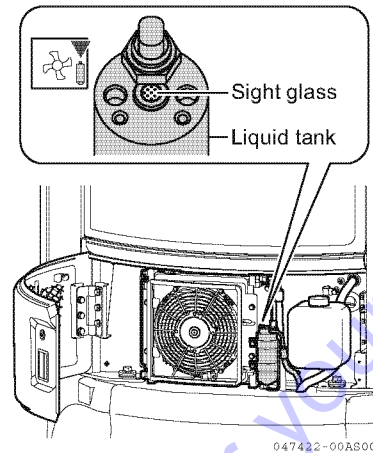

IMPORTANT
If the refrigerant quantity is not normal, ask your dealer for check and repair.

Refrigerant type: R-134a

Quantity : 1.43 to 1.65 lbs. (650 to 750 g)

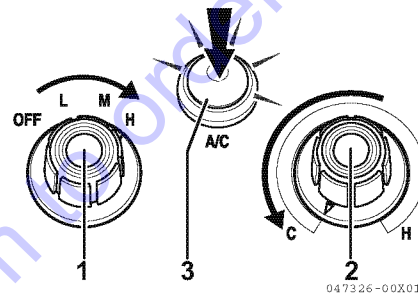

Check list for the refrigerant quantity

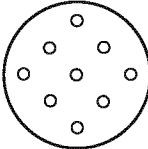
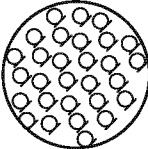
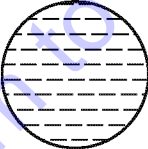
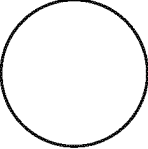
Air conditioner condition	Normal	Abnormal		
Temperatures of high and low pressure pipes	Temperature difference is big. High pressure pipe : hot Low pressure pipe : cold Compressor discharge side temperature : 158°F (70°C) Compressor intake side temperature : 41°F (5°C)	High pressure pipe is warm and low pressure pipe is rather cool. Temperature difference is not so big.	There is almost no difference in temperature between high and low pressure pipes.	High pressure pipe is hot and low pressure pipe is rather warm. There is some difference in temperature between them.
Sight glass	Almost transparent. Even if air bubble flow is seen, it becomes transparent as the engine speed changes.  046691-00X00	Air bubble flow is always seen. It is sometimes transparent or white.  046692-00X00	Flow of mist or the like is seen slightly.  046730-00X00	No air bubble flow is seen even cabin windows, idling engine, and rotating fan to the maximum.  046731-00X00
Pipe connection	Normal	Some parts are contaminated by oil.	Some parts are badly contaminated by oil.	Normal
Refrigerant quantity	Refrigerant quantity is adequate and normal.	Refrigerant might leak in a small amount from some part.	Almost all refrigerant leaks and does not remain.	Refrigerant quantity is too large.

*1 :When the outside air temperature is low, air bubble might be seen even if the refrigerant quantity is adequate.

*2 :When there is no refrigerant, no air bubble is seen, either. Therefore, be sure to check the difference in temperature between the high and low pressure pipes.

APPENDIX TABLE

1.	List of consumables	329
2.	Fuel, oil and cooling water ...	329
3.	Required tools	330
4.	Torque table	331
5.	List of safety parts	332
6.	List of error codes displayed on LCD monitor	333

Go to Discount-Equipment.com to order your parts

1. List of consumables

The parts in () represent those which must be replaced at the same time.

Item	Name	Q'ty	Replacing time interval
Engine oil filter	Oil filter 80×80 L	1	Every 500 service hours
Hydraulic oil tank return filter	Filter element	1	Every 500 service hours (At first 250 service hours)
Fuel filter	Fuel filter element	1	Every 500 service hours
Air cleaner	Cleaner element	1	Every 500 service hours
Bucket	Point teeth	4	
	(Lock pin)	(4)	
	(Rubber pin)	(4)	
	Side cutter (left)	1	
	Side cutter (right)	1	
	(Bolt 14×35)	(6)	
	(Nut 14)	(6)	

2. Fuel, oil and cooling water

Part be refilled	Oil type	Recommendations with regard to temperature ranges						Prescribed amount of oil	Amount of oil to be changed	
		(°F)	-4	-14	32	50	68			86
		(°C)	(-20)	(-10)	(0)	(10)	(20)	(30)		
Engine oil pan	Engine oil	SAE 10W CF						7.7 Qts. (7.3 L)	7.7 Qts. (7.3 L)	
		SAE 10W-30 CF								
		SAE 15W-40 CF								
Travel reduction gear	Gear oil	SAE 90 (GL-4)						0.5 Qts. (0.5 L) (For right and left each)	0.5 Qts. (0.5 L) (For right and left each)	
Hydraulic oil system	Hydraulic oil	ISO VG46						In the tank 10.6 Gals. (40 L)	10.6 Gals. (40 L)	
								Other parts 5.8 Gals. (22 L)		
Fuel tank	Light oil	No. 1-D or No. 2-D diesel fuel						10.8 Gals. (41 L)	-	
Cooling system	Water	YANMAR genuine long-life coolant (LLC) added						Radiator	-	
								4.0 Qts. (3.8 L)		
								Subtank		
								0.4 Qts. (0.4 L)		

3. Required tools

The following tools are required for servicing:

No.	Name	Part number	Q'ty
1	Screw driver (universal system)	104200-92350	1
2	Filter wrench 68	119332-92751	1
3	Filter wrench 80	119640-92750	1
4	Filter wrench LO	171301-92750	1
5	Pressuring nozzle	172122-05101	1
6	Wrench 8×10	28110-080100	1
7	Wrench 12×14	28110-120140	2
8	Wrench 17×19	28110-170190	1
9	Wrench 22×24	28110-220240	2
10	Wrench 27×30	28110-270300	1
11	Wrench 32×36	28110-320360	1
12	Hexagon bar wrench 4	28150-040000	1
13	Hexagon bar wrench 5	28150-050000	1
14	Hexagon bar wrench 8	28150-080000	1
15	Box wrench 27×140	28227-271400	1
16	Turning handle 12×250	28230-120250	1
17	Grease hose	933110-09701	1
18	Grease injector 800	933110-09802	1
19	Pliers 200	933171-00470	1

4. Torque table

Bolts or nuts in the metric system should be tightened at the torque described below unless specified otherwise.

Item		Thread size × pitch	Tightening torque ft·lbf (N·m)	Remarks
Hexagon bolt (7T) Nut	Coarse threads	M6×1	7.23 to 8.68 (9.8 to 11.8)	<ul style="list-style-type: none"> • Apply 80% tightening torque when tightened to aluminum. • Apply 60% tightening torque for 4T bolt and lock nut. • Use fine thread screws for engine only.
		M8×1.25	16.6 to 21.0 (22.6 to 28.4)	
		M10×1.5	32.6 to 43.4 (44.1 to 58.8)	
		M12×1.75	57.9 to 72.3 (78.5 to 98.1)	
		M14×2	86.8 to 108.5 (117.7 to 147.1)	
		M16×2	123.0 to 151.9 (166.7 to 206.0)	
		M18×2.5	173.6 to 209.8 (235.4 to 284.4)	
	M20×2.5	238.7 to 296.6 (323.6 to 402.1)		
	Fine threads	M14×1.5	94.0 to 108.5 (127.5 to 147.1)	
M16×1.5		155.5 to 177.2 (210.8 to 240.3)		
PT plug		1/8	7.2 (9.8)	
		1/4	14.5 (19.6)	
		3/8	21.7 (29.4)	
		1/2	43.4 (58.8)	
Pipe joint bolt		M8	9.4 to 12.3 (12.7 to 16.7)	
		M12	18.1 to 25.3 (24.5 to 34.3)	
		M14	28.9 to 36.2 (39.2 to 49.0)	
		M16	36.2 to 43.4 (49.0 to 58.8)	

IMPORTANT

If a part to be tightened is made of resin like a panel board, excessive tightening torque may damage the tightened part. Be careful when tightening.

5. List of safety parts

No.	Safety parts to be replaced periodically	Q'ty	Replacement time intervals
1	Fuel hose (fuel tank to water separator)	1	Earlier of either every 2 years or every 4000 service hours
2	Fuel hose (water separator to feed pump)	1	
3	Fuel hose (feed pump to fuel filter)	1	
4	Fuel hose (fuel filter to fuel injection pump)	1	
5	Fuel hose (fuel filter to fuel tank)	1	
6	Fuel hose (fuel injection pump to fuel filter)	1	
7	Fuel hose (fuel injection valve to fuel injection valve)	2	
8	Fuel hose (fuel injection valve to fuel injection pump)	1	
9	Fuel tube cap	1	
10	Main pump outlet hose (P1, P2, P3 to C/V)	3	

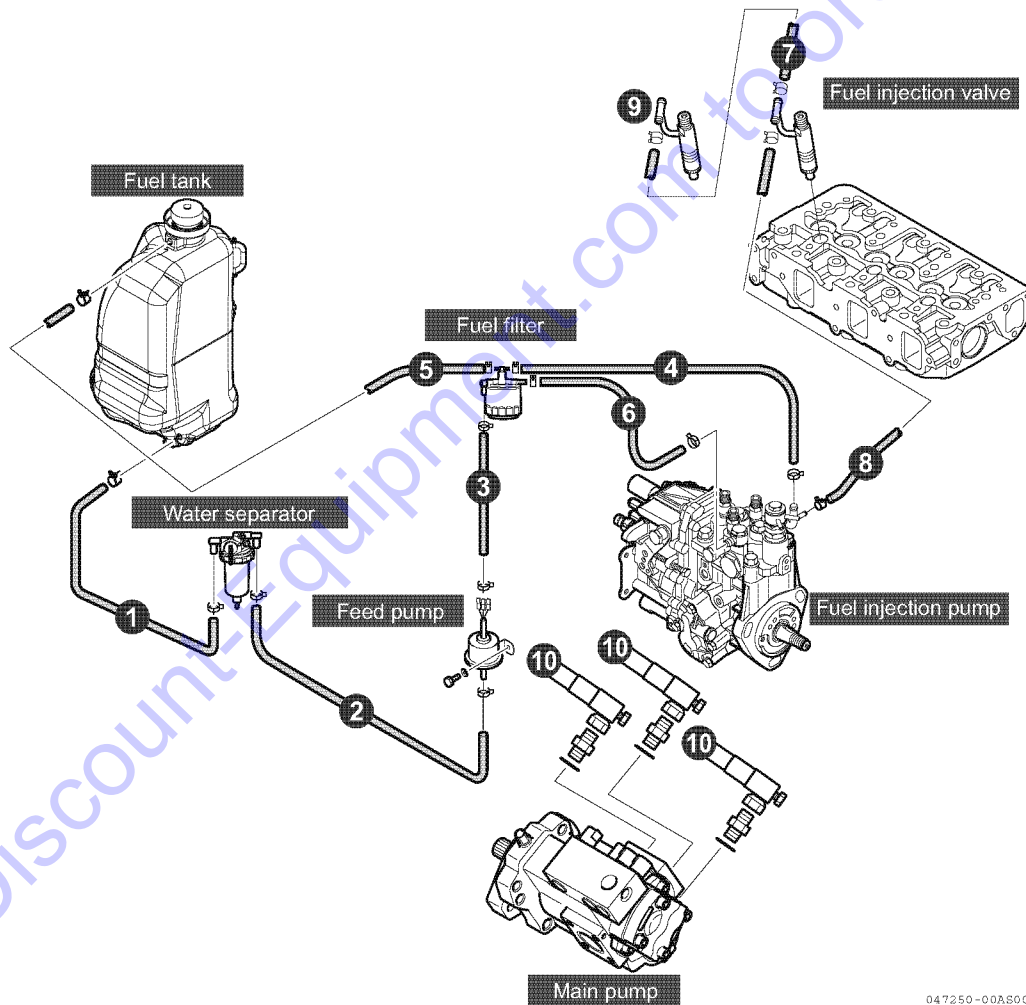

6. List of error codes displayed on LCD monitor

If an error that falls into the "Warning" category occurs, the warning lamp flashes. In such cases, immediately stop operation and take necessary corrective measures.

If an error that falls into the "Caution" category occurs, the caution lamp flashes. In such cases, take necessary corrective measures as soon as possible.

For error items with "Service" shown in the column of "Corrective measures," contact the nearest dealer for inspection and repair.

If an error code other than the ones listed in this table is displayed, contact the nearest dealer.

Error code	Classification	Error description	Corrective measures
00 000091.00	Caution	Accelerator sensor failure	Service
00 000091.01	Caution	Accelerator sensor failure	Service
00 000091.02	Caution	Accelerator sensor failure	Service
00 000091.03	Caution	Accelerator sensor failure	Service
00 000091.04	Caution	Accelerator sensor failure	Service
00 000091.15	Caution	Accelerator sensor failure	Service
00 000100.01	Warning	Abnormal engine oil pressure	Refer to "Troubleshooting"
00 000100.04	Warning	Engine oil pressure switch failure	Service
00 000110.00	Warning	Abnormal coolant temperature	Refer to "Troubleshooting"
00 000110.02	Warning	Coolant temperature sensor failure	Service
00 000110.03	Warning	Coolant temperature sensor failure	Service
00 000110.04	Warning	Coolant temperature sensor failure	Service
00 000158.00	Caution	Abnormal power supply voltage	Service
00 000158.01	Caution	Abnormal power supply voltage	Check battery or service
00 000167.01	Caution	Insufficient battery charge	Refer to "Troubleshooting"
00 000167.04	Caution	Battery charge switch failure	Service
00 000190.00	Warning	Engine overspeed	Service
00 000628.02	Warning	Engine controller failure (FlashROM failure)	Service
00 000628.02	Warning	Engine controller failure (FlashROM failure)	Service
00 000628.12	Warning	Engine controller failure (FlashROM failure)	Service
00 000630.02	Warning	Engine controller failure (EEPROM failure)	Service
00 000630.12	Caution	Engine controller failure (EEPROM failure)	Service
00 000638.02	Warning	Engine failure	Service
00 000638.03	Warning	Rack actuator failure	Service
00 000638.04	Warning	Rack actuator failure	Service
00 000638.07	Warning	Rack actuator failure	Service
00 000639.12	Caution	CAN communication failure	Service
00 001078.04	Warning	Speed sensor failure	Service
00 001079.02	Caution	Abnormal sensor 5V power supply	Service
00 001079.03	Caution	Abnormal sensor 5V power supply	Service
00 001079.04	Caution	Abnormal sensor 5V power supply	Service

Error code	Classification	Error description	Corrective measures
00 001136.00	Caution	Abnormal engine controller internal temperature	Service
00 001136.02	Caution	Engine controller internal temperature sensor failure	Service
00 001136.03	Caution	Engine controller internal temperature sensor failure	Service
00 001136.04	Caution	Engine controller internal temperature sensor failure	Service
00 001210.03	Warning	Rack position sensor failure	Service
00 001210.04	Caution	Rack position sensor failure	Service
00 001485.04	Caution	Engine controller main relay failure	Service
00 522241.02	Caution	Rack actuator relay failure	Service
00 522241.03	Warning	Rack actuator relay failure	Service
00 522241.04	Warning	Rack actuator relay failure	Service
00 522242.02	Caution	Cold start device failure	Service
00 522242.03	Caution	Cold start device failure	Service
00 522242.04	Caution	Cold start device failure	Service
00 522243.02	Caution	Air heater relay failure	Service
00 522243.03	Caution	Air heater relay failure	Service
00 522243.04	Caution	Air heater relay failure	Service
00 522251.03	Caution	EGR stepping motor failure	Service
00 522251.04	Caution	EGR stepping motor failure	Service
00 522252.03	Caution	EGR stepping motor failure	Service
00 522252.04	Caution	EGR stepping motor failure	Service
00 522253.03	Caution	EGR stepping motor failure	Service
00 522253.04	Caution	EGR stepping motor failure	Service
00 522254.03	Caution	EGR stepping motor failure	Service
00 522254.04	Caution	EGR stepping motor failure	Service
00 522314.00	Caution	Abnormal coolant temperature	Refer to "Troubleshooting"
00 522727.12	Caution	Engine controller failure (Sub CPU failure)	Service
00 522727.12	Caution	Engine controller failure (Sub CPU failure)	Service
00 522727.12	Caution	Engine controller failure (Sub CPU failure)	Service
00 522728.12	Warning	Engine controller failure (Map data error)	Service
28 000096.02	Caution	Fuel sensor failure	Service
28 000096.04	Caution	Fuel sensor failure	Service
28 000100.00	Warning	Abnormal engine oil pressure	Refer to "Troubleshooting"
28 000110.00	Warning	Abnormal cooling water temperature	Refer to "Troubleshooting"
28 000110.02	Caution	Cooling water temperature sensor failure	Service
28 000110.04	Caution	Cooling water temperature sensor failure	Service
28 000167.00	Caution	Insufficient battery charge	Refer to "Troubleshooting"
28 000639.12	Warning	CAN communication failure (engine controller)	Service
28 520777.02	Caution	Hydraulic oil temperature sensor failure	Service
28 520777.04	Caution	Hydraulic oil temperature sensor failure	Service

Error code	Classification	Error description	Corrective measures
28 520780.00	Caution	Air cleaner clogging	Refer to "Checking and cleaning the air cleaner"
28 520805.12	Warning	CAN communication failure (hydraulic controller)	Service
E1 000091.02	Caution	Accelerator sensor failure	Service
E1 000091.03	Caution	Accelerator sensor failure	Service
E1 000091.04	Caution	Accelerator sensor failure	Service
E1 016640.08	Caution	Alternator failure	Service
E1 024832.03	Warning	Abnormal sensor 5V power supply	Service
E1 025088.02	Caution	Hydraulic controller failure (EEPROM error)	Service
E1 025088.12	Caution	Hydraulic controller failure (EEPROM error)	Service
E1 025600.09	Caution	CAN communication failure (engine controller)	Service
E1 025856.09	Caution	CAN communication failure (LCD monitor)	Service
E1 026112.12	Caution	Hydraulic controller failure	Service
E1 026368.12	Caution	Engine controller failure	Service
E1 030464.05	Caution	Pump proportional solenoid valve failure	Service
E1 030464.06	Caution	Pump proportional solenoid valve failure	Service
E1 033024.00	Caution	Abnormal controller power supply voltage (high)	Service
E1 033024.01	Caution	Abnormal controller power supply voltage (low)	Check battery or service
E1 033024.11	Caution	Abnormal controller power supply voltage (low)	Check battery or service
E1 033792.02	Caution	Hydraulic controller failure	Service
E1 034048.02	Caution	Hydraulic controller failure (option unmatched error)	Service



www.discount-equipment.com

YANMAR

YANMAR CONSTRUCTION EQUIPMENT CO., LTD.

Copyright© 2019 YANMAR CONSTRUCTION EQUIPMENT CO., LTD. All Rights Reserved.
This manual may not be reproduced or copied in whole or in part, without the written consent of
YANMAR CONSTRUCTION EQUIPMENT CO., LTD.

OAKB3-EN0126
2019.08-0L

Go to Discount-Equipment.com to order your parts

PARTS FINDER

**Search Website
by Part Number**



**Search Manual
Library For Parts
Manual & Lookup Part
Numbers – Purchase
or Request Quote**

Search Manuals

Enter your information to help us find the right parts manual for your equipment.

* Brand:

* Model:

* Serial:

* Part Number:

SEARCH

**Can't Find Part or
Manual? Request Help
by Manufacturer,
Model & Description**

Parts Order Form

Please fill in the following information to help us find the right part for your equipment.

Manufacturer:	<input type="text"/>
Model:	<input type="text"/>
Description:	<input type="text"/>
Part Number:	<input type="text"/>
Quantity:	<input type="text"/>
Notes:	<input type="text"/>

Submit

Discount-Equipment.com is your online resource for quality parts & equipment.

Florida: **561-964-4949** Outside Florida TOLL FREE: **877-690-3101**

Need parts?

Click on this link: <http://www.discount-equipment.com/category/5443-parts/> and choose one of the options to help get the right parts and equipment you are looking for. Please have the machine model and serial number available in order to help us get you the correct parts. If you don't find the part on the website or on one of the online manuals, please fill out the request form and one of our experienced staff members will get back to you with a quote for the right part that your machine needs.

We sell worldwide for the brands: Genie, Terex, JLG, MultiQuip, Mikasa, Essick, Whiteman, Mayco, Toro Stone, Diamond Products, Generac Magnum, Airman, Haulotte, Barreto, Power Blanket, Nifty Lift, Atlas Copco, Chicago Pneumatic, Allmand, Miller Curber, Skyjack, Lull, Skytrak, Tsurumi, Husquvarna Target, Stow, Wacker, Sakai, Mi-T-M, Sullair, Basic, Dynapac, MBW, Weber, Bartell, Bennar Newman, Haulotte, Ditch Runner, Menegotti, Morrison, Contec, Buddy, Crown, Edco, Wyco, Bomag, Laymor, EZ Trench, Bil-Jax, F.S. Curtis, Gehl Pavers, Heli, Honda, ICS/PowerGrit, IHI, Partner, Imer, Clipper, MMD, Koshin, Rice, CH&E, General Equipment, Amida, Coleman, NAC, Gradall, Square Shooter, Kent, Stanley, Tamco, Toku, Hatz, Kohler, Robin, Wisconsin, Northrock, Oztec, Toker TK, Rol-Air, APT, Wylie, Ingersoll Rand / Doosan, Innovatech, Con X, Ammann, Mecalac, Makinex, Smith Surface Prep, Small Line, Wanco, Yanmar