



An Oshkosh Corporation Company



[www.Discount-Equipment.com](http://www.Discount-Equipment.com)

# Operation and Safety Manual

*Original Instructions - Keep this manual with the machine at all times.*

**Models**

**3369LE, 4069LE**

**M3369, M4069**

**PVC 2004**

**ANSI CE**



**AS/NZS**

**31217134**

January 31, 2020 - Rev A

**TO PURCHASE THIS PRODUCT PLEASE CONTACT US**



**Equipment Financing and  
Extended Warranties Available**



**Discount-Equipment.com is your online resource for  
commercial and industrial quality parts and equipment sales.**

**561-964-4949**

**visit us on line @ [www.discount-equipment.com](http://www.discount-equipment.com)**

Select an option below to find your Equipment

**Search by Manufacturer**

**Search by Product Type**

**Request a Quote**

We sell worldwide for the brands: Genie, Terex, JLG, MultiQuip, Mikasa, Essick, Whiteman, Mayco, Toro Stone, Diamond Products, Generac Magnum, Airman, Haulotte, Barreto, Power Blanket, Nifty Lift, Atlas Copco, Chicago Pneumatic, Allmand, Miller Curber, Skyjack, Lull, Skytrak, Tsurumi, Husquvarna Target, Stow, Wacker, Sakai, Mi-T-M, Sullair, Basic, Dynapac, MBW, Weber, Bartell, Bennar Newman, Haulotte, Ditch Runner, Menegotti, Morrison, Contec, Buddy, Crown, Edco, Wyco, Bomag, Laymor, EZ Trench, Bil-Jax, F.S. Curtis, Gehl Pavers, Heli, Honda, ICS/PowerGrit, IHI, Partner, Imer, Clipper, MMD, Koshin, Rice, CH&E, General Equipment, Amida, Coleman, NAC, Gradall, Square Shooter, Kent, Stanley, Tamco, Toku, Hatz, Kohler, Robin, Wisconsin, Northrock, Oztec, Toker TK, Rol-Air, APT, Wylie, Ingersoll Rand / Doosan, Innovatech, Con X, Ammann, Mecalac, Makinex, Smith Surface Prep, Small Line, Wanco, Yanmar



## **WARNING**

Operating, servicing and maintaining this vehicle or equipment can expose you to chemicals including engine exhaust, carbon monoxide, phthalates, and lead, which are known to the State of California to cause cancer and birth defects or other reproductive harm. To minimize exposure, avoid breathing exhaust, do not idle the engine except as necessary, service your vehicle or equipment in a well-ventilated area and wear gloves or wash your hands frequently when servicing. For more information go to [www.P65Warnings.ca.gov](http://www.P65Warnings.ca.gov).

To order go to [www.1500.com/equipment.com](http://www.1500.com/equipment.com)

## **FOREWORD**

The Mobile Elevating Work Platform (MEWP) models covered in this manual are designed and tested to meet or exceed various compliance standards. Please refer to the manufacturer's nameplate affixed to the subject MEWP for specific standard compliance information.

This manual is a very important tool! Keep it with the machine at all times.

The purpose of this manual is to provide owners, users, operators, lessors, and lessees with the precautions and operating procedures essential for the safe and proper machine operation for its intended purpose.

Due to continuous product improvements, JLG Industries, Inc. reserves the right to make specification changes without prior notification. Contact JLG Industries, Inc. for updated information.

Refer to [www.JLG.com](http://www.JLG.com) for Warranty, Product Registration, and other machine-related documentation.

## **SAFETY ALERT SYMBOLS AND SAFETY SIGNAL WORDS**



This is the Safety Alert Symbol. It is used to alert you to the potential personal injury hazards. Obey all safety messages that follow this symbol to avoid possible injury or death

### **⚠ DANGER**

INDICATES AN IMMINENTLY HAZARDOUS SITUATION. IF NOT AVOIDED, WILL RESULT IN SERIOUS INJURY OR DEATH. THIS DECAL WILL HAVE A RED BACKGROUND.

### **⚠ WARNING**

INDICATES A POTENTIALLY HAZARDOUS SITUATION. IF NOT AVOIDED, COULD RESULT IN SERIOUS INJURY OR DEATH. THIS DECAL WILL HAVE AN ORANGE BACKGROUND.

### **⚠ CAUTION**

INDICATES A POTENTIALLY HAZARDOUS SITUATION. IF NOT AVOIDED, MAY RESULT IN MINOR OR MODERATE INJURY. IT MAY ALSO ALERT AGAINST UNSAFE PRACTICES. THIS DECAL WILL HAVE A YELLOW BACKGROUND.

### **NOTICE**

INDICATES INFORMATION OR A COMPANY POLICY THAT RELATES DIRECTLY OR INDIRECTLY TO THE SAFETY OF PERSONNEL OR PROTECTION OF PROPERTY.

**REVISION LOG**

Original Issue

A - January 31, 2020

To order go to [Discount-Equipment.com](http://Discount-Equipment.com)

**SECTION - 1 - SAFETY PRECAUTIONS**

1.1 GENERAL..... 1-1

1.2 PRE-OPERATION..... 1-2

    Operator Training and Knowledge..... 1-2

    Workplace Inspection ..... 1-3

    Machine Inspection ..... 1-3

1.3 OPERATION ..... 1-4

    General ..... 1-4

    Trip and Fall Hazards ..... 1-5

    Electrocution Hazards ..... 1-6

    Tipping Hazards..... 1-7

    Crushing and Collision Hazards ..... 1-11

1.4 TOWING, LIFTING, AND HAULING ..... 1-12

1.5 MAINTENANCE ..... 1-13

    Maintenance Hazards ..... 1-13

    Battery Hazards ..... 1-14

**SECTION - 2 - USER RESPONSIBILITIES, MACHINE PREPARATION AND INSPECTION**

2.1 PERSONNEL TRAINING..... 2-1

    Operator Training ..... 2-1

    Training Supervision ..... 2-1

    Operator Responsibility ..... 2-1

    Machine Familiarization ..... 2-2

2.2 PREPARATION, INSPECTION, AND MAINTENANCE ..... 2-2

    Inspection and Maintenance Table..... 2-3

2.3 PRE-START INSPECTION ..... 2-4

2.4 WALK-AROUND INSPECTION ..... 2-6

    Inspection Diagram..... 2-8

2.5 FUNCTION CHECK ..... 2-9

2.6 OSCILLATING AXLE - LOCKOUT CYLINDER TEST (IF EQUIPPED)..... 2-11

    Left Side Wheel Test ..... 2-11

    Right Side Wheel Test..... 2-12

    Limit Switch Locations ..... 2-13

**SECTION - 3 - MACHINE CONTROLS, INDICATORS, AND OPERATION**

3.1 GENERAL ..... 3-1

3.2 DESCRIPTION ..... 3-1

3.3 OPERATING CHARACTERISTICS AND LIMITATIONS ..... 3-2

    Placards..... 3-2

    Capacities ..... 3-2

    Stability ..... 3-2

3.4 PLATFORM LOADING ..... 3-2

3.5 GROUND CONTROL STATION..... 3-3

3.6 PLATFORM CONTROL STATION..... 3-5

    Platform Controls..... 3-6

    Platform/Ground Select..... 3-8

    Raising & Lowering ..... 3-8

    Leveling Jacks (If Equipped)..... 3-8

    Platform Extension ..... 3-8

## TABLE OF CONTENTS

Platform Handrails Fold Down Procedure (If Equipped)	3-8
Steering	3-9
Traveling Forward and Reverse	3-9
Parking and Stowing	3-11
Battery Charging Procedure	3-11
Safety Prop	3-12
Lifting and Tie-Down	3-13
3.7 DECALS	3-15
ANSI, ANSI Export, CSA, Japan	3-15
CE, AUS	3-18

### SECTION - 4 - EMERGENCY PROCEDURES

4.1 GENERAL	4-1
4.2 EMERGENCY OPERATION	4-1
Operator Unable to Control Machine	4-1
Righting of Tipped Machine	4-1
Platform Caught Overhead	4-1
4.3 EMERGENCY TOWING PROCEDURES	4-2
4.4 MANUAL DESCENT SYSTEM	4-2
4.5 INCIDENT NOTIFICATION	4-3

### SECTION - 5 - ACCESSORIES

5.1 1/2" AIRLINE	5-2
5.2 PLATFORM WORKLIGHTS	5-2
5.3 PLATFORM RAIL PADDING	5-3
With Deck Bumpers and Proximity Switches	5-3

5.4 DC/AC POWER INVERTER	5-4
Safety Precautions	5-5
Preparation and Inspection	5-5
Operation	5-5
5.5 PROGRAMMABLE SECURITY LOCK (PSL™)	5-6
Machine Power Up	5-7
Machine Power Down	5-7
Changing the Operator's Code	5-7

### SECTION - 6 - GENERAL SPECIFICATIONS AND OPERATOR MAINTENANCE

6.1 INTRODUCTION	6-1
6.2 SUPPLEMENTAL INFORMATION	6-1
6.3 OPERATING SPECIFICATIONS	6-2
Platform Capacities	6-4
Dimensional Data	6-5
Capacities	6-5
Tires	6-5
Batteries (Electric Machines)	6-6
Engine	6-7
Lubrication	6-10
6.4 OPERATOR MAINTENANCE	6-11
6.5 TIRES AND WHEELS	6-13
Tire Damage	6-13
Tire Replacement	6-13
Wheel Replacement	6-14
Wheel Installation	6-14



**SECTION - 7 - INSPECTION AND REPAIR LOG**

**LIST OF FIGURES**

3-1. Platform Control Station.....3-5  
3-2. Grade and Sideslope .....3-10  
3-3. Decal Installation (ANSI) .....3-15  
6-1. Engine Operating Temperature Specifications - ....  
(Kubota) Sheet 1 of 26-8  
6-2. Engine Operating Temperature Specifications - ....  
(Kubota) Sheet 2 of 26-9

**LIST OF TABLES**

1-1 Minimum Approach Distances (M.A.D.) ..... 1-7  
1-2 Beaufort Scale (For Reference Only) ..... 1-9  
2-1 High Drive Cutout ..... 2-9  
2-2 Tilt vs. Height ..... 2-10  
5-1 Available Accessories ..... 5-1  
6-1 Engine Specifications (Generator - If Equipped) . 6-7  
6-2 Engine Battery Specifications..... 6-7  
6-3 Wheel Torque Chart..... 6-15

## SECTION 1. SAFETY PRECAUTIONS

### 1.1 GENERAL

This section outlines the necessary precautions for proper and safe machine usage and maintenance. In order to promote proper machine usage, it is mandatory that a daily routine is established based on the content of this manual. A maintenance program, using the information provided in this manual and the Service and Maintenance Manual, must also be established by a qualified person and must be followed to ensure that the machine is safe to operate.

The owner/user/operator/lessor/lessee of the machine must not accept operating responsibility until this manual has been read, training is accomplished, and operation of the machine has been completed under the supervision of an experienced and qualified operator.

These sections contain the responsibilities of the owner, user, operator, lessor, and lessee concerning safety, training, inspection, maintenance, application, and operation. If there are any questions with regard to safety, training, inspection, maintenance, application, and operation, please contact JLG Industries, Inc. ("JLG").

#### **WARNING**

**FAILURE TO COMPLY WITH THE SAFETY PRECAUTIONS LISTED IN THIS MANUAL COULD RESULT IN MACHINE DAMAGE, PROPERTY DAMAGE, PERSONAL INJURY OR DEATH.**

### 1.2 PRE-OPERATION

#### Operator Training and Knowledge

- Read, understand, and study the Operation and Safety Manual in its entirety before operating the machine. For clarification, questions, or additional information regarding any portions of this manual, contact JLG Industries, Inc.

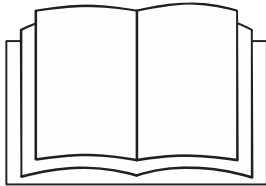

- Only personnel who have received proper training regarding the inspection, application and operation of MEWPs (including recognition and avoiding hazards associated with their operation) shall be authorized to operate a MEWP.

- Only properly trained personnel who have received unit-specific familiarization shall operate a MEWP. The user shall determine if personnel are qualified to operate the MEWP prior to operation.
- Read, understand, and obey all DANGERS, WARNINGS, CAUTIONS, and operating instructions on the machine and in this manual.
- Ensure that the machine is to be used in a manner which is within the scope of its intended application as determined by JLG.
- All operating personnel must have a thorough understanding of the intended purpose and function of the MEWP controls, including platform, ground, and emergency descent controls.
- Read, understand, and obey all applicable employer, local, and governmental regulations as they pertain to your utilization and application of the machine.

## Workplace Inspection

- Precautions to avoid all hazards in the work area must be taken by the user before and during operation of the machine.
- Do not operate or raise the platform from a position on trucks, trailers, railway cars, floating vessels, scaffolds or other equipment unless the application is approved in writing by JLG.
- Before operation, check work area for overhead hazards such as electric lines, bridge cranes, and other potential overhead obstructions.
- Check operating surfaces for holes, bumps, drop-offs, obstructions, debris, concealed holes, and other potential hazards.
- Check the work area for hazardous locations. Do not operate the machine in hazardous environments unless approved for that purpose by JLG.
- Ensure that the ground conditions are adequate to support the maximum tire load indicated on the tire load decals located on the chassis adjacent to each wheel.
- This machine can be operated in nominal ambient temperatures of 0° F to 104° F (-20° C to 40° C). Consult JLG to optimize operation outside of this temperature range.

## Machine Inspection

- Do not operate this machine until the inspections and functional checks have been performed as specified in Section 2 of this manual.
- Do not operate this machine until it has been serviced and maintained according to the maintenance and inspection requirements as specified in the machine's Service and Maintenance Manual.
- Ensure all safety devices are operating properly. Modification of these devices is a safety violation.

### **WARNING**

**MODIFICATION OR ALTERATION OF A MEWP SHALL BE MADE ONLY WITH PRIOR WRITTEN PERMISSION FROM THE MANUFACTURER.**

- Do not operate any machine on which the safety or instruction placards or decals are missing or illegible.
- Check the machine for modifications to original components. Ensure that any modifications have been approved by JLG.
- Avoid accumulation of debris on platform floor. Keep mud, oil, grease, and other slippery substances from footwear and platform floor.

### 1.3 OPERATION

#### General

- Machine operation requires your full attention. Bring the machine to a full stop before using any device, i.e. cell phones, two-way radios, etc. that will distract your attention from safely operating the machine.
- Do not use the machine for any purpose other than positioning personnel, their tools, and equipment.
- Before operation, the user must be familiar with the machine capabilities and operating characteristics of all functions.
- Never operate a malfunctioning machine. If a malfunction occurs, shut down the machine. Remove the unit from service and notify the proper authorities.
- Do not remove, modify, or disable any safety devices.
- Never slam a control switch or lever through neutral to an opposite direction. Always return switch to neutral and stop before moving the switch to the next function. Operate controls with slow and even pressure.
- Do not allow personnel to tamper with or operate the machine from the ground with personnel in the platform, except in an emergency.
- Do not carry materials directly on platform railing unless approved by JLG.
- When two or more persons are in the platform, the operator shall be responsible for all machine operations.
- Always ensure that power tools are properly stowed and never left hanging by their cord from the platform work area.
- Do not assist a stuck or disabled machine by pushing or pulling except by pulling at the chassis tie-down lugs.
- Fully lower platform and shut off all power before leaving machine.
- Remove all rings, watches, and jewelry when operating machine. Do not wear loose fitting clothing or long hair unrestrained which may become caught or entangled in equipment.
- Persons under the influence of drugs or alcohol or who are subject to seizures, dizziness or loss of physical control must not operate this machine.
- Hydraulic cylinders are subject to thermal expansion and contraction. This may result in changes to the platform position while the machine is stationary. Factors affecting thermal movement can include the length of time the machine will remain stationary, hydraulic oil temperature, ambient air temperature and platform position.

## Trip and Fall Hazards

- Prior to operation, ensure all gates and rails are fastened and secured in their proper position.

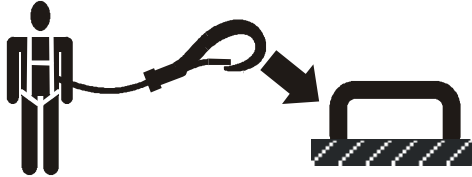

- JLG Industries, Inc. recommends that all persons in the platform wear a full body harness with a lanyard attached to an authorized lanyard anchorage point while operating this machine. For further information regarding fall protection requirements on JLG products, contact JLG Industries, Inc.
- Identify the designated lanyard anchorage point(s) at the platform and securely attach the lanyard. Attach only one (1) lanyard per lanyard anchorage point.
- Enter and exit only through gate area. Use extreme caution when entering or leaving platform. Ensure that the platform assembly is fully lowered. Face the platform when entering or leaving the platform. Always maintain “three point contact” with the machine, using two hands and one foot or two feet and one hand at all times during entry and exit.

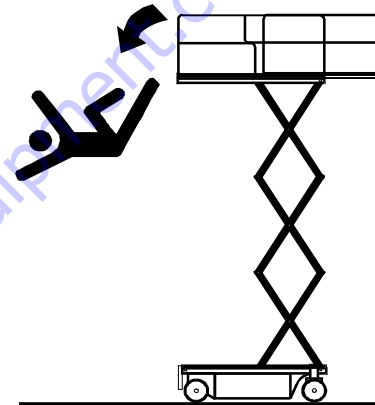

- Keep both feet firmly positioned on the platform floor at all times. Never position ladders, boxes, steps, planks, or similar items on unit to provide additional reach for any purpose.
- Never use the scissor arm assembly to gain access to or leave the platform.
- Keep oil, mud, and slippery substances cleaned from footwear and the platform floor.

### Electrocution Hazards

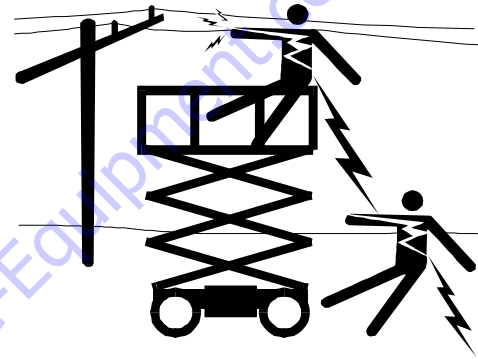
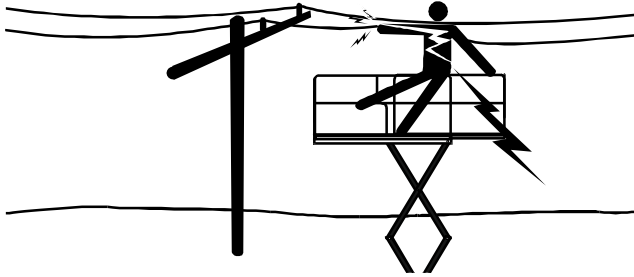

- This machine is not insulated and does not provide protection from contact or proximity to electrical current.
- Maintain distance from electrical lines, apparatus, or any energized (exposed or insulated) parts according to the Minimum Approach Distance (MAD) as shown in Table 1-1.
- Allow for machine movement and electrical line swaying.
- Maintain a clearance of at least 10 ft (3 m) between any part of the machine and its occupants, their tools, and their equipment from any electrical line or apparatus carrying up to 50,000 volts. One foot additional clearance is required for every additional 30,000 volts or less.
- The minimum approach distance may be reduced if insulating barriers are installed to prevent contact, and the barriers are rated for the voltage of the line being guarded. These barriers shall not be part of (or attached to) the machine. The minimum approach distance shall be reduced to a distance within the designed working dimensions of the insulating barrier. This determination shall be made by a qualified person in accordance with the employer, local, or governmental requirements for work practices near energized equipment.

**DANGER**

**DO NOT MANEUVER MACHINE OR PERSONNEL INSIDE PROHIBITED ZONE (MAD). ASSUME ALL ELECTRICAL PARTS AND WIRING ARE ENERGIZED UNLESS KNOWN OTHERWISE.**

**Table 1-1. Minimum Approach Distances (M.A.D.)**

<b>VOLTAGE RANGE (Phase to Phase)</b>	<b>MINIMUM APPROACH DISTANCE in Feet (Meters)</b>
0 to 50 KV	10 (3)
Over 50KV to 200 KV	15 (5)
Over 200 KV to 350 KV	20 (6)
Over 350 KV to 500 KV	25 (8)
Over 500 KV to 750 KV	35 (11)
Over 750 KV to 1000 KV	45 (14)
<b>NOTE:</b> <i>This requirement shall apply except where employer, local or governmental regulations are more stringent.</i>	

### Tipping Hazards

- Ensure that the ground conditions are adequate to support the maximum tire load indicated on the tire load decals located on the chassis adjacent to each wheel. Do not travel on unsupported surfaces.
- The user must be familiar with the operating surface before driving. Do not exceed the allowable sideslope and grade while driving.
- Do not elevate platform or drive with platform elevated while on or near a sloping, uneven, or soft surface. Ensure machine is positioned on a smooth, firm surface within the limits of the maximum operating slope before elevating platform or driving with the platform in the elevated position.
- Before driving on floors, bridges, trucks, and other surfaces, check allowable capacity of the surfaces.
- Never exceed the maximum platform capacity as specified on the platform. Keep all loads within the confines of the platform, unless authorized by JLG.



## SECTION 1 - SAFETY PRECAUTIONS

---

- Keep the chassis of the machine a minimum of 2 ft (0.6 m) from holes, bumps, drop-offs, obstructions, debris, concealed holes, and other potential hazards at the ground level.
- Do not operate the machine when wind conditions exceed specifications shown in Section 6 of this manual or as shown on the capacity placard on the platform billboard.
- Do not operate the machine when wind conditions exceed specifications shown in Section 6.3 or as shown on the capacity placard on the platform billboard. Factors affecting wind speed are; platform elevation, surrounding structures, local weather events, and approaching storms.
- Wind speed can be significantly greater at height than at ground level.
- Wind speed can change rapidly. Always consider approaching weather events, the time required to lower the platform, and methods to monitor current and potential wind conditions.
- Do not cover or increase surface area of the platform or the load. Do not carry large surface area items in the platform when operating outdoors. The addition of such items increases the exposed wind area of the machine. Increased areas exposed to wind will decrease stability.
- Do not increase the platform size with unauthorized modifications, deck extensions, or attachments.

### **WARNING**

**DO NOT OPERATE THE MACHINE WHEN WIND CONDITIONS EXCEED SPECIFICATIONS SHOWN IN SECTION 6.3 OR AS SHOWN ON THE CAPACITY PLACARD ON THE PLATFORM BILLBOARD.**

Table 1-2. Beaufort Scale (For Reference Only)

BEAUFORT NUMBER	WIND SPEED		DESCRIPTION	LAND CONDITIONS
	mph	m/s		
0	0	0-0.2	Calm	Calm. Smoke rises vertically.
1	1-3	0.3-1.5	Light air	Wind motion visible in smoke.
2	4-7	1.6-3.3	Light breeze	Wind felt on exposed skin. Leaves rustle.
3	8-12	3.4-5.4	Gentle breeze	Leaves and smaller twigs in constant motion.
4	13-18	5.5-7.9	Moderate breeze	Dust and loose paper raised. Small branches begin to move.
5	19-24	8.0-10.7	Fresh breeze	Smaller trees sway.
6	25-31	10.8-13.8	Strong breeze	Large branches in motion. Flags waving near horizontal. Umbrella use becomes difficult.
7	32-38	13.9-17.1	Near Gale/Moderate Gale	Whole trees in motion. Effort needed to walk against the wind.
8	39-46	17.2-20.7	Fresh Gale	Twigs broken from trees. Cars veer on road.
9	47-54	20.8-24.4	Strong Gale	Light structure damage.

## SECTION 1 - SAFETY PRECAUTIONS

---

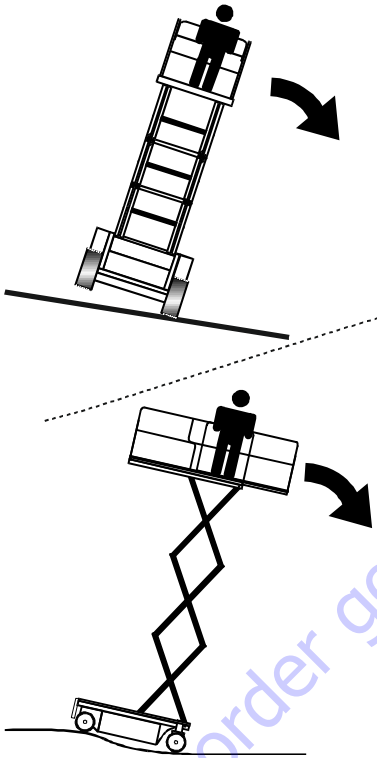

- Never attempt to use the machine as a crane. Do not tie-off machine to any adjacent structure. Never attach wire, cable, or any similar items to platform.
- If the scissor arm assembly or platform is caught so that one or more wheels are off the ground, all persons must be removed before attempting to free the machine. Use cranes, forklift trucks, or other appropriate equipment to stabilize machine.

**Crushing and Collision Hazards**

- Approved head gear must be worn by all operating and ground personnel.
- Keep hands and limbs out of the scissor arm assembly during operation and when elevated without safety prop engaged.
- Watch for obstructions around machine and overhead when driving. Check clearances above, on sides, and bottom of platform when lifting or lowering platform.
- During operation, keep all body parts inside platform railing.

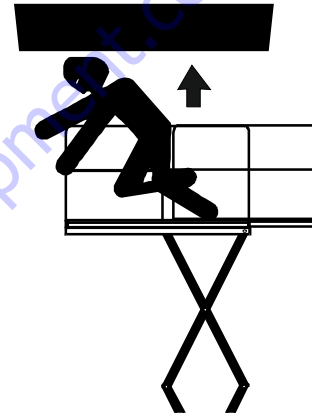

- Always post a lookout when driving in areas where vision is obstructed.
- Keep non-operating personnel at least 6 ft (1.8 m) away from machine during all operations.
- Under all travel conditions, the operator must limit travel speed according to conditions of ground surface, congestion, visibility, slope, location of personnel, and other factors.

## SECTION 1 - SAFETY PRECAUTIONS

---

- Be aware of stopping distances in all drive speeds. When driving in high speed, reduce drive speed before stopping. Travel grades in low speed only.
- Do not use high speed drive in restricted or close quarters or when driving in reverse.
- Exercise extreme caution at all times to prevent obstacles from striking or interfering with operating controls and persons in the platform.
- Ensure that operators of other overhead and floor level machines are aware of the MEWP's presence. Disconnect power to overhead cranes. Barricade floor area if necessary.
- Do not operate over ground personnel. Warn personnel not to work, stand, or walk under a raised platform. Position barricades on floor as necessary.

### **WARNING**

**IF DRIVING MACHINE WITH THE PLATFORM CONTROL STATION FROM GROUND, DO NOT HANG THE CONTROL BOX ON ANY PART OF THE MACHINE WHILE DRIVING. HOLD THE CONTROL BOX AND KEEP AT LEAST 3 FT (1 M) DISTANCE FROM MACHINE.**

## 1.4 TOWING, LIFTING, AND HAULING

- Never allow personnel in platform while towing, lifting, or hauling.
- This machine should not be towed, except in the event of emergency, malfunction, power failure, or loading/unloading. Refer to emergency towing procedures.
- Ensure platform is fully retracted and completely empty of tools prior to towing, lifting or hauling.
- When lifting machine with a forklift, position forks only at designated areas of the machine. Lift with a forklift of adequate capacity.
- Refer to Section 3 for lifting information.

## 1.5 MAINTENANCE

This sub-section contains general safety precautions which must be observed during maintenance of this machine. Additional precautions to be observed during machine maintenance are inserted at the appropriate points in this manual and in the Service and Maintenance Manual. It is of utmost importance that maintenance personnel pay strict attention to these precautions to avoid possible injury to personnel or damage to the machine or property. A maintenance program must be established by a qualified person and must be followed to ensure that the machine is safe.

### Maintenance Hazards

- Shut off power to all controls and ensure that all moving parts are secured from inadvertent motion prior to performing any adjustments or repairs.
- Never work under an elevated platform until it has been fully lowered to the full down position, if possible, or otherwise supported and restrained from movement with appropriate safety props, blocking, or overhead supports.
- DO NOT attempt to repair or tighten any hydraulic hoses or fittings while the machine is powered on or when the hydraulic system is under pressure.
- Always relieve hydraulic pressure from all hydraulic circuits before loosening or removing hydraulic components.
- DO NOT use your hand to check for leaks. Use a piece of cardboard or paper to search for leaks. Wear gloves to help protect hands from spraying fluid.



## SECTION 1 - SAFETY PRECAUTIONS

---

- Use only replacement parts or components that are approved by JLG. To be considered approved, replacement parts or components must be identical or equivalent to original parts or components.
- Never attempt to move heavy parts without the aid of a mechanical device. Do not allow heavy objects to rest in an unstable position. Ensure adequate support is provided when raising components of the machine.
- Use only approved non-flammable cleaning solvents.
- Do not replace items critical to stability, such as batteries or solid tires, with items of different weight or specification. Do not modify unit in any way to affect stability.
- Reference the Service and Maintenance Manual for the weights of critical stability items.

### **WARNING**

**MODIFICATION OR ALTERATION OF A MEWP SHALL BE MADE ONLY WITH PRIOR WRITTEN PERMISSION FROM THE MANUFACTURER.**

### **Battery Hazards**

- Always disconnect batteries when servicing electrical components or when performing welding on the machine.
- Do not allow smoking, open flame, or sparks near battery during charging or servicing.
- Do not contact tools or other metal objects across the battery terminals.
- Always wear hand, eye, and face protection when servicing batteries. Ensure that battery acid does not come in contact with skin or clothing.

### **CAUTION**

**BATTERY FLUID IS HIGHLY CORROSIVE. AVOID CONTACT WITH SKIN AND CLOTHING AT ALL TIMES. IMMEDIATELY RINSE ANY CONTACTED AREA WITH CLEAN WATER AND SEEK MEDICAL ATTENTION.**

- Charge batteries only in a well ventilated area.
- Avoid overfilling the battery fluid level. Add distilled water to batteries only after the batteries are fully charged.

## **SECTION 2. USER RESPONSIBILITIES, MACHINE PREPARATION AND INSPECTION**

### **2.1 PERSONNEL TRAINING**

The Mobile Elevating Work Platform (MEWP) is a personnel handling device, so it is necessary that it be operated and maintained only by trained personnel.

#### **Operator Training**

Operator training must cover:

1. Reading and understanding the Operation and Safety Manual.
2. Thorough understanding of the intended purpose and function of the MEWP controls, including platform, ground, and emergency descent controls.
3. Control labels, instructions, and warnings on the machine.
4. Applicable regulations, standards, and safety rules.
5. Use of approved fall protection equipment.
6. Enough knowledge of the mechanical operation of the machine to recognize a malfunction or potential malfunction.
7. The safest means to operate the machine where overhead obstructions, other moving equipment, and obstacles, depressions, holes, and drop-offs exist.

8. Means to avoid the hazards of unprotected electrical conductors.
9. Selection of the appropriate MEWPs and available options for the work to be performed considering specific job requirements, with involvement from the MEWP owner, user, and/or supervisor.
10. The responsibility of the operator to ensure all platform occupants have a basic level of knowledge to work safely on the MEWP, and to inform them of applicable regulations, standards, and safety rules.
11. The requirement for familiarization in addition to training

#### **Training Supervision**

Training must be done under the supervision of a qualified person in an open area free of obstructions until the trainee has developed the ability to safely control and operate the machine.

#### **Operator Responsibility**

The operator must be instructed that they have the responsibility and authority to shut down the machine in case of a malfunction or other unsafe condition of either the machine or the job site.



### **Machine Familiarization**

**NOTE:** *Responsibilities for familiarization may vary by region.*

Only properly trained personnel who have received unit-specific familiarization shall operate a MEWP. The user shall determine if personnel are qualified to operate the MEWP prior to operation. The user shall ensure that after familiarization, the operator operates the MEWP for a sufficient period of time to achieve proficiency. When authorized by the user, self-familiarization can be achieved, if authorized, by a properly trained operator reading, understanding and following the manufacturer's operator's manual.

Prior to users authorization of an operator to use a specific model of MEWP, the user shall ensure the operator is familiarized on the following:

1. Location of the manual storage compartment and the requirement to ensure the required manual(s) are present on the MEWP;
2. Purpose and function of the machine controls and indicators at the platform and ground control stations;
3. Purpose, location, and function of the emergency controls;
4. Operating characteristics and limitations;
5. Features and devices;
6. Accessories and optional equipment.

### **2.2 PREPARATION, INSPECTION, AND MAINTENANCE**

The Inspection and Maintenance Table covers the machine inspections and maintenance recommended by JLG Industries, Inc. Consult local regulations for further requirements for MEWPs. The frequency of inspections and maintenance must be increased as necessary when the machine is used in a harsh or hostile environment, if the machine is used with increased frequency, or if the machine is used in a severe manner.

## SECTION 2 - USER RESPONSIBILITIES, MACHINE PREPARATION AND INSPECTION

### Inspection and Maintenance Table

Type	Frequency	Primary Responsibility	Service Qualification	Reference
Pre-Start Inspection	Before using each day; or whenever there's an Operator change.	User or Operator	User or Operator	Operator and Safety Manual
Pre-Delivery Inspection (See Note)	Before each sale, lease, or rental delivery.	Owner, Dealer, or User	Qualified JLG Mechanic	Service and Maintenance Manual and applicable JLG inspection form
Frequent Inspection	In service for 3 months or 150 hours, whichever comes first; or Out of service for a period of more than 3 months; or Purchased used.	Owner, Dealer, or User	Qualified JLG Mechanic	Service and Maintenance Manual and applicable JLG inspection form
Annual Machine Inspection (See Note)	Annually, no later than 13 months from the date of prior inspection.	Owner, Dealer, or User	Factory-Trained Service Technician (Recommended)	Service and Maintenance Manual and applicable JLG inspection form
Preventative Maintenance	At intervals as specified in the Service and Maintenance Manual.	Owner, Dealer, or User	Qualified JLG Mechanic	Service and Maintenance Manual

**NOTE:** Inspection forms are available from JLG. Use the Service and Maintenance Manual to perform inspections.

#### NOTICE

**JLG INDUSTRIES, INC. RECOGNIZES A FACTORY-TRAINED SERVICE TECHNICIAN AS A PERSON WHO HAS SUCCESSFULLY COMPLETED THE JLG SERVICE TRAINING SCHOOL FOR THE SPECIFIC JLG PRODUCT MODEL.**

### 2.3 PRE-START INSPECTION

The Pre-Start Inspection should include each of the following:

1. **Cleanliness** – Check all surfaces for leakage (oil, fuel, or battery fluid) or foreign objects. Report any leakage to the proper maintenance personnel.
2. **Structure** - Inspect the machine structure for dents, damage, weld or parent metal cracks or other discrepancies.

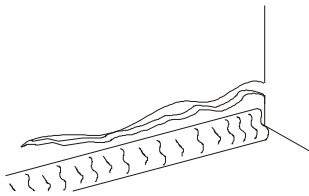

Parent Metal Crack

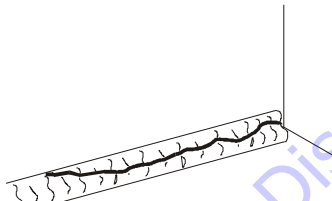

Weld Crack

3. **Decals and Placards** – Check all for cleanliness and legibility. Make sure none of the decals and placards are missing. Make sure all illegible decals and placards are cleaned or replaced.
4. **Operation and Safety Manuals** – Make sure a copy of the Operation and Safety Manual, AEM Safety Manual (ANSI markets only), and ANSI Manual of Responsibilities (ANSI markets only) is enclosed in the weather resistant storage container.
5. **Walk-Around Inspection** – Perform as instructed in Section 2.4.
6. **Battery** – Charge as required.
7. **Fuel** - (Combustion Engine Powered Machines) – Add the proper fuel as necessary.
8. **Engine Oil Supply** - Ensure that the engine oil level is at the full mark on the dipstick and the filler cap is secure

## SECTION 2 - USER RESPONSIBILITIES, MACHINE PREPARATION AND INSPECTION

9. **Fluid Levels** - Be sure to check the engine oil and the hydraulic oil levels.
10. **Accessories/Attachments** - Refer to the Accessories section in this manual or accessory installed upon the machine for specific inspection, operation, and maintenance instructions.
11. **Function Check** – Once the Walk-Around Inspection is complete, perform a functional check of all systems in an area free of overhead and ground level obstructions. Refer to Section 4 for more specific instructions on the operation of each function.
12. **Platform Gate** – Keep gate and surrounding area clean and unobstructed. Ensure the gate closes properly and is not bent or damaged. Keep gate closed at all times except when entering/exiting the platform and loading/unloading materials.
13. **Lanyard Anchorage Points** – JLG Industries, Inc. recommends personnel in the platform wear a full body harness with a lanyard attached to an authorized lanyard anchorage point.

### **WARNING**

**IF THE MACHINE DOES NOT OPERATE PROPERLY, TURN OFF THE MACHINE IMMEDIATELY! REPORT THE PROBLEM TO THE PROPER MAINTENANCE PERSONNEL. DO NOT OPERATE THE MACHINE UNTIL IT IS DECLARED SAFE FOR OPERATION.**

### 2.4 WALK-AROUND INSPECTION

Begin the "Walk-Around Inspection" at Item 1, as noted on the diagram. Continue Left (counterclockwise viewed from top) checking each item in sequence for the conditions listed in the following checklist.

#### **⚠ WARNING**

**TO AVOID POSSIBLE INJURY, BE SURE MACHINE POWER IS "OFF" DURING "WALK-AROUND INSPECTION".**

#### **NOTICE**

**DO NOT OVERLOOK VISUAL INSPECTION OF CHASSIS UNDERSIDE. CHECKING THIS AREA OFTEN RESULTS IN DISCOVERY OF CONDITIONS WHICH COULD CAUSE EXTENSIVE MACHINE DAMAGE.**

**NOTE:** *On each item, make sure there are no loose or missing parts, that they are securely fastened, and that no visible damage exists in addition to any other criteria mentioned.*

1. **Platform Control Console** – Placard secure and legible, control lever and switches return to neutral when activated and released, control lever lock and emergency stop switch function properly, manual in storage box.
2. **Leveling Jacks** – See Note
3. **Spindle, Tie Rod and Steer Linkage (left front)** – See Note
4. **Wheels and Tires** – Properly secured, no missing lug nuts. Refer to section 6, Tires and Wheels. Inspect wheels for damage and corrosion.
5. **Steer Cylinder** – See Note
6. **Hydraulic Reservoir** – Recommended hydraulic fluid level on level indicator on tank. Breather cap secure and working.

## SECTION 2 - USER RESPONSIBILITIES, MACHINE PREPARATION AND INSPECTION

---

7. **Hydraulic Pump** – See Note
8. **Hydraulic Motor** – See Note
9. **Battery Compartment** – Proper electrolyte level.
10. **Battery Disconnect** – See Note
11. **Oscillating Axle, Oscillation Cylinder** – See Note
12. **Drive Hubs** – See Note
14. **Brake, Left Rear** – See Note
14. **Limit Switch** – See Note
15. **Ladder** – See Note
16. **Manual Descent** – See Note
17. **Limit Switch** – See Note
18. **Brake, Right Rear** – See Note
19. **Oscillation Cylinder** – See Note
20. **Battery Disconnect** – See Note
21. **Lift Cylinder** – See Note
22. **Generator Fuel Supply** – See Note
23. **Ground Controls** – Placard secure and legible, control switches return to neutral position when activated and released, emergency stop switch functions properly. Control markings legible.
24. **Control Valve** – No unsupported wires or hoses; no damaged or broken wires.
25. **Scissor Arms and Sliding Wear Pads** – See Note
26. **Spindle, Tie Rod and Steer Linkage (right front)** – See Note
27. **Battery Charger or Generator** – See Note
28. **Platform/Handrail Installation (Not Shown)** – See Note

## SECTION 2 - USER RESPONSIBILITIES, MACHINE PREPARATION AND INSPECTION

### Inspection Diagram

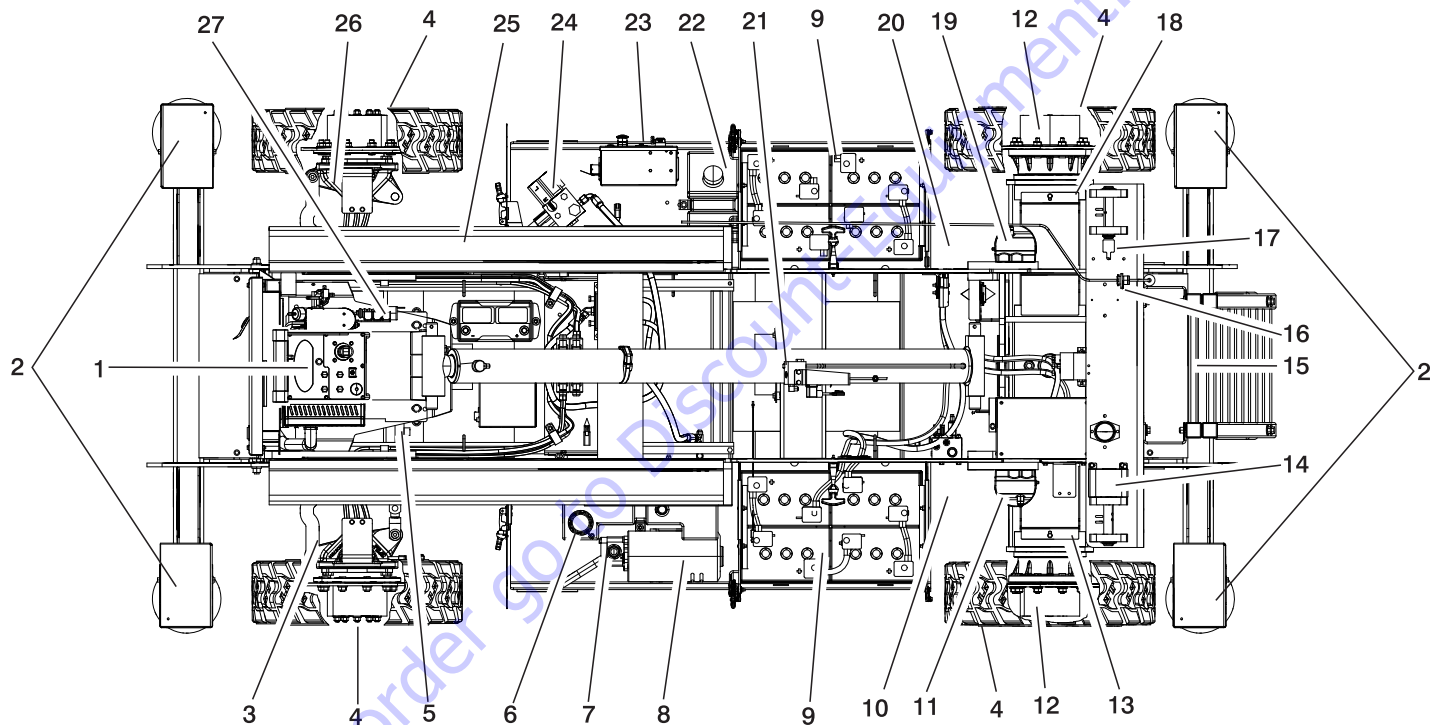

## 2.5 FUNCTION CHECK

Perform the Function Check as follows:

1. From the ground emergency control panel with no load in the platform:
  - a. Ensure that the key selector switch and the platform lift switch operate properly.
  - b. Ensure that all machine functions are disabled when the Emergency Stop Button is depressed.
  - c. With the platform raised a few feet (1 m), ensure that the manual descent control (T-handle located at the rear of the machine) lowers the platform.
2. From the platform control console:
  - a. Ensure that the control console is firmly secured in the proper location.
  - b. Ensure that all guards protecting switches are in place.
  - c. Operate all switch functions, drive/lift mode select switch, and horn button.
  - d. Operate all platform joystick functions to ensure proper operation of drive, lift, steer, and enable trigger switch operation.
  - e. Ensure all machine functions stop when function control is released or when joystick trigger is released.

- f. Ensure that all machine functions are disabled when the platform Emergency Stop Button is depressed.
- g. With the platform elevated on a smooth, firm, level surface with no overhead obstructions, drive the machine to check if the high drive cutout speed limit is engaged at the height indicated in Table 2-1. Ensure drive speed is reduced from a top speed to a slower speed.

**Table 2-1. High Drive Cutout**

Model	High Drive Cutout	Drive Cutout	Drive at Creep Speed
3369LE/M3369	67 in (1.7 m)	--	--
4069LE/M4069	84 in (2.1 m)	30 ft (9.1 m)	--
M4069 (AUS Full Drive Height Model)	84 in (2.1 m)	--	28 ft - 30 ft (8.5 m - 9.1 m)



## SECTION 2 - USER RESPONSIBILITIES, MACHINE PREPARATION AND INSPECTION

3. With the platform in the stowed position:
  - a. Drive the machine on a grade, not to exceed the rated gradeability, and stop to ensure the brakes hold.
  - b. Check the tilt indicator light to ensure proper operation. The light should be illuminated if tilted beyond allowed settings in Table 2-2.

**Table 2-2. Tilt vs. Height**

Height	Tilt	
	Left - Right	Front - Back
<b>3369LE/M3369</b>		
< 25 ft (7.6 m)	5°	5°
< 30 ft (9.1 m)	4°	5°
Full Height		
CSA	3°	3°
All Other Markets	3°	5°
<b>3369LE/M3369 - CE 37 mph (16.7 m/s) Wind Speed Option</b>		
< 25 ft (7.6 m)	4°	5°
Full Height	2°	4°
<b>4069LE/M4069</b>		
< 30 ft (9.1 m)	5°	5°
< 36 ft (11 m)	4°	5°
Full Height		
CSA	3°	3°
All Other Markets	3°	5°

**NOTE:** When the tilt indicator warning is activated, drive, lift up, and steer functions are disabled and the platform must be fully lowered (stowed) to drive.

## **2.6 OSCILLATING AXLE - LOCKOUT CYLINDER TEST (IF EQUIPPED)**

### **NOTICE**

**LOCKOUT CYLINDER SYSTEM TEST MUST BE PERFORMED QUARTERLY, ANY TIME A SYSTEM COMPONENT IS REPLACED, OR WHEN IMPROPER SYSTEM OPERATION IS SUSPECTED.**

**NOTE:** *Ensure platform is fully lowered prior to beginning lockout cylinder test, and that the surface used to approach the ramp is flat and level.*

### **Left Side Wheel Test**

1. Place a 4 inch (10.16 cm) high block with ascension ramp in front of left wheel of the oscillating axle.
2. From platform control station, select LOW drive speed.
3. Set the DRIVE control switch and carefully drive the machine up ascension ramp until left oscillating axle wheel is on top of block.
4. Verify the axle oscillates to maintain contact with the ground/ramp. (All four wheels on the ground).

5. Raise machine platform above stowed position approximately 7 ft (2.1 m) on the 3369LE or 9 ft (2.7 m) on the 4069LE.
6. Carefully drive the machine back off the block and ramp.
7. Have an assistant check to see that the left oscillating axle wheel that was on the block is in position on the ground. The axle should oscillate so that all four wheels maintain contact with the ground.
8. In the current position (platform raised and all four tires on flat and level surface), carefully drive machine up the ramp block again.
9. Have an assistant check to verify that the axle did not oscillate and remained locked (one wheel is off of the ground).
10. Carefully drive the machine back off the block and ramp.
11. Lower the machine platform; the lockout cylinder should then release and allow wheel to rest on the ground. It may be necessary to activate DRIVE to release cylinders.
12. If the lockout cylinders do not function properly, have qualified personnel correct the malfunction prior to any further operation.

## **SECTION 2 - USER RESPONSIBILITIES, MACHINE PREPARATION AND INSPECTION**

---

### **Right Side Wheel Test**

1. Place a 4 inch (10.16 cm) high block with ascension ramp in front of right wheel of the oscillating axle.
2. From platform control station, select LOW drive speed.
3. Set the DRIVE control switch and carefully drive the machine up ascension ramp until right oscillating axle wheel is on top of block.
4. Verify the axle oscillates to maintain contact with the ground/ramp. (All four wheels on the ground).
5. Raise machine platform above stowed position approximately 7 ft (2.1 m) on the 3369LE or 9 ft (2.7 m) on the 4069LE.
6. Carefully drive the machine back off the block and ramp.
7. Have an assistant check to see that the right oscillating axle wheel that was on the block is in position on the ground. The axle should oscillate so that all four wheels maintain contact with the ground.
8. In the current position (platform raised and all four tires on flat and level surface), carefully drive machine up the ramp block again.
9. Have an assistant check to verify that the axle did not oscillate and remained locked (one wheel is off of the ground).
10. Carefully drive the machine back off the block and ramp.
11. Lower the machine platform; the lockout cylinder should then release and allow wheel to rest on the ground. It may be necessary to activate DRIVE to release cylinders.
12. If the lockout cylinders do not function properly, have qualified personnel correct the malfunction prior to any further operation.

**Limit Switch Locations**

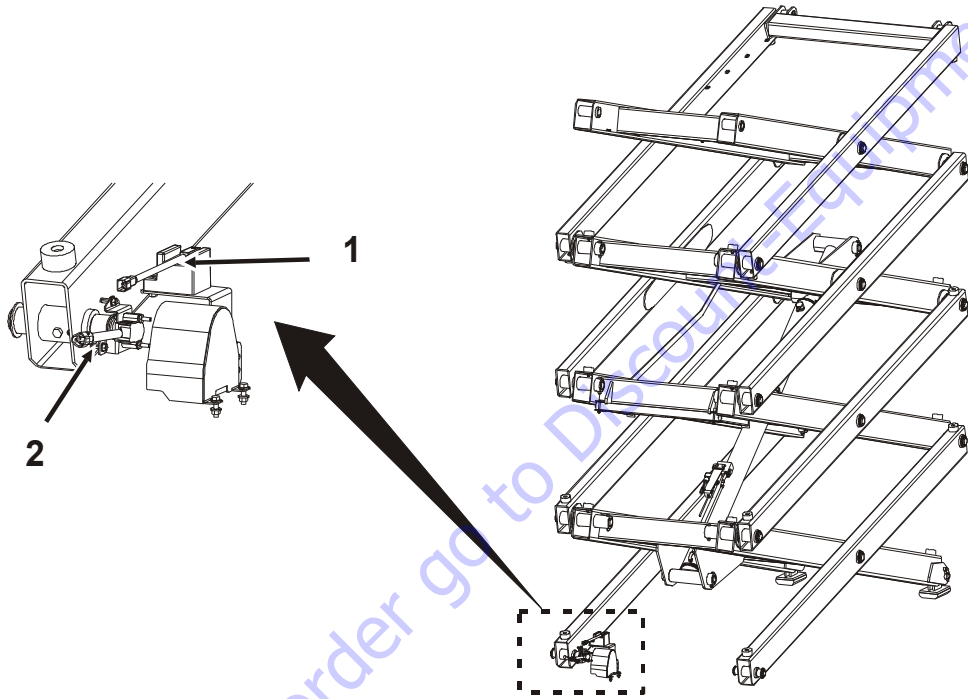

- 1. Proximity Sensor Switch
- 2. Rotary Angle Sensor Switch

**TO PURCHASE THIS PRODUCT PLEASE CONTACT US**



**Equipment Financing and  
Extended Warranties Available**



**Discount-Equipment.com is your online resource for  
commercial and industrial quality parts and equipment sales.**

**561-964-4949**

**visit us on line @ [www.discount-equipment.com](http://www.discount-equipment.com)**

Select an option below to find your Equipment

**Search by Manufacturer**

**Search by Product Type**

**Request a Quote**

We sell worldwide for the brands: Genie, Terex, JLG, MultiQuip, Mikasa, Essick, Whiteman, Mayco, Toro Stone, Diamond Products, Generac Magnum, Airman, Haulotte, Barreto, Power Blanket, Nifty Lift, Atlas Copco, Chicago Pneumatic, Allmand, Miller Curber, Skyjack, Lull, Skytrak, Tsurumi, Husquvarna Target, Stow, Wacker, Sakai, Mi-T-M, Sullair, Basic, Dynapac, MBW, Weber, Bartell, Bennar Newman, Haulotte, Ditch Runner, Menegotti, Morrison, Contec, Buddy, Crown, Edco, Wyco, Bomag, Laymor, EZ Trench, Bil-Jax, F.S. Curtis, Gehl Pavers, Heli, Honda, ICS/PowerGrit, IHI, Partner, Imer, Clipper, MMD, Koshin, Rice, CH&E, General Equipment, Amida, Coleman, NAC, Gradall, Square Shooter, Kent, Stanley, Tamco, Toku, Hatz, Kohler, Robin, Wisconsin, Northrock, Oztec, Toker TK, Rol-Air, APT, Wylie, Ingersoll Rand / Doosan, Innovatech, Con X, Ammann, Mecalac, Makinex, Smith Surface Prep, Small Line, Wanco, Yanmar

## SECTION 3. MACHINE CONTROLS, INDICATORS, AND OPERATION

### 3.1 GENERAL

#### **NOTICE**

**THE MANUFACTURER HAS NO DIRECT CONTROL OVER MACHINE APPLICATION AND OPERATION. THE USER AND OPERATOR ARE RESPONSIBLE FOR CONFORMING WITH GOOD SAFETY PRACTICES.**

This section provides the necessary information needed to understand machine control and their functions.

#### **⚠ WARNING**

**DO NOT RAISE PLATFORM EXCEPT UNLESS THE MACHINE IS ON A SMOOTH, FIRM SURFACE, WITHIN THE LIMITS OF THE MAXIMUM OPERATING SLOPE, FREE OF OBSTRUCTIONS AND HOLES.**

**TO AVOID SERIOUS INJURY, DO NOT OPERATE MACHINE IF ANY CONTROL LEVERS OR TOGGLE SWITCHES CONTROLLING PLATFORM MOVEMENT DO NOT RETURN TO THE OFF OR NEUTRAL POSITION WHEN RELEASED.**

**IF THE PLATFORM DOES NOT STOP WHEN A CONTROL SWITCH OR LEVER IS RELEASED, USE THE EMERGENCY STOP SWITCH TO STOP THE MACHINE.**

### 3.2 DESCRIPTION

This machine is a Mobile Elevating Work Platform (MEWP) used to position personnel along with their necessary tools and materials at work locations.

This machine has a primary operator control station in the platform. From this control station, the operator can drive and steer the machine in both forward and reverse directions and raise and lower the platform.

The machine can be driven on a smooth, firm surface within the limits of the maximum operating slope from an elevated platform position.

The machine also has a ground control station which can override the platform control station. Ground controls operate lift up and down. Except for performing inspections and function checks, ground controls are to be used only in an emergency to lower the platform to the ground should the operator in the platform be unable to do so.

### 3.3 OPERATING CHARACTERISTICS AND LIMITATIONS

#### Placards

Important points to remember during operation are provided at the control stations by DANGER, WARNING, CAUTION, NOTICE, and INSTRUCTION placards. This information is placed at various locations for the express purpose of alerting personnel of potential hazards constituted by the operating characteristics and limitations of the machine. See foreword for definitions of placard safety signal words.

#### Capacities

Raising platform above horizontal with or without any load in platform is based on the following criteria:

1. Machine is positioned on a smooth, firm surface within the limits of the maximum operating slope.
2. Load is within manufacturer's rated capacity.
3. All machine systems are functioning properly.

#### Stability

This machine, as originally manufactured by JLG and operated within its rated capacity on a smooth, firm surface, within the limits of the maximum operating slope, provides a stable aerial platform for all platform positions.

### 3.4 PLATFORM LOADING

The platform maximum rated load capacity is shown on a placard located on the platform billboard and ground control station and is based upon the machine positioned on a smooth, firm surface within the limits of the maximum operating slope. Refer to Section 6.3 for the maximum platform capacity.

The platform is entered through an entry gate at the rear of the platform. Keep entry gate closed at all times except when entering/exiting the platform and loading/unloading materials.

**NOTE:** *It is important to remember that the load should be evenly distributed on the platform. The load should be placed near the center of the platform when possible.*

### 3.5 GROUND CONTROL STATION

**⚠ WARNING**

**DO NOT OPERATE FROM GROUND CONTROL STATION WITH PERSONNEL IN PLATFORM EXCEPT IN AN EMERGENCY.**

**NOTE:** When machine is shut down, the ground control emergency stop switch must be positioned to OFF to prevent draining the batteries.

- 1. Power/Emergency Stop** - A two-position red mushroom shaped switch furnishes power to Platform/ Ground Select switch when pulled out (on). When pushed in (off), power is shut off to the Platform/ Ground Select switch.
- 2. Platform/Ground Select** - A three position, key operated switch supplies power to platform control console when positioned to platform. With the key held in the ground position, power is shut off to platform and only ground controls are operable.

**NOTE:** With Platform/Ground Select in center position, power is shut off to controls at both operating stations.

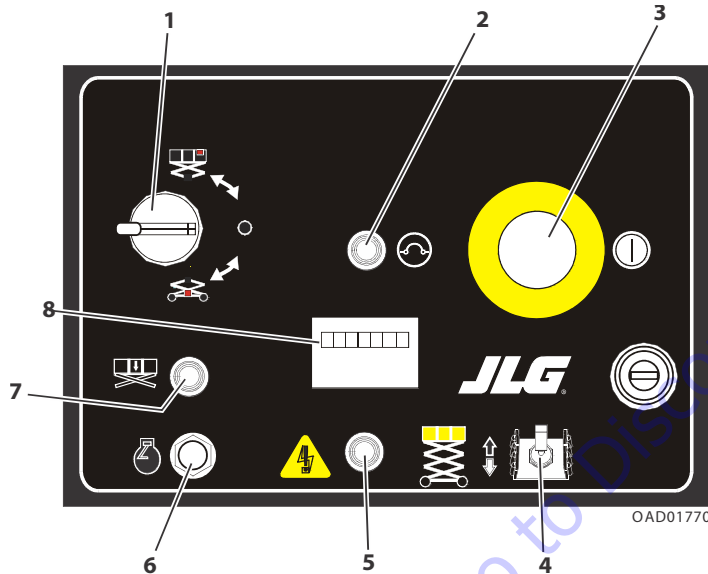

- |                                  |                                |
|----------------------------------|--------------------------------|
| 1. Platform/Ground Select Switch | 5. System Fault Indicator      |
| 2. Circuit Breaker               | 6. Generator Switch (Optional) |
| 3. Emergency Stop Switch         | 7. Overload Indicator (LSS)    |
| 4. Lift/Lower Switch             | 8. Hourmeter                   |



## SECTION 3 - MACHINE CONTROLS, INDICATORS, AND OPERATION

---

3. **Lift/Lower Switch** - A three position, momentary contact lift control switch provides raising and lowering of the platform when positioned to up or down.
4. **Generator Start Switch (Optional)** - A momentary contact, push button switch is provided to manually start the optional generator
5. **Overload Indicator (LSS)** - Indicates the platform has been overloaded. An audible alarm will also signal when the platform is overloaded.

**NOTE:** *If the Overload Indicator is illuminated, all functions will be prevented from the platform controls. Using the ground controls or manual descent, fully lower the machine and reduce the weight in the platform to not exceed the rated workload indicated on the capacity decal.*

6. **Hourmeter** - The hourmeter indicates the number of hours the machine has been operated.
7. **Circuit Breaker** - If the circuit breaker opens this indicates a short or overload on the machine.
8. **System Fault** - Illuminates when there is any type of fault in the electrical system.

3.6 PLATFORM CONTROL STATION

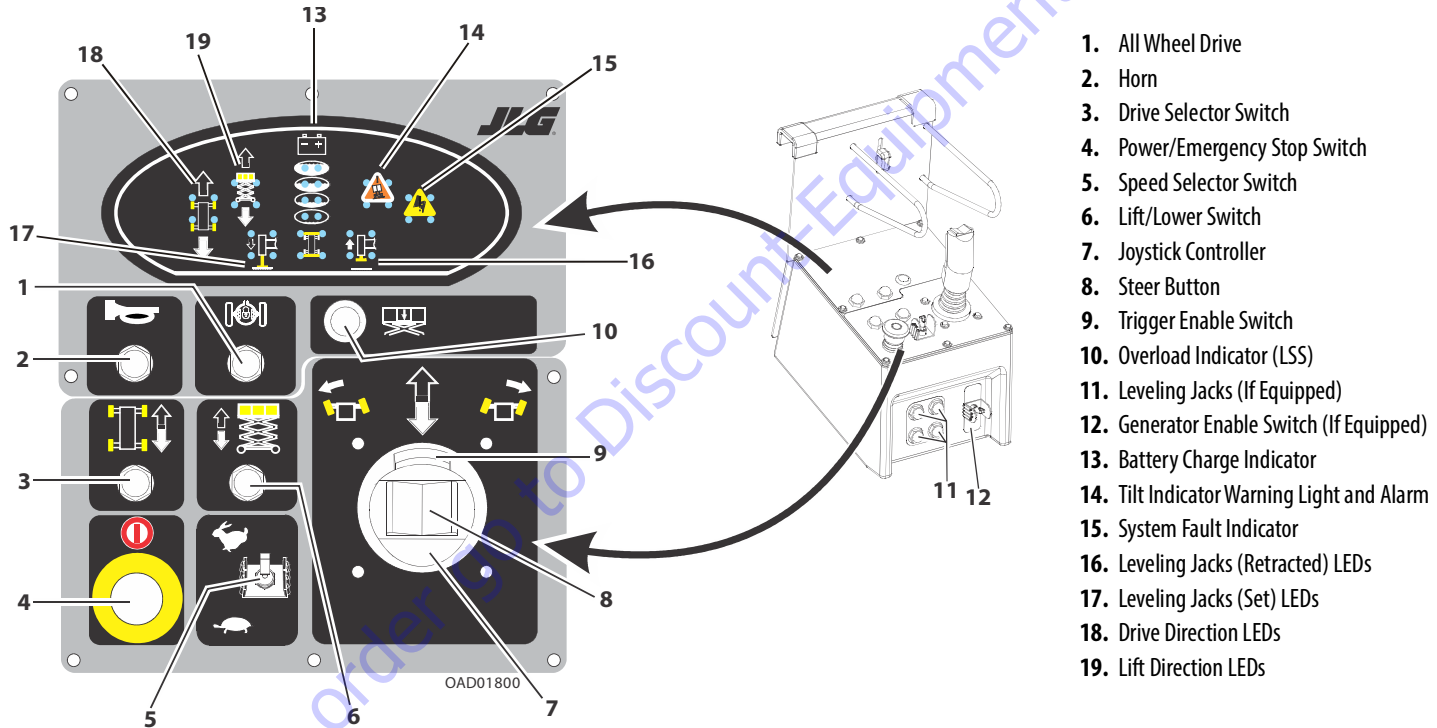

1. All Wheel Drive
2. Horn
3. Drive Selector Switch
4. Power/Emergency Stop Switch
5. Speed Selector Switch
6. Lift/Lower Switch
7. Joystick Controller
8. Steer Button
9. Trigger Enable Switch
10. Overload Indicator (LSS)
11. Leveling Jacks (If Equipped)
12. Generator Enable Switch (If Equipped)
13. Battery Charge Indicator
14. Tilt Indicator Warning Light and Alarm
15. System Fault Indicator
16. Leveling Jacks (Retracted) LEDs
17. Leveling Jacks (Set) LEDs
18. Drive Direction LEDs
19. Lift Direction LEDs

Figure 3-1. Platform Control Station

### Platform Controls

1. **All Wheel Drive (Optional)** - Activating the All Wheel Drive switch allows the operator to engage the front drive motors for a pre-set time of 10 seconds. The control system may also engage the posi-track function automatically. This occurs when the rear wheels begin to slip and the joystick is engaged at 75%. This is pre-set to remain engaged for 10 seconds.

**NOTE:** All Wheel Drive does not aid in climbing a grade.

2. **Horn** - If pressed, this switch supplies power to the horn.
3. **Drive Selector Switch** - When selected, the drive function will be active for 3 seconds. The operator has 3 seconds to select the desired direction of travel.

#### **WARNING**

**DO NOT OPERATE MACHINE IF HIGH DRIVE SPEED OPERATES WHEN PLATFORM IS RAISED ABOVE THE STOWED POSITION. FOR AUSTRALIAN FULL DRIVE HEIGHT MODEL, DO NOT OPERATE IF LOW DRIVE SPEED IS NOT CUT BACK TO CREEP DRIVE SPEED ONCE PLATFORM IS RAISED ABOVE 28 - 30 FT (8.5 - 9.1 M)**

4. **Power/Emergency Stop Switch** - A two-position red mushroom shaped switch furnishes power to Platform/Ground Select switch when pulled out (on).

When pushed in (off), power is shut off to the Platform/Ground Select switch.

5. **Speed Selector Switch** - The two position speed switch controls high or low range travel speed.

**NOTE:** Travel speed will automatically be reduced to low drive when the platform is raised above the stowed position. For M4069 (AUS Full Drive Height Model), low drive speed is cut back to creep drive speed above 28 - 30 ft (8.5 - 9.1 m) up to the maximum height of 40 ft (12.2 m).

6. **Lift /Lower Switch** - When selected, the lift function will be active for 3 seconds. The operator has 3 seconds to select the desired direction of lift.

#### **WARNING**

**DO NOT LOWER WITHOUT COMPLETELY RETRACTING THE PLATFORM EXTENSION.**

7. **Joystick Controller** - The Joystick controls four functions: drive, steer, lift and optional outriggers. The drive or the lift function switch must be selected before operating the joystick. The controller is 'ramped' to allow variable speed.
8. **Steer Button** - Steering is controlled by a thumb-operated switch on top of the Joystick.

9. **Trigger Enable Switch** - This trigger switch is located on the front of the joystick controller. It acts as an enable and must be depressed before operating dive, steer, and lift functions. When released, the function in operation will stop.
10. **Overload Indicator (LSS)** - Indicates the platform has been overloaded. An audible alarm will also signal when the platform is overloaded.

**NOTE:** *If the Overload Indicator is illuminated, all functions will be prevented from the platform controls. Using the ground controls or manual descent, fully lower the machine and reduce the weight in the platform to not exceed the rated workload indicated on the capacity decal.*

11. **Leveling Jacks (If Equipped, Mandatory on M4069 AUS Full Drive Height Model)** - When selected, the leveling jack function will be active for 3 seconds in order to raise or lower the jacks. Indicator lights will illuminate signaling the leveling jacks are being set or retracted.
12. **Generator Enable Switch (If Equipped)** - The Generator Enable Switch, when in the off position, allows the operator to prevent the generator engine from starting when using the machine indoors. When in the on position (and the ground Emergency Stop Switch on

[pulled out]), the generator is enabled to automatically start when the batteries need charged.

13. **Battery Charge Indicator** - This indicates the level of charge remaining in the batteries.
14. **Tilt Indicator Warning LED** - The red warning LED on control panel illuminates when the chassis is on a slope greater than what the machine is programmed for. The Tilt Alarm Warning Horn is activated when the chassis is on a slope greater than what the machine is programmed for and the platform is elevated.
15. **System Fault Indicator** - When this indicator light is flashing, a system fault has occurred, possibly stopping machine operation. If the code cannot be cleared by the operator, the machine will require service by a qualified JLG mechanic.
16. **Leveling Jacks (Retracted) LEDs (If Equipped)** - Indicates when the leveling jacks are being retracted.
17. **Leveling Jacks (Set) LEDs (If Equipped)** - Indicates when the leveling jacks are being set.
18. **Drive Direction LEDs** - Indicate in which direction the machine is driving.
19. **Lift Direction LEDs** - Indicates whether the machine is being lifted or lowered.

### Platform/Ground Select

The Platform/Ground Select switch directs power to the Ground or Platform controls as selected. For power, the POWER/EMERGENCY STOP switch must also be pulled out (on).

### Raising & Lowering

To raise or lower the platform, either use Lift or Lower function and hold switch until desired elevation is reached.

#### **⚠ WARNING**

**DO NOT LOWER WITHOUT COMPLETELY RETRACTING PLATFORM EXTENSION.**

### Leveling Jacks (If Equipped)

Once the leveling jacks leave the stowed position (fully retracted) but are not fully extended, the lift and drive functions are cut out.

After all four jacks are extended and touch a solid surface only the drive function is cut out. Drive function is restored once the jacks are stowed (fully retracted) again.

### Platform Extension

The machine is equipped with a mechanical extension deck. To extend the deck, lift handle up on the left and right side of the platform to release the latch and use the handle to push the extension deck out. When the deck reaches the end of its travel, push handle down to latch, this will lock and hold the deck in place. To retract the deck, reverse operation.

### Platform Handrails Fold Down Procedure (If Equipped)

#### **⚠ WARNING**

**ONLY FOLD DOWN THE RAILS WHEN THE MACHINE IS IN THE STOWED (PLATFORM FULLY LOWERED) POSITION. DO NOT RAISE THE PLATFORM WITH THE RAILS FOLDED DOWN. THE RAILS MUST BE IN THE UPRIGHT POSITION AND PROPERLY PINNED WHEN RAISING THE PLATFORM.**

1. Remove the two pins from platform extension gate and fold gate to the left side handrail.
2. Remove the pin from extension left side handrail, lift up and fold down handrail onto platform deck.
3. Remove the pin from extension right side handrail, lift up and fold down onto platform deck.
4. Remove the two pins from rear handrail, lift up and fold gate down onto platform deck.
5. Lift up left handrail, fold handrail down onto platform deck.
6. Lift up right handrail, fold handrail down onto platform deck.

#### **⚠ WARNING**

**AFTER THE RAILS HAVE BEEN FOLDED DOWN, USE EXTREME CAUTION WHEN EXITING AND ENTERING THE PLATFORM. ENTER AND EXIT PLATFORM ONLY AT THE GATE AREA AND LADDER PROVIDED.**

**⚠ WARNING**

**IF DRIVING MACHINE WITH THE PLATFORM CONTROL STATION FROM GROUND, DO NOT HANG THE CONTROL BOX ON ANY PART OF THE MACHINE WHILE DRIVING. HOLD THE CONTROL BOX AND KEEP AT LEAST 3 FT (1 M) DISTANCE FROM MACHINE.**

**Steering**

Position thumb switch on drive/lift/steer controller to right for steering right, or to left for steering left.

**⚠ WARNING**

**TO AVOID LOSS OF TRAVEL CONTROL OR UPSET ON GRADES AND SIDE SLOPES, DO NOT DRIVE MACHINE ON GRADES OR SIDE SLOPES EXCEEDING THOSE SPECIFIED ON WARNING PLACARD AT PLATFORM.**

**Traveling Forward and Reverse**

1. At platform controls, pull out emergency stop switch and select the drive switch.
2. Position drive controller to forward or reverse as desired.

**⚠ WARNING**

**DIRECTION OF DRIVE AND STEER MOVEMENT MAY BE OPPOSITE FROM NORMAL OPERATION. BEFORE DRIVING, LOCATE THE BLACK/WHITE ORIENTATION ARROWS ON BOTH THE CHASSIS AND THE PLATFORM CONTROLS. MOVE THE DRIVE CONTROLS IN A DIRECTION MATCHING THE ORIENTATION ARROWS.**

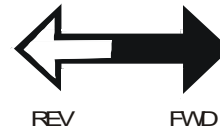

**IF TILT ALARM IS ON WHEN PLATFORM IS RAISED, STOP DRIVING AND LOWER PLATFORM COMPLETELY, THEN REPOSITION MACHINE SO THAT IT IS LEVEL BEFORE RAISING PLATFORM.**

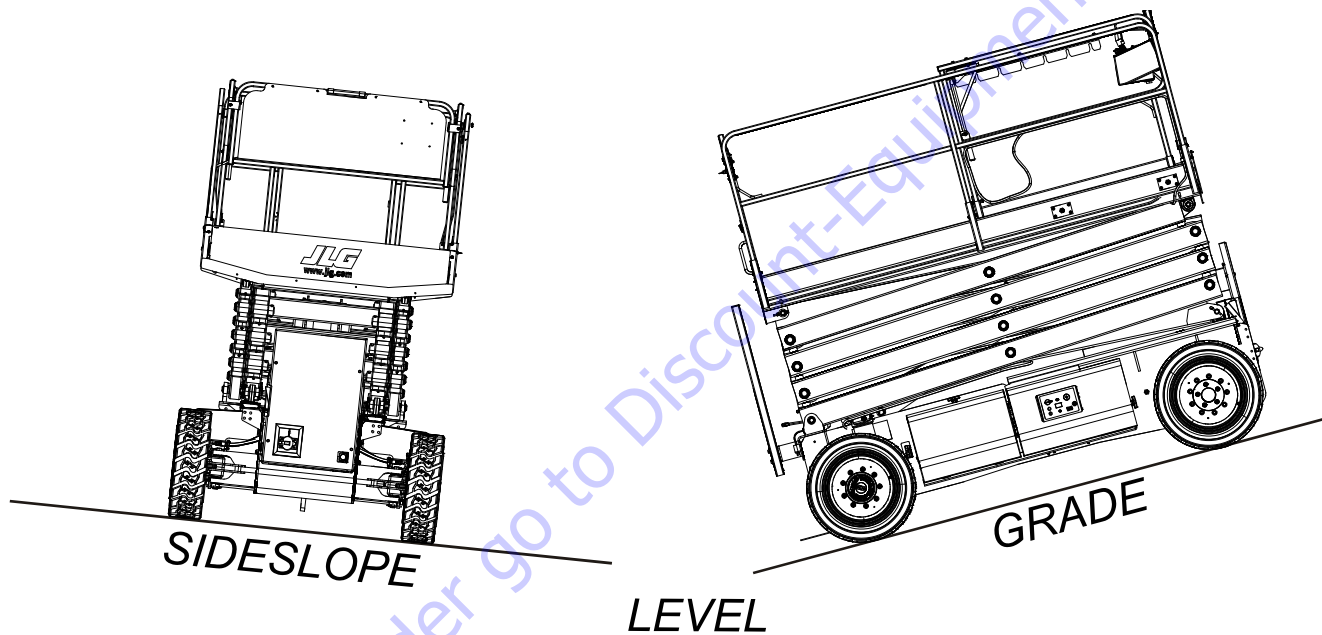

Figure 3-2. Grade and Sideslope

OAD01780

### Parking and Stowing

**NOTE:** When parking overnight, batteries should be charged properly to ensure readiness for next workday.

Park and stow the machine as follows:

1. Drive machine to a reasonably well-protected and well-ventilated area.
2. Ensure platform is fully lowered.
3. Position the emergency stop switch to the off position.
4. If necessary, cover the instruction placards, caution, and warning decals so they will be protected from hostile environment.
5. Chock at least two wheels when parking machine for an extended period of time.
6. Turn the platform/off/ground control select switch to off and remove the key to disable the machine and prevent unauthorized use.

### Battery Charging Procedure

The battery charger receptacle is located at the front of the machine. The receptacle is located in the molded front panel.

1. Connect the charger receptacle to a 115 volt (220 volt) power outlet with a 15 amp minimum capacity.
2. The batteries are charged fully when the 100% LED is lit. At this time, the charger will shut off automatically.

**NOTE:** Discharged batteries will take approximately 23 hours to charge.



### Safety Prop

#### **⚠ WARNING**

NEVER WORK UNDER AN ELEVATED PLATFORM UNTIL IT HAS BEEN RESTRAINED FROM MOVEMENT WITH THE SAFETY PROP, BLOCKING, OR OVERHEAD SLING.

#### **⚠ CAUTION**

THE SAFETY PROP MUST BE USED WHENEVER MAINTENANCE PERFORMED ON THE MACHINE REQUIRES THE SCISSOR ARMS BE RAISED. ENSURE THERE IS NO LOAD IN THE PLATFORM.

The red safety prop is located at the rear of the machine in the armstack. To engage the safety prop:

1. From the Ground Control Station, raise the platform enough to allow the safety prop to be engaged.
2. Pull the ring to release the safety prop, then pull prop down until it hangs vertically.
3. Lower the platform until the safety prop rests on the cross-shaft below.
4. To disengage, lift up the platform, pull ring to release the prop, then lower the platform.

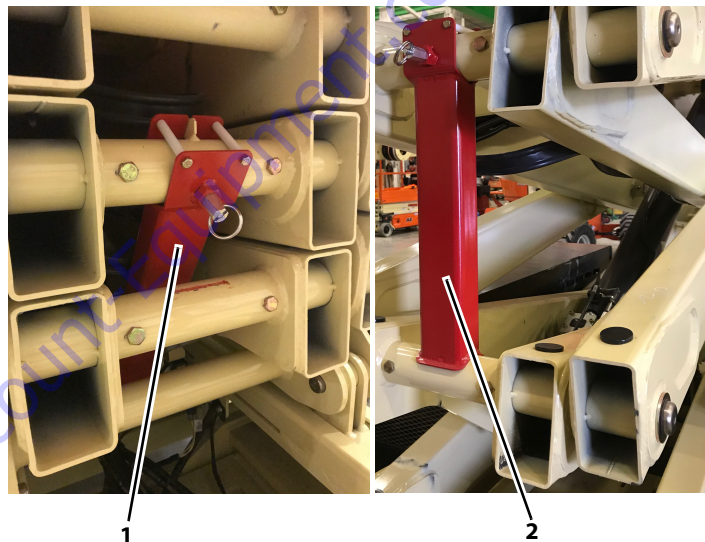

1. Prop Disengaged
2. Prop Engaged

Lifting and Tie-Down

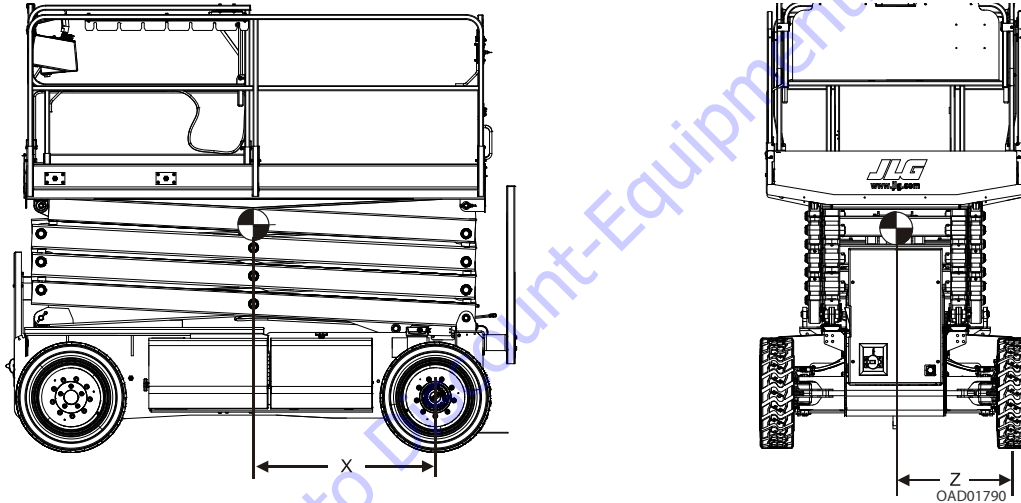

MODEL	FRONT AXLE lb (kg)	REAR AXLE lb (kg)	GVW lb (kg)	WHEELBASE in (m)	X in (m)	Z in (m)
3369LE - ANSI	4,860 (2204)	4,900 (2223)	9,760 (4427)	91.5 (2,324)	45.5 (1,156)	30 (0,762)
3369LE - CE/AUS	5,002 (2269)	5,057 (2294)	10,060 (4563)	91.5 (2,324)	45.5 (1,156)	30 (0,762)
4069LE - ANSI	5,300 (2404)	5,260 (2386)	10,560 (4790)	91.5 (2,324)	45.5 (1,156)	30 (0,762)
4069LE - CE/AUS	5,300 (2594)	5,260 (2622)	11,500 (5216,3)	91.5 (2,324)	45.9 (1,166)	30 (0,762)

### SECTION 3 - MACHINE CONTROLS, INDICATORS, AND OPERATION

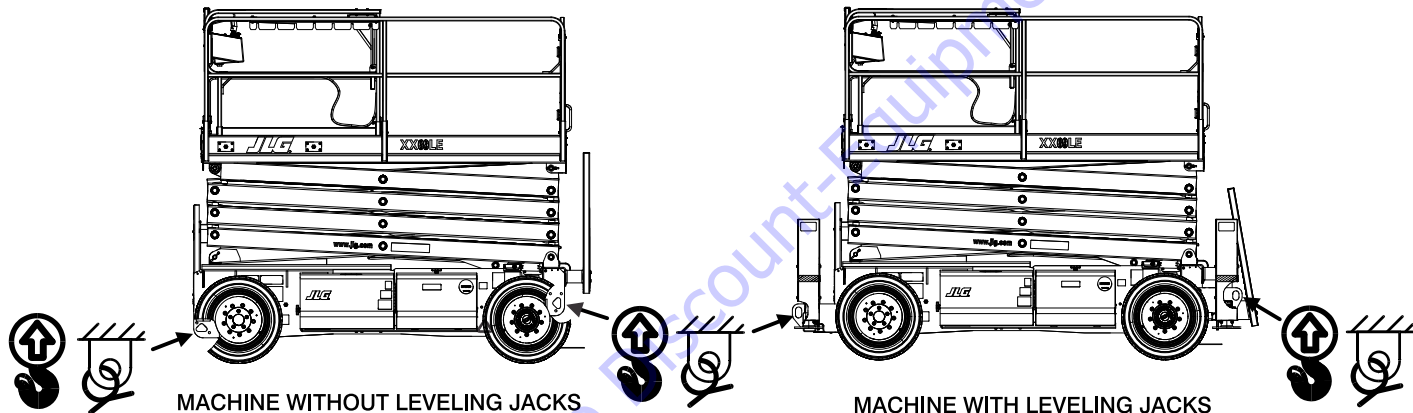

### 3.7 DECALS

ANSI, ANSI Export, CSA, Japan

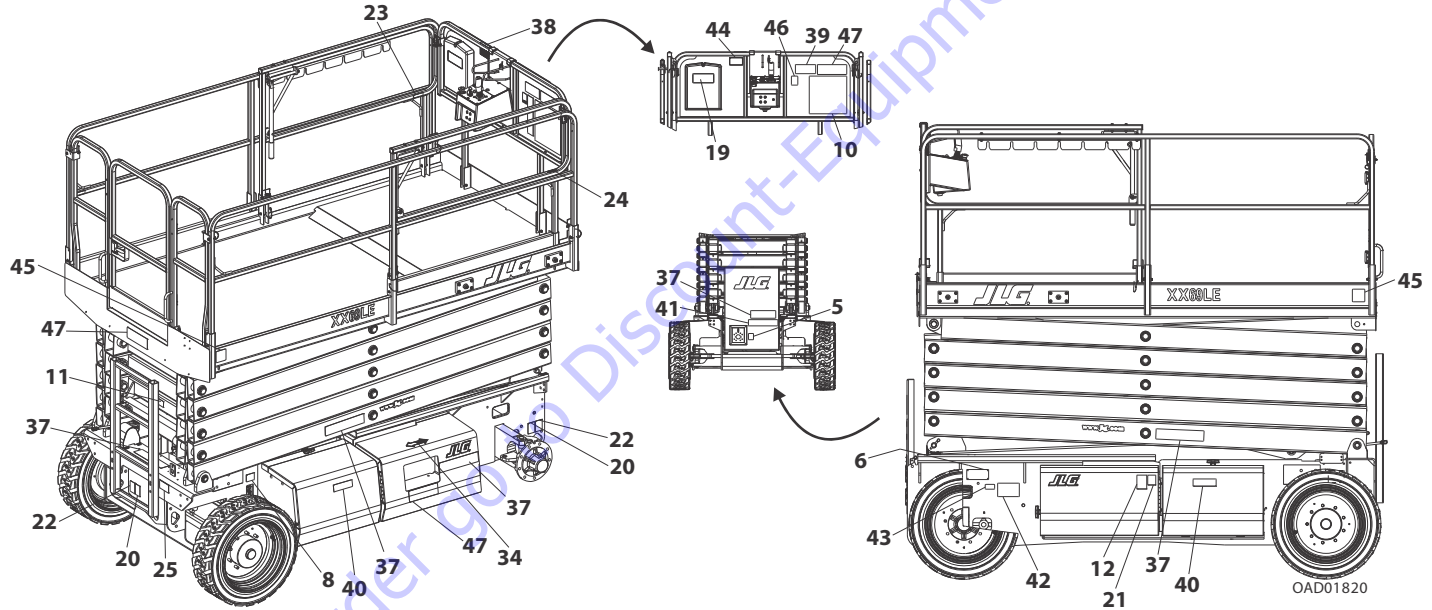

### SECTION 3 - MACHINE CONTROLS, INDICATORS, AND OPERATION

Item	ANSI 0270591	ENG/FRE 0272653	ENG/SPA 0270600	SPA/POR 0270601	JAPAN 0270602	ENG/CHI 0272005	ENG/KOR 0275688
1-4	--	--	--	--	--	--	--
5	1701644	1701644	1701644	1701644	1701644	1701644	1701644
6	1705303	1705303	--	--	--	--	--
7	--	--	--	--	--	--	--
8	1702155	1702155	1702155	1702155	1702155	1702155	1702155
9	--	--	--	--	--	--	--
10	1703816	1704684	1704691	1704699	1704278	1705195	1707021
11	1704211	1704211	1704211	1704211	1704211	1704211	1704211
12	1704412	1704412	1704412	1704412	1704412	1704412	1704412
13-18	--	--	--	--	--	--	--
19	1701509	1701509	1701509	1701509	1701509	1701509	1701509
20	1703811	1703811	1703811	1703811	1703811	1703811	1703811
21	1703812	1703812	1703812	1703812	1703812	1703812	1703812
22	1703814	1703814	1703814	1703814	1703814	1703814	1703814
23	1704277	1704277	1704277	1704277	1704277	1704277	1704277
24	1703819	1703819	1703819	1703819	1703819	1703819	1703819
25	1703822	1703822	1703822	1703822	1703822	1703822	1703822
26-33	--	--	--	--	--	--	--

**SECTION 3 - MACHINE CONTROLS, INDICATORS, AND OPERATION**

<b>Item</b>	<b>ANSI 0270591</b>	<b>ENG/FRE 0272653</b>	<b>ENG/SPA 0270600</b>	<b>SPA/POR 0270601</b>	<b>JAPAN 0270602</b>	<b>ENG/CHI 0272005</b>	<b>ENG/KOR 0275688</b>
34	1703687	1703687	1703687	1703687	1703687	1703687	1703687
35-36	--	--	--	--	--	--	--
37	1703818	1704686	1704693	1704701	1705394	1705193	1707018
38	1703821	1704687	1704694	1704702	1705398	1705194	1707020
39	1704903	1704912	1704914	1704916	1704918	1705098	1707024
40	1703813	1704340	1704339	1704341	1704342	1704344	1707022
41	1704284	1704329	1704328	1704330	1704331	1704333	1707025
42	1001223055	1001223971	1001224049	1001224052	1001224053	1001224050	1001223055
43	1001228370	1001228370	--	--	--	--	--
44	1001231801	--	--	--	--	--	--
45	--	--	--	--	--	1001244298	--
46	--	--	--	--	--	1001244301	--
47	1001125438 (3369LE, M3369) 1001125437 (4069LE, M4069)	1001125438 (3369LE, M3369) 1001125437 (4069LE, M4069)	1001125438 (3369LE, M3369) 1001125437 (4069LE, M4069)	1001125438 (3369LE, M3369) 1001125437 (4069LE, M4069)	1001125438 (3369LE, M3369) 1001125437 (4069LE, M4069)	1001125438 (3369LE, M3369) 1001125437 (4069LE, M4069)	1001125438 (3369LE, M3369) 1001125437 (4069LE, M4069)

# SECTION 3 - MACHINE CONTROLS, INDICATORS, AND OPERATION

CE, AUS

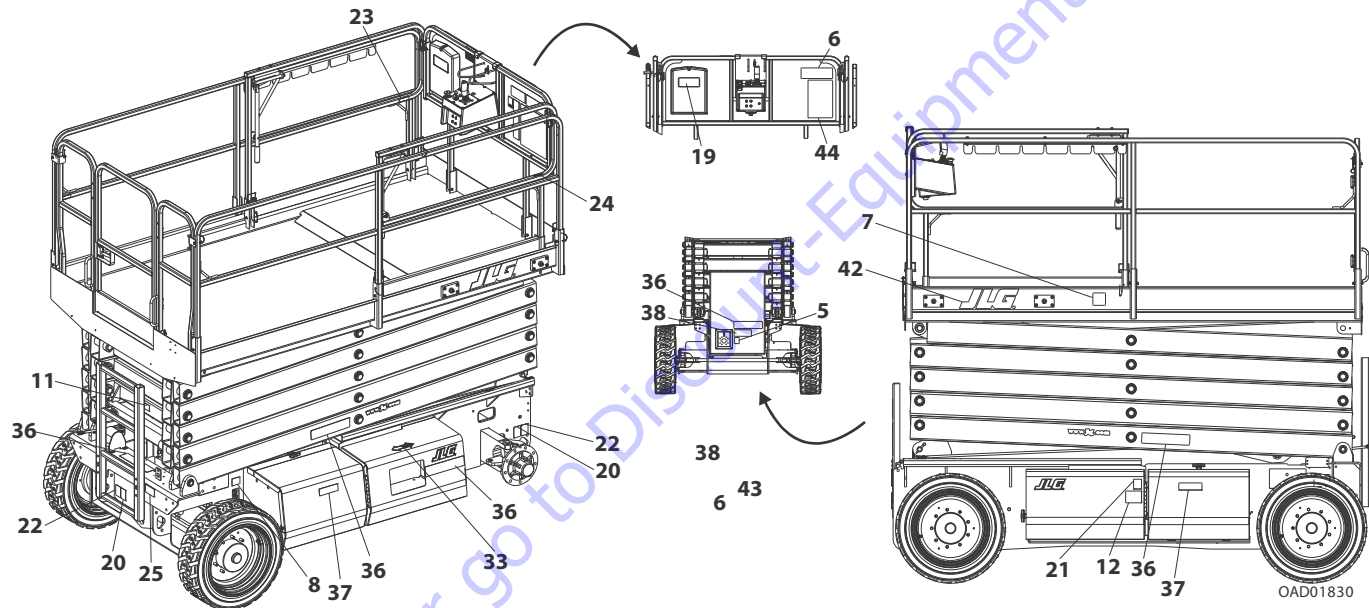

**SECTION 3 - MACHINE CONTROLS, INDICATORS, AND OPERATION**

<b>Item</b>	<b>0275084 (3369LE, 4069LE)</b>	<b>0275085 (M3369, M4069)</b>
1-4	--	--
5	1701644	1701644
6	1706338	1706338
7	--	1705084
8	1702155	1702155
9	--	--
10	--	--
11	1704211	1704211
12	1704412	1704412
13-18	--	--
19	1701509	1701509
20	1703811	1703811
21	1703812	1703812
22	1703814	1703814
23	1704277	1704277
24	1703819	1703819
25	1703822	1703822
26-32	--	--

<b>Item</b>	<b>0275084 (3369LE, 4069LE)</b>	<b>0275085 (M3369, M4069)</b>
33	1703687	1703687
34-35	--	--
36	1706338	1706338
37	1705670	1705670
38	1706492	1706492
39-41	--	--
42	1702773	1702773
43	1701435	1701435
44	1704530 (3369LE) 1706491 (3369LE - CE Only) 1704580 (4069LE)	1704530 (M3369) 1704580 (M4069)



## SECTION 4. EMERGENCY PROCEDURES

### 4.1 GENERAL

This section explains the steps to be taken in case of an emergency situation while operating.

### 4.2 EMERGENCY OPERATION

#### Operator Unable to Control Machine

**NOTE:** *If the platform operator is pinned, trapped or unable to operate or control machine:*

1. Other personnel should operate the machine from ground controls only as required.
2. Other qualified personnel on the platform may use the platform controls. **DO NOT CONTINUE OPERATION IF CONTROLS DO NOT FUNCTION PROPERLY.**
3. Cranes, forklift trucks or other equipment which may be available are to be used to remove platform occupants and stabilize motion of the machine.

#### Righting of Tipped Machine

A fork truck of suitable capacity or equivalent equipment should be placed under the elevated side of the chassis, with a crane or other suitable lifting equipment used to lift the platform while the chassis is lowered by the forklift or other equipment.

#### Platform Caught Overhead

If the platform becomes jammed or snagged in overhead structures or equipment, do the following:

1. Shut off the machine.
2. Rescue all people in the platform before freeing the machine. Personnel must be out of the platform before operating any controls on the machine.
3. Use cranes, forklifts or other equipment to stabilize motion of the machine to prevent a tip over as required.
4. From the ground controls, carefully free the platform from the object.
5. Once clear, restart the machine and return the platform to a safe position.
6. Inspect the machine for damage. If the machine is damaged or does not operate properly, turn off the machine immediately. Report the problem to the proper maintenance personnel. Do not operate the machine until it is declared safe for operation.

### 4.3 EMERGENCY TOWING PROCEDURES

Towing this machine is prohibited. However, provisions for moving the machine have been incorporated. The following procedures are to be used ONLY for emergency.

1. Chock wheels securely.
2. Engage the brake release on both drive hubs by loosening the bolts, completely reversing hub caps, and retightening the bolts.
3. Connect towing equipment and remove chocks.

After towing machine, complete the following procedure:

1. Position machine on a firm level surface.
2. Chock wheels securely.
3. Disengage the brake release on both drive hubs by loosening the bolts, completely reversing hub caps, and retightening the bolts.
4. Remove chocks.

### 4.4 MANUAL DESCENT SYSTEM

The manual descent system is used, in the event of total power failure, to lower the platform using gravity. Pull the handle located at the rear of the machine just behind the ladder.

#### **⚠ CAUTION**

**MANUAL DESCENT ON THE 4069LE DOES NOT COMPLETELY LOWER THE PLATFORM. TO LOWER COMPLETELY, USE THE LOWER FUNCTION AT THE GROUND CONTROL. THE PLATFORM WILL LOWER THE LAST SEVERAL INCHES (CM) AT GRAVITY SPEED. KEEP CLEAR OF DESCENDING PLATFORM.**

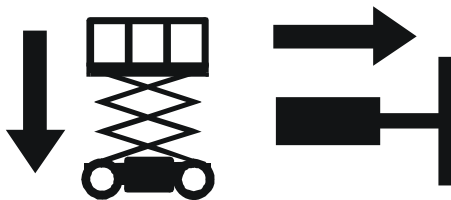

## 4.5 INCIDENT NOTIFICATION

JLG Industries, Inc. must be notified immediately of any incident involving a JLG product. Even if no injury or property damage is evident, JLG must be contacted by telephone and provided with all necessary details.

- USA: 877-JLG-SAFE (554-7233)
- EUROPE: (32) 0 89 84 82 20
- AUSTRALIA: (61) 2 65 811111
- E-mail: productsafety@jlg.com

Failure to notify the manufacturer of an incident involving a JLG Industries product within 48 hours of such an occurrence may void any warranty consideration on that particular machine.

### **NOTICE**

**FOLLOWING ANY INCIDENT, THOROUGHLY INSPECT THE MACHINE. DO NOT ELEVATE THE PLATFORM UNTIL IT IS CERTAIN THAT ALL DAMAGE HAS BEEN REPAIRED AND THAT ALL CONTROLS ARE OPERATING CORRECTLY. TEST ALL FUNCTIONS FIRST FROM THE GROUND CONTROL STATION THEN FROM THE PLATFORM CONTROL CONSOLE.**

## SECTION 5. ACCESSORIES

Table 5-1. Available Accessories

Accessory	Market					
	ANSI (USA Only)	ANSI	CSA	CE	AUS	JPN
1/2" Airline	√	√	√	√	√	√
Platform Worklights	√	√	√	√	√	√
Platform Rail Padding	√	√	√	√	√	√
DC/AC Power Inverter	√	√	√	√	√	√
Programmable Security Lock				√		

5.1 1/2" AIRLINE

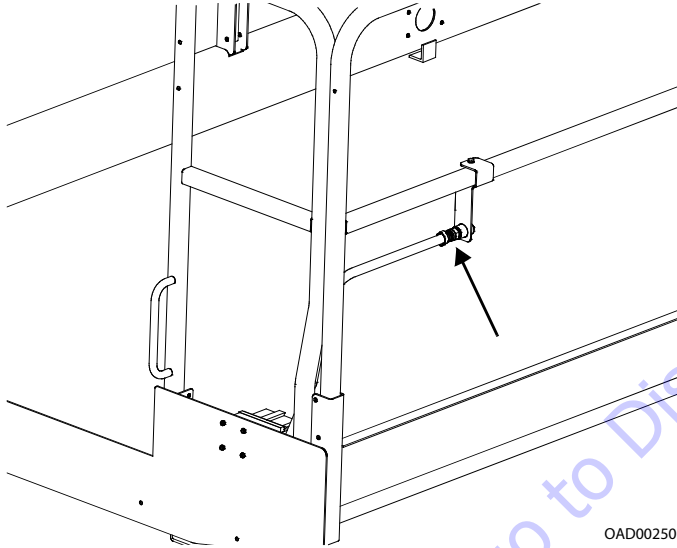

OAD00250

The 1/2 Airline is a fitting for air-powered tools that is mounted in the platform.

5.2 PLATFORM WORKLIGHTS

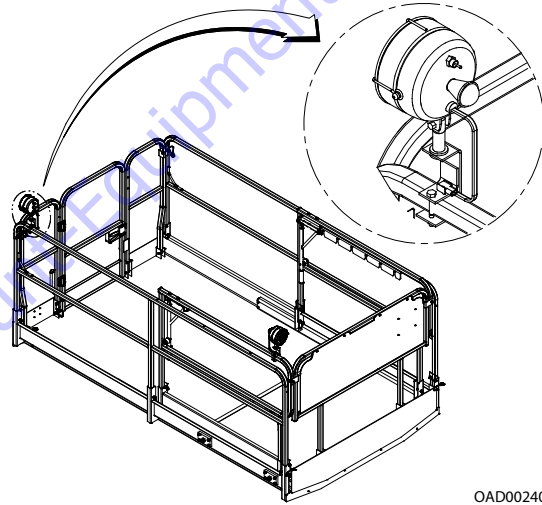

OAD00240

The Platform Worklights accessory consists of two 12V lights mounted to the platform railings.

### 5.3 PLATFORM RAIL PADDING

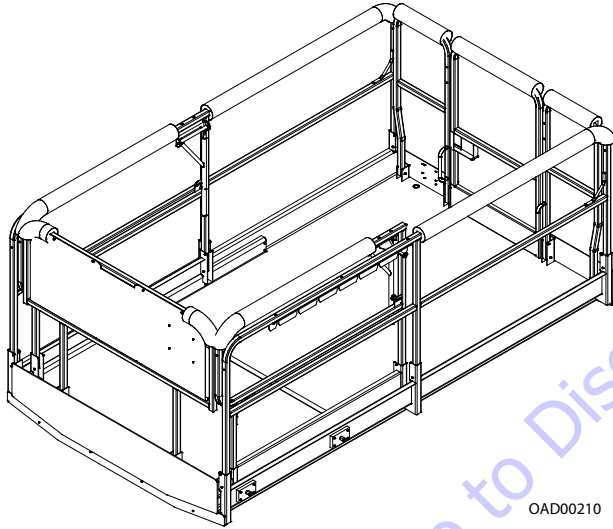

Platform Rail Padding provides bumpers to the top platform rails in order to prevent damage to the platform itself as well as objects it may come into contact with during operation.

### With Deck Bumpers and Proximity Switches

1. Deck Bumpers
2. Proximity Switches

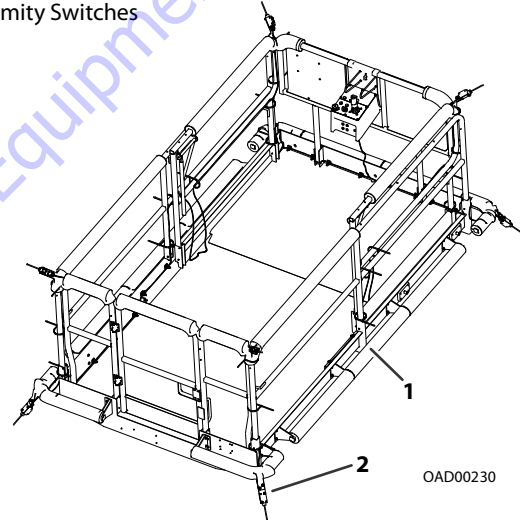

This accessory is also available with deck bumpers and proximity switches, which attaches a padded frame and switches to the bottom of the platform.

5.4 DC/AC POWER INVERTER

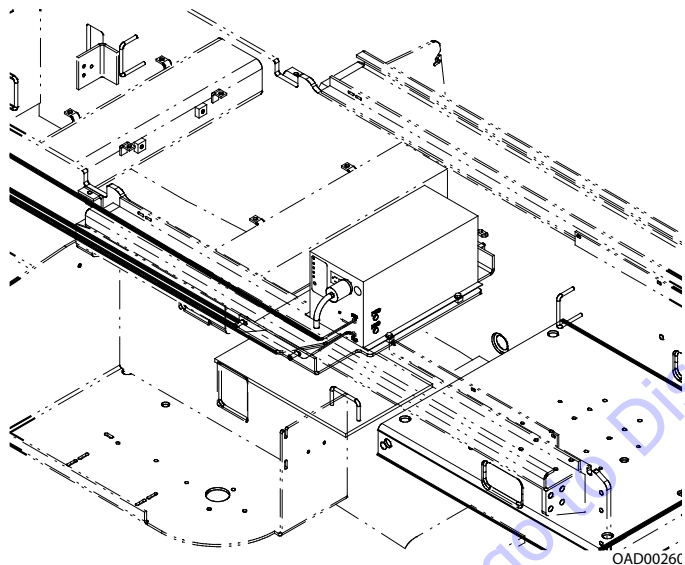

The DC to AC Power Inverter is used to convert DC voltage from the onboard system batteries to AC voltage for use at the platform AC output receptacle.

DESCRIPTION	SPECIFICATION
Electrical System Voltage (DC)	24V
Power Inverter:	Power Bright
DC Input:	
DC Input Voltage:	44 to 56VDC
Operating Temperature:	-4°F (-20°C) to 113°F (+45°C)
AC Output:	
Output Power (Continuous):	1000W
Output Power (Surge):	3600W
Output Power (AC):	Up to 8.3A
Output Voltage (AC):	117V +/- 10%
Output Frequency:	60 Hz
Type:	Modified Sine Wave
Protection:	
Output Reverse DC Polarity:	3 X 25A Replaceable Fuse

## **Safety Precautions**

- This inverter will only operate from a 24V power source. Do not attempt to connect the inverter to any other power source, including any AC power source.
- Danger of shock or electrocution - treat inverter output the same as commercial AC power.
- Do not allow water or other liquids to contact the inverter.

## **Preparation and Inspection**

- Do not use appliances with damaged or wet cords.
- Route appliance cords and extension cords to prevent accidental pinching, crushing, abrading and tripping people,
- Do not use the inverter near flammable materials or in any locations that may accumulate flammable fumes or gases. This is an electrical device that can briefly spark when electrical connections are made or broken.

## **Operation**

1. Set the inverter ON/OFF switch to the ON position at the ground control station.
2. Only plug in tools or appliances rated within the maximum output wattage at the platform AC receptacle mounted on the platform.



### 5.5 PROGRAMMABLE SECURITY LOCK (PSL™)

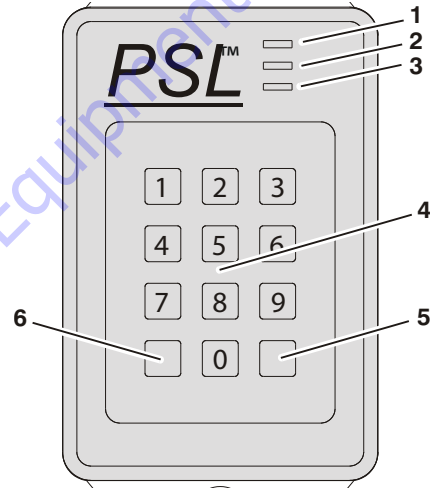
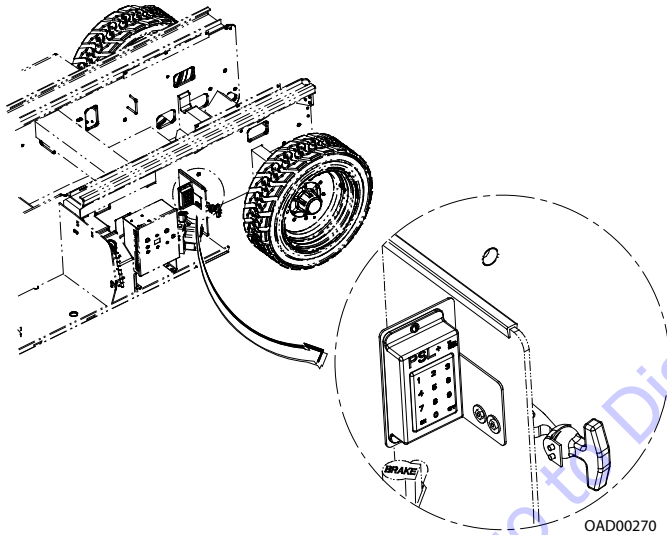

- |                       |               |
|-----------------------|---------------|
| 1. ON (Green LED)     | 4. Key Pad    |
| 2. ACCEPT (Amber LED) | 5. OFF Switch |
| 3. PROGRAM (Red LED)  | 6. ON Switch  |

The optional keyless Programmable Security Lock switch can be programmed with a four-digit Operator's Code to allow only those persons with the code to power-up and operate the machine.

### Machine Power Up

**NOTE:** *When entering the Operator's Code on the keypad, a short beep indicates a properly depressed key, a long beep indicates an error in depressing key. If an error occurs, restart the code entry process again.*

1. Enter the programmed four digit Operator's Code on the key pad. The ACCEPT - AMBER LED indicator will be lit if the code is correct.
2. Press the keypad ON button. The ON - GREEN LED indicator will light and power will be supplied to the Ground Control Station.
3. At the ground control station, turn the main power selector switch from OFF to either Platform Control Mode or Ground Control Mode. At the Platform Control Console set the key switch to the ON position.

The machine will now operate normally.

### Machine Power Down

1. At the Ground Control Station set the main power selector switch to the OFF position.
2. Press the OFF button on the PSL™ keypad. No LEDs on the PSL™ box will be lit.

### Changing the Operator's Code

The Operator's Code can be changed should the need occur. A separate Permanent Code matched to the serial number of the PSL™ box is included on a sheet in the PSL™ user manual supplied with the machine.

1. Enter the Permanent Code on the key pad. The PROGRAM - RED LED will be lit if correct code is entered.

**NOTE:** *ON or OFF cannot be one of the four digits of the new Operator's code.*

2. Enter a new four digit Operator's Code on the keypad. The ACCEPT - AMBER LED will light up if the new Operator's Code is accepted.
3. Press the OFF button on the keypad to activate the new Operator's Code.

*The new Operator's Code will remain in the PSL™ even when power is removed from the equipment, or until that code is changed again using the Permanent Code.*

## SECTION 6. GENERAL SPECIFICATIONS AND OPERATOR MAINTENANCE

### 6.1 INTRODUCTION

This section of the manual provides additional necessary information to the operator for proper operation and maintenance of this machine.

The maintenance portion of this section is intended as information to assist the machine operator to perform daily maintenance tasks only, and does not replace the more thorough Preventive Maintenance and Inspection Schedule included in the Service and Maintenance Manual.

#### Other Publications Available Specific to this Machine:

Service and Maintenance Manual .....	31217135
Illustrated Parts Manual.....	31215086

### 6.2 SUPPLEMENTAL INFORMATION

The following information is provided in accordance with the requirements of the European Machinery Directive 2006/42/EC and is only applicable to CE machines.

For electric powered machines, the equivalent continuous A-Weighted sound pressure level at the work platform is less than 70dB(A).

For combustion engine powered machines, guaranteed Sound Power Level (LWA) per European Directive 2000/ 14/EC (Noise Emission in the Environment by Equipment for Use Outdoors) based on test methods in accordance with Annex III, Part B, Method 1 and 0 of the directive, is 109 dB.

The vibration total value to which the hand-arm system is subjected does not exceed 2,5 m/s<sup>2</sup>. The highest root mean square value of weighted acceleration to which the whole body is subjected does not exceed 0,5 m/s<sup>2</sup>.

## SECTION 6 - GENERAL SPECIFICATIONS AND OPERATOR MAINTENANCE

### 6.3 OPERATING SPECIFICATIONS

Specification	3369LE/M3369		4069LE/M4069	
	All Other Markets	CE/AUS	All Other Markets	CE/AUS
Gross Machine Weight	10,060 lb (4,563 kg)		11,500 lb (5,216 kg)	
Maximum Platform Height	33 ft (10.1m)		40 ft (12.2m)	
Platform Lift Time (No Load)	36 - 40sec		52 - 60sec	
Platform Lower Time (No Load)	41 - 48sec		49 - 51 sec	
Ground Clearance	8 in (20cm)		8 in (20 cm)	
Maximum Drive Speed	3 mph (4.8 kmh)		3 mph (4.8 kmh)	
Drive Speed (Reduced)	16 - 24sec/50 ft (15 m)		16 - 24sec/50 ft (15 m)	
Drive Speed (High)	10.6 - 12 sec/50 ft (15 m)		10.6 - 12 sec/50 ft (15 m)	
Drive Speed (Creep) (AUS Full Drive Height)	--		--	142 - 146 sec/25 ft (7.6 m)
Maximum Stowed Travel Grade (Gradeability)	35% (19°)		35% (19°)	
Maximum Stowed Travel Grade (Sideslope)	8.75% (5°)		8.75% (5°)	
Maximum Allowable Operating Slope	Front to Back	5°	5°	
	Side to Side	3°	3°	

**SECTION 6 - GENERAL SPECIFICATIONS AND OPERATOR MAINTENANCE**

Specification	3369LE/M3369		4069LE/M4069	
	All Other Markets	CE/AUS	All Other Markets	CE/AUS
Max. Slope (CE machines with 37 mph (16.7 m/s) windspeed rating only) Front to Back Side to Side	--	4° 2°	--	--
Maximum Tire Load	3,200 lb (1,452 kg)		3,700 lb (1,680 kg)	
Maximum Ground Bearing Pressure	57 psi (4 kg/cm <sup>2</sup> )		61 psi (4.3 kg/cm <sup>2</sup> )	
Maximum Operating Hydraulic Pressure	3,000 psi (207 bar)		3,000 psi (207 bar)	
Electrical System Voltage	48 volt		48 volt	
Turning Radius Inside Outside	7.5 ft (2.3 m) 16 ft (4.9 m)		7.5 ft (2.3 m) 16 ft (4.9 m)	

## SECTION 6 - GENERAL SPECIFICATIONS AND OPERATOR MAINTENANCE

### Platform Capacities

Specification	3369LE/M3369		4069LE/M4069	
	All Other Markets	CE/AUS	All Other Markets	CE/AUS
Maximum Workload (Capacity)	1,000 lb (454 kg)	450 kg	800 lb (363 kg)	360 kg
Maximum Number of Persons	2	2	2	2
Deck Extension Capacity	250 lb (113 kg)	120 kg	250 lb (113 kg)	120 kg
Max. Allowable Wind Speed (Standard rating)	28 mph (12.5 m/s)	12.5 m/s	28 mph (12.5 m/s)	12.5 m/s
Max. Allowable Wind Speed (Optional Rating for CE Only)	--	16.7 m/s (37 mph) (CE Only)	--	--
Maximum Horizontal Manual Side Force	400 N (90 lb)	400 N	534 N (120 lb)	400 N

## SECTION 6 - GENERAL SPECIFICATIONS AND OPERATOR MAINTENANCE

### Dimensional Data

	3369LE/M3369	4069LE/M4069
Transport Height (rails down)	76.5 in (1.9 m)	79 in (2 m)
Machine Length	121 in (3.1 m)	
Machine Width	69 in (1.75 m)	
Wheelbase	91.5 in (2.3 m)	

### Capacities

Fuel Tank (M Models only)	Approx. 0.9 gal (3.3 L)
Hydraulic Tank	8.25 gal (31.2 L)
Hydraulic System	8.5 gal (32.1 L)
Generator Crankcase	1.37 qt (1.3 L)
Drive Hub (Each)	18.26 oz (0.54 L)

### Tires

SIZE	IN240/55-17.5 FF	27.2/10.5-15 FF Turf
Load Rating	8,550 lb @ 105 psi (3,878 kg @ 724 kPa) 7,960 lb @ 95 psi (3,611 kg @ 655 kPa) 7,730 lb @ 90 psi (3,506 kg @ 621 kPa)	4,019 lb @ 42 psi (1,823 kg @ 290 kPa) 2,180 lb @ 32 psi (989 kg @ 221 kPa)
Ply Rating	10 Ply	6 Ply
Wheel Nut Torque	170 ft. lb. (230 Nm)	170 ft. lb. (230 Nm)

**Batteries (Electric Machines)**

TYPE	6V-370-S	EVL16A-A (AGM)
Voltage	6	6
Reserve Capacity	810 min	841 min
Amp Hour Rating	@ 20 hour rate - 375	@ 20 hour rate - 390

**NOTICE**

JLG MACHINES EQUIPPED WITH DELTA Q BATTERY CHARGERS ARE DESIGNED FOR THE BEST PERFORMANCE WITH OEM FACTORY APPROVED BATTERIES.

APPROVED JLG REPLACEMENT BATTERIES ARE AVAILABLE THROUGH JLG' S AFTERMARKET PARTS DISTRIBUTION CENTERS OR JLG' S AFTERMARKET PROGRAMS. FOR ASSISTANCE WITH PROPER BATTERY REPLACEMENT, PLEASE CONTACT YOUR LOCAL JLG SUPPORT OFFICE.

BATTERIES APPROVED BY JLG HAVE BEEN TESTED FOR COMPATIBILITY WITH THE ALGORITHM PROGRAMMING OF THE DELTA Q BATTERY CHARGER TO OPTIMIZE BATTERY LIFE AND MACHINE CYCLE TIMES. THE USE OF NON APPROVED BATTERIES IN YOUR JLG EQUIPMENT MAY RESULT IN PERFORMANCE ISSUES OR BATTERY CHARGER FAULT CODES. JLG ASSUMES NO RESPONSIBILITY FOR SERVICE OR PERFORMANCE ISSUES ARISING FROM THE USE OF NON APPROVED BATTERIES.



**Engine**

**Table 6-1. Engine Specifications (Generator - If Equipped)**

TYPE	Air Cooled, 4 Cycle, Kubota Diesel OC60-D (T4F)
Displacement	16.85 cu. in (0.276L)
Bore x Stroke	2.83 in x 2.68 in (72 mm x 68 mm)
Number of cylinders	1
Horsepower	5.6HP/3600 rpm (4.5 kw/3600 rpm)
Fuel Type	Diesel (SAE No. 2-D)
Glow Plug	Pre-heater on @ 104° F (40° C)
Weight	38 lb (17.24 kg)
Air Cleaner	Paper Element Type

**Table 6-2. Engine Battery Specifications**

BCI Group Size	51R-675
Cranking Performance	550 Amps @ 32° F (0° C) 450 Amps @ 0° F (-18° C)
Reserve Capacity	80 minutes @ 80° F (27° C)
Weight	29 lb (13.15 kg)

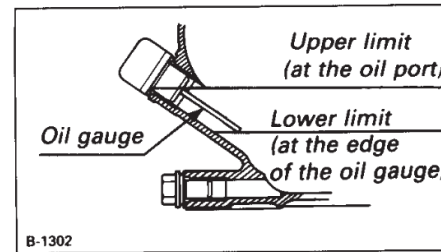
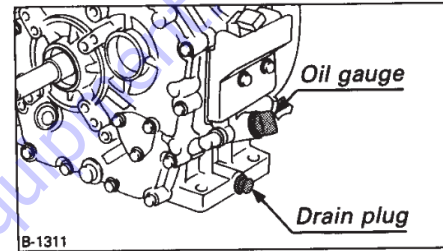

**Kubota OC60-D Engine - Oil Dip Stick and Drain Location**

## SECTION 6 - GENERAL SPECIFICATIONS AND OPERATOR MAINTENANCE

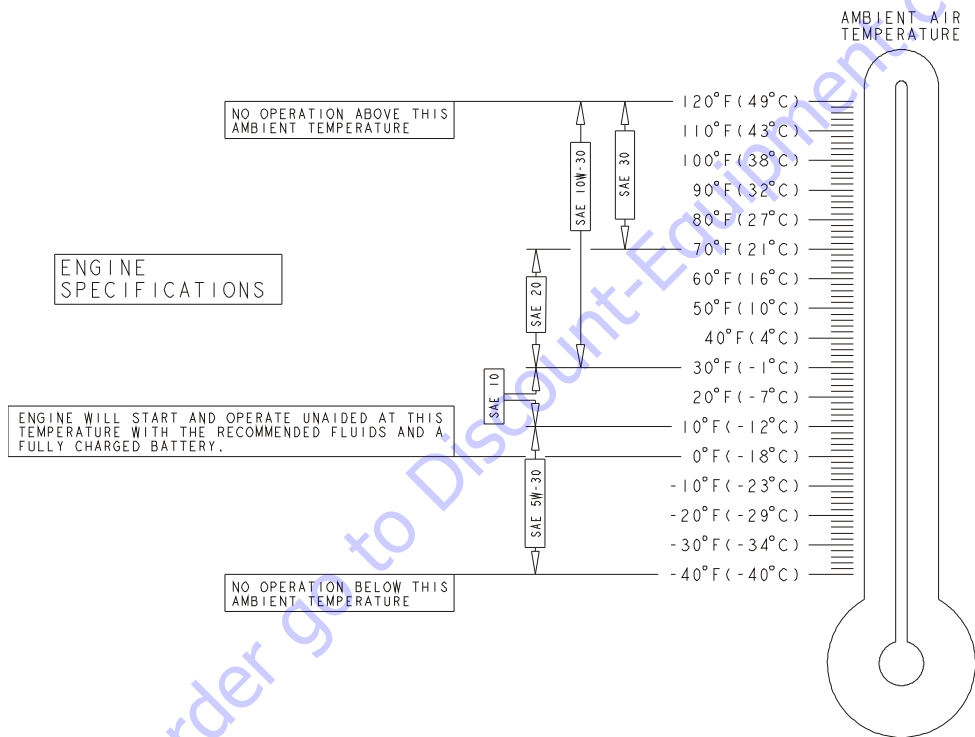
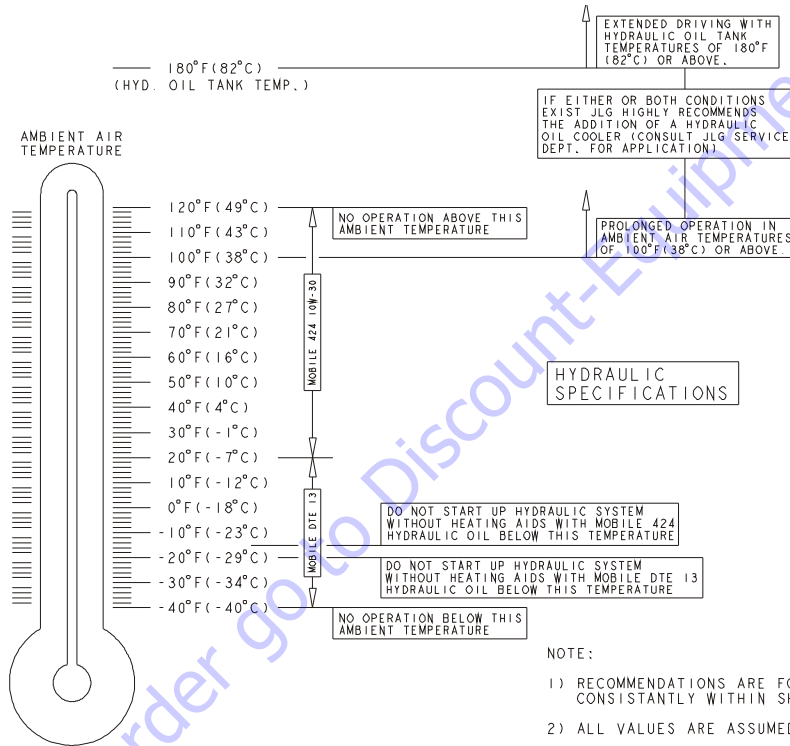

Figure 6-1. Engine Operating Temperature Specifications - (Kubota) Sheet 1 of 2

## SECTION 6 - GENERAL SPECIFICATIONS AND OPERATOR MAINTENANCE



**Figure 6-2. Engine Operating Temperature Specifications - (Kubota) Sheet 2 of 2**

## SECTION 6 - GENERAL SPECIFICATIONS AND OPERATOR MAINTENANCE

### Lubrication

#### Hydraulic Oil

HYDRAULIC SYSTEM OPERATING TEMPERATURE RANGE	SAE VISCOSITY GRADE
0° to +23°F (-18° to -5°C)	10W
0° to +210°F (-18° to +100°C)	10W-20, 10W-30
+50° to +210°F (+10° to +100°C)	20W-20

**NOTE:** Hydraulic oils must have anti-wear qualities at least to API Service Classification GL-3, and sufficient chemical stability for mobile hydraulic system service.

**NOTE:** Aside from JLG recommendations, it is not advisable to mix oils of different brands or types, as they may not contain the same required additives or be of comparable viscosities.

### Lubrication Specifications

KEY	SPECIFICATIONS
MPG	Multipurpose Grease having a minimum dripping point of 350° F. Excellent water resistance and adhesive qualities, and being of extreme pressure type. (Timken OK 40 pounds minimum.)
EPGL	Extreme Pressure Gear Lube (oil) meeting API service classification GL-5 or MIL-Spec MIL-L-2105.
EO	Engine (crankcase) Oil. Gas - API SF/SG class, MIL-L-2104. Diesel - API CC/CD class, MIL-L-2104B/MIL-L-2104C.
HO	Hydraulic Oil. API service classification GL-3, e.g. Mobil 424.

6.4 OPERATOR MAINTENANCE

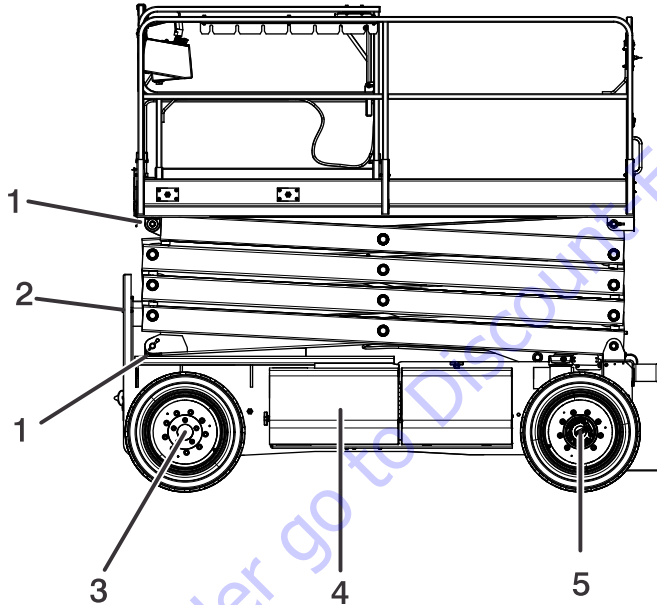

- 1. Sliding Wear Pads
- 2. Engine Compartment
- 3. Wheel Bearings
- 4. Hydraulic Oil
- 5. Drive Hub

## **SECTION 6 - GENERAL SPECIFICATIONS AND OPERATOR MAINTENANCE**

---

6. Sliding Wear Pads  
Lube Points - 8 Sliding Wear Pads  
Lube - MPG  
Interval - Every month or 50 hours.
7. Engine Compartment (Generator - If Equipped) - The engine compartment is mounted on a sliding tray that pulls out from the front of the machine.
  - a. Engine Oil Check/Fill  
Capacity - See Engine Manual  
Lube - See Engine Manual  
Interval - Check level daily; change per manufacturer's engine manual.
  - b. Air Cleaner  
Lube Point - Filter Element  
Interval - Check every 3 months or 150 hours; change every 6 months or 300 hours.
  - c. Fuel Filter  
Lube Point - Filter Element  
Interval - Clean every 3 months or 150 hours; change every 6 months or 300 hours.
8. Wheel Bearings  
Lube Points - Front Wheels (2)  
Lube - MPG  
Interval - Every 2 years or 1200 hours
9. Hydraulic Oil  
Lube Point - Fill Level/Drain Plug  
Lube - HO  
Interval - Check oil every 10 hours of operation; change oil every 2 years or 1200 hours of operation.
10. Drive Hub  
Lube Point - Fill Plug  
Lube - EPGL  
Interval - Every 2 years or 1200 hours

### 6.5 TIRES AND WHEELS

#### Tire Damage

For polyurethane foam filled tires, JLG Industries, Inc. recommends that when any of the following are discovered, measures must be taken to remove the JLG product from service immediately and arrangements must be made for replacement of the tire or tire assembly.

- a smooth, even cut through the cord plies which exceeds 3 in. (7.5 cm) in total length
- any tears or rips (ragged edges) in the cord plies which exceeds 1 in. (2.5 cm) in any direction
- any punctures which exceed 1 in. (2.5 cm) in diameter
- any damage to the bead area cords of the tire

If a tire is damaged but is within the above noted criteria, the tire must be inspected on a daily basis to insure the damage has not propagated beyond the allowable criteria.

#### Tire Replacement

JLG recommends a replacement tire be the same size, ply and brand as originally installed on the machine. Please refer to the JLG Parts Manual for the part number of the approved tires for a particular machine and model. If not using a JLG approved replacement tire, we recommend that replacement tires have the following characteristics:

- Equal or greater ply/load rating and size of original
- Tire tread contact width equal or greater than original
- Wheel diameter, width, and offset dimensions equal to the original.

Unless specifically approved by JLG Industries Inc. do not replace a foam filled tire assembly with a pneumatic tire. When selecting and installing a replacement tire, ensure that all tires are inflated to the pressure recommended by JLG. Due to size variations between tire brands, both tires on the same axle should be the same.

### Wheel Replacement

The rims installed on each product model have been designed for stability requirements which consist of track width, tire pressure, and load capacity. Size changes such as rim width, center piece location, larger or smaller diameter, etc., without written factory recommendations, may result in an unsafe condition regarding stability.

### Wheel Installation

It is extremely important to apply and maintain proper wheel mounting torque.

#### **WARNING**

**WHEEL NUTS MUST BE INSTALLED AND MAINTAINED AT THE PROPER TORQUE TO PREVENT LOOSE WHEELS, BROKEN STUDS, AND POSSIBLE DANGEROUS SEPARATION OF WHEEL FROM THE AXLE. BE SURE TO USE ONLY THE NUTS MATCHED TO THE CONE ANGLE OF THE WHEEL.**

Tighten the lug nuts to the proper torque to prevent wheels from coming loose. Use a torque wrench to tighten the fasteners. If you do not have a torque wrench, tighten the fasteners with a lug wrench, then immediately have a service garage or dealer tighten the lug nuts to the proper torque. Over-tightening will result in breaking the studs or permanently deforming the mounting stud holes in the wheels. The proper procedure for attaching wheels is as follows:

1. Start all nuts by hand to prevent cross threading. DO NOT use a lubricant on threads or nuts.
2. Tighten nuts in the following sequence:



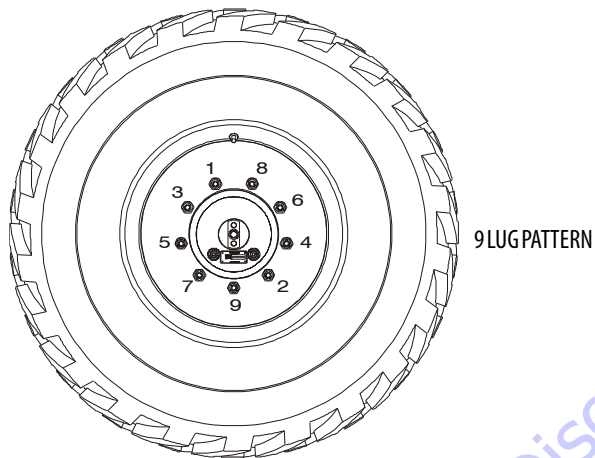

9 LUG PATTERN

**Table 6-3. Wheel Torque Chart**

TORQUE SEQUENCE		
1st Stage	2nd Stage	3rd Stage
40-50 ft lbs (60-70 Nm)	90-105 ft lbs (125-150 Nm)	145-170 ft lbs (200-240 Nm)

Wheel nuts should be torqued after first 50 hours of operation and after each wheel removal. Check torque every 3 months or 150 hours of operation.

- The tightening of the nuts should be done in stages. Following the recommended sequence, tighten the nuts per wheel torque chart, Table 6-3 on page 6-15.

**TO PURCHASE THIS PRODUCT PLEASE CONTACT US**



**Equipment Financing and  
Extended Warranties Available**



**Discount-Equipment.com is your online resource for  
commercial and industrial quality parts and equipment sales.**

**561-964-4949**

**visit us on line @ [www.discount-equipment.com](http://www.discount-equipment.com)**

Select an option below to find your Equipment

**Search by Manufacturer**

**Search by Product Type**

**Request a Quote**

We sell worldwide for the brands: Genie, Terex, JLG, MultiQuip, Mikasa, Essick, Whiteman, Mayco, Toro Stone, Diamond Products, Generac Magnum, Airman, Haulotte, Barreto, Power Blanket, Nifty Lift, Atlas Copco, Chicago Pneumatic, Allmand, Miller Curber, Skyjack, Lull, Skytrak, Tsurumi, Husquvarna Target, Stow, Wacker, Sakai, Mi-T-M, Sullair, Basic, Dynapac, MBW, Weber, Bartell, Bennar Newman, Haulotte, Ditch Runner, Menegotti, Morrison, Contec, Buddy, Crown, Edco, Wyco, Bomag, Laymor, EZ Trench, Bil-Jax, F.S. Curtis, Gehl Pavers, Heli, Honda, ICS/PowerGrit, IHI, Partner, Imer, Clipper, MMD, Koshin, Rice, CH&E, General Equipment, Amida, Coleman, NAC, Gradall, Square Shooter, Kent, Stanley, Tamco, Toku, Hatz, Kohler, Robin, Wisconsin, Northrock, Oztec, Toker TK, Rol-Air, APT, Wylie, Ingersoll Rand / Doosan, Innovatech, Con X, Ammann, Mecalac, Makinex, Smith Surface Prep, Small Line, Wanco, Yanmar

**JLG**<sup>®</sup>

An Oshkosh Corporation Company

**Discount  
Equipment**

[www.Discount-Equipment.com](http://www.Discount-Equipment.com)

To order go to [Discount-Equipment.com](http://www.Discount-Equipment.com)