



An Oshkosh Corporation Company



www.Discount-Equipment.com

Service and Maintenance Manual

Models

330LRT

430LRT

PVC 2004

31217159

March 6, 2020 - Rev A

ANSI



CE

AS/NZS



PARTS FINDER

**Search Website
by Part Number**



**Search Manual
Library For Parts
Manual & Lookup Part
Numbers – Purchase
or Request Quote**

Search Manuals

Enter your information to search for manuals and parts.

* Brand:

* Model:

* Serial:

* Part Number:

SEARCH

**Can't Find Part or
Manual? Request Help
by Manufacturer,
Model & Description**

Parts Order Form

Please fill in the following information:

Manufacturer:

Model:

Description:

Quantity:

Part Number:

Part Name:

Part Description:

Part Location:

Part Condition:

Part Status:

Part Price:

Part Weight:

Part Dimensions:

Part Material:

Part Color:

Part Finish:

Part Coating:

Part Treatment:

Part Protection:

Part Packaging:

Part Labeling:

Part Marking:

Part Identification:

Part Tracking:

Part Inventory:

Part Control:

Part Management:

Part Optimization:

Part Innovation:

Part Sustainability:

Part Resilience:

Part Adaptability:

Part Scalability:

Part Flexibility:

Part Versatility:

Part Reliability:

Part Durability:

Part Longevity:

Part Performance:

Part Efficiency:

Part Effectiveness:

Part Productivity:

Part Profitability:

Part ROI:

Part Value:

Part Contribution:

Part Impact:

Part Influence:

Part Reach:

Part Penetration:

Part Adoption:

Part Usage:

Part Engagement:

Part Satisfaction:

Part Loyalty:

Part Retention:

Part Churn:

Part Acquisition:

Part Conversion:

Part Funnel:

Part Attribution:

Part Analytics:

Part Reporting:

Part Dashboard:

Part Alerts:

Part Notifications:

Part Updates:

Part Newsletters:

Part Social Media:

Part Influencers:

Part Partners:

Part Suppliers:

Part Distributors:

Part Retailers:

Part Customers:

Part Stakeholders:

Part Community:

Part Ecosystem:

Part Network:

Part Ecosystem:

Part Network:

Part Ecosystem:

Part Network:

Discount-Equipment.com is your online resource for quality parts & equipment.

Florida: **561-964-4949** Outside Florida TOLL FREE: **877-690-3101**

Need parts?

Click on this link: <http://www.discount-equipment.com/category/5443-parts/> and choose one of the options to help get the right parts and equipment you are looking for. Please have the machine model and serial number available in order to help us get you the correct parts. If you don't find the part on the website or on once of the online manuals, please fill out the request form and one of our experienced staff members will get back to you with a quote for the right part that your machine needs.

We sell worldwide for the brands: Genie, Terex, JLG, MultiQuip, Mikasa, Essick, Whiteman, Mayco, Toro Stone, Diamond Products, Generac Magnum, Airman, Haulotte, Barreto, Power Blanket, Nifty Lift, Atlas Copco, Chicago Pneumatic, Allmand, Miller Curber, Skyjack, Lull, Skytrak, Tsurumi, Husquvarna Target, , Stow, Wacker, Sakai, Mi-T- M, Sullair, Basic, Dynapac, MBW, Weber, Bartell, Bennar Newman, Haulotte, Ditch Runner, Menegotti, Morrison, Contec, Buddy, Crown, Edco, Wyco, Bomag, Laymor, Barreto, EZ Trench, Bil-Jax, F.S. Curtis, Gehl Pavers, Heli, Honda, ICS/PowerGrit, IHI, Partner, Imer, Clipper, MMD, Koshin, Rice, CH&E, General Equipment, ,AMida, Coleman, NAC, Gradall, Square Shooter, Kent, Stanley, Tamco, Toku, Hatz, Kohler, Robin, Wisconsin, Northrock, Oztec, Toker TK, Rol-Air, Small Line, Wanco, Yanmar

SECTION A. INTRODUCTION - MAINTENANCE SAFETY PRECAUTIONS

A GENERAL

This section contains the general safety precautions which must be observed during maintenance of the Mobile Elevating Work Platform (MEWP). It is of utmost importance that maintenance personnel pay strict attention to these warnings and precautions to avoid possible injury to themselves or others, or damage to the equipment. A maintenance program must be followed to ensure that the machine is safe to operate.

⚠ WARNING

MODIFICATION OR ALTERATION OF A MOBILE ELEVATING WORK PLATFORM SHALL BE MADE ONLY WITH WRITTEN PERMISSION FROM THE MANUFACTURER.

The specific precautions to be observed during maintenance are inserted at the appropriate point in the manual. These precautions are, for the most part, those that apply when servicing hydraulic and larger machine component parts.

Your safety, and that of others, is the first consideration when engaging in the maintenance of equipment. Always be conscious of weight. Never attempt to move heavy parts without the aid of a mechanical device. Do not allow heavy objects to rest in an unstable position. When raising a portion of the equipment, ensure that adequate support is provided.

⚠ WARNING

SINCE THE MACHINE MANUFACTURER HAS NO DIRECT CONTROL OVER THE FIELD INSPECTION AND MAINTENANCE, SAFETY IN THIS AREA IS THE RESPONSIBILITY OF THE OWNER/OPERATOR.

B HYDRAULIC SYSTEM SAFETY

It should be noted that the machine's hydraulic systems operate at extremely high potentially dangerous pressures. Every effort should be made to relieve any system pressure prior to disconnecting or removing any portion of the system.



Relieve system pressure by cycling the applicable control several times with the engine stopped and ignition on, to direct any line pressure back into the reservoir. Pressure feed lines to system components can then be disconnected with minimal fluid loss.

C MAINTENANCE

⚠ WARNING

FAILURE TO COMPLY WITH SAFETY PRECAUTIONS LISTED IN THIS SECTION MAY RESULT IN MACHINE DAMAGE, PERSONNEL INJURY, OR DEATH, AND IS A SAFETY VIOLATION.

- Use only replacement parts or components that are approved by JLG. To be considered approved, replacement parts or components must be identical or equivalent to original parts or components.
- No smoking is mandatory. Never refuel during electrical storms. Ensure that fuel cap is closed and secure at all other times.
- Remove all rings, watches and jewelry when performing any maintenance.
- Do not wear long hair unrestrained, or loose-fitting clothing and neckties which are apt to become caught on or entangled in equipment.
- Observe and obey all warnings and cautions on machine and in service manual.
- Keep oil, grease, water, etc. wiped from standing surfaces and hand holds.
- Use caution when checking a hot, pressurized coolant system.
- Never work under an elevated platform until it has been safely restrained from any movement by blocking or overhead sling, or the safety prop has been engaged.
- Before making adjustments, lubricating or performing any other maintenance, shut off all power controls.
- Battery should always be disconnected during replacement of electrical components.
- Keep all support equipment and attachments stowed in their proper place.
- Use only approved, nonflammable cleaning solvents.

REVISION LOG

Original Issue

A - March 6, 2020

Go to Discount-Equipment.com to order your parts

TABLE OF CONTENTS

SUBJECT - SECTION, PARAGRAPH	PAGE NO.
SECTION A - INTRODUCTION - MAINTENANCE SAFETY PRECAUTIONS	
A General	A-1
B Hydraulic System Safety	A-1
C Maintenance	A-1
SECTION 1 - SPECIFICATIONS	
1.1 Specifications	1-1
Machine Specifications	1-1
Generator Specifications (If Equipped)	1-1
Dimensional Data	1-1
Fluid Capacities	1-1
Drive Information	1-2
Steering Information	1-2
Tires	1-2
Critical Stability Weights	1-2
1.2 Serial Number Location	1-2
1.3 Lubrication	1-3
Hydraulic Oil Specifications	1-3
1.4 Hydraulic Pressure Settings	1-4
1.5 Hydraulic Cylinder Specifications	1-4
1.6 Engine Specifications	1-4
1.7 Elevation/Tilt Limit Settings	1-6
1.8 ThreadLocking Compound	1-9
1.9 Torque Charts	1-10
SAE Fastener Torque Chart	1-10
Metric Fastener Torque Chart	1-16
SECTION 2 - GENERAL	
2.1 Machine Preparation, Inspection, and Maintenance	2-1
General	2-1
Preparation, Inspection, and Maintenance	2-1
Pre-Start Inspection	2-1
Pre-Delivery Inspection and Frequent Inspection	2-1
Annual Machine Inspection	2-1
Preventative Maintenance	2-1
2.2 Preventive Maintenance and Inspection Schedule	2-2
Maintenance and Inspection Schedule Codes	2-2
Footnotes	2-4

TABLE OF CONTENTS

2.3	Service And Guidelines	2-5
	General.....	2-5
	Safety and Workmanship.....	2-5
	Cleanliness	2-5
	Components Removal and Installation	2-5
	Component Disassembly and Reassembly	2-5
	Pressure-Fit Parts	2-5
	Bearings.....	2-5
	Gaskets.....	2-5
	Bolt Usage and Torque Application	2-5
	Hydraulic Lines and Electrical Wiring	2-6
	Hydraulic System	2-6
	Lubrication	2-6
	Battery	2-6
	Lubrication and Servicing	2-6
2.4	Lubrication And Information.....	2-6
	Hydraulic System	2-6
	Hydraulic Oil.....	2-6
	Changing Hydraulic Oil	2-7
	Lubrication Specifications.....	2-7
2.5	Service Maintenance Components	2-7
	Setting Scissor Arm Safety Prop	2-7
	General Maintenance Tips.....	2-8
	Fuel Tank	2-9
	Drive Hub	2-9
	Scissor Arms - Sliding Wear Pads	2-9
	Hydraulic Oil Tank	2-9
	Hydraulic Charge Filter.....	2-9
	Oil Change with Filter	2-10
	Fuel/Water Separator Filter (Diesel) - Kubota.....	2-10
	Fuel Strainer (Diesel) - Kubota	2-10
	Fuel Filter (Gas) - Kubota	2-11
	Air Filter	2-11
	Engine Coolant	2-11
2.6	Cylinder Drift Test	2-12
	Platform Drift	2-12
	Cylinder Drift	2-12
2.7	Pins and Composite Bearing Repair Guidelines	2-12
SECTION 3 - CHASSIS, PLATFORM, & SCISSOR ARMS		
3.1	Operating Characteristics.....	3-1
	Leveling Jacks (If Equipped)	3-1
	Generator	3-1
	Lift	3-1
	Drive	3-1
3.2	Tires, Wheels & Drive Assembly	3-1
	Tire Damage.....	3-1
	Tire Replacement	3-2
	Wheel Replacement	3-2
	Wheel Installation.....	3-2
	Drive Assembly	3-3

3.3	Drive Hub	3-4
	Roll and Leak Testing.....	3-4
	Tightening and Torquing Bolts	3-4
	Oil Information	3-4
	Main Disassembly for Drive Hub	3-8
	Hub-Spindle Disassembly	3-8
	Cover Disassembly	3-9
	Carrier Disassembly	3-9
	Carrier Assembly	3-9
	Cover Sub-Assembly	3-11
	Hub-Spindle Sub-Assembly	3-12
	Main Assembly	3-14
	Tool List	3-19
	Re-Aligning Torque Hub Input Coupling	3-19
3.4	Drive Motor (Sauer).....	3-20
	Description	3-20
	Shaft Seal Replacement	3-20
	Loop Flushing Valve	3-21
	Troubleshooting	3-22
	Disassembly	3-23
	Inspection	3-26
	Assembly	3-29
	Initial Start-Up Procedures	3-34
3.5	Axle Installation	3-35
	Removal	3-35
	Assembly	3-35
3.6	Steer Installation (All Markets Except for CE and JAPAN)	3-36
	Steer Cylinder Removal	3-36
	Spindle Removal	3-36
	Assembly	3-36
3.7	Steer Installation (CE and Japan Markets).....	3-37
	Steer Cylinder Removal	3-37
	Spindle Removal	3-37
	Assembly	3-38
	Axle Lockout Cylinder	3-39
3.8	Leveling Jacks (If Equipped).....	3-40
	Cylinder Removal	3-40
	Assembly Removal	3-41
3.9	Platform	3-42
	Platform Control Station	3-43
	Joystick Controller	3-44
3.10	Scissor Arms.....	3-45
	Lift Cylinder Removal	3-45
	Scissor Arms Removal	3-45
	Scissor Arm Assembly Removal.....	3-45
3.11	Side Compartment Covers	3-50
	Cover Removal.....	3-52
	Cover Installation	3-52
3.12	Ground Control Station.....	3-52
	Control Station Removal	3-52
	Ground Control Station Components	3-53
	Options Control Module	3-54

TABLE OF CONTENTS

3.13	Battery.....	3-55
3.14	Fuel Tank	3-56
3.15	Hydraulic Tank	3-57
3.16	Kubota Engine	3-58
	Engine Tray - Swing Out.....	3-58
	Engine Removal	3-59
	Dual Fuel/LPG System.....	3-61
	Changing From Gasoline to LP Gas	3-61
	Changing From LP Gas to Gasoline	3-61
	Using Liquid Petroleum (LP) Gas.....	3-61
	Propane Fuel System Pressure Relief.....	3-61
	Propane Fuel System Leak Test.....	3-61
	Generator (If Equipped)	3-62
	Exhaust System	3-63
	Dual Fuel - Gas/Lpg	3-63
	Diesel	3-63
	Air Cleaner System.....	3-64
	Radiator	3-65
	Engine Electrical Component Locations	3-66
	Hydraulic Pump Installation	3-69
	Pump Coupling Assembly.....	3-70
	Engine Speed Sensor (Kubota Diesel Engine)	3-71
	Throttle Actuator Adjustment	3-72
	Air Gap Setting	3-72
	Diagnosis of Actuator.....	3-73
	Adjustment of The Actuator.....	3-74
	Adjustment Verification of Actuator	3-75

SECTION 4 - BASIC HYDRAULIC INFORMATION & SCHEMATICS

4.1	Cylinders - Theory of Operation	4-1
4.2	Valves - Theory of Operation.....	4-1
	Solenoid Control Valves (Bang-Bang)	4-1
	Relief Valves	4-1
	Crossover Relief Valves.....	4-1
4.3	Cylinder Checking Procedure	4-1
	Cylinders Without Counterbalance Valves	4-1
	Cylinders With Single Counterbalance Valve	4-2
4.4	Oscillating Axle - Lockout Cylinder Test (If Equipped)	4-2
	Left Side Wheel Test	4-2
	Right Side Wheel Test	4-3
4.5	Drive Pump Pre-fill Procedure.....	4-3
	Pre-Fill of the Drive Pump Housing Without HOC	4-3
	Pre-Fill of the Drive Pump Housing With HOC.....	4-3
	Priming the Gear Pump	4-3
4.6	Drive Pump Start-up Procedure	4-4
4.7	Hydraulic Component Start-Up Procedures & Recommendations	4-4

4.8	Hydraulic Valves.....	4-6
	Main Hydraulic Valve.....	4-7
	Main Hydraulic Valve (CE Only).....	4-10
	Flow Divider Valve.....	4-12
	Leveling Jack Directional Valve (If Equipped).....	4-13
	Leveling Jack Valves (If Equipped).....	4-14
	Leveling Jack Manifold Valve (If Equipped).....	4-15
	Pressure Relief Valve - Setting Procedures.....	4-16
4.9	Gear Pump.....	4-17
4.10	Axial HI 45 Pump.....	4-19
	General Repair Instructions.....	4-21
	Start-Up Procedure.....	4-21
	Removing the Pump.....	4-22
	Electric Control Module.....	4-23
	Control Solenoids.....	4-23
	Shaft Seal, Roller Bearing & Shaft Replacement.....	4-24
	Charge Pump.....	4-24
	Charge Check/HPRV.....	4-26
	Charge Pressure Relief Valve.....	4-26
	Pressure Limiter Valve Replacement.....	4-27
4.11	Charge Pump Filter.....	4-28
4.12	Cylinder Repair.....	4-29
	Disassembly.....	4-29
	Cleaning and Inspection.....	4-30
	Assembly.....	4-31
4.13	Cylinder Assemblies.....	4-35
	Oscillating Axle Cylinder Bleeding Procedure.....	4-41
4.14	Hydraulic Schematics.....	4-42
SECTION 5 - JLG CONTROL SYSTEM		
5.1	Analyzer.....	5-1
	Connecting the Analyzer.....	5-1
	Using the Analyzer.....	5-2
	Changing the Access Level.....	5-3
	Adjusting Parameters.....	5-4
	Machine Setup.....	5-4
	System Fault/DTC Indication.....	5-5
5.2	ANALYZER MENU FLOW CHART.....	5-6
5.3	Diagnostic Troubleshooting codes (DTC's) and Flash Codes Description.....	5-9
5.4	Chassis Tilt Sensor Installation.....	5-18
5.5	Location of Additional Sensors.....	5-19
5.6	Calibration Procedures.....	5-20
	Chassis Tilt Sensor.....	5-20
	Oscillating Axle Tilt Sensor (If Equipped).....	5-20
	Set Stow Elevation.....	5-21
	Load Sensing.....	5-21
	Joystick.....	5-21

TABLE OF CONTENTS

5.7	Service Mode Procedures	5-21
	ECM Override (Dual Fuel Only)	5-21
	Elevation Service	5-21
	EEPROM Reset	5-21
	Allow Drive	5-22
	Allow Leveling Jack Retract	5-22
5.8	Machine Configuration and Programming Settings	5-23
SECTION 6 - LSS SETUP/CALIBRATION/SERVICE		
6.1	Connecting the JLG Control System Analyzer	6-1
6.2	Help Menu & Fault Codes	6-1
6.3	Diagnostic Menu	6-2
6.4	Personalities	6-2
6.5	Machine Setup Menu	6-3
6.6	Calibration Menu	6-3
6.7	Service	6-5
	Description	6-5
6.8	Calibration	6-6
	Procedure	6-6
	Testing & Evaluation	6-6
6.9	Troubleshooting	6-8
SECTION 7 - GENERAL ELECTRICAL INFORMATION & SCHEMATICS		
7.1	General	7-1
7.2	Multimeter Basics	7-1
	Grounding	7-1
	Backprobing	7-1
	Min/Max	7-1
	Polarity	7-1
	Scale	7-1
	Voltage Measurement	7-2
	Resistance Measurement	7-2
	Continuity Measurement	7-3
	Current Measurement	7-3
	Continuity Measurement Over Long Distances	7-4
	Requirements:	7-4
	Procedure	7-4
7.3	Applying Silicone Dielectric Compound to Electrical Connections	7-4
7.4	Dielectric Grease Application	7-5
	AMP Mate-N-Lok	7-5
	AMP Faston	7-5
	AMP Micro-Fit	7-5
	AMP Mini Fit Jr	7-5
	Mini Fit Sr	7-6
	DIN Connectors	7-6
	Exceptions	7-6
7.5	AMP Connector	7-7
	Assembly	7-7
	Disassembly	7-9
	Wedge Lock	7-9
	Service - Voltage Reading	7-10

7.6	Working with Deutsch Connectors	7-11
	DT/DTP Series Assembly	7-11
	DT/DTP Series Disassembly	7-11
	HD30/HDP20 Series Assembly	7-12
	HD30/HDP20 Series Disassembly	7-12
7.7	Switches	7-13
	Basic Check	7-13
	Limit Switches	7-13
	Automatic Switches	7-14
	Switch Wiring - Low Side, High Side	7-14
7.8	Electrical Schematics	7-15

Go to Discount-Equipment.com to order your parts

LIST OF FIGURES

FIGURE NO.	TITLE	PAGE NO.
1-1.	Serial Number Location.....	1-2
1-2.	Hydraulic Oil Operating Temperature Specifications.....	1-7
1-3.	Engine Oil Operating Temperature Specifications - Kubota (Dual Fuel Engine).....	1-7
1-4.	Engine Oil Operating Temperature Specifications - Kubota (Diesel Engine).....	1-8
2-1.	Scissor Arm - Safety Prop Assembly.....	2-7
2-2.	Safety Prop Actuator Rod.....	2-8
2-3.	Service Maintenance Components.....	2-8
2-4.	Kubota Dual Fuel (WG972-GL-E4).....	2-10
2-5.	Kubota Diesel (D1305-E3B and D1305-E4B).....	2-10
3-1.	Drive Assembly (Fairfield/Sauer).....	3-3
3-2.	Drive Hub (Cross-Section).....	3-5
3-3.	Drive Hub.....	3-6
3-4.	Cluster Gear Punch Marks.....	3-16
3-5.	Drive Motor Cross Section.....	3-20
3-6.	Removing the Shaft Seal.....	3-20
3-7.	Loop Flushing Spool.....	3-21
3-8.	Loop Flushing Spool.....	3-23
3-9.	Plugs, Fittings, and Speed Sensor.....	3-23
3-10.	End Cap.....	3-24
3-11.	Valve Plate & Rear Shaft Bearing.....	3-24
3-12.	Cylinder Kit.....	3-25
3-13.	Shaft Seal.....	3-25
3-14.	Shaft & Front Bearing.....	3-25
3-15.	Swash Plate & Servo Piston.....	3-25
3-16.	Cylinder Kit Disassembly.....	3-26
3-17.	Servo Piston.....	3-29
3-18.	Cylinder Kit Assembly.....	3-30
3-19.	Swash Plate and Journal Bearing.....	3-30
3-20.	Shaft and Front Bearing.....	3-31
3-21.	Cylinder Kit Installation.....	3-31
3-22.	Servo Spring and Minimum Angle Stop.....	3-31
3-23.	Valve Plate and Rear Bearing.....	3-32
3-24.	End Cap.....	3-32
3-25.	Shaft Seal.....	3-33
3-26.	Plugs and Fittings Installation.....	3-33
3-27.	Loop Flushing Spool.....	3-34
3-28.	Axle Installation.....	3-35
3-29.	Steering Assembly.....	3-36
3-30.	Steering Assembly.....	3-37
3-31.	Axle Lockout Cylinder.....	3-39
3-32.	Leveling Jack Cylinder Removal.....	3-40
3-33.	Leveling Jacks Assembly.....	3-41
3-34.	Platform Removal.....	3-42
3-35.	Platform Control Station.....	3-43
3-36.	Joystick Controller.....	3-44
3-37.	Scissor Arm Component - 330LRT Assembly 1 of 2.....	3-46
3-38.	Scissor Arm Component - 330LRT Assembly 2 of 2.....	3-47
3-39.	Scissor Arm Component - 430LRT Assembly 1 of 2.....	3-48
3-40.	Scissor Arm Component - 430LRT Assembly 2 of 2.....	3-49
3-41.	Left Side - Engine Compartment Covers.....	3-50
3-42.	Right Side - Hydraulic/Fuel Compartment Covers.....	3-51
3-43.	Ground Control Station Removal.....	3-52
3-44.	Ground Control Station Components.....	3-53
3-45.	Optional Control Module.....	3-54

3-46.	Battery Removal	3-55
3-47.	Fuel Tank Installation	3-56
3-48.	Hydraulic Tank Removal	3-57
3-49.	Engine Swing Out Tray Components	3-58
3-50.	Engine Tray In Swing Out Position.....	3-58
3-51.	Engine Removal (All Engines)	3-59
3-52.	AC Generator Installation	3-62
3-53.	Exhaust System (Kubota Engine)	3-63
3-54.	Air Cleaner System (Kubota Engine)	3-64
3-55.	Radiator Installation (All Engines).....	3-65
3-56.	Duel Fuel Engine - Control Module Location.....	3-66
3-57.	Duel Fuel Engine Compartment - Electrical Component Locations.....	3-67
3-58.	Diesel Engine Compartment - Electrical Component Locations (T4F).....	3-68
3-59.	Hydraulic Pump Assemblies.....	3-69
3-60.	Pump Coupling Assembly (All Engines).....	3-70
3-61.	Engine Speed Sensor Installation.....	3-71
3-62.	Throttle Assembly and Linkages.....	3-72
3-63.	Air Gap Setting	3-72
3-64.	Adjustment of the Actuator	3-74
3-64.	Adjustment of the Actuator	3-74
3-65.	Adjustment Verification of Actuator	3-75
4-1.	Hydraulic Compartment Control Valves	4-6
4-2.	Main Valve Port Identification	4-7
4-3.	Main Valve Port Identification (CE Only)	4-10
4-4.	Flow Divider Valve	4-12
4-5.	Leveling Jack Directional Valve.....	4-13
4-6.	Leveling Jack Valves	4-14
4-7.	Leveling Jack Manifold Valve	4-15
4-8.	Tandem Gear Pump - Diesel.....	4-17
4-9.	Gear Pump - Dual Fuel - Gas/LPG	4-18
4-10.	Axial HI 45 Pump	4-19
4-11.	Axial HI 45 Pump - Cross Section View	4-20
4-12.	Charge Pump Filter	4-28
4-13.	Lift Cylinder Holding Valve and Fitting Removal	4-29
4-14.	Cylinder Barrel Support	4-29
4-15.	Lift Cylinder Capscrew Removal	4-29
4-16.	Cylinder Rod Support	4-30
4-17.	Tapered Bushing Removal	4-30
4-18.	Bushing Installation.....	4-31
4-19.	Rod Seal Installation	4-31
4-20.	Poly-Pak Piston Seal Installation	4-31
4-21.	Wiper Seal Installation	4-32
4-22.	Installation of Head Seal Kit	4-32
4-23.	Piston Seal Kit Installation	4-32
4-24.	Tapered Bushing Installation	4-33
4-25.	Seating the Tapered Bearing	4-33
4-26.	Rod Assembly Installation.....	4-33
4-27.	Lift Cylinder Valve Cartridge Torque Values	4-37
4-28.	Oscillating Axle Cylinder	4-38
4-29.	Leveling Jack Cylinder	4-39
4-30.	Leveling Jack Torques.....	4-40
4-31.	Oscillating Axle Cylinder Bleeding.....	4-41
4-32.	Hydraulic Schematics (CE) - Sheet 1 of 2	4-42
4-33.	Hydraulic Schematics (CE) - Sheet 2 of 2	4-43
4-34.	Hydraulic Schematics (ANSI) - Sheet 1 of 2	4-44
4-35.	Hydraulic Schematics (ANSI) - Sheet 2 of 2	4-45
5-1.	Analyzer Menu Flow Chart (Version P1.3) - Sheet 1 of 3.....	5-6
5-2.	Analyzer Menu Flow Chart (Version P1.3) - Sheet 2 of 3.....	5-7

LIST OF FIGURES

5-3.	Analyzer Menu Flow Chart (Version P1.3) - Sheet 3 of 3	5-8
5-4.	Chassis Tilt Sensor Location	5-18
5-5.	Chassis Tilt Sensor Removal	5-18
5-6.	Chassis Sensor Locations	5-19
6-1.	Load Sensing System Components	6-5
6-2.	LSS Module Load Cell Connector Pinout (J5, J6, J7, J8)	6-11
6-3.	LRT Wiring Diagram	6-12
7-1.	Voltage Measurement (DC)	7-2
7-2.	Resistance Measurement	7-2
7-3.	Continuity Measurement	7-3
7-4.	Current Measurement (DC)	7-3
7-5.	AMP Connector	7-7
7-6.	Connector Assembly (1 of 4)	7-7
7-7.	Connector Assembly (2 of 4)	7-7
7-8.	Connector Assembly (3 of 4)	7-8
7-9.	Connector Assembly (4 of 4)	7-8
7-10.	Connector Disassembly	7-9
7-11.	Connector Installation	7-10
7-12.	DT/DTP Contact Installation	7-11
7-13.	DT/DTP Contact Removal	7-11
7-14.	HD/HDP Contact Installation	7-12
7-15.	HD/HDP Locking Contacts Into Position	7-12
7-16.	HD/HDP Contact Removal	7-12
7-17.	HD/HDP Unlocking Contacts	7-12
7-18.	Electrical Schematic - Sheet 1 of 10	7-15
7-19.	Electrical Schematic - Sheet 2 of 10	7-16
7-20.	Electrical Schematic - Sheet 3 of 10	7-17
7-21.	Electrical Schematic - Sheet 4 of 10	7-18
7-22.	Electrical Schematic - Sheet 5 of 10	7-19
7-23.	Electrical Schematic - Sheet 6 of 10	7-20
7-24.	Electrical Schematic - Sheet 7 of 10	7-21
7-25.	Electrical Schematic - Sheet 8 of 10	7-22
7-26.	Electrical Schematic - Sheet 9 of 10	7-23
7-27.	Electrical Schematic - Sheet 10 of 10	7-24

LIST OF TABLES

TABLE NO.	TITLE	PAGE NO.
1-1	Mobilfluid 424.....	1-3
1-2	Mobil DTE 10 Excel 32.....	1-3
1-3	UCon Hydrolube HP-5046.....	1-3
1-4	Mobil EAL 224H.....	1-3
1-5	Mobil SHC Hydraulic EAL 46.....	1-4
1-6	Mobil EAL ENVIROSYN H 46.....	1-4
1-7	Kubota Diesel (D1305-E4B).....	1-4
1-8	Kubota (WG972-GL-E4 - Dual Fuel).....	1-5
1-9	Kubota (D1305-E3B - Diesel).....	1-5
1-10	Tilt Cutout Settings.....	1-6
2-1	Inspection and Maintenance.....	2-2
2-2	Preventive Maintenance & Inspection Schedule.....	2-3
3-1	Wheel Torque Chart.....	3-2
3-2	Drive Hub Part Description.....	3-7
3-3	Excessive Noise and/or Vibration.....	3-22
3-4	System Operating Hot.....	3-22
3-5	Won't Shift or Slow to Start.....	3-22
3-6	Displacement Identifiers.....	3-25
3-7	Slipper Foot Thickness & End Play.....	3-27
3-8	Cylinder Block Measurements.....	3-27
3-9	Joystick Specifications.....	3-44
3-10	Joystick Plug Loading Chart.....	3-44
3-11	AC Generator Specifications.....	3-62
4-1	Main Valve Port Identification.....	4-8
4-2	Main Valve Torque Specs (All Specs Except CE).....	4-8
4-3	Main Valve Porting Specs.....	4-8
4-4	Main Valve Port Identification (CE Only).....	4-11
4-5	Main Valve Torque Specs (CE Only).....	4-11
4-6	Main Valve Porting Specs (CE Only).....	4-11
4-7	Leveling Jack Directional Valve Torque Specs.....	4-14
4-8	Leveling Jack Valves Torque Specs.....	4-14
4-9	Leveling Jack Manifold Valve Torque Specs.....	4-15
4-10	Gear Pump Specs - Diesel.....	4-17
4-11	Gear Pump - Dual Fuel - Gas/LPG.....	4-18
4-12	Axial HI 45 Pump Specs.....	4-19
4-13	Holding Valve Torque Specifications.....	4-33
5-1	Tilt Sensor Harness (SN3).....	5-18
5-2	Machine Configuration Programming Information (Version P1.3).....	5-23
5-3	Machine Tilt Configuration (Version P1.3).....	5-25
5-4	Machine Model Personality Adjustment.....	5-26
6-1	LSS Fault Codes.....	6-1
6-2	Diagnostic Menu Descriptions.....	6-2
6-3	Personalities.....	6-2
6-4	Machine Setup.....	6-3
6-5	Calibration Values.....	6-4
6-6	LSS Troubleshooting Chart - General.....	6-8
6-7	LSS Troubleshooting Chart - Calibration.....	6-8
6-8	LSS Troubleshooting Chart - Measurement Performance.....	6-9
6-9	LSS Troubleshooting Chart - Host System Functionality.....	6-10
6-10	LSS Module System Interface Connector - Power & Digital (J1 - Grey).....	6-11
6-11	LSS Module System Interface Connector - Communication (J1 - Black).....	6-11
6-12	LSS Module Load Cell Connector Pinout (J5, J6, J7, J8).....	6-11

PARTS FINDER

**Search Website
by Part Number**



**Search Manual
Library For Parts
Manual & Lookup Part
Numbers – Purchase
or Request Quote**

Search Manuals

Enter your information to search for manuals and parts.

* Brand:

* Model:

* Serial:

* Part Number:

SEARCH

**Can't Find Part or
Manual? Request Help
by Manufacturer,
Model & Description**

Parts Order Form

Please fill in the following information:

Manufacturer:

Model:

Description:

Quantity:

Part Number:

Part Name:

Part Description:

Part Location:

Part Condition:

Part Status:

Part Material:

Part Color:

Part Weight:

Part Dimensions:

Part Notes:

Submit

Discount-Equipment.com is your online resource for quality parts & equipment.

Florida: **561-964-4949** Outside Florida TOLL FREE: **877-690-3101**

Need parts?

Click on this link: <http://www.discount-equipment.com/category/5443-parts/> and choose one of the options to help get the right parts and equipment you are looking for. Please have the machine model and serial number available in order to help us get you the correct parts. If you don't find the part on the website or on one of the online manuals, please fill out the request form and one of our experienced staff members will get back to you with a quote for the right part that your machine needs.

We sell worldwide for the brands: Genie, Terex, JLG, MultiQuip, Mikasa, Essick, Whiteman, Mayco, Toro Stone, Diamond Products, Generac Magnum, Airman, Haulotte, Barreto, Power Blanket, Nifty Lift, Atlas Copco, Chicago Pneumatic, Allmand, Miller Curber, Skyjack, Lull, Skytrak, Tsurumi, Husquvarna Target, , Stow, Wacker, Sakai, Mi-T- M, Sullair, Basic, Dynapac, MBW, Weber, Bartell, Bennar Newman, Haulotte, Ditch Runner, Menegotti, Morrison, Contec, Buddy, Crown, Edco, Wyco, Bomag, Laymor, Barreto, EZ Trench, Bil-Jax, F.S. Curtis, Gehl Pavers, Heli, Honda, ICS/PowerGrit, IHI, Partner, Imer, Clipper, MMD, Koshin, Rice, CH&E, General Equipment, ,AMida, Coleman, NAC, Gradall, Square Shooter, Kent, Stanley, Tamco, Toku, Hatz, Kohler, Robin, Wisconsin, Northrock, Oztec, Toker TK, Rol-Air, Small Line, Wanco, Yanmar

SECTION 1. SPECIFICATIONS

1.1 SPECIFICATIONS

Machine Specifications

Specification	330LRT	430LRT
Maximum Occupants	6	6 (5 - CE - Dual Ext.)
Maximum Workload (Capacity):		
Single Extension Platform:	2250 lb (1022 kg)	1500 lb (682 kg)
Dual Extension Platform:	2000 lb (909 kg)	1250 lb (568 kg)
MegaDeck Platform:	2000 lb (909 kg)	-
Max. on Extension (Each):	500 lb (226 kg)	500 lb (226 kg)
Maximum Stowed Travel Grade - Gradeability	45% (24°)	
Maximum Stowed Travel Grade - Sideslope	5°	
Maximum Platform Working Height	33 ft (10 m)	43 ft (13.11 m)
Maximum Drive Height	33 ft (10 m)	43 ft (13.11 m)
Maximum Drive Speed		
Platform Lowered: High	3.5 mph (5.6 kph)	
Mid	2.0 mph (3.21 kph)	
Low	1.0 mph (1.61 kph)	
Platform Elevated (> 9 ft 6 in):	0.5 mph (0.8 kph)	
Lift Up Time (At Rated Load) (Stowed to Full Height)	35 seconds	45 seconds
Lift Down Time (At Rated Load) (Full Height to Stowed)	37 seconds	47 seconds
Maximum Wind Speed	28 mph (12.5 m/s)	
Maximum Horizontal Manual Side Force:		
ANSI/ANSI Export/CSA:	300 lb force (1335 N)	
CE/AUS/JPN:	90 lb force (400 N)	
Maximum Tire Load (Each)	4400 lb (1996 kg)	
Ground Bearing Pressure w/Standard tires	48 psi (3.37 kg/ cm ²)	56 psi (3.94 kg/ cm ²)
Leveling Jack Pad Bearing Pressure	69 psi (4.85 kg/cm ²)	
Hydraulic System Pressure		
Main Relief:	2700 psi (186 bar)	
Lift Up Relief:	2700 psi (186 bar)	
Steer Relief:	2500 psi (172 bar)	
Leveling Jack Relief:	2500 psi (172 bar)	
Electrical System Voltage	12 Volt	

Specification	330LRT	430LRT
Inside Turning Radius	106.5 in (2.70 m)	
Outside Turning Radius	233.5 in (5.93 m)	
Gross Vehicle Weight		
Dual Fuel/Diesel - ANSI/ANSI Exp./CSA/CE/AUS/JPN		
w/ One Extension:	11,820 lb (5372 kg)	14,300 lb (6486 kg)
w/Two Extensions:	12,350 lb (5614 kg)	14,830 lb (6727 kg)
w/MegaDeck:	14,225 lb (6466 kg)	N/A
NOTE: Certain options or country standards increase weight.		

Generator Specifications (If Equipped)

Type:	Brush Type, Synchronous, Revolving Field
Regulation:	
3 Phase:	240 Volt, 7.5 Kw, 18.3 Amps, 1.0 pf
1 Phase:	240 Volt, 6 Kw, 26 Amps, 1.0 pf
1 Phase:	120 Volt, 6 Kw, 50 Amps, 1.0 pf
Peak:	3 Phase - 8.5 Kw, - 1 Phase - 6.0 Kw
Max Rated Temperature:	104 F (40C)
Rotational Inertia:	78 Lb. - IN - IN

Dimensional Data

	330LRT	430LRT
Wheelbase	117 in (297 cm)	117 in (297 cm)
Ground Clearance (center/platform stowed)	13.63 in (34.6 cm)	13.63 in (34.6 cm)
Machine Height (top of rails/platform stowed)	109 in (277 cm)	118 in (300 cm)
Machine Width	92.6 in (235 cm)	92.6 in (235 cm)
Machine Length (leveling jack to leveling jack)	192.2 in (488.3 cm)	192.2 in (488.3 cm)

Fluid Capacities

Fuel Tank Capacity	Diesel: Gasoline: LPTank:	22 gal (83.3 L) 22 gal (83.3 L) 43.5 lb (20 kg)
Hydraulic Tank		32.3 gal (122.2 L)
Engine Oil	Diesel: Dual Fuel:	6 qt (5.7 L) 3.6 qt (3.4 L)
Engine Coolant		7 qt (6.67 L)
Drive Brake (Each)		2.7 oz (0.08 L)
Drive Hub (Each)		17 oz (0.5 L)

Drive Information

Model	330LRT	430LRT
High Drive, Forward, Range	9-10 (sec/50ft)	9-10 (sec/50ft)
High Drive, Reverse, Range	9-10 (sec/50ft)	9-10 (sec/50ft)
Elevation Switch Height	6-9 ft (1.8-2.7 m)	7-10 ft (2-3 m)
Elevated Drive, F/R, Range	34 (sec/25 ft)	34 (sec/25 ft)
Gradeability Requirement	45%	45%

Steering Information

Model	330LRT	430LRT
Toe In/Out, (+/-) Max	0.25 in (6.35 mm)	0.25 in (6.35 mm)
Steer Angle, Inside Tire	42-44 degrees	42-44 degrees
Steer Angle, Outside Tire	32-34 degrees	32-34 degrees

Tires

Size	Ply Rating	Foam Fill Tire Assembly Rating	Wheel Nut Torque
12x16.5 Foam Filled (Non-Marking)	10	90 PSI @ 8,000 lb. (3700 Kg) - Static Load	170 ft lb - DRY (230 Nm)
33/1550x16.5 Foam Filled	14	90 PSI @ 14,176 lb. (6430 Kg) - Static Load	170 ft lb - DRY (230 Nm)
33/16LL600 Foam Filled (Sand Tire)	10	38 PSI @ 10,300 lb. (4672 Kg) - Static Load	170 ft lb - DRY (230 Nm)
315/55/D20 Foam Filled	12	80 PSI @ 9,650 lb. (4377 Kg) - Static Load	170 ft lb - DRY (230 Nm)

Critical Stability Weights

⚠ WARNING

DO NOT REPLACE ITEMS CRITICAL TO STABILITY WITH ITEMS OF DIFFERENT WEIGHT OR SPECIFICATION (FOR EXAMPLE: FILLED TIRES, ENGINE). DO NOT MODIFY UNIT IN ANY WAY TO AFFECT STABILITY.

Component	LRT
Wheel and Tire (each) - 12x16.5, Foam Filled	328 lb (149 kg)
Engine Only (Kubota - Diesel)	209 lb (95.1 kg)
Engine Only (Kubota - Gas/LP)	158 lb (71.4 kg)
Battery (with Generator)	171.3 lb (77.7 kg)

1.2 SERIAL NUMBER LOCATION

For machine identification, the serial number plate is located at the rear of the machine on the center of the axle. In addition, should the serial number plate be damaged or missing, the machine serial number is stamped on the lip of the rear axle.

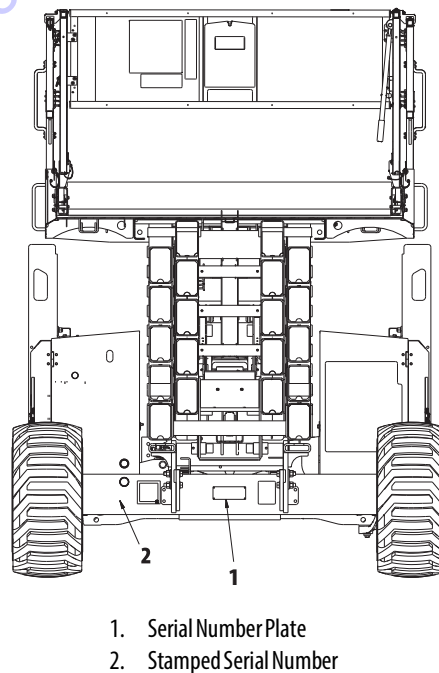

Figure 1-1. Serial Number Location

1.3 LUBRICATION

NOTE: Hydraulic oils must have anti-wear qualities at least to API Service Classification GL-3, and sufficient chemical stability for mobile hydraulic system service.

NOTE: Aside from JLG recommendations, it is not advisable to mix oils of different brands or types, as they may not contain the same required additives or be of comparable viscosities.

KEY	SPECIFICATIONS
MPG	Multipurpose Grease - Having a minimum dripping point of 350°F. Excellent water resistance and adhesive qualities, and being of extreme pressure type. (Timken OK 40 pounds minimum.)
EPGL	Extreme Pressure Gear Lube (oil) - Meeting API service classification GL-5 or MIL-Spec MIL-L-2105.
EO	Engine Oil (crankcase)
HO	Hydraulic Oil

Hydraulic Oil Specifications

Table 1-1. Mobilfluid 424

Inspection Data	Recommended	Optional
SAE Grade	10W-30	10W-20
Gravity, API	29.0	29.3
Density, LB/GAL, 60°F	7.35	7.3
Flash Point, °F(°C)	442(228)	380(193)
Pour Point, °F(°C)	-46(-43)	-30(-34)
Viscosity		
Brookfield, cPat -18°C	2700	
Brookfield, cPat 0°F		2500
Viscosity, cST at 40°C	55	52.1
Viscosity, cST at 100°C	9.3	8.95
Viscosity Index	152	152
Viscosity, Susat 100°F		26.0
Viscosity, Susat 210°F		56.8
Color, ASTM D 1500	3.0	

Table 1-2. Mobil DTE 10 Excel 32

ISO Viscosity Grade	32
Pour Point, °C Max.	-54
Flash Point, °C Min.	250
Viscosity	
cSt @ 40°C	32.7
cSt @ 100°C	6.63
cSt @ 100°F	32.7
cSt @ 212°F	6.63
Viscosity Index	164
Density (Kg/l) @ 15°C	0.8468
Density (lb/in ³) @ 60°F	0.0305

Table 1-3. UCon Hydrolube HP-5046

pH	9.1
Specific Gravity, 20/20°F	1.082
Pour Point, °C(°F)	<-50(<58)
Appearance	Red Liquid
Viscosity	
at 0°C (32°F)	340cST(1600SUS)
at 40°C (104°F)	46cST(215SUS)
at 65°C (150°F)	22cST(106SUS)
Viscosity Index	170

Table 1-4. Mobil EAL 224H

Type	Biodegradable Vegetable Oil
ISO Viscosity Grade	32/46
Specific Gravity	0.922
Pour Point °C(°F)	-32°(-25°)
Flash Point °C(°F)	220°(428°)
Rust Protection, ASTM D 665A & BB	Pass Color, ASTM D 1500 Max 2.0
Operating Temp -17°-162°C	(0-180°F) (Store above 14°C (32°F))
Viscosity	
ASTM D445 cST 40°C	37
ASTM D445 cST 100°C	8.4
Viscosity Index, ASTM D 2270	213

SECTION 1 - SPECIFICATIONS

Table 1-5. Mobil SHC Hydraulic EAL 46

ISO Viscosity Grade	46
Density@15°C	0.93
Pour Point, °C (°F), ASTM D97	-33(-27)
Flash Point, °C (°F), Min., ASTM D97	298(568)
Operating Temp °C(°F)	-29°(-20) to 93(200)
Viscosity	
ASTM D 445 cST 40°C	43.3
ASTM D 445 cST 100°C	7.7
Viscosity Index	149

Table 1-6. Mobil EAL ENVIROSYN H 46

ISO Viscosity Grade	46
Density@15°C	0.874
Pour Point, °C (°F), ASTM D97	-45°C(-49)
Flash Point, °C (°F), Min., ASTM D97	260°C(500)
Operating Temp °C(°F)	-29°(-20) to 93(200)
Viscosity	
ASTM D 445 cST 40°C	48.8
ASTM D 445 cST 100°C	7.8
Viscosity Index	145

1.4 HYDRAULIC PRESSURE SETTINGS

Description	Setting
Main Relief Pressure	2700 psi (186 bar)
Steer Relief Pressure Left	2500 psi (172 bar)
Steer Relief Pressure Right	2500 psi (172 bar)
Leveling Jack Relief Pressure	2500 psi (172 bar)

1.5 HYDRAULIC CYLINDER SPECIFICATIONS

Description	Bore	Stroke	Rod Dia.
Lift Cylinder	4.5 in (114.3mm)	83 in (2108.2 mm)	3.5 in (88.9 mm)
Leveling Jack Cylinder	2.5 in (63.5 mm)	27 in (686 mm)	2 in (51 mm)
RAM Lockout Cylinder (Oscillating Axle)	3.62 in (92 mm)	4 in (101.6 mm)	3.5 in (88.9 mm)
Steer Cylinder	2.75 in (70 mm)	8.94 in (227.1 mm)	1.97 in (50 mm)

1.6 ENGINE SPECIFICATIONS

Table 1-7. Kubota Diesel (D1305-E4B)

Emissions	CARB, EPA - Tier 4 Final, China Stage III, and EU Stage V
Fuel Type:	Diesel: - Low Sulfur (<500 ppm) - Ultra Low Sulfur (15 ppm) (Required to meet Stage V) - up to 5% biodiesel
No. of Cylinders	3
Oil Pan Capacity	1.51 gal (5.7 L)
Engine RPM Control	Mechanical
Low RPM Set	1200 RPM
High RPM Set	2600 RPM
Alternator	60 Amp, 12V, Belt Drive
Battery	112 Amp-Hour, 950 Cold Cranking Amps, 12VDC
Fuel Consumption: Low RPM High RPM	0.41 gal/hr (1.5 L/hr) 2.0 gal/hr (7.6 L/hr)
Displacement	1.261 L (77 cu. in.)
Gross Power	24.8 Hp (18.5 Kw) @ 2600 RPM
Gross Torque	59.1 Ft. lb. (80.1 Nm) @ 1700 RPM

Table 1-8. Kubota (WG972-GL-E4 - Dual Fuel)

Emissions	U.S. EPA Phase 3 and CARB SSI
Fuel Type:	Gasoline - 87 Octane minimum - Ethanol/Gas Mix-10% max. - Methanol/Gas Mix-5% max. LP - Liquid Petroleum
No. of Cylinders	3
Oil Pan Capacity	0.90 gal (3.4 L)
Engine RPM Control	Electronic - ECM
Low RPM Set	1200 RPM
High RPM Set	3500 RPM
Alternator	60 Amp, 12V, Belt Drive
Battery	112 Amp-Hour, 950 Cold Cranking Amps, 12VDC
Fuel Consumption: Low RPM High RPM	0.38 gal/hr (1.45 L/hr) - Gas 1.85 lb/hr (0.84 kg/hr) - LP 1.76 gal/hr (6.66 L/hr) - Gas 9.3 lb/hr (4.23 kg/hr) - LP
Displacement	0.962L (58.7 cu. in.)
Gross Power	GAS - 30.6 Hp (22.8 Kw) @ 3500 RPM LP - 30.0 Hp (21.6 Kw) @ 3500 RPM
Gross Torque	GAS - 49.1 Ft. lb (66.6 Nm) @ 2400 RPM LP - 48.8 Ft. lb (66.2 Nm) @ 1800 RPM

1.7 ELEVATION/TILT LIMIT SETTINGS

The machine is equipped with the following limit switches (refer to Table 1-9):

- **Elevation Switch/Rotary Position Sensor** - High drive speed is cut out when platform is raised above **6 to 9 ft (2 to 3 m)**.
- **Tilt Indicator Warning Light and Alarm** - A red warning light on the control panel illuminates and an audible alarm sounds when the chassis is at or beyond the tilt cutout settings.

⚠ WARNING

IF THE TILT INDICATOR WARNING LIGHT/ALARM IS ACTIVATED WHEN PLATFORM IS RAISED, LOWER PLATFORM AND DRIVE TO A SMOOTH, FIRM, LEVEL SURFACE.

Table 1-9. Tilt Cutout Settings

Model	Market	Front to Rear	Side to Side	Lift Up and Drive prevented when Elevated and Tilted (Front to Back) beyond the following heights.	Lift Up and Drive prevented when elevated and tilted (Side to Side) beyond the following heights.
330LRT	ANSI ANSI Exp. CE AUS	±5°	±3°	33 ft (10 m)	33 ft (10 m)
	CSA	±3°	±3°	33 ft (10 m)	33 ft (10 m)
430LRT	ANSI ANSI Exp. CE AUS	±5°	±3°	43 ft (13 m)	43 ft (13 m)
	CSA	±3°	±3°	43 ft (13 m)	43 ft (13 m)

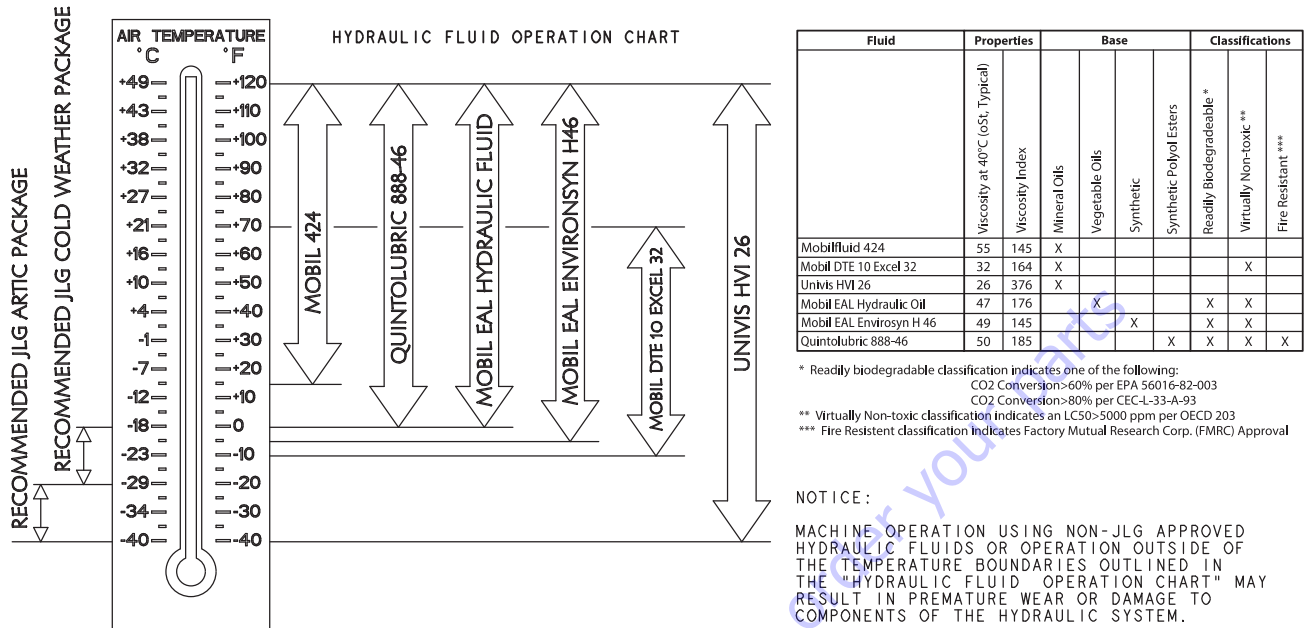

Figure 1-2. Hydraulic Oil Operating Temperature Specifications

4150740B

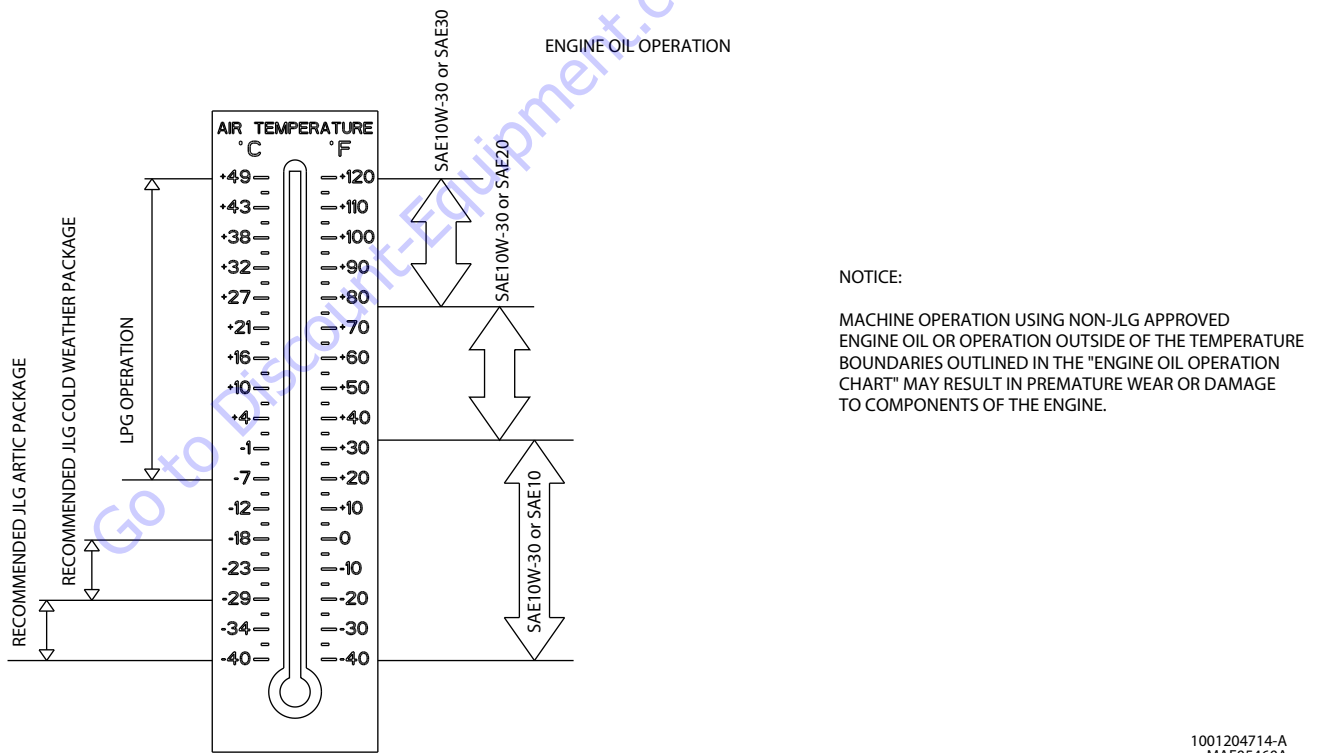
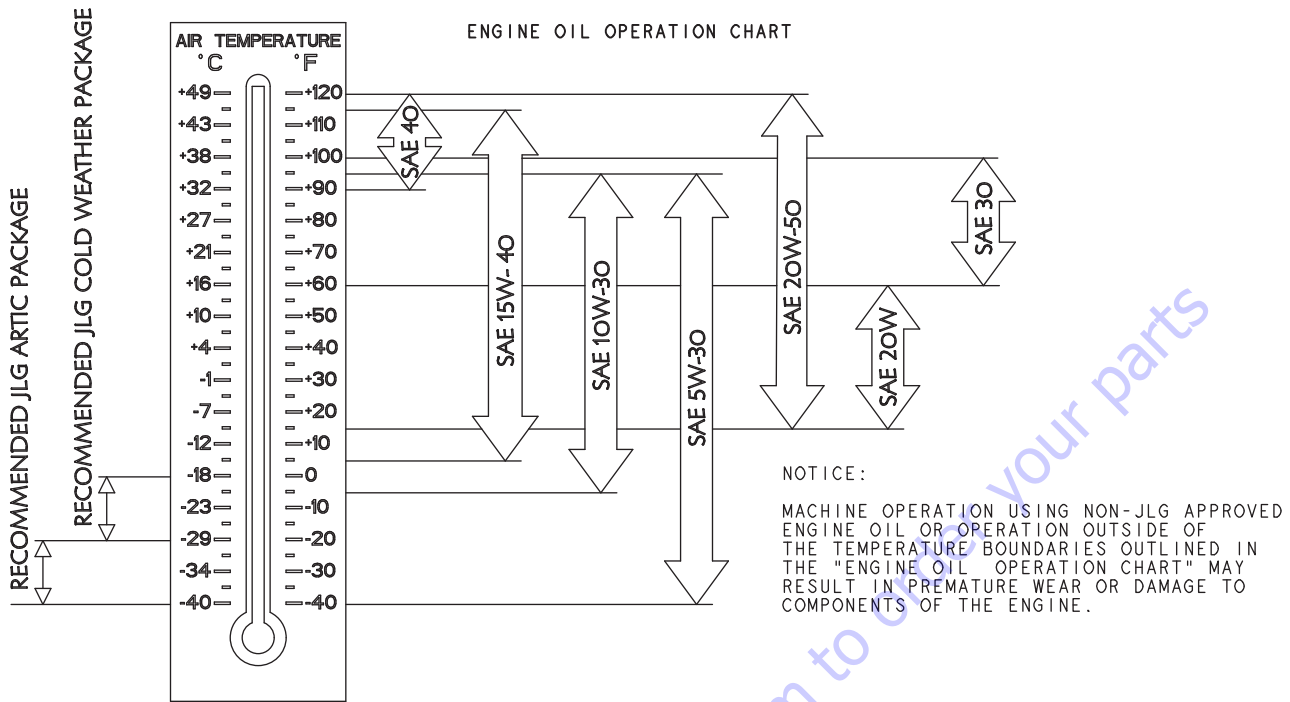

Figure 1-3. Engine Oil Operating Temperature Specifications - Kubota (Dual Fuel Engine)

1001204714-A
MAF05460A



1001120075 C

Figure 1-4. Engine Oil Operating Temperature Specifications - Kubota (Diesel Engine)

1.8 THREADLOCKING COMPOUND

JLGN	Loctite®	ND Industries	Description
0100011	242™	Vibra-TITE™ 121	Medium Strength (Blue)
1001095650	243™	Vibra-TITE™ 122	Medium Strength (Blue)
0100019	271™	Vibra-TITE™ 140	High Strength (Red)
0100071	262™	Vibra-TITE™ 131	Medium - High Strength (Red)

NOTE: Loctite® 243™ can be substituted in place of Loctite® 242™. Vibra-TITE™ 122 can be substituted in place of Vibra-TITE™ 121.

Go to Discount-Equipment.com to order your parts

SECTION 1 - SPECIFICATIONS

1.9 TORQUE CHARTS

SAE Fastener Torque Chart

Values for Zinc Yellow Chromate Fasteners (Ref 4150707)												
SAE GRADE 5 BOLTS & GRADE 2 NUTS												
Size	TPI	Bolt Dia	Tensile Stress Area	Clamp Load	Torque (Dry)		Torque Lubricated		Torque (Loctite® 242™ or 271™ or Vibra-TITE™ 111 or 140)		Torque (Loctite® 262™ or Vibra-TITE™ 111)	
					IN-LB	[N.m]	IN-LB	[N.m]	IN-LB	[N.m]	IN-LB	[N.m]
		In	Sq In	LB	IN-LB	[N.m]	IN-LB	[N.m]	IN-LB	[N.m]	IN-LB	[N.m]
4	40	0.1120	0.00604	380	8	0.9	6	0.7				
	48	0.1120	0.00661	420	9	1.0	7	0.8				
6	32	0.1380	0.00909	580	16	1.8	12	1.4				
	40	0.1380	0.01015	610	18	2.0	13	1.5				
8	32	0.1640	0.01400	900	30	3.4	22	2.5				
	36	0.1640	0.01474	940	31	3.5	23	2.6				
10	24	0.1900	0.01750	1120	43	4.8	32	3.5				
	32	0.1900	0.02000	1285	49	5.5	36	4				
1/4	20	0.2500	0.0318	2020	96	10.8	75	9	105	12		
	28	0.2500	0.0364	2320	120	13.5	86	10	135	15		
		In	Sq In	LB	FT-LB	[N.m]	FT-LB	[N.m]	FT-LB	[N.m]	FT-LB	[N.m]
5/16	18	0.3125	0.0524	3340	17	23	13	18	19	26	16	22
	24	0.3125	0.0580	3700	19	26	14	19	21	29	17	23
3/8	16	0.3750	0.0775	4940	30	41	23	31	35	48	28	38
	24	0.3750	0.0878	5600	35	47	25	34	40	54	32	43
7/16	14	0.4375	0.1063	6800	50	68	35	47	55	75	45	61
	20	0.4375	0.1187	7550	55	75	40	54	60	82	50	68
1/2	13	0.5000	0.1419	9050	75	102	55	75	85	116	68	92
	20	0.5000	0.1599	10700	90	122	65	88	100	136	80	108
9/16	12	0.5625	0.1820	11600	110	149	80	108	120	163	98	133
	18	0.5625	0.2030	12950	120	163	90	122	135	184	109	148
5/8	11	0.6250	0.2260	14400	150	203	110	149	165	224	135	183
	18	0.6250	0.2560	16300	170	230	130	176	190	258	153	207
3/4	10	0.7500	0.3340	21300	260	353	200	271	285	388	240	325
	16	0.7500	0.3730	23800	300	407	220	298	330	449	268	363
7/8	9	0.8750	0.4620	29400	430	583	320	434	475	646	386	523
	14	0.8750	0.5090	32400	470	637	350	475	520	707	425	576
1	8	1.0000	0.6060	38600	640	868	480	651	675	918	579	785
	12	1.0000	0.6630	42200	700	949	530	719	735	1000	633	858
1 1/8	7	1.1250	0.7630	42300	800	1085	600	813	840	1142	714	968
	12	1.1250	0.8560	47500	880	1193	660	895	925	1258	802	1087
1 1/4	7	1.2500	0.9690	53800	1120	1518	840	1139	1175	1598	1009	1368
	12	1.2500	1.0730	59600	1240	1681	920	1247	1300	1768	1118	1516
1 3/8	6	1.3750	1.1550	64100	1460	1979	1100	1491	1525	2074	1322	1792
	12	1.3750	1.3150	73000	1680	2278	1260	1708	1750	2380	1506	2042
1 1/2	6	1.5000	1.4050	78000	1940	2630	1460	1979	2025	2754	1755	2379
	12	1.5000	1.5800	87700	2200	2983	1640	2224	2300	3128	1974	2676

- NOTES: 1. THESE TORQUE VALUES DO NOT APPLY TO CADMIUM PLATED FASTENERS
 2. ALL TORQUE VALUES ARE STATIC TORQUE MEASURED PER STANDARD AUDIT METHODS TOLERANCE = ±10%
 3. * ASSEMBLY USES HARDENED WASHER

5000059K

SAE Fastener Torque Chart (Continued)

Values for Zinc Yellow Chromate Fasteners (Ref 4150707)										
SAE GRADE 8 (HEX HD) BOLTS & GRADE 8 NUTS*										
Size	TPI	Bolt Dia	Tensile Stress Area	Clamp Load	Torque (Dry or Loctite® 263) K=0.20		Torque (Loctite® 242™ or 271™ or Vibra-TITE™ 111 or 140) K=0.18		Torque (Loctite® 262™ or Vibra-TITE™ 131) K=0.15	
					IN-LB	[N.m]	IN-LB	[N.m]	IN-LB	[N.m]
		In	Sq In	LB	IN-LB	[N.m]	IN-LB	[N.m]	IN-LB	[N.m]
4	40	0.1120	0.00604							
	48	0.1120	0.00661							
6	32	0.1380	0.00909							
	40	0.1380	0.01015							
8	32	0.1640	0.01400							
	36	0.1640	0.01474	1320	43	5				
10	24	0.1900	0.01750	1580	60	7				
	32	0.1900	0.02000	1800	68	8				
1/4	20	0.2500	0.0318	2860	143	16	129	15		
	28	0.2500	0.0364	3280	164	19	148	17		
		In	Sq In	LB	FT-LB	[N.m]	FT-LB	[N.m]	FT-LB	[N.m]
5/16	18	0.3125	0.0524	4720	25	35	20	25	20	25
	24	0.3125	0.0580	5220	25	35	25	35	20	25
3/8	16	0.3750	0.0775	7000	45	60	40	55	35	50
	24	0.3750	0.0878	7900	50	70	45	60	35	50
7/16	14	0.4375	0.1063	9550	70	95	65	90	50	70
	20	0.4375	0.1187	10700	80	110	70	95	60	80
1/2	13	0.5000	0.1419	12750	105	145	95	130	80	110
	20	0.5000	0.1599	14400	120	165	110	150	90	120
9/16	12	0.5625	0.1820	16400	155	210	140	190	115	155
	18	0.5625	0.2030	18250	170	230	155	210	130	175
5/8	11	0.6250	0.2260	20350	210	285	190	260	160	220
	18	0.6250	0.2560	23000	240	325	215	290	180	245
3/4	10	0.7500	0.3340	30100	375	510	340	460	280	380
	16	0.7500	0.3730	33600	420	570	380	515	315	430
7/8	9	0.8750	0.4620	41600	605	825	545	740	455	620
	14	0.8750	0.5090	45800	670	910	600	815	500	680
1	8	1.0000	0.6060	51500	860	1170	770	1045	645	875
	12	1.0000	0.6630	59700	995	1355	895	1215	745	1015
1 1/8	7	1.1250	0.7630	68700	1290	1755	1160	1580	965	1310
	12	1.1250	0.8560	77000	1445	1965	1300	1770	1085	1475
1 1/4	7	1.2500	0.9690	87200	1815	2470	1635	2225	1365	1855
	12	1.2500	1.0730	96600	2015	2740	1810	2460	1510	2055
1 3/8	6	1.3750	1.1550	104000	2385	3245	2145	2915	1785	2430
	12	1.3750	1.3150	118100	2705	3680	2435	3310	2030	2760
1 1/2	6	1.5000	1.4050	126500	3165	4305	2845	3870	2370	3225
	12	1.5000	1.5800	142200	3555	4835	3200	4350	2665	3625

NOTES: 1. THESE TORQUE VALUES DO NOT APPLY TO CADMIUM PLATED FASTENERS

5000059K

2. ALL TORQUE VALUES ARE STATIC TORQUE MEASURED PER STANDARD AUDIT METHODS TOLERANCE = ±10%

3. * ASSEMBLY USES HARDENED WASHER

SECTION 1 - SPECIFICATIONS

SAE Fastener Torque Chart (Continued)

Values for Magni Coating Fasteners (Ref 4150701)										
SAE GRADE 5 BOLTS & GRADE 2 NUTS										
Size	TPI	Bolt Dia	Tensile Stress Area	Clamp Load	Torque (Dry) K=0.17		Torque (Loctite® 242™ or 271™ or Vibra-TITE™ 111 or 140) K=0.16		Torque (Loctite® 262™ or Vibra-TITE™ 131) K=0.15	
					IN-LB	[N.m]	IN-LB	[N.m]	IN-LB	[N.m]
		In	Sq In	LB	FT-LB	[N.m]	FT-LB	[N.m]	FT-LB	[N.m]
4	40	0.1120	0.00604	380	7	0.8				
	48	0.1120	0.00661	420	8	0.9				
6	32	0.1380	0.00909	580	14	1.5				
	40	0.1380	0.01015	610	14	1.6				
8	32	0.1640	0.01400	900	25	2.8				
	36	0.1640	0.01474	940	26	2.9				
10	24	0.1900	0.01750	1120	36	4.1				
	32	0.1900	0.02000	1285	42	4.7				
1/4	20	0.2500	0.0318	2020	86	9.7	80	9		
	28	0.2500	0.0364	2320	99	11.1	95	11		
		In	Sq In	LB	FT-LB	[N.m]	FT-LB	[N.m]	FT-LB	[N.m]
5/16	18	0.3125	0.0524	3340	15	20	14	19	15	20
	24	0.3125	0.0580	3700	15	20	15	21	15	20
3/8	16	0.3750	0.0775	4940	25	35	25	34	25	34
	24	0.3750	0.0878	5600	30	40	28	38	25	34
7/16	14	0.4375	0.1063	6800	40	55	40	54	35	48
	20	0.4375	0.1187	7550	45	60	44	60	40	54
1/2	13	0.5000	0.1419	9050	65	90	60	82	55	75
	20	0.5000	0.1599	10700	75	100	71	97	65	88
9/16	12	0.5625	0.1820	11600	90	120	87	118	80	109
	18	0.5625	0.2030	12950	105	145	97	132	90	122
5/8	11	0.6250	0.2260	14400	130	175	120	163	115	156
	18	0.6250	0.2560	16300	145	195	136	185	125	170
3/4	10	0.7500	0.3340	21300	225	305	213	290	200	272
	16	0.7500	0.3730	23800	255	345	238	324	225	306
7/8	9	0.8750	0.4620	29400	365	495	343	466	320	435
	14	0.8750	0.5090	32400	400	545	378	514	355	483
1	8	1.0000	0.6060	38600	545	740	515	700	480	653
	12	1.0000	0.6630	42200	600	815	563	765	530	721
1 1/8	7	1.1250	0.7630	42300	675	920	635	863	595	809
	12	1.1250	0.8560	47500	755	1025	713	969	670	911
1 1/4	7	1.2500	0.9690	53800	955	1300	897	1219	840	1142
	12	1.2500	1.0730	59600	1055	1435	993	1351	930	1265
1 3/8	6	1.3750	1.1550	64100	1250	1700	1175	1598	1100	1496
	12	1.3750	1.3150	73000	1420	1930	1338	1820	1255	1707
1 1/2	6	1.5000	1.4050	78000	1660	2260	1560	2122	1465	1992
	12	1.5000	1.5800	87700	1865	2535	1754	2385	1645	2237

- NOTES: 1. THESE TORQUE VALUES DO NOT APPLY TO CADMIUM PLATED FASTENERS
 2. ALL TORQUE VALUES ARE STATIC TORQUE MEASURED PER STANDARD AUDIT METHODS TOLERANCE = ±10%
 3. * ASSEMBLY USES HARDENED WASHER

5000059K

SAE Fastener Torque Chart (Continued)

Values for Magni Coating Fasteners (Ref 4150701)										
SAE GRADE 8 (HEX HD) BOLTS & GRADE 8 NUTS*										
Size	TPI	Bolt Dia	Tensile Stress Area	Clamp Load	Torque (Dry or Loctite® 263) K=0.17		Torque (Loctite® 242™ or 271™ or Vibra-TITE™ 111 or 140) K=0.16		Torque (Loctite® 262™ or Vibra-TITE™ 131) K=0.15	
					IN-LB	[N.m]	IN-LB	[N.m]	IN-LB	[N.m]
		In	Sq In	LB	IN-LB	[N.m]	IN-LB	[N.m]	IN-LB	[N.m]
4	40	0.1120	0.00604							
	48	0.1120	0.00661							
6	32	0.1380	0.00909							
	40	0.1380	0.01015							
8	32	0.1640	0.01400							
	36	0.1640	0.01474	1320	37	4				
10	24	0.1900	0.01750	1580	51	6				
	32	0.1900	0.02000	1800	58	7				
1/4	20	0.2500	0.0318	2860	122	14	114	13		
	28	0.2500	0.0364	3280	139	16	131	15		
		In	Sq In	LB	FT-LB	[N.m]	FT-LB	[N.m]	FT-LB	[N.m]
5/16	18	0.3125	0.0524	4720	20	25	20	25	20	25
	24	0.3125	0.0580	5220	25	35	20	25	20	25
3/8	16	0.3750	0.0775	7000	35	50	35	50	35	50
	24	0.3750	0.0878	7900	40	55	40	55	35	50
7/16	14	0.4375	0.1063	9550	60	80	55	75	50	70
	20	0.4375	0.1187	10700	65	90	60	80	60	80
1/2	13	0.5000	0.1419	12750	90	120	85	115	80	110
	20	0.5000	0.1599	14400	100	135	95	130	90	120
9/16	12	0.5625	0.1820	16400	130	175	125	170	115	155
	18	0.5625	0.2030	18250	145	195	135	185	130	175
5/8	11	0.6250	0.2260	20350	180	245	170	230	160	220
	18	0.6250	0.2560	23000	205	280	190	260	180	245
3/4	10	0.7500	0.3340	30100	320	435	300	410	280	380
	16	0.7500	0.3730	33600	355	485	335	455	315	430
7/8	9	0.8750	0.4620	41600	515	700	485	660	455	620
	14	0.8750	0.5090	45800	570	775	535	730	500	680
1	8	1.0000	0.6060	51500	730	995	685	930	645	875
	12	1.0000	0.6630	59700	845	1150	795	1080	745	1015
1 1/8	7	1.1250	0.7630	68700	1095	1490	1030	1400	965	1310
	12	1.1250	0.8560	77000	1225	1665	1155	1570	1085	1475
1 1/4	7	1.2500	0.9690	87200	1545	2100	1455	1980	1365	1855
	12	1.2500	1.0730	96600	1710	2325	1610	2190	1510	2055
1 3/8	6	1.3750	1.1550	104000	2025	2755	1905	2590	1785	2430
	12	1.3750	1.3150	118100	2300	3130	2165	2945	2030	2760
1 1/2	6	1.5000	1.4050	126500	2690	3660	2530	3440	2370	3225
	12	1.5000	1.5800	142200	3020	4105	2845	3870	2665	3625

- NOTES: 1. THESE TORQUE VALUES DO NOT APPLY TO CADMIUM PLATED FASTENERS
2. ALL TORQUE VALUES ARE STATIC TORQUE MEASURED PER STANDARD AUDIT METHODS TOLERANCE = ±10%
3. * ASSEMBLY USES HARDENED WASHER

5000059K

SECTION 1 - SPECIFICATIONS

SAE Fastener Torque Chart (Continued)

Values for Magni Coating Fasteners (Ref 4150701)										
SOCKET HEAD CAPSCREWS										
Size	TPI	Bolt Dia	Tensile Stress Area	Clamp Load See Note 4	Torque (Dry) K=0.17		Torque (Loctite® 242™ or 271™ or Vibra-TITE™ 111 or 140) or Precoat® 85 K=0.16		Torque (Loctite® 262™ or Vibra-TITE™ 131) K=0.15	
					IN-LB	[N.m]	IN-LB	[N.m]	IN-LB	[N.m]
		In	Sq In	LB	FT-LB	[N.m]	FT-LB	[N.m]	FT-LB	[N.m]
4	40	0.1120	0.00604							
	48	0.1120	0.00661							
6	32	0.1380	0.00909							
	40	0.1380	0.01015							
8	32	0.1640	0.01400							
	36	0.1640	0.01474							
10	24	0.1900	0.01750							
	32	0.1900	0.02000							
1/4	20	0.2500	0.0318	2860	122	14	114	13		
	28	0.2500	0.0364	3280	139	16	131	15		
		In	Sq In	LB	FT-LB	[N.m]	FT-LB	[N.m]	FT-LB	[N.m]
5/16	18	0.3125	0.0524	4720	20	25	20	25	20	25
	24	0.3125	0.0580	5220	25	35	20	25	20	25
3/8	16	0.3750	0.0775	7000	35	50	35	50	35	50
	24	0.3750	0.0878	7900	40	55	40	55	35	50
7/16	14	0.4375	0.1063	9550	60	80	55	75	50	70
	20	0.4375	0.1187	10700	65	90	60	80	60	80
1/2	13	0.5000	0.1419	12750	90	120	85	115	80	110
	20	0.5000	0.1599	14400	100	135	95	130	90	120
9/16	12	0.5625	0.1820	16400	130	175	125	170	115	155
	18	0.5625	0.2030	18250	145	195	135	185	130	175
5/8	11	0.6250	0.2260	20350	180	245	170	230	160	220
	18	0.6250	0.2560	23000	205	280	190	260	180	245
3/4	10	0.7500	0.3340	30100	320	435	300	415	280	380
	16	0.7500	0.3730	33600	355	485	335	455	315	430
7/8	9	0.8750	0.4620	41600	515	700	485	660	455	620
	14	0.8750	0.5090	45800	570	775	535	730	500	680
1	8	1.0000	0.6060	51500	730	995	685	930	645	875
	12	1.0000	0.6630	59700	845	1150	795	1080	745	1015
1 1/8	7	1.1250	0.7630	68700	1095	1490	1030	1400	965	1310
	12	1.1250	0.8560	77000	1225	1665	1155	1570	1085	1475
1 1/4	7	1.2500	0.9690	87200	1545	2100	1455	1980	1365	1855
	12	1.2500	1.0730	96600	1710	2325	1610	2190	1510	2055
1 3/8	6	1.3750	1.1550	104000	2025	2755	1905	2590	1785	2430
	12	1.3750	1.3150	118100	2300	3130	2165	2945	2030	2760
1 1/2	6	1.5000	1.4050	126500	2690	3660	2530	3440	2370	3225
	12	1.5000	1.5800	142200	3020	4105	2845	3870	2665	3625

- NOTES: 1. THESE TORQUE VALUES DO NOT APPLY TO CADMIUM PLATED FASTENERS 5000059K
 2. ALL TORQUE VALUES ARE STATIC TORQUE MEASURED PER STANDARD AUDIT METHODS TOLERANCE = ±10%
 3. * ASSEMBLY USES HARDENED WASHER
 4. CLAMP LOAD LISTED FOR SHCS IS SAME AS GRADE 8 OR CLASS 10.9 AND DOES NOT REPRESENT FULL STRENGTH CAPABILITY OF SHCS.
 IF HIGHER LOAD IS REQUIRED, ADDITIONAL TESTING IS REQUIRED.

SAE Fastener Torque Chart (Continued)

Values for Zinc Yellow Chromate Fasteners (Ref 4150707)*										
SOCKET HEAD CAPSCREWS										
Size	TPI	Bolt Dia	Tensile Stress Area	Clamp Load See Note 4	Torque (Dry) K=0.17		Torque (Loctite® 242™ or 271™ or Vibra-TITE™ 111 or 140) or Precoat® 85 K=0.16		Torque (Loctite® 262™ or Vibra-TITE™ 131) K=0.15	
					IN-LB	[N.m]	IN-LB	[N.m]	IN-LB	[N.m]
		In	Sq In	LB	FT-LB	[N.m]	FT-LB	[N.m]	FT-LB	[N.m]
4	40	0.1120	0.00604							
	48	0.1120	0.00661							
6	32	0.1380	0.00909							
	40	0.1380	0.01015							
8	32	0.1640	0.01400							
	36	0.1640	0.01474							
10	24	0.1900	0.01750							
	32	0.1900	0.02000							
1/4	20	0.2500	0.0318	2860	122	14	114	13		
	28	0.2500	0.0364	3280	139	16	131	15		
		In	Sq In	LB	FT-LB	[N.m]	FT-LB	[N.m]	FT-LB	[N.m]
5/16	18	0.3125	0.0524	4720	20	25	20	25	20	25
	24	0.3125	0.0580	5220	25	35	20	25	20	25
3/8	16	0.3750	0.0775	7000	35	50	35	50	35	50
	24	0.3750	0.0878	7900	40	55	40	55	35	50
7/16	14	0.4375	0.1063	9550	60	80	55	75	50	70
	20	0.4375	0.1187	10700	65	90	60	80	60	80
1/2	13	0.5000	0.1419	12750	90	120	85	115	80	110
	20	0.5000	0.1599	14400	100	135	95	130	90	120
9/16	12	0.5625	0.1820	16400	130	175	125	170	115	155
	18	0.5625	0.2030	18250	145	195	135	185	130	175
5/8	11	0.6250	0.2260	20350	180	245	170	230	160	220
	18	0.6250	0.2560	23000	205	280	190	260	180	245
3/4	10	0.7500	0.3340	30100	320	435	300	415	280	380
	16	0.7500	0.3730	33600	355	485	335	455	315	430
7/8	9	0.8750	0.4620	41600	515	700	485	660	455	620
	14	0.8750	0.5090	45800	570	775	535	730	500	680
1	8	1.0000	0.6060	51500	730	995	685	930	645	875
	12	1.0000	0.6630	59700	845	1150	795	1080	745	1015
1 1/8	7	1.1250	0.7630	68700	1095	1490	1030	1400	965	1310
	12	1.1250	0.8560	77000	1225	1665	1155	1570	1085	1475
1 1/4	7	1.2500	0.9690	87200	1545	2100	1455	1980	1365	1855
	12	1.2500	1.0730	96600	1710	2325	1610	2190	1510	2055
1 3/8	6	1.3750	1.1550	104000	2025	2755	1905	2590	1785	2430
	12	1.3750	1.3150	118100	2300	3130	2165	2945	2030	2760
1 1/2	6	1.5000	1.4050	126500	2690	3660	2530	3440	2370	3225
	12	1.5000	1.5800	142200	3020	4105	2845	3870	2665	3625

- NOTES: 1. THESE TORQUE VALUES DO NOT APPLY TO CADMIUM PLATED FASTENERS
2. ALL TORQUE VALUES ARE STATIC TORQUE MEASURED PER STANDARD AUDIT METHODS TOLERANCE = ±10%
3. * ASSEMBLY USES HARDENED WASHER
4. CLAMP LOAD LISTED FOR SHCS IS SAME AS GRADE 8 OR CLASS 10.9 AND DOES NOT REPRESENT FULL STRENGTH CAPABILITY OF SHCS. IF HIGHER LOAD IS REQUIRED, ADDITIONAL TESTING IS REQUIRED.

5000059K

SECTION 1 - SPECIFICATIONS

Metric Fastener Torque Chart

Values for Zinc Yellow Chromate Fasteners (Ref 4150707)*							
CLASS 8.8 METRIC (HEX/SOCKET HEAD) BOLTS CLASS 8 METRIC NUTS							
Size	Pitch	Tensile Stress Area	Clamp Load See Note 4	Torque (Dry or Loctite® 263™)	Torque (Lube)	Torque (Loctite® 262™ or 271™ or Vibra-TITE™ 131)	Torque (Loctite® 242™ or 271™ or Vibra-TITE™ 111 or 141)
		Sq mm	KN	[N.m]		[N.m]	[N.m]
3	0.5	5.03	2.19	1.3	1.0	1.2	1.4
3.5	0.6	6.78	2.95	2.1	1.6	1.9	2.3
4	0.7	8.78	3.82	3.1	2.3	2.8	3.4
5	0.8	14.20	6.18	6.2	4.6	5.6	6.8
6	1	20.10	8.74	11	7.9	9.4	12
7	1	28.90	12.6	18	13	16	19
8	1.25	36.60	15.9	26	19	23	28
10	1.5	58.00	25.2	50	38	45	55
12	1.75	84.30	36.7	88	66	79	97
14	2	115	50.0	140	105	126	154
16	2	157	68.3	219	164	197	241
18	2.5	192	83.5	301	226	271	331
20	2.5	245	106.5	426	320	383	469
22	2.5	303	132.0	581	436	523	639
24	3	353	153.5	737	553	663	811
27	3	459	199.5	1080	810	970	1130
30	3.5	561	244.0	1460	1100	1320	1530
33	3.5	694	302.0	1990	1490	1790	2090
36	4	817	355.5	2560	1920	2300	2690
42	4.5	1120	487.0	4090	3070	3680	4290

NOTES:

1. THESE TORQUE VALUES DO NOT APPLY TO CADMIUM PLATED FASTENERS
2. ALL TORQUE VALUES ARE STATIC TORQUE MEASURED PER STANDARD AUDIT METHODS TOLERANCE = ±10%
3. * ASSEMBLY USES HARDENED WASHER
4. CLAMP LOAD LISTED FOR SHCS IS SAME AS GRADE 8 OR CLASS 10.9 AND DOES NOT REPRESENT FULL STRENGTH CAPABILITY OF SHCS. IF HIGHER LOAD IS REQUIRED, ADDITIONAL TESTING IS REQUIRED.

5000059K

Metric Fastener Torque Chart (Continued)

Values for Zinc Yellow Chromate Fasteners (Ref 4150707)*						
CLASS 10.9 METRIC (HEX HEAD) BOLTS, CLASS 10 METRIC NUTS CLASS 12.9 SOCKET HEAD CAPSCREWS M3 - M5*						
Size	Pitch	Tensile Stress Area	Clamp Load See Note 4	Torque (Dry or Loctite® 263™) K=0.20	Torque (Lube or Loctite® 242™ or 271™ or Vibra-TITE™ 111 or 140) K=0.18	Torque (Loctite® 262™ or Vibra-TITE™ 131) K=0.15
		Sq mm	KN	[N.m]	[N.m]	[N.m]
3	0.5	5.03	3.13			
3.5	0.6	6.78	4.22			
4	0.7	8.78	5.47			
5	0.8	14.20	8.85			
6	1	20.10	12.5			
7	1	28.90	18.0	25	23	19
8	1.25	36.60	22.8	37	33	27
10	1.5	58.00	36.1	70	65	55
12	1.75	84.30	52.5	125	115	95
14	2	115	71.6	200	180	150
16	2	157	97.8	315	280	235
18	2.5	192	119.5	430	385	325
20	2.5	245	152.5	610	550	460
22	2.5	303	189.0	830	750	625
24	3	353	222.0	1065	960	800
27	3	459	286.0	1545	1390	1160
30	3.5	561	349.5	2095	1885	1575
33	3.5	694	432.5	2855	2570	2140
36	4	817	509.0	3665	3300	2750
42	4.5	1120	698.0	5865	5275	4395

NOTES:

1. THESE TORQUE VALUES DO NOT APPLY TO CADMIUM PLATED FASTENERS
2. ALL TORQUE VALUES ARE STATIC TORQUE MEASURED PER STANDARD AUDIT METHODS TOLERANCE = ±10%
3. * ASSEMBLY USES HARDENED WASHER
4. CLAMP LOAD LISTED FOR SHCS IS SAME AS GRADE 8 OR CLASS 10.9 AND DOES NOT REPRESENT FULL STRENGTH CAPABILITY OF SHCS. IF HIGHER LOAD IS REQUIRED, ADDITIONAL TESTING IS REQUIRED.

5000059K

SECTION 1 - SPECIFICATIONS

Metric Fastener Torque Chart (Continued)

Values for Magni Coated Fasteners (Ref 4150701)*						
CLASS 8.8 METRIC (HEX/SOCKET HEAD) BOLTS CLASS 8 METRIC NUTS						
Size	Pitch	Tensile Stress Area	Clamp Load See Note 4	Torque (Dry or Loctite® 263™) K=0.17	Torque (Lube or Loctite® 242™ or 271™ or Vibra-TITE™ 111 or 140) K=0.16	Torque (Loctite® 262™ or Vibra-TITE™ 131) K=0.15
		Sq mm	KN	[N.m]	[N.m]	[N.m]
3	0.5	5.03	2.19	1.1	1.1	1.0
3.5	0.6	6.78	2.95	1.8	1.7	1.5
4	0.7	8.78	3.82	2.6	2.4	2.3
5	0.8	14.20	6.18	5.3	4.9	4.6
6	1	20.10	8.74	9	8.4	7.9
7	1	28.90	12.6	15	14	13
8	1.25	36.60	15.9	22	20	19
10	1.5	58.00	25.2	43	40	38
12	1.75	84.30	36.7	75	70	66
14	2	115	50.0	119	110	105
16	2	157	68.3	186	175	165
18	2.5	192	83.5	256	240	225
20	2.5	245	106.5	362	340	320
22	2.5	303	132.0	494	465	435
24	3	353	153.5	627	590	555
27	3	459	199.5	916	860	810
30	3.5	561	244.0	1245	1170	1100
33	3.5	694	302.0	1694	1595	1495
36	4	817	355.5	2176	2050	1920
42	4.5	1120	487.0	3477	3275	3070

NOTES:

1. THESE TORQUE VALUES DO NOT APPLY TO CADMIUM PLATED FASTENERS
2. ALL TORQUE VALUES ARE STATIC TORQUE MEASURED PER STANDARD AUDIT METHODS TOLERANCE = ±10%
3. * ASSEMBLY USES HARDENED WASHER
4. CLAMP LOAD LISTED FOR SHCS IS SAME AS GRADE 8 OR CLASS 10.9 AND DOES NOT REPRESENT FULL STRENGTH CAPABILITY OF SHCS. IF HIGHER LOAD IS REQUIRED, ADDITIONAL TESTING IS REQUIRED.

5000059K

Metric Fastener Torque Chart (Continued)

Values for Magni Coated Fasteners (Ref 4150701)*						
CLASS 10.9 METRIC (HEX HEAD) BOLTS CLASS 10 METRIC NUTS, CLASS 12.9 SOCKET HEAD CAPSCREWS M6 AND ABOVE*						
Size	Pitch	Tensile Stress Area	Clamp Load See Note 4	Torque (Dry or Loctite® 263™) K=0.17	Torque (Lube or Loctite® 242™ or 271™ or Vibra-TITE™ 111 or 140) K=0.18	Torque (Loctite® 262™ or Vibra-TITE™ 131) K=0.15
		Sq mm	KN	[N.m]	[N.m]	[N.m]
3	0.5	5.03	3.13			
3.5	0.6	6.78	4.22			
4	0.7	8.78	5.47			
5	0.8	14.20	8.85			
6	1	20.10	12.5	13	12	11
7	1	28.90	18.0	21	20	19
8	1.25	36.60	22.8	31	29	27
10	1.5	58.00	36.1	61	58	55
12	1.75	84.30	52.5	105	100	95
14	2	115	71.6	170	160	150
16	2	157	97.8	265	250	235
18	2.5	192	119.5	365	345	325
20	2.5	245	152.5	520	490	460
22	2.5	303	189.0	705	665	625
24	3	353	222.0	905	850	800
27	3	459	286.0	1315	1235	1160
30	3.5	561	349.5	1780	1680	1575
33	3.5	694	432.5	2425	2285	2140
36	4	817	509.0	3115	2930	2750
42	4.5	1120	698.0	4985	4690	4395

- NOTES: 1. THESE TORQUE VALUES DO NOT APPLY TO CADMIUM PLATED FASTENERS 5000059K
2. ALL TORQUE VALUES ARE STATIC TORQUE MEASURED PER STANDARD AUDIT METHODS TOLERANCE = $\pm 10\%$
3. * ASSEMBLY USES HARDENED WASHER
4. CLAMP LOAD LISTED FOR SHCS IS SAME AS GRADE 8 OR CLASS 10.9 AND DOES NOT REPRESENT FULL STRENGTH CAPABILITY OF SHCS.
IF HIGHER LOAD IS REQUIRED, ADDITIONAL TESTING IS REQUIRED.

SECTION 2. GENERAL

2.1 MACHINE PREPARATION, INSPECTION, AND MAINTENANCE

General

This section provides the necessary information needed by those personnel that are responsible to place the machine in operation readiness and maintain its safe operating condition. For maximum service life and safe operation, ensure that all the necessary inspections and maintenance have been completed before placing the machine into service. With proper care, maintenance, and inspections performed per JLG's recommendations with any and all discrepancies corrected, this product will be fit for continued use.

Preparation, Inspection, and Maintenance

It is important to establish and conform to a comprehensive inspection and preventive maintenance program. The following table outlines the periodic machine inspections and maintenance recommended by JLG Industries, Inc. Consult your national, regional, or local regulations for further requirements for Mobile Elevating Work Platforms. The frequency of inspections and maintenance must be increased as environment, severity and frequency of usage requires.

Pre-Start Inspection

It is the User's or Operator's primary responsibility to perform a Pre-Start Inspection of the machine prior to use daily or at each change of operator. Reference the Operation and Safety Manual for completion procedures for the Pre-Start Inspection. The Operation and Safety Manual must be read in its entirety and understood prior to performing the Pre-Start Inspection.

Pre-Delivery Inspection and Frequent Inspection

The Pre-Delivery Inspection and Frequent Inspection shall be performed by a qualified JLG equipment mechanic. JLG Industries, Inc. recognizes a qualified JLG equipment mechanic as a person who, by possession of a recognized degree, certificate, extensive knowledge, training, or experience, has successfully demonstrated the ability and proficiency to service, repair, and maintain the subject JLG product model.

The Pre-Delivery Inspection and Frequent Inspection procedures are performed in the same manner, but at different times. The Pre-Delivery Inspection shall be performed prior to each sale, lease, or rental delivery. The Frequent Inspection shall be accomplished for each machine in service for 3 months or 150 hours (whichever comes first); out of service for a period of more than

3 months; or when purchased used. The frequency of this inspection must be increased as environment, severity and frequency of usage requires.

Reference the JLG Pre-Delivery and Frequent Inspection Form and the Inspection and Preventative Maintenance Schedule for items requiring inspection during the performance of these inspections. Reference the appropriate areas of this manual for servicing and maintenance procedures.

Annual Machine Inspection

JLG recommends that the Annual Machine Inspection be performed by a Factory-Trained Service Technician on an annual basis, no later than thirteen (13) months from the date of the prior Annual Machine Inspection. JLG Industries, Inc. recognizes a Factory-Trained Service Technician as a person who has successfully completed the JLG Service Training School for the subject JLG product model. Reference the machine Service and Maintenance Manual and appropriate JLG inspection form for performance of this inspection.

Reference the JLG Annual Machine Inspection Form and the Inspection and Preventative Maintenance Schedule for items requiring inspection during the performance of this inspection. Reference the appropriate areas of this manual for servicing and maintenance procedures.

For the purpose of receiving safety-related bulletins, it is important that JLG Industries, Inc. has updated ownership information for each machine. When performing each Annual Machine Inspection, notify JLG Industries, Inc. of the current machine ownership.

Preventative Maintenance

In conjunction with the specified inspections, maintenance shall be performed by a qualified JLG equipment mechanic. JLG Industries, Inc. recognizes a qualified JLG equipment mechanic as a person who, by possession of a recognized degree, certificate, extensive knowledge, training, or experience, has successfully demonstrated the ability and proficiency to service, repair, and maintain the subject JLG product model.

Reference the Preventative Maintenance Schedule and the appropriate areas of this manual for servicing and maintenance procedures. The frequency of service and maintenance must be increased as environment, severity and frequency of usage requires.

Table 2-1. Inspection and Maintenance

Type	Frequency	Primary Responsibility	Service Qualification	Reference
Pre-Start Inspection	Prior to use each day; or At each Operator change.	User or Operator	User or Operator	Operation and Safety Manual
Pre-Delivery Inspection	Prior to each sale, lease, or rental delivery.	Owner, Dealer, or User	Qualified JLG Mechanic	Service and Maintenance Manual and applicable JLG inspection form
Frequent Inspection	In service for 3 months or 150 hours, whichever comes first; OR, out of service for a period of more than 3 months; OR, purchased used.	Owner, Dealer, or User	Qualified JLG Mechanic	Service and Maintenance Manual and applicable JLG inspection form
Annual Machine Inspection	Annually, no later than 13 months from the date of the prior inspection.	Owner, Dealer, or User	Factory-Trained Service Technician (recommended)	Service and Maintenance Manual and applicable JLG inspection form
Preventative Maintenance	At intervals as specified in the Service and Maintenance Manual.	Owner, Dealer, or User	Qualified JLG Mechanic	Service and Maintenance Manual

2.2 PREVENTIVE MAINTENANCE AND INSPECTION SCHEDULE

The preventive maintenance and inspection checks are listed and defined in the following table. This table is divided into two basic parts, the "AREA" to be inspected and the "INTERVAL" at which the inspection is to take place. Under the "AREA" portion of the table, the various systems along with the components that make up that system are listed. The "INTERVAL" portion of the table is divided into two columns representing the various inspection time periods. The numbers listed within the interval column represent the applicable inspection code for which that component is to be checked.

The checks and services listed in this schedule are not intended to replace any local or regional regulations that may pertain to this type of equipment nor should the lists be considered as all inclusive. Variances in interval times may occur due to climate and/or conditions and depending on the location and use of the machine.

NOTICE

JLG INDUSTRIES REQUIRES THAT A COMPLETE ANNUAL INSPECTION BE PERFORMED IN ACCORDANCE WITH THE "ANNUAL MACHINE INSPECTION REPORT" FORM.

NOTE: *This machine requires periodic safety and maintenance inspections by a JLG Dealer. A decal located on the frame affords a place to record (stamp) inspection dates. Notify dealer if inspection is overdue.*

Maintenance and Inspection Schedule Codes

1. Check for proper and secure installation.
2. Visual inspection for damage, cracks, distortion, or excessive wear.
3. Check for proper adjustment.
4. Check for cracked or broken welds.
5. Operates properly.
6. Returns to neutral or "off" position when released.
7. Clean and free of debris.
8. Interlocks function properly.
9. Check for signs of leakage.
10. Decals installed and legible.
11. Check for proper fluid level.
12. Check for chafing and proper routing.
13. Check for proper tolerances.
14. Properly lubricated.
15. Torqued to proper specification.
16. No gouges, excessive wear, or cords showing.
17. Properly inflated and seated around rim.
18. Proper and authorized components.
19. Fully charged.
20. No loose connections, corrosion, or abrasions.
21. Verify.
22. Perform.
23. Sealed properly.
24. Overrides platform controls.
25. Remove pump motor cover and blow away any brush wear dust from cover, brushes, and brush holder assembly.
26. Replace.

Table 2-2. Preventive Maintenance & Inspection Schedule

AREA ON MACHINE	INTERVAL	
	PRE-DELIVERY (a) OR FREQUENT (b) INSPECTION	ANNUAL (c) (YEARLY) INSPECTION
FUNCTIONS/CONTROLS		
Platform Controls	5,6,7	5,6,7
Ground Controls	5,6	5,6
Function Control, Guards, or Detents	5	5
Function Enable System	5,8	5,8
Emergency Stop Switches (Ground & Platform)	5	5
Manual Descent or Auxiliary Power	5	5
PLATFORM ASSEMBLY		
Platform	1	1
Guard Rails	1,2,4	1,2,4
Gate	1,5	1,5
Floor	1,2	1,2
Lanyard Anchorage Point	1,4,10	1,4,10
SCISSOR ARMS		
Scissor Arms	1,2,4	1,2,4
Arm Safety Prop	1,5	1,5
Cylinder Pins, Pivot Pins & Attaching Hardware	1,2	1,2
Arm Pins, Wear Pads & Attaching Hardware	1,2	1,2
CHASSIS ASSEMBLY		
Side-Compartment Door Installation	1,5,7	1,5,7
Static Strap	1	1
Wheel and Tire Assemblies	2,15,16	2,15,16
Drive Motors	1,7,9	1,7,9
Platform Ladder	1,7	1,7
Drive Brakes	1,7	1,7
Drive Torque Hubs	1,7	1,7
Engine Mounts	1	1
Battery	9	18
Engine Oil	5	5
Exhaust System	1,5	1,5
Fuel Tank	1,9	1,9
Air Cleaner****	7	26

Table 2-2. Preventive Maintenance & Inspection Schedule (Continued)

AREA ON MACHINE	INTERVAL	
	PRE-DELIVERY (a) OR FREQUENT (b) INSPECTION	ANNUAL (c) (YEARLY) INSPECTION
HYDRAULIC/ELECTRIC SYSTEM		
Hydraulic Pump	1,2,9	1,2,9
Hydraulic Control Valves	1,9	1,9
Hydraulic Fluid***	11	11
Hydraulic Filter*	—	26
Hydraulic Hoses, Lines and Fittings	1,9	1,9
Hydraulic Oil Tank, Cap, and Breather	5,7,9	5,7,9
Hydraulic Cylinders (Steer and Lift)	2,7,9	2,7,9
GENERAL		
Operation & Safety Manual in Storage Box	21	21
ANSI Manual of Responsibilities and AEM Safety Manual in Storage Box (ANSI and ANSI Export ONLY)	21	21
Capacity Decals Installed, Secure, Legible	21	21
All Decals/Placards Installed, Secure, Legible	21	21
Annual Machine Inspection Due	—	21
No Unauthorized Modifications or Additions	21	21
All Relevant Safety Publications Incorporated	21	21,22
General Structural Condition and Welds	2,4	2,4
All Fasteners, Pins, Shields, and Covers	1,2	1,2
Grease and Lubricate to Specifications	22	22
Function Test of All Systems	22	22
Paint and Appearance	7	7
Notify JLG of change in Machine Ownership		22
* Replace Annually - JLG PN - 70005423. ** Replace when system performance is degraded. *** Every two years, drain and remove hydraulic oil reservoir, clean pick-up screen, refill with fresh hydraulic fluid. **** Replace every six (6) months.		

Footnotes

- (a) Prior to each sale, lease, or delivery.
- (b) In service for 3 months; or Out of service for 3 months or more; or Purchased used.
- (c) Annually, no later than 13 months from the date of the prior inspection.

2.3 SERVICE AND GUIDELINES

General

The following information is provided to assist you in the use and application of servicing and maintenance procedures contained in this book.

Safety and Workmanship

Your safety, and that of others, is the first consideration when engaging in the maintenance of equipment. Always be conscious of weight. Never attempt to move heavy parts without the aid of a mechanical device. Do not allow heavy objects to rest in an unstable position. When raising a portion of the equipment, ensure that adequate support is provided.

Cleanliness

1. The most important single item in preserving the long service life of a machine is to keep dirt and foreign materials out of the vital components. Precautions have been taken to safeguard against this. Shields, covers, seals, and filters are provided to keep air, fuel, and oil supplies clean; however, these items must be maintained on a scheduled basis in order to function properly.
2. At any time when air, fuel, or oil lines are disconnected, clean adjacent areas as well as the openings and fittings themselves. As soon as a line or component is disconnected, cap or cover all openings to prevent entry of foreign matter.
3. Clean and inspect all parts during servicing or maintenance, and assure that all passages and openings are unobstructed. Cover all parts to keep them clean. Be sure all parts are clean before they are installed. New parts should remain in their containers until they are ready to be used.

Components Removal and Installation

4. Use adjustable lifting devices, whenever possible, if mechanical assistance is required. All slings (chains, cables, etc.) should be parallel to each other and as near perpendicular as possible to top of part being lifted.
5. Should it be necessary to remove a component on an angle, keep in mind that the capacity of an eyebolt or similar bracket lessens, as the angle between the supporting structure and the component becomes less than 90°.
6. If a part resists removal, check to see whether all nuts, bolts, cables, brackets, wiring, etc., have been removed and that no adjacent parts are interfering.

Component Disassembly and Reassembly

When disassembling or reassembling a component, complete the procedural steps in sequence. Do not partially disassemble or assemble one part, then start on another. Always recheck your work to assure that nothing has been overlooked. Do not make any adjustments, other than those recommended, without obtaining proper approval.

Pressure-Fit Parts

When assembling pressure-fit parts, use an anti-seize or molybdenum disulfide base compound to lubricate the mating surface.

Bearings

1. When a bearing is removed, cover it to keep out dirt and abrasives. Clean bearings in nonflammable cleaning solvent and allow to drip dry. Compressed air can be used but do not spin the bearing.
2. Discard bearings if the races and balls (or rollers) are pitted, scored, or burned.
3. If bearing is found to be serviceable, apply a light coat of oil and wrap it in clean (waxed) paper. Do not unwrap reusable or new bearings until they are ready to install.
4. Lubricate new or used serviceable bearings before installation. When pressing a bearing into a retainer or bore, apply pressure to the outer race. If the bearing is to be installed on a shaft, apply pressure to the inner race.

Gaskets

Check that holes in gaskets align with openings in the mating parts. If it becomes necessary to hand-fabricate a gasket, use gasket material or stock of equivalent material and thickness. Be sure to cut holes in the right location, as blank gaskets can cause serious system damage.

Bolt Usage and Torque Application

1. Use bolts of proper length. A bolt which is too long will bottom before the head is tight against its related part. If a bolt is too short, there will not be enough thread area to engage and hold the part properly. When replacing bolts, use only those having the same specifications of the original, or one which is equivalent.

2. Unless specific torque requirements are given within the text, standard torque values should be used on heat-treated bolts, studs, and steel nuts, in accordance with recommended shop practices (See Torque Chart Section 1).

Hydraulic Lines and Electrical Wiring

Clearly mark or tag hydraulic lines and electrical wiring, as well as their receptacles, when disconnecting or removing them from the unit. This will assure that they are correctly reinstalled.

Hydraulic System

1. Keep the system clean. If evidence of metal or rubber particles are found in the hydraulic system, drain and flush the entire system.
2. Disassemble and reassemble parts on a clean work surface. Clean all metal parts with non-flammable cleaning solvent. Lubricate components, as required, to aid assembly.

Lubrication

Service applicable components with the amount, type, and grade of lubricant recommended in this manual, at the specified intervals. When recommended lubricants are not available, consult your local supplier for an equivalent that meets or exceeds the specifications listed.

Battery

Clean battery, using a non-metallic brush and a solution of baking soda and water. Rinse with clean water. After cleaning, thoroughly dry battery and coat terminals with an anti corrosion compound.

Lubrication and Servicing

Components and assemblies requiring lubrication and servicing are shown in the Lubrication Chart in Section 1.

2.4 LUBRICATION AND INFORMATION

Hydraulic System

1. The primary enemy of a hydraulic system is contamination. Contaminants enter the system by various means, e.g., using inadequate hydraulic oil, allowing moisture, grease, filings, sealing components, sand, etc., to enter when performing maintenance, or by permitting the pump to cavitate due to insufficient system warm-up or leaks in the pump supply (suction) lines.
2. The design and manufacturing tolerances of the component working parts are very close, therefore, even the smallest amount of dirt or foreign matter entering a system can cause wear or damage to the components and generally results in faulty operation. Every precaution must be taken to keep hydraulic oil clean, including reserve oil in storage. Hydraulic system filters should be checked, cleaned, and/or replaced as necessary, at the specified intervals required in the Lubrication Chart in Section 1. Always examine filters for evidence of metal particles.
3. Cloudy oils indicate a high moisture content which permits organic growth, resulting in oxidation or corrosion. If this condition occurs, the system must be drained, flushed, and refilled with clean oil.
4. It is not advisable to mix oils of different brands or types, as they may not contain the same required additives or be of comparable viscosities. Good grade mineral oils, with viscosities suited to the ambient temperatures in which the machine is operating, are recommended for use.

NOTE: Metal particles may appear in the oil or filters of new machines due to the wear-in of meshing components.

Hydraulic Oil

1. Refer to Section 1 for recommendations for viscosity ranges.
2. JLG recommends Standard UTTO Fluid, which has an SAE viscosity of 10W-30 and a viscosity index of 152.

NOTE: Start-up of hydraulic system with oil temperatures below -15°F (-26°C) is not recommended. If it is necessary to start the system in a sub-zero environment, it will be necessary to heat the oil with a low density, 100VAC heater to a minimum temperature of -15°F (-26°C).

- The only exception to the above is to drain and fill the system with Premium Hydraulic Fluid oil or its equivalent. This will allow start up at temperatures down to -20°F (-29°C). However, use of this oil will give poor performance at temperatures above 120°F (49°C). Systems using Premium Hydraulic Fluid should not be operated at temperatures above 200°F (94°C) under any condition.

Changing Hydraulic Oil

- Use of any of the recommended hydraulic oils eliminates the need for changing the oil on a regular basis. However, filter elements must be changed after the first 50 hours of operation and every 300 hours thereafter. If it is necessary to change the oil, use only those oils meeting or exceeding the specifications appearing in this manual. If unable to obtain the same type of oil supplied with the machine, consult local supplier for assistance in selecting the proper equivalent. Avoid mixing petroleum and synthetic base oils. JLG Industries recommends changing the hydraulic oil annually.
- Use every precaution to keep the hydraulic oil clean. If the oil must be poured from the original container into another, be sure to clean all possible contaminants from the service container. Always clean the mesh element of the filter and replace the cartridge any time the system oil is changed.
- While the unit is shut down, a good preventive maintenance measure is to make a thorough inspection of all hydraulic components, lines, fittings, etc., as well as a functional check of each system, before placing the machine back in service.

Lubrication Specifications

Specified lubricants, as recommended by the component manufacturers, are always the best choice, however, multi-purpose greases usually have the qualities which meet a variety of single purpose grease requirements. Should any question arise, regarding the use of greases in maintenance stock, consult your local supplier for evaluation. Refer to Section 1 for an explanation of the lubricant key designations appearing in the Lubrication Chart.

2.5 SERVICE MAINTENANCE COMPONENTS

Setting Scissor Arm Safety Prop

CAUTION

THE SAFETY PROP MUST BE USED WHENEVER MAINTENANCE PERFORMED ON THE MACHINE REQUIRES THE SCISSOR ARMS TO BE RAISED.

- To engage the safety props, raise the unloaded platform high enough to allow the safety props to rotate vertically into position. (See Figure 2-1.)
- Rotate the rod keeper plate and release the safety prop actuator rod at the front of the machine. (See Figure 2-2.)
- Lift the actuator rod (flat) up out of the slot in the keeper plate bracket and pull the actuator rod to align the safety props vertically with the scissor arm center pins above and below the safety prop mounting pins.
- Set the actuator rod (flat at the set position) into the slot on the keeper plate bracket and rotate the keeper plate to lock the actuator rod in this position.
- Lower the platform arms until the safety prop rests on the scissor arm center pin mounts above and below the safety prop.

Maintenance can now begin.

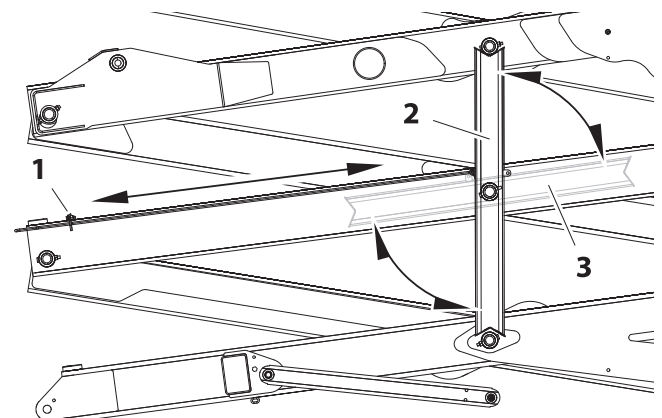

Figure 2-1. Scissor Arm - Safety Prop Assembly

- Actuator Rod/Rod Keeper Plate.
- Safety Prop in set position.
- Safety Prop in stowed position.

To store the safety prop, raise the platform, release the actuator rod from the keeper plate bracket, push the safety prop rod so that the safety props are restored back to its stowed position. Lock the actuator rod in place with the keeper plate till next use.

⚠ WARNING

TO AVOID PERSONAL INJURY, USE SAFETY PROP FOR ALL MAINTENANCE REQUIRING PLATFORM TO BE ELEVATED.

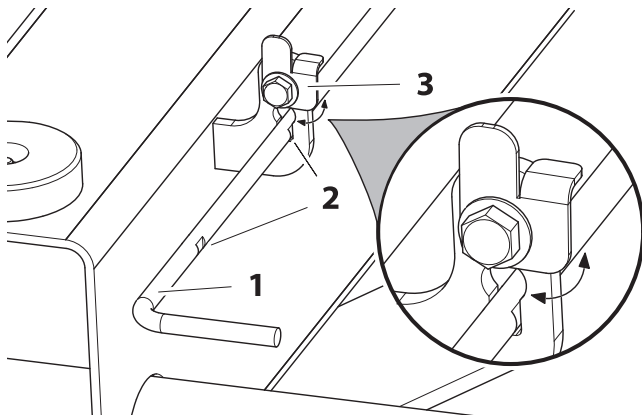

Figure 2-2. Safety Prop Actuator Rod

- 1. Safety Prop Actuator Rod
- 2. Notch Flats on Rod
- 3. Rod Keeper Plate

General Maintenance Tips

NOTE: Be sure to lubricate like items on each side of machine.

NOTE: Recommended lubricating intervals are based on machine operations under normal conditions. For machines used in multi-shift operations and/or exposed to hostile environments or conditions, lubrication frequencies must be increased accordingly.

Operate hydraulic functions through one complete cycle before checking hydraulic oil level in tank. Oil should be visible in ADD sight window on hydraulic tank. If oil is not visible, add oil until oil is visible in both ADD and FULL sight windows on tank. Do not overfill tank.

Any time the pump coupling is removed, coat splines of coupling with Texaco Code 1912 grease prior to assembly.

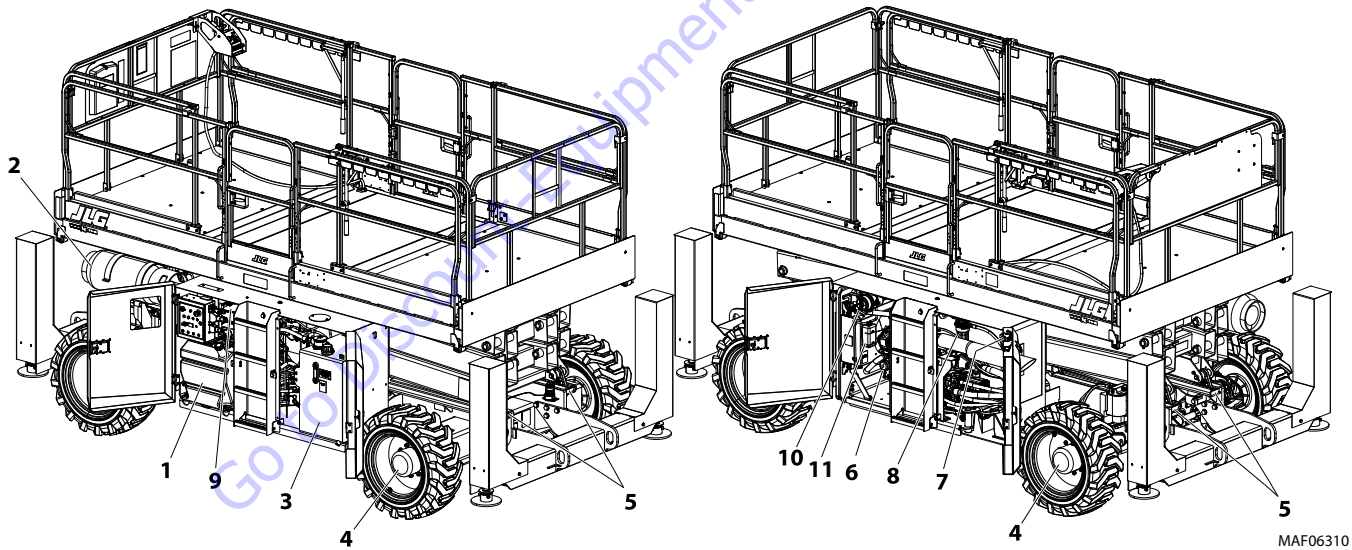

- 1. Fuel Tank - (Gasoline or Diesel)
- 2. Fuel Tank w/Shut-Off Valve - (LP Only)
- 3. Hydraulic Oil Tank
- 4. Drive Hubs
- 5. Scissor Arm - Sliding Wear Pads
- 6. Oil Change w/Filter - Kubota
- 7. Fuel/Water Separator Filter - Kubota-Diesel
- 8. Hydraulic Charge Filter - Kubota - Diesel
- 9. Fuel Filter/Fuel Pump - Kubota- Gasoline
- 10. Air Filter
- 11. Engine Coolant

Figure 2-3. Service Maintenance Components

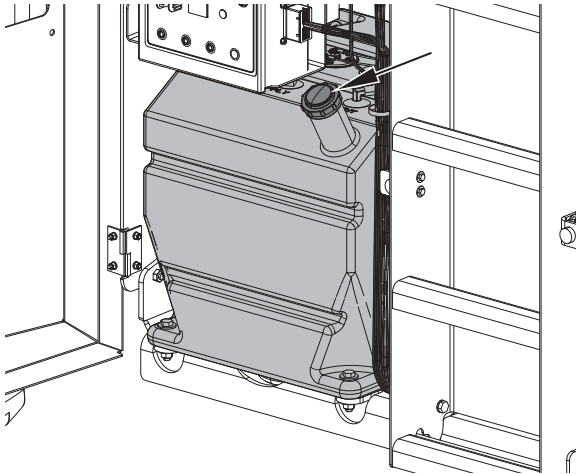
Fuel Tank

- Fuel - Diesel or Gasoline (Per Engine Type - Reference Decal on Machine)
- Capacity - 22 gal (83.2 l)

Drive Hub

- Lube Points - Fill Plugs (4)
- Lube - EPGL
- Interval - Every 2 years or 1200 hours
- Capacity - 24 oz (0.7 l)

Scissor Arms - Sliding Wear Pads

- Lube Points - 8 Sliding Wear Pads.
- Lube - MPG
- Interval - Every month or 50 hours

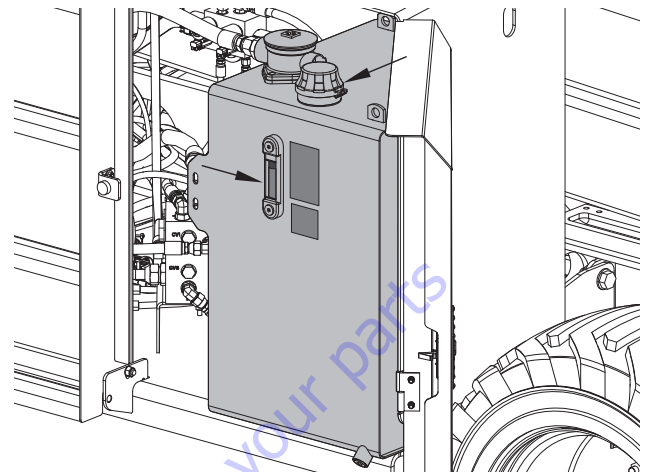
Hydraulic Oil Tank

- Lube Point - Fill Cap/Fill Level
- Lube - HO - API service classification GL-3 (Refer to Figure 1-2.)
- Interval - Check oil every 10 hours of operation; change oil every 2 years or 1200 hours of operation.
- Capacity - 32.3 gal (122.2 l)

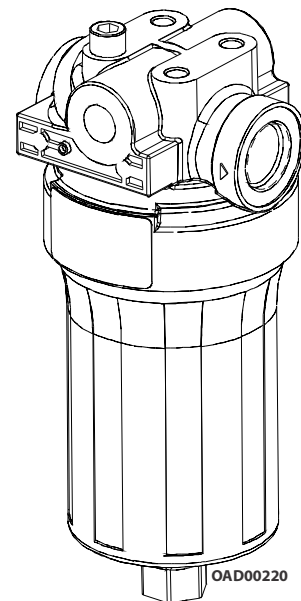
Hydraulic Charge Filter

- Lube Point(s) - Replaceable Element
- Interval - Change after first 50 hours and after every six months or 300 hours.

Oil Change with Filter

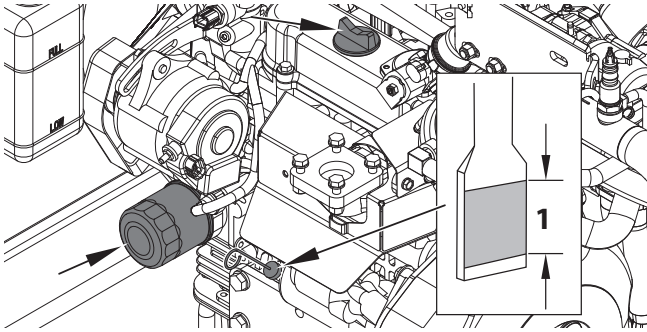

Figure 2-4. Kubota Dual Fuel (WG972-GL-E4)

NOTE: Exhaust system shown removed for illustrative purposes only.

- Lube Point(s) - Fill Cap/Spin-on Element
- Capacity - 0.9 Gal. (3.4 L) engine only
- Lube - EO - Minimum API SN, Viscosity - See Figure 1-3., Engine Oil Operating Temperature Specifications - Kubota (Dual Fuel Engine)
- Interval - Every Year or 200 hours of operation
- Check oil level daily, maintain within marked level (1)/ Change in accordance with engine manual.

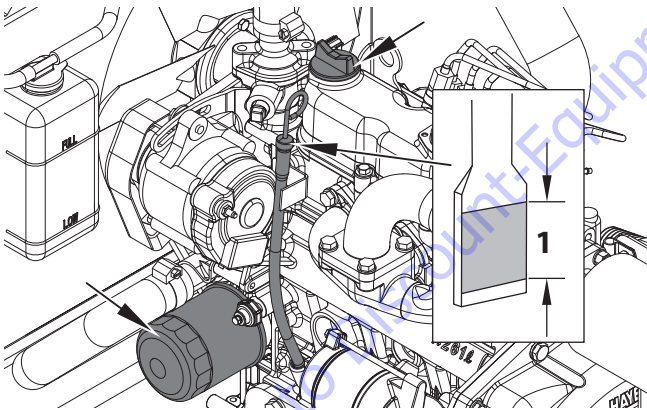
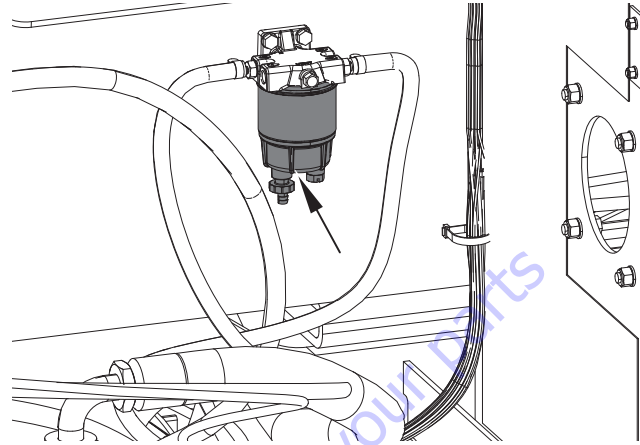

Figure 2-5. Kubota Diesel (D1305-E4B)

- Lube Point(s) - Fill Cap/Spin-on Element
- Capacity - 1.51 gal. (5.7 L) Engine Oil
- Lube - EO - Minimum API CI-4 - Viscosity, See Figure 1-4., Engine Oil Operating Temperature Specifications - Kubota (Diesel Engine)
- Interval - Every Year or 200 hours of operation
- Check oil level daily, maintain within marked level (1)/ Change in accordance with engine manual.

Fuel/Water Separator Filter (Diesel) - Kubota



NOTE: Mounted inside engine cabinet on right-rear cabinet wall behind battery and exhaust pipe.

- Lube Point(s) - Replaceable Element
- Interval - Change every 500 hours, every other oil change, or annually, whichever comes first.
- Interval (Water Bowl) - Empty Daily. Loosen drain cock on underside of fuel filter and allow all water to drain into a container until clear fuel is visible, Tighten drain.

Fuel Strainer (Diesel) - Kubota

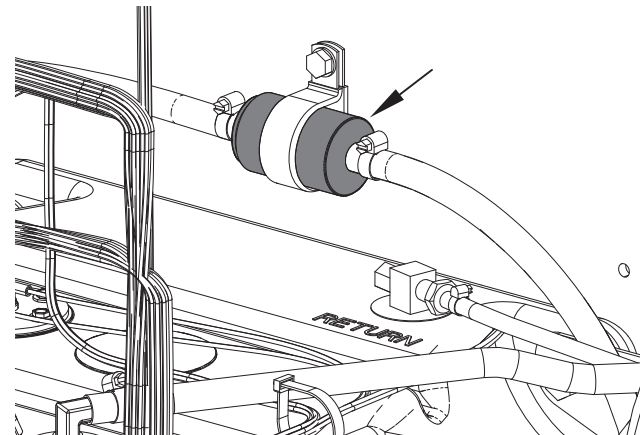

NOTE: Mounted inside fuel/hydraulic cabinet on left-rear cabinet wall behind fuel tank.

- Lube Point(s) - Replaceable Element.
- Interval - Every Year or 600 hours of operation.

Fuel Filter (Gas) - Kubota

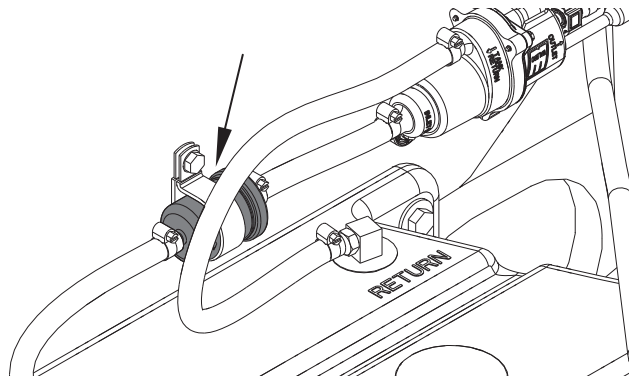

NOTE: Mounted inside fuel/hydraulic cabinet on left-rear cabinet wall behind fuel tank.

- Lube Point(s) - Replaceable Element.
- Interval - Every Year or 100 hours of operation.

Air Filter

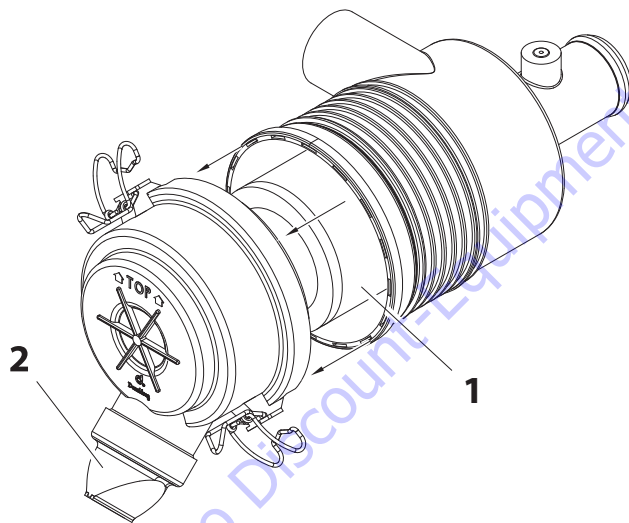

- Lube Point(s) - Replaceable Primary Filter Element (1) (Dry Type)
- Interval - Every 6 months or 300 hours of operation. Under severe operating conditions (such as a very dusty work area) check condition of filter more often.
- Once a week, squeeze the evacuator valve (2) on bottom of air cleaner assembly to allow collected debris to fall out of the air cleaner.

Engine Coolant

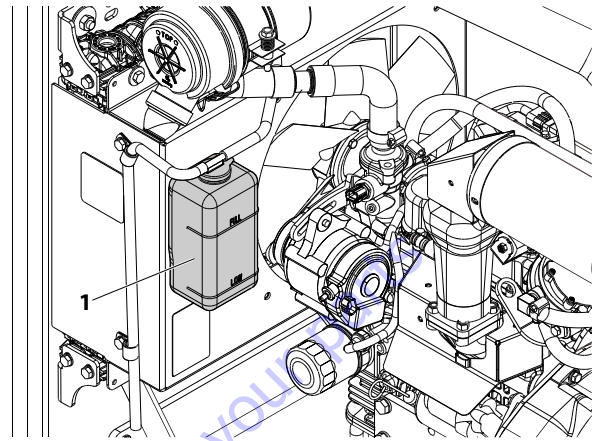

MAF06110

- Lube Point - Fill Cap/Fill Level
- Interval - Check coolant level daily. Ensure it is between the "FULL" and "LOW" lines (1). If coolant level is low, allow fluid to cool, then add as required.

2.6 CYLINDER DRIFT TEST

Maximum acceptable cylinder drift is to be measured using the following methods.

Platform Drift

Measure the drift of the platform to the ground. Fully extend the scissor arms from stowed position with the rated load in the platform and power off. Maximum allowable drift is 2 in. (5 cm) in 10 minutes. If the machine does not pass this test, proceed with the following.

Cylinder Drift

Cylinder Bore Diameter		Max. Acceptable Drift in 10 Minutes	
inches	mm	inches	mm
3	76.2	0.026	0.66
3.5	89	0.019	0.48
4	101.6	0.015	0.38
5	127	0.009	0.22
6	152.4	0.006	0.15
7	177.8	0.005	0.13

Drift is to be measured at the cylinder rod with a calibrated dial indicator. The cylinder oil must be at ambient temperature and temperature stabilized.

The cylinder must have the normal load, which is the normal platform load applied.

If the cylinder passes this test, it is acceptable.

NOTE: This information is based on 6 drops per minute cylinder leakage.

2.7 PINS AND COMPOSITE BEARING REPAIR GUIDELINES

Filament wound bearings.

1. Pinned joints should be disassembled and inspected if the following occurs:
 - a. Excessive sloppiness in joints.
 - b. Noise originating from the joint during operation.
2. Filament wound bearings should be replaced if any of the following is observed:
 - a. Frayed or separated fibers on the liner surface.
 - b. Cracked or damaged liner backing.
 - c. Bearings that have moved or spun in their housing.
 - d. Debris embedded in liner surface.
3. Pins should be replaced if any of the following is observed (pin should be properly cleaned prior to inspection):
 - a. Detectable wear in the bearing area.
 - b. Flaking, peeling, scoring, or scratches on the pin surface.
 - c. Rusting of the pin in the bearing area.
4. Re-assembly of pinned joints using filament wound bearings.
 - a. Housing should be blown out to remove all dirt and debris. Bearings and bearing housings must be free of all contamination.
 - b. Bearing/pins should be cleaned with a solvent to remove all grease and oil. Filament wound bearing are a dry joint and should not be lubricated.
 - c. Pins should be inspected to ensure it is free of burrs, nicks, and scratches which would damage the bearing during installation and operation.

PARTS FINDER

**Search Website
by Part Number**



**Search Manual
Library For Parts
Manual & Lookup Part
Numbers – Purchase
or Request Quote**

Search Manuals

Enter your information to search for manuals and parts.

* Brand:

* Model:

* Serial:

* Part Number:

SEARCH

**Can't Find Part or
Manual? Request Help
by Manufacturer,
Model & Description**

Parts Order Form

Please fill in the following information:

Manufacturer:

Model:

Description:

Quantity:

Part Number:

Part Name:

Part Description:

Part Category:

Part Location:

Part Status:

Part Condition:

Part Date:

Part Price:

Part Weight:

Part Dimensions:

Part Material:

Part Notes:

Part Images:

Part Attachments:

Part Links:

Part References:

Part Comments:

Part Actions:

Part Status:

Part Condition:

Part Date:

Part Price:

Part Weight:

Part Dimensions:

Part Material:

Part Notes:

Part Images:

Part Attachments:

Part Links:

Part References:

Part Comments:

Part Actions:

Discount-Equipment.com is your online resource for quality parts & equipment.

Florida: **561-964-4949** Outside Florida TOLL FREE: **877-690-3101**

Need parts?

Click on this link: <http://www.discount-equipment.com/category/5443-parts/> and choose one of the options to help get the right parts and equipment you are looking for. Please have the machine model and serial number available in order to help us get you the correct parts. If you don't find the part on the website or on once of the online manuals, please fill out the request form and one of our experienced staff members will get back to you with a quote for the right part that your machine needs.

We sell worldwide for the brands: Genie, Terex, JLG, MultiQuip, Mikasa, Essick, Whiteman, Mayco, Toro Stone, Diamond Products, Generac Magnum, Airman, Haulotte, Barreto, Power Blanket, Nifty Lift, Atlas Copco, Chicago Pneumatic, Allmand, Miller Curber, Skyjack, Lull, Skytrak, Tsurumi, Husquvarna Target, , Stow, Wacker, Sakai, Mi-T- M, Sullair, Basic, Dynapac, MBW, Weber, Bartell, Bennar Newman, Haulotte, Ditch Runner, Menegotti, Morrison, Contec, Buddy, Crown, Edco, Wyco, Bomag, Laymor, Barreto, EZ Trench, Bil-Jax, F.S. Curtis, Gehl Pavers, Heli, Honda, ICS/PowerGrit, IHI, Partner, Imer, Clipper, MMD, Koshin, Rice, CH&E, General Equipment, ,AMida, Coleman, NAC, Gradall, Square Shooter, Kent, Stanley, Tamco, Toku, Hatz, Kohler, Robin, Wisconsin, Northrock, Oztec, Toker TK, Rol-Air, Small Line, Wanco, Yanmar

SECTION 3. CHASSIS, PLATFORM, & SCISSOR ARMS

3.1 OPERATING CHARACTERISTICS

Leveling Jacks (If Equipped)

The machine may be equipped with auto leveling jacks. These leveling jacks are operated through one switch unlike the traditional four switch system.

The leveling jacks are operated by a proportional control valve with individual cylinders controlled by bang-bang valves.

NOTE: *Engine speed will run at high idle. Once all four jacks contact the ground, the system will go from set mode into level mode, then the engine will return to idle.*

OPERATION

1. Select the level function on the three-position switch located on the platform control box.
2. Extend the jacks by moving the joystick forward and retract by moving joystick backward.
3. Tilt Indicator will go out once machine is level.

NOTE: *If the machine is not level, it will not lift. Reaching the end of stroke on any of the cylinders means the machine cannot be lifted.*

NOTE: *There is a limit switch on each cylinder that senses when the cylinder is fully retracted. When all four are fully retracted, the stowed light in the platform control box will light. If a 2/5 flash code appears through the system fault light at the platform control station, the machine is unable to level. Reposition the machine and try again.*

Leveling jacks are operational (extend or retract) only if the machine is in the stowed position.

The arm stack tilt sensor and the rotary angle (elevation) sensor work in conjunction to determine the machine is stowed.

Failure of any of these sensors will prevent leveling jacks operation.

Generator

When the generator switch is activated, the engine RPM will increase to high idle.

When a function is selected for operation, which requires a higher engine speed than the generator, the generator will automatically shut off during the operation of the function. Once the function has stopped, the generator will be active again.

Lift

There is a flow control valve which controls both the lift up and lift down speeds.

Anytime you abruptly change lift directions, there is a three second delay between lift up and lift down.

Drive

If driving at high drive up a grade and you hit an 8° incline, the drive function will cut back to mid drive speed. The drive pump will shift back into high drive once the incline decreases to 5°. There will be a 2 second delay before the machine goes back into high drive.

3.2 TIRES, WHEELS & DRIVE ASSEMBLY

Tire Damage

For pneumatic tires, JLG Industries, Inc. recommends that when any cut, rip, or tear is discovered that exposes sidewall or tread area cords in the tire, measures must be taken to remove the JLG product from service immediately. Arrangements must be made for replacement of the tire or tire assembly.

For polyurethane foam filled tires, JLG Industries, Inc. recommends that when any of the following are discovered, measures must be taken to remove the JLG product from service immediately and arrangements must be made for replacement of the tire or tire assembly.

- A smooth, even cut through the cord plies which exceeds 3 inches (7.5 cm) in total length.
- Any tears or rips (ragged edges) in the cord plies which exceeds 1 inch (2.5 cm) in any direction.
- Any punctures which exceed 1 inch in diameter.
- Any damage to the bead area cords of the tire.

If a tire is damaged but is within the above noted criteria, the tire must be inspected on a daily basis to ensure the damage has not propagated beyond the allowable criteria.

Tire Replacement

JLG recommends a replacement tire be the same size, ply and brand as originally installed on the machine. Please refer to the JLG Parts Manual for the part number of the approved tires for a particular machine model. If not using a JLG approved replacement tire, we recommend that replacement tires have the following characteristics:

- Equal or greater ply/load rating and size of original.
- Tire tread contact width equal or greater than original.
- Wheel diameter, width, and offset dimensions equal to the original.
- Approved for the application by the tire manufacturer (including inflation pressure and maximum tire load).

Unless specifically approved by JLG Industries Inc., do not replace a foam filled or ballast filled tire assembly with a pneumatic tire. When selecting and installing a replacement tire, ensure that all tires are inflated to the pressure recommended by JLG. Due to size variations between tire brands, both tires on the same axle should be the same.

Wheel Replacement

The rims installed on each product model have been designed for stability requirements which consist of track width, tire pressure, and load capacity. Size changes such as rim width, center piece location, larger or smaller diameter, etc., without written factory recommendations, may result in an unsafe condition regarding stability.

Wheel Installation

It is extremely important to apply and maintain proper wheel mounting torque.

⚠ WARNING

WHEEL NUTS MUST BE INSTALLED AND MAINTAINED AT THE PROPER TORQUE TO PREVENT LOOSE WHEELS, BROKEN STUDS, AND POSSIBLE DANGEROUS SEPARATION OF WHEEL FROM THE AXLE. BE SURE TO USE ONLY THE NUTS MATCHED TO THE CONE ANGLE OF THE WHEEL.

Tighten the lug nuts to the proper torque to prevent wheels from coming loose. Use a torque wrench to tighten the fasteners. If you do not have a torque wrench, tighten the fasteners with a lug wrench, then immediately have a service garage or dealer tighten the lug nuts to the proper torque. Over-tightening will result in breaking the studs or permanently deforming the mounting stud holes in the wheels. The proper procedure for attaching wheels is as follows:

1. Start all nuts by hand to prevent cross threading. DO NOT use a lubricant on threads or nuts.
2. Tighten nuts in the following sequence:

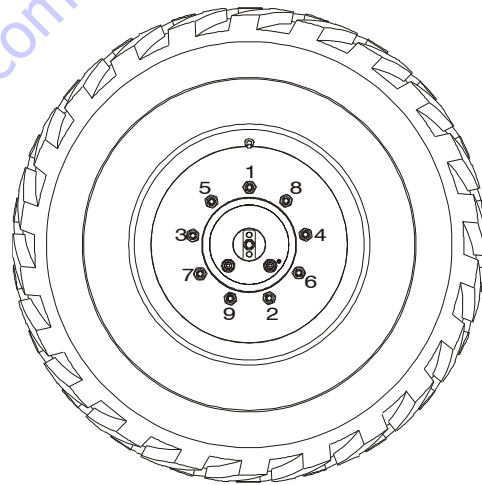

3. The tightening of the nuts should be done in stages. Following the recommended sequence, tighten nuts per wheel torque chart.

Table 3-1. Wheel Torque Chart

TORQUE SEQUENCE (DRY)		
1st Stage	2nd Stage	3rd Stage
40-50-ft. lb. (60-70 Nm)	90-105 lb-ft (125-150 Nm)	170 lb-ft (230 Nm)

4. Wheel nuts should be torqued after first 50 hours of operation and after each wheel removal. Check torque every 3 months or 150 hours of operation.

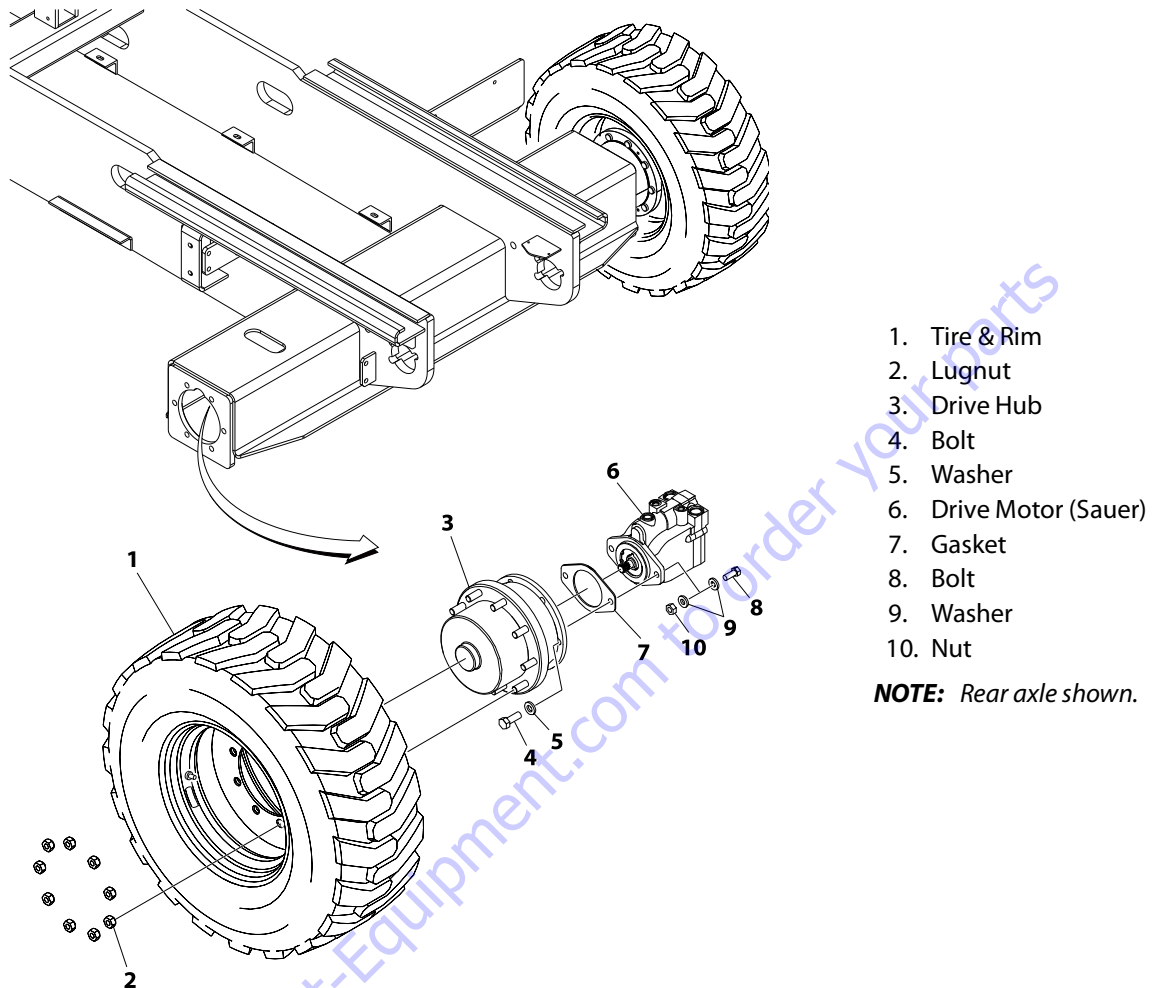
Drive Assembly

1. Tire & Rim
2. Lugnut
3. Drive Hub
4. Bolt
5. Washer
6. Drive Motor (Sauer)
7. Gasket
8. Bolt
9. Washer
10. Nut

NOTE: Rear axle shown.

Figure 3-1. Drive Assembly

REMOVAL

⚠ WARNING

SHUT MACHINE OFF, BRACE AXLES AND CHALK WHEELS TO PREVENT MACHINE FROM MOVING DURING REPAIRS.

1. Disconnect, cap, and label all hydraulic lines attached to Drive Motor (6). If applicable, disconnect all electrical wiring.
2. With axle raised and supported, remove the Tires (1) from the Drive Hub (3) by removing the 9 Lugnuts (2).
3. Remove the Drive Hub (3) and Drive Motor (6) from the axle by removing the 6 Bolts (4) and Washers (5).
4. The Drive Motor (6) can be removed from the Drive Hub (3) by removing the 2 Bolts (8), Nuts (10) and Washers (9).

INSTALLATION

1. Follow "Removal" procedures in reverse order.
2. Refer to Table 3-1, Wheel Torque Chart when torquing Lugnuts (2).

NOTE: For detailed information on the Drive Hub and Drive Motor, refer to Section 3.3, Drive Hub and Section 3.4, Drive Motor (Sauer).

3.3 DRIVE HUB

Roll and Leak Testing

Always roll and leak test Drive-Hubs after assembly to make sure that the unit's gears and sealants are working properly. The following information briefly outlines what to look for when performing these tests.

THE ROLL TEST

The purpose of a roll test is to determine if the unit's gears are rotating freely and properly. You should be able to rotate the gears in your unit by applying a constant force to the roll checker. If you feel more drag in the gears only at certain points, then the gears are not rolling freely and you should examine them for improper installation or defects. Some gear packages roll with more difficulty than others. Do not be concerned if the gears in your unit seem to roll hard as long as they roll with consistency.

THE LEAK TEST

The purpose of a leak test is to make sure the unit is air tight. You can tell if your unit has a leak if the pressure gauge reading on your air checker starts to fall once you have pressurized the unit. Leaks will most likely occur at the main seal or wherever o-rings or gaskets are located. Usually you can detect the exact location of a leak by brushing a soap and water solution around the main seal and where o-rings or gaskets meet the exterior of the unit, then checking for air bubbles. If you detect a leak in a seal, o-ring, or gasket, replace the part immediately.

Tightening and Torquing Bolts

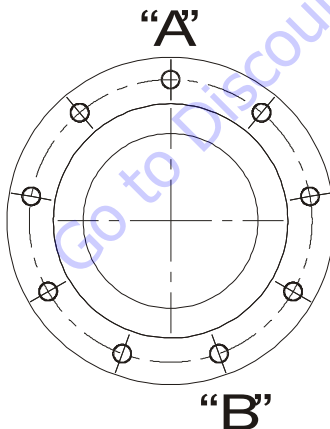

If you use an air impact wrench to tighten bolts, take extreme care to ensure that you do NOT tighten the bolts beyond their indicated torque specification. Never use an impact wrench to tighten shoulder bolts. Always tighten all shoulder bolts by hand.

The following steps describe the proper procedure for tightening and torquing bolts or socket head capscrews in a bolt circle.

1. Tighten (but do not torque) bolt "A" until snug.
2. Go to the opposite side of the bolt circle and tighten bolt "B" until equally snug.
3. Continue around the bolt circle and tighten the remaining bolts.
4. Now use a torque wrench to apply the specified torque to bolt "A".
5. Continue around the bolt circle and apply an equal torque to the remaining bolts.

Oil Information

1. TYPE – EP90
On normal applications, use EP90. On applications where the lubricant must meet special requirements, the O.E.M. should be able to recommend a suitable substitute.
 2. OIL TEMPERATURE
Continuous – 160°F (70°C) Intermittent – 200°F (95°C).
 3. OIL CHANGE
Initial – After 50 hours or 50,000 revolutions of operation.
Subsequent – After 1000 hours or (1) year, whichever comes first.
- NOTE:** Higher temperatures make it necessary to change oil more frequently.
4. OIL FILL LEVEL AND VOLUME
Unit mounted horizontal – half full
Approximate volume - 17 oz. (0.5 ltr)
 5. REAR BRAKES
Rear brakes require 2.7 oz. (0.08 ltr) of DTE 13M hydraulic fluid each to function properly.

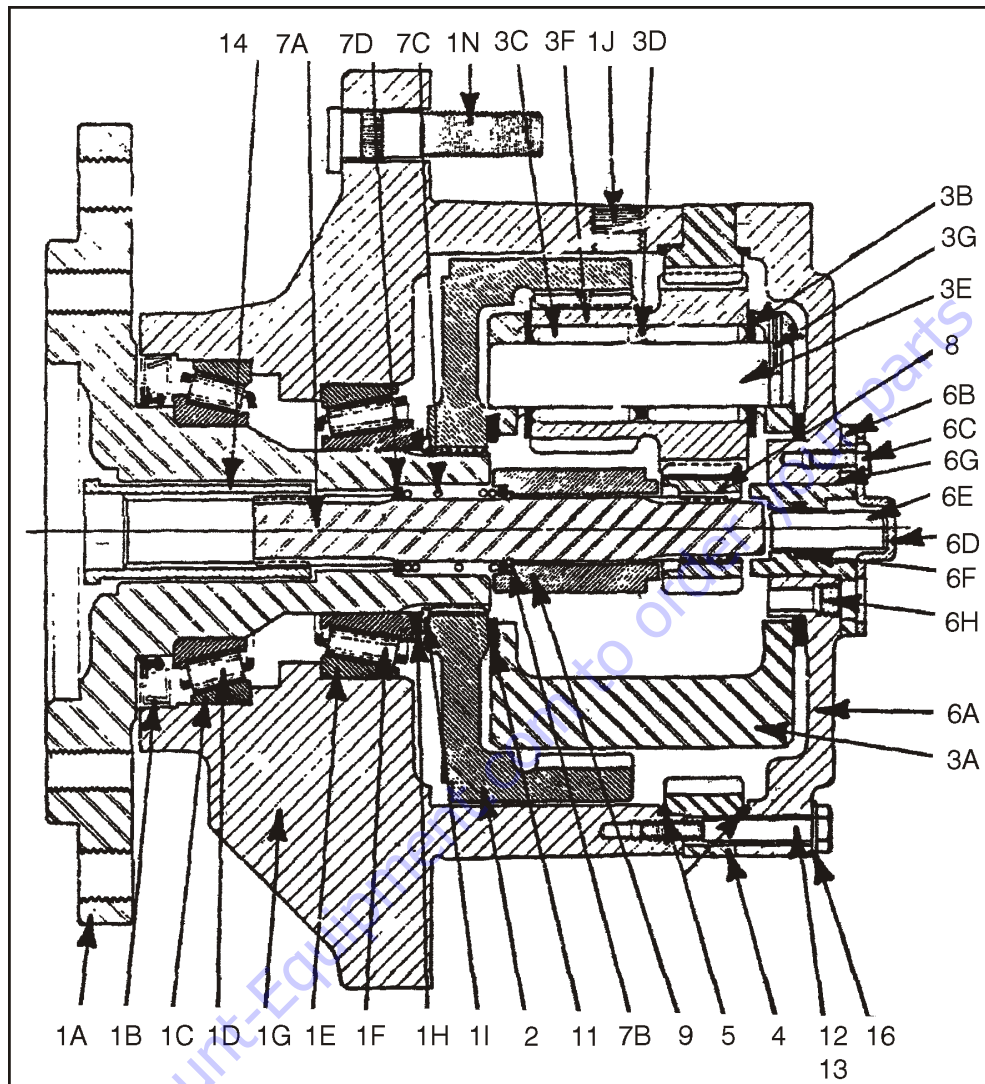

- | | | | |
|---|--|--|---|
| <p>1. Hub-Spindle Sub-Assembly</p> <ul style="list-style-type: none"> A. Spindle B. Seal C. Bearing Cup D. Bearing Cone E. Bearing Cup F. Bearing Cone G. Hub H. Spacer I. Retaining Ring J. Pipe Plug N. Stud | <p>2. Internal Gear</p> <p>3. Carrier Sub-Assembly</p> <ul style="list-style-type: none"> A. Carrier Housing B. Thrust Washer C. Needle Roller D. Spacer E. Planet Shaft F. Cluster Gear G. Roll Pin <p>4. Ring Gear</p> <p>5. O Ring</p> | <p>6. Cover Sub-Assembly</p> <ul style="list-style-type: none"> A. Cover B. Cover Cap C. Bolt D. Disconnect Cap E. Disconnect Rod F. O Ring G. O Ring H. Pipe Plug | <p>7. Input Shaft Sub Assembly</p> <ul style="list-style-type: none"> A. Input Shaft B. Retaining Ring C. Spring D. Spacer <p>8. Input Gear</p> <p>9. Thrust Spacer</p> <p>11. Bolt</p> <p>12. Shoulder Bolt</p> <p>13. Coupling</p> <p>14. Flat Washer</p> |
|---|--|--|---|

Figure 3-2. Drive Hub (Cross-Section)

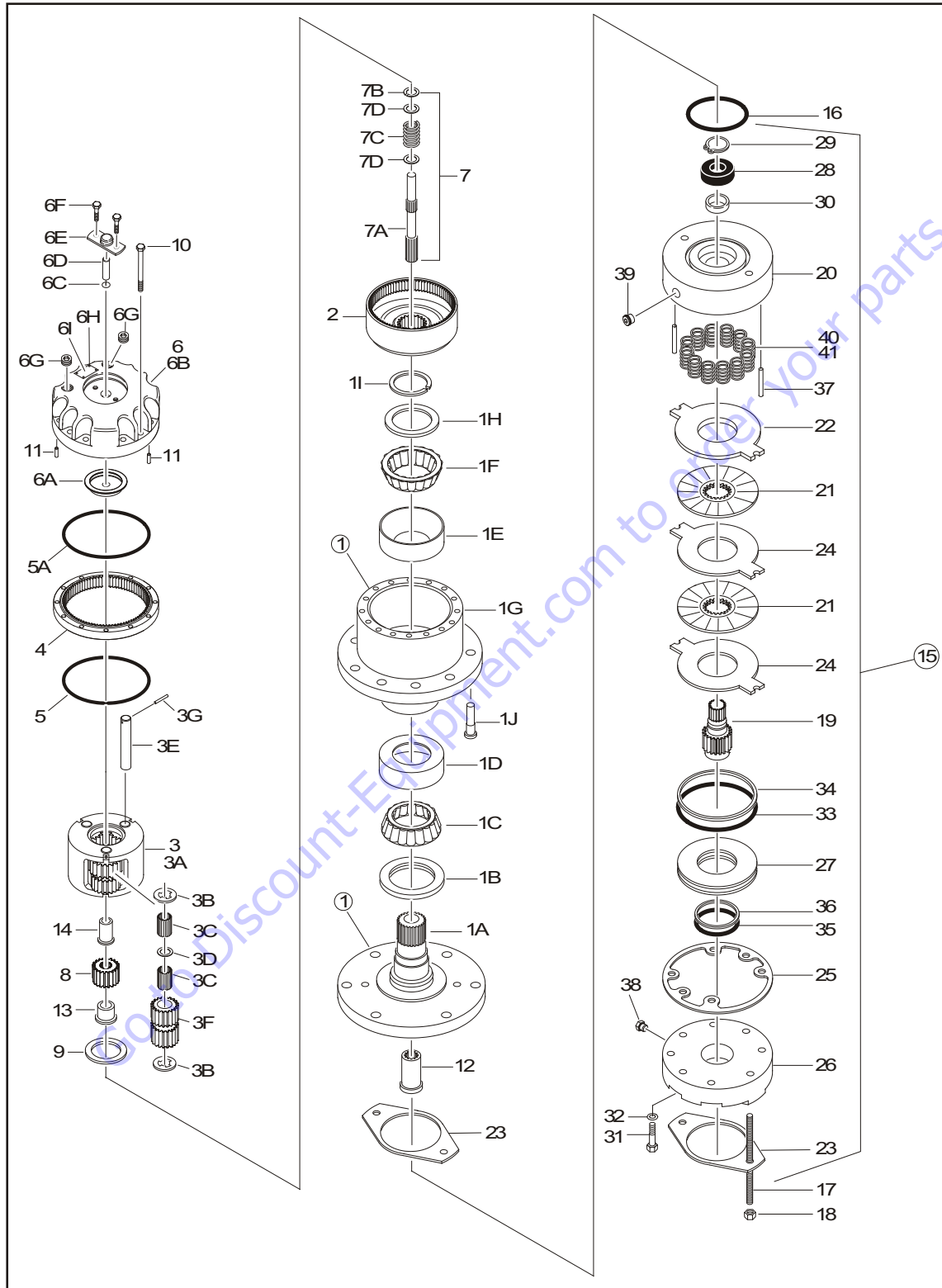

Figure 3-3. Drive Hub

NOTE: Refer to Figure 3-3., Drive Hub.

Table 3-2. Drive Hub Part Description

Item #	Description
1	Spindle/Housing Assembly
1A	Spindle
1B	Seal
1C	Bearing Cone
1D	Bearing Cup
1E	Bearing Cup
1F	Bearing Cone
1G	Housing/Ring Gear
1H	Thrust Washer
1I	Retaining Ring
1J	Wheel Stud
2	Internal Gear
3	Carrier Assembly
3A	Carrier
3B	Retaining Ring
3C	Needle Bearing
3D	Thrust Washer
3E	Planet Shaft
3F	Planet Gear
3G	Rollpin
4	Ring Gear
5	O-Ring
5A	O-Ring
6	Cover Assembly
6A	Thrust Spacer
6B	Cover Plate
6C	O-Ring
6D	Disconnect Rod
6E	Disengage Cap
6F	Bolt 1/2"-20NC x 1/2"
6G	Pipe Plug
6H	Rivet
6I	ID Plate
7	Input Shaft Assembly
7A	Shaft
7B	Retaining Ring
7C	Spring
7D	Thrust Spacer

Table 3-2. Drive Hub Part Description

Item #	Description
8	Sun Gear
9	Thrust Washer
10	Bolt
11	Dowell Pin
12	Coupling
13	Input Spacer
14	Input Spacer
15	Brake Assembly
16	O-Ring
17	Threaded Rod
18	Nut 1/2"-13NC
BRAKE ASSEMBLY	
19	Shaft
20	Housing
21	Friction Plate
22	Pressure Plate
23	Gasket
24	Outer Plate
25	Gasket
26	Cylinder
27	Piston
28	Ball Bearing
29	Retaining Ring
30	Shaft Seal
31	Capscrew
32	Lockwasher
33	O-Ring
34	Backup Ring
35	O-Ring
36	Backup Ring
37	Dowel Pin
38	Plug
39	Plug
40	Spring Kit (Natural)
41	Spring Kit (Blue)

Main Disassembly for Drive Hub

NOTE: Refer to Figure 3-2. for part location and listing.

1. Turn hub (1G) over onto its side. Remove coupling (14) from the wide end of spindle (1A).
2. Mark location of shoulder bolt holes on outside of ring gear and hub for easy re-alignment when rebuilding. Remove the four shoulder bolts (13) and twelve bolts (12) from cover (6).
3. Remove the sixteen flat washers (16) from cover (6).
4. Lift cover sub-assembly (6) off of ring gear (4), and set cover on table, interior side facing up.

⚠ CAUTION

BEWARE OF SHARP EDGES IN THE COUNTERBORE WHEN YOU REMOVE THE O-RING.

5. Remove o-ring (5) from the counterbore around the edge of cover (6A). Discard the o-ring.

NOTE: If o-ring is not in the cover counterbore, it is in the ring gear counterbore. Remove it from the hub and discard it.

6. Remove thrust washer (11) from the counterbore in top of carrier (3A).
7. Remove input gear (8) from the middle of carrier sub-assembly (3).
8. Lift ring gear (4) off of hub (1G).
9. Lift carrier sub-assembly (3) out of hub (1G).
10. Remove thrust spacer (9) from input shaft (7) in the middle of spindle (1A).
11. Lift input shaft sub-assembly (7) out of middle of spindle (1A), and stand input shaft (7A) on its splined end.

⚠ CAUTION

WEAR SAFETY GLASSES DURING THIS STEP, AND BE AWARE THAT SPRING AND SPACERS COMPRESSED BY RETAINING RING MAY POP SUDDENLY OFF SHAFT WHEN YOU REMOVE THE RETAINING RING.

12. Using retaining ring pliers, remove retaining ring (7B) from the groove on input shaft (7A).
13. Remove one spacer (7D), one spring (7C), and other spacer (7D) from input shaft (7A).
14. Remove thrust washer (11) from around spindle (1A).
15. Lift internal gear (2) out of hub (1G).

⚠ CAUTION

BEWARE OF SHARP EDGES IN COUNTERBORE WHEN YOU REMOVE THE O-RING.

16. Remove o-ring (5) from the counterbore in hub (1G). Discard the o-ring.

17. At this point the main disassembly for drive hub is complete.

Hub-Spindle Disassembly

NOTE: Start with large end of hub facing up, large end of spindle facing down.

⚠ CAUTION

WEAR SAFETY GLASSES DURING THIS STEP.

1. Remove retaining ring (1I) from around spindle (1A) in hub (1G).
2. Remove spacer (1H) from around spindle (1A) in hub (1G).
3. Set hub (1G), small end/spindle facing down, up on something that will support the hub's flange while it lifts hub up so spindle is not resting on anything. Carefully press or hammer spindle (1A) down and out of hub (1G).

NOTE: If seal (1B) and bearing cone (1D) come out of hub and rest on spindle, remove these parts from the spindle and set them aside. Discard the seal.

4. If seal and bearing cone did not come out of the small end of hub (1G) when spindle is pressed out of hub, remove seal (1B) and bearing cone (1D) from the small end of hub. Discard the seal.
5. Bearing cone (1F) should be lying loose in wide end of hub (1G). Remove bearing cone (1F) from inside hub.

NOTE: If you use a punch and hammer, make sure you do not strike the counterbore with the punch when you remove the bearing cup.

6. Remove bearing cup (1C) from the counterbore in the small end of hub (1G).

NOTE: If using a punch and hammer, make sure to not strike the counterbore with the punch when removing the bearing cup.

7. Turn hub (1G) over and lift it out of the flange-support. Remove bearing cup (1E) from the counterbore in the wide end of hub.
8. Turn hub (1G) over onto its small end. Remove two pipe plugs (1J) from the two pipe plug holes in the side of hub.

NOTE: If the unit does not have studs, skip this step:

9. Press the nine studs (1N) out of the stud holes in hub (1G).
10. At this point the hub-spindle disassembly is complete.

Cover Disassembly

1. Remove the two bolts (6C) holding disconnect cap (6D) to cover (6A).
2. Remove disconnect cap (6D) from top of cover cap (6B) and cover (6A).
3. Remove the two bolts (6C) attaching cover cap (6B) to cover (6A).
4. Remove cover cap (6B) from cover (6A).
5. Remove disconnect rod (6K) from cover cap (6B).
6. Pry o-ring (6F) out of the groove inside cover cap (6B). Discard the o-ring.
7. Remove o-ring (6G) from the flange of cover cap (6B). Discard the o-ring.
8. Remove pipe plug (6H) from cover (6A).
9. At this point the cover disassembly is complete.

Carrier Disassembly

NOTE: When removing the needle rollers from the cluster gears, discard the old needle rollers and use new ones during re-assembly.

1. Using a punch and hammer, drive roll pin (3G) into planet shaft (3E).

NOTE: Be sure to drive the roll pin all the way into the planet shaft. Failure to do so could result in damage to the carrier when removing the planet shaft from the carrier.

2. Using a punch and hammer, drive the planet shaft (3E) out of the planet shaft hole in the carrier housing (3A).
3. When removing the planet shaft (3E) from the carrier housing, one thrust washer (38), one cluster gear (3F), and one more thrust washer will come off of the planet shaft and come to rest inside the carrier. Remove these parts from inside the carrier.
4. Remove 16 needle rollers (3C) from inside one end of cluster gear (3F). Discard the needle rollers.
5. Remove one spacer (3D) from inside cluster gear (3F).
6. Remove the remaining 16 needle rollers (3C) from the other side of cluster gear (3F). Discard the needle rollers.
7. Repeat steps 1-6 to remove and disassemble the two remaining cluster gears.
8. At this point the carrier disassembly is complete.

Carrier Assembly

1. Apply grease to the inside of one cluster gear (3F) and line one half of cluster gear with 16 needle rollers (3C).



2. Place one spacer (3D) inside cluster gear (3F) so that it rests on top of the needle rollers.



3. Line the remaining half of cluster gear (3F) with 16 needle rollers.

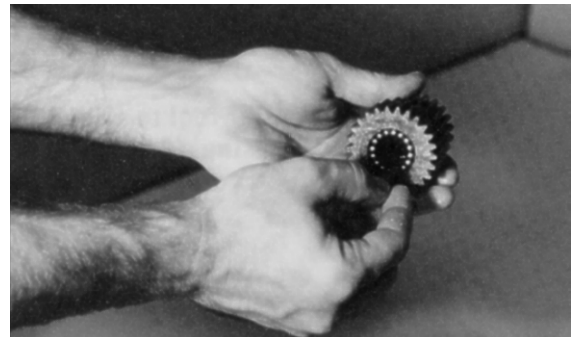

SECTION 3 - CHASSIS, PLATFORM, & SCISSOR ARMS

4. Set carrier housing (3A) sideways on a table. Insert a planet shaft (3E), roll pin hole last, into one of the planet shaft holes from roll-pin-holed side of carrier housing.

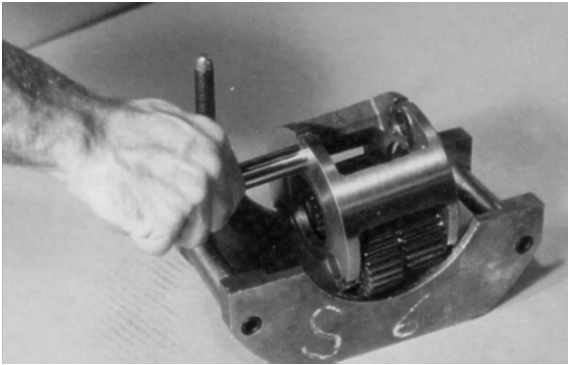

5. Place one thrust washer (3B) onto the end of planet shaft (3E) inside carrier. Fit tang of thrust washer into the slot on the inside edge of the planet shaft hole.

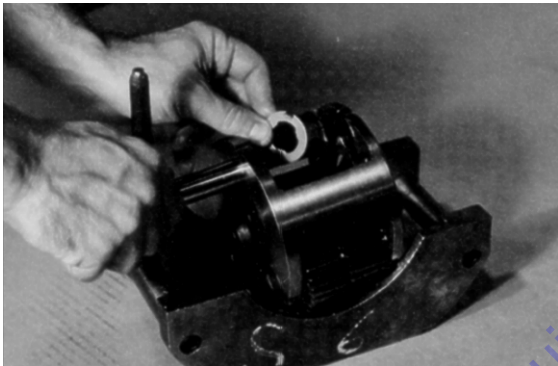

6. Following the thrust washer, place the cluster gear (3F), large end toward roll pin hole in carrier housing, onto the planet shaft (3E).



7. Following the cluster gear, place one more thrust washer (3B) onto planet shaft (3E) through the opposite planet shaft hole in carrier housing (3A).

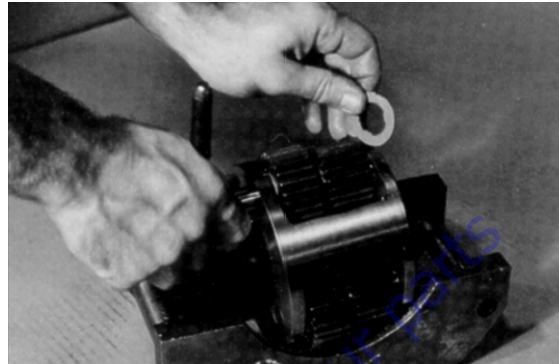

8. Use an alignment punch or similar tool to align the roll pin holes in carrier housing (3A) and planet shaft (3E).

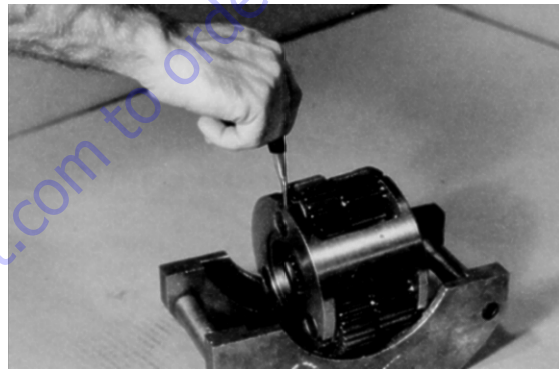

9. Drive roll pin (3G) down into the aligned roll pin holes in carrier housing (3A) and planet shaft (3E).

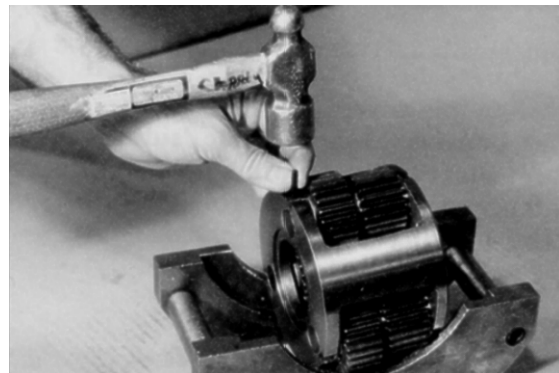

10. Repeat steps 1 thru 9 to assemble and install the two remaining cluster gears.
11. Carrier sub-assembly is complete.

Cover Sub-Assembly

1. Using the disconnect rod, push o-ring (6F) into the groove inside the cover cap (6B).

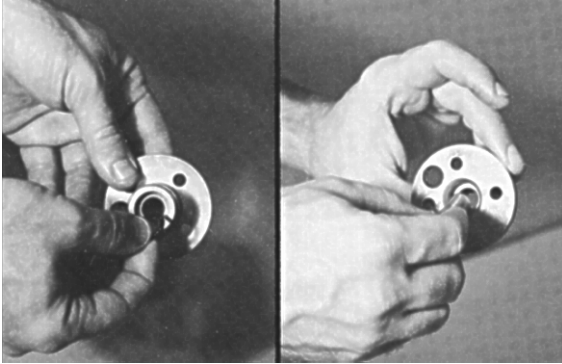

2. Place the o-ring (6G) onto the cover cap (6B) so that it rests against the flange of the cover cap.

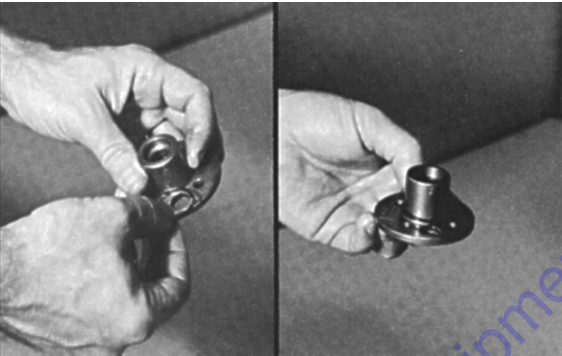

3. Insert disconnect rod (6E) into cover cap (6B).



4. Set cover (6A) on table, exterior side up. Place cover cap (6B) onto cover (6A), aligning the pipe plug hole in the cover cap over the pipe plug hole in the cover.



5. Place two of the cover cap bolts (6C) into any two bolt holes that are 180° apart on the cover cap (6B) and tighten bolts.



6. Using a torque wrench, apply 2.95 to 3.69 ft. lbs. (4 to 5 Nm) of torque to both bolts (6C).

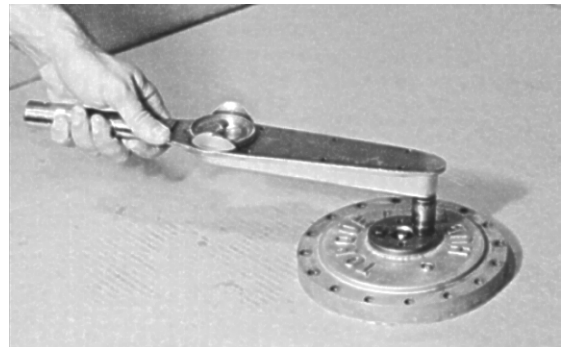

SECTION 3 - CHASSIS, PLATFORM, & SCISSOR ARMS

7. With the large end down, place the disconnect cap (6D) onto the cover cap (6B), aligning the pipe plug hole in the disconnect cap over the pipe plug hole in the cover cap.



8. Place the two remaining bolts (6C) into the bolt holes in the disconnect cap (6D), and tighten the bolts.



9. Using a torque wrench, apply 2.95 to 3.69 ft. lbs. (4 to 5 Nm) of torque to both bolts (6C).

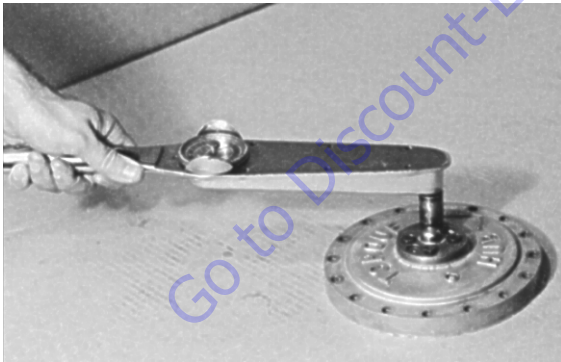

10. Apply a light coat of "Never-Seize" to pipe plug (6H) and tighten it into the pipe plug hole in the cover (6A).



Hub-Spindle Sub-Assembly

NOTE: Make sure the cup sits square with the counterbore before pressing.

1. Set hub (1G) onto its large end. Press bearing cup (1C) into the counterbore in the small end of the hub (1G).

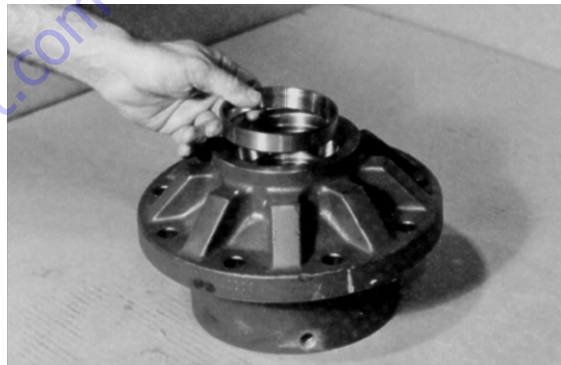

2. Press the nine studs (1N) into the stud holes in hub (1G).

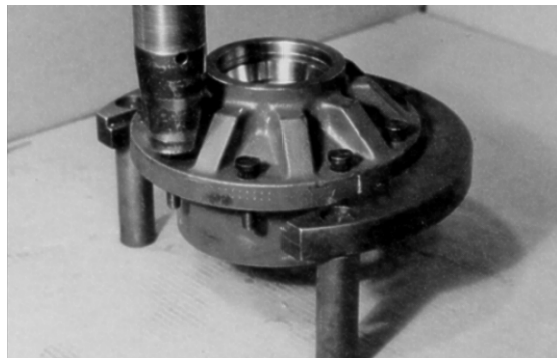

3. Apply a light coat of "Never-Seize" to two pipe plugs (1J) and tighten them into the two pipe plug holes in the side of the hub (1G).

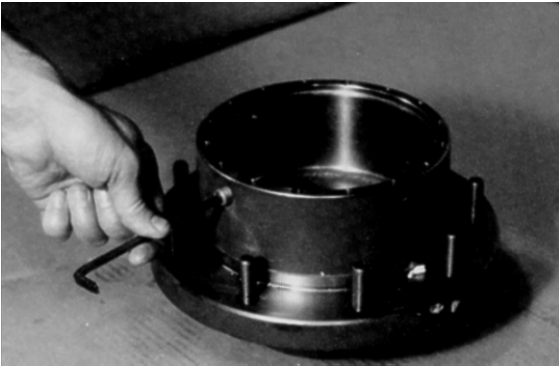

NOTE: Make sure the cup sits square with the counterbore before pressing.

4. Turn hub (1G) over onto its small end. Press bearing cup (1E) down into the counterbore in the deep end of the hub (1G).

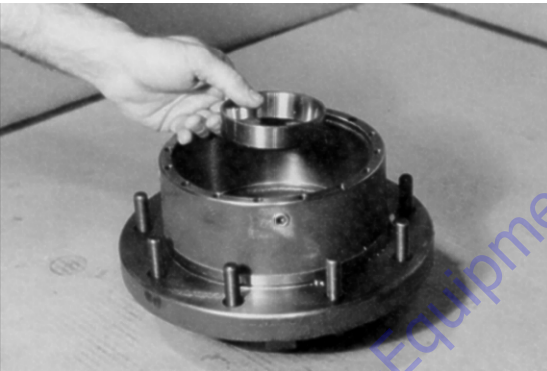

5. Set hub (1G) onto its large end. Place bearing cone (1D) into bearing cup (1C).



6. Press seal (1B) into the small end of hub (1G).



7. Oil spindle, then lower hub (1G), small end down, onto spindle (1A).



8. Press bearing cone (1F) onto spindle (1A) in hub (1G).

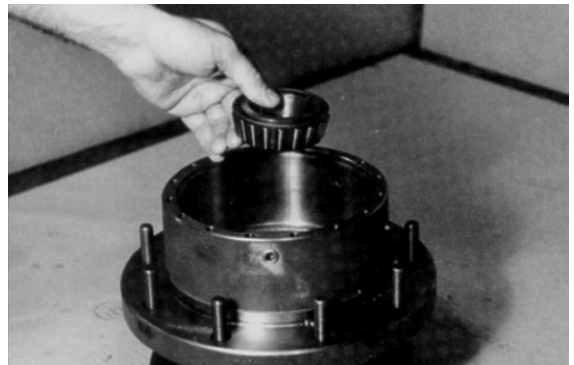

9. Place spacer (1H) onto spindle (1A) in hub (1G).



NOTE: Make sure the retaining ring is securely seated in the groove.

10. Place retaining ring (1I) over the spacer onto spindle (1A) in hub (1G).



11. At this point the hub-spindle sub-assembly is complete.

Main Assembly

⚠ WARNING

BEWARE OF SHARP EDGES IN COUNTERBORE WHEN INSTALLING THE O-RING.

1. Grease o-ring (5) and place it into the counterbore in hub (1G).

NOTE: O-ring may be stretched or pinched together to make it fit the counterbore exactly.

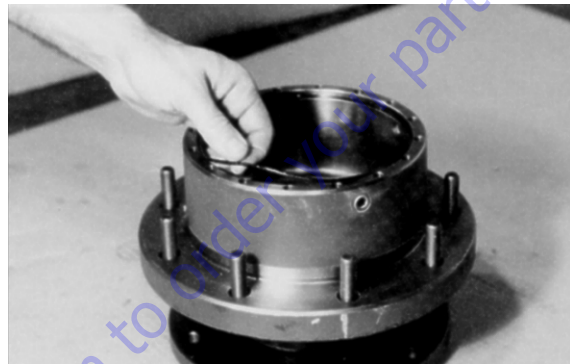

2. Oil all exposed surfaces inside hub (1G).



3. Place internal gear (2) into hub (1G) so that its internal splines mesh with the external splines of spindle (1A). Oil internal gear (2).

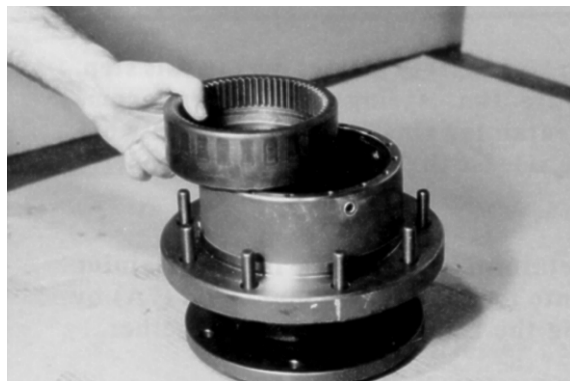

- Place thrust washer (11) around spindle (1A) so it rests on the bottom of the internal gear (2).



- Place other spacer (7D) onto the smooth end of input shaft (7A).



- Stand input shaft (7A) on its splined end. Place one spacer (7D) onto the smooth end of input shaft (7A).



⚠ WARNING

WEAR SAFETY GLASSES DURING THIS STEP, AND BE AWARE THAT SPRING AND SPACERS, COMPRESSED BY RETAINING RING, MAY POP SUDDENLY OFF SHAFT IF THE RING IS RELEASED BEFORE IT IS PROPERLY IN PLACE.

- Using retaining ring pliers, insert retaining ring (7B) into the groove on input shaft (7A) by compressing the spring and spacers together.

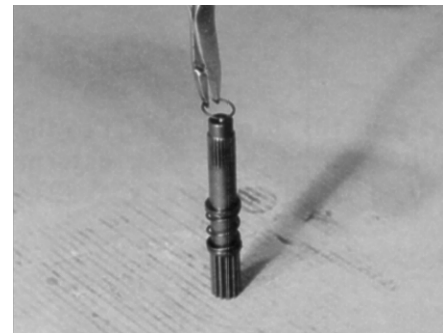

- Place one spring (7C) onto the smooth end of input shaft (7A).



- With large splined end down, place input shaft sub-assembly (7) into spindle (1A).

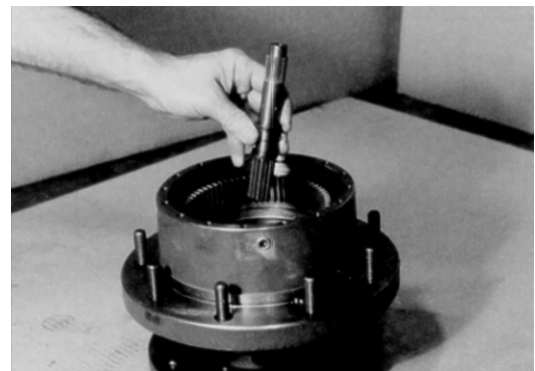

10. Place thrust spacer (9) onto input shaft (7).

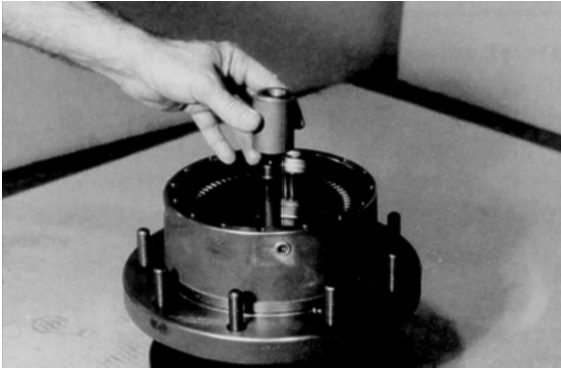

11. Set carrier sub-assembly (3) on a flat work surface so the large ends of cluster gears (3F) face up. Locate the punch marks on the face of each cluster gear (3F) and position them at 12 o'clock.

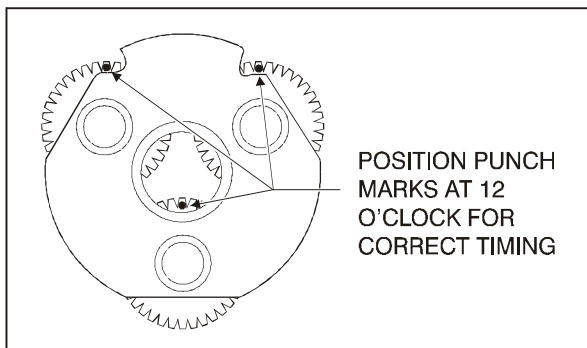
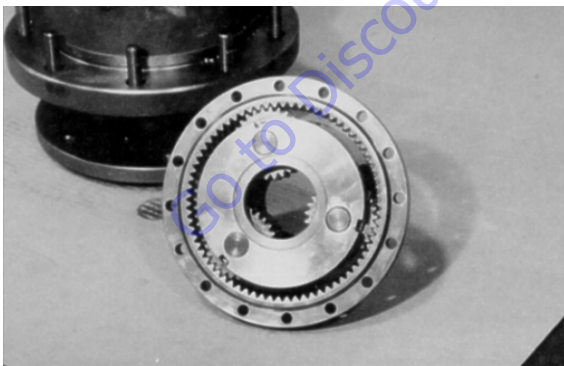

Figure 3-4. Cluster Gear Punch Marks

12. With "X" marked side facing up, place the ring gear (4) around cluster gears (3F).

NOTE: This will hold the punch marks in position while installing the carrier into the hub.



13. Place the carrier sub assembly (3) and ring gear (4) together into mesh with internal gear (2), aligning the "X" marked shoulder bolt hole in the ring gear (4) over one of the shoulder bolt holes in the hub. Mark the location of shoulder bolt holes on the outside of ring gear and hub.

NOTE: You may lift the ring gear off the hub to align the shoulder bolt holes. The ring gear and carrier are installed together only to keep the punch marks on the carrier in place.

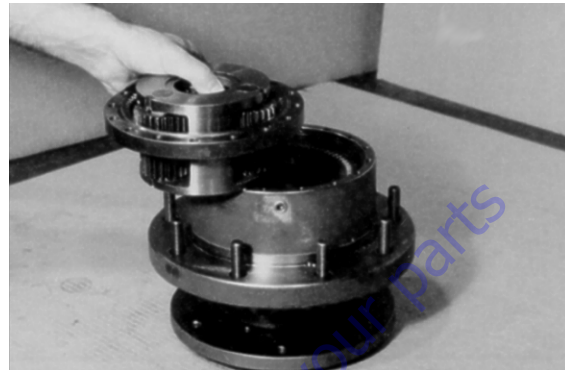

14. With the internal splines facing up (counterbore end facing down), place input gear (8) into mesh with carrier sub-assembly (3).



15. Oil all exposed surfaces inside the hub (1G). Place thrust washer (11) into the counterbore in top of the carrier.

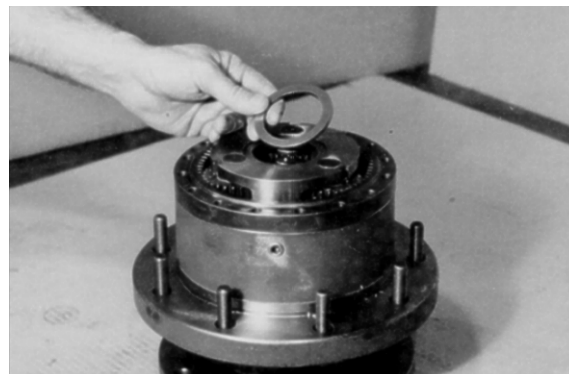

⚠ WARNING

BEWARE OF SHARP EDGES IN THE COUNTERBORE WHEN YOU INSTALL THE O-RING.

16. Set the cover (6A) on table, interior side up. Grease o-ring (5) and place it into the counterbore around the edge of cover (6A).

NOTE: The o-ring may be stretched or pinched together to make it fit the counterbore exactly.



17. Place cover sub-assembly (6) onto ring gear (4), aligning the pipe plug holes according to the alignment prior to disassembly.



18. Place four flatwashers (16) on top of the bolt holes in the cover sub-assembly.



19. Place shoulder bolts (13) into the four shoulder bolt holes in cover (6) and tighten by hand.

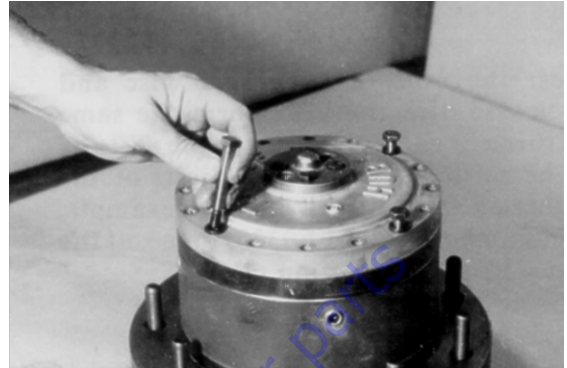

20. Place the remaining 12 flatwashers (16) onto the remaining bolt holes in cover (6).



21. Place the 12 bolts into the remaining bolt holes in cover (6) and tighten.



SECTION 3 - CHASSIS, PLATFORM, & SCISSOR ARMS

22. Torque the shoulder bolts (13) 18 to 25 ft. lbs. (25 to 34 Nm). Torque bolts (12) 18 to 25 ft. lbs. (25 to 34 Nm).

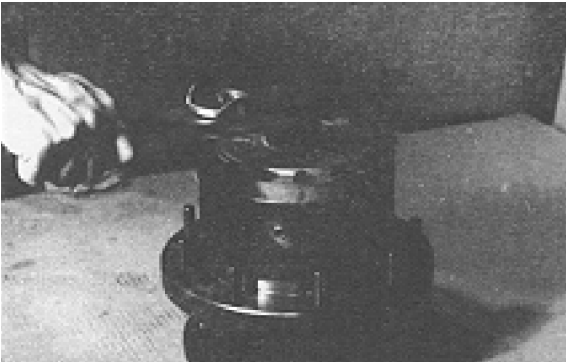

23. Turn hub (1G) over onto its side. Insert coupling (14) into the end of the spindle (1A).

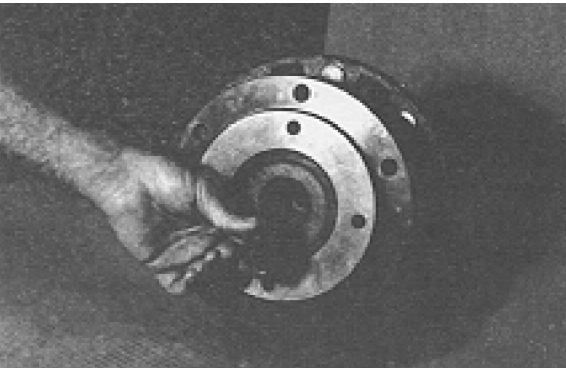

24. Roll test the unit in both clockwise and counterclockwise directions. Perform the same number of turns in each direction as the ratio of the unit. The ratio is the last two digits of the model number on the unit's ID tag.

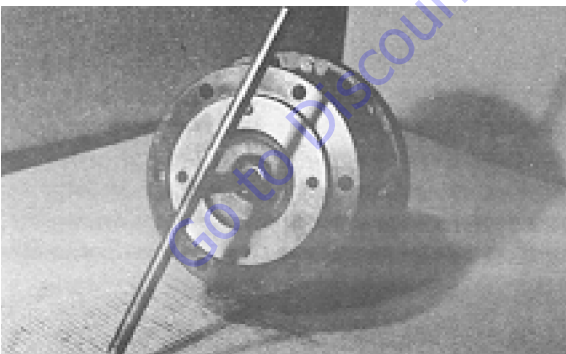

25. Leak test the unit at a pressure of 5 psi (0.34 bar) for 2 to 3 minutes.



26. At this point the main assembly is complete.



Tool List

The following specialized tools are used to assemble this unit. The tool diagrams included in this manual are intended for the customer who may wish to have a tool made. All tools exist as one piece and must be made from mild steel. All dimensions are given in inches.

NOTE: In order to improve tool life, tools may be carburized and hardened. If this is done, however, the tools must be ground on all surfaces labeled with a "G" on the tool diagram.

1. T-118126 SEAL PRESSING TOOL for SEAL (1B).

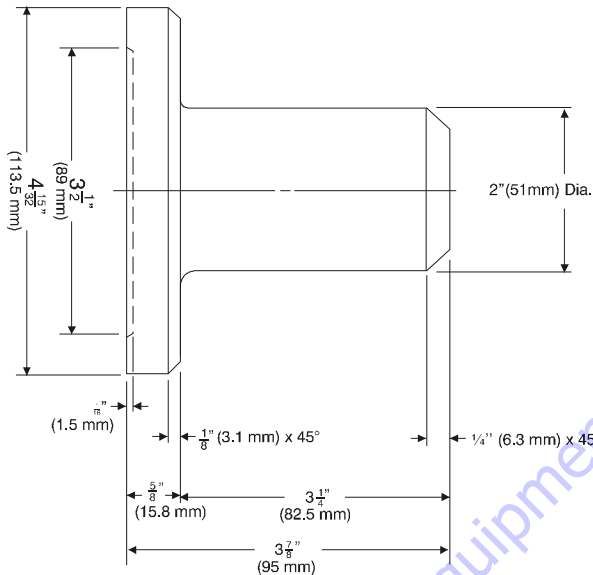

2. T-138903 ASSEMBLY PRESSING TOOL for CUP (1C).

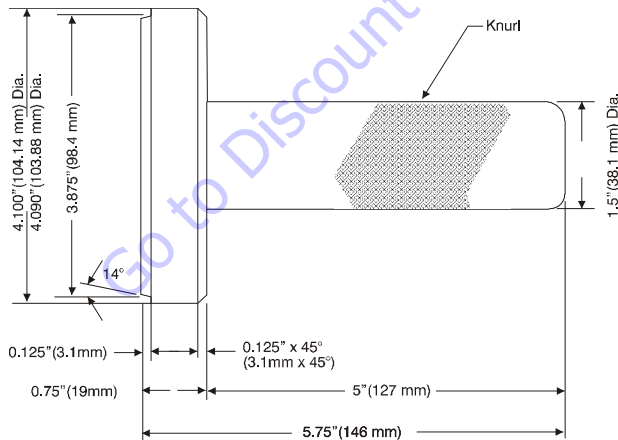

3. T-140433 ASSEMBLY PRESSING TOOL for CUP (1E).

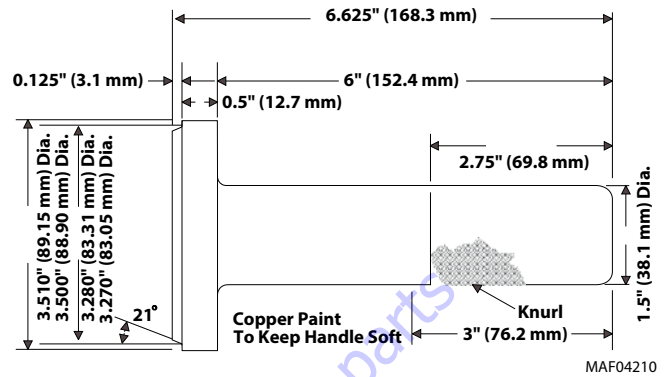

4. T-109691 ASSEMBLY PRESSING TOOL for CONE (1F).

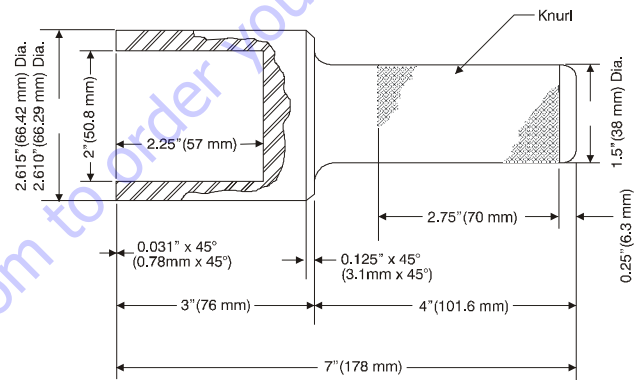

* These tools are for specific seals, cups or cones. There is a specific tool for each cup and cone.

Re-Aligning Torque Hub Input Coupling

The following procedure applies to torque hubs with integral brakes.

EQUIPMENT REQUIRED

1. Hydraulic power supply (hand pump) capable of producing 200 psi (13.8 bar).
2. Hydraulic fittings to adapt hydraulic supply to brake release port on hub.

PROCEDURE

1. Using appropriate fittings, connect a line from the hydraulic power supply to the brake port.
2. Pressurize the brake release port 155 to 200 psi (10.6 to 13.8 bar) to release the brake.
3. Verify that the brake is released by rotating the input coupling or hub spindle.
4. Once the brake is released, the input coupling will be free to re-align with the drive motor.
5. Install the drive motor on the hub, then release the hydraulic pressure at the brake release port. The coupling will remain in position.
6. Disconnect the hydraulic power supply and reconnect the line going into the brake release port.

3.4 DRIVE MOTOR (SAUER)

Description

The drive motors are low to medium power, two-position axial piston motors incorporating an integral servo piston. They are designed for operation in both open and closed circuit applications. The standard control is a direct acting single line hydraulic control. The integral servo piston controls motor displacement.

The motors are spring biased to maximum displacement and hydraulically shifted to minimum displacement. Minimum and maximum displacement can be set with fixed internal stops. The large diameter servo piston allows smooth acceleration and deceleration with relatively large circuit orificing.

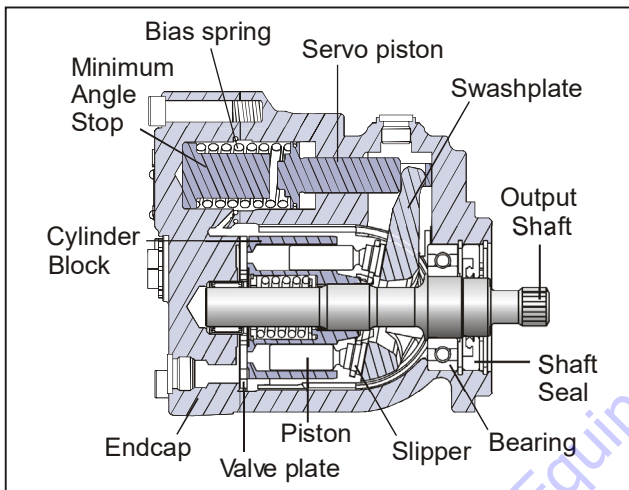
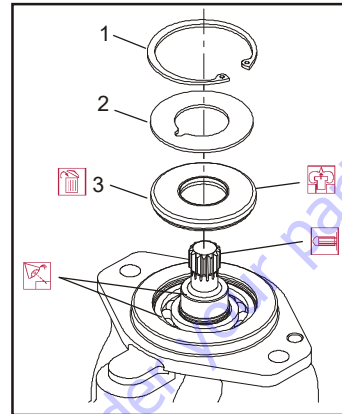

Figure 3-5. Drive Motor Cross Section

Shaft Seal Replacement

REMOVAL

1. Remove the snap ring (1) retaining the shaft seal and support washer.



1. Snap Ring
2. Support Washer
3. Shaft Seal

Figure 3-6. Removing the Shaft Seal

2. Remove the support washer (2).
3. Carefully pry out the shaft seal (3).

To avoid damaging the shaft during removal, install a large sheet metal screw into the chuck of a slide hammer. Drive the screw into the seal surface and use the slide hammer to pull the seal.

4. Discard the seal.

INSPECT THE COMPONENTS

Inspect the new seal, the motor housing seal bore, and the sealing area on the shaft for rust, wear, and contamination. Polish the shaft and clean the housing if necessary.

INSTALLATION

1. Cover the shaft splines with an installation sleeve to protect the shaft seal during installation.
2. Install a new shaft seal with the cupped side facing the motor. Press seal into housing until it bottoms out. Press evenly to avoid binding and damaging the seal.
3. Install seal support washer.
4. Install snap ring.
5. Remove the installation sleeve.

Loop Flushing Valve

REMOVAL

1. Using a 11/16 in. internal hex wrench, remove plug (1) and (2).

4. Using pliers, remove centering springs (7, 8, and 9).
5. Remove spring retaining washers (10 and 11).
6. Remove shift spool (12).
7. Remove orifice poppet (13).

INSPECT THE COMPONENTS

Inspect new O-rings and the sealing area for rust, wear, or contamination. Also check springs and poppet for wear.

INSTALLATION

1. Install orifice poppet (13).
2. Install shift spool (12).
3. Install spring retaining washers onto springs (10 and 11).
4. Carefully install centering springs (7, 8, and 9).
5. Install new O-rings (6, 4, and 5).
6. Using a 1/4 in. hex wrench, torque plug (3) to 20 ft. lbs. (27 Nm).
7. Using a 11/16 in. internal hex, torque plugs (2 and 1) to 27 ft. lbs. (37 Nm).

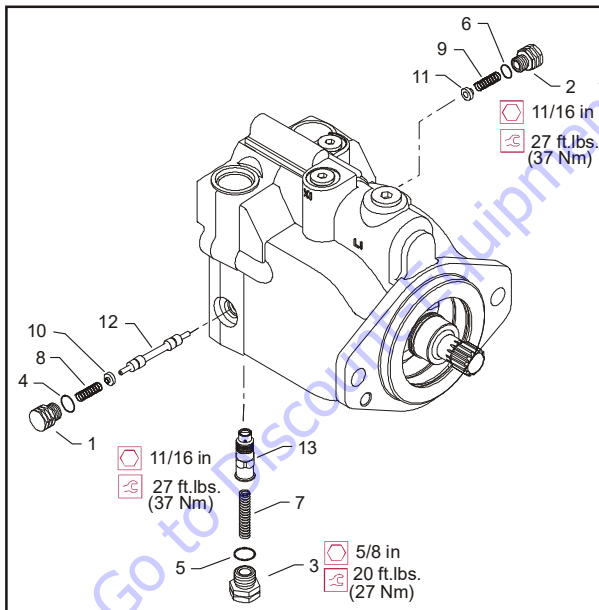

- | | | |
|-----------|------------|--------------------|
| 1. Plug | 6. O-ring | 11. Washer |
| 2. Plug | 7. Spring | 12. Shift Spool |
| 3. Plug | 8. Spring | 13. Orifice Poppet |
| 4. O-ring | 9. Spring | |
| 5. O-ring | 10. Washer | |

Figure 3-7. Loop Flushing Spool

2. Using a 1/4 in. hex wrench, remove plug (3).
3. Remove O-rings (4, 5, and 6).

Troubleshooting

Table 3-3. Excessive Noise and/or Vibration

Item	Description	Action
Check oil level in reservoir and oil supply to the motor.	Insufficient hydraulic fluid could lead to cavitation that would cause system noise.	Fill the reservoir to the proper level and ensure that oil supply to the motor is adequate and the lines are unobstructed.
Check for air in the system.	Air trapped within the system lines, or the motor itself, could result in cavitation that would cause system noise.	Ensure that all of the system lines and components are purged of air.
Inspect the output shaft couplings.	A loose or incorrect shaft coupling will produce vibrations that could result in system noise.	Ensure that the correct coupling is used and that it fits properly onto the shaft.
Inspect the output shaft alignment.	Misaligned shafts create excessive frictional vibration that could result in system noise.	Ensure that the shafts are properly aligned.
Hydraulic oil viscosity above limits.	Viscosity above acceptable limits will result in cavitation that would lead to system noise.	Replace hydraulic oil with appropriate fluid for operating conditions.

Table 3-4. System Operating Hot

Item	Description	Action
Check oil level in reservoir and oil supply to the pump.	Insufficient amount of hydraulic fluid will not meet the cooling demands of the system.	Fill the reservoir to the proper level.
Inspect the heat exchanger, (if so equipped).	If the heat exchanger fails, or becomes obstructed, it may not meet the cooling demands of the system.	Ensure that heat exchanger is receiving adequate air flow and that the heat exchanger is in good operating condition. Repair or replace as necessary.
Check the system relief valves.	If a system relief valve becomes unseated for an extended period of time or fails for any other reason, the system could become overheated.	Repair or replace any malfunctioning relief valves as applicable and verify that the loads on the machine are not excessive.

Table 3-5. Won't Shift or Slow to Start

Item	Description	Action
Check the signal line to the servo control port.	Obstructed or restricted flow through the servo control signal lines could result in slow shift or no shift conditions within the motor.	Ensure that the signal lines are not obstructed or restricted and that signal pressure is adequate to shift the motor.
Check that the correct supply and drain orifices are properly installed, and are not obstructed.	Supply and drain orifices determine the shift rate of the motor. The smaller the orifice, the longer the time it takes to shift the motor. Obstruction will also increase shift times.	Ensure that the proper control orifices are installed in the motor and verify that they are not obstructed. Clean or replace as necessary.

Disassembly

NOTE: Removal of the endcap voids warranty.

During assembly, coat all moving parts with a film of clean hydraulic oil. This assures that these parts will be lubricated during start-up.

Replace all O-Rings and gaskets.

It is recommended that all O-rings be replaced. Lightly lubricate all O-rings with clean petroleum jelly prior to assembly.

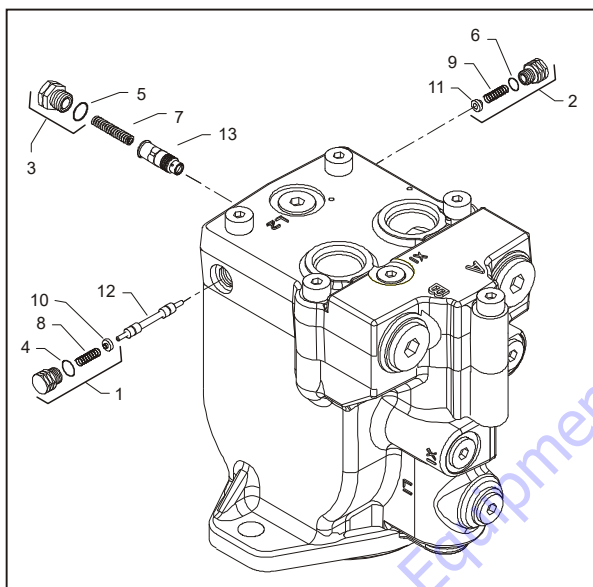

- | | | | |
|-----------|-----------|------------|--------------------|
| 1. Plug | 5. O-ring | 9. Spring | 12. Shift Spool |
| 2. Plug | 6. O-ring | 10. Washer | 13. Orifice Poppet |
| 3. Plug | 7. Spring | 11. Washer | |
| 4. O-ring | 8. Spring | | |

Figure 3-8. Loop Flushing Spool

1. Using a 11/16 in wrench, remove plug (1) and (2).
2. Using a 5/8 in hex wrench, remove plug (3).
3. Remove O-rings (4, 5, and 6).
4. Using pliers, remove centering springs (7, 8, and 9).
5. Remove spring retaining washers (10 and 11).
6. Remove shift spool (12).
7. Remove orifice poppet (13).

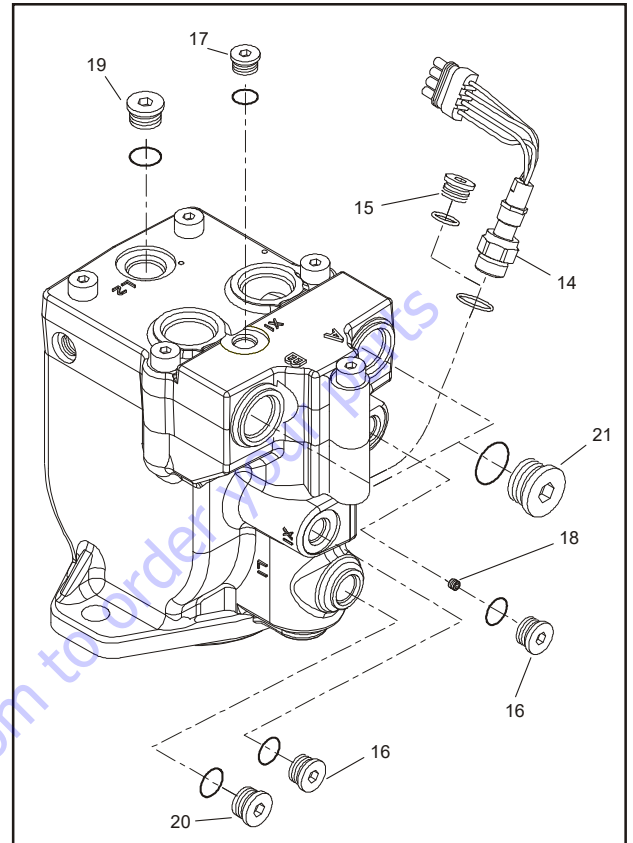

- | | |
|-----------------------|--------------------|
| 14. Lock Nut | 18. Cavity Plug |
| 15. O-ring Plug | 19. Drain Plug |
| 16. Control Line Plug | 20. Drain Plug |
| 17. Control Line Plug | 21. Work Port Plug |

Figure 3-9. Plugs, Fittings, and Speed Sensor

8. Remove all fittings from the unit. Discard any O-rings on the fittings.
9. Using an 11/16 in hex wrench, loosen the speed sensor lock nut (14) if equipped. Then remove the speed sensor using a 1/2 in. hex wrench. Units without speed sensor have an O-ring plug (15) installed in that location; remove it with a 1/4 in. internal hex wrench.
10. Using a 1/4 in internal hex wrench, remove control line plugs (16, 17). Discard O-rings. Using a 3 mm hex wrench, remove cavity plug (18, if equipped with two-line control) from X2 cavity.
11. Using a 5/16 in internal hex wrench, remove drain plugs (19, 20). Discard O-rings.
12. Using a 9/16 in internal hex wrench, remove work port plugs (21, if equipped with axial ports). Discard O-rings.

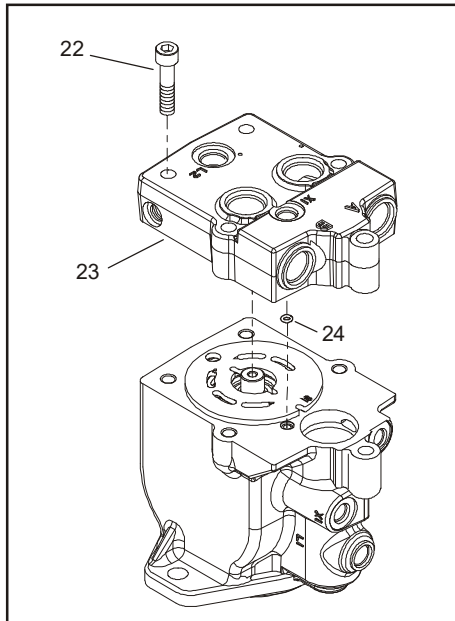

- 22. Screw
- 23. End Cap
- 24. O-ring

Figure 3-10. End Cap

13. Using an 8 mm internal hex wrench, remove the endcap screws (22).
14. Remove the endcap (23). Remove O-ring (24) from the housing or endcap.

When the endcap screws are removed, pressure from the servo spring will cause the endcap to bind on the shaft. Press down on the portion of the endcap covering the servo piston and hold the endcap level while removing.

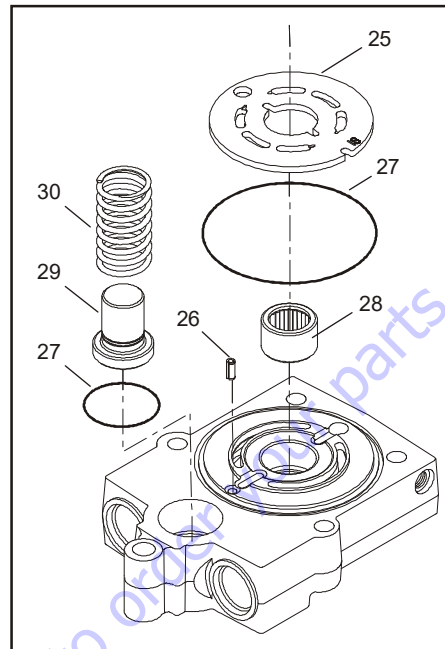

- 25. Valve Plate
- 26. End Cap
- 27. O-ring
- 28. Rear Shaft Bearing
- 29. Minimum Angle Stop
- 30. Servo Spring

Figure 3-11. Valve Plate & Rear Shaft Bearing

⚠ CAUTION

TAKE CARE NOT TO SCRATCH THE SURFACE OF THE VALVE PLATE.

15. Remove the valve plate (25) and timing pin (26) from the endcap.

Each displacement has a unique valve plate. For identification, the last two digits of the valve plate part number are stamped on its surface.

16. Remove and discard the O-rings (27).
17. Remove the rear shaft bearing (28) from the endcap with a bearing puller.

The bearing may be difficult to remove with a puller. Try this as an alternative: Pack the bearing cavity with heavy grease. After the shaft is removed, insert it into the bearing cavity and tap lightly with a soft mallet on the splined end. The grease will force the bearing out. Use caution not to drive the bearing past the rear shaft journal as the bearing may become trapped on the shaft and damaged.

18. Remove minimum angle stop (29) and servo spring (30) from the housing.

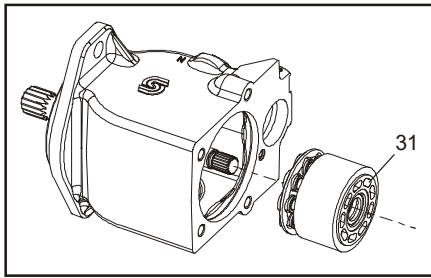

31. Cylinder Kit Assembly

Figure 3-12. Cylinder Kit

- Turn the housing on its side and remove the cylinder kit assembly (31). Set the assembly aside, being careful not to scratch the running surface.

NOTE: Grooves on the surface of the cylinder kit identify its displacement:

Table 3-6. Displacement Identifiers

# of Grooves	Frame L	Frame K
1	25	38
2	30	45
3	35	--

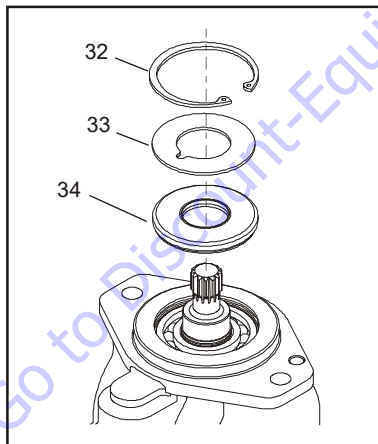

- 32. Snap Ring
- 33. Support Washer
- 34. Shaft Seal

Figure 3-13. Shaft Seal

- Turn the housing over and remove the snap ring (32) retaining the shaft seal and support washer. Remove the support washer (33) and carefully pry out the shaft seal (34). Discard the seal.

To avoid damaging the shaft during seal removal, install a large sheet metal screw into the chuck of a slide hammer. Drive the screw into the seal surface and use the slide hammer to pull the seal.

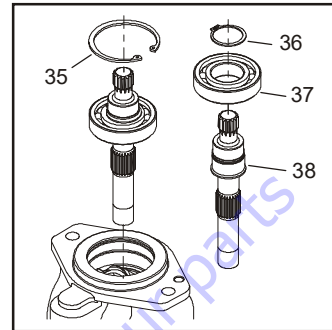

- 35. Inner Snap Ring
- 36. Snap Ring
- 37. Bearing
- 38. Shaft

Figure 3-14. Shaft & Front Bearing

- Remove the inner snap ring (35) and the shaft / bearing assembly.
- Remove the snap-ring (36) retaining the shaft front bearing. Pull the bearing (37) off of the shaft (38).

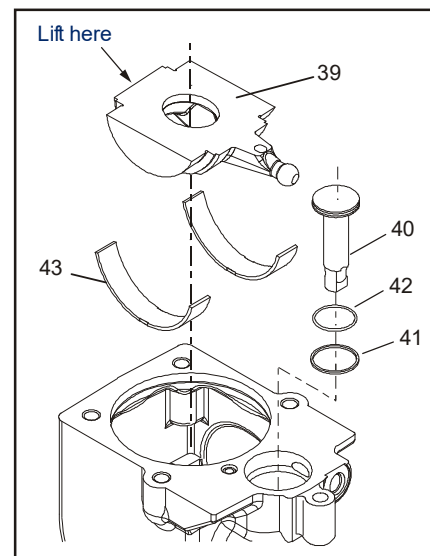

- 39. Swashplate
- 40. Servo Piston
- 41. Piston Seal
- 42. O-ring
- 43. Journal Bearings

Figure 3-15. Swash Plate & Servo Piston

23. Turn housing over and remove the swashplate (39) by lifting on the end opposite the servo lever.
24. Remove the servo piston (40). Remove the piston seal (41) and O-ring (42) from the servo piston. Discard the seal and O-ring.
25. Remove the journal bearings (43) from the housing. If the bearings are to be reused, note the location and orientation of each bearing for reassembly.

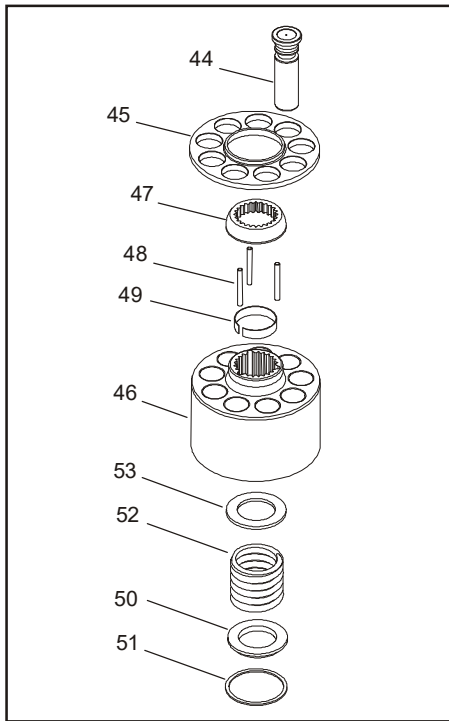

- | | |
|----------------------|-------------------------------|
| 44. Piston | 49. Retaining Ring |
| 45. Slipper Retainer | 50. Block Spring Washer |
| 46. Cylinder Block | 51. Spiral Retaining Ring |
| 47. Ball Guide | 52. Block Spring |
| 48. Holddown Pins | 53. Inner Block Spring Washer |

Figure 3-16. Cylinder Kit Disassembly

26. Remove pistons (44) and slipper retainer (45) from the cylinder block (46).

The pistons are not selectively fitted, however units with high hourly usage may develop wear patterns. Number the pistons and bores for reassembly if they are to be reused.

27. Remove the ball guide (47), hold-down pins (48), and retaining ring (49) from the cylinder block.

NOTE: Most repairs do not require block spring removal. Perform this procedure only if you suspect problems with the block spring.

⚠ WARNING

RISK OF PERSONAL INJURY: COMPRESSING THE BLOCK SPRING REQUIRES FORCE OF ABOUT 80 TO 90 LBF (350 TO 400 N). USE A PRESS SUFFICIENT TO MAINTAIN THIS FORCE WITH REASONABLE EFFORT. ENSURE THE SPRING IS SECURE BEFORE ATTEMPTING TO REMOVE THE SPIRAL RETAINING RING. RELEASE THE PRESSURE SLOWLY AFTER THE RETAINING RING IS REMOVED.

28. Turn the block over. Using a press, apply pressure on the block spring washer (50) to compress the block spring. Compress the spring enough to safely remove the spiral retaining ring (51). While maintaining pressure, unwind the spiral retaining ring (51). Carefully release the pressure and remove the outer block spring washer (50), block spring (52), and inner block spring washer (53) from the cylinder block.

Inspection

After disassembly, wash all parts (including the end-cap and housing) thoroughly with clean solvent and allow to air dry. Blow out oil passages in the housing and end-cap with compressed air. Conduct inspection in a clean area and keep all parts free from contamination. Clean and dry parts again after any rework or resurfacing.

PISTON

Inspect the pistons for damage and discoloration. Discolored pistons may indicate excessive heat; do not reuse.

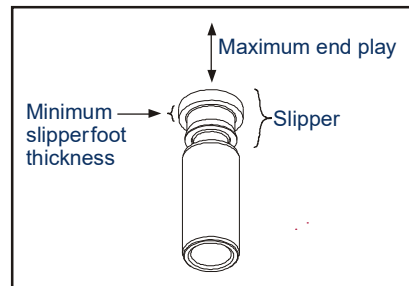

SLIPPERS

Inspect the running surface of the slippers. Replace any piston assemblies with scored or excessively rounded slipper edges. Measure the slipper foot thickness. Replace any piston assemblies with excessively worn slippers. Check the slipper axial end-play. Replace any piston assemblies with excessive end-play.

Minimum slipper foot thickness and maximum axial end-play are given in the table below.

CYLINDER BLOCK

Measure the cylinder block height. Replace blocks worn beyond the minimum height specification. Inspect the running surface of the cylinder block. Replace or resurface worn or scratched blocks. Blocks may be resurfaced

Table 3-7. Slipper Foot Thickness & End Play

Measurement		L Frame	K Frame
Slipper Foot Thickness	mm (in.)	2.71 (0.11)	4.07 (0.16)
Piston/Slipper End Play		0.15 (0.006)	

to the specifications shown in the drawing, provided resurfacing will not reduce the block height below the minimum specification. Table 3-8, Cylinder Block Measurements.

Table 3-8. Cylinder Block Measurements

Measurement		L25	L30	L35	K38	K45
Minimum Cylinder Block Height (A)	mm (in.)	50.8 (2.00)	50.8 (2.00)	50.8 (2.00)	54.4 (2.14)	54.4 (2.14)
Cylinder Block Surface Flatness		0.002 (0.0000079)	0.002 (0.0000079)	0.002 (0.0000079)	0.002 (0.0000079)	0.002 (0.0000079)

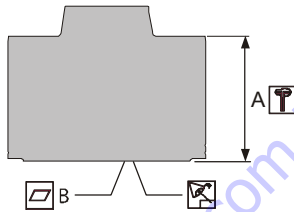

BALL GUIDE AND SLIPPER RETAINER

Inspect the ball guide and slipper retainer for damage, discoloration, or excessive wear. A discolored ball guide or slipper retainer indicates excessive heat. Do not reuse.

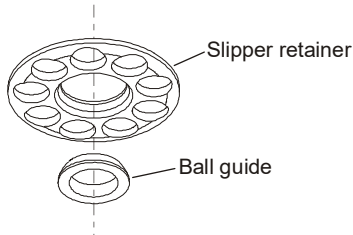

VALVE PLATE

The condition of the valve plate is critical to the efficiency of the motor. Inspect the valve plate surfaces carefully for excessive wear, grooves, or scratches. Replace or resurface grooved or scratched valve plates. Measure the valve plate thickness and replace if worn beyond the minimum specification. Valve plates may be resurfaced to the specifications shown in the drawing, provided resurfacing will not reduce the thickness below the minimum specification.

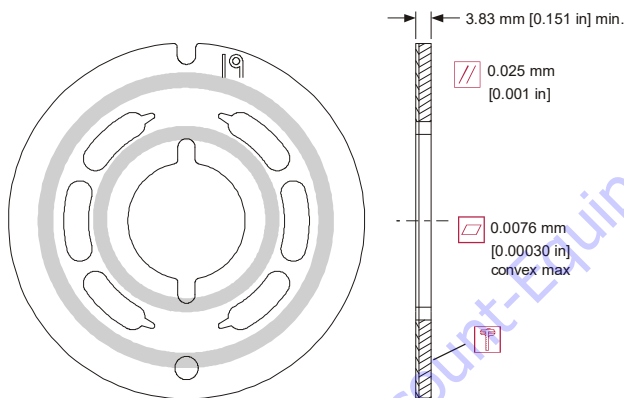

SWASHPLATE AND JOURNAL BEARINGS

Inspect the running face, servo ball-joint, and swashplate journal surfaces for damage or excessive wear. Some material transfer may appear on these surfaces and is acceptable providing the surface condition meets specifications shown. Measure the swashplate thickness from the journals to the running face. Replace swashplate if damaged or worn beyond minimum specification. Replace swashplate if the difference in thickness from one side to the other exceeds specification.

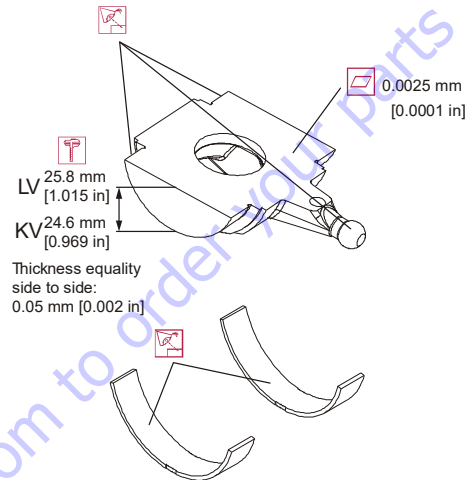

Inspect the journal bearings for damage or excessive wear. Replace journal bearings if scratched, warped, or excessively worn. The polymer wear layer must be smooth and intact.

SHAFT BEARINGS

Inspect bearings for excessive wear or contamination. Rotate the bearings while feeling for uneven movement. Bearings should spin smoothly and freely. Replace bearings that appear worn or do not rotate smoothly.

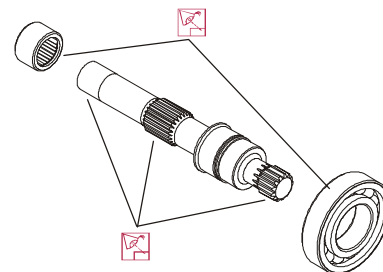

SHAFT

Inspect the motor shaft. Look for damage or excessive wear on the output and block splines. Inspect the bearing surfaces and sealing surface. Replace shafts with damaged or excessively worn splines, bearing surfaces, or sealing surfaces.

SERVO PISTON AND MINIMUM ANGLE STOP

Inspect the minimum angle stop, servo piston head, and servo piston ball-socket for damage or excessive wear. Replace if necessary.

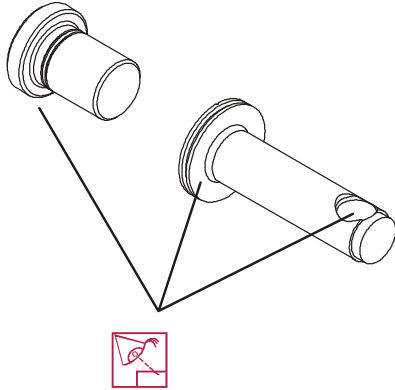
**LOOP FLUSHING SPOOL**

Inspect the loop flushing spool. Check for cracks or damage. Replace if necessary.

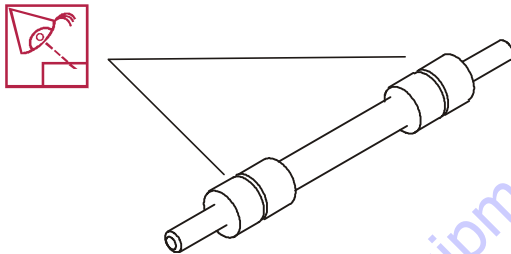
**Assembly**

1. Install new O-ring (1) and piston seal (2) to the servo piston (3). Install the piston seal over the O-ring.

Installing the piston seal stretches it, making it difficult to install the servo piston in its bore. Allow 30 minutes for the seal to relax after installation. To speed up seal relaxation, compress the seal by installing the piston head into the servo cavity in the end-cap and let it stand for at least five minutes.

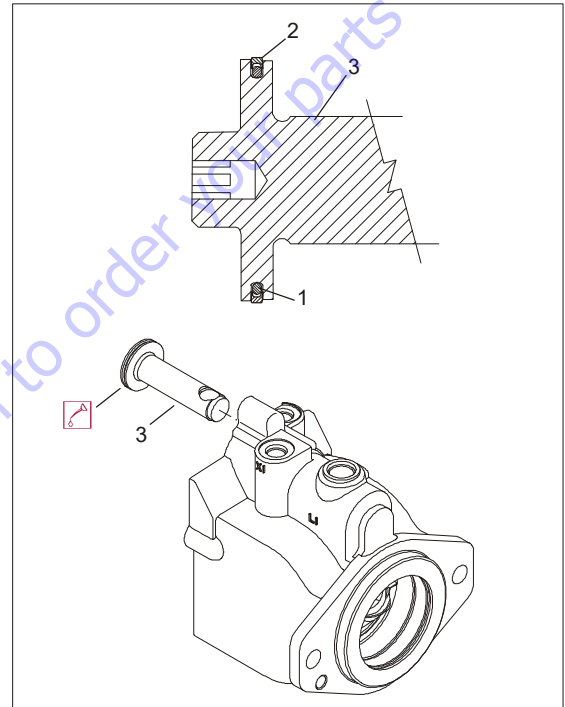

1. O-ring
2. Piston Seal
3. Servo Piston

Figure 3-17. Servo Piston

2. After piston seal has relaxed, lubricate and install servo piston into the housing bore. Align the piston with the ball socket facing the inside of the housing.

⚠ WARNING

RISK OF PERSONAL INJURY: COMPRESSING THE BLOCK SPRING REQUIRES ABOUT 80 TO 90 LBF (350 TO 400 N) OF FORCE. USE A PRESS SUFFICIENT TO MAINTAIN THIS FORCE WITH REASONABLE EFFORT. ENSURE THE SPRING IS SECURE BEFORE ATTEMPTING TO INSTALL THE SPIRAL RETAINING RING. RELEASE THE PRESSURE SLOWLY AFTER THE RETAINING RING IS INSTALLED.

3. Install the inner block spring washer (4), block spring (5), and outer washer (6) into the cylinder block. Using a press, compress the block spring enough to expose the retaining ring groove. Wind the spiral

retaining ring (7) into the groove in the cylinder block.

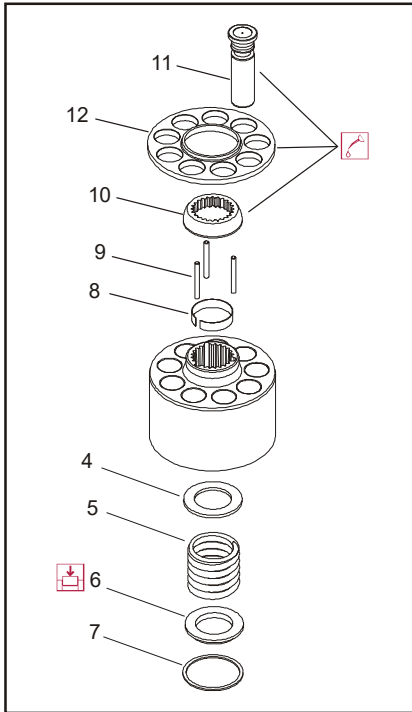

- | | |
|--------------------------|----------------------|
| 4. Block Spring Washer | 9. Holddown Pins |
| 5. Block Spring | 10. Ball Guide |
| 6. Outer Washer | 11. Piston |
| 7. Spiral Retaining Ring | 12. Slipper Retainer |
| 8. Retaining Ring | |

Figure 3-18. Cylinder Kit Assembly

4. Turn the block over and install the retaining ring (8), hold-down pins (9), and ball guide (10) to the cylinder block.
5. Install the pistons (11) to the slipper retainer (12). Install the piston/retainer assembly into the cylinder block. Ensure the concave surface of the retainer seats on the ball guide. If you're reusing the pistons, install them to the original block bores. Lubricate the pistons, slippers, retainer, and ball guide before assembly. Set the cylinder kit aside on a clean surface until needed.
6. Install the journal bearings (13) into the housing seats. Use assembly grease to keep the bearings seated during assembly. Ensure the locating nubs drop into the cavities in the seats. If you're reusing

the bearings, install them in the original location and orientation. Lubricate the journal bearings.

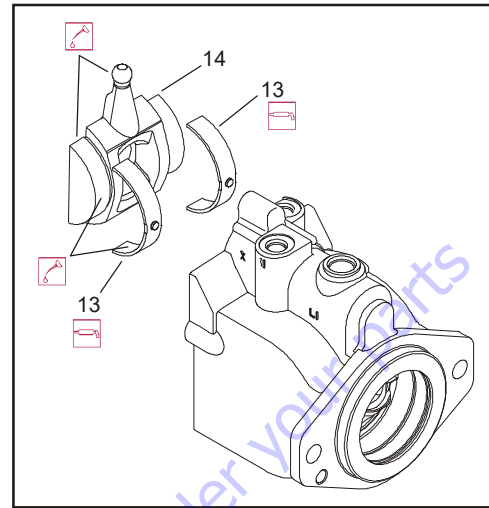

- 13. Journal Bearings
- 14. Swash Plate

Figure 3-19. Swash Plate and Journal Bearing

7. Install the swashplate (14) into the housing. Tilt the swashplate and guide the servo lever ball into its socket in the servo piston rod. Ensure the swashplate seats into the journal bearings and moves freely. Lubricate the running surface of the swashplate.

8. Press front shaft bearing (15) onto shaft (16). Press bearing onto shaft with lettering facing out. Lubricate bearing rollers. Install snap-ring (17) onto shaft.

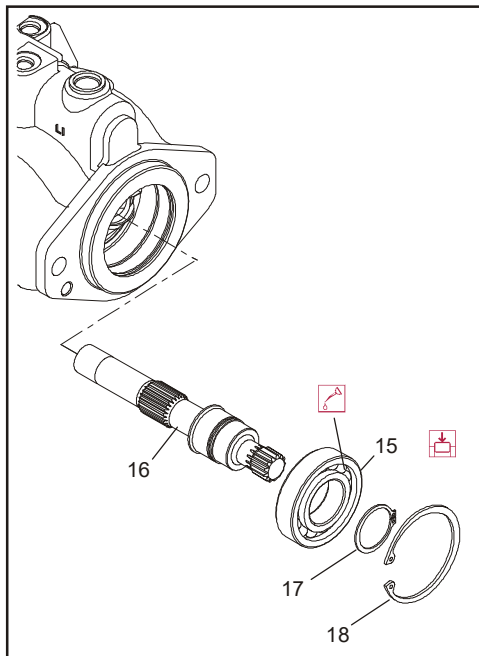

- 15. Front Shaft Bearing
- 16. Shaft
- 17. Snap Ring
- 18. Snap Ring

Figure 3-20. Shaft and Front Bearing

9. While holding the swashplate in place, turn the housing on its side. Install the install shaft/bearing assembly into housing from the flange end. Install the snap-ring (18).
10. Verify swashplate and bearings are properly seated. Install the cylinder kit (19) onto the shaft. Install with the slippers facing the swashplate. Rock the shaft to align the block splines and slide the cylinder kit into place. Orient the motor with the shaft pointing downward and verify the cylinder kit, swashplate,

journal bearings, and servo piston are all secure and properly installed.

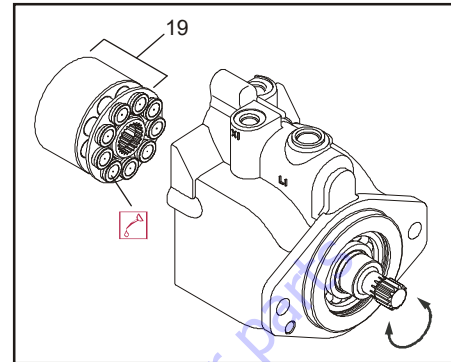

- 19. Cylinder Kit

Figure 3-21. Cylinder Kit Installation

11. Lubricate and install the servo spring (20), and minimum angle stop (21) into the housing bore.

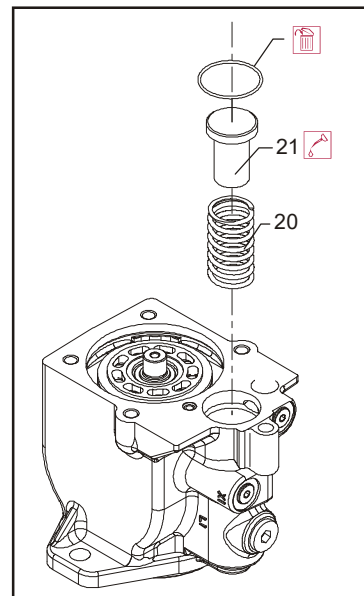

- 20. Servo Spring
- 21. Minimum Angle Stop

Figure 3-22. Servo Spring and Minimum Angle Stop

12. Press the rear shaft bearing (22) into the endcap. Install the bearing with letters facing out. Press until

bearing surface is 0.08 ± 0.01 in (2 ± 0.25 mm) above endcap surface.

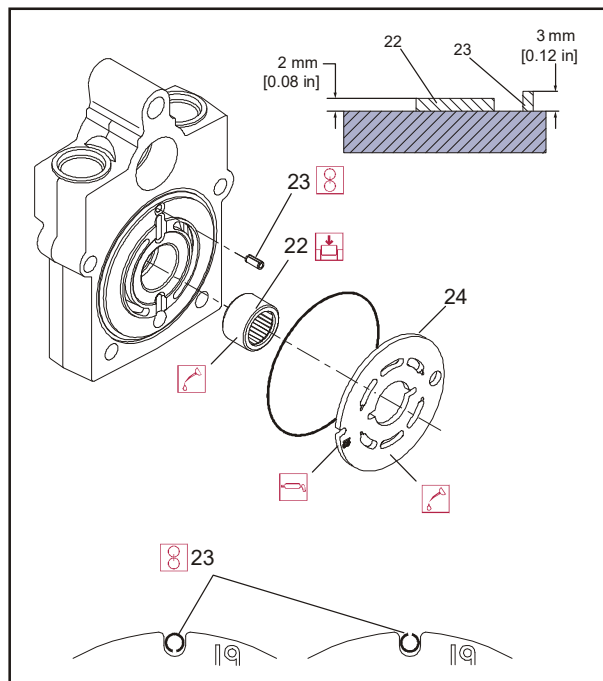

- 22. Rear Shaft Bearing
- 23. Timing Pin
- 24. Valve Plate

Figure 3-23. Valve Plate and Rear Bearing

13. Install timing pin (23) into its bore in the endcap. Install the pin with its groove facing toward or away from the shaft. Press the pin until the end protrudes 0.12 ± 0.01 in (3 ± 0.25 mm) above endcap surface.
14. Install the valve plate (24) onto the endcap. Install the valve plate with the yellow surface toward the cylinder block. Align the slot in the valve plate with the timing pin. Apply a liberal coat of assembly grease to the endcap side of the valve plate to keep it in place during installation.
15. Install the endcap (25) onto the housing with the endcap screws (26). Check to ensure the endcap will properly seat onto the housing without interference. Improper assembly of the internal components may

prevent the endcap from seating properly. Ensure the O-rings seat properly when installing the endcap.

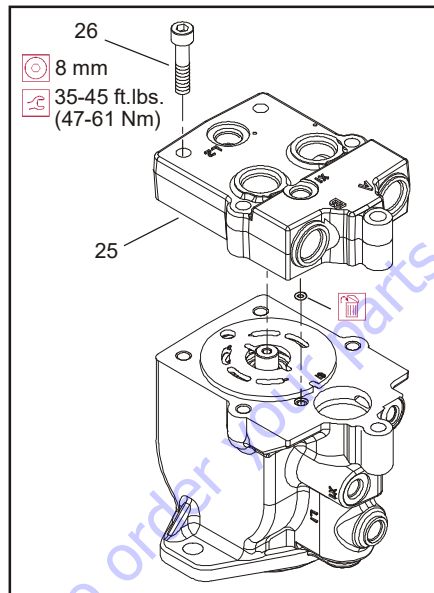

- 25. End Cap
- 26. Screw

Figure 3-24. End Cap

16. Using an 8 mm internal hex wrench, tighten the endcap screws. Tighten the screws in opposite corners slowly and evenly to compress the servo spring and properly seat the endcap. Torque endcap screws 35-45 lb-ft (47-61 Nm).
17. Before installing the shaft seal, ensure the shaft turns smoothly with less than 120 in.lbs. (13.5 Nm) of force. If the shaft does not turn smoothly within the specified maximum force, disassemble and check the unit.
18. Cover shaft splines with an installation sleeve. Install a new shaft seal (27) with the cup side facing the motor. Press seal into housing until it bottoms out.

Press evenly to avoid binding and damaging the seal. Install seal support washer (28) and snap ring (29).

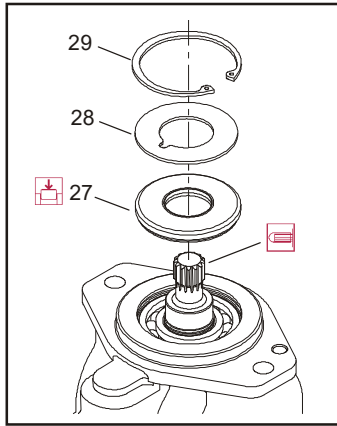

- 27. Shaft Seal
- 28. Seal Support Washer
- 29. Snap Ring

Figure 3-25. Shaft Seal

19. Install remaining plugs and fittings to the housing. Refer to the drawing below for wrench sizes and installation torques.

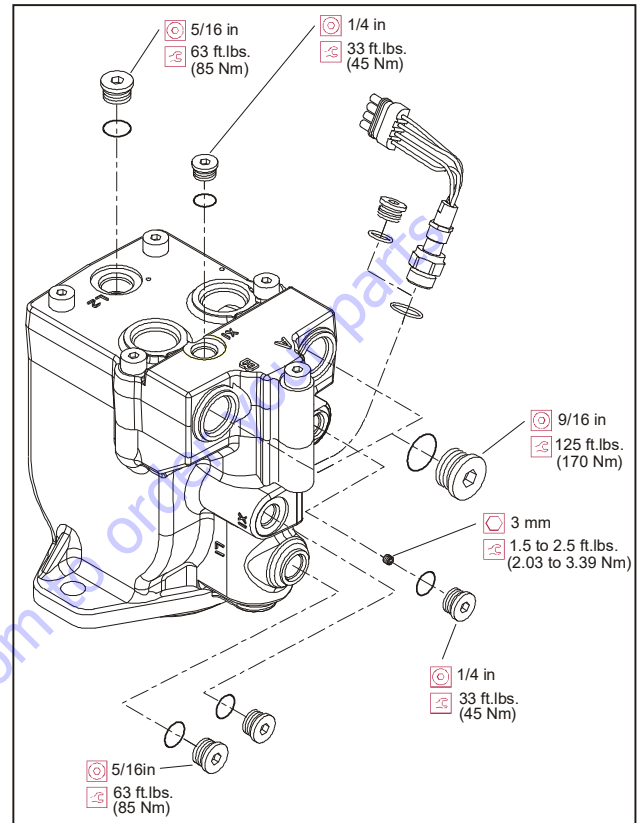
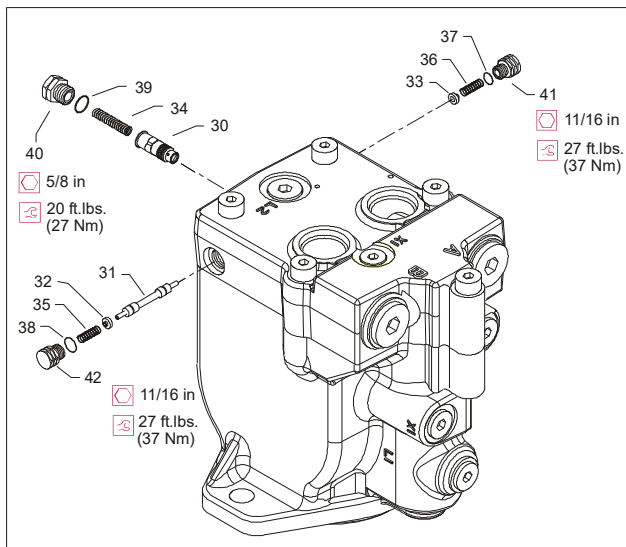

Figure 3-26. Plugs and Fittings Installation

20. Install orifice poppet (30).



- | | | | |
|--------------------|------------|------------|----------|
| 30. Orifice Poppet | 34. Spring | 37. O-ring | 40. Plug |
| 31. Shift Spool | 35. Spring | 38. O-ring | 41. Plug |
| 32. Spring | 36. Spring | 39. O-ring | 42. Plug |
| 33. Spring | | | |

Figure 3-27. Loop Flushing Spool

21. Install shift spool (31).
22. Install spring retaining washers onto springs (32 and 33).
23. Carefully install centering springs (34, 35, and 36).
24. Install new O-rings (37, 38, and 39).
25. Using a 5/8 in wrench torque plug (40) to 20 ft. lb. (27 Nm).
26. Using a 11/16 in wrench, torque plugs (41 and 42) to 27 lb-ft (37 Nm).

Initial Start-Up Procedures

Follow this procedure when starting-up a new motor or when installing a motor that has been removed.

Prior to installing the motor, inspect for damage incurred during shipping. Make certain all system components (reservoir, hoses, valves, fittings, heat exchanger, etc.) are clean prior to filling with fluid.

1. Fill the reservoir with recommended hydraulic fluid. Always filter fluid through a 10 micron filter when pouring into the reservoir. Never reuse hydraulic fluid.
2. Fill the inlet line leading from the pump to the reservoir. Check the inlet line for properly tightened fittings and ensure it is free of restrictions and air leaks.
3. Fill the pump and motor housing with clean hydraulic fluid. Pour filtered oil directly into the upper most case drain port.
4. To ensure the pump and motor stay filled with oil, install case drain lines into the upper most case drain ports.
5. Install a 0 to 500 psi (0 to 35 bar) gauge in the charge pressure gauge port of the pump to monitor system pressure during start up.
6. While watching the pressure gauge, run the engine at the lowest possible speed until system pressure builds to normal levels [minimum 160 psi (11 bar)]. Once system pressure is established, increase to full operating speed. If system pressure is not maintained, shut down the prime mover, determine cause, and take corrective action.
7. Operate the hydraulic system for at least fifteen minutes under light load conditions.
8. Check and adjust control settings as necessary after installation.
9. Shut down the prime mover and remove the pressure gauge. Replace plug at the charge pressure gauge port.
10. Check the fluid level in the reservoir; add clean filtered fluid if necessary. The motor is now ready for operation.

3.5 AXLE INSTALLATION

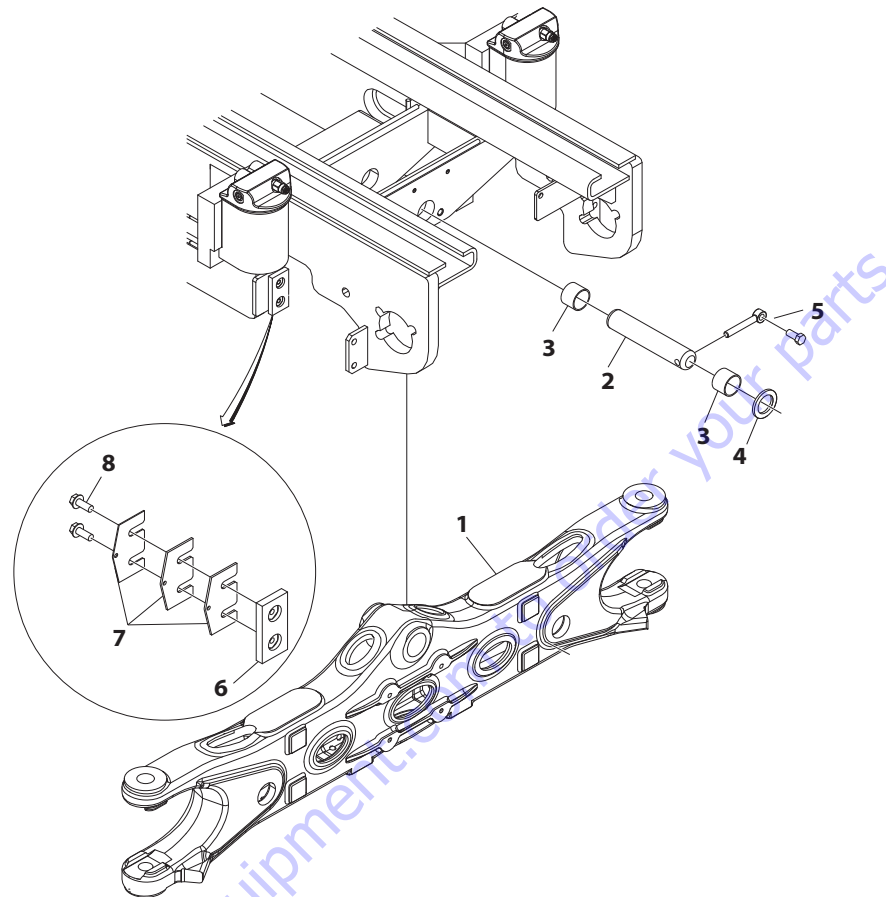

- | | | | |
|--------------|----------------------|------------------------|--------------------|
| 1. Axle | 3. Pivot Pin Bushing | 5. Pin Keeper and Bolt | 7. Wear Pad Shims |
| 2. Pivot Pin | 4. Thrust Washer | 6. Wear Pad | 8. Hex Head Screws |

Figure 3-28. Axle Installation

Removal**⚠ CAUTION**

SUPPORT THE FRAME AND AXLE BEFORE ATTEMPTING ANY REMOVAL AND/OR ASSEMBLY PROCEDURES.

1. Disable machine operation. Remove wheel and drive assemblies.
2. Remove the bolt and pin keeper (5).
3. Push the axle pivot pin (2) out and remove the thrust washer (4) and bushings.(3).
4. Axle (1) can now be moved away from the frame.

Assembly

1. When installing the axle assembly, follow Removal Steps in reverse.
2. If removed, shim the wear pad to achieve a maximum gap of 1/16 in. (1.5mm) between the pad and the axle machined surface.

NOTE: Apply Medium Strength Threadlocking Compound to bolts (8) attaching wear pad (6) to the frame.

3.7 STEER INSTALLATION (CE AND JAPAN MARKETS)

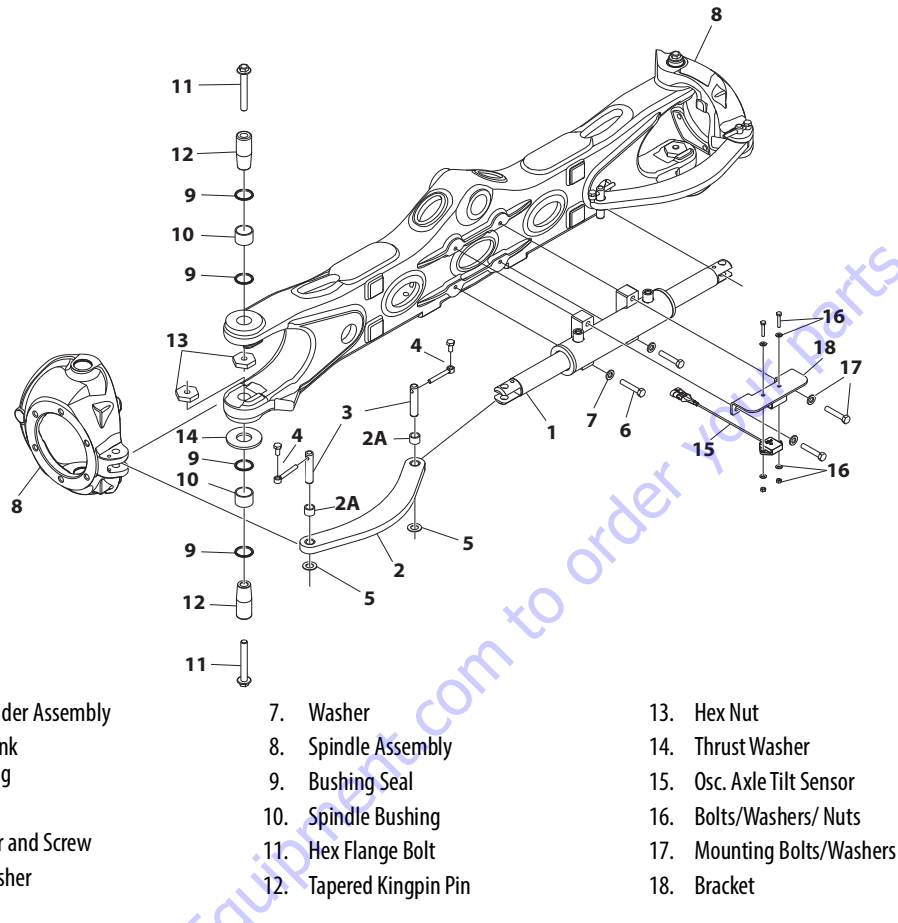

Figure 3-30. Steering Assembly

Steer Cylinder Removal

1. Disable machine operation and block all wheels. Disconnect, cap and label all hydraulic lines on steer cylinder (1).
2. Unplug the axle tilt sensor electrical connection.
3. Remove the screws and pin keeper (4), pin (3) and bearings (2A) connecting cylinder rod to tie rod (2). Slide the tie rod out of the cylinder rod, capture the thrust washer (5) on bottom of tie rod.
4. Support steer cylinder. Remove 4 bolts (6) and washers (7) connecting cylinder to axle. Carefully remove cylinder.

Spindle Removal

1. Remove wheel and drive assembly prior to spindle (8) removal.
2. Disconnect tie rod (2) from spindle by removing screw and pin keeper (4), pin (3) and bearings (2A).
3. Support spindle. Remove spindle from axle by removing flange bolts (11) from nuts (13). Remove the 2 tapered king pins (12) from the tapered kingpin bores on the axle, and thrust washer (14) from lower axle. Remove spindle from axle.

Assembly

1. When assembling steer cylinder and spindle, follow Removal Steps in reverse.

NOTE: Apply Medium Strength Threadlocking Compound to bolts (4, 6, 11). Torque flange bolt (11) to 108 ft. lb. (147 Nm).

Inspect bushing seals (9). Replace if damaged.

Ensure large thrust washer (14) is installed between spindle (8) and bottom of axle.

Be certain spindle nut (13) is aligned and seated in the machined groove on the axle before tightening.

NOTE: Torque chassis tilt sensor assembly bolts (16) to 106 in. lbs (12 Nm).

- **Oscillating Axle Tilt Sensor (10)** - If this sensor is not wired correctly, a CANBUS FAILURE - OSCILLATING AXLE TILT SENSOR fault will appear.

Go to Discount-Equipment.com to order your parts

Axle Lockout Cylinder

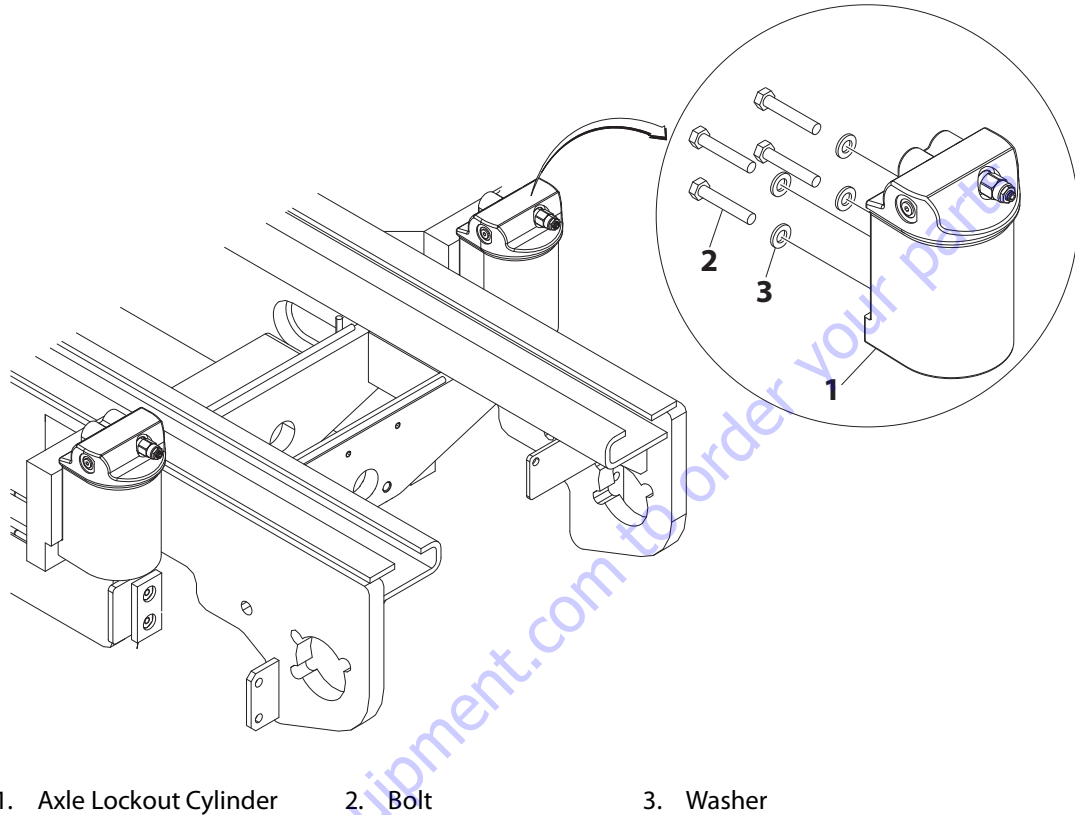

1. Axle Lockout Cylinder 2. Bolt 3. Washer

Figure 3-31. Axle Lockout Cylinder

REMOVAL

1. Disable machine operation.
2. Disconnect, cap and label hydraulic lines on the axle lockout cylinder (1).
3. Remove the four bolts (2) and washers (3) connecting the cylinder to the frame.
4. Carefully remove cylinder from the frame.

INSTALLATION

1. Attach cylinder to frame using four bolts (2) and washers (3).

NOTE: Make sure the shoulder on the lockout cylinder is firmly against the bottom of the mounting plates on the frame before torquing bolts. Apply Medium Strength Threadlocking Compound and Threadlocking Compound to bolts (2).
2. Uncap and reconnect hydraulic lines to cylinder.

NOTE: Refer to Section 4.13, Cylinder Assemblies for axle lockout cylinder breakdown and bleeding procedure.
3. Operate axle lockout cylinder function to ensure proper functioning.

3.8 LEVELING JACKS (IF EQUIPPED)

Cylinder Removal

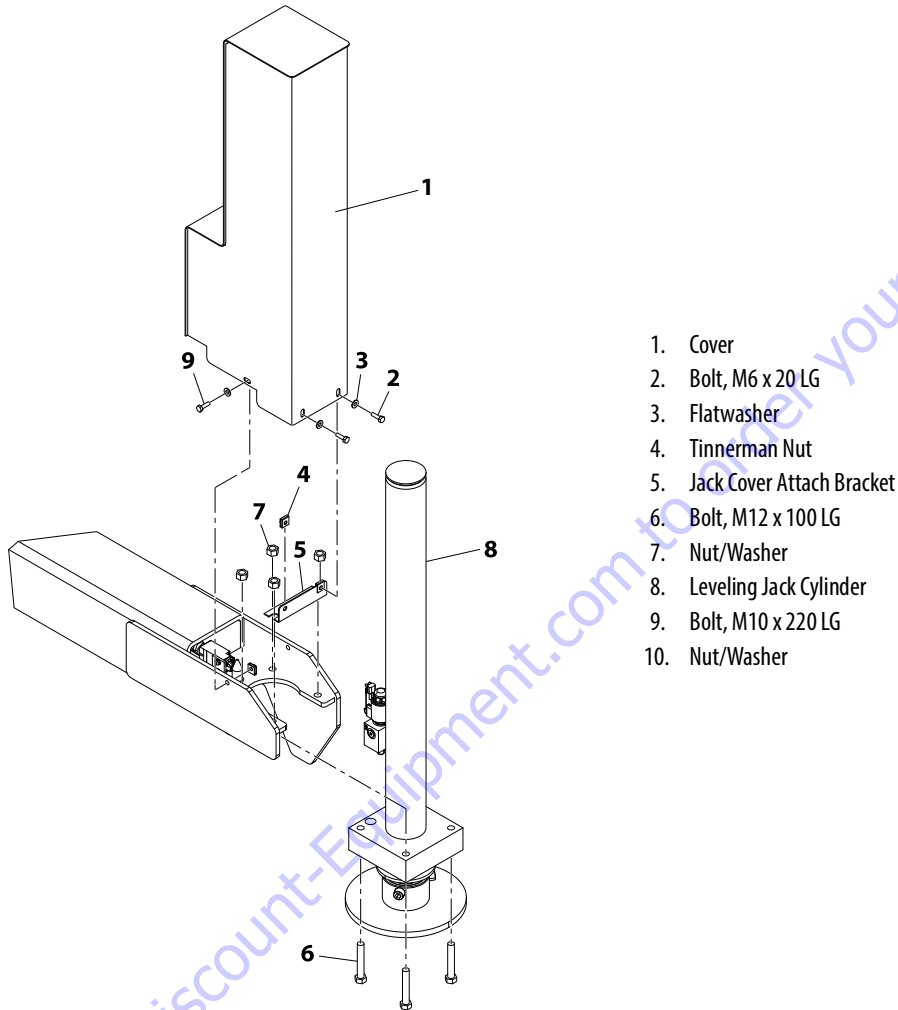

1. Cover
2. Bolt, M6 x 20 LG
3. Flatwasher
4. Tinnerman Nut
5. Jack Cover Attach Bracket
6. Bolt, M12 x 100 LG
7. Nut/Washer
8. Leveling Jack Cylinder
9. Bolt, M10 x 220 LG
10. Nut/Washer

Figure 3-32. Leveling Jack Cylinder Removal

REMOVAL

1. Disable machine operation.
2. Remove the three bolts (2 and 9), and flatwashers (3) from cover (1). Carefully lift cover up and off of machine.
3. Disconnect, cap and label all hydraulic lines and wires connected to the leveling jack cylinder (8).
4. Support cylinder. Remove the four bolts (6) and nuts (7) attaching cylinder to cylinder mount. Remove jack cover attach bracket (5).
5. Carefully remove cylinder from mount.

INSTALLATION

1. Follow Removal Steps in reverse.
- NOTE:** Refer to Figure 4.13, Cylinder Assemblies for cylinder breakdown.
2. Operate leveling jacks to ensure proper operation.

Assembly Removal

NOTE: Applies to both front and rear of machine.

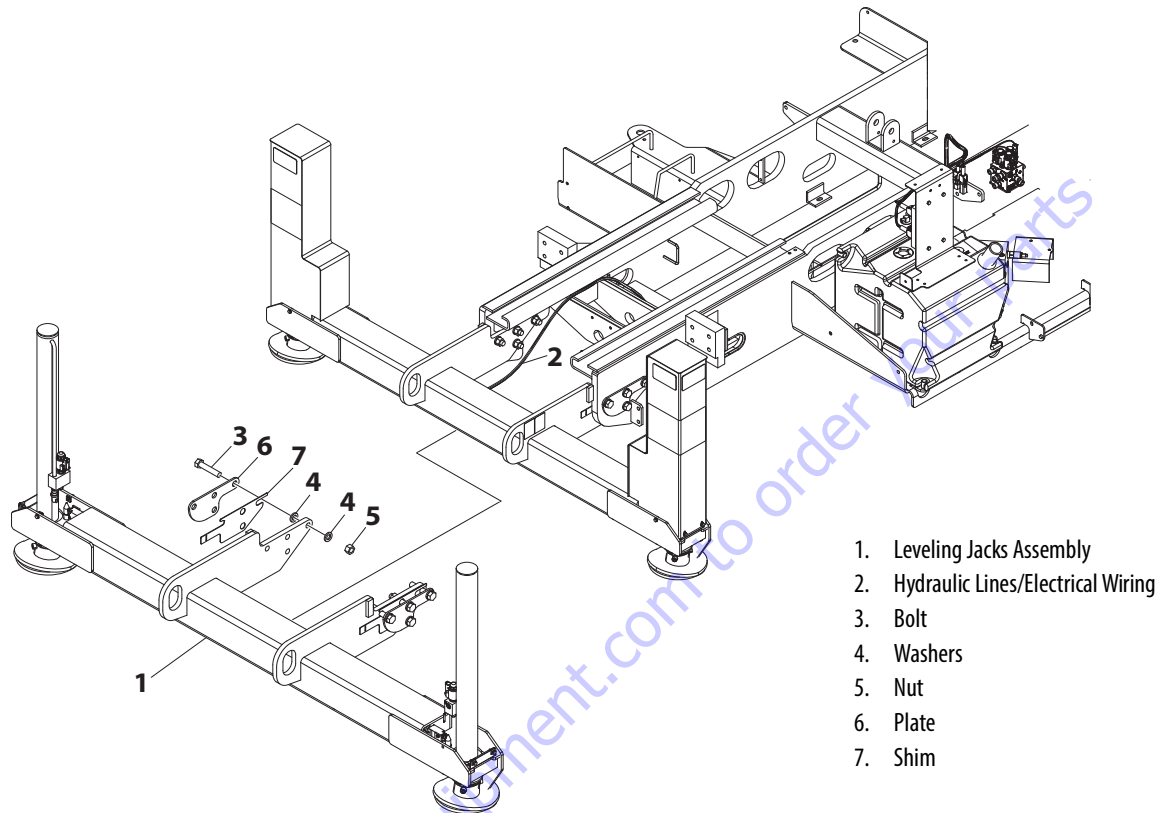

Figure 3-33. Leveling Jacks Assembly

REMOVAL



SUPPORT THE LEVELING JACKS ASSEMBLY BEFORE ATTEMPTING ANY REMOVAL AND/OR ASSEMBLY PROCEDURES.

1. Disable machine operation and block all wheels.
2. Remove covers from leveling jack cylinders (refer to Figure 3-32., Leveling Jack Cylinder Removal).
3. Disconnect, cap and label hydraulic lines (2) connected to leveling jack cylinders. Disconnect and label all electrical wiring attached to cylinder and switches. Remove hoses and wiring from the leveling jack tube assembly.
4. Remove the eight bolts (3), washers (4), nuts (5) doubler plate (6) and shim (7) through the frame.
5. Carefully lower assembly from the frame.

INSTALLATION

1. Follow Removal Steps in reverse.

NOTE: Mount doubler plate on outside of frame rail.

2. Insert hoses and wiring into the leveling jack tube assembly. Uncap and reconnect hydraulic lines and electrical wires to cylinders and switches.
3. Enable machine and unblock all wheels.
4. Operate leveling jacks to ensure proper operation.

3.9 PLATFORM

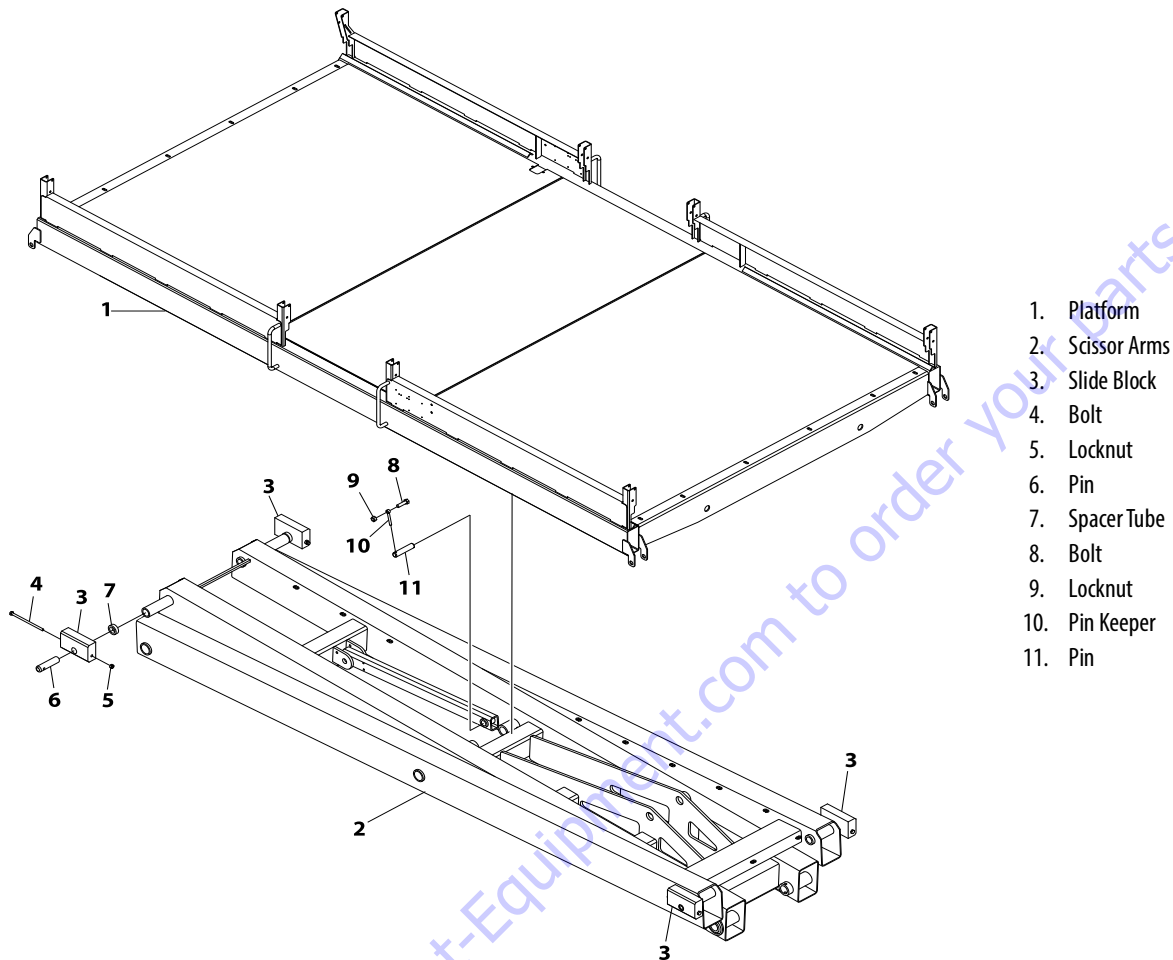

- 1. Platform
- 2. Scissor Arms
- 3. Slide Block
- 4. Bolt
- 5. Locknut
- 6. Pin
- 7. Spacer Tube
- 8. Bolt
- 9. Locknut
- 10. Pin Keeper
- 11. Pin

Figure 3-34. Platform Removal

CAUTION

NEVER WORK UNDER ELEVATED PLATFORM WITHOUT FIRST PROPERLY SUPPORTING THE PLATFORM AND BRACING/BLOCKING SCISSOR ARM ASSEMBLY.

REMOVAL

1. Disable machine operation.
2. Place lifting straps at each end of the platform (1). Using an overhead crane lift platform.

NOTE: Use lifting straps and overhead crane capable of lifting at least 6000 lbs (2722 kg).

3. Disconnect, cap and label hydraulic lines on deck extension cylinders. Disconnect and label all electrical wires going to platform.
4. Detach the center attach link from the platform by removing the bolt (8), locknut (9) pin keeper (10) and pin (11).

5. With scissor arm assembly (2) braced, remove the slide block (3) at each corner of the platform by removing the bolt (4), locknut (5), pin (6) and spacer tube (7).
6. Lift platform away from the machine.

INSTALLATION

1. Follow Removal Steps in reverse.

NOTICE

TIGHTEN BOLTS (4) AND LOCKNUTS (5) TO JUST MAKE CONTACT WITH THE SLIDE BLOCKS (3). DO NOT OVERTIGHTEN.

Platform Control Station

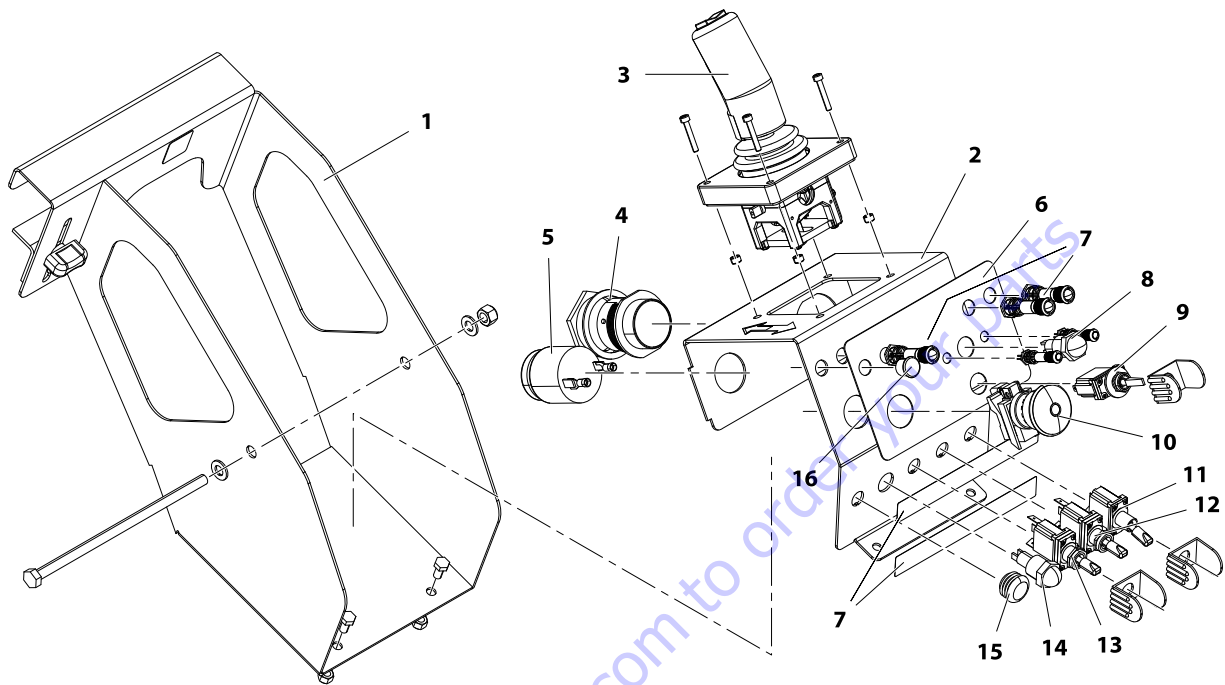

- | | | | |
|-----------------------------|---|---|-------------------------|
| 1. Mounting Bracket | 5. Alarm Speaker | 9. Select Switch/Guard | 13. Engine Start Switch |
| 2. Control Box Plate | 6. Function Decal | 10. Stop Switch | 14. Horn Switch |
| 3. Joystick Controller | 7. LED Indicator | 11. Fuel Select or Glow Plug Switch/
Guard | 15. Blank Plug |
| 4. Wiring Harness Connector | 8. Leveling Jack Switch/LEDS
(If Equipped) | 12. Speed Select Switch | 16. Blank Plug |

Figure 3-35. Platform Control Station

NOTICE

DO NOT SWITCH PLATFORM CONTROL BOXES FROM ONE MACHINE TO ANOTHER. IF BOXES ARE SWITCHED, THE MACHINE WILL NOT POWER UP IN PLATFORM MODE, AND THE SYSTEM DISTRESS INDICATOR ON THE PLATFORM CONTROL BOX WILL REMAIN LIT.

DISASSEMBLY

1. Disconnect the cable from the harness connector (4) on the underside of the platform control station.
2. Remove the control box plate (2) from the mounting bracket (1) by removing the three bolts and washers.
3. Once loaded control box plate is removed, switches, buttons and bulbs can be removed for replacement.
4. Remove the the four screws and nuts to remove the joystick controller (3).
5. The harness can be removed from the box by removing the harness connector terminal nut (4), and disconnecting all the wiring inside the control box.

ASSEMBLY

1. Follow Disassembly Procedures in reverse.
 2. Ensure electrical wires are properly and securely attached to switches, buttons and bulbs.
- NOTE:** Ensure wires are not pinched when installing the loaded control box plate back onto the mounting bracket.
3. Reattach wiring cable to harness connector (4) on underside of platform control station.
 4. Mount control station to platform rail.
 5. Operate functions with platform control console to ensure proper operation.

Joystick Controller

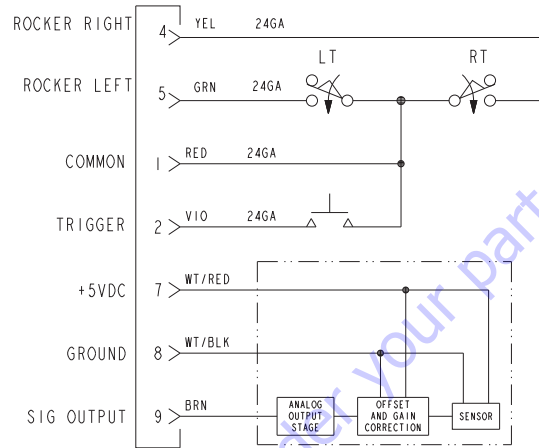
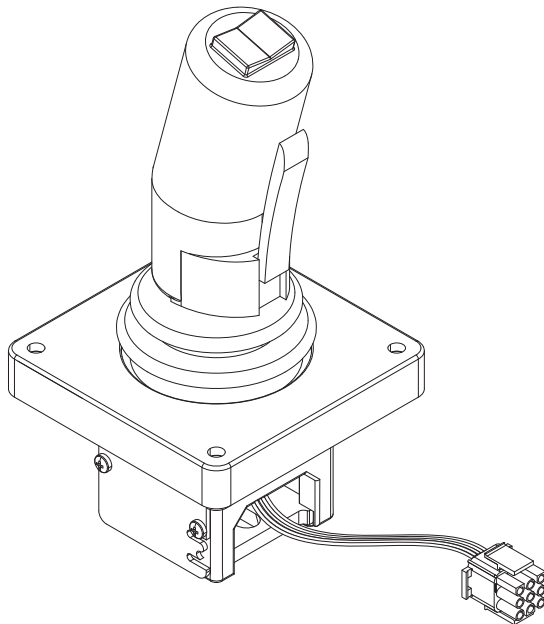

Figure 3-36. Joystick Controller

Table 3-9. Joystick Specifications

Type	Single Axis (Y Axis Only)
Input Voltage	5V
Current Consumption	10mA @ 12VDC
Centered Output Voltage	2.50VDC
Reverse Voltage	4.0VDC
Forward Voltage	1.0VDC

Table 3-10. Joystick Plug Loading Chart

Terminal	Color	Function
1	RED	Handle COM
2	VIOLET	Trigger N.O.
3		Spare
4	YELLOW	Rocker Right
5	GREEN	Rocker Left
6		Spare
7	White/RED	+5VDC
8	White/BLACK	Ground
9	BROWN	SIG Output

3.10 SCISSOR ARMS

Lift Cylinder Removal

REMOVAL

CAUTION

NEVER WORK UNDER ELEVATED SCISSOR ARMS WITHOUT FIRST PROPERLY BRACING/BLOCKING SCISSOR ARM ASSEMBLY.

1. Remove platform (refer to Figure 3-34.).
2. Elevate the scissor arm assembly enough to gain access to the upper and lower connection pins. Block/brace scissor arms and disable machine.
3. Disconnect, cap and label all hydraulic lines connected to the lift cylinder. Disconnect and label all electrical wires connected to lift cylinder.
4. Attach lifting straps to overhead crane and lift cylinder and support cylinder before attempting to remove from arm assembly.
5. Remove the cylinder upper pin by removing the bolt, nut and collar. Push pin out.
6. Remove the lower pin by removing the bolt and nut. Push pin out.
7. Carefully lift cylinder up and out of arm assembly.

INSTALLATION

1. Follow Removal Steps in reverse.
2. After assembly, operate lift cylinder to ensure proper operation.

NOTE: Refer to Figure 4.13, Cylinder Assemblies for cylinder breakdown.

Scissor Arms Removal

CAUTION

NEVER WORK UNDER ELEVATED SCISSOR ARMS WITHOUT FIRST PROPERLY BRACING/BLOCKING SCISSOR ARM ASSEMBLY.

NOTE: Scissor arms can be removed individually or as an entire assembly.

ARM REMOVAL

1. Remove platform (refer to Figure 3-34.) and lift cylinder (refer to Figure 3-37.).
2. Disconnect, cap and label all hydraulic hoses and wiring attached to scissor arms.
3. Support the scissor arms being removed.
4. Remove the pin from the scissor arm by removing the two bolts, nuts and collar.
5. Push pin and bearing out from scissor arms.
6. Repeat at each connecting pin.

INSTALLATION

1. Follow Removal Steps in reverse.

Scissor Arm Assembly Removal

CAUTION

NEVER WORK UNDER ELEVATED SCISSOR ARMS WITHOUT FIRST PROPERLY BRACING/BLOCKING SCISSOR ARM ASSEMBLY.

REMOVAL:

NOTE: Applies to all four corners.

1. Remove platform (refer to Figure 3-34., Platform Removal).
2. Disconnect, cap and label all hydraulic hoses and wiring attached to scissor arms and lift cylinder.
3. Support the scissor arm assembly with appropriate lifting straps and overhead crane.
4. Disconnect the scissor arm assembly from the four sliders by removing the bolts and nuts.
5. Push pins out.
6. Carefully lift arm assembly up and away from chassis.

INSTALLATION:

Follow Removal Steps in reverse.

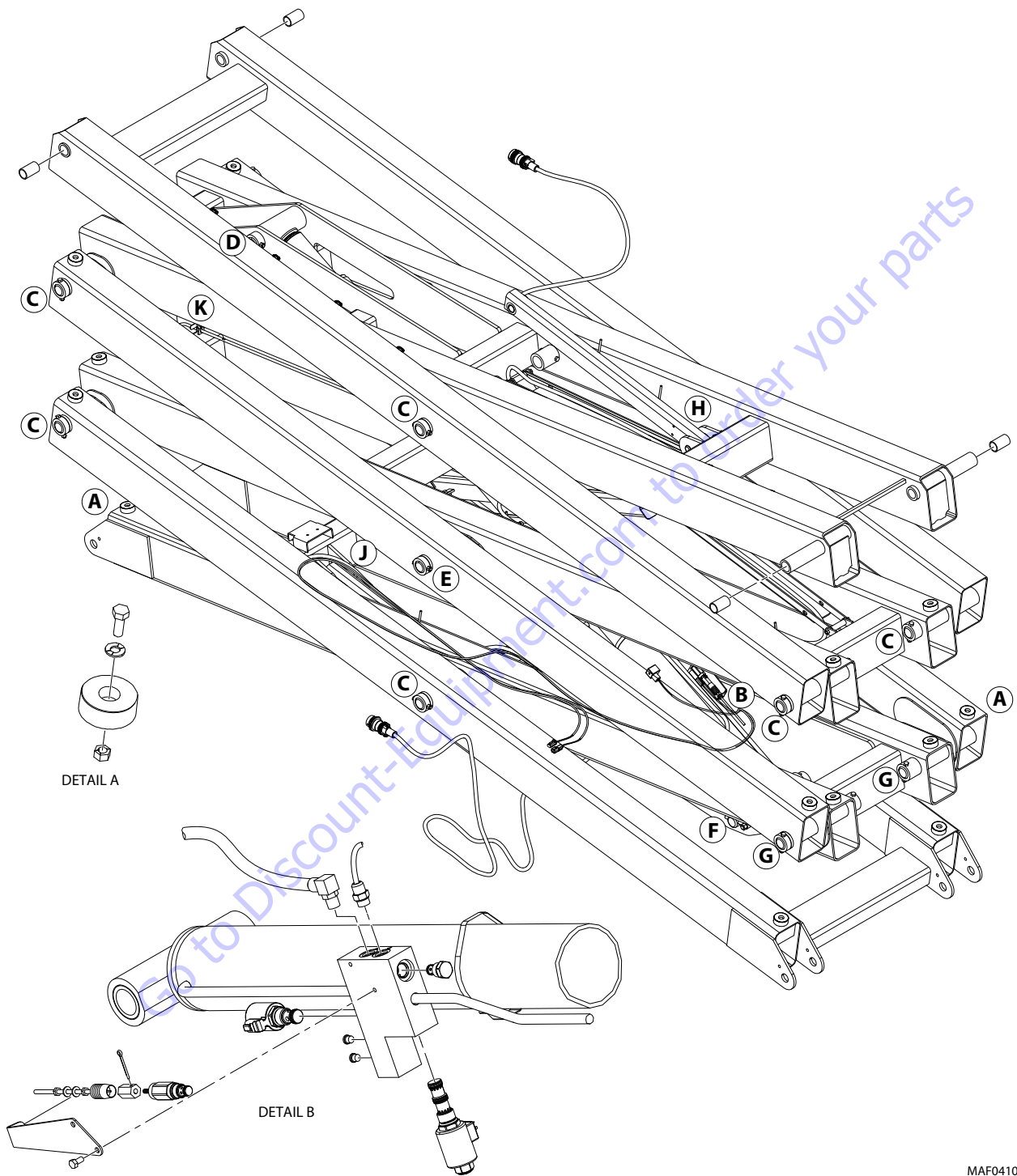

MAF04100

Figure 3-37. Scissor Arm Component - 330LRT Assembly 1 of 2

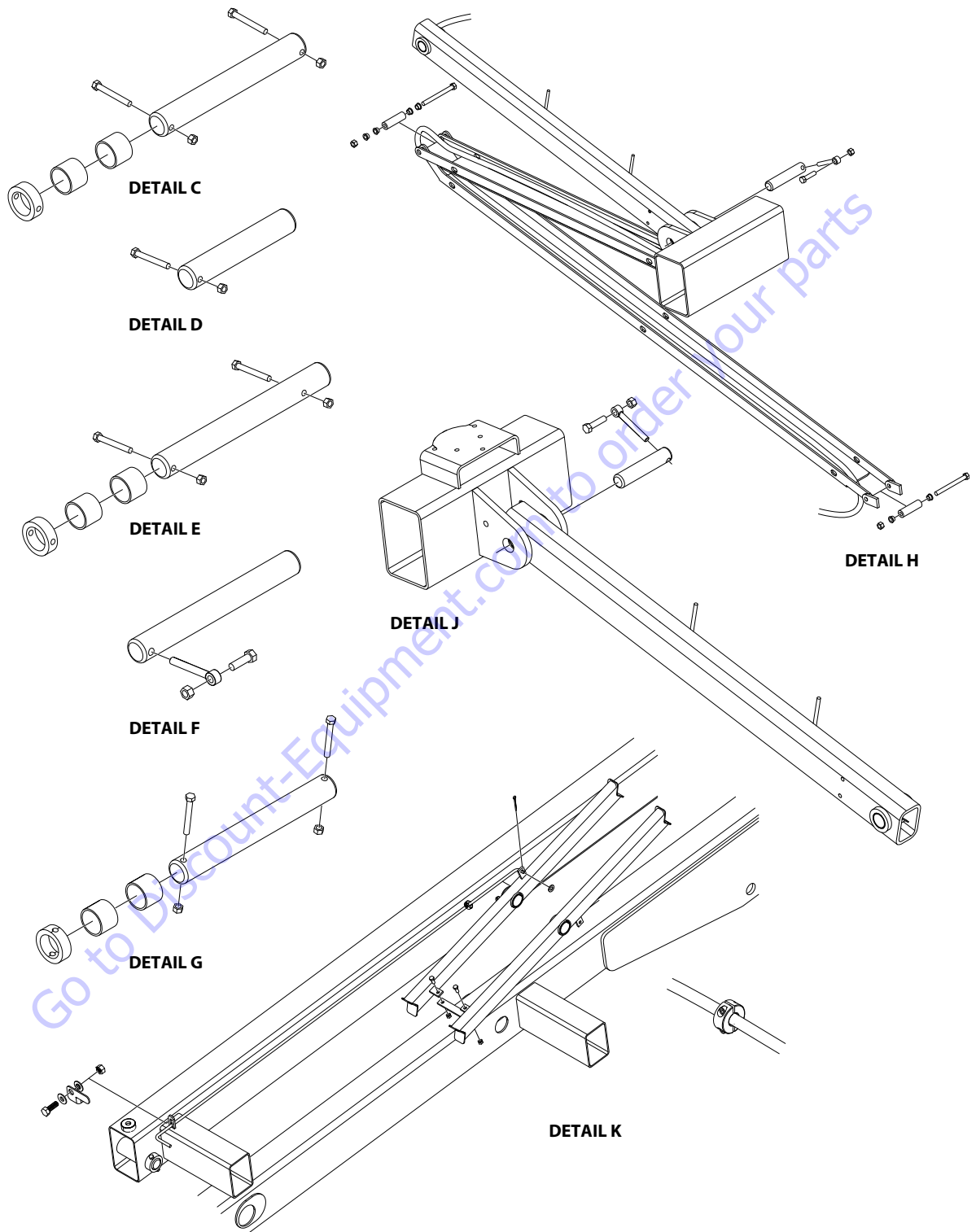
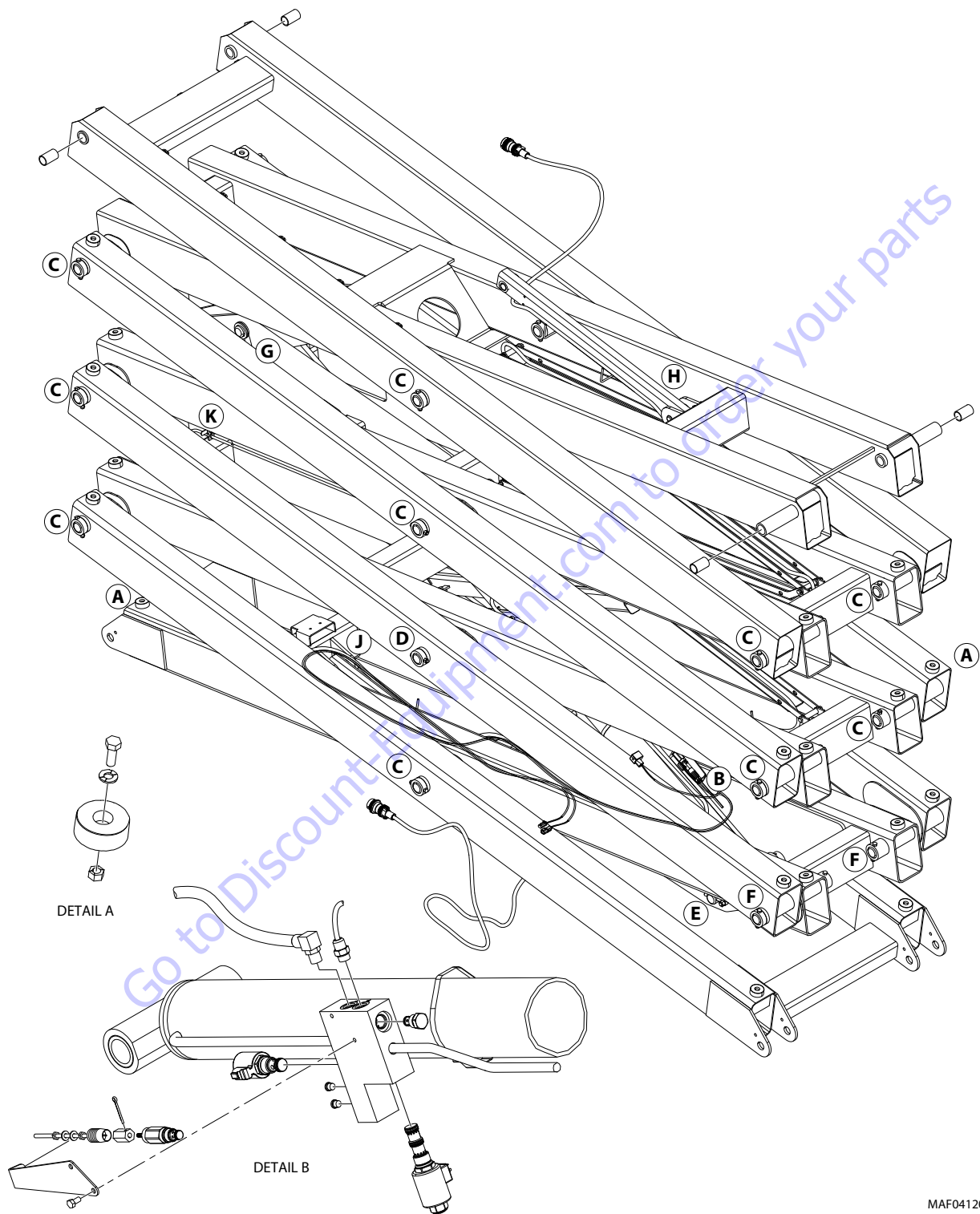

Figure 3-38. Scissor Arm Component - 330LRT Assembly 2 of 2

MAF04111



MAF04120

Figure 3-39. Scissor Arm Component - 430LRT Assembly 1 of 2

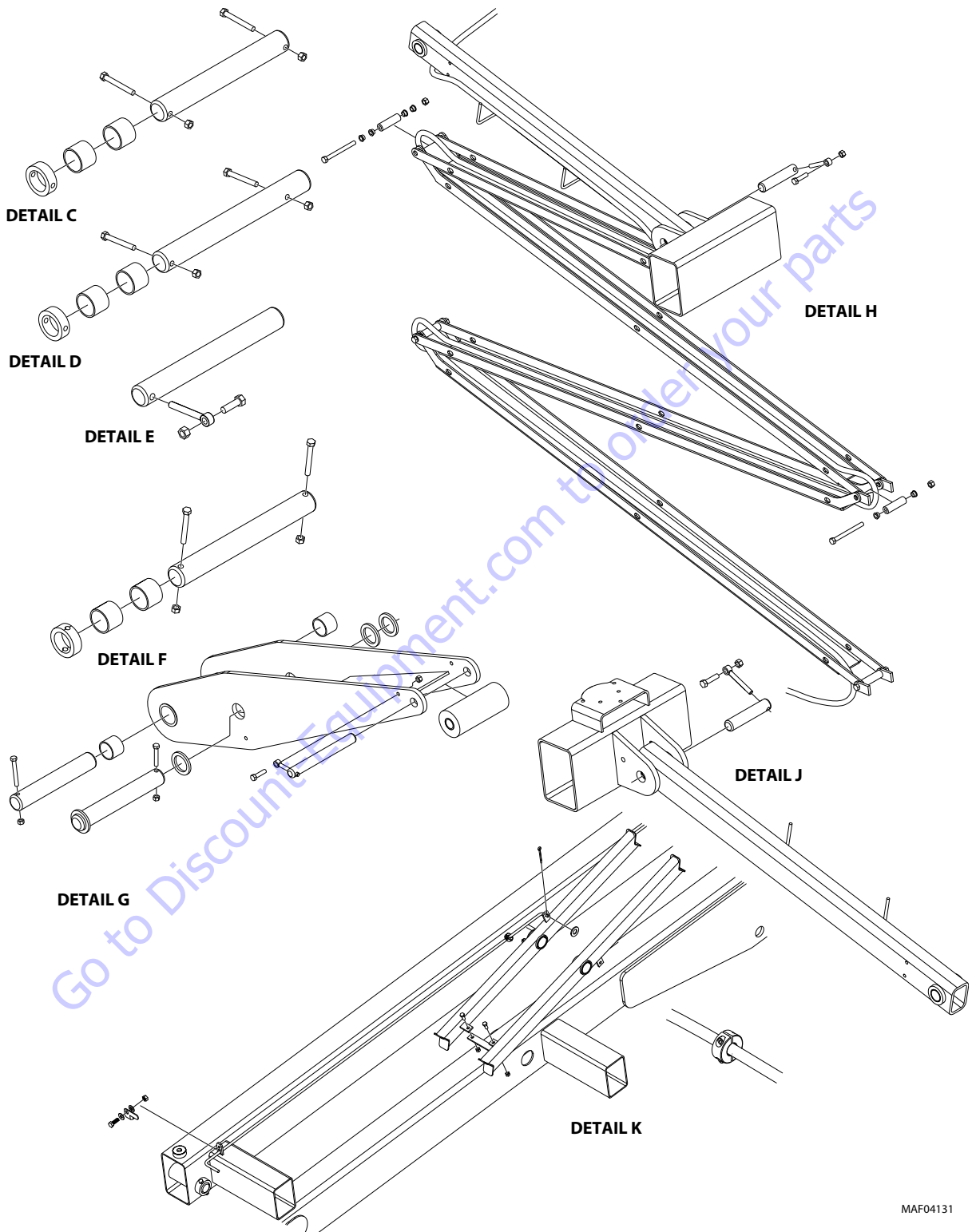

MAF04131

Figure 3-40. Scissor Arm Component - 430LRT Assembly 2 of 2

3.11 SIDE COMPARTMENT COVERS

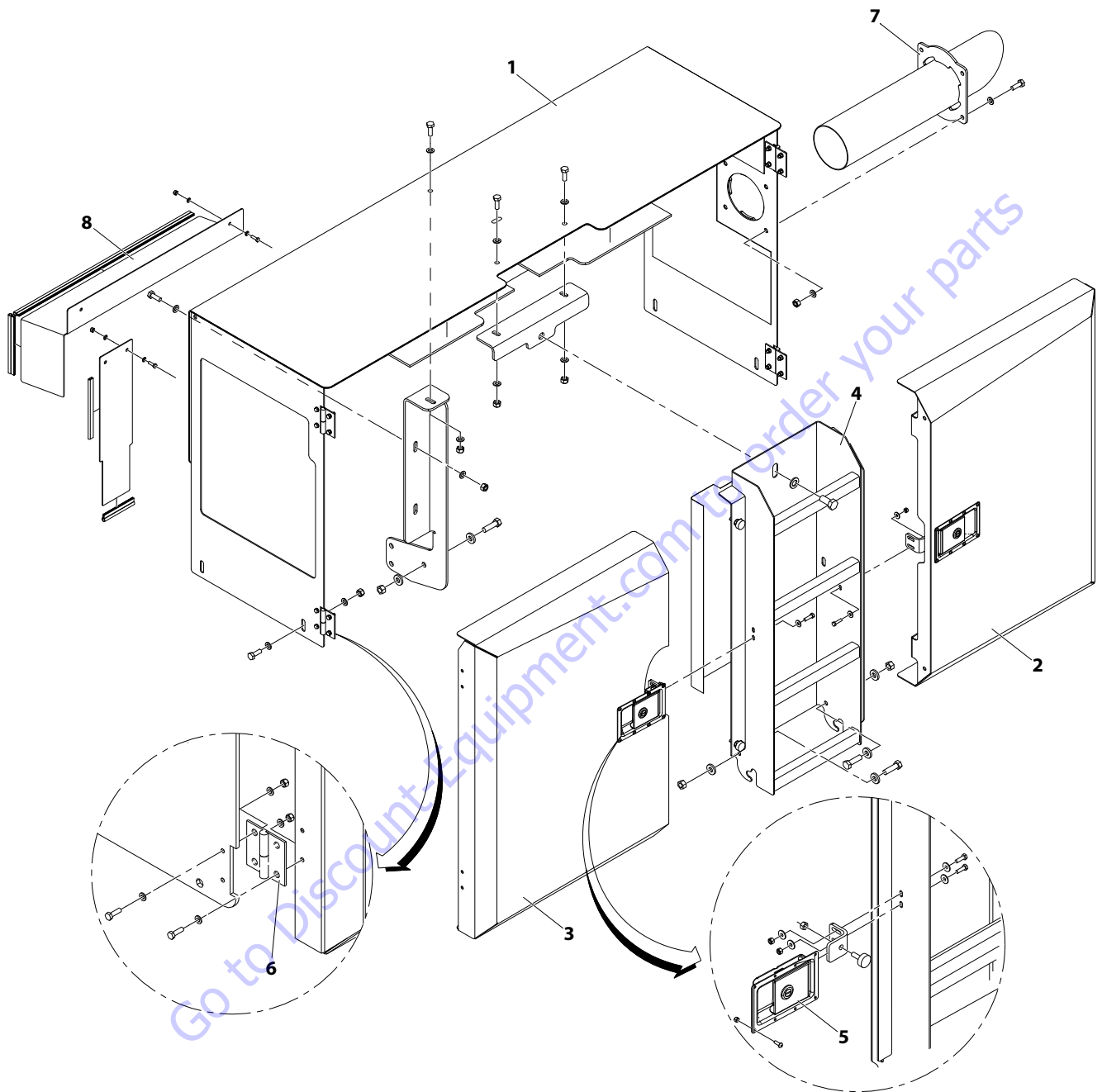

MAF06300

Figure 3-41. Left Side - Engine Compartment Covers

- | | | |
|----------------------------------|------------------------|------------------------|
| 1. Engine Main Compartment Cover | 4. Ladder Assembly | 7. Engine Exhaust Tube |
| 2. Front Engine Door | 5. Door Latch Assembly | 8. Generator Shield |
| 3. Rear Engine Door | 6. Door Hinge Assembly | |

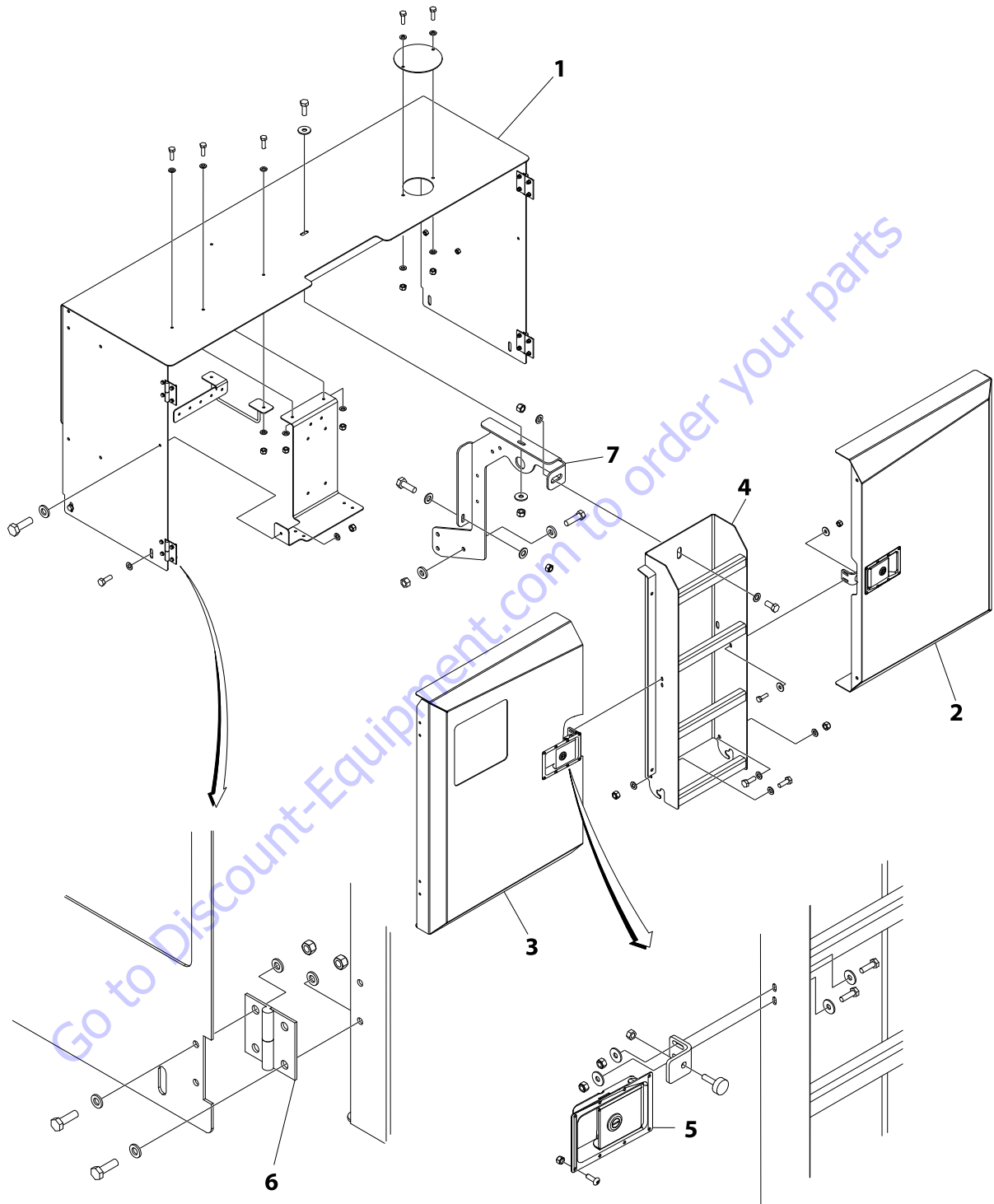

Figure 3-42. Right Side - Hydraulic/Fuel Compartment Covers

- | | | |
|--|------------------------|------------------------|
| 1. Hydraulic/Fuel Main Compartment Cover | 4. Ladder Assembly | 6. Door Hinge Assembly |
| 2. Hydraulic Tank Door | 5. Door Latch Assembly | 7. Support Ladder |
| 3. Fuel Tank Door | | |

Cover Removal

⚠ WARNING

NEVER WORK UNDER AN ELEVATED PLATFORM UNTIL IT HAS BEEN RESTRAINED FROM MOVEMENT WITH SAFETY PROPS, BLOCKING, OR OVERHEAD SLING.

NOTE: Procedures apply to both left and right side compartment hoods.

1. Elevate the platform to a height where, when removed and lifted, the compartment covers clear the underside of the platform. Engage the arm safety prop and/or block the scissor arms to prevent lowering.
2. Disable machine operation.
3. If removing the main compartment cover, the hinged cover and any outer covers/doors must be removed first.
4. Attach lifting straps to each end of the large compartment cover and support with an overhead lifting device.
5. Remove the bolts on the hinges to remove the door from the cover.
6. Remove the bolts and washers, from the front covers or doors, remove and lay aside.
7. Remove the ladder from the support bracket by removing the bolts, washers and nuts.
8. Remove the bolts and washers, from the front, top and back of the large compartment cover.

NOTE: On engine side only, remove the exhaust pipe shield from the cover by removing the bolts, washers, and nuts.

9. Carefully lift the main compartment cover up and away from the machine.

Cover Installation

1. Follow Removal Steps in reverse.

3.12 GROUND CONTROL STATION

Control Station Removal

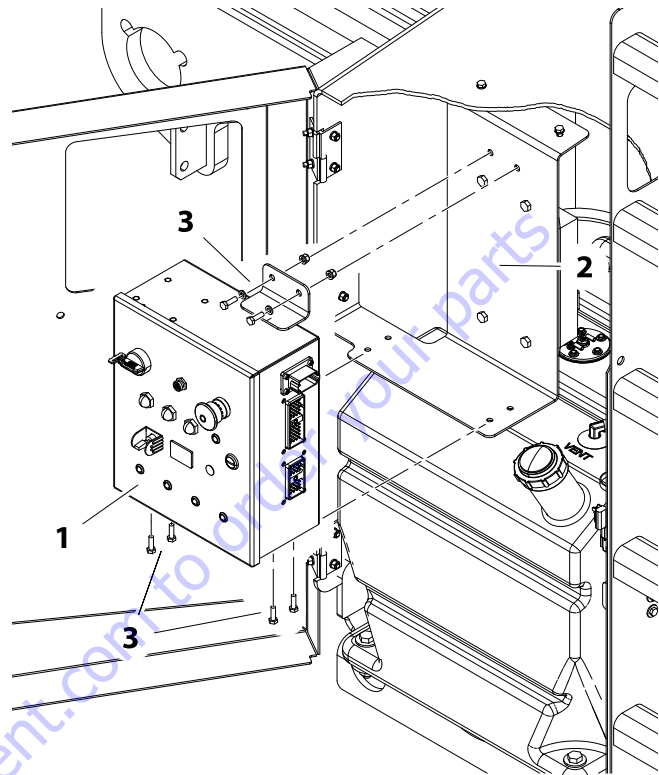

- | | |
|-----------------------|-------------------------------------|
| 1. Ground Control Box | 3. Mounting Bolts, Nuts and Washers |
| 2. Control Box Mount | |

Figure 3-43. Ground Control Station Removal

REMOVAL

1. Disconnect and label the harnesses from the ground control box (1).
2. Remove the ground control box from the control box mount (2) by removing the four lower and two upper bolts, nuts and washers (3).

INSTALLATION

1. Follow Removal Steps in reverse.

Ground Control Station Components

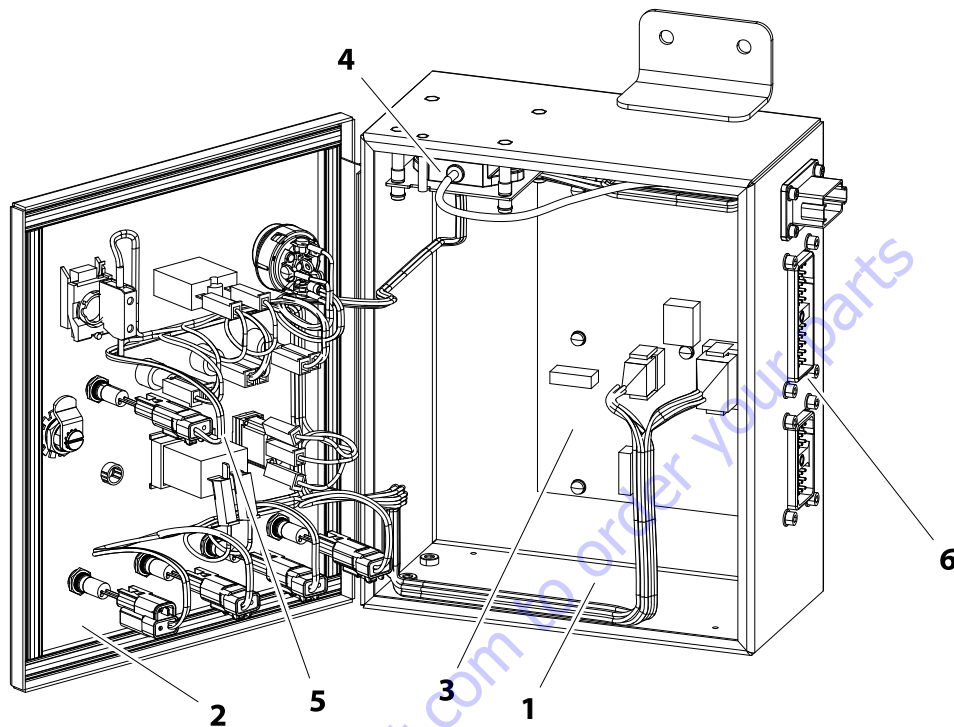

- | | |
|-----------------------|---------------------------------|
| 1. Ground Control Box | 4. Chassis Tilt Sensor |
| 2. Lid | 5. Control Switches and Buttons |
| 3. Circuit Board | 6. Machine Harness Connectors |

Figure 3-44. Ground Control Station Components

DISASSEMBLY

1. Disconnect the harnesses from the ground control box (1).
2. Open the lid (2) to gain access to components inside the ground control box.
3. Disconnect any wires and/or plugs from damaged components (3, 4, or 5).
4. Remove and replace components if necessary.

ASSEMBLY

1. Reattach any wires and/or plugs.
2. Close lid (2) and secure.
3. Reattach machine harnesses to the ground control box (6).

NOTE: If tilt sensor or the ground control station box is removed and replaced, the tilt sensor must be calibrated (refer to Section 5.5, Location of Additional Sensors).

Options Control Module

The Options Control Module provides additional machine harness connections for additional machine components such as the Leveling Jacks and LSS control system. If determined faulty, this module is only replaceable and not serviceable.

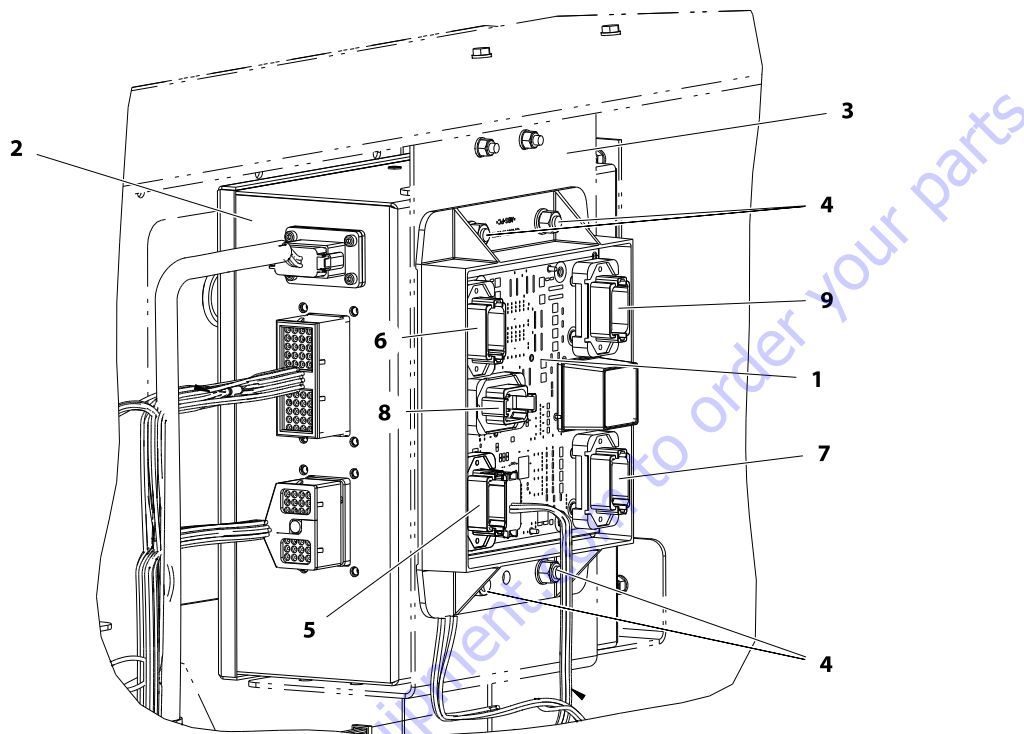

- | | |
|---------------------------------------|-----------------|
| 1. Option Control Module | 6. J2-Connector |
| 2. Ground Control Station | 7. J3-Connector |
| 3. Station/Module Mounting Plate | 8. J4-Connector |
| 4. Module Mounting Bolts/Nuts/Washers | 9. J5-Connector |
| 5. J1-Connector | |

Figure 3-45. Optional Control Module

REMOVAL

1. Tag and Disconnect the wiring harness(s) from the J-Connectors on the module.
2. Remove the four nuts and washers (4) from the mounting bolts.
3. Remove the module from the mounting plate.

INSTALLATION

1. Mount new module to the mounting plate using the four bolts, nuts and washers (4)
2. Reconnect the J-Connector wiring harness(s).
3. Power up machine and operate functions to check proper operation.

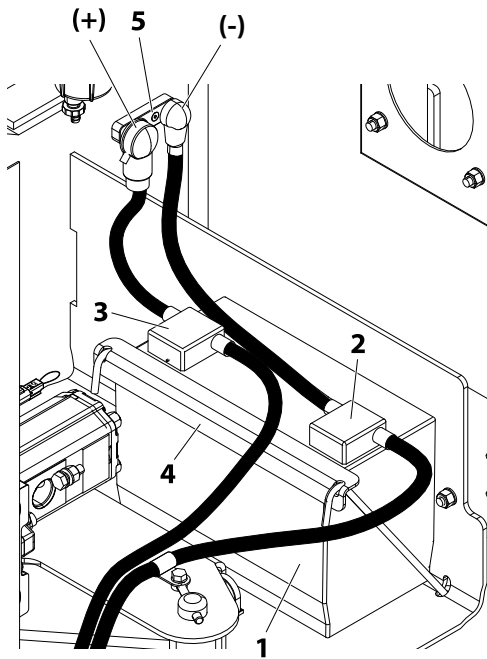
3.13 BATTERY**Figure 3-46. Battery Removal**

- | | |
|-------------------------|---------------------------------|
| 1. Battery | 4. Bracket, Bolt, Nut & Washers |
| 2. Battery Terminal (-) | 5. Auxiliary Power Block |
| 3. Battery Terminal (+) | |

REMOVAL

1. Disconnect the red battery cable from the positive battery terminal (3).
2. Disconnect the black battery cable from the negative (2) battery terminal.
3. Remove the bolts, nuts, and washers to remove the hold-down bracket (4) securing the battery in place. Remove battery.
4. With the positive battery cable disconnected, if necessary, the auxiliary power block (5) can be removed by first disconnecting the cables from the block. Remove the bolts, washers and nuts securing the block to the machine compartment cover.

INSTALLATION

1. Place battery in the seat. Negative battery terminal (2) should be closest to outside of machine.
2. Secure battery in place with the hold-down bracket, bolt, nut and washers (4).
3. Reconnect red battery cable to positive battery terminal (3). Secure terminal cover in place over terminal.
4. Reconnect black battery cable to negative battery terminal (2).
5. If removed, secure auxiliary power block (5) to machine using two bolts, nuts and washers. Reconnect cables.

3.14 FUEL TANK

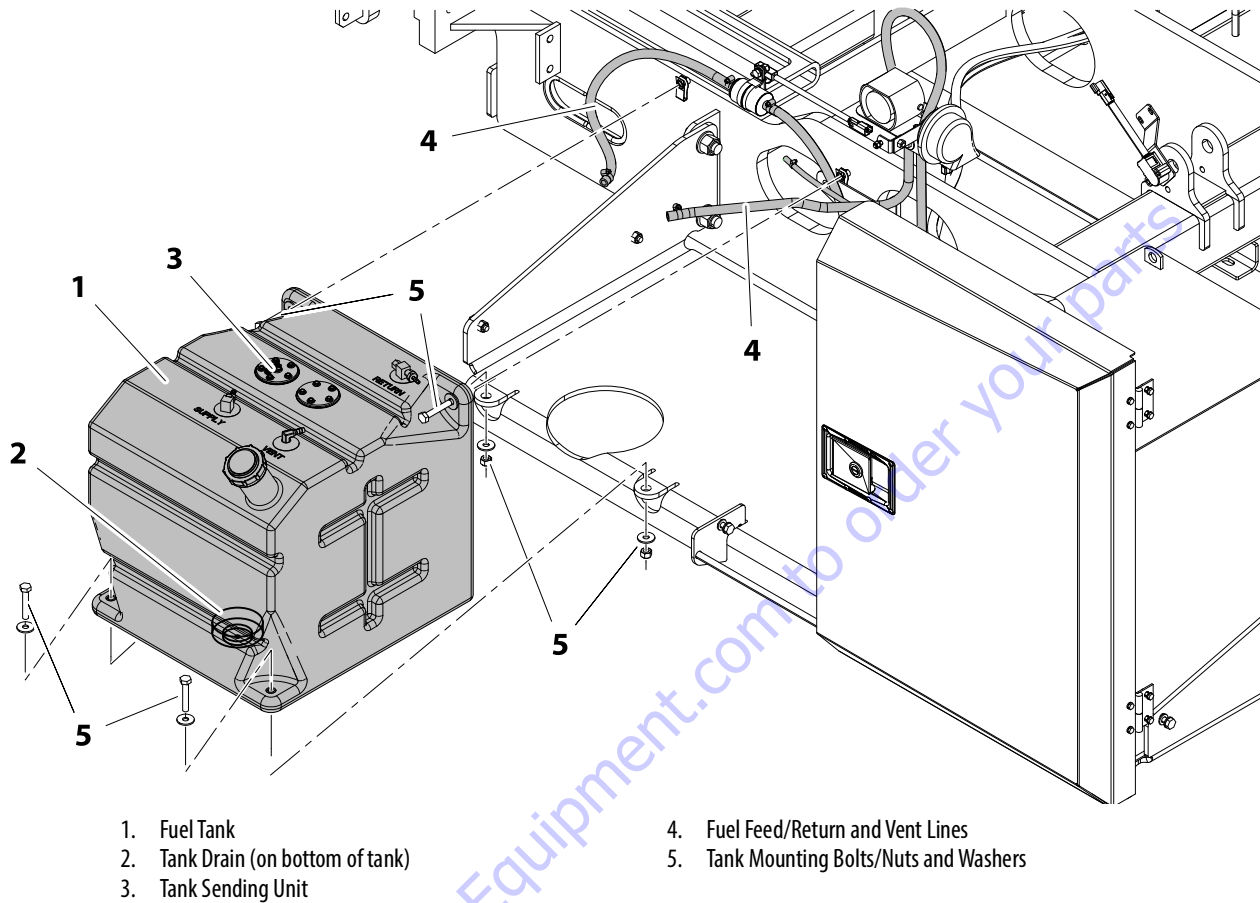

Figure 3-47. Fuel Tank Installation

REMOVAL

NOTE: Outer cabinet, ladder and door shown removed for illustrative clarity only.

1. Disable machine operation.
2. Drain fuel from the fuel tank (1, 2). Store fuel in appropriate receptacle.
3. Disconnect and cap the fuel and vent lines (4) attached to the fuel tank.
4. Remove the bolts, washers and nuts (5) from the bottom front and top rear of the fuel tank.
5. Remove the fuel tank from the hydraulic compartment.
6. If necessary, remove the tank sending unit (3) from the tank.

INSTALLATION

1. Follow Removal Steps in reverse.

NOTE: If removed, reuse or replace sending unit gasket, as necessary. Before reinstalling, apply Low Strength Threadlocking Compound to threads of tank sending unit bolts.

If removed, before reinstalling into tank insert apply pipe sealant (High Strength Threadlocking Compound) to fuel and vent line fittings on the fuel tank (1).

Apply (High Strength Threadlocking Compound thread sealant) to threads of tank aluminum drain plug before installing. Do not over tighten.

2. Refill fuel tank with proper fuel.

NOTICE

ENSURE PROPER FUEL LINES ARE ATTACHED TO PROPER FITTING ON FUEL TANK. FUEL TANK IS LABELED WITH RETURN LINE, SUPPLY LINE AND VENT LINE.

3. Ensure there is no fuel leakage.

3.15 HYDRAULIC TANK

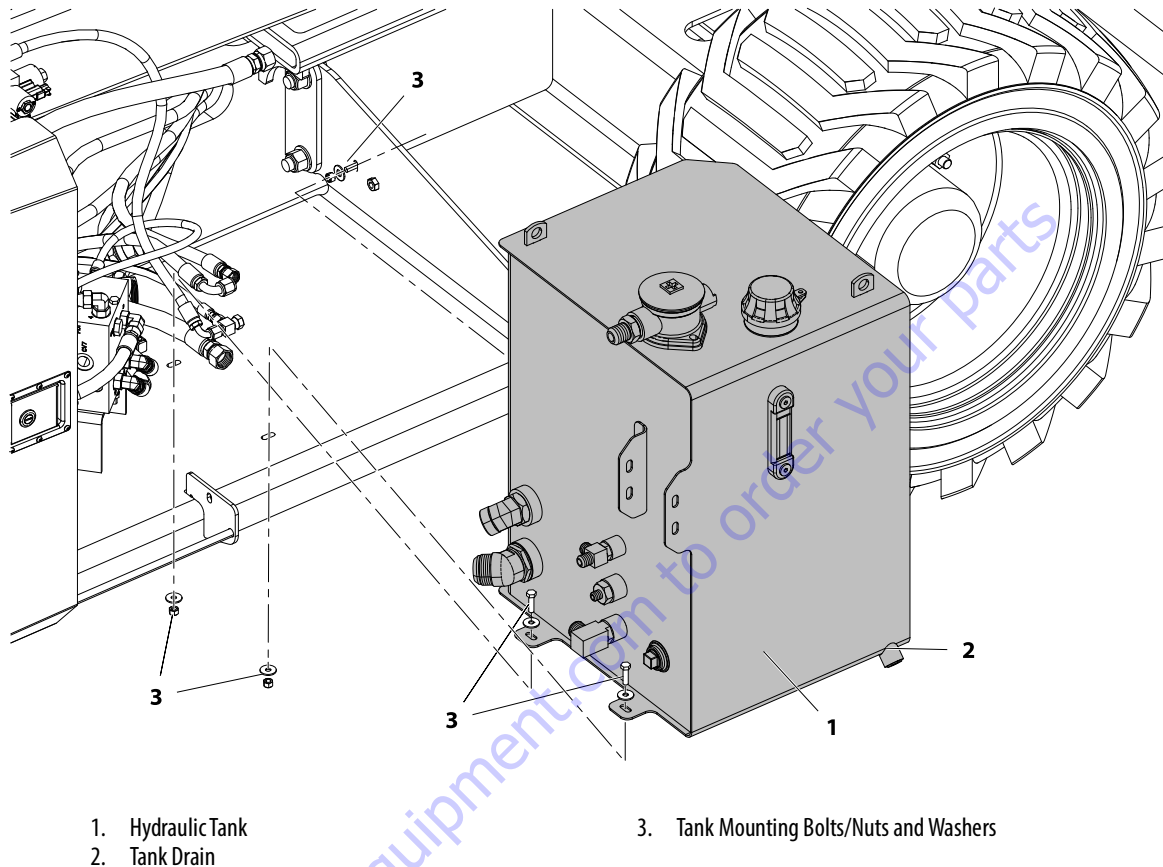

Figure 3-48. Hydraulic Tank Removal

REMOVAL

NOTE: It is recommended to remove the side compartment cover before attempting to remove the hydraulic tank (refer to Section 3.11, Side Compartment Covers).

1. Disable machine operation.
2. Drain hydraulic fluid from hydraulic tank (1) by opening the drain plug (2). Store hydraulic fluid in appropriate receptacle.
3. Disconnect, cap and label all hoses connected to tank.
4. Remove the bolts, washers, and nuts (3) attaching the hydraulic tank to the machine. Remove tank from machine.

NOTE: Hydraulic tank has two lifting lugs on the top corners for lifting.
Empty tank weighs approximately 105 lbs (47.6 kg).

INSTALLATION

1. Follow Removal Steps in reverse.
2. Ensure drain plug (2) is tight. Refill hydraulic tank (1) with 34 gal (128.7 l) hydraulic fluid.

3.16 KUBOTA ENGINE

Engine Tray - Swing Out

NOTE: When servicing components on the back side of the engine, remove the tray (2) and ladder (3), bolts, nuts and washers to swing the engine tray out for better access (as shown below).

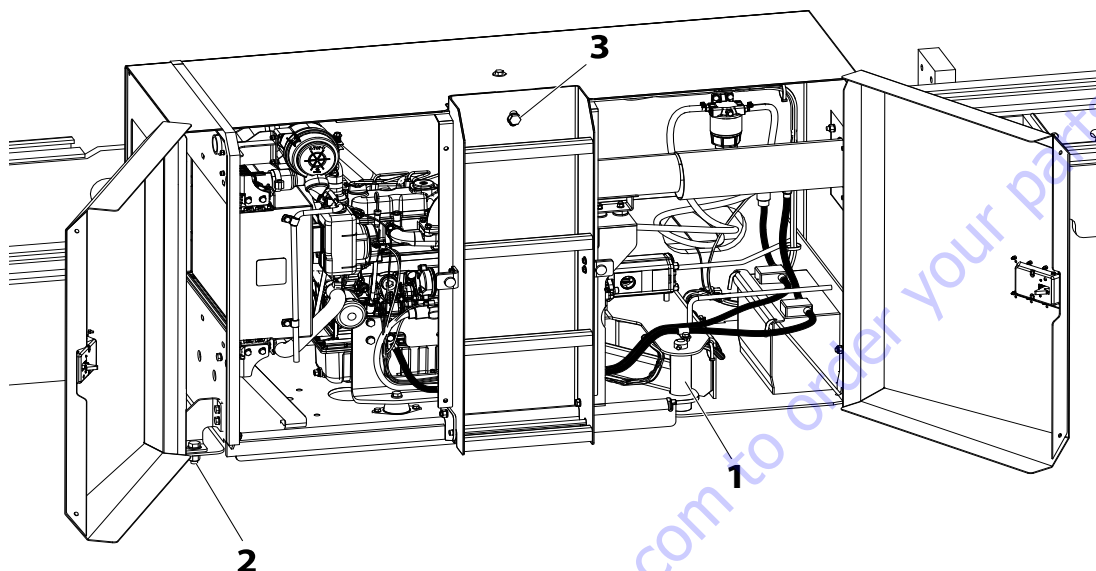

- 1. Tray Pivot Pin
- 2. Tray to Frame - Bolt, Nut and Washer
- 3. Ladder To Cabinet - Bolt, Nut, and Washer

Figure 3-49. Engine Swing Out Tray Components

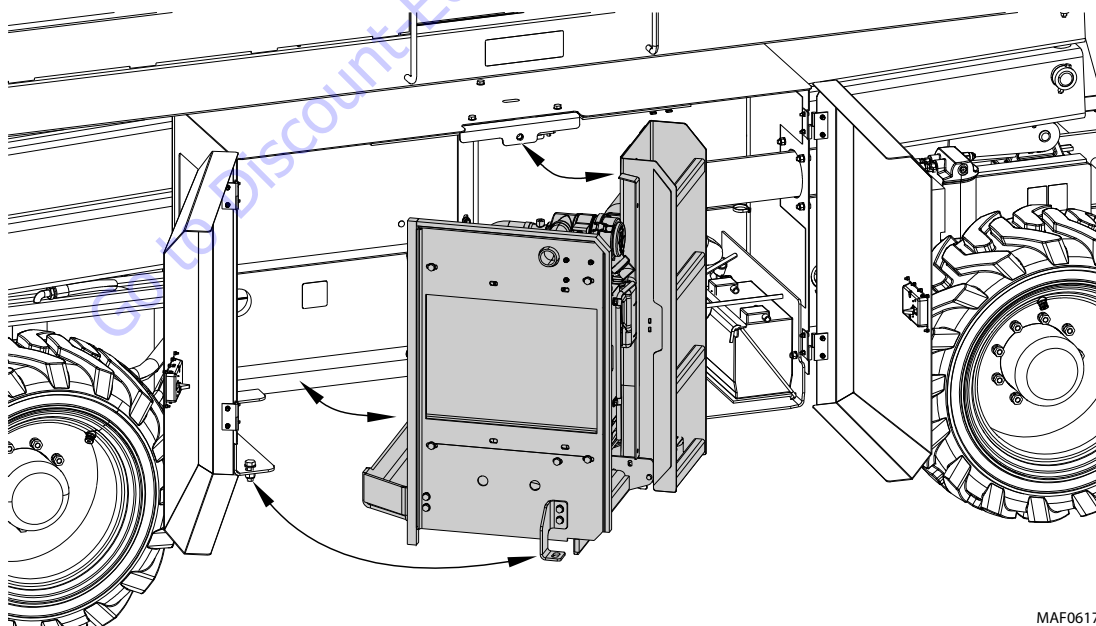

MAF06170

Figure 3-50. Engine Tray In Swing Out Position

Engine Removal

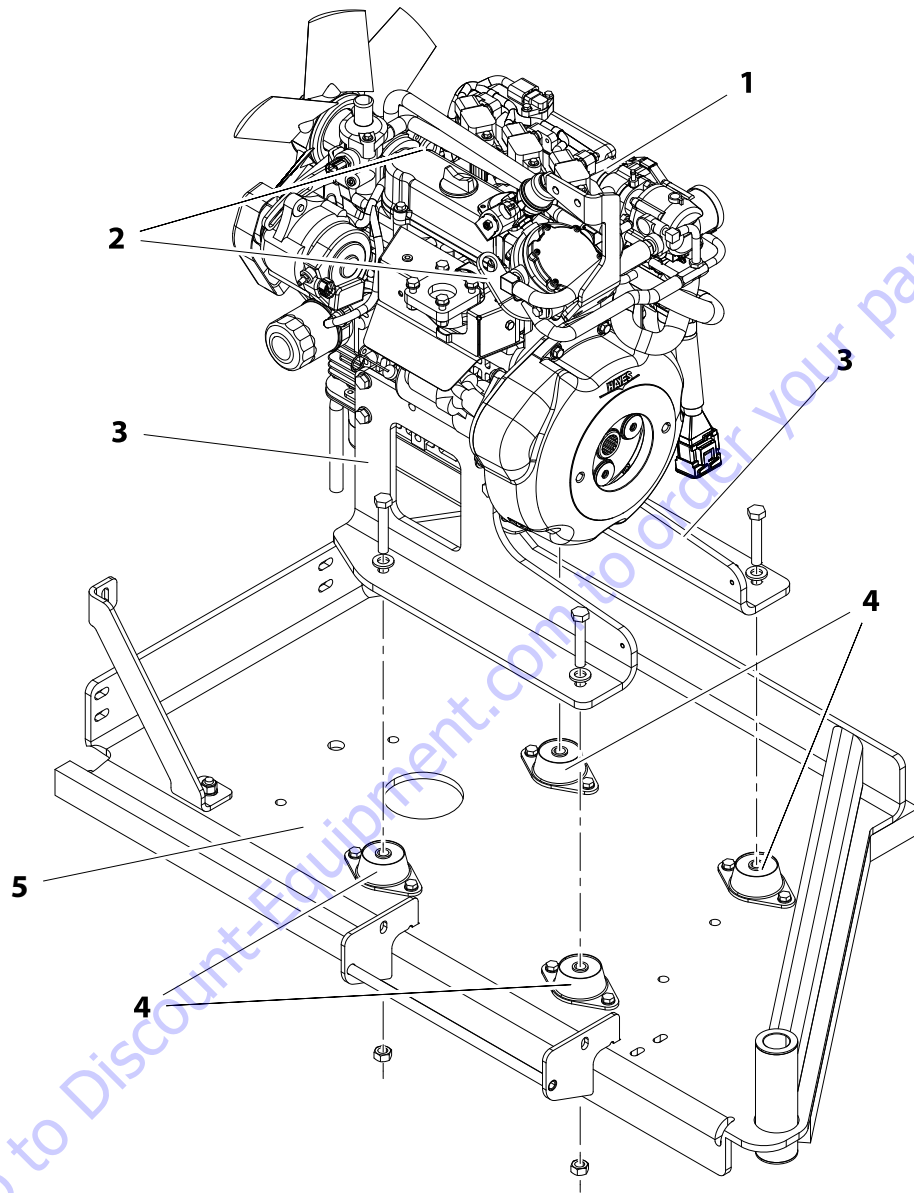

- 1. Kubota Engine (Shown)
- 2. Engine Lifting Lugs
- 3. Left/Right Side Engine Mounting Brackets

- 4. Engine Isolator Mount
- 5. Swinging Engine Tray

Figure 3-51. Engine Removal (All Engines)

⚠ CAUTION

ALLOW ENGINE AND COMPONENTS TO COOL DOWN BEFORE SERVICING.

REMOVAL

1. Disable machine operation. Disconnect battery positive (+) terminal. Swing engine tray (5) out for access to both sides of engine.
2. Remove platform ladder and brackets, exhaust system, air cleaner system, hydraulic pumps and radiator cooling system, as necessary.
3. Disconnect, cap and label all hoses connected to engine (1). Disconnect and label all electrical wiring connected to engine.
4. Using the lifting lugs (2) at the front and rear corners of the engine, support engine (1) with lifting device capable of lifting 500 lbs (227 kg) (refer to engine manual for proper lifting information).
5. Remove the four large bolts, nuts, and washers securing the left/right side engine mounting brackets (3) to the isolator mounts (4) and tray.
6. Slowly lift the engine up and out of the engine compartment.

NOTICE

IF NOT REMOVED, BE CAREFUL NOT TO DAMAGE THE RADIATOR FAN ON THE RADIATOR HOUSING WHEN LIFTING THE ENGINE.

INSTALLATION

1. Follow Removal Steps in reverse.

NOTE: *Apply Medium Strength Threadlocking Compound to the engine mount bolts*

Go to Discount-Equipment.com to order your parts

Dual Fuel/LPG System

⚠ CAUTION

IT IS POSSIBLE TO SWITCH FROM ONE FUEL SOURCE TO THE OTHER WITHOUT ALLOWING THE ENGINE TO STOP. EXTREME CARE MUST BE TAKEN AND THE FOLLOWING INSTRUCTIONS MUST BE FOLLOWED.

Changing From Gasoline to LP Gas

NOTE: Before climbing onto the platform, open hand valve on LP gas supply tank by turning valve counterclockwise.

1. Start engine from platform control station.
2. With the engine under a no load condition, open the hand valve on the LP gas supply tank by turning counterclockwise.
3. While the engine is operating, place the two position LPG/GAS SELECT switch at the platform control station to LP gas.

Changing From LP Gas to Gasoline

1. With the engine operating on LP gas under a no load condition, position the LPG/GAS SELECT switch at the platform station to the GAS SELECT position.
2. If the engine 'stumbles' because of a lack of gasoline, place the switch to the LPG position until the engine regains smoothness, then return the switch to the GAS SELECT position. Repeat as necessary until the engine runs smoothly on gasoline.
3. Close the hand valve on the LP gas supply tank by turning clockwise.

Using Liquid Petroleum (LP) Gas

⚠ WARNING

CLOSE FUEL VALVE ON TANK WHEN PARKING SCISSOR LIFT MORE THAN MOMENTARILY.

WHEN REFUELING LPG POWERED SCISSOR LIFTS, ALWAYS FOLLOW MANUFACTURERS SPECIFICATIONS AND/OR APPLICABLE REGULATIONS.

1. If machine is to be left overnight or longer, it must be parked outside or the LPG tank removed and stored outside.
2. LPG is extremely flammable. No smoking.
3. Only trained and authorized personnel are permitted to operate filling equipment.
4. Fill LPG tanks outdoors. Stay at least 50 ft (15 m) from buildings, motor vehicles, electrical equipment or other ignition sources. Stay at least 15 ft (5 m) from LPG storage tanks.
5. During transfer of LPG, metal components can become very cold. Always wear gloves when refilling or changing tanks to prevent "freeze burns" to skin.

6. Do not store LPG tanks near heat or open flame. For complete instructions on the storage of LPG fuels, refer to ANSI/NFPA 58 & 505 or applicable standards.

⚠ WARNING

DO NOT USE AN LPG TANK THAT IS DAMAGED. A DAMAGED TANK MUST BE REMOVED FROM SERVICE. FROST ON THE SURFACE OF A TANK, VALVES, OR FITTINGS INDICATES LEAKAGE. A STRONG ODOR OF LPG FUEL CAN INDICATE A LEAK.

Propane Fuel System Pressure Relief

⚠ CAUTION

THE PROPANE FUEL SYSTEM OPERATES AT PRESSURES UP TO 312 PSI (21.5 BAR). TO MINIMIZE THE RISK OF FIRE AND PERSONAL INJURY, RELIEVE THE PROPANE FUEL SYSTEM PRESSURE (WHERE APPLICABLE) BEFORE SERVICING THE PROPANE FUEL SYSTEM COMPONENTS.

To relieve propane fuel system pressure:

1. Close the manual shut-off valve on the propane fuel tank.
2. Start and run the vehicle until the engine stalls.
3. Turn the ignition switch OFF.

⚠ CAUTION

RESIDUAL VAPOR PRESSURE WILL BE PRESENT IN THE FUEL SYSTEM. ENSURE THE WORK AREA IS WELL VENTILATED BEFORE DISCONNECTING ANY FUEL LINE.

Propane Fuel System Leak Test

⚠ CAUTION

NEVER USE AN OPEN FLAME OF ANY TYPE TO CHECK FOR PROPANE FUEL SYSTEM LEAKS.

Always inspect the propane fuel system for leaks after performing service. Check for leaks at the fittings of the serviced or replaced component. Use a commercially available liquid leak detector or an electronic leak detector. When using both methods, use the electronic leak detector first to avoid contamination by the liquid leak detector.

Generator (If Equipped)

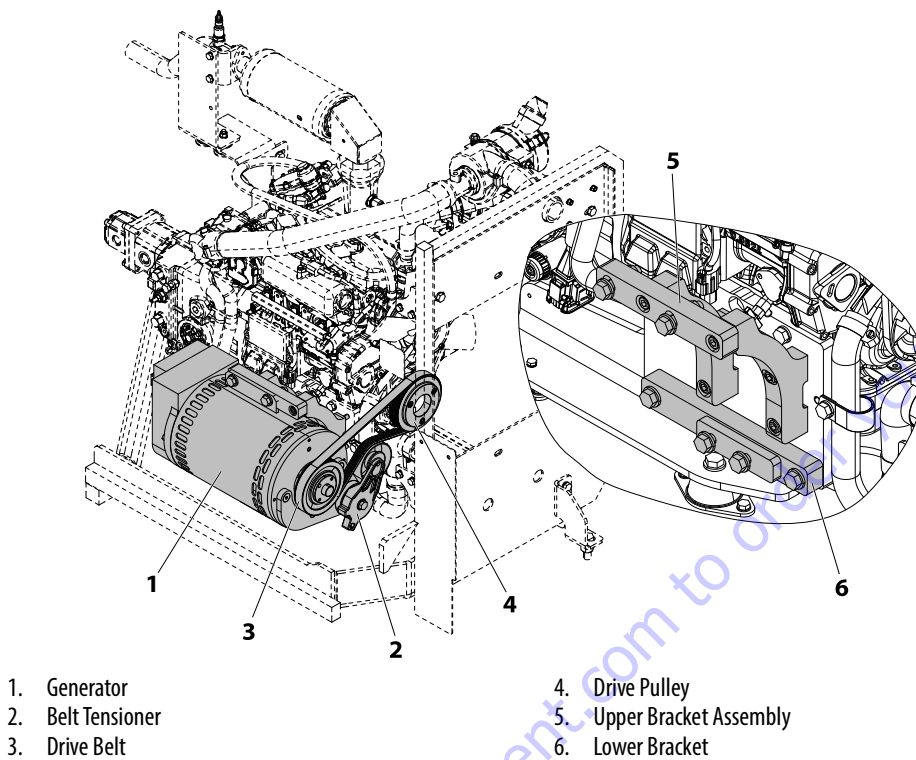

Figure 3-52. AC Generator Installation

CAUTION

ALLOW ENGINE AND COMPONENTS TO COOL DOWN BEFORE SERVICING.

REMOVAL

1. Disable machine operation. Rotate engine tray to access back of engine.
2. Disconnect and label electrical wires attached to generator (1).
3. Remove drive belt tension using the belt tensioner and remove belt from generator pulley.
4. Remove the generator from the engine by removing the two upper bracket (5) bolts, nuts, and washers. And the lower pivot, belt tensioner bolt, nut, and washer.
5. Replace belt if damaged.

INSTALLATION

1. Follow Removal Steps in reverse. Ensure belt is tight before securing generator with the bolts.

NOTE: Apply Medium Strength Threadlocking Compound to the threads of the generator mounting bolts.

Table 3-11. AC Generator Specifications

DESCRIPTION	7500 KW	4500 KW
Voltage	120/240V AC	120/240V AC - 60Hz 110/230V AC - 50Hz
Continuous	7.5 KW - 240V - 3 Phase 6.0 KW - 240V - 1 Phase 6.0 KW - 120V - 1 Phase	4.0 KW - 1 Phase
Peak	8.5 KW - 3 Phase 6.0 KW - 1 Phase	4.0 KW
Amps Peak	18.3 Amps - 3 Phase 26 Amps - 1 Phase 50 Amps - 1 Phase	20 Amps

NOTE: The generator control box is mounted on the rear wall of the Hydraulic/Fuel Tank cabinet just behind the ground control station. The platform junction box is mounted under the platform deck on the Hydraulic/Fuel Tank cabinet side of the machine. See Section 6, Electrical Schematics generator electrical configuration.

Exhaust System

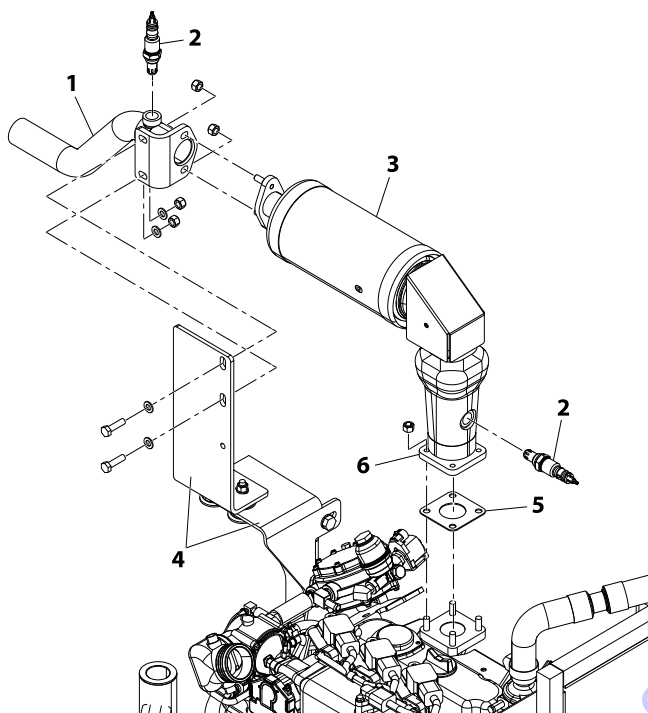

Dual Fuel - Gas/LPG

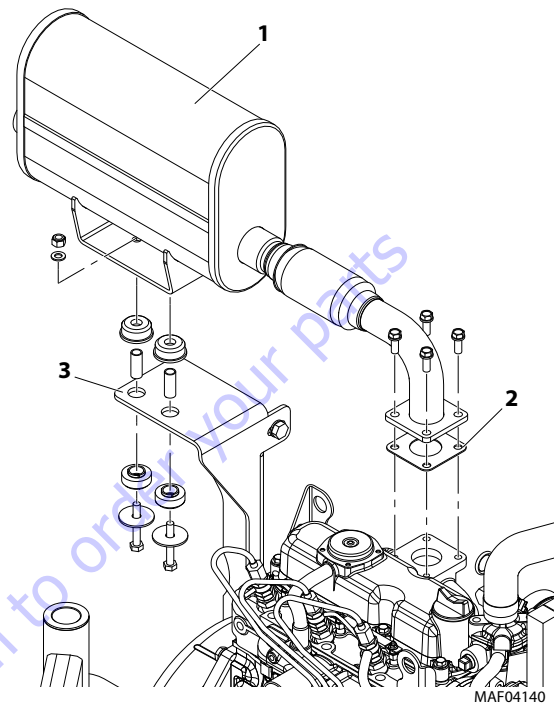

Diesel

Figure 3-53. Exhaust System (Kubota Engine)

- | | |
|--------------|---------------------|
| 1. Tail Pipe | 4. Mounting Bracket |
| 2. O2 Sensor | 5. Gasket |
| 3. Muffler | 6. Exhaust Pipe |

- | | |
|------------|---------------------|
| 1. Muffler | 3. Mounting Bracket |
| 2. Gasket | |

Dual Fuel - Gas/LPG

CAUTION

ALLOW ENGINE AND COMPONENTS TO COOL DOWN BEFORE SERVICING.

REMOVAL

1. Disable machine operation.
2. Disconnect the O2 sensor (2) wiring. Disassemble the tail pipe (1) from the muffler (3) by removing the attaching hardware.
3. Disassemble the muffler (3) from the exhaust pipe (6) removing by the attaching hardware. Also remove the two bolts and washers attaching the muffler to the mounting bracket (4).
4. Disconnect the O2 Sensor (2) wiring. Disassemble the exhaust pipe (6) from the engine exhaust manifold by removing the attaching hardware.

INSTALLATION

1. Follow Removal Steps in reverse.

NOTE: Torque on O2 Sensors is 32 ft. lb. (44 Nm).

Diesel

CAUTION

ALLOW ENGINE AND COMPONENTS TO COOL DOWN BEFORE SERVICING.

REMOVAL

1. Disable machine operation.
2. Unbolt the muffler (1) from the mounting bracket (3) by removing the bolts, nuts, and washers from the rubber isolating mounts.
3. Disassemble the muffler (1) from the exhaust manifold by removing the four bolts, washers, and gasket (2) attaching it to the manifold.

INSTALLATION

1. Follow Removal Steps in reverse.

Air Cleaner System

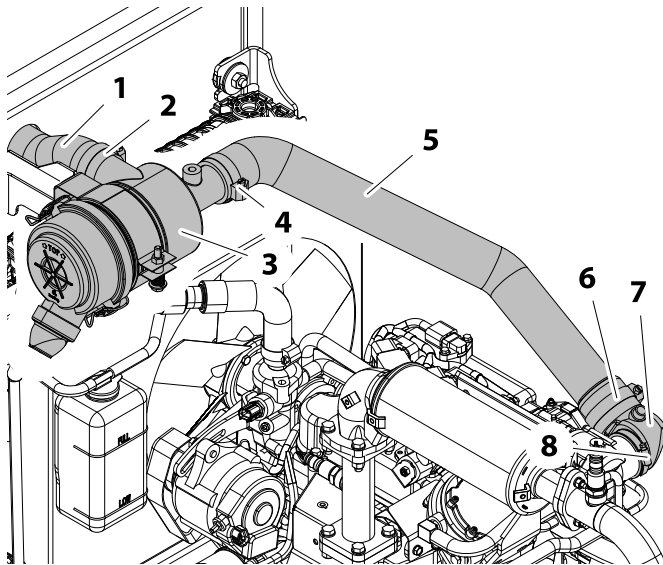

Dual Fuel - Gas/LPG

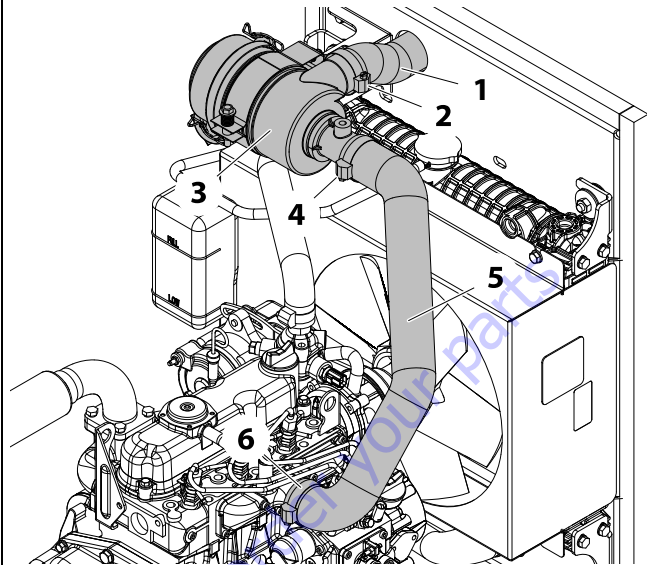

Diesel

Figure 3-54. Air Cleaner System (Kubota Engine)

- | | |
|----------------------|----------------|
| 1. Inlet Hose | 5. Intake Pipe |
| 2. Clamp | 6. Clamp |
| 3. Air Cleaner Assy. | 7. 90° Elbow |
| 4. Clamp | 8. Clamp |

- | | |
|----------------------|----------------|
| 1. Inlet Hose | 5. Intake Pipe |
| 2. Clamp | 6. Clamp |
| 3. Air Cleaner Assy. | |
| 4. Clamp | |

⚠ CAUTION

ALLOW ENGINE AND COMPONENTS TO COOL DOWN BEFORE SERVICING.

REMOVAL

1. Disable machine operation. If necessary, swing engine tray out for better access to components.
2. Loosen the clamp (4) and (8) attaching the intake pipe to the air cleaner assembly (3) and engine intake manifold. Disconnect the intake pipe from the air cleaner assembly and remove the complete intake pipe from the engine assembly.
3. To remove the air cleaner assembly (3) from the air cleaner bracket clamp, Unscrew the main clamp screw on the clamp until the air cleaner is loose in the bracket. Release the latches on the end and remove the end cap from the air cleaner assembly. Slide the air cleaner assembly with inlet hose out of the bracket clamp.

NOTE: The filter element can be removed from the air cleaner by releasing the latches on the end of the air cleaner. Replace filter element as needed. See Section 2.5, Service Maintenance Components.

INSTALLATION

1. Follow Removal Steps in reverse.

⚠ CAUTION

ALLOW ENGINE AND COMPONENTS TO COOL DOWN BEFORE SERVICING.

REMOVAL

1. Disable machine operation. If necessary, swing engine tray out for better access to components.
2. Loosen the clamp (4) and (6) attaching the intake pipe to the air cleaner assembly (3) and engine intake manifold. Disconnect the intake pipe from the air cleaner assembly and remove the complete intake pipe from the engine assembly.
3. To remove the air cleaner assembly (3) from the air cleaner bracket clamp, Unscrew the main clamp screw on the clamp until the air cleaner is loose in the bracket. Release the latches on the end and remove the end cap from the air cleaner assembly. Slide the air cleaner assembly with inlet hose out of the bracket clamp.

NOTE: The filter element can be removed from the air cleaner by releasing the latches on the end of the air cleaner. Replace filter element as needed. See Section 2.5, Service Maintenance Components.

INSTALLATION

1. Follow Removal Steps in reverse.

Radiator

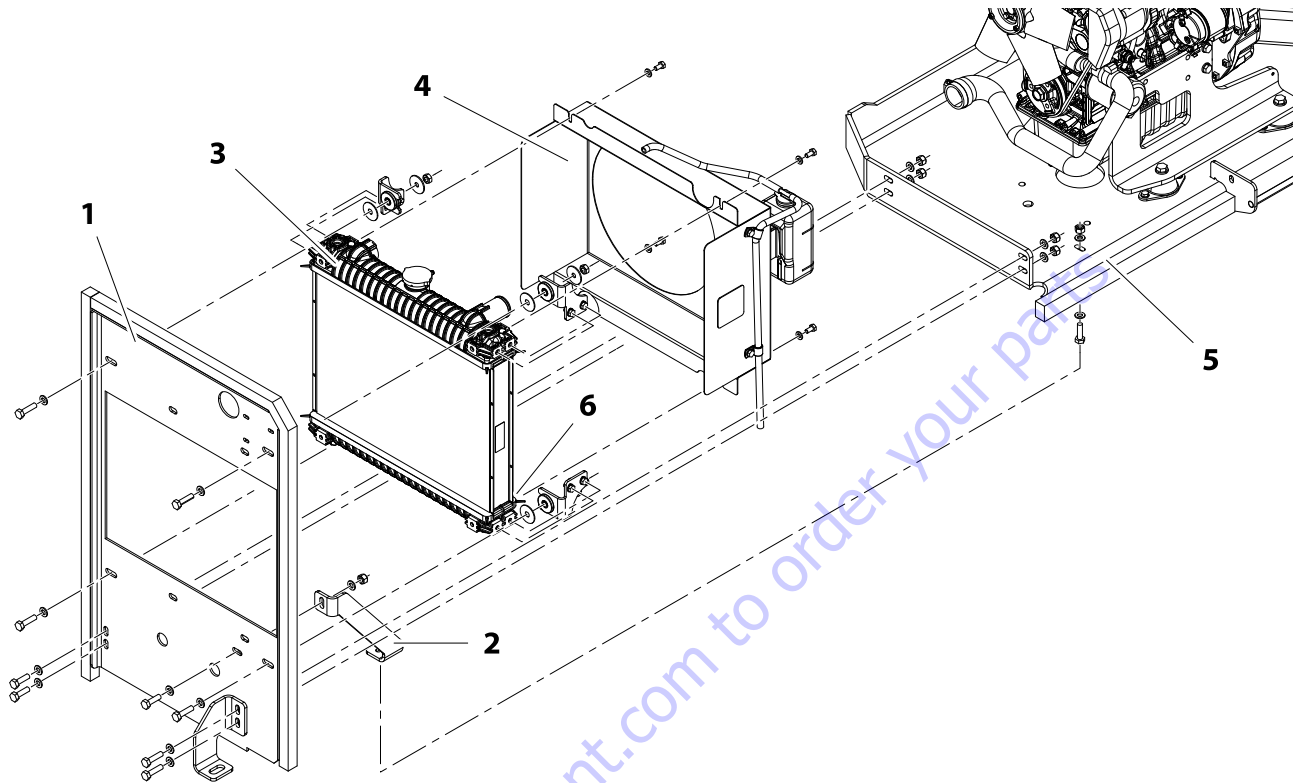

Figure 3-55. Radiator Installation (All Engines)

- | | |
|---------------------------------|------------------------------|
| 1. Radiator Mounting Plate | 4. Fan Shroud Assembly |
| 2. Mounting Plate Lower Support | 5. Engine Tray |
| 3. Radiator Assembly | 6. Radiator Petcock Location |

⚠ WARNING

ALLOW RADIATOR TO COOL DOWN BEFORE SERVICING.

REMOVAL

1. Disable machine operation. Swing engine tray out for better access to components.
2. Drain the coolant from the radiator into a suitable container by opening the petcock (6) on the bottom left corner of the radiator.
3. Disconnect the:
 - Upper and lower radiator hoses from the radiator.
 - If necessary remove the air cleaner or disconnect the intake pipe hose connector at the radiator mounting plate.
4. Support the radiator mounting plate assembly (1) and remove the four large bolts holding the mounting plate to the engine swivel tray (4), and the lower support bracket (2).

5. Re-check that all connections, hoses, etc. are disconnected and remove complete radiator mounting plate (1) assembly from the engine tray.
6. Disassemble the radiator shroud (3), and radiator assembly (2) from the radiator mounting plate assembly (1).

INSTALLATION

1. Follow Removal Steps in reverse.

NOTE: Refill with fresh clean coolant properly balanced.

Engine Electrical Component Locations

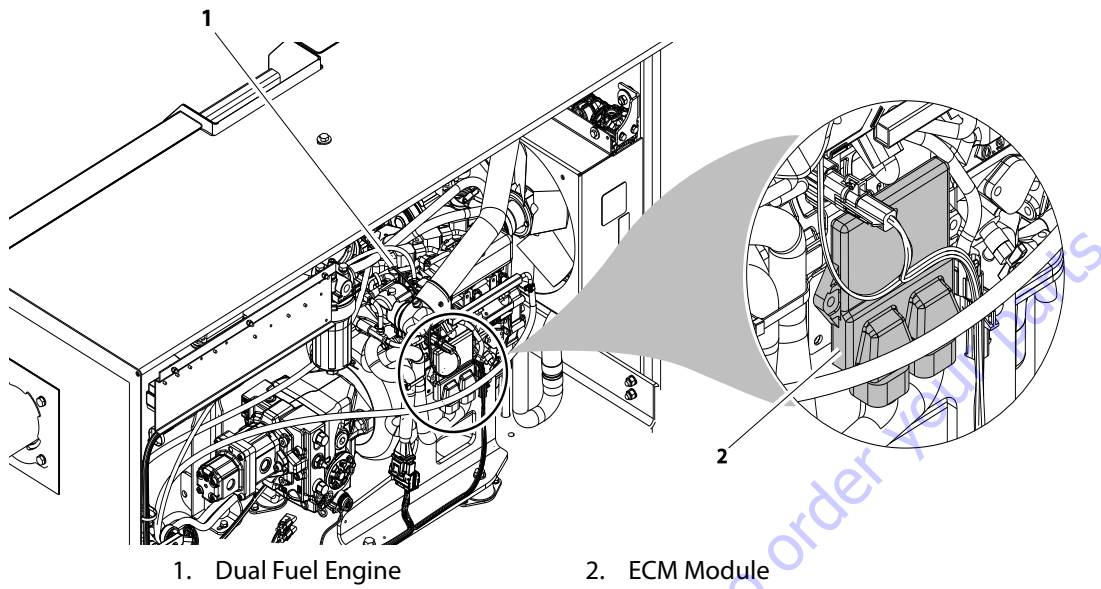

Figure 3-56. Dual Fuel Engine - Control Module Location

Go to Discount-Equipment.com to order tools

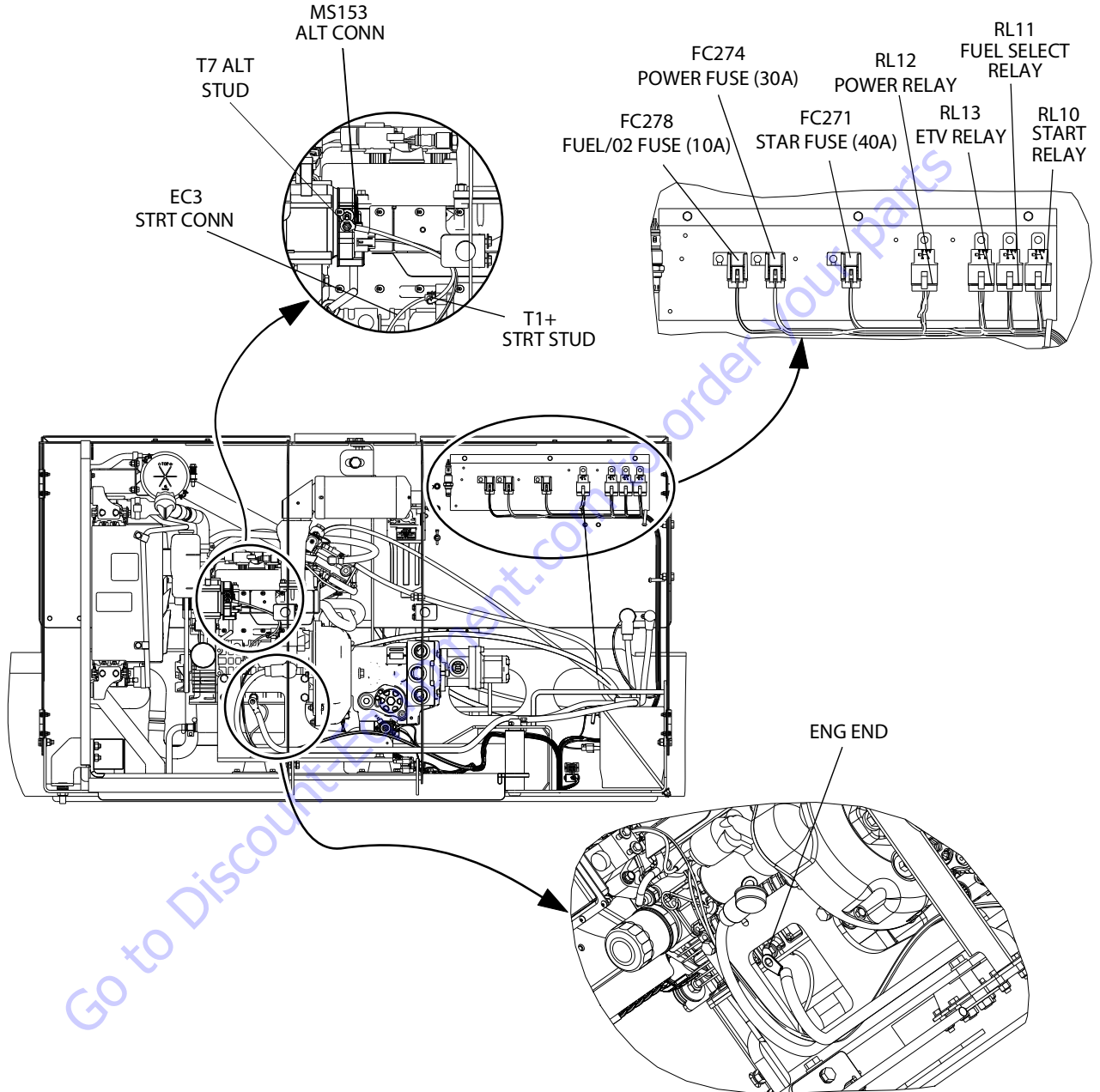

Figure 3-57. Dual Fuel Engine Compartment - Electrical Component Locations

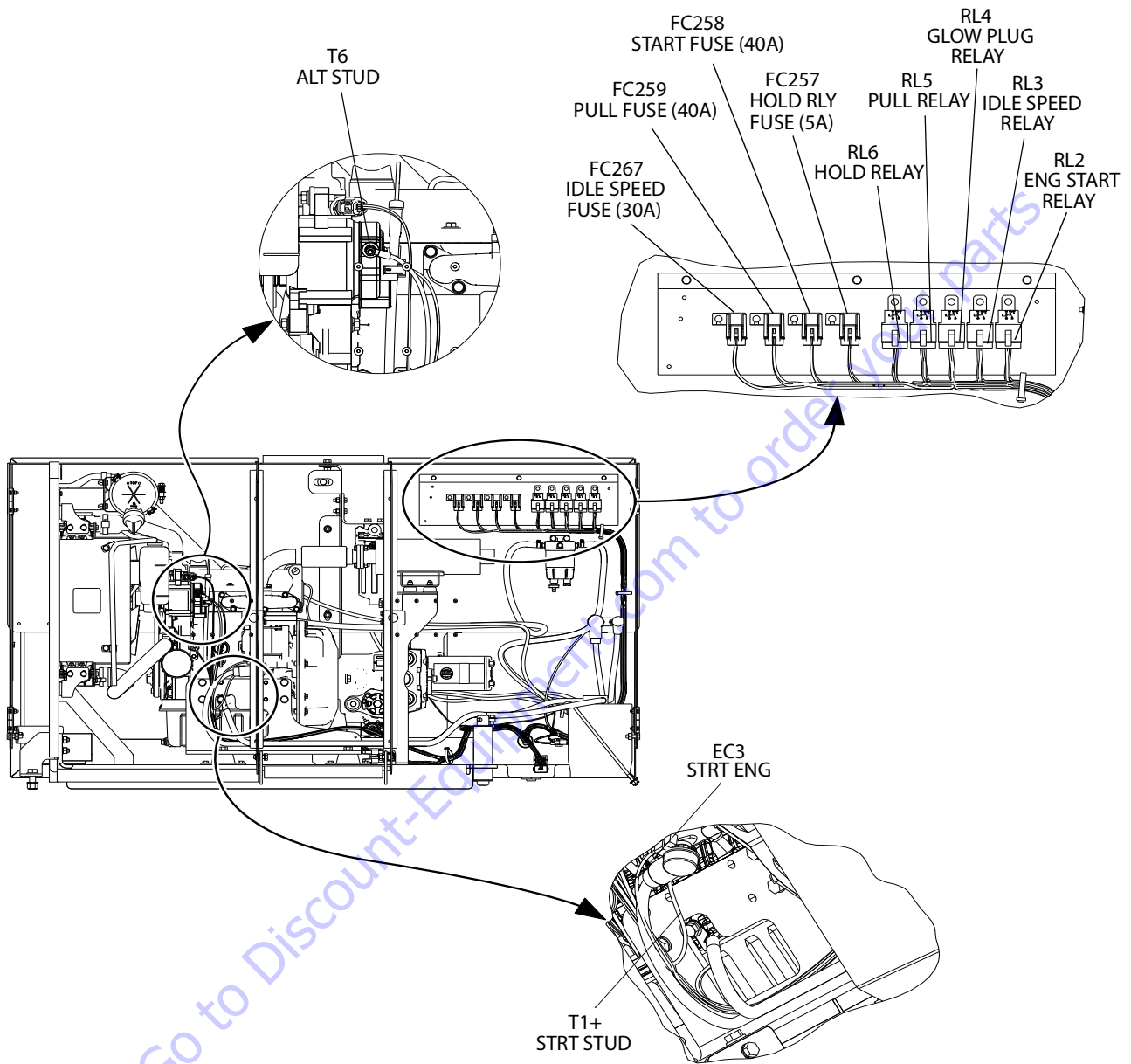

Figure 3-58. Diesel Engine Compartment - Electrical Component Locations (T4F)

Hydraulic Pump Installation

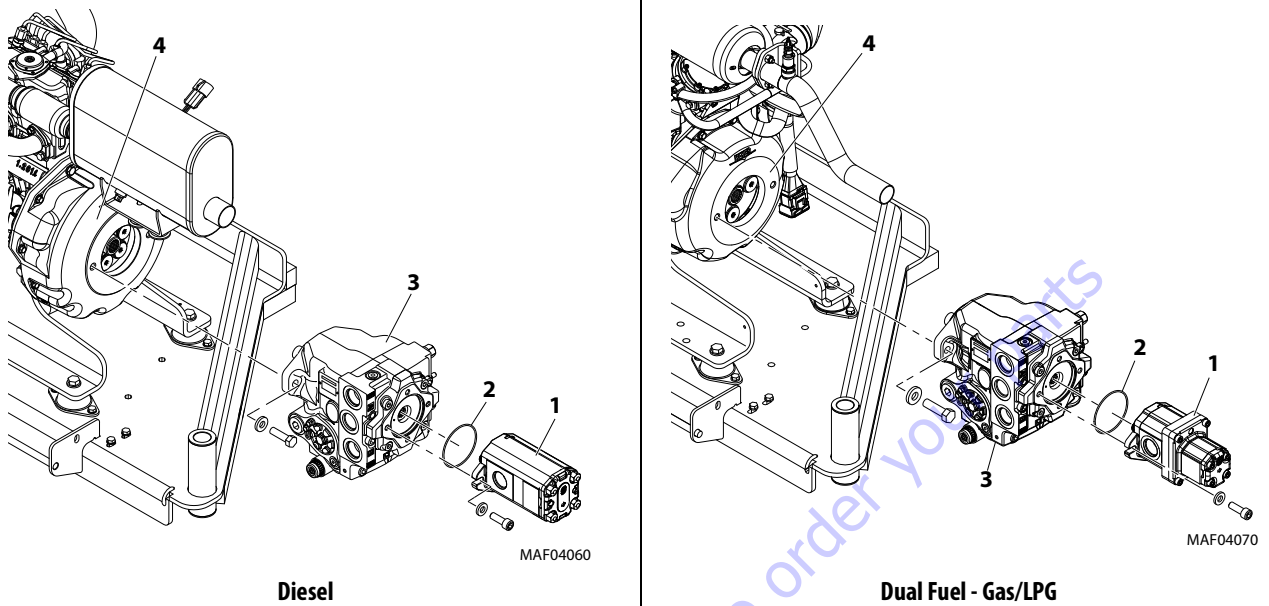

Figure 3-59. Hydraulic Pump Assemblies

- | | | | |
|--------------|-----------|--------------------|------------------|
| 1. Gear Pump | 2. O-Ring | 3. Axial Hi45 Pump | 4. Pump Coupling |
|--------------|-----------|--------------------|------------------|

⚠ CAUTION

ALLOW ENGINE AND COMPONENTS TO COOL DOWN BEFORE SERVICING.

REMOVAL

1. Disable machine operation. Disconnect, cap and label all hydraulic hoses connected to pumps (1, 3). Disconnect and label all wiring connected to pumps.
2. Remove the two bolts and washers attaching the gear pump (1) to the Axial Pump (3). Carefully remove the gear pump.
3. Remove and discard the o-ring (2).
4. Remove the two bolts and washers attaching the axial pump (3) to the coupling (4) of the motor. Carefully remove the axial pump.

INSTALLATION

1. Follow Removal Steps in reverse.

NOTE: Apply grease to internal splines of pump coupling (1) and external splines of piston pump (4) shaft prior to installing pump.

Install a new o-ring (2) during installation.

Apply Medium Strength Threadlocking Compound to bolts.

Torque mounting bolts to 50 ft. lbs. (70 Nm)

NOTE: Refer to Section 4.9, Gear Pump and Section 4.10, Axial HI 45 Pump for more information on pumps.

Pump Coupling Assembly

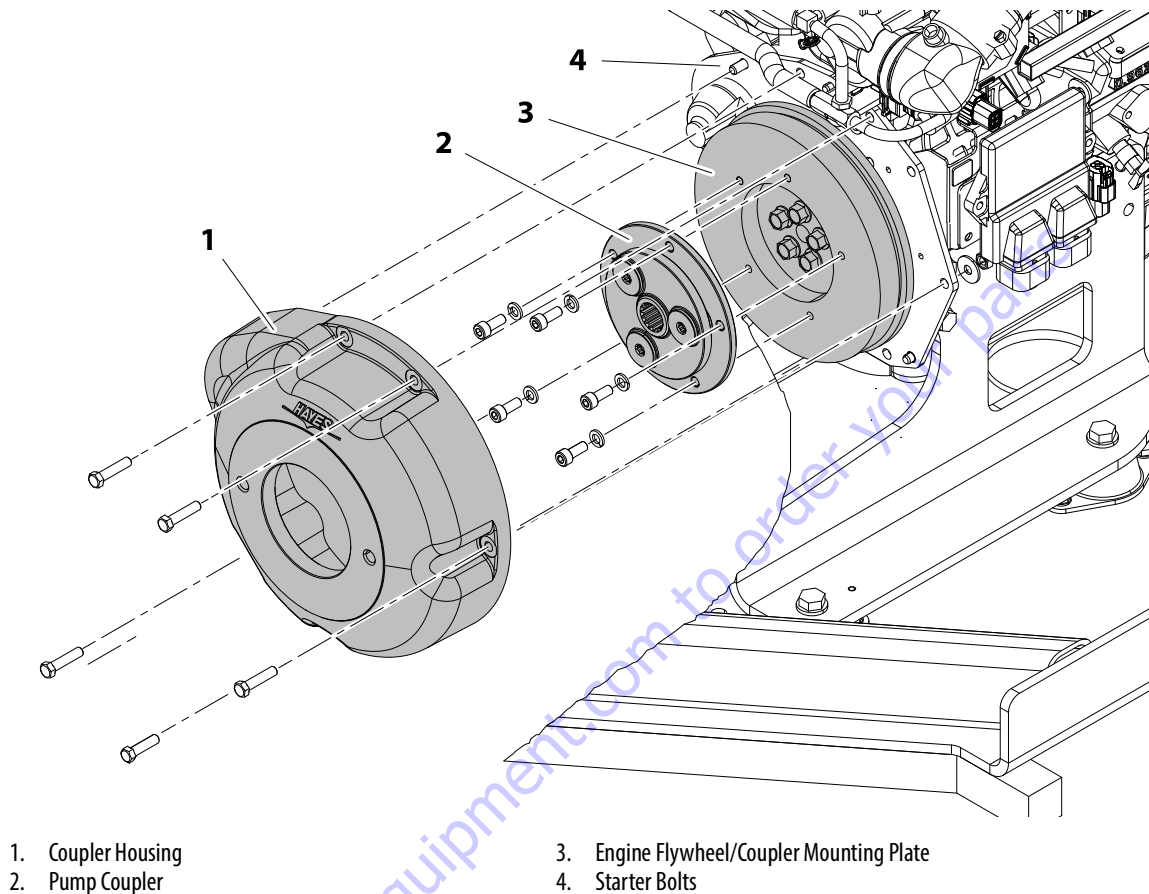

Figure 3-60. Pump Coupling Assembly (All Engines)

⚠ CAUTION

ALLOW ENGINE AND COMPONENTS TO COOL DOWN BEFORE SERVICING.

REMOVAL

1. Disable machine operation. Disconnect the battery positive (+) terminal.
2. Remove exhaust system and pump assemblies, as necessary.
3. Remove the five bolts, washers and nuts, plus the two starter bolts holding the coupler housing (1) to the engine block plate. Support starter, do not hang by electrical wiring. Remove the coupler housing (1).
4. Remove the five pump coupler bolts to remove the pump coupling from the engine flywheel/mounting plate (3). Remove coupling plate (2).

INSTALLATION

1. Follow Removal Steps in reverse.

NOTE: Apply Medium Strength Threadlocking Compound to bolts.

Torque coupling to flywheel bolts to 50 ft. lb. (68 Nm).

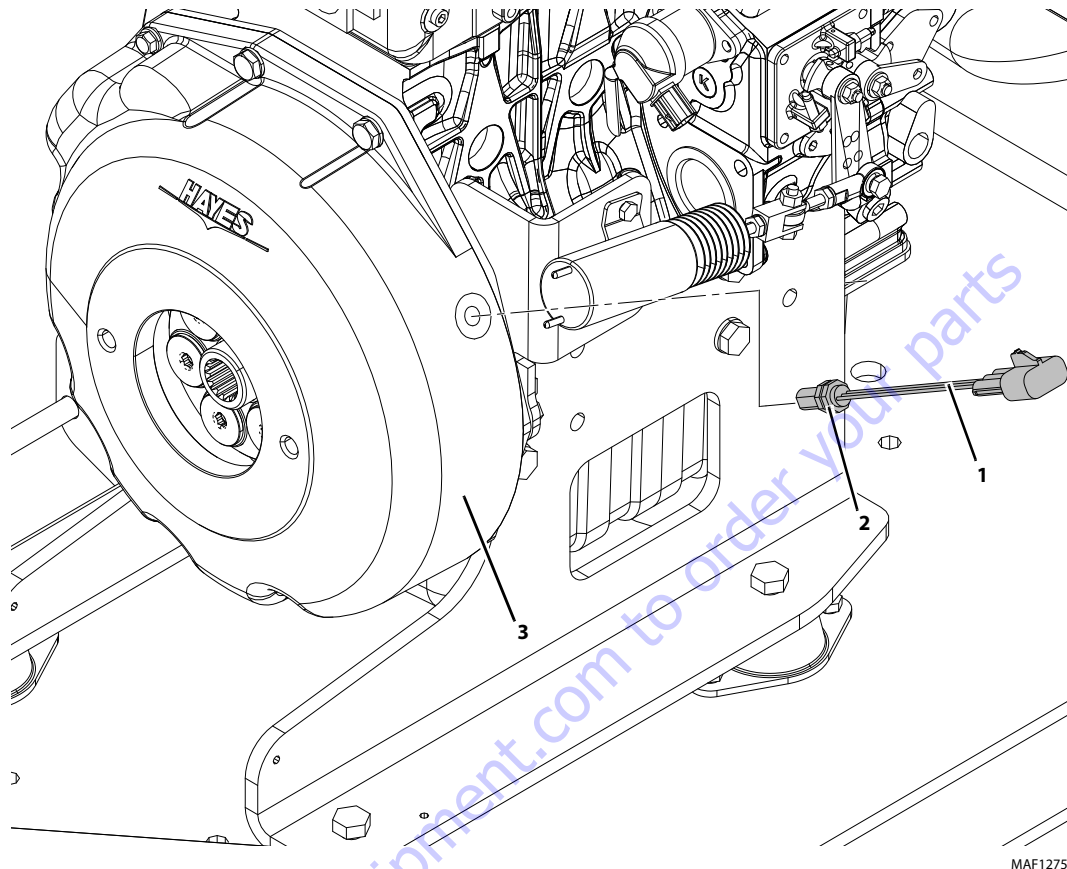
Engine Speed Sensor (Kubota Diesel Engine)

1. Speed Sensor
2. Nut
3. Coupler Housing

Figure 3-61. Engine Speed Sensor Installation**⚠ CAUTION**

ALLOW ENGINE AND COMPONENTS TO COOL DOWN BEFORE SERVICING.

REMOVAL

1. Park the machine on firm and level surface.
2. Shut the engine OFF and disconnect the battery power from the machine.
3. Open Engine side compartment doors and disconnect ground wire from battery.
4. Swing out the engine tray by removing the hardware at the following locations: engine tray stay bracket, top ladder bolt.

5. Loosen the nut (2) on the engine sensor and remove the engine speed sensor (1) from the Coupler Housing (3).

INSTALLATION

1. Install engine speed sensor (1) into the coupler housing (3) until the sensor contact the flywheel.
2. Back out the engine speed sensor (1) by hand, 0.5 to 1 turns. Ensure the flats on the engine speed sensor are vertical.
3. Tighten the nut on the speed sensor (2) using a spanner to the required torque specification (106 in. lbs (12 Nm)).
4. Swing engine tray back into position by installing the hardware at the following locations: engine tray stay bracket, top ladder bolt.
5. Reconnect ground wire to battery terminal and close engine side compartment doors.

Throttle Actuator Adjustment

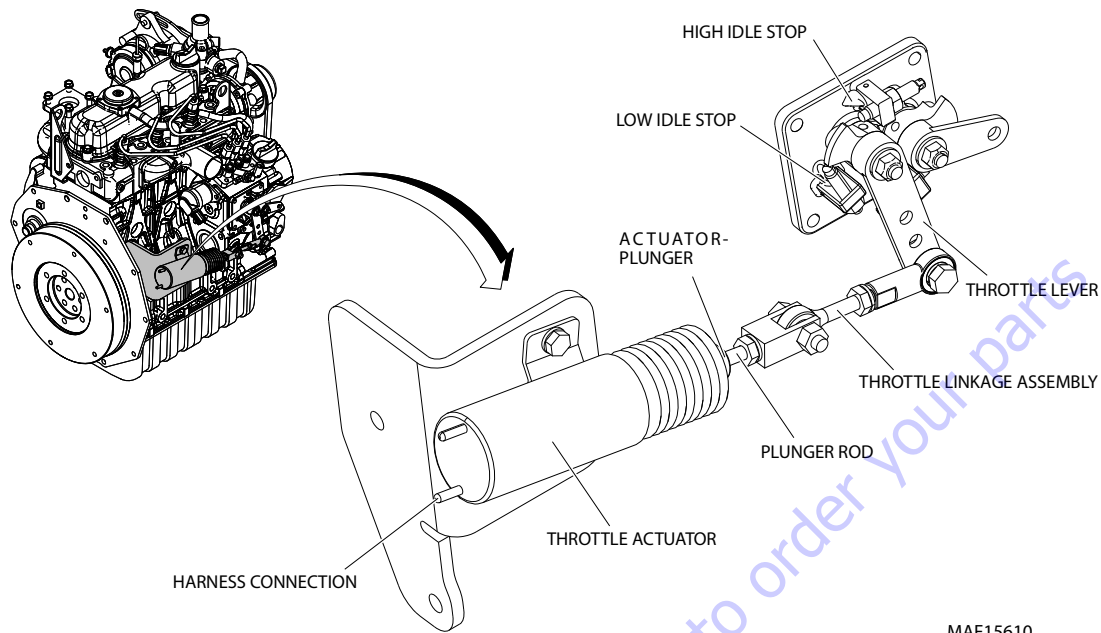

MAF15610

NOTE: Illustration shows actuator in de-energized state.

Figure 3-62. Throttle Assembly and Linkages

Air Gap Setting

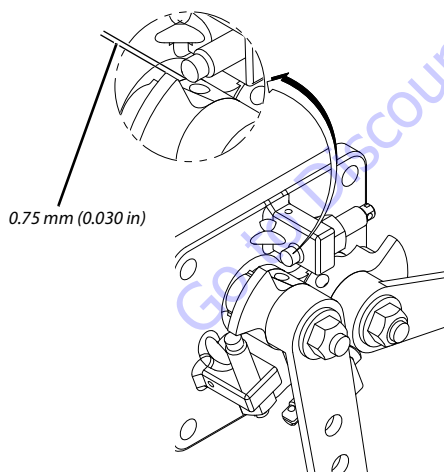

MAF15600

Figure 3-63. Air Gap Setting

AIR GAP SETTING PROCEDURE

1. The distance between the throttle arm and the high idle stop must be 0.75 mm (0.030 in) when the actuator is energized.

NOTE: When the actuator solenoid is energized, the actuator plunger must be fully seated to prevent coil burn-out.

Diagnosis of Actuator

The common failure modes that are found in the actuator are as follows.

Description	Item Check List	Action
Throttle actuator plunger or rod separation	Inspect the actuator. Check if the plunger and threaded rod have separated or if the threaded rod spins in the plunger.	Replace the actuator
Ground fault	Make sure that the actuator harness is not damaged.	Replace the harness if damage is found.
	Inspect the ground wire connection.	If necessary remove the ground or chassis connection and clean the paint or oil from the connection location.
Blown fuse	Examine the respective 30 Amp fuse to confirm if it is still good. Blown fuse can indicate coil burnout.	If the fuse has been overloaded/ burned-out, replace the respective fuses.
Throttle actuator coil burnout	Coil burnout will result if the plunger is not able to fully retract or if the machine switches between high idle and low idle multiple times in less than a minute.	If the actuator coil is burned-out, replace the actuator
	The actuator coil becomes burned-out due to the following reasons: <ul style="list-style-type: none"> • Repeated blown fuses • The distance between the throttle arm and high idle stop is not maintained as 0.75 mm (0.030 in) • If the resistance in de-energized state and energized state is outside limit 	

Adjustment of The Actuator

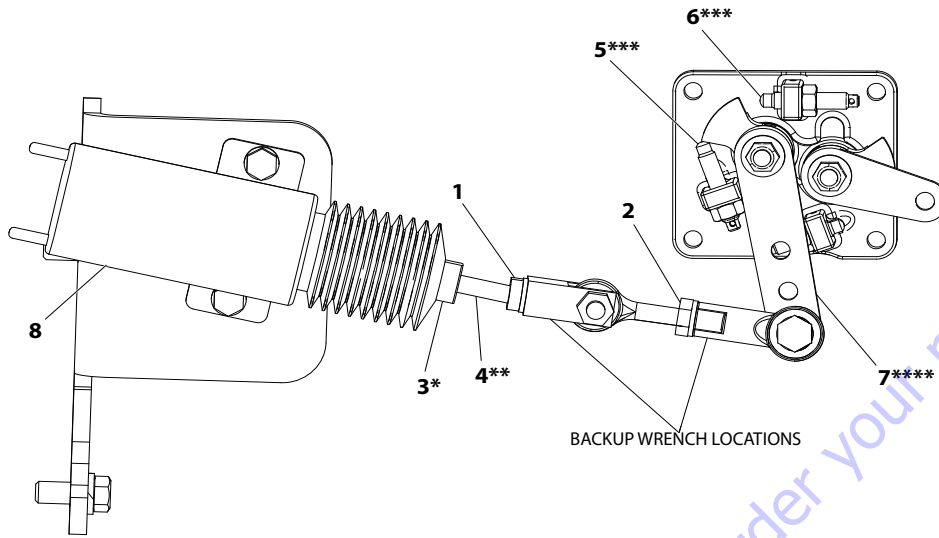

MAF15590

- * Do not use flats on plunger to tighten linkage.
- ** Do not attempt to adjust rod to plunger connection.
- *** Do not tamper or adjust the low and high idle settings.
- **** Do not reposition the throttle lever.

- | | |
|----------------------------------|----------------------|
| 1. Clevis Adjustment Connection | 5. Low Idle Stop |
| 2. Eyebolt Adjustment Connection | 6. High Idle Stop |
| 3. Actuator Plunger | 7. Throttle Lever |
| 4. Plunger Rod | 8. Throttle Actuator |

Figure 3-64. Adjustment of the Actuator

ADJUSTMENT OF THE ACTUATOR PROCEDURE

1. Adjust the nuts at the clevis connection or at the eye bolt connection to maintain the proper air gap between the throttle arm and the high idle stop, if necessary.

NOTE: Make sure that the plunger rod does not rub the eyebolt.

2. Make sure that the linkage and clevis is correctly adjusted before tightening of linkage assembly.
3. Use lockwasher and jam nut to tighten the linkage assembly.

Adjustment Verification of Actuator

1. Measure the plunger travel distance from energized to de-energized position. The travel distance must not be more than 1 in.
2. Verify plunger moves freely without binding.
3. If binding occurs, check the plunger rod. It should not come into contact with the eye bolt. Also verify the spacer is installed on the correct side of lever arm.
4. Use digital multimeter to measure de-energized state (0 to 1 ohms) and energized state (14 to 17 ohms) of actuator.



Figure 3-65. Adjustment Verification of Actuator

SECTION 4. BASIC HYDRAULIC INFORMATION & SCHEMATICS

4.1 CYLINDERS - THEORY OF OPERATION

Cylinders are of the double acting type. The steer system incorporates a double acting cylinder. A double acting cylinder is one that requires oil flow to operate the cylinder rod in both directions. Directing oil (by actuating the corresponding control valve to the piston side of the cylinder) forces the piston to travel toward the rod end of the barrel, extending the cylinder rod (piston attached to rod). When the oil flow is stopped, movement of the rod will stop. By directing oil to the rod side of the cylinder, the piston will be forced in the opposite direction and the cylinder rod will retract.

NOTE: *The lift cylinder is a single acting cylinder which takes hydraulic pressure to extend and gravity to retract.*

A holding valve is used in the lift circuit to prevent retraction of the cylinder rod should a hydraulic line rupture or a leak develop between the cylinder and its related control valve.

4.2 VALVES - THEORY OF OPERATION

Solenoid Control Valves (Bang-Bang)

Control valves used are four-way three-position solenoid valves of the sliding spool design. When a circuit is activated and the control valve solenoid energizes, the spool is shifted and the corresponding work port opens to permit oil flow to the component in the selected circuit, with the opposite work port opening to reservoir. Once the circuit is deactivated (control returned to neutral), the valve spool returns to neutral (center) and oil flow is then directed through the valve body and returns to reservoir. A typical control valve consists of the valve body, sliding spool, and two solenoid assemblies. The spool is machine fitted in the bore of the valve body. Lands on the spool divide the bore into various chambers, which, when the spool is shifted, align with corresponding ports in the valve body open to common flow. At the same time other ports would be blocked to flow. The spool is spring-loaded to center position, therefore when the control is released, the spool automatically returns to neutral, prohibiting any flow through the circuit.

Relief Valves

Main relief valves are installed at various points within the hydraulic system to protect associated systems and components against excessive pressure. Excessive pressure can be developed when a cylinder reaches its limit of travel and the flow of pressurized fluid continues from the system control. The relief valve provides an alternate path for the continuing flow from the pump, thus preventing rupture of the cylinder, hydraulic line or fitting. Complete failure of the system pump is also avoided by relieving circuit pressure. The relief valve is installed in the circuit between the pump outlet (pressure line) and the cylinder of the circuit, generally as an integral part of the system valve bank. Relief pressures are set slightly higher than the load requirement, with the valve diverting excess pump delivery back to the reservoir when operating pressure of the component is reached.

Crossover Relief Valves

Crossover relief valves are used in circuits where the actuator requires an operating pressure lower than that supplied to the system. When the circuit is activated and the required pressure at the actuator is developed, the crossover relief diverts excess pump flow to the reservoir. Individual, integral relief's are provided for each side of the circuit.

4.3 CYLINDER CHECKING PROCEDURE

NOTE: *Cylinder check must be performed anytime a system component is replaced or when improper system operation is suspected.*

Cylinders Without Counterbalance Valves

1. Using all applicable safety precautions, activate engine and fully extend cylinder to be checked. Shut down engine.
2. Carefully disconnect hydraulic hoses from retract port of cylinder. There will be some initial weeping of hydraulic fluid which can be caught in a suitable container. After the initial discharge, there should be no further drainage from the retract port.
3. Activate engine and extend cylinder.
4. If cylinder retract port leakage is less than 6-8 drops per minute, carefully reconnect hose to port and retract cylinder. If leakage continues at a rate of 6-8 drops per minute or more, cylinder repair must be made.

5. With cylinder fully retracted, shut down engine and carefully disconnect hydraulic hose from cylinder extend port.
6. Activate engine and retract cylinder. Check extend port for leakage.
7. If extend port leakage is less than 6-8 drops per minute, carefully reconnect hose to extend port, than activate cylinder through one complete cycle and check for leaks. If leakage continues at a rate of 6-8 drops per minute or more, cylinder repairs must be made.

Cylinders With Single Counterbalance Valve

NOTICE

OPERATE ALL FUNCTIONS FROM GROUND CONTROL STATION ONLY.

1. Using all applicable safety precautions, activate hydraulic system.
2. Shut down hydraulic system and allow machine to sit for 10-15 minutes. If machine is equipped with bang-bang or proportional control valves, turn ignition switch to on, move control switch or lever for applicable cylinder in each direction, then turn ignition switch to off. If machine is equipped with hydraulic control valves, move control lever for applicable cylinder in each direction. This is done to relieve pressure in the hydraulic lines.
Carefully remove hydraulic hoses from appropriate cylinder port block.
3. There will be initial weeping of hydraulic fluid, which can be caught in a suitable container. After the initial discharge, there should be no further leakage from the ports. If leakage continues at a rate of 6-8 drops per minute or more, the counterbalance valve is defective and must be replaced.
4. To check piston seals, carefully remove the counterbalance valve from the retract port. After initial discharge, there should be no further leakage from the ports. If leakage occurs at a rate of 6-8 drops per minute or more, the piston seals are defective and must be replaced.
5. If no repairs are necessary or when repairs have been made, replace counterbalance valve and carefully connect hydraulic hoses to cylinder port block.
6. If used, remove lifting device supporting platform or release and stow safety prop, activate hydraulic system and run cylinder through one complete cycle to check for leaks.

4.4 OSCILLATING AXLE - LOCKOUT CYLINDER TEST (IF EQUIPPED)

NOTICE

LOCKOUT CYLINDER SYSTEM TEST MUST BE PERFORMED QUARTERLY, ANY TIME A SYSTEM COMPONENT IS REPLACED, OR WHEN IMPROPER SYSTEM OPERATION IS SUSPECTED.

NOTE: *Ensure platform is fully lowered prior to beginning lockout cylinder test, and that the surface used to approach the ramp is flat and level.*

Left Side Wheel Test

1. Place a 4 inch (10.16 cm) high block with ascension ramp in front of left wheel of the oscillating axle.
2. From platform control station, select LOW drive speed.
3. Set the DRIVE control switch into position and carefully drive the machine up ascension ramp until left oscillating axle wheel is on top of block.
4. Verify the axle oscillates to maintain contact with the ground/ramp. (All four wheels on the ground).
5. Raise machine platform above stowed position to drive cutout height, approximately 6 to 9 ft. (2 to 3m) for the 330LRT and 430LRT.
6. Carefully drive the machine back off the block and ramp.
7. Have an assistant check to see that the left oscillating axle wheel that was on the block is in position on the ground. The axle should oscillate so that all four wheels maintain contact with the ground.
8. In the current position (platform raised and all four tires on flat and level surface), carefully drive machine up the ramp block again.
9. Have an assistant check to verify that the axle did not oscillate and remained locked (one wheel is off of the ground).
10. Carefully drive the machine back off the block and ramp.
11. Lower the machine platform; the lockout cylinder should then release and allow wheel to rest on the ground. It may be necessary to activate DRIVE to release cylinders.
12. If the lockout cylinders do not function properly, have qualified personnel correct the malfunction prior to any further operation.

Right Side Wheel Test

1. Place a 4 inch (10.16 cm) high block with ascension ramp in front of right wheel of the oscillating axle.
2. From platform control station, select LOW drive speed.
3. Set the DRIVE control switch into position and carefully drive the machine up ascension ramp until right oscillating axle wheel is on top of block.
4. Verify the axle oscillates to maintain contact with the ground/ramp. (All four wheels on the ground).
5. Raise machine platform above stowed position to drive cutout height, approximately 6 to 9 ft. (2 to 3m) for the 330LRT and 430LRT.
6. Carefully drive the machine back off the block and ramp.
7. Have an assistant check to see that the right oscillating axle wheel that was on the block is in position on the ground. The axle should oscillate so that all four wheels maintain contact with the ground.
8. In the current position (platform raised and all four tires on flat and level surface), carefully drive machine up the ramp block again.
9. Have an assistant check to verify that the axle did not oscillate and remained locked (one wheel is off of the ground).
10. Carefully drive the machine back off the block and ramp.
11. Lower the machine platform; the lockout cylinder should then release and allow the axle to oscillate. It may be necessary to activate DRIVE to release cylinders.
12. If the lockout cylinders do not function properly, have qualified personnel correct the malfunction prior to any further operation.

4.5 DRIVE PUMP PRE-FILL PROCEDURE

The drive pump should be pre-filled with recommended hydraulic fluid prior to machine start up.

Before starting this procedure inspect the unit for any damage incurred during shipping and handling. Make certain all components are clean prior to filling with hydraulic fluid.

The methods to pre-fill pump is as follows:

Pre-Fill of the Drive Pump Housing Without HOC

These types of pumps should never be dry started. Pre-fill the pump as follows:

1. The drive pump has 2 case drain ports. Both are SAE #12 ports. The lower port has a 3/4 in. hose going back to tank. The other port has an SAE #12 plug in. Using a 9/16 Allen wrench remove the plug.
2. Fill the hydraulic tank.
3. Fluid from the hydraulic tank will back flush into the pump housing through the 3/4 in. case drain hose. Air will be forced out of the open port on the pump. When oil starts flowing out of the open port, re-install and tighten the plug. The pump case is now pre-filled.

Pre-Fill of the Drive Pump Housing With HOC

1. The drive pump has both case drain ports filled by hoses due to the HOC.
2. Repeat steps 1 to 3 as above, except instead of loosening the SAE #12 plug, loosen the hose on the bottom of the case drain manifold, located near the hydraulic tank. This is the hose connected to the pump L2 port.

Priming the Gear Pump

The gear pump is mounted with the suction hose up. Air trapped in this area can cause an air lock on start up. during this period, the pump is running dry, which can cause gear wear, which affects the volumetric efficiency of the pump.

1. Fill the hydraulic tank to the full mark.
2. Using a 3/4 in. wrench, loosen the pressure hose small section of the gear pump (steering section). The hose fitting does not need to be removed, just loosened enough to let the air escape.
3. When oil leaks at the hose end, re-torque the hose end to 115 lb-ft (155 Nm). The pump is primed and the pumps are ready to start.

4.6 DRIVE PUMP START-UP PROCEDURE

NOTICE

THE FOLLOWING PROCEDURE SHOULD ALWAYS BE PERFORMED WHEN STARTING A NEW PUMP OR WHEN RESTARTING AN INSTALLATION IN WHICH EITHER THE PUMP OR MOTOR HAVE BEEN REMOVED FROM THE SYSTEM.

THE FOLLOWING PROCEDURE MAY REQUIRE THE MACHINE TO BE DISABLED (WHEELS RAISED OFF THE GROUND, DRIVE FUNCTION DISCONNECTED, ETC.) WHILE PERFORMING THE PROCEDURE IN ORDER TO PREVENT INJURY TO TECHNICIAN AND OTHER PERSONNEL. TAKE NECESSARY SAFETY PRECAUTIONS BEFORE MOVING THE MACHINE.

Prior to installing pump and/or motor, inspect unit(s) for damage incurred during shipping and handling. Make certain all system components (reservoir, hoses, valves, fittings, heat exchanger, etc.) are clean prior to filling with hydraulic fluid.

Fill reservoir with recommended hydraulic fluid, which should be passed through a 10 micron (nominal, no bypass) filter prior to entering the reservoir. The use of contaminated fluid will cause damage to components, which may result in unexpected machine movement.

The inlet line leading from the reservoir to the pump should be filled prior to start-up. Check inlet line for properly tightened fittings and make sure it is free of restrictions and air leaks.

Be certain to fill pump and/or motor housing with clean hydraulic fluid prior to start-up. Fill housing by pouring filtered oil into upper case drain port.

Install a 0 to 500 psi (0 to 35 bar) pressure gauge in the charge pressure gauge port to monitor charge pressure during start-up.

It is recommended that the external control input signal electrical connections be disconnected at the pump control until after initial start-up. This will allow the pump to remain in its neutral position.

“Jog” or slowly rotate prime mover until charge pressure starts to rise. Start prime mover and run at the lowest possible RPM until charge pressure has been established. Excess air may be bled from high pressure lines through high pressure gauge ports.

WARNING

DO NOT START PRIME MOVER UNLESS PUMP IS IN NEUTRAL POSITION (0 DEGREES SWASHPLATE ANGLE). TAKE PRECAUTIONS TO PREVENT MACHINE MOVEMENT IN CASE PUMP IS ACTUATED DURING INITIAL START-UP.

Once charge pressure has been established, increase speed to normal operating RPM. Charge pressure should be approximately 220 psi (15.5 bar) minimum. If charge pressure is incorrect, shut down and determine cause for improper pressure.

WARNING

INADEQUATE CHARGE PRESSURE WILL AFFECT THE OPERATOR'S ABILITY TO CONTROL THE MACHINE.

Shut down prime mover and connect external control input signal. Start prime mover, checking to ensure pump remains in neutral. With prime mover at normal operating speed, slowly check for forward and reverse machine operation.

Charge pressure should remain at 220 psi to 240 psi (15.5 bar to 16.9 bar) minimum during forward or reverse operation. Continue to cycle slowly between forward and reverse for at least five minutes.

Shut down prime mover, remove gauges, and plug ports. Check reservoir level and add fluid if necessary.

4.7 HYDRAULIC COMPONENT START-UP PROCEDURES & RECOMMENDATIONS

From a hydrostatic component standpoint, the goal at system start up is to put into functional operation, the hydrostatic system in such a way as to preserve the designed life span of the system. The following start-up procedure should be adhered to whenever a new pump or motor is initially installed into a machine, or a system is restarted after either a pump or motor has been removed and/or replaced.

WARNING

THE FOLLOWING PROCEDURE MAY REQUIRE THE MACHINE TO BE DISABLED (WHEELS RAISED OFF THE GROUND, WORK FUNCTIONS DISCONNECTED, ETC.) WHILE PERFORMING THE PROCEDURE IN ORDER TO PREVENT INJURY. TAKE NECESSARY SAFETY PRECAUTIONS BEFORE MOVING THE VEHICLE/MACHINE.

Prior to installing the pump and/or motor, inspect the unit(s) for damage that may have been incurred during shipping and handling. Ensure all system components (reservoir, hoses, valves, fittings, heat exchanger, etc.) are clean prior to filling with fluid.

Fill the reservoir with recommended hydraulic fluid. This fluid should be passed through a 10 micron (nominal, no bypass) filter prior to entering the reservoir. The use of contaminated fluid will cause damage to the components, which may result in unexpected vehicle/machine movement.

NOTE: *If a pump or motor is being replaced due to internal damage, the remaining units (pump or motors) need to be inspected for damage and contamination, and the entire hydraulic system will need to be flushed and the fluid replaced. Failure to do so may cause considerable damage to the entire system.*

The inlet line leading from the reservoir to the pump must be filled prior to start-up. Check the inlet line for property tightened fittings and make sure it is free of restrictions and air leaks.

NOTE: *In most cases, the reservoir is above the pump inlet so that the pressure head created by the higher oil level helps to keep the inlet pressures within an acceptable range and prevent high vacuum levels. However, due to hose routing or low reservoir locations, there may be air trapped within this line. It is important to ensure that the air is bled from this line. This can be accomplished by loosening the hose at the fitting closest to the pump. When oil begins to flow, the line is full, the air has been purged, and the fitting can be retightened to its specified torque. If the tank needs to be pressurized in order to start the flow of oil, a vacuum reading should be taken at the inlet of the pump during operation in order to verify that the pump is not being asked to draw an inlet vacuum higher than it is capable of.*

Be certain to fill the pump and/or motor housing with clean hydraulic fluid prior to start up. Fill the housing by pouring filtered oil into the upper case drain port.

NOTE: *It is highly recommended to use the highest possible case drain port, this ensures that the housing contains as much oil as possible and offers the greatest amount of lubrication to the internal components.*

In initial start-up conditions, it may be convenient to fill the housing, just prior to installing the case drain line. Component, (especially motor), location may be such that access to the case drain port after installation is not realistic.

Make certain that the oil being used to fill the component housing is as clean as possible. Store the fill container in such a way as to prevent it from becoming contaminated.

Install a 60 bar (or 1000 psi) pressure gauge in the charge pressure gauge port in order to monitor the charge pressure during start-up.

It is recommended that the external control input signal, (electrical connections for EDC), be disconnected at the pump control until after initial start-up. This will ensure that the pump remains in its neutral position.

⚠ WARNING

DO NOT START THE ENGINE UNLESS PUMP IS IN THE NEUTRAL POSITION (0 DEGREES SWASHPLATE ANGLE). TAKE PRECAUTIONS TO PREVENT MACHINE MOVEMENT IN CASE PUMP IS ACTUATED DURING INITIAL START-UP.

"Jog" or slowly rotate the engine until charge pressure starts to rise. Start the engine and run at the lowest possible RPM until charge pressure has been established. Excess air should be bled from the system lines as close to the motors as possible.

NOTE: *With the engine on low idle, "crack", (loosen-don't remove), the system lines at the motor(s). Continue to run the engine at low idle and tighten the system lines as soon as oil is observed to leak from them. When oil is observed to "leak" at the motor, the line is full, the air has been purged, and the system hoses should be retightened to their specified torque.*

Once charge pressure has been established, increase speed to normal operating RPM. Charge pressure should be as indicated in the pump model code. If charge pressure is inadequate, shut down and determine the cause for improper pressure.

⚠ WARNING

INADEQUATE CHARGE PRESSURE WILL AFFECT THE OPERATOR'S ABILITY TO CONTROL THE MACHINE.

Shut down the engine and connect the external control input signal. Also reconnect the machine function(s), if disconnected earlier. Start the engine, checking to be certain the pump remains in neutral. With the engine at normal operating RPM, slowly check for forward and reverse machine operation.

Charge pressure may slightly decrease during forward or reverse operation. Continue to cycle slowly between forward and reverse for at least five minutes.

Shut down engine, remove gauges, and plug ports. Check reservoir level and add filtered fluid if needed.

The machine is now ready for operation.

4.8 HYDRAULIC VALVES

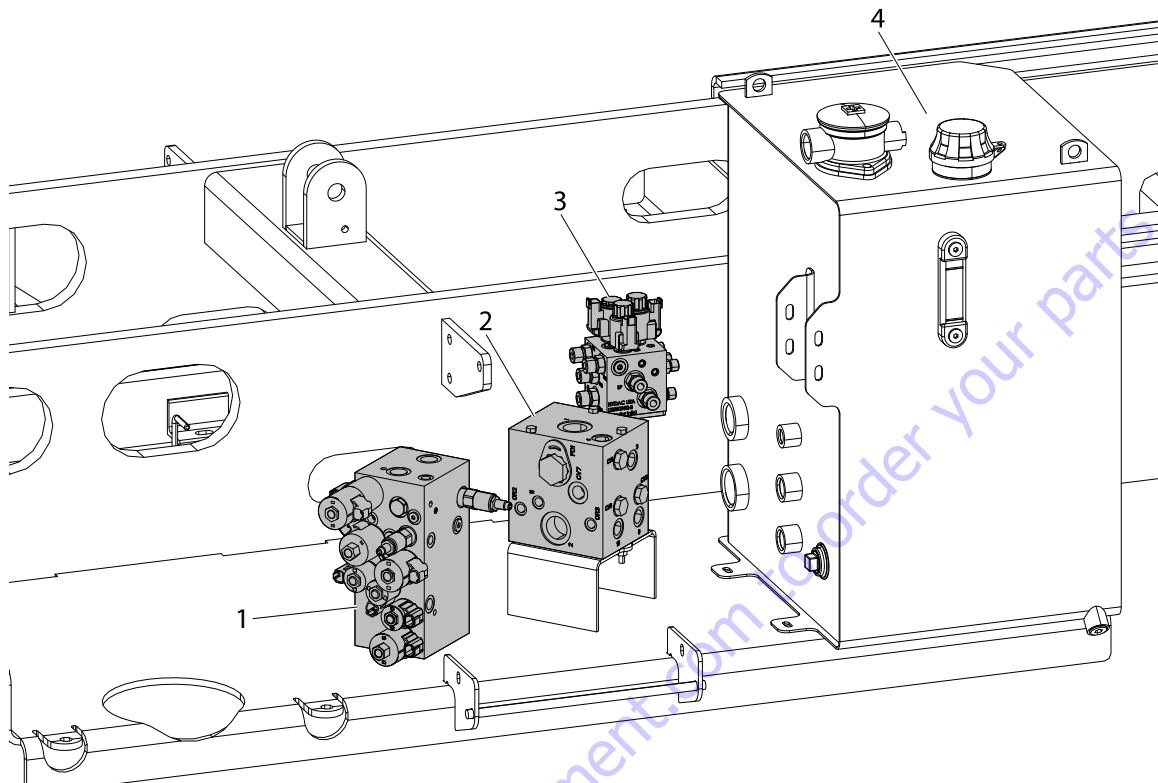

- | | |
|-----------------------|--------------------------------------|
| 1. Main Valve | 3. Leveling Jack Valve (If Equipped) |
| 2. Flow Divider Valve | 4. Hydraulic Tank |

Figure 4-1. Hydraulic Compartment Control Valves

REMOVAL

1. Disconnect, cap and label all hydraulic hoses and any electrical harness connected to valves.
2. Remove the valve blocks from the hydraulic tray by removing the attaching bolts.

INSTALLATION

1. Re-attach valve blocks to tray with bolts.
2. Re-connect all hydraulic lines and electrical harness.

Main Hydraulic Valve

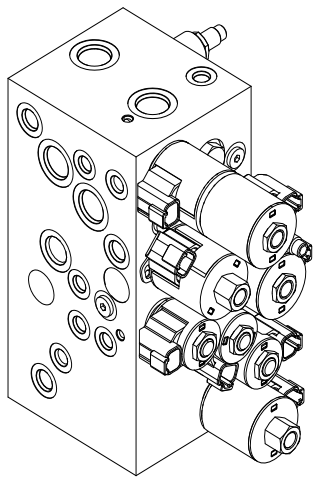

MAIN HYDRAULIC VALVE

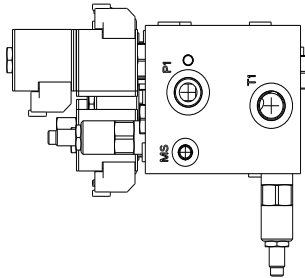

TOP

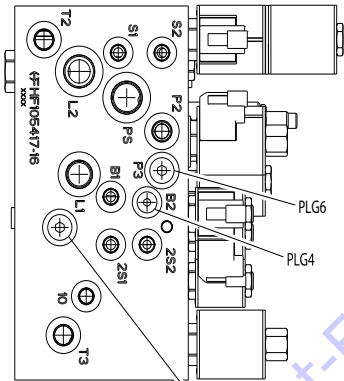

LEFT SIDE

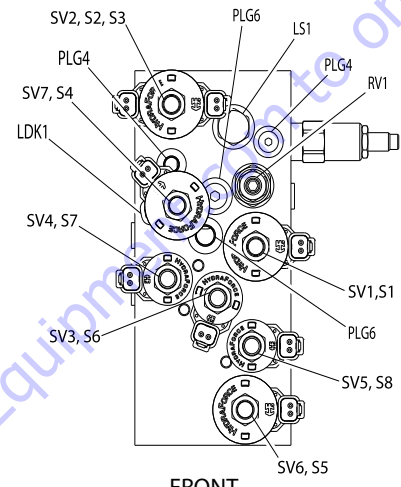

FRONT

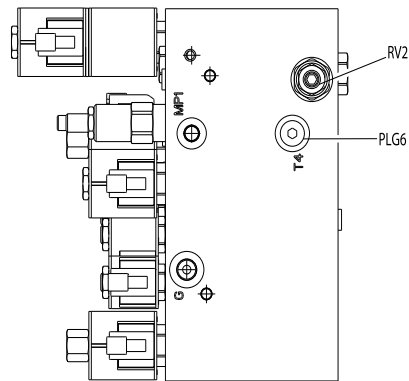

RIGHT SIDE

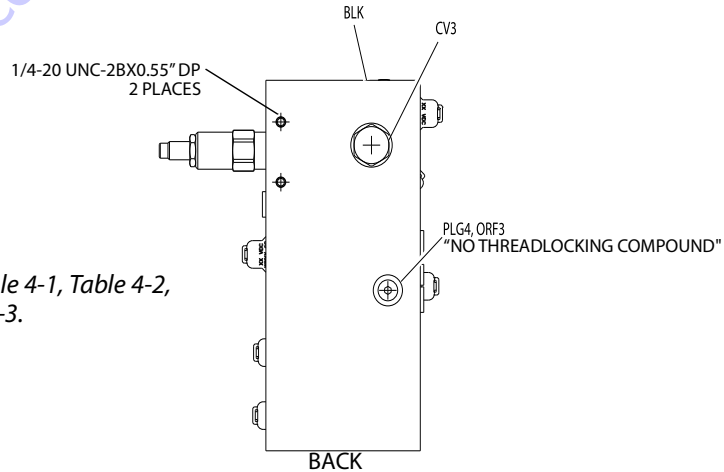

BACK

NOTE: Refer to Table 4-1, Table 4-2, and Table 4-3.

Figure 4-2. Main Valve Port Identification

Table 4-1. Main Valve Port Identification

Port	Functionality	To Port
L1	To Lift Cylinder	Lift Cylinder
L2	To Lift Cylinder	Lift Cylinder
T3	Main RT Valve (Left Side)	T - Outrigger Valve
P1	Main RT Valve (Left Side)	Outlet - Tandem Gear Pump
S1	Main RT Valve (Left Side)	Steer Cylinder
S2	Main RT Valve (Left Side)	Steer Cylinder
G	Main RT Valve (Left Side) (Tee at Port)	P - Axle Lockout Valve M3 - Axial Pump
2S2	Main RT Valve (Left Side)	Union Tee
T1	Main RT Valve (Left Side)	Return to Tank
T2	Main RT Valve (Right Side)	12 - Flow Divider
P2	Main RT Valve (Right Side)	LP - Leveling Jack Valve
PS	Main RT Valve (Right Side)	Outlet - Tandem Gear Pump
MS	Main RT Valve (Right Side)	Diagnostic Port
MP1	Main RT Valve (Right Side)	Diagnostic Port

Table 4-2. Main Valve Torque Specs (All Specs Except CE)

Component	Functionality	Torque
RV2	Manifold Relief Valve	19 - 21ft. lb.
RV1	Lift Circuit Relief Valve	25 ft. lb.
LS1	Steer Cylinder Shuttle Valve	20 ft. lb.
CV3	Lift Cylinders Tank Port Check Valve	24 - 26ft. lb.
SV7	Lift Pump Unloader Valve (Dump)	24 - 26ft. lb.
SV6		24 - 26ft. lb.
SV5		19 - 21ft. lb.
SV4	Hydraulic Brakes	19 - 21ft. lb.
SV3	Motors 2 Speed Control	19 - 21ft. lb.
SV2	Steer Valve	24 - 26ft. lb.
SV1	Lift Up Valve	24 - 26ft. lb.
S1-S5	Coil 4304112 7.1 Ohm @20°C	8.5 ft. lb.
S6-S8	Coil 4304012 8.8 Ohm @20°C	4.5 ft. lb.
PLG6		23ft.lb.
PLG4		13ft.lb.

Table 4-3. Main Valve Porting Specs

Port	Size
P1,L2,T1 & PS	SAE 10
L1	SAE 08
G, P2,P3,T2,T3 & T4	SAE 06
All Others	SAE 04

NOTE: For internal hydraulic circuits Figure 4.32 on Page 4.42.

Table 4-4. Main Valve Port Identification (CE Only)

Port	Functionality	To Port
L1	To Lift Cylinder	Lift Cylinder
L2	To Lift Cylinder	Lift Cylinder
T3	Main RT Valve (Left Side)	T - Outrigger Valve
P1	Main RT Valve (Left Side)	Outlet - Tandem Gear Pump
S1	Main RT Valve (Left Side)	Steer Cylinder
S2	Main RT Valve (Left Side)	Steer Cylinder
G	Main RT Valve (Left Side) (Tee at Port)	P - Axle Lockout Valve M3 - Axial Pump
2S2	Main RT Valve (Left Side)	Union Tee
T1	Main RT Valve (Left Side)	Return to Tank
T2	Main RT Valve (Right Side)	12 - Flow Divider
P2	Main RT Valve (Right Side)	LP - Leveling Jack Valve
PS	Main RT Valve (Right Side)	Outlet - Tandem Gear Pump
MS	Main RT Valve (Right Side)	Diagnostic Port
MP1	Main RT Valve (Right Side)	Diagnostic Port

Table 4-5. Main Valve Torque Specs (CE Only)

Component	Functionality	Torque
SV2	Steer Valve	24 - 26ft. lb.
SV3	Motors 2 Speed Control	19 - 21ft. lb.
SV4	Hydraulic Brakes	19 - 21ft. lb.
SV5		19 - 21ft. lb.
SV6		19 - 21ft. lb.
SV7		24 - 26ft. lb.
SV8		24 - 26ft. lb.
SV9		24 - 26ft. lb.
CV3	Lift Cylinders Tank Port Check Valve	24 - 26ft. lb.
LS1	Steer Cylinder Shuttle Valve	20ft. lb.
RV2	Manifold Relief Valve	26ft. lb.
RV3	Steer Cylinder Relief Valve	19 - 21ft. lb.
SV1	Lift Up Valve	24 - 26ft. lb.
S1 - S6	Coil 4304112 7.1 Ohm @20°C	8.5ft. lb.
S7 - S10	Coil 4304012 8.8 Ohm @20°C	4.5ft. lb.
PLG6		23ft. lb.
PLG4		13ft. lb.

Table 4-6. Main Valve Porting Specs (CE Only)

Port	Size
P1, L2, T1 & PS	SAE 10
L1	SAE 08
G, P2, P3, T2, T3 & T4	SAE 06
All Others	SAE 04

NOTE: For internal hydraulic circuits Figure 4.32 on Page 4.42.

Flow Divider Valve

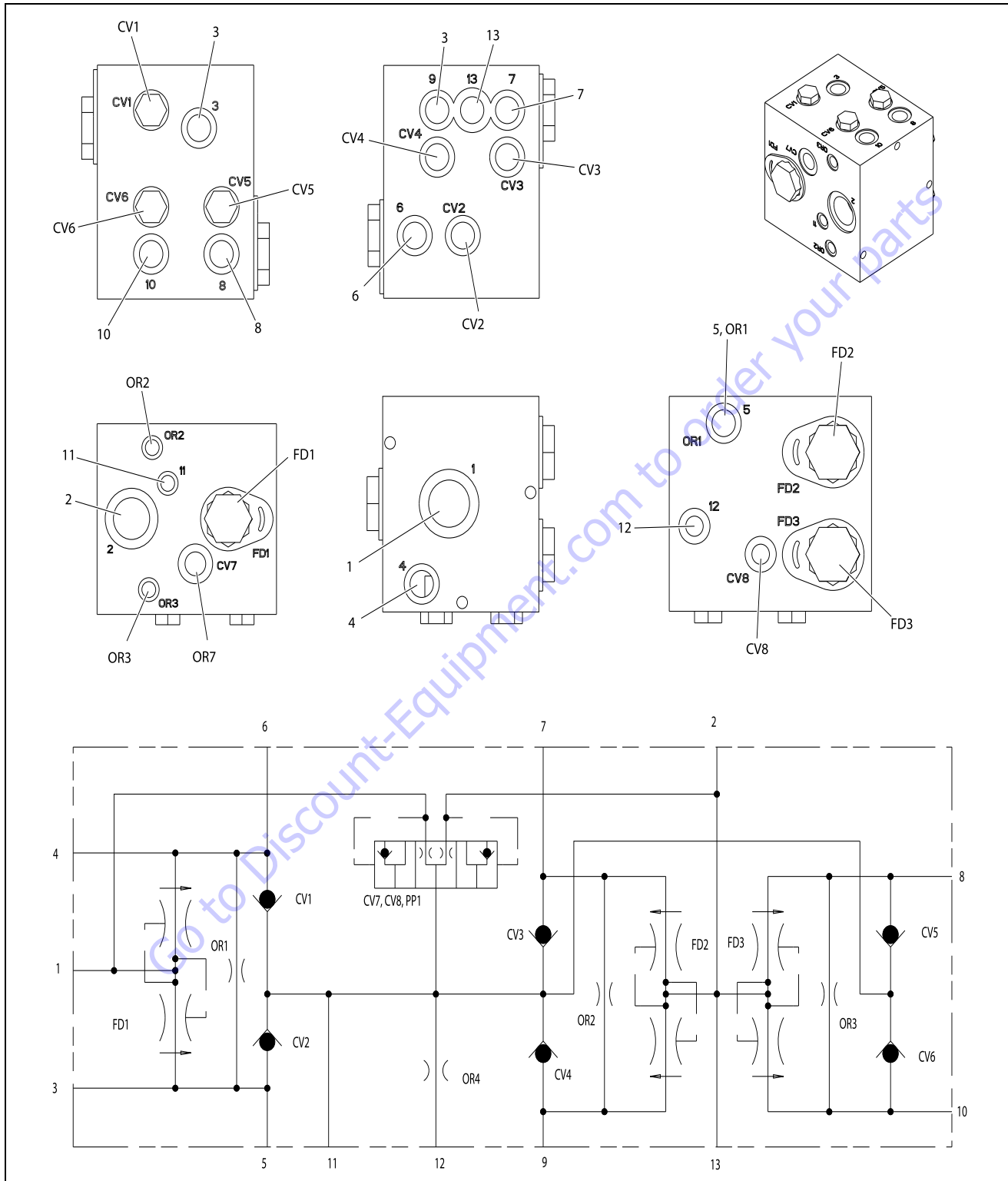

Figure 4-4. Flow Divider Valve

Leveling Jack Directional Valve (If Equipped)

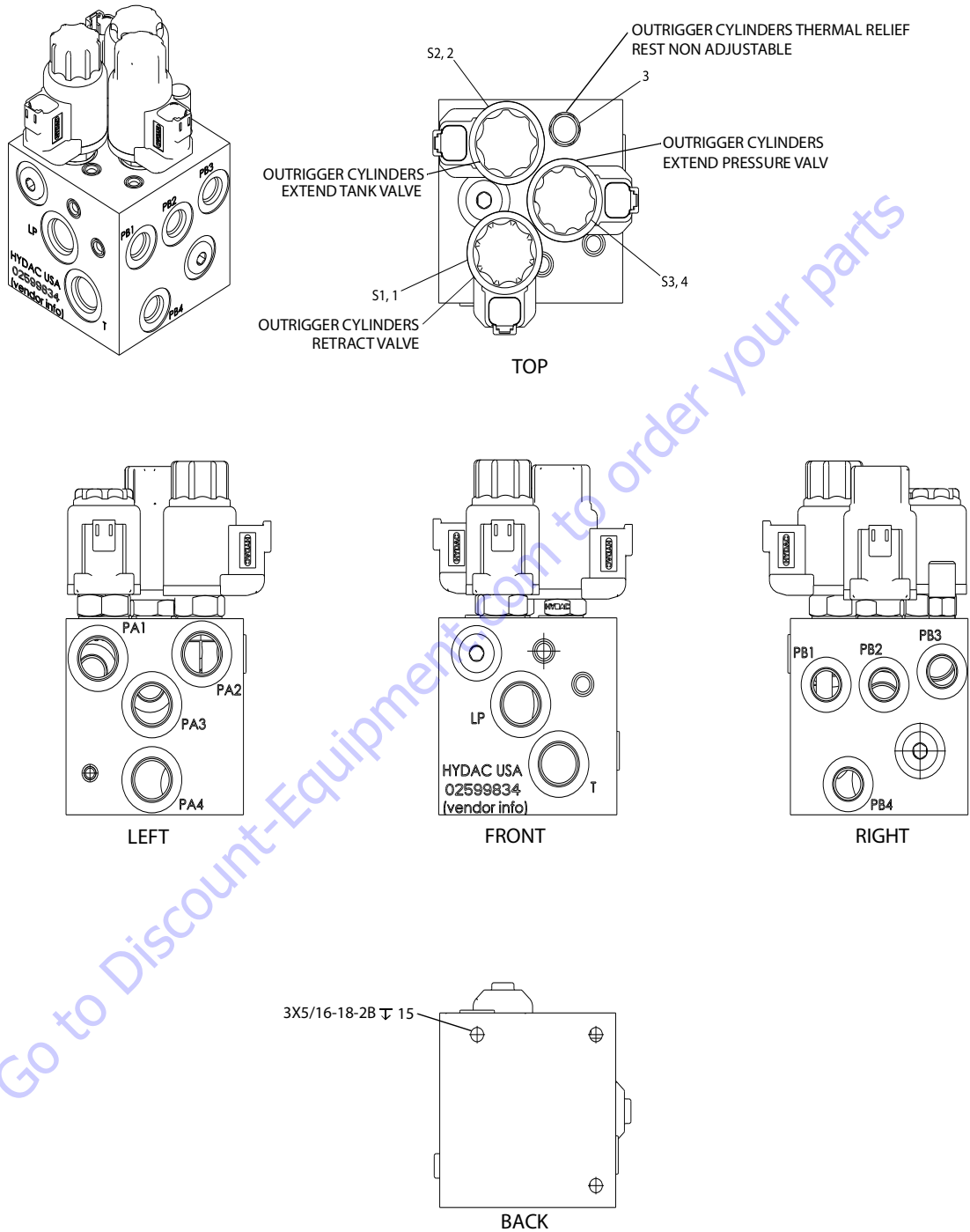

Figure 4-5. Leveling Jack Directional Valve

NOTE: For valve torque specs see Table 4-7 on page 4-14.
For internal hydraulic circuits Figure 4.32 on Page 4.42.

Table 4-7. Leveling Jack Directional Valve Torque Specs
See Figure 4-5. on page 4-13

Component	Functionality	Torque
S1	Leveling Jack Cylinders Retract Valve	18.5 - 22 ft. lb. (25-30 Nm)
S2	Leveling Jack Cylinders Extend Tank Valve	28 - 33 ft. lb. (38-45 Nm)
S3	Leveling Jack Cylinders Extend Pressure Valve	22 - 26 ft. lb. (30 - 35 Nm)
Coils S1-3	Coils 12VDC, 8 Ohms	3 - 4.5 ft. lb. (4 Nm)

Leveling Jack Valves (If Equipped)

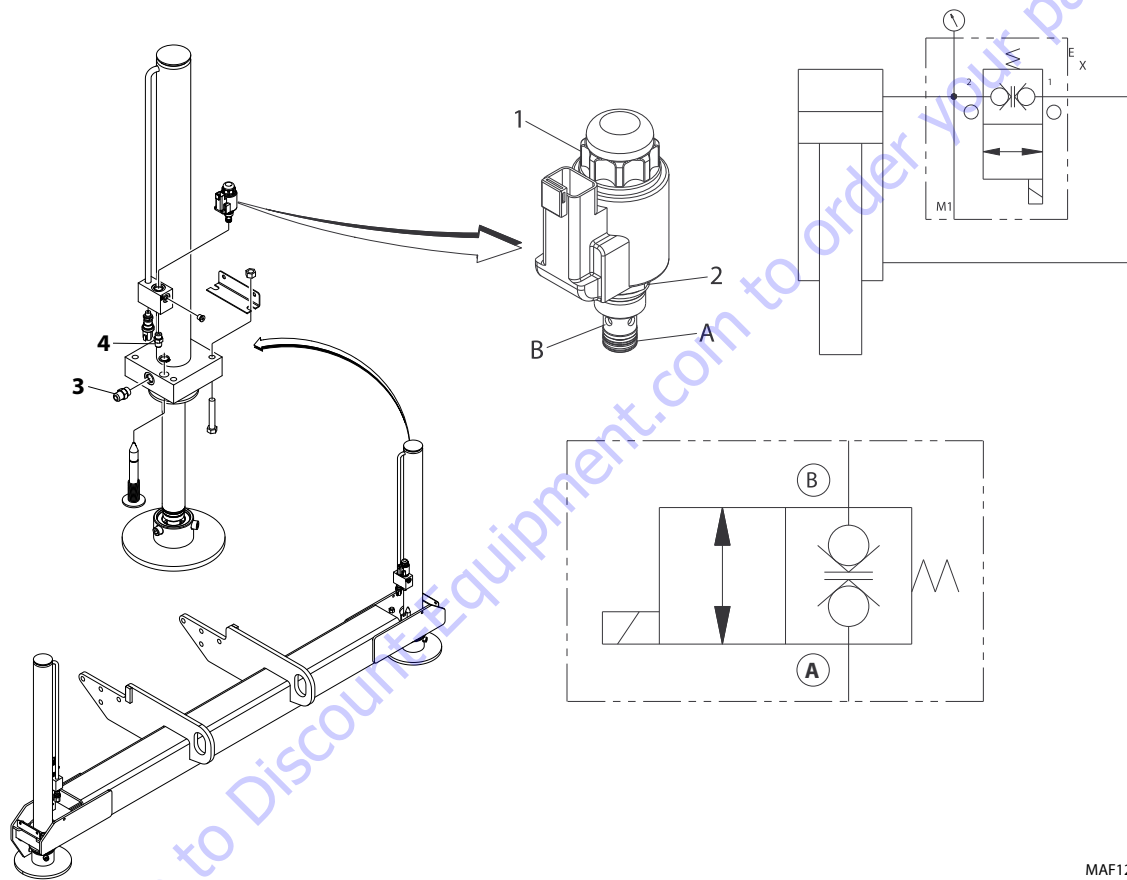

NOTE: Applies to all four Leveling Jacks.

MAF12910

Figure 4-6. Leveling Jack Valves

Table 4-8. Leveling Jack Valves Torque Specs

Item	Torque
1	3 to 4.5 lb-ft (4 to 6 Nm)
2	18.5 to 22 lb-ft (25 to 30 Nm)
3	35.8 to 43.8 lb-ft (48.6 to 59.4 Nm)
4	28.9 to 35.2 lb-ft (39.2 to 47.8 Nm)

Leveling Jack Manifold Valve (If Equipped)

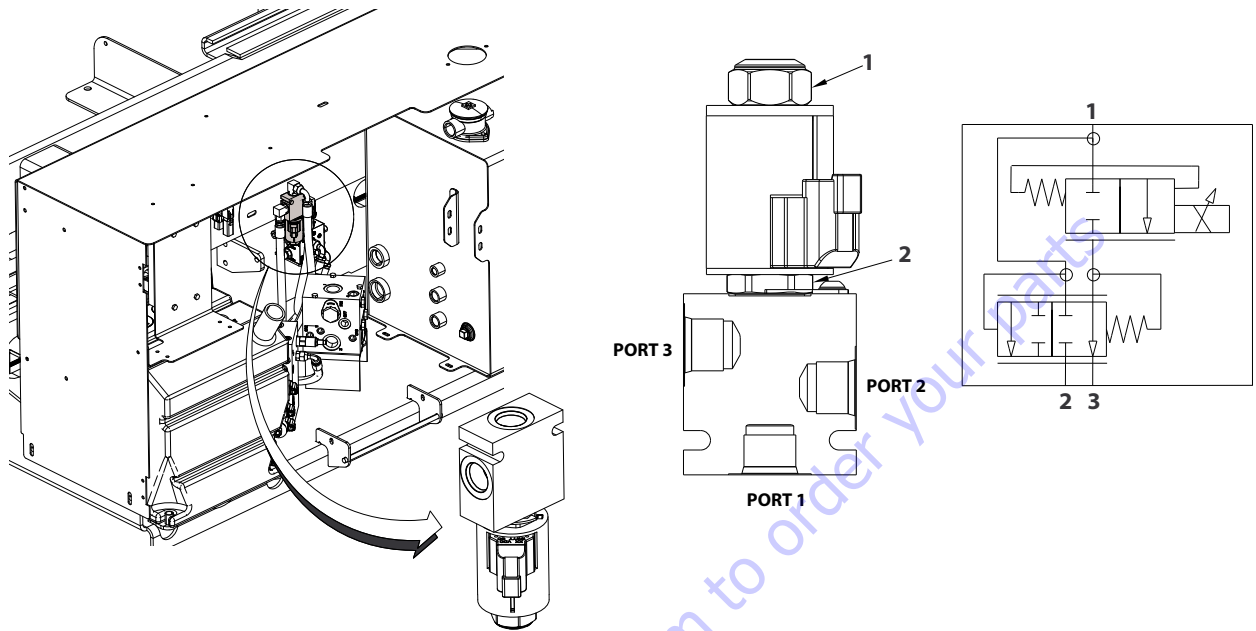

MAF06141

Figure 4-7. Leveling Jack Manifold Valve

NOTE: For valve torque specs see Table 4-9 on page 4-15.
For internal hydraulic circuits see Figure 4-32. on page 4-43

Table 4-9. Leveling Jack Manifold Valve Torque Specs

Item	Torque
1	10 to 12 lb-ft (14 to 15 Nm)
2	24 to 26 lb-ft (33 to 35 Nm)

Pressure Relief Valve - Setting Procedures

Cold temperatures have a significant impact on pressure readings. JLG Industries Inc. recommends operating the machine until the hydraulic system has warmed to normal operating temperatures prior to checking pressures. JLG Industries Inc. also recommends the use of a calibrated gauge. Pressure readings are acceptable if they are within $\pm 5\%$ of specified pressures.

(See Main Valve Port Identification - Figure 4-2. on page 4-7)

1. Main Relief;

- a. Locate the lift up solenoid valve (SV1). It is the middle solenoid on the main valve assembly.
- b. Remove the coil nut and coil from the cartridge. Do not remove the wire out of the coil plug.
- c. Install a pressure gauge, 3000 PSI or higher, at port MP1, located on the face 90 degrees towards right.
- d. Start the engine and activate lift up. The gauge should read 2700 PSI.
- e. The main relief (RV1/RV2) is located on the same face as solenoid valve, and is the top relief cartridge. Adjust clockwise to increase, counter-clockwise to decrease.
- f. Re-install the coil onto the lift up solenoid valve (SV1) and torque coil nut to 5 ft-lbs.

2. Steer Work Port Relief Valve;

- a. Install a pressure gauge, 3000 PSI or higher, at port MS, located on the top face (opposite face to mounting holes).
- b. Start the engine and activate steer right or left. The gauge should read 2500 PSI.
- c. The steer work port relief (RV2/RV3) is located on the same face as port MP1, and is the lowest relief valve. Adjust clockwise to increase, counter-clockwise to decrease.
This one relief valve takes care of both right and left.

3. Outrigger Jack Retract Relief Valve;

- a. Install a pressure gauge, 3000 PSI or higher, at port MP1 of the main control valve.
- b. Start the engine and activate the auto level function, then proceed to full extension by using the rocker switch "trim" function.
- c. Next, fully retract leveling jacks. Repeat this cycle four more times to bleed all air from circuit.
- d. The relief valve is fixed type & the Relief is set at the vendor side. The relief valve is located on the outrigger valve, the same face as the solenoid valves.

4.9 GEAR PUMP

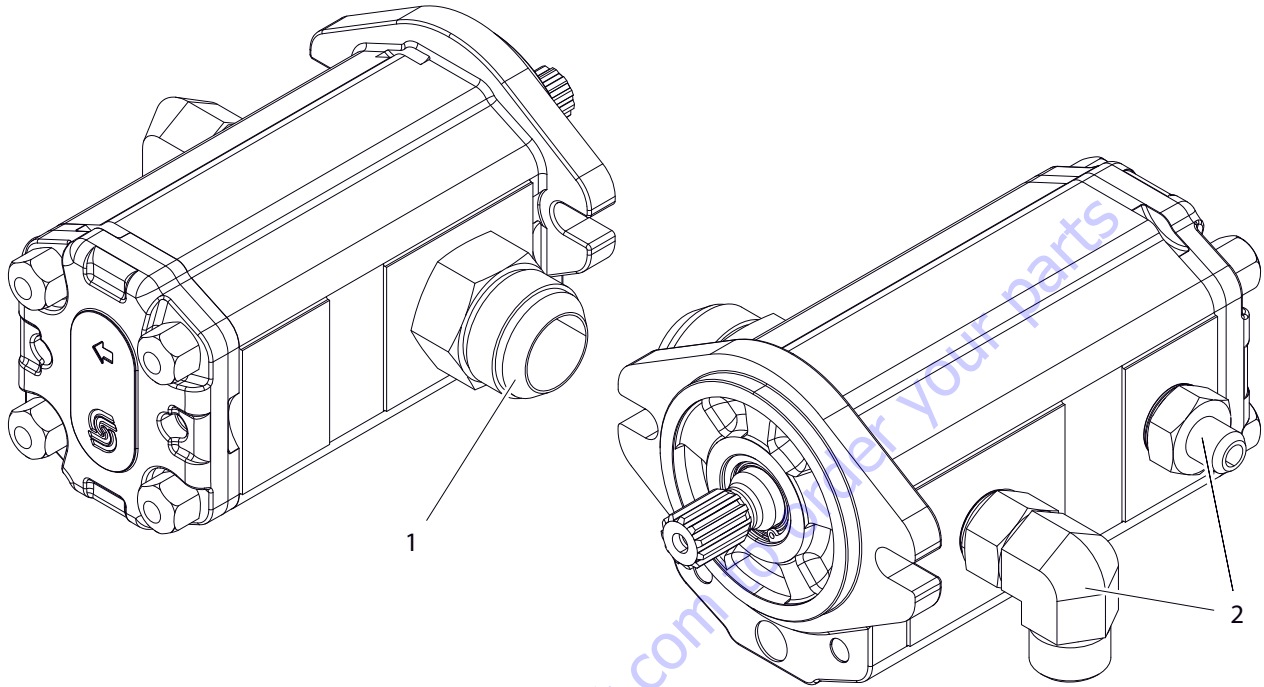

1. Inlet Port from Hydraulic Tank, 1-5/16-12 SAE STD THD - SAE #16 ORB
 2. Outlet Ports, 7/8-14 SAE STD THD - SAE #10 ORB

Figure 4-8. Tandem Gear Pump - Diesel

Table 4-10. Gear Pump Specs - Diesel

Rotation (Viewing Drive End)		Clockwise
Displacement	Front:	14.4 cc/rev 175 GPM
	Rear:	3.9 cc/rev 47 GPM
Max Rated Speed (with max. fluid viscosity of 50mm ² /sec.)		2800 rpm
Rated Pressure	Continuous	3045 psi (210 bar)
	Intermittent	3336 psi (230 bar)
	Peak	3336 psi (230 bar)
Minimum Speed at Rated Pressure	Front	1000 rpm
	Rear	1400 rpm

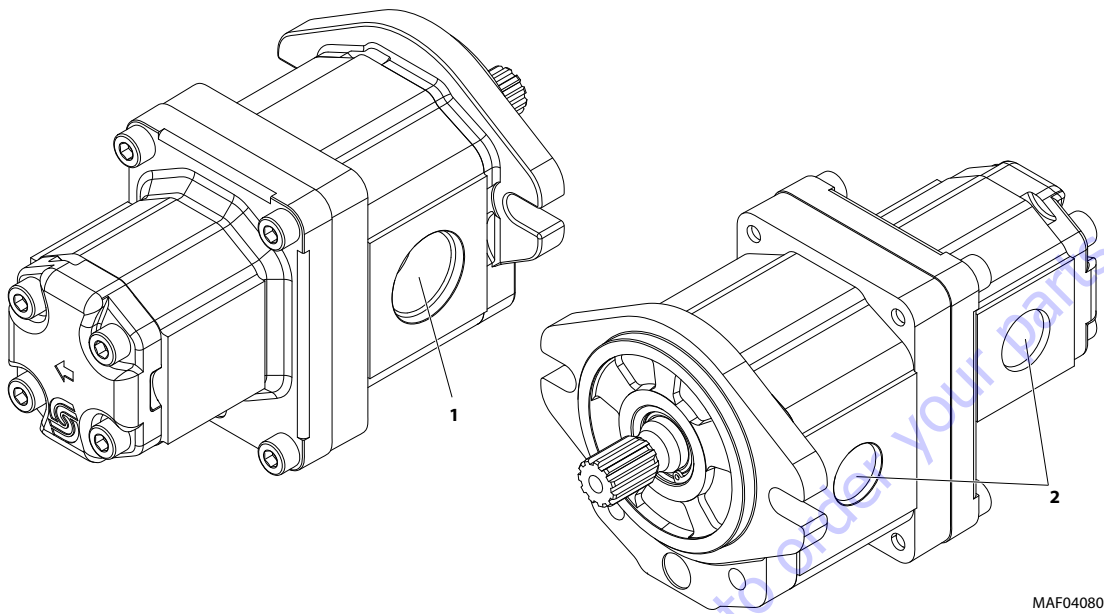

1. Inlet Port from Hydraulic Tank, 1-5/16-12 SAE STD THD - SAE #16 ORB 2. Outlet Ports, 7/8-14 SAE STD THD - SAE #10 ORB

Figure 4-9. Gear Pump - Dual Fuel - Gas/LPG

Table 4-11. Gear Pump - Dual Fuel - Gas/LPG

Rotation (Viewing Drive End)		Clockwise
Displacement	Front:	8.4cc/rev 8.9 GPM
	Rear:	2.62cc/rev 2.77 GPM
Max Rated Speed (with max. fluid viscosity of 50mm ² /sec.)		4000 rpm
Rated Pressure	Continuous	3046 psi (210 bar)
	Intermittent	-
	Peak	3336 psi (230 bar)
Minimum Speed at Rated Pressure		1000 rpm

4.10 AXIAL HI 45 PUMP

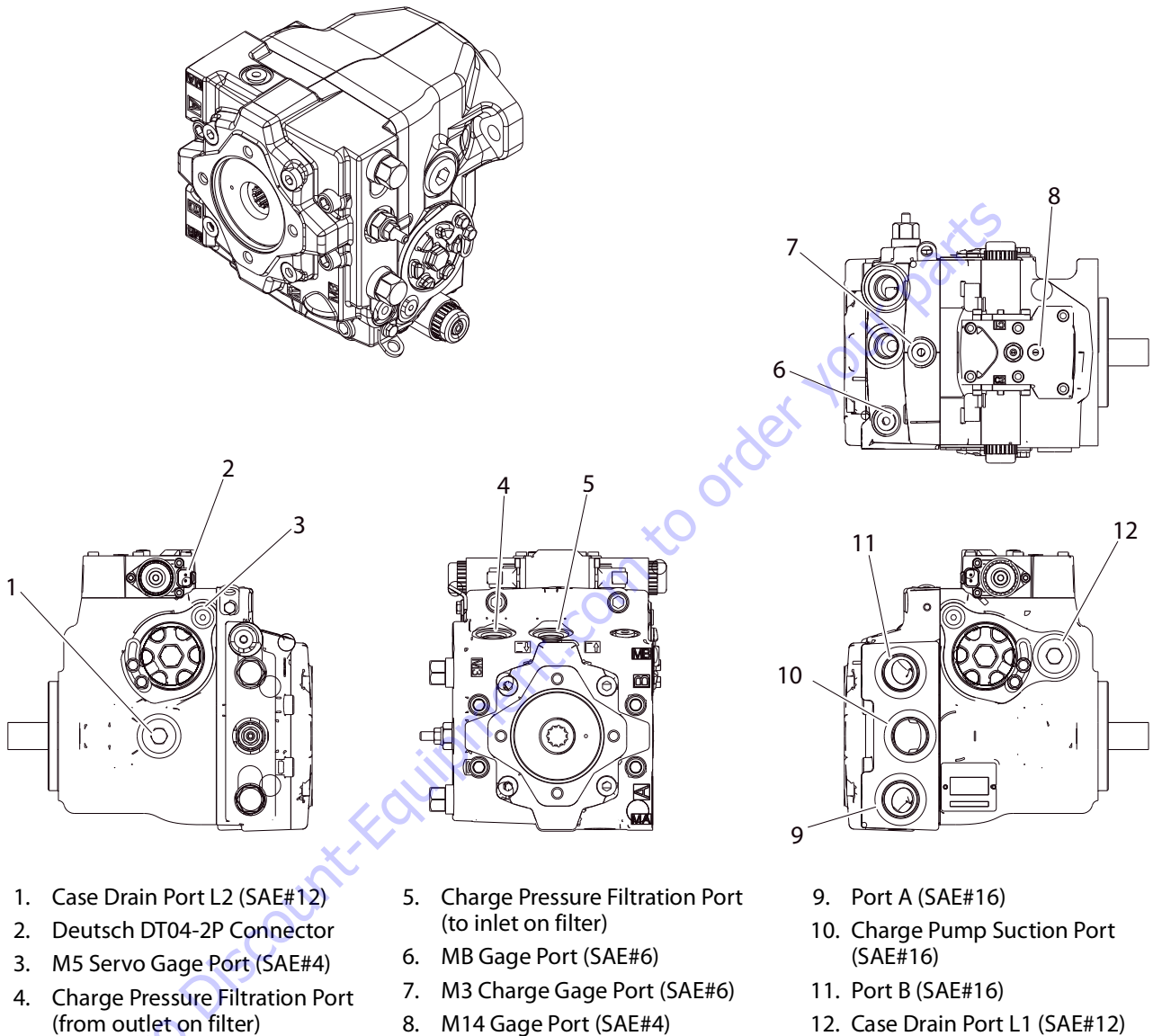

- 1. Case Drain Port L2 (SAE#12)
- 2. Deutsch DT04-2P Connector
- 3. M5 Servo Gage Port (SAE#4)
- 4. Charge Pressure Filtration Port (from outlet on filter)
- 5. Charge Pressure Filtration Port (to inlet on filter)
- 6. MB Gage Port (SAE#6)
- 7. M3 Charge Gage Port (SAE#6)
- 8. M14 Gage Port (SAE#4)
- 9. Port A (SAE#16)
- 10. Charge Pump Suction Port (SAE#16)
- 11. Port B (SAE#16)
- 12. Case Drain Port L1 (SAE#12)

Figure 4-10. Axial HI 45 Pump

Table 4-12. Axial HI 45 Pump Specs

Rotation	Clockwise
Max Pressure	6525 psi (450 bar)
Displacement	2.75 in ³ (45 cm ³)
Control Current	755 mA Threshold 1640 mA Max Displacement

Table 4-12. Axial HI 45 Pump Specs

12CC Charge Pump Pressure	348 psi (24 bar)
Max Operating Speed	3500 rpm

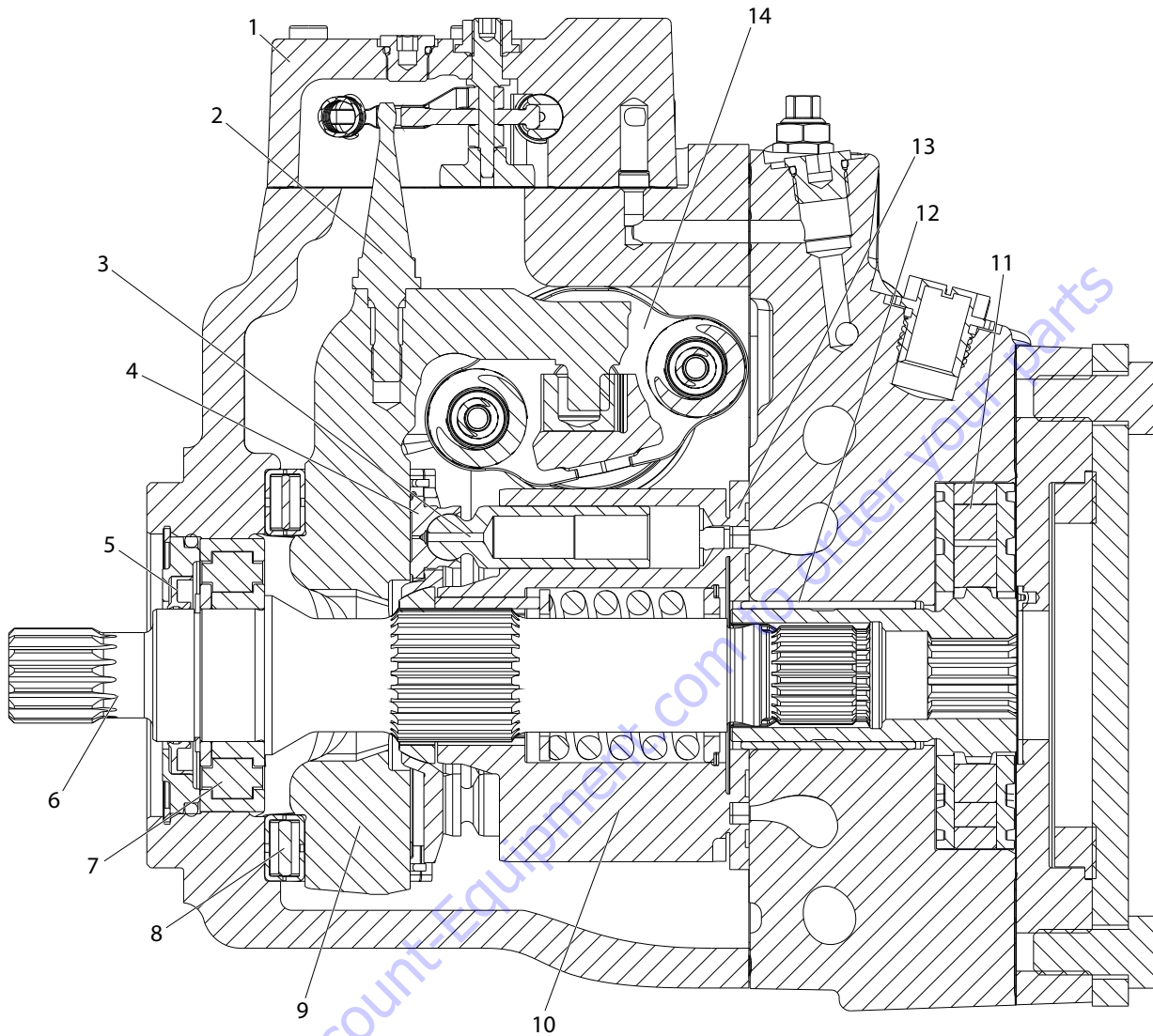

- | | | |
|----------------------------------|-----------------------|------------------|
| 1. Electric Displacement Control | 6. Shaft | 11. Charge Pump |
| 2. Swashplate Feedback Pin | 7. Front Bearing | 12. Rear Bearing |
| 3. Piston | 8. Swashplate Bearing | 13. Valve Plate |
| 4. Slipper | 9. Swashplate | 14. Servo Piston |
| 5. Shaft Seal | 10. Cylinder Block | |

Figure 4-11. Axial HI 45 Pump - Cross Section View

General Repair Instructions

REMOVAL

⚠ CAUTION

PRIOR TO PERFORMING REPAIRS, REMOVE THE UNIT FROM THE MACHINE. CHOCK WHEELS ON THE MACHINE TO INHIBIT MOVEMENT. BE AWARE THAT HYDRAULIC FLUID MAY BE UNDER HIGH PRESSURE AND/OR HOT. INSPECT THE OUTSIDE OF THE PUMP AND FITTINGS FOR DAMAGE. CAP HOSES AFTER REMOVAL TO PREVENT CONTAMINATION.

KEEP IT CLEAN

Clean the outside of the pump thoroughly before disassembly. Take care not to contaminate system ports. Clean parts using a clean solvent wash and air dry.

NOTICE

AS WITH ANY PRECISION EQUIPMENT, YOU MUST KEEP ALL PARTS FREE OF FOREIGN MATERIAL AND CHEMICALS. PROTECT ALL EXPOSED SEALING SURFACES AND CAVITIES FROM DAMAGE AND FOREIGN MATERIAL. IF LEFT UNATTENDED, COVER THE PUMP WITH A PROTECTIVE LAYER OF PLASTIC.

REPLACE ALL O-RINGS & GASKETS

Replace all o-rings and seals during service. Lightly lubricate o-rings with clean petroleum jelly prior to assembly.

SECURE THE UNIT

Place the unit in a stable position with the shaft pointing downward. It will be necessary to secure the pump while removing and torquing fasteners and components.

NOTICE

PERFORMING MINOR REPAIRS ACCORDING TO THIS SECTION WILL NOT AFFECT THE PUMP'S WARRANTY. MAJOR REPAIRS REQUIRING THE REMOVAL OF THE UNIT'S CENTER SECTION, SERVO SLEEVES, OR FRONT FLANGE VOIDS WARRANTY.

Start-Up Procedure

Follow this procedure when starting-up a new pump installation or when restarting an installation in which the pump has been removed and re-installed on the machine. Ensure pump has been thoroughly tested on a test stand before installing on a machine.

These pumps should never be dry started. The time it takes for the charge pump to create a vacuum to draw in the fluid, send it out through the charge pump filter and then back in to the pump may take 30-40 seconds. During this time the surface between the cylinder barrel and valve plate are running dry. This can affect the volumetric efficiency of the pump and cause premature failure of the pump. Pre-filling the case also reduces the time it takes for the pump to create a vacuum to draw fluid into the pump.

⚠ WARNING

TO PROTECT AGAINST UNINTENDED MOVEMENT, SECURE THE MACHINE OR DISABLE/DISCONNECT THE MECHANISM WHILE SERVICING.

NOTE: *Prior to installing the pump, inspect for damage that may have occurred during shipping.*

1. Ensure that the machine hydraulic oil and system components (reservoir, hoses, valves, fittings, and heat exchanger) are clean and free of any foreign material.
2. Install new system filter element(s) if necessary. Check that inlet line fittings are properly tightened and there are no air leaks.
3. Install the pump. Install a 1000 psi (50 bar) gauge in the charge pressure gauge port M3.
4. Fill the housing by adding filtered oil in the upper case drain port. If the control is installed on top, open the construction plug in the top of the control to assist in air bleed.
5. Fill the reservoir with hydraulic fluid of the recommended type and viscosity. Use a 10-micron filler filter. Fill inlet line from reservoir to pump. Ensure construction plug in control is closed after filling.
6. Disconnect the pump from all control input signals.
7. Close construction plug removed in step 4.

NOTICE

AFTER START-UP, THE FLUID LEVEL IN THE RESERVOIR MAY DROP DUE TO SYSTEM COMPONENTS FILLING. DAMAGE TO HYDRAULIC COMPONENTS MAY OCCUR IF THE FLUID SUPPLY RUNS OUT. ENSURE RESERVOIR REMAINS FULL OF FLUID DURING START-UP.

AIR ENTRAPMENT IN OIL UNDER HIGH PRESSURE MAY DAMAGE HYDRAULIC COMPONENTS. CHECK CAREFULLY FOR INLET LINE LEAKS. DO NOT RUN AT MAXIMUM PRESSURE UNTIL SYSTEM IS FREE OF AIR AND FLUID HAS BEEN THOROUGHLY FILTERED.

8. Disable the engine to prevent it from starting. Crank the starter for several seconds. Do not exceed the engine manufacturer's recommendation. Wait 30 seconds and then crank the engine a second time as stated above. This operation helps remove air from the system lines. Refill the reservoir to recommended full oil level.
9. When the gauge begins to register charge pressure, enable and start engine. Let the engine run for a minimum of 30 seconds at low idle to allow the air to work itself out of the system. Check for leaks at all line connections and listen for cavitation. Check for proper fluid level in reservoir.
10. When adequate charge pressure is established (as shown in model code), increase engine speed to normal operating rpm to further purge residual air from the system.
11. Shut off engine. Connect pump control signal. Start engine, checking to be certain pump remains in neutral. Run engine at normal operating speed and carefully check for forward and reverse control operation.
12. Continue to cycle between forward and reverse for at least five minutes to bleed all air and flush system contaminants out of loop.

NOTE: Normal charge pressure fluctuation may occur during forward and reverse operation.

13. Check that the reservoir is full. Remove charge pressure gauge. The pump is now ready for operation.

Removing the Pump

NOTICE

CONTAMINATION CAN DAMAGE INTERNAL COMPONENTS AND VOID THE MANUFACTURER'S WARRANTY.

TAKE PRECAUTIONS TO ENSURE SYSTEM CLEANLINESS WHEN REMOVING AND INSTALLING SYSTEM LINES.

DISASSEMBLY

1. With the prime mover off, thoroughly clean all dirt and grime from the outside of the pump.
2. Tag, disconnect, and cap each hydraulic line connected to the pump. As hydraulic lines are disconnected, plug each open port, to ensure that dirt and contamination do not get into the pump.
3. Remove the pump and its auxiliary pump (if applicable) as a single unit.

NOTE: Be careful, do not damage solenoids and electrical connections when using straps or chains to support the pump.

INSPECTION

1. Ensure the work surface and surrounding area are clean and free of contaminants such as dirt and grime.
2. Inspect the system for contamination.
3. Look at the hydraulic fluid for signs of system contamination, oil discoloration, foam in the oil, sludge, or metal particles.

REASSEMBLY

1. Before replacing the pump, replace all filters and drain the hydraulic system. Flush the system lines and fill the reservoir with the correct, filtered hydraulic fluid.
2. Fill the pump with clean, filtered hydraulic fluid.
3. Attach the pump to the prime mover. Torque mounting screws according to the manufacturers recommendation.
4. Replace all hydraulic lines. Ensure the charge inlet line is filled with fluid.

Electric Control Module

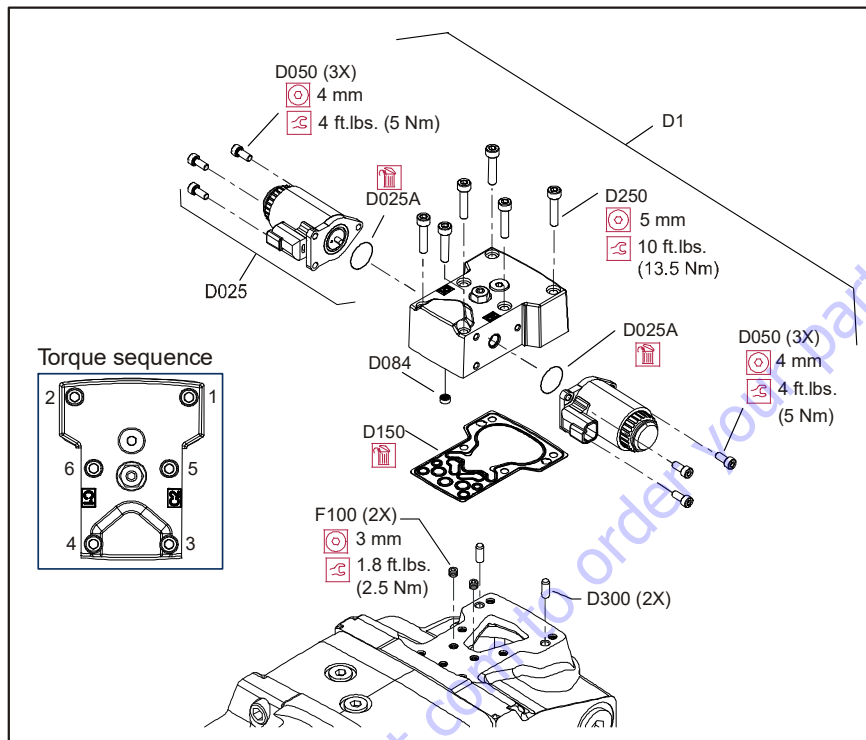

REMOVAL

1. Using a 5 mm internal hex wrench, remove the six capscrews (D250).
2. Remove the control module and gasket (D150). Discard the gasket.
3. If necessary, remove orifices (F100) using a 3 mm internal hex wrench. Tag and number them for reinstallation.

INSPECTION

1. Inspect the machined surfaces on the control and top of the pump. If you find any nicks or scratches, replace the component.

REASSEMBLY

NOTE: Ensure you install dowel pins (D300) in housing before installing control.

1. Install a new gasket (D150).
2. If you removed screen (D084), install a new one. Install with the mesh facing outward (see drawing).
3. If previously removed, install orifices (F100) using a 3 mm internal hex wrench. Torque to 1.8 lb-ft (2.5 Nm).
4. Install the control module and six capscrews (D250).
5. Using a 5 mm internal hex wrench, torque the capscrews (D250) to 10 lb-ft (13.5 Nm).

Control Solenoids

REMOVAL

1. Disconnect electrical connection and remove the three capscrews (D050) using a 4 mm internal hex wrench.
2. Remove the solenoid (D025) and O-ring (D025A). Discard the O-ring.
3. If necessary, remove the coil using a 12 point 26 mm socket.

INSPECTION

1. Inspect the machined surface on the control. If you find any nicks or scratches, replace the component.

REASSEMBLY

1. Lubricate new O-ring (D025A) using petroleum jelly and install.
2. Install solenoid with three capscrews (D050) using a 4 mm internal hex wrench. Torque screws to 5 Nm (4 lb-ft).
3. Install coil using a 12 point 26 mm socket. Torque coil nut to 3.7 lb-ft (5 Nm).
4. Reconnect electrical connections and test the pump for proper operation.

Shaft Seal, Roller Bearing & Shaft Replacement

NOTE: The shaft assembly is serviceable without disassembling the pump. Orient the pump on the work surface so the shaft is pointing to the side.

REMOVAL

1. Unwind the spiral ring (J300) from the housing to release the shaft/seal/bearing subassembly.
2. Pry on the lip of the seal carrier (J275) to dislodge it from the pump. Remove the seal carrier. Remove and discard O-ring (J260). Press the seal (J250) out of the carrier and discard.
3. Pull the shaft (J100) with bearing (J150) out of the pump. If necessary, tap lightly on the shaft to dislodge it from the cylinder block.
4. Remove the retaining ring (J200) using retaining ring pliers. Press the bearing off the shaft.

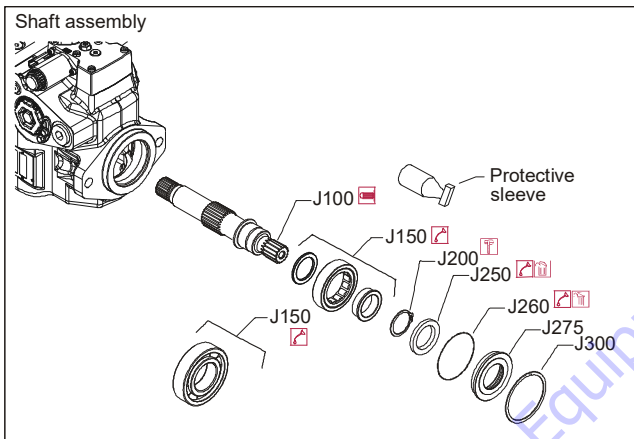

INSPECTION

1. Inspect the shaft journals for wear, scratching, and pits. Check the splines for fretting; replace if damaged. Rotate the bearing, if it does not rotate smoothly, replace it.

REASSEMBLY

1. Press the bearing (J150) onto the shaft (J100) and replace the retaining ring (J200). Ensure the retaining ring diameter is less than 1.53 in (38.84 mm) when installed on the shaft.
2. Install the shaft/bearing assembly into the pump.
3. Lubricate and install a new O-ring (J260) onto seal carrier (J275). Press a new seal (J250) into the seal carrier. Press the seal until it is flush within 0.005 in

(+0.12mm) or 0.0028 in (-0.72 mm) of the inside lip of the carrier: see illustration.

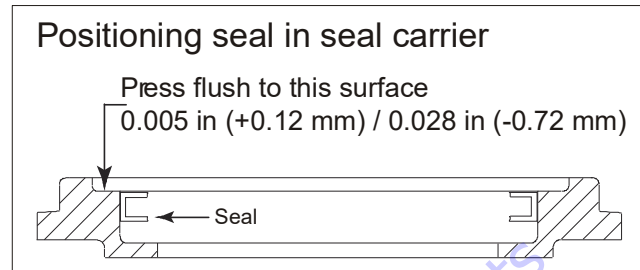

4. Cover the shaft with a protective sleeve while installing the seal carrier. Hand press the seal carrier into the housing. Ensure the seal carrier clears the spiral ring groove in the housing. Remove the protective sleeve.
5. Wind the spiral ring into the housing. Ensure the inside diameter of the spiral ring is greater than 2.677 in (68 mm) after installation.

Charge Pump

If the pump has an auxiliary pump attached, remove the auxiliary pump and connecting shaft before removing the auxiliary pad.

REMOVAL

1. Position pump so end cover or auxiliary pad is on top.
2. If necessary, remove auxiliary pump (not shown), or shipping cover (K300) and pad seal (K250) as shown on following page.
3. Remove end cover/auxiliary pad screws (K400) using a 10 mm internal hex wrench.

NOTE: Alignment pins (G450) are in end cover. They may dislodge during disassembly.

4. Remove and discard gasket (K150).
5. Remove thrust washer (K500). Note thrust washer orientation.
6. Use a small hook to remove pressure balance plate (S200) and seal (S300). Note plate orientation. Discard seal.
7. Remove coupling (K200). Use a small hook if necessary.
8. Remove the charge pump outer ring (S150), and gearset (S100).
9. Remove valve plate (S250) with seal (S300). Discard seal

INSPECTION

1. Inspect the components for wear, scratches or pitting. Carefully inspect the valve and pressure balance plates. Scratches on these components will cause a loss of charge pressure. If any component shows signs of wear, scratching or pitting, replace it.

REASSEMBLY

1. Install new seals (S300) in the valve (S250) and pressure-balance (S200) plates.
2. Install valve plate (S250) in the same orientation as removed.
3. Lubricate and install charge pump (S100) and outer ring (S150).
4. Install charge pump coupling (K200).
5. Install pressure balance plate (S200) in the same orientation as removed.
6. Install the thrust washer (K500). Coated side goes toward charge pump coupling (K200).
7. Install a new cover gasket. (K150). If removed, install guide pins (K450).
8. Install the auxiliary pad or charge pump cover and capscrews. Using a 10mm internal hex wrench, torque the capscrews (K400) to 68 lb-ft (92 Nm). Torque in sequence below.
9. Reinstall auxiliary pump or pad seal (K250) and shipping cover (K300).

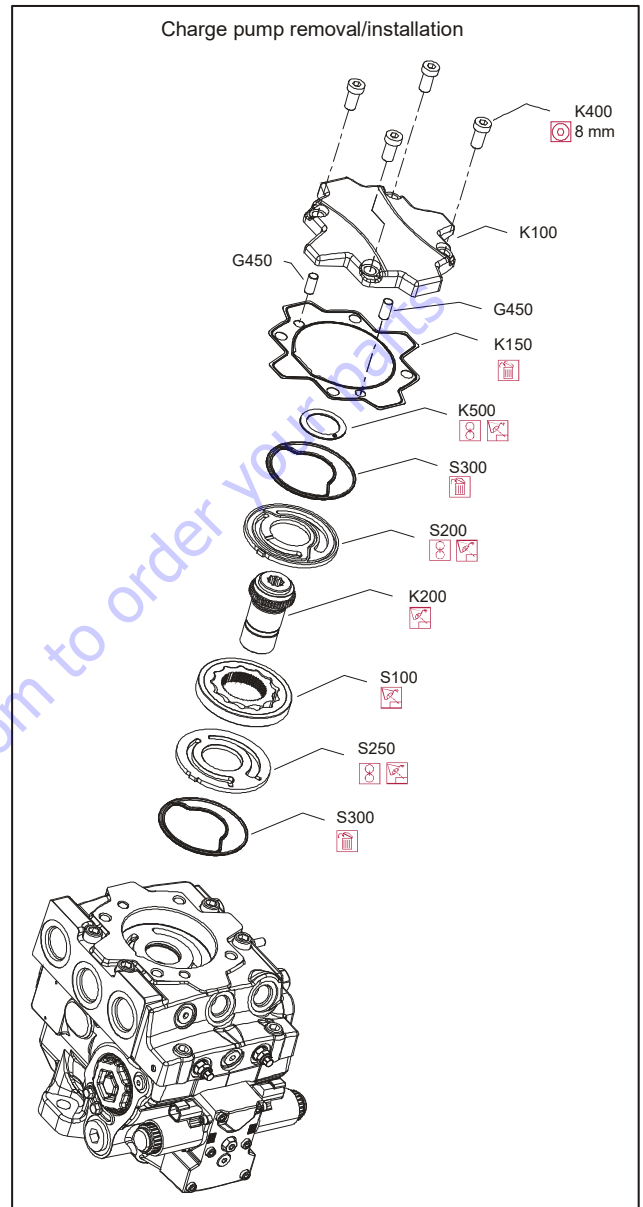
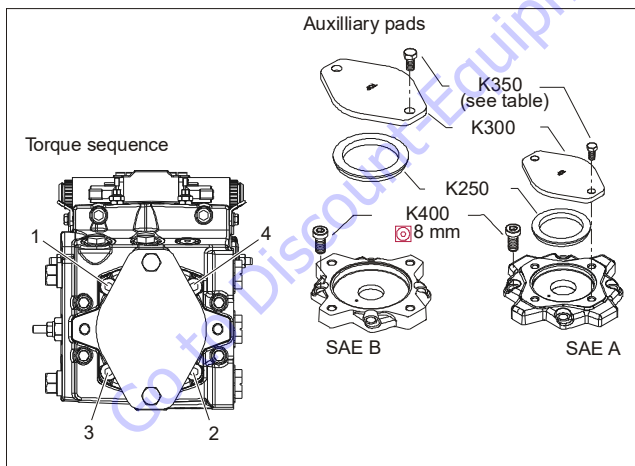

Cover Screw K350

Cover Pad	Wrench Size; Torque
A	17 mm; 35 lb-ft (48 Nm)
B, C	19 mm; 58 lb-ft (77 Nm)

Charge Check/HPRV

REMOVAL

1. Using a 22 mm hex wrench, remove the HPRVs (L100/L200). Remove and discard the O-rings (L060) and backup rings (L068).

INSPECTION

1. Inspect the sealing surfaces in the pump for nicks or scratches. Check the valves for damage. Replace any damaged components.

REASSEMBLY

1. Lubricate and install new backup rings (L068) and O-rings (L060).
2. Install HPRVs. Torque to the value in the illustration below.
3. Operate the machine through full range of controls to ensure proper operation. Check for leaks.

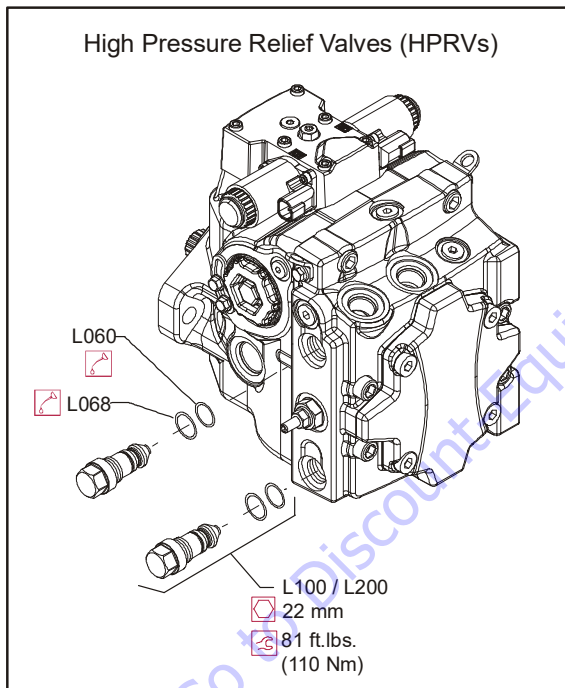

Charge Pressure Relief Valve

Replace the charge pressure relief valve (V10) as a complete unit. Do not attempt to repair the internal components of the valve. Torque to 38 lb-ft (52 Nm).

REMOVAL

1. Using a 22 mm wrench, remove the charge pressure relief valve (V10). Discard seal (V024).

INSPECTION

1. Inspect the sealing surfaces of the pump for nicks or scratches.

REASSEMBLY

1. Lubricate and install new seal (V024).
2. Install the charge pressure relief valve. Torque to 38 lb-ft (52 Nm).
3. Operate machine through full range of controls to ensure proper operation.

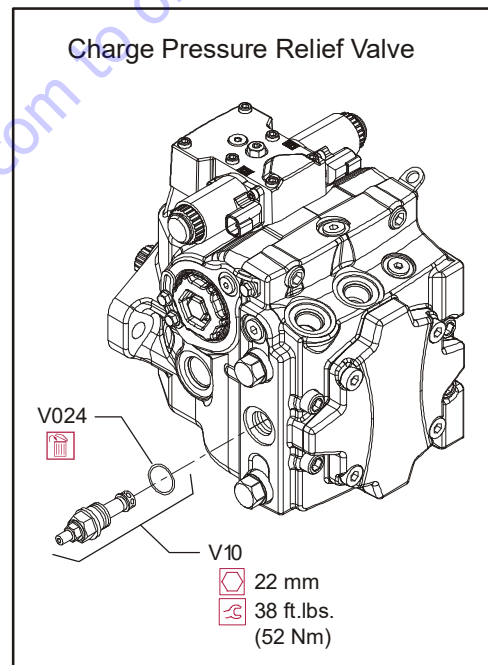

Pressure Limiter Valve Replacement

NOTE: Replace the pressure limiter valve as a complete unit.
Do not attempt to repair individual components.

REMOVAL

1. Using a 14 mm wrench, remove the pressure limiter valves (L300/L400). Discard O-rings.

INSPECTION

1. Inspect the sealing surfaces of the pump for nicks or scratches.

REASSEMBLY

1. Install new O-ring. Lubricate O-ring with petroleum jelly.
2. Replace pressure limiter valves. Torque to 22 lb-ft (30 Nm).
3. Operate pump at full range of controls to ensure proper machine operation.

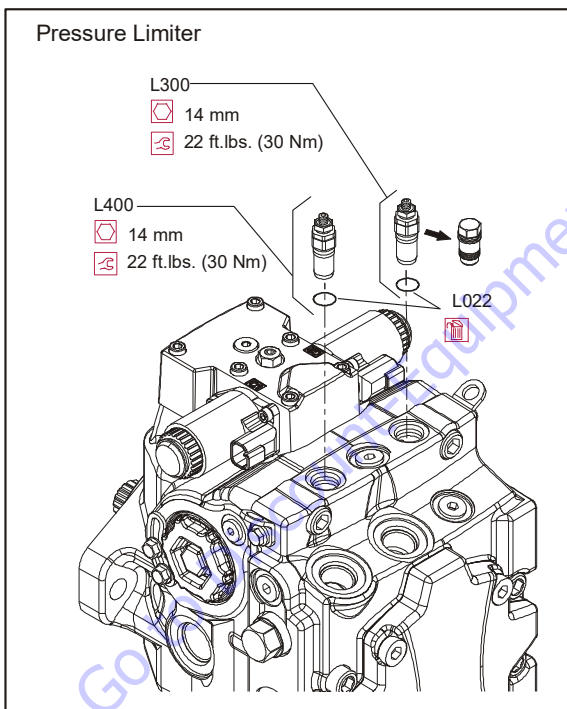

4.11 CHARGE PUMP FILTER

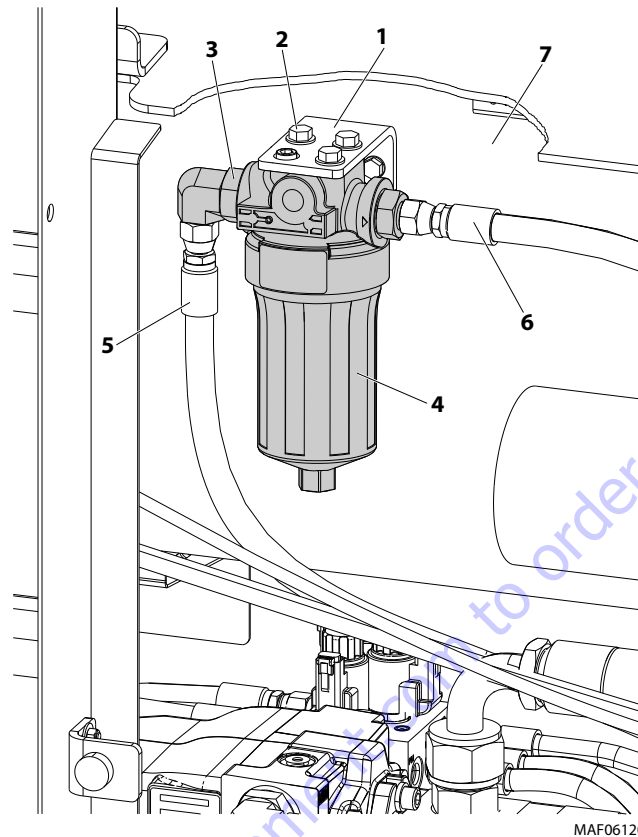

Figure 4-12. Charge Pump Filter

- | | |
|------------------------------------|--|
| 1. Mounting Bracket | 5. Inlet Hose from Port F (Out) - Axial Pump |
| 2. Filter to Bracket Bolts/Washers | 6. Outlet Hose to Port E (Return) - Axial Pump |
| 3. Filter Assembly | 7. Rear Wall of Engine Compartment |
| 4. Filter Bowl | |

REMOVAL

1. Disconnect and cap the hydraulic lines (5 and 6) on the filter assembly (3).
2. Remove the mounting bolts/washers (2) on top to remove the filter assembly from the bracket.

INSTALLATION

1. Attach filter assembly (3) to mounting bracket (1) using the mounting bolts/washers (2).
2. Uncap and reconnect the hydraulic lines (5 and 6) to the filter.

NOTE: If removed and reinstalled, filter bowl torque is 30 ft. lb. (40 Nm).

4.12 CYLINDER REPAIR

NOTE: The following are general procedures that apply to all cylinders on this machine. Procedures that apply to a specific cylinder will be so noted.

Disassembly

NOTICE

DISASSEMBLY OF THE CYLINDER SHOULD BE PERFORMED ON A CLEAN WORK SURFACE IN A DIRT FREE WORK AREA.

1. Connect a suitable auxiliary hydraulic power source to the cylinder port block fitting.

WARNING

DO NOT FULLY EXTEND CYLINDER TO THE END OF STROKE. RETRACT CYLINDER SLIGHTLY TO AVOID TRAPPING PRESSURE.

2. Operate the hydraulic power source and extend the cylinder. Shut down and disconnect the power source. Adequately support the cylinder rod, if applicable.
3. If applicable, remove the cartridge-type holding valve and fittings from the cylinder port block. Discard o-rings.

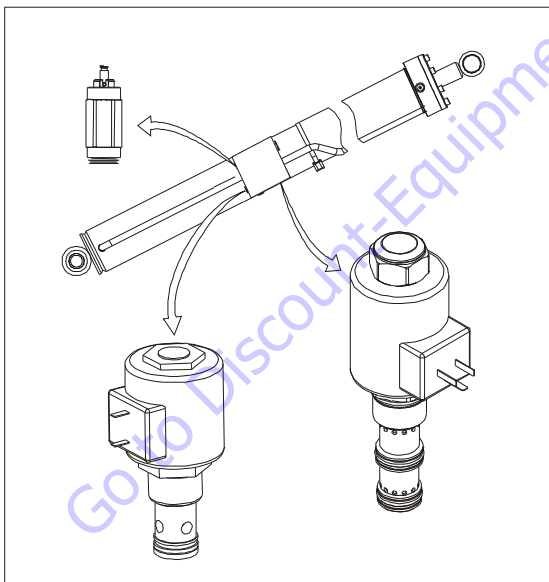

Figure 4-13. Lift Cylinder Holding Valve and Fitting Removal

4. Place the cylinder barrel into a suitable holding fixture.

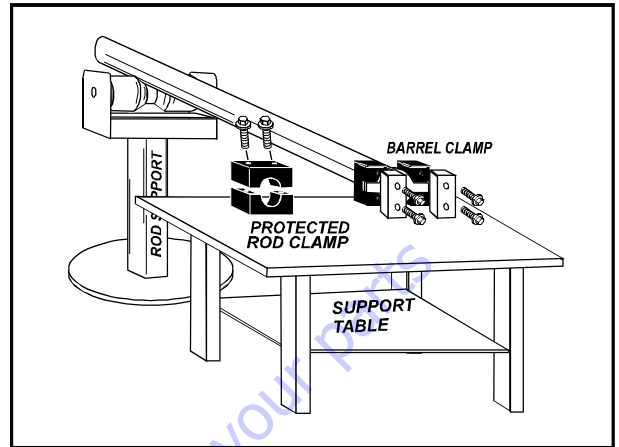

Figure 4-14. Cylinder Barrel Support

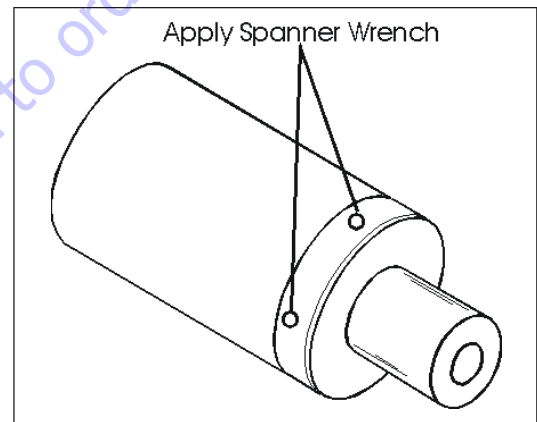
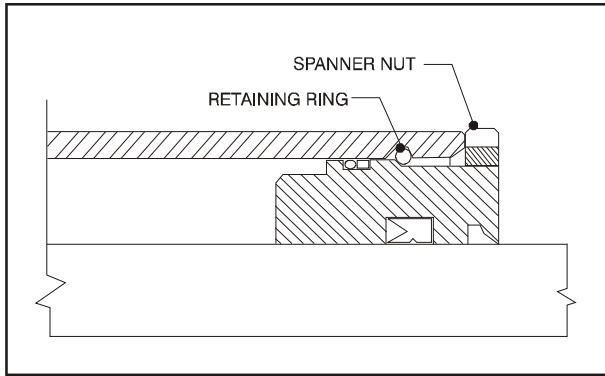

Figure 4-15. Lift Cylinder Capscrew Removal

NOTE: Steps 6 and 7 apply only to the steer cylinder.

5. Using a spanner wrench, loosen the spanner nut retainer, and remove spanner nut from cylinder barrel.
6. Being careful not to mar the surface of the rod, use a punch or wooden dowel and hammer to drive the rod guide about one inch down into the cylinder bore. Using a screw driver, carefully push one end of the round retaining ring back towards the inside of the cylinder and then slip the screwdriver tip under that end. Pull the ring out of the groove toward the wall mouth. Once one end of the retaining ring is free from the groove, the remainder can be easily pried free using ones fingers or pliers.



- Attach a suitable pulling device to the cylinder rod port block end or cylinder rod end, as applicable.

NOTICE

EXTREME CARE SHOULD BE TAKEN WHEN REMOVING THE CYLINDER ROD, HEAD, AND PISTON. AVOID PULLING THE ROD OFF-CENTER, WHICH COULD CAUSE DAMAGE TO THE PISTON AND CYLINDER BARREL SURFACES.

- With the barrel securely clamped, apply pressure to the rod pulling device and carefully withdraw the complete rod assembly from the cylinder barrel.

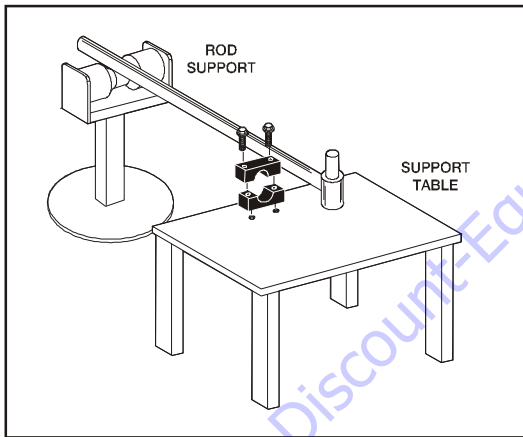

Figure 4-16. Cylinder Rod Support

- Using suitable protection, clamp the cylinder rod in a vise or similar holding fixture as close to the piston as possible.

NOTE: Step 11 applies only to the steer cylinder.

- Loosen and remove the nut which attaches the piston to the rod, and remove the piston.
- Loosen and remove the capscrews, if applicable, which attach the tapered bushing to the piston.
- Insert the capscrews in the threaded holes in the outer piece of the tapered bushing. Progressively tighten the capscrews until the bushing is loose on the piston.

- Remove the bushing from the piston.

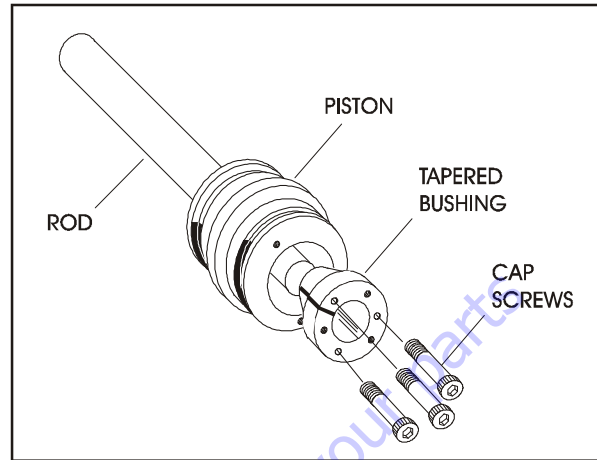

Figure 4-17. Tapered Bushing Removal

- Screw the piston counter-clockwise, by hand, and remove the piston from cylinder rod.
- Remove and discard the piston o-rings, seal rings, and backup rings.
- Remove piston spacer, if applicable, from the rod.
- Remove the rod from the holding fixture. Remove the cylinder head gland and retainer plate, if applicable. Discard the o-rings, backup rings, rod seals, and wiper seals.

Cleaning and Inspection

- Clean all parts thoroughly in an approved cleaning solvent.
- Inspect the cylinder rod for scoring, tapering, ovality, or other damage. If necessary, dress rod with Scotch Brite or equivalent. Replace rod if necessary.
- Inspect threaded portion of rod for excessive damage. Dress threads as necessary.
- Inspect inner surface of cylinder barrel tube for scoring or other damage. Check inside diameter for tapering or ovality. Replace if necessary.
- Inspect threaded portion of barrel for damage. Dress threads as necessary.
- Inspect piston surface for damage and scoring and for distortion. Dress piston surface or replace piston as necessary.
- Inspect threaded portion of piston for damage. Dress threads as necessary.
- Inspect seal and o-ring grooves in piston for burrs and sharp edges. Dress applicable surfaces as necessary.
- Inspect cylinder head inside diameter for scoring or other damage and for ovality and tapering. Replace as necessary.

10. Inspect threaded portion of head for damage. Dress threads as necessary.
11. Inspect seal and o-ring grooves in head for burrs and sharp edges. Dress applicable surfaces as necessary.
12. Inspect cylinder head outside diameter for scoring or other damage and ovality and tapering. Replace as necessary.
13. If applicable, inspect rod and barrel bearings for signs of correct excessive wear or damage. Replace as necessary.
 - a. Thoroughly clean hole, (steel bushing) of burrs, dirt etc. to facilitate bearing installation.
 - b. Inspect steel bushing for wear or other damage. If steel bushing is worn or damaged, rod/barrel must be replaced.
 - c. Lubricate inside of steel bushing with WD40 prior to bearing installation.
 - d. Using an arbor of the correct size, carefully press the bearing into steel bushing.

NOTE: Install pin into the Gar-Max bearing dry. Lubrication is not required with nickel plated pins and bearings.

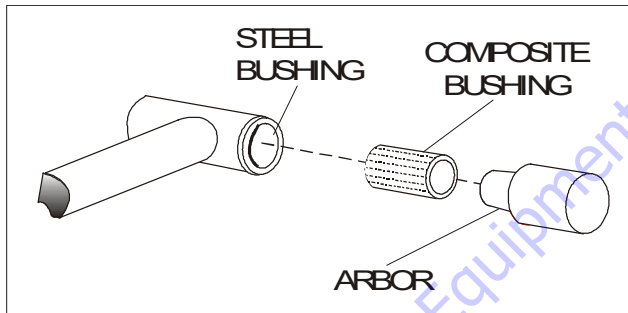

Figure 4-18. Bushing Installation

14. Inspect travel limiting collar or spacer for burrs and sharp edges. If necessary, dress inside diameter surface with Scotch Brite or equivalent.
15. If applicable, inspect port block fittings and holding valve. Replace as necessary.
16. Inspect the oil ports for blockage or the presence of dirt or other foreign material. Repair as necessary.
17. If applicable, inspect piston rings for cracks or other damage. Replace as necessary.

Assembly

NOTE: Prior to cylinder assembly, ensure that the proper cylinder seal kit is used. See your JLG Parts Manual.

Apply a light film of hydraulic oil to all components prior to assembly.

1. A special tool is used to install a new rod seal into the applicable cylinder head gland groove.

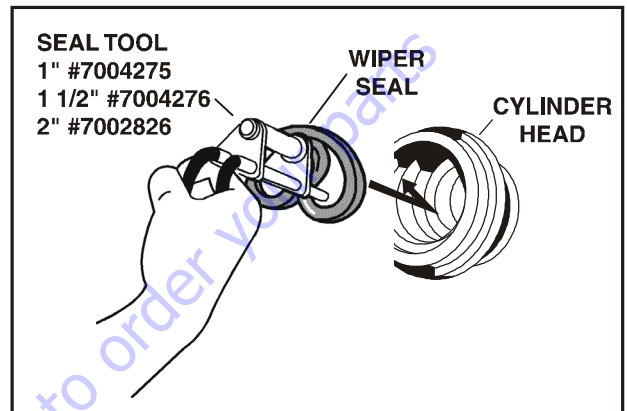

Figure 4-19. Rod Seal Installation

NOTICE

WHEN INSTALLING 'POLY-PAK' PISTON SEALS, ENSURE SEALS ARE INSTALLED PROPERLY. REFER TO WIPER SEAL INSTALLATION FOR CORRECT SEAL ORIENTATION. IMPROPER SEAL INSTALLATION COULD RESULT IN CYLINDER LEAKAGE AND IMPROPER CYLINDER OPERATION.

WHEN INSTALLING THE WIPER SEAL ON THE LOWER (TOWER) LIFT CYLINDER, APPLY HIGH STRENGTH THREADLOCKING COMPOUND ON THE WIPER SEAL IN THREE EVENLY SPACED PLACES TO AID IN RETENTION OF THE SEAL.

2. Use a soft mallet to tap a new wiper seal into the applicable cylinder head gland groove. Install a new wear ring into the applicable cylinder head gland-groove.

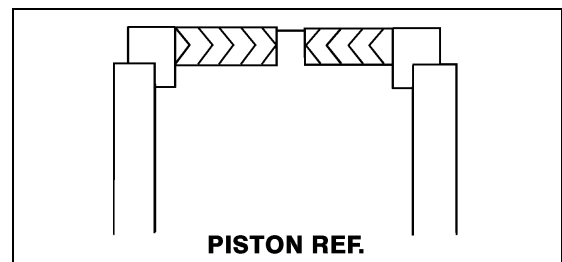

Figure 4-20. Poly-Pak Piston Seal Installation

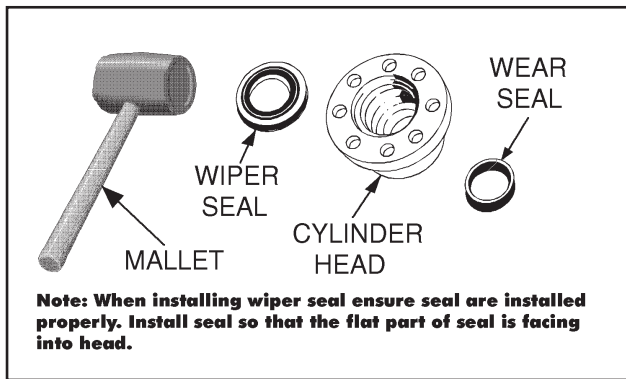

Figure 4-21. Wiper Seal Installation

3. Place a new o-ring and backup seal in the applicable outside diameter groove of the cylinder head.

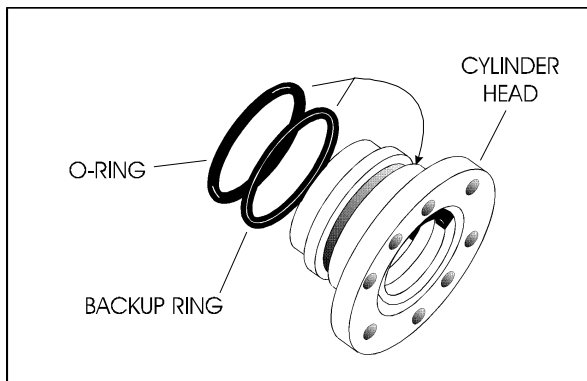

Figure 4-22. Installation of Head Seal Kit

4. Install washer ring onto rod. Carefully install the head gland on the rod, ensuring that the wiper and rod seals are not damaged or dislodged. Push the head along the rod to the rod end, as applicable.
5. Carefully slide the piston spacer on the rod.
6. If applicable, correctly place new o-ring in the inner piston diameter groove. (The backup ring side facing the o-ring is grooved.)
7. If applicable, correctly place new seals and guide lock rings in the outer piston diameter groove. (A tube, with I.D. slightly larger than the O.D. of the piston is recommended to install the solid seal.)

NOTE: The backup rings for the solid seal have a radius on one side. This side faces the solid seal. [See magnified insert in (See Figure 4-23.)] The split of seals and backup rings must be positioned so as not to be in alignment with each other.

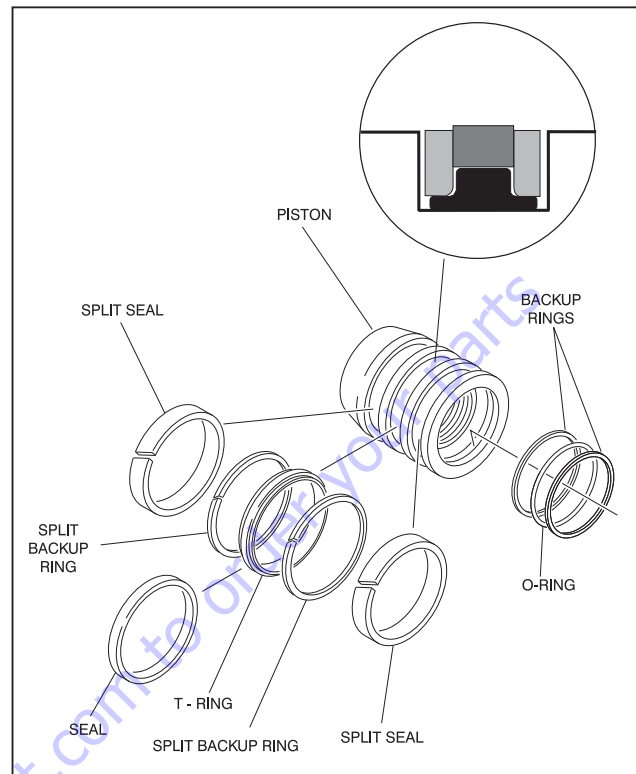

Figure 4-23. Piston Seal Kit Installation

1. Using suitable protection, clamp the cylinder rod in a vise or similar holding fixture as close to piston as possible.
 2. Carefully thread the piston on the cylinder rod hand tight, ensuring that the o-ring and backup rings are not damaged or dislodged.
 3. Thread piston onto rod until it abuts the spacer end and install the tapered bushing.
- NOTE:** When installing the tapered bushing, piston and mating end of rod must be free of oil.
4. Assemble the tapered bushing loosely into the piston and insert JLG capscrews (not vendor capscrews) through the drilled holes in the bushing and into the tapped holes in the piston.

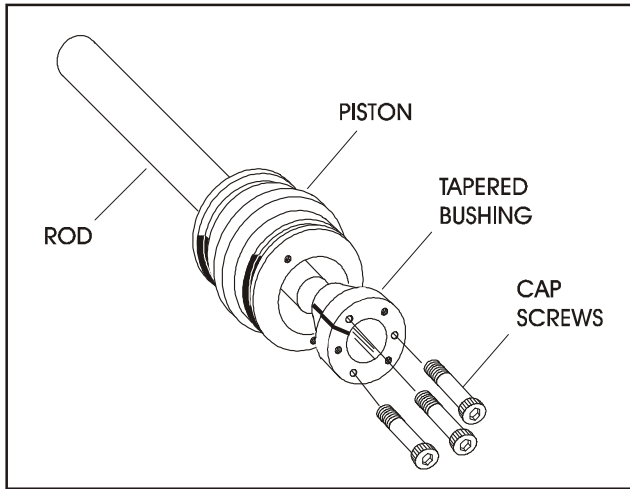

Figure 4-24. Tapered Bushing Installation

5. Tighten the capscrews evenly and progressively in rotation to the specified torque value.
6. After the screws have been torqued, tap the tapered bushing with a hammer (16 to 24 oz.) and brass shaft (approximately 3/4" in diameter) as follows;
 - a. Place the shaft against the cylinder rod and in contact with the bushing in the spaces between the capscrews.
 - b. Tap each space once; this means the tapered bushing is tapped 3 times as there are 3 spaces between the capscrews.

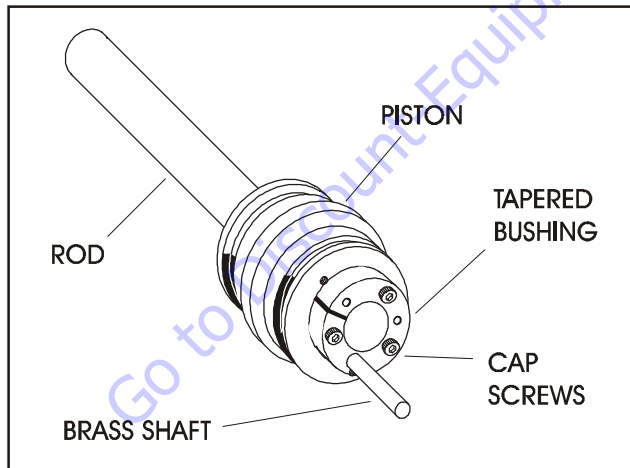

Figure 4-25. Seating the Tapered Bearing

7. Re-torque the capscrews evenly and progressively in rotation to the specified torque value.
8. Remove the cylinder rod from the holding fixture.
9. Place new guide locks and seals in the applicable outside diameter grooves of the cylinder piston. (See Figure 4-23.)
10. Position the cylinder barrel in a suitable holding fixture.

NOTICE

EXTREME CARE SHOULD BE TAKEN WHEN INSTALLING THE CYLINDER ROD, HEAD, AND PISTON. AVOID PULLING THE ROD OFF-CENTER, WHICH COULD CAUSE DAMAGE TO THE PISTON AND CYLINDER BARREL SURFACES.

11. With barrel clamped securely, and while adequately supporting the rod, insert the piston end into the barrel cylinder. Ensure that the piston loading o-ring and seal ring are not damaged or dislodged.
12. Continue pushing the rod into the barrel until the cylinder head gland can be inserted into the barrel cylinder.
13. Secure the cylinder head gland using the washer ring and socket head bolts.

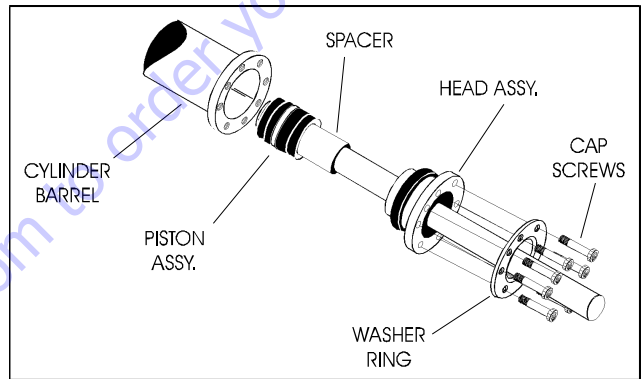

Figure 4-26. Rod Assembly Installation

14. After the cylinder has been reassembled, the rod should be pushed all the way in (fully retracted) prior to the reinstallation of any holding valve or valves.
15. If applicable, install the cartridge-type holding valve and fittings in the rod port block, using new o-rings as applicable. (See Table 4-13, Holding Valve Torque Specifications).
16. Push the piston onto the rod until it abuts the spacer end and install the attaching nut

WARNING

WHEN REBUILDING THE CYLINDERS, APPLY MEDIUM STRENGTH THREADLOCKING COMPOUND TO PISTON NUT AND SETSCREW, THEN TORQUE PISTON NUT.

NOTE: The Steer Cylinder uses snap rings to secure piston.

Table 4-13. Holding Valve Torque Specifications

Description	Torque Value
Sun-7/8 hex M20x1.5 thds	30-35 lb-ft (41-48 Nm)

Table 4-13. Holding Valve Torque Specifications

Description	Torque Value
Sun - 1-1/8 hex 1 - 14 UNS thds	45 - 50 lb-ft (61 - 68 Nm)
Sun - 1-1/4 hex M36 x 2 thds	150 - 153 lb-ft (204 - 207 Nm)
Racine - 1-1/8 hex 1-1/16 - 12 thds	50 - 55 lb-ft (68 - 75 Nm)
Racine - 1-3/8 hex 1-3/16 - 12 thds	75 - 80 lb-ft (102 - 109 Nm)
Racine - 1-7/8 hex 1-5/8 - 12 thds	100 - 110 lb-ft (136 - 149 Nm)

17. Prior to setscrew installation spot drill rod before installing the setscrew(s) which secure the piston attaching nut to the diameter groove.
18. Remove the cylinder rod from the holding fixture.
19. Position the cylinder barrel in a suitable holding fixture.

NOTICE

EXTREME CARE SHOULD BE TAKEN WHEN INSTALLING THE CYLINDER ROD, HEAD, AND PISTON. AVOID PULLING THE ROD OFF-CENTER, WHICH COULD CAUSE DAMAGE TO THE PISTON AND CYLINDER BARREL SURFACES.

20. With barrel clamped securely, and while adequately supporting the rod, insert the piston end into the barrel cylinder. Ensure that the piston loading o-ring and seal ring are not damaged or dislodged.
21. Continue pushing the rod into the barrel until the cylinder head gland can be inserted into the barrel cylinder.
22. If applicable, secure the cylinder head retainer using a suitable chain wrench.
23. After the cylinder has been reassembled, the rod should be pushed all the way in (fully retracted) prior to the reinstallation of any holding valve or valves.
24. If applicable, install the cartridge-type holding valve and fittings in the port block using new o-rings as applicable. Refer to Table 4-13, Holding Valve Torque Specifications.

Go to Discount-Equipment.com to find your parts

4.13 CYLINDER ASSEMBLIES

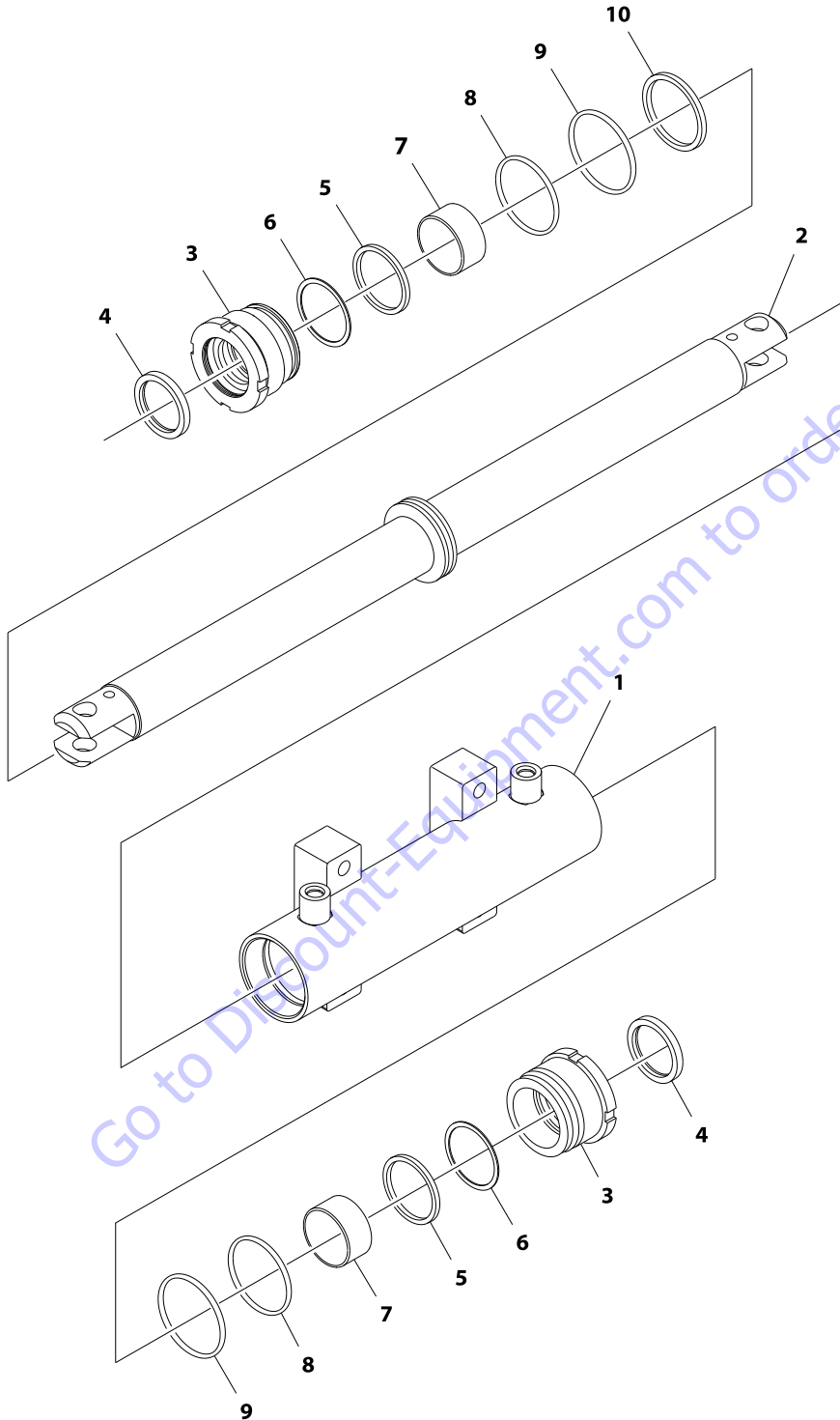

STEER CYLINDER)

1. Barrel
2. Rod
3. Head - Torque to 434 ft. lb. (588 Nm)
4. Wiper
5. Rod Seal
6. Backup Ring
7. Dry Bearing
8. O-Ring
9. O-Ring
10. Piston Seal

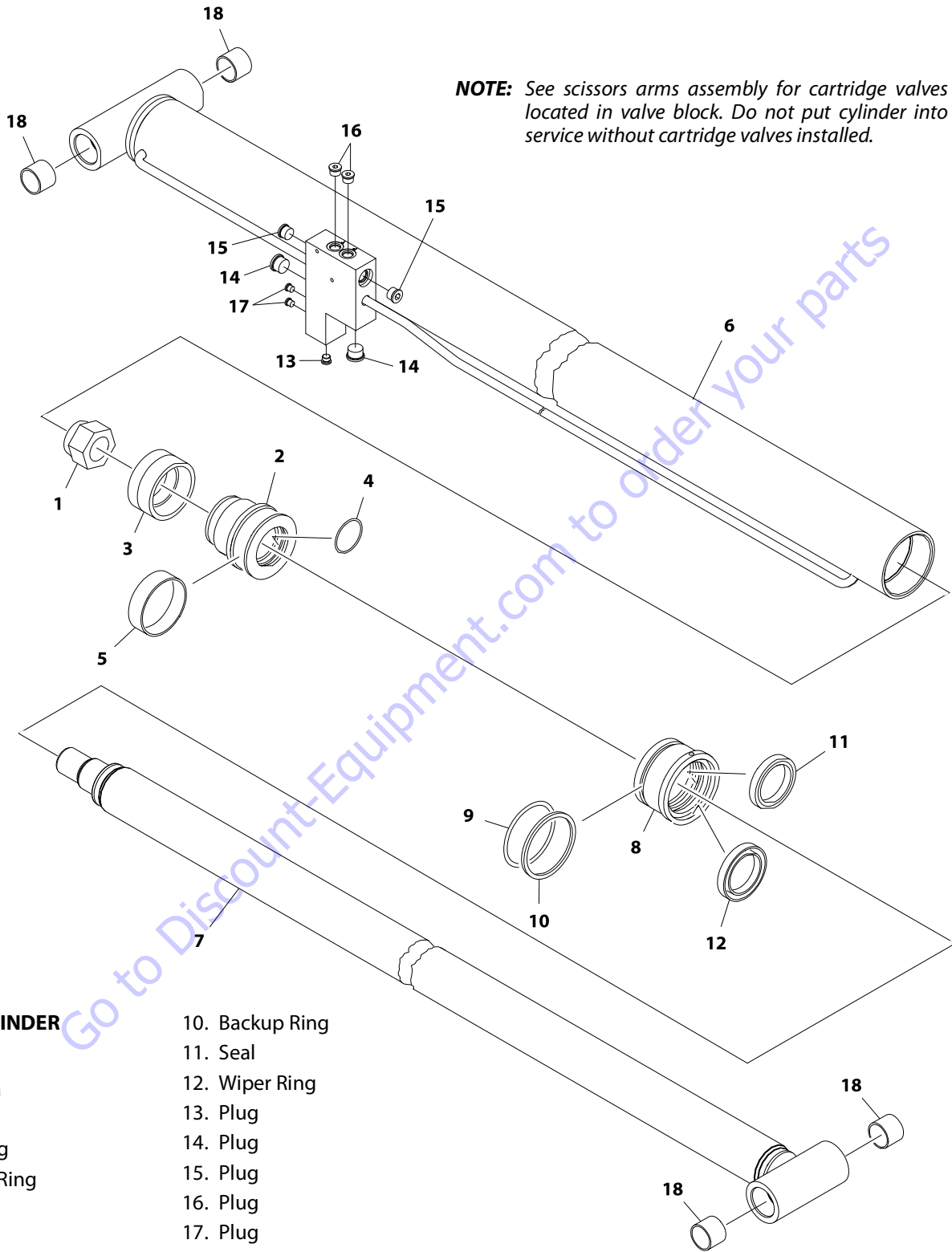

NOTE: See scissors arms assembly for cartridge valves located in valve block. Do not put cylinder into service without cartridge valves installed.

LIFT CYLINDER

- | | |
|--------------|-----------------|
| 1. Nut | 10. Backup Ring |
| 2. Piston | 11. Seal |
| 3. Seal | 12. Wiper Ring |
| 4. O-Ring | 13. Plug |
| 5. Wear Ring | 14. Plug |
| 6. Barrel | 15. Plug |
| 7. Rod | 16. Plug |
| 8. Head | 17. Plug |
| 9. O-Ring | 18. Bushing |

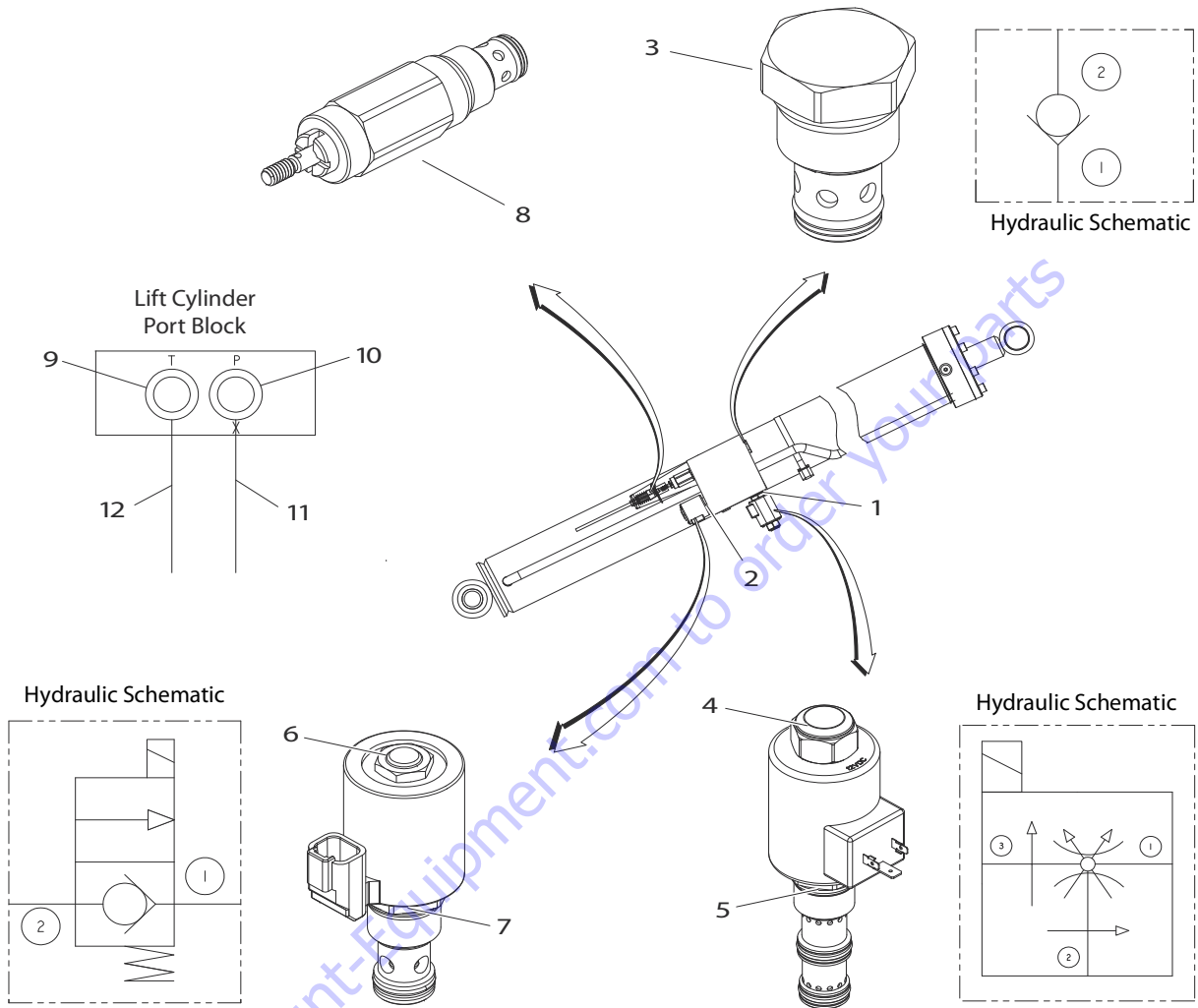

Item	Torque
1	100 lb-ft (135.6 Nm)
2	100 lb-ft (135.6 Nm)
3	25 lb-ft (33.9 Nm)
4	10 - 12 lb-ft (13.6 - 16.3 Nm)
5	35 lb-ft (47.5 Nm)
6	5 lb-ft (6.8 Nm)
7	30 lb-ft (40.7 Nm)
8	25 lb-ft (33.9 Nm)
9	40 lb-ft (54.2 Nm)
10	40 lb-ft (54.2 Nm)
11	40 lb-ft (54.2 Nm)
12	60 lb-ft (81.3 Nm)

Figure 4-27. Lift Cylinder Valve Cartridge Torque Values

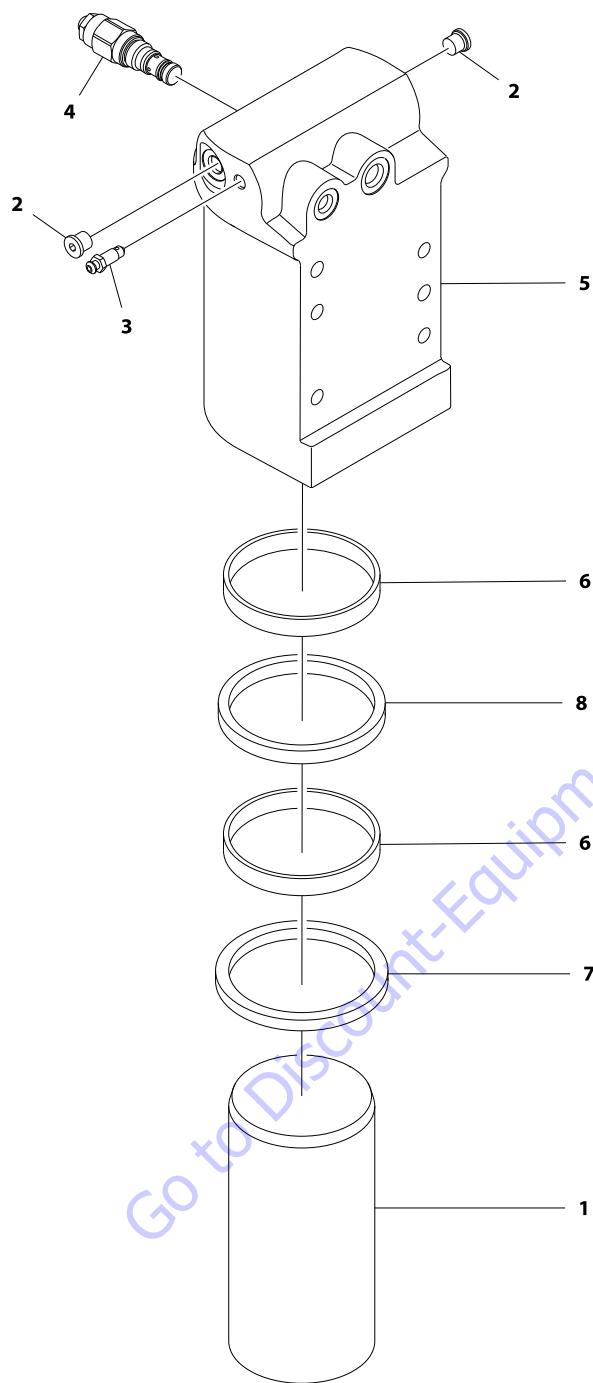

1. Rod
2. Plug
3. Bleeder Valve
4. CounterBalance Valve
5. Barrel
6. Wear Ring
7. Seal
8. Wiper

NOTE: Torque item #4 to 22 lb-ft (30 Nm).

NOTE: Torque item #2 to 22-24 lb-ft (30-32.5 Nm).

⚠ WARNING

THE CYLINDER ROD CAN SLIDE OUT OF THE CYLINDER IF THE BLEEDER VALVE IS LOOSENED.

Figure 4-28. Oscillating Axle Cylinder

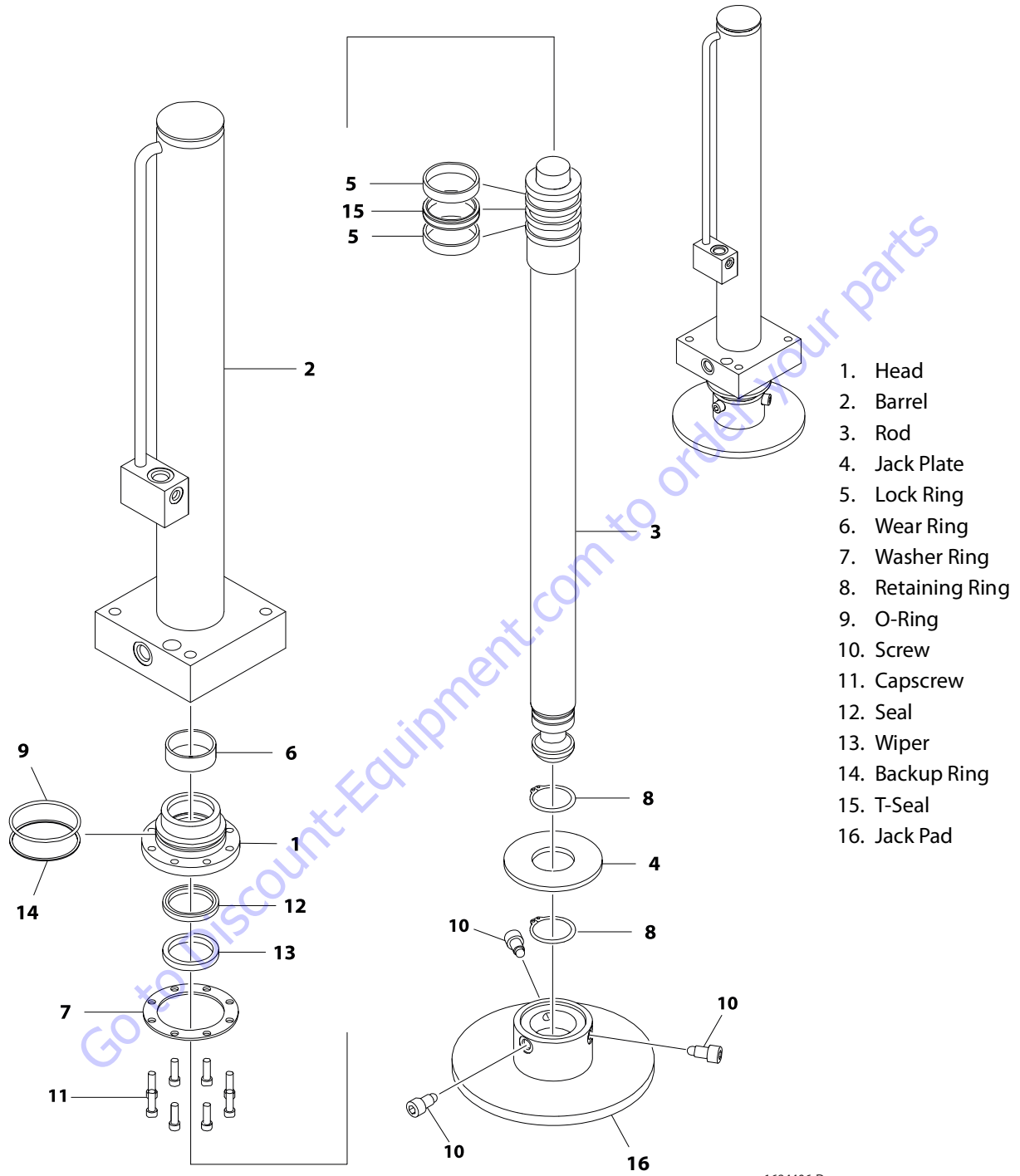

1. Head
2. Barrel
3. Rod
4. Jack Plate
5. Lock Ring
6. Wear Ring
7. Washer Ring
8. Retaining Ring
9. O-Ring
10. Screw
11. Capscrew
12. Seal
13. Wiper Ring
14. Backup Ring
15. T-Seal
16. Jack Pad

1684406-D
MAF24290D

Figure 4-29. Leveling Jack Cylinder

NOTE: Apply a light coat of grease to the Cylinder Rod (3) before installing the Jack Pad (16).

NOTE: Apply Medium Strength Threadlocking Compound to Capscrews (11) torque to 30 lb-ft (40.7 Nm).

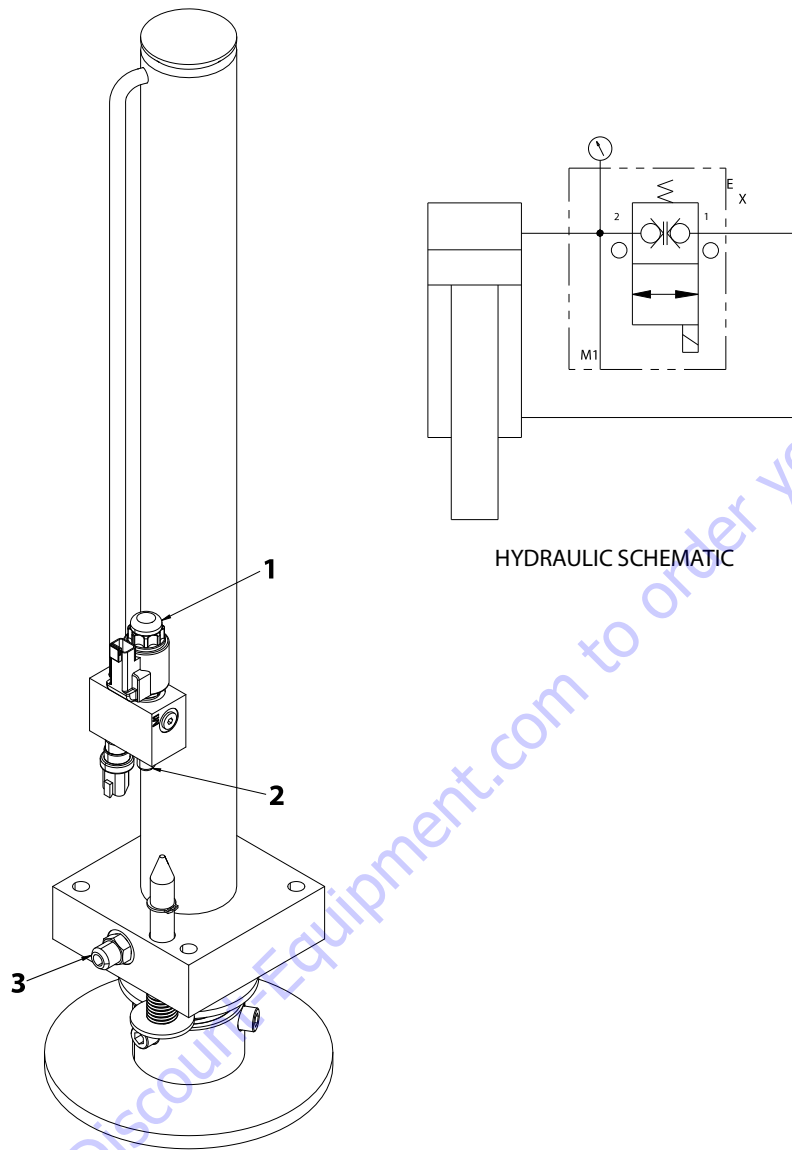

Item	Description	Torque
1	Solenoid Directional Valve	39.8 lb-ft (54 Nm)
2	Straight Fitting	32.1 lb-ft (43.5 Nm)
3	Straight Fitting	39.8 lb-ft (54 Nm)

Figure 4-29. Leveling Jack Torques

Oscillating Axle Cylinder Bleeding Procedure

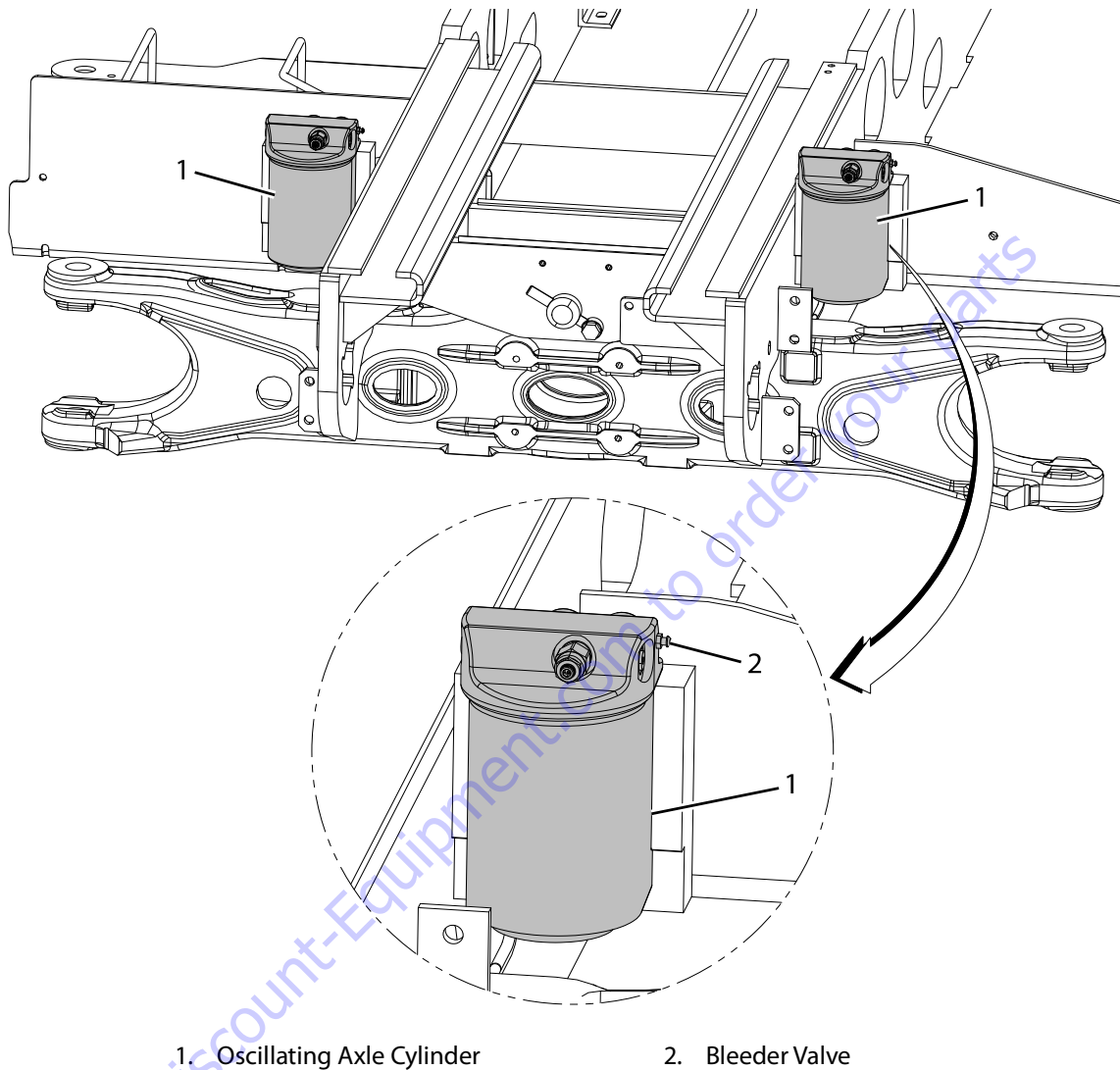

Figure 4-30. Oscillating Axle Cylinder Bleeding

1. Start the engine.
2. Raise the arms high enough so that the left axle cylinder bleeder valve can be accessed.
3. Let engine run at idle.
4. Position a suitable container [approximately 0.5 gal (1.9 l)] over the bleeder valve.
5. Using a 3/8 in. wrench, slowly open bleeder valve.
6. Keep the container close enough to the bleeder valve to catch the aerated oil.
7. Open the bleeder valve enough to get a fast stream of oil.

NOTE: A fast stream of oil will exhaust the air out of the hoses and cylinder better than a slow stream of oil.

8. Every 3-4 seconds, close the bleeder valve so that a slower stream of oil is being purged. When only oil and no air is being purged, close the bleeder valve.
9. A new system can take 10-15 seconds per cylinder to bleed.

NOTICE

ANYTIME EITHER OF THE HOSES PLUMBING TO THE CYLINDERS ARE BROKEN INTO, AIR HAS BEEN INTRODUCED INTO THE SYSTEM. THE CYLINDERS MUST BE BLED.

4.14 HYDRAULIC SCHEMATICS

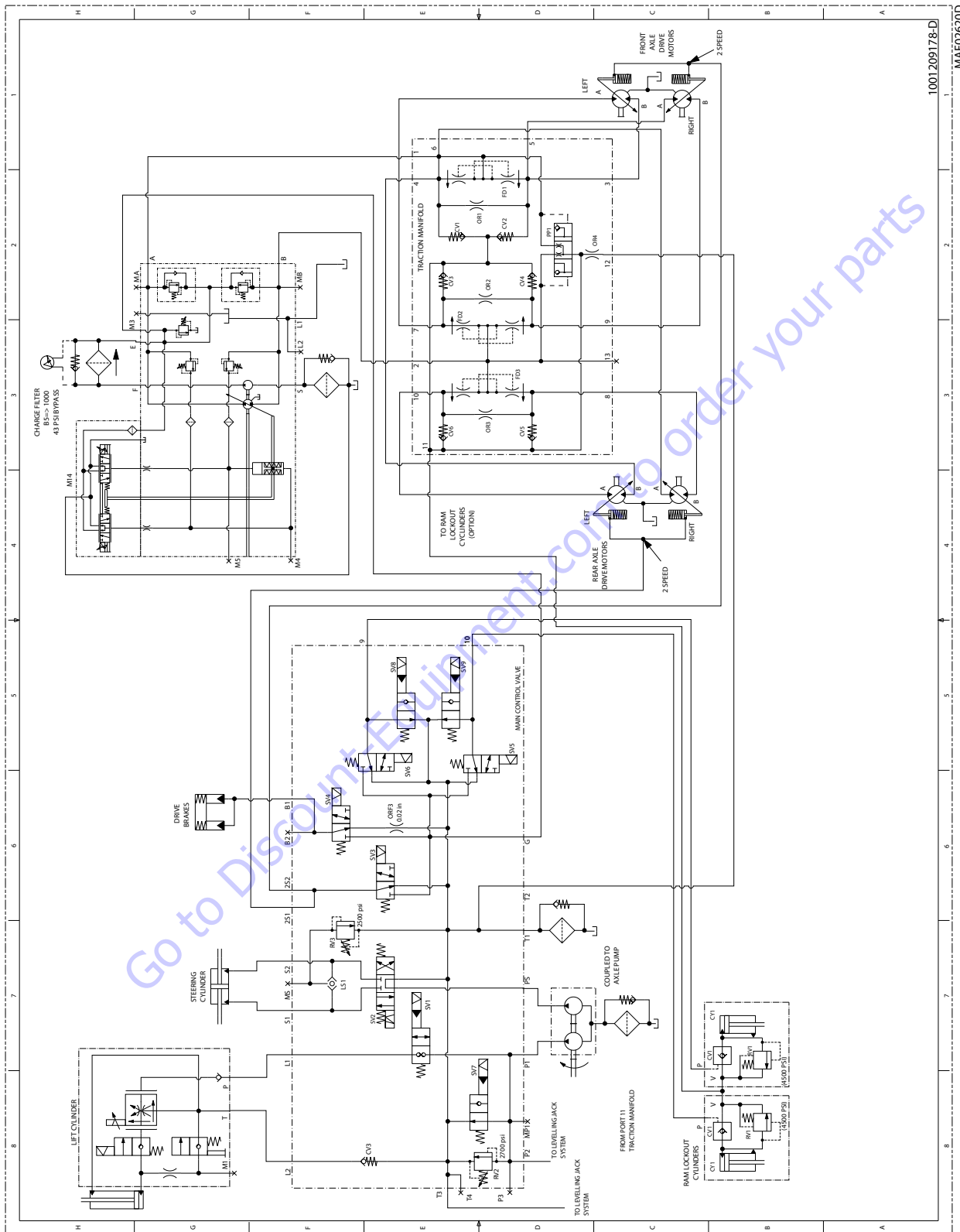

Figure 4-31. Hydraulic Schematics (CE) - Sheet 1 of 2

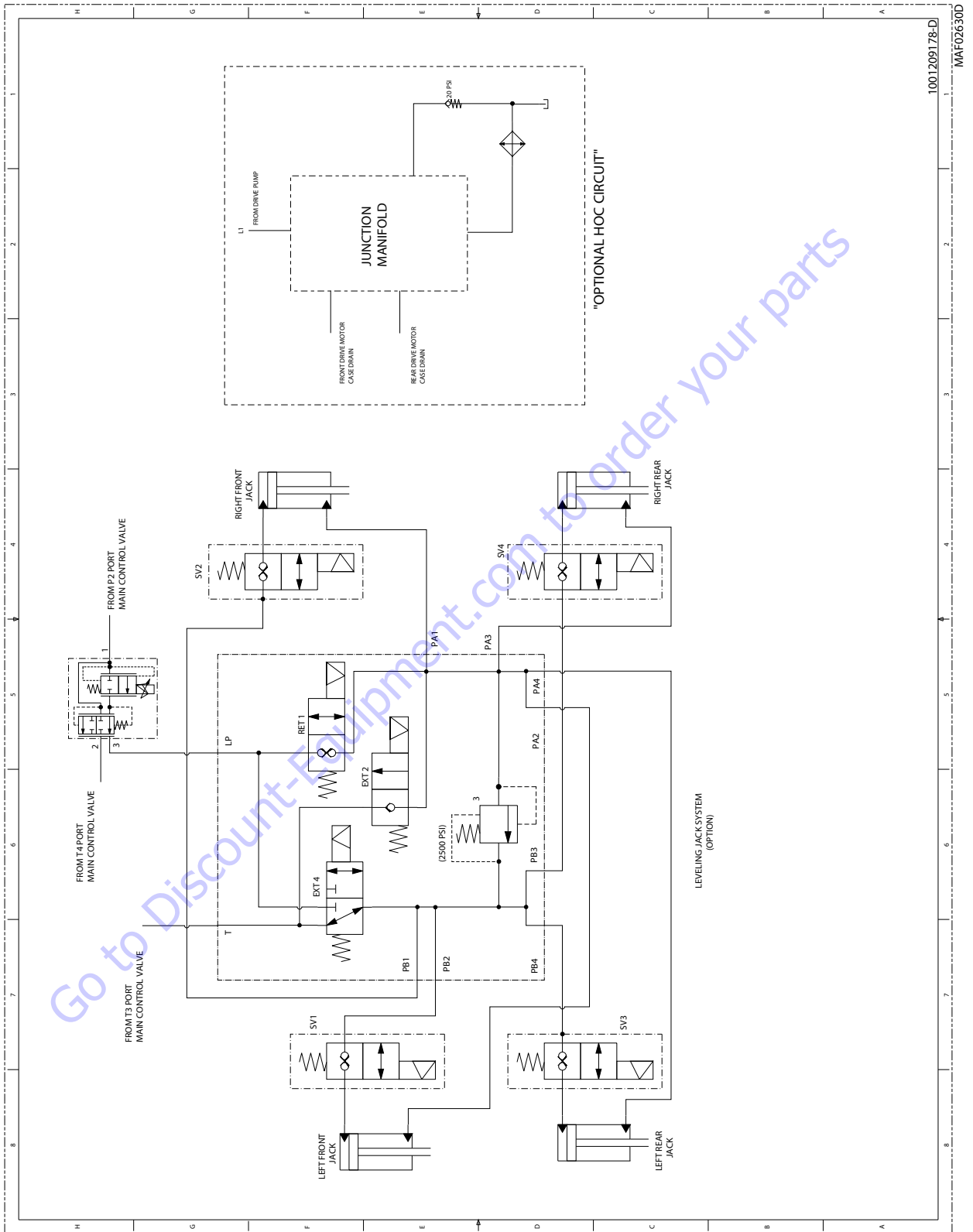

Figure 4-32. Hydraulic Schematics (CE) - Sheet 2 of 2

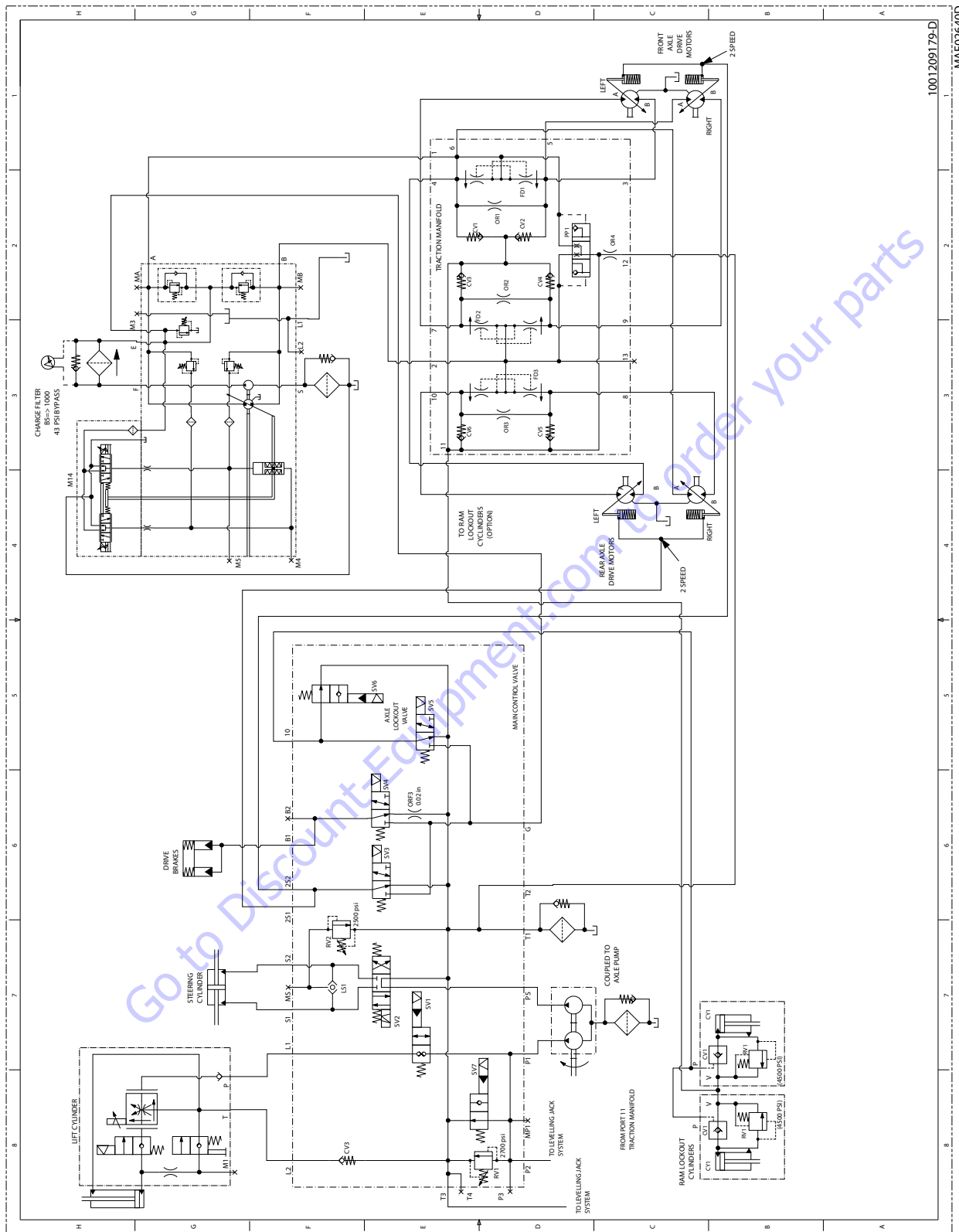

Figure 4-33. Hydraulic Schematics (ANSI) - Sheet 1 of 2

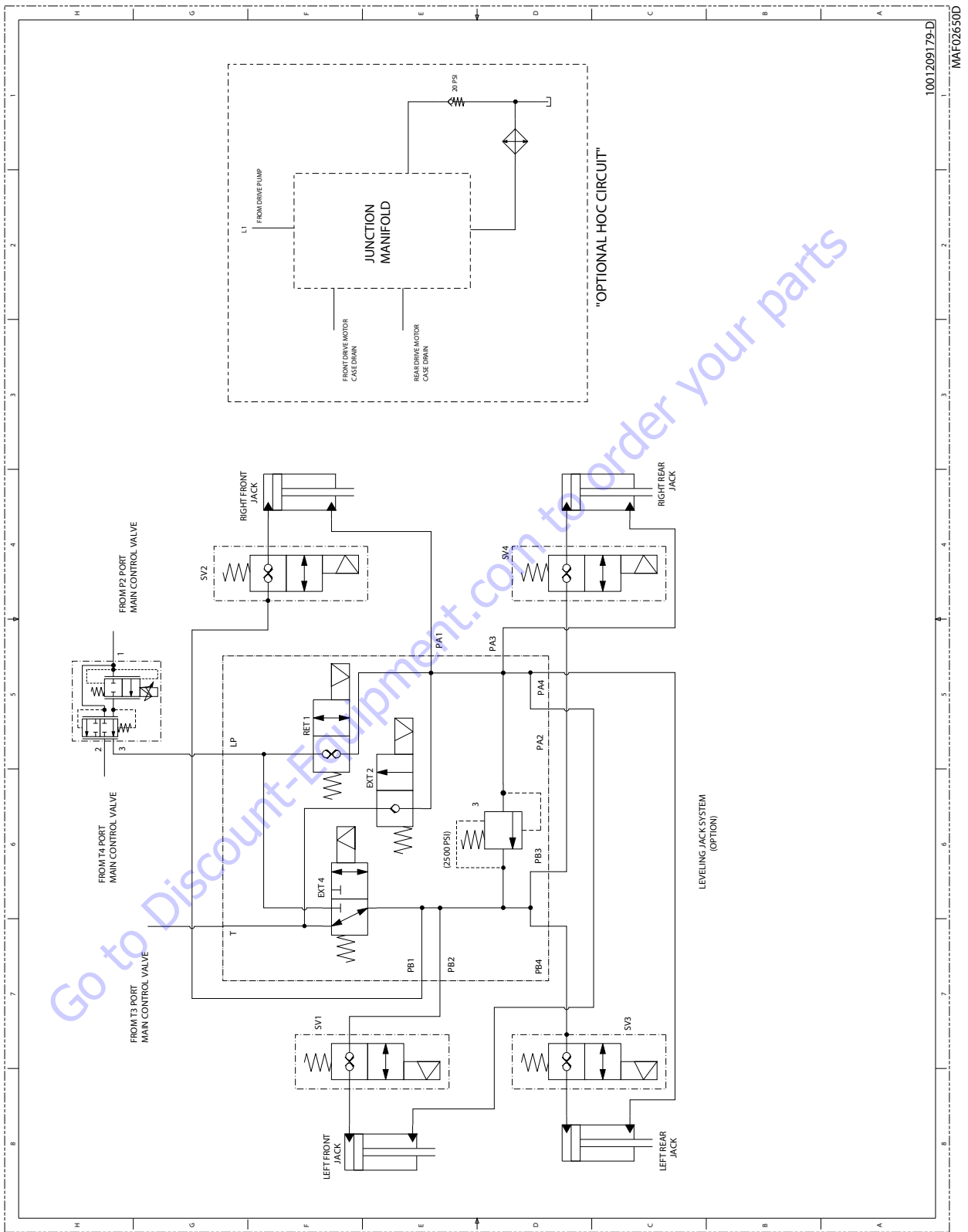
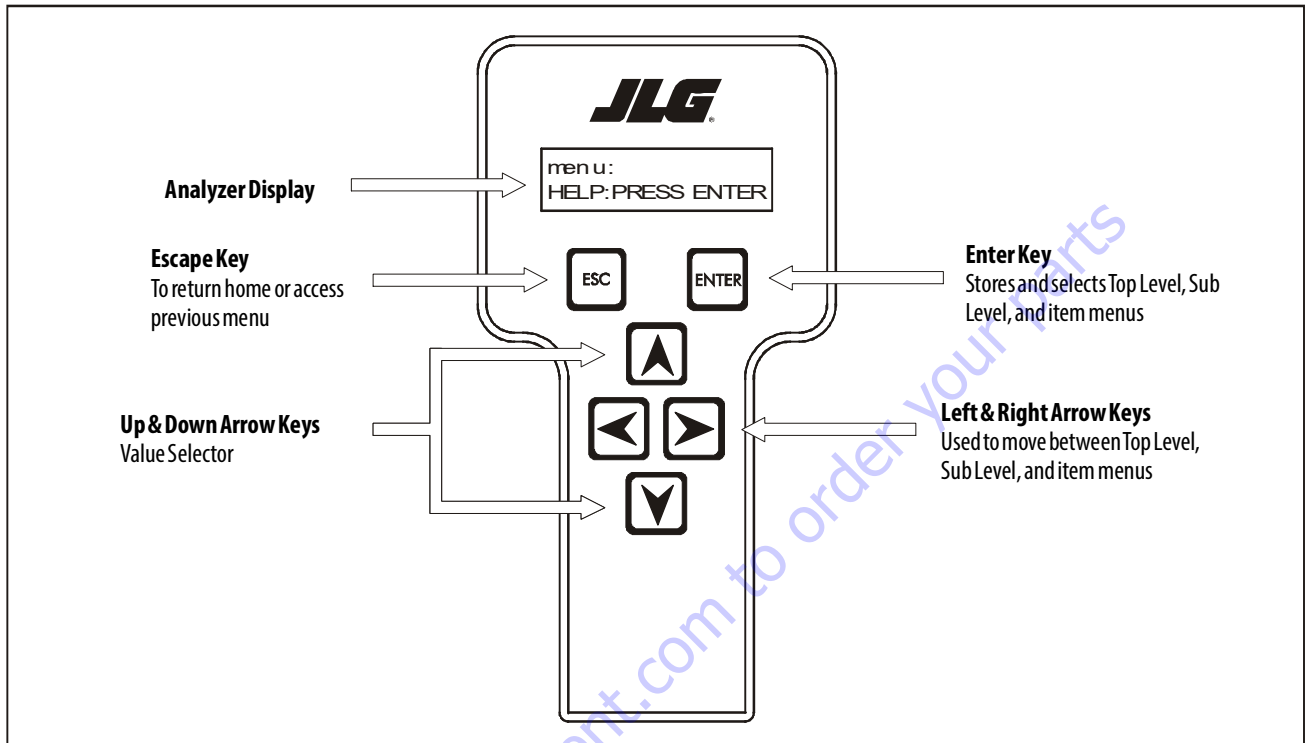

Figure 4-34. Hydraulic Schematics (ANSI) - Sheet 2 of 2

SECTION 5. JLG CONTROL SYSTEM

5.1 ANALYZER



Connecting the Analyzer

1. Connect the four pin end of the cable supplied with the Analyzer to the four position connector J6 on the PCB in the ground control station (1); or, connect at the platform control station connector X32 (2). Connect the remaining end of the cable to the analyzer.

NOTE: The cable has a four pin connector at each end. It cannot be connected backwards.

2. Power up the control system by turning the lower key to the platform position and pulling out both emergency stop buttons.

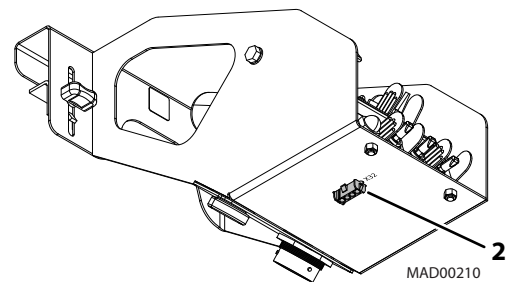
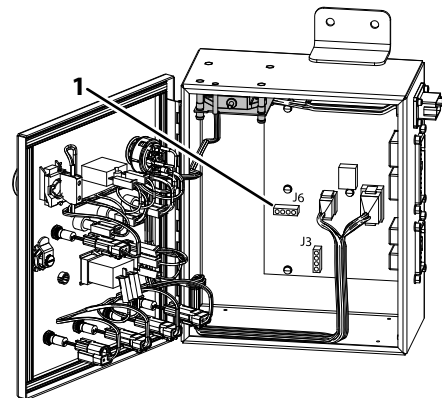

1. Ground Control Box Connector
2. Platform Control Box Connector

Using the Analyzer

With the machine power on and the analyzer connected properly, the analyzer will display the following:

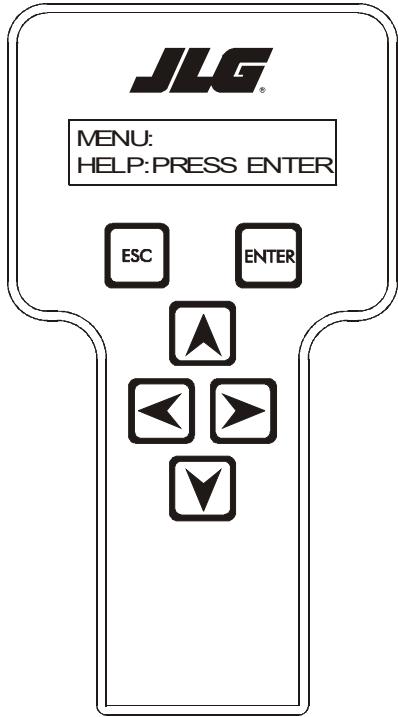

HELP:

PRESS ENTER

At this point, using the **RIGHT** and **LEFT** arrow keys, you can move between the top level menu items. To select a displayed menu item, press **ENTER**. To cancel a selected menu item, press **ESC**; then you will be able to scroll using the right and left arrow keys to select a different menu item.

The top level menus are as follows:

- ACCESS LEVEL
- PERSONALITIES
- MACHINE SETUP
- CALIBRATIONS
- ACTIVATE TESTS
- HELP
- DIAGNOSTICS

If you press **ENTER**, at the HELP:PRESS ENTER display, and a fault is present during power up, the analyzer display will scroll the fault across the screen. If there was no fault detected during power up, the display will read: In platform mode, **HELP: EVERYTHING OK**, In ground mode, **GROUND MODE OK**.

If **ENTER** is pressed again, the display moves to the following display:

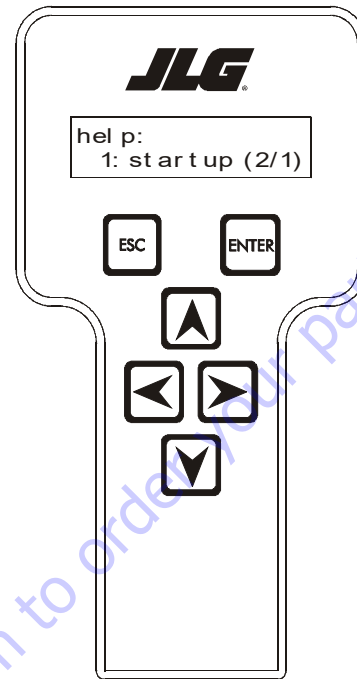

LOGGED HELP

1: STARTUP (2/1): (Or last recorded fault)

At this point, the analyzer will display the current fault, if any are present. You may scroll through the fault logs to view what the last fifteen faults were. Use the right and left arrow keys to scroll through the fault logs. To return to the beginning, press **ESC** two times.

When a top level menu is selected, a new set of menu items may be offered; If for example you choose Personalities:

- DRIVE
- LIFT
- GROUND MODE

Pressing **ENTER** with any of the above displayed menus will display additional sub-menus within the selected menu. In some cases the next level is the parameter or information to be changed. Refer to the flow chart for what menus are available within the top level menus. You may only view the personality settings for selected menus while in access level 2. Remember, you may always cancel a selected menu item by pressing the **ESC** key.

Changing the Access Level

When the analyzer is first connected, you will be in access level 2 which enables you to only view most configuration settings which cannot be changed until you enter a password to advance to a lower level. This ensures that a setting cannot be accidentally altered. To change the access level, the correct password must be entered. To enter the password, scroll to the **ACCESS LEVEL** menu. For example:

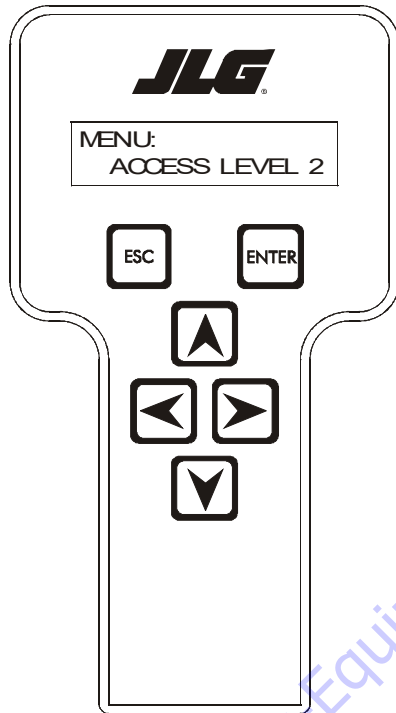

MENU:
ACCESS LEVEL 2

Press **ENTER** to select the **ACCESS LEVEL** menu.

Using the **UP** or **DOWN** arrow keys, enter the first digit of the password, 3.

Then using the **RIGHT** arrow key, position the cursor to the right one space to enter the second digit of the password.

Use the **UP** or **DOWN** arrow key to enter the second digit of the password which is 3.

Repeat this process until you have entered all five digits of the password which is **33271**.

Once the correct password is displayed, press **ENTER**. The access level should display the following, if the password was entered correctly:

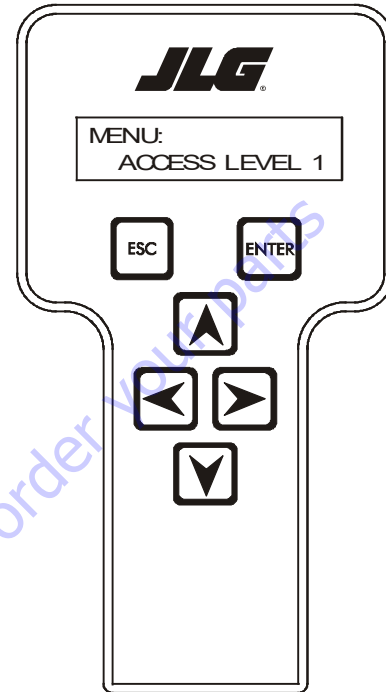

MENU:
ACCESS LEVEL 1

Repeat the above steps if the correct access level is not displayed or you can not adjust the personality settings.

Adjusting Parameters

Once you have gained access to level 1, and a personality item is selected, press the UP or DOWN arrow keys to adjust its value, for example:

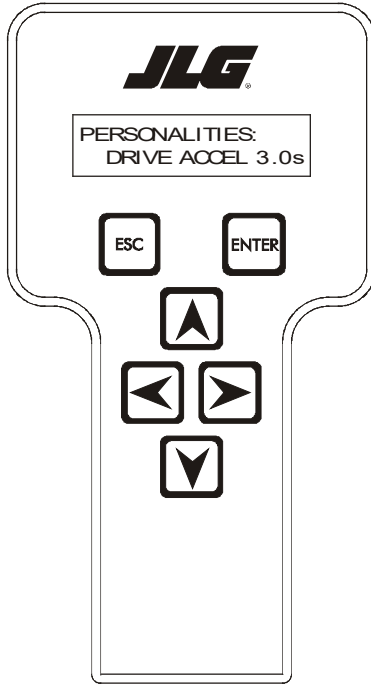

PERSONALITIES:
DRIVE ACCEL 3.0s

There will be a minimum and maximum for the value to ensure efficient operation. The value will not increase if the **UP** arrow is pressed when at the maximum value nor will the value decrease if the **DOWN** arrow is pressed and the value is at the minimum value for any particular personality. If the value does not change when pressing the up and down arrows, check the access level to ensure you are at access level 1.

Machine Setup

When a machine digit item is selected, press the **UP** or **DOWN** arrow keys to adjust its value, for example:

⚠ WARNING

FAILURE TO MAKE THE PROPER SETTINGS FOR THE PARTICULAR MACHINE CAN RESULT IN IMPROPER OPERATION.

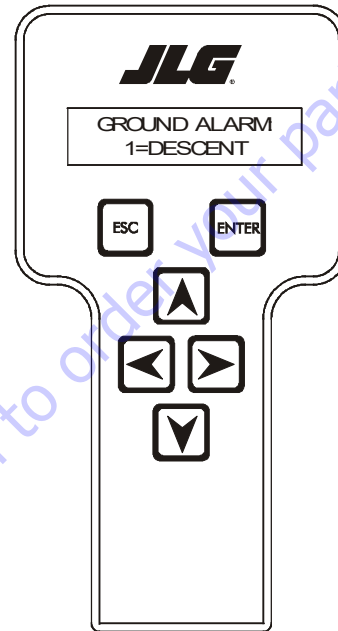

GROUND ALARM:
1=DESCENT

The effect of the machine digit value is displayed along with its value. The above display would be selected if the machine was equipped with a ground alarm and you wanted it to sound when driving. There are certain settings allowed to install optional features or select the machine model.

When selecting the machine model to match the size of the machine, the personality settings will return to default settings.

NOTE: For default settings on machines, refer to Table 5-2 and Table 5-4.

Password 33271 will give you access to level 1, which will permit you to change all machine personalities and/or machine setup settings.

⚠ WARNING

CHANGING THESE SETTINGS MAY ADVERSELY AFFECT THE PERFORMANCE OF YOUR MACHINE.

System Fault/DTC Indication

The Analyzer also displays DTCs. DTC flash codes are indicated by the number of flashes and pauses of the System Fault indicator on the face of the platform control box.

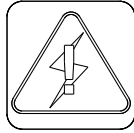

For more information on DTCs and flash code descriptions, refer to Section 5.3, Diagnostic Troubleshooting codes (DTC's) and Flash Codes Description.

NOTICE

IT IS A GOOD PRACTICE TO AVOID PRESSURE-WASHING ELECTRICAL/ELECTRONIC COMPONENTS. SHOULD PRESSURE-WASHING BE UTILIZED TO WASH AREAS CONTAINING ELECTRICAL/ELECTRONIC COMPONENTS, JLG INDUSTRIES, INC. RECOMMENDS A MAXIMUM PRESSURE OF 750 PSI (52 BAR) AT A MINIMUM DISTANCE OF 12 INCHES (30.5 CM) AWAY FROM THESE COMPONENTS. IF ELECTRICAL/ELECTRONIC COMPONENTS ARE SPRAYED, SPRAYING MUST NOT BE DIRECT AND BE FOR BRIEF TIME PERIODS TO AVOID HEAVY SATURATION.

Go to Discount-Equipment.com to order your parts

5.2 ANALYZER MENU FLOW CHART

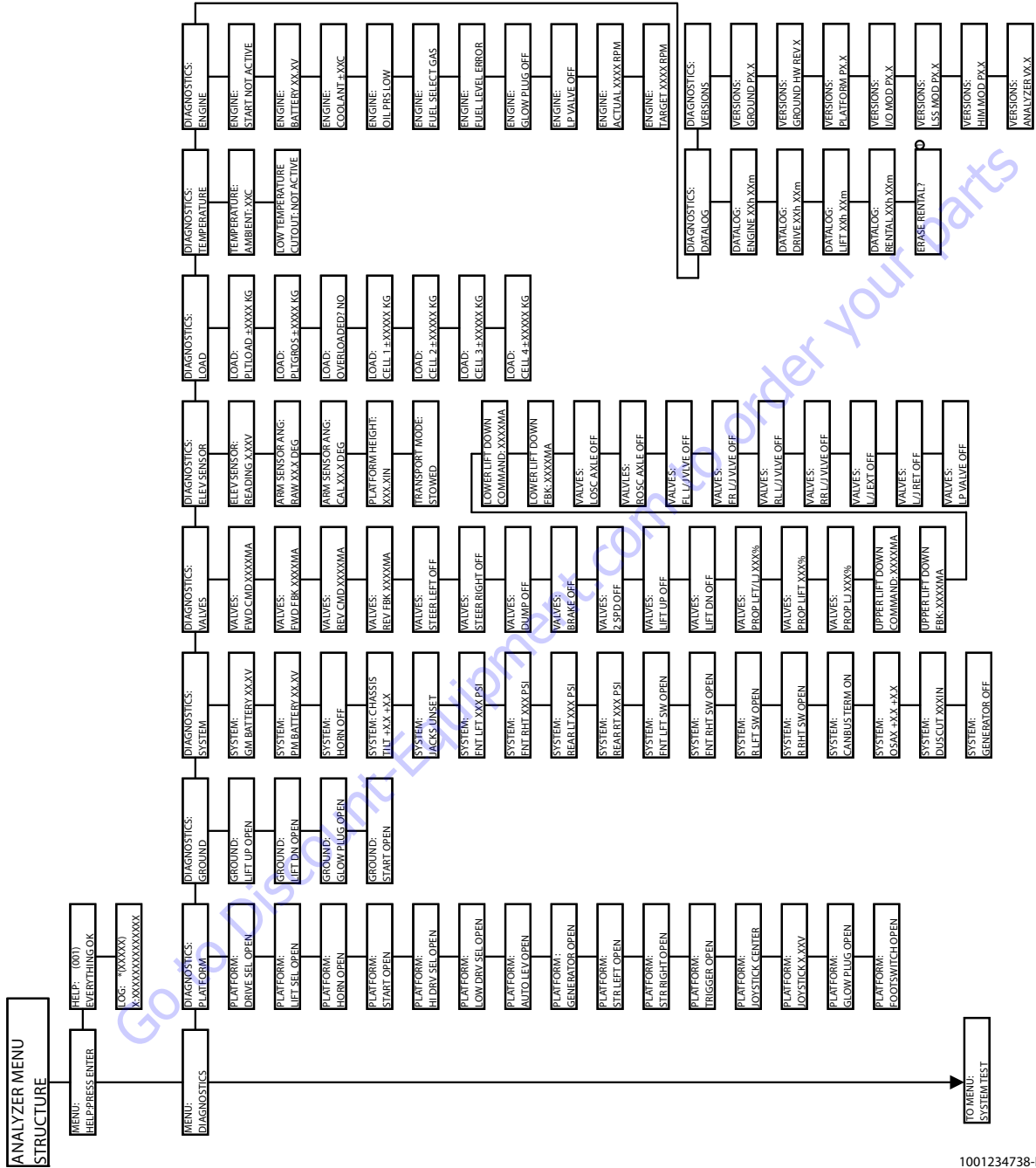
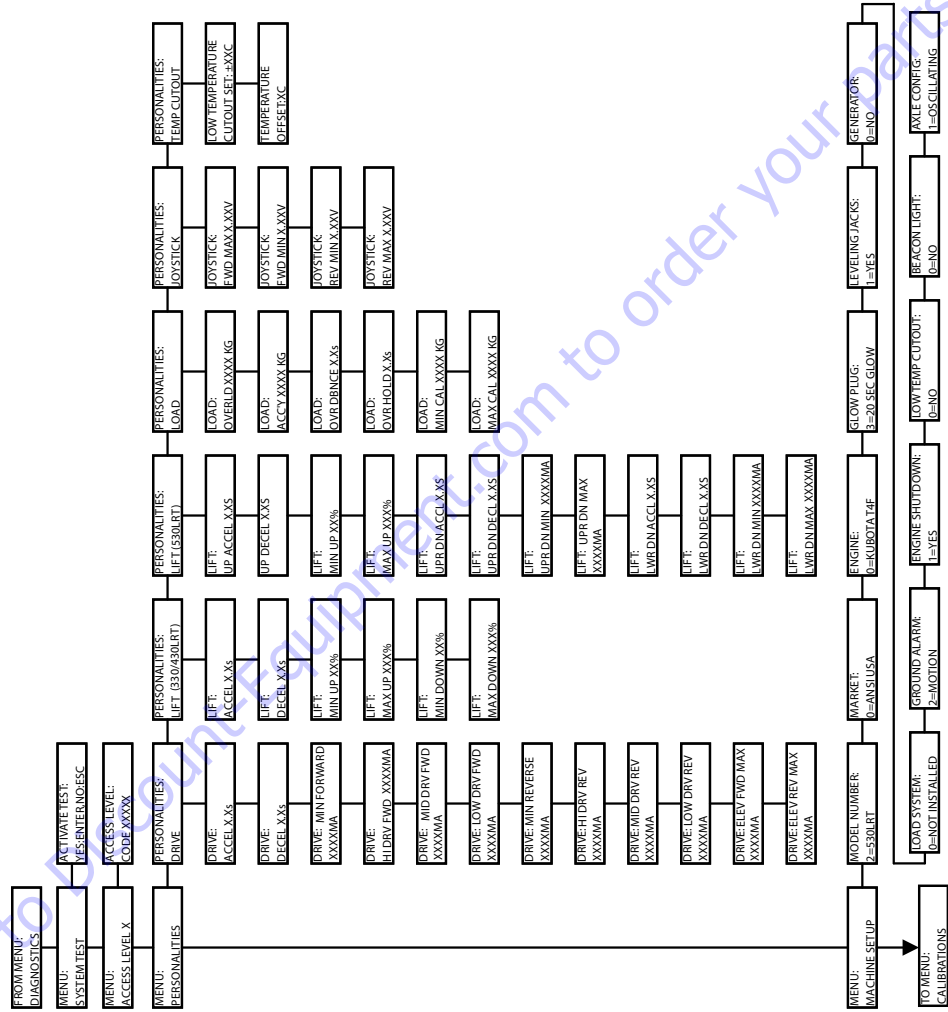

Figure 5-1. Analyzer Menu Flow Chart (Version P1.3) - Sheet 1 of 3



1001234738-E
MAF03050E

Figure 5-2. Analyzer Menu Flow Chart (Version P1.3) - Sheet 2 of 3

5.3 DIAGNOSTIC TROUBLESHOOTING CODES (DTC'S) AND FLASH CODES DESCRIPTION

DTC Code	Flash Code	Description	Item Check List
001	0 0	"Everything Ok"	<ul style="list-style-type: none"> No issues detected
004	0 0	"Driving At Cutback - Above Elevation"	<ul style="list-style-type: none"> The platform is determined to be elevated (Reference platform height calculation section).
005	0 0	"Drive & Lift Up Prevented - Tilted & Elevated"	<ul style="list-style-type: none"> Platform is elevated, and machine tilt exceeds the model and market specific limits.
009	0 0	"Drive Prevented - Elevated Above Drive Cutout Height"	<ul style="list-style-type: none"> Attempting to drive with the platform elevated to over 32 feet. The control system prevents driving. Lower the platform to under 32 feet.
0041	0 0	"Front Left Leveling Jack At End Of Stroke"	<ul style="list-style-type: none"> Front Left Leveling Jack cylinder has reached end of stroke. Check if the cylinder is at end of stroke (normal operation). Check the wiring to the Front Left Leveling Jack end of stroke switch.
0042	0 0	"Front Right Leveling Jack At End Of Stroke"	<ul style="list-style-type: none"> Front Right Leveling Jack cylinder has reached end of stroke. Check if the cylinder is at end of stroke (normal operation). Check the wiring to the Front Right Leveling Jack end of stroke switch.
0043	0 0	"Rear Left Leveling Jack At End Of Stroke"	<ul style="list-style-type: none"> Rear Left Leveling Jack cylinder has reached end of stroke. Check if the cylinder is at end of stroke (normal operation). Check the wiring to the Rear Left Leveling Jack end of stroke switch.
0044	0 0	"Rear Right Leveling Jack At End Of Stroke"	<ul style="list-style-type: none"> Rear Right Leveling Jack cylinder has reached end of stroke. Check if the cylinder is at end of stroke (normal operation). Check the wiring to the Rear Right Leveling Jack end of stroke switch.
0045	0 0	"Engine Shutdown Commanded - Check Engine Sensors"	<ul style="list-style-type: none"> The engine coolant temperature is high or the oil pressure is low. The control system shuts down the engine. DIESEL - Check the engine oil pressure and engine coolant temperature sensors for damage. Check the engine oil pressure input J2-17 (should be low when not overheating). Check the engine coolant input J2-25 (resistive).
211	2 1	"Power Cycle"	<ul style="list-style-type: none"> Power was cycled ON
212	2 1	"Keyswitch Faulty - Platform & Ground Active Together"	<ul style="list-style-type: none"> The Platform and Ground mode switches are both high. Check the Ground Module inputs for Ground Mode (J4-4) and Platform Mode (J1-2).
221	2 2	"Function Problem - Horn Permanently Selected"	<ul style="list-style-type: none"> Horn switch input is closed during power up.
223	2 2	"Function Problem - Drive & Lift Active Together"	<ul style="list-style-type: none"> Drive and Lift Digital Inputs on the Platform Control Module are HIGH simultaneously for 1000ms.
224	2 2	"Function Problem - Steer Left Permanently Selected"	<ul style="list-style-type: none"> Left steer select switch input is closed during power up.
225	2 2	"Function Problem - Steer Right Permanently Selected"	<ul style="list-style-type: none"> Right steer select switch input is closed during power up.
228	2 2	"Function Locked Out - Accelerator Not Centered"	<ul style="list-style-type: none"> Joystick is not centered during start-up of the machine. Joystick signal must remain at neutral voltage for 1000 ms after start-up or fault will activate.
229	2 2	"Function Problem - Trigger Permanently Closed"	<ul style="list-style-type: none"> The Trigger Switch CAN message and LRT Ground Module Trigger DI are conflicting with each one another.

SECTION 5 - JLG CONTROL SYSTEM

DTC Code	Flash Code	Description	Item Check List
232	2 3	"Ground Lift Up/down Active Together"	<ul style="list-style-type: none"> • Ground lift up and lift down inputs both closed. The control system prevents lifting and lowering. • Check if the Ground lift switch is damaged, obstructed, or jammed. • Check Ground input J4-7 (should be low when lift up is not selected). • Check Ground input J4-8 (should be low when lift down is not selected).
241	2 4	"Ambient Temperature Sensor - Out Of Range Low"	<ul style="list-style-type: none"> • The temperature is below the allowed minimum value. The control system prevents lift up. The control system limits driving to turtle speed if elevated. • Check the wires to the Chassis Tilt Sensor. • Replace the Chassis Tilt Sensor (also sends temperature).
242	2 4	"Ambient Temperature Sensor - Out Of Range High"	<ul style="list-style-type: none"> • The temperature is above the allowed maximum value. The control system prevents lift up. The control system limits driving to turtle speed if elevated. • Check the wires to the Chassis Tilt Sensor. • Replace the Chassis Tilt Sensor (also sends temperature).
243	2 4	"Front Left Leveling Jack Pressure Transducer Failure"	<ul style="list-style-type: none"> • Front Left Leveling Jack pressure transducer reading is outside of the allowed range. • Check the wiring to the Front Left Leveling Jack pressure transducer.
244	2 4	"Front Right Leveling Jack Pressure Transducer Failure"	<ul style="list-style-type: none"> • Front Right Leveling Jack pressure transducer reading is outside of the allowed range. • Check the wiring to the Front Right Leveling Jack pressure transducer.
245	2 4	"Rear Left Leveling Jack Pressure Transducer Failure"	<ul style="list-style-type: none"> • Rear Left Leveling Jack pressure transducer reading is outside of the allowed range. • Check the wiring to the Rear Left Leveling Jack pressure transducer.
246	2 4	"Rear Right Leveling Jack Pressure Transducer Failure"	<ul style="list-style-type: none"> • Rear Right Leveling Jack pressure transducer reading is outside of the allowed range. • Check the wiring to the Rear Right Leveling Jack pressure transducer.
247	2 4	"Front Left Leveling Jack Stow Switch Faulty"	<ul style="list-style-type: none"> • Front Left Outrigger stow switch is closed (digital input is high) while all Leveling Jacks are set.
248	2 4	"Front Right Leveling Jack Stow Switch Faulty"	<ul style="list-style-type: none"> • Front Right Outrigger stow switch is closed (digital input is high) while all Leveling Jacks are set.
249	2 4	"Rear Left Leveling Jack Stow Switch Faulty"	<ul style="list-style-type: none"> • Rear Left Outrigger stow switch is closed (digital input is high) while all Leveling Jacks are set.
251	2 5	"Elev Angle Sensor Faulty - Not Mounted or Voltage Out Of Range"	<ul style="list-style-type: none"> • Elevation angle sensor's voltage is > 4.85V or < 0.30V.
252	2 5	"Elev Angle Sensors Have Not Been Calibrated"	<ul style="list-style-type: none"> • The EEPROM value for Arm Stack Arm Angle and Rotary Sensor values for Stowed are default EEPROM values.
2111	2 1	"Engine Start Prevented - Platform Start Switch High At Power Up"	<ul style="list-style-type: none"> • Start switch is closed during power up.
2210	2 2	"Trigger Closed Too Long While In Neutral"	<ul style="list-style-type: none"> • Trigger has been squeezed for 10 seconds while the joystick was in the center position. • Check the Platform Trigger input J1-1 (should be high when trigger is squeezed).
2232	2 2	"Function Locked Out - Drive & Lift Both Open"	<ul style="list-style-type: none"> • The Platform Drive and Lift inputs are both open. The control system prevents any function selects. • Check Platform inputs J1-3 (should be high in drive mode) and J1-4 (should be high in lift mode).
2237	2 2	"Joystick Faulty - Steer Switches Active Together"	<ul style="list-style-type: none"> • Steer switch inputs are both closed at the same time.

DTC Code	Flash Code	Description	Item Check List
2239	2 2	"Function Locked Out - Joystick Calibration Faulty"	<ul style="list-style-type: none"> Joystick calibration is not valid. The control system prevents any function selects. Calibrate the Platform Joystick.
2267	2 2	"Joystick Faulty - Wiper Out Of Range"	<ul style="list-style-type: none"> Joystick Wiper is outside the acceptable voltage range. Check the wires to the joystick.
2269	2 2	"Function Problem - High Speed & Creep Active Together"	<ul style="list-style-type: none"> The High Speed and Low Speed Drive Inputs are active Simultaneously for 1000ms.
2282	2 2	"Function Problem - Generator Permanently Selected"	<ul style="list-style-type: none"> Generator select switch input is closed during power up.
2284	2 2	"Function Problem - Trigger Switch Wiring Short to Ground"	<ul style="list-style-type: none"> CAN messages and DI on ground board are conflicting with one another
22101	2 2	"Function Problem - Drive & Level Active Together"	<ul style="list-style-type: none"> Machine Setup Leveling Jacks is set to 1=YES <p>Drive and Level Digital Inputs on the Platform Control Module are HIGH simultaneously for 1000ms</p>
2299	2 2	"Function Problem - Lift and Level Active Together"	<ul style="list-style-type: none"> Machine Setup Leveling Jacks is set to 1=YES <p>Lift and Level Digital Inputs on the Platform Control Module are HIGH simultaneously for 1000ms</p>
22100	2 2	"Function Problem - Drive & Lift & Level All Open"	<ul style="list-style-type: none"> Machine Setup Leveling Jacks is set to 1=YES <p>The Lift/Level/Drive Mode Digital Inputs are LOW simultaneously for 1000ms.</p>
22102	2 2	"Trigger Faulty"	<ul style="list-style-type: none"> Disagreement between the trigger input at the platform and the ground. Trigger reads low at the platform module Trigger reads high at the ground module
23245	2 3	"Elevation Sensors - Disagreement"	<ul style="list-style-type: none"> DTC 252 - ELEVATION ANGLE SENSORS NOT CALIBRATED is NOT Active AND Rotary Sensor Voltage > 1.5V (indicating elevated) and Adjusted Arm Angle > -4 deg (indicating stowed) for 1000ms OR Rotary Sensor Voltage > 3V (indicating close to full height) and Adjusted Arm Angle > -30 deg (indicating not close to full height) for 1000ms
2410	2 4	"Rear Right Leveling Jack Stow Switch Faulty"	<ul style="list-style-type: none"> Rear Right Outrigger stow switch is closed (digital input is high) while all Leveling Jacks are set
2512	2 5	"Elev Angle Sensor Not Detecting Change"	<ul style="list-style-type: none"> DTC 6661, 8114, 8117 Not Active AND The Platform Calculated Height is ... > 100 inches AND < 350 inches AND Model = 330LRT OR > 120 inches AND < 450 inches AND Model = 430LRT OR > 140 inches AND < 600 inches AND Model = 530LRT AND Lift Up/LJ Flow Control (530LRT) or Lift Flow Control (330/430LRT) Command > LIFT UP MIN + 15% AND RDGFilteredAdjustedArmTiltAngle does not change more than 0.50 degrees for 5000mS

SECTION 5 - JLG CONTROL SYSTEM

DTC Code	Flash Code	Description	Item Check List
2555	2 5	"Function Prevented - Selected Before FSW"	<ul style="list-style-type: none"> Machine Setup Market == Korea AND Machine Setup Footswitch is 1=YES AND Footswitch is open while the joystick is not in the neutral/center position
2568	2 5	"Temperature Cutout Active - Ambient Temperature Too Low"	<ul style="list-style-type: none"> The temperature is too low. The control system may prevent lift up, drive, steer. Check the wires to the Chassis Tilt Sensor. Replace the Chassis Tilt Sensor (also sends temperature).
2580	2 5	"Lift Up Prevented - Leveling Jacks Not Set"	<ul style="list-style-type: none"> Attempting to lift up with the platform elevated too high with out the leveling jacks set. The control system prevents lifting. Lower the platform to stowed. Set the leveling jacks.
2588	2 5	"Function Prevented - Leveling Jacks State Unknown"	<ul style="list-style-type: none"> One or more of the leveling jack's switches are not in the stowed position and the jacks are not in the set position.
2590	2 5	"Functions Locked Out - ECM Lost"	<ul style="list-style-type: none"> MACHINE SETUP -> ENGINE = KUBOTA D/F ECM and CANbus communication is lost for 250mS
23107	2 3	"Function Problem - Lift Up Permanently Selected"	<ul style="list-style-type: none"> Ground lift up switch is closed during a power up.
23108	2 3	"Function Problem - Lift Down Permanently Selected"	<ul style="list-style-type: none"> Ground lift down switch is closed during a power up.
23153	2 3	"Function Problem - Engine Start Permanently Selected"	<ul style="list-style-type: none"> Ground start switch is closed during power up.
3517	3 5	"Front Left Leveling Jack Short To Ground"	<ul style="list-style-type: none"> The Front Left Leveling Jack is shorted to ground. Check the wiring to the Front Left Leveling Jack.
3518	3 5	"Front Left Leveling Jack Short To Battery"	<ul style="list-style-type: none"> The Front Left Leveling Jack is shorted to battery. Check the wiring to the Front Left Leveling Jack.
3519	3 5	"Front Left Leveling Jack Open Circuit"	<ul style="list-style-type: none"> The Front Left Leveling Jack is open circuit. Check the wiring to the Front Left Leveling Jack.
3520	3 5	"Front Right Leveling Jack Short To Ground"	<ul style="list-style-type: none"> The Front Right Leveling Jack is shorted to ground. Check the wiring to the Front Right Leveling Jack.
3521	3 5	"Front Right Leveling Jack Short To Battery"	<ul style="list-style-type: none"> The Front Right Leveling Jack is shorted to battery. Check the wiring to the Front Right Leveling Jack.
3522	3 5	"Front Right Leveling Jack Open Circuit"	<ul style="list-style-type: none"> The Front Right Leveling Jack is open circuit. Check the wiring to the Front Right Leveling Jack.
3523	3 5	"Rear Left Leveling Jack Short To Ground"	<ul style="list-style-type: none"> The Rear Left Leveling Jack is shorted to ground. Check the wiring to the Front Left Leveling Jack.
3524	3 5	"Rear Left Leveling Jack Short To Battery"	<ul style="list-style-type: none"> The Rear Left Leveling Jack is shorted to battery. Check the wiring to the Front Left Leveling Jack.
3525	3 5	"Rear Left Leveling Jack Open Circuit"	<ul style="list-style-type: none"> The Rear Left Leveling Jack is open circuit. Check the wiring to the Front Left Leveling Jack.
3526	3 5	"Rear Right Leveling Jack Short To Ground"	<ul style="list-style-type: none"> The Rear Right Leveling Jack is shorted to ground. Check the wiring to the Rear Right Leveling Jack.
3527	3 5	"Rear Right Leveling Jack Short To Battery"	<ul style="list-style-type: none"> The Rear Right Leveling Jack is shorted to battery. Check the wiring to the Rear Right Leveling Jack.
3528	3 5	"Rear Right Leveling Jack Open Circuit"	<ul style="list-style-type: none"> The Rear Right Leveling Jack is open circuit. Check the wiring to the Rear Right Leveling Jack.
3529	3 5	"Leveling Jack Extend Valve Short To Ground"	<ul style="list-style-type: none"> The Leveling Jack extend valve is shorted to ground. Check the wiring to the Leveling Jack extend valve.

DTC Code	Flash Code	Description	Item Check List
3530	3 5	"Leveling Jack Extend Valve Short To Battery"	<ul style="list-style-type: none"> The Leveling Jack extend valve is shorted to battery. Check the wiring to the Leveling Jack extend valve.
3531	3 5	"Leveling Jack Extend Valve Open Circuit"	<ul style="list-style-type: none"> The Leveling Jack extend valve is open circuit. Check the wiring to the Leveling Jack extend valve.
3532	3 5	"Leveling Jack Retract Valve Short To Ground"	<ul style="list-style-type: none"> The Leveling Jack retract valve is shorted to ground. Check the wiring to the Leveling Jack retract valve.
3533	3 5	"Leveling Jack Retract Valve Short To Battery"	<ul style="list-style-type: none"> The Leveling Jack retract valve is shorted to battery. Check the wiring to the Leveling Jack retract valve.
3534	3 5	"Leveling Jack Retract Valve Open Circuit"	<ul style="list-style-type: none"> The Leveling Jack retract valve is open circuit. Check the wiring to the Leveling Jack retract valve.
33132	3 3	"Throttle Actuator - Short to Battery"	<ul style="list-style-type: none"> The Engine RPM is not commanded to high idle however the control system detects high idle.
33280	3 3	"Glowplug - Short to Battery"	<ul style="list-style-type: none"> The platform or ground glow plug input is detected high at power up.
33318	3 3	"Drive Forward Valve - Short to Battery"	<ul style="list-style-type: none"> The HIM has detected a STB on the Drive Forward Valve output and communicated it to the LRT Ground Module via CAN
33319	3 3	"Drive Forward Valve - Short to Ground"	<ul style="list-style-type: none"> The HIM has detected a STG on the Drive Forward Valve output and communicated it to the LRT Ground Module via CAN
33317	3 3	"Drive Forward Valve - Open Circuit"	<ul style="list-style-type: none"> The HIM has detected a OC on the Drive Forward Valve output and communicated it to the LRT Ground Module via CAN <p>Only detectable when a function is active</p>
33321	3 3	"Drive Reverse Valve - Short to Battery"	<ul style="list-style-type: none"> The HIM has detected a STB on the Drive Reverse Valve output and communicated it to the LRT Ground Module via CAN
33322	3 3	"Drive Reverse Valve - Short to Ground"	<ul style="list-style-type: none"> The HIM has detected a STG on the Drive Reverse Valve output and communicated it to the LRT Ground Module via CAN
33320	3 3	"Drive Reverse Valve - Open Circuit"	<ul style="list-style-type: none"> The HIM has detected a OC on the Drive Reverse Valve output and communicated it to the LRT Ground Module via CAN <p>Only detectable when a function is active</p>
33750	3 3	"Upper Lift Down Valve - Short to Battery"	<ul style="list-style-type: none"> The HIM has detected a STB on the Upper Lift Down Valve output and communicated it to the LRT Ground Module via CAN <p>AND Machine Setup Model - 530LRT</p>
33751	3 3	"Upper Lift Down Valve - Short to Ground"	<ul style="list-style-type: none"> The HIM has detected a STG on the Upper Lift Down Valve output and communicated it to the LRT Ground Module via CAN <p>AND Machine Setup Model - 530LRT</p>
33752	3 3	"Upper Lift Down Valve - Open Circuit"	<ul style="list-style-type: none"> The HIM has detected a OC on the Upper Lift Down Valve output and communicated it to the LRT Ground Module via CAN <p>Only detectable when a function is active</p> <p>AND Machine Setup Model - 530LRT</p>
33753	3 3	"Lower Lift Down Valve - Short to Battery"	<ul style="list-style-type: none"> The HIM has detected a STB on the Lower Lift Down Valve output and communicated it to the LRT Ground Module via CAN <p>AND Machine Setup Model - 530LRT</p>

SECTION 5 - JLG CONTROL SYSTEM

DTC Code	Flash Code	Description	Item Check List
33754	3 3	"Lower Lift Down Valve - Short to Ground"	<ul style="list-style-type: none"> The HIM has detected a STG on the Lower Lift Down Valve output and communicated it to the LRT Ground Module via CAN AND Machine Setup Model - 530LRT
33755	7 8	"Lower Lift Down Valve - Open Circuit"	<ul style="list-style-type: none"> The HIM has detected a OC on the Lower Lift Down Valve output and communicated it to the LRT Ground Module via CAN Only detectable when a function is active AND Machine Setup Model - 530LRT
4381	4 3	"Fuel Sensor - Short to Battery"	<ul style="list-style-type: none"> The control system measures Fuel Sensor A2D value > 1023 counts
432	4 3	"Fuel Sensor Short To Ground"	<ul style="list-style-type: none"> The fuel sensor value is under the minimum allowed value. Check the fuel sensor input J2-34 (resistive).
4382	4 3	"Fuel Sensor - Open Circuit"	<ul style="list-style-type: none"> The control system measures Fuel Sensor A2D value > 768 counts
433	4 3	"Oil Pressure Short To Battery"	<ul style="list-style-type: none"> Engine oil pressure is high while the engine is not running for 30 seconds. Check the engine oil pressure input J2-17 (should be low when not overheating). Check the speed sensor wiring.
434	4 3	"Oil Pressure Short To Ground"	
435	4 3	"Coolant Temperature Short To Ground"	
437	4 3	"Engine Trouble Code"	<ul style="list-style-type: none"> Fault was reported by the engine controller. Check the engine.
438	4 3	"Engine Temperature High"	<ul style="list-style-type: none"> Engine temperature is over 110 degrees C.
441	4 4	"Battery Too Low - System Shut Down"	<ul style="list-style-type: none"> Battery voltage is under 9 Volts. Check the battery charge and cables.
442	4 4	"Battery Too High - System Shut Down"	<ul style="list-style-type: none"> Battery voltage is over 16 Volts. Check the battery charge and cables.
4310	4 3	"No Alternator Output"	<ul style="list-style-type: none"> The Alternator input is high after 15 seconds of engine running. Check alternator input J2-21 (should be low if engine is running).
4311	4 3	"Oil Pressure Low"	<ul style="list-style-type: none"> Engine oil pressure low after 10 seconds of running. Check engine oil pressure input J2-17 (should be high if engine is running).
4322	4 3	"Loss of Engine Speed Sensor"	<ul style="list-style-type: none"> Oil Pressure is present, Diesel Rpm is equal to zero and Speed Sensor Loss Counter has timed out.
4323	4 3	"Speed Sensor Reading Invalid Speed"	<ul style="list-style-type: none"> The speed sensor reading is over the maximum allowed value. Check the speed sensor wiring.
4352	4 3	"Coolant Temp Sensor Out Of Range High"	<ul style="list-style-type: none"> Engine coolant temp value is over the maximum allowed value. Check the engine coolant input J2-25 (resistive).
4353	4 3	"Coolant Temp Sensor Out Of Range Low"	<ul style="list-style-type: none"> Engine coolant temp value is under the minimum allowed value. Check the engine coolant input J2-25 (resistive).
4430	4 4	"Battery Low"	<ul style="list-style-type: none"> Battery voltage is under 11 Volts. Check the battery charge and cables.
662	6 6	"Canbus Failure - Platform Module"	<ul style="list-style-type: none"> The control system failed to receive messages from the Platform Module. All data from Platform Module is marked invalid. Check wiring to the Platform Module.
666	6 6	"Canbus Failure - Engine Controller"	<ul style="list-style-type: none"> MACHINE SETUP -> ENGINE = KUBOTA D/F ECM and CANbus communication is lost for 250mS.

DTC Code	Flash Code	Description	Item Check List
663	6 6	"LSS Not Sending Can Messages"	<ul style="list-style-type: none"> LSS Module CANbus messages not received for 250mS AND LOAD CFG = LOAD PINS AND LOAD != NO
664	6 6	"Canbus Failure - Accessory Module"	<ul style="list-style-type: none"> Canbus communication with the accessory module port has been lost for 1000ms
6649	6 6	"Canbus Failure - Temp/Tilt Sensor"	<ul style="list-style-type: none"> Ground module has lost communication with the tilt/temperature (0xC1) sensor via Canbus for greater than or equal to 250ms AND Low Temperature Cutout is configured
671	6 7	"Accessory Fault"	<ul style="list-style-type: none"> CAN faults reported by the Accessory Module.
6635	6 6	"Canbus Failure - Chassis Tilt Sensor"	<ul style="list-style-type: none"> The control system failed to receive messages from the Chassis Tilt Sensor. The control system behaves tilted. The Chassis Tilt Sensor is located inside the left chassis cover. Check wiring to the Chassis Tilt Sensor.
6650	6 6	"Canbus Failure - Oscillating Axle Tilt Sensor"	<ul style="list-style-type: none"> MACHINE SETUP -> AXLE = OSCILLATING AND MODEL = 330/430LRT and MARKET = CE OR MACHINE SETUP MODEL = 530LRT and AXLE = OSCILLATING AND Ground module has lost communication with the oscillating axle tilt sensor (0xC3) via CANbus for greater than or equal to 250ms .
6660	6 6	"Canbus Failure - Leveling Jacks Module"	<ul style="list-style-type: none"> CAN communication is lost with the leveling jacks module for 250ms.
6661	6 6	"Canbus Failure - Arm Stack Tilt Sensor"	<ul style="list-style-type: none"> Arm Stack Tilt Sensor CANbus messages not received for 250mS.
6671		"Canbus Failure - Hydraulics Improvement Module"	<ul style="list-style-type: none"> The LRT Ground Module has not received HIM messages for 250ms
813	8 1	"Chassis Tilt Sensor Not Calibrated"	<ul style="list-style-type: none"> The chassis tilt sensor has never been calibrated so the control system assumes the vehicle is tilted. Control system determines that the chassis tilt sensor EEPROM values have never been calibrated.
814	8 1	"Chassis Tilt Sensor Out Of Range"	<ul style="list-style-type: none"> The Chassis Tilt Sensor Raw X or Raw Y axis reads > +35 deg or < -35 deg.
818	8 1	"Tilt Sensor Stagnant"	<ul style="list-style-type: none"> If DTCs 6635, 813, 814 are not active, AND Commanded Drive Fwd or Rev > Max Low Drive Forward or Max Low Drive Reverse Personalities, AND Chassis Tilt Sensor Raw X or Raw Y axis does not change by 0.01 deg within 5000ms The control system assumes the machine is tilted, and lift up is prevented. Drive will only be allowed when the raw rotary (angle) sensor voltage is < min voltage + 0.25V, and the platform is stowed.
825	8 2	"LSS Has Not Been Calibrated"	<ul style="list-style-type: none"> Machine Setup LOAD != NO AND the control system detects that LSS has not been calibrated.
829	8 2	"Functions Cutout - Platform Overloaded"	<ul style="list-style-type: none"> Machine Setup -> LOAD != NO AND The platform load exceeds the "overload weight" value.
821	8 2	"LSS Cell #1 Error"	<ul style="list-style-type: none"> LOAD CFG = LOAD PINS and LOAD != NO AND LSS Module Reports Cell #1 DTC
822	8 2	"LSS Cell #2 Error"	<ul style="list-style-type: none"> LOAD CFG = LOAD PINS and LOAD != NO AND LSS Module Reports Cell #2 DTC

SECTION 5 - JLG CONTROL SYSTEM

DTC Code	Flash Code	Description	Item Check List
823	8 2	"LSS Cell #3 Error"	<ul style="list-style-type: none"> LOAD CFG = LOAD PINS and LOAD != NO AND LSS Module Reports Cell #3 DTC
824	8 2	"LSS Cell #4 Error"	<ul style="list-style-type: none"> LOAD CFG = LOAD PINS and LOAD != NO AND LSS Module Reports Cell #4 DTC
837	8 3	"Platform LSS Sensor 1 - Short To Battery"	<ul style="list-style-type: none"> Pressure Transducer Number 1 is reading higher then 3360PSI. Check Sensor wiring.
838	8 3	"Platform LSS Sensor 1 - Short To Ground Or Open Circuit"	<ul style="list-style-type: none"> Pressure Transducer Number 1 is reading lower then 0 PSI. Check Sensor wiring.
873	8 7	"Machine Safety System Override Occurred"	<ul style="list-style-type: none"> The Platform was moved while overloaded using the MSSO button. Can be reset only with an Analyzer, via the CALIBRATIONS > MSSO RESET > MSSO RESET menu.
8113	8 1	"Axle Tilt Sensor Has Not Been Calibrated"	<ul style="list-style-type: none"> Ground module is indicating that the EEPROM which stores the axle tilt sensor calibration is blank. MACHINE SETUP -> AXLE = OSCILLATING AND MODEL = 330/430LRT and MARKET = CE OR MACHINE SETUP MODEL = 530LRT and AXLE = OSCILLATING.
8114	8 1	"Arm Stack Tilt Sensor Out Of Range"	<ul style="list-style-type: none"> The Arm Stack Tilt Sensor Raw Arm Angle reading is < -90 degrees (factors in max arm angle plus 40% grade) OR greater than 40 degrees (conservatively assumes a minimum arm angle of 0 degrees plus a downhill grade of 40%) DTC 813 CHASSIS TILT SENSOR NOT CALIBRATED is not Active.
8115	8 1	"Axle Tilt Sensor Out Of Range"	<ul style="list-style-type: none"> The Axle Tilt Sensor Raw X or Raw Y axis reads: 530 LRT: > +25 deg or < -25 deg 330/430 LRT > +30 deg or < -30 deg
8118	8 1	"Axle Tilt Sensor Stagnant"	<ul style="list-style-type: none"> If DTC's 6650, 8113, 8115 are not active, AND Commanded Drive Fwd or Rev > Max Low Drive Forward or Max Low Drive Reverse Personalities, AND the Axle Tilt Sensor Raw X or Raw Y axis does not change by 0.01 deg within 5000ms If above elevation, drive and lift up functions are prevented.
991	9 9	"LSS Watchdog Reset"	<ul style="list-style-type: none"> LOAD CFG = LOAD PINS and LOAD != NO LSS Module reports watchdog reset fault 0x40
992	9 9	"LSS EEPROM Error"	<ul style="list-style-type: none"> LOAD CFG = LOAD PINS and LOAD != NO LSS Module reports EEPROM fault 0x40
993	9 9	"LSS Internal Error - Pin Excitation"	<ul style="list-style-type: none"> LOAD CFG = LOAD PINS and LOAD != NO LSS Module reports excitation fault 0x01
994	9 9	"LSS Internal Error - DRDY Missing From A/D"	<ul style="list-style-type: none"> LOAD CFG = LOAD PINS and LOAD != NO LSS Module reports DRDY fault 0x10
998	9 9	"EEPROM Failure - Check All Settings"	<ul style="list-style-type: none"> EEPROM checksum did not match saved checksum for a memory bank. Bank (personalities, machine configuration, calibrations, or fault log) reset to defaults. Replace controller.
9910	9 9	"Functions Locked Out - Platform Module Software Version Improper"	<ul style="list-style-type: none"> DTC 662 does not exist AND The LRT Ground Module software major version number does not match the major version number of the platform module software

DTC Code	Flash Code		Description	Item Check List
9979	9	9	"Functions Locked Out - Ground Module Software Version Improper"	<ul style="list-style-type: none"> Digital Input J4-10 = FALSE (indicating S299 control module has been placed on a pre S299 machine)
99333	9	9	"Functions Locked Out - Him Module Software Version Improper"	<ul style="list-style-type: none"> DTC 6671 does not exist AND The LRT Ground Module software major version number does not match the major version number of the HIM module software
99187	9	9	"LSS Internal Error - Driver Failure"	<ul style="list-style-type: none"> LOAD CFG = LOAD PINS and LOAD != NO LSS Module reports driver fault 0x04

Go to Discount-Equipment.com to order your parts

5.4 CHASSIS TILT SENSOR INSTALLATION

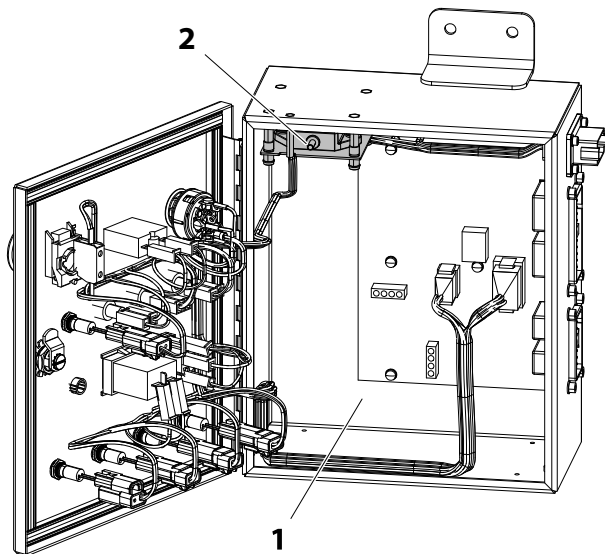

1. Ground Control Box 2. Tilt Sensor Assembly

Figure 5-4. Chassis Tilt Sensor Location

NOTE: Refer to Figure 5-5., Chassis Tilt Sensor Removal for numbers in parenthesis.

1. Disconnect the batteries.
2. Open the ground control box to gain access to the tilt sensor assembly.
3. Disconnect the tilt sensor wiring connector (SN3) from the (X03) harness connector on the side of the box.
4. Remove the four screws (3), lock washers (4), standoff insulators (5), and washers (6) to remove the tilt sensor (1) and sensor mount (2) from the ground control box.
5. The tilt sensor (1) can be removed from the sensor mount (2) by removing the two screws (7) and washers (6).

NOTE: Follow the above procedures in reverse order when installing the chassis tilt sensor assembly. Torque screws (7) to 106 in. lbs (12 Nm).

NOTE: After installing, be sure to calibrate the chassis tilt sensor (refer Section 5 for calibration procedure.)

Chassis Tilt Sensor - If this sensor is not wired correctly or if you have the wrong part number you will get CAN-BUS FAILURE - CHASSIS TILT SENSOR

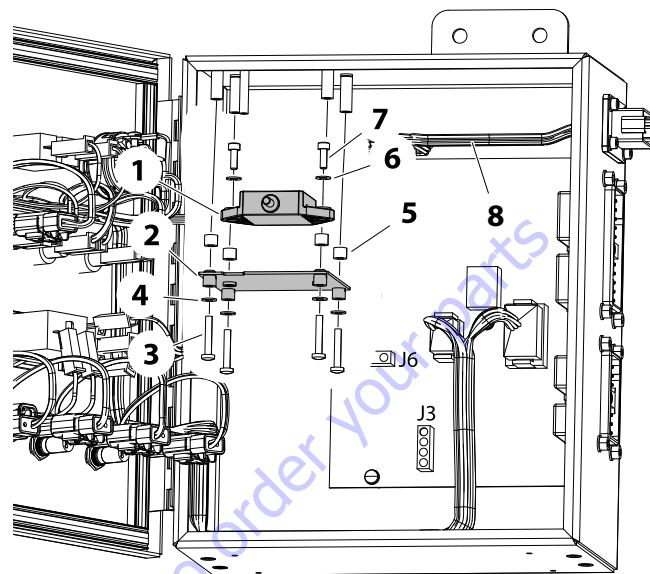

1. Chassis Tilt Sensor 5. Stand-off Insulators
 2. Sensor Mount 6. Washers
 3. Mount Screws 7. Sensor Screws
 4. Lockwashers 8. (SN3) (X03) Harness Connector

Figure 5-5. Chassis Tilt Sensor Removal

Table 5-1. Tilt Sensor Harness (SN3)

Wire Color	Function	Connector Pin
White	VCC	1
Yellow	GND	2
Green	CANH	3
Brown	CANL	4

5.5 LOCATION OF ADDITIONAL SENSORS

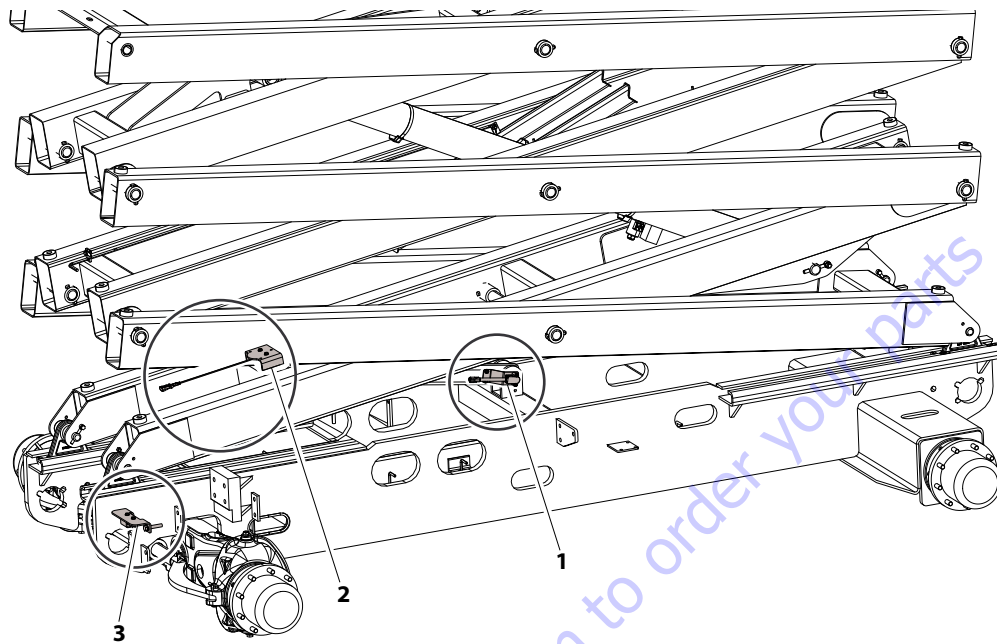

MAF21360

1. Rotary Angle (Elevation) Sensor (on scissor arm link at chassis)
2. Arm Stack Tilt Sensor (on bracket under cross-member)
3. Oscillating Axle Tilt Sensor (mounted to front oscillating axle) (if equipped)

Figure 5-6. Chassis Sensor Locations

5.6 CALIBRATION PROCEDURES

Chassis Tilt Sensor

(Item 1, Figure 5-5.)

1. Drive the machine onto a measured level surface ($\pm 0.5^\circ$ for both x and y axis).
2. Using the Analyzer, go to MENU: CALIBRATION; TILT SENSOR. Press Enter. LEVEL VEHICLE will display. Press Enter again to calibrate.
3. Both axis' raw angles need to be within $\pm 5.0^\circ$, otherwise the machine is not level and the software will prohibit calibration. Should this occur, check for the following:
 - a. **Machine mounting and/or grade:**
With a digital level, measure the top of the Ground Control box for levelness. If unable to get a good reading, check the box's mounting surface for levelness.

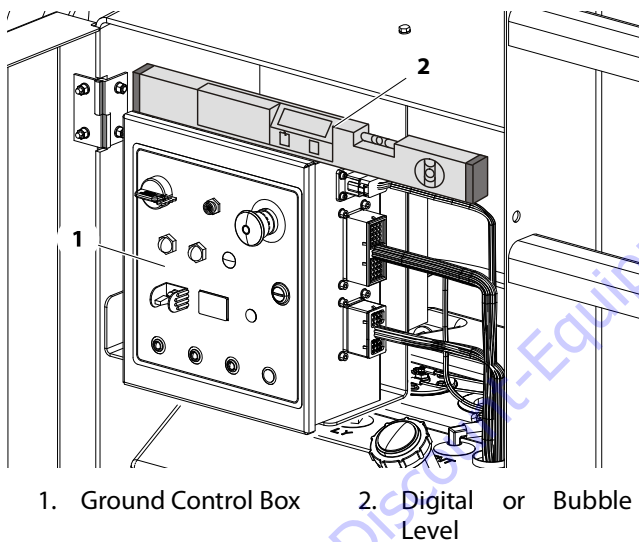

1. Ground Control Box 2. Digital or Bubble Level

- b. **Tilt sensor mounting on machine or wedged crooked in control box:**
If the machine mounting/grade appears acceptable, open the Ground Control box carefully. Observe whether the tilt sensor is properly seated.
- c. **Tilt sensor has developed an offset shift:**
Remove the tilt sensor from the Ground Control box, but keep both the tilt sensor and Ground Control box electrically connected. Level one axis of the tilt sensor and observe the raw reading (should be within $\pm 2.0^\circ$). Do the same for the other axis. If either axis is greater than $\pm 2.0^\circ$, replace the tilt sensor.

Some possible reasons that the tilt sensor will not calibrate are:

- a. The surface the machine is sitting on is off level by a few degrees (flat doesn't imply level; parking lots are often not level).
- b. The tilt sensor has failed one or both of the channels (X axis and Y axis).
- c. Tilt sensor has moisture intrusion that has shifted its output.
- d. Water and/or corrosion in the box has corrupted electrical connections or caused a tilt sensor or ground control board failure (observe any cracks in the box).
- e. The Ground Control Box, as mounted on the machine, does not allow the tilt sensor to be level.

For the following troubleshooting steps, a bubble level (smaller is better) will be needed and the machine must be on a level surface:

1. On the Analyzer, go to Diagnostics/System and read the tilt angle. If either angle reports $+20.0^\circ$, there is an electrical/electronic failure (tilt sensor, control board, electrical connections).
 - a. Open the Ground Control Box.
 - b. Disconnect the sensor and clean any corrosion off of the tilt sensor and control board connections.
 - c. Reassemble and test. If fault persists, replace tilt sensor.
2. If the Analyzer displays angles other than $+20.0^\circ$, attempt to calibrate. If machine will not calibrate, note the reason displayed on Analyzer:
 - a. SENSOR FAILURE – tilt sensor internal frequency is out of range (replace sensor).
 - b. NOT LEVEL - tilt sensor has either developed an offset or it is too unlevel as mounted on the machine.

Oscillating Axle Tilt Sensor (If Equipped)

(Item 4, Figure 5-6.)

1. Place machine on level surface
2. Start with machine in the stow position
3. Go to CALIBRATIONS > AXLE TILT
4. Select Enter
5. Analyzer says "Level Vehicle"
6. Select Enter
7. Analyzer will display the Axle Tilt Calibration Values
8. Hit Escape to leave menu

Set Stow Elevation

1. Place machine on level surface.
2. Start with machine in the stow position.
3. Go to CALIBRATIONS > SET STOW ELEV.
4. Select Enter.
5. Analyzer says "Calibrate Stow Elev Sensor?"
6. Select Enter.
7. Analyzer will display "Complete".
8. Hit Escape to leave menu.

Load Sensing

NOTE: Before beginning this calibration procedure, park the machine on a firm, level surface. Ensure the platform is stowed and empty.

1. Using the Analyzer, navigate to CALIBRATIONS > LOAD SENSING.
2. Press ENTER for Yes.
3. The Analyzer will display COMPLETE!
4. Press Escape to leave the menu.

Joystick

1. In the platform at the platform control box, ensure the joystick is in the center (neutral) position.
2. Using the Analyzer, navigate to CALIBRATIONS > JOYSTICK. Press Enter.
3. Push the joystick to its furthest forward position, then press Enter.
4. Return the joystick to the center position, then press Enter.
5. Push the joystick to its furthest backwards position, then press Enter.
6. The Analyzer will display COMPLETE.
7. Press Escape to leave the menu.

5.7 SERVICE MODE PROCEDURES

ECM Override (Dual Fuel Only)

Use this service menu when ECM CAN communication is lost on a machine equipped with Dual Fuel, but Elevated Drive, Auto-Level, or Generator function is needed. This service mode will bypass the ECM CAN loss DTCs and allow the machine to function as normal.

1. Using the Analyzer, navigate to SERVICE MODE > ECM OVERRIDE.
2. Input the pass code **22954** and select Enter.
3. The Analyzer will display ALLOW FUNCTIONS? Select Enter for YES.
4. Analyzer will display FUNCTS ALLOWED.
5. Select Escape to leave menu.

Elevation Service

This procedure allows a service technician to elevate the platform when an active DTC is preventing elevation by bypassing the DTC and allowing the platform to lift up. This mode remains active until a power cycle occurs. Once power is cycled, the DTC will become active again, and Elevation Service mode must be reactivated to lift.

1. Using the Analyzer, navigate to SERVICE MODE > ELEV SERVICE.
2. Input the pass code **87189** and select Enter.
3. Select Enter to activate the Elevation Service Mode.
4. Analyzer will display COMPLETE!
5. Elevation Service is now active. Select Escape to leave menu.

EEPROM Reset

This procedure clears all the machine's calibrations and returns the machine personalities and set-up to default settings. After Reset EEPROM, all calibration procedures will need to be completed. Use this service mode when: a machine is having multiple issues and clearing the EEPROM may help to fix the problem; a service technician wants to clear all machine calibrations and return the machine to default settings; or a module is moved from one machine to another and must be cleared and returned to default.

1. Using the Analyzer, navigate to SERVICE MODE > EEPROM RESET.
2. Input the pass code **35470** and select Enter.
3. Select Enter to activate EEPROM Reset.
4. Analyzer will display COMPLETE.
5. All settings will be reset. Select Escape to leave menu.

Allow Drive

This mode allows a service technician to drive the machine when an active DTC prevents normal drive functionality. Before initiating this service mode, the service technician must verify the platform is stowed and the leveling jacks are retracted before drive function will be enabled. Drive speed will only be allowed at elevated speed.

1. Using the Analyzer, navigate to SERVICE MODE > ALLOW DRIVE.
2. Input the pass code **82221** and select Enter.
3. The Analyzer will display ALLOW DRIVE? Select Enter.
4. The Analyzer will display PLATFORM STOWED? Select Enter.
5. The Analyzer will display L/J RETRACTED? Select Enter.
6. The Analyzer will display DRIVE ALLOWED. Select Escape to leave menu.

Allow Leveling Jack Retract

This mode allows a service technician to retract the leveling jacks when an active DTC prevents normal leveling jack functionality. Before initiating this service mode, the service technician must verify the platform is stowed before the leveling jacks can be retracted.

1. Using the Analyzer, navigate to SERVICE MODE > ALLOW LJ RETRACT.
2. Input the pass code
3. **54749** and select Enter.
4. The Analyzer will display ALLOW LJ RETRACT? Select Enter.
5. The Analyzer will display PLATFORM STOWED? Select Enter.
6. The Analyzer will display RETRACT ALLOWED. Select Escape to leave menu.

5.8 MACHINE CONFIGURATION AND PROGRAMMING SETTINGS

The Machine Configuration Programming must be completed before any Personality settings (Table 5-4) can be changed. Changing the Personality settings first and then changing the Model of the Machine Configuration will cause the Personality settings to return to default values.

Table 5-2. Machine Configuration Programming Information (Version P1.3)

Configuration Digit	Setting	Description	Default Number
MODEL NUMBER: 1	0 1 2	330 LRT 430 LRT 530 LRT	2
MARKET: 2	0 1 2 3 4 5	ANSI USA ANSI EXPORT CSA CE AUSTRALIA KOREA	0
ENGINE: 3	0 1 2	KUBOTA T4F KUBOTA T4I KUBOTA D/F	0
GLOW PLUGS: 4	0 1 2 3	NO GLOW PLUGS 5 SEC GLOW 10 SEC GLOW 20 SEC GLOW	3
LEVELING JACKS: 5	0 1	No - Leveling Jacks not installed on vehicle. YES - Leveling Jacks are installed on vehicle.	1
GENERATOR: 6	0 1	NO - Generator is not installed on vehicle. YES - Generator is installed on vehicle.	0
LOAD SYSTEM: 7*	0 1 2	NOT INSTALLED - No overload detection. CUTOUT PLT - Platform controls are disabled when overloaded. CUTOUT ALL - Platform and Ground controls are disabled when overloaded. NOTE: * Different Defaults by market: CE = 2	1
GROUND ALARM: 8*	0 1 2	NOT INSTALLED - Vehicle alarm will function for Overload (if LOAD enabled). DESCENT - Vehicle alarm will function for Overload (if LOAD enabled) and during Lift Down motion. MOTION - Vehicle alarm will function for Overload (if LOAD enabled), during Drive motion, and during Lift motion. NOTE: * Different Defaults by market: CE = 0	2
ENGINE SHUTDOWN: 9	0 1	NO - The engine will not be automatically shutdown. SHUTDOWN - The engine will automatically shutdown in the event of high engine coolant temperature, low oil pressure, or a temperature sensor or oil pressure sensor fault.	1
LOW TEMP CUTOUT: 10	0 1	NO - The machine will not have low temperature cutout functionality. YES - The machine is equipped with low temperature cutout capability for the CE and ANSI EXPORT markets.	0
BEACON LIGHT: 11*	0 1	NO - The beacon light will never flash except for when being used by Electronic Arm Guards (CE market). See footnote. YES - The beacon light will flash at 1 Hertz all the time the machine is powered and not being used by Electronic Arm Guards (CE market). See footnote. NOTE: * The beacon light will ALWAYS be used for unique visual indication (flash at 1 Hertz for 2 seconds, then off for 1 second) for the Electronic Arm Guards feature (only equipped on CE market) regardless of the BEACON LIGHT setting.	0

SECTION 5 - JLG CONTROL SYSTEM

Table 5-2. Machine Configuration Programming Information (Version P1.3)

Configuration Digit	Setting	Description	Default Number
AXLE CONFIG: 12	0 1	FIXED - The machine is not equipped with an oscillating axle. OSCILLATING - The machine is equipped with an oscillating axle.	0
			1001241348_C

NOTE: Bold Numbers indicate the default setting for that market. Plain text indicates another available selection. SHADED CELLS indicates hidden menu or selection in that market.

CONFIG. DIGIT	1	2	3	4	5	6	7	8	9	10	11	12
330LRT	MODEL NUMBER	MARKET	ENGINE	GLOW PLUG	LEVELING JACKS	GENERATOR	LOAD SYSTEM	GROUND ALARM	ENGINE SHUTDOWN	LOW TEMP CUTOUT	BEACON LIGHT	AXLE CONFIG.
ANSIUSA	0	0	0 1 2	0 1 2 3	0 1	0 1 2	0 1 X	0 1 2	0 1	0 X	0 1 0	0 1
ANSIEXPORT	0	1	0 1 2	0 1 2 3	0 1	0 1 2	0 1 X	0 1 2	0 1	0 1	0 1 0	0 1
CSA	0	2	0 1 2	0 1 2 3	0 1	0 1 2	0 1 X	0 1 2	0 1	0 X	0 1 0	0 1
CE	0	3	0 1 2	0 1 2 3	0 1	0 1 2	0 X 2	0 1 2	0 1	0 1	0 1 0	0 1
AUSTRALIA	0	4	0 1 2	0 1 2 3	0 1	0 1 2	0 1 X X	X X 2	0 1	0 X	0 1 0	0 1
KOREA	0	5	0 1 2	0 1 2 3	0 1	0 1 2	0 1 X	0 1 2	0 1	0 1	0 1 0	0 1
												1001241348_C

CONFIG. DIGIT	1	2	3	4	5	6	7	8	9	10	11	12
430LRT	MODEL NUMBER	MARKET	ENGINE	GLOW PLUG	LEVELING JACKS	GENERATOR	LOAD SYSTEM	GROUND ALARM	ENGINE SHUTDOWN	LOW TEMP CUTOUT	BEACON LIGHT	AXLE CONFIG.
ANSIUSA	1	0	0 1 2	0 1 2 3	0 1	0 1 2	0 1 X	0 1 2	0 1	0 X	0 1 0	0 1
ANSIEXPORT	1	1	0 1 2	0 1 2 3	0 1	0 1 2	0 1 X	0 1 2	0 1	0 1	0 1 0	0 1
CSA	1	2	0 1 2	0 1 2 3	0 1	0 1 2	0 1 X	0 1 2	0 1	0 X	0 1 0	0 1
CE	1	3	0 1 2	0 1 2 3	0 1	0 1 2	0 X 2	0 1 2	0 1	0 1	0 1 0	0 1
AUSTRALIA	1	4	0 1 2	0 1 2 3	0 1	0 1 2	0 1 X X	X X 2	0 1	0 X	0 1 0	0 1
KOREA	1	5	0 1 2	0 1 2 3	0 1	0 1 2	0 1 X	0 1 2	0 1	0 1	0 1 0	0 1
												1001241348_C

NOTE: Bold Numbers indicate the default setting for that market. Plain text indicates another available selection. SHADED CELLS indicates hidden menu or selection in that market.

Table 5-3. Machine Tilt Configuration (Version P1.3)

Model	Market	Lift Up and Drive prevented when Elevated and Tilted Front to Back beyond the following limits:	Lift Up and Drive prevented when Elevated and Tilted Side to Side beyond the following limits:
330LRT	ANSI USA	$\pm 5^\circ$ to Full Height	$\pm 3^\circ$ to Full Height
	ANSI EXPORT	$\pm 5^\circ$ to Full Height	$\pm 3^\circ$ to Full Height
	CSA	$\pm 3^\circ$ to Full Height	$\pm 3^\circ$ to Full Height
	CE	$\pm 5^\circ$ to Full Height	$\pm 3^\circ$ to Full Height
	AUSTRALIA	$\pm 5^\circ$ to Full Height	$\pm 3^\circ$ to Full Height
	KOREA	$\pm 5^\circ$ to Full Height	$\pm 3^\circ$ to Full Height
430LRT	ANSI USA	$\pm 5^\circ$ to Full Height	$\pm 3^\circ$ to Full Height
	ANSI EXPORT	$\pm 5^\circ$ to Full Height	$\pm 3^\circ$ to Full Height
	CSA	$\pm 3^\circ$ to Full Height	$\pm 3^\circ$ to Full Height
	CE	$\pm 5^\circ$ to Full Height	$\pm 3^\circ$ to Full Height
	AUSTRALIA	$\pm 5^\circ$ to Full Height	$\pm 3^\circ$ to Full Height
	KOREA	$\pm 5^\circ$ to Full Height	$\pm 3^\circ$ to Full Height
			1001241348_C

Table 5-4. Machine Model Personality Adjustment

Adjustment	Adjustment Range	Model Default Values	
		330LRT	430LRT
DRIVE			
Accel	0.1 - 5.0 (sec)	2.0	2.0
Decel	0.1 - 3.0 (sec)	2.0	2.0
Min Forward	500-800 mA	680	690
Hi Drv Fwd	1000-1800 mA	1500	1400
Mid Drv Fwd	1100-1500 mA	1400	1300
Low Drv Fwd	900-1100 mA	1000	950
Min Reverse	500-800 mA	650	690
Hi Drv Rev	1000-1800 mA	1500	1400
Mid Drv Rev	1100-1500 mA	1400	1300
Low Drv Rev	900-1100 mA	1000	950
Elev Fwd Max	700-1000 mA	860	850
Elev Rev Max	700-1000 mA	860	850
LIFT			
Accel	0.1 - 5.0 (sec)	2.0	2.0
Decel	0.1 - 3.0 (sec)	1.0	1.0
Up Accel	0.1 - 5.0 (sec)	NA	NA
Up Decel	0.1 - 3.0 (sec)	NA	NA
Min Up	0 - 35%	19	19
Max Up	0 - 75%	55	55
Min Down	0 - 35%	19	19
Max Down	0 - 75%	45	45
LOAD			
Overload	450-1220 kg	950	590
Accy	0-680 kg	0.0	0.0
Overload Dbnce	0.1 - 10.0 (sec)	3.0	3.0
Overload Hold	0.5 - 10 (sec)	5.0	5.0
JOYSTICK			
Fwd Max	0.00 - 5.00V	1.1	1.1
Fwd Min	0.00 - 5.00V	2.25	2.25
Rev Min	0.00 - 5.00V	2.75	2.75
Rev Max	0.00 - 5.00V	3.9	3.9
TEMP CUTOUT			
Cutout Set	-30 - 0 (C)	-27	-27
1001241349_B			
NOTE: These settings may be changed in order to achieve optimal performance.			

SECTION 6. LSS SETUP/CALIBRATION/SERVICE

6.1 CONNECTING THE JLG CONTROL SYSTEM ANALYZER

1. Connect the cable supplied with the Analyzer to the host control system located at the ground control station. There is also an alternate connection on the under side of the platform control station. Connect the remaining end of the cable to the analyzer.

NOTE: The cable has a four-pin connector at each end of the cable; The cable cannot be connected backwards.

2. Power-up the Control System by turning the key to the Platform or Ground position and pulling both emergency stop buttons.

6.2 HELP MENU & FAULT CODES

The Help Menu is a troubleshooting tool to communicate detected System Faults to the technician. The following table documents the Faults for the Load Sensing System. To access the Help Menu, use the LEFT and RIGHT arrow keys to select HELP: PRESS ENTER from the Top Level Menu. Press the ENTER key to view the menu.

When accessing the Help Menu, the JLG Analyzer will display EVERYTHING OK if the platform is not overloaded and no difficulties are detected. Otherwise, the JLG Analyzer will display OVERLOADED.

In the event of difficulty, the user can press ENTER again to display Logged Help, which is a record of the last 16 Fault Messages. The following table lists each Help/Logged Message, the Flash Code (for each Fault, the module will flash the two-digit code on its LED) triggered by the Fault, and a Description of the Situation (cause).

Table 6-1. LSS Fault Codes

HELP/LOGGED MESSAGE	FLASH CODE	DESCRIPTION OF SITUATION
PLATFORM OVERLOADED	2-5	The platform load measured at the Load Sensing System is excessive. Functions from the platform control are prevented, and functions from the ground control may be prevented, depending on machine.
BATTERY TOO HIGH	4-4	Incoming Supply Voltage > 34.0Vdc. The control system's battery voltage is too high. This may be due to over-charging or improper charger operation.
BATT TOO LOW	4-4	Incoming Supply Voltage < 9.0Vdc. The control system's battery voltage is too low due to excessive electrical load or discharge. This may compromise ability to predict weight. Recharge batteries or check for damaged batteries.
CANBUS FAILURE: LSS MODULE	6-6	The control system failed to receive messages from the LSS Module. Check wiring at the LSS Module and along scissor arms leading up to platform.
CELL #1 ERROR	8-1	Cell #1's Bridge < 2V, > 3V, or could not read Cell #1's Internal Memory. This situation indicates damage to the sensor or its wiring.
CELL #2 ERROR	8-2	Cell #2's Bridge < 2V, > 3V, or could not read Cell #2's Internal Memory. This situation indicates damage to the sensor or its wiring.
CELL #3 ERROR	8-3	Cell #3's Bridge < 2V, > 3V, or could not read Cell #3's Internal Memory. This situation indicates damage to the sensor or its wiring.
CELL #4 ERROR	8-4	Cell #4's Bridge < 2V, > 3V, or could not read Cell #4's Internal Memory. This situation indicates damage to the sensor or its wiring.
WATCHDOG RST	9-1	Microprocessor's Watchdog Timer Triggered. This is an indication that the LSS Module has been exposed to excessive electrical noise, or has experienced a hardware difficulty.
EEPROM ERROR	9-2	Memory used to retain Personality/Machine Setup/Calibration has been corrupted and must be reset by verifying all entries and re-calibrating. After resolution, re-cycle power to clear difficulty.
LSS NOT CALIBRATED	9-3	Calibration has not been successfully completed. A new LSS Module will display this message until properly calibrated.
LSS INTERNAL ERROR - PIN EXCITATION	9-9	Pin excitation < 4.25V. The sensors may be excessively loading the excitation supply, or the LSS Module may have hardware difficulty.
LSS INTERNAL ERROR - DRDY MISSING FROM A/D	9-9	DRDY Interrupt from LSS Module's A/D converter missing. This may indicate an LSS Module hardware difficulty.

6.3 DIAGNOSTIC MENU

NOTE: If necessary refer to Section 5 - Analyzer Menu Flow Charts.

The Diagnostic Load Menu is another troubleshooting tool for the Load Sensing System. Sensor and status information is presented in real-time for the technician.

To access the Diagnostic Menu, use the LEFT and RIGHT Arrow keys to select DIAGNOSTICS from the Top Level Menu. Press the ENTER key to select the menu.

NOTE: The Diagnostic, Load menu is not available when the LSS is not enabled. (Machine Setup, Load is set to 0=Not Installed)

Press the LEFT and RIGHT Arrow keys to view the load sub-menus and press the enter key. Once in the load sub-menu, press the LEFT and RIGHT arrow keys to view the various displays.

The table below details the structure of the Diagnostic, Load Menu, and describes the meaning of each piece of information presented.

Table 6-2. Diagnostic Menu Descriptions

DIAGNOSTICS MENU (DISPLAYED ON ANALYZER 1ST LINE)	PARAMETER (DISPLAYED ON ANALYZER 2ND LINE)	PARAMETER VALUE (DISPLAYED ON ANALYZER 2ND LINE)	DESCRIPTION
LOAD:			
	PLTLOAD	±XXXX Kg	Displays (Total Measured Force – Empty Platform Calibration), in kilograms
	PLTGROS	±XXXX Kg	Displays Total Measured Force (Sum of Pins 1 thru 4 LOAD) in kilograms
	OVERLOADED?	Yes / No	Displays Current LSS Module Overload Status
	CELL 1	±XXXX Kg	Displays Calibrated Cell Reading in kilograms
	CELL 2	±XXXX Kg	Displays Calibrated Cell Reading in kilograms
	CELL 3	±XXXX Kg	Displays Calibrated Cell Reading in kilograms
	CELL 4	±XXXX Kg	Displays Calibrated Cell Reading in kilograms
	ANALYZER	VX.XXXX	Displays Analyzer Software Version

6.4 PERSONALITIES

The following parameter in the PERSONALITIES, LOAD menu adjust performance of the LSS. All adjustments must be made in Access Level 1 (33271).

Table 6-3. Personalities

SUBMENU (DISPLAYED ON ANALYZER1ST LINE)	PARAMETER (DISPLAYED ON ANALYZER 2ND LINE)	DESCRIPTION
LOAD:	ACC'YXXXX KG	Displays/adjusts a derating for accessories.
	OVRDBNCE3 S	Displays/adjusts the debounce delay before an overload.
	OVRHOLD5 S	Displays/adjusts the minimum delay before an overload can be released.

6.5 MACHINE SETUP MENU

The LOAD submenu within the machine setup menu is used to configure the LSS. To access the Machine Setup, Load menu, use the Left and Right arrow keys to select MACHINE SETUP from the Top Level Menu. Press the ENTER key to select the menu. Press the Left and Right arrow keys to select LOAD from the MACHINE SETUP menu. Press the Enter key to view the submenu.

The following table details the structure of the load submenu and describes the meaning of the parameter.

Table 6-4. Machine Setup

SUBMENU (DISPLAYED ON ANALYZER 1ST LINE)	PARAMETER (DISPLAYED ON ANALYZER 2ND LINE)	DESCRIPTION
LOAD:	0=NOT INSTALLED	Displays/adjusts the LSS Module
	1=CUTOUT PLT	
	2=CUTOUT ALL	

6.6 CALIBRATION MENU

The Load submenu within the Calibration Menu is used to zero the Empty Platform weight.

To access the Calibration Load Menu, use the LEFT and RIGHT Arrow keys to select CALIBRATION from the Top Level Menu. Press the ENTER key to select the menu. Press the LEFT and RIGHT arrow keys to select LOAD from the CALIBRATION menu. Press the ENTER key to view the submenu.

NOTE: The Calibration Menu is not available in Access Level 2.

Upon entry to the Calibration, Load Menu, the analyzer will display the following:

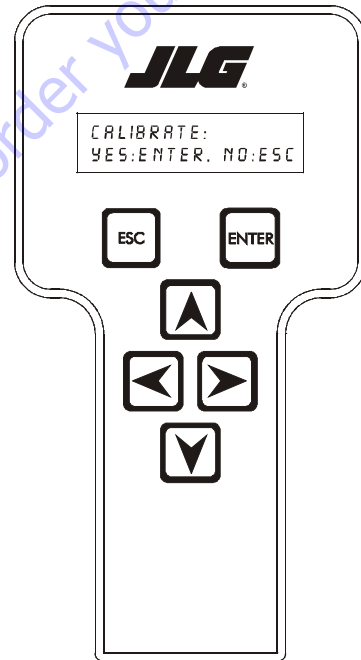

CALIBRATE:
YES:ENTER, NO:ESC

Pressing the ESC key will return the user to the top level menu and not disturb the prior calibration information.

SECTION 6 - LSS SETUP/CALIBRATION/SERVICE

Pressing the ENTER key will confirm that the platform is empty (except for factory-installed options outside the Rated Load). The LSS Module will calculate the total of all load cell readings and ensure that the total is greater than minimum calibration value, but less than maximum calibration value. If successful, the Analyzer will show the following:

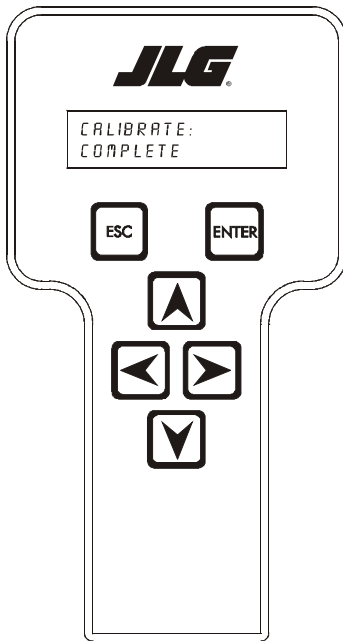

CALIBRATE:
COMPLETE

Table 6-5. Calibration Values

MODELS	330RT	430LRT
Minimum Calibration Value	225 KG (496 LB)	225 KG (496 LB)
Maximum Calibration Value	1150KG (2535.3 LB)	1000KG (2204.6 LB)

If the empty platform weight is less than minimum calibration value, the calibration attempt will be unsuccessful and the Analyzer will show the following:

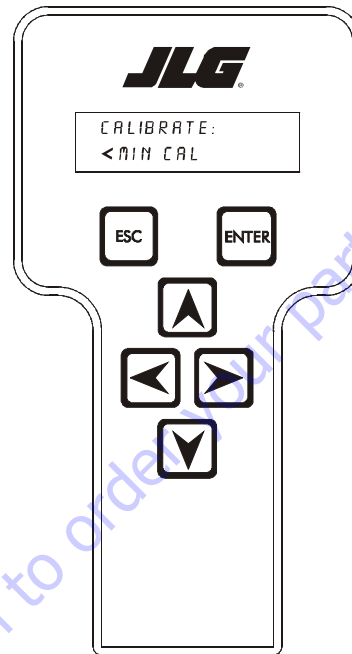

CALIBRATE:
< MIN CAL

If the empty platform weight is greater than maximum calibration value, the calibration attempt will be unsuccessful and the Analyzer will show the following:

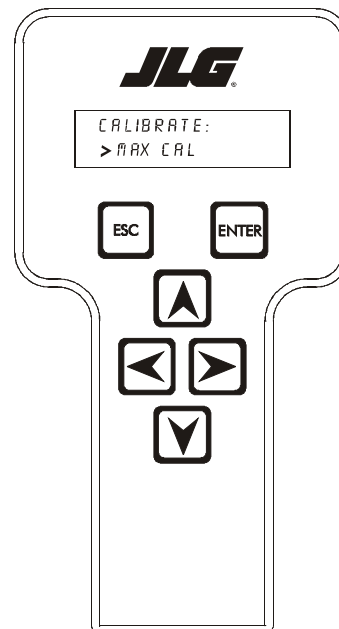

CALIBRATE:
> MAX CAL

6.7 SERVICE

Description

The system consists of the LSS Module, four Shear Pin Load Cells (sensors), Wire Harness, and various brackets and fasteners. The LSS Module is mounted beneath the platform on a bracket. The Shear Pin Load Cells mount between the platform and the arm structure in such a way that all support force for the platform is applied through them (for measurement). The four Shear Pin Load Cells plug directly into the LSS Module. The Wire Harness connects the LSS Module to the Host Control System.

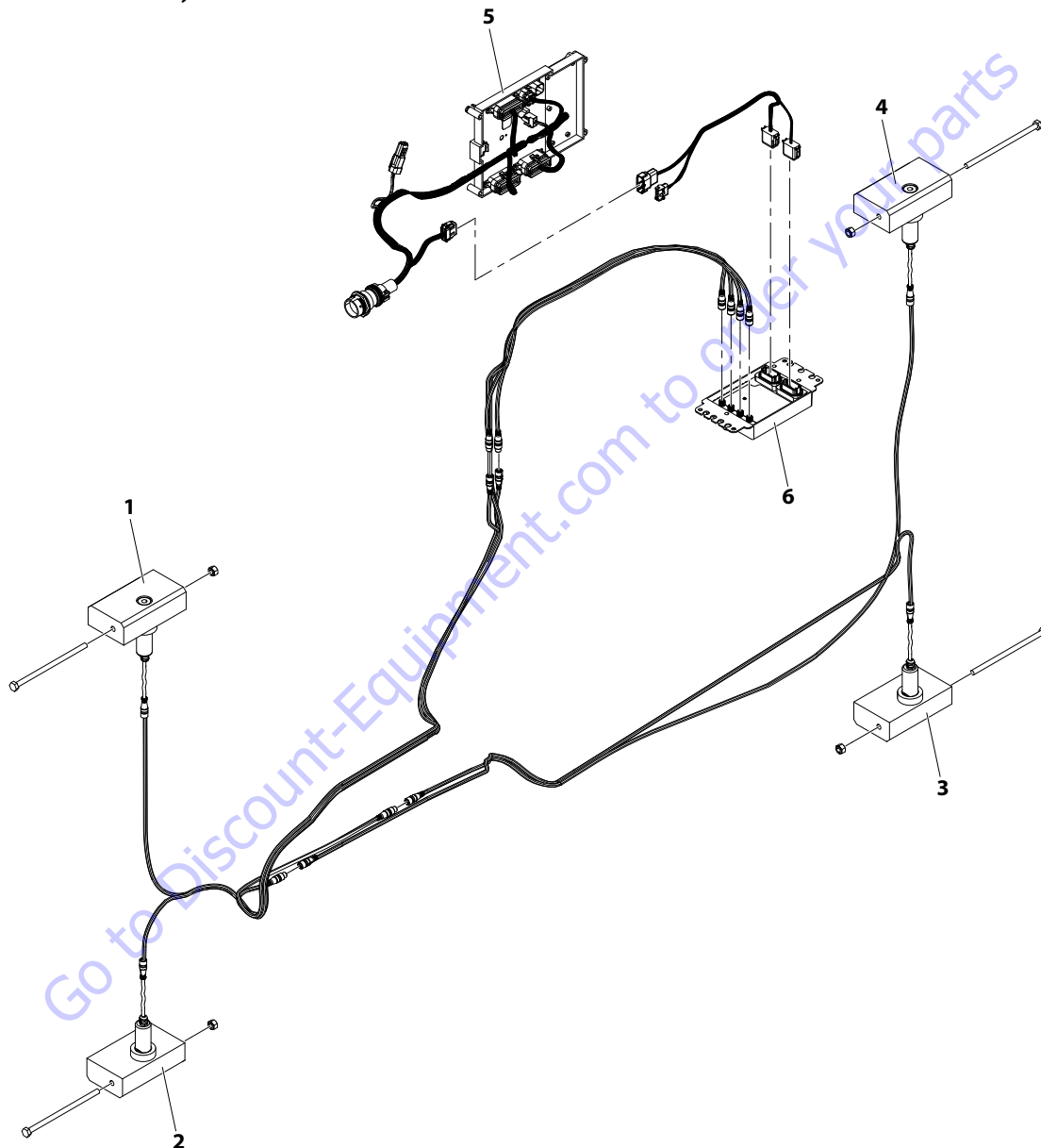

- | | |
|--|---------------------------------------|
| 1. Slide Block/Load Cell (Left Front) | 4. Slide Block/Load Cell (Right Rear) |
| 2. Slide Block/Load Cell (Right Front) | 5. Platform Interface Module |
| 3. Slide Block/Load Cell (Left Rear) | 6. LSS System Module |

Figure 6-1. Load Sensing System Components

MAF04280

6.8 CALIBRATION

Procedure

1. Plug the JLG Analyzer into the LSS Module on the Host Control System and enter the Access Level 1 Password. Do not confuse the Host Control System and LSS Module's Analyzer Connections. Proceed to the ACCESS LEVEL menu and enter the Access Level 1 Password (33271).
2. Park the vehicle on a level surface. The platform should be fully stowed and level within $\pm 5^\circ$ (both directions).
3. Configure the LSS Module for the proper model and Desired Units. Proceed to the LSS Module's MACHINE SETUP, MODEL sub-menu and select the applicable model. Press the RIGHT ARROW to view the Units Selection. Select "UNITS=LBS" for platform load measurement in Pounds, and "UNITS=KG" for measurement in Kilograms.

NOTICE

EARLY RT'S REQUIRE A CONFIGURATION TO THE LSS MODULE. PLUG THE JLG ANALYZER INTO THE MODULE'S CONNECTION BENEATH THE DECK AND ENTER THE ACCESS LEVEL 1 PASSWORD (33271). UNDER MACHINE SETUP ENSURE THAT MODEL=260MRT.

4. Remove everything except JLG Accessories from the Platform. Empty the platform to allow the Load Sensing System to record its weight during calibration. All tools, debris, and customer-installed devices shall be removed. Permanently-fixed JLG Accessories shall remain and their contribution toward Rated Load will be accounted for in the next step.
5. Configure the LSS Module for JLG Accessories. The contribution of each permanently-fixed JLG Accessory toward Rated Load must be determined. JLG Accessories are decal'd with their effective contribution toward Rated Load. If this decal is missing, reference the appropriate manual for the JLG Accessory. Once determined, the contributions of all permanently-fixed JLG Accessories mounted in the platform of the vehicle shall be added together and entered in the Analyzer's PERSONALITIES, ACC'Y display (using the proper units).
6. Execute a Calibration via the JLG Analyzer. Proceed to the Analyzer's CALIBRATION top level menu and press ENTER. Press ESC to abort a calibration or ENTER to calibrate (tare). If successful, the Analyzer will display "COMPLETE". If unsuccessful, a message will be displayed that will help lead to a resolution (reference the Troubleshooting section of this manual). Press ESC to return to the top level menu.

Testing & Evaluation

Refer to the Troubleshooting section of this manual if the Load Sensing System fails to meet these guidelines.

1. Plug the JLG Analyzer into the Host Control System.
2. Park the vehicle on a level surface. The platform should be fully stowed and level within $\pm 5^\circ$ (both directions).
3. Observe the Empty Platform Weight. Proceed to the DIAGNOSTICS, PLTLOAD sub-menu and observe the measured platform load. All tools, debris, and customer-installed devices shall be removed during evaluation. Ideally, the PLTLOAD should be zero but can vary $\pm 15\text{lbs}$ ($\pm 7\text{kg}$). Further, the reading should be stable and should not vary by more than $\pm 2\text{lbs}$ ($\pm 1\text{kg}$) (unless there is heavy influence from wind or vibration).
4. Use the Technician's Weight to Evaluate. The technician should enter the platform and record the PLTLOAD reading while standing in the center of the platform, and then each corner. The average of the readings should be the estimated weight of the technician. The range of the readings should be no more than 40lbs (18kg) (max PLTLOAD reading - min PLTLOAD reading).
5. Confirm Host Control System Warnings and Interlocks. Using the vehicle's key switch, select Platform Mode and power-up. Start the vehicle's engine (if equipped) and ensure that all controls are functional and the Load Sensing System's Overload Visual and Audible Warnings are not active. Simulate an Overload by unplugging the Shear Pin Load Cell connected to J5 on the LSS Module. The Overload Visual Warning should flash, and the Audible Warning (at Platform and Ground) should sound for 5 seconds On, and 2 seconds Off. With the engine running (if equipped), all platform control should be prevented. Cycle the Platform EMS to stop the engine and then power-up again. The Overload Visual and Audible Warning should continue. Install the disconnected Shear Pin Load Cell back in J5 on the LSS Module. The Overload Visual and Audible Warnings should cease and normal control function should return. Switch the vehicle's key switch to Ground Mode and repeat the above procedure. The Overload Visual Warning at the Ground Controls should flash, and the Audible Warning (at Platform and Ground) should sound for 5 seconds On, 2 seconds Off. However, the controls should remain functional when using the engine (if the Host Controls System's MACHINE SETUP, LOAD is set to "2=CUTOOUT PLT". If set to "3=CUTOOUT ALL", then Ground Controls will be prevented when using the platform). Re-fit the Shear Pin Load Cell connector to J5 on the LSS Module and carefully tighten by hand, and then with a small pair of locking pliers to seat the O-ring seal.

6. Confirm Load Sensing System Performance with Calibrated Weights. Operate the vehicle from Ground Control and place the platform in the fully stowed position for safety. Place 120% of the machines rated load in the center of the platform and ensure that the overload visual and audible warnings are active. Reduce the platform load to 100% rated load and ensure that the warnings are not active. For vehicles with multiple capacities, evaluate each operating mode with the proper rated load.

Go to Discount-Equipment.com to order your parts

6.9 TROUBLESHOOTING

The following tables are furnished to provide possible resolutions for common difficulties. Difficulties are classified as General, Calibration, Measurement Performance, and Host System Functionality. Also refer to Electrical Schematic in Section 7 for wiring circuit diagnostics.

Table 6-6. LSS Troubleshooting Chart - General

DIFFICULTY	POSSIBLE RESOLUTION
JLG Analyzer does not display "HELP: PRESS ENTER" when connected to LSS Module's connection, but the module's LED is lit or flashing.	<p>The JLG Analyzer is failing to communicate with the LSS Module, but the LSS Module is powered (indicated by module's LED). Investigate JLG Analyzer serial communication and power supply connections.</p> <ol style="list-style-type: none"> 1. If the Analyzer displays "CONNECTING. . ." or "CONNECTION ERROR" after a short interval, examine the Analyzer harness on J2. J2-2 should connect to Pin 3 on the Analyzer, and J2-11 should connect to Pin 2. 2. If the Analyzer does not display anything (and there is no backlighting), examine the Analyzer's power supply. Remove the harness connection from J2 and ensure that J2-1 has approximately 12V, and J2-12 is 0V. The harness should connect J2-1 to Pin 1 on the Analyzer, and J2-12 to Pin 4 on the Analyzer. 3. The JLG Analyzer is suspect. Substitute to determine cause of failure. 4. The LSS Module is suspect. Substitute to determine cause of failure.
LED on LSS Module does not light.	<p>The LSS Module is un-powered, a short exists, or the device is damaged.</p> <ol style="list-style-type: none"> 1. LSS Module's power supply is improper. Check for the presence of approximately 12V on J1-1, and 0V on J1-2. The module's power supply comes from the Platform Console Box. Use the Wiring Diagram to trace the conductors to their source. 2. There is a short circuit on the reference voltage present on J5-J8. Unplug the connectors one at a time and observe if the module begins to function after a particular connection is removed. If so, carefully inspect the wiring between the module and that sensor. 3. There is a short circuit on the pre-regulated supply for the JLG Analyzer present on J2-1. Unplug J2's connector and observe whether the module begins to function. If so, examine the Analyzer harness for defect. 4. The LSS Module is suspect. Substitute to determine cause of failure.

Table 6-7. LSS Troubleshooting Chart - Calibration

Difficulty	Possible Resolution
JLG Analyzer displays "<MIN CAL" after attempt is made to Calibrate.	<p>The LSS Module expected the empty platform to weight more for calibration.</p> <ol style="list-style-type: none"> 1. The platform is being supported by something other than the four Shear Pin Load Cells. This includes binding between the slide block/spacer bushing/arm tube assembly (bushing should be free enough to rotate by hand). For proper operation, the platform's entire weight must be transferred through the Shear Pin Load Cells and into the arm support structure for an accurate calibration. 2. The wrong Model Selection was made under the LSS Module's MACHINE SETUP, MODEL. This should be set to the proper MODEL. Improper selection may lead the LSS Module to expect different empty platform weights. 3. The calibration difficulty may be a result of a Measurement Performance issue. Review the Possible Resolutions under that category.
JLG Analyzer displays ">MAX CAL" after attempt is made to Calibrate.	<p>The LSS Module expects the empty platform to weigh less for calibration.</p> <ol style="list-style-type: none"> 1. Tools, debris, or customer-installed accessories have not been removed before calibration. The LSS Module must tare an empty platform and its optional JLG Accessories. 2. The wrong Model Selection was made under the LSS Module's MACHINE SETUP, MODEL. This should be set to MODEL. Improper selection may lead the LSS Module to expect different empty platform weights. 3. The calibration difficulty may be a result of a Measurement Performance issue. Review the Possible Resolutions under that category.

Table 6-8. LSS Troubleshooting Chart - Measurement Performance

DIFFICULTY	POSSIBLE RESOLUTION
<p>Empty Platform Weight (DIAGNOSTICS, PLTLOAD) is not within ± 15lbs (± 7kg) of zero.</p> <p style="text-align: center;">or</p> <p>Platform Load readings (DIAGNOSTICS, PLTLOAD) are unstable by more than ± 2lbs (± 1kg) (without the influence of vibration or wind).</p> <p style="text-align: center;">or</p> <p>There are large variations in Platform Load (DIAGNOSTICS, PLTLOAD) based on the location of the load. Tolerance to variations is 40lbs (18kg) for an evaluation using the technician's weight, and $\pm 5\%$ of Rated Load when using calibrated weights.</p>	<p>The LSS Module is unable to properly measure the platform weight.</p> <ol style="list-style-type: none"> 1. One of the Shear Pin Load Cells is not properly plugged into the LSS Module. Since the connectors seal with an O-ring and are located in a crowded area, it is possible that the connectors are threaded together, but poor electrical contact is made. Attempt to wiggle the molded portion of each connector on J5-J8. If properly tightened, the molded portion should not move. Also, examine each Shear Pin Load Cell's readings via the JLG Analyzer. Proceed to the DIAGNOSTICS, CELL 1-4, LOAD displays and determine if the readings are reasonable. Note that it is possible to have only two sensors carrying all of the platform load due to fit between the platform and support structure (this is normal). 2. Wiring leading to one of the Shear Pin Load Cells is damaged. Examine each sensor's reading using the JLG Analyzer. Proceed to the DIAGNOSTICS, CELL 1-4, LOAD displays and determine if the readings are reasonable and responsive to slight downward pressure above the sensor being viewed. Carefully inspect sensor wiring where it passes through cable clamps for signs of damage. Inspect wiring where damage to the channel is apparent. If damage to the sensor's cordset is found, replace the appropriate Shear Pin Load Cell since the cordset is not serviceable (connector is molded for moisture resistance; cordset is soldered into sensor beneath welded stainless steel cover). If damage to the sensors extension cordset is found, unplug both ends and fit a replacement. 3. One of the Shear Pin Load Cells was not assembled properly during installation. Examine each sensor's reading using the JLG Analyzer. Proceed to the DIAGNOSTICS, CELL 1-4, LOAD displays and determine if the readings are reasonable. It is often helpful to apply slight downward pressure above the sensor being examined and observe that its output increases (increasing force measurement; decreasing means the sensor is mounted upside-down). Compare the order of assembly to the detail on the Installation Drawing and ensure that the only contact between the platform and the support is through the sensor bodies (nothing else touches except wires). Re-assemble according to print if necessary. 4. Damage to the platform or arm structure has occurred or one of the components is out-of-tolerance. Twists in the platform, for instance, will cause huge off-axis forces to be applied to the Shear Pin Load Cells, disturbing their primary measurement axis readings. If Lift Up / Down is noisy or not smooth, examine this issue thoroughly. Resolution is to replace the damaged or faulty component. Watch for Shear Pin Load Cell damage (yield) as a result of this difficulty. 5. One of the Shear Pin Load Cells is contaminated by debris or moisture. Examine each sensor's reading using the JLG Analyzer. Proceed to the DIAGNOSTICS, CELL 1-4, LOAD displays and determine if the readings are reasonable and stable (not changing by more than ± 2lbs (± 1kg) (without the influence of vibration or wind). Lack of measurement stability is a key indication of contamination. Unplug the appropriate connector (J5 is CELL 1, J6 is CELL 2, J7 is CELL 3, and J8 is CELL 4) and inspect for dirt or moisture. Look carefully into the female connector on the sensor's cordset for evidence of contamination. Debris should be brushed away with a soft bristle brush (do not introduce any cleaners as they will leave conductive residue). Moisture should be allowed to evaporate or accelerated with a heat-gun (use low heat and be carefully to not melt connector materials). Moisture intrusion into the molded portion of the connector (capillary action into the wire bundle) or the Shear Pin Load Cell itself will require replacement of the sensor. 6. One of the Shear Pin Load Cells has been mechanically damaged (yielded). Any Shear Pin Load Cell that is physically deformed or has damage to one of the stainless steel covers should be replaced immediately. It is also possible to have invisible mechanical damage resulting from an extreme overload (>4200lbs [>1900kg] for 1.25 in diam.; >5700 lbs or 2600 KG for 2 inch diam.). This can be detected by supporting the platform with an overhead crane and by removing the suspect sensor (no weight resting on the Shear Pin Load Cell). Examine the sensor's reading using the JLG Analyzer. Proceed to the DIAGNOSTICS, CELL 1-4, LOAD displays and observe whether the unloaded sensors read with ± 15lbs (± 7kg) of zero (individually). Replace sensors that read excessive force when physically unloaded. 7. The LSS Module is suspect. Interchange the Shear Pin Load Cell connections (J5-J8) and observe the results via the JLG Analyzer. Proceed to the DIAGNOSTICS, CELL 1-4, LOAD displays and observe the readings. If the problem seems to remain with a particular sensor, carefully re-examine the issues above. If the problems seems to remain with a particular LSS Module channel, substitute another module.

Table 6-9. LSS Troubleshooting Chart - Host System Functionality

Difficulty	Possible Resolution
<p>The Visual and Audible Overload Warnings fail to sound when platform is loaded beyond Rated Load, or when simulated by unplugging a Shear Pin Load Cell from the LSS Module. Controls remain functional at Platform and Ground Control positions.</p>	<p>The Host Control System is failing to regard the overload signal from the LSS Module, or the signal is shorted.</p> <ol style="list-style-type: none"> 1. The Load Sensing System must be enabled within the Host Control System. Plug the JLG Analyzer into the Host Control System, enter the Access Level 1 password (33271), and examine the MACHINE SETUP, LOAD sub-menu. The selection "CUTOUT PLT" should be displayed for European Community compliance (platform controls prevented during overload, ground controls remain operational). In country- or customer-specific circumstance, the selection "3=CUTOUT ALL" is used (platform and ground controls prevented during overload). 2. The signal between the LSS Module and the Host Control System is shorted. The Platform Module's J1-20 is an input, and it connected to the J1-5 output on the LSS Module To examine the status of this signal, plug the JLG Analyzer into the Host Control System, enter the Access Level 1 password (33271), and examine the DIAGNOSTICS, SYSTEM, LOAD display. The display will indicate "OK" when the Platform Module's input is energized (approximately 12V), and "OVERLOADED" when it is de-energized (0V). Refer to the Wiring Diagram for Load Sensing System for details. 3. Observe the LSS Module's assessment of overload using the JLG Analyzer plugged into the LSS Module's connection. Proceed to the DIAGNOSTICS, OVERLOADED? display. The display should indicate "OVERLOADED? N" when the platform is empty, and "OVERLOADED? Y" when the platform is overloaded. If the assessment is improper, the difficulty may be a result of a General or Measurement Performance issue. Review the Possible Resolutions under those categories. 4. If the LSS Module's J1-5 Output does not appears to coincide with the DIAGNOSTICS, OVERLOADED? display, then the LSS Module is suspect. Substitute to determine cause of failure.
<p>The Visual and Audible Overload Warnings sound even when the platform is empty. Controls are prevented in the same manner as when overloaded.</p>	<p>The LSS Module is un-powered, un-calibrated, or is experiencing a Measurement Performance difficulty. Alternately, the Host Control System is not receiving the proper signal from the LSS Module.</p> <ol style="list-style-type: none"> 1. Ensure that the LSS Module is powered. The LSS Module's LED will be lit or flash if the module is powered. If not, ensure that approximately 12V is present between J1-1 and J1-2 on the LSS Module (J1-1 is positive). Trace the Ignition and Ground supply wires into the Host Control System's wiring harness using the wiring diagram to locate the difficulty. 2. Plug a JLG Analyzer into the LSS Module's connection and ensure that the Host Control System is powered-up. When HELP:PRESS ENTER is displayed, press the ENTER key on the Analyzer. If "EVERYTHING OK" is displayed, it is probable that the Overload Signal from the LSS Module is not reaching the Host Control System. This signal is present on LSS Module's J1-5 and is approximately 12V normally, and 0V during an overload. This signal eventually reaches the Main Terminal Box to provide the overload signal. Refer to the Wiring Diagram for wire color, number, and terminal information. 3. If the Analyzer displayed "OVERLOADED" in the previous step, press the ENTER key again. If "NO CAL" is displayed, the Load Sensing System has not been properly calibrated. Refer to the Calibration portion of this manual. 4. If another fault is displayed, refer to the portion of this manual that describes Fault Messages and their causes. 5. The difficulty may be a result of a Measurement Performance issue. Review the Possible Resolutions under those categories.
<p>Controls remain functional at the Ground Control position during an overload, or when simulated by unplugging a Shear Pin from the LSS Module. The Control at the Platform Control position are prevented.</p>	<p>The Host Control System is configured to prevent platform controls only in the event of overload. Alternately, the Host Control System can be configured to prevent ground and platform controls for country- or customer-specific circumstances.</p> <p>Plug the JLG Analyzer into the LSS Module's connection and enter the Access Level 1 password (33271). Proceed to the MACHINE SETUP, LOAD sub-menu. Set this parameter to "CUTOUT PLT" to prevent platform controls in the event of overload. Set this parameter to "CUTOUT ALL" to prevent platform and ground controls in the event of overload.</p>

Table 6-10. LSS Module System Interface Connector - Power & Digital (J1 - Grey)

PIN	SIGNAL	DESCRIPTION
1	VBAT	Positive Power Supply from Host Control System (12-24V)
2	GND	Negative Power Supply from Host Control System (0V)
3	GND-2	Connects to GND
4	N/C	Unused
5	DO1	Overload Indicator Output (Normal=VBAT / Overload=0V)
6	DO2	Warning Indicator Output (Normal=0V / Overloaded=VBAT for 5 Sec, 0V for 2 Sec)
7	DI3	Unused
8	DI2	Select OVERLD3 Personality Rating (No=0V / Yes=VBAT)
9	DI1	Select OVERLD2 Personality Rating (No=0V / Yes=VBAT)
10	GND-2	Connects to GND
11	VBAT-2	Connects to VBAT
12	VBAT-2	Connects to VBAT

Table 6-11. LSS Module System Interface Connector - Communication (J1 - Black)

PIN	SIGNAL	DESCRIPTION
1	APWR	Pre-Regulated Supply for JLG Analyzer (Analyzer Pin 1; approx. 12V)
2	TX	RS-232 for JLG Analyzer (Analyzer Pin 3)
3	TRP1	120 Ohm CANbus Terminator
4	CANH-1	CANbus Interface High
5	CANS-1	CANbus Shield Termination (Not same as GND)
6	CANH-2	Connects to CANH-1
7	CANL-2	Connects to CANL-1
8	CANS-2	Connects to CANS-1
9	CANL-1	CANbus Interface Low
10	TRP2	120 Ohm CANbus Terminator
11	RX	RS-232 for JLG Analyzer (Analyzer Pin 2)
12	GND	Ground for JLG Analyzer (Analyzer Pin 4)

Table 6-12. LSS Module Load Cell Connector Pinout (J5, J6, J7, J8)

PIN	SIGNAL	DESCRIPTION
1	+ Signal	Positive Sensor Output (approx. 2.5V)
2	Cal Clock	Serial Clock to Sensor's Integrated Memory
3	- Excitation	Negative Sensor Supply Voltage (approx. 0V)
4	+Excitation	Positive Sensor Supply Voltage (approx. 5V)
5	-Signal	Negative Sensor Output (approx. 2.5V)
6	Cal Data	Serial Data from Sensor's Integral Memory

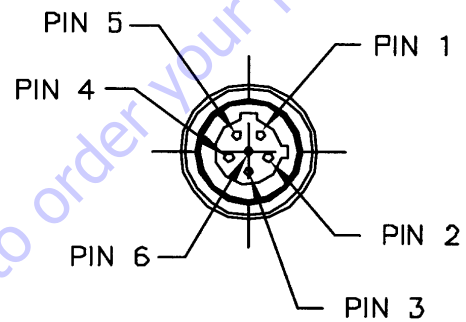

NOTE: Physical connector as viewed looking into the cable end

Figure 6-2. LSS Module Load Cell Connector Pinout (J5, J6, J7, J8)

SECTION 7. GENERAL ELECTRICAL INFORMATION & SCHEMATICS

7.1 GENERAL

This section contains general electrical information and schematics to be used for locating and correcting most of the operating problems which may develop. If a problem should develop which is not presented in this section or which is not corrected by listed corrective actions, technically qualified guidance should be obtained before proceeding with any maintenance.

NOTICE

IT IS A GOOD PRACTICE TO AVOID PRESSURE-WASHING ELECTRICAL/ELECTRONIC COMPONENTS. SHOULD PRESSURE-WASHING BE UTILIZED TO WASH AREAS CONTAINING ELECTRICAL/ELECTRONIC COMPONENTS, JLG INDUSTRIES, INC. RECOMMENDS A MAXIMUM PRESSURE OF 750 PSI (52 BAR) AT A MINIMUM DISTANCE OF 12 INCHES (30.5 CM) AWAY FROM THESE COMPONENTS. IF ELECTRICAL/ELECTRONIC COMPONENTS ARE SPRAYED, SPRAYING MUST NOT BE DIRECT AND BE FOR BRIEF TIME PERIODS TO AVOID HEAVY SATURATION.

7.2 MULTIMETER BASICS

A wide variety of multimeters or Volt Ohm Meters (VOM) can be used for troubleshooting your equipment. A digital meter with reasonable accuracy (within 7%) is recommended for the measurements in these procedures. This section shows diagrams of a common, digital VOM configured for several different circuit measurements. Instructions for your VOM may vary. Please consult the meter operator's manual for more information.

Grounding

"Grounding the meter" means to take the black lead (which is connected to the COM (common) or negative port) and touch it to a good path to the negative side of the Voltage source.

Backprobing

To "backprobe" means to take the measurement by accessing a connector's contact on the same side as the wires, the back of the connector. Readings can be done while maintaining circuit continuity this way. If the connector is the sealed type, great care must be taken to avoid damaging the seal around the wire. It is best to use probes or probe tips specifically designed for this technique, especially on sealed connectors. Whenever possible insert probes into the side of the connector such that the test also checks both terminals of the connection. It is possible to inspect a connection within a closed connector by backprobing both sides of a connector terminal and measuring resistance. Do this after giving each wire a gentle pull to ensure the wires are still attached to the contact and contacts are seated in the connector.

Min/Max

Use of the "Min/Max" recording feature of some meters can help when taking measurements of intermittent conditions while alone. For example, you can read the voltage applied to a solenoid when it is only operational while a switch, far from the solenoid and meter, is held down.

Polarity

Finding a negative Voltage or current reading when expecting a positive reading frequently means the leads are reversed. Check what reading is expected, the location of the signal and that the leads are connected to the device under test correctly. Also check that the lead on the "COM" port goes to the ground or negative side of the signal and the lead on the other port goes to the positive side of the signal.

Scale

M = Mega = 1,000,000 * (Displayed Number)

k = kilo = 1,000 * (Displayed Number)

m = mili = (Displayed Number) / 1,000

μ = micro = (Displayed Number) / 1,000,000

Example: 1.2 k Ω = 1200 Ω

Example: 50 mA = 0.05 A

Voltage Measurement

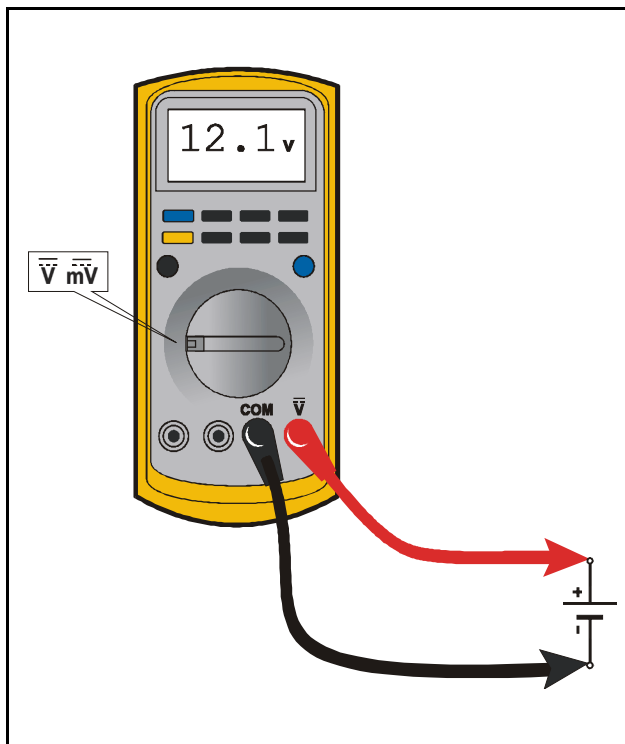

Figure 7-1. Voltage Measurement (DC)

- If meter is not auto ranging, set it to the correct range (See multimeter's operation manual).
- Use firm contact with meter leads.

Resistance Measurement

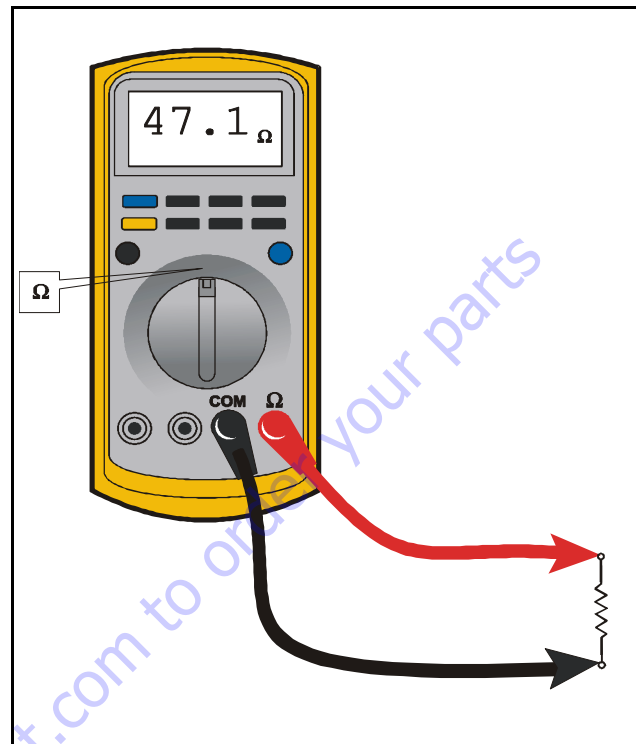
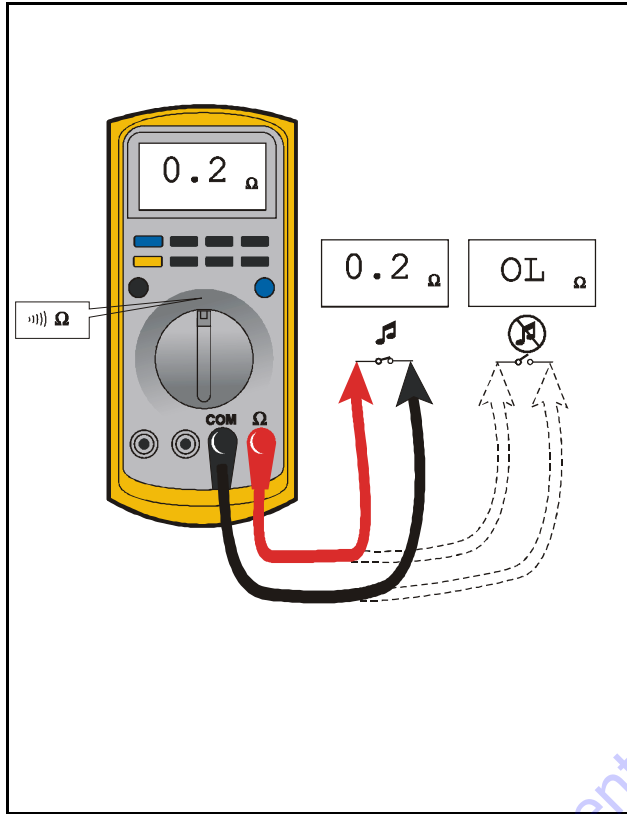
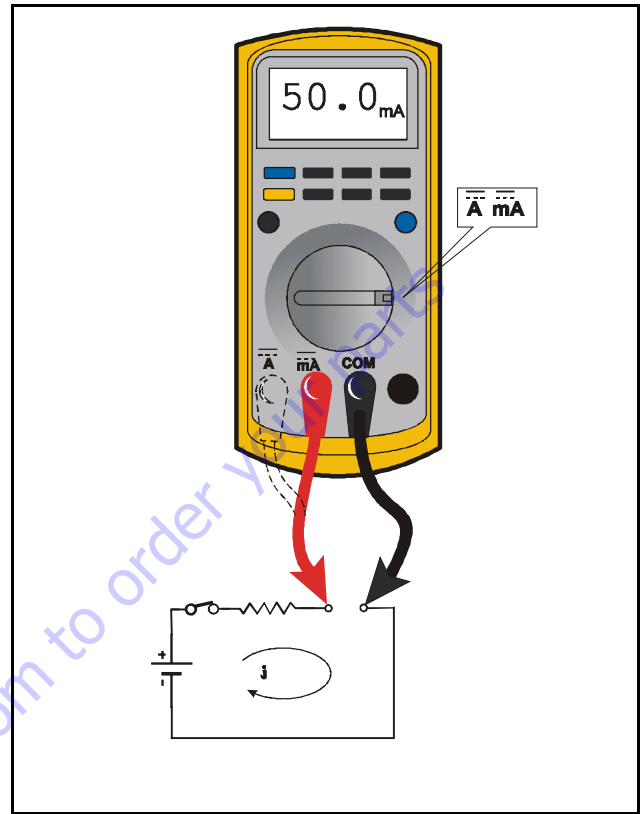

Figure 7-2. Resistance Measurement

- First test meter and leads by touching leads together. Resistance should read a short circuit (very low resistance).
- Circuit power must be turned OFF before testing resistance.
- Disconnect component from circuit before testing.
- If meter is not auto ranging, set it to the correct range (See multimeter's operation manual).
- Use firm contact with meter leads.

Continuity Measurement**Figure 7-3. Continuity Measurement**

- Some meters require a separate button press to enable audible continuity testing.
- Circuit power must be turned OFF before testing continuity.
- Disconnect component from circuit before testing.
- Use firm contact with meter leads.
- First test meter and leads by touching leads together. Meter should produce an audible alarm, indicating continuity.

Current Measurement**Figure 7-4. Current Measurement (DC)**

- Set up the meter for the expected current range.
- Be sure to connect the meter leads to the correct jacks for the current range you have selected.
- If meter is not auto ranging, set it to the correct range (See multi meter's operation manual).
- Use firm contact with meter leads.

Continuity Measurement Over Long Distances

When trying to determine continuity of a harness or wire, longer than the reach of standard instrument leads, is possible to perform the check without excessively long leads. Using the other wires in the harness one can determine the condition of a particular wire in the harness.

Requirements:

- Harness with at least three separate wires including the wire under test.
- These wires must be able to be isolated from other wires, etc.
- Jumper or method to connect contacts on one side of harness.
- Meter that can measure resistance or continuity.

Procedure

Test multimeter leads resistance. Subtract this value from the measured resistance of the wires to get a more accurate measurement.

Consult the circuit schematic to determine which wires to use in addition to wire under test, here called wire #1 and wire #2, and how to isolate these wires. These wires should appear in the same connectors as the wire under test or are within reach of the jumper.

1. Disconnect all connections associated with the wire under test and the two additional wires. If harness is not completely isolated disconnect battery terminals also, as a precaution.
2. Measure continuity between all three wires, the wire under test, wire #1 and wire #2. These should be open. If not, repair the shorted wires or replace the harness.
3. On one side, jumper from contact of wire #1 and wire #2.
4. Measure continuity between wire #1 and wire #2. If there is continuity, both wires are good and can be used for this test. If there is not continuity, either wire could be bad. Check connections and measurement setup. Redo measurement. If still no continuity, repair wires or consult schematic for other wires to use for test.
5. Jumper from wire under test to wire #1.
6. Measure continuity. If there is continuity, the wire under test is good. Resistance of a wire increases as the length increases and as the diameter decreases.

One can find the continuity of two wires, here #1 and #2, at once by following steps 1 through 4. If there is a problem the third wire is used to troubleshoot the other wires. To find the problem, start at step 1 and use the entire procedure.

7.3 APPLYING SILICONE DIELECTRIC COMPOUND TO ELECTRICAL CONNECTIONS

Silicone Dielectric Compound must be used on all electrical connections for the following reasons:

- To prevent oxidation at the mechanical joint between male and female pins.
- To prevent electrical malfunction caused by low level conductivity between pins when wet.

Use the following procedure to apply Silicone Dielectric Compound to the electrical connectors.

1. To prevent oxidation and low level conductivity, silicone dielectric grease must be packed completely around male and female pins on the inside of the connector after the mating of the housing to the header. This is easily achieved by using a syringe to fill the header with silicone dielectric compound, to a point just above the top of the male pins inside the header. When assembling the housing to the header, it is possible that the housing will become air locked, thus preventing the housing latch from engaging.
2. Pierce one of the unused wire seals to allow the trapped air inside the housing to escape.
3. Install a hole plug into this and/or any unused wire seal that has silicone dielectric compound escaping from it.

7.4 DIELECTRIC GREASE APPLICATION

The following is general guidance for the installation of dielectric grease in a connector system.

1. Use dielectric grease in a tube for larger connection points or apply with a syringe for small connectors.
2. Apply dielectric grease to plug/male connector housing which typically contains sockets contact/female terminals.
3. Leave a layer of dielectric grease on the mating face of the connector, completely covering each connector terminal hole. Refer the pictures shown below.
4. Assemble the connector system immediately to prevent moisture ingress or dust contamination.

The following connector systems are specifically addressed because of their widespread use at JLG. However, this guidance may be applied to similar devices.

AMP Mate-N-Lok

This connector system is widely used inside enclosures for general-purpose interconnect. Follow the general guidance for installation.

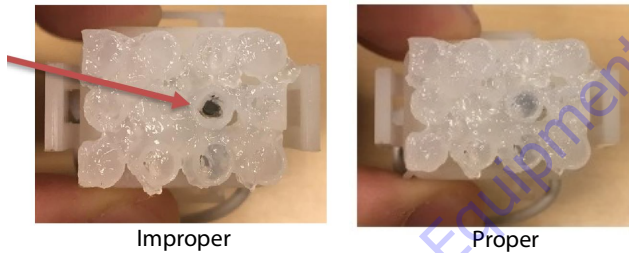

AMP Faston

This connector system is typically used on operator switches at JLG. Follow the general guidance for installation.

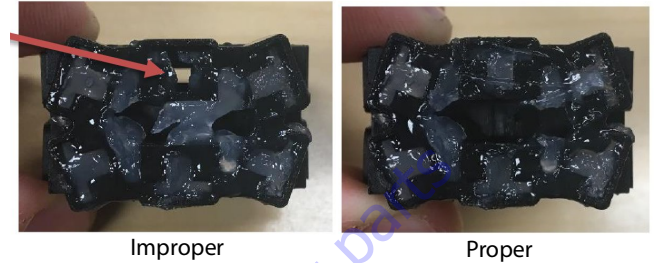

AMP Micro-Fit

This connector system is typically used on control modules at JLG. Follow the general guidance for installation.

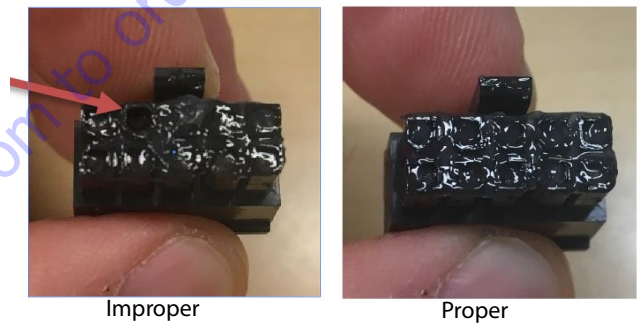

AMP Mini Fit Jr

This connector system is typically used on control modules at JLG. Follow the general guidance for installation.

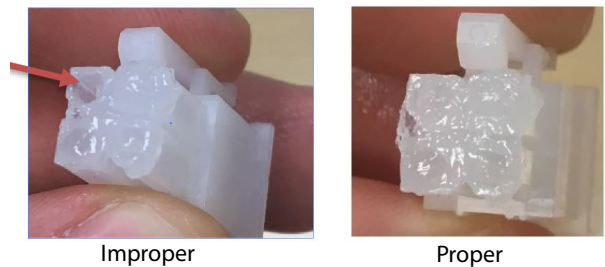

Mini Fit Sr

This connector system is typically used on control modules at JLG. Follow the general guidance for installation.



Improper

Proper

DIN Connectors

This connector is typically used on hydraulic valves. Follow the installation instructions.



Improper

Proper

Exceptions

Some waterproof connector applications do benefit from dielectric grease, and some non waterproof connectors do not benefit from dielectric grease.

In the exceptions below, we have found dielectric grease is not needed for some applications, and in some cases can interfere with the intended connection. Dielectric grease shall be used as an exception in other applications.

Enclosures

Application of dielectric grease is not required in properly sealed enclosures. To meet criteria, the enclosure must be rated to at least IP56 (dust protected; protected from powerful jets of water).

Carling Switch Connectors

Carling switches may experience high impedance, or discontinuity, due to silicone dielectric grease ingress when switching inductive loads. Therefore, dielectric grease shall not be applied to Carling switch mating connectors unless specifically noted.

Scissor Platform Cable at the Platform Control

Some waterproof connectors are exposed to the elements when disconnected by the customer benefit from having protection using dielectric grease.



7.5 AMP CONNECTOR

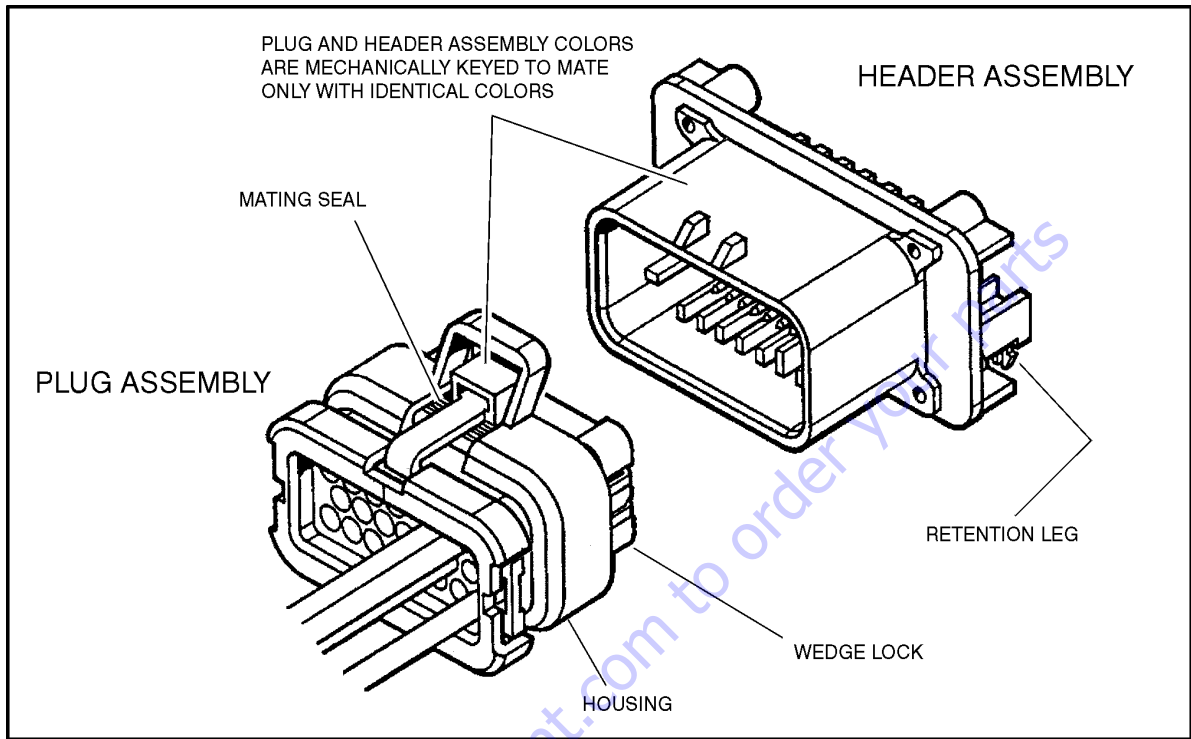

Figure 7-5. AMP Connector

Assembly

Check to be sure the wedge lock is in the open, or as-shipped, position (See Figure 7-6., Connector Assembly (1 of 4)). Proceed as follows:

1. To insert a contact, push it straight into the appropriate circuit cavity as far as it will go (See Figure 7-7., Connector Assembly (2 of 4)).
2. Pull back on the contact wire with a force of 1 or 2 lbs. to be sure the retention fingers are holding the contact (See Figure 7-7., Connector Assembly (2 of 4)).

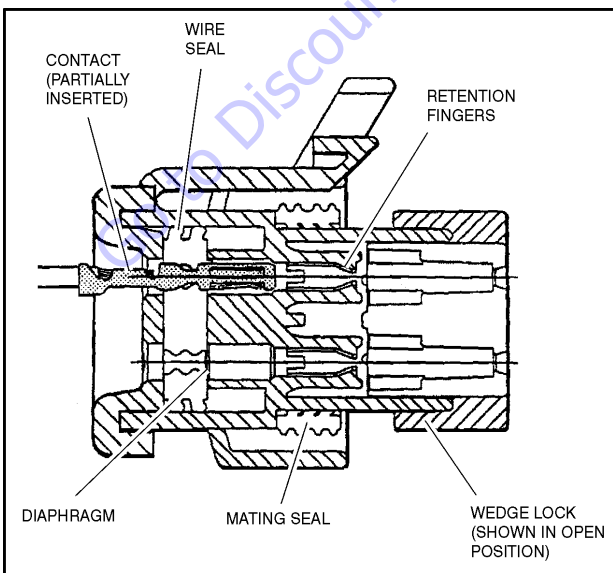

Figure 7-6. Connector Assembly (1 of 4)

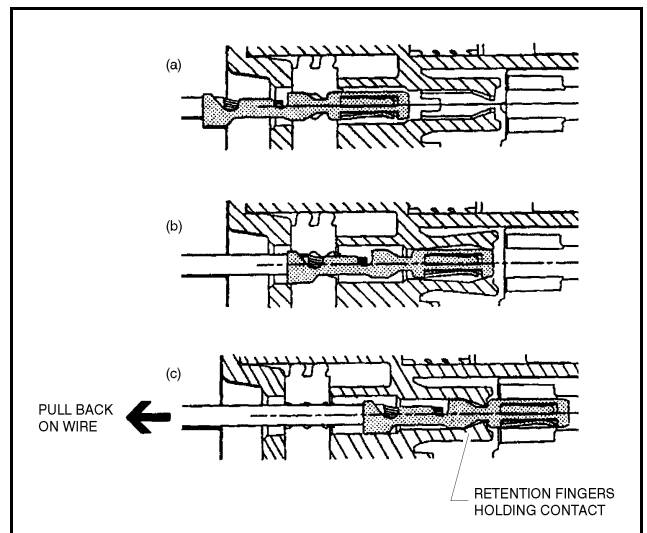

Figure 7-7. Connector Assembly (2 of 4)

3. After all required contacts have been inserted, the wedge lock must be closed to its locked position. Release the locking latches by squeezing them inward (See Figure 7-8., Connector Assembly (3 of 4)).

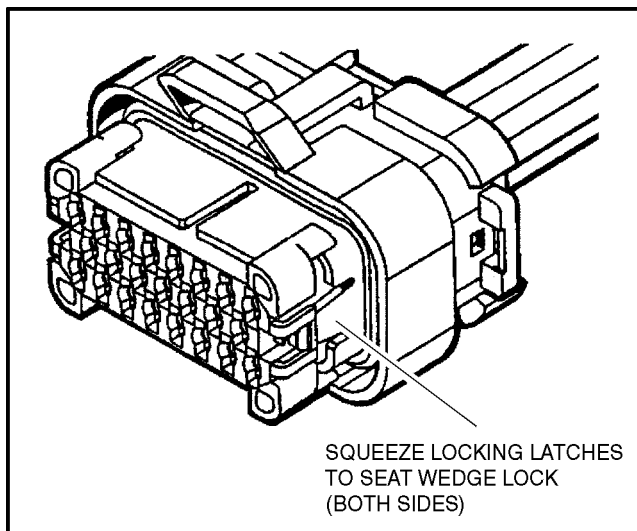

Figure 7-8. Connector Assembly (3 of 4)

4. Slide the wedge lock into the housing until it is flush with the housing (See Figure 7-9., Connector Assembly (4 of 4)).

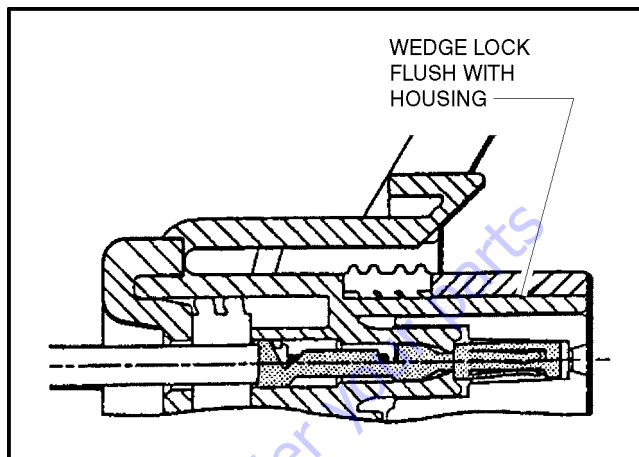

Figure 7-9. Connector Assembly (4 of 4)

Disassembly

1. Insert a 4.8 mm (3/16 in.) wide screwdriver blade between the mating seal and one of the red wedge lock tabs.
2. Pry open the wedge lock to the open position.
3. While rotating the wire back and forth over a half turn (1/4 turn in each direction), gently pull the wire until the contact is removed.

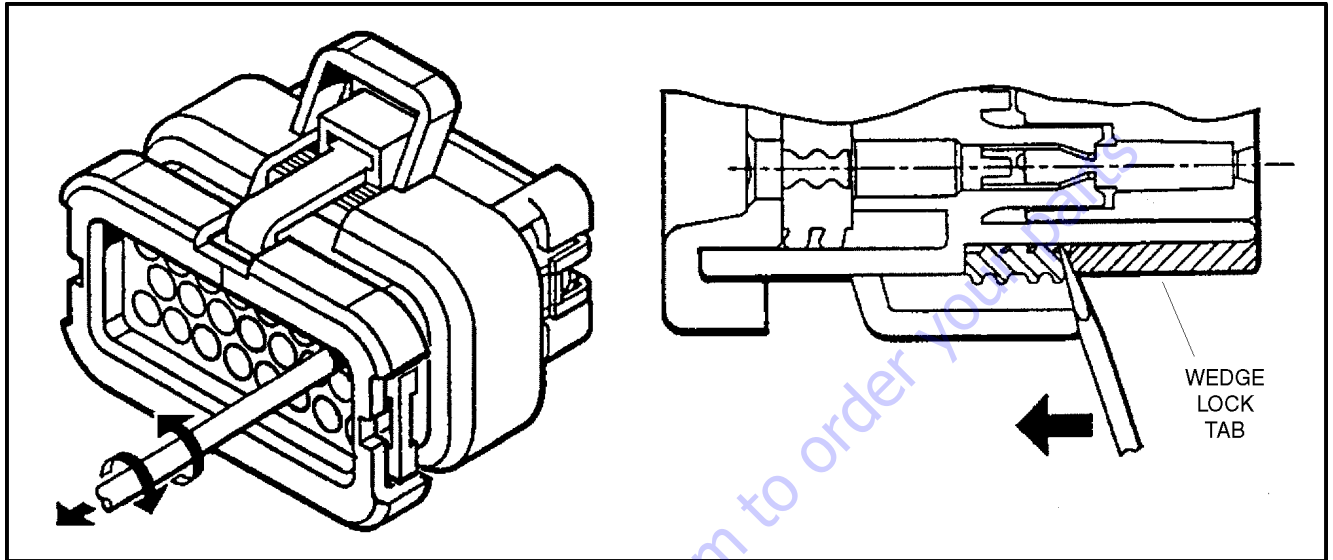

Figure 7-10. Connector Disassembly

NOTE: The wedge lock should never be removed from the housing for insertion or removal of the contacts.

Wedge Lock

The wedge lock has slotted openings in the forward, or mating end. These slots accommodate circuit testing in the field, by using a flat probe such as a pocket knife. DO NOT use a sharp point such as an ice pick.

Service - Voltage Reading

CAUTION

DO NOT PIERCE WIRE INSULATION TO TAKE VOLTAGE READINGS.

It has been common practice in electrical troubleshooting to probe wires by piercing the insulation with a

sharp point. This practice should be discouraged when dealing with the AMP SEAL plug assembly, or any other sealed connector system. The resulting pinholes in the insulation will allow moisture to invade the system by traveling along the wire strands. This nullifies the effectiveness of the connector seals and could result in system failure.

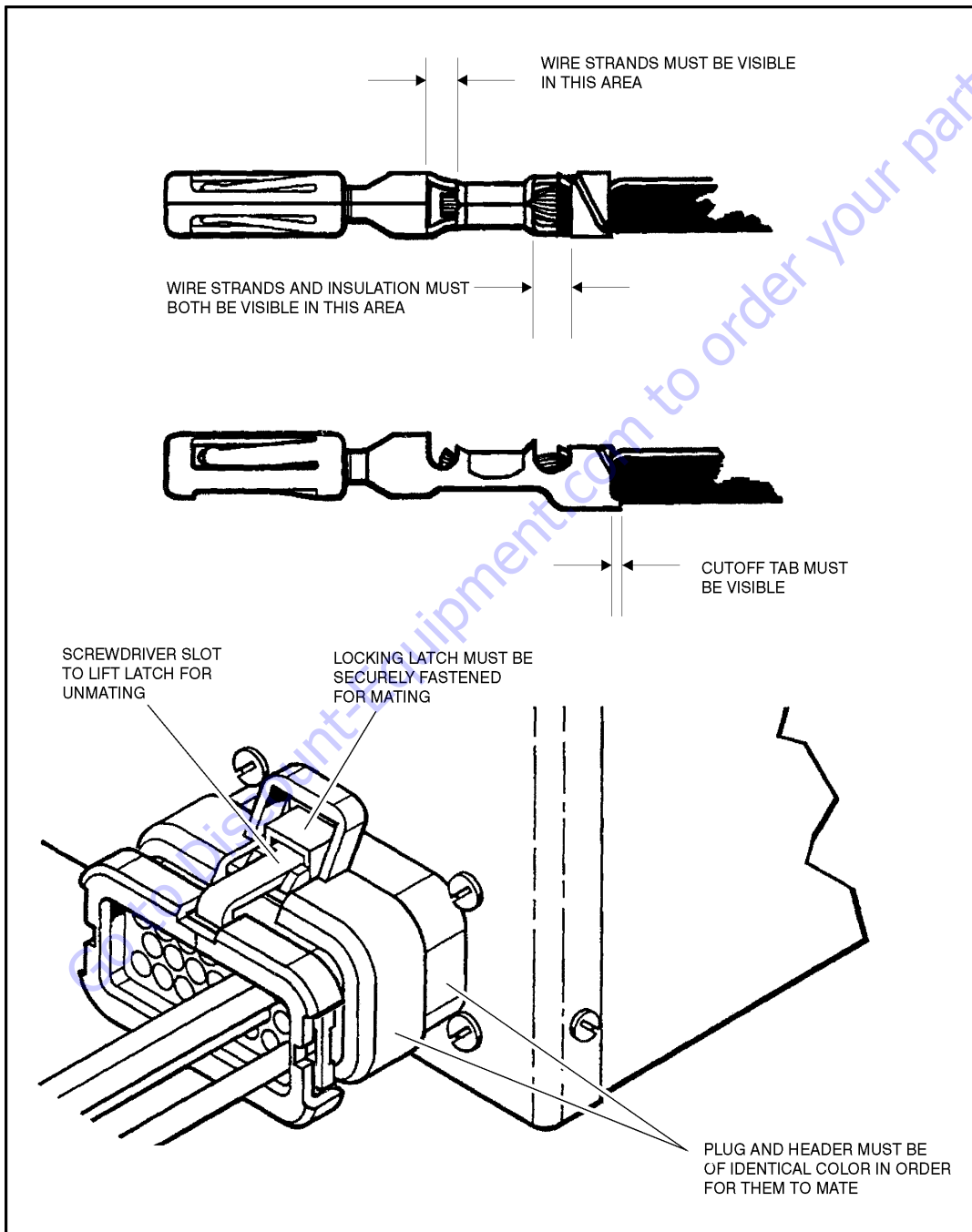

Figure 7-11. Connector Installation

7.6 WORKING WITH DEUTSCH CONNECTORS

DT/DTP Series Assembly

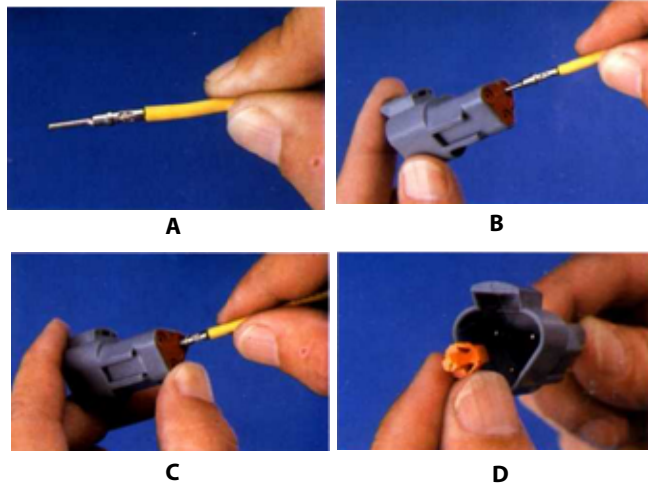

Figure 7-12. DT/DTP Contact Installation

1. Grasp crimped contact about 25 mm behind the contact barrel.
2. Hold connector with rear grommet facing you.
3. Push contact straight into connector grommet until a click is felt. A slight tug will confirm that it is properly locked in place.
4. Once all contacts are in place, insert wedgelock with arrow pointing toward exterior locking mechanism. The wedgelock will snap into place. Rectangular wedges are not oriented. They may go in either way.

NOTE: The receptacle is shown - use the same procedure for plug.

DT/DTP Series Disassembly

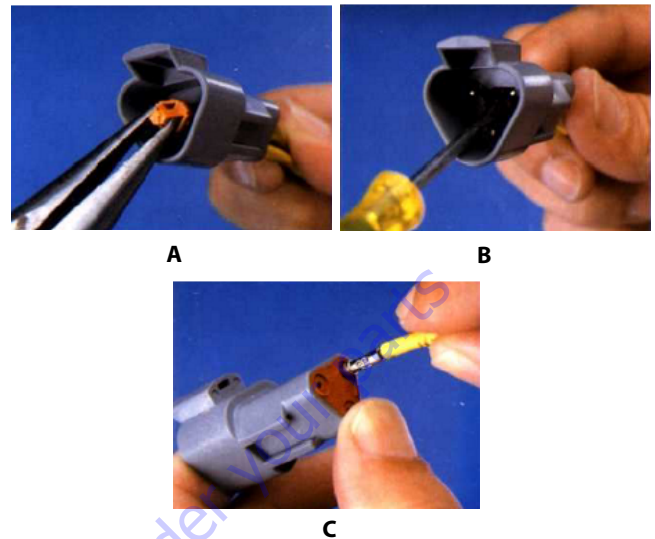

Figure 7-13. DT/DTP Contact Removal

1. Remove wedgelock using needlenose pliers or a hook shaped wire to pull wedge straight out.
2. To remove the contacts, gently pull wire backwards, while at the same time releasing the locking finger by moving it away from the contact with a screwdriver.
3. Hold the rear seal in place, as removing the contact may displace the seal.

HD30/HDP20 Series Assembly

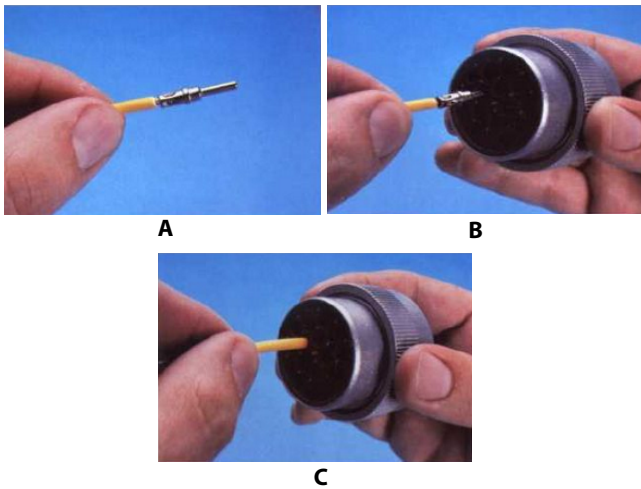

Figure 7-14. HD/HDP Contact Installation

1. Grasp contact about 25 mm behind the contact crimp barrel.
2. Hold connector with rear grommet facing you.
3. Push contact straight into connector grommet until a positive stop is felt. A slight tug will confirm that it is properly locked in place.

CONTACT

Figure 7-15. HD/HDP Locking Contacts Into Position

NOTE: For unused wire cavities, insert sealing plugs for full environmental sealing.

HD30/HDP20 Series Disassembly

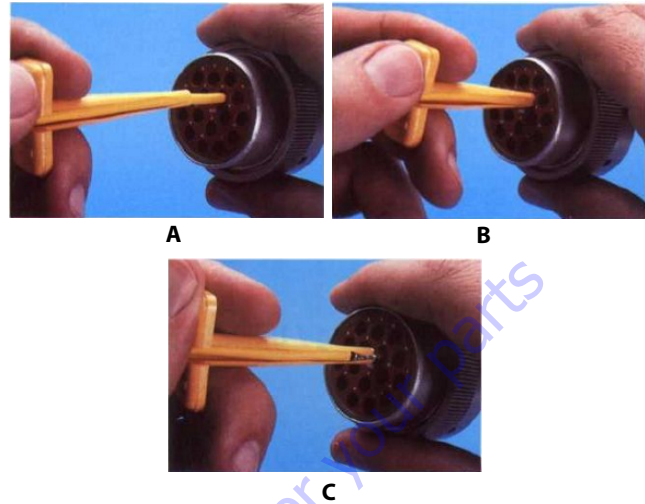

Figure 7-16. HD/HDP Contact Removal

1. With rear insert toward you, snap appropriate size extractor tool over the wire of contact to be removed.
2. Slide tool along into the insert cavity until it engages contact and resistance is felt.
3. Pull contact-wire assembly out of connector.

CONTACT REMOVAL

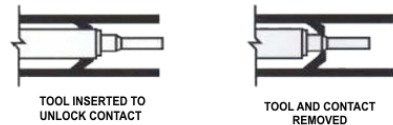

Figure 7-17. HD/HDP Unlocking Contacts

NOTE: Do Not twist or insert tool at an angle.

7.7 SWITCHES

Basic Check

The following check determines if the switch is functioning properly, not the circuit in which the switch is placed. A switch is functioning properly when there is continuity between the correct terminals or contacts only when selected.

1. De-energize the circuit.
2. Isolate the switch from the rest of the circuit if possible. If not possible, keep in mind it may affect readings.
3. Access the terminals to the switch.
4. If the switch has two terminals:
 - a. Measure resistance across the terminals.
 - b. Change the switch position.
 - c. Measure resistance again with the leads in the same positions. If the meter was reading short, it should read an open. If the meter was reading open it should read short.
5. If the switch has more than two terminals, consult the schematic or switch diagram to determine what terminals will be connected. The test is similar to testing a switch with two terminals.
 - a. Place one meter lead on the common contact and the other on a different contact in the same circuit.
 - b. Cycle through all positions of the switch. The meter should read short only when the switch connects the two terminals and open otherwise.
 - c. If the switch has more than one common contact repeat the process for that circuit.

Limit Switches

Limit switches are used to control movement or indicate position. Mechanical limit switches are just like manually operated switches except that the moving object operates the switch. These switches can be tested the same way as a standard switch by manually operating the sensing arm.

Another type of limit switch used by JLG is the inductive proximity switch, also referred to as a "prox switch". Inductive proximity switches are actuated only by ferrous metal (metal that contains Iron, such as steel) near the switch. They do not require contact, and must be energized to actuate. These types of switches can be used to detect boom or platform position, for example. These switches have a sensing face where the switch can detect ferrous metal close to it. To find the sensing face, take note how the switch is mounted and how the mechanisms meet the switch. Test this type of switch as follows:

1. Remove prox switch from its mount.
2. Reconnect harness if it was disconnected for step a, and turn on machine.
3. Hold switch away from metal and observe switch state in the control system diagnostics using the Analyzer. See vehicle or control system documentation on how to do this.
4. Place sensing face of switch on the object to be sensed by the switch. If that is not available, use a piece of ferrous metal physically similar to it. The switch state in the control system diagnostics should change.
5. When reinstalling or replacing switch be sure to follow mounting instructions and properly set the gap between the switch and object sensed.

Automatic Switches

If the switch is actuated automatically, by temperature or pressure for example, find a way to manually actuate the switch to test it. Do this either by applying heat or pressure, for example, to the switch. These switches may need to be energized to actuate.

1. Connect instrumentation to monitor and/or control the parameter the switch is measuring.
2. Observe switch state in control system with the Analyzer. See vehicle or control system documentation on how to do this.
3. Operate system such that the switch actuates. This could be going over a certain pressure or temperature, for example. The state indicated in the control system should change.

Switch Wiring - Low Side, High Side

When controlling a load, a switch can be wired between the positive side of the power source and the load. This switch is called a "high side" switch. The switch supplies the power to the load. When a switch is wired between the negative side of the power source and the load, it is a "low side" switch. The switch provides the ground to the load.

A low side switch will allow voltage to be present on the load. No power is applied because the switch is stopping current flow. This voltage can be seen if the measurement is taken with one test lead on the load and the other on the battery negative side or grounded to the vehicle. What is actually being measured is the voltage drop across the switch. This could mislead a technician into thinking the load is receiving power but not operating. To produce an accurate picture of power or voltage applied to the load, measure voltage across the load's power terminals. Also, the technician can measure the voltage at both power terminals with respect to batteryground. The difference between those two measurements is the voltage applied to the load.

Go to Discount-Equipment.com for more information

7.8 ELECTRICAL SCHEMATICS

330/430LRT ELECTRICAL SCHEMATIC

SHEET 2: PLATFORM CONTROL BOX
HARNESS, PLATFORM BOX

SHEET 3: PLATFORM MODULE & OPTIONS
HARNESS, PLATFORM I/O MODULE
HARNESS, SOFT TOUCH OPTION

SHEET 4: ARM STACK & BATTERY CABLES
CABLE, ARM STACK, PROPORTIONAL LIFT
CABLE, ARM STACK, HOLD VALVE
CABLE, ARM STACK, PLATFORM CONTROL,330LRT
CABLE, ARM STACK, PLATFORM CONTROL,430LRT
CABLE, BATTERY KIT

SHEET 5: GROUND CONTROL BOX
HARNESS, GROUND CONTROL BOX TILT SENSOR
HARNESS, GROUND CONTROL BOX

SHEET 6: CHASSIS
HARNESS, CHASSIS

SHEET 7: DIESEL ENGINE & DUAL FUEL ENGINE
HARNESS, ENGINE, DIESEL
HARNESS, ENGINE, DUAL FUEL
WIRE, 10 GA FUSIBLE LINK

SHEET 8: LEVELING JACKS OPTION
HARNESS, LEVELING JACKS OPTION

SHEET 9: GENERATOR & LIGHTING OPTIONS
HARNESS, 7500W GEN CONTROL
CABLE, 7500W GEN POWER, 330LRT
CABLE, 7500W GEN POWER, 430LRT
HARNESS, BOX SWITCH
HARNESS, HEAD/TAIL LIGHTS
HARNESS, WORK LIGHTS
HARNESS, FLOOD LIGHT SWITCH

SHEET 10: LOAD SENSE, HYD OIL COOLER
HARNESS, LOAD SENSE
HARNESS, HYD OIL COOLER

SHEET 1

1001236135-D
MAF03890D

Figure 7-18. Electrical Schematic - Sheet 1 of 10

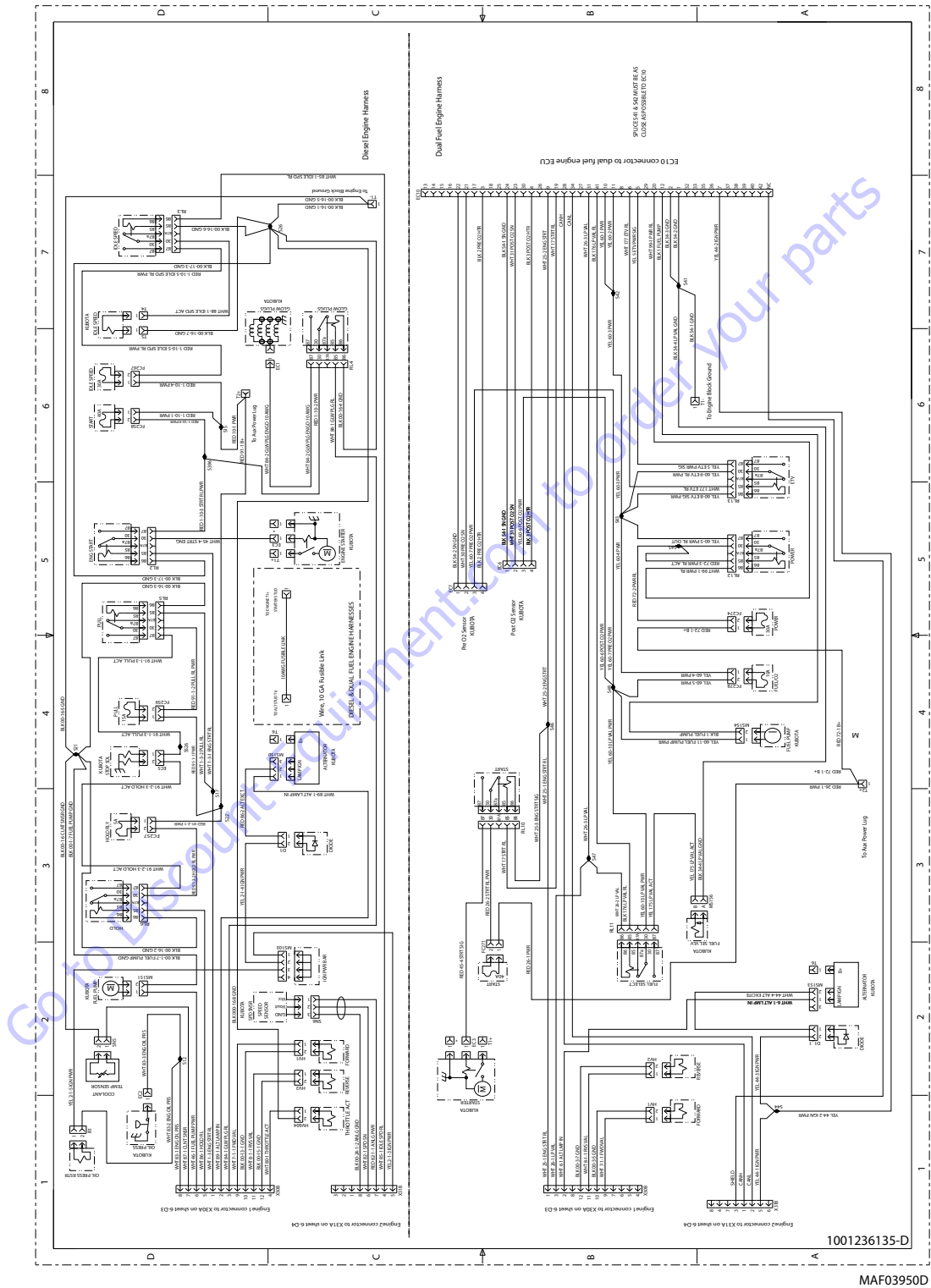

Figure 7-24. Electrical Schematic - Sheet 7 of 10

SECTION 7 - GENERAL ELECTRICAL INFORMATION & SCHEMATICS

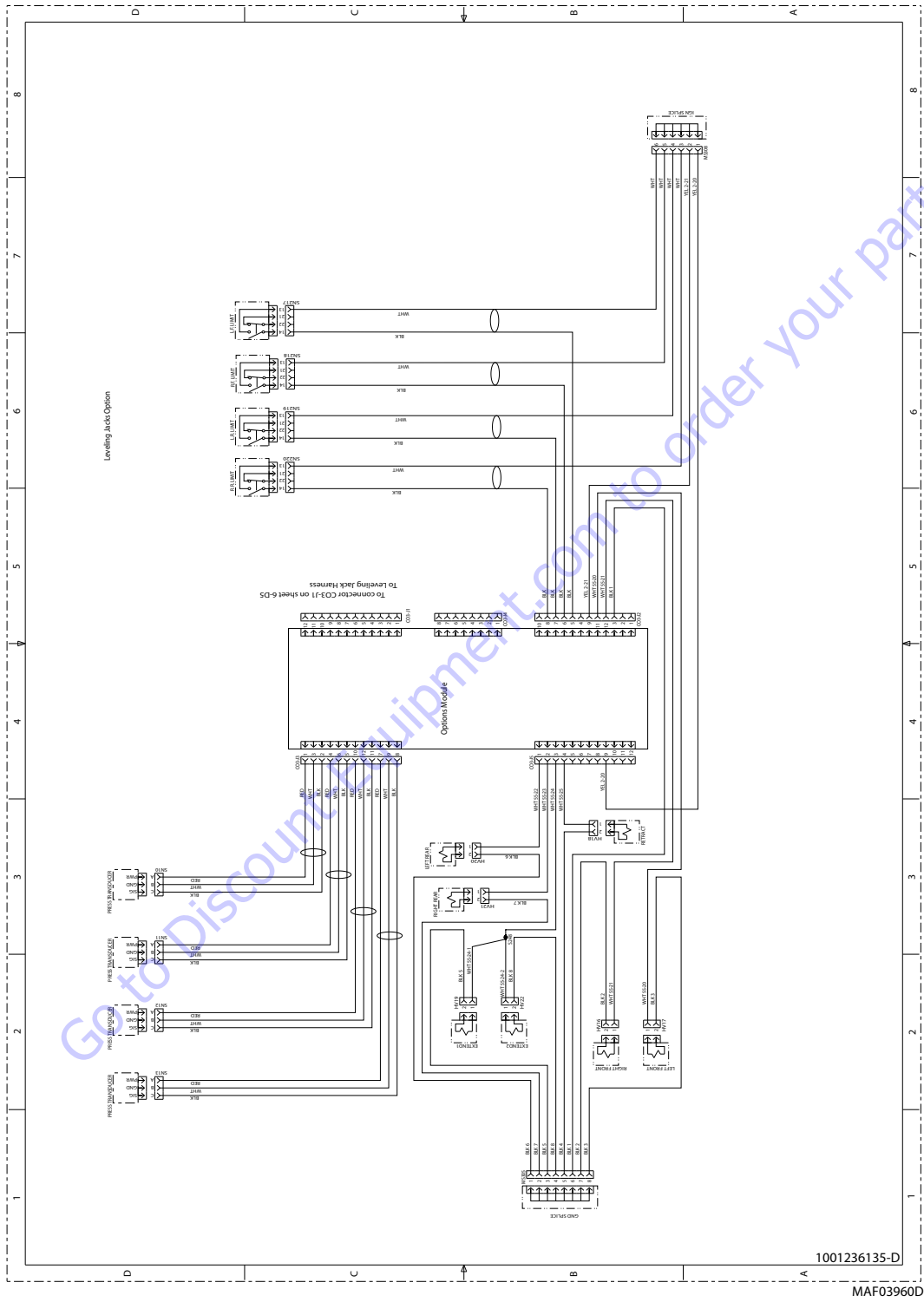

Figure 7-25. Electrical Schematic - Sheet 8 of 10

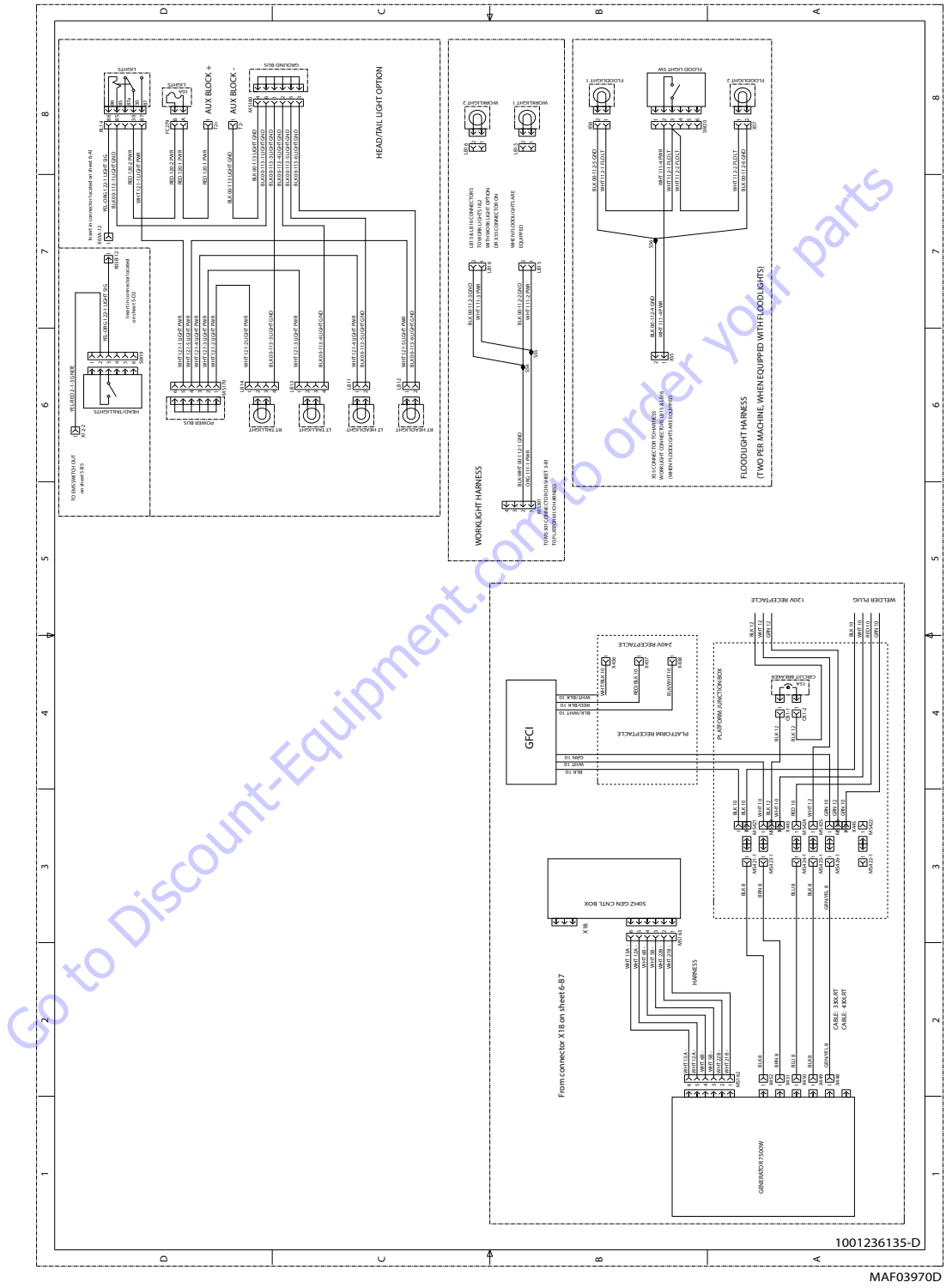

Figure 7-26. Electrical Schematic - Sheet 9 of 10

SECTION 7 - GENERAL ELECTRICAL INFORMATION & SCHEMATICS

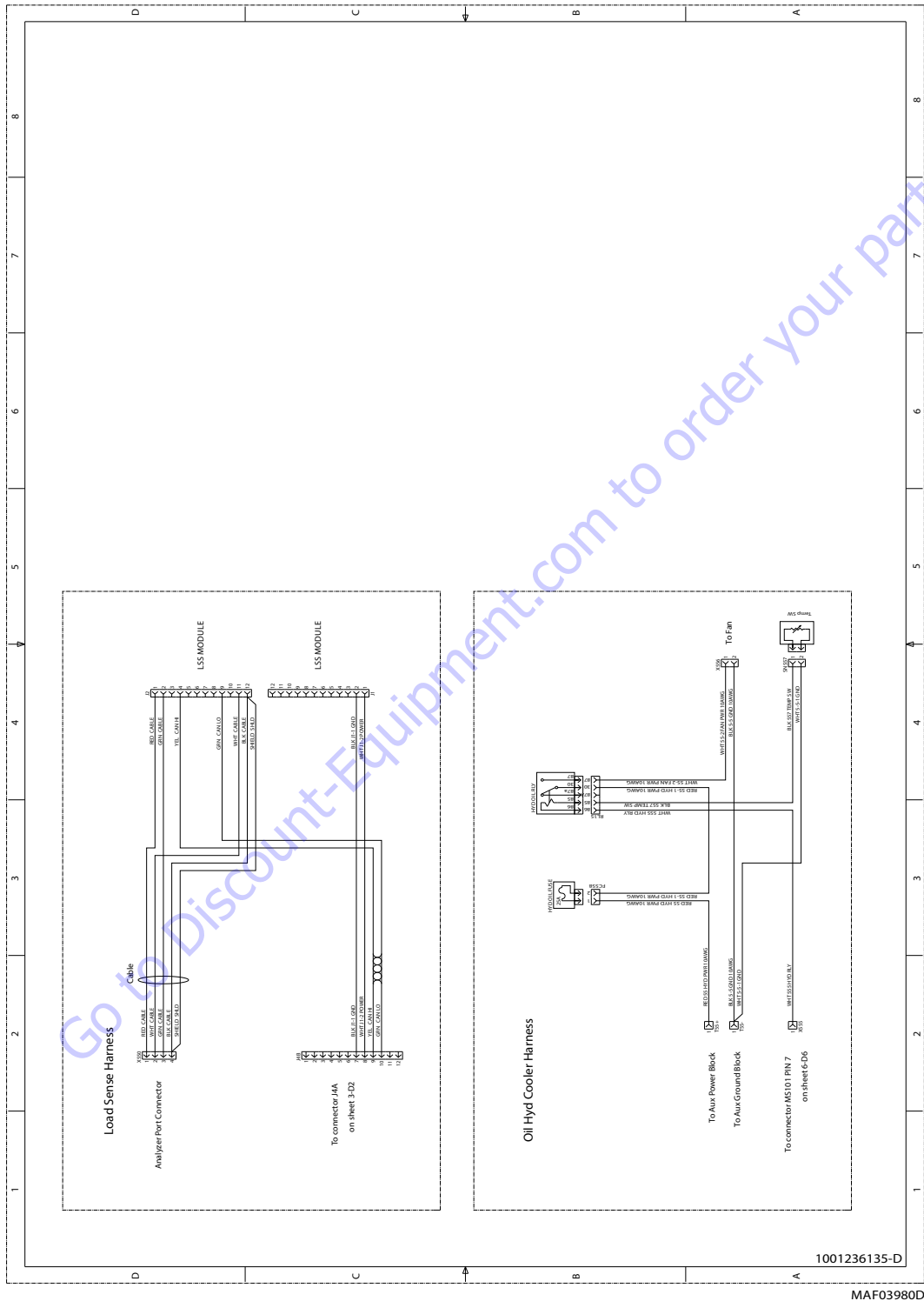

Figure 7-27. Electrical Schematic - Sheet 10 of 10

PARTS FINDER

**Search Website
by Part Number**



**Search Manual
Library For Parts
Manual & Lookup Part
Numbers – Purchase
or Request Quote**

Search Manuals

Enter your information to search for manuals and parts.

* Brand:

* Model:

* Serial:

* Part Number:

SEARCH

**Can't Find Part or
Manual? Request Help
by Manufacturer,
Model & Description**

Parts Order Form

Please fill in the following information:

Manufacturer:

Model:

Description:

Quantity:

Part Number:

Part Name:

Part Description:

Part Location:

Part Condition:

Part Status:

Part Material:

Part Color:

Part Weight:

Part Dimensions:

Part Price:

Part Notes:

Submit

Discount-Equipment.com is your online resource for quality parts & equipment.

Florida: **561-964-4949** Outside Florida TOLL FREE: **877-690-3101**

Need parts?

Click on this link: <http://www.discount-equipment.com/category/5443-parts/> and choose one of the options to help get the right parts and equipment you are looking for. Please have the machine model and serial number available in order to help us get you the correct parts. If you don't find the part on the website or on once of the online manuals, please fill out the request form and one of our experienced staff members will get back to you with a quote for the right part that your machine needs.

We sell worldwide for the brands: Genie, Terex, JLG, MultiQuip, Mikasa, Essick, Whiteman, Mayco, Toro Stone, Diamond Products, Generac Magnum, Airman, Haulotte, Barreto, Power Blanket, Nifty Lift, Atlas Copco, Chicago Pneumatic, Allmand, Miller Curber, Skyjack, Lull, Skytrak, Tsurumi, Husquvarna Target, , Stow, Wacker, Sakai, Mi-T- M, Sullair, Basic, Dynapac, MBW, Weber, Bartell, Bennar Newman, Haulotte, Ditch Runner, Menegotti, Morrison, Contec, Buddy, Crown, Edco, Wyco, Bomag, Laymor, Barreto, EZ Trench, Bil-Jax, F.S. Curtis, Gehl Pavers, Heli, Honda, ICS/PowerGrit, IHI, Partner, Imer, Clipper, MMD, Koshin, Rice, CH&E, General Equipment, ,AMida, Coleman, NAC, Gradall, Square Shooter, Kent, Stanley, Tamco, Toku, Hatz, Kohler, Robin, Wisconsin, Northrock, Oztec, Toker TK, Rol-Air, Small Line, Wanco, Yanmar

JLG[®]

An Oshkosh Corporation Company

**Discount
Equipment**

www.Discount-Equipment.com

Go to Discount-Equipment.com to order your parts