



An Oshkosh Corporation Company



www.Discount-Equipment.com

Operation and Safety Manual

Original Instructions - Keep this manual with the machine at all times.

Model
260MRT
PVC 2004

ANSI   **AS/NZS**

31217128
January 31, 2020 - Rev A

TO PURCHASE THIS PRODUCT PLEASE CONTACT US



**Equipment Financing and
Extended Warranties Available**



**Discount-Equipment.com is your online resource for
commercial and industrial quality parts and equipment sales.**

561-964-4949

visit us on line @ www.discount-equipment.com

Select an option below to find your Equipment

Search by Manufacturer

Search by Product Type

Request a Quote

We sell worldwide for the brands: Genie, Terex, JLG, MultiQuip, Mikasa, Essick, Whiteman, Mayco, Toro Stone, Diamond Products, Generac Magnum, Airman, Haulotte, Barreto, Power Blanket, Nifty Lift, Atlas Copco, Chicago Pneumatic, Allmand, Miller Curber, Skyjack, Lull, Skytrak, Tsurumi, Husquvarna Target, Stow, Wacker, Sakai, Mi-T-M, Sullair, Basic, Dynapac, MBW, Weber, Bartell, Bennar Newman, Haulotte, Ditch Runner, Menegotti, Morrison, Contec, Buddy, Crown, Edco, Wyco, Bomag, Laymor, EZ Trench, Bil-Jax, F.S. Curtis, Gehl Pavers, Heli, Honda, ICS/PowerGrit, IHI, Partner, Imer, Clipper, MMD, Koshin, Rice, CH&E, General Equipment, Amida, Coleman, NAC, Gradall, Square Shooter, Kent, Stanley, Tamco, Toku, Hatz, Kohler, Robin, Wisconsin, Northrock, Oztec, Toker TK, Rol-Air, APT, Wylie, Ingersoll Rand / Doosan, Innovatech, Con X, Ammann, Mecalac, Makinex, Smith Surface Prep, Small Line, Wanco, Yanmar



WARNING

Operating, servicing and maintaining this vehicle or equipment can expose you to chemicals including engine exhaust, carbon monoxide, phthalates, and lead, which are known to the State of California to cause cancer and birth defects or other reproductive harm. To minimize exposure, avoid breathing exhaust, do not idle the engine except as necessary, service your vehicle or equipment in a well-ventilated area and wear gloves or wash your hands frequently when servicing. For more information go to www.P65Warnings.ca.gov.

FOREWORD

The Mobile Elevating Work Platform (MEWP) models covered in this manual are designed and tested to meet or exceed various compliance standards. Please refer to the manufacturer's nameplate affixed to the subject MEWP for specific standard compliance information.

This manual is a very important tool! Keep it with the machine at all times.

The purpose of this manual is to provide owners, users, operators, lessors, and lessees with the precautions and operating procedures essential for the safe and proper machine operation for its intended purpose.

Due to continuous product improvements, JLG Industries, Inc. reserves the right to make specification changes without prior notification. Contact JLG Industries, Inc. for updated information.

Refer to www.JLG.com for Warranty, Product Registration, and other machine-related documentation.

SAFETY ALERT SYMBOLS AND SAFETY SIGNAL WORDS



THIS IS THE SAFETY ALERT SYMBOL. IT IS USED TO ALERT YOU TO THE POTENTIAL PERSONAL INJURY HAZARDS. OBEY ALL SAFETY MESSAGES THAT FOLLOW THIS SYMBOL TO AVOID POSSIBLE INJURY OR DEATH.

DANGER

INDICATES AN IMMINENTLY HAZARDOUS SITUATION. IF NOT AVOIDED, WILL RESULT IN SERIOUS INJURY OR DEATH. THIS DECAL WILL HAVE A RED BACKGROUND.

WARNING

INDICATES A POTENTIALLY HAZARDOUS SITUATION. IF NOT AVOIDED, COULD RESULT IN SERIOUS INJURY OR DEATH. THIS DECAL WILL HAVE AN ORANGE BACKGROUND.

CAUTION

INDICATES A POTENTIALLY HAZARDOUS SITUATION. IF NOT AVOIDED, MAY RESULT IN MINOR OR MODERATE INJURY. IT MAY ALSO ALERT AGAINST UNSAFE PRACTICES. THIS DECAL WILL HAVE A YELLOW BACKGROUND.

NOTICE

INDICATES INFORMATION OR A COMPANY POLICY THAT RELATES DIRECTLY OR INDIRECTLY TO THE SAFETY OF PERSONNEL OR PROTECTION OF PROPERTY.

REVISION LOG

Original Issue A - January 31, 2020

To order go to Discount-Equipment.com

SECTION - 1 - SAFETY PRECAUTIONS

1.1 GENERAL 1-1

1.2 PRE-OPERATION 1-1

 Operator Training and Knowledge 1-1

 Workplace Inspection 1-2

 Machine Inspection 1-2

1.3 OPERATION 1-3

 General 1-3

 Trip and Fall Hazards 1-4

 Electrocution Hazards 1-5

 Tipping Hazards 1-6

 Crushing and Collision Hazards 1-9

1.4 TOWING, LIFTING, AND HAULING 1-10

1.5 MAINTENANCE 1-10

 General 1-10

 Maintenance Hazards 1-10

 Battery Hazards 1-11

SECTION - 2 - USER RESPONSIBILITIES, MACHINE PREPARATION, AND INSPECTION

2.1 PERSONNEL TRAINING 2-1

 Operator Training 2-1

 Training Supervision 2-1

 Operator Responsibility 2-1

 Machine Familiarization 2-2

2.2 PREPARATION, INSPECTION, AND MAINTENANCE 2-2

 Inspection and Maintenance Table 2-3

2.3 PRE-START INSPECTION 2-4

2.4 WALK-AROUND INSPECTION 2-5

2.5 FUNCTION CHECK 2-8

2.6 DUAL FUEL SYSTEM (IF EQUIPPED) 2-9

SECTION - 3 - MACHINE CONTROLS, INDICATORS, AND MACHINE OPERATION

3.1 GENERAL 3-1

3.2 DESCRIPTION 3-1

3.3 OPERATING CHARACTERISTICS AND LIMITATIONS 3-2

 Placards 3-2

 Capacities 3-2

 Stability 3-2

3.4 PLATFORM LOADING 3-2

3.5 CONTROLS AND INDICATORS 3-3

 Ground Control Station 3-3

 Platform Control Station 3-6

 Platform Control Front Panel 3-9

 Indicator Panel LEDs 3-11

3.6 ENGINE OPERATION 3-13

 Power Selector Switch 3-13

 Emergency Stop Switch 3-13

 Starting Procedure 3-13

3.7 OPERATING CHARACTERISTICS 3-14

 Leveling Jacks 3-14

 Auto Leveling 3-14

 Manual Level Adjustment (Trim) 3-15

TABLE OF CONTENTS

3.8	PLATFORM	3-16
	Platform Loading.....	3-16
	Raising.....	3-16
	Lowering.....	3-17
	Platform Extension	3-17
3.9	DRIVING.....	3-18
	Steering.....	3-19
	Driving Forward.....	3-19
	Driving in Reverse	3-19
3.10	PARKING AND STOWING	3-21
3.11	TIE DOWN	3-21
	Lifting.....	3-21
3.12	TOWING.....	3-22
3.13	PLATFORM RAILS - FOLD-DOWN PROCEDURE.....	3-24
3.14	DECALS	3-28
	ANSI, ANSI Export, CSA	3-28
	CE, AUS	3-32

SECTION - 4 - EMERGENCY PROCEDURES

4.1	GENERAL.....	4-1
	Manual Descent.....	4-1
4.2	EMERGENCY OPERATION.....	4-2
	Operator Unable to Control Machine.....	4-2
	Platform Caught Overhead	4-2
	Righting of Tipped Machine	4-3
	Post-Incident Inspection	4-3
4.3	INCIDENT NOTIFICATION.....	4-3

SECTION - 5 - ACCESSORIES

5.1	1/2 AIRLINE.....	5-2
5.2	PLATFORM WORKLIGHTS	5-2
5.3	PLATFORM RAIL PADDING	5-3
	With Deck Bumpers	5-3

SECTION - 6 - GENERAL SPECIFICATIONS AND OPERATOR MAINTENANCE

6.1	INTRODUCTION.....	6-1
6.2	SPECIFICATIONS	6-2
	Operating Specifications	6-2
	Platform Capacity	6-2
	Dimensional Data	6-3
	Batteries	6-3
	Tires	6-3
	Capacities.....	6-3
	Lubrication.....	6-5
6.3	OPERATOR MAINTENANCE.....	6-8
	Safety Prop.....	6-8
	Inspection Check Points	6-9
6.4	TIRES AND WHEELS	6-11
	Tire Damage	6-11
	Tire Replacement.....	6-11
	Wheel Replacement	6-12
	Wheel Installation	6-12
6.5	SUPPLEMENTAL INFORMATION	6-13

SECTION - 7 - INSPECTION AND REPAIR LOG

LIST OF FIGURES

2-1. Walk Around Inspection Diagram..... 2-5
3-1. Grade and Sideslope Depiction..... 3-20
3-2. Lifting Chart 3-23
3-3. Platform Rails - Fold Down Sequence - Front/Rear
Rails 3-25
3-4. Platform Rails - Fold Down Sequence - Deck Extension Side
Rails..... 3-26
3-5. Platform Rails - Fold Down Sequence - Main Platform Side
Rails..... 3-27
6-1. Engine Operating Temperature Specifications (Kubota)- .
Sheet 1 of 26-6
6-2. Engine Operating Temperature Specifications (Kubota)- .
Sheet 2 of 26-7

LIST OF TABLES

Minimum Approach Distances (M.A.D.) 1-6
Beaufort Scale (For Reference Only)..... 1-7
Tilt Activation Setting 2-8
Available Accessories..... 5-1

SECTION 1. SAFETY PRECAUTIONS

1.1 GENERAL

This section outlines the necessary precautions for proper and safe machine usage and maintenance. In order to promote proper machine usage, it is mandatory that a daily routine is established based on the content of this manual. A maintenance program, using the information provided in this manual and the Service and Maintenance Manual, must also be established by a qualified person and must be followed to ensure that the machine is safe to operate.

The owner/user/operator/lessor/lessee of the machine should not accept operating responsibility until this manual has been read, training is accomplished, and operation of the machine has been completed under the supervision of an experienced and qualified operator.

These sections contain the responsibilities of the owner, user, operator, lessor, and lessee concerning safety, training, inspection, maintenance, application, and operation. If there are any questions with regard to safety, training, inspection, maintenance, application, and operation, please contact JLG Industries, Inc. ("JLG").

WARNING

FAILURE TO COMPLY WITH THE SAFETY PRECAUTIONS LISTED IN THIS MANUAL COULD RESULT IN MACHINE DAMAGE, PROPERTY DAMAGE, PERSONAL INJURY OR DEATH.

1.2 PRE-OPERATION

Operator Training and Knowledge

- Read, understand, and study the Operation and Safety Manual in its entirety before operating the machine. For clarification, questions, or additional information regarding any portions of this manual, contact JLG Industries, Inc.

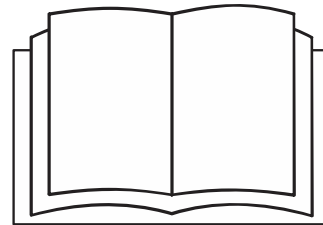

- Only personnel who have received proper training regarding the inspection, application, and operation of MEWPs (including recognition and avoiding hazards associated with their operation) shall be authorized to operate a MEWP.
- Only properly trained personnel who have received unit-specific familiarization shall operate a MEWP. The user shall determine if personnel are qualified to operate the MEWP prior to operation.

SECTION 1 - SAFETY PRECAUTIONS

- Read, understand, and obey all DANGERS, WARNINGS, CAUTIONS, and operating instructions on the machine and in this manual.
- Ensure that the machine is to be used in a manner which is within the scope of its intended application as determined by JLG.
- All operating personnel must have a thorough understanding of the intended purpose and function of the MEWP controls, including platform, ground, and emergency descent controls.
- Read, understand, and obey all applicable employer, local, and governmental regulations as they pertain to your utilization and application of the machine.

Workplace Inspection

- Precautions to avoid all hazards in the work area must be taken by the user before operation of the machine.
- Do not operate or raise the platform from a position on trucks, trailers, railway cars, floating vessels, scaffolds or other equipment unless the application is approved in writing by JLG.
- Before operation, check work area for overhead hazards such as electric lines, bridge cranes, and other potential overhead obstructions.
- Check operating surfaces for holes, bumps, drop-offs, obstructions, debris, concealed holes, and other potential hazards.
- Check the work area for hazardous locations. Do not operate the machine in hazardous environments unless approved for that purpose by JLG.

- Ensure that the ground conditions are adequate to support the maximum tire load indicated on the tire load decals located on the chassis adjacent to each wheel.

Machine Inspection

- Do not operate this machine until the inspections and functional checks have been performed as specified in Section 2 of this manual.
- Do not operate this machine until it has been serviced and maintained according to the maintenance and inspection requirements as specified in the machine's Service and Maintenance Manual.
- Ensure all safety devices are operating properly. Modification of these devices is a safety violation.

WARNING

MODIFICATION OR ALTERATION OF A MEWP SHALL BE MADE ONLY WITH PRIOR WRITTEN PERMISSION FROM THE MANUFACTURER

- Do not operate any machine on which the safety or instruction placards or decals are missing or illegible.
- Check the machine for modifications to original components. Ensure that any modifications have been approved by JLG.
- Avoid accumulation of debris on platform floor. Keep mud, oil, grease, and other slippery substances from footwear and platform floor.

1.3 OPERATION

General

- Machine operation requires your full attention. Bring the machine to a full stop before using any device, i.e. cell phones, two-way radios, etc. that will distract your attention from safely operating the machine.
- Do not use the machine for any purpose other than positioning personnel, their tools, and equipment.
- Before operation, the user must be familiar with the machine capabilities and operating characteristics of all functions.
- Never operate a malfunctioning machine. If a malfunction occurs, shut down the machine. Remove the unit from service and notify the proper authorities.
- Do not remove, modify, or disable any safety devices.
- Never slam a control switch or lever through neutral to an opposite direction. Always return switch to neutral and stop before moving the switch to the next function. Operate controls with slow and even pressure.
- Do not allow personnel to tamper with or operate the machine from the ground with personnel in the platform, except in an emergency.
- Do not carry materials directly on platform railing unless approved by JLG.
- When two or more persons are in the platform, the operator shall be responsible for all machine operations.
- Always ensure that power tools are properly stowed and never left hanging by their cord from the platform work area.
- Do not assist a stuck or disabled machine by pushing or pulling except by pulling at the chassis tie-down lugs.
- Fully lower platform and shut off all power before leaving machine.
- Remove all rings, watches, and jewelry when operating machine. Do not wear loose fitting clothing or long hair unrestrained which may become caught or entangled in equipment.
- Persons under the influence of drugs or alcohol or who are subject to seizures, dizziness or loss of physical control must not operate this machine.
- Hydraulic cylinders are subject to thermal expansion and contraction. This may result in changes to the platform position while the machine is stationary. Factors affecting thermal movement can include the length of time the machine will remain stationary, hydraulic oil temperature, ambient air temperature, and platform position.

Trip and Fall Hazards

- Prior to operation, ensure all gates and rails are fastened and secured in their proper position.

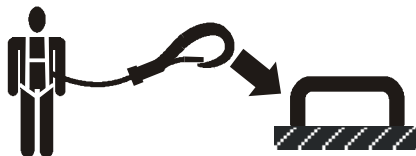

- JLG Industries, Inc. recommends that all persons in the platform wear a full body harness with a lanyard attached to an authorized lanyard anchorage point while operating this machine. For further information regarding fall protection requirements on JLG products, contact JLG Industries, Inc.
- Identify the designated lanyard anchorage point(s) at the platform and securely attach the lanyard. Attach only one (1) lanyard per lanyard anchorage point.
- Enter and exit only through gate area. Use extreme caution when entering or leaving the platform. Ensure that the platform assembly is fully lowered. Face the machine when entering or leaving the platform. Always maintain "three point contact" with the machine, using two hands and one foot or two feet and one hand at all times during entry and exit.

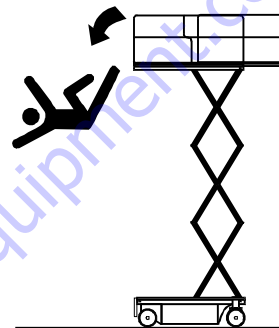

- Keep both feet firmly positioned on the platform floor at all times. Never position ladders, boxes, steps, planks, or similar items on unit to provide additional reach for any purpose.
- Never use the scissor arm assembly to gain access to or leave the platform.
- Keep oil, mud, and slippery substances cleaned from footwear and the platform floor.

Electrocution Hazards

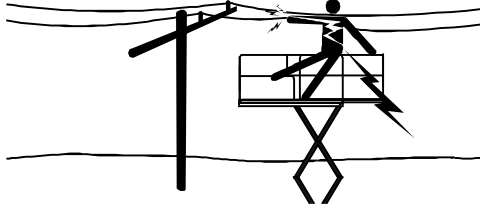

- This machine is not insulated and does not provide protection from contact or proximity to electrical current.
- Maintain safe clearance from electrical lines, apparatus, or any energized (exposed or insulated) parts in accordance with the Minimum Approach Distance (MAD) as specified in Table 1-1.
- Allow for machine movement and electrical line swaying.
- Maintain a clearance of at least 10 ft (3 m) between any part of the machine and its occupants, their tools, and their equipment from any electrical line or apparatus carrying up to 50,000 volts. One foot additional clearance is required for every additional 30,000 volts or less.

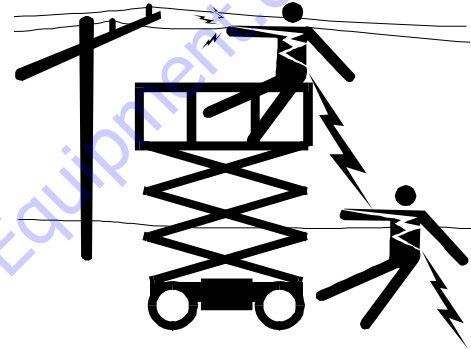

- The minimum approach distance may be reduced if insulating barriers are installed to prevent contact, and the barriers are rated for the voltage of the line being guarded. These barriers shall not be part of (or attached to) the machine. The minimum approach distance shall be reduced to a distance within the designed working dimensions of the insulating barrier. This determination shall be made by a qualified person in accordance with the employer, local, or governmental requirements for work practices near energized equipment.

⚠ DANGER

DO NOT MANEUVER MACHINE OR PERSONNEL INSIDE PROHIBITED ZONE (MAD). ASSUME ALL ELECTRICAL PARTS AND WIRING ARE ENERGIZED UNLESS KNOWN OTHERWISE.

SECTION 1 - SAFETY PRECAUTIONS

Table 1-1. Minimum Approach Distances (M.A.D.)

Voltage Range (Phase to Phase)	MINIMUM APPROACH DISTANCE in Feet (Meters)
0 to 50KV	10 (3)
Over 50 kV to 200 KV	15 (5)
Over 200KV to 350 KV	20 (6)
Over 350 KV to 500 KV	25 (8)
Over 500 KV to 750 KV	35 (11)
Over 750 KV to 1000 KV	45 (14)
NOTE:	<i>This requirement shall apply except where employer, local or governmental regulations are more stringent.</i>

Tipping Hazards

- Ensure that the ground conditions are adequate to support the maximum tire load indicated on the tire load decals located on the chassis adjacent to each wheel. Do not travel on unsupported surfaces.
- The user must be familiar with the operating surface before driving. Do not exceed the allowable sideslope and grade while driving
- Do not elevate platform or drive with platform elevated while on or near a sloping, uneven, or soft surface. Ensure machine is positioned on a smooth, firm surface within the limits of the maximum operating slope before elevating platform or driving with the platform in the elevated position.

- Before driving on floors, bridges, trucks, and other surfaces, check allowable capacity of the surfaces.
- Never exceed the maximum platform capacity as specified on the platform. Keep all loads within the confines of the platform, unless authorized by JLG.
- Keep the chassis of the machine a minimum of 0.6 m (2 ft) from holes, bumps, drop-offs, obstructions, debris, concealed holes, and other potential hazards at the ground level.
- Do not operate the machine when wind conditions exceed specifications shown in Section 6.2 or as shown on the capacity placard on the platform billboard. Factors affecting wind speed are; platform elevation, surrounding structures, local weather events, and approaching storms.
- Wind speed can be significantly greater at height than at ground level.
- Wind speed can change rapidly. Always consider approaching weather events, the time required to lower the platform, and methods to monitor current and potential wind conditions.
- Do not cover or increase surface area of the platform or the load. Do not carry large surface area items in the platform when operating outdoors. The addition of such items increases the exposed wind area of the machine. Increased areas exposed to wind will decrease stability.
- Do not increase the platform size with unauthorized modifications, deck extensions, or attachments.

⚠ WARNING

DO NOT OPERATE THE MACHINE WHEN WIND CONDITIONS EXCEED SPECIFICATIONS SHOWN IN SECTION 6.2 OR AS SHOWN ON THE CAPACITY PLACARD ON THE PLATFORM BILLBOARD.

Table 1-2. Beaufort Scale (For Reference Only)

Beaufort Number	Wind Speed		Description	Land Conditions
	mph	m/s		
0	0	0-0.2	Calm	Calm. Smoke rises vertically
1	1-3	0.3-1.5	Light air	Wind motion visible in smoke
2	4-7	1.6-3.3	Light breeze	Wind felt on exposed skin. Leaves rustle
3	8-12	3.4-5.4	Gentle breeze	Leaves and smaller twigs in constant motion
4	13-18	5.5-7.9	Moderate breeze	Dust and loose paper raised. Small branches begin to move.
5	19-24	8.0-10.7	Fresh breeze	Smaller trees sway.
6	25-31	10.8-13.8	Strong breeze	Large branches in motion. Whistling heard in overhead wires. Umbrella use becomes difficult.
7	32-38	13.9-17.1	Near Gale/Moderate Gale	Whole trees in motion. Effort needed to walk against the wind.
8	39-46	17.2-20.7	Fresh Gale	Twigs broken from trees. Cars veer on road.
9	47-54	20.8-24.4	Strong Gale	Light structure damage.

SECTION 1 - SAFETY PRECAUTIONS

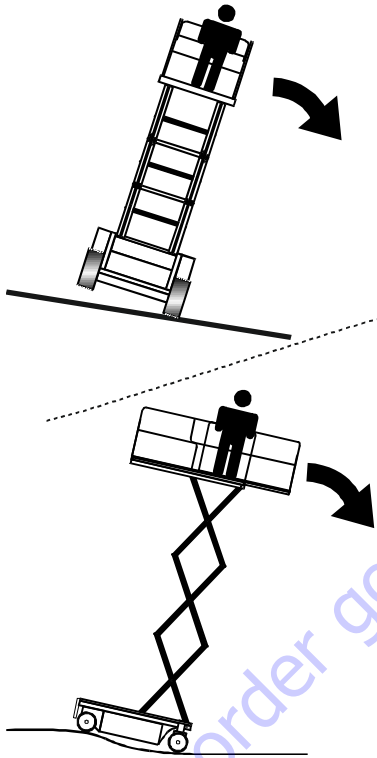

- Never attempt to use the machine as a crane. Do not tie-off machine to any adjacent structure. Never attach wire, cable, or any similar items to platform.
- If scissor arm assembly or platform is caught so that one or more wheels are off the ground, all persons must be removed before attempting to free the machine. Use cranes, forklift trucks, or other appropriate equipment to stabilize machine.

Crushing and Collision Hazards

- Approved head gear must be worn by all operating and ground personnel.
- Keep hands and limbs out of the scissor arm assembly during operation.
- Watch for obstructions around machine and overhead when driving. Check clearances above, on sides, and bottom of platform when lifting or lowering platform.

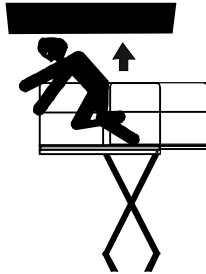

- During operation, keep all body parts inside platform railing.
- Always post a lookout when driving in areas where vision is obstructed.
- Keep non-operating personnel at least 6 ft (1.8 m) away from machine during all driving operations.
- Under all travel conditions, the operator must limit travel speed according to conditions of ground surface, congestion, visibility, slope, location of personnel, and other factors causing hazards of collision or injury to personnel.

- Be aware of stopping distances in all drive speeds. When driving in high speed, reduce drive speed before stopping. Travel grades in low speed only.
- Do not use high speed drive in restricted or close quarters or when driving in reverse.
- Exercise extreme caution at all times to prevent obstacles from striking or interfering with operating controls and persons in the platform.
- Ensure that operators of other overhead and floor level machines are aware of the MEWP's presence. Disconnect power to overhead cranes. Barricade floor area if necessary.
- Do not operate over ground personnel. Warn personnel not to work, stand, or walk under a raised platform. Position barricades on floor as necessary.

⚠ WARNING

IF DRIVING MACHINE WITH THE PLATFORM CONTROL STATION FROM GROUND, DO NOT HANG THE CONTROL BOX ON ANY PART OF THE MACHINE WHILE DRIVING. HOLD THE CONTROL BOX AND KEEP AT LEAST 3 FT (1 M) DISTANCE FROM MACHINE.

1.4 TOWING, LIFTING, AND HAULING

- Never allow personnel in platform while towing, lifting, or hauling.
- This machine should not be towed, except in the event of emergency, malfunction, power failure, or loading/unloading. Refer to emergency towing procedures.
- Ensure platform is fully retracted and completely empty of tools prior to towing, lifting or hauling.
- When lifting machine with a forklift, position forks only at designated areas of the machine. Lift with a forklift of adequate capacity.
- Refer to Section 4 for lifting information.

1.5 MAINTENANCE

General

This section contains general safety precautions which must be observed during maintenance of this machine. Additional precautions to be observed during machine maintenance are inserted at the appropriate points in this manual and in the Service and Maintenance Manual. It is of utmost importance that maintenance personnel pay strict attention to these precautions to avoid possible injury to personnel or damage to the machine or property. A maintenance program must be established by a qualified person and must be followed to ensure that the machine is safe.

Maintenance Hazards

- Shut off power to all controls and ensure that all operating systems are secured from inadvertent motion prior to performing any adjustments or repairs.
- Never work under an elevated platform until it has been fully lowered to the full down position, if possible, or otherwise supported and restrained from movement with appropriate safety props, blocking, or overhead supports.
- DO NOT attempt to repair or tighten any hydraulic hoses or fittings while the machine is powered on or when the hydraulic system is under pressure.

- Always relieve hydraulic pressure from all hydraulic circuits before loosening or removing hydraulic components.
- DO NOT use your hand to check for leaks. Use a piece of cardboard or paper to search for leaks. Wear gloves to help protect hands from spraying fluid.
- Use only replacement parts or components that are approved by JLG. To be considered approved, replacement parts or components must be identical or equivalent to original parts or components.
- Never attempt to move heavy parts without the aid of a mechanical device. Do not allow heavy objects to rest in an unstable position. Ensure adequate support is provided when raising components of the machine.
- Use only approved non-flammable cleaning solvents.
- Do not replace items critical to stability, such as batteries or tires, with items of different weight or specification. Do not modify unit in any way to affect stability.
- Refer to the Service and Maintenance Manual for the weights of critical stability items.



Battery Hazards

- Always disconnect batteries when servicing electrical components or when performing welding on the machine.
- Do not allow smoking, open flame, or sparks near battery during charging or servicing.
- Do not contact tools or other metal objects across the battery terminals.
- Always wear hand, eye, and face protection when servicing batteries. Ensure that battery acid does not come in contact with skin or clothing.

WARNING

BATTERY FLUID IS HIGHLY CORROSIVE. AVOID CONTACT WITH SKIN AND CLOTHING AT ALL TIMES. IMMEDIATELY RINSE ANY CONTACTED AREA WITH CLEAN WATER AND SEEK MEDICAL ATTENTION.

- Charge batteries only in a well-ventilated area.
- Avoid overfilling the battery fluid level. Add distilled water to batteries only after the batteries are fully charged.

WARNING

MODIFICATION OR ALTERATION OF A MEWP SHALL BE MADE ONLY WITH PRIOR WRITTEN PERMISSION FROM THE MANUFACTURER.

SECTION 1 - SAFETY PRECAUTIONS



NOTES:

A series of horizontal lines for taking notes, organized into two columns. The left column contains 15 lines, and the right column contains 15 lines. A large, light blue watermark is oriented diagonally across the page, reading "To order go to Discount-Equipment.com".

Machine Familiarization

NOTE: *Responsibilities for familiarization may vary by region.*

Only properly trained personnel who have received unit-specific familiarization shall operate a MEWP. The user shall determine if personnel are qualified to operate the MEWP prior to operation. The user shall ensure that after familiarization, the operator operates the MEWP for a sufficient period of time to achieve proficiency. When authorized by the user, self-familiarization can be achieved, if authorized, by a properly trained operator reading, understanding and following the manufacturer's operator's manual.

Prior to users authorization of an operator to use a specific model of MEWP, the user shall ensure the operator is familiarized on the following:

1. Location of the manual storage compartment and the requirement to ensure the required manual(s) are present on the MEWP;
2. Purpose and function of the machine controls and indicators at the platform and ground control stations;
3. Purpose, location, and function of the emergency controls;
4. Operating characteristics and limitations;
5. Features and devices;
6. Accessories and optional equipment.

2.2 PREPARATION, INSPECTION, AND MAINTENANCE

The following table covers the machine inspections and maintenance recommended by JLG Industries, Inc. Consult local regulations for further requirements for aerial work platforms. The frequency of inspections and maintenance must be increased as necessary when the machine is used in a harsh or hostile environment, if the machine is used with increased frequency, or if the machine is used in a severe manner.

SECTION 2 - USER RESPONSIBILITIES, MACHINE PREPARATION, AND INSPECTION

Inspection and Maintenance Table

Type	Frequency	Primary Responsibility	Service Qualification	Reference
Pre-Start Inspection	Before using each day; or whenever there's an Operator change.	User or Operator	User or Operator	Operator and Safety Manual
Pre-Delivery Inspection (See Note)	Before each sale, lease, or rental delivery.	Owner, Dealer, or User	Qualified JLG Mechanic	Service and Maintenance Manual and applicable JLG inspection form
Frequent Inspection	In service for 3 months or 150 hours, whichever comes first; or Out of service for a period of more than 3 months; or Purchased used.	Owner, Dealer, or User	Qualified JLG Mechanic	Service and Maintenance Manual and applicable JLG inspection form
Annual Machine Inspection (See Note)	Annually, no later than 13 months from the date of prior inspection.	Owner, Dealer, or User	Factory-Trained Service Technician (Recommended)	Service and Maintenance Manual and applicable JLG inspection form
Preventative Maintenance	At intervals as specified in the Service and Maintenance Manual.	Owner, Dealer, or User	Qualified JLG Mechanic	Service and Maintenance Manual

NOTE: Inspection forms are available from JLG. Use the Service and Maintenance Manual to perform inspections.

NOTICE

JLG INDUSTRIES, INC. RECOGNIZES A FACTORY-TRAINED SERVICE TECHNICIAN AS A PERSON WHO HAS SUCCESSFULLY COMPLETED THE JLG SERVICE TRAINING SCHOOL FOR THE SPECIFIC JLG PRODUCT MODEL.

SECTION 2 - USER RESPONSIBILITIES, MACHINE PREPARATION, AND INSPECTION

2.3 PRE-START INSPECTION

The Pre-Start Inspection should include each of the following:

1. **Cleanliness** – Check all surfaces for leakage (oil, fuel, or battery fluid) or foreign objects. Report any leakage to the proper maintenance personnel.
2. **Structure** – Inspect the machine structure for dents, damage, weld or parent metal cracks or other discrepancies.

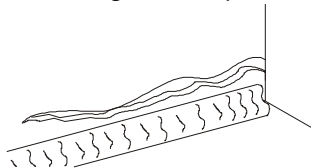

Parent Metal Crack

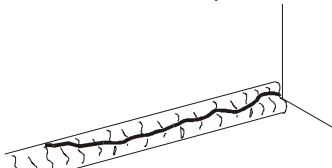

Weld Crack

2. **Decals and Placards** – Check all for cleanliness and legibility. Make sure none of the decals and placards are missing. Make sure all illegible decals and placards are cleaned or replaced.
3. **Operation and Safety Manuals** – Ensure a copy of the Operation and Safety Manual, AEM Safety Manual (ANSI markets only), and ANSI Manual of Responsibilities (ANSI markets only) are enclosed in the weather-resistant storage box.
4. **Walk-Around Inspection** – Perform as instructed.
5. **Battery** – Charge as required.

6. **Fuel** – (Combustion Engine Powered Machines) – Add the proper fuel as necessary.
7. **Engine Oil Supply** – Ensure that the engine oil level is at the full mark on the dipstick and the filler cap is secure
8. **Fluid Levels** – Be sure to check the engine oil and the hydraulic oil levels.
9. **Accessories/Attachments** – Refer to the Accessories section in this manual or the accessory installed upon the machine for specific inspection, operation, and maintenance instructions.
10. **Function Check** – Once the Walk-Around Inspection is complete, perform a functional check of all systems in an area free of overhead and ground level obstructions. Refer to Section 4 for more specific instructions on the operation of each function.
11. **Platform Gate** – Keep gate and surrounding area clean and unobstructed. Check that gate closes properly and is not bent or damaged. Keep gate closed at all times except when entering/exiting the platform and loading/unloading materials.
12. **Lanyard Anchorage Points** – JLG Industries, Inc. recommends personnel in the platform wear a full body harness with a lanyard attached to an authorized lanyard anchorage point.

WARNING

IF THE MACHINE DOES NOT OPERATE PROPERLY, TURN OFF THE MACHINE IMMEDIATELY! REPORT THE PROBLEM TO THE PROPER MAINTENANCE PERSONNEL. DO NOT OPERATE THE MACHINE UNTIL IT IS DECLARED SAFE FOR OPERATION.

2.4 WALK-AROUND INSPECTION

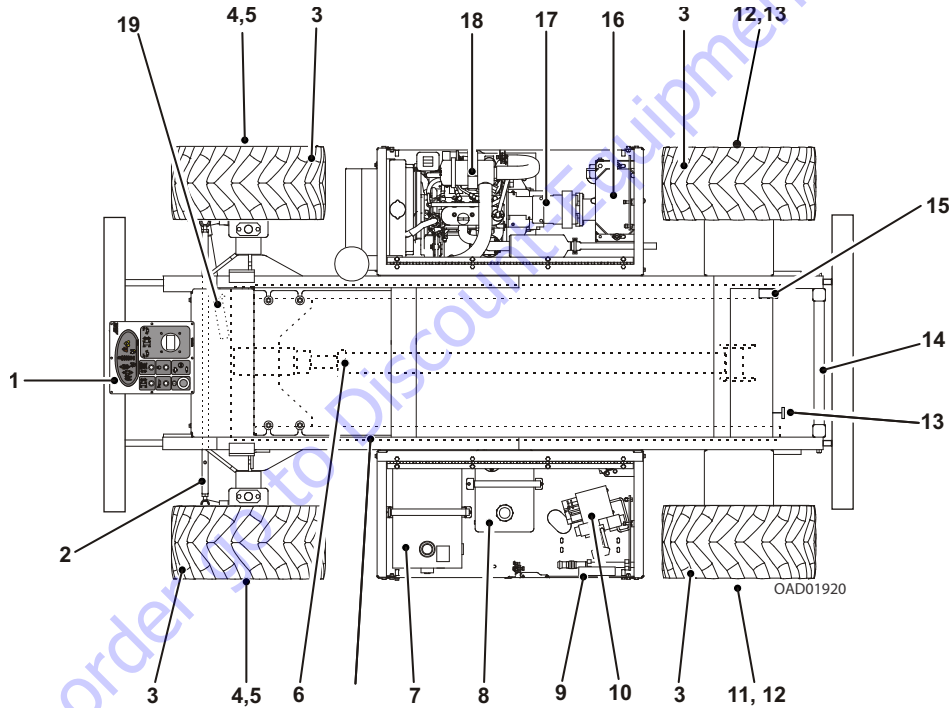

SECTION 2 - USER RESPONSIBILITIES, MACHINE PREPARATION, AND INSPECTION

Begin the Walk-Around Inspection at Item 1, as noted on the diagram. Continue to the right (counterclockwise viewed from top) checking each item in sequence for the conditions listed in the following checklist.

WARNING

TO AVOID POSSIBLE INJURY, BE SURE MACHINE POWER IS "OFF" DURING WALK-AROUND INSPECTION.

NOTICE

DO NOT OVERLOOK VISUAL INSPECTION OF CHASSIS UNDERSIDE. CHECKING THIS AREA OFTEN RESULTS IN DISCOVERY OF CONDITIONS WHICH COULD CAUSE EXTENSIVE MACHINE DAMAGE.

NOTE: *On each item, make sure there are no loose or missing parts, that they are securely fastened, and that no visible damage exists in addition to any other criteria mentioned.*

- 1. Platform Controls** - Properly secured, no loose or missing parts, no visible damage. Placards secure and legible, control switches return to neutral when activated and released, emergency stop switch functions properly. Control markings legible, manual in manual storage box.
- 2. Steer Linkage** - See Note.
- 3. Wheels and Tires** - Properly secured, no missing lug nuts. Refer to section 6, Tires and Wheels. Inspect wheels for damage and corrosion.
- 4. Drive Motor, Left Front (4 Wheel Drive)** - See Note. No evidence of leakage.
- 5. Drive Brake, Left Front (4 Wheel Drive)** - See Note. No evidence of leakage.

SECTION 2 - USER RESPONSIBILITIES, MACHINE PREPARATION, AND INSPECTION

6. **Lift Cylinder** - See Note.
7. **Fuel Tank (Gasoline or Diesel Engine)** - Filler cap secure, sight gauge visible, no damage or leaks.
8. **Hydraulic Tank** - Filler cap secure, sight gauge visible, no damage or leaks.
9. **Ground Controls** - Placard secure and legible, control switches return to neutral position when activated and released, emergency stop switch functions properly. Control markings legible.
10. **Control Valve** - See Note.
11. **Drive Motor, Left Rear** - See Note.
12. **Drive Brake, Left Rear** - No loose or missing parts, no visible damage, no evidence of leakage.
13. **Manual Descent Cable and Pull Handle** - See Note.
14. **Ladder** - No damage, securely attached.
15. **Speed Cutout Switch** - No visible damage, properly secured.
16. **Battery Installation (Gasoline or Diesel Engine)** - Proper electrolyte level, cables secure, no damage or corrosion. Hold-downs secure.
17. **Hydraulic Pump** - Pump properly secured, no visible damage, no evidence of leakage. Hoses and fittings properly secured, no visible damage, no evidence of leaks.
18. **Engine Installation** - Engine oil to full mark on dipstick, oil filler cap secure. Muffler/exhaust system properly secured, no leakage. Air filter assembly secure, no loose or missing parts, element clean. Radiator cap secure, coolant to correct level.
19. **Steer Cylinder and Tie Rod Ends** - No loose or missing parts, no visible damage. No steer cylinder leaks or damage.
20. **Platform Assembly (Not Shown)** - See Note. Platform deck extension operates properly.

2.5 FUNCTION CHECK

Perform the Function Check as follows:

1. From the ground control panel with no load in the platform:
 - a. Check that all guards protecting switches are in place.
 - b. Operate all functions (refer to Section 3.5 for Ground Controls and Indicators).
 - c. Ensure that all machine functions are disabled when the Emergency Stop Button is activated.
 - d. Check that auxiliary descent, lift down operates with engine off and power on.

NOTE: *Be sure the platform extension is retracted before lowering.*

2. From the platform control console:
 - a. Ensure that the control console is firmly secured in the proper location.
 - b. Ensure that all guards protecting switches are in place.
 - c. Operate all switch functions, drive/lift mode select switch, and horn button.
 - d. Check the high drive cut out switch by raising the platform beyond the preset high drive speed cutout height of 90 - 96 in (2.3 - 2.4 m) and ensure the high drive speed cuts out.

- e. Ensure that all machine functions are disabled when the Emergency Stop Button is pushed in.
 - f. Ensure all machine functions stop when function control is released or when joystick trigger is released.
 - g. Ensure that all LEDs in the control box are working properly.
 - h. Check that the platform extension extends and retracts properly.
3. With the platform in the stowed position:
 - a. Drive the machine on a grade, not to exceed the rated gradeability, and stop to ensure the drive motor brakes hold.
 - b. Check the tilt indicator light to ensure proper operation. The light should be illuminated if tilted beyond allowed settings in Table 2-1.

Table 2-1. Tilt Activation Setting

All Markets		
Front to Back	Standard	5°
	Long Leveling Jacks Option (AUS Only)	6°
Side to Side		3°

2.6 DUAL FUEL SYSTEM (IF EQUIPPED)

⚠ CAUTION

IT IS POSSIBLE TO SWITCH FROM ONE FUEL SOURCE TO THE OTHER WITHOUT ALLOWING THE ENGINE TO STOP. EXTREME CARE MUST BE TAKEN AND THE FOLLOWING INSTRUCTIONS MUST BE FOLLOWED.

Changing from Gasoline to LP Gas.

1. Start the engine from the ground control station.
2. Open the hand valve on the LP Gas supply tank by turning counterclockwise.

⚠ CAUTION

BE SURE ALL GASOLINE IS EXHAUSTED BEFORE SWITCHING TO LP GAS.

3. While the engine is operating, place the LPG/GAS SELECT switch at the platform control station to the LP Gas position.

Changing from LP Gas to Gasoline.

1. With the engine operating on LP gas under a no load condition, position the LPG/GAS SELECT switch at the platform control station to the GAS SELECT position.
2. If the engine 'stumbles' because of a lack of gasoline, place the switch to the LPG position until the engine regains smoothness, then return the switch to the GAS SELECT position. Repeat as necessary until the engine runs smoothly on gasoline.

Close the hand valve on the LP gas supply tank by turning clockwise.

TO PURCHASE THIS PRODUCT PLEASE CONTACT US



**Equipment Financing and
Extended Warranties Available**



**Discount-Equipment.com is your online resource for
commercial and industrial quality parts and equipment sales.**

561-964-4949

visit us on line @ www.discount-equipment.com

Select an option below to find your Equipment

Search by Manufacturer

Search by Product Type

Request a Quote

We sell worldwide for the brands: Genie, Terex, JLG, MultiQuip, Mikasa, Essick, Whiteman, Mayco, Toro Stone, Diamond Products, Generac Magnum, Airman, Haulotte, Barreto, Power Blanket, Nifty Lift, Atlas Copco, Chicago Pneumatic, Allmand, Miller Curber, Skyjack, Lull, Skytrak, Tsurumi, Husquvarna Target, Stow, Wacker, Sakai, Mi-T-M, Sullair, Basic, Dynapac, MBW, Weber, Bartell, Bennar Newman, Haulotte, Ditch Runner, Menegotti, Morrison, Contec, Buddy, Crown, Edco, Wyco, Bomag, Laymor, EZ Trench, Bil-Jax, F.S. Curtis, Gehl Pavers, Heli, Honda, ICS/PowerGrit, IHI, Partner, Imer, Clipper, MMD, Koshin, Rice, CH&E, General Equipment, Amida, Coleman, NAC, Gradall, Square Shooter, Kent, Stanley, Tamco, Toku, Hatz, Kohler, Robin, Wisconsin, Northrock, Oztec, Toker TK, Rol-Air, APT, Wylie, Ingersoll Rand / Doosan, Innovatech, Con X, Ammann, Mecalac, Makinex, Smith Surface Prep, Small Line, Wanco, Yanmar

SECTION 3. MACHINE CONTROLS, INDICATORS, AND MACHINE OPERATION

3.1 GENERAL

NOTICE

THE MANUFACTURER HAS NO DIRECT CONTROL OVER MACHINE APPLICATION AND OPERATION, THE USER AND OPERATOR ARE RESPONSIBLE FOR CONFORMING WITH GOOD SAFETY PRACTICES.

This section provides the necessary information needed to understand machine controls, indicators, and operation.

⚠ WARNING

DO NOT RAISE PLATFORM EXCEPT ON A SMOOTH, FIRM SURFACE, WITHIN THE LIMITS OF THE MAXIMUM OPERATING SLOPE, FREE OF OBSTRUCTIONS AND HOLES.

TO AVOID SERIOUS INJURY, DO NOT OPERATE MACHINE IF ANY CONTROL LEVERS OR TOGGLE SWITCHES CONTROLLING PLATFORM MOVEMENT DO NOT RETURN TO THE OFF OR NEUTRAL POSITION WHEN RELEASED.

IF THE PLATFORM DOES NOT STOP WHEN A CONTROL SWITCH OR LEVER IS RELEASED, USE THE EMERGENCY STOP SWITCH TO STOP THE MACHINE.

3.2 DESCRIPTION

This machine is a Mobile Elevating Work Platform (MEWP) used to position personnel, along with their necessary tools and materials at work locations.

This MEWP has a primary operator control station in the platform. From this control station, the operator can drive and steer the machine in both forward and reverse directions, raise and lower the platform and set the machine leveling jacks.

The machine can be driven on a smooth, firm surface within the limits of the maximum operating slope from an elevated platform position.

The machine also has a ground control station that can override the platform control station. Ground controls operate lift up and down. Except for performing inspections and the function check, ground controls are to be used only in an emergency to lower the platform to the ground should the operator in the platform be unable to do so.

3.3 OPERATING CHARACTERISTICS AND LIMITATIONS

Placards

Important points to remember during operation are provided at the control stations by DANGER, WARNING, CAUTION, IMPORTANT and INSTRUCTION placards. This information is placed at various locations for the express purpose of alerting personnel of potential hazards constituted by the operating characteristics and load limitations of the machine. See foreword for definitions of the above placards.

Capacities

Raising platform above horizontal with or without any load in platform is based on the following criteria:

1. Machine is positioned on a smooth, firm surface within the limits of the maximum operating slope.
2. Load is within manufacturer's rated capacity.
3. All machine systems are functioning properly.

Stability

This machine, as originally manufactured by JLG and operated within its rated capacity on a smooth, firm surface, within the limits of the maximum operating slope, provides a stable aerial platform for all platform positions.

3.4 PLATFORM LOADING

The platform maximum rated load capacity is shown on a placard located on the platform billboard and is based upon the machine positioned on a smooth, firm surface, within the limits of the maximum operating slope. Refer to Section 6.2 for the maximum platform capacity.

The platform is entered through an entry gate at the rear of the platform. Keep gate closed at all times except when entering/exiting the platform and loading/unloading materials.

NOTE: *It is important to remember that the load should be evenly distributed on the platform. The load should be placed near the center of the platform when possible.*

3.5 CONTROLS AND INDICATORS

Ground Control Station

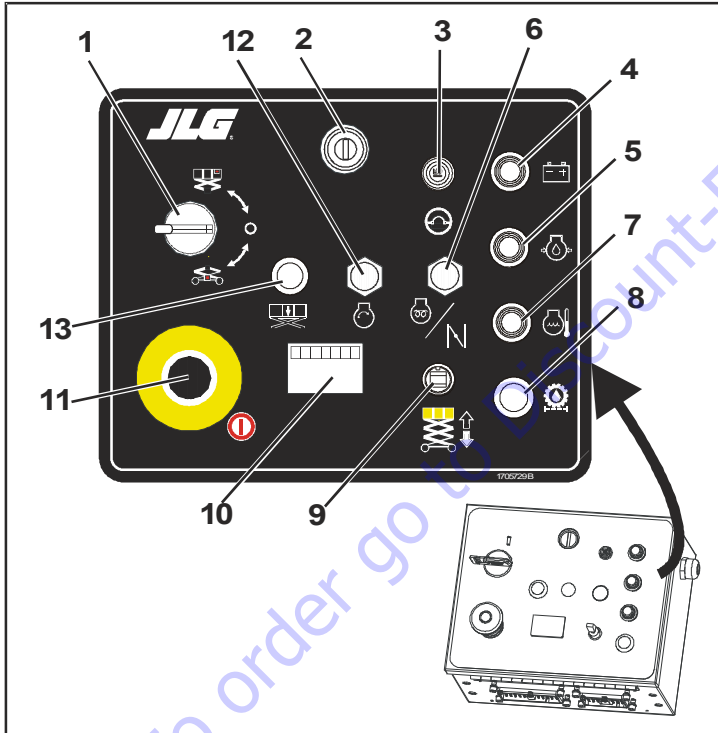

1. Ground/Platform/OFF Key Selector Switch
2. Latch
3. Circuit Breaker
4. Alternator LED
5. Oil Pressure LED
6. Glow Plug Switch
7. Coolant Temperature LED
8. Hydraulic Charge Pressure LED
9. Lift Switch
10. Hourmeter
11. Emergency Stop Switch
12. Start Switch
13. Overload Indicator (LSS)

SECTION 3 - MACHINE CONTROLS, INDICATORS, AND MACHINE OPERATION

WARNING

DO NOT OPERATE FROM GROUND CONTROL STATION WITH PERSONNEL IN THE PLATFORM EXCEPT IN AN EMERGENCY.

NOTE: When the machine is shut down for overnight parking or battery charging, the EMERGENCY STOP and POWER SELECTOR switches must be positioned to OFF to prevent draining the batteries.

- 1. Ground/Platform/OFF Key Selector Switch** - A three position, key-operated power selector switch supplies operating power to the platform or ground controls, as selected. When positioned to platform, the switch provides power to the emergency stop switch at the platform controls. When positioned to ground, the switch provides power to the emergency stop switch at the ground controls. With the power selector switch in the center off position, power is shut off to both platform and ground controls and the key can be removed to disable the machine.

NOTE: With the Power Selector switch in the off position, the key can be removed in order to incapacitate the machine on the jobsite to avoid unauthorized use of the machine.

With the POWER SELECTOR switch positioned to GROUND, ground functions will operate at low speed at all times.

NOTE: Low speed is the default speed for all functions. When the platform is elevated, all functions operate in creep speed only.

- 2. Latch** - Allows box to be opened and closed.
- 3. Circuit Breaker** - This 10 Amp circuit breaker, located on the left side of the platform control box, restores interrupted power to the platform controls.
- 4. Alternator LED** - Illuminates when the alternator drops below a pre-set level.
- 5. Oil Pressure LED** - Illuminates when the engine oil pressure drops below 7 psi (0.48 bar).
- 6. Glow Plug Switch (Diesel Engine Only)** - A momentary contact, push button type switch that supplies electrical power to the engine's glow plugs, when depressed, to assist cold starting.
- 7. Coolant Temperature LED** - Illuminates when engine coolant temperature becomes overheated.

SECTION 3 - MACHINE CONTROLS, INDICATORS, AND MACHINE OPERATION

8. **Charge Pressure** - Illuminates when the charge pressure drops below 70 psi (4.8 bar), indicating the charge filter is clogged and needs to be replaced. The indicator is also connected to a temperature sensor to prevent false signals from being generated when the hydraulic oil is below normal operating temperature.
9. **Lift Switch** - A three position, momentary contact Lift control switch provides raising and lowering of the platform when positioned to up or down.
10. **Hourmeter** - The machine may be equipped with an hourmeter to indicate the number of hours the machine has been operated.
11. **Emergency Stop Switch** - A two-position, red, mushroom-shaped ignition/emergency stop switch, when positioned to ON with the power selector switch positioned to ground, furnishes operating power to the ground control station. In addition, the switch can be used to turn off power to the function controls in the event of an emergency. Power is turned on by pulling the switch out (on), and is turned off by pushing the switch in (off).
12. **Start Switch** - A momentary contact, push button type switch that supplies electrical power to the starter solenoid when the emergency stop switch is in the ON position and the start button is depressed.
13. **Overload Indicator (LSS)** - The Overload Indicator indicates when the platform has been overloaded. An audible alarm will also signal when the platform is overloaded.

NOTE: *If the Overload Indicator is illuminated, all functions will be prevented from the platform controls. Using the ground controls or manual descent, fully lower the machine and reduce the weight in the platform so as to not exceed the rated workload indicated on the capacity decal.*

SECTION 3 - MACHINE CONTROLS, INDICATORS, AND MACHINE OPERATION

Platform Control Station

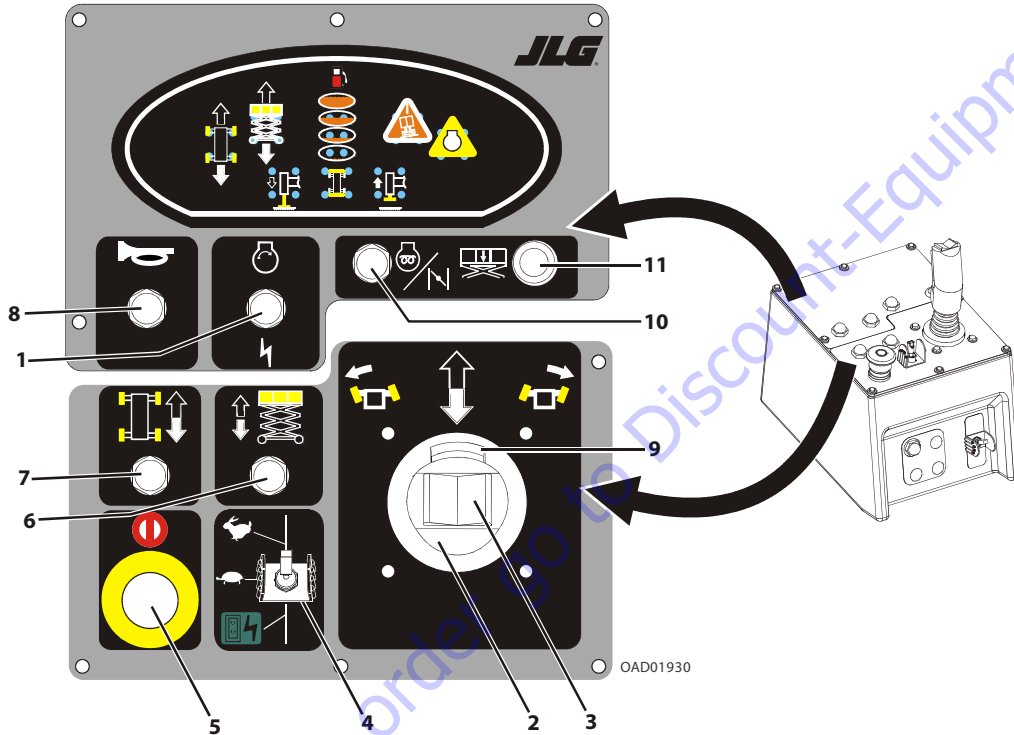

1. Start Switch
2. Joystick Controller
3. Steer Control Switch
4. Speed/Generator Switch
5. Emergency Stop Switch
6. Lift Select Switch
7. Drive Select Switch
8. Horn
9. Trigger (Enable) Switch
10. Glow Plug Switch
11. Overload Indicator (LSS)

SECTION 3 - MACHINE CONTROLS, INDICATORS, AND MACHINE OPERATION

1. **Start Switch** - A momentary contact, push button type switch that supplies electrical power to the starter solenoid when the emergency stop switch is in the on position and the start button is depressed.
2. **Joystick Controller** - The Joystick controls three functions: drive, lift, and drive/lift speed. The drive or the lift function switch must be selected prior to moving the machine with the Joystick. The speed is controlled by the travel distance of the Joystick.
3. **Steer Control Switch** - The thumb-operated steer switch on top of the Joystick handle activates the steer wheels in the direction it is moved (right or left).

4. **Speed/Generator Switch** - The three position speed/generator switch permits the operator to select either high range, low range or the generator (if equipped).

NOTE: *The machine cannot be lifted up from platform controls or driven when the generator is selected.*

*4 wheel drive is operational in **low drive** only.*

CAUTION

DO NOT USE HIGH ENGINE SPEED WHEN DRIVING IN CLOSE QUARTERS OR WHEN DRIVING IN REVERSE.

NOTE: *If machine is being operated in high range speed and the platform is raised above 90 - 96 in (2.3-2.4 m), the engine speed switch will cut out returning drive speed to low until the platform is again lowered below the cut out level.*

SECTION 3 - MACHINE CONTROLS, INDICATORS, AND MACHINE OPERATION

5. **Emergency Stop Switch** - A two-position, red, mushroom-shaped emergency stop switch functions to provide power to the platform control station and also to turn off power to the platform function controls in the event of an emergency. With the Power selector switch positioned to platform, power is turned on by pulling the switch out (on), and is turned off by pushing the switch in (off).

CAUTION

DO NOT LOWER WITHOUT COMPLETELY RETRACTING THE PLATFORM EXTENSION.

6. **Lift Select Switch** - The lift switch provides for raising and lowering the platform. Lift is activated by pressing the enable switch and positioning the joystick forward or backward.
7. **Drive Select Switch** - The drive switch provides for driving the lift. Drive is activated by selecting the drive switch and positioning the joystick forward or backward.

8. **Horn** - This push-button switch, when activated, permits the operator to warn jobsite personnel when the machine is operating in the area.
9. **Trigger (Enable) Switch** - Trigger on the front of the joystick must be held in to perform joystick controlled movements.
10. **Glow Plug Switch (Diesel Engine Only)** - A momentary contact, push button type switch that supplies electrical power to the engine's glow plugs, when depressed, to assist cold starting.
11. **Overload Indicator (LSS)** - The Overload Indicator indicates when the platform has been overloaded. An audible alarm will also signal when the platform is overloaded.

NOTE:

If the Overload Indicator is illuminated, all functions will be prevented from the platform controls. Using the ground controls or manual descent, fully lower the machine and reduce the weight in the platform so as to not exceed the rated workload indicated on the capacity decal.

Platform Control Front Panel

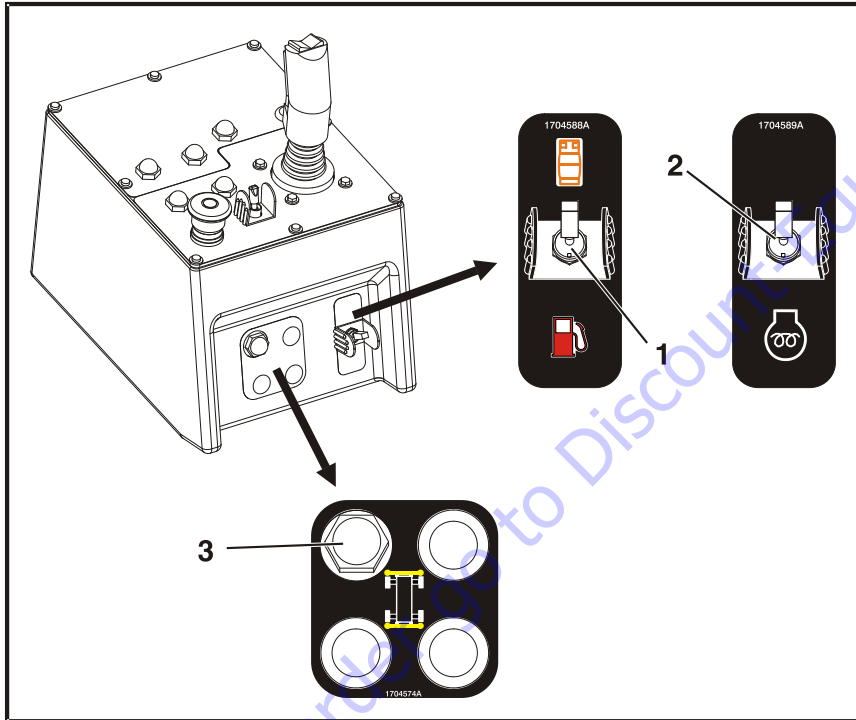

1. Dual Fuel Selector Switch
2. Diesel Fuel Selector Switch
3. Leveling Jacks Switch (If Equipped)

SECTION 3 - MACHINE CONTROLS, INDICATORS, AND MACHINE OPERATION

- 1. Fuel/Glow Plug Selector Switch** - Selects which fuel source will be used. LPG vs. Gasoline or Diesel for diesel machines.
- 2. Auto Leveling Jacks** - The leveling jacks switch is located on the front of the platform control box. When depressed, the outrigger light will illuminate on the indicator pad. Moving the control handle forward will lower the leveling jacks. Moving the control handle backward will raise the leveling jacks. Once the machine is level, the jacks will discontinue extending and the jack set light will illuminate.

NOTE: *After initial ground contact is made, the auto level function will pause 2-5 seconds and then begin to properly level the machine to the specified market specification. Once level, the tilt light on the platform control box will stop blinking.*

NOTE: *There is an override feature on the Auto Leveling system that allows the operator to adjust (trim) the level of the machine to the left or right when the platform is completely lowered. Use the following instructions to adjust the level of the machine.*

- a.** Select the leveling jack selection switch and squeeze the red trigger switch on the controller.
- b.** To adjust the leveling jacks to the left, activate the switch on top of the controller to the left. To adjust to the right, activate the switch on top of the controller to the right. The leveling jack indicator light for the side selected will be lit.

Indicator Panel LEDs

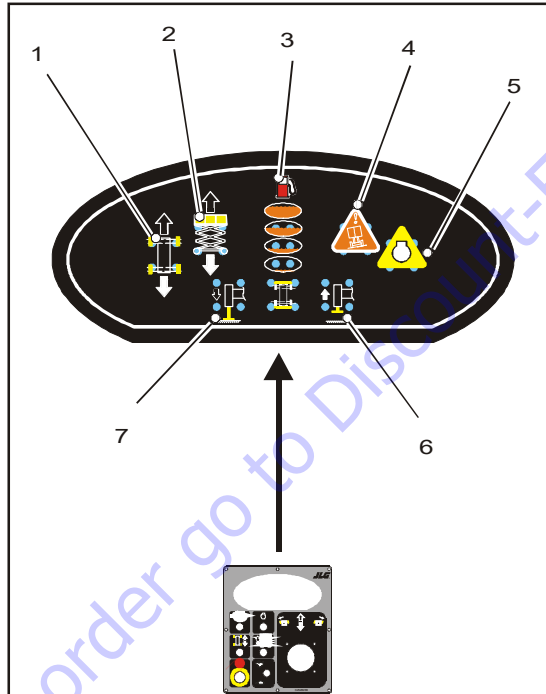

1. Drive
2. Lift
3. Fuel Gauge
4. Tilt
5. Engine Distress
6. Leveling Jacks (Retracted)
7. Leveling Jacks (Set)

SECTION 3 - MACHINE CONTROLS, INDICATORS, AND MACHINE OPERATION

1. **Drive** - This LED will illuminate when the drive select button is activated.
2. **Lift** - This LED will illuminate when the lift select button is activated.
3. **Fuel Gauge** - This series of LED's give the operator a visual of the amount of fuel remaining.
4. **Tilt Alarm Warning Light** - This red warning light on the control panel will illuminate when the chassis is on a severe slope.
5. **Engine/Filter Distress Light** - This warning light, when illuminated, warns the operator of an engine or hydraulic system fault condition. A bank of warning lights, located at the ground control station, indicates the specific fault condition to the operator. The indicator lights are: Alternator, Charge Pressure, Engine Temperature, Oil Pressure, and Return Filter.
6. **Leveling Jacks (retracted)** - This set of lights will illuminate once all the leveling jacks are retracted.
7. **Leveling Jacks (extended)** - This set of lights will illuminate once all the leveling jacks are extended.

CAUTION

IF THE TILT INDICATOR WARNING LIGHT/ALARM IS ACTIVATED WHEN PLATFORM IS RAISED, LOWER PLATFORM AND DRIVE TO A SMOOTH, FIRM SURFACE WITHIN THE LIMITS OF THE MAXIMUM OPERATING SLOPE.

CAUTION

DO NOT OPERATE MACHINE IF HIGH DRIVE SPEED OPERATES WHEN PLATFORM IS RAISED ABOVE THE STOWED POSITION.

3.6 ENGINE OPERATION

Power Selector Switch

The power selector switch functions to direct electrical power to the desired control station. With the switch in the ground position, power is supplied to the emergency stop switch at the ground control station. When the switch is in the platform position, power is supplied to the emergency stop switch at the platform control station. The switch should be in the off position when parking the machine overnight.

Emergency Stop Switch

This switch, when in the on (out) position, provides electrical power to the ground controls or platform controls, as applicable. In addition, the switch can be used to turn off power (push the switch IN) to the function controls in the event of an emergency.

Starting Procedure

NOTE: Initial starting should always be performed from the Ground Control Station.

1. Check engine oil before attempting to start engine; if necessary, add oil in accordance with Engine Manufacturers Manual.
2. Pull out the red EMERGENCY STOP switch (ON).
3. Position the PLATFORM/GROUND SELECT switch to the desired operating control station (PLATFORM or GROUND).
4. If operating a dual fuel machine, place the LPG/GASOLINE SELECT switch to the desired position.

NOTE: If the LPG system is selected, ensure that the hand valve on the LPG supply tank is opened prior to attempting to start the engine.

NOTICE

IF ENGINE FAILS TO START PROMPTLY, DO NOT CRANK FOR AN EXTENDED PERIOD. SHOULD ENGINE FAIL TO START ONCE AGAIN, ALLOW STARTER TO "COOL OFF" FOR 2 TO 3 MINUTES. IF ENGINE FAILS TO START AFTER SEVERAL ATTEMPTS, REFER TO ENGINE MAINTENANCE MANUAL.

IF STARTING MACHINE FROM THE PLATFORM CONTROL STATION, PLACE THE ENGINE SPEED CONTROL TO THE LOW POSITION PRIOR TO STARTING THE ENGINE.

5. If starting the machine from the ground controls, position the EMERGENCY STOP switch to ON and depress the START button and hold until the engine starts. If starting from the platform controls, position the platform EMERGENCY STOP switch to ON and depress the START button and hold until the engine starts.

NOTICE

ALLOW ENGINE TO WARM-UP FOR A FEW MINUTES BEFORE APPLYING ANY LOAD.

6. After the engine has had sufficient time to warm up, proceed with operation of the unit.

3.7 OPERATING CHARACTERISTICS

Leveling Jacks

The machine may be equipped with auto leveling jacks with a manual adjust feature. These leveling jacks are operated through one switch unlike the traditional four switch system. The leveling jacks are operated by a bang-bang valve.

NOTE: *The engine speed will drop when the leveling jacks are activated.*

Auto Leveling

1. With the machine in the stowed position turn the power on, start machine and depress the leveling jack selection switch located on the front of the platform control box.
2. While squeezing the red trigger switch on the controller, move the controller forward.
3. Once the leveling jacks make contact with the ground surface there will be up to a 5 second delay before the actual auto leveling begins.

NOTE: *Due to varying ground conditions, there may be several delays between machine level corrections. Be sure ample time is allowed for all leveling adjustments to be completed.*

SECTION 3 - MACHINE CONTROLS, INDICATORS, AND MACHINE OPERATION

4. Continue to engage the leveling jacks until the tilt light stops blinking and is no longer lit.

NOTE: If you receive a 2/5 flash code through the system fault light at the platform control station the machine is unable to level. You must reposition and try again.

5. To retract the leveling jacks, move the controller backward until the desired position is obtained.

NOTE: The tilt light serves as an indicator that the machine is outside the allowable lifting operation. When the machine reaches a position within level of the specific market specification, the tilt light will go out. Once the light is out, the level adjustment of the machine may still be improved. (See Manual Level Adjustment (Trim) section).

NOTE: There is a limit switch that senses when all four cylinders are fully retracted and this will light up the four leveling jack lights in the platform control station.

The proximity sensor will not allow the jacks to be extended or retracted when the machine is elevated. If there is a proximity sensor failure you cannot use the leveling jacks.

Manual Level Adjustment (Trim)

NOTE: There is an override feature on the Leveling Jack system that allows the operator to adjust (trim) the level of the machine to the left or right when the platform is completely lowered. Use the following instructions to adjust the level of the machine.

6. With the machine in the stowed position turn the power on, start machine and depress the leveling jack selection switch located on the front of the platform control box.
7. To adjust (trim) the machine to the right, activate the steer switch on the top of the controller to the right until the desired position is reached.
8. To adjust (trim) the machine to the left, activate the steer switch on the top of the controller to the left until the desired position is reached.

NOTE: Anytime the trim function is used there is a possibility that the machine may become out of level. At this time the machine will no longer lift but the machine can be lowered.

NOTE: The machine must be in the stowed position before the trim function is operable.

3.8 PLATFORM

Raising

Platform Loading

The platform maximum rated load capacity is shown on a placard located on the platform billboard and ground control station and is based upon the machine positioned on a smooth, firm surface within the limits of the maximum operating slope. Refer to Section 6.2 for the maximum platform capacity.

The platform is entered through an entry gate at the rear of the platform. Keep entry gate closed at all times except when entering/exiting the platform and loading/unloading materials.

NOTE: *It is important to remember that the load should be evenly distributed on the platform. The load should be placed near the center of the platform when possible.*

WARNING

DO NOT RAISE PLATFORM EXCEPT ON A SMOOTH, FIRM, AND LEVEL SURFACE WITHIN THE LIMITS OF THE MAXIMUM OPERATING SLOPE, FREE OF OBSTRUCTIONS AND HOLES.

1. If the machine is shut down, place the power selector switch to desired position (platform or ground).
2. Position the applicable emergency stop Switch to the on position.
3. If operating from the ground controls, position the lift switch to up and hold until desired elevation is achieved. If operating from the platform controls, press the enable switch then position the lift switch to up and hold until desired elevation is reached. The lift switch is part of the enable circuit, which supplies power to the lift switch for 3 seconds after the enable switch is pressed. If the lift switch is not activated within 3 seconds after the enable switch is pressed, power is removed from the circuit and the enable switch must be pressed again before activating the lift switch.

Lowering

WARNING

ENSURE SCISSOR ARM AREA IS FREE OF PERSONNEL PRIOR TO LOWERING PLATFORM.

ENSURE PLATFORM EXTENSION IS COMPLETELY RETRACTED PRIOR TO LOWERING PLATFORM.

If operating from the ground controls, position the lift switch to down and hold until desired elevation is achieved or until platform is fully lowered.

If operating from the platform controls, press the lift switch and then position the joystick to down and hold until desired elevation is reached or until platform is fully lowered.

WARNING

DO NOT LOWER WITHOUT COMPLETELY RETRACTING THE PLATFORM EXTENSION.

Platform Extension

The machine is equipped with a mechanical extension deck, which adds 3 ft (0.9 m) to the front of the platform, giving the operator better access to work-sites.

To extend the deck, squeeze the release lever on the handle on the left side of the platform to release the lock pin, then use the handle and handrail to push the extension deck out.

To retract the deck, squeeze the release lever to release the lock pin and use the handle and handrail to pull and retract the deck. Be sure the lock pin is locked in place after the deck is retracted.

Maximum capacity of the deck extension is 300 lbs (136 kg).

WARNING

DO NOT LOWER WITHOUT COMPLETELY RETRACTING THE PLATFORM EXTENSION.

3.9 DRIVING

⚠ WARNING

DO NOT DRIVE WITH PLATFORM RAISED EXCEPT ON A SMOOTH, FIRM AND LEVEL SURFACE WITHIN THE LIMITS OF THE MAXIMUM OPERATING SLOPE, FREE OF OBSTRUCTIONS AND HOLES.

TO AVOID LOSS OF TRAVEL CONTROL OR UPSET ON GRADES AND SIDESLOPES, DO NOT DRIVE MACHINE ON GRADES EXCEEDING THOSE SPECIFIED ON CAUTION PLACARD AT PLATFORM.

⚠ WARNING

DIRECTION OF DRIVE AND STEER MOVEMENT MAY BE OPPOSITE FROM NORMAL OPERATION. BEFORE DRIVING, LOCATE THE BLACK/WHITE ORIENTATION ARROWS ON BOTH THE CHASSIS AND THE PLATFORM CONTROLS. MOVE THE DRIVE CONTROLS IN A DIRECTION MATCHING THE ORIENTATION ARROWS.



IF TILT ALARM IS ON WHEN PLATFORM IS RAISED, STOP DRIVING AND LOWER PLATFORM COMPLETELY, THEN REPOSITION MACHINE SO THAT IT IS LEVEL BEFORE RAISING PLATFORM.

Steering

To steer the machine, the thumb operated steer control switch on the controller handle is positioned to the right for traveling right, or to the left for traveling left. When released, the switch will return to the center-off position and the wheels will remain in the previously selected position. To return the wheels to the straightened position, the switch must be activated in the opposite direction until the wheels are centered.

Driving Forward

1. Place the power selector switch at the ground control station to platform.
2. Position the emergency stop switch at the platform control station to the on position.
3. Press the drive switch and move the joystick forward and hold for the duration of travel.
Drive speed is determined by the distance the control handle is moved from the center off position.
For additional drive speed, position the high engine speed switch to high while operating in the drive forward mode.

Driving in Reverse

1. Position the power selector switch at the ground control station to platform.
2. Position the emergency stop switch at the platform control station to the on position.
3. Press the drive switch and move the drive controller rearward and hold for the duration of travel.
Drive speed is determined by the distance the control handle is moved from the center off position.
Do not activate the high engine speed switch when traveling in reverse.

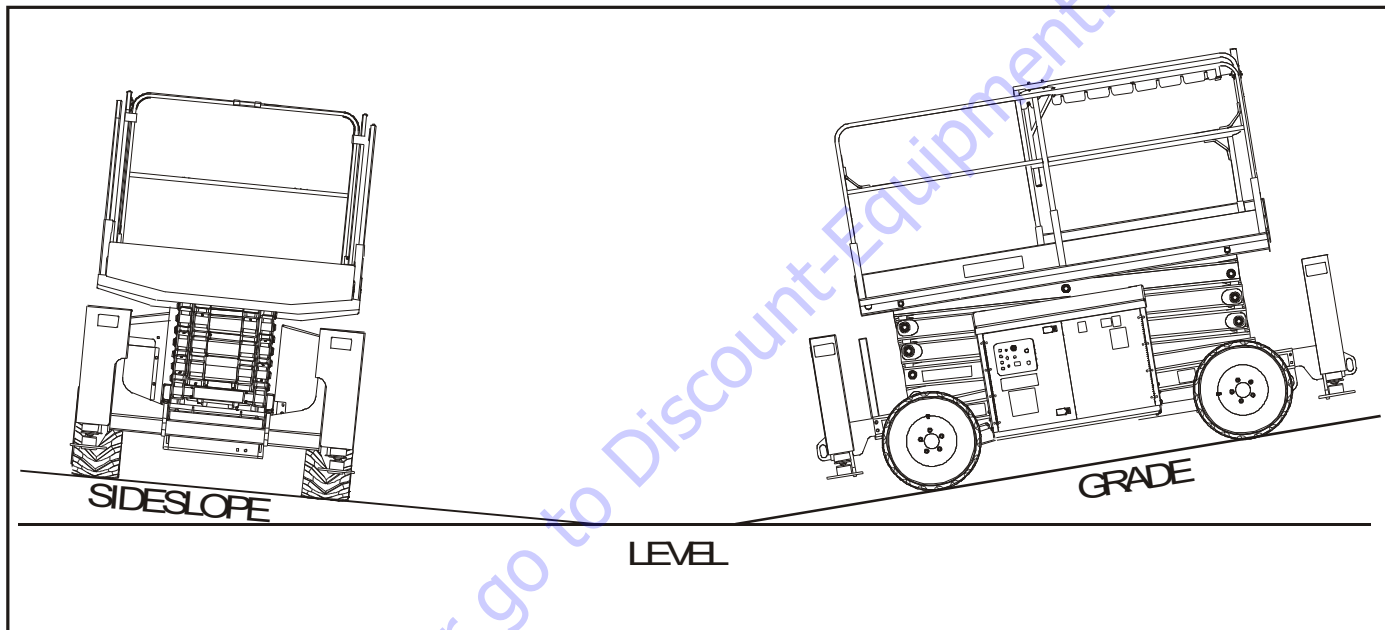

Figure 3-1. Grade and Sideslope Depiction

3.10 PARKING AND STOWING

Park and stow the machine as follows:

1. Drive the machine to a reasonably well-protected and well-ventilated area.
2. Ensure the platform is fully lowered.
3. Position the emergency stop switch to the off position.
4. If necessary, cover the instruction placards, caution and warning decals so that they will be protected from hostile environment.
5. Chock at least two wheels when parking the machine for an extended period of time.
6. Turn the power selector switch to off and remove the key to disable the machine from unauthorized use.

3.11 TIE DOWN

When transporting the machine, the platform extension must be fully retracted and the platform fully lowered in the stowed mode with the machine securely tied down to the truck or trailer deck. Four tie down eyes, one at each corner of the machine frame, are provided for machine tie-down.

Lifting

If it becomes necessary to lift the machine, it is possible to do so from the tie down/lift lugs. These lugs enable the machine to be lifted using cranes or other suitable lifting devices.

NOTE: *If lifting becomes necessary from the lifting lugs, JLG Industries Inc. recommends the use of a proper spreader bar to avoid damage to the machine.*

Cranes or other lifting devices must be capable of handling 7660 lb (3475 kg)

3.12 TOWING

Although towing the machine is prohibited, provisions for moving the machine, in case of a malfunction or power failure, have been incorporated. The following procedures are to be used ONLY for emergency movement to a suitable maintenance area.

1. Chock the wheels securely.
2. Locate the brake cartridge on the hydraulic control valve, located adjacent to the hydraulic oil tank on the left side of the machine. Depress the plunger on the brake cartridge.
3. Locate the brake release pump, in front of the hydraulic control valve. Install the handle on the brake release pump and pump it to release the brake. Remove handle when finished.
4. Using suitable equipment for assistance, remove the chocks, winch or tow the machine to an appropriate maintenance area.

WARNING

USE EXTREME CAUTION WHEN OPENING THE TOW VALVE. THE DRIVE FUNCTION WILL STILL OPERATE WITH THE TOW VALVE OPEN, BUT THE BRAKE IS DISABLED. ENSURE THE TOW VALVE REMAINS CLOSED AT ALL TIMES, EXCEPT WHEN THE MACHINE IS BEING TOWED. CLOSE THE TOW VALVE IMMEDIATELY AFTER TOWING IS COMPLETED.

After moving the machine, complete the following procedures:

1. Position the machine on a firm, level surface.
2. Chock the wheels securely.
3. Turn knob counterclockwise to engage wheel brakes.
4. Turn the knob on the brake pump clockwise until tight. this places the machine back into normal operation
5. Remove the chocks from the wheels.

SECTION 3 - MACHINE CONTROLS, INDICATORS, AND MACHINE OPERATION

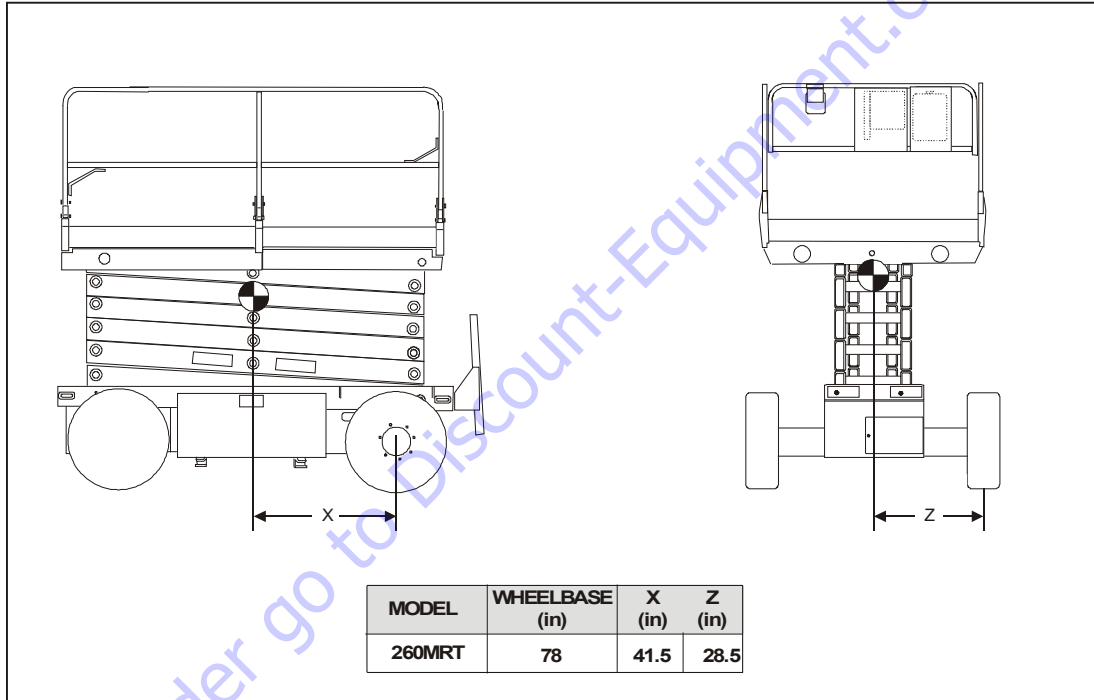

Figure 3-2. Lifting Chart

3.13 PLATFORM RAILS - FOLD-DOWN PROCEDURE

WARNING

ONLY FOLD DOWN THE RAILS WHEN THE MACHINE IS IN THE STOWED (PLATFORM FULLY LOWERED) POSITION. DO NOT RAISE THE PLATFORM WITH THE RAILS FOLDED DOWN. THE RAILS MUST BE IN THE UPRIGHT POSITION AND PROPERLY PINNED WHEN RAISING THE PLATFORM.

The platform rails fold down in the following sequence;
(See Figure 3-3., Figure 3-4. and Figure 3-5.)

- Rear Gate Rail (6 Pins)
- Front Rail (2 Pins)
- Left Extension Deck Rail (1 Pin)
- Right Extension Deck Rail (1 Pin)
- Left Platform Side Rail (3 Pins)
- Right Platform Side Rail (3 Pins)

1. To fold down each of the rails, remove the bail pins for that rail.
2. Taking a firm hold on the top rail, carefully lower until the top rail is fully folded in the down position.

WARNING

AFTER THE RAILS HAVE BEEN FOLDED DOWN, USE EXTREME CAUTION WHEN EXITING AND ENTERING THE PLATFORM. ENTER AND EXIT PLATFORM ONLY AT THE GATE AREA AND LADDER PROVIDED.

WARNING

IF DRIVING MACHINE WITH THE PLATFORM CONTROL STATION FROM GROUND, DO NOT HANG THE CONTROL BOX ON ANY PART OF THE MACHINE WHILE DRIVING. HOLD THE CONTROL BOX AND KEEP AT LEAST 3 FT (1 M) DISTANCE FROM MACHINE.

3. To raise the rails back to the upright position, unfold the rails in the reverse sequence they were folded. Firmly pull the rails back up into position and replace the bail pins into the rails.

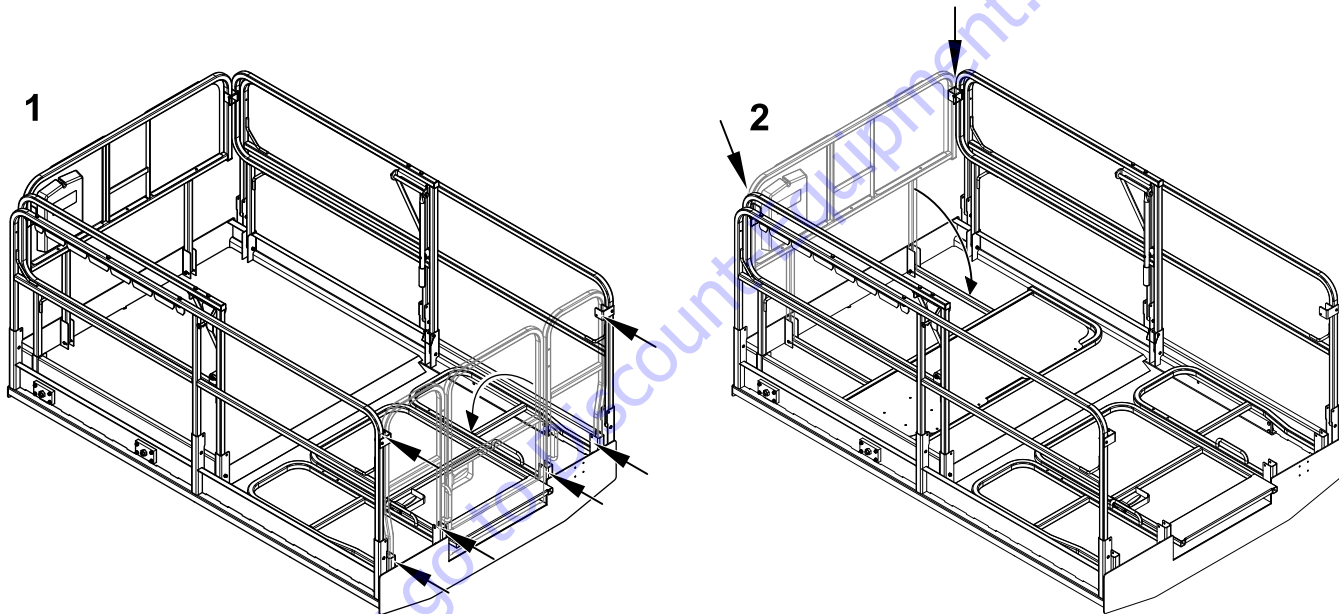

Figure 3-3. Platform Rails - Fold Down Sequence - Front/Rear Rails

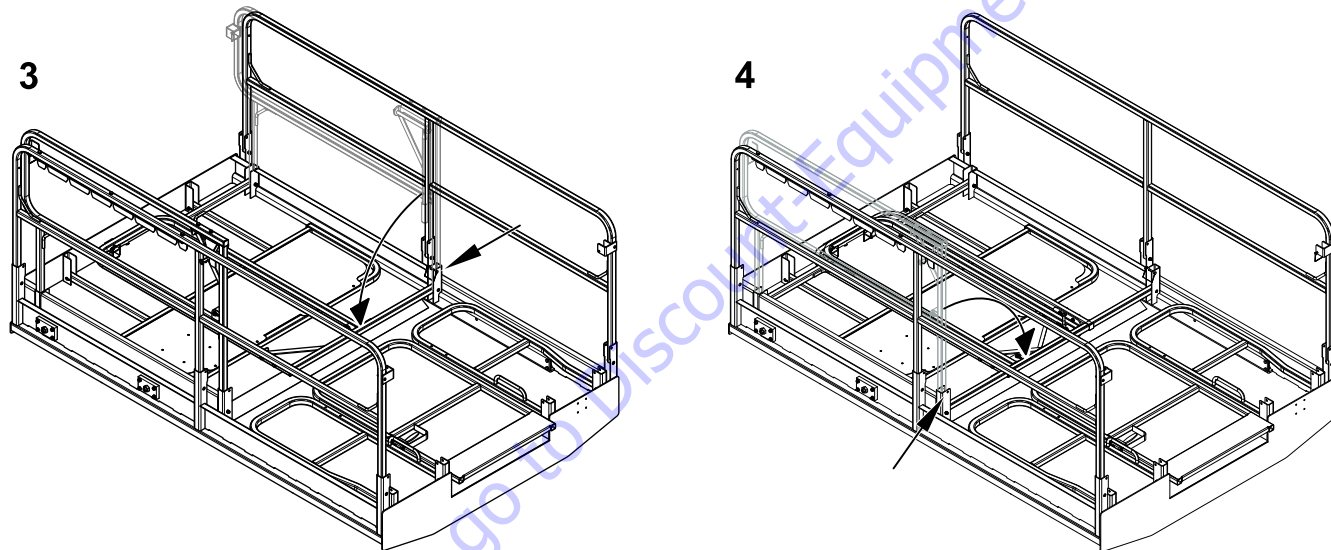

Figure 3-4. Platform Rails - Fold Down Sequence - Deck Extension Side Rails

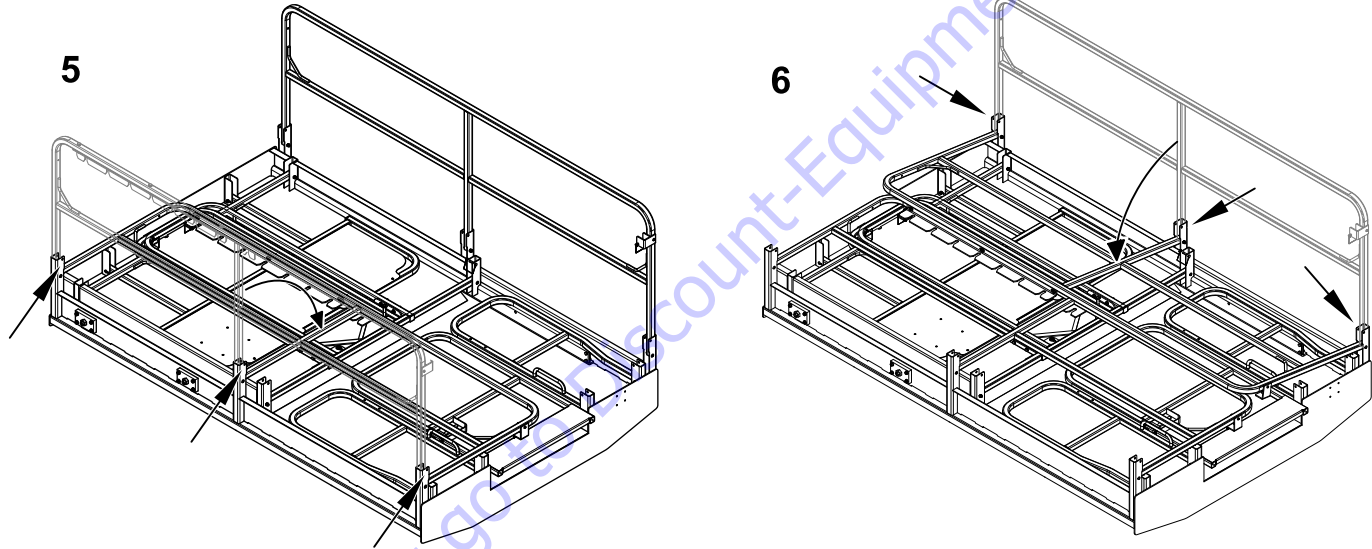
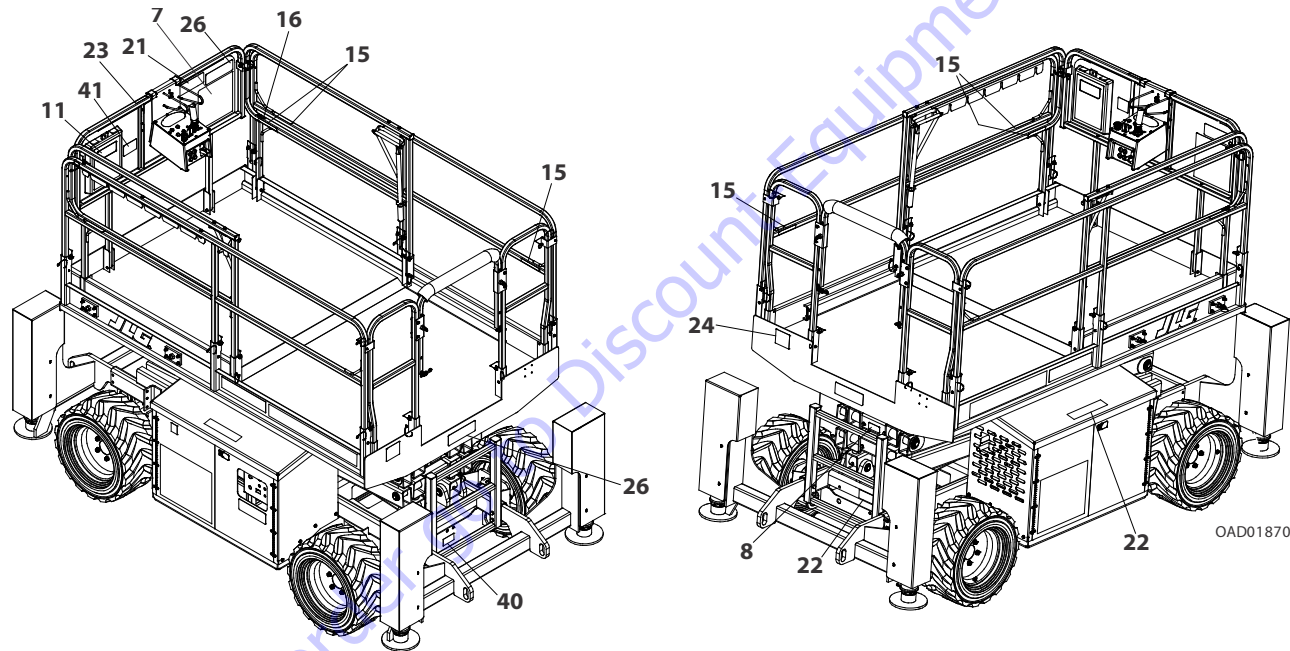

Figure 3-5. Platform Rails - Fold Down Sequence - Main Platform Side Rails

3.14 DECALS

ANSI, ANSI Export, CSA



SECTION 3 - MACHINE CONTROLS, INDICATORS, AND MACHINE OPERATION

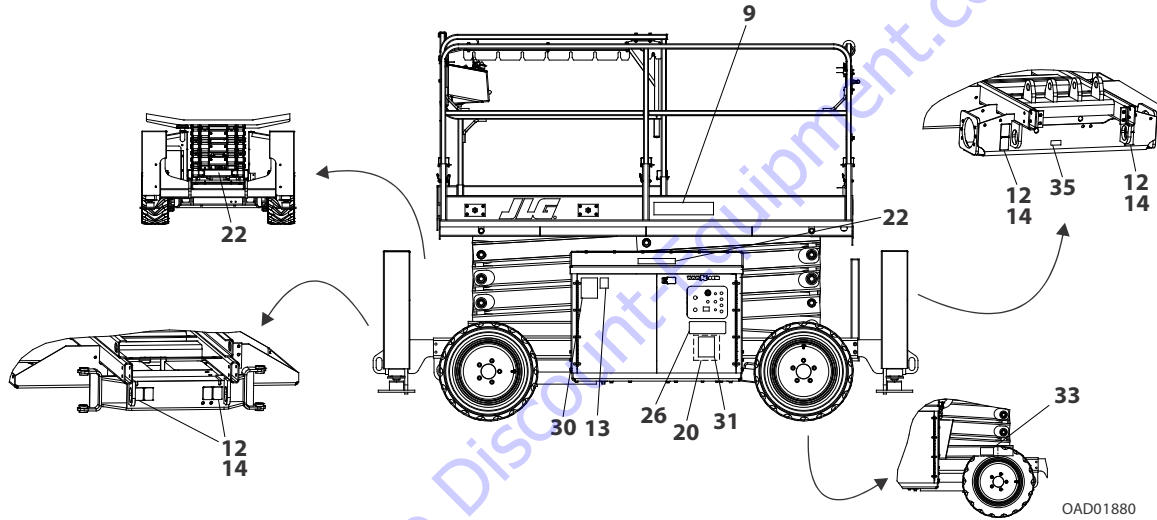

SECTION 3 - MACHINE CONTROLS, INDICATORS, AND MACHINE OPERATION

Item	ANSI (0259792-N)	SPA, POR (0259795-K)	ENG, SPA (0259794-K)	ENG, FRE (0272257-H)
1-6	--	--	--	--
7	1703816	1704699	1704691	1704684
8	1704138	1704138	1704138	1704138
9	1704529	1704529	1704529	1704529
10	--	--	--	--
11	1701509	1701509	1701509	1701509
12	1703811	1703811	1703811	1703811
13	1703812	1703812	1703812	1703812
14	1703814	1703814	1703814	1703814
15	1704277	1704277	1704277	1704277
16	1703819	1703819	1703819	1703819
17-19	--	--	--	--
20	1704556	1704623	1704695	1704688
21	1703696	1704748	1704598	1704597
22	1703818	1704701	1704693	1704686
23	1703821	1704702	1704694	1704687
24-25	--	--	--	--
26	3252689	3252689	3252689	3252689
27-29	--	--	--	--
30	1704412	1704412	1704412	1704412

SECTION 3 - MACHINE CONTROLS, INDICATORS, AND MACHINE OPERATION

Item	ANSI (0259792-N)	SPA, POR (0259795-K)	ENG, SPA (0259794-K)	ENG, FRE (0272257-H)
31-32	--	--	--	--
33	1705303	--	--	1705303
34	--	--	--	--
35	1001223055	1001224052	1001224049	1001223971
36-39	--	--	--	--
40	1001223453	--	--	1001223453
41	1001231801	--	--	--

SECTION 3 - MACHINE CONTROLS, INDICATORS, AND MACHINE OPERATION

CE, AUS

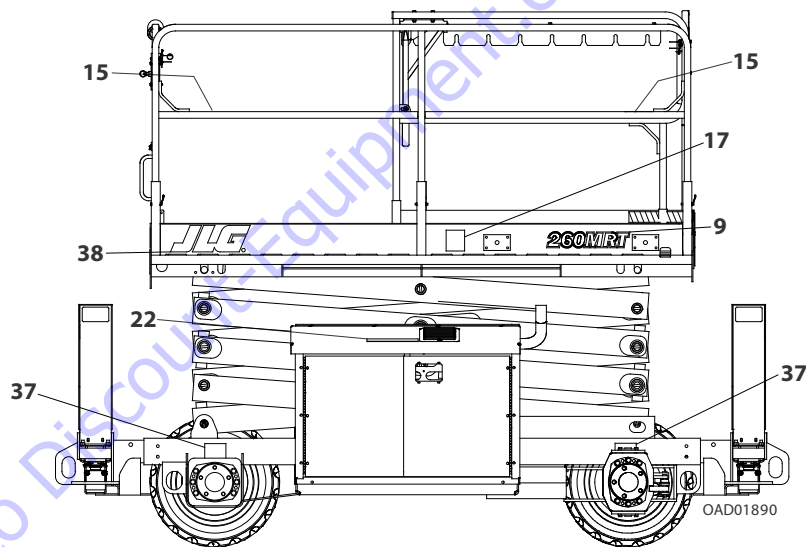
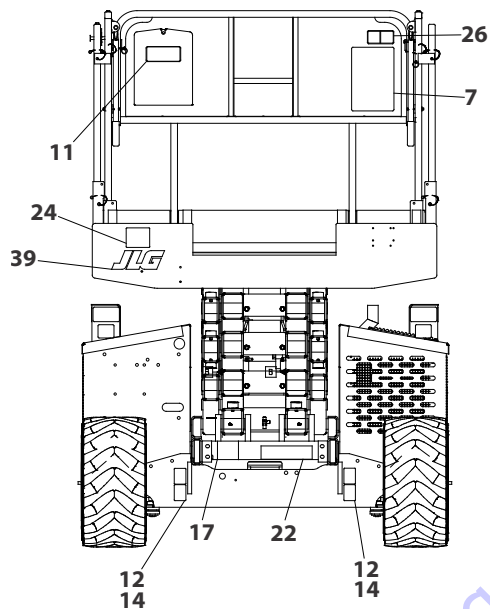

SECTION 3 - MACHINE CONTROLS, INDICATORS, AND MACHINE OPERATION

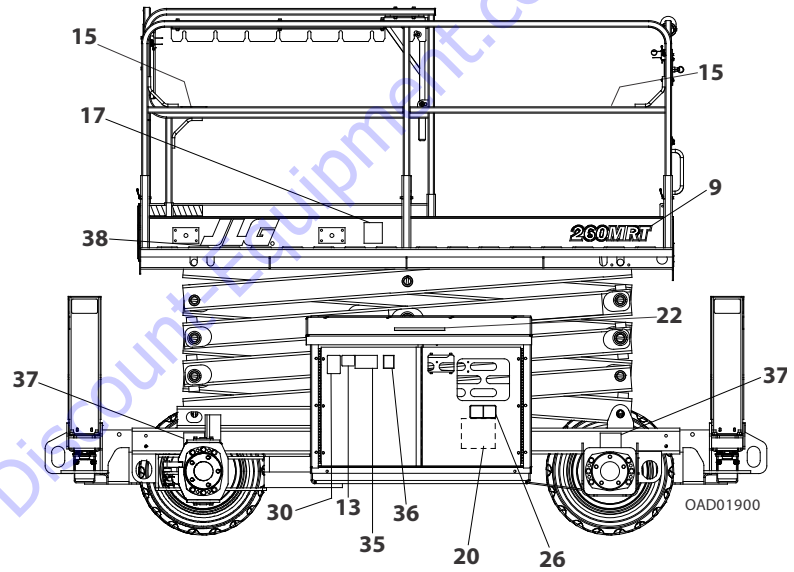
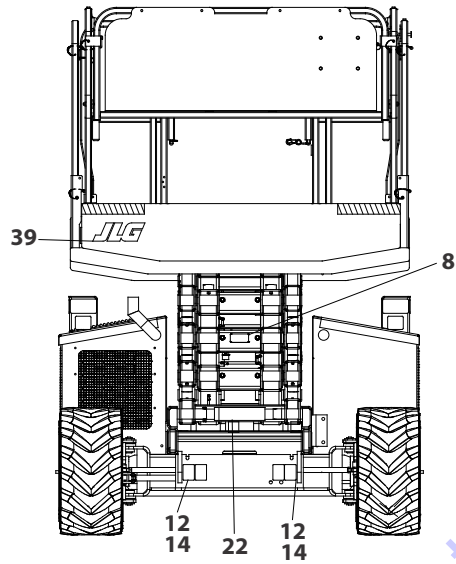

SECTION 3 - MACHINE CONTROLS, INDICATORS, AND MACHINE OPERATION

Item	CE, AUS (0275087-G)
1-6	--
7	1704548
8	1704138
9	1704529
10	--
11	1701509
12	1703811
13	1703812
14	1703814
15	1704277
16	1703819
17	1705084
18-19	--
20	1706332
21	--
22	1706338
23-25	--
26	1705671

Item	CE, AUS (0275087-G)
27-29	
30	1704412
31-34	--
35	1702788
36	1701542 (Dual Fuel) 1701505 (Diesel)
37	1704559
38	1702773
39	1701435

TO PURCHASE THIS PRODUCT PLEASE CONTACT US



**Equipment Financing and
Extended Warranties Available**



**Discount-Equipment.com is your online resource for
commercial and industrial quality parts and equipment sales.**

561-964-4949

visit us on line @ www.discount-equipment.com

Select an option below to find your Equipment

Search by Manufacturer

Search by Product Type

Request a Quote

We sell worldwide for the brands: Genie, Terex, JLG, MultiQuip, Mikasa, Essick, Whiteman, Mayco, Toro Stone, Diamond Products, Generac Magnum, Airman, Haulotte, Barreto, Power Blanket, Nifty Lift, Atlas Copco, Chicago Pneumatic, Allmand, Miller Curber, Skyjack, Lull, Skytrak, Tsurumi, Husquvarna Target, Stow, Wacker, Sakai, Mi-T-M, Sullair, Basic, Dynapac, MBW, Weber, Bartell, Bennar Newman, Haulotte, Ditch Runner, Menegotti, Morrison, Contec, Buddy, Crown, Edco, Wyco, Bomag, Laymor, EZ Trench, Bil-Jax, F.S. Curtis, Gehl Pavers, Heli, Honda, ICS/PowerGrit, IHI, Partner, Imer, Clipper, MMD, Koshin, Rice, CH&E, General Equipment, Amida, Coleman, NAC, Gradall, Square Shooter, Kent, Stanley, Tamco, Toku, Hatz, Kohler, Robin, Wisconsin, Northrock, Oztec, Toker TK, Rol-Air, APT, Wylie, Ingersoll Rand / Doosan, Innovatech, Con X, Ammann, Mecalac, Makinex, Smith Surface Prep, Small Line, Wanco, Yanmar

SECTION 4. EMERGENCY PROCEDURES

4.1 GENERAL

This section explains the steps to be taken in case of an emergency situation during operation.

Manual Descent

The manual descent valve is used, in the event of total power failure, to lower the platform using gravity. The manual descent ring is located on the front of the machine frame, between the scissor arms. The ring is connected, by a cable, to the manual descent valve on the lift cylinder. Pulling the manual descent ring opens the valve spool, lowering the platform.

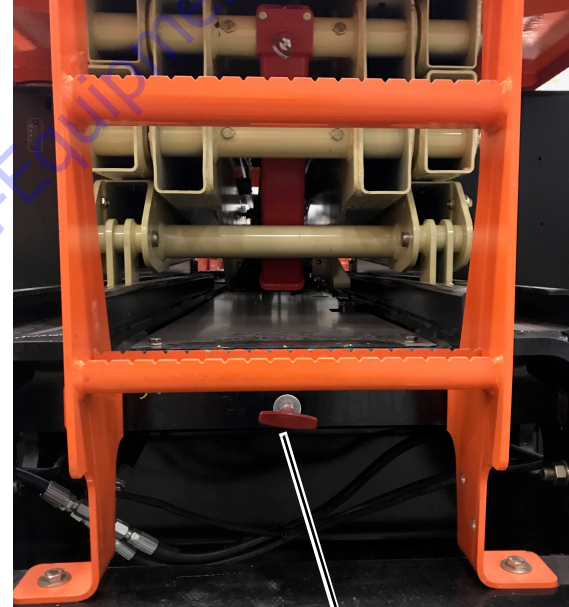

4.2 EMERGENCY OPERATION

Use of Ground Controls

NOTICE

KNOW HOW TO USE THE GROUND CONTROLS IN AN EMERGENCY SITUATION.

Ground personnel must be thoroughly familiar with the machine operating characteristics and the ground control functions. Training should include operation of the machine, review and understanding of this section and hands-on operation of the controls in simulated emergencies.

Operator Unable to Control Machine

1. Operate the machine from ground controls ONLY with the assistance of other personnel and equipment (cranes, overhead hoists, etc.) as may be required to safely remove the danger or emergency condition.
2. Other qualified personnel on the platform may use the platform controls. **DO NOT CONTINUE OPERATION IF CONTROLS DO NOT FUNCTION NORMALLY.**
3. Cranes, forklift trucks or other equipment which may be available are to be used to remove platform occupants and stabilize motion of the machine in case machine controls are inadequate or malfunction when used.

Platform Caught Overhead

If the platform becomes jammed or snagged in overhead structures or equipment, do the following:

1. Shut off the machine.
2. Rescue all people in the platform before freeing the machine. Personnel must be out of the platform before operating any controls on the machine.
3. Use cranes, forklifts or other equipment to stabilize motion of the machine to prevent a tip over as required.
4. From the ground controls, carefully free the platform from the object.
5. Once clear, restart the machine and return the platform to a safe position.
6. Inspect the machine for damage. If the machine is damaged or does not operate properly, turn off the machine immediately. Report the problem to the proper maintenance personnel. Do not operate the machine until it is declared safe for operation.

Righting of Tipped Machine

A forklift of suitable capacity or equivalent equipment should be placed under the elevated side of the chassis, with a crane or other suitable lifting equipment used to lift the platform while the chassis is lowered by the forklift or other equipment.

Post-Incident Inspection

Following any incident, thoroughly inspect the machine and test all functions first from the ground controls, then from the platform controls. Do not lift above 10 feet (3 meters) until you are secure that all damage has been repaired, if required, and that all controls are operating correctly.

4.3 INCIDENT NOTIFICATION

JLG Industries, Inc. must be notified immediately of any incident involving a JLG product. Even if no injury or property damage is evident, JLG must be contacted by telephone and provided with all necessary details.

- USA: 877-JLG-SAFE (554-7233)
- EUROPE: (32) 0 89 84 82 20
- AUSTRALIA: (61) 2 65 811111
- E-mail: productsafety@jlg.com

Failure to notify the manufacturer of an incident involving a JLG Industries product within 48 hours of such an occurrence may void any warranty consideration on that particular machine.

NOTICE

FOLLOWING ANY INCIDENT, THOROUGHLY INSPECT THE MACHINE. DO NOT ELEVATE THE PLATFORM UNTIL IT IS CERTAIN THAT ALL DAMAGE HAS BEEN REPAIRED AND THAT ALL CONTROLS ARE OPERATING CORRECTLY. TEST ALL FUNCTIONS FIRST FROM THE GROUND CONTROL STATION THEN FROM THE PLATFORM CONTROL CONSOLE.

SECTION 5. ACCESSORIES

Table 5-1. Available Accessories

Accessory	Market				
	ANSI (USA Only)	ANSI	CSA	CE	AUS
1/2 Airline	√	√	√	√	√
Platform Worklights	√	√	√	√	√
Platform Rail Padding	√	√		√	

5.1 1/2 AIRLINE

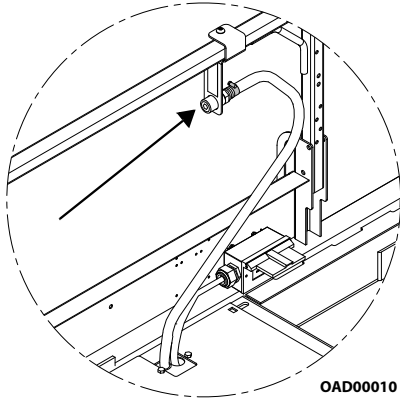

The 1/2 Airline is a fitting for air-powered tools that is mounted in the platform.

5.2 PLATFORM WORKLIGHTS

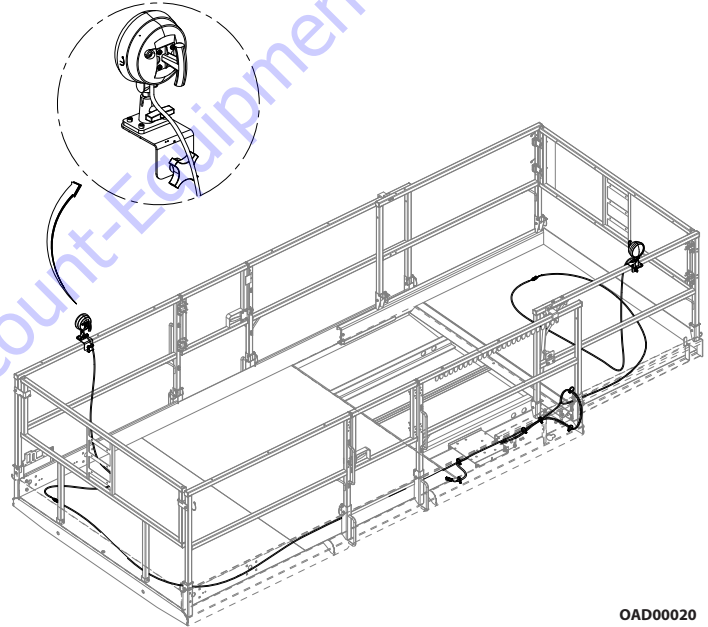

The Platform Worklights accessory consists of two 12V lights mounted to the platform railings.

5.3 PLATFORM RAIL PADDING

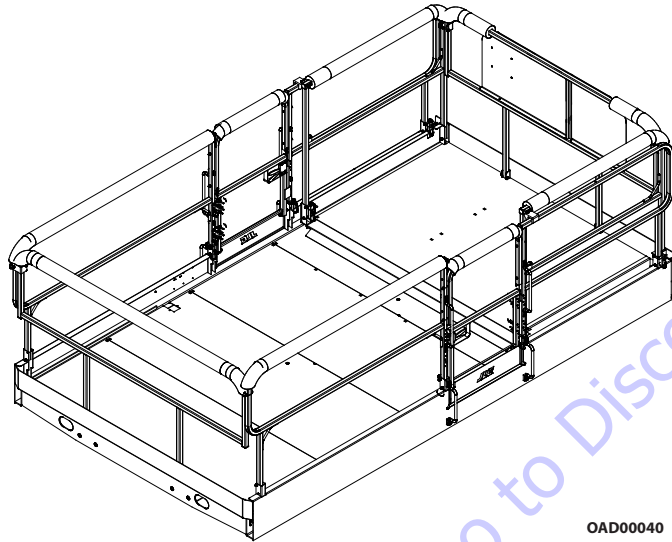

Platform Rail Padding provides bumpers to the top platform rails in order to prevent damage to the platform itself as well as objects it may come into contact with during operation.

With Deck Bumpers

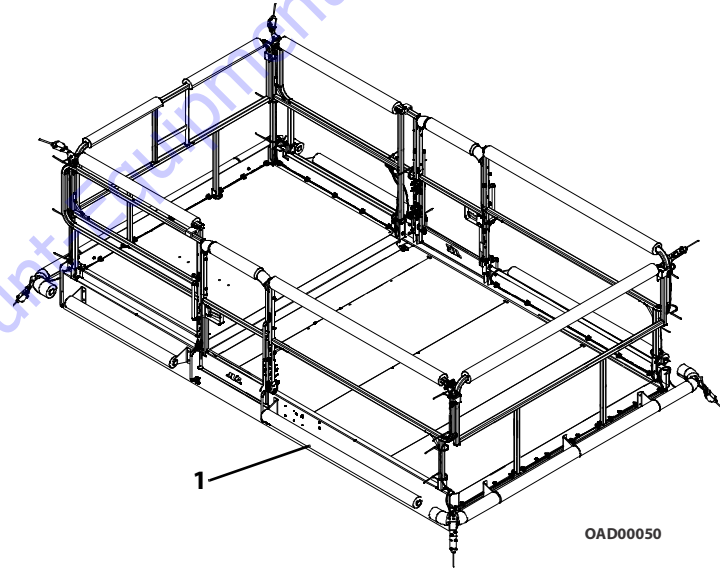

1. Deck Bumpers

This accessory is also available with proximity switches, which attaches a padded frame to the bottom of the platform.

SECTION 6. GENERAL SPECIFICATIONS AND OPERATOR MAINTENANCE

6.1 INTRODUCTION

This section of the manual provides additional necessary information to the operator for proper operation and maintenance of this machine.

The maintenance portion of this section is intended as information to assist the machine operator to perform daily maintenance tasks only, and does not replace the more thorough Preventive Maintenance and Inspection Schedule included in the Service and Maintenance Manual.

Other Publications Available Specific to this Machine:

Service and Maintenance Manual	31217913
Illustrated Parts Manual	31215867

SECTION 6 - GENERAL SPECIFICATIONS AND OPERATOR MAINTENANCE

6.2 SPECIFICATIONS

Operating Specifications

Maximum Platform Height	26 ft (8 m)
Maximum Stowed Travel Grade (Gradeability)	35% (19°)
Maximum Stowed Travel Grade (Sideslope)	8.75% (5°)
Maximum Allowable Operating Slope	
Front to Back (Standard)	5°
Long Leveling Jacks Option (AUS Only)	6°
Side to Side	3°
Maximum Tire Load	2,600 lb (1,180 kg)
Maximum Ground Bearing Pressure	33 psi (2.3 kg/cm ²)
Turning Radius	
Inside	6.99 ft (2.13 m)
Outside	12.69 ft (3.87 m)
Wheelbase	6.5 ft (2 m)
Gross Machine Weight (Approximate)	8,160 lb (3,701 kg)
Maximum Drive Speed	3.5 mph (5.6 kmh)
Drive Speed (Slow) - sec./25 ft (7.6 m)	7-11
Drive Speed (Fast) - sec./25 ft (7.6 m)	4.8-5.8
Elevated Drive Speed - sec./25ft (7.6 m)	34.5 -37
Elevation Switch Height (drive speed slow)	90-96 in (2.3-2.4 m)

Platform Lift Up Speed (No Load)	Dual Fuel Diesel	25 - 29 seconds 32 - 34 seconds
Platform Lowering Speed (No Load)		21-27 seconds
Maximum Operating Hydraulic Pressure		3,300 psi (234 bar)
Electrical System Voltage		12V
Ground Clearance		8 in (20.3 cm)

Platform Capacity

Maximum Occupants		2
Maximum Capacity	ANSI CE/AUS	1,250 lb (568 kg) 570 kg
Deck Extension Capacity	ANSI CE/AUS	300 lb (136 kg) 140 kg
Maximum Allowable Wind Speed		28 mph (12.5m/s)
Maximum Horizontal Side Force	ANSI CE/AUS	187 lb (832 N) 400 N (90 lb)

Dimensional Data

Overall Height Stowed (Rails Up)	Standard	96.16 in (2.44 m)
Long Leveling Jacks Option (Australia Only)		97.41 ft (2.47 m)
Platform Height (Platform Stowed)	Standard	50.46 in (1.28 m)
Long Leveling Jacks Option (Australia Only)		51.66 in (1.31 m)
Platform Dimensions (Extension Retracted)		5.5 ft x 8.5 ft (1.6 x 2.6 m)
Platform Dimensions (Extension Extended)		5.5 ft x 12.5 ft (1.6 x 3.8 m)
Overall Machine Dimensions		5.75 ft x 8.75 ft (1.8 m x 2.7 m)

Batteries

Voltage	12V
Cranking Performance	700 @ 0° F
Reserve Capacity	115 minutes @ 80° F

Tires

Size	26X12-15 Foam Filled
Ply Rating	8
Inflation Pressure	55 psi (4 bar)
Wheel Nut Torque	105 ft.lb. (142 Nm)

Capacities

Fuel Tank		7.2 gal (27.2 L)
Hydraulic Tank		15 gal (56.8 L)
Engine Crankcase	Dual Fuel	3.43 qt (3.25 L)
	Diesel	5.38 qt (5.1 L)
Coolant	Dual Fuel	4 qt (3.8 L)
	Diesel	4.8 qt (4.55 L)

SECTION 6 - GENERAL SPECIFICATIONS AND OPERATOR MAINTENANCE

Engine

Kubota Dual Fuel (WG752-GL-G3)

Emissions	CARB, EPA Phase 3
Fuel Type	Gasoline - 87 Octane minimum - Ethanol/Gas Mix-10% maximum - Methanol/Gas Mix-5% maximum - LP (Liquid Petroleum)
Number of Cylinders	3
Oil Pan Capacity	0.86 gal (3.25 L)
Engine RPM Control	
Low RPM Set	1500 RPM
High RPM Set	3600 RPM
Alternator	40 Amp, 12V
Gross Power	Gas - 18.5 Hp (24.8 kW) @ 3600 RPM LP - 17.7 Hp (23.8 kW) @ 3600 RPM
Gross Torque	Gas - 40.5 ft. lb. (54.9 Nm) @ 2400 RPM LP - 38.3 ft.lb. (52 Nm) @ 2400 RPM

Kubota Diesel (D1005-E4B)

Emissions	CARB, EPA Tier 4 Final, and EU Stage V
Fuel Type:	Diesel: - Low Sulfur (<500 ppm) - Ultra Low Sulfur (15 ppm) <i>(Required to meet Stage V)</i> - up to 5% biodiesel
Number of Cylinders	3
Oil Pan Capacity	1.35 gal (5.1 L)
Engine RPM Control	Mechanical
Low RPM Set	900 RPM
High RPM Set	3220 RPM
Alternator	40 Amp, 12V
Gross Power	24.8 Hp (18.5 kW) @ 3000 RPM
Gross Torque	46.3 ft. lb. (62.8 Nm) @ 2200 RPM

Lubrication

Hydraulic Oil

HYDRAULIC SYSTEM OPERATING TEMPERATURE RANGE	SAE VISCOSITY GRADE
0° to +23°F (-18° to -5°C)	10W
0° to +210°F (-18° to +100°C)	10W-20, 10W-30
+50° to +210°F (+10° to +100°C)	20W-20

NOTE: Hydraulic oils must have anti-wear qualities at least to API Service Classification GL-3, and sufficient chemical stability for mobile hydraulic system service. JLG Industries recommends Standard UTTO Fluid hydraulic oil, which has an SAE viscosity index of 152.

NOTE: Aside from JLG recommendations, it is not advisable to mix oils of different brands or types, as they may not contain the same required additives or be of comparable viscosities.

Lubrication Specifications

KEY	SPECIFICATIONS
MPG	Multipurpose Grease having a minimum dripping point of 350° F. Excellent water resistance and adhesive qualities, and being of extreme pressure type. (Timken OK 40 pounds minimum.)
EPGL	Extreme Pressure Gear Lube (oil) meeting API service classification GL-5 or MIL-Spec MIL-L-2105.
EO	Engine (crankcase) Oil. Gas - API SF/SG class, MIL-L-2104. Diesel - API CC/CD class, MIL-L-2104B/MIL-L-2104C.
HO	Hydraulic Oil. API service classification GL-3, e.g. Mobil 424.

SECTION 6 - GENERAL SPECIFICATIONS AND OPERATOR MAINTENANCE

ENGINE SPECIFICATIONS

4150548_E

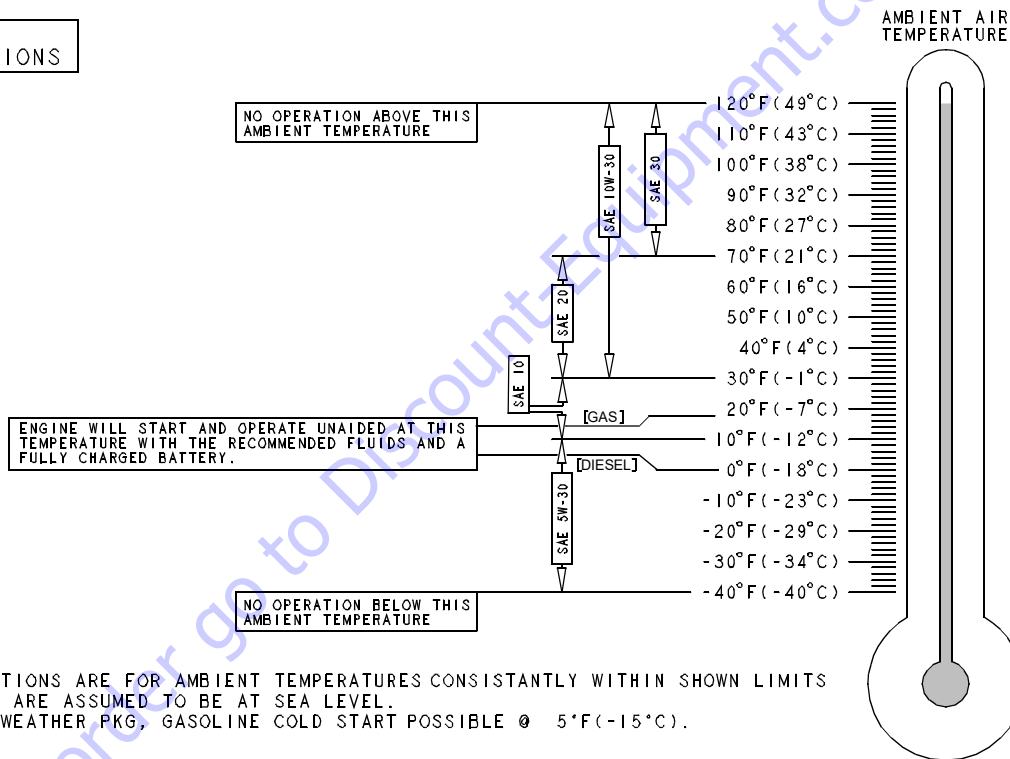

Figure 6-1. Engine Operating Temperature Specifications (Kubota)- Sheet 1 of 2

SECTION 6 - GENERAL SPECIFICATIONS AND OPERATOR MAINTENANCE

HYDRAULIC SPECIFICATIONS

4150548_E

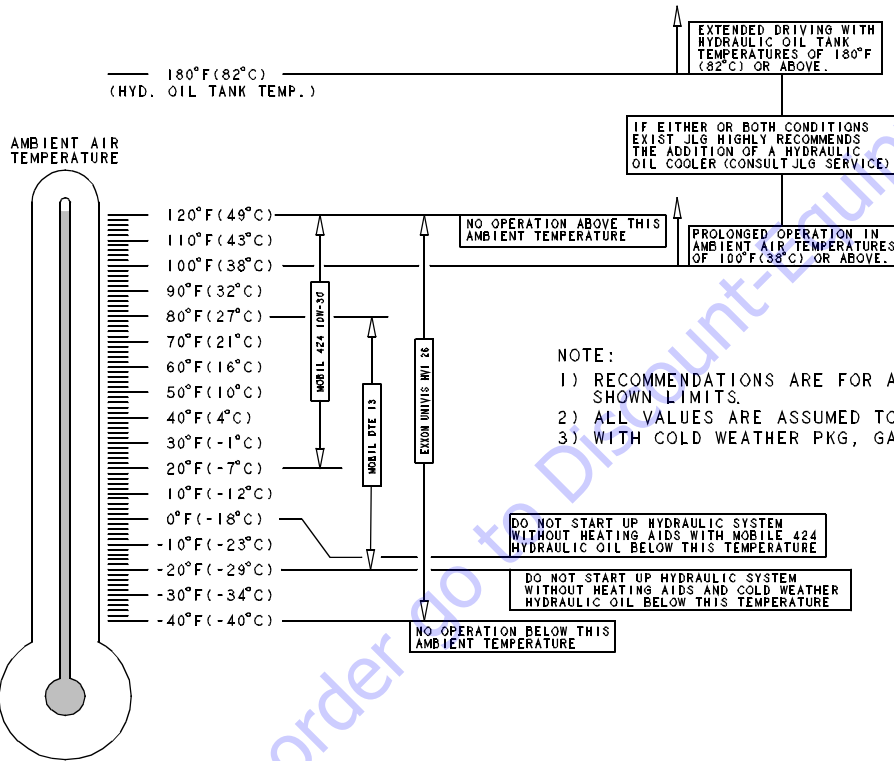

Figure 6-2. Engine Operating Temperature Specifications (Kubota)- Sheet 2 of 2

6.3 OPERATOR MAINTENANCE

Safety Prop

 CAUTION

TO AVOID PERSONAL INJURY, THE SAFETY PROP MUST BE USED WHENEVER MAINTENANCE PERFORMED ON THE MACHINE REQUIRES THE SCISSOR ARMS TO BE RAISED.

To engage the safety prop, with no load in the platform, raise the platform, then rotate the prop clockwise until it hangs vertically. Lower the platform until the safety prop rests on the point provided on the frame. Maintenance can now begin.

To store the safety prop, raise the platform so that the prop can be rotated counterclockwise until it rests on the stop provided on the scissor arms.

Inspection Check Points

1 AND 2 ON
OPPOSITE SIDE

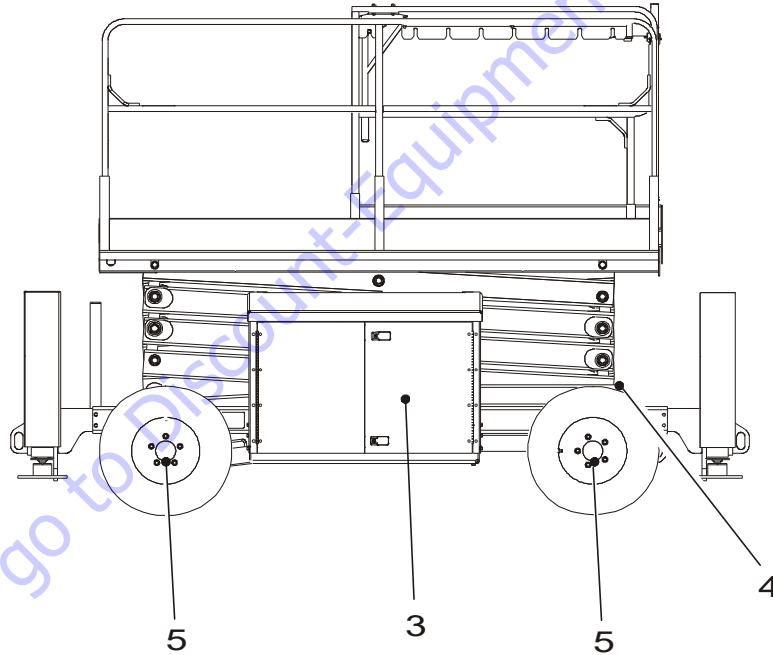

SECTION 6 - GENERAL SPECIFICATIONS AND OPERATOR MAINTENANCE

NOTE: Be sure to lubricate like items on each side

NOTE: Recommended lubricating intervals are based on machine operations under normal conditions. For machines used in multi-shift operations and/or exposed to hostile environments or conditions, lubrication frequencies must be increased accordingly.

Operate hydraulic functions through one complete cycle before checking hydraulic oil level in tank. Oil should be visible in ADD sight window on hydraulic tank. If oil is not visible, add oil until oil is visible in both ADD and FULL sight windows on tank. Do not overfill tank.

1. Hydraulic Oil
Lube Point - Fill Level/Drain Plug
Lube - HO
Interval - Check oil every 10 hours of operation; change oil every 2 years or 1200 hours of operation.
2. Hydraulic Filter Element
Interval - Initial change 40 hours, every 250 hours of operation thereafter.
3. Engine Compartment
 - a. Engine Oil Check/Fill
Capacity - See Engine Manual
Lube - See Engine Manual
4. Sliding Wear Pads
Lube Points - 8 Sliding Wear Pads
Lube - MPG
Interval - Every month or 50 hours.
5. Drive Hub
Lube Point - Fill Plug
Lube - EPGL
Interval - Every 2 years or 1200 hours

Interval - Check level daily; change per manufacturer's engine manual.

- b. Air Cleaner
Lube Point - Filter Element
Interval - Check every 3 months or 150 hours; change every 6 months or 300 hours.
- c. Fuel Filter
Lube Point - Filter Element
Interval - Clean every 3 months or 150 hours; change every 6 months or 300 hours.

6.4 TIRES AND WHEELS

Tire Damage

For polyurethane foam-filled tires, JLG Industries, Inc. recommends that when any of the following are discovered, measures must be taken to remove the JLG product from service immediately and arrangements must be made for replacement of the tire or tire assembly.

- a smooth, even cut through the cord plies which exceeds 7.5 cm (3 in) in total length
- any tears or rips (ragged edges) in the cord plies which exceeds 2.5 cm (1 in) in any direction
- any punctures which exceed 2.5cm in diameter
- any damage to the bead area cords of the tire

If a tire is damaged but is within the above noted criteria, the tire must be inspected on a daily basis to insure the damage has not propagated beyond the allowable criteria.

Tire Replacement

JLG recommends a replacement tire be the same size, ply and brand as originally installed on the machine. please refer to the JLG Parts Manual for the part number of the approved tires for a particular machine and model. If not using a JLG approved replacement tire, JLG recommends that replacement tires have the following characteristics:

- Equal or greater ply/load rating and size of original
- Tire tread contact width equal or greater than original
- Wheel diameter, width, and offset dimensions equal to the original.
- Approved for application by the tire manufacturer (Including inflation pressure and maximum tire load).

When selecting and installing a replacement tire, ensure that all tires are inflated to the pressure recommended by JLG. Due to size variations between tire brands, both tires on the same axle should be the same.

Wheel Replacement

The rims installed on each product model have been designed for stability requirements which consist of track width, tire pressure, and load capacity. Size changes such as rim width, center piece location, larger or smaller diameter, etc., without written factory recommendations, may result in an unsafe condition regarding stability.

Wheel Installation

It is extremely important to apply and maintain proper wheel mounting torque.

⚠ WARNING

WHEEL NUTS MUST BE INSTALLED AND MAINTAINED AT THE PROPER TORQUE TO PREVENT LOOSE WHEELS, BROKEN STUDS, AND POSSIBLE DANGEROUS SEPARATION OF WHEEL FROM THE AXLE. BE SURE TO USE ONLY THE NUTS MATCHED TO THE CONE ANGLE OF THE WHEEL.

Tighten the lug nuts to the proper torque to prevent wheels from coming loose. Use a torque wrench to tighten the fasteners. If you do not have a torque wrench, tighten the fasteners with a lug wrench, then immediately have a service garage or dealer tighten the lug nuts to the proper torque. Over-tightening will result in breaking the studs or permanently deforming the mounting stud holes in the wheels. The proper procedure for attaching wheels is as follows:

1. Start all nuts by hand to prevent cross threading. DO NOT use a lubricant on threads or nuts.
2. Tighten nuts in the following sequence:

5 LUG PATTERN

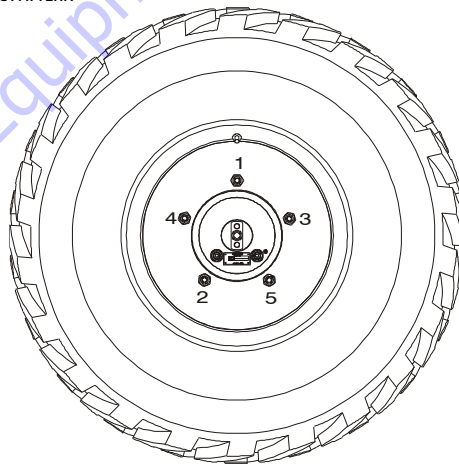

3. The tightening of the nuts should be done in stages. Using the recommended sequence, tighten the nuts per wheel torque chart following.

TORQUE SEQUENCE		
1st Stage	2nd Stage	3rd Stage
35 - 55 ft. lb. (49 - 77 Nm)	65 - 80 ft. lb. (91 - 112 Nm)	90 - 105 ft. lb. (126 - 142 Nm)

4. Wheel nuts should be torqued after the first 50 hours of operation and after each wheel removal. Check torque every 3 months or 150 hours of operation.

6.5 SUPPLEMENTAL INFORMATION

The following information is provided in accordance with the requirements of the European Machinery Directive 2006/42/EC and is only applicable to CE machines.

For electric powered machines, the equivalent continuous A-Weighted sound pressure level at the work platform is less than 70dB(A).

For combustion engine powered machines, guaranteed Sound Power Level (LWA) per European Directive 2000/ 14/EC (Noise Emission in the Environment by Equipment for Use Outdoors) based on test methods in accordance with Annex III, Part B, Method 1 and 0 of the directive, is 104 dB.

The vibration total value to which the hand-arm system is subjected does not exceed 2,5 m/s². The highest root mean square value of weighted acceleration to which the whole body is subjected does not exceed 0,5 m/s².

JLG[®]

An Oshkosh Corporation Company

**Discount
Equipment**

www.Discount-Equipment.com