

4527A

REACH MORE MORE REACH

- 51 ft working height

- 27 ft maximum outreach

- Platform jib + boom extension

- Automatic leveling

- Hydraulic outriggers

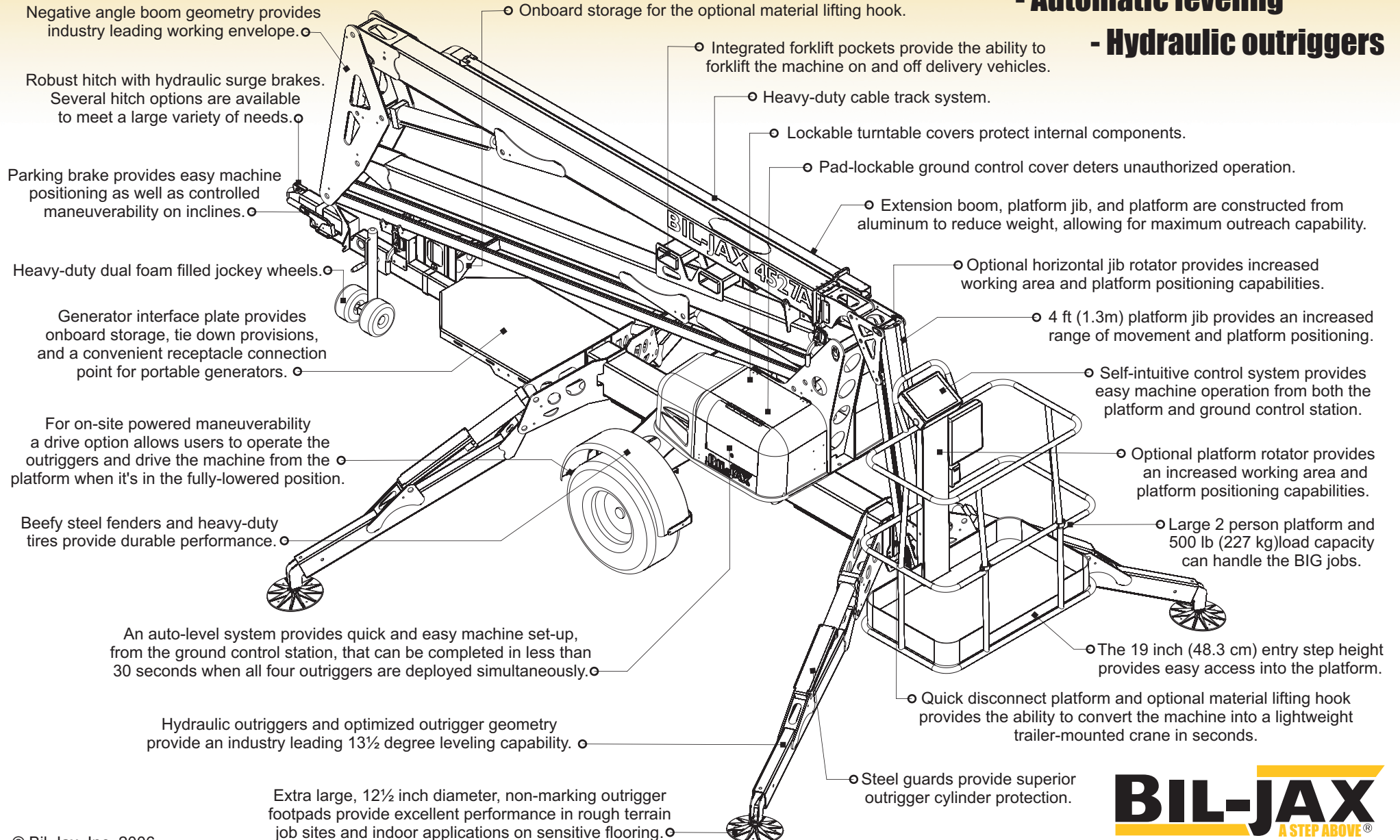

BIL-JAX 4527A

Automatic Leveling System

A self-leveling system provides quick and easy set-up in less than 30 seconds.

Hydraulic Outriggers

Optimized outrigger geometry provides industry leading leveling capability.

Working Envelope and Outreach

The articulating boom design features an upper telescopic extension boom that can be positioned at a negative angle and a platform jib providing exceptional reach, working envelope, and platform positioning capability.

Easy to Use

Both the platform and ground control station feature an easy-to-understand display panel with control buttons that are logically positioned around a single machine image for easy identification of button functions.

Versatile

A quick-disconnect platform and optional Material Lifting System provides the ability to convert the machine into a light duty crane.

Easy to Transport

The boom is easily towed with a Class 3 hitch. Convenient integrated forklift pockets are also provided.

Standard Features

- 51 ft (15.7 m) maximum working height
- 27 ft (8.2 m) working outreach
- 500 lb (227 kg) lift capacity
- Extension boom and platform jib
- Outrigger interlocks and tilt alarm/sensor
- Automatic leveling hydraulic outriggers
- Multiple control function speeds
- Self-leveling platform
- 110/60 GFI outlet in platform
- Surge and parking brakes
- Hour meter
- 12½-inch diameter non-marking footpads
- Heavy-duty 2-inch ball hitch

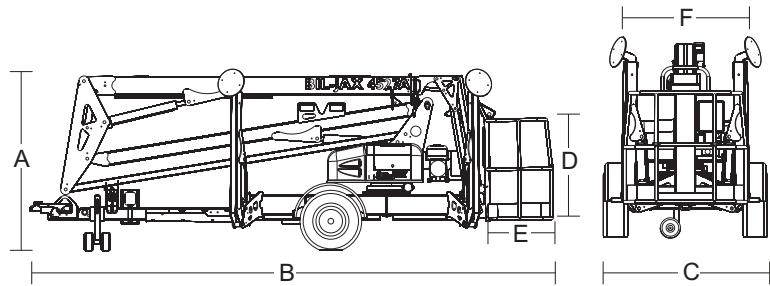

Product Specifications

	US	Metric
Working height ¹	51 ft	15.7 m
Maximum platform height ²	45 ft	13.7 m
Horizontal outreach		
Maximum (from centerline)	27 ft	8.2 m
Maximum (from edge of footpad)	21 ft	6.4 m
Up and over height	20 ft 9 in	6.3 m
Turntable rotation	700° non-continuous	
Load capacity	500 lbs	227 kg
(A) Height - stowed	76 3/4 in	195 cm
(B) Length - stowed	19 ft 6 in	5.9 m
(C) Width - stowed	5 ft 5 1/2 in	166 cm
(D) Height - platform	43 in	109 cm
(E) Length - platform	30 in	76 cm
(F) Width - platform	48 in	122 cm
Platform rotation (optional)	90° / manual	
Jib length	4 ft 3 in	1.3 m
Jib vertical motion	150° (+70 / -80)	
Jib rotation (optional)	180° / hydraulic	
Outrigger type	Hydraulic	
Leveling system	Auto Leveling	
Leveling capability	13 1/2°	
Outrigger footprint - length	12 ft 4 in	3.8 m
Outrigger footprint - width	11 ft 4 in	3.5 m
Footpad diameter	12 1/2 in	32 cm
Tow speed rating	65 mph	105 km/h
Tongue weight	170 lbs	77 kg
Overrun brakes	Standard	
Parking brake	Standard	
Tire size	ST 225/75 R15D	
Standard control system	24V DC	
Batteries	4 x 6V 245 amp-hr	
Charger	40 amp	
Total weight ³	3,880 lbs	1,760 kg

¹ The metric equivalent of working height adds 2 m to the maximum platform height.

U.S. adds 6 ft to the maximum platform height.

² Maximum platform height when outriggers are fully extended on a level surface.

³ Weight will vary depending on options and/or market destination.

Options:

- Material lifting system
- DC/Gas hybrid
- Drive and set
- Platform rotation
- Jib rotation
- Air line to platform
- Water line to platform
- Spare tire & wheel
- Tool tray
- Adjustable height combination hitch
- Various combination hitch couplers
- Custom colors

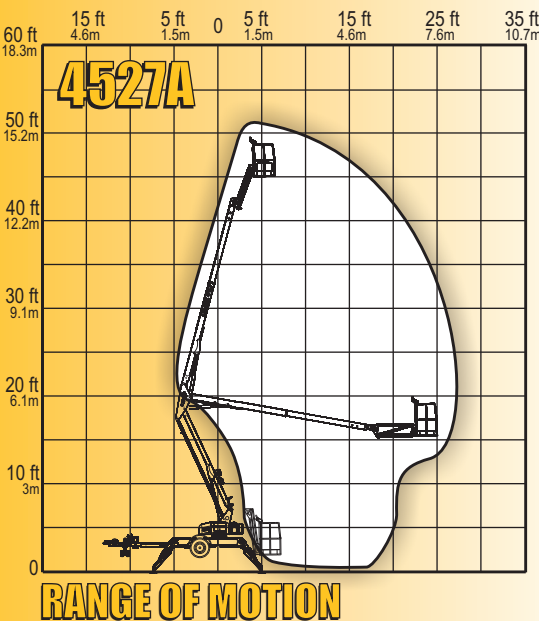

BIL-JAX TRAILER-MOUNTED
A STEP ABOVE® **BOOMS**

125 Taylor Parkway
Archbold, OH 43502-9309
419-445-8915 / 800-537-0540
Fax 419-445-0367 / www.biljax.com