



An Oshkosh Corporation Company



www.Discount-Equipment.com

Operation and Safety Manual

Original Instructions - Keep this manual with the machine at all times.

Models

450A

450AJ

PVC 2001

ANSI   **AS/NZS** **MOL70**

31215021

February 4, 2020 - Rev B

TO PURCHASE THIS PRODUCT PLEASE CONTACT US



**Equipment Financing and
Extended Warranties Available**



**Discount-Equipment.com is your online resource for
commercial and industrial quality parts and equipment sales.**

561-964-4949

visit us on line @ www.discount-equipment.com

Select an option below to find your Equipment

Search by Manufacturer

Search by Product Type

Request a Quote

We sell worldwide for the brands: Genie, Terex, JLG, MultiQuip, Mikasa, Essick, Whiteman, Mayco, Toro Stone, Diamond Products, Generac Magnum, Airman, Haulotte, Barreto, Power Blanket, Nifty Lift, Atlas Copco, Chicago Pneumatic, Allmand, Miller Curber, Skyjack, Lull, Skytrak, Tsurumi, Husquvarna Target, Stow, Wacker, Sakai, Mi-T-M, Sullair, Basic, Dynapac, MBW, Weber, Bartell, Bennar Newman, Haulotte, Ditch Runner, Menegotti, Morrison, Contec, Buddy, Crown, Edco, Wyco, Bomag, Laymor, EZ Trench, Bil-Jax, F.S. Curtis, Gehl Pavers, Heli, Honda, ICS/PowerGrit, IHI, Partner, Imer, Clipper, MMD, Koshin, Rice, CH&E, General Equipment, Amida, Coleman, NAC, Gradall, Square Shooter, Kent, Stanley, Tamco, Toku, Hatz, Kohler, Robin, Wisconsin, Northrock, Oztec, Toker TK, Rol-Air, APT, Wylie, Ingersoll Rand / Doosan, Innovatech, Con X, Ammann, Mecalac, Makinex, Smith Surface Prep, Small Line, Wanco, Yanmar



WARNING

Operating, servicing and maintaining this vehicle or equipment can expose you to chemicals including engine exhaust, carbon monoxide, phthalates, and lead, which are known to the State of California to cause cancer and birth defects or other reproductive harm. To minimize exposure, avoid breathing exhaust, do not idle the engine except as necessary, service your vehicle or equipment in a well-ventilated area and wear gloves or wash your hands frequently when servicing. For more information go to www.P65Warnings.ca.gov.

To order go to DiscountEquipment.com

FOREWORD

The Mobile Elevating Work Platform (MEWP) models covered in this manual are designed and tested to meet or exceed various compliance standards. Please refer to the manufacturer's nameplate affixed to the subject MEWP for specific standard compliance information.

This manual is a very important tool! Keep it with the machine at all times.

The purpose of this manual is to provide owners, users, operators, lessors, and lessees with the precautions and operating procedures essential for the safe and proper machine operation for its intended purpose.

Due to continuous product improvements, JLG Industries, Inc. reserves the right to make specification changes without prior notification. Contact JLG Industries, Inc. for updated information.

Refer to www.JLG.com for Warranty, Product Registration, and other machine-related documentation.

SAFETY ALERT SYMBOLS AND SAFETY SIGNAL WORDS



This is the Safety Alert Symbol. It is used to alert you to the potential personal injury hazards. Obey all safety messages that follow this symbol to avoid possible injury or death

DANGER

INDICATES AN IMMINENTLY HAZARDOUS SITUATION. IF NOT AVOIDED, WILL RESULT IN SERIOUS INJURY OR DEATH. THIS DECAL WILL HAVE A RED BACKGROUND.

WARNING

INDICATES A POTENTIALLY HAZARDOUS SITUATION. IF NOT AVOIDED, COULD RESULT IN SERIOUS INJURY OR DEATH. THIS DECAL WILL HAVE AN ORANGE BACKGROUND.

CAUTION

INDICATES A POTENTIALLY HAZARDOUS SITUATION. IF NOT AVOIDED, MAY RESULT IN MINOR OR MODERATE INJURY. IT MAY ALSO ALERT AGAINST UNSAFE PRACTICES. THIS DECAL WILL HAVE A YELLOW BACKGROUND.

NOTICE

INDICATES INFORMATION OR A COMPANY POLICY THAT RELATES DIRECTLY OR INDIRECTLY TO THE SAFETY OF PERSONNEL OR PROTECTION OF PROPERTY.

REVISION LOG

Original Issue A - October 10, 2019
Revision B - February 4, 2020

To order go to Discount-Equipment.com

SECTION - 1 - SAFETY PRECAUTIONS

1.1 GENERAL 1-1

1.2 PRE-OPERATION 1-1

 Operator Training and Knowledge 1-1

 Workplace Inspection 1-2

 Machine Inspection 1-3

1.3 OPERATION 1-3

 General 1-3

 Trip and Fall Hazards 1-4

 Electrocution Hazards 1-5

 Tipping Hazards 1-7

 Crushing and Collision Hazards 1-10

1.4 TOWING, LIFTING, AND HAULING 1-11

1.5 MAINTENANCE 1-11

 Maintenance Hazards 1-11

 Battery Hazards 1-12

SECTION - 2 - USER RESPONSIBILITIES, MACHINE PREPARATION, AND INSPECTION

2.1 PERSONNEL TRAINING 2-1

 Operator Training 2-1

 Training Supervision 2-1

 Operator Responsibility 2-2

 Machine Familiarization 2-2

2.2 PREPARATION, INSPECTION, AND MAINTENANCE 2-2

 Pre-Start Inspection 2-5

 Function Check 2-10

 SkyGuard Function Test 2-11

2.3 OSCILLATING AXLE LOCKOUT TEST 2-12

SECTION - 3 - MACHINE CONTROLS AND INDICATORS

3.1 GENERAL 3-1

3.2 CONTROLS AND INDICATORS 3-1

 Ground Control Console 3-5

 Ground Control Indicator Panel 3-9

 Ground Control Console Display Gauge 3-11

 Platform Console 3-15

 Platform Control Indicator Panel 3-20

SECTION - 4 - MACHINE OPERATION

4.1 DESCRIPTION 4-1

4.2 OPERATING CHARACTERISTICS AND LIMITATIONS 4-1

 Capacities 4-1

 Platform Load Sensing System (LSS) 4-2

 Stability 4-2

4.3 ENGINE OPERATION 4-4

 Starting Procedure 4-4

 Shutdown Procedure 4-5

 Fuel Reserve / Shut-Off System 4-6

4.4 DIESEL PARTICULATE FILTER (IF EQUIPPED) 4-7

 Standstill Cleaning 4-7

 Maintenance Standstill Cleaning Initiation Methods 4-9

 Canceling Maintenance Standstill 4-9

 Unsuccessful Cleaning Event 4-10

 DPF Filter Replacement due to Ash Load 4-10

TABLE OF CONTENTS

| | | |
|------|--|------|
| 4.5 | TRAVELING (DRIVING) | 4-15 |
| | Traveling Forward and Reverse | 4-16 |
| | Traveling on a Grade | 4-17 |
| 4.6 | STEERING | 4-17 |
| 4.7 | PLATFORM | 4-17 |
| | Platform Level Adjustment | 4-17 |
| | Platform Rotation | 4-17 |
| 4.8 | BOOM | 4-18 |
| | Swinging the Boom | 4-18 |
| | Raising and Lowering the Tower Boom | 4-18 |
| | Raising and Lowering the Main Boom | 4-18 |
| | Telescoping the Main Boom | 4-19 |
| 4.9 | FUNCTION SPEED CONTROL | 4-19 |
| 4.10 | MACHINE SAFETY SYSTEM OVERRIDE (MSSO) (IF EQUIPPED) | 4-19 |
| 4.11 | SKYGUARD OPERATION | 4-19 |
| | SkyGuard | 4-20 |
| | SkyGuard - SkyLine | 4-20 |
| | SkyGuard - SkyEye | 4-20 |
| | SkyGuard Function Table | 4-21 |
| 4.12 | SHUT DOWN AND PARK | 4-22 |
| | Shut Down and Park | 4-22 |
| 4.13 | LIFTING AND TIE DOWN | 4-22 |
| | Lifting | 4-22 |
| | Tie Down | 4-22 |

SECTION - 5 - EMERGENCY PROCEDURES

| | | |
|-----|--|-----|
| 5.1 | GENERAL | 5-1 |
| 5.2 | INCIDENT NOTIFICATION | 5-1 |
| 5.3 | EMERGENCY OPERATION | 5-1 |
| | Operator Unable to Control Machine | 5-1 |
| | Platform or Boom Caught Overhead | 5-2 |
| 5.4 | MANUAL SWING OVERRIDE | 5-2 |
| 5.5 | EMERGENCY TOWING PROCEDURES | 5-3 |
| 5.6 | MACHINE SAFETY SYSTEM OVERRIDE (MSSO) (IF EQUIPPED) | 5-4 |

SECTION - 6 - ACCESSORIES

| | | |
|-----|--|-----|
| 6.1 | FALL ARREST PLATFORM | 6-3 |
| | Safety Precautions | 6-3 |
| 6.2 | PIPE RACKS | 6-3 |
| | Capacity Specifications (Australia Only) | 6-4 |
| | Safety Precautions | 6-4 |
| | Preparation and Inspection | 6-4 |
| | Operation | 6-4 |
| 6.3 | SKYGLAZIER™ | 6-5 |
| | Capacity Specifications | 6-5 |
| | Safety Precautions | 6-6 |
| | Preparation and Inspection | 6-6 |
| | Operation | 6-6 |
| 6.4 | SKYPOWER™ | 6-7 |
| | Generator Output | 6-7 |
| | Accessory Ratings | 6-7 |
| | Safety Precautions | 6-8 |

| | | | | | |
|-----|----------------------------------|------|-----|--|------|
| | Preparation and Inspection | 6-8 | | Major Component Weights | 7-8 |
| | Operation | 6-8 | 7.3 | OPERATOR MAINTENANCE | 7-18 |
| 6.5 | SKYWELDER™ | 6-8 | 7.4 | TIRES & WHEELS | 7-30 |
| | Accessory Ratings | 6-9 | | Tire Replacement | 7-30 |
| | Generator Output | 6-9 | | Wheel and Tire Replacement | 7-30 |
| | Welding Accessories | 6-9 | | Wheel Installation | 7-30 |
| | Safety Precautions | 6-10 | 7.5 | PROPANE FUEL FILTER REPLACEMENT (KUBOTA ENGINE) | 7-31 |
| | Preparation and Inspection | 6-10 | | Removal | 7-31 |
| | Operation | 6-10 | | Installation | 7-32 |
| 6.6 | SOFT TOUCH™ | 6-11 | 7.6 | PROPANE FUEL SYSTEM PRESSURE RELIEF | 7-33 |
| 6.7 | SKYSENSE™ | 6-11 | 7.7 | SUPPLEMENTAL INFORMATION | 7-33 |
| | Preparation and Inspection | 6-12 | | | |
| | Operation | 6-12 | | | |
| | SkySense Alarm | 6-14 | | | |
| | Override Button | 6-14 | | | |
| | SkySense Coverage Areas | 6-15 | | | |

SECTION - 8 - INSPECTION AND REPAIR LOG

SECTION - 7 - GENERAL SPECIFICATIONS & OPERATOR MAINTENANCE

| | | |
|-----|--|-----|
| 7.1 | INTRODUCTION | 7-1 |
| 7.2 | OPERATING SPECIFICATIONS AND PERFORMANCE | |
| | DATA | 7-1 |
| | Operating Specifications | 7-1 |
| | Dimensional Data | 7-2 |
| | Capacities | 7-2 |
| | Tires | 7-3 |
| | Engine Data | 7-3 |
| | Hydraulic Oil | 7-5 |

| | | |
|------|---|------|
| 1-1 | Minimum Approach Distances (M.A.D.) | 1-6 |
| 1-2 | Beaufort Scale (For Reference Only)..... | 1-9 |
| 2-1 | Inspection and Maintenance Table | 2-3 |
| 4-1 | Ash Load DPF Filter Replacement..... | 4-11 |
| 4-2 | Maintenance Standstill Cleaning..... | 4-12 |
| 4-3 | Standstill Cleaning: DPF Filled with Soot | 4-13 |
| 4-2 | Decal Legend - Kubota Engine-Powered Machines ... | 4-26 |
| 4-4 | Decal Legend - Language Markets | 4-30 |
| 6-1 | Available Accessories | 6-1 |
| 6-2 | Options/Accessories Relationship Table..... | 6-2 |
| 7-1 | Operating Specifications | 7-1 |
| 7-2 | Dimensional Data..... | 7-2 |
| 7-3 | Capacities | 7-2 |
| 7-4 | Tires | 7-3 |
| 7-5 | Deutz D201 1L03 | 7-3 |
| 7-6 | Deutz D2.9L4 | 7-4 |
| 7-7 | Kubota WG 2503 | 7-4 |
| 7-8 | Hydraulic Oil..... | 7-5 |
| 7-9 | Mobilfluid 424 Specs..... | 7-5 |
| 7-10 | DTE 10 Excel 15 Specs | 7-6 |
| 7-11 | Quintolubric 888-46..... | 7-6 |
| 7-12 | Mobil EAL 224H Specs..... | 7-7 |
| 7-13 | Exxon Univis HVI 26 Specs..... | 7-7 |
| 7-14 | Critical Stability Weights..... | 7-8 |
| 7-15 | Lubrication Specifications..... | 7-18 |
| 7-16 | Wheel Torque Chart..... | 7-31 |
| 8-1 | Inspection and Repair Log..... | 8-1 |

LIST OF FIGURES

| | | | | | |
|-------|---|------|-----------------|--|------|
| 2-1. | Basic Nomenclature..... | 2-4 | Deutz 2.9L..... | 7-11 | |
| 3-1. | Ground Control Console without MSSO..... | 3-2 | 7-4. | Hydraulic Oil Operation Chart - Sheet 1 of 2..... | 7-12 |
| 3-2. | Ground Control Console with MSSO..... | 3-3 | 7-5. | Hydraulic Oil Operation Chart - Sheet 2 of 2..... | 7-13 |
| 3-2. | Ground Control Panel with MSSO and DPF..... | 3-4 | 7-6. | Engine Oil Operation Chart - Kubota..... | 7-14 |
| 3-3. | Ground Control Indicator Panel..... | 3-8 | 7-7. | Operator Maintenance and Lubrication Diagram - Deutz 2.3L Engine..... | 7-15 |
| 3-4. | Splash Screen..... | 3-11 | 7-8. | Operator Maintenance and Lubrication Diagram - Deutz 2.9L Engine..... | 7-16 |
| 3-5. | Diagnostic Screen..... | 3-12 | 7-9. | Operator Maintenance and Lubrication Diagram - Kubota Engine..... | 7-17 |
| 3-6. | Engine Diagnostic Screen..... | 3-12 | 7-10. | Kubota Filter Lock Assembly..... | 7-32 |
| 3-7. | Ground Control Console Display Gauge..... | 3-13 | | | |
| 3-8. | Platform Control Console..... | 3-14 | | | |
| 3-9. | Platform Control Indicator Panel..... | 3-19 | | | |
| 4-1. | Position of Least Forward Stability..... | 4-3 | | | |
| 4-2. | Position of Least Backward Stability..... | 4-4 | | | |
| 4-3. | Grade and Side Slopes..... | 4-14 | | | |
| 4-4. | Traveling on a Grade..... | 4-17 | | | |
| 4-5. | Lifting and Tie Down Chart..... | 4-23 | | | |
| 4-6. | Decal Location Sheet 1 of 6..... | 4-24 | | | |
| 4-7. | Decal Location Sheet 2 of 6..... | 4-25 | | | |
| 4-8. | Decal Location Sheet 3 of 6..... | 4-26 | | | |
| 4-9. | Decal Location Sheet 4 of 6..... | 4-27 | | | |
| 4-10. | Decal Location Sheet 5 of 6..... | 4-28 | | | |
| 4-11. | Decal Location Sheet 6 of 6..... | 4-29 | | | |
| 6-1. | SkySense Platform Panel Indicators..... | 6-13 | | | |
| 7-1. | Engine Operating Temperature Specifications - Deutz 2.3L - Sheet 1 of 2..... | 7-9 | | | |
| 7-2. | Engine Operating Temperature Specifications - Deutz 2.3L - Sheet 2 of 2..... | 7-10 | | | |
| 7-3. | Engine Operating Temperature Specifications - | | | | |

SECTION 1. SAFETY PRECAUTIONS

1.1 GENERAL

This section outlines the necessary precautions for proper and safe machine usage and maintenance. It is mandatory that a daily routine is established based on the content of this manual to promote proper machine usage. A maintenance program, using the information provided in this manual and the Service and Maintenance Manual, must also be established by a qualified person and must be followed to ensure that the machine is safe to operate.

The owner/user/operator/lessor/lessee of the machine must not accept operating responsibility until this manual has been read, training is accomplished, and operation of the machine has been completed under the supervision of an experienced and qualified operator.

This section contains the responsibilities of the owner, user, operator, lessor, and lessee concerning safety, training, inspection, maintenance, application, and operation. If there are any questions with regard to safety, training, inspection, maintenance, application, and operation, please contact JLG Industries, Inc. ("JLG").

WARNING

FAILURE TO COMPLY WITH THE SAFETY PRECAUTIONS LISTED IN THIS MANUAL COULD RESULT IN MACHINE DAMAGE, PROPERTY DAMAGE, PERSONAL INJURY OR DEATH.

1.2 PRE-OPERATION

Operator Training and Knowledge

- Read, understand, and study the Operation and Safety Manual in its entirety before operating the machine. For clarification, questions, or additional information regarding any portions of this manual, contact JLG Industries, Inc.

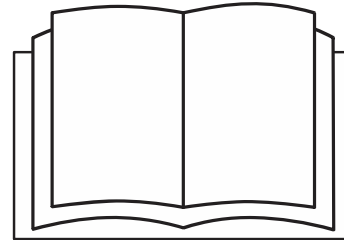

SECTION 1 - SAFETY PRECAUTIONS

- Only personnel who have received proper training regarding the inspection, application and operation of MEWPs (including recognition and avoiding hazards associated with their operation) shall be authorized to operate a MEWP.
- Only properly trained personnel who have received unit-specific familiarization shall operate a MEWP. The user shall determine if personnel are qualified to operate the MEWP prior to operation.
- Read, understand, and obey all DANGERS, WARNINGS, CAUTIONS, and operating instructions on the machine and in this manual.
- Ensure that the machine is to be used in a manner which is within the scope of its intended application as determined by JLG.
- All operating personnel must have a thorough understanding of the intended purpose and function of the MEWP controls, including platform, ground and emergency descent controls.
- Read, understand, and obey all applicable employer, local, and governmental regulations as they pertain to your utilization and application of the machine.

Workplace Inspection

- Precautions to avoid all hazards in the work area must be taken by the user before and during operation of the machine.
- Do not operate or raise the platform from a position on trucks, trailers, railway cars, floating vessels, scaffolds or other equipment unless the application is approved in writing by JLG.
- Before operation, check work area for overhead hazards such as electric lines, bridge cranes, and other potential overhead obstructions.
- Check operating surfaces for holes, bumps, drop-offs, obstructions, debris, concealed holes, and other potential hazards.
- Check the work area for hazardous locations. Do not operate the machine in hazardous environments unless approved for that purpose by JLG.
- Ensure that the ground conditions are adequate to support the maximum tire load indicated on the tire load decals located on the chassis adjacent to each wheel. Do not travel on unsupported surfaces.

Machine Inspection

- Do not operate this machine until the inspections and functional checks as specified in Section 2 of this manual have been performed.
- Do not operate this machine until it has been serviced and maintained according to the maintenance and inspection requirements as specified in the machine's Service and Maintenance Manual.
- Ensure all safety devices are operating properly. Modification of these devices is a safety violation.

WARNING

MODIFICATION OR ALTERATION OF A MEWP SHALL BE MADE ONLY WITH PRIOR WRITTEN PERMISSION FROM THE MANUFACTURER.

- Do not operate any machine on which the safety or instruction placards or decals are missing or illegible.
- Check the machine for modifications to original components. Ensure that any modifications have been approved by JLG.
- Avoid accumulation of debris on platform floor. Keep mud, oil, grease, and other slippery substances from footwear and platform floor.

1.3 OPERATION

General

- Machine operation requires your full attention. Bring the machine to a full stop before using any device, i.e. cell phones, two-way radios, etc. that will distract your attention from safely operating the machine.
- Do not use the machine for any purpose other than positioning personnel, their tools, and equipment.
- Before operation, the user must be familiar with the machine capabilities and operating characteristics of all functions.
- Never operate a malfunctioning machine. If a malfunction occurs, shut down the machine. Remove the unit from service and notify the proper authorities.
- Do not remove, modify, or disable any safety devices.
- Never slam a control switch or lever through neutral to an opposite direction. Always return switch to neutral and stop before moving the switch to the next function. Operate controls with slow and even pressure.
- Do not allow personnel to tamper with or operate the machine from the ground with personnel in the platform, except in an emergency.

SECTION 1 - SAFETY PRECAUTIONS

- Do not carry materials directly on platform railing unless approved by JLG.
- When two or more persons are in the platform, the operator shall be responsible for all machine operations.
- Always ensure that power tools are properly stowed and never left hanging by their cord from the platform work area.
- When driving, always position boom over rear axle in line with the direction of travel. Remember, if boom is over the front axle, steer and drive functions will be reversed.
- Do not assist a stuck or disabled machine by pushing or pulling except by pulling at the chassis tie-down lugs.
- Fully lower platform and shut off all power before leaving machine.
- Remove all rings, watches, and jewelry when operating machine. Do not wear loose fitting clothing or long hair unrestrained which may become caught or entangled in equipment.
- Persons under the influence of drugs or alcohol or who are subject to seizures, dizziness or loss of physical control must not operate this machine.

- Hydraulic cylinders are subject to thermal expansion and contraction. This may result in changes to the platform position while the machine is stationary. Factors affecting thermal movement can include the length of time the machine will remain stationary, hydraulic oil temperature, ambient air temperature, and platform position.

Trip and Fall Hazards

- Prior to operation, ensure all gates are closed and fastened in their proper position.
- During operation, occupants in the platform must wear a full body harness with a lanyard attached to an authorized lanyard anchorage point. Attach only one (1) lanyard per lanyard anchorage point.

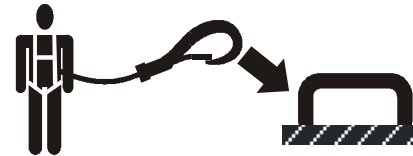

- Enter and exit only through gate area. Use extreme caution when entering or leaving platform. Ensure that the platform assembly is fully lowered. Face the platform when entering or leaving the platform. Always maintain three points of contact with the machine, using two hands and one foot or two feet and one hand at all times during entry and exit.

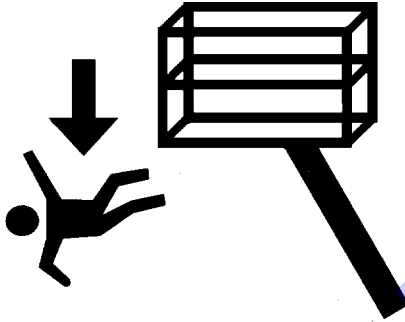

- Keep both feet firmly positioned on the platform floor at all times. Never position ladders, boxes, steps, planks, or similar items on unit to provide additional reach for any purpose.
- Keep oil, mud, and slippery substances cleaned from footwear and the platform floor.

Electrocution Hazards

- This machine is not insulated and does not provide protection from contact or proximity to electrical current.

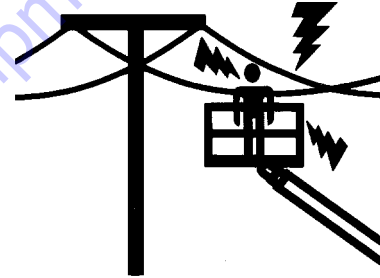

SECTION 1 - SAFETY PRECAUTIONS

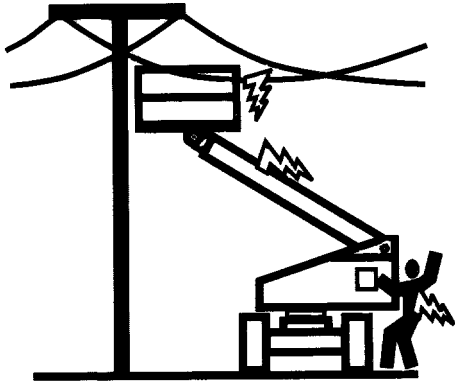

- Maintain distance from electrical lines, apparatus, or any energized (exposed or insulated) parts according to the Minimum Approach Distance (MAD) as shown in Table 1-1.
- Allow for machine movement and electrical line swaying.

Table 1-1. Minimum Approach Distances (M.A.D.)

| Voltage Range (Phase to Phase) | MINIMUM APPROACH DISTANCE in Feet (Meters) |
|---|---|
| 0 to 50 KV | 10 (3) |
| Over 50KV to 200 KV | 15 (5) |
| Over 200 KV to 350 KV | 20 (6) |
| Over 350 KV to 500 KV | 25 (8) |
| Over 500 KV to 750 KV | 35 (11) |
| Over 750 KV to 1000 KV | 45 (14) |

NOTE: *This requirement shall apply except where employer, local or governmental regulations are more stringent.*

- Maintain a clearance of at least 10 ft. (3m) between any part of the machine and its occupants, their tools, and their equipment from any electrical line or apparatus carrying up to 50,000 volts. One foot additional clearance is required for every additional 30,000 volts or less.

- The minimum approach distance may be reduced if insulating barriers are installed to prevent contact, and the barriers are rated for the voltage of the line being guarded. These barriers shall not be part of (or attached to) the machine. The minimum approach distance shall be reduced to a distance within the designed working dimensions of the insulating barrier. This determination shall be made by a qualified person in accordance with the employer, local, or governmental requirements for work practices near energized equipment.

⚠ DANGER

DO NOT MANEUVER MACHINE OR PERSONNEL INSIDE PROHIBITED ZONE (MAD). ASSUME ALL ELECTRICAL PARTS AND WIRING ARE ENERGIZED UNLESS KNOWN OTHERWISE.

Tipping Hazards

- Ensure that the ground conditions are adequate to support the maximum tire load indicated on the tire load decals located on the chassis adjacent to each wheel. Do not travel on unsupported surfaces.
- The user must be familiar with the operating surface before driving. Do not exceed the allowable sideslope and grade while driving.

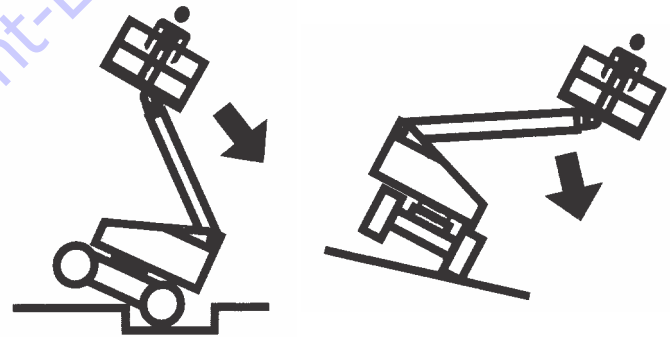

- Do not elevate platform or drive with platform elevated while on or near a sloping, uneven, or soft surface. Ensure machine is positioned on a smooth, firm surface within the limits of the maximum operating slope before elevating platform or driving with the platform in the elevated position.

SECTION 1 - SAFETY PRECAUTIONS

- Before driving on floors, bridges, trucks, and other surfaces, check allowable capacity of the surfaces.
- Never exceed the maximum platform capacity as specified on the platform. Keep all loads within the confines of the platform, unless authorized by JLG.
- Keep the chassis of the machine a minimum of 2 ft. (0.6m) from holes, bumps, drop-offs, obstructions, debris, concealed holes, and other potential hazards at the ground level.
- Do not push or pull any object with the boom.
- Never attempt to use the machine as a crane. Do not tie-off machine to any adjacent structure. Never attach wire, cable, or any similar items to platform.
- If boom assembly or platform is in a position that one or more wheels are off the ground, all persons must be removed before attempting to stabilize the machine. Use cranes, forklift trucks, or other appropriate equipment to stabilize machine.
- Do not operate the machine when wind conditions exceed specifications shown in Section 7.2 of this manual or as shown on the capacity placard on the platform billboard. Factors affecting wind speed are; platform elevation, surrounding structures, local weather events, and approaching storms.
- Wind speed can be significantly greater at height than at ground level.
- Wind speed can change rapidly. Always consider approaching weather events, the time required to lower the platform, and methods to monitor current and potential wind conditions.
- Do not cover or increase surface area of the platform or the load. Do not carry large surface area items in the platform when operating outdoors. The addition of such items increases the exposed wind area of the machine. Increased areas exposed to wind will decrease stability.
- Do not increase the platform size with unauthorized modifications or attachments.

NOTICE

DO NOT OPERATE THE MACHINE WHEN WIND CONDITIONS EXCEED SPECIFICATIONS SHOWN IN SECTION 7.2 OR AS SHOWN ON THE CAPACITY PLACARD ON THE PLATFORM BILLBOARD.

Table 1-2. Beaufort Scale (For Reference Only)

| Beaufort Number | Wind Speed | | Description | Land Conditions |
|-----------------|------------|-----------|-------------------------|---|
| | mph | m/s | | |
| 0 | 0 | 0-0.2 | Calm | Calm. Smoke rises vertically |
| 1 | 1-3 | 0.3-1.5 | Light air | Wind motion visible in smoke |
| 2 | 4-7 | 1.6-3.3 | Light breeze | Wind felt on exposed skin. Leaves rustle |
| 3 | 8-12 | 3.4-5.4 | Gentle breeze | Leaves and smaller twigs in constant motion |
| 4 | 13-18 | 5.5-7.9 | Moderate breeze | Dust and loose paper raised. Small branches begin to move. |
| 5 | 19-24 | 8.0-10.7 | Fresh breeze | Smaller trees sway. |
| 6 | 25-31 | 10.8-13.8 | Strong breeze | Large branches in motion. Flags waving near horizontal. Umbrella use becomes difficult. |
| 7 | 32-38 | 13.9-17.1 | Near Gale/Moderate Gale | Whole trees in motion. Effort needed to walk against the wind. |
| 8 | 39-46 | 17.2-20.7 | Fresh Gale | Twigs broken from trees. Cars veer on road. |
| 9 | 47-54 | 20.8-24.4 | Strong Gale | Light structure damage. |

Crushing and Collision Hazards

- Approved head gear must be worn by all operating and ground personnel.
- Watch for obstructions around machine and overhead when driving. Check clearances above, on sides, and bottom of platform during all operations.

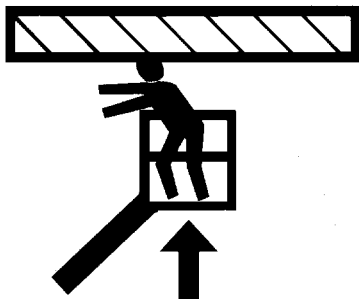

- During operation, keep all body parts inside platform railing.
- Use the boom functions, not the drive function, to position the platform close to obstacles.
- Always post a lookout when driving in areas where vision is obstructed.

- Keep non-operating personnel at least 6 ft. (1.8m) away from machine during all operations.
- Under all travel conditions, the operator must limit travel speed according to conditions of ground surface, congestion, visibility, slope, location of personnel, and other factors.
- Be aware of stopping distances in all drive speeds. When driving in high speed, reduce drive speed before stopping. Travel grades in low speed only.
- Do not use high speed drive in restricted or close quarters or when driving in reverse.
- Exercise extreme caution at all times to prevent obstacles from striking or interfering with operating controls and persons in the platform.
- Ensure that operators of other overhead and floor level machines are aware of the MEWP's presence. Disconnect power to overhead cranes.
- Do not operate over ground personnel. Warn personnel not to work, stand, or walk under a raised boom or platform. Position barricades on floor if necessary.

1.4 TOWING, LIFTING, AND HAULING

- Never allow personnel in platform while towing, lifting, or hauling.
- This machine should not be towed, except in the event of emergency, malfunction, power failure, or loading/unloading. Refer to the Emergency Procedures section of this manual for emergency towing procedures.
- Ensure boom is in the stowed position and, if equipped, the turntable locked prior to towing, lifting or hauling. The platform must be completely empty of tools.
- When lifting machine, lift only at designated areas of the machine. Lift the unit with equipment of adequate capacity.
- Refer to the Machine Operation section of this manual for lifting information.

1.5 MAINTENANCE

This sub-section contains general safety precautions which must be observed during maintenance of this machine. Additional precautions to be observed during machine maintenance are inserted at the appropriate points in this manual and in the Service and Maintenance Manual. It is of utmost importance that maintenance personnel pay strict attention to these precautions to avoid possible injury to personnel or damage to the machine or property. A maintenance program must be established by a qualified person and must be followed to ensure that the machine is safe.

Maintenance Hazards

- Shut off power to all controls and ensure that all moving parts are secured from inadvertent motion prior to performing any adjustments or repairs.
- Never work under an elevated platform until it has been fully lowered to the full down position, if possible, or otherwise supported and restrained from movement with appropriate safety props, blocking, or overhead supports.
- DO NOT attempt to repair or tighten any hydraulic hoses or fittings while the machine is powered on or when the hydraulic system is under pressure.
- Always relieve hydraulic pressure from all hydraulic circuits before loosening or removing hydraulic components.

SECTION 1 - SAFETY PRECAUTIONS

- DO NOT use your hand to check for leaks. Use a piece of cardboard or paper to search for leaks. Wear gloves to help protect hands from spraying fluid.



- Use only replacement parts or components that are approved by JLG. To be considered approved, replacement parts or components must be identical or equivalent to original parts or components.
- Never attempt to move heavy parts without the aid of a mechanical device. Do not allow heavy objects to rest in an unstable position. Ensure adequate support is provided when raising components of the machine.
- Do not use machine as a ground for welding.
- When performing welding or metal cutting operations, precautions must be taken to protect the chassis from direct exposure to weld and metal cutting spatter.
- Do not refuel the machine with the engine running.
- Use only approved non-flammable cleaning solvents.
- Do not replace items critical to stability, such as batteries or solid tires, with items of different weight or specification. Do not modify the MEWP in any way to affect stability.
- Refer to the Service and Maintenance Manual for the weights of critical stability items.

⚠ WARNING

MODIFICATION OR ALTERATION OF A MEWP SHALL BE MADE ONLY WITH PRIOR WRITTEN PERMISSION FROM THE MANUFACTURER.

Battery Hazards

- Always disconnect batteries when servicing electrical components or when performing welding on the machine.
- Do not allow smoking, open flame, or sparks near battery during charging or servicing.
- Do not contact tools or other metal objects across the battery terminals.
- Always wear hand, eye, and face protection when servicing batteries. Ensure that battery acid does not come in contact with skin or clothing.

⚠ CAUTION

BATTERY FLUID IS HIGHLY CORROSIVE. AVOID CONTACT WITH SKIN AND CLOTHING AT ALL TIMES. IMMEDIATELY RINSE ANY CONTACTED AREA WITH CLEAN WATER AND SEEK MEDICAL ATTENTION.

- Charge batteries only in a well ventilated area.
- Avoid overfilling the battery fluid level. Add distilled water to batteries only after the batteries are fully charged.

SECTION 2. USER RESPONSIBILITIES, MACHINE PREPARATION, AND INSPECTION

2.1 PERSONNEL TRAINING

The Mobile Elevating Work Platform (MEWP) is a personnel handling device; so it is necessary that it be operated and maintained only by trained personnel.

Operator Training

Operator training must cover:

1. Reading and understanding the Operation and Safety Manual.
2. Thorough understanding of the intended purpose and function of the MEWP controls, including platform, ground, and emergency descent controls.
3. Control labels, instructions, and warnings on the machine.
4. Applicable regulations, standards, and safety rules.
5. Use of approved fall protection equipment.
6. Enough knowledge of the mechanical operation of the machine to recognize a malfunction or potential malfunction.
7. The safest means to operate the machine where overhead obstructions, other moving equipment, and obstacles, depressions, holes, and drop-offs exist.
8. Means to avoid the hazards of unprotected electrical conductors.
9. Selection of the appropriate MEWP and available options for the work to be performed considering specific job requirements, with involvement from the MEWP owner, user, and/or supervisor.
10. The responsibility of the operator to ensure all platform occupants have a basic level of knowledge to work safely on the MEWP, and to inform them of applicable regulations, standards, and safety rules.
11. The requirement for familiarization in addition to training.

Training Supervision

Training must be delivered by a qualified person in an open area, free of hazards until the trainee has demonstrated the ability to safely control and operate the machine.

Operator Responsibility

The operator must be instructed they have the responsibility and authority to shut down the machine in case of a malfunction or other unsafe condition of either the machine or the job site.

Machine Familiarization

NOTE: Responsibilities for familiarization may vary by region.

Only properly trained personnel who have received unit-specific familiarization shall operate a MEWP. The user shall determine if personnel are qualified to operate the MEWP prior to operation. The user shall ensure that after familiarization, the operator operates the MEWP for a sufficient period of time to achieve proficiency. When authorized by the user, self-familiarization can be achieved, if authorized, by a properly trained operator reading, understanding and following the manufacturer's operator's manual.

Prior to users authorization of an operator to use a specific model of MEWP, the user shall ensure the operator is familiarized on the following:

1. Location of the manual storage compartment and the requirement to ensure the required manual(s) are present on the MEWP;
2. Purpose and function of the machine controls and indicators at the platform and ground control stations;
3. Purpose, location, and function of the emergency controls;

4. Operating characteristics and limitations;
5. Features and devices;
6. Accessories and optional equipment.

2.2 PREPARATION, INSPECTION, AND MAINTENANCE

The following table covers machine inspections and maintenance required by JLG Industries, Inc. Consult local regulations for further requirements for MEWPs. Frequency of inspections and maintenance must be increased as necessary when machine is used in a harsh or hostile environment, if machine is used with increased frequency, or if machine is used in a severe manner.

SECTION 2 - USER RESPONSIBILITIES, MACHINE PREPARATION, AND INSPECTION

Table 2-1. Inspection and Maintenance Table

| Type | Frequency | Primary Responsibility | Service Qualification | Reference |
|--------------------------------------|---|------------------------|--|---|
| Pre-Start Inspection | Before using each day; or whenever there's an Operator change. | User or Operator | User or Operator | Operator and Safety Manual |
| Pre-Delivery Inspection (See Note) | Before each sale, lease, or rental delivery. | Owner, Dealer, or User | Qualified JLG Mechanic | Service and Maintenance Manual and applicable JLG inspection form |
| Frequent Inspection (See Note) | In service for 3 months or 150 hours, whichever comes first; or Out of service for a period of more than 3 months; or Purchased used. | Owner, Dealer, or User | Qualified JLG Mechanic | Service and Maintenance Manual and applicable JLG inspection form |
| Annual Machine Inspection (See Note) | Annually, no later than 13 months from the date of prior inspection. | Owner, Dealer, or User | Factory Trained Service Technician (Recommended) | Service and Maintenance Manual and applicable JLG inspection form |
| Preventative Maintenance | At intervals as specified in the Service and Maintenance Manual. | Owner, Dealer, or User | Qualified JLG Mechanic | Service and Maintenance Manual |

NOTE: Inspection forms are available from JLG. Use the Service and Maintenance Manual to perform inspections.

NOTICE

JLG INDUSTRIES, INC. RECOGNIZES A FACTORY TRAINED SERVICE TECHNICIAN AS A PERSON WHO HAS SUCCESSFULLY COMPLETED THE JLG SERVICE TRAINING SCHOOL FOR THE SPECIFIC JLG PRODUCT MODEL.

SECTION 2 - USER RESPONSIBILITIES, MACHINE PREPARATION, AND INSPECTION

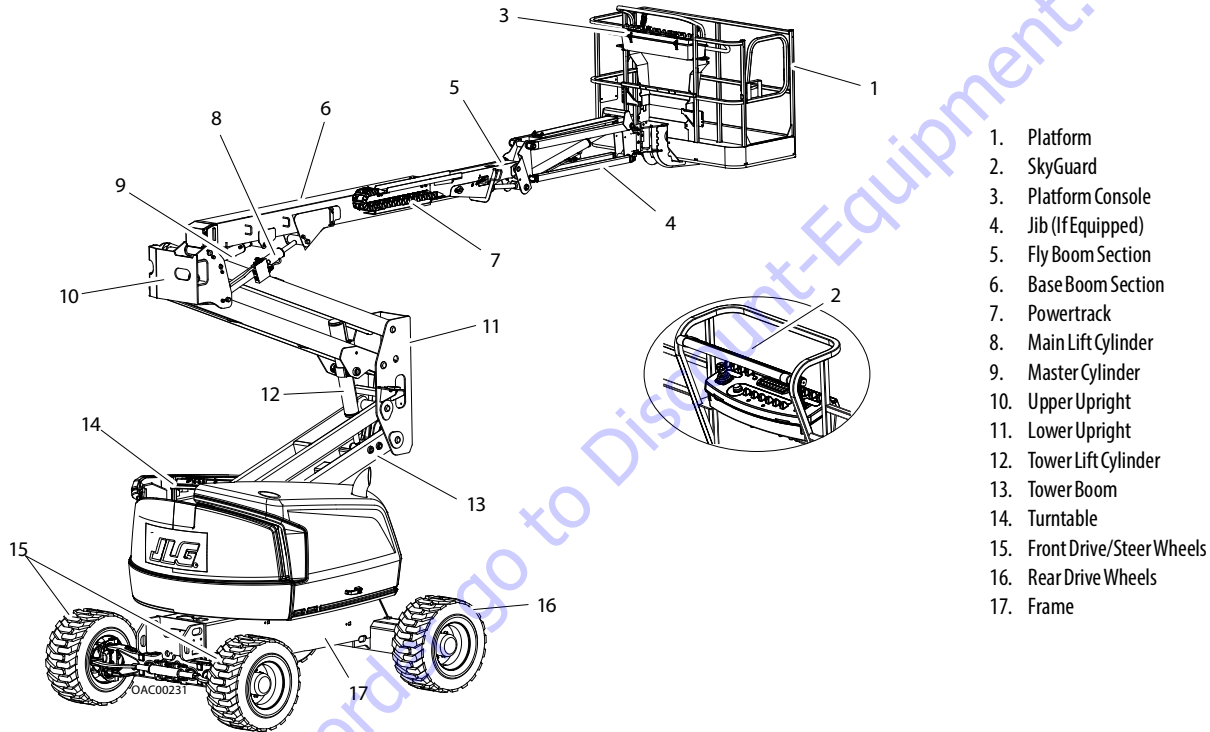
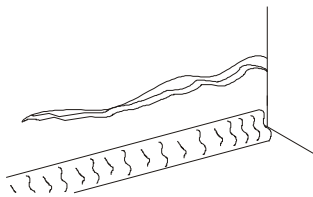

Figure 2-1. Basic Nomenclature

Pre-Start Inspection

The Pre-Start Inspection should include each of the following:

1. **Cleanliness** – Check all surfaces for leakage (oil, fuel, or battery fluid) or foreign objects. Report any leakage to the proper maintenance personnel.
2. **Structure** – Inspect the machine structure for dents, damage, weld or parent metal cracks or other discrepancies.



Parent Metal Crack

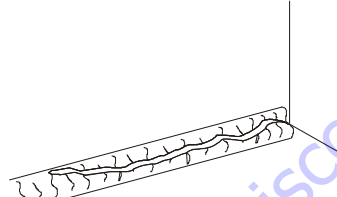

Weld Crack

3. **Decals and Placards** – Check all for cleanliness and legibility. Make sure none of the decals and placards are missing. Make sure all illegible decals and placards are cleaned or replaced.
4. **Operation and Safety Manuals** – Make sure a copy of the Operation and Safety Manual, AEM Safety Manual (ANSI markets only), and ANSI Manual of Responsibilities (ANSI markets only) is enclosed in the weather resistant storage container.

5. **Walk-Around Inspection** – Perform as instructed.
6. **Battery** – Charge as required.
7. **Fuel** (Combustion Engine Powered Machines) – Add the proper fuel as necessary.
8. **Engine Oil Supply** – Ensure the engine oil level is at the Full mark on the dipstick and the filler cap is secure.
9. **Hydraulic Oil** – Check the hydraulic oil level. Ensure hydraulic oil is added as required.
10. **Accessories/Attachments** – Refer to the Accessories section in this manual or the accessory installed upon the machine for specific inspection, operation, and maintenance instructions.
11. **Function Check** – Once the Walk-Around Inspection is complete, perform a functional check of all systems in an area free of overhead and ground level obstructions. Refer to Section 4 for more specific operating instructions.
12. **Platform Gate** – Keep gate and surrounding area clean and unobstructed. Verify the gate closes properly and is not bent or damaged. Keep gate closed at all times except when entering/exiting the platform and loading/unloading materials.

SECTION 2 - USER RESPONSIBILITIES, MACHINE PREPARATION, AND INSPECTION

- 13. Lanyard Attach Points** – During operation, occupants in the platform must wear a full body harness with a lanyard attached to an authorized lanyard anchorage point. Attach only one (1) lanyard per lanyard anchorage point.

⚠ WARNING

IF THE MACHINE DOES NOT OPERATE PROPERLY, TURN OFF THE MACHINE IMMEDIATELY! REPORT THE PROBLEM TO THE PROPER MAINTENANCE PERSONNEL. DO NOT OPERATE THE MACHINE UNTIL IT IS DECLARED SAFE FOR OPERATION.

To order go to Discount-Equipment.com

Walk-Around Inspection

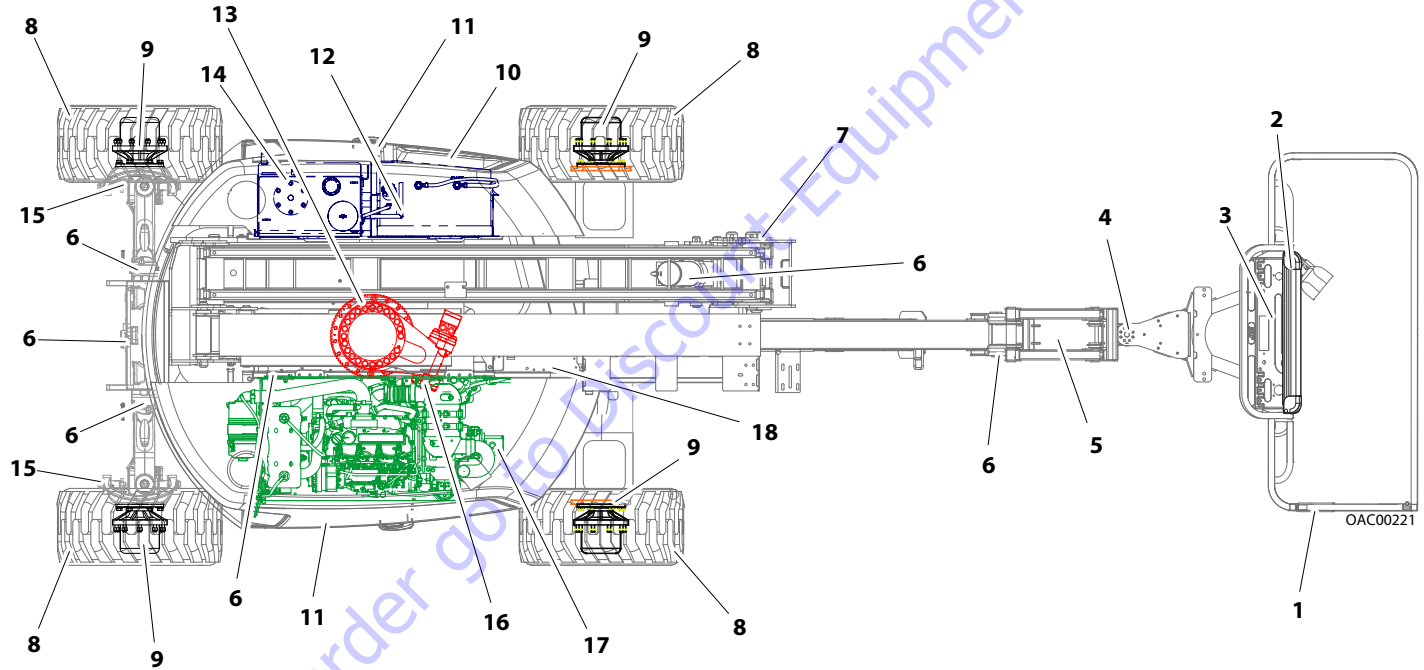

SECTION 2 - USER RESPONSIBILITIES, MACHINE PREPARATION, AND INSPECTION

Begin the Walk-Around Inspection at Item 1, as noted on the diagram. Continue checking each item in sequence for the conditions listed in the following checklist.

WARNING

TO AVOID POSSIBLE INJURY, BE SURE MACHINE POWER IS OFF. DO NOT OPERATE MACHINE UNTIL ALL MALFUNCTIONS HAVE BEEN CORRECTED.

NOTICE

DO NOT OVERLOOK VISUAL INSPECTION OF CHASSIS UNDERSIDE. CHECKING THIS AREA MAY RESULT IN DISCOVERY OF CONDITIONS WHICH COULD CAUSE EXTENSIVE MACHINE DAMAGE.

***INSPECTION NOTE:** On all components, make sure there are no loose or missing parts, that they are securely fastened, and no visible damage, leaks or excessive wear exists in addition to any other criteria mentioned.*

- 1. Platform Assembly and Gate** - Footswitch works properly, not modified, disabled or blocked. Gate latches and hinges in working condition.
- 2. SkyGuard** - See Inspection Note.
- 3. Platform Control Console** - Switches and levers return to neutral when activated and released, decals/placards secure and legible, control markings legible.
- 4. Platform Rotator** - See Inspection Note.
- 5. Jib Assembly and Jib Rotator (If Equipped)** - See Inspection Note.
- 6. All Hydraulic Cylinders** - No visible damage; pivot pins and hydraulic hoses undamaged, not leaking.
- 7. Boom Sections/Uprights/Turntable** - See Inspection Note.
- 8. Wheel/Tire Assemblies** - Properly secured, no missing lug nuts. Inspect for worn tread, cuts, tears or other discrepancies. Inspect wheels for damage and corrosion.
- 9. Drive Motor, Brake, and Hub** - No evidence of leakage.
- 10. Ground Control Console** - Switches and levers return to neutral when activated and released, decals/placards secure and legible, control markings legible.
- 11. Hood Assemblies** - See Inspection Note.
- 12. Fuel Tank** - See Inspection Note
- 13. Turntable Bearing** - Evidence of proper lubrication. No evidence of loose bolts or looseness between bearing and machine.
- 14. Hydraulic Reservoir** - See Inspection Note.

SECTION 2 - USER RESPONSIBILITIES, MACHINE PREPARATION, AND INSPECTION

15. **Tie Rod Ends and Steering Spindles** - See Inspection Note
16. **Swing Motor and Worm Gear** - No evidence of damage.
17. **Hydraulic Pump** - See Inspection Note.
18. **Battery Compartment** - Batteries have proper electrolyte level; cables tight; no visible damage or corrosion.

Function Check

WARNING

TO AVOID SERIOUS INJURY, DO NOT OPERATE MACHINE IF ANY CONTROL LEVERS OR TOGGLE SWITCHES CONTROLLING PLATFORM MOVEMENTS DO NOT RETURN TO THE OFF POSITION WHEN RELEASED.

WARNING

TO AVOID A COLLISION AND INJURY IF PLATFORM DOES NOT STOP WHEN A CONTROL SWITCH OR LEVER IS RELEASED, REMOVE FOOT FROM FOOTSWITCH OR USE EMERGENCY STOP TO STOP MACHINE.

Perform the Function Check as follows:

1. From the ground control console with no load in the platform:
 - a. Ensure that all machine functions are disabled when the Emergency Stop Button is pushed in.
 - b. Ensure all functions stop when the function switch is released.
 - c. Operate all functions and ensure proper operation;
 - d. Ensure proper operation of the manual descent controls, as described in Section 5.5 of this manual.
2. From the platform control console:
 - a. Ensure that the control console is firmly secured in the proper location
 - b. Check that all guards protecting the switches or locks are in place.
 - c. Ensure that all machine functions are disabled when the Emergency Stop Button is pushed in.
 - d. Ensure that all machine functions stop when the footswitch is released.
 - e. Operate all functions and ensure proper operation.
3. With the platform in the stowed position:
 - a. Drive the machine on a grade, not to exceed the maximum operating slope, and stop to ensure the brakes hold;
 - b. Check that the tilt indicator is illuminated to ensure proper operation.
4. Swing the boom over either of the rear tires and ensure that the Drive Orientation indicator illuminates and that the Drive Orientation Override switch must be used for the drive function to operate.

5. With the machine positioned on a smooth, firm surface within the limits of the maximum operating slope, elevate the boom above 5 degrees of horizontal; Select high speed drive mode. Carefully attempt to drive and ensure the drive speed is reduced.

SkyGuard Function Test

NOTE: Refer to Section 4.10 for additional information on SkyGuard operation.

From the Platform Console in an area free from obstructions:

1. Operate the telescope out function.
2. Activate the SkyGuard sensor:
 - a. **SkyGuard** - Apply approximately 50 lb (222 Nm) of force to yellow bar.
 - b. **SkyGuard - SkyLine** - Press cable to break magnetic connection between the cable and right bracket.
 - c. **SkyGuard - SkyEye** - Put arm or hand in path of sensor beam.
3. Once the sensor has been activated, verify the following conditions:
 - a. Telescope out function stops and telescope in function operates for a short duration.

- b. The horn sounds.
- c. If equipped with a SkyGuard beacon, the beacon illuminates.

4. Disengage the SkyGuard sensor, release controls, then recycle the footswitch. Ensure normal operation is available.

NOTE: On machines equipped with SkyLine, reattach magnetic end of the cable to the bracket.

If SkyGuard remains activated after function reversal or cutout, depress and hold the SkyGuard Override Switch to allow normal use of machine functions until the sensor is disengaged.

2.3 OSCILLATING AXLE LOCKOUT TEST

NOTICE

LOCKOUT SYSTEM TEST MUST BE PERFORMED QUARTERLY, ANY TIME A SYSTEM COMPONENT IS REPLACED, OR WHEN IMPROPER SYSTEM OPERATION IS SUSPECTED.

NOTE: *Ensure boom is fully retracted, lowered, and centered between rear wheels prior to beginning lockout cylinder test.*

1. Place a 6 inch (15.2 cm) high block with ascension ramp in front of left front wheel.
2. From platform control console, start engine.
3. Place the Drive control lever to the forward position and carefully drive machine up ascension ramp until left front wheel is on top of block.
4. Carefully activate Swing control lever and position boom over right side of machine or raise the main boom enough to get it out of the transport position.
5. Place Drive control lever to Reverse and drive machine off of block and ramp.
6. Have an assistant check to see that left front or right rear wheel remains elevated in position off of ground.
7. Carefully return boom to stowed position (centered between rear wheels if swung or fully lowered if raised). When boom reaches stowed position, lockout cylinders should release and allow wheel to rest on ground, it may be necessary to activate Drive to release cylinders.
8. Place the 6 inch (15.2 cm) high block with ascension ramp in front of right front wheel.
9. Place Drive control lever to Forward and carefully drive machine up ascension ramp until right front wheel is on top of block.
10. Repeat steps 4 thru 7 to check the opposite side of the oscillating axle.
11. If lockout cylinders do not function properly, have qualified personnel correct the malfunction prior to any further operation.

SECTION 3. MACHINE CONTROLS AND INDICATORS

3.1 GENERAL

NOTICE

THE MANUFACTURER HAS NO DIRECT CONTROL OVER MACHINE APPLICATION AND OPERATION. THE USER AND OPERATOR ARE RESPONSIBLE FOR CONFORMING WITH GOOD SAFETY PRACTICES.

This section provides the necessary information needed to understand control functions.

3.2 CONTROLS AND INDICATORS

NOTE: *The indicator panels use different shaped symbols to alert the operator to different types of operational situations that could arise. The meaning of those symbols are explained below.*



Indicates a potentially hazardous situation, which if not corrected, could result in serious injury or death. This indicator will be red.



Indicates an abnormal operating condition, which if not corrected, may result in machine interruption or damage. This indicator will be yellow.



Indicates important information regarding the operating condition, i.e. procedures essential for safe operation. This indicator will be green with the exception of the capacity indicator which will be yellow.

SECTION 3 - MACHINE CONTROLS AND INDICATORS

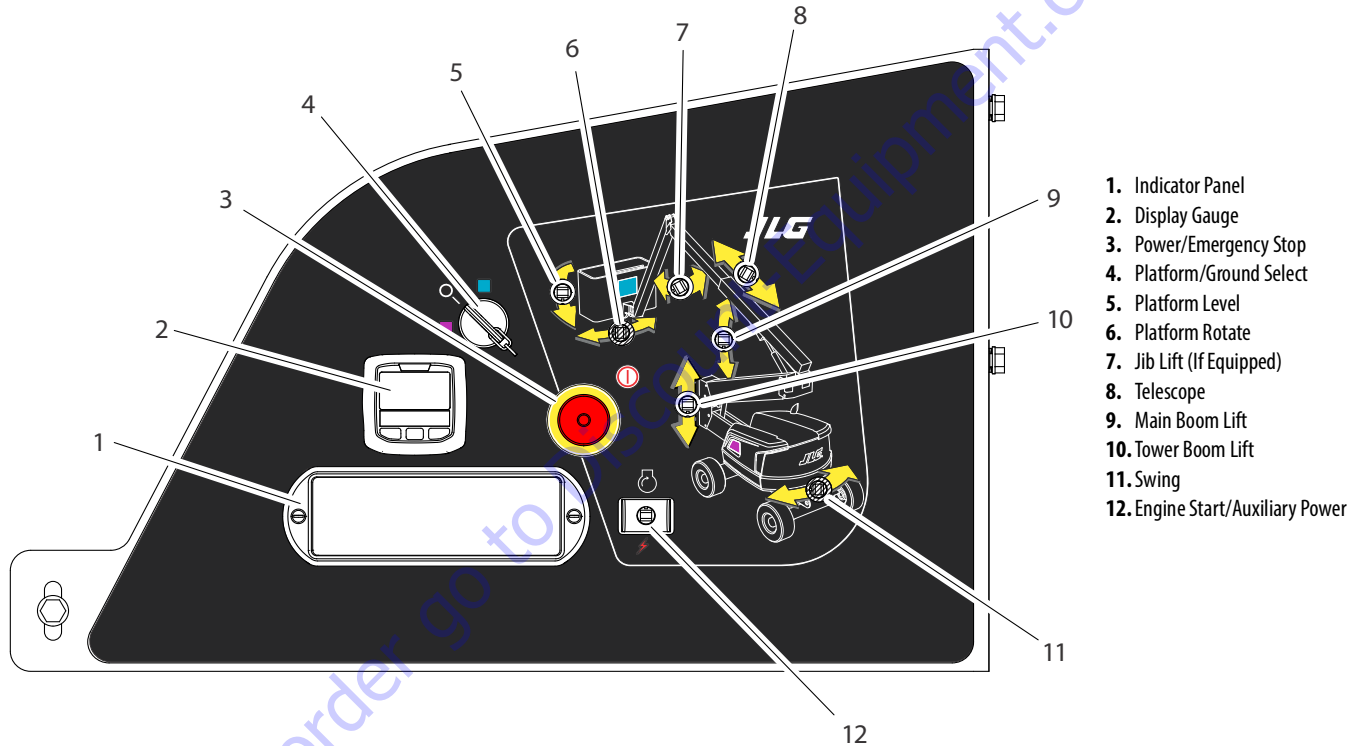

Figure 3-1. Ground Control Console without MSSO

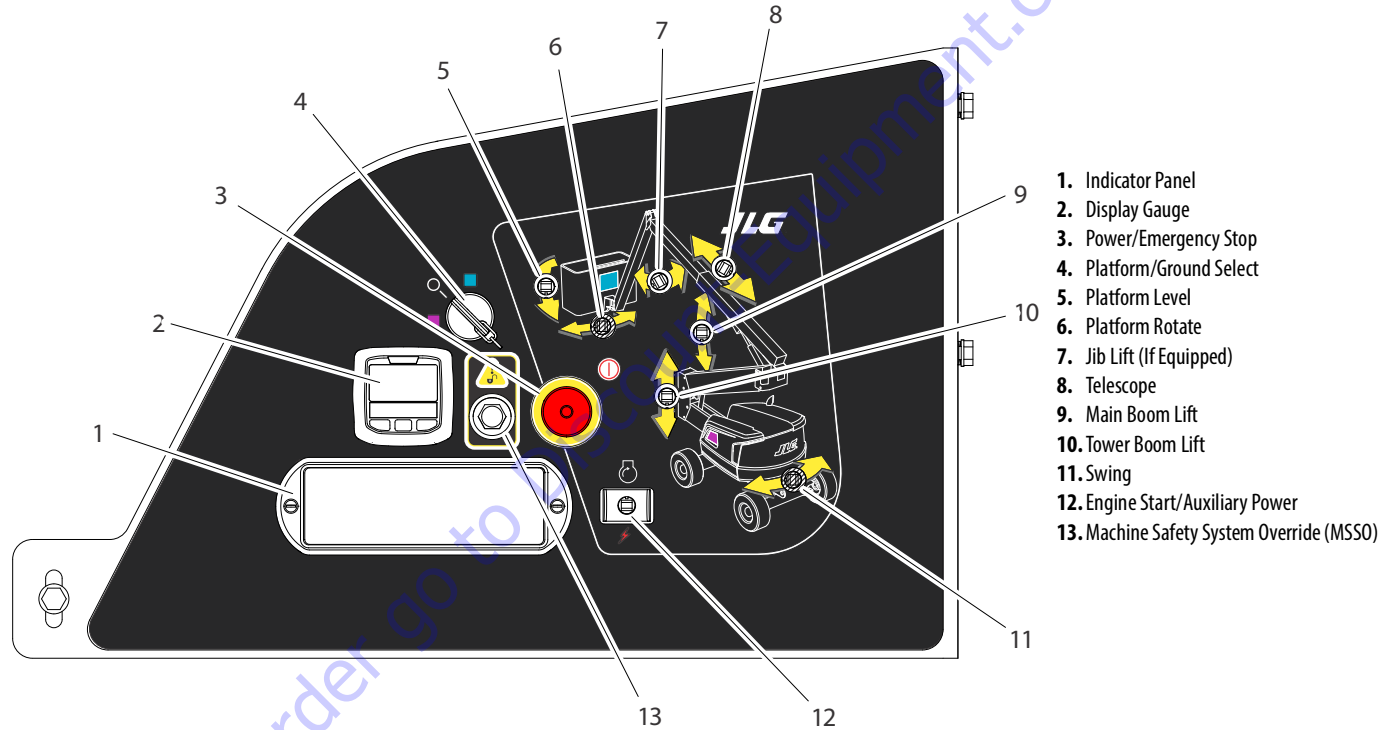

Figure 3-2. Ground Control Console with MSSO

SECTION 3 - MACHINE CONTROLS AND INDICATORS

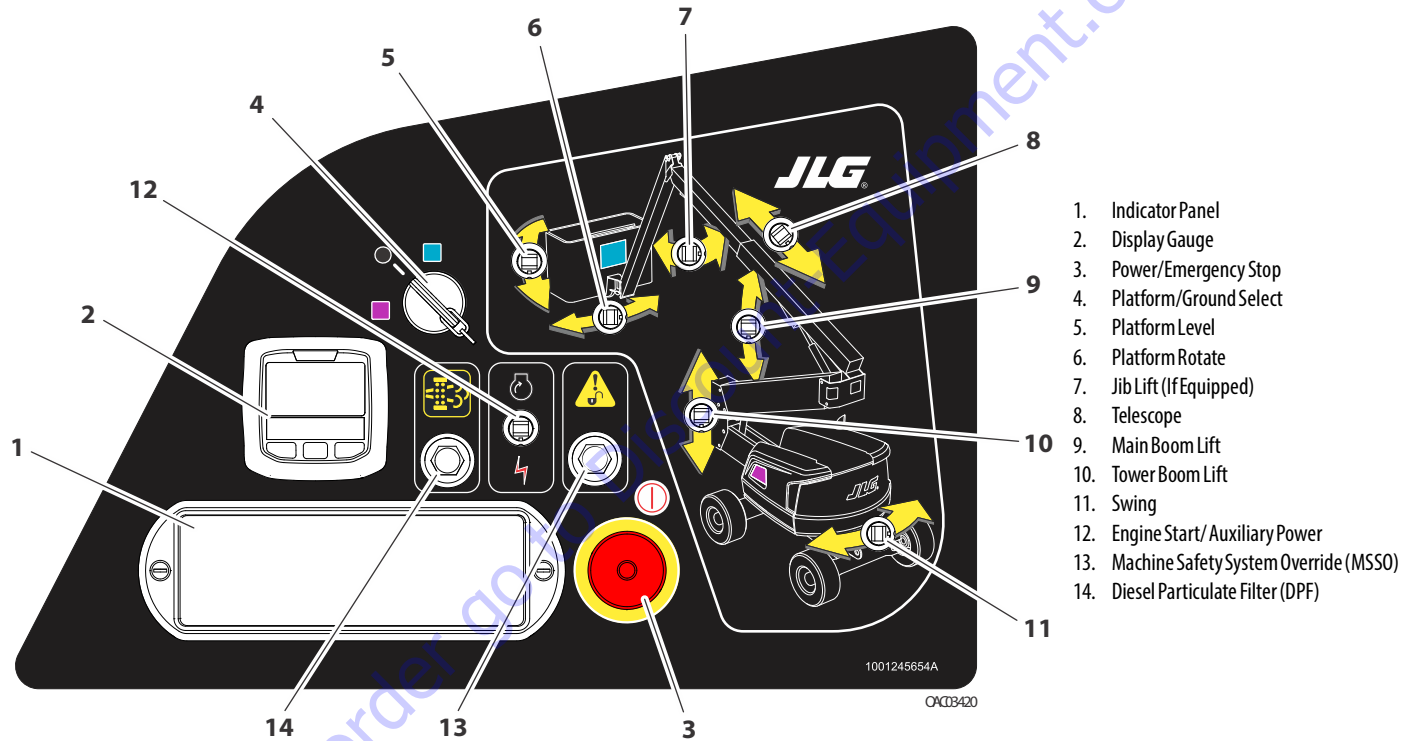

Figure 3-2. Ground Control Panel with MSSO and DPF

Ground Control Console

⚠ WARNING

TO AVOID SERIOUS INJURY, DO NOT OPERATE MACHINE IF ANY CONTROL LEVERS OR TOGGLE SWITCHES CONTROLLING PLATFORM MOVEMENT DO NOT RETURN TO THE OFF OR NEUTRAL POSITION WHEN RELEASED.

1. Indicator Panel

The Indicator Panel contains indicator lights that signal problem conditions or functions operating during machine operation.

2. Display Gauge

Registers the amount of time the machine has been in use, with engine running. The hourmeter registers up to 16,500 hours and cannot be reset.



⚠ CAUTION

WHEN THE MACHINE IS SHUT DOWN THE POWER/EMERGENCY STOP SWITCH MUST BE POSITIONED TO THE OFF POSITION TO PREVENT DRAINING THE BATTERIES.

3. Power/Emergency Stop Switch

A two-position red mushroom shaped switch supplies power to Platform/Ground Select switch when pulled out (on). When pushed in (off), power is shut off to the Platform/Ground Select switch.

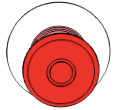

NOTE: *When the Platform/Ground Select Switch is in the center position, power is shut off to the controls at both operating consoles. Remove the key to prevent the controls from being actuated.*

4. Platform/Ground Select Switch

The three position, key operated switch supplies power to the platform control console when positioned to Platform. With the switch key turned to the Ground position only ground controls are operable.

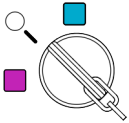

⚠ WARNING

ONLY USE THE PLATFORM LEVELING OVERRIDE FUNCTION FOR SLIGHT LEVELING OF THE PLATFORM. INCORRECT USE COULD CAUSE THE LOAD/OCCUPANTS TO SHIFT OR FALL. FAILURE TO DO SO COULD RESULT IN DEATH OR SERIOUS INJURY.

SECTION 3 - MACHINE CONTROLS AND INDICATORS

5. Platform Leveling Override

A three position switch allows the operator to adjust the automatic self leveling system. This switch is used to adjust platform level in situations such as ascending/descending a grade.

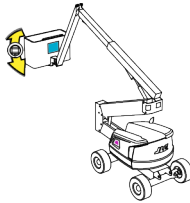

6. Platform Rotate

Provides rotation of the platform.

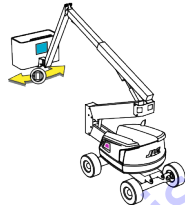

7. Jib Lift (If Equipped)

Provides raising and lowering of the jib.

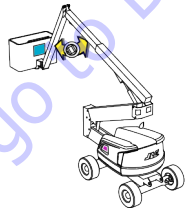

8. Telescope Control

Provides extension and retraction of the boom.

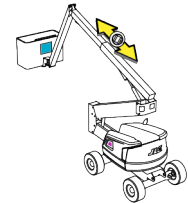

9. Main Boom Lift

Provides raising/lowering of the main boom when positioning up or down.

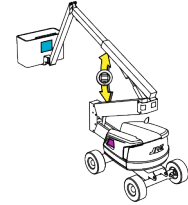

10. Tower Boom Lift

Provides raising and lowering of the tower boom.

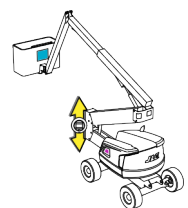

SECTION 3 - MACHINE CONTROLS AND INDICATORS

11. Swing

Provides 355 degrees non-continuous turntable rotation.

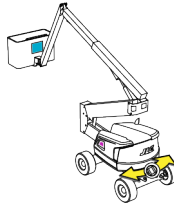

12. Engine Start/ Auxiliary Power

To start the engine, the switch must be held Up until the engine starts.

To use auxiliary power, the switch must be held Down for duration of function use.



13. Machine Safety System Override (MSSO) (If Equipped)

Provides override of function controls that are locked out such as in the event of Load Sense System activation.



14. Diesel Particulate Filter (DPF)

This button initiates the standstill exhaust system cleaning.



SECTION 3 - MACHINE CONTROLS AND INDICATORS

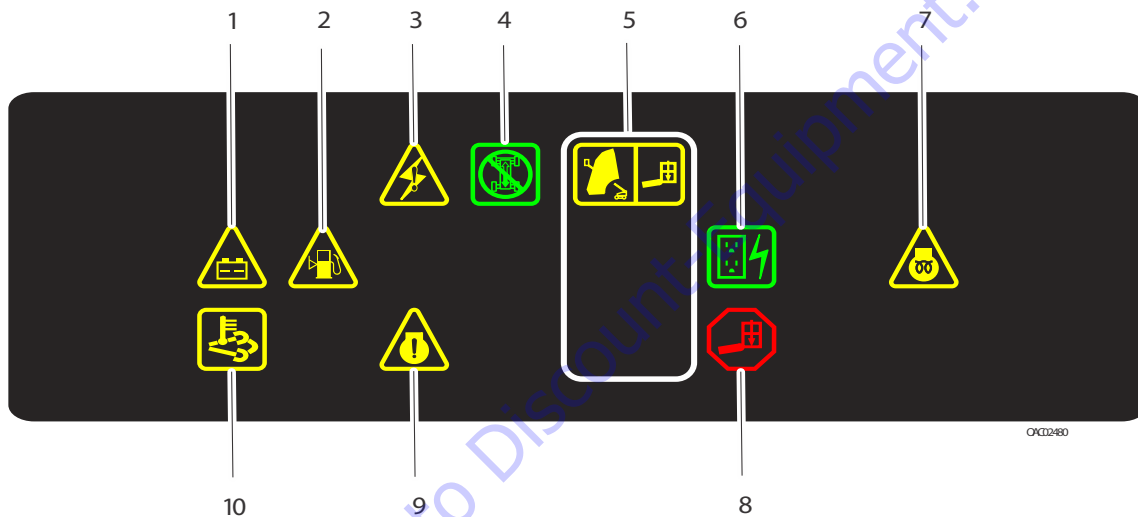

- | | | |
|------------------------|----------------------------|---------------------------|
| 1. Battery Charge | 5. Capacity Zone Indicator | 9. Engine Error |
| 2. Low Fuel Indicator | 6. Generator | 10. Emissions Temperature |
| 3. System Distress | 7. Glow Plugs | |
| 4. Drive Steer Disable | 8. Platform Overload | |

Figure 3-3. Ground Control Indicator Panel

Ground Control Indicator Panel

(See Figure 3-3., Ground Control Indicator Panel)

1. Battery Charge Indicator

Indicates a problem in the battery or charging circuit, and service is required.



2. Low Fuel Level Indicator

Indicates the fuel level is low. The Fuel Reserve/Cut-Out System will shut the engine down (or allow it start and run for an additional minute, depending upon machine setup) before the fuel tank is emptied.



3. System Distress Indicator

The light indicates that the JLG Control System has detected an abnormal condition and a Diagnostic Trouble Code has been set in the system memory. Refer to the Service Manual for instructions concerning the trouble codes and trouble code retrieval.



The system distress indicator light will illuminate for 2-3 seconds when the key is positioned to the on position to act as a self test.

4. Drive and Steer Disable Indicator (If Equipped)

Indicates the Drive and Steer Disable function has been activated.



5. Platform Capacity Zone Indicator

Indicates the platform capacity zone for the current position of the platform. Restricted capacities are permitted at restricted platform positions (shorter boom lengths and higher boom angles).



6. AC Generator Indicator (If Equipped)

Indicates the generator is in operation.



7. Glow Plug Indicator

Indicates the glow plugs are operating. After turning on ignition, wait until light goes out before cranking engine.



8. Platform Overload Indicator

Indicates the platform has been overloaded.



SECTION 3 - MACHINE CONTROLS AND INDICATORS

9. Engine Error Indicator

Indicates an engine error fault requiring service or is requesting a cleaning sequence.



10. Emissions Temperature Indicator

Indicator illuminates when exhaust temperature reaches 1022° F (550° C).



Ground Control Console Display Gauge

(See Figure 3-7., Ground Control Console Display Gauge)

The Display Gauge shows engine hours, fuel level (if applicable), and Diagnostic Trouble Codes (DTCs) from both the JLG Control System and the engine control system. During machine start up, with no active DTCs in the control system, the splash screen will show for 3 seconds and then switch to main screen. If there is an active DTC while powering up the machine, the splash screen will show for 3 seconds, and then launch the Diagnostics Screen. The indicator lamp will light when there is an active DTC in the Fault Log.



Figure 3-4. Splash Screen

SECTION 3 - MACHINE CONTROLS AND INDICATORS

The Diagnostic Screen will show active and inactive faults from the JLG Control System on the screen. An asterisk (*) will be displayed to show active faults.

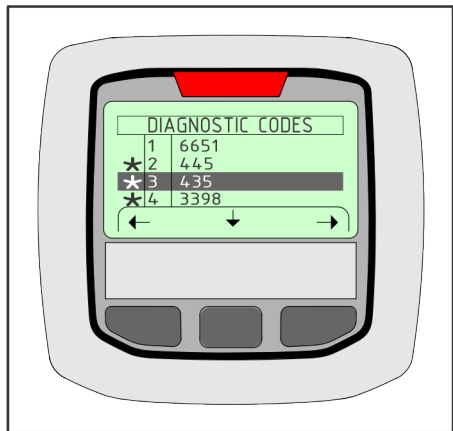

Figure 3-5. Diagnostic Screen

The Engine Diagnostics Screen will show SPN (Suspect Parameter Number), FMI (Failure Mode Identifier), and Occurrence count information. Engine SPN text is not scrollable. If there is more than one engine trouble code, the operator must exit from the Engine DTC Screen to see other SPN and FMI information.

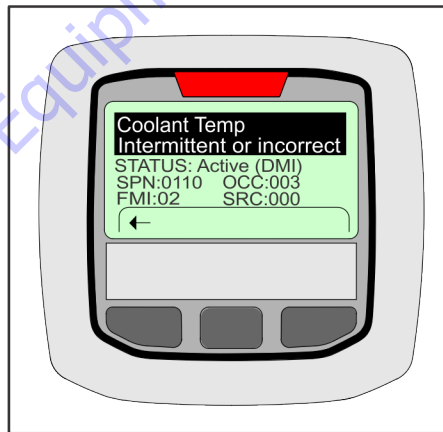

Figure 3-6. Engine Diagnostic Screen

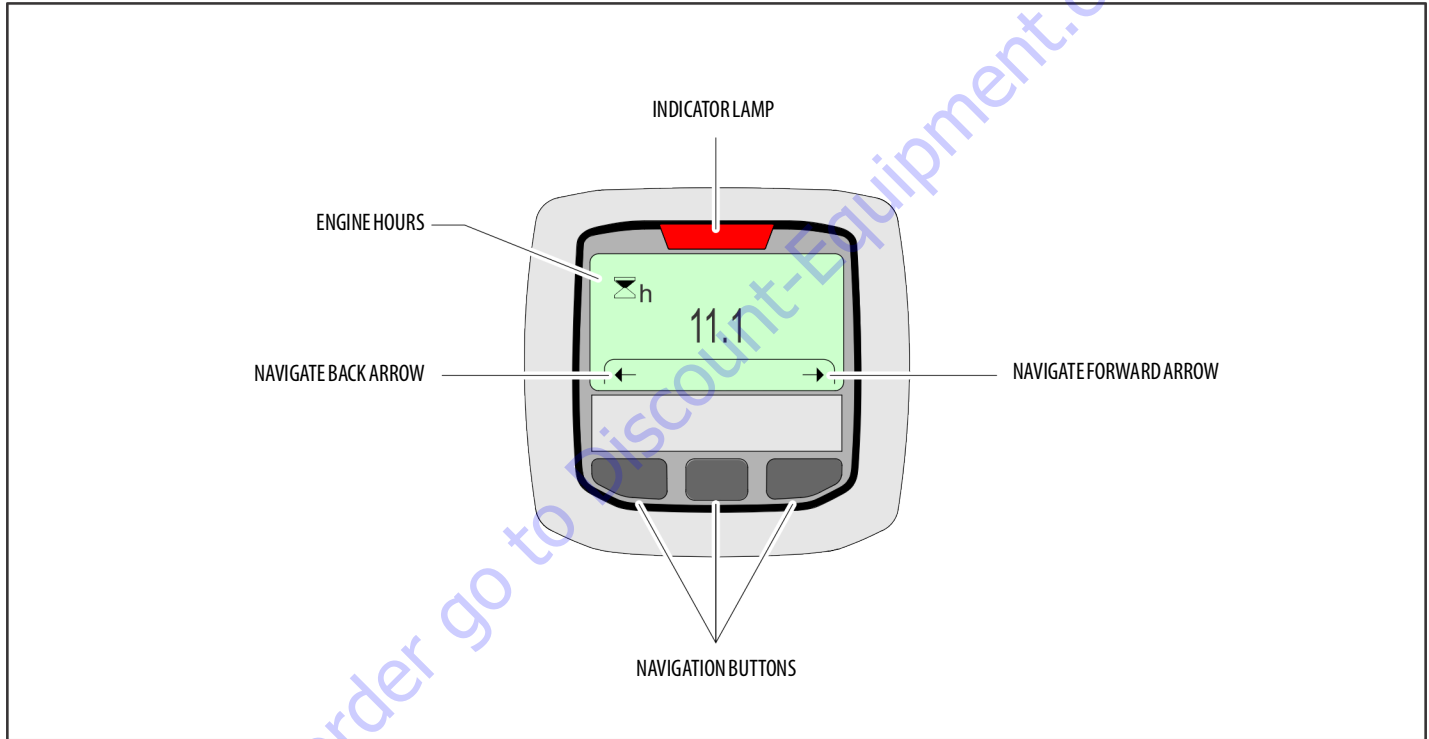
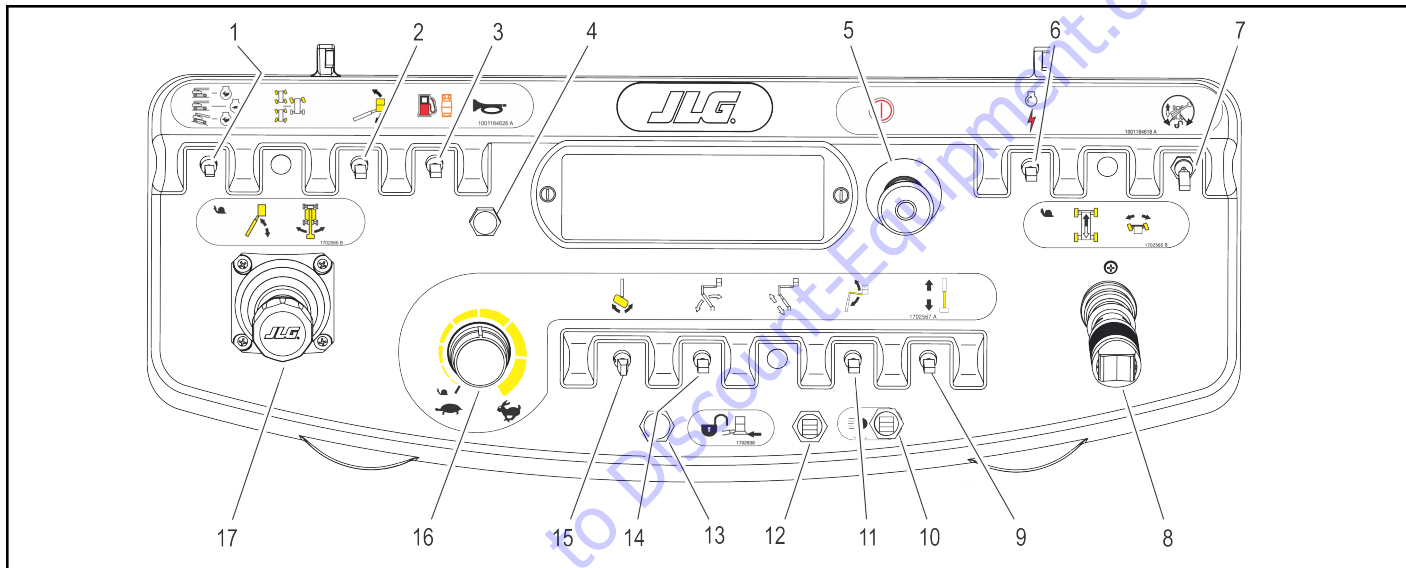

Figure 3-7. Ground Control Console Display Gauge

SECTION 3 - MACHINE CONTROLS AND INDICATORS



- | | | | |
|-------------------------------|-------------------------------|---|--------------------------------|
| 1. Drive Speed/Torque Select | 6. Start/Auxiliary Power | 10. Lights (If Equipped) | 14. Tower Boom Lift |
| 2. Platform Leveling Override | 7. Drive Orientation Override | 11. Jib Lift (If Equipped) | 15. Platform Rotate |
| 3. Fuel Select | 8. Drive/Steer | 12. Soft Touch/SkyGuard/SkySense Override | 16. Function Speed Control |
| 4. Horn | 9. Telescope | 13. Soft Touch/SkyGuard Indicator/SkySense Mute | 17. Main Lift/Swing Controller |
| 5. Power/Emergency Stop | | | |

Figure 3-8. Platform Control Console

Platform Console

(See Figure 3-8., Platform Control Console)

⚠ WARNING

TO AVOID SERIOUS INJURY, DO NOT OPERATE MACHINE IF ANY CONTROL LEVERS OR TOGGLE SWITCHES CONTROLLING PLATFORM MOVEMENT DO NOT RETURN TO THE OFF OR NEUTRAL POSITION WHEN RELEASED.

1. Drive Speed Switch

The forward position gives maximum drive speed. The back position gives maximum torque for rough terrain and climbing grades. The center position allows the machine to be driven as quietly as possible.

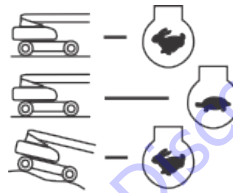

⚠ WARNING

ONLY USE THE PLATFORM LEVELING OVERRIDE FUNCTION FOR SLIGHT LEVELING OF THE PLATFORM. INCORRECT USE COULD CAUSE THE LOAD/OCCUPANTS TO SHIFT OR FALL. FAILURE TO DO SO COULD RESULT IN DEATH OR SERIOUS INJURY.

2. Platform Leveling Override

A three position switch allows the operator to adjust the automatic self leveling system. This switch is used to adjust platform level in situations such as ascending/descending a grade.

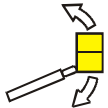

3. Fuel Select (Dual Fuel Engine Only) (If Equipped)

Moving the switch to the appropriate position selects gasoline or liquid propane fuel.



4. Horn

A push-type HORN switch supplies electrical power to an audible warning device when pressed.



SECTION 3 - MACHINE CONTROLS AND INDICATORS

5. Power/Emergency Stop Switch

A two-position red mushroom shaped switch furnishes power to PLATFORM Controls when pulled out (on). When pushed in (off), power is shut off to the platform functions.

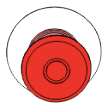

6. Start/Auxiliary Power

When pushed forward, the switch energizes the starter motor to start the engine.



The Auxiliary Power control switch energizes the electrically operated hydraulic pump. (Switch must be held ON for duration of auxiliary pump use.)



The auxiliary pump functions to provide sufficient oil flow to operate the basic machine functions should the main pump or engine fail. The auxiliary pump will operate tower boom lift, tower telescope, main boom lift, main telescope and swing.

7. Drive Orientation Override

When the boom is swung over the rear tires or further in either direction, the Drive Orientation indicator will illuminate when the drive function is selected. Push and release the switch, and within 3 seconds move the Drive/Steer control to activate drive or steer. Before driving, locate the black/white orientation arrows on both the chassis and the platform controls. Move the drive controls in a direction matching the directional arrows for the intended direction of travel.

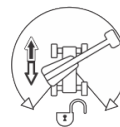

NOTE: To operate the Drive joystick, pull up on the locking ring below the handle.

NOTE: The Drive joystick is spring loaded and will automatically return to neutral (off) position when released.

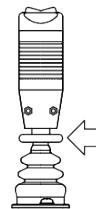

8. Drive/Steer

Push forward to drive forward, pull back to drive in reverse. Steering is accomplished via a thumb-activated rocker switch on the end of the steer handle.

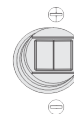
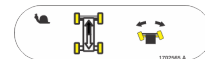

9. Telescope

Provides extension and retraction of the main boom.

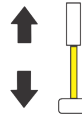

10. Lights (If Equipped)

This switch operates the accessory lights package if the machine is so equipped.



11. Jib Lift (If Equipped)

Provides for raising or lowering of the jib by positioning up/down.

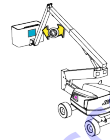

12. Soft Touch/SkyGuard/SkySense Override Switch

For machines equipped with SkyGuard:

The SkyGuard override switch enables functions cut out by the Skyguard system to be operated again, allowing the operator to resume use of machine functions.



For machines equipped with both SkyGuard and Soft Touch:

The switch operates like the SkyGuard override switch as described above. The switch also enables the functions cut out by the Soft Touch system to operate again at creep speed, allowing the operator to move the platform away from the obstacle that caused the shutdown situation.



For machines equipped with both SkyGuard and SkySense:

The switch operates like the SkyGuard override switch as described above. The switch also enables the functions cut out by the SkySense system to operate again at creep speed, allowing the operator to move the platform closer to the obstacle that caused the shutdown situation if desired.



13. Soft Touch/SkyGuard Indicator/SkySense Mute Switch

Indicates the Soft Touch bumper is against an object or the SkyGuard sensor has been activated. All controls are cut out until the override button is pushed. For Soft Touch, controls are then active in the Creep Mode or for SkyGuard, controls will work normally.

SECTION 3 - MACHINE CONTROLS AND INDICATORS

When Soft Touch is active, the indicator will be on continuously and the alarm will sound. When SkyGuard is active, the indicator will flash, and the horn will sound continuously.

If machine is equipped with SkySense, the switch will mute the SkySense speakers.

14. Tower Boom Lift

Provides for raising and lowering of tower boom.

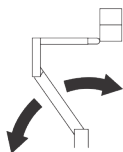

15. Platform Rotate

Provides rotation of the platform when positioned to the right or left.



16. Function Speed Control

This control affects the speed of Telescope, Tower Lift and Jib Lift. Turning the knob all the way counterclockwise until it clicks puts Drive, Main Lift, and Swing into Creep mode.

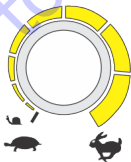

NOTE: To operate the Main Boom Lift/Swing joystick, pull up on the locking ring below the handle.

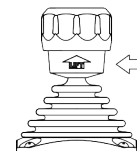

NOTE: The Main Boom Lift/Swing joystick is spring loaded and will automatically return to neutral (off) position when released.

17. Main Lift/Swing Controller

Provides main lift and swing. Push forward to lift up, pull backward to boom down. Move right to swing right, move left to swing left. Moving the joystick activates switches to provide the functions selected.

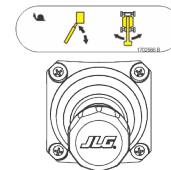

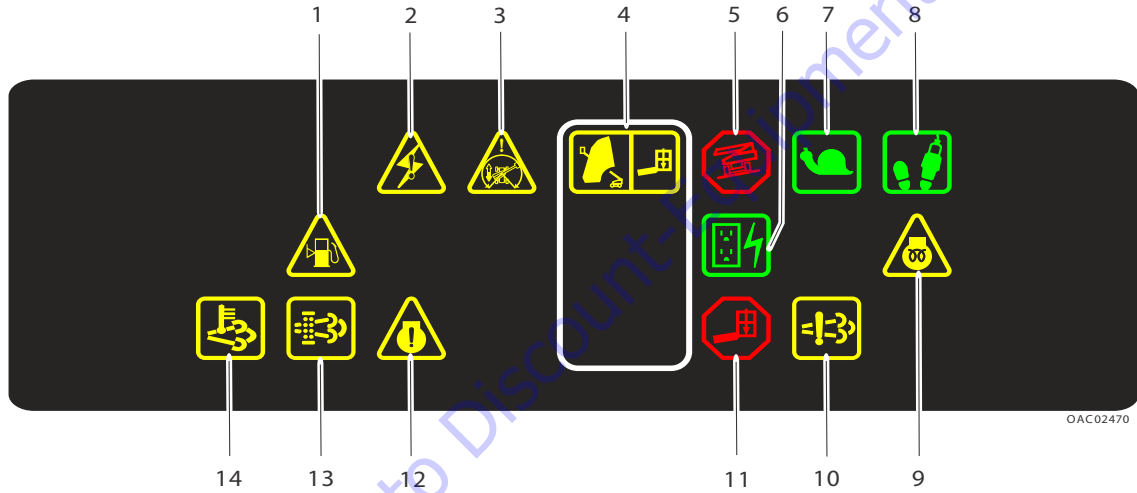

OAC02470

- | | | |
|----------------------------|-----------------------|---|
| 1. Low Fuel Indicator | 6. Generator | 11. Platform Overload |
| 2. System Distress | 7. Creep | 12. Engine Error |
| 3. Drive Orientation | 8. Footswitch Enable | 13. Diesel Particulate Filter Indicator |
| 4. Capacity Zone Indicator | 9. Glow Plugs | 14. Emissions Temperature |
| 5. Tilt Alarm/Warning | 10. Emissions Failure | |

Figure 3-9. Platform Control Indicator Panel

SECTION 3 - MACHINE CONTROLS AND INDICATORS

Platform Control Indicator Panel

(See Figure 3-9., Platform Control Indicator Panel)

NOTE: The indicator lights will illuminate for approximately 1 second when the key is positioned to the on position to act as a self test.

1. Low Fuel Level Indicator



Indicates the fuel level is low. The Fuel Reserve/Cut-Out System will shut the engine down (or allow it start and run for an additional minute, depending upon machine setup) before the fuel tank is emptied.

2. System Distress Indicator



The light indicates that the JLG Control System has detected an abnormal condition and a Diagnostic Trouble Code has been set in the system memory. Refer to the Service Manual for instructions concerning the trouble codes and trouble code retrieval.

3. Drive Orientation Indicator



When the boom is swung beyond the rear drive tires or further in either direction, the Drive Orientation indicator will illuminate when the drive function is selected. This is a signal for the operator to verify that the

drive control is being operated in the proper direction (i.e. controls reversed situations).

4. Platform Capacity Zone Indicator



Indicates the platform capacity zone for the current position of the platform. Restricted capacities are permitted at restricted platform positions (shorter boom lengths and higher boom angles).

5. Tilt Alarm Warning Light and Alarm



This red illuminator indicates the chassis is on a slope. If the boom is above horizontal and the machine is on a slope, the tilt alarm warning light will illuminate, an alarm will sound, available functions are placed in Creep speed, and drive is cut out in the direction of travel. Drive in the opposite direction may be allowed under certain conditions.

| Tilt Angle | Market |
|------------|------------|
| 5° | AllMarkets |

⚠ WARNING

IF TILT WARNING LIGHT IS ILLUMINATED WHEN BOOM IS RAISED OR EXTENDED, RETRACT AND LOWER TO BELOW HORIZONTAL THEN REPOSITION MACHINE SO THAT IT IS LEVEL BEFORE EXTENDING BOOM OR RAISING BOOM ABOVE HORIZONTAL.

6. AC Generator Indicator (If Equipped)

Indicates the generator is in operation.



7. Creep Speed Indicator

When the Function Speed Control is turned to the creep position, the indicator acts as a reminder that all functions are set to the slowest speed. The light will be on continuously if the operator selects creep speed or if the control system puts the machine into creep speed. In addition, if the control system puts one or more individual functions in creep speed, the indicator flashes when that function is selected.



8. Enable Indicator/Footswitch

To operate any function, the footswitch must be depressed and the function selected within seven seconds. The enable indicator shows that the controls are enabled. If a function is not selected within seven sec-



onds, or if a seven second lapse between ending one function and beginning the next function, the enable light will go out and the footswitch must be released and depressed again to enable the controls.

Releasing the footswitch removes power from all controls and applies the drive brakes.

⚠ WARNING

TO AVOID SERIOUS INJURY, DO NOT REMOVE, MODIFY OR DISABLE THE FOOTSWITCH BY BLOCKING OR ANY OTHER MEANS.

⚠ WARNING

FOOTSWITCH MUST BE ADJUSTED IF FUNCTIONS ACTIVATE WHEN SWITCH ONLY OPERATES WITHIN LAST 1/4" OF TRAVEL, TOP OR BOTTOM.

9. Glow Plug/Wait to Start Indicator

Indicates the glow plugs are operating. After turning on ignition, wait until light goes out before starting engine.



10. Engine Emissions System Failure Indicator

Indicator illuminates when there is a fault with the Emissions After Treatment system.



SECTION 3 - MACHINE CONTROLS AND INDICATORS

11. Platform Overload Indicator

Indicates the platform has been overloaded.



12. Engine Error Indicator

Indicates an engine error fault requiring service.



13. Diesel Particulate Filter (DPF) Indicator

Icon will illuminate when standstill exhaust system cleaning is required.



14. Emissions Temperature Indicator

Indicator illuminates when exhaust temperature reaches 1022° F (550° C).



TO PURCHASE THIS PRODUCT PLEASE CONTACT US



**Equipment Financing and
Extended Warranties Available**



**Discount-Equipment.com is your online resource for
commercial and industrial quality parts and equipment sales.**

561-964-4949

visit us on line @ www.discount-equipment.com

Select an option below to find your Equipment

Search by Manufacturer

Search by Product Type

Request a Quote

We sell worldwide for the brands: Genie, Terex, JLG, MultiQuip, Mikasa, Essick, Whiteman, Mayco, Toro Stone, Diamond Products, Generac Magnum, Airman, Haulotte, Barreto, Power Blanket, Nifty Lift, Atlas Copco, Chicago Pneumatic, Allmand, Miller Curber, Skyjack, Lull, Skytrak, Tsurumi, Husquvarna Target, Stow, Wacker, Sakai, Mi-T-M, Sullair, Basic, Dynapac, MBW, Weber, Bartell, Bennar Newman, Haulotte, Ditch Runner, Menegotti, Morrison, Contec, Buddy, Crown, Edco, Wyco, Bomag, Laymor, EZ Trench, Bil-Jax, F.S. Curtis, Gehl Pavers, Heli, Honda, ICS/PowerGrit, IHI, Partner, Imer, Clipper, MMD, Koshin, Rice, CH&E, General Equipment, Amida, Coleman, NAC, Gradall, Square Shooter, Kent, Stanley, Tamco, Toku, Hatz, Kohler, Robin, Wisconsin, Northrock, Oztec, Toker TK, Rol-Air, APT, Wylie, Ingersoll Rand / Doosan, Innovatech, Con X, Ammann, Mecalac, Makinex, Smith Surface Prep, Small Line, Wanco, Yanmar

SECTION 4. MACHINE OPERATION

4.1 DESCRIPTION

This machine is a mobile elevating work platform used to position personnel, along with their necessary tools and materials at work locations.

The primary operator control station is in the platform. From this control station, the operator can drive and steer the machine in both forward and reverse directions. The operator can raise or lower the upper or lower boom or swing the boom to the left or right. Standard boom swing is 360 degree non-continuous left and right of the stowed position. The machine has a Ground Control Station which will override the Platform Control Station. Ground Controls operate all functions except drive and steer. Except for performing inspections and the Function Check, the ground controls are used in an emergency to lower the platform to the ground should the operator in the platform be unable to do so.

4.2 OPERATING CHARACTERISTICS AND LIMITATIONS

Capacities

The boom can be raised above horizontal with or without any load in platform, if:

1. Machine is positioned on a smooth, firm surface within the limits of the maximum operating slope.
2. Load is within manufacturers rated design capacity.
3. All machine systems are functioning properly.
4. Machine is as originally equipped from JLG.

Platform Load Sensing System (LSS)

The Platform Load Sensing System provides the platform capacity to the control system.

If the LSS system senses an overload condition, boom functions will be disabled, the overload indicator is illuminated at both control stations, and the overload alarm will sound. Reduce the weight in the platform to not exceed the rated workload indicated on the capacity decal, then the controls will work again.

Stability

Machine stability is based on two (2) conditions which are called FORWARD and BACKWARD stability. The machine's position of least FORWARD stability is shown in Figure 4-1., and its position of least BACKWARD stability is shown in Figure 4-2.

WARNING

TO AVOID FORWARD OR BACKWARD TIPPING, DO NOT OVERLOAD MACHINE OR OPERATE THE MACHINE BEYOND THE LIMITS OF THE MAXIMUM OPERATING SLOPE.

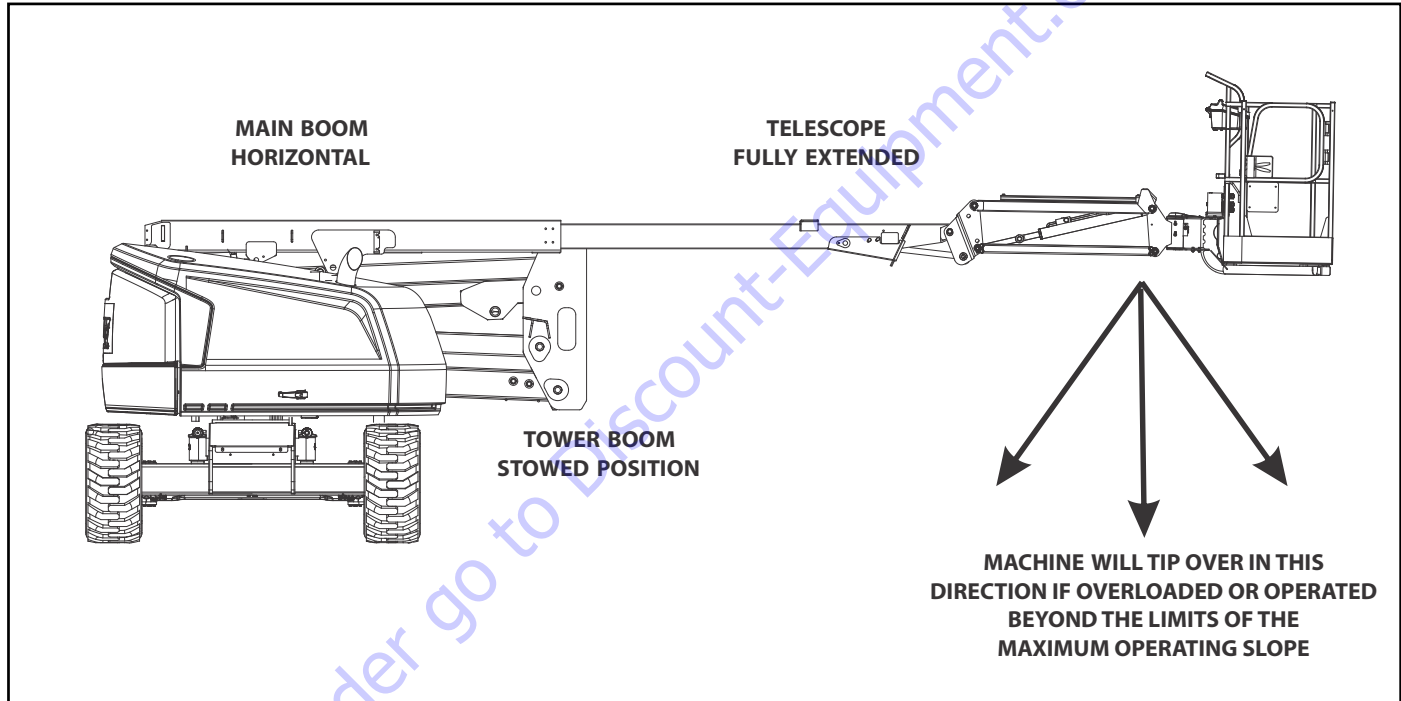

Figure 4-1. Position of Least Forward Stability

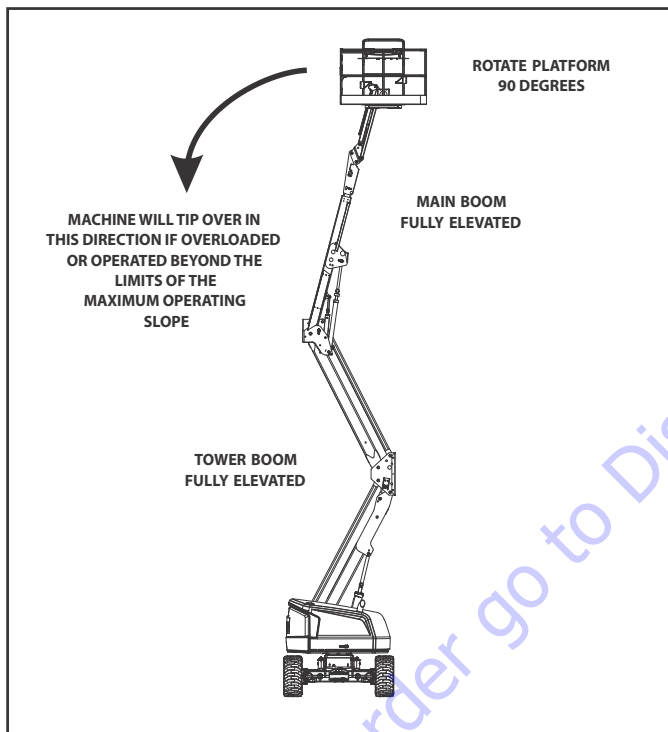
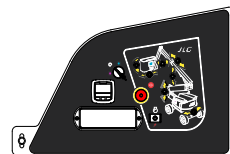

Figure 4-2. Position of Least Backward Stability

4.3 ENGINE OPERATION

NOTE: Initial starting must always be performed from the Ground Control station.



Starting Procedure

CAUTION

IF ENGINE FAILS TO START PROMPTLY, DO NOT CRANK FOR AN EXTENDED TIME. SHOULD ENGINE FAIL TO START AGAIN, ALLOW STARTER TO COOL OFF FOR 2-3 MINUTES. IF ENGINE FAILS AFTER SEVERAL ATTEMPTS, REFER TO ENGINE MAINTENANCE MANUAL.

NOTE: Diesel engines only: After turning on ignition, operator must wait until glow plug indicator light goes out before cranking engine.



1. Turn key of Platform/Ground Select switch to Ground.



2. Pull the Power/Emergency Stop switch to On.



3. Push the Engine Start switch until engine starts.



⚠ CAUTION

ALLOW ENGINE TO WARM-UP FOR A FEW MINUTES AT LOW SPEED BEFORE APPLYING ANY LOAD.

4. After engine has had sufficient time to warm up, push in the Power/Emergency Stop switch and shut engine off.

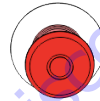

5. Turn Platform/Ground Select switch to Platform.



6. Pull out the Ground Console Power/Emergency Stop switch to provide power to the platform controls.



7. From Platform, pull Power/Emergency Stop switch out.



8. Push the Engine Start switch until engine starts.



NOTE: Footswitch must be in released (up) position before starter will operate. If starter operates with footswitch in the depressed position, DO NOT OPERATE MACHINE.

Shutdown Procedure

⚠ CAUTION

IF AN ENGINE MALFUNCTION CAUSES AN UNSCHEDULED SHUTDOWN, DETERMINE THE CAUSE AND CORRECT IT BEFORE RESTARTING THE ENGINE.

1. Remove all load and allow engine to operate at low speed for 3-5 minutes; this allows further reduction of internal engine temperature.
2. Push Power/Emergency Stop switch in.



SECTION 4 - MACHINE OPERATION

3. Turn Platform/Ground Select switch to Off.

Refer to Engine Manufacturer's manual for detailed information.



Fuel Reserve / Shut-Off System

NOTE: Reference the Service and Maintenance Manual along with a qualified JLG Mechanic to verify your machine setup.

The Fuel Shutoff System monitors the fuel in the tank and senses when the fuel level is getting low. The JLG Control System automatically shuts the engine down before the fuel tank is emptied unless the machine is set up for Engine Restart.



If fuel level reaches the Empty range, the Low Fuel light will begin to flash once a second and there will be approximately 60 minutes of engine run time left. If the system is in this condition and automatically shuts down the engine or if the operator manually shuts down the engine before the 60 minute run time is complete, the Low Fuel light will flash 10 times a second and the engine will react according to machine setup. Setup options are as follows:

- Engine One Restart - When the engine shuts down, the operator will be permitted to cycle power and restart the engine once with approximately 2 minutes of run time. After the 2 minute run time is complete or if the engine is shut down by the operator prior to the completion of the 2 minute run time, it cannot be restarted until fuel is added to the tank.
- Engine Restart - When the engine shuts down, the operator will be permitted to cycle power and restart the engine for approximately 2 minutes of run time. After the 2 minutes of run time is complete, the operator may cycle power and restart the engine for an additional 2 minutes of run time. The operator can repeat this process until there is no more fuel available.
- Engine Stop - When the engine shuts down, no restarts will be permitted until fuel is added to the tank.

4.4 DIESEL PARTICULATE FILTER (IF EQUIPPED)

Diesel Particulate Filter (DPF) is an emissions control system used in diesel engines and requires operator interaction to make sure proper operation of the system.

For peak operation, the DPF system must be cleaned using one of two methods, Standstill Cleaning and Maintenance Standstill Cleaning. Standstill Cleaning is any cleaning requested by the engine outside of the regular maintenance window (for example, if the system detects excessive soot in the DPF canister). Maintenance Standstill Cleaning is cleaning requested by the engine on the regular maintenance interval.

NOTE: *The system will reset the maintenance interval back to zero hours after Standstill or Maintenance Standstill Cleaning events are performed.*

Standstill Cleaning

The following conditions must be met to perform Standstill Cleaning.

- Machine must be stationary
- Boom in the stowed position
- No personnel in platform
- Engine must be idling
- Coolant temperature must be above 104° F (40° C)
- Machine in Ground Station mode

1. The Diesel Particulate Filter (DPF) Indicator on the Platform Control Panel will flash when standstill cleaning is required.
2. Move the machine to an suitable area free of flammables and personnel that could be exposed to hot exhaust.



SECTION 4 - MACHINE OPERATION

3. Launch the cleaning process by pressing the DPF button on the Ground Console for 3 seconds. The Indicator Gauge will display the following screen.

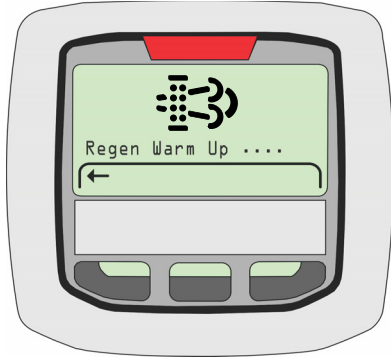

4. The Main Cleaning process will begin and last for approximately 30 to 60 minutes. The following screen will show that the process has begun and includes a status bar that indicates the progress of the cleaning process.

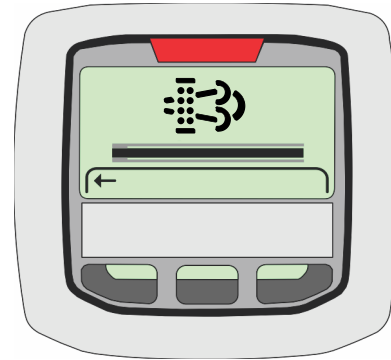
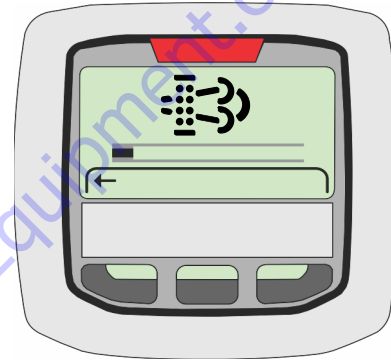

5. After the cleaning process is complete, the engine will run for approximately 5 minutes to allow the Engine and Exhaust After Treatment (EAT) to cool down. The Indicator Gauge will display the "Regen Complete" screen as shown and the Emissions Temperature indicator will no longer be illuminated.

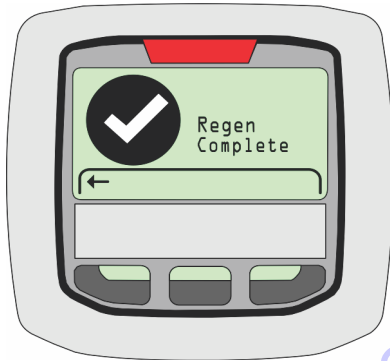

Maintenance Standstill Cleaning Initiation Methods

Maintenance Standstill Cleaning can be started by one of two methods, by using the Analyzer or the DPF button on the Ground Console. All the same conditions as outlined under Standstill Cleaning must be met.

Canceling Maintenance Standstill

Maintenance Standstill Cleaning will be stopped immediately if:

- The Platform/Ground Select switch is switched from Ground to Platform mode
- Any function switch is enabled to perform a boom function
- The Engine is powered down

If Maintenance Standstill Cleaning is interrupted, it must be re-initiated and the Indicator Gauge will display the "Regen Failed" screen as shown.

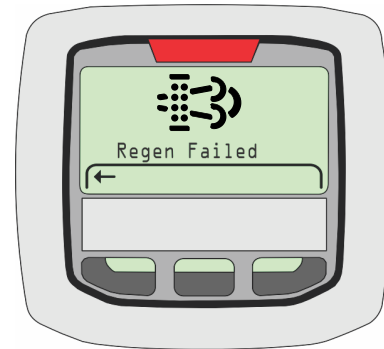

Unsuccessful Cleaning Event

If there is an unsuccessful cleaning event, the DPF icon will show on the display gauge. Possible causes of an Unsuccessful Cleaning Event are:

- Engine is not warmed up
- DEF tank is frozen
- Machine functions operated during cleaning event in progress
- Other engine faults are active

The Gauge will display "Regen Failed" screen as shown. If the cleaning event has failed, the process must be repeated.



DPF Filter Replacement due to Ash Load

The DPF collects non-burnable particulates which cannot be removed by the Standstill Cleaning process. Build up of the ash load requires filter maintenance and/or exchange.

DPF filter maintenance or exchange requirement is indicated by the DPF Exchange icon shown on the display gauge.

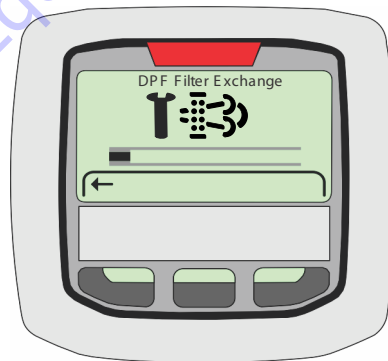

















Table 4-1. Ash Load DPF Filter Replacement

| | Ash Load | DPF Filter Exchange Indicator | Engine Error Indicator | Derate |
|--------------------------|--------------|---|--|---|
| Normal Operation | <100% | -- | -- | None |
| Filter Exchange Required | $\geq 100\%$ |  | -- | None |
| Warning Level | $\geq 105\%$ | Blinking  | -- | None |
| Warning Level | $\geq 110\%$ | Blinking  | Continuous  | Machine placed in Creep and DTC active. Contact Deutz Dealer |













SECTION 4 - MACHINE OPERATION

Table 4-2. Maintenance Standstill Cleaning

| Standstill Cleaning Levels | | Machine Hours Since Last Cleaning | Engine Error Indicator | DPF Indicator | Emissions Temperature Indicator* | Derate | Comments |
|----------------------------|---------------------|---|---|---|---|--|---|
| 0 | Normal Operation | 0-500 | -- | -- |  | None | Between 500 and 650 hours, cleaning cycle can be initiated with JLG analyzer. |
| | | 500-650 | | | | | |
| 1 | Standstill Required | 650-750 | -- | Blinking  |  | None | Engine coolant temperature must be >40° C and machine must be in ground station mode. |
| 2 | Warning Level | 750-775 | Continuous  | Blinking  |  | Machine placed in Creep and DTC active | |
| 3 | Shut Off Level | >775 | Blinking  | Rapid Blinking  |  | Idle Lock. Boom Functions Locked Out and trapped in Transport. | Contact Deutz Dealer |
| 4 | Filter Exchange | DPF Regeneration NOT POSSIBLE DPF Filter exchange required | Blinking  | Rapid Blinking  |  | Idle Lock. Boom Functions Locked Out and trapped in Transport. | |

* Emissions Temperature indicator continuously ON during Standstill Cleaning

Table 4-3. Standstill Cleaning: DPF Filled with Soot

| Soot Levels | Soot Load/ Time | DPF Cleaning Initiation Methods | Engine Error Indicator | DPF Indicator | Emissions Temperature Indicator* | Derate | Comments |
|---------------------|---------------------------------|---|---|---|---|---|--|
| Normal Operation | <99% | -- | -- | -- |  | None | -- |
| Standstill Required | 100% to 109% or 100 Hours | Switch in JLG Machine or JLG Analyzer | -- | Blinking  |  | None | Will remain in Standstill mode for 100 hours or until the soot load reaches 109% |
| Warning Level | 109% to 125% or 25 Hours | Switch in JLG Machine or JLG Analyzer | Continuous  | Blinking  |  | Machine placed in Creep and DTC active | Will remain in Warning level (Derate) for 25 hours or until the soot load reaches 125% |
| Shut Off Level | 125% to 161% | DPF Cleaning Not Possible | Blinking  | Rapid Blinking  |  | Idle Lock. Boom Functions Locked Out and Trapped in Transport | Contact Deutz Dealer |
| Filter Exchange | >161% | DPF Cleaning Not Possible | Blinking  | Rapid Blinking  |  | Idle Lock. Boom Functions Locked Out and Trapped in Transport | |

* Emissions Temperature indicator continuously ON during Standstill Cleaning

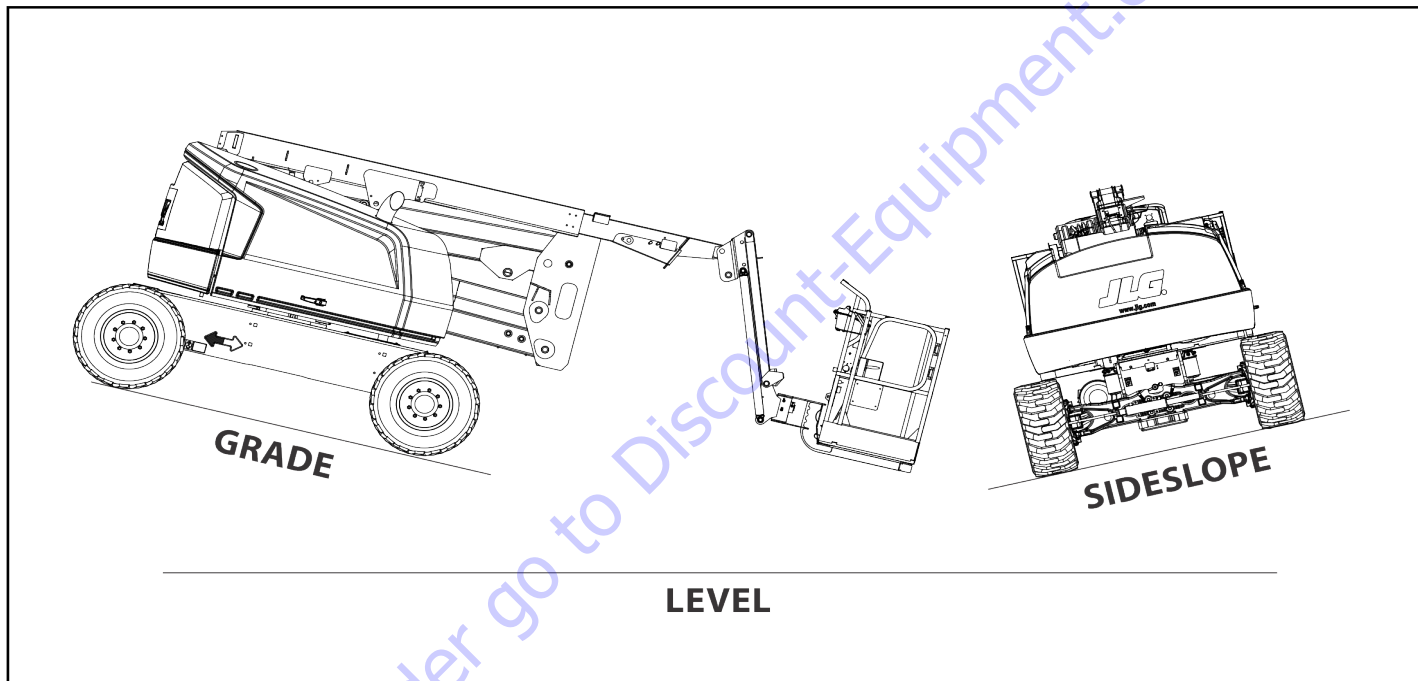

Figure 4-3. Grade and Side Slopes

4.5 TRAVELING (DRIVING)

See Figure 4-3., *Grade and Side Slopes*

NOTE: Refer to the Operating Specifications table for Gradeability and Sideslope ratings.

All ratings for Gradeability and Sideslope are based upon the machine's boom being in the stowed position, fully lowered, and retracted.

Traveling is limited by two factors:

1. Gradeability, which is the percent of grade of the incline the machine can climb.
2. Sideslope, which is the angle of the slope the machine can be driven across.

⚠ WARNING

DO NOT DRIVE WITH BOOM ABOVE HORIZONTAL EXCEPT ON A SMOOTH, FIRM SURFACE WITHIN THE LIMITS OF THE MAXIMUM OPERATING SLOPE.

TO AVOID LOSS OF TRAVEL CONTROL OR TIP OVER ON GRADES AND SIDE SLOPES, DO NOT DRIVE MACHINE ON GRADES EXCEEDING THOSE SPECIFIED IN THE OPERATING SPECIFICATIONS SECTION OF THIS MANUAL.

DO NOT DRIVE ON SIDESLOPES WHICH EXCEED 5 DEGREES.

USE EXTREME CAUTION WHEN DRIVING IN REVERSE AND AT ALL TIMES WHEN DRIVING WITH PLATFORM ELEVATED.

BEFORE DRIVING, LOCATE THE BLACK/WHITE ORIENTATION ARROWS ON BOTH THE CHASSIS AND THE PLATFORM CONTROLS. MOVE THE DRIVE CONTROLS IN A DIRECTION MATCHING THE DIRECTIONAL ARROWS FOR THE INTENDED DIRECTION OF TRAVEL.

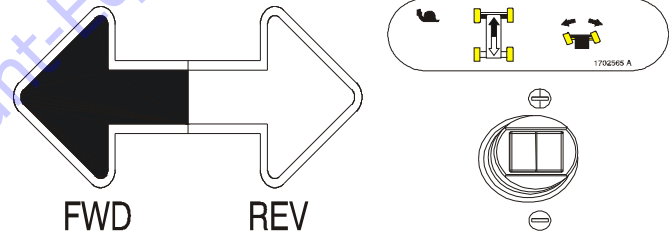

Traveling Forward and Reverse

1. At Platform Controls, pull out Emergency Stop switch, start the engine, and activate footswitch.

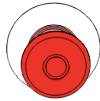

2. Position Drive controller to Forward or Reverse as desired.

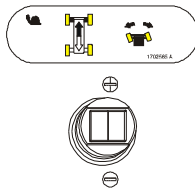

This machine is equipped with a Drive Orientation Indicator. The yellow light on the platform control console indicates that the boom is swung beyond the rear drive tires and the machine may Drive/Steer in the opposite direction from the movement of the controls. If the indicator is illuminated, operate the Drive function in the following manner:

1. Match the black and white direction arrows on both platform control console and the chassis to determine the direction the machine will travel.

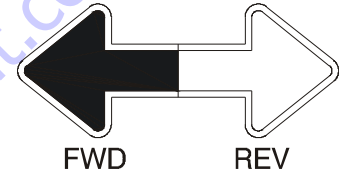

2. Push and release the Drive Orientation Override switch. Within 3 seconds, slowly move the Drive control toward the arrow matching the intended direction of machine travel. The indicator light will flash during the 3 second interval until the drive function is selected.

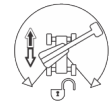

Traveling on a Grade

When traveling a grade, maximum braking and traction are obtained with the boom stowed, in position over the rear (drive) axle, and in line with the direction of travel. Drive the machine forward when climbing a grade, and in reverse when descending a grade. Do not exceed the machine's maximum rated gradeability.

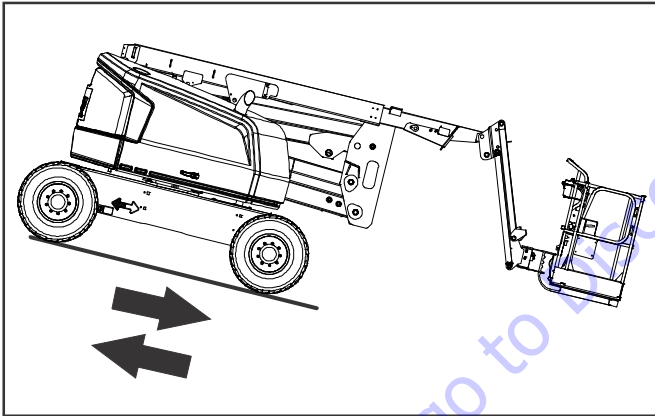

Figure 4-4. Traveling on a Grade

NOTICE

IF THE BOOM IS OVER THE FRONT (STEER) AXLE, DIRECTION OF STEER AND DRIVE MOVEMENT WILL BE OPPOSITE FROM THE MOVEMENT OF THE CONTROLS.

4.6 STEERING

Position thumb switch on Drive/Steer controller to Right for steering right, or to Left for steering left.



4.7 PLATFORM

Platform Level Adjustment

WARNING

ONLY USE THE PLATFORM LEVELING OVERRIDE FUNCTION FOR SLIGHT LEVELING OF THE PLATFORM. INCORRECT USE COULD CAUSE THE LOAD/OCCUPANTS TO SHIFT OR FALL. FAILURE TO DO SO COULD RESULT IN DEATH OR SERIOUS INJURY.

To Level Up or Down - Position the Platform/Level control switch Up or Down and hold until the platform is level.

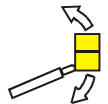

Platform Rotation

To rotate the platform to the left or right, use the Platform Rotate control switch to select the direction and hold until desired position is reached.



4.8 BOOM

⚠ WARNING

A RED TILT WARNING LIGHT IS LOCATED ON THE CONTROL CONSOLE WHICH LIGHTS WHEN THE CHASSIS IS ON AN EXCESSIVE SLOPE. DO NOT SWING OR RAISE BOOM ABOVE HORIZONTAL WHEN LIGHT IS LIT.

DO NOT DEPEND ON TILT ALARM AS A LEVEL INDICATOR FOR THE CHASSIS. TILT ALARM INDICATES CHASSIS IS ON AN EXCESSIVE SLOPE. CHASSIS MUST BE LEVEL BEFORE SWINGING, OR RAISING BOOM ABOVE HORIZONTAL OR DRIVING WITH THE BOOM ELEVATED.

TO AVOID TIP OVER IF RED TILT WARNING LIGHT LIGHTS WHEN BOOM IS RAISED ABOVE HORIZONTAL, LOWER PLATFORM TO GROUND LEVEL. THEN REPOSITION MACHINE SO THAT CHASSIS IS LEVEL BEFORE RAISING BOOM.

TRAVELING WITH BOOM BELOW HORIZONTAL IS PERMITTED ON GRADES AND SIDE SLOPES SPECIFIED IN THE OPERATING SPECIFICATIONS SECTION OF THIS MANUAL.

⚠ WARNING

TO AVOID SERIOUS INJURY, DO NOT OPERATE MACHINERY IF ANY CONTROL LEVER OR TOGGLE SWITCH CONTROLLING PLATFORM MOVEMENT DOES NOT RETURN TO THE 'OFF' OR NEUTRAL POSITION WHEN RELEASED.

⚠ CAUTION

TO AVOID A COLLISION AND INJURY IF PLATFORM DOES NOT STOP WHEN A CONTROL SWITCH OR LEVER IS RELEASED, REMOVE FOOT FROM FOOTSWITCH OR USE EMERGENCY STOP SWITCH TO STOP THE MACHINE.

Swinging the Boom

To swing boom, use Swing control switch to select Right or Left direction.



Raising and Lowering the Tower Boom

To raise or lower the Tower Boom, position Tower Boom Lift switch to Up or Down until desired height is reached.



Raising and Lowering the Main Boom

To raise or lower the Main Boom, use Main Boom Lift controller to select Up or Down movement.



Telescoping the Main Boom

To extend or retract the main boom, use the Main Telescope Control Switch to select In or Out movement.

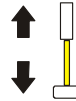

4.9 FUNCTION SPEED CONTROL

This control affects the speed of telescope, tower boom lift and jib lift. Turning the knob all the way counterclockwise until it clicks puts drive, main lift, platform rotate, and swing into creep mode.



4.10 MACHINE SAFETY SYSTEM OVERRIDE (MSSO) (IF EQUIPPED)

The Machine Safety System Override (MSSO) is used to override function controls for Emergency Platform Retrieval only. Refer to Section 5.6, Machine Safety System Override (MSSO) for operating procedures.



4.11 SKYGUARD OPERATION

SkyGuard provides enhanced control panel protection. When the SkyGuard sensor is activated, functions in use at the time of activation will reverse or cutout. The SkyGuard Function Table provides more details on these functions.

During activation, the horn will sound and, if equipped with a SkyGuard beacon, the beacon will illuminate until sensor and footswitch are disengaged.

If the SkyGuard sensor remains activated after function reversal or cutout, depress and hold the SkyGuard Override Switch to allow normal functions until the sensor is disengaged.

Consult the following illustrations to determine which type of SkyGuard the machine has and how it is activated. Regardless of type, SkyGuard function according to the SkyGuard Function Table does not change.

SkyGuard

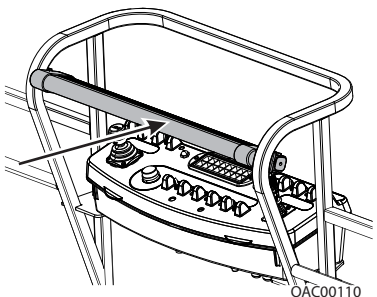

Approximately 50 lb (222 Nm) of force is applied to yellow bar.

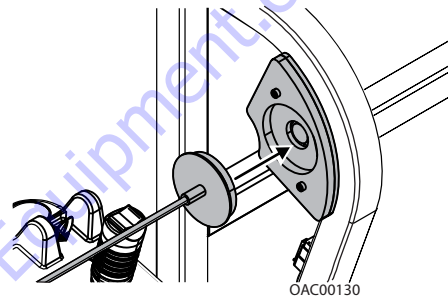

Reattach magnetic end of cable to bracket if it becomes disconnected.

SkyGuard - SkyLine

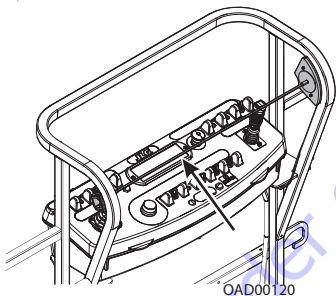

Cable is pressed, breaking the magnetic connection between the cable and right bracket.

SkyGuard - SkyEye

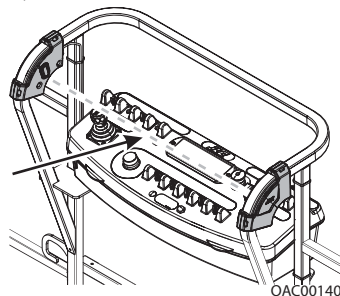

Operator passes through path of sensor beam.

SkyGuard Function Table

| Drive Forward | Drive Reverse | Steer | Swing | Tower Lift Up | Tower Lift Down | Boom Lift Up | Boom Lift Down | Boom Tele Out | Boom Tele In | Jib Lift | Basket Level | Basket Rotate |
|--|---------------|-------|-------|---------------|-----------------|--------------|----------------|---------------|--------------|----------|--------------|---------------|
| R*/C** | R | C | R | R | C | R | R | R | C | C | C | C |
| R= Indicates Reversal is Activated | | | | | | | | | | | | |
| C= Indicates Cutout is Activated | | | | | | | | | | | | |
| *DOS (Drive Orientation System) Enabled | | | | | | | | | | | | |
| ** DOS Not Enabled, machine is driving straight without steering, and any other hydraulic function is active | | | | | | | | | | | | |

4.12 SHUT DOWN AND PARK

Shut Down and Park

The preferred procedures to shut down and park the machine are as follows:

1. Drive machine to a reasonably well protected area.
2. Ensure boom is fully retracted and lowered over rear axle.
3. Shut down Emergency Stop at Platform Controls.
4. Shut down Emergency Stop at Ground Controls. Position Platform/Ground Select switch to center Off (center position).
5. If necessary, cover Platform Controls to protect instruction placards, warning decals, and operating controls from hostile environment.

NOTICE

IF PARKING A MEWP WITH THE BOOM ELEVATED IN AN EFFORT TO CONSERVE SPACE, BOOMS MAY BE ELEVATED, BUT SHALL NOT BE EXTENDED. IT IS THE OPERATOR'S RESPONSIBILITY TO ENSURE ALL SAFETY PRECAUTIONS IN SECTION 1 OF THIS MANUAL ARE FOLLOWED FOR EACH UNIQUE SITUATION.

4.13 LIFTING AND TIE DOWN

(See Figure 4-5.)

Lifting

1. Refer to the Serial Number Plate, refer to the Specifications section of this manual, or weigh the individual unit to find out the Gross Vehicle Weight.
2. Place the boom in the stowed position.
3. Remove all loose items from the machine.
4. Properly adjust the rigging to prevent damage to the machine and so the machine remains level.

Tie Down

NOTICE

WHEN TRANSPORTING THE MACHINE IN THE STOWED POSITION, THE BOOM MUST BE FULLY LOWERED INTO THE BOOM REST.

1. Place the boom in the stowed position or storage position.
2. Remove all loose items from the machine.
3. Secure the chassis and the platform using straps or chains of adequate strength.

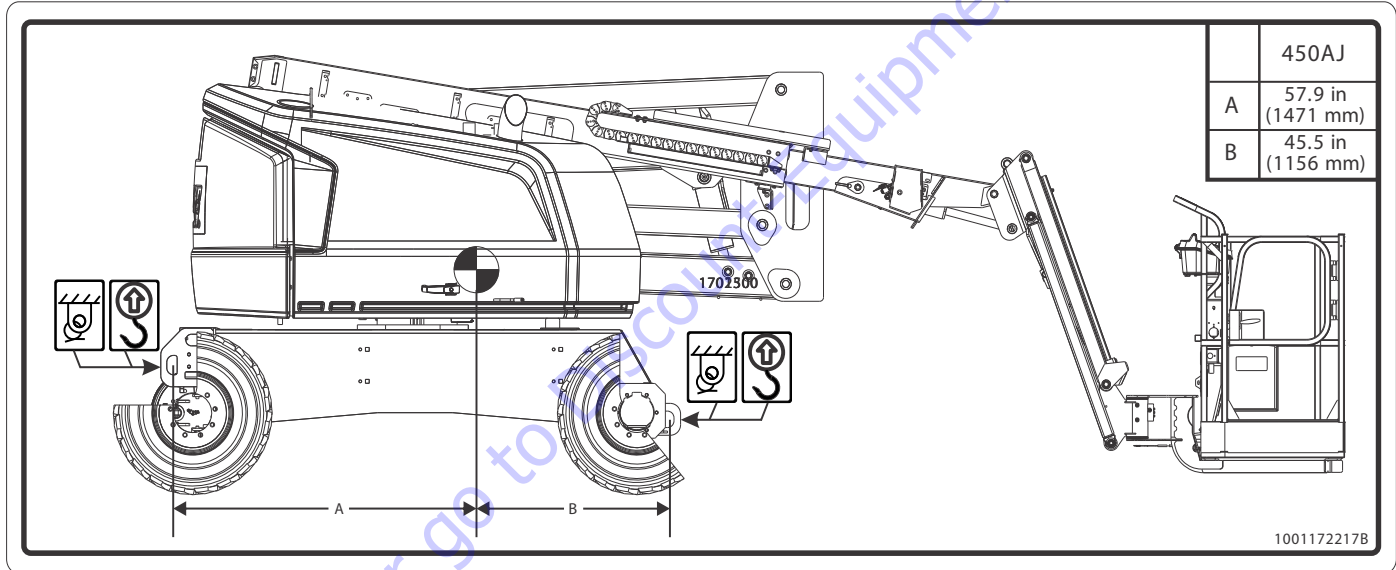

Figure 4-5. Lifting and Tie Down Chart

SECTION 4 - MACHINE OPERATION

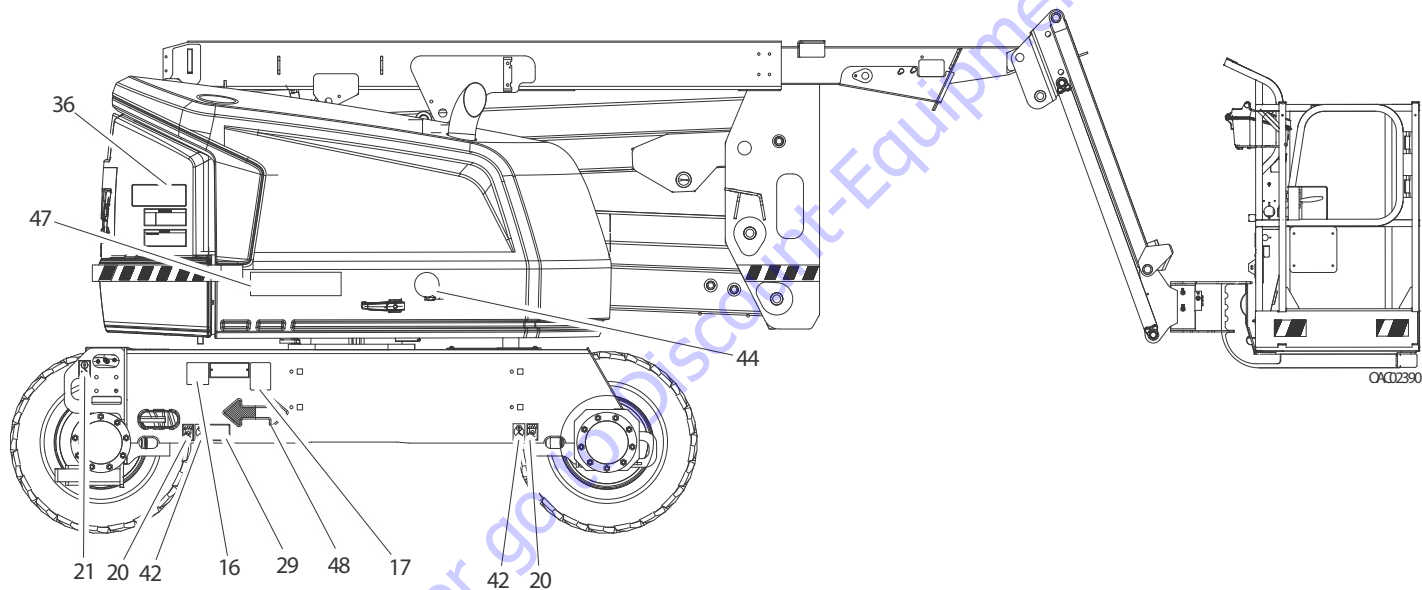

Figure 4-6. Decal Location Sheet 1 of 6

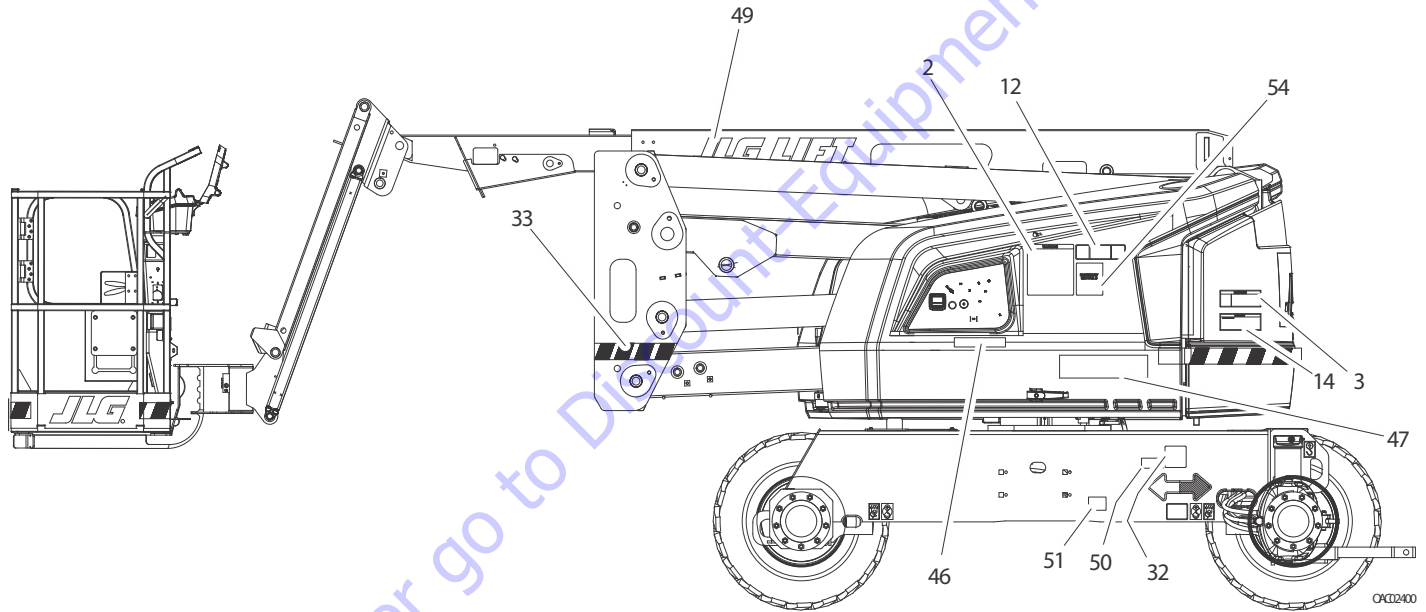

Figure 4-7. Decal Location Sheet 2 of 6

SECTION 4 - MACHINE OPERATION

Table 4-2. Decal Legend - Kubota Engine-Powered Machines

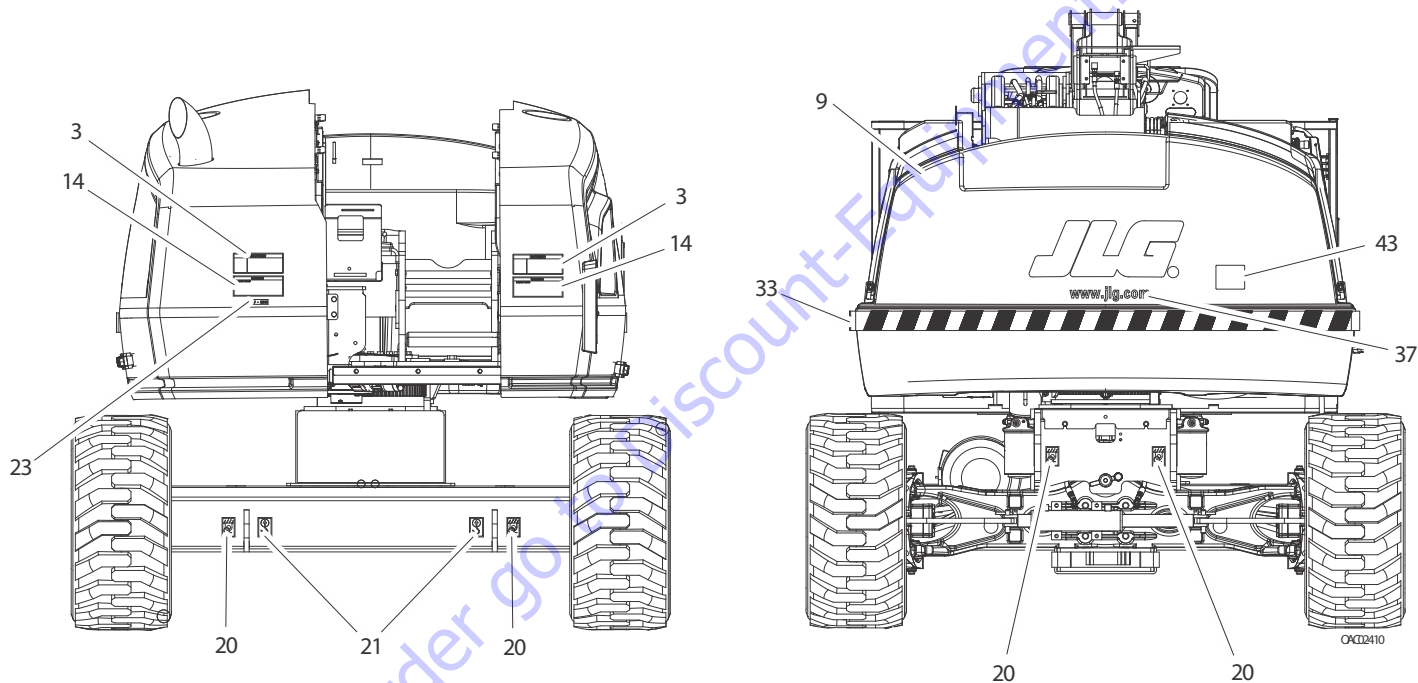

Figure 4-8. Decal Location Sheet 3 of 6

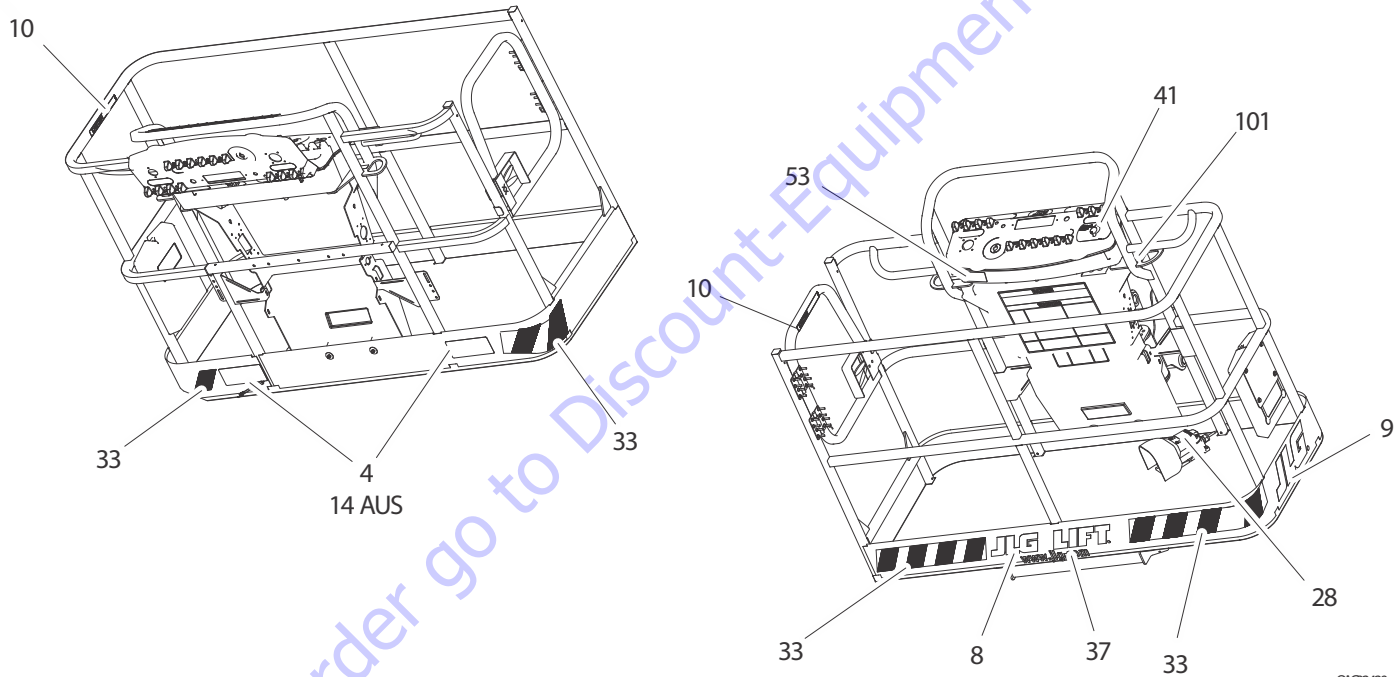

Figure 4-9. Decal Location Sheet 4 of 6

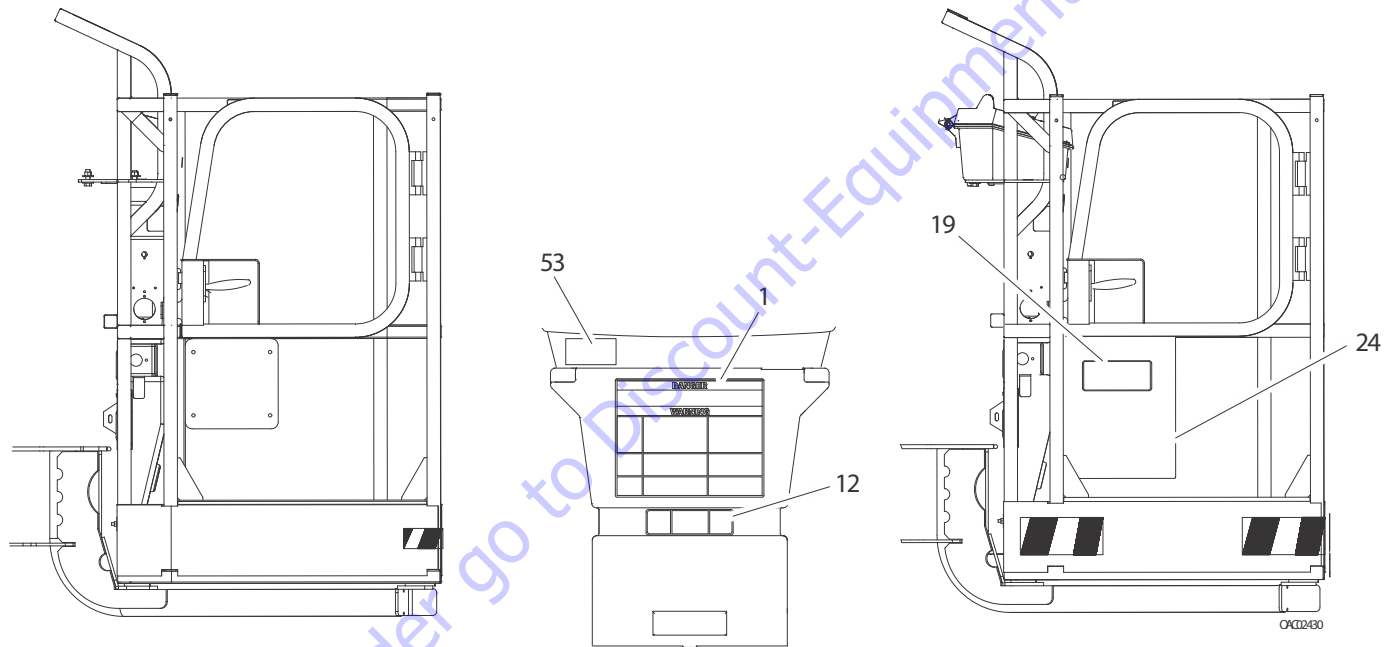

Figure 4-10. Decal Location Sheet 5 of 6

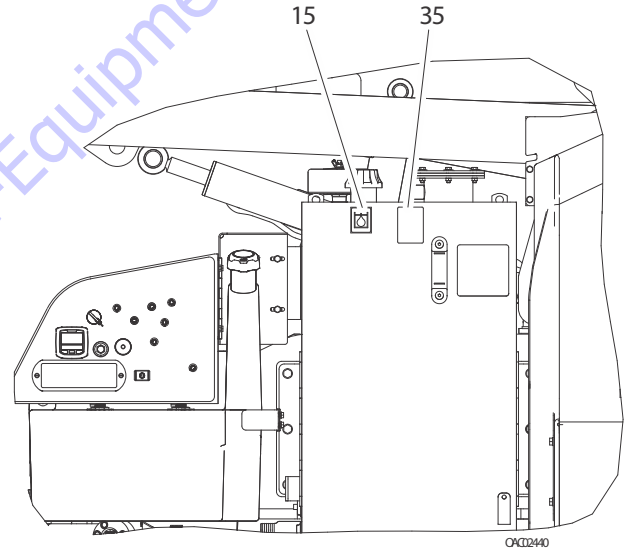
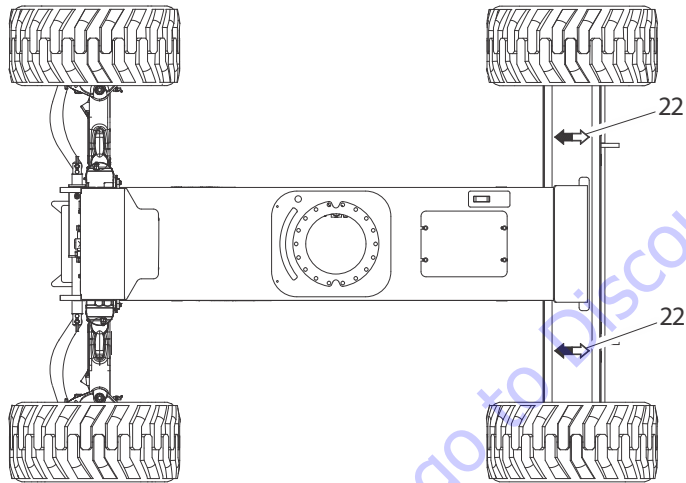

Figure 4-11. Decal Location Sheet 6 of 6

SECTION 4 - MACHINE OPERATION

Table 4-4. Decal Legend - Language Markets

| Item # | ANSI 1001246402-B | Australia 1001162522-G | Japan 1001256208-A | Korea 1001256205-A | French 1001246403-B | Chinese 1001256206-A | Portuguese 1001256207-A | CE 1001162528-I | Spanish 1001246407-B |
|--------|----------------------|---------------------------|-----------------------|-----------------------|------------------------|-------------------------|----------------------------|--------------------|-------------------------|
| 1 | 1703797 | 1001162429 | 1703926 | 1703927 | 1703924 | 1703925 | 1703928 | 1001162429 | 1703923 |
| 2 | 1705336 | 1705822 | 1705344 | 1705345 | 1705347 | 1001116849 | 1705349 | 1705822 | 1705917 |
| 3 | 1703805 | 1705961 | 1703938 | 1703939 | 1703936 | 1703937 | 1703940 | 1705961 | 1703935 |
| 4 | 1703804 | -- | 1703950 | 1703951 | 1703948 | 1703949 | 1703952 | -- | 1703947 |
| 8 | 1702774 | 1702774 | 1702774 | 1702774 | 1702774 | 1702774 | 1702774 | -- | 1702774 |
| 9 | 1702773 | 1702773 | 1702773 | 1702773 | 1702773 | 1702773 | 1702773 | 1702773 | 1702773 |
| 10 | 1702868 | -- | -- | 1705969 | 1704000 | 1705968 | 1704002 | -- | 1704001 |
| 12 | 1001255511 | 1001190913 | 1001255517 | 1001255513 | 1001255512 | 1001255514 | 1001255515 | 1001190913 | 1001255516 |
| 14 | 1703953 | 1701518 | 1703944 | 1703945 | 1703942 | 1703943 | 1705903 | 1701518 | 1703941 |
| 15 | 1701504 | 1701504 | 1701504 | 1701504 | 1701504 | 1701504 | 1701504 | 1701504 | 1701504 |
| 16 | 1702631 | 1702631 | 1702631 | 1702631 | 1702631 | 1702631 | 1702631 | 1702631 | 1702631 |
| 17 | 1001131269 | -- | -- | -- | 1001131269 | -- | -- | -- | -- |
| 19 | 1701509 | 1701509 | 1701509 | 1701509 | 1701509 | 1701509 | 1701509 | 1701509 | 1701509 |
| 20 | 1702300 | 1702300 | 1702300 | 1702300 | 1702300 | 1702300 | 1702300 | 1702300 | 1702300 |
| 21 | 1701500 | 1701500 | 1701500 | 1701500 | 1701500 | 1701500 | 1701500 | 1701500 | 1701500 |
| 22 | 1703687 | 1703687 | 1703687 | 1703687 | 1703687 | 1703687 | 1703687 | 1703687 | 1703687 |
| 23 | 3251243 | -- | -- | -- | 3251243 | -- | 3251243 | -- | 3251243 |
| 24 | 0860520 | 0860520 | 0860520 | 0860520 | 0860520 | 0860520 | 0860520 | 0860520 | 0860520 |

Table 4-4. Decal Legend - Language Markets

| Item # | ANSI 1001246402-B | Australia 1001162522-G | Japan 1001256208-A | Korea 1001256205-A | French 1001246403-B | Chinese 1001256206-A | Portuguese 1001256207-A | CE 1001162528-I | Spanish 1001246407-B |
|------------|----------------------|---------------------------|-----------------------|-----------------------|------------------------|-------------------------|----------------------------|--------------------|-------------------------|
| 28 | 3252347 | 1705828 | 1703980 | 1703981 | 1703984 | 1703982 | 1703985 | 1705828 | 1703983 |
| 29 - 450A | 1001195746 | 1001195746 | 1001195746 | 1001195746 | 1001195746 | 1001195746 | 1001195746 | 1001195746 | 1001195746 |
| 29 - 450AJ | 1704752 | 1704752 | 1704752 | 1704752 | 1704752 | 1704752 | 1704752 | 1704752 | 1704752 |
| 32 | 1700818 | -- | -- | -- | 1704271 | -- | -- | -- | -- |
| 33 | 1001188883 | 1001188883 | 1001188883 | 1001188883 | 1001188883 | 1001188883 | 1001188883 | 1001188883 | 1001188883 |
| 35 | 1704412 | 1704412 | 1704412 | 1704412 | 1704412 | 1704412 | 1704412 | 1704412 | 1704412 |
| 36 | 1001172217 | 1001172217 | 1001172217 | 1001172217 | 1001172217 | 1001172217 | 1001172217 | 1001172217 | 1001172217 |
| 37 | 1704885 | 1704885 | 1704885 | 1704885 | 1704885 | 1704885 | 1704885 | -- | 1704885 |
| 41 | 1705351 | -- | 1705426 | 1705427 | 1705429 | 1705430 | 1705905 | -- | 1705910 |
| 42 | 1701499 | 1701499 | 1701499 | 1701499 | 1701499 | 1701499 | 1701499 | 1701499 | 1701499 |
| 43 | 3251813 | 1001204510 | -- | -- | 3251813 | -- | 3251813 | 1001204510 | 3251813 |
| 46 | -- | 1001112551 | -- | -- | -- | -- | -- | 1001189882 | -- |
| 47 - 450A | 1703774 | 1703774 | 1703774 | 1703774 | 1703774 | 1703774 | 1703774 | 1703774 | 1703774 |
| 47 - 450AJ | 1001172801 | 1001172801 | 1001172801 | 1001172801 | 1001172801 | 1001172801 | 1001172801 | 1001172801 | 1001172801 |
| 48 | 1701529 | 1701529 | 1701529 | 1701529 | 1701529 | 1701529 | 1701529 | 1701529 | 1701529 |
| 49 | 1702860 | 1702860 | 1702860 | 1702860 | 1702860 | 1702860 | 1702860 | -- | 1702860 |
| 50 | 1001143852 | 1001143852 | 1001143852 | 1001143852 | 1001143852 | 1001143852 | 1001143852 | 1001143852 | 1001143852 |
| 51 | -- | -- | -- | -- | -- | -- | -- | 1001181145 | -- |

SECTION 4 - MACHINE OPERATION

Table 4-4. Decal Legend - Language Markets

| Item # | ANSI 1001246402-B | Australia 1001162522-G | Japan 1001256208-A | Korea 1001256205-A | French 1001246403-B | Chinese 1001256206-A | Portuguese 1001256207-A | CE 1001162528-I | Spanish 1001246407-B |
|--------|----------------------|---------------------------|-----------------------|-----------------------|------------------------|-------------------------|----------------------------|--------------------|-------------------------|
| 52 | 1001223453 | -- | -- | -- | 1001223453 | -- | -- | 1001244298 | -- |
| 53 | 1001231801 | -- | -- | -- | -- | -- | -- | -- | -- |
| 54 | -- | -- | -- | -- | -- | 1001244298 | -- | -- | -- |
| 100 | 1001232026 | 1001232026 | 1001232026 | 1001232026 | 1001232026 | 1001232026 | 1001232026 | 1001232026 | 1001232026 |
| 101 | 1704277 | 1704277 | 1704277 | 1704277 | 1704277 | 1704277 | 1704277 | 1704277 | 1704277 |

SECTION 4 - MACHINE OPERATION

| Item # | ANSI 1001246405-B | CSA French 1001246406-B |
|---------------|------------------------------|--|
| 1 | 1703797 | 1703924 |
| 2 | 1705336 | 1705347 |
| 3 | 1703805 | 1703936 |
| 4 | 1703804 | 1703948 |
| 10 | 1702868 | 1704000 |
| 12 | 1001255511 | 1001255512 |
| 14 | 1703953 | 1703942 |
| 15 | 1701504 | 1701504 |
| 16 | 1702631 | 1702631 |
| 17 | 1001131269 | 1001131269 |
| 19 | 1701509 | 1701509 |
| 20 | 1702300 | 1702300 |
| 21 | 1701500 | 1701500 |
| 22 | 1703687 | 1703687 |
| 23 | 3251243 | 3251243 |
| 28 | 3252347 | 1703984 |
| 33 | 1001188883 | 1001188883 |

| Item # | ANSI 1001246405-B | CSA French 1001246406-B |
|---------------|------------------------------|--|
| 35 | 1704412 | 1704412 |
| 36 | 1001172217 | 1001172217 |
| 37 | 1704885 | 1704885 |
| 41 | 1705351 | 1705429 |
| 42 | 1701499 | 1701499 |
| 43 | 3251813 | 3251813 |
| 48 | 1701529 | 1701529 |
| 49 | 1702860 | 1702860 |
| 51 | 1001223055 | 1001223971 |
| 52 | 1001223453 | 1001223453 |
| 53 | 1001231801 | -- |
| 100 | 1001232026 | 1001232026 |
| 101 | 1704277 | 1704277 |

SECTION 5. EMERGENCY PROCEDURES

5.1 GENERAL

This section explains the steps to be taken in case of an emergency situation while operating.

5.2 INCIDENT NOTIFICATION

JLG Industries, Inc. must be notified immediately of any incident involving a JLG product. Even if no injury or property damage is evident, the factory should be contacted by telephone and provided with all necessary details.

- USA: 877-JLG-SAFE (554-7233)
- EUROPE: (32) 0 89 84 82 20
- AUSTRALIA: (61) 2 65 811111
- E-mail: ProductSafety@JLG.com

Failure to notify the manufacturer of an incident involving a JLG Industries product within 48 hours of such an occurrence may void any warranty consideration on that particular machine.

NOTICE

FOLLOWING ANY INCIDENT, THOROUGHLY INSPECT THE MACHINE AND TEST ALL FUNCTIONS FIRST FROM THE GROUND CONTROLS, THEN FROM THE PLATFORM CONTROLS. DO NOT LIFT ABOVE 3 M (10 FT.) UNTIL YOU ARE SURE THAT ALL DAMAGE HAS BEEN REPAIRED, IF REQUIRED, AND THAT ALL CONTROLS ARE OPERATING CORRECTLY.

5.3 EMERGENCY OPERATION

Operator Unable to Control Machine

IF THE PLATFORM OPERATOR IS PINNED, TRAPPED OR UNABLE TO OPERATE OR CONTROL MACHINE:

1. Other personnel should operate the machine from ground controls only as required.
2. Other qualified personnel on the platform may use the platform controls. DO NOT CONTINUE OPERATION IF CONTROLS DO NOT FUNCTION PROPERLY.
3. Cranes, forklift trucks or other equipment can be used to stabilize motion of the machine.

Platform or Boom Caught Overhead

If the platform or boom becomes jammed or snagged in overhead structures or equipment, do the following:

1. Shut off the machine.
2. Rescue all people in the platform before freeing the machine. Personnel must be out of the platform before operating any controls on the machine.
3. Use cranes, forklifts, or other equipment to stabilize motion of the machine to prevent a tip over as required.
4. From the ground controls, use the Auxiliary Power System (if equipped) to carefully free the platform or boom from the object.
5. Once clear, restart the machine and return the platform to a safe position.
6. Inspect the machine for damage. If the machine is damaged or does not operate properly, turn off the machine immediately. Report the problem to the proper maintenance personnel. Do not operate the machine until it is declared safe for operation.

5.4 MANUAL SWING OVERRIDE

The manual swing override is used to manually swing the boom and turntable assembly in the event of a total power failure when the platform is positioned over a structure or obstacle. To operate the manual swing override, proceed as follows:

1. Using a 7/8 inch socket and ratchet wrench, locate nut on swing worm gear on left side of machine.
2. Install wrench on nut and ratchet in the direction desired.

5.5 EMERGENCY TOWING PROCEDURES

Towing this machine is prohibited. However, provisions for moving the machine have been incorporated. The following procedures are to be used **ONLY** for emergency movement to a suitable maintenance area.

NOTICE

THE ALLOWABLE TOWING SPEED IS 1.9 MPH (3 KM/H). THE MAXIMUM ALLOWABLE TOWING DISTANCE IS 0.6 MILES (1 KM).

1. Chock wheels securely.
2. Engage the mechanical release on both drive hubs by loosening, completely reversing, and tightening the two bolts on each hub.
3. Connect suitable equipment, remove chocks, and move machine.

After moving machine, complete the following procedure:

1. Position machine on a firm level surface.
2. Chock wheels securely.
3. Disengage the mechanical release on both drive hubs by loosening, completely reversing, and tightening the two bolts on each hub.
4. Remove chocks from wheels as desired.

5.6 MACHINE SAFETY SYSTEM OVERRIDE (MSSO) (IF EQUIPPED)

The Machine Safety System Override (MSSO) is only to be used to retrieve an operator that is pinned, trapped, or unable to operate the machine. The MSSO will override function controls that are locked out from the platform and ground consoles. An example of this would be in the case of Load Sense System activation.



NOTE: *If the MSSO functionality is used, a fault code is set in the JLG Control System which must be reset by a qualified JLG Service Technician.*

NOTE: *No functional checks of the MSSO system are necessary. The JLG Control system will set a Diagnostic Trouble Code if the control switch is faulty.*

To operate the MSSO:

1. From the ground control console, place the Platform/ Ground Select switch in the Ground position.
2. Pull out the Power/Emergency Stop control.
3. Start the engine or MSSO will function through the Auxiliary Power system.
4. Press and hold the MSSO switch and the control switch for the desired function.

SECTION 6. ACCESSORIES

Table 6-1. Available Accessories

| Accessory | Market | | | | | |
|---------------------------------|--------------------|------|-----|----|-----|-------|
| | ANSI (USA Only) | ANSI | CSA | CE | AUS | China |
| Fall Arrest Platform (30" x60") | √ | | √ | | | |
| Pipe Racks | √ | √ | √ | √ | √ | √ |
| SkyGlazier™ | √ | | √ | | √ | |
| SkyPower™ | √ | √ | √ | √ | √ | √ |
| SkyWelder™ | √ | √ | √ | | | √ |
| SoftTouch™ | √ | √ | √ | √ | √ | √ |
| SkySense™ | √ | √ | √ | √ | √ | √ |

SECTION 6 - ACCESSORIES

Table 6-2. Options/Accessories Relationship Table

| ACCESSORY | REQUIRED ITEM | COMPATIBLE WITH (Note 1) | INCOMPATIBLE WITH | INTERCHANGABLE WITH (Note 2) |
|--|---------------|-----------------------------|--|------------------------------|
| Pipe Racks | | SkyPower™ | Platform MMR**, Platform MTR*, SkySense, Soft Touch | SkyGlazier™, SkyWelder™ |
| SkyGlazier™ | | SkyPower™ | 4' Platform, Pipe Racks, Platform MTR*, SkySense, Soft Touch | SkyWelder™ |
| SkyPower™ | | SkyGlazier™, SkyWelder™ | | |
| SkyWelder™ | SkyPower™ | | 4' Platform, Pipe Racks, Platform MTR*, SkySense, Soft Touch | SkyGlazier™ |
| Soft Touch | | SkyPower™ | Pipe Racks, SkySense, SkyGlazier™, SkyWelder™ | |
| SkySense | | SkyPower™ | Pipe Racks, Soft Touch, Platform MMR**, Platform MTR*, SkyGlazier™, SkyWelder™ | |
| Note 1: Any non-"Sky" accessory not listed under "INCOMPATIBLE WITH" is assumed to be compatible. | | | | |
| Note 2: Can be used on same unit but not simultaneously. | | | | |
| * Platform MTR = Platform Mesh to Top Rail; ** Platform MMR = Platform Mesh to Mid Rail | | | | |

6.1 FALL ARREST PLATFORM

NOTE: See the JLG External Fall Arrest System manual (PN 3128935) for more information.

The external fall arrest system is designed to provide a lanyard attach point while allowing the operator to access areas outside the platform. Exit/enter the platform through the gate area only. The system is designed for use by one person.

Personnel must use fall protection at all times. A full body harness is required with lanyard not to exceed 6 ft (1.8 m) in length, that limits the maximum arrest force to 900 lb (408 kg) for the trans-faster type and 1350 lb (612 kg) for the shuttle type fall arrest system.

Safety Precautions

⚠ WARNING

DO NOT OPERATE ANY MACHINE FUNCTIONS WHILE OUTSIDE THE PLATFORM. USE CAUTION WHEN ENTERING/EXITING THE PLATFORM AT ELEVATION.

6.2 PIPE RACKS

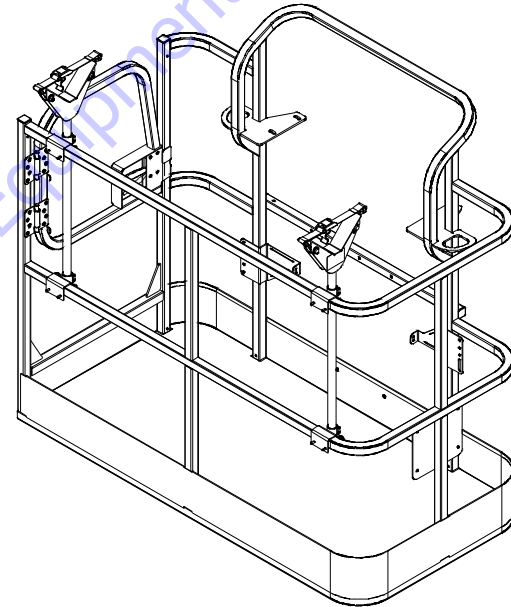

Pipe Racks provide a way to store pipe or conduit inside the platform in order to prevent rail damage and optimize platform utility. This accessory consists of two racks with adjustable straps to secure the load in place.

Capacity Specifications (Australia Only)

| Max. Capacity in Racks | Max. Platform Capacity (With Max. Weight in Racks) |
|--|---|
| 80 kg | 184 kg |
| Max. Length of Material in Racks: 6.0 m Min. Length of Material in Racks: 2.4 m | |

Safety Precautions

WARNING

REDUCE PLATFORM CAPACITY BY 100 LB (45.5 KG) WHEN INSTALLED.

WARNING

WEIGHT IN RACKS PLUS WEIGHT IN PLATFORM MUST NOT EXCEED RATED CAPACITY.

NOTICE

THE MAXIMUM LOAD IN THE RACKS IS 180 LB (80 KG) EVENLY DISTRIBUTED BETWEEN THE TWO RACKS.

NOTICE

THE MAXIMUM LENGTH OF MATERIAL IN RACKS IS 20 FT (6.1 M).

- Ensure no personnel are beneath the platform.
- Do not exit platform over rails or stand on rails.
- Do not drive machine without material secured
- Return racks to the stowed position when not in use.
- Use this option only on approved models.

Preparation and Inspection

- Ensure racks are secured to the platform rails.
- Replace torn or frayed tie-down straps.

Operation

1. To prepare racks for loading, remove locking pins, rotate each rack 90 degrees from stowed to working position, then secure with locking pins.
2. Loosen and remove tie-down straps. Place material on racks with weight evenly distributed between both racks.
3. Route the tie-down straps at each end across loaded material and tighten.
4. To remove material, loosen and remove tie-down straps, then carefully remove material from racks.

NOTE: *Reinstall tie-down straps across any remaining material before continuing machine operations.*

6.3 SKYGLAZIER™

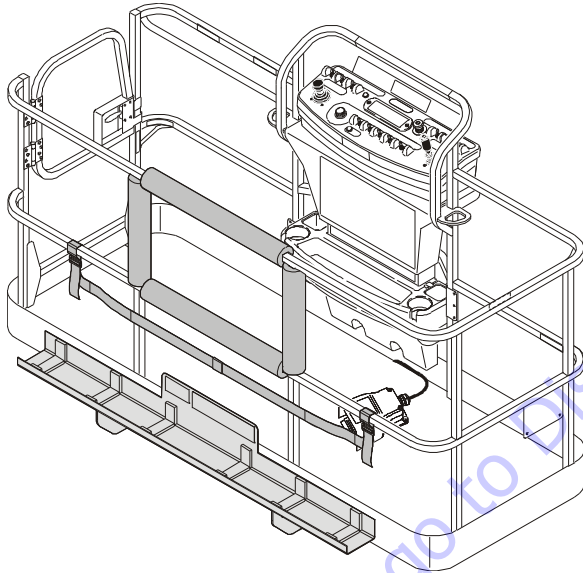

SkyGlazier™ allows glaziers to position panels efficiently. The glazier package consists of a tray that attaches the bottom of the platform. The panel rests on the tray and against top-rail of the platform, which is padded to prevent damage. SkyGlazier™ includes a strap to secure the panel to the platform rail.

Capacity Specifications

| Capacity Zone * | Max. Tray Capacity | Max. Platform Capacity (With Max. Weight in Tray) |
|--|--------------------|--|
| 500 lb (227 kg) | 150 lb (68 kg) | 250 lb (113 kg) |
| 550 lb (250 kg) | 150 lb (68 kg) | 250 lb (113 kg) |
| 600 lb (272 kg) | 150 lb (68 kg) | 250 lb (113 kg) |
| 750 lb (340 kg) | 150 lb (68 kg) | 440 lb (200 kg) |
| 1000 lb (454 kg) | 250 lb (113 kg) | 500 lb (227 kg) |
| * Refer to the capacity decals installed on the machine for capacity zone information. | | |
| Required Platform Type: Side-Entry | | |
| Max. Dimensions of Panel: 32 sq ft (3 sq m) | | |

Safety Precautions

WARNING

ENSURE PANEL IS SECURED WITH STRAP.

WARNING

DO NOT OVERLOAD TRAY OR PLATFORM. TOTAL MACHINE CAPACITY IS REDUCED WHEN TRAY IS INSTALLED.

WARNING

WITH SKYGLAZIER™ INSTALLED, THE ORIGINAL PLATFORM CAPACITY RATINGS ARE REDUCED AS SPECIFIED IN THE SPECIFICATIONS TABLE ABOVE. DO NOT EXCEED THE NEW PLATFORM CAPACITY RATING. REFER TO CAPACITY DECAL LOCATED ON TRAY.

WARNING

AN INCREASE OF THE AREA EXPOSED TO THE WIND WILL DECREASE STABILITY. LIMIT PANEL AREA TO 32 SQ FT (3 SQ M).

- Ensure no personnel are beneath platform.
- Do not exit platform over rails or stand on rails.
- Remove tray when not in use.
- Use this option only on approved models.

Preparation and Inspection

- Check for cracked welds and damage to tray.
- Ensure tray is properly secured to platform.
- Ensure strap is not torn or frayed.

Operation

1. Load SkyGlazier™ tray with panel.
2. Route the adjustable strap around the panel and tighten until secure.
3. Position panel to its desired location.

6.4 SKYPOWER™

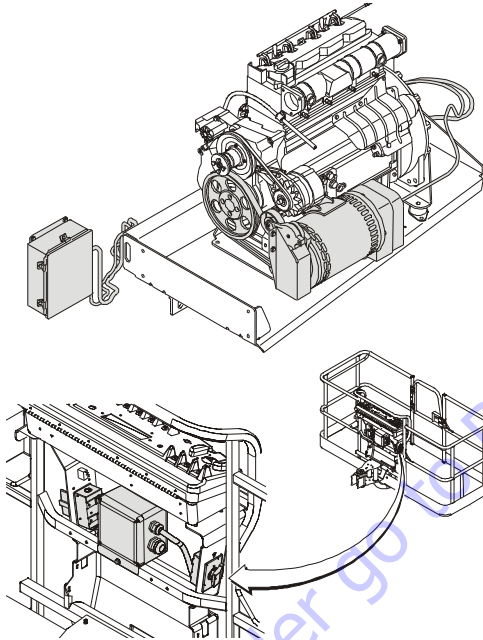

The SkyPower™ system supplies AC power to the platform through an AC receptacle to run tools, lights, cutting, and welding equipment.

All power regulation components are located in a watertight box connected by cable to the generator. The generator supplies power when running at the specified speed with the power switch on (switch is located on platform). A three-pole, 30 Amp circuit breaker protects the generator from overload.

Generator Output

ANSI Specifications:

- 3-phase: 240 V, 60 Hz, 7.5 kW
- 1-phase: 240 V/120 V, 60 Hz, 6 kW

CE Specifications:

- 3-phase: 240 V, 7.5 kW, 18.3 A, 1.0-pf
- 1-phase: 240 V, 6.0 kW, 26 A, 1.0-pf
- 1-phase: 120 V, 6.0 kW, 50 A, 1.0-pf

Peak:

- 3-phase: 8.5 kW
- 1-phase: 6.0 kW

Accessory Ratings

- 3000 rpm (50 Hz)
- 3600 rpm (60 Hz)

Safety Precautions

⚠ WARNING

DO NOT OVERLOAD PLATFORM.

- Ensure no personnel are beneath platform.
- This factory-installed option is available only on specified models.
- Keep lanyard attached at all times.
- Do not use electrical tools in water.
- Use correct voltage for tool being used.
- Do not overload circuit.

Preparation and Inspection

- Ensure generator is secure.
- Check condition of belt and wiring.

Operation

Start the engine, then turn on the generator.

See the Miller Generator Technical Manual (PN 3121677) for more information.

6.5 SKYWELDER™

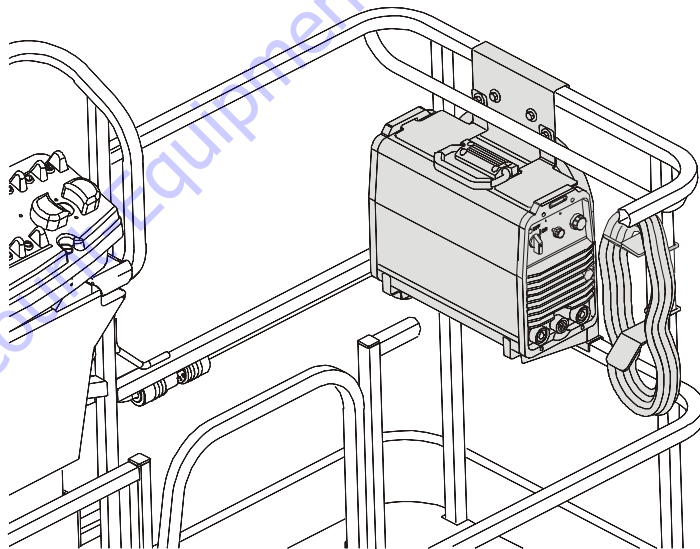

SkyWelder™ is capable of TIG and Stick welding, producing 200 Amps at 100% duty cycle or 250 Amps at 50% duty cycle. It receives power from the SkyPower™ system.

Accessory Ratings

| Welding Mode | Input Power | Rated Output | Welding Amperage Range | Maximum Open Circuit Voltage | Amps Input At Rated Load Output (50/60 Hz) | | | | |
|----------------------------|-------------|-------------------------------------|------------------------|------------------------------|--|-------|-------|------|-----|
| | | | | | 230 V | 460 V | 575 V | kVa | kW |
| Stick (SMAW) TIG (GTAW) | 3-phase | 280 Amp at 31.2V, 35% Duty Cycle | 5-250 A | 79VDC | 32 | 17 | 13 | 15.7 | 10 |
| | | 200 Amp at 28V, 100% Duty Cycle | | | 20 | 11 | 8 | 10.3 | 6.4 |
| | 1-phase | 200 Amp at 28V, 50% Duty Cycle | 5-200 A | 79VDC | 35 | ----- | ----- | 9.8 | 6.5 |
| | | 150 Amp at 28V, 100% Duty Cycle | | | 34 | ----- | ----- | 6.9 | 4.4 |

Generator Output

Engine Speed of 1800 rpm +/- 10%.

ANSI Specifications:

- 3-phase: 240 V, 60 Hz, 7.5 kW
- 1-phase: 240 V/120 V, 60 Hz, 6 kW

Welding Accessories

- 12 ft welding leads with clamp and stinger (stored in the platform)
- Fire extinguisher

Safety Precautions

⚠ WARNING

DO NOT OVERLOAD PLATFORM.

⚠ WARNING

DE-RATE THE PLATFORM BY 70 LB (32 KG) WHEN WELDER IS IN THE PLATFORM.

- Check for cracked welds and damage to welder supports.
- Check for proper and secure installation of welder and bracket.
- Ensure no personnel are beneath platform.
- Do not exit platform over rails or stand on rails.
- Use this option only on approved models.
- Keep lanyard attached at all times.
- Ensure correct polarity of leads.
- Wear proper welding apparel.
- Use correct rod size and current settings.
- Do not use electrical cords without ground.
- Do not use electrical tools in water.
- Do not weld to the platform.

- Do not ground through the platform.
- Do not use a high frequency arc starter with TIG welder.

Preparation and Inspection

- Connect ground clamp to metal being welded.
- Ensure there is a good ground connection and observe proper polarity.

Operation

Start the engine, turn on the generator, then turn on the welder.

See the Miller Welder Owner's Manual (PN 3128957) for more information.

6.6 SOFT TOUCH™

A padding kit is mounted to the platform rails and a frame suspended below the platform. Limit switches deactivate platform functions when the padded framework contacts an adjacent structure. A button on the platform console allows override of the system.

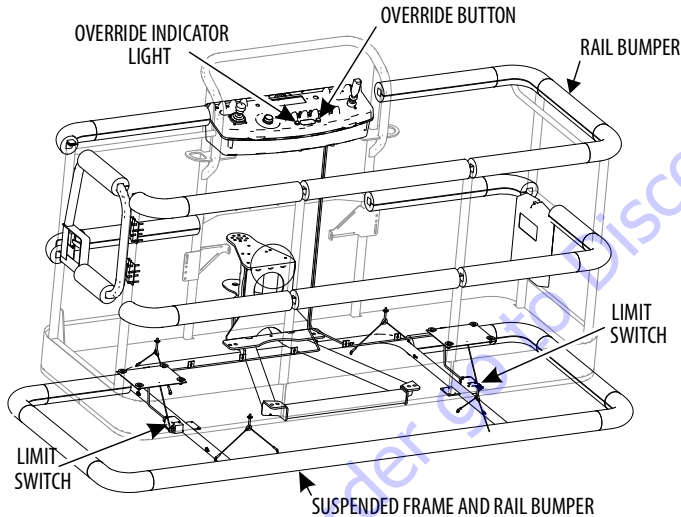

31215021

6.7 SKYSENSE™

⚠ WARNING

SKYSENSE IS NOT INTENDED TO REPLACE OR REDUCE THE NEED FOR THE OPERATOR TO BE AWARE OF THE ENVIRONMENT AROUND THE MACHINE. HAZARDS THAT WILL CAUSE SERIOUS INJURY OR DEATH MAY NOT BE PREVENTED OR REDUCED BY SKYSENSE. THE OPERATOR MUST ALWAYS LOOK IN THE DIRECTION OF TRAVEL, AVOID POWER LINES, AVOID OBSTACLES THAT COULD STRIKE THE MACHINE OR PERSONS IN THE PLATFORM, AND FOLLOW ALL INSTRUCTIONS, DECALS, AND OTHER WARNINGS PROVIDED WITH THIS MACHINE.

THE OPERATOR MUST NOT RELY ON SKYSENSE AS A SUBSTITUTE FOR FOLLOWING THE INSTRUCTIONS AND WARNINGS CONTAINED IN THE MANUALS AND PLACARDS PROVIDED WITH THIS MACHINE.

SKYSENSE IS INTENDED TO ASSIST THE OPERATOR. SKYSENSE MAY NOT DETECT CERTAIN OBJECTS DEPENDING ON SHAPE, TYPE OF MATERIAL, OR ORIENTATION OF THE OBJECT TO THE SENSORS. IT IS THE OPERATOR'S RESPONSIBILITY TO BE AWARE OF THEIR SURROUNDINGS AT ALL TIMES.

⚠ WARNING

REDUCE THE PLATFORM CAPACITY BY 10 LB (4.5 KG) PER BAR WHEN INSTALLED ON THE PLATFORM.

NOTE: SkySense is not active when operating the machine from the ground controls.

6-11

Preparation and Inspection

Pre-Operation Inspection:

1. Inspect each of the SkySense tubes for dents, cracks, or other damage.
2. Inspect each SkySense sensor for any damage to the housing or sensor.

To test the SkySense system:

1. Ensure there are no obstructions within 10 feet around or above the platform and the machine is on a smooth, firm surface within the limits of the maximum operating slope.
2. From the platform control console, elevate the boom until the bottom of the platform is at least 6 feet off the ground.
3. Continue to elevate the platform.
4. While elevating, wave your hand over one of the upward facing sensors. The machine should stop, and the LED should be red.
5. Ensure the area below the platform is clear of obstructions and lower the platform. The machine should slow down, (SkySense Status LED will blink yellow with increasing frequency) and stop, (SkySense Status LED will be illuminated solid red) when the bottom of the platform is approximately 1 foot from the ground.

6. Recycle the footswitch and press the override button on the platform control console.
7. Continue to lower the platform. The machine should move in the elevated drive speed mode (SkySense Status LED will remain red).

NOTE: *The SkySense system will not stop machine operation while in Creep.*

Operation

SkySense slows a machine's drive speed to elevated drive speed when it is a certain distance away from an object, known as the "warning zone." If the machine continues to approach the object and moves into the "stop zone," SkySense stops all machine functions.

For proportional functions activated by the joystick, the size of the warning zone varies based on the amount of joystick activation. The stop zone always activates at the same distance from the object regardless of the joystick's position.

If the function has reached the warning zone, release and re-engage to return to normal drive speed in the opposite direction. If the machine has reached the SkySense stop zone, release the function and recycle the footswitch to activate a function in the opposite direction.

SkySense is active during the following functions:

- Boom Lift Up/Down
- Platform Rotate
- Telescope Out
- Swing
- Reverse Drive

NOTE: During active Drive Orientation System (DOS), SkySense is active when driving in both forward and reverse directions.

There are two LED indicators on the platform control box that signal SkySense activity.

- **No LED:** Normal operation.
- **LED Flashing Yellow:** Machine is in SkySense warning zone and will reduce to elevated drive height speed. Flash frequency correlates to closeness of object.
- **LED Red:** Machine is in SkySense stop zone and all machine functions will cease.
- **LED Flashing Red:** SkySense sensor is obstructed or damaged. Obstructions must be removed and proper function verified. Damaged sensors must be replaced.

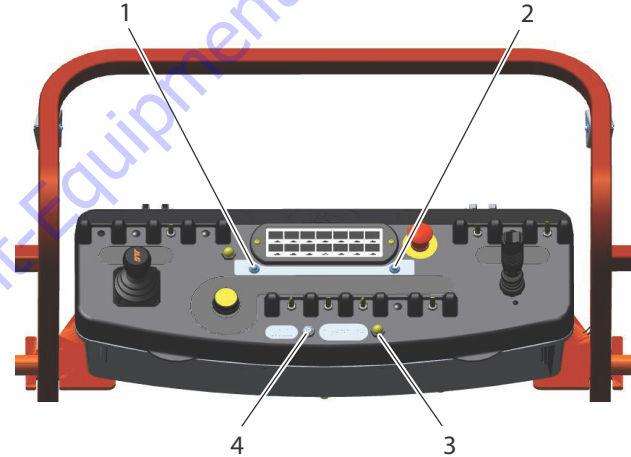

1. LED Indicator Light
2. LED Indicator Light
3. Override Button
4. Mute Speaker Switch

Figure 6-1. SkySense Platform Panel Indicators

SkySense Alarm

Activation of SkySense is signaled by an audible alarm which indicates SkySense activity when reaching the warning or stop zones.

In the warning zone, the audible alarm will pulse and increase in frequency as the machine moves closer to the object. In the stop zone, the alarm will sound a continuous tone.

Additionally, when the machine is in the stop zone, the platform control panel audible alarm will sound. The system may be reset by recycling the footswitch.

The audible SkySense alarms can be muted by a switch on the platform control console, although LEDs will continue to light. The platform control panel alarm will sound when the machine enters the SkySense stop zone even when muted.

Override Button

The yellow override button allows operators to bypass normal SkySense operation in order to move closer to an object in the stop zone.

When the operator overrides the SkySense via the override button to get closer to a work surface, the machine will maintain elevated speed and flash the appropriate indicator color based on location in either the warning or stop zones.

SkySense Coverage Areas

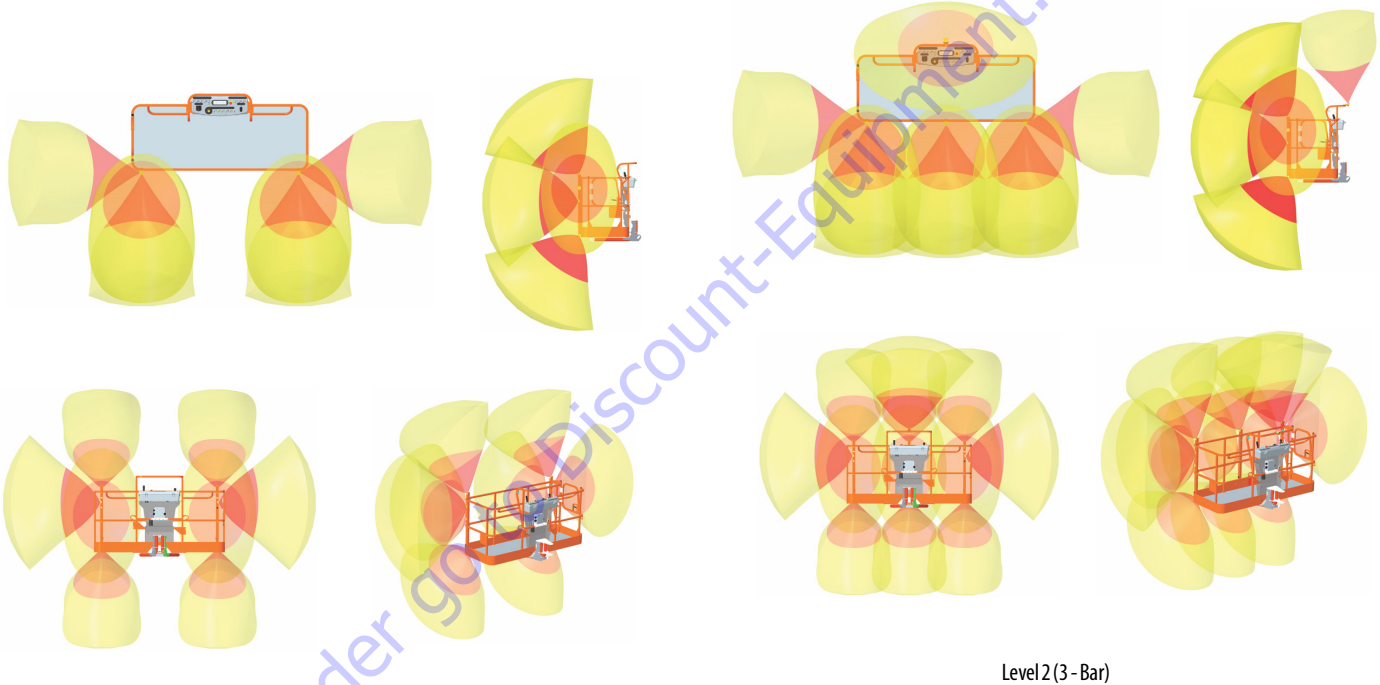

Level 1 (2-Bar)

Level 2 (3-Bar)

NOTE: Sensor Cones shown are approximations for reference only.

SECTION 7. GENERAL SPECIFICATIONS & OPERATOR MAINTENANCE

7.1 INTRODUCTION

This section of the manual provides additional necessary information to the operator for proper operation and maintenance of this machine.

The maintenance portion of this section is intended as information to assist the machine operator to perform daily maintenance tasks only, and does not replace the more thorough Preventive Maintenance and Inspection Schedule included in the Service and Maintenance Manual.

Other Publications Available:

Service and Maintenance Manual 31215022
 Illustrated Parts Manual 31215023

7.2 OPERATING SPECIFICATIONS AND PERFORMANCE DATA

Operating Specifications

Table 7-1. Operating Specifications

| | |
|---|----------------------------------|
| Capacity: Unrestricted: | 550 lb (249.5 kg) |
| Maximum Operating Slope | 5° |
| Maximum Travel Grade, stowed Position (Gradeability) | 45% |
| Maximum Travel Grade, stowed Position (Side Slope) | 5° |
| Drive Speed - Stowed | 4.25 mph (6.8 km/h) |
| Gross Machine Weight - Approximate | 13,250 lb (6010 kg) |
| Maximum Ground Bearing Pressure | 65 psi (4.6 kg/cm ²) |
| Maximum Wind Speed | 28 mph (12.5 m/s) |
| Max. Tire Load | 7200 lb (3266 kg) |
| System Voltage | 12VDC |

SECTION 7 - GENERAL SPECIFICATIONS & OPERATOR MAINTENANCE

Table 7-1. Operating Specifications

| | |
|-----------------------------------|--------------------|
| Maximum Main Relief Hyd. Pressure | 4060 psi (280 Bar) |
| Average Fuel Consumption | 0.85 gph (3.2 lph) |

Dimensional Data

Table 7-2. Dimensional Data

| | |
|-----------------------------|------------------|
| Turning Radius (Inside) | 6'9" (2.06 m) |
| Turning Radius (Outside) | 15'8" (4.78 m) |
| Machine Height (stowed) | 89.3" (2269 mm) |
| Machine Length (stowed) | 258.9" (6576 mm) |
| Up and Over Platform Height | 24' (7.3 m) |
| Horizontal Reach | 25' (7.62 m) |
| Machine Width | 92.6" (2353 mm) |
| Wheel Base | 93.0" (2362 mm) |
| Platform Height | 45'9" (13.72 m) |
| Ground Clearance | 16.4" (417 mm) |

Capacities

Table 7-3. Capacities

| | |
|--|---------------------------------------|
| Hydraulic System | 38 gal. (143.8 L) |
| Hydraulic Oil Tank (to Full Level) | 31.7 Gal. (119.9 L) |
| Drive Hub | 24 oz. (0.7 L) |
| Drive Brake | 27 oz. (0.8 L) |
| Engine Coolant Deutz 2.9L Kubota | 2.9 gal. (11.3L) 2.25 gal. (8.5 L) |

Tires

Table 7-4. Tires

| Size | Type | Pressure | Weight |
|--------------|-------------|----------|-----------------|
| 33/1550x16.5 | Foam-Filled | N/A | 395 lb (179 kg) |
| 12x16.5 | Foam-Filled | N/A | 328 lb (149 kg) |
| 315/55 D20 | Foam-Filled | N/A | 286 lb (130 kg) |
| | Solid | N/A | 286 lb (130 kg) |
| 33x12-20 | Solid | N/A | 285 lb (129 kg) |

Engine Data

Table 7-5. Deutz D2011L03

| | |
|------------------------------|------------------------------------|
| Fuel | Diesel |
| No. of Cylinders | 3 |
| Bore | 3.7 in (94 mm) |
| Stroke | 4.4 in (112 mm) |
| Displacement | 142 cu. in (2331 cm ³) |
| Oil Capacity | |
| crankcase | 6.3 qt (6L) |
| cooler | 3.7 qt (3.5L) |
| total capacity | 10 qt (9.5L) |
| Low RPM | 1200 |
| Mid RPM | |
| Tower Lift, Upper Lift, Tele | |
| Swing, Basket Level, Basket | 1800 |
| Rotate, Jib Lift | 1500 |
| High RPM | 2800 |

SECTION 7 - GENERAL SPECIFICATIONS & OPERATOR MAINTENANCE

Table 7-6. Deutz D2.9L4

| | |
|---------------------------|------------------------------------|
| Type | Liquid Cooled |
| Number of Cylinders | 4 |
| Bore | 3.6 in (92 mm) |
| Stroke | 4.3 in (110 mm) |
| Total Displacement | 178 cu. in (2925 cm ³) |
| Firing Order | 1-3-4-2 |
| Output | 49 hp (36.5 kW) |
| Oil Capacity | 2.4 gal (8.9 L) |
| Coolant Capacity (System) | 3.2 gal (12.1 L) |
| Average Fuel Consumption | 1.2 gph (4.1 Lph) |
| Min. Low Engine RPM | 1200 |
| Mid Engine RPM | 1800 |
| Max. High Engine RPM | 2500 |

Table 7-7. Kubota WG 2503

| | | | | |
|--------------------------------|-----------------------------|-------------|-----------|------------|
| Fuel | Gasoline or Gasoline/LP Gas | | | |
| BHP | | | | |
| Gasoline | 45.5 kW @ 2700 rpm | | | |
| LP | 46 Kw @ 2700 rpm | | | |
| Bore | 3.46 in (88 mm) | | | |
| Stroke | 4.03 in (102.4 mm) | | | |
| Displacement | 153 cu.in(2.5 L) | | | |
| Oil Capacity w/filter | 2.5 gal (9.5 L) | | | |
| Coolant Capacity (engine only) | 1.4 gal (5.4 L) | | | |
| Max. RPM | 2700 | | | |
| Fuel Consumption - Gasoline | In Drive | 2.35 Gal/Hr | 8.92 L/Hr | -- |
| | @ Idle | 0.48 Gal/Hr | 1.83 L/Hr | -- |
| Fuel Consumption - LP | In Drive | 2.56 Gal/Hr | 9.72 L/Hr | 5.64 kg/Hr |
| | @ Idle | 0.62 Gal/Hr | 2.36 L/Hr | 1.37 kg/Hr |

Hydraulic Oil

Table 7-8. Hydraulic Oil

| Hydraulic System Operating Temperature Range | S.A.E. Viscosity Grade |
|--|------------------------|
| +0° to +180°F (-18° to +83°C) | 10W |
| +0° to +210°F (-18° to +99°C) | 10W-20, 10W30 |
| +50° to +210°F (+10° to +99°C) | 20W-20 |

NOTE: Hydraulic oils require anti-wear qualities at least API Service Classification GL-3, and sufficient chemical stability for mobile hydraulic system service.

NOTE: Machines may be equipped with standard UTTO biodegradable and non-toxic hydraulic oil. This is a fully synthetic hydraulic oil that possesses the same anti-wear and rust protection characteristics as mineral oils, but will not adversely affect the ground water or the environment when spilled or leaked in small amounts.

NOTE: Aside from JLG recommendations, it is not advisable to mix oils of different brands or types, as they may not contain the same required additives or be of comparable viscosities. If use of hydraulic oil other than standard UTTO is desired, contact JLG Industries for proper recommendations.

Table 7-9. Mobilfluid 424 Specs

| SAE Grade | 10W30 |
|-------------------------|---------------|
| Gravity, API | 29.0 |
| Density, Lb/Gal. 60°F | 7.35 |
| Pour Point, Max | -46°F (-43°C) |
| Flash Point, Min. | 442°F (228°C) |
| Viscosity | |
| Brookfield, cP at -18°C | 2700 |
| at 40°C | 55 cSt |
| at 100°C | 9.3 cSt |
| Viscosity Index | 152 |

SECTION 7 - GENERAL SPECIFICATIONS & OPERATOR MAINTENANCE

Table 7-10. DTE 10 Excel 15 Specs

| | |
|---------------------|---------------|
| ISO Viscosity Grade | #15 |
| Pour Point, Max | -65°F (-54°C) |
| Flash Point, Min. | 360°F (182°C) |
| Viscosity | |
| at 40°C | 15.8 cSt |
| at 100°C | 4.1 cSt |
| at 100°F | 15.8 cSt |
| at 210°F | 4.1 cSt |
| Viscosity Index | 168 |

Table 7-11. Quintolubric 888-46

| | |
|--------------------------|--------------------|
| Density | 0.91 @ 15°C (59°F) |
| Pour Point | <-20°C (<-4°F) |
| Flash Point | 275°C (527°F) |
| Fire Point | 325°C (617°F) |
| Autoignition Temperature | 450°C (842°F) |
| Viscosity | |
| at 0°C (32°F) | 360 cSt |
| at 20°C (68°F) | 102 cSt |
| at 40°C (104°F) | 46 cSt |
| at 100°C (212°F) | 10 cSt |
| Viscosity Index | 220 |

SECTION 7 - GENERAL SPECIFICATIONS & OPERATOR MAINTENANCE

Table 7-12. Mobil EAL 224H Specs

| | |
|---|---|
| Type | Synthetic Biodegradable |
| ISO Viscosity Grade | 32/46 |
| Specific Gravity | .922 |
| Pour Point, Max | -25°F (-32°C) |
| Flash Point, Min. | 428°F (220°C) |
| Operating Temp. | 0 to 180°F (-17 to 162°C) |
| Weight | 7.64 lb. per gal. (0.9 kg per liter) |
| Viscosity | |
| at 40°C | 37 cSt |
| at 100°C | 8.4 cSt |
| Viscosity Index | 213 |
| NOTE: Must be stored above 32°F (14°C) | |

Table 7-13. Exxon Univis HVI 26 Specs

| | |
|---|---------------|
| Specific Gravity | 32.1 |
| Pour Point | -76°F (-60°C) |
| Flash Point | 217°F (103°C) |
| Viscosity | |
| at 40°C | 25.8 cSt |
| at 100°C | 9.3 cSt |
| Viscosity Index | 376 |
| NOTE: Mobil/Exxon recommends that this oil be checked on a yearly basis for viscosity. | |

Major Component Weights

⚠ WARNING

DO NOT REPLACE ITEMS CRITICAL TO STABILITY WITH ITEMS OF DIFFERENT WEIGHT OR SPECIFICATION (FOR EXAMPLE: BATTERIES, FILLED TIRES, PLATFORM) DO NOT MODIFY UNIT IN ANY WAY TO AFFECT STABILITY.

Table 7-14. Critical Stability Weights

| Components | LB | KG. |
|-----------------------------------|-----------|------------|
| Counterweight | 1875 ± 75 | 850.5 ± 34 |
| Tire and Wheel - 20x9 Foam-Filled | 220 | 99.8 |
| Tire and Wheel - 18x7 | 230 | 104.3 |
| Platform & Console - 30x60 | 242.5 | 110 |
| Platform & Console - 30x48 | 216 | 98 |
| Battery | 66 | 30 |

SECTION 7 - GENERAL SPECIFICATIONS & OPERATOR MAINTENANCE

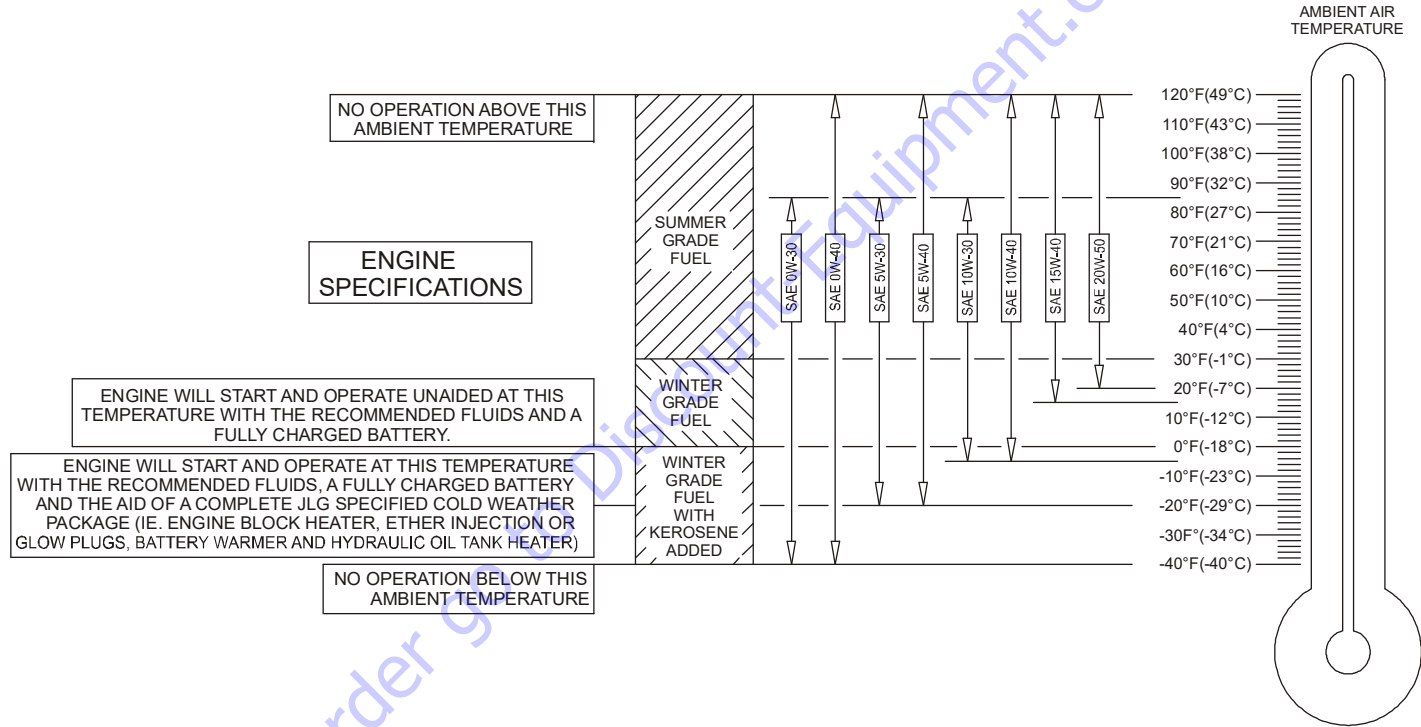

Figure 7-1. Engine Operating Temperature Specifications - Deutz 2.3L - Sheet 1 of 2

SECTION 7 - GENERAL SPECIFICATIONS & OPERATOR MAINTENANCE

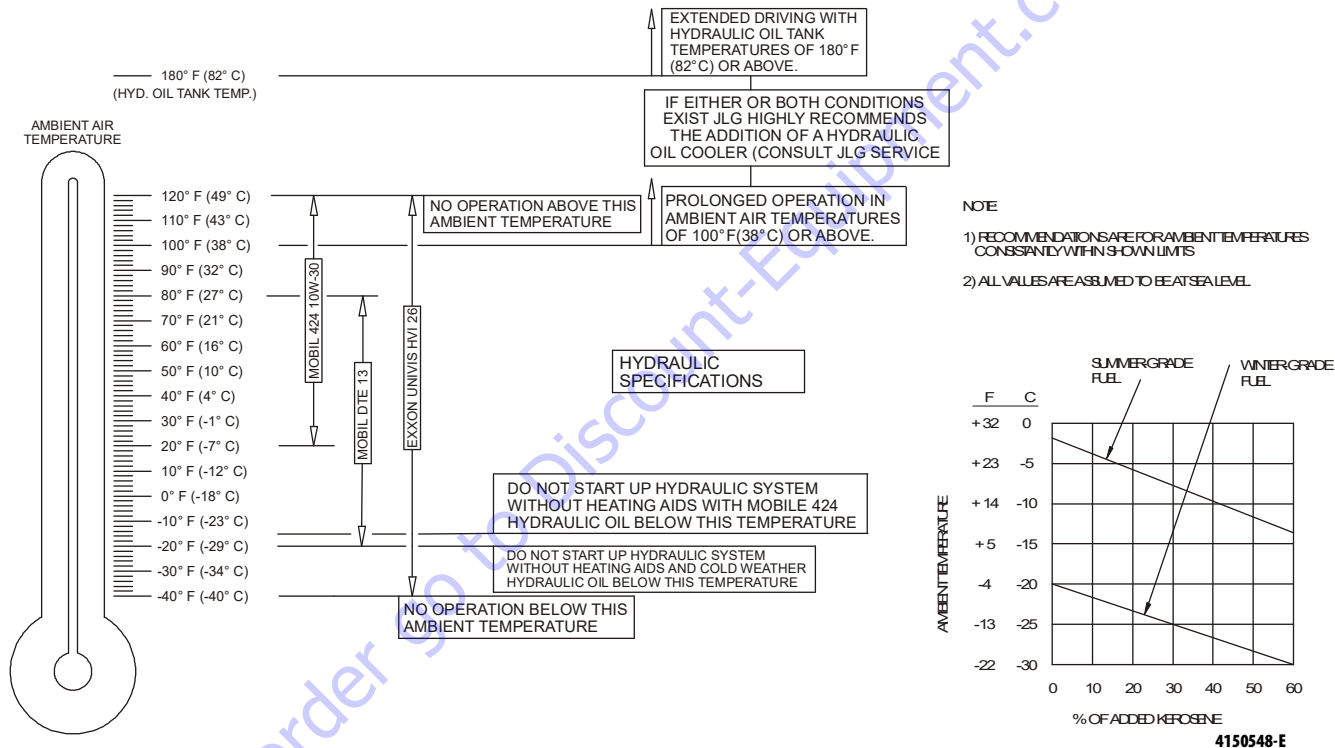

Figure 7-2. Engine Operating Temperature Specifications - Deutz 2.3L - Sheet 2 of 2

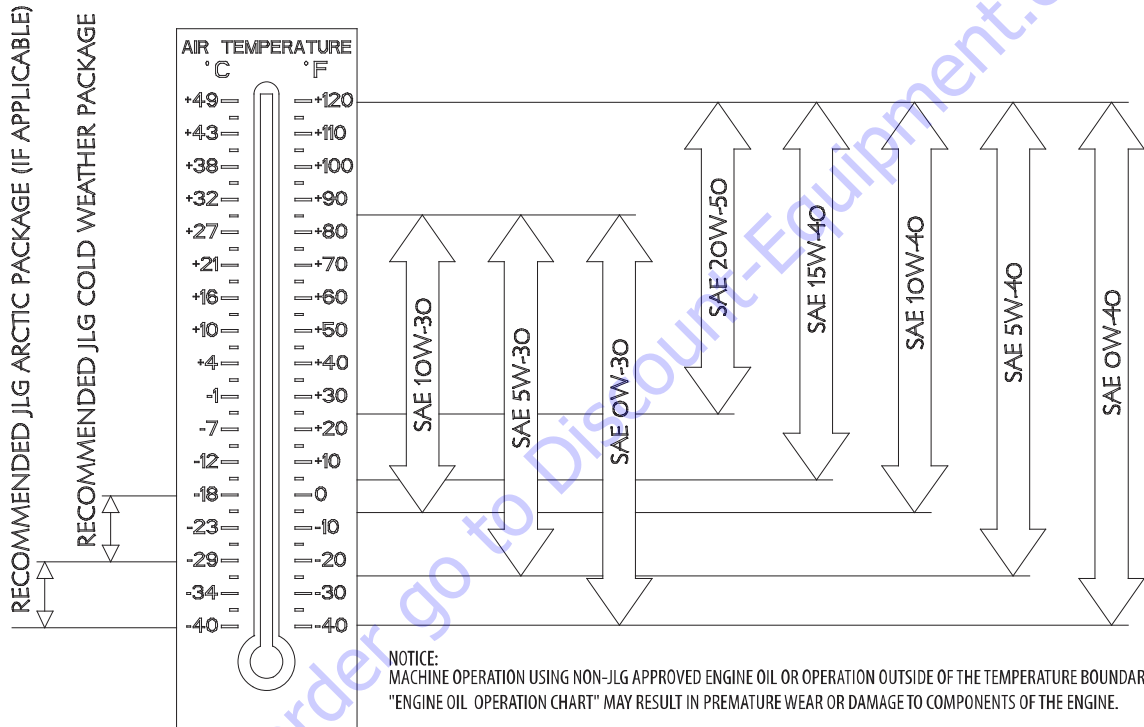
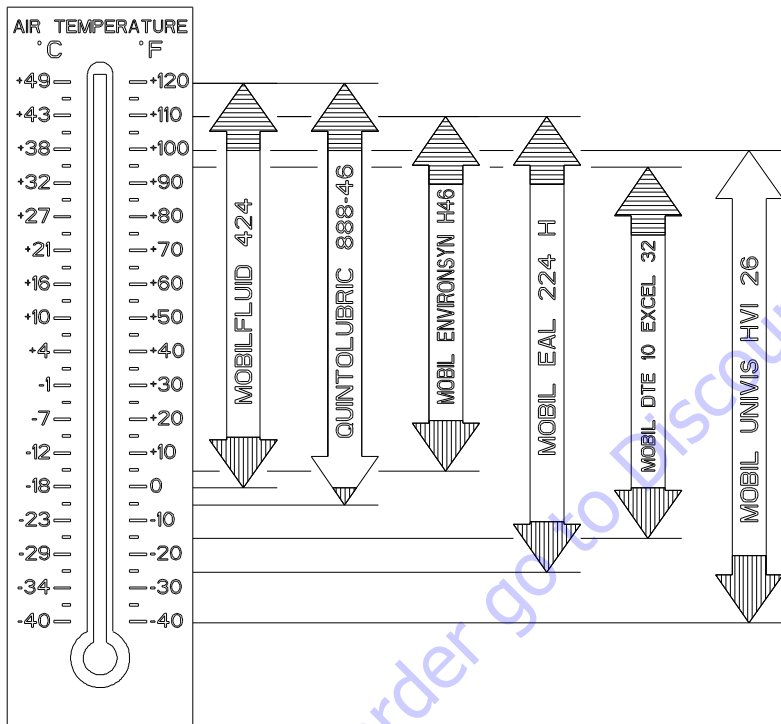

Figure 7-3. Engine Operating Temperature Specifications - Deutz 2.9L

1001159165-A

SECTION 7 - GENERAL SPECIFICATIONS & OPERATOR MAINTENANCE



THE ADDITION OF A HYDRAULIC OIL-COOLER IS HIGHLY RECOMMENDED FOR PROLONGED OPERATION IN THIS TEMPERATURE RANGE (CONSULT JLG SERVICE)

OPERATION IN THIS TEMPERATURE RANGE SHOULD INCLUDE THE USE OF HYDRAULIC SYSTEM HEATING AIDS (CONSULT JLG SERVICE)

THE ADDITION OF A HYDRAULIC OIL-COOLER IS NOT RECOMMENDED FOR OPERATION IN THIS TEMPERATURE RANGE

Figure 7-4. Hydraulic Oil Operation Chart - Sheet 1 of 2

1001206353 A

SECTION 7 - GENERAL SPECIFICATIONS & OPERATOR MAINTENANCE

| Fluid | Properties | | Base | | | | Classification | | |
|-----------------------|-------------------------------------|------------|--------------|----------------|-----------|-------------------------|------------------------|-----------------------|-------------------|
| | Viscosity @ 40° C (CST, Typical) | Visc Index | Mineral Oils | Vegetable Oils | Synthetic | Synthetic Polyol Esters | Readily Biodegradable* | Virtually Non-toxic** | Fire Resistant*** |
| Mobilfluid 424 | 55 | 145 | X | | | | | | |
| Mobil DTE 10 Excel 32 | 32 | 141 | X | | | | | | |
| UNIVIS HVI 26 | 26 | 376 | X | | | | | | |
| Mobil EAL 224 H | 36 | 212 | | X | | | X | X | |
| Mobil EnviroSyn H 46 | 49 | 145 | | | X | | X | X | |
| Quintolubric 888-46 | 50 | 185 | | | | X | X | X | X |

- * Readily biodegradable classification indicates one of the following:
CO2 Conversion > 60% per EPA 560/6-82-003
CO2 Conversion > 80% per CEC-L-33-A-93
- ** Virtually Non-toxic classification indicates an LC50 > 5000 ppm per OECD 203
- *** Fire Resistant classification indicates Factory Mutual Research Corp. (FMRC) Approval

NOTICE:
MACHINE OPERATION USING NON-JLG APPROVED HYDRAULIC FLUIDS OR OPERATION OUTSIDE OF THE TEMPERATURE BOUNDARIES OUTLINED IN THE "HYDRAULIC FLUID OPERATION CHART" MAY RESULT IN PREMATURE WEAR OR DAMAGE TO COMPONENTS OF THE HYDRAULIC SYSTEM.

Figure 7-5. Hydraulic Oil Operation Chart - Sheet 2 of 2

SECTION 7 - GENERAL SPECIFICATIONS & OPERATOR MAINTENANCE

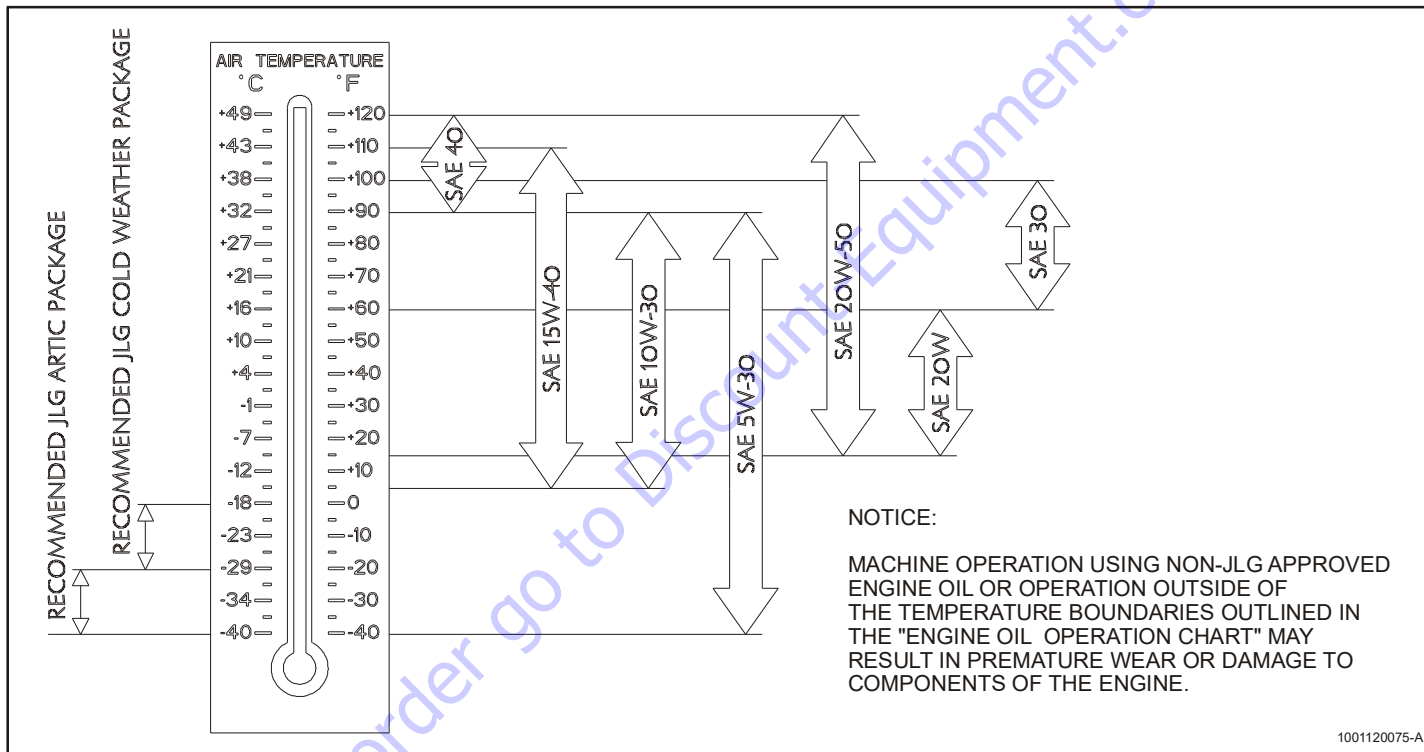

Figure 7-6. Engine Oil Operation Chart - Kubota

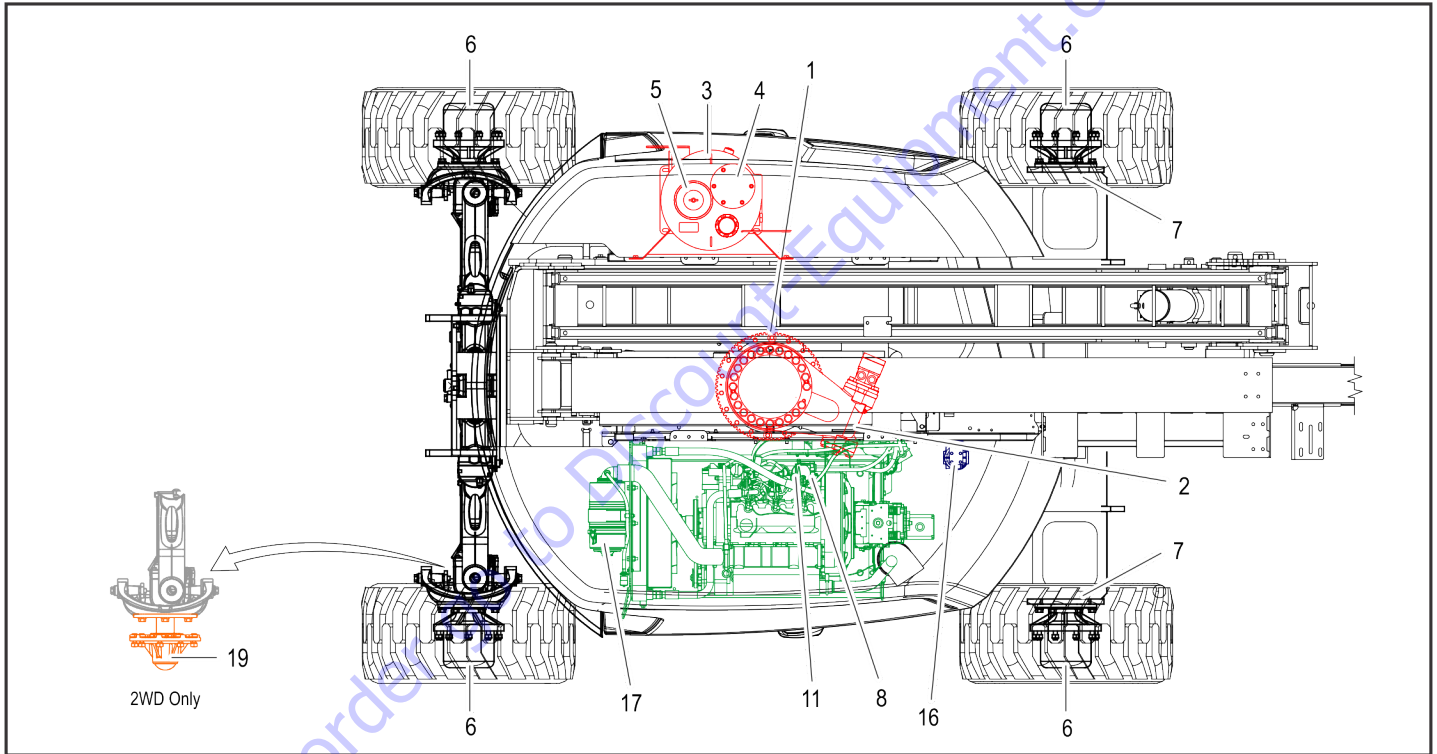

Figure 7-7. Operator Maintenance and Lubrication Diagram - Deutz 2.3L Engine

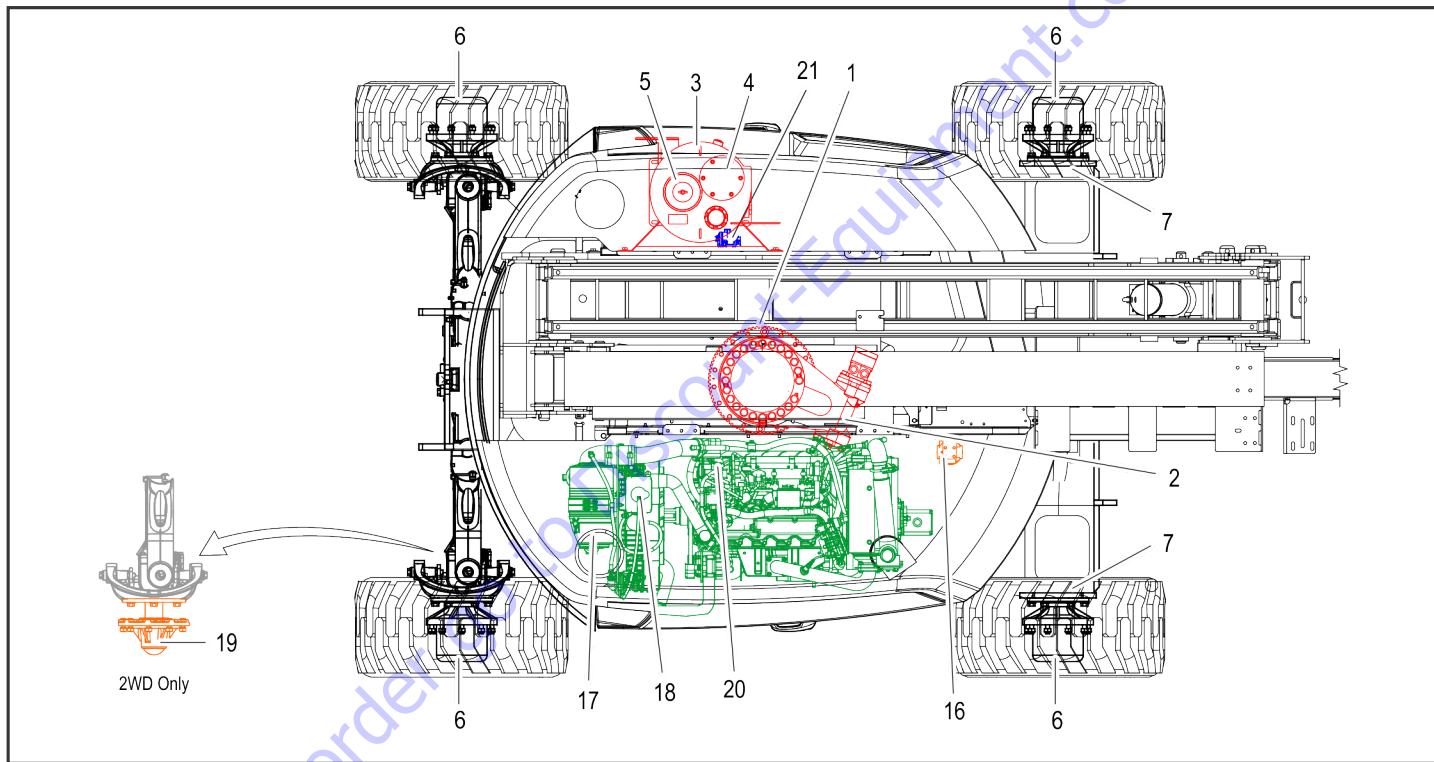

Figure 7-9. Operator Maintenance and Lubrication Diagram - Kubota Engine

SECTION 7 - GENERAL SPECIFICATIONS & OPERATOR MAINTENANCE

7.3 OPERATOR MAINTENANCE

NOTE: The following numbers correspond to those in Figure 7-7., Operator Maintenance and Lubrication Diagram - Deutz 2.3L Engine.

Table 7-15. Lubrication Specifications.

| KEY | SPECIFICATIONS |
|--|---|
| BG* | Bearing Grease (JLG Part No. 3020029) Mobilith SHC 460. |
| HO | Hydraulic Oil. API service classification GL-4, e.g. Mobilfluid 424. |
| EPGL | Extreme Pressure Gear Lube (oil) meeting API Service Classification GL-5 or Mil-Spec Mil-L-2105. |
| MPG | Multipurpose Grease having a minimum dripping point of 350°F (177°C). Excellent water resistance and adhesive qualities, and being of extreme pressure type. (Timken OK 40 pounds minimum.) |
| EO | Engine (crankcase). Gas (5W30) - API SN, - Arctic ACEA A1/BI, A5/B5 - API SM, SL, SJ, EC, CF, CD - ILSAC GF-4. Diesel (15W40, 5W30 Arctic) - API CJ-4. |
| *MPG may be substituted for these lubricants, if necessary, but service intervals will be reduced. | |

NOTICE

LUBRICATION INTERVALS ARE BASED ON MACHINE OPERATION UNDER NORMAL CONDITIONS. FOR MACHINES USED IN MULTI-SHIFT OPERATIONS AND/OR EXPOSED TO HOSTILE ENVIRONMENTS OR CONDITIONS, LUBRICATION FREQUENCIES MUST BE INCREASED ACCORDINGLY.

1. Swing Bearing

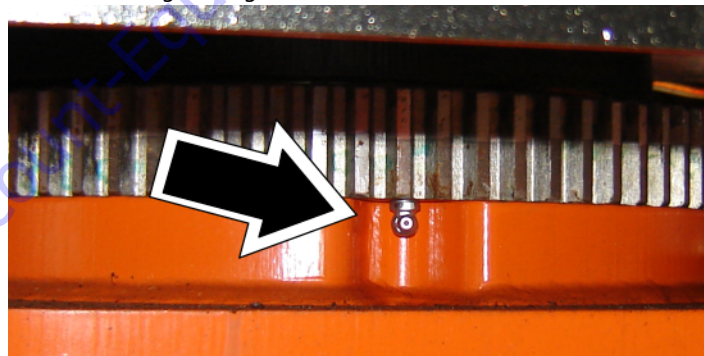

Lube Point(s) - Fitting

Capacity - A/R

Lube - BG

Interval - Every 3 months or 150 hrs of operation

Comments - Apply grease and rotate in 90 degree intervals until bearing is completely lubricated

2. Swing Bearing/Worm Gear Teeth

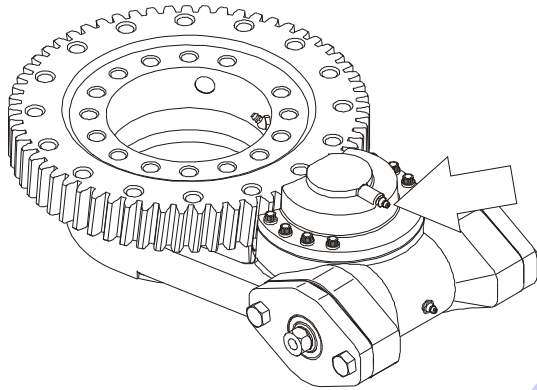

Lube Point(s) - Grease Fitting
Capacity - A/R
Lube - Lubriplate 930-AAA
Interval - A/R

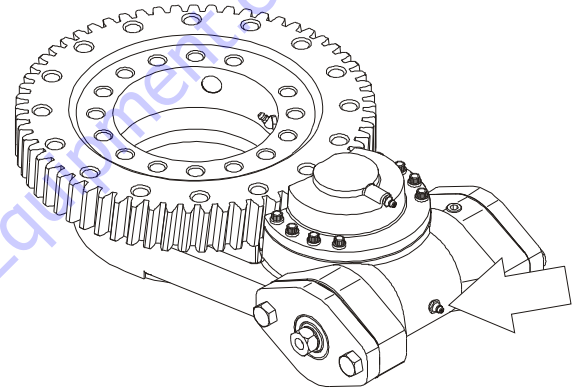

Lube Point(s) - Grease Fitting
Capacity - A/R
Lube - Mobil SHC 007
Interval - A/R

⚠ CAUTION

DO NOT OVERGREASE BEARINGS. OVERGREASING BEARINGS WILL RESULT IN DAMAGE TO OUTER SEAL IN HOUSING.

SECTION 7 - GENERAL SPECIFICATIONS & OPERATOR MAINTENANCE

3. Hydraulic Tank

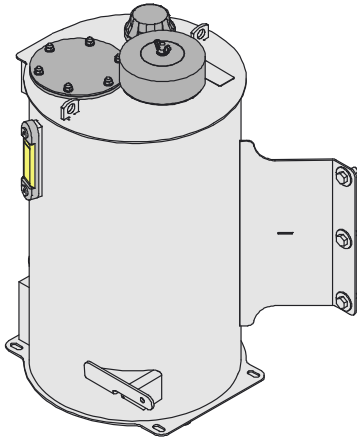

Lube Point(s) - Fill Cap

Capacity - 15 Gal. (57 L) to Full Level

Lube - HO

Interval - Check Level daily; Change every 2 years or 1200 hours of operation.

Comments - On new machines, those recently overhauled, or after changing hydraulic oil, operate all systems a minimum of two complete cycles and recheck oil level in reservoir.

4. Hydraulic Return Filter

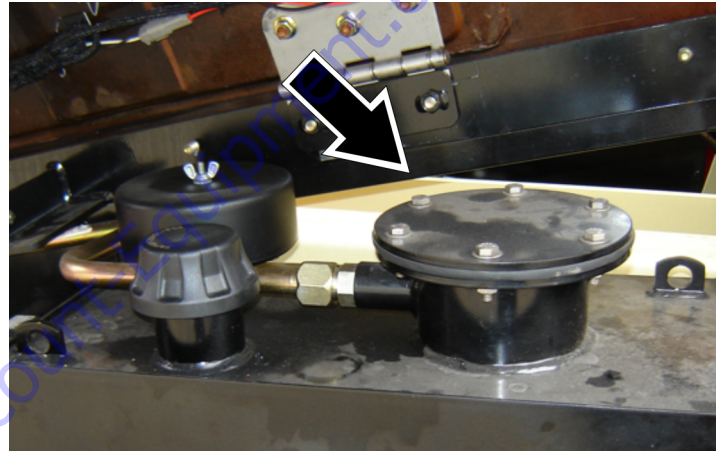

Lube Point(s) - Replaceable Element

Interval - Change after first 50 hours and every 6 months or 300 hours thereafter.

5. Hydraulic Tank Breather

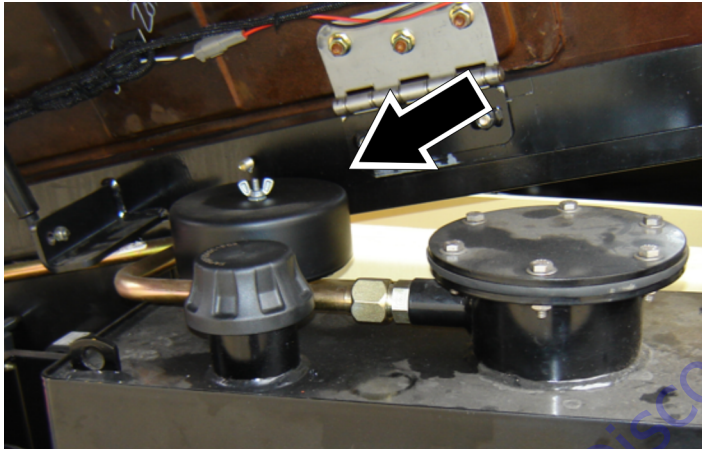

Interval - Change after first 50 hrs. and every 6 months or 300 hrs. thereafter.

Comments - Remove wing nut and cover to replace. Under certain conditions, it may be necessary to replace on a more frequent basis.

6. Wheel Drive Hub

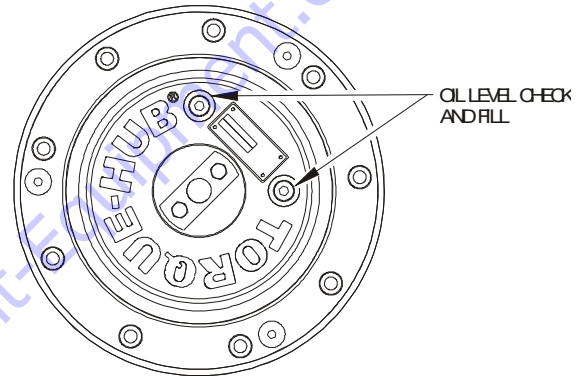

Lube Point(s) - Level/Fill Plug
Capacity - 24 oz. (0.8 L)(1/2 Full)
Lube - EPGL

Interval - Check level every 3 months or 150 hrs of operation; change every 2 years or 1200 hours of operation

SECTION 7 - GENERAL SPECIFICATIONS & OPERATOR MAINTENANCE

7. Drive Brake

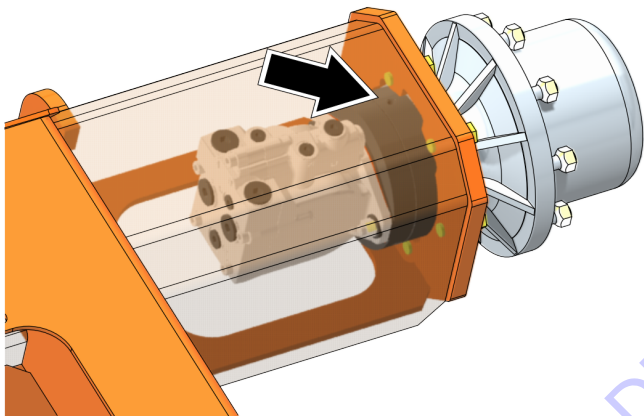

Lube Point(s) - Fill Plug
Capacity - 2.7 oz. (89 mL)
Lube - DTE-10 Excel 32
Interval - Change as necessary

8. Oil Change with Filter - Deutz 2.3 L3

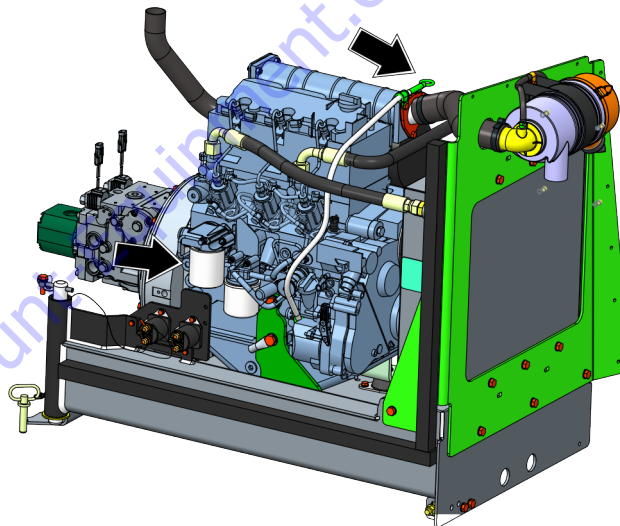

Lube Point(s) - Fill Cap/Spin-on Element
Capacity - 10 Quarts (9.5 L) w/Filter
Lube - EO
Interval - Check level daily; change every 500 hours or six months, whichever comes first. Adjust final oil level by mark on dipstick.

SECTION 7 - GENERAL SPECIFICATIONS & OPERATOR MAINTENANCE

9. Oil Change w/Filter - Deutz 2.9 L4

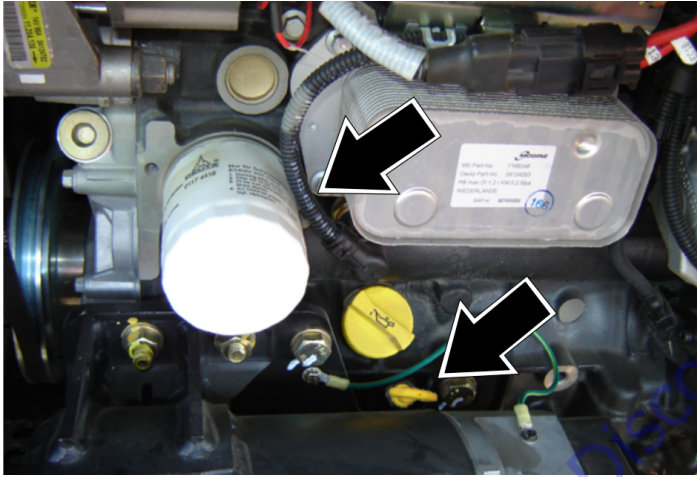

Lube Point(s) - Fill Cap/Spin-on Element
Capacity - 2.4 gal (8.9 L)
Lube - EO
Interval - Every Year or 600 hours of operation
Comments - Check level daily/Change in accordance with engine manual

10. Fuel Filter/Water Separator - Deutz 2.3 L3

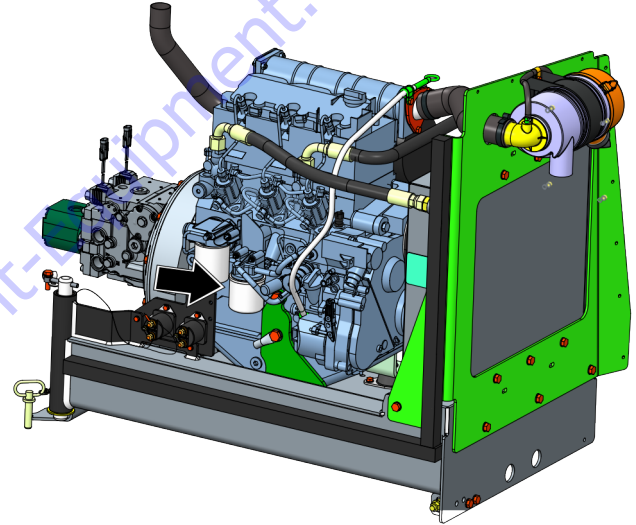

Lube Point(s) - Replaceable Element
Interval - Every year or 500 hours of operation

SECTION 7 - GENERAL SPECIFICATIONS & OPERATOR MAINTENANCE

11. Fuel Pre-Filter - Deutz D2.9



Lube Point(s) - Replaceable Element
Interval - Drain water daily; Every year or 600 hours of operation

12. Fuel Filter - Deutz D2.9



Lube Point(s) - Replaceable Element
Interval - Every year or 600 hours of operation

SECTION 7 - GENERAL SPECIFICATIONS & OPERATOR MAINTENANCE

13. Fuel Filter (Gasoline)

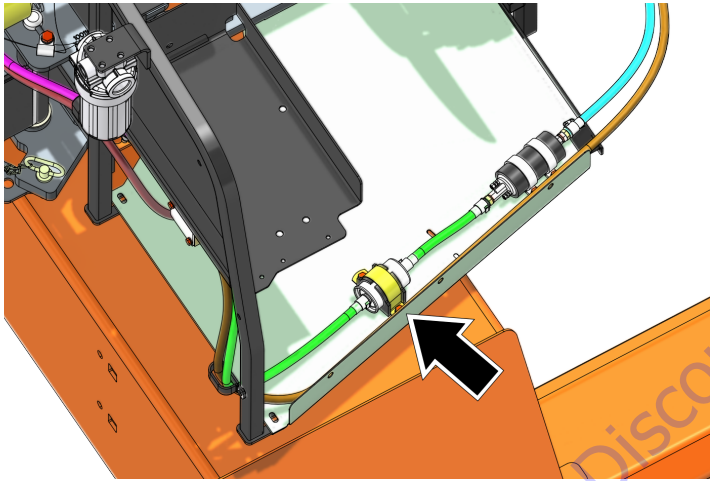

Lube Point(s) - Replaceable Element
Interval - Every 6 months or 300 hours of operation

14. Fuel Filter (Propane)

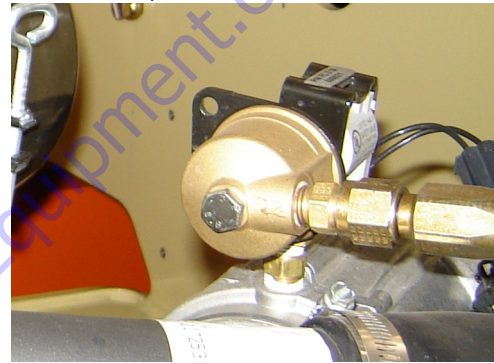

Interval - 3 Months or 150 hours of operation
Comments - Replace filter.

SECTION 7 - GENERAL SPECIFICATIONS & OPERATOR MAINTENANCE

15. Charge Filter

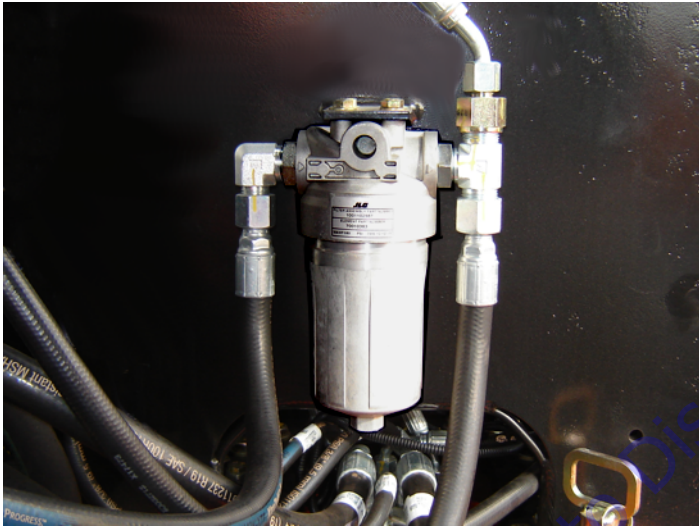

Interval - Change after first 50 hrs. and every 6 months or 300 hrs. thereafter.

Comments - Remove the engine tray retaining bolt and pull out engine tray to gain access.

16. Air Filter

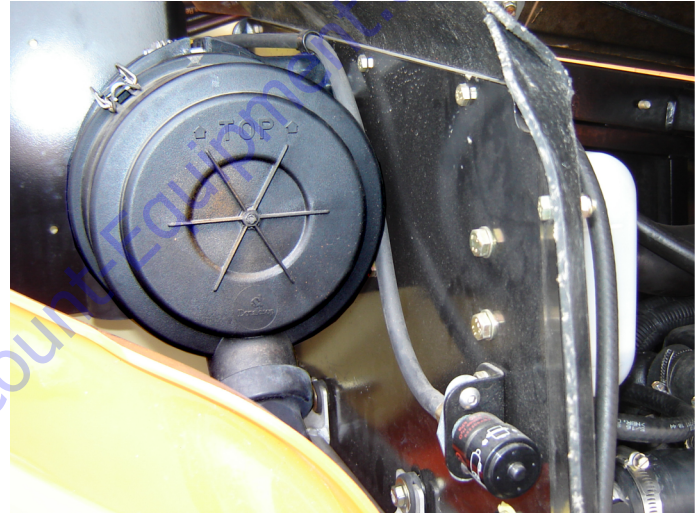

Lube Point(s) - Replaceable Element

Interval - Every 6 months or 300 hours of operation or as indicated by the condition indicator

Comments - Check Dust Valve daily

SECTION 7 - GENERAL SPECIFICATIONS & OPERATOR MAINTENANCE

17. Engine Coolant

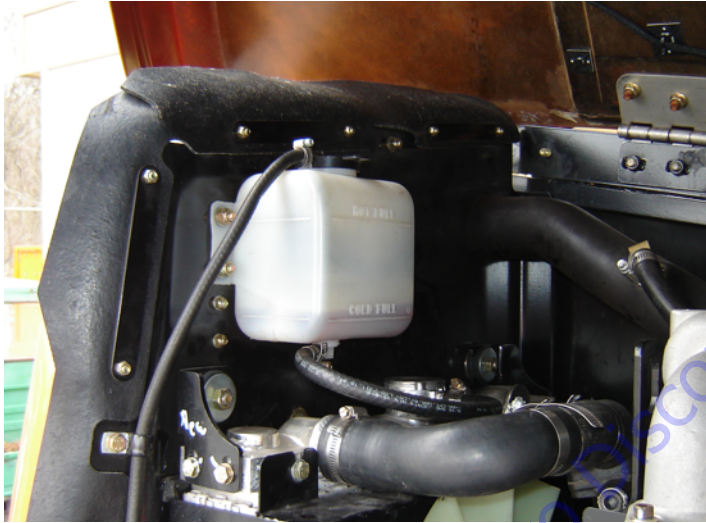

Lube Point(s) - Fill Cap
Capacity (Deutz 2.9L)- 2.9 gal. (11.3L)
Capacity (GM 3.0L)- 2.4 gal. (9.1L)
Capacity (Kubota) - 2.25 gal. (8.5 L)
Lube - Anti-Freeze
Interval - Check level daily; change every 1000 hours or two years, whichever comes first.

18. Wheel Bearings

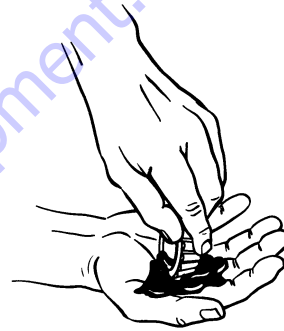

Lube Point(s) - Repack
Capacity - A/R
Lube - MPG
Interval - Every 2 years or 1200 hours of operation

SECTION 7 - GENERAL SPECIFICATIONS & OPERATOR MAINTENANCE

19. Oil Change w/Filter - Kubota

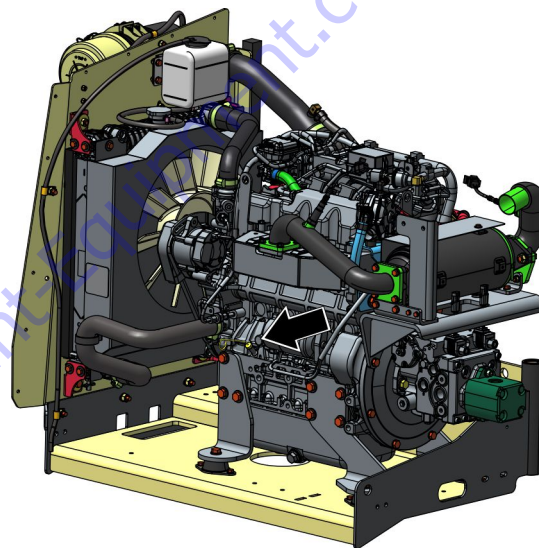
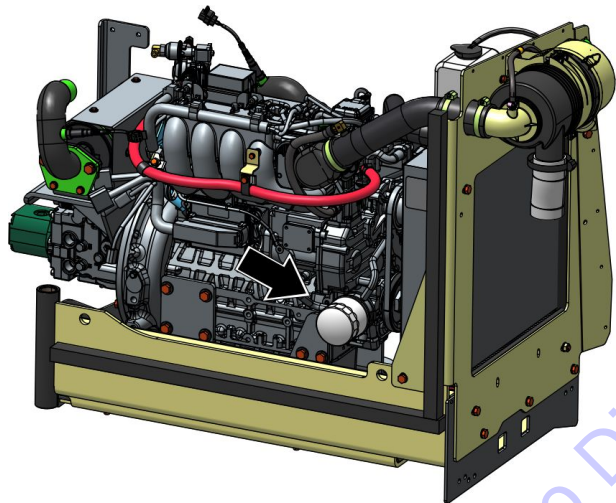

Lube Point(s) - Fill Cap/Spin-on Element

Capacity - 2.5 gal. (9.5 L) w/filter

Lube - EO

Interval - 3 Months or 150 hours of operation

Comments - Check level daily/Change in accordance with engine manual

20. Fuel Filter - Kubota

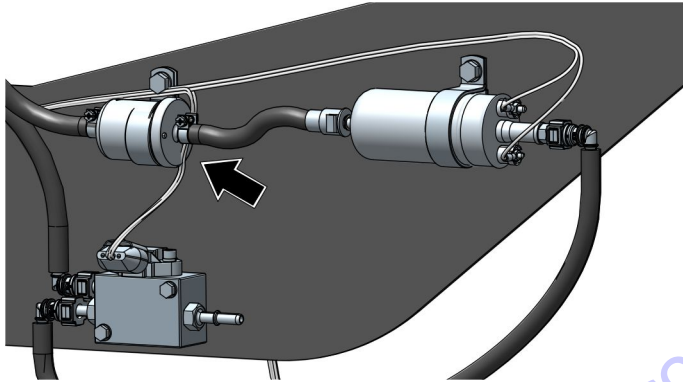

Lube Point(s) - Replaceable Component
Interval - Every year or 600 hours of operation

21. Fuel Filter (Propane) - Kubota

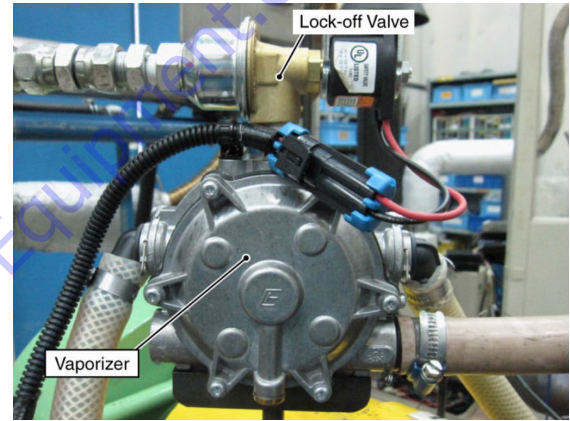

Interval - Every year or 1000 hours of operation
Comments - Replace filter. Refer to Section 7.5, Propane Fuel Filter Replacement (Kubota Engine)

7.4 TIRES & WHEELS

Tire Replacement

JLG recommends a replacement tire be the same size, ply and brand as originally installed on the machine. Please refer to the JLG Parts Manual for the part number of the approved tires for a particular machine model. If not using a JLG approved replacement tire, we recommend that replacement tires have the following characteristics:

- Equal or greater ply/load rating and size of original
- Tire tread contact width equal or greater than original
- Wheel diameter, width, and offset dimensions equal to the original
- Approved for the application by the tire manufacturer (including maximum tire load)

Unless specifically approved by JLG Industries Inc. do not replace a foam filled or ballast filled tire assembly with a pneumatic tire. When selecting and installing a replacement tire, ensure that all tires are inflated to the pressure recommended by JLG. Due to size variations between tire brands, both tires on the same axle should be the same.

Wheel and Tire Replacement

The rims installed on each product model have been designed for stability requirements which consist of track width, tire pressure, and load capacity. Size changes such as rim width, center piece location, larger or smaller diameter, etc., without written factory recommendations, may result in an unsafe condition regarding stability.

Wheel Installation

It is extremely important to apply and maintain proper wheel mounting torque.

WARNING

WHEEL NUTS MUST BE INSTALLED AND MAINTAINED AT THE PROPER TORQUE TO PREVENT LOOSE WHEELS, BROKEN STUDS, AND POSSIBLE DANGEROUS SEPARATION OF WHEEL FROM THE AXLE. BE SURE TO USE ONLY THE NUTS MATCHED TO THE CONE ANGLE OF THE WHEEL.

Tighten the lug nuts to the proper torque to prevent wheels from coming loose. Use a torque wrench to tighten the fasteners. If you do not have a torque wrench, tighten the fasteners with a lug wrench, then immediately have a service garage or dealer tighten the lug nuts to the proper torque. Over-tightening will result in breaking the studs or permanently deforming the mounting stud holes in the wheels. The proper procedure for attaching wheels is as follows:

1. Start all nuts by hand to prevent cross threading. DO NOT use a lubricant on threads or nuts.
2. Tighten nuts in the following sequence.

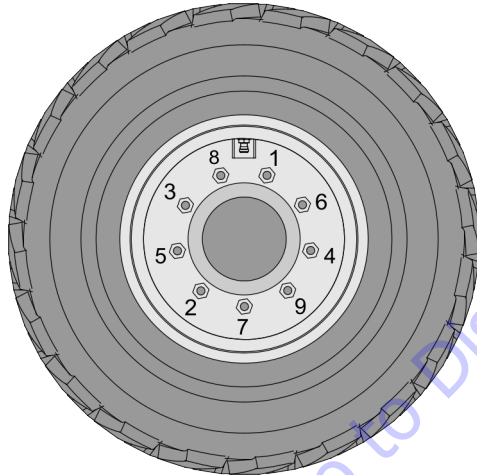

3. The tightening of the nuts should be done in stages. Following the recommended sequence, tighten nuts per wheel torque.
4. Wheel nuts should be torqued after first 50 hours of operation and after each wheel removal. Check and torque every 3 months or 150 hours of operation.

Table 7-16. Wheel Torque Chart

| TORQUE SEQUENCE | | |
|-------------------|--------------------|---------------------|
| 1st Stage | 2nd Stage | 3rd Stage |
| 40 ft lbs (55 Nm) | 95 ft lbs (130 Nm) | 170 ft lbs (230 Nm) |

7.5 PROPANE FUEL FILTER REPLACEMENT (KUBOTA ENGINE)

Removal

1. Relieve the propane fuel system pressure. Refer to Propane Fuel System Pressure Relief.
2. Disconnect the negative battery cable.
3. Slowly loosen the bowl retaining nut and remove the nut and filter housing from the Electric lock off assembly.
4. Remove the filter from the housing.
5. Remove and discard the housing seal.
6. Remove and discard the retaining nut seal.

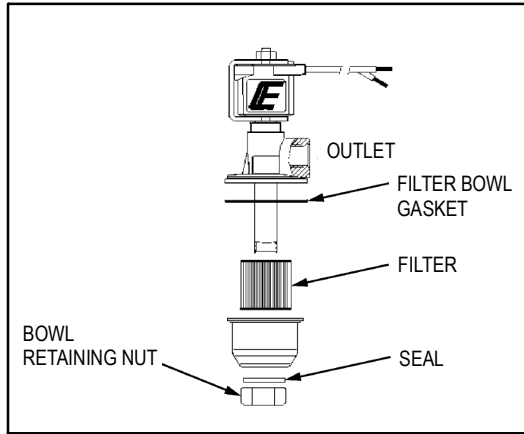

Figure 7-10. Kubota Filter Lock Assembly

Installation

1. If equipped, install the filter bowl gasket.
2. Install the filter into the housing.
3. Install the filter bowl up to the bottom of the electric lock off.
4. Tighten the filter bowl retainer nut.
5. Open manual shut-off valve. Start the vehicle and leak check the propane fuel system at each serviced fitting.

7.6 PROPANE FUEL SYSTEM PRESSURE RELIEF

⚠ CAUTION

THE PROPANE FUEL SYSTEM OPERATES AT PRESSURES UP TO 312 PSI (21.5 BAR). TO MINIMIZE THE RISK OF FIRE AND PERSONAL INJURY, RELIEVE THE PROPANE FUEL SYSTEM PRESSURE (WHERE APPLICABLE) BEFORE SERVICING THE PROPANE FUEL SYSTEM COMPONENTS.

To relieve propane fuel system pressure:

1. Close the manual shut-off valve on the propane fuel tank.
2. Start and run the vehicle until the engine stalls.
3. Turn the ignition switch OFF.

⚠ CAUTION

RESIDUAL VAPOR PRESSURE WILL BE PRESENT IN THE FUEL SYSTEM. ENSURE THE WORK AREA IS WELL VENTILATED BEFORE DISCONNECTING ANY FUEL LINE.

7.7 SUPPLEMENTAL INFORMATION

The following information is provided in accordance with the requirements of the European Machinery Directive 2006/42/EC and is only applicable to CE machines.

For electric powered machines, the equivalent continuous A-Weighted sound pressure level at the work platform is less than 70dB(A).

For combustion engine powered machines, guaranteed Sound Power Level (LWA) per European Directive 2000/14/EC (Noise Emission in the Environment by Equipment for Use Outdoors) based on test methods in accordance with Annex III, Part B, Method 1 and 0 of the directive, is 102 dB.

The vibration total value to which the hand-arm system is subjected does not exceed $2,5 \text{ m/s}^2$. The highest root mean square value of weighted acceleration to which the whole body is subjected does not exceed $0,5 \text{ m/s}^2$.

TO PURCHASE THIS PRODUCT PLEASE CONTACT US



**Equipment Financing and
Extended Warranties Available**



**Discount-Equipment.com is your online resource for
commercial and industrial quality parts and equipment sales.**

561-964-4949

visit us on line @ www.discount-equipment.com

Select an option below to find your Equipment

Search by Manufacturer

Search by Product Type

Request a Quote

We sell worldwide for the brands: Genie, Terex, JLG, MultiQuip, Mikasa, Essick, Whiteman, Mayco, Toro Stone, Diamond Products, Generac Magnum, Airman, Haulotte, Barreto, Power Blanket, Nifty Lift, Atlas Copco, Chicago Pneumatic, Allmand, Miller Curber, Skyjack, Lull, Skytrak, Tsurumi, Husquvarna Target, Stow, Wacker, Sakai, Mi-T-M, Sullair, Basic, Dynapac, MBW, Weber, Bartell, Bennar Newman, Haulotte, Ditch Runner, Menegotti, Morrison, Contec, Buddy, Crown, Edco, Wyco, Bomag, Laymor, EZ Trench, Bil-Jax, F.S. Curtis, Gehl Pavers, Heli, Honda, ICS/PowerGrit, IHI, Partner, Imer, Clipper, MMD, Koshin, Rice, CH&E, General Equipment, Amida, Coleman, NAC, Gradall, Square Shooter, Kent, Stanley, Tamco, Toku, Hatz, Kohler, Robin, Wisconsin, Northrock, Oztec, Toker TK, Rol-Air, APT, Wylie, Ingersoll Rand / Doosan, Innovatech, Con X, Ammann, Mecalac, Makinex, Smith Surface Prep, Small Line, Wanco, Yanmar

JLG[®]

An Oshkosh Corporation Company

**Discount
Equipment**

www.Discount-Equipment.com

To order go to www.Discount-Equipment.com