



An Oshkosh Corporation Company



www.Discount-Equipment.com

Service and Maintenance Manual

Model
800S
860SJ

PVC 2001

31215049

January 15, 2020 - Rev A

ANSI

CE



AS/NZS

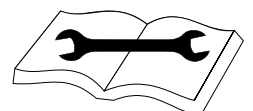

PARTS FINDER

**Search Website
by Part Number**



**Search Manual
Library For Parts
Manual & Lookup Part
Numbers – Purchase
or Request Quote**

Search Manuals

Enter your information to search for manuals and parts.

* Brand:

* Model:

* Serial:

* Part Number:

SEARCH

**Can't Find Part or
Manual? Request Help
by Manufacturer,
Model & Description**

Parts Order Form

Please fill in the following information:

Manufacturer:

Model:

Description:

Quantity:

Part Number:

Part Name:

Part Description:

Part Category:

Part Location:

Part Status:

Part Condition:

Part Material:

Part Color:

Part Weight:

Part Dimensions:

Part Price:

Part Notes:

Submit

Discount-Equipment.com is your online resource for quality parts & equipment.

Florida: **561-964-4949** Outside Florida TOLL FREE: **877-690-3101**

Need parts?

Click on this link: <http://www.discount-equipment.com/category/5443-parts/> and choose one of the options to help get the right parts and equipment you are looking for. Please have the machine model and serial number available in order to help us get you the correct parts. If you don't find the part on the website or on once of the online manuals, please fill out the request form and one of our experienced staff members will get back to you with a quote for the right part that your machine needs.

We sell worldwide for the brands: Genie, Terex, JLG, MultiQuip, Mikasa, Essick, Whiteman, Mayco, Toro Stone, Diamond Products, Generac Magnum, Airman, Haulotte, Barreto, Power Blanket, Nifty Lift, Atlas Copco, Chicago Pneumatic, Allmand, Miller Curber, Skyjack, Lull, Skytrak, Tsurumi, Husquvarna Target, , Stow, Wacker, Sakai, Mi-T- M, Sullair, Basic, Dynapac, MBW, Weber, Bartell, Bennar Newman, Haulotte, Ditch Runner, Menegotti, Morrison, Contec, Buddy, Crown, Edco, Wyco, Bomag, Laymor, Barreto, EZ Trench, Bil-Jax, F.S. Curtis, Gehl Pavers, Heli, Honda, ICS/PowerGrit, IHI, Partner, Imer, Clipper, MMD, Koshin, Rice, CH&E, General Equipment, ,AMida, Coleman, NAC, Gradall, Square Shooter, Kent, Stanley, Tamco, Toku, Hatz, Kohler, Robin, Wisconsin, Northrock, Oztec, Toker TK, Rol-Air, Small Line, Wanco, Yanmar

SECTION A. INTRODUCTION - MAINTENANCE SAFETY PRECAUTIONS

A GENERAL

This section contains the general safety precautions which must be observed during maintenance of the Mobile Elevating Work Platform (MEWP). It is of utmost importance that maintenance personnel pay strict attention to these warnings and precautions to avoid possible injury to themselves or others, or damage to the equipment. A maintenance program must be followed to ensure that the machine is safe to operate.

⚠ WARNING

MODIFICATION OR ALTERATION OF A MOBILE ELEVATING WORK PLATFORM SHALL BE MADE ONLY WITH WRITTEN PERMISSION FROM THE MANUFACTURER.

The specific precautions to be observed during maintenance are inserted at the appropriate point in the manual. These precautions are, for the most part, those that apply when servicing hydraulic and larger machine component parts.

Your safety, and that of others, is the first consideration when engaging in the maintenance of equipment. Always be conscious of weight. Never attempt to move heavy parts without the aid of a mechanical device. Do not allow heavy objects to rest in an unstable position. When raising a portion of the equipment, ensure that adequate support is provided.

⚠ WARNING

SINCE THE MACHINE MANUFACTURER HAS NO DIRECT CONTROL OVER THE FIELD INSPECTION AND MAINTENANCE, SAFETY IN THIS AREA RESPONSIBILITY OF THE OWNER/OPERATOR.

B HYDRAULIC SYSTEM SAFETY

It should be noted that the machines hydraulic systems operate at extremely high potentially dangerous pressures. Every effort should be made to relieve any system pressure prior to disconnecting or removing any portion of the system.

Do not use your hand to check for leaks. Use a piece of cardboard or paper to search for leaks. Wear gloves to help protect hands from spraying fluid.

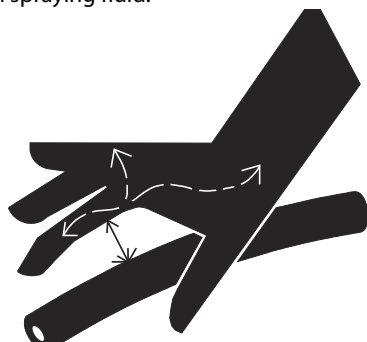

C MAINTENANCE

⚠ WARNING

FAILURE TO COMPLY WITH SAFETY PRECAUTIONS LISTED IN THIS SECTION COULD RESULT IN MACHINE DAMAGE, PERSONNEL INJURY OR DEATH AND IS A SAFETY VIOLATION.

- USE ONLY REPLACEMENT PARTS OR COMPONENTS THAT ARE APPROVED BY JLG. TO BE CONSIDERED APPROVED, REPLACEMENT PARTS OR COMPONENTS MUST BE IDENTICAL OR EQUIVALENT TO ORIGINAL PARTS OR COMPONENTS.
- NO SMOKING IS MANDATORY. NEVER REFUEL DURING ELECTRICAL STORMS. ENSURE THAT FUEL CAP IS CLOSED AND SECURE AT ALL OTHER TIMES.
- REMOVE ALL RINGS, WATCHES AND JEWELRY WHEN PERFORMING ANY MAINTENANCE.
- DO NOT WEAR LONG HAIR UNRESTRAINED, OR LOOSE-FITTING CLOTHING AND NECKTIES WHICH ARE APT TO BECOME CAUGHT ON OR ENTANGLED IN EQUIPMENT.
- OBSERVE AND OBEY ALL WARNINGS AND CAUTIONS ON MACHINE AND IN SERVICE MANUAL.
- KEEP OIL, GREASE, WATER, ETC. WIPED FROM STANDING SURFACES AND HAND HOLDS.
- USE CAUTION WHEN CHECKING A HOT, PRESSURIZED COOLANT SYSTEM.
- NEVER WORK UNDER AN ELEVATED BOOM UNTIL BOOM HAS BEEN SAFELY RESTRAINED FROM ANY MOVEMENT BY BLOCKING OR OVERHEAD SLING, OR BOOM SAFETY PROP HAS BEEN ENGAGED.
- BEFORE MAKING ADJUSTMENTS, LUBRICATING OR PERFORMING ANY OTHER MAINTENANCE, SHUT OFF ALL POWER CONTROLS.
- BATTERY SHOULD ALWAYS BE DISCONNECTED DURING REPLACEMENT OF ELECTRICAL COMPONENTS.
- KEEP ALL SUPPORT EQUIPMENT AND ATTACHMENTS STOWED IN THEIR PROPER PLACE.
- USE ONLY APPROVED, NONFLAMMABLE CLEANING SOLVENTS.

REVISION LOG

Original Issue

A - January 15, 2020

Go to Discount-Equipment.com to order your parts

SECTION NO.	TITLE	PAGE NO.
SECTION A - INTRODUCTION - MAINTENANCE SAFETY PRECAUTIONS		
A	General	A-1
B	Hydraulic System Safety	A-1
C	Maintenance	A-1
SECTION 1 - SPECIFICATIONS		
1.1	Operating Specifications	1-1
	Machine Specifications	1-1
1.2	Specifications and Performance Data	1-1
1.3	Capacities	1-1
1.4	Component Data	1-2
	Engine Data	1-2
	Battery	1-2
1.5	Tires	1-3
1.6	Torque Requirements	1-3
1.7	Lubrication	1-3
	Hydraulic Oil	1-3
1.8	Pressure Settings	1-5
1.9	Major Component Weights	1-5
1.10	Operator Maintenance	1-7
1.11	Serial Number Location	1-12
1.12	ThreadLocking Compound	1-13
1.13	Torque Charts	1-14
	SAE Fastener Torque Chart	1-14
	Metric Fastener Torque Chart	1-20
SECTION 2 - GENERAL		
2.1	Machine Preparation, Inspection, and Maintenance	2-1
	General	2-1
	Preparation, Inspection, and Maintenance	2-1
	Pre-Start Inspection	2-1
	Pre-Delivery Inspection and Frequent Inspection	2-1
	Annual Machine Inspection	2-1
	Preventive Maintenance	2-1
2.2	Service and Guidelines	2-2
	General	2-2
	Safety and Workmanship	2-2
	Cleanliness	2-2
	Components Removal and Installation	2-2
	Component Disassembly and Reassembly	2-3
	Pressure-Fit Parts	2-3
	Bearings	2-3
	Gaskets	2-3
	Bolt Usage and Torque Application	2-3
	Hydraulic Lines and Electrical Wiring	2-3
	Hydraulic System	2-3
	Lubrication	2-4
	Battery	2-4
	Lubrication and Servicing	2-4
2.3	Lubrication and Information	2-4
	Hydraulic System	2-4
	Hydraulic Oil	2-4
	Changing Hydraulic Oil	2-4
	Lubrication Specifications	2-4

TABLE OF CONTENTS

SECTION NO.	TITLE	PAGE NO.
2.4	Cylinder Drift Test	2-5
	Theory	2-5
	Cylinder Leakage Test	2-5
	Cylinder Thermal Drift	2-5
2.5	Pins and Composite Bearing Repair Guidelines	2-6
2.6	Welding on JLG Equipment	2-6
	Do the Following When Welding on JLG Equipment	2-6
	Do NOT Do the Following When Welding on JLG Equipment	2-6
 SECTION 3 - CHASSIS & TURNTABLE		
3.1	Tires & Wheels	3-1
	Tire Damage	3-1
	Tire Replacement	3-1
	Wheel Replacement	3-1
	Wheel Installation	3-1
3.2	Lockout Cylinder Bleeding	3-2
3.3	Oscillating Axle Lockout Test	3-8
3.4	Free Wheeling Option	3-8
	To Disengage Drive Motors and Brakes (Free Wheel) for Emergency Towing	3-8
	To Engage Drive Motors and Brakes (Normal Operation)	3-8
3.5	Wheel Drive Assembly (2WD)	3-9
	Removal	3-9
	Installation	3-9
3.6	Wheel Drive Assembly (4WD)	3-11
	Removal	3-11
	Installation	3-11
3.7	Drive Hub	3-13
	Roll and Leak Test	3-13
	Disassembly	3-14
	Assembly	3-23
3.8	Drive Brake	3-28
	Disassembly	3-28
	Inspection	3-28
	Assembly	3-28
3.9	Drive Motor	3-30
	Description	3-30
	Shaft Seal Replacement	3-30
	Loop Flushing Valve	3-31
	Troubleshooting	3-32
	Disassembly	3-33
	Inspection	3-37
	Assembly	3-39
	Initial Start-up Procedures	3-44
3.10	Chassis Tilt Indicator System	3-45
3.11	Transport Position Sensing System	3-45
	Beyond Transport - Drive Speed Cutback System	3-45
	Drive/Steer – Boom Function Interlock System	3-45
3.12	Drive Orientation System	3-45
3.13	Oscillating Axle System	3-46
3.14	Drive System	3-46

SECTION NO.	TITLE	PAGE NO.
3.15	Swing Drive.....	3-47
	Roll, Leak And Brake Testing.....	3-47
	Tightening and Torquing Bolts.....	3-48
	Motor Control Valve Disassembly.....	3-49
	Motor and Brake Disassembly.....	3-50
	Main Drive Disassembly.....	3-51
	Hub-Shaft Disassembly.....	3-52
	Carrier Disassembly.....	3-53
	Hub-Shaft Assembly.....	3-54
	Carrier Assembly.....	3-54
	Main Drive Assembly.....	3-55
	Motor and Brake Assembly.....	3-56
	Motor Control Valve Assembly.....	3-56
3.16	Swing Motor.....	3-63
	Disassembly and inspection.....	3-63
	Assembly.....	3-70
	One Piece Stator Construction.....	3-78
3.17	Procedure For Setting Swing Gear Backlash.....	3-79
3.18	Swing Bearing.....	3-82
	Turntable Bearing Mounting Bolt Condition Check.....	3-82
	Wear Tolerance.....	3-85
	Swing Bearing Removal.....	3-85
	Swing Bearing Torque Values.....	3-88
3.19	Rotary Coupling.....	3-89
3.20	Generator.....	3-94
	Maintenance Schedule.....	3-94
	Overload Protection.....	3-94
	Inspecting Brushes, Replacing Brushes, and Cleaning Slip Rings.....	3-94
	Troubleshooting.....	3-96
	Generator Disassembly and Assembly.....	3-97
	Lead Connection List for Generator.....	3-104
3.21	Ford Engine.....	3-105
3.22	Deutz Engine.....	3-116
3.23	Deutz TD 2.9 L4 China III Engine.....	3-125
	Check Oil Level.....	3-131
	Change Engine Oil.....	3-131
	Change Oil Filter.....	3-132
	Change Fuel Filters.....	3-132
	Replacing the Fuel Pre-Filter.....	3-133
	Water in Fuel Sensing System (Optional).....	3-134
	Draining Water.....	3-134
	Auxiliary Fuel Filter.....	3-134
3.24	Deutz D2011LO40 Tier 4I Engine.....	3-136
	Checking Oil Level.....	3-144
	Changing Engine Oil.....	3-144
	Changing Oil Filter.....	3-145
	Replace Fuel Filter.....	3-145
	Clean Fuel Strainer.....	3-146
	Spark Arrester Cleaning Instructions.....	3-146
	Glow Plugs.....	3-146
3.25	Deutz EMR 2.....	3-147
3.26	Ford 2.5L Engine Fuel System Repair.....	3-206
	Propane Fuel Filter Replacement.....	3-206
	Propane Fuel System Pressure Relief.....	3-206
	Propane Fuel System Leak Test.....	3-206
3.27	Counterweight.....	3-207

TABLE OF CONTENTS

SECTION NO.	TITLE	PAGE NO.
SECTION 4 - BOOM & PLATFORM		
4.1	Platform and Boom System	4-1
	Platform Control Enable System.....	4-1
	Platform Control Enable System.....	4-1
	Ground Control Keyswitch System	4-1
	Function Speed Control System.....	4-1
	Main Lift End of Stroke Damping System	4-1
4.2	Platform	4-2
	Platform Valve Removal	4-2
	Platform Valve Installation	4-3
	Platform Support Removal.....	4-5
	Platform Support Installation	4-6
4.3	Rotator And Level Cylinder	4-8
	Removal	4-8
	800S	4-8
	860SJ	4-8
	Installation	4-10
	800S	4-10
	860SJ	4-10
4.4	Main Boom Powertrack	4-11
	Removal	4-11
4.5	Powertrack Maintenance	4-13
	One Piece Bracket Maintenance.....	4-13
	Two Piece Bracket Maintenance.....	4-15
	Snap Rings and Screws	4-17
4.6	Main Boom Assembly.....	4-18
	Removal	4-18
	Boom Disassembly	4-19
	Inspection.....	4-26
	Boom Assembly	4-26
	Installation	4-30
	Telescope Cylinder/Boom Cable Removal	4-31
	Telescope Cylinder/Boom Cable Installation.....	4-32
	Lift Cylinder Removal	4-35
	Lift Cylinder Installation.....	4-36
4.7	Jib (860SJ Only)	4-37
	Removal	4-37
	Disassembly.....	4-37
	Inspection.....	4-38
	Assembly	4-38
	Installation	4-38
4.8	Wire Rope.....	4-39
	Inspection.....	4-39
	Three Month Inspection	4-40
	Additional Inspection Required If:.....	4-40
	12 Year or 7000 Hour Replacement.....	4-40
	Additional Replacement Criteria	4-40
4.9	Boom Rope Torquing Procedures	4-40
	Torque Procedures	4-40
4.10	Elevation, Dual Capacity & Transport Switches - 800S	4-41
4.11	Elevation, Dual Capacity & Transport Switch - 860SJ	4-43

SECTION NO.	TITLE	PAGE NO.
4.12	Electronic Platform Leveling	4-45
	Description	4-45
	Normal Operation	4-48
	Platform Leveling Fault	4-49
	CAN Errors	4-51
	Replacing the Level Sensors	4-51
	Additional Platform and Jib Valves	4-51
	Platform Leveling Calibration Procedure	4-51
4.13	Helac Rotary actuator	4-53
	Theory of Operation	4-53
	Tools Required for Assembly/Disassembly	4-56
	Disassembly	4-57
	Inspection	4-60
	Assembly	4-60
	Installing Counterbalance Valve	4-65
	Greasing Thrust Washers	4-66
	Testing the Actuator	4-66
	Installation and Bleeding	4-67
	Troubleshooting	4-68
4.14	Load Sensing device	4-69
	Calibrating the Load Sensor	4-69
4.15	Skyguard®	4-71
	Operation	4-71
	Function Test	4-71
	Diagnostics & Troubleshooting	4-72
4.16	Bolt-On External Fall Arrest	4-73
	Inspection Before Use	4-73
	Installation	4-73
 SECTION 5 - BASIC HYDRAULICS INFORMATION & SCHEMATICS		
5.1	Lubricating O-Rings in the Hydraulic System	5-1
	Cup and Brush	5-1
	Dip Method	5-2
	Spray Method	5-2
	Brush-on Method	5-2
5.2	Hydraulic Connection Assembly And Torque Specification	5-3
	Tapered Thread Types	5-3
	Straight Thread Types, Tube and Hose Connections	5-3
	Straight Thread Types, Port Connections	5-4
	Flange Connection Types	5-4
	Tightening Methods	5-4
	Assembly And Torque Specifications	5-5
	Assembly Instructions for American Standard Pipe Thread Tapered (NPTF) Connections	5-6
	Assembly Instructions for British Standard Pipe Thread Tapered (BSPT) Connections	5-7
	Assembly Instructions for 37° (JIC) Flare Fittings	5-8
	Assembly Instructions for 45° SAE Flare Fittings	5-12
	Assembly Instructions for O-Ring Face Seal (ORFS) Fittings	5-14
	Assembly Instructions for DIN 24° Flare Bite Type Fittings (MBTL and MBTS)	5-16
	Assembly Instructions for Bulkhead (BH) Fittings	5-18
	Assembly Instructions for O-Ring Boss (ORB) Fittings	5-22
	Assembly Instructions for Adjustable Port End Metric (MFF) Fittings	5-30
	Assembly Instructions for Metric ISO 6149 (MPP) Port Assembly Stud Ends	5-38
	Assembly Instructions for Adjustable Port End (BSPP) Fittings	5-42
	Assembly Instructions for Flange Connections: (FL61 and FL62)	5-50
	Double Wrench Method	5-53
	FFWR and TFFT Methods	5-54
	Adjustable Stud End Assembly	5-54
	O-ring Installation (Replacement)	5-55

TABLE OF CONTENTS

SECTION NO.	TITLE	PAGE NO.
5.3	Hydraulic Cylinders	5-56
	Axle Lockout Cylinder (US Market)	5-56
	Axle Lockout Cylinder (China Market)	5-58
	Jib Lift Cylinder (860SJ US Market)	5-60
	Jib Lift Cylinder (860SJ China Market)	5-66
	Main Boom Lift Cylinder (800S)	5-72
	Main Boom Lift Cylinder (860SJ US Market)	5-78
	Main Boom Lift Cylinder (860SJ China Market)	5-83
	Platform Level Cylinder (800S and 860SJ US Market)	5-89
	Platform Level Cylinder (860SJ China Market)	5-95
	Steer Cylinder (800S and 860SJ US Market)	5-101
	Steer Cylinder (860SJ China Market)	5-106
	Telescope Cylinder	5-112
5.4	Pressure Setting Procedure	5-120
	Set Up of the Function Pump	5-120
	Adjustments Made at the Main Valve Block	5-121
	Adjustments Made at the Platform Valve Assembly	5-121
5.5	Start Up Procedures	5-128
	Start Up After Overhaul or Replacement of Components	5-128
5.6	Hydraulic Schematics	5-130
SECTION 6 - JLG CONTROL SYSTEM		
6.1	JLG Control System Analyzer Kit Instructions	6-1
	Introduction	6-1
	To Connect the JLG Control System Analyzer	6-2
	Using the Analyzer	6-2
	Changing the Access Level of the Hand Held Analyzer	6-3
	Adjusting Configuration Using the Hand Held Analyzer	6-4
	Machine Setup	6-4
	Level Vehicle Description	6-5
6.2	Machine Personality Settings and Function Speeds	6-16
6.3	Machine Orientation When Doing Speed Tests	6-18
	Test Notes	6-19
6.4	CANBUS Communications	6-20
	Analyzer Diagnostics Menu Structure	6-33
SECTION 7 - BASIC ELECTRICAL INFORMATION & SCHEMATICS		
7.1	General	7-1
7.2	Multimeter Basics	7-1
	Grounding	7-1
	Backprobing	7-1
	Min/Max	7-1
	Polarity	7-1
	Scale	7-1
	Voltage Measurement	7-1
	Resistance Measurement	7-2
	Continuity Measurement	7-2
	Current Measurement	7-3
7.3	Applying Silicone Dielectric Compound to Electrical Connections	7-3
	Installation of Dielectric Grease	7-4
	AMP Mate-N-Lok	7-4
	AMP Faston	7-4
	AMP Micro-Fit	7-4
	AMP Mini Fit Jr	7-4
	Mini Fit Sr	7-5
	DIN Connectors	7-5
	Exceptions	7-5

SECTION NO.	TITLE	PAGE NO.
7.4	AMP Connector	7-6
	Assembly	7-6
	Disassembly	7-8
	Wedge Lock	7-8
	Service - Voltage Reading	7-8
7.5	Deutsch Connectors	7-10
	DT/DTP Series Assembly	7-10
	DT/DTP Series Disassembly	7-10
	HD30/HDP20 Series Assembly	7-11
	HD30/HDP20 Series Disassembly	7-11
7.6	Telematics Gateway	7-12
	Telematics-Ready (TCU) Plug	7-12
7.7	Electrical Schematics	7-16

Go to Discount-Equipment.com to order your parts

FIGURE NO.	TITLE	PAGE NO.
1-1.	Operator Maintenance and Lubrication Diagram	1-6
1-2.	Deutz 2011 Engine Dipstick	1-9
1-3.	Serial Number Locations	1-12
2-1.	Engine Operating Temperature Specifications - Ford	2-10
2-2.	Engine Operating Temperature Specifications - Deutz	2-11
3-1.	Axle and Steering Installation without Tow Package- Sheet 1 of 2	3-4
3-2.	Axle and Steering Installation without Tow Package- Sheet 2 of 2	3-5
3-3.	Axle and Steering Installation with Tow Package- Sheet 1 of 2	3-6
3-4.	Axle and Steering Installation with Tow Package- Sheet 2 of 2	3-7
3-5.	Torque Hub Installation (2WD)	3-10
3-5.	Torque Hub Installation (4WD)	3-12
3-6.	Main Cover Plate Disassembly	3-14
3-7.	Carrier Subassembly Removal	3-15
3-8.	Carrier Subassembly Removal	3-16
3-9.	Carrier Disassembly	3-17
3-10.	Coupling Disassembly	3-18
3-11.	Input Shaft Disassembly	3-19
3-12.	Cover Disassembly	3-20
3-13.	Housing Spindle Disassembly	3-21
3-14.	Housing Cross Section	3-22
3-15.	Housing Cross Section	3-22
3-16.	Timing Mark on Carrier Subassembly	3-26
3-17.	Drive Brake	3-29
3-18.	Drive Motor Cross Section	3-30
3-19.	Removing the Shaft Seal	3-30
3-20.	Loop Flushing Spool	3-31
3-21.	Loop Flushing Spool	3-33
3-22.	Plugs, Fittings and Speed Sensor	3-33
3-23.	End Cap	3-34
3-24.	Valve Plate & Rear Shaft Bearing	3-34
3-25.	Cylinder Kit	3-35
3-26.	Shaft Seal	3-35
3-27.	Shaft & Front Bearing	3-35
3-28.	Swashplate & Servo Piston	3-36
3-29.	Cylinder Kit Disassembly	3-36
3-30.	Servo Piston	3-39
3-31.	Cylinder Kit Assembly	3-40
3-32.	Swashplate and Journal Bearing	3-40
3-33.	Shaft and Front Bearing	3-41
3-34.	Cylinder Kit Installation	3-41
3-35.	Servo Spring and Minimum Angle Stop	3-41
3-36.	Valve Plate and Rear Bearing	3-42
3-37.	End Cap	3-42
3-38.	Shaft Seal	3-43
3-39.	Plugs and Fittings Installation	3-43
3-40.	Loop Flushing Spool	3-44
3-41.	Motor Control Valve	3-49
3-42.	Motor and Brake	3-50
3-43.	Main Drive Assembly	3-51
3-44.	Hub-Shaft	3-52
3-45.	Carrier	3-53
3-46.	Swing Drive Assembly	3-57
3-47.	Swing Motor and Brake Assembly	3-58
3-48.	Bearing Cone Press Tool (T144566)	3-59
3-49.	Bearing Cone Pressing Tool (T145741)	3-59
3-50.	Bearing Cup Pressing Tool (T149013)	3-60
3-51.	Locknut Wrench Tool (T151047)	3-60

FIGURE NO.	TITLE	PAGE NO.
3-52.	Bearing Cup Pressing Tool (T155291)	3-61
3-53.	Seal Press Tool (T175741).....	3-61
3-54.	Swing Drive Test Plate (T187845)	3-62
3-55.	Leak Test Adapter Plate (T201476).....	3-62
3-56.	Swing Drive Motor	3-64
3-57.	Swing Bearing Torque Sequence	3-80
3-58.	Swing Drive and Turntable Bearing	3-81
3-59.	Swing Bearing Tolerance Boom Placement (Sheet 1 of 2).....	3-83
3-60.	Swing Bearing Tolerance Boom Placement (Sheet 2 of 2).....	3-84
3-61.	Swing Bolt Feeler Gauge Check.....	3-85
3-62.	Swing Bearing Tolerance Measuring Point	3-85
3-63.	Swing Bearing Removal (800S).....	3-86
3-64.	Swing Bearing Removal (860SJ).....	3-87
3-65.	Rotary Coupling Seal Installation	3-89
3-66.	Rotary Coupling Cutaway	3-90
3-67.	Rotary Coupling Port Location (7 Port)	3-91
3-68.	Rotary Coupling Installation	3-92
3-69.	Inspecting Generator Brushes, Replacing Brushes, and Cleaning Slip Rings	3-95
3-70.	Generator Disassembly and Assembly	3-97
3-71.	Generator Troubleshooting Circuit Diagram (Sheet 1 of 2).....	3-98
3-72.	Generator Troubleshooting Circuit Diagram (Sheet 2 of 2).....	3-99
3-73.	Generator Electrical Circuit Diagram	3-100
3-74.	Power Board PC1 Electrical Circuit Diagram	3-101
3-75.	Power Board PC2 Electrical Circuit Diagram (Sheet 1 of 2).....	3-102
3-76.	Power Board PC2 Electrical Circuit Diagram (Sheet 2 of 2).....	3-103
3-77.	Ford Engine Installation - Sheet 1 of 4.....	3-105
3-78.	Ford Engine Installation - Sheet 2 of 4.....	3-106
3-79.	Ford Engine Installation - Sheet 3 of 4.....	3-107
3-80.	Ford Engine Installation - Sheet 4 of 4.....	3-108
3-81.	Deutz T4F TD2.9L Engine Components - Sheet 1 of 2	3-116
3-82.	Deutz T4F TD2.9L Engine Components - Sheet 2 of 2	3-117
3-83.	Deutz T4F TD2.9L Engine Installation - Sheet 1 of 7	3-118
3-84.	Deutz T4F TD2.9L Engine Installation - Sheet 2 of 7	3-119
3-85.	Deutz T4F TD2.9L Engine Installation - Sheet 3 of 7	3-120
3-86.	Deutz T4F TD2.9L Engine Installation - Sheet 4 of 7	3-121
3-87.	Deutz T4F TD2.9L Engine Installation - Sheet 5 of 7	3-122
3-88.	Deutz T4F TD2.9L Engine Installation - Sheet 6 of 7	3-123
3-89.	Deutz T4F TD2.9L Engine Installation - Sheet 7 of 7	3-124
3-90.	Deutz TD 2.9 L4 China III Engine Installation - Sheet 1 of 6	3-125
3-91.	Deutz TD 2.9 L4 China III Engine Installation - Sheet 2 of 6	3-126
3-92.	Deutz TD 2.9 L4 China III Engine Installation - Sheet 3 of 6	3-127
3-93.	Deutz TD 2.9 L4 China III Engine Installation - Sheet 4 of 6	3-128
3-94.	Deutz TD 2.9 L4 China III Engine Installation - Sheet 5 of 6	3-129
3-95.	Deutz TD 2.9 L4 China III Engine Installation - Sheet 6 of 6	3-130
3-96.	Deutz 2.9 T4F Dipstick Markings	3-131
3-97.	Engine Oil Viscosity	3-131
3-98.	Location of Fuel Pre-Filter	3-133
3-99.	Components of Fuel Pre-Filter	3-133
3-100.	Components of Auxiliary Fuel Filter	3-134
3-101.	Deutz D2011LO40 Tier 4I Engine Installation (860SJ) - Sheet 1 of 4	3-136
3-102.	Deutz D2011LO40 Tier 4I Engine Installation (860SJ) - Sheet 2 of 4	3-137
3-103.	Deutz D2011LO40 Tier 4I Engine Installation (860SJ) - Sheet 3 of 4	3-138
3-104.	Deutz D2011LO40 Tier 4I Engine Installation (860SJ) - Sheet 4 of 4	3-139
3-105.	Deutz D2011 (T4I) Engine Installation (Without Arctic Package) - Sheet 1 of 2.....	3-140
3-106.	Deutz D2011 (T4I) Engine Installation (Without Arctic Package) - Sheet 2 of 2.....	3-141
3-107.	Deutz D2011 (T4I) Engine Installation (With Arctic Package) - Sheet 1 of 2.....	3-142
3-108.	Deutz D2011 (T4I) Engine Installation (With Arctic Package) - Sheet 2 of 2.....	3-143

LIST OF FIGURES

FIGURE NO.	TITLE	PAGE NO.
3-109.	Deutz Dipstick Markings	3-144
3-110.	Engine Oil Viscosity	3-144
3-111.	EMR 2 Engine Side Equipment	3-147
3-112.	Deutz EMR 2 Troubleshooting Flow Chart	3-148
3-113.	Deutz EMR 2 Vehicle Side Connection Diagram	3-149
3-114.	Deutz EMR 2 Engine Side Connection Diagram - Sheet 1 of 2	3-150
3-115.	Deutz EMR 2 Engine Side Connection Diagram - Sheet 2 of 2	3-151
3-116.	EMR 2 Engine Plug Pin Identification	3-152
3-117.	EMR 2 Vehicle Plug Pin Identification	3-153
3-118.	EMR2 Fault Codes - Sheet 1 of 5	3-154
3-119.	EMR2 Fault Codes - Sheet 2 of 5	3-155
3-120.	EMR2 Fault Codes - Sheet 3 of 5	3-156
3-121.	EMR2 Fault Codes - Sheet 4 of 5	3-157
3-122.	EMR2 Fault Codes - Sheet 5 of 5	3-158
3-123.	Filter Lock Assembly	3-206
3-124.	Counterweight Bolt Torque	3-207
4-1.	Location of Components Platform Support	4-5
4-2.	Platform Support Torque Values	4-7
4-3.	Removal/Installation of Components - Rotator and Level Cylinder	4-9
4-3.	Main Boom Powertrack Components	4-11
4-4.	Powertrack Installation Main Boom	4-12
4-5.	Boom Assembly Cutaway - Sheet 1 of 2	4-21
4-6.	Boom Assembly Cutaway - Sheet 2 of 2	4-22
4-7.	Boom Components - Sheet 1 of 2	4-23
4-8.	Boom Components - Sheet 2 of 2	4-24
4-9.	Disassembly of Sheave Assembly	4-25
4-10.	Disassembly Wire Rope Routing Procedure	4-25
4-11.	Dimension of Sheaves When New	4-26
4-12.	Proximity Switch Adjustment	4-27
4-13.	Routing Installation of Retract Wire Ropes	4-28
4-14.	Jib Assembly - Removal/Installation	4-37
4-14.	Wire Rope Wire Breaks	4-39
4-15.	Wire Rope Kink	4-39
4-16.	Sheave Groove Wear	4-39
4-17.	Clamping Wire Ropes	4-40
4-18.	Elevation and Transportation Switches - 800S (Sheet 1 of 2)	4-41
4-19.	Elevation and Transportation Switches - 800S (Sheet 2 of 2)	4-42
4-20.	Elevation and Transportation Switches - 860SJ (Sheet 1 of 2)	4-43
4-21.	Elevation and Transportation Switches - 860SJ (Sheet 2 of 2)	4-44
4-22.	Level Switches - 800S	4-46
4-23.	Level Switches - 860SJ	4-47
4-24.	Rotary Actuator (Exploded View)	4-54
4-25.	Rotary Actuator (Cutaway View)	4-55
4-26.	Rotator Counterbalance Valve	4-65
4-27.	Load Sensing Device	4-70
4-28.	Bolt-On External Fall Arrest Cable Tension	4-73
4-29.	Bolt-On External Fall Arrest System	4-75
5-1.	NPTF thread	5-3
5-2.	BSPT thread	5-3
5-3.	JIC Thread	5-3
5-4.	SAE Thread	5-3
5-5.	ORFS Thread	5-3
5-6.	MTBL-MBTS Thread	5-3
5-7.	Bulkhead Thread	5-3
5-8.	MFF-BSPP Thread	5-4
5-9.	ORB-MPP Thread	5-4
5-10.	Torque Wrench Angle	5-5

FIGURE NO.	TITLE	PAGE NO.
5-11.	Double Wrench Method	5-53
5-12.	FFWR Method	5-54
5-13.	Adjustable Stud End Assembly	5-55
5-14.	Axle Lockout Cylinder (US Market)	5-57
5-15.	Axle Lockout Cylinder (China Market)	5-59
5-16.	Cylinder Barrel Support	5-60
5-17.	Capscrew Removal	5-60
5-18.	Cylinder Rod Support	5-60
5-19.	Jib Lift Cylinder (860SJ US Market)	5-61
5-20.	Tapered Bushing Removal	5-62
5-21.	Composite Bearing Installation	5-63
5-22.	Rod Seal Installation	5-63
5-23.	Cylinder Head Seal Installation	5-63
5-24.	Wiper Seal Installation	5-64
5-25.	Installation of Head Seal Kit	5-64
5-26.	Tapered Bushing Installation	5-64
5-27.	Seating the Tapered Bearing	5-64
5-28.	Hydrolock Piston Seal Installation	5-65
5-29.	Piston Seal Kit Installation	5-65
5-30.	Rod Assembly Installation	5-65
5-31.	Cylinder Barrel Support	5-66
5-32.	Cylinder Head Removal	5-66
5-33.	Cylinder Rod Support	5-66
5-34.	Jib Lift Cylinder (860SJ China Market)	5-67
5-35.	Piston Removal	5-68
5-36.	Piston Disassembly	5-68
5-37.	Cylinder Head Disassembly	5-68
5-38.	Composite Bushing Installation	5-69
5-39.	Cylinder Head Assembly	5-69
5-40.	Head Seal Kit Installation	5-70
5-41.	Piston Assembly	5-70
5-42.	Piston Seal Kit Installation	5-70
5-43.	Piston Installation	5-70
5-44.	Cylinder Head Installation	5-71
5-45.	Cylinder Barrel Support	5-72
5-46.	Capscrew Removal	5-72
5-47.	Cylinder Rod Support	5-72
5-48.	Main Boom Lift Cylinder (800S)	5-73
5-49.	Tapered Bushing Removal	5-74
5-50.	Composite Bearing Installation	5-75
5-51.	Rod Seal Installation	5-75
5-52.	Cylinder Head Seal Installation	5-75
5-53.	Wiper Seal Installation	5-76
5-54.	Installation of Head Seal Kit	5-76
5-55.	Tapered Bushing Installation	5-76
5-56.	Seating the Tapered Bearing	5-76
5-57.	Piston Seal Kit Installation	5-77
5-58.	Rod Assembly Installation	5-77
5-59.	Cylinder Barrel Support	5-78
5-60.	Cylinder Head Removal	5-78
5-61.	Cylinder Rod Support	5-78
5-62.	Main Boom Lift Cylinder (860SJ US Market)	5-79
5-63.	Piston Removal	5-80
5-64.	Piston Seal Disassembly	5-80
5-65.	Cylinder Head Disassembly	5-80
5-66.	Composite Bearing Installation	5-81
5-67.	Wiper Seal Installation	5-81

FIGURE NO.	TITLE	PAGE NO.
5-68.	Cylinder Head Assembly	5-82
5-69.	Piston Seal Installation	5-82
5-70.	Cylinder Head Tightening	5-82
5-71.	Cylinder Barrel Support	5-83
5-72.	Cylinder Head Removal	5-83
5-73.	Cylinder Rod Support	5-83
5-74.	Main Boom Lift Cylinder (860SJ China Market)	5-84
5-75.	Piston Removal	5-85
5-76.	Composite Bearing Installation	5-86
5-77.	Rod Seal Installation	5-86
5-78.	Cylinder Head Seal Installation	5-86
5-79.	Wiper Seal Installation	5-87
5-80.	Installation of Head Seal Kit	5-87
5-81.	Piston Installation	5-87
5-82.	Piston Seal Kit Installation	5-87
5-83.	Cylinder Head Installation	5-88
5-84.	Cylinder Barrel Support	5-89
5-85.	Capscrew Removal	5-89
5-86.	Cylinder Rod Support	5-89
5-87.	Platform Level Cylinder (800S and 860SJ US Market)	5-90
5-88.	Tapered Bushing Removal	5-91
5-89.	Composite Bearing Installation	5-92
5-90.	Rod Seal Installation	5-92
5-91.	Cylinder Head Seal Installation	5-92
5-92.	Wiper Seal Installation	5-93
5-93.	Installation of Head Seal Kit	5-93
5-94.	Tapered Bushing Installation	5-93
5-95.	Seating the Tapered Bearing	5-93
5-96.	Hydrolock Piston Seal Installation	5-94
5-97.	Piston Seal Kit Installation	5-94
5-98.	Rod Assembly Installation	5-94
5-99.	Cylinder Barrel Support	5-95
5-100.	Cylinder Head Removal	5-95
5-101.	Cylinder Rod Support	5-95
5-102.	Platform Level Cylinder (860SJ China Market)	5-96
5-103.	Piston Removal	5-97
5-104.	Composite Bearing Installation	5-98
5-105.	Rod Seal Installation	5-98
5-106.	Cylinder Head Seal Installation	5-98
5-107.	Wiper Seal Installation	5-99
5-108.	Installation of Head Seal Kit	5-99
5-109.	Piston Installation	5-99
5-110.	Hydrolock Piston Seal Installation	5-99
5-111.	Piston Seal Kit Installation	5-100
5-112.	Cylinder Head Installation	5-100
5-113.	Cylinder Barrel Support	5-101
5-114.	Spanner Nut Removal	5-101
5-115.	Cylinder Rod Support	5-101
5-116.	Steer Cylinder (US Market)	5-102
5-117.	Composite Bearing Installation	5-104
5-118.	Rod Seal Installation	5-104
5-119.	Cylinder Head Seal Installation	5-104
5-120.	Wiper Seal Installation	5-105
5-121.	Installation of Head Seal Kit	5-105
5-122.	Installation of Piston Seal Kit	5-105
5-123.	Cylinder Barrel Support	5-106
5-124.	Cylinder Head Removal	5-106

FIGURE NO.	TITLE	PAGE NO.
5-125.	Cylinder Rod Support	5-106
5-126.	Steer Cylinder (860SJ China Market)	5-107
5-127.	Composite Bearing Installation	5-109
5-128.	Rod Seal Installation.....	5-109
5-129.	Cylinder Head Seal Installation	5-109
5-130.	Wiper Seal Installation.....	5-110
5-131.	Installation of Head Seal Kit.....	5-110
5-132.	Installation of Piston Seal Kit.....	5-110
5-133.	Installation of Steel Rope	5-111
5-134.	Cylinder Head Installation	5-111
5-135.	Cylinder Barrel Support.....	5-112
5-136.	Capscrew Removal	5-112
5-137.	Cylinder Rod Support	5-112
5-138.	Telescopic Cylinder	5-113
5-139.	Tapered Bushing Removal.....	5-114
5-140.	Composite Bearing Installation	5-115
5-141.	Rod Seal Installation.....	5-115
5-142.	Cylinder Head Seal Installation	5-115
5-143.	Wiper Seal Installation.....	5-116
5-144.	Installation of Head Seal Kit.....	5-116
5-145.	Tapered Bushing Installation	5-116
5-146.	Seating the Tapered Bearing	5-117
5-147.	Piston Seal Kit Installation	5-117
5-148.	Rod Assembly Installation	5-118
5-149.	Control Valve Installation.....	5-119
5-150.	Main Valve Identification	5-122
5-151.	Main Valve Cartridge Torque Values	5-123
5-152.	Platform Valve Identification (800S).....	5-124
5-153.	Platform Valve Cartridge Torque Values (800S)	5-125
5-154.	Platform Valve Identification (860SJ).....	5-126
5-155.	Platform Valve Cartridge Torque Values (860SJ)	5-127
5-156.	Hydraulic Schematic - Sheet 1 of 6	5-130
5-157.	Hydraulic Schematic - Sheet 2 of 6	5-131
5-158.	Hydraulic Schematic - Sheet 3 of 6	5-132
5-159.	Hydraulic Schematic - Sheet 4 of 6	5-133
5-160.	Hydraulic Schematic - Sheet 5 of 6	5-134
5-161.	Hydraulic Schematic - Sheet 6 of 6	5-135
6-1.	Hand Held Analyzer	6-1
6-2.	ADE Block Diagram.....	6-7
6-3.	Analyzer Flow Chart - Diagnostics (Software Version P6.30) - Sheet 1 of 7	6-21
6-4.	Analyzer Flow Chart - Diagnostics (Software Version P6.30) - Sheet 2 of 7	6-22
6-5.	Analyzer Flow Chart - Diagnostics (Software Version P6.30) - Sheet 3 of 7	6-23
6-6.	Analyzer Flow Chart - Diagnostics (Software Version P6.30) - Sheet 4 of 7	6-24
6-7.	Analyzer Flow Chart - Diagnostics (Software Version P6.30) - Sheet 5 of 7	6-25
6-8.	Analyzer Flow Chart - Diagnostics (Software Version P6.30) - Sheet 6 of 7	6-26
6-9.	Analyzer Flow Chart - Diagnostics (Software Version P6.30) - Sheet 7 of 7	6-27
6-10.	Fault Code Light and module Location.....	6-28
6-11.	Analyzer Connecting Points	6-29
6-12.	Ground Control Module - Sheet 1 of 3.....	6-30
6-13.	Ground Control Module - Sheet 2 of 3.....	6-31
6-14.	Ground Control Module - Sheet 3 of 3.....	6-32
7-1.	Voltage Measurement (DC).....	7-1
7-2.	Resistance Measurement.....	7-2
7-3.	Continuity Measurement.....	7-2
7-4.	Current Measurement (DC).....	7-3
7-5.	Connector Assembly Figure 1	7-6
7-6.	AMP Connector	7-6

LIST OF FIGURES

FIGURE NO.	TITLE	PAGE NO.
7-7.	Connector Assembly Figure 2.....	7-7
7-8.	Connector Assembly Figure 3.....	7-7
7-9.	Connector Assembly Figure 4.....	7-7
7-10.	Connector Disassembly.....	7-8
7-11.	Connector Installation.....	7-9
7-12.	DT/DTP Contact Installation.....	7-10
7-13.	DT/DTP Contact Removal.....	7-10
7-14.	HD/HDP Contact Installation.....	7-11
7-15.	HD/HDP Locking Contacts Into Position.....	7-11
7-16.	HD/HDP Contact Removal.....	7-11
7-17.	HD/HDP Unlocking Contacts.....	7-11
7-18.	Telematics Gateway Harness - Sheet 1 of 3.....	7-13
7-19.	Telematics Gateway Harness - Sheet 2 of 3.....	7-14
7-20.	Telematics Gateway Harness - Sheet 3 of 3.....	7-15
7-21.	Electrical Schematic - Sheet 1 of 19.....	7-16
7-22.	Electrical Schematic - Sheet 2 of 19.....	7-17
7-23.	Electrical Schematic - Sheet 3 of 19.....	7-18
7-24.	Electrical Schematic - Sheet 4 of 19.....	7-19
7-25.	Electrical Schematic - Sheet 7 of 19.....	7-20
7-26.	Electrical Schematic - Sheet 8 of 19.....	7-21
7-27.	Electrical Schematic - Sheet 7 of 19.....	7-22
7-28.	Electrical Schematic - Sheet 7 of 19.....	7-23
7-29.	Electrical Schematic - Sheet 9 of 19.....	7-24
7-30.	Electrical Schematic - Sheet 10 of 19.....	7-25
7-31.	Electrical Schematic - Sheet 11 of 19.....	7-26
7-32.	Electrical Schematic - Sheet 12 of 19.....	7-27
7-33.	Electrical Schematic - Sheet 13 of 19.....	7-28
7-34.	Electrical Schematic - Sheet 14 of 19.....	7-29
7-35.	Electrical Schematic - Sheet 15 of 19.....	7-30
7-36.	Electrical Schematic - Sheet 16 of 19.....	7-32
7-37.	Electrical Schematic - Sheet 17 of 19.....	7-33
7-38.	Electrical Schematic - Sheet 18 of 19.....	7-34
7-39.	Electrical Schematic - Sheet 19 of 19.....	7-35

Go to Discount-Equipment.com to order your parts

TABLE NO.	TITLE	PAGE NO.
1-1	Deutz D2011L04 Specifications	1-2
1-2	Deutz TD 2.9 Specifications	1-2
1-3	Ford 2.5L DF, MSG-425	1-2
1-4	Deutz TD 2.9 L4 China III Specifications	1-2
1-5	Mobilfluid 424 Specs	1-3
1-6	UCon Hydrolube HP-5046	1-4
1-7	Mobil DTE 10 Excel 32 Specs	1-4
1-8	Mobil EAL 224H Specs	1-4
1-9	Exxon Univis HVI 26 Specs	1-4
2-1	Inspection and Maintenance	2-2
2-2	Cylinder Drift	2-5
2-3	Inspection and Preventive Maintenance Schedule	2-7
3-1	Wheel Torque Chart	3-2
3-2	Excessive Noise and/or Vibration	3-32
3-3	System Operating Hot	3-32
3-4	Won't Shift or Slow to Start	3-32
3-5	Displacement Identifiers	3-35
3-6	Slipper Foot Thickness & End Play	3-37
3-7	Cylinder Block Measurements	3-38
3-8	Drive Mode Speeds	3-46
3-9	Coupling Port Information Table (7 port)	3-93
3-10	Troubleshooting	3-96
3-11	Lead Connection List for Generator	3-104
3-12	CAN to DTC Cross Reference (Ford Engine)	3-109
3-13	Engine Fault Codes (Deutz Engine)	3-159
4-1	Troubleshooting	4-68
4-2	SkyGuard Function Table	4-72
5-1	NPTF Pipe Thread	5-6
5-2	BSPT Pipe Thread	5-7
5-3	37° Flare (JIC) Thread - Steel	5-9
5-4	37° Flare (JIC) Thread - Aluminum/Brass	5-10
5-5	45° Flare (SAE) - Steel	5-13
5-6	45° Flare (SAE) - Aluminum/Brass	5-13
5-7	O-ring Face Seal (ORFS) - Steel	5-14
5-8	O-ring Face Seal (ORFS) - Aluminum/Brass	5-15
5-9	DIN 24° Cone (MBTL & MBTS)	5-17
5-10	Bulkhead Fittings (BH) - INCH	5-19
5-11	Bulkhead Fittings (BH) - METRIC	5-20
5-12	O-ring Boss (ORB) - Table 1 of 6	5-23
5-13	O-ring Boss (ORB) - Table 2 of 6	5-24
5-14	O-ring Boss (ORB) - Table 3 of 6	5-25
5-15	O-ring Boss (ORB) - Table 4 of 6	5-26
5-16	O-ring Boss (ORB) - Table 5 of 6	5-27
5-17	O-ring Boss (ORB) - Table 6 of 6	5-28
5-18	Metric Flat Face Port (MFF) - L Series - Table 1 of 3	5-31
5-19	Metric Flat Face Port (MFF) - L Series - Table 2 of 3	5-32
5-20	Metric Flat Face Port (MFF) - L Series - Table 3 of 3	5-33
5-21	Metric Flat Face Port (MFF) - S Series - Table 1 of 3	5-34
5-22	Metric Flat Face Port (MFF) - S Series - Table 2 of 3	5-35
5-23	Metric Flat Face Port (MFF) - S Series - Table 3 of 3	5-36
5-24	Metric Pipe Parallel O-Ring Boss (MPP)	5-39
5-25	British Standard Parallel Pipe Port (BSPP) - L Series - Table 1 of 3	5-43
5-26	British Standard Parallel Pipe Port (BSPP) - L Series - Table 2 of 3	5-44
5-27	British Standard Parallel Pipe Port (BSPP) - L Series - Table 3 of 3	5-45
5-28	British Standard Parallel Pipe Port (BSPP) - S Series - Table 1 of 3	5-46
5-29	British Standard Parallel Pipe Port (BSPP) - S Series - Table 2 of 3	5-47
5-30	British Standard Parallel Pipe Port (BSPP) - S Series - Table 3 of 3	5-48

LIST OF TABLES

TABLE NO.	TITLE	PAGE NO.
5-31	Flange Code (FL61 & FL62) -Inch Fasteners	5-51
5-32	Flange Code (FL61 & FL62) - Metric Fasteners.....	5-52
5-33	Main Valve Coil Resistance.....	5-122
5-34	Cartridge Torque Values	5-123
5-35	Coil Torque Values.....	5-123
5-36	Cartridge Torque Values	5-125
5-37	Coil Torque Values.....	5-125
5-38	Cartridge Torque Values	5-127
5-39	Coil Torque Values.....	5-127
6-1	Analyzer Abbreviations	6-5
6-2	Machine Configuration Programming Information (Software Version P6.31).....	6-8
6-3	800S Machine Configuration Programming Settings (Software Version P6.31)	6-14
6-4	860SJ Machine Configuration Programming Settings (Software Version P6.31)	6-15
6-5	Machine Personality Settings and Function Speeds (Software Version P6.31)	6-16
6-6	Function Speeds (In Seconds).....	6-19
6-7	Adjustments - Personality Descriptions.....	6-33
6-8	Diagnostic Menu Descriptions	6-35
6-9	Diagnostic Trouble Code Chart (DTC)	6-37

Go to Discount-Equipment.com to order your parts

PARTS FINDER

**Search Website
by Part Number**



**Search Manual
Library For Parts
Manual & Lookup Part
Numbers – Purchase
or Request Quote**

Search Manuals

Enter your information to search for parts manuals and lookup part numbers.

* Brand:

* Model:

* Serial:

* Part Number:

SEARCH

**Can't Find Part or
Manual? Request Help
by Manufacturer,
Model & Description**

Parts Order Form

Please fill in the following information to request help finding a part or manual.

Manufacturer:

Model:

Description:

Quantity:

Part Number:

Part Name:

Part Description:

Part Location:

Part Condition:

Part Status:

Part Material:

Part Color:

Part Weight:

Part Dimensions:

Part Price:

Part Availability:

Part Lead Time:

Part Notes:

Submit

Discount-Equipment.com is your online resource for quality parts & equipment.

Florida: **561-964-4949** Outside Florida TOLL FREE: **877-690-3101**

Need parts?

Click on this link: <http://www.discount-equipment.com/category/5443-parts/> and choose one of the options to help get the right parts and equipment you are looking for. Please have the machine model and serial number available in order to help us get you the correct parts. If you don't find the part on the website or on once of the online manuals, please fill out the request form and one of our experienced staff members will get back to you with a quote for the right part that your machine needs.

We sell worldwide for the brands: Genie, Terex, JLG, MultiQuip, Mikasa, Essick, Whiteman, Mayco, Toro Stone, Diamond Products, Generac Magnum, Airman, Haulotte, Barreto, Power Blanket, Nifty Lift, Atlas Copco, Chicago Pneumatic, Allmand, Miller Curber, Skyjack, Lull, Skytrak, Tsurumi, Husquvarna Target, , Stow, Wacker, Sakai, Mi-T- M, Sullair, Basic, Dynapac, MBW, Weber, Bartell, Bennar Newman, Haulotte, Ditch Runner, Menegotti, Morrison, Contec, Buddy, Crown, Edco, Wyco, Bomag, Laymor, Barreto, EZ Trench, Bil-Jax, F.S. Curtis, Gehl Pavers, Heli, Honda, ICS/PowerGrit, IHI, Partner, Imer, Clipper, MMD, Koshin, Rice, CH&E, General Equipment, ,AMida, Coleman, NAC, Gradall, Square Shooter, Kent, Stanley, Tamco, Toku, Hatz, Kohler, Robin, Wisconsin, Northrock, Oztec, Toker TK, Rol-Air, Small Line, Wanco, Yanmar

SECTION 1. SPECIFICATIONS

1.1 OPERATING SPECIFICATIONS

Machine Specifications

Maximum Work Load (Capacity) All Markets Unrestricted: Restricted:	500 lb (227 kg) Refer to Capacity Decals on machine for restricted platform capacities
Maximum Capacity - Dual Rating All Markets 800S 860SJ	1000 lb (454 kg) 750 lb (340 kg)
Maximum Operating Slope	4°
Maximum Travel Grade (Gradeability)* 2WD 4WD	25% 45%
Maximum Travel Grade (Side Slope)*	4°
Maximum Vertical Platform Height: 800S 860SJ	80 ft. (24.38 m) 86 ft. (26.20 m)
Maximum Horizontal Platform Reach 800S 860SJ	71 ft. (21.6 m) 75 ft. (22.9 m)
Turning Radius (outside)	19.75 ft. (6.02 m)
Turning Radius (inside)	12.5 ft. (3.8 m)
Maximum Drive Speed	3.48 mph (5.6 km/h)
Max. Hydraulic System Pressure	4500 psi (310 Bar)
Maximum Wind Speed	28 mph (12.5 m/s)
Maximum Manual Force	400 N
Electrical System Voltage	12 Volts
Gross Machine Weight (Platform Empty) 800S 860SJ	33,030 lb (14,982 kg) 36,230 lb (16,433 kg)
* With boom in stowed position	

1.2 SPECIFICATIONS AND PERFORMANCE DATA

Swing	360°
Tail Swing	4 ft. 8 in. (1.42 m)
Platforms	36 in. x 72 in. (0.91m x 1.83m) 36 in. x 96 in. (0.91m x 2.44m)
Overall Width	8 ft. 2 in. (2.48 m)
Stowed Height 800S 860SJ	9 ft. 11 in. (3.02 m) 10 ft. (3.04 m)
Stowed Length 800S 860SJ	37 ft. 3.25 in. (11.4 m) 40 ft. (12.2 m)
Wheel base	10 ft. (3.06 m)
Ground Clearance	11 in. (0.28 m)
Drive Speed Stowed 2WD Stowed 4WD Elevated	3.0 mph (5.6 kph) 3.5 mph (5.6 kph) 0.75 mph (1.2 kph)
Ground Bearing Pressure - 800S	72 psi (5.06 kgm/cm ²)
Ground Bearing Pressure - 800SJ	81 psi (5.7 kgm/cm ²)
Max. Tire Load 800S 860SJ	17,350 lb (7870 kg) 20,200 lb (9163 kg)

1.3 CAPACITIES

Fuel Tank	Approx. 31 gallons (117 liters)
Fuel Tank (Optional)	Approx. 52.8 gallons (200 liters)
Drive Hub	58 ounces (1.7 L)
Hydraulic Tank (to Full Line on Sight Gauge)	Approx. 40 gallons (151 liters)
Engine Oil Capacity Deutz D2011L04 Cooling System Crankcase Total Capacity Deutz TD 2.9L Ford 2.5L	5 Quarts (4.5 L) 11 Quarts (10.5 L) w/Filter 16 Quarts (15 L) 2.4 Gallon (8.9 L) w/Filter 7 Quarts (6.6 L) w/Filter

1.4 COMPONENT DATA

Engine Data

Table 1-1. Deutz D2011L04 Specifications

Type	Liquid Cooled (Oil)
Fuel	Diesel
Oil Capacity	5 qt (4.5 L)
Cooling System	11 qt (10.5 L) w/Filter
Crankcase	16 qt (15 L)
Total Capacity	
Idle RPM	1000
Low RPM	1800
High RPM	2600
Alternator	55 Amp, Belt Drive
Fuel Consumption	0.88 GPH (3.33 lph)
Battery	1000 Cold Cranking Amps, 210 minutes Reserve Capacity, 12 VDC
Horsepower	61.6 @ 2600 RPM, full load

Table 1-2. Deutz TD 2.9 Specifications

Fuel	Ultra Low Sulfur Diesel (15 ppm)
Output	67 hp (50 kW)
Torque	173 ft. lbs. (234 Nm) @ 1800 rpm
Oil Capacity (Crankcase)	2.4 Gallon (8.9 L) w/Filter
Cooling System	3.3 Gallon (12.5 L)
Low RPM	1200 ± 50 rpm
High RPM	2600 ± 50 rpm
Alternator	95 Amp
Fuel Consumption	1.06 GPH (4.0 LPH)

Table 1-3. Ford 2.5L DF, MSG-425

Fuel	Gasoline or Gasoline/LP Gas
BHP	
Gasoline	84 hp @ 3200 rpm
LP	80 hp @ 3200 rpm
Bore	4.0 in. (101.6 mm)
Stroke	3.6 in. (91.44 mm)
Displacement	181 cu.in. (3.0 L, 2966 cc)
Oil Capacity w/filter	7 qt (6.6 L)
Minimum Oil Pressure at idle	6 psi (0.4 Bar) @ 1000 rpm
Hot	18 psi (1.2 Bar) @ 2000 rpm
Coolant Capacity	0.63 Gallon (2.4 L)
Low RPM	1000 ± 50 rpm
High RPM	3200 ± 50 rpm
Alternator Rating	12V, 150 Amp
Starter Rating	12V 64.4A @ 3574 RPM
Fan Ratio	1:3
Fuel Consumption Gasoline	0.99 GPH (3.74 LPH)
LP	5.67 GPH (2.57 LPH)
Max Output (Torque) Gasoline	142 ft. lbs. (192Nm) @ 2400 RPM
LP	145 ft. lbs. (197Nm) @ 2400 RPM

Table 1-4. Deutz TD 2.9 L4 China III Specifications

Fuel	China Low Sulfur Diesel (500 ppm)
No. of Cylinders	4
Output	67 hp (50 kW)
Torque	173 ft. lbs. (234 Nm) @ 1800 rpm
Displacement	177 cu.in. (2.9 L, 2900cc)
Oil Capacity (Crankcase)	2.11 Gallon (8.0 L) w/Filter
Cooling System	3.3 Gallons (12.5 L)
Low RPM	1200 ± 50 rpm
High RPM	2600 ± 50 rpm
Alternator	95 Amp
Fuel Consumption	0.91 GPH (3.44 lph)

Battery

Voltage	12 Volt
Type	31-950
Cold Cranking Amps	950 CCA @ 0°F (-18°C)
Reserve Capacity	205 Minutes @ 80°F (27°C)

1.5 TIRES

Size	Type	Ply Rating	Load Range	Pressure
15-625	Foam-Filled	16	H	N/A
18-625	Foam-Filled	16	H	N/A

1.6 TORQUE REQUIREMENTS

Description	Torque Value (Dry)	Interval Hours
Wheel Lugs	300 ft. lbs. (407 Nm)	150
Swing Bearing Bolts	190 ft. lbs. (258 Nm)	50/600*
Starter Solenoid Contacts Coil	95 in. lbs. (9.5 Nm) 40 in. lbs. (4 Nm)	As required
*Check swing bearing bolts for security after first 50 hours of operation and every 600 hours thereafter (See Swing Bearing in Section 3).		
NOTE: When maintenance becomes necessary or a fastener has loosened, refer to the Torque Chart to determine proper torque value.		

1.7 LUBRICATION

Hydraulic Oil

Hydraulic System Operating Temperature Range	S.A.E. Viscosity Grade
+0° to +180°F (-18° to +83°C)	10W
+0° to +210°F (-18° to +99°C)	10W-20, 10W30
+50° to +210°F (+10° to +99°C)	20W-20

NOTE: Hydraulic oils must have anti-wear qualities at least to API Service Classification GL-3, and sufficient chemical stability for mobile hydraulic system service. JLG Industries recommends Standard UTTO Fluid, which has an SAE viscosity index of 152.

NOTE: When temperatures remain consistently below 20 degrees F. (-7 degrees C.), JLG Industries recommends the use of Premium Hydraulic Fluid.

NOTE: Aside from JLG recommendations, it is not advisable to mix oils of different brands or types, as they may not contain the same required additives or be of comparable viscosities. If use of hydraulic oil other than standard UTTO is desired, contact JLG Industries for proper recommendations.

Table 1-5. Mobilfluid 424 Specs

SAE Grade	10W30
Gravity, API	29.0
Density, Lb/Gal. 60°F	7.35
Pour Point, Max	-46°F (-43°C)
Flash Point, Min.	442°F (228°C)
Viscosity	
Brookfield, cP at -18°C	2700
at 40°C	55 cSt
at 100°C	9.3 cSt
Viscosity Index	152

SECTION 1 - SPECIFICATIONS

Table 1-6. UCon Hydrolube HP-5046

Type	Synthetic Biodegradable
Specific Gravity	1.082
Pour Point, Max	-58°F (-50°C)
pH	9.1
Viscosity	
at 0°C (32°F)	340 cSt (1600SUS)
at 40°C (104°F)	46 cSt (215SUS)
at 65°C (150°F)	22 cSt (106SUS)
Viscosity Index	170

Table 1-7. Mobil DTE 10 Excel 32 Specs

ISO Viscosity Grade	#32
Specific Gravity	0.877
Pour Point, Max	-40°F (-40°C)
Flash Point, Min.	330°F (166°C)
Viscosity	
at 40°C	33 cSt
at 100°C	6.6 cSt
at 100°F	169 SUS
at 210°F	48 SUS
cp at -20°F	6,200
Viscosity Index	140

Table 1-8. Mobil EAL 224H Specs

Type	Synthetic Biodegradable
ISO Viscosity Grade	32/46
Specific Gravity	.922
Pour Point, Max	-25°F (-32°C)
Flash Point, Min.	428°F (220°C)
Operating Temp.	0 to 180°F (-17 to 162°C)
Weight	7.64 lb. per gal. (0.9 kg per liter)
Viscosity	
at 40°C	37 cSt
at 100°C	8.4 cSt
Viscosity Index	213
NOTE: Must be stored above 32°F (14°C)	

Table 1-9. Exxon Univis HVI 26 Specs

Specific Gravity	32.1
Pour Point	-76°F (-60°C)
Flash Point	217°F (103°C)
Viscosity	
at 40°C	25.8 cSt
at 100°C	9.3 cSt
Viscosity Index	376
NOTE: Mobil/Exxon recommends that this oil be checked on a yearly basis for viscosity.	

1.8 PRESSURE SETTINGS

Telescope Out	2500 psi (172 Bar)
Swing, Left & Right	1700 psi (117 Bar)
Steer	2500 psi (172 Bar)
Platform Level Up	2600 psi (179 Bar)
Platform Level Down	1800 psi (124 Bar)
Jib, Up & Down	1700 psi (117 Bar)

1.9 MAJOR COMPONENT WEIGHTS

Component	Pounds	Kilograms
Turntable (bare)	3700	1678
Counterweight (800S)	7000	3175
Counterweight (860SJ)	8750	3969
Upright	1050	476
Tower	685	311
Fly Boom (SJ)	472	214
Fly Boom (S)	490	222
Mid Boom (SJ)	750	340
Mid Boom (S)	740	336
Base Boom (SJ)	1400	635
Base Boom (S)	1410	640
Boom Assembly	3337	1514
Telescope Cylinder (800S)	590	268
Telescope Cylinder (860SJ)	579	263
Slave Cylinder	73	33
Torque Hub (2WD)	218	99
Tire & Wheel (FF)	544	247

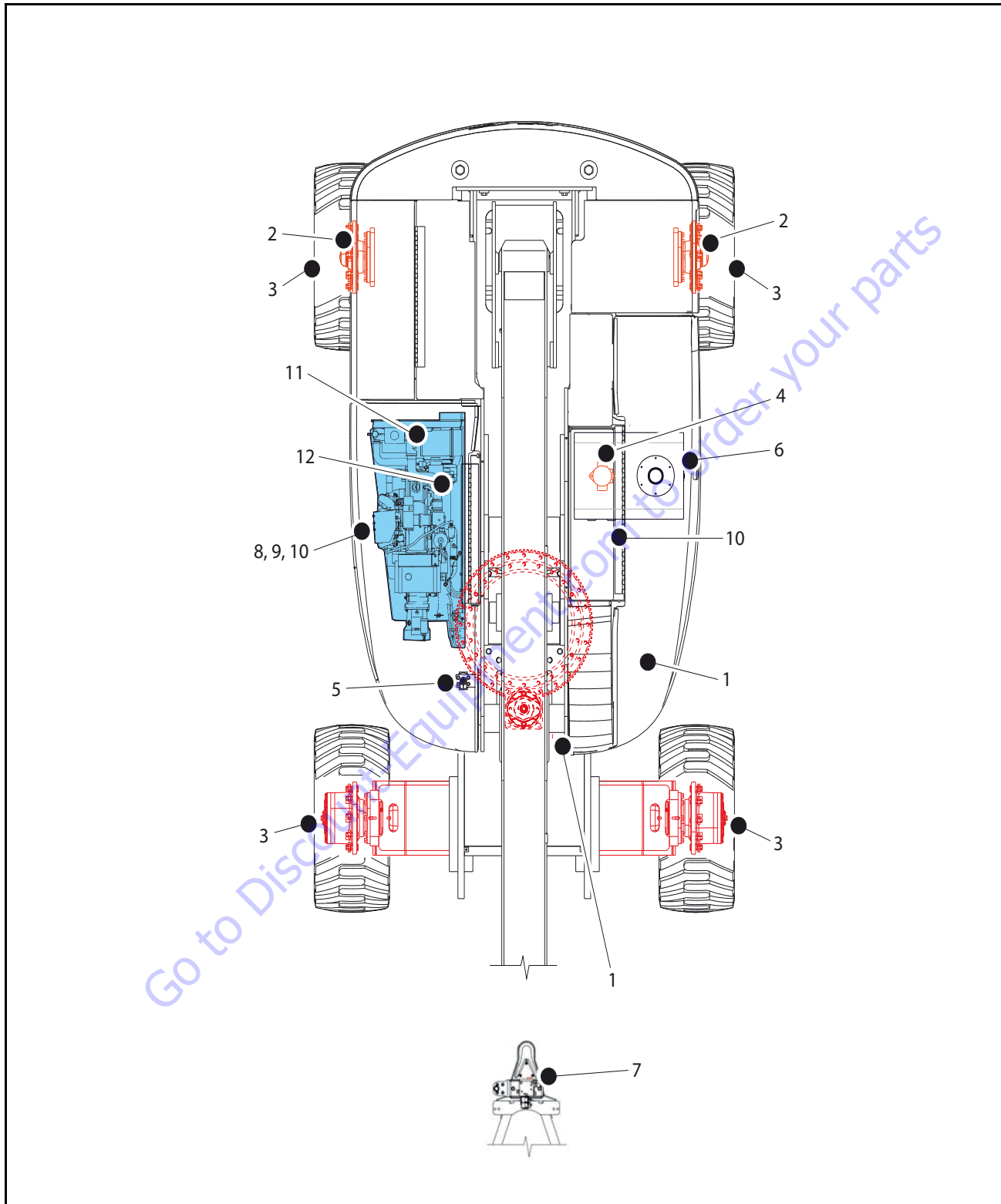

Figure 1-1. Operator Maintenance and Lubrication Diagram

1.10 OPERATOR MAINTENANCE

NOTE: The following numbers correspond to those in Figure 1-1., Operator Maintenance and Lubrication Diagram.

KEY	SPECIFICATIONS
MPG	Multipurpose Grease having a minimum dripping point of 350°F (177°C). Excellent water resistance and adhesive qualities, and being of extreme pressure type (Timken OK 40 pounds minimum).
EPGL	Extreme Pressure Gear Lube (oil) meeting API service classification GL-5 or MILSpec MIL-L-2105.
HO	Hydraulic Oil. API service classification GL-3, e.g. Mobilfluid 424.
EO	Engine (crankcase). Gas (5W30)- API SN, -Arctic ACEA A1/B1, A5/B5 - APISM, SL, SJ, EC, CF, CD - ILSAC GF-4. Diesel (15W40, 5W30 Arctic) - API CJ-4.

NOTICE

LUBRICATION INTERVALS ARE BASED ON MACHINE OPERATION UNDER NORMAL CONDITIONS. FOR MACHINES USED IN MULTI-SHIFT OPERATIONS AND/OR EXPOSED TO HOSTILE ENVIRONMENTS OR CONDITIONS, LUBRICATION FREQUENCIES MUST BE INCREASED ACCORDINGLY.

NOTE: It is recommended as a good practice to replace all filters at the same time.

1. Swing Bearing - Internal Ball Bearing



Lube Point(s) - 1 Grease Fittings
 Capacity - A/R
 Lube - MPG
 Interval - Every 3 months or 150 hrs of operation
 Comments - Remote Access.

2. Wheel Bearings

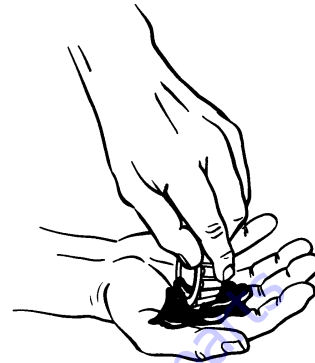

Lube Point(s) - Repack
 Capacity - A/R
 Lube - MPG
 Interval - Every 2 years or 1200 hours of operation.

3. Wheel Drive Hub

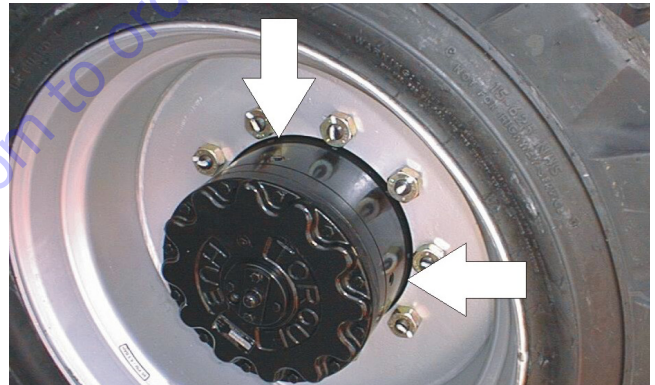

Lube Point(s) - Level/Fill Plug
 Capacity - 44 oz. (1.3 L) - 1/2 Full
 Lube - EPGL
 Interval - Check level every 3 months or 150 hours of operation; change every 2 years or 1200 hours of operation
 Comments - Place Fill port at 12 o'clock position and Check port at 3 o'clock position. Pour lubricant into fill port until it just starts to flow out of check port.

SECTION 1 - SPECIFICATIONS

4. Hydraulic Return Filter

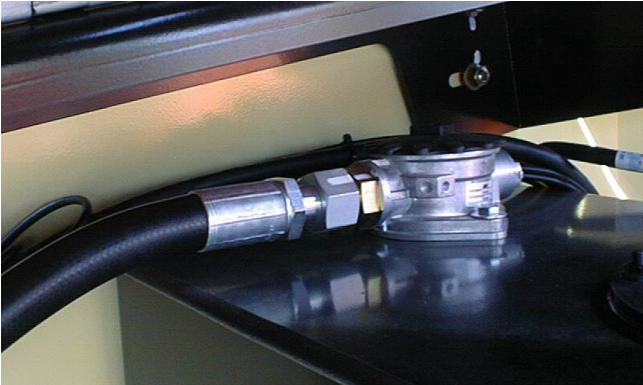

Interval - Change after first 50 hours and every 6 months or 300 hours thereafter or as indicated by Condition Indicator.

5. Hydraulic Charge Filter



Interval - Change after first 50 hours and every 6 months or 300 hours thereafter or as indicated by Condition Indicator (if equipped).

6. Hydraulic Tank



Lube Point(s) - Fill Cap
Capacity - Tank (to Full mark on sight gauge)- Approx. 21 gallons (79.5 liters)
System Capacity - 59 gallons (223 liters)
Lube - HO
Interval - Check Level daily; Change every 2 years or 1200 hours of operation.

7. Platform Filter

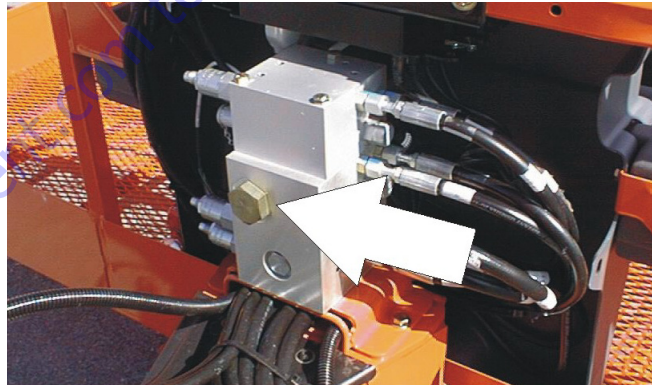

Interval - Change as necessary.

8. A. Oil Change w/Filter - Deutz

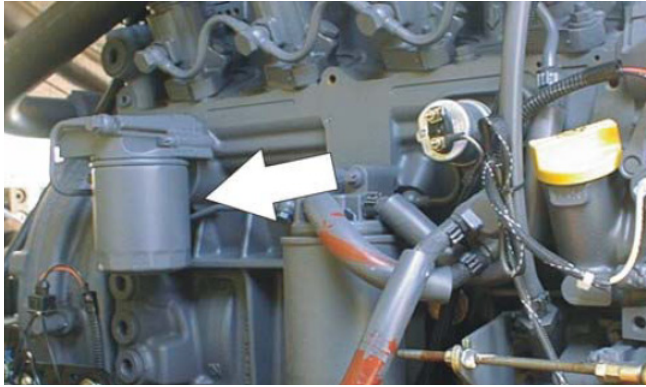

Lube Point(s) - Fill Cap/Spin-on Element
 Capacity - 11 Quarts(10.5 L) Crankcase;
 Lube - EO
 Interval - Every Year or 1200 hours of operation
 Comments - Check level daily/Change in accordance with engine manual.

B. Oil Change w/Filter - Deutz TD2.9



Lube Point(s) - Fill Cap/Spin-on Element
 Capacity - 9.6 Quarts (9.0 L)
 Lube - EO
 Interval - Every Year or 600 hours of operation

Comments - Check level daily/Change in accordance with engine manual.

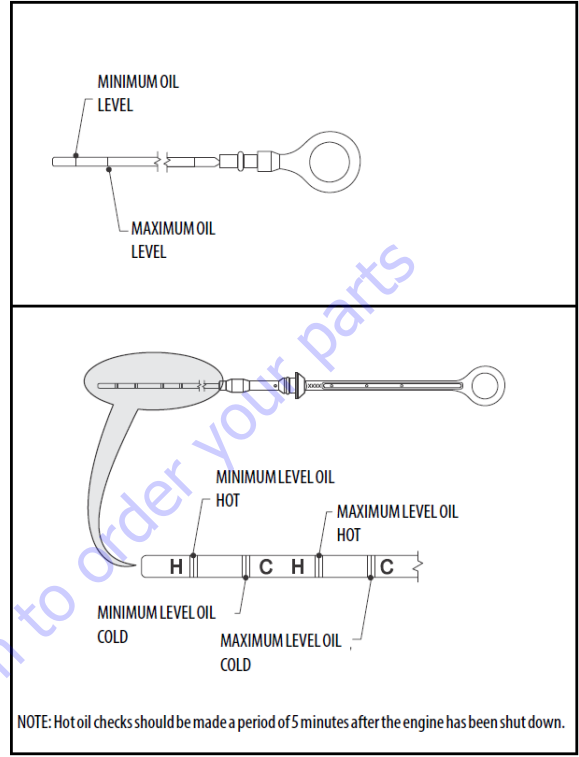
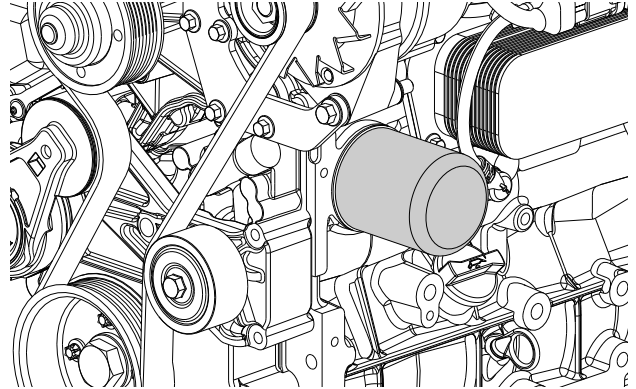

Figure 1-2. Deutz 2011 Engine Dipstick

C. Oil Change w/Filter - Deutz TD 2.9 L4 China III



Lube Point(s) - Fill Cap/Spin-on Element
 Capacity - 8.5 Quarts (8.0 L)
 Lube - EO
 Interval - Every Year or 600 hours of operation
 Comments - Check level daily/Change in accordance with engine manual.

SECTION 1 - SPECIFICATIONS

9. Oil Change w/Filter - Ford 2.5L Engine



Lube Point(s) - Fill Cap/Spin-on Element
Capacity - 4.5 qt. (4.25 L) w/filter
Lube - EO
Interval - 3 Months or 150 hours of operation
Comments - Check level daily/Change in accordance with engine manual.

10. A. Fuel Filter - Deutz D2011



Lube Point(s) - Replaceable Element
Interval - Every Year or 600 hours of operation.

B. Fuel Filter - Deutz TD2.9 (On Hydraulic Tank)

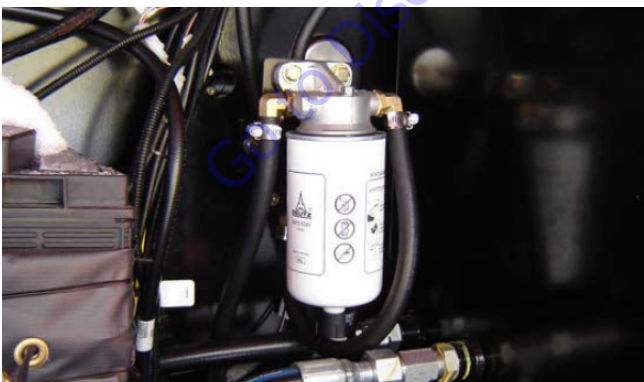

Lube Point(s) - Replaceable Element
Interval - Change in accordance with engine manual.

C. Fuel Filter - Deutz TD2.9 (On Engine)



Lube Point(s) - Replaceable Element
Interval - Change in accordance with engine manual.

D. Fuel Filter - Deutz TD 2.9 L4 China III

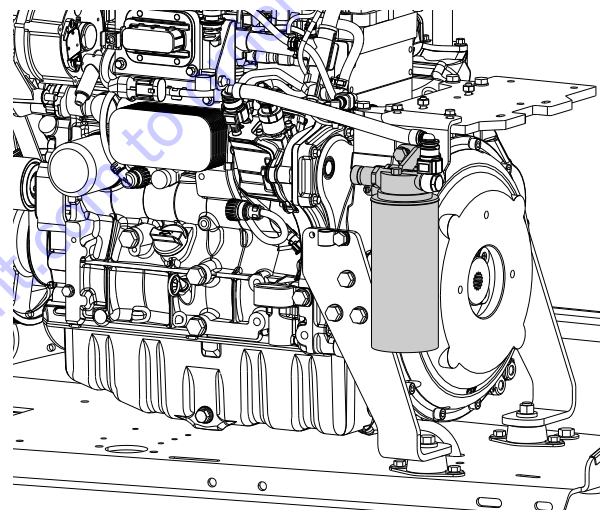

MAE19150

Lube Point(s) - Replaceable Element
Interval - Change in accordance with engine manual

E. Fuel/Water Separator - Deutz TD 2.9 L4 China III

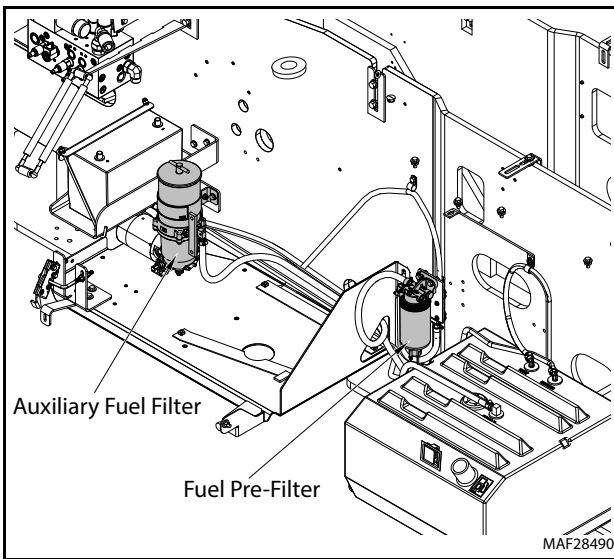

Lube Point(s) - Replaceable Element

Interval - Drain water daily; Change every year or 600 hours of operation.

11. A. Air Filter



Lube Point(s) - Replaceable Element

Interval - Every 6 months or 300 hours of operation or as indicated by the condition indicator.

B. Air Filter (Deutz TD 2.9)

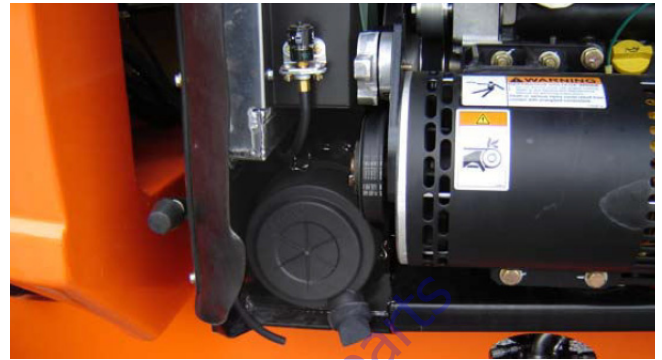

Lube Point(s) - Replaceable Element

Interval - Every 6 months or 300 hours of operation or as indicated by the condition indicator.

C. Air Filter (Deutz TD 2.9 L4 China III)

Lube Point(s) - Replaceable Element

Interval - Every 6 months or 300 hours of operation or as indicated by the condition indicator

12. Fuel Filter (Propane) - Ford 2.5L Engine

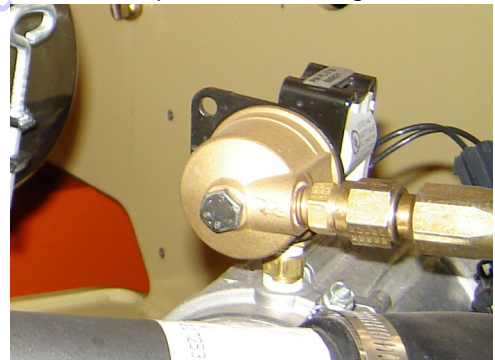

Interval - 3 Months or 150 hours of operation

Comments - Replace filter. Refer to Propane Fuel Filter Replacement.

1.11 SERIAL NUMBER LOCATION

A serial number plate is affixed to the left rear side of the frame. If the serial number plate is damaged or missing, the machine serial number is stamped on the left side of the frame.

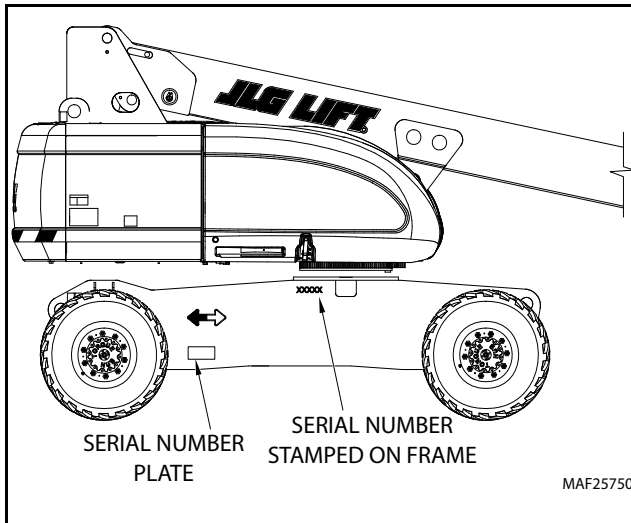

Figure 1-3. Serial Number Locations

Go to Discount-Equipment.com to order your parts

1.12 THREADLOCKING COMPOUND

JLG PN	Loctite®	ND Industries	Description
0100011	242™	Vibra-TITE™ 121	Medium Strength (Blue)
1001095650	243™	Vibra-TITE™ 122	Medium Strength (Blue)
0100019	271™	Vibra-TITE™ 140	High Strength (Red)
0100071	262™	Vibra-TITE™ 131	Medium - High Strength (Red)

NOTE: Loctite® 243™ can be substituted in place of Loctite® 242™. Vibra-TITE™ 122 can be substituted in place of Vibra-TITE™ 121.

Go to Discount-Equipment.com to order your parts

SECTION 1 - SPECIFICATIONS

1.13 TORQUE CHARTS

SAE Fastener Torque Chart

Values for Zinc Yellow Chromate Fasteners (Ref 4150707)												
SAE GRADE 5 BOLTS & GRADE 2 NUTS												
Size	TPI	Bolt Dia	Tensile Stress Area	Clamp Load	Torque (Dry)		Torque Lubricated		Torque (Loctite® 242™ or 271™ or Vibra-TITE™ 111 or 140)		Torque (Loctite® 262™ or Vibra-TITE™ 111)	
					IN-LB	[N.m]	IN-LB	[N.m]	IN-LB	[N.m]	IN-LB	[N.m]
		In	Sq In	LB	IN-LB	[N.m]	IN-LB	[N.m]	IN-LB	[N.m]	IN-LB	[N.m]
4	40	0.1120	0.00604	380	8	0.9	6	0.7				
	48	0.1120	0.00661	420	9	1.0	7	0.8				
6	32	0.1380	0.00909	580	16	1.8	12	1.4				
	40	0.1380	0.01015	610	18	2.0	13	1.5				
8	32	0.1640	0.01400	900	30	3.4	22	2.5				
	36	0.1640	0.01474	940	31	3.5	23	2.6				
10	24	0.1900	0.01750	1120	43	4.8	32	3.5				
	32	0.1900	0.02000	1285	49	5.5	36	4				
1/4	20	0.2500	0.0318	2020	96	10.8	75	9	105	12		
	28	0.2500	0.0364	2320	120	13.5	86	10	135	15		
		In	Sq In	LB	FT-LB	[N.m]	FT-LB	[N.m]	FT-LB	[N.m]	FT-LB	[N.m]
5/16	18	0.3125	0.0524	3340	17	23	13	18	19	26	16	22
	24	0.3125	0.0580	3700	19	26	14	19	21	29	17	23
3/8	16	0.3750	0.0775	4940	30	41	23	31	35	48	28	38
	24	0.3750	0.0878	5600	35	47	25	34	40	54	32	43
7/16	14	0.4375	0.1063	6800	50	68	35	47	55	75	45	61
	20	0.4375	0.1187	7550	55	75	40	54	60	82	50	68
1/2	13	0.5000	0.1419	9050	75	102	55	75	85	116	68	92
	20	0.5000	0.1599	10700	90	122	65	88	100	136	80	108
9/16	12	0.5625	0.1820	11600	110	149	80	108	120	163	98	133
	18	0.5625	0.2030	12950	120	163	90	122	135	184	109	148
5/8	11	0.6250	0.2260	14400	150	203	110	149	165	224	135	183
	18	0.6250	0.2560	16300	170	230	130	176	190	258	153	207
3/4	10	0.7500	0.3340	21300	260	353	200	271	285	388	240	325
	16	0.7500	0.3730	23800	300	407	220	298	330	449	268	363
7/8	9	0.8750	0.4620	29400	430	583	320	434	475	646	386	523
	14	0.8750	0.5090	32400	470	637	350	475	520	707	425	576
1	8	1.0000	0.6060	38600	640	868	480	651	675	918	579	785
	12	1.0000	0.6630	42200	700	949	530	719	735	1000	633	858
1 1/8	7	1.1250	0.7630	42300	800	1085	600	813	840	1142	714	968
	12	1.1250	0.8560	47500	880	1193	660	895	925	1258	802	1087
1 1/4	7	1.2500	0.9690	53800	1120	1518	840	1139	1175	1598	1009	1368
	12	1.2500	1.0730	59600	1240	1681	920	1247	1300	1768	1118	1516
1 3/8	6	1.3750	1.1550	64100	1460	1979	1100	1491	1525	2074	1322	1792
	12	1.3750	1.3150	73000	1680	2278	1260	1708	1750	2380	1506	2042
1 1/2	6	1.5000	1.4050	78000	1940	2630	1460	1979	2025	2754	1755	2379
	12	1.5000	1.5800	87700	2200	2983	1640	2224	2300	3128	1974	2676

- NOTES: 1. THESE TORQUE VALUES DO NOT APPLY TO CADMIUM PLATED FASTENERS
 2. ALL TORQUE VALUES ARE STATIC TORQUE MEASURED PER STANDARD AUDIT METHODS TOLERANCE = ±10%
 3. * ASSEMBLY USES HARDENED WASHER

5000059K

SAE Fastener Torque Chart (Continued)

Values for Zinc Yellow Chromate Fasteners (Ref 4150707)										
SAE GRADE 8 (HEX HD) BOLTS & GRADE 8 NUTS*										
Size	TPI	Bolt Dia	Tensile Stress Area	Clamp Load	Torque (Dry or Loctite® 263) K=0.20		Torque (Loctite® 242™ or 271™ or Vibra-TITE™ 111 or 140) K=0.18		Torque (Loctite® 262™ or Vibra-TITE™ 131) K=0.15	
					IN-LB	[N.m]	IN-LB	[N.m]	IN-LB	[N.m]
4	40	0.1120	0.00604							
	48	0.1120	0.00661							
6	32	0.1380	0.00909							
	40	0.1380	0.01015							
8	32	0.1640	0.01400							
	36	0.1640	0.01474	1320	43	5				
10	24	0.1900	0.01750	1580	60	7				
	32	0.1900	0.02000	1800	68	8				
1/4	20	0.2500	0.0318	2860	143	16	129	15		
	28	0.2500	0.0364	3280	164	19	148	17		
		In	Sq In	LB	FT-LB	[N.m]	FT-LB	[N.m]	FT-LB	[N.m]
5/16	18	0.3125	0.0524	4720	25	35	20	25	20	25
	24	0.3125	0.0580	5220	25	35	25	35	20	25
3/8	16	0.3750	0.0775	7000	45	60	40	55	35	50
	24	0.3750	0.0878	7900	50	70	45	60	35	50
7/16	14	0.4375	0.1063	9550	70	95	65	90	50	70
	20	0.4375	0.1187	10700	80	110	70	95	60	80
1/2	13	0.5000	0.1419	12750	105	145	95	130	80	110
	20	0.5000	0.1599	14400	120	165	110	150	90	120
9/16	12	0.5625	0.1820	16400	155	210	140	190	115	155
	18	0.5625	0.2030	18250	170	230	155	210	130	175
5/8	11	0.6250	0.2260	20350	210	285	190	260	160	220
	18	0.6250	0.2560	23000	240	325	215	290	180	245
3/4	10	0.7500	0.3340	30100	375	510	340	460	280	380
	16	0.7500	0.3730	33600	420	570	380	515	315	430
7/8	9	0.8750	0.4620	41600	605	825	545	740	455	620
	14	0.8750	0.5090	45800	670	910	600	815	500	680
1	8	1.0000	0.6060	51500	860	1170	770	1045	645	875
	12	1.0000	0.6630	59700	995	1355	895	1215	745	1015
1 1/8	7	1.1250	0.7630	68700	1290	1755	1160	1580	965	1310
	12	1.1250	0.8560	77000	1445	1965	1300	1770	1085	1475
1 1/4	7	1.2500	0.9690	87200	1815	2470	1635	2225	1365	1855
	12	1.2500	1.0730	96600	2015	2740	1810	2460	1510	2055
1 3/8	6	1.3750	1.1550	104000	2385	3245	2145	2915	1785	2430
	12	1.3750	1.3150	118100	2705	3680	2435	3310	2030	2760
1 1/2	6	1.5000	1.4050	126500	3165	4305	2845	3870	2370	3225
	12	1.5000	1.5800	142200	3555	4835	3200	4350	2665	3625

- NOTES: 1. THESE TORQUE VALUES DO NOT APPLY TO CADMIUM PLATED FASTENERS
2. ALL TORQUE VALUES ARE STATIC TORQUE MEASURED PER STANDARD AUDIT METHODS TOLERANCE = ±10%
3. * ASSEMBLY USES HARDENED WASHER

5000059K

SECTION 1 - SPECIFICATIONS

SAE Fastener Torque Chart (Continued)

Values for Magni Coating Fasteners (Ref 4150701)										
SAE GRADE 5 BOLTS & GRADE 2 NUTS										
Size	TPI	Bolt Dia	Tensile Stress Area	Clamp Load	Torque (Dry) K=0.17		Torque (Loctite® 242™ or 271™ or Vibra-TITE™ 111 or 140) K=0.16		Torque (Loctite® 262™ or Vibra-TITE™ 131) K=0.15	
					IN-LB	[N.m]	IN-LB	[N.m]	IN-LB	[N.m]
		In	Sq In	LB	IN-LB	[N.m]	IN-LB	[N.m]	IN-LB	[N.m]
4	40	0.1120	0.00604	380	7	0.8				
	48	0.1120	0.00661	420	8	0.9				
6	32	0.1380	0.00909	580	14	1.5				
	40	0.1380	0.01015	610	14	1.6				
8	32	0.1640	0.01400	900	25	2.8				
	36	0.1640	0.01474	940	26	2.9				
10	24	0.1900	0.01750	1120	36	4.1				
	32	0.1900	0.02000	1285	42	4.7				
1/4	20	0.2500	0.0318	2020	86	9.7	80	9		
	28	0.2500	0.0364	2320	99	11.1	95	11		
		In	Sq In	LB	FT-LB	[N.m]	FT-LB	[N.m]	FT-LB	[N.m]
5/16	18	0.3125	0.0524	3340	15	20	14	19	15	20
	24	0.3125	0.0580	3700	15	20	15	21	15	20
3/8	16	0.3750	0.0775	4940	25	35	25	34	25	34
	24	0.3750	0.0878	5600	30	40	28	38	25	34
7/16	14	0.4375	0.1063	6800	40	55	40	54	35	48
	20	0.4375	0.1187	7550	45	60	44	60	40	54
1/2	13	0.5000	0.1419	9050	65	90	60	82	55	75
	20	0.5000	0.1599	10700	75	100	71	97	65	88
9/16	12	0.5625	0.1820	11600	90	120	87	118	80	109
	18	0.5625	0.2030	12950	105	145	97	132	90	122
5/8	11	0.6250	0.2260	14400	130	175	120	163	115	156
	18	0.6250	0.2560	16300	145	195	136	185	125	170
3/4	10	0.7500	0.3340	21300	225	305	213	290	200	272
	16	0.7500	0.3730	23800	255	345	238	324	225	306
7/8	9	0.8750	0.4620	29400	365	495	343	466	320	435
	14	0.8750	0.5090	32400	400	545	378	514	355	483
1	8	1.0000	0.6060	38600	545	740	515	700	480	653
	12	1.0000	0.6630	42200	600	815	563	765	530	721
1 1/8	7	1.1250	0.7630	42300	675	920	635	863	595	809
	12	1.1250	0.8560	47500	755	1025	713	969	670	911
1 1/4	7	1.2500	0.9690	53800	955	1300	897	1219	840	1142
	12	1.2500	1.0730	59600	1055	1435	993	1351	930	1265
1 3/8	6	1.3750	1.1550	64100	1250	1700	1175	1598	1100	1496
	12	1.3750	1.3150	73000	1420	1930	1338	1820	1255	1707
1 1/2	6	1.5000	1.4050	78000	1660	2260	1560	2122	1465	1992
	12	1.5000	1.5800	87700	1865	2535	1754	2385	1645	2237

- NOTES: 1. THESE TORQUE VALUES DO NOT APPLY TO CADMIUM PLATED FASTENERS
 2. ALL TORQUE VALUES ARE STATIC TORQUE MEASURED PER STANDARD AUDIT METHODS TOLERANCE = ±10%
 3. * ASSEMBLY USES HARDENED WASHER

5000059K

SAE Fastener Torque Chart (Continued)

Values for Magni Coating Fasteners (Ref 4150701)										
SAE GRADE 8 (HEX HD) BOLTS & GRADE 8 NUTS*										
Size	TPI	Bolt Dia	Tensile Stress Area	Clamp Load	Torque (Dry or Loctite® 263) K=0.17		Torque (Loctite® 242™ or 271™ or Vibra-TITE™ 111 or 140) K=0.16		Torque (Loctite® 262™ or Vibra-TITE™ 131) K=0.15	
					IN-LB	[N.m]	IN-LB	[N.m]	IN-LB	[N.m]
		In	Sq In	LB	IN-LB	[N.m]	IN-LB	[N.m]	IN-LB	[N.m]
4	40	0.1120	0.00604							
	48	0.1120	0.00661							
6	32	0.1380	0.00909							
	40	0.1380	0.01015							
8	32	0.1640	0.01400							
	36	0.1640	0.01474	1320	37	4				
10	24	0.1900	0.01750	1580	51	6				
	32	0.1900	0.02000	1800	58	7				
1/4	20	0.2500	0.0318	2860	122	14	114	13		
	28	0.2500	0.0364	3280	139	16	131	15		
		In	Sq In	LB	FT-LB	[N.m]	FT-LB	[N.m]	FT-LB	[N.m]
5/16	18	0.3125	0.0524	4720	20	25	20	25	20	25
	24	0.3125	0.0580	5220	25	35	20	25	20	25
3/8	16	0.3750	0.0775	7000	35	50	35	50	35	50
	24	0.3750	0.0878	7900	40	55	40	55	35	50
7/16	14	0.4375	0.1063	9550	60	80	55	75	50	70
	20	0.4375	0.1187	10700	65	90	60	80	60	80
1/2	13	0.5000	0.1419	12750	90	120	85	115	80	110
	20	0.5000	0.1599	14400	100	135	95	130	90	120
9/16	12	0.5625	0.1820	16400	130	175	125	170	115	155
	18	0.5625	0.2030	18250	145	195	135	185	130	175
5/8	11	0.6250	0.2260	20350	180	245	170	230	160	220
	18	0.6250	0.2560	23000	205	280	190	260	180	245
3/4	10	0.7500	0.3340	30100	320	435	300	410	280	380
	16	0.7500	0.3730	33600	355	485	335	455	315	430
7/8	9	0.8750	0.4620	41600	515	700	485	660	455	620
	14	0.8750	0.5090	45800	570	775	535	730	500	680
1	8	1.0000	0.6060	51500	730	995	685	930	645	875
	12	1.0000	0.6630	59700	845	1150	795	1080	745	1015
1 1/8	7	1.1250	0.7630	68700	1095	1490	1030	1400	965	1310
	12	1.1250	0.8560	77000	1225	1665	1155	1570	1085	1475
1 1/4	7	1.2500	0.9690	87200	1545	2100	1455	1980	1365	1855
	12	1.2500	1.0730	96600	1710	2325	1610	2190	1510	2055
1 3/8	6	1.3750	1.1550	104000	2025	2755	1905	2590	1785	2430
	12	1.3750	1.3150	118100	2300	3130	2165	2945	2030	2760
1 1/2	6	1.5000	1.4050	126500	2690	3660	2530	3440	2370	3225
	12	1.5000	1.5800	142200	3020	4105	2845	3870	2665	3625

- NOTES: 1. THESE TORQUE VALUES DO NOT APPLY TO CADMIUM PLATED FASTENERS
2. ALL TORQUE VALUES ARE STATIC TORQUE MEASURED PER STANDARD AUDIT METHODS TOLERANCE = ±10%
3. * ASSEMBLY USES HARDENED WASHER

5000059K

SECTION 1 - SPECIFICATIONS

SAE Fastener Torque Chart (Continued)

Values for Magni Coating Fasteners (Ref 4150701)										
SOCKET HEAD CAPSCREWS										
Size	TPI	Bolt Dia	Tensile Stress Area	Clamp Load See Note 4	Torque (Dry) K=0.17		Torque (Loctite® 242™ or 271™ or Vibra-TITE™ 111 or 140) or Precoat® 85 K=0.16		Torque (Loctite® 262™ or Vibra-TITE™ 131) K=0.15	
					IN-LB	[N.m]	IN-LB	[N.m]	IN-LB	[N.m]
		In	Sq In	LB	IN-LB	[N.m]	IN-LB	[N.m]	IN-LB	[N.m]
4	40	0.1120	0.00604							
	48	0.1120	0.00661							
6	32	0.1380	0.00909							
	40	0.1380	0.01015							
8	32	0.1640	0.01400							
	36	0.1640	0.01474							
10	24	0.1900	0.01750							
	32	0.1900	0.02000							
1/4	20	0.2500	0.0318	2860	122	14	114	13		
	28	0.2500	0.0364	3280	139	16	131	15		
		In	Sq In	LB	FT-LB	[N.m]	FT-LB	[N.m]	FT-LB	[N.m]
5/16	18	0.3125	0.0524	4720	20	25	20	25	20	25
	24	0.3125	0.0580	5220	25	35	20	25	20	25
3/8	16	0.3750	0.0775	7000	35	50	35	50	35	50
	24	0.3750	0.0878	7900	40	55	40	55	35	50
7/16	14	0.4375	0.1063	9550	60	80	55	75	50	70
	20	0.4375	0.1187	10700	65	90	60	80	60	80
1/2	13	0.5000	0.1419	12750	90	120	85	115	80	110
	20	0.5000	0.1599	14400	100	135	95	130	90	120
9/16	12	0.5625	0.1820	16400	130	175	125	170	115	155
	18	0.5625	0.2030	18250	145	195	135	185	130	175
5/8	11	0.6250	0.2260	20350	180	245	170	230	160	220
	18	0.6250	0.2560	23000	205	280	190	260	180	245
3/4	10	0.7500	0.3340	30100	320	435	300	415	280	380
	16	0.7500	0.3730	33600	355	485	335	455	315	430
7/8	9	0.8750	0.4620	41600	515	700	485	660	455	620
	14	0.8750	0.5090	45800	570	775	535	730	500	680
1	8	1.0000	0.6060	51500	730	995	685	930	645	875
	12	1.0000	0.6630	59700	845	1150	795	1080	745	1015
1 1/8	7	1.1250	0.7630	68700	1095	1490	1030	1400	965	1310
	12	1.1250	0.8560	77000	1225	1665	1155	1570	1085	1475
1 1/4	7	1.2500	0.9690	87200	1545	2100	1455	1980	1365	1855
	12	1.2500	1.0730	96600	1710	2325	1610	2190	1510	2055
1 3/8	6	1.3750	1.1550	104000	2025	2755	1905	2590	1785	2430
	12	1.3750	1.3150	118100	2300	3130	2165	2945	2030	2760
1 1/2	6	1.5000	1.4050	126500	2690	3660	2530	3440	2370	3225
	12	1.5000	1.5800	142200	3020	4105	2845	3870	2665	3625

- NOTES: 1. THESE TORQUE VALUES DO NOT APPLY TO CADMIUM PLATED FASTENERS 5000059K
 2. ALL TORQUE VALUES ARE STATIC TORQUE MEASURED PER STANDARD AUDIT METHODS TOLERANCE = ±10%
 3. * ASSEMBLY USES HARDENED WASHER
 4. CLAMP LOAD LISTED FOR SHCS IS SAME AS GRADE 8 OR CLASS 10.9 AND DOES NOT REPRESENT FULL STRENGTH CAPABILITY OF SHCS. IF HIGHER LOAD IS REQUIRED, ADDITIONAL TESTING IS REQUIRED.

SAE Fastener Torque Chart (Continued)

Values for Zinc Yellow Chromate Fasteners (Ref 4150707)*										
SOCKET HEAD CAPSCREWS										
Size	TPI	Bolt Dia	Tensile Stress Area	Clamp Load See Note 4	Torque (Dry) K=0.17		Torque (Loctite® 242™ or 271™ or Vibra-TITE™ 111 or 140) or Precoat® 85 K=0.16		Torque (Loctite® 262™ or Vibra-TITE™ 131) K=0.15	
					IN-LB	[N.m]	IN-LB	[N.m]	IN-LB	[N.m]
		In	Sq In	LB	IN-LB	[N.m]	IN-LB	[N.m]	IN-LB	[N.m]
4	40	0.1120	0.00604							
	48	0.1120	0.00661							
6	32	0.1380	0.00909							
	40	0.1380	0.01015							
8	32	0.1640	0.01400							
	36	0.1640	0.01474							
10	24	0.1900	0.01750							
	32	0.1900	0.02000							
1/4	20	0.2500	0.0318	2860	122	14	114	13		
	28	0.2500	0.0364	3280	139	16	131	15		
		In	Sq In	LB	FT-LB	[N.m]	FT-LB	[N.m]	FT-LB	[N.m]
5/16	18	0.3125	0.0524	4720	20	25	20	25	20	25
	24	0.3125	0.0580	5220	25	35	20	25	20	25
3/8	16	0.3750	0.0775	7000	35	50	35	50	35	50
	24	0.3750	0.0878	7900	40	55	40	55	35	50
7/16	14	0.4375	0.1063	9550	60	80	55	75	50	70
	20	0.4375	0.1187	10700	65	90	60	80	60	80
1/2	13	0.5000	0.1419	12750	90	120	85	115	80	110
	20	0.5000	0.1599	14400	100	135	95	130	90	120
9/16	12	0.5625	0.1820	16400	130	175	125	170	115	155
	18	0.5625	0.2030	18250	145	195	135	185	130	175
5/8	11	0.6250	0.2260	20350	180	245	170	230	160	220
	18	0.6250	0.2560	23000	205	280	190	260	180	245
3/4	10	0.7500	0.3340	30100	320	435	300	415	280	380
	16	0.7500	0.3730	33600	355	485	335	455	315	430
7/8	9	0.8750	0.4620	41600	515	700	485	660	455	620
	14	0.8750	0.5090	45800	570	775	535	730	500	680
1	8	1.0000	0.6060	51500	730	995	685	930	645	875
	12	1.0000	0.6630	59700	845	1150	795	1080	745	1015
1 1/8	7	1.1250	0.7630	68700	1095	1490	1030	1400	965	1310
	12	1.1250	0.8560	77000	1225	1665	1155	1570	1085	1475
1 1/4	7	1.2500	0.9690	87200	1545	2100	1455	1980	1365	1855
	12	1.2500	1.0730	96600	1710	2325	1610	2190	1510	2055
1 3/8	6	1.3750	1.1550	104000	2025	2755	1905	2590	1785	2430
	12	1.3750	1.3150	118100	2300	3130	2165	2945	2030	2760
1 1/2	6	1.5000	1.4050	126500	2690	3660	2530	3440	2370	3225
	12	1.5000	1.5800	142200	3020	4105	2845	3870	2665	3625

- NOTES: 1. THESE TORQUE VALUES DO NOT APPLY TO CADMIUM PLATED FASTENERS
2. ALL TORQUE VALUES ARE STATIC TORQUE MEASURED PER STANDARD AUDIT METHODS TOLERANCE = ±10%
3. * ASSEMBLY USES HARDENED WASHER
4. CLAMP LOAD LISTED FOR SHCS IS SAME AS GRADE 8 OR CLASS 10.9 AND DOES NOT REPRESENT FULL STRENGTH CAPABILITY OF SHCS. IF HIGHER LOAD IS REQUIRED, ADDITIONAL TESTING IS REQUIRED.

5000059K

SECTION 1 - SPECIFICATIONS

Metric Fastener Torque Chart

Values for Zinc Yellow Chromate Fasteners (Ref 4150707)*							
CLASS 8.8 METRIC (HEX/SOCKET HEAD) BOLTS CLASS 8 METRIC NUTS							
Size	Pitch	Tensile Stress Area	Clamp Load See Note 4	Torque (Dry or Loctite® 263™)	Torque (Lube)	Torque (Loctite® 262™ or 271™ or Vibra-TITE™ 131)	Torque (Loctite® 242™ or 271™ or Vibra-TITE™ 111 or 141)
		Sq mm	KN	[N.m]		[N.m]	[N.m]
3	0.5	5.03	2.19	1.3	1.0	1.2	1.4
3.5	0.6	6.78	2.95	2.1	1.6	1.9	2.3
4	0.7	8.78	3.82	3.1	2.3	2.8	3.4
5	0.8	14.20	6.18	6.2	4.6	5.6	6.8
6	1	20.10	8.74	11	7.9	9.4	12
7	1	28.90	12.6	18	13	16	19
8	1.25	36.60	15.9	26	19	23	28
10	1.5	58.00	25.2	50	38	45	55
12	1.75	84.30	36.7	88	66	79	97
14	2	115	50.0	140	105	126	154
16	2	157	68.3	219	164	197	241
18	2.5	192	83.5	301	226	271	331
20	2.5	245	106.5	426	320	383	469
22	2.5	303	132.0	581	436	523	639
24	3	353	153.5	737	553	663	811
27	3	459	199.5	1080	810	970	1130
30	3.5	561	244.0	1460	1100	1320	1530
33	3.5	694	302.0	1990	1490	1790	2090
36	4	817	355.5	2560	1920	2300	2690
42	4.5	1120	487.0	4090	3070	3680	4290

NOTES:

1. THESE TORQUE VALUES DO NOT APPLY TO CADMIUM PLATED FASTENERS
2. ALL TORQUE VALUES ARE STATIC TORQUE MEASURED PER STANDARD AUDIT METHODS TOLERANCE = ±10%
3. * ASSEMBLY USES HARDENED WASHER
4. CLAMP LOAD LISTED FOR SHCS IS SAME AS GRADE 8 OR CLASS 10.9 AND DOES NOT REPRESENT FULL STRENGTH CAPABILITY OF SHCS. IF HIGHER LOAD IS REQUIRED, ADDITIONAL TESTING IS REQUIRED.

5000059K

Metric Fastener Torque Chart (Continued)

Values for Zinc Yellow Chromate Fasteners (Ref 4150707)*						
CLASS 10.9 METRIC (HEX HEAD) BOLTS, CLASS 10 METRIC NUTS CLASS 12.9 SOCKET HEAD CAPSCREWS M3 - M5*						
Size	Pitch	Tensile Stress Area	Clamp Load See Note 4	Torque (Dry or Loctite® 263™) K=0.20	Torque (Lube or Loctite® 242™ or 271™ or Vibra-TITE™ 111 or 140) K=0.18	Torque (Loctite® 262™ or Vibra-TITE™ 131) K=0.15
		Sq mm	KN	[N.m]	[N.m]	[N.m]
3	0.5	5.03	3.13			
3.5	0.6	6.78	4.22			
4	0.7	8.78	5.47			
5	0.8	14.20	8.85			
6	1	20.10	12.5			
7	1	28.90	18.0	25	23	19
8	1.25	36.60	22.8	37	33	27
10	1.5	58.00	36.1	70	65	55
12	1.75	84.30	52.5	125	115	95
14	2	115	71.6	200	180	150
16	2	157	97.8	315	280	235
18	2.5	192	119.5	430	385	325
20	2.5	245	152.5	610	550	460
22	2.5	303	189.0	830	750	625
24	3	353	222.0	1065	960	800
27	3	459	286.0	1545	1390	1160
30	3.5	561	349.5	2095	1885	1575
33	3.5	694	432.5	2855	2570	2140
36	4	817	509.0	3665	3300	2750
42	4.5	1120	698.0	5865	5275	4395

NOTES:

1. THESE TORQUE VALUES DO NOT APPLY TO CADMIUM PLATED FASTENERS
2. ALL TORQUE VALUES ARE STATIC TORQUE MEASURED PER STANDARD AUDIT METHODS TOLERANCE = ±10%
3. * ASSEMBLY USES HARDENED WASHER
4. CLAMP LOAD LISTED FOR SHCS IS SAME AS GRADE 8 OR CLASS 10.9 AND DOES NOT REPRESENT FULL STRENGTH CAPABILITY OF SHCS. IF HIGHER LOAD IS REQUIRED, ADDITIONAL TESTING IS REQUIRED.

5000059K

SECTION 1 - SPECIFICATIONS

Metric Fastener Torque Chart (Continued)

Values for Magni Coated Fasteners (Ref 4150701)*						
CLASS 8.8 METRIC (HEX/SOCKET HEAD) BOLTS CLASS 8 METRIC NUTS						
Size	Pitch	Tensile Stress Area	Clamp Load See Note 4	Torque (Dry or Loctite® 263™) K=0.17	Torque (Lube or Loctite® 242™ or 271™ or Vibra-TITE™ 111 or 140) K=0.16	Torque (Loctite® 262™ or Vibra-TITE™ 131) K=0.15
		Sq mm	KN	[N.m]	[N.m]	[N.m]
3	0.5	5.03	2.19	1.1	1.1	1.0
3.5	0.6	6.78	2.95	1.8	1.7	1.5
4	0.7	8.78	3.82	2.6	2.4	2.3
5	0.8	14.20	6.18	5.3	4.9	4.6
6	1	20.10	8.74	9	8.4	7.9
7	1	28.90	12.6	15	14	13
8	1.25	36.60	15.9	22	20	19
10	1.5	58.00	25.2	43	40	38
12	1.75	84.30	36.7	75	70	66
14	2	115	50.0	119	110	105
16	2	157	68.3	186	175	165
18	2.5	192	83.5	256	240	225
20	2.5	245	106.5	362	340	320
22	2.5	303	132.0	494	465	435
24	3	353	153.5	627	590	555
27	3	459	199.5	916	860	810
30	3.5	561	244.0	1245	1170	1100
33	3.5	694	302.0	1694	1595	1495
36	4	817	355.5	2176	2050	1920
42	4.5	1120	487.0	3477	3275	3070

NOTES:

1. THESE TORQUE VALUES DO NOT APPLY TO CADMIUM PLATED FASTENERS
2. ALL TORQUE VALUES ARE STATIC TORQUE MEASURED PER STANDARD AUDIT METHODS TOLERANCE = ±10%
3. * ASSEMBLY USES HARDENED WASHER
4. CLAMP LOAD LISTED FOR SHCS IS SAME AS GRADE 8 OR CLASS 10.9 AND DOES NOT REPRESENT FULL STRENGTH CAPABILITY OF SHCS. IF HIGHER LOAD IS REQUIRED, ADDITIONAL TESTING IS REQUIRED.

5000059K

Metric Fastener Torque Chart (Continued)

Values for Magni Coated Fasteners (Ref 4150701)*						
CLASS 10.9 METRIC (HEX HEAD) BOLTS CLASS 10 METRIC NUTS, CLASS 12.9 SOCKET HEAD CAPSCREWS M6 AND ABOVE*						
Size	Pitch	Tensile Stress Area	Clamp Load See Note 4	Torque (Dry or Loctite® 263™) K=0.17	Torque (Lube or Loctite® 242™ or 271™ or Vibra-TITE™ 111 or 140) K=0.18	Torque (Loctite® 262™ or Vibra-TITE™ 131) K=0.15
		Sq mm	KN	[N.m]	[N.m]	[N.m]
3	0.5	5.03	3.13			
3.5	0.6	6.78	4.22			
4	0.7	8.78	5.47			
5	0.8	14.20	8.85			
6	1	20.10	12.5	13	12	11
7	1	28.90	18.0	21	20	19
8	1.25	36.60	22.8	31	29	27
10	1.5	58.00	36.1	61	58	55
12	1.75	84.30	52.5	105	100	95
14	2	115	71.6	170	160	150
16	2	157	97.8	265	250	235
18	2.5	192	119.5	365	345	325
20	2.5	245	152.5	520	490	460
22	2.5	303	189.0	705	665	625
24	3	353	222.0	905	850	800
27	3	459	286.0	1315	1235	1160
30	3.5	561	349.5	1780	1680	1575
33	3.5	694	432.5	2425	2285	2140
36	4	817	509.0	3115	2930	2750
42	4.5	1120	698.0	4985	4690	4395

NOTES:

1. THESE TORQUE VALUES DO NOT APPLY TO CADMIUM PLATED FASTENERS
2. ALL TORQUE VALUES ARE STATIC TORQUE MEASURED PER STANDARD AUDIT METHODS TOLERANCE = ±10%
3. * ASSEMBLY USES HARDENED WASHER
4. CLAMP LOAD LISTED FOR SHCS IS SAME AS GRADE 8 OR CLASS 10.9 AND DOES NOT REPRESENT FULL STRENGTH CAPABILITY OF SHCS. IF HIGHER LOAD IS REQUIRED, ADDITIONAL TESTING IS REQUIRED.

5000059K

SECTION 2. GENERAL

2.1 MACHINE PREPARATION, INSPECTION, AND MAINTENANCE

General

This section provides the necessary information needed by those personnel that are responsible to place the machine in operation readiness and maintain its safe operating condition. For maximum service life and safe operation, ensure that all the necessary inspections and maintenance have been completed before placing the machine into service. With proper care, maintenance, and inspections performed per JLG's recommendations, and with any and all discrepancies corrected, this product will be fit for continued use.

Preparation, Inspection, and Maintenance

It is important to establish and conform to a comprehensive inspection and preventive maintenance program. The following table outlines the periodic machine inspections and maintenance recommended by JLG Industries, Inc. Consult your national, regional, or local regulations for further requirements for Mobile Elevating Work Platform. The frequency of inspections and maintenance must be increased as environment, severity and frequency of usage requires.

Pre-Start Inspection

It is the User's or Operator's primary responsibility to perform a Pre-Start Inspection of the machine prior to use daily or at each change of operator. Reference the Operation and Safety Manual for completion procedures for the Pre-Start Inspection. The Operation and Safety Manual must be read in its entirety and understood prior to performing the Pre-Start Inspection.

Pre-Delivery Inspection and Frequent Inspection

The Pre-Delivery Inspection and Frequent Inspection shall be performed by a qualified JLG equipment mechanic. JLG Industries, Inc. recognizes a qualified JLG equipment mechanic as a person who, by possession of a recognized degree, certificate, extensive knowledge, training, or experience, has successfully demonstrated the ability and proficiency to service, repair, and maintain the subject JLG product model.

The Pre-Delivery Inspection and Frequent Inspection procedures are performed in the same manner, but at different times. The Pre-Delivery Inspection shall be performed prior to each sale, lease, or rental delivery. The Frequent Inspection shall be accomplished for each machine in service for 3 months or 150 hours (whichever comes first); out of service for a period of more than 3 months; or when purchased used. The frequency of this inspection must be increased as environment, severity and frequency of usage requires.

Reference the JLG Pre-Delivery and Frequent Inspection Form and the Inspection and Preventive Maintenance Schedule for items requiring inspection during the performance of these inspections. Reference the appropriate areas of this manual for servicing and maintenance procedures.

Annual Machine Inspection

The Annual Machine Inspection must be performed on an annual basis, no later than thirteen (13) months from the date of the prior Annual Machine Inspection. JLG Industries recommends this task be performed by a Factory-Trained Service Technician. JLG Industries, Inc. recognizes a Factory-Trained Service Technician as a person who has successfully completed the JLG Service Training School for the subject JLG product model. Reference the machine Service and Maintenance Manual and appropriate JLG inspection form for performance of this inspection.

Reference the JLG Annual Machine Inspection Form and the Inspection and Preventive Maintenance Schedule for items requiring inspection during the performance of this inspection. Reference the appropriate areas of this manual for servicing and maintenance procedures.

For the purpose of receiving safety-related bulletins, it is important that JLG Industries, Inc. has updated ownership information for each machine. When performing each Annual Machine Inspection, notify JLG Industries, Inc. of the current machine ownership.

Preventive Maintenance

In conjunction with the specified inspections, maintenance shall be performed by a qualified JLG equipment mechanic. JLG Industries, Inc. recognizes a qualified JLG equipment mechanic as a person who, by possession of a recognized degree, certificate, extensive knowledge, training, or experience, has successfully demonstrated the ability and proficiency to service, repair, and maintain the subject JLG product model.

Reference the Preventive Maintenance Schedule and the appropriate areas of this manual for servicing and maintenance procedures. The frequency of service and maintenance must be increased as environment, severity and frequency of usage requires.

Table 2-1. Inspection and Maintenance

Type	Frequency	Primary Responsibility	Service Qualification	Reference
Pre-Start Inspection	Prior to use each day; or At each Operator change.	User or Operator	User or Operator	Operation and Safety Manual
Pre-Delivery Inspection	Prior to each sale, lease, or rental delivery.	Owner, Dealer, or User	Qualified JLG Mechanic	Service and Maintenance Manual and applicable JLG inspection form.
Frequent Inspection	In service for 3 months or 150 hours, whichever comes first; or Out of service for a period of more than 3 months; or purchased used.	Owner, Dealer, or User	Qualified JLG Mechanic	Service and Maintenance Manual and applicable JLG inspection form.
Annual Machine Inspection	Annually, no later than 13 months from the date of the prior inspection.	Owner, Dealer, or User	Factory Trained Service Technician (Recommended)	Service and Maintenance Manual and applicable JLG inspection form.
Preventative Maintenance	At intervals as specified in the Service and Maintenance Manual.	Owner, Dealer, or User	Qualified JLG Mechanic	Service and Maintenance Manual

2.2 SERVICE AND GUIDELINES

General

The following information is provided to assist you in the use and application of servicing and maintenance procedures contained in this book.

Safety and Workmanship

Your safety, and that of others, is the first consideration when engaging in the maintenance of equipment. Always be conscious of weight. Never attempt to move heavy parts without the aid of a mechanical device. Do not allow heavy objects to rest in an unstable position. When raising a portion of the equipment, ensure that adequate support is provided.

Cleanliness

1. The most important single item in preserving the long service life of a machine is to keep dirt and foreign materials out of the vital components. Precautions have been taken to safeguard against this. Shields, covers, seals, and filters are provided to keep air, fuel, and oil supplies clean; however, these items must be maintained on a scheduled basis in order to function properly.

2. At any time when air, fuel, or oil lines are disconnected, clear adjacent areas as well as the openings and fittings themselves. As soon as a line or component is disconnected, cap or cover all openings to prevent entry of foreign matter.
3. Clean and inspect all parts during servicing or maintenance, and assure that all passages and openings are unobstructed. Cover all parts to keep them clean. Be sure all parts are clean before they are installed. New parts should remain in their containers until they are ready to be used.

Components Removal and Installation

1. Use adjustable lifting devices, whenever possible, if mechanical assistance is required. All slings (chains, cables, etc.) should be parallel to each other and as near perpendicular as possible to top of part being lifted.
2. Should it be necessary to remove a component on an angle, keep in mind that the capacity of an eyebolt or similar bracket lessens, as the angle between the supporting structure and the component becomes less than 90 degrees.
3. If a part resists removal, check to see whether all nuts, bolts, cables, brackets, wiring, etc., have been removed and that no adjacent parts are interfering.

Component Disassembly and Reassembly

When disassembling or reassembling a component, complete the procedural steps in sequence. Do not partially disassemble or assemble one part, then start on another. Always recheck your work to assure that nothing has been overlooked. Do not make any adjustments, other than those recommended, without obtaining proper approval.

Pressure-Fit Parts

When assembling pressure-fit parts, use a molybdenum disulfide base compound or equivalent to lubricate the mating surface.

Bearings

1. When a bearing is removed, cover it to keep out dirt and abrasives. Clean bearings in nonflammable cleaning solvent and allow to drip dry. Compressed air can be used but do not spin the bearing.
2. Discard bearings if the races and balls (or rollers) are pitted, scored, or burned.
3. If bearing is found to be serviceable, apply a light coat of oil and wrap it in clean (waxed) paper. Do not unwrap reusable or new bearings until they are ready to install.
4. Lubricate new or used serviceable bearings before installation. When pressing a bearing into a retainer or bore, apply pressure to the outer race. If the bearing is to be installed on a shaft, apply pressure to the inner race.

Gaskets

Check that holes in gaskets align with openings in the mating parts. If it becomes necessary to hand-fabricate a gasket, use gasket material or stock of equivalent material and thickness. Be sure to cut holes in the right location, as blank gaskets can cause serious system damage.

Bolt Usage and Torque Application

NOTICE

SELF LOCKING FASTENERS, SUCH AS NYLON INSERT AND THREAD DEFORMING LOCKNUTS, ARE NOT INTENDED TO BE REINSTALLED AFTER REMOVAL.

1. Always use new replacement hardware when installing locking fasteners. Use bolts of proper length. A bolt which is too long will bottom before the head is tight against its related part. If a bolt is too short, there will not be enough thread area to engage and hold the part properly. When replacing bolts, use only those having the same specifications of the original, or one which is equivalent.
2. Unless specific torque requirements are given within the text, standard torque values should be used on heat-treated bolts, studs, and steel nuts, in accordance with recommended shop practices (See Torque Chart Section 1).

Hydraulic Lines and Electrical Wiring

Clearly mark or tag hydraulic lines and electrical wiring, as well as their receptacles, when disconnecting or removing them from the unit. This will assure that they are correctly reinstalled.

Hydraulic System

1. Keep the system clean. If evidence of metal or rubber particles are found in the hydraulic system, drain and flush the entire system.
2. Disassemble and reassemble parts on clean work surface. Clean all metal parts with non-flammable cleaning solvent. Lubricate components, as required, to aid assembly.

Lubrication

Service applicable components with the amount, type, and grade of lubricant recommended in this manual, at the specified intervals. When recommended lubricants are not available, consult your local supplier for an equivalent that meets or exceeds the specifications listed.

Battery

Clean battery using a non-metallic brush and a solution of baking soda and water. Rinse with clean water. After cleaning, thoroughly dry battery and coat terminals with an anti corrosion compound.

Lubrication and Servicing

Components and assemblies requiring lubrication and servicing are shown in the Lubrication Chart in Section 1.

2.3 LUBRICATION AND INFORMATION

Hydraulic System

1. The primary enemy of a hydraulic system is contamination. Contaminants enter the system by various means, e.g., using inadequate hydraulic oil, allowing moisture, grease, filings, sealing components, sand, etc., to enter when performing maintenance, or by permitting the pump to cavitate due to insufficient system warm-up or leaks in the pump supply (suction) lines.
2. The design and manufacturing tolerances of the component working parts are very close, therefore, even the smallest amount of dirt or foreign matter entering a system can cause wear or damage to the components and generally results in faulty operation. Every precaution must be taken to keep hydraulic oil clean, including reserve oil in storage. Hydraulic system filters should be checked, cleaned, and/or replaced as necessary, at the specified intervals required in the Lubrication Chart in Section 1. Always examine filters for evidence of metal particles.
3. Cloudy oils indicate a high moisture content which permits organic growth, resulting in oxidation or corrosion. If this condition occurs, the system must be drained, flushed, and refilled with clean oil.
4. It is not advisable to mix oils of different brands or types, as they may not contain the same required additives or be of comparable viscosities. Good grade mineral oils, with viscosities suited to the ambient temperatures in which the machine is operating, are recommended for use.

NOTE: *Metal particles may appear in the oil or filters of new machines due to the wear-in of meshing components.*

Hydraulic Oil

1. Refer to Section 1 for recommendations for viscosity ranges.

Changing Hydraulic Oil

1. Filter elements must be changed after the first 50 hours of operation and every 300 hours (unless specified otherwise) thereafter. If it is necessary to change the oil, use only those oils meeting or exceeding the specifications appearing in this manual. If unable to obtain the same type of oil supplied with the machine, consult local supplier for assistance in selecting the proper equivalent. Avoid mixing petroleum and synthetic base oils.
2. Use every precaution to keep the hydraulic oil clean. If the oil must be poured from the original container into another, be sure to clean all possible contaminants from the service container. Always clean the mesh element of the filter and replace the cartridge any time the system oil is changed.
3. While the unit is shut down, a good preventive maintenance measure is to make a thorough inspection of all hydraulic components, lines, fittings, etc., as well as a functional check of each system, before placing the machine back in service.

Lubrication Specifications

Specified lubricants, as recommended by the component manufacturers, are always the best choice, however, multi-purpose greases usually have the qualities which meet a variety of single purpose grease requirements. Should any question arise, regarding the use of greases in maintenance stock, consult your local supplier for evaluation. Refer to Section 1 for an explanation of the lubricant key designations appearing in the Lubrication Chart.

2.4 CYLINDER DRIFT TEST

Theory

When a hydraulic cylinder is supporting a load, cylinder drift may occur as a result of any of the circumstances below:

- Normal leakage of load holding valves or malfunction of load holding valves. See Cylinder Leakage Test and Table 2-2, Cylinder Drift below for evaluation.
- Damaged or worn piston seals.
- Normal thermal expansion or contraction of the hydraulic oil within cylinders (See Cylinder Thermal Drift below).

The first two circumstances may result in cylinder movement due to oil leaking out of the cylinder externally or by leaking back to tank or due to oil leaking internally from one cylinder chamber to the other.

Thermal expansion or contraction of oil in hydraulic cylinders is a normal occurrence and does not result in oil leaking out of the cylinder or leaking internally from one cylinder chamber to the other. Thermal expansion or contraction is the tendency for materials to change size in response to a change in temperature.

Cylinder Leakage Test

Cylinder oil must be at stabilized ambient temperature before beginning this test.

Measure drift at cylinder rod with a calibrated dial indicator.

In an area free of obstructions, cylinder must have load applied and appropriately positioned to detect drift.

Cylinder leakage is acceptable if it passes this test.

Table 2-2. Cylinder Drift

Cylinder Bore Diameter		Max. Acceptable Drift in 10 Minutes	
inches	mm	inches	mm
3	76.2	0.026	0.66
3.5	89	0.019	0.48
4	101.6	0.015	0.38
5	127	0.009	0.22
6	152.4	0.006	0.15
7	177.8	0.005	0.13
8	203.2	0.004	0.10
9	228.6	0.003	0.08

NOTE: This information is based on 6 drops per minute cylinder leakage.

Cylinder Thermal Drift

The oil in all hydraulic cylinders will expand or contract due to thermal effects over time and may result in changes to the boom and/or platform position while the machine is stationary. These effects occur as the cylinder oil changes temperature, usually from a higher oil temperature as it cools and approaches the ambient air temperature. Results of these effects are related to several factors including cylinder length and change in temperature over the time the cylinder remains stationary.

2.5 PINS AND COMPOSITE BEARING REPAIR GUIDELINES

Filament wound bearings.

1. Pinned joints should be disassembled and inspected if the following occurs:
 - a. Excessive sloppiness in joints.
 - b. Noise originating from the joint during operation.
2. Filament wound bearings should be replaced if any of the following is observed:
 - a. Frayed or separated fibers on the liner surface.
 - b. Cracked or damaged liner backing.
 - c. Bearings that have moved or spun in their housing.
 - d. Debris embedded in liner surface.
3. Pins should be replaced if any of the following is observed (pin should be properly cleaned prior to inspection):
 - a. Detectable wear in the bearing area.
 - b. Flaking, peeling, scoring, or scratches on the pin surface.
 - c. Rusting of the pin in the bearing area.
4. Re-assembly of pinned joints using filament wound bearings.
 - a. Housing should be blown out to remove all dirt and debris. Bearings and bearing housings must be free of all contamination.
 - b. Bearing / pins should be cleaned with a solvent to remove all grease and oil. Filament wound bearing are a dry joint and should not be lubricated unless otherwise instructed (i.e. sheave pins).
 - c. Pins should be inspected to ensure it is free of burrs, nicks and scratches which would damage the bearing during installation and operation.

2.6 WELDING ON JLG EQUIPMENT

NOTE: This instruction applies to repairs, or modifications to the machine and to welding performed from the machine on an external structure, or component.

Do the Following When Welding on JLG Equipment

- Disconnect the battery.
- Disconnect the moment pin connection (where fitted).
- Ground only to structure being welded.

Do NOT Do the Following When Welding on JLG Equipment

- Ground on frame and weld on any other area than the chassis.
- Ground on turntable and weld on any other area than the turntable.
- Ground on the platform/support and weld on any other area than the platform/support.
- Ground on a specific boom section and weld on any other area than that specific boom section.
- Allow pins, wear pads, wire ropes, bearings, gearing, seals, valves, electrical wiring, or hoses to be between the grounding position and the welded area.

NOTICE

FAILURE TO COMPLY WITH THE ABOVE REQUIREMENTS MAY RESULT IN COMPONENT DAMAGE (I.E. ELECTRONIC MODULES, SWING BEARING, COLLECTOR RING, BOOM WIRE ROPES ETC.).

NOTE: Refer the Operation and Safety Manual for completion procedures for the Pre-Start Inspection.

Table 2-3. Inspection and Preventive Maintenance Schedule

AREA	Inspections	
	Pre-Delivery ¹ or Frequent ² (Quarterly) Inspection	Annual ³ (Yearly) Inspection
Boom Assembly		
Boom Weldments	1,2	1,2
Hose/Cable Carrier Installations	1,2	1,2
Pivot Pins and Pin Retainers	1,2	1,2
Sheaves, Sheave Pins	1,2	1,2
Bearings	1,2	1,2
Wear Pads	1,2	1,2
Covers or Shields	1,2	1,2
Extend/Retract Chain or Cable Systems ⁴	1,2	1,2
Platform Assembly		
Railing	2	2
Gate	1,2,3	1,2,3
Floor	2	2
Rotator	1,2,3,4	1,2,3,4
Lanyard Anchorage Point	1,2,6	1,2,6
Turntable Assembly		
Swing Bearing or Worm Gear	1 ⁵⁰ , 2	1 ⁵⁰ , 2
Oil Coupling	4	4
Swing Drive System	1,4	1,4
Turntable Lock	1,2,3	1,2,3
Hood, Hood Props, Hood Latches	3	3
Chassis Assembly		
Tires	1,2	1,2
Wheel Nuts/Bolts	1 ⁵⁰	1 ⁵⁰
Wheel Bearings	1,2,4,5	1,2,4,5
Oscillating Axle/Lockout Cylinder Systems	1,2,4,5	1,2,4,5
Steer Components	1,2	1,2
Spindle Thrust Bearing/Washers	1,2	1,2
Drive Hubs	1,4	1,4

SECTION 2 - GENERAL

Table 2-3. Inspection and Preventive Maintenance Schedule

AREA	Inspections	
	Pre-Delivery ¹ or Frequent ² (Quarterly) Inspection	Annual ³ (Yearly) Inspection
Functions/Controls		
Platform Controls return to neutral/off when released	1,3,6,9	1,3,6,9
Ground Controls return to neutral/off when released	1,3,6,9	1,3,6,9
Function Control Locks, Guards, or Detents	1,3,9	1,3,9
Footswitch (shuts off function when released)	1,3,9	1,3,9
Emergency Stop Switches (Ground & Platform) arrest all platform movement	1,3,6	1,3,6
Function Limit or Cutout Switch Systems	1,3,9	1,3,9
Capacity Indicator	1,3,9	1,3,9
Drive Brakes	1,3,9	1,3,9
Swing Brakes	1,3,9	1,3,9
Auxiliary Power	1,3,9	1,3,9
Power System		
Engine Idle, Throttle, and RPM	1,3,7	1,3,7
Engine Fluids: Oil	4	4
Engine Fluids: Coolant	1,4,7	1,4,7
Air Filter	1,4	1,4
Fuel Filter(s)	1,5	1,5
Drain Oil Build Up in 2-Stage Vaporizer (LP Only)	1,4	1,4
Exhaust System	1,4	1,4
Batteries	1,4	1,4
Battery Fluid	4	4
Battery Charger	1,3	1,3
Intake System	1,2	1,2
Glow Plug (Diesel Only)	1,2,3	1,2,3
Serpentine Belt, Tensioner, Pulleys	1,2,3	1,2,3
Fuel Reservoir, Cap, and Breather	1,2,4	1,2,4
Hydraulic/Electric System		
Hydraulic Pumps	1,2,4	1,2,4
Hydraulic Cylinders	1,2,4,5	1,2,4,5
Cylinder Attachment Pins and Pin Retainers	1,2	1,2
Hydraulic Hoses, Lines, and Fittings	1,2,4	3
Hydraulic Reservoir, Cap, and Breather	1,2,3,4,5	1,2,3,4,5
Hydraulic Filter(s)	1,4,5	1,4,5
Hydraulic Fluid	4,5	4,5
Electrical Connections	1,2	1,2
Instruments, Gauges, Switches, Lights, Horn	1,3	1,3

Table 2-3. Inspection and Preventive Maintenance Schedule

AREA	Inspections	
	Pre-Delivery ¹ or Frequent ² (Quarterly) Inspection	Annual ³ (Yearly) Inspection
General		
All Decals/Placards Installed, Secure, Legible	9	9
Annual Machine Inspection Due	-	9
No Unauthorized Modifications or Additions	9	9
All Relevant Safety Publications Incorporated	9	9
General Structural Condition and Welds	2	2
All Fasteners, Pins, Shields, and Covers	1,2	1,2
Grease and Lubricate to Specifications	9	9
Function Test of All Systems	9	9
Paint and Appearance	5	5
Stamp Inspection Date on Frame	-	9
Notify JLG of Machine Ownership	-	9
Footnotes:		
¹ Prior to each sale, lease, or delivery		
² In service for 3 months; Out of service for 3 months or more; Purchased used		
³ Annually, no later than 13 months from the date of the prior inspection, Includes all daily and quarterly inspections, mandated by regulating body		
⁴ Replace every 12 years or 7,000 hours		
⁵⁰ Indicates a 50 hour interval required to perform task after initial use of machine. This only occurs once in machine life		
²⁵⁰ Indicates a 250 hour interval required to perform task after initial use of machine. This only occurs once in machine life		
Performance Codes:		
1 - Check for proper and secure: installation, adjustment, or torque		
2 - Visual inspection for damage: (cracks, corrosion, abrasions, distortion, excessive wear, broken welds, gouges, chafing and threads showing)		
3 - Proper operation		
4 - Check for proper sealing, signs of leakage and fluid level		
5 - Clean and free of debris		
6 - Decals installed and legible		
7 - Check for proper tolerances, routing, and lubrication		
8 - Fully Charged		
9 - Verify/Perform		

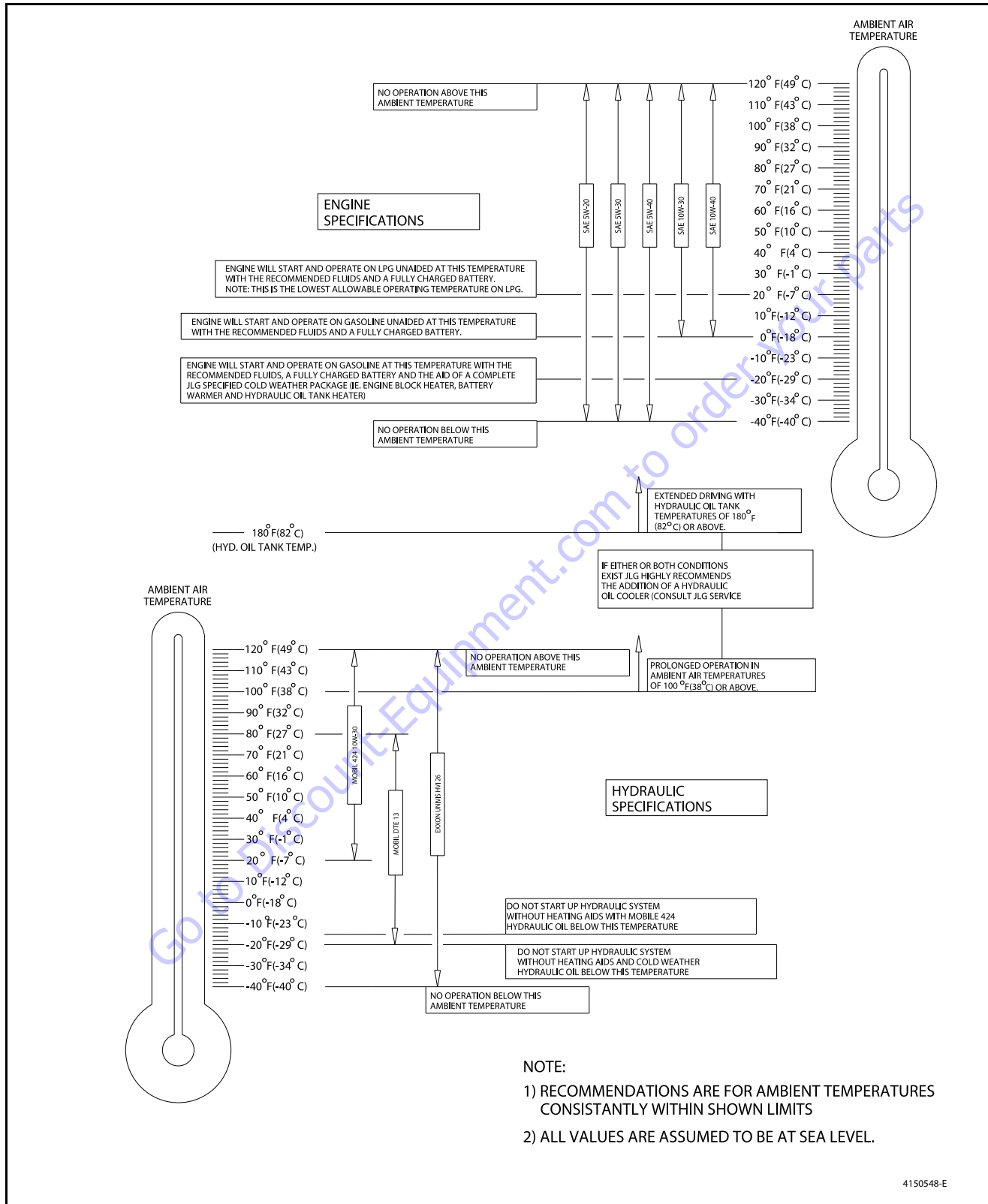

Figure 2-1. Engine Operating Temperature Specifications - Ford

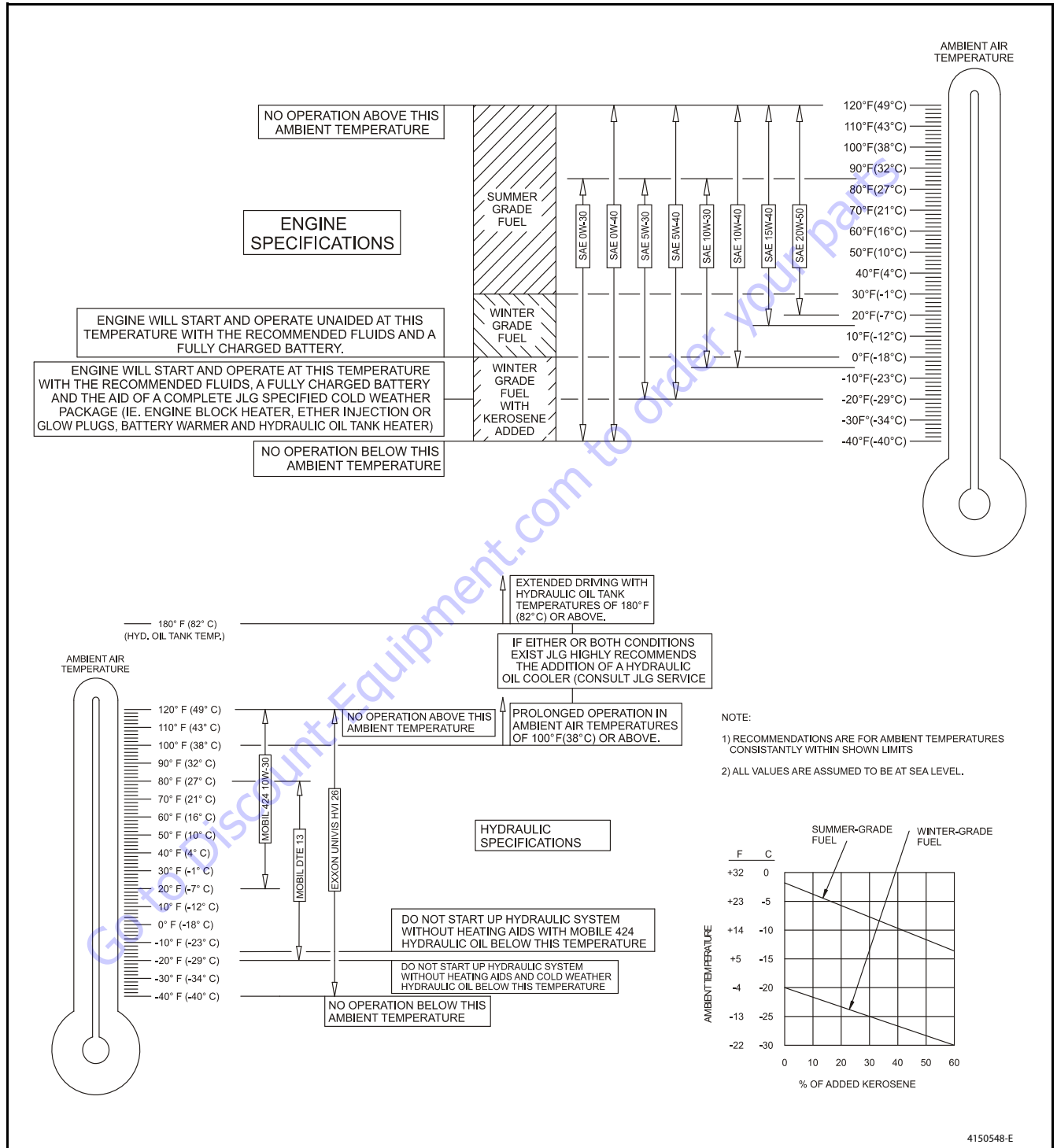

Figure 2-2. Engine Operating Temperature Specifications - Deutz

PARTS FINDER

**Search Website
by Part Number**



**Search Manual
Library For Parts
Manual & Lookup Part
Numbers – Purchase
or Request Quote**

**Can't Find Part or
Manual? Request Help
by Manufacturer,
Model & Description**

Discount-Equipment.com is your online resource for quality parts & equipment.

Florida: **561-964-4949** Outside Florida TOLL FREE: **877-690-3101**

Need parts?

Click on this link: <http://www.discount-equipment.com/category/5443-parts/> and choose one of the options to help get the right parts and equipment you are looking for. Please have the machine model and serial number available in order to help us get you the correct parts. If you don't find the part on the website or on once of the online manuals, please fill out the request form and one of our experienced staff members will get back to you with a quote for the right part that your machine needs.

We sell worldwide for the brands: Genie, Terex, JLG, MultiQuip, Mikasa, Essick, Whiteman, Mayco, Toro Stone, Diamond Products, Generac Magnum, Airman, Haulotte, Barreto, Power Blanket, Nifty Lift, Atlas Copco, Chicago Pneumatic, Allmand, Miller Curber, Skyjack, Lull, Skytrak, Tsurumi, Husquvarna Target, , Stow, Wacker, Sakai, Mi-T- M, Sullair, Basic, Dynapac, MBW, Weber, Bartell, Bennar Newman, Haulotte, Ditch Runner, Menegotti, Morrison, Contec, Buddy, Crown, Edco, Wyco, Bomag, Laymor, Barreto, EZ Trench, Bil-Jax, F.S. Curtis, Gehl Pavers, Heli, Honda, ICS/PowerGrit, IHI, Partner, Imer, Clipper, MMD, Koshin, Rice, CH&E, General Equipment, ,AMida, Coleman, NAC, Gradall, Square Shooter, Kent, Stanley, Tamco, Toku, Hatz, Kohler, Robin, Wisconsin, Northrock, Oztec, Toker TK, Rol-Air, Small Line, Wanco, Yanmar

SECTION 3. CHASSIS & TURNTABLE

3.1 TIRES & WHEELS

Tire Damage

For polyurethane foam filled tires, JLG Industries, Inc. recommends that when any of the following are discovered, measures must be taken to remove the JLG product from service immediately and arrangements must be made for replacement of the tire or tire assembly.

- a smooth, even cut through the cord plies which exceeds 3 in. (7.5 cm) in total length.
- any tears or rips (ragged edges) in the cord plies which exceeds 1 in. (2.5 cm) in any direction.
- any punctures which exceed 1 in. in diameter.
- any damage to the bead area cords of the tire.

If a tire is damaged but is within the above noted criteria, the tire must be inspected on a daily basis to ensure the damage has not propagated beyond the allowable criteria.

Tire Replacement

JLG recommends a replacement tire be the same size, ply and brand as originally installed on the machine. Please refer to the JLG Parts Manual for the part number of the approved tires for a particular machine model. If not using a JLG approved replacement tire, we recommend that replacement tires have the following characteristics:

- Equal or greater ply/load rating and size of original.
- Tire tread contact width equal or greater than original.
- Wheel diameter, width and offset dimensions equal to the original.
- Approved for the application by the tire manufacturer (including inflation pressure and maximum tire load).

Unless specifically approved by JLG Industries Inc. do not replace a foam filled or ballast filled tire assembly with a pneumatic tire. Due to size variations between tire brands, both tires on the same axle should be the same and all four tires should contain the same fill media.

Wheel Replacement

The rims installed on each product model have been designed for stability requirements which consist of track width and load capacity. Size changes such as rim width, center piece location, larger or smaller diameter, etc., without written factory recommendations, may result in an unsafe condition regarding stability.

Wheel Installation

It is extremely important to apply and maintain proper wheel mounting torque.

WARNING

WHEEL NUTS MUST BE INSTALLED AND MAINTAINED AT THE PROPER TORQUE TO PREVENT LOOSE WHEELS, BROKEN STUDS AND POSSIBLE DANGEROUS SEPARATION OF WHEEL FROM THE AXLE. BE SURE TO USE ONLY THE NUTS MATCHED TO THE CONE ANGLE OF THE WHEEL.

Tighten the lug nuts to the proper torque to prevent wheels from coming loose. Use a torque wrench to tighten the fasteners. If you do not have a torque wrench, tighten the fasteners with a lug wrench, then immediately have a service garage or dealer tighten the lug nuts to the proper torque. Over-tightening will result in breaking the studs or permanently deforming the mounting stud holes in the wheels. The proper procedure for attaching wheels is as follows:

1. Start all nuts by hand to prevent cross threading. DO NOT use a lubricant on threads or nuts.

- Tighten nuts in the following sequence:

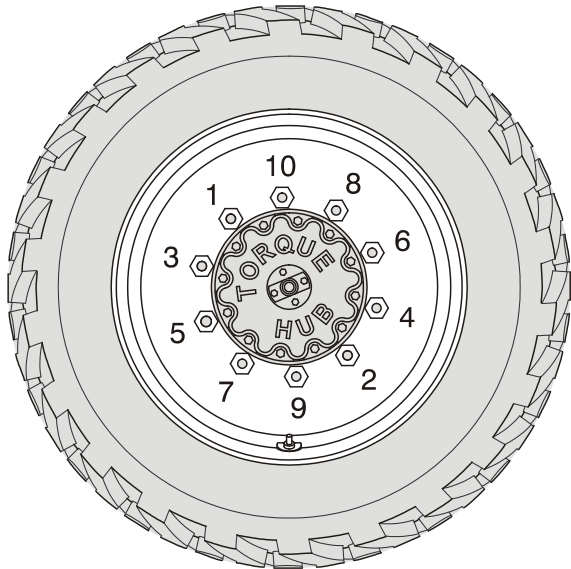

- The tightening of the nuts should be done in stages. Following the recommended sequence, tighten nuts per wheel torque chart.

Table 3-1. Wheel Torque Chart

TORQUE SEQUENCE		
1st Stage	2nd Stage	3rd Stage
70 ft. lbs. (95 Nm)	170 ft. lbs. (230 Nm)	300 ft. lbs. (406 Nm)

- Wheel nuts should be torqued after first 50 hours of operation and after each wheel removal. Check torque every 3 months or 150 hours of operation.

3.2 Lockout Cylinder Bleeding

- Start the engine.
- Position the turntable to the normal stowed position.
- Attach clear tubing to bleeder valve nipple.
- Position a small bucket/bottle in front of the lockout cylinder bleeder valve and insert clear tubing.
- Using a 3/8 in. wrench, loosen the bleeder valve, turning counterclockwise slowly. Bleed air from the top of lockout cylinder. Capture hydraulic oil until a steady unbroken stream of hydraulic oil is viewed. Tighten/close the bleeder valve while stream of hydraulic oil is running.
- Locate the bleeder valve on the opposite side lockout cylinder. Repeat the process.

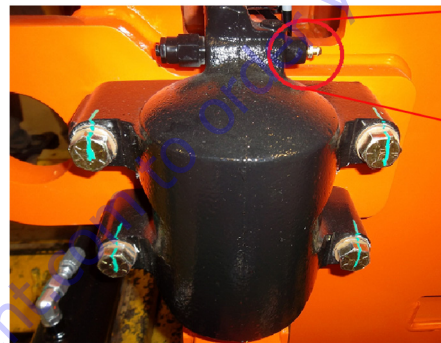

Bleeder Valve

SECTION 3 - CHASSIS & TURNTABLE

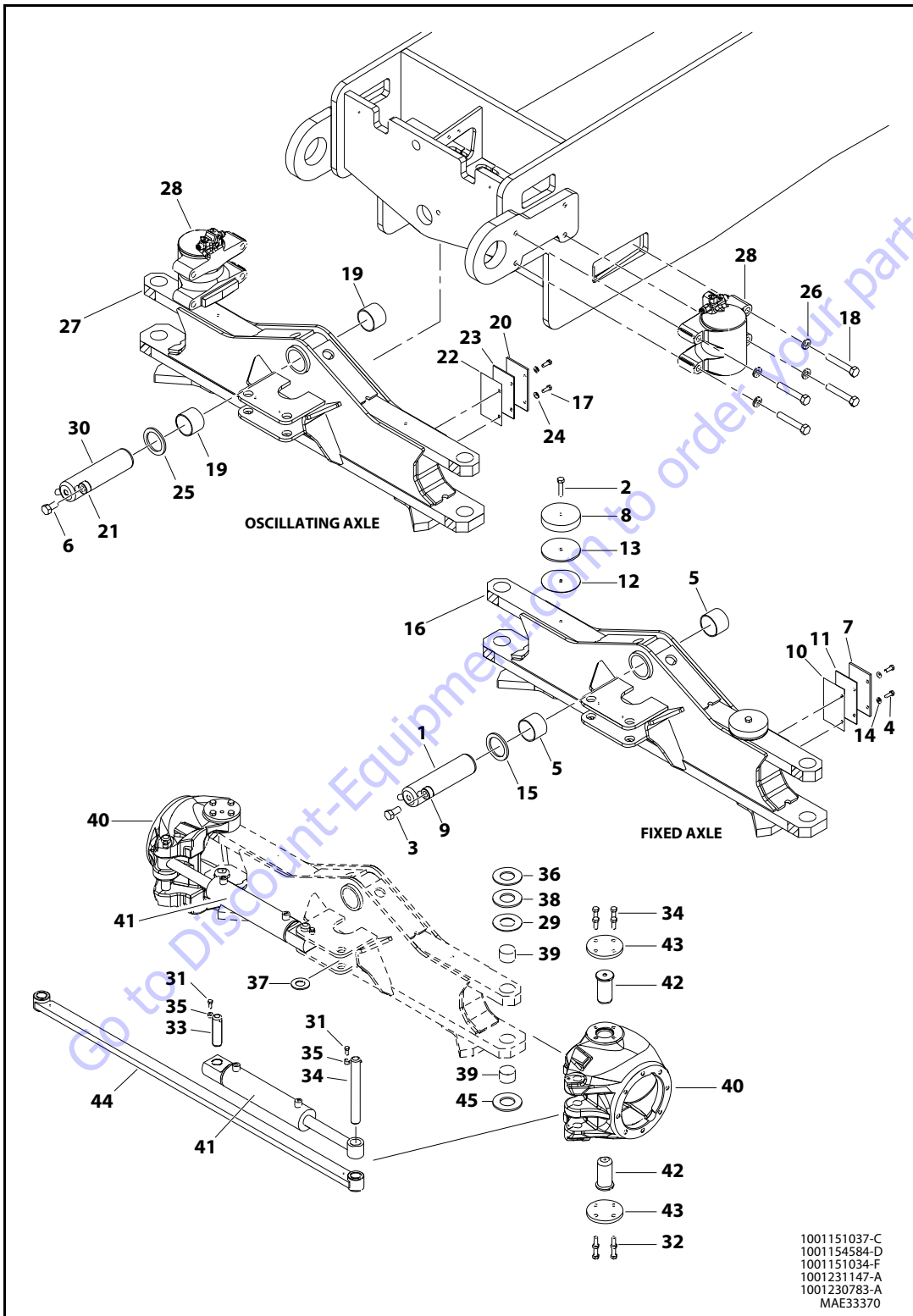

Figure 3-1. Axle and Steering Installation without Tow Package- Sheet 1 of 2

- | | | | |
|---------------|--------------------|---------------------------|-----------------------------|
| 1. Pin | 13. Shim | 25. Special Washer | 37. Special Washer |
| 2. Bolt | 14. Flat Washer | 26. Flat Washer | 38. Thrust Washer |
| 3. Bolt | 15. Special Washer | 27. Axle | 39. Bearing |
| 4. Bolt | 16. Axle | 28. Axle Lockout Cylinder | 40. Spindle |
| 5. Bushing | 17. Bolt | 29. Thrust Washer | 41. Steer Cylinder Assembly |
| 6. Bolt | 18. Bolt | 30. Pin | 42. Kingpin |
| 7. Shim Wear | 19. Bushing | 31. Bolt | 43. Plate |
| 8. Stop Plate | 20. Wear Shim | 32. Bolt | 44. Tie-Rod |
| 9. Pin Keeper | 21. Keeper Shaft | 33. Pin | 45. Thrust Washer |
| 10. Shim | 22. Wear Shim | 34. Pin | |
| 11. Shim | 23. Wear Shim | 35. Pin Keeper | |
| 12. Shim | 24. Flat Washer | 36. Thrust Washer | |

Figure 3-2. Axle and Steering Installation without Tow Package- Sheet 2 of 2

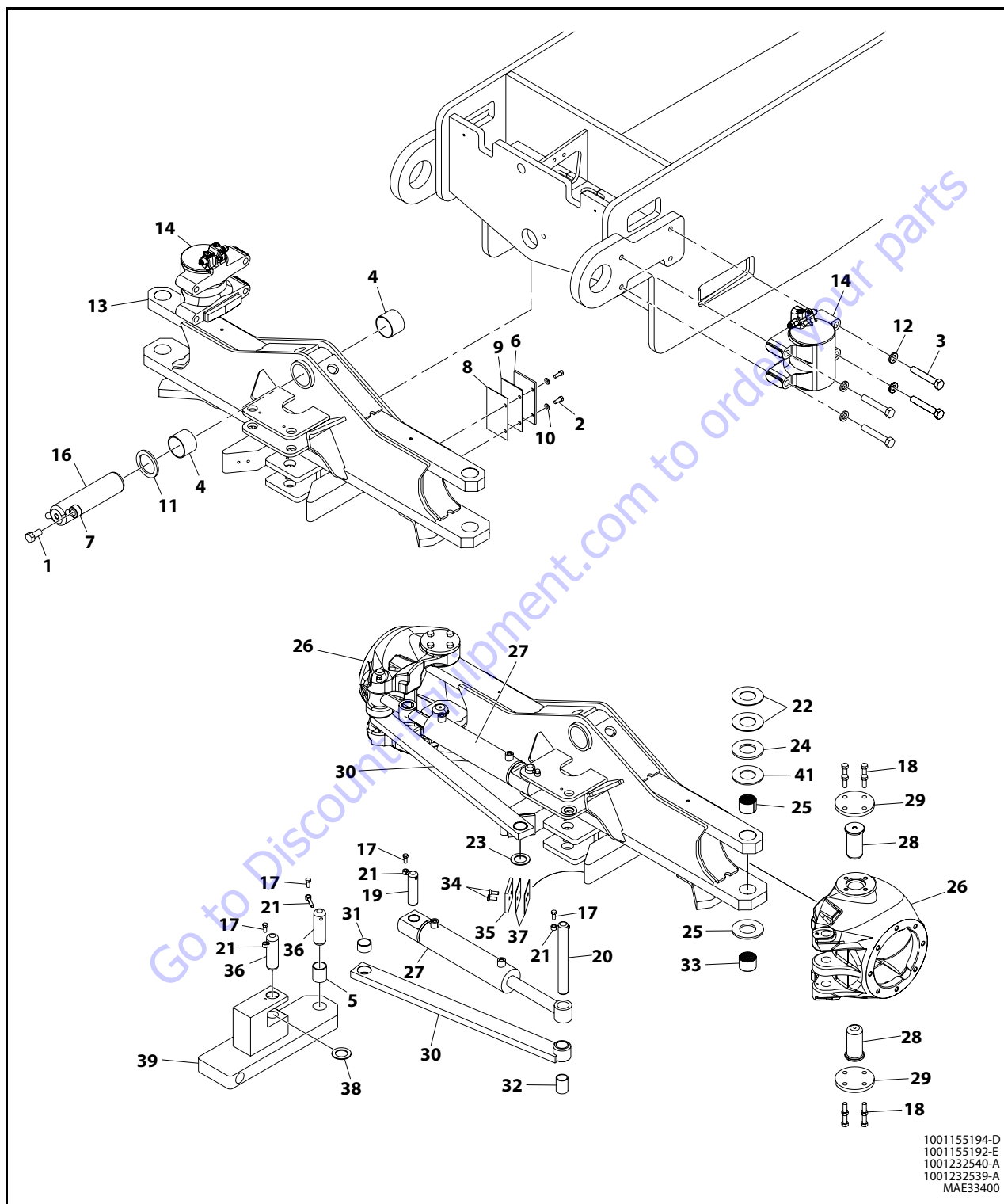

Figure 3-3. Axle and Steering Installation with Tow Package- Sheet 1 of 2

- | | | | |
|-------------------|---------------------------|--------------------|-------------------|
| 1. Bolt | 11. Special Washer | 21. Pin Keeper | 31. Bushing |
| 2. Bolt | 12. Flat Washer | 22. Thrust Washer | 32. Bushing |
| 3. Bolt | 13. Axle | 23. Special Washer | 33. Thrust Washer |
| 4. Bushing | 14. Axle Lockout Cylinder | 24. Thrust Washer | 34. Screw |
| 5. Bushing | 15. Thrust Washer | 25. Bearing | 35. Stop Pad |
| 6. Axle Wear Shim | 16. Pin | 26. Spindle | 36. Hitch Pin |
| 7. Keeper Shaft | 17. Bolt | 27. Steer Cylinder | 37. Shim |
| 8. Axle Wear Shim | 18. Bolt | 28. Kingpin | 38. Thrust Washer |
| 9. Axle Wear Shim | 19. Pin | 29. Plate | 39. Link |
| 10. Flat Washer | 20. Pin | 30. Tie-rod | |

Figure 3-4. Axle and Steering Installation with Tow Package- Sheet 2 of 2

3.3 OSCILLATING AXLE LOCKOUT TEST

NOTICE

LOCKOUT SYSTEM TEST MUST BE PERFORMED QUARTERLY, ANY TIME A SYSTEM COMPONENT IS REPLACED, OR WHEN IMPROPER SYSTEM OPERATION IS SUSPECTED.

NOTE: Ensure boom is fully retracted, lowered and centered between drive wheels prior to beginning lockout cylinder test.

1. Place a 6 in. (15.2 cm) high block with ascension ramp in front of left front wheel.
2. From platform control console, start engine.
3. Place FUNCTION SPEED CONTROL and DRIVE SPEED/TORQUE SELECT control switches to their respective LOW positions.
4. Place DRIVE control lever to FORWARD position and carefully drive machine up ascension ramp until left front wheel is on top of block.
5. Carefully activate SWING control lever and position boom over right side of machine.
6. With boom over right side of machine, place DRIVE control lever to REVERSE and drive machine off of block and ramp.
7. Have an assistant check to see that left front wheel or right rear wheel remains elevated in position off of ground.
8. Carefully activate SWING control lever and return boom to stowed position (centered between drive wheels). When boom reaches center, stowed position, lockout cylinders should release and allow wheel to rest on ground, it may be necessary activate DRIVE to release cylinders.
9. Place the 6 in. (15.2 cm) high block with ascension ramp in front of right front wheel.
10. Place DRIVE control lever to FORWARD and carefully drive machine up ascension ramp until right front wheel is on top of block.
11. Carefully activate SWING control lever and position boom over left side of machine.
12. With boom over left side of machine, place DRIVE control lever to REVERSE and drive machine off of block and ramp.
13. Have an assistant check to see that right front wheel remains locked in position off of ground.
14. Carefully activate SWING control lever and return boom to stowed position (centered between drive wheels). When boom reaches center, stowed position, lockout cylinders should release and allow wheel to rest on ground, it may be necessary activate DRIVE to release cylinders.

15. If lockout cylinders do not function properly, have qualified personnel correct the malfunction prior to any further operation.

3.4 FREE WHEELING OPTION

To Disengage Drive Motors and Brakes (Free Wheel) for Emergency Towing

1. Chock wheels securely if not on flat level surface.
2. Disconnect both drive hubs by reversing the disconnect caps in the center of the hubs.
3. If equipped, move steer/tow selector valve to float (tow) position by pulling control knob out.

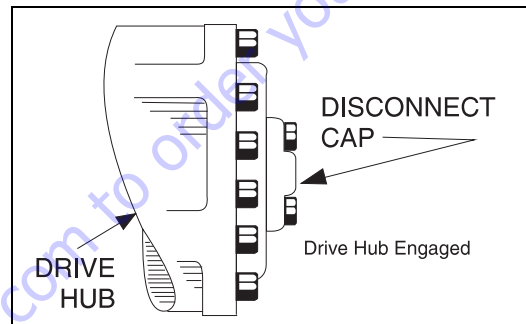

To Engage Drive Motors and Brakes (Normal Operation)

1. If equipped, move steer/tow valve to steer position by pushing valve knob in.
2. Connect both drive hubs by inverting disconnect cap in center of hub.
3. Remove chocks from wheels as required.

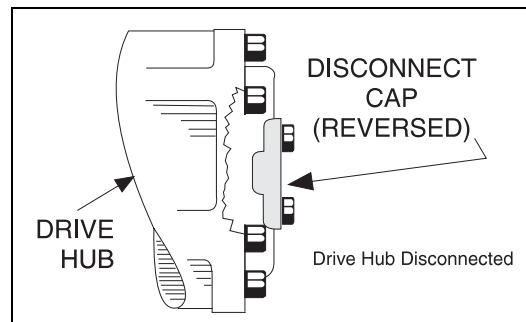

3.5 WHEEL DRIVE ASSEMBLY (2WD)

Removal

NOTE: The drive motor can be removed through the axle flange as part of the wheel drive assembly or they can be removed separately through the bottom of the frame while leaving the torque hub bolted to the axle.

1. Use a jack to lift the frame enough so the tire and wheel assembly is off of the ground. Place blocking strong enough to support the weight of the machine under the frame and remove the jack.

NOTE: The foam-filled tire & wheel assembly weighs approximately 2176 lb (987 kg).

2. Remove hardware securing wheel and remove wheel assembly. Using suitable lifting device lift the wheel assembly and place in a suitable area.
3. Tag and disconnect the hydraulic lines running to the drive motor. Cap or plug all openings to ensure no dirt enters the hydraulic system.

NOTE: The torque hub and drive motor assembly weighs approximately 275 lb (125 kg).

4. Use a supporting device capable of handling the weight of the torque hub, drive brake and drive motor and unbolt the torque hub from the frame. Remove the entire assembly from the machine.
5. Remove the capscrews and washers that secure the drive motor to the torque hub and remove the drive motor. Remove and discard the brake gasket between the drive motor and torque hub.

Installation

NOTE: The torque hub and drive motor assembly weighs approximately 275 lb (125 kg).

NOTE: The foam-filled tire & wheel assembly weighs approximately 2176 lb (987 kg).

1. Install a new brake gasket between the drive motor and torque hub. Apply a coat of Medium Strength Thread-locking Compound on capscrews. Install the washers and capscrews to secure the torque hub and drive motor and torque to 70 ft. lbs. (95 Nm).
2. Place the torque hub flange against the mounting flange on the axle and fasten it in place with the bolts and washers. Torque the bolts to 190 ft. lbs. (260 Nm).
3. Using adequate support to install wheel on wheel assembly and secure with bolts and washers. Torque the lugnuts to 300 ft. lbs. (407 Nm).
4. Install the tire and wheel assembly.

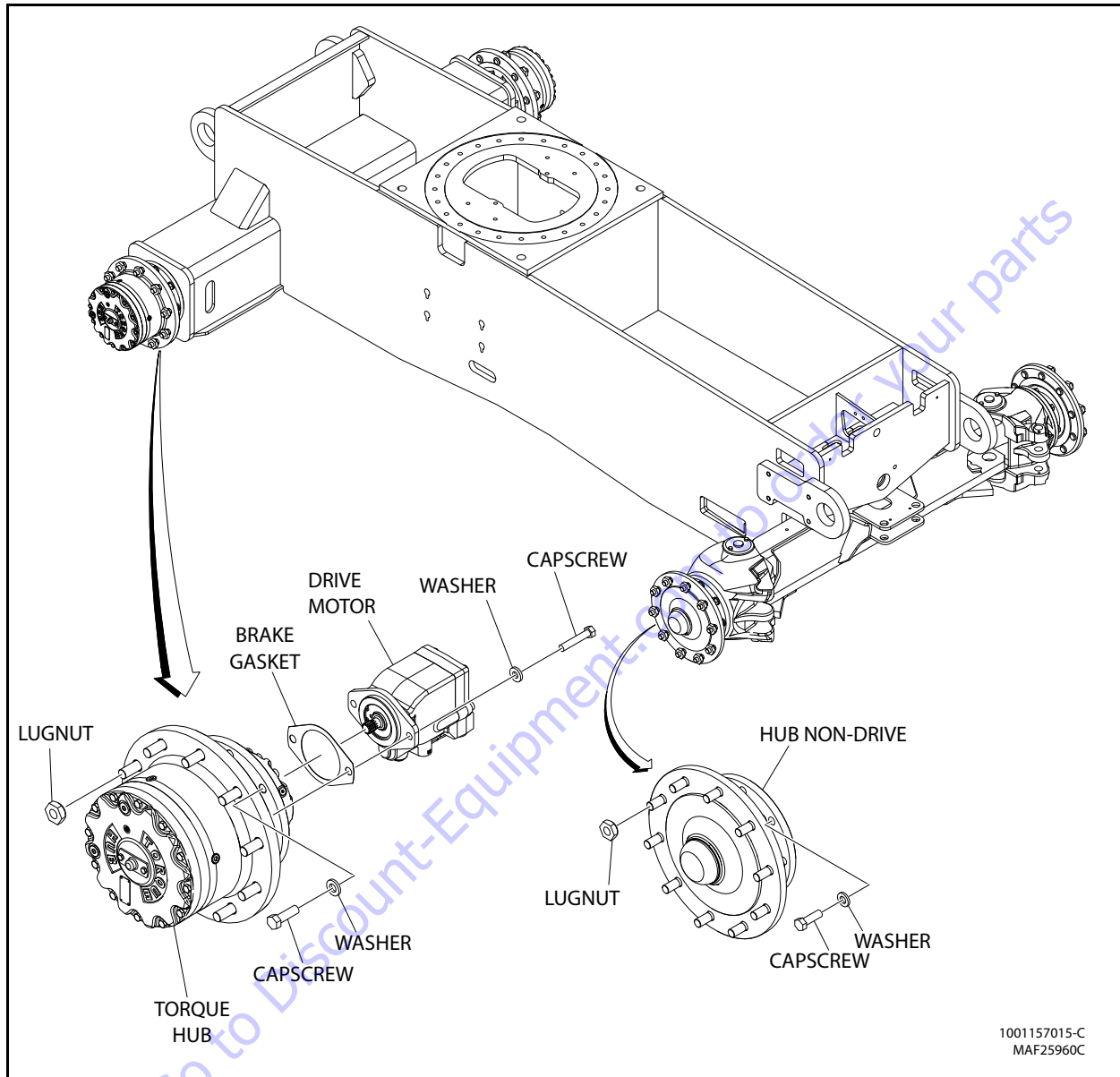

Figure 3-5. Torque Hub Installation (2WD)

3.6 WHEEL DRIVE ASSEMBLY (4WD)

Removal

NOTE: The drive motor can be removed through the axle flange as part of the wheel drive assembly or they can be removed separately through the bottom of the frame while leaving the torque hub bolted to the axle.

1. Use a jack to lift the frame enough so the tire and wheel assembly is off of the ground. Place blocking strong enough to support the weight of the machine under the frame and remove the jack.

NOTE: The foam-filled tire & wheel assembly weighs approximately 2176 lb (987 kg).

2. Remove hardware securing wheel and remove wheel assembly. Using suitable lifting device lift the wheel assembly and place in a suitable area.
3. Tag and disconnect the hydraulic lines running to the drive motor. Cap or plug all openings to ensure no dirt enters the hydraulic system.

NOTE: The torque hub and drive motor assembly weighs approximately 270 lb (122 kg).

4. Use a supporting device capable of handling the weight of the torque hub and drive motor and unbolt the torque hub from the frame. Remove the entire assembly from the machine.
5. Remove the capscrews and washers that secure the drive motor to the torque hub and remove the drive motor. Remove and discard the brake gasket between the drive motor and torque hub.

Installation

NOTE: The torque hub and drive motor assembly weighs approximately 270 lb (122 kg).

NOTE: The foam-filled tire & wheel assembly weighs approximately 2176 lb (987 kg).

1. Install a new brake gasket between the drive motor and torque hub. Apply a coat of Medium Strength Thread-Locking Compound on capscrews.
2. Install the washers and capscrews to secure the torque hub and drive motor and torque to 70 ft. lbs. (95 Nm).
3. Place the torque hub flange against the mounting flange on the axle and fasten it in place with the bolts and washers. Torque the bolts to 190 ft. lbs. (260 Nm).
4. Using adequate support to install wheel on wheel assembly and secure with bolts and washers. Torque the lugnuts to 300 ft. lbs. (407 Nm).
5. Install the tire and wheel assembly.

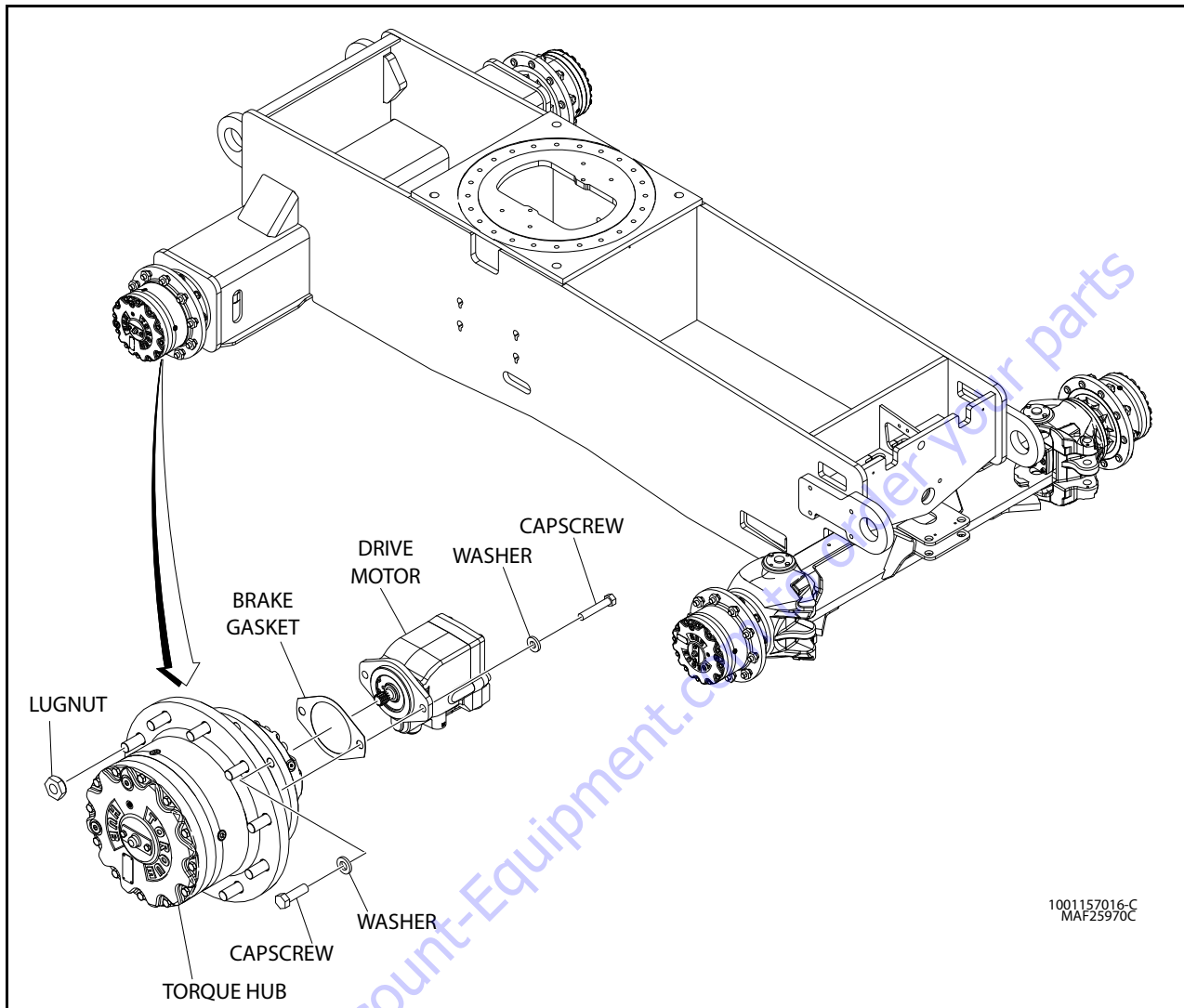

Figure 3-5. Torque Hub Installation (4WD)

3.7 DRIVE HUB

Roll and Leak Test

Torque-Hub® units should always be roll and leak tested before disassembly (if possible) and after assembly to make sure the unit's gears, bearings and seals are working properly. The following information briefly outlines what to look for when performing these tests.

THE ROLL TEST

The purpose of the roll test is to determine if the unit's gears are rotating consistently, easily and properly. Release the brake by applying 400 psi (27.5 bar) to the brake port. To perform a roll test, use the recommended tool from table below (or something equivalent) to apply constant rotational force to the input of the gearbox. If more drag is felt in the gears only at certain points, then the gears are not rolling consistently and easily and should be examined for improper installation or defects. Some gear packages roll with more difficulty than others. Do not be concerned if the gears in the unit seem to roll hard as long as they roll with consistency. Rotate the gearbox both clockwise and counterclockwise the same number of turns as the ratio of the unit. The gearbox ratio is the same number as the last three numbers on the ID tag.

THE LEAK TEST

The purpose of a leak test is to make sure the unit is airtight. To perform a leak test use the leak test fixture from the table below. If the tool is not available, the gearbox must be sealed to perform the test. This can be accomplished by assembling the sealed input device onto the gearbox at the input end and replace one of the oil plugs with an air chuck. Do not exceed 10 psi (0.7 bar) pressure during the leak test. Higher pressure will create a false sealing effect in assemblies with lip-seals. The unit has a leak if the pressure gauge reading on your leak check fitting starts to fall after the gearbox has been pressurized and allowed to equalize. Leaks will most likely occur at the pipe plugs, the main seal or wherever o-rings or gaskets are located. The exact location of a leak can usually be detected by brushing a soap and water solution around the main seal and where the o-rings or gaskets meet on the exterior of the unit and then checking for air bubbles. If a leak is detected in a seal, o-ring, or gasket, the part must be replaced and the unit rechecked. Leak test at 10 psi (0.7 bar) for 20 minutes.

TIGHTENING AND TORQUING BOLTS

If an air impact wrench is used to tighten bolts, extreme care should be taken to ensure the bolts are not tightened beyond their specified torque. The following steps describe how to tighten and torque bolts or socket head capscrews in a bolt circle.

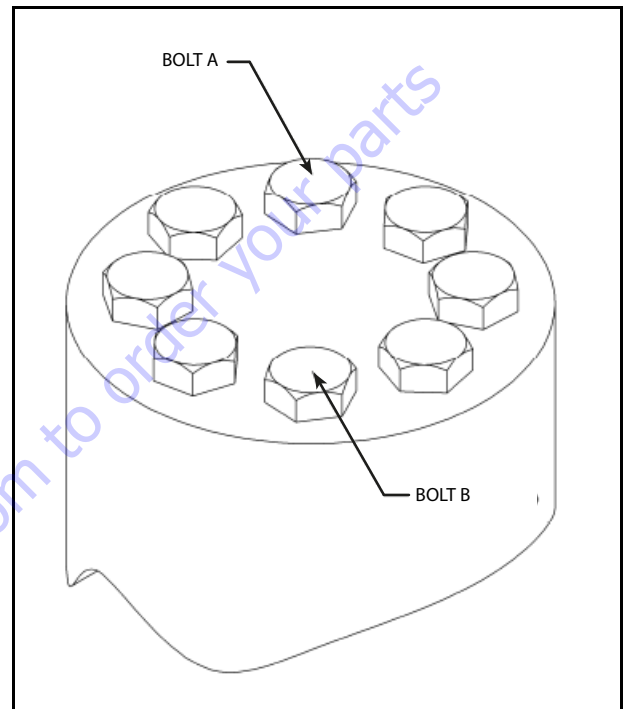

1. Tighten (but do not torque) bolt "A" until snug.
2. Go to the opposite side of the bolt circle and tighten bolt "B" until equally snug.
3. Crisscross around the bolt circle and tighten the remaining bolts.
4. Use a torque wrench to apply the specified torque to bolt "A".
5. Using the same sequence, crisscross around the bolt circle and apply an equal torque to the remaining bolts.

Disassembly

MAIN COVER PLATE DISASSEMBLY

NOTE: Refer to Figure 3-6., Figure 3-7. & Figure 3-8.

1. Perform roll check and leak check prior to disassembling the unit.

2. Remove the magnetic pipe plug (6H) from cover plate (6A) and drain the oil out of the gearbox.

NOTE: Record the condition and volume of the oil.

3. Remove eight bolts (17) followed by four special bolts (18) from cover subassembly.
4. Lift the cover subassembly off of the unit.
5. Lift ring gear (4) off the unit.

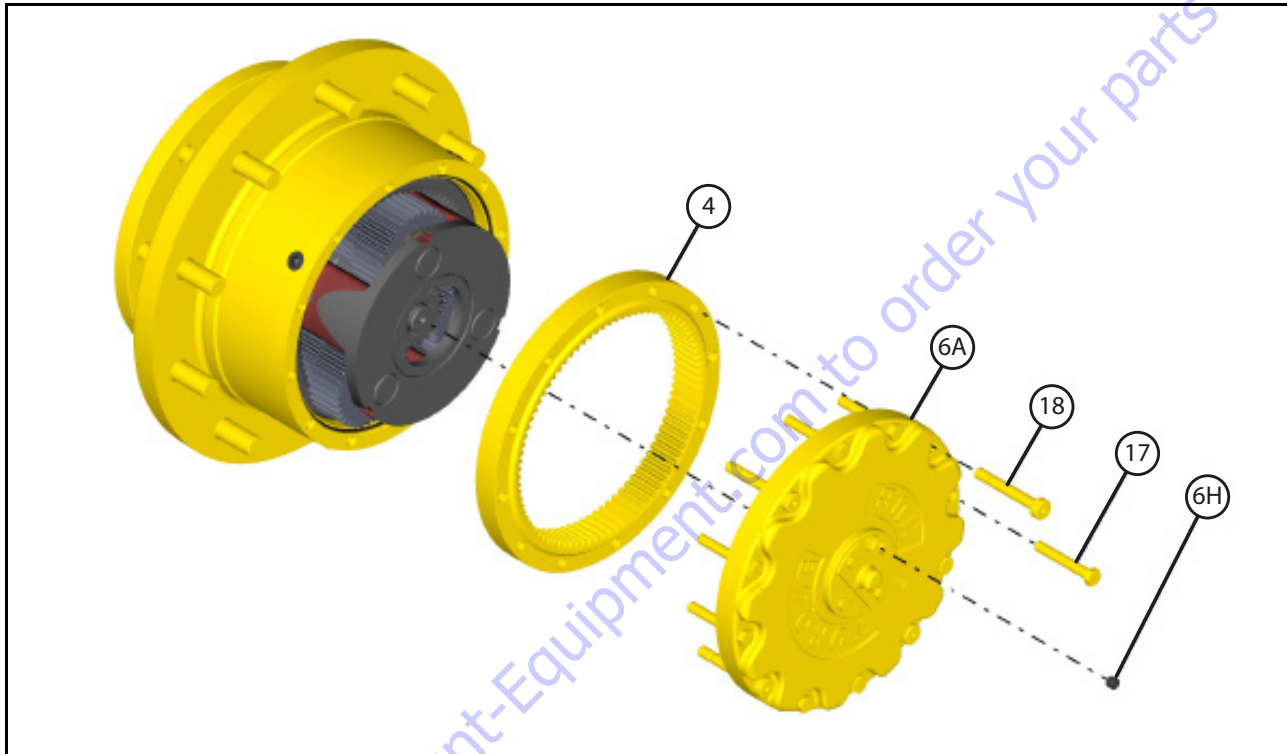

- 4. Ring Gear
- 6A. Cover Plate
- 6H. Pipe Plug
- 17. Hex Bolt
- 18. Special Bolt

Figure 3-6. Main Cover Plate Disassembly

6. If applicable remove spacer (14) from the input shaft (11).
7. Remove the sun gear (13).
8. Lift out the Carrier subassembly from the unit.
9. Remove the input spacer (12) from the unit.
10. Remove two thrust spacers (15) and thrust bearing (16) from the internal gear (2).
11. Remove internal gear (2) from the unit.
12. Remove input shaft subassembly from the hub spindle subassembly.
13. Take out input coupling subassembly of the hub spindle subassembly.

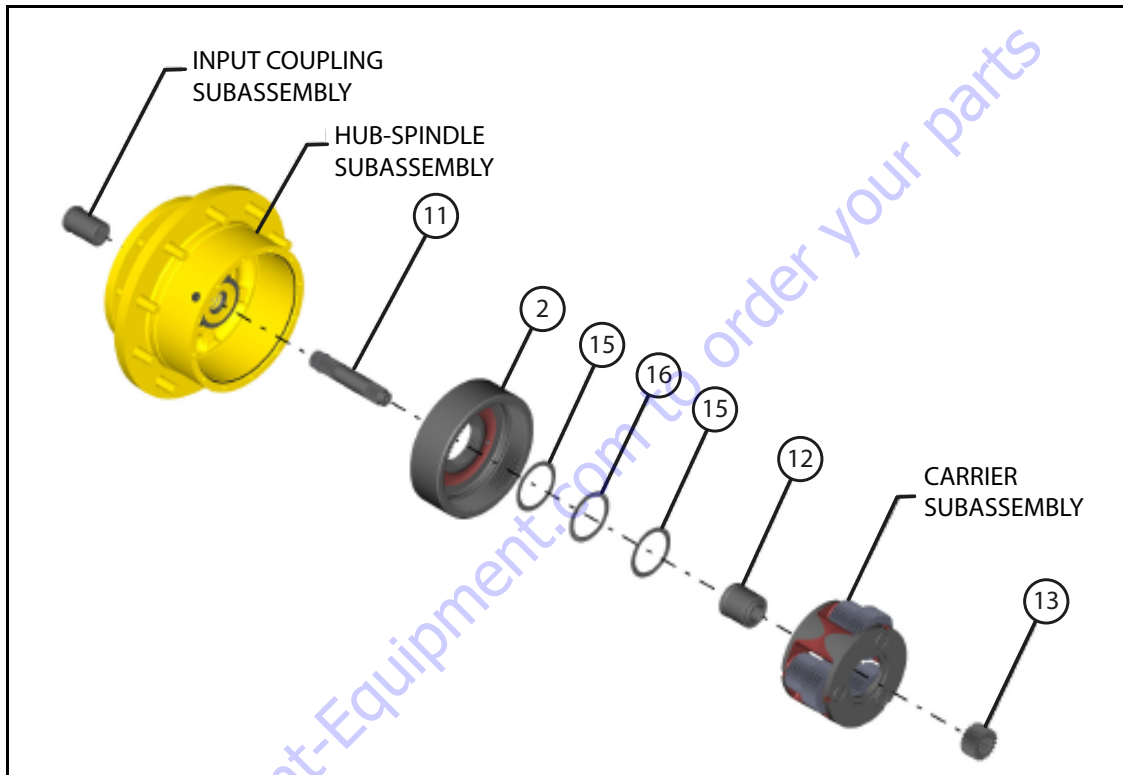

- 2. Internal Gear
- 11. Input Shaft
- 12. Input Spacer
- 13. Sun Gear
- 15. Thrust Washer
- 16. Thrust Bearing

Figure 3-7. Carrier Subassembly Removal

NOTE: Figure 3-6. refers to 30, 35, 50, 64 & 73: 1 Ratios.

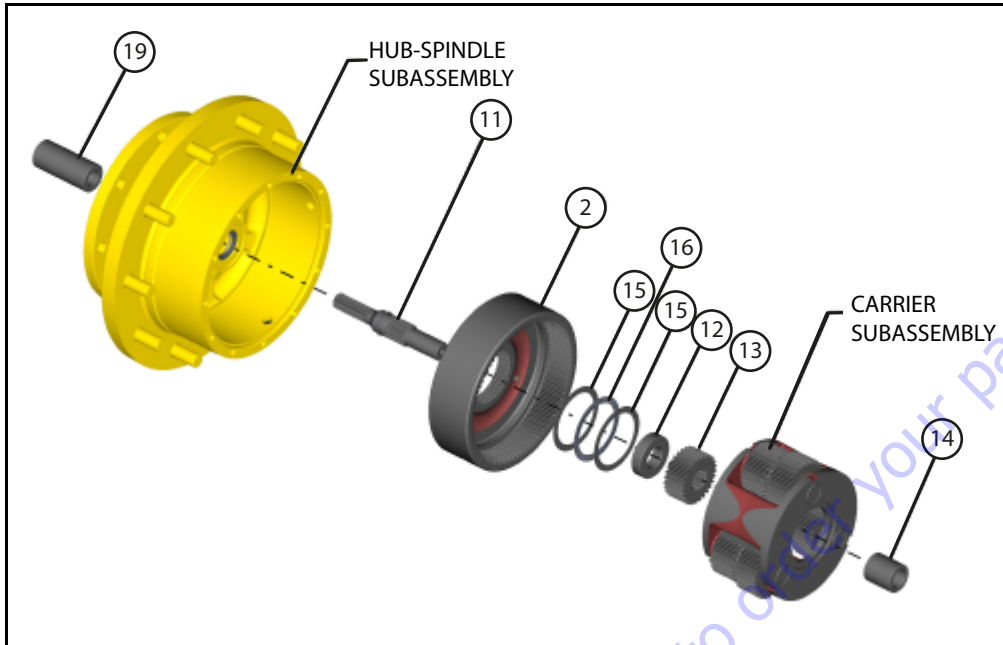

- 2. Internal Gear
- 11. Input Shaft
- 12. Input Spacer
- 13. Sun Gear
- 14. Spacer
- 15. Thrust Washer
- 16. Thrust Bearing
- 19. Coupling

Figure 3-8. Carrier Subassembly Removal

NOTE: Figure 3-7. refers to 18, 24, 31 & 43: 1 Ratios.

CARRIER DISASSEMBLY

NOTE: Refer to Figure 3-9.

1. Drive planet shaft (3E) out of the carrier pin holes, forcing the roll pin (3G) to shear off.
2. Hold on to the planet gear (3F) and push the planet shaft (3E) out of the carrier (3A) the thrust washers (3B) & (3h) will slide off the shaft as it is removed.
3. Using a hammer and punch, drive the roll pin (3G) out of the planet shaft (3E) and carrier (3A).
4. Remove first set of needle bearings (3C) from the inside of the planet gear (3F).
5. Remove thrust washer (3D) from planet gear (3F).
6. Remove second set of needle bearings (3C) from the inside of the planet gear (3F).
7. Repeat steps from 1 to 6 for the remaining two planet gears (3F).

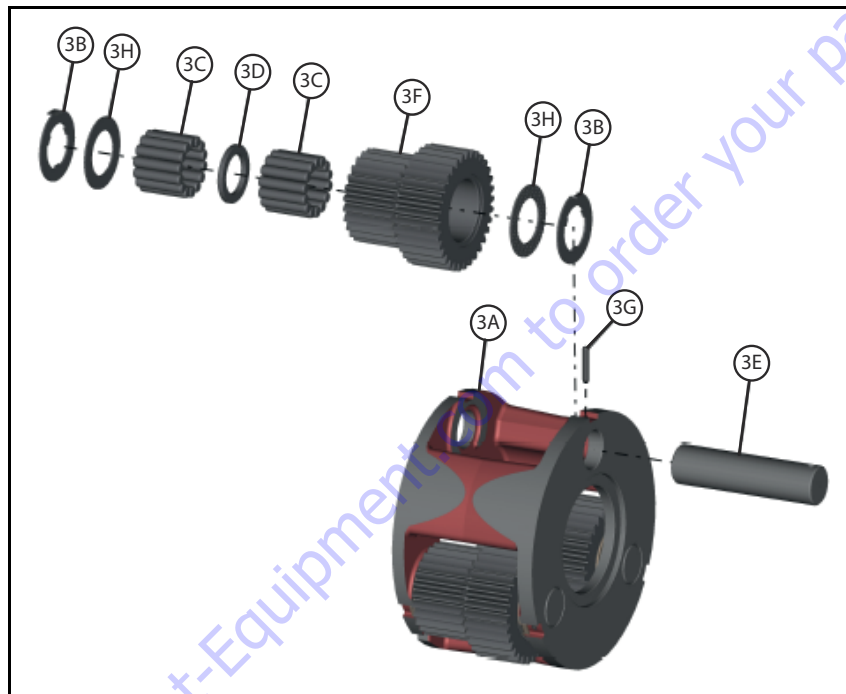

- 3A. Carrier
- 3B. Washer
- 3C. Needle Bearing
- 3D. Thrust Washer
- 3E. Planet Shaft
- 3F. Cluster Gear
- 3G. Roll Pin
- 3H. Ball Indent Washer

Figure 3-9. Carrier Disassembly

COUPLING DISASSEMBLY

NOTE: Refer to Figure 3-10.

1. If necessary, remove Internal retaining ring (20) from the groove of coupling (19).
2. If necessary, remove external retaining ring (21) from the groove of coupling (19).

⚠ CAUTION

SAFETY GLASSES MUST BE WORN DURING THIS NEXT STEPS.

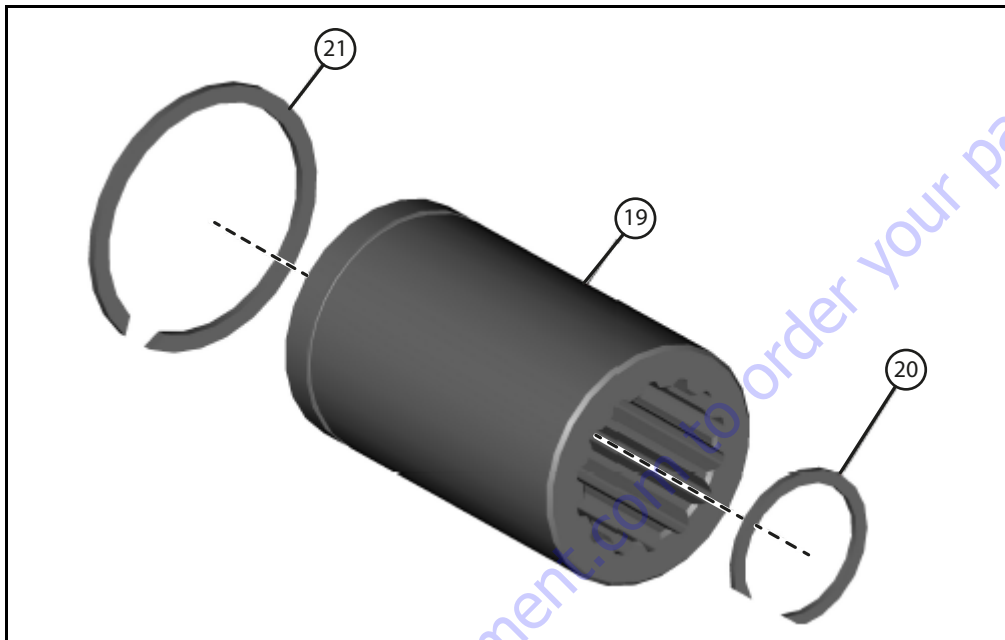

- 19. Coupling
- 20. Internal Retaining Ring
- 21. External Retaining Ring

Figure 3-10. Coupling Disassembly

INPUT SHAFT DISASSEMBLY

NOTE: Refer to Figure 3-11.

1. If necessary, remove external retaining ring (10) from the groove of the input shaft (11).

⚠ CAUTION

SAFETY GLASSES MUST BE WORN DURING THIS NEXT STEPS.

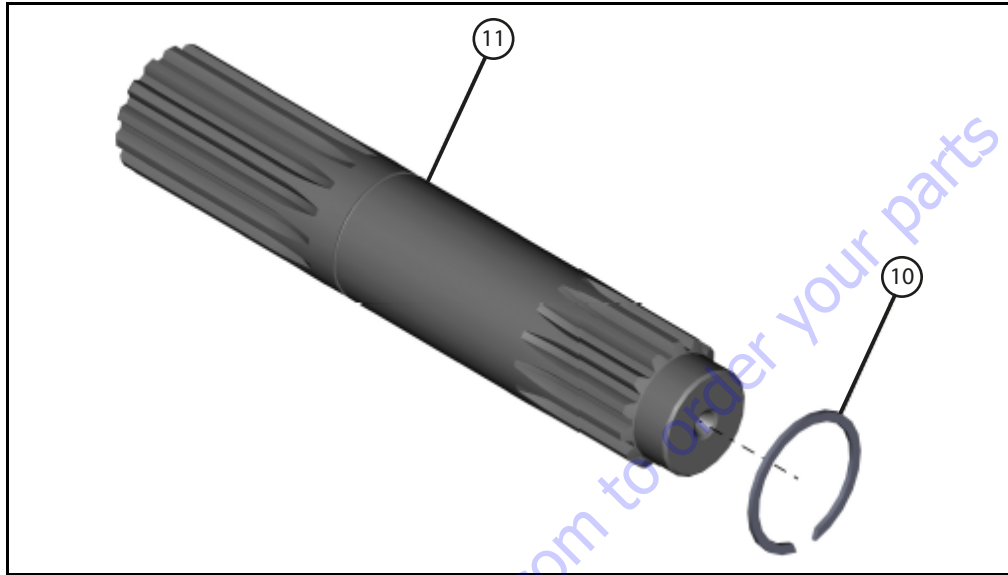

10. External Retaining Ring
11. Input Shaft

Figure 3-11. Input Shaft Disassembly

COVER DISASSEMBLY

NOTE: Refer to Figure 3-12.

1. Remove the O-ring (5) from groove in cover (6A) and discard O-ring (5).
2. Remove two thrust washers (15) and thrust bearing (16) from cover (6A).
3. Remove two hex bolts (6C) from disengage cap (6D), if required.
4. Remove the disengage cap (6D) from the cover cap (6B).

5. Pull the disengage rod (6E) out of the cover cap (6B).
6. Remove O-ring (6F) from the cover cap (6B) and discard it.
7. Remove two hex bolts (6C) from cover cap (6B), if required.
8. Remove cover cap (6B) from cover plate (6A).
9. Remove O-ring (6G) and discard it.
10. Remove pipe plug (6H) from the cover (6A).

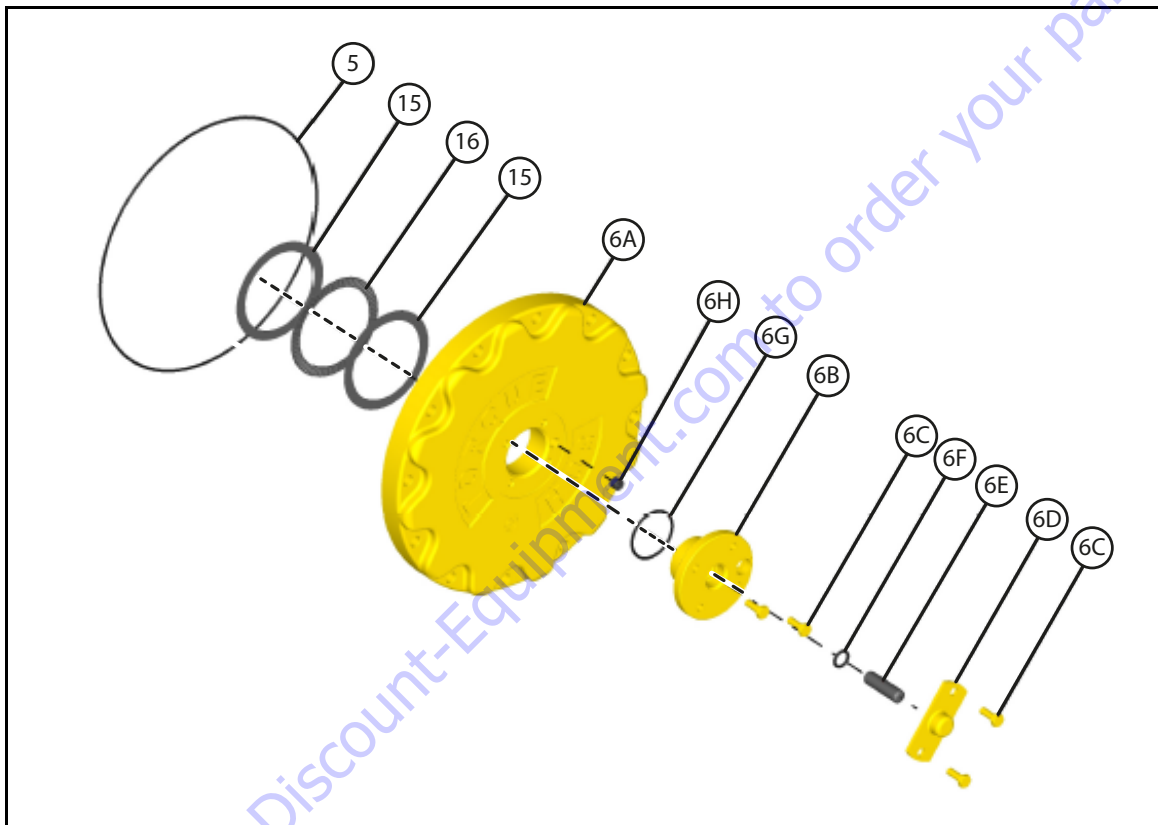

- | | |
|-------------------|--------------------|
| 5. O-ring | 6F. O-ring |
| 6A. Cover Plate | 6G. O-ring |
| 6B. Cover Cap | 6H. Pipe Plug |
| 6C. Hex Bolt | 15. Thrust Washer |
| 6D. Disengage Cap | 16. Thrust Bearing |
| 6E. Disengage Rod | |

Figure 3-12. Cover Disassembly

HOUSING-SPINDLE DISASSEMBLY

NOTE: Refer to Figure 3-13.

⚠ CAUTION

SAFETY GLASSES MUST BE WORN DURING THESE NEXT STEPS.

1. Remove Internal retaining ring (9) from the groove of the spindle (1A).

2. Remove thrust washer (7) from the spindle (1A).
3. Remove spring (8) from the spindle (1A).
4. Remove thrust washer (7) from the spindle (1A).
5. Set the unit on a bench so that the spindle (1A) flange is down.

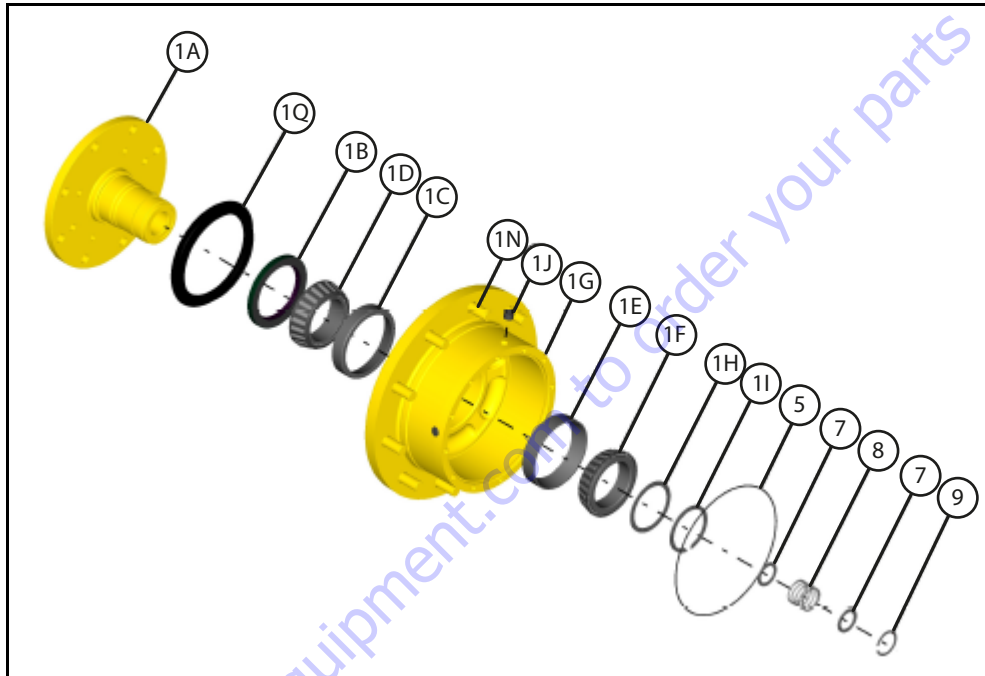

- | | |
|-------------------|-----------------------------|
| 1A. Spindle | 1I. External Retaining Ring |
| 1B. Lip Seal | 1J. Pipe Plug |
| 1C. Bearing Cup | 1N. Stud |
| 1D. Bearing Cone | 1Q. Boot Seal |
| 1E. Bearing Cup | 5. O-ring |
| 1F. Bearing Cone | 7. Thrust Washer |
| 1G. Housing | 8. Spring |
| 1H. Thrust Washer | 9. Internal Retaining Ring |

Figure 3-13. Housing Spindle Disassembly

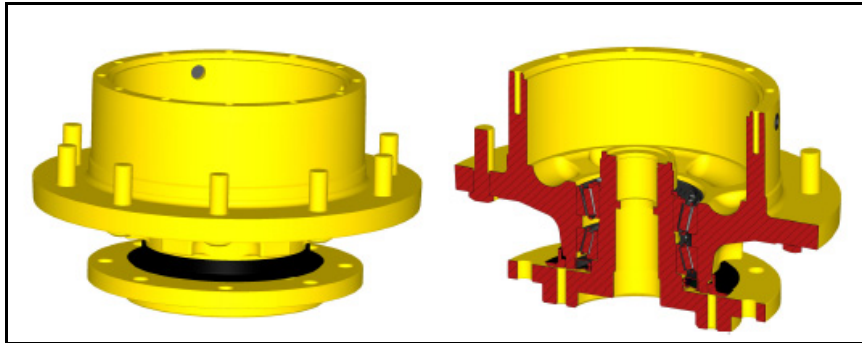

Figure 3-14. Housing Cross Section

6. Remove the O-ring (5) from the housing (1G) and discard it.

⚠ CAUTION

SAFETY GLASSES MUST BE WORN DURING THESE NEXT STEPS.

7. Remove retaining ring (1I) from the groove of spindle (1A).

8. Remove thrust washer (1H) from the spindle (1A).
9. Remove two pipe plugs (1J) from the housing (1G).

10. Turn the unit over and carefully place the unit on a support base until the spindle (1A) post rests on it. Ensure there is enough gap to lower the housing (1G) down.

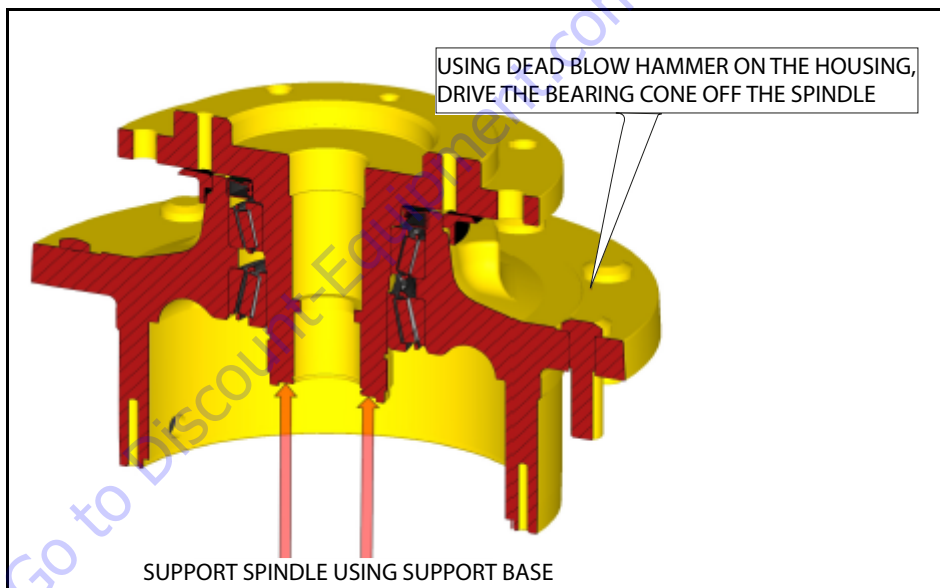

Figure 3-15. Housing Cross Section

11. Use a dead blow hammer on the housing (1G) flange to drive the inboard bearing cone (1F) off of the spindle (1A).
12. Lift the spindle (1A) out of the housing (1G).
13. If required, remove boot seal (1Q) from the housing (1G).
14. Remove lip seal (1B) from the housing (1G).
15. Remove the bearing cone (1D) from the bearing cup (1C).

16. Using a hammer and punch drive the inboard bearing cup (1E) out of the housing (1G). Be careful not to damage the counterbore in the housing.
17. Turn the housing (1G) over and drive the outboard bearing cup (1C) out of the housing (1G). Be careful not to damage the counterbore in the housing.

Assembly

COVER SUBASSEMBLY

NOTE: Refer to Figure 3-12.

1. Screw pipe plug (6H) into cover plate (6A) using thread sealant and hand hexagonal wrench.
2. Apply grease and position o-ring (6G) over cover cap (6B) until it rests against the flange.
3. Blow out internal groove of cover cap (6B) with air hose. Place greased o-ring (6F) into internal groove of cover cap (6B).

NOTE: The disconnect rod (6E) may be used to push the greased o-ring (6F) into position in the o-ring groove of the cover cap (6B).

4. Place cover cap (6B) into cover plate (6A) with larger flange hole on cover cap (6B) located over pipe plug (6H) fasten cover cap (6B) with two bolts (6C) located 180 degrees apart. Torque bolts to 70-80 in. lbs. (95- 108 Nm).
5. Place disengage cap (6D) on cover cap (6B) with nipple facing out. Secure with two bolts (6C) located 180 degrees apart. Torque bolts (6C) to 70-80 in. lbs. (95-108 Nm).
6. Turn cover plate (6A) over and push disconnect rod (6E) into cover cap (6B), until disconnect rod (6E) bottoms out on the disengage cap (6D).
7. Grease and install o-ring (5) into groove on the cover plate (6A).
8. Grease and install thrust washers (15) and thrust bearing (16) into cover plate (6A).

NOTE: Thrust washers (15) has to be assembled onto either sides of thrust bearing (16) and then, this has to be greased and installed as a single unit into cover plate (6A).

CARRIER SUBASSEMBLY

NOTE: Refer to Figure 3-9.

1. Apply a liberal coat of grease to the bore of cluster gear (3F). This will enable the needle rollers (3C) to be held in place during assembly.
2. Install first row of 14 needle rollers (3C) into the bore of cluster gear (3F).

NOTE: The last roller installed must be installed end wise. That is the end of the last roller must be placed in between the ends of the two rollers that form the space and then slid parallel to the other rollers into place.

3. Place one spacer (3D) on top of the needle rollers (3C) inside the planet gear (3F).
4. Install second row of 14 needle rollers (3C) into the bore of cluster gear (3F) against spacer (3D). Grease and install ball indent washers (3H) onto the counterbores of either sides of cluster gear (3F) with indents away from the cluster gears.
5. Place carrier (3A) into tool fixture so that one of the roll pin holes is straight up.

6. Start planet shaft (3E), with end opposite roll pin hole first, through the planet shaft hole in carrier (3A), making sure that the roll pin hole with the large chamfer in the planet shaft is straight up.
7. Using ample grease to hold it in position, slide one thrust washer (3B) over planet shaft (3E) with tang resting in the cast slot of carrier (3A).
8. With large end of cluster gear (3F) facing the roll pin hole in the carrier (3A), place cluster gear (3F) into position in carrier (3A) and push planet shaft (3E) through the cluster gear (3F) without going all the way through.
9. Slide the second thrust washer (3B) between the cluster gear (3F) and the carrier (3A) with the tang of washer located in the cast slot of carrier (3A). Finish sliding planet shaft (3E) through the thrust washers (3H) & (3B) and into carrier (3A).
10. Position the chamfered side on the planet shaft (3E) roll pin hole so that it is in line with the hole in the carrier (3A) using a 1/8 in. (3.17 mm) diameter punch.
11. After using a 3/16 in. (4.76 mm) punch to align the two roll pin holes. Drive the roll pin (3G) through carrier (3A) and into planet shaft (3E) until the roll pin (3G) is flush with the bottom of the cast tang slot in the carrier (3A). Use a 1/4 in. (6.35 mm) pin punch to make sure the roll pin (3G) is flush in the slot.
12. Repeat the steps from 1 through 11 for the remaining two cluster gears (3F).

HOUSING SPINDLE SUBASSEMBLY

NOTE: Refer to Figure 3-13.

1. If required, using stud pressing fixture press studs (1N) into the flange holes of the hub (1G), be sure stud heads are tight to the hub flange face.
2. Place hub (1G) on table such that long hub end is up.
3. Press bearing cup (1E) using T148905 with the large diameter side up into cover end of hub (1G).
4. Turn hub (1G) over and press bearing cup (1C) into hub (1G) using T148905 with small diameter side up.

NOTE: Apply generous amount of lubricating oil on all bearings at the time of installation.

5. Place bearing cone (1D) on bearing cup (1C).
6. Press bearing seal (1B) with the open face down into the hub (1G), be sure seal is flush with the hub face.

NOTE: Generally Seals should not be reused.

7. If the unit requires seal boot (1Q) place on hub (1G) with flange end facing up. Coat the inside surface of the seal - boot - flange with liberal amount of grease.
8. Place spindle (1A) with large diameter end down on the bench and coat the seal shoulder with oil.
9. Place hub (1G) onto spindle (1A) making sure the seal (1B) is in position on the seal shoulder of spindle (1A).

NOTE: The bearing cone (1F) is a press fit onto spindle (1A) and is installed using snap ring assembly tool T205660.

10. Place snap ring assembly tool T205660 onto spindle (1A).
11. Place bearing cone (1F) onto the tapered portion of snap ring assembly tool T205660.
12. Place spacer (1H) and retaining ring (1I) onto the top of the bearing cone (1F).
13. Slowly press bearing cone (1F) spacer (1H) and retaining ring (1I) all at once using a bearing pressing tool, T137970, until the retaining ring (1I) falls into the retaining ring groove on the spindle (1A).
14. Install pipe plug (1J) into hub (1G).
15. Grease and install o-ring (5) into hub (1G).
16. Grease and install thrust washer (7) into spindle (1A).
17. Install spring (8) into spindle (1A) until it bottoms on thrust washer (7).
18. Grease and place second thrust washer (7) on spring (8).
19. Using retaining ring pliers, push retaining ring (9) against thrust washer (7) until retaining ring snaps into place in the spindle (1A) groove.

COUPLING SUBASSEMBLY

NOTE: Refer to Figure 3-10.

⚠ CAUTION

SAFETY GLASSES MUST BE WORN DURING THESE NEXT STEPS.

1. If necessary, install external retaining ring (21) into groove on OD of coupling (19).
2. If necessary, install Internal retaining ring (20) into retaining ring groove of the coupling (19).

INPUT SHAFT SUBASSEMBLY

NOTE: Refer to Figure 3-11.

⚠ CAUTION

SAFETY GLASSES MUST BE WORN DURING THESE NEXT STEPS.

1. If necessary, install retaining ring (10) onto the groove of input shaft (11).

CARRIER SUBASSEMBLY

NOTE: Refer to Figure 3-6., Figure 3-7. & Figure 3-8.

1. Place hub-spindle subassembly on the table with spindle flange side down.
2. Set the internal gear (2) with the spline down, so that the spline of the spindle (1A) is in mesh with the internal spline of the internal gear (2).

3. Install input shaft subassembly with the retaining ring end down into the spindle counterbore.
4. Slide thrust spacer (12) over the input shaft (11) make sure the large end is against the spindle (1A).

NOTE: Refer to Figure 3-8. with 18, 24, 31 & 43: 1 Ratios.

5. Place carrier subassembly with the large end of cluster gears facing up. Position all three punch marks on the face of large gears at 12 o'clock and secure the gear teeth using timing fixture.
6. With longer shoulder side of ring gear (4) facing down, place the ring gear into mesh with the cluster gear (3F) and remove this assembly from timing fixture.

NOTE: Be sure that the punch marks remain in their correct location during ring gear (4) installation.

7. Place Thrust washer (15), thrust bearing (16) and thrust washer (15), in order on the pilot diameter on internal gear (2).

NOTE: For 30, 35, 50, 54 & 73:1 ratios Skip step 8.

8. Install input gear (13) with counterbore down in mesh with the input shaft (11) splines counterbore down.
9. With small end of cluster gear (3F) down and while holding ring gear (4) in mesh with carrier sub assembly, place assembly into internal gear (2).

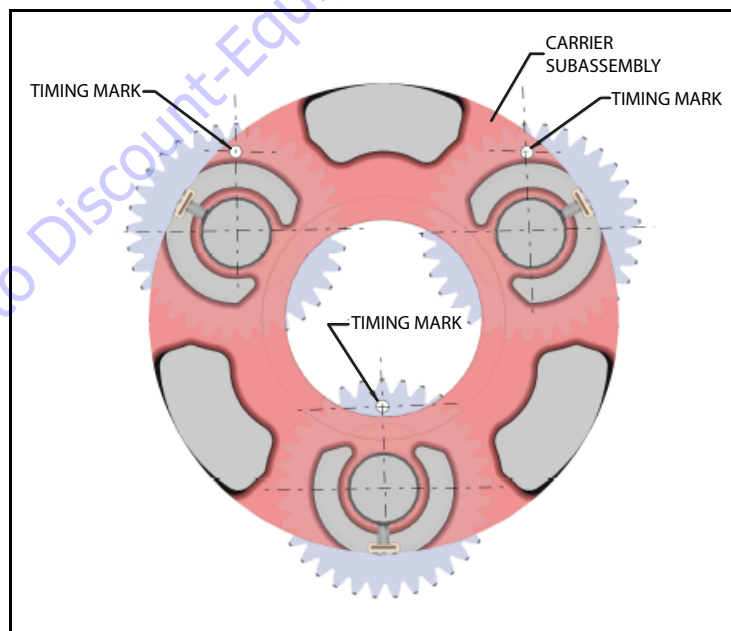

Figure 3-16. Timing Mark on Carrier Subassembly

- 10.** Once in place rotate the ring gear (4) until hole marked "X" is aligned with one of shoulder bolt holes in hub (1G).

NOTE: *If the gears do not mesh easily or carrier sub assembly does not rotate freely, then remove the carrier and Ring gear and check timing (Step 5).*

NOTE: *Check each cluster gear (3F) to make sure that the timing punch-marks is in line with a tooth on the large end & a tooth on the small end of the cluster gear. THESE TWO TEETH MUST BE IN LINE WITH THE PUNCH-MARKS ON EVERY CLUSTER GEAR (3F).*

NOTE: *For 30, 35, 50, 54 & 73:1 ratios Skip step 11.*

- 11.** Install spacer (14) onto the input shaft (11) against the input gear (13).

NOTE: *Refer to Figure 3-8. with 18, 24, 31 & 43: 1 Ratios*

NOTE: *For 18,24, 37 & 43:1 ratios Skip step 12.*

- 12.** Install input gear (13) with counterbore down to mesh with the teeth of cluster gear (3F).

- 13.** Install cover subassembly onto the ring gear (4) being sure that the pipe plugs in the hub (1G) and cover (6A) are in time with each other. Be sure the thrust washers (15) & (16) remain on the cover (6).

- 14.** Install four shoulder bolts (18) into the four marked counterbore holes in the hub (1G) start shoulder bolts (18) by hand for the length of at least two threads or two full turns before running down and torque to 45-47 ft. lbs. (61- 64 Nm).

- 15.** Place the remaining eight bolts (17) into the remaining holes and torque to 45-47 ft. lbs. (61- 64 Nm).

- 16.** Turn the assembly over and insert Input Coupling Sub-assembly into the spindle (1A) counterbore.

- 17.** The unit should now be leak and roll checked as per "The Roll Test" and "The Leak Test". The motor can be reinstalled into the gearbox for the leak check to seal it off and the unit pressurized through a pipe plug hole on the cover.

3.8 DRIVE BRAKE

Disassembly

1. Supporting brake; remove the six socket head capscrews and washers (13 & 14) in equal increments to ensure the spring pressure within the brake is reduced gradually and evenly.

If a press is available, the cylinder housing (8) can be restrained while removing the six capscrews and washers (13 & 14).

The brake assembly can now be fully dismantled and the parts examined.

2. Remove cylinder housing (8) and piston (9) subassembly and dismantle if required, removing O-ring seals (15 & 17) and backing rings (16 & 18) as necessary.
3. Remove gasket (7) from housing (2).
4. Remove friction plates (3 & 6) and pressure plate (4).
5. Remove two dowel pins (19).
6. Remove springs (22 & 23).
7. Should it be necessary to replace ball bearing (10) or shaft seal (12), reverse remainder of brake subassembly, supporting on face C of housing (2).
8. Remove internal retaining ring (11).
9. Using arbor press or similar to break Threadlocking Compound seal, remove brake shaft (1) from housing (2) and lay aside.
10. Reverse housing (2) and press out ball bearing (10). Shaft seal (12) can also be removed if necessary.

Inspection

1. Inspect friction plates (3 & 6) and friction surface on pressure plate (4) for wear or damage.
2. Examine friction plates (3) and brake shaft (1) for wear or damage to the splines.
3. Examine input and output splines of brake shaft (1) for wear or damage.
4. Examine compression springs (22 & 23) for damage or fatigue.
5. Check ball bearing (10) for axial float or wear.
6. Examine O-ring seals (15 & 17) and backing rings (16 & 18) for damage.

Assembly

1. Lightly lubricate rotary shaft seal (12) and assemble to housing (2) taking care not to damage seal lip.
2. Apply ring of Medium Strength Threadlocking Compound or equivalent adhesive to full circumference of housing (2) bearing recess adjacent to shoulder.

Apply complete coverage of Medium Strength Threadlocking Compound to outside diameter of bearing (10) and assemble fully in housing (2), retaining with internal retaining ring (11). Remove excess adhesive with a clean cloth.

Press shaft (1) through bearing (10), ensuring bearing inner ring is adequately supported.

3. Assemble correct quantity of springs (22 & 23) in orientation required.
4. Lubricate O-ring seals (15 & 17) with Molykote 55M (or equivalent) silicon grease and assemble together with backing rings (16 & 18) to piston (9). To ensure correct brake operation. It is important that the backing rings are assembled opposite to the pressurized side of piston.
5. Correctly orientate piston (9) aligning spaces with the two dowel pin holes and, assemble into cylinder housing (8) taking care not to damage seals and carefully lay aside.
6. Locate 2-off pins (19) in housing (2) followed by pressure plate (4) and friction plates i.e. an inner (3) followed by an outer (6) in correct sequence.
7. Position gasket (7) in correct orientation.
8. Align two holes in cylinder with dowel pins (19) and assemble piston & cylinder sub-assembly to remainder of brake securing with 6 capscrews and washers (13 & 14). Torque to 55 ft.lbs. (75 Nm).

NOTE: The use of a suitable press (hydraulic or arbor) pressing down on cylinder end face B will ease assembly of the capscrews (13).

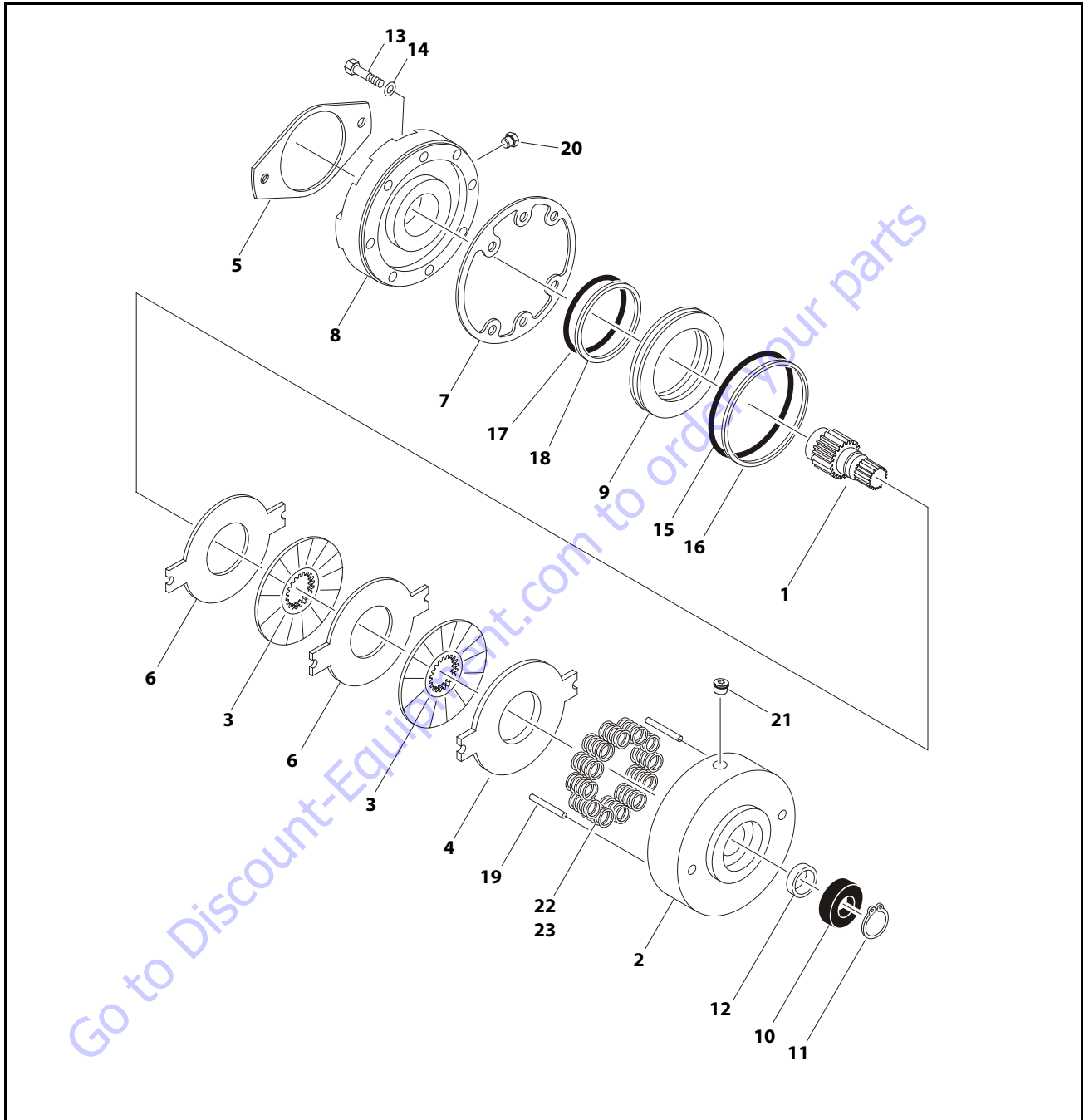

- | | | | | |
|-------------------|------------------|--------------------|-----------------|----------------------|
| 1. Shaft | 6. Outer Plate | 11. Retaining Ring | 16. Backup Ring | 21. Plug |
| 2. Housing | 7. Gasket | 12. Shaft Seal | 17. O-ring | 22. Spring (Natural) |
| 3. Friction Plate | 8. Cylinder | 13. Capscrew | 18. Backup Ring | 23. Spring (Blue) |
| 4. Pressure Plate | 9. Piston | 14. Lockwasher | 19. Dowel Pin | |
| 5. Gasket | 10. Ball Bearing | 15. O-ring | 20. Plug | |

Figure 3-17. Drive Brake

3.9 DRIVE MOTOR

Description

The drive motors are low to medium power, two-position axial piston motors incorporating an integral servo piston. They are designed for operation in both open and closed circuit applications. The standard control is a direct acting single line hydraulic control. The integral servo piston controls motor displacement.

The motors are spring biased to maximum displacement and hydraulically shifted to minimum displacement. Minimum and maximum displacement can be set with fixed internal stops. The large diameter servo piston allows smooth acceleration and deceleration with relatively large circuit orificing.

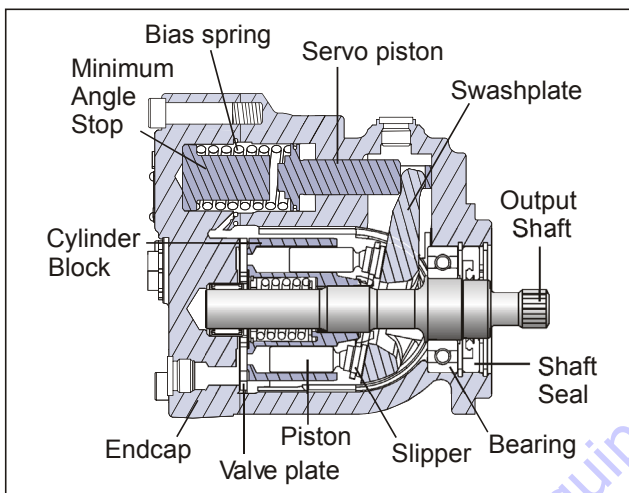
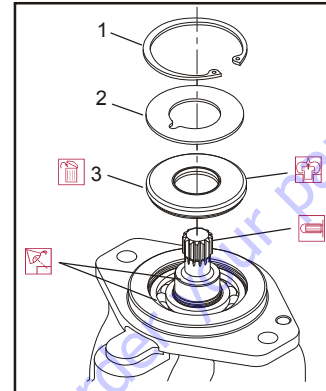

Figure 3-18. Drive Motor Cross Section

Shaft Seal Replacement

REMOVAL

1. Remove the snap ring (1) retaining the shaft seal and support washer.



1. Snap Ring
2. Support Washer
3. Shaft Seal

Figure 3-19. Removing the Shaft Seal

2. Remove the support washer (2).
3. Carefully pry out the shaft seal (3).

NOTE: To avoid damaging the shaft during removal, install a large sheet metal screw into the chuck of a slide hammer. Drive the screw into the seal surface and use the slide hammer to pull the seal.

4. Discard the seal.

INSPECT THE COMPONENTS

Inspect the new seal, the motor housing seal bore and the sealing area on the shaft for rust, wear and contamination. Polish the shaft and clean the housing if necessary.

INSTALLATION

1. Cover the shaft splines with an installation sleeve to protect the shaft seal during installation.
2. Install a new shaft seal with the cupped side facing the motor. Press seal into housing until it bottoms out. Press evenly to avoid binding and damaging the seal.
3. Install seal support washer.
4. Install snap ring.
5. Remove the installation sleeve.

Loop Flushing Valve

REMOVAL

- Using a 11/16 in. internal hex wrench remove plug (1) and (2).

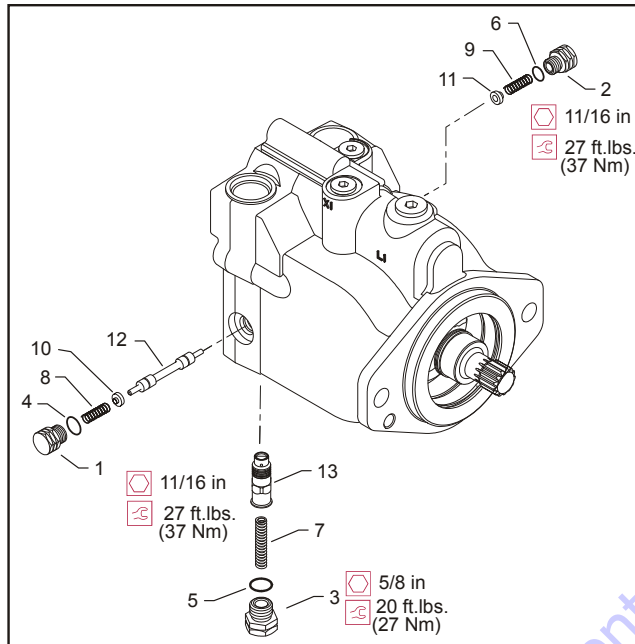

- | | | |
|-----------|------------|--------------------|
| 1. Plug | 6. O-ring | 11. Washer |
| 2. Plug | 7. Spring | 12. Shift Spool |
| 3. Plug | 8. Spring | 13. Orifice Poppet |
| 4. O-ring | 9. Spring | |
| 5. O-ring | 10. Washer | |

Figure 3-20. Loop Flushing Spool

- Using a 1/4 in. hex wrench remove plug (3).
- Remove O-rings (4, 5 and 6).
- Using pliers, remove centering springs (7, 8 and 9).
- Remove spring retaining washers (10 and 11).
- Remove shift spool (12).
- Remove orifice poppet (13).

INSPECT THE COMPONENTS

Inspect new O-rings and the sealing area for rust, wear, or contamination. Also check springs and poppet for wear.

INSTALLATION

- Install orifice poppet (13).
- Install shift spool (12).
- Install spring retaining washers onto springs (10 and 11).
- Carefully install centering springs (7, 8 and 9).
- Install new O-rings (6, 4 and 5).
- Using a 1/4 in. hex wrench torque plug (3) to 20 ft. lbs. (27 Nm).
- Using a 11/16 in. internal hex, torque plugs (2 and 1) to 27 ft. lbs. (37 Nm).

Troubleshooting

Table 3-2. Excessive Noise and/or Vibration

Item	Description	Action
Check oil level in reservoir and oil supply to the motor.	Insufficient hydraulic fluid could lead to cavitation that would cause system noise.	Fill the reservoir to the proper level and ensure that oil supply to the motor is adequate and the lines are unobstructed.
Check for air in the system.	Air trapped within the system lines, or the motor itself, could result in cavitation that would cause system noise.	Ensure that all of the system lines and components are purged of air.
Inspect the output shaft couplings.	A loose or incorrect shaft coupling will produce vibrations that could result in system noise.	Ensure that the correct coupling is used and that it fits properly onto the shaft.
Inspect the output shaft alignment.	Misaligned shafts create excessive frictional vibration that could result in system noise.	Ensure that the shafts are properly aligned.
Hydraulic oil viscosity above limits.	Viscosity above acceptable limits will result in cavitation that would lead to system noise.	Replace hydraulic oil with appropriate fluid for operating conditions.

Table 3-3. System Operating Hot

Item	Description	Action
Check oil level in reservoir and oil supply to the pump.	Insufficient amount of hydraulic fluid will not meet the cooling demands of the system.	Fill the reservoir to the proper level.
Inspect the heat exchanger, (if so equipped).	If the heat exchanger fails, or becomes obstructed, it may not meet the cooling demands of the system.	Ensure that heat exchanger is receiving adequate air flow and that the heat exchanger is in good operating condition. Repair or replace as necessary.
Check the system relief valves.	If a system relief valve becomes unseated for an extended period of time or fails for any other reason, the system could become overheated.	Repair or replace any malfunctioning relief valves as applicable and verify that the loads on the machine are not excessive.

Table 3-4. Won't Shift or Slow to Start

Item	Description	Action
Check the signal line to the servo control port.	Obstructed or restricted flow through the servo control signal lines could result in slow shift or no shift conditions within the motor.	Ensure that the signal lines are not obstructed or restricted and that signal pressure is adequate to shift the motor.
Check that the correct supply and drain orifices are properly installed and are not obstructed.	Supply and drain orifices determine the shift rate of the motor. The smaller the orifice, the longer the time it takes to shift the motor. Obstruction will also increase shift times.	Ensure that the proper control orifices are installed in the motor and verify that they are not obstructed. Clean or replace as necessary.

Disassembly

NOTE: Removal of the end cap voids warranty.

During assembly, coat all moving parts with a film of clean hydraulic oil. This assures that these parts will be lubricated during start-up.

Replace all O-Rings and gaskets.

It is recommended that all O-rings be replaced. Lightly lubricate all O-rings with clean petroleum jelly prior to assembly.

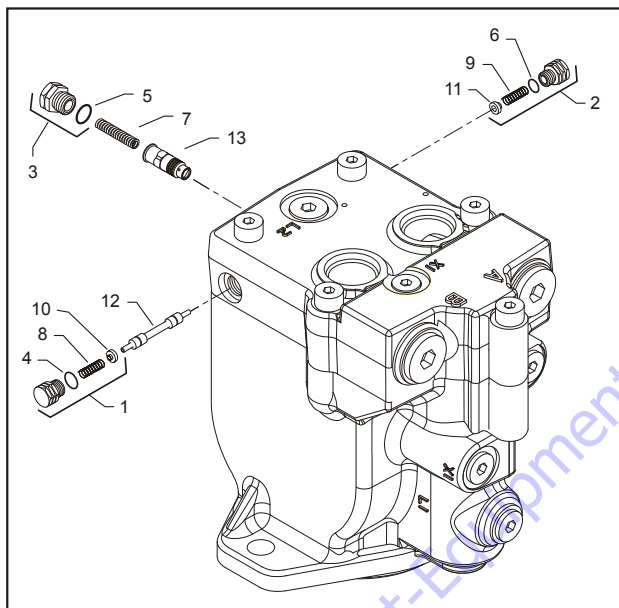

- | | | | |
|-----------|-----------|------------|--------------------|
| 1. Plug | 5. O-ring | 9. Spring | 12. Shift Spool |
| 2. Plug | 6. O-ring | 10. Washer | 13. Orifice Poppet |
| 3. Plug | 7. Spring | 11. Washer | |
| 4. O-ring | 8. Spring | | |

Figure 3-21. Loop Flushing Spool

1. Using a 11/16 in. wrench remove plug (1) and (2).
2. Using a 5/8 in. hex wrench remove plug (3).
3. Remove O-rings (4, 5 and 6).
4. Using pliers, remove centering springs (7, 8 and 9).
5. Remove spring retaining washers (10 and 11).
6. Remove shift spool (12).
7. Remove orifice poppet (13).

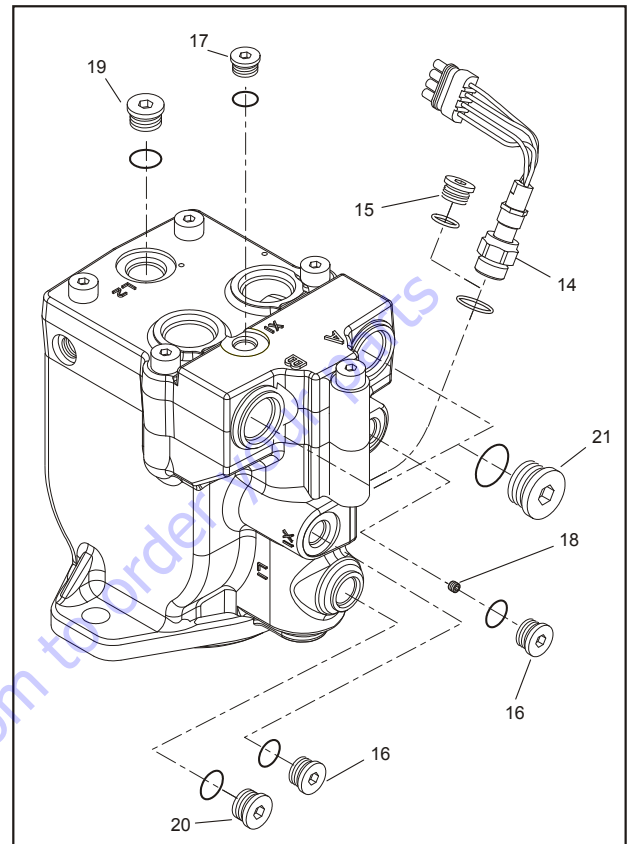

- | | |
|-----------------------|--------------------|
| 14. Lock Nut | 18. Cavity Plug |
| 15. O-ring Plug | 19. Drain Plug |
| 16. Control Line Plug | 20. Drain Plug |
| 17. Control Line Plug | 21. Work Port Plug |

Figure 3-22. Plugs, Fittings and Speed Sensor

8. Remove all fittings from the unit. Discard any O-rings on the fittings.
9. Using an 11/16 in. hex wrench, loosen the speed sensor lock nut (14) if equipped. Then remove the speed sensor using a 1/2 in. hex wrench. Units without speed sensor have an O-ring plug (15) installed in that location; remove it with a 3/4 inch internal hex wrench.
10. Using a 1/4 in. internal hex wrench, remove control line plugs (16, 17). Discard O-rings. Using a 3 mm hex wrench, remove cavity plug (18, if equipped with two-line control) from X2 cavity.
11. Using a 5/16 in. internal hex wrench, remove drain plugs (19, 20). Discard O-rings.
12. Using a 9/16 in. internal hex wrench, remove work port plugs (21, if equipped with axial ports). Discard O-rings.

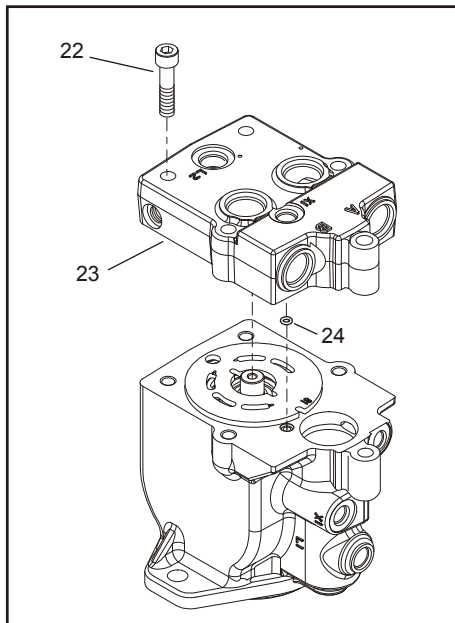

- 22. Screw
- 23. End Cap
- 24. O-ring

Figure 3-23. End Cap

13. Using an 8 mm internal hex wrench, remove the end capscrews (22).
14. Remove the end cap (23). Remove O-ring (24) from the housing or end cap.

NOTE: When the end capscrews are removed, pressure from the servo spring will cause the end cap to bind on the shaft. Press down on the portion of the end cap covering the servo piston and hold the end cap level while removing.

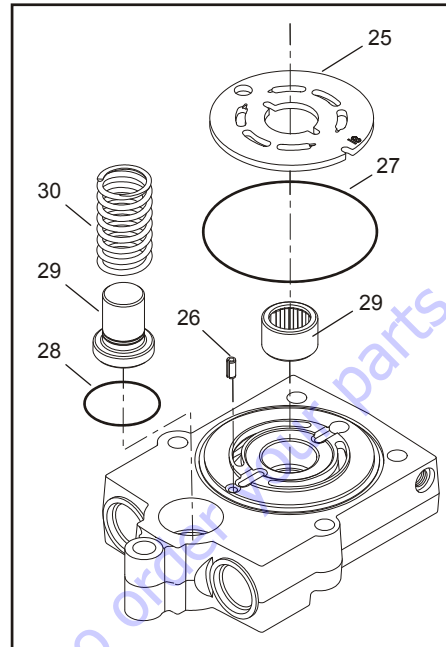

- 25. Valve Plate
- 26. End Cap
- 27. O-ring
- 28. O-ring
- 29. Angle Stop
- 30. Servo Spring

Figure 3-24. Valve Plate & Rear Shaft Bearing

CAUTION

TAKE CARE NOT TO SCRATCH THE SURFACE OF THE VALVE PLATE.

15. Remove the valve plate (25) and timing pin (26) from the end cap.

NOTE: Each displacement has a unique valve plate. For identification, the last two digits of the valve plate part number are stamped on its surface.

16. Remove and discard the O-rings (27 and 28).
17. Remove the rear shaft bearing (29) from the end cap with a bearing puller.

NOTE: The bearing may be difficult to remove with a puller. Try this as an alternative: Pack the bearing cavity with heavy grease. After the shaft is removed, insert it into the bearing cavity and tap lightly with a soft mallet on the splined end. The grease will force the bearing out. Use caution not to drive the bearing past the rear shaft journal as the bearing may become trapped on the shaft and damaged.

18. Remove minimum angle stop (29) and servo spring (30) from the housing.

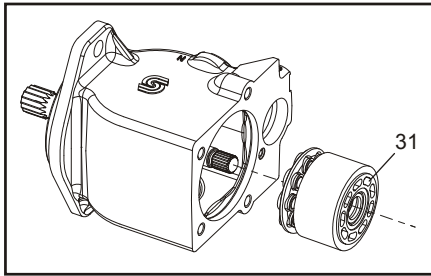

31. Cylinder Kit Assembly

Figure 3-25. Cylinder Kit

19. Turn the housing on its side and remove the cylinder kit assembly (31). Set the assembly aside, being careful not to scratch the running surface.

NOTE: Grooves on the surface of the cylinder kit identify its displacement:

Table 3-5. Displacement Identifiers

# of Grooves	Frame L	Frame K
1	25	38
2	30	45
3	35	--

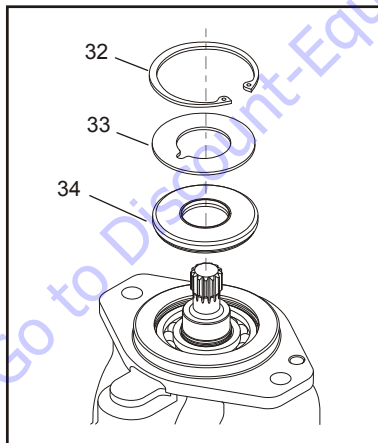

32. Snap Ring
33. Support Washer
34. Shaft Seal

Figure 3-26. Shaft Seal

20. Turn the housing over and remove the snap ring (32) retaining the shaft seal and support washer. Remove the support washer (33) and carefully pry out the shaft seal (34). Discard the seal.

NOTE: To avoid damaging the shaft during seal removal. Install a large sheet metal screw into the chuck of a slide hammer. Drive the screw into the seal surface and use the slide hammer to pull the seal.

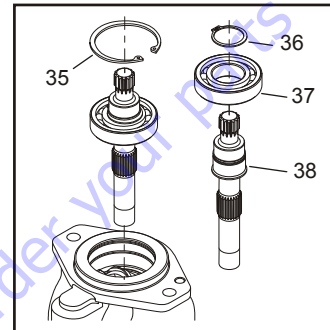

35. Inner Snap Ring
36. Snap Ring
37. Bearing
38. Shaft

Figure 3-27. Shaft & Front Bearing

21. Remove the inner snap ring (35) and the shaft / bearing assembly.
22. Remove the snap-ring (36) retaining the shaft front bearing. Pull the bearing (37) off of the shaft (38).

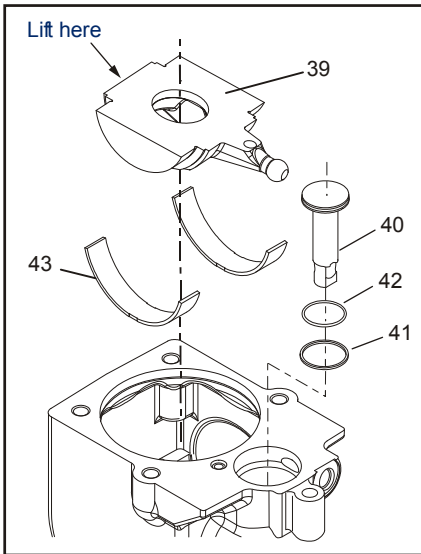

- 39. Swashplate
- 40. Servo Piston
- 41. Piston Seal
- 42. O-ring
- 43. Journal Bearings

Figure 3-28. Swashplate & Servo Piston

23. Turn housing over and remove the swashplate (39) by lifting on the end opposite the servo lever.
24. Remove the servo piston (40). Remove the piston seal (41) and O-ring (42) from the servo piston. Discard the seal and O-ring.
25. Remove the journal bearings (43) from the housing. If the bearings are to be reused, note the location and orientation of each bearing for reassembly.

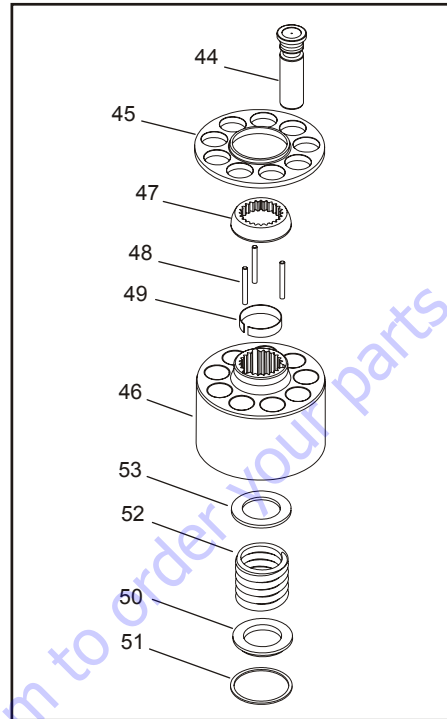

- 44. Piston
- 45. Slipper Retainer
- 46. Cylinder Block
- 47. Ball Guide
- 48. Holddown Pins
- 49. Retaining Ring
- 50. Block Spring Washer
- 51. Spiral Retaining Ring
- 52. Block Spring
- 53. Inner Block Spring Washer

Figure 3-29. Cylinder Kit Disassembly

26. Remove pistons (44) and slipper retainer (45) from the cylinder block (46).
- NOTE:** The pistons are not selectively fitted, however units with high hourly usage may develop wear patterns. Number the pistons and bores for reassembly if they are to be reused.
27. Remove the ball guide (47), hold-down pins (48) and retaining ring (49) from the cylinder block.
- NOTE:** Most repairs do not require block spring removal. Perform this procedure only if you suspect problems with the block spring.

⚠ WARNING

RISK OF PERSONAL INJURY: COMPRESSING THE BLOCK SPRING REQUIRES FORCE OF ABOUT 80 TO 90 LBF (350 TO 400 N). USE A PRESS SUFFICIENT TO MAINTAIN THIS FORCE WITH REASONABLE EFFORT. ENSURE THE SPRING IS SECURE BEFORE ATTEMPTING TO REMOVE THE SPIRAL RETAINING RING. RELEASE THE PRESSURE SLOWLY AFTER THE RETAINING RING IS REMOVED.

- 28. Turn the block over. Using a press, apply pressure on the block spring washer (50) to compress the block spring. Compress the spring enough to safely remove the spiral retaining ring (51). While maintaining pressure, unwind the spiral retaining ring (51). Carefully release the pressure and remove the outer block spring washer (50), block spring (52) and inner block spring washer (53) from the cylinder block.

Inspection

After disassembly, wash all parts (including the end-cap and housing) thoroughly with clean solvent and allow to air dry. Blow out oil passages in the housing and end cap with compressed air. Conduct inspection in a clean area and keep all parts free from contamination. Clean and dry parts again after any rework or resurfacing.

PISTON

Inspect the pistons for damage and discoloration. Discolored pistons may indicate excessive heat; do not reuse.

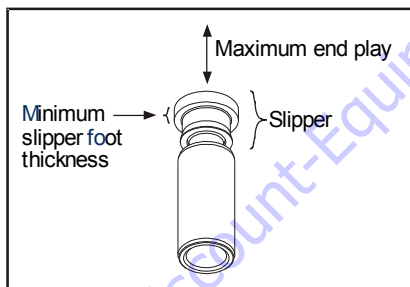

SLIPPERS

Inspect the running surface of the slippers. Replace any piston assemblies with scored or excessively rounded slipper edges. Measure the slipper foot thickness. Replace any piston assemblies with excessively worn slippers. Check the slipper axial end-play. Replace any piston assemblies with excessive end-play.

Minimum slipper foot thickness and maximum axial end-play are given in the table below.

Table 3-6. Slipper Foot Thickness & End Play

Measurement	L Frame mm (in.)	K Frame mm (in.)
Slipper Foot Thickness	2.71 (0.11)	4.07 (0.16)
Piston/Slipper End Play	0.15 (0.006)	

CYLINDER BLOCK

Measure the cylinder block height. Replace blocks worn beyond the minimum height specification. Inspect the running surface of the cylinder block. Replace or resurface worn or scratched blocks. Blocks may be resurfaced to the specifications shown in the drawing, provided resurfacing will not reduce the block height below the minimum specification. Table 3-7, Cylinder Block Measurements.

Table 3-7. Cylinder Block Measurements

Measurement	L25 mm (in.)	L30 mm (in.)	L35 mm (in.)	K38 mm (in.)	K45 mm (in.)
Minimum Cylinder Block Height (A)	50.8 (2.00)	50.8 (2.00)	50.8 (2.00)	54.4 (2.14)	54.4 (2.14)
Cylinder Block Surface Flatness	0.002 (7.9)	0.002 (0.0000079)	0.002 (0.0000079)	0.002 (0.0000079)	0.002 (0.0000079)

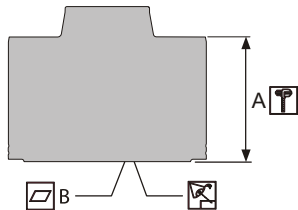

BALL GUIDE AND SLIPPER RETAINER

Inspect the ball guide and slipper retainer for damage, discoloration, or excessive wear. A discolored ball guide or slipper retainer indicates excessive heat. Do not reuse.

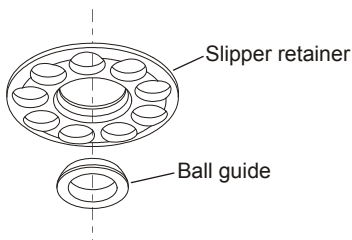

VALVE PLATE

The condition of the valve plate is critical to the efficiency of the motor. Inspect the valve plate surfaces carefully for excessive wear, grooves, or scratches. Replace or resurface grooved or scratched valve plates. Measure the valve plate thickness and replace if worn beyond the minimum specification. Valve plates may be resurfaced to the specifications shown in the drawing, provided resurfacing will not reduce the thickness below the minimum specification.

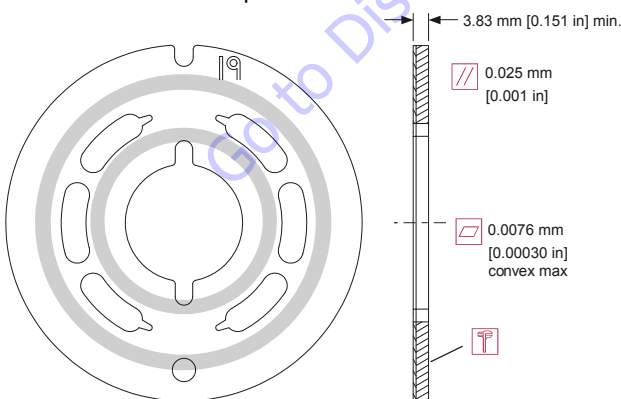

SWASHPLATE AND JOURNAL BEARINGS

Inspect the running face, servo ball-joint and swashplate journal surfaces for damage or excessive wear. Some material transfer may appear on these surfaces and is acceptable providing the surface condition meets specifications shown. Measure the swashplate thickness from the journals to the running face. Replace swashplate if damaged or worn beyond minimum specification. Replace swashplate if the difference in thickness from one side to the other exceeds specification.

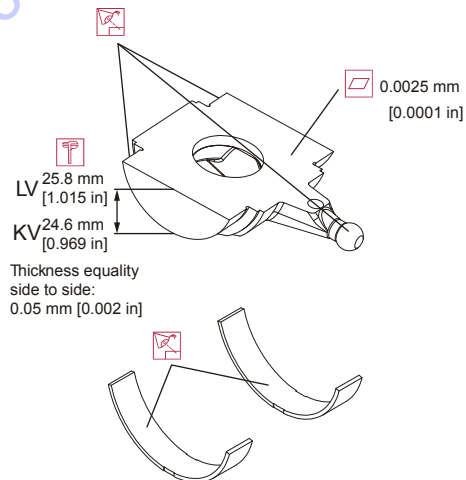

Inspect the journal bearings for damage or excessive wear. Replace journal bearings if scratched, warped, or excessively worn. The polymer wear layer must be smooth and intact.

SHAFT BEARINGS

Inspect bearings for excessive wear or contamination. Rotate the bearings while feeling for uneven movement. Bearings should spin smoothly and freely. Replace bearings that appear worn or do not rotate smoothly.

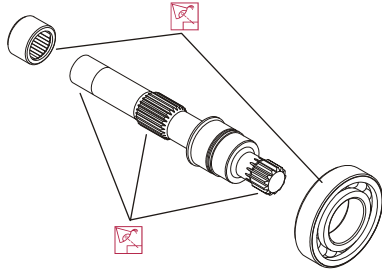

SHAFT

Inspect the motor shaft. Look for damage or excessive wear on the output and block splines. Inspect the bearing surfaces and sealing surface. Replace shafts with damaged or excessively worn splines, bearing surfaces, or sealing surfaces.

SERVO PISTON AND MINIMUM ANGLE STOP

Inspect the minimum angle stop, servo piston head and servo piston ball-socket for damage or excessive wear. Replace if necessary.

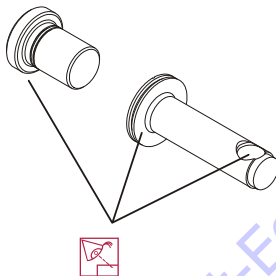

LOOP FLUSHING SPOOL

Inspect the loop flushing spool. Check for cracks or damage. Replace if necessary.

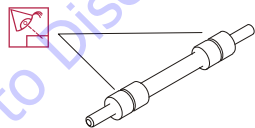

Assembly

1. Install new O-ring (1) and piston seal (2) to the servo piston (3). Install the piston seal over the O-ring.

NOTE: *Installing the piston seal stretches it, making it difficult to install the servo piston in its bore. Allow 30 minutes for the seal to relax after installation. To speed up seal relaxation, compress the seal by installing the piston head into the servo cavity in the end-cap and let it stand for at least five minutes.*

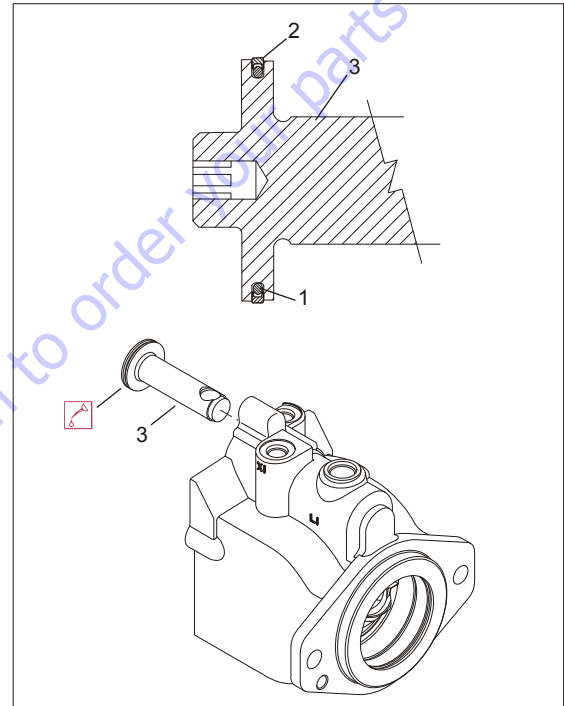

1. O-ring
2. Piston Seal
3. Servo Piston

Figure 3-30. Servo Piston

2. After piston seal has relaxed, lubricate and install servo piston into the housing bore. Align the piston with the ball socket facing the inside of the housing.

⚠ WARNING

RISK OF PERSONAL INJURY: COMPRESSING THE BLOCK SPRING REQUIRES ABOUT 80 TO 90 LBF (350 TO 400 N) OF FORCE. USE A PRESS SUFFICIENT TO MAINTAIN THIS FORCE WITH REASONABLE EFFORT. ENSURE THE SPRING IS SECURE BEFORE ATTEMPTING TO INSTALL THE SPIRAL RETAINING RING. RELEASE THE PRESSURE SLOWLY AFTER THE RETAINING RING IS INSTALLED.

3. Install the inner block spring washer (4), block spring (5) and outer washer (6) into the cylinder block. Using a press, compress the block spring enough to expose the retaining ring groove. Wind the spiral retaining ring (7) into the groove in the cylinder block.

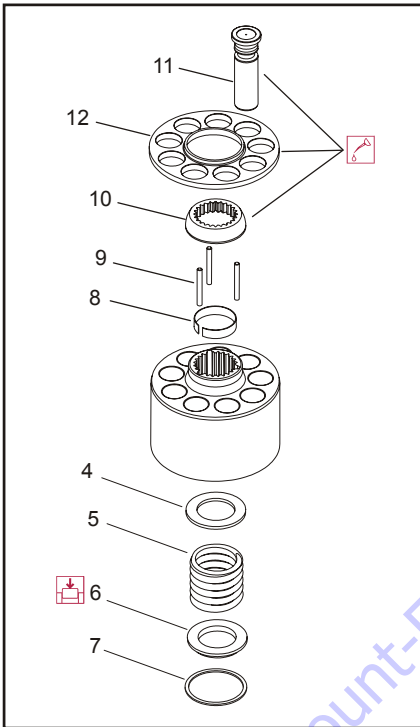

- | | |
|--------------------------|----------------------|
| 4. Block Spring Washer | 9. Holddown Pins |
| 5. Block Spring | 10. Ball Guide |
| 6. Outer Washer | 11. Piston |
| 7. Spiral Retaining Ring | 12. Slipper Retainer |
| 8. Retaining Ring | |

Figure 3-31. Cylinder Kit Assembly

4. Turn the block over and install the retaining ring (8), hold-down pins (9) and ball guide (10) to the cylinder block.
5. Install the pistons (11) to the slipper retainer (12). Install the piston/retainer assembly into the cylinder block. Ensure the concave surface of the retainer seats on the ball guide. If you're reusing the pistons, install them to the original block bores. Lubricate the pistons, slippers, retainer and ball guide before assembly. Set the cylinder kit aside on a clean surface until needed.
6. Install the journal bearings (13) into the housing seats. Use assembly grease to keep the bearings seated during assembly. Ensure the locating nubs drop into the cavities in the seats. If you're reusing the bearings, install them in the original location and orientation. Lubricate the journal bearings.

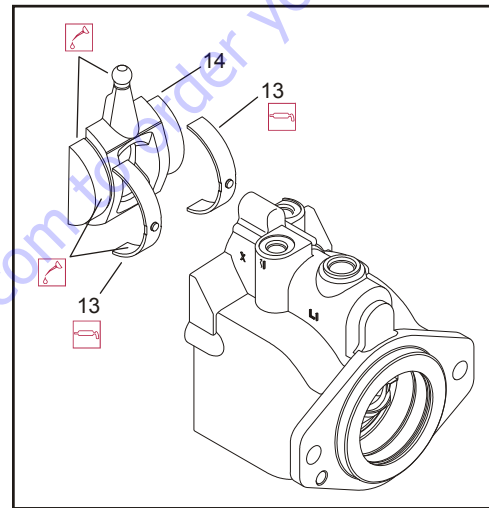

- 13. Journal Bearings
- 14. Swashplate

Figure 3-32. Swashplate and Journal Bearing

7. Install the swashplate (14) into the housing. Tilt the swashplate and guide the servo lever ball into its socket in the servo piston rod. Ensure the swashplate seats into the journal bearings and moves freely. Lubricate the running surface of the swashplate.

8. Press front shaft bearing (15) onto shaft (16). Press bearing onto shaft with lettering facing out. Lubricate bearing rollers. Install snap-ring (17) onto shaft.

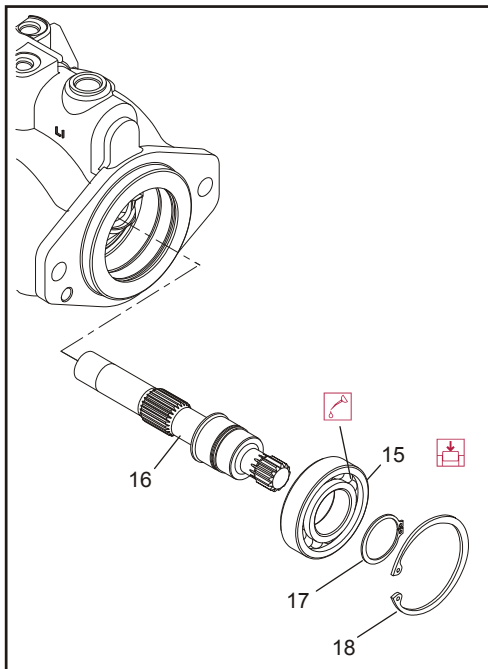

- 15. Front Shaft Bearing
- 16. Shaft
- 17. Snap Ring
- 18. Snap Ring

Figure 3-33. Shaft and Front Bearing

9. While holding the swashplate in place, turn the housing on its side. Install the install shaft/bearing assembly into housing from the flange end. Install the snap-ring (18).

10. Verify swashplate and bearings are properly seated. Install the cylinder kit (19) onto the shaft. Install with the slippers facing the swashplate. Rock the shaft to align the block splines and slide the cylinder kit into place. Orient the motor with the shaft pointing downward and verify the cylinder kit, swashplate, journal bearings and servo piston are all secure and properly installed.

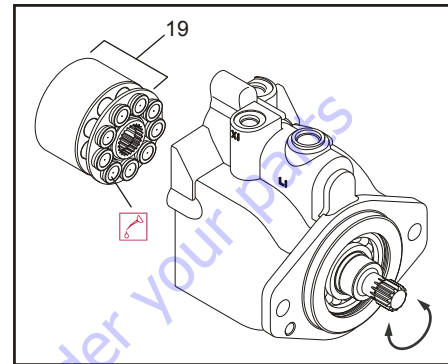

19. Cylinder Kit

Figure 3-34. Cylinder Kit Installation

11. Lubricate and install the servo spring (20) and minimum angle stop (21) into the housing bore.

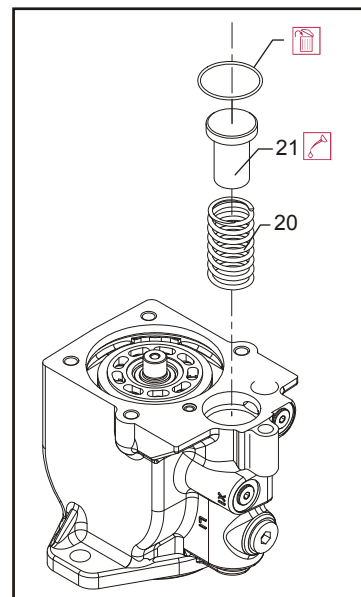

- 20. Servo Spring
- 21. Minimum Angle Stop

Figure 3-35. Servo Spring and Minimum Angle Stop

12. Press the rear shaft bearing (22) into the end cap. Install the bearing with letters facing out. Press until bearing surface is 0.08 ± 0.01 in. (2 ± 0.25 mm) above end cap surface.

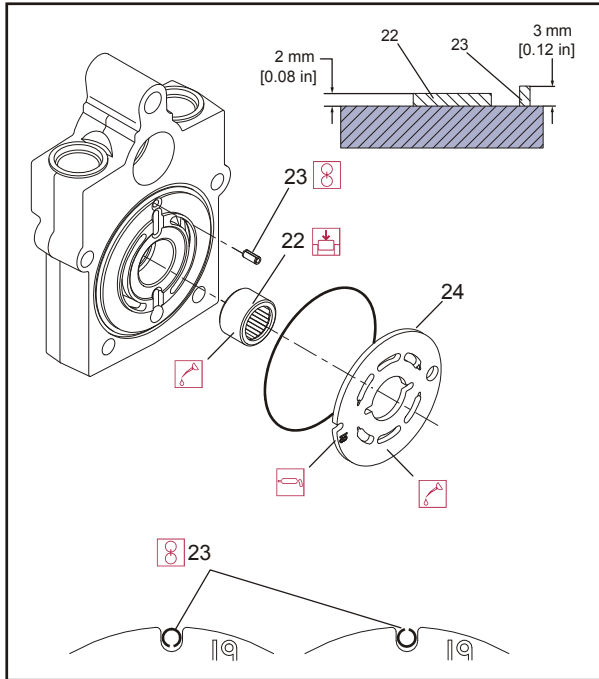

22. Rear Shaft Bearing
23. Timing Pin
24. Valve Plate

Figure 3-36. Valve Plate and Rear Bearing

13. Install timing pin (23) into its bore in the end cap. Install the pin with its groove facing toward or away from the shaft. Press the pin until the end protrudes 0.12 ± 0.01 in. (3 ± 0.25 mm) above end cap surface.
14. Install the valve plate (24) onto the end cap. Install the valve plate with the yellow surface toward the cylinder block. Align the slot in the valve plate with the timing pin. Apply a liberal coat of assembly grease to the end cap side of the valve plate to keep it in place during installation.

15. Install the end cap (25) onto the housing with the end capscrews (26). Check to ensure the end cap will properly seat onto the housing without interference. Improper assembly of the internal components may prevent the end cap from seating properly. Ensure the O-rings seat properly when installing the end cap.

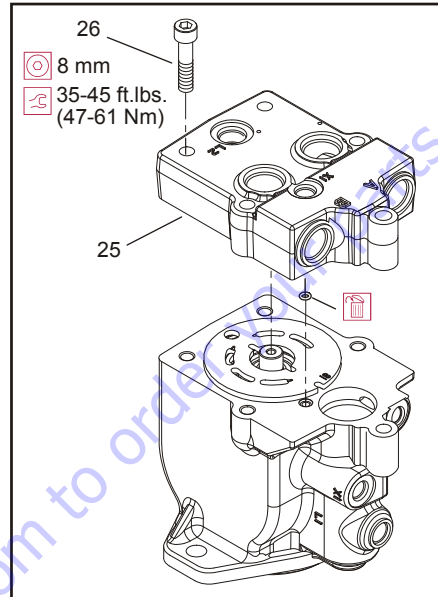

25. End Cap
26. Screw

Figure 3-37. End Cap

16. Using an 8 mm internal hex wrench, tighten the end capscrews. Tighten the screws in opposite corners slowly and evenly to compress the servo spring and properly seat the end cap. Torque end capscrews 35-45 ft. lbs. (47-61 Nm).
17. Before installing the shaft seal, ensure the shaft turns smoothly with less than 120 in. lbs. (13.5 Nm) of force. If the shaft does not turn smoothly within the specified maximum force, disassemble and check the unit.

18. Cover shaft splines with an installation sleeve. Install a new shaft seal (27) with the cup side facing the motor. Press seal into housing until it bottoms out. Press evenly to avoid binding and damaging the seal. Install seal support washer (28) and snap ring (29).

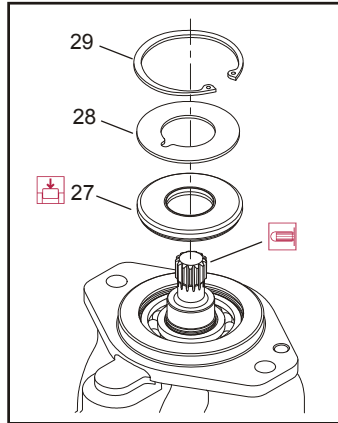

- 27. Shaft Seal
- 28. Seal Support Washer
- 29. Snap Ring

Figure 3-38. Shaft Seal

19. Install remaining plugs and fittings to the housing. Refer to the drawing below for wrench sizes and installation torques.

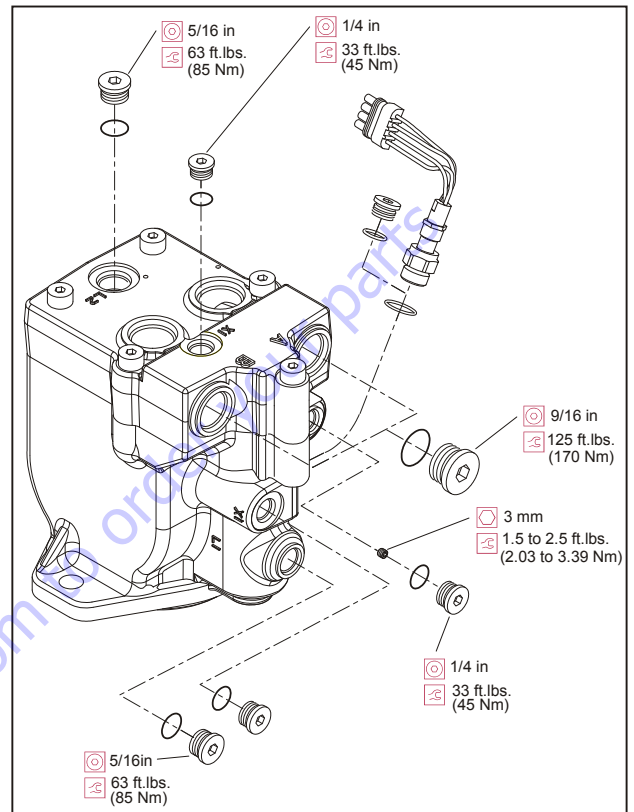
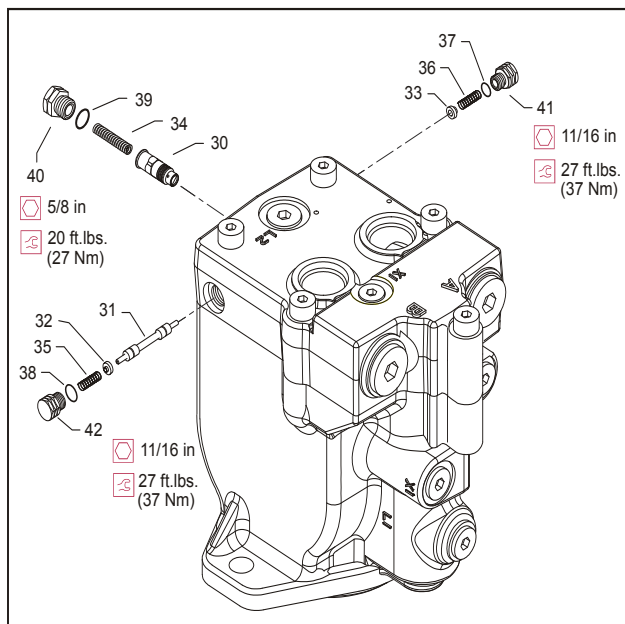

Figure 3-39. Plugs and Fittings Installation

20. Install orifice poppet (30).



- | | | | |
|--------------------|------------|------------|----------|
| 30. Orifice Poppet | 34. Spring | 37. O-ring | 40. Plug |
| 31. Shift Spool | 35. Spring | 38. O-ring | 41. Plug |
| 32. Spring | 36. Spring | 39. O-ring | 42. Plug |
| 33. Spring | | | |

Figure 3-40. Loop Flushing Spool

21. Install shift spool (31).
22. Install spring retaining washers onto springs (32 and 33).
23. Carefully install centering springs (34, 35 and 36).
24. Install new O-rings (37, 38 and 39).
25. Using a 5/8 in. wrench torque plug (40) to 20 ft. lbs. (27 Nm).
26. Using a 11/16 in. wrench, torque plugs (41 and 42) to 27 ft. lbs. (37 Nm).

Initial Start-up Procedures

Follow this procedure when starting-up a new motor or when installing a motor that has been removed.

⚠ WARNING

UNINTENDED MOVEMENT OF THE MACHINE OR MECHANISM MAY CAUSE INJURY TO THE TECHNICIAN OR BYSTANDERS. TO PROTECT AGAINST UNINTENDED MOVEMENT, SECURE THE MACHINE OR DISABLE / DISCONNECT THE MECHANISM WHILE SERVICING.

Prior to installing the motor, inspect for damage incurred during shipping. Make certain all system components (reservoir, hoses, valves, fittings, heat exchanger, etc.) are clean prior to filling with fluid.

1. Fill the reservoir with recommended hydraulic fluid. Always filter fluid through a 10 micron filter when pouring into the reservoir. Never reuse hydraulic fluid.
2. Fill the inlet line leading from the pump to the reservoir. Check the inlet line for properly tightened fittings and be certain it is free of restrictions and air leaks.
3. Fill the pump and motor housing with clean hydraulic fluid. Pour filtered oil directly into the upper most case drain port.
4. To ensure the pump and motor stay filled with oil, install case drain lines into the upper most case drain ports.
5. Install a 0 to 500 psi (0 to 35 bar) gauge in the charge pressure gauge port of the pump to monitor system pressure during start up.

NOTE: Follow recommendations in the vehicle / machine operator's manual for prime mover start up procedures.

6. While watching the pressure gauge, run the engine at the lowest possible speed until system pressure builds to normal levels (minimum 160 psi [11 bar]). Once system pressure is established, increase to full operating speed. If system pressure is not maintained, shut down the prime mover, determine cause and take corrective action.
7. Operate the hydraulic system for at least fifteen minutes under light load conditions.
8. Check and adjust control settings as necessary after installation.
9. Shut down the prime mover and remove the pressure gauge. Replace plug at the charge pressure gauge port.
10. Check the fluid level in the reservoir; add clean filtered fluid if necessary. The motor is now ready for operation.

3.10 CHASSIS TILT INDICATOR SYSTEM

The Chassis Tilt Indicator System measures the turntable angle with respect to ground level. The control system compares the reading to a preset turntable tilt angle value.

When machine is in transport position (see "Transport Position Sensing System" for detail), it can travel at up to maximum speed until it tilts more than 8 degree, then the system will limit the drive speed to maximum displacement mode (slow drive speed).

When machine is out of transport position and the turntable tilts more than the preset value, the boom functions can only operate in creep speed mode and the drive function is disabled. The operator must return the machine into transport mode in order to continue drive the machine.

Default tilt sensor preset value is 4 degree, but it can be selected between 4 degree and 3 degree by JLG hand held Analyzer.

3.11 TRANSPORT POSITION SENSING SYSTEM

The transport position sensing system consists of two limit switches.

1. Elevation Switch – It opens when the boom is elevated beyond a specific angle. Switch activated when the boom is raised 9 degree above horizontal for the 800S and 12 degree above horizontal for the 860SJ.
2. Transport Switch – It opens when the boom is extended beyond a specific length. Switch opens when the boom is extended 18 in. from the fully retracted position.

Transport position sensing system uses switches with "positive opening" contacts. These switches are used in a way that requires switch contacts to be physically broken to the open position when the machine is in the "unsafe" condition.

When the machine is in the "safe" condition, the switch must be allowed to return to the closed state. This requires switch arm cams to be positioned in a way that the switch arm is actuated while the machine is in the "unsafe" condition and the switch arm is free while the machine is in the "safe" condition.

The position of the articulated jib not considered. This system used to control the following systems:

1. Beyond Transport - Drive Speed Cutback System
2. Drive/Steer - Boom Function Interlock System

Beyond Transport - Drive Speed Cutback System

When the boom is positioned beyond the transport position as described in "Transport Position Sensing System", the drive motors are automatically restricted to their maximum displacement position (slow speed).

See the "Chassis Tilt Indicator System" for interaction with the tilt sensor.

Drive/Steer – Boom Function Interlock System

The Drive/Steer – Boom Function Interlock System uses the "Transport Position Sensing System" to sense when the boom is out of the transport position. All controls are simultaneously functional when the booms are within the transport position as on the standard machine.

When the boom is beyond the transport position, the control functions are interlocked to prevent simultaneous operation of any boom function with drive/steer. The first function set to be operated while in this mode, becomes the master function set. In other words, while operating drive/steer functions the boom functions are disable. Similarly, while operating boom functions drive/steer functions are disable.

3.12 DRIVE ORIENTATION SYSTEM

This is intended to indicate to the operator conditions that could make the direction of movement of the chassis different than the direction of movement of the drive/steer control handle.

The system indicates to the operator the need to match the black and white directional arrows on the platform control panel to the arrows on the chassis. The system uses a proximity switch mounted on the hydraulic swivel, an indicator light and a spring return override switch on the platform display panel. The proximity switch trips when the turntable is swing +/- 45 degrees off center of the normal driving position. This occurs roughly when the main boom is swing past a rear tire.

When the turntable is in the normal drive position with the boom between the rear tires, no indications or interlocks are made. When the machine is actively driving when the turntable is swing past the switch point, the system is ignored until drive/steer is released.

When drive is initiated with the boom swing past the switch point, the DOS indicator will flash, and the drive/steer functions will be disabled. The operator must engage the DOS override switch to enable Drive/steer (high drive will remain disabled).

When the DOS is enabled, the DOS indicator will be illuminated continuously, and a 3 second enable timer will be started and will continue for 3 seconds after the end of the last drive/steer command. If the timer expires, the DOS override switch must be re-engaged to enable drive/steer.

3.13 OSCILLATING AXLE SYSTEM

The oscillating front axle is attached to the frame by a pivot pin, which allows all four wheels to remain on the ground when traveling on rough terrain.

The oscillating axle incorporates two lockout cylinders connected between the frame and the axle. The lockout cylinders let axle oscillation when pilot pressure allows flow through the axle cylinder holding valves.

When the turntable moved off center, as recognized by a cam valve in the hydraulic swivel coupling, pilot pressure removed from the axle cylinder holding valves and the cylinders are locked.

When the turntable moved back to center after the cylinders have been locked, the cylinders may not fully release until drive is actuated.

3.14 DRIVE SYSTEM

The four-wheel drive system consists of one variable displacement closed loop pump, four variable displacement piston motors, gear reduction hubs, and a traction control manifold that includes three flow dividers/combiners.













The two-wheel drive system consists of one variable displacement closed loop pump, two variable displacement piston motors, gear reduction hubs, and a traction control manifold that includes one flow dividers/combiner.

Drive speed is varied by a combination of drive pump displacement, engine speed, and motor displacement. Traction control is full time and is present in all drive modes. There are three drive modes that can be selected at the platform console.

The functionality of the drive system is dependent on the position of the boom (In Transport or Out of Transport) using the "Beyond Transport - Drive Speed Cutback System".

The following chart describes how the system works in each drive mode. Actual RPM may vary according to selected engine. See commanded engine RPM for specific Engine Speed value.

Table 3-8. Drive Mode Speeds

Boom Position	Drive Selection (Toggle Switch Location on the Platform Console)	Engine Speed when Drive Control is Activated	Approx. Max. Speed (MPH)
In Transport	Max Speed  - 	High - 2600 RPM	3.8
	Mid-Engine  - 	Mid - 1800 RPM	0.9
	Max Torque  - 	High - 2600 RPM	1.3
Out of Transport	Max Speed  - 	High - 2600 RPM	0.4
	Mid-Engine  - 	Mid - 1800 RPM	0.4
	Max Torque  - 	High - 2600 RPM	0.4

3.15 SWING DRIVE

Roll, Leak And Brake Testing

Torque-Hub units should always be roll and leak tested before disassembly and after assembly to make sure that the unit's gears, bearings and seals are working properly. The following information briefly outlines what to look for when performing these tests.

NOTE: *The brake must be released before performing the roll test. This can be accomplished by either pressure testing using the Brake Leak Test procedure below or by tightening the 12 bolts into the piston through the end plate (See Brake Disassembly Procedure).*

NOTE: *Bolts must be removed while performing brake release test.*

Roll Test

The purpose of the roll test is to determine if the unit's gears are rotating freely and properly. Remove Motor and release the brake by applying 400 psi to the brake port.

To perform a roll test, use a tool capable of applying constant rotational force to the input of the gearbox.

If more drag is felt in the gears only at certain points, then the gears are not rolling consistently and easily and should be examined for improper installation or defects.

Some gear packages roll with more difficulty than others.

Do not be concerned if the gears in the unit seem to roll hard as long as they roll with consistency.

Rotate the gearbox 36 revolutions both clockwise and counterclockwise.

Leak Test (Main Unit)

The purpose of a leak test is to make sure the unit is airtight. Use tool T201476 refer to Figure 3-55. for details to perform the leak test. If the tool is not available, the gearbox must be sealed to perform the test. This can be accomplished by assembling the sealed input device onto the gearbox at the input end and replace one of the oil plugs with an air chuck.

NOTE: *Do not exceed 10 psi (0.7 Bar) pressure during the leak test.*

Higher pressure will create a false sealing effect in assemblies with lip-seals. The unit has a leak if the pressure gauge reading on your leak check fitting starts to fall after the gearbox has been pressurized and allowed to equalize. Leaks will most likely occur at the pipe plugs, the main seal or wherever O-rings or gaskets are located.

The exact location of a leak can usually be detected by brushing a soap and water solution around the main seal and where the O-rings or gaskets meet on the exterior of the unit and then checking for air bubbles.

If a leak is detected in a seal, O-ring, or gasket, the part must be replaced, and the unit rechecked. Leak test at 10 psi (0.7 bar) for 20 minutes.

Brake Test

Prior to brake check remove Motor, Tubing and Elbow as per Motor disassembly instruction. To perform a brake check, use a 7/16-20 thread fitting. Install a hydraulic hand pump with pressure gauge into brake port in Brake Housing using thread fitting.

Place ROLL TEST Tool previously used or equivalent into Sun Gear (8). Apply 25 in.lbs. (2.7 Nm) torque.

While trying to rotate tool, pump the handle on the hydraulic hand pump and increase the pressure until the brake releases. The brake is released when you are able to rotate the tool.

Record the release pressure. If brake does not release within 197 to 210 psi, check to see if it has the proper number of springs using the SPRING CHECKING PROCEDURE.

Increase to maximum pressure to 2000 psi and hold at that pressure for one minute. If the brake does not leak or lose pressure, the unit has passed the brake test. If brake loses pressure, contact JLG service department.

While brake is still released, roll check the unit for one revolution of the output member by rotating the tool. Bleed off pressure slowly while rotating the ROLL TEST Tool previously used.

Record the pressure at which the brake locks up. Using a clean rag, wipe off excess fluid from around brake port and install the pipe plug.

Spring Checking Procedure

Install two Flat Socket Head Capscrews 0.250-20 UNC, 1/2 in. length into holes in brake piston. Tighten bolts evenly to ensure that brake piston remains straight while being compressed into brake cavity of brake housing.

Carefully remove retaining ring from brake housing. Slowly remove bolts evenly from the input brake. Remove the pressure plate from the end of the input brake and count the number of springs in brake.

If number of springs matches the number 14, go to the next step. If number of springs does not match the number 14, install the correct number of springs.

Tightening and Torquing Bolts

If an air impact wrench is used to tighten bolts, extreme care should be taken to ensure that the bolts are not tightened beyond their specified torque.

The following steps describe how to tighten and torque bolts or socket head Capscrews in a bolt circle.

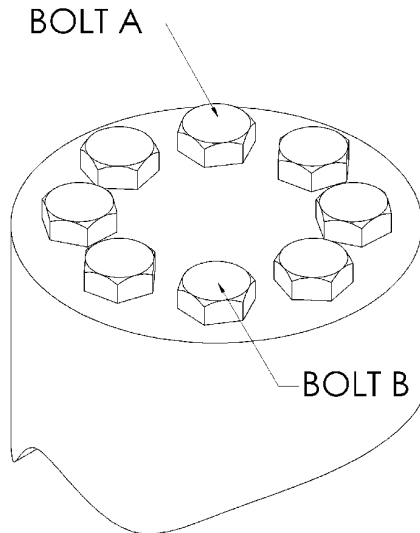

1. Tighten (but do not torque) bolt "A" until snug.
2. Go to the opposite side of the bolt circle and tighten bolt "B" until equally snug.
3. Crisscross around the bolt circle and tighten remaining bolts.
4. Now use a torque wrench to apply the specified torque to bolt "A".
5. Using the same sequence, crisscross around the bolt circle and apply an equal torque to the remaining bolts.

Motor Control Valve Disassembly

NOTE: Refer to Figure 3-41.

1. Place unit on bench with the motor end up.
2. Remove O-ring Plug (1P) and drain the oil from the gearbox.
3. Remove Hydraulic Tubing Assembly (35) by loosening fittings on both ends of tube with a wrench.
4. Using a wrench, loosen jam nuts on Elbow Fittings (30) and remove fittings from Brake (6) and Motor Control Valve (32).
5. Remove O-ring Plugs (23) from Motor Control Valve (32).
6. Remove Motor Control Valve (32) from Motor (31) by removing the four Bolts (21) and washers (22).
7. Remove O-ring (99) between Motor Control Valve (32) and Motor (31). Discard O-ring.

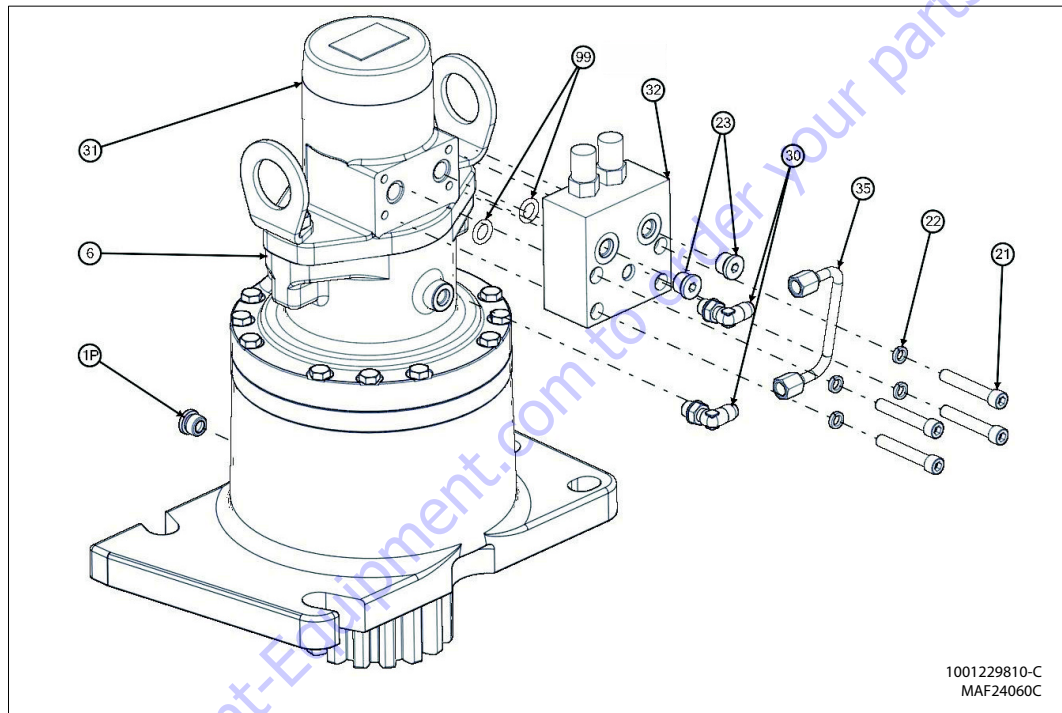

- | | |
|--------------------|-------------------------|
| 1P. O-ring Plug | 30. Elbow Fitting |
| 6. Hydraulic Brake | 31. Hydraulic Motor |
| 21. Hex Bolt | 32. Motor Control Valve |
| 22. Lockwasher | 35. Hydraulic Tubing |
| 23. Plug | 99. O-ring |

Figure 3-41. Motor Control Valve

Motor and Brake Disassembly

NOTE: Refer to Figure 3-42.

1. With unit resting on bench with Motor (31) end up, loosen Hex Bolts (29) and remove Lift Lugs (28) from the Motor (31).
2. Pull Motor (31) straight up and remove Motor (31) from Brake Housing (6).
3. Remove O-ring (26) from between Motor (31) and Brake Housing (6).
4. Insert and tighten the 0.250 – 20 UNC flat Socket Head Capscrews through the Pressure Plate (8M) and into the Brake Piston (8A) to compress the springs and relieve pressure on the Retaining Ring (8N).
5. Using retaining ring pliers, remove Retaining Ring (8N) which holds the Brake Piston assembly in place.

6. Lift Brake Piston Assembly (8A) out of the Brake Housing (6). If the Brake Piston assembly (8A) will not lift out, apply less than 50 psi air to the “brake port” to remove Brake Piston(8A). Remove the Inner (Rotor) (8J), Outer (Stator) Plates (8K), from inside Brake Housing (6).
7. Remove O-rings (8D, 8F) and Backup Rings (8E, 8H) from the Brake Housing (6). Discard O-rings and Backup Rings.
8. Remove 0.250 – 20 UNC flat Socket Head Capscrews and lift the Pressure Plate (8M) from the Brake Piston (8A).
9. Apply less than 50 psi (3.45 bar) air to the “brake port” to remove Brake Piston (8A).

⚠ CAUTION

THE PISTON MAY MOVE QUICKLY. EYE PROTECTION SHOULD BE WORN DURING THIS PROCEDURE.

10. Remove Rotors (8J) and Stators (8K) from Brake Housing (6).

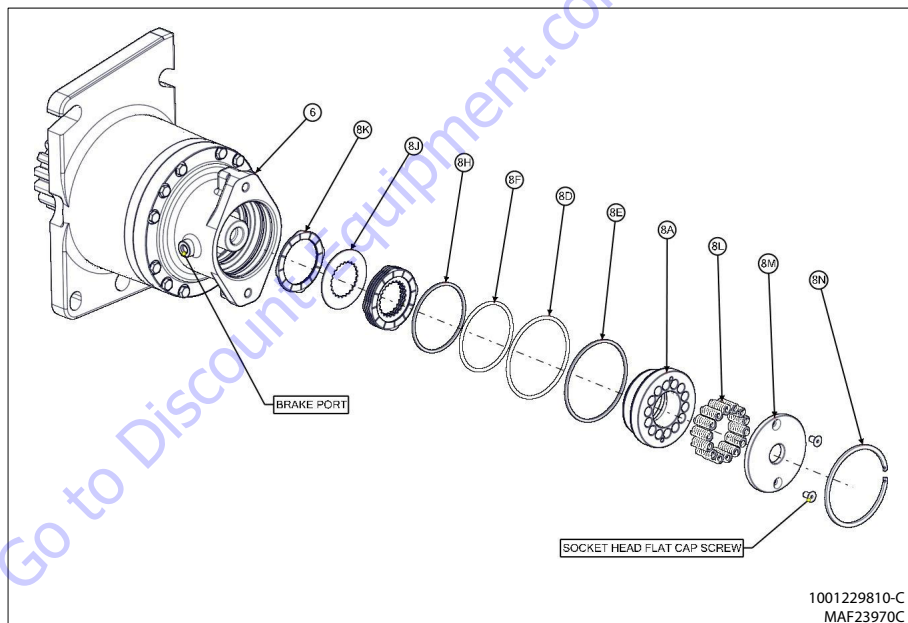

- | | |
|------------------------|-----------------------------|
| 6. Brake Housing | 8J. Brake Rotor |
| 8A. Brake Piston | 8K. Brake Stator |
| 8D. O-ring | 8L. Spring |
| 8E. O-ring/Backup Ring | 8M. Pressure Plate |
| 8F. O-ring | 8N. Internal Retaining Ring |
| 8H. O-ring/Backup Ring | |

Figure 3-42. Motor and Brake

Main Drive Disassembly

NOTE: Refer to Figure 3-43.

1. Remove Sun Gear (8) with Retaining Ring (44) inside.
2. With the unit resting on the Output Shaft (Pinion) (1A), remove the Bolts (12) from the Brake Housing (6).
3. Remove the Brake Housing (6) from the main assembly.
4. Remove O-ring (5A) from between Brake Housing (6) and Ring Gear (4).
5. Remove Thrust Washer (11) from between Brake Housing (6) and Carrier Subassembly.
6. Remove Ring Gear (4) from Housing (1G).
7. Remove O-ring (5) from between Ring Gear (4) and Housing (1G).
8. Remove Carrier Sub-Assembly.
9. Remove Thrust Washer (11) from between Carrier Sub-Assembly and Internal Gear (2).
10. Remove Internal Gear (2).

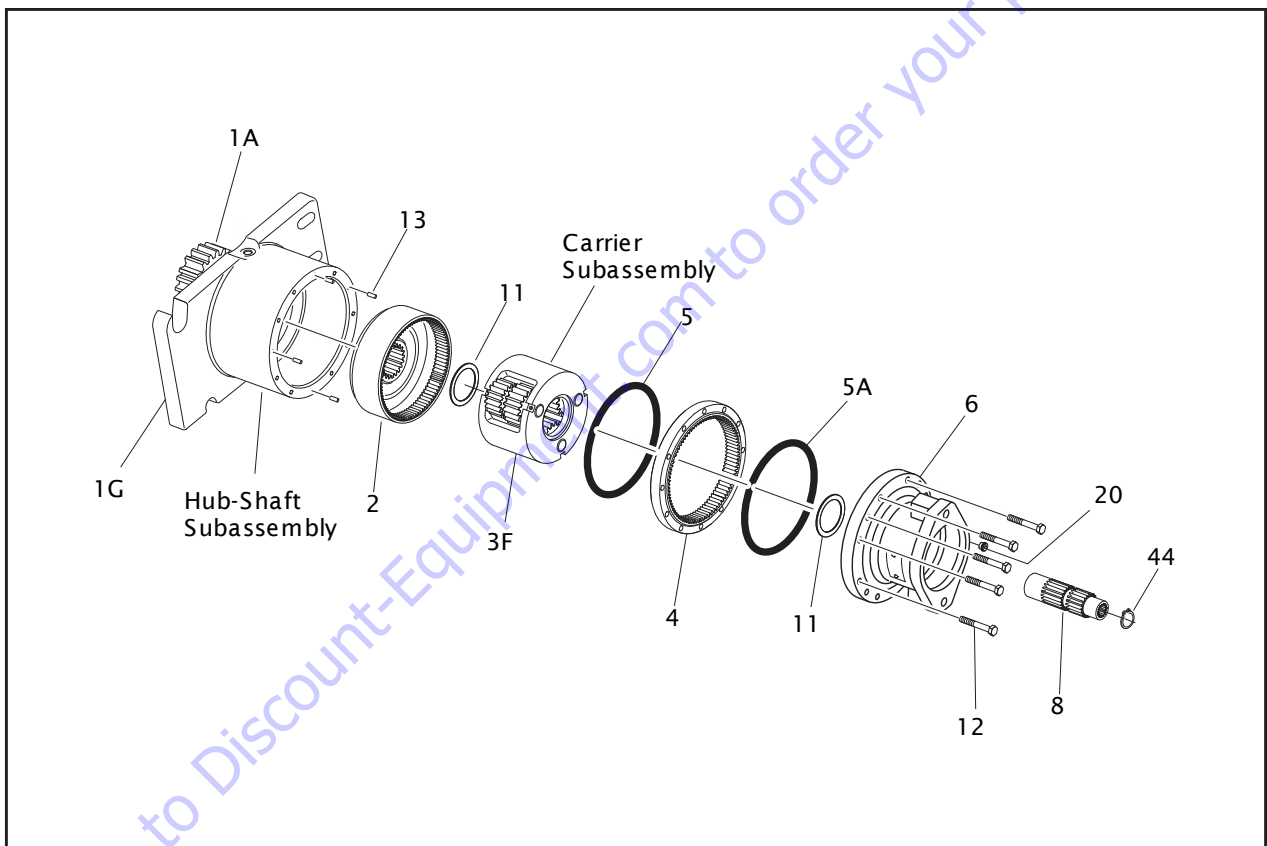

- | | | |
|---------------------------|-------------------|---------------|
| 1A. Output Shaft (Pinion) | 5. O-ring | 12. Bolt |
| 1G. Housing | 5A. O-ring | 13. Dowel Pin |
| 2. Internal Gear | 6. Brake Housing | 20. Pipe Plug |
| 3F. Carrier subassembly | 8. Sun Gear | 44. Ring |
| 4. Ring Gear | 11. Thrust Washer | |

Figure 3-43. Main Drive Assembly

Hub-Shaft Disassembly

NOTE: Refer to Figure 3-44.

1. Using retaining ring pliers remove Retaining Ring (1I) from groove in Output Shaft (1A) and discard.

⚠ CAUTION

EYE PROTECTION SHOULD BE WORN DURING THIS PROCEDURE.

2. Remove Thrust Washer (1H).
3. While supporting the Housing (1G) on the Output Shaft (1A) end, press the Output Shaft (1A) out of the Housing (1G).

NOTE: The Lip Seal (1B) will be pressed out of the Housing (1G) by the Bearing Cone (1D) during this step.

4. Remove the Bearing Cone (1E) from the Housing (1G).
5. Use a bearing puller to remove the Bearing Cone (1D) from the Shaft (1A).
6. Bearing Cups (1C & 1F) will remain in Housing (1G).

NOTE: If bearing replacement is necessary, the Bearing Cups (1C & 1F) can be removed with a slide hammer puller or driven out with a punch.

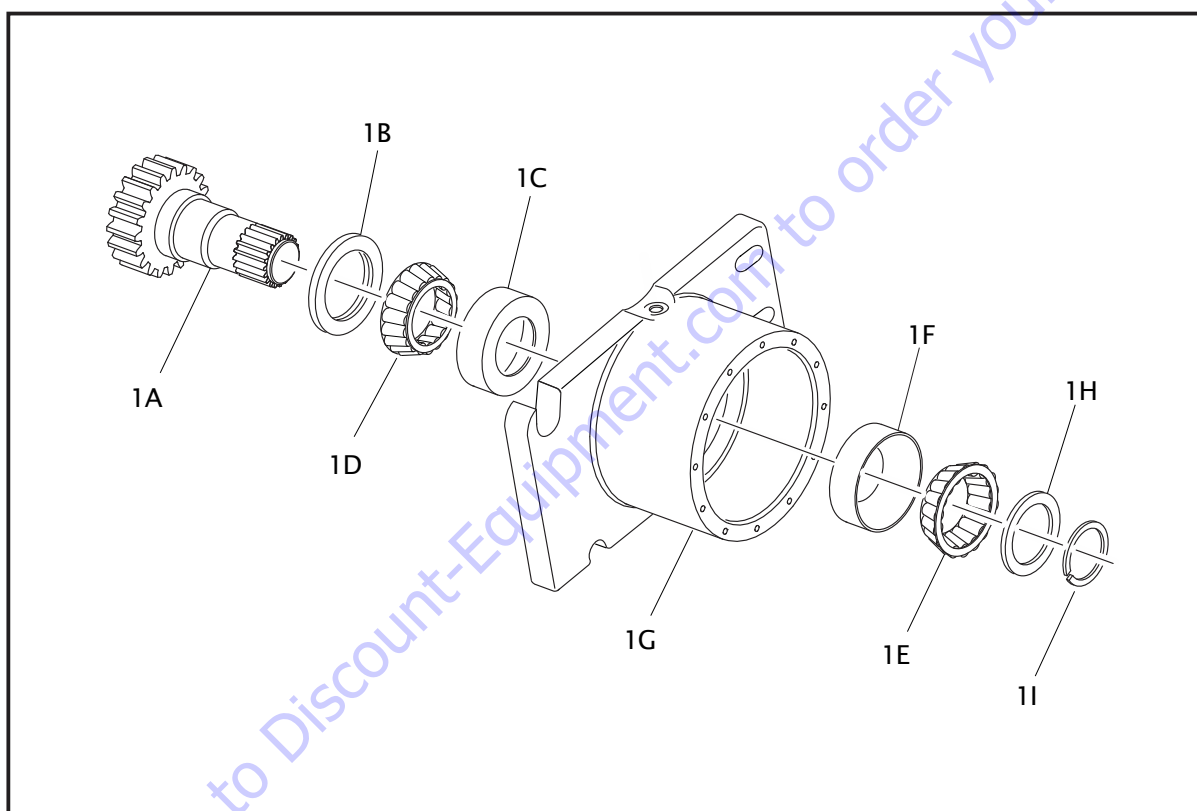

- | | |
|------------------|--------------------|
| 1A. Output Shaft | 1F. Bearing Cup |
| 1B. Lip Seal | 1G. Housing |
| 1C. Bearing Cup | 1H. Thrust Washer |
| 1D. Bearing Cone | 1I. Retaining Ring |
| 1E. Bearing Cone | |

Figure 3-44. Hub-Shaft

Carrier Disassembly

NOTE: Refer to Figure 3-45.

1. Using a 3/16 in. punch drive the Roll Pin (3G) which holds the Planet Shaft (3E) in the Carrier (3A) down into the Planet Shaft (3E) until it bottoms.

NOTE: Make sure that the Roll Pin has bottomed. Otherwise, damage to the carrier could occur when the Planet Shaft is removed.

2. Remove the Planet Shaft (3E) from the Carrier (3A). Use a small punch to remove the Roll Pin (3D) from the Planet Shaft (3E).
3. Slide the Planet Gear (3F), the two Thrust Washers (3B) out of the Carrier (3A).
4. Remove both rows of Needle Bearings (3C) and the Spacer (3D) from the bore of the Planet Gear (3F).
5. Repeat Steps 1 thru 4 for the remaining two Cluster Gears (3F).

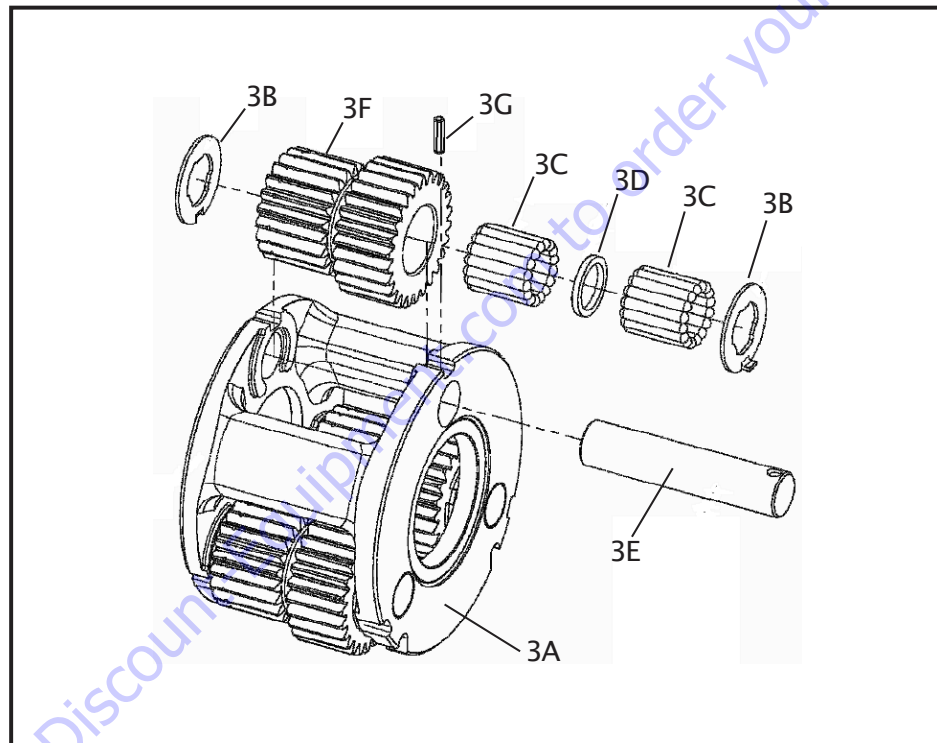

- | | |
|--------------------|------------------|
| 3A. Carrier | 3E. Planet Shaft |
| 3B. Thrust Washers | 3F. Cluster Gear |
| 3C. Needle Bearing | 3G. Roll Pin |
| 3D. Spacer | |

Figure 3-45. Carrier

Hub-Shaft Assembly

NOTE: Refer to Figure 3-44.

1. Press Bearing Cup (1C) into Housing (1G) taking care to ensure cup starts square with the bore of Hub (1G).
2. Place Bearing Cone (1D) in Bearing Cup (1C) in Housing (1G).
3. Press or tap Seal (1B) Into the counterbore of Housing (1G) to the point where it becomes flush with the Housing (1G) face. Care should be taken to ensure Seal (1B) is being correctly installed (smooth face up). Apply grease to the rubber portion of the seal bore.
4. Invert Hub (1G) and press Bearing Cup (1E) into counterbore of Housing (1G).
5. Carefully lower Housing (1G) onto the Output Shaft (1A) until Bearing Cone (1D) contacts the Output Shaft (1A).
6. Press on the small end of the Bearing Cone (1D), being careful not to contact the bearing cage, until the Bearing Cone (1D) seats on the shoulder of the Output Shaft (1A).
7. Start the Bearing Cone (1F) onto the Output Shaft (1A).
8. Press or tap the Bearing Cone (1F) onto the Output Shaft (1A) until it is just seated in the Bearing Cup (1E). while rotating the Housing (G).
9. Install Bearing Spacer (1H) onto Output Shaft (1A) and against Bearing Cone (1F).
10. Install Retaining Ring (1I) into the groove in the Output Shaft (1A). This Retaining Ring (1I) should never be reused in a repair or rebuild.

⚠ WARNING

EYE PROTECTION SHOULD BE WORN DURING THIS PROCEDURE.

11. Tap the Retaining Ring (1I) with a soft metal punch to ensure that the Retaining Ring (1I) is completely seated in the groove of the Output Shaft (1A).

⚠ WARNING

EYE PROTECTION SHOULD BE WORN DURING THIS PROCEDURE.

12. Install O-ring Plug (1P) and torque to 23 to 24 ft. lbs. (31 to 32 Nm).

Carrier Assembly

NOTE: Refer to Figure 3-45.

1. Apply a liberal Coat of grease to the bore of Cluster Gear (3F). This will enable the Needle Rollers (3C) to be held in place during assembly.
2. Install the first row of Needle Rollers (3C) into the bore of Cluster Gear (3F).
3. Insert Spacer (3D) into bore of Cluster Gear (3F) on top of the Needle Rollers (3C).
4. Place second row of Needle Rollers (3C) into bore of Cluster Gear (3F) against Spacer (3D).
5. Place Carrier (3A) so that one of the roll pin holes is straight up.
6. Start Planet Shaft (3E) through the hole in Carrier (3A). Using ample grease to hold it in position, slide one Thrust Washer (3B) over the Planet Shaft (3E) with the tang resting in the cast slot of the Carrier (3A).
7. With large end of Cluster Gear (3F) facing the roll pin hole in the Carrier, place the Cluster Gear into position in carrier (3A) and push Planet Shaft (3E) through the Cluster Gear (3F) without going all the way through.
8. Slide the second Thrust Washer (3B) between the Cluster Gear (3F) and the Carrier (3A) with the tang of the washer located in the cast slot of the Carrier (3A). Finish sliding the Planet Shaft (3E) through the Thrust Washer (3B) and into the Carrier (3A).
9. Position the non-chamfered side on the Planet Shaft (3E) roll pin hole so that it is in line with the hole in the Carrier (3A) using a 1/8 in. (3 mm) diameter punch.
10. After using a 3/16 in. (5 mm) punch to align the two roll pin holes. Drive the Roll Pin (3G) through Carrier (3A) and into the Planet Shaft (3E) until the Roll Pin (3G) is flush with the bottom of the cast slot in the Carrier (3A) outside diameter at the thrust washer (3B) tang. Use a 1/4" (6 mm) pin punch to make sure the Roll Pin (3G) is flush in the slot.
11. Repeat Steps 1 through 10 for the remaining two Cluster Gears (3F).

Main Drive Assembly

NOTE: Refer to Figure 3-43.

1. With the Hub Shaft Sub-Assembly resting on the Shaft (1A) install Internal Gear (2). The spline of the Internal Gear (2) bore will mesh with the spline of the Output Shaft (1A). This will be a tight fit.
2. Inspect the location of the Internal Gear (2) on the Output Shaft (1A). The portion of the Output Shaft (1A) should protrude through the Internal Gear (2) bore.
3. Install 4 Dowel Pins (13) into counterbore holes in Hub (1G).
4. Install Thrust Washer (11) in counterbore of Carrier Sub-Assembly (Small Cluster-Gear end) Use grease to hold in place.
5. Place O-ring (5) into Hub counterbore. Use grease to hold O-ring in place.

⚠ WARNING

BEWARE OF SHARP EDGES OF THE COUNTERBORE WHILE SEATING THIS O-RING.

6. Place Carrier Sub-Assembly on bench with the large end of Cluster Gears (3F) facing up with one at the 12 o'clock position. Find the punch marked tooth on each gear at the large end and locate at 12 o'clock (straight up) from each planet pin. Marked tooth will be located just under the Carrier on upper two gears. Check the timing through the slots in the carrier (See Carrier Sub-Assembly).
7. With large shoulder side of Ring Gear (4) facing down, place Ring Gear (4) over (into mesh with) cluster gears (3F). Be sure that cluster gear timing marks (punch marks) remain in correct location during Ring Gear (4) installation. The side of the Ring Gear (4) with an "X" or punch mark stamped on it should be up.
8. While holding Ring Gear (4) and Cluster Gears (3F) in mesh, place small end of Cluster Gears (3F) into mesh with the Internal Gear (2). On the Ring Gear (4) locate the hole marked "X", or punch marked, over one of the marked counterbored holes (Step 5) in Hub (1G). Check timing through the slots in the carrier. Rotate carrier in assembly to check for freedom of rotation.

NOTE: If gears do not mesh easily or Carrier Assembly does not rotate freely, then remove the Carrier and Ring Gear and check the Cluster Gear timing.

9. Install Thrust Washer (11) into the counterbore on the face of the carrier. Use grease to hold in place.
10. Place O-ring (5A) into counterbore of Brake Housing (6). Use grease to hold O-Ring in place.

⚠ CAUTION

BEWARE OF SHARP EDGES OF THE COUNTERBORE WHILE SEATING THIS O-RING.

11. Install the Brake Housing (6), taking care to correctly align Pipe Plug (20) with those in the Hub (1G).
12. Install Bolts (12) through the Brake Housing (6) into the Hub (1G) and torque to 23-27 ft. lbs. (31-37 Nm).
13. With gearbox standing on the pinion end fill gearbox with 43 oz. of ISO 80W90 gear oil.
14. Install Retaining Ring (44) into the groove in the Sun Gear (8).
15. Install the Sun Gear (8) into mesh with the Planet Gears (3F).
16. Install Pipe Plug (20) into Brake Housing (6) torque to 23-24 ft. lbs. (31-32 Nm).

Motor and Brake Assembly

NOTE: Refer to Figure 3-42.

1. Starting with a Stator (8K), alternately stack and install Stators (8K) into Lobes of Brake Housing (6) and Rotors (8J) (internal splines) onto splines of Sun Gear (8).

NOTE: There should always be a Stator on the top and bottom of the stack.

2. Insert Brake Piston (8A) completely into Brake Housing (6) without O-rings (8D, 8F) and Backup Rings (8E, 8H) to check fit of brake. The Brake Piston (8A) should slide into Brake Housing (6) without being forced. If Brake Piston (8A) does not fit, check for burrs or size problems before proceeding.
3. Grease O-rings (8D, 8F) and install smaller diameter O-Ring (8F) into smaller diameter O-Ring groove in Brake Housing (6) and install larger diameter O-Ring (8D) into larger diameter O-Ring groove in Brake Housing (6).
4. Insert smaller diameter Solid Backup Ring (8H) into smaller groove in Brake Housing (6) between O-Ring (8F) and side of groove towards Output Shaft (1A).
5. Insert larger diameter Solid Backup Ring (8E) into groove in Brake Housing (6) between O-Ring (8D) and side of groove towards Motor (31).
6. Lightly grease cylinder walls of Brake Housing (6) and install Brake Piston (8A) into Brake Housing (6). If necessary, place T-134711 on top of brake and lightly tap until Brake Piston (8A) contacts brake disk stack.
7. Insert 8 Springs (8L) into Brake Piston (8A) spring holes.
8. Install Pressure Plate (8M) into Brake Housing (6) bore and onto top of Springs (8L).
9. Insert and tighten the 0.250 – 20 UNC Flat Head Capscrews through the Pressure Plate (8M) and into the Brake Piston (8A) to compress the springs. Tighten Socket Head Capscrews incrementally to evenly compress the Springs (8L).

CAUTION

CAUTION: SAFETY GLASSES MUST BE WORN DURING THESE NEXT STEPS.

10. Using retaining ring pliers, install large Retaining Ring (8N) into groove in Brake Housing (6) making sure that it is seated properly.

NOTE: Use caution when installing retaining ring (8N) into Brake Housing (6). It may cause injury if it slips out of retaining ring pliers.

11. Remove the Flat Head Capscrews from the Brake Piston (8A) incrementally to release the tension of the springs slowly. Discard Flat Head Capscrews.

12. The Unit should undergo brake test refer instruction on page 47.
13. Grease and install the O-Ring (26) into the Motor (31) pilot.
14. Install Motor (31) into the Brake Housing (6). Insure the motor valve mounting face is aligned with the radial brake release port in the Housing (1G).
15. Install Bolts (29) into Brake Housing (6) through Lifting Lugs (28) and Motor (31) flange. Torque bolts to 80-100 ft. lbs. (108-136 Nm).

Motor Control Valve Assembly

NOTE: Refer to Figure 3-41.

1. Install O-Rings (99) into counterbore on Motor Valve face. Assemble the Motor control Valve (32) onto the Motor (31) with Bolt (21) and Lock Washers (22). Torque Bolts (21) to 18-20 ft. lbs. (23-26 Nm).

NOTE: Be sure to align the holes in the control valve with the motor ports.

2. Install Elbow Fittings (30) into Brake (6). Do not tighten jam nuts.
3. Install Elbow Fittings (30) into Motor Control Valve (32). Do not tighten jam nuts.
4. Assemble Tube (35) into Elbow Fittings (30) and torque to 13-15 ft.lbs (18-20 Nm). Tighten the jam nuts on the Elbow Fittings (30) and torque to 13-15 ft.lbs. (18-20 Nm).
5. Install one O-ring Plug (23) into Motor Control Valve (32) and torque to 18-20 ft. lbs. (23-26 Nm).
6. Pressure test brake, tube and control valve connections by applying 3000 psi (207 bar) pressure to the open port in the Motor Control Valve (32) and holding for 1 minute. Check for leaks at the control-valve-motor interface and the tube connections. Release pressure and install the remaining O-ring Plug (23) into Motor Control Valve (32) and torque to 18-20 ft. lbs. (23-26 Nm).

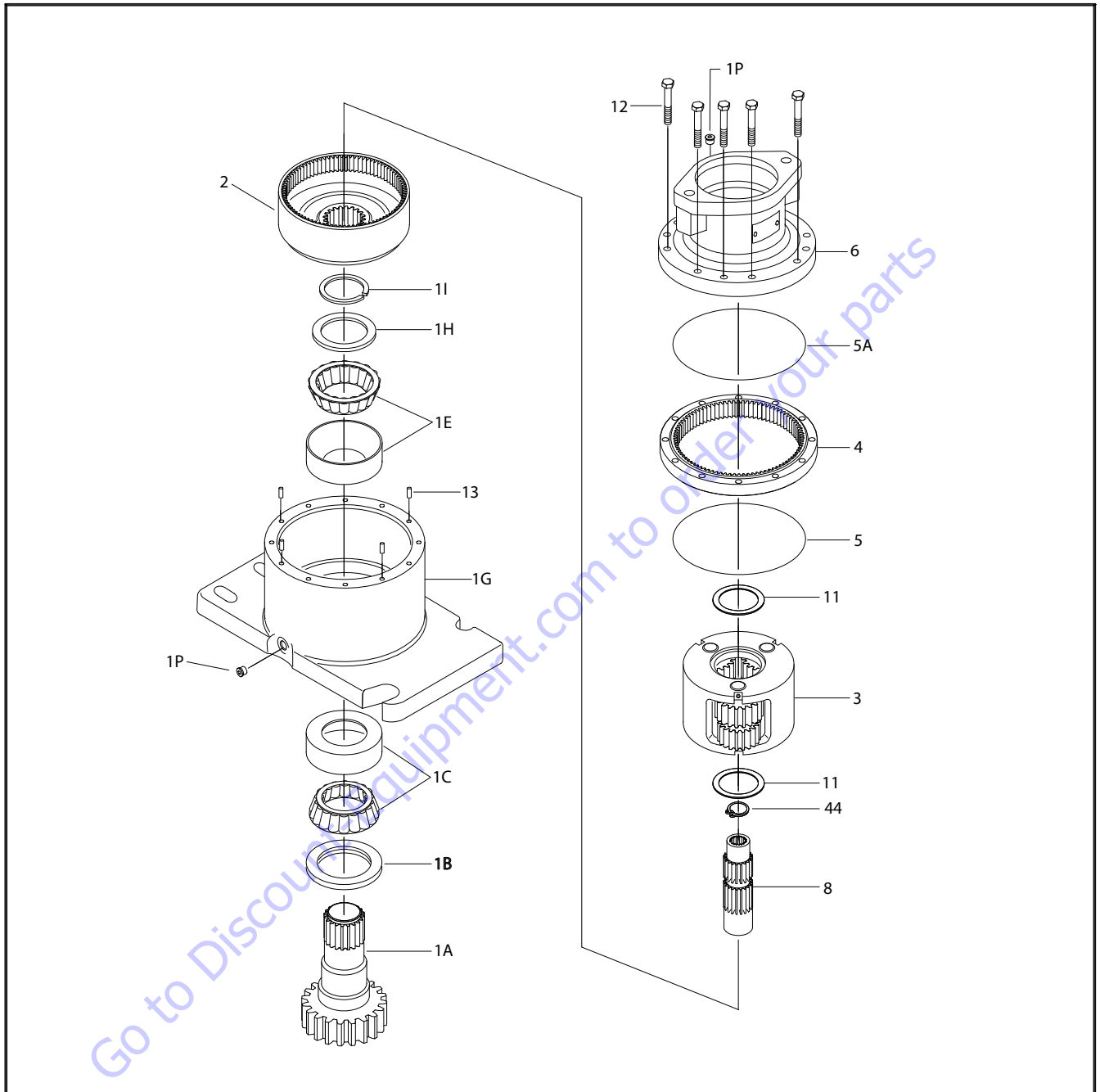

- | | | | | |
|------------------|--------------------|---------------------|-------------------|-----------------------------|
| 1A. Output Shaft | 1G. Housing | 2. Internal Gear | 5A. O-Ring | 12. Bolt |
| 1B. Lip Seal | 1H. Tanged Washer | 3. Carrier Assembly | 6. Brake Housing | 13. Dowel Pin |
| 1C. Bearing | 1I. Retaining Ring | 4. Ring Gear | 8. Sun Gear | 1P. Pipe Plug |
| 1D. Bearing | 1P. Pipe Plug | 5. O-Ring | 11. Thrust washer | 44. Internal Retaining Ring |

Figure 3-46. Swing Drive Assembly

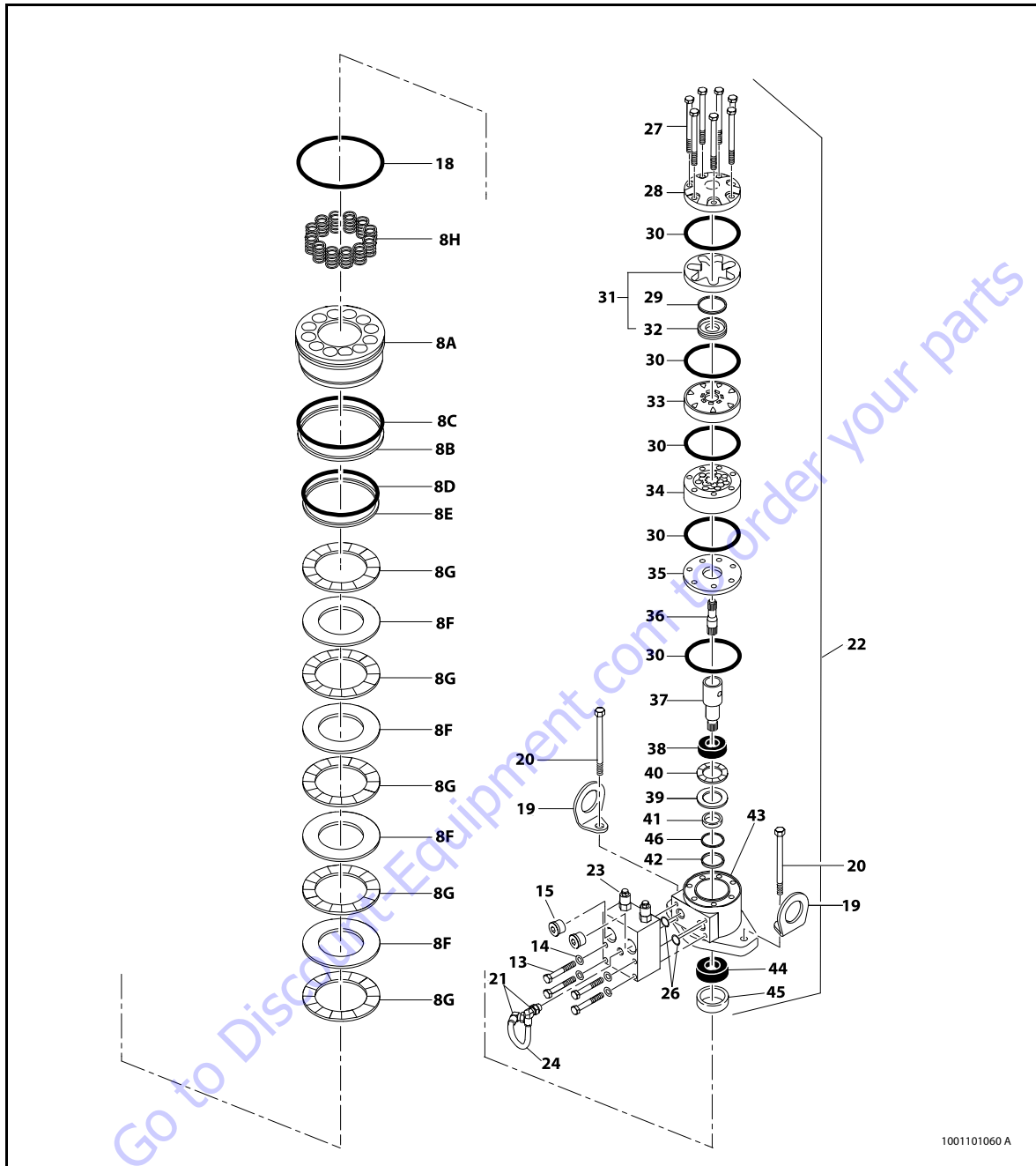

- | | | | | |
|-----------------|-------------------|------------------------------|--------------------|--------------------|
| 8A. Piston | 8H. Spring | 21. Elbow | 32. Ring | 40. Thrust Bearing |
| 8B. O-Ring | 13. Thrust Washer | 24. Tube | 33. Manifold | 41. Inner Seal |
| 8C. Backup Ring | 14. Lock washer | 26. O-ring | 34. Rotor Set | 43. Backup Washer |
| 8D. O-Ring | 15. Pipe Plug | 27. Bolt | 35. Wear Plate | 43. Housing |
| 8E. Backup Ring | 18. O-Ring | 28. End Cover | 36. Drive Link | 44. Backup Washer |
| 8F. Rotor Disc | 19. Lifting lug | 29. Commutator Seal | 37. Coupling Shaft | 45. Seal |
| 8G. Stator Disc | 20. Bolt | 30. Ring Seal | 38. Inner Bearing | 46. Washer |
| | | 31. Commutator and Ring Assy | 39. Thrust Washer | |

Figure 3-47. Swing Motor and Brake Assembly

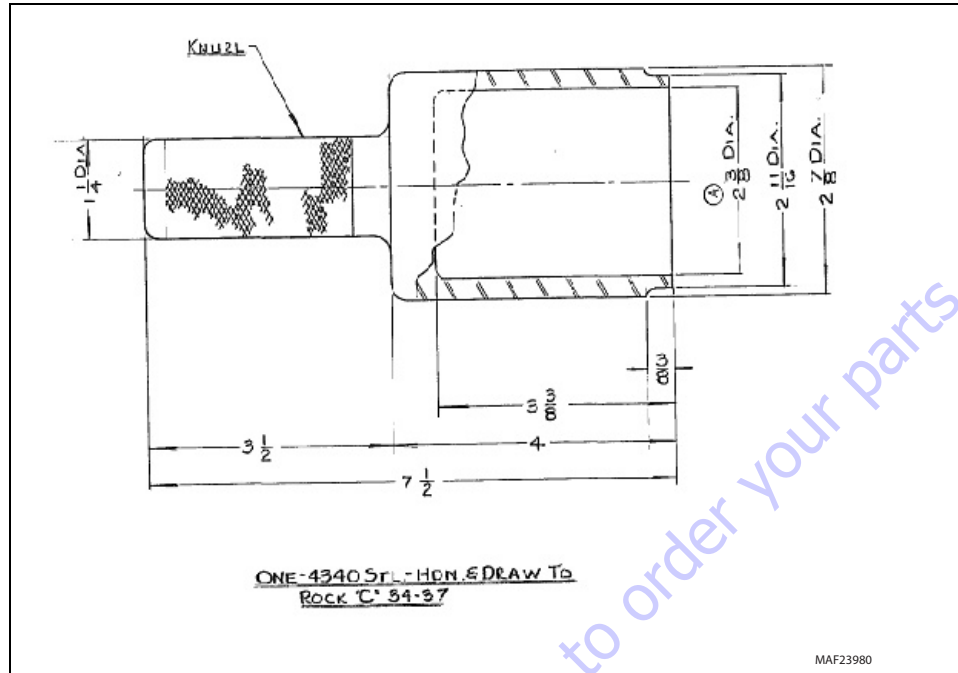

Figure 3-48. Bearing Cone Press Tool (T144566)

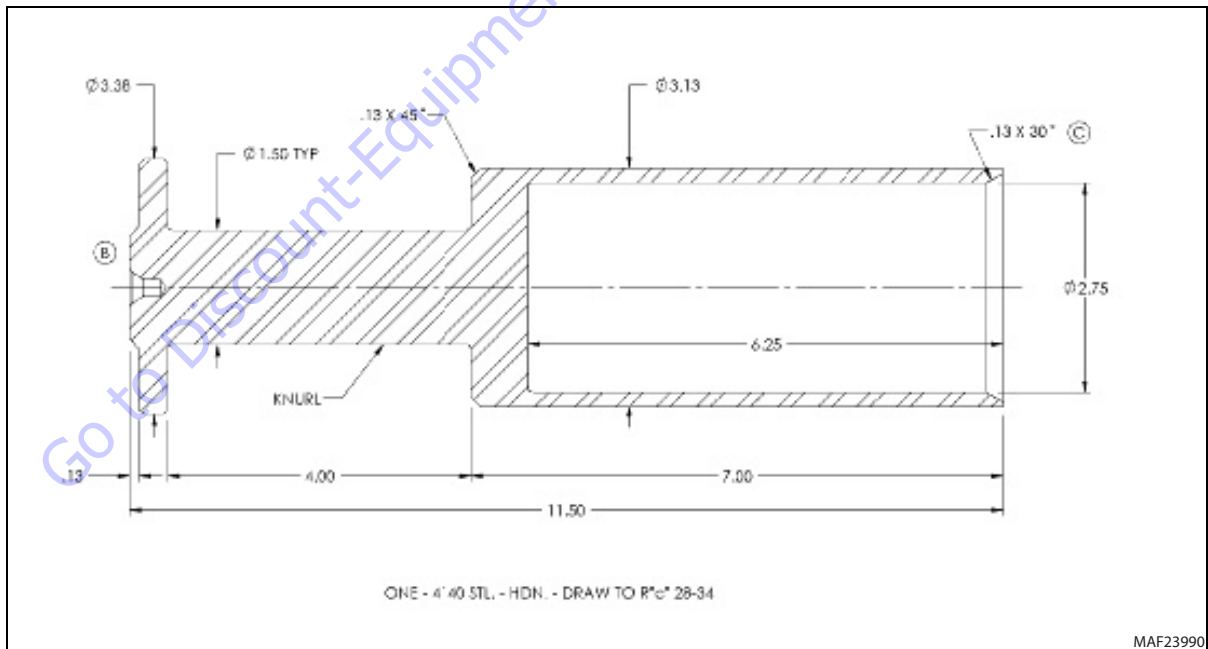

Figure 3-49. Bearing Cone Pressing Tool (T145741)

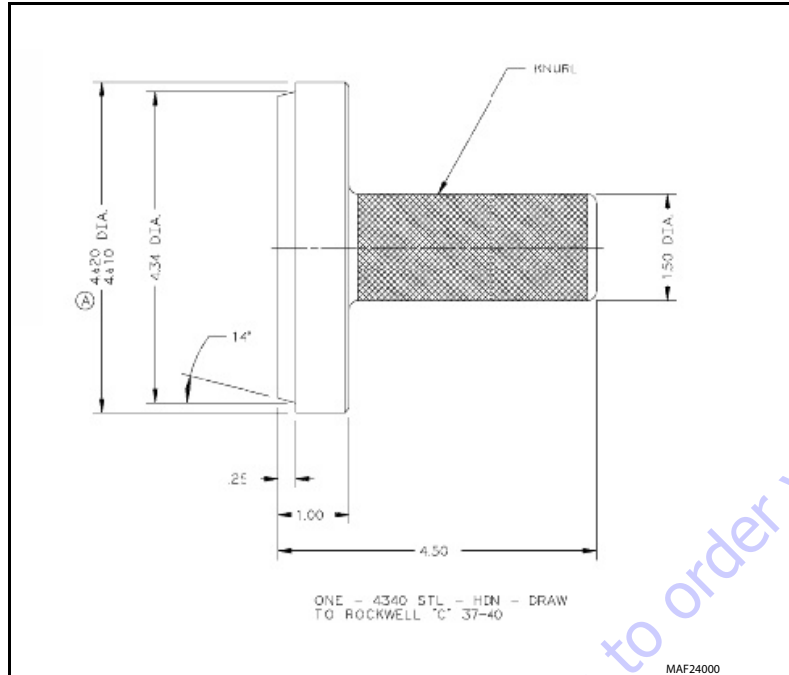

Figure 3-50. Bearing Cup Pressing Tool (T149013)

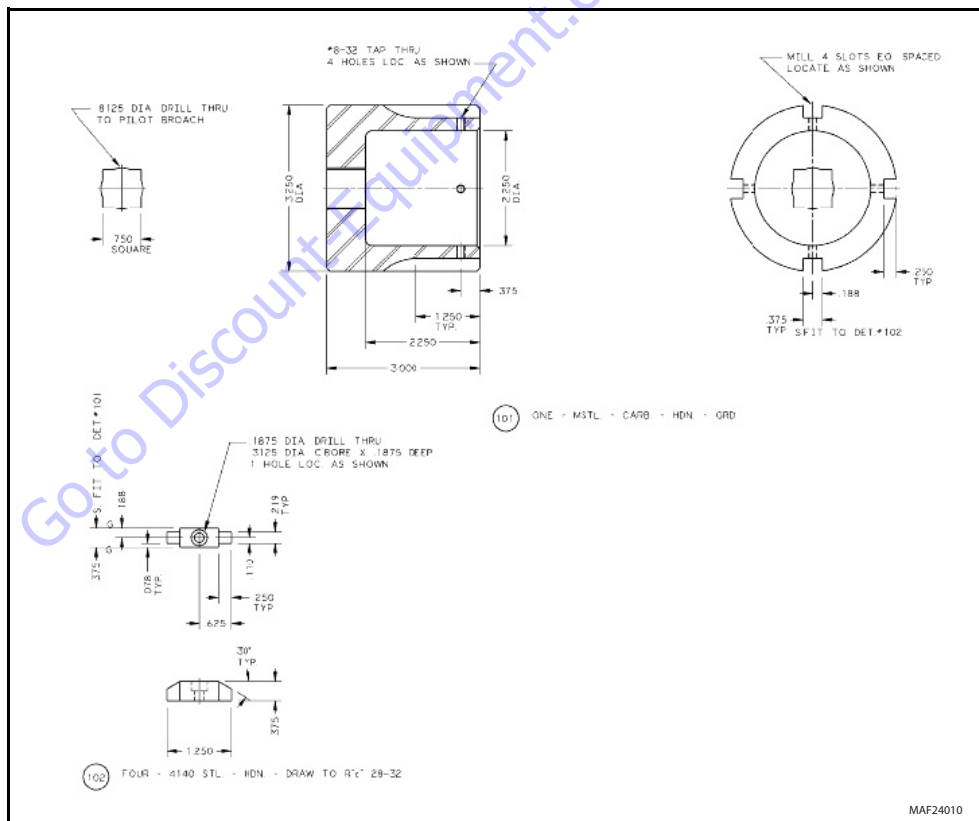

Figure 3-51. Locknut Wrench Tool (T151047)

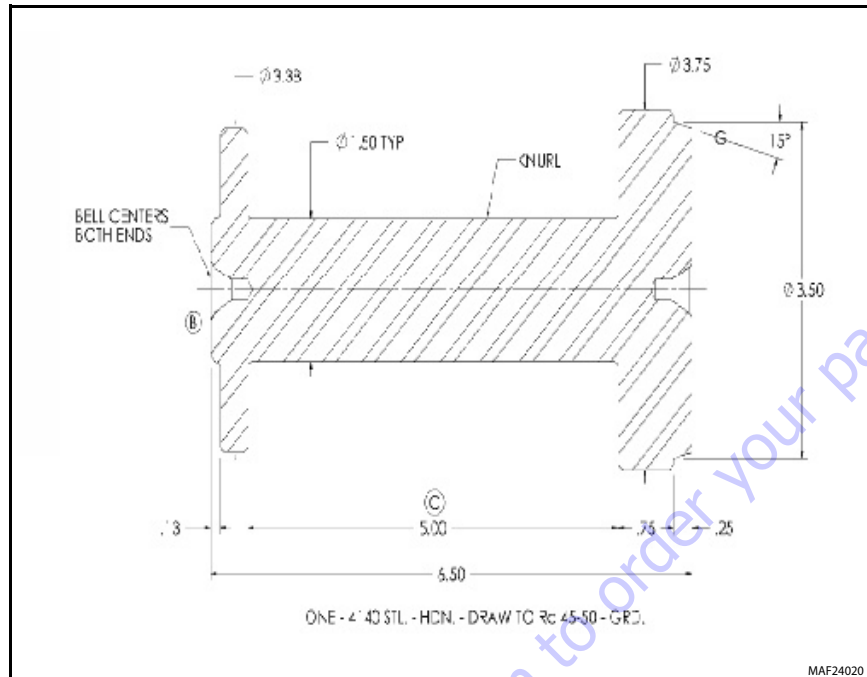

Figure 3-52. Bearing Cup Pressing Tool (T155291)

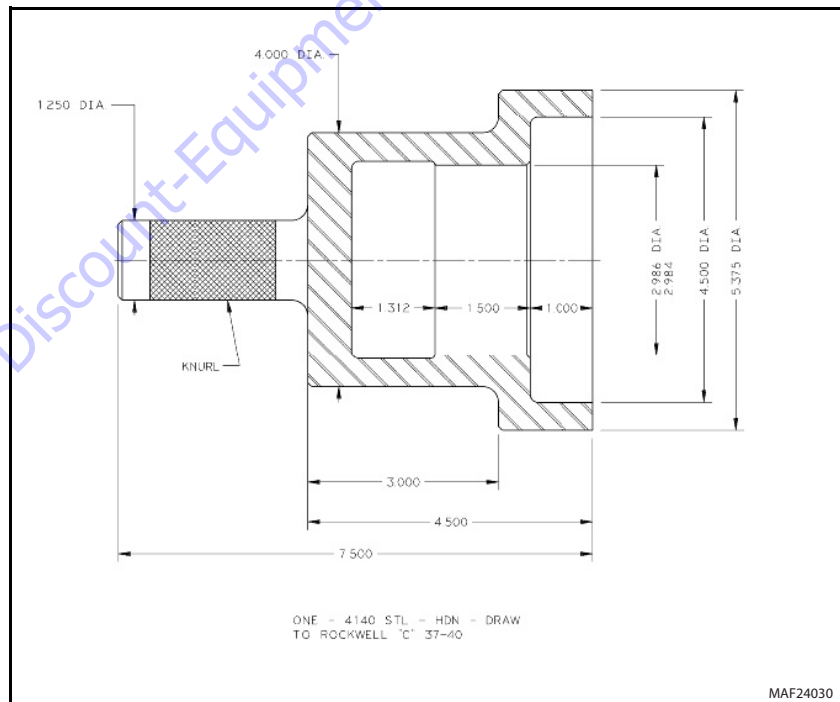

Figure 3-53. Seal Press Tool (T175741)

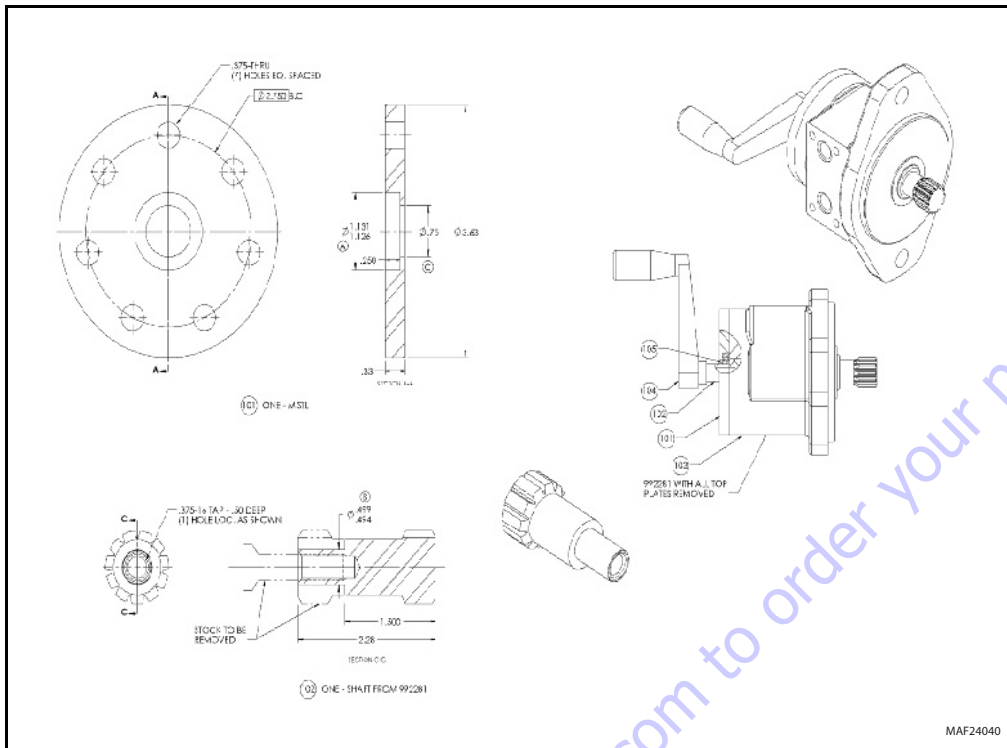

Figure 3-54. Swing Drive Test Plate (T187845)

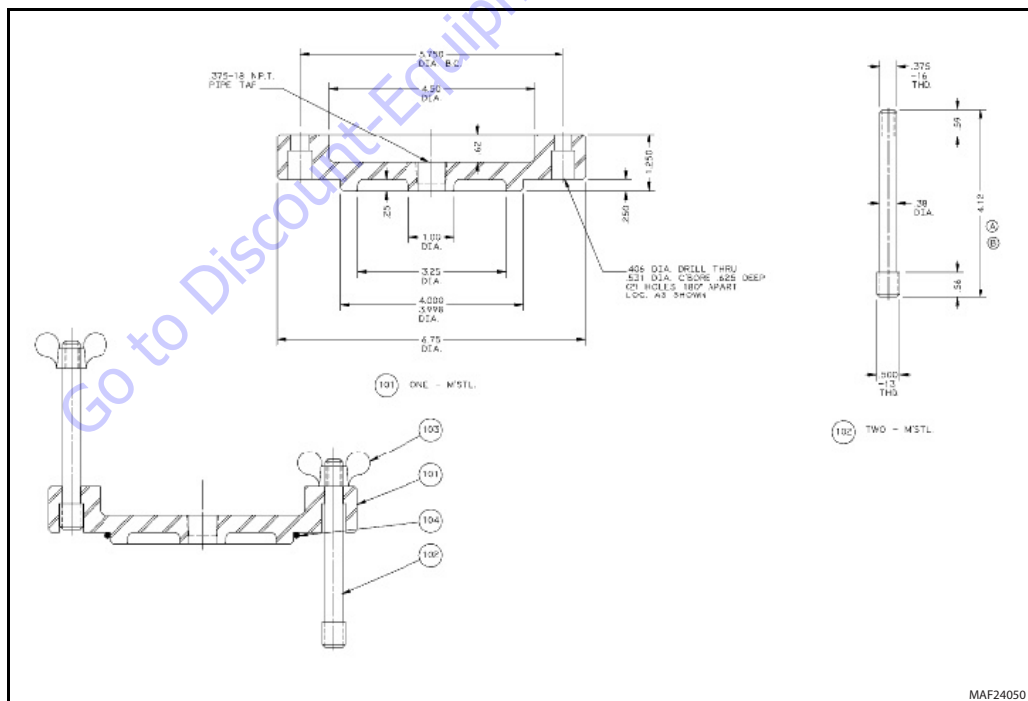
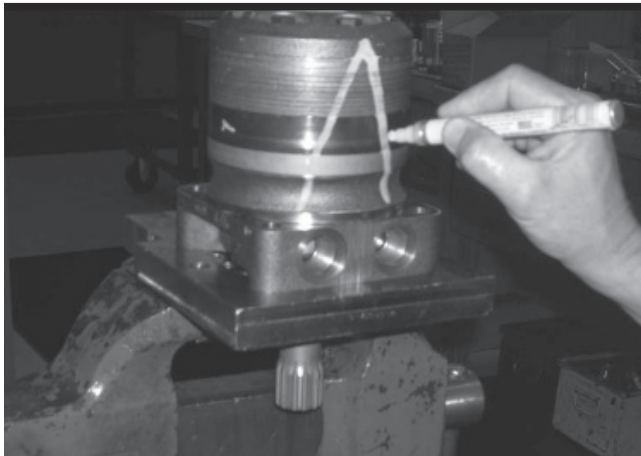

Figure 3-55. Leak Test Adapter Plate (T201476)

3.16 SWING MOTOR

Disassembly and inspection

1. Place the Torqmotor™ in a soft jawed vice, with coupling shaft (12) pointed down and the vise jaws clamping firmly on the sides of the housing (18) mounting flange or port bosses. Remove manifold port O-Rings (18A) if applicable.



⚠ WARNING

IF THE TORQMOTOR™ IS NOT FIRMLY HELD IN THE VISE, IT COULD BE DISLODGED DURING THE SERVICE PROCEDURES, CAUSING INJURY.

2. Scribe an alignment mark down and across the Torqmotor™ components from end cover (2) to housing (18) to facilitate reassembly orientation where required. Loosen two shuttle or relief valve plugs (21) for disassembly later if included in end cover. 3/16 or 3/8 inch Allen wrench or 1 inch hex socket required.

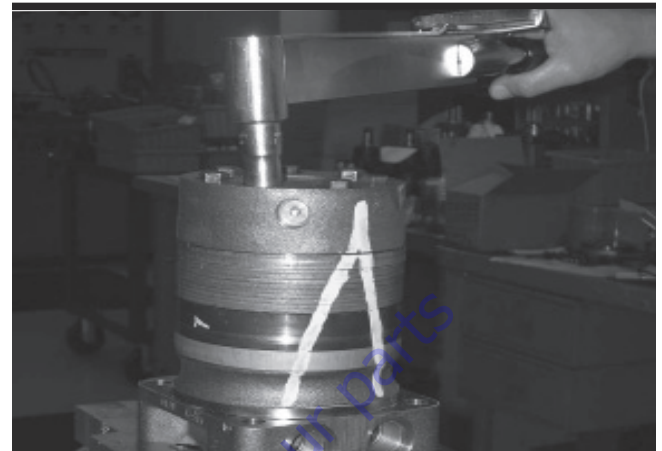
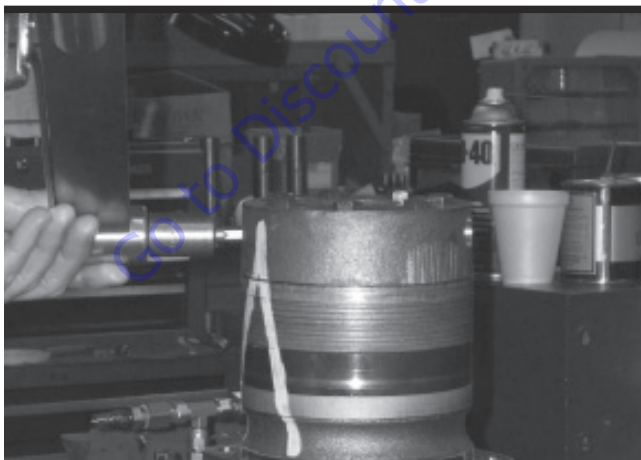

3. Remove the five, six, or seven special ring head bolts (1) using an appropriate 1/2 or 9/16 inch size socket. Inspect bolts for damaged threads, or sealing rings, under the bolt head. Replace damaged bolts.



4. Remove end cover assembly (2) and seal ring (4). Discard seal ring.



NOTE: Refer to the appropriate "alternate cover construction" on the exploded view to determine the end cover construction being serviced.

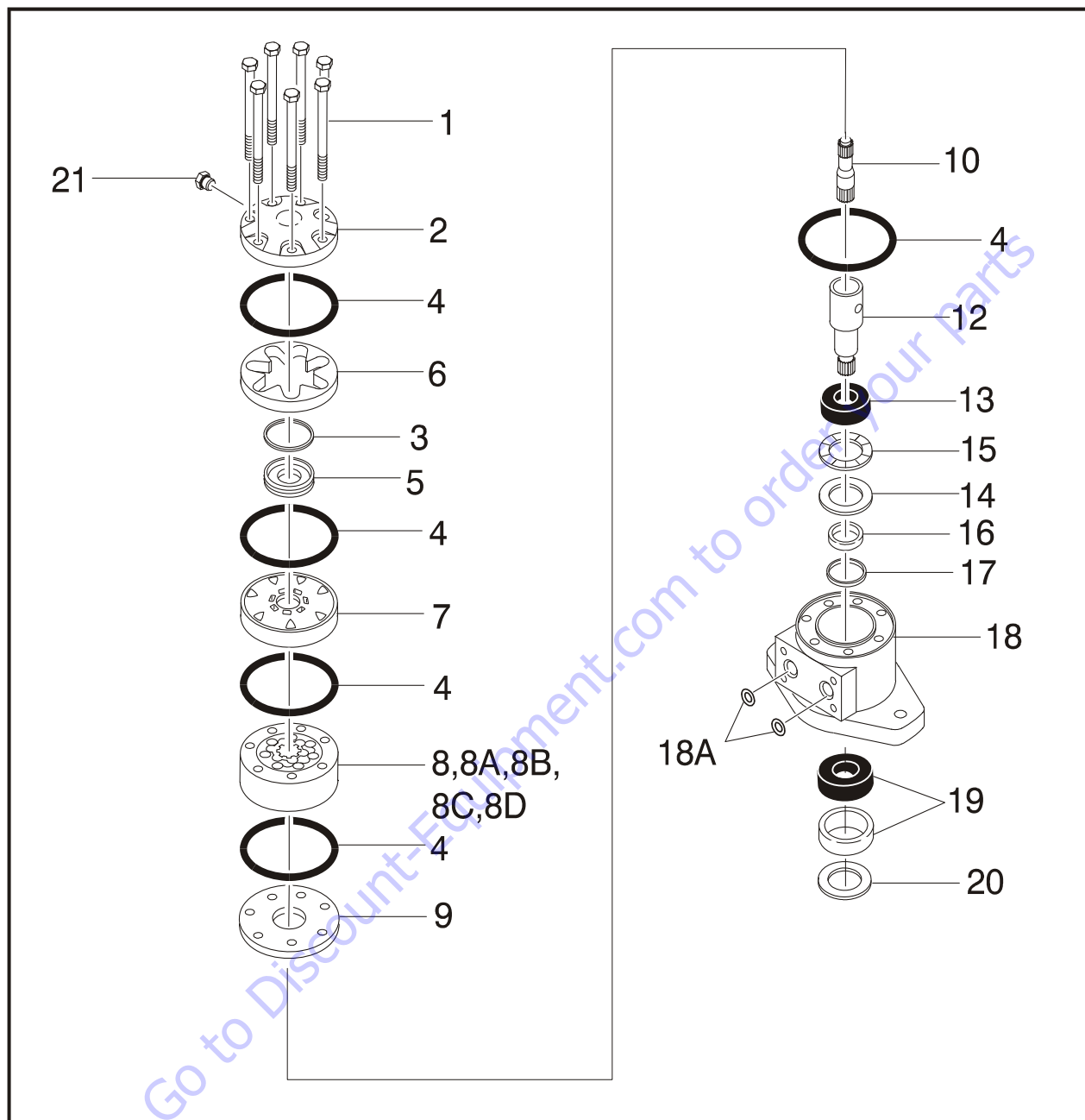

- | | | | |
|-------------------------|---------------------------|----------------------------|----------------------------|
| 1. Special Bolts | 8. Rotor Set | 12. Coupling Shaft | 18A. O-Ring |
| 2. End Cover | 8A. Rotor | 13. Bearing/Bushing, Inner | 19. Bearing/Bushing, Outer |
| 3. Seal Ring-Commutator | 8B. Stator or Stator Vane | 14. Thrust Washer | 20. Dirt & Water Seal |
| 4. Seal Ring | 8D. Stator Half | 15. Thrust Bearing | 21. Plug |
| 5. Commutator Ring | 9. Wear Plate | 16. Seal | |
| 6. Commutator Ring | 10. Drive Link | 17. Backup Washer | |
| 7. Manifold | 11. Not Used | 18. Housing | |

Figure 3-56. Swing Drive Motor

5. If the end cover (2) is equipped with shuttle valve components, remove the two previously loosened plugs (21).

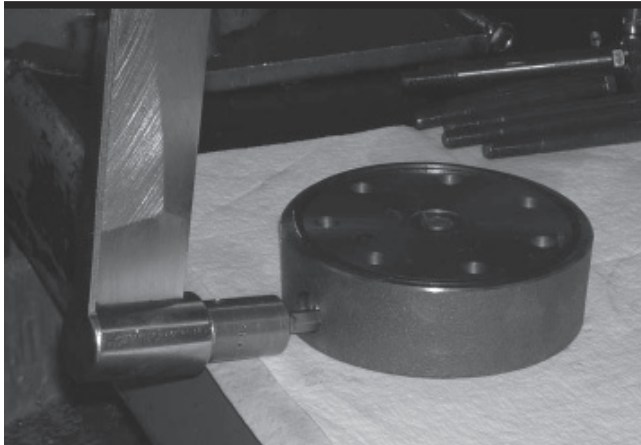

NOTICE

BE READY TO CATCH THE SHUTTLE VALVE OR RELIEF VALVE COMPONENTS THAT WILL FALL OUT OF THE END COVER VALVE CAVITY WHEN THE PLUGS ARE REMOVED.

NOTE: O- ring is not included in seal kit but serviced separately, if required.

NOTE: The insert and if included the orifice plug in the end cover (2) must not be removed as they are serviced as an integral part of the end cover.

6. Thoroughly wash end cover (2) in proper solvent and blow dry. Be sure the end cover valve apertures, including the internal orifice plug, are free of contamination. Inspect end cover for cracks and the bolt head recesses for good bolt head sealing surfaces. Replace end cover as necessary.

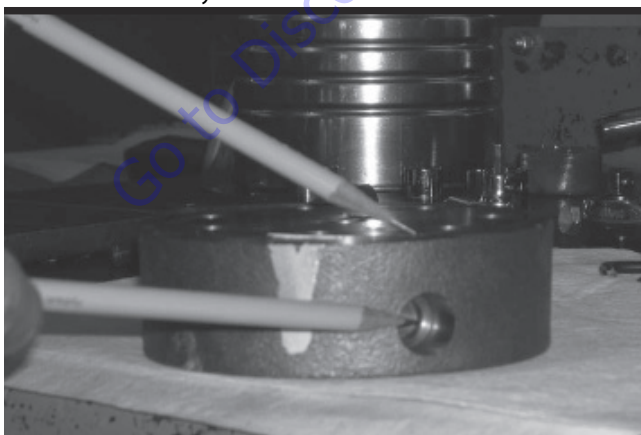

NOTE: A polished pattern (not scratches) on the cover from rotation of the commutator (5) is normal. Discoloration would indicate excess fluid temperature, thermal shock, or excess speed and require system investigation for cause and close

inspection of end cover, commutator, manifold and rotor set.

7. Remove commutator ring (6). Inspect commutator ring for cracks, or burrs.



8. Remove commutator (5) and seal ring (3) Remove seal ring from commutator, using an air hose to blow air into ring groove until seal ring is lifted out and discard seal ring. Inspect commutator for cracks or burrs, wear, scoring, spalling or brinelling. If any of these conditions exist, replace commutator and commutator ring as a matched set.

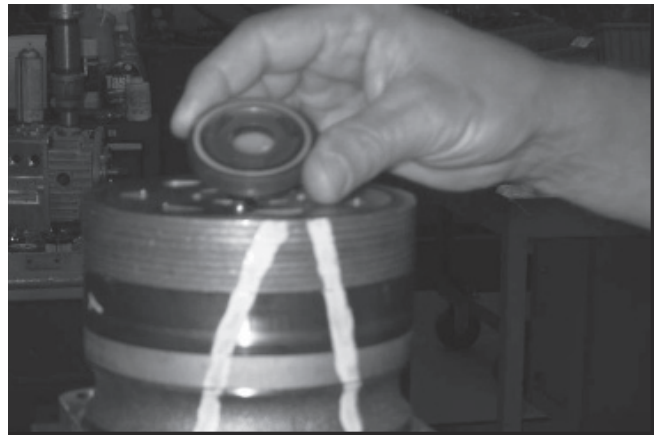

SECTION 3 - CHASSIS & TURNTABLE

9. Remove manifold (7) and inspect for cracks surface scoring, brinelling or spalling. Replace manifold if any of these conditions exist. A polished pattern on the ground surface from commutator or rotor rotation is normal. Remove and discard the seal rings (4) that are on both sides of the manifold.

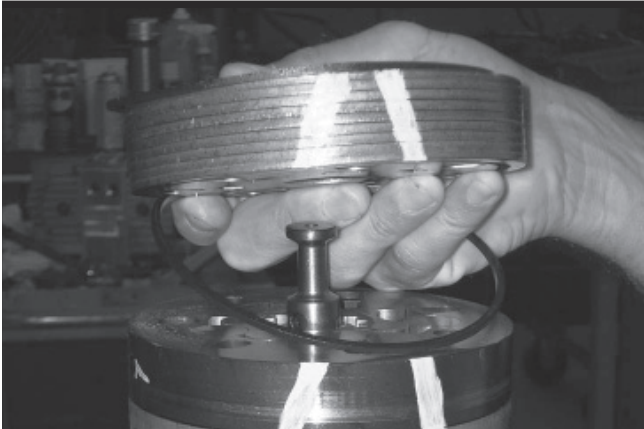

NOTE: The manifold is constructed of plates bonded together to form an integral component not subject to further disassembly for service. Compare configuration of both sides of them as if old to ensure that same surface is reassembled against the rotor set.

10. Remove rotor set (8) and warplane (9), together to retain the rotor set in its assembled form, maintaining the same rotor vane (8C) to stator (8B) contact surfaces. The drive link (10) may come away from the coupling shaft (12) with the rotor set and wear plate. You may have to shift the rotor set on the warplane to work the drive link out of the rotor (8A) and warplane. Inspect the rotor set in its assembled form for nicks, scoring, or spalling on any surface and for broken or worn splines. If the rotor set component requires replacement, the complete rotor set must be replaced as it is a matched set. Inspect the warplane for cracks, brinelling, or scoring. Discard seal ring (4) that is between the rotor set and wear plate.

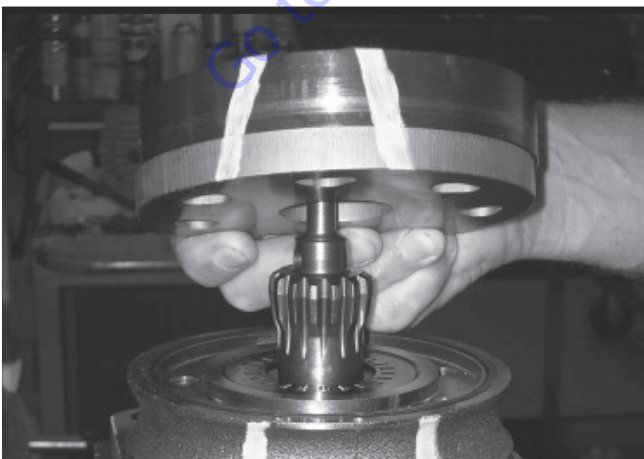

NOTE: The rotor set (8) components may become disassembled during service procedures. Marking the surface of the rotor and stator that is facing UP, with etching ink or grease pencil before removal from Torqmotor™ will ensure correct reassembly of rotor into stator and rotor set into Torqmotor™. Marking all rotor components and mating spline components for exact repositioning at assembly will ensure maximum wear life and performance of rotor set and Torqmotor™.



NOTE: Series TG and TH may have a rotor set with two stator halves (8B & 8D) with a seal ring (4) between them and two sets of seven vanes (8C & 8E). Discard seal ring only if stator halves become disassembled during the service procedures.

NOTE: A polished pattern on the wear plate from rotor rotation is normal.

11. Place rotor set (8) and wear plate (9) on a flat surface and center rotor (8A) in stator (8B) such that two rotor lobes (180 degrees apart) and a roller vane (8C) centerline are on the same stator centerline. Check the rotor lobe to roller vane clearance with a feeler gage at this common centerline. If there is more than 0.005 inches (0.13 mm) of clearance, replace rotor set.

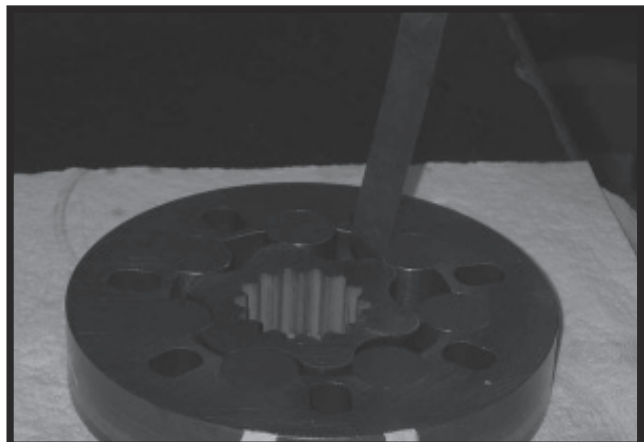

NOTE: If rotor set (8) has two stator halves (8B & 8D) and two sets of seven vanes (8C & 8E) as shown in the alternate construction TG rotor set assembly view, check the rotor lobe to roller vane clearance at both ends of rotor.

12. Remove drive link (10) from coupling shaft (12) if it was not removed with rotor set and wear plate. Inspect drive link for cracks and worn or damaged splines. No perceptible lash (play) should be noted between mating spline parts. Remove and discard seal ring (4) from housing (18).

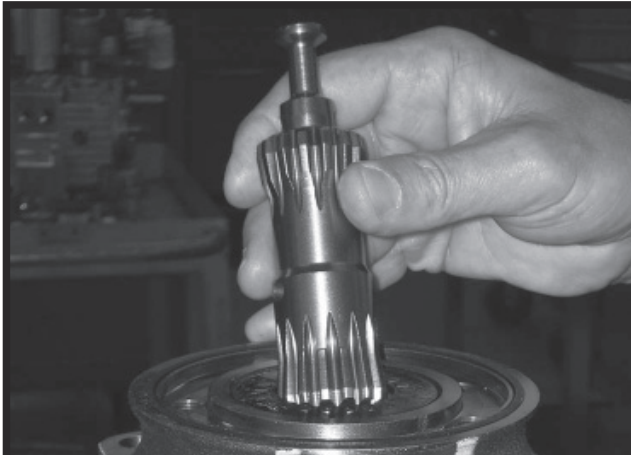

13. Remove thrust bearing (11) from top of coupling shaft (12). Inspect for wear, brinelling, corrosion and a full complement of retained rollers.



14. Check exposed portion of coupling shaft (12) to be sure you have removed all signs of rust and corrosion which might prevent its withdrawal through the seal and bearing. Crocus cloth or fine emery paper may be used. Remove any key (12A), nut (12B), washer (12C), bolt (12D), lock washer (12E), or retaining ring (12F).

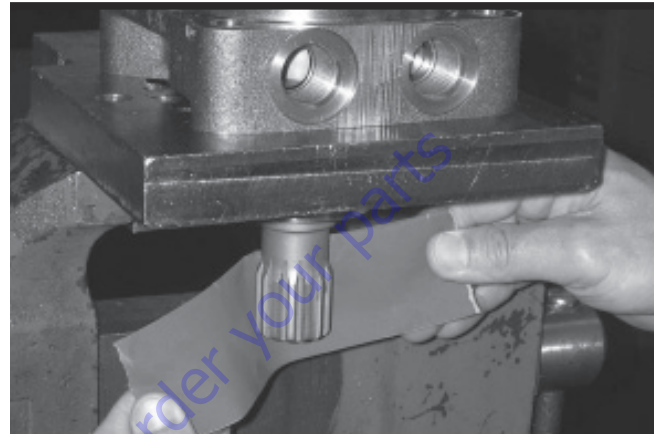

15. Remove coupling shaft (12), by pushing on the output end of shaft. Inspect coupling shaft bearing and seal surfaces for spalling, nicks, grooves, severe wear or corrosion and discoloration. Inspect for damaged or worn internal and external splines or keyway. Replace coupling shaft if any of these conditions exist.

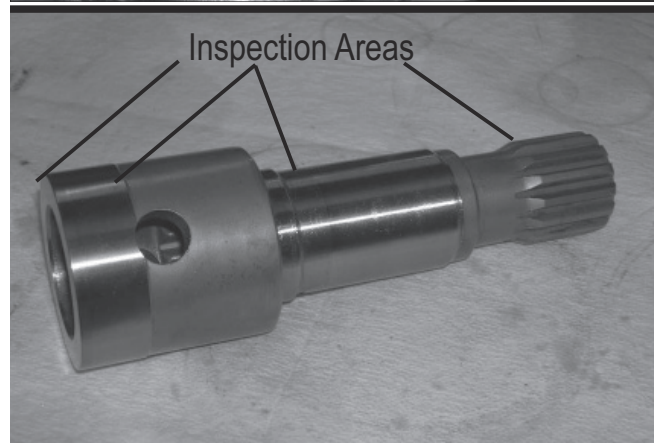

SECTION 3 - CHASSIS & TURNTABLE

NOTE: Minor shaft wear in seal area is permissible. If wear exceeds 0.020 inches (0.51 mm) diametrically, replace coupling shaft.

NOTE: A slight "polish" is permissible in the shaft bearing areas. Anything more would require coupling shaft replacement.

16. Remove and discard seal ring (4) from housing (18).
17. Remove thrust bearing (15) and thrust washer (14) Inspect for wear, brinelling, corrosion and a full complement of retained rollers.



18. Remove seal (16) and backup washer (17) from Small Frame, housing (18). Discard both.



19. Remove housing (18) from vise, invert it and remove and discard seal
20. A blind hole bearing or seal puller is required.



21. Inspect housing (18) assembly for cracks, the machined surfaces for nicks, burrs, brinelling or corrosion. Remove burrs that can be removed without changing dimensional characteristics. Inspect tapped holes for thread damage. If the housing is defective in these areas, discard the housing assembly.

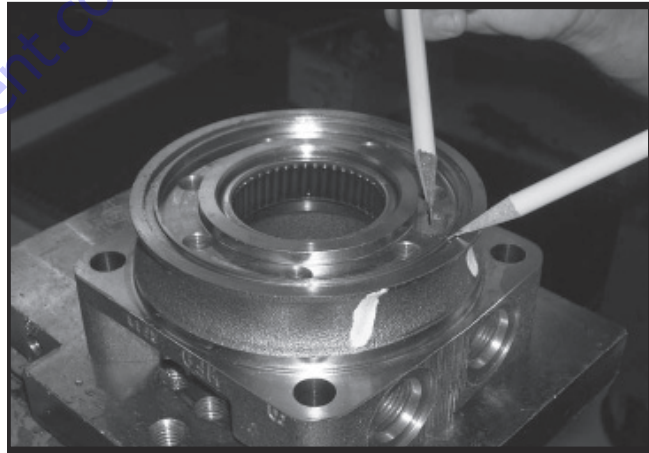

22. If the housing (18) assembly has passed inspection to this point, inspect the housing bearings/bushings (19) and (13) and if they are captured in the housing cavity the two thrust washers (14) and thrust bearing (15). The bearing rollers must be firmly retained in the bearing cages, but must rotate and orbit freely. All rollers and thrust washers must be free of brinelling and corrosion. The bearing rollers must be firmly retained in the bearing cages, but must rotate and orbit freely. All rollers and thrust washers must be free of brinelling and corrosion. The bushing (19) or (13) to coupling shaft diameter clearance must not exceed 0.010 inch (0.025 mm). A bearing, bushing, or thrust washer that does not pass inspection must be replaced. If the housing has passed this inspection the disassembly of the Torqmotor™ is completed.

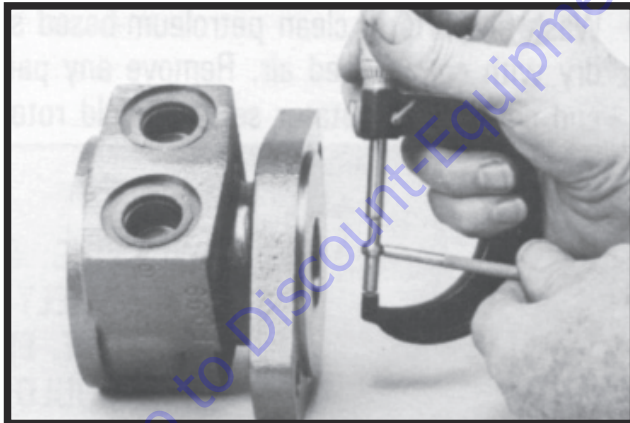
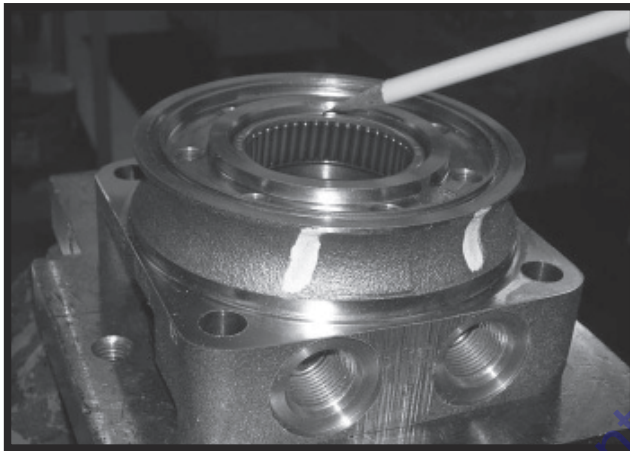

NOTE: The depth or location of bearing/bushing (13) in relation to the housing wear plate surface and the depth or location of bearing/bushing (19) in relation to the beginning of bearing/bushing counterbore should be measured and noted before removing the bearings/ bushings. This will facilitate the correct reassembly of new bearings/bushings.



23. If the bearings, bushing or thrust washers must be replaced use a suitable size bearing puller to remove bearing/bushings (19) and (13) from housing (18) without damaging the housing. Remove thrust washers (14) and thrust bearing (15) if they were previously retained in the housing by bearing (13).

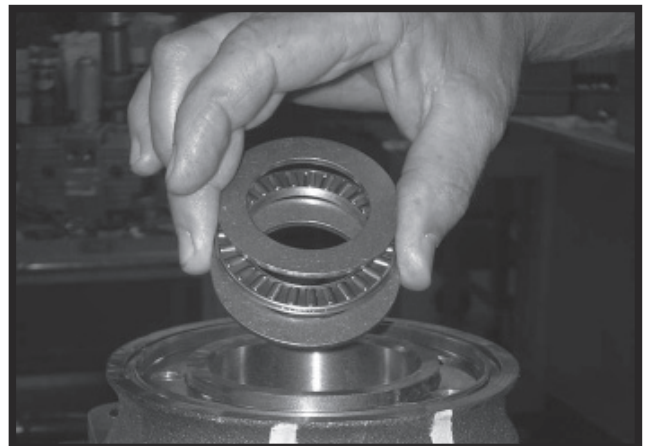

Assembly

Replace all seals and seal rings with new ones each time you reassemble the Torqmotor™ unit. Lubricate all seals and seal rings with SAE 10W40 oil or clean grease before assembly.

NOTE: Individual seals and seal rings as well as a complete seal kit are available. The parts should be available through most OEM parts distributors or Parker approved Torqmotor™ distributors. (Contact your local dealer for availability).

NOTE: Unless otherwise indicated, do not oil or grease parts before assembly.

Wash all parts in clean petroleum-based solvents before assembly. Blow them dry with compressed air. Remove any paint chips from mating surfaces of the end cover, commutator set, manifold rotor set, wear plate and housing and from port and sealing areas.

⚠ DANGER

SINCE THEY ARE FLAMMABLE, BE EXTREMELY CAREFUL WHEN USING ANY SOLVENT. EVEN A SMALL EXPLOSION OR FIRE COULD CAUSE INJURY OR DEATH.

⚠ WARNING

WEAR EYE PROTECTION AND BE SURE TO COMPLY WITH OSHA OR OTHER MAXIMUM AIR PRESSURE REQUIREMENTS.

1. If the housing (18) bearing components were removed for replacement, thoroughly coat and pack a new outer bearing/bushing (19) with clean corrosion resistant grease recommended in the material section. Press the new bearing/bushing into the counterbore at the mounting flange end of the housing, using the appropriate sized bearing mandrel, which will control the bearing/ bushing depth.

Torqmotor™ housings require the use of bearing mandrel to press bearing/ bushing (19) into the housing to a required depth of 0.151/0.161 inches (3.84/4.09 mm) from the end of the bearing counterbore.

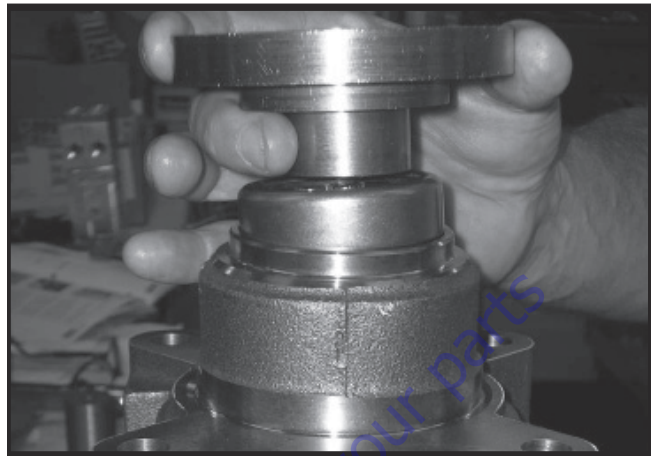
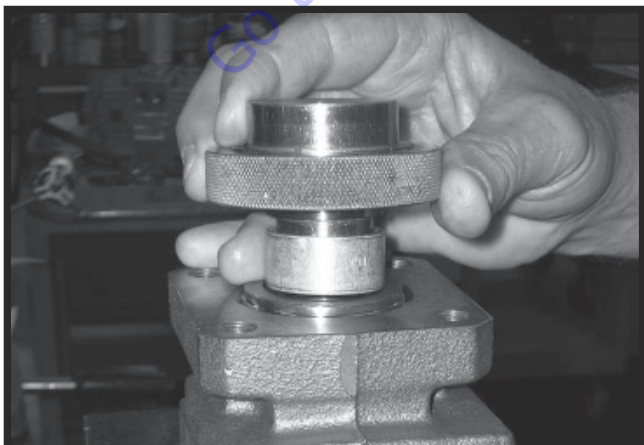

NOTE: Bearing mandrel must be pressed against the lettered end of bearing shell. Take care that the housing bore is square with the press base and the bearing/bushing is not cocked when pressing a bearing/bushing into the housing.

NOTICE

IF THE BEARING MANDREL SPECIFIED IN THE "TOOLS AND MATERIALS REQUIRED FOR SERVICING" SECTION IS NOT AVAILABLE AND ALTERNATE METHODS ARE USED TO PRESS IN BEARING/BUSHING (13) AND (19) THE BEARING/BUSHING DEPTHS SPECIFIED MUST BE ACHIEVED TO ENSURE ADEQUATE BEARING SUPPORT AND CORRECT RELATIONSHIP TO ADJACENT COMPONENTS WHEN ASSEMBLED.

NOTICE

BECAUSE THE BEARING/BUSHINGS (13) AND (19) HAVE A PRESS FIT INTO THE HOUSING THEY MUST BE DISCARDED WHEN REMOVED. THEY MUST NOT BE REUSED.

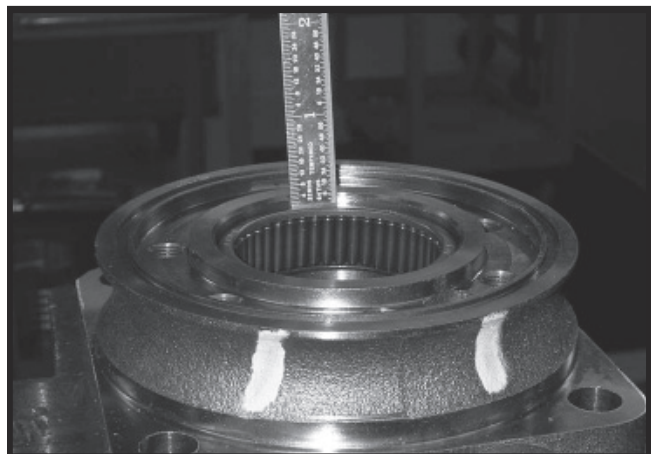

2. The Torqmotor™ inner housing bearing/bushing (13) can now be pressed into its counterbore in housing (18) flush to 0.03 inch (.76 mm) below the housing wear plate contact face. Use the opposite end of the bearing mandrel that was used to press in the outer bearing/bushing (19).

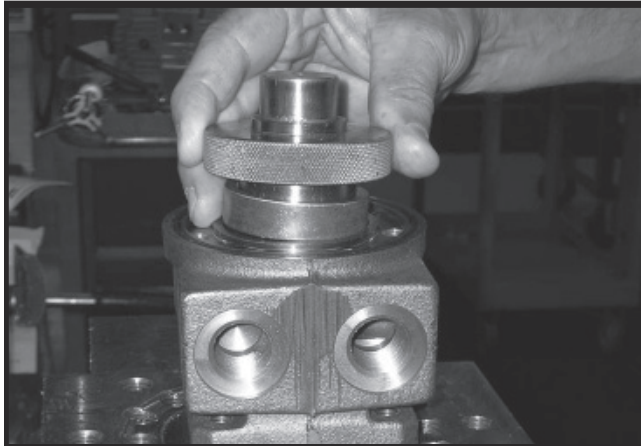

3. Press a new dirt and water seal (20) into the housing (18) outer bearing counterbore.

The Torqmotor™ dirt and water seal (20) must be pressed in until its flange is flush against the housing.

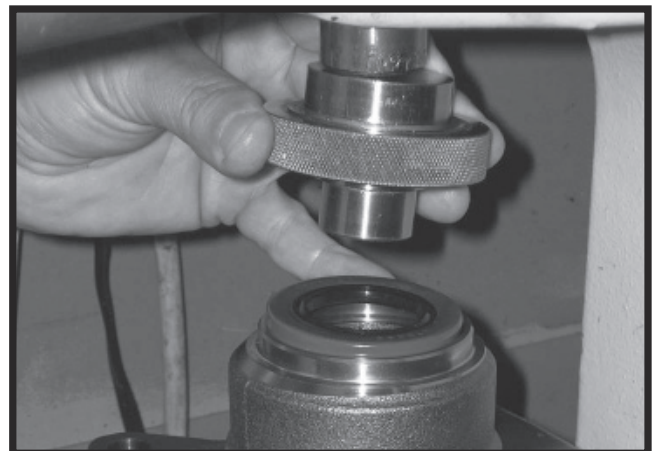
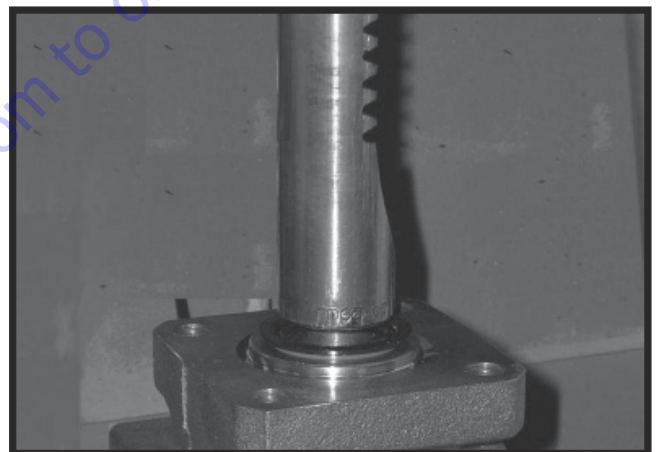

SECTION 3 - CHASSIS & TURNTABLE

- Place housing (18) assembly into a soft jawed vise with the coupling shaft bore down, clamping against the mounting flange.

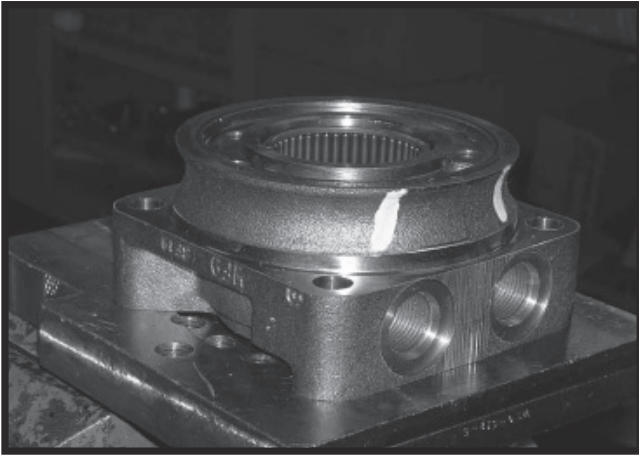

- On the Torqmotor™ assemble a new backup washer (17) and new seal (16) with the seal lip facing toward the inside of Torqmotor™, into their respective counterbores in housing (18) if they were not assembled in procedure 2.

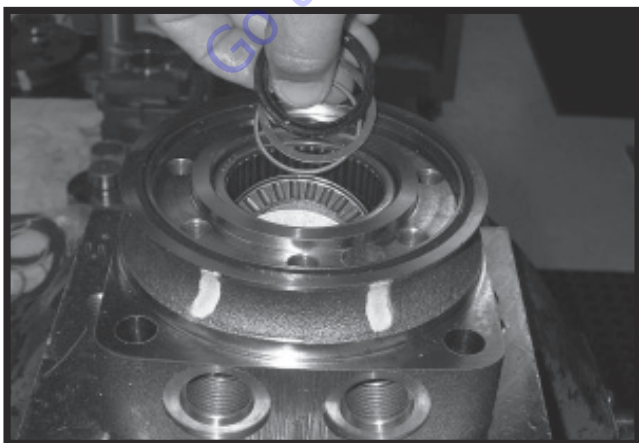

NOTICE

ORIGINAL DESIGN LARGE FRAME, TF & TG TORQMOTORS™ THAT DO NOT HAVE BACKUP WASHER (25) WHEN DISASSEMBLED MUST BE ASSEMBLED WITH A NEW BACKUP WASHER (17), NEW BACKUP WASHER (25) AND NEW SEAL (16).

- Assemble thrust washer (14) then thrust bearing (15) that was removed from the Torqmotor™.

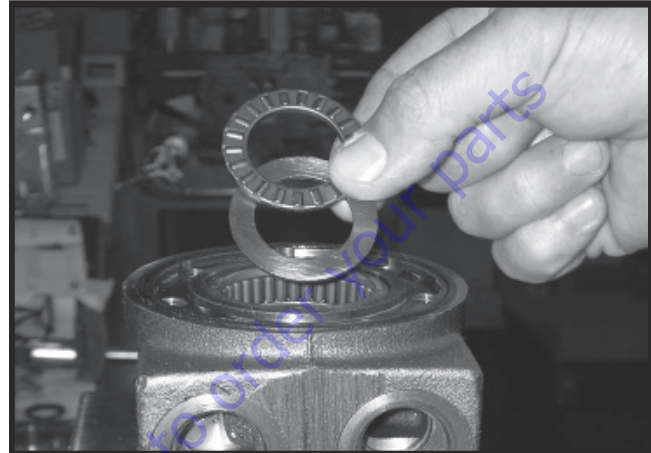

NOTE: Torqmotors™ require one thrust washer (14) with thrust bearing (15). The coupling shaft will be seated directly against the thrust.

- Apply masking tape around splines or keyway on shaft (12) to prevent damage to seal.

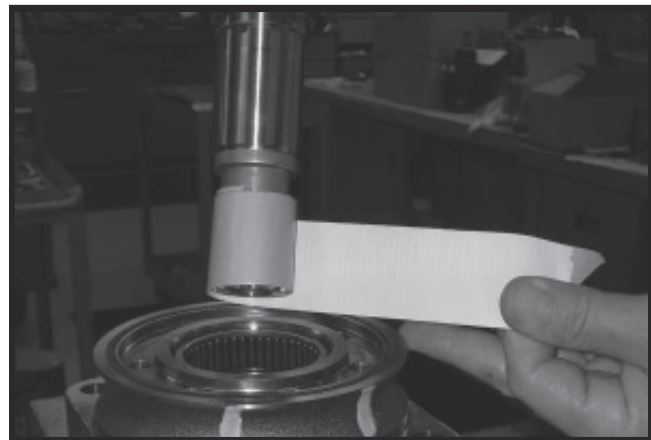

8. Be sure that a generous amount of clean corrosion resistant grease has been applied to the lower (outer) housing bearing/bushing (19). Install the coupling shaft (12) into housing (18), seating it against the thrust bearing (15) in the housings.

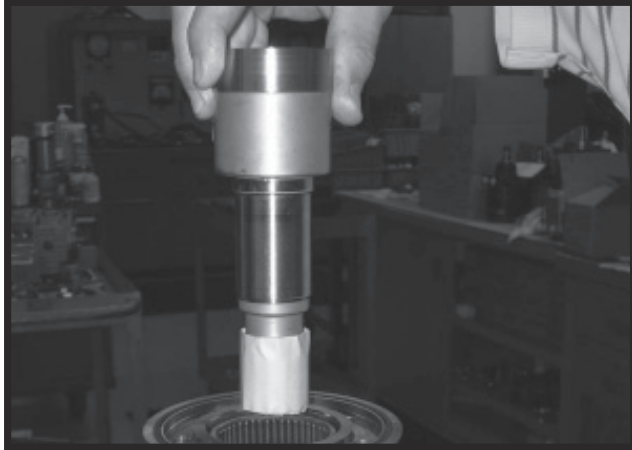

NOTICE

THE OUTER BEARING (19) IS NOT LUBRICATED BY THE SYSTEM'S HYDRAULIC FLUID. BE SURE IT IS THOROUGHLY PACKED WITH THE RECOMMENDED GREASE, PARKER GEAR GREASE SPECIFICATION #045236, E/M LUBRICANT #K-70M.

NOTE: Mobil Mobilith SHC[®] 460.

NOTE: A 102Tube (PN 406010) is included in each seal kit.

NOTE: The coupling shaft (12) will be flush or just below the housing wear plate surface on Torqmotors™ when properly seated. The coupling shaft must rotate smoothly on the thrust bearing package.



9. Apply a small amount of clean grease to a new seal ring (4) and insert it into the housing (18) seal ring groove.

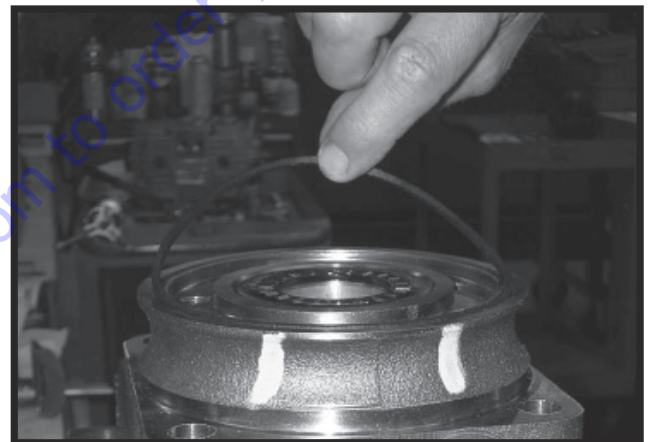

NOTE: One or two alignment studs screwed finger tight into housing (18) bolt holes, approximately 180 degrees apart, will facilitate the assembly and alignment of components as required in the following procedures. The studs can be made by cutting off the heads of either 3/8-24 UNF 2A or 5/16-24 UNF 2A bolts as required that are over 0.5 inch (12.7 mm) longer than the bolts (1) used in the Torqmotor™.

SECTION 3 - CHASSIS & TURNTABLE

10. Install drive link (10) the long splined end down into the coupling shaft (12) and engage the drive link splines into mesh with the coupling shaft splines.

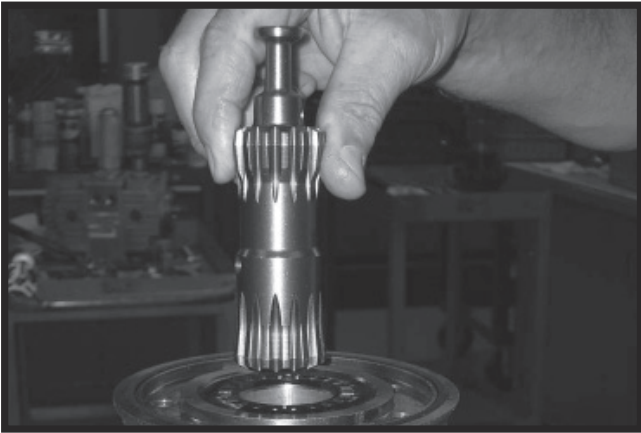

NOTE: Use any alignment marks put on the coupling shaft and drive link before disassembly to assemble the drive link splines in their original position in the mating coupling shaft splines.

11. Assemble wear plate (9) over the drive link (10) and alignment studs onto the housing (18).

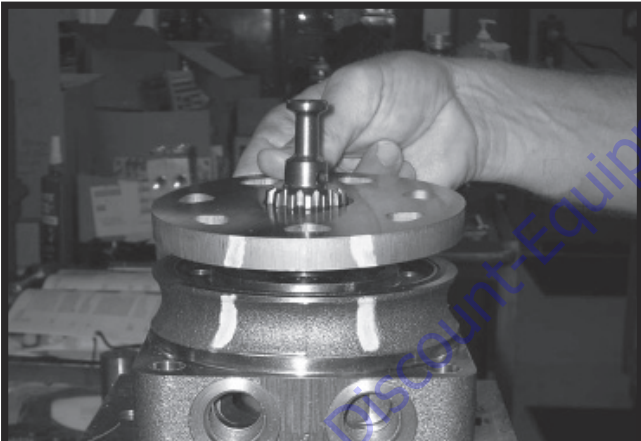

12. Apply a small amount of clean grease to a new seal ring (4) and assemble it into the seal ring groove on the wear plate side of the rotor set stator (8B).

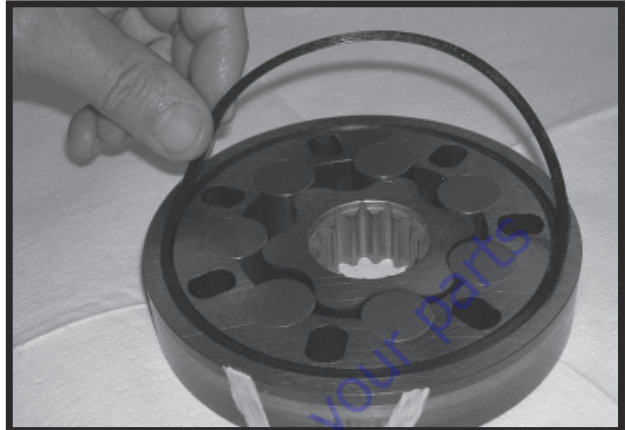

13. Install the assembled rotor set (8) onto wear plate (9) with rotor (8A) counterbore and seal ring side down and the splines into mesh with the drive link splines.

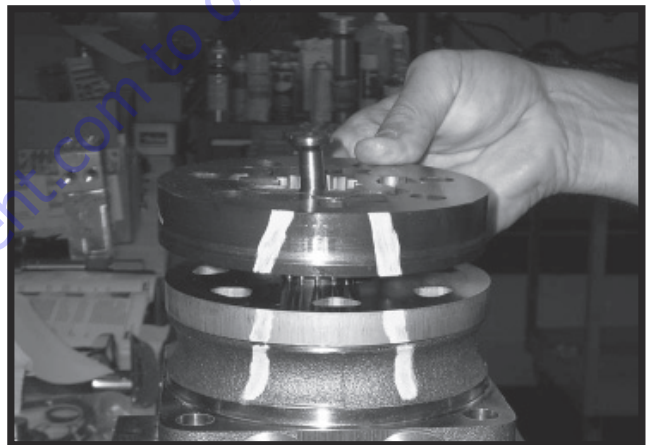

NOTE: It may be necessary to turn one alignment stud out of the housing (18) temporarily to assemble rotor set (8) or manifold (7) over the drive link.

NOTE: If necessary, go to the appropriate, "Rotor Set Component Assembly Procedure."

NOTE: The rotor set rotor counterbore side must be down against wear plate for drive link clearance and to maintain the original rotor-drive link spline contact. A rotor set without a counterbore and that was not etched before disassembly can be reinstalled using the drive link spline pattern on the rotor splines if apparent, to determine which side was down. The rotor set seal ring groove faces toward the wear plate (9).

14. Apply clean grease to a new seal ring (4) and assemble it in the seal ring groove in the rotor set contact side of manifold (7).

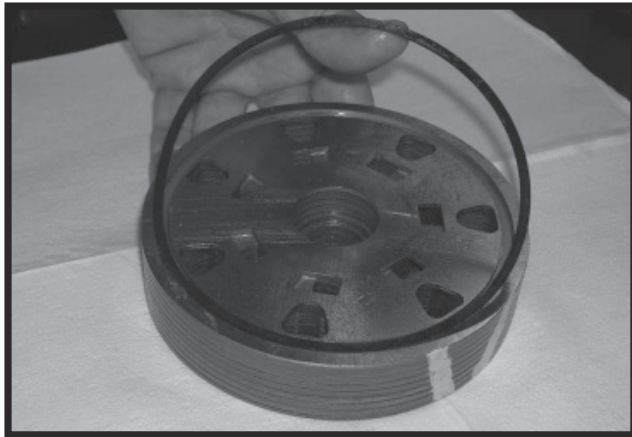

NOTE: The manifold (7) is made up of several plates bonded together permanently to form an integral component. The manifold surface that must contact the rotor set has it's series of irregular shaped cavities on the largest circumference or circle around the inside diameter. The polished impression left on the manifold by the rotor set is another indication of which surface must contact the rotor set.

15. Assemble the manifold (7) over the alignment studs and drive link (10) and onto the rotor set. Be sure the correct manifold surface is against the rotor set.

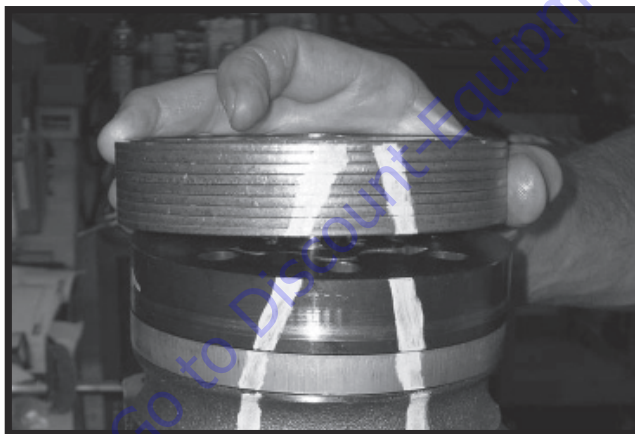

16. Apply grease to a new seal ring (4) and insert it in the seal ring groove exposed on the manifold.



17. Assemble the commutator ring (6) over alignment studs onto the manifold.

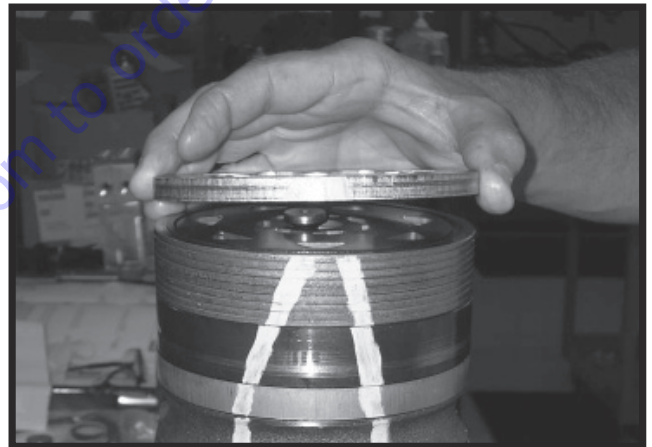

18. Assemble a new seal ring (3) flat side up, into commutator (5) and assemble commutator over the end of drive link (10) onto manifold (7) with seal ring side up.

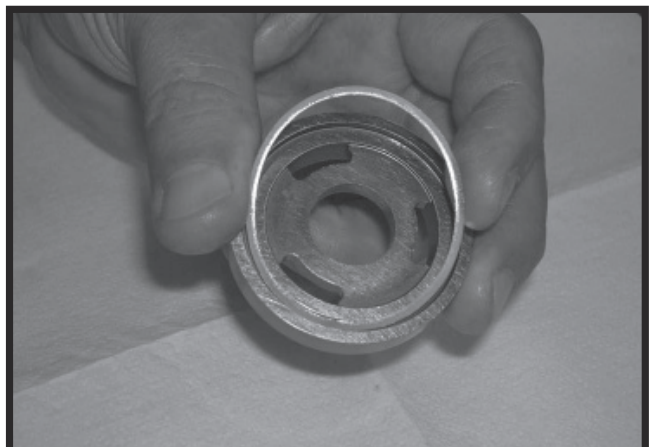

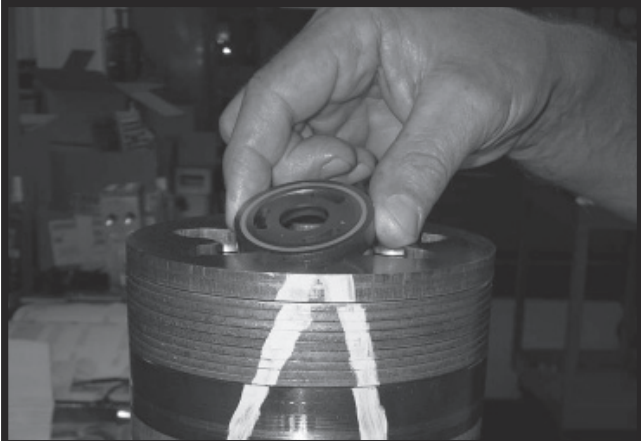

- 19.** Assemble a new seal ring (4) into end cover (2) and assemble end cover over the alignment studs and onto the commutator set. If the end cover has only 5 bolt holes be sure the cover holes are aligned with the 5 threaded holes in housing (18). The correct 5 bolt end cover bolt hole relationship to housing port bosses.

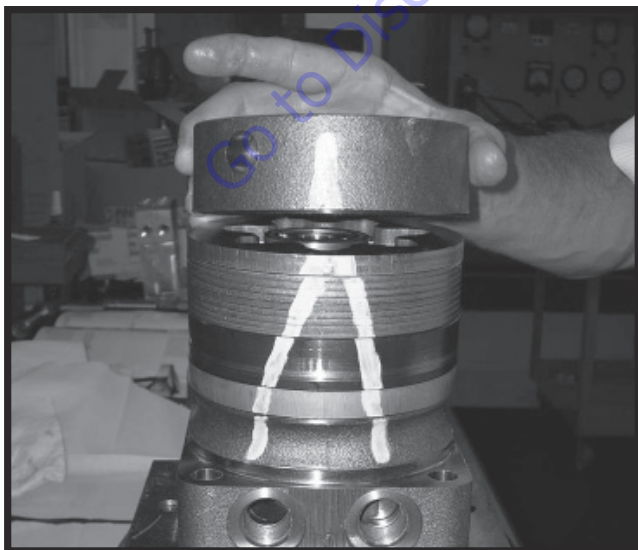
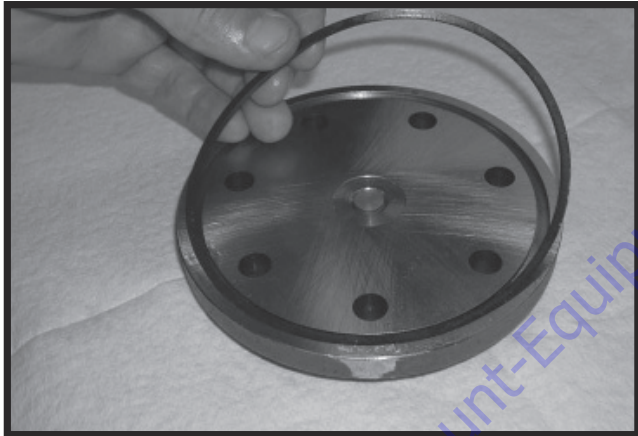
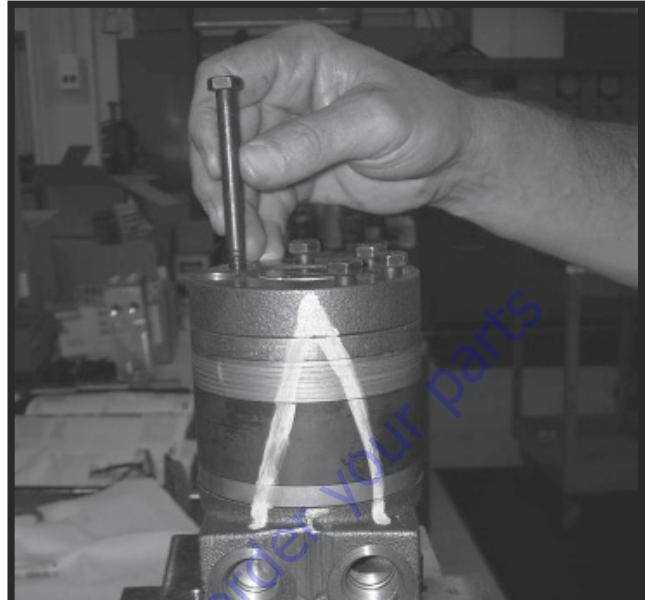

20. Assemble the 5 or 7 special bolts (1) and screw in finger tight. Remove and replace the two alignment studs with bolts after the other bolts are in place. Alternately and progressively tighten the bolts to pull the end cover and other components into place with a final torque of 50-55 ft. lbs. (68-75 Nm) for the seven 3/8-24 threaded bolts.

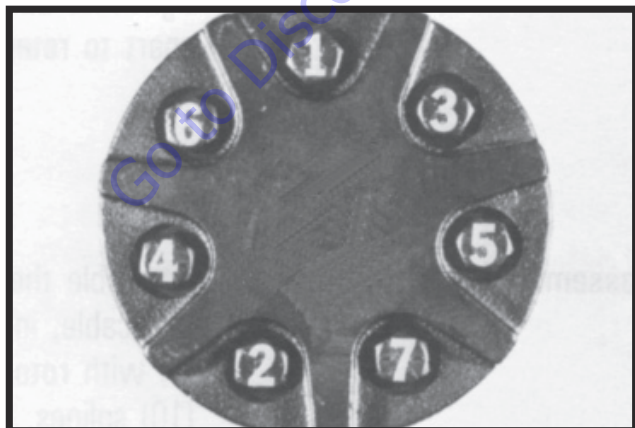
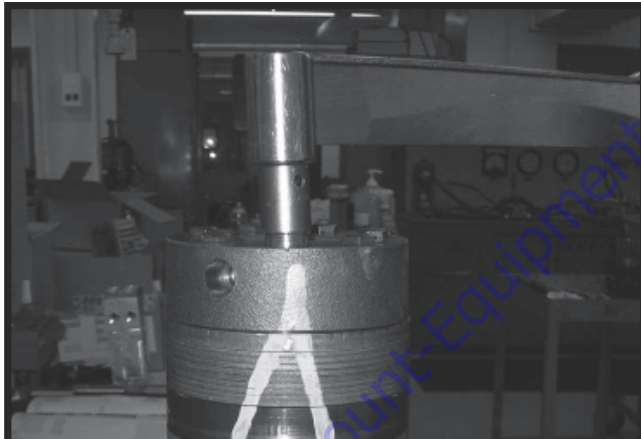
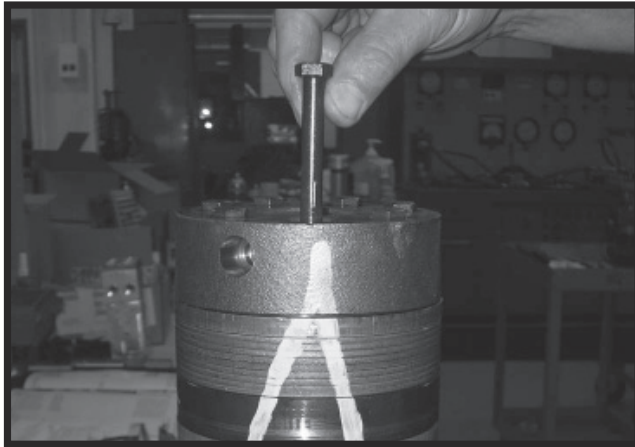

NOTE: The special bolts required for use with the relief or shuttle valve (24) end cover assembly (2) are longer than the bolts required with standard and cover assembly. Refer to the individual service parts lists or parts list charts for correct service part number if replacement is required.

21. Torque the two shuttle valve plug assemblies (21) in end cover assembly to 9-12 ft. lbs. (12-16 Nm) if cover is so equipped.

Torque the two relief valve plug assemblies (21) in end cover assembly to 45-55 ft. lbs. (61-75 Nm) if cover is so equipped.

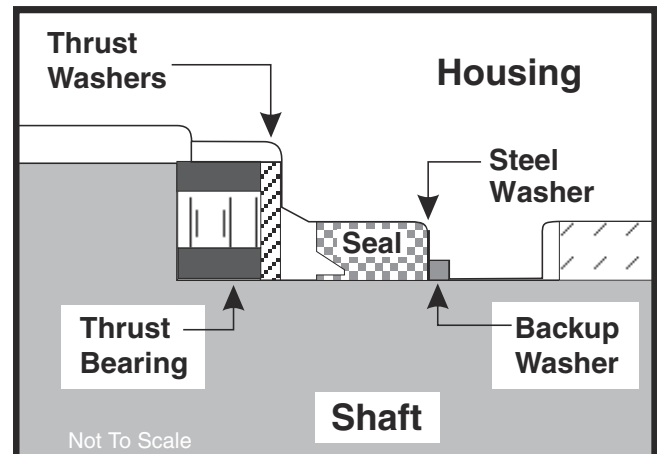
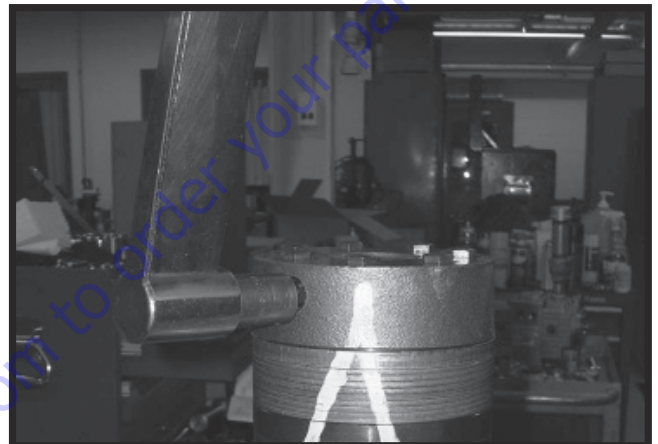

One Piece Stator Construction

A disassembled rotor (8A) stator (8B) and vanes (8C) that cannot be readily assembled by hand can be assembled by the following procedures.

1. Place stator (8B) onto wear plate (9) with seal ring (4) side down, after following Torqmotor™ assembly procedures 1 through 13. Be sure the seal ring is in place.



2. If assembly alignment studs are not being utilized, align stator bolt holes with wear plate and housing bolt holes and turn two bolts (1) finger tight into bolt holes approximately 180 degrees apart to retain stator and wear plate stationary.
3. Assemble the rotor (8A), counterbore down if applicable, into stator (8B) and onto wear plate (9) with rotor splines into mesh with drive link (10) splines.



NOTE: If the manifold side of the rotor was etched during Torqmotor disassembly, this side should be up. If the rotor is not etched and does not have a counterbore, use the drive link spline contact pattern apparent on the rotor splines to determine the rotor side that must be against the wear plate.

4. Assemble six vanes (8C), or as many vanes that will readily assemble into the stator vane pockets.

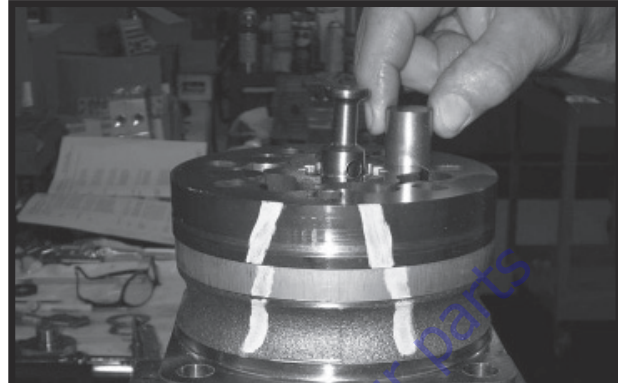

NOTICE

EXCESSIVE FORCE USED TO PUSH THE ROTOR VANES INTO PLACE COULD SHEAR OFF THE COATING APPLIED TO THE STATOR VANE POCKETS.

5. Grasp the output end of coupling shaft (12) with locking pliers or other appropriate turning device and rotate coupling shaft, drive link and rotor to seat the rotor and the assembled vanes (8C) into stator (8B), creating the necessary clearance to assemble the seventh or full complement of seven vanes. Assemble the seven vanes using minimum force.



6. Remove the two assembled bolts (1) if used to retain stator and wear plate.

3.17 Procedure For Setting Swing Gear Backlash

Ensure mounting plate and turntable base plate are clean and painted with a uniform coating of minimum thickness (no runs, drips, etc.).

Set backlash to 0.008 to 0.012 in. (0.203 - 0.304 mm) using the following procedure:

1. Place the machine on firm, level ground.
2. Place shim (JLG PN 1001125492) between pinion and bearing at bearing high spot (shown below). The bearing high spot should be stamped with "X" on the surface below teeth and marked with yellow paint in the tooth space.

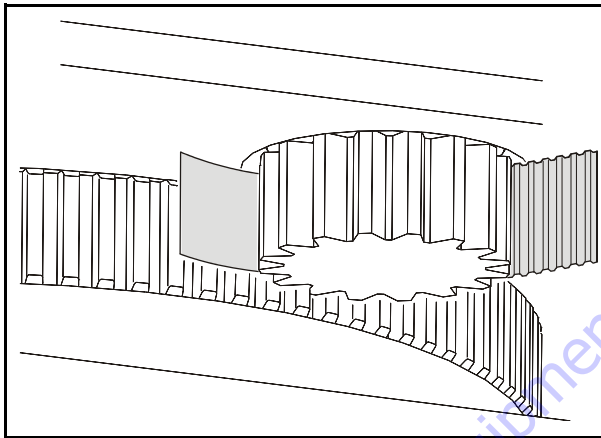

3. Apply High Strength Threadlocking Compound and torque pivot bolt to 205 ft. lbs. (280 Nm) (shown below).

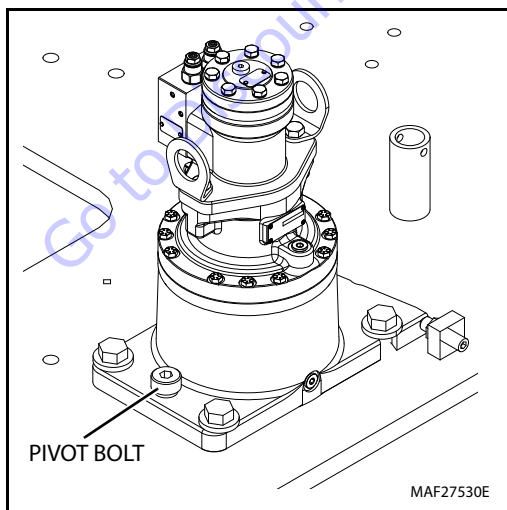

NOTE: Torque shoulder bolt against turntable baseplate. Shoulder bolt will not tighten against the swing drive mounting plates.

1. Remove turntable lock pin.
2. Apply High Strength Threadlocking Compound and pre-torque swing drive mounting bolts to 30 ft. lbs. (42 Nm).

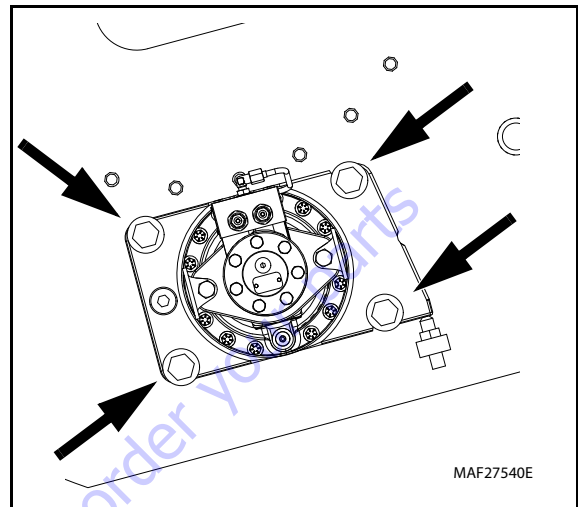

3. Tighten the setscrew until the pinion is completely snug against the shim and bearing and then back off the setscrew.

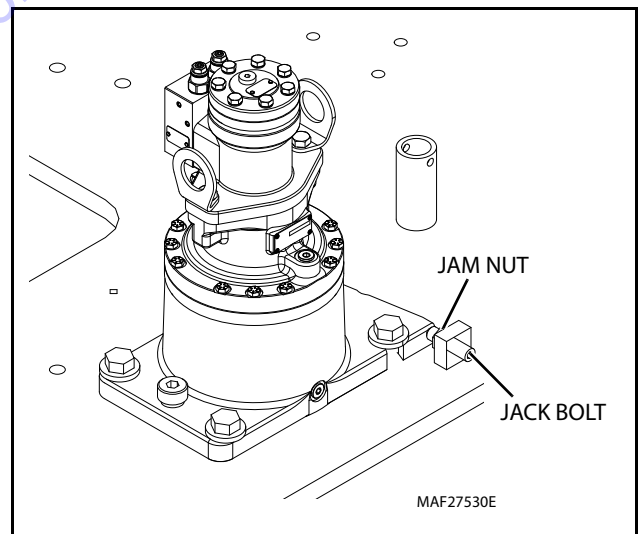

1. Apply High Strength Threadlocking Compound and torque jack bolt 50 ft. lbs. (68 Nm).
2. Apply High Strength Threadlocking Compound to the jam nut and tighten.

SECTION 3 - CHASSIS & TURNTABLE

3. Torque the capscrews shown in step 5 to 340 ft. lbs. (461 Nm).

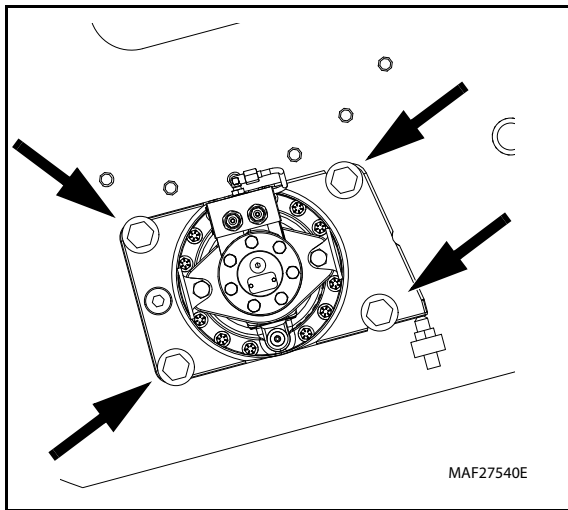

4. Remove shim and discard.

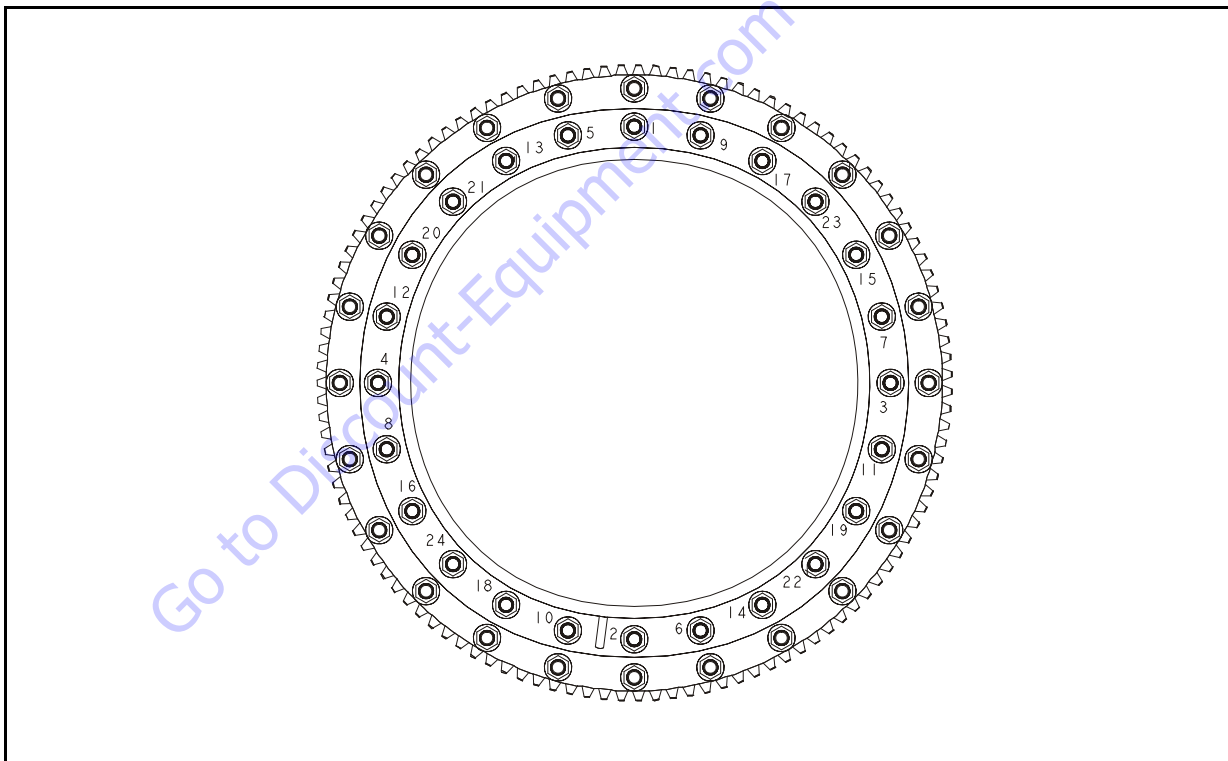

NOTE: *Swing Bearing Torque Sequence is typical for both inner and outer races.*

Figure 3-57. Swing Bearing Torque Sequence

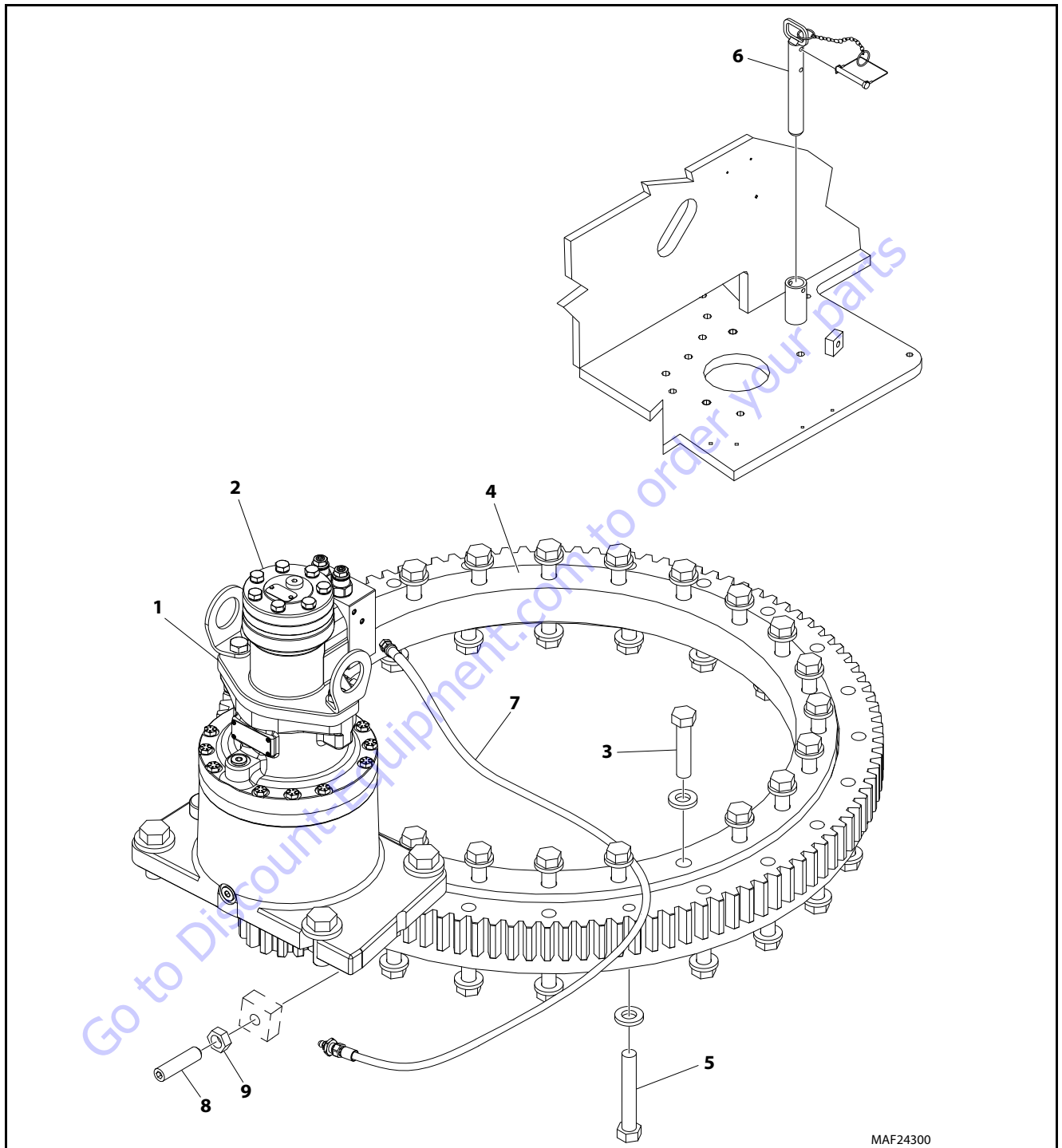

MAF24300

- | | | |
|----------------------------|----------------------------|----------------|
| 1. Swing Drive | 4. Swing Bearing | 7. Grease Line |
| 2. Swing Motor | 5. Outer Race Bearing Bolt | 8. Bolt |
| 3. Inner Race Bearing Bolt | 6. Turntable Lock Pin | 9. Jam Nut |

Figure 3-58. Swing Drive and Turntable Bearing

3.18 SWING BEARING

Turntable Bearing Mounting Bolt Condition Check

NOTICE

THE SWING BEARING IS ONE OF THE MOST CRITICAL POINTS ON A MOBILE ELEVATING WORK PLATFORM. IT IS HERE THAT THE STRESSES OF LIFTING ARE CONCENTRATED, AT THE CENTER OF ROTATION. BECAUSE OF THIS, PROPER MAINTENANCE OF THE SWING BEARING BOLTS IS A MUST FOR SAFE OPERATION.

NOTE: This check is designed to replace the existing bearing bolt torque checks on JLG Lifts in service. This check must be performed after the first 50 hours of machine operation and every 600 hours of machine operation thereafter. If during this check any bolts are found to be missing or loose, replace missing or loose bolts with new bolts and torque to the value specified in the torque chart, after lubricating the bolt threads with High Strength Threadlocking Compound. After replacing and retorquing bolt or bolts recheck all existing bolts for looseness.

1. Check the frame to bearing attach bolts as follows:
 - a. Elevate the fully extended main boom to horizontal. (See Figure 3-60.).
 - b. At the positions indicated on Figure 3-61. try to insert a 0.0015 in. feeler gauge between the bolt and hardened washer at the arrow indicated position.
 - c. Ensure that the 0.0015 in. feeler gauge will not penetrate under the bolt head to the bolt shank.
 - d. Swing the turntable 90 degrees and check some selected bolts at the new position.
 - e. Continue rotating the turntable at 90 degrees intervals until a sampling of bolts have been checked in all quadrants.

2. Check the turntable to bearing Attach bolts as follows:
 - a. Elevate the fully retracted main boom to full elevation.
 - b. At the position indicated on Figure 3-59., try to insert the 0.0015 in. feeler gauge between the bolt head and hardened washer at the arrow indicated position.
 - c. Lower the boom to horizontal and fully extend the boom.
 - d. At the position indicated on Figure 3-61., try and insert the 0.0015 in. feeler gauge between the bolt head and hardened washer at the arrow indicated position.

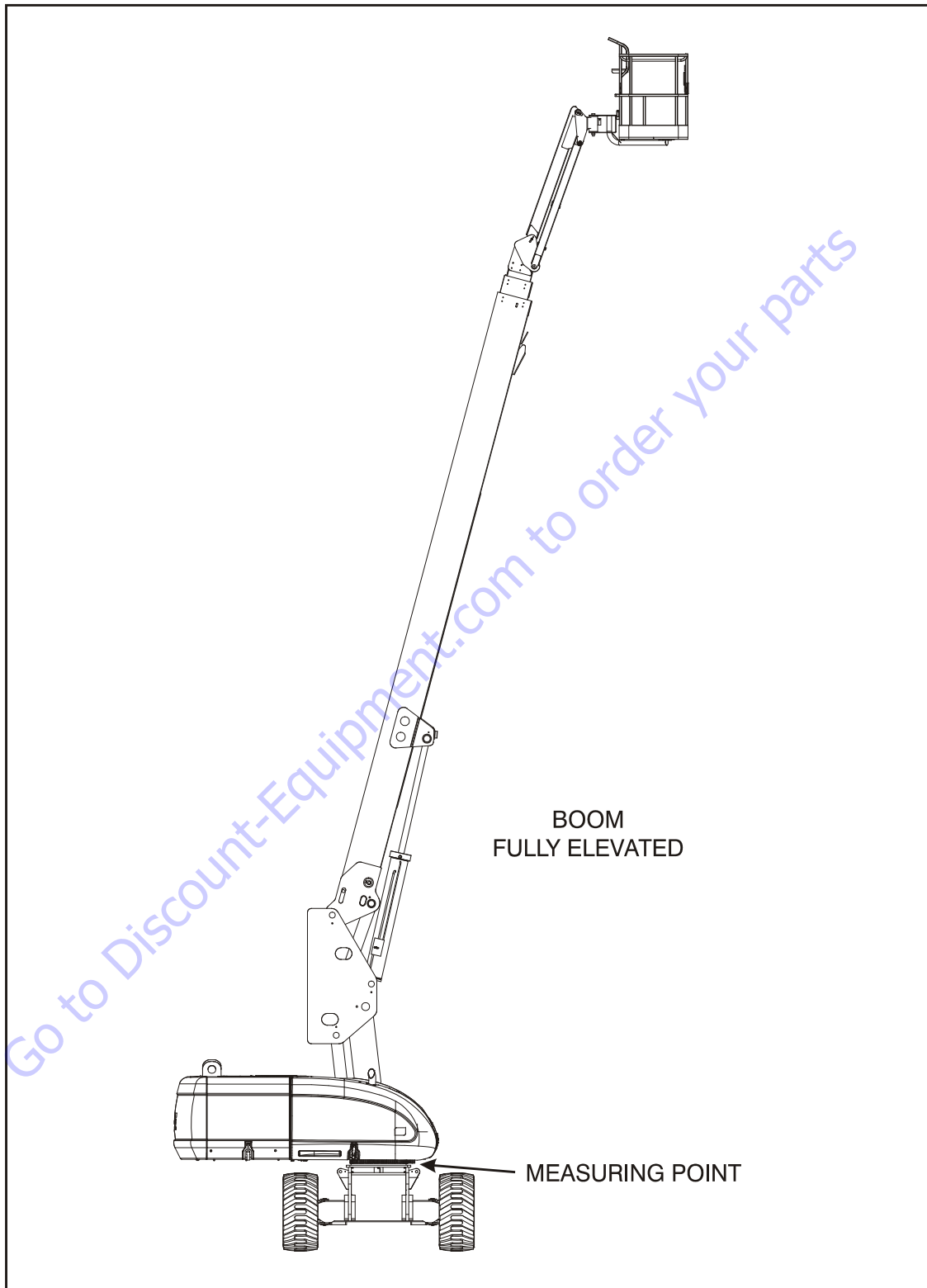

Figure 3-59. Swing Bearing Tolerance Boom Placement (Sheet 1 of 2)

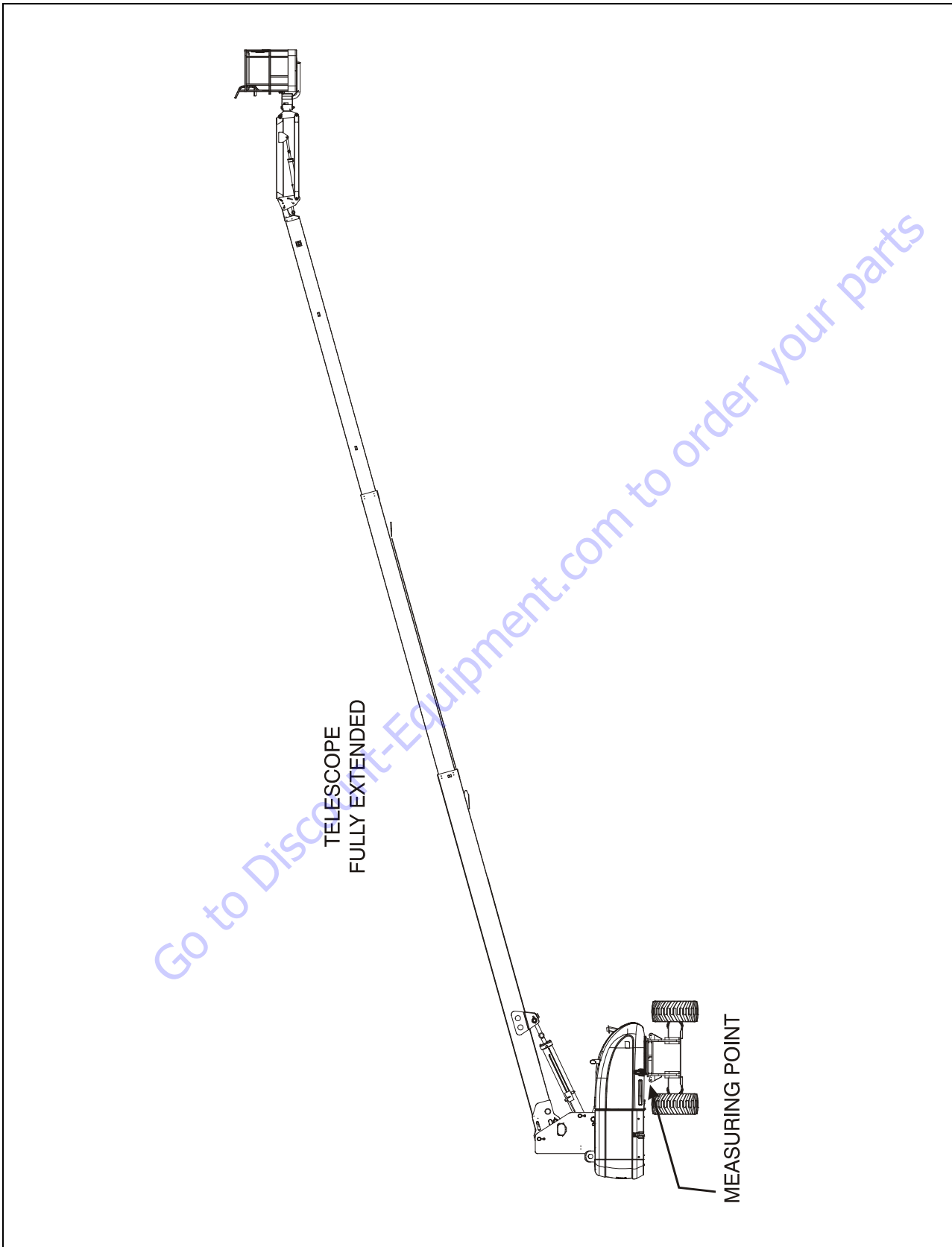

Figure 3-60. Swing Bearing Tolerance Boom Placement (Sheet 2 of 2)

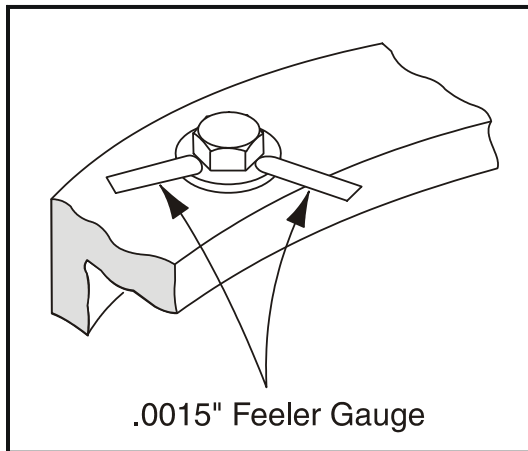

Figure 3-61. Swing Bolt Feeler Gauge Check

Wear Tolerance

1. From the underside of the machine, at rear center, with the main boom fully elevated and fully retracted as shown in Figure 3-59., Swing Bearing Tolerance Boom Placement (Sheet 1 of 2), using a magnetic base dial indicator, measure and record the distance between the swing bearing and turntable. See Figure 3-62., Swing Bearing Tolerance Measuring Point.
2. At the same point, with the main boom at horizontal and fully extended as shown in Figure 3-60., Swing Bearing Tolerance Boom Placement (Sheet 2 of 2). Using a magnetic base dial indicator, measure and record the distance between the swing bearing and turntable. See Figure 3-62., Swing Bearing Tolerance Measuring Point.
3. If a difference greater than 0.079 in. (2.00 mm) is determined, the swing bearing should be replaced.
4. If a difference less than 0.079 in. (2.00 mm) is determined and any of the following conditions exist, the bearing should be removed, disassembled and inspected for the following:
 - a. Metal particles in the grease.
 - b. Increased drive power required.
 - c. Noise.
 - d. Rough rotation.
5. If bearing inspection shows no defects, reassemble and return to service.

NOTICE

THE SWING BEARING IS ONE OF THE MOST CRITICAL POINTS ON A MOBILE ELEVATING WORK PLATFORM. IT IS HERE THAT THE STRESSES OF LIFTING ARE CONCENTRATED, AT THE CENTER OF ROTATION. BECAUSE OF THIS, PROPER MAINTENANCE OF THE SWING BEARING BOLTS IS A MUST FOR SAFE OPERATION.

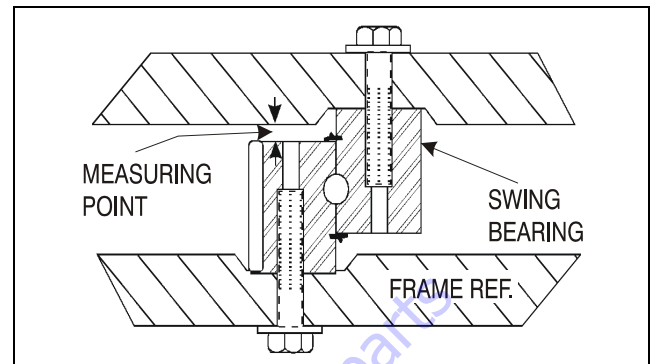

Figure 3-62. Swing Bearing Tolerance Measuring Point

Swing Bearing Removal

1. From Ground Control station, operate the boom adequately to provide access to frame opening to rotary coupling.

WARNING

NEVER WORK BENEATH THE BOOM WITHOUT FIRST ENGAGING BOOM SAFETY PROP OR PROVIDING ADEQUATE OVERHEAD SLING SUPPORT AND/OR BLOCKING.

2. Attach an adequate support sling to the boom and draw all slack from sling. Prop or block the boom if feasible.
3. From inside turntable, remove mounting hardware which attach rotary coupling retaining yoke brackets to turntable.

NOTICE

HYDRAULIC LINES AND PORTS SHOULD BE CAPPED IMMEDIATELY AFTER DISCONNECTING LINES TO AVOID THE ENTRY OF CONTAMINANTS INTO THE SYSTEM.

4. Tag and disconnect the hydraulic lines from the fittings on the top of the rotary coupling. Use a suitable container to retain any residual hydraulic fluid. Immediately cap lines and ports.
5. Attach suitable overhead lifting equipment to the base of the turntable weldment.
6. Use a suitable tool to scribe a line on the inner race of the swing bearing and on the underside of the turntable. This will aid in aligning the bearing upon installation. Remove the bolts and washers which attach the turntable to the bearing inner race. Discard the bolts.
7. Use the lifting equipment to carefully lift the complete turntable assembly from the bearing. Ensure that no damage occurs to the turntable, bearing or frame-mounted components.

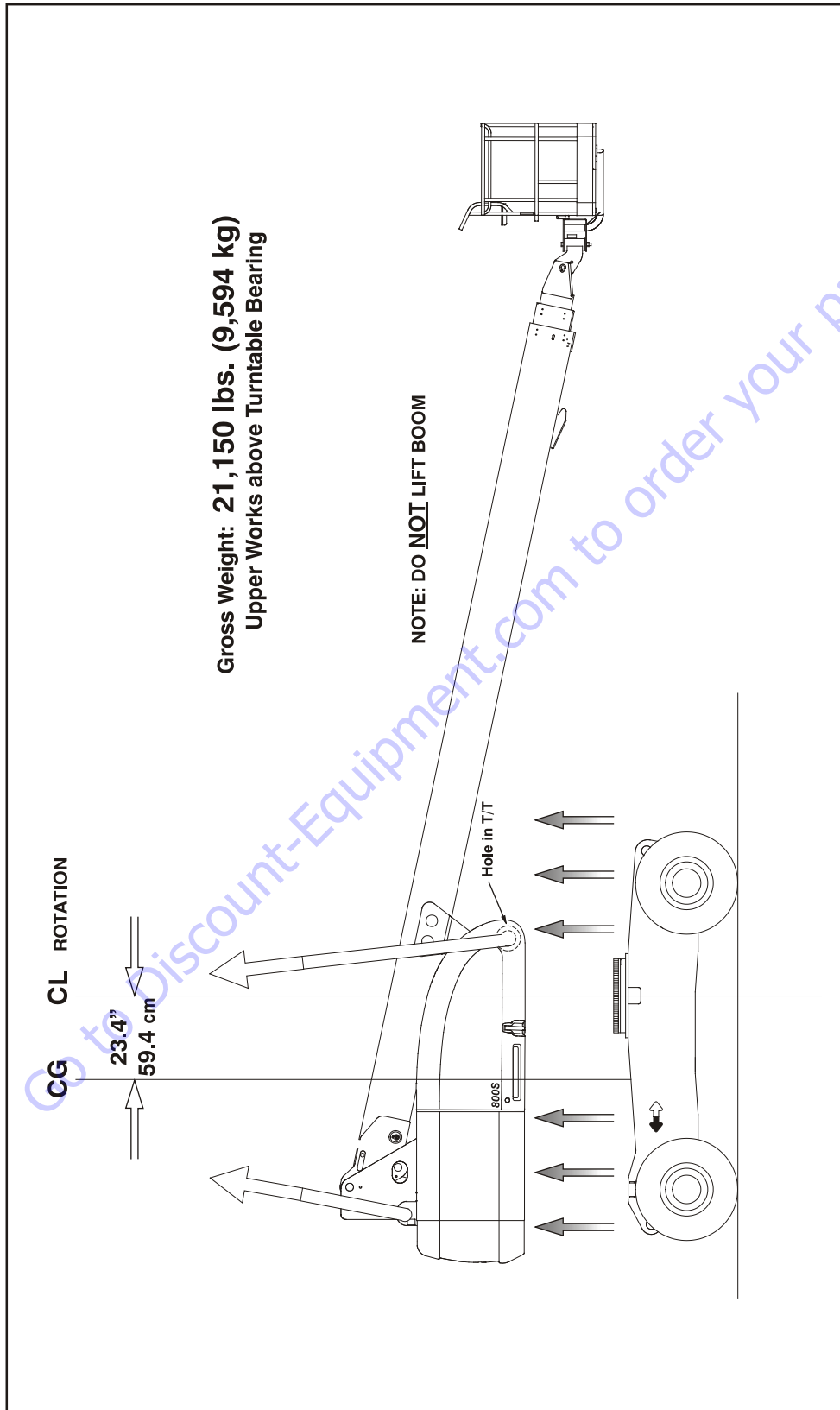

Figure 3-63. Swing Bearing Removal (800S)

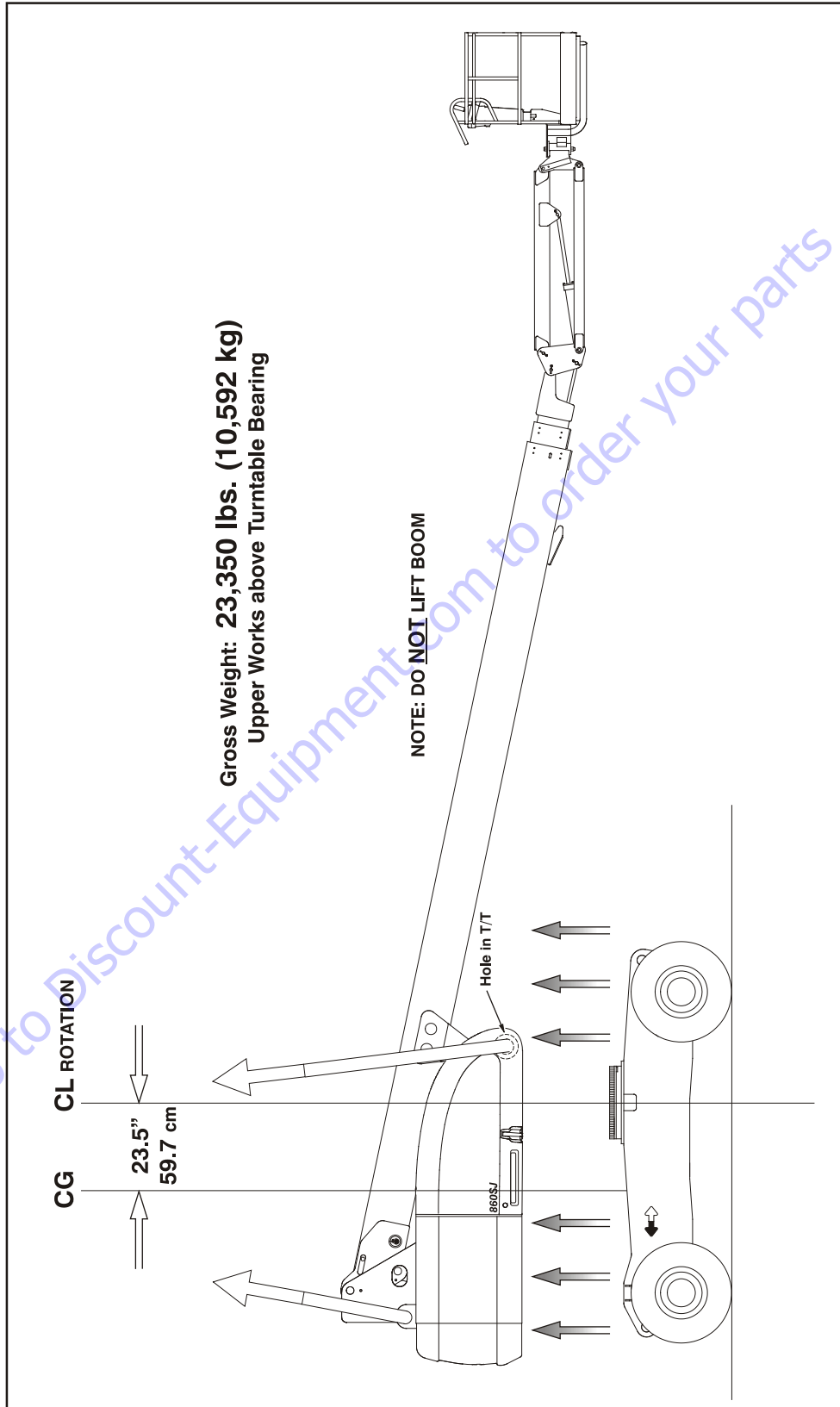

Figure 3-64. Swing Bearing Removal (860SJ)

8. Carefully place the turntable on a suitably supported trestle.
9. Use a suitable tool to scribe a line on the outer race of the swing bearing and the frame. This line will aid in aligning the bearing upon installation. Remove the bolts and washers which attach the outer race of the bearing to the frame. Discard the bolts. Use suitable lifting equipment to remove the bearing from the frame, then move the bearing to a clean, suitably supported work area.

SWING BEARING INSTALLATION

1. Using suitable lifting equipment, carefully lower the swing bearing into position on the frame. Ensure the scribed line of the outer race of the bearing aligns with the scribed line on the frame. If a new swing bearing is used, ensure that the filler plug fitting is at 90 degrees from the fore and aft center line of the frame.

⚠ CAUTION

JLG INDUSTRIES RECOMMENDS THAT ALL REMOVED BEARING BOLTS BE DISCARDED AND REPLACED WITH NEW BOLTS. SINCE THE SWING BEARING IS THE ONLY STRUCTURAL LINK BETWEEN THE FRAME AND TURNTABLE, IT IS IMPERATIVE THAT SUCH REPLACEMENT HARDWARE MEETS JLG SPECIFICATIONS. USE OF GENUINE JLG HARDWARE IS HIGHLY RECOMMENDED.

2. Apply a light coating of High Strength Threadlocking Compound to the new bearing bolts and loosely install the bolts and washers through the frame and outer race of bearing.

NOTICE

IF COMPRESSED AIR OR ELECTRICALLY OPERATED IMPACT WRENCH IS USED FOR TIGHTENING THE BEARING ATTACHMENT BOLTS, THE TORQUE SETTING ACCURACY OF THE TOOL SHOULD BE CHECKED PRIOR TO USE.

3. Refer to the Torque Sequence diagram as shown in Figure 3-57., Swing Bearing Torque Sequence. Clean any residue off the new bearing bolts, then apply a light coating of High Strength Threadlocking Compound and install the bolts and washers through the frame and outer race of the bearing. Tighten the bolts to an initial torque of 190 ft. lbs. (260 Nm) w/High Strength Threadlocking Compound.
4. Remove the lifting equipment from the bearing.
5. Using suitable lifting equipment, carefully position the turntable assembly above the machine frame.
6. Carefully lower the turntable onto the swing bearing, ensuring that the scribed line of the inner race of the bearing aligns with scribed line on the turntable. If a new swing bearing is used, ensure that the filler plug fit-

ting is at 90 degrees from the fore and aft center line of the turntable.

7. Clean any residue off the new bearing bolts, then apply a light coating of High Strength Threadlocking Compound and install the bolts and washers through the turntable and inner race of the bearing.
8. Following the Torque Sequence diagram shown in Figure 3-57., Swing Bearing Torque Sequence, tighten the bolts to a torque of 190 ft. lbs. (260 Nm).
9. Remove the lifting equipment.
10. Install the rotary coupling retaining yoke brackets, apply a light coating of High Strength Threadlocking Compound to the attaching bolts and secure the yoke to the turntable with the mounting hardware.
11. Connect the hydraulic lines to the rotary coupling as tagged prior to removal.
12. At ground control station, use boom lift control to lower boom to stowed position.
13. Using all applicable safety precautions, activate the hydraulic system and check the swing system for proper and safe operation.

Swing Bearing Torque Values

1. Outer Race - 190 ft. lbs. (258 Nm) w/High Strength Threadlocking Compound.
2. Inner Race - 190 ft. lbs. (258 Nm) w/High Strength Threadlocking Compound.
3. See Swing Bearing Torquing Sequence.

⚠ WARNING

CHECK THE INNER AND OUTER SWING BEARING BOLTS FOR MISSING OR LOOSENESS AFTER FIRST 50 HOURS OF OPERATION AND EVERY 600 HOURS THEREAFTER.

3.19 ROTARY COUPLING

Use the following procedure to install the seal kit.

1. If not already removed, remove the axle oscillation valve from the cylinder barrel. The spool of the valve protrudes into the barrel and will damage the spool and seals if left in place.
2. Remove snap ring (7) from end.
3. Remove thrust ring (3) from the same end.
4. Remove center body (1) from housing (3).
5. Cut off old seals (2, 4, 5).
6. Remove proximity switch.
7. Assemble lip seals (2) in direction shown in Figure 3-65., Rotary Coupling Seal Installation.
8. Reassemble O-ring (4).
9. Heat cap seals (5) in hydraulic oil for 5 minutes at 300° F (149° C).
10. Assemble cap seals over O-rings.
11. Reinsert center body into housing (lube with hydraulic oil).
12. Replace thrust ring and snap ring.

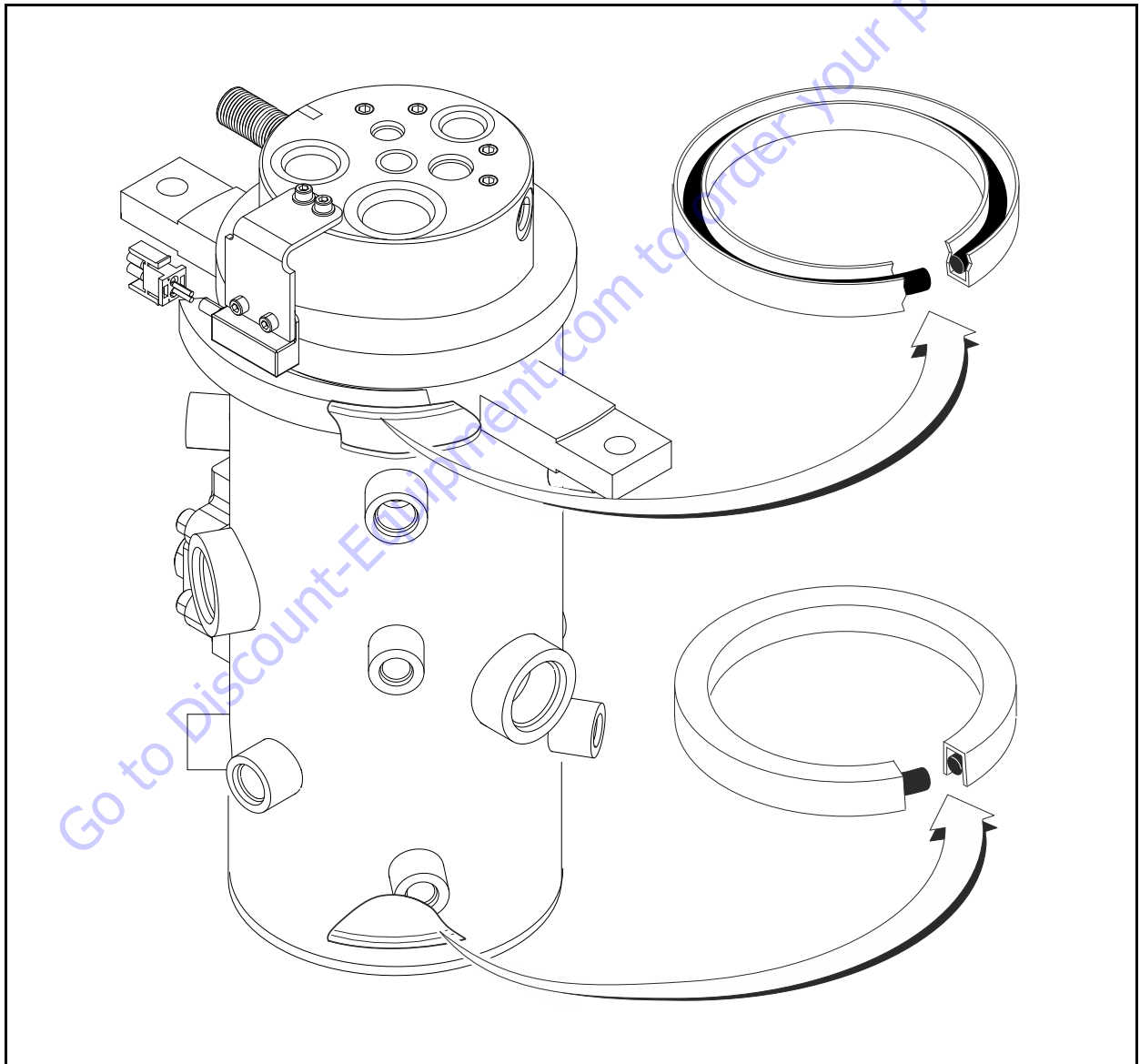
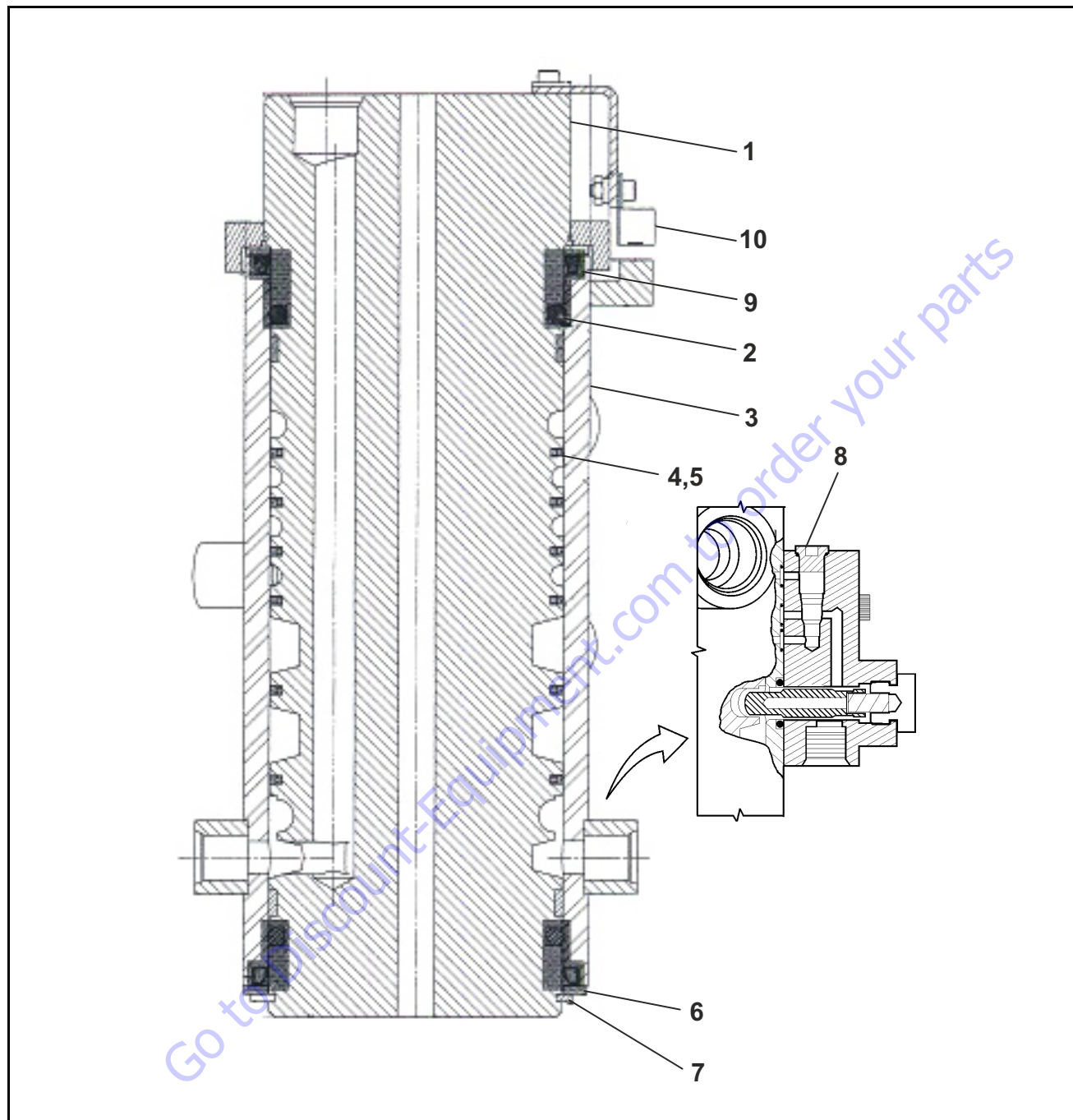

Figure 3-65. Rotary Coupling Seal Installation



- | | |
|----------------|-----------------------------------|
| 1. Center Body | 6. Thrust Ring |
| 2. Seal | 7. Snap Ring |
| 3. Housing | 8. Valve Block (Axle Oscillation) |
| 4. O-ring | 9. O-ring |
| 5. Seal | 10. Proximity Switch |

Figure 3-66. Rotary Coupling Cutaway

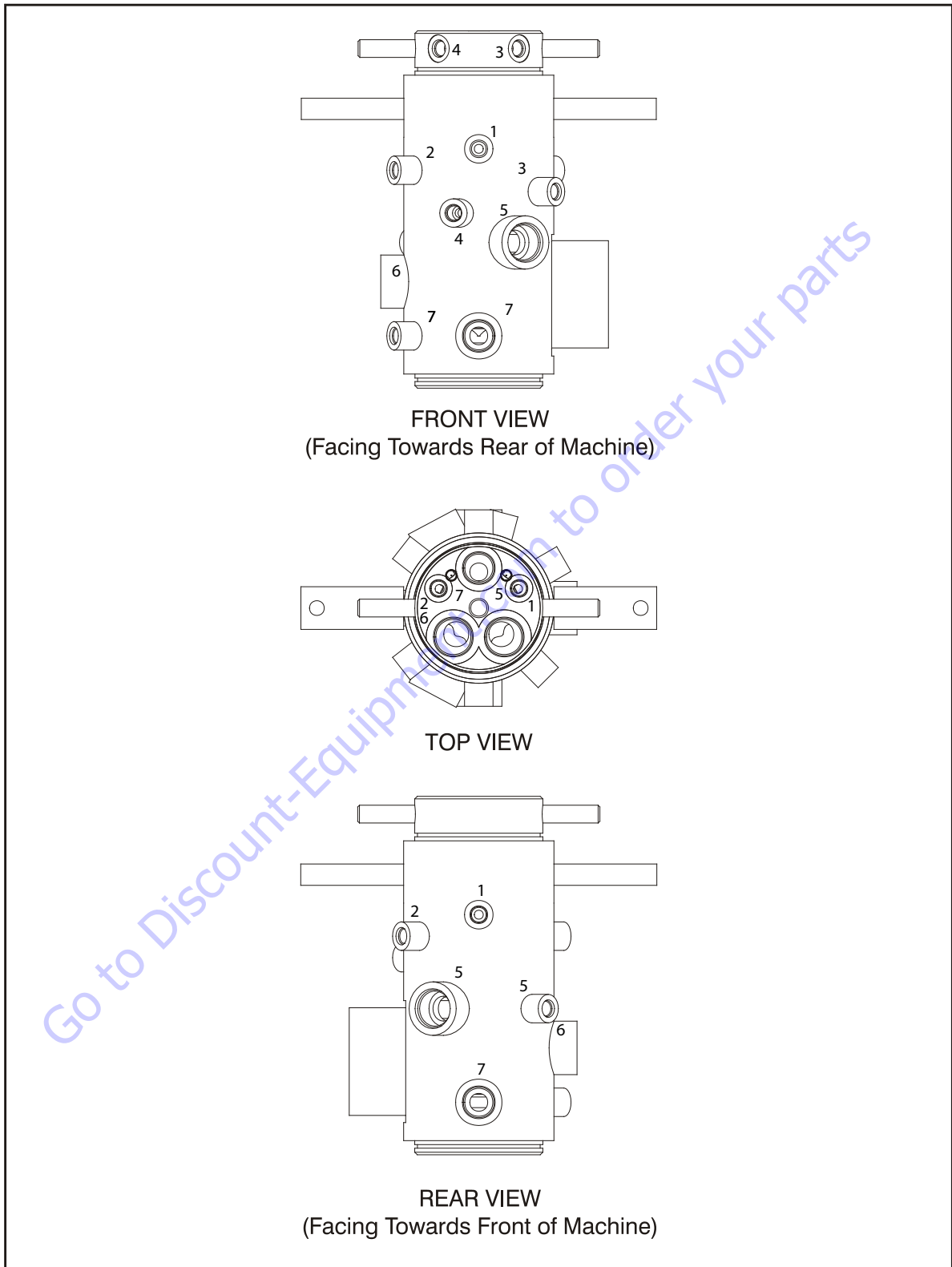
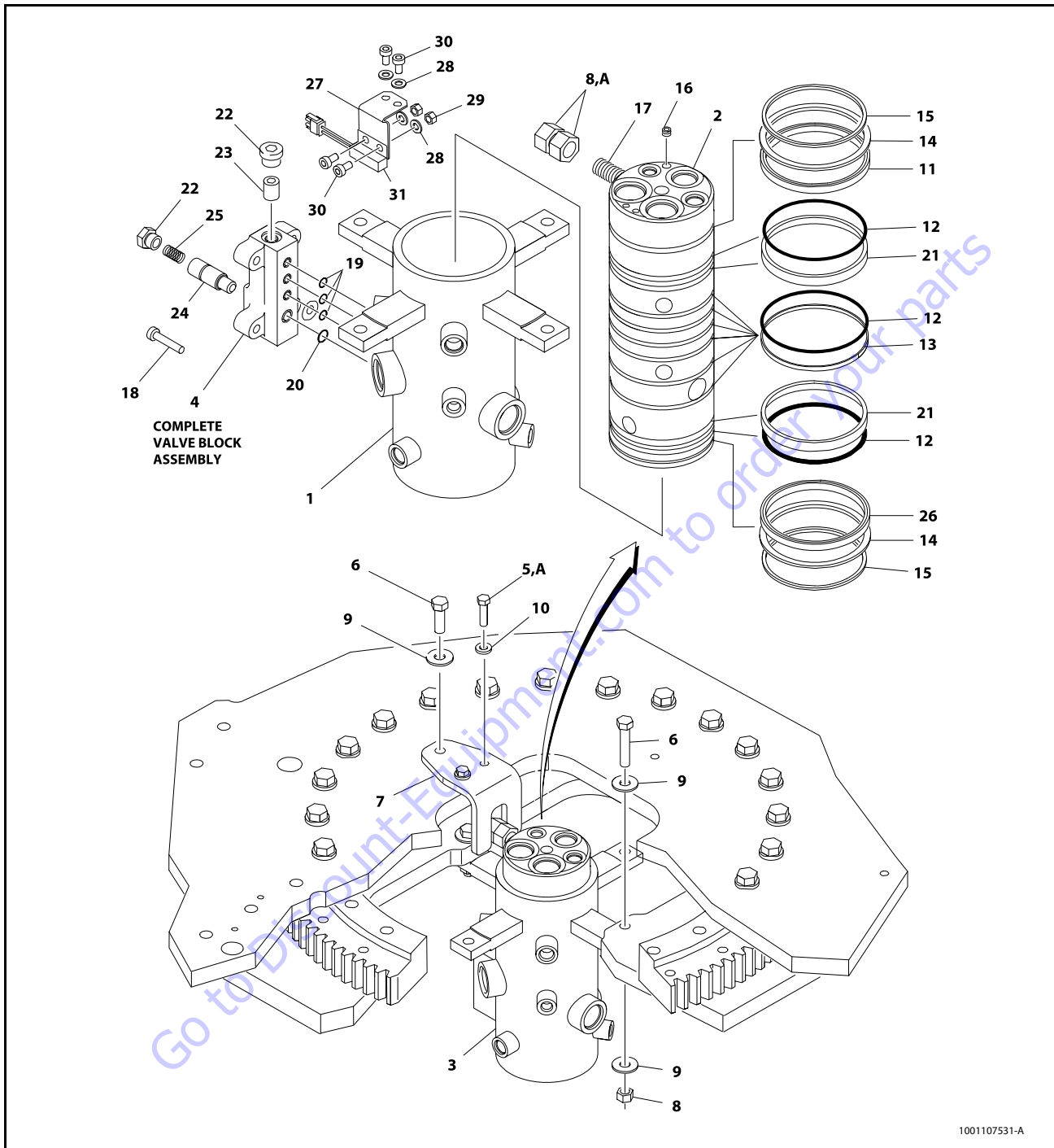

Figure 3-67. Rotary Coupling Port Location (7 Port)



- | | | | | | |
|-------------------------|------------|--------------------|--------------|-------------------|----------------------|
| 1. Housing | 7. Bracket | 13. Cap Seal | 18. Capscrew | 23. Check Valve | 28. Washer |
| 2. Body | 8. Locknut | 14. Thrust Ring | 19. O-ring | 24. Plunger Valve | 29. Locknut |
| 3. Rotary Coupling | 9. Washer | 15. Retaining Ring | 20. O-ring | 25. Spring | 30. Capscrew |
| 4. Block Valve Assembly | 10. Washer | 16. Plug | 21. Bearing | 26. Seal | 31. Proximity Switch |
| 5. Bolt | 11. Seal | 17. Torque Lug | 22. Plug | 27. Bracket | |
| 6. Bolt | 12. O-ring | | | | |

Figure 3-68. Rotary Coupling Installation

Table 3-9. Coupling Port Information Table (7 port)

Port No.	Outlets	Port Size	Description	Operating Pressure PSI (Bar)	Proof Pressure PSI (Bar)
1	1	-8	Brake	450 (31)	675 (46.5)
2	2	-6	2 Speed	4500 (310)	6750 (465)
3	1	-6	Steer	2500 (172)	3750 (258.5)
4	1	-6	Steer	2500 (172)	3750 (258.5)
5	2	1-6, 1-16	Drive Reverse	4500 (310)	6750 (465)
6	1	-16	Drive Forward	4500 (310)	6750 (465)
7	3	2-8, 1-6	Drain	250 (17)	375 (26)

Go to Discount-Equipment.com to order your parts

3.20 GENERATOR

Maintenance Schedule

EVERY 250 HOURS

Every 250 hours of operation, check the drive belt for proper tension.

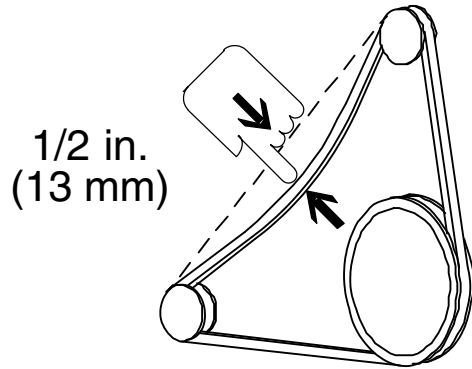

EVERY 500 HOURS

Every 500 hours of operation, service the generator brushes and slip rings. Hostile environments may require more frequent service.

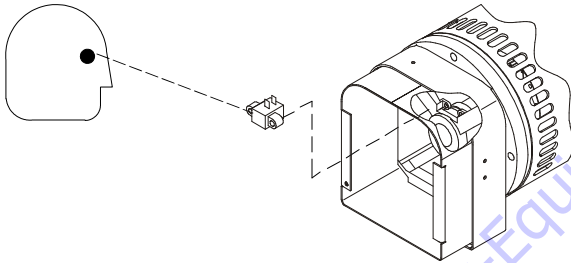

Every 500 hours of service, blow out the inside of the generator. If operating in a hostile environment, clean monthly.

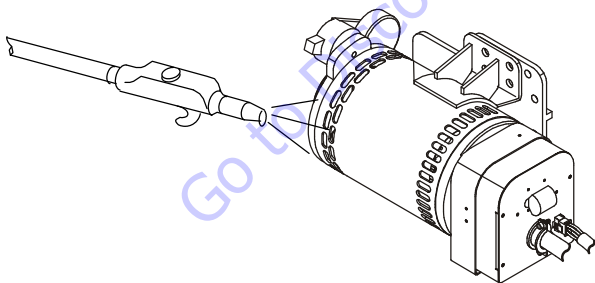

Overload Protection

CAUTION

STOP THE ENGINE WHENEVER CHECKING OR INSPECTING THE CIRCUIT BREAKER.

The circuit breaker protects the generator windings from overload. If the circuit breaker opens, generator output stops. If the circuit breaker continues to open, check for faulty equipment connected to the platform receptacles.

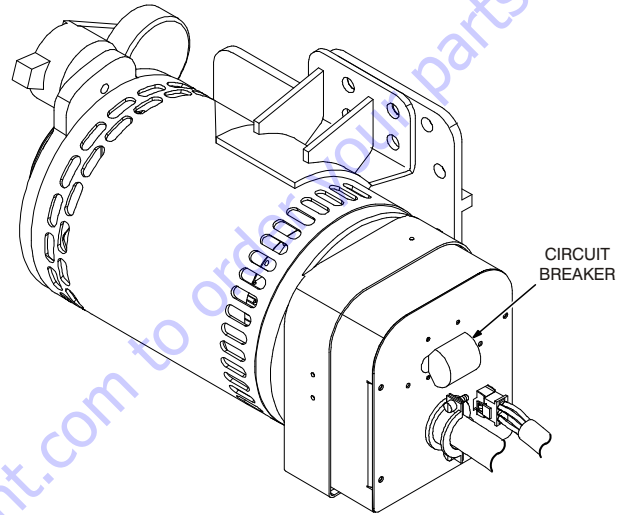

Inspecting Brushes, Replacing Brushes, and Cleaning Slip Rings

Refer to Figure 3-69., *Inspecting Generator Brushes, Replacing Brushes, and Cleaning Slip Rings.*

INSPECTING BRUSH POSITION

Inspect brush alignment with slip rings. View alignment through the air vents in the stator barrel. The brushes must ride completely on the slip rings.

INSPECTING BRUSHES

Remove the end panel. Inspect the wires. Remove the brush holder assembly. Pull the brushes from the holders.

Replace the brushes if damaged, or if the brush is at or near minimum length.

CLEANING SLIP RINGS

Visually inspect the slip rings. Under normal use, the rings turn dark brown.

If the slip rings are corroded or their surface is uneven, remove the belt to turn the shaft by hand for cleaning.

Clean the rings with 220 grit emery paper. Remove as little material as possible. If the rings are deeply pitted and do not clean up, consult generator factory service.

Reinstall the belt, brush holder assembly, and end panel.

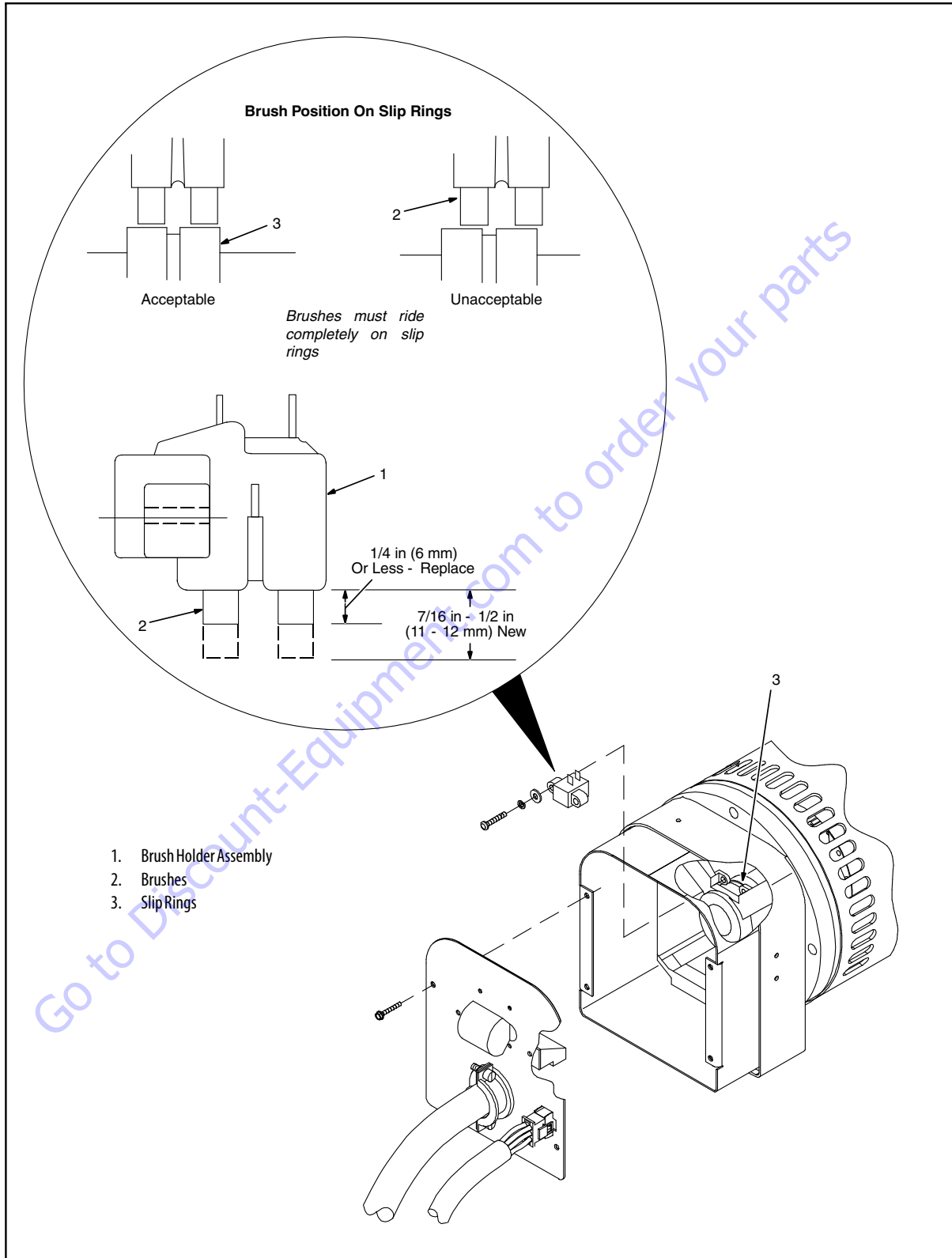

Figure 3-69. Inspecting Generator Brushes, Replacing Brushes, and Cleaning Slip Rings

Troubleshooting

Table 3-10. Troubleshooting

Trouble	Remedy
No generator output at platform AC receptacles.	Be sure generator control switch is turned on at platform.
	Check and secure electrical connections at platform, generator, and control box.
	Be sure all equipment is turned off when starting unit.
	Reset circuit breaker CB1.
	Check plug PLG3 connection and/or connections at receptacles RC3 and RC5.
	Be sure + 12 volts DC input voltage is being supplied to control box.
	Check slip rings, wiring to brushes, and brush position on slip rings. Install new brushes if necessary.
	Disconnect leads 12 and 13 from brushes, and check continuity across slip rings (nominal reading is 26 ohms). Replace generator if rotor is open.
	Disconnect stator weld leads 1, 2, and 3 from circuit breaker CB1, and check continuity between leads. Replace generator if necessary.
	Disconnect plug PLG4 and check continuity between exciter leads 5 and 6. Replace generator if necessary.
	Check power board PC1 and connections, and replace if necessary.
Check control board PC2 and connections, and replace if necessary.	
Low generator output at platform AC receptacles.	Verify generator is running at 3600 rpm (60 Hz) or 3000 rpm (50 Hz).
	Check slip rings, wiring to brushes, and brush position on slip rings. Install new brushes if necessary.
	Disconnect leads 12 and 13 from brushes, and check continuity across slip rings nominal reading is 26 ohms). Replace generator if rotor is open.
	Disconnect stator weld leads 1, 2, and 3 from circuit breaker CB1, and check continuity between leads. Replace generator if necessary.
	Disconnect plug PLG4 and check continuity between exciter leads 5 and 6. Replace generator if necessary.
	Check power board PC1 and connections, and replace if necessary.
	Check control board PC2 and connections, and replace if necessary.
High generator output at platform AC receptacles.	Verify generator is running at 3600 rpm (60 Hz) or 3000 rpm (50 Hz).
	Check slip rings, wiring to brushes, and brush position on slip rings. Install new brushes if necessary.
	Check power board PC1 and connections, and replace if necessary.
	Check control board PC2 and connections, and replace if necessary.
Erratic generator output at platform AC receptacles.	Check and secure electrical connections at platform, generator, and control box.
	Verify generator is running at 3600 rpm (60 Hz) or 3000 rpm (50 Hz).
	Check slip rings, wiring to brushes, and brush position on slip rings. Install new brushes if necessary.
	Disconnect leads 12 and 13 from brushes, and check continuity across slip rings nominal reading is 26 ohms). Replace generator if rotor is open.
	Check power board PC1 and connections, and replace if necessary
	Check control board PC2 and connections, and replace if necessary

Generator Disassembly and Assembly

Refer to Figure 3-71. and Figure 3-72. to determine if trouble is in stator, rotor, control box, or combination of these components.

1. Rotor
2. Stator Assembly

⚠ CAUTION

DO NOT DAMAGE ROTOR OR STATOR WINDINGS DURING DISASSEMBLY AND ASSEMBLY PROCEDURE.

DISASSEMBLY

1. Mark and disconnect all electrical leads, secure using cable ties.

2. Remove brush holder assembly.
3. Disassemble generator parts shown in Figure 3-70.
4. Clean all parts with approved solvent and dry with compressed air, If applicable.
5. Inspect all part for damage. Replace if necessary.

ASSEMBLY

1. Assemble generator parts using torque values in table.
2. Reconnect all leads. Use cable ties to secure leads away from moving or hot parts.

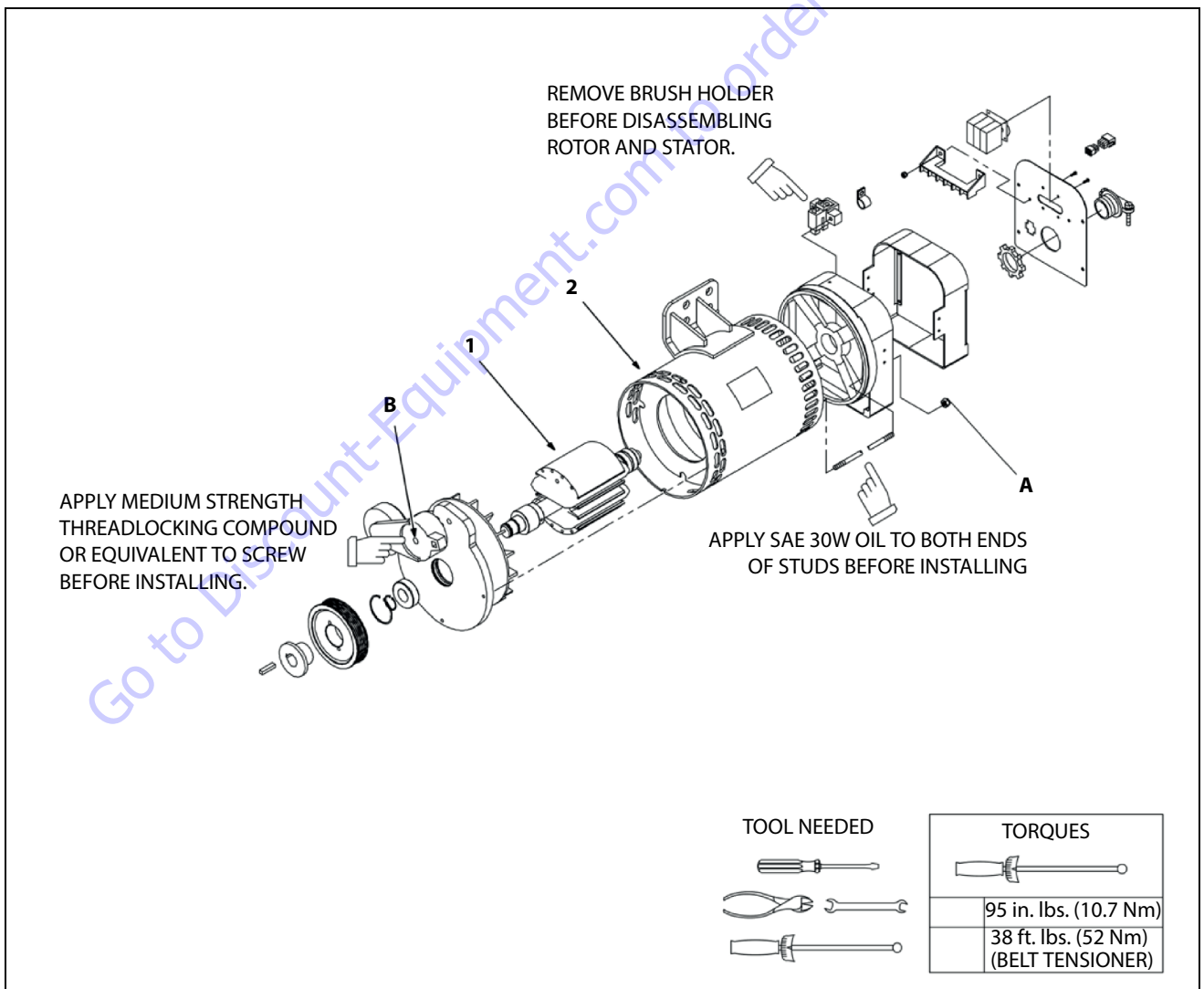

Figure 3-70. Generator Disassembly and Assembly

Resistance Values	
a) Tolerance - $\pm 10\%$ unless specified	
b) Condition - 70°F (21°C); cold machine (no warm-up)	
c) Wiring Diagram	
d) Stop generator before checking resistance	
R1	26 ohms
R2	1 ohm
R3 thru R5	Less than 1 ohm

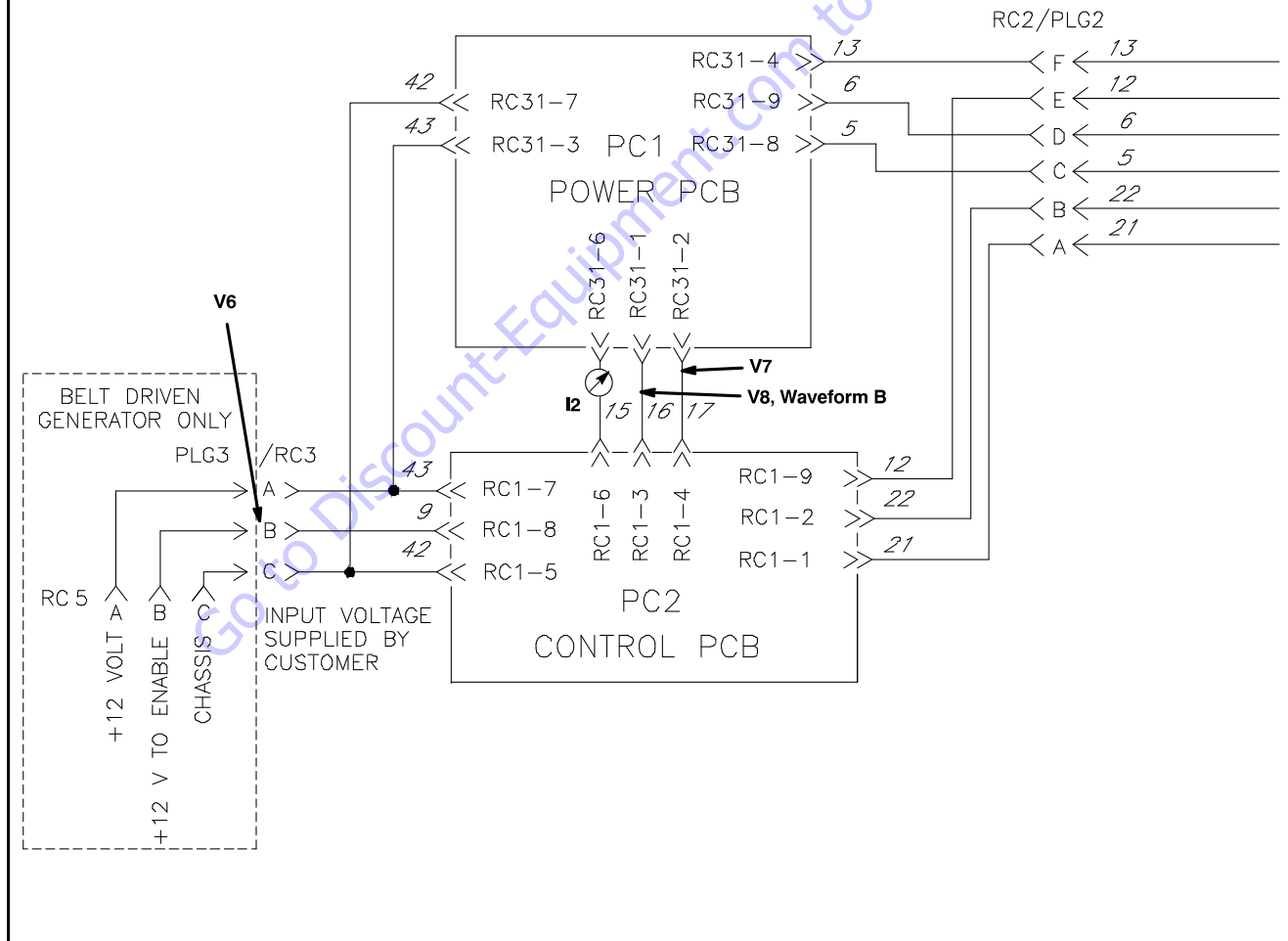
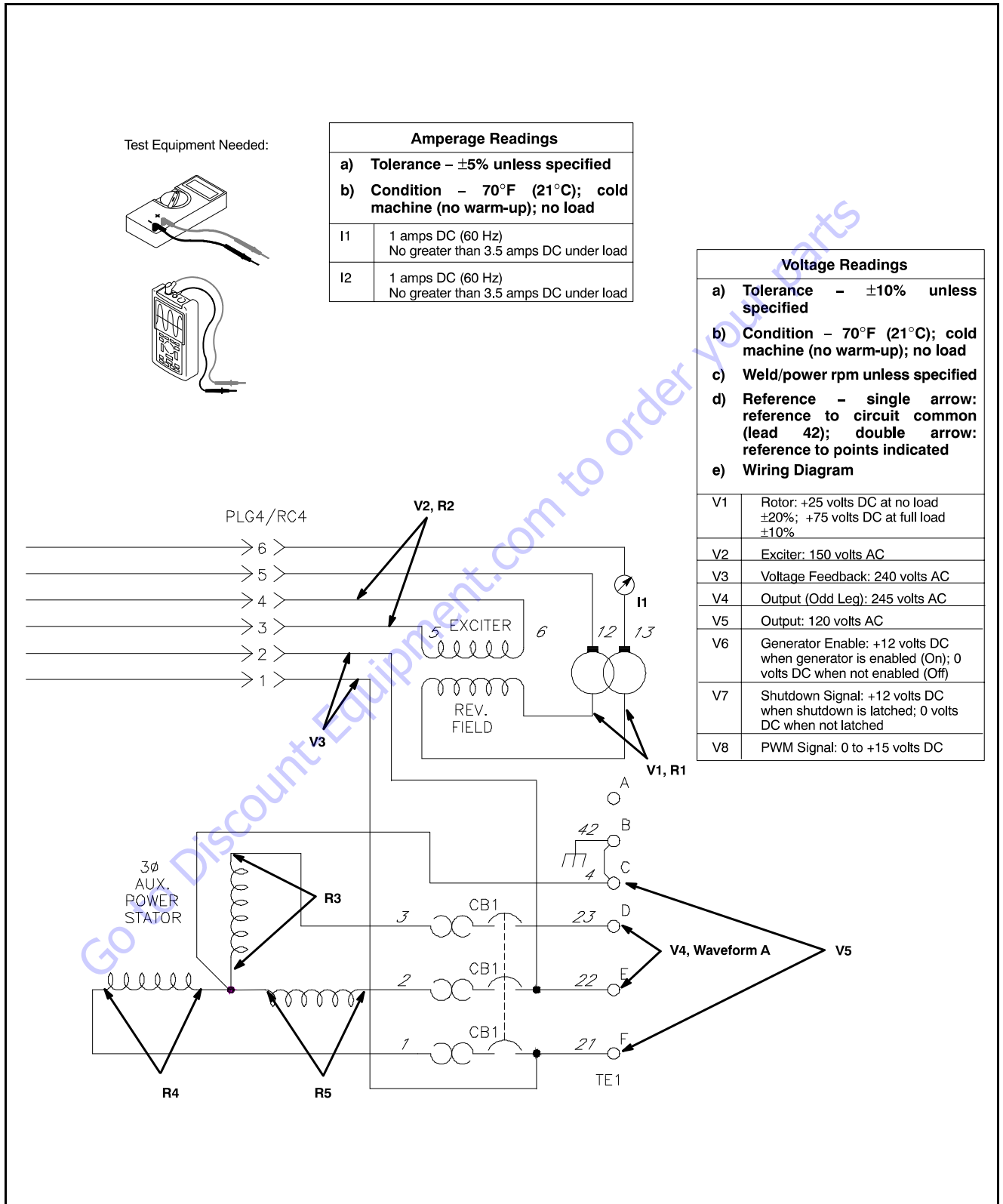

Figure 3-71. Generator Troubleshooting Circuit Diagram (Sheet 1 of 2)



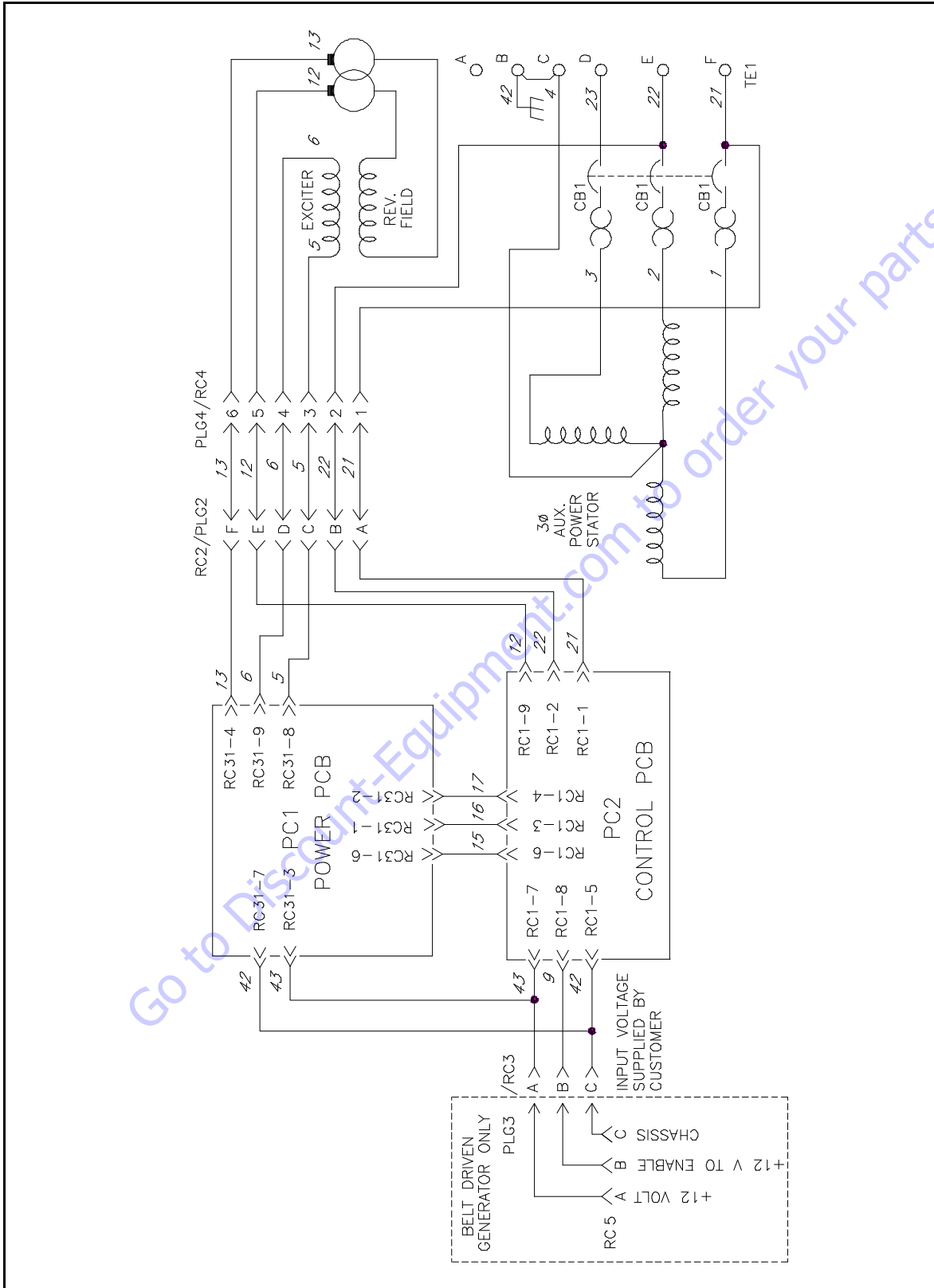

Figure 3-73. Generator Electrical Circuit Diagram

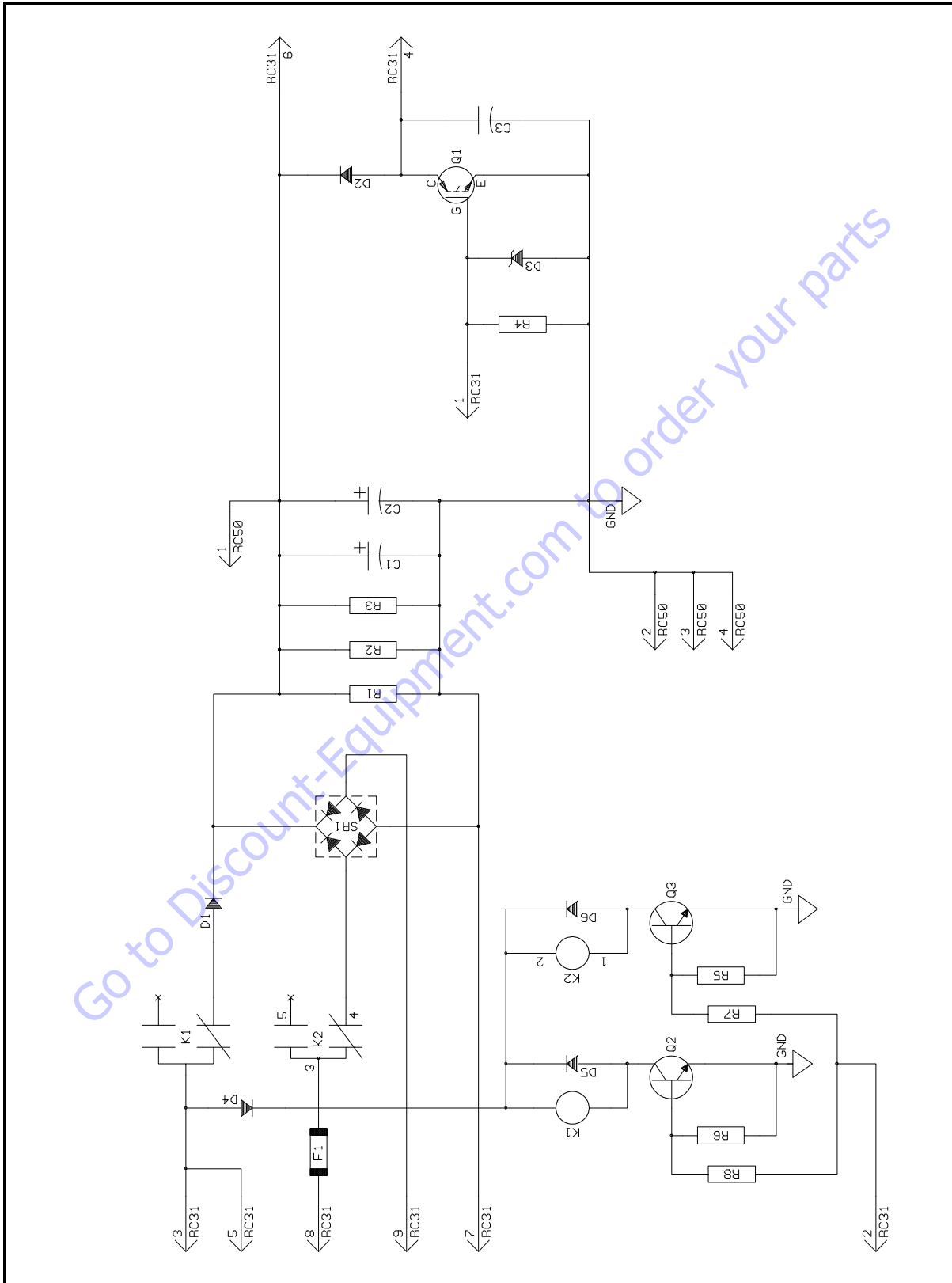

Figure 3-74. Power Board PC1 Electrical Circuit Diagram

SECTION 3 - CHASSIS & TURNTABLE

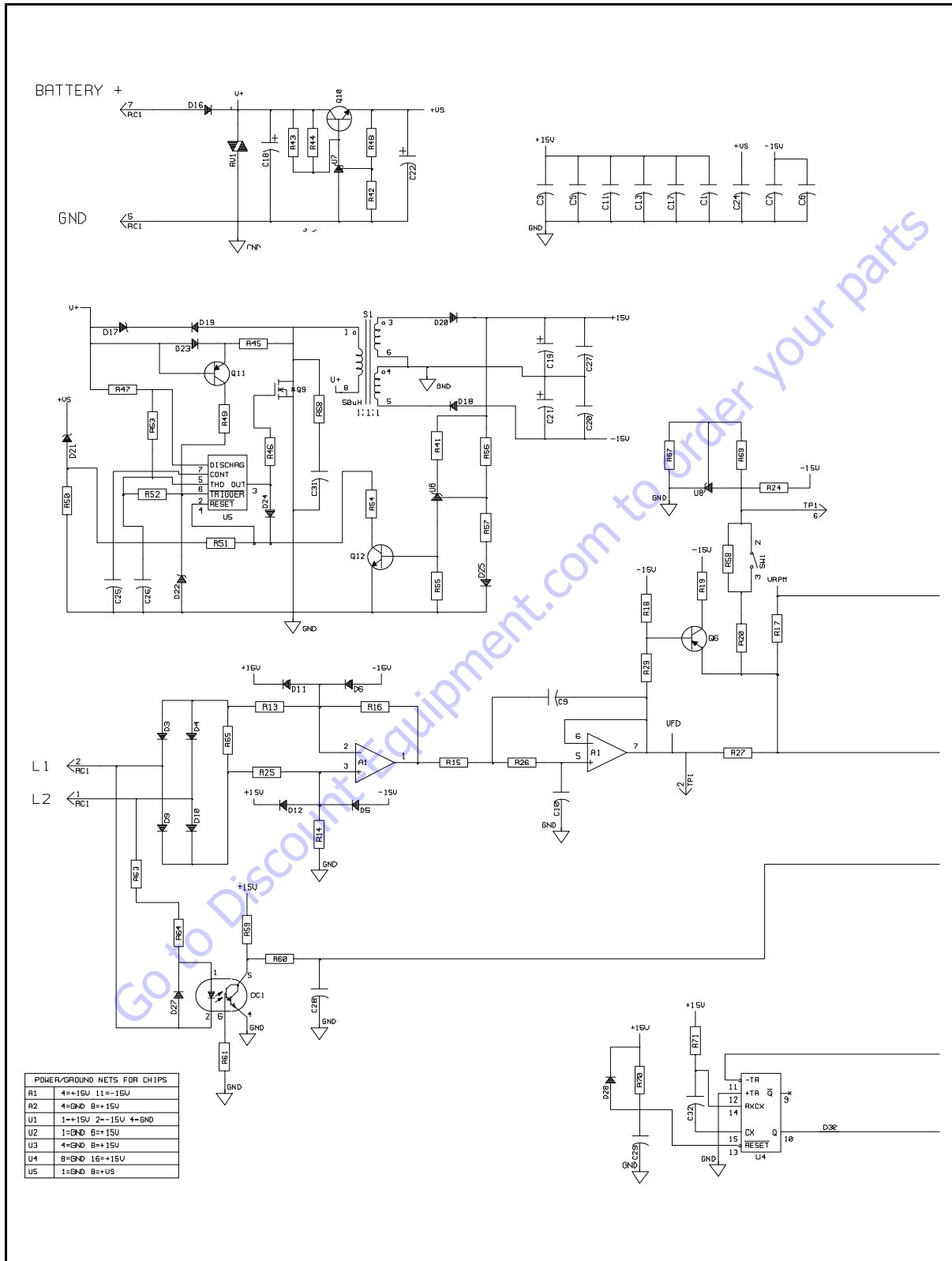

Figure 3-75. Power Board PC2 Electrical Circuit Diagram (Sheet 1 of 2)

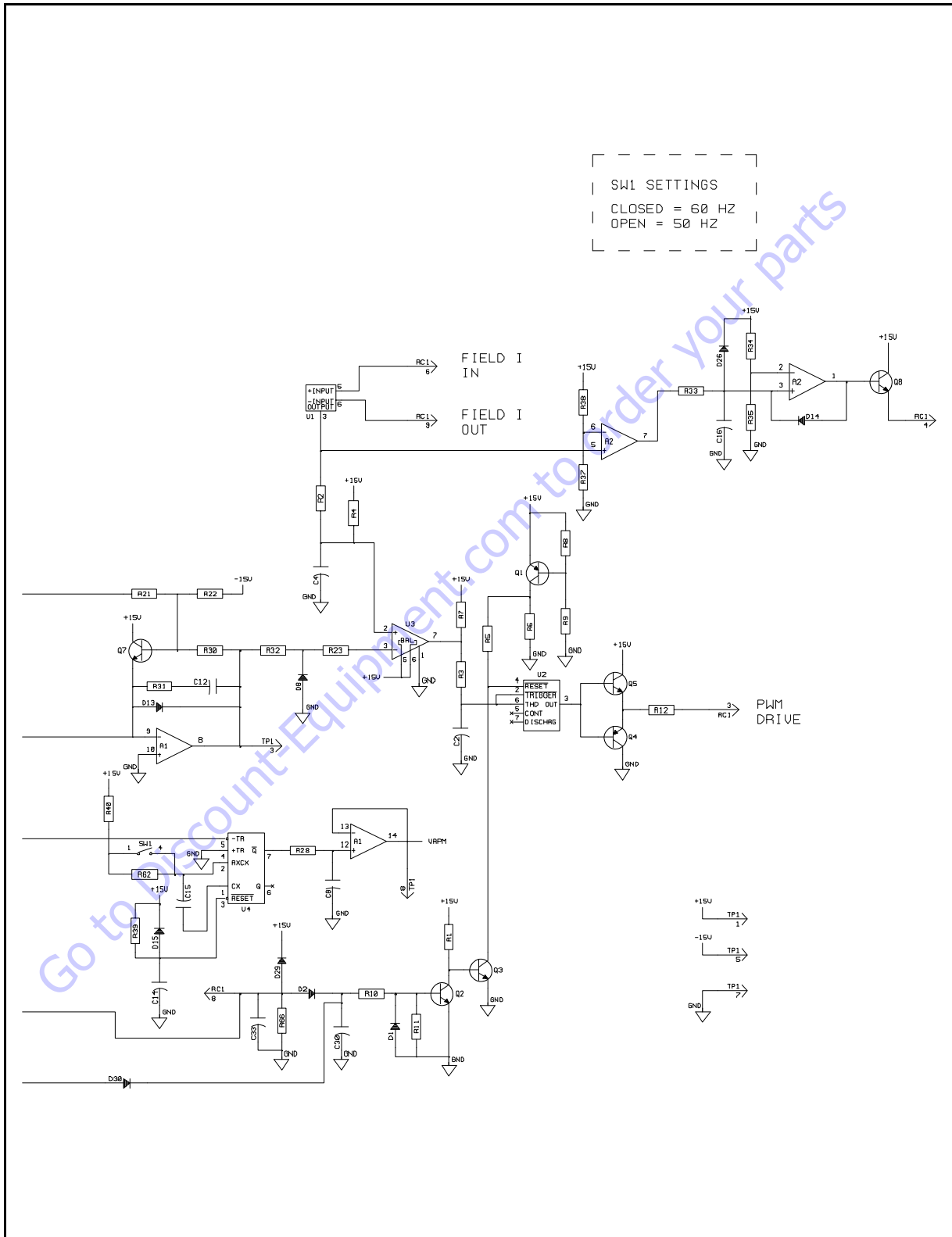

Figure 3-76. Power Board PC2 Electrical Circuit Diagram (Sheet 2 of 2)

Lead Connection List for Generator

NOTE: Apply small amount of dielectric grade, nonconductive electric grease to connectors where factory-applied grease had been present.

NOTE: Table shows physical lead connections and should be used with circuit diagram (table replaces wiring diagram).

Table 3-11. Lead Connection List for Generator

Leads	Connections
1A	STATOR TO CB1
2A	STATOR TO CB1
3A	STATOR TO CB1
4A	STATOR TO TE1 (C)
5A	STATOR TO RC4 (3)
5B	PLG2 (C) TO PLG4 (3)
5C	RC2 (C) PLG31 (8)
6A	STATOR TO RC4 (4)
6B	PLG2 (D) TO PLG4 (4)
6C	RC2 (D) PLG31 (9)
9A	RC5 (B) TO PLG3 (B) (Customer Supplied)
9B	RC3 (B) PLG1 (8)
12A	PLG2 (E) TO PLG4 (5)
12B	RC2 (E) PLG1 (9)
12C	RC4 (5) TO BRUSH
13A	PLG2 (F) TO PLG4 (6)
13B	RC2 (F) PLG31 (4)
13C	RC4 (6) TO BRUSH
15A	PLG1 (6) TO PLG31 (6)
16A	PLG1 (3) TO PLG31 (1)
17A	PLG1 (4) TO PLG31 (2)
21A	CB1 TO TE1 (F)
21B	PLG2 (A) TO PLG4 (1)
21C	PLG1 (1) TO RC2 (A)
21D	RC4 (1) TO CB1
22A	CB1 TO TE1 (E)
22B	PLG2 (B) TO PLG4 (2)
22C	PLG1 (2) TO RC2 (B)
22D	RC4 (2) TO CB1
23A	CB1 TO TE1 (D)
42A	RC5 (C) TO PLG3 (C) (Customer Supplied)
42B	RC3 (C) TO CONNECTION POINT 1
42C	PLG31 (7) TO CONNECTION POINT 1
42D	PLG1 (5) TO CONNECTION POINT 1
42F	END BELL SHROUD TO ENGINE MOUNT
42G	CHASSIS TO TE1 (B)
43A	RC5 (A) TO PLG3 (A) (Customer Supplied)
43B	RC3 (A) TO CONNECTION POINT 2
43C	PLG31 (3) TO CONNECTION POINT 2
43D	PLG1 (7) TO CONNECTION POINT 2

3.21 FORD ENGINE

NOTE: Detailed Engine service instructions are provided in the following publications: Service Manual 3128849.

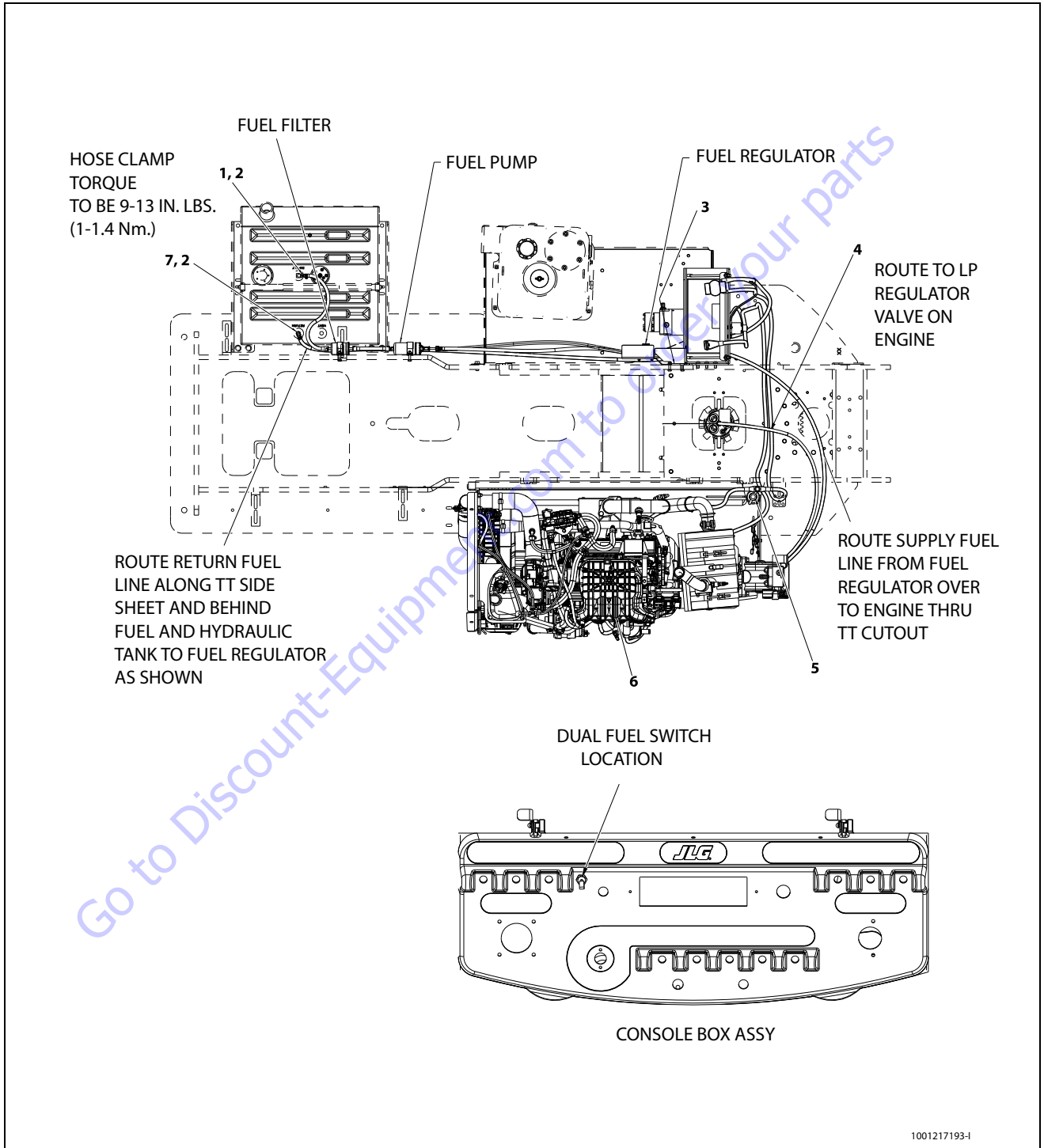

Figure 3-77. Ford Engine Installation - Sheet 1 of 4

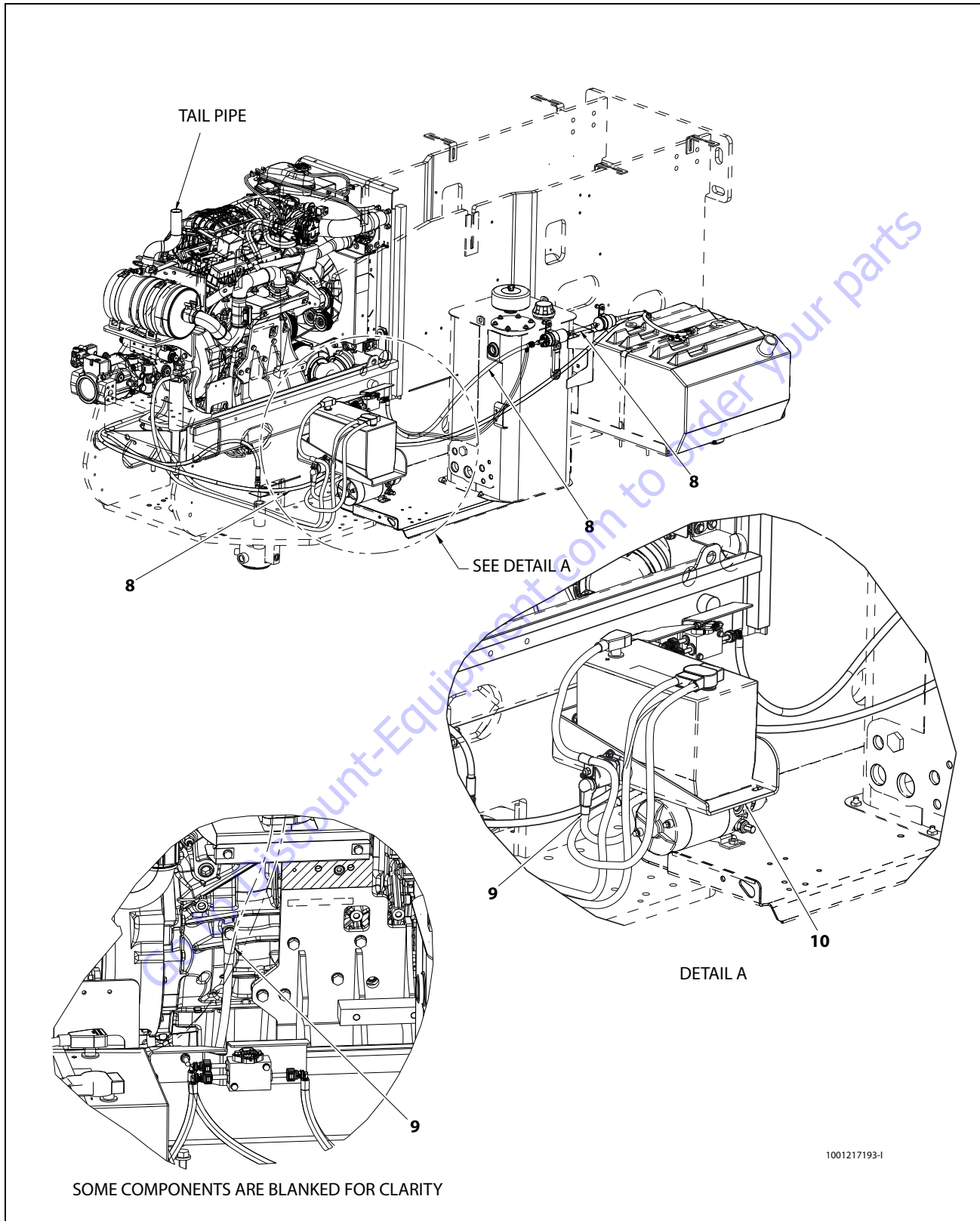
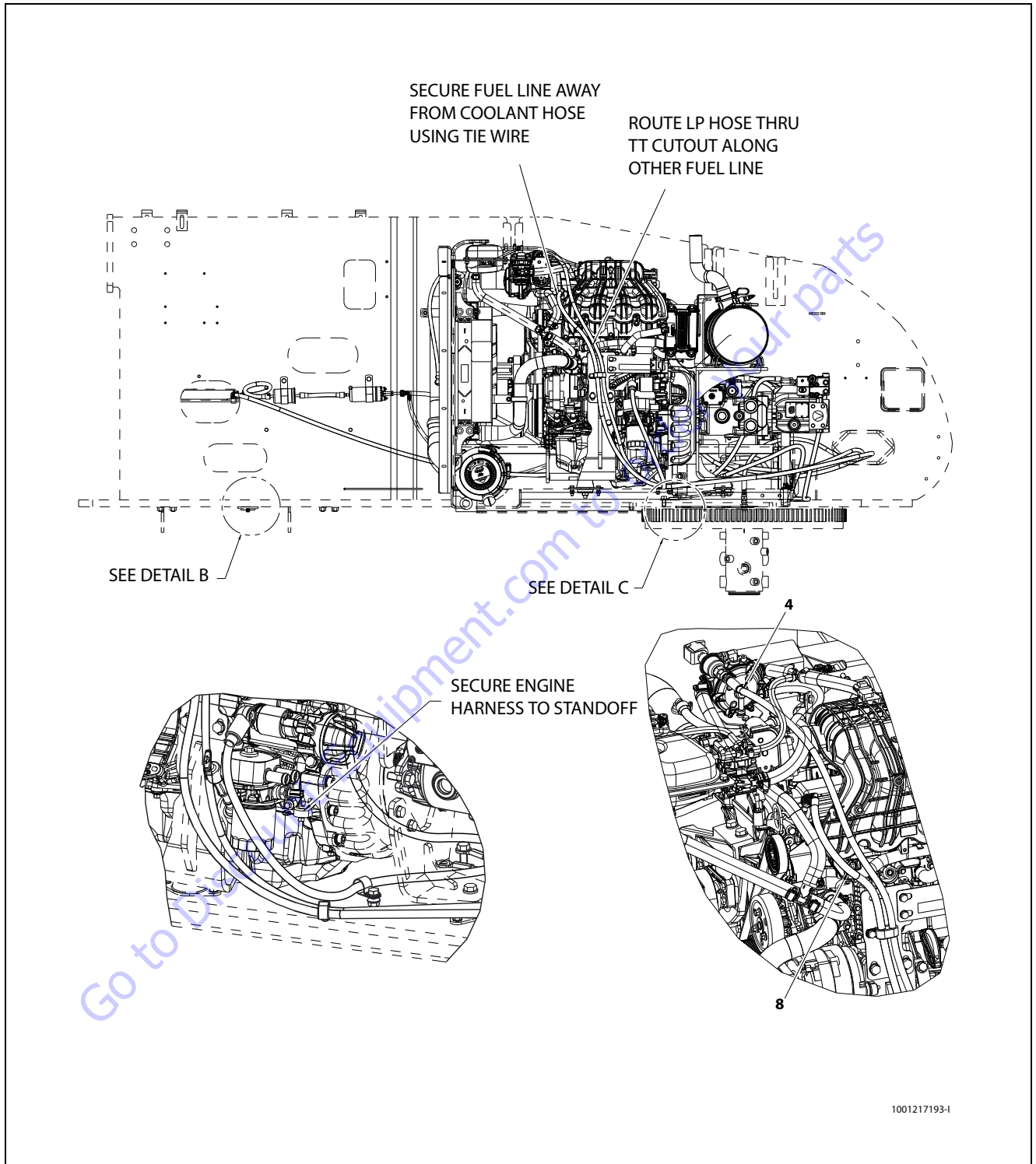

Figure 3-78. Ford Engine Installation - Sheet 2 of 4



- | | | | |
|---------------------------------|---------------------------|----------------------------|---------------------|
| 1. High Pressure Fuel Hose | 4. LP Gas Hose | 7. High Pressure Fuel Hose | 10. Battery Bracket |
| 2. Hose Clamp | 5. Engine Tray Pin | 8. High Pressure Fuel Hose | |
| 3. Fuel Regulator Mount Bracket | 6. Ford Engine with Pumps | 9. Battery Cable Kit | |

Figure 3-79. Ford Engine Installation - Sheet 3 of 4

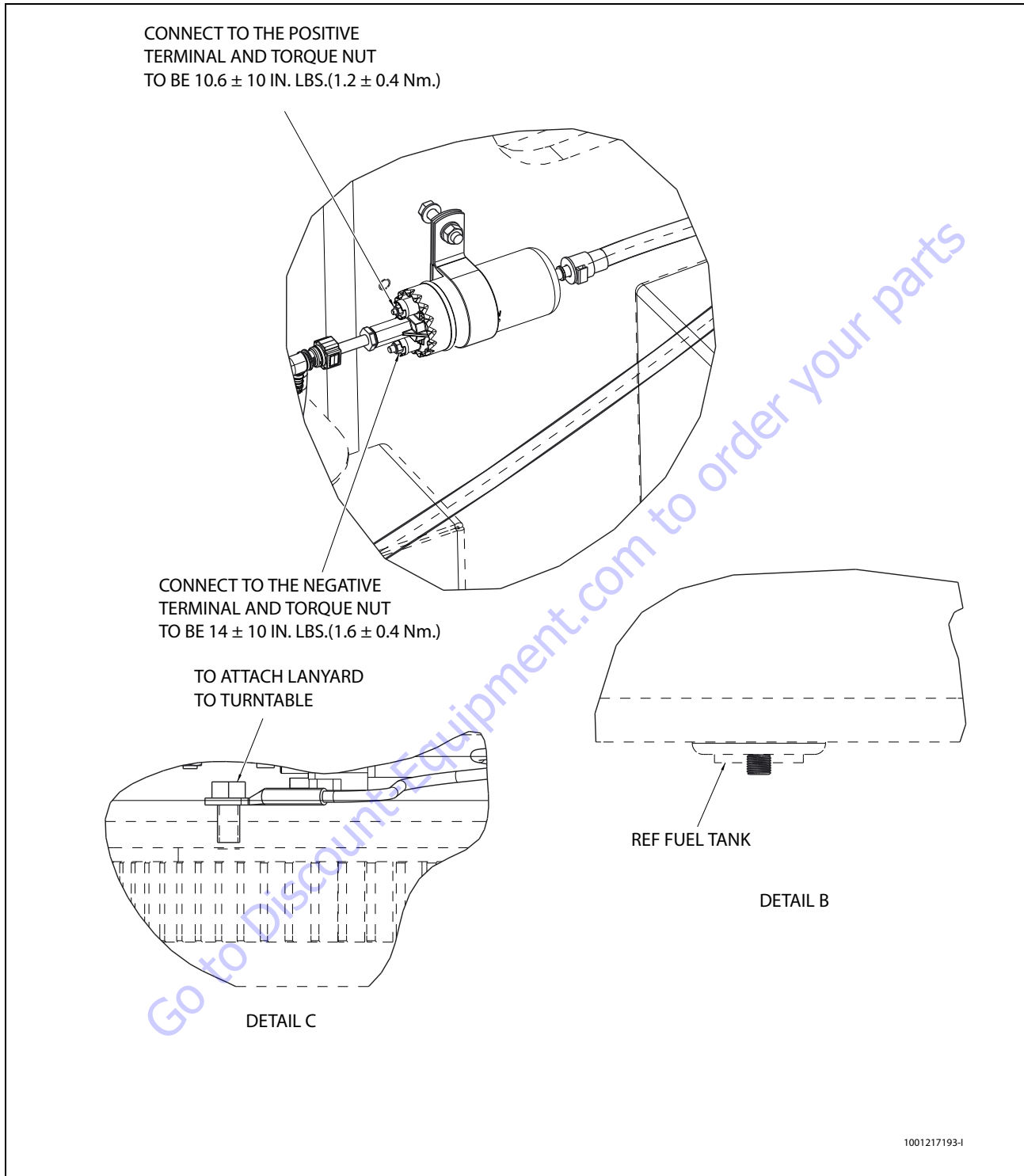

Figure 3-80. Ford Engine Installation - Sheet 4 of 4

Table 3-12. CAN to DTC Cross Reference (Ford Engine)

SPN	FMI	DTC	DTC and Description
0	31	1531	Gov1/2/3 interlock failure
0	31	1621	RS-485 Rx inactive
0	31	1622	RS-485 Rx noise
0	31	1623	RS-485 Rx bad packet format
0	31	1624	RS-485 remote shutdown request
29	0	2116	FPP2 higher than IVS
29	1	2140	FPP2 lower than IVS
29	3	2128	FPP2 voltage high
29	4	2127	FPP2 voltage low
51	0	221	TPS1-2 higher than expected
51	1	121	TPS1-2 lower than expected
51	3	123	TPS1 voltage high
51	4	122	TPS1 voltage low
51	7	2111	Unable to reach lower TPS
51	7	2112	Unable to reach higher TPS
51	31	2135	TPS1/2 simultaneous voltages out-of-range
84	8	502	Roadspeed input loss of signal
91	0	2115	FPP1 higher than IVS
91	1	2139	FPP1 lower than IVS
91	3	2122	FPP1 voltage high
91	4	2123	FPP1 voltage low
91	9	1651	J1939 ETC message receipt loss while in-gear
91	16	2126	FPP1-2 higher than expected
91	18	2121	FPP1-2 lower than expected
91	19	1630	J1939 ETC message receipt loss
91	31	1121	FPP1/2 simultaneous voltages out-of-range (redundancy lost)
94	0	88	Fuel pressure higher than expected
94	1	87	Fuel pressure lower than expected
94	3	92	FP high voltage
94	4	91	FP low voltage
100	0	521	Oil pressure sender high pressure
100	1	524	Oil pressure low
100	1	524	Oil pressure sender low pressure
100	3	523	Oil pressure sender high voltage
100	4	522	Oil pressure sender low voltage
100	18	520	Oil pressure sender low pressure stage 1
102	0	234	Boost control overboost failure
102	1	299	Boost control underboost failure
102	2	236	TIP active
102	3	238	TIP high voltage
102	4	237	TIP low voltage
105	0	127	IAT higher than expected stage 2

SECTION 3 - CHASSIS & TURNTABLE

Table 3-12. CAN to DTC Cross Reference (Ford Engine)

SPN	FMI	DTC	DTC and Description
105	3	113	IAT voltage high
105	4	112	IAT voltage low
105	15	111	IAT higher than expected stage 1
106	4	107	MAP voltage low
106	16	108	MAP pressure high
108	0	2229	BP pressure high
108	1	129	BP pressure low
110	0	217	ECT higher than expected stage 2
110	0	1522	CHT higher than expected stage 2
110	3	118	ECT voltage high
110	4	117	ECT voltage low
110	15	116	ECT higher than expected stage 1
110	16	1521	CHT higher than expected stage 1
168	15	563	Vbat voltage high
168	17	562	Vbat voltage low
173	0	2428	EGT temperature high
174	3	183	FT high voltage
174	4	182	FT low voltage
441	0	1417	EMWT1 higher than expected stage 2
441	3	1411	EMWT1 voltage high
441	4	1413	EMWT1 voltage low
441	15	1415	EMWT1 higher than expected stage 1
442	0	1418	EMWT2 higher than expected stage 2
442	3	1412	EMWT2 voltage high
442	4	1414	EMWT2 voltage low
442	15	1416	EMWT2 higher than expected stage 1
515	0	1112	RPM above spark rev limit level
515	15	219	RPM higher than max allowed govern speed
515	16	1111	RPM above fuel rev limit level
558	5	2130	IVS stuck at-idle, FPP1/2 match
558	6	2131	IVS stuck off-idle, FPP1/2 match
628	13	601	Microprocessor failure - FLASH
629	31	606	Microprocessor failure - COP
629	31	1612	Microprocessor failure - RTI 1
629	31	1613	Microprocessor failure - RTI 2
629	31	1614	Microprocessor failure - RTI 3
629	31	1615	Microprocessor failure - A/D
629	31	1616	Microprocessor failure - Interrupt
630	12	604	Microprocessor failure - RAM
632	31	359	Fuel run-out longer than expected
636	2	336	CRANK input signal noise
636	4	337	Crank signal loss
636	8	16	Crank and/or cam could not synchronize during start

Table 3-12. CAN to DTC Cross Reference (Ford Engine)

SPN	FMI	DTC	DTC and Description
639	12	1626	CAN-J1939 Tx fault
639	12	1627	CAN-J1939 Rx fault
639	13	1628	J1939 CAN address / engine-number conflict
645	3	2619	Tach output short to power
645	4	2618	Tach output ground short
651	5	261	Injector 1 open or short to ground
651	6	262	Injector 1 coil shorted
652	5	264	Injector 2 open or short to ground
652	6	265	Injector 2 coil shorted
653	5	267	Injector 3 open or short to ground
653	6	268	Injector 3 coil shorted
654	5	270	Injector 4 open or short to ground
654	6	271	Injector 4 coil shorted
655	5	273	Injector 5 open or short to ground
655	6	274	Injector 5 coil shorted
656	5	276	Injector 6 open or short to ground
656	6	277	Injector 6 coil shorted
657	5	279	Injector 7 open or short to ground
657	6	280	Injector 7 coil shorted
658	5	282	Injector 8 open or short to ground
658	6	283	Injector 8 coil shorted
659	5	285	Injector 9 open or short to ground
659	6	286	Injector 9 coil shorted
660	5	288	Injector 10 open or short to ground
660	6	289	Injector 10 coil shorted
695	9	1629	J1939TSC1 message receipt loss
697	3	1632	PWM1-Gauge1 short to power
697	5	1631	PWM1-Gauge1 open / ground short
698	3	1634	PWM2-Gauge2 short to power
698	5	1633	PWM2-Gauge2 open / ground short
699	3	1636	PWM3-Gauge3 short to power
699	5	1635	PWM3-Gauge3 open / ground short
700	3	1638	PWM4 short to power
700	5	1637	PWM4 open / ground short
701	3	1511	AUX analog Pull-Up 1 high voltage
701	4	1512	AUX analog Pull-Up 1 low voltage
702	3	1513	AUX analog Pull-Up 2 high voltage
702	4	1514	AUX analog Pull-Up 2 low voltage
703	3	1517	AUX analog Pull-Up 3 high voltage
703	4	1518	AUX analog Pull-Up 3 low voltage
704	3	1541	AUX analog Pull-Up/Down 1 high voltage
704	4	1542	AUX analog Pull-Up/Down 1 low voltage
705	3	1543	AUX analog Pull-Up/Down 2 high voltage

SECTION 3 - CHASSIS & TURNTABLE

Table 3-12. CAN to DTC Cross Reference (Ford Engine)

SPN	FMI	DTC	DTC and Description
705	4	1544	AUX analog Pull-Up/Down 2 low voltage
706	3	1545	AUX analog Pull-Up/Down 3 high voltage
706	4	1546	AUX analog Pull-Up/Down 3 low voltage
707	3	1551	AUX digital 1 high voltage
707	4	1552	AUX digital 1 low voltage
708	3	1553	AUX digital 2 high voltage
708	4	1554	AUX digital 2 low voltage
709	3	1555	AUX digital 3 high voltage
709	3	1555	Water Intrusion Detection
709	4	1556	AUX digital 3 low voltage
710	3	1515	AUX analog Pull-Down 1 high voltage
710	4	1516	AUX analog Pull-Down 1 low voltage
711	3	1561	AUX analog Pull-Down 2 high voltage
711	4	1561	AUX analog Pull-Down 2 low voltage
712	3	1561	AUX analog Pull-Down 3 high voltage
712	4	1561	AUX analog Pull-Down 3 low voltage
713	3	1547	AUX analog Pull-Up/Down 4 high voltage
713	4	1548	AUX analog Pull-Up/Down 4 low voltage
723	2	341	CAM input signal noise
723	4	342	Loss of CAM input signal
731	2	326	Knock1 excessive or erratic signal
731	4	327	Knock1 sensor open or not present
920	3	1643	Buzzer control short to power
920	4	1641	Buzzer control ground short
920	5	1642	Buzzer open
924	3	1640	PWM5 short to power
924	5	1639	PWM5 open / ground short
925	3	1662	PWM6 short to power
925	5	1661	PWM6 open / ground short
926	3	1664	PWM7 short to power
926	5	1663	PWM7 open / ground short
1079	3	643	Sensor supply voltage 1 high
1079	4	642	Sensor supply voltage 1 low
1079	31	1611	Sensor supply voltage 1 and 2 out-of-range
1080	3	653	Sensor supply voltage 2 high
1080	4	652	Sensor supply voltage 2 low
1110	31	1625	J1939 shutdown request
1192	3	1131	WGP voltage high
1192	4	1132	WGP voltage low
1213	3	1645	MIL control short to power
1213	4	1644	MIL control ground short
1213	5	650	MIL open
1268	5	2300	Spark coil 1 primary open or short to ground

Table 3-12. CAN to DTC Cross Reference (Ford Engine)

SPN	FMI	DTC	DTC and Description
1268	6	2301	Spark coil 1 primary shorted
1269	5	2303	Spark coil 2 primary open or short to ground
1269	6	2304	Spark coil 2 primary shorted
1270	5	2306	Spark coil 3 primary open or short to ground
1270	6	2307	Spark coil 3 primary shorted
1271	5	2309	Spark coil 4 primary open or short to ground
1271	6	2310	Spark coil 4 primary shorted
1272	5	2312	Spark coil 5 primary open or short to ground
1272	6	2313	Spark coil 5 primary shorted
1273	5	2315	Spark coil 6 primary open or short to ground
1273	6	2316	Spark coil 6 primary shorted
1274	5	2318	Spark coil 7 primary open or short to ground
1274	6	2319	Spark coil 7 primary shorted
1275	5	2321	Spark coil 8 primary open or short to ground
1275	6	2322	Spark coil 8 primary shorted
1276	5	2324	Spark coil 9 primary open or short to ground
1276	6	2325	Spark coil 9 primary shorted
1277	5	2327	Spark coil 10 primary open or short to ground
1277	6	2328	Spark coil 10 primary shorted
1321	3	617	Start relay coil short to power
1321	4	616	Start relay ground short
1321	5	615	Start relay coil open
1323	11	1311	Cylinder 1 misfire detected
1323	31	301	Cylinder 1 emissions/catalyst damaging misfire
1324	11	1312	Cylinder 2 misfire detected
1324	31	302	Cylinder 2 emissions/catalyst damaging misfire
1325	11	1313	Cylinder 3 misfire detected
1325	31	303	Cylinder 3 emissions/catalyst damaging misfire
1326	11	1314	Cylinder 4 misfire detected
1326	31	304	Cylinder 4 emissions/catalyst damaging misfire
1327	11	1315	Cylinder 5 misfire detected
1327	31	305	Cylinder 5 emissions/catalyst damaging misfire
1328	11	1316	Cylinder 6 misfire detected
1328	31	306	Cylinder 6 emissions/catalyst damaging misfire
1329	11	1317	Cylinder 7 misfire detected
1329	31	307	Cylinder 7 emissions/catalyst damaging misfire
1330	11	1318	Cylinder 8 misfire detected
1330	31	308	Cylinder 8 emissions/catalyst damaging misfire
1347	5	628	Fuel-pump high-side open or short to ground
1347	6	629	Fuel-pump high-side short to power
1348	3	629	Fuel pump relay coil short to power
1348	4	628	Fuel pump relay control ground short
1348	5	627	Fuel pump relay coil open

SECTION 3 - CHASSIS & TURNTABLE

Table 3-12. CAN to DTC Cross Reference (Ford Engine)

SPN	FMI	DTC	DTC and Description
1385	0	1425	ERWT1 higher than expected stage 2
1385	3	1419	ERWT1 voltage high
1385	4	1421	ERWT1 voltage low
1385	15	1423	ERWT1 higher than expected stage 1
1386	0	1426	ERWT2 higher than expected stage 2
1386	3	1420	ERWT2 voltage high
1386	4	1422	ERWT2 voltage low
1386	15	1424	ERWT2 higher than expected stage 1
1485	3	687	Power relay coil short to power
1485	4	686	Power relay ground short
1485	5	685	Power relay coil open
2646	3	1666	PWM8 short to power
2646	5	1665	PWM8 open / ground short
2647	3	1670	PWM9 short to power
2647	5	1669	PWM9 open / ground short
3050	11	420	Catalyst inactive on gasoline (Bank 1)
3050	11	1165	Catalyst inactive on LPG
3050	11	1166	Catalyst inactive on NG
3051	11	430	Catalyst inactive on gasoline (Bank 2)
3056	3	8906	UEGO return voltage shorted high
3056	4	8907	UEGO return voltage shorted low
3217	3	8910	UEGO sense cell voltage high
3217	4	8911	UEGO sense cell voltage low
3217	5	134	EG01 open / lazy
3218	3	8908	UEGO pump voltage shorted high
3218	4	8909	UEGO pump voltage shorted low
3221	3	8904	UEGO cal resistor voltage high
3221	4	8905	UEGO cal resistor voltage low
3221	31	8901	UEGO microprocessor internal fault
3222	0	8916	UEGO sense cell impedance high
3222	3	8902	UEGO heater supply high voltage
3222	4	8903	UEGO heater supply low voltage
3222	10	8914	UEGO sense cell slow to warm up
3225	0	8917	UEGO pump cell impedance high
3225	1	8918	UEGO pump cell impedance low
3225	3	8912	UEGO pump voltage at high drive limit
3225	4	8913	UEGO pump voltage at low drive limit
3225	10	8915	UEGO pump cell slow to warm up
3227	5	154	EG02 open / lazy
3256	5	140	EG03 open / lazy
3266	5	160	EG04 open / lazy
3468	3	188	Gaseous fuel temperature sender high voltage
3468	4	187	Gaseous fuel temperature sender low voltage

Table 3-12. CAN to DTC Cross Reference (Ford Engine)

SPN	FMI	DTC	DTC and Description
3673	3	223	TPS2 voltage high
3673	4	222	TPS2 voltage low
4236	0	1151	Closed-loop LPG high
4236	0	1153	Closed-loop NG high
4236	0	1155	Closed-loop gasoline bank1 high
4236	1	1152	Closed-loop LPG low
4236	1	1154	Closed-loop NG low
4236	1	1156	Closed-loop gasoline bank1 low
4237	0	171	Adaptive-learn gasoline bank1 high
4237	0	1161	Adaptive-learn LPG high
4237	0	1163	Adaptive-learn NG high
4237	1	172	Adaptive-learn gasoline bank1 low
4237	1	1162	Adaptive-learn LPG low
4237	1	1164	Adaptive-learn NG low
4238	0	1157	Closed-loop gasoline bank2 high
4238	1	1158	Closed-loop gasoline bank2 low
4239	0	174	Adaptive-learn gasoline bank2 high
4239	1	175	Adaptive-learn gasoline bank2 low
520197	2	331	Knock2 excessive or erratic signal
520197	4	332	Knock2 sensor open or not present
520199	11	1122	FPP1/2 do not match each other or IVS (redundancy lost)
520199	11	2120	FPP1 invalid voltage and FPP2 disagrees with IVS (redundancy lost)
520199	11	2125	FPP1/2 do not match each other or IVS (redundancy lost)
520201	5	509	IAC coil open/short
520201	6	508	IAC ground short
520226	3	916	Shift actuator feedback out-of-range
520226	7	919	Shift unable to reach desired gear
520226	31	920	Shift actuator or drive circuit failed
520260	0	1171	MegaJector delivery pressure higher than expected
520260	1	1172	MegaJector delivery pressure lower than expected
520260	3	1174	MegaJector voltage supply high
520260	4	1175	MegaJector voltage supply low
520260	12	1176	MegaJector internal actuator fault detection
520260	12	1177	MegaJector internal circuitry fault detection
520260	12	1178	MegaJector internal comm fault detection
520260	31	1173	MegaJector comm lost
520401	0	1182	Fuel impurity level high
520800	7	11	Intake cam/ distributor position error
520801	7	24	Exhaust cam position error
520803	31	1183	MegaJector autozero/ lockoff failure

NOTE: For detail Diagnostic Trouble Code of Ford Engine refer DTC manual (PN 3128850).

3.22 DEUTZ ENGINE

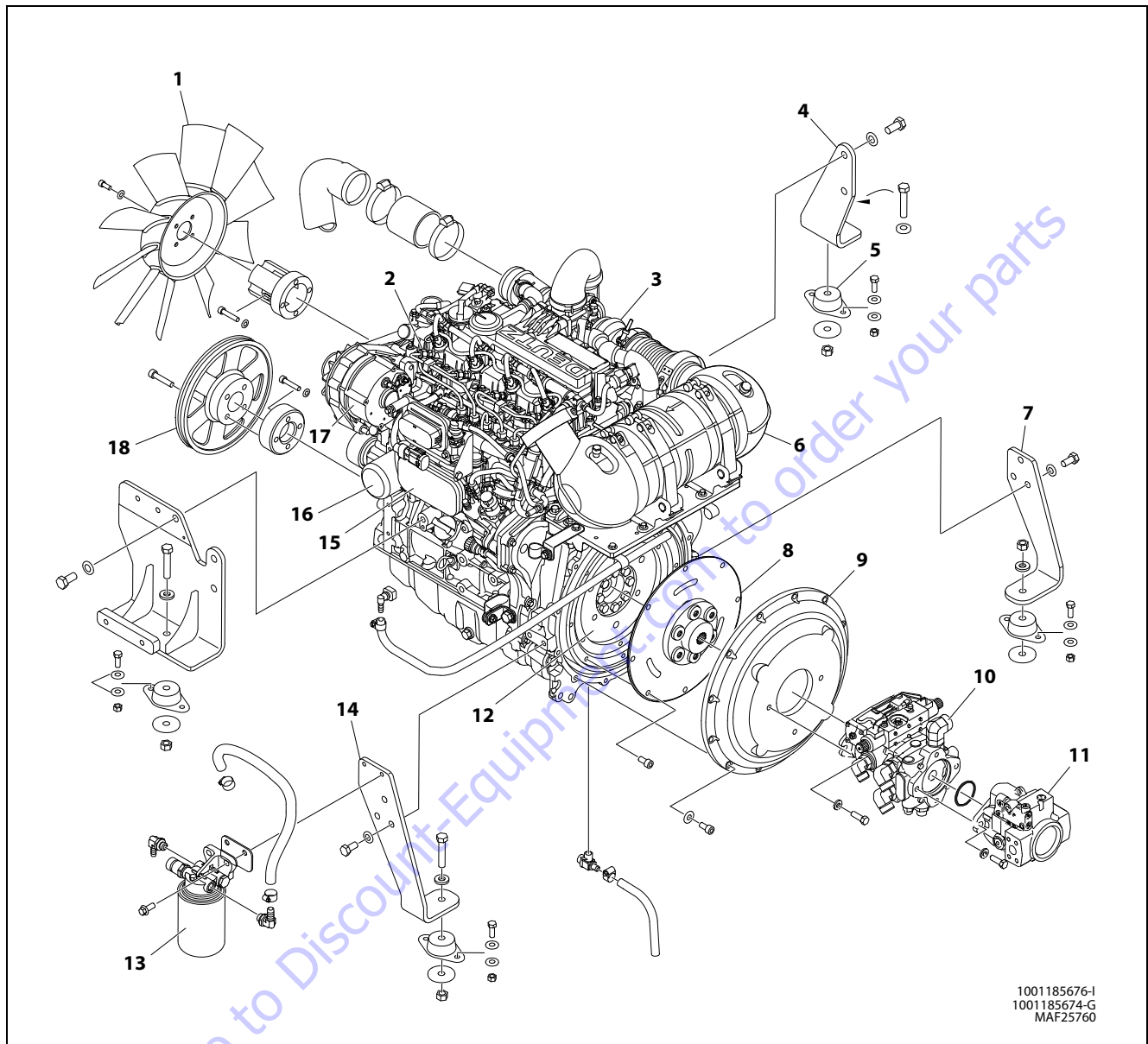

1001185676-I
1001185674-G
MAF25760

- | | | |
|-----------------------|------------------------|----------------------------------|
| 1. Fan | 7. Rear Engine Mount | 13. Fuel Filter |
| 2. Fuel Injector | 8. Coupling | 14. Front Engine/Generator Mount |
| 3. Turbocharger | 9. Pump Adapter Plate | 15. Oil Cooler |
| 4. Front Engine Mount | 10. Pump Assembly | 16. Oil Filter |
| 5. Motor Mount | 11. Gear Pump Assembly | 17. Alternator |
| 6. Muffler | 12. Flywheel | 18. Pulley |

Figure 3-81. Deutz T4F TD2.9L Engine Components - Sheet 1 of 2

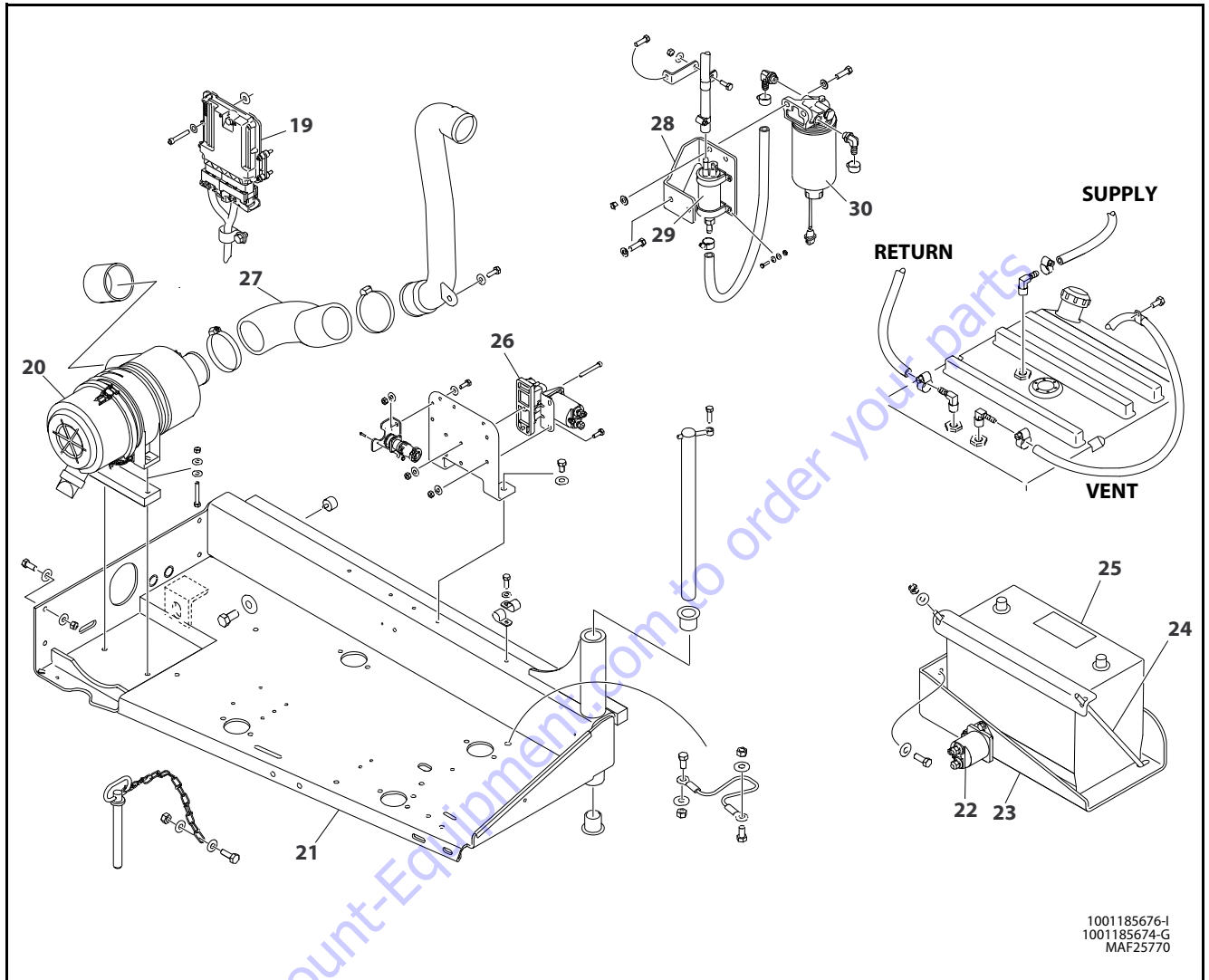

- | | | |
|--------------------------|------------------------|---------------------------|
| 19. Engine Control Unit | 23. Battery Bracket | 27. Intake Pipe |
| 20. Air Cleaner Assembly | 24. Battery Hold-down | 28. Fuel Pump Mount Plate |
| 21. Tray | 25. Battery | 29. Fuel Pump |
| 22. Relay | 26. Power Module Relay | 30. Fuel Filter |

Figure 3-82. Deutz T4F TD2.9L Engine Components - Sheet 2 of 2

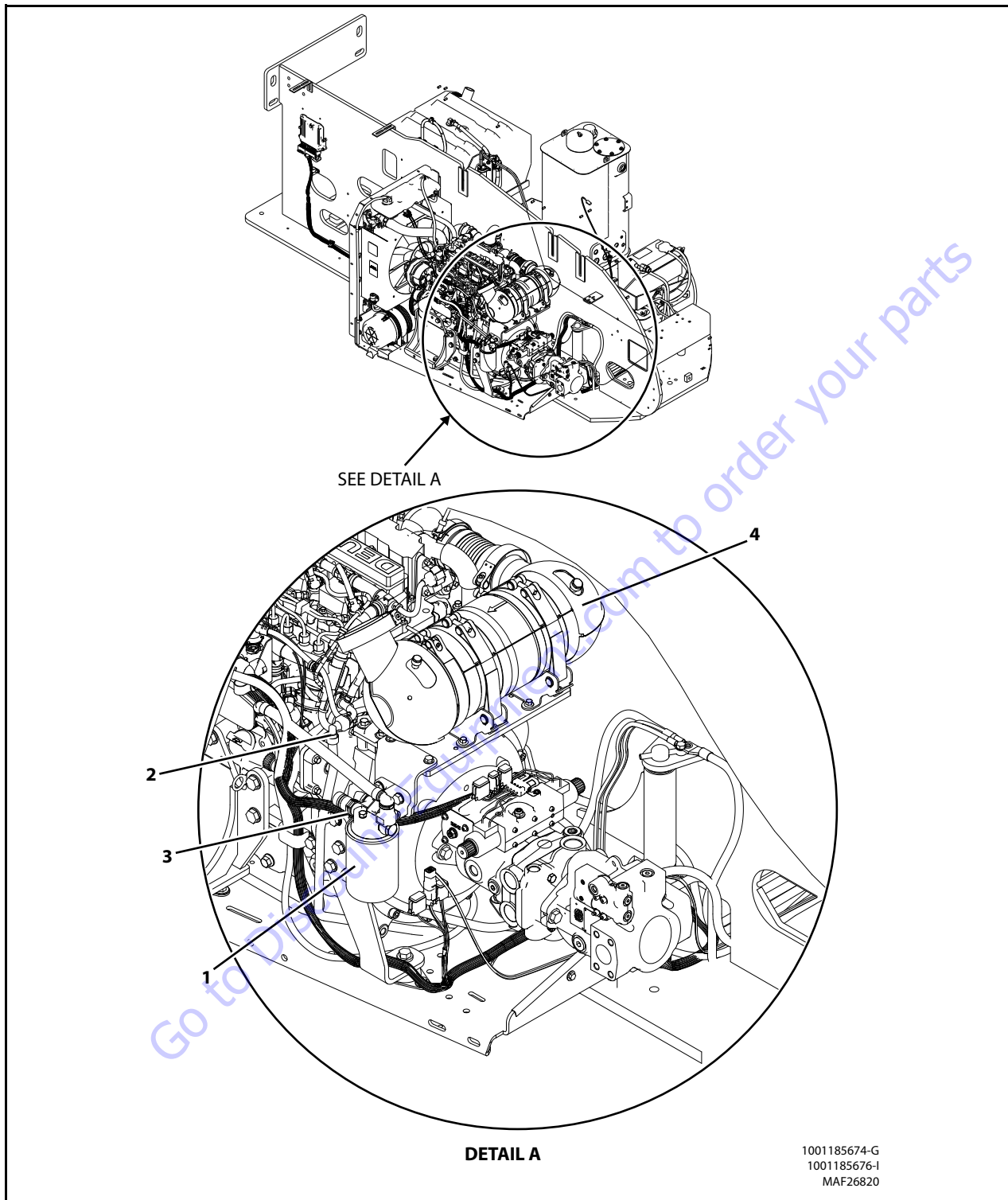

- 1. Fuel Filter
- 2. Return Fuel Line
- 3. Supply Line End
- 4. Air Cleaner Assembly

Figure 3-83. Deutz T4F TD2.9L Engine Installation - Sheet 1 of 7

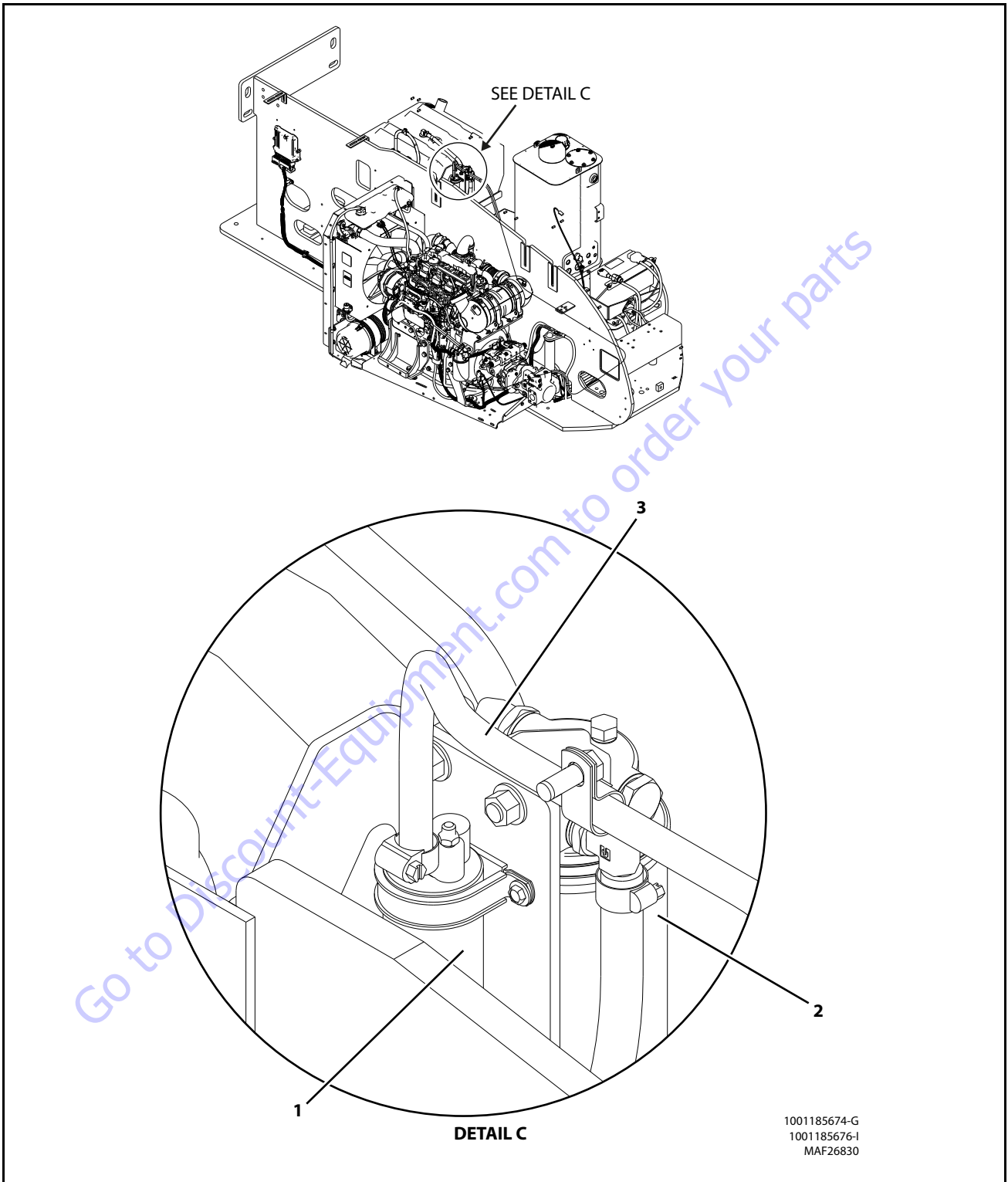

1. Fuel Pump

2. Fuel Filter

3. Supply Line

Figure 3-84. Deutz T4F TD2.9L Engine Installation - Sheet 2 of 7

SECTION 3 - CHASSIS & TURNTABLE

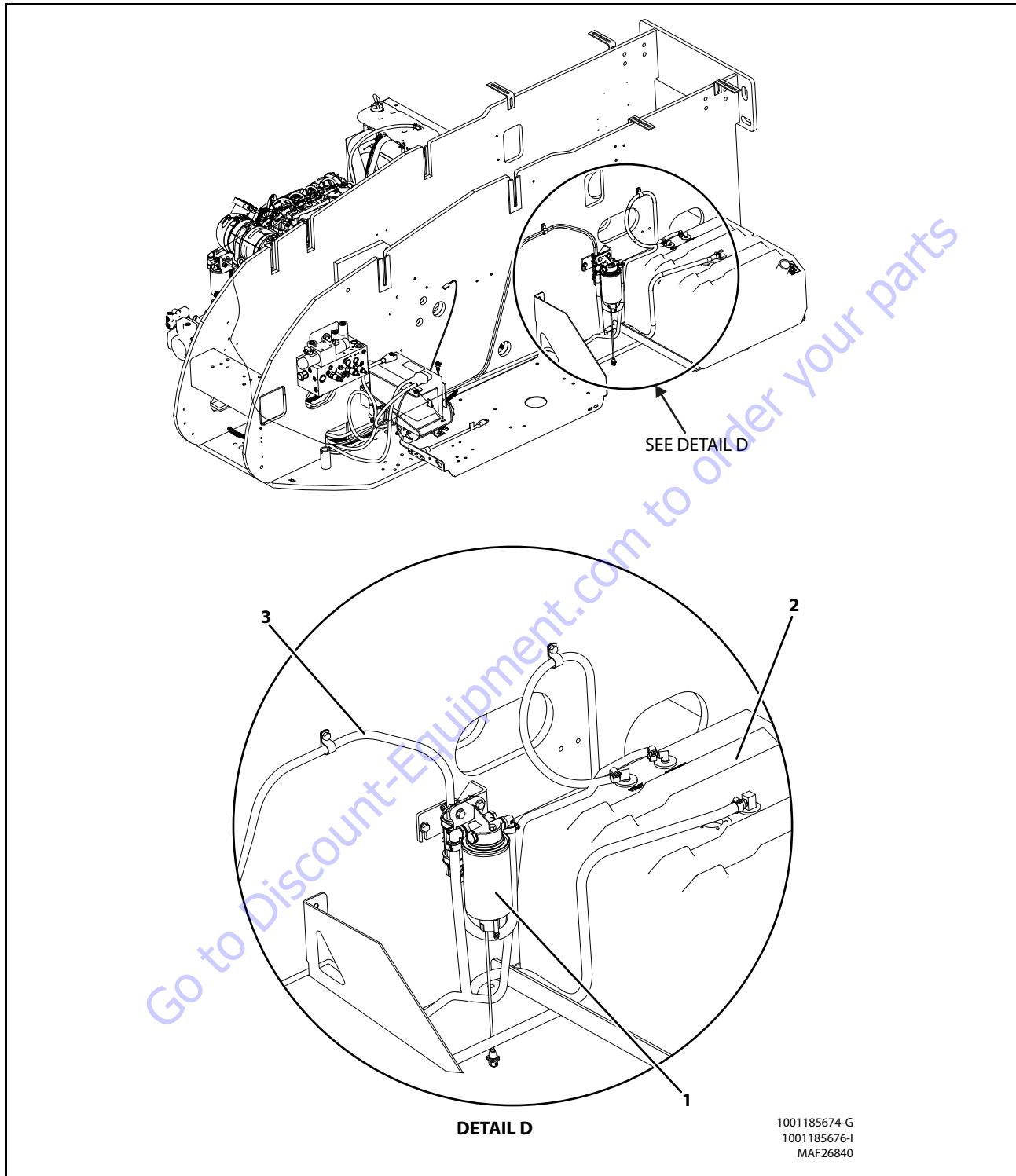

1. Fuel Filter

2. Fuel Tank

3. Supply Line

Figure 3-85. Deutz T4F TD2.9L Engine Installation - Sheet 3 of 7

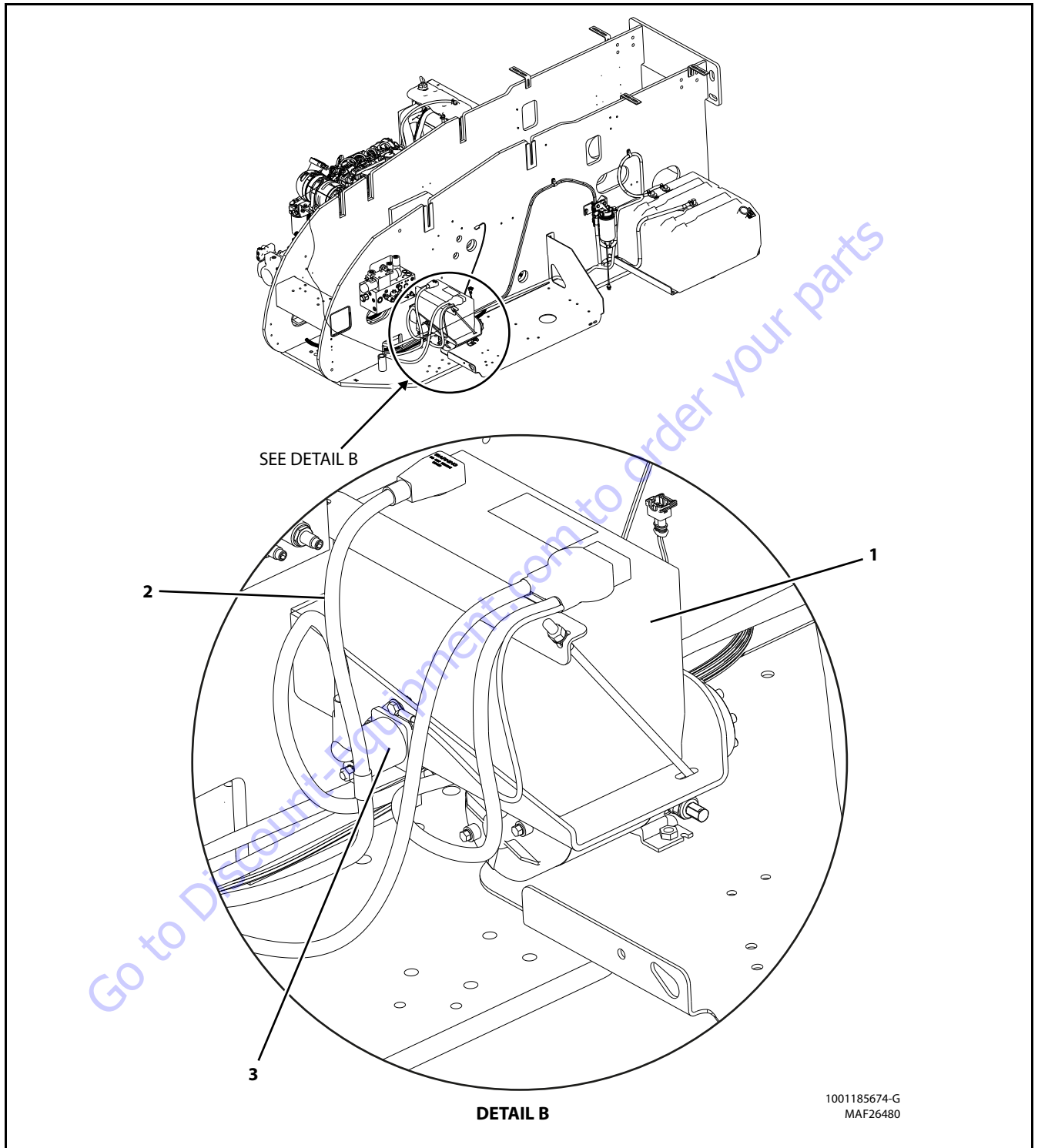

1. Battery

2. Battery Cable

3. Relay

Figure 3-86. Deutz T4F TD2.9L Engine Installation - Sheet 4 of 7

SECTION 3 - CHASSIS & TURNTABLE

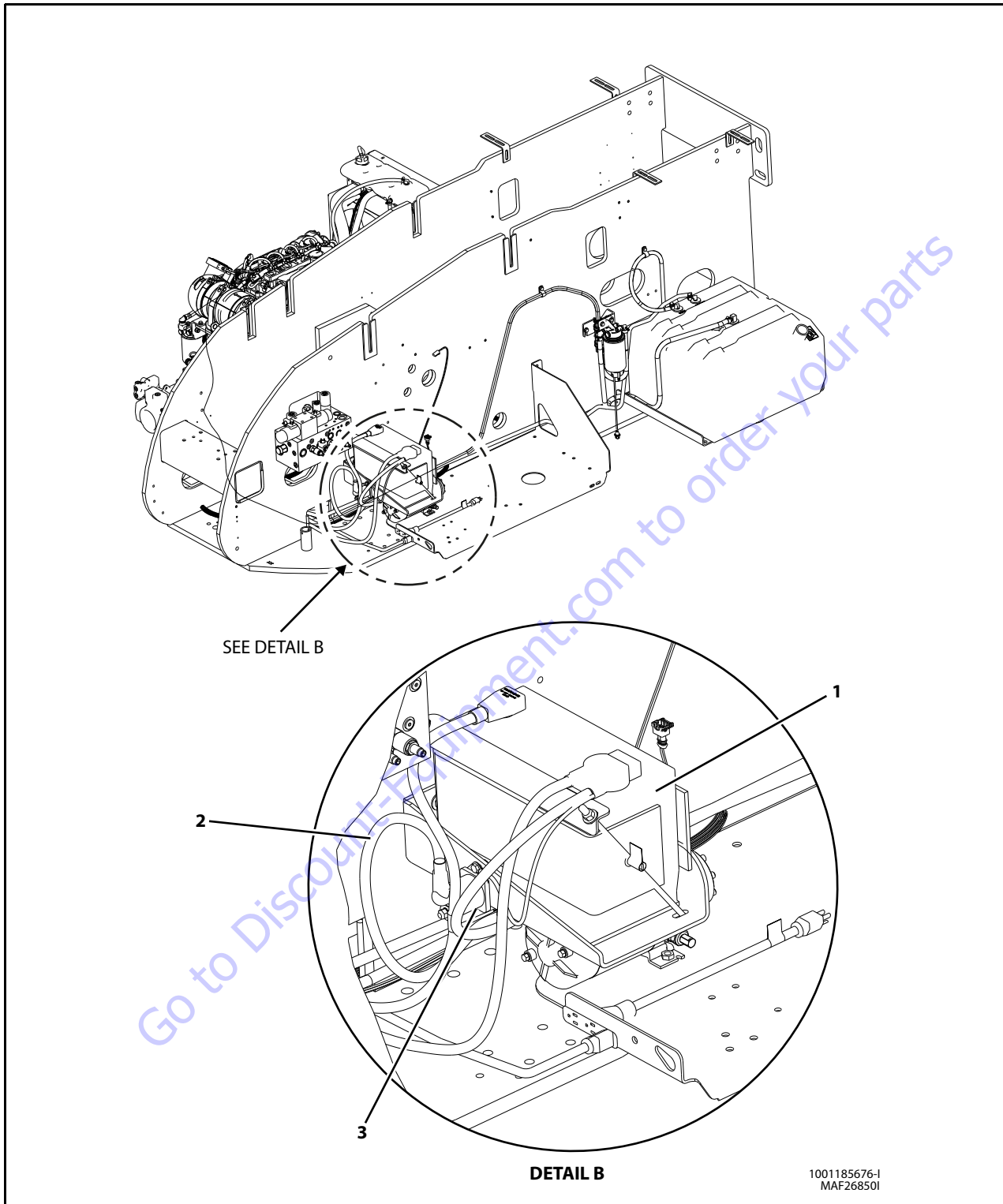

1. Battery

2. Battery Cable

3. Relay

Figure 3-87. Deutz T4F TD2.9L Engine Installation - Sheet 5 of 7

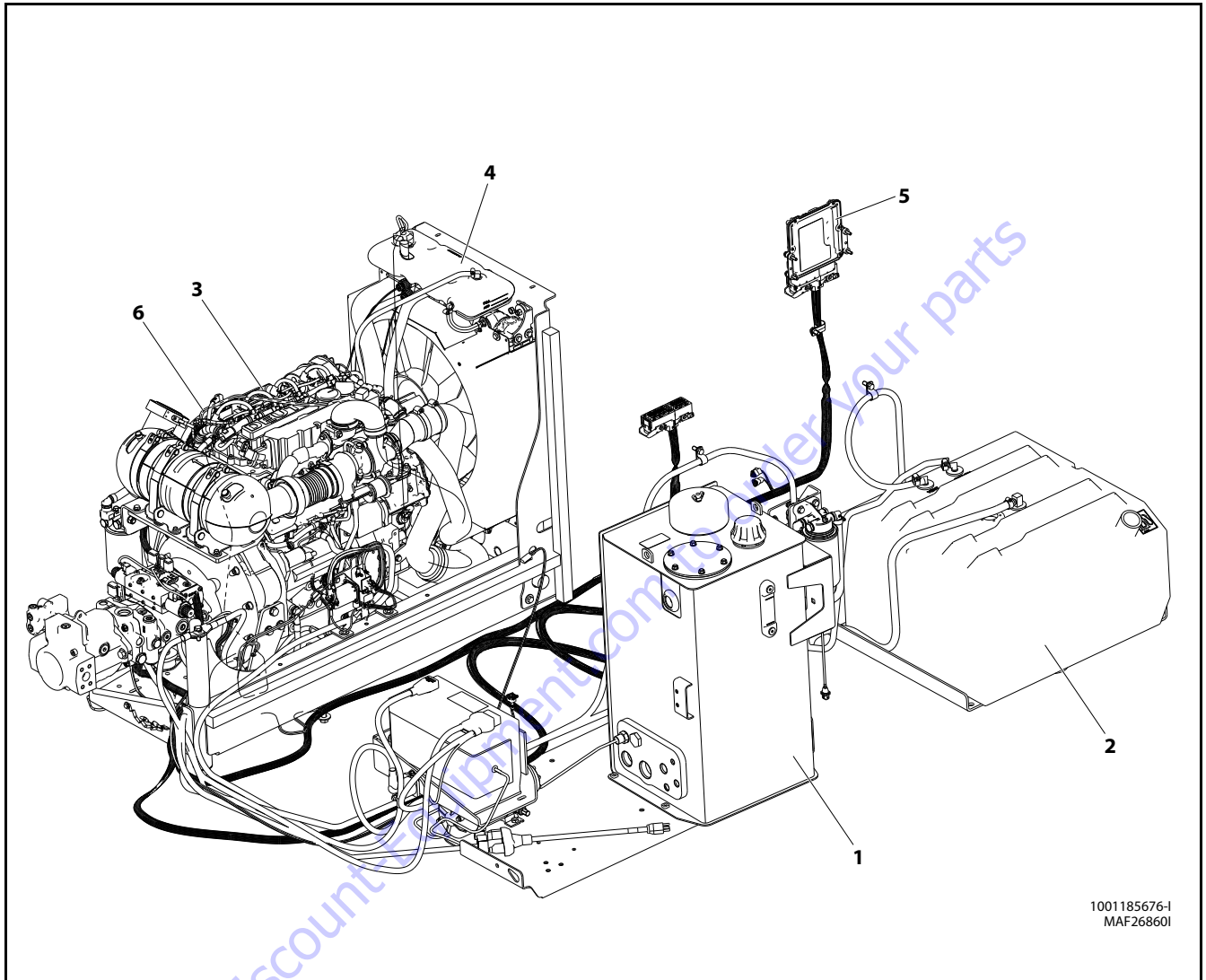

- | | | |
|-------------------|------------------------|--------------------|
| 1. Hydraulic Tank | 3. Engine | 5. Control Module |
| 2. Fuel Tank | 4. Tank Surge Assembly | 6. Breather Heater |

Figure 3-88. Deutz T4F TD2.9L Engine Installation - Sheet 6 of 7

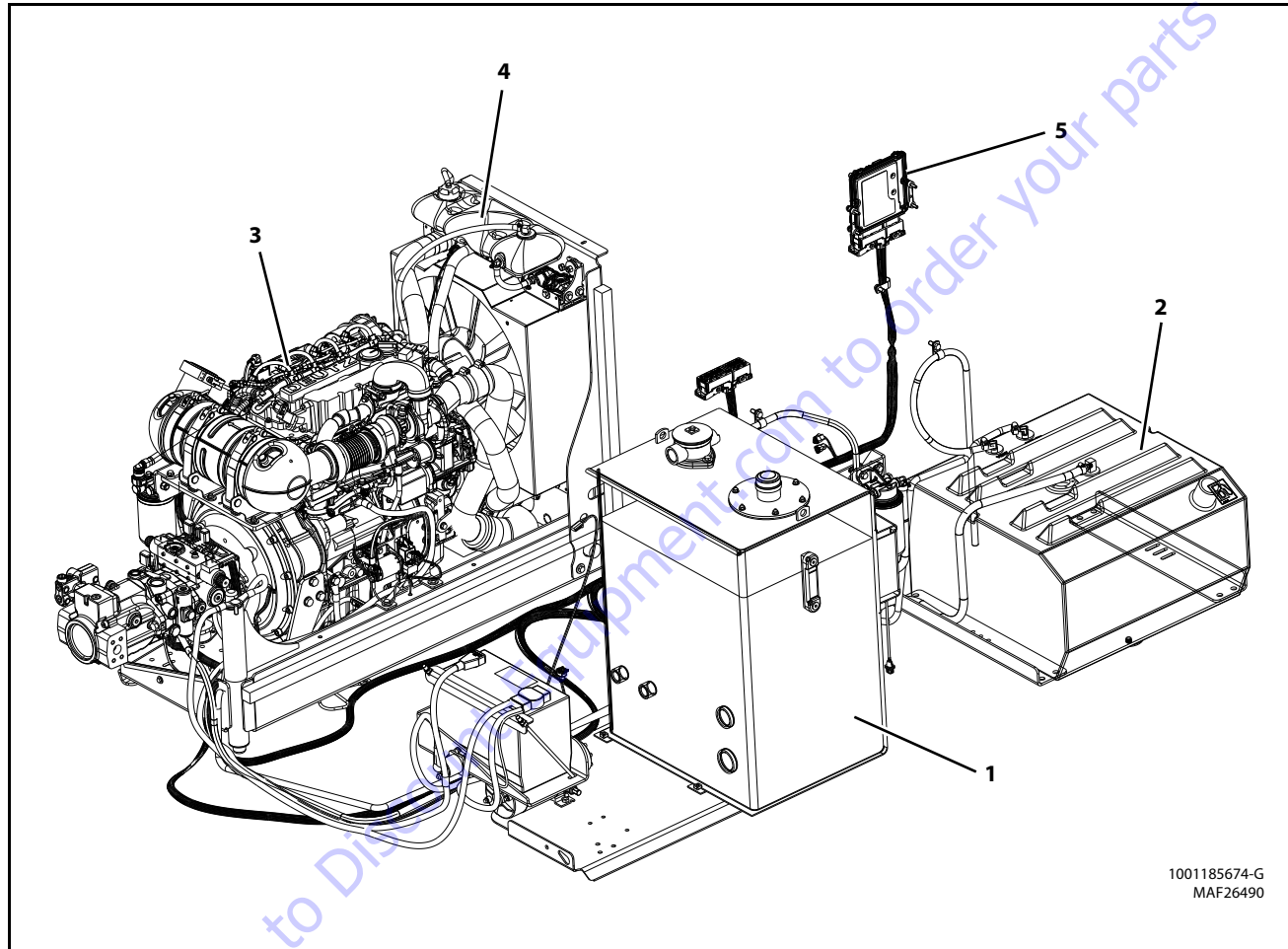

1001185674-G
MAF26490

1. Hydraulic Tank 2. Fuel Tank 3. Engine 4. Tank Surge Assembly 5. Control Module

Figure 3-89. Deutz T4F TD2.9L Engine Installation - Sheet 7 of 7

3.23 DEUTZ TD 2.9 L4 CHINA III ENGINE

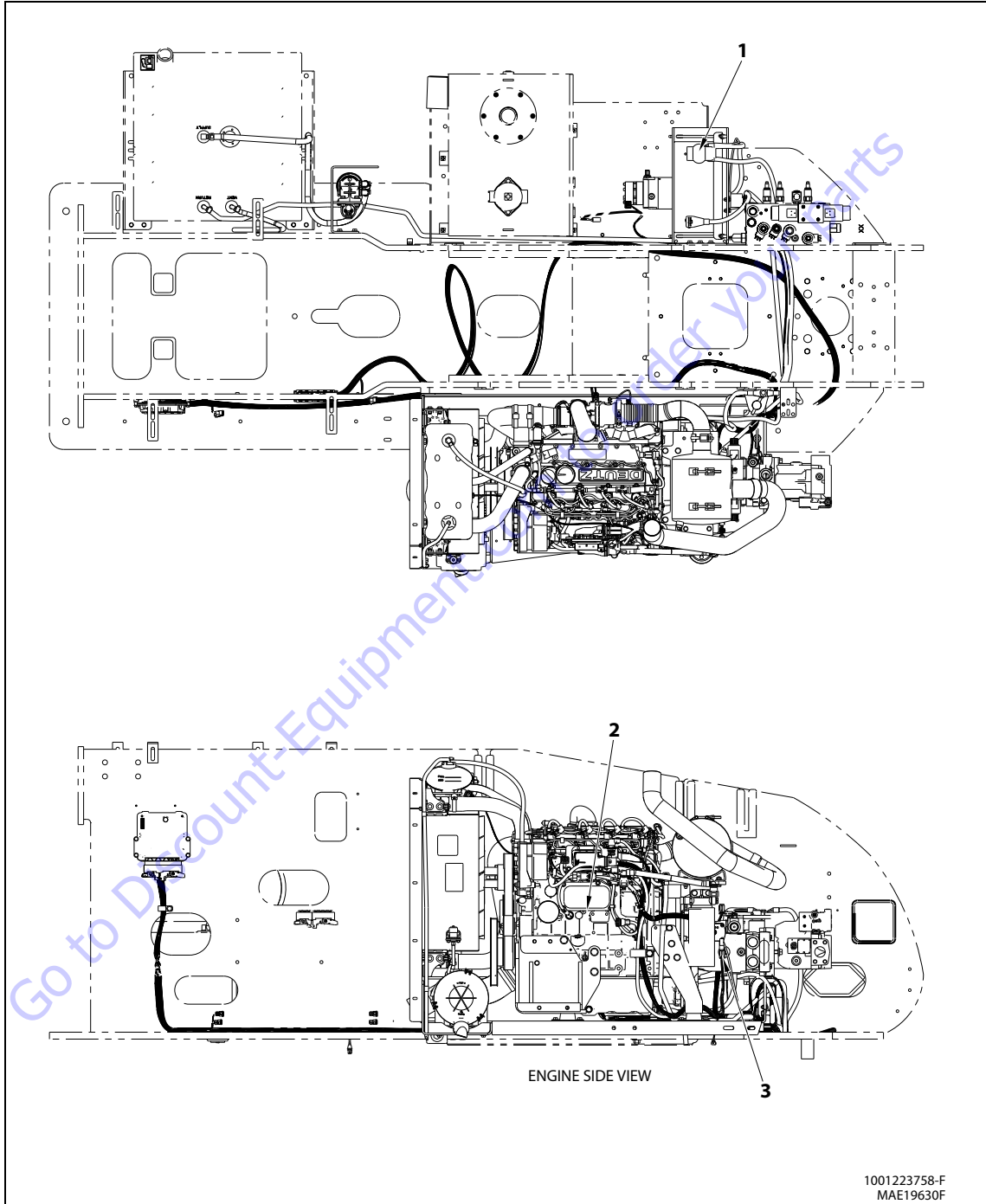

Figure 3-90. Deutz TD 2.9 L4 China III Engine Installation - Sheet 1 of 6

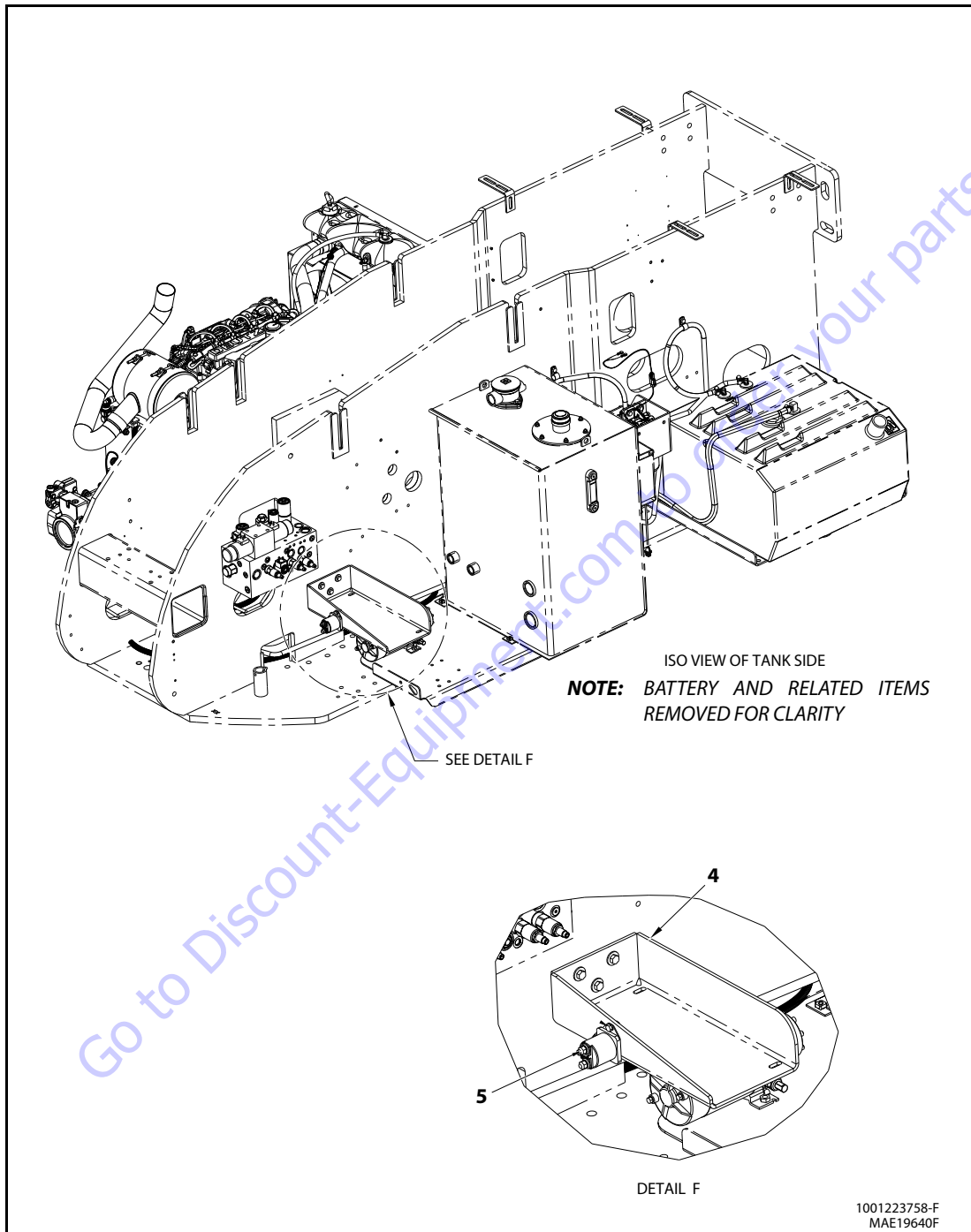

Figure 3-91. Deutz TD 2.9 L4 China III Engine Installation - Sheet 2 of 6

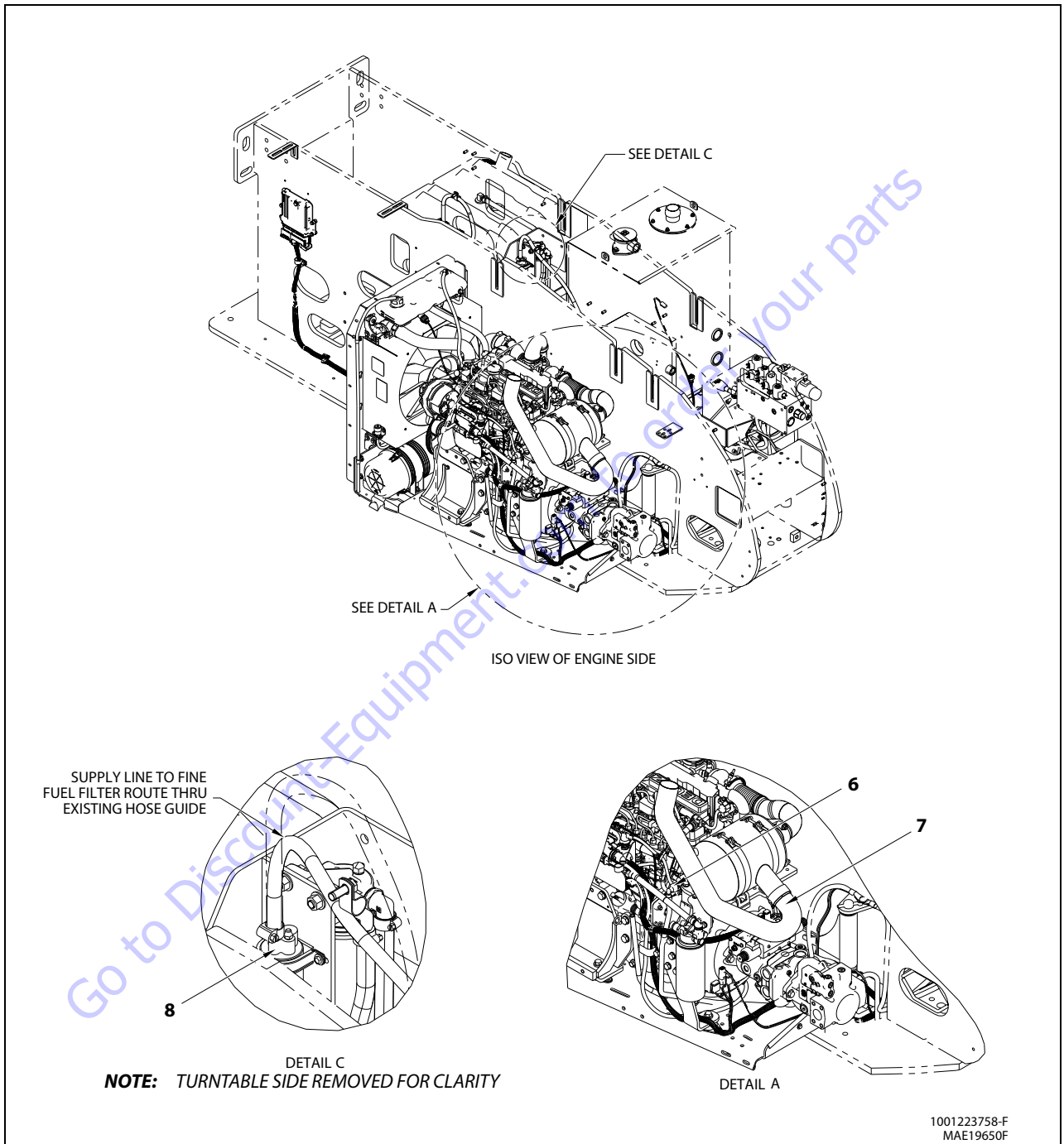

Figure 3-92. Deutz TD 2.9 L4 China III Engine Installation - Sheet 3 of 6

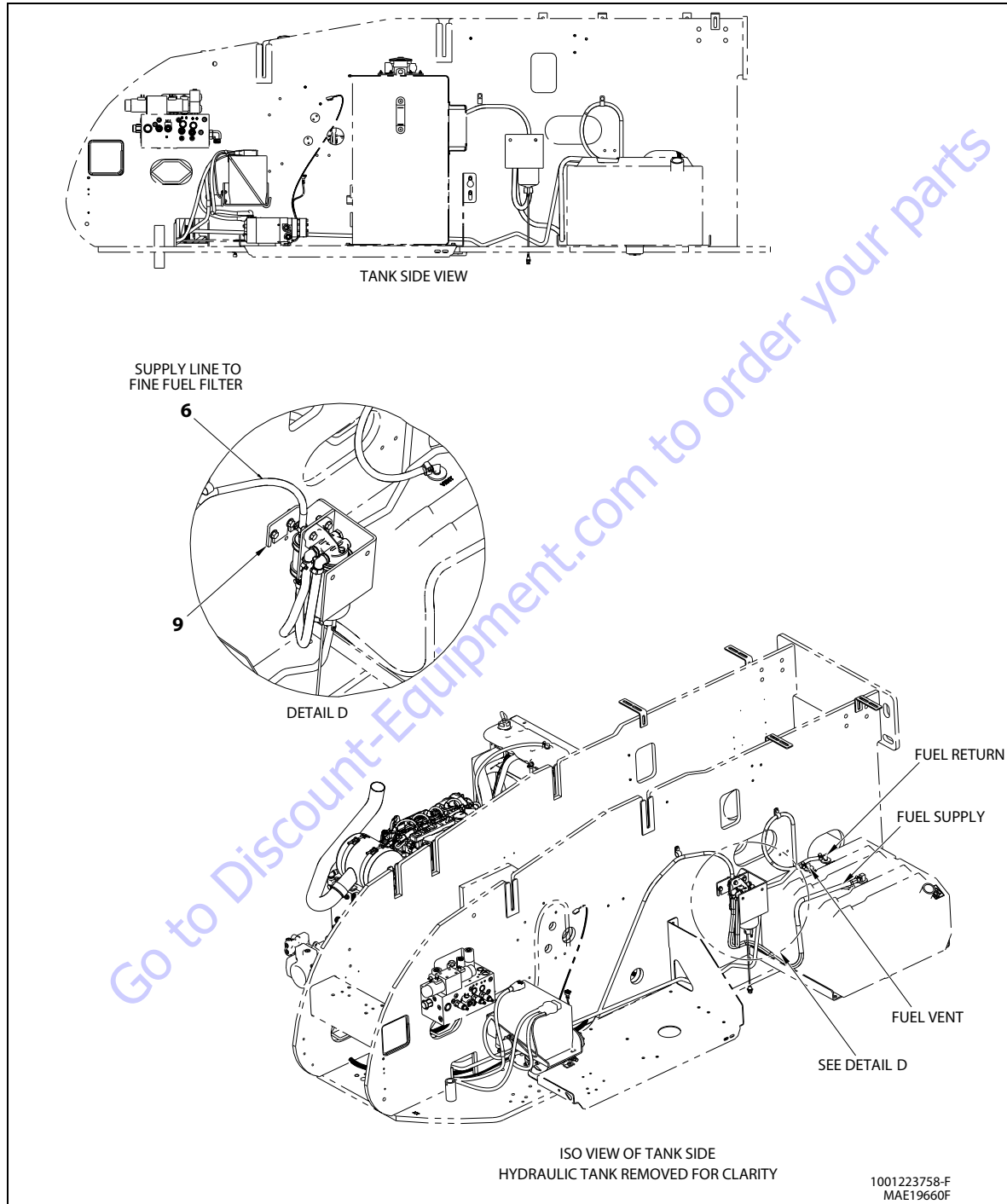

Figure 3-93. Deutz TD 2.9 L4 China III Engine Installation - Sheet 4 of 6

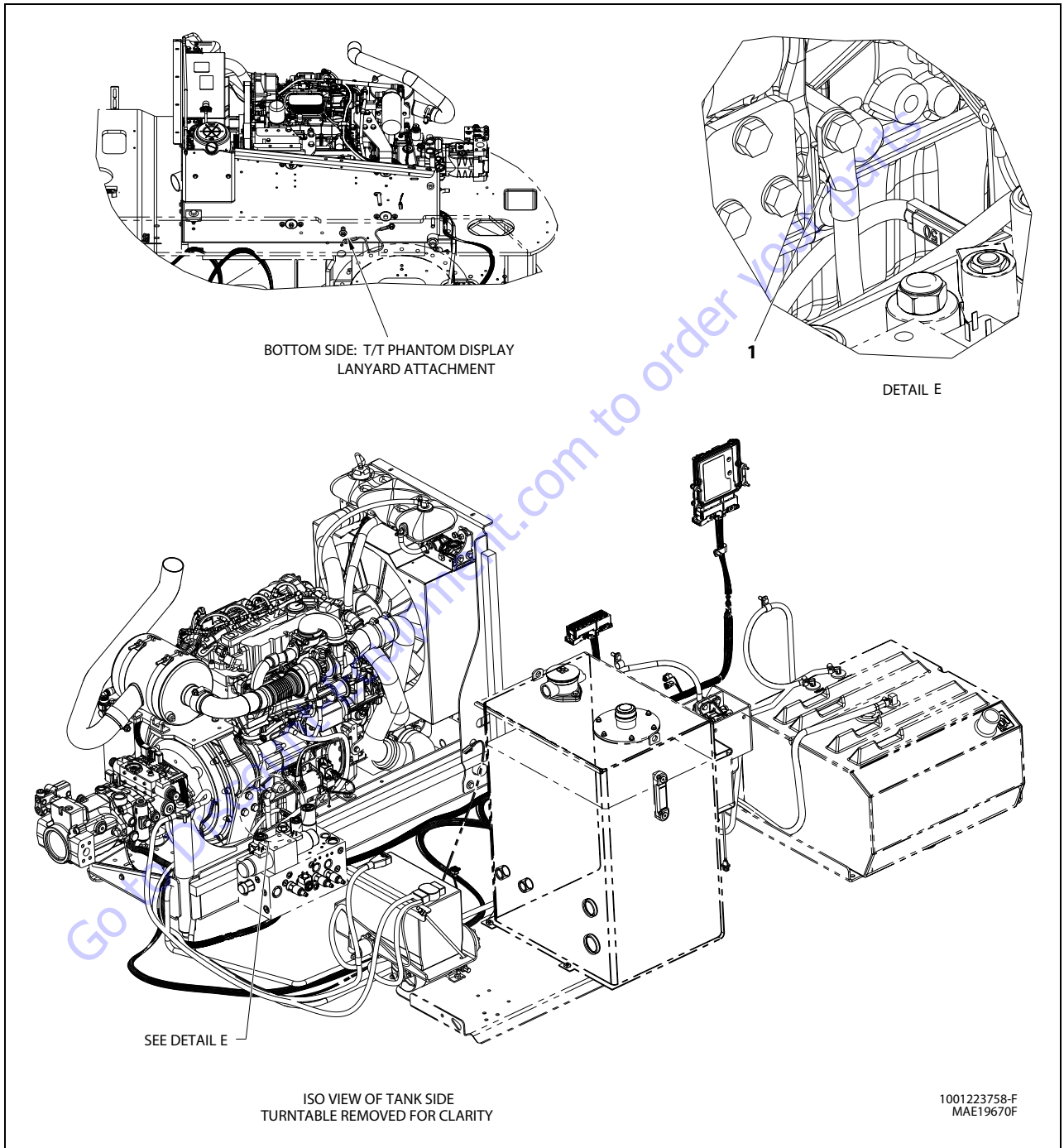
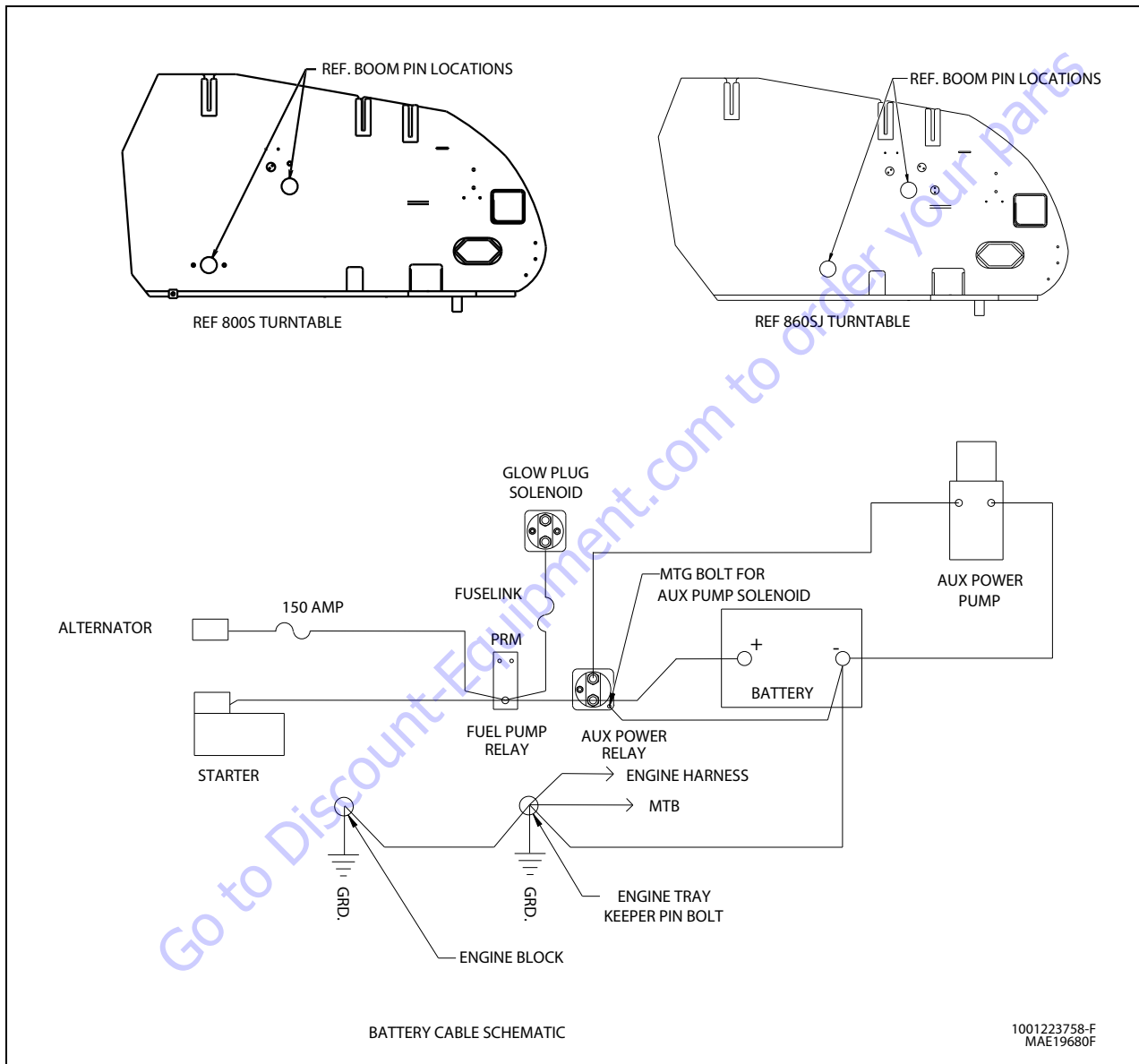

Figure 3-94. Deutz TD 2.9 L4 China III Engine Installation - Sheet 5 of 6

SECTION 3 - CHASSIS & TURNTABLE



- | | | |
|--------------------------------------|----------------------------|----------------------|
| 1. Battery Cable Kit | 4. Battery Bracket | 7. Exhaust Pipe |
| 2. Deutz China III Engine with Pumps | 5. Solenoid Assembly Relay | 8. Gear Clamp |
| 3. Deutz Engine Fuel Harness | 6. Fuel Hose | 9. Fuel Pump Bracket |

Figure 3-95. Deutz TD 2.9 L4 China III Engine Installation - Sheet 6 of 6

NOTE: Refer to engine manufacturer's manual for detailed operating and maintenance instructions.

Check Oil Level

1. Make sure machine and engine are level and switch engine OFF before checking oil level.
2. Remove oil dipstick and wipe with clean cloth.
3. Insert dipstick to the stop and remove again.
4. Check oil level. Top oil level as shown in figure below with an approved grade and type of oil outlined in engine manufacturer's operator's manual.

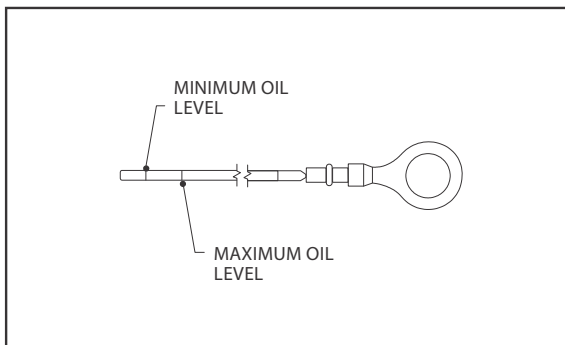

Figure 3-96. Deutz 2.9 T4F Dipstick Markings

5. Replace dipstick until fully seated.

Change Engine Oil

1. Allow engine to warm up. Engine oil should reach approximately 176° F (80° C).
2. Make sure machine and engine are level.
3. Switch off engine.
4. Place oil tray under engine.

CAUTION

HOT ENGINE OIL CAN CAUSE BURNS. AVOID CONTACT WITH HOT OIL WHEN DRAINING.

NOTICE

COLLECT USED OIL IN A CONTAINER SUITABLE FOR DISPOSAL OR RECYCLING. DISPOSE OF USED ENGINE OIL IN ACCORDANCE WITH ENVIRONMENTAL REGULATIONS.

5. Open oil drain valve and drain oil.
6. Close oil drain valve.
7. Pour in new engine oil. Refer to Section 1 for capacity and Figure 3-97., Engine Oil Viscosity.

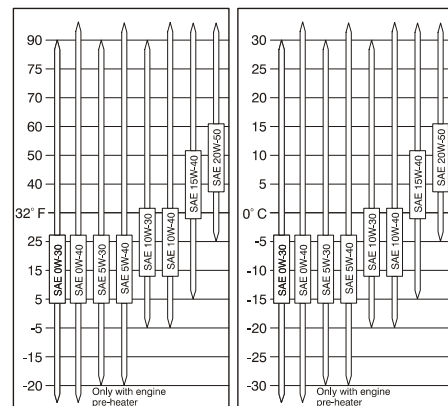
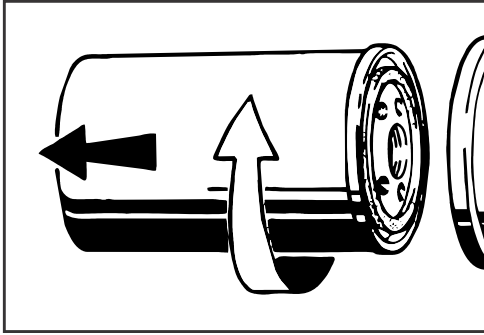

Figure 3-97. Engine Oil Viscosity

Change Oil Filter

1. Wipe area around filter to clean any dirt from area.
2. Using a suitable oil filter removal tool, loosen lube oil filter cartridge and spin off.



3. Catch any escaping oil.
4. Clean any dirt from filter carrier sealing surface.
5. Lightly coat new oil filter rubber gasket with clean oil
6. Screw in new filter by hand until gasket is flush.
7. Hand-tighten filter another half-turn.

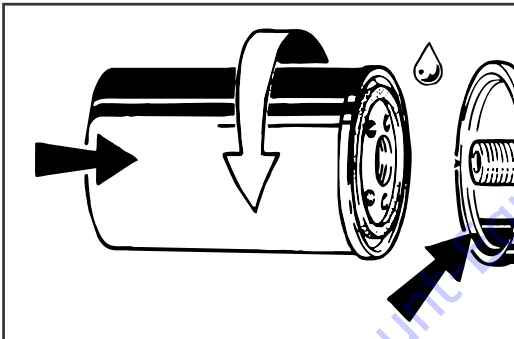

8. Check oil level.
9. Check oil pressure.
10. Check oil filter cartridge for leaks.

Change Fuel Filters

⚠ WARNING

FUEL IS FLAMMABLE AND CAN CAUSE DEATH OR SERIOUS INJURY. MAKE SURE NO OPEN FLAMES OR SPARKS ARE IN THE AREA WHEN WORKING ON FUEL SYSTEM. DO NOT SMOKE WHEN WORKING ON THE FUEL SYSTEMS.

1. Wipe area around filter to clean any dirt from area.
2. Disconnect water sensor connector (Pre-filter Only).
3. Remove fuel filter cartridge. Catch any escaping fuel.

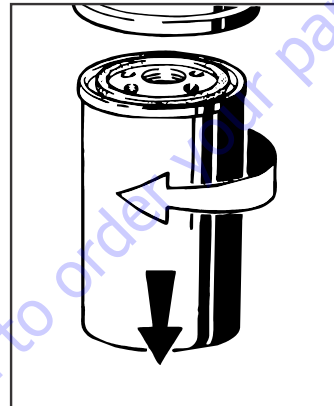

4. Clean dirt from filter carrier sealing surface.
5. Apply light film of oil or diesel fuel to rubber gasket of new filter cartridge.
6. Screw in new filter by hand until gasket is flush. Hand-tighten filter another half-turn.

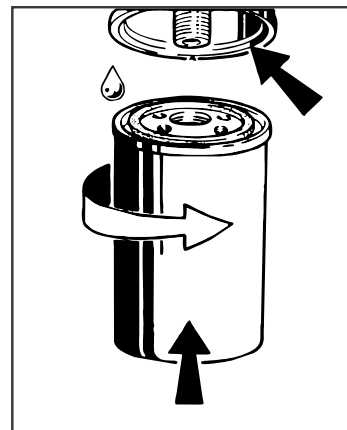

7. Connect water sensor connector (Pre-filter Only).
8. Open fuel shut-off valve.
9. Check for leaks.

Replacing the Fuel Pre-Filter

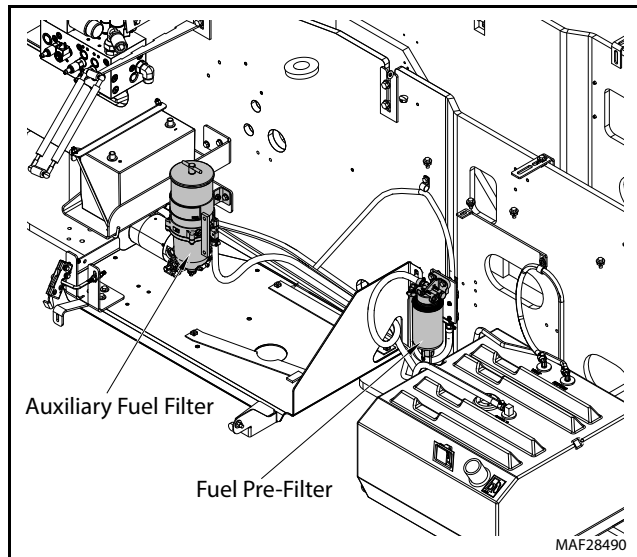
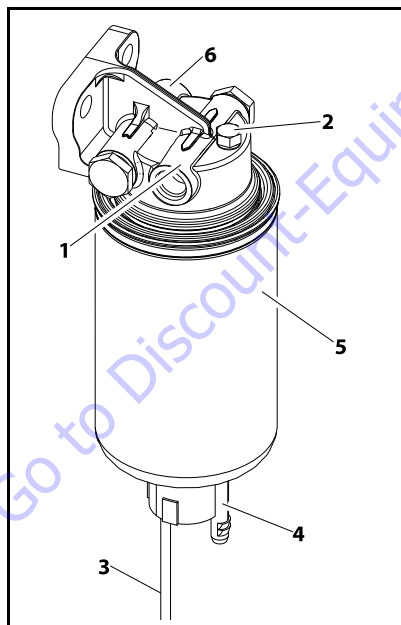

Figure 3-98. Location of Fuel Pre-Filter

NOTE: Refer Figure 3-99., Components of Fuel Pre-Filter.



- | | |
|---|----------------------------------|
| 1. Fuel Supply Flow to the Pump | 4. Drain Plug |
| 2. Venting Screw | 5. Filter Element |
| 3. Electrical Connection for Water Level Sensor | 6. Fuel Inlet from the Fuel Tank |

Figure 3-99. Components of Fuel Pre-Filter

⚠ WARNING

WHEN WORKING ON THE FUEL SYSTEM, MAKE SURE THERE ARE NO OPEN FLAMES OR SPARKS IN THE AREA. DO NOT SMOKE WHEN WORKING ON THE FUEL SYSTEM.

1. Switch off the engine.
2. Fuel supply from the fuel tank may need to be blocked to prevent fuel flow from the tank.
3. Place suitable collecting container under drain plug.
4. Disconnect electrical connections from water sensor.
5. Loosen drain plug and drain liquid.
6. Remove filter element.
7. Catch any escaping fuel.
8. Clean any dirt of the sealing surfaces of the new filter element and opposite side of filter head.
9. Wet the sealing surfaces of new filter element slightly with fuel.
10. Install new filter onto the filter head in clockwise direction. Torque to 12.5-13.3 ft. lbs. (17-18 Nm).
11. Install the drain plug and tighten to torque 1-1.4 ft. lbs. (1.3-1.9 Nm).
12. Connect electrical connection to water sensor.
13. Check for leaks after starting engine.

Water in Fuel Sensing System (Optional)

The Water in Fuel Sensing System detects when there is an excessive amount of water in the fuel and sets a DTC code in the JLG Control System to alert the operator and/or service technician.

When Water in Fuel condition occurs, the machine will respond in the following way:

- The engine will shut down automatically.
- The JLG Control System will set DTC 4375 - Water in Fuel.
- An alarm will sound from the active control station (ground or platform).
- If in platform mode, the Low Fuel Indicator will flash.
- Engine Restart will be permitted after the machine senses the Water in Fuel condition, but will only run for 2 minutes and the engine will shut down again. This restart process will continue until the Water in Fuel condition is corrected.

Draining Water

Frequency of water draining is determined by the contamination level of the fuel. Inspect or drain the collection bowl of water daily or as necessary. The collection bowl must be drained before contaminants reach the top of the turbine or when the Water Detection Module (optional) indicates it's time to drain water.

Pressure Applications / Installations:

1. Open the drain plug on the bottom of the bowl to evacuate water and contaminants with a suitable collection container in place.
2. Close the drain after all the water and contaminants have been evacuated.

NOTE: Do not leave the drain open too long as it may completely drain the entire filter assembly of water and fuel.

Auxiliary Fuel Filter

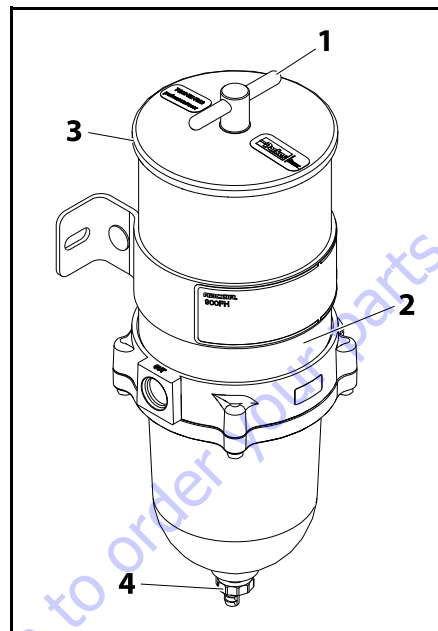

- | | |
|-------------------|---------------|
| 1. T-handle | 3. Lid |
| 2. Filter Element | 4. Drain Plug |

Figure 3-100. Components of Auxiliary Fuel Filter

⚠ WARNING

WHEN WORKING ON THE FUEL SYSTEM, MAKE SURE THERE ARE NO OPEN FLAMES OR SPARKS IN THE AREA. DO NOT SMOKE WHEN WORKING ON THE FUEL SYSTEM.

ELEMENT REPLACEMENT

Frequency of element replacement is determined by the contamination level of the fuel. Replace the elements every 500 hours, if power loss is noticed or annually, whichever comes first.

1. Switch off the engine.
2. Fuel supply from the fuel tank may need to be blocked to prevent fuel flow from the tank.
3. Wipe the area around the filter to clean any dirt from the area.
4. Remove the T-handle and lid.
5. Remove the element by holding the bail handles and slowly pulling upward with a twisting motion. Dispose of properly.
6. Replace old lid gasket and T-handle O-ring with new seals (supplied with new element). Lubricate both seals with motor oil or diesel fuel before installation.
7. Refer to Priming of auxiliary fuel filter or fill the unit with clean fuel, then replace the lid and T-handle then tighten snugly by hand only.

NOTE: Do not use any tool for removal and installation of T-handle.

PRIMING OF AUXILIARY FUEL FILTER

1. Remove the T-handle and lid from the top of the filter assembly.
2. Fill the filter assembly with clean fuel.
3. Lubricate lid gasket and T-handle O-ring with clean fuel or motor oil.
4. Replace the lid and T-handle and tighten snugly by hand only.

NOTE: Do not use any tool for removal and installation of T-handle.

5. Start engine and check for fuel system leaks.
6. Correct as necessary with engine off and pressure relieved from filter assembly.

DRAINING WATER

Frequency of water draining is determined by the contamination level of the fuel. Inspect or drain the collection bowl of water daily or as necessary. The collection bowl must be drained before contaminants reach the top of the turbine or when the Water Detection Module (optional) indicates it's time to drain water.

Pressure Applications / Installations:

1. Open the self-venting drain plug on the bottom of the bowl to evacuate water and contaminants with a suitable collection container in place. Head pressure will push any water and contaminants out of the drain while keeping the filter primed.
2. Close the drain after all the water and contaminants have been evacuated.
3. If necessary, follow priming of auxiliary fuel filter.

NOTE: Do not leave the drain open too long as it may completely drain the entire filter assembly of water and fuel.

3.24 DEUTZ D2011LO40 TIER 4I ENGINE

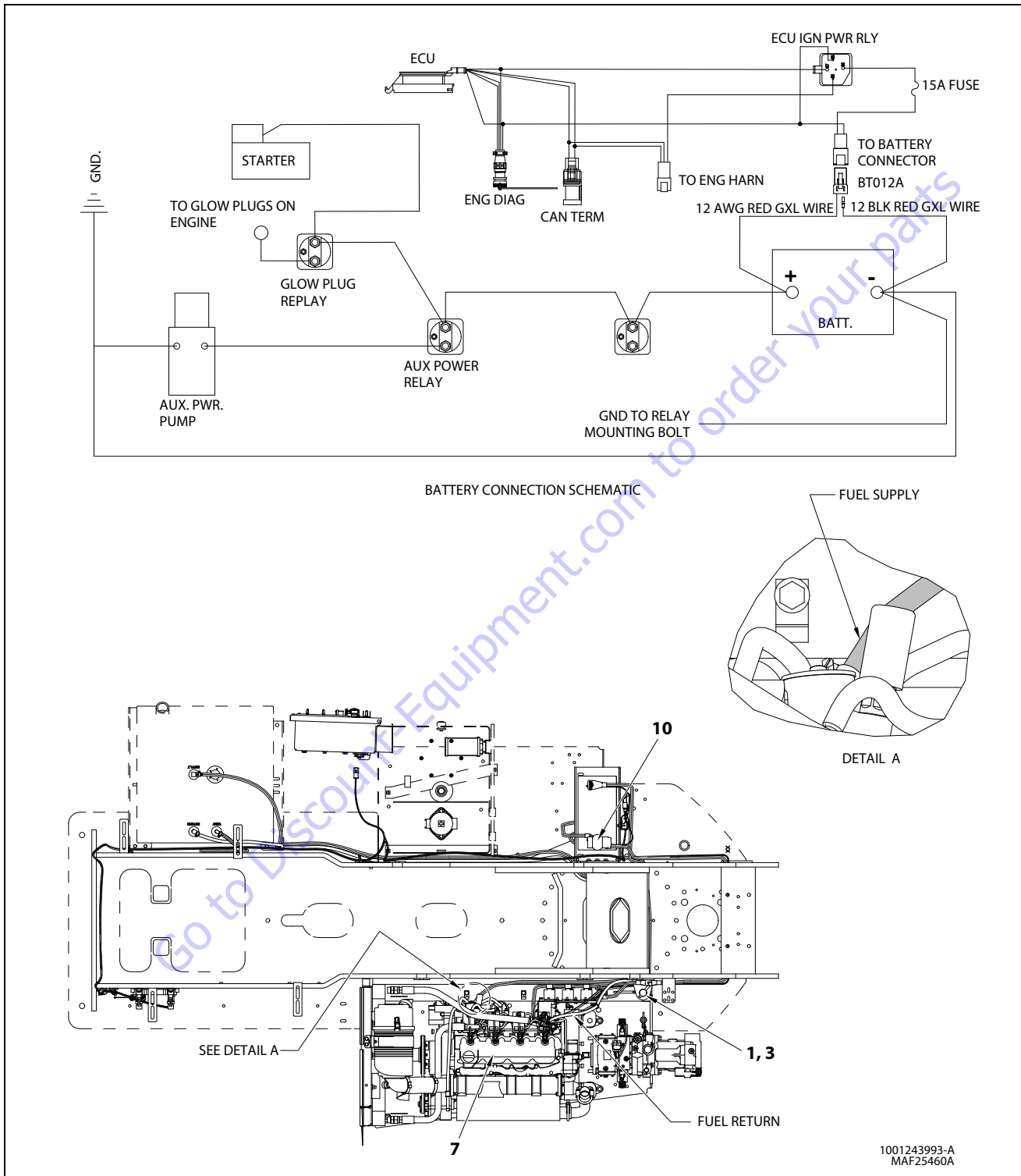

Figure 3-101. Deutz D2011LO40 Tier 4I Engine Installation (860SJ) - Sheet 1 of 4

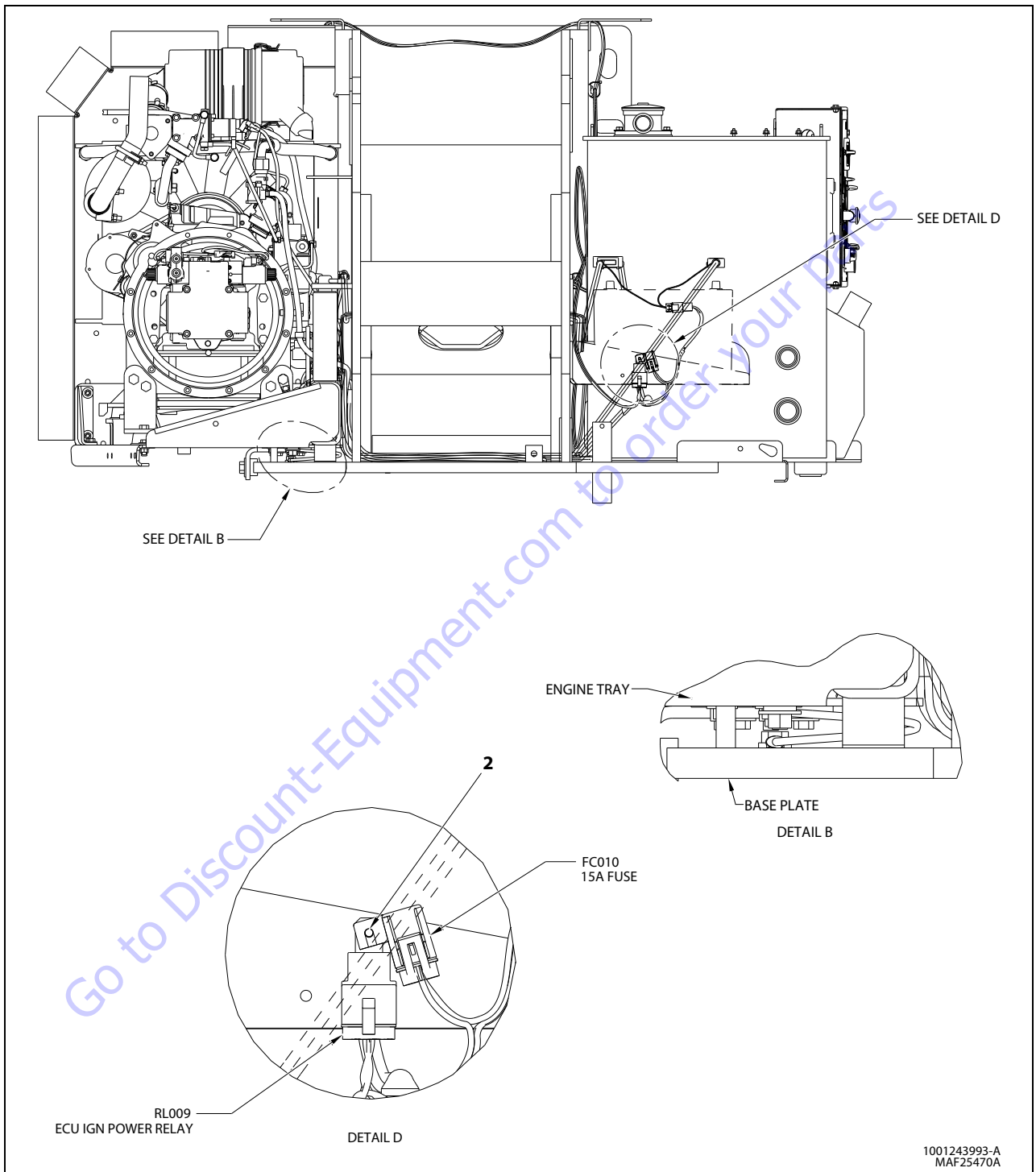

Figure 3-102. Deutz D2011LO40 Tier 4I Engine Installation (860SJ) - Sheet 2 of 4

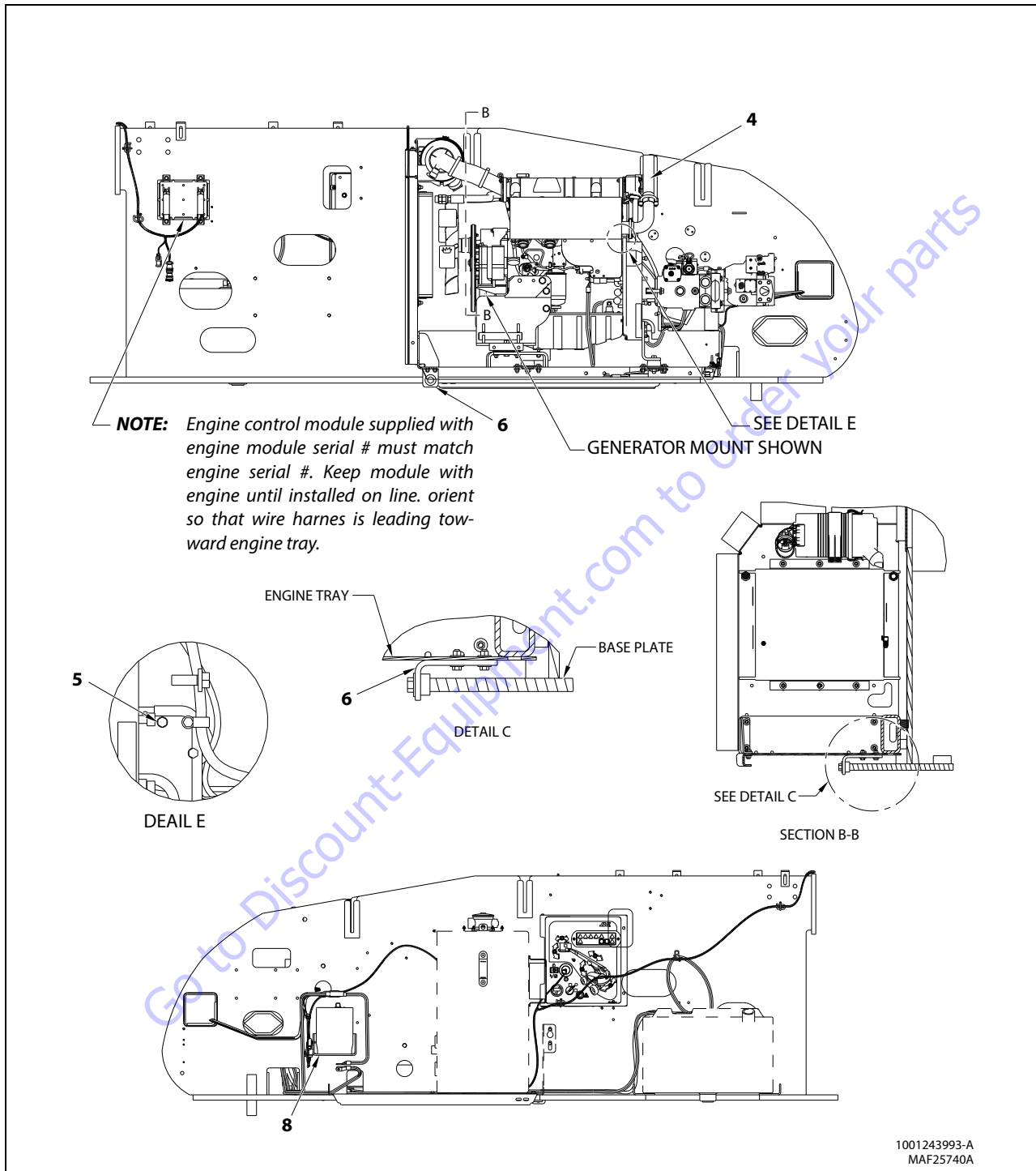
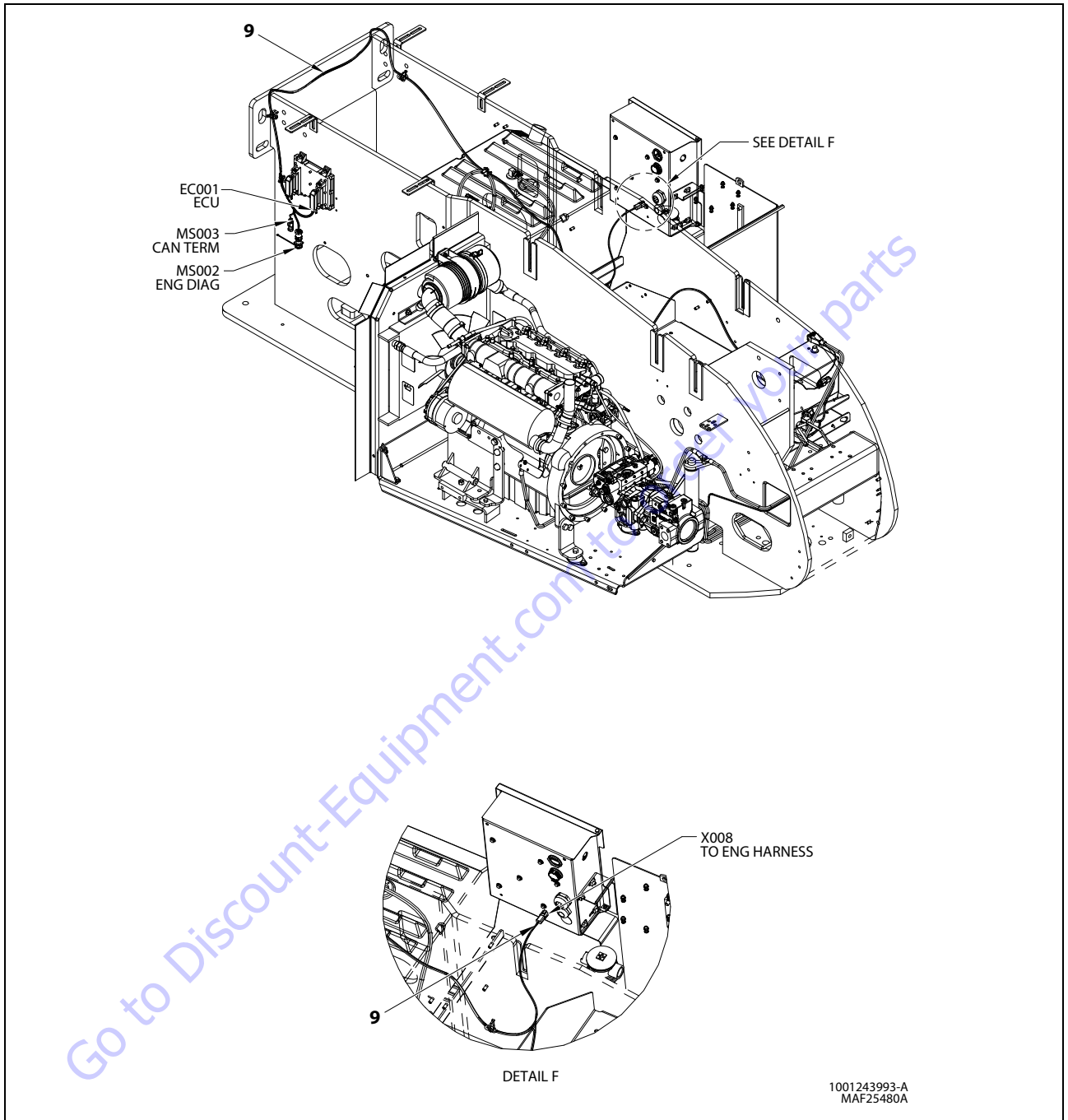

Figure 3-103. Deutz D2011LO40 Tier 4I Engine Installation (860SJ) - Sheet 3 of 4



- | | | |
|------------------------|---------------------|-----------------------|
| 1. Engine Tray Pin | 5. Worklight Spacer | 9. ECU Jumper Harness |
| 2. Weather Proof Relay | 6. Tray Hold Plate | 10. Battery Cable Kit |
| 3. Shaft Keeper | 7. Deutz T4I Engine | |
| 4. Exhaust Tube | 8. Battery Bracket | |

Figure 3-104. Deutz D2011LO40 Tier 4I Engine Installation (860SJ) - Sheet 4 of 4

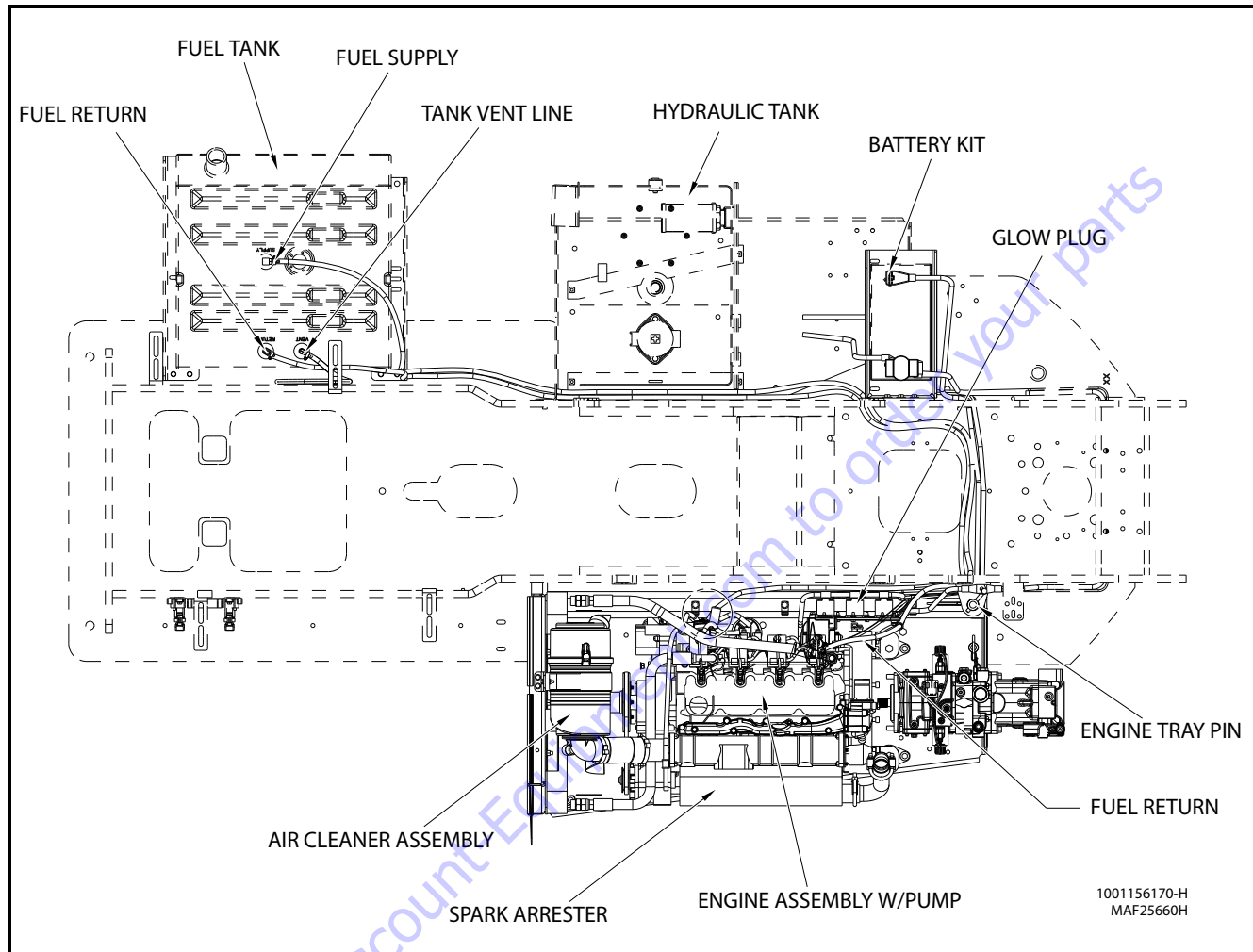

Figure 3-105. Deutz D2011 (T4I) Engine Installation (Without Arctic Package) - Sheet 1 of 2

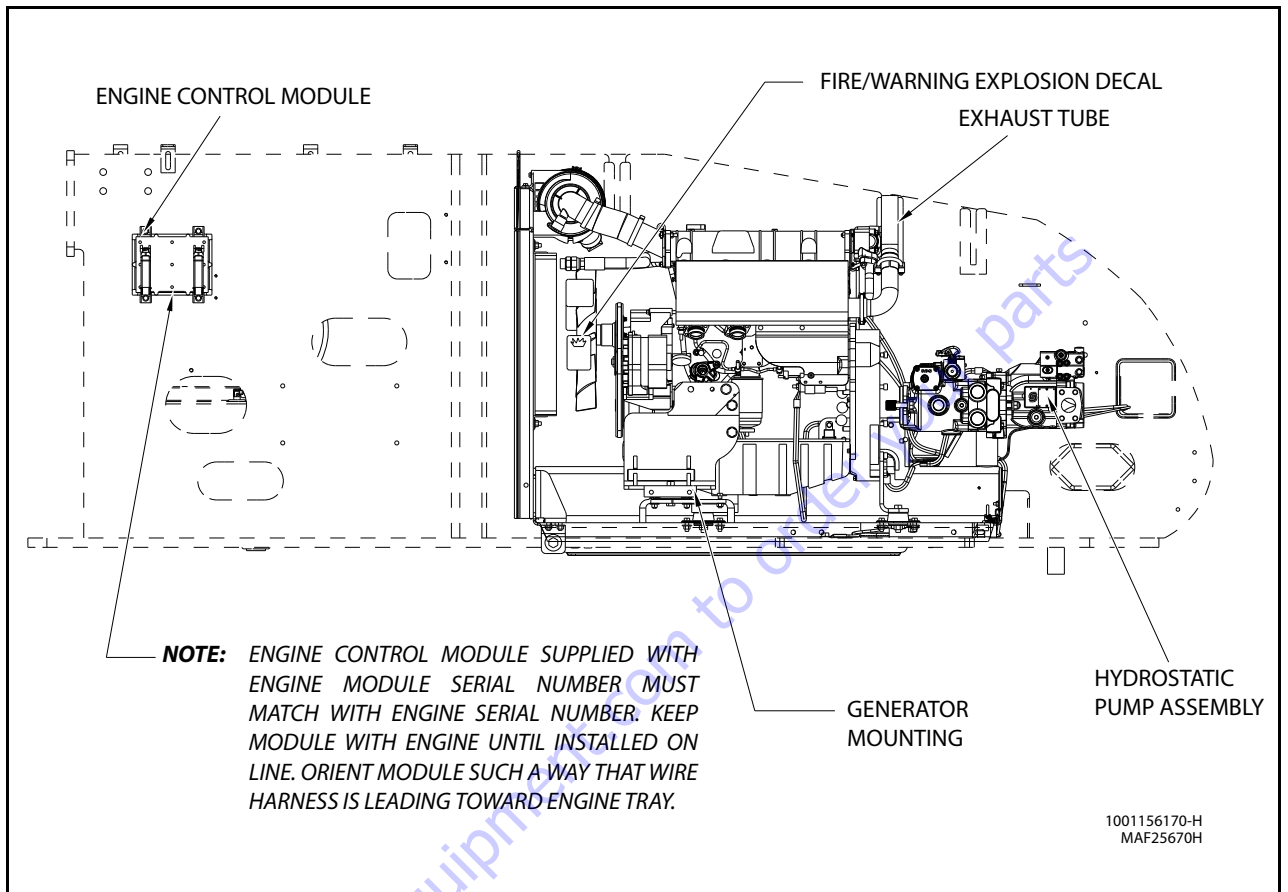

Figure 3-106. Deutz D2011 (T4I) Engine Installation (Without Arctic Package) - Sheet 2 of 2

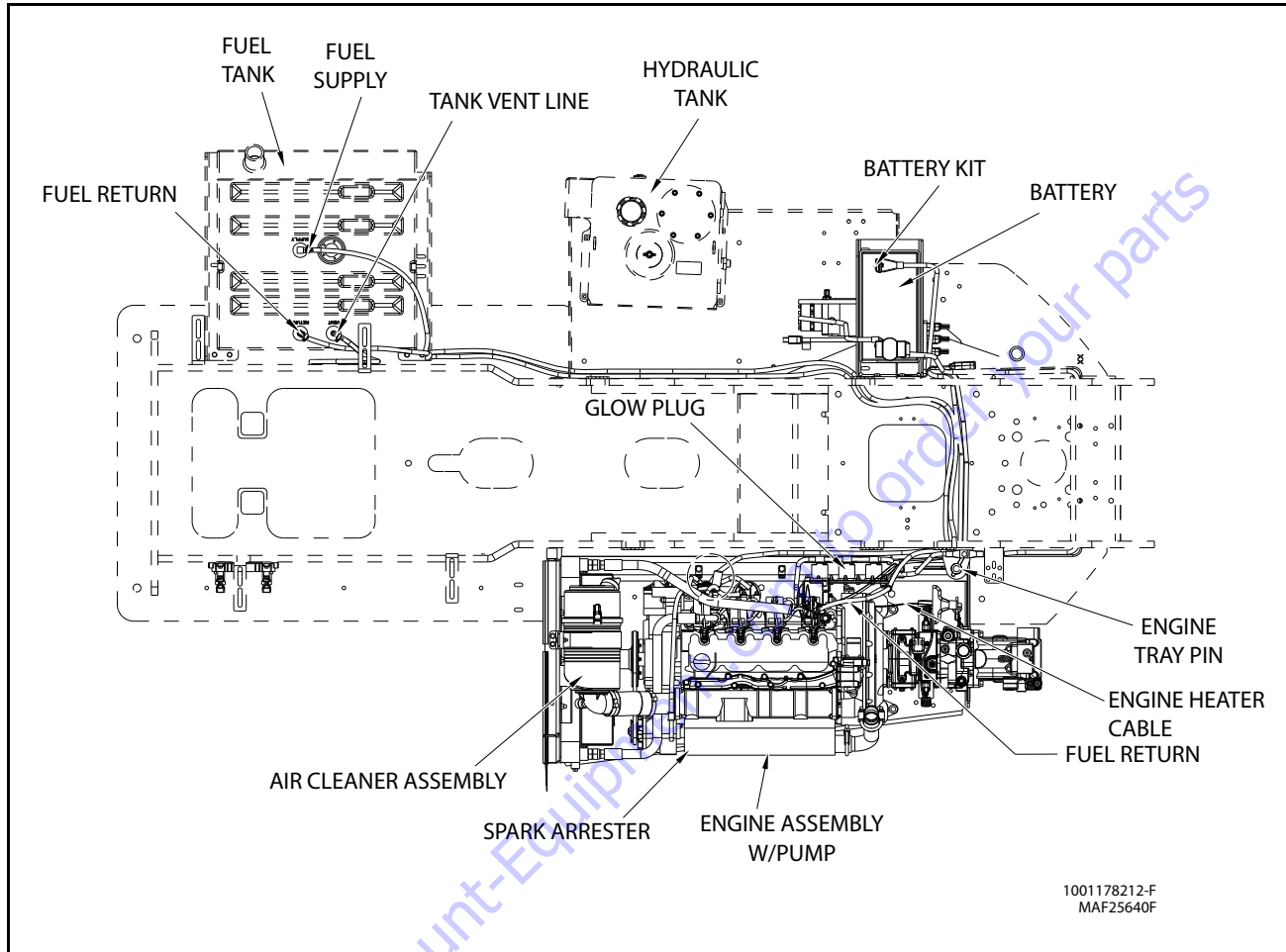

Figure 3-107. Deutz D2011 (T4I) Engine Installation (With Arctic Package) - Sheet 1 of 2

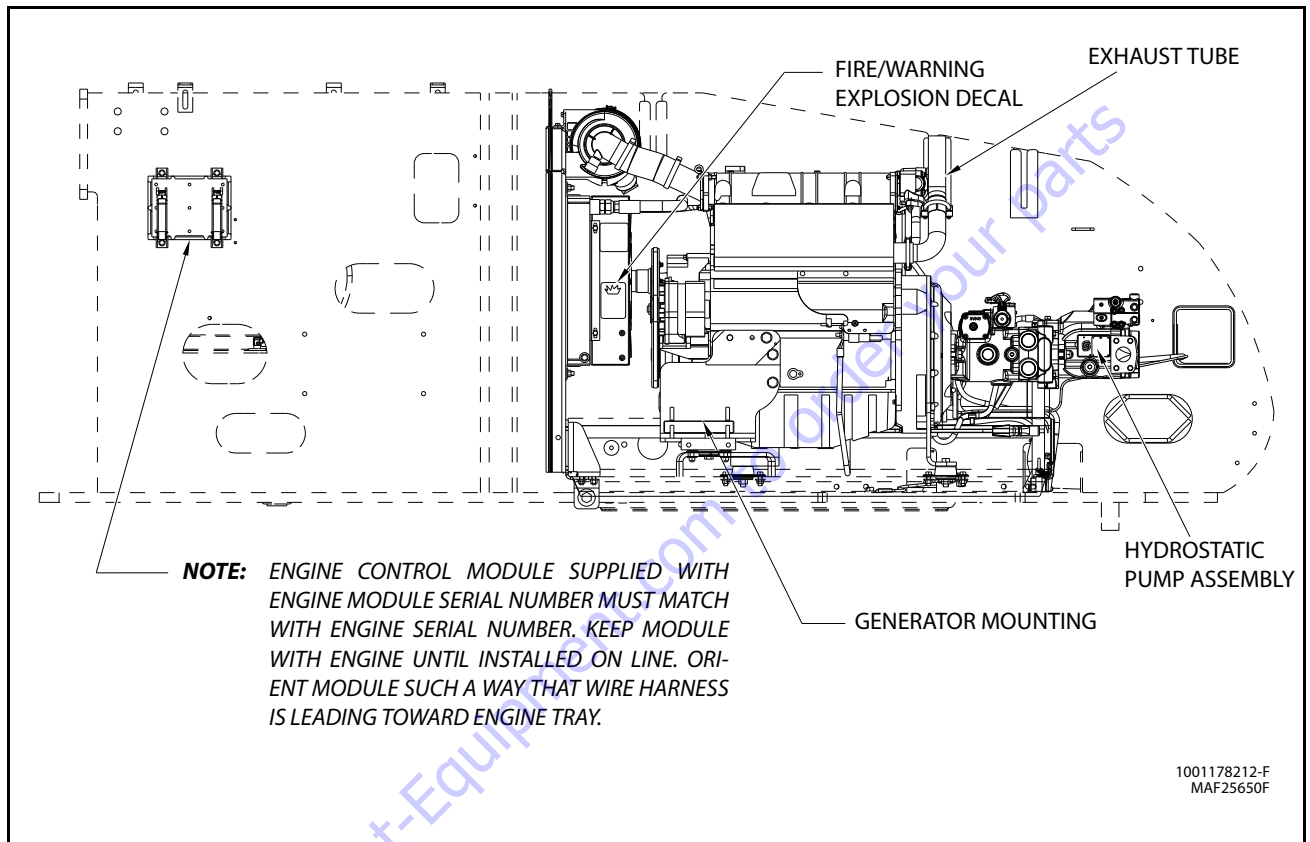

Figure 3-108. Deutz D2011 (T4I) Engine Installation (With Arctic Package) - Sheet 2 of 2

NOTE: Refer to engine manufacturer's manual for detailed operating and maintenance instructions.

Checking Oil Level

1. Make sure machine and engine are level and switch engine OFF before checking oil level.
2. Remove oil dipstick and wipe with clean cloth.
3. Insert dipstick to the stop and remove again.
4. Check oil level. Top oil level as shown in figure below with an approved grade and type of oil outlined in engine manufacturer's operator's manual.

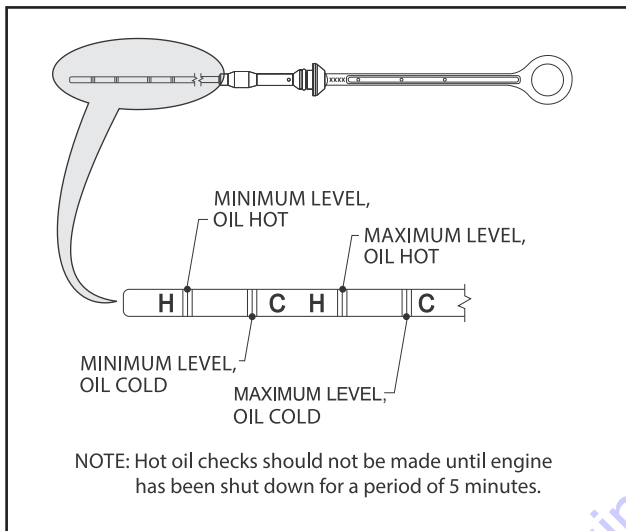

Figure 3-109. Deutz Dipstick Markings

5. Replace dipstick until fully seated.

Changing Engine Oil

1. Allow engine to warm up. Engine oil should reach approximately 176° F (80° C).
2. Make sure machine and engine are level and switch off engine.
3. Place oil tray under engine.

CAUTION

HOT ENGINE OIL CAN CAUSE BURNS. AVOID CONTACT WITH HOT OIL WHEN DRAINING.

NOTICE

COLLECT USED OIL IN A CONTAINER SUITABLE FOR DISPOSAL OR RECYCLING. DISPOSE OF USED ENGINE OIL IN ACCORDANCE WITH ENVIRONMENTAL REGULATIONS.

4. Open oil drain valve and drain oil.
5. Close oil drain valve.
6. Pour in new engine oil. Refer to Section 1 for capacity and Figure 3-110., Engine Oil Viscosity.

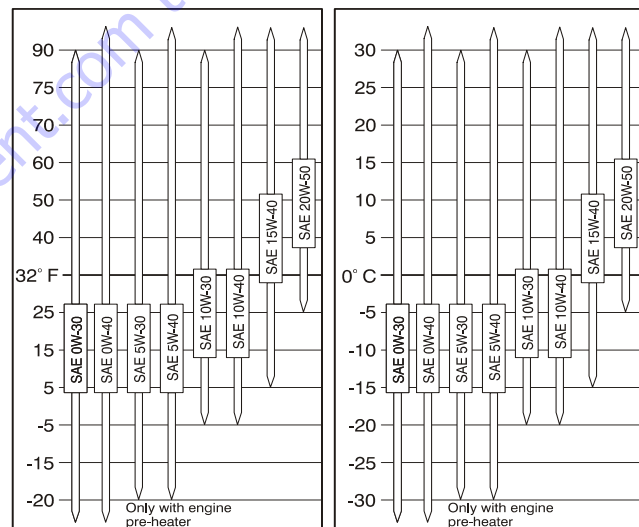
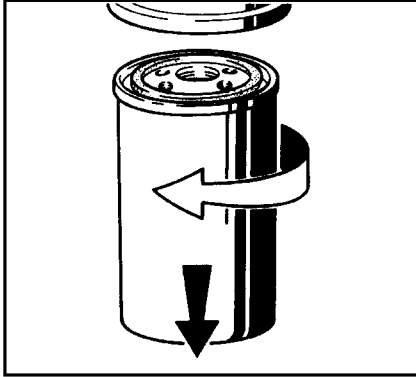

Figure 3-110. Engine Oil Viscosity

Changing Oil Filter

1. Wipe area around filter to clean any dirt from area.
2. Using a suitable oil filter removal tool, loosen lube oil filter cartridge and spin off.



3. Catch any escaping oil.
4. Clean any dirt from filter carrier sealing surface.
5. Lightly coat new oil filter rubber gasket with clean oil.

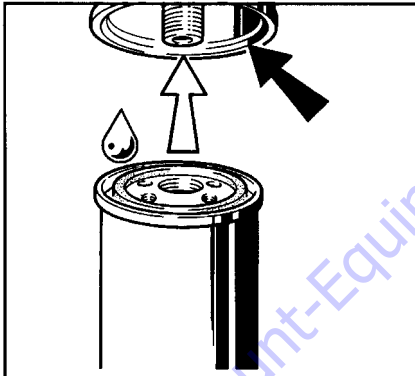

6. Screw in new filter by hand until gasket is flush.

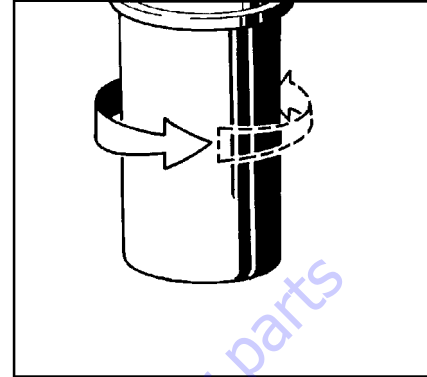

7. Hand-tighten filter another half-turn.
8. Check oil level.
9. Check oil pressure.
10. Check oil filter cartridge for leaks.

Replace Fuel Filter

⚠ WARNING

FUEL IS FLAMMABLE AND CAN CAUSE DEATH OR SERIOUS INJURY. MAKE SURE NO OPEN FLAMES OR SPARKS ARE IN THE AREA WHEN WORKING ON FUEL SYSTEM. DO NOT SMOKE WHEN WORKING ON FUEL SYSTEM.

1. Wipe area around filter to clean any dirt from area.
2. Remove fuel filter cartridge. Catch any escaping fuel.
3. Clean dirt from filter carrier sealing surface.
4. Apply light film of oil or diesel fuel to rubber gasket of new filter cartridge.
5. Screw in new filter by hand until gasket is flush. Hand-tighten filter another half-turn.
6. Open fuel shut-off valve.
7. Check for leaks.

Clean Fuel Strainer

⚠ WARNING

FUEL IS FLAMMABLE AND CAN CAUSE DEATH OR SERIOUS INJURY. MAKE SURE NO OPEN FLAMES OR SPARKS ARE IN THE AREA WHEN WORKING ON FUEL SYSTEM. DO NOT SMOKE WHEN WORKING ON FUEL SYSTEM.

1. Unscrew hexagonal nut (1).

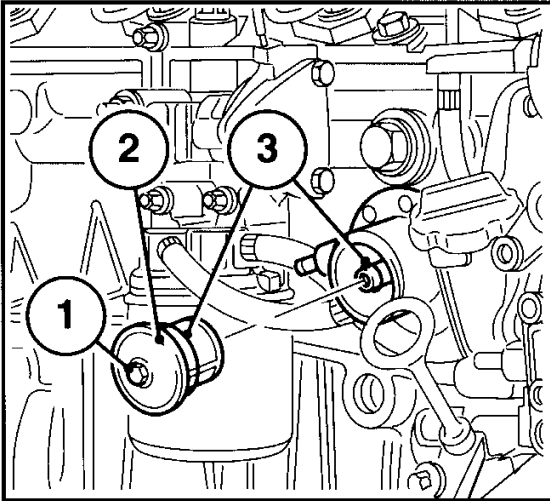

2. Remove fuel strainer cover (2).
3. Clean fuel strainer with diesel fuel and replace as needed.
4. Place seal (3) in position.
5. Install fuel strainer cover (2). Tighten screw (1).
6. Check for leaks.

Spark Arrester Cleaning Instructions

1. Remove cleanout plug in bottom of spark arrester (muffler).
2. Without causing deformation (or any type of damage to spark arrester) repeatedly tap on arrester near cleanout plug. This may be enough to begin spark trap drainage.
3. An industrial vacuum cleaner can do a complete job at this point.
 - a. Or, IN A SAFE AREA, start engine. Alternate between low idle and high idle for two to three minutes.
 - b. Or, operate engine as required by application for two to three minutes.
4. Install cleanout plug.

Glow Plugs

If glow plug option is enabled in the JLG Control System, glow plug and indicator lamp will be energized when Power/Emergency Stop switch is pulled on if ambient air temperature is less than 50° F (10° C) and engine coolant temperature is less than 140° F (60° C).

This determination occurs one second after the Power/Emergency Stop switch has been pulled on. Lamp and glow plugs remain energized for period of time specified by setting in the JLG Control System. Engine start is disabled during this period.

On Deutz engines, glow plugs continue (post glow) after engine has started three times the machine digit setting.

3.25 DEUTZ EMR 2

The EMR2 consists of the sensors, the control unit and the actuator. Engine-side controls as well as the JLG Control System are connected by means of separate cable harnesses to the EMR control unit.

The sensors attached to the engine provide the electronics in the control unit with all the relevant physical parameters. In accordance with the information of the current condition of the engine and the preconditions (throttle position etc.), the EMR2 controls an actuator that operates the control rod of the injection pump and thus doses the fuel quantity in accordance with the performance requirements.

The exact position of the regulating rod is reported back and, if necessary, is corrected, by means of the control rod travel sensor, situated together with the rotation magnets in a housing of the actuator.

The EMR2 is equipped with safety devices and measures in the hardware and software in order to ensure emergency running (Limp home) functions.

In order to switch the engine off, the EMR2 is switched in a de-energized fashion over the ignition switch. A strong spring in the actuator presses the control rod in the de-energized condition into the zero position. As a redundancy measure, an additional solenoid serves for switching off and this, independently of the actuator, also moves the control rod in the de-energized condition into the zero position.

After the programming, that is carried out over the ISO9141 interface, the EMR2 possesses a motor-specific data set and this is then fixedly assigned to the engine. Included in this are the various application cases as well as the customer's wishes regarding a particular scope of function.

Each EMR2 module is matched by serial number to the engine. Modules cannot be swapped between engines.

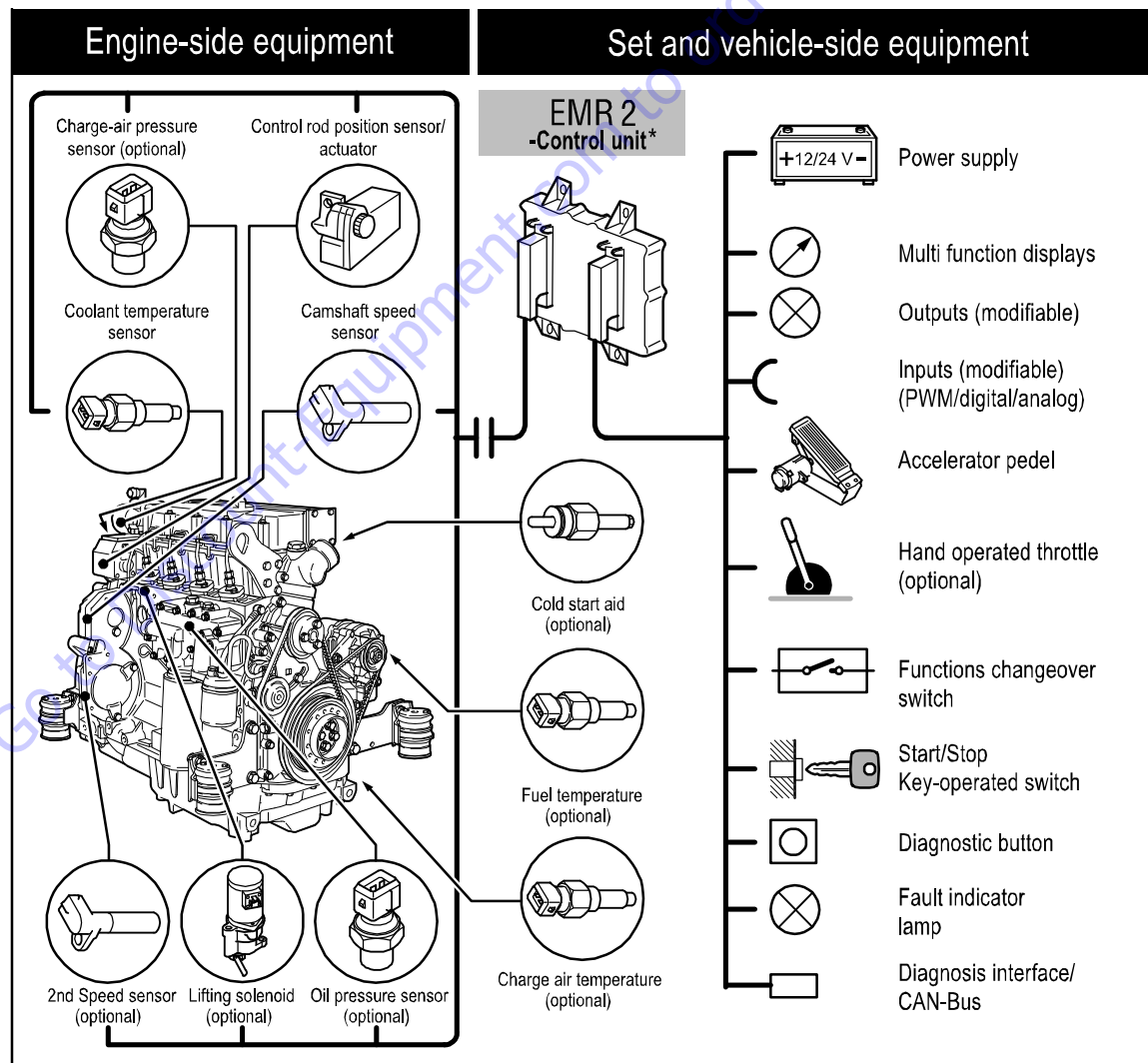

Figure 3-111. EMR 2 Engine Side Equipment

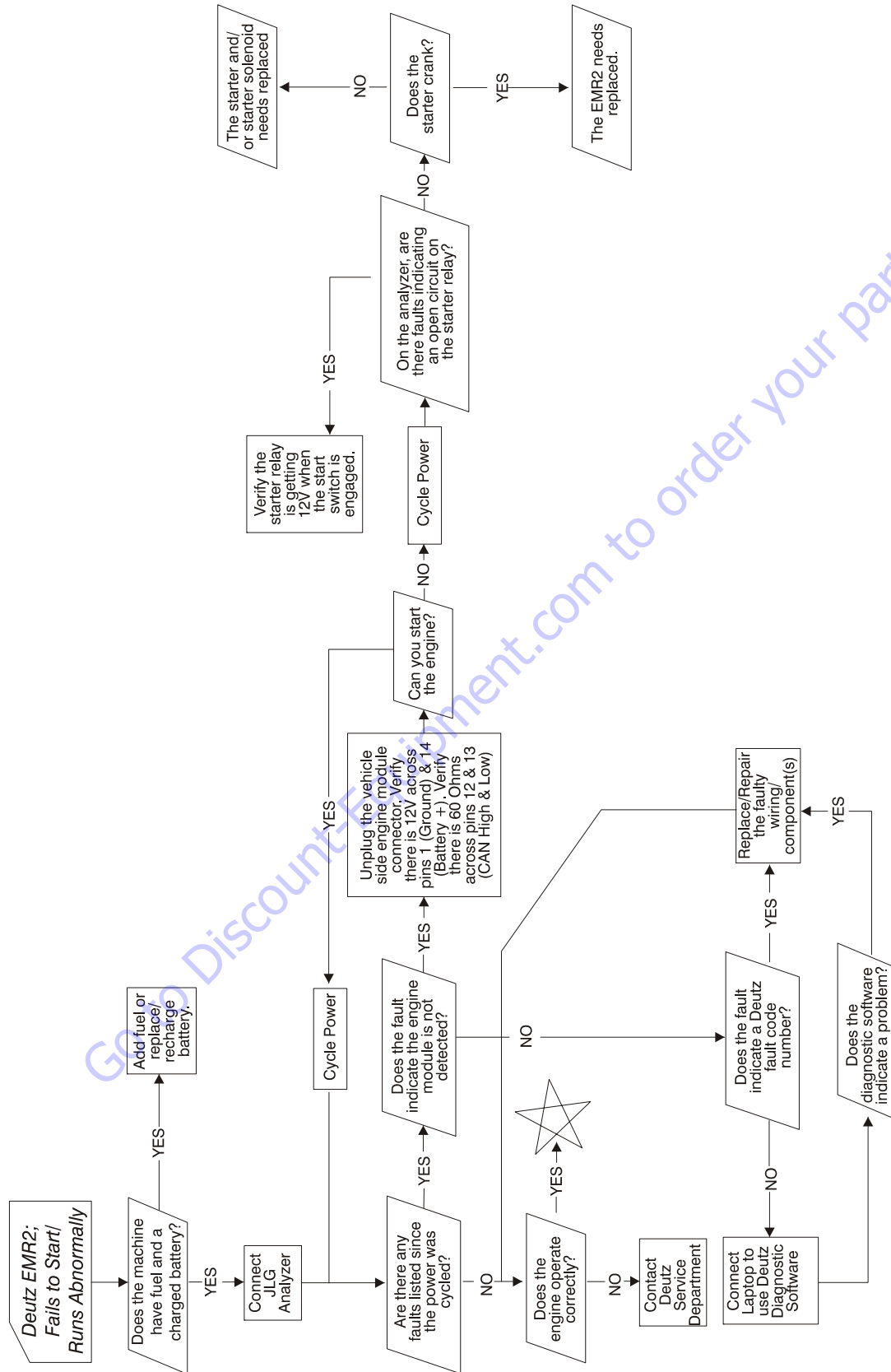

Figure 3-112. Deutz EMR 2 Troubleshooting Flow Chart

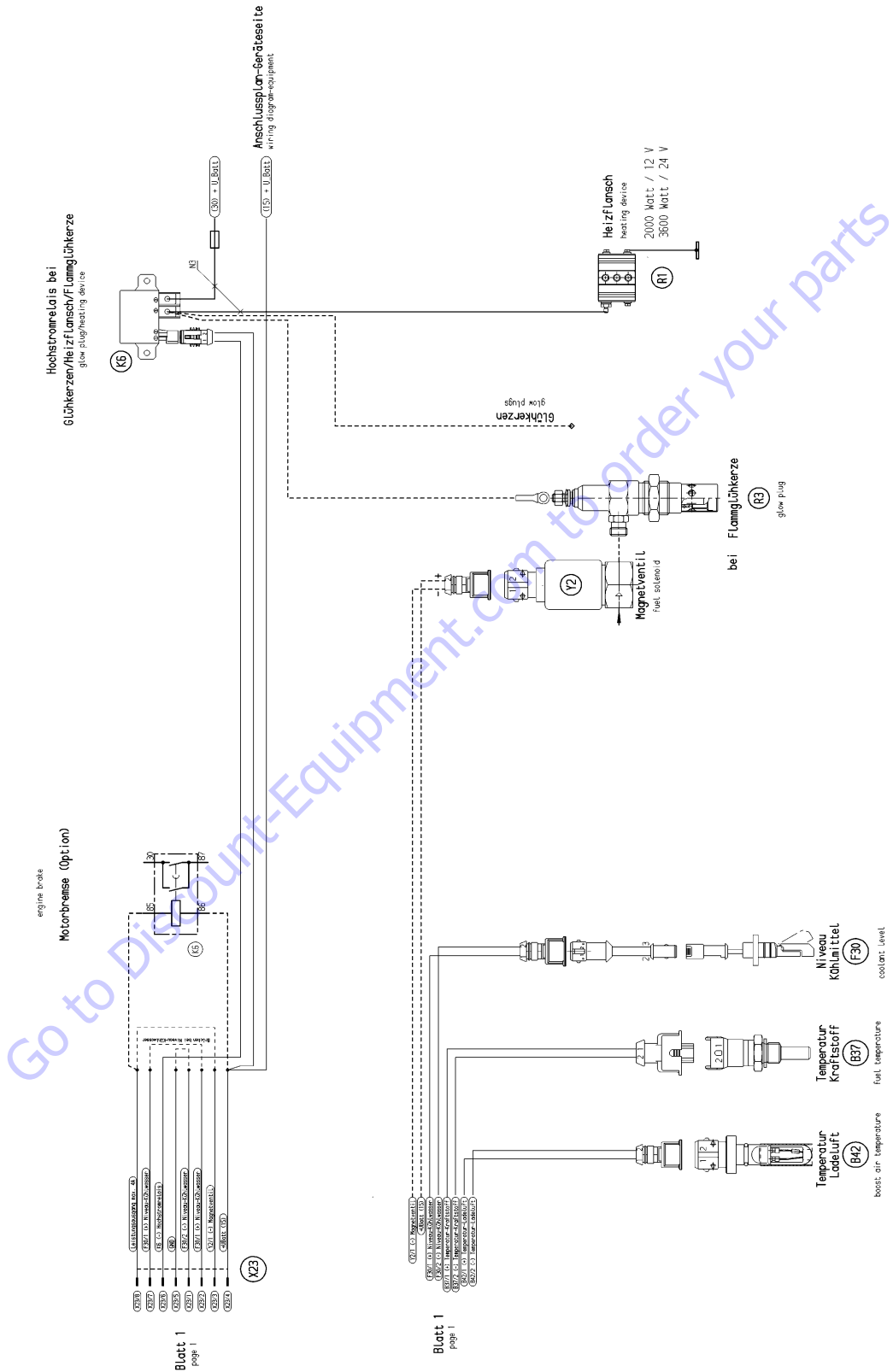
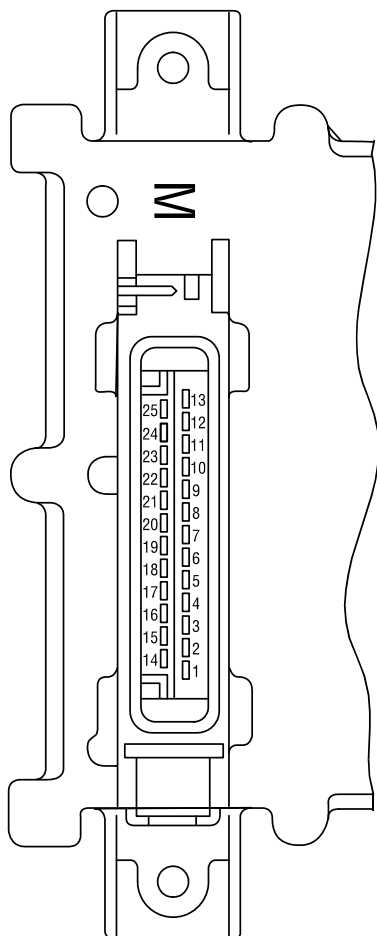

Figure 3-115. Deutz EMR 2 Engine Side Connection Diagram - Sheet 2 of 2



Pin No.	Designation	Description
1	Reserve	Reserve
2	Output: digital 3	Digital output for solenoid ¹⁾
3	Output: digital 4	For heating flange (optional)/ glow plug (optional)
4	Input (optional) Temp 1	Fuel temperature ²⁾
5	Input (optional) Temp 2	Charge air temperature
6	Input (optional) DigIn 5	Coolant level / oil level
7	Output: PWM2/digital 6	
8	GND	Reference potential for analog signal at pin 9
9	Input: analog 7	Analog input for Coolant temperature sensor (NTC)
10	GND	Reference potential for analog signal at pin 11
11	Multi-function input: speed 2/DigIn 2	Digital input second engine speed (crankshaft) (optional) and speed signal (optional)
12	GND	Reference potential for analog signal at pin 13
13	Input: speed 1	Digital input first engine speed (camshaft)
14	STG -	PWM output, signal for actuator coil
15	STG +	PWM output, signal for actuator coil
16	Screen	Screening regulating rod travel sensor (for lines 17, 18, 19)
17	RF -	General connection for reference and measuring coil
18	RF REF	Analog input, reference signal of the reference coil
19	RF MESS	Analog input, measuring signal of the measuring coil
20	GND	Reference potential for signal at pin 21
21	Input: analog 4/digital 9	Analog input 4 (sensor signal oil pressure sensor) or digital input 9
22	+5 V REF	+5 V Reference voltage for signal at pin 21 (max. 15 mA)
23	GND	Reference potential for signal at pin 24
24	Input: analog 2/digital 7	Analog input 2 (sensor signal charge air) or digital input 7
25	+5 V LDA	+5 V Reference potential for signal at pin 24 (max. 15 mA)

1) For continuous power: < 4 A

2) Corresponds to special function "fuel temperature compensation at the EMR (0211 2571)

Figure 3-116. EMR 2 Engine Plug Pin Identification

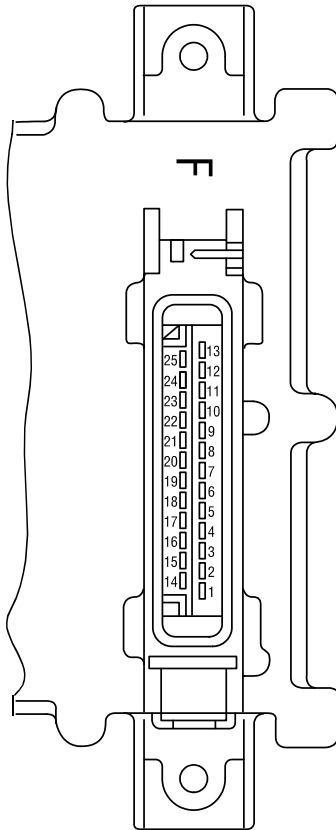

Pin-No.	Designation	Description
1	U Batt -	Negative pole at battery (clamp 31)
2	GND	Reference potential for signal
3	Output: digital 2	PWM or digital output, various functions
4	Input / output: DigInOut	Fault lamp and diagnostic button
5	Output: PWM 1/Dig 1	PWM or digital output, various functions
6	Multi-function input: DigIn 3	Genset applications/gear shift/motor brake
7	Input: digital 10/velocity	Speed signal (tacho input)
8	NC	Not occupied
9	NC	Not occupied
10	L-line	Serial ISO 9141 interface
11	K-line	Serial ISO 9141 interface
12	CAN high	Interface for CAN-Bus
13	CAN low	Interface for CAN-Bus
14	U Batt +	Positive pole for battery (clamp 15)
15	Output: digital 5	Digital output, various functions
16	Output: digital 7/Frequency	Frequency, PWM or digital output, various functions
17	Ground	Reference potential for signal at pins 18, 19 and 21
18	Input: digital 1 / PWM 1	PWM 1 or digital input 1, various functions
19	Multi-function input: DigIn 4	Performance curve switching/genset applications
20	Multi-function input: digital 8 / analog 3	Hand hand throttle/genset applications, Digital (8) or analog input (3)
21	Input: digital 2 / PWM 2	PWM 2 or digital input 2, various functions
22	Screen	Screening (e.g. for lines hand throttle or PWG)
23	GND	Reference potential for signal at pin 24
24	Input: analog 1 / digital 6	Analog input 1 (pedal value sensor, PWG) or digital input 6
25	+5 V REF	+5 V Reference voltage for signal at pin 24

Figure 3-117. EMR 2 Vehicle Plug Pin Identification

SECTION 3 - CHASSIS & TURNTABLE

Fault group	Fault no. (in SERDIA)	Fault locality/ Fault description	SPN	FMI	Cause	Remarks	Help
Zero error display	-	No faults	524287	31	No active faults present		
Revolutions / speed acquisition	01	Speed sensor 1	190	8	Sensor failure. Distance from gear too far. Additional fault impulses. Cable joint interrupted.	Governor in emergency operation (if sensor 2 available). Emergency switch-off (if sensor 2 not available or failed). Governor in emergency operation (with sensor 1) Emergency switch-off (if sensor 1 not available or failed).	Check distance. Check cable connection. Check sensor and replace if required.
	03	Speed sensor	84	8	Tacho failed. Additional fault impulses. Cable connection interrupted.	Governor in emergency operation.	Check cable connection and Tacho. Replace if required.
	04	Excess speed switch-off	190	0	Speed was/is in excess of limit.e. Check PID setting. Check rods. Check actuator and replace if required. Check cable to actuator (impulse on incorrect speed). Check No. of teeth. For vehicles check for possible thrust mode.	Engine stop.	Check parameter (21). Check speed settings.
	07	Charge air pressure	102	2			
Sensors	08	Oil pressure	100	2			
	09	Coolant temperature	110	2	Fault at corresponding sensor entry (e.g. short circuit or cable break).	With failure of the sensor the associated monitoring function is de-activated.	Check sensor cable. Check sensor and replace if required. Check fault limits for sensor.
	10	Charge air temperature	105	2			
	11	Fuel temperature	174	2			

NOTE: SID is equal to 512. To get SPN #, add 512 + number. For example, SID 254 would be 512+254 or an SPN of 766.

Figure 3-118. EMR2 Fault Codes - Sheet 1 of 5

Fault group	Fault no. (in SERDIA)	Fault locality/ Fault description	SPN	FMI	Cause	Remarks	Help
Functional fault warning	30	Oil pressure warning	100	1	Oil pressure below speed-dependent warning line characteristic	Fault message (disappears when oil pressure is again above recovery limit). After a delay time - fill limitation.	Check engine (oil level, oil pump). Check oil pressure sensor and cable. Check oil pressure warning line characteristic.
	31	Coolant temperature warning	110	0	Coolant temperature has exceeded warning level.	Fault message (disappears when coolant temperature again drops below recovery level). After a delay time - fill limitation.	Check coolant. Check coolant temperature sensor and cable.
	32	Charge air temperature warning	105	0	Charge air temperature has exceeded warning level.	Fault message (disappears when charge air temperature gain drops below recovery level). After a delay time - fill limitation.	Check charge air. Check charge air-temperature sensor and cable.
	34	Coolant level warning	111	1	Switch input "Low coolant level" is active.	Fault message.	Check coolant level. Check coolant level sensor and cable.
	35	Speed warning (with thrust mode operation).	SID 190	14	revolutions was/is above (top) revolution speed limit. "Thrust mode" function is active.		Check parameters. Check speed settings.
	36	Fuel temperature warning	174	0	Fuel-temperature has exceeded warning level.	Check PID setting. Check rods. Check actuator and replace if required. Check cable to actuator. Check speed sensor (impulses on incorrect speed). Check No. of teeth. For vehicles check for possible thrust mode.	Check fuel. Check fuel temperature sensor and cable.

NOTE: SID is equal to 512. To get SPN #, add 512 + number. For example, SID 254 would be 512+254 or an SPN of 766.

Figure 3-119. EMR2 Fault Codes - Sheet 2 of 5

SECTION 3 - CHASSIS & TURNTABLE

Fault group	Fault no. (in SERDIA)	Fault locality/ Fault description	SPN	FMI	Cause	Remarks	Help
Functional fault, switch-off	42	Charge air temperature switch-off	105	0	Charge air temperature has exceeded switch-off limit.	Emergency stop	Check charge air. Check charge air-temperature sensor and cable. Check switch-off limit.
	44	Coolant level switch-off	111	1	Switch input "Low coolant level" is active.	Emergency stop. Start lock.	Check coolant level. Check coolant level sensor and cable.
Actuator	50	Feedback	SID 24	12	Actuator not connected. Fault in actuator confirmation.	Emergency switch-off. Actuator cannot be operated.	Check actuator, replace if required. Check cable, check fault limits for "Confirmation".
	52	Reference feedback	SID 24	13			Check actuator, replace if required. Check cable, check fault limits for "Rifeness confirmation".
	53	Control travel difference	SID 23	7	Injection pump/actuator jammed or not connected. Difference between nominal/actual control travel is > 10 % of the overall control path.	Fault message (disappears when difference is < 10 %).	Check actuator/actuator rods / injection pump, replace if required. Check actuator cable.
	59	Auto calibration BOSCH-EDC pumps faulty operation	SID 23	13	No automatic actuator equalization possible. Incorrect input of the actuator reference values.	Engine stop / start lock. Governor cannot be taken into use. EDC actuator calibration required.	Check actuator and replaced if required. Check feedback cable. Check fault limits and reference values of the feedback. Program the fault limits for feedback, save values. Switch ignition off and on again. Check again, if faulty, inform DEUTZ-Service and carry out automatic equalization again. Set fault limits again.

NOTE: SID is equal to 512. To get SPN #, add 512 + number. For example, SID 254 would be 512+254 or an SPN of 766.

Figure 3-120. EMR2 Fault Codes - Sheet 3 of 5

Fault group	Fault no. (in SERDIA)	Fault locality/ Fault description	SPN	FMI	Cause	Remarks	Help
Hardware inputs/ outputs	60	Digital output 3 (Switch-off solenoid, pin M 2)	SID 51	2	Fault (short circuit / cable break) at digital output.	Driver level is switched off.	Check cable of digital output (cable break or short circuit).
	62	Digital output 6, pin M 7	SID 60	2		Fault message.	
	63	Excess voltage switch-off solenoid	SID 51	6			
	67	Error Hand Setp1	91	11			
	68	Error CAN Setp1	898	2			
	Communication	70	CAN-Bus controller	SID 231	12	CAN-controller for CAN-bus is faulty. Fault removal despite re-initialising continuously not possible	Application-dependent.
71		CAN interface SAE J 1939	SID 231	9	Overflow in input buffer or a transmission cannot be placed on the bus.		Check CAN connection, cable connection. Check sensor and replace if required.
74		Cable break, short circuit or bus-error	SID 231	14			
Memory	76	Parameter programming (write EEPROM)	SID 253	12	Fault in parameter programming in the governor fixed value memory.		Switch ignition off and on again. Check again. If faulty inform DEUTZ Service
	77	Cyclic program test	SID 240	12	Constant monitoring of program memory shows error (so-called "Flash-test").	Emergency switch-off. engine cannot be started.	
	78	Cyclic RAM test	SID 254	2	Constant monitoring of working memory shows error.		(Note values of parameters (3895 and 3896). Switch ignition off and on again. Check again. If faulty inform DEUTZ Service.

NOTE: SID is equal to 512. To get SPN #, add 512 + number. For example, SID 254 would be 512+254 or an SPN of 766.

Figure 3-121. EMR2 Fault Codes - Sheet 4 of 5

Fault group	Fault no. (in SERDIA)	Fault locality/ Fault description	SPN	FMI	Cause	Remarks	Help
Control unit hardware	80	Power supply (Actuator)	SID 254	2	Power supply for actuator not in the permissible range.	Fault message (disappears when power again in the normal range).	Switch ignition off and on again. Check again. If faulty inform DEUTZ Service.
	83	Reference voltage 1	SID 254	2	Reference voltage for actuator not in the permissible range.	Fault message (disappears when power again in the normal range). Auxiliary value 5 V	Check voltage supply. Switch ignition off and on again. Check again. If faulty inform DEUTZ Service.
	84	Reference voltage 2	SID 254	2			
	85	Reference voltage 4	SID 254	2			
	86	Internal temperature	171	12	Internal temperature for control unit not in permissible range.	Fault message (disappears when power again in the normal range).	Switch ignition off and on again. Check again. If faulty inform DEUTZ Service.
87	Atmospheric pressure	108	12	Atmospheric pressure not in permissible range.	Fault message (disappears when power again in normal range). Atmospheric pressure monitoring function de-activated.	Switch ignition off and on again. Check again. If faulty inform DEUTZ Service.	
Program logic	90	Parameter fault (EEPROM retrieval or checksum faulty).	SID 253	2	No data found or checksum of data is faulty (note: fault only occurs during setting of parameter / saving or reset).	Engine cannot be started.	Check data for correct settings. Save parameters. Switch ignition off and on again. Check again. If faulty inform DEUTZ Service.
	93	Stack overflow	SID 240	2	Internal calculation fault (so-called "Stack overflow" fault).	Emergency switch-off. Engine cannot be started.	Note parameters (3897 and 3898). Switch ignition off and on again. Check again. If faulty inform DEUTZ Service.
	94	Internal fault	SID 254	2			

NOTE: SID is equal to 512. To get SPN #, add 512 + number. For example, SID 254 would be 512+254 or an SPN of 766.

Figure 3-122. EMR2 Fault Codes - Sheet 5 of 5

Table 3-13. Engine Fault Codes (Deutz Engine)

SPN	FMI	Deutz Code	Blink Code	Description	Possible Cause	Action
29	2	978	1-2-6	Diagnostic fault check of synchronism of hand throttle and Low idle switch (LIS).	Plausibility error between sensor and idle switch	Threshold for error detection is an internal ECU threshold. The accelerator pedal must have detected full load and idle plausibility at least once.
29	3	932	1-2-6	Diagnostic fault check of short circuit to supply voltage (signal range check high) of acceleration pedal signal.	The signal exceeds the applicable threshold; signal range violation	If the signal is below the applicable threshold APP_uRawSRChiHTLIS_C, the signal range violation is reset after the healing debouncing. In case when the CCP is active (CCP_stActive = 1) and the reading from the EEPROM memory is successful, the signal is below the threshold APP_uHTLISCCPHi[1], a signal range violation is reset after debouncing.
29	4	937	1-2-6	Diagnostic fault check of short circuit to ground (signal range check low) of acceleration pedal signal	The signal is below the applicable threshold; signal range violation	If the signal exceeds the applicable threshold APP_uRawSRCLoHTLIS_C, the signal range violation is reset after the healing debouncing. In case when the CCP is active (CCP_stActive = 1) and the reading from the EEPROM memory is successful, the signal exceeds the threshold APP_uHTLISCCPLo[1], a signal range violation is reset after debouncing.
91	3	935	2-2-6	Analog accelerator pedal sensor 1 or double accelerator pedal sensor: the voltage measured by ECU is out of the target range or the calculated pedal position is implausible compared with the position of the second pedal	Sensor defect. Short cut to battery or open loop.	Check cabling, check accelerator pedal sensor and if necessary replace it, check connection cable and if necessary repair or replace it. If the signal is below the applicable threshold APP_uRaw1SRCHigh_C, the signal range violation is reset after the healing debouncing.
91	4	940	2-2-6	Analog accelerator pedal sensor 1 or double accelerator pedal sensor: the voltage measured by ECU is out of the target range or the calculated pedal position is implausible compared with the position of the second pedal	Short circuit to ground.	Check cabling, check accelerator pedal sensor and if necessary replace it, check connection cable and if necessary repair or replace it If the signal exceeds the applicable threshold APP_uRaw1SRCLow_C, the signal range violation is reset after the healing

Table 3-13. Engine Fault Codes (Deutz Engine)

SPN	FMI	Deutz Code	Blink Code	Description	Possible Cause	Action
91	11	976	2-2-6	Diagnostic fault check of synchronism of single potentiometer and Low idle switch(LIS).	Measured voltage of accelerator pedal 1 is out of plausible range.	Threshold for error detection is an internal ECU threshold. Check cabling, check accelerator pedal and pedal sensor and if necessary replace it, check connection cable and if necessary repair or replace it. When the PWM period APP_tIPWMPer is in between APP_tISRCLoPWMPer_C and APP_tISRCHiPWMPer_C.
94	1	474	216	Low fuel pressure: the low fuel pressure calculated by ECU is underneath the target range; the ECU activates a system reaction	Fuel pressure below warning threshold	Check low fuel pressure system (fuel feed pump, relay, fuse, wiring, sensor) and if necessary repair or replace it.
94	3	472	216	Low fuel pressure sensor: the voltage of sensor measured by ECU is out of the target range	cable break or short circuit, sensor defective, connection cable damaged Short cut to battery or open loop	Check cabling, if sensor not working, check sensor and if necessary replace it, check connection cable and if necessary repair or replace it
94	4	473	216	Low fuel pressure sensor: the voltage of sensor measured by ECU is out of the target range	cable break or short circuit, sensor defective, connection cable damaged short cut to ground	Check cabling, if sensor not working, check sensor and if necessary replace it, check connection cable and if necessary repair or replace it
97	3	464	228	Fuel filter water level sensor: the voltage of sensor measured by ECU is out of the target range	Sensor not connected or sensor defect.	Check of wiring and water in fuel sensor. Check cabling, if charge Water in Fuel sensor is not working, check sensor and if necessary replace it, check connection cable and if necessary repair or replace it.
97	4	465	228	Fuel filter water level sensor: the voltage of sensor measured by ECU is out of the target range.	cable break or short circuit, sensor defective, connection cable damaged. Short cut to ground.	Check sensor and if necessary replace it, check connection cable and if necessary repair or replace it.
97	12	1157	228	Fuel filter water level sensor: the maximum level is exceeded	Water level in fuel pre-filter reservoir over limit (bad fuel quality)	Measure Voltage at Water in Fuel Sensor and renew harness if needed.
100	1	736	231	Oil pressure is below the target range (warning threshold)	Oil pressure too low (pressure below warning threshold)	Threshold for error detection is an internal ECU threshold. Check oil level, check engine for oil leakage, measure oil pressure external to evaluate sensor value
100	1	737	231	Oil pressure is below the target range (shut off threshold)	Oil pressure too low (pressure below shut off threshold).	Threshold for error detection is an internal ECU threshold. Check oil level, check engine for oil leakage, measure oil pressure external to evaluate sensor value.
100	3	732	224	Oil pressure sensor: the voltage of sensor measured by ECU is out of the target range	short circuit to battery or cable break	check battery and wiring Check cabling. If sensor not working, check sensor and if necessary replace it, check connection cable and if necessary repair or replace it.

Table 3-13. Engine Fault Codes (Deutz Engine)

SPN	FMI	Deutz Code	Blink Code	Description	Possible Cause	Action
100	4	733	224	Oil pressure sensor: the voltage of sensor measured by ECU is out of the target range	Short circuit to ground	The sensed raw voltage value Oil_uRawPSwmp is above Oil_SRCPSwmp.uMin_C Check cabling, if sensor not working, check sensor and if necessary replace it, check connection cable and if necessary repair or replace it No detail informationen!
102	1	774	223	charge air pressure below lower limit	measured charge air pressure below the threshold.	Check complete air system of engine for massive leakage, especially from compressor to intake air manifold. Check air filter. Exchange charge air pressure sensor.
102	2	88	223	Charge air pressure measured by sensor is above the shut off threshold.	Charged air cooler pressure below threshold.	Check waste gate system if necessary replace TC, check CAC if all channels are clean, check charge air piping if necessary.
102	2	89	223	Charge air pressure measured by sensor is above the warning threshold	Charge air pressure above shut off threshold	Check waste gate system if necessary replace TC, check CAC if all channels are clean, check charge air piping if necessary.
102	2	772	223	Deviation between sensed intake manifold pressure is not plausible compared to environment pressure. Which sensor is not okay can not be said.	deviation between ambient pressure sensor and charge air pressure sensor at not running engine to high	1) Exchange boost pressure sensor 2) Exchange ECU
102	3	776	223	Charge air pressure sensor: the measured voltage of sensor by ECU is out of the target range	The Sensor Voltage is above the Threshold.	Check cabling, if charge air pressure/temperature sensor is not working, check sensor and if necessary replace it, check connection cable and if necessary repair or replace it.
102	4	777	223	Charge air pressure sensor: the measured voltage of sensor by ECU is out of the target range	The Sensor Voltage is below the Threshold.	Check cabling, if charge air pressure/temperature sensor is not working, check sensor and if necessary replace it, check connection cable and if necessary repair or replace it
105	0	996	233	Charge air temperature downstream calculated by ECU is above the target range. The ECU activates a system reaction.	Charge air temperature (downstream) over warning threshold.	Check CAC system and clean it. Check fan functionality. Check cooling performance with temperature measurement.
105	0	997	233	Charge air temperature downstream calculated by ECU is under the shut down threshold. The ECU activates a system reaction.	Charge air temperature (downstream) over the low threshold.	Check CAC system and clean it. Check fan functionality. Check cooling performance with temperature measurement.
105	1	992	128	Charged Air cooler down stream temperature. Temperature below lower physical threshold.	Sensed temperature within intake air manifold < threshold.	actual temperature below -40°C? exchange sensor
105	3	994	128	Charge air temperature sensor: the voltage of sensor measured by ECU is out of the target range.	Short circuit to battery. sensor voltage > limit	The sensor raw signal Air_uRawTCACDs (voltage) > Air_SRC TCACDs.uMin_C. Check CAC-sensor and if necessary replace it, check connection cable and if necessary repair or replace it.

SECTION 3 - CHASSIS & TURNTABLE

Table 3-13. Engine Fault Codes (Deutz Engine)

SPN	FMI	Deutz Code	Blink Code	Description	Possible Cause	Action
105	4	995	128	Charge air temperature sensor: the voltage of sensor measured by ECU is out of the target range.	Short circuit to ground or open load. sensor voltage < limit.	The sensor raw signal Air_uRawTCACDs (voltage) is below Air_SRCTCACDs.uMin_C. Check CAC-sensor and if necessary replace it, check connection cable and if necessary repair or replace it
107	0	752	136	Air filter differential pressure: the pressure difference of the intake air between the filter inlet and outlet calculated by ECU is above the target range and the ECU activates a system reaction	Pressure loss above target range with system reaction, air filter clogged or defective, sensor not working, connection cable damaged Pressure value above warning threshold	Check air filter and if necessary clean or renew it, check cabling, check sensor and if necessary replace it, check connection cable and if necessary repair or replace it
110	0	98	232	Coolant temperature: the coolant temperature calculated by ECU is above the target range; the ECU activates a system reaction	Cooling temperature too high. Coolant temperature above warning threshold	Clean radiator, check fan drive, check coolant level, check cooling system in general, check thermostat function, check water pump
110	0	99	232	Coolant temperature: the coolant temperature calculated by ECU is above the target range. The ECU activates a system reaction	Coolant temperature above shut off threshold.	Clean radiator, check fan drive, check coolant level, check cooling system in general, check thermostat function, check water pump
110	1	93	225	Coolant temperature sensor: the voltage of the sensor measured by ECU is out of the target range.	Suspected components: wiring harness, coolant temperature sensor.	Check wiring harness and connected Coolant Temp Sens.
110	3	96	225	Coolant temperature sensor: the voltage of the sensor measured by ECU is out of the target range	Short cut to battery or open load.	Check sensor and if necessary replace it, check connection cable and if necessary repair or replace it.
110	4	97	225	Coolant temperature sensor: the voltage of the sensor measured by ECU is out of the target range	Voltage Surveillance has found shortcut to Ground at Coolant Temperature Sensor.	Check sensor and if necessary replace it, check connection cable and if necessary repair or replace it Measure Voltage at Coolant Temperature Sensor and renew harness if needed.
111	1	101	235	Coolant level: the coolant level calculated by ECU is underneath the allowed minimum.	Coolant level too low, leakage in cooling system, sensor defective, wiring damaged.	Check coolant level, inspect cooling system for leakage and if necessary repair it, check sensor and wiring
157	3	877	147	Rail pressure sensor: the voltage of sensor measured by ECU is out of the target range.	Short cut to battery. Damaged rail pressure sensor.	Check cabling, check rail pressure sensor and if necessary replace it, check connection cable and if necessary repair or replace it.
157	4	878	147	Rail pressure sensor: the voltage of sensor measured by ECU is out of the target range.	Check cabling, check rail pressure sensor and if necessary replace it, check connection cable and if necessary repair or replace it.	Check cabling, check rail pressure sensor and if necessary replace it, check connection cable and if necessary repair or replace it.
164	2	1381	839	Rail pressure safety function is not executed correctly	Rail pressure is still above threshold.	Threshold for error detection is an internal ECU threshold. Reset the fault and at reappearance check ECU and injection system
168	0	1180	318	Battery voltage: the voltage measured by ECU is out of the target range	Battery voltage over limit	Check alternator, regulator of alternator and if necessary replace it, check wiring and voltage of alternator
168	1	1181	318	Battery voltage: the voltage measured by ECU is out of the target range	Battery voltage below limit	Check alternator, cabling, contact resistance, safety fuses, too high load in energy system, check battery and if necessary replace it

Table 3-13. Engine Fault Codes (Deutz Engine)

SPN	FMI	Deutz Code	Blink Code	Description	Possible Cause	Action
168	2	47	318	Battery voltage: the voltage measured by ECU is out of the target range, system reaction is initiated	If Battery voltage (Ubatt_U) > 17V or 31V for more than =0.5sec a warning is generated Battery voltage above warning threshold	Check wiring harness and connected alternator.
168	3	45	318	Battery voltage: the voltage measured by ECU is out of the target range, system reaction is initiated	Battery voltage above warning threshold (~38,9Volt), Short cut to battery possible.	Check wiring harness and connected alternator.
168	4	46	318	Battery voltage: the voltage measured by ECU is out of the target range, system reaction is initiated	Battery voltage below warning threshold, Short cut to ground	Check wiring harness and connected alternator.
171	3	417	312	Sensor error SCR-System environment temperature; DPF-System air inlet temperature; signal range check high	open loop to sensor	Check cabling, if environment temperature sensor is not working, check sensor and if necessary replace it, check connection cable and if necessary repair or replace it.
171	4	418	312	Sensor error SCR-System environment temperature; DPF-System air inlet temperature; signal range check low	short circuit to Ground	Check cabling, if environment temperature sensor is not working, check sensor and if necessary replace it, check connection cable and if necessary repair or replace it
172	0	1425	226	sensed intake air temperature at air filter > physical high limit	sensed intake air temperature at air filter > physical high limit	Check outside conditions: Temperature > Threshold within the intake air system of the engine? E.G: engine sucks in air from hot asphalt out of paver bucket Sensor positioned within black air filter housing above engine lid at hot environmental conditions and idling or similar? => if yes check with application team to adapt limits if not check sensor and wiring harness exchange sensor
172	1	1183	226	sensed air temperature within air intake path of engine below physical low limit	sensed air temperature within air intake path of engine below physical low limit	Cold start and ambient temperature < threshold Check wiring harness to AFST-sensor Exchange AFST-sensor
190	0	389	214	Engine speed: the engine speed calculated by ECU is above the target range; the ECU activates a system reaction	Overspeed monitoring during 1 level of FOC (Failure overrun condition) if engine speed was over Limit.	check powertrain settings regarding overspeed
190	2	421	213	ECU measures a deviation between camshaft and crankshaft angle to target.	Offset error between crankshaft and camshaft.	Threshold for error detection is an internal ECU threshold, occurs by offset between crankshaft and camshaft. Check increment wheel position, clean and adjust if necessary, check sensor position. Check Camshaft and Crankshaft sensor or wiring.
190	8	419	212	Camshaft speed sensor: the ECU receives no signal and uses the signal from crankshaft speed sensor as alternative to calculate the engine speed	When disturbed camshaft signal detected. Error in sensor or wiring.	Threshold for error detection is an internal ECU threshold, occurs by disturbed camshaft signal. Check increment wheel position, clean and adjust if necessary, check sensor position. Check Camshaft Sensor or wiring.

SECTION 3 - CHASSIS & TURNTABLE

Table 3-13. Engine Fault Codes (Deutz Engine)

SPN	FMI	Deutz Code	Blink Code	Description	Possible Cause	Action
190	8	422	212	Sensor crankshaft speed; disturbed signal	Error in sensor or wiring. Crankshaft sensor defect.	Threshold for error detection is an internal ECU threshold, occurs by disturbed crankshaft signal. Check increment wheel position, clean and adjust if necessary, check sensor position. Check Crankshaft Sensor or wiring.
190	11	390	214	Engine speed: the engine speed calculated by ECU is above the target range; the ECU activates a system reaction	Overspeed monitoring during 2 level of FOC (Failure overrun condition) if engine speed was over limit.	check powertrain settings regarding overspeed
190	12	420	212	Camshaft speed sensor: the ECU receives no signal and uses the signal from camshaft speed sensor as alternative to calculate the engine speed Threshold:	Error in sensor or wiring.	Threshold for error detection is an internal ECU threshold, occurs by disturbed or no camshaft signal. Check increment wheel position, clean and adjust if necessary, check sensor position. Check Camshaft Sensor or wiring.
190	12	423	212	Crankshaft speed sensor: the ECU receives no signal and uses the signal from camshaft speed sensor as alternative to calculate the engine speed.	Error in sensor or wiring.	Threshold for error detection is an internal ECU threshold, occurs by disturbed or no Crankshaft signal. Check increment wheel position, clean and adjust if necessary, check Crankshaft sensor position or wiring.
190	14	391	214	Engine speed: the engine speed calculated by ECU is above the target range; the ECU activates a system reaction	Overspeed monitoring during ORC (Override conditions) if engine speed was over 2900rpm	check powertrain settings regarding overspeed
190	14	1222	2-1-2	Camshaft- and Crankshaft speed sensor signal not available on CAN or defect.	Sensors for engine speed are defect.	Threshold for error detection is an internal ECU threshold. Check wiring, check cables and repair or replace if necessary.
411	0	791	693	delta pressure across venturi in EGR line above physical high limit	sensed value of venturi difference pressure > high limit	Threshold for error detection is an internal ECU threshold. EGR-Valve blocked open EGR-Valve actuator defect EGR-cooler defect (check for coolant water) Reed Valve defect Intake throttle blocked in closed position => Check intake throttle Exhaust pressure too high => Check Exhaust pressure Check Nox-sensor upstream SCR catalyst dp venturi sensor defect
411	1	792	693	delta pressure across venturi in EGR line below physical low limit	sensed value of venturi difference pressure < low limit	Threshold for error detection is an internal ECU threshold. Check correct mounting of difference pressure sensor at venturi tube Exchange difference pressure sensor broken
411	3	795	693	The sensed raw voltage Air_uRawPEGRDeltaP is above the maximum threshold.	EGR Delta pressure Sensor defect	Check cabling, if charge EGR Delta pressure sensor is not working, check sensor and if necessary replace it, check connection cable and if necessary repair or replace it.
411	4	381	693	Range check cannot be done or interrupted.	EGR or wiring defect	Check wiring harness and connected EGR.

Table 3-13. Engine Fault Codes (Deutz Engine)

SPN	FMI	Deutz Code	Blink Code	Description	Possible Cause	Action
411	4	796	693	The sensed raw voltage value Air_uRawPEGRDeltaP is above the minimum threshold.	EGR Delta pressure Sensor defect	Check cabling. If charge EGR Delta pressure sensor is not working, check sensor and if necessary replace it, check connection cable and if necessary repair or replace it.
411	11	793	693	DFC is stored in EEPROM and status kept until check is allowed to be carried out again DFC can be reset by service routine 216	deviation between desired O2 concentration in intake air manifold and the real O2-concentration within intake air manifold > limit	Threshold for error detection is an internal ECU threshold. EGR-Valve mechanically blocked open or closed EGR-pipe blocked with metall plate instead sealing downstream EGR-Valve EGR-Valve actuator defect EGR-cooler defect (check for coolant water) Reed Valve defect Intake throttle blocked in closed position => Check intake throttle Exhaust pressure too high => Check Exhaust pressure Check Nox-sensor upstream SCR catalyst dp venturi sensor defect
412	3	1007	682	EGR downstream temperature sensor: the voltage of sensor measured by ECU is out of the target range.	Short circuit to battery. sensor voltage > limit	Check wiring harness to TEGR-sensor. Exchange TEGR-sensor.
412	4	1008	682	EGR downstream temperature sensor: the voltage of sensor measured by ECU is out of the target range.	Short circuit to ground or open load. sensor voltage < limit	Check wiring harness to TEGR-sensor. Exchange TEGR-sensor.
630	12	376	281	Internal hardware monitoring: the ECU finds an error during the access to its EEPROM memory or works with an alternative value	Section could not be erased	Threshold for error detection is an internal ECU threshold. There is no healing possible for the error. In the every new initialization phase, the debounce level is set to zero. If not programmed, EEPROM is defect --> ECU is defect, reprogramm ECU and if necessary replace it.
630	12	377	281	Internal hardware monitoring: the ECU finds an error during the access to its EEPROM memory or works with an alternative value	Minimum 3 blocks could not be readed, EEPROM has Checksum Error	There is no healing possible for the error. In the every new initialization phase, the debounce level is set to zero. If not programmed, EEPROM is defect --> ECU is defect, reprogramm ECU and if necessary replace it
630	12	378	281	Internal hardware monitoring: the ECU finds an error during the access to its EEPROM memory or works with an alternative value	Block could not be written for minimum 3 times	Threshold for error detection is an internal ECU threshold. If not programmed, EEPROM is defect --> ECU is defect, reprogramm ECU and if necessary replace it.
639	14	84	271	CAN bus 0: the ECU is not allowed to send messages, because the status "BusOff" is detected.	CAN BusOff error; CAN 0 (Customer CAN)	Threshold for error detection is an internal ECU threshold. BusOff bit for CAN A node is set. Check wiring of CAN bus and if necessary repair it, check connection cable and if necessary repair or replace it, check resistance in CAN lines (120 Ohm)

Table 3-13. Engine Fault Codes (Deutz Engine)

SPN	FMI	Deutz Code	Blink Code	Description	Possible Cause	Action
651	3	580	154	Injector cyl. 1: the current drop measured by ECU is above the target range	Suspected Components: injector cylinder 1 wiring harness, cable break or short circuit, sensor defective, connection cable damaged	Threshold for error detection is an internal ECU threshold. Check wiring harness, injectors and if necessary repair/replace it. Use SerDia Injector test for diagnosis.
651	5	568	154	Injector cyl. 1: interruption of electrical connection	Interruption of electronic connection Injector cyl. 1	Threshold for error detection is an internal ECU threshold. Check wiring harness, injectors and if necessary repair/replace it.
652	3	581	155	Injector cyl. 2: the current drop measured by ECU is above the target range	Suspected Components: injector cylinder 2 wiring harness, cable break or short circuit, sensor defective, connection cable damaged	Threshold for error detection is an internal ECU threshold. Check wiring harness, injectors and if necessary repair/replace it. Use SerDia Injector test for diagnosis.
652	5	569	155	Injector cyl. 2: interruption of electrical connection	Interruption of electronic connection Injector cyl. 2	Threshold for error detection is an internal ECU threshold. Check wiring harness, injectors and if necessary repair/replace it.
653	3	582	156	Injector cyl. 3: the current drop measured by ECU is above the target range	Suspected Components: injector cylinder 3 wiring harness, cable break or short circuit, sensor defective, connection cable damaged	Threshold for error detection is an internal ECU threshold. Check wiring harness, injectors and if necessary repair/replace it. Use SerDia Injector test for diagnosis.
653	5	570	156	Injector cyl. 3: interruption of electrical connection	Interruption of electronic connection Injector cyl. 3	Threshold for error detection is an internal ECU threshold. Check wiring harness, injectors and if necessary repair/replace it.
654	3	583	161	Injector cyl. 4: the current drop measured by ECU is above the target range	Suspected Components: injector cylinder 4 wiring harness, cable break or short circuit, sensor defective, connection cable	Threshold for error detection is an internal ECU threshold. Check wiring harness, injectors and if necessary repair/replace it. Use SerDia Injector test for diagnosis.
654	5	571	161	Injector cyl. 4: interruption of electrical connection	Interruption of electronic connection Injector cyl. 4	Threshold for error detection is an internal ECU threshold. Check wiring harness, injectors and if necessary repair/replace it.
655	3	584	162	Injector cyl. 5: the current drop measured by ECU is above the target range	Suspected Components: injector cylinder 5 wiring harness, cable break or short circuit, sensor defective, connection cable	Threshold for error detection is an internal ECU threshold. Check wiring harness, injectors and if necessary repair/replace it. Use SerDia Injector test for diagnosis.
655	5	572	162	Injector cyl. 5: interruption of electrical connection	Interruption of electronic connection Injector cyl. 5	Threshold for error detection is an internal ECU threshold. Check wiring harness, injectors and if necessary repair/replace it.
656	3	585	163	Injector cyl. 6: the current drop measured by ECU is above the target range	Suspected Components: injector cylinder 6 wiring harness, cable break or short circuit, sensor defective, connection cable	Threshold for error detection is an internal ECU threshold. Check wiring harness, injectors and if necessary repair/replace it. Use SerDia Injector test for diagnosis.

Table 3-13. Engine Fault Codes (Deutz Engine)

SPN	FMI	Deutz Code	Blink Code	Description	Possible Cause	Action
656	5	573	163	Injector cyl. 6: interruption of electrical connection	Interruption of electronic connection Injector cyl. 6	Threshold for error detection is an internal ECU threshold. Check wiring harness, injectors and if necessary repair/replace it.
676	11	543	263	Cold start aid relay error.	Relay defect or wire harness problem	Threshold for error detection is an internal ECU threshold. check wire harness, replace relay
676	11	544	263	Cold start aid relay open load	Relay or wire harness	Threshold for error detection is an internal threshold. check wire harness, replace relay
677	3	956	512	Start relay (high side power stage): the current drop measured by ECU is above the target range.	Short cut HighSide-output to battery.	Threshold for error detection is an internal ECU threshold. Check cabling and start relay and if necessary replace it, check connection cable and if necessary repair or replace it.
677	3	960	512	Start relay (low side power stage): the current drain measured by ECU is above the target range.	Shortcut LowSide-Output to battery.	Threshold for error detection is an internal ECU threshold. Check cabling and start relay and if necessary replace it, check connection cable and if necessary repair or replace it.
677	4	957	512	Start relay (high side power stage): the current drain measured by ECU is above the target range.	Shortcut HighSide-output to ground.	Threshold for error detection is an internal ECU threshold. Check cabling and start relay and if necessary replace it, check connection cable and if necessary repair or replace it.
677	4	961	512	Start relay (low side power stage): the current drop measured by ECU is above the target range.	Shortcut LowSide-Output to ground.	Threshold for error detection is an internal ECU threshold. Check cabling and start relay and if necessary replace it, check connection cable of terminal 50 and if necessary repair or replace it.
677	5	958	512	Start relay (low side power stage): the current drop measured by ECU is above the target range	Open circuit/disconnection LowSide-Output.	Threshold for error detection is an internal ECU threshold. Check cabling and start relay and if necessary replace it, check connection cable and if necessary repair or replace it.
677	12	959	512	Start relay (low side power stage): the current drop measured by ECU is above the target range.	Temperature over limit.	Threshold for error detection is an internal ECU threshold. Check cabling and start relay and if necessary replace it, check connection cable and if necessary repair or replace it.
691	8	928	928	Supply module heater: PWM time periode out of valid range.	PWM signal for temperature readout from supply module to the control unit is out of range. Supply modul defect, fault in the wiring.	The Time period of the received PWM signal SCR_ttiSMPerPwm is within the specified range of 150ms to 250ms Supply module check and replace if necessary. Check the wiring.

Table 3-13. Engine Fault Codes (Deutz Engine)

SPN	FMI	Deutz Code	Blink Code	Description	Possible Cause	Action
729	3	549	263	wiring to the intake air heater device is faulty.	Intake Air Heater Device: overload, short-circuit	Threshold for error detection is an internal ECU threshold. Electrical error, Check wiring to the intake air heater device.
729	4	551	263	wiring to the air intake heater is faulty	Relay (for cold start aid) cable break or short to ground:	Threshold for error detection is an internal ECU threshold. Electrical error, check wiring to the air intake heater.
729	5	545	263	The cold start aid relay is according to wiring faulty.	Relay defect or wire harness problem	Threshold for error detection is an internal ECU threshold. Electrical error, check wires
729	12	547	263	The cold start aid relay is overheated, which causes this error	High temperature around the cold start relay.	Check the functionality of relay and replace it if needed. Check the temperature around the cold start relay during worst case operation.
898	9	305	118	TimeoutErrorofCAN-Receive-FrameTSC1TE-active	Timeout Error (Missing CAN Bus message)	Check CAN Bus cabling (Bus shedding, polarity, short circuit, power interrupt), test protocol of receiver, check CAN functional range.
1079	13	946	282	Internal hardware monitoring: the ECU detects a deviation of the target range of the power supply voltage of sensor output 1.	Suspected components EDC17cv52 Pin A19: DEF press / Exh.PressBeforeTurb (P3) / Air Pump Press / BrnFuelPressAfterDV2 Pin K19: Fan Speed Sensor Pin A21: LDF6T / OilPress / LowFuelPress Pin A17: Rail Pressure Sensor Suspected components EDC17cv54 Pin A21: CAM speed Pin K44: Delta Press Venturi / Poti EGR or Inlet Throttle Pin A24: LDF6T / OilPress / LowFuelPressPin K43: Reserve 5V Sensor Supply Pin A09: second footpedal Suspected components EDC17cv56 Pin A21: Cam speed Pin K44: DEF press / Air FilterDiffPress Pin A24: LDF6T / OilPress / LowFuelPress Pin K43: second footpedal Pin A09: Delta Press Venturi	Check cabling of external components, check working voltage and if necessary correct it, check connection cable and if necessary repair or replace it, if error is not removable, change ECU.
1080	13	947	282	Internal hardware monitoring: the ECU detects a deviation of the target range of the power supply voltage of sensor output 2.	Suspected components EDC17cv52 Pin K16: second footpedal Pin A20: Exh.PressAfterTurb/DPFDiffPress/ BrnDV1Press/HCIPressDV1DV2 Suspected components EDC17cv54 Pin K45: DPF Diff Press / Exh. Press After Turb / Fan Speed Sensor Pin A46: first footpedal Suspected components EDC17cv56 Pin A22: Fan Speed Sensor Pin K45: Position EGR or Intake throttle flap Pin K46: First footpedal	Check cabling of external components, check working voltage and if necessary correct it, check connection cable and if necessary repair or replace it, if error is not removable, change ECU.

Table 3-13. Engine Fault Codes (Deutz Engine)

SPN	FMI	Deutz Code	Blink Code	Description	Possible Cause	Action
1109	2	121	341	Request of engine shut off: the operator ignores the engine shut off request within an allowed period.	Engine Shut Off demand has been ignored by the user	Depending on error requested a shut off.
1136	0	1398	681	ECU internal temperature; temperature measured by ECU is out of the target range	Short-Circuit in ECU, ECU heated by hot air	Close warm air circuits, replace ECU
1231	14	85	271	CAN bus 1: the ECU is not allowed to send messages, because the status "BusOff" is detected Warning, no diagnostic with SERDIA2010 possible	CAN BusOff error; CAN 1 (Diagnostic CAN)	Threshold for error detection is an internal ECU threshold. BusOff bit for CAN B node is set. Check wiring of CAN bus and if necessary repair it, check connection cable and if necessary repair or replace it, check resistance in CAN lines (120 Ohm)
1235	14	86	271	CAN bus 2: the ECU is not allowed to send messages, because the status "BusOff" is detected. Warning, depends on engine, EAT.	CAN BusOff error; CAN 2 (Engine CAN)	Threshold for error detection is an internal ECU threshold. BusOff bit for CAN C node is set. Check wiring of CAN bus and if necessary repair it, check connection cable and if necessary repair or replace it, check resistance in CAN lines (120 Ohm)
1237	2	747	145	Override switch switch: the ECU receives a permanent signal.	Switch is blocked, taster locked, connection cable damaged plausibility error "override switch > 250ms pressed".	If the Block Button is pressed shorter than the Maximum Plausible pressing Time. Check cabling, if sensor is not working, check switch and if necessary replace it, check connection cable and if necessary repair or replace it.
1761	0	1593	129	The urea tank level sensor detects a value higher than the maximum allowed threshold	Suspected components: Urea Quality Sensor defect mechanical defect at the float gauge	Check level sensor and float gauge
1761	1	1594	129	The DEF tank level sensor detects a value lower than the minimum allowed threshold	Suspected components: Urea Quality Sensor defect mechanical defect at the float gauge	Check level sensor and float gauge
1761	14	1655	138	The urea tank volume ratio is below the threshold of <5%	actual urea tank level SCRUTnk_rVol_mp [%] is below applicable threshold 5%	Check urea level => if empty, then fill in urea Check DEF level sensor. If there is urea in the tank, then move the floater of the level sensor. The floater must be free. If you lift the sensor body, then SCRUTnk_rVol_mp must change. Exchange DEF level sensor, if no change of value or it's implausible.
1761	14	1656	138	The urea tank volume ratio is below the threshold of <2.5%	actual urea tank level SCRUTnk_rVol_mp [%] is below 2.5%	Check urea level => if empty, then fill in urea Check DEF level sensor. If there is urea in the tank, then move the floater of the level sensor. The floater must be free. If you lift the sensor body, then SCRUTnk_rVol_mp must change. Exchange DEF level sensor, if no change of value or it's implausible.

Table 3-13. Engine Fault Codes (Deutz Engine)

SPN	FMI	Deutz Code	Blink Code	Description	Possible Cause	Action
1761	14	1880	138	The DEF tank level is below the threshold.	actual DEF tank level SCRUTnk_rVol_mp [%] is below the threshold	Check DEF level => if empty, refill Check DEF level sensor. If there is urea in the tank loose the sensor and move it. The floater must be free and move if you lift the sensor body. SCRUTnk_rVol_mp must change. Compare SCRUTnk_rVol_mp to: 1 = SCR_rawUTnkLvl 2 = SCR_rAdapUtnkLvl 3 = SCRUTnk_rActTnkVol *SCRUTnk_facVolPer_mp In case of malfunction, exchange DEF level sensor.
2791	0	1763	415	Internal actuator temperature is above threshold.	Overheating of EGR actuator during operation.	Let EGR actuator cool down and check heat accumulation during worst case operation.
2791	2	1753	415	corrupted CAN communication with actuator.	CAN bus error or faulty EGR actuator.	Threshold for error detection is an internal ECU threshold. Check other CAN bus components. If no message is sent, fix the wiring. If o.k. exchange EGR actuator.
2791	3	1758	415	Overvoltage at EGR actuator.	High voltage from the battery	Check battery voltage.
2791	4	1759	415	Undervoltage at EGR actuator.	Low voltage from the battery.	Check battery voltage.
2791	6	1757	415	Overcurrent to EGR actuator.	High voltage from battery. EGR actuator is blocked or moving very hard.	Check battery voltage. Check if EGR is blocked or not running smoothly. If everything is o.k. change EGR actuator.
2791	7	1752	415	EGR actuator is mechanically blocked.	EGR actuator faulty or blocked.	Threshold for error detection is an internal ECU threshold. Check the EGR actuator and EGR valve to mechanical blockage / clean. Check for free movement of the valve. If it's blocked, then exchange the EGR valve.
2791	7	1761	415	EGR actuator spring broken.	mechanical damage of spring due to overstress.	Threshold for error detection is an internal ECU threshold. Exchange EGR actuator.
2791	12	1755	415	Internal electrical fault of EGR actuator.	Internal damage of EGR actuator due to high temperature or electrical wiring issue.	Threshold for error detection is an internal ECU threshold. Exchange EGR actuator.
2791	13	1754	415	EGR actuator can not learn stop positions. Possibly only second failure if other EGRTV failures occur.	Error detection during the learning process.	Threshold for error detection is an internal ECU threshold. Start Serdia Usecase to reset EGR actuator. Check EGR valve and mounting situation. If o.k. change EGR actuator.
2791	13	1756	415	EGR actuator can not learn stop positions because procedure was interrupted.	Interruption of learning process due to mechanical damage.	Threshold for error detection is an internal ECU threshold. Start Serdia Usecase to reset EGR actuator.
2791	13	1760	415	Stop positions of EGR valve not o.k.	Mechanical damage of EGR actuator. EGR valve is blocked or moving very hard.	Threshold for error detection is an internal ECU threshold. Start Serdia Usecase to reset EGR actuator.
2791	16	1762	415	Internal actuator temperature above threshold.	overheating of EGR actuator	Let EGR actuator cool down, check heat accumulation during worst case operation.

Table 3-13. Engine Fault Codes (Deutz Engine)

SPN	FMI	Deutz Code	Blink Code	Description	Possible Cause	Action
2797	4	1337	565	Injector diagnosis: Timeout of Injetor detection cylinder bank 0	Short-Circuit to ground on component wiring	Threshold for error detection is an internal ECU threshold. Check wiring, component, ECU Note: affected injector has to be evaluated according to firing order
2797	4	1339	565	Injector test: Short cut to ground on cylinder bank 0	Short-Circuit to ground on component wiring	Check wiring, component, ECU Note: affected injector has to be evaluated according to firing order
2798	4	1338	566	Injector diagnosis: Timeout of Injetor detection cylinder bank 1	Short-Circuit to ground on component wiring	Threshold for error detection is an internal ECU threshold. Check wiring, component, ECU Note: affected injector has to be evaluated according to firing order
2798	4	1340	566	Injector test: Short cut to ground on cylinder bank 1	Short-Circuit to ground on component wiring	Check wiring, component, ECU Note: affected injector has to be evaluated according to firing order
3031	0	1135	669	The urea tank temperature sensor detects a value above the maximum allowed threshold	Sensed urea tank temperature > physical range high limit	Case "CANBUS sensor": Check urea tank temperature: really hot? Check CANBus-message of DEF sensor urea tank temperature Com_dRxSCR2Byt2 Compare it to Com_dRxSCR1Byt1 (urea temperature at quality sensor) identical? Tank heater permantly on? Check wiring of DEF-quality sensor Case "analog DEFT & Level sensor": Check urea tank temperature: really hot? Check urea tank temperature SCR_tSensUTnkT Compare urea tank temperature to EnvT_tor to SCR_tSMT (the urea temperature inside the supply module) identical? Tank heater permantly on? Check wiring of analog DEFT & Level sensor
3031	1	1136	669	The urea tank temperature sensor detects a value lower than the minimum allowed threshold.	sensed urea tank temperature < physical range low limit	Case "CANBUS sensor": Check ambient temperature EnvT_t=> About -40 °C? If yes Error could be plausible Check CANBus-message of DEF sensor urea tank temperature Com_dRxSCR2Byt2 Compare it to Com_dRxSCR1Byt1 (urea temperature at quality sensor) identical? Check wiring of DEF-quality sensor Check quality sensor Case "analog DEFT & Level sensor": Check urea tank temperature: really that cold? Check ambient temperature EnvT_t=> About -40 °C? If yes Error could be plausible Check urea tank temperature SCR_tSensUTnkT Check wiring of analog DEFT & Level sensor Check analog DEFT & Level sensor
3224	2	129	596	DLC Error of CAN-Receive-Frame AT1IG1Vol NOX Sensor (SCR-system upstream cat; DPF-system downstream cat); length of frame incorrect	Not Used	Threshold for error detection is an internal ECU threshold. Check Nox-Sensor and the wiring from CAN-BUS.

SECTION 3 - CHASSIS & TURNTABLE

Table 3-13. Engine Fault Codes (Deutz Engine)

SPN	FMI	Deutz Code	Blink Code	Description	Possible Cause	Action
3224	9	130	597	Timeout Error of CAN-Receive-Frame AT1IG1Vol; NOX sensor (SCR-system upstream cat; DPF-system downstream cat)	Failure of the CAN Bus message	NOX sensor and sensor connection check
3234	2	138	114	DLC Error of CAN-Receive-Frame AT101Vol NOX Sensor (SCR-system downstream cat; DPF-system downstream cat); length of frame incorrect	Failure of the CAN Bus message	NOX downstream sensor and sensor connection check
3234	9	139	117	Timeout Error of CAN-Receive-Frame AT10G1Vol; NOX sensor (SCR-system downstream cat; DPF-system downstream cat)	Failure of the CAN Bus message	NOX downstream sensor and sensor connection check
3361	3	1077	677	Urea dosing valve (low side power stage): the current drain measured by ECU is above the target range	Fault in the wiring	Threshold for error detection is an internal ECU threshold See substitute function Check the wiring
3361	3	1078	677	Urea dosing valve (high side power stage): the current drain measured by ECU is above the target range	Fault in the wiring	Threshold for error detection is an internal ECU threshold Check the wiring
3361	4	1079	677	Urea dosing valve (low side power stage): the current drain measured by ECU is above the target range	Fault in the wiring	Check the wiring
3361	4	1080	677	Urea dosing valve (high side power stage): the current drain measured by ECU is above the target range	Fault in the wiring	Threshold for error detection is an internal ECU threshold Check the wiring
3361	6	1075	677	Urea dosing valve: the current measured value by ECU at the end of the injection is too high	Fault in the wiring Defect urea dosing injection valve	Check wiring Check the urea dosing injection valve
3519	3	1898	277	The integrated diagnostic of the temperature sensor of the Urea Quality Sensor recognized a short circuit to battery. The UQS Sensor is a combined sensor of tank temperature, filling grade and DEF quality and it is also an CAN sensor --> no PIN	Wrong diagnostic of the short circuits logic inside the temperature sensor of the UQS CAN Communication corrupted	Check the wiring to the suction unit in the DEF tank. Check the CAN bus communication of the suction unit. In case the communication is corrupt, exchange the suction unit.
3519	4	1899	277	The integrated diagnostic of the temperature sensor of the Urea Quality Sensor recognized a short circuit to ground	DEF quality sensor in the suction unit of the DEF tank is defect CAN Communication corrupted	Check the wiring to the suction unit of the DEF tank. Check the CAN bus communication from the suction unit. In case the signal is corrupt, exchange the suction unit in the DEF tank.

Table 3-13. Engine Fault Codes (Deutz Engine)

SPN	FMI	Deutz Code	Blink Code	Description	Possible Cause	Action
3519	12	1895	277	The integrated temperature sensor of the Urea Quality Sensor measures higher temperature than threshold	Temperature sensor inside the UQS defect. CAN Communication corrupted. Overheating of the DEF tank due to malfunction of the heating valve. Flow direction of coolant is wrong due to mixed up the hoses routed to the heating valve. Overheating of the DEF tank due to heat transfer from neighbor parts.	Check the temperature sensor signal for plausibility. In case of improper signal, exchange the suction unit in the tank. Check CAN bus communication for proper signal. In case of improper signal, exchange the suction unit in the tank. Check the function of heating valve and routing of the hoses. The coolant flow through the heating valve must be observed according to the shown arrow. In case all actions above are OK, check the real temperature in the DEF tank during worst case condition and improve the installation of the DEF tank.
3519	13	1908	277	Temperature at UQS out of range the specified thresholds; invalid quality of the temperature	Suspected Components Tank heater DEF sensor	Check temperature system and/or DEF quality sensor
3520	2	1904	2-7-8	Measured DEF Quality from UQS is too low. Quality value received from UQS is < 22% for a certain time and a certain number or for measuring conditions not observed for a certain time.	Suspected components: Urea quality sensor defect Wrong installation (measuring air) Urea level sensor defect Non urea filled in tank CANBUS problems Evaluation conditions for new quality check not fulfilled after one previous mal detection	Check that there is liquid urea of known quality in the tank first Check urea tank level. Add urea until level is at least 10 cm above sensor. Ensure that urea is not frozen / sufficient urea is liquid Check Sensor: Are urea tank temperature and level displayed? Changes the level if you refill urea? Check electrical connection Check CANBus New quality detection is carried out if urea refill is detected or if an quality evaluation was triggered and was not finished successfully: To provoke a quality measurement: refill urea, at least 10 % of tank volume Wait until quality evaluation was carried out, can take up to 30 minutes => check value. It should be about 33 % Exchange quality sensor
3520	3	1896	278	The integrated diagnostic of the Urea Quality Sensor recognized a short circuit to battery	wiring harness of UQS corrupted CAN Communication corrupted	Threshold for error detection is an internal ECU threshold. Check the wiring harness from the ECU to the suction unit of the DEF tank Check the CAN bus communication. If the signal is corrupt, then exchange the suction unit.
3520	4	1897	278	The integrated diagnostic of the Urea Quality Sensor recognized a short circuit to ground.	wiring harness to the suction unit in the DEF tank is corrupted CAN Communication corrupted	Threshold for error detection is an internal ECU threshold. Check the wiring to the suction unit in the DEF tank. Check the CAN bus communication. In case the communication is corrupt, exchange the suction unit in the DEF tank.

SECTION 3 - CHASSIS & TURNTABLE

Table 3-13. Engine Fault Codes (Deutz Engine)

SPN	FMI	Deutz Code	Blink Code	Description	Possible Cause	Action
3520	13	1907	278	Urea quality at UQS out of range the specified thresholds; invalid quality of the urea quality	Suspected components DEF quality sensor DEF	Check DEF quality and/or DEF quality sensor
3532	3	1911	127	The urea quality value from the sensor is greater than the maximum physical range threshold Comment: tank temperature is measured by the UQS sensor	Suspected Components: UQS defect	Check DEF quality and/or sensor.
3532	4	1912	127	The urea quality value from the sensor is lower than the minimum physical range threshold.	Suspected Components: UQS defect	Check DEF quality and/or Sensor.
3711	12	1455	711	Temperature Phy_tPFWgh, the weighted DPF temperature < Threshold 1 Temperature Phy_tPFWgh, the weighted DPF temperature > Threshold 2 towards the end of the stand-still main phase.	temperature Phy_tPFWgh, the weighted DPF temperature, is below or above the target temperature towards the end of the stand-still main phase.	Check temperature upstream DOC Exh_tSensOxiCatUs within Stand-still: > 450 °C? If not: => Check air path of engine: EGR-Valve, Intake-Throttle, Turbocharger and Piping each for leakage and correct function Check temperature difference across DOC by Exh_tSensOxiCatDs - Exh_tSensOxiCatUs within Stand-still: < 100°C? If not: Check exhaust pipe downstream turbo charger for oil? check injectors: is an injector got stuck? Too many hydrocarbons in exhaust? White smoke (at hot EAT system, not at cold start)? Check air path of engine: EGR-Valve, Intake-Throttle, Turbocharger and Piping each for leakage and correct function Check exhaust gas temperature sensors within EAT-system: T upstream DOCC, T downstream DOC & T upstream SCR catalyst all three of them can influence Phy_tPFWgh
3936	14	1917	2-8-6	Standstill escalation by time. In case the standstill request will not be released within 50 h by the driver this fault code will be set.	Stand-still request ignored by the operator. Display / stand-still request lamp broken.	Perform Stand-still. If soot load level of DPF has increased too high already call service to perform stand-still. In case the DPF soot load level remove DPF => Exchange DPF.
4334	0	1122	665	The absolute pressure value of the urea pump is greater than an applicable maximal filtered pressure threshold	Suspected Components: Urea pump defect Supply module pressure sensor defect Pump contains dirty parts	Check the urea pump Check the supply module pressur sensor Clean the urea pump (filter)
4334	1	1123	665	Urea supply module pressure sensor: The absolute pressure value of the urea pump is less than an applicable minimal filtered pressure threshold	Check the urea pump Check the supply module pressur sensor Clean the urea pump (filter)	Check the urea pump Check the supply module pressur sensor Clean the urea pump (filter)

Table 3-13. Engine Fault Codes (Deutz Engine)

SPN	FMI	Deutz Code	Blink Code	Description	Possible Cause	Action
4334	2	1866	665	absolute difference of sensed urea pump pressure (SCR_pAbsSensUPmpP) and ambient pressure (EnvP_p) > limit abs(UPmpP_pDiffPmpEnv_mp) > UPmpP_pDiffPmpEnv_C (250 hPa)	absolute difference of sensed urea pump pressure (SCR_pAbsSensUPmpP) and ambient pressure (EnvP_p) > limit abs(UPmpP_pDiffPmpEnv_mp) > UPmpP_pDiffPmpEnv_C	Check environment pressure sensor (EnvP_p) => plausible value? Engine shut-off and immediately re-started? => Shut-off again. Wait until after run of ECU has finished, re-Start engine Back-flow line free? Does the urea pump pressure show values < 1000 hPa in SCR state emptying (64)? Check revision valve => Does the urea pump pressure show values < 1000 hPa in SCR state emptying (64)? => exchange supply module Supply module pressure sensor defect => exchange supply module
4341	3	1104	675	Urea heater supply line: the current drain measured by ECU is above the target range	Electrical error	Threshold for error detection is an internal ECU threshold Check wire harness Check supply line
4341	4	1105	675	Urea heater supply line: the current drain measured by ECU is above the target range	Electrical error	Threshold for error detection is an internal ECU threshold Check wire harness Check supply line
4341	5	1102	675	Urea heater supply line: the current drain measured by ECU is above the target range	Electrical error	Threshold for error detection is an internal ECU threshold Check wire harness Check supply line
4343	3	1096	673	Urea pressure line heater: the current drain measured by ECU is above the target range	shortcut to battery If this error detected during the heating phase is a result error: KWP 1089 broken heating element in pressure line	Threshold for error detection is an internal ECU threshold Check wiring Check heating element
4343	4	1097	673	Urea pressure line heater: the current drain measured by ECU is above the target range	Shortcut to ground If this error detected during the heating phase is a result error: KWP 1089 Short cut to ground or broken wiring, broken heating element in pressure line	Threshold for error detection is an internal ECU threshold Check wiring Check heating element
4343	5	1094	673	Urea pressure line heater: the current drain measured by ECU is above the target range	Open load If this error detected during the heating phase is a result error: KWP 1089 Broken wiring, broken heating element in pressure line	Threshold for error detection is an internal ECU threshold Check wiring Check heating element
4345	3	1092	674	Urea backflow line heater: the current drain measured by ECU is above the target range	Shortcut to battery If this error detected during the heating phase is a result error: KWP 1089 Short cut to battery or broken wiring, broken heating element in backflow line	Threshold for error detection is an internal ECU threshold Check wiring Check heating element
4345	4	1093	674	Urea backflow line heater: the current drain measured by ECU is above the target range	Shortcut to ground If this error detected during the heating phase is a result error: KWP 1089 Short cut to ground or broken wiring, broken heating element in backflow line	Threshold for error detection is an internal ECU threshold Check wiring Check heating element

Table 3-13. Engine Fault Codes (Deutz Engine)

SPN	FMI	Deutz Code	Blink Code	Description	Possible Cause	Action
4345	5	1090	674	Urea backflow line heater: the current drain measured by ECU is above the target range	Open load If this error detected during the heating phase is a result error: KWP 1089 Broken wiring, broken heating element in back-flow line	Threshold for error detection is an internal ECU threshold Check wiring Check heating element
4360	0	1069	668	The filtered urea cat upstream temperature is greater than an applicable maximum temperature threshold	Sensed temperature upstream SCR > physical high limit	Check temperature difference across DOC (Exh_tOxiCatDs-Exh_tOxiCatUs) at higher engine load => high difference > 100 K? If yes, the engine emits too many Hydrocarbons => check injectors: is an injector got stuck? => Check EGR Valve If difference normal the exhaust out of the engine itself is too hot: => Check air path of engine: EGR-Valve, Intake-Throttle, Turbocharger and Piping each for leakage and correct function If that error was set while stand-still operation the error source could be exothermal soot burn off in DPF (which should not happen) => Dismount DPF and check it visually exchange temperature sensor upstream SCR
4360	1	1070	668	The filtered temperature before urea cat is less than an applicable minimum temperature threshold	Sensed temperature upstream SCR catalyst < than physical low limit	Cold start and ambient temperature < Threshold? Missdetection? Check wiring harness to UCatUsT-sensor Exchange UCatUsT-sensor
4360	2	1865	668	Error at static plausibility check: absolut temperature difference of sensed temperature upstream SCR catalyst and ambient temperature > as static plausibility limit at engine cold start (engine was off for at least 8 h), temperature upstream of SCR catalyst is expected to be identical to ambient temperature => see enable conditions for details. Error at dynamic plausibility check: temperature difference of sensed temperature upstream SCR catalyst and ambient temperature < as dynamic plausibility limit dynamic check is blocked if static plausibility check is already faulty => Temperature upstream SCR catalyst must be by 40°C higher than ambient temperature if engine runs and a certain delay time has expired.	Error at static plausibility check: absolut temperature difference of sensed temperature upstream SCR catalyst and ambient temperature > as static plausibility limit at engine cold start (engine was off for at least 8 h), temperature upstream of SCR catalyst is expected to be identical to ambient temperature => see enable conditions for details. Error at dynamic plausibility check: temperature difference of sensed temperature upstream SCR catalyst and ambient temperature < as dynamic plausibility limit dynamic check is blocked if static plausibility check is already faulty => Temperature upstream SCR catalyst must be by 40°C higher than ambient temperature if engine runs and a certain delay time has expired.	Check whether temperature sensor upstream of SCR catalyst is physically mounted within exhaust pipe If cold start condition can be made sure (engine was off for at least 8 h) compare values of EnvT_t, EngDa_tEng, Exh_tOxiCatUs, Exh_tOxiCatDs and SCR_tSensUCatUsT at ignition on, without starting the engine. All identical? Compare values of Exh_tOxiCatUs, Exh_tOxiCatDs and SCR_tSensUCatUsT after 15 min in constant operation point: show all similar values (30 K tolerance width). Are ambient temperature and (EnvT_t), cooling water temperature (EngDa_tEng) plausible? Sensor coated with urea crystals? Dismount urea injector and inspect temperature sensor upstream SCR catalyst visually Check wiring of sensor Replace sensor
4361	3	1072	668	Urea catalyst upstream temperature sensor: the voltage of sensor measured by ECU is out of the target range	Voltage of temperature sensor upstream SCR catalyst > maximum limit Short circuit to battery	Check sensor Check wiring Replace UCatUsT-sensor
4361	4	1073	668	Urea catalyst upstream temperature sensor: the voltage of sensor measured by ECU is out of the target range	Voltage of temperature sensor upstream SCR catalyst < minimum limit Short circuit to ground	Check sensor Check wiring Replace UCatUsT-sensor

Table 3-13. Engine Fault Codes (Deutz Engine)

SPN	FMI	Deutz Code	Blink Code	Description	Possible Cause	Action
4365	2	1137	6-6-9	Signal error in case of Urea tank temperature transmitted via CAN-signal Com_tUTnKT.	CAN message is not send properly.	Check sensor connector Check CANbus
4365	3	1138	6-6-9	Urea tank temperature sensor: he current drain measured by ECU is above the target range.	Shortcut or open load.	Threshold for error detection is an internal ECU threshold. The Sensed raw voltage value SCR_uRawUTnKT is below SCR_SRCUTnKT.uMax_C. Check wiring.
4365	3	1914	669	Internal error of DEF quality sensor.	Suspected componetes: DEF quality sensor Wiring harness	Check wiring harness and DEF quality sensor
4365	4	1139	6-6-9	Urea tank temperature sensor: he current drain measured by ECU is above the target range.	Shortcut or open load.	Threshold for error detection is an internal ECU threshold. The sensed raw voltage value SCR_uRawUTnKT is above SCR_SRCUTnKT.uMin_C. Check wiring.
4365	4	1915	6-6-9	Internal error of DEF quality sensor.	Suspected componetes: DEF quality sensor Wiring harness	Check wiring harness and DEF quality sensor
4366	3	1112	671	Urea tank heating valve: the current drain measured by ECU is above the target range	Shortcut to battery If this error detected during the heating phase is a result error: KWP 1089 Broken wiring Urea tank heating valve defect	Threshold for error detection is an internal ECU threshold Check wiring Check urea tank heating valve
4366	4	1113	671	Urea tank heating valve: the current drain measured by ECU is above the target range	Shortcut to ground If this error detected during the heating phase is a result error: KWP 1089 Broken wiring Urea tank heating valve defect	Threshold for error detection is an internal ECU threshold Check wiring Check urea tank heating valve
4366	5	1110	671	Urea tank heating valve: the current drain measured by ECU is above the target range	Open load If this error detected during the heating phase is a result error: KWP 1089 Broken wiring Urea tank heating valve defect	Threshold for error detection is an internal ECU threshold Check wiring Check urea tank heating valve
4375	3	1120	666	Urea supply module pump: the current drain measured by ECU is above the target range	Shortcut to battery If this error detected during the heating phase is a result error: KWP 1089 Broken wiring Pump in urea supply module defect	Threshold for error detection is an internal ECU threshold The hardware detects absence of any short circuit to battery on the PWM output power stage for the urea pump module actuator Check wiring Check pump in the urea supply module
4375	4	1121	666	Urea supply module pump: the current drain measured by ECU is above the target range	Shortcut to ground If this error detected during the heating phase is a result error: KWP 1089 Broken wiring Pump in urea supply module defect	Threshold for error detection is an internal ECU threshold The hardware detects a short circuit to ground error on the PWM output power stage for the UreaPump Module Motor Actuator. The error is updated by setting bit 1 of measuring point UPmp-Mot_stPrev1stRslt_mp Check wiring Check pump in the urea supply module

SECTION 3 - CHASSIS & TURNTABLE

Table 3-13. Engine Fault Codes (Deutz Engine)

SPN	FMI	Deutz Code	Blink Code	Description	Possible Cause	Action
4375	5	1118	666	Urea supply module pump: the ECU can not measure any reaction during pump control	Open load Broken wiring Pump in urea supply module defect	Threshold for error detection is an internal ECU threshold The hardware detects the presence of load on the PWM output power stage for the urea pump module actuator. Check wiring Check pump in the urea supply module
4376	3	1131	667	Urea supply module reversal valve: the current drain measured by ECU is above the target range	Shortcut to battery Fault in the wiring Reversal valve in the urea supply module defect	Threshold for error detection is an internal ECU threshold Check wiring Check urea supply modul
4376	4	1132	667	Urea supply module reversal valve: the current drain measured by ECU is above the target range	Shortcut to ground Fault in the wiring Reversal valve in the urea supply module defect	Threshold for error detection is an internal ECU threshold Check wiring Check urea supply modul
4376	5	1129	667	Urea supply module reversal valve: the current drain measured by ECU is above the target range	Open load Fault in the wiring Reversal valve in the urea supply module defect	Threshold for error detection is an internal ECU threshold Check wiring Check urea supply modul
4765	0	1039	683	The exhaust temperature value from the sensor before DOC is above an applicable upper shutoff threshold TOxiCatUs_tShOffThresHiAds_C = Threshold 1 in Normal and Heatmodes (TOxiCatUs_tShOffThresHiRgn_C = Threshold 2 in stand-still)	sensed temperature upstream DOC > shut-off limit	Check air path of engine: EGR-Valve, Intake-Throttle, Check Turbocharger and Piping each for leakage and correct function Check injectors: is an injector got stuck? Exchange temperature sensor upstream DOC
4765	0	1040	683	The exhaust temperature value from the sensor before DOC is above an applicable upper warning threshold TOxiCatUs_tWarnThresHi_C = Threshold	Sensed temperature upstream DOC > warning limit	Check air path of engine: EGR-Valve, Intake-Throttle, Turbocharger and Piping each for leakage and correct function Check injectors: is an injector got stuck? Exchange temperature sensor upstream DOC

Table 3-13. Engine Fault Codes (Deutz Engine)

SPN	FMI	Deutz Code	Blink Code	Description	Possible Cause	Action
4768	2	1036	683	<p>Static plausibility check: The exhaust temperature value from the sensor before DOC, the exhaust temperature value from the sensor after DOC, the temperature value from the sensor before SCR-Cat, the environment temperature and the coolant engine temperature their ratios to each other exceed their related thresholds.</p> <p>Dynamic plausibility check with environment temperature sensor value: The exhaust temperature value from the sensor before DOC is lower than an applicable environment temperature threshold</p>	<p>Static plausibility check: The exhaust temperature value from the sensor before DOC, the exhaust temperature value from the sensor after DOC, the temperature value from the sensor before SCR-Cat, the environment temperature and the coolant engine temperature their ratios to each other exceed their related thresholds. (difference between temperature after DOC and temperature before DOC > Threshold 1 difference between temperature before DOC and before SCR > Threshold 2 difference between temperature after DOC and before SCR < Threshold 3 difference between temperature after DOC and ambient temperature < Threshold 4 difference between temperature ambient temperature and engine temperature < Threshold 5)</p> <p>Dynamic plausibility check with environment temperature sensor value: The exhaust temperature value from the sensor before DOC is lower than an applicable environment temperature threshold (< environmental temperature + Threshold 6)</p>	<p>Check ambient temperature => value plausible? upstream DOC sensor mounted within exhaust line? T upstream DOC sensor physically mounted in correct position upstream DOC? (not upstream SCR or downstream DOC?) Check T upstream DOC sensor Check other T-sensors within EAT-system (Exh_tOxiCatDs & UCatUsT_tFt_mp show plausible values? No errors on them?</p>
4768	2	1881	683	<p>At engine cold start conditions the sensed exhaust gas temperature downstream DOC (Exh_tSensTOxiCatDs) has exceeded the sum of ambient temperature (EnvT_t) + offset (40°C) earlier than the sensed exhaust gas temperature upstream of DOC (Exh_tSensTOxiCatUs).</p> <p>The check is only performed once each ignition cycle and only if the start is judged a cold start.</p> <p>Error status is frozen for that ignition cycle. No healing possible.</p>	<p>Difference temperature of exhaust gas temperature downstream DOC and fixed ambient temperature at ignition on exceeds a certain limit earlier than the difference temperature of exhaust gas temperature upstream DOC and fixed ambient temperature at ignition on.</p>	<p>Check whether all exhaust gas temperature sensors within the EAT system are mounted properly: Within the exhaust line and at correct positions. Check the position of the sensor upstream SCR which might be physically mounted in the wrong position. If cold start condition can be made sure (engine was off for at least 8 h) compare values of EnvT_t, EngDa_tEng, Exh_tOxiCatUs, Exh_tOxiCatDs and SCR_tSensUCatUsT at ignition on, without starting the engine. All identical? Then the sensors itself are okay. Check exhaust piping for leakage. Check wiring of sensors Replace sensors Check DOC => physically intact?</p>
4768	3	1044	683	<p>Oxidation catalyst upstream temperature sensor: the voltage of sensor measured by ECU is out of the target range</p>	<p>The sensed raw voltage value Exh_uRawTOxiCatUs is above Exh_SRCTOxiCatUs.uMax_C Shortcut to battery</p>	<p>Check wiring harness to temperature sensor upstream DOC Exchange temperature sensor upstream DOC</p>
4768	4	1045	683	<p>Oxidation catalyst upstream temperature sensor: the voltage of sensor measured by ECU is out of the target range</p>	<p>The sensed raw voltage value Exh_uRawTOxiCatUs is below Exh_SRCTOxiCatUs.uMin_C Shortcut to ground</p>	<p>Check wiring harness to temperature sensor upstream DOC Exchange temperature sensor upstream DOC</p>

SECTION 3 - CHASSIS & TURNTABLE

Table 3-13. Engine Fault Codes (Deutz Engine)

SPN	FMI	Deutz Code	Blink Code	Description	Possible Cause	Action
5763	3	1024	594	Actuator of the external EGR valve: the ECU detects a short circuit to battery or open load.	Short cut to battery or open loop.	Check cabling, actuator defect, check actuator and if necessary replace it, check connection cable and if necessary repair or replace it.
5763	3	1226	594	Actuator EGR-valve: short cut to battery is detected	Short-Circuit to battery on component wiring	Threshold for error detection is an internal ECU threshold. Check wiring, component, ECU Check repair with SerDia 2010 use case
5763	3	1227	594	Actuator EGR-valve: short cut to battery on ECU pin is detected	Short-Circuit to battery on component wiring	Threshold for error detection is an internal ECU threshold. Check wiring, component, ECU Check repair with SerDia 2010 use case
5763	4	1025	594	Actuator of the external EGR valve: the ECU detects a short circuit to ground.	Short cut to ground	Check cabling, actuator defect, check actuator and if necessary replace it, check connection cable and if necessary repair or replace it.
5763	4	1228	594	Actuator EGR-valve: short cut to ground on ECU pin is detected	Short-Circuit to ground on component wiring	Threshold for error detection is an internal ECU threshold. Check wiring, component, ECU Check repair with SerDia 2010 use case
5763	4	1229	594	Actuator EGR-valve: short cut to battery on ECU pin is detected	Short-Circuit to ground on component	Threshold for error detection is an internal ECU threshold. Check wiring, component, ECU Check repair with SerDia 2010 use case
5763	4	1232	5-9-4	Actuator error EGR-Valve (2.9;3.6) or Throttle-Valve (4.1;6.1;7.8); Voltage below threshold 3.6) Drosselklappe (4.1;6.1;7.8); Voltage below threshold;	Monitoring for CY146 Under Voltage.	Threshold for error detection is an internal ECU threshold. Check wiring, component
5763	5	1023	5-9-4	Actuator error EGR-Valve; signal range check low, measured current is below target	Short circuit to ground.	Check wiring, check cables and repair or replace if necessary, check actuator with SERDIA 2010 test for EGR and if necessary replace it.
5763	6	1014	594	Actuator error EGR-Valve. Signal range check high.	Short cut to batterie.	Check wiring and repair or replace if necessary, check actuator with SERDIA test for EGR and if necessary replace it.
5763	6	1022	5-9-4	Actuator error EGR-Valve; signal range check high, measured current by ECU is over target	Short circuit to battery or open circuit.	Check cabling, actuator defect, check actuator and if necessary replace it, check connection cable and if necessary repair or replace it.
5763	6	1223	594	Actuator EGR-Valve: Open load on ECU output is detected	Open circuit on component wiring	Threshold for error detection is an internal ECU threshold. Check wiring, component, ECU Check repair with SerDia 2010 use case
5763	6	1224	594	Actuator EGR-valve: too high current is going into the actuator. Output is switched off	Overload on component wiring	Threshold for error detection is an internal ECU threshold. Check wiring, component, ECU Check repair with SerDia 2010 use case

Table 3-13. Engine Fault Codes (Deutz Engine)

SPN	FMI	Deutz Code	Blink Code	Description	Possible Cause	Action
5763	6	1230	5-9-4	Actuator error EGR-valve; Overload by short-circuit	Short Circuit over Load	Threshold for error detection is an internal ECU threshold. Check wiring, component
5763	7	1016	594	Actuator position for EGR valve is not plausible, internal error, angular misalignment of the flap.	Position error of throttle flap (deviation > 7%).	Threshold for error detection is an internal ECU threshold. Threshold for error detection, deviation from setpoint > 7%. Troubleshooting with SERDIA 2010 Use Case "EGR Diagnostic".
5763	11	1231	5-9-4	Power stage overtemperature due to high current.	Temperature dependent Over Current	Threshold for error detection is an internal ECU threshold. Check wiring, component
520521	5	1015	594	Actuator error EGR-Valve. Signal range check low.	Short cut to ground.	Check wiring and repair or replace if necessary, check actuator with SERDIA test for EGR and if necessary replace it.
523009	9	825	253	The pressure relief valve (PRV) has reached the number of allowed activations.	Rail pressure has exceeded the trigger threshold of the pressure limiting valve.	Replace pressure relief valve (PRV) and reset fault with Serdia.
523009	10	833	2-5-3	The pressure relief valve (PRV) has reached the allowed opening time.	Rail pressure has exceeded the trigger threshold of the pressure limiting valve.	Replace pressure relief valve (PRV) and reset fault with Serdia.
523212	9	171	3-3-3	Timeout Error of CAN-Receive-Frame ComEngPrt; Engine Protection	Timeout Error (Missing CAN Bus message)	Check wiring harness and customer devices
523240	9	179	527	Timeout CAN-message FunModCtl; Function Mode Control	Timeout Error (Missing CAN Bus message)	Check CAN Bus cabling (Bus scheduling, polarity, short circuit, power interrupt), test protocol of receiver, check CAN functional range.
523350	4	565	151	Injector cylinder bank 1: the current drop measured by ECU is above the target range	Short circuit injection bank 1 (all injectors of this bank can be affected)	Threshold for error detection is an internal ECU threshold. Check wiring harness, injectors and if necessary repair/replace it.
523352	4	566	152	Injector cylinder bank 2: the current drop measured by ECU is above the target range	Short circuit injection bank 2 (all injectors of this bank can be affected)	Threshold for error detection is an internal ECU threshold. Check wiring harness, injectors and if necessary repair/replace it.
523354	12	567	153	Internal hardware monitoring: the ECU detects an error of its injector high current output. Chip of CY33x defect power stage components	Defective powerstage in ECU	Threshold for error detection is an internal ECU threshold. If error is not removable, change ECU.
523450	4	839	1-4-3	Diagnostic fault check for min error of COM message.	The sensed raw value is less than the threshold.	Check cabling, check sensor and if necessary replace it, check connection cable and if necessary repair or replace it.
523470	2	826	146	The pressure relief valve (PRV) has been opened due to excessive pressure.	Rail pressure has exceeded the trigger threshold of the pressure limiting valve.	Threshold for error detection is an internal ECU threshold. Reset the fault and at reappearance check injection system.
523470	2	827	146	The pressure relief valve (PRV) has been opened due to excessive pressure.	Rail pressure has exceeded the trigger threshold of the pressure limiting valve.	Threshold for error detection is an internal ECU threshold. Reset the fault and at reappearance check injection system.

SECTION 3 - CHASSIS & TURNTABLE

Table 3-13. Engine Fault Codes (Deutz Engine)

SPN	FMI	Deutz Code	Blink Code	Description	Possible Cause	Action
523470	7	876	146	Rail pressure is out of the expected average range.	Rail pressure is out of the expected average range. PRV can not be opened.	(A) Check rail pressure relief valve and replace if necessary. (B) Check high pressure pumps, pressure relief valve and metering unit. (C) Change components if necessary
523470	11	831	146	Rail pressure relief valve can not be opened due to the rail pressure.	Rail pressure out of tolerance range (PRV can not be opened by a pressure peak in this operating point)	Threshold for error detection is an internal ECU threshold. Check rail pressure, check rail pressure sensor for plausibility, check FCU.
523470	11	832	146	Rail pressure is out of the expected average range. The PRV can not be opened at this operating point with a pressure shock.	Averaged rail pressure is outside the expected tolerance range.	Threshold for error detection is an internal ECU threshold. Check PRV and replace if necessary.
523470	12	828	146	Rail pressure relief valve: is open. Shutoff conditions.	Shut Off after PRV Open	Threshold for error detection is an internal ECU threshold. Check PRV opening counter and if necessary replace PRV, check rail-pressure sensor for plausibility and if necessary replace it, check FCU and if necessary replace it.
523470	12	829	146	Rail pressure relief valve is open. Warning conditions.	Warning PRV open	Threshold for error detection is an internal ECU threshold. Check PRV opening counter and if necessary replace PRV, check rail-pressure sensor for plausibility and if necessary replace it, check FCU and if necessary replace it.
523470	14	830	146	Rail pressure relief valve is open. (PRV)	Open PRV	Threshold for error detection is an internal ECU threshold. Only after ECU reset. Check PRV opening counter and if necessary replace it, check rail-pressure sensor for plausibility and if necessary replace it, check FCU and if necessary replace it.
523550	12	980	515	Terminal 50 was operated for more than 2 minutes. This may happen due to short to battery or wrong usage of Terminal 50. Starter control is disabled until this error is healed.	Start information to Starter (T50-switch) erratic/defect.	Threshold for error detection is an internal ECU threshold. Check cabling, if sensor not working, check start switch and if necessary replace it, check connection cable and if necessary repair or replace it.
523601	13	948	282	Internal hardware monitoring: the ECU detects a deviation of the target range of the power supply voltage of sensor output 3.	Suspected components EDC17cv52 Pin A18: DeltaPressVenturi / Position intake throttle flap Pin K20: First footpedal Pin K21: Air FilterDiffPress Suspected components EDC17cv54 and cv56 Pin A07: Rail pressure	Check cabling of external components, check working voltage and if necessary correct it, check connection cable and if necessary repair or replace it, if error is not removable, change ECU.
523612	3	644	555	supply voltage too high	not used	Threshold for error detection is an internal ECU threshold.

Table 3-13. Engine Fault Codes (Deutz Engine)

SPN	FMI	Deutz Code	Blink Code	Description	Possible Cause	Action
523612	4	646	555	supply voltage too low	not used	Threshold for error detection is an internal ECU threshold.
523612	12	387	555	Internal hardware monitoring: the CPU of the ECU is reset and the cause is logged internally; no item will be created in error memory	Injector shut off demand for the ICO coordinator System responses: not	Threshold for error detection is an internal ECU threshold. Caution! Sequence error, check error memory for other errors.
523612	12	612	555	Internal hardware monitoring: the CPU of the ECU is reset and the cause is logged internally; no item will be created in error memory.	Plausibility check failed (MoCADC_uNTP_mp is higher than MoCADC_uNTPMax_C).	Threshold for error detection is an internal ECU threshold. If error is still present, exchange ECU.
523612	12	613	555	Internal hardware monitoring: the CPU of the ECU is reset and the cause is logged internally; no item will be created in error memory	Analysis of test voltage (Value is out of the target -> ECU internal error)	Threshold for error detection is an internal ECU threshold. Check wiring, check connected sensors actuators. If error is still present, exchange ECU.
523612	12	614	555	Internal hardware monitoring: the CPU of the ECU is reset and the cause is logged internally; no item will be created in error memory	Analysis of the ratiometric correction (Value is out of the target -> ECU internal error)	Threshold for error detection is an internal ECU threshold. Check wiring, check connected sensors actuators. If error is still present, exchange ECU.
523612	12	615	555	Internal hardware monitoring: the CPU of the ECU is reset and the cause is logged internally; no item will be created in error memory	Error report due to an error in the plausibility of Function Coordination (FC) and Monitoring Modul (MM) (ECU internal error)	Threshold for error detection is an internal ECU threshold. If error is still present, exchange ECU.
523612	12	616	555	Internal hardware monitoring: the CPU of the ECU is reset and the cause is logged internally; no item will be created in error memory	Error report due to an interrupted SPI communication (ECU internal error)	Threshold for error detection is an internal ECU threshold. If error is still present, exchange ECU.
523612	12	617	555	Internal hardware monitoring: the CPU of the ECU is reset and the cause is logged internally; no item will be created in error memory	multiple error in complete ROM-test during postdrive detected (ECU internal error)	Threshold for error detection is an internal ECU threshold. If error is still present, exchange ECU.
523612	12	618	555	Internal hardware monitoring: the CPU of the ECU is reset and the cause is logged internally; no item will be created in error memory	Too less bytes received by monitoring memory from CPU as response (ECU internal error). Loss of synchronization sending bytes to the monitoring memory from CPU	Threshold for error detection is an internal ECU threshold. If error is still present, exchange ECU.
523612	12	619	555	Internal hardware monitoring: the CPU of the ECU is reset and the cause is logged internally; no item will be created in error memory	Suspected components: Injector ECU wiring harness/connector	Threshold for error detection is an internal ECU threshold. If error is still present, exchange ECU.
523612	12	620	555	Internal hardware monitoring: the CPU of the ECU is reset and the cause is logged internally; no item will be created in error memory	Error trying to set MM Response time (ECU internal error)	Threshold for error detection is an internal ECU threshold. If error is still present, exchange ECU.
523612	12	621	555	Internal hardware monitoring: the CPU of the ECU is reset and the cause is logged internally; no item will be created in error memory	Error detected in the internal ECU communication, Too many SPI errors during MoCSOP execution	Threshold for error detection is an internal ECU threshold. If error is still present, exchange ECU.

Table 3-13. Engine Fault Codes (Deutz Engine)

SPN	FMI	Deutz Code	Blink Code	Description	Possible Cause	Action
523612	12	623	555	Internal hardware monitoring: the CPU of the ECU is reset and the cause is logged internally; no item will be created in error memory	Error in the check of the shut-off path test of the under voltage detection (ECU internal error). Diagnostic fault check to report the error in undervoltage monitoring	Threshold for error detection is an internal ECU threshold. If error is still present, exchange ECU.
523612	12	624	555	Internal hardware monitoring: the CPU of the ECU is reset and the cause is logged internally; no item will be created in error memory	Error in the check of the shut-off path of the monitoring module (ECU internal error).	Threshold for error detection is an internal ECU threshold. If error is still present, exchange ECU.
523612	12	625	555	Internal hardware monitoring: the CPU of the ECU is reset and the cause is logged internally; no item will be created in error memory	Time out error trying to set or cancelling the alarm task (ECU internal error). Failure setting the alarm task period	Threshold for error detection is an internal ECU threshold. If error is still present, exchange ECU.
523612	12	627	555	Internal hardware monitoring: the CPU of the ECU is reset and the cause is logged internally; no item will be created in error memory	Error in time monitoring of the shut-off path test (ECU internal error). Diagnostic fault check to report the timeout in the shut off path test	Threshold for error detection is an internal ECU threshold. If error is still present, exchange ECU.
523612	12	628	555	Internal hardware monitoring: the CPU of the ECU is reset and the cause is logged internally; no item will be created in error memory	Error in the check of the shut-off path test of the over voltage detection (ECU internal error). Diagnostic fault check to report the error in overvoltage monitoring	Threshold for error detection is an internal ECU threshold. If error is still present, exchange ECU.
523612	12	629	555	The two voltage values (ADC_VAL1, ADC_VAL2), detected by the accelerator pedal, are not plausible to each other.	Defect pedal or wiring	Threshold for error detection is an internal ECU threshold. Check Pedal, repair or exchange the Pedal. Check wiring. If error is still present, exchange ECU.
523612	12	630	555	Impermissible offset between the engine speed of level 2 and level 1	Calculated engine speed in level 1/2 implausible (-> ECU internal error).	Threshold for error detection is an internal ECU threshold. If error is still present, exchange ECU.
523612	12	631	555	Diagnostic fault check to report the plausibility error between level 1 energizing time and level 2 information	Implausible injection energizing time for either Pilx or MI1 or Polx.	Threshold for error detection is an internal ECU threshold. If error is still present, exchange ECU.
523612	12	632	555	Error in the plausibility of the start of energising angles	Implausible start of energising of either Pilx or MI1 or Polx.	Threshold for error detection is an internal ECU threshold. If error is still present, exchange ECU.
523612	12	633	555	Error in the plausibility of the energising times of the zero fuel quantity calibration	The energising times of the zero fuel quantity calibration ZFC is out of the target. (-> ECU internal error)	Threshold for error detection is an internal ECU threshold. If error is still present, exchange ECU.
523612	12	634	555	Error in the plausibility of Pol2 efficiency.	Error in the plausibility of Pol2 efficiency.	Threshold for error detection is an internal ECU threshold. If error is still present, exchange ECU.
523612	12	635	555	Error in the Pol2 shut-off.	Error in the Pol2 shut-off.	Threshold for error detection is an internal ECU threshold. If error is still present, exchange ECU.
523612	12	636	555	Error in the plausibility of Pol3 efficiency.	Error in the plausibility of Pol3 efficiency.	Threshold for error detection is an internal ECU threshold. If error is still present, exchange ECU.

Table 3-13. Engine Fault Codes (Deutz Engine)

SPN	FMI	Deutz Code	Blink Code	Description	Possible Cause	Action
523612	12	637	555	Engine speed: the engine speed calculated by ECU is above the target range; the ECU activates a system reaction	Error in the plausibility of current energising time with maximum permitted energising time. Diagnostic fault check to report the error due to Over Run	Threshold for error detection is an internal ECU threshold. If error is still present, exchange ECU.
523612	12	638	555	Error in the plausibility of the wave correction parts	Error in the plausibility of the wave correction parts	Threshold for error detection is an internal ECU threshold. If error is still present, exchange ECU.
523612	12	639	555	Plausibility error of the Rail pressure sensor	In case the gradient of rail pressure is larger than the max threshold or lesser than the min threshold. Rail metering unit defect. Leakage in the Rail System.	Threshold for error detection is an internal ECU threshold. Check metering unit or cable. Check Rail pressure. Check the Rail System of leakage.
523612	12	640	555	Error in the torque comparison between permissible engine torque and current actual torque	Error in the torque comparison between the permissible inner engine torque and the current plausible actual torque.	Threshold for error detection is an internal ECU threshold. If error is still present, exchange ECU.
523612	12	641	555	Diagnosis of curr path limitation forced by ECU monitoring level 2	The torque comparison is not plausible with the torque monitoring.	Threshold for error detection is an internal ECU threshold. If error is still present, exchange ECU.
523612	12	642	555	Diagnosis of lead path limitation forced by ECU monitoring level 2	The setpoint path of the air system is limited by the limitation torque of the functional control unit monitoring.	Threshold for error detection is an internal ECU threshold. If error is still present, exchange ECU.
523612	12	643	555	Diagnosis of set path limitation forced by ECU monitoring level 2.	If the quantity setpoint is exceeds the limit of the torque function.	Threshold for error detection is an internal ECU threshold. If error is still present, exchange ECU.
523612	12	714	555	Error report "WDA wire is active" due to a defect query/response communication	Error detection by monitoring module	Threshold for error detection is an internal ECU threshold. Software reset.
523612	12	715	555	Error report "ABE wire is active" due to undervoltage detection	The reason is that a slow dropping of the vehicle electrical system voltage (defective autobattery) should not lead the ECU OCWDA's diagnose to enter an error in the fault memory due to an undervoltage recognition.	Threshold for error detection is an internal ECU threshold. Software reset.
523612	12	716	555	Error report "ABE/WDA wire is active" due to overvoltage detection	If the ABE/WDA powerstage shut-off is active due to an overvoltage detection.	Threshold for error detection is an internal ECU threshold. software reset.
523612	12	717	555	Error report "ABE/WDA active" due to an unknown reason	The reason is that a slow dropping of the vehicle electrical system voltage (defective autobattery) should not lead the ECU OCWDA's diagnose to enter an error in the fault memory due to an undervoltage recognition.	Threshold for error detection is an internal ECU threshold. Software reset.
523612	12	1170	555	Internal hardware monitoring: the CPU of the ECU is reset and the cause is logged internally; no item will be created in error memory	Error during positive test (ECU internal error). Diagnostic fault check to report that the positive test failed	Threshold for error detection is an internal ECU threshold. Reflash ECU. If error is still activ replace ECU.

Table 3-13. Engine Fault Codes (Deutz Engine)

SPN	FMI	Deutz Code	Blink Code	Description	Possible Cause	Action
523612	12	1857	555	Fault in the monitoring during the engine start. Start requested in level 1, but not released in level 2 which leads to no fuel injection.	wiring is not according DEUTZ requirements engine start conditions are not observed low battery voltage during start malfunction of starter	Threshold for error detection is an internal ECU threshold. check other active errors and fix them. check all needed engine start conditions, e.g. neutral switch. check the engine speed during starting of the engine. If it's too low, then check the battery voltage and then check the starter for malfunction.
523612	14	973	555	Internal hardware monitoring: the CPU of the ECU is reset and the cause is logged internally; no item will be created in error memory.	Visibility of Software resets in DSM	Threshold for error detection is an internal ECU threshold.
523612	14	974	555	Internal hardware monitoring: the CPU of the ECU is reset and the cause is logged internally; no item will be created in error memory.	Visibility of Software resets in DSM	Threshold for error detection is an internal ECU threshold.
523612	14	975	555	Internal hardware monitoring: the CPU of the ECU is reset and the cause is logged internally; no item will be created in error memory	Visibility of Software Resets in DSM	Threshold for error detection is an internal ECU threshold. If possible the software update has to be done. Replace the ECU.
523613	0	856	134	Rail pressure: the fuel pressure in rail calculated by ECU is below the target range which is dependant on the engine speed.	Pressure governor deviation exceeds the limiting value based on the engine speed.	Threshold for error detection is an internal ECU threshold. (A) Check for leakage (B) Check fuel-primary pressure (C) Change components, check sensor and if necessary replace it, check fuel system and if necessary repair it
523613	0	857	134	Rail pressure: the fuel pressure in rail calculated by ECU is below the target range which is dependant on the engine speed.	maximum positive deviation of rail pressure exceeded concerning set flow of fuel.	Threshold for error detection is an internal ECU threshold. (A) Check for leakage (B) Check fuel-primary pressure (C) Change components, check sensor and if necessary replace it, check fuel system and if necessary repair it
523613	0	858	134	Rail pressure: the fuel pressure in rail calculated by ECU is above the target range which is dependant on the engine speed.	leakage is detected based on fuel quantity balance.	Threshold for error detection is an internal ECU threshold. (A) Check backflow pressure (B) Check Injector function with SerDia (C) Change components (metering unit, injector) if necessary
523613	0	859	134	Rail pressure: the fuel pressure in rail calculated by ECU is above the target range which is dependant on the engine speed.	Maximum negative rail pressure deviation with metering unit on lower limit is exceeded.	Threshold for error detection is an internal ECU threshold. (A) Check backflow pressure (B) Check Injector function with SerDia (C) Change components (metering unit, injector) if necessary
523613	0	862	134	Rail pressure: the fuel pressure in rail calculated by ECU is above the target range.	Rail pressure exceeds the limiting value.	(A) Check backflow pressure (B) Check pressure relief valve and metering unit. (C) Change components if necessary

Table 3-13. Engine Fault Codes (Deutz Engine)

SPN	FMI	Deutz Code	Blink Code	Description	Possible Cause	Action
523613	1	861	134	Rail pressure: the fuel pressure in rail calculated by ECU is below the target range which is dependant on the engine speed.	Rail pressure falls below the limiting value based on the engine speed.	Threshold for error detection is an internal ECU threshold. (A) Check backflow pressure (B) Check Injector function with SerDia (C) Change components (metering unit, injector) if necessary
523613	2	864	134	Rail pressure metering unit, Setpoint of metering unit in overrun mode not plausible.	Pressure pump delivery quantity in overrun exceeds the threshold based on the pressure.	Threshold for detection is an internal ECU threshold. (A) Check backflow pressure (B) Check pressure relief valve and metering unit. (C) Change components if necessary
523615	3	594	135	Fuel metering unit: the current drain measured by ECU is above the target range	short circuit to battery high side	Threshold for error detection is an internal ECU threshold. Check wiring harness and metering unit if necessary repair/replace it.
523615	3	596	135	Fuel metering unit: the current drain measured by ECU is above the target range	short circuit to battery low side	Threshold for error detection is an internal ECU threshold. Check wiring harness and metering unit if necessary repair/replace it.
523615	4	595	135	Fuel metering unit: the current drain measured by ECU is above the target range	short circuit to ground high side	Threshold for error detection is an internal ECU threshold. Check wiring harness and metering unit if necessary repair/replace it.
523615	4	597	135	Fuel metering unit: the current drain measured by ECU is above the target range	short circuit to ground low side	Threshold for error detection is an internal ECU threshold. Check wiring harness and metering unit if necessary repair/replace it.
523615	5	592	135	Detecting an open load fault in the metering unit	wiring harness defective, cable break	Threshold for error detection is an internal ECU threshold. Check wiring harness and metering unit if necessary repair/replace it.
523615	12	593	135	powerstage of metering unit is overheated	over temperature	Threshold for error detection is an internal ECU threshold. Check functionality of metering unit and replace it if needed. Check temperature of metering unit and improve the installation in case of overheating.
523632	3	1127	665	Urea supply module pressure sensor: the current drain measured by ECU is above the target range	Shortcut to battery Broken wiring Pressure sensor in urea supply module defect	Check wiring Check pressure sensor in urea supply module
523632	4	1128	665	Urea supply module pressure sensor: the current drain measured by ECU is above the target range The sensed raw voltage value SCR_uRawUPmpP is above SCR_SRCUPmpP.uMin_C	Shortcut to ground Broken wiring Pressure sensor in urea supply module defect	Check wiring Check pressure sensor in urea supply module
523632	11	1117	666	Urea supply module pump: the current drain measured by ECU is above the target range	When the pump motor does not switch to pump actuation mode after temperature measurement has been carried out.	Threshold for error is an internal ECU threshold

SECTION 3 - CHASSIS & TURNTABLE

Table 3-13. Engine Fault Codes (Deutz Engine)

SPN	FMI	Deutz Code	Blink Code	Description	Possible Cause	Action
523698	11	122	591	Shut off request from supervisory monitoring function	Engine Shut Off due to supervisory function	Threshold for error detection is an internal ECU threshold. Check error memory for additional errorcode to find root cause. Depending on additional error follow the documented "Take action for repair".
523718	3	1100	676	Urea heater relay: the current drain measured by ECU is above the target range	Shortcut to battery If this error detected during the heating phase it is a result error: KWP 1089 Broken wiring, broken relay	Threshold for error detection is an internal ECU threshold Check wiring Check SCR main relay
523718	4	1101	676	Urea heater relay: the current drain measured by ECU is above the target range	Shortcut to ground If this error detected during the heating phase it is a result error: KWP 1089 Broken wiring, broken relay	Threshold for error detection is an internal ECU threshold Check wiring Check SCR main relay
523718	5	1098	676	Urea heater relay: the current drain measured by ECU is above the target range	Open load If this error detected during the heating phase it is a result error: KWP 1089 Broken wiring broken relay	Threshold for error detection is an internal ECU threshold Test SCR main relay Check cabling, if necessary replace relay.
523719	4	1109	672	Urea supply module heater: the current drain measured by ECU is above the target range	Shortcut to ground If this error detected during the heating phase it is a result error: KWP 1089 Broken wiring Heating element in supply module defect	Threshold for error detection is an internal ECU threshold Check wiring Check cabling, if necessary replace supply module
523719	5	1106	672	Urea supply module heater: the current drain measured by ECU is above the target range	Open load If this error detected during the heating phase it is a result error: KWP 1089 Broken wiring Heating element in supply module defect	Threshold for error detection is an internal ECU threshold Check wiring Check cabling, if necessary replace supply module
523720	8	925	148	Supply module heater: Duration of switch on is too long.	uty cycle for temperature readout from supply module heater to the control unit is out of range; Supply modul defect, fault in the wiring.	When the received supply module heater temperature duty cycle SCR_rSMT is out of the failurerange (SCR_rSMFailMax_C < SCR_rSMHtrT < SCR_rSMFailMin_C) Supply module check and replace if necessary. Check the wiring.
523720	8	926	148	Supply module heater: Dutycycle timing over error threshold.	Duty cycle for temperature readout from supply module heater to the control unit is not valid. Supply modul defect, fault in the wiring.	When the received supply module heater duty cycle SCR_rSMHtrT is in the valid range (SCR_r- Supply module check and replace if necessary. Check the wiring.
523721	8	930	689	Supply module heater: Dutycycle timing over error threshold.	Duty cycle for temperature readout from supply module to the control unit is out of range. Supply modul defect, fault in the wiring.	Supply module check and replace if necessary. Check the wiring.

Table 3-13. Engine Fault Codes (Deutz Engine)

SPN	FMI	Deutz Code	Blink Code	Description	Possible Cause	Action
523721	8	931	689	Supply module heater: Duty cycle timing out of valid range.	Duty cycle for temperature readout from supply module to the control unit is not valid. Supply modul defect, fault in the wiring.	When the received supply module duty cycle SCR_rSMT is in the valid range (SCR_rSMTVld-Min_C <= SCR_rSMT <= SCR_rSMTVldMax_C), OR in the failure range (SCR_rSMFailMin_C <= SCR_rSMT <= SCR_rSMFailMax_C) Supply module check and replace if necessary. Check wiring.
523721	11	927	689	Supply module heater: temperature measurement not available.	Duty cycle for temperature readout from supply module heater to the control unit is not available. Supply modul defect, fault in the wiring.	Threshold for detection is an internal ECU threshold. No erasing in the current driving cycle. Supply module check and replace if necessary. Check the wiring.
523722	8	929	691	Supply module heater: Faulty PWM signal from supply module.	PWM Signal for temperature readout from supply module to the control unit is not valid. Supply modul defect, fault in the wiring.	Threshold for error detection is an internal ECU threshold. When valid Sync followed by temperature information signal is received AND valid sync and temperature signal for both information is received one after the other. Supply module check and replace if necessary. Check the wiring.
523776	9	291	119	Timeout Error of CAN-Receive-Frame TSC1TE-active	Timeout Error (Missing CAN Bus message)	Threshold for error detection is an internal ECU threshold. Check CAN Bus cabling (Bus scheduling, polarity, short circuit, power interrupt), test protocol of receiver, check CAN functional range.
523777	9	292	119	Message TSC1-TE has been missing (passive)	Passive timeout Error (Missing CAN Bus message)	Check CAN Bus cabling (Bus scheduling, polarity, short circuit, power interrupt), test protocol of receiver, check CAN functional range, check actuator
523895	13	559	1-5-8	Missing or wrong injector adjustment value programming (IMA) injector 1 (in firing order).	Missing or wrong injector adjustment value for cyl. 1.	Threshold for error detection is an internal ECU threshold. Check correct injector adjustment value (IMA). Use SERDIA UseCase to check it.
523896	13	560	1-5-8	Missing or wrong injector adjustment value programming (IMA) injector 2 (in firing order).	Missing or wrong injector adjustment value for cyl. 2.	Threshold for error detection is an internal ECU threshold. check dataset and flash correct injector adjustment value (IMA). Use SERDIA UseCase to check it.
523897	13	561	1-5-8	Missing or wrong injector adjustment value programming (IMA) injector 3 (in firing order).	Missing or wrong parametrisation of injector adjustment cyl. 3.	Threshold for error detection is an internal ECU threshold. Check correct injector adjustment value (IMA).
523898	13	562	1-5-8	Missing or wrong injector adjustment value programming (IMA) injector 4 (in firing order).	Missing or wrong injector adjustment value for cyl. 4.	Threshold for error detection is an internal ECU threshold. Check correct injector adjustment value (IMA).
523899	13	563	1-5-8	Missing or wrong injector adjustment value programming (IMA) injector 5 (in firing order).	Missing or wrong injector adjustment value for cyl. 5.	Threshold for error detection is an internal ECU threshold. Check correct injector adjustment value (IMA).

SECTION 3 - CHASSIS & TURNTABLE

Table 3-13. Engine Fault Codes (Deutz Engine)

SPN	FMI	Deutz Code	Blink Code	Description	Possible Cause	Action
523900	13	564	1-5-8	Missing or wrong injector adjustment value programming (IMA) injector 6 (in firing order).	Missing or wrong injector adjustment value for cyl. 6.	Threshold for error detection is an internal ECU threshold. Check correct injector adjustment value (IMA).
523912	4	73	7-2-2	@ engines < 4l: Throttle valve error, Open Load or Short cut to Battery, blocked valve or wrong control signal for valve. @ engines with Burner T4i: Pressure Sensor error after valve (DV2), lower limit reached	The sensed raw voltage value is below the minimum threshold.	The sensed raw voltage value DPM_uRawBrnDVDsP is above the minimum threshold DPM_SRCBrnDVDsPuMin_C @ CRT < 4l: check throttle valve @ engines with Burner T4i: check back-pressure valve
523924	4	42	167	Overload at Pins O_V_RH2x: A01, K74, K91. Components on A01, K74, K91 cannot be activated. Internal ECU power stage switched off.	Suspected components: 1- Pin K91: Clutch switch, Brake switch, Engine brake demand, Regeneration activation, Parking brake, Gearbox N, Fan control 1 2- Pin K74: Boost air cooler bypass or electrical fuel pump relay, Fan control 2/fuel valve for flame star	Threshold for error detection is an internal ECU threshold. Check wiring harness and connected loads on pins A01, K74, K91 and/or reflash ECU. If error is still present, exchange ECU.
523925	3	38	731	Short circuit to battery error of actuator relay 2. Components on Pin A88, K57 cannot be activated. Internal ECU power stage switched off.	Suspected Components: 1- Lamps K57: Warn Ash Charge, Diagnostic, Warn Coolant Temp/Level, Warn Oil, Warn Boost Air, Warn Air Filter, Warn Water in Fuel, SCR, Regeneration, Engine Running. 2- Relay Preheat A88 3- Exhaust Flap A88	Check wiring harness and connected loads on pins A88, K57.
523925	4	43	731	Short circuit to ground actuator relais 3 Overload at Pins O_V_RH3x: A88, K57	Suspected components: 1- Pin A88: Preheat relay, Exhaust flap 2- Pin K 57: - control lamps: - OBD, preheat lamp, warning temp., warning oil, maintenance lamp, regeneration indicator, alternator management, engine running, diagnostic	Threshold for error detection is an internal ECU threshold. Check wiring harness and connected loads on pins A88, K57. If error is still present, exchange ECU.
523926	4	44	732	Short circuit to ground aktuator relais 4. Overload at Pins O_V_PCV: A90	Suspected components: Fan, Wiring harness	Threshold for error detection is an internal ECU threshold. Check wiring harness and connected loads on pin A90. If error is still present, exchange ECU.
523927	3	40	733	Short circuit to battery error of actuator relay 2. Components on Pin A04, A05 cannot be activated. Internal ECU power stage switched off.	Suspected Components: 1- Urea Pump A04 2- SCR Heater A05	Check wiring harness and connected loads on pins A04, A05.
523935	12	168	763	Timeout Error of CAN-Transmit-Frame EEC3VOL1; Engine send messages	Fault is detected if a TimeOut of the EEC3VOL1 frame has occurred.	Check wiring harness and customer nodes
523936	12	169	764	Timeout Error of CAN-Transmit-Frame EEC3VOL2; Engine send messages	Timeout Error (Missing CAN Bus message)	Check wiring harness and customer nodes

Table 3-13. Engine Fault Codes (Deutz Engine)

SPN	FMI	Deutz Code	Blink Code	Description	Possible Cause	Action
523938	9	133	766	Timeout Error (BAM to packet) for CAN-Receive-Frame AT11GCVol1 information; factors & Sensorcalibration for NOX Sensor (SCR-system upstream cat; DPF-system downstream cat)	Failure of the CAN Bus message	NOX sensor and sensor connection check
523939	9	134	766	Broadcast Announce Message of the calibration message of the upstream catalytic NOx sensor has failed. Timeout Error (BAM to BAM) for CAN-Receive-Frame AT11GCVol1 information. factors & Sensorcalibration for NOX Sensor (SCR-system upstream cat, DPF-system downstream cat).	Defective Nox sensor, faulty parameterization	NOX sensor and sensor connection check
523940	9	135	766	Timeout Error (PCK2PCK) for CAN-Receive-Frame AT11GCVol1 information; factors & Sensorcalibration for NOX Sensor (SCR-system upstream cat; DPF-system downstream cat)	Failure of the CAN Bus message	NOX sensor and sensor connection check
523941	9	140	767	Timeout Error (BAM to packet) for CAN-Receive-Frame AT10GCVol2 information; factors & Sensorcalibration for NOX Sensor (SCR-system downstream cat; DPF-system downstream cat)	Timeout Error (Missing CAN Bus message)	NOX downstream sensor and sensor connection check
523942	9	141	767	Timeout Error (BAM to BAM) for CAN-Receive-Frame AT10GCVol2 information, Calibration message 1 of the after catalyst NOx sensor has failed. Factors & Sensorcalibration for NOX Sensor (SCR-system downstream cat, DPF-system downstream cat)	Defective Nox sensor, faulty parameterization.	NOX downstream sensor and sensor connection check.
523943	9	142	767	Timeout Error (PCK2PCK) for CAN-Receive-Frame AT10GCVol2 information; factors & Sensorcalibration for NOX Sensor (SCR-system downstream cat; DPF-system downstream cat)	The fault is detected when a timeout error in packet 2 of NOxSenVol2Rx frame occurs.	NOX downstream sensor and sensor connection check
523960	0	1011	771	Physical range check high for EGR cooler downstream temperature.	Sensed temperature downstream EGR-cooler > limit.	EGR-Valve blocked open EGR-Valve actuator defect EGR-cooler defect (check for coolant water) Reed Valve defect Intake throttle blocked in closed position Exhaust pressure too high Check Nox-sensor upstream SCR catalyst dp venturi sensor defect
523960	1	1012	771	Physical range check low for EGR cooler downstream temperature.	sensor voltage > lower limit	EGR-Valve blocked open EGR-Valve actuator defect EGR-cooler defect (check for coolant water) Reed Valve defect Intake throttle blocked in closed position Exhaust pressure too high Check Nox-sensor upstream SCR catalyst dp venturi sensor defect

SECTION 3 - CHASSIS & TURNTABLE

Table 3-13. Engine Fault Codes (Deutz Engine)

SPN	FMI	Deutz Code	Blink Code	Description	Possible Cause	Action
523982	0	360	737	Powerstage diagnosis disabled; Indicating that battery voltage is not high.	Powerstage diagnostic can be deactivated due to too high battery voltage.	Check wiring, check alternator, check cables and repair or replace if necessary.
523982	1	361	737	Powerstage diagnosis disabled; Indicating that battery voltage is not low.	Powerstage diagnostic can be deactivated due to too low battery voltage.	Check wiring, check alternator, check cables and repair or replace if necessary.
523984	3	1239	788	Actuator relay 5: the voltage measured by ECU is out of the target range	Short-Circuit to battery to component	Threshold for error detection is an internal ECU threshold. Check wiring, component, ECU
523986	4	1241	176	Actuator relay 4: the voltage measured by ECU is out of the target range	Short-Circuit to ground to component	Threshold for error detection is an internal ECU threshold. Check wiring, component, ECU
523987	4	1242	791	Actuator relay 5: the voltage measured by ECU is out of the target range	Short-Circuit to ground to component	Threshold for error detection is an internal ECU threshold. Check wiring, component, ECU
524050	11	1434	8-3-6	CAN; not used	not used	not used
524051	11	1435	8-3-7	CAN; not used	not used	not used
524057	2	1505	8-4-3	Low fuel pressure: the low fuel pressure calculated by ECU is underneath the target range; the ECU activates a system reaction	Fuel pressure below warning threshold	Threshold for error detection is an internal ECU threshold. Check low fuel pressure system (fuel feed pump, relay, fuse, wiring, sensor) and if necessary repair or replace it.
524063	3	1558	869	SCR heater main relay; short circuit to battery Threshold 1 < SCRHtr_rUHtrMeasRatio_mp < Threshold 2	Short-Circuit to battery on wiring to component	Check wiring, component
524063	4	1559	869	Connection between heating valve (Y31) on the control unit Pin A:92 and Load side SCR heater main relay (K31) is a short cut to ground. Threshold 1 < SCRHtr_rUHtrMeasRatio_mp < Threshold 2	Faulty wiring, faulty heater relay (K27-K31), defective heating valve (Y31), broken element in heating.	Disconnect plug from heating valve (Y31) and reset fault. If fault is still present you have to look in the wiring of Y31 to the control unit Pin A:92. If error is no longer present, you have to check the wiring of Y31 via relay K31 and possibly the heating cables and relay (K27-K30).
524063	5	1555	869	Urea backflow line heater: broken wiring detected Threshold 1 < SCRHtr_rUHtrMeasRatio_mp < Threshold 2	Open Load on wiring to component	Check wiring, component
524063	5	1556	869	Urea main relay: broken wiring detected Threshold 1 < SCRHtr_rUHtrMeasRatio_mp < Threshold 2	relay defect relay not connected wiring harness broken problems with supply voltage	Check wiring, component
524063	5	1557	869	Urea pressure line heater: broken wiring detected Threshold 1 < SCRHtr_rUHtrMeasRatio_mp < Threshold 2	Open load on wiring to component	Check wiring, component
524063	5	1560	869	SCR relay for suction line not connected Threshold 1 < SCRHtr_rUHtrMeasRatio_mp < Threshold 2	relay defect relay not connected wiring harness broken problems with supply voltage	Check wiring, component

Table 3-13. Engine Fault Codes (Deutz Engine)

SPN	FMI	Deutz Code	Blink Code	Description	Possible Cause	Action
524063	5	1561	869	Open load on wiring to component Threshold 1 < SCRHtr_rUHtrMeasRatio_mp < Threshold 2	Open load on wiring to component	Check wiring, component
524063	5	1562	869	SCR heater tank; open load	Open load on wiring to component	Check wiring, component
524063	12	1646	869	SCR supply module temperature is not reaching a threshold before a calibratable time is exceeded. Corresponding to the environmental Temperature a specific defrosting time is given. After starting the defrosting a clock counter is starting. Does the counter reach the given defrosting time limit, an error will be detected. Is the temperature reached in time the clock counter will be reset Example: by using the calibrated temperature/time curve --> environmental temperature 0°C --> defrosting time limit 6000s --> if the clock counter reaches 6000s the error will be detected	Suspected components: Environment temperature sensor defect SCR supply module temperature sensor defect SCR supply module electrical heater defect	Check Environment temperature sensor SCR supply module temperature sensor SCR supply module electrical heater
524065	0	1565	892	The relativ pressure value of the exhaust gas from the urea cat upstream sensor is greater than an applicable maximum pressure threshold	sensed pressure upstream SCR catalyst > physical high range limit f(exhaust volume flow) UCatUsP_pRelFlt_mp > UCatUsP_pMax_mp	Check for crystallisation in exhaust line upstream SCR and dwnstream of urea injector Check correct connection from exhaust line to pressure sensor upstream SCR catalyst: syphons?, water in tube?, water in sensor? Check that exhaust pipe outlet is free (downstream SCR catalyst) Check wiring of pressure sensor upstream SCR catalyst Check pressure sensor upstream SCR catalyst: sensor has no connection to vehicle body? => Ensure that sensor is free Does sensor oscillate heavily at engine low idle / high idle? => try to suppress the oscillating Exchange pressure sensor upstream SCR catalyst Check calculated exhaust volume flow of engine within EDC: SCR_dvolSCRUs pausable? If not: Check T sensor upstream SCR catalyst, check complete engine air path: EGR-Valve, Intake throttle, turbocharger, piping for leakage and function Check SCR catalyst: Broken? Exchange SCR-Catalyst

Table 3-13. Engine Fault Codes (Deutz Engine)

SPN	FMI	Deutz Code	Blink Code	Description	Possible Cause	Action
524065	1	1566	892	The relative pressure value of the exhaust gas from the urea cat upstream sensor is less than an applicable minimum pressure threshold	sensed pressure upstream SCR catalyst > physical high range limit f(exhaust volume flow) UCatUsP_pRelFlt_mp < UCatUsP_pMin_mp	Check correct connection from exhaust line to pressure sensor upstream SCR catalyst: leakage? Check electric connector: 4h pin open / new connector type used? pressure exchange from inside electrical connector with the environment possible Check exhaust line: any leakages upstream of SCR catalyst? Check wiring of pressure sensor upstream SCR catalyst Exchange pressure sensor upstream SCR catalyst Check calculated exhaust volume flow of engine within EDC: SCR_dvolSCRUs possible? If not: Check T sensor upstream SCR catalyst, check complete engine air path: EGR-Valve, Intake throttle, turbocharger, piping for leakage and function Check SCR catalyst: Broken? Exchange SCR-Catalyst
524065	2	1598	892	Comparison of urea cat upstream exhaust gas- and environment pressure, the difference should not exceed a certain limit abs(UCatUsP_pDiffEnvCat_mp) > Threshold	absolut value of difference between sensed pressure upstream SCR catalyst and environmental pressure > limit abs(UCatUsP_pDiffEnvCat_mp) > Threshold	Check electric connector: 4h pin open / new connector type used? pressure exchange from inside electrical connector with the environment possible? water in sensor? sensor frozen? Check wiring of pressure sensor upstream SCR catalyst Exchange pressure sensor upstream SCR catalyst Check intake manifold pressure sensor (Air_pCADCs) Check ambient pressure sensor (EnvP_p)
524065	3	1569	892	voltage of pressure sensor upstream SCR > voltage high limit	voltage of pressure sensor upstream SCR > voltage high limit	Check wiring of pressure sensor upstream SCR catalyst Check pressure sensor upstream SCR catalyst Exchange pressure sensor upstream SCR catalyst
524065	4	1570	892	voltage of pressure sensor upstream SCR < voltage low limit	voltage of pressure sensor upstream SCR < voltage low limit	Check wiring of pressure sensor upstream SCR catalyst. Check pressure sensor upstream SCR catalyst. Exchange pressure sensor upstream SCR catalyst

Table 3-13. Engine Fault Codes (Deutz Engine)

SPN	FMI	Deutz Code	Blink Code	Description	Possible Cause	Action
524067	0	1581	894	Filtered urea supply module heater temperature value is above an applicable maximum heater temperature threshold of the supply module The temperature is read out via the PWM signal of the urea pump. That is only possible in status init of the SCR-system short after ignition was switched on. When that state is left the sensed temperature value is frozen.	sensed temperature of supply module heater > physical high range limit	Compare SCR_tSMT with SCR_tSMHtrT. Both show the same value? Check urea tank temperature (SCR_tAdapUTnkT). Very hot (> 70°C), urea tank heater permanent on? Does the pump never stop working? Check wiring to supply module Compare SCR_tSMT with SCR_tSMHtrT. Both show different values or urea tank temperature (SCR_tAdapUTnkT) is cold: exchange urea pump unit Supply module heater temperature sensor defect Supply module heater defect Supply module defect
524067	0	1585	894	Filtered urea supply module temperature value (SCR_tSMT) is above an applicable maximum temperature threshold of the supply module The temperature is read out via the PWM signal of the urea pump. That is only possible in status init of the SCR-system short after ignition was switched on. When that state is left the sensed temperature value is frozen.	sensed temperature of urea within supply module > physical high range limit	Compare SCR_tSMT with SCR_tSMHtrT. Both show the same value? Check urea tank temperature (SCR_tAdapUTnkT). Very hot (> 70°C), urea tank heater permanent on? Does the pump never stop working? Check wiring to supply module Compare SCR_tSMT with SCR_tSMHtrT. Both show different values or urea tank temperature (SCR_tAdapUTnkT) is cold: exchange urea pump unit Supply module temperature sensor defect Supply module heater defect Supply module defect
524067	1	1582	894	Filtered urea supply module heater temperature value is below an applicable minimum heater temperature threshold of the supply module The temperature is read out via the PWM signal of the urea pump. That is only possible in status init of the SCR-system short after ignition was switched on. When that state is left the sensed temperature value is frozen.	sensed temperature of supply module heater < threshold	Check ambient temperature EnvT_t < Threshold? Compare SCR_tSMT with SCR_tSMHtrT Check wiring with regard to supply module heater exchange urea pump unit Supply module heater temperature sensor defect Supply module defect
524067	1	1586	894	Filtered urea supply module temperature (SCR_tSMT) value is below an applicable minimum temperature threshold of the supply module The temperature is read out via the PWM signal of the urea pump. That is only possible in status init of the SCR-system short after ignition was switched on. When that state is left the sensed temperature value is frozen.	sensed temperature of urea within supply module < physical low range limit	Check ambient temperature EnvT_t < threshold? Compare SCR_tSMT with SCR_tSMHtrT Check wiring with regard to supply module heater exchange urea pump unit Supply module temperature sensor defect Supply module defect

Table 3-13. Engine Fault Codes (Deutz Engine)

SPN	FMI	Deutz Code	Blink Code	Description	Possible Cause	Action
524067	2	1867	894	absolute difference of sensed temperature of supply module heater temperature and ambient temperature UPmpT_tDiffPmpHtrAmb_mp > threshold	absolute difference of sensed temperature of supply module heater temperature and ambient temperature UPmpT_tDiffPmpHtrAmb_mp > threshold	Compare SCR_tSMT with SCR_tSMHtrT, EnvT_t and CEngTds_t and SCR_tAdapUTnkT => All identical? If not: Has the machine been brought from cold environment into a warm one or vice versa without engine running, e.g. at workshop? Environment temperature sensor defect Coolant temperature sensor defect Supply module temperature sensor defect Problem at Supply module unit (broken?) => exchange supply module
524067	2	1868	894	absolute difference of sensed temperature of supply module temperature and ambient temperature > threshold	absolute difference of sensed temperature of supply module temperature and ambient temperature UPmpT_tDiffPmpAmb_mp > threshold	Compare SCR_tSMT with SCR_tSMHtrT, EnvT_t and CEngTds_t and SCR_tAdapUTnkT => All identical? If not: Has the machine been brought from cold environment into a warm one or vice versa without engine running, e.g. at workshop? Environment temperature sensor defect Coolant temperature sensor defect Supply module temperature sensor defect Problem at Supply module unit (broken?) => exchange supply module
524074	9	1533	246	Open load sensor internally at NOx-sensor downstream SCR	Open load sensor internally at NOx-sensor downstream SCR	Threshold for error detection is an internal ECU threshold. Check NOx-Sensor downstream SCR catalyst: water inside? Shake out sensor after dismantling. => If water inside, replace sensor. Check mounting position of sensor and judge it regarding condense water formation / agglomeration. Check wiring harness Exchange sensor
524075	11	1534	247	Short circuit sensor internally at NOx-sensor downstream SCR	Short circuit sensor internally at NOx-sensor downstream SCR	Threshold for error detection is an internal ECU threshold. Check NOx-Sensor downstream SCR catalyst: water inside? Shake out sensor after dismantling. => If water inside, replace sensor. Check mounting position of sensor and judge it regarding condense water formation / agglomeration? Rearrange if critical and possible Check wiring harness Exchange sensor

Table 3-13. Engine Fault Codes (Deutz Engine)

SPN	FMI	Deutz Code	Blink Code	Description	Possible Cause	Action
524076	9	1535	248	Open line sensor internally at NOx-sensor downstream SCR NOx Sensors are CAN Sensors --> no HW Pin on the ECU	Open line sensor internally at NOx-sensor downstream SCR	Threshold for error detection is an internal ECU threshold. Check NOx-Sensor upstream SCR catalyst: water inside? Shake out sensor after dismounting. => If water inside, replace sensor. Check mounting position of sensor and judge it regarding condense water formation / agglomeration. Check wiring harness Exchange sensor
524077	11	1536	249	Short circuit sensor internally at NOx-sensor downstream SCR NOx Sensors are CAN Sensors --> no HW Pin on the ECU	Short circuit sensor internally at NOx-sensor downstream SCR	Threshold for error detection is an internal ECU threshold. Check NOx-Sensor upstream SCR catalyst: water inside? Shake out sensor after dismounting. => If water inside, replace sensor. Check mounting position of sensor and judge it regarding condense water formation / agglomeration. Check wiring harness Exchange sensor
524078	9	1537	255	Lambda value of NOx-Sensor downstream SCR is out of range. When the filtered Lambda concentration value at the sensor (ComRxSCR_rFltLamDs_mp) is greater than the physical range check max. lambda threshold	sensed lambda value of Nox-sensor downstream SCR catalyst is > physical high limit ComRxSCR_rCanLamDs_mp > threshold	Check whether NOx-sensor downstream SCR catalyst is physically mounted within the exhaust line Check Lambda values of NOx-sensor downstream SCR catalyst at idle conditions, ComRxSCR_rCanLamDs_mp > threshold? Compare to ComRxSCR_rCanLamUs_mp. Values must be almost identical Check CANBus of NOx-sensor downstream SCR catalyst Check NOx-sensor downstream SCR catalyst wiring Check NOx-sensor downstream SCR catalyst itself Replace NOx-sensor downstream SCR catalyst

Table 3-13. Engine Fault Codes (Deutz Engine)

SPN	FMI	Deutz Code	Blink Code	Description	Possible Cause	Action
524079	9	1538	256	sensed lambda value of NOx-sensor downstream SCR catalyst is < physical low limit ComRxSCR_rCanLamDs_mp < threshold	sensed lambda value of NOx-sensor downstream SCR catalyst is < physical low limit ComRxSCR_rCanLamDs_mp < threshold	Compare to ComRxSCR_rCanLamUs_mp. ComRxSCR_rCanLamDs_mp must be almost identical! If almost identical, Check air path of engine: EGR-Valve, Intake-Throttle, Turbocharger and Piping each for leakage and correct function Check injection system of engine. Injector stuck? if sensed lambda upstream SCR higher (ComRxSCR_rCanLamUs_mp): Diesel in Urea-tank? Check CANBus of NOx-sensor downstream SCR catalyst Check NOx-sensor downstream SCR catalyst wiring Check NOx-sensor downstream SCR catalyst itself Replace NOx-sensor downstream SCR catalyst
524080	9	1539	257	sensed lambda value of Nox-sensor upstream SCR catalyst is > physical high limit ComRxSCR_rCanLamUs_mp > Threshold	sensed lambda value of Nox-sensor upstream SCR catalyst is > physical high limit ComRxSCR_rCanLamUs_mp > Threshold	Check whether NOx-sensor upstream SCR catalyst is physically mounted within the exhaust line Check Lambda values of NOx-sensor upstream SCR catalyst at idle conditions, ComRxSCR_rCanLamUs_mp < Threshold? Compare to ComRxSCR_rCanLamDs_mp. Must be almost identical Check CANBus of NOx-sensor upstream SCR catalyst Check NOx-sensor upstream SCR catalyst wiring Check NOx-sensor upstream SCR catalyst itself Replace NOx-sensor upstream SCR catalyst
524081	9	1540	258	sensed lambda value of Nox-sensor upstream SCR catalyst is < physical low limit ComRxSCR_rCanLamUs_mp < Threshold	sensed lambda value of Nox-sensor upstream SCR catalyst is < physical low limit ComRxSCR_rCanLamUs_mp < Threshold	Check air path of engine: EGR-Valve, Intake-Throttle, Turbocharger and Piping each for leakage and correct function Check injection system of engine. Injector stuck? Check CANBus of NOx-sensor upstream SCR catalyst Check NOx-sensor upstream SCR catalyst wiring Check NOx-sensor upstream SCR catalyst itself Replace NOx-sensor upstream SCR catalyst
524083	9	1542	261	sensed NOx-value of NOx-sensor downstream SCR catalyst < Threshold	sensed Nox-value of Nox-sensor downstream SCR catalyst < physical low limit	Check CANBus of NOx-sensor downstream SCR catalyst Check NOx-sensor downstream SCR catalyst wiring Check NOx-sensor downstream SCR catalyst itself Replace NOx-sensor downstream SCR catalyst

Table 3-13. Engine Fault Codes (Deutz Engine)

SPN	FMI	Deutz Code	Blink Code	Description	Possible Cause	Action
524085	9	1544	912	sensed Nox-value of Nox-sensor upstream SCR catalyst < Threshold	sensed Nox-value of Nox-sensor upstream SCR catalyst < physical low limit	Check CANBus of NOx-sensor upstream SCR catalyst Check NOx-sensor upstream SCR catalyst wiring Check NOx-sensor upstream SCR catalyst itself Replace NOx-sensor upstream SCR catalyst
524100	9	1666	924	Timeout error of CAN-Transmit-Frame Com-DPFHisDat.	Open load on CANBUS wiring.	Check wiring, component.
524104	9	1676	928	Timeout error of CAN-Receive-Frame Com-RxDPFctl. CM1 Module Customer Recieve Message.	Time out of Check CANBUS EAT Control Receive Message, PGN65348. The message is not received.	Threshold for error detection is an internal ECU threshold. Check CANBUS EAT Control Receive Message, PGN65348. CM1 Module Customer Recieve Message.
524118	9	1672	9-4-2	Timeout error of CAN-Receive-Frame ComRxCM1	If the frame CM1 message is not transmitted successfully	Check CAN Bus cabling (Bus sheduling, polarity, short circuit, power interrupt), test protocol of receiver, check CAN functional range.
524121	9	1683	9-4-5	Timeout error of CAN-Receive-Frame Com-RxTrbChActr	Timeout Error (Missing CAN Bus message)	Check CAN Bus cabling (Bus sheduling, polarity, short circuit, power interrupt), test protocol of receiver, check CAN functional range.
524125	9	1687	9-4-9	Timeout error of CAN-Receive-Frame Com-TxTrbChActr	Timeout Error (Missing CAN Bus message)	Check CAN Bus cabling (Bus sheduling, polarity, short circuit, power interrupt), test protocol of receiver, check CAN functional range.
524141	7	1827	192	DEF dosing valve is blocked with crystalized urea or other deposits.	While SCR system is starting up and fter urea pressure reaches 10000 hPa, the DEF dosing module is tested. Expectation is that urea pressure drops below 1500 hPa if injector works properly. The test is repeated up to 3 times before an error is set. SCRsysPresMon_stPresDropDet_mp=0 while SCRCo_stStatus_mp=16. Suspected component: wiring harness DEF dosing valve The error is stored into the EEPROM of the ECU and status at ECU shut down is regained at ignition on.	Check electrical connection of urea injector: - wiring harness - connector Conduct SERDIA use-case "injection test". If it is faulty: - remove urea injector from exhaust line: - check for crystallisation direct on injector nozzle / plate - rinse it thoroughly in water - remount urea injector and conduct SERDIA use-case "injection test" If the error is still active, then exchange urea injector.
524141	7	1858	192	DEF dosing valve is blocked with crystalized urea or other deposits.	While SCR system is starting up and fter urea pressure reaches 10000 hPa, the DEF dosing module is tested. Expectation is that urea pressure drops below 1500 hPa if injector works properly. The test is repeated up to 3 times before an error is set. SCRsysPresMon_stPresDropDet_mp=0 while SCRCo_stStatus_mp=16. Suspected component: wiring harness DEF dosing valve The error is stored into the EEPROM of the ECU and status at ECU shut down is regained at ignition on.	Check electrical connection of urea injector: - wiring harness - connector Conduct SERDIA use-case "injection test". If it is faulty: - remove urea injector from exhaust line: - check for crystallisation direct on injector nozzle / plate - rinse it thoroughly in water - remount urea injector and conduct SERDIA use-case "injection test" If the error is still active, then exchange urea injector.

Table 3-13. Engine Fault Codes (Deutz Engine)

SPN	FMI	Deutz Code	Blink Code	Description	Possible Cause	Action
524147	13	1639	966	No proper urea pressure level could be build up within the SCR system state "Fill Lines" => SCRCO_stStatus_mp = 1 within some minutes	This error shows up, if no proper urea pressure level could be build up within the SCR system state "Fill Lines" => SCRCO_stStatus_mp = 1 within some minutes Once the urea pump pressure has exceeded the threshold the error is declared as okay. Suspected components: Suction line blocked PWM Powerstage has a defect and a default value which leads not to a rising pressure Pump Pressure sensor defect pump filter contains dirty parts reverting valve continuously open	Make sure that frozen lines, pump or tank can be excluded! Check whether there is urea in the urea tank Check urea lines: All lines connected? The right lines connected to the correct places? Suction line blocked? No leakage? Not also urea to the outside but also air into the lines, especially in the suction line! Perform service routine "pressure test": Does the urea pump work? => check wiring harness & PWM signal for pump Does the urea pressure rise? DFC already healed? If all unsuccessful so far: Check urea pressure sensor: At ignition on and SCR system state = 0 ("Init check"), SCR_pAbsAdapUPmpP shall be identical to EnvP_p. Fulfilled: Sensor okay! Check reverting valve => see DFC_SCRCoRevVlvBlk Check pump filter: dirt inside? Suspected components: Urea pump broken Reverting valve continuously open Urea suction line, backflow line broken or connection swapped PWM Powerstage has a defect Pump Pressure sensor broken
524152	2	1874	971	CAN message is not received for a definite time => error is set. As soon as the message is received the error heals.	CAN message is not received for a definite time => error is set. As soon as the message is received the error heals.	Check electrical connection of urea quality sensor Check engine CAN bus Check urea quality sensor itself Exchange urea quality sensor
524153	2	1875	997	CAN message is not received for a definite time => error is set. As soon as the message is received the error heals.	CAN message is not received for a definite time => error is set. As soon as the message is received the error heals.	Check electrical connection of suction unit sensor (combined sensor with tank level and tank temperature) Check engine CAN bus Check level sensor itself Exchange suction unit
524156	9	1705	972	Timeout error of CAN-Receive-Frame ComRxEBC2 from wheel speed sensor.	Timeout Error (Missing CAN Bus message) Defect on wheel speed sensor.	Check CAN Bus cabling (Bus scheduling, polarity, short circuit, power interrupt), test protocol of receiver, check CAN functional range. Replace the wheel speed sensor.

Table 3-13. Engine Fault Codes (Deutz Engine)

SPN	FMI	Deutz Code	Blink Code	Description	Possible Cause	Action
524177	7	1863	995	The error shows up, if no proper urea pressure could be build up within the SCR system state "Fill Lines" => SCRCo_stStatus_mp = 1.	This error shows up, if no proper urea pressure could be build up within the SCR system state "Fill Lines" => SCRCo_stStatus_mp = 1. 3 cases can lead to the error: Case A: increasing pressure is detected within 15s the check has passed => no error Case B: The pressure threshold was not reached within the 60s but case A was not positiv. Case C: The minimum pressure of 3000 hPa was not reached within the 60s.	Make sure that DEF lines, pump and tank are not frozen. Check for DEF level in the tank. Check DEF lines: Are all DEF lines connected? Is the suction line blocked? Is there any leakage? Not only urea to the outside but also air into the lines, especially in the suction line! Perform SERDIA usecase "pressure test": Does the DEF pump work? => check wiring harness & PWM signal for pump. Does the urea pressure increase? All errors are already healed? If still unsuccessful so far: Check urea pressure sensor: At ignition on and SCR system state = 0 ("Init check"), SCR_pAbsAdapUPmpP shall be identical to EnvP_p. Fulfilled: Sensor okay! Check DEF pump filter: Is any dirt inside? Suspected components: Suction line PWM Powerstage has a defect and a default value which leads not to a rising pressure DEF pump pressure sensor defect DEF pump filter contains dirty parts

Table 3-13. Engine Fault Codes (Deutz Engine)

SPN	FMI	Deutz Code	Blink Code	Description	Possible Cause	Action
524178	7	1864	996	The urea pump is not able to control the urea pressure between 9bar and 11 bar.	The urea pump controller is not able to control the urea pressure between 9bar and 11 bar due to malfunction in the SCR system. Suspected components: - DEF pump broken - Reverting valve continuously open - Urea suction line, backflow line broken or connection swapped - PWM Powerstage has a defect - Pump Pressure sensor broken	Make sure that DEF lines, pump and tank are not frozen. Check for DEF level in the tank Check DEF lines: All lines connected? The right lines connected to the correct places? Suction line blocked? Is there any leakage? Not also urea to the outside but also air into the lines, especially in the suction line! Perform SERDIA usecase "pressure test": Does the DEF pump work properly? => check wiring harness & PWM signal for pump Does the DEF pressure rise? Is the error healed? If still unsuccessful so far: - Check DEF pressure sensor: At ignition on and SCR system state = 0 ("Init check"), SCR_pAbsAdapUPmpP shall be identical to EnvP_p. Fulfilled: Sensor okay! - Check reverting valve - Check DEF pump filter: dirt inside? Suspected components: DEF pump broken Reverting valve continuously open DEF suction line, backflow line broken or connection swapped PWM Powerstage has a defect DEF pump pressure sensor broken
524190	14	1891	272	Not enough urea in tank or low urea quality or hardware tampering failure is detected or hardware failure is detected	Low DEF tank level Low DEF quality Hardware Tampering is active Hardware Failure is active	Check DEF level in tank. If there is no DEF, refill up to volume above the warning threshold. Check the DEF quality in the tank. If wrong fluid is filled, refill with proper DEF. Check other errors based on hardware malfunctions.
524191	14	1892	273	A low DEF tank level or a low DEF quality is detected or hardware tampering (system components are pinched off) or hardware failures as shortcut to battery, shortcut to ground etc. are detected.	Low DEF tank level Low DEF quality Hardware Tampering is active Hardware Failure is active	Threshold for error detection is an internal ECU threshold. Check the DEF level in tank. If there is no DEF, refill up above the warning level. Check DEF quality filled in the tank. Check other errors based on hardware tampering or failure.

Table 3-13. Engine Fault Codes (Deutz Engine)

SPN	FMI	Deutz Code	Blink Code	Description	Possible Cause	Action
524193	8	1893	275	The total time in standstill-regeneration mode exceeds the long-limit threshold within last 500h total engine run time. The error is activated if the engine runs to many times in Standstill regeneration.	Stand-still mode is very often aborted by the operator. Stand-still mode does not reach required temperature level and regeneration level is therefore reached after a short time again	Read out stand-still statistics => see service manual: Stand-still operation finished or often interrupted by driver / engine shut-off? => Run stand-still and instruct operator Stand-still operation required often by soot load => Check dp DPF pressure sensor Stand-still mode does not reach required temperature level: Check engine air path: Intake Trottle, EGR-Valve and turbocharger okay? Any leakage in engine air intake system or exhaust gas system? Check temperature sensors within exhaust system: upstream DOC, downstream DOC If soot load level of DPF allow it: Perform Stand-still and check reached temperature level upstream and downstream DOC: T upstream DOC in the range of 480-550°C? Downstream DOC after 25 min stand-still main phase 590°C are reached? Temperature traces are steady and even? Temperature downstream DOC higher than upstream DOC but difference does not exceed 100 K? Very small difference (< 10 K after 25 min stand-still main phase, 590 °C downstream DOC are not reached) => exchange DOC Very big difference (> 100 K after 25 min stand-still main phase, 590 °C downstream DOC exceeded) => check injection system of engine & engine air path

Table 3-13. Engine Fault Codes (Deutz Engine)

SPN	FMI	Deutz Code	Blink Code	Description	Possible Cause	Action
524194	8	1894	276	<p>The total time in standstill-regeneration mode exceeds the long-limit threshold: 2,5h stand-still operation within 50h total motor run time.</p> <p>The error is activated if the engine runs to much time in short Standstill regeneartion.</p>	<p>Stand-still mode is aborted / interrupted too often by the operator</p> <p>Stand-still is required too often due to miscalculation in the soot model</p> <p>Stand-still mode does not reache temperature level and regeneration level is therefore reached after a short time again.</p>	<p>Read out stand-still statistics => see service manual:</p> <p>Stand-still operation finished or often interrupted by driver / engine shut-off? => Run stand-still and instruct operator</p> <p>Stand-still operation required often by soot load => Check dp DPF pressure sensor</p> <p>Stand-still mode does not reach required temperature level:</p> <p>Check engine air path: Intake Trottle, EGR-Valve and turbocharger okay?</p> <p>Any leakage in engine air intake sytem or exhaust gas system?</p> <p>Check temperature sensors within exhaust system: upstream DOC, downstream DOC</p> <p>If soot load level of DPF allows it:</p> <p>Perform Stand-still and check reached temperature level upstream and downstream DOC: T upstream DOC in the range of 480-550°C? Downstream DOC after 25 min stand-still main phase 590°C are reached?</p> <p>Temerature traces are steady and even?</p> <p>Temperature downstream DOC higher than upstream DOC but difference does not exceed 100 K?</p> <p>Very small difference (< 10 K after 25 min stand-still main phase, 590 °C downstream DOC are not reached) => exchange DOC</p> <p>Very big difference (> 100 K after 25 min stand-still main phase, 590 °C downstream DOC exceeded) => check injection system of engine & engine air path</p>

Table 3-13. Engine Fault Codes (Deutz Engine)

SPN	FMI	Deutz Code	Blink Code	Description	Possible Cause	Action
524195	14	1900	279	The standstill request of detected crystallization is ignored for more than 5h(>300min) This will be activated if there is a standstill request activated by Crystallisation Monitoring.	Back pressure upstream SCR catalyst has reached a level which indicates crystallisation inside of exhaust line. The error detection depends on the sensed pressure upstream of the SCR catalyst and the calculated exhaust volume flow through the mixer pipe. In case of error is set, but no crystallisation can be found in the mixing pipe, a possible reason can be the defect sensors: - exhaust pressure & temperature upstream of the SCR catalyst, - the ambient pressure - the exhaust mass flow => Check air path system at the engine.	Dismount urea injector from exhaust line and inspect visually the injector and the exhaust line for urea crystallisation upstream of SCR catalyst: If crystallisation can be clearly seen, then standstill must be processed. Has the engine been operated in low load for longer time? If yes, then it could be the reason for crystallisation. Does the NOx-Sensors work properly? Compare ComRxSCR_rNOxUs to ComRxSCR_rNOxDs, when ComRxSCR_stNOxRdyUs = 1 & ComRxSCR_stNOxRdyDs = 1 (Warm engine and EAT-system, SCRT_tCatAvgExhGs_mp > 250°C, SCR_stStatus = "Dosing" = 8): sensed NOx upstream of SCR catalyst must be higher than downstream of SCR catalyst. Go to idle and wait until SCR system enters status "stand-by" (no dosing), SCRT_tCatAvgExhGs_mp < 225°C: ComRxSCR_rNOxUs = ComRxSCR_rNOxDs Clean urea injector: rinse it thoroughly under water Check EGR-Path: difference pressure sensor at venturi tube, EGR cooler, EGR-Valve, Reed-Valve, Intake throttle regarding function and leakage. Does the EGR-cooler leak water in the exhaust? Check air path for leakage Check turbocharger No crystallisation can be seen in the mixing pipe: Check exhaust pressure sensor upstream of SCR catalyst (SCR_pSensUCatUsP): tube, water in sensor? Check environmental pressure sensor (EnvP_p): plausible? Check exhaust temperature sensor upstream of SCR-catalyst (SCR_tSensUCatUsT): plausible compared to Exh_tOxiCatUs & Exh_tOxiCatDs e.g. when engine has idled for 20 minutes? => Run stand-still to remove crystallisation and to reset the DFC
5232719	3	1108	672	Urea supply module heater: the current drain measured by ECU is above the target range	Short circuit to battery If this error detected during the heating phase it is a result error:KWP 1089 Broken wiring Heating element in supply module defect	Threshold for error detection is an internal ECU threshold Check wiring Check cabling, if necessary replace supply module

3.26 FORD 2.5L ENGINE FUEL SYSTEM REPAIR

Propane Fuel Filter Replacement

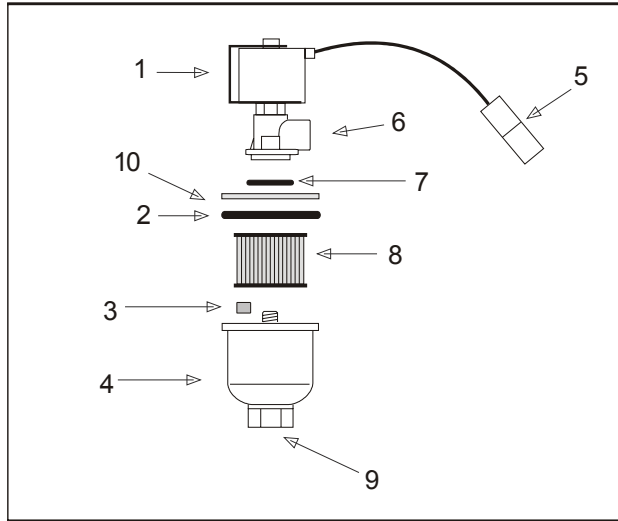

- | | |
|-------------------------------|----------------|
| 1. Electric Lock off Solenoid | 6. Fuel Outlet |
| 2. Housing Seal | 7. O-ring |
| 3. Filter Magnet | 8. Filter |
| 4. Filter Housing | 9. Fuel Inlet |
| 5. Electrical Connector | 10. Ring |

Figure 3-123. Filter Lock Assembly

REMOVAL

1. Relieve the propane fuel system pressure. Refer to Propane Fuel System Pressure Relief.
2. Disconnect the negative battery cable.
3. Slowly loosen the Filter housing and remove it.
4. Pull the filter housing from the Electric lock off assembly.
5. Remove the filter from the housing.
6. Locate Filter magnet and remove it.
7. Remove and discard the housing seal.
8. If equipped, remove and discard the retaining bolt seal.
9. Remove and discard mounting plate to lock off O-ring seal.

INSTALLATION

NOTICE

BE SURE TO REINSTALL THE FILTER MAGNET INTO THE HOUSING BEFORE INSTALLING NEW SEAL

1. Install the mounting plate to lock off O-ring seal.
2. If equipped, install the retaining bolt seal.
3. Install the housing seal.

4. Drop the magnet into the bottom of the filter housing.
5. Install the filter into the housing.
6. If equipped, install the retaining bolt into the filter housing.
7. Install the filter up to the bottom of the electric lock off.
8. Tighten the filter bowl retainer to 106 in lbs (12 Nm).
9. Open manual shut-off valve. Start the vehicle and leak check the propane fuel system at each serviced fitting. Refer to Propane Fuel System Leak Test.

Propane Fuel System Pressure Relief

CAUTION

THE PROPANE FUEL SYSTEM OPERATES AT PRESSURES UP TO 312 PSI (21.5 BAR). TO MINIMIZE THE RISK OF FIRE AND PERSONAL INJURY, RELIEVE THE PROPANE FUEL SYSTEM PRESSURE (WHERE APPLICABLE) BEFORE SERVICING THE PROPANE FUEL SYSTEM COMPONENTS.

To relieve propane fuel system pressure:

1. Close the manual shut-off valve on the propane fuel tank.
2. Start and run the vehicle until the engine stalls.
3. Turn the ignition switch OFF.

CAUTION

RESIDUAL VAPOR PRESSURE WILL BE PRESENT IN THE FUEL SYSTEM. ENSURE THE WORK AREA IS WELL VENTILATED BEFORE DISCONNECTING ANY FUEL LINE.

Propane Fuel System Leak Test

CAUTION

NEVER USE AN OPEN FLAME OF ANY TYPE TO CHECK FOR PROPANE FUEL SYSTEM LEAKS.

Always inspect the propane fuel system for leaks after performing service. Check for leaks at the fittings of the serviced or replaced component. Use a commercially available liquid leak detector or an electronic leak detector. When using both methods, use the electronic leak detector first to avoid contamination by the liquid leak detector

3.27 COUNTERWEIGHT

If the counterweight has been removed, ensure the retaining bolts are torqued to the proper value as shown in Figure 3-124., Counterweight Bolt Torque.

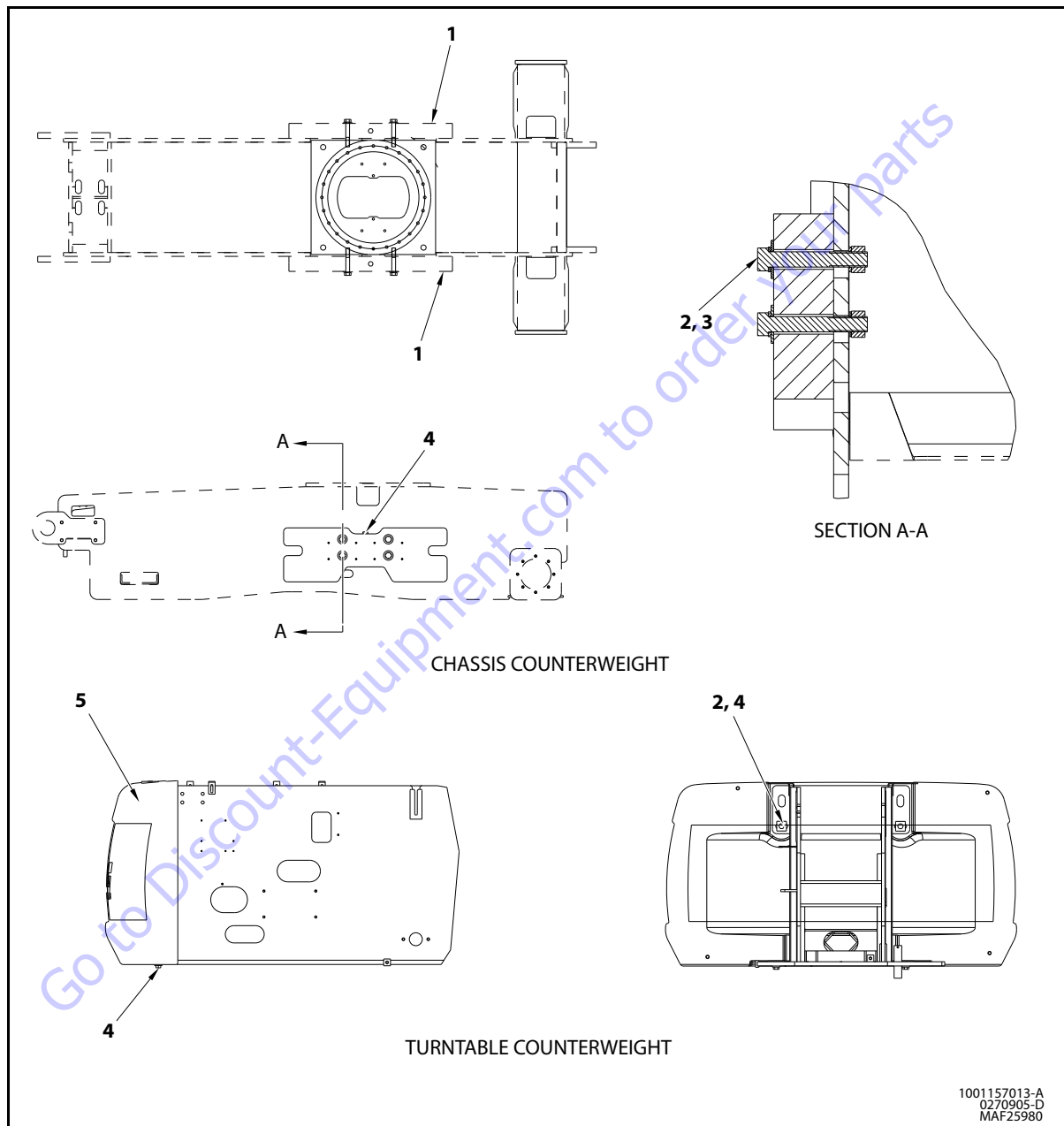

- | | |
|---|--|
| 1. Counterweight Plate | 3. Torque bolts to 480 ft. lbs. (651 Nm) |
| 2. Apply High Strength Threadlocking Compound to Bolt Threads and to Threads in Counterweight | 4. Torque bolts to 285 ft. lbs. (388 Nm) |
| | 5. Counterweight Casting |

Figure 3-124. Counterweight Bolt Torque

PARTS FINDER

**Search Website
by Part Number**



**Search Manual
Library For Parts
Manual & Lookup Part
Numbers – Purchase
or Request Quote**

A screenshot of the "Search Manuals" form. The form has a title "Search Manuals" and a subtitle "Please provide information to help us locate the manual and/or parts you need." It includes fields for "Brand", "Model", "Serial", "Part Number", and "Quantity". There is a "Search" button at the bottom.

**Can't Find Part or
Manual? Request Help
by Manufacturer,
Model & Description**

A screenshot of the "Parts Order Form". The form has a title "Parts Order Form" and a subtitle "Please fill in as much information as possible." It includes fields for "Manufacturer", "Model", "Description", "Part Number", "Quantity", and "Comments". There is a "Submit" button at the bottom.

Discount-Equipment.com is your online resource for quality parts & equipment.

Florida: **561-964-4949** Outside Florida TOLL FREE: **877-690-3101**

Need parts?

Click on this link: <http://www.discount-equipment.com/category/5443-parts/> and choose one of the options to help get the right parts and equipment you are looking for. Please have the machine model and serial number available in order to help us get you the correct parts. If you don't find the part on the website or on once of the online manuals, please fill out the request form and one of our experienced staff members will get back to you with a quote for the right part that your machine needs.

We sell worldwide for the brands: Genie, Terex, JLG, MultiQuip, Mikasa, Essick, Whiteman, Mayco, Toro Stone, Diamond Products, Generac Magnum, Airman, Haulotte, Barreto, Power Blanket, Nifty Lift, Atlas Copco, Chicago Pneumatic, Allmand, Miller Curber, Skyjack, Lull, Skytrak, Tsurumi, Husquvarna Target, , Stow, Wacker, Sakai, Mi-T- M, Sullair, Basic, Dynapac, MBW, Weber, Bartell, Bennar Newman, Haulotte, Ditch Runner, Menegotti, Morrison, Contec, Buddy, Crown, Edco, Wyco, Bomag, Laymor, Barreto, EZ Trench, Bil-Jax, F.S. Curtis, Gehl Pavers, Heli, Honda, ICS/PowerGrit, IHI, Partner, Imer, Clipper, MMD, Koshin, Rice, CH&E, General Equipment, ,AMida, Coleman, NAC, Gradall, Square Shooter, Kent, Stanley, Tamco, Toku, Hatz, Kohler, Robin, Wisconsin, Northrock, Oztec, Toker TK, Rol-Air, Small Line, Wanco, Yanmar

SECTION 4. BOOM & PLATFORM

4.1 PLATFORM AND BOOM SYSTEM

Platform Control Enable System

The platform controls make use of a time dependent enable circuit to limit the time availability of "live" or enabled controls.

To operate any directional function, the footswitch must be depressed before activation of the function. When the footswitch is depressed, the controls are enabled, and the operator has 7 seconds to operate any function.

The controls will remain enabled as long as the operator continues to use any function and will remain enabled 7 seconds after the last function has been used. While the controls are "live", the enabled light will be illuminated in the platform display panel.

When the time limit has been reached, the enabled light will turn off and the controls will be disabled.

To continue use of the machine the controls must be re-enabled to start the timer system over again. Do this by releasing all functions, then releasing and re-depressing the footswitch.

Platform Control Enable System

This system consists of single load cell and two linkages mounted to the platform rotator and replaces the platform support on machines that get this installation. The load cell includes a sealed circuit and is connected directly to a CAN-based platform control panel within the platform box.

This system compares the capacity to the measured weight in the platform. When the capacity is exceeded, or when there is a fault in the system, the platform overload indicator will flash, the platform alarm will sound at the rate of 5 sec/min and all platform controls (except auxiliary power) will be disabled. The ground controls are unaffected.

Ground Control Keyswitch System

The ground control keyswitch is used for selecting the active control of the machine between the platform or ground control stations and as another shut off switch for machine power.

The key is removable only in the off position, which allows the ground control station to have ultimate priority over the platform control.

Function Speed Control System

The platform controls for the jib, lift, and main telescope functions are controlled through a common variable speed control knob.

This knob feeds the valve driver of each control circuit allowing a smooth ramp up, controlled maximum output speed, and ramp down.

Each function has its own personality settings allowing the characteristics of each function to be modified using the standard analyzer. Not all functions will respond the same to the changes in the function speed knob position.

The variable speed control knob when turned counterclockwise and into the detent position (shown with a snail on the control panel decal), will place all functions, including proportional functions, in creep.

Main Lift End of Stroke Damping System

The main boom lift cylinder is constructed in a way that causes the lift cylinder oil flow to be restricted by an orifice while raising the boom within 5 degree of maximum elevation. This restriction slows the boom lift speed while raising the boom. The oil flow is not restricted while lowering the boom and therefor the speed is not altered.

4.2 PLATFORM

Platform Valve Removal

1. Tag and disconnect the hydraulic lines from the platform control valve. Use suitable container to retain any residual hydraulic fluid. Cap hydraulic lines and ports.
2. Remove hardware securing high pressure filter to filter mounting bracket. Remove high pressure filter.

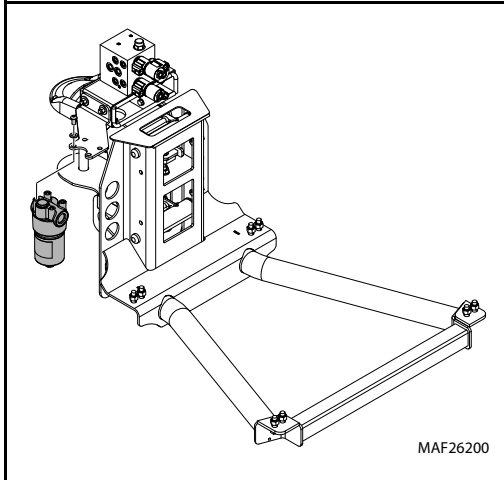

3. Remove hardware securing filter mounting bracket to valve mount. Remove filter mounting bracket.

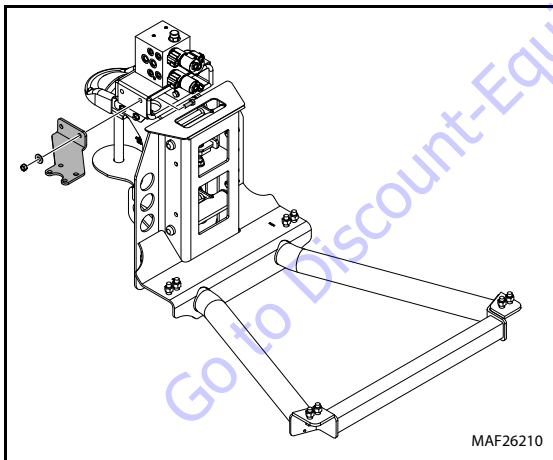

4. Remove hardware securing cover to the platform support. Remove cover.

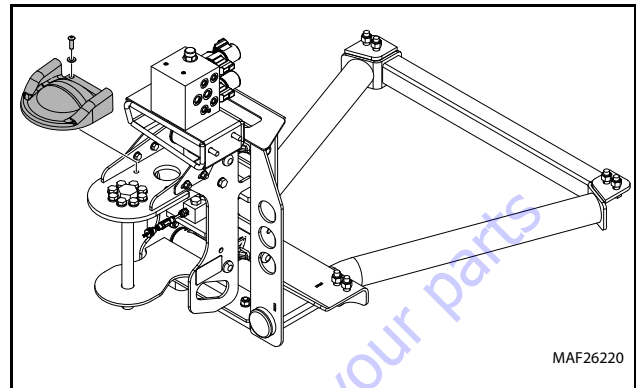

5. Remove hardware securing the mounting bracket to the platform support. Take out the mounting bracket along with platform control valve.

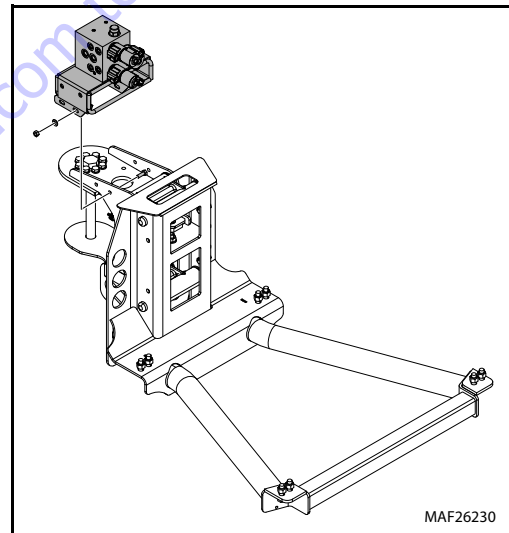

6. Remove hardware securing the platform control valve to the mounting bracket. Remove platform control valve.

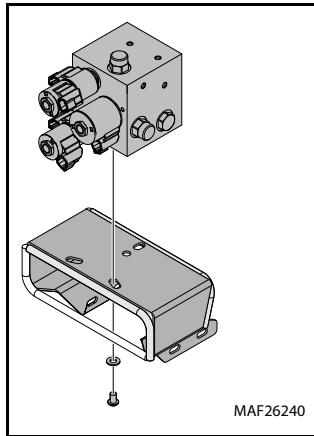

Platform Valve Installation

1. Install platform control valve onto the mounting bracket and secure using hardware.

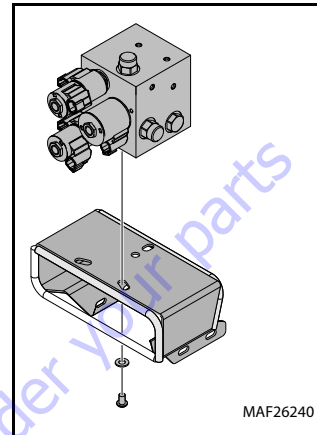

2. Install the mounting bracket onto the platform support and secure using hardware.

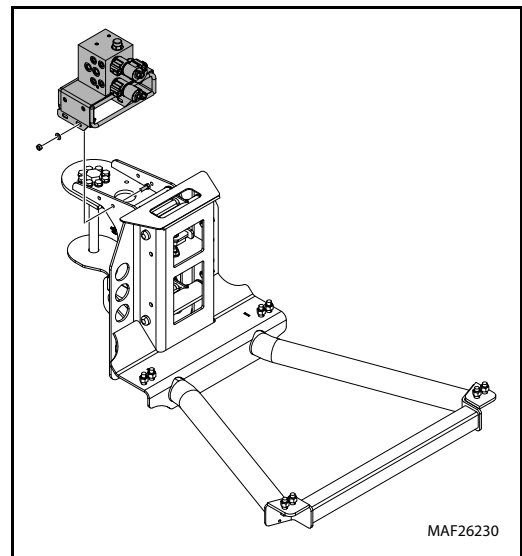

SECTION 4 - BOOM & PLATFORM

3. Install cover onto the platform support and secure with mounting hardware.

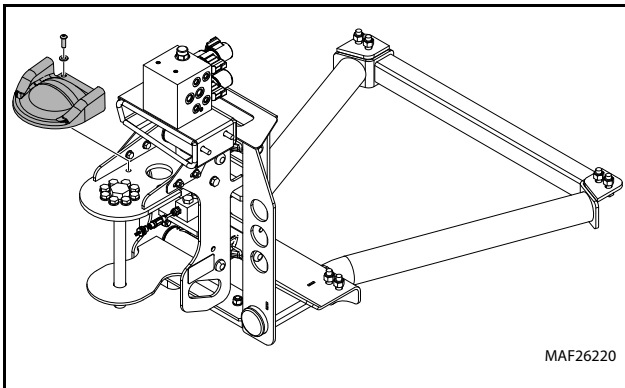

4. Install filter mounting bracket on side of valve mount and secure with mounting hardware.

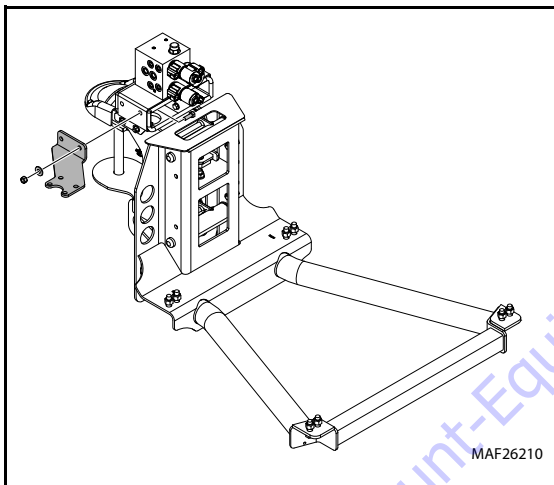

5. Install high pressure filter onto filter mounting bracket and secure with mounting hardware.

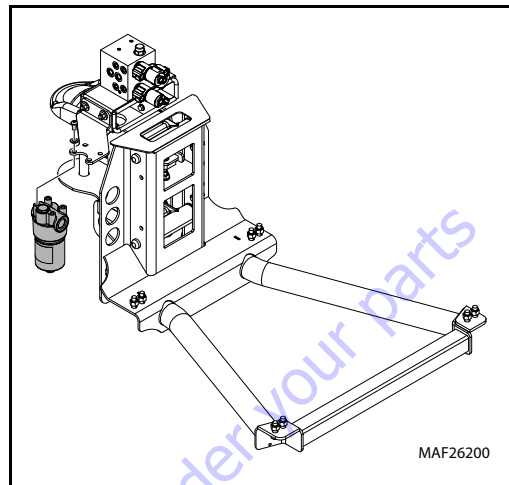

6. Remove tag and reconnect the hydraulic lines to the platform control valve.

Platform Support Removal

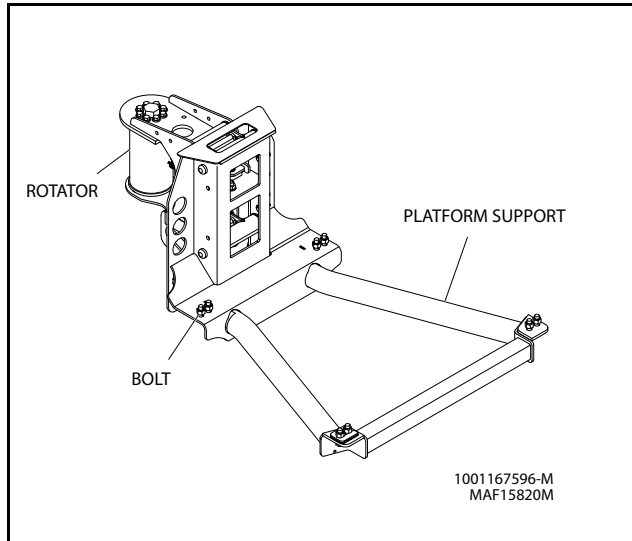
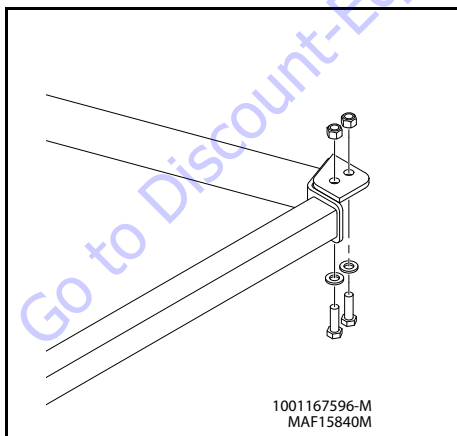

Figure 4-1. Location of Components Platform Support

1. Disconnect electrical cables from control console.
2. Tag and disconnect the hydraulic lines from the rotator. Use suitable container to retain any residual hydraulic fluid. Cap hydraulic lines and ports.
3. Remove the bolts securing the platform to the platform support, then remove the platform.

NOTE: The platform support weighs approximately 125 lb (56.8 kg).



4. Using a suitable lifting device, support the platform support.

5. Remove the bolts and locknuts securing the support to the rotator.

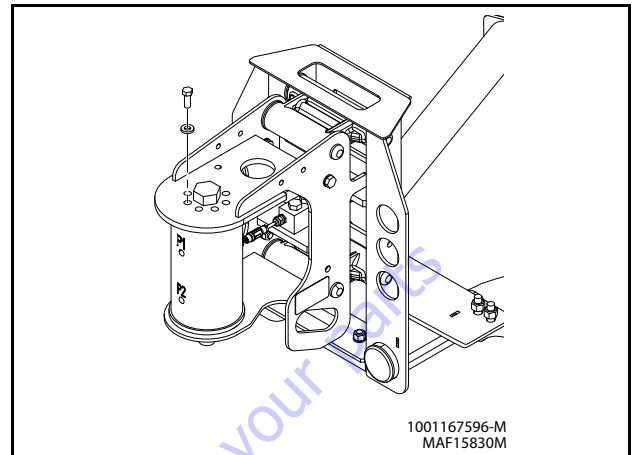

6. Using a suitable brass drift and hammer, remove the rotator shaft, then remove the support from the rotator.

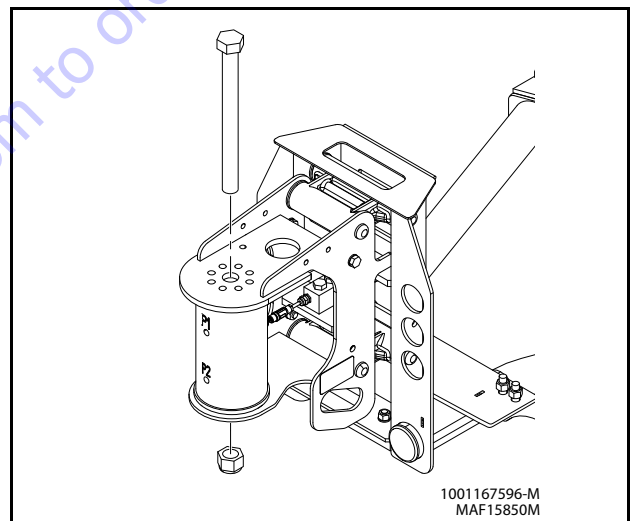

Platform Support Installation

1. Using a suitable device, support the platform support and position it on the rotator.

NOTE: The platform support weighs approximately 125 lb (56.8 kg).

2. Install the rotator center bolt.

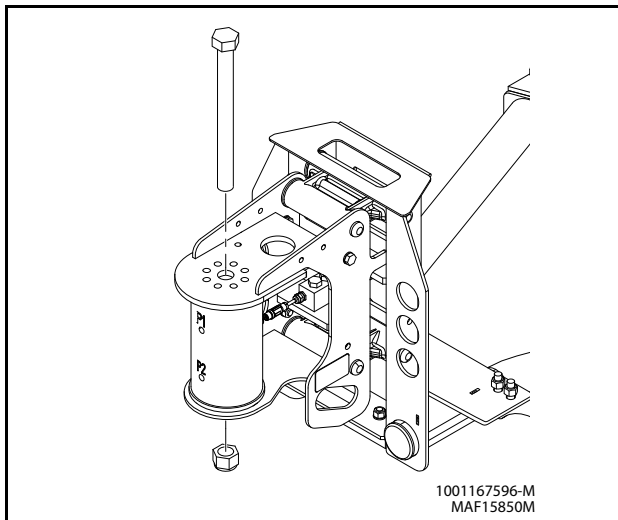

3. Apply Medium Strength Threadlocking Compound to the bolts and locknuts securing the support to the rotator and install the bolts and locknuts.

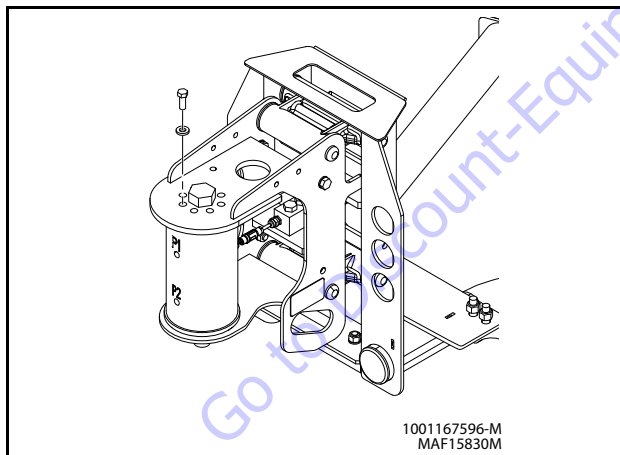

4. Torque the nut on the rotator center bolt to 586 ft. lbs. (795 Nm). Torque the retaining bolts to 40 ft. lbs. (55 Nm).

5. Position the platform on the platform support and install the bolts securing the platform to the platform support.

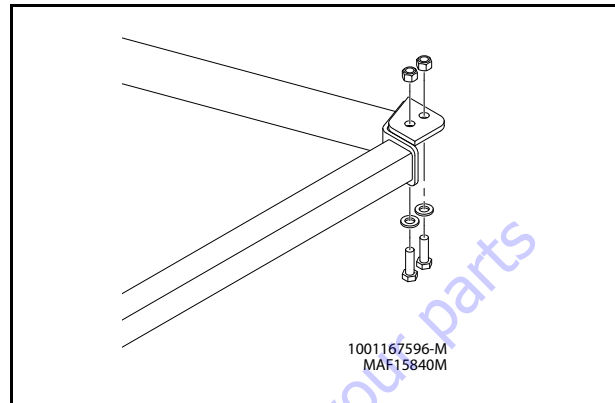

6. Connect the electrical cables to the platform control console.

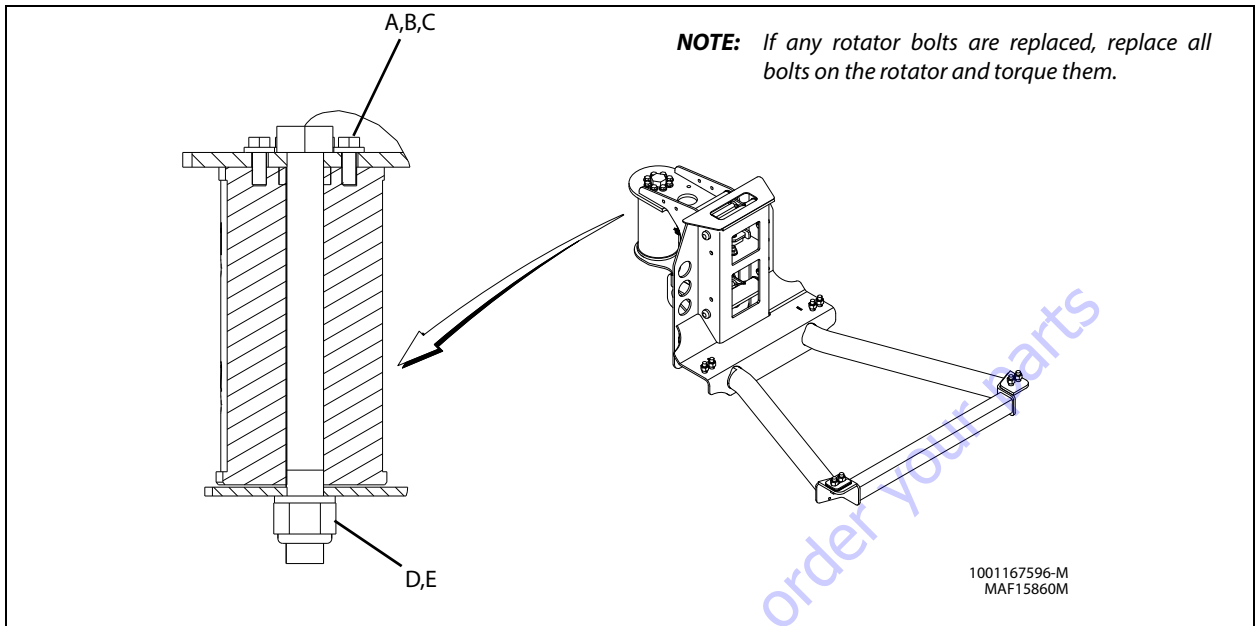

- A Torque to 40 ft. lbs. (55 Nm)
- B Medium Strength Threadlocking Compound
- C Torque to 586 ft. lbs. (795 Nm)
- D Check torque every 150 hours of operation
- E Torque to 75.5 ft. lbs. (97 Nm)

Figure 4-2. Platform Support Torque Values

4.3 ROTATOR AND LEVEL CYLINDER

Removal

NOTE: Refer Figure 4-3., Removal/Installation of Components - Rotator and Level Cylinder.

800S

1. Remove the Platform and Platform Support. Refer Section 4.2 - Platform.
2. Extend the fly boom section out to gain access to the platform level cylinder pin.
3. Tag and disconnect hydraulic lines to rotator. Use suitable container to retain any residual hydraulic fluid. Cap or plug all openings of hydraulic lines and ports.

NOTE: The rotator weighs approximately 54 lb (25 kg).

4. Supporting the rotator, remove hardware from pin #1. Using a suitable brass drift and hammer remove pin #1.

NOTE: The platform level cylinder weighs approximately 63.3 lb (28.7 kg).

5. Supporting the platform level cylinder, remove the hardware from pin #2. Using a suitable brass drift and hammer, remove pin #2 from the rotator and remove the rotator.
6. Tag and disconnect hydraulic lines to platform level cylinder. Use suitable container to retain any residual hydraulic fluid. Cap or plug all openings of hydraulic lines and ports.
7. Remove the hardware from pin #3. Using a suitable brass drift and hammer remove pin #3 from the fly boom and remove platform level cylinder.

860SJ

1. Remove the Platform and Platform Support. Refer Section 4.2 - Platform.
2. Extend the fly boom section out to gain access to the platform level cylinder pin.
3. Tag and disconnect hydraulic lines to rotator. Use suitable container to retain any residual hydraulic fluid. Cap or plug all openings of hydraulic lines and ports.

NOTE: The rotator weighs approximately 58 lb (26 kg).

NOTE: The jib assembly weighs approximately 303 lb to 305 lb (137 kg to 139 kg).

4. Supporting the rotator and jib assembly, remove hardware from pin #1. Using a suitable brass drift and hammer remove pin #1 from the jib assembly.
5. Remove the hardware from pin #2. Using a suitable brass drift and hammer, remove pin #2 from the jib assembly and remove the rotator.

NOTE: The platform level cylinder weighs approximately 72 lb to 84 lb (32.8 kg to 38.0 kg).

6. Supporting the platform level cylinder, remove the hardware from pin #3. Using a suitable brass drift and hammer remove pin #3 from the jib assembly.
7. Remove the hardware from pin #4. Using a suitable brass drift and hammer remove pin #4 from the fly boom. Remove the platform level cylinder.

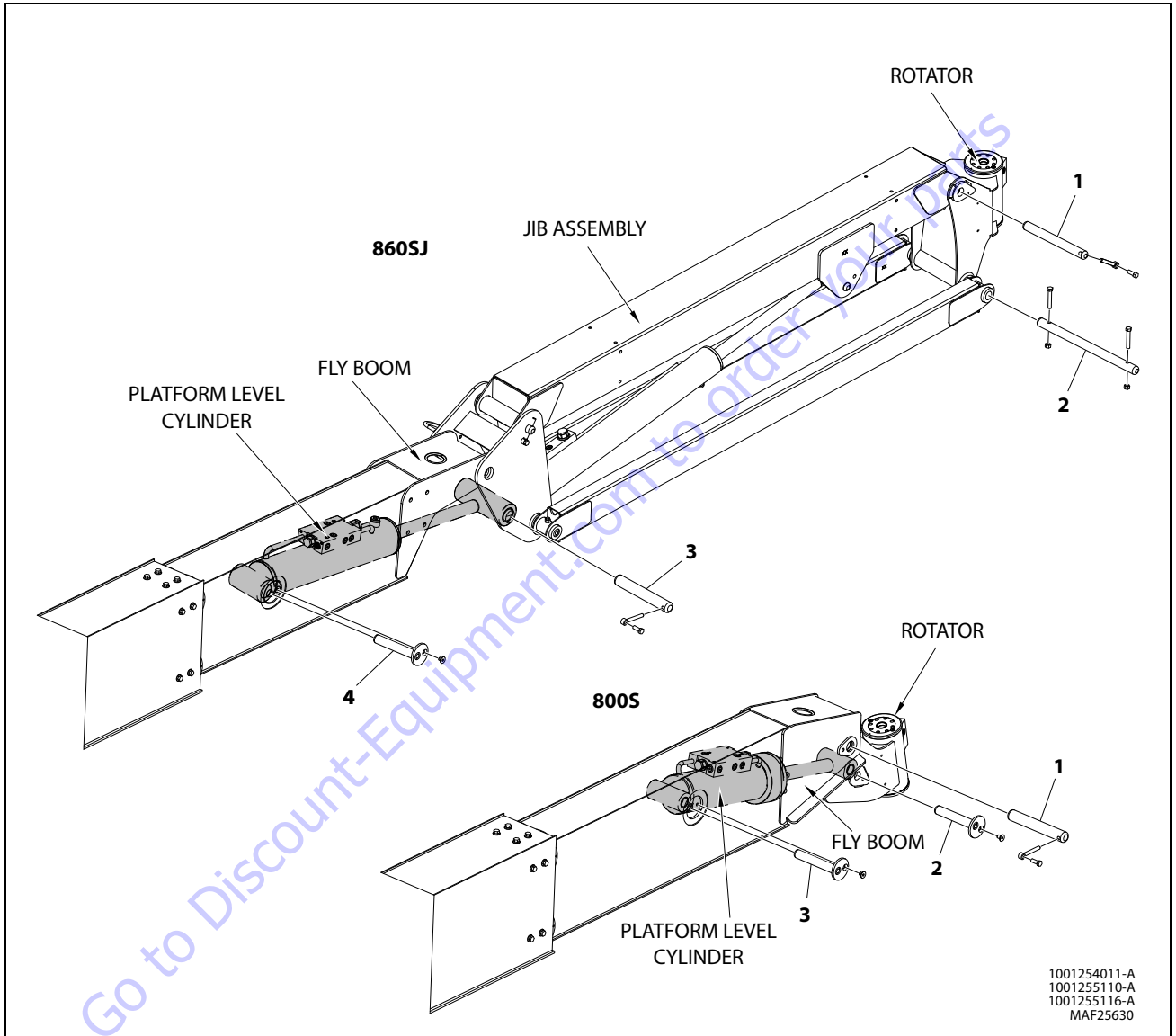

Figure 4-3. Removal/Installation of Components - Rotator and Level Cylinder

Installation

NOTE: Refer Figure 4-3., Removal/Installation of Components - Rotator and Level Cylinder.

800S

NOTE: The platform level cylinder weighs approximately 63.3 lb (28.7 kg).

1. Support the platform level cylinder. Using a suitable brass drift and hammer, install pin #3 to the fly boom. Install hardware securing pin #3.

NOTE: The rotator weighs approximately 54 lb (25 kg).

2. Support the rotator, using a suitable brass drift and hammer, install pin #2 to the rotator. Install hardware securing pin #2.
3. Using a suitable brass drift and hammer, install pin #1 to the rotator. Install hardware securing pin #1 and torque to 35 ft. lbs. (48 Nm).
4. Remove cap or plugs from openings of hydraulic lines and ports and connect hydraulic lines to rotator and platform level cylinder as tagged during removal.

860SJ

NOTE: The platform level cylinder weighs approximately 72 lb to 84 lb (32.8 kg to 38.0 kg).

1. Support the platform level cylinder. Using a soft head mallet, install pin #4 to the fly boom. Install hardware securing pin #4.

NOTE: The jib assembly weighs approximately 303 lb to 305 lb (137 kg to 139 kg).

2. Support the jib assembly. Using a soft head mallet install pin #3 to jib assembly. Install hardware securing pin #3.

NOTE: The rotator weighs approximately 58 lb (26 kg).

3. Support the rotator, using a soft head mallet, install pin #2 to the jib assembly. Install hardware securing pin #2 and torque to 35 ft. lbs. (48 Nm).
4. Using head mallet install pin #1 to jib assembly and install the rotator. Install hardware securing pin #1 and torque to 35 ft. lbs. (48 Nm).
5. Remove cap or plugs from openings of hydraulic lines and ports and connect hydraulic lines to rotator and platform level cylinder as tagged during removal.

4.4 MAIN BOOM POWERTRACK

Removal

1. Disconnect wiring harness connectors located in tower upright.

NOTICE

HYDRAULIC LINES AND PORTS SHOULD BE CAPPED IMMEDIATELY AFTER DISCONNECTING LINES TO AVOID ENTRY OF CONTAMINANTS INTO SYSTEM.

2. Tag and disconnect hydraulic lines from connectors at boom assembly. Use suitable container to retain any residual hydraulic fluid. Cap hydraulic lines and ports.
3. Remove hydraulic lines and electrical cables from Powertrack.
4. Using suitable lifting equipment, adequately support Powertrack weight along entire length.

5. Remove bolt #1 securing the push tube on the fly boom section.

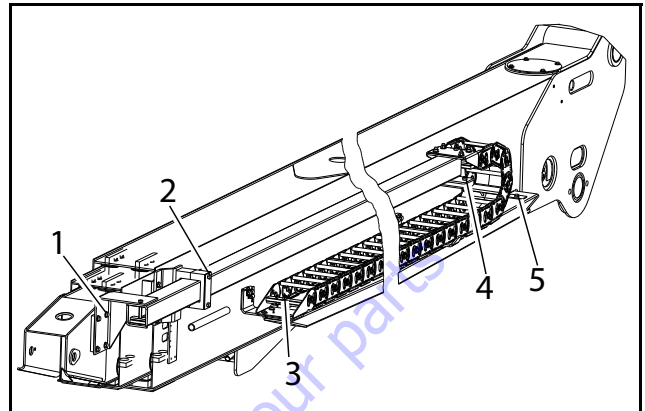

Figure 4-3. Main Boom Powertrack Components

6. Remove bolt #2 securing the push tube on the mid boom section.
7. With Powertrack supported and using all applicable safety precautions, remove bolts #3, #4 and #5 securing rail to the base boom section. Remove Powertrack from boom section.

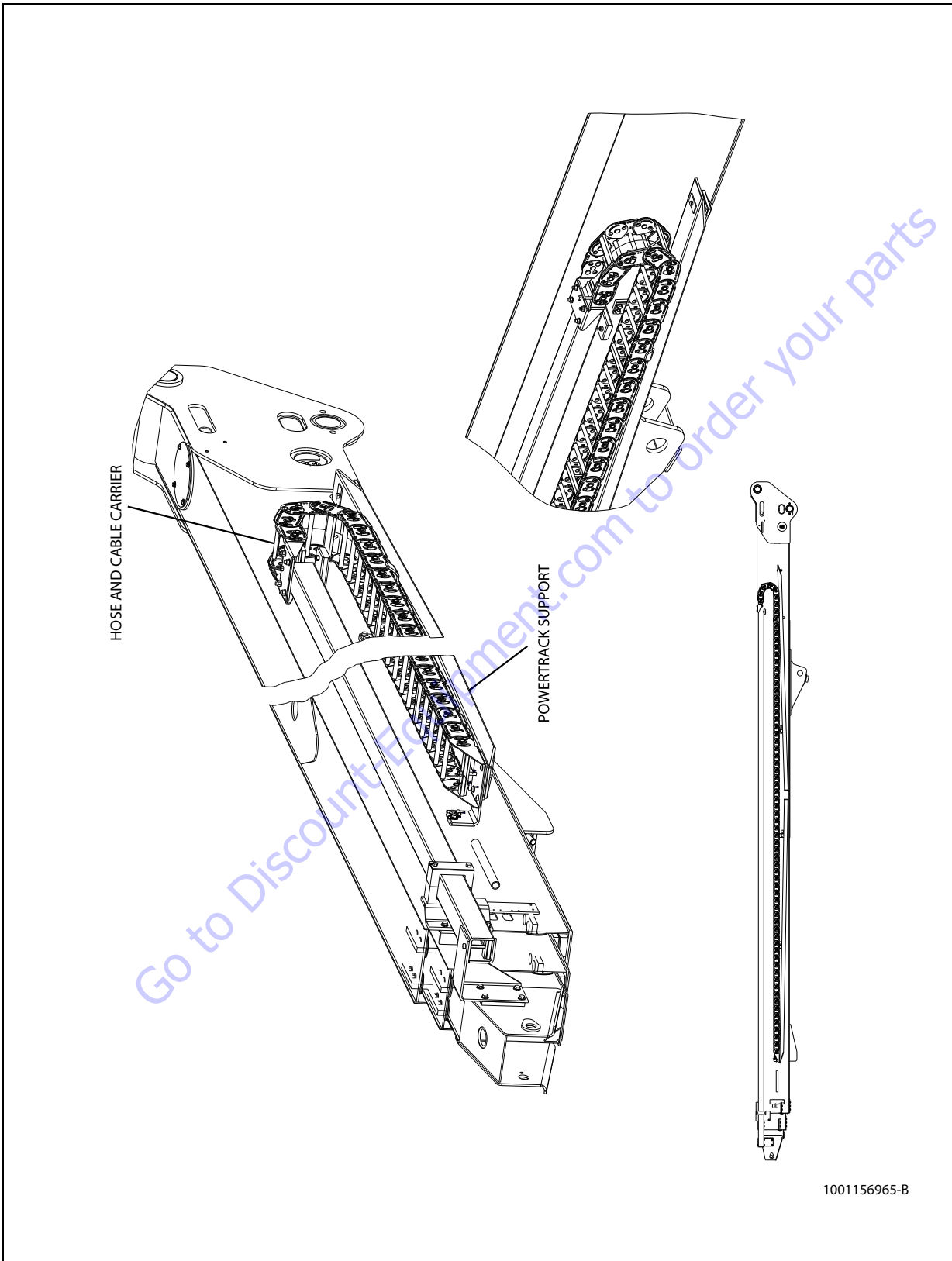

Figure 4-4. Powertrack Installation Main Boom