

OPERATION MANUAL



MODEL DIS185SSI4F Air Compressor (ISUZU 4LE2T DIESEL ENGINE)



www.Discount-Equipment.com

Revision #1 (09/04/19)

THIS MANUAL MUST ACCOMPANY THE EQUIPMENT AT ALL TIMES.

TO PURCHASE THIS PRODUCT PLEASE CONTACT US



**Equipment Financing and
Extended Warranties Available**



**Discount-Equipment.com is your online resource for
commercial and industrial quality parts and equipment sales.**

561-964-4949

visit us on line @ www.discount-equipment.com

Select an option below to find your Equipment

Search by Manufacturer

Search by Product Type

Request a Quote

We sell worldwide for the brands: Genie, Terex, JLG, MultiQuip, Mikasa, Essick, Whiteman, Mayco, Toro Stone, Diamond Products, Generac Magnum, Airman, Haulotte, Barreto, Power Blanket, Nifty Lift, Atlas Copco, Chicago Pneumatic, Allmand, Miller Curber, Skyjack, Lull, Skytrak, Tsurumi, Husquvarna Target, Stow, Wacker, Sakai, Mi-T-M, Sullair, Basic, Dynapac, MBW, Weber, Bartell, Bennar Newman, Haulotte, Ditch Runner, Menegotti, Morrison, Contec, Buddy, Crown, Edco, Wyco, Bomag, Laymor, EZ Trench, Bil-Jax, F.S. Curtis, Gehl Pavers, Heli, Honda, ICS/PowerGrit, IHI, Partner, Imer, Clipper, MMD, Koshin, Rice, CH&E, General Equipment, Amida, Coleman, NAC, Gradall, Square Shooter, Kent, Stanley, Tamco, Toku, Hatz, Kohler, Robin, Wisconsin, Northrock, Oztec, Toker TK, Rol-Air, APT, Wylie, Ingersoll Rand / Doosan, Innovatech, Con X, Ammann, Mecalac, Makinex, Smith Surface Prep, Small Line, Wanco, Yanmar

PROPOSITION 65 WARNING



To order go to Discount-Equipment.com

REPORTING SAFETY DEFECTS

If you believe that your vehicle has a defect that could cause a crash or could cause injury or death, you should immediately inform the National Highway Traffic Safety Administration (NHTSA) in addition to notifying Multiquip Inc. at 1-800-421-1244.

If NHTSA receives similar complaints, it may open an investigation, and if it finds that a safety defect exists in a group of vehicles, it may order a recall and remedy campaign. However, NHTSA cannot become involved in individual problems between you, your dealer, or Multiquip Inc.

To contact NHTSA, you may either call the Vehicle Safety Hotline toll-free at 1-888-327-4236 (TTY: 1-800-424-9153), go to <http://www.safercar.gov>, or write to:

Administrator
NHTSA
1200 New Jersey Avenue, SE
Washington, DC 20590

You can also obtain information about motor vehicle safety from <http://www.safercar.gov>.

DIS185SSI4F AIR COMPRESSOR

| | |
|--|-------|
| Proposition 65 Warning | 3 |
| Reporting Safety Defects..... | 4 |
| Table Of Contents..... | 5 |
| Nameplate/Safety Information..... | 6 |
| Safety Information | 7-13 |
| Specifications (Compressor/Engine) | 14 |
| Specifications (Trailer/A-Frame) | 15 |
| Dimensions..... | 16 |
| General Information..... | 17 |
| Applications | 18 |
| Major Components (Battery Side) | 19 |
| Major Components (Fuel Tank Side) | 20 |
| Major Components (Front/Rear/Top)..... | 21 |
| Control Panel..... | 22-23 |
| Inspection/Setup..... | 24-28 |
| Operation..... | 29-34 |
| Preparation For Long Term Storage | 35 |
| Maintenance (Engine) | 36-43 |
| Maintenance (Compressor)..... | 44-47 |
| Trailer Maintenance | 48-49 |
| Trailer Guidelines..... | 50-64 |
| System Error Fault Codes | 65 |
| DTC Troubleshooting Codes | 66-68 |
| Troubleshooting (Compressor) | 69 |
| Troubleshooting (Engine)..... | 70-71 |
| System Diagram | 72 |
| Engine Wiring Diagram..... | 73 |

NAMEPLATE/SAFETY INFORMATION

NAMEPLATE AND SAFETY LABELS

Safety labels are attached to the generator as shown in Figure 1. Keep these safety labels clean at all times. When the safety labels become worn or damaged, contact your nearest dealer or the Multiquip Parts Dept.

NOTICE
For safety label part numbers, reference the parts section of this manual.

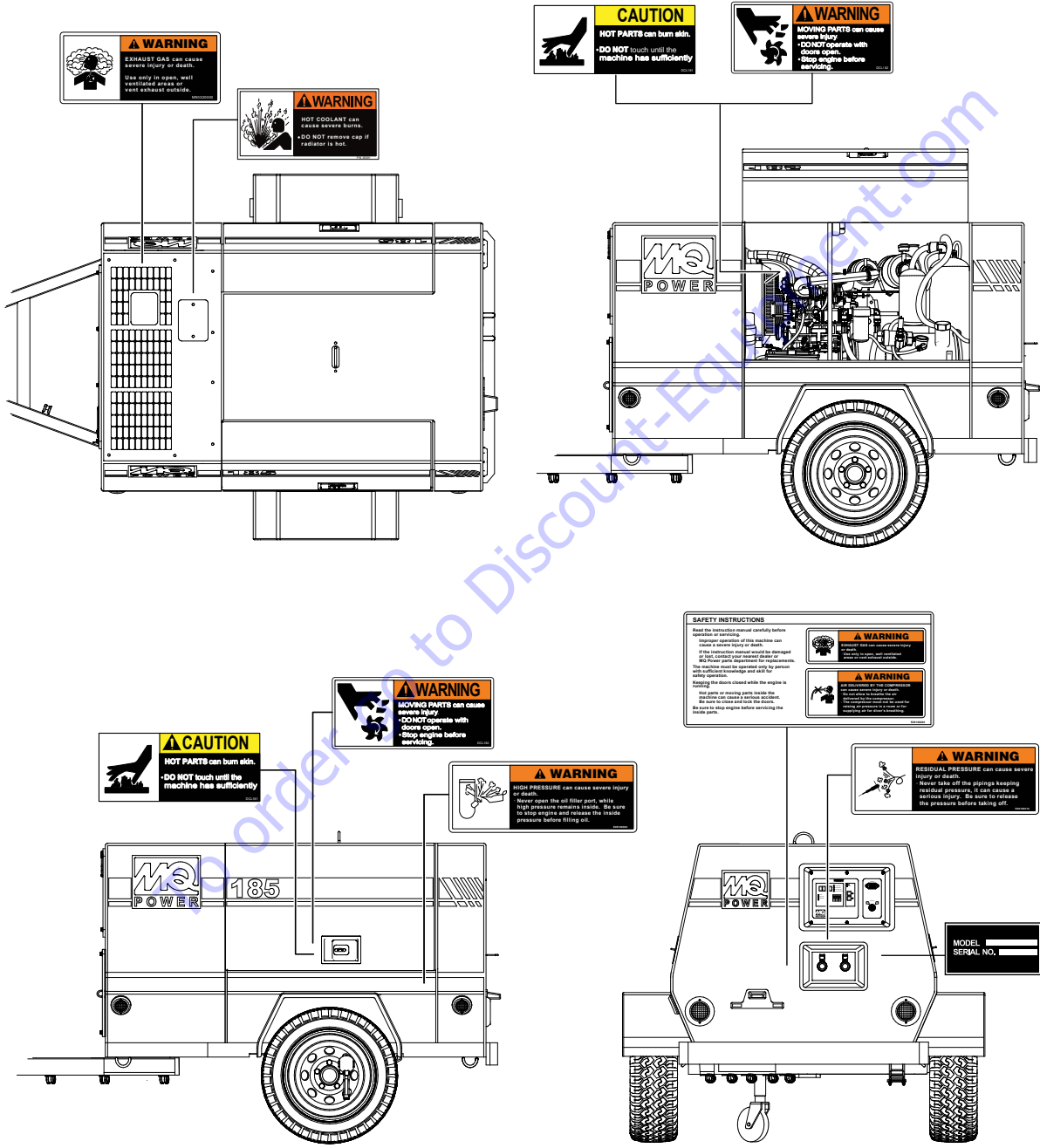

Figure 1. Nameplate And Safety Decals

SAFETY INFORMATION

DO NOT operate or service the equipment before reading the entire manual. Safety precautions should be followed at all times when operating this equipment. Failure to read and understand the safety messages and operating instructions could result in injury to yourself and others.

SAFETY MESSAGES

The four safety messages shown below will inform you about potential hazards that could injure you or others. The safety messages specifically address the level of exposure to the operator and are preceded by one of four words: **DANGER**, **WARNING**, **CAUTION** or **NOTICE**.

SAFETY SYMBOLS

 **DANGER**

Indicates a hazardous situation which, if not avoided, **WILL** result in **DEATH** or **SERIOUS INJURY**.

 **WARNING**

Indicates a hazardous situation which, if not avoided, **COULD** result in **DEATH** or **SERIOUS INJURY**.







 **CAUTION**

Indicates a hazardous situation which, if not avoided, **COULD** result in **MINOR** or **MODERATE INJURY**.

NOTICE

Addresses practices not related to personal injury.

Potential hazards associated with the operation of this equipment will be referenced with hazard symbols which may appear throughout this manual in conjunction with safety messages.

| Symbol | Safety Hazard |
|--|----------------------------|
|  | Lethal exhaust gas hazards |
|  | Explosive fuel hazards |
|  | Burn hazards |
|  | Overspeed hazards |
|  | Rotating parts hazards |
|  | Pressurized fluid hazards |
|  | Electric shock hazards |

SAFETY INFORMATION

GENERAL SAFETY

CAUTION

- **NEVER** operate this equipment without proper protective clothing, shatterproof glasses, respiratory protection, hearing protection, steel-toed boots and other protective devices required by the job or city and state regulations.





- **NEVER** operate this equipment when not feeling well due to fatigue, illness or when under medication. 
- **NEVER** operate this equipment under the influence of drugs or alcohol.



- **ALWAYS** check the equipment for loosened threads or bolts before starting.
- **DO NOT** use the equipment for any purpose other than its intended purposes or applications.

NOTICE

- This equipment should only be operated by trained and qualified personnel 18 years of age and older.
- Whenever necessary, replace nameplate, operation and safety decals when they become difficult read.
- Manufacturer does not assume responsibility for any accident due to equipment modifications. Unauthorized equipment modification will void all warranties.
- **NEVER** use accessories or attachments that are not recommended by MQ Power for this equipment. Damage to the equipment and/or injury to user may result.
- **ALWAYS** know the location of the nearest fire extinguisher. 
- **ALWAYS** know the location of the nearest first aid kit. 

- **ALWAYS** know the location of the nearest phone or **keep a phone on the job site**. Also, know the phone numbers of the nearest **ambulance, doctor** and **fire department**. This information will be invaluable in the case of an emergency.

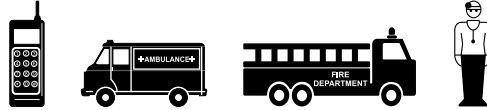

AIR COMPRESSOR SAFETY

DANGER

- **NEVER** operate the equipment in an explosive atmosphere or near combustible materials. An explosion or fire could result causing severe **bodily harm or even death**. 
- Keep the towing vehicle or equipment carrier, compressor hoses, tools, and all personnel at least 10 feet (3 m) from power lines and buried cables.
- **DO NOT** use air from this air compressor for respiration (breathing).
- Stay clear of the compressor during electrical storms! It can attract lightning.
- **DO NOT** engage in horseplay with air hoses as death or serious injury may result.
- **NEVER** use air compressor for respirator equipment by which compressed air is supplied for human consumption. The compressed air contains carbon monoxide and other contaminants. Such air may cause serious injury or death if used by a person for respiration.
- This compressor is not designed for air pressurized construction methods and underwater diving jobs.
- **NEVER** use compressed air for human consumption such as pressurizing diving air tanks. Consumption of compressed air can cause death while diving.

SAFETY INFORMATION

⚠ WARNING

- **NEVER** disconnect any **emergency or safety devices**. These devices are intended for operator safety. Disconnection of these devices can cause severe injury, bodily harm or even death. Disconnection of any of these devices will void all warranties.
- If air compressor is operated indoors, discharge engine exhaust fumes outdoors.
- Locate the air compressor so that exhaust fumes are not apt to be carried towards personnel.
- **NEVER** blow compressed air directly at people. Scattered dust, or foreign debris in the compressed air may cause serious injuries.
- Blowing compressed air on food is prohibited.
- **NEVER**, under any circumstances, open the oil filler cap on oil chamber tank while air compressor is running or immediately after stopping operation. It is very dangerous and may cause serious injury.
- Residual air pressure can cause severe bodily injury.
- Residual air pressure in the oil chamber tank could force both extremely hot compressed air and oil to jet out causing scalding or severe bodily harm.

⚠ CAUTION

- **NEVER** lubricate components or attempt service on a running machine.
- Fuels, fluids, coolants, lubricants, and battery electrolyte used in the air compressor are typical of the industry. Care should be taken to avoid accidental ingestions and/or skin contact
- Keep personnel away from the discharge opening of hoses, tools or other points of compressed air.

NOTICE

- **ALWAYS** ensure air compressor is on level ground before use.
- **ALWAYS** keep the machine in proper running condition.
- Fix damage to machine and replace any broken parts immediately.

- **NEVER** operate the air compressor with the service valves open unless air hoses and/or pipes are connected.
- **ALWAYS** store equipment properly when it is not being used. Equipment should be stored in a clean, dry location out of the reach of children and unauthorized personnel
- **DO NOT** use pneumatic air tools that are rated above the maximum psi rating of the compressor.
- Select tools, air hoses, pipes, valves, filters and other fittings accordingly. **DO NOT** exceed the manufacturer's rated safe operating pressures for these items.
- **DO NOT** use air to pressures higher than 30 psi (207 kPa, 2.1 kgf/cm²) for cleaning purposes.
- When refilling the oil chamber tank with oil, stop the engine, and make sure that the pressure gauge indicates **zero** psi, and that there is no residual pressure. Then gradually loosen the oil filler cap .
- Make sure the air pressure reads zero before performing any maintenance.
- When removing dust and debris that have accumulated in such devices such as air filters, by blowing compressed air, wear safety glasses, etc. to protect eyes.
- When the air compressor has to be unavoidably operated (temporarily) with its port open, be sure to mount a silencer to reduce noise and wear protective materials such as earplugs to prevent damage to hearing. For service testing only.

ENGINE SAFETY

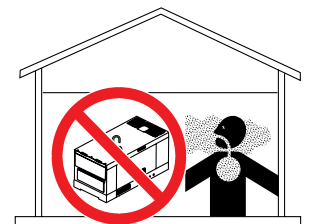

⚠ DANGER

- The engine fuel exhaust gases contain poisonous carbon monoxide. This gas is colorless and odorless, and can cause death if inhaled.
- The engine of this equipment requires an adequate free flow of cooling air. **NEVER** operate this equipment in any enclosed or narrow area where free flow of the air is restricted. If the air flow is restricted it will cause injury to people and property and serious damage to the equipment or engine.



SAFETY INFORMATION

⚠ WARNING

- **DO NOT** place hands or fingers inside engine compartment when engine is running.
- **NEVER** operate the engine with heat shields or guards removed.
- Keep fingers, hands hair and clothing away from all moving parts to prevent injury. 
- **DO NOT** remove the radiator cap while the engine is hot. High pressure boiling water will gush out of the radiator and severely scald any persons in the general area of the generator. 
- **DO NOT** remove the coolant drain plug while the engine is hot. Hot coolant will gush out of the coolant tank and severely scald any persons in the general area of the generator.
- **DO NOT** remove the engine oil drain plug while the engine is hot. Hot oil will gush out of the oil tank and severely scald any persons in the general area of the generator.

⚠ CAUTION

- **NEVER** touch the hot exhaust manifold, muffler or cylinder. Allow these parts to cool before servicing equipment. 

NOTICE

- **NEVER** run engine without an air filter or with a dirty air filter. Severe engine damage may occur. Service air filter frequently to prevent engine malfunction.
- **NEVER** tamper with the factory settings of the engine or engine governor. Damage to the engine or equipment can result if operating in speed ranges above the maximum allowable. 

- Wet stacking is a common problem with diesel engines which are operated for extended periods with light or no load applied. When a diesel engine operates without sufficient load (less than 40% of the rated output), it will not operate at its optimum temperature. This will allow unburned fuel to accumulate in the exhaust system, which can foul the fuel injectors, engine valves and exhaust system, including turbochargers, and reduce the operating performance.

In order for a diesel engine to operate at peak efficiency, it must be able to provide fuel and air in the proper ratio and at a high enough engine temperature for the engine to completely burn all of the fuel.

Wet stacking does not usually cause any permanent damage and can be alleviated if additional load is applied to relieve the condition. It can reduce the system performance and increase maintenance. Applying an increasing load over a period of time until the excess fuel is burned off and the system capacity is reached usually can repair the condition. This can take several hours to burn off the accumulated unburned fuel.

- State Health Safety Codes and Public Resources Codes specify that in certain locations, spark arresters must be used on internal combustion engines that use hydrocarbon fuels. A spark arrester is a device designed to prevent accidental discharge of sparks or flames from the engine exhaust. Spark arresters are qualified and rated by the United States Forest Service for this purpose. In order to comply with local laws regarding spark arresters, consult the engine distributor or the local Health and Safety Administrator.

SAFETY INFORMATION

FUEL SAFETY

DANGER

- **DO NOT** start the engine near spilled fuel or combustible fluids. Diesel fuel is extremely flammable and its vapors can cause an explosion if ignited.
- **ALWAYS** refuel in a well-ventilated area, away from sparks and open flames.
- **ALWAYS** use extreme caution when working with **flammable** liquids.
- **DO NOT** fill the fuel tank while the engine is running or hot.
- **DO NOT** overfill tank, since spilled fuel could ignite if it comes into contact with hot engine parts or sparks from the ignition system.
- Store fuel in appropriate containers, in well-ventilated areas and away from sparks and flames.
- **NEVER** use fuel as a cleaning agent.
- **DO NOT** smoke around or near the equipment. Fire or explosion could result from fuel vapors or if fuel is spilled on a hot engine.



TOWING SAFETY

CAUTION

- Check with your local county or state safety towing regulations, in addition to meeting **Department of Transportation (DOT) Safety Towing Regulations**, before towing your generator.
- Refer to MQ Power trailer manual for additional safety information.
- In order to reduce the possibility of an accident while transporting the generator on public roads, **ALWAYS** make sure the trailer that supports the generator and the towing vehicle are mechanically sound and in good operating condition.
- **ALWAYS** shutdown engine before transporting.



- Make sure the hitch and coupling of the towing vehicle are rated equal to, or greater than the trailer “gross vehicle weight rating.”
- **ALWAYS** inspect the hitch and coupling for wear. **NEVER** tow a trailer with defective hitches, couplings, chains, etc.
- Check the tire air pressure on both towing vehicle and trailer. **Trailer tires should be inflated to 50 psi cold.** Also check the tire tread wear on both vehicles.
- **ALWAYS** make sure the trailer is equipped with a **safety chain**.
- **ALWAYS** properly attach trailer’s safety chains to towing vehicle.
- **ALWAYS** make sure the vehicle and trailer directional, backup, brake and trailer lights are connected and working properly.
- DOT Requirements include the following:
 - Connect and test electric brake operation.
 - Secure portable power cables in cable tray with tie wraps.
- The maximum speed for highway towing is **55 MPH** unless posted otherwise. Recommended off-road towing is not to exceed **15 MPH** or less depending on type of terrain.
- Avoid sudden stops and starts. This can cause skidding, or jack-knifing. Smooth, gradual starts and stops will improve towing.
- Avoid sharp turns to prevent rolling.
- Trailer should be adjusted to a level position at all times when towing.
- Raise and lock trailer wheel stand in up position when towing.
- Place **chock blocks** underneath wheel to prevent **rolling** while parked.
- Place **support blocks** underneath the trailer’s bumper to prevent **tipping** while parked.
- Use the trailer’s swivel jack to adjust the trailer height to a level position while parked.

SAFETY INFORMATION

BATTERY SAFETY

DANGER

- **DO NOT** drop the battery. There is a possibility that the battery will explode.
- **DO NOT** expose the battery to open flames, sparks, cigarettes, etc. The battery contains combustible gases and liquids. If these gases and liquids come into contact with a flame or spark, an explosion could occur.



WARNING

- **ALWAYS** wear safety glasses when handling the battery to avoid eye irritation. The battery contains acids that can cause injury to the eyes and skin.
- Use well-insulated gloves when picking up the battery.
- **ALWAYS** keep the battery charged. If the battery is not charged, combustible gas will build up.
- **ALWAYS** recharge the battery in a well-ventilated environment to avoid the risk of a dangerous concentration of combustible gasses.
- If the battery liquid (dilute sulfuric acid) comes into contact with **clothing or skin**, rinse skin or clothing immediately with plenty of water.
- If the battery liquid (dilute sulfuric acid) comes into contact with **eyes**, rinse eyes immediately with plenty of water and contact the nearest doctor or hospital to seek medical attention.



CAUTION

- **ALWAYS** disconnect the **NEGATIVE** battery terminal before performing service on the generator.
- **ALWAYS** keep battery cables in good working condition. Repair or replace all worn cables.

ENVIRONMENTAL SAFETY/DECOMMISSIONING

NOTICE

Decommissioning is a controlled process used to safely retire a piece of equipment that is no longer serviceable. If the equipment poses an unacceptable and unrepairable safety risk due to wear or damage or is no longer cost effective to maintain (beyond life-cycle reliability) and is to be decommissioned (demolition and dismantlement), be sure to follow rules below.

- **DO NOT** pour waste or oil directly onto the ground, down a drain or into any water source.
- Contact your country's Department of Public Works or recycling agency in your area and arrange for proper disposal of any electrical components, waste or oil associated with this equipment.
- When the life cycle of this equipment is over, remove battery and bring to appropriate facility for lead reclamation. Use safety precautions when handling batteries that contain sulfuric acid.
- When the life cycle of this equipment is over, it is recommended that the trowel frame and all other metal parts be sent to a recycling center.



Metal recycling involves the collection of metal from discarded products and its transformation into raw materials to use in manufacturing a new product.

Recyclers and manufacturers alike promote the process of recycling metal. Using a metal recycling center promotes energy cost savings.

EMISSIONS INFORMATION

NOTICE

The diesel engine used in this equipment has been designed to reduce harmful levels of carbon monoxide (CO), hydrocarbons (HC) and nitrogen oxides (NOx) contained in diesel exhaust emissions.

This engine has been certified to meet US EPA Evaporative emissions requirements in the installed configuration.

Attempting to modify or make adjustments to the engine emission system by unauthorized personnel without proper training could damage the equipment or create an unsafe condition.

Additionally, modifying the fuel system may adversely affect evaporative emissions, resulting in fines or other penalties.

Emission Control Label

The emission control label is an integral part of the emission system and is strictly controlled by regulations.

The label must remain with the engine for its entire life.

If a replacement emission label is needed, please contact your authorized engine distributor.

SPECIFICATIONS (COMPRESSOR/ENGINE)

Table 1. Compressor Specifications

| | |
|---|--|
| Model | DIS185SSI4F |
| Type | Single Stage, Oil-Cooled, Screw Type Rotary Compressor |
| Actual Free Air Delivery | 185 cfm (5.2 m ³ min) |
| Rated Operating Pressure | 100 psi (6.9 bar) |
| Maximum Operating Pressure | 105 psi (7.2 bar) |
| Minimum Operating Pressure | 85 psi (5.9 bar) |
| Lube Oil Capacity | 4.5 gallons (17 liters) |
| Oil Chamber | 6.1 gallons (23 liters) |
| Compressor Lube Oil | Chevron CETUS PAO 32 or Shell Corena RS32 (XHVI) |
| Air Service Connections | Two 3/4" NPT |
| Cooling System | Oil Cooler |
| Air Cleaner | 2-Stage Filter |
| Sound Level, Full Load @ 23 Feet | 69 dB(A) |
| Dry Weight (Approx.) | 2,116 lbs. (960 kg) |
| Wet Weight (Approx.) | 2,337 lbs. (1060 kg) |

Table 2. Engine Specifications

| | | |
|---|---|---|
| Model | Isuzu/4LE2T Tier 4 | |
| Type | 4-Cycle, Water-Cooled, Direct Injection, Turbocharged | |
| No. of Cylinders | 4 cylinders | |
| Bore x Stroke | 3.35 in. x 3.78 in. (85 mm x 96 mm) | |
| Displacement | 133 cu. in. (2.179 liter) | |
| Rated Output | 48.3 hp | |
| Rated Engine Speed | 2400 rpm | |
| Engine Idle Speed | 1350 rpm | |
| Starting | Electric | |
| Coolant Capacity | 2.1 gal. (7.9 liters) ¹ | |
| Lube Oil Capacity | 2.7 gal. (10.4 liters) ² | |
| Lubricating Type Oil | API service class CJ-4 SAE or JASO DH-2 | |
| Fuel Type | ASTM-D975-No.1/No.2-D/Ultra Low Sulfur Diesel Fuel | |
| Fuel Tank Capacity | 22 gal. (83 liters) | |
| Fuel Consumption | 2.52 gal. (9.5 L)/hr at full load | 1.36 gal. (5.1 L)/hr at 1/2 load |
| Battery | 12V, Group 27 (CCA 0°F 840A) X 1 | |
| Exhaust Gas After Treatment System | DOC | |

¹ Includes engine and radiator hoses

² Includes filters

SPECIFICATIONS (TRAILER/A-FRAME)

Table 3. Specifications (Trailer/A-Frame)

| | | |
|---|--|---|
| Trailer and Frame | Material | Formed Steel Channel Frame |
| | Number of Axles | 1 |
| | Capacity - Axle Rating | 3,500 lbs. (1,588 kg) |
| | Tires | ST205/75D 14" LR-C |
| | Certifications | DOT |
| | Brakes | Surge Hydraulic-Actuated Drum Brakes |
| | | Electric-Actuated Drum Brakes |
| | Tow Bar | Bolt-On A-Frame |
| | Adjustable Channel/Coupler | 2" Ball, 10,000 lbs. (4,536 kg) Option |
| | | 2-5/16" Ball, 14,000 lbs. (6,350 kg) Option |
| | | 3" Pintle, 14,000 lbs. (9,072 kg) |
| | Tongue Mounted Swivel Jack With Caster Wheel | 2,000 lbs. (907 kg) |
| Tail, Stop, Turn and Side Marker Lamps. | DOT Approved | |
| Suspension | Leaf Spring | |

To order go to Discount-Equipment.com

DIMENSIONS

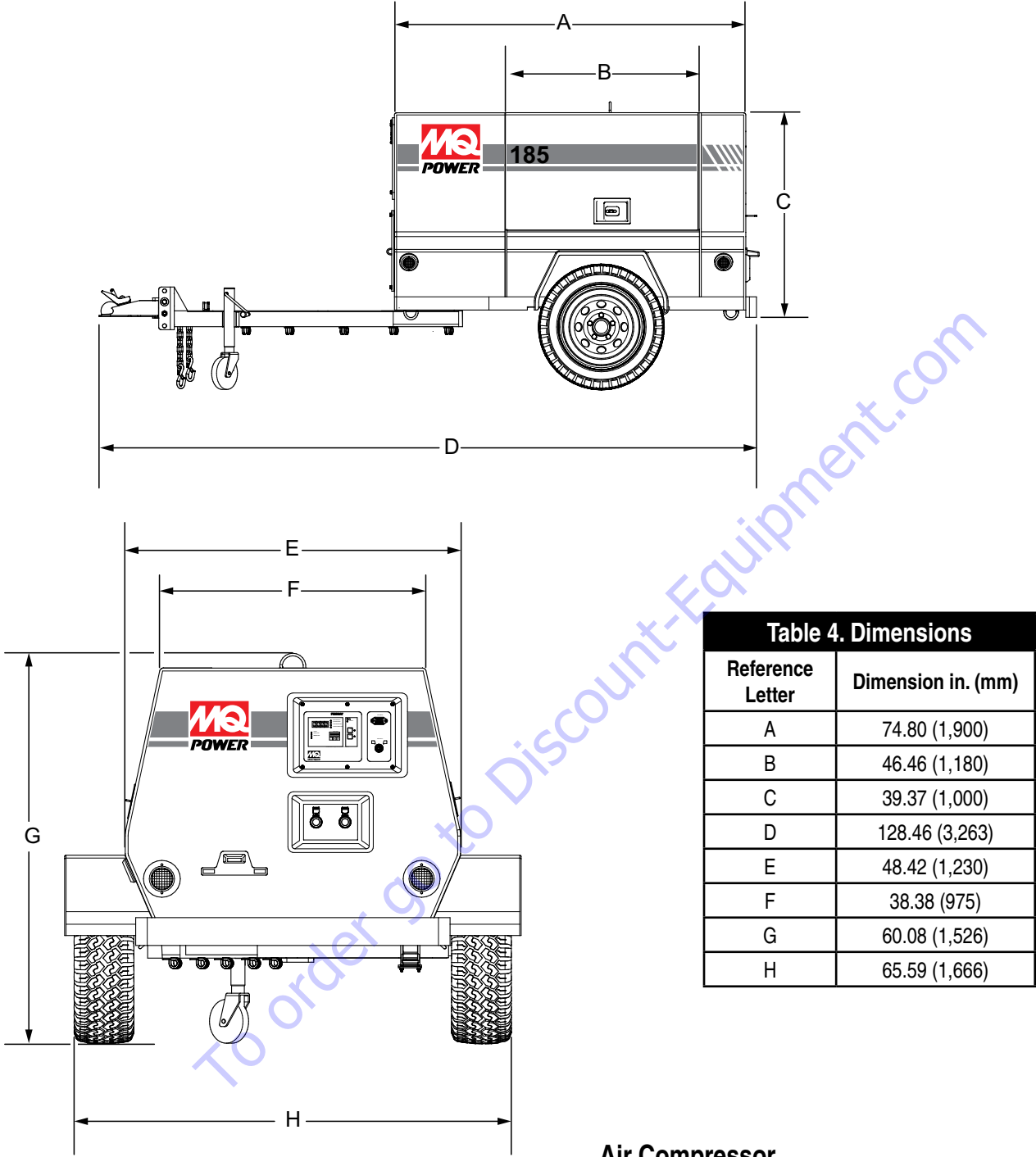

Figure 2. Dimensions

Air Compressor

The Multiquip DIS185SSI4F is a 185 ft³/minute rotary screw type air compressor designed as a supplemental pneumatic power source for pneumatically operated power tools.

GENERAL INFORMATION

CONTROL PANEL

The control panel is provided with the following:

■ Digital Controller

- 7-Segment Display
- Display Status LED
- Error Code Status LED
- Warm-Up Time LED
- Delivery Air Pressure Status LED
- Engine Speed Status LED
- Discharge Air Temperature Status LED
- Water Temperature Status LED
- Fuel Level Status LEDs
- Engine Diagnostic Tool
- Menu Button
- Up-Down Selection Arrows
- Battery Charge Status LED
- Preheat Status LED
- Run Button/Status LED
- Stop Button/Status LED

■ Hour Meter

■ Main Switch (Ignition Switch)

AIR OUTPUT PORTS

This compressor is equipped with two air output ports. Both ports are equipped with quick-disconnect fittings and can be turned off or on by turning the control valve handle to the appropriate position.

⚠ WARNING

Be careful when disconnecting air compressor hose lines. Residual pressure can cause severe injury. Be sure to release (bleed) residual pressure before removing hose line.

NOTICE

NEVER operate the air compressor with the doors **open** (Figure 3). Operation with the doors open may cause insufficient cooling of the unit, and engine damage may result. Close the doors for normal operation.

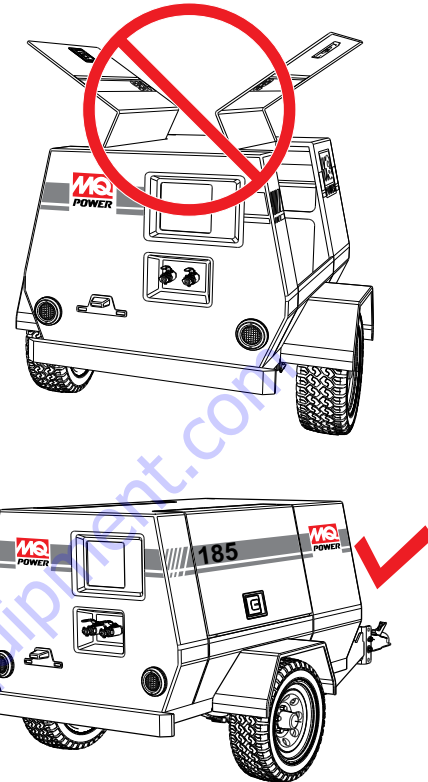

Figure 3. Doors Closed

TRANSPORT

This compressor is trailer-mounted for easy transport by a towing vehicle. Trailer is equipped with an adjustable 4-hole channel that accepts either a ball or pintle coupler. All tail stop, turn signal and side marker lamps are D.O.T.-approved.

ENGINE

This compressor is powered by a 4-cylinder, 4-cycle water cooled, direct injection, turbocharged, air-cooled EGR Isuzu 4LE2T diesel engine. This engine is designed to meet every performance requirement for the air compressor. Reference Table 2 for engine specifications.

ELECTRIC GOVERNOR SYSTEM

The electric governor system controls the RPMs of the engine. When the engine demand increases or decreases, the governor system regulates the frequency variation to $\pm 0.25\%$.

APPLICATIONS

This air compressor can be used for a variety of pneumatic applications (Figure 4), such as concrete pump (shotcrete), vibratory screed, jackhammer, nail gun, spray paint gun, impact wrench, and pressure washer, just to name a few.

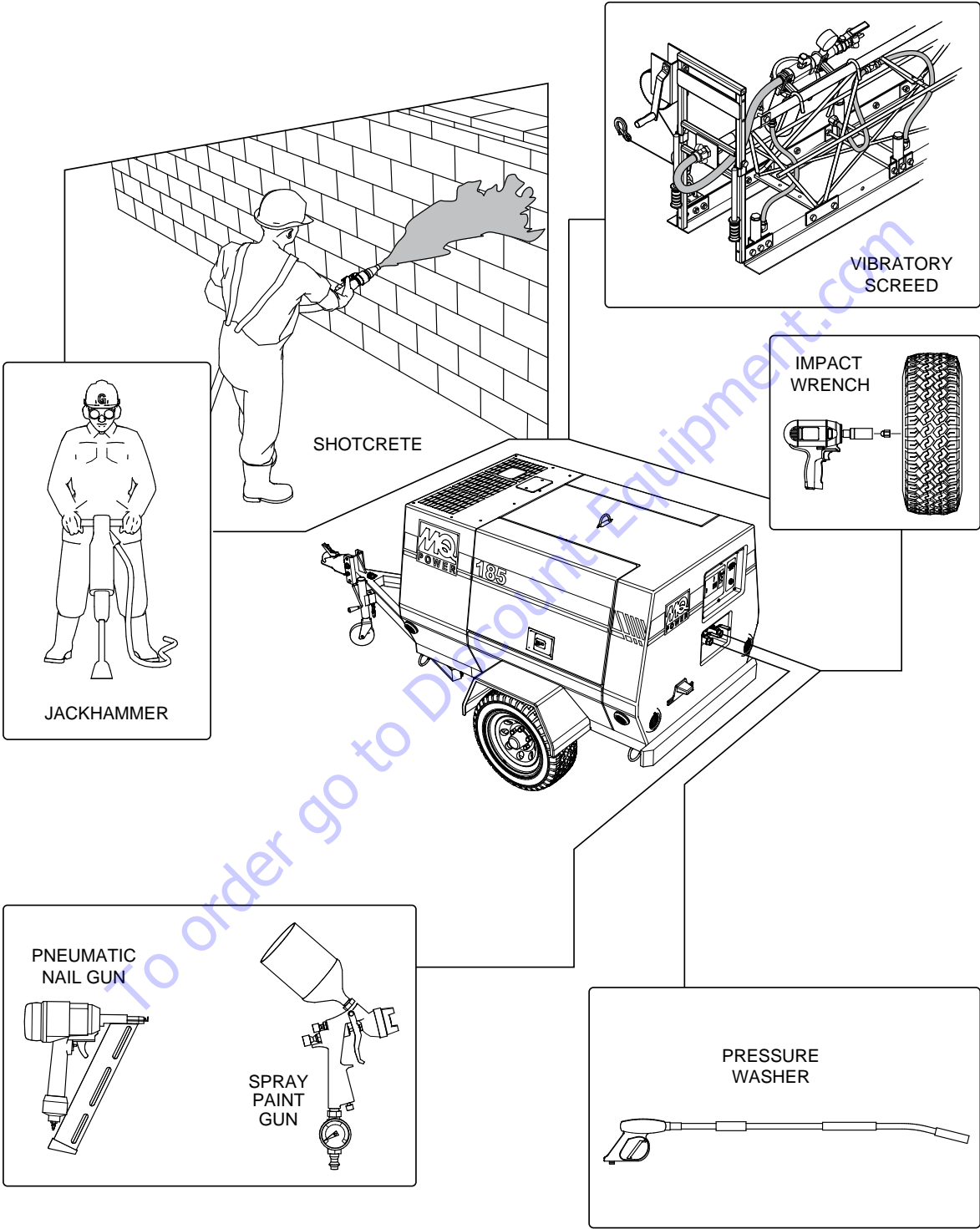

Figure 4. Air Compressor Applications

MAJOR COMPONENTS (BATTERY SIDE)

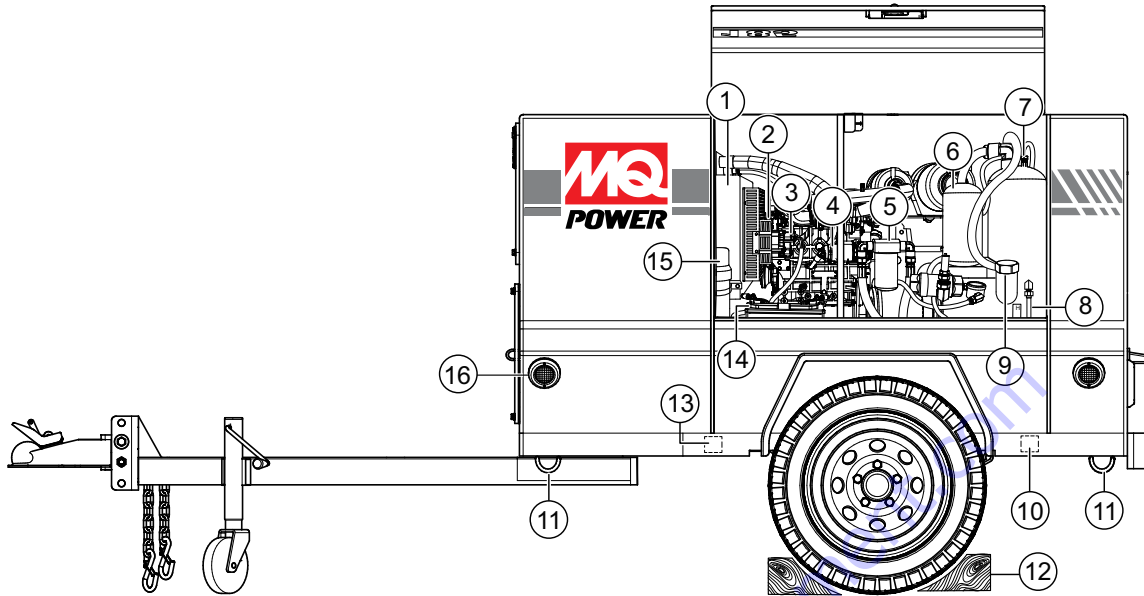

Figure 5. Major Components (Battery Side)

1. **Radiator/Cap** — Holds coolant/water necessary to allow the engine to operate at a safe temperature. Allow the engine to cool before removing radiator cap. The possibility exists of severe scalding if cap is removed while engine is hot.
2. **V-Belt** — **ALWAYS** make sure the V-belt is properly tensioned. A loose or defective V-belt can adversely affect the performance of the engine.
3. **Alternator** — Provides alternating current to the +12VDC electrical system. Replace with only manufacturer recommended type alternator.
4. **Starter Solenoid** — Starts engine when ignition key is placed in the "ON" position.
5. **Secondary Hydraulic Filter** — Spin-on type, filters hydraulic oil for contaminants not filtered by the primary hydraulic filter.
6. **Primary Hydraulic Filter** — Spin-on type, initial filtration of hydraulic oil for contaminants.
7. **Compressed Air Receiver Tank** — Stores 185 cubic feet of compressed air.
8. **Compressor Oil Sight Tube** — Indicates the amount of oil in the air receiver tank oil chamber. Fill with synthetic type oil/lubricant as specified in Table 1.
9. **Oil Chamber Fill Cap** — Remove this cap/plug and fill with type oil as specified in Table 1. **DO NOT** remove cap until unit has cooled and the high internal pressure within the air receiver tank has dissipated.
10. **Oil Chamber Drain Plug** — Remove this plug to drain the oil in the oil chamber.
11. **Tie-Down Points** — Used to tie down air compressor with straps or chains to allow even application of force to the front and rear of the equipment during transport.
12. **Chock Block** — Place blocks (not included as part of the air compressor package) under each trailer wheel to prevent rolling.
13. **Engine Oil Drain Plug** — Remove this plug to drain the oil from the engine crankcase.
14. **Battery** — Provides +12VDC to the electrical system. Replace with only recommended type battery.
15. **Documentation Canister** — Storage for documentation and other information regarding the air compressor.
16. **Side Marker Lamps** — There are four side marker lights located on air compressor. The front circular lights (tongue side) are amber. The rear rectangular reflectors are red.

MAJOR COMPONENTS (FUEL TANK SIDE)

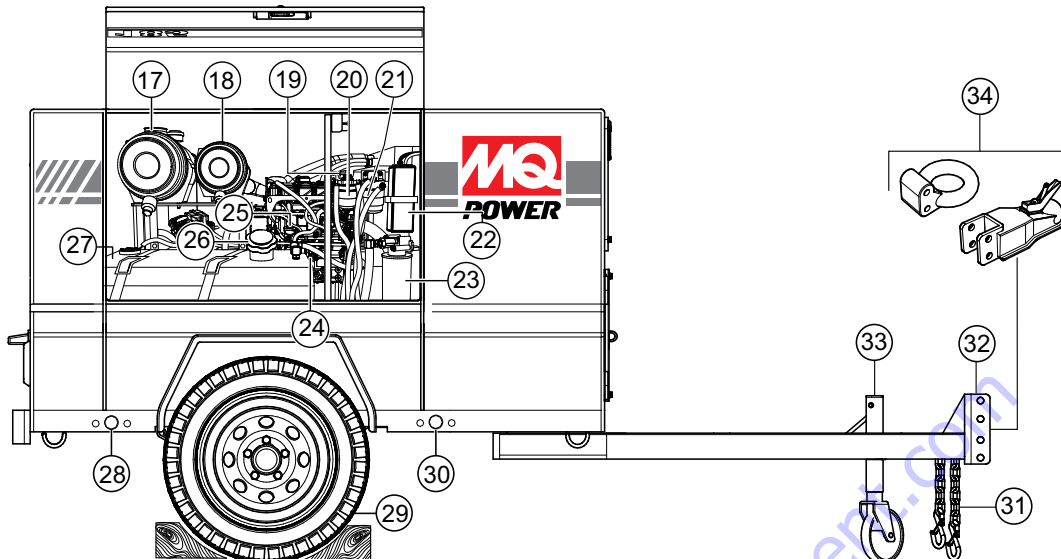

Figure 6. Major Components (Fuel Tank Side)

17. **Compressor Air Filter** — Loosen clips on side of air filter canister to gain access to filter element. Replace with only manufacturer recommended type air filter.
18. **Engine Air Filter** — Loosen clips on side of air filter canister to gain access to filter element. Replace with only manufacturer recommended type air filter.
19. **Engine Oil Filler Cap (Top)** — Remove this cap to add engine oil. Use only the recommended type oil as listed in Table 2.
20. **Fuel Filter (Main)** — Prevents dirt and other debris from entering the fuel system. Change fuel filter as recommended in the maintenance section of this manual.
21. **Fuel Filter (Pre)** — Prevents dirt and other debris from entering the fuel system. Change fuel filter as recommended in the maintenance section of this manual.
22. **Coolant Recovery Tank** — Supplies coolant to the radiator when radiator coolant level is low. Fill to indicated level as shown on bottle/tank.
23. **Engine Oil Filter** — Provides filtering for the engine oil. Change oil filter as recommended in the maintenance section of this manual. Use only the recommended type oil as listed in Table 2.
24. **Engine Oil Dipstick** — Remove to check the amount and condition of the oil in the crankcase.
25. **Engine Oil Filler Cap (Side)** — Remove this cap to add engine oil. Use only the recommended type oil as listed in Table 2.
26. **Fuel Cap** — Remove this cap to add fuel. Add fuel type as specified in Table 2. Always keep an adequate amount of fuel in the fuel tank. **DO NOT** top off. Wipe up any spilled fuel immediately.
27. **Fuel Tank** — Holds 22.0 gallons (83 liters) of diesel fuel.
28. **Fuel Drain Plug** — Remove this plug to drain fuel from the fuel tank.
29. **Tires** — This compressor uses an ST175-80D size tire. Replace only with recommended tire size. **NEVER** tow compressor with bad or worn tires.
30. **Coolant Drain Plug** — Remove this plug to drain the coolant from the radiator.
31. **Safety Chains** — **ALWAYS** attach safety chains to the towing vehicle. **NEVER** tow the air compressor with the safety chains unattached. Make sure safety chains are crossed when towing.
32. **Adjustable Channel** — 4-hole channel, allows 3-position adjustable coupler height
33. **Jack Stand** — Use this jackstand to support the trailer tongue when attaching the compressor to a towing vehicle.
34. **Couplers** — This unit can accept 2-inch, 2 ⁵/₁₆-inch and 3-inch pintle couplers.

MAJOR COMPONENTS (FRONT/REAR/TOP)

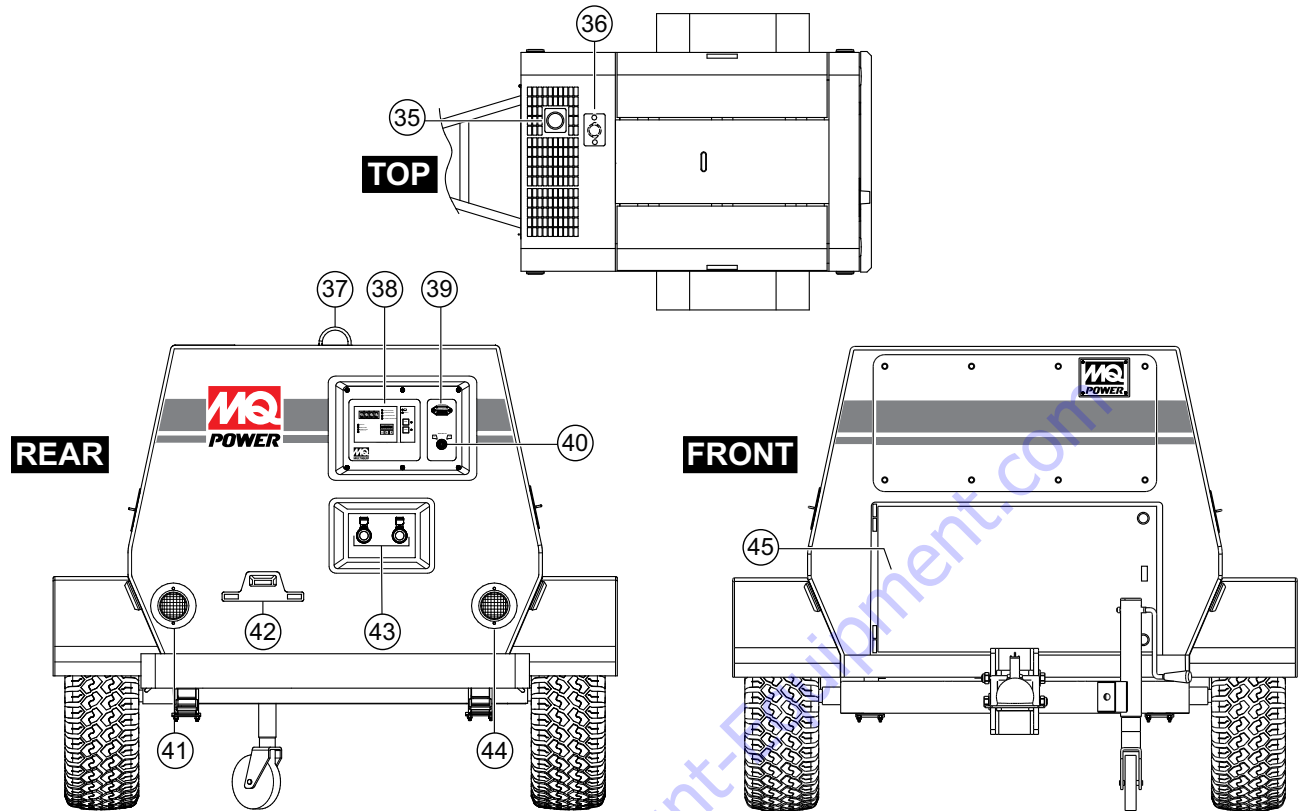

Figure 7. Major Components (Front, Rear And Top)

35. **Exhaust Port** — Never block this exhaust port. Use only in well-ventilated areas. Always vent exhaust gas outside.
36. **Coolant Inlet Port** — Remove cover plate to add coolant to the radiator. Never remove radiator cap when radiator is hot.
37. **Lifting Hook** — Attach a suitable lifting device, capable of lifting 2400 lbs. (1,089 kg), to this lifting point. This lifting point has been positioned for a fully balanced/configured air compressor. Removal of any components will unbalance the compressor.
38. **Control Panel** — Includes digital controller and status LEDs. Digital controller is linked to the electronic control unit of the engine.
39. **Hour Meter** — Indicates the number of hours machine has been in use.
40. **Ignition Switch** — To start engine, insert key into ignition switch (main switch) and turn clockwise to the **ON** position. When unit is not in use, turn ignition key to **OFF** position and remove key.
41. **Left Tail/Brake Light** — Before towing the air compressor, make sure that light is operational and is working correctly. **NEVER** tow the air compressor if light is inoperative.
42. **License Plate Light** — This light illuminates the license plate. **NEVER** tow the air compressor if light is inoperative.
43. **Air Output Valves** — Connect pneumatic air tools to these valves. **NEVER** remove air hoses from these valves while residual air pressure exists. Make sure there is no residual air pressure before removing hoses.
44. **Right Tail/Brake Light** — Before towing the air compressor, make sure that light is operational and is working correctly. **NEVER** tow the air compressor if light is inoperative.
45. **Storage Compartment** — Use this compartment to store tools, hoses etc.

CONTROL PANEL

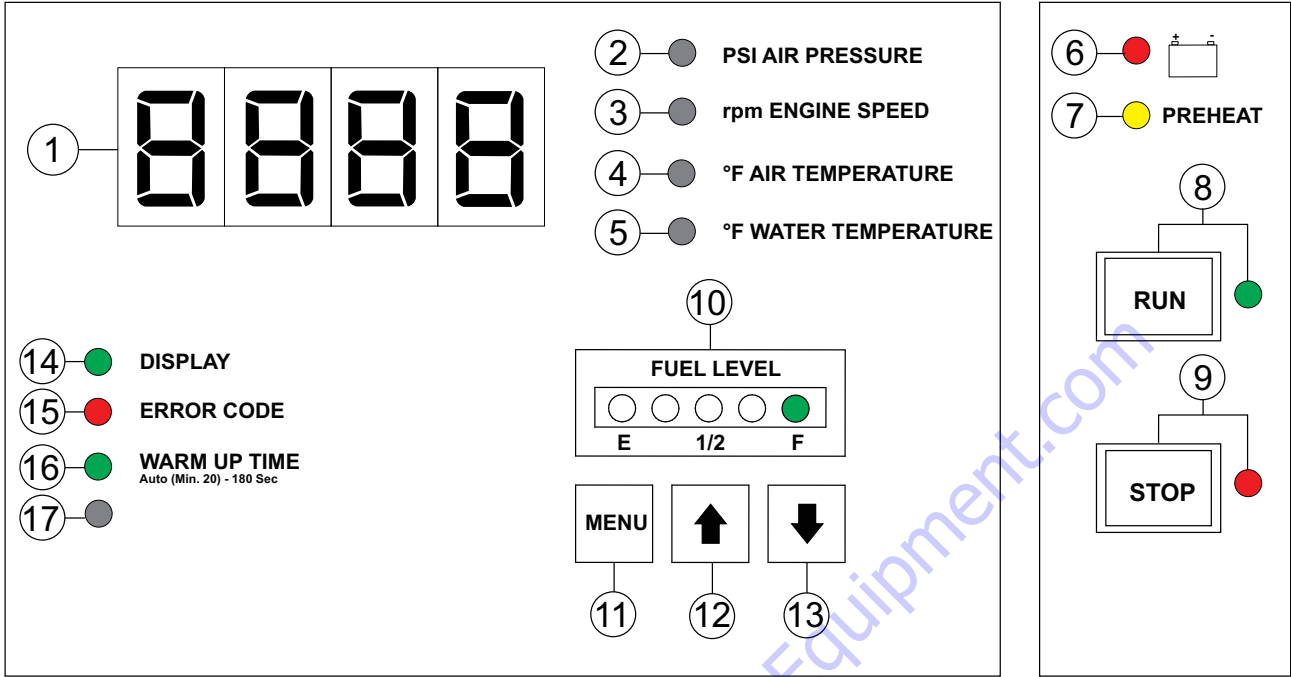

Figure 8. Control Panel

CONTROL PANEL

The definitions below describe the controls and functions of the control panel (Figure 8).

1. **7-Segment Display** — Displays compressor and engine related information. During operation, pressing the down arrow (↓) button will cycle the display between engine speed, air temperature and water temperature. In addition, this display will indicate engine error codes and alarm messages.
2. **Air Pressure LED** — When lit (**ON**) the output pressure value (psi) will be displayed on the 7-segment display.
3. **Engine Speed LED** — When lit (**ON**) the engine speed (rpm) will be displayed on the 7-segment display.
4. **Air Temperature LED** — When lit (**ON**) the air temperature (°F) will be displayed on the 7-segment display.
5. **Engine Water/Coolant Temperature LED** — When lit (**ON**) the engine water/coolant temperature (°F) will be displayed on the 7-segment display.
6. **Battery Charge LED** — Is lit (**RED**) when the ignition switch is placed in the **ON** position. Will turn **OFF** after engine has started. LED will illuminate if a charging error has occurred, such as a broken fan belt.
7. **Pre-Heat LED** — When the ignition switch is placed in the **ON** position, this LED will illuminate (**YELLOW**) to indicate pre-heating of the engine glow plugs. When the LED turns off, this indicates that the preheat cycle is complete and the engine will start automatically.
8. **Run Button/LED** — Press this button for at least 2 seconds to start the air compressor. Ignition key must be in the **ON** position. The **RUN LED (GREEN)** will turn on, indicating the air compressor is now ready for use.
9. **Stop Button** — Press this button to stop the air compressor. The **STOP LED (RED)** will turn on, indicating that the air compressor is no longer active.
10. **Fuel Tank LEDs** — Indicates amount of fuel in the fuel tank. As fuel level approaches empty (1.2 – 3.4 gal.), **RED LED** will light at **half** intensity. When **RED LED** lights at **full** intensity (1.8 gal. or less), engine will shutdown.
11. **Menu Button** — When the menu button is pressed, the 7-segment display will cycle between display, error codes and warm-up times. The selected items can be confirmed or changed using the up (↑) or down (↓) arrow buttons.
12. **Up Arrow (↑) Button** — Press this button to scroll upwards. Works in conjunction with the menu button. Selected items can be confirmed or changed.
13. **Down Arrow (↓) Button** — Press this button to scroll downwards. Works in conjunction with the menu button. Selected items can be confirmed or changed.
14. **7-Segment Display LED** — When lit (**ON**) operating parameters and settings such as compressor air pressure (psi), engine speed (rpm), compressor air temperature (°F), and engine water temperature (°F) can be viewed on the display.
15. **Error Code LED** — This LED will light **RED** during operation if the engine control unit detects a mechanical or electrical fault in the air compressor. Error codes can be accessed from the display.
16. **Warm-Up Time LED** — This LED will light upon initial start-up and will remain lit until the air compressor reaches safe operational temperature. The default warm-up time is 5 seconds. For cold weather conditions, the unit can be set for a range between 30 – 180 seconds.
17. **Other Functions LED** — This LED is not selectable with the normal menu button. It is displayed when a setting change is performed during a pre-shipping test or when the unit is being serviced by maintenance workers.

CHECKING ENGINE OIL

1. To check the engine oil level, place the air compressor on secure level ground with the engine stopped.
2. Remove the engine oil dipstick from its holder (Figure 9) and wipe clean.

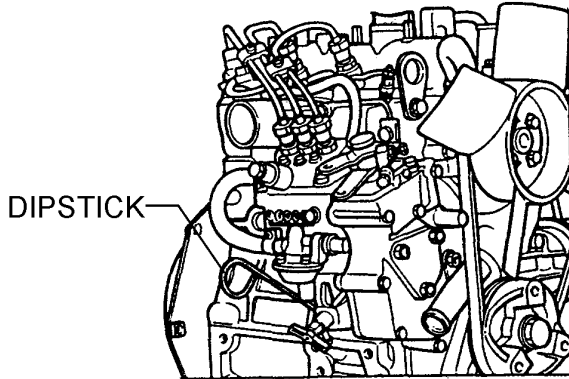

Figure 9. Dipstick Removal

3. Re-insert oil dipstick then remove oil dipstick from its holder. Check the oil level shown on the dipstick (Figure 10).

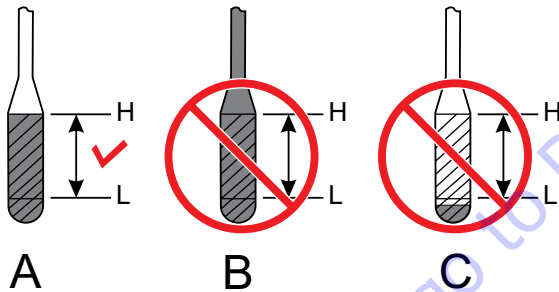

Figure 10. Engine Oil Dipstick

4. Verify that the engine oil level is maintained between the **H** and **L** markings on the dipstick as referenced in Figure 10A.
5. If the engine oil level is low (Figure 10C), remove the oil filler cap (Figure 11) and fill to a safe operating level (max) as indicated by the dipstick (Figure 10A).

NOTICE

When adding engine oil, **DO NOT** overfill (Figure 10B).

6. Fill with recommended type oil as listed in Table 2 and Table 5. Maximum oil capacity is 2.7 gallons (10.4 liters).

NOTICE

When checking the engine oil, be sure to check if the oil is **clean**. If the oil is not clean, drain the oil by removing the oil drain plug, and refill with the correct amount of oil as specified in Table 2. Oil should be warm before draining.

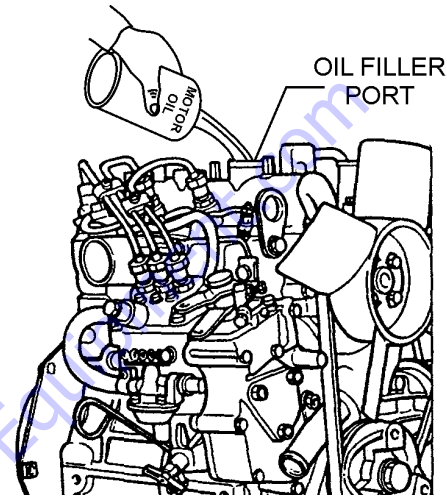

Figure 11. Engine Oil Filler Port

NOTICE

The viscosity of the engine oil is an important factor in determining engine wear. When an oil of inappropriate viscosity is used, rapid engine wear or failure may occur. Use oil of an appropriate viscosity suitable for the outside air temperature as referenced in Table 5.

Table 5. Oil Type

| Temperature | Oil Type |
|--|-----------|
| -22° ~ +86° F (-30° ~ +30° C) | SAE10W-30 |
| -22° ~ +86° F or greater (-30° ~ +30° C or greater) | SAE10W-40 |
| 5° ~ +86° F or greater (-15° ~ +30° C or greater) | SAE15W-40 |

CHECKING COMPRESSOR OIL

1. To check the compressor oil level, place the air compressor on secure level ground with the engine stopped.
2. Verify that the tubular sight gauge (Figure 12) indicates the appropriate compressor oil level.

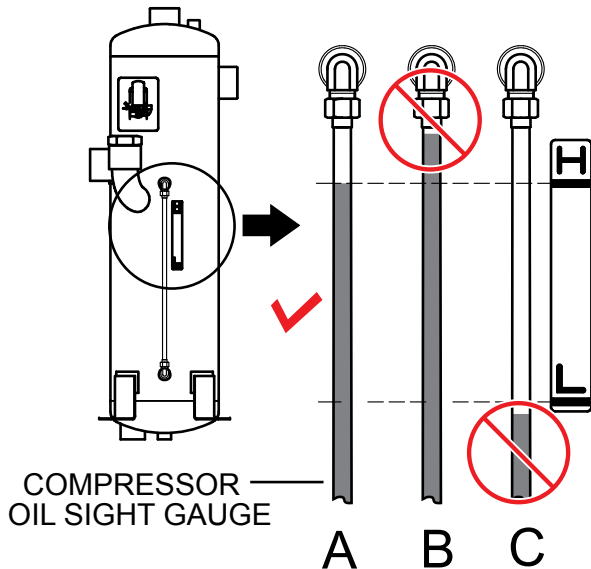

Figure 12. Checking Compressor Oil Level

3. Verify that the compressor oil level is maintained between the **H** and **L** markings on the sight gauge (clear plastic tube) as referenced in Figure 12A.
4. If the compressor oil level is low (Figure 12C), remove the compressor oil fill plug (Figure 13) and fill to a safe operating level (max) as indicated by the sight gauge (Figure 12A).

NOTICE

When adding compressor oil, **DO NOT** overfill (Figure 12B).

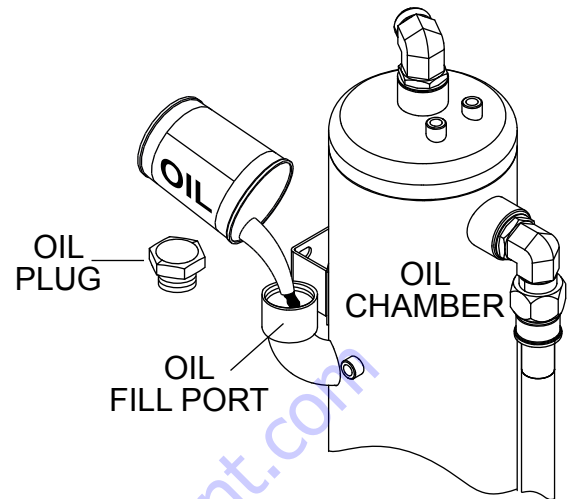

Figure 13. Adding Oil (Oil Chamber)

CHECK OIL CHAMBER DRAINAGE

NOTICE

Sometimes, excessive amounts of water may accumulate within the oil chamber. This water must be removed from the oil chamber before the air compressor can be placed into operation.

1. Place a drain pan/container underneath oil chamber drain valve (street-side) as shown in Figure 14.
2. Open the oil chamber drain valve (Figure 14) slightly and let contents flow (drain) until oil is visible. Once oil is visible, close drain valve immediately.

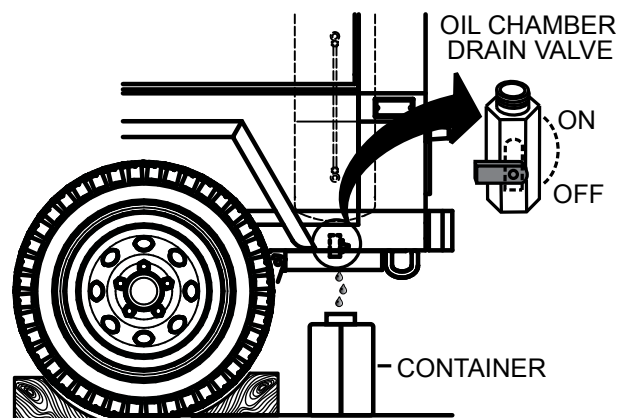



Figure 14. Oil Chamber Drainage

INSPECTION/SETUP

COOLANT (ANTIFREEZE/SUMMER COOLANT/WATER)

Isuzu recommends antifreeze/summer coolant for use in their engines, which can be purchased in concentrate (and mixed with 50% demineralized water) or pre-diluted. See the **Isuzu Engine Owner's Manual** for further details.

WARNING



If adding coolant/antifreeze mix to the radiator, **DO NOT** remove the radiator cap until the unit has completely cooled. The possibility of **hot** coolant exists which can cause severe burns.

Day-to-day addition of coolant is done from the coolant recovery tank. When adding coolant to the radiator, **DO NOT** remove the radiator cap until the unit has completely cooled. See Table 6 for engine, radiator, and recovery tank coolant capacities. Make sure the coolant level in the recovery tank is always between the “**FULL**” and “**LOW**” markings.

NOTICE

Normally, only the coolant level in the recovery tank needs to be checked. However, the radiator cap should be opened once a week to verify that coolant is visible (full) in the radiator.

| Component | Capacity |
|---------------------|----------------------|
| Engine and Radiator | 2.1 gal (7.4 liters) |
| Reserve Tank | N/A |

1. Verify that the coolant level in the coolant recovery tank is between the **FULL** and **LOW** markings as shown in Figure 15.

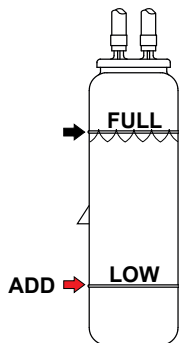

Figure 15. Coolant Recovery Tank

2. If coolant level is **LOW**, add coolant immediately and fill to the **FULL** marking on the coolant recovery tank.

Operation in Freezing Weather

When operating in freezing weather, be certain the proper amount of antifreeze (Table 7) has been added.

| Vol % Anti-Freeze | Freezing Point | |
|-------------------|----------------|-----|
| | °C | °F |
| 50 | -37 | -34 |

NOTICE

When the antifreeze is mixed with water, the antifreeze mixing ratio **must be** less than 50%.

CLEANING THE RADIATOR

The engine may overheat if the radiator fins become overloaded with dust or debris. Periodically clean the radiator fins with compressed air. Cleaning inside the machine is dangerous, so clean only with the engine turned **off** and the **negative** battery terminal disconnected.

FAN BELT TENSION

A slack fan belt may contribute to overheating, or to insufficient charging of the battery. Inspect the fan belt for damage and wear and adjust it in accordance with the **Isuzu Engine Owner's Manual**.

The fan belt tension is proper if the fan belt bends 10 to 15 mm (Figure 16) when depressed with the thumb as shown below.

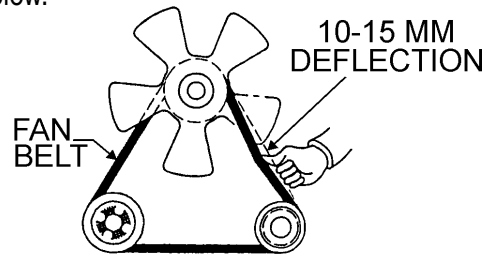



Figure 16. Fan Belt Tension

CAUTION



NEVER place hands near the belts or fan while the air compressor is running.

FUEL CHECK

1. Place the main switch (ignition key) in the **ON** position.
2. Check the fuel level gauge as shown in Figure 17.

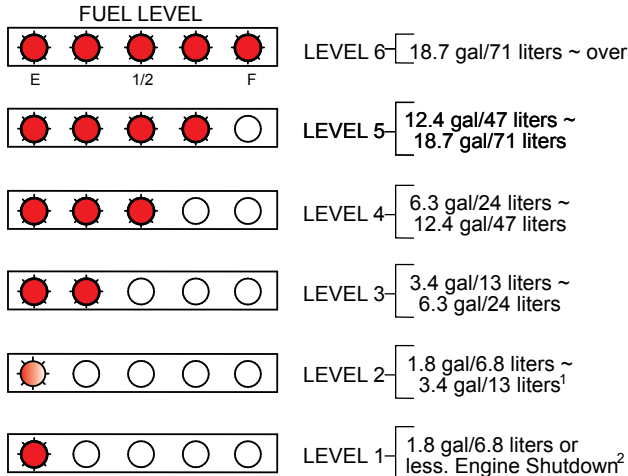

¹ Half Lit Red LED

² Full Lit Red LED

Figure 17. Fuel Gauge Check

REFUELING

DANGER



Fuel spillage on a **hot** engine can cause a **fire** or **explosion**. If fuel spillage occurs, wipe up the spilled fuel completely to prevent fire hazards. **NEVER** smoke around or near the air compressor.

WARNING



Diesel fuel and its vapors are dangerous to your health and the surrounding environment. Avoid skin contact and/or inhaling fumes.

CAUTION

ALWAYS place air compressor on firm level ground before refueling to prevent spilling and maximize the amount of fuel that can be pumped/poured into the fuel tank.

NOTICE

ONLY use #2 diesel fuel (ultra low sulfur diesel fuel) when refueling. When refueling, be sure to use a strainer for filtration.

3. If fuel level is low, lift and open the enclosure door (curbside). Remove fuel cap from fuel tank and fill fuel tank (Figure 18) with #2 diesel fuel. **DO NOT** fill the tank beyond capacity.

NOTICE

DO NOT OVERFILL fuel system. Leave room for fuel expansion. Fuel expands when heated.

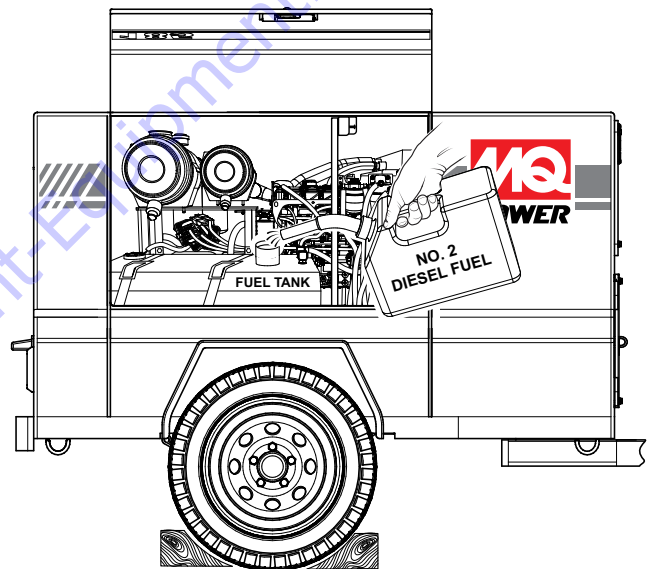

Figure 18. Adding Fuel

4. Pay attention to the fuel tank capacity when replenishing fuel. Refer to the fuel tank capacity listed in Table 2.
5. The fuel tank cap must be closed tightly after filling. Handle fuel in a safety container. If the container does not have a spout, use a funnel.

AIR CLEANER

Periodic cleaning/replacement of the air cleaner is necessary. Inspect air cleaner in accordance with the Isuzu Engine Owner's Manual and maintenance section of this manual.

BATTERY

This unit is a negative ground type. **DO NOT** connect in reverse. Always maintain battery fluid level between the specified marks. Battery life will be shortened if proper fluid levels are not maintained. Add only distilled water when replenishment is necessary.

DO NOT over fill. Check to see whether the battery cables are loose. Poor contact may result in poor starting or malfunctions. **Always** keep the terminals firmly tightened. Coat the terminals only with an approved battery terminal treatment compound. Replace battery with only recommended type battery. The battery type used in this generator is BCI Group 27.

The battery is sufficiently charged if the specific gravity of the battery fluid is 1.28 (at 68° F). If the specific gravity should fall to 1.245 or lower, the battery is dead and needs to be recharged or replaced.

Before charging the battery with an external electric source, be sure to disconnect the battery cables.

Battery Cable Installation

ALWAYS be sure the battery cables (Figure 19) are properly connected to the battery terminals as shown below. The **red cable** is connected to the positive terminal of the battery, and the **black cable** is connected to the negative terminal of the battery.

CAUTION

ALWAYS disconnect the negative terminal **FIRST** and reconnect negative terminal **LAST**.

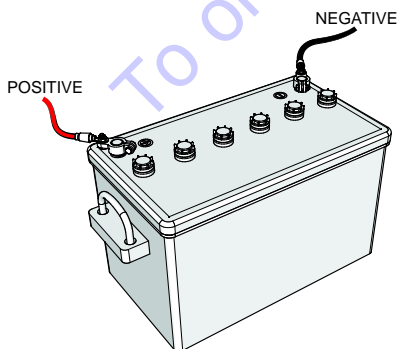

Figure 19. Battery Connections

When connecting the battery, do the following:

1. **NEVER** connect the battery cables to the battery terminals when the main switch (ignition switch) is in the **ON** position.
2. Place a small amount of battery terminal treatment compound around both battery terminals. This will ensure a good connection and will help prevent corrosion around the battery terminals.

NOTICE

If the battery cable is incorrectly connected, electrical damage to the generator will occur. Pay close attention to the polarity of the battery terminals when connecting the battery.

CAUTION

Inadequate battery connections may cause poor starting of the generator, and create other malfunctions.

ALTERNATOR

The polarity of the alternator is negative grounding type. When an inverted circuit connection takes place, the circuit will be in short circuit instantaneously, resulting in alternator failure.

DO NOT put water directly on the alternator. Entry of water into the alternator can cause corrosion and damage the alternator.

WIRING

Inspect the entire air compressor for bad or worn electrical wiring or connections. If any wiring or connections are exposed (insulation missing) replace wiring immediately.

PIPING AND HOSE CONNECTION

Inspect all piping, oil hose, and fuel hose connections for wear and tightness. Tighten all hose clamps and check hoses for leaks.

If any hose (**fuel or oil**) lines are defective, replace them immediately.

AIR HOSE CONNECTION

1. Connect the load air hose to the air outlet valves as shown in Figure 20.
2. Make sure that both air outlet valve handles are placed in the **CLOSED** position.

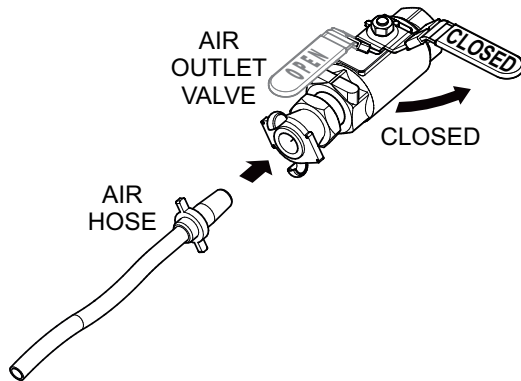

Figure 20. Connecting Air Hose

START-UP

1. Turn the main switch (ignition switch) key to the **ON** position (Figure 21).

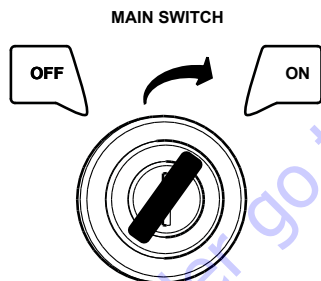

Figure 21. Main Switch (ON Position)

2. Next, press the **RUN** button (Figure 22) on the control panel for at least 2 seconds to start the preheat cycle.

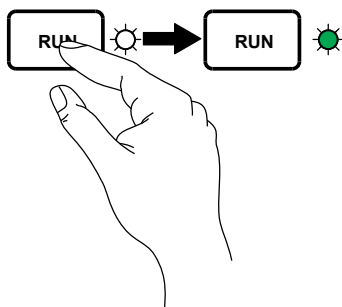

Figure 22. Run Button (Starting)

3. Verify that the **preheat** LED on the control panel is lit (**YELLOW**).
4. The engine will start automatically after the preheat cycle has been completed.
5. Once the engine has started and has reached normal operating speed, the **RUN** LED (Figure 22) will turn on and the unit will enter warm-up mode.
6. When the warm-up time is set to **AUTO** mode (default), the engine fluid will be checked automatically. The warm-up cycle will continue until the engine fluid temperature has reached 86 °F (30 °C).
7. During warm-up (Figure 23) the compressor air pressure will be displayed on the 7-segment display and the display LED will be lit (**GREEN**).

NOTICE

Units are shipped from the factory in **AUTO** mode. When in **AUTO** mode, the warm-up time is set to a minimum of 5 seconds. To change the warm-up cycle time, please reference "**WARM-UP ADJUSTMENT**" in the operation section of this manual.

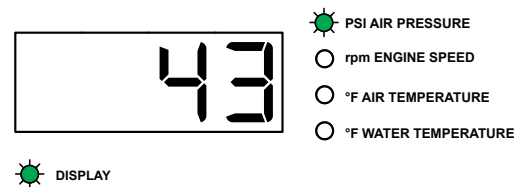

Figure 23. Warm-up Mode

8. Once the engine temperature has reached 86 °F (30 °C), the warm-up cycle will end and the unit will switch to the no load mode.
9. Verify that the compressor air pressure has increased (Figure 24) by reading the value on the 7-segment display

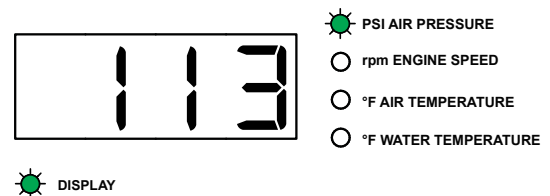

Figure 24. No Load Mode

OPERATION

10. Place the selected air outlet valve (Figure 25) in the **OPEN** position to deliver compressed air to the load.

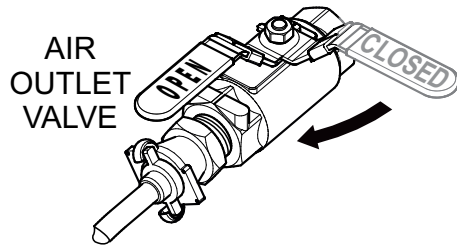

Figure 25. Air Outlet Valve (OPEN)

11. Verify that the engine speed increases evenly when opening the air outlet valve and smoothly decreases when closing the valve.
12. Press the down arrow button (↓) to cycle through the various compressor/engine operating parameters while the unit is running for **no load** and **full load** conditions (Figure 26).

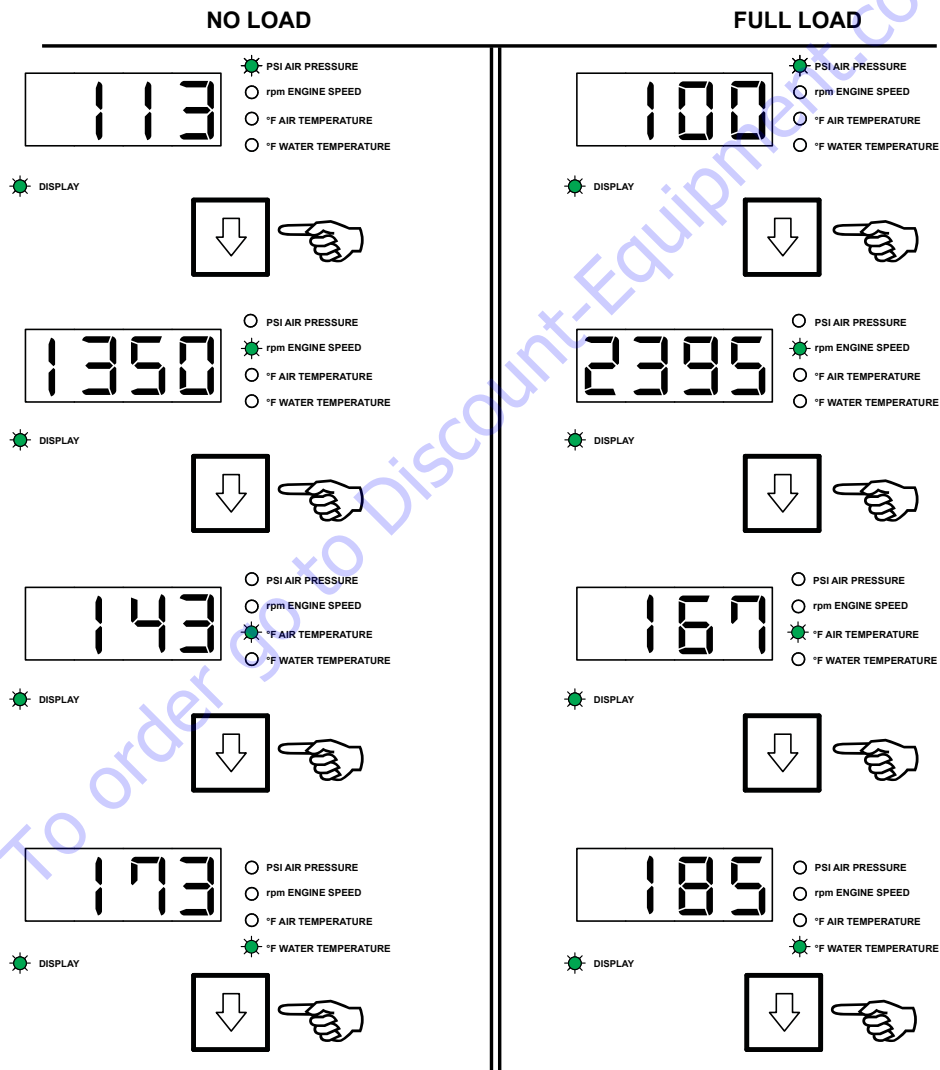

Figure 26. Engine Operating Parameters

WARM-UP ADJUSTMENT

In cold weather conditions, a longer warm-up time than normal may be desired. To change the warm-up time, do the following.

1. Make sure the main switch (ignition switch) key is turned to the **ON** position (Figure 27).

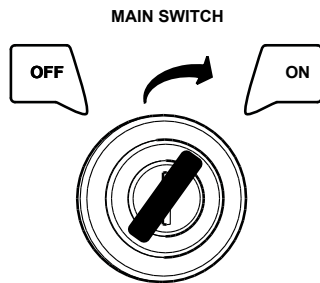

Figure 27. Main Switch (ON Position)

2. The 7-segment display will show the output pressure setting (Figure 28). Press the **MENU** button repeatedly until the **WARM UP TIME** LED lights up.

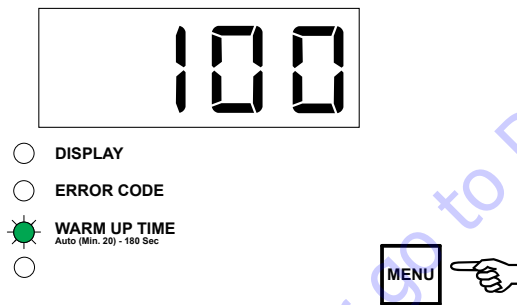

Figure 28. Warm-Up Adjustment

3. By default, the 7-segment display will read "AUTO" (Figure 29).



Figure 29. Warm-Up Adjustment

4. Press the **UP ARROW** button (↑) to change the setting from "AUTO" (default) to **30**, **60**, **90**, **120**, or **180** seconds (Figure 30). Verify the time selected by reading the value on the 7-segment display.

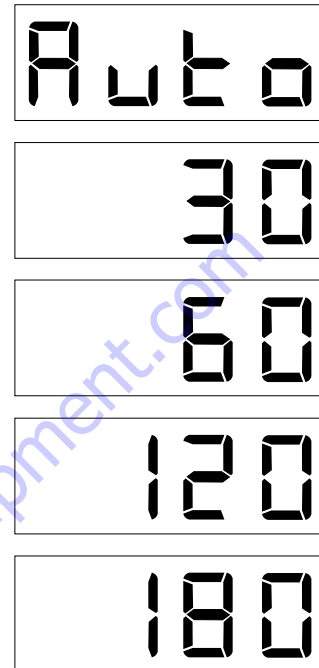

Figure 30. Warm-Up Adjustment

PRESSURE ADJUSTMENT

1. Make sure the main switch (ignition switch) key is turned to the **ON** position (Figure 31).

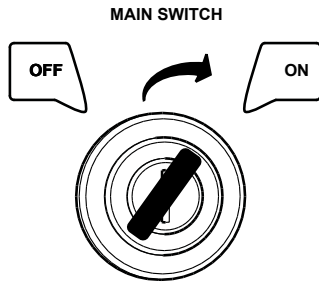

Figure 31. Main Switch (ON Position)

2. Press and hold the **MENU** and **STOP** buttons simultaneously (Figure 32).

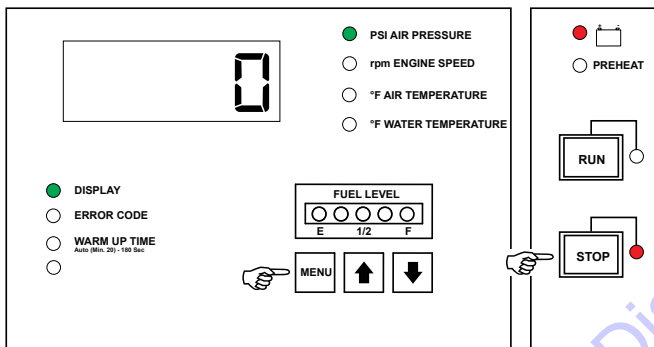

Figure 32. Pressure Adjustment

3. The 7-segment display will now read "0 ---" and the **OTHER FUNCTIONS** LED will light up (Figure 33).

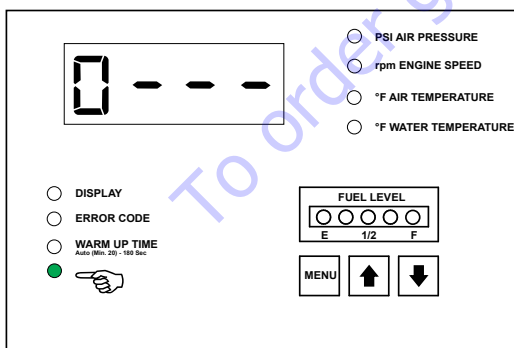

Figure 33. Pressure Adjustment

4. Press the **DOWN ARROW** (↓) button repeatedly until the first digit on the 7-segment display reads "F" (Figure 34).



Figure 34. Pressure Adjustment

5. Press the **MENU** button.
6. Press the **DOWN ARROW** (↓) button repeatedly until the second digit on the 7-segment display reads "d" (Figure 35).

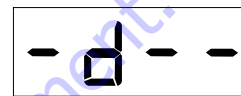

Figure 35. Pressure Adjustment

7. Press the **MENU** button.
8. Press the **DOWN ARROW** (↓) button repeatedly until the third digit on the 7-segment display reads "C" (Figure 36).

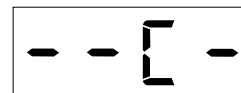

Figure 36. Pressure Adjustment

9. Press the **MENU** button.
10. Press the **DOWN ARROW** (↓) button repeatedly until the last digit on the 7-segment display reads "1" (Figure 37).

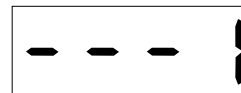

Figure 37. Pressure Adjustment

11. Press the **MENU** button.

12. The display will now read "P1" (Figure 38). Press the **MENU** button again.

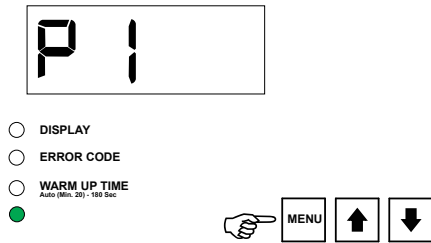

Figure 38. Pressure Adjustment

13. The 7-segment display will now show the default pressure setting of "100" (Figure 39).



Figure 39. Pressure Adjustment

14. Press the **DOWN ARROW** (↓) button to cycle through the available pressure settings of **85, 95, 100** or **105** psi (Figure 40). Press **MENU** to select the desired pressure setting.

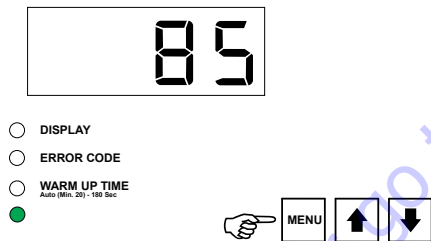

Figure 40. Pressure Adjustment

15. Once the desired pressure setting has been selected, "P1" will again be shown on the 7-segment display (Figure 41). Press and hold the **STOP** button to return to normal operating mode.

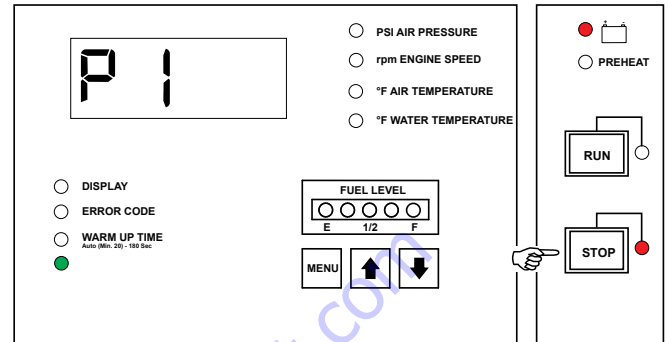

Figure 41. Pressure Adjustment

16. The 7-segment display will now read "0" and the **DISPLAY LED** will light up (Figure 42).

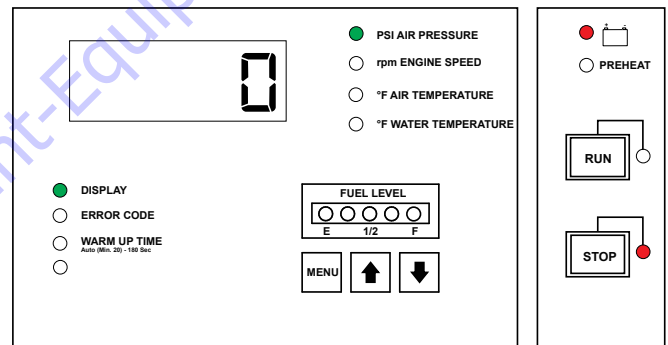

Figure 42. Pressure Adjustment

SHUTDOWN

WARNING

NEVER discharge the compressed air via the air outlet valve, as oil may be mixed with the discharged air. This discharged air (residual pressure) can cause severe bodily injury. Allow the compressed air to dissipate completely (approximately 90 seconds) before removing air hoses from the air outlet valves.

1. Place the selected air outlet valve (Figure 43) in the **CLOSED** position to stop the flow of compressed air to the load.

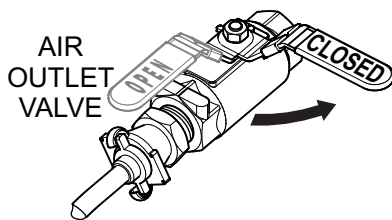

Figure 43. Air Outlet Valve (CLOSED)

2. Verify that engine speed decreases to no load speed (approx. 1350 rpm).
3. Run the engine at no load for 3–5 minutes until it cools.
4. Press the **STOP** button (Figure 44) on the control panel. The compressed air remaining in the air compressor will automatically discharge. **DO NOT** use the air outlet valves to discharge the remaining air.

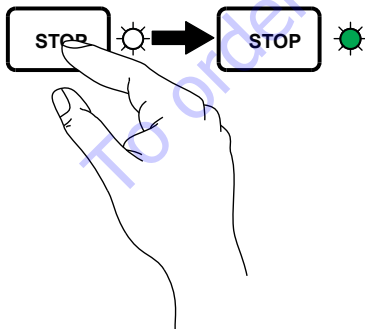

Figure 44. STOP Button (Unit Shutdown)

5. Turn the main switch (ignition switch) key to the **OFF** position (Figure 45). Remove key and place in a safe location.

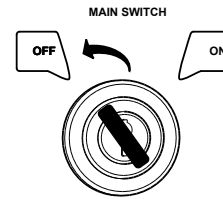

Figure 45. Main Switch (OFF Position)

RESTART

NOTICE

The residual air pressure inside the compressor tank must be zero before the engine can be restarted. Wait at least **90 seconds** before attempting to restart the engine.

1. Turn the main switch (ignition switch) key to the **ON** position (Figure 46).

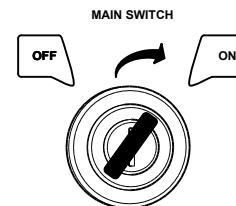

Figure 46. Main Switch (RTP Verification)

2. Press the down arrow key (↓) to select PSI air pressure. The **PSI AIR PRESSURE** LED should light up (**GREEN**).
3. If there is residual pressure remaining inside the tank, the 7-segment display will indicate "rtp" (residual tank pressure) as shown in Figure 47. When this message is displayed, the engine cannot be immediately restarted. Wait **90 seconds**, until the pressure reading on the 7-segment display indicates zero, before attempting to restart.

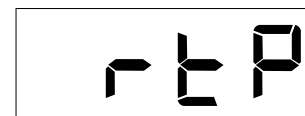

Figure 47. Residual Tank Pressure

4. Once the remaining tank pressure has discharged and the 7-segment display reads "0", press and hold the **RUN** button on the control panel for at least 2 seconds to restart the compressor.

PREPARATION FOR LONG TERM STORAGE

Air Compressor Storage

An air compressor unit should not be stored without proper preservation for more than six (6) weeks. This is not a hard rule as the location must be taken into consideration. In very damp climates compressors can be stored for one (1) to two (2) weeks and in very dry climates a compressor can be stored for ten (10) to twelve (12) weeks:

- Put the unit in a temporary cabin if it is stored outside. Avoid leaving the unit outside with a sheet cover directly on the paint for a long time, as this will cause rust to the unit.
- Drain the existing lubricant from the engine oil pan. Pour new lubricant in the engine to clean its inside. After running for a while, drain it again.
- Run the engine until all the fuel is completely consumed.
- Apply and spread lubricant on moving parts.
- Fill the crankcase with preservative oil.
- Remove the suction and discharge valve cover plates and spray preservative oil over valves.
- Seal the engine, air intake ports, muffler opening, air filter, and other opening with a vinyl sheet, packing tape, moisture resistant tape, or plastic pipe plugs to prevent moisture buildup and dust from getting in the unit.
- Completely charge the battery and disconnect the grounding wires.
- Remove the battery from the unit, if possible, and store it in a dry place. Charge the battery at least once every month when in long-term storage.
- Drain coolant and remaining oil from the unit.
- Completely drain the oil from the crankcase and refill with fresh oil.
- Clean all external parts of the air compressor with a cloth.
- If air compressor is mounted on a trailer, jack trailer up and place on blocks so tires do not touch the ground or block and completely remove the tires.
- Cover the air compressor and store in a clean, dry place.

TO PURCHASE THIS PRODUCT PLEASE CONTACT US



**Equipment Financing and
Extended Warranties Available**



**Discount-Equipment.com is your online resource for
commercial and industrial quality parts and equipment sales.**

561-964-4949

visit us on line @ www.discount-equipment.com

Select an option below to find your Equipment

Search by Manufacturer

Search by Product Type

Request a Quote

We sell worldwide for the brands: Genie, Terex, JLG, MultiQuip, Mikasa, Essick, Whiteman, Mayco, Toro Stone, Diamond Products, Generac Magnum, Airman, Haulotte, Barreto, Power Blanket, Nifty Lift, Atlas Copco, Chicago Pneumatic, Allmand, Miller Curber, Skyjack, Lull, Skytrak, Tsurumi, Husquvarna Target, Stow, Wacker, Sakai, Mi-T-M, Sullair, Basic, Dynapac, MBW, Weber, Bartell, Bennar Newman, Haulotte, Ditch Runner, Menegotti, Morrison, Contec, Buddy, Crown, Edco, Wyco, Bomag, Laymor, EZ Trench, Bil-Jax, F.S. Curtis, Gehl Pavers, Heli, Honda, ICS/PowerGrit, IHI, Partner, Imer, Clipper, MMD, Koshin, Rice, CH&E, General Equipment, Amida, Coleman, NAC, Gradall, Square Shooter, Kent, Stanley, Tamco, Toku, Hatz, Kohler, Robin, Wisconsin, Northrock, Oztec, Toker TK, Rol-Air, APT, Wylie, Ingersoll Rand / Doosan, Innovatech, Con X, Ammann, Mecalac, Makinex, Smith Surface Prep, Small Line, Wanco, Yanmar

MAINTENANCE (ENGINE)

BASIC ENGINE INSPECTION AND MAINTENANCE

See Table 9 below for a general engine inspection and maintenance checklist. For more detailed maintenance, refer to the Isuzu Engine Owner's Manual.

| Table 9. Inspection/Maintenance | | 10 Hrs DAILY | 250 Hrs | 500 Hrs or Every 12 Months | 3000 Hrs or Every 36 Months | OTHER |
|------------------------------------|---|-----------------|---------|----------------------------------|-----------------------------------|---------------------|
| Engine | Check Engine Oil and Coolant Levels | X | | | | |
| | Check Fuel Filter/Water Separator Bowl | X | | | | |
| | Check Air Cleaner/Element | X | | | | |
| | Exhaust System*5 | | X | | | |
| | Check for Leaks/Hoses/Clamps*4 | X | | | | |
| | Check for Loosening of Parts | X | | | | |
| | Change Engine Oil and Oil Filter *1 | | X | | | |
| | Clean Unit, Inside and Outside | | X | | | |
| | Replace Fuel Filter Elements | | | X | | |
| | Check Engine Mounts | | | X | | |
| | Service Battery | | | X | | |
| | Check Air Intake Hoses | | | X | | |
| | Check Fan Belt Condition | | | X | | |
| | Check Automatic Belt Tensioner | | | X | | |
| | Check Electrical Ground Connection | | | X | | |
| | Clean Radiator, Check Cooling System | | | X | | |
| | Coolant Solution Analysis, Add SCAs As Required | | | X | | |
| | Pressure Test Cooling System | | | X | | |
| | Check Engine Speed | | | X | | |
| | Test Thermostats | | | | X | |
| | Check and Adjust Engine Valve Clearance | | | | X | |
| | Test Glow Plugs | | | | X | |
| | Flush and Refill Cooling System*2 | | | | | 2 yrs. or 2000 hrs. |
| Clean Inside of Fuel Tank | | | | | 1000 hrs. | |
| Check Crankcase Ventilation Filter | | | | | 1500 hrs. | |
| Replace Air Cleaner Elements *3 | | | | | As Required | |

*1 During initial operation of a new engine, change oil and filter between a minimum of 100 hrs. and a maximum of 250 hrs. Service interval depends on type of oil.

*2 Add "Supplemental Coolant Additives (SCAs)" to recharge the engine coolant.

*3 Replace primary air filter element when restriction indicator shows a vacuum of 625 mm (25 in. H₂O).

*4 If blowby hose needs to be replaced, ensure that the slope of the blowby hose is at least a 1/2 inch per foot, with no sags or dips that could collect moisture and/or oil.

*5 Accumulation of carbon (soot, unburned fuel) in the exhaust pipe line and muffler could cause not only system derates but also could lead to fire incident. To destroy the soot and unburned fuel, run the unit at rated power for some period of time until the exhaust gas become mostly colorless every 250 hours operation time. Carbon will be generated more readily when the unit operates at less than 30% of rated power. In this case, perform the above procedures at shorter interval times.

MAINTENANCE (ENGINE)

GENERAL INSPECTION

Prior to each use, the air compressor should be cleaned and inspected for deficiencies. Check for loose, missing or damaged nuts, bolts or other fasteners. Also check for fuel, oil, and coolant leaks. Use Table 9 as a general guideline for engine maintenance.

AIR CLEANER (DAILY/500 HOURS)

NOTICE

If the engine is operating in very **dusty** or **dry** grass conditions, a clogged air cleaner will result. This can lead to a loss of power, excessive carbon buildup in the combustion chamber, and high fuel consumption. Change air cleaner **more frequently** if these conditions exist.

This Isuzu diesel engine is equipped with a replaceable, high-density paper air cleaner element (Figure 48). This air cleaner is equipped with an inner element that is used as a backup filter should the main element become damaged.

Remove air cleaner elements and clean the heavy duty paper element with a light spray of compressed air. Replace the air cleaner element every 500 hours.

CAUTION



Wear protective equipment such as approved safety glasses or face shields and dust masks or respirators when cleaning air filters with compressed air.

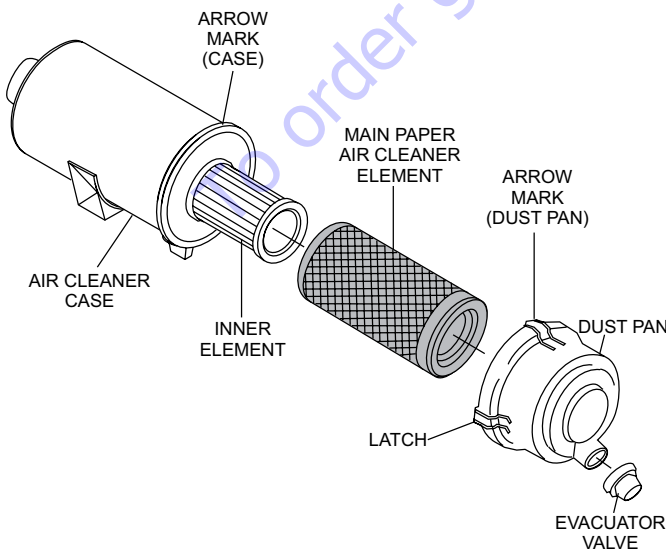

Figure 48. Air Cleaner

1. Release the latches located on either side of the air cleaner dust pan, and remove the dust pan.
2. Remove the air cleaner element.
3. Check the air cleaner daily or before starting the engine
4. Check for and correct heavy buildup of dirt and debris along with loose or damaged components.

NOTICE

Operating the engine with loose or damaged air cleaner components could allow unfiltered air into the engine causing premature wear and failure.

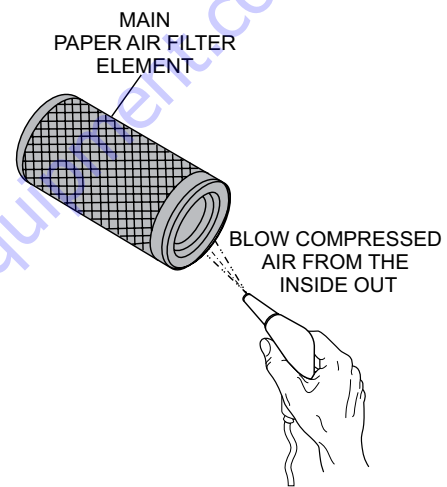

Figure 49. Cleaning Paper Air Filter Element

NOTICE

DO NOT use **excessive** air pressure or the paper air filter element will be damaged and will need to be replaced.

5. To clean the main element (paper air filter) as referenced in Figure 49, tap the filter element several times on a hard surface to remove dirt, or blow compressed air (not to exceed 30 psi [207 kPa, 2.1 kgf/cm²]) through the filter element from the inside out.
6. Replace the element if it is damaged or excessively dirty.
7. Clean the inside of the dust pan.
8. Reinstall the main paper element and inner element back into air cleaner case.
9. Reinstall the air cleaner dust pan and secure the latches.

MAINTENANCE (ENGINE)

NOTICE

DO NOT run the engine with the air cleaner removed or without an element.

ENGINE OIL (CHECK DAILY)

1. When checking or adding oil, place the compressor so the engine is level.
2. Pull the engine oil dipstick from its holder.
3. Determine if engine oil is low. Oil level should be between the upper and lower limit (Figure 50) on the dipstick.

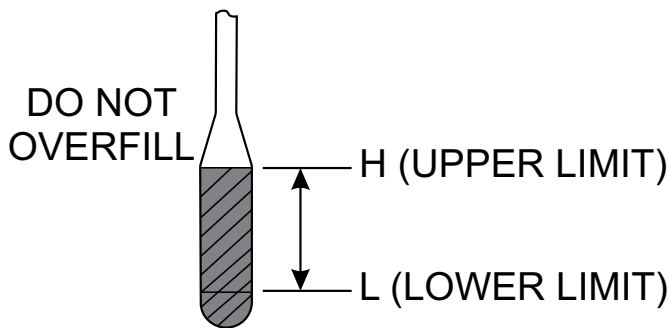

Figure 50. Dipstick Engine Oil Level

4. If oil level is low, add correct amount of engine oil to bring oil level to a normal safe level (See Recommended Viscosity Grades, Table 10).
5. Allow enough time for any added oil to make its way to the oil pan before rechecking.

| Table 10. Oil Selection Chart | | OIL: SAE | |
|-------------------------------|-----|----------|--------|
| °F | °C | | |
| 122 | 50 | | |
| 104 | 40 | | |
| 86 | 30 | 5W/30 | 5W/40 |
| 68 | 20 | 10W | 10W/30 |
| 50 | 10 | | 10W/40 |
| 32 | 0 | | 15W/40 |
| 14 | -10 | | 20W/20 |
| -4 | -20 | | 30 |
| -22 | -30 | | 40 |
| -40 | -40 | | |

CHANGING ENGINE OIL AND FILTER (500 HOURS)

Change the engine oil and filter every 500 hours. Refer to Table 10 for recommended oil viscosity.

1. Prepare an oil collector to drain the oil into.
2. Remove the oil filler cap while draining the oil to allow the oil to drain easily.
3. The engine oil drain valve is located underneath the trailer frame (street-side). Place the valve knob in the **OPEN** position (Figure 51) to drain the engine oil.

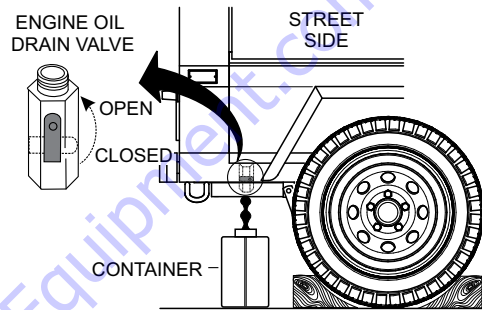

Figure 51. Draining Engine Oil

4. After oil is sufficiently drained, place the drain valve knob in the **CLOSED** position
5. Using a filter wrench, turn the engine oil filter counterclockwise to remove.
6. Clean sealing surface on engine where filter mounts.
7. Coat the seal (Figure 52) of the new oil filter with clean engine oil.

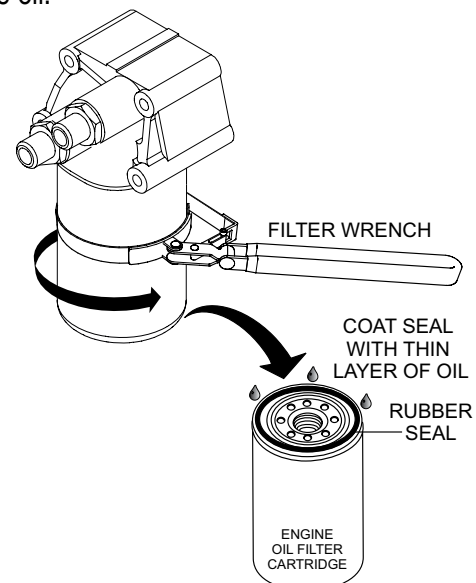

Figure 52. Oil Filter/Seal

MAINTENANCE (ENGINE)

8. Install new filter first by hand until it contacts the engine sealing surface. Tighten it another 3/4 turn using the filter wrench.
9. Fill engine crankcase with high quality detergent oil classified "For Service CF, or CF-4". Fill to the upper limit of dipstick. **DO NOT** overfill. Crankcase oil capacity with oil filter replacement is 2.7 gal. (10.2 liters).
10. Run the engine for several minutes. Watch for oil leakage. Shut the engine down and allow it to sit for several minutes. Top off the oil to the upper limit on the dipstick.

FLUSHING OUT RADIATOR AND REPLACING COOLANT (EVERY 500 HOURS)

- Open both cocks located at the crankcase side and the lower part of the radiator, and drain coolant. Open the radiator cap while draining. Remove the overflow tank and drain.
- Check hoses for softening and kinks. Check clamps for signs of leakage.
- Tighten both cocks and replace the overflow tank.
- Replace with coolant as recommended by the engine manufacturer.
- Close radiator cap tightly.
- Flush the radiator by running clean tap water through radiator until signs of rust and dirt are removed. **DO NOT** clean radiator core with any objects, such as a screwdriver.

WARNING



Allow engine to **cool** before flushing out radiator. Flushing the radiator while hot could cause serious burns from water or steam.

RADIATOR (1000 HOURS)

1. Check radiator for leaks that may indicate corrosion or damage.
2. Check coolant level daily. Top off as necessary. Always use recommended coolant/antifreeze. Use the mixing ratios specified by the coolant/antifreeze manufacturer. Replace coolant/antifreeze at least once a year.
3. Check radiator hoses for fatigue or cracking. Replace any defective hoses immediately.
4. Check radiator cap seal and replace as necessary.
5. The radiator (Figure 53) should be sprayed (cleaned) with a high-pressure washer when excessive amounts of dirt and debris have accumulated on the cooling fins or tube. When using a high-pressure washer, stand at least 5 feet (1.5 meters) away from the radiator to prevent damage to the fins and tube.

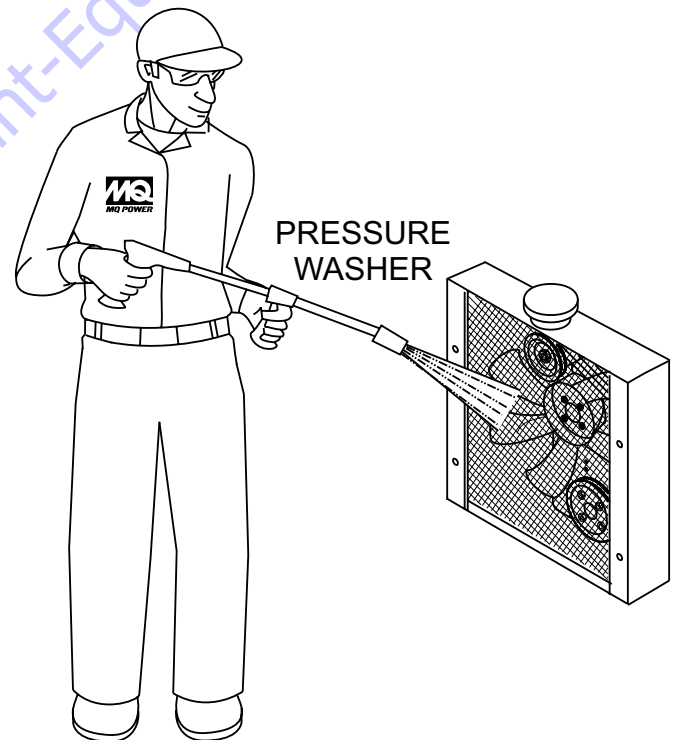

Figure 53. Radiator Cleaning

MAINTENANCE (ENGINE)

NOTICE

Radiator fins damage easily. **NEVER** use high-pressure water or compressed air at greater than 28 psi (193 kPa) to clean the radiator fins, and **NEVER** use a wire brush to clean the fins.

6. If there is a large amount of contamination on the radiator fins, use detergent with tap water to clean fins, and rinse thoroughly.

V-BELT (DAILY)

Visually examine the V-belt (Figure 54) and determine if it is full of tiny cracks, frayed, has pieces of rubber missing, is peeling, or is otherwise damaged.

Also, examine the belt and determine if it is **oil soaked** or **"glazed"** (hard shiny appearance on the sides of the belt). Either of these two conditions can cause the belt to run hot, which can weaken it and increase the danger of it breaking.

If the V-belt exhibits any of the above wear conditions, replace the V-belt immediately.

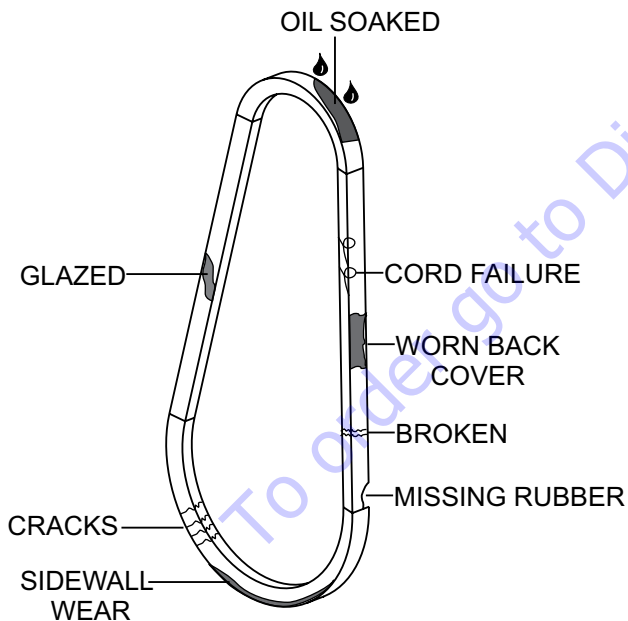

Figure 54. V-Belt Inspection

FUEL FILTER ELEMENT (CHECK DAILY)

This compressor has two fuel filters (main and pre). Each filter contains a paper element that will require replacement. Replace the paper element every 500 hours in each filter as shown below:

1. Prepare a fuel collector to drain the fuel into.
2. Loosen the drain plug and air bleeder plug to discharge the fuel inside the filter.

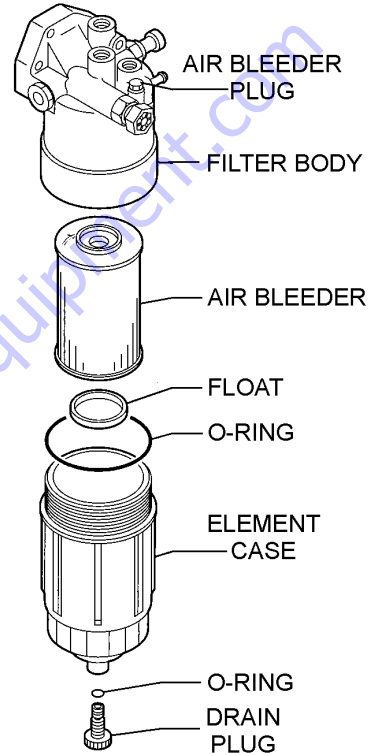

Figure 55. Fuel Filter (Pre)

3. Use a filter wrench to remove the case from the filter body.
4. Wipe the filter body with a clean cloth to remove any debris that may have accumulated.
5. Insert the new fuel filter element into the case.
6. Replace the case and drain plug o-rings. Apply a small amount onto each o-ring.
7. Reassemble fuel filter.
8. Torque element case to 22.4 ft-lbs (30 Nm).
9. Torque drain plug to 1.4 ft-lbs (2 Nm).
10. Remove the air from the fuel system. Reference Isuzu Owner's Manual, "Bleeding the Fuel System".

MAINTENANCE (ENGINE)

CLEANING FUEL TANK (1000 HOURS)

After prolonged use, water and other impurities accumulate in the bottom of the fuel tank. Inspect the fuel tank occasionally for water contamination and drain the contents if necessary.

During cold weather, the more empty volume inside the tank, the easier it is for water to condense. This can be reduced by keeping the fuel tank full with diesel fuel.

CLEANING INSIDE THE FUEL TANK

1. Prepare a fuel collector to drain the fuel into.
2. The fuel drain bolt is located at the rear of the trailer frame (curb-side). Loosen the drain bolt (Figure 56) to remove any fuel remaining inside the fuel tank.

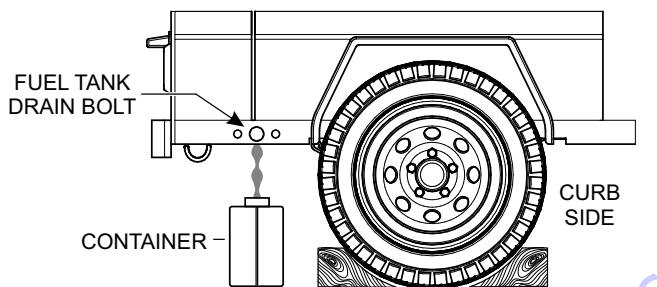

Figure 56. Draining Fuel Tank

3. Using a pressure washer (Figure 57), wash out any deposits or debris that have accumulated inside the fuel tank.

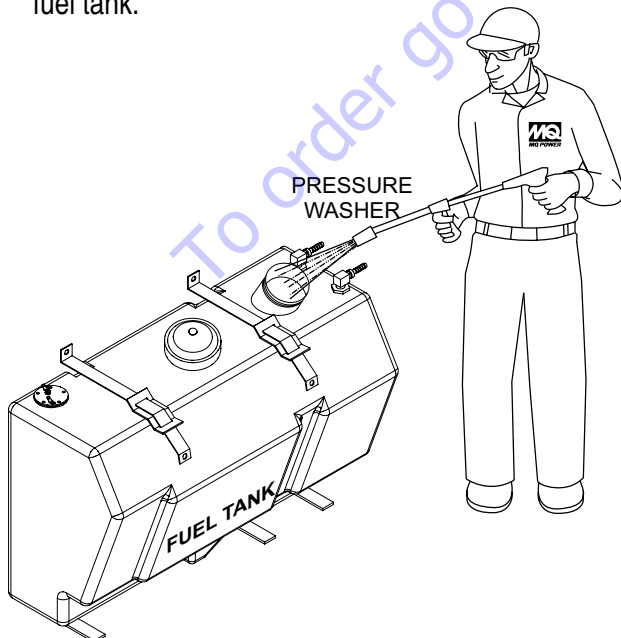

Figure 57. Cleaning Fuel Tank

ELECTROMAGNETIC FUEL PUMP (500 HOURS)

The filter inside the fuel pump is either a paper type or steel mesh type depending on fuel pump type. Clean or replace the fuel pump filter as follows:

1. Disconnect any electrical connections that are attached to the fuel pump.
2. Prepare a fuel collector to drain the fuel into. Secure any fuel lines to prevent fuel from spilling.
3. Remove fuel pump from air compressor enclosure.
4. Next, remove the filter and gasket from the fuel pump housing.

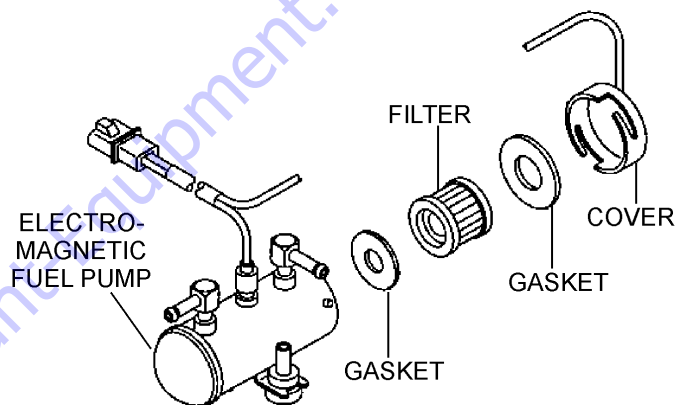

Figure 58. Electromagnetic Fuel Pump

NOTICE

When the fuel pump filter is removed, always make sure to replace both gaskets and clean the magnet portion inside the cover.

5. Clean or replace fuel pump filter. Replace both gaskets.
6. Reassemble fuel pump and mount back onto air compressor enclosure.
7. Reconnect all fuel lines and electrical components.
8. Check for fuel leaks.

MAINTENANCE (ENGINE)

CHECKING BATTERY SPECIFIC GRAVITY (250 HOURS)

1. To determine if the battery needs charging, measure the **specific gravity** of the battery acid.
2. The relationship between battery charge (charging rate) and specific gravity is shown in Table 11.

Table 11. Battery Fluid Temp./Specific Gravity

| | | 68° F (20° C) | 32° F (0° C) | 14° F (-10° C) |
|--|------|------------------|-----------------|-------------------|
| | | 100% | 90% | 80% |
| Charging Rate% | 100% | 1.28 | 1.29 | 1.30 |
| | 90% | 1.26 | 1.27 | 1.28 |
| | 80% | 1.24 | 1.25 | 1.26 |
| | 75% | 1.23 | 1.24 | 1.25 |
| Each value has a deviation of ± 0.01 | | | | |
| When the charging rate is below 75% , battery needs to be recharged. | | | | |

BATTERY CHARGING

NOTICE

Before charging, always make sure that both the **BLACK** and **RED** battery cables have been removed from the negative and positive battery post. Failure to remove these cables may cause damage to the alternator.

1. Always remove the **BLACK** cable first. This cable is connected to the **negative** terminal of the battery.
2. Next, remove the **RED** cable that is connected to the **positive** terminal of the battery.
3. Attach the **positive** cable clamp from the battery charger to the positive post on the battery.
4. Attach the **negative** cable clamp from the battery charger to the negative post on the battery.
5. To prevent an explosion, open all vent caps on the battery so that the battery can discharge dangerous fumes/gas properly.
6. Turn on battery charger and adjust as recommended by battery manufacturer.
7. If battery fluid temperature exceeds 113° F (45° C), stop charging and let battery cool.
8. Once the battery is **fully charged**, remove battery charger cables from battery.

NOTICE

When reconnecting the battery cables, always connect the **RED** (positive) battery cable first.

Be careful of the polarity when reconnecting the battery cables. Reversing the polarity could cause serious damage to the alternator and other electronic components.

9. Reconnect the **RED** battery cable to the positive post on the battery.
10. Reconnect the **BLACK** battery cable to the negative post on the battery.

MAINTENANCE (ENGINE)

CONNECTING BOOSTER/JUMPER CABLES

Before attempting to jump start, attach booster cables to the air compressor and make sure of the following:

- Make sure booster cables are of adequate size to match current capacity of battery.
- Source battery (working battery) should be of equal voltage and amperage as battery being jumped.
- When attaching booster cable clamps, make sure clamps are attached firmly to battery posts. This will prevent arcing.
- Never allow the positive and negative booster cables to make contact when connected to a live battery.
- When connecting the booster cable with the **BLACK** clamp to the air compressor's ground point, the ground point should be at least 1 ft. (305 mm) away from the battery.

The following steps outline the procedure for **connecting** booster cables to the air compressor's battery.

1. Connect one end of the booster cable with the **RED** clamp (Figure 59) to the positive terminal on the air compressor's battery.

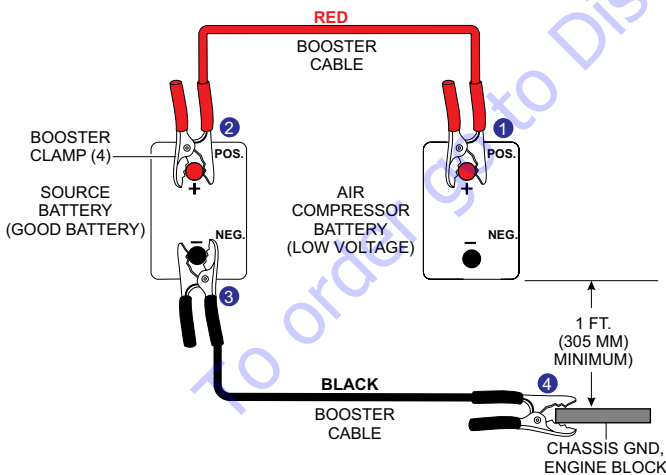

Figure 59. Connecting Booster Cables

2. Connect the other end of the booster cable with the **RED** clamp to the positive terminal on the source battery (working good battery).
3. Connect one end of the booster cable with the **BLACK** clamp to the negative terminal on the source battery.

4. Connect the other end of the booster cable with the **BLACK** clamp to the negative ground point (chassis ground/frame) on the air compressor.

REMOVAL OF BOOSTER/JUMPER CABLES

The following steps outline the procedure for **removing** booster cables from the air compressor's battery.

1. Remove the booster cable with the **BLACK** clamp (Figure 60) from the negative ground point (chassis ground/frame) on the air compressor.

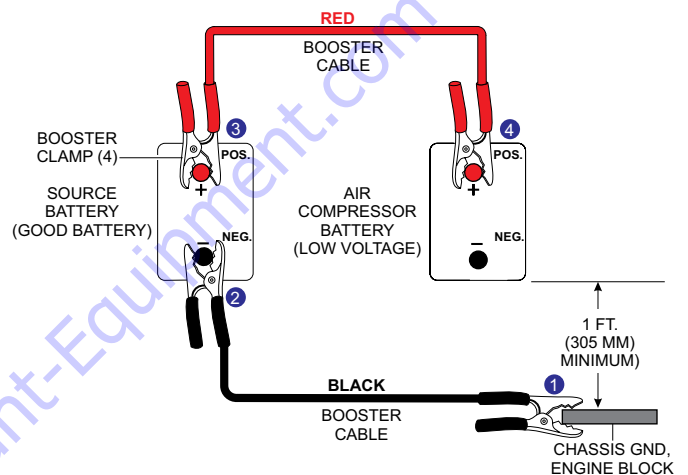

Figure 60. Removing Booster Cables

2. Remove the other end of the booster cable with the **BLACK** clamp from the negative terminal on the source battery.
3. Remove the booster cable with the **RED** clamp from the positive terminal on the source battery.
4. Remove the other end of the booster cable with the **RED** clamp from the positive terminal on the air compressor.

MAINTENANCE (COMPRESSOR)

BASIC AIR COMPRESSOR INSPECTION AND MAINTENANCE

See Table 12 for a general air compressor inspection and maintenance checklist.

| Table 12. Compressor Maintenance Schedule Table 12 | | | | | | | |
|--|-------|----------|----------|----------------|------------|-----------|-----------|
| DESCRIPTION | Daily | 100 hrs. | 250 hrs. | 500 hrs. | 1000 hrs. | 2000 hrs. | 4000 hrs. |
| Check Compressor Oil Level | ◆ | | | | | | |
| Draining Through Oil Chamber Drain | ◆ | | | | | | |
| Clean Air Cleaner Element | | ◆ | | | | | |
| Check And Clean Oil Return Filter Orifice | | | | ◆ | | | |
| Check Operation Of The Safety Valve | | | | ◆ | | | |
| Replace Air Cleaner Element | | | | | ◇ | | |
| Replace Compressor Oil | | | | ◇ ¹ | ◇ | | |
| Replace Compressor Oil Filter Cartridge | | | | ◇ ¹ | ◇ | | |
| Check Inlet Valve Seal | | | | | ◆ | | |
| Replace O-Ring In Minimum Pressure Valve | | | | | ◇ | | |
| Replace O-Ring In Compressor Oil Filter Port | | | | | ◇ | | |
| Check Rubber Suspension | | | | | ◆ | | |
| Check Acoustic Sheet | | | | | ◆ | | |
| Check Oil Separator Cartridge | | | | Or 2 Years | | ◇ | |
| Check Nylon And Rubber Hose | | | | Or 3 Years | | ◇ | |
| Check And Replace Electro-Pneumatic Valve | | | | | | ◇ | |
| Check And Replace Coupling Element | | | | | Or 2 Years | | ◇ |

(1) For initial operation of a new compressor, change compressor oil and oil filter cartridge after 500 hours.

(2) For commercial use, log hours of operation to determine proper maintenance intervals.

(3) ◆ = Check or clean, ◇ = Replace.

MAINTENANCE (COMPRESSOR)

COMPRESSOR OIL CHAMBER FILL PORT O-RING (1000 HOURS)

1. Remove the compressor oil fill plug (Figure 61) from the oil chamber fill port.

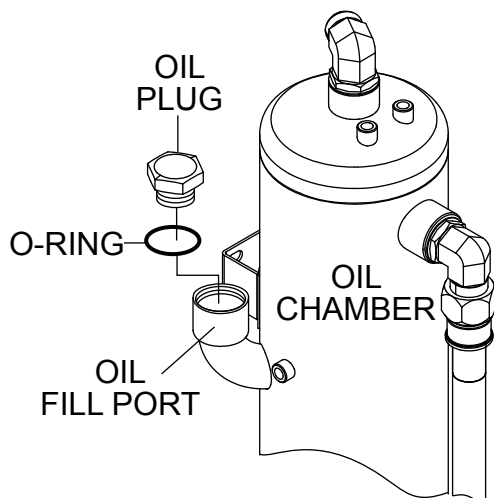

Figure 61. O-Ring Replacement (Oil Chamber)

2. Remove the existing o-ring from the oil fill plug.
3. Place new o-ring onto oil plug.
4. Screw oil fill plug back onto oil chamber fill port.

AIR CLEANER ELEMENT (DAILY/500 HOURS)

Follow the same procedure as outlined in the Engine Air Cleaner Maintenance section.

MINIMUM PRESSURE VALVE (1000 HOURS)

1. Remove the minimum pressure valve (Figure 62) from the air separator oil filter.

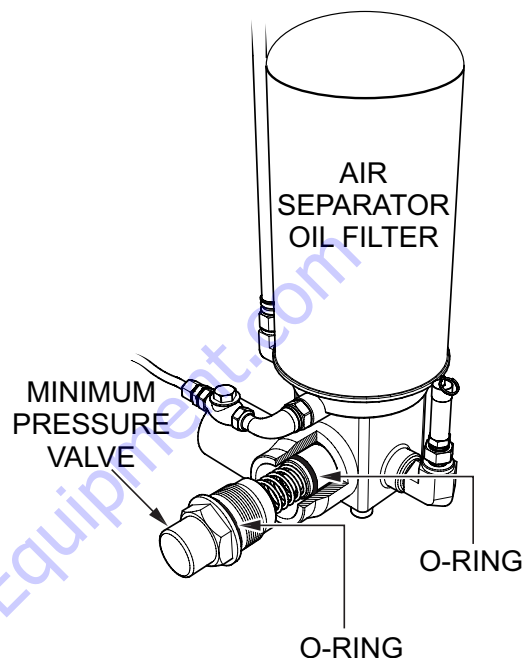

Figure 62. Minimum Pressure Valve

2. Clean or replace valve. Replace both o-rings
3. Reinstall valve with new o-rings.

OIL RETURN FILTER ORIFICE

1. Remove the oil return filter orifice as shown in Figure 63.

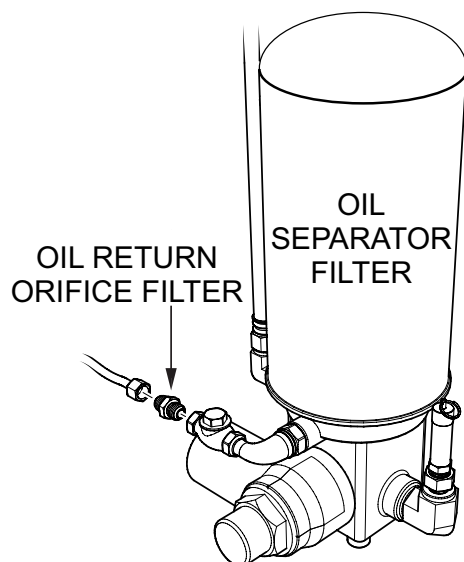

Figure 63. Oil Return Orifice Filter

MAINTENANCE (COMPRESSOR)

2. Replace filter and reinstall.

COMPRESSOR OIL FILTER CARTRIDGE

1. Using a filter wrench, turn the oil filter cartridge (Figure 64) counterclockwise to remove.

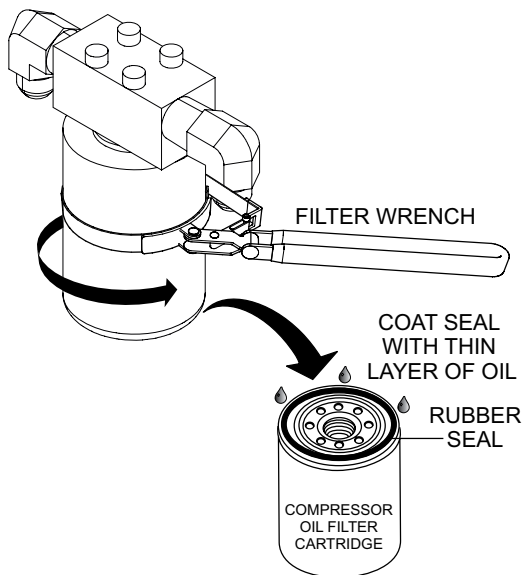

Figure 64. Compressor Oil Filter

2. Clean sealing surface on body where filter mounts.
3. Coat the rubber seal on the new oil filter with clean compressor oil (Figure 64).
4. Install new filter back onto unit and hand tighten.
5. Using a filter wrench, tighten filter 2/3 turn clockwise until filter cartridge is firmly seated.
6. Run the engine and verify that the compressor oil level is between the **H** and **L** markings on the compressor oil level gauge (Figure 65).

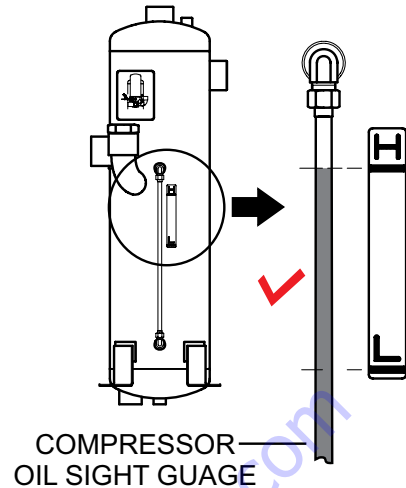

Figure 65. Compressor Oil Sight Gauge

OIL SEPARATOR FILTER CARTRIDGE (ONCE A YEAR OR 2000 HOURS)

NOTICE

The service life of the oil separator filter is dependent upon the operation conditions of the air compressor.

Replacement is required when oil in the delivery system is present in the air valves.

1. Using a filter wrench, turn the oil separator filter cartridge (Figure 66) counterclockwise to remove.

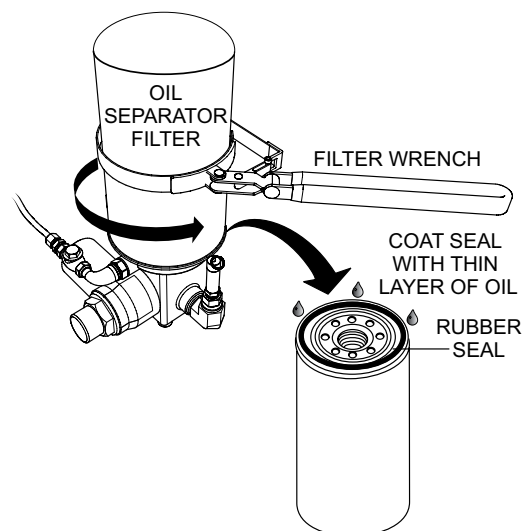

Figure 66. Air Separator Oil Filter

2. Clean sealing surface on body where filter mounts.

MAINTENANCE (COMPRESSOR)

3. Coat the seal on the new oil separator filter cartridge with clean engine oil (Figure 66).
4. Install new filter back onto unit and hand tighten.
5. Using a filter wrench, tighten filter 1/2 turn clockwise until filter cartridge is firmly seated.

COMPRESSOR SAFETY RELIEF VALVE (DAILY)

1. Start the engine and let run under **no load** for at least 5 minutes to build up pressure in the air compressor tank.
2. Use the 7-segment display to verify that the air pressure is between 110–115 psi (758–793 kPa).
3. Next, pull the compressor **safety valve ring** (Figure 67) and verify that the air pressure is released through the valve.

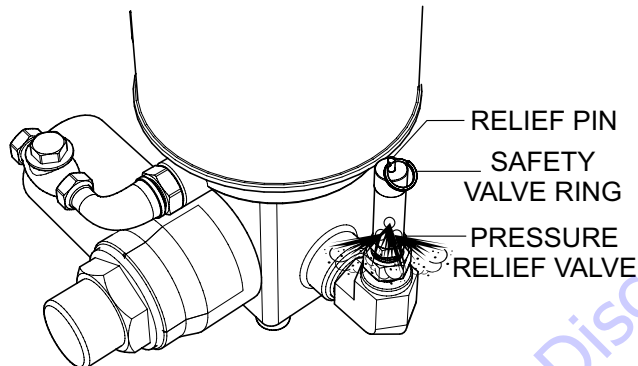

Figure 67. Pressure Relief

4. If pressure is released when the ring is pulled, the pressure relief valve is working correctly.
5. If pressure is not released when the ring is pulled, replace the pressure relief valve.
6. At completion of testing, release the **relief pin** to close the valve.
7. Turn engine off.

CHECKING INLET VALVE SEAL (1000 HOURS)

1. Inspect the inlet valve seal (Figure 68) for wear or deformations.
2. Clean or replace seal.

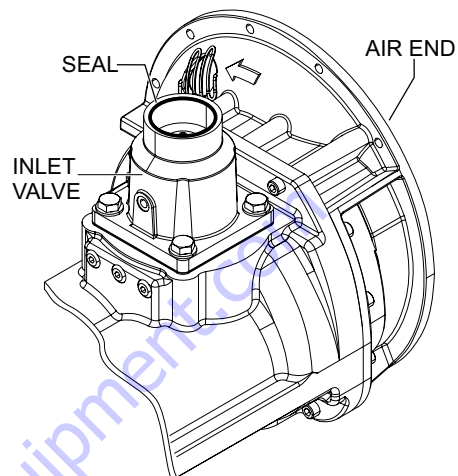

Figure 68. Inlet Valve Seal

TRAILER MAINTENANCE

TRAILER MAINTENANCE

The following trailer maintenance guidelines are intended to assist the operator with preventive maintenance.

Adjustable Channel

Your trailer may be equipped with an adjustable channel (Figure 69) that allows the coupler to be raised or lowered to a desired height. Periodically check the channel bolts for damage or loosening.

NOTICE

When replacing channel mounting hardware (nuts, bolts and washers), **NEVER** substitute with substandard hardware. Pay close attention to **bolt length** and **grade**. **ALWAYS** use manufacturer's recommended parts when replacing channel mounting hardware.

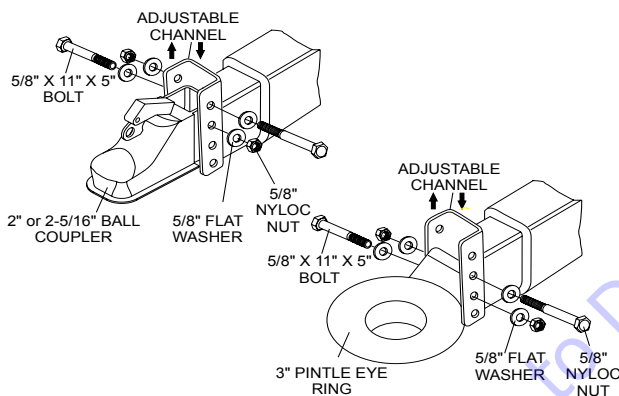

Figure 69. Adjustable Channel

Wheel Bearings

Wheel bearings (Figure 70) must be inspected and lubricated once a year or 12,000 miles to ensure safe operation of your trailer.

If trailer wheel bearings are immersed in water, they must be replaced.

⚠ DANGER

If trailer wheels are under water for an extended period of time, wheel bearings may fail. If this is the case, service wheel bearings immediately.

The possibility exists of the wheels falling off, causing equipment damage and severe bodily harm or even death!

If the trailer is not being used for an extended period of time, have the bearings inspected and packed more frequently (at least every six months and prior to use).

Follow the steps below to disassemble the wheel hub and service the wheel bearings. See Figure 70.

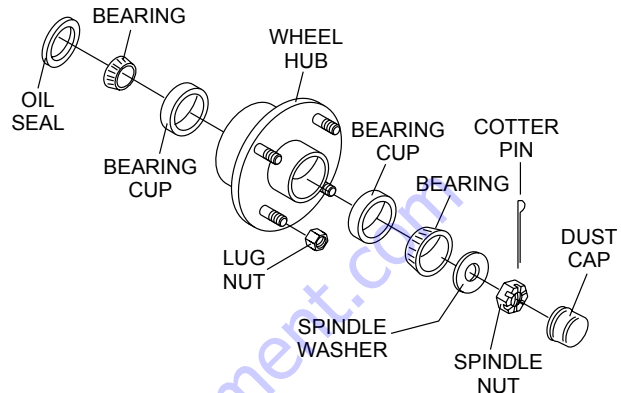

Figure 70. Wheel Hub Components

- After removing the dust cap, cotter pin, spindle nut and spindle washer, remove the hub to inspect the bearings for wear and damage.
- Replace bearings that have flat spots on rollers, broken roller cages, rust or pitting. Always replace bearings and cups in sets. The inner and outer bearings are to be replaced at the same time.
- Replace seals that have nicks, tears or wear.
- Lubricate the bearings with a high quality EP-2 automotive wheel bearing grease.

WHEEL HUB ADJUSTMENT

Every time the wheel hub is removed and the bearings are reassembled, follow the steps below to check the wheel bearings for free running and adjust.

- Turn the hub slowly, by hand, while tightening the spindle nut until you can no longer turn the hub by hand.
- Loosen the spindle nut until you are just able to turn it (the spindle nut) by hand. Do not turn the hub while the spindle nut is loose.
- Install a new cotter pin through the spindle nut and axle.
- Check the adjustments. Both the hub and the spindle nut should be able to move freely (the spindle nut motion will be limited by the cotter pin).

TRAILER MAINTENANCE

⚠ DANGER

NEVER crawl under the trailer unless it is on firm and level ground and resting on properly placed and secured jackstands.

The possibility exists of the trailer falling, thus causing equipment damage and severe bodily harm or even death!

⚠ DANGER

When performing trailer inspection and maintenance activities, you must jack up the trailer using jacks and jackstands.

When jacking and using jackstands, place them so as to clear wiring, brake lines, and suspension parts (e.g. springs, torsion bars). Place jacks and jackstands inside of the perimeter strip on the supporting structure to which the axles are attached.

⚠ DANGER

Improper weld repair will lead to early failure of the trailer structure and can cause serious injury or death.

DO NOT repair cracked or broken welds unless you have a certified welder perform the repair. Otherwise, have the welds repaired by your dealer.

⚠ WARNING

If the trailer is involved in an accident, have it inspected immediately by qualified personnel. In addition, the trailer should be inspected annually for signs of wear or deformations.

LEAF SUSPENSION

The leaf suspension springs and associated components (Figure 71) should be visually inspected every 6,000 miles for signs of excessive wear, elongation of bolt holes, and loosening of fasteners. Replace all damaged parts (suspension) immediately.

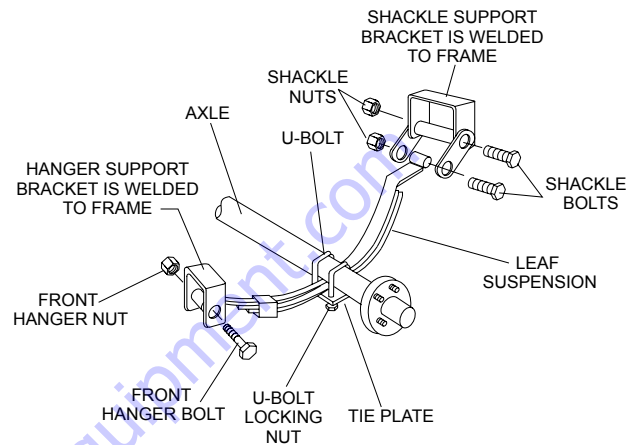

Figure 71. Leaf Suspension

⚠ DANGER

Worn or broken suspension parts can cause loss of control, damage to equipment and severe bodily injury, or even death!

Check suspension regularly.

TRAILER GUIDELINES

The following guidelines are intended to assist the operator in the operation and handling of a trailer.

Safety precautions should be followed at all times when operating a trailer. Failure to read, understand and follow the safety guidelines could result in injury to yourself and others. Loss of control of the trailer or tow vehicle can result in death or serious injury.

COMMON CAUSES FOR LOSS OF TRAILER

- Driving too fast for the conditions (maximum speed when towing a trailer is 55 mph).
- Overloading the trailer or loading the trailer unevenly.
- Trailer improperly coupled to the hitch.
- No braking on trailer.
- Not maintaining proper tire pressure.
- Not keeping lug nuts tight.
- Not properly maintaining the trailer structure.
- Ensure machine is towed level to tow vehicle.

TRAILER TOWING GUIDELINES

- Recheck the load tiedowns to make sure the load will not shift during towing.
- Before towing, check coupling, safety chain, safety brake, tires, wheels and lights.
- Check the lug nuts or bolts for tightness.
- Check coupler tightness after towing 50 miles.
- Use your mirrors to verify that you have room to change lanes or pull into traffic.
- Use your turn signals well in advance. Allow plenty of stopping space for your trailer and tow vehicle.
- Allow plenty of stopping space for your trailer and tow vehicle.
- **DO NOT** drive so fast that the trailer begins to sway due to speed.
- Allow plenty of room for passing. A rule of thumb is that the passing distance with a trailer is 4 times the passing distance without the trailer.

- Shift your automatic transmission into a lower gear for city driving.
- **ALWAYS** use lower gears for climbing and descending grades.
- **DO NOT** ride the brakes while descending grades, they may get so hot that they stop working. Then you will potentially have a runaway tow vehicle and trailer.
- To conserve fuel, don't use full throttle to climb a hill. Instead, build speed on the approach.
- Slow down for bumps in the road. Take your foot off the brake when crossing the bump.
- **DO NOT** brake while in a curve unless absolutely necessary. Instead, slow down before you enter the curve and power through the curve. This way, the towing vehicle remains in charge.
- **DO NOT** apply the brakes to correct extreme trailer swaying. Continued pulling of the trailer, and even slight acceleration, will provide a stabilizing force.
- Anticipate the trailer "swaying." Swaying is the trailer reaction to the air pressure wave caused by passing trucks and buses. Continued pulling of the trailer provides a stabilizing force to correct swaying. **DO NOT** apply the brakes to correct trailer swaying.
- Use lower gear when driving down steep or long grades. Use the engine and transmission as a brake. Do not ride the brakes, as they can overheat and become ineffective.
- Be aware of your trailer height, especially when approaching roofed areas and around trees.
- Make regular stops, about once each hour. Confirm that:
 - Coupler is secure to the hitch and is locked.
 - Electrical connectors are secure.
 - There is appropriate slack in the safety chains.
 - There is appropriate slack in the breakaway switch pullpin cable.
 - Tires are not visibly low on pressure.

TRAILER GUIDELINES

DRIVING CONDITIONS

When towing a trailer, you will have decreased acceleration, increased stopping distance, and increased turning radius (which means you must make wider turns to keep from hitting curbs, vehicles, and anything else that is on the inside corner). In addition, you will need a longer distance to pass, due to slower acceleration and increased length.

- Be alert for slippery conditions. You are more likely to be affected by slippery road surfaces when driving a tow vehicle with a trailer, than driving a tow vehicle without a trailer.
- Check rearview mirrors frequently to observe the trailer and traffic.
- **NEVER** drive faster than what is safe.

WARNING

Driving too fast for severe road conditions can result in loss of control and cause death or serious injury.

Decrease your speed as road, weather, and lighting conditions deteriorate.

Always check for local trailer tow speed limits in your area.

WARNING

Do not transport people on the trailer. The transport of people puts their lives at risk and may be illegal.

COUPLING TO THE TOW VEHICLE

Follow all of the safety precautions and instructions in this manual to ensure safety of persons, equipment, and satisfactory life of the trailer. Always use an adequate tow vehicle and hitch. If the vehicle or hitch is not properly selected and matched to the Gross Vehicle Weight Rating (GVWR) of your trailer, you can cause an accident that could lead to death or serious injury.

If you already have a tow vehicle, know your vehicle tow rating and make certain the trailer's rated capacity is less than or equal to the tow vehicle's rated towing capacity. If you already have (or plan to buy) a trailer, make certain that the tow rating of the tow vehicle is equal to or greater than that of the trailer.

The trailer VIN tag contains the critical safety information

for the use of your trailer. Again, be sure your hitch and tow vehicle are rated for the Gross Vehicle Weight Rating of your trailer.

WARNING

Proper selection and condition of the coupler and hitch are essential to safely towing your trailer. A loss of coupling may result in death or serious injury.

- Be sure the hitch load rating is equal to or greater than the load rating of the coupler.
- Be sure the hitch size matches the coupler size.
- Observe the hitch for wear, corrosion and cracks before coupling. Replace worn, corroded or cracked hitch components before coupling the trailer to the tow vehicle.
- Be sure the hitch components are tight before coupling the trailer to the tow vehicle.

WARNING

An improperly coupled trailer can result in death or serious injury.

DO NOT move the trailer until:

- The coupler is secured and locked to hitch.
- The safety chains are secured to the tow vehicle.
- The trailer jack(s) are fully retracted.

DO NOT tow the trailer on the road until:

- Tires and wheels are checked.
- The trailer brakes are checked.
- The breakaway switch is connected to the tow vehicle.
- The load is secured to the trailer.
- The trailer lights are connected and checked.

WARNING

Use of a hitch with a load rating less than the load rating of the trailer can result in loss of control and may lead to death or serious injury.

Use of a tow vehicle with a towing capacity less than the load rating of the trailer can result in loss of control, and may lead to death or serious injury.

Be sure your hitch and tow vehicle are rated for the Gross Vehicle Weight Rating of your trailer.

TRAILER GUIDELINES

INOPERABLE BRAKES, LIGHTS OR MIRRORS

Be sure that the brakes and all of the lights on your trailer are functioning properly before towing your trailer. Check the trailer taillights by turning on your tow vehicle headlights. Check the trailer brake lights by having someone step on the tow vehicle brake pedal while you look at trailer lights. Do the same thing to check the turn signal lights. See Trailer Wiring Diagram section in this manual.

Standard mirrors usually do not provide adequate visibility for viewing traffic to the sides and rear of a towed trailer. You must provide mirrors that allow you to safely observe approaching traffic.

WARNING

Improper electrical connection between the tow vehicle and the trailer will result in inoperable lights and can lead to collision.

Before each tow, check that the tail lights, brake lights and turn signals work.

TRAILER TOWING TIPS

Driving a vehicle with a trailer in tow is vastly different from driving the same vehicle without a trailer in tow. Acceleration, maneuverability and braking are all diminished with a trailer in tow.

It takes longer to get up to speed, you need more room to turn and pass, and more distance to stop when towing a trailer. You will need to spend time adjusting to the different feel and maneuverability of the tow vehicle with a loaded trailer.

Because of the significant differences in all aspects of maneuverability when towing a trailer, the hazards and risks of injury are also much greater than when driving without a trailer. You are responsible for keeping your vehicle and trailer in control, and for all the damage that is caused if you lose control of your vehicle and trailer.

As you did when learning to drive an automobile, find an open area with little or no traffic for your first practice trailering. Of course, before you start towing the trailer, you must follow all of the instructions for inspection, testing, loading and coupling. Also, before you start towing, adjust the mirrors so you can see the trailer as well as the area to the rear of it.

Drive slowly at first, 5 mph or so, and turn the wheel to get the feel of how the tow vehicle and trailer combination responds. Next, make some right and left hand turns. Watch in your side mirrors to see how the trailer follows the tow vehicle. Turning with a trailer attached requires more room.

Stop the rig a few times from speeds no greater than 10 mph. If your trailer is equipped with brakes, try using different combinations of trailer brake and tow vehicle brake. Note the effect that the trailer brakes have when they are the only brakes used. When properly adjusted, the trailer brakes will come on just before the tow vehicle brakes.

It will take practice to learn how to back up a tow vehicle with a trailer attached. Take it slow. Before backing up, get out of the tow vehicle and look behind the trailer to make sure that there are no obstacles.

Some drivers place their hands at the bottom of the steering wheel, and while the tow vehicle is in reverse, “think” of the hands as being on the top of the wheel. When the hands move to the right (counterclockwise, as you would do to turn the tow vehicle to the left when moving forward), the rear of the trailer moves to the right. Conversely, rotating the steering wheel clockwise with your hands at the bottom of the wheel will move the rear of the trailer to the left while backing up.

If you are towing a bumper hitch rig, be careful not to allow the trailer to turn too much because it will hit the rear of the tow vehicle. To straighten the rig, either pull forward or turn the steering wheel in the opposite direction.

TRAILER VIN TAG

Figure A below is a sample of the Vehicle Identification Number (VIN) Tag which is typically located on the left front of the trailer. See Figure B for location.

| | | | |
|--|--------------------------------|----------|---|
| UFACTURED BY / FABRIQUE PAR: | | DATE | |
| R / PNRV | KG (LB) | KG (LB) | TIRES / PNEU |
| R (EACH AXLE) / PNEU (CHAQUE ESSIEU) | | | |
| / JANT | | | |
| / INFL. PRESS. / PRESS. DE GONFL. A FROID | KPA (| | PSI / LPO <input type="checkbox"/> SINGLE <input type="checkbox"/> DUAL |
| VEHICLE CONFORMS TO ALL APPLICABLE U.S. FEDERAL MOTOR VEHICLE SAFETY STANDARDS IN EFFECT ON THE DATE OF MANUFACTURE SHOWN ABOVE. VEHICLE CONFORMS TO ALL APPLICABLE STANDARDS PRESCRIBED UNDER THE CANADIAN MOTOR VEHICLE SAFETY REGULATIONS IN EFFECT ON THE DATE OF MANUFACTURE. - LE VEHICULE EST DNE A TOUTES LES NORMES QUI LI SONT APPLICABLES EN VERTU DU REGLEMENT SUR LA SECURITE DES VEHICULES AUTOMOBILES DU CANADA EN VIGUEUR A LA DATE DE SA FABRICATION. | | | |
| / N.I.N.: | TYPE / TYPE: TRAILER TRA / REM | | FD-306 REV A |

Figure A. Vehicle VIN Tag

TRAILER GUIDELINES

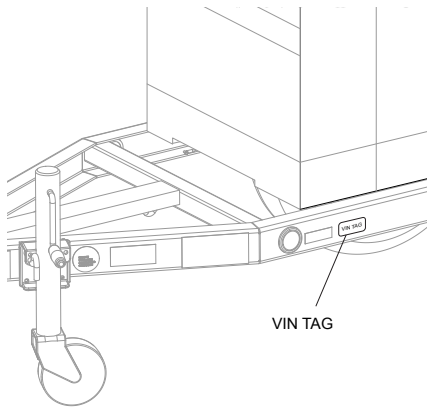

Figure B. VIN Tag Location

The trailer VIN Tag contains the following critical safety information for the use of your trailer.

GAWR: The maximum gross weight that an axle can support. It is the lowest of axle, wheel, or tire rating.

Usually, the tire or wheel rating is lower than the axle rating, and determines GAWR.

GVWR: The maximum allowable gross weight of the trailer and its contents. The gross weight of the trailer includes the weight of the trailer and all of the items within it. GVWR is sometimes referred to as GTWR (Gross Trailer Weight Rating), or MGTW (Maximum Gross Trailer Weight). GVWR, GTWR and MGTW are all the same rating.

The sum total of the GAWR for all trailer axles may be less than the GVWR for the trailer, because some of the trailer load is to be carried by the tow vehicle, rather than by the trailer axle(s). The total weight of the cargo and trailer must not exceed the GVWR, and the load on an axle must not exceed its GAWR.

PSIC: The tire pressure (psi) measured when cold.

VIN: The Vehicle Identification Number.

EMPTY WEIGHT: Some information that comes with the trailer (such as the Manufacturer's Statement of Origin) is not a reliable source for "empty" or "net" weight. The shipping documents list average or standard weights and your trailer may be equipped with options.

To determine the "empty" or "net" weight of your trailer, weigh it on an axle scale. To find the weight of the trailer using an axle scale, you must know the axle weights of your tow vehicle without the trailer coupled. Some of the trailer weight will be transferred from the trailer to the tow vehicle axles, and an axle scale weighs all axles, including the tow vehicle axles.

TOW VEHICLE

The towing hitch attached to your tow vehicle must have a capacity equal to or greater than the load rating of the trailer you intend to tow. The hitch capacity must also be matched to the tow vehicle capacity. Your vehicle dealer can provide and install the proper hitch on your tow vehicle.

SUSPENSION SYSTEM

Sway bars, shock absorbers, heavy duty springs, heavy duty tires and other suspension components may be required to sufficiently tow the trailer and pump.

SIDE VIEW MIRRORS

The size of the trailer that is being towed and your state law regulations determine the size of the mirrors. However, some states prohibit extended mirrors on a tow vehicle, except while a trailer is actually being towed. In this situation, detachable extended mirrors are necessary. Check with your dealer or the appropriate state agency for mirror requirements.

HEAVY DUTY FLASHER

A Heavy Duty Flasher is an electrical component that may be required when your trailer turn signal lights are attached to the tow vehicle flasher circuit.

ELECTRICAL CONNECTOR

An Electrical Connector connects the lights on the trailer to the lights on the towing vehicle.

EMERGENCY FLARES AND TRIANGLE REFLECTORS

It is wise to carry these warning devices even if you are not towing a trailer. It is particularly important to have these when towing a trailer because the hazard flashers of your towing vehicle will not operate for as long a period of time when the battery is running both the trailer lights and tow vehicle lights.

TRAILER GUIDELINES

SAFETY CHAINS

If the coupler connection comes loose, the safety chains can keep the trailer attached to the tow vehicle. With properly rigged safety chains, it is possible to keep the tongue of the trailer from digging into the road pavement, even if the coupler-to-hitch connection comes apart.

JACKSTAND

A device on the trailer that is used to raise and lower the coupler. The jack is sometimes called the “landing gear” or the “tongue jack”.

COUPLER TYPES

Two types of coupler used with the trailer are discussed below.

- Ball Hitch Coupler
- Pintel Eye Coupler

BALL HITCH COUPLER

A ball hitch coupler (Figure C) connects to a ball that is located on or under the rear bumper of tow vehicle. This system of coupling a trailer to a tow vehicle is sometimes referred to as “bumper pull.”

A ball hitch trailer may be fitted with a tongue jack that can raise and lower the coupler. The tongue jack is mounted to the A-frame (front or tongue) part of the trailer. By rotating the jack handle clockwise, the jack will extend and raise the tongue of the trailer.

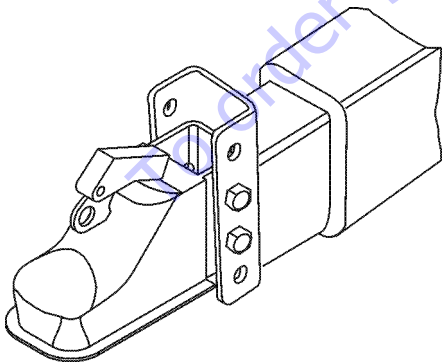

Figure C. Ball Hitch Coupler

Before each tow, coat the ball with a thin layer of automotive bearing grease to reduce wear and ensure proper operation. Check the locking device that secures the coupler to the ball for proper operation.

If you see or feel evidence of wear, such as flat spots, deformations, pitting or corrosion, on the ball or coupler, immediately have your dealer inspect them to determine the proper action to prevent possible failure of the ball and coupler system. All bent or broken coupler parts must be replaced before towing the trailer.

The coupler handle lever must be able to rotate freely and automatically snap into the latched position. Oil the pivot points, sliding surfaces, and spring ends with SAE 30W motor oil. Keep the ball socket and latch mechanism clean. Dirt or contamination can prevent proper operation of the latching mechanism.

The load rating of the coupler and the necessary ball size are listed on the trailer tongue. You must provide a hitch and ball for your tow vehicle where the load rating of the hitch and ball is equal to or greater than that of trailer.

Also, the ball size must be the same as the coupler size. If the hitch ball is too small, too large, is underrated, is loose or is worn, the trailer can come loose from the tow vehicle and may cause death or serious injury.

THE TOW VEHICLE, HITCH AND BALL MUST HAVE A RATED TOWING CAPACITY EQUAL TO OR GREATER THAN THE TRAILER **Gross Vehicle Weight Rating (GVWR)**. IT IS ESSENTIAL THAT THE HITCH BALL BE OF THE SAME SIZE AS THE COUPLER.

The ball size and load rating (capacity) are marked on the ball. Hitch capacity is marked on the hitch.

WARNING

Coupler-to-hitch mismatch can result in uncoupling, leading to death or serious injury.

Be sure the **LOAD RATING** of the hitch ball is equal or greater than the load rating of the coupler.

Be sure the **SIZE** of the hitch ball matches the size of the ball coupler.

TRAILER GUIDELINES

WARNING

A worn, cracked or corroded hitch ball can fail while towing and may result in death or serious injury.

Before coupling trailer, inspect the hitch ball for wear, corrosion and cracks.

Replace worn or damaged hitch ball.

WARNING

A loose hitchball nut can result in uncoupling, leading to death or serious injury.

Be sure the hitch ball is tight to the hitch before coupling the trailer.

- Rock the ball to make sure it is tightened to the hitch, and visually check that the hitch ball nut is solid against the lock washer and hitch frame.
- Wipe the inside and outside of the coupler. Clean and visually inspect it for cracks and deformations. Feel the inside of the coupler for worn spots and pits.
- Be sure the coupler is secured tightly to the tongue of the trailer. All coupler fasteners must be visibly solid against the trailer frame.
- The bottom surface of the coupler must be above the top of the hitch ball. Use the tongue jackstand to support the trailer tongue. Wood or concrete blocks may also be used.

Coupling the Trailer to the Tow Vehicle (Ball Coupler)

- Lubricate the hitch ball and the inside of the coupler with a thin layer of automotive bearing grease.
- Slowly back up the tow vehicle so that the hitch ball is near or aligned under the coupler.
- Using the jackstand at the front of trailer (tongue), turn the jackstand crank handle to raise the trailer. If the ball coupler does not line up with the hitch ball, adjust the position of the tow vehicle.
- Open the coupler locking mechanism. Ball couplers have a locking mechanism with an internal moving piece and an outside handle. In the open position, the coupler is able to drop fully onto the hitch ball.

- Lower the trailer (Figure D) until the coupler fully engages the hitch ball.

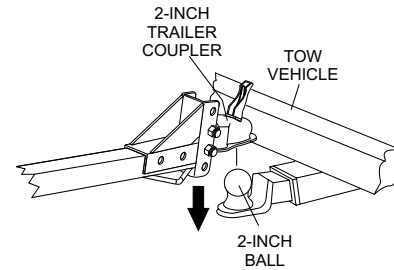

Figure D. Ball Hitch Coupling Mechanism

- Engage the coupler locking mechanism. In the engaged position, the locking mechanism securely holds the coupler to the hitch ball.
- Insert a pin or lock through the hole in the locking mechanism.
- Be sure the coupler is all the way on the hitch ball and the locking mechanism is engaged. A properly engaged locking mechanism will allow the coupler to raise the rear of the tow vehicle. Using the trailer jackstand, verify that you can raise the rear of the tow vehicle by 1 inch after the coupler is locked to the hitch.
- Lower the trailer so that its entire tongue weight is held by the hitch.
- Raise the jackstand to a height where it will not interfere with the road.

NOTICE

Overloading can damage the tongue jack. **DO NOT** use the tongue jack to raise the tow vehicle more than one inch.

If the coupler cannot be secured to the hitch ball, do not tow the trailer. Call your dealer for assistance. Lower the trailer so that its entire tongue weight is held by the hitch and continue retracting the jack to its fully retracted position.

TRAILER GUIDELINES

Attaching Safety Chain

Visually inspect the safety chains and hooks for wear or damage. Replace worn or damaged safety chains and hooks before towing.

Attach the safety chains so that they:

- Cross underneath the coupler. See Figure E.

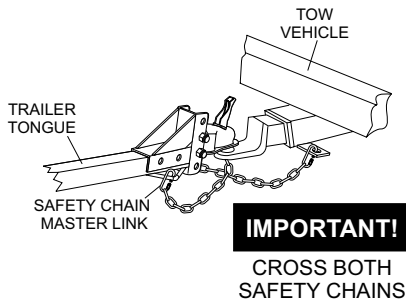

Figure E. Attaching Safety Chain (Ball Hitch)

- Loop around a frame member of the tow vehicle or holes provided in the hitch system (DO NOT attach them to an interchangeable part of the hitch assembly).
- Have enough slack to permit tight turns, but not be close to the road surface, so if the trailer uncouples, the safety chains can hold the tongue up above the road

WARNING

Improper rigging of the safety chains can result in loss of control of the trailer and tow vehicle, leading to death or serious injury, if the trailer uncouples from the tow vehicle.

- Fasten chains to frame of tow vehicle. DO NOT fasten chains to any part of the hitch unless the hitch has holes or loops specifically for that purpose.
- Cross chains underneath hitch and coupler with enough slack to permit turning and to hold tongue up, if the trailer comes loose.

Connecting Trailer Lights

Connect the trailer lights to the tow vehicle's electrical system using the electric connectors at the front of the trailer (tongue). Refer to the wiring diagram shown in the trailer wiring diagram section of this manual. Before towing the trailer check for the following:

- Running lights (turn on tow vehicle headlights).
- Brake Lights (step on tow vehicle brake pedal).
- Backup Lights (place tow vehicle gear shift in reverse).
- Turn Signals (activate tow vehicle directional signal lever).

WARNING

Improper electrical connection between the tow vehicle and the trailer will result in inoperable lights and electric brakes, and can lead to collision.

Before each tow:

- Check that the taillights, brake lights and turn signals work.
- Check that the electric brakes work by operating the brake controller inside the tow vehicle.

Uncoupling the Ball Hitch

Follow these steps to uncouple ball hitch from tow vehicle:

- Block trailer tires to prevent the trailer from rolling, before jacking the trailer up.
- Disconnect the electrical connector.
- Disconnect the breakaway brake switch cable. Promptly replace the pullpin in the switchbox.
- Before extending jackstand, make certain the ground surface below the jackstand foot will support the tongue load.
- Rotate the jackstand handle (or crank) clockwise. This will slowly extend the jack and transfer the weight of the trailer tongue to the jack.

PINTLE HITCH COUPLER

A pintle eye coupler (Figure F) connects to a pintle-hook hitch that is located on or under the rear bumper of the tow vehicle. This system of coupling a trailer to a tow vehicle is sometimes referred to as a “lunette eye, tow ring or G.I. hitch.”

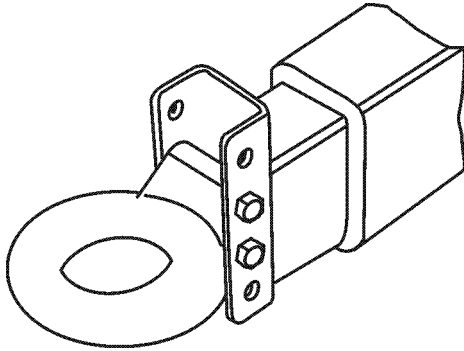

Figure F. Pintle Hitch Coupler

A pintle hitch trailer may be fitted with a tongue jackstand that can raise and lower the coupler. The tongue jack is mounted to the A-frame (front or tongue) part of the trailer. By rotating the jack handle clockwise, the jack will extend and raise the tongue of the trailer.

The load rating of the coupler and the necessary pintle hitch size are listed on the trailer tongue. You must provide a pintle hitch and pintle coupler for your tow vehicle, where the load rating of the pintle hitch and pintle coupler is equal to or greater than that of your trailer.

Also, the pintle hitch size must be the same as the pintle coupler size. If the hitch is too small, too large, underrated, loose or worn, the trailer can come loose from the tow vehicle, and may cause death or serious injury.

Pintle Coupler and Pintle Hook

Before each tow, check the locking device that secures the coupler to the pintle hook assembly.

The pintle hook lever must be able to operate freely and automatically snap into place into the latched position. Lightly oil the pivot points and sliding surfaces with SAE30W motor oil to prevent rust and help ensure proper operation of the latching mechanism.

If you see or feel evidence of wear, such as flat spots, deformations, pitting or corrosion, on the pintle hook or coupler, immediately have your dealer inspect them to determine the proper action to prevent possible failure of the ball and coupler system. All bent or broken coupler parts must be replaced before towing the trailer.

THE TOW VEHICLE, PINTLE HITCH AND PINTLE COUPLER MUST HAVE A RATED TOWING CAPACITY EQUAL TO OR GREATER THAN THE TRAILER **Gross Vehicle Weight Rating (GVWR)**.

IT IS ESSENTIAL THAT THE PINTLE HITCH BE OF THE SAME SIZE AS THE PINTLE COUPLER.

The coupler size and load rating (capacity) are marked on the coupler. Hitch capacity is marked on the hitch.

WARNING

Coupler-to-hitch mismatch can result in uncoupling, leading to death or serious injury.

Be sure the **LOAD RATING** of the pintle hitch hook is equal or greater than the load rating of the pintle eye coupler.

Be sure the **SIZE** of the pintle hitch hook matches the size of the pintle eye coupler.

WARNING

A worn, cracked or corroded pintle hitch hook can fail while towing, and may result in death or serious injury.

Before coupling trailer, inspect the pintle hitch hook for wear, corrosion and cracks.

Replace worn or damaged pintle hitch hook.

- Rock the pintle eye coupler to make sure it is secured tightly to the hitch.
- Wipe the inside and outside of the pintle coupler. Clean and inspect it visually for cracks and deformations. Feel the inside of the coupler for worn spots and pits.
- Be sure the coupler is secured tightly to the tongue of the trailer. All coupler fasteners must be visibly solid against the trailer frame.

TRAILER GUIDELINES

- Raise the bottom surface of the coupler to be above the top of the pintle hitch hook. Use the tongue jackstand to support the trailer tongue. Wood or concrete blocks may also be used.

WARNING

A defective pintle hitch not properly fastened can result in uncoupling, leading to death or serious injury.

Be sure the pintle hook is securely tightened to the tow vehicle before coupling the trailer.

Coupling Trailer to Tow Vehicle (Pintle Coupler)

- Slowly back up the tow vehicle so that the pintle hitch hook is near or aligned under the pintle eye ring coupler.
- Using the jackstand at the front of trailer (tongue), turn the jackstand crank handle to raise the trailer. If the pintle eye coupler does not line up with the pintle hitch hook, adjust the position of the tow vehicle.
- OPEN the pintle hook locking mechanism (Figure G). Place the hook inside the eye coupler. CLOSE the pintle hook mechanism.

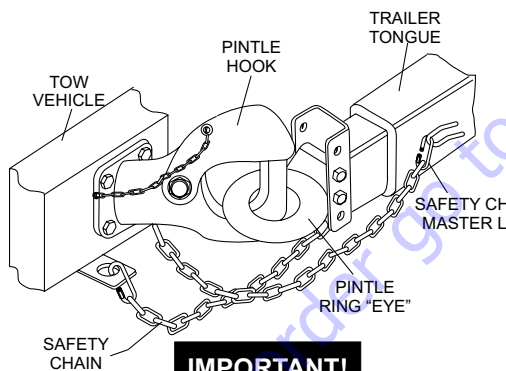

Figure G. Attaching Safety Chain (Pintle Hitch)

- Insert a pin or lock through the hole in the locking mechanism.
- Be sure the pintle hook is inserted completely through the eye ring and the locking mechanism is engaged. A properly engaged locking mechanism will allow the coupler to raise the rear of the tow vehicle. Using the trailer jack, test to see that you can raise the rear of the tow vehicle by 1-inch after the coupler is locked to the hitch.

- Lower the trailer so that its entire tongue weight is held by the hitch.
- Raise the jackstand to a height where it will not interfere with the road.

TIRE SAFETY

Unsafe Tires, Lug Nuts or Wheels

Trailer tires and wheels are more likely to fail than car tires and wheels because they carry a heavier load. Therefore, it is essential to inspect the trailer tires before each tow.

If a tire has a bald spot, bulge, cuts, is showing any cords, or is cracked, replace the tire before towing. If a tire has uneven tread wear, take the trailer to a dealer service center for diagnosis.

Uneven tread wear can be caused by tire imbalance, axle misalignment or incorrect inflation.

Tires with too little tread will not provide adequate tracking on wet roadways and can result in loss of control, leading to death or serious injury.

Improper tire pressure causes an unstable trailer and can result in a tire blowout and loss of control. Therefore, before each tow you must also check the tire pressure. Tire pressure must be checked when tires are cold.

Allow 3 hours cool-down after driving as much as 1 mile at 40 mph before checking tire pressure. Trailer tires will be inflated to higher pressures than passenger vehicle tires.

Since trailer wheels and lug nuts (or bolts) are subjected to greater side loads than automobile wheels, they are more prone to loosen. Before each tow, check to make sure they are tight.

The proper tightness (torque) for lug nuts is listed in the lug nut tightening section of this manual. Use a torque wrench to tighten the lug nuts. If you do not have a torque wrench, use a lug wrench (from your tow vehicle) and tighten the nuts as much as you can. Then have a service garage or trailer dealer tighten the lug nuts to the proper torque.

TRAILER GUIDELINES

⚠ WARNING

Metal creep between the wheel rim and lug nuts will cause rim to loosen and could result in a wheel coming off, leading to death or serious injury.

Tighten lug nuts before each tow.

Lug nuts are also prone to loosen after first being assembled. When driving a new trailer (or after wheels have been remounted), check to make sure they are tight after the first 10, 25 and 50 miles of driving and before each tow thereafter.

Failure to perform this check can result in a wheel parting from the trailer and a crash, leading to death or serious injury.

⚠ WARNING

Lug nuts are prone to loosen after initial installation, which can lead to death or serious injury.

Check lug nuts for tightness on a new trailer or when wheel(s) have been remounted after the first 10, 25 and 50 miles of driving.

⚠ WARNING

Improper lug nut torque can cause a wheel parting from the trailer, leading to death or serious injury.

Be sure lug nuts are tight before each tow.

⚠ WARNING

Improper tire pressure can result in a blowout and loss of control, which can lead to death or serious injury.

Be sure tires are inflated to pressure indicated on side wall before towing trailer.

Determining Load Limit of Trailer

Determining the load limits of a trailer includes more than understanding the load limits of the tires alone. On all trailers there is a Federal certification/VIN label that is located on the forward half of the left (road) side of the unit. This certification/VIN label will indicate the trailer's Gross Vehicle Weight Rating (GVWR). This is the most weight the fully loaded trailer can weigh. It will also provide the

Gross Axle Weight Rating (GAWR). This is the most a the axle can weigh.

There is a vehicle placard (Figure H) located in the same location as the certification label described above. This placard provides tire and loading information. In addition, this placard will show a statement regarding maximum cargo capacity.

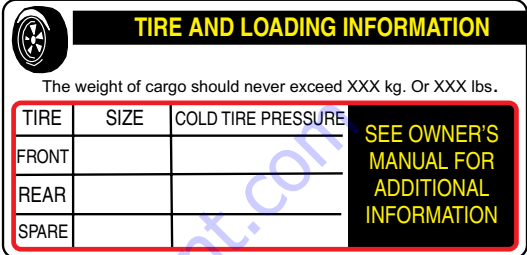

Figure H. Trailer Tire Placard

If additional work items (hoses, tools, clamps etc.) are going to be added to the trailer, be sure they are distributed evenly to prevent overloading front to back and side to side. Heavy items should be placed low and as close to the axle positions as reasonable. Too many items on one side may overload a tire.

Excessive loads and/or underinflation cause tire overloading and, as a result, abnormal tire flexing occurs. This situation can generate an excessive amount of heat within the tire. Excessive heat may lead to tire failure. It is the air pressure that enables a tire to support the load, so proper inflation is critical. The proper air pressure may be found on the certification/VIN label and/or on the Tire and Loading Information placard. This value should never exceed the maximum cold inflation pressure stamped on the tire.

Perform the following steps to determine the load limit of your trailer.

Step 1.

Locate the statement, "The weight of cargo should never exceed XXX kg or XXX lbs.," on your vehicle's Tire and Loading Information placard (Figure I). This value equals the available amount of equipment load capacity.

Step 2.

Determine the weight of the equipment being loaded on the tow vehicle. That weight may not safely exceed the available equipment load capacity. The trailer's Tire Information Placard is attached adjacent to or near the trailer's VIN (Certification) label at the left front of the trailer (See Figure I).

Determining Load Limit of Tow Vehicle

Step 1.

Locate the statement, "The combined weight of occupants and cargo should never exceed XXX lbs.," on your vehicle's placard.

Step 2.

Determine the combined weight of the driver and passengers who will be riding in your vehicle.

Step 3.

Subtract the combined weight of the driver and passengers from XXX kilograms or XXX pounds.

Step 4.

The resulting figure equals the available amount of cargo and luggage capacity. For example, if the "XXX" amount equals 1400 lbs. and there will be five 150 lb. passengers in your vehicle, the amount of available cargo and luggage capacity is 650 lbs. ($1400 - 750 (5 \times 150) = 650$ lbs.).

Step 5.

Determine the combined weight of luggage and cargo being loaded on the vehicle. That weight may not safely exceed the available cargo and luggage capacity calculated in Step 4.

If your vehicle will be towing a trailer, load from your trailer will be transferred to your vehicle. Consult the tow vehicle's manual to determine how this weight transfer reduces the available cargo and luggage capacity of your vehicle.

Studies of tire safety show that maintaining proper tire pressure, observing tire and vehicle load limits (not carrying more weight in your vehicle than your tires or vehicle can safely handle), avoiding road hazards and inspecting tires for cuts, slashes and other irregularities are the most important things you can do to avoid tire failure, such as tread separation or blowout and flat tires. These actions, along with other care and maintenance activities, can also:

- Improve vehicle handling.
- Help protect you and others from avoidable breakdowns and accidents.
- Improve fuel economy.
- Increase the tire life.

Use the information contained in this section to make tire safety a regular part of your vehicle maintenance routine. Recognize that the time you spend is minimal compared with the inconvenience and safety consequences of a flat tire or other tire failure.

TIRE FUNDAMENTALS

Federal law requires tire manufacturers to place standardized information on the sidewall of all tires (Figure I). This information identifies and describes the fundamental characteristics of the tire and also provides a tire identification number for safety standard certification and in case of a recall.

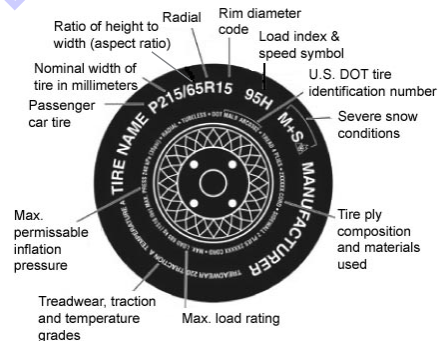

Figure I. Standard Tire Sidewall Information

P: The "P" indicates the tire is for passenger vehicles.

Next number: This three-digit number gives the width in millimeters of the tire from sidewall edge to sidewall edge. In general, the larger the number, the wider the tire.

Next number: This two-digit number, known as the aspect ratio, gives the tire's ratio of height to width. Numbers of 70 or lower indicate a short sidewall for improved steering response and better overall handling on dry pavement.

P: The "R" stands for radial. Radial ply construction of tires has been the industry standard for the past 20 years.

TRAILER GUIDELINES

Next number: This two-digit number is the wheel or rim diameter in inches. If you change your wheel size, you will have to purchase new tires to match the new wheel diameter.

Next number: This two- or three-digit number is the tire's load index. It is a measurement of how much weight each tire can support. You may find this information in your owner's manual. If not, contact a local tire dealer. *Note:* You may not find this information on all tires because it is not required by law.

M+S: The "M+S" or "M/S" indicates that the tire has some mud and snow capability. Most radial tires have these markings; hence, they have some mud and snow capability.

Speed Rating: The speed rating denotes the speed at which a tire is designed to be driven for extended periods of time. The ratings range from 99 miles per hour (mph) to 186 mph. These ratings are listed in Table A. *Note:* You may not find this information on all tires because it is not required by law.

| Letter Rating | Speed Rating |
|---------------|--------------|
| Q | 99 mph |
| R | 106 mph |
| S | 112 mph |
| T | 118 mph |
| U | 124 mph |
| H | 130 mph |
| V | 149 mph |
| W | 168* mph |
| Y | 186* mph |

U.S. DOT Tire Identification Number: This begins with the letters "DOT" and indicates that the tire meets all federal standards. The next two numbers or letters are the plant code where it was manufactured, and the last four numbers represent the week and year the tire was built. For example, the numbers 3197 means the 31st week of 1997. The other numbers are marketing codes used at the manufacturer's discretion. This information is used to contact consumers if a tire defect requires a recall.

Tire Ply Composition and Materials Used: The number of plies indicates the number of layers of rubber-coated fabric

in the tire. In general, the greater the number of plies, the more weight a tire can support. Tire manufacturers also must indicate the materials in the tire, which include steel, nylon, polyester, and others.

Maximum Load Rating: This number indicates the maximum load in kilograms and pounds that can be carried by the tire.

Maximum Permissible Inflation Pressure: This number is the greatest amount of air pressure that should ever be put in the tire under normal driving conditions.

Uniform Tire Quality Grading Standards (UTQGS)

Treadwear Number: This number indicates the tire's wear rate. The higher the treadwear number is, the longer it should take for the tread to wear down. For example, a tire graded 400 should last twice as long as a tire graded 200.

Traction Letter: This letter indicates a tire's ability to stop on wet pavement. A higher graded tire should allow you to stop your car on wet roads in a shorter distance than a tire with a lower grade. Traction is graded from highest to lowest as "AA", "A", "B", and "C".

Temperature Letter: This letter indicates a tire's resistance to heat. The temperature grade is for a tire that is inflated properly and not overloaded. Excessive speed, underinflation or excessive loading, either separately or in combination, can cause heat build-up and possible tire failure. From highest to lowest, a tire's resistance to heat is graded as "A", "B", or "C".

Refer to Figure J for additional tire information for light trucks.

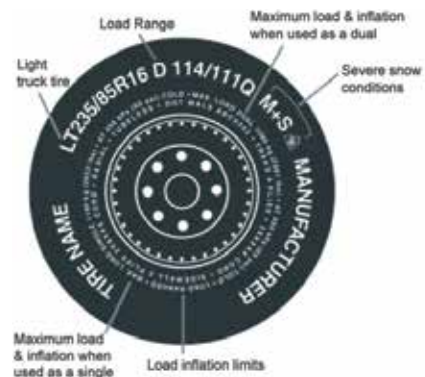

Figure J. UTQGS Tire Information

TRAILER GUIDELINES

Tires for light trucks have other markings besides those found on the sidewalls of passenger tires.

LT: The “LT” indicates the tire is for light trucks or trailers.

ST: An “ST” is an indication the tire is for trailer use only.

Max. Load Dual kg (lbs) at kPa (psi) Cold: This information indicates the maximum load and tire pressure when the tire is used as a dual, that is, when four tires are put on each rear axle (a total of six or more tires on the vehicle).

Max. Load Single kg (lbs) at kPa (psi) Cold: This information indicates the maximum load and tire pressure when the tire is used as a single.

Load Range: This information identifies the tire’s load-carrying capabilities and its inflation limits.

Tire Safety Tips

- Slow down if you have to go over a pothole or other object in the road.
- **DO NOT** run over curbs or other foreign objects in the roadway, and try not to strike the curb when parking.
- Check tire inflation pressure weekly during use to insure the maximum tire life and tread wear.
- **DO NOT** bleed air from tires when they are hot.
- Inspect tires for uneven wear patterns on the tread, cracks, foreign objects, or other signs of wear or trauma.
- Remove bits of glass and foreign objects wedged in the tread.
- Make sure your tire valves have valve caps.
- **ALWAYS** check tire pressure on tow vehicle and trailer before towing. Check tire pressure at least once a month.-
- **DO NOT** overload tow vehicle. Check the tire information and loading placard for safe allowable tire loading conditions.







Tire Repair

The proper repair of a punctured tire requires a plug for the hole and a patch for the area inside the tire that surrounds the puncture hole. Punctures through the tread can be repaired if they are not too large, but punctures to the sidewall should not be repaired. Tires must be removed from the rim to be properly inspected before being plugged and patched.

Replacing Worn or Damaged Tires

Replace the tire before towing the trailer if the tire treads have less than 1/16 inch depth or the telltale bands are visible. Check inflation pressure weekly during use to insure the maximum tire life and tread wear. A bubble, cut or bulge in a side wall can result in a tire blowout. Inspect both side walls of each tire for any bubble, cut or bulge; and replace a damaged tire before towing the trailer.

Table B below will help pinpoint the causes and solutions of tire wear problems.

| Wear Pattern | | Cause | Solution |
|---|-------------|---------------------------------|---|
|  | Center Wear | Over inflation. | Adjust pressure to particular load per tire manufacturer. |
|  | Edge Wear | Under inflation. | Adjust pressure to particular load per tire manufacturer. |
|  | Side Wear | Loss of camber or overloading. | Make sure load does not exceed axle rating. Align wheels. |
|  | Toe Wear | Incorrect toe-in. | Align wheels. |
|  | Cupping | Out-of-balance. | Check bearing adjustment and balance tires. |
|  | Flat Spots | Wheel lockup and tire skidding. | Avoid sudden stops when possible and adjust brakes. |

WARNING



ALWAYS wear safety glasses when removing or installing force fitted parts. **DO NOT** attempt to repair or modify a wheel. **DO NOT** install an inner-tube to correct a leak through through the rim. If the rim is cracked, the air pressure in the inner tube may cause pieces of the rim to explode (break off) with great force and cause serious eye or bodily injury.

TRAILER GUIDELINES

Wheel Rims

If the trailer has been struck, or impacted, on or near the wheels, or if the trailer has struck a curb, inspect the rims for damage (i.e. being out of round); and replace any damaged wheel. Inspect the wheels for damage every year, even if no obvious impact has occurred.

Wheels, Bearings and Lug Nuts

A loose, worn or damaged wheel bearing is the most common cause of brakes that grab.

To check wheel bearings, jack trailer and check wheels for side-to-side looseness. If the wheels are loose, or spin with a wobble, the bearings must be serviced or replaced. Check inflation pressure weekly during use to insure the maximum tire life and tread wear. Most trailer axles are built with sealed bearings that are not serviceable. Sealed bearings must be replaced as complete units.

WARNING

Lug nuts are prone to loosen after initial installation, which can lead to death or serious injury. Check all wheel lug nuts periodically.

Lug Nut Torque Requirements

It is extremely important to apply and maintain proper wheel mounting torque on the trailer. Be sure to use only the fasteners matched to the cone angle of the wheel. Proper procedure for attachment of the wheels is as follows:

1. Start all wheel lug nuts by hand.
2. Torque all lug nuts in sequence. See Figure K. DO NOT torque the wheel lug nuts all the way down. Tighten each lug nut in 3 separate passes as defined by Table C.

NOTICE

NEVER use an pneumatic air gun to tighten wheel lug nuts.

Over-tightening lug nuts will result in breaking the studs or permanently deforming the mounting stud holes in the wheels.

3. Check to see if the lug nuts are tight after the first 10, 25 and 50 miles of driving and before each tow thereafter

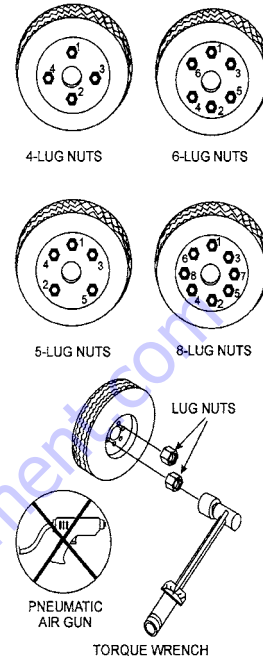

Figure K. Wheel Lug Nuts Tightening Sequence

| Table C. Tire Torque Requirements | | | |
|-----------------------------------|-------------------|--------------------|-------------------|
| Wheel Size | First Pass FT-LBS | Second Pass FT-LBS | Third Pass FT-LBS |
| 12" | 20-25 | 35-40 | 50-65 |
| 13" | 20-25 | 35-40 | 50-65 |
| 14" | 20-25 | 50-60 | 90-120 |
| 15" | 20-25 | 50-60 | 90-120 |
| 16" | 20-25 | 50-60 | 90-120 |

Lights and Signals

Before each tow, check the trailer taillights, stoplights, turn signals and any clearance lights for proper operation.

Replace any broken or burned-out lamps as necessary. Check the wire harness for cuts, fraying or other damage. If it needs replacing, contact your dealer.

WARNING

Improper operating taillights, stoplights and turn signals can cause collisions.

Check all lights before each tow.

TRAILER GUIDELINES

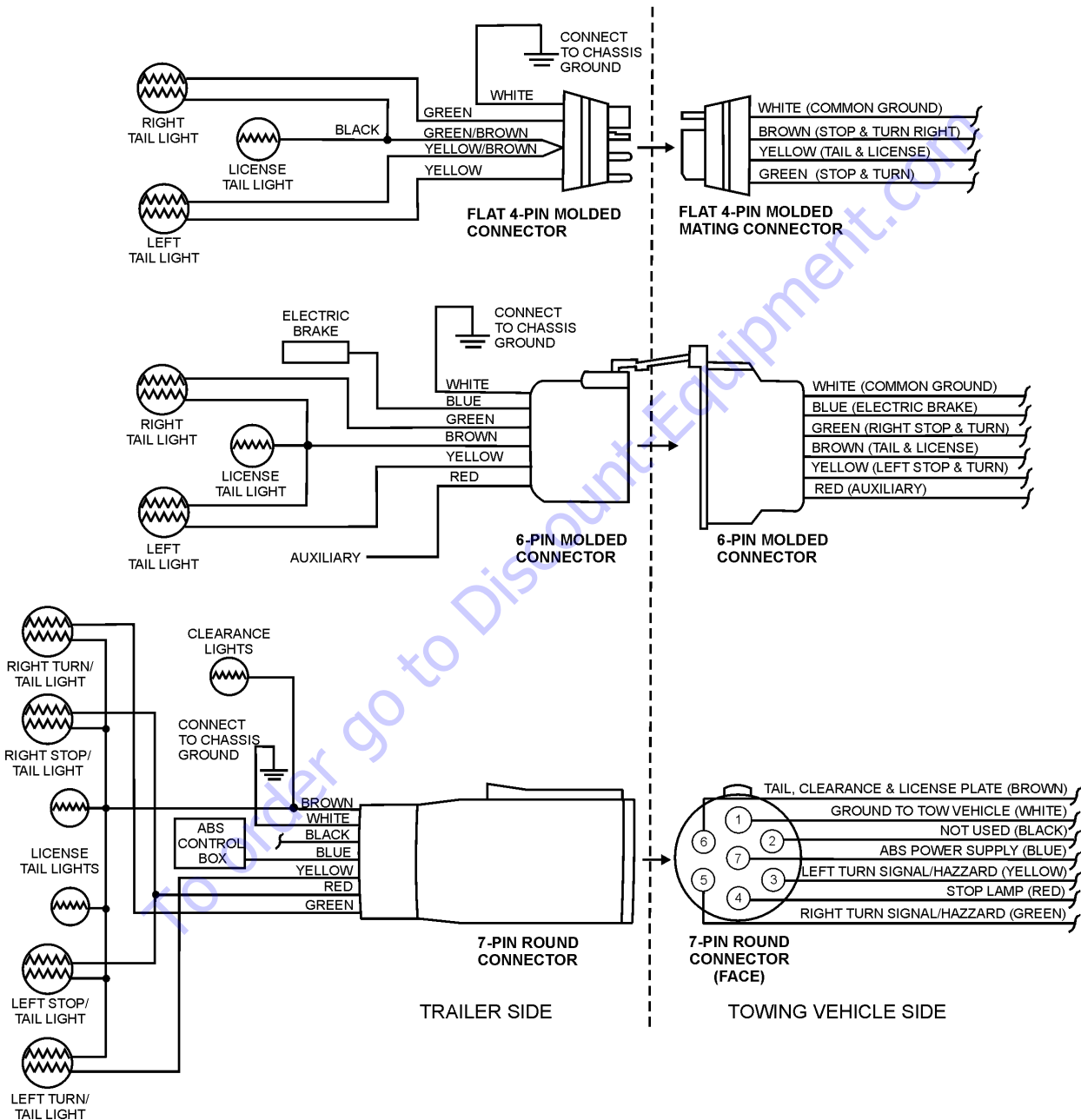

Figure L. Trailer to Tow Vehicle Wiring Diagram

SYSTEM ERROR FAULT CODES

EMERGENCY STOP AND DIGITAL CONTROLLER DISPLAY

The engine will not start if an error is detected before starting. If an error is detected during operation, the engine will be shutdown and the digital controller will display the error code and the error code LED will light. Error codes that are displayed with an "E" are emergency shutdown codes. Error codes that are displayed with an "A" are alarm codes. Reference Table 14 (next page) for engine sensor error DTC codes. Reference Table 13 below for a brief explanation of the engine and air compressor error codes.

Table 13. Engine/Air Compressor Error Codes

| Engine Status | Error Code | Details of Trouble | Corrective Action |
|-----------------------------|--------------------------------------|--|--|
| Engine Shutdown | E 01 | P1 Pressure Sensor abnormal. | Check harness connector at pressure sensor P1. |
| | E 02 | P2 Pressure Sensor abnormal. | Check harness connector at pressure sensor P2. |
| | E 03 | P3 Pressure Sensor abnormal. | Check harness connector at pressure sensor P3. |
| | E 04 | Discharge Air Temp. Sensor abnormal. | Check harness connector at discharge air temp sensor. |
| | E 05 | Fuel Level Sender abnormal. | Replace fuel sender. |
| | E 06 | Controller circuit board signal error "1". | Check harness connectors between circuit board (CU-40) and display board (CM-40). |
| | E 07 | Controller circuit board signal error "2". | Check the harness connectors between circuit board (CU-40) and display board (CM-40). |
| | E 10 | Engine Low Speed | Adjust using load. |
| | E 11 | Battery Charging abnormal. | Check fan belt. Adjust using load. Inspect charge relay circuit for charging generator. |
| | E 12 | Emergency Stop device "1" signal input. | (Option) |
| | L.oil.P | Engine Low oil pressure | Replenish engine oil. |
| | H.co.t | High Engine Coolant Temperature. | Check coolant system for leaks and radiator for coolant level. |
| | E 14 | Low Fuel Level. (Empty) | Refill fuel. |
| | E 15 | Engine controller processing time out error | Check DTC codes. Restart the engine. |
| | E 16 | Emergency Stop device "2" signal input. | (Option) |
| | E 18 | Engine CAN signal error. | Check the CAN wires between circuit board (CU-40) and ECM. |
| | E 20 | High Discharge Air Temperature. | Check and clean oil cooler. Replenish compressor oil. |
| | E 22 | Discharge Air pressure abnormally high | Check and repair proportional solenoid valve. |
| | E 23 | Proportional Sol. V abnormally low current | Inspect the harness between proportional solenoid valve, circuit board (CU-40), and ECM. |
| | E 24 | Proportional Sol. V over current. | |
| E 97 | Memory error. | Turn main switch OFF and ON again. If error code remains, replace circuit board (CU-40). | |
| E 99 | Controller microprocessor WDT error. | Turn main switch OFF and ON again. If error code remains, replace circuit board (CU-40). | |
| (No engine behavior change) | A 10 | Engine Air Filter clogging. | Check and clean air cleaner element. |
| | A 21 | Compressor Oil Filter clogging. | Replace compressor oil filter. |

DTC TROUBLESHOOTING CODES

All other Controller Area Network (CAN) signal error codes (CAN, Suspect Parameter Number (SPN) and Failure Mode Identifier (FMI) from the Isuzu Engine Control Module (ECM) will be converted to Diagnostic Troubleshooting Codes (DTC) and will be displayed on the controller. Reference Table 14 below for a brief explanation of the error codes.

Table 14. Sensor System Diagnostic Troubleshooting Codes (DTC)

| Sensor Sensor | | | |
|--|----------|--|---|
| Engine Status | DTC Code | Details of Trouble | Corrective Action |
| Unable to restart engine. | 0340 | Cam Sensor. No signal | Measure 4.5–5V from Pwr. Supply to GND. ¹ |
| Engine stall | 0335 | Crank sensor. No signal | Measure 4.5–5V from Pwr. Supply to GND. ¹ |
| Engine stall | 0336 | Crank sensor. Abnormal signal | See below. ¹ |
| Unable to restart engine | 0016 | Cam sensor phase shifting. | See below. ¹ |
| Engine stall | 0113 | Intake air temp. sensor. (High voltage) | Measure 5.5V from signal to GND. ¹ |
| Engine stall | 0112 | Intake air temperature sensor. (Low voltage) | Measure 4.5V on diagnosis tool. ¹ |
| Engine stall | 0118 | Water temperature sensor. (High voltage) | Measure 5.5V from signal to GND. ¹ |
| Engine stall | 0117 | Water temperature sensor. (Low voltage) | Measure 4.5V on diagnosis tool. ¹ |
| (No engine behavior change) | 0098 | Manifold tem (IMT) sensor. (High voltage) | Measure 5.5V from signal to GND. ¹ |
| (No engine behavior change) | 0097 | Manifold temp. (IMT) sensor. (Low voltage) | Measure 4.5V on diagnosis tool. ¹ |
| Engine stall | 0238 | Boost pressure sensor. (High voltage) | Measure 0.1V on diagnosis tool. ¹ |
| Engine stall | 0237 | Boost pressure sensor. (Low voltage) | Measure 4.5–5V from Pwr. Supply to GND. ¹ |
| Engine stall | 0409 | EGR position sensor. | Measure 4.5–5V from Pwr. Supply to GND. ¹ |
| Engine stall | 2229 | Barometric pressure sensor. (High voltage) | Measure 0.1V on diagnosis tool. ¹ |
| Engine stall | 2228 | Barometric pressure sensor. (Low voltage) | Measure 4.5–5V from Pwr. Supply to GND. ¹ |
| (No engine behavior change) | 0183 | Fuel Temperature sensor. (High voltage) | Measure 5.5V from signal to GND. ¹ |
| (No engine behavior change) | 0182 | Fuel Temperature sensor. (Low voltage) | Measure 4.5V on diagnosis tool. ¹ |
| Engine stall | 0193 | Common rail pressure sensor. (High voltage) | Measure 5.5V from signal to GND. ¹ |
| Engine stall | 0192 | Common rail pressure sensor. (Low voltage) | Measure 4.5V on diagnosis tool. ¹ |
| (No engine behavior change) | 0523 | Engine oil pressure sensor. (High voltage) | Measure 0.1V on diagnosis tool. ¹ |
| (No engine behavior change) | 0522 | Engine oil pressure sensor. (Low voltage) | Measure 4.5–5V from Pwr. Supply to GND. ¹ |
| (No engine behavior change) | 1098 | Boost temperature sensor. (High voltage) | Measure 5.5V from signal to GND. ¹ |
| (No engine behavior change) | 1097 | Boost temperature sensor. (Low voltage) | Measure 4.5V on diagnosis tool. ¹ |
| Sensor 1, system malfunction (No engine behavior change) Sensor 2, system malfunction Engine speed reduced (idle running) | 2123 | Accelerator sensor 1. (High voltage) | Check the circuit between control board(CU-40) and the ECM. |
| | 2122 | Accelerator sensor 1. (Low voltage) | Check the circuit between control board(CU-40) and the ECM. Check the Jumper wire on main relay is not connected. |
| | 2128 | Accelerator sensor 2. (High voltage) | Check the circuit between control board(CU-40) and the ECM. |
| | 2127 | Accelerator sensor 2. (Low voltage) | |
| | 2138 | Accelerator sensor 1-2 comparison | |

¹Check harness connector at sensor for proper voltage. If the voltage is within the proper range then change the sensor. If the voltage is out of range then check the circuit between the sensor and the ECM for short to ground, battery or ignition power. If there are no problems then check for loose connections in the ECM harness. If there are no problems then change the ECM.

DTC TROUBLESHOOTING CODES (CONTINUED)

| Sensor System Diagnostic Troubleshooting Codes (DTC Continued) | | | |
|--|----------|--|--|
| External Device System Codes | | | |
| Engine Status | DTC Code | Details of Trouble | Corrective Action |
| Engine Stall | 0404 | EGR valve control. | Check EGR for blockage, inspect eng harness. |
| | 1404 | EGR zero-point learning. | Remove EGR to inspect, inspect eng harness. |
| | 0092 | SCV driving system +B short. | Inspect the high side and low side circuits. |
| | 0091 | SCV driving sys. disconnection, gnd. short. | Inspect the high side and low side circuits. |
| Engine rough/stall (3 cylinder operation) | 0201 | Injection nozzle #1 driving sys. disconnection. | Measure the resistance in the charge voltage circuit (< 1.0 Ohms). If correct, measure voltage from injector to ground (1.0 V). |
| | 0202 | Injection nozzle #2 driving sys. disconnection. | |
| | 0203 | Injection nozzle #3 driving sys. disconnection. | |
| | 0204 | Injection nozzle #4 driving sys. disconnection. | |
| Fuel System | | | |
| | 0089 | Common rail pressure, pump over pressure feed | For low pressure check filter first then check the fuel rail pressure (FRP) sensor for proper voltage(0.9-1.0V). If out of range check harness from FRP to ECM. If correct, change fuel rail assy. |
| | 0087 | Pressure limiter open. | |
| | 1093 | Common rail pressure low. Pump pressure insufficient | |
| | 0093 | Common rail pressure low, No pump pressure | Check complete fuel system for leaks. If no leaks are found, refer to above corrective action. |
| Engine Protection | | | |
| Engine shutdown | 0217 | Overheat. | Check coolant system for leaks and radiator for coolant level. If correct, check coolant level circuit. |
| (No engine behavior change) | 0219 | Overrun. | Observe engine speed at no load. If no error check CKP sensor circuit and sensor. |
| Engine shutdown | 0521 | Engine oil pressure down | Inspect engine oil system for leaks. If correct, check oil pressure sensor circuit. If there are no problems change sensor. |
| External Circuit System | | | |
| (No engine behavior change) | 0380 | Glow relay. | Inspect relay circuit from glow relay to ignition switch. If there are no problems, change glow relay. |
| | 0615 | Starter cut relay. | Inspect starter relay circuit from relay to ECM. If correct,change starter relay. |
| Engine shutdown | 0685 | Main relay system. Not connected | Inspect main relay circuit. If connected, change main relay. Also inspect slow blow fuse for a short circuit. |
| (No engine behavior change) | 0687 | Main relay system. Not disconnected | |
| | | 0563 | Battery system high voltage. |

DTC TROUBLESHOOTING CODES (CONTINUED)

Sensor System Diagnostic Troubleshooting Codes (DTC Continued)

Internal Circuit System

| | | | |
|---|------|--|--|
| Engine rough/stall (2 cylinder operation) | 1261 | Charge circuit. (Bank 1) | Replace ECM |
| | 1262 | Charge circuit. (Bank 2) | |
| Engine shutdown (Unable to restart) | 06AF | Injector Integrated Circuit (IC). | Replace ECM |
| | 06AF | Injector IC check sum. | |
| | 06AF | Injector IC connection. | |
| (No engine behavior change) | 1606 | SWITCH-IC_1 internal. | Replace ECM |
| | 1606 | SWITCH-IC_1 connection. | |
| Engine stall | 060B | Analog Digital (A/D) conversion. | Replace ECM |
| | 160B | ADIC. | Replace ECM |
| Engine stall (Unable to start) | 0606 | Central Processing Unit (CPU_ | Replace ECM |
| Engine stall | 0606 | CPU monitoring IC. | |
| Eng. shutdown (Unable to start) | 0601 | Read Only Memory (ROM) | Replace ECM |
| (No engine behavior change) | 1621 | Electrically Erasable Programmable Read Only Memory (EEPROM) | Verify all sections of tools are connected securely. If DTC remains, replace ECM. |
| (No engine behavior change) | 0641 | 5V power supply 1 voltage | Inspect 5V power supply circuit for accelerator position sensor, fuel filter sensor and boost pressure sensor for proper voltage between sensor and ECM. If error is found, repair circuit. |
| Engine stall | 0651 | 5V power supply 2 voltage | Inspect 5V power supply circuit for barometric pressure sensor, CMP sensor, FRP sensor and EGR position sensor for proper voltage between sensor and ECM. If error is found, repair circuit. |
| (No engine behavior change) | 0697 | 5V power supply 3 voltage | Inspect 5V power supply circuit for oil pressure sensor between sensor and ECM. If error is found, repair circuit. |
| Engine stall | 1655 | 5V power supply 4 voltage | Inspect 5V power supply circuit for CKP sensor between sensor and ECM. If error is found, repair circuit. |
| Eng. shutdown, Unable to start | 0604 | Random Access Memory (RAM) | Replace ECM |
| (No engine behavior change) | 0602 | QR code. | Verify the injector ID code and fuel delivery rate data are input correctly. If not, replace ECM |
| Engine rough/stall (2 cylinder operation) | 2146 | Injection nozzle common 1 driving system. | Inspect engine harness between injectors and ECM. If problem is found, repair the circuit |
| | 2149 | Injection nozzle common 2 driving system. | |

Communication System

| | | | |
|-------------------------------------|------|---------------|--|
| Engine speed reduced (Idle running) | 0073 | CAN Bus. | Measure resistance on CAN wiring (60 Ohm). If incorrect, check the termination resistor (120 Ohm). If correct, check resistance on CAN wires at ECM connector. If error, change ECM. |
| | 0101 | CAN time-out. | |

TROUBLESHOOTING (COMPRESSOR)

Table 15. Troubleshooting (Compressor)

| Sympton | Possible Problem | Corrective Action |
|------------------------------------|--|--|
| Air Pressure too high | Pressure sensor defective? | Check or replace sensor |
| | Proportional solenoid valve frozen? | Check or replace solenoid |
| | Inlet valve seal damaged? | Check or replace inlet valve |
| | Air pressure control pipe frozen? | Check or replace air pressure control pipe |
| | Compressor oil too thick? | Replace with proper oil viscosity |
| Problem in Fuel System | Fuel tank empty? | Add fuel |
| | Air mixed in fuel system? | Fully extract air. Check for loosened fuel line |
| | Fuel filter clogged? | Check or replace fuel filter and clean tank |
| | Fuel has deteriorated? | Add fuel. Check or replace entire fuel system |
| | Fuel injection system is defective? | Check or replace fuel injection system. |
| | Engine oil level too full? | Reduce oil to correct engine oil level |
| | Engine oil is too thick? | Refill engine crankcase with correct type of oil for cold weather conditions |
| | Engine oil pressure is reduced? | Replace engine oil and filter |
| | Engine overheats? | Clean cooling air system and cooling fin areas |
| | Warm up time not sufficient in cold weather conditions? | Comply with cold starting instructions and proper oil viscosity. |
| Emergency Stop Circuit is Abnormal | Switch or sensor is defective? | Check or repair switch or sensor |
| | Wiring to water temp. sensor, oil pressure sensor, discharge air temp. sensor is disconnected? | Check or repair water temp. sensor, oil pressure or discharge air temp. sensor |
| | Engine control unit is defective? | Replace or repair engine control unit |
| No Air Is Delivered | Service valve is closed? | Open valve |
| | Minimum pressure valve is abnormal? | Clean or replace pressure valve |
| | Proportional solenoid valve is abnormal? | Check or replace solenoid valve |
| | Pressure sensor P1 or P2 is abnormal? | Check or replace pressure sensor P1 or P2 |
| Safety Valve Operates | Pressure control piping is frozen? | Check or replace frozen pressure control piping |
| | Proportional solenoid valve is frozen? | Check or replace frozen proportional solenoid valve |
| | Air leaks from control pressure pipe? | Check or replace control pressure pipe |
| | Pressure sensor P1 or P2 is frozen? | Check or replace pressure sensor P1 or P2 |
| | Safety valve is set to low value? | Replace safety valve |
| | Air leaks from inlet valve seal? | Check or replace inlet valve seal |

TROUBLESHOOTING (ENGINE)

| Troubleshooting (Engine) | | |
|--|--|---|
| Symptom | Possible Problem | Solution |
| Engine will not start or start is delayed, although engine can be turned over. | No Fuel reaching injection pump? | Add fuel. Check entire fuel system. |
| | Defective fuel pump? | Replace fuel pump. |
| | Fuel filter clogged? | Replace fuel filter and clean tank. |
| | Faulty fuel supply line? | Replace or repair fuel line. |
| | Compression too low? | Check piston, cylinder and valves. Adjust or repair per engine repair manual. |
| | Fuel pump not working correctly? | Repair or replace fuel pump. |
| | Oil pressure too low? | Check engine oil pressure. |
| | Low starting temperature limit exceeded? | Comply with cold starting instructions and proper oil viscosity. |
| | Defective battery? | Charge or replace battery. |
| | Air or water mixed in fuel system? | Check carefully for loosened fuel line coupling, loose cap nut, etc. |
| At low temperatures engine will not start. | Engine oil too thick? | Refill engine crankcase with correct type of oil for winter environment. |
| | Defective battery? | Replace battery. |
| Engine fires but stops soon as starter is switched off. | Fuel filter blocked? | Replace fuel filter. |
| | Fuel supply blocked? | Check the entire fuel system. |
| | Defective fuel pump? | Replace fuel pump. |
| Engine stops by itself during normal operation. | Fuel tank empty? | Add fuel. |
| | Fuel filter blocked? | Replace fuel filter. |
| | Defective fuel pump? | Replace fuel pump. |
| | Mechanical oil pressure shutdown sensor stops the engine due to low oil? | Add oil. Replace low oil shutdown sensor if necessary. |
| Low engine power, output and speed. | Fuel tank empty? | Replace fuel filter. |
| | Fuel filter clogged? | Replace fuel filter. |
| | Fuel tank venting is inadequate? | Ensure that tank is adequately vented. |
| | Leaks at pipe unions? | Check threaded pipe unions tape and tighten unions as required. |
| | Speed control lever does not remain in selected position? | See engine manual for corrective action. |
| | Engine oil level too full? | Correct engine oil level. |
| | Injection pump wear? | Use No. 2-D diesel fuel only. Check the fuel injection pump element and delivery valve assembly and replace as necessary. |

TROUBLESHOOTING (ENGINE CONTINUED)

| Troubleshooting (Engine) - continued | | |
|---|--|---|
| Symptom | Possible Problem | Solution |
| Low engine power output and low speed, black exhaust smoke. | Air filter blocked? | Clean or replace air filter. |
| | Incorrect valve clearances? | Adjust valves per engine specification. |
| | Malfunction at injector? | See engine manual. |
| Engine overheats. | Too much oil in engine crankcase? | Drain off engine oil down to uppermark on dipstick. |
| | Entire cooling air system contaminated/ blocked? | Clean cooling air system and cooling fin areas. |
| | Fan belt broken or elongated? | Change belt or adjust belt tension. |
| | Coolant insufficient? | Replenish coolant. |
| | Radiator net or radiator fin clogged with dust? | Clean net or fin carefully. |
| | Fan, radiator, or radiator cap defective? | Replace defective part. |
| | Thermostat defective? | Check thermostat and replace if necessary. |
| Head gasket defective or water leakage? | Replace parts. | |

SYSTEM DIAGRAM

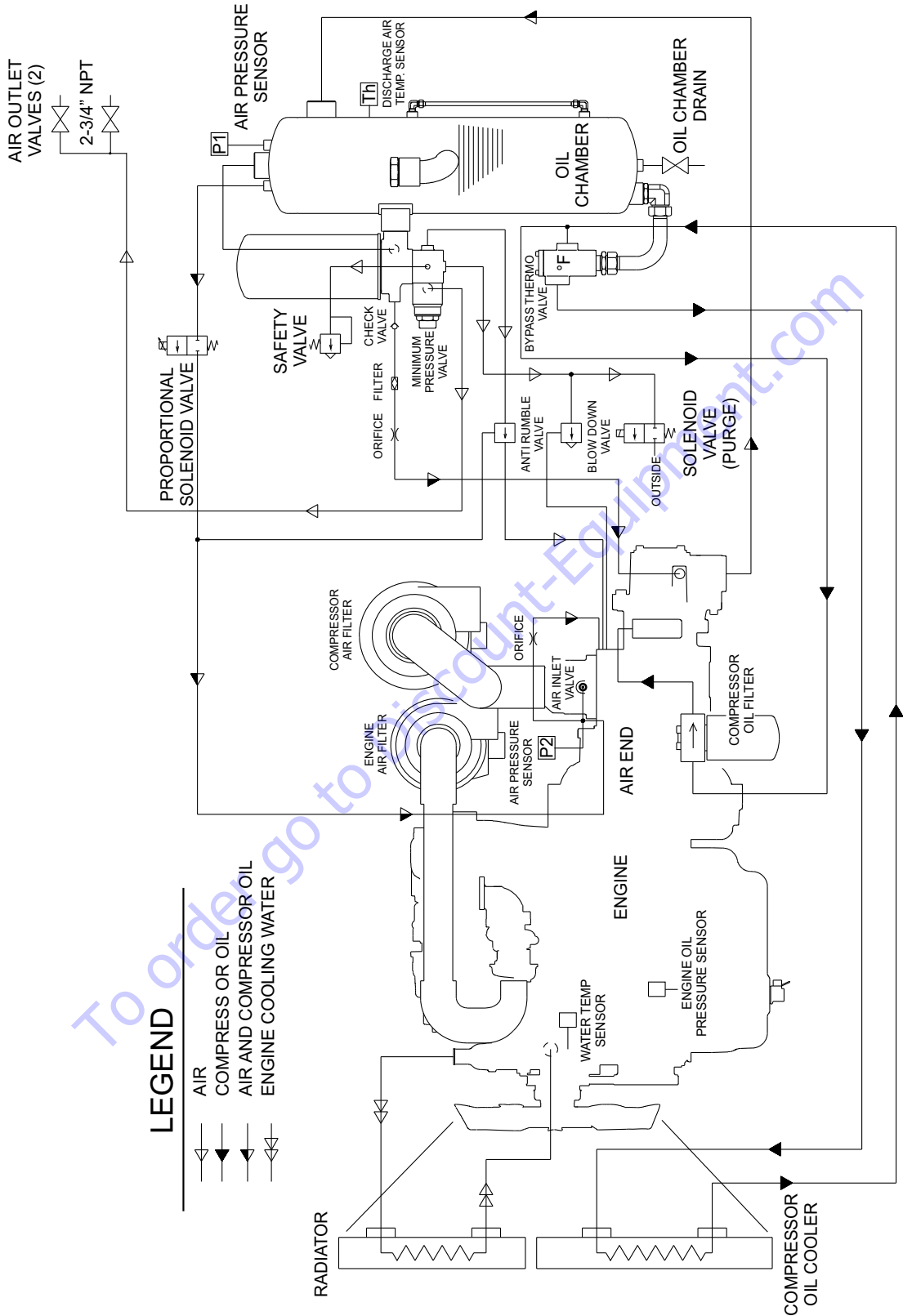

LEGEND

-  AIR
-  COMPRESSOR OIL
-  AIR AND COMPRESSOR OIL
-  ENGINE COOLING WATER

TO PURCHASE THIS PRODUCT PLEASE CONTACT US



**Equipment Financing and
Extended Warranties Available**



**Discount-Equipment.com is your online resource for
commercial and industrial quality parts and equipment sales.**

561-964-4949

visit us on line @ www.discount-equipment.com

Select an option below to find your Equipment

Search by Manufacturer

Search by Product Type

Request a Quote

We sell worldwide for the brands: Genie, Terex, JLG, MultiQuip, Mikasa, Essick, Whiteman, Mayco, Toro Stone, Diamond Products, Generac Magnum, Airman, Haulotte, Barreto, Power Blanket, Nifty Lift, Atlas Copco, Chicago Pneumatic, Allmand, Miller Curber, Skyjack, Lull, Skytrak, Tsurumi, Husquvarna Target, Stow, Wacker, Sakai, Mi-T-M, Sullair, Basic, Dynapac, MBW, Weber, Bartell, Bennar Newman, Haulotte, Ditch Runner, Menegotti, Morrison, Contec, Buddy, Crown, Edco, Wyco, Bomag, Laymor, EZ Trench, Bil-Jax, F.S. Curtis, Gehl Pavers, Heli, Honda, ICS/PowerGrit, IHI, Partner, Imer, Clipper, MMD, Koshin, Rice, CH&E, General Equipment, Amida, Coleman, NAC, Gradall, Square Shooter, Kent, Stanley, Tamco, Toku, Hatz, Kohler, Robin, Wisconsin, Northrock, Oztec, Toker TK, Rol-Air, APT, Wylie, Ingersoll Rand / Doosan, Innovatech, Con X, Ammann, Mecalac, Makinex, Smith Surface Prep, Small Line, Wanco, Yanmar

OPERATION MANUAL



www.Discount-Equipment.com

© COPYRIGHT 2019, MULTIQUIP INC.

Multiquip Inc, the MQ logo and the MQ Power logo are registered trademarks of Multiquip Inc. and may not be used, reproduced, or altered without written permission. All other trademarks are the property of their respective owners and used with permission.

This manual MUST accompany the equipment at all times. This manual is considered a permanent part of the equipment and should remain with the unit if resold.

The information and specifications included in this publication were in effect at the time of approval for printing. Illustrations, descriptions, references and technical data contained in this manual are for guidance only and may not be considered as binding. Multiquip Inc. reserves the right to discontinue or change specifications, design or the information published in this publication at any time without notice and without incurring any obligations.

