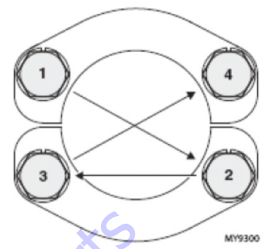
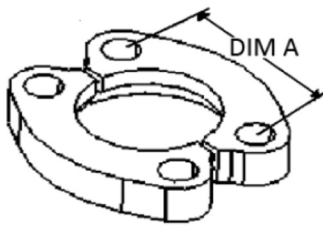

Table 5-31. Flange Code (FL61 & FL62) -Inch Fasteners

TYPE/FITTING IDENTIFICATION						STEEL 4-BOLT FLANGE SAE J518 (INCH FASTENERS)												
TYPE	Inch Flange SAE Dash Size	Flange Size		A*		Bolt Thread Size	Fastener Torque for Flanges Equipped with GRADE 5 Screws						Fastener Torque for Flanges Equipped with GRADE 8 Screws					
		(in)	(mm)	(in)	(mm)		[Ft-Lb]			[N-m]			[Ft-Lb]			[N-m]		
						(UNF)	Min	Nom	Max	Min	Nom	Max	Min	Nom	Max	Min	Nom	Max
CODE 61 SPLIT FLANGE (FL61)	8	0.50	13	1.50	38.10	5/16-18	18	19	19	24	25	26	24	25	26	32	34	35
	12	0.75	19	1.88	47.75	3/8-16	32	33	35	43	45	47	44	46	49	60	63	66
	16	1.00	25	2.06	52.32	3/8-16	32	33	35	43	45	47	44	46	49	60	63	66
	20	1.25	32	2.31	58.67	7/16-14	52	54	57	70	74	77	68	71	75	92	97	101
	24	1.50	38	2.75	69.85	1/2-13	77	81	85	105	110	116	111	116	122	150	158	165
	32	2.00	51	3.06	77.72	1/2-13	77	81	85	105	110	116	111	116	122	150	158	165
	40	2.50	64	3.50	88.90	1/2-13	77	81	85	105	110	116	111	116	122	150	158	165
	48	3.00	76	4.19	106.43	5/8-11	155	163	170	210	221	231	218	228	239	295	310	325
	56	3.50	89	4.75	120.65	5/8-11	155	163	170	210	221	231	218	228	239	295	310	325
	64	4.00	102	5.13	130.30	5/8-11	155	163	170	210	221	231	218	228	239	295	310	325
	80	5.00	127	6.00	152.40	5/8-11	155	163	170	210	221	231	218	228	239	295	310	325
CODE 62 SPLIT FLANGE (FL62)	8	0.50	13	1.59	40.39	5/16-18	--	--	--	--	--	--	24	25	26	32	34	35
	12	0.75	19	2.00	50.80	3/8-16	--	--	--	--	--	--	44	46	49	60	63	66
	16	1.00	25	2.25	57.15	7/16-14	--	--	--	--	--	--	68	71	75	92	97	101
	20	1.25	32	2.62	66.55	1/2-13	--	--	--	--	--	--	111	116	122	150	158	165
	20	1.25	32	2.62	66.55	--	--	--	--	--	--	--	--	--	--	--	--	--
	24	1.50	38	3.12	79.25	5/8-11	--	--	--	--	--	--	218	228	239	295	310	325
	32	2.00	51	3.81	96.77	3/4-10	--	--	--	--	--	--	332	348	365	450	473	495

\* A dimension for reference only.



**SECTION 5 - HYDRAULICS AND HYDRAULIC SCHEMATICS**

**Table 5-32. Flange Code (FL61 & FL62) - Metric Fasteners**

TYPE/FITTING IDENTIFICATION						STEEL 4-BOLT FLANGE SAE J518 (INCH FASTENERS)												
TYPE	Inch Flange SAE Dash Size	Flange Size		A*		Bolt Thread Size  (Metric)	Fastener Torque for Flanges Equipped with CLASS 8.8 Screws						Fastener Torque for Flanges Equipped with CLASS 10.9 Screws					
		(in)	(mm)	(in)	(mm)		[Ft-Lb]			[N-m]			[Ft-Lb]			[N-m]		
							Min	Nom	Max	Min	Nom	Max	Min	Nom	Max	Min	Nom	Max
CODE 61 SPLIT FLANGE (FL61)	8	0.50	13	1.50	38.10	(Metric)	Min	Nom	Max	Min	Nom	Max	Min	Nom	Max	Min	Nom	Max
	12	0.75	19	1.88	47.75	M8x1.25	18	19	19	24	25	26	18	19	19	24	25	26
	16	1.00	25	2.06	52.32	M10x1.5	37	39	41	50	53	55	37	39	41	50	53	55
	20	1.25	32	2.31	58.67	M10x1.5	37	39	41	50	53	55	37	39	41	50	53	55
	24	1.50	38	2.75	69.85	M10x1.5	37	39	41	50	53	55	37	39	41	50	53	55
	32	2.00	51	3.06	77.72	M12x1.75	68	71	75	92	97	101	68	71	75	92	97	101
	40	2.50	64	3.50	88.90	M12x1.75	68	71	75	92	97	101	68	71	75	92	97	101
	48	3.00	76	4.19	106.43	M12x1.75	68	71	75	92	97	101	68	71	75	92	97	101
	56	3.50	89	4.75	120.65	M16x2	155	163	170	210	221	231	155	163	170	210	221	231
	64	4.00	102	5.13	130.30	M16x2	155	163	170	210	221	231	155	163	170	210	221	231
	80	5.00	127	6.00	152.40	M16x2	155	163	170	210	221	231	155	163	170	210	221	231
CODE 62 SPLIT FLANGE (FL62)	8	0.50	13	1.59	40.39	M8x1.25	--	--	--	--	--	--	24	25	26	32	34	35
	12	0.75	19	2.00	50.80	M10x1.5	--	--	--	--	--	--	52	54	57	70	74	77
	16	1.00	25	2.25	57.15	M12x1.75	--	--	--	--	--	--	96	101	105	130	137	143
	20	1.25	32	2.62	66.55	M12x1.75	--	--	--	--	--	--	96	101	105	130	137	143
	20	1.25	32	2.62	66.55	M14x2	--	--	--	--	--	--	133	139	146	180	189	198
	24	1.50	38	3.12	79.25	M16x2	--	--	--	--	--	--	218	228	239	295	310	325
	32	2.00	51	3.81	96.77	M20x2.5	--	--	--	--	--	--	406	426	446	550	578	605

\* A dimension for reference only.

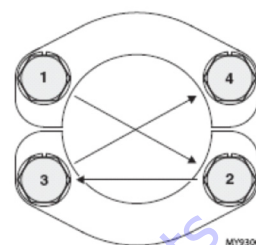
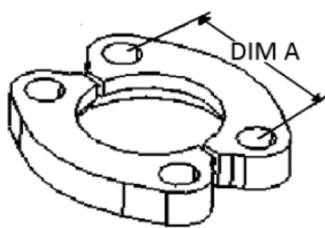

### Double Wrench Method

To prevent undesired hose or connector rotation, two wrenches must be used; one torque wrench and one backup wrench. If two wrenches are not used, inadvertent component rotation may occur which absorbs torque and causes improper joint load and leads to leaks. For hose connections,

the 'layline' printed on the hose is a good indicator of proper hose installation. A twisted lay-line usually indicates the hose is twisted. See Figure 5-11. for double wrench method requirements.

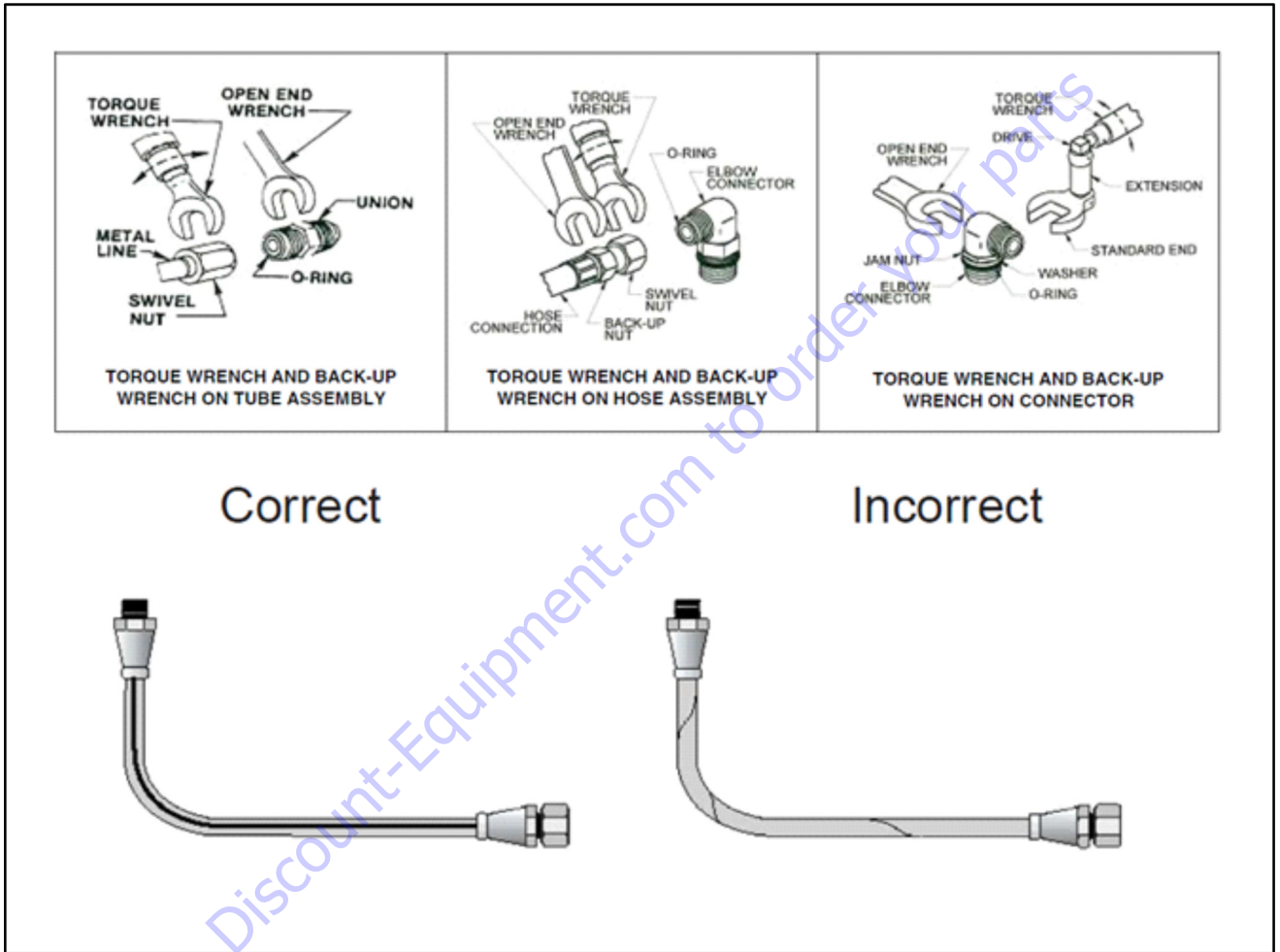

Figure 5-11. Double Wrench Method

### FFWR and TFFT Methods

#### FFWR (FLATS FROM WRENCH RESISTANCE METHOD)

1. Tighten the swivel nut to the mating fitting until no lateral movement of the swivel nut can be detected; finger tight condition.
2. Mark a dot on one of the swivel hex nut flats and another dot in line on the connecting tube adapter. See Figure B.1.
3. Use the double wrench method per Appendix A, turn the swivel nut to tighten as shown in Figure 5-11. The nut is to be rotated clockwise the number of hex flats as defined by the applicable Table in Section 5.0.
4. After the connection has been properly tightened, mark a straight line across the connecting parts, not covering the dots, to indicate the connection has been properly tightened. See Figure 5-12.

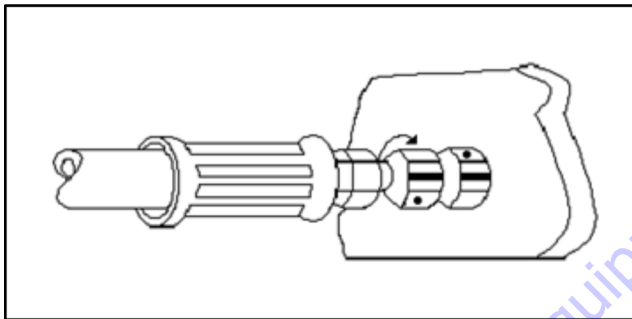

Figure 5-12. FFWR Method

#### TFFT (TURNS FROM FINGER TIGHT METHOD)

1. Tighten the swivel nut to the mating fitting until no lateral movement of the swivel nut can be detected; finger tight condition.
2. Mark a dot on one of the swivel hex nut flats and another dot in line on the connecting tube adapter.
3. Use the double wrench method per Appendix A, turn the swivel nut to tighten. The nut is to be rotated clockwise the number of turns as defined by the applicable Table in Section 5.0.
4. After the connection has been properly tightened, mark a straight line across the connecting parts, not covering the dots, to indicate the connection has been properly tightened.

### Adjustable Stud End Assembly

For Adjustable Stud End Connections; the following assembly steps are to be performed:

1. Lubricate the o-ring with a light coat of hydraulic oil.
2. Position #1 – The o-ring should be located in the groove adjacent to the face of the backup washer. The washer and o-ring should be positioned at the extreme top end of the groove as shown.
3. Position #2 – Position the locknut to just touch the backup washer as shown. The locknut in this position will eliminate potential backup washer damage during the next step.
4. Position #3 – Install the connector into the straight thread box port until the metal backup washer contacts the face of the port as shown.
5. Position #4 – Adjust the connector to the proper position by turning out (counterclockwise) up to a maximum of one turn as shown to provide proper alignment with the mating connector, tube assembly, or hose assembly.
6. Position #5 – Using two wrenches, use the backup wrench to hold the connector in the desired position and then use the torque wrench to tighten the locknut to the appropriate torque.
7. Visually inspect, where possible, the joint to ensure the o-ring is not pinched or bulging out from under the washer and that the backup washer is properly seated flat against the face of the port.



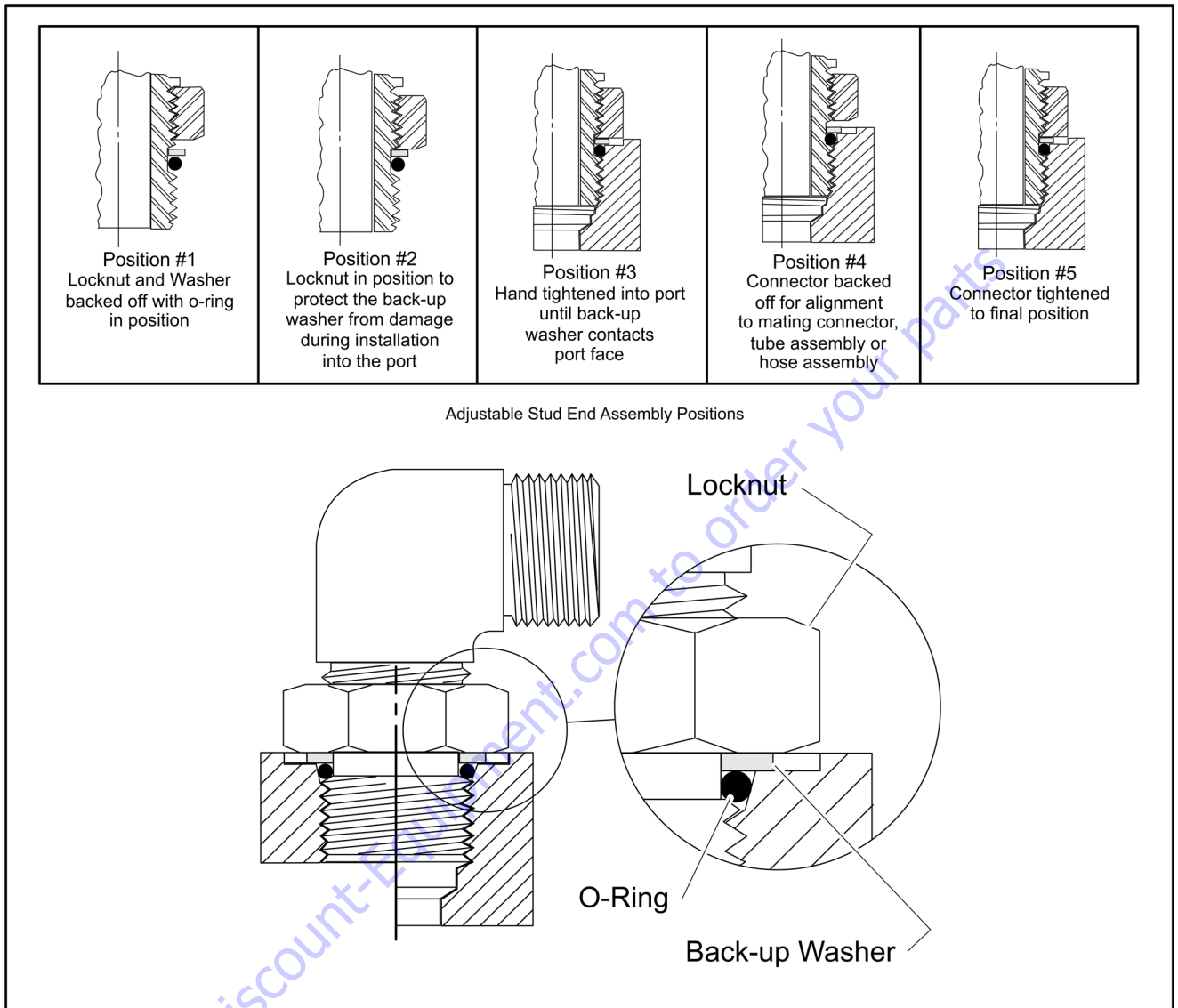

Figure 5-13. Adjustable Stud End Assembly

### O-ring Installation (Replacement)

Care must be taken when installing o-rings over threads during replacement or installation. o-rings could become nicked or torn. A damaged o-ring could lead to leakage problems.

1. Inspect o-ring for tears or nicks. If any are found replace o-ring.
2. Ensure proper o-ring to be installed. Many o-rings look the same but are of different material, different hardness, or are slightly different diameters or widths.
3. Use a thread protector when replacing o-rings on fittings.
4. In ORB; ensure o-ring is properly seated in groove. On straight threads, ensure o-ring is seated all the way past the threads prior to installation.
5. Inspect o-ring for any visible nicks or tears. Replace if found.

5.3 HYDRAULIC CYLINDERS

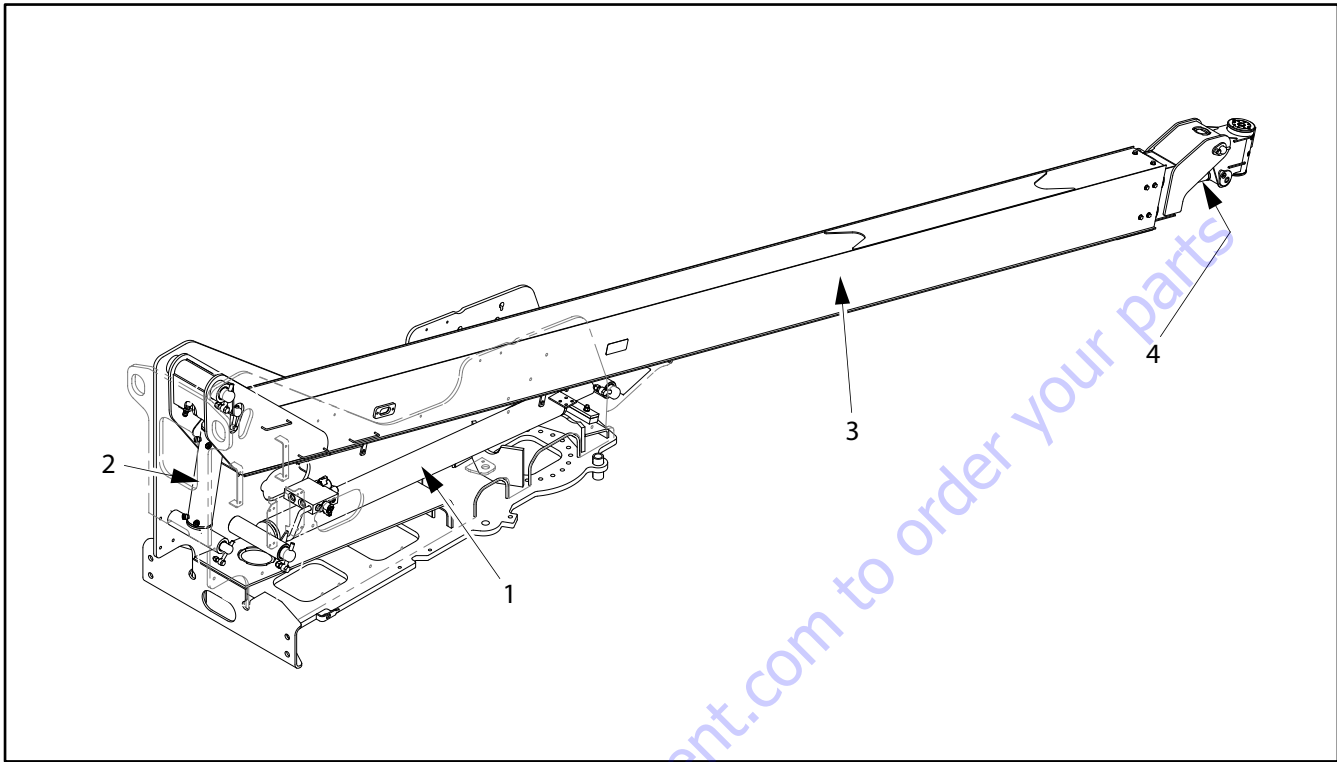

- 1. Lift
- 2. Master
- 3. Telescope
- 4. Platform Level

Figure 5-14. Hydraulic Cylinder Locations - 400SC

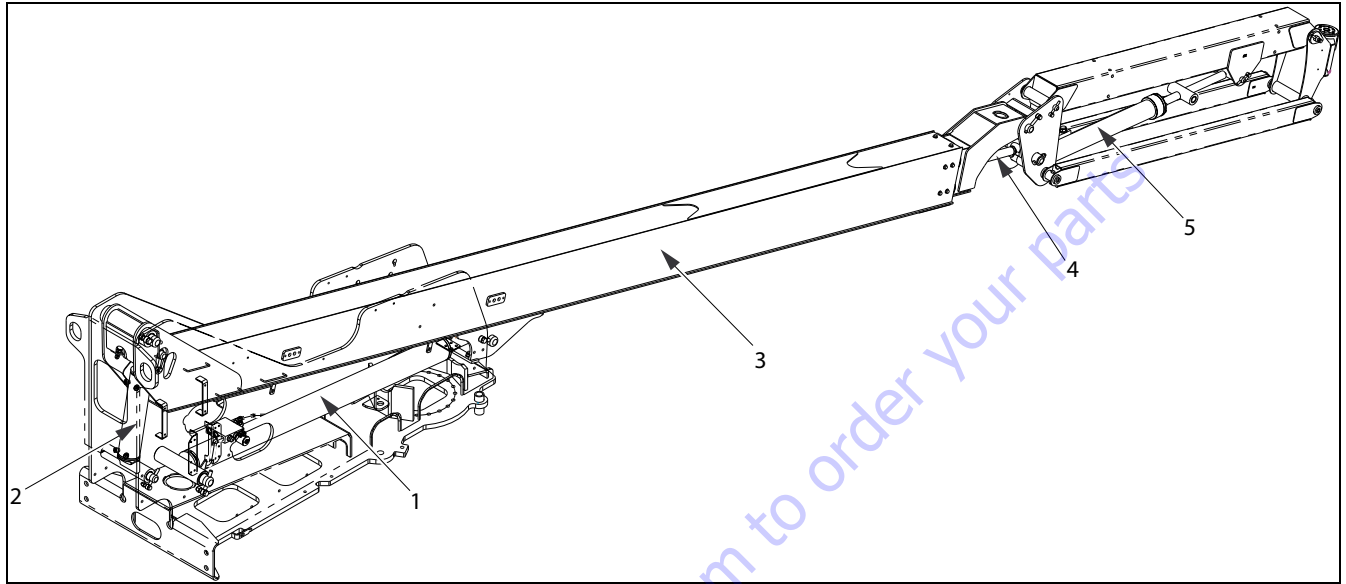

- 1. Lift
- 2. Master
- 3. Telescope
- 4. Platform Level
- 5. Jib

Figure 5-15. Hydraulic Cylinder Locations - 460SJC

**Disassembly and Assembly Instructions**

1. Make sure the work area is large enough for the entire cylinder and clean and free of dirt. Ensure the cylinder can be secured firmly in place during disassembly.
2. Prepare all the necessary tools and replacement parts.

**General Information**

1. Clean any burrs or contamination from the surface of the cylinder before disassembly.
2. Handle every part with care. Each part is precision made and hitting parts together or letting them fall could damage the machined surfaces.
3. Do not twist or strike parts to get them apart. This will damage the part and/or threads, resulting in leakage and poor function.
4. Do not let the cylinder in a disassembled condition for a long period of time. It only takes a short period of time for the parts to rust.

**Standard of Maintenance**

Parts and seals should be replaced according to the conditions as follows.

1. Bushings - 1/4 of the bushing is worn off.
2. Seal and Slide Ring - Replace during disassembly.
3. Pin Bushing - When it is worn down.
4. Rod - Bent or warped more than 0.5mm/1m.

**Inspection After Assembly**

Operation Inspection Without Load	There is no problem when fully extended 5 times without load						
Dimension	Check the retracted length and stroke						
Inspection of the Surface	When each of the cylinders are pressurized with test pressure on the piston end, it should not be loose and have no change in pressure or external leakage						
Inspection of external leakage	Check the oil leakage at the rod area. Refer to Figure 5-16., Acceptable Oil Leakage on Cylinder Rod.						
Inspection of internal leakage	Leakage Unit: ml/ 10 minutes						
	Bore (mm)	Leakage (ml)	Bore (mm)	Leakage (ml)	Bore (mm)	Leakage (ml)	Remark
	32	0.4	100	4	160	10	
	40	0.6	125	5.6	180	12.6	
	50	1	140	6	200	15.6	
	63	1.6			220	20	
	80	2.3			250	22	

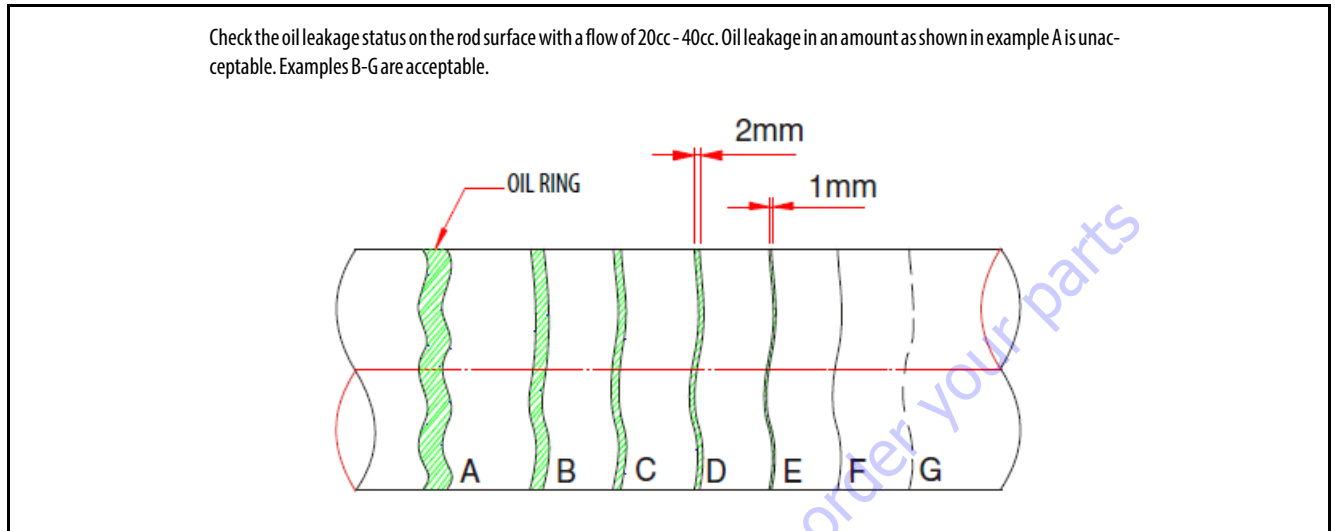
**Value of Oil Leakage at Rod Area****Figure 5-16. Acceptable Oil Leakage on Cylinder Rod**

## 5.4 MAIN LIFT, TELESCOPE AND JIB LIFT CYLINDER

### Disassembly

1. Remove the oil from the cylinder.
2. Fix the cylinder in a vertical or horizontal position. Vertical position is convenient for disassembly and assembly. Fix the base by inserting the pin not to be rotated. Remove any hoses, valves, or fittings that may be in the way.

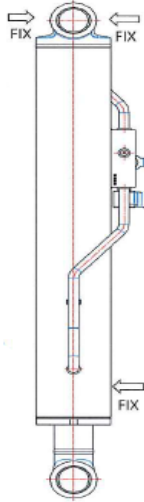

Figure 5-17. Fixing the cylinder

3. Unscrew the cylinder head.

Glands that are threaded into the barrel are locked in place with caulking. Using a spanner wrench, unscrew the gland from the barrel. (It is easier to do this with rod pulled out 5cm from the gland). If there is no caulking, continue with the disassembly process.

4. Remove the Rod assembly.
  - a. Check if the cap or plug has been removed from the cylinder ports.
  - b. Place a suitable container under the cylinder to catch any oil coming out of the cylinder.
  - c. After the Rod assembly is pulled from the barrel, unscrew the head using a spanner wrench.

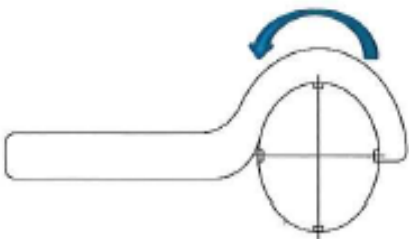

Figure 5-18. Cylinder Head Removal

- d. After disassembling the rod assembly, place it on a support.

### ⚠ CAUTION

IF THE CYLINDER IS AT A VERTICAL POSITION FOR DISASSEMBLY, GIVE ATTENTION TO THE FOLLOWING; WHEN THE HEAD IS UNSCREWED AND THE ROD ASSEMBLY IS PULLED FROM THE BARREL, THERE IS A SPACE BETWEEN THE HEAD AND PISTON. IT IS POSSIBLE FOR THE HEAD TO SUDDENLY SLIDE DOWN, POSSIBLY CAUSING INJURY. TO PREVENT THIS, THE HEAD SHOULD BE PUSHED AGAINST THE PISTON BEFORE PROCEEDING.



### ⚠ CAUTION

IF A CYLINDER IS AT A HORIZONTAL POSITION FOR DISASSEMBLY, GIVE ATTENTION TO THE FOLLOWING; IT IS POSSIBLE FOR THE ROD TO FALL AND BE DAMAGED WHEN REMOVED FROM THE BARREL IF NOT PROPERLY SUPPORTED. PLACE SUPPORT UNDER THE BARREL AS SHOWN BELOW.

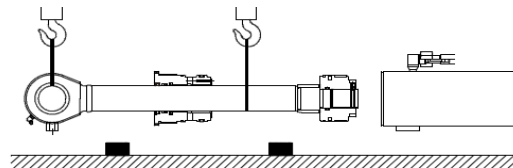

5. Place the Rod assembly on blocking. Use the pin hole to keep it from rotating.
6. Unscrew the Piston Nut.
  - a. Caulking is used to lock the setscrew so grind the caulking area and then unscrew the set screw.
  - b. Remove the steel ball.
  - c. Unscrew the piston nut. The piston nut is secured with a torque specified in Table 5-34, Piston Nut Torque. 1.5 x this torque is needed to remove the nut. If the stronger torque is needed, use a power wrench operated by a hydraulic unit.

**NOTE:** If it is not a set screw type, continue with the disassembly of the piston nut.

7. Remove the PISTON NUT, PISTON and GLAND in sequence.
8. Piston nut, piston, gland disassembly.

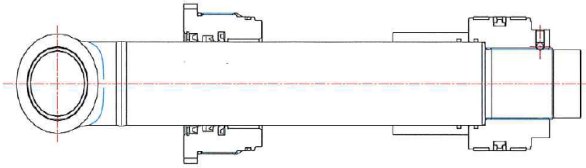

**Figure 5-19. Piston and Gland Disassembly**

- a. Unscrew the Piston Nut.
  - b. Take the piston apart by sliding off the rod in the direction of the rod threads.
  - c. Take the gland apart by sliding off the rod in the direction of the rod threads.
9. Take apart piston seals.

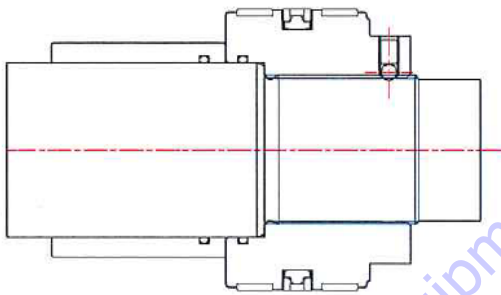
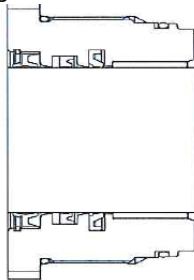

**Figure 5-20. Piston Seal Removal**

- a. The wear ring is easily taken apart by hand.
- b. The piston seal is a two piece seal; the ring at the outer side is easily removed. Remove the ring inside of the piston seal.
- c. Remove the O-ring.

**NOTE:** All seals must be discarded after removal. They cannot be reused.

10. Remove the gland seal.



**Figure 5-21. Gland Seal Removal**

- a. Remove the rod seal and backup ring.
- b. Remove the retaining ring with a flat-head screwdriver prior to removing the dust wiper and remove the dust wiper.
- c. Remove the o-ring and backup ring.
- d. The bushing is pressed in and must be removed by using a tool as shown below.

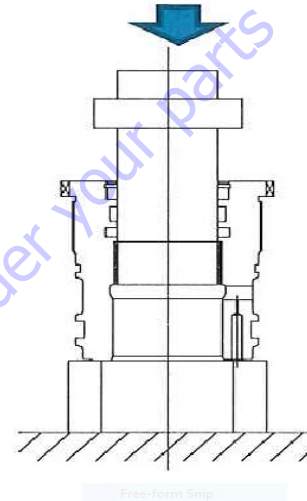

**Figure 5-22. Bush Removal**

**NOTICE**

**DISCARD ALL SEALS AFTER REMOVAL AND REPLACE THEM WITH NEW ONES FOR ASSEMBLY.**

**11. MRP BEARING DISASSEMBLY**

To remove the MRP bearing, break it into pieces.

**12. WASHING AND STORAGE**

All removed parts should be washed with cleaning solution and then coated with light oil to prevent rust. If the cylinder is not to be reassembled right away, store the parts and put a covering over them.

**Assembly**

**CAUTION**

**TAKE CARE NOT TO LET ANY PAINT CHIPS OR DIRT FALL INSIDE THE CYLINDER. THIS COULD CAUSE LEAKAGE.**

1. Pin bushing assembly

Coat the opening with oil to aid in assembly and press the bushing into the rod.

2. Gland seal assemblies

- a. Coat the opening with oil to aid in assembly and press the bushing into place with the proper tool.
- b. Rod seal assembly (Keep the right direction and do not make damage to seal).
- c. Install dust wiper assembly.
- d. Assemble backup ring, o-ring (Check the sequence of backup ring, o-ring.)

3. Piston Seal Assembly

- a. Assembly the seal assembly.
- b. Install the o-ring into the groove.
- c. Using a proper tool, press the piston seal onto the piston. When installing the piston seal, it is stretched while passing over the head.
- d. Install the wear ring assembly by spreading it apart.

4. Rod assembly

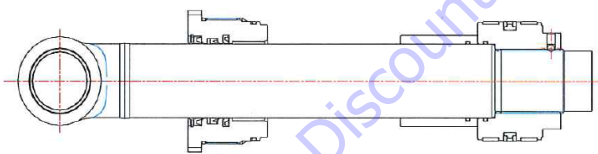

**Figure 5-23. Fix Rod Assembly**

- a. Secure the rod assembly.
- b. Install the Head onto the rod assembly. Take care as not to damage the lip of the dust wiper and rod seal.

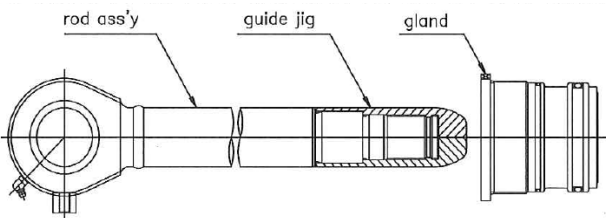

**Figure 5-24. Install Cylinder Head**

c. Assemble piston.

- d. Torque the Piston nut as specified in Table 5-34, Piston Nut Torque. Lack of the torque can result in internal leakage, the piston coming unscrewed, and thread damage. If over torqued, the piston surface which meets the rod will be damaged.

**Table 5-34. Piston Nut Torque**

Cylinder	Piston
Main Lift	1353.10 - 1464.28 Nm (998 - 1018 lb ft)
Jib Lift	93.55 - 114.43 Nm (69 - 84.4 lb ft)
Telescope	878.57 - 1073.80 Nm(648 - 792 lb ft)

5. Assemble the Rod Assembly.

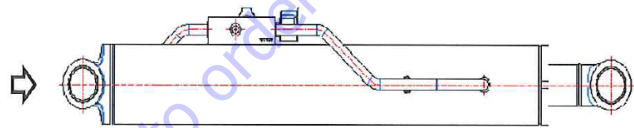
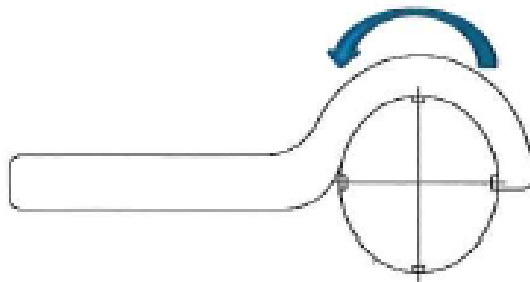

**Figure 5-25. Rod Assembly Installation**

- a. Secure the barrel at a vertical or horizontal position.
- b. Insert the assembly into the barrel.
- c. When piston is inserted to the barrel take care as to not damage the seal rings.

6. Gland assembly.

Install the gland using a spanner wrench as shown below.



**Figure 5-26. Gland Installation**

**Table 5-35. Gland Torque**

Cylinder	Gland
Main Lift	773.08 - 945 Nm (570.20 - 697 lb ft)
Jib Lift	26.70 - 32.13 Nm (19.7 - 23.7 lb ft)
Telescope	57.07 - 69.82 Nm (42.1 - 51.5 lb ft)



**7. Caulking.**

Caulk at the machined area of the cylinder barrel end so that it locks the cylinder head in place and it does not unscrew from the barrel. If there is no caulking hole, caulking is not necessary.

**8. Test Operation**

- a.** Install the cylinder on a machine. Fill the cylinder with oil and then have the cylinder slowly operated a minimum of 8 cycles. If it is operated too fast in the beginning, cavitation will result.
- b.** It is important to make sure all air is cycled from the cylinder.
- c.** Grease the end of the pin.

Go to Discount-Equipment.com to order your parts

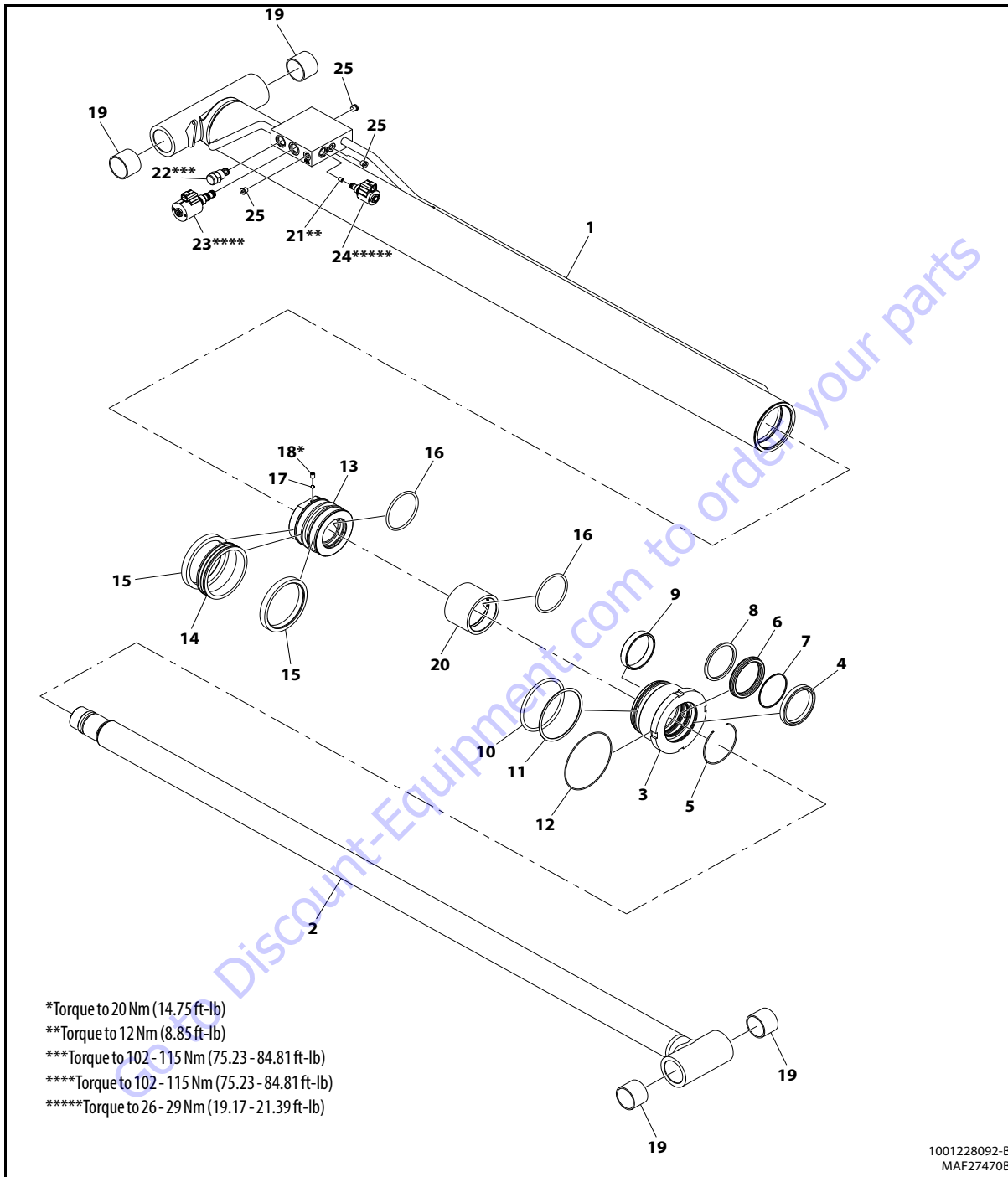

- |                  |              |                 |              |                             |
|------------------|--------------|-----------------|--------------|-----------------------------|
| 1. Barrel        | 6. Rod Seal  | 11. Backup Ring | 16. O-Ring   | 21. Orifice                 |
| 2. Rod           | 7. O-Ring    | 12. O-Ring      | 17. Ball     | 22. Cartridge, Check Valve  |
| 3. Gland         | 8. Ring      | 13. Piston      | 18. Setscrew | 23. Cartridge, Poppet Valve |
| 4. Wiper         | 9. Wear Ring | 14. Piston Seal | 19. Bearing  | 24. Cartridge, Poppet Valve |
| 5. Retainer Ring | 10. O-Ring   | 15. Ring, Wear  | 20. Spacer   | 25. Plug                    |

Figure 5-27. Main Lift Cylinder (400SC/460SJC)

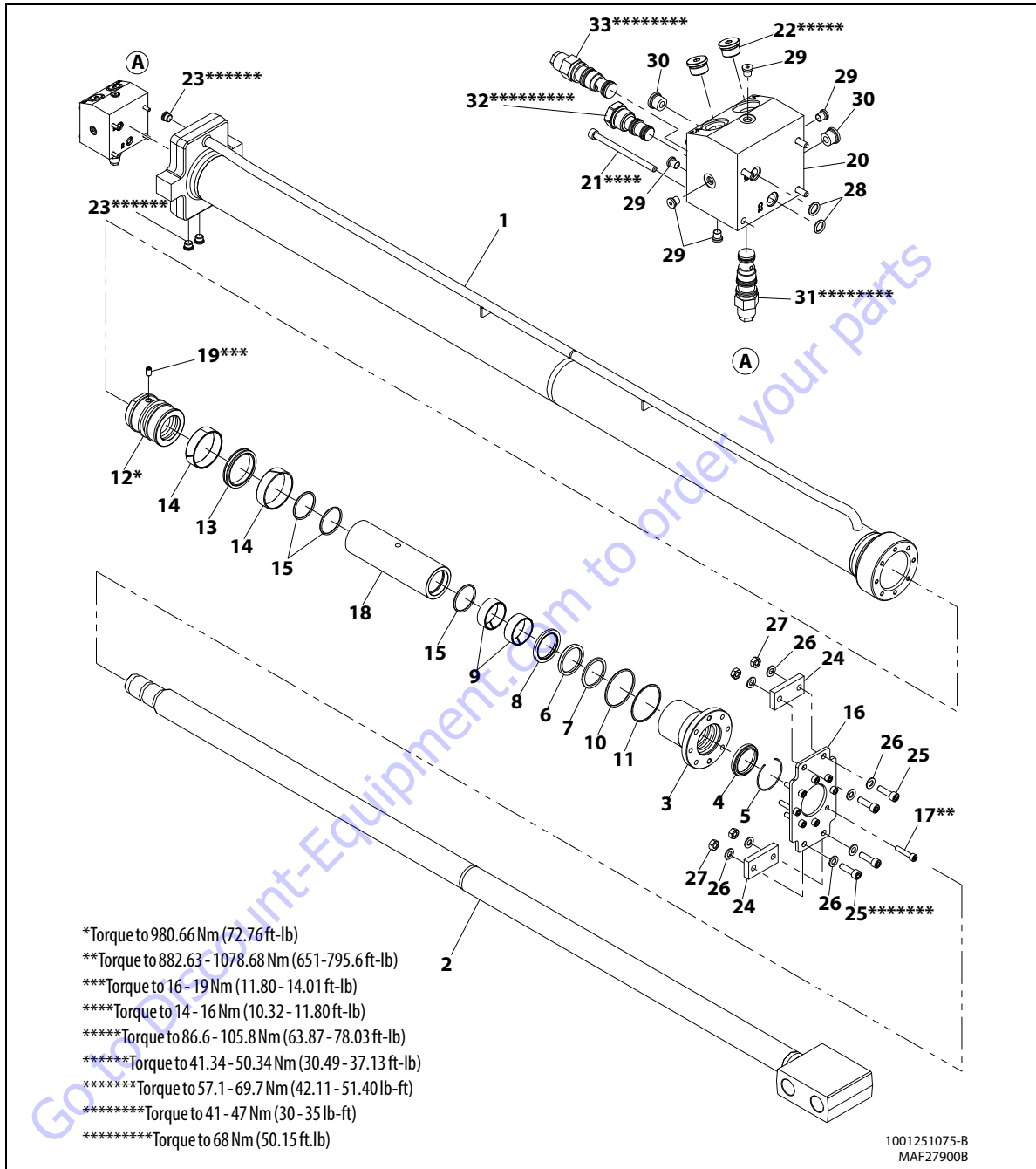

- |                |                 |                          |              |                                     |
|----------------|-----------------|--------------------------|--------------|-------------------------------------|
| 1. Barrel      | 8. Wear Ring    | 16. Plate                | 23. Plug     | 30. Plug                            |
| 2. Rod         | 9. Wear Ring    | 17. Capscrew             | 24. Wear Pad | 31. Cartridge, Counterbalance Valve |
| 3. Head        | 10. O-Ring      | 18. Spacer               | 25. Bolt     | 32. Cartridge, Shuttle Valve        |
| 4. Wiper       | 11. Backup Ring | 19. Set Screw            | 26. Washer   | 33. Cartridge, Counterbalance Valve |
| 5. Retain Ring | 12. Piston      | 20. Valve Block Assembly | 27. Nut      |                                     |
| 6. Seal        | 13. Seal        | 21. Capscrew             | 28. O-Ring   |                                     |
| 7. Backup Ring | 14. Wear Ring   | 22. Plug, O-Ring         | 29. Plug     |                                     |
|                | 15. O-Ring      |                          |              |                                     |

Figure 5-28. Telescope Cylinder

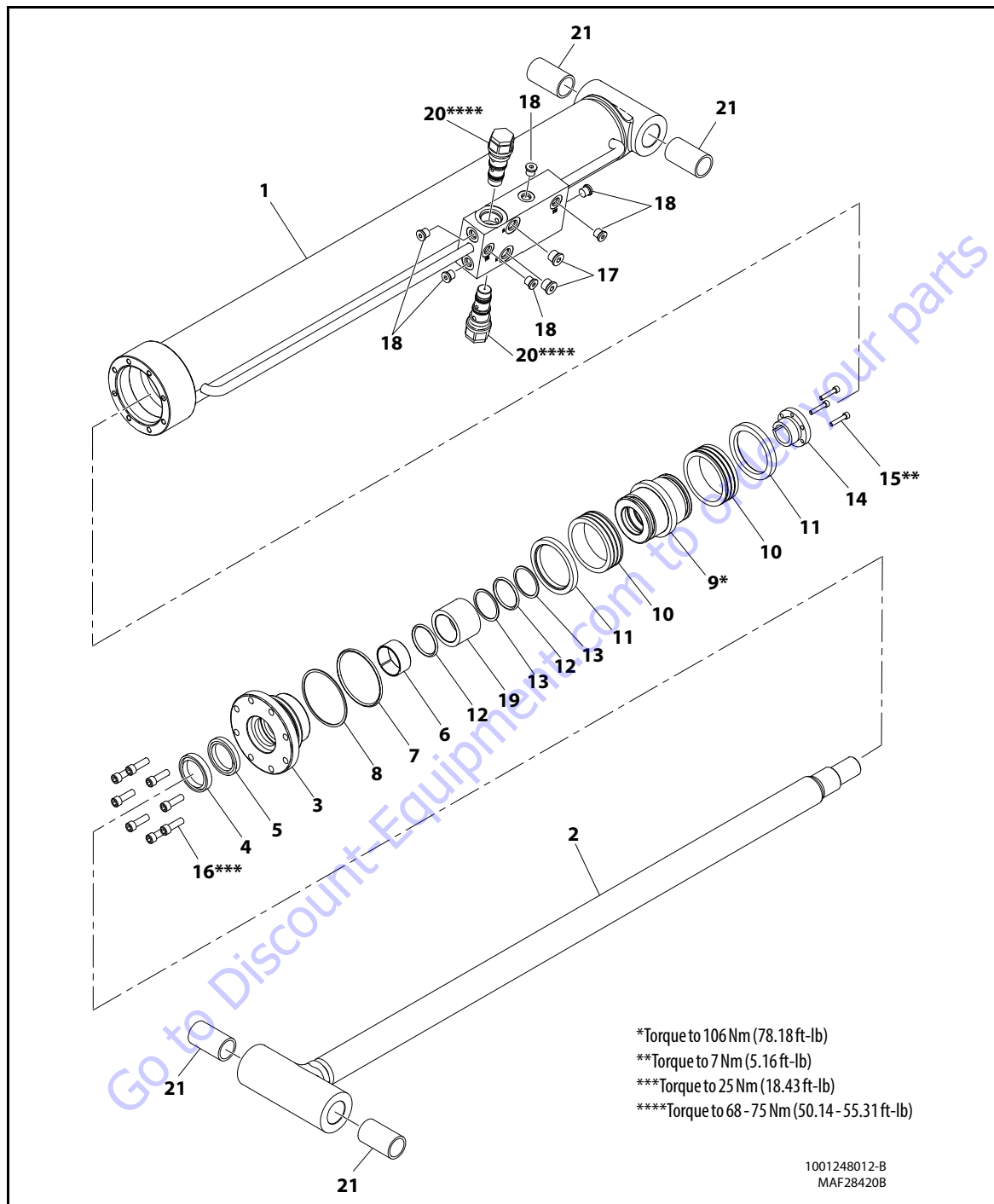

- |           |                |                 |                           |                      |
|-----------|----------------|-----------------|---------------------------|----------------------|
| 1. Barrel | 5. Rod Seal    | 9. Piston       | 13. Backup Ring           | 17. Plug, O-Ring     |
| 2. Rod    | 6. Wear Ring   | 10. Piston Seal | 14. Tapered Bush          | 18. Plug, O-Ring     |
| 3. Head   | 7. O-Ring      | 11. Ring, Lock  | 15. Capscrew, Socket Head | 19. Spacer           |
| 4. Wiper  | 8. Backup Ring | 12. O-Ring      | 16. Capscrew              | 20. Cartridge, Valve |
|           |                |                 |                           | 21. Bushing          |

Figure 5-28. Jib Lift Cylinder (460 SJC)

## Master cylinder

Refer to Figure 5-32.

### DISASSEMBLY

#### NOTICE

CONTAMINATION MAY DAMAGE EQUIPMENT. DISASSEMBLE CYLINDER ON A CLEAN WORK SURFACE IN A DIRT FREE WORK AREA.

1. Connect a suitable auxiliary hydraulic power source to cylinder port block fitting.

#### WARNING

DO NOT FULLY EXTEND CYLINDER TO END OF STROKE. RETRACT CYLINDER SLIGHTLY TO AVOID TRAPPING PRESSURE.

2. Operate hydraulic power source and extend cylinder. Shut down and disconnect power source. Adequately support cylinder rod, if applicable.
3. If applicable, remove cartridge-type holding valve and fittings from cylinder port block. Discard O-rings.
4. Place cylinder barrel in a suitable holding fixture. Tap around outside of cylinder head end cap with hammer to break thread-locking compound.

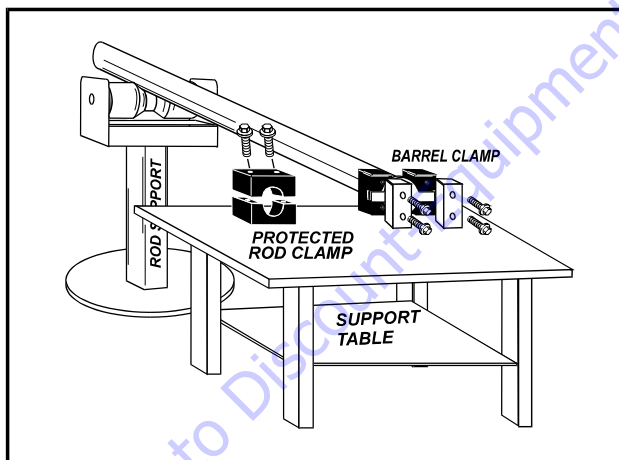

Figure 5-29. Cylinder Barrel Support

5. Unscrew cylinder head with hook spanner wrench.

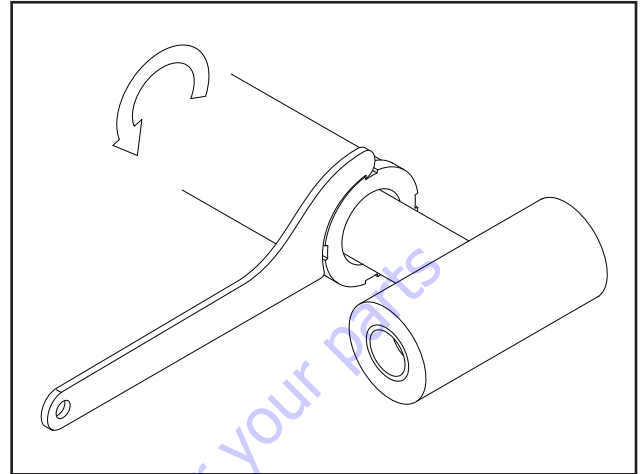

Figure 5-30. Cylinder Head Removal.

#### NOTICE

PULLING ROD OFF-CENTER CAN DAMAGE PISTON AND CYLINDER BARREL SURFACES. USE EXTREME CARE WHEN REMOVING CYLINDER ROD, HEAD, AND PISTON.

6. Clamp barrel securely. Pull rod assembly from barrel.

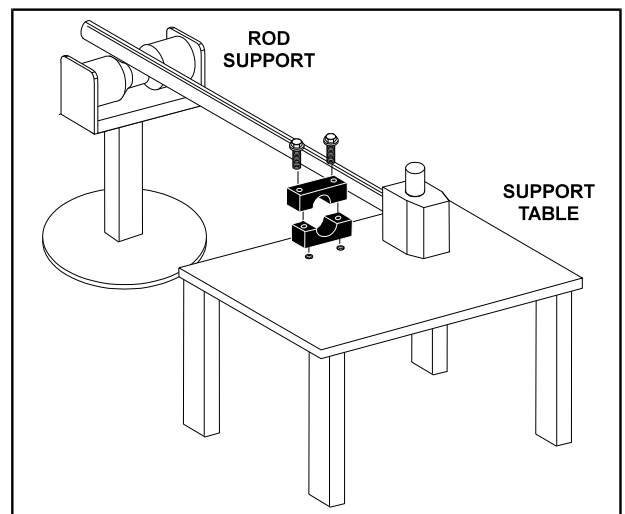
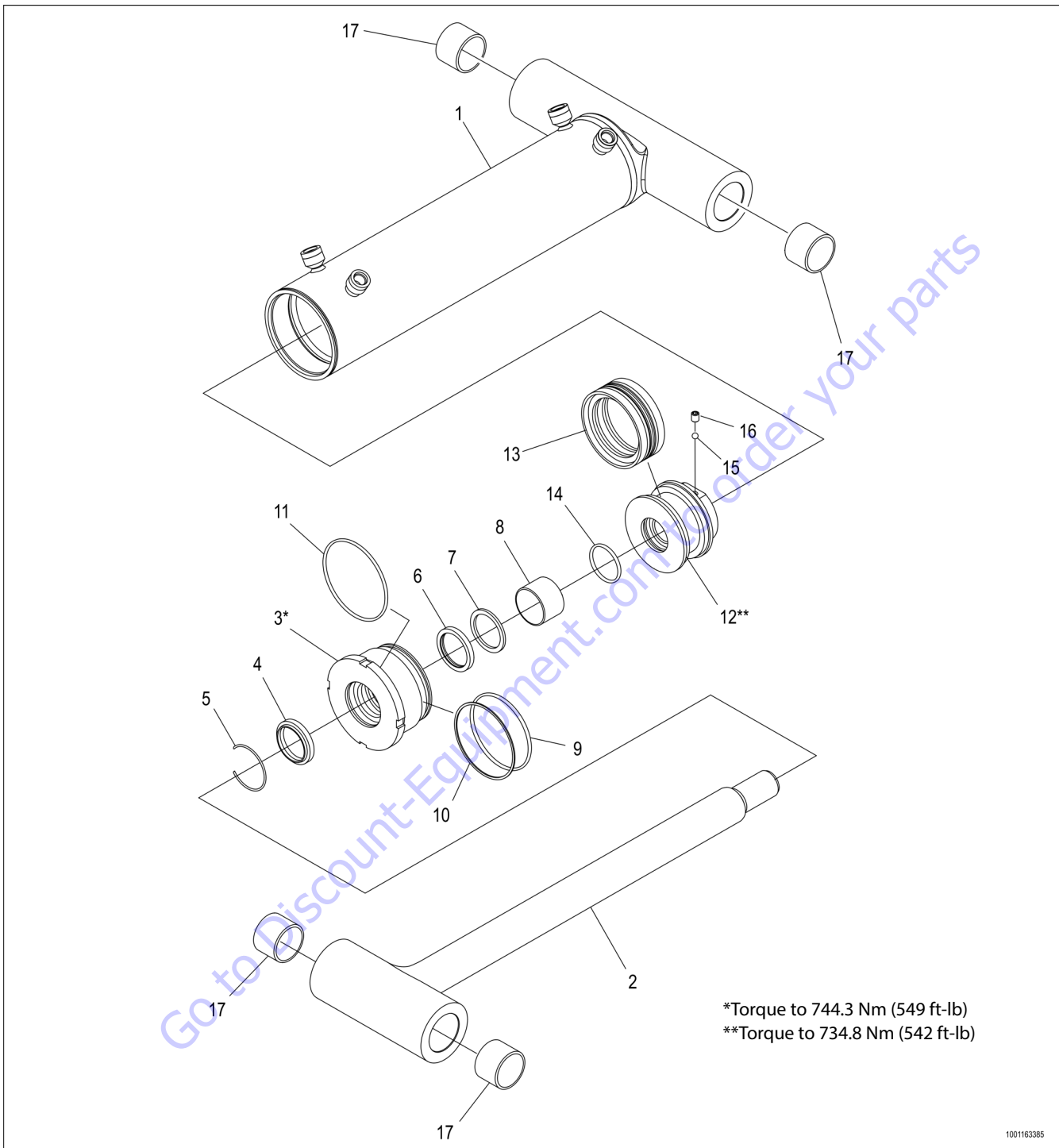

Figure 5-31. Cylinder Rod Support



- |                  |                   |                |                 |            |              |
|------------------|-------------------|----------------|-----------------|------------|--------------|
| 1. Barrel        | 4. Wiper          | 7. Rod Seal    | 10. Backup Ring | 13. Seal   | 16. Setscrew |
| 2. Rod           | 5. Retaining Ring | 8. Dry Bearing | 11. O-Ring      | 14. O-Ring | 17. Bearing  |
| 3. Cylinder Head | 6. Backup Ring    | 9. O-Ring      | 12. Piston      | 15. Ball   |              |

Figure 5-32. Master Cylinder

8. Loosen setscrew (16) retaining ball (15) in piston (12).
9. Screw piston counterclockwise and remove from rod.
10. Remove and discard O-ring (14) and seal (13).

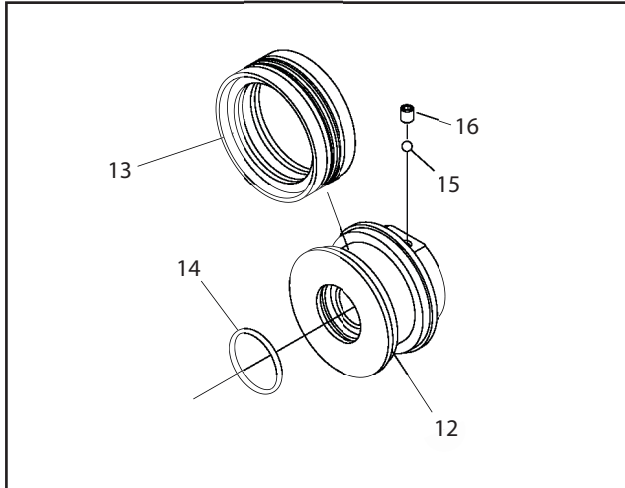

**Figure 5-33. Piston Disassembly**

11. Remove rod from holding fixture.
12. Remove cylinder head assembly (3) from rod (2).
13. Remove and discard O-ring (9), backup ring (10), and O-ring (11) from cylinder head.
14. Remove and discard retaining ring (5), wiper (4), dry bearing (8), rod seal (7), and backup ring (6) from cylinder head (3).

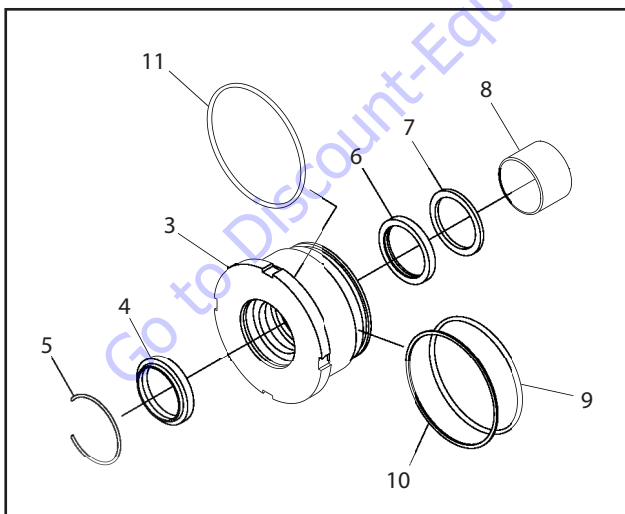

**Figure 5-34. Cylinder Head Disassembly**

### CLEANING AND INSPECTION

1. Clean all parts in approved cleaning solvent.
2. Inspect cylinder rod for scoring, tapering, ovality, or other damage. If necessary, dress rod with Scotch Brite or equivalent. Replace rod if necessary.
3. Inspect threaded portion of rod for excessive damage. Dress threads as necessary.
4. Inspect inner surface of cylinder barrel for scoring or other damage. Check inside diameter for tapering or ovality. Replace if necessary.
5. Inspect threaded portion of barrel for damage. Dress threads as necessary.
6. Inspect piston surface for damage, scoring and distortion. Dress piston surface or replace piston as necessary.
7. Inspect threaded portion of piston for damage. Dress threads as necessary.
8. Inspect seal and O-ring grooves in piston for burrs and sharp edges. Dress surfaces as necessary.
9. Inspect cylinder head inside diameter for scoring or other damage. Replace as necessary.
10. Inspect threaded portion of head for damage. Dress threads as necessary.
11. Inspect seal and O-ring grooves in head for burrs and sharp edges. Dress surfaces as necessary.
12. Inspect cylinder head outside diameter for scoring or other damage, ovality, and tapering. Replace as needed.
13. Inspect rod and barrel bearings for signs of excessive wear or damage. If worn or damaged, rod/barrel must be replaced.
14. Inspect oil ports for blockage or presence of dirt or other foreign material. Repair as necessary.

**COMPOSITE BUSHING**

1. Clean hole (steel bushing) of burrs, dirt etc. for easier bushing installation.
2. Lubricate inside of steel bushing with WD40 before bearing installation.
3. Press composite bushing in steel bushing using an arbor.

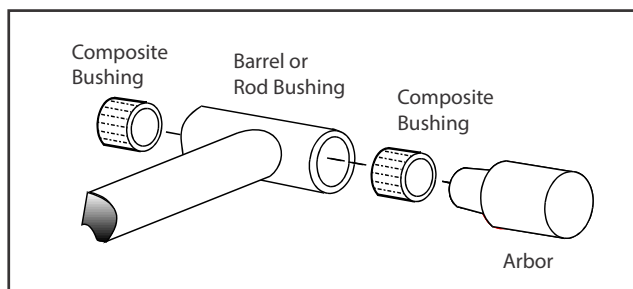

Figure 5-35. Composite Bushing Installation

**CYLINDER ASSEMBLY**

**NOTICE**

**INCORRECT SEAL INSTALLATION CAN CAUSE CYLINDER LEAKS AND IMPROPER CYLINDER OPERATION. ENSURE ALL PISTON SEALS ARE CORRECTLY INSTALLED. REFER TO CROSS SECTION ILLUSTRATIONS FOR CORRECT SEAL ORIENTATION.**

**NOTE:** Use correct cylinder seal kit for cylinder assembly. See your JLG Parts Manual.

Apply a light film of hydraulic oil to all components before assembly.

1. Support rod in holding fixture.
2. Install backup ring (6), rod seal (7), and dry bearing (8) in cylinder head (3).
3. Install wiper (4) and retaining ring (5) in cylinder head.
4. Install O-ring (11) on cylinder head.
5. Install backup ring (10) and O-ring (9) on cylinder head.
6. Slide cylinder head assembly on rod (2) to rod end. Do not dislodge or damage seals.

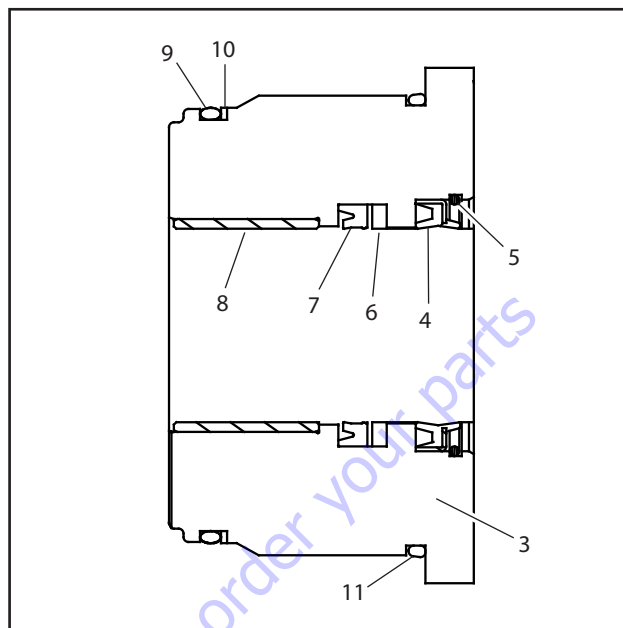

Figure 5-36. Cylinder Head Seal Installation

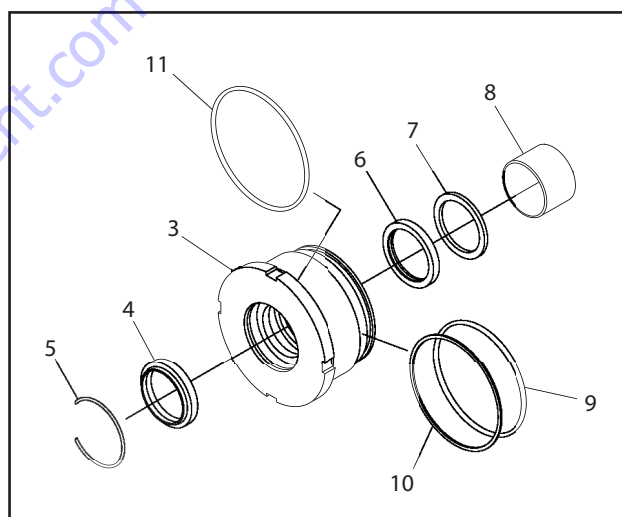

Figure 5-37. Cylinder Head Assembly



7. Install O-ring (14) in piston (12).
8. Install seal (16) on piston.
9. Apply Medium Strength Threadlocking Compound to piston threads. Install piston on rod. Torque to 734.8 Nm (542 ft-lb).
10. Install ball (15) and setscrew (16).

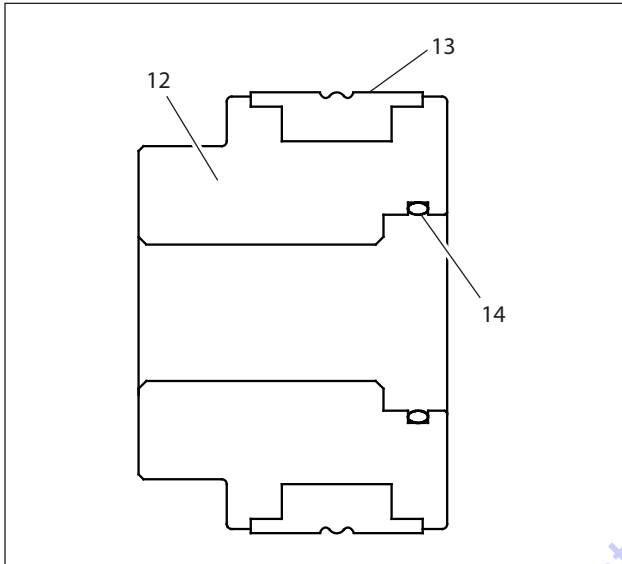

Figure 5-38. Piston Seal Installation

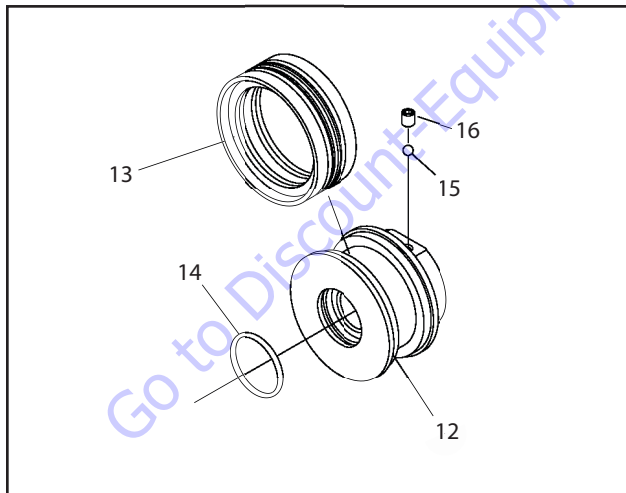

Figure 5-39. Piston Assembly

11. Position cylinder barrel in a suitable holding fixture.

**NOTICE**

INSERTING ROD OFF-CENTER CAN DAMAGE PISTON AND CYLINDER BARREL SURFACES. USE EXTREME CARE WHEN INSTALLING CYLINDER ROD, HEAD, AND PISTON.

12. Clamp barrel securely and support rod. Insert piston end into barrel cylinder. Do not damage or dislodge seal.
13. Remove cylinder rod from holding fixture.
14. Place cylinder barrel in suitable holding fixture.

**NOTICE**

INSERTING ROD OFF-CENTER CAN DAMAGE PISTON AND CYLINDER BARREL SURFACES. USE EXTREME CARE WHEN INSTALLING CYLINDER ROD, HEAD, AND PISTON.

15. Clamp barrel securely and support rod. Insert piston end into barrel cylinder. Do not damage or dislodge piston O-rings and backup ring.
16. Continue pushing rod into barrel. Screw in cylinder head. Torque to 737 ft-lb (1000 Nm).

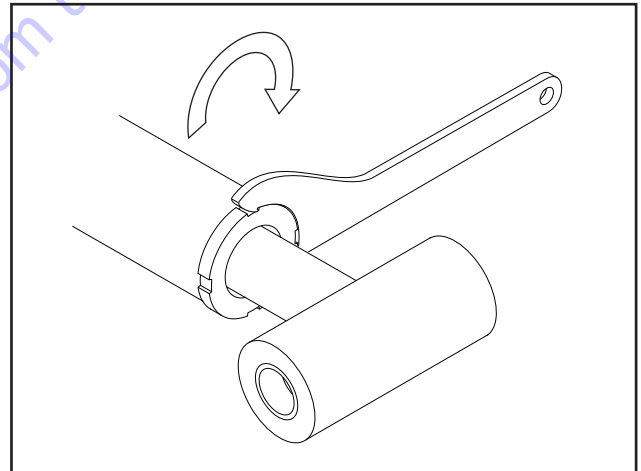

Figure 5-40. Cylinder Head Installation

## Platform Level Cylinder

### DISASSEMBLY

Refer to Figure 5-44.

#### NOTICE

CONTAMINATION MAY DAMAGE EQUIPMENT. DISASSEMBLE CYLINDER ON A CLEAN WORK SURFACE IN A DIRT FREE WORK AREA.

1. Connect a suitable auxiliary hydraulic power source to cylinder port block fitting.

#### WARNING

DO NOT FULLY EXTEND CYLINDER TO THE END OF STROKE. RETRACT CYLINDER SLIGHTLY TO AVOID TRAPPING PRESSURE.

2. Operate hydraulic power source and extend cylinder. Shut down and disconnect power source. Adequately support cylinder rod, if applicable.
3. Remove cartridge-type counterbalance valve and fittings from cylinder port block. Discard O-rings.
4. Place cylinder barrel in a suitable holding fixture. Tap around outside of cylinder head retainer with a suitable hammer to break thread-locking compound.

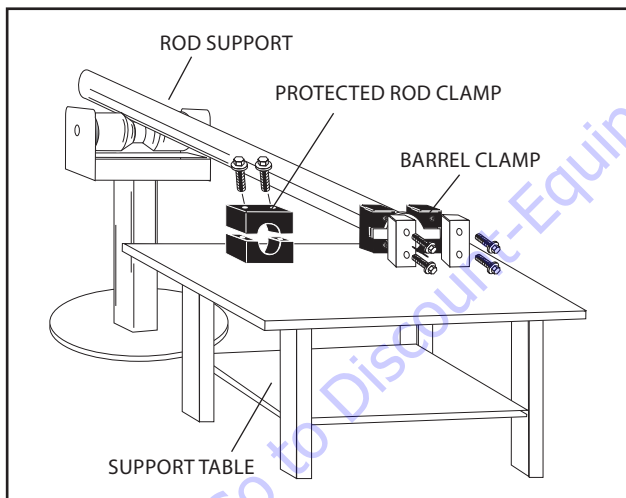

Figure 5-41. Cylinder Barrel Support

5. Unscrew cylinder head with hook spanner.

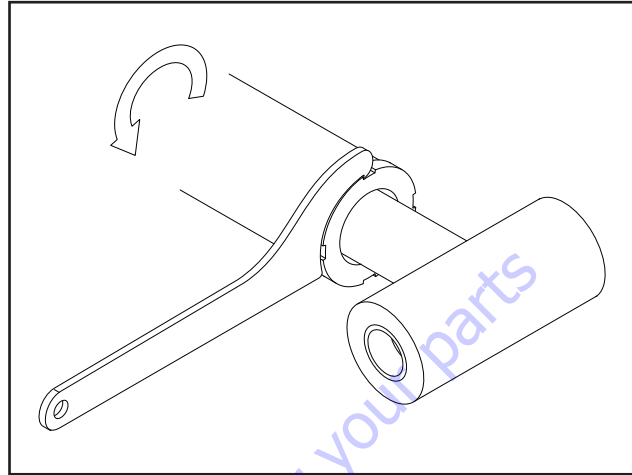

Figure 5-42. Removing Cylinder Head

#### NOTICE

PULLING ROD OFF-CENTER CAN DAMAGE PISTON AND CYLINDER BARREL SURFACES. USE EXTREME CARE WHEN REMOVING CYLINDER ROD, HEAD, AND PISTON.

6. Clamp barrel securely. Pull rod assembly and cylinder head from barrel.
7. Protect cylinder rod from damage and clamp in a vise or holding fixture as close to piston as possible.

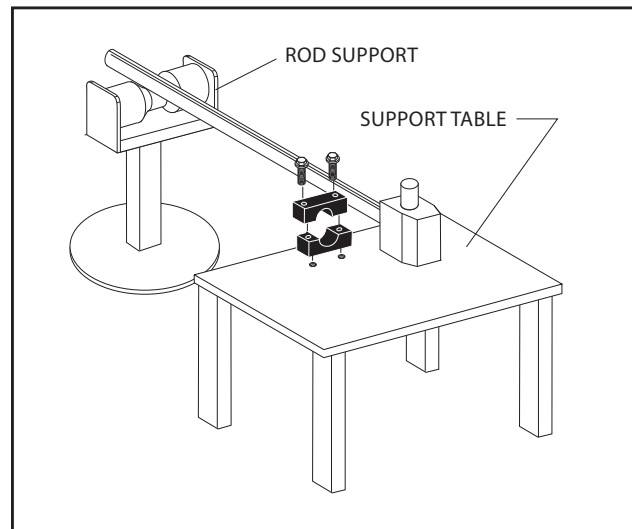
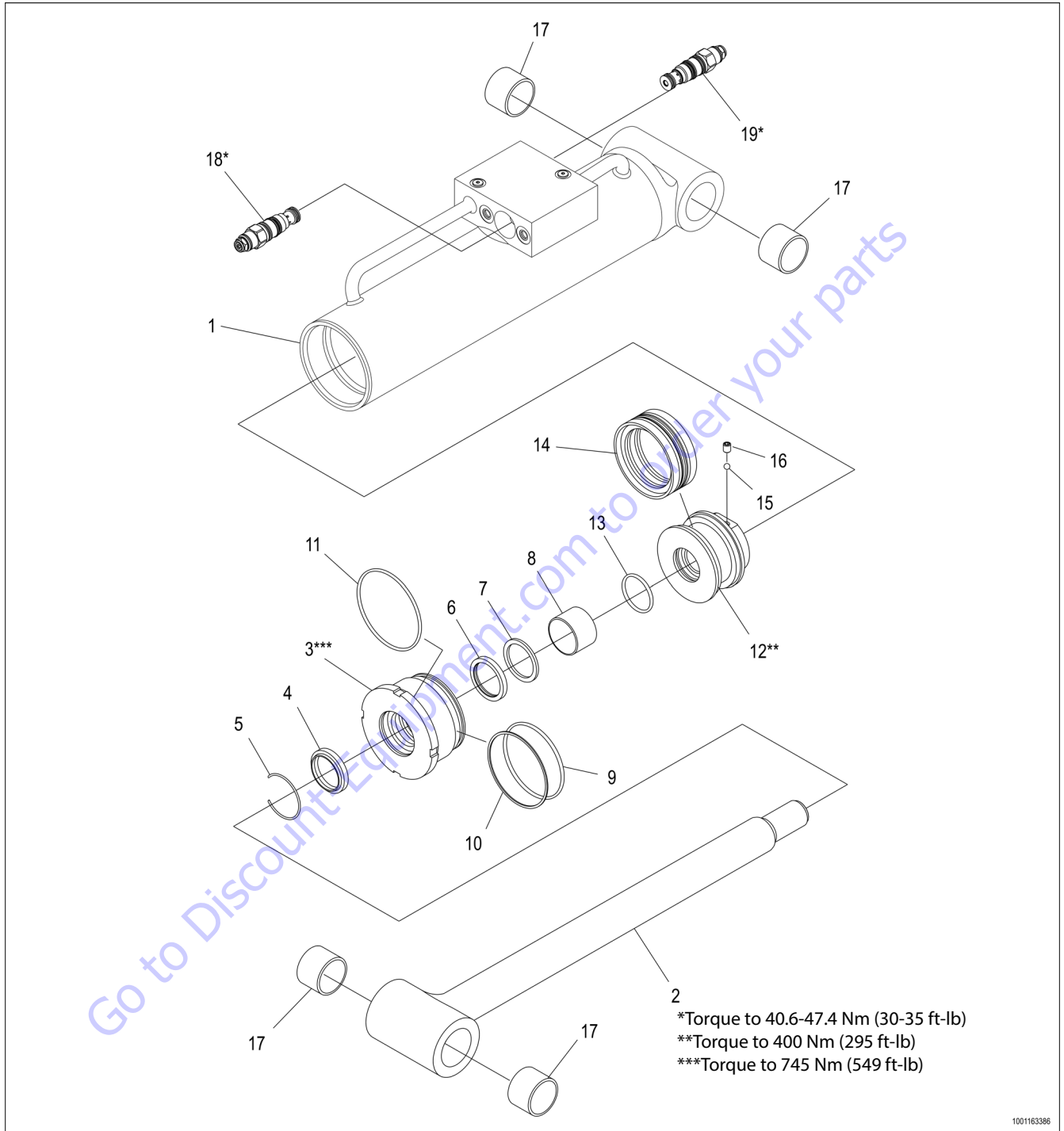

Figure 5-43. Cylinder Rod Support



- |           |                   |                 |                 |                          |
|-----------|-------------------|-----------------|-----------------|--------------------------|
| 1. Barrel | 5. Retaining Ring | 9. O-Ring       | 13. O-Ring      | 17. Bearing              |
| 2. Rod    | 6. Rod Seal       | 10. Backup Ring | 14. Piston Seal | 18. Counterbalance Valve |
| 3. Head   | 7. Backup Ring    | 11. O-Ring      | 15. Ball        | 19. Counterbalance Valve |
| 4. Wiper  | 8. Dry Bearing    | 12. Piston      | 16. Setscrew    |                          |

Figure 5-44. Platform Level Cylinder

8. Loosen setscrew (16) retaining ball (15) in piston (12).
9. Screw piston counterclockwise and remove from rod.
10. Remove and discard O-ring (14) and seal (13).

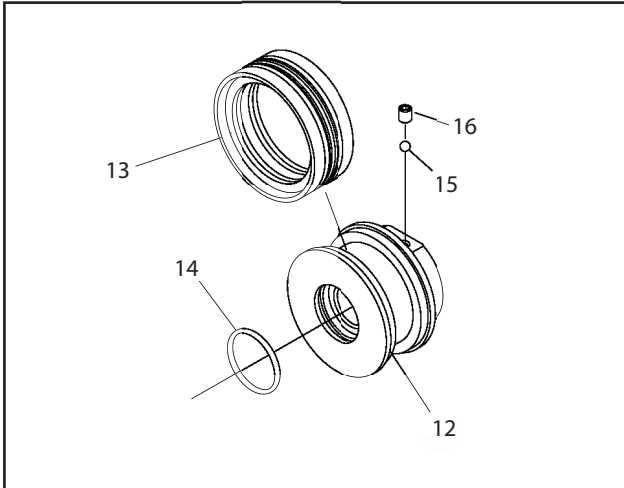

**Figure 5-46. Piston Disassembly**

11. Remove rod from holding fixture.
12. Remove cylinder head assembly (3) from rod (2).
13. Remove and discard O-ring (9), backup ring (10), and O-ring (11) from cylinder head.
14. Remove and discard retaining ring (5), wiper (4), dry bearing (8), rod seal (7), and backup ring (6) from cylinder head (3).

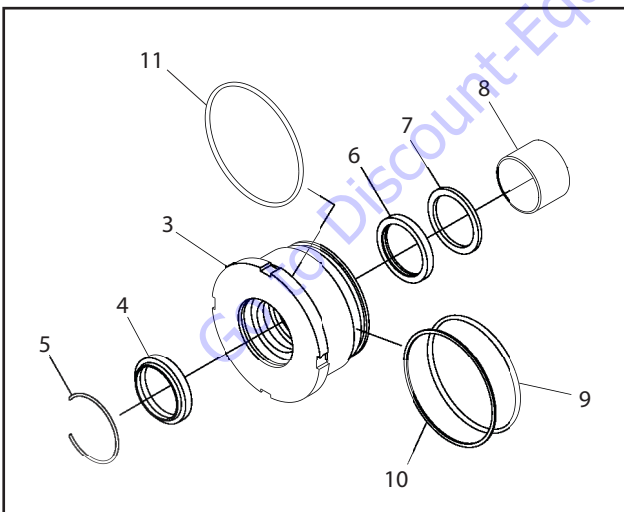

**Figure 5-47. Cylinder Head Disassembly**

**CLEANING AND INSPECTION**

1. Clean all parts in approved cleaning solvent.
2. Inspect cylinder rod for scoring, tapering, ovality, or other damage. If necessary, dress rod with Scotch Brite or equivalent. Replace rod if necessary.
3. Inspect threaded portion of rod for excessive damage. Dress threads as necessary.
4. Inspect inner surface of cylinder barrel for scoring or other damage. Check inside diameter for tapering or ovality. Replace if necessary.
5. Inspect threaded portion of barrel for damage. Dress threads as necessary.
6. Inspect piston surface for damage, scoring and distortion. Dress piston surface or replace piston as necessary.
7. Inspect threaded portion of piston for damage. Dress threads as necessary.
8. Inspect seal and O-ring grooves in piston for burrs and sharp edges. Dress surfaces as necessary.
9. Inspect cylinder head inside diameter for scoring or other damage. Replace as necessary.
10. Inspect threaded portion of head for damage. Dress threads as necessary.
11. Inspect seal and O-ring grooves in head for burrs and sharp edges. Dress surfaces as necessary.
12. Inspect cylinder head outside diameter for scoring or other damage, ovality, and tapering. Replace as needed.
13. Inspect rod and barrel bearings for signs of excessive wear or damage. If worn or damaged, rod/barrel must be replaced.
14. Inspect port block fittings and valves. Replace as needed. Torque valves to specifications shown in Figure 5-44., Platform Level Cylinder.
15. Inspect oil ports for blockage or presence of dirt or other foreign material. Repair as necessary.

**COMPOSITE BUSHING**

1. Clean hole (steel bushing) of burrs, dirt etc. for easier bushing installation.
2. Lubricate inside of steel bushing with WD40 before bearing installation.
3. Press composite bushing in steel bushing using an arbor.

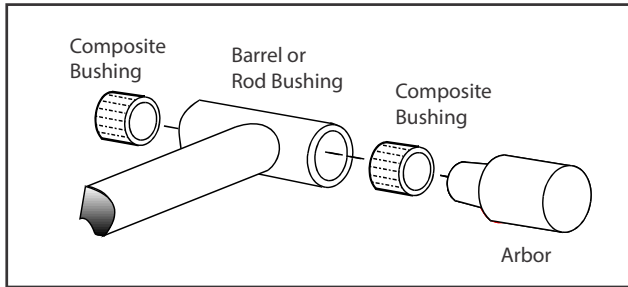

**Figure 5-48. Composite Bushing Installation**

**CYLINDER ASSEMBLY**

**NOTICE**

**INCORRECT SEAL INSTALLATION CAN CAUSE CYLINDER LEAKS AND IMPROPER CYLINDER OPERATION. ENSURE ALL PISTON SEALS ARE CORRECTLY INSTALLED. REFER TO CROSS SECTION ILLUSTRATIONS FOR CORRECT SEAL ORIENTATION.**

**NOTE:** Use correct cylinder seal kit for cylinder assembly. See your JLG Parts Manual.

Apply a light film of hydraulic oil to all components before assembly.

1. Support rod in holding fixture.
2. Install backup ring (6), rod seal (7), and dry bearing (8) in cylinder head (3).
3. Install wiper (4) and retaining ring (5) in cylinder head.
4. Install O-ring (11) on cylinder head.
5. Install backup ring (10) and O-ring (9) on cylinder head.
6. Slide cylinder head assembly on rod (2) to rod end. Do not dislodge or damage seals.

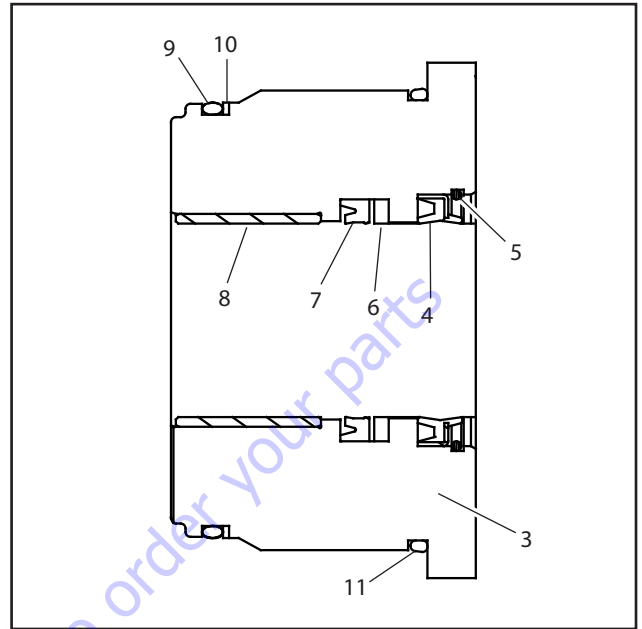

**Figure 5-49. Cylinder Head Seal Installation**

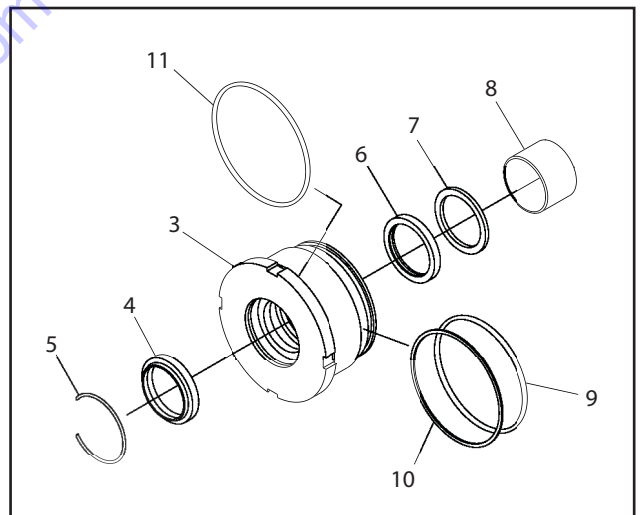

**Figure 5-50. Cylinder Head Assembly**

## SECTION 5 - HYDRAULICS AND HYDRAULIC SCHEMATICS

7. Install O-ring (14) in piston (12).
8. Install seal (16) on piston.
9. Apply Medium Strength Threadlocking Compound to piston threads. Install piston on rod. Torque to 400 Nm (295 ft-lb).
10. Install ball (15) and setscrew (16).

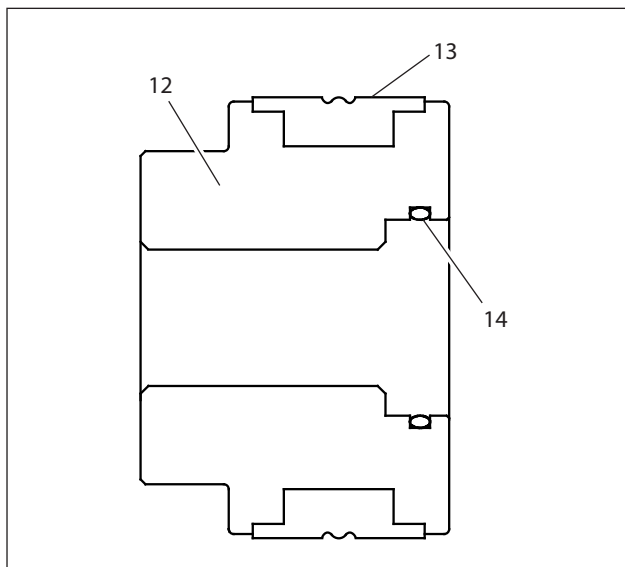

Figure 5-51. Piston Seal Installation

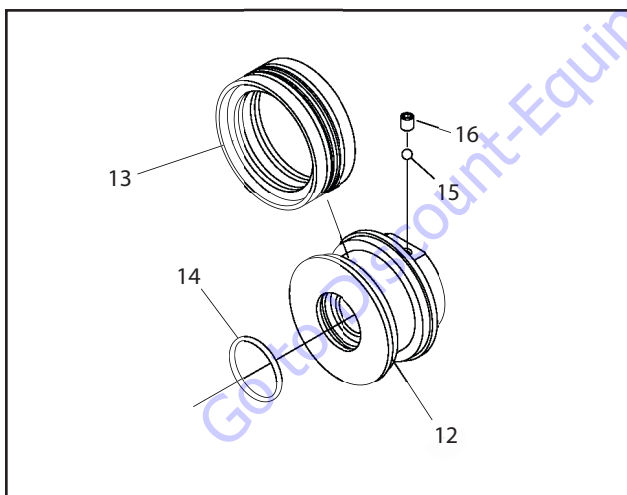

Figure 5-52. Piston Assembly

11. Position cylinder barrel in a suitable holding fixture.

### NOTICE

INSERTING ROD OFF-CENTER CAN DAMAGE PISTON AND CYLINDER BARREL SURFACES. USE EXTREME CARE WHEN INSTALLING CYLINDER ROD, HEAD, AND PISTON.

12. Clamp barrel securely and support rod. Insert piston end into barrel cylinder. Do not damage or dislodge seal.
13. Remove cylinder rod from holding fixture.
14. Place cylinder barrel in suitable holding fixture.

### NOTICE

INSERTING ROD OFF-CENTER CAN DAMAGE PISTON AND CYLINDER BARREL SURFACES. USE EXTREME CARE WHEN INSTALLING CYLINDER ROD, HEAD, AND PISTON.

15. Clamp barrel securely and support rod. Insert piston end into barrel cylinder. Do not damage or dislodge piston O-rings and backup ring.
16. Continue pushing rod into barrel. Screw in cylinder head. Torque to 745 Nm (549 ft-lb).

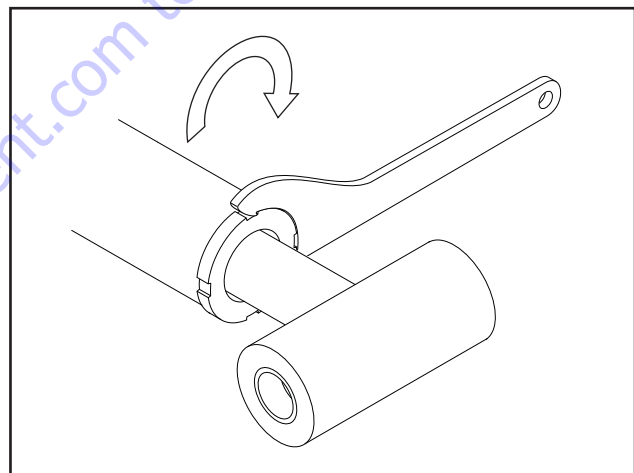

Figure 5-53. Cylinder Head Installation

5.5 HYDRAULIC SYSTEM INSTALLATION

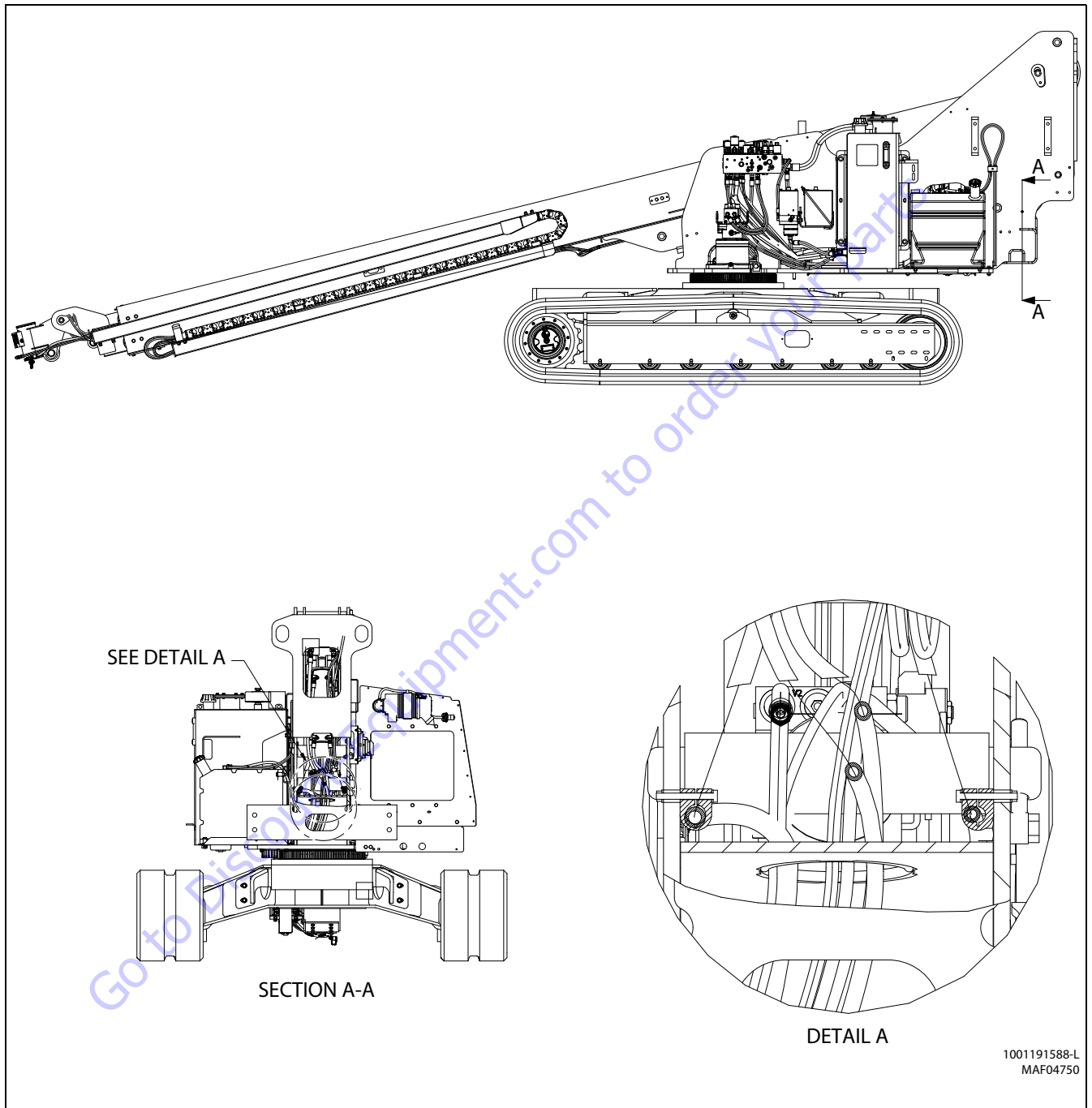

Figure 5-54. Hydraulic System Installation (400SC) - Sheet 1 of 16

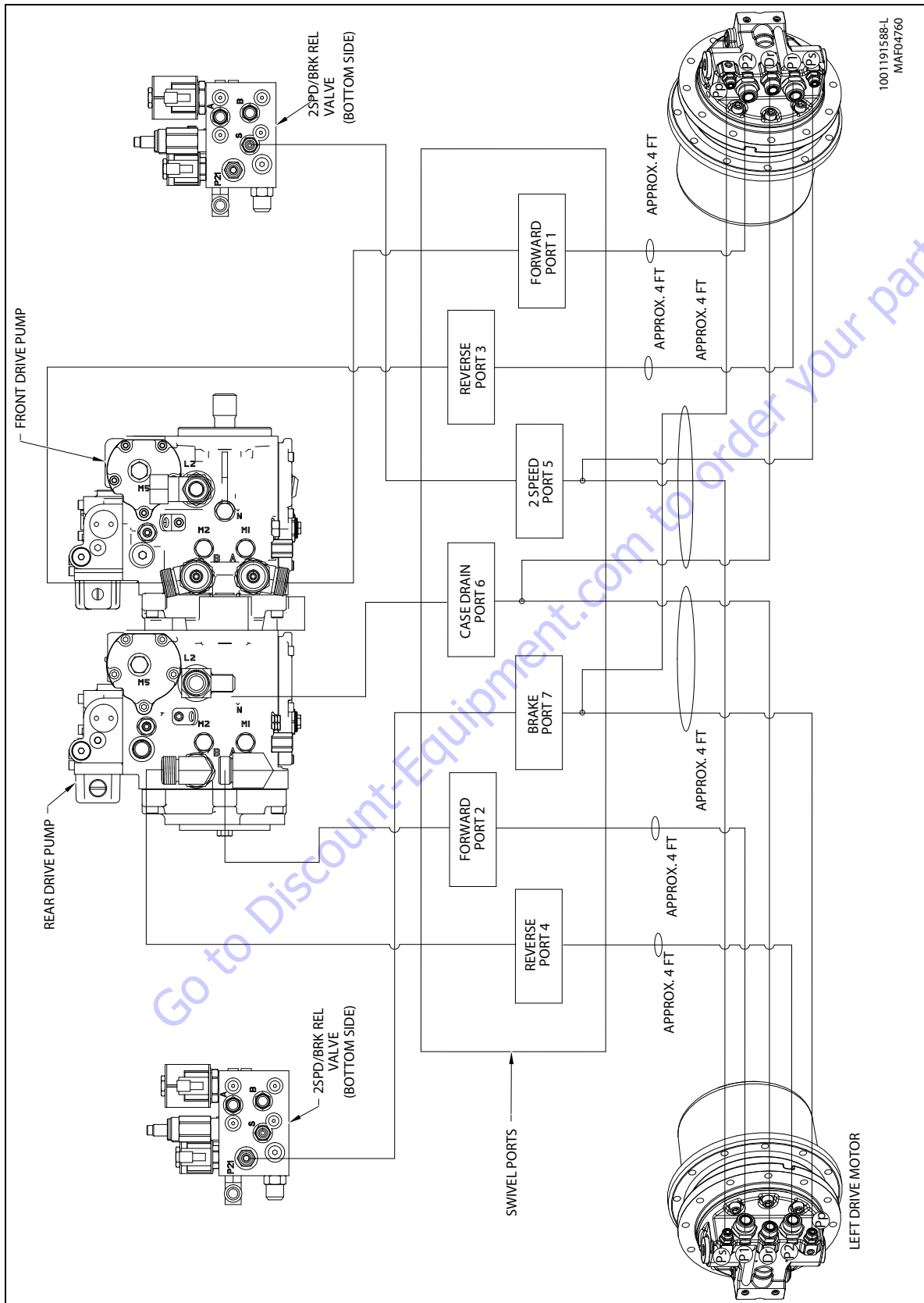

Figure 5-55. Hydraulic System Installation (400SC) - Sheet 2 of 16





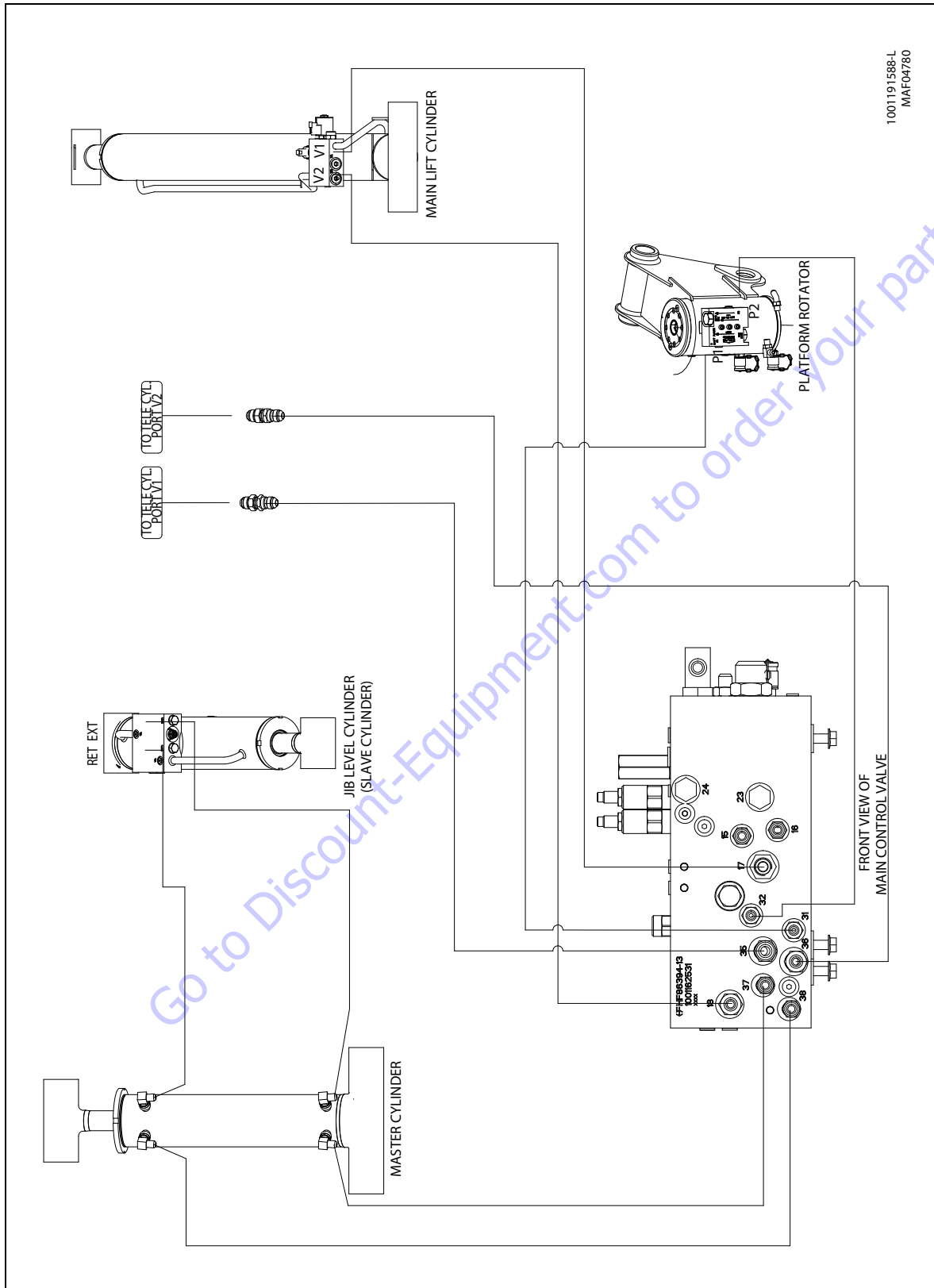

Figure 5-57. Hydraulic System Installation (400SC) - Sheet 4 of 16

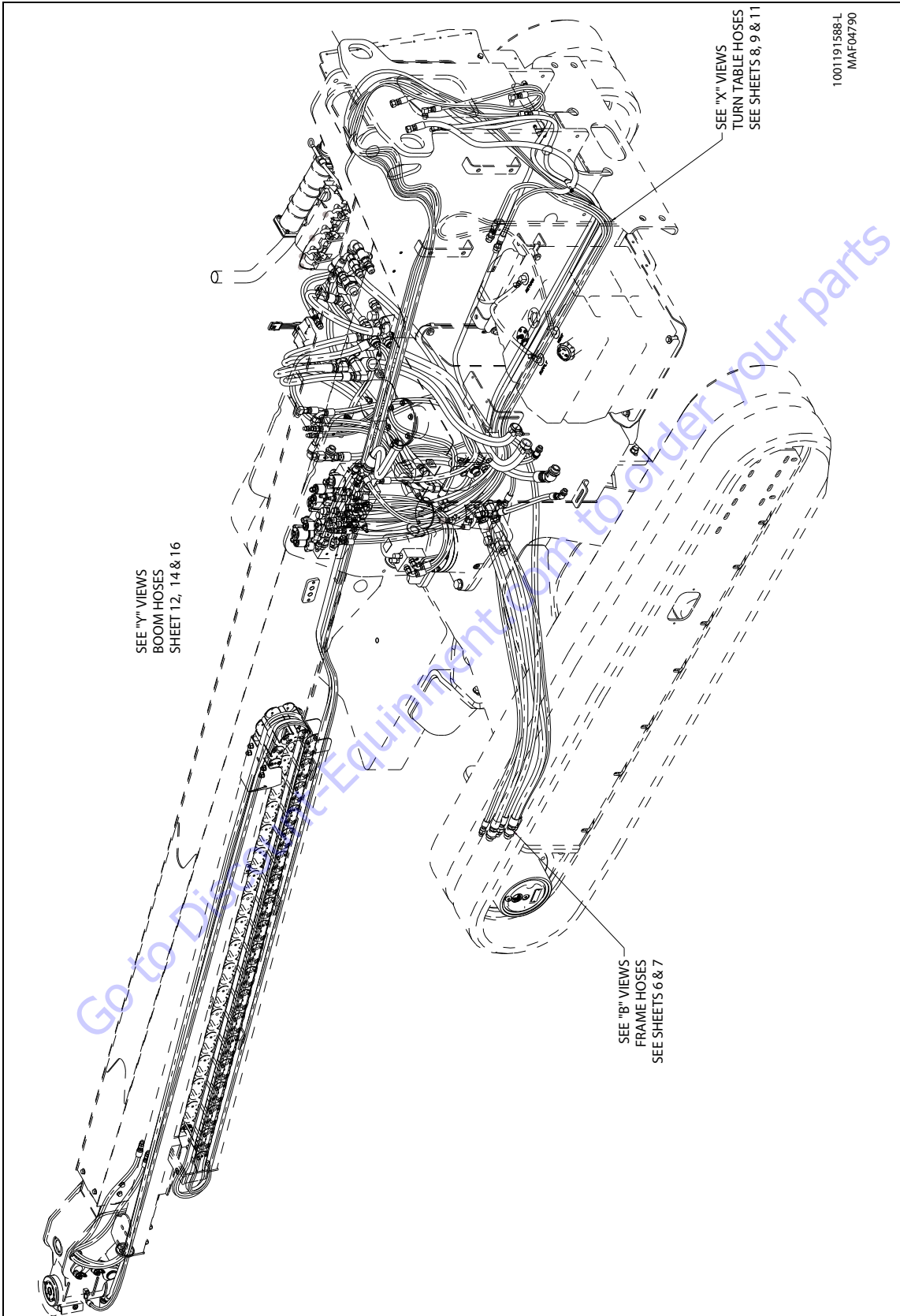

Figure 5-58. Hydraulic System Installation (400SC) - Sheet 5 of 16

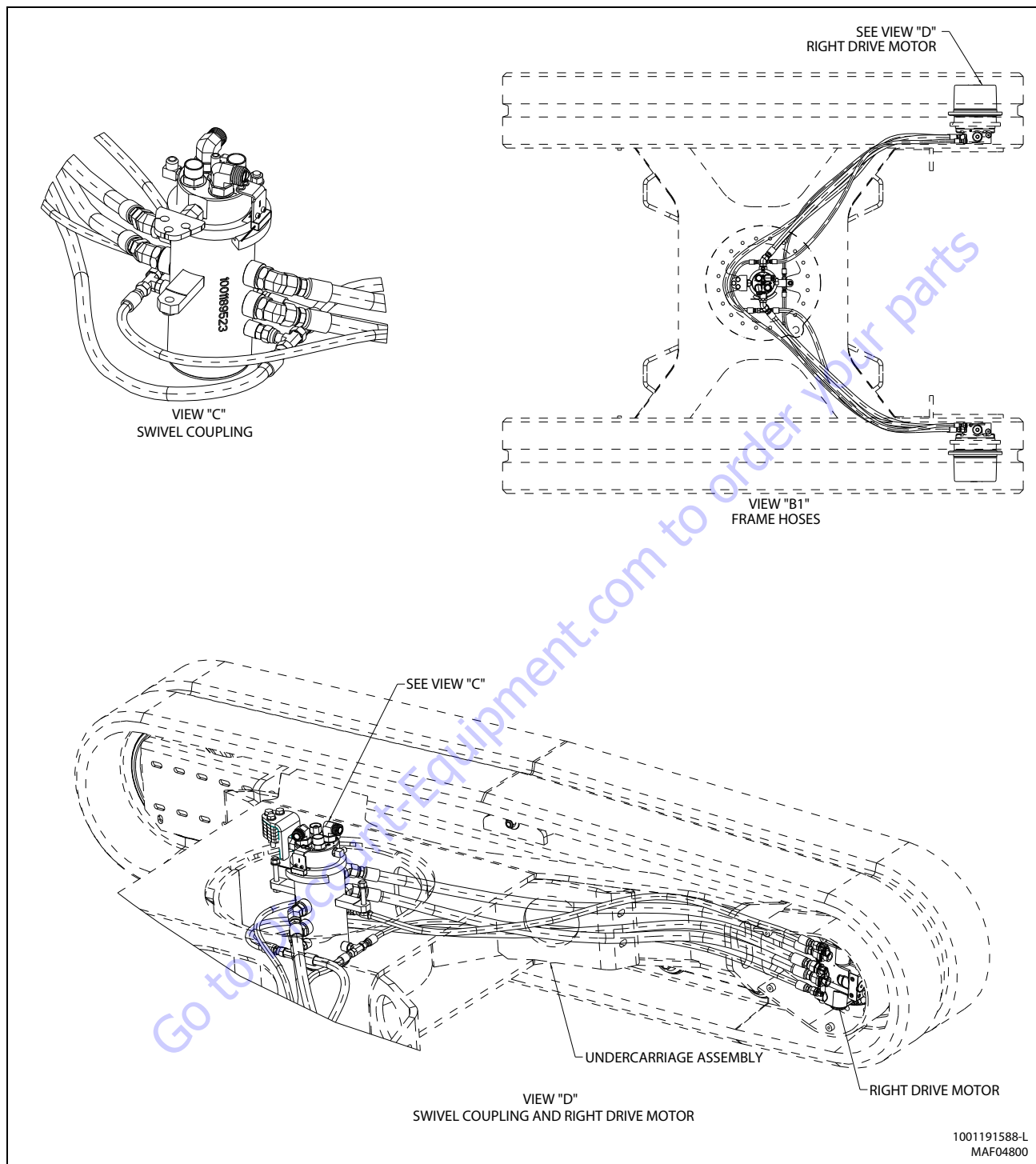
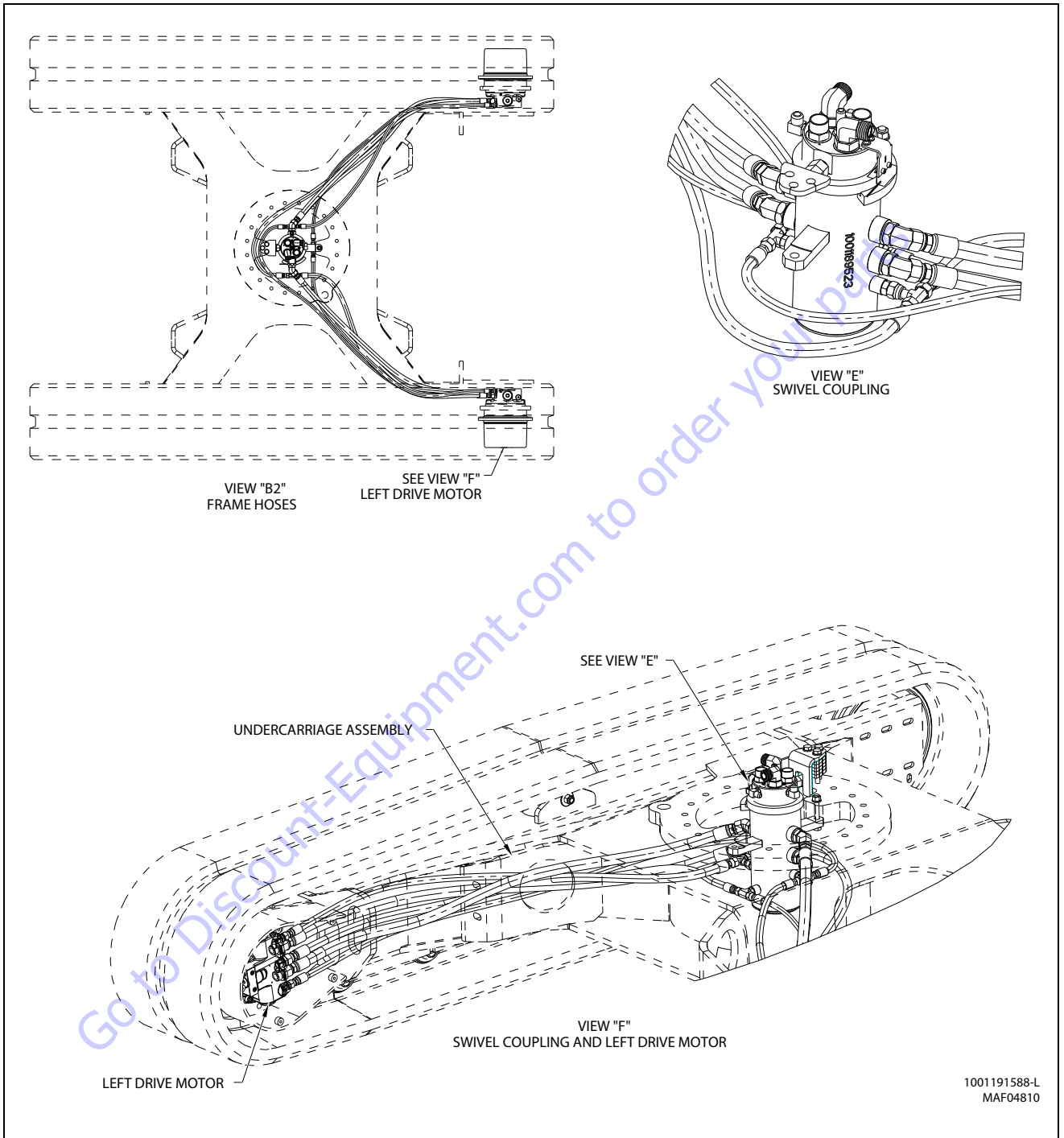

Figure 5-59. Hydraulic System Installation (400SC) - Sheet 6 of 16



1001191588-L  
MAF04810

Figure 5-60. Hydraulic System Installation (400SC) - Sheet 7 of 16

**SECTION 5 - HYDRAULICS AND HYDRAULIC SCHEMATICS**

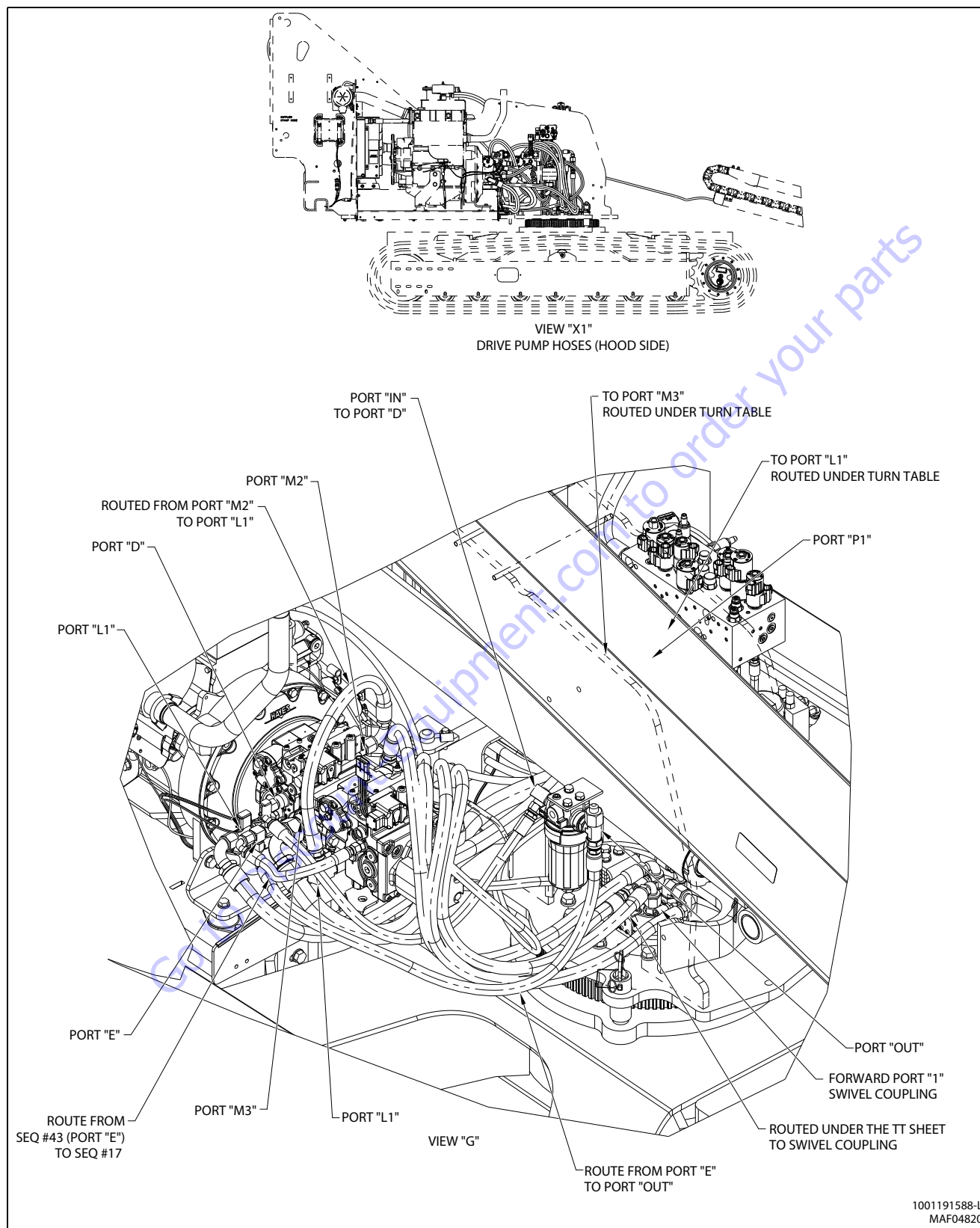

**Figure 5-61. Hydraulic System Installation (400SC) - Sheet 8 of 16**



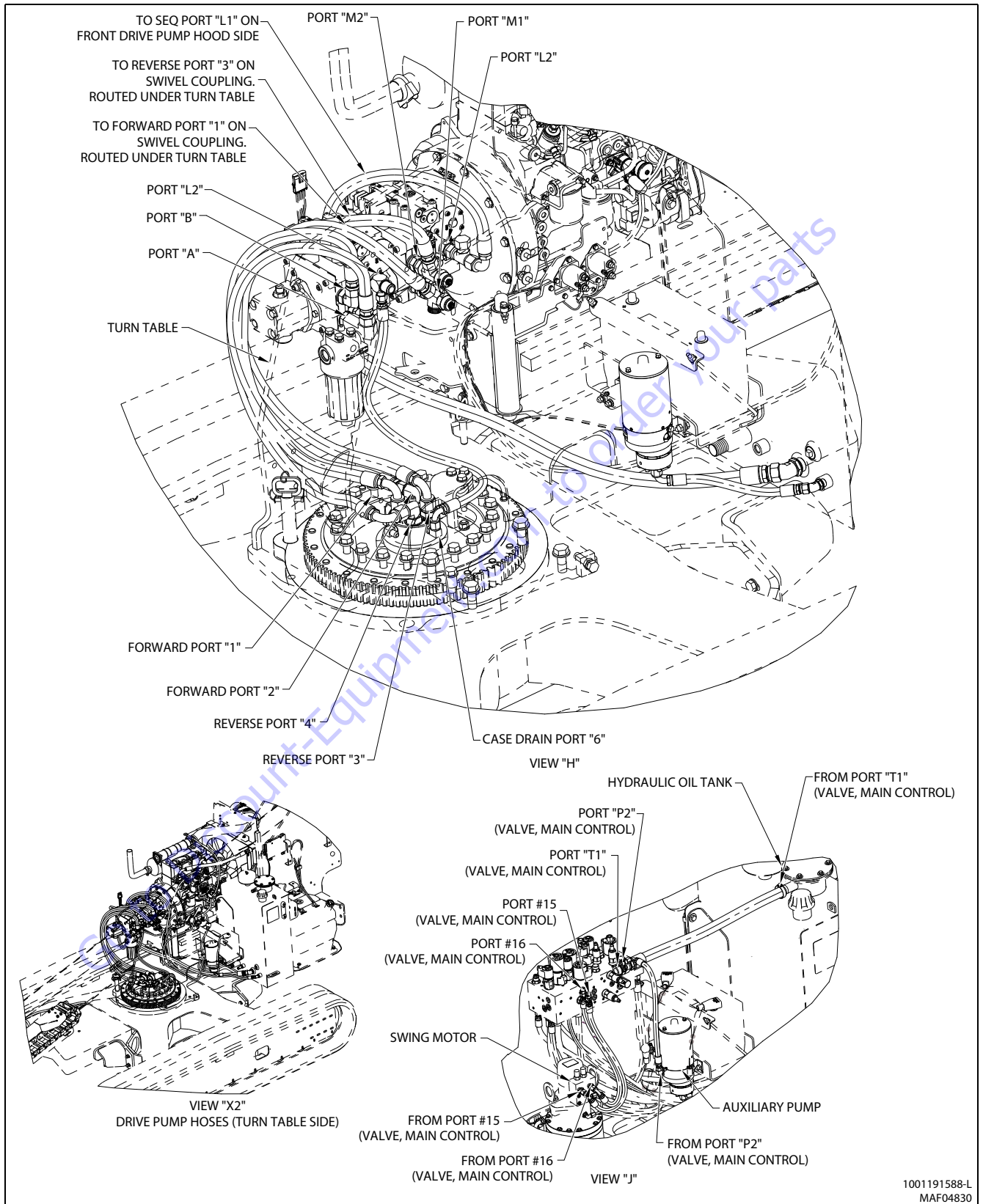
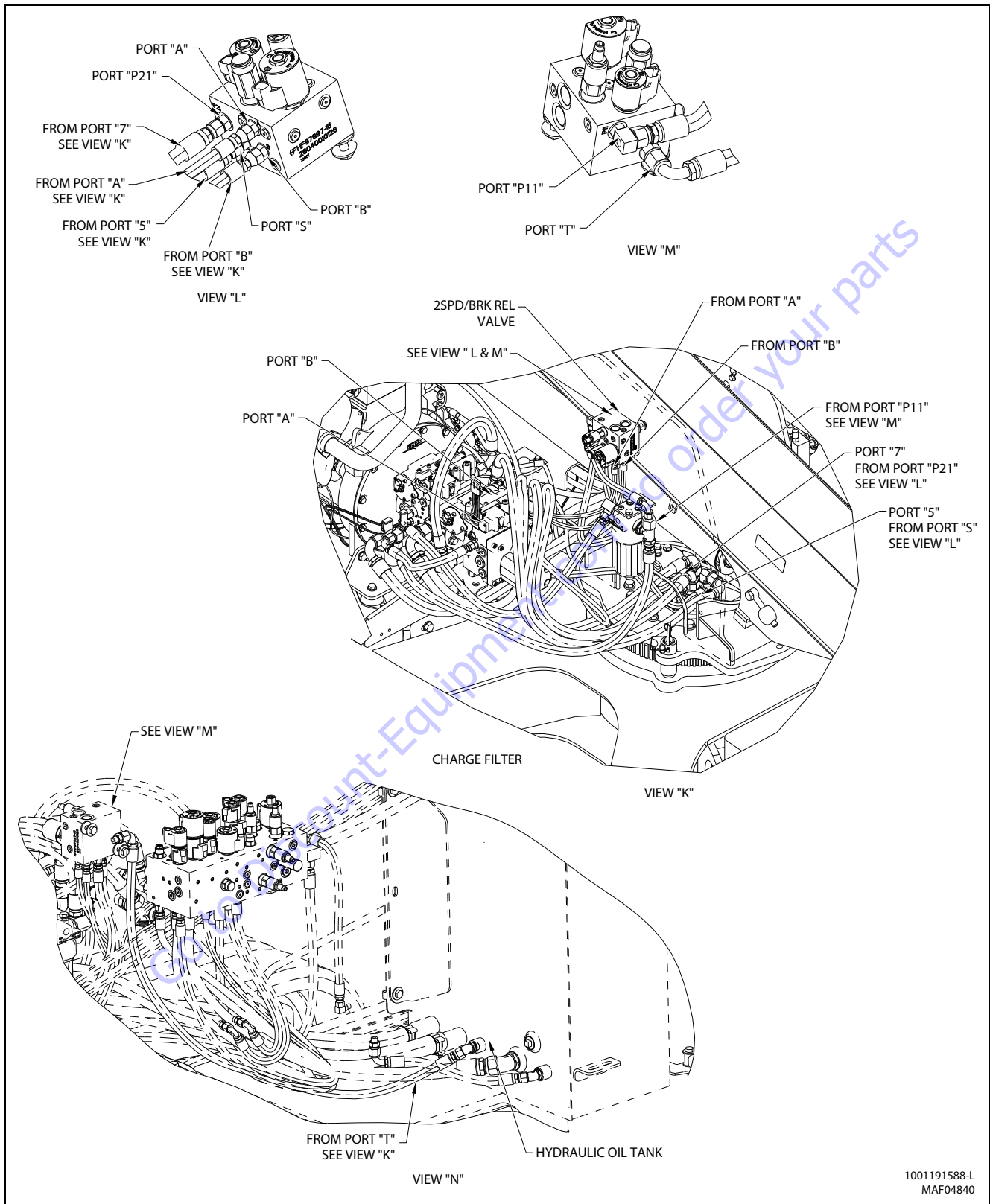

Figure 5-62. Hydraulic System Installation (400SC) - Sheet 9 of 16

**SECTION 5 - HYDRAULICS AND HYDRAULIC SCHEMATICS**



1001191588-L  
MAF04840

**Figure 5-63. Hydraulic System Installation (400SC) - Sheet 10 of 16**



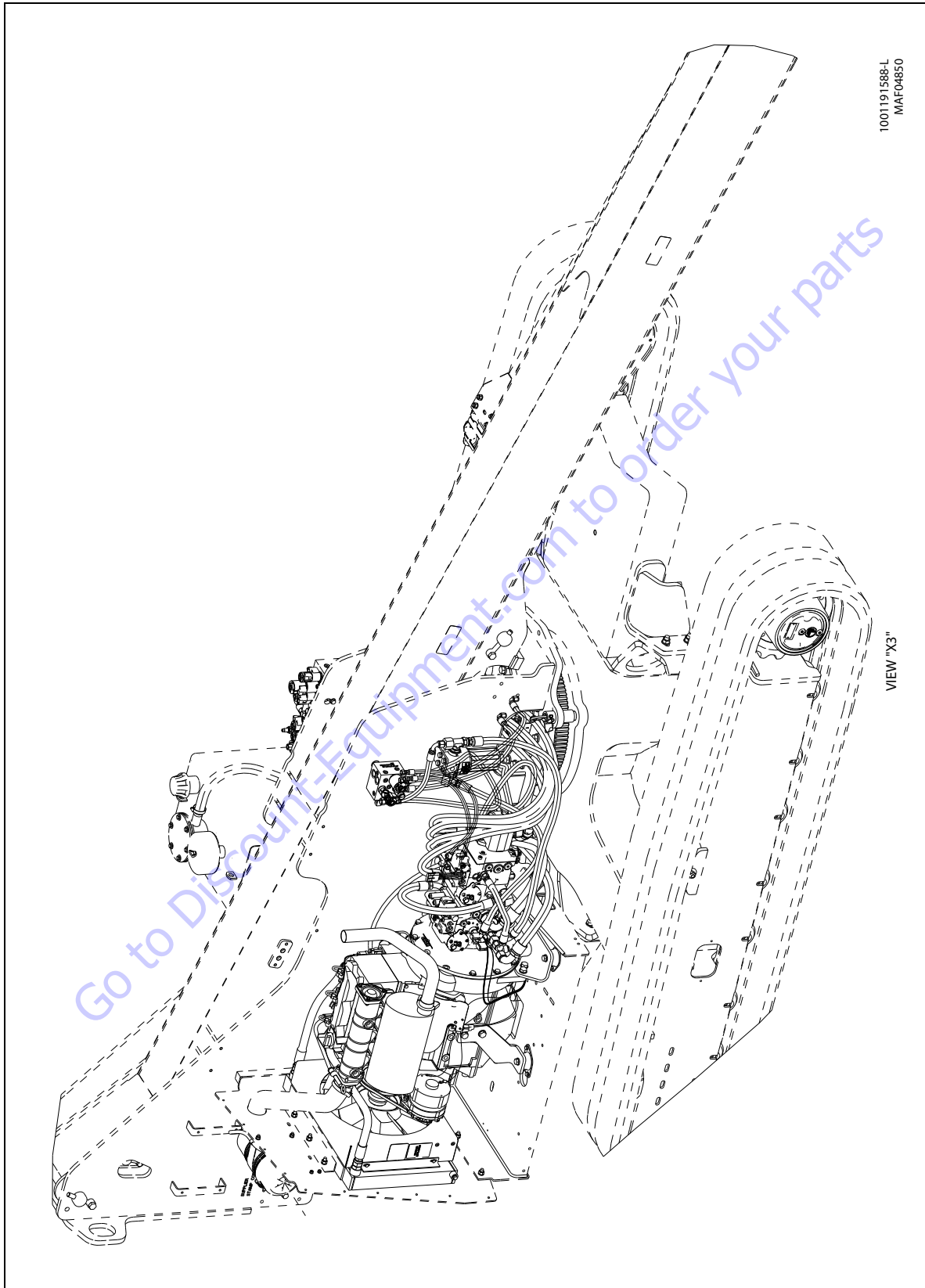

Figure 5-64. Hydraulic System Installation (4005C) - Sheet 11 of 16

SECTION 5 - HYDRAULICS AND HYDRAULIC SCHEMATICS

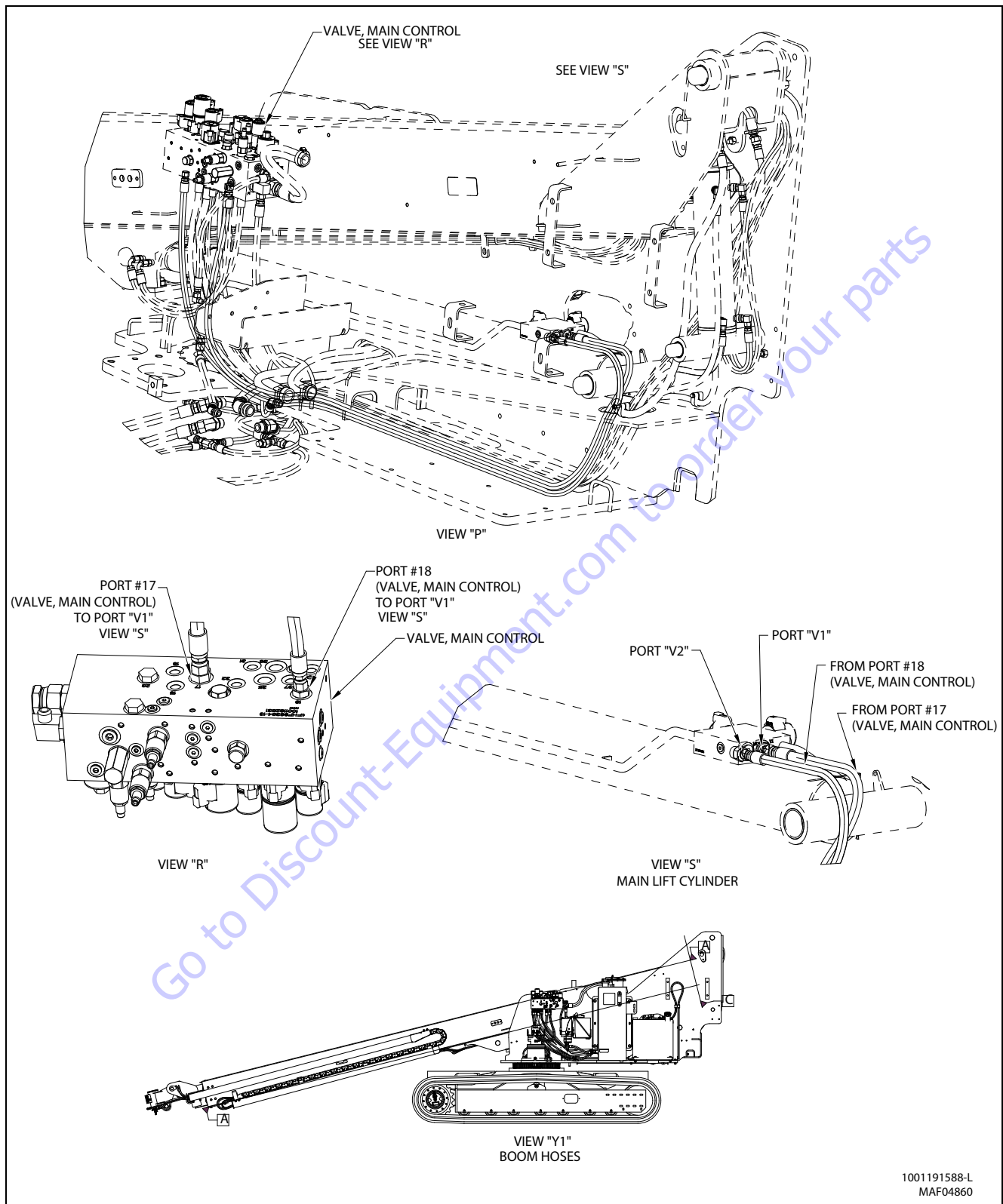

Figure 5-65. Hydraulic System Installation (400SC) - Sheet 12 of 16

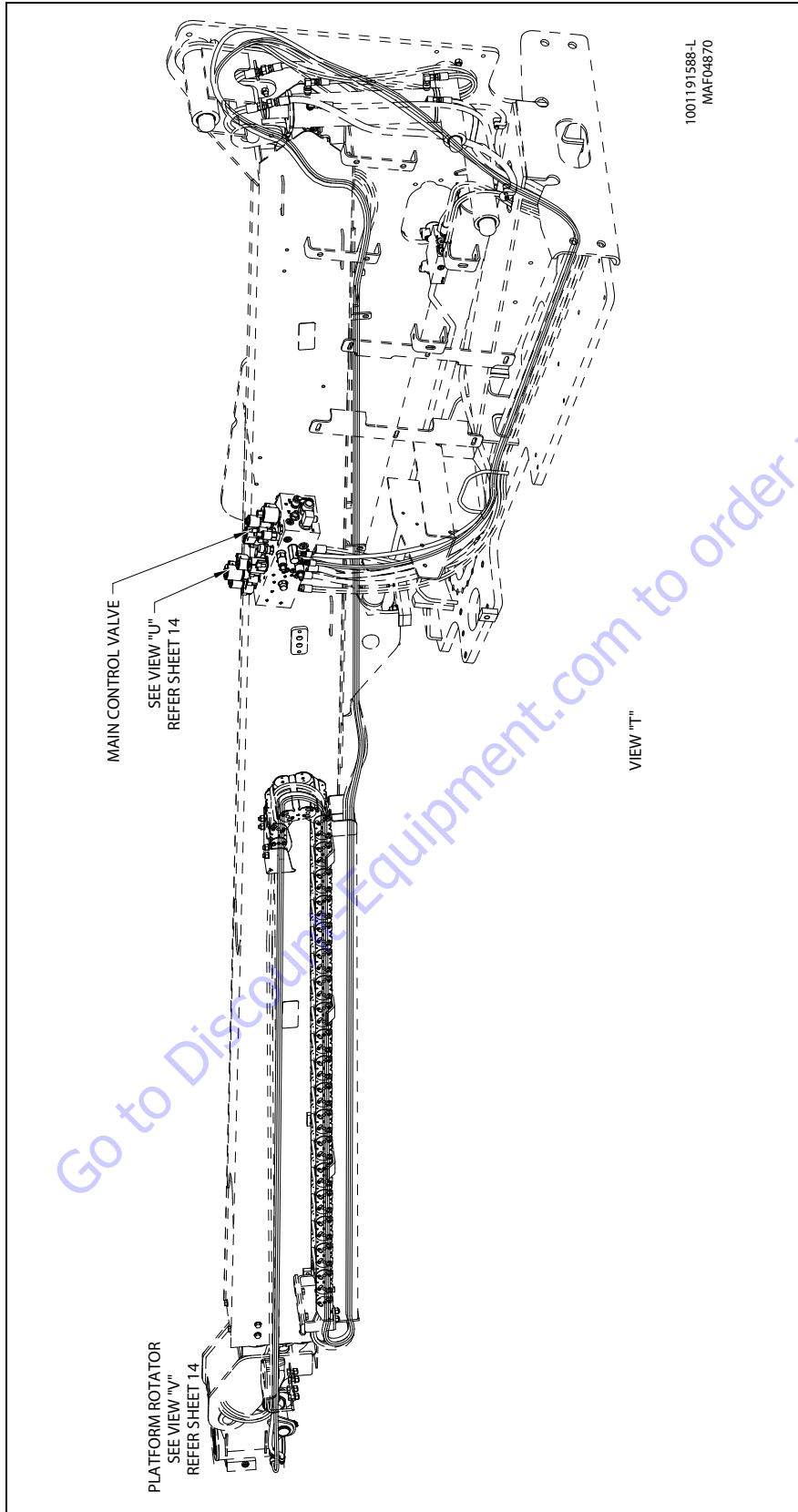

Figure 5-66. Hydraulic System Installation (400SC) - Sheet 13 of 16

SECTION 5 - HYDRAULICS AND HYDRAULIC SCHEMATICS

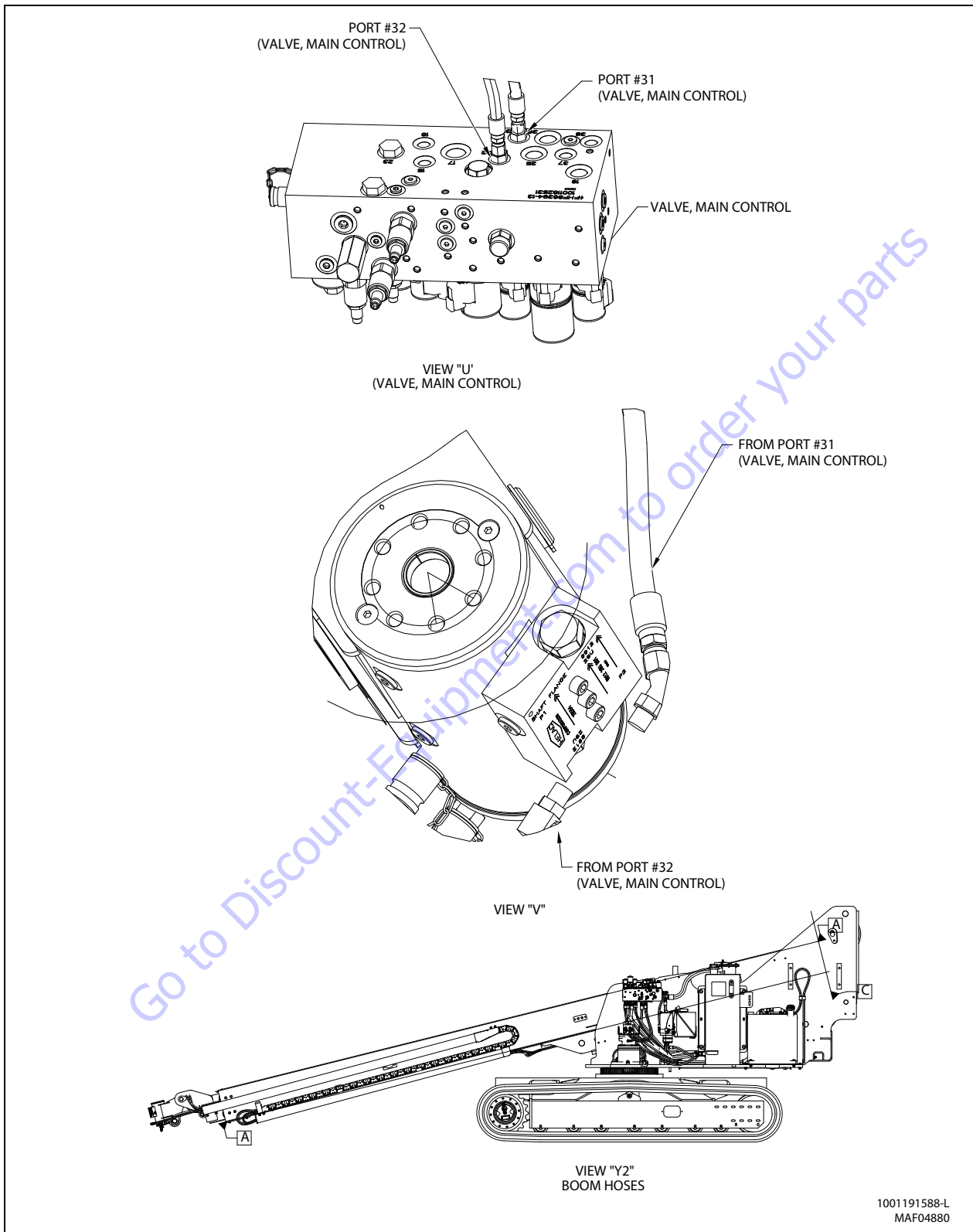

Figure 5-67. Hydraulic System Installation (400SC) - Sheet 14 of 16

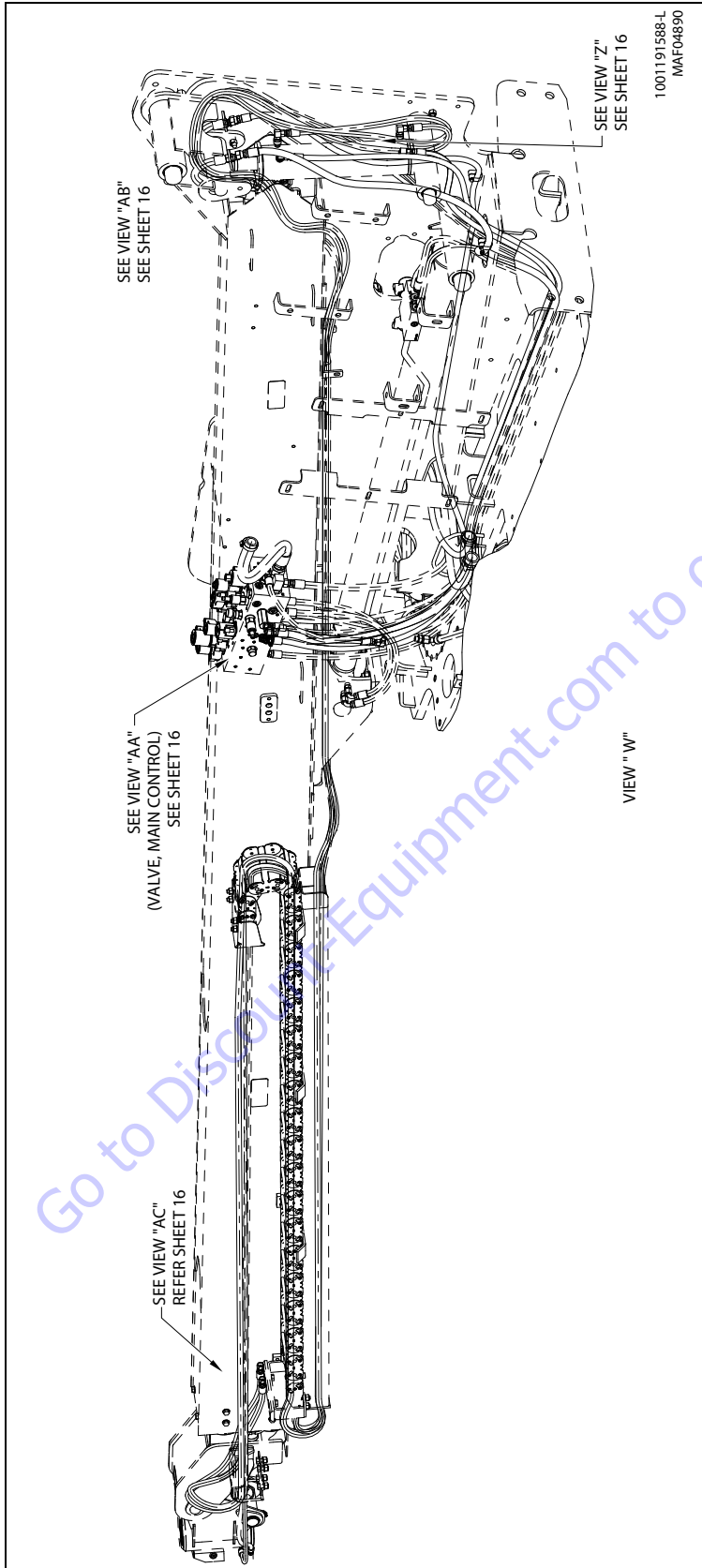
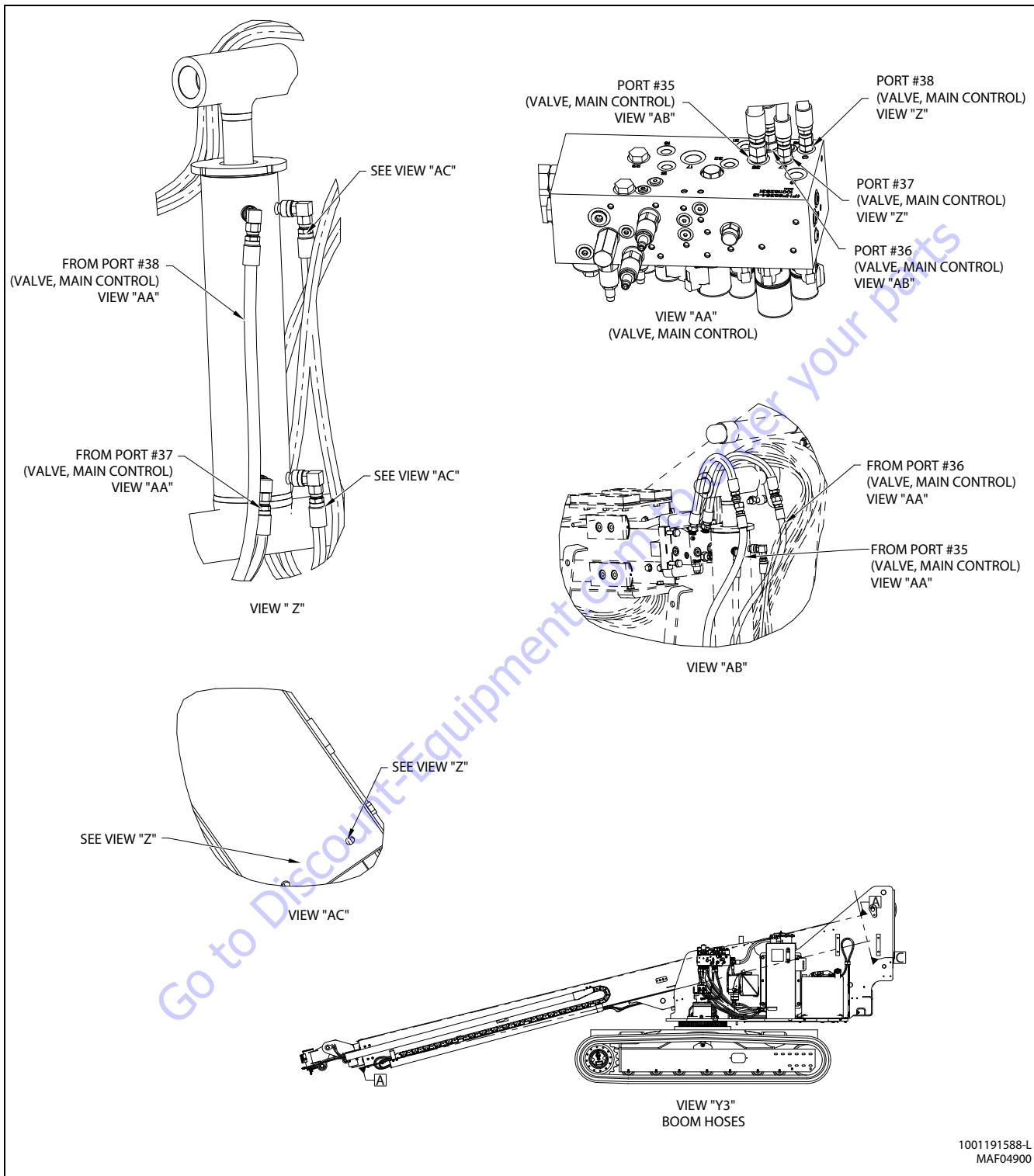

Figure 5-68. Hydraulic System Installation (400SC) - Sheet 15 of 16

**SECTION 5 - HYDRAULICS AND HYDRAULIC SCHEMATICS**



**Figure 5-69. Hydraulic System Installation (400SC) - Sheet 16 of 16**

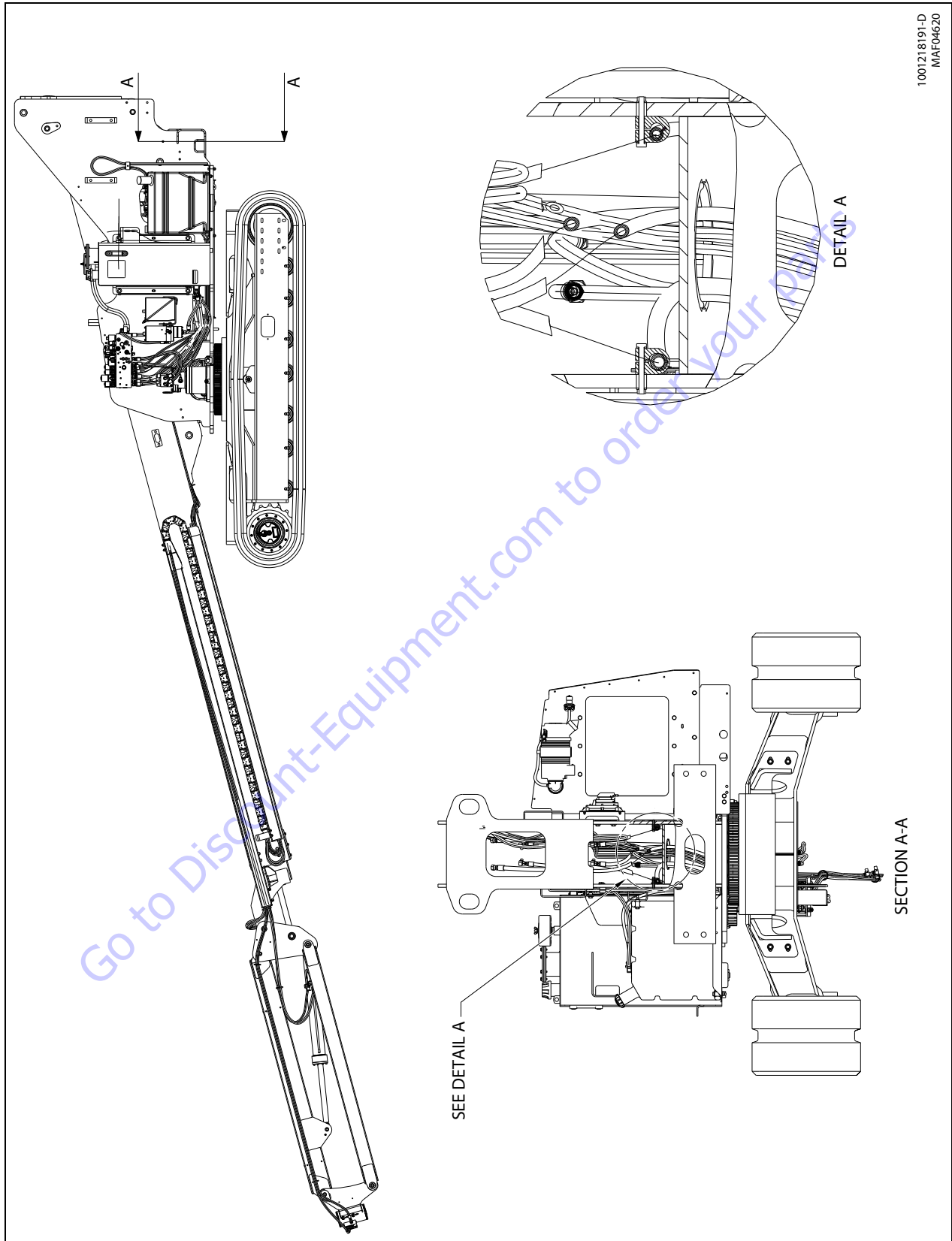

Figure 5-70. Hydraulic System Installation (460SJC) - Sheet 1 of 15

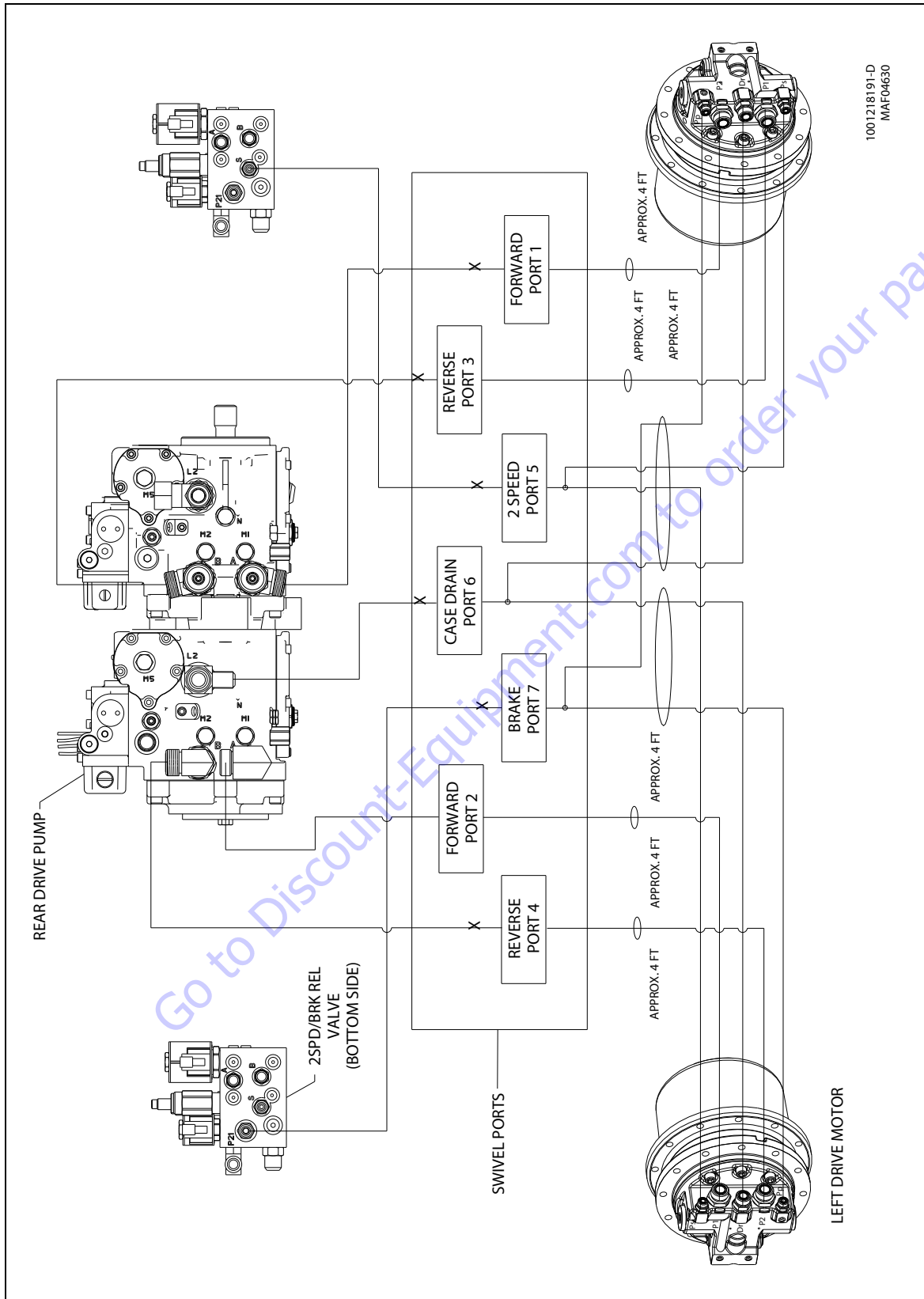

Figure 5-71. Hydraulic System Installation (460SJC) - Sheet 2 of 15



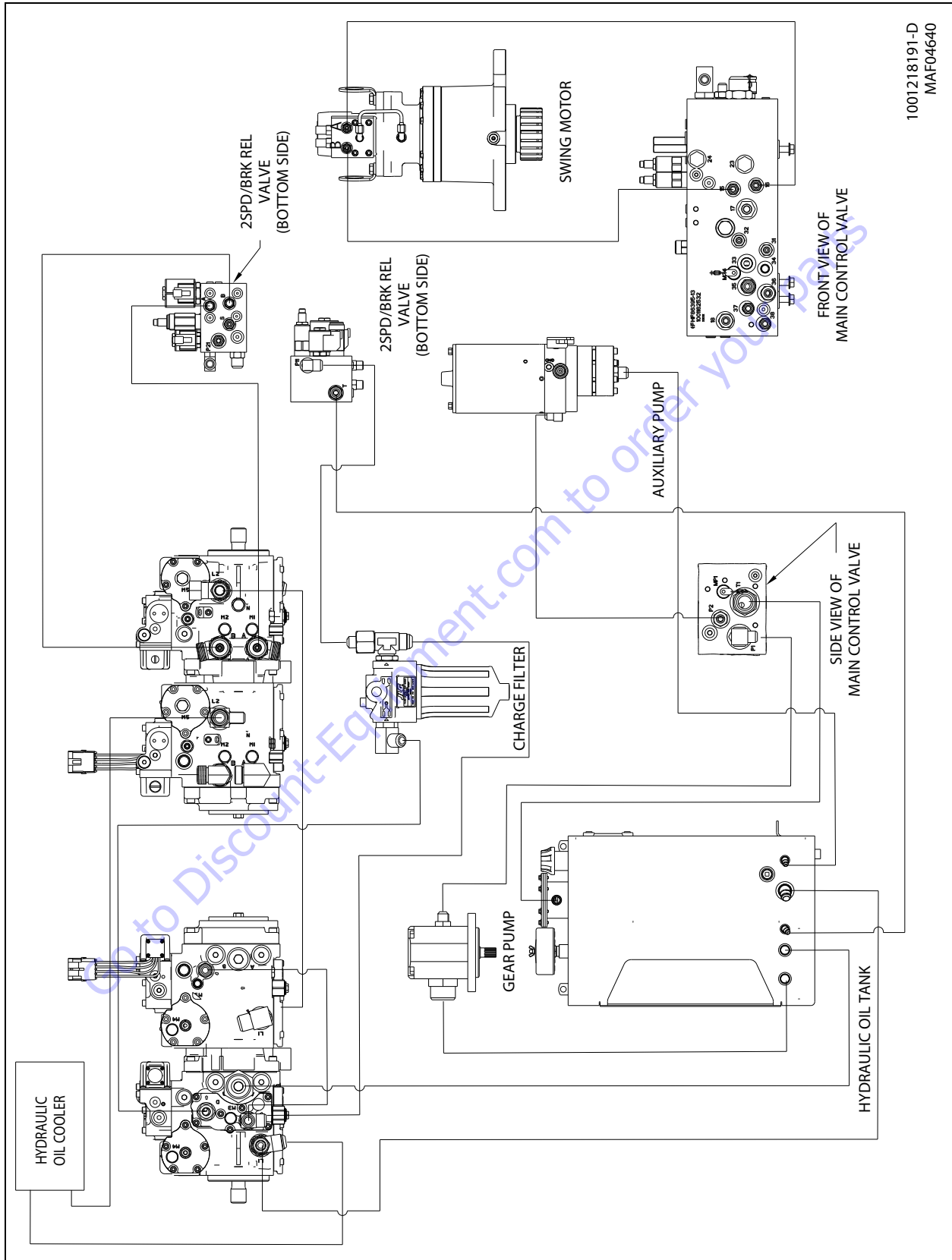

Figure 5-72. Hydraulic System Installation (460SJC) - Sheet 3 of 15

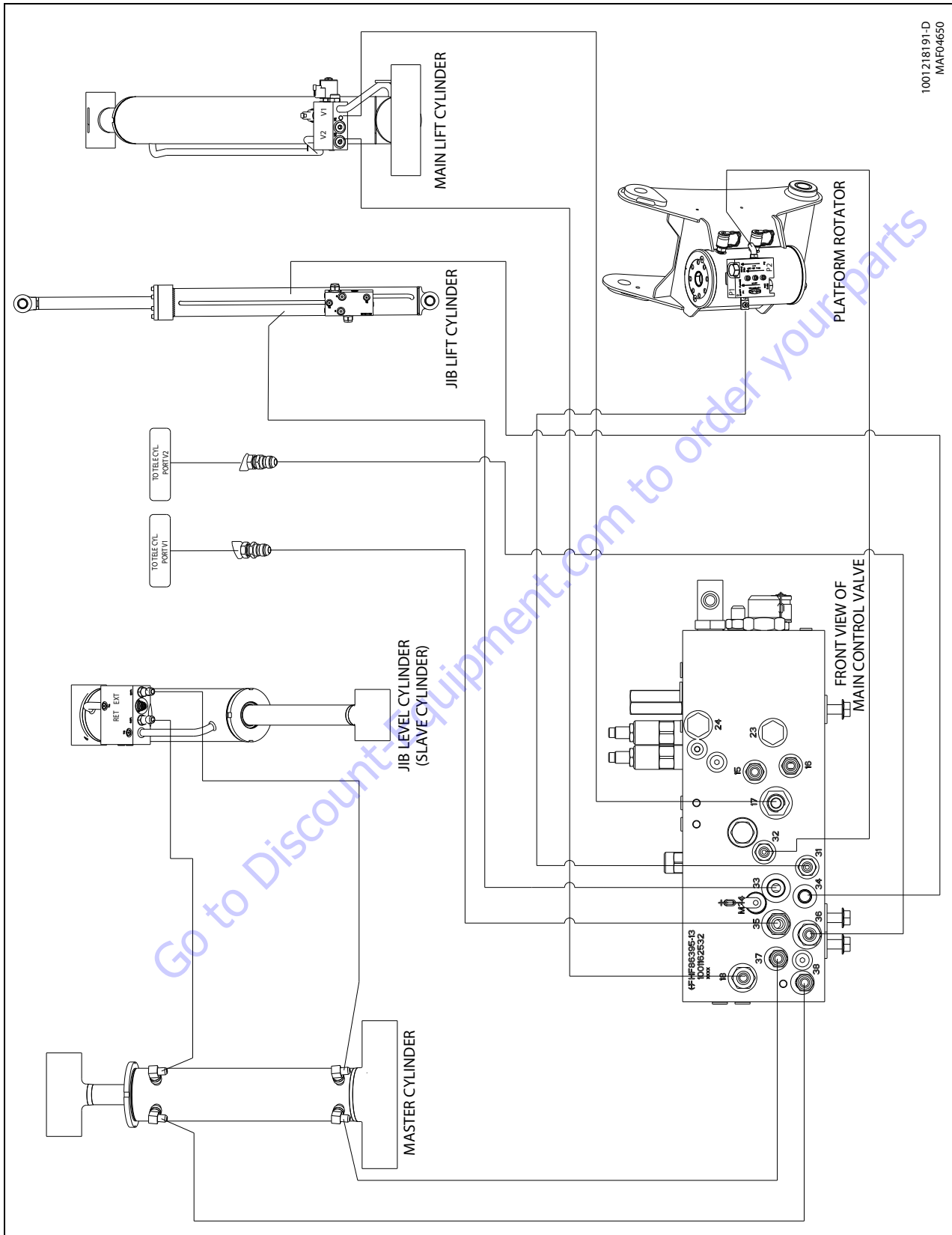

Figure 5-73. Hydraulic System Installation (460SJC) - Sheet 4 of 15

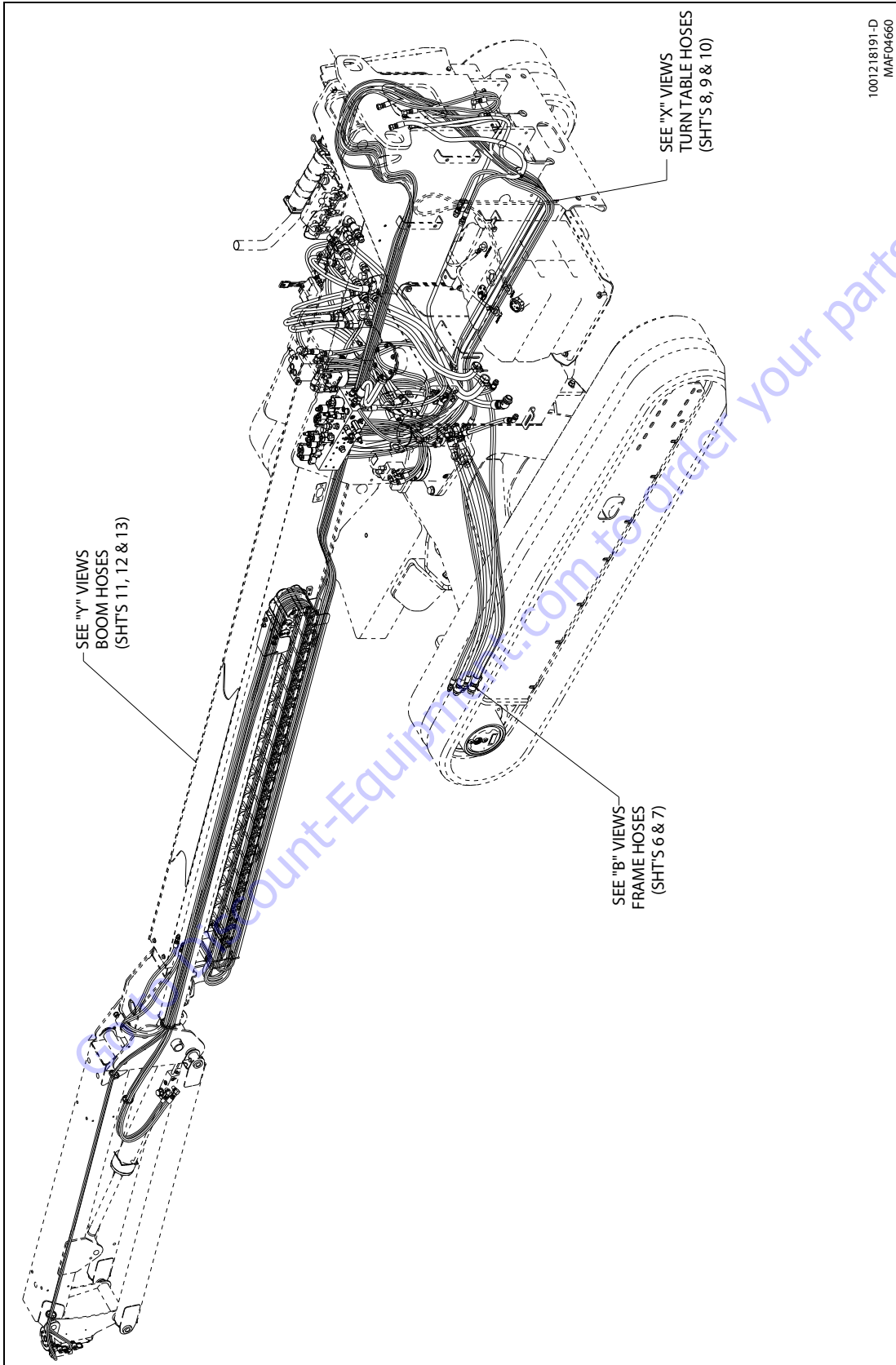

Figure 5-74. Hydraulic System Installation (460SJC) - Sheet 5 of 15

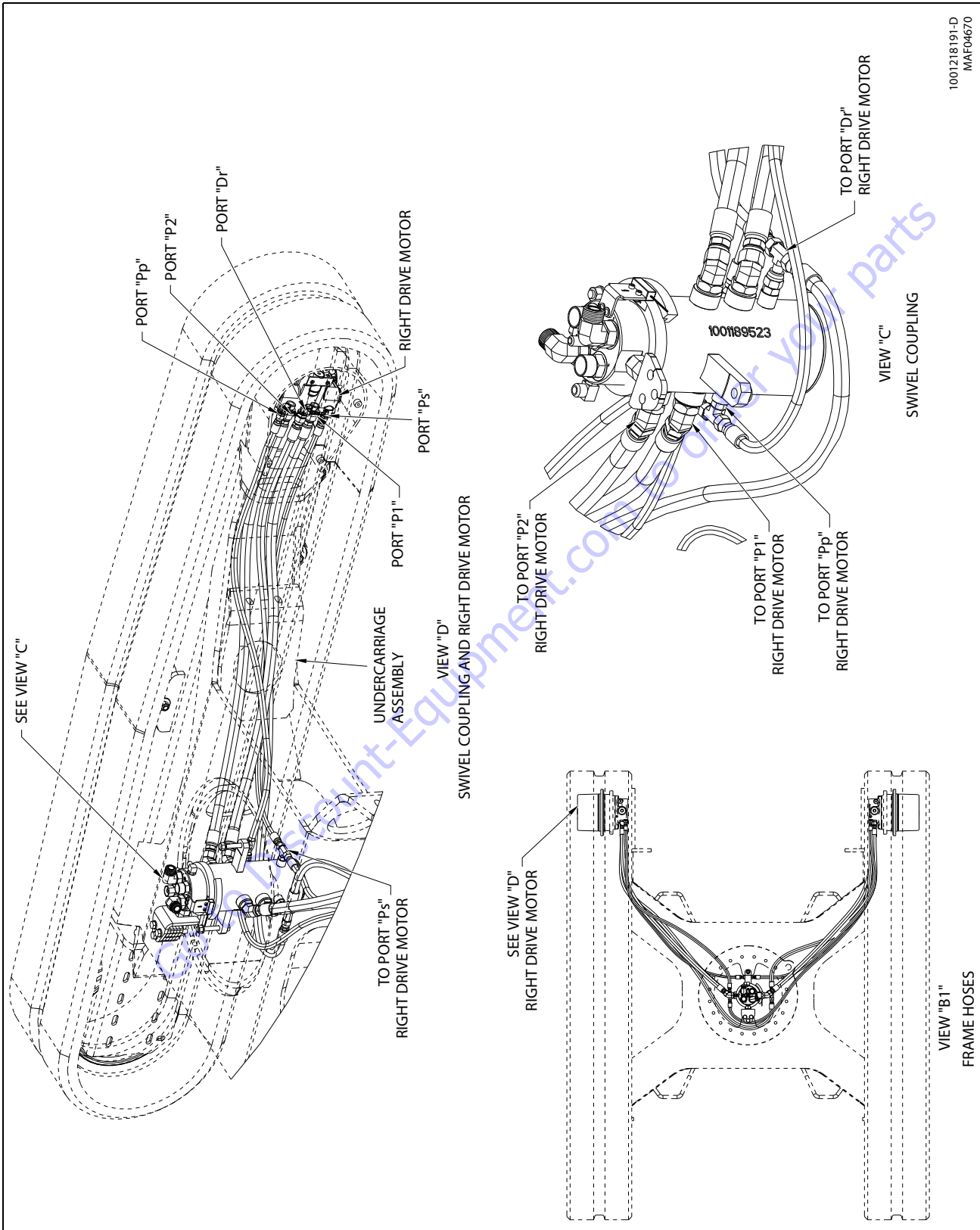
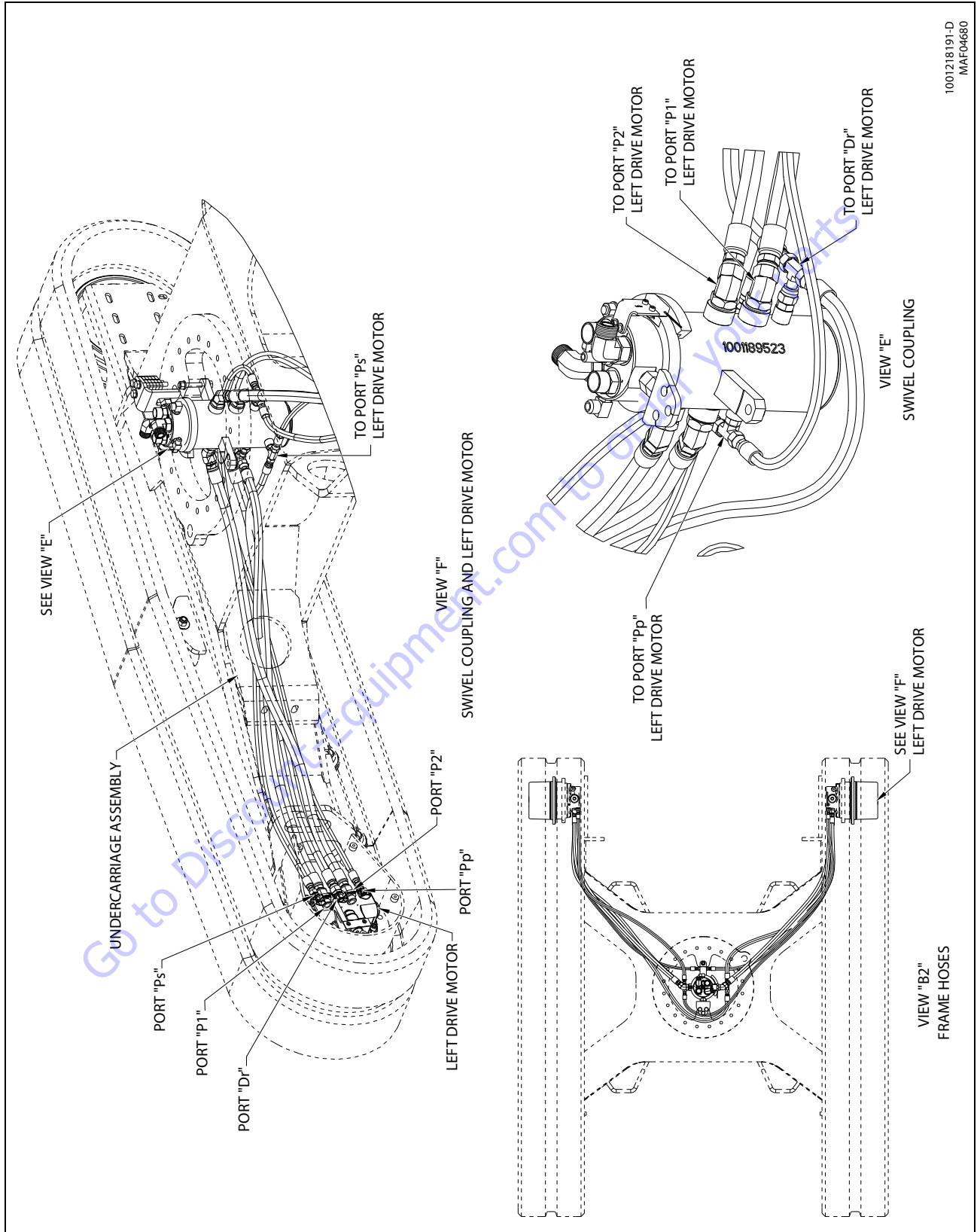
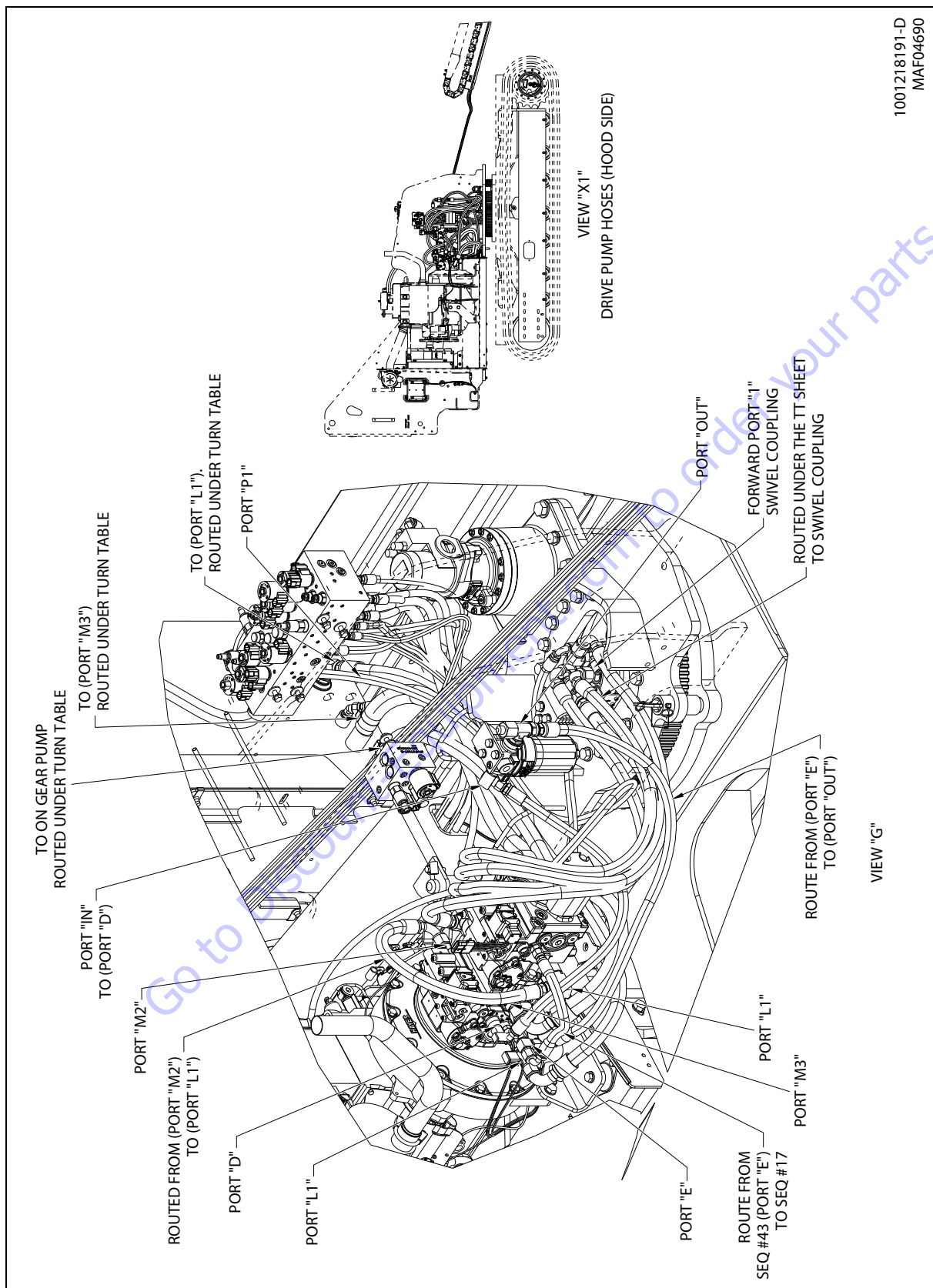

Figure 5-75. Hydraulic System Installation (460SJC) - Sheet 6 of 15



1001218191-D  
MAF04680

Figure 5-76. Hydraulic System Installation (460SJC) - Sheet 7 of 15



1001218191-D  
MAF04690

Figure 5-77. Hydraulic System Installation (460SJC) - Sheet 8 of 15



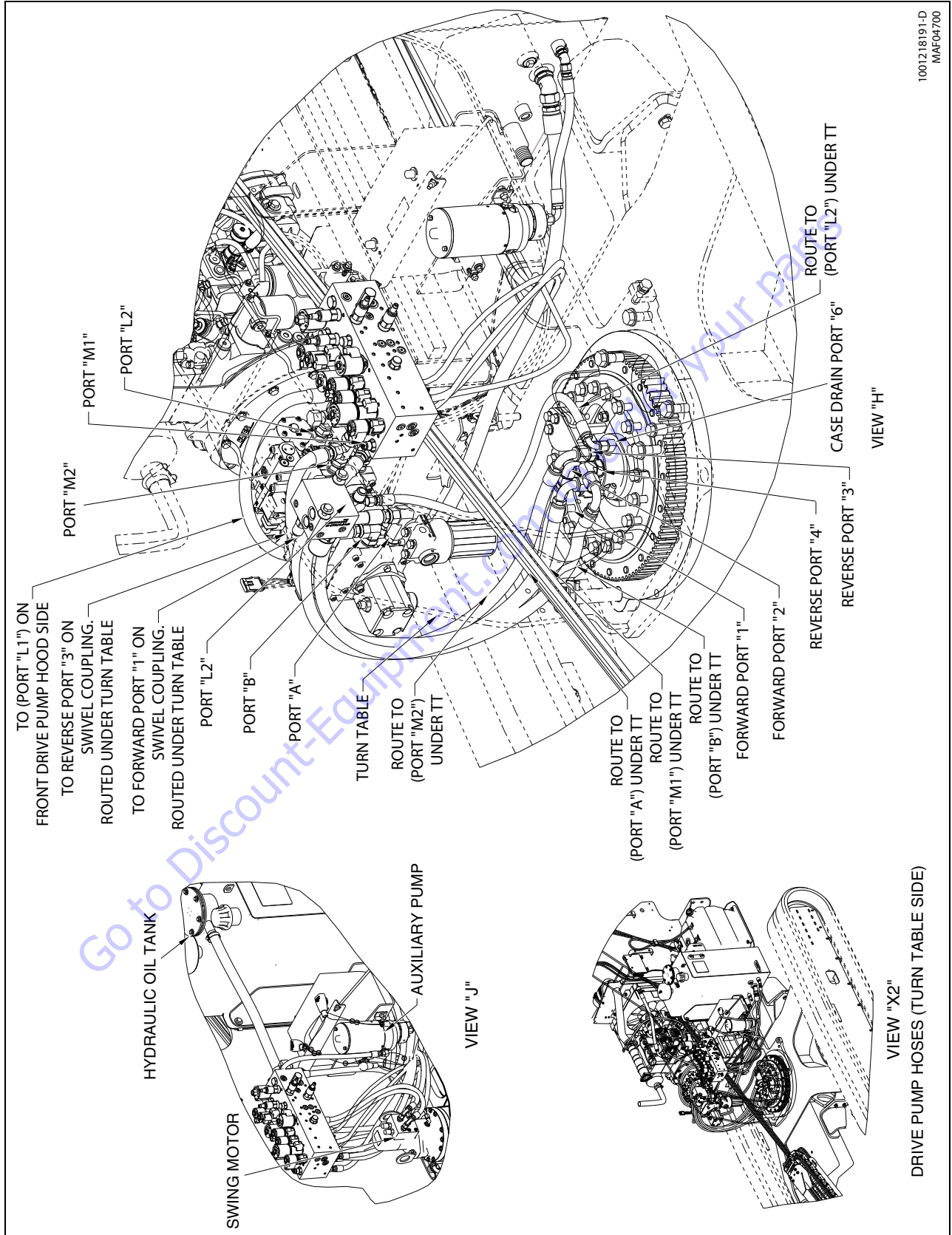

Figure 5-78. Hydraulic System Installation (460SJC) - Sheet 9 of 15

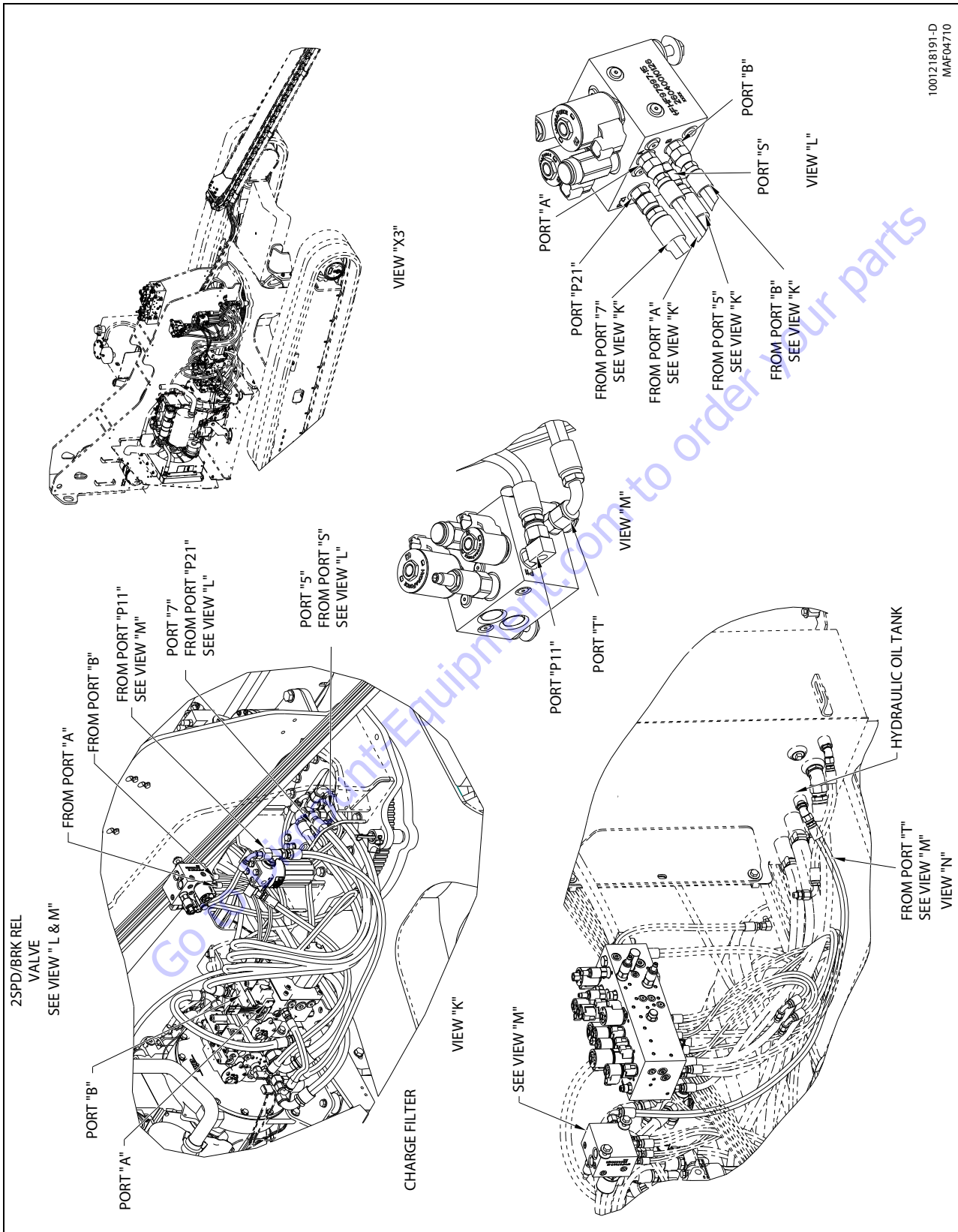

Figure 5-79. Hydraulic System Installation (4605JC) - Sheet 10 of 15



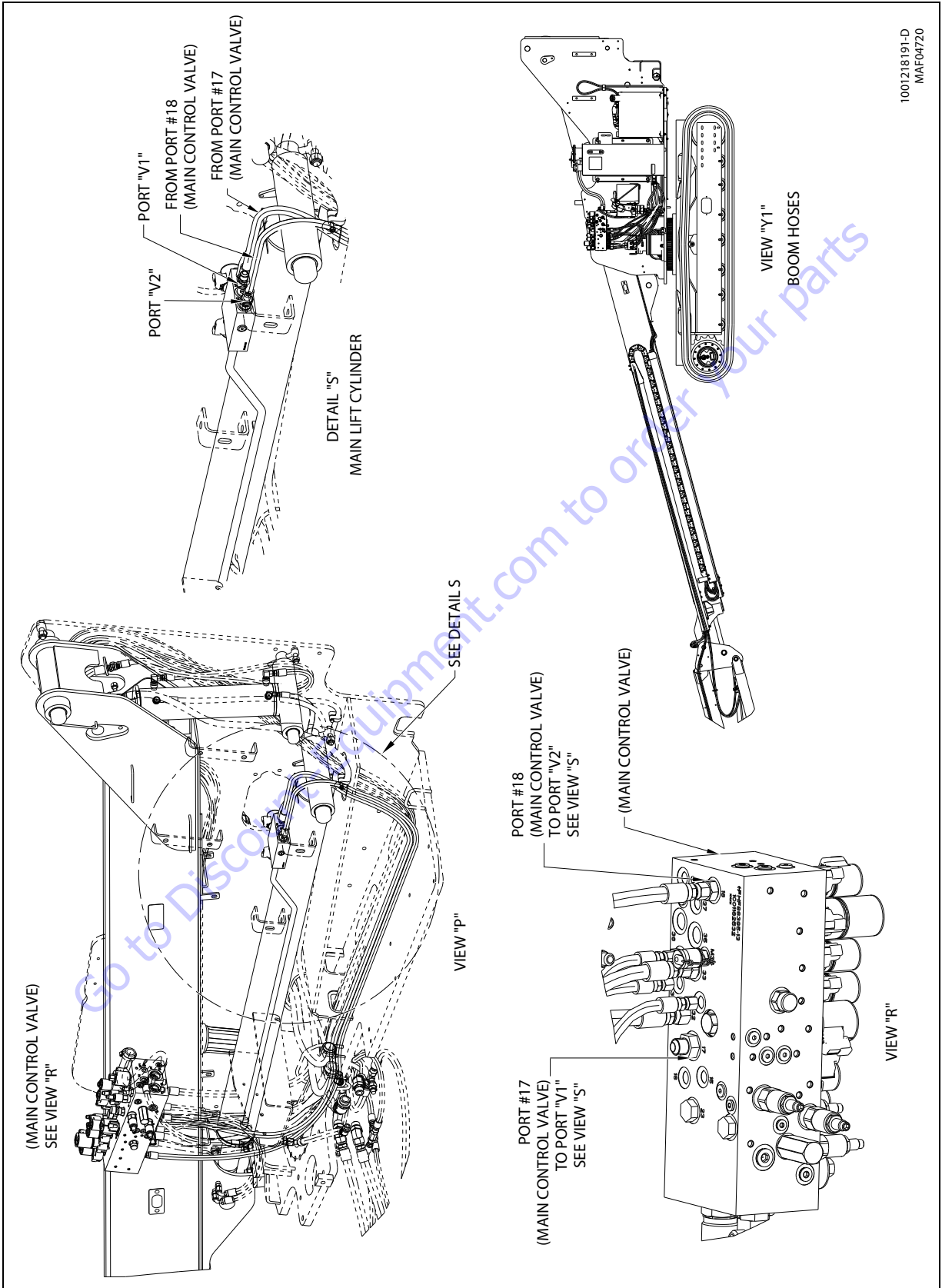

Figure 5-80. Hydraulic System Installation (460SJC) - Sheet 11 of 15

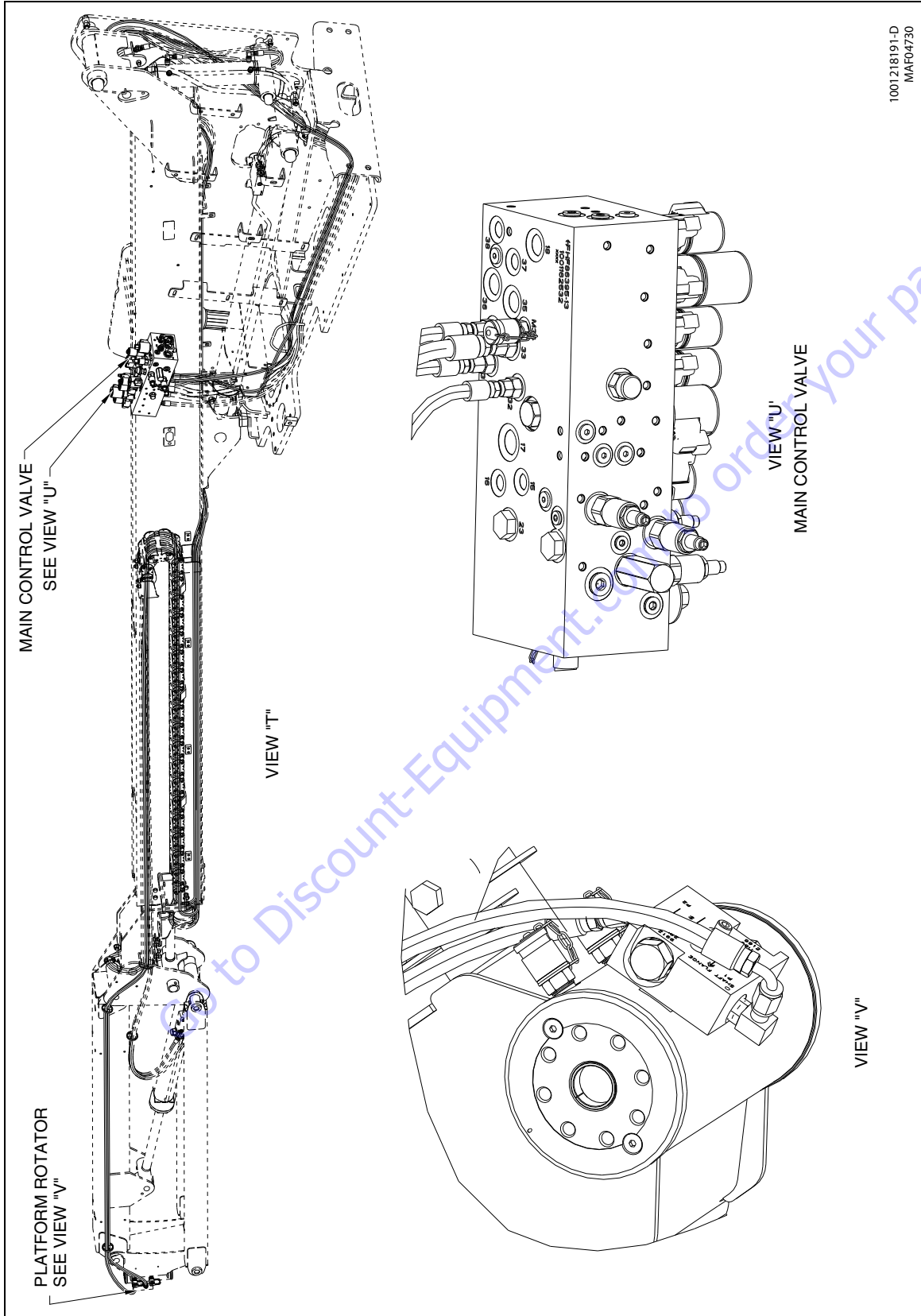
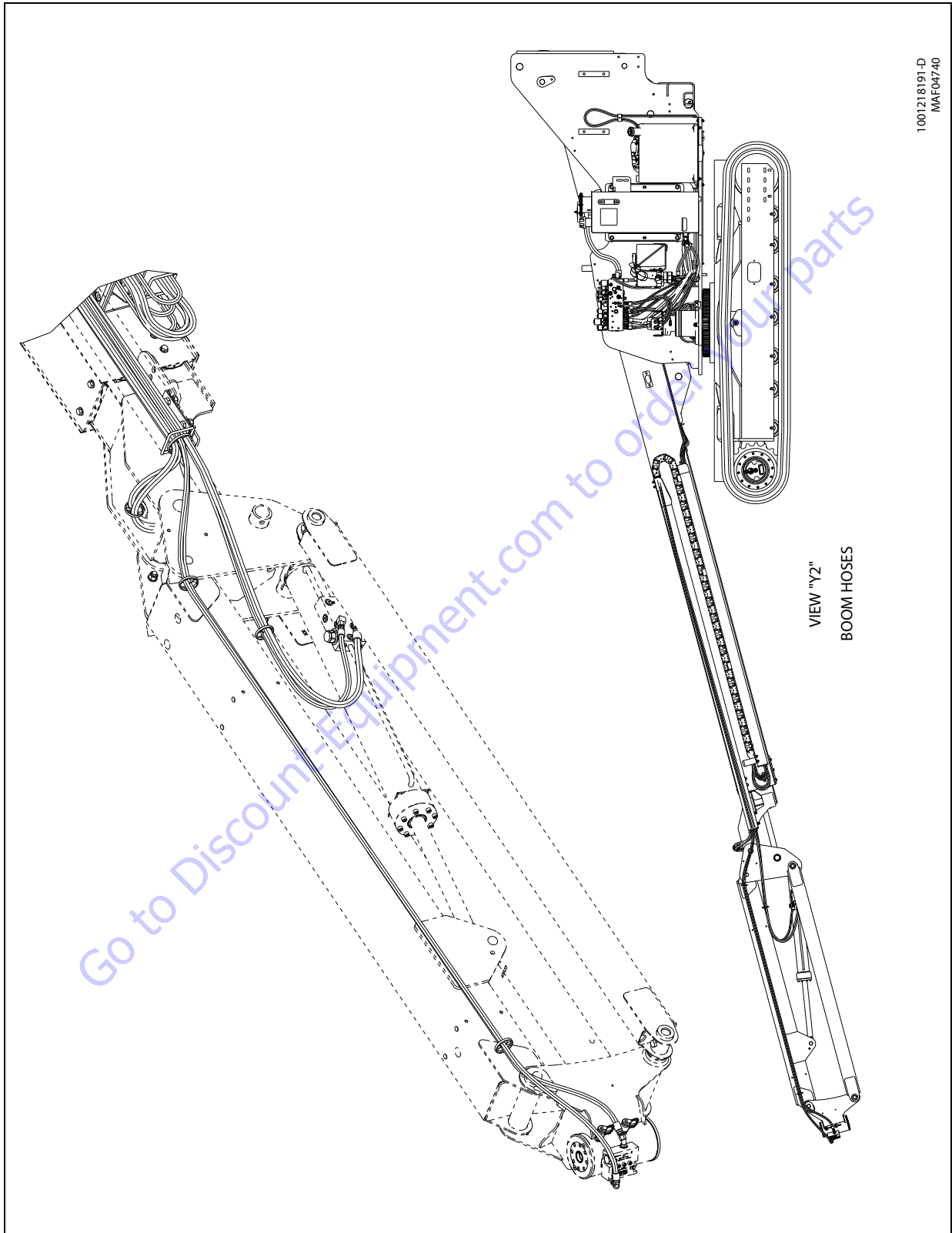

Figure 5-81. Hydraulic System Installation (460SJC) - Sheet 12 of 15



1001218191-D  
MAF04740

Figure 5-82. Hydraulic System Installation (4605JC) - Sheet 13 of 15

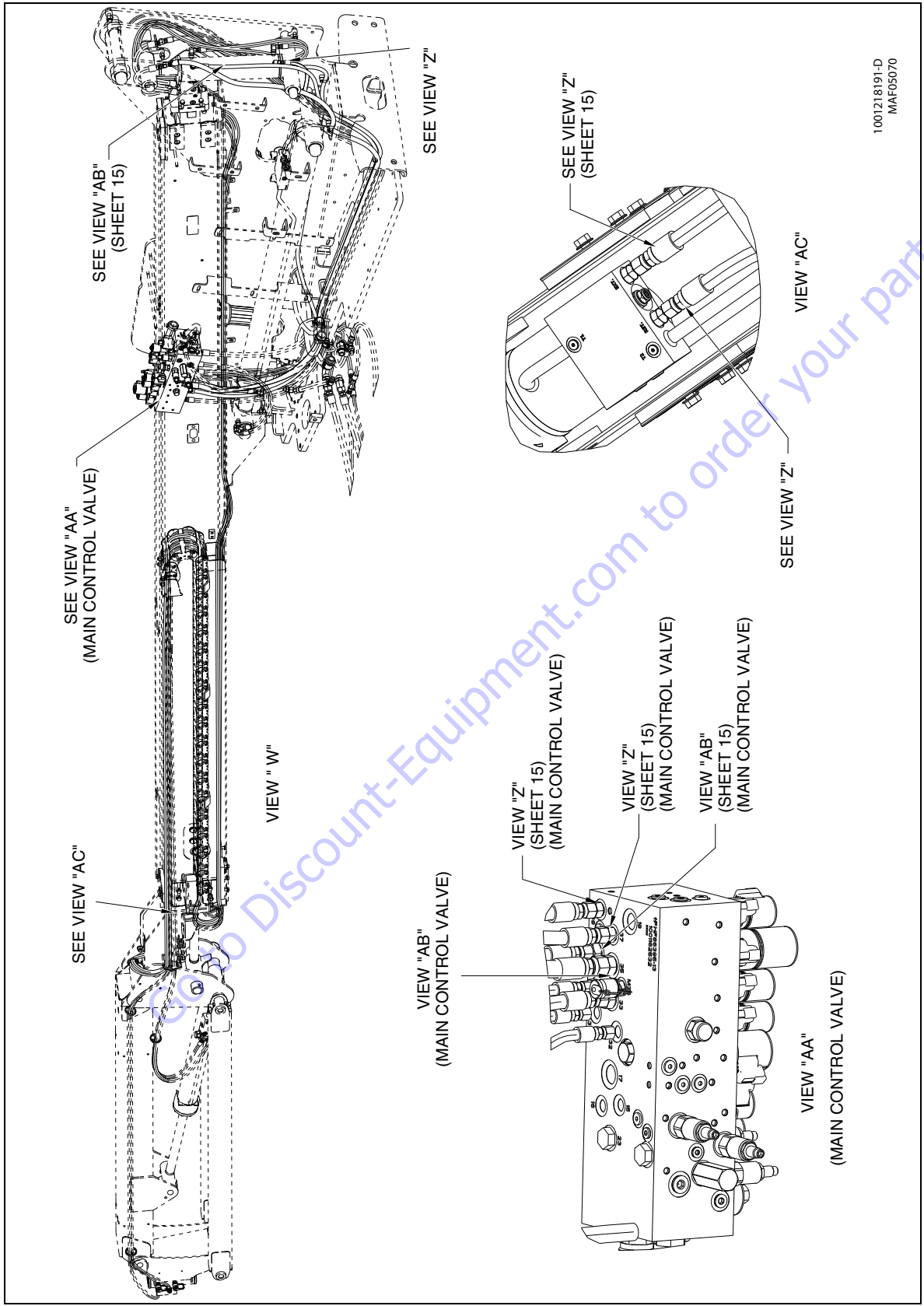

Figure 5-83. Hydraulic System Installation (4605JC) - Sheet 14 of 15

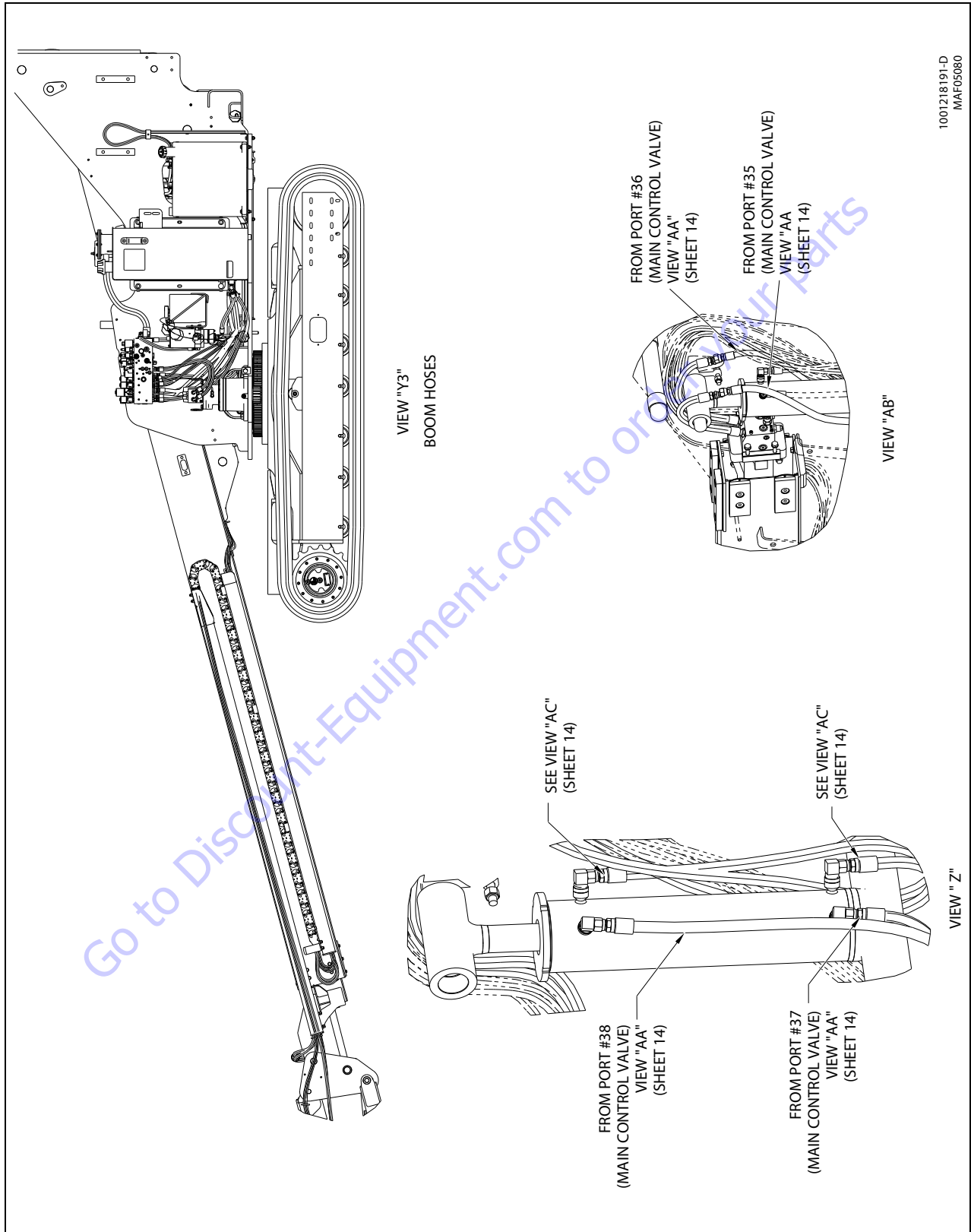

Figure 5-84. Hydraulic System Installation (460SJC) - Sheet 15 of 15

## 5.6 PRESSURE SETTING PROCEDURE

Cold temperatures have a significant impact on pressure readings. JLG Industries Inc. recommends operating the machine until the hydraulic system has warmed to normal operating temperatures prior to checking pressures. JLG Industries Inc. also recommends the use of a calibrated gauge. Pressure readings are acceptable if they are within  $\pm 5\%$  of specified pressures.

To ensure all pressures are set correctly, the following procedures must be followed.

### Main System Relief

1. Install a pressure gauge at MP1 port of the Main Control Valve capable of reading pressures up to 4000 psi (275 Bar).

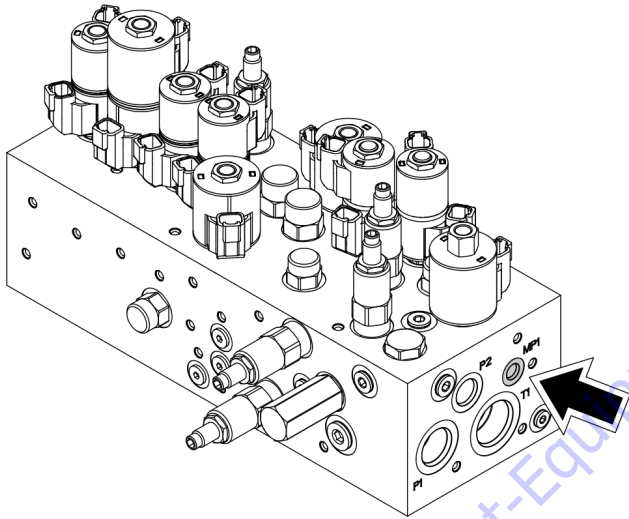

2. Activate telescope in function continuously at end of stroke. Observed pressure should be  $3000 \pm 75$  psi ( $207 \pm 6$  Bar).

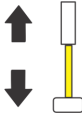

3. If necessary, loosen jam nut and adjust the Main System Relief valve clockwise to increase and counterclockwise to decrease.

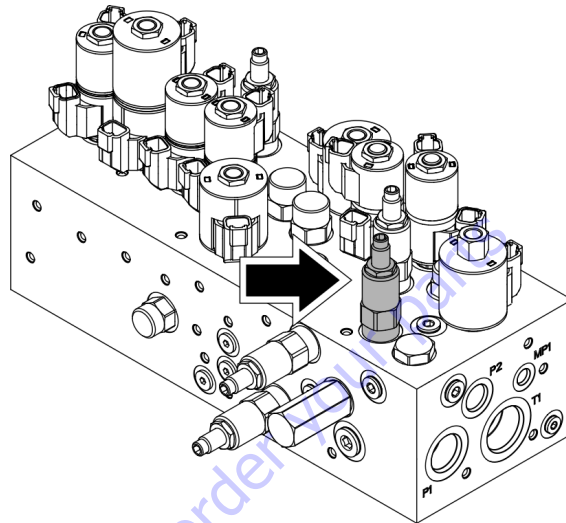

### Steer Left Relief

1. Install a pressure gauge at port MP1 of the Main Control Valve capable of reading pressures up to 4000 psi (275 Bar).

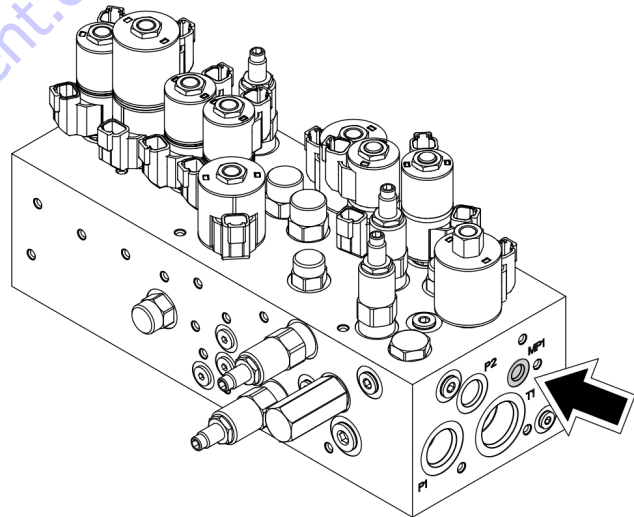

2. Activate Steer Left function continuously at end of stroke. Pressure that is observed should be  $2750 \pm 75$  psi ( $190 \pm 6$  Bar).



3. If necessary, loosen jam nut and adjust the Steer Left Relief valve clockwise to increase and counterclockwise to decrease.

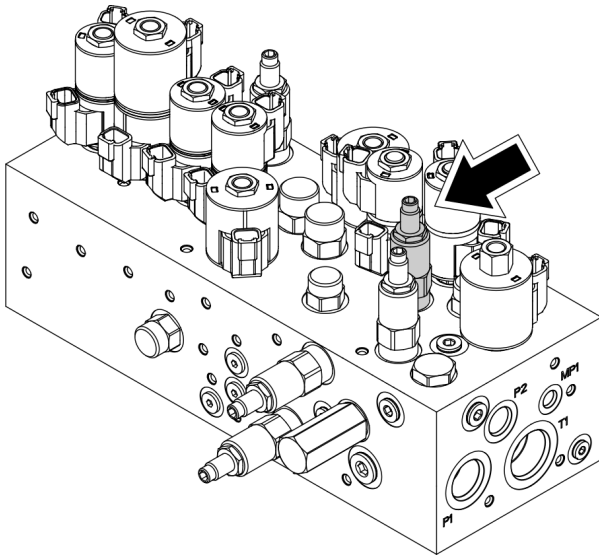

**NOTE:** Steer left pressure at port 24 is 2500 psi (173 Bar); a gauge may be placed there for troubleshooting.

3. If necessary, loosen jam nut and adjust the Steer Right Relief valve clockwise to increase and counterclockwise to decrease.

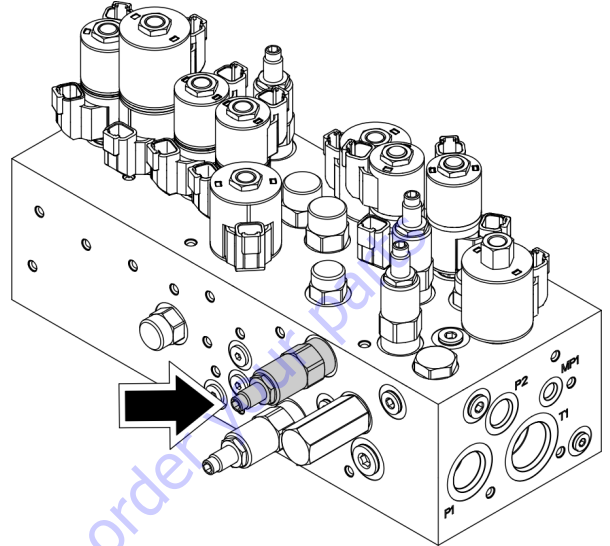

**NOTE:** Steer Right pressure at port 23 is 2500 psi (173 Bar); a gauge may be placed there for troubleshooting.

### Steer Right Relief

1. Install a pressure gauge at port MP1 of the Main Control Valve capable of reading pressures up to 4000 psi (275 Bar).

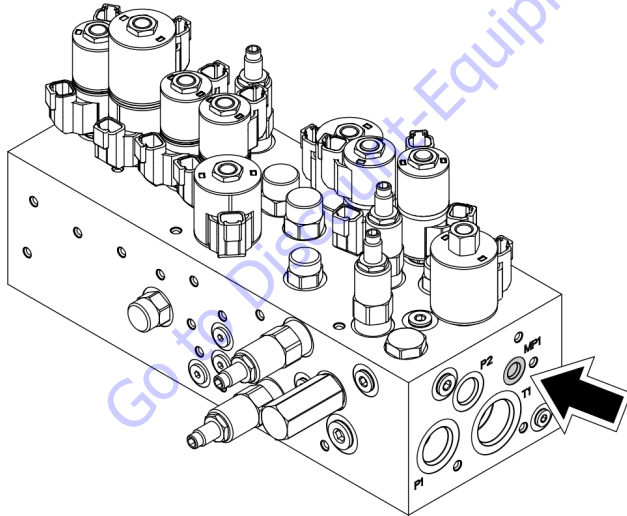

2. Activate Steer Right function continuously at end of stroke. Pressure that is observed should be  $2750 \pm 75$  psi ( $190 \pm 6$  Bar).

### Boom Swing Relief

1. Install a pressure gauge at port MP1 of the Main Control Valve capable of reading pressures up to 3000 psi (207 Bar).

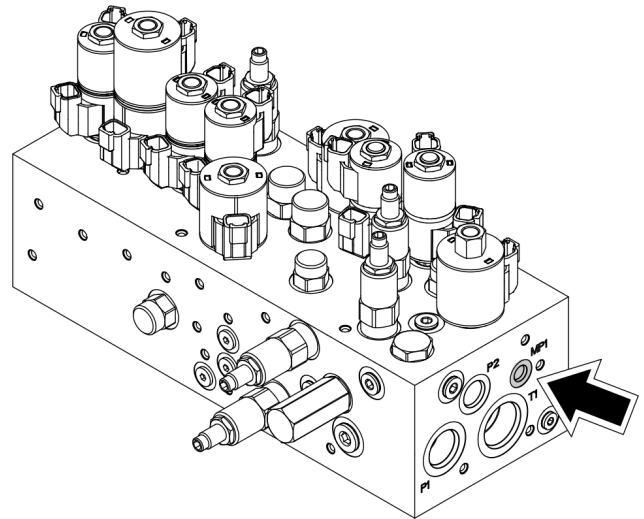

2. Activate Boom Swing Right or Left function continuously against the stop or lock. Observed pressure should be  $1700 \pm 50$  psi ( $117 \pm 4$  Bar).

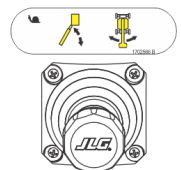

## SECTION 5 - HYDRAULICS AND HYDRAULIC SCHEMATICS

3. If necessary, loosen jam nut and adjust the Boom Swing Relief valve clockwise to increase and counterclockwise to decrease.

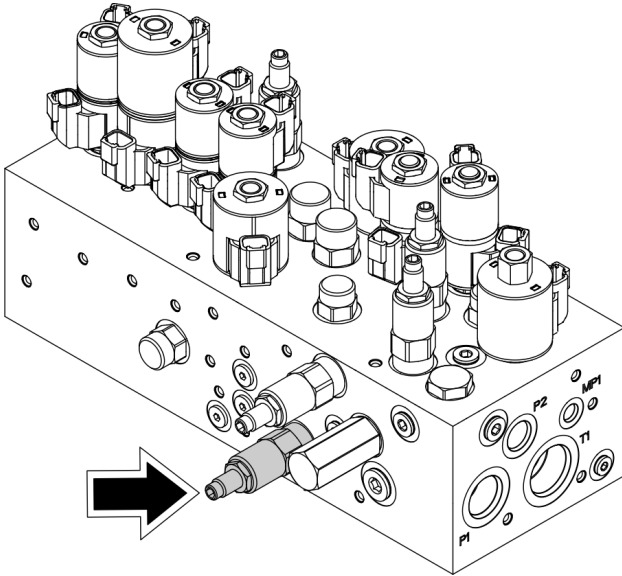

3. If necessary, loosen jam nut and adjust the Jib Lift Down Relief valve clockwise to increase and counterclockwise to decrease.

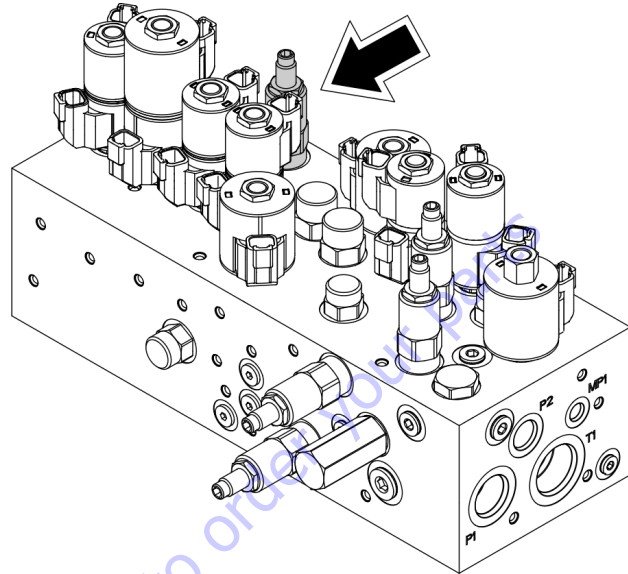

**NOTE:** Boom Swing Right pressure at port 15 and Boom Swing Left pressure at port 16 is 1600 psi (110 bar); a gauge may be placed there for troubleshooting.

### Jib Lift Down Relief (460SJC)

1. Install a pressure gauge at port M34 of the Main Control Valve capable of reading pressures up to 3000 psi (207 Bar)

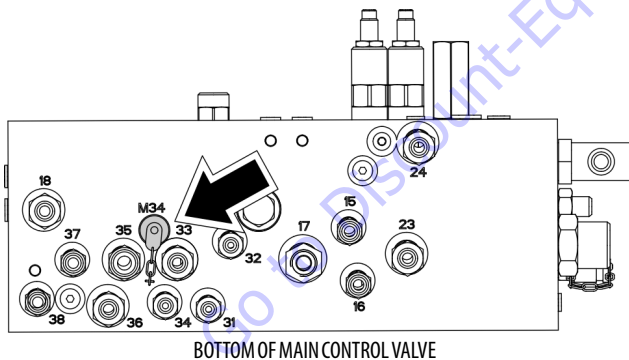

2. Activate Jib Lift Down function continuously at end of stroke. Observed pressure should be  $1200 \pm 50$  psi ( $83 \pm 4$  Bar).

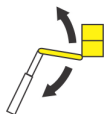

### Platform Level Up Relief

The Platform Level Up relief is pre-set and does not normally need to be checked or adjusted. If necessary, the following procedure may be utilized for trouble shooting purposes:

1. Lift the main boom up enough to allow the platform to be fully leveled up.
2. Activate Level Up to end of stroke.

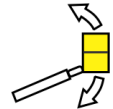

3. Remove hose from Level Up port on main control valve (Port 37) - "T" a pressure gauge capable of reading pressures up to 4000 psi (275 bar) to this port. Reconnect hose.

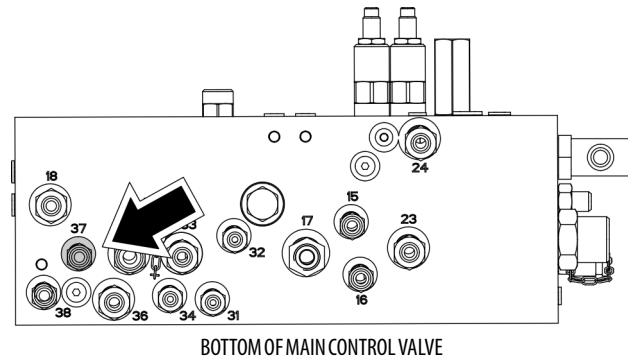



4. Activate Main Boom Lift Down function using Auxiliary Mode continuously until fully lowered. Observed pressure should be  $220 \pm 6$  bar ( $3200 \pm 80$  psi).
5. If necessary, loosen jam nut and adjust Platform Level Up Relief valve clockwise to decrease and counterclockwise to increase.

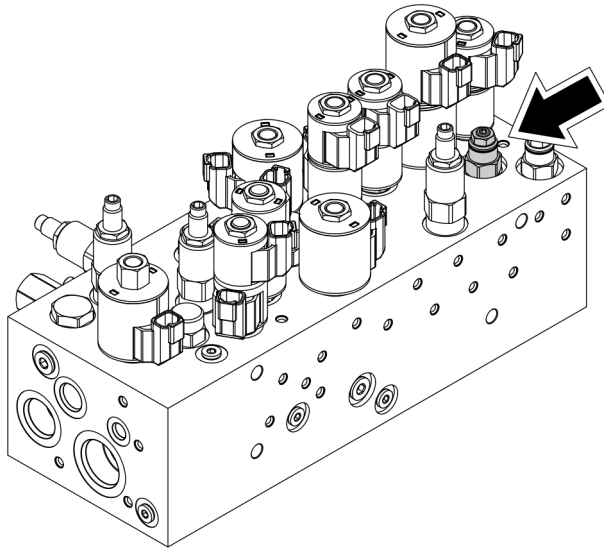

3. Remove the hose from the Level Down port on the main control valve (Port 38) - "T" a pressure gauge capable of reading pressures up to 207 bar (3000 psi) to this port. Reconnect hose.

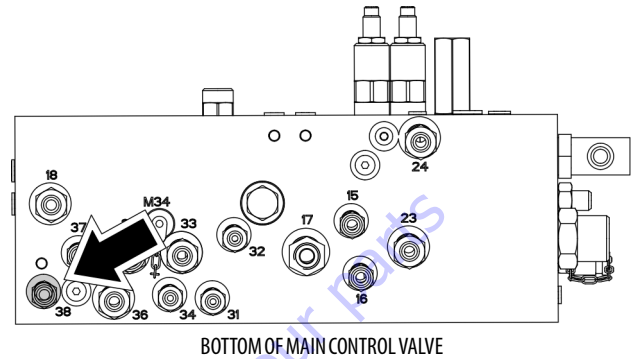

6. Remove the "T" and gauge. Reinstall hose.

### Platform Level Down Relief

The Platform Level Down relief is pre-set and does not normally need checked or adjusted. If necessary, use the following procedure for trouble shooting:

1. Lift main boom up enough to allow platform to be fully leveled down.
2. Activate Level Down to end of stroke.

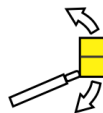

4. Activate Platform Level Down function continuously at end of stroke. Observed pressure should be  $138 \pm 4$  bar ( $2000 \pm 50$  psi).
5. If necessary, loosen jam nut and adjust Platform Level Down Relief valve clockwise to decrease and counterclockwise to increase.

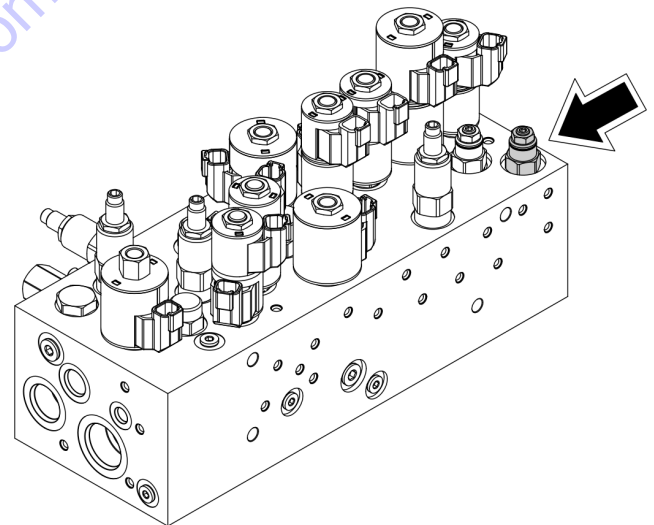
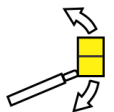

6. Remove the "T" and gauge. Reinstall hose.

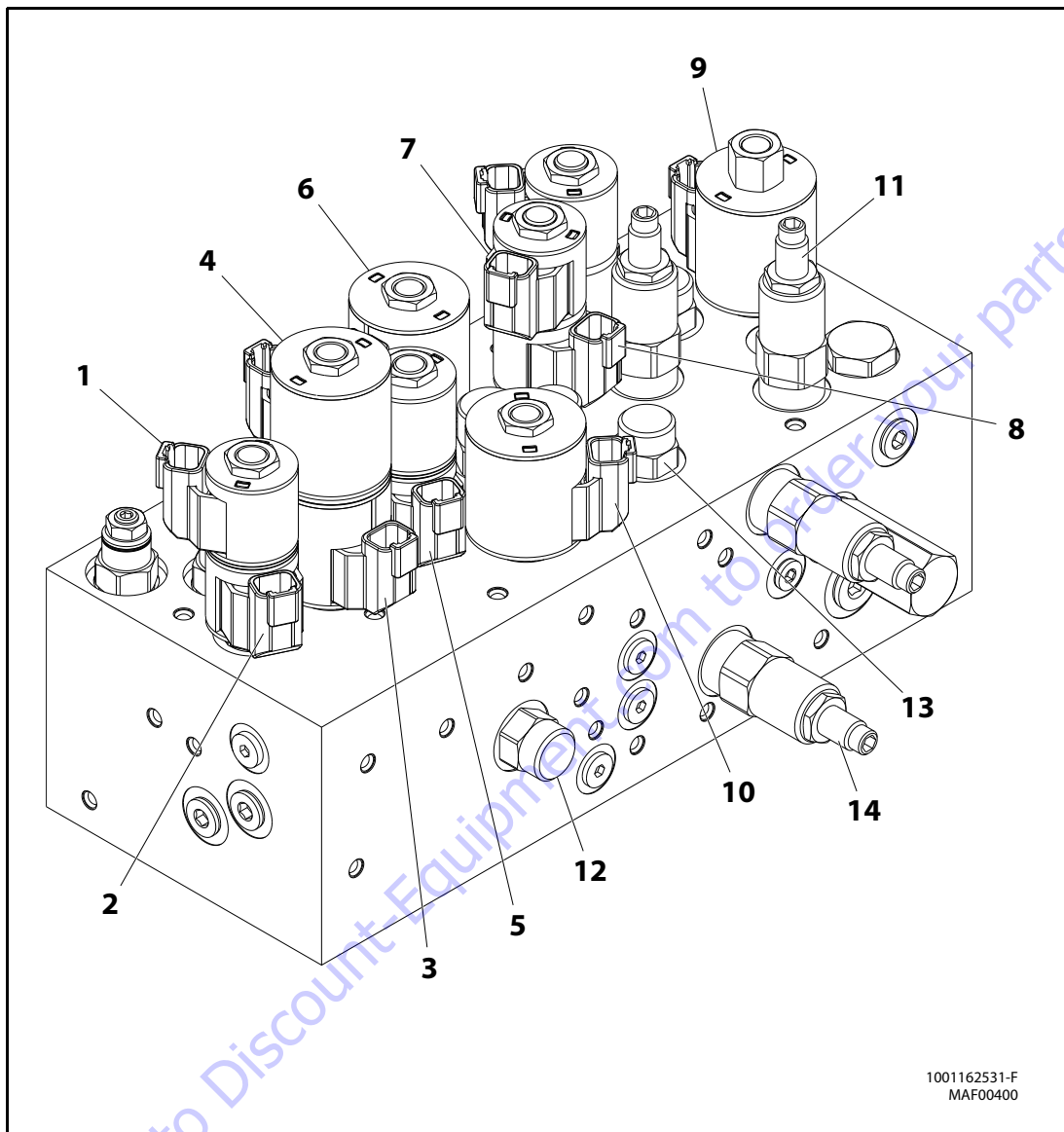

- |                 |                  |                          |
|-----------------|------------------|--------------------------|
| 1. Level Up     | 6. Main Lift Up  | 11. Main System Relief   |
| 2. Level Down   | 7. Swing Right   | 12. Flow Regulator       |
| 3. Tele In      | 8. Swing Left    | 13. Pressure Compensator |
| 4. Tele Out     | 9. Main Dump     | 14. Swing Relief         |
| 5. Rotate Right | 10. Flow Control |                          |

Figure 5-85. Main Control Valve Identification (400SC) - Sheet 1 of 2

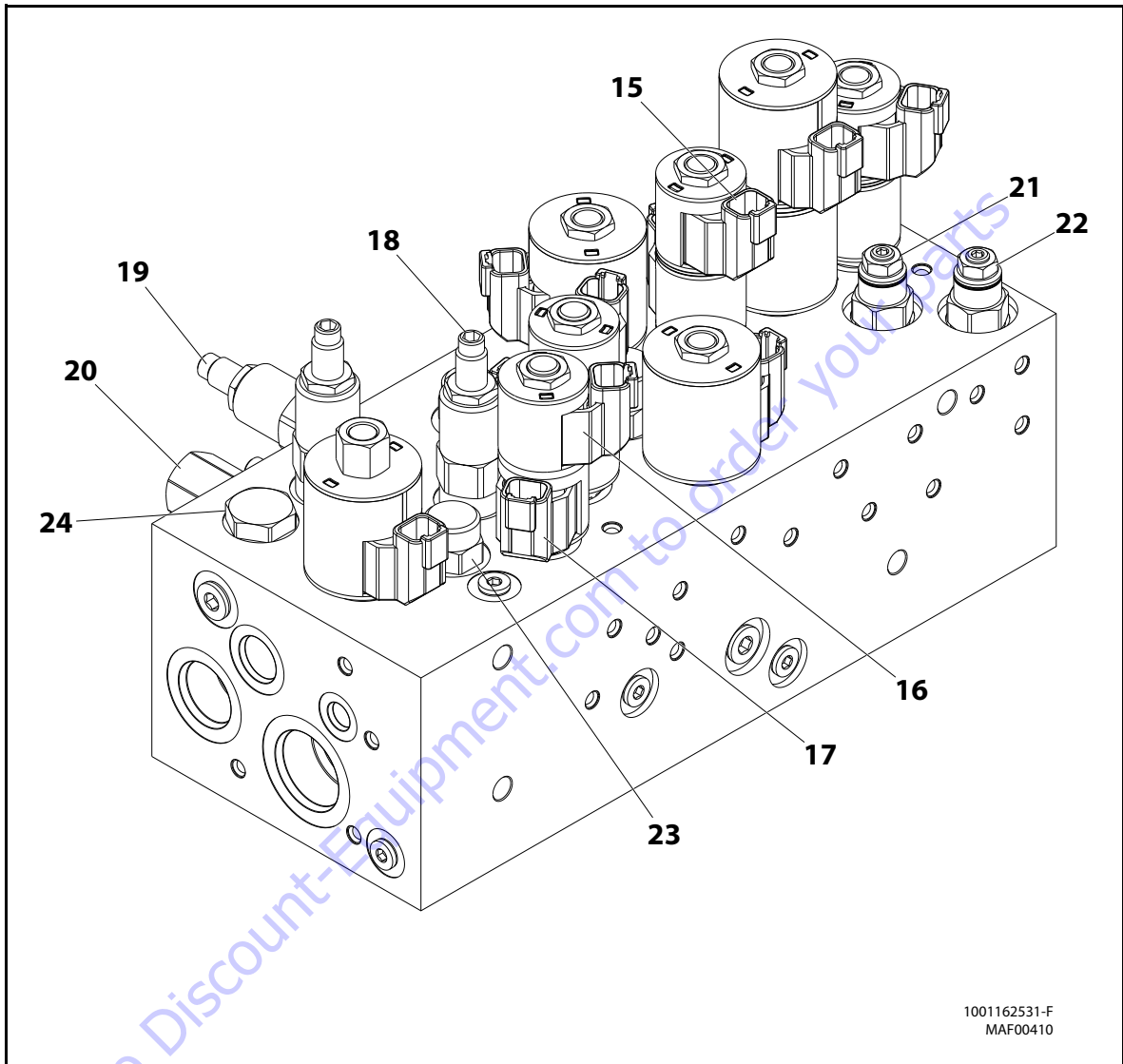

1001162531-F  
MAF00410

- |                       |                        |                    |
|-----------------------|------------------------|--------------------|
| 15. Rotate Left       | 19. Steer Right Relief | 23. Flow Regulator |
| 16. Steer Left        | 20. Flow Regulator     | 24. Check Valve    |
| 17. Steer Right       | 21. Level Up Relief    |                    |
| 18. Steer Left Relief | 22. Level Down Relief  |                    |

**Figure 5-86. Main Control Valve Identification (400SC) - Sheet 2 of 2**

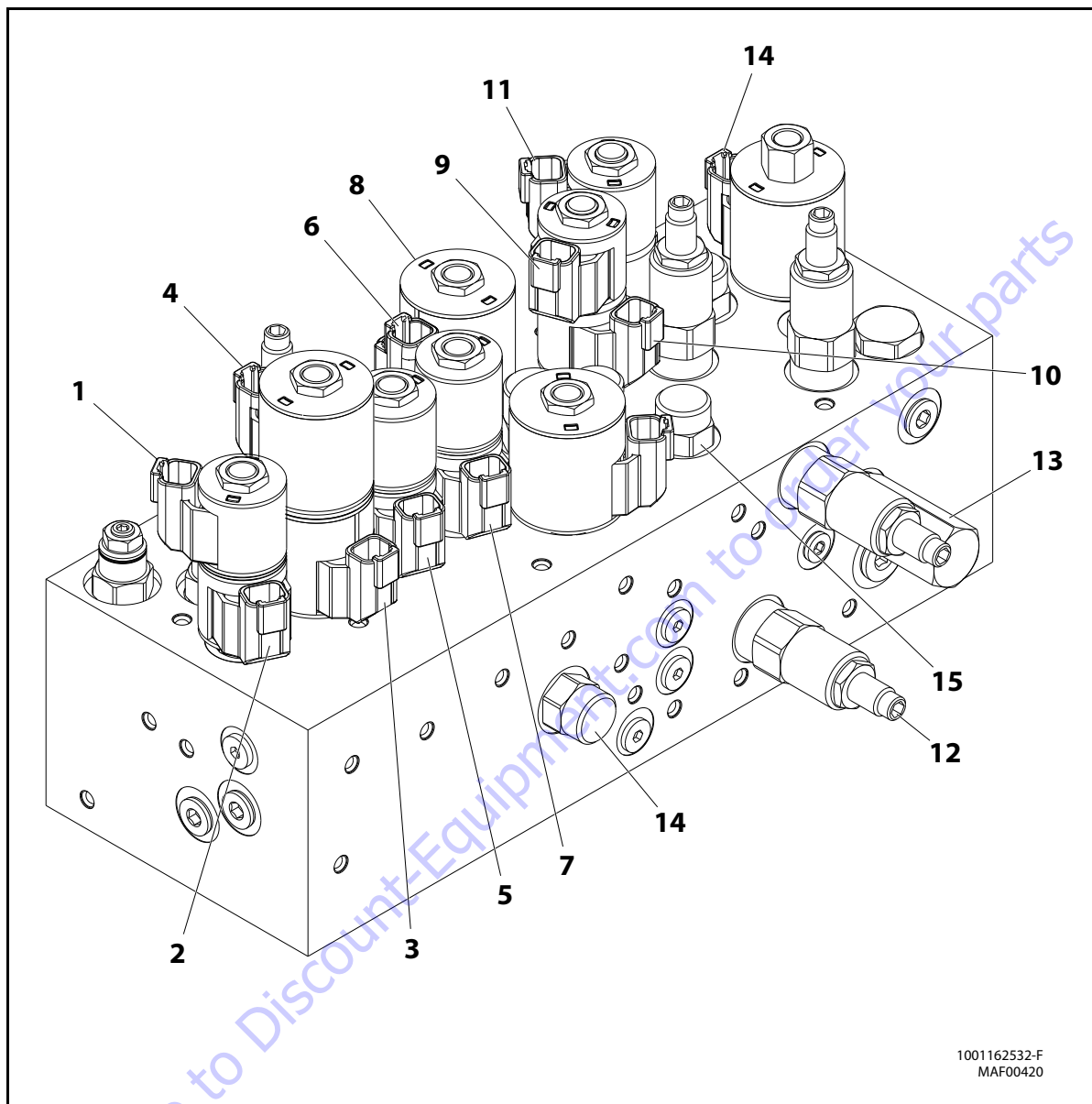

- |               |                 |                  |                          |
|---------------|-----------------|------------------|--------------------------|
| 1. Level Up   | 5. Jib Down     | 9. Swing Right   | 13. Flow Regulator       |
| 2. Level Down | 6. Rotate Left  | 10. Swing Left   | 14. Flow Regulator       |
| 3. Tele In    | 7. Rotate Right | 11. Steer Left   | 15. Pressure Compensator |
| 4. Tele Out   | 8. Main Lift Up | 12. Swing Relief |                          |

Figure 5-87. Main Control Valve Identification - 460SJC - Sheet 1 of 2

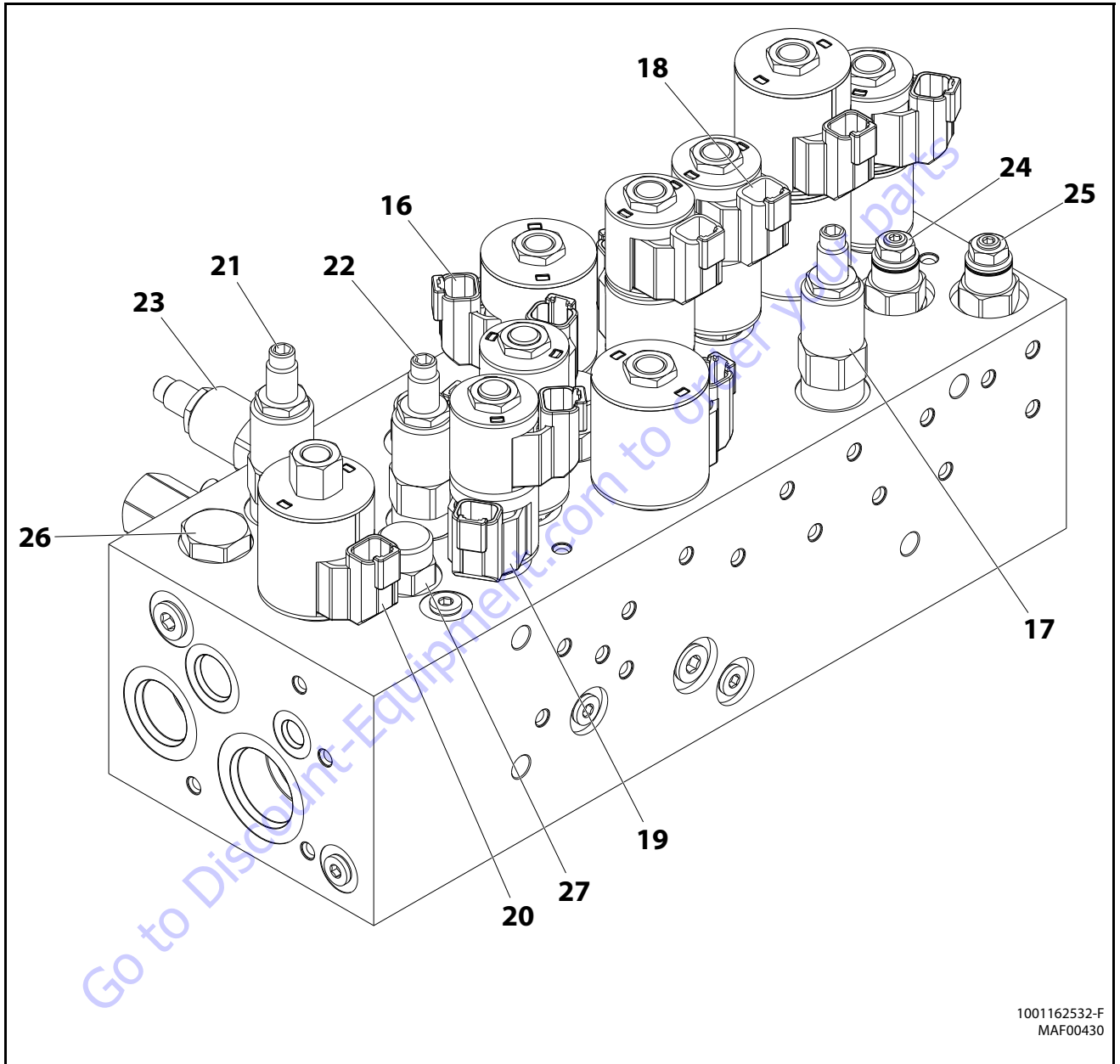

1001162532-F  
MAF00430

- |                     |                        |                       |
|---------------------|------------------------|-----------------------|
| 16. Flow Control    | 20. Main Dump          | 24. Level Up Relief   |
| 17. Jib Lift Relief | 21. Steer Relief       | 25. Level Down Relief |
| 18. Jib Up          | 22. Swing Left Relief  | 26. Check Valve       |
| 19. Steer Relief    | 23. Swing Right Relief | 27. Flow Regulator    |

Figure 5-88. Main Control Valve Identification - 460SJC - Sheet 2 of 2

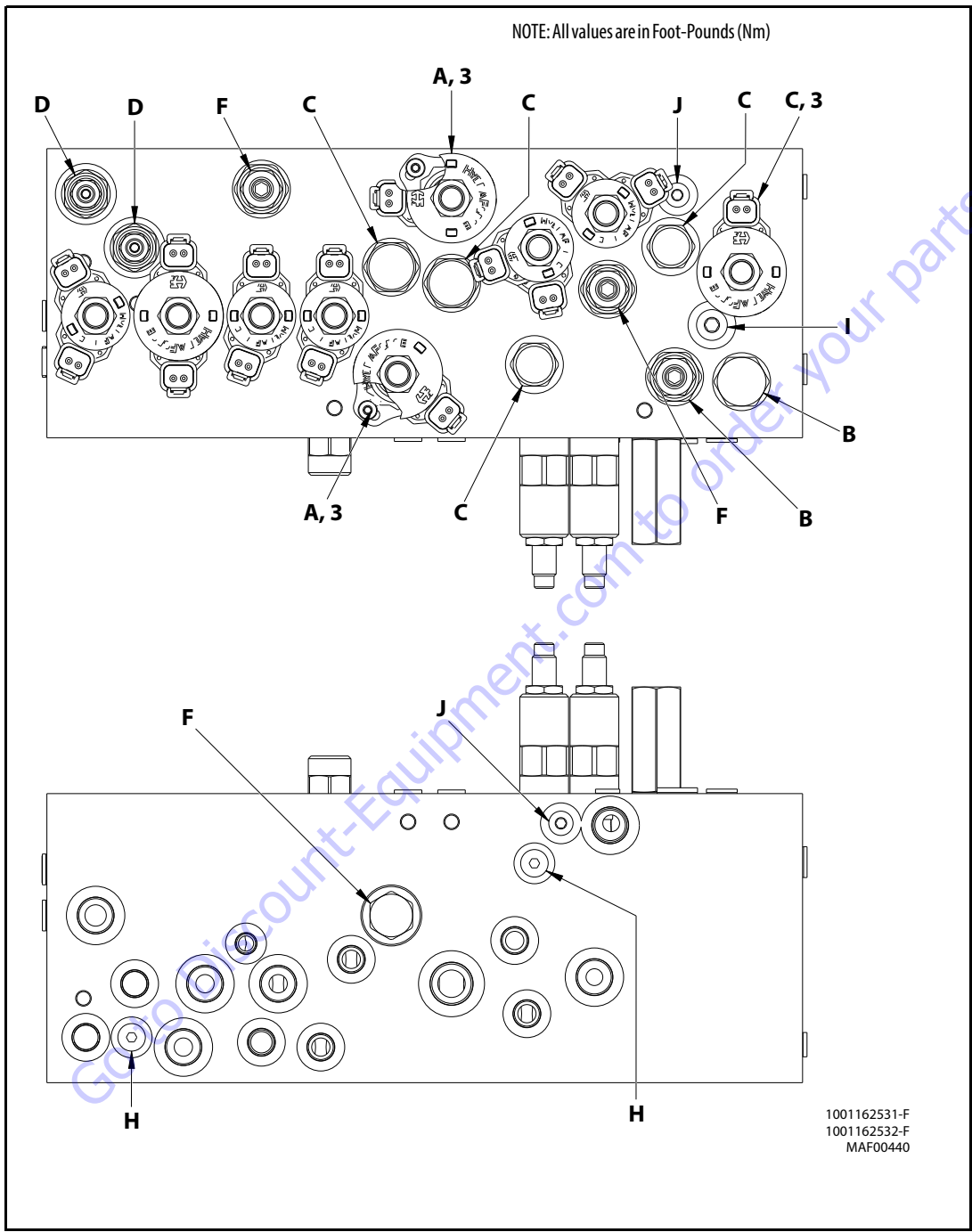

Figure 5-89. Main Control Valve Torque Values - Sheet 1 of 2

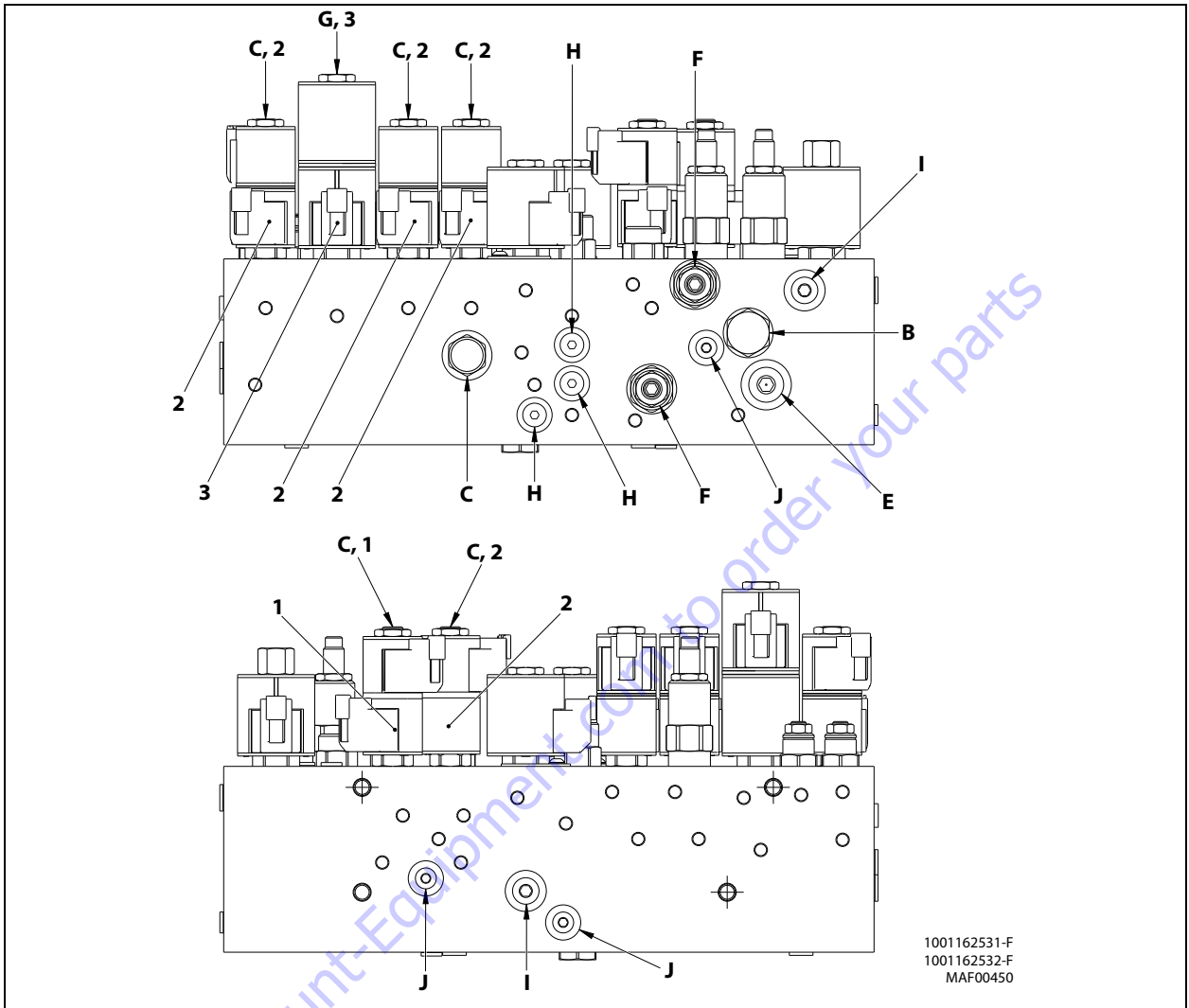

Table 5-36. Cartridge Torque Values

	Ft. lbs.	Nm
A	48	65
B	43	58
C	38	51
D	35	47
E	30	41
F	28	38
G	25	34
H	13	18
I	12	16
J	8	11

Table 5-37. Coil Torque Values

	Ft. lbs.	Nm
1	4.5	6
2	4.5	6
3	6	8

Table 5-38. Coil Resistance Values

	Temperature	Resistance
1	20°C	6.2
2	20°C	8.8
3	20°C	7.1

Figure 5-90. Main Control Valve Torque Values - Sheet 2 of 2

### 5.7 DRIVE PUMP PRE-FILL PROCEDURE

#### **NOTICE**

**HYDRAULIC DRIVE PUMP CASE MUST BE PRE-FILLED BEFORE STARTING ENGINE. FAILURE TO DO SO CAN CAUSE PUMP FAILURE.**

1. Fill hydraulic reservoir.
2. Determine if hydraulic oil tank sight level gauge is higher than other hydraulic components.
  - a. Determine if hydraulic oil tank sight level gauge is higher than hydraulic drive pump assembly.
  - b. Determine if hydraulic oil tank sight level gauge is higher than all hydraulic hose loops or routings between hydraulic tank and drive pump assembly.
  - c. If sight level gauge is the highest hydraulic oil level point, go to step 3.
  - d. If sight level gauge is NOT the highest hydraulic oil level point, low pressure air may need to be applied to the hydraulic oil tank (fill cap via air regulator) in conjunction with step 4 to get hydraulic oil to move over air locks created by these high spots.
3. If machine is equipped with a hydraulic oil cooler option:
  - a. Determine if there is a hydraulic 'tee' fitting installed at the hydraulic drive pump that has a 'cap' fitting attached to it. (this will generally be at or near the top of the hydraulic drive pump body). This 'cap' fitting is used to manually fill the hydraulic drive pump case.
  - b. Remove 'cap' fitting.
  - c. Fill hydraulic drive pump case with hydraulic oil.
  - d. Reattach and torque 'cap' fitting.
  - e. Prefilling hydraulic drive pump w/oil cooler option is complete (Step #4 can be omitted at this point.)
4. If machine is NOT equipped with a hydraulic oil cooler option,
  - a. Locate a case access port on the hydraulic drive pump - preferably one located at or near the top or upper sides of the pump.
  - b. Using the proper wrench, remove O-ring plug to allow air to escape from the hydraulic drive pump case.
  - c. Hydraulic oil will flow by gravity from hydraulic tank to the drive pump.
  - d. When hydraulic oil starts to flow out this port, pump is full.
  - e. Re-install O-ring plug and torque.
5. Pre-filling hydraulic drive pump is complete.



5.8 HYDRAULIC SCHEMATIC

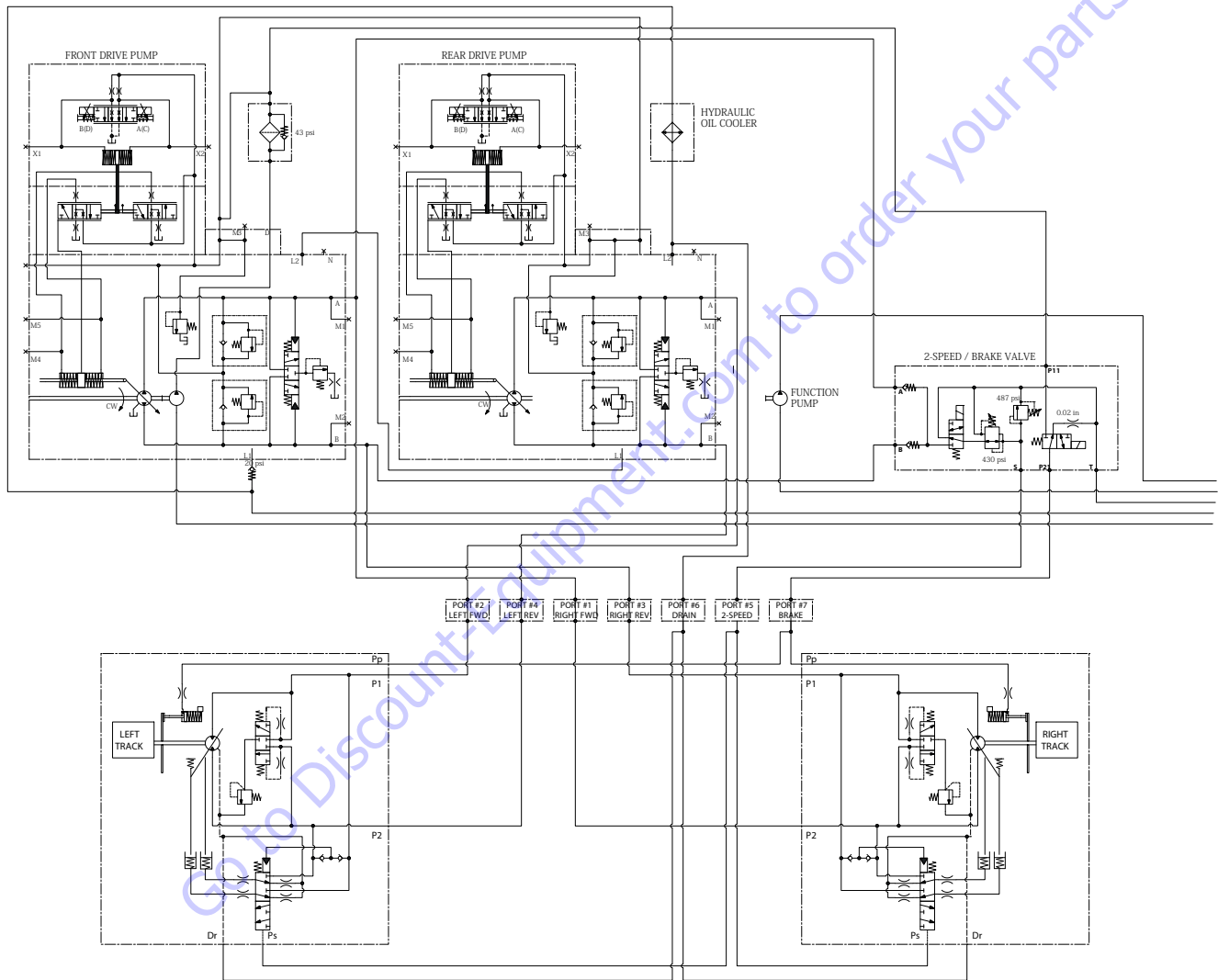

1001178276C

Figure 5-91. Hydraulic Schematic (400SC) - Sheet 1 of 2

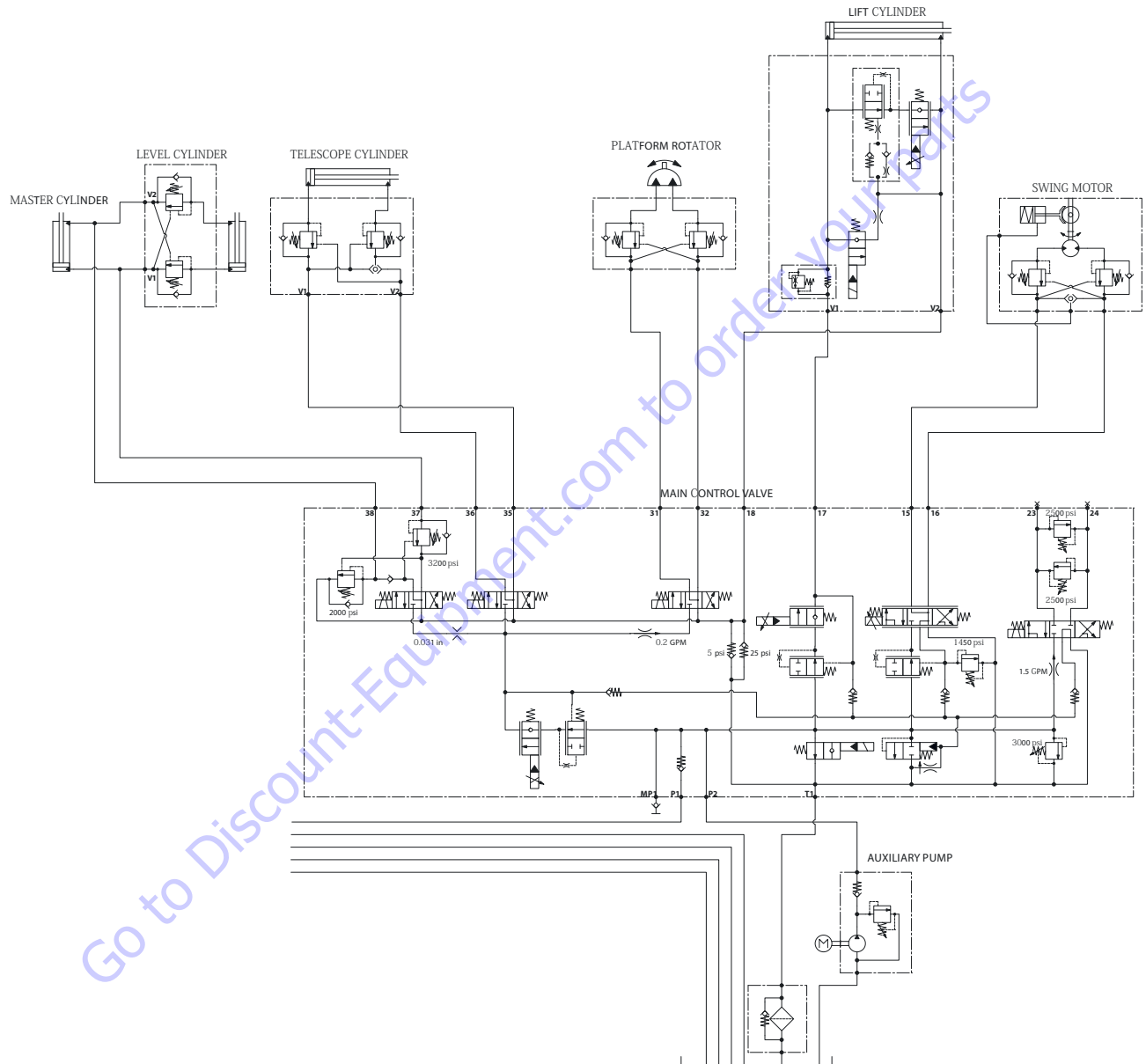

1001178276C

Figure 5-92. Hydraulic Schematic (400SC) - Sheet 2 of 2

**SECTION 5 - HYDRAULICS AND HYDRAULIC SCHEMATICS**

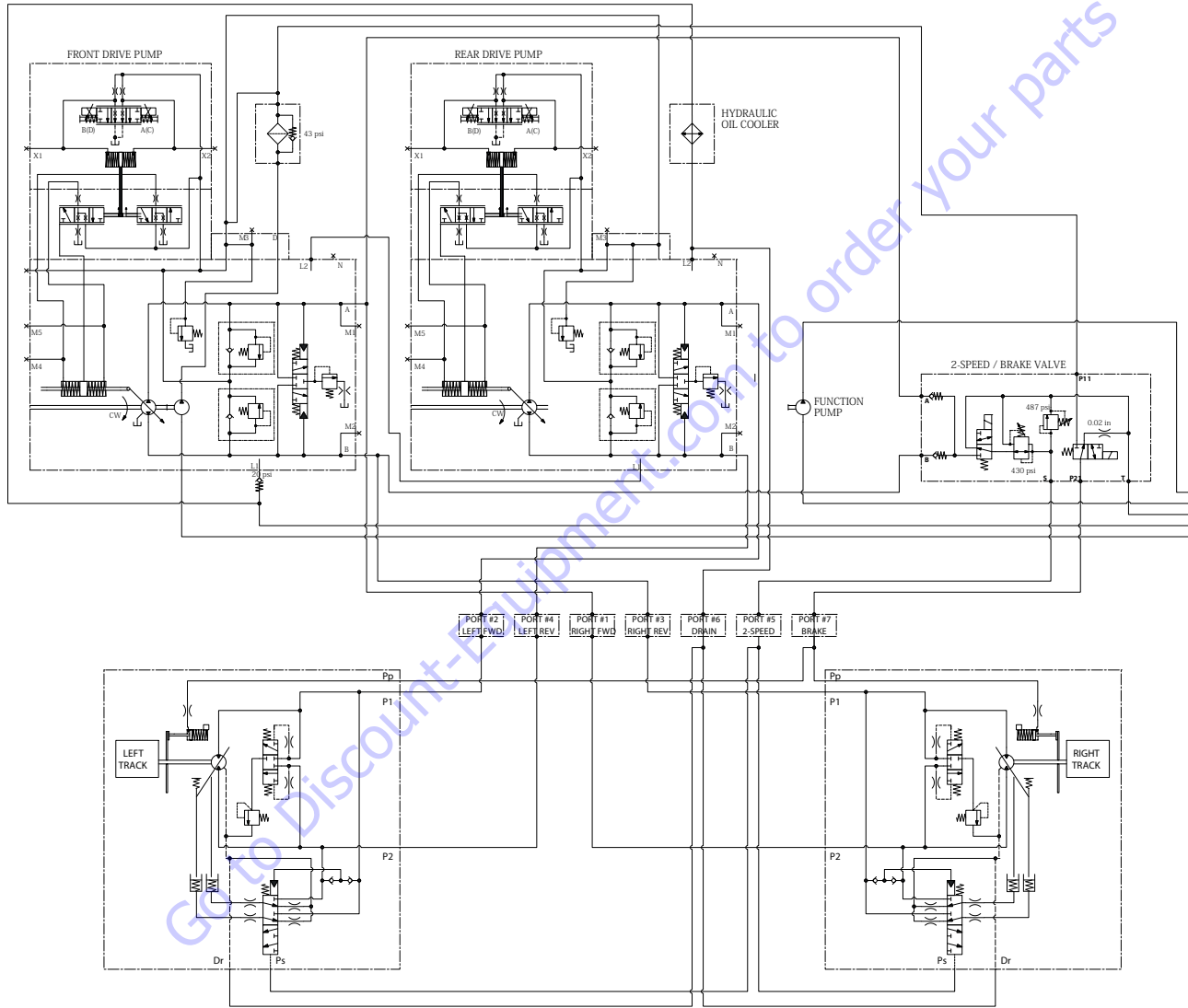

1001178276C

**Figure 5-93. Hydraulic Schematic (460SJC) - Sheet 1 of 2**

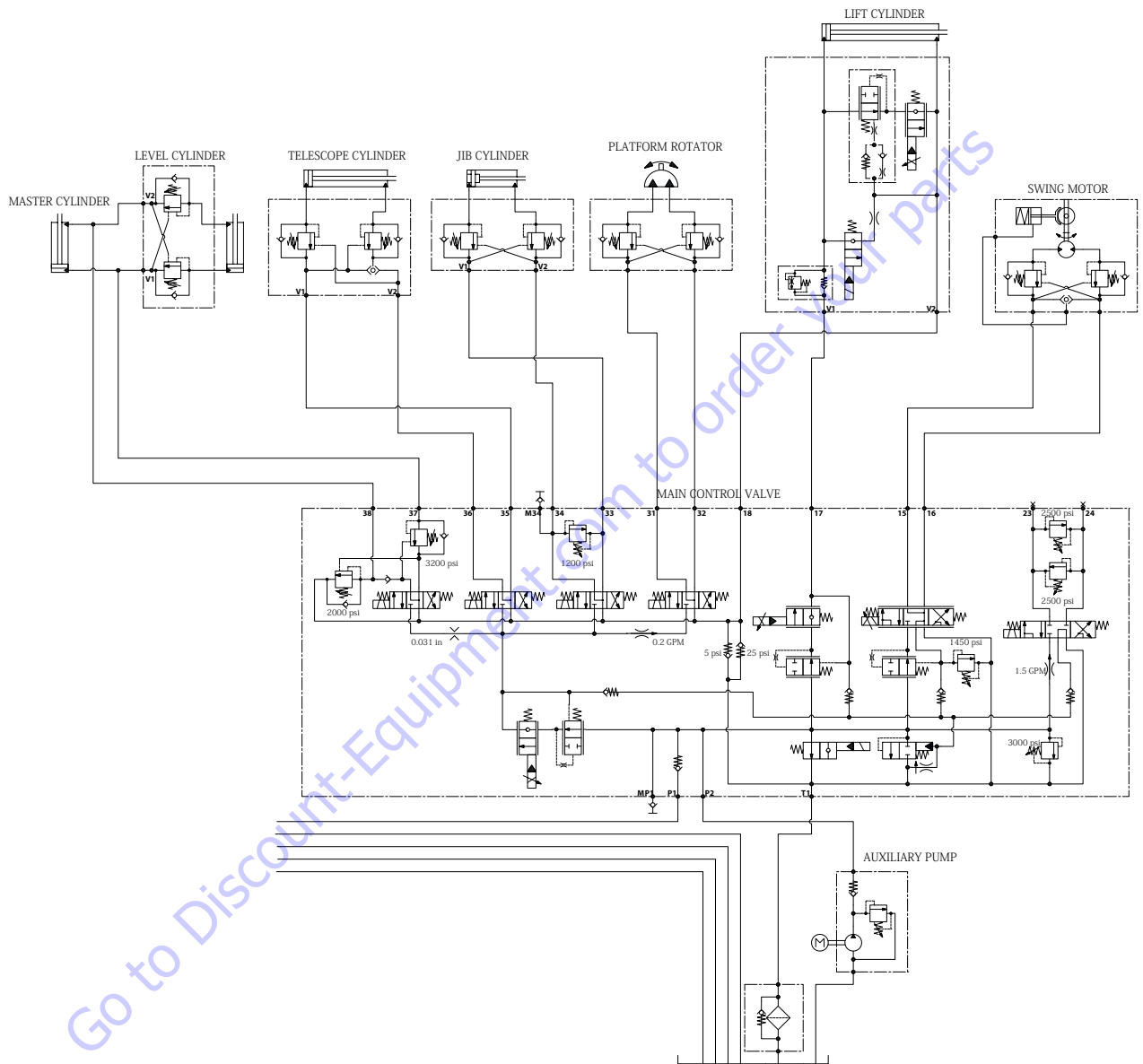

1001178276C

Figure 5-94. Hydraulic Schematic (460SJC) - Sheet 2 of 2

# PARTS FINDER

**Search Website  
by Part Number**



**Search Manual  
Library For Parts  
Manual & Lookup Part  
Numbers – Purchase  
or Request Quote**

A screenshot of the "Search Manuals" form. It includes fields for "Brand", "Serial Number", "Model", "Part Number", "Part Name", and "Quantity". There is a "Search" button at the bottom.

**Can't Find Part or  
Manual? Request Help  
by Manufacturer,  
Model & Description**

A screenshot of the "Parts Order Form". It is a structured form with multiple rows and columns for entering part details. The title "Parts Order Form" is at the top right.

Discount-Equipment.com is your online resource for quality parts & equipment.

Florida: **561-964-4949** Outside Florida TOLL FREE: **877-690-3101**

**Need parts?**

Click on this link: <http://www.discount-equipment.com/category/5443-parts/> and choose one of the options to help get the right parts and equipment you are looking for. Please have the machine model and serial number available in order to help us get you the correct parts. If you don't find the part on the website or on one of the online manuals, please fill out the request form and one of our experienced staff members will get back to you with a quote for the right part that your machine needs.

We sell worldwide for the brands: Genie, Terex, JLG, MultiQuip, Mikasa, Essick, Whiteman, Mayco, Toro Stone, Diamond Products, Generac Magnum, Airman, Haulotte, Barreto, Power Blanket, Nifty Lift, Atlas Copco, Chicago Pneumatic, Allmand, Miller Curber, Skyjack, Lull, Skytrak, Tsurumi, Husquvarna Target, , Stow, Wacker, Sakai, Mi-T- M, Sullair, Basic, Dynapac, MBW, Weber, Bartell, Bennar Newman, Haulotte, Ditch Runner, Menegotti, Morrison, Contec, Buddy, Crown, Edco, Wyco, Bomag, Laymor, Barreto, EZ Trench, Bil-Jax, F.S. Curtis, Gehl Pavers, Heli, Honda, ICS/PowerGrit, IHI, Partner, Imer, Clipper, MMD, Koshin, Rice, CH&E, General Equipment, ,AMida, Coleman, NAC, Gradall, Square Shooter, Kent, Stanley, Tamco, Toku, Hatz, Kohler, Robin, Wisconsin, Northrock, Oztec, Toker TK, Rol-Air, Small Line, Wanco, Yanmar

## SECTION 6. JLG CONTROL SYSTEM

6.1 JLG CONTROL SYSTEM ANALYZER KIT  
INSTRUCTIONS

## Introduction

**NOTICE**

WHEN INSTALLING A NEW POWER MODULE CONTROLLER ON THE MACHINE, THE CONTROLLER MUST BE PROGRAMMED FOR PROPER MACHINE CONFIGURATION, INCLUDING OPTIONS.

**NOTICE**

AVOID PRESSURE-WASHING ELECTRICAL/ELECTRONIC COMPONENTS. IF PRESSURE-WASHING IS USED TO WASH AREAS CONTAINING ELECTRICAL/ELECTRONIC COMPONENTS, JLG INDUSTRIES, INC. RECOMMENDS A MAXIMUM PRESSURE OF 52 BAR (750 PSI) AT A MINIMUM DISTANCE OF 30.5 CM (12 IN) AWAY FROM THESE COMPONENTS. IF ELECTRICAL/ELECTRONIC COMPONENTS ARE SPRAYED, SPRAYING MUST NOT BE DIRECT AND FOR BRIEF TIME PERIODS TO AVOID HEAVY SATURATION.

The JLG designed Control System is a 12 volt based control unit installed on the boom lift.

The JLG Control System has reduced the need for exposed terminal strips, diodes and trimpots and provides simplicity in

viewing and adjusting the various personality settings for smooth control of: acceleration, deceleration, creep, min speed, and max.-speed for all boom, drive, and steering functions.

The main lift, swing, and drive are controlled by individual joysticks, with steering being controlled by a rocker switch built into the top the drive joystick. To activate Drive, Lift, and Swing simply pull up on the slide lock location on the joystick and move the handle into the direction desired.

The control system will control the voltage output to the valves and pump, as programmed for smooth operation and maximum cycle time. Ground control speeds for all boom functions can also be programmed into the control system.

The JLG Control System controller has a built in LED to indicate any faults. The system stores recent faults which may be accessed for troubleshooting. Optional equipment includes a soft touch system, head and tail lights, and ground alarm. These options may be added later but must be programmed into the control system when installed.

The Control System may be accessed utilizing a custom designed, hand held analyzer (Analyzer Kit, JLG part no. 2901443) which will display two lines of information at a time, by scrolling through the program.

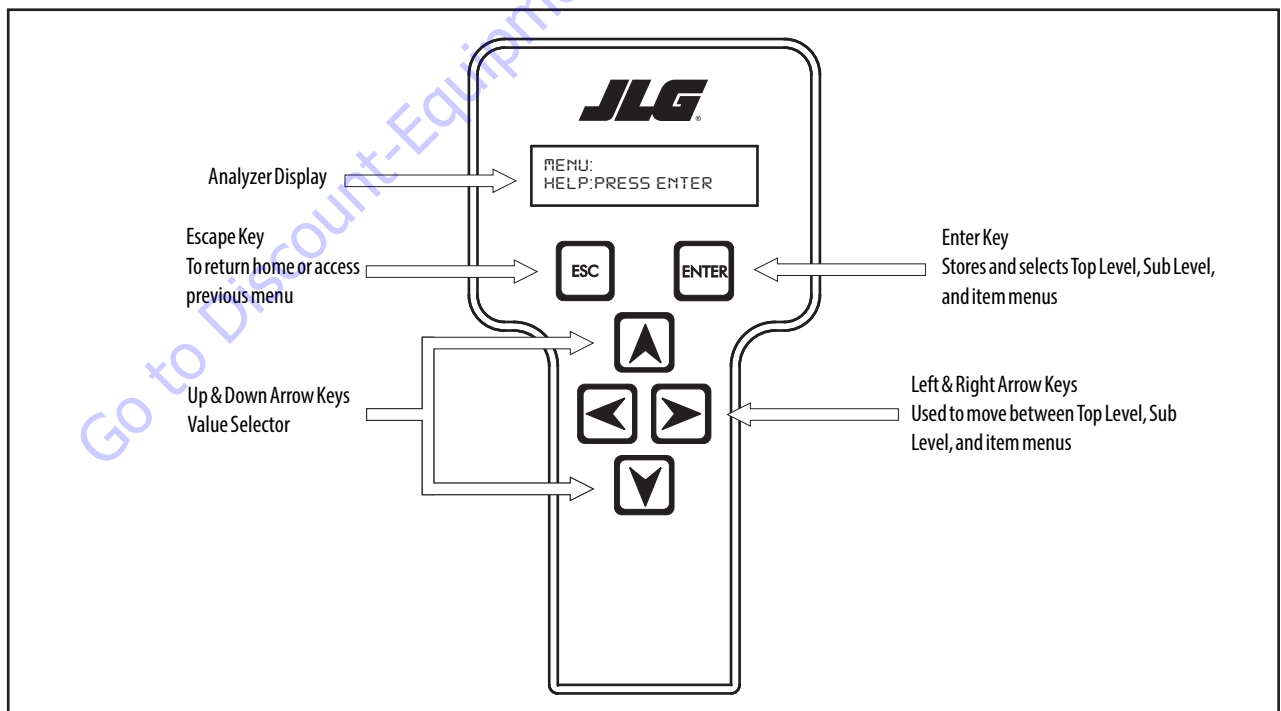

Figure 6-1. Hand Held Analyzer

### To Connect the JLG Control System Analyzer

1. Connect four pin end of cable supplied with analyzer, to the motor controller module located in the platform box or at the power module. connect remaining end of cable to the analyzer.

**NOTE:** The cable has a four pin connector at each end of the cable. the cable cannot be connected backwards.

2. Power up the Control System by turning the lower key to platform or ground position and pulling both emergency stop buttons out.

### Using the Analyzer

With machine power on and analyzer connected properly, the analyzer will display the following:

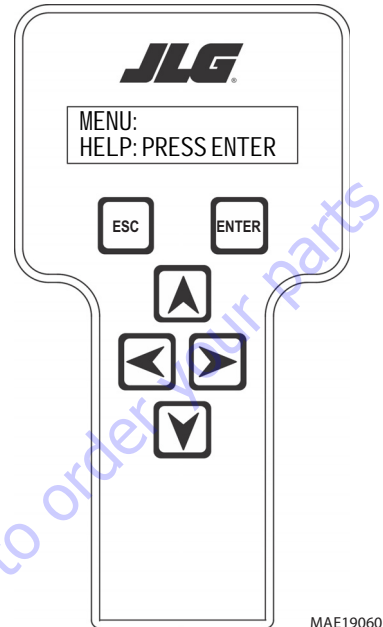

**HELP:  
PRESS ENTER**

At this point, using the RIGHT  and LEFT  arrow keys, you can move between the top level menu items. To

select a displayed menu item, press ENTER . To cancel a

selected menu item, press Escape ; then you will be able to scroll using the right and left arrow keys to select a different menu item.

The top level menus are as follows:

- HELP
- DIAGNOSTICS
- ACTIVATE TEST
- ACCESS LEVEL
- PERSONALITIES
- MACHINE SETUP
- CALIBRATIONS (SERVICE ACCESS ONLY)

If you press **ENTER**  at the **HELP: PRESS ENTER** display, and a fault is present, the analyzer display will scroll the fault across the screen. If there was no fault detected, the display will read: **HELP: EVERYTHING OK**. If powered up at the ground station, the display will read: **GROUND OK**.

If **ENTER**  is pressed again, the display moves to the following display:

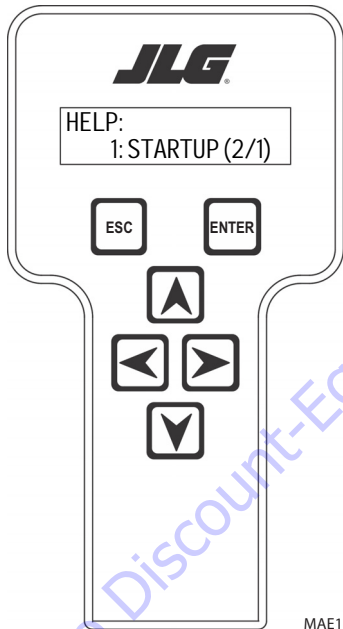

MAE19060

**LOGGED HELP**  
**1: STARTUP (2/1)**

At this point, the analyzer will display the last fault the system has seen, if any are present. You may scroll through the fault logs to view what the last 25 faults were. Use the right and left arrow keys to scroll through the fault logs. To return to the

beginning, press **ESCAPE**  two times. **STARTUP (2/1)** indicates a power up.

When a top level menu is selected, a new set of menu items may be offered: for example:

- DRIVE
- BOOM
- SYSTEM
- DATALOG
- VERSIONS

Pressing **ENTER**  with any of the above displayed menus, will display additional sub-menus within the selected menu. In some cases, such as **DRIVE**, the next level is the parameter or information to be changed. Refer to the flow chart for what menus are available within the top level menus. You may only view personality settings for selected menus while in access level 2. Remember, you may always cancel a selected menu

item by pressing the **ESCAPE**  key.

**Changing the Access Level of the Hand Held Analyzer**

When the analyzer is first connected, you will be in Operator Access which enables you to only view most settings which cannot be changed until you enter a password to advance to a lower level. This ensures a setting cannot be accidentally altered. To change the access level, the correct password must be entered. To enter password, scroll to the **ACCESS LEVEL** menu. For example:

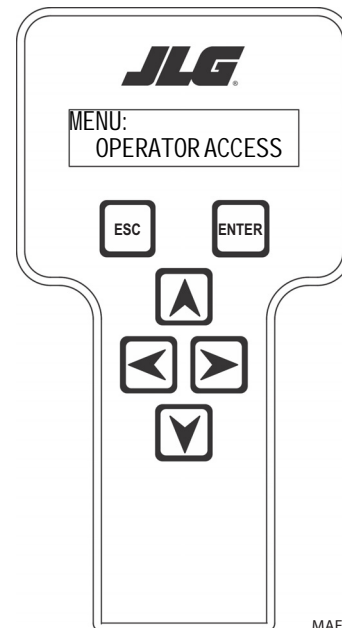

MAE19060



**ACCESS LEVEL:**  
**CODE 00000**



Press **ENTER**  to select the **ACCESS LEVEL** menu.

Using the **UP**  or **DOWN**  arrow keys, enter first digit of the password, 3.

Then using the **RIGHT**  arrow key, position the cursor to the right one space to enter the second digit of the password.

Use the **UP**  or **DOWN**  arrow key to enter the second digit of the password which is 33271.

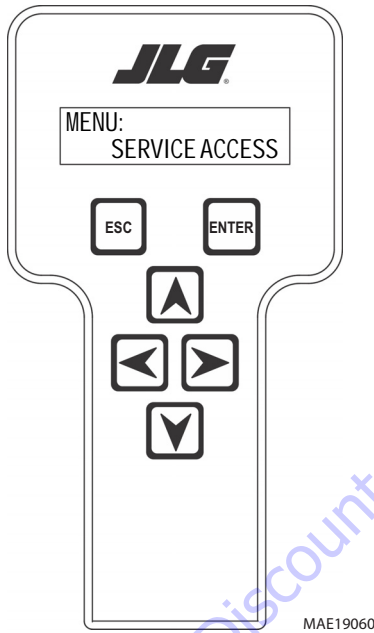

Once the correct password is displayed, press **ENTER** . The access level should display the following, if password was correctly entered:



**MENU:  
SERVICE ACCESS**

Repeat above steps if correct access level is not displayed or you can not adjust personality settings.

### Adjusting Parameters Using Hand Held Analyzer

Once you have gained access to level 1, and a personality item is selected, press the **UP**  or **DOWN**  arrow keys to adjust its value, for example:

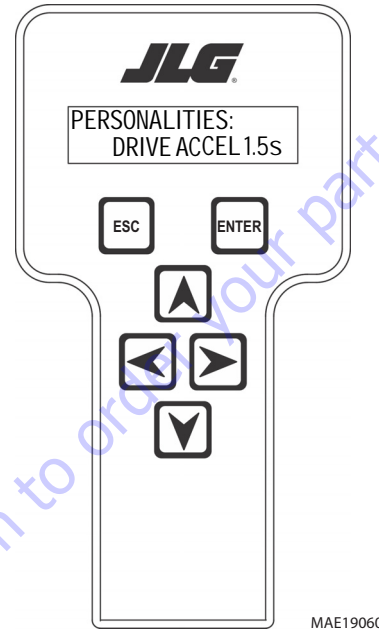



**DRIVE:  
ACCEL 1.5s**

There will be a minimum and maximum for the value to ensure efficient operation. The Value will not increase if the **UP**

 arrow is pressed when at the maximum value nor will

the value decrease if the **DOWN**  arrow is pressed and the value is at the minimum value for any particular personality. If value does not change when pressing up and down arrows, check access level to ensure you are at access level 1.

## Machine Setup

When a machine digit item is selected, press **UP**  or **DOWN**  arrow keys to adjust its value, for example:

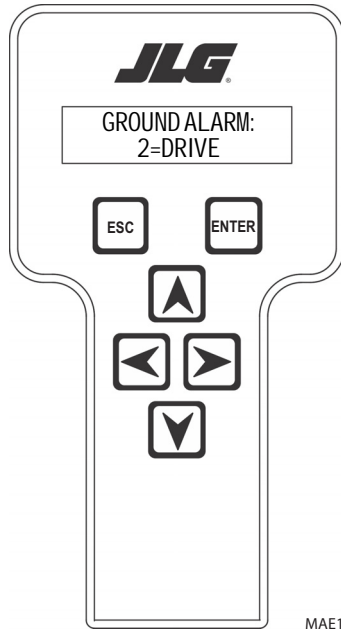

### GROUND ALARM: 2 = DRIVE

The effect of the machine digit value is displayed along with its value. The above display would be selected if the machine was equipped with a ground alarm and you wanted it to sound when driving. There are certain settings allowed to install optional features or select the machine model.

When selecting machine model to match size of the machine, personality settings will default to factory recommended settings.

**NOTE:** Refer to *Personality Ranges/Defaults* for recommended factory settings.

**NOTE:** Password 33271 will give you access to level 1, which will permit you to change all machine personality settings.

There is a setting that JLG strongly recommends that you do not change. This setting is so noted below:

### ELEVATION CUTBACK

#### **WARNING**

CHANGING THIS SETTING MAY ADVERSELY AFFECT MACHINE PERFORMANCE.

#### **NOTICE**

AVOID PRESSURE-WASHING ELECTRICAL/ELECTRONIC COMPONENTS. IF PRESSURE-WASHING IS USED TO WASH AREAS CONTAINING ELECTRICAL/ELECTRONIC COMPONENTS, JLG INDUSTRIES INC. RECOMMENDS A MAXIMUM PRESSURE OF 52 BAR (750 PSI) AT A MINIMUM DISTANCE OF 30.5CM (12 IN) AWAY FROM THESE COMPONENTS. IF ELECTRICAL/ELECTRONIC COMPONENTS ARE SPRAYED, SPRAYING MUST NOT BE DIRECT AND BE FOR BRIEF TIME PERIODS TO AVOID HEAVY SATURATION.

## Ground Control Console Display Gauge

(See Figure 6-5., Ground Control Console Display Gauge)

The Display Gauge shows engine hours, fuel level (if applicable), and Diagnostic Trouble Codes (DTCs) from the JLG Control System and engine control system. During machine start up, with no active DTCs in the control system, the splash screen displays for 3 seconds and then switches to the main screen. If there is an active DTC while powering up the machine, the splash screen displays for 3 seconds, then launches the Diagnostics Screen. The indicator lamp will light when there is an active DTC in the Fault Log.



Figure 6-2. Splash Screen

The Diagnostic Screen will show active and inactive faults from the JLG Control System on the screen. An asterisk (\*) will be displayed to show active faults.

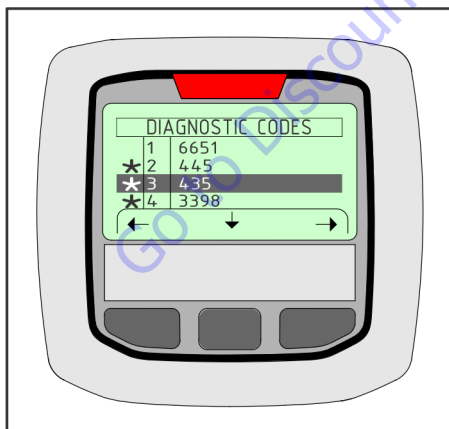

Figure 6-3. Diagnostic Screen

The Engine Diagnostics Screen will show SPN (Suspect Parameter Number), FMI (Failure Mode Identifier), and Occurrence count information. Engine SPN text is not scrollable. If there is more than one engine trouble code, the operator must exit from the Engine DTC Screen to see other SPN and FMI information.

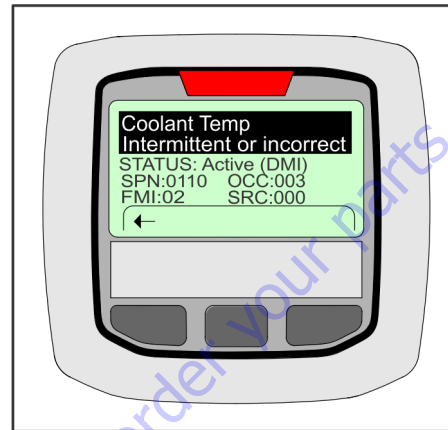

Figure 6-4. Engine Diagnostic Screen

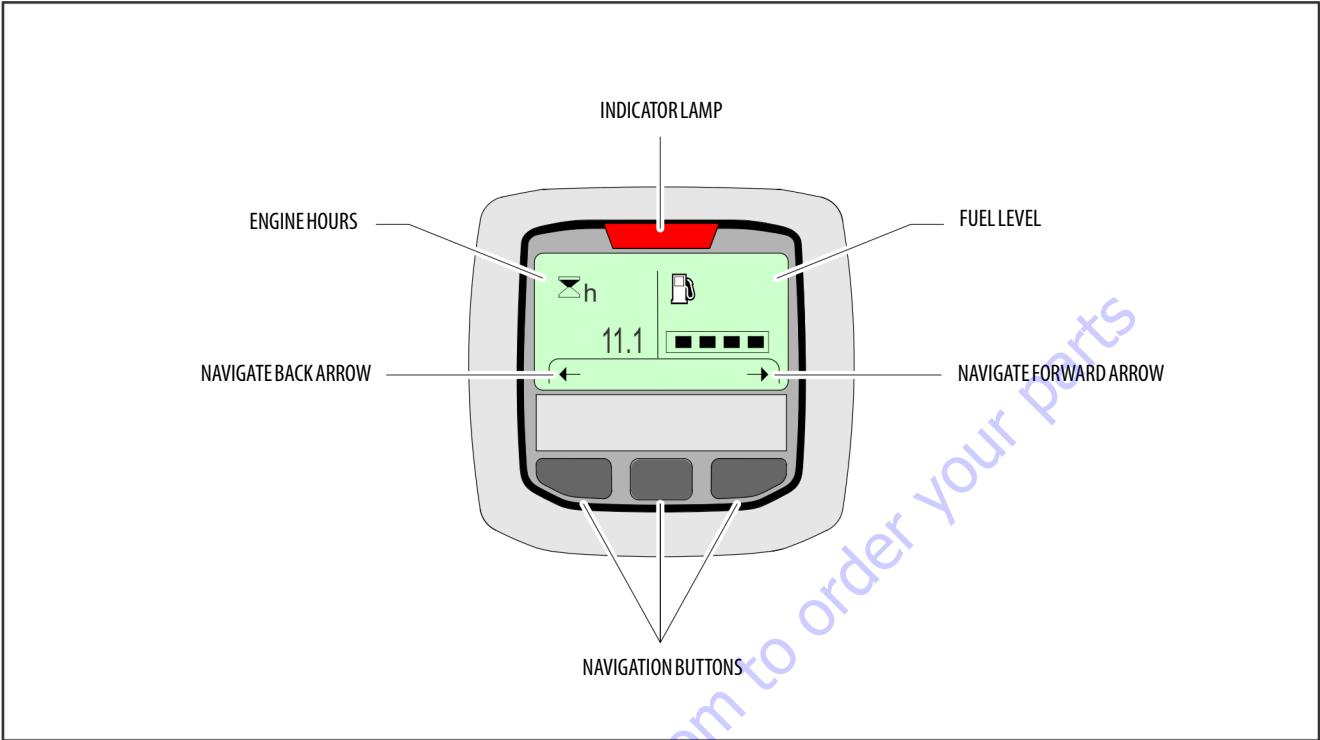

Figure 6-5. Ground Control Console Display Gauge

Go to Discount-Equipment.com to order your parts

## SECTION 6 - JLG CONTROL SYSTEM

**Table 6-1. Analyzer Abbreviations**

ABBREVIATION	MEANING
ACCEL	ACCELERATE
ACT	ACTIVE
A/D	ANALOG DIGITAL CONVERTER COUNT
AMB.	AMBIENT
ANG	ANGLE
AUX	AUXILIARY
BCS	BOOM CONTROL SYSTEM
BM	BOOM LENGTH ANGLE MODULE
BLAM	BOOM LENGTH ANGLE MODULE
BR	BROKEN
BSK	BASKET
CAL	CALIBRATION
CL	CLOSED
CM	CHASSIS MODULE
CNTL	CONTROL
CNTRL	CONTROL
C/O	CUTOUT
CONT(S)	CONTRACTOR(S)
COOR	COORDINATED
CRKPT	CRACK POINT
CRP	CREEP
CUT	CUTOUT
CYL	CYLINDER
DECEL	DECELERATE
D	DOWN
DN	DOWN
DWN	DOWN
DEG.	DEGREE
DOS	DRIVE ORIENTATION SYSTEM
DRV	DRIVE
E	ERROR
E&T	ELEVATED & TILTED
ELEV	ELEVATION
ENG	ENGINE
EXT	EXTEND
F	FRONT
FL	FLOW
FNT	FRONT
FOR	FORWARD
FWD	FORWARD
FSW	FOOT SWITCH
FUNC	FUNCTION
G	GROUND

**Table 6-1. Analyzer Abbreviations**

ABBREVIATION	MEANING
GND	GROUND
GRN	GREEN
GM	GROUND MODULE
H	HOURS
HW	HARDWARE
HWFS	HARDWARE FAILSAFE
I	IN or CURRENT
JOY	JOYSTICK
L	LEFT
LB	POUND
LEN	LENGTH
LIM	LIMIT
LT	LEFT
LVL	LEVEL
M	MINUTES
MIN	MINIMUM
MAX	MAXIMUM
M	MAIN
MN	MAIN
NO	NORMALLY OPEN or NO
NC	NORMALLY CLOSED
O	OUT
O/C	OPEN CIRCUIT
OP	OPEN
O/R	OVERRIDE or OUTRIGGER
O//R	OVERRIDE
OSC	OSCILLATING
OVRD	OVERRIDE
P	PLATFORM
P	PRESSURE
PCV	PROPORTIONAL CONTROL VALVE
PLAT	PLATFORM
PLT	PLATFORM
PM	PLATFORM MODULE
POT	POTENTIOMETER
PRES	PRESSURE
PRS	PRESSURE
PT	POINT
R	REAR or RIGHT
REV	REVERSE or REVISION
RET	RETRACT
ROT.	ROTATE
RT	RIGHT

Table 6-1. Analyzer Abbreviations

ABBREVIATION	MEANING
S/C	SHORT CIRCUIT
SEL	SELECTOR
SN	SERIAL NUMBER
SPD	SPEED
STOW	STOWED
STOWD	STOWED
SW	SWITCH or SOFTWARE
TELE	TELESCOPE
TEMP	TEMPERATURE
TORQ.	TORQUE
TRN	TRANSPORT
T/T	TURNTABLE
T	TOWER
TURNTBL	TURNTABLE
TWR	TOWER
U	UPPER or UP
V	VOLT
VER	VERSION
VLV	VALVE
WIT	WITNESS
YEL	YELLOW

Go to Discount-Equipment.com to order your parts



Figure 6-6. Analyzer Connecting Points

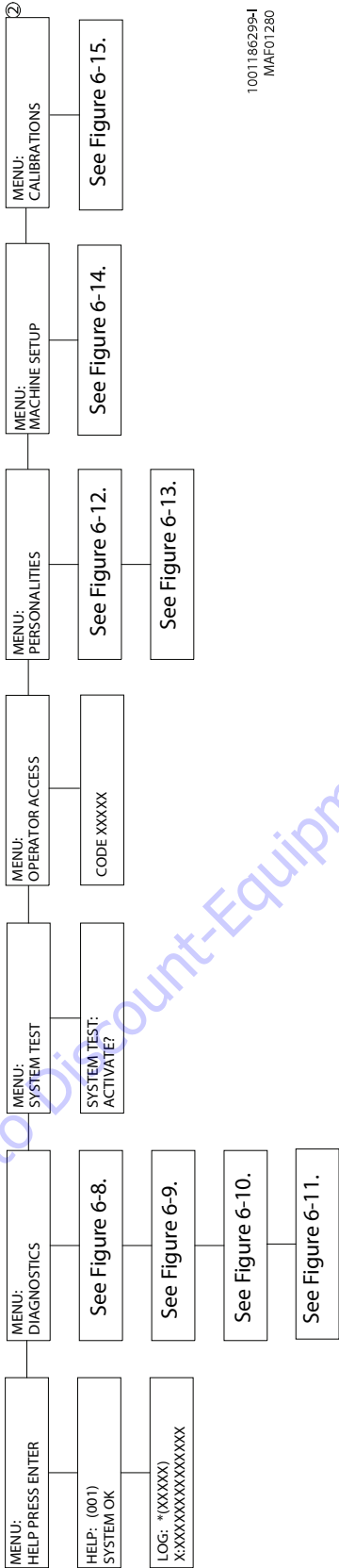

1001186299-I  
MAF01280

**NOTE:** The layout shown includes all possible analyzer screens. Please note that some screens may not be available depending upon machine configuration.

Figure 6-7. Analyzer Flow Chart (Software Version P2.10)



**SECTION 6 - JLG CONTROL SYSTEM**

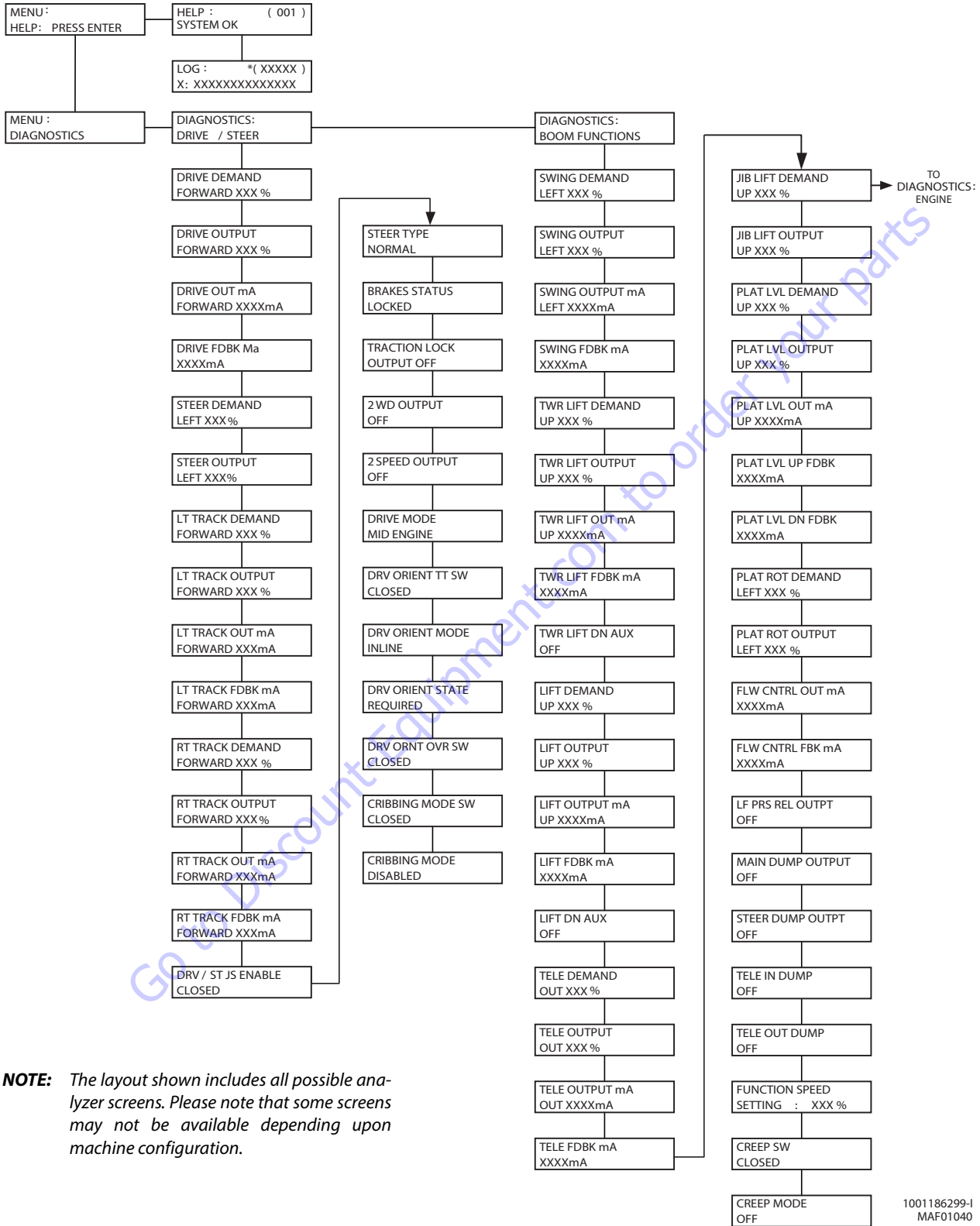

**NOTE:** The layout shown includes all possible analyzer screens. Please note that some screens may not be available depending upon machine configuration.

**Figure 6-8. Analyzer Flow Chart - Diagnostics (Software Version P2.10) - Sheet 1 of 4**

1001186299-1  
MAF01040

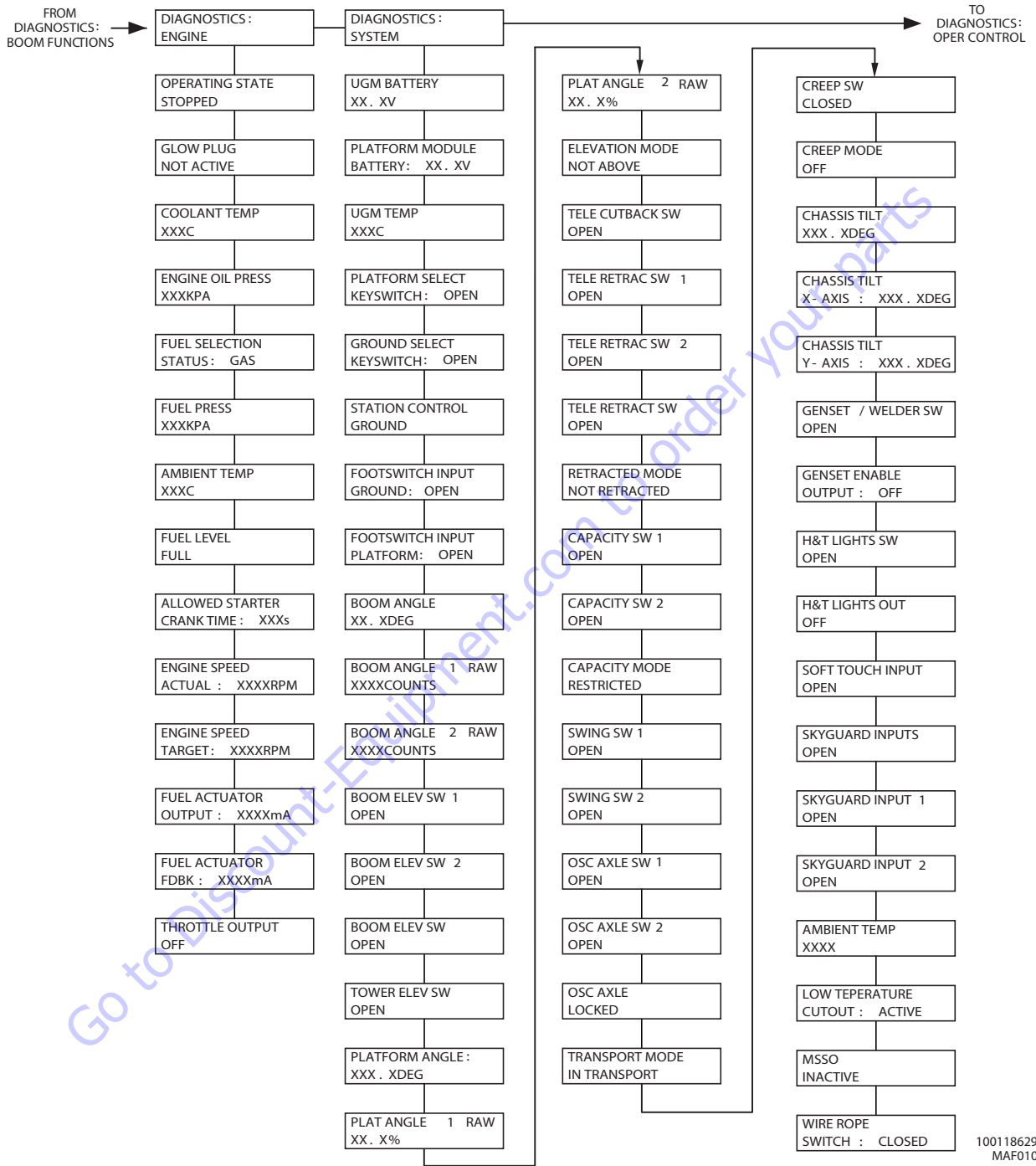

**NOTE:** The layout shown includes all possible analyzer screens. Please note that some screens may not be available depending upon machine configuration.

Figure 6-9. Analyzer Flow Chart - Diagnostics (Software Version P2.10) - Sheet 2 of 4

**SECTION 6 - JLG CONTROL SYSTEM**

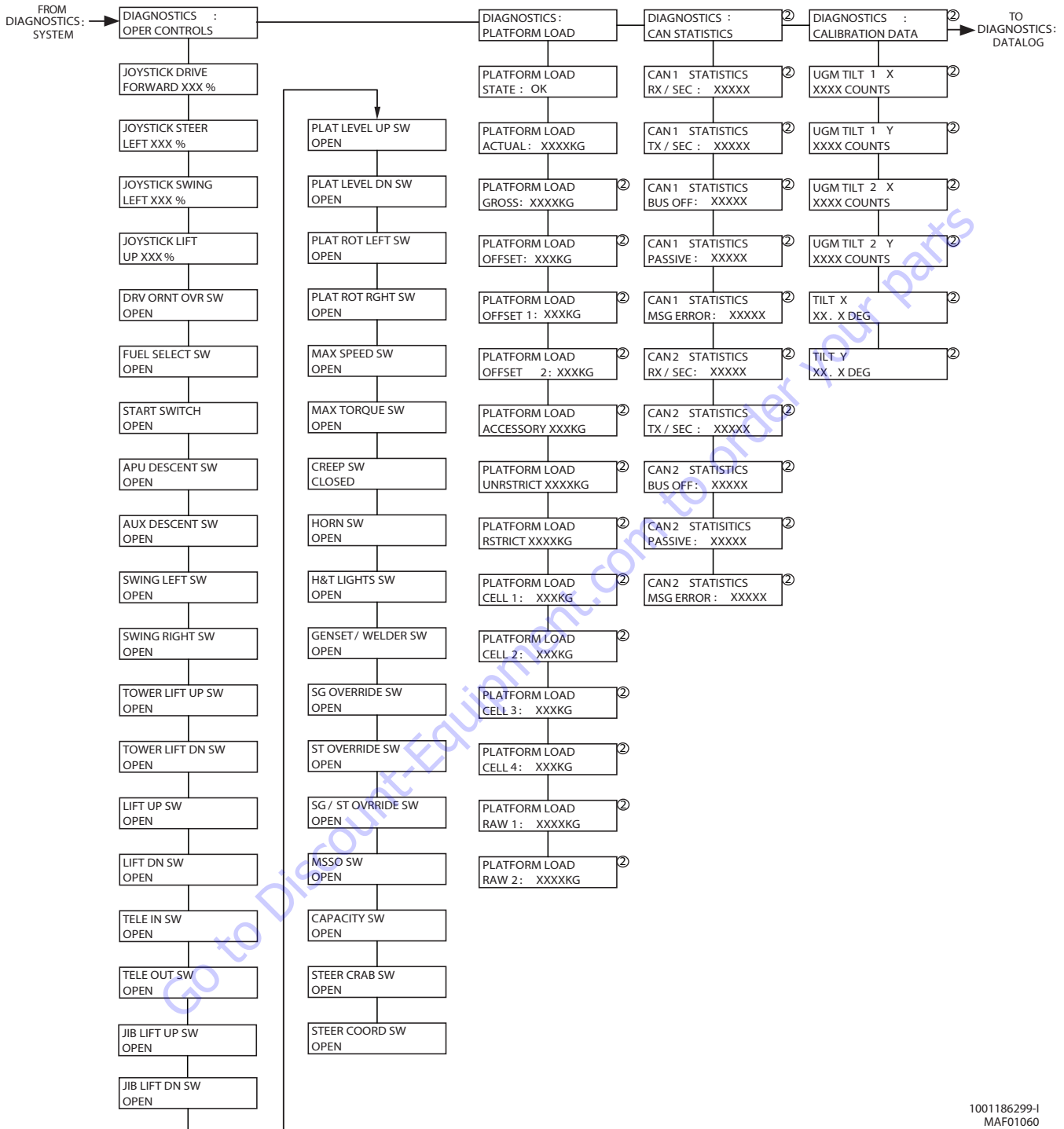

1001186299-I  
MAF01060

**NOTE:** The layout shown includes all possible analyzer screens. Please note that some screens may not be available depending upon machine configuration.

**Figure 6-10. Analyzer Flow Chart - Diagnostics (Software Version P2.10) - Sheet 3 of 4**

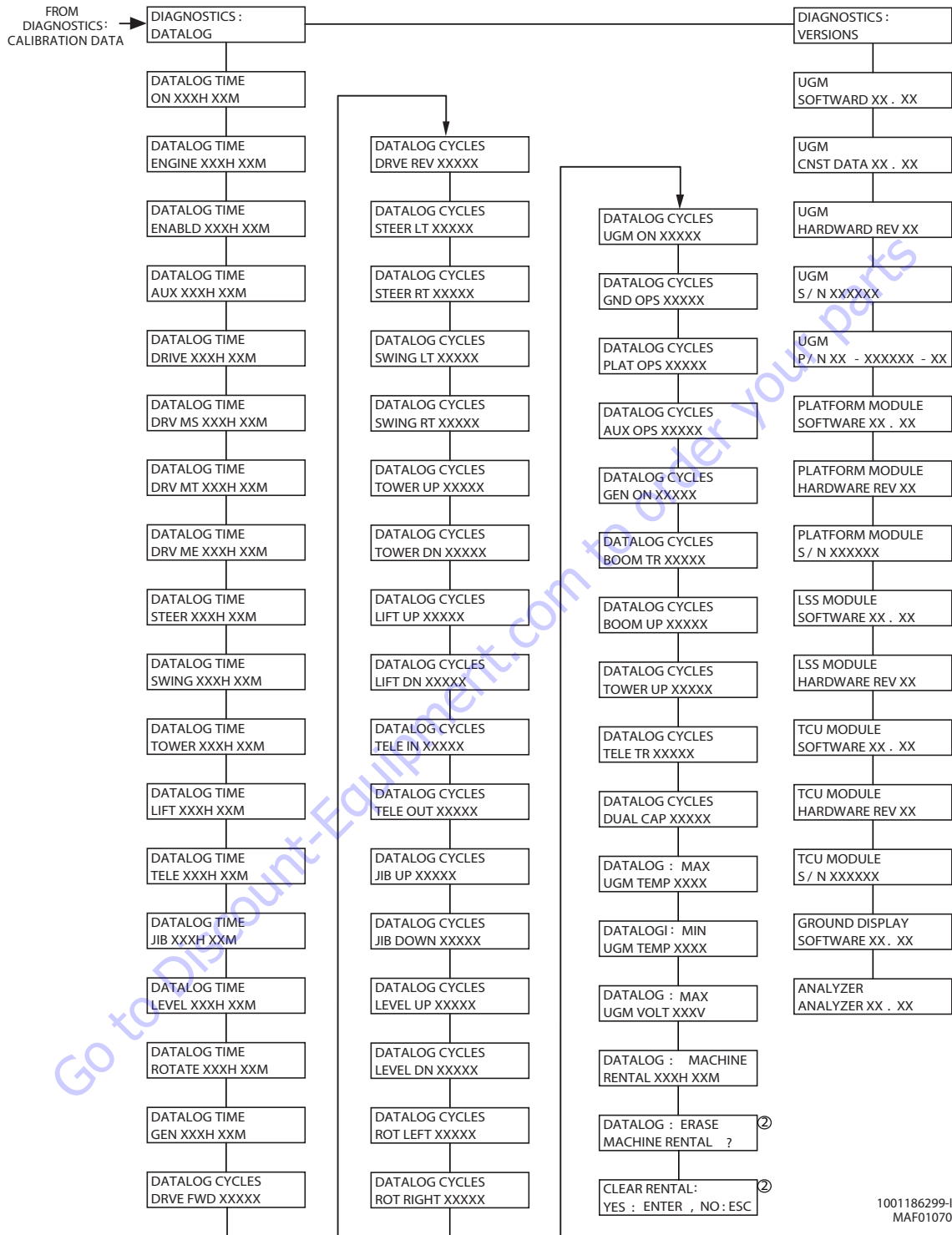

**NOTE:** The layout shown includes all possible analyzer screens. Please note that some screens may not be available depending upon machine configuration.

**Figure 6-11. Analyzer Flow Chart - Diagnostics (Software Version P2.10) - Sheet 4 of 4**

**SECTION 6 - JLG CONTROL SYSTEM**

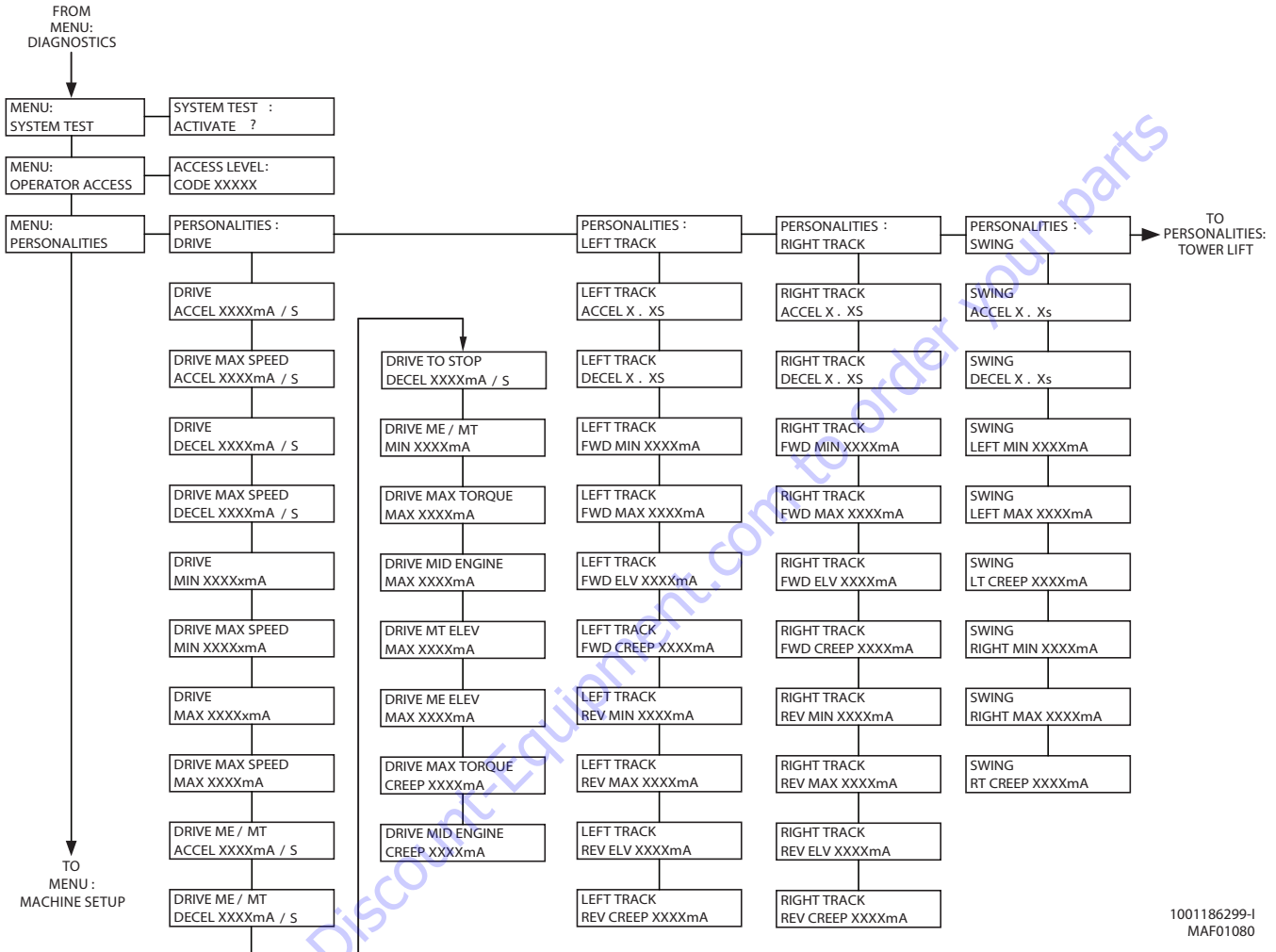

**NOTE:** The layout shown includes all possible analyzer screens. Please note that some screens may not be available depending upon machine configuration.

**Figure 6-12. Analyzer Flow Chart - Personalities (Software Version P2.10) - Sheet 1 of 2**

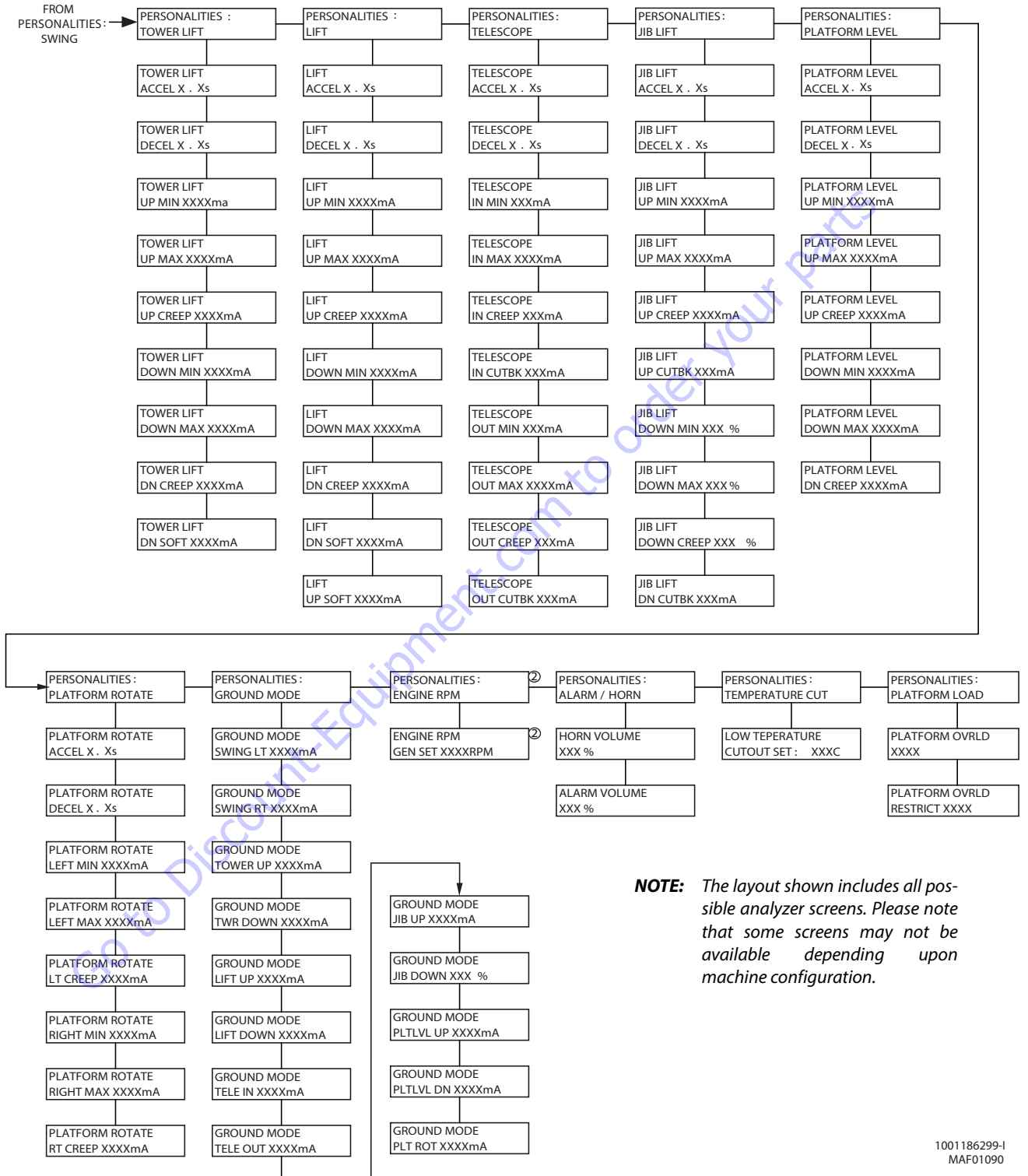
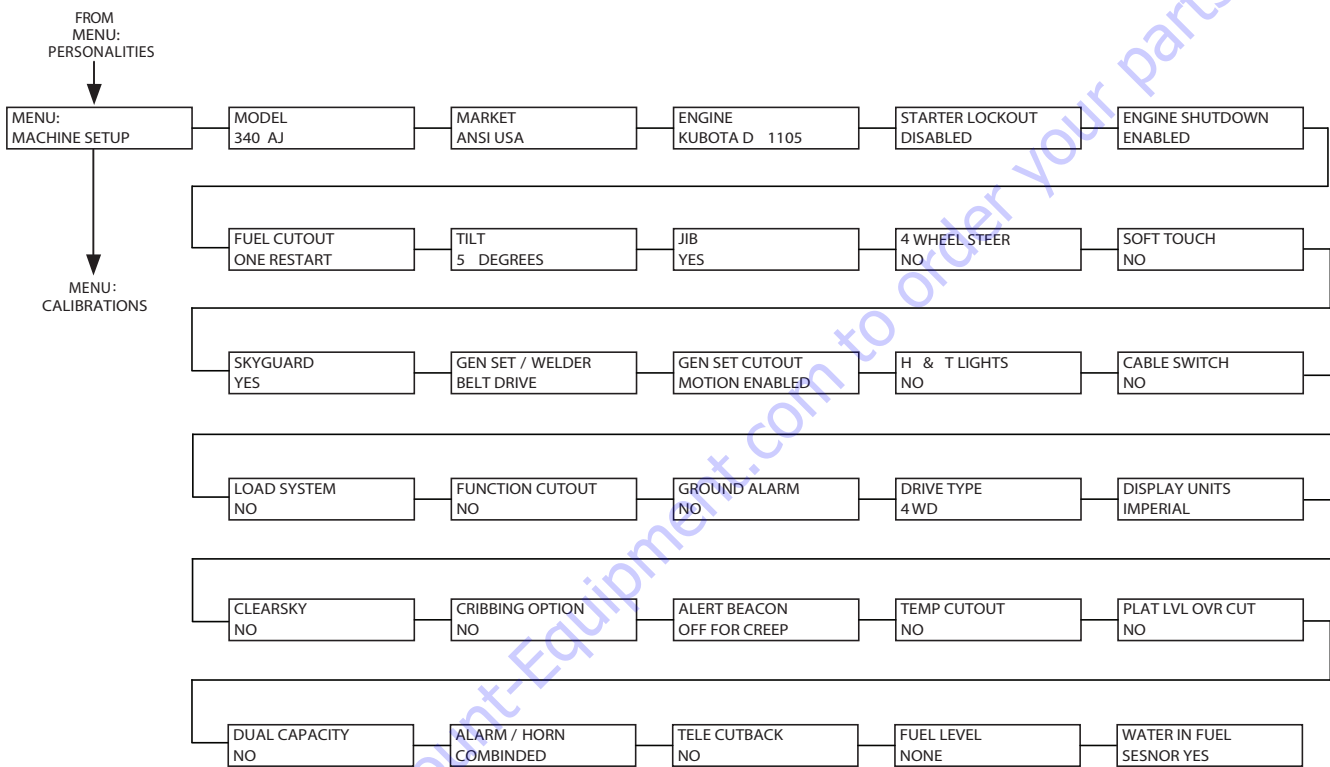

Figure 6-13. Analyzer Flow Chart - Personalities (Software Version P2.10) - Sheet 2 of 2

## SECTION 6 - JLG CONTROL SYSTEM



1001186299-I  
MAF01100

**NOTE:** The layout shown includes all possible analyzer screens. Please note that some screens may not be available depending upon machine configuration.

Figure 6-14. Analyzer Flow Chart - Machine setup (Software Version P2.10)

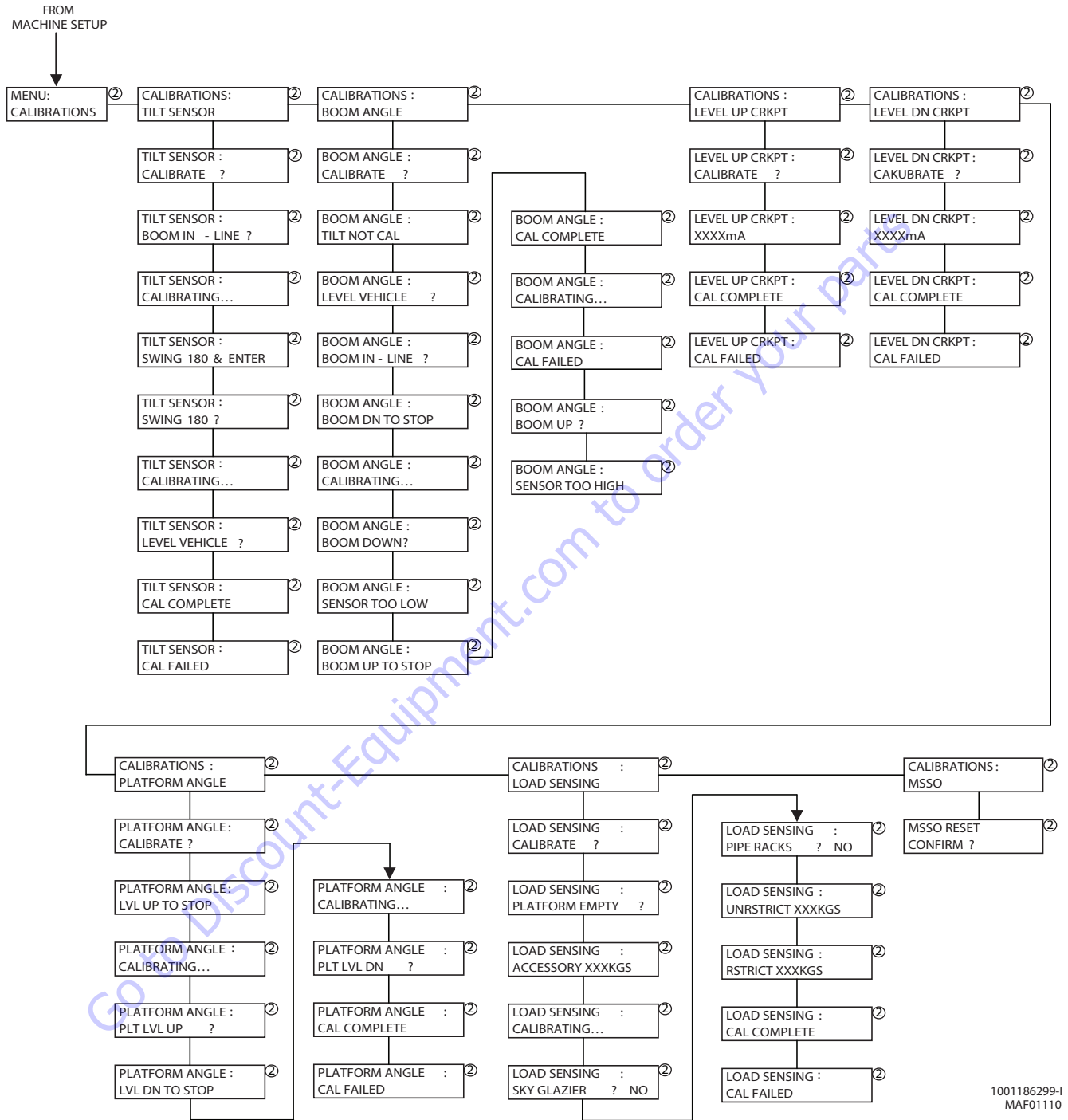

**NOTE:** The layout shown includes all possible analyzer screens. Please note that some screens may not be available depending upon machine configuration.

Figure 6-15. Analyzer Flow Chart - Calibrations (Software Version P2.10)



**SECTION 6 - JLG CONTROL SYSTEM**

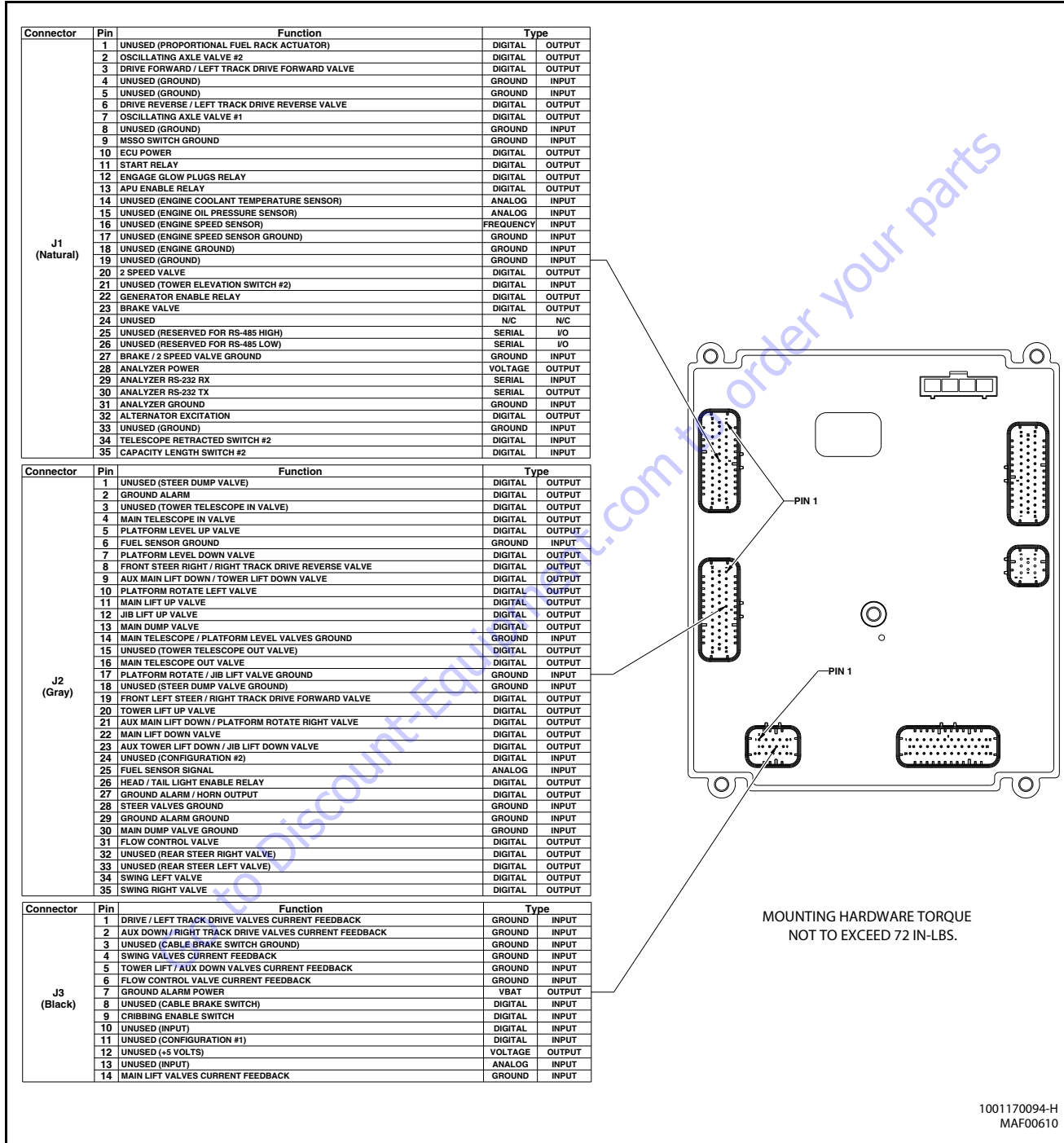

**Figure 6-16. Ground Control Module - Sheet 1 of 3**

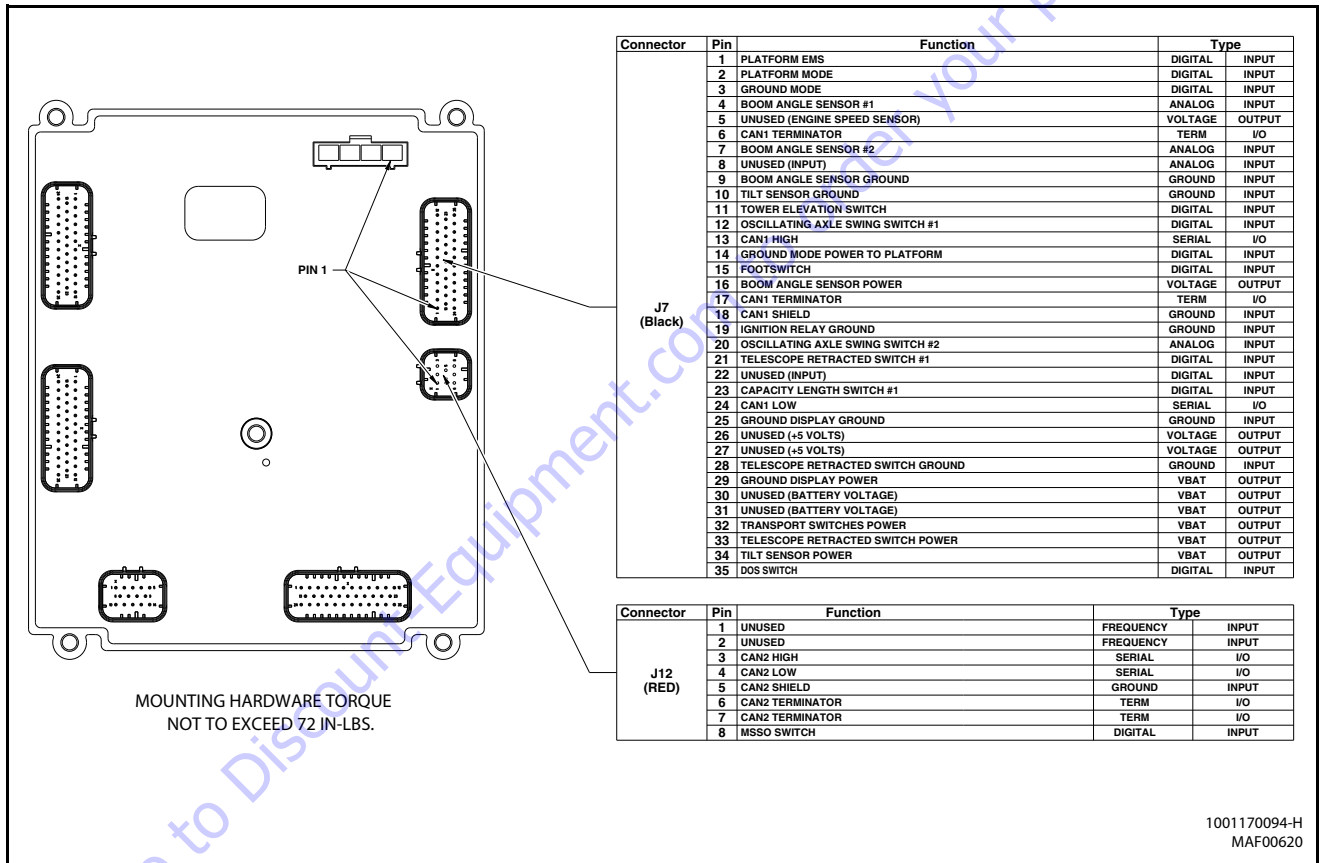

1001170094-H  
MAF00620

Figure 6-17. Ground Control Module - Sheet 2 of 3

## SECTION 6 - JLG CONTROL SYSTEM

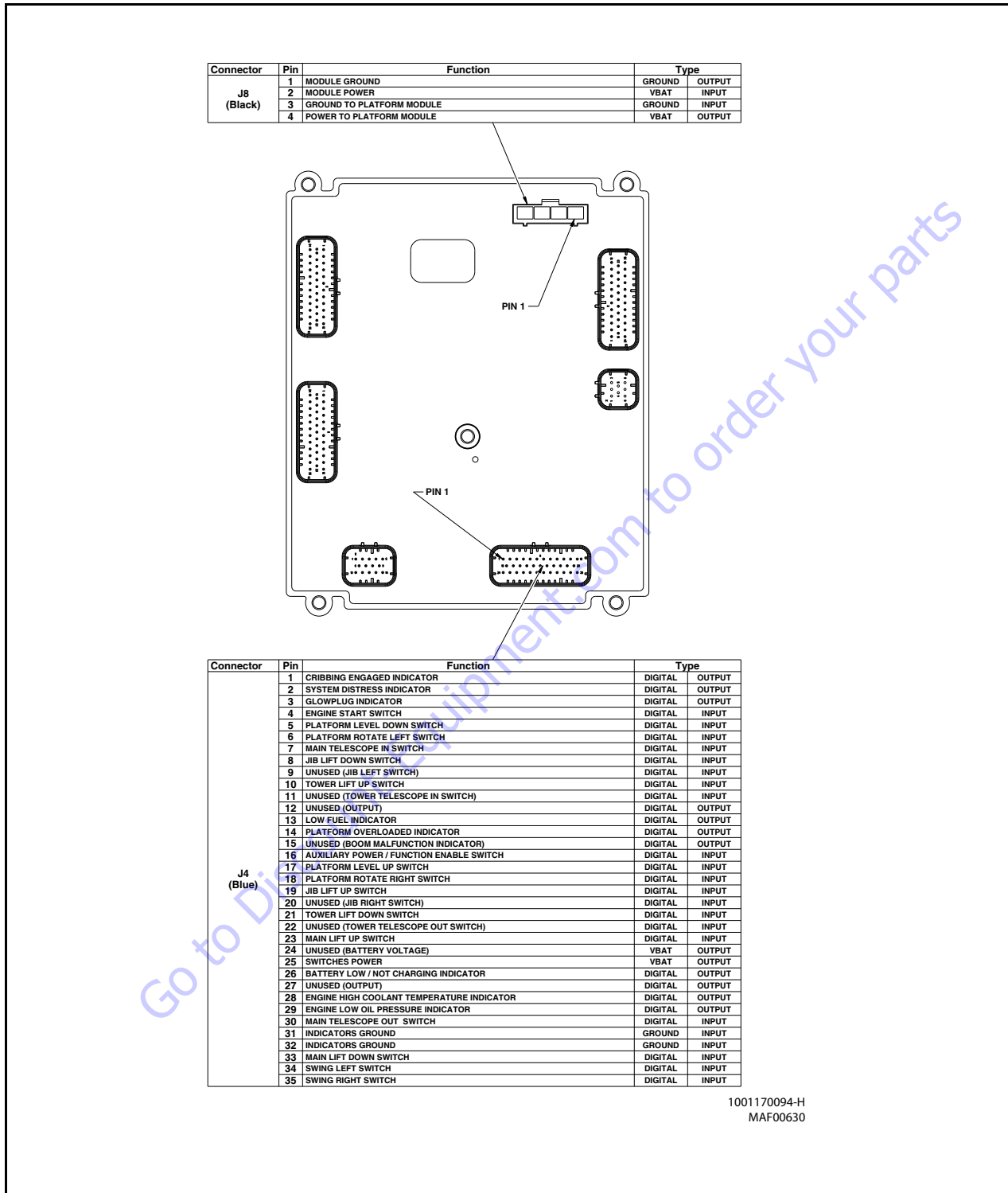
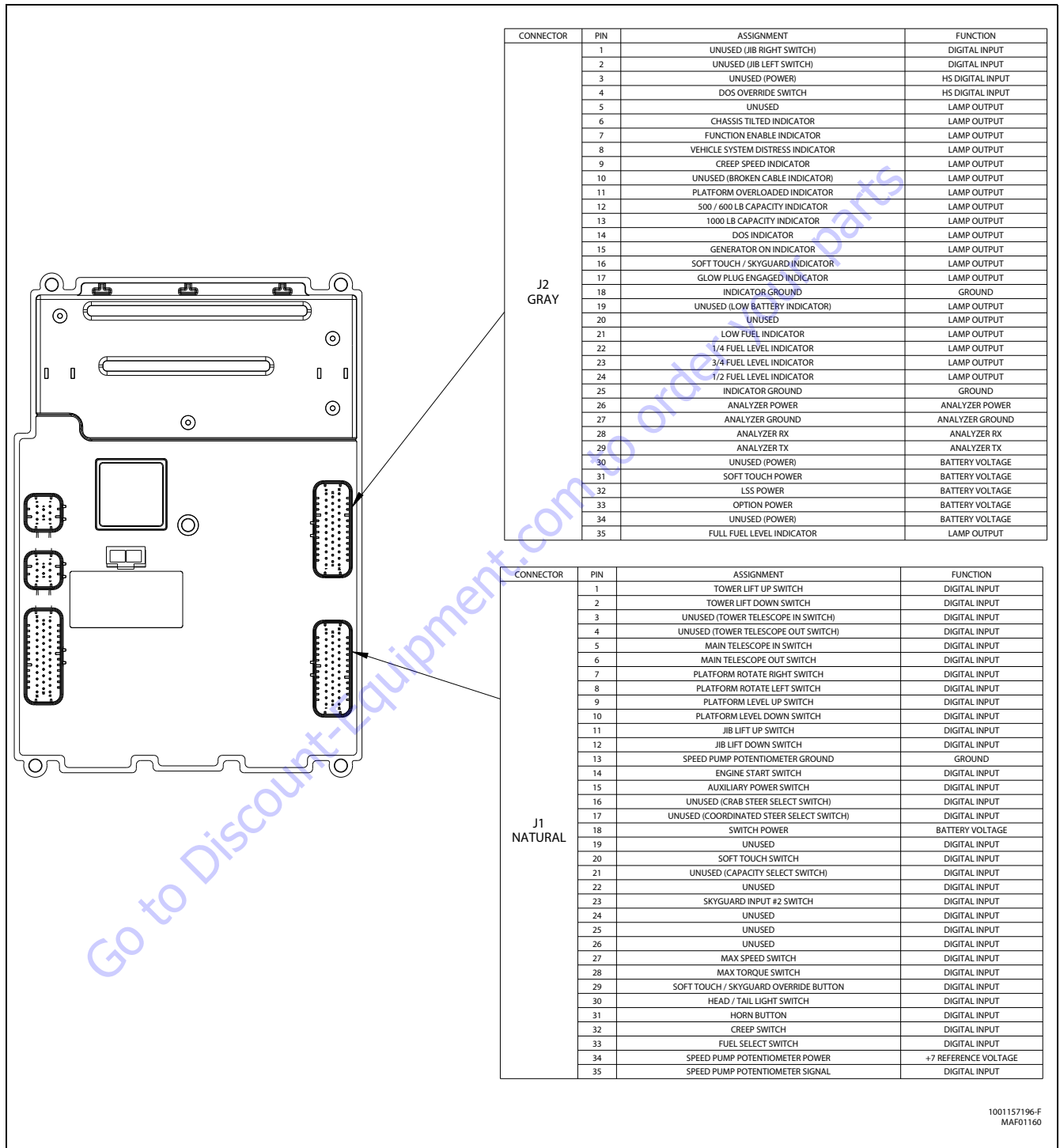

Figure 6-18. Ground Control Module - Sheet 3 of 3



1001157196-F  
MAF01160

Figure 6-19. Platform Module - Sheet 1 of 2

# SECTION 6 - JLG CONTROL SYSTEM

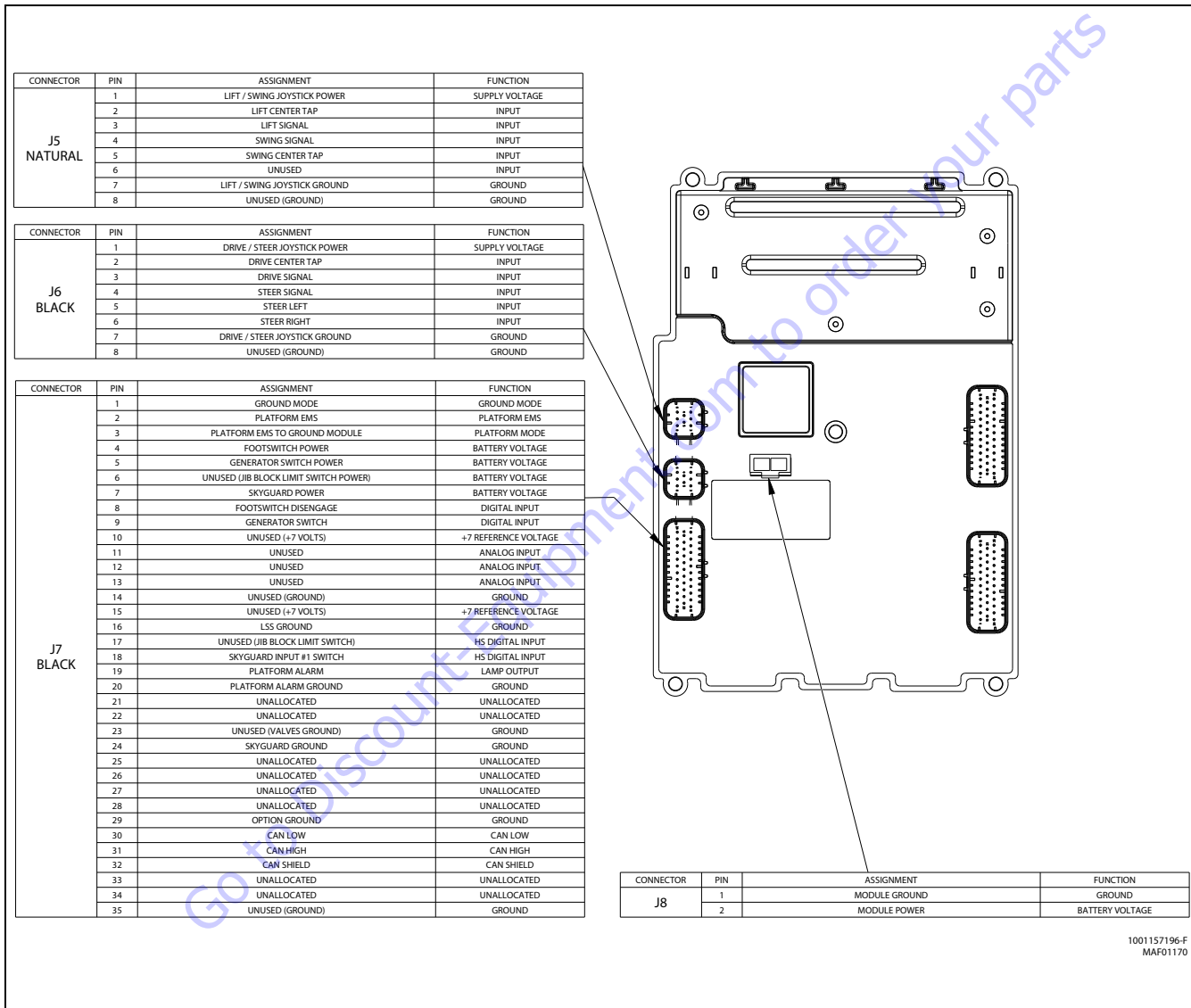

Figure 6-20. Platform Module - Sheet 2 of 2

Table 6-2. Machine Configuration Programming Information (Software Version P2.10)

Configuration Label/Digit	Number	Description	Default Number
MODEL NUMBER: 1	0	????: Visible only on a Non-Configured UGM.	2
	1	400S	
	2	<b>400SC</b>	
	3	450AJ	
MARKET: 2	1	<b>ANSI USA</b>	1
	2	ANSI EXPORT	
	3	CSA	
	4	CE	
	5	AUSTRALIA	
	6	JAPAN	
	7	GB	
* Certain model selections will limit market options.			
ENGINE: 3*	1	KUBOTA D110S	4
	2	GM DUAL FUEL: GM/PS10.97L Dual Fuel (Tier 3)	
	3	KUBOTA DUAL FUEL	
	4	<b>DEUTZ EMR2: (Tier 4i)</b>	
	5	DEUTZ EMR4: (Tier 4f)	
* Only visible under certain model selections. * Certain model selections will limit engine options. * Certain market selections will limit engine options.			
FLYWHEEL TEETH: 4*	1	<b>98 TEETH: 98 flywheel teeth.</b>	1
* This menu item is not visible.			
GLOW PLUG: 5*	1	NO GLOW PLUGS: No glow plugs installed.	2
	2	<b>IN-CYLINDER: Glow plugs installed in each cylinder.</b>	
* This menu item is not visible.			

## SECTION 6 - JLG CONTROL SYSTEM

Configuration Label/Digit	Number	Description	Default Number
STARTER LOCKOUT: 6*	1	<b>DISABLED: Automatic pre-glow time determined by ambient air temperature; engine start can be attempted at any time during pre-glow.</b>	1
	2	ENABLED: Automatic pre-glow time determined by ambient air temperature; engine start is NOT permitted until pre-glow is finished.	
*Only visible for Engine Selection = Kubota D1105, Deutz EMR2 or Deutz EMR4.			
ENGINE SHUTDOWN: 7	1	DISABLED: No engine shutdown.	2
	2	<b>ENABLED: Shutdown engine for high coolant temperature fault or low oil pressure fault.</b>	
FUEL CUTOUT: 8*	1	ONE RESTART: One restart with limited run time when near Empty.	4
	2	ENGINE STOP: No starting permitted when near Empty.	
	3	NONE	
	4	<b>RESTART: Restarts allowed with limited run time when near Empty.</b>	
*Only visible for Engine Selection = Kubota D1105, Deutz EMR2 or Deutz EMR4.			
*Only visible if Fuel Level Menu selection is not NONE.			

Configuration Label/Digit	Number	Description	Default Number
TILT: 9*	1	5 DEGREES: Reduces the maximum speed of all boom functions to creep when tilted more than 5 degrees and above elevation; also reduces drive speed to creep.	9
	2	4.5 DEGREES: Reduces the maximum speed of all boom functions to creep when tilted more than 4.5 degrees and above elevation; also reduces drive speed to creep.	
	3	4 DEGREES: Reduces the maximum speed of all boom functions to creep when tilted more than 4 degrees and above elevation; also reduces drive speed to creep.	
	4	3 DEGREES: Reduces the maximum speed of all boom functions to creep when tilted more than 3 degrees and above elevation; also reduces drive speed to creep.	
	5	5 DEG + CUT: Reduces the maximum speed of all boom functions to creep when tilted more than 5 degrees and above elevation; also disallows tower lift up, drive, telescope out and lift up.	
	6	4.5 DEG + CUT: Reduces the maximum speed of all boom functions to creep when tilted more than 4.5 degrees and above elevation; also disallows tower lift up, drive, telescope out and lift up.	
	7	4 DEG + CUT: Reduces the maximum speed of all boom functions to creep when tilted more than 4 degrees and above elevation; also disallows tower lift up, drive, telescope out and lift up.	
	8	3 DEG + CUT: Reduces the maximum speed of all boom functions to creep when tilted more than 3 degrees and above elevation; also disallows tower lift up, drive, telescope out and lift up.	
	9	<b>5 DEG + DRV CUT: Reduces the maximum speed of all boom functions to creep when tilted more than 5 degrees and above elevation; also reduces drive speed to creep when drive reversal is allowed, drive is disallowed otherwise.</b>	
	10	4.5 DEG + DRV CT: Reduces the maximum speed of all boom functions to creep when tilted more than 4.5 degrees and above elevation; also reduces drive speed to creep when drive reversal is allowed, drive is disallowed otherwise.	
	11	4 DEG + DRV CUT: Reduces the maximum speed of all boom functions to creep when tilted more than 4 degrees and above elevation; also reduces drive speed to creep when drive reversal is allowed, drive is disallowed otherwise.	
	12	3 DEG + DRV CUT: Reduces the maximum speed of all boom functions to creep when tilted more than 3 degrees and above elevation; also reduces drive speed to creep when drive reversal is allowed, drive is disallowed otherwise.	
<p>* Certain market selections will limit tilt options and alter default setting.            * Drive Reversal feature of X DEG + DRV CUT does not apply to crawlers.            Note: Any of the selections above will light the tilt lamp when a tilted condition occurs and will sound the platform alarm when the machine is also above elevation.</p>			
JIB: 10*	1	NO: No jib installed.	2
	2	<b>YES: Jib installed, which has up and down movements only.</b>	
<p>* Certain model selections will limit visibility.</p>			
SOFT TOUCH: 11	1	<b>NO: No Soft Touch system installed.</b>	1
	2	YES: Soft Touch system installed.	



## SECTION 6 - JLG CONTROL SYSTEM

Configuration Label/Digit	Number	Description	Default Number
SKYGUARD: 12	1	NO: No SkyGuard system installed.	2
	2	YES: SkyGuard system installed.	
GEN SET/WELDER: 13	1	NO: No generator installed.	1
	2	BELT DRIVE: Belt driven setup.	
GEN SET CUTOUT: 14*	1	MOTION ENABLED: Motion enabled when generator is ON.	1
	2	MOTION CUTOUT: Motion cutout in platform mode only.	
* Only visible if Gen Set / Welder Menu selection is not NO.			
H & T LIGHTS: 15*	1	NO: No head and tail lights installed.	1
	2	YES: Head and tail lights installed.	
* Only visible under certain model selections.			
LOAD SYSTEM: 16*	1	NO: No load sensor installed.	1
	2	WARN ONLY: Functions in creep, overload lamp lit, platform alarm beeps (5 sec ON, 2 sec OFF).	
	3	CUTOUT PLATFORM: All functions cutout, overload lamp lit, platform alarm beeps (5 sec ON, 2 sec OFF).	
	4	CUTOUT ALL: All functions cutout, flash overload light (500mS on, 500mS off), platform alarm beeps (5 sec ON, 2 sec OFF).	
	5	SPECIAL 1: Functions in creep, overload lamp lit, disables telescope out & lift up, platform alarm beeps (5 sec ON, 2 sec OFF).	
* Only visible under certain market selections.			
* Certain market selections will limit load system options or alter default setting.			
FUNCTION CUTOUT: 17*	1	NO: No drive cutout.	1
	2	BOOM CUTOUT: Boom function cutout while driving above elevation.	
	3	DRIVE CUTOUT: Drive & steer cutout above elevation.	
	4	DRIVE CUT E&T: Drive & steer cutout above elevation and tilted.	
* Only visible under certain market selections.			
* Certain market selections will limit function cutout options or alter default setting.			
GROUND ALARM: 18	1	NO: No ground alarm installed.	4
	2	DRIVE: Travel alarm sounds when the drive function is active.	
	3	DESCENT: Descent alarm sounds when lift down is active.	
	4	MOTION: Motion alarm sounds when any function is active.	

Configuration Label/Digit	Number	Description	Default Number
DRIVE TYPE: 19*	1	<b>4WD: 4 wheel drive.</b>	1
	2	2WD: 2 wheel drive.	
* Only visible under certain model selections.			
DISPLAY UNITS: 20*	1	METRIC: Celsius, Kilograms, KiloPascal.	2
	2	<b>IMPERIAL: Fahrenheit, Pounds, Pounds/in<sup>2</sup>.</b>	
* Certain market selections will alter default setting.			
CLEARSKY: 21	1	<b>NO: ClearSky (telematics) options is disabled.</b>	1
	2	YES: ClearSky (telematics) option is enabled.	
* Only visible under certain model selections.			
CRIBBING OPTION: 22*	1	<b>NO: Cribbing Option is disabled.</b>	1
	2	YES: Cribbing Option is enabled.	
* Only visible under certain model selections.			
* Only visible under certain market selections.			
ALERT BEACON: 23	1	<b>OFF FOR CREEP</b>	1
	2	IN CREEP 20FPM	
TEMP CUTOUT: 24*	1	<b>NO: No Low Temp Cutout system installed.</b>	1
	2	YES: Low Temp Cutout system installed.	
* Only visible under certain market selections.			
PLAT LVL OVR CUT: 25	1	<b>NO: Platform Level functions above elevation.</b>	1
	2	YES: Platform Level does not function above elevation.	
ALARM / HORN: 26	1	SEPARATE: Ambient alarm installed.	2
	2	<b>COMBINED: Single Horn / Alarm installed.</b>	
TELE CUTBACK: 27*	1	<b>NO: Telescope Cutback Option is disabled.</b>	1
	2	YES: Telescope Cutback Option is enabled.	
* Only visible under certain model selections.			

**SECTION 6 - JLG CONTROL SYSTEM**

Configuration Label/Digit	Number	Description	Default Number
FUEL LEVEL: 28*	1	NONE: Fuel Level Switch / Sensor is not installed.	3
	2	SWITCH: Fuel Level Switch is installed.	
	3	<b>SENSOR: Fuel Level Sensor is installed.</b>	
* Only visible under certain model selections.			
WATER IN FUEL SESNOR: 29*	1	<b>NO: Water in Fuel Sensor is not installed.</b>	1
	2	YES: Water in Fuel Sensor is installed.	
* Only visible under certain market selections.			
* Only visible for Engine Selection = Deutz EMR4.			

1001193425-H

Go to Discount-Equipment.com to order your parts

Table 6-3. Machine Configuration Programming Settings - 400SC

400SC	ANSI USA	ANSI Export	CSA	CE	Australia	Japan
Model Number	2	2	2	2	2	2
Market	1	2	3	4	5	6
Engine	X	X	X	X	X	X
	2	2	2	X	X	2
	3	3	3	X	X	3
	4	4	4	4	4	4
	5	5	5	5	5	5
Flywheel Teeth	X	X	X	X	X	X
Glow Plug	2	2	2	2	2	2
Starter Lockout	1	1	1	1	1	1
	2	2	2	2	2	2
Engine Shut-down	1	1	1	1	1	1
	2	2	2	2	2	2
Fuel Cutout	1	1	1	1	1	1
	2	2	2	2	2	2
	X	X	X	X	X	X
	4	4	4	4	4	4
Tilt	1	1	1	1	1	1
	X	X	X	X	X	X
	3	3	3	3	3	3
	4	4	4	4	4	4
	5	5	5	5	5	5
	X	X	X	X	X	X
	7	7	7	7	7	7
	8	8	8	8	8	8
	9	9	9	9	9	9
	X	X	X	X	X	X
	11	11	11	11	11	11
	12	12	12	12	12	12
Jib	1	1	1	1	1	1
	2	2	2	2	2	2
Soft Touch	1	1	1	1	1	1
	2	2	2	2	2	2
SkyGuard	1	1	1	1	1	1
	2	2	2	2	2	2
Gen Set / Welder	1	1	1	1	1	1
	2	2	2	2	2	2
Gen Set Cutout	1	1	1	1	1	1
	2	2	2	2	2	2

Table 6-3. Machine Configuration Programming Settings - 400SC

400SC	ANSI USA	ANSI Export	CSA	CE	Australia	Japan
Head & Taillights	1	1	1	1	1	1
	2	2	2	2	2	2
Load System	1	1	1	X	X	1
	X	2	X	X	X	2
	X	3	X	X	3	3
	X	4	X	4	X	4
	X	X	X	X	X	X
Function Cutout	1	1	1	X	1	1
	X	2	2	2	2	2
	3	3	3	X	3	3
Ground Alarm	X	X	X	X	X	X
	1	1	1	1	1	1
	2	2	2	2	2	2
	3	3	3	3	3	3
Drive Type	4	4	4	4	4	4
	1	1	1	1	1	1
	X	X	X	X	X	X
Display Units	1	1	1	1	1	1
	2	2	2	2	2	2
Clearsky	1	1	1	1	1	1
	2	2	2	2	2	2
Cribbing Option	1	X	X	X	X	X
	2	X	X	X	X	X
Alert Beacon	1	1	1	1	1	1
	2	2	2	2	2	2
Temp Cutout	1	1	1	1	1	1
	X	2	X	2	X	X
Plat Lvl Ovr Cut	1	1	1	1	1	1
	2	2	2	2	2	2
Alarm/Horn	1	1	1	1	1	1
	2	2	2	2	2	2
TELE CUTBACK	X	X	X	X	X	X
	X	X	X	X	X	X
FUEL LEVEL	X	X	X	X	X	X
	X	X	X	X	X	X
	3	3	3	3	3	3
WATER IN FUEL SENSOR	1	1	1	1	1	1
	2	2	2	2	2	2

**BOLD BLUE TEXT** indicates the default setting. Plain text indicates another available selection. **RED ITALIC TEXT** indicates the default when option is factory installed. SHADED CELLS indicate hidden menu or selection.

**SECTION 6 - JLG CONTROL SYSTEM**

**Table 6-4. Machine Configuration Programming Settings - 460SJC**

460SJC	ANSI USA	ANSI Export	CSA	CE	Australia	Japan
Model Number	2	2	2	2	2	2
Market	1	2	3	4	5	6
Engine	X	X	X	X	X	X
	2	2	2	X	X	2
	3	3	3	X	X	3
	4	4	4	4	4	4
	5	5	5	5	5	5
Flywheel Teeth	X	X	X	X	X	X
Glow Plug	2	2	2	2	2	2
Starter Lockout	1	1	1	1	1	1
	2	2	2	2	2	2
Engine Shutdown	1	1	1	1	1	1
	2	2	2	2	2	2
Fuel Cutout	1	1	1	1	1	1
	2	2	2	2	2	2
	X	X	X	X	X	X
	4	4	4	4	4	4
Tilt	1	1	1	1	1	1
	X	X	X	X	X	X
	3	3	3	3	3	3
	4	4	4	4	4	4
	5	5	5	5	5	5
	X	X	X	X	X	X
	7	7	7	7	7	7
	8	8	8	8	8	8
	9	9	9	9	9	9
	X	X	X	X	X	X
	11	11	11	11	11	11
	12	12	12	12	12	12
Jib	1	1	1	1	1	1
	2	2	2	2	2	2
Soft Touch	1	1	1	1	1	1
	2	2	2	2	2	2
SkyGuard	1	1	1	1	1	1
	2	2	2	2	2	2
Gen Set / Welder	1	1	1	1	1	1
	2	2	2	2	2	2
Gen Set Cutout	1	1	1	1	1	1
	2	2	2	2	2	2

**Table 6-4. Machine Configuration Programming Settings - 460SJC**

460SJC	ANSI USA	ANSI Export	CSA	CE	Australia	Japan
Head & Taillights	1	1	1	1	1	1
	2	2	2	2	2	2
Load System	1	1	1	X	X	1
	X	2	X	X	X	2
	X	3	X	X	3	3
	X	4	X	4	X	4
	X	X	X	X	X	X
Function Cutout	1	1	1	X	1	1
	X	2	2	2	2	2
	3	3	3	X	3	3
	X	X	X	X	X	X
Ground Alarm	1	1	1	1	1	1
	2	2	2	2	2	2
	3	3	3	3	3	3
	4	4	4	4	4	4
Drive Type	1	1	1	1	1	1
	X	X	X	X	X	X
Display Units	1	1	1	1	1	1
	2	2	2	2	2	2
Clearsky	1	1	1	1	1	1
	2	2	2	2	2	2
Cribbing Option	1	X	X	X	X	X
	2	X	X	X	X	X
Alert Beacon	1	1	1	1	1	1
	2	2	2	2	2	2
Temp Cutout	1	1	1	1	1	1
	X	2	X	2	X	X
Plat Lvl Ovr Cut	1	1	1	1	1	1
	2	2	2	2	2	2
Alarm/Horn	1	1	1	1	1	1
	2	2	2	2	2	2
TELE CUTBACK	X	X	X	X	X	X
	X	X	X	X	X	X
FUEL LEVEL	X	X	X	X	X	X
	X	X	X	X	X	X
	3	3	3	3	3	3
WATER IN FUEL SENSOR	1	1	1	1	1	1
	2	2	2	2	2	2

**BOLD BLUE TEXT** indicates the default setting. Plain text indicates another available selection. **RED ITALIC TEXT** indicates the default when option is factory installed. SHADED CELLS indicate hidden menu or selection.

## 6.2 LSS SYSTEM

The JLG-designed Load Sensing System (LSS) measures platform load via a sensor mounted in the platform support structure. If the actual platform load exceeds the selected Rated Load, the following will occur:

1. The Overload Visual Warning Indicator will flash at the selected control position (platform or ground). 
2. The Platform and Ground Alarms will sound 5 seconds On, and 2 seconds Off.
3. All normal movement will be prevented from the platform control position (optional - ground control functions may be prevented).
4. Further movement is permitted by:
  - a. Removing the excess platform load until actual platform load is less than Rated Load.
  - b. Operation of the overriding emergency system (Auxiliary Power Unit).
  - c. By an authorized person at the ground control position (optional - ground control functions may be prevented).

### NOTICE

**THE LOAD SENSING SYSTEM MUST BE CALIBRATED WHEN ONE OR MORE OF THE FOLLOWING CONDITIONS OCCUR:**

- a. LSS Sensor removal or replacement
- b. Addition or removal of certain platform mounted accessories. (Refer to Calibration)
- c. Platform is removed, replaced, repaired or shows evidence of impact.



### NOTICE

**THE LOAD SENSING SYSTEM REQUIRES PERIODIC FUNCTION VERIFICATION NOT TO EXCEED 6 MONTHS FROM PREVIOUS VERIFICATION. REFER TO TESTING & EVALUATION.**

All calibration procedures are menu driven through the use of a JLG Analyzer.

## Diagnostic Menu

The Diagnostic Menu is another troubleshooting tool for the Load Sensing System. Sensor and status information is presented in real-time for the technician. Several sub-menus exist to organize the data.

To access the Diagnostic Menu, use the LEFT  and RIGHT  Arrow keys to select DIAGNOSTICS from the Top Level

Menu. Press the ENTER key  to view the menu.

Press the LEFT and RIGHT Arrow keys to view the displays and select the various sub-menus. To access a sub-menu, press the ENTER key. Once in a sub-menu, press the LEFT and RIGHT Arrow keys to view the various displays (just like a Top Level

menu). To exit a sub-menu, press the ESC key .

Table 6-5, Diagnostic Menu Descriptions details the structure of the Diagnostic Menu, and describes the meaning of each piece of information presented.

**Table 6-5. Diagnostic Menu Descriptions**

Diagnosics Menu (Displayed on Analyzer 1 <sup>st</sup> Line)	Parameter (Displayed on Analyzer 2 <sup>nd</sup> Line)	Parameter Value (Displayed on Analyzer 2 <sup>nd</sup> Line)	Description
PLATFORM LOAD	STATE:	OK / OVERLOAD	LSS Status.
PLATFORM LOAD	ACTUAL:	XXX.X KG	Calibrated weight of the platform. ??? if Platform Load is Unhealthy**.
PLATFORM LOAD (service*)	GROSS:	XXX.X KG	Gross weight of the platform. ??? if both Cells are Unhealthy**.
PLATFORM LOAD (service*)	OFFSET 1:	XXX.X KG	Stored offset weight of Cell 1. ??? if LSS is not calibrated.
PLATFORM LOAD (service*)	OFFSET 2:	XXX.X KG	Stored offset weight of Cell 1. ??? if LSS is not calibrated.
PLATFORM LOAD (service*)	ACCESSORY	XXX.X KG	Stored accessory weight. ??? if LSS is not calibrated.
PLATFORM LOAD (service*)	UNRESTRICT	XXX.X KG	UGM will set Unrestricted Rated Load as defined by Machine Configuration.
PLATFORM LOAD (service*)	RESTRICT	XXX.X KG	UGM will set Restricted Rated Load as defined by Machine Configuration.
PLATFORM LOAD (service*)	RAW 1:	XXX.X KG	Gross value from Cell 1. ??? if Unhealthy**.
PLATFORM LOAD (service*)	RAW 2:	XXX.X KG	Gross value from Cell 2. ??? if Unhealthy**.

\* Indicates only visible in service view mode

\*\* Typically indicates a DTC is active

## Calibration Procedure

1. Remove everything from the platform, except permanently fixed JLG Accessories, to allow the Load Sensing System to record its' weight during calibration. This includes all tools, debris, and customer-installed devices.
2. Plug the JLG Analyzer into the Machine at the Ground Station and enter Service Access Password 33271.
3. The platform should be approximately level for calibration. Level the platform from ground control (if necessary) to within +/- 5°.
4. To access the Calibration Menu, use the LEFT and RIGHT Arrow keys to select CALIBRATION from the Top Level Menu. The screen will read:

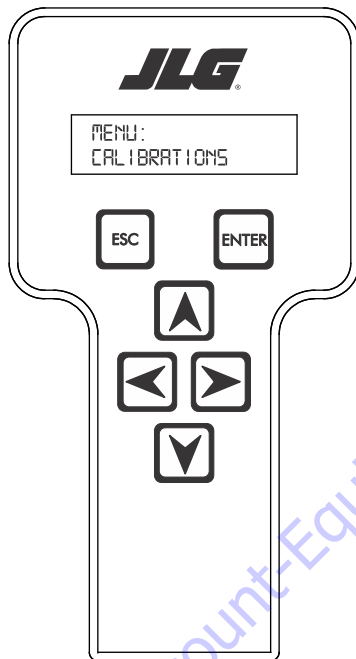

**NOTE:** The Calibration Menu is not available in OPERATOR ACCESS.

5. Press the ENTER key  to view the menu. Upon entry to the Calibration Menu, the JLG Control System will link to the Analyzer and the screen will read:

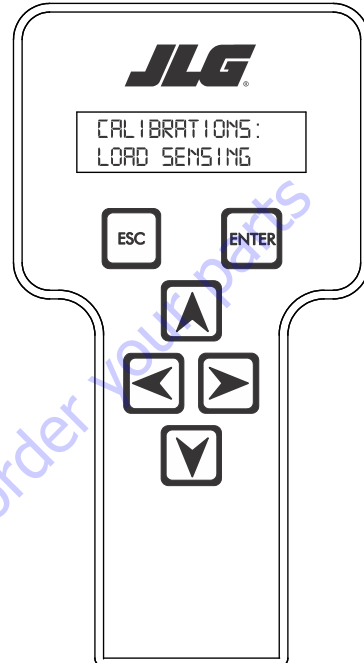

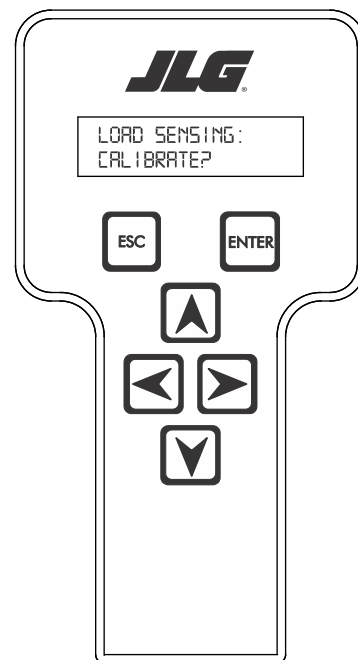

6. Press Enter . The Screen will read:





**NOTE:** Calibration will auto fail if LSS DTC's are active (443, 444, 4479, 4480, 663, 821, 822, 823, 824, 8218, 8222 -> 8238, 991, 992, 993, 994 or 99285).

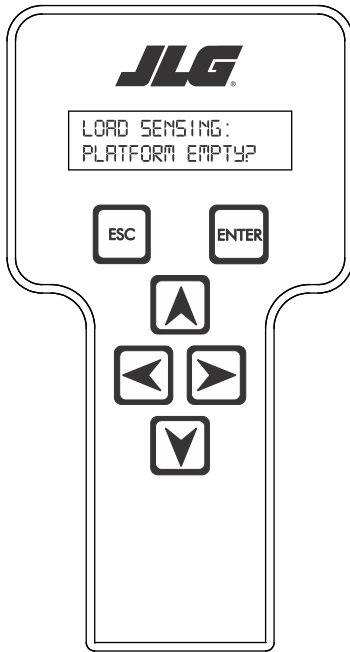

Pressing the ESC key  after starting calibration and before calibration is complete will display the CAL FAILED message. This will not disturb the prior calibration information.

7. Press ENTER . The analyzer screen will read:



8. If the platform is empty, press ENTER . The screen will read:

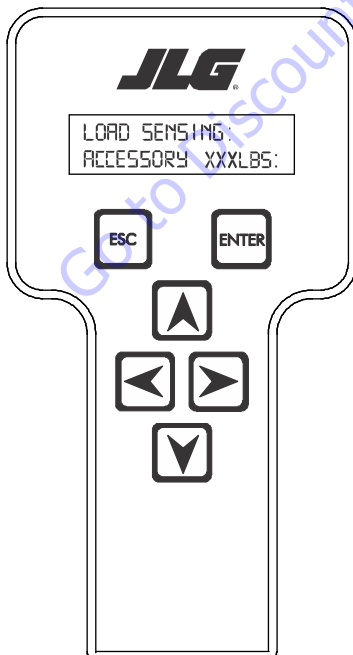

**NOTE:** Accessory weight will reset to 0 lb each time the machine is re-calibrated and will need to be re-entered.

**NOTE:** The Accessory weight will be temporarily stored in the Control System until calibration has been completed successfully.

Refer to Table 6-6, Accessory Weights. Use the up and down analyzer keys to enter the accessory weight(s) (in lb). When all the accessory weights are entered, press

ENTER . The screen will read:

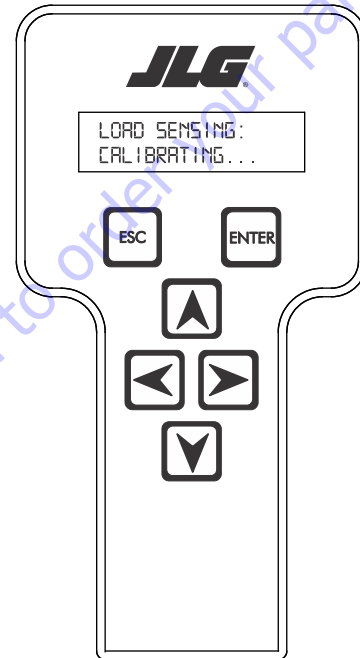

Table 6-6. Accessory Weights

Accessory	Weight
SkyWelder (stick welder)	70 lb (32 kg)
SkyWelder Prep	Prep only = 15 lb (7 kg) Full install = 70 lb (32 kg)
SkyCutter (plasma cutter)	70 lb (32 kg)
SkCutter / SkyWelder Combo	140 lb (64 kg)
Fire Extinguisher	45 lb (20 kg)
Overhead Soft Touch	80 lb (36 kg)
Work Surface	20 lb (9 kg)

**NOTE:** Not all Accessories are available on every JLG model. Some Accessory combinations are prohibited due to excessive weight and/or load restriction. If any installed JLG Accessories are labeled with weight decals but are not listed in the table above, include their weight when entering the ACC WEIGHT value.

- The control system will calculate the load cell readings and ensure it is greater than 130 lb (59 kg), but less than 575 lb (261 kg).

If the platform weight is not within the allowed range, the calibration attempt will be unsuccessful and the Analyzer will show the following:

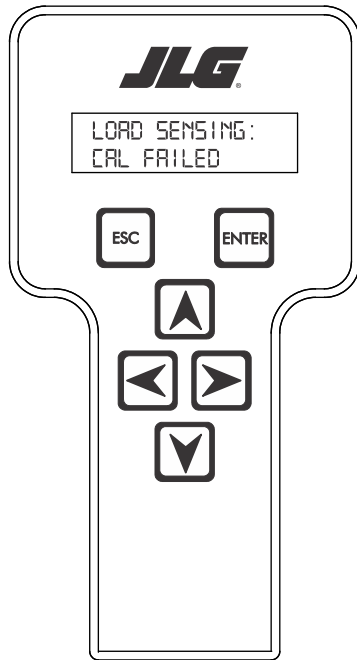

- Press ENTER . The control system will ask for installed accessories. The screen will show the following:

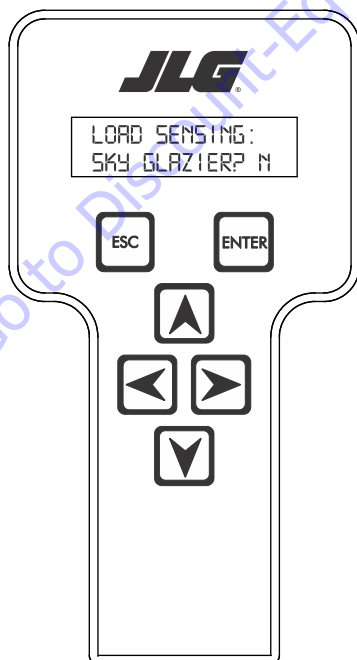

- Use the analyzer keys to select N for no or Y for yes. Press

ENTER . The screen will read:

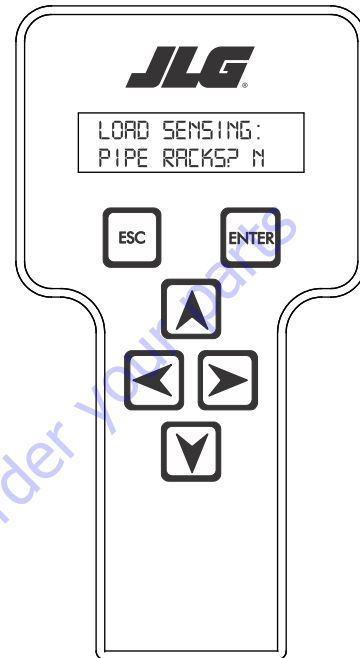

12. Use the analyzer keys to select N for no or Y for yes. Press

ENTER . The control system will default to an estimate of unrestricted capacity, which can be adjusted if necessary. Refer to Table 6-7, SkyGlazier Capacity Reductions and Table 6-8, Pipe Rack Capacity Reductions.

The screen will read:

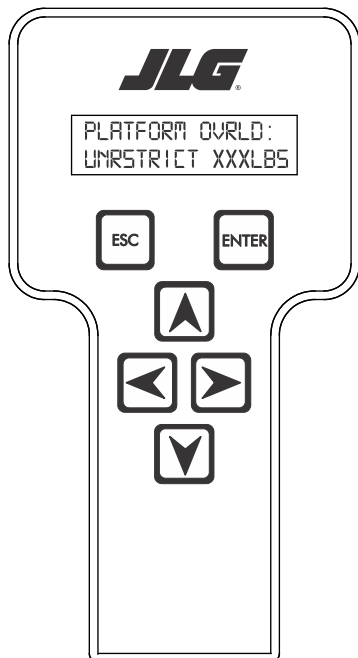

Table 6-7. SkyGlazier Capacity Reductions

Capacity	PLATFORM OVRLD	PLATFORM OVRLD RESTRICT
500 lb (227 kg)	400 lb (181 kg)	n/a
550 lb (250 kg)	400 lb (181 kg)	n/a
600 lb (272 kg)	400 lb (181 kg)	n/a
750 lb (340 kg)	n/a	590 lb (268 kg)
1000 lb (454 kg)	n/a	750 lb (340 kg)

Note: If both SkyGlazier and Pipe Racks are configured, capacity will be the lower of the two values.

Table 6-8. Pipe Rack Capacity Reductions

Capacity	PLATFORM OVRLD	PLATFORM OVRLD RESTRICT
500 lb (227 kg)	400 lb (181 kg)	n/a
550 lb (250 kg)	450 lb (204 kg)	n/a
600 lb (272 kg)	500 lb (227 kg)	n/a
750 lb (340 kg)	n/a	650 lb (295 kg)
1000 lb (454 kg)	n/a	900 lb (408 kg)

Note: If both SkyGlazier and Pipe Racks are configured, capacity will be the lower of the two values.

13. Press ENTER . The following screen will be displayed for restricted capacity, which can be adjusted if necessary. Refer to Table 6-7, SkyGlazier Capacity Reductions and Table 6-8, Pipe Rack Capacity Reductions.

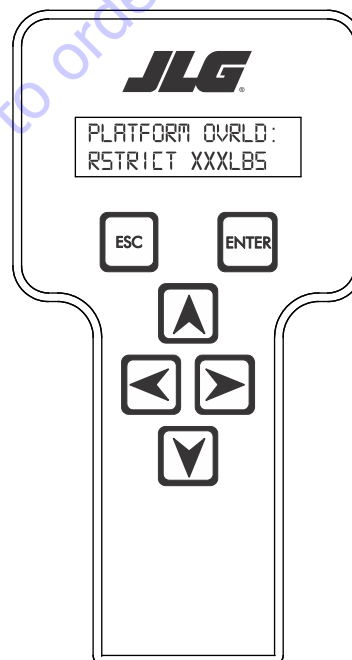

14. Press ENTER . If calibration is successful, the screen will read:

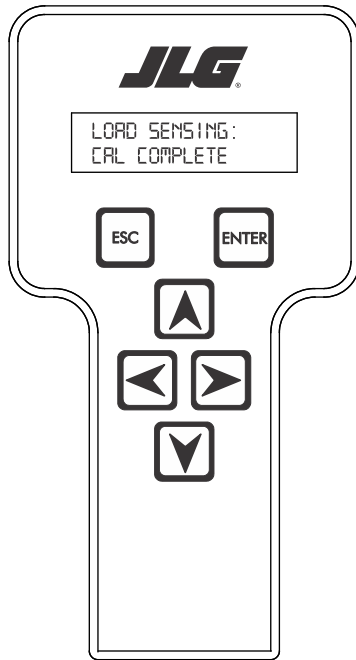

Go to Discount-Equipment.com to order your parts

### Testing & Evaluation

Refer to Troubleshooting if the Load Sensing System fails to meet these guidelines.

1. Connect the JLG Analyzer.
2. Level the Platform. The platform should be approximately level for analysis, or the guidelines below will not be applicable. Level the platform from Ground Control (if necessary) to within  $\pm 5$  degrees.
3. Observe the Empty Platform Weight. Proceed to the DIAGNOSTICS, PLTLOAD sub-menu and observe the measured platform load. All tools, debris, and customer-installed devices shall be removed during evaluation. Ideally, the PLTLOAD should be zero but can vary  $\pm 15$ lb ( $\pm 7$ kg). Further, the reading should be stable and should not vary by more than  $\pm 2$ lb ( $\pm 1$ kg) (unless there is heavy influence from wind or vibration).
4. Use the Technician's Weight to Evaluate. The technician should enter the platform and record the PLTLOAD reading while standing in the center of the platform.
5. Confirm Control System Warnings and Interlocks. Using the keyswitch, select Platform Mode and power-up. Start the vehicle's engine and ensure that all controls are functional and the Load Sensing System's Overload Visual and Audible Warnings are not active. Simulate an Overload by unplugging the Shear Beam Load Cell. The Overload Visual Warning should flash, and the Audible Warning (at Platform and Ground) should sound for 5 seconds On, and 2 seconds Off. With the engine running, all control should be prevented. Cycle the Platform EMS to stop the engine and then power-up again. The Overload Visual and Audible Warning should continue. Confirm that controls are responsive when using the Auxiliary Power Unit for emergency movement. Reconnect the Load Cell. The Overload Visual and Audible Warnings should cease and normal control function should return. Switch the vehicle's keyswitch to Ground Mode and repeat the above procedure. The Overload Visual Warning at the Ground Controls should flash, and the Audible Warning (at Platform and Ground) should sound for 5 seconds On, 2 seconds Off. However, the controls should remain functional when using the engine and the Auxiliary Power Unit (if the Control System's MACHINE SETUP, LOAD is set to "2=CUTOUT PLT". If set to "3=CUTOUT ALL", then Ground Controls will be prevented when using the engine as in the platform).
6. Confirm Control System Capacity Indication (optional for vehicles with Dual Capacity Ratings). For vehicles equipped with a Capacity Select switch on the Platform Console Box, it is necessary to examine an additional interface between the Load Sensing System and the Control System. Using the keyswitch, select Platform Mode and power-up. If necessary, put the boom in the transport position (completely stowed) and center the Jib Plus (if equipped). Place the Capacity Select switch in the unrestricted position and ensure that the proper indicator illuminates on the Platform Console Box. Plug the JLG Analyzer into the Analyzer connection and proceed to the DIAGNOSTICS, SYSTEM submenu. Ensure that the CAPACITY displays indicate OFF. Place the Capacity Select switch in the unrestricted position (if so equipped) and ensure that the proper indicator illuminates on the Platform Console Box (but does not flash). For vehicles with unrestricted capacity, ensure that the unrestricted CAPACITY display indicates ON but the restricted CAPACITY indicates OFF. For vehicles with restricted capacity, ensure that the unrestricted CAPACITY display indicates OFF but the restricted CAPACITY indicates ON.
7. Confirm Load Sensing System Performance with Calibrated Weights. Operate the vehicle from Ground Control and place the boom in the transport position (fully stowed) for safety. Plug the JLG Analyzer into the control system connection and proceed to the DIAGNOSTICS, PLTLOAD display. Place 500lb (230kg) in the platform and ensure that PLTLOAD is with  $\pm 5\%$  of the actual weight. For Dual Capacity vehicles, do the same for the alternate capacity (unrestricted or restricted).

## Troubleshooting

The following tables are furnished to provide possible resolutions for common difficulties. Difficulties are classified as General, Calibration, Measurement Performance, and Host System Functionality.

**Table 6-9. LSS Troubleshooting Chart**

Difficulty	Possible Resolution
<p>Empty Platform Weight (DIAGNOSTICS, PLATFORM LOAD) is not within <math>\pm 15\text{lb}</math> (<math>\pm 7\text{kg}</math>) of zero.</p> <p>or</p> <p>Platform Load readings (DIAGNOSTICS, PLATFORM LOAD) are unstable by more than <math>\pm 2\text{lb}</math> (<math>\pm 1\text{kg}</math>) (without the influence of vibration or wind).</p> <p>or</p> <p>There are large variations in Platform Load (DIAGNOSTICS, PLATFORM LOAD) based on the location of the load. Tolerance to variations is 20lb for an evaluation using the technician's weight, and <math>\pm 5\%</math> of Rated Load when using calibrated weights.</p>	<p>The LSS System is unable to properly measure the platform weight.</p> <ol style="list-style-type: none"> <li>1. The Load Cell is not properly plugged into the LSS Harness. It is possible poor electrical contact is made.</li> <li>2. Wiring leading to the Load Cell is damaged. Carefully inspect sensor wiring where it passes through cable clamps for signs of damage. Inspect wiring where damage to the channel is apparent.</li> <li>3. The Load Cell was not assembled properly during installation. Examine the sensor's reading using the JLG Analyzer. Proceed to the DIAGNOSTICS, CELL, LOAD displays and determine if the readings are reasonable. It is often helpful to apply slight downward pressure above the sensor and observe that its output increases (increasing force measurement; decreasing means the sensor is mounted upside-down).</li> <li>4. The Load Cell is contaminated by debris or moisture. Examine the sensor's reading using the JLG Analyzer. Proceed to the DIAGNOSTICS, CELL, LOAD displays and determine if the readings are reasonable and stable (not changing by more than <math>\pm 2\text{lb}</math> (<math>\pm 1\text{kg}</math>) (without the influence of vibration or wind). Lack of measurement stability is a key indication of contamination. Unplug the connector and inspect for dirt or moisture. Look carefully into the female connector on the sensor's cordset for evidence of contamination. Debris should be brushed away with a soft bristle brush (do not introduce any cleaners as they will leave conductive residue). Moisture should be allowed to evaporate or accelerated with a heat-gun (use low heat and be carefully to not melt connector materials). Moisture intrusion into the molded portion of the connector (capillary action into the wire bundle) or the Shear Beam Load Cell itself will require replacement of the sensor.</li> <li>5. The Load Cell has been mechanically damaged. If the Load Cell is physically deformed or has damage to the cover it should be replaced immediately. It is also possible to have invisible mechanical damage resulting from an extreme overload (<math>&gt;6000\text{lb}</math> [<math>&gt;2722\text{kg}</math>]).</li> </ol>
<p>The Visual and Audible Overload Warnings fail to sound when platform is loaded beyond Rated Load, or when simulated by unplugging the Load Cell. Controls remain functional at Platform and Ground Control positions.</p>	<p>The Control System is failing to regard the overload signal from the LSS System, or the signal is shorted.</p> <ol style="list-style-type: none"> <li>1. The Load Sensing System must be enabled within the Control System. Plug the JLG Analyzer into the Control System, enter the Access Level 1 password (33271), and examine the MACHINE SETUP, LOAD sub-menu. The selection "2=CUTOUT PLT" should be displayed (platform controls prevented during overload, ground controls remain operational). In country- or customer-specific circumstance, the selection "3=CUTOUT ALL" is used (platform and ground controls prevented during overload).</li> </ol>
<p>The Ground Audible Warning fails to sound, but the Platform Audible Warning sounds properly.</p>	<p>The Ground Alarm is missing or improperly installed. Verify that the device is mounted. Verify wiring from the Main Terminal Box and Ground Module.</p>
<p>Controls remain functional at the Ground Control position during an overload, or when simulated by unplugging the Load Cell. The Controls at the Platform Control position are prevented when using the engine, but not when using the Auxiliary Power Unit.</p>	<p>The JLG Control System is configured to prevent platform controls only in the event of overload. Alternately, the Host Control System can be configured to prevent ground and platform controls for country- or customer-specific circumstances.</p> <p>Using the JLG Analyzer, enter the Access Level 1 password (33271). Proceed to the MACHINE SETUP, LOAD sub-menu. Set this parameter to "2=CUTOUT PLT" to prevent platform controls in the event of overload. Set this parameter to "3=CUTOUT ALL" to prevent platform and ground controls in the event of overload.</p>

### 6.3 RESETTING THE MSSO SYSTEM

1. Use the following procedure to reset the MSSO system.
2. Position the Platform/Ground select switch to the desired position.
3. Plug the analyzer into the connector coming from the ground control module or from the platform console.

**NOTE:** If performing the procedure from the platform console, the Emergency Stop switch on the ground console must also be pulled out.

4. Pull out the Emergency Stop switch.
5. The analyzer screen should read:

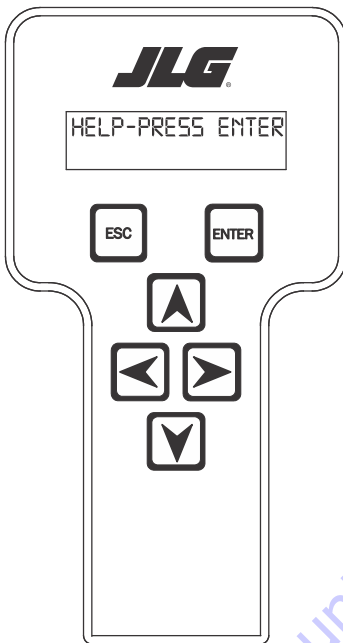

6. Use the arrow button to reach OPERATOR ACCESS. Press



7. Enter the Access Code, 33271.

8. Use the right Arrow key to reach MENU: CALIBRATIONS.



9. Use the arrow keys to reach the LOAD SENSING menu. The screen should read:

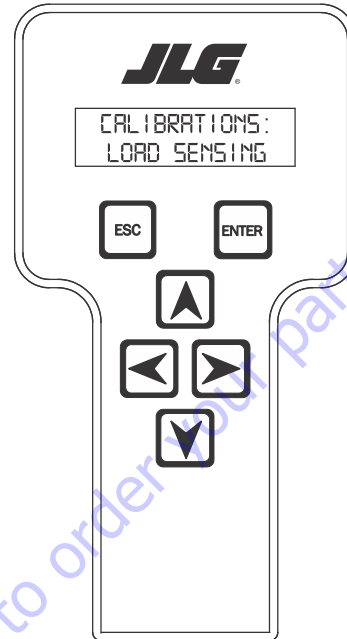



10. Press ENTER .

11. Use the left arrow key  or right arrow key  arrow to reach MSSO RESET.

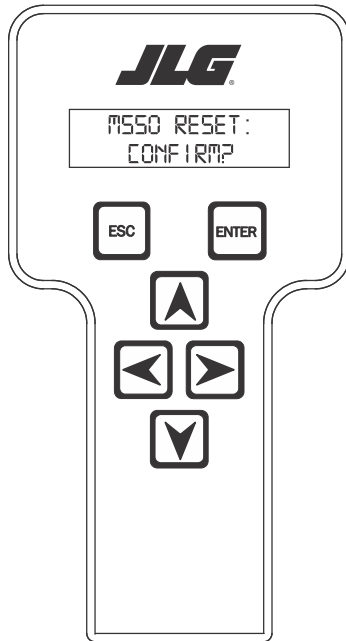
12. Press Enter . The screen will read:



13. Press Enter . The JLG Control System will reset an active 873 DTC and the MSSO System will be reset. Press Escape  to return to the CALIBRATIONS menu.



## 6.4 MACHINE MODEL ADJUSTMENT

### Adjustment Notes

1. Personality settings can be adjusted anywhere within the adjustment range in order to achieve optimum machine performance.
2. Stop watch should be started with the function movement, not with actuation of the joystick or switch.
3. Drive speeds should be set to the values below regardless of the tire size.
4. All speed tests are run from the platform, these speeds do not reflect the ground control operation.
5. Function Speed Control knob must be at full speed (turned clockwise completely) unless noted.



6. Some flow control functions may not work with the Function Speed Control knob clicked into the creep position.



7. Functional speeds may vary due to cold thick hydraulic oil. Test should be run with the oil temperature above 38° C (100° F)

### Machine Orientation When Performing Test

#### DRIVE (BELOW ELEVATION)

1. Test should be done on a smooth, level surface. The Drive Select Switch should be in the "Max Speed" position.
2. Start approximately 7.6 m (25 ft) from starting point so the unit is at a maximum speed when starting the test.
3. Results should be recorded for a 61 m (200ft) course.
4. Drive forward, "High Speed", record time.



#### DRIVE (ABOVE ELEVATION)

1. Test should be done on a smooth, level surface. Drive Select Switch should be in the "Max Speed" position.
2. Boom should be > 10° above horizontal to ensure drive is operating in Max Torque mode.
3. Results should be recorded for a 15.2 m (50 ft) course.
4. Drive forward, record time.
5. Drive Reverse, record time.
6. Turn Platform Speed Control Knob fully counterclockwise to enter Creep mode.

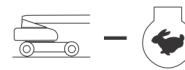

7. Creep light on Panel must be energized.



8. Verify that machine will Drive Forward and Reverse.
9. Return Knob to fully clockwise.

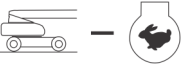

**CRAWLER DRIVE (BELOW ELEVATION)**

1. Test should be done on a smooth, level surface. The Drive Select Switch should be in the "Max Speed" position. 
2. Start approximately 7.6 m (25 ft) from starting point so the unit is at a maximum speed when starting the test.
3. Results should be recorded for a 61 m (200ft) course.
4. Adjust the Left track/Right track drive FWD/REV maximums to achieve the best straight tracking performance without introducing steer.
5. Drive forward, "High Speed", record time.
6. Drive Reverse, "High Speed", record time.

**CRAWLER DRIVE (ABOVE ELEVATION)**

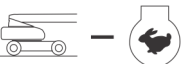
1. Test should be done on a smooth, level surface. The Drive Select Switch should be in the "Max Speed" position. 
2. Boom should be > 10° above horizontal to ensure the drive is operating in Max Torque mode.
3. Results should be recorded for a 15.2 m (50ft) course.
4. Adjust the Left track/Right track FWD/REV Elevated drive maximum to achieve the best straight tracking without introducing steer.
5. Drive forward, record time.
6. Drive Reverse, record time.
7. Lower boom below < 5° and retract boom.

8. Turn Platform Speed Control Knob fully counterclockwise to enter Creep mode.



9. Creep light on Panel must be energized.



10. Verify that machine will Drive Forward and Reverse.



11. If needed, Adjust the Left track/Right track drive FWD/REV creep drive maximums to achieve the best straight tracking performance.
12. Return Knob to fully clockwise.

**SWING**

1. Boom at full elevation, Telescope retracted. Swing Right until over rear axle or end stop (if equipped).
2. Swing Left 360° or end stop (if equipped), record time.
3. Swing Right 360° or end stop (if equipped), record time.
4. Turn Platform Speed Control Knob fully counterclockwise to enter Creep mode.

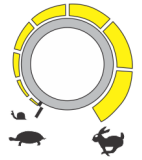

5. Creep light on Panel must be energized.



6. Verify that machine will swing left and right.
7. Return Function Speed Knob to fully clockwise.

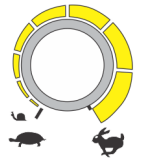

**TOWER LIFT**

1. Tower Lift in stowed position, Telescope Retracted.
2. Tower Lift Up, record time.
3. Tower Lift Down, record time.
4. Turn Platform Speed Control Knob fully counterclockwise to enter Creep mode.



5. Creep light on Panel must be energized.



6. Verify that machine will Tower Up and Down. Return Knob to fully clockwise.

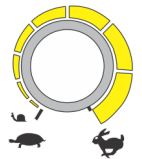

**MAIN LIFT**

1. Main Lift in stowed position, Telescope Retracted.
2. Main Lift Up, record time.
3. Main Lift Down, record time.
4. Turn Platform Speed Control Knob fully counterclockwise to enter Creep mode.



5. Creep light on Panel must be energized.



6. Verify that machine will Lift Up and Down.
7. Return Knob to fully clockwise.



**TELESCOPE**

1. Main Lift at full elevation, Telescope Retracted.
2. Telescope Out, record time.
3. Telescope In, record time.
4. Turn Platform Speed Control Knob fully counterclockwise to enter Creep mode.



5. Creep light on Panel must be energized.



6. Verify that machine will Telescope In and Out.
7. Return Knob to fully clockwise.



**JIB LIFT**

1. Platform level and centered with the boom. Jib Lift Down until stop.
2. Jib Lift Up, record time.
3. Jib Lift Down, record time.
4. Turn Platform Speed Control Knob fully counterclockwise to enter Creep mode.



5. Creep light on Panel must be energized.



6. Verify that machine will Jib Lift Up and Down.
7. Return Knob to fully clockwise.



**PLATFORM ROTATE**

1. Platform level, Rotate Platform Right until stop
2. Platform Left, record time.
3. Platform Right, record time.
4. Turn Platform Speed Control Knob fully counterclockwise to enter Creep mode.



5. Creep light on Panel must be energized.



6. Verify that machine will Platform Rotate Left and Right.
7. Return Knob to fully clockwise.



**NOTE:** When the platform speed control knob is turned fully counterclockwise. The platform rotate may not work, this is acceptable.

Table 6-10. Machine Model Adjustment Speeds

FUNCTION	ADJUSTMENT RANGES	400SC / 460SJC MODEL DEFAULTS	MODEL TIME RANGES (IN SECONDS)		
			400SC	460SJC	
<b>DRIVE</b>					
	Accel	25 – 2000 mA/s	N/A		
	Decel	25 – 2000 mA/s	N/A		
	Min	250 – 1000 mA	N/A		
	Max	250 – 1400 mA	N/A	N/A	N/A
Drive to Stop	Decel	25 – 2000 mA/s	N/A		
MT: Elevated	Max	250 – 1200 mA	N/A	N/A	N/A
ME: Elevated	Max	250 – 1200 mA	N/A	N/A	N/A
Max Torque	Creep	250 – 1200 mA	N/A		
Mid Engine	Creep	250 – 1200 mA	N/A		
ME = Max Engine, MT = Max Torque					
<b>DRIVE LEFT TRACK</b>					
	Accel	0 – 5s	1.0s		
	Decel	0 – 5s	1.0s		
FORWARD	Min	0 – 160 mA	50 mA		
	Max	0 – 160 mA	143 mA	80 – 90	80 – 90
	Elevated	0 – 105 mA	90 mA	80 – 90	80 – 90
	Creep	0 – 105 mA	90 mA		
REVERSE	Min	0 – 160 mA	55 mA		
	Max	0 – 160 mA	135 mA	80 – 90	80 – 90
	Elevated	0 – 105 mA	95 mA	80 – 90	80 – 90
	Creep	0 – 105 mA	95 mA		
<b>DRIVE RIGHT TRACK</b>					
	Accel	0 – 5s	1.0s		
	Decel	0 – 5s	1.0s		
FORWARD	Min	0 – 160 mA	50 mA		
	Max	0 – 160 mA	140 mA	80 – 90	80 – 90
	Elevated	0 – 105 mA	95 mA	80 – 90	80 – 90
	Creep	0 – 105 mA	95 mA		
REVERSE	Min	0 – 160 mA	60 mA		
	Max	0 – 160 mA	145 mA	80 – 90	80 – 90
	Elevated	0 – 105 mA	100 mA	80 – 90	80 – 90
	Creep	0 – 105 mA	100 mA		
<b>SWING</b>					
	Accel	0 – 5s	2.2s		
	Decel	0 – 5s	1.2s		
LEFT	Min	250 – 1400 mA	420 mA		
	Max	250 – 1400 mA	860 mA	70 – 90	70 – 90
	Creep	250 – 1400 mA	650 mA		

**SECTION 6 - JLG CONTROL SYSTEM**

**Table 6-10. Machine Model Adjustment Speeds**

FUNCTION		ADJUSTMENT RANGES	400SC / 460SJC MODEL DEFAULTS	MODEL TIME RANGES (IN SECONDS)	
				400SC	460SJC
RIGHT	Min	250 – 1400 mA	400 mA		
	Max	250 – 1400 mA	800 mA	70 – 90	70 – 90
	Creep	250 – 1400 mA	650 mA		
<b>TOWER LIFT</b>					
	Accel	0 – 5s	N/A		
	Decel	0 – 5s	N/A		
UP	Min	250 – 1400 mA	N/A		
	Max	250 – 1400 mA	N/A	N/A	N/A
	Creep	250 – 1400 mA	N/A		
DOWN	Min	250 – 1400 mA	N/A		
	Max	250 – 1400 mA	N/A	N/A	N/A
	Creep	250 – 1400 mA	N/A		
	Soft Down	250 – 1400 mA	N/A		
<b>LIFT</b>					
	Accel	0 – 5 s	1.5 s		
	Decel	0 – 5 s	0.8 s		
UP	Min	250 – 1400 mA	400 mA		
	Max	250 – 1400 mA	900 mA	33 – 40	33 – 40
	Creep	250 – 1400 mA	600 mA		
DOWN	Min	250 – 1400 mA	380 mA		
	Max	250 – 1400 mA	750 mA	33 – 40	33 – 40
	Creep	250 – 1400 mA	500 mA		
	Soft Down	250 – 1400 mA	450 mA		
	Soft Down	250 – 1400 mA	450 mA		
<b>TELESCOPE</b>					
	Accel	0 – 5 s	1 s		
	Decel	0 – 5 s	0.8 s		
IN	Min	250 – 1400 mA	415 mA		
	Max	250 – 1400 mA	890 mA	33 – 40	33 – 40
	Creep	250 – 1400 mA	580 mA		
OUT	Min	250 – 1400 mA	415 mA		
	Max	250 – 1400 mA	780 mA	33 – 40	33 – 40
	Creep	250 – 1400 mA	525 mA		
<b>JIB LIFT</b>					
	Accel	0 – 5 s	1.2 s		
	Decel	0 – 5 s	0.5 s		
UP	Min	250 – 1400 mA	350 mA		
	Max	250 – 1400 mA	690 mA	18 – 22	18 – 22
	Creep	250 – 1400 mA	500 mA		

Table 6-10. Machine Model Adjustment Speeds

FUNCTION		ADJUSTMENT RANGES	400SC / 460SJC MODEL DEFAULTS	MODEL TIME RANGES (IN SECONDS)	
				400SC	460SJC
DOWN	Min	250 – 1400 mA	350 mA		
	Max	250 – 1400 mA	630 mA	18 – 22	18 – 22
	Creep	250 – 1400 mA	450 mA		
<b>PLATFORM LEVEL</b>					
	Accel	0 – 5 s	0 s		
	Decel	0 – 5 s	0 s		
UP	Min	250 – 1400 mA	400 mA		
	Max	250 – 1400 mA	600 mA		
	Creep	250 – 1400 mA	600 mA		
DOWN	Min	250 – 1400 mA	400 mA		
	Max	250 – 1400 mA	600 mA		
	Creep	250 – 1400 mA	600 mA		
<b>PLATFORM ROTATE</b>					
	Accel	0 – 5 s	0 s		
	Decel	0 – 5 s	0 s		
LEFT	Min	250 – 1400 mA	500 mA		
	Max	250 – 1400 mA	600 mA	20 – 25	20 – 25
	Creep	250 – 1400 mA	600 mA		
RIGHT	Min	250 – 1400 mA	500 mA		
	Max	250 – 1400 mA	600 mA	20 – 25	20 – 25
	Creep	250 – 1400 mA	600 mA		
<b>GROUND MODE</b>					
SWING	Left	250 – 1400 mA	855 mA		
	Right	250 – 1400 mA	795 mA		
TOWER LIFT	Up	250 – 1400 mA	N/A		
	Down	250 – 1400 mA	N/A		
LIFT	Up	250 – 1400 mA	895 mA		
	Down	250 – 1400 mA	745 mA		
TELESCOPE	In	250 – 1400 mA	885 mA		
	Out	250 – 1400 mA	775 mA		
JIB	Up	250 – 1400 mA	685 mA		
	Down	250 – 1400 mA	625 mA		
PLATFORM	Up/Down	250 – 1400 mA	595 mA		
PLATFORM	Left/Right	250 – 1400 mA	595 mA		

100119361E

## 6.5 SYSTEM TEST

The Control System Incorporates a built-in system test to check the system components and functions. To use this function, use the following procedures.

### Test from the Platform

1. Position the Platform/Ground select switch to the Platform position.



MAE17700

2. Plug the analyzer into the connector at the base of the platform control box.



MAE15680

3. Pull out the Emergency Stop switch and Start the engine.



MAE17820

4. The analyzer screen should read:

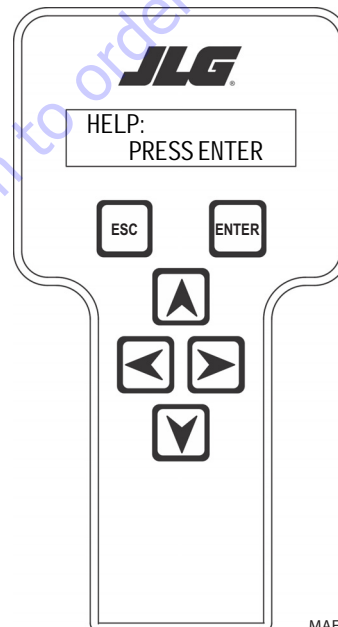

MAE19060

5. Use the arrow button to reach SYSTEM TEST. Hit Enter. The analyzer will prompt you asking if you want to activate the system test; hit Enter again to activate.
6. Follow the flow path in (See Figure 6-21.), System Test Flow Chart - Platform Tests and go through the component tests. Hit the ESC key during any part of the test to return to the main menu without completing all tests or wait until all tests are complete. During the TEST ALL INPUTS sequence, the analyzer allows control switches to be operated and shows if they are closed (CL) or open (OP).

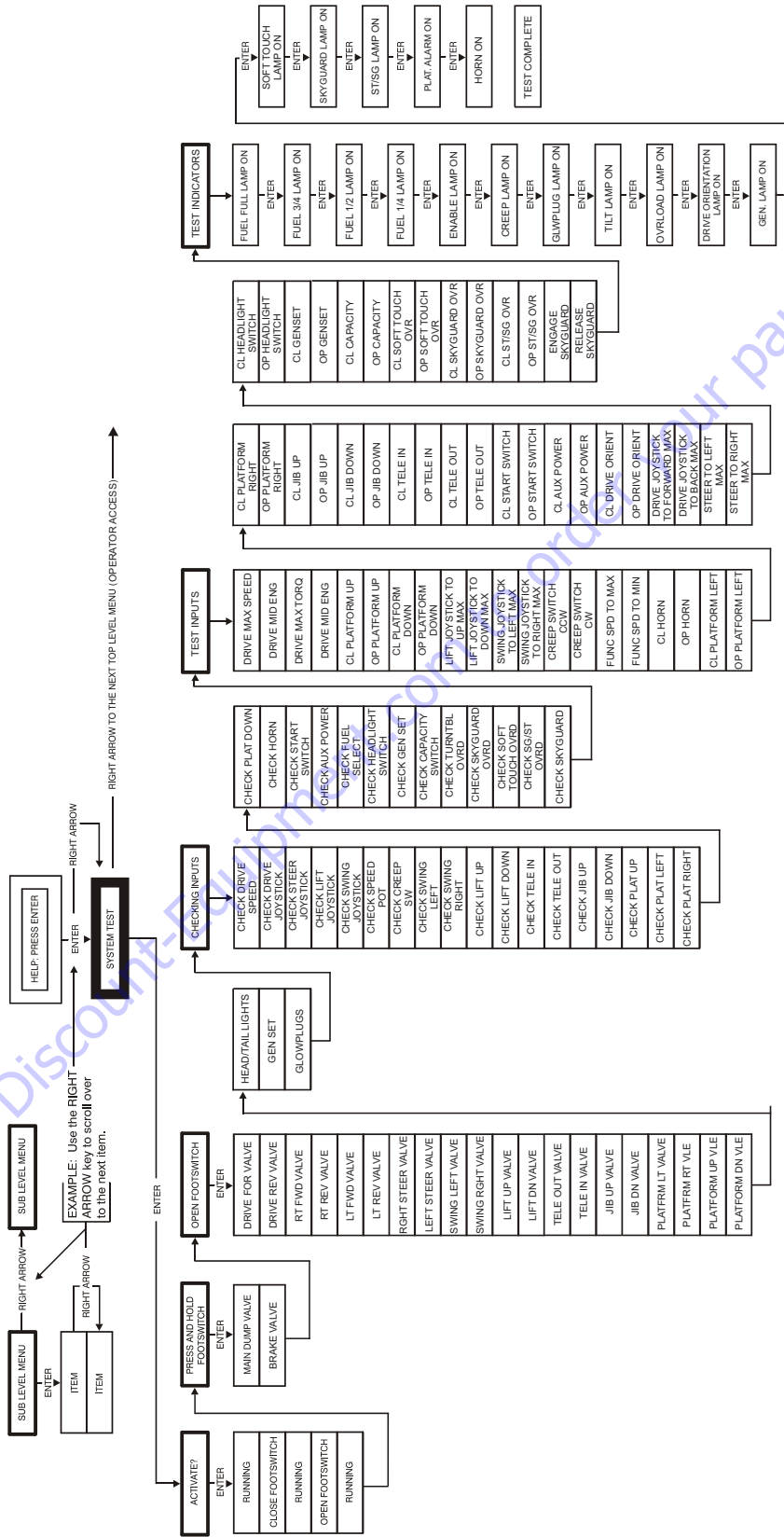

Figure 6-21. System Test Flow Chart- Platform Tests



**Test from the Ground Station**

1. Position the Platform/Ground select switch to the Platform position.



MAE17700

2. Plug the analyzer into the connector inside the Ground control box.

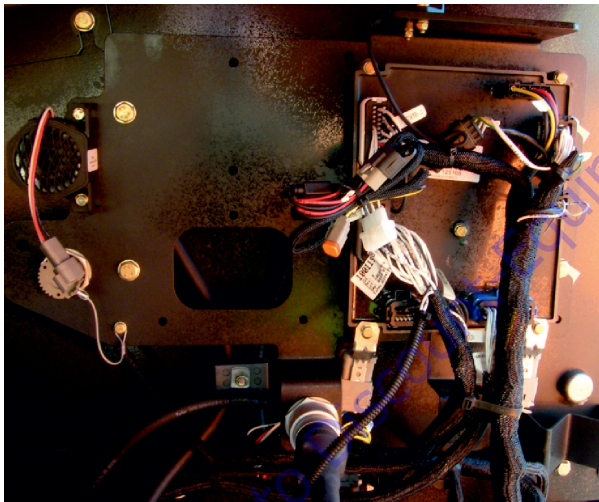

MAE17710

3. Pull out the Emergency Stop switch and Start the engine.



MAE17700

4. The analyzer screen should read:

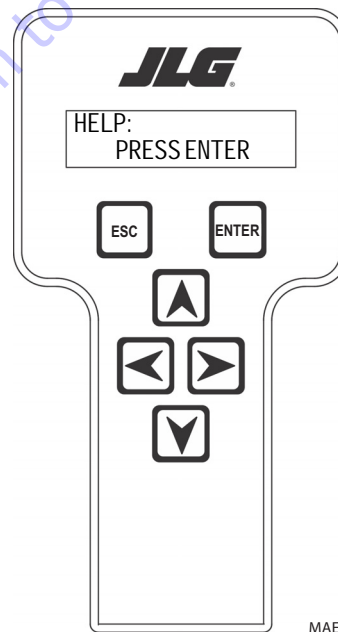

MAE19060

5. Use the arrow button to reach SYSTEM TEST. Hit Enter. The analyzer will prompt you asking if you want to activate the system test; hit Enter again to activate.
6. Follow the flow path in (See Figure 6-22.), System Test Flow Chart - Platform Tests and go through the component tests. Hit the ESC key during any part of the test to return to the main menu without completing all tests or wait until all tests are complete. During the TEST ALL INPUTS sequence, the analyzer allows control switches to be operated and shows if they are closed (CL) or open (OP).

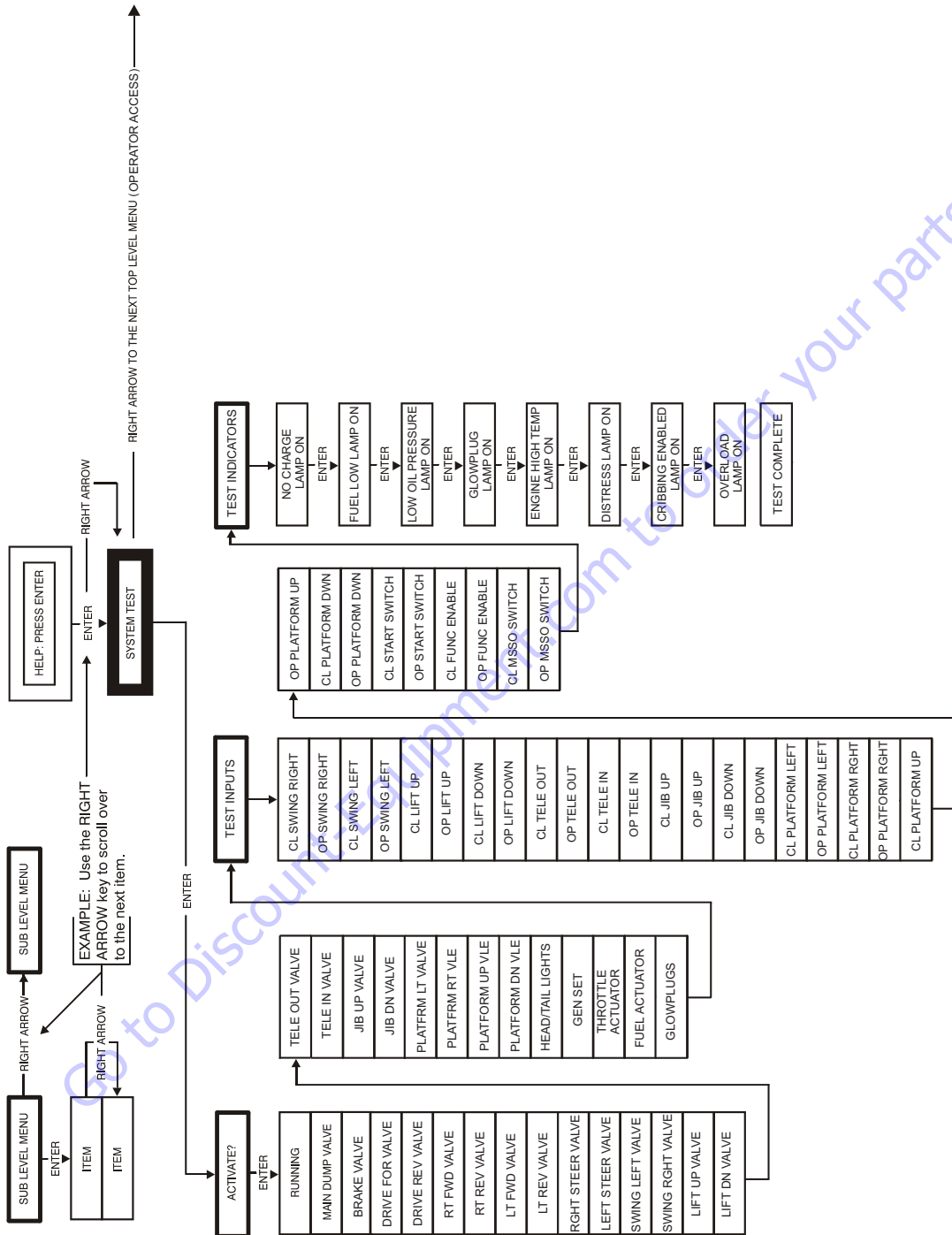

Figure 6-22. System Test Flow Chart - Ground Station Tests

MAE17460

6.6 SYSTEM TEST MESSAGES

Table 6-11. System Test Messages

Message Displayed on Analyzer	Message Displayed on Analyzer	Description
RUNNING		Initial display when system test is run while running certain "critical" checks are made.
	CHECKGROUND/ PLATFORM SELECT	The analyzer must be connected to the active control station to run the system test.
	BATTERY VOLTAGE TOO LOW	The system test may not run properly with battery voltage below 11V.
	BATTERY VOLTAGE TOO HIGH	The system test may not operate properly with the battery voltage above 16V.
	CHECK CAN WIRING	The system test will not operate properly unless the CAN bus is functional.
	ENGINE RUNNING?	The LOSS OF ENGINE SPEED SENSOR fault 4322 is active or CANBUS FAILURE – ENGINE CONTROLLER fault 666 is active
	HIGH TILT ANGLE	The CHASSIS TILT SENSOR OUT OF RANGE fault 814 is active
	HOT ENGINE	The HIGH ENGINE TEMP fault 438 is active
	OPEN FOOTSWITCH	In platform mode, the footswitch must be open at the start of the test.
	CLOSE FOOTSWITCH	In platform mode, the operator must close the footswitch when this message is displayed
	BAD FOOTSWITCH	The two footswitch signals are not changing together, probably because one is open circuit. Check footswitch and wiring.
	OPEN FOOTSWITCH	In platform mode, the operator must open the footswitch when this message is displayed.
PLATFORM OVERLOADED	Load Sensing is configured and the ground module considers the platform to be overloaded	
TESTING VALVES		Indicates that the valve test is beginning. Each valve is alternately energized and de-energized; checks are made for open- and short- circuit valve coils. NOTE: In platform mode, the footswitch must be closed. NOTE: Tower lift valves are not tested if TOWER LIFT=NO. Tower telescope valves are not tested if TOWER TELE=NO. Jib valves are not tested if JIB = NO. Extendable axle valves are not tested if EXT AXLES=NO. Four wheel steer valves are not tested if 4WS=NO. NOTE: Left/right jib valves are not tested unless JIB = SIDESWING. Problems that can be reported include below messages
	CANT TEST VALVES	There is a wiring problem, which prevents the valve test from functioning correctly. Check valve wiring. Check ground alarm & hour meter wiring.
	XXXXXXX S/C	The named valve is drawing too much current so is presumed to be short-circuited. Check valve wiring
	XXXXXXX O/C	The named valve is drawing too little current so is presumed to be open-circuit. Check valve wiring
CHECKING INPUTS		Indicates that the inputs test is beginning. Every input is checked to ensure that it is in its "normal" position; function switches should be open, cutout switches should be closed, joysticks should be in neutral. In platform mode any non-neutral platform switch or joystick is reported; any active cutouts are reported. In ground mode any non-neutral ground switches is reported; any active cutouts are reported. NOTE: Switches, which are not in use (due to the settings of machine digits), are not checked. NOTE: The pump pot is checked only for a wire-off condition; it can be at any demand from creep to maximum. Problems that can be reported include below messages.
	CHECKXXXXXX	The named switch is not in its "normal" position. Check switch & wiring.
	CHECKXXXXXX JOY	The named joystick appears to be faulty. Check joystick.

Table 6-11. System Test Messages

Message Displayed on Analyzer	Message Displayed on Analyzer	Description
TESTING LAMPS		Indicates that the lamps test is beginning. Each lamp is energized in turn; a prompt asks for confirmation that the lamp is lit. ENTER must be pressed or clicked to continue the test. NOTE: Lamps, which are not in use (due to the settings of machine digits), are not checked. NOTE: Platform Lamps are only tested in platform mode. NOTE: The GM overload lamp and 500# capacity lamp are not tested. NOTE: Head and tail lamps are tested in both platform and ground mode if enabled by a machine digit.
TESTING ALARMS		Indicates that the alarms test is beginning. Each alarm is energized in turn; a prompt asks for confirmation that the alarm is sounding.
		ENTER must be pressed or clicked to continue the test.
		NOTE: The platform alarm and the horn are only tested in platform mode.
		NOTE: The ground alarm is not tested if GROUND ALARM = NO.
TEST ALL INPUTS?		Prompts whether to check every operator input. If ESC is pressed or clicked, the system test ends. If ENTER is pressed or clicked, each operator input is prompted for in turn. In platform mode every platform switch and joystick is tested. In ground mode every ground switch is tested. NOTE: Tower lift switches are not tested if TOWER LIFT=NO. Tower telescope switches are not tested if TOWER TELE=NO. Jib switches are not tested if JIB = NO. Extendable axle switches are not tested if EXT AXLES=NO. Four wheel steer switches are not tested if 4WS=NO. NOTE: Left/right jib switches are not tested unless JIB = SIDESWING. Prompts displayed during the operator input test below messages.
	CLOSE XXXXXXX	The named switch should be closed.
	OPEN XXXXXXX	The named switch should be opened.
	XXXXXXX XXXXXXX TO MAX	The named joystick should be pushed to its full extent in the named direction.
	XXXXXXX XXXXXXX TO MIN	The named joystick should be returned to neutral from the named direction.
	PUMP POT TO MAX	The pump pot should be turned to maximum.
	PUMP POT TO MIN	The pump pot should be turned to minimum.
	MULTIPLE CLOSURE	More than one operator input is closed; if only one has been operated, there could be a short between two inputs.
TESTS COMPLETE		Indicates that the system test is complete. Any problems reported should have been noted and should now be rectified. Press ESC/CANCEL to return to the RUN SYSTEM TEST Analyzer menu.

## 6.7 MACHINE DIAGNOSTICS PARAMETERS

Table 6-12. Machine Diagnostics Parameters

Diagnosics Submenu (Displayed on Analyzer 1 <sup>st</sup> Line)	Parameter (Displayed on Analyzer 1 <sup>st</sup> Line)	Parameter Value (Displayed on Analyzer 2 <sup>nd</sup> Line)	Description
DRIVE/STEER	DRIVE DEMAND	FORWARD/REVERSE XXX%	Direction and command percentage of Drive as reported by PM
	DRIVE OUTPUT	FORWARD/REVERSE XXX%	Direction and current output percentage
	DRIVE OUT mA	FORWARD/REVERSE XXXmA	Direction and current output command
	DRIVE FDBK mA	XXXXmA	Current feedback measurement
	STEER DEMAND	LEFT/RIGHT XXX%	Direction and command percentage of Steer as reported by PM.
	STEER OUPUT	LEFT/RIGHT XXX%	Direction and PWM output percentage
	BRAKES STATUS	LOCKED/RELEASED	Status of Brake Valve output
	2 SPEED OUTPUT	ON/OFF	Status of 2 Speed Valve output
	DRIVE MODE	MAX SPEED/MAX TORQUE/MID ENGINE	Drive Mode Status
	DRV ORIENT TT SW	OPEN/CLOSED	State of DOS Switch
	DRV ORIENT MODE	INLINE/SWUNG	DOS state
	DRV ORIENT STATE	CONFIRMED/REQUIRED	InLine and DOS Active = Confirmed
	DRV ORNT OVR SW	CLOSED/OPEN	State of Drive Orientation Override Switch
	CRIBBING MODE SW	CLOSED/OPEN	State of Cribbing Mode Switch; only displayed if MACHINE SETUP → CRIBBING = YES
	CRIBBING MODE	DISABLED/ENABLED	Reflects state of Cribbing Mode Switch; only displayed if MACHINE SETUP → CRIBBING = YES
	LT TRACK DEMAND	FORWARD/REVERSE XXX%	Direction and command percentage of Left Track Drive as reported by PM (400SC)
	LT TRACK OUTPUT	FORWARD/REVERSE XXX%	Direction and current Left Track output percentage (400SC)
	LT TRACK OUT mA	FORWARD/REVERSE XXXmA	Direction and current Left Track output command
	LT TRACK FDBK mA	XXXXmA	Left Track current feedback measurement (400SC)
	RT TRACK DEMAND	FORWARD/REVERSE XXX%	Direction and command percentage of Right Track Drive as reported by PM (400SC)
RT TRACK OUTPUT	FORWARD/REVERSE XXX%	Direction and current Right Track output percentage (400SC)	
RT TRACK OUT mA	FORWARD/REVERSE XXXmA	Direction and current Right Track output command (400SC)	
RT TRACK FDBK mA	XXXXmA	Right Track current feedback measurement (400SC)	
BOOM FUNCTIONS	SWING DEMAND	LEFT/RIGHT XXX%	Direction and percentage of input command from Swing Joystick or Ground %
	SWING OUTPUT	LEFT/RIGHT XXX%	Direction and current output percentage
	SWING OUTPUT mA	LEFT/RIGHT XXXmA	Direction and current output command
	SWING FDBK mA	XXXXmA	Current feedback measurement
	LIFT DEMAND	UP/DOWN XXX%	Direction and percentage of Lift input command

Table 6-12. Machine Diagnostics Parameters

Diagnosics Submenu (Displayed on Analyzer 1 <sup>st</sup> Line)	Parameter (Displayed on Analyzer 1 <sup>st</sup> Line)	Parameter Value (Displayed on Analyzer 2 <sup>nd</sup> Line)	Description
BOOM FUNCTIONS	LIFT OUTPUT	UP/DOWN XXX%	Direction and current output percentage
	LIFT OUTPUT mA	UP/DOWN XXXmA	Direction and current output command
	LIFT FDBK mA	XXXmA	Current feedback measurement
	LIFT DN AUX	ON/OFF	Status of Aux Lift Down
	TELE DEMAND	IN/OUT XXX%/CREEP	Direction and percentage of input command (or CREEP if selected) from Function Speed Pot or Ground%
	TELE OUTPUT	IN/OUT XXX%	Direction and current output percentage for Flow Control Valve mapped to Tele Personalities
	JIB LIFT DEMAND	UP/DOWN XXX%/CREEP	Direction and percentage of input command (or CREEP if selected) from Function Speed Pot or Ground%; only displayed if MACHINE SETUP → JIB = YES
	JIB LIFT OUTPUT	UP/DOWN XXX%	For Up, direction and current output percentage for Flow Control mapped to Jib Lift Up Personality range; for Down, direction and PWM output percentage; only displayed if MACHINE SETUP → JIB = YES
	PLAT LVL DEMAND	UP/DOWN XXX%/CREEP	"Direction and percentage of input command (or CREEP if selected) from Function Speed Pot or Ground%"
	PLAT LVL OUTPUT	UP/DOWN XXX%	"Direction and current output percentage for Flow Control mapped to Platform Level Personality range"
	PLAT ROT DEMAND	LEFT/RIGHT XXX%/CREEP	"Direction and percentage of input command (or CREEP if selected) from Function Speed Pot or Ground%"
	PLAT ROT OUTPUT	LEFT/RIGHT XXX%	"Direction and current output percentage for Flow Control mapped to Platform Rotate Personality range"
	FLW CNTRL OUT mA	XXXmA	Current output command
	FLW CNTRL FBK mA	XXXmA	Current feedback measurement
	MAIN DUMP OUTPUT	ON/OFF	Status of Main Dump Valve
	FUNCTION SPEED	SETTING: XXX%	Displays the percentage demand from the Function Speed Potentiometer.
	CREEP SW	OPEN/CLOSED	Status of Creep Switch Input
	CREEP MODE	ON/OFF	Displays status of Creep Mode
ENGINE	OPERATING STATE	STOPPED/CRANKING/ STARTING/RUNNING	Displays Engine State
	GLOW PLUG	NOT ACTIVE/ACTIVE	Display diagnostic if glow plugs configured: MACHINE SETUP → GLOW PLUG ≠ NO GLOW PLUGS
	COOLANT TEMP	XXC/XXF	Degrees F or C displayed depending on Machine Setup Configuration
	ENGINE OIL PRESS	XXXPsi/XXXXKPA	If Deutz, display transmitted value
	FUEL PRESS	XXXPsi/XXXXKPA	MACHINE SETUP → ENGINE = EMR 4
	AMBIENT TEMP	XXC/XXF	
	FUEL LEVEL	FULL; ¾; ½; ¼; LOW; EMPTY; OK; ERROR	MACHINE SETUP → FUEL LEVEL ≠ NONE
	ALLOWED STARTER	CRANK TIME: XXs	MACHINE SETUP → ENGINE ≠ DUAL FUEL
	ENGINE SPEED	ACTUAL XXXXRPM	RPM read from speed sensor
ENGINE SPEED	TARGET XXXXRPM	UGM—commanded Target RPM	

## SECTION 6 - JLG CONTROL SYSTEM

**Table 6-12. Machine Diagnostics Parameters**

Diagnosics Submenu (Displayed on Analyzer 1 <sup>st</sup> Line)	Parameter (Displayed on Analyzer 1 <sup>st</sup> Line)	Parameter Value (Displayed on Analyzer 2 <sup>nd</sup> Line)	Description
SYSTEM	UGM BATTERY	XX.XV	UGM measured battery voltage
	PLATFORM MODULE	BATTERY XX.XV	PM measured battery voltage
	UGM TEMP	XXXC/XXXF	UGM on-board temperature measurement
	PLATFORM SELECT	KEYSWITCH: OPEN KEYSWITCH: CLOSED	Displays whether Platform Keyswitch position is being selected
	GROUND SELECT	KEYSWITCH: OPEN KEYSWITCH: CLOSED	Displays whether Ground Keyswitch position is being selected
	STATION CONTROL	GROUND/PLATFORM	Displays Active control station per System Mode definition
	FOOTSWITCH INPUT	GROUND: OPEN GROUND: CLOSED	State of Footswitch input at UGM
	FOOTSWITCH INPUT	PLATFORM: OPEN PLATFORM: CLOSED	State of Footswitch input at PM (closed when footswitch not activated)
	BOOM ANGLE	XX.XDEG	Boom Angle with respect to sign
	BOOM ANGLE 1 RAW	XXXXCOUNTS	Boom Angle sensor #1 raw A/D counts
	BOOM ANGLE 2 RAW	XXXXCOUNTS	Boom Angle sensor #2 raw A/D counts
SYSTEM	ELEVATION MODE	ABOVE/NOT ABOVE	Elevation State
	TELE RETRAC SW 1	OPEN/CLOSED	"State of Telescope Retracted Proximity Switch #1; High = CLOSED"
	TELE RETRAC SW 2	OPEN/CLOSED	"State of Telescope Retracted Proximity Switch #2; High = OPEN"
	RETRACTED MODE	RETRACTED/NOT RETRACTED	Telescope Retracted State
	CAPACITY SW 1	OPEN/CLOSED	"State of Capacity Length Proximity Switch #1; High = CLOSED; only displayed if Dual Capacity is configured"
	CAPACITY SW 2	OPEN/CLOSED	"State of Capacity Length Proximity Switch #2; High = OPEN; only displayed if Dual Capacity is configured"
	CAPACITY MODE	RESTRICTED/UNRESTRICT ED/ERROR	Dual Capacity State; Dual Capacity is configured
	OSC AXLE	LOCKED/NOT LOCKED	Oscillating Axle State
	TRANSPORT MODE	IN TRANSPORT/OUT OF TRANSPORT	Transport Position
	CREEP SW	OPEN/CLOSED	Status of Creep Switch Input
	CREEP MODE	ON/OFF	Displays status of Creep Mode
	CHASSIS TILT	XX.XDEG	Combined X/Y Absolute Angle
	CHASSIS TILT	X-AXIS: XX.XDEG	X Angle with respect to sign
	CHASSIS TILT	Y-AXIS: XX.XDEG	Y Angle with respect to sign
	GENSET/WELDER SW	OPEN/CLOSED	Platform Generator Enable switch; only displayed if MACHINE SETUP → GEN SET/WELDER ≠ NO
	GENSET ENABLE	OUTPUT: ON/OFF	UGM Generator Relay Enable output; only displayed if MACHINE SETUP → GEN SET/WELDER ≠ NO
	H&T LIGHTS SW	OPEN/CLOSED	Only displayed if in Platform Mode and MACHINE SETUP → H&T LIGHTS = YES
	H&T LIGHTS OUT	ON/OFF	UGM Nite Brite Relay Enable output; only displayed if in Platform Mode and MACHINE SETUP → H&T LIGHTS = YES



Table 6-12. Machine Diagnostics Parameters

Diagnosics Submenu (Displayed on Analyzer 1 <sup>st</sup> Line)	Parameter (Displayed on Analyzer 1 <sup>st</sup> Line)	Parameter Value (Displayed on Analyzer 2 <sup>nd</sup> Line)	Description
SYSTEM	SOFT TOUCH INPUT	OPEN/CLOSED	State of Soft Touch Platform Input (J1-20); closed when active; only displayed if in Platform Mode and MACHINE SETUP → SOFT TOUCH = YES.
	SKYGUARD INPUTS	OPEN/CLOSED/DISAGREE	SkyGuard Input #1 (PLT J7-18) AND SkyGuard Input #2 (PLT J1-23) state; only displayed if in Platform Mode and MACHINE SETUP → SKYGUARD = YES.
	SKYGUARD INPUT 1	OPEN/CLOSED	State of SkyGuard Platform Input #1 (J7-18); relay NC contacts – closed when active; only displayed if in Platform Mode and MACHINE SETUP → SKYGUARD = YES.
	SKYGUARD INPUT 2	OPEN/CLOSED	State of SkyGuard Platform Input #2 (J1-23); relay NC contacts – closed when active; only displayed if in Platform Mode and MACHINE SETUP → SKYGUARD = YES.
	AMBIENT TEMP	XXXC/XXXF	Ambient Temperature sensor reading; Only displayed if MACHINE SETUP → TEMP CUTOUT = YES
	LOW TEMPERATURE	CUTOUT: ACTIVE/INACTIVE/FAULTY	Status of Low Temperature Cutout; Only displayed if MACHINE SETUP → TEMP CUTOUT = YES
	MSSO	ACTIVE/INACTIVE	Status of MSSO; Only displayed if MACHINE SETUP → MARKET = CE
OPER CONTROLS	JOYSTICK DRIVE	FORWARD/REVERSE XXX%	Drive Joystick drive direction and command percentage as reported from PM; only displayed if in Platform Mode
	JOYSTICK STEER	LEFT/RIGHT XXX%	Drive Joystick steer direction and percentage command as reported from PM; only displayed if in Platform Mode
	JOYSTICK SWING	LEFT/RIGHT XXX%	Lift/Swing Joystick Swing direction and percentage command as reported from PM; only displayed if in Platform Mode
	JOYSTICK LIFT	UP/DOWN XXX%	Lift/Swing Joystick Lift direction and percentage command as reported from PM; only displayed if in Platform Mode
	DRV ORNT OVR SW	CLOSED/OPEN	State of Drive Orientation Override Switch if in Platform Mode
	FUEL SELECT SW	OPEN/CLOSED	Status of Platform Toggle Switch Input if in Platform Mode and MACHINE SETUP → ENGINE
	START SWITCH	OPEN/CLOSED	Status of Ground/Platform Toggle Switch Input
	SWING LEFT SW	OPEN/CLOSED	Status of Ground Toggle Switch Input if in Ground Mode
	SWING RIGHT SW	OPEN/CLOSED	Status of Ground Toggle Switch Input if in Ground Mode



Table 6-12. Machine Diagnostics Parameters

Diagnosics Submenu (Displayed on Analyzer 1 <sup>st</sup> Line)	Parameter (Displayed on Analyzer 1 <sup>st</sup> Line)	Parameter Value (Displayed on Analyzer 2 <sup>nd</sup> Line)	Description
OPER CONTROLS	LIFT UP SW	OPEN/CLOSED	Status of Ground Toggle Switch Input if in Ground Mode
	LIFT DN SW	OPEN/CLOSED	Status of Ground Toggle Switch Input if in Ground Mode
	TELE IN SW	OPEN/CLOSED	Status of Ground/Platform Toggle Switch Input
	TELE OUT SW	OPEN/CLOSED	Status of Ground/Platform Toggle Switch Input
	JIB LIFT UP SW	OPEN/CLOSED	Status of Ground/Platform Toggle Switch Input; only displayed if MACHINE SETUP → JIB = YES
	JIB LIFT DN SW	OPEN/CLOSED	Status of Ground/Platform Toggle Switch Input; only displayed if MACHINE SETUP → JIB = YES
	PLAT LEVEL UP SW	OPEN/CLOSED	Status of Ground/Platform Toggle Switch Input
	PLAT LEVEL DN SW	OPEN/CLOSED	Status of Ground/Platform Toggle Switch Input
	PLAT ROT LEFT SW	OPEN/CLOSED	Status of Ground/Platform Toggle Switch Input
	PLAT ROT RIGHT SW	OPEN/CLOSED	Status of Ground/Platform Toggle Switch Input
	MAX SPEED SW	OPEN/CLOSED	Status of Platform Toggle Switch Input; only displayed if in Platform Mode
	MAX TORQUE SW	OPEN/CLOSED	Status of Platform Toggle Switch Input; only displayed if in Platform Mode
	CREEP SW	OPEN/CLOSED	Status of Creep Switch Input; only displayed if in Platform Mode
	HORN SW	OPEN/CLOSED	Status of Platform Switch Input; only displayed if in Platform Mode
	H&T LIGHT SW	OPEN/CLOSED	Status of Platform Toggle Switch Input; only displayed if in Platform Mode and MACHINE SETUP → H&T LIGHTS = YES
	GENSET/WELDER SW	OPEN/CLOSED	Status of Platform Toggle Switch Input; only displayed if MACHINE SETUP → GEN SET/WELDER ≠ NO
	SG OVERRIDE SW	OPEN/CLOSED	Status of Platform SkyGuard Override Switch Input; only displayed if in Platform Mode MACHINE SETUP → SOFT TOUCH = NO and MACHINE SETUP → SKYGUARD = YES
	ST OVERRIDE SW	OPEN/CLOSED	Status of Platform SkyGuard Override Switch Input; only displayed if in Platform Mode MACHINE SETUP → SOFT TOUCH = YES and MACHINE SETUP → SKYGUARD = NO
	SG/ST OVRIDE SW	OPEN/CLOSED	Status of Platform SkyGuard Override Switch Input; only displayed if in Platform Mode and MACHINE SETUP → SOFT TOUCH = YES and MACHINE SETUP → SKYGUARD = YES
	MSSO SW	OPEN/CLOSED	Status of Ground MSSO Switch Input; only displayed if MACHINE SETUP → MARKET = CE
CAPACITY SW	OPEN/CLOSED	Status of Platform Dual Capacity Switch Input (400S, 18RS, 24RS); only displayed if Dual Capacity is configured	

Table 6-12. Machine Diagnostics Parameters

Diagnosics Submenu (Displayed on Analyzer 1 <sup>st</sup> Line)	Parameter (Displayed on Analyzer 1 <sup>st</sup> Line)	Parameter Value (Displayed on Analyzer 2 <sup>nd</sup> Line)	Description
PLATFORM LOAD (DISPLAY ONLY IF MACHINE SETUP LOAD SYSTEM NO)	PLATFORM LOAD	STATE: OK/OVERLOAD	LSS Status
	PLATFORM LOAD	ACTUAL: XXX.XKG	Platform Load ??? if Platform Load == Unhealthy
	PLATFORM LOAD2	GROSS: XXX.XKG	If 4-Cell LSS; Combined weight of all cells (accounting for sign) If 1-Cell LSS; Platform Gross used to calculate Platform Load ??? if (Platform Gross 1 == Unhealthy and Platform Gross 2 == Unhealthy)
	PLATFORM LOAD2	OFFSET: XXX.XKG	If 4-Cell LSS; Stored Platform Empty weight
	PLATFORM LOAD2	OFFSET 1: XXX.XKG	If 1-Cell LSS; Stored Unloaded Platform Weight of Strain Gauge 1 ??? if DTC 825 is active
	PLATFORM LOAD2	OFFSET 2: XXX.XKG	If 1-Cell LSS; Stored Unloaded Platform Weight of Strain Gauge 2 ??? if DTC 825 is active
	PLATFORM LOAD2	ACC'Y XXX.XKG	Stored Accessory weight; ??? if DTC 825 is active
	PLATFORM LOAD2	CELL 1: XXX.XKG	If 4-Cell LSS; Gross weight reading of Cell 1
	PLATFORM LOAD2	CELL 2: XXX.XKG	If 4-Cell LSS; Gross weight reading of Cell 2
	PLATFORM LOAD2	CELL 3: XXX.XKG	If 4-Cell LSS; Gross weight reading of Cell 3
	PLATFORM LOAD2	CELL 4: XXX.XKG	If 4-Cell LSS; Gross weight reading of Cell 4
	PLATFORM LOAD2	RAW 1: XXX.XKG	If 1-Cell LSS; Platform Gross 1; ??? if Platform Gross 1 == Unhealthy
	PLATFORM LOAD2	RAW 2: XXX.XKG	If 1-Cell LSS; Platform Gross 2; ??? if Platform Gross 2 == Unhealthy
	CAN STATISTICS2	CAN 1 STATISTICS	RX/SEC: XXX
CAN 1 STATISTICS		TX/SEC: XXX	
CAN 1 STATISTICS		BUS OFF: XXX	
CAN 1 STATISTICS		PASSIVE: XXX	
CAN 1 STATISTICS		MSG ERROR: XXXX	
CAN 2 STATISTICS		RX/SEC: XXX	
CAN 2 STATISTICS		TX/SEC: XXX	
CAN 2 STATISTICS		BUS OFF: XXX	
CAN 2 STATISTICS		PASSIVE: XXX	
CAN 2 STATISTICS		MSG ERROR: XXXX	

Table 6-12. Machine Diagnostics Parameters

Diagnostics Submenu (Displayed on Analyzer 1 <sup>st</sup> Line)	Parameter (Displayed on Analyzer 1 <sup>st</sup> Line)	Parameter Value (Displayed on Analyzer 2 <sup>nd</sup> Line)	Description
DEBUG UGM I/O <sup>2</sup>	DEBUG DIAG DIGITAL INPUTS	DIG IN J1-21 HIGH/LOW DIG IN J1-34 HIGH/LOW DIG IN J1-35 HIGH/LOW DIG IN J2-24 HIGH/LOW DIG IN J3-8 HIGH/LOW DIG IN J3-9 HIGH/LOW DIG IN J3-10 HIGH/LOW DIG IN J3-11 HIGH/LOW DIG IN J4-4 HIGH/LOW DIG IN J4-5 HIGH/LOW DIG IN J4-6 HIGH/LOW	Left and Right arrow keys scroll through the inputs. 1 <sup>st</sup> Line = DIG IN JX.XX and 2 <sup>nd</sup> Line displays measurement value
DEBUG UGM I/O <sup>2</sup>	DEBUG DIAG DIGITAL INPUTS	DIG IN J4-7 HIGH/LOW DIG IN J4-8 HIGH/LOW DIG IN J4-9 HIGH/LOW DIG IN J4-10 HIGH/LOW DIG IN J4-11 HIGH/LOW DIG IN J4-16 HIGH/LOW DIG IN J4-17 HIGH/LOW DIG IN J4-18 HIGH/LOW DIG IN J4-19 HIGH/LOW DIG IN J4-20 HIGH/LOW DIG IN J4-21 HIGH/LOW DIG IN J4-22 HIGH/LOW DIG IN J4-23 HIGH/LOW DIG IN J4-30 HIGH/LOW DIG IN J4-33 HIGH/LOW DIG IN J4-34 HIGH/LOW DIG IN J4-35 HIGH/LOW DIG IN J7-2 HIGH/LOW DIG IN J7-3 HIGH/LOW DIG IN J7-12 HIGH/LOW DIG IN J7-15 HIGH/LOW DIG IN J7-21 HIGH/LOW DIG IN J12-8 HIGH/LOW	Left and Right arrow keys scroll through the inputs. 1 <sup>st</sup> Line = DIG IN JX.XX and 2 <sup>nd</sup> Line displays measurement value

Table 6-12. Machine Diagnostics Parameters

Diagnostics Submenu (Displayed on Analyzer 1 <sup>st</sup> Line)	Parameter (Displayed on Analyzer 1 <sup>st</sup> Line)	Parameter Value (Displayed on Analyzer 2 <sup>nd</sup> Line)	Description
DEBUG UGM I/O <sup>2</sup>	DEBUG DIAG DIGITAL OUTPUTS	DIG OUT J1-2 ON/OFF DIG OUT J1-7 ON/OFF DIG OUT J1-11 ON/OFF DIG OUT J1-12 ON/OFF DIG OUT J1-13 ON/OFF DIG OUT J1-23 ON/OFF DIG OUT J1-32 ON/OFF DIG OUT J2-2 ON/OFF DIG OUT J2-3 ON/OFF DIG OUT J2-4 ON/OFF DIG OUT J2-5 ON/OFF DIG OUT J2-7 ON/OFF DIG OUT J2-10 ON/OFF DIG OUT J2-12 ON/OFF DIG OUT J2-13 ON/OFF DIG OUT J2-15 ON/OFF DIG OUT J2-16 ON/OFF DIG OUT J2-21 ON/OFF DIG OUT J2-23 ON/OFF DIG OUT J2-32 ON/OFF DIG OUT J2-33 ON/OFF DIG OUT J4-1 ON/OFF DIG OUT J4-2 ON/OFF	Left and Right arrow keys scroll through the inputs. 1 <sup>st</sup> Line = DIG OUT JX.XX and 2 <sup>nd</sup> Line displays output value
	DEBUG DIAG DIGITAL OUTPUTS	DIG OUT J4-3 ON/OFF DIG OUT J4-13 ON/OFF DIG OUT J4-14 ON/OFF DIG OUT J4-15 ON/OFF DIG OUT J4-26 ON/OFF DIG OUT J4-27 ON/OFF DIG OUT J4-28 ON/OFF DIG OUT J4-29 ON/OFF DIG OUT LED ON/OFF	Left and Right arrow keys scroll through the inputs. 1 <sup>st</sup> Line = DIG OUT JX.XX and 2 <sup>nd</sup> Line displays output value

Table 6-12. Machine Diagnostics Parameters

Diagnostics Submenu (Displayed on Analyzer 1 <sup>st</sup> Line)	Parameter (Displayed on Analyzer 1 <sup>st</sup> Line)	Parameter Value (Displayed on Analyzer 2 <sup>nd</sup> Line)	Description
DEBUG UGM I/O <sup>2</sup>	DEBUG DIAG PWM OUTPUTS	PWM J1-1 XXX.XX% XXXHz PWM J1-3 XXX.XX% XXXHz PWM J1-6 XXX.XX% XXXHz PWM J1-10 XXX.XX% XXXHz PWM J1-20 XXX.XX% XXXHz PWM J1-22 XXX.XX% XXXHz PWM J2-8 XXX.XX% XXXHz PWM J2-9 XXX.XX% XXXHz PWM J2-11 XXX.XX% XXXHz PWM J2-19 XXX.XX% XXXHz PWM J2-20 XXX.XX% XXXHz PWM J2-22 XXX.XX% XXXHz PWM J2-26 XXX.XX% XXXHz PWM J2-27 XXX.XX% XXXHz PWM J2-31 XXX.XX% XXXHz PWM J2-34 XXX.XX% XXXHz PWM J2-35	Left and Right arrow keys scroll through the inputs. 1 <sup>st</sup> Line = PWM JX.XX and 2 <sup>nd</sup> Line displays output duty cycle and frequency.

Go to Discount Equipment.com to order your parts

Table 6-12. Machine Diagnostics Parameters

Diagnosics Submenu (Displayed on Analyzer 1 <sup>st</sup> Line)	Parameter (Displayed on Analyzer 1 <sup>st</sup> Line)	Parameter Value (Displayed on Analyzer 2 <sup>nd</sup> Line)	Description		
DEBUG UGM I/O <sup>2</sup>	DEBUG DIAG PWM OUTPUTS	XXX.XX% XXXHz	Left and Right arrow keys scroll through the inputs. 1 <sup>st</sup> Line = PWM JX.XX and 2 <sup>nd</sup> Line displays output duty cycle and frequency.		
		FET J3-1			
		XXX.XX% XXXHz			
		FET J3-2			
		XXX.XX% XXXHz			
		FET J3-4			
		XXX.XX% XXXHz			
		FET J3-5			
		XXX.XX% XXXHz			
		FET J3-6			
		XXX.XX% XXXHz			
		FET J3-14			
		XXX.XX% XXXHz			
		PWM J4-12			
XXX.XX% XXXHz					
DEBUG UGM I/O <sup>2</sup>	ANALOG INPUTS	ADC J1-14 XXXX	Left and Right arrow keys scroll through the inputs. 1 <sup>st</sup> Line = ADC JX.XX and 2 <sup>nd</sup> Line displays raw A/D counts XXXX of measurement		
		ADC J1-15 XXXX			
DEBUG UGM I/O <sup>2</sup>	ANALOG INPUTS	ADC J2-25 XXXX	Left and Right arrow keys scroll through the inputs. 1 <sup>st</sup> Line = ADC JX.XX and 2 <sup>nd</sup> Line displays raw A/D counts XXXX of measurement		
		ADC J3-13 XXXX			
		ADC J7-2 XXXX			
		ADC J7-04 XXXX			
		ADC J7-07 XXXX			
		ADC J7-08 XXXX			
		ADC J7-20 XXXX			
		ADC J8-02 XXXX			
		FREQUENCY INPUTS		FREQ IN J1-16 XXXXX Hz	Left and Right arrow keys scroll through the inputs. 1 <sup>st</sup> Line = FREQ IN JX.XX and 2 <sup>nd</sup> Line displays frequency of measurement XXXXX Hz
				FREQ IN J12-1 XXXXX Hz	
FREQ IN J12-2 XXXXX Hz					
CALIBRATION DATA <sup>2</sup>	TILT X	XX.XX Deg	Calibration X offset for mechanical mounting of External Tilt sensor		
	TILT Y	XX.XX Deg	Calibration Y offset for mechanical mounting of External Tilt sensor		

Table 6-12. Machine Diagnostics Parameters

Diagnosics Submenu (Displayed on Analyzer 1 <sup>st</sup> Line)	Parameter (Displayed on Analyzer 1 <sup>st</sup> Line)	Parameter Value (Displayed on Analyzer 2 <sup>nd</sup> Line)	Description
DATALOG	DATALOG TIME	ON XXXXH XXM	*Controller On time
	DATALOG TIME	ENGINE XXXXH XXM	*Engine Running time
	DATALOG TIME	ENABLD XXXXH XXM	*Combined time for Machine Enabled in Platform Mode while ENGINE RUNNING + any function active while in Ground Mode (excludes APU/Emergency Descent)
	DATALOG TIME	AUX XXXXH XXM	Auxiliary Power/Emergency Descent Active time
	DATALOG TIME	DRIVE XXXXH XXM	Drive Forward + Reverse time
	DATALOG TIME	DRV MS XXXXH XXM	Max Speed Drive Forward + Reverse time
	DATALOG TIME	DRV MT XXXXH XXM	Max Torque Drive Forward + Reverse time
	DATALOG TIME	DRV ME XXXXH XXM	Mid Engine Drive Forward + Reverse time
	DATALOG TIME	DRV CP XXXXH XXM	Creep Drive Forward + Reverse time
	DATALOG TIME	STEER XXXXH XXM	Steer Left + Right time
	DATALOG TIME	SWING XXXXH XXM	Swing Left + Right time
	DATALOG TIME	LIFT XXXXH XXM	Lift Up + Down time
	DATALOG TIME	TELE XXXXH XXM	Tele In + Out time
	DATALOG TIME	JIB XXXXH XXM	Jib Lift Up + Down time (MACHINE SETUP → JIB = YES)
	DATALOG TIME	LEVEL XXXXH XXM	Platform Level Up + Down time
	DATALOG TIME	ROTATE XXXXH XXM	Platform Rotate Left + Right time
	DATALOG TIME	GEN XXXXH XXM	*Generator Enable Relay on time
	For time logging of functions with 30-second resolution, the first 15 seconds of function run time shall be logged as a ½ minute increment and there after every 30 seconds of run time shall be logged as a ½ minute increment.		
	*The functions annotated with an asterisk in the description are function timers with 60-second resolution, for which the timer in the rule above is doubled.		
	DATALOG CYCLES	DRVE FWD XXXXXXXX	Number of times Drive Forward is commanded
DATALOG CYCLES	DRVE REV XXXXXXXX	Number of times Drive Reverse is commanded	
DATALOG CYCLES	STEER LT XXXXXXXX	Number of times Steer Left Output is commanded	
DATALOG CYCLES	STEER RT XXXXXXXX	Number of times Steer Right Output is commanded	
DATALOG CYCLES	SWING LT XXXXXXXX	Number of times Swing Left output is commanded	
DATALOG CYCLES	SWING RT XXXXXXXX	Number of times Swing Right output is commanded	
DATALOG CYCLES	LIFT UP XXXXXXXX	Number of times Lift Up output is commanded	
DATALOG CYCLES	LIFT DN XXXXXXXX	Number of times Lift Down output is commanded	
DATALOG CYCLES	TELE IN XXXXXXXX	Number of times Tele In output is commanded	
DATALOG CYCLES	TELE OUT XXXXXXXX	Number of times Tele Out output is commanded	
DATALOG CYCLES	JIB UP XXXXXXXX	Number of times Jib Lift Up is commanded (MACHINE SETUP → JIB = YES)	
DATALOG CYCLES	JIB DOWN XXXXXXXX	Number of times Jib Lift Down is commanded (MACHINE SETUP → JIB = YES)	
DATALOG CYCLES	LEVEL UP XXXXXXXX	Number of times Level Up is commanded	

Table 6-12. Machine Diagnostics Parameters

Diagnostics Submenu (Displayed on Analyzer 1 <sup>st</sup> Line)	Parameter (Displayed on Analyzer 1 <sup>st</sup> Line)	Parameter Value (Displayed on Analyzer 2 <sup>nd</sup> Line)	Description
DATALOG	DATALOG CYCLES	LEVEL DN XXXXXXX	Number of times Level Down is commanded
	DATALOG CYCLES	ROT LEFT XXXXXXX	Number of times Rotate Left is commanded
	DATALOG CYCLES	ROT RIGHT XXXXXXX	Number of times Rotate Right is commanded
	DATALOG CYCLES	UGM ON XXXXXXX	Number of times Power is applied
	DATALOG CYCLES	GND OPS XXXXXXX	Number of times machine is in Ground Mode and any function is active (excludes APU/Emergency Descent)
	DATALOG CYCLES	PLAT OPS XXXXXXX	Number of times machine is Enabled from Platform Station (excludes APU/Emergency Descent)
	DATALOG CYCLES	AUX OPS XXXXXXX	Number of times machine Auxiliary Power/Emergency Descent is Enabled
	DATALOG CYCLES	GEN ON XXXXXXX	Number of times Generator Enable Relay is turned On; information logged and stored only if machine configured for generator.
	DATALOG CYCLES	BOOM TR XXXXXXX	Number of times the Boom transitions from Below Elevation to Above Elevation
	DATALOG CYCLES	BOOM UP XXXXXXX	Number of times the Boom transitions from < 47 deg to > 50 deg
	DATALOG CYCLES	TELE TR XXXXXXX	"Number of times the Boom transitions from Retracted to Not Retracted position"
	DATALOG CYCLES	DUAL CAP XXXXXXX	Number of times the Boom transitions from Restricted to Unrestricted mode (Dual Capacity is configured)
	Cycle counter shall increment up to a limit of 1,000,000, except Steer shall have a limit of 2,000,000 per direction.		
	DATALOG: MAX	UGM TEMP XXXC/ UGM TEMP XXXF	Hottest Temp observed by UGM
	DATALOG: MIN	UGM TEMP XXXC/ UGM TEMP XXXF	Coldest Temp observed by UGM
DATALOG: MAX	UGM VOLT XX.XV	Maximum input voltage observed by UGM	
DATALOG: MACHINE	RENTAL XXXXH XXM	*Stores Machine hours since last memory clear	
DATALOG: ERASE <sup>2</sup>	MACHINE RENTAL?	Erases stored machine rental hours	
VERSIONS:	UGM	SOFTWARE PX.X	
	UGM	CNST DATA PX.X	
	UGM	HARDWARE REV X	
	UGM	SN XXXXXX	
	UGM	PN XXXXXXXXXX	
VERSIONS:	PLATFORM MODULE	SOFTWARE PX.X	
	PLATFORM MODULE	HARDWARE REV X	
	PLATFORM MODULE	SN XXXXXX	
	LSS MODULE	SOFTWARE PX.X	Displayed on if LSS is configured (4-Cell LSS)
	LSS MODULE	HARDWARE REV X	Display if LSS is configured (4-Cell LSS)
	TCU MODULE	SOFTWARE X.Xx	Displayed on if TCU is configured
	TCU MODULE	HARDWARE REV X	Displayed on if TCU is configured
	TCU MODULE	SN XXXXXX	Displayed on if TCU is configured
	GROUND DISPLAY	SOFTWARE PX.X	Displayed
	ANALYZER	ANALYZER vX.X	



6.8 MACHINE FAULT CODES

Table 6-13. Diagnostic Trouble Code Chart

DTC	Help Message	Fault Condition/Trigger (For configurable items, fault applies only if configured. All listed conditions to be met unless stated otherwise)	Conditions Required for Movement and/or to Clear Fault	4005C	4605JC
Note: "Controls Initialized" means all controls have been released / returned to neutral, and the machine enable (footswitch) has been released.					
001	EVERYTHING OK	"Machine is in Platform Mode; The UGM determines no problems exist"		X	X
002	GROUND MODE OK	"Machine is in Ground Mode; The UGM determines no problems exist"		X	X
0010	RUNNING AT CUTBACK – OUT OF TRANSPORT POSITION	Machine is in the Out of Transport position	Machine is not in the Out of Transport position	X	X
0011	FSW OPEN	"Machine is in Platform Mode; Any of the following Platform inputs become active after power up, but before Machine Enabled: Drive joystick is not in the neutral position Steer; Telescope; Platform Level; Platform Rotate; Jib Lift (if MACHINE SETUP ? JIB = YES)"	Controls initialized	X	X
0012	RUNNING AT CREEP - CREEP SWITCH OPEN	"Machine is in Platform Mode; Platform Creep switch input = HIGH; DTC 0013 is not active"	Platform Creep switch input = Low	X	X
0013	RUNNING AT CREEP - TILTED AND ABOVE ELEVATION	"Machine is in Platform Mode; The Boom is Above Elevation; Machine chassis is considered Tilted"	Not all of the trigger conditions are met	X	X
0015	LOAD SENSOR READING UNDER WEIGHT	"MACHINE SETUP → LOAD SYSTEM ≠ NO; Load System is the 1-Cell LSS; UGM determines that the Platform Load < - 50 lb for 2 seconds; Do not report if DTC (0030, 825 or 8211) is active or if Platform Load == Unhealthy"	"UGM determines that the Platform Load >= -50 lb for 5 seconds"	X	X
0030 <sup>1</sup>	RUNNING AT CREEP – PLATFORM STOWED	Platform Stowed State = Set	Platform Stowed State = Cleared	X	X
0031	FUEL LEVEL LOW – ENGINE SHUTDOWN	MACHINE SETUP → FUEL LEVEL ≠ NONE; Engine Shutdown has occurred due to Fuel Level = EMPTY condition.	Power Cycled	X	X
0035	APU ACTIVE	Auxiliary Power/Emergency Descent Mode is active	Auxiliary Power/Emergency Descent Mode is not active	X	X
0036	FUNCTION PREVENTED - FUNCTION SELECTED BEFORE GROUND ENABLE	Machine is in Ground Mode; Any of the following Ground inputs become active after power up, but before Machine Enabled: Lift; Swing; Telescope; Platform Level; Platform Rotate; Jib Lift (if MACHINE SETUP → JIB = YES)	Controls initialized	X	X
0039	SKYGUARD ACTIVE – FUNCTIONS CUTOUT	MACHINE SETUP → SKYGUARD = YES; Machine is in Platform Mode; SkyGuard Enabled	Not all of the trigger conditions are met	X	X

Table 6-13. Diagnostic Trouble Code Chart

DTC	Help Message	Fault Condition/Trigger (For configurable items, fault applies only if configured. All listed conditions to be met unless stated otherwise)	Conditions Required for Movement and/or to Clear Fault	400SC	460SJC
211	POWER CYCLE			X	X
212	KEYSWITCH FAULTY	UGM Ground Mode input J7-3 input = High; UGM Platform Mode input J7-2 input = High	(J7-3 input = LOW) or (J7-2 input = LOW)	X	X
213	FSW FAULTY	The ground footswitch input and platform footswitch input have been both HIGH or both LOW for greater than or equal to 1 second	Power Cycled	X	X
221	FUNCTION PROBLEM - HORN PERMANENTLY SELECTED	Machine is in Platform Mode; The Horn switch input = High at Startup	The Horn switch input = Low	X	X
224	FUNCTION PROBLEM - STEER LEFT PERMANENTLY SELECTED	Machine is in Platform Mode; The Steer Left switch input = High at Startup	The Steer Left switch input = Low; Steer Left and Right and full Drive speed permitted after controls are initialized	X	X
225	FUNCTION PROBLEM - STEER RIGHT PERMANENTLY SELECTED	Machine is in Platform Mode; The Steer Right switch input = High at Startup	The Steer Right switch input = Low; Steer Left and Right and full Drive speed permitted after controls are initialized	X	X
227	STEER SWITCHES FAULTY	The Steer Left switch input = High; The Steer Right switch input = High; (detectable in Platform or Ground mode)	The Steer Left switch input = Low; The Steer Right switch input = Low; Steer and full Drive speed permitted after controls are initialized	X	X
2211	FSW INTERLOCK TRIPPED	Machine is in Platform Mode; The Footswitch is active for more than seven seconds with no Drive, Steer, or Boom commands	The footswitch is released	X	X
2212	DRIVE LOCKED - JOYSTICK MOVED BEFORE FOOTSWITCH	Machine is in Platform Mode; The UGM detects one of the following conditions: Drive joystick is not in the neutral position at Startup; Drive joystick is not in the neutral position when Footswitch becomes active or while DTC 2213, 2221 or 2223 is active	If triggered by the Drive joystick not being in the neutral position at Startup, then (Drive joystick is returned to its neutral position) and (Drive and Steer permitted after controls initialized) If triggered by the Drive joystick not being in the neutral position when Footswitch becomes active or while DTC 2213, 2221 or 2223, then controls initialized	X	X
2213	STEER LOCKED - SELECTED BEFORE FOOTSWITCH	Machine is in Platform Mode; A Steer input is active when Footswitch becomes active or while DTC 2212, 2221 or 2223 is active	Controls initialized	X	X
2216	D/S JOY. OUT OF RANGE HIGH	The PM detects that the Drive or Steer joystick signal voltage > 8.1V and reports the fault to the UGM.	The PM no longer reports the fault	X	X
2217	D/S JOY. CENTER TAP BAD	The PM detects that the Drive or Steer center tap voltage is not between 3.31 volts and 3.75 volts and reports the fault to the UGM	The PM detects that the drive/steer center tap voltage is between 3.31 and 3.75 volts and no longer reports the fault to the UGM	X	X
2219	L/S JOY. OUT OF RANGE HIGH	The PM detects that the Lift or Swing joystick signal voltage > 8.1V and reports the fault to the UGM.	The PM detects that the Lift and Swing joystick signal voltage is < 8.1V and no longer reports the fault to the UGM	X	X

## SECTION 6 - JLG CONTROL SYSTEM

**Table 6-13. Diagnostic Trouble Code Chart**

DTC	Help Message	Fault Condition/Trigger (For configurable items, fault applies only if configured. All listed conditions to be met unless stated otherwise)	Conditions Required for Movement and/or to Clear Fault	400SC	4605JC
2220	L/S JOY. CENTER TAP BAD	The PM detects that the Lift or Swing center tap voltage is not between 3.31 volts and 3.75 volts and reports the fault to the UGM	The PM detects that the lift/swing center tap voltage is between 3.31 and 3.75 volts and no longer reports the fault to the UGM	X	X
2221	LIFT/SWING LOCKED - JOYSTICK MOVED BEFORE FOOTSWITCH	Machine is in Platform Mode; The UGM detects one of the following conditions: Lift and/or Swing joystick is not in the neutral position at Startup; Lift and/or Swing joystick is not in the neutral position when Footswitch becomes active or while DTC 2212, 2213 or 2223 is active	If triggered by the Lift and/or Swing joystick not being in the neutral position at Startup, then (Lift and/or Swing joystick is returned to its neutral position) and (Lift and Swing permitted after controls initialized) If triggered by the Lift and/or Swing joystick is not in the neutral position when Footswitch becomes active or while DTC 2212, 2213 or 2223 is active, then controls initialized	X	X
2222	WAITING FOR FSW TO BE OPEN	Machine is in Platform Mode; Footswitch is active at Start Up	Controls initialized	X	X
2223	FUNCTION SWITCHES LOCKED - SELECTED BEFORE ENABLE	Machine is in Platform Mode; Any of the following Platform inputs are active when Footswitch becomes active or while DTC 2212, 2213 or 2221 is active: Tower Lift; Telescope; Platform Level; Platform Rotate; Jib Lift (if MACHINE SETUP → JIB = YES)	Controls initialized	X	X
2224	FOOTSWITCH SELECTED BEFORE START	Machine is in Platform Mode; The engine is stopped; Startup time has expired; The Footswitch is active before the Platform Engine Start switch input = High	The Platform Engine Start switch input = Low;	X	X
2247	FUNCTION PROBLEM - PLATFORM ROTATE LEFT PERMANENTLY SELECTED	Machine is in Platform Mode; The Platform Rotate Left switch input = High at Startup	The Platform Rotate Left switch input = Low; Platform Rotate Left and Right permitted after controls are initialized	X	X
2248	FUNCTION PROBLEM - PLATFORM ROTATE RIGHT PERMANENTLY SELECTED	Machine is in Platform Mode; The Platform Rotate Right switch input = High at Startup	The Platform Rotate Right switch input = Low; Platform Rotate Left and Right permitted after controls are initialized	X	X
2249	FUNCTION PROBLEM - JIB LIFT UP PERMANENTLY SELECTED	Machine is in Platform Mode; MACHINE SETUP → JIB = YES; The Jib Lift Up switch input = High at Startup	The Jib Lift Up switch input = Low; Jib Lift Up and Down permitted after controls are initialized	X	X
2250	FUNCTION PROBLEM - JIB LIFT DOWN PERMANENTLY SELECTED	Machine is in Platform Mode; MACHINE SETUP → JIB = YES; The Jib Lift Down switch input = High at Startup	The Jib Lift Down switch input = Low; Jib Lift Up and Down permitted after controls are initialized	X	X
2251	FUNCTION PROBLEM - TELESCOPE IN PERMANENTLY SELECTED	Machine is in Platform Mode; The Telescope In switch input = High at Startup	The Telescope In switch input = Low; Telescope permitted after controls are initialized	X	X
2252	FUNCTION PROBLEM - TELESCOPE OUT PERMANENTLY SELECTED	Machine is in Platform Mode; The Telescope Out switch input = High at Startup	The Telescope Out switch input = Low; Telescope permitted after controls are initialized	X	X
2257	FUNCTION PROBLEM - TOWER LIFT UP PERMANENTLY SELECTED	Machine is in Platform Mode; The Tower Lift Up switch input = High at Startup	The Tower Lift In switch input = Low; Tower Lift Up and Down permitted after controls are initialized		

Table 6-13. Diagnostic Trouble Code Chart

DTC	Help Message	Fault Condition/Trigger (For configurable items, fault applies only if configured. All listed conditions to be met unless stated otherwise)	Conditions Required for Movement and/or to Clear Fault	400SC	4605JC
2258	FUNCTION PROBLEM - TOWER LIFT DOWN PERMANENTLY SELECTED	Machine is in Platform Mode; The Tower Lift Down switch input = High at Startup	The Tower Lift Down switch input = Low; Tower Lift Up and Down permitted after controls are initialized		
2262	FUNCTION PROBLEM - PLATFORM LEVEL UP PERMANENTLY SELECTED	Machine is in Platform Mode; The Platform Level Up switch input = High at Startup	The Platform Level Up switch input = Low; Platform Level Up and Down permitted after controls are initialized	X	X
2263	FUNCTION PROBLEM - PLATFORM LEVEL DOWN PERMANENTLY SELECTED	Machine is in Platform Mode; The Platform Level Down switch input = High at Startup	The Platform Level Down switch input = Low; Platform Level Up and Down permitted after controls are initialized	X	X
2264	FUNCTION PROBLEM - DOS OVERRIDE PERMANENTLY SELECTED	Machine is in Platform Mode; The DOS Override switch input = High at Startup	The DOS Override switch input = Low	X	X
2286	FUNCTION PROBLEM - SOFT TOUCH / SKYGUARD OVERRIDE PERMANENTLY SELECTED	[(MACHINE SETUP → SKYGUARD = YES) or (MACHINE SETUP → SOFT TOUCH = YES)]; Machine is in Platform Mode; The Soft Touch / SkyGuard Override switch input = High at Startup	The Soft Touch / SkyGuard Override switch input = Low	X	X
234	FUNCTION SWITCHES FAULTY - CHECK DIAGNOSTICS/BOOM	The UGM detects one of the following conditions (continuous monitoring): The machine is in Ground Mode and both direction inputs of the following boom controls are engaged at the same time: Engine Start/Aux, Telescope, Platform Level, Platform Rotate, Jib Lift, Tower Lift, Lift, or Swing. The machine is in Platform Mode and both direction inputs of the following boom controls are engaged at the same time: Engine Start/Aux, Telescope, Platform Level, Platform Rotate, Jib Lift (MACHINE SETUP → JIB = YES); or for Drive Mode – Max Speed/ Max Torque	None of the boom controls that trigger this fault have both of their direction inputs engaged at the same time	X	X
235	FUNCTION SWITCHES LOCKED - SELECTED BEFORE AUX POWER	The UGM detects one of the following conditions: The machine is in Ground Mode and the engine is stopped and the ground APU/Function Enable switch becomes engaged while a Ground control input is already engaged. The machine is in Platform Mode and the engine is stopped and the platform APU/Auxiliary Descent switch becomes engaged while a Platform control input is already engaged.	The applicable APU/Auxiliary Descent switch is disengaged or all applicable control inputs become disengaged or the engine state becomes ENGINE RUNNING	X	X
236	FUNCTION SWITCHES LOCKED - SELECTED BEFORE START SWITCH	The UGM detects one of the following conditions: The machine is in Ground Mode and the engine is stopped and any configured boom control is already engaged and the ground start switch changes from not engaged to engaged. The machine is in Platform Mode and the engine is stopped and any drive/steer or configured boom control is already engaged and the footswitch is not engaged and the platform start switch changes from not engaged to engaged.	The selected station's start switch is no longer engaged	X	X

## SECTION 6 - JLG CONTROL SYSTEM

**Table 6-13. Diagnostic Trouble Code Chart**

DTC	Help Message	Fault Condition/Trigger (For configurable items, fault applies only if configured. All listed conditions to be met unless stated otherwise)	Conditions Required for Movement and/or to Clear Fault	400SC	460SJC
237	START SWITCH LOCKED - SELECTED BEFORE KEYSWITCH	The start switch for the selected station is engaged during the UGM startup sequence	The selected station's start switch is no longer engaged	X	X
2310	FUNCTION PROBLEM - GROUND ENABLE PERMANENTLY SELECTED	Machine is in Ground Mode; The Ground Enable switch input = High at Startup	Controls initialized	X	X
2343	BOOM ANGLE SENSOR - NOT CALIBRATED	The Boom Angle Sensor has not been calibrated	Boom angle sensor calibrated	X	X
2344	BOOM ANGLE SENSOR - OUT OF RANGE HIGH	The UGM detects that Boom Angle Sensor #1 or Boom Angle Sensor #2 signal voltage > 4.5V.	Power Cycled	X	X
2345	BOOM ANGLE SENSOR - OUT OF RANGE LOW	The UGM detects that Boom Angle Sensor #1 or Boom Angle Sensor #2 signal voltage < 0.5V.	Power Cycled	X	X
2346	BOOM ANGLE SENSOR - NOT RESPONDING	The UGM detects the following conditions: The UGM detects < 1 deg change of Boom Angle Main Lift Up or Main Lift Down output value ≥ Creep output value Main Lift Up or Main Lift Down has been active longer than 5 seconds.	Power Cycled	X	X
2370	FUNCTION PROBLEM - JIB LIFT UP PERMANENTLY SELECTED	Machine is in Ground Mode; MACHINE SETUP → JIB = YES; The Jib Lift Up switch input = High at Startup	The Jib Lift Up switch input = Low; Jib Lift Up and Down permitted after controls are initialized	X	X
2371	FUNCTION PROBLEM - JIB LIFT DOWN PERMANENTLY SELECTED	Machine is in Ground Mode; MACHINE SETUP → JIB = YES; The Jib Lift Down switch input = High at Startup	The Jib Lift Down switch input = Low; Jib Lift Up and Down permitted after controls are initialized	X	X
2372	FUNCTION PROBLEM - SWING LEFT PERMANENTLY SELECTED	Machine is in Ground Mode; The Swing Left switch input = High at Startup	The Swing Left switch input = Low; Swing Left and Right permitted after controls are initialized	X	X
2373	FUNCTION PROBLEM - SWING RIGHT PERMANENTLY SELECTED	Machine is in Ground Mode; The Swing Right switch input = High at Startup	The Swing Left switch input = Low; Swing Left and Right permitted after controls are initialized	X	X
2396	BOOM ANGLE SENSOR DISAGREEMENT	The UGM detects that Boom Angle Sensor #1 and Boom Angle Sensor #2 readings disagree ≥ 2.5 deg for longer than 5 seconds; Do not report if DTC 2343 is active	Power Cycled	X	X
23104	BOOM TRANSPORT SWITCH DISAGREEMENT	The UGM detects that Boom Elevation switch #1 and switch #2 are not reporting congruent switch states, as defined in the Boom Elevation Switch Evaluation section.	Power Cycled		
23105	FUNCTION PROBLEM - TOWER LIFT UP PERMANENTLY SELECTED	Machine is in Ground Mode; The Tower Lift Up switch input = High at Startup	The Tower Lift Up switch input = Low; Tower Lift Up and Down permitted after controls are initialized		