



An Oshkosh Corporation Company



[www.Discount-Equipment.com](http://www.Discount-Equipment.com)

---

# ***Operation and Safety Manual***

*Original Instructions - Keep this manual with the machine at all times.*

**Model**

**X770AJ**

**ANSI**



**3121703**

November 18, 2019 - Rev E

---

**TO PURCHASE THIS PRODUCT PLEASE CONTACT US**



**Equipment Financing and  
Extended Warranties Available**



**Discount-Equipment.com is your online resource for  
commercial and industrial quality parts and equipment sales.**

**561-964-4949**

**visit us on line @ [www.discount-equipment.com](http://www.discount-equipment.com)**

Select an option below to find your Equipment

**Search by Manufacturer**

**Search by Product Type**

**Request a Quote**

We sell worldwide for the brands: Genie, Terex, JLG, MultiQuip, Mikasa, Essick, Whiteman, Mayco, Toro Stone, Diamond Products, Generac Magnum, Airman, Haulotte, Barreto, Power Blanket, Nifty Lift, Atlas Copco, Chicago Pneumatic, Allmand, Miller Curber, Skyjack, Lull, Skytrak, Tsurumi, Husquvarna Target, Stow, Wacker, Sakai, Mi-T-M, Sullair, Basic, Dynapac, MBW, Weber, Bartell, Bennar Newman, Haulotte, Ditch Runner, Menegotti, Morrison, Contec, Buddy, Crown, Edco, Wyco, Bomag, Laymor, EZ Trench, Bil-Jax, F.S. Curtis, Gehl Pavers, Heli, Honda, ICS/PowerGrit, IHI, Partner, Imer, Clipper, MMD, Koshin, Rice, CH&E, General Equipment, Amida, Coleman, NAC, Gradall, Square Shooter, Kent, Stanley, Tamco, Toku, Hatz, Kohler, Robin, Wisconsin, Northrock, Oztec, Toker TK, Rol-Air, APT, Wylie, Ingersoll Rand / Doosan, Innovatech, Con X, Ammann, Mecalac, Makinex, Smith Surface Prep, Small Line, Wanco, Yanmar





## **WARNING**

Operating, servicing and maintaining this vehicle or equipment can expose you to chemicals including engine exhaust, carbon monoxide, phthalates, and lead, which are known to the State of California to cause cancer and birth defects or other reproductive harm. To minimize exposure, avoid breathing exhaust, do not idle the engine except as necessary, service your vehicle or equipment in a well-ventilated area and wear gloves or wash your hands frequently when servicing. For more information go to [www.P65Warnings.ca.gov](http://www.P65Warnings.ca.gov).

## **FOREWORD**

The Mobile Elevating Work Platform (MEWP) models covered in this manual are designed and tested to meet or exceed various compliance standards. Please refer to the manufacturer's nameplate affixed to the subject MEWP for specific standard compliance information.

This manual is a very important tool! Keep it with the machine at all times.

The purpose of this manual is to provide owners, users, operators, lessors, and lessees with the precautions and operating procedures essential for the safe and proper machine operation for its intended purpose.

Due to continuous product improvements, JLG Industries, Inc. reserves the right to make specification changes without prior notification. Contact JLG Industries, Inc. for updated information.

Refer to [www.JLG.com](http://www.JLG.com) for Warranty, Product Registration, and other machine-related documentation.

**SAFETY ALERT SYMBOLS AND SAFETY SIGNAL WORDS**



This is the Safety Alert Symbol. It is used to alert you to the potential personal injury hazards. Obey all safety messages that follow this symbol to avoid possible injury or death.

**⚠ DANGER**

INDICATES AN IMMINENTLY HAZARDOUS SITUATION. IF NOT AVOIDED, WILL RESULT IN SERIOUS INJURY OR DEATH. THIS DECAL WILL HAVE A RED BACKGROUND.

**⚠ WARNING**

INDICATES A POTENTIALITY HAZARDOUS SITUATION. IF NOT AVOIDED, COULD RESULT IN SERIOUS INJURY OR DEATH. THIS DECAL WILL HAVE AN ORANGE BACKGROUND.

**⚠ CAUTION**

INDICATES A POTENTIALITY HAZARDOUS SITUATION. IF NOT AVOIDED, MAY RESULT IN MINOR OR MODERATE INJURY. IT MAY ALSO ALERT AGAINST UNSAFE PRACTICES. THIS DECAL WILL HAVE A YELLOW BACKGROUND.

**NOTICE**

INDICATES INFORMATION OR A COMPANY POLICY THAT RELATES DIRECTLY OR INDIRECTLY TO THE SAFETY OF PERSONNEL OR PROTECTION OF PROPERTY.

**⚠ WARNING**

**THIS PRODUCT MUST COMPLY WITH ALL SAFETY RELATED BULLETINS. CONTACT JLG INDUSTRIES, INC. OR THE LOCAL AUTHORIZED JLG REPRESENTATIVE FOR INFORMATION REGARDING SAFETY RELATED BULLETINS WHICH MAY HAVE BEEN ISSUED FOR THIS PRODUCT.**

**NOTICE**

**JLG INDUSTRIES, INC. SENDS SAFETY RELATED BULLETINS TO THE OWNER OF RECORD OF THIS MACHINE. CONTACT JLG INDUSTRIES, INC. TO ENSURE THAT THE CURRENT OWNER RECORDS ARE UPDATED AND ACCURATE.**

**NOTICE**

**JLG INDUSTRIES, INC. MUST BE NOTIFIED IMMEDIATELY IN ALL INSTANCES WHERE JLG PRODUCTS HAVE BEEN INVOLVED IN AN ACCIDENT INVOLVING BODILY INJURY OR DEATH OF PERSONNEL OR WHEN SUBSTANTIAL DAMAGE HAS OCCURRED TO PERSONAL PROPERTY OR THE JLG PRODUCT.**

**For :**

- Accident Reporting
- Product Safety Publications
- Current Owner Updates
- Questions Regarding Product Safety
- Standards and Regulations Compliance Information
- Questions Regarding Special Product Applications
- Questions Regarding Product Modifications

**Contact :**

Product Safety and Reliability Department  
JLG Industries, Inc.  
13224 Fountainhead Plaza  
Hagerstown, MD 21742  
USA

or Your Local JLG Office  
(See addresses on inside of manual cover)

**In USA:**

Toll Free: 877-JLG-SAFE (877-554-7233)

**Outside USA:**

Phone: 240-420-2661

E-mail: ProductSafety@JLG.com

**REVISION LOG**

Original Issue	A - June 9, 2016
Revised	B - March 16, 2017
Revised	C - April 3, 2018
Revised	D - June 29, 2018
Revised	E - November 18, 2019

To order go to [Discount-Equipment.com](http://Discount-Equipment.com)

<b>SECTION - PARAGRAPH, SUBJECT</b>	<b>PAGE</b>	<b>SECTION - PARAGRAPH, SUBJECT</b>	<b>PAGE</b>
FOREWORD.....	1-A	Operator Training.....	2-1
SAFETY ALERT SYMBOLS AND SAFETY SIGNAL		Training Supervision.....	2-1
WORDS.....	1-B	Operator Responsibility.....	2-1
Contact :.....	1-c	2.2 PREPARATION, INSPECTION, AND	
In USA:.....	1-c	MAINTENANCE.....	2-2
Outside USA:.....	1-c	Pre-Start Inspection.....	2-4
REVISION LOG.....	1-D	Daily Walk-Around Inspection.....	2-6
		Function Check.....	2-8
<b>SECTION - 1 - SAFETY PRECAUTIONS</b>		<b>SECTION - 3 - MACHINE CONTROLS, INDICATORS AND</b>	
1.1 GENERAL.....	1-1	<b>OPERATION</b>	
1.2 PRE-OPERATION.....	1-1	3.1 GROUND CONTROL STATION.....	3-3
Operator Training and Knowledge.....	1-1	3.2 PLATFORM/REMOTE CONTROL STATION.....	3-6
Workplace Inspection.....	1-2	Control Position On The Ground:.....	3-6
Machine Inspection.....	1-3	Control Position From In The Platform:.....	3-7
1.3 OPERATION.....	1-3	Platform/Remote Control Station Functions.....	3-9
General.....	1-3	Platform/Remote Control Station LCD Display.....	3-12
Trip and Fall Hazards.....	1-4	<b>SECTION - 4 - MACHINE OPERATION</b>	
Electrocution Hazards.....	1-5	4.1 DESCRIPTION.....	4-1
Tipping Hazards.....	1-7	4.2 BOOM OPERATING CHARACTERISTICS AND	
Crushing and Collision Hazards.....	1-9	LIMITATIONS.....	4-1
1.4 TOWING, LIFTING, AND HAULING.....	1-10	Capacities.....	4-1
1.5 MAINTENANCE.....	1-10	Stability.....	4-1
Maintenance Hazards.....	1-10	4.3 ENGINE OPERATION.....	4-2
Battery Hazards.....	1-12	Diesel Starting Procedure.....	4-2
<b>SECTION - 2 - PREPARATION AND INSPECTION</b>		Diesel Engine Shutdown Procedure.....	4-3
2.1 PERSONNEL TRAINING.....	2-1		

## TABLE OF CONTENTS

SECTION - PARAGRAPH, SUBJECT	PAGE	SECTION - PARAGRAPH, SUBJECT	PAGE
Electric Engine Starting Procedure - AC Voltage Machine . . . . .	4-3	Platform Removal/Installation . . . . .	4-24
4.4 BASE AND BOOM/JIB ALIGNMENT . . . . .	4-5	4.8 BATTERY CHARGING - DIESEL/AC-ELECTRIC . . . . .	4-25
4.5 TRACKS - DRIVING, STEERING AND TRACK WIDTH ADJUST . . . . .	4-6	Battery Charging - Daily . . . . .	4-25
Track width adjust . . . . .	4-6	4.9 BATTERY CHARGING - LITHIUM-ION MACHINE . . . . .	4-26
Travelling (Drive and Steer) . . . . .	4-7	Charging the Battery Pack . . . . .	4-27
Travelling (Grades and Side Slopes) . . . . .	4-7	Charge Curve . . . . .	4-29
Jib Position for Travelling . . . . .	4-9	Cold Weather Charging . . . . .	4-29
4.6 OUTRIGGER OPERATION . . . . .	4-10	Cooling Fans . . . . .	4-29
Variable Outrigger Positioning . . . . .	4-11	4.10 SHUT DOWN AND PARK . . . . .	4-30
Operating with Outriggers Set to 24° -		4.11 LIFTING AND TIE DOWN . . . . .	4-31
Restricted Work Area Of Operation . . . . .	4-12	Lifting . . . . .	4-31
Setting Outriggers From the Platform/Remote Console . . . . .	4-17	Tie Down. . . . .	4-32
Retracting The Outriggers . . . . .	4-18	4.12 MACHINE DECALS . . . . .	4-34
4.7 BOOM/PLATFORM OPERATION . . . . .	4-19	<b>SECTION - 5 - EMERGENCY PROCEDURES</b>	
Overload Alarm . . . . .	4-19	5.1 GENERAL . . . . .	5-1
Platform Level Adjustment . . . . .	4-19	5.2 INCIDENT NOTIFICATION . . . . .	5-1
Raise And Lower The Tower Boom . . . . .	4-20	5.3 EMERGENCY OPERATION . . . . .	5-2
Raise And Lower The Main Boom . . . . .	4-20	Power Main Cut-Off Switch Location . . . . .	5-2
Telescope The Main Boom . . . . .	4-20	Operator Unable to Control Machine . . . . .	5-3
Platform Rotation . . . . .	4-20	Platform or Boom Caught Overhead . . . . .	5-3
Raise And Lower The Jib . . . . .	4-20	Manual Descent with Engine Running and Electrical Power . . . . .	5-4
Swinging The Boom . . . . .	4-20	Using Emergency/Ground Controls from Ground . . . . .	5-6
SkyGuard Operation (If Equipped) . . . . .	4-23	Manual Descent with Engine Running but without Electrical Power . . . . .	5-8
Emergency Lowering . . . . .	4-24		

<b>SECTION - PARAGRAPH, SUBJECT</b>	<b>PAGE</b>	<b>SECTION - PARAGRAPH, SUBJECT</b>	<b>PAGE</b>
Manual Descent without Engine or Electrical Power . . . . .	5-10	Engine Fuel Filter/Sediment Bowl (if equipped)	6-14
Outrigger/Track Movement Emergency Procedure: . . . . .	5-12	Engine Cooling System and Fluid (if equipped)	6-14
5.4 SAFETY DEVICES BYPASS KEY USE . . . . .	5-14	Hydraulic Oil . . . . .	6-15
Using Emergency Descent In Case Of An Outrigger Losing Contact With The Ground . . . . .	5-15	Hydraulic Oil Filter Cartridge . . . . .	6-15
Machine Realignment Emergency Procedure . . . . .	5-16	Rubber Track Maintenance/Replacement . . . . .	6-16
		Wire Cable Inspection . . . . .	6-19
		Wire Cable Adjustment . . . . .	6-20
		Wear Pad Inspection . . . . .	6-21
		Turntable Attach Bolts . . . . .	6-21
		Battery Maintenance and Charging - Diesel/AC-Electric. . . . .	6-21
<b>SECTION - 6 - GENERAL SPECIFICATIONS AND OPERATOR MAINTENANCE</b>		6.4 ELECTRIC MOTOR MAINTENANCE . . . . .	6-22
6.1 INTRODUCTION . . . . .	6-1	Electric Motor . . . . .	6-22
6.2 OPERATING SPECIFICATIONS . . . . .	6-2	6.5 PLATFORM/REMOTE CONTROL SERVICE MENU . . . . .	6-22
Dimensional Data . . . . .	6-2	Service Button . . . . .	6-22
Chassis . . . . .	6-2	Menu Input . . . . .	6-23
Capacities . . . . .	6-3	Errors Menu . . . . .	6-25
Engine Data . . . . .	6-3	Working Hours Menu . . . . .	6-25
Electric Motor Data . . . . .	6-3	Set-up Menu . . . . .	6-25
Lithium-Ion Battery Pack Specifications . . . . .	6-4	Joystick Menu . . . . .	6-25
Major Component Weights . . . . .	6-4	6.6 LITHIUM-ION MACHINE - MAINTAINANCE . . . . .	6-26
6.3 SERVICE/MAINTENANCE . . . . .	6-5	Battery Pack System Components and Maintenance . . . . .	6-26
Cleaning the Machine . . . . .	6-5	Lithium-Ion Machine Fault Codes . . . . .	6-27
Lubrication . . . . .	6-7	BMS Fault Codes - (Battery Management System) . . . . .	6-30
Hydraulic Oil Specifications . . . . .	6-8		
Engine Air Filter . . . . .	6-13		
Engine Oil . . . . .	6-13		
Engine Oil Filter (if equipped) . . . . .	6-14		



## TABLE OF CONTENTS

SECTION - PARAGRAPH, SUBJECT	PAGE
Battery Charger Fault Codes . . . . .	6-31
6.7 LITHIUM-ION BATTERY PACK - HANDLING IN DANGEROUS CONDITIONS . . . . .	6-33
Procedure For Handling Hot Cells . . . . .	6-33
Procedure For Handling Vented Cells . . . . .	6-34
Procedure For Exploded Cells . . . . .	6-36
Lithium Battery Fire . . . . .	6-37

### SECTION - 7 - INSPECTION AND REPAIR LOG

SECTION - PARAGRAPH, SUBJECT	PAGE
<b>LIST OF FIGURES</b>	
2-1. Daily Walk-Around Inspection . . . . .	2-7
2-2. SkyGuard™ Sensor and Override Switch Location . . . . .	2-9
3-1. Basic Machine Component Locations. . . . .	3-1
3-2. Ground Control Station . . . . .	3-5
3-3. Platform/Remote Control Station. . . . .	3-10
4-1. Ground/Emergency Control Box. . . . .	4-2
4-2. Grade and Side Slope Definition. . . . .	4-8
4-3. Outrigger Positions . . . . .	4-12
4-4. Boom Area of Operation for Various Outrigger Positions (Sheet 1 of 2) . . . . .	4-14
4-5. Boom Area Of Operation for Various Outrigger Positions (Sheet 2 of 2) . . . . .	4-15
4-6. Platform/Remote Control Box . . . . .	4-21
4-7. Platform - Load/Reach Chart - X770AJ . . . . .	4-22
4-8. SkyGuard™ Sensor and Override Switch Location . . . . .	4-23
4-9. Machine Lifting Points . . . . .	4-31
4-10. Lifting Machine - Attach Points . . . . .	4-32
4-11. Machine Tie-Down Points . . . . .	4-33
4-12. Decal installation - Standard - Left Side . . . . .	4-34
4-13. Decal Installation - Standard - Right Side . . . . .	4-35
5-1. Platform/Remote Control Station. . . . .	5-5
5-2. Ground Control Station . . . . .	5-7
5-3. Hand Pump - Chassis Control Valve Tray. . . . .	5-9
6-1. Lubrication and Maintenance Point Locations . . . . .	6-6

<b>SECTION - PARAGRAPH, SUBJECT</b>	<b>PAGE</b>
6-2. Hydraulic Oil Specifications . . . . .	6-8
6-3. Hydraulic Oil Operating Temperatures . . . . .	6-9

<b>SECTION - PARAGRAPH, SUBJECT</b>	<b>PAGE</b>
-------------------------------------	-------------

**LIST OF TABLES**

1-1 Minimum Approach Distances (M.A.D.) . . . . .	1-6
1-2 Beaufort Scale (For Reference Only) . . . . .	1-8
2-1 Inspection and Maintenance Table . . . . .	2-3
3-1 LCD Display Icon Descriptions . . . . .	3-15
3-2 LCD Display Error Descriptions . . . . .	3-17
4-1 SkyGuard™ Function Table . . . . .	4-23
4-2 X770AJ - Decal Installation - Standard . . . . .	4-36
6-1 Operating Specifications . . . . .	6-2
6-2 Dimensional Data . . . . .	6-2
6-3 Chassis Data . . . . .	6-2
6-4 Capacities . . . . .	6-3
6-5 Kubota D902 Specifications . . . . .	6-3
6-6 Electric Motor Specifications . . . . .	6-3
6-7 Lithium Ion Specifications . . . . .	6-4
6-8 Major Component Weights . . . . .	6-4
6-9 Hydraulic Oil Specifications . . . . .	6-7
6-10 Component Maintenance Intervals - X770AJ - with Diesel Engine . . . . .	6-10
6-11 Component Maintenance Intervals - X770AJ - with Lithium-Ion Battery Pack . . . . .	6-12
6-12 Inverter Fault Codes . . . . .	6-27
6-13 Battery Charger Fault Codes . . . . .	6-31



## **SECTION 1. SAFETY PRECAUTIONS**

### **1.1 GENERAL**

This section outlines the necessary precautions for proper and safe machine usage and maintenance. It is mandatory that a daily routine is established based on the content of this manual to promote proper machine usage. A maintenance program, using the information provided in this manual and the Service and Maintenance Manual, must also be established by a qualified person and must be followed to ensure that the machine is safe to operate.

The owner/user/operator/lessor/lessee of the machine must not accept operating responsibility until this manual has been read, training is accomplished, and operation of the machine has been completed under the supervision of an experienced and qualified operator.

This section contains the responsibilities of the owner, user, operator, lessor, and lessee concerning safety, training, inspection, maintenance, application, and operation. If there are any questions with regard to safety, training, inspection, maintenance, application, and operation, please contact JLG Industries, Inc. ("JLG").

### **⚠ WARNING**

**FAILURE TO COMPLY WITH THE SAFETY PRECAUTIONS LISTED IN THIS MANUAL COULD RESULT IN MACHINE DAMAGE, PROPERTY DAMAGE, PERSONAL INJURY OR DEATH.**

### **1.2 PRE-OPERATION**

#### **Operator Training and Knowledge**

- Read, understand, and study the Operation and Safety Manual in its entirety before operating the machine. For clarification, questions, or additional information regarding any portions of this manual, contact JLG Industries, Inc.

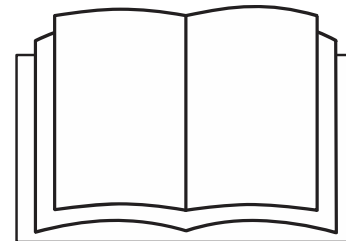

## **SECTION 1 - SAFETY PRECAUTIONS**

---

- Only personnel who have received proper training regarding the inspection, application and operation of MEWPs (including recognition and avoiding hazards associated with their operation) shall be authorized to operate a MEWP.
- Only properly trained personnel who have received unit-specific familiarization shall operate a MEWP. The user shall determine if personnel are qualified to operate the MEWP prior to operation.
- Read, understand, and obey all DANGERS, WARNINGS, CAUTIONS, and operating instructions on the machine and in this manual.
- Ensure that the machine is to be used in a manner which is within the scope of its intended application as determined by JLG.
- All operating personnel must have a thorough understanding of the intended purpose and function of the MEWP controls, including platform, ground and emergency descent controls.
- Read, understand, and obey all applicable employer, local, and governmental regulations as they pertain to your utilization and application of the machine.

### **Workplace Inspection**

- Precautions to avoid all hazards in the work area must be taken by the user before and during operation of the machine.
- Do not operate or raise the platform from a position on trucks, trailers, railway cars, floating vessels, scaffolds or other equipment unless the application is approved in writing by JLG.
- Before operation, check work area for overhead hazards such as electric lines, bridge cranes, and other potential overhead obstructions.
- Check operating surfaces for holes, bumps, drop-offs, obstructions, debris, concealed holes, and other potential hazards.
- Check the work area for hazardous locations. Do not operate the machine in hazardous environments unless approved for that purpose by JLG.
- Ensure that the ground conditions are adequate to support the maximum outrigger load indicated on the outrigger load decals located on the machine.

### Machine Inspection

- Do not operate this machine until the inspections and functional checks as specified in Section 2 of this manual have been performed.
- Do not operate this machine until it has been serviced and maintained according to the maintenance and inspection requirements as specified in the machine's Service and Maintenance Manual.
- Ensure all safety devices are operating properly. Modification of these devices is a safety violation.

#### **WARNING**

**MODIFICATION OR ALTERATION OF A MEWP SHALL BE MADE ONLY WITH PRIOR WRITTEN PERMISSION FROM THE MANUFACTURER.**

- Do not operate any machine on which the safety or instruction placards or decals are missing or illegible.
- Check the machine for modifications to original components. Ensure that any modifications have been approved by JLG.
- Avoid accumulation of debris on platform floor. Keep mud, oil, grease, and other slippery substances from footwear and platform floor.

### 1.3 OPERATION

#### General

- Machine operation requires your full attention. Bring the machine to a full stop before using any device, i.e. cell phones, two-way radios, etc. that will distract your attention from safely operating the machine.
- Do not use the machine for any purpose other than positioning personnel, their tools, and equipment.
- Before operation, the user must be familiar with the machine capabilities and operating characteristics of all functions.
- Never operate a malfunctioning machine. If a malfunction occurs, shut down the machine. Remove the unit from service and notify the proper authorities.
- Do not remove, modify, or disable any safety devices.
- Never slam a control switch or lever through neutral to an opposite direction. Always return switch to neutral and stop before moving the switch to the next function. Operate controls with slow and even pressure.

## SECTION 1 - SAFETY PRECAUTIONS

---

- Do not allow personnel to tamper with or operate the machine from the ground with personnel in the platform, except in an emergency.
- Do not carry materials directly on platform railing unless approved by JLG.
- When two or more persons are in the platform, the operator shall be responsible for all machine operations.
- Always ensure that power tools are properly stowed and never left hanging by their cord from the platform work area.
- When driving, always position boom over rear axle in line with the direction of travel. Remember, if boom is over the front axle, steer and drive functions will be reversed.
- Do not assist a stuck or disabled machine by pushing or pulling except by pulling at the chassis tie-down lugs.
- Fully lower platform and shut off all power before leaving machine.
- Remove all rings, watches, and jewelry when operating machine. Do not wear loose fitting clothing or long hair unrestrained which may become caught or entangled in equipment.

- Persons under the influence of drugs or alcohol or who are subject to seizures, dizziness or loss of physical control must not operate this machine.
- Hydraulic cylinders are subject to thermal expansion and contraction. This may result in changes to the platform position while the machine is stationary. Factors affecting thermal movement can include the length of time the machine will remain stationary, hydraulic oil temperature, ambient air temperature and platform position.

### Trip and Fall Hazards

- Prior to operation, ensure all gates are closed and fastened in their proper position.
- During operation, occupants in the platform must wear a full body harness with a lanyard attached to an authorized lanyard anchorage point. Attach only one (1) lanyard per lanyard anchorage point.

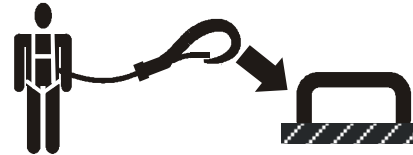

- Enter and exit only through gate area. Use extreme caution when entering or leaving platform. Ensure

that the platform assembly is fully lowered. Face the platform when entering or leaving the platform. Always maintain "three point contact" with the machine, using two hands and one foot or two feet and one hand at all times during entry and exit.

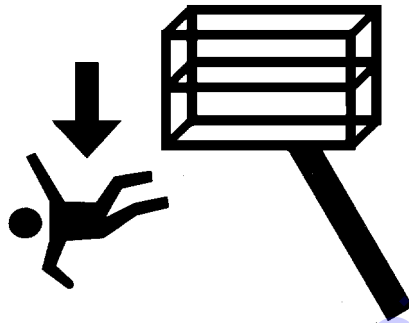

- Keep both feet firmly positioned on the platform floor at all times. Never position ladders, boxes, steps, planks, or similar items on unit to provide additional reach for any purpose.
- Keep oil, mud, and slippery substances cleaned from footwear and the platform floor.

### Electrocution Hazards

- This machine is not insulated and does not provide protection from contact or proximity to electrical current.

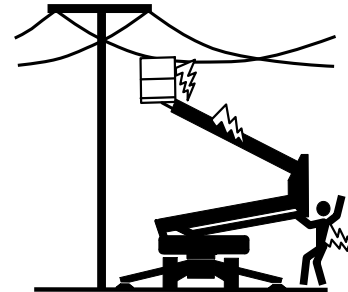
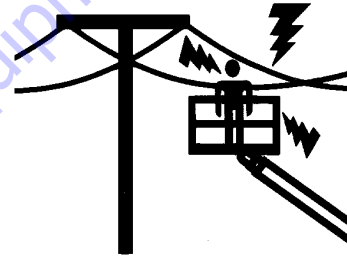



## SECTION 1 - SAFETY PRECAUTIONS

- Maintain distance from electrical lines, apparatus, or any energized (exposed or insulated) parts according to the Minimum Approach Distance (MAD) as shown in Table 1-1.
- Allow for machine movement and electrical line swaying.

**Table 1-1. Minimum Approach Distances (M.A.D.)**

Voltage Range (Phase to Phase)	MINIMUM APPROACH DISTANCE in Feet (Meters)
0 to 50 KV	10 (3)
Over 50KV to 200 KV	15 (5)
Over 200 KV to 350 KV	20 (6)
Over 350 KV to 500 KV	25 (8)
Over 500 KV to 750 KV	35 (11)
Over 750 KV to 1000 KV	45 (14)

**NOTE:** *This requirement shall apply except where employer, local or governmental regulations are more stringent.*

- Maintain a clearance of at least 10 ft. (3m) between any part of the machine and its occupants, their tools, and their equipment from any electrical line or apparatus carrying up to 50,000 volts. One foot addi-

tional clearance is required for every additional 30,000 volts or less.

- The minimum approach distance may be reduced if insulating barriers are installed to prevent contact, and the barriers are rated for the voltage of the line being guarded. These barriers shall not be part of (or attached to) the machine. The minimum approach distance shall be reduced to a distance within the designed working dimensions of the insulating barrier. This determination shall be made by a qualified person in accordance with the employer, local, or governmental requirements for work practices near energized equipment

### **DANGER**

**DO NOT MANEUVER MACHINE OR PERSONNEL INSIDE PROHIBITED ZONE (MAD). ASSUME ALL ELECTRICAL PARTS AND WIRING ARE ENERGIZED UNLESS KNOWN OTHERWISE.**

### **Tipping Hazards**

- Ensure that the ground conditions are adequate to support the maximum outrigger load indicated on the outrigger load decals located on the machine. Do not travel on unsupported surfaces.

## SECTION 1 - SAFETY PRECAUTIONS

- The user must be familiar with the operating surface before driving. Do not exceed the allowable side-slope and grade while driving.

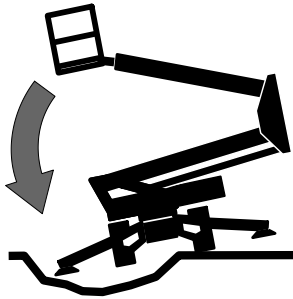

- Do not elevate platform while on or near a sloping, uneven, or soft surface. Ensure machine is positioned on a smooth, firm surface within the limits of the maximum operating slope before elevating platform.
- Before driving on floors, bridges, trucks, and other surfaces, check allowable capacity of the surfaces.
- Do not elevate the platform unless the machine is on a firm operating surface and outriggers are properly set.

- Never exceed the maximum platform capacity as specified on the platform. Keep all loads within the confines of the platform, unless authorized by JLG.
- Keep the chassis and outriggers of the machine a minimum of 2 ft. (0.6m) from holes, bumps, drop-offs, obstructions, debris, concealed holes, and other potential hazards at the ground level.
- Do not push or pull any object with the boom.
- Never attempt to use the machine as a crane. Do not tie-off machine to any adjacent structure. Never attach wire, cable, or any similar items to platform.
- Do not operate the machine when wind conditions exceed 28 mph (12.5 m/s). Refer to Table 1-2, Beaufort Scale (For Reference Only). Factors affecting wind speed are; platform elevation, surrounding structures, local weather events, and approaching storms.
- Wind speed can be significantly greater at height than at ground level.
- Wind speed can change rapidly. Always consider approaching weather events, the time required to lower the platform, and methods to monitor current and potential wind conditions.
- Do not cover or increase surface area of the platform or the load. Do not carry large surface area items into the platform when operating outdoors. The addition

## **SECTION 1 - SAFETY PRECAUTIONS**

---

of such items increases the exposed wind area of the machine. Increased areas exposed to wind will decrease stability.

- Do not increase the platform size with unauthorized modifications or attachments.
- If boom assembly or platform is in a position that one or more outriggers are off the ground, all persons must be removed before attempting to stabilize the machine. Use cranes, forklift trucks, or other appropriate equipment to stabilize machine.

To order go to [Discount-Equipment.com](http://Discount-Equipment.com)

**NOTICE**

**DO NOT OPERATE THE MACHINE WHEN WIND CONDITIONS EXCEED SPECIFICATIONS SHOWN IN SECTION 6, FIGURE 1-2 OR AS SHOWN ON THE CAPACITY PLACARD ON THE PLATFORM BILLBOARD.**

**Table 1-2. Beaufort Scale (For Reference Only)**

Beaufort Number	Wind Speed		Description	Land Conditions
	mph	m/s		
0	0	0-0.2	Calm	Calm. Smoke rises vertically
1	1-3	0.3-1.5	Light air	Wind motion visible in smoke
2	4-7	1.6-3.3	Light breeze	Wind felt on exposed skin. Leaves rustle
3	8-12	3.4-5.4	Gentle breeze	Leaves and smaller twigs in constant motion
4	13-18	5.5-7.9	Moderate breeze	Dust and loose paper raised. Small branches begin to move.
5	19-24	8.0-10.7	Fresh breeze	Smaller trees sway.
6	25-31	10.8-13.8	Strong breeze	Large branches in motion. Flags waving near horizontal. Umbrella use becomes difficult.
7	32-38	13.9-17.1	Near Gale/Moderate Gale	Whole trees in motion. Effort needed to walk against the wind.
8	39-46	17.2-20.7	Fresh Gale	Twigs broken from trees. Cars veer on road.
9	47-54	20.8-24.4	Strong Gale	Light structure damage.

## SECTION 1 - SAFETY PRECAUTIONS

---

### Crushing and Collision Hazards

- Approved head gear must be worn by all operating and ground personnel.
- Check work area for clearances overhead, on sides, and bottom of platform when lifting or lowering platform, and driving.

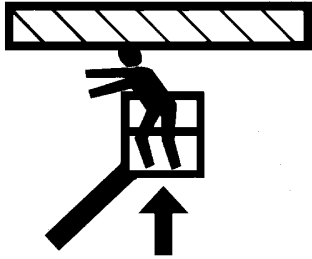

- During operation, keep all body parts inside platform railing.
- Use the boom functions, not the drive function, to position the platform close to obstacles.
- Always post a lookout when driving in areas where vision is obstructed.
- Keep non-operating personnel at least 6 ft. (1.8m) away from machine during all operations.

- Under all travel conditions, the operator must limit travel speed according to conditions of ground surface, congestion, visibility, slope, location of personnel, and other factors.
- Be aware of stopping distances in all drive speeds. When driving in high speed, switch to low speed before stopping. Travel grades in low speed only.
- Do not use high speed drive in restricted or close quarters or when driving in reverse.
- Exercise extreme caution at all times to prevent obstacles from striking or interfering with operating controls and persons in the platform.
- Ensure that operators of other overhead and floor level machines are aware of the MEWP's presence. Disconnect power to overhead cranes.
- Do not operate over ground personnel. Warn personnel not to work, stand, or walk under a raised boom or platform. Position barricades on floor if necessary.

### 1.4 TOWING, LIFTING, AND HAULING

- Never allow personnel in platform while towing, lifting, or hauling.
- Ensure boom is in the stowed position and the turntable locked prior to towing, lifting or hauling. The platform must be completely empty of tools.
- When lifting machine, lift only at designated areas of the machine. Lift the unit with equipment of adequate capacity.
- Refer to the Machine Operation section of this manual for lifting information.

### 1.5 MAINTENANCE

This sub-section contains general safety precautions which must be observed during maintenance of this machine. Additional precautions to be observed during machine maintenance are inserted at the appropriate points in this manual and in the Service and Maintenance Manual. It is of utmost importance that maintenance personnel pay strict attention to these precautions to avoid possible injury to personnel or damage to the machine or property. A maintenance program must be established by a qualified person and must be followed to ensure that the machine is safe.

#### Maintenance Hazards

- Shut off power to all controls and ensure that all moving parts are secured from inadvertent motion prior to performing any adjustments or repairs.
- Never work under an elevated platform until it has been fully lowered to the full down position, if possible, or otherwise supported and restrained from movement with appropriate safety props, blocking, or overhead supports.
- DO NOT attempt to repair or tighten any hydraulic hoses or fittings while the machine is powered on or when the hydraulic system is under pressure.

## SECTION 1 - SAFETY PRECAUTIONS

---

- Always relieve hydraulic pressure from all hydraulic circuits before loosening or removing hydraulic components.
- DO NOT use your hand to check for leaks. Use a piece of cardboard or paper to search for leaks. Wear gloves to help protect hands from spraying fluid.



- Use only replacement parts or components that are approved by JLG. To be considered approved, replacement parts or components must be identical or equivalent to original parts or components.
- Never attempt to move heavy parts without the aid of a mechanical device. Do not allow heavy objects to rest in an unstable position. Ensure adequate support is provided when raising components of the machine.

- Do not use machine as a ground for welding.
- When performing welding or metal cutting operations, precautions must be taken to protect the chassis from direct exposure to weld and metal cutting spatter.
- Do not refuel the machine with the engine running.
- Use only approved non-flammable cleaning solvents.
- Do not replace items critical to stability, such as batteries or solid tires, with items of different weight or specification. Do not modify the MEWP in any way to affect stability.
- Refer to the Service and Maintenance Manual for the weights of critical stability items.

### **⚠ WARNING**

**MODIFICATION OR ALTERATION OF A MEWP SHALL BE MADE ONLY WITH PRIOR WRITTEN PERMISSION FROM THE MANUFACTURER.**

## **Battery Hazards**

- Always disconnect batteries when servicing electrical components or when performing welding on the machine.
- Do not allow smoking, open flame, or sparks near battery during charging or servicing.
- Do not contact tools or other metal objects across the battery terminals.
- Always wear hand, eye, and face protection when servicing batteries. Ensure that battery acid does not come in contact with skin or clothing.

### **CAUTION**

**BATTERY FLUID IS HIGHLY CORROSIVE. AVOID CONTACT WITH SKIN AND CLOTHING AT ALL TIMES. IMMEDIATELY RINSE ANY CONTACTED AREA WITH CLEAN WATER AND SEEK MEDICAL ATTENTION.**

- Charge batteries only in a well ventilated area.
- Avoid overfilling the battery fluid level. Add distilled water to batteries only after the batteries are fully charged.



To order go to [Discount-Equipment.com](http://Discount-Equipment.com)

### SECTION 2. PREPARATION AND INSPECTION

#### 2.1 PERSONNEL TRAINING

The MEWP (mobile elevating work platform) is a personnel handling device; so it is necessary that it be operated and maintained only by trained personnel.

##### Operator Training

Operator training must cover:

1. Reading and understanding the Operation and Safety Manual.
2. Thorough understanding of the intended purpose and function of the MEWP controls, including platform, ground, and emergency descent controls.
3. Control labels, instructions, and warnings on the machine.
4. Applicable regulations, standards, and safety rules.
5. Use of approved fall protection equipment.
6. Enough knowledge of the mechanical operation of the machine to recognize a malfunction or potential malfunction.
7. The safest means to operate the machine where overhead obstructions, other moving equipment, and obstacles, depressions, holes, and drop-offs exist.

8. Means to avoid the hazards of unprotected electrical conductors.
9. Selection of the appropriate MEWPs and available options for the work to be performed considering specific job requirements, with involvement from the MEWP owner, user, and/or supervisor.
10. The responsibility of the operator to ensure all platform occupants have a basic level of knowledge to work safely on the MEWP, and to inform them of applicable regulations, standards, and safety rules.
11. The requirement for familiarization in addition to training.

##### Training Supervision

Training must be delivered by a qualified person in an open area free of hazards until the trainee has demonstrated the ability to safely control and operate the machine.

##### Operator Responsibility

The operator must be instructed that he/she has the responsibility and authority to shut down the machine in case of a malfunction or other unsafe condition of either the machine or the job site.

## SECTION 2 - PREPARATION AND INSPECTION

---

### 2.2 PREPARATION, INSPECTION, AND MAINTENANCE

The following table covers machine inspections and maintenance required by JLG Industries, Inc. Consult local regulations for further requirements for MEWPs. Frequency of inspections and maintenance must be increased as necessary when machine is used in a harsh or hostile environment, if machine is used with increased frequency, or if machine is used in a severe manner.

#### Machine Familiarization

**NOTE:** Responsibilities for familiarization may vary by region.

Only properly trained personnel who have received unit-specific familiarization shall operate a MEWP. The user shall determine if personnel are qualified to operate the MEWP prior to operation. The user shall ensure that after familiarization, the operator operates the MEWP for a sufficient period of time to achieve proficiency. When authorized by the user, self-familiarization can be achieved, if authorized, by a properly trained operator reading, understanding and following the manufacturer's operator's manual.

Prior to users authorization of an operator to use a specific model of MEWP, the user shall ensure the operator is familiarized on the following:

1. Location of the manual storage compartment and the requirement to ensure the required manual(s) are present on the MEWP;
2. Purpose and function of the machine controls and indicators at the platform and ground control stations;
3. Purpose, location, and function of the emergency controls;
4. Operating characteristics and limitations;
5. Features and devices;
6. Accessories and optional equipment.

## SECTION 2 - PREPARATION AND INSPECTION

**Table 2-1. Inspection and Maintenance Table**

Type	Frequency	Primary Responsibility	Service Qualification	Reference
Pre-Start Inspection	Before using each day; or whenever there's an Operator change.	User or Operator	User or Operator	Operation and Safety Manual
Pre-Delivery Inspection (See Note)	Before each sale, lease, or rental delivery.	Owner, Dealer, or User	Qualified JLG Mechanic	Service and Maintenance Manual and applicable JLG inspection form
Frequent Inspection	In service for 3 months or 150 hours, whichever comes first; or Out of service for a period of more than 3 months; or Purchased used.	Owner, Dealer, or User	Qualified JLG Mechanic	Service and Maintenance Manual and applicable JLG inspection form
Annual Machine Inspection	Annually, no later than 13 months from the date of prior inspection.	Owner, Dealer, or User	Factory Trained Service Technician (Recommended)	Service and Maintenance Manual and applicable JLG inspection form
Preventative Maintenance	At intervals as specified in the Service and Maintenance Manual.	Owner, Dealer, or User	Qualified JLG Mechanic	Service and Maintenance Manual

**NOTE:** Inspection forms are available from JLG. Refer to Section 6 - Operators Maintenance when performing inspections.

### **NOTICE**

**JLG INDUSTRIES, INC. RECOGNIZES A FACTORY TRAINED SERVICE TECHNICIAN AS A PERSON WHO HAS SUCCESSFULLY COMPLETED THE JLG SERVICE TRAINING SCHOOL FOR THE SPECIFIC JLG PRODUCT MODEL.**

## SECTION 2 - PREPARATION AND INSPECTION

### Pre-Start Inspection

The Pre-Start Inspection should include each of the following:

1. **Cleanliness** – Check all surfaces for leakage (oil, fuel, or battery fluid) or foreign objects. Report any leakage to the proper maintenance personnel.
2. **Structure** - Inspect the machine structure for dents, damage, weld or parent metal cracks or other discrepancies.

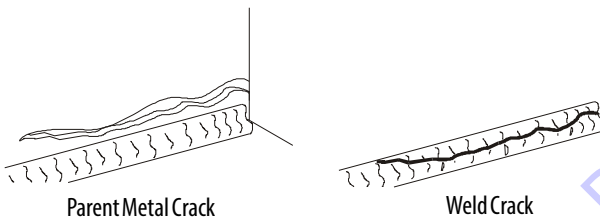

3. **Decals and Placards** – Check all for cleanliness and legibility. Make sure none of the decals and placards are missing. Make sure all illegible decals and placards are cleaned or replaced.
4. **Operation and Safety Manuals** – Make sure a copy of the Operation and Safety Manual, AEM Safety Manual (ANSI markets only), and ANSI Manual of Responsibilities (ANSI markets only) is enclosed in the weather resistant storage container.
5. **Walk-Around Inspection** – Refer to Figure 2-1.
6. **Battery** – Charge as required.
7. **Fuel** (Combustion Engine Powered Machines) – Add the proper fuel as necessary.
8. **Engine Oil Supply** (Combustion Engine Powered Machines) - Ensure the engine oil level is at the Full mark on the dipstick and the filler cap is secure.
9. **Hydraulic Oil** – Check the hydraulic oil level. Ensure hydraulic oil is added as required.
10. **Function Check** – Once the “Walk-Around” Inspection is complete, perform a functional check of all systems in an area free of overhead and ground level obstructions. Refer to Section 4 for more specific operating instructions.

## SECTION 2 - PREPARATION AND INSPECTION

---

11. **Platform Gate** – Keep gate and surrounding area clean and unobstructed. Verify the gate closes properly and is not bent or damaged. Keep gate closed at all times except when entering/exiting the platform and loading/unloading materials.
12. **Lanyard Attach Points** – During operation, occupants in the platform must wear a full body harness with a lanyard attached to an authorized lanyard anchorage point. Attach only one (1) lanyard per lanyard anchorage point.

### **WARNING**

**IF THE MACHINE DOES NOT OPERATE PROPERLY, TURN OFF THE MACHINE IMMEDIATELY! REPORT THE PROBLEM TO THE PROPER MAINTENANCE PERSONNEL. DO NOT OPERATE THE MACHINE UNTIL IT IS DECLARED SAFE FOR OPERATION.**

## SECTION 2 - PREPARATION AND INSPECTION

---

### Daily Walk-Around Inspection

#### General

Begin the "Walk-Around Inspection" at Item 1, as noted on the diagram. Continue checking each item in sequence for the conditions listed in the following checklist.

#### **⚠ WARNING**

**TO AVOID POSSIBLE INJURY, BE SURE MACHINE POWER IS OFF. DO NOT OPERATE MACHINE UNTIL ALL MALFUNCTIONS HAVE BEEN CORRECTED.**

#### **NOTICE**

**DO NOT OVERLOOK VISUAL INSPECTION OF CHASSIS UNDERSIDE. CHECKING THIS AREA MAY RESULT IN DISCOVERY OF CONDITIONS WHICH COULD CAUSE EXTENSIVE MACHINE DAMAGE.**

**INSPECTION NOTE:** *On all components, make sure there are no loose or missing parts, that they are securely fastened, and no visible damage, leaks or excessive wear exists in addition to any other criteria mentioned.*

- 1. Platform Assembly, Foot Switch, Ladder and Gate** - Foot switch in good working order, not modified, disabled or blocked. Manuals in storage container, access bar slides up and down properly, platform properly installed and with both caps screwed on. See Inspection Note.

- 2. Platform/Remote & Ground Control Stations** - Switches and levers return to neutral, decals/placards secure and legible, control markings legible.
- 3. Outriggers** - See Inspection Note; pads pivot freely.
- 4. Electrical & Hydraulic Cover Assemblies** - See Inspection Note.
- 5. Boom Sections & Turntable** - See Inspection Note.
- 6. Drive Tracks** - Properly Adjusted. See Inspection Note.
- 7. Diesel Engine or Lithium ION Battery Pack** - Free of debris and See Inspection Note.
- 8. Swing Drive & Turntable Bearing**- Check for proper lubrication. See Inspection Note.
- 9. Hydraulic Tank** - Hydraulic oil level correct and See Inspection Note.
- 10. Electric Engine and Hydraulic Pump** - See Inspection Note.
- 11. Platform Rotator & Machine Bubble Level** - See Inspection Note.

## SECTION 2 - PREPARATION AND INSPECTION

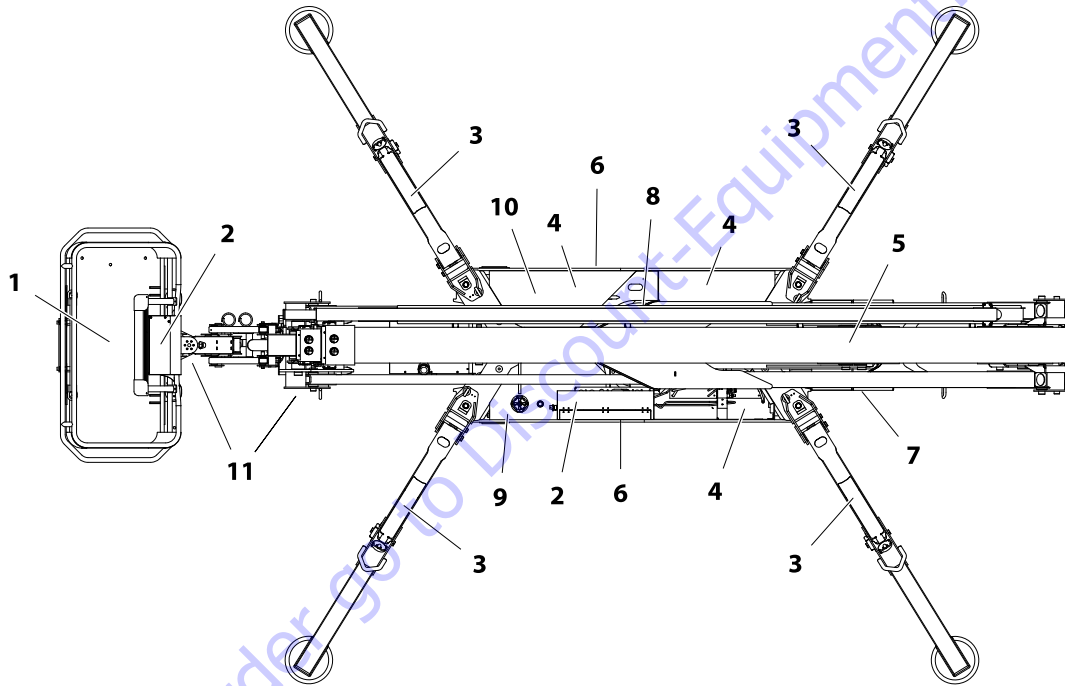

**Figure 2-1. Daily Walk-Around Inspection**



### Function Check

#### **WARNING**

**ENSURE NO FUNCTIONS (EXCEPT TRACK FUNCTIONS) OPERATE WHEN OUT-RIGGERS ARE NOT PROPERLY SET.**

After properly setting up on outriggers, perform the function check as follows:

1. From the ground control console with no load in the platform:
  - a. Check all guards protecting function control switches and controllers are in place.
  - b. Operate all functions.
  - c. Ensure all machine functions are disabled when Emergency Stop Button is pushed in.
  - d. Ensure all boom functions stop when function enable switch is released.
  - e. Ensure main lift down, tower lift down, and jib lift down, work properly when using the emergency lowering controls.
2. From the platform control console:
  - a. Ensure that the control console is firmly secured in the proper location.
  - b. Check that all guards protecting the function control switches and controllers are in place;
  - c. Operate all functions.
  - d. Ensure all boom functions stop when the foot switch is released.
  - e. Ensure that all machine functions are disabled when the Emergency Stop Button is pushed in.
  - f. Ensure main lift down, tower lift down, and jib lift down, work properly when using the emergency lowering controls.
3. SkyGuard™ Function Test (If Equipped)
  - a. From the platform controls, test the SkyGuard™ feature by setting up machine and operating the telescope out functions and then activating the SkyGuard™ sensor. The telescope out function will stop and the telescope in function will operate for a short duration, also the ground alarm will sound until the SkyGuard™ sensor or footswitch is disengaged.
  - b. Disengage the SkyGuard™ sensor, release controls, recycle the foot switch, make sure normal operation is available.
  - c. If SkyGuard™ remains activated after function reversal or cutout, depress and hold the SkyGuard™ Override Switch (button number 8) to allow normal use of machine functions until the SkyGuard™ sensor is disengaged.

## SECTION 2 - PREPARATION AND INSPECTION

---

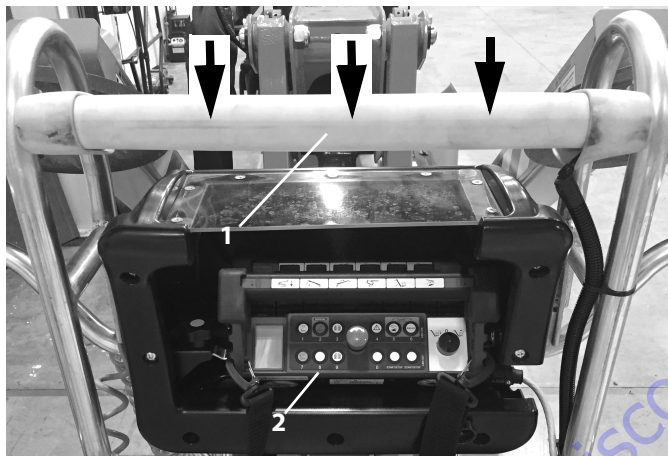

1. SkyGuard™ Sensor
2. SkyGuard™ Override Switch  
(button number 8)

**Figure 2-2. SkyGuard™ Sensor and Override Switch Location**

**SECTION 3. MACHINE CONTROLS, INDICATORS AND OPERATION**

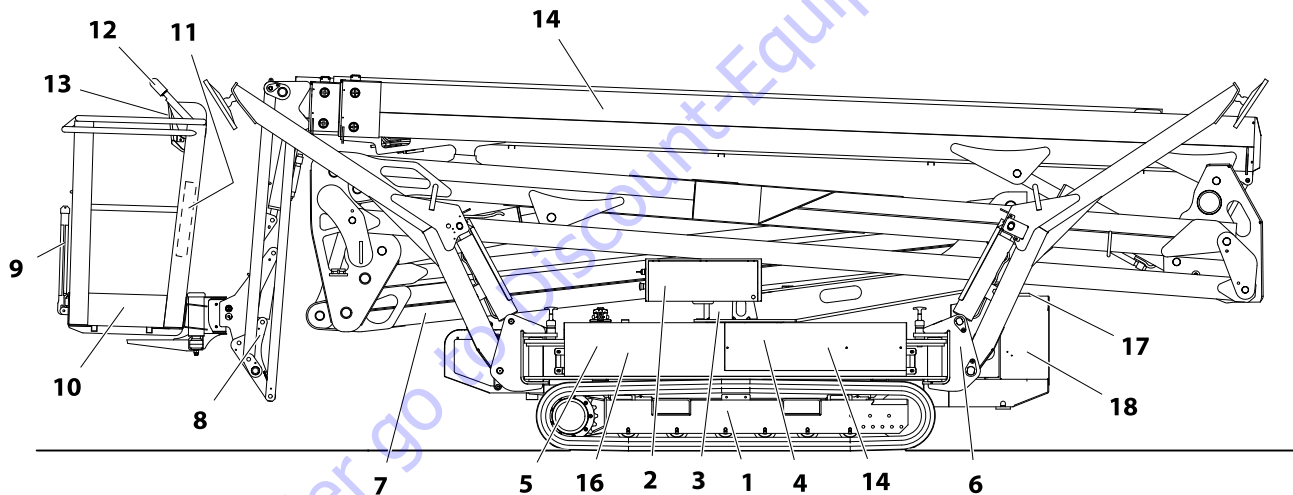

**Figure 3-1. Basic Machine Component Locations**

## **SECTION 3 - MACHINE CONTROLS, INDICATORS AND OPERATION**

---

### **Basic Machine Component Locations**

1. Extendible Track Undercarriage
2. Ground/Emergency Controls and Boom/Jib Hydraulic Control Compartment
3. Turntable
4. Track/Outrigger/Drive/Steer/Hand Pump Hydraulic Control Valve Compartment
5. Hydraulic Oil tank
6. Outriggers
7. Tower Boom Assembly
8. Jib
9. Ladder
10. Platform
11. Manuals Compartment
12. SkyGuard™ Sensor (If Equipped)
13. Platform/Remote Control Station
14. Main Boom
15. Electric Components Compartment (same area left side of machine)
16. Electric Motor/Pump Compartment (same area left side of machine)
17. Lithium ION - Battery Charger LED Indicator - on top of battery pack (if equipped)
18. Diesel Engine Compartment or Lithium ION - Battery Pack, Inverter, and Battery Charger Compartment (if equipped)

## SECTION 3 - MACHINE CONTROLS, INDICATORS AND OPERATION

---

### WARNING

TO AVOID SERIOUS INJURY, DO NOT OPERATE MACHINE IF ANY CONTROL LEVERS OR SWITCHES CONTROLLING PLATFORM MOVEMENT DO NOT RETURN TO THE OFF POSITION WHEN RELEASED.

### 3.1 GROUND CONTROL STATION

See Figure 3-2., Ground Control Station

### NOTICE

WHEN THE MACHINE IS SHUT DOWN BOTH EMERGENCY STOP SWITCHES AND THE KEY SWITCH ON THE ENGINE MUST BE SET TO THE OFF POSITION TO PREVENT DRAINING THE BATTERY. FOR PROLONGED SHUTDOWN OR WHILE PERFORMING MAINTENANCE/REPAIRS, TURN OFF THE BATTERY DISCONNECT SWITCH.

#### 1. Main Power Key Switch

This switch must be turned to the ON (I) position before power is supplied to the Power/Emergency Stop switch. When machine is not in use, the key can be removed in the OFF (O) position.

#### 2. Power/Emergency Stop Switch

A two-position red switch supplies power to PLATFORM/GROUND/REMOTE SELECT switch when twisted clockwise to be in the out (on) position. When pushed in (off), power is shut off to the PLATFORM and GROUND controls.

#### 3. Platform/Ground/Remote Select Switch

This three position selector switch provides power to the platform when in the center (neutral) position.

With the key switch turned clockwise and held, only the ground controls are operational.

With the key switch turned counter-clockwise, the ground control electrical connector is enabled and the platform (remote) control station can be operated from the ground position.

#### 4. Engine Start Buttons

To start the engine at the ground control, the main power key switch (*item 1*) must be set to ON, emergency stop button (*item 2*) reset to ON and set the select switch (*item 3*) in the center (neutral) position. The engine start button (*item 4*) must be pushed in until the engine starts. The button on the RIGHT is for ELECTRIC MOTOR start, the button on the LEFT is for GAS/DIESEL ENGINE start.

**NOTE:** *When the machine is not stabilized and the engine is not running, an alarm will sound to indicate that the key switch on the engine is ON. Turn OFF the key switch on the engine when not in operation.*

## SECTION 3 - MACHINE CONTROLS, INDICATORS AND OPERATION

---

### 5. Function Enable Light

Illuminates when outriggers are properly set and boom functions are allowed. Not illuminated indicates outriggers are not properly set and boom functions are not allowed.

### 6. Function Enable Lever

This lever must be engaged and held UP in order to operate the boom functions from the ground controls, items 7 through 13. Do not operate the boom controls unless the green light (*item 5*) is illuminated to indicate if operation is possible (*machine stabilized*) from these controls.

### 7. Swing Control

Provides swing to the left or right of the boom assembly.

### 8. Tower Boom Lift Control

Provides raising and lowering of the tower boom.

### 9. Main Boom Lift Control

Provides raising and lowering of the main boom.

### 10. Main Boom Telescope Control

Provides extension and retraction of the main boom.

### 11. Jib Lift

Provides raising and lowering of the jib.

### 12. Platform Rotate Control

Provides rotating the platform to the right or left.

## **WARNING**

**ONLY USE THE PLATFORM LEVELING OVERRIDE FUNCTION FOR SLIGHT LEVELING OF THE PLATFORM. INCORRECT USE COULD CAUSE THE LOAD/OCCUPANT TO SHIFT OR FALL. FAILURE TO DO SO COULD RESULT IN DEATH OR SERIOUS INJURY.**

### 13. Platform Level Control

Provides for positioning the platform up and down to adjust the level of the platform.

## SECTION 3 - MACHINE CONTROLS, INDICATORS AND OPERATION

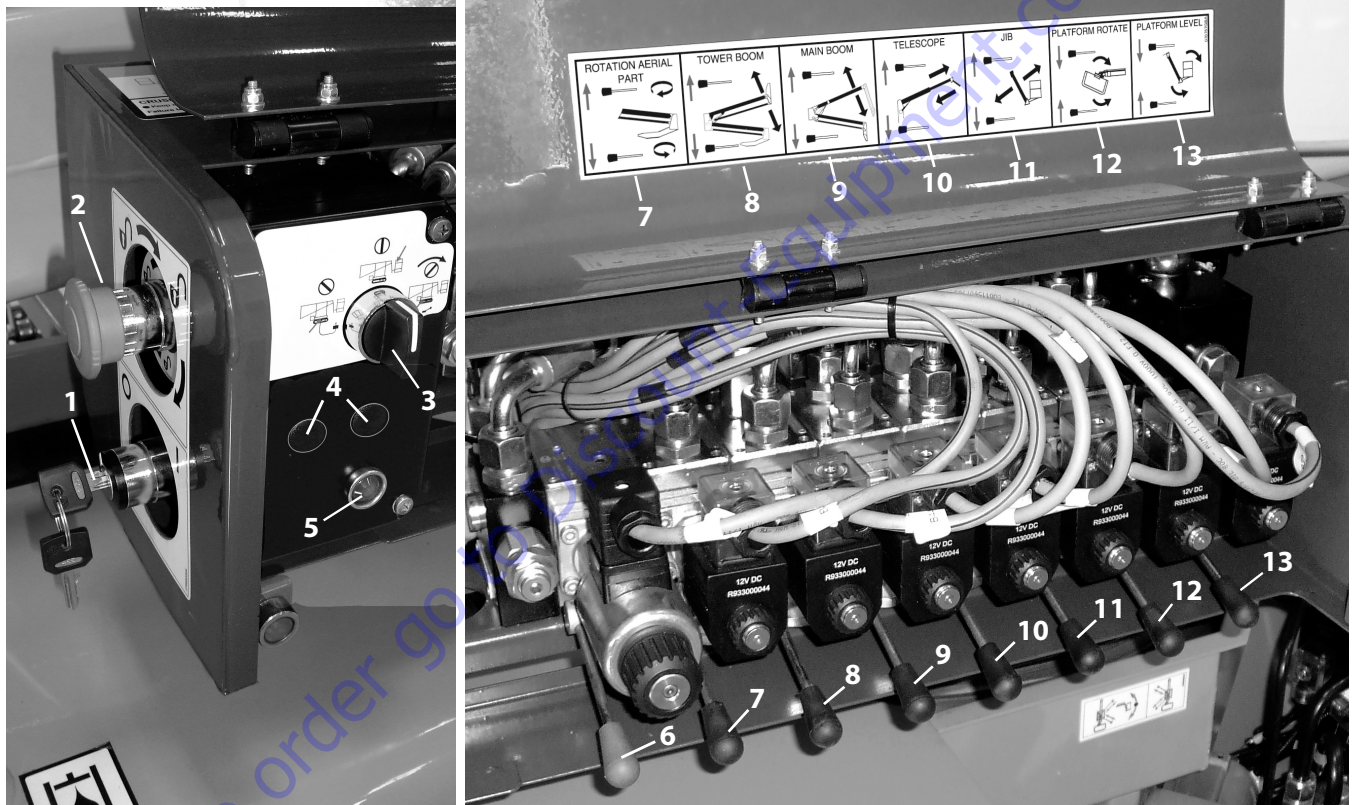

Figure 3-2. Ground Control Station

## SECTION 3 - MACHINE CONTROLS, INDICATORS AND OPERATION

### 3.2 PLATFORM/REMOTE CONTROL STATION

#### Control Position On The Ground:

Using the platform/remote control station from this control position is for function check and maintenance only.

Do not operate machine using the platform/remote control station from this position if anyone is in the platform.

#### **⚠ WARNING**

**WHEN OPERATING THE MACHINE FROM THE GROUND POSITION KEEP AT A DISTANCE OF AT LEAST 6 FT (1.8M) FROM THE TRACKS.**

Ground control position for the platform/remote control is possible by connecting the platform/remote control station to the (optional) ground/remote control cable (*item 1*) see photo below.

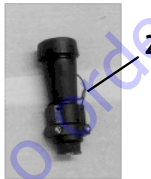
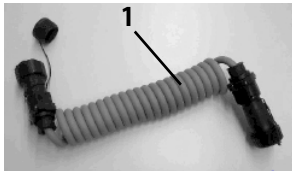

**NOTE:** Before removing or connecting the special adapter plug, depress the emergency stop buttons and the key on the engine must be in the OFF position.

Unscrew the special adapter plug (*item 2*) from the platform/remote cable connector and attach to the optional ground/remote flex cable (*item 1*) when operating the control station at the ground position.

Connect the ground/remote control cable to the ground/remote cable connector on the left side of the machine at the electrical components cabinet (*see below*).

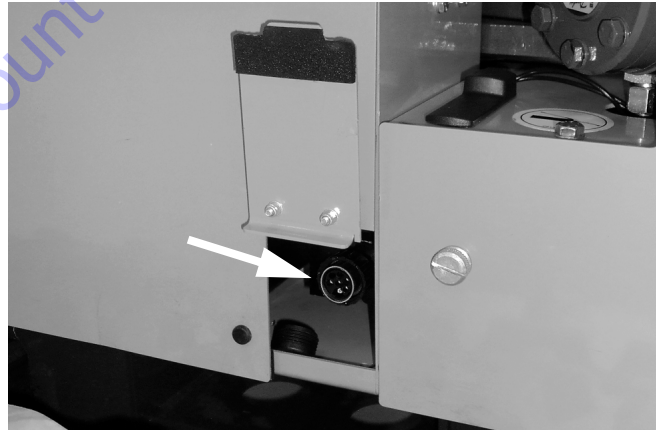



## SECTION 3 - MACHINE CONTROLS, INDICATORS AND OPERATION

To enable this position it is necessary to have the selector switch at the ground controls (*Item 3 - Figure 3-2.*) turned counterclockwise, this selector switch also overrides the footswitch in the platform.

### **⚠ WARNING**

**TO AVOID SERIOUS INJURY, DO NOT OPERATE MACHINE IF ANY CONTROL LEVERS OR CONTROL SWITCHES CONTROLLING PLATFORM MOVEMENT DO NOT RETURN TO THE OFF OR NEUTRAL POSITION WHEN RELEASED.**

**NOTE:** *Before removing or connecting the special adapter plug, press the emergency stop buttons and place key on the engine in the OFF position. Before connecting the special adapter plug ensure there is no moisture in the electrical connectors at any time.*

Re-connect the special adapter plug (*item 2*) on the ground/remote cable connector (*item 1*) as shown in photo, when using the platform/remote control station at the platform.

### **Control Position From In The Platform:**

The platform/remote control is connected to the machine at the platform using a flexible cable.

Always remember to close the platform/remote control station lid when not in use.

**NOTE:** *Before removing or connecting the flex cable, the machine must be turned OFF and the key on the engine must be in the OFF position.*

### **Installing the Platform/Remote Control Station At The Platform**

1. Connect the flexible control cable at the platform to the Platform/Remote Control Station box connector on the right side of the control box.

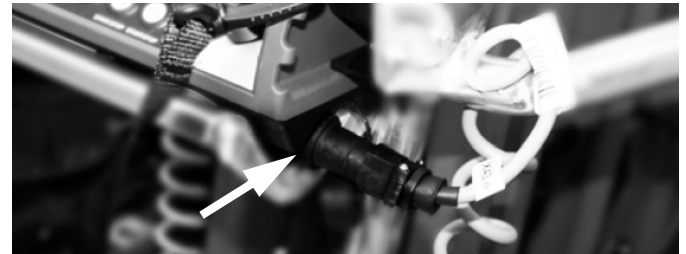

2. In the platform, slide the remote control station assembly into the storage box and place the rib on the right side of the control station assembly

## SECTION 3 - MACHINE CONTROLS, INDICATORS AND OPERATION

---

under the metal tab attached to the storage box assembly.

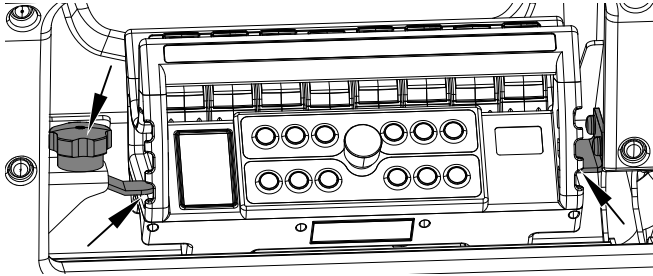

3. Lower remote control station assembly into the storage box, ensure the attached flexible cable slides into the slot also on the right side of the box.

4. On the left side of the control station secure the box by turning the handle on the locking tab clockwise locking the rib of the control station under the rotating metal tab of the handle assembly.
5. To remove the control station assembly, reverse the four steps above.

**NOTE:** *The Platform/Remote control box may also be used to operate tracks, outriggers, and track widening (if equipped) by removing it from the platform storage box and plugging in at the ground control position. All boom functions will be disabled when platform/remote box is operated from the ground position.*

## SECTION 3 - MACHINE CONTROLS, INDICATORS AND OPERATION

### Platform/Remote Control Station Functions

#### Platform Foot Switch (see photo below)

To operate any function, the footswitch must be depressed and a function selected within seven seconds. If a function is not selected within seven seconds, or if a seven second lapse between ending one function and beginning the next function, the footswitch must be released and depressed again to enable the controls.

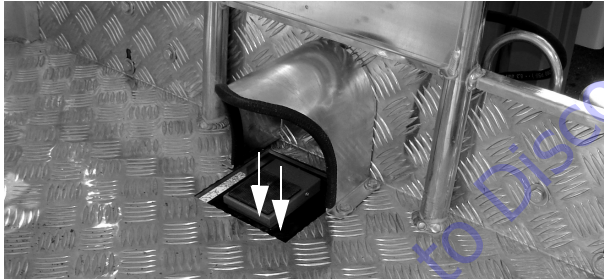

See Figure 3-3. on page 3-10, Platform Control Console for remaining items.

**NOTE:** Buttons 1, 2, 3, 4, 5, 6, 7, 8, 9, serve a double function - they can be used to operate a machine function (icon on button) or used as numerical keys (per number below the button) when the SERVICE button 6 (item 6) sub-menus is activated on the LCD display.

1. Outrigger - Automatic Retract  
This control allows the operator to control the retraction of all 4 outriggers at one time.
2. Outrigger - Manual  
This control allows the operator to control the extension or retraction of one outrigger at a time.
3. Track Width Adjust  
This control allows the operator to widen the track.
4. Emergency Lowering  
This button allows the operator to lower the boom if engine power is not working.

**NOTE:** Buttons 5 and 6 when pressed simultaneously also activate the horn.

5. Speed Selector/Horn  
This button allows the operator to select the desired engine speed for operation.
6. Service Menu/Horn  
This button allows the operator to access the Service Menu.
7. Outrigger - Automatic Set And Level  
This control allows the operator to control the extension of all 4 outriggers at one time.

**SECTION 3 - MACHINE CONTROLS, INDICATORS AND OPERATION**

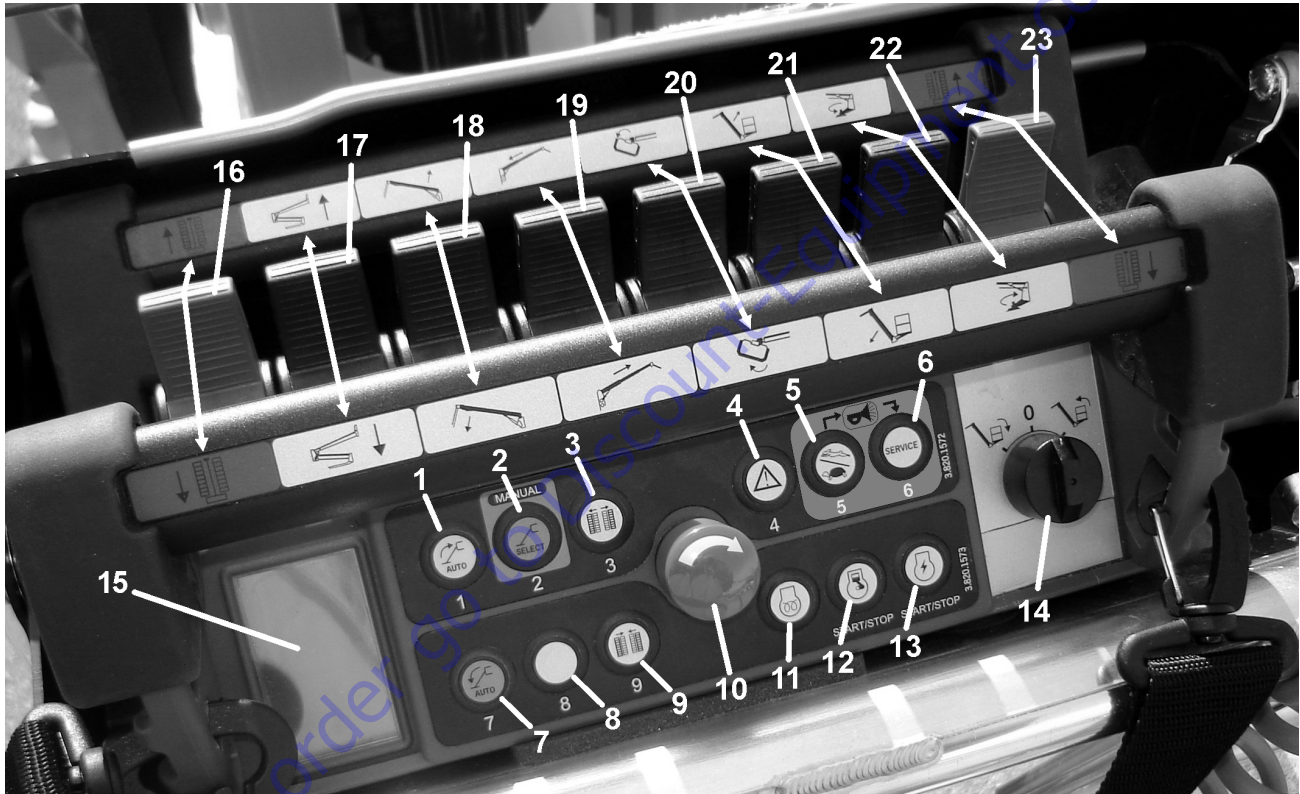

**Figure 3-3. Platform/Remote Control Station**

## SECTION 3 - MACHINE CONTROLS, INDICATORS AND OPERATION

---

### 8. Selector Button

Used for selecting an item when the Service Menu button is pressed (*item 6*).

This button is also used as the SkyGuard™ Override switch. When the SkyGuard™ system is engaged, press this button to override and disengage SkyGuard™.

### 9. Track Width Adjust

This control allows the operator to narrow the track.

### 10. Power/Emergency Stop

A two-position red switch supplies power to PLATFORM Controls when turned counterclockwise (on). When pushed in (off), power is shut off to the platform and ground controls.

### 11. Glow Plug (*Diesel Engine Only*)

This button allows the operator to pre-heat the diesel engine in cold climates.

### 12. Gas/Diesel Engine Starter

This button allows the operator to start or stop the gas/diesel engine.

### 13. Electric Engine Start

This button allows the operator to start or stop the electric engine.

### 14. Platform Level Switch

The control allows the operator to adjust the level of the platform up or down.

### 15. Display

Display shows status of machine and operating information. Wait until a display screen appears before starting operation.

**NOTE:** *Controllers (16 through 23), the speed of component movement is proportional to the controller distance from the center neutral position.*

### ERROR



Movement of a controller without first pressing the platform footswitch is indicated by the depress footswitch error icon on the platform/remote LCD display.

### 16. Left Side Track Drive And Steer

This control when moved forward or rearward simultaneously with the right side track control (24), allows the operator to move the machine in a straight forward or reverse direction. If each control is moved individually, different amounts or in opposite directions steering the machine occurs.

## SECTION 3 - MACHINE CONTROLS, INDICATORS AND OPERATION

---

17. Tower Boom Lift  
This control allows the operator to raise and lower the tower boom.
18. Main Boom Lift  
This control allows the operator to raise and lower the main boom.
19. Main Boom Telescope  
This switch allows the operator to extend and retract the main boom.
20. Platform Rotate  
This switch allows the operator to rotate the platform to the right or left.
21. Jib  
This control allows the operator to raise and lower the jib.
22. Swing  
This control allows the operator to swing the boom assembly to the right or left.
23. Right Side Track Drive And Steer  
This control when moved forward or rearward simultaneously with the left side track control (17), allows the operator to move the machine in a straight forward or reverse direction or, if each

control is moved individually or in opposite directions, to steer the machine.

### Platform/Remote Control Station LCD Display

At machine start-up and during machine operation the main LCD display screen (item 15 - Figure 3-3.) is activated. There are eight (8) display positions which indicate machine status during various stages of operation.

1	2
3	4
5	6
7	8

## SECTION 3 - MACHINE CONTROLS, INDICATORS AND OPERATION

**Position 1** Reduced operating area if all outriggers are not fully deployed.

1	2
3	4
5	6
7	8



**Position 2** Currently Unused.

1	2
3	4
5	6
7	8

**Position 3** Displays if selected engine (gas/diesel or electric) is on or off. The X on the icon indicates the engine is off.

1	2
3	4
5	6
7	8



**Position 4** Displays selected engine speed.

1	2
3	4
5	6
7	8



**Position 5** Displays outriggers are properly set and boom functions are allowed. No display indicates outriggers are not properly set and boom functions are not allowed.

1	2
3	4
5	6
7	8



**Position 6** Indicates boom, jib, turntable, and base are aligned. Drive, steer, track width adjustment and outrigger functions are operational if this symbol below is present. No symbol indicates these functions are not operational. Drive and steer are operational if all 4 outriggers are not contacting the ground.

1	2
3	4
5	6
7	8



## SECTION 3 - MACHINE CONTROLS, INDICATORS AND OPERATION

**Position 7** Can indicate any of the following situations:

1	2
3	4
5	6
7	8

- An emergency stop is pushed in (off).
- A low battery. Batteries need charging by running the gas/diesel engine or connecting to a power source.
- Tower boom sensor is faulty.
- Main boom sensor is faulty. Boom functions are cut out.
- Swing sensor is faulty.
- CANBUS communication is faulty.
- Electronic fault.
- Lithium ION - Signals an error in the BMS - Battery Management System
- Skyguard™ - System Enabled.
- Battery cold/heater activated system is enabled.

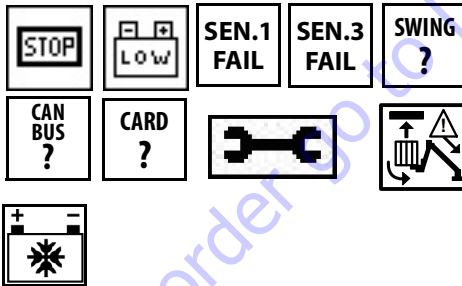

or:

- 50 Hr. - 1st Service Interval - See Section 6 - Table 6-10 and Table 6-11, Component Maintenance Intervals.



**Position 8**

1	2
3	4
5	6
7	8























- Indicates emergency lowering has been selected.
- Lithium ION - Battery Charge Status and Battery Charger Plugged In.























## SECTION 3 - MACHINE CONTROLS, INDICATORS AND OPERATION

**Table 3-1. LCD Display Icon Descriptions**

	Gas/Diesel engine running		Electric motor running		Remove weight or remote control from platform		Machine Maximum Tilt Angle Exceeded
	Minimum speed		Standard speed		Lower and Retract Boom		Rotate outrigger
	Emergency lowering		Battery voltage low		Machine in prohibited area		Close manually
	Overload in platform		Weight in platform too low		Cables sensor fault		RPM signal missing
	Safety bypass active		Tower Boom cylinder sensor fault		Gas/Diesel engine OFF		Electric motor OFF
	Battery cold/ eater activated system enabled				Boom retracted and aligned		Machine stabilized

## SECTION 3 - MACHINE CONTROLS, INDICATORS AND OPERATION

**Table 3-1. LCD Display Icon Descriptions (Continued)**

	Maximum speed		Emergency stop pressed		Turntable bearing sensor signal missing		CAN BUS signal missing
	Press footswitch		Select a control		Board or software wrong		Close the jib arm.
	Swing to the right or left		Raise tower boom arms		Wrong remote control connection (on the basket, at the ground)		Stabilization from basket with remote control not placed
	Tower cylinder sensor missing		Cables sensor missing				
	Reduced operating area active		It is possible to only operate the jib				
	Raise outrigger		Double line sensor error, check error menu				

## SECTION 3 - MACHINE CONTROLS, INDICATORS AND OPERATION

**Table 3-2. LCD Display Error Descriptions**

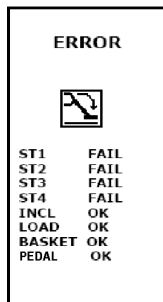

One of the most important error displays in regard to boom movements; this visualization displays why boom movement has been prohibited; in regard to outrigger set, inclination (tilt) platform load, platform/remote control box and footswitch status.

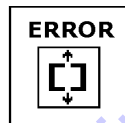

Retract and align the machine

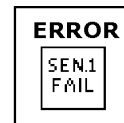

Error in sensor on tower boom cylinder

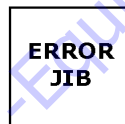

Retract the JIB to work with 200kg



Overload in platform

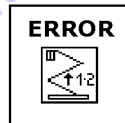

It is necessary to raise the tower boom

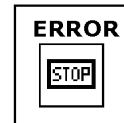

An emergency stop is pressed



Platform/Remote Control Box is not connected properly



Lift the outriggers to move the tracks

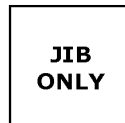

It is possible to only operate the JIB



It is necessary to rotate the turntable

## SECTION 3 - MACHINE CONTROLS, INDICATORS AND OPERATION

Table 3-2. LCD Display Error Descriptions (Continued)



Error in sensor on main boom cylinder

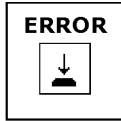

Press the footswitch to operate the controls



Error in sensor on main boom



Retract the outrigger to rotate it



Operation not permitted with emergency lowering



Oil pressure missing = engine turns off  
*Diesel Only*

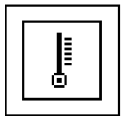

Engine temperature too high = Motor remains at min.  
*Diesel Only*

**TO PURCHASE THIS PRODUCT PLEASE CONTACT US**



**Equipment Financing and  
Extended Warranties Available**



**Discount-Equipment.com is your online resource for  
commercial and industrial quality parts and equipment sales.**

**561-964-4949**

**visit us on line @ [www.discount-equipment.com](http://www.discount-equipment.com)**

Select an option below to find your Equipment

**Search by Manufacturer**

**Search by Product Type**

**Request a Quote**

We sell worldwide for the brands: Genie, Terex, JLG, MultiQuip, Mikasa, Essick, Whiteman, Mayco, Toro Stone, Diamond Products, Generac Magnum, Airman, Haulotte, Barreto, Power Blanket, Nifty Lift, Atlas Copco, Chicago Pneumatic, Allmand, Miller Curber, Skyjack, Lull, Skytrak, Tsurumi, Husquvarna Target, Stow, Wacker, Sakai, Mi-T-M, Sullair, Basic, Dynapac, MBW, Weber, Bartell, Bennar Newman, Haulotte, Ditch Runner, Menegotti, Morrison, Contec, Buddy, Crown, Edco, Wyco, Bomag, Laymor, EZ Trench, Bil-Jax, F.S. Curtis, Gehl Pavers, Heli, Honda, ICS/PowerGrit, IHI, Partner, Imer, Clipper, MMD, Koshin, Rice, CH&E, General Equipment, Amida, Coleman, NAC, Gradall, Square Shooter, Kent, Stanley, Tamco, Toku, Hatz, Kohler, Robin, Wisconsin, Northrock, Oztec, Toker TK, Rol-Air, APT, Wylie, Ingersoll Rand / Doosan, Innovatech, Con X, Ammann, Mecalac, Makinex, Smith Surface Prep, Small Line, Wanco, Yanmar

### SECTION 4. MACHINE OPERATION

#### 4.1 DESCRIPTION

This machine is a Mobile Elevating Work Platform (MEWP) used to position personnel, along with their necessary tools and materials at work locations.

This MEWP has a primary operator control station in the platform. The operator can control drive, steer, boom/platform functions and outriggers. The machine has a Ground Control Station which will override the Platform Control Station. Ground Controls operate boom and platform functions. Except for performing inspections and the function check, the ground controls are to be used in an emergency to lower the platform to the ground should the operator in the platform be unable to do so.

This machine is equipped with an ALL MOTION alarm warning system to alert other personnel in the work area of any machine movement during operation. The motion alarm system is activated during machine function movement such as track, boom, or outrigger operation.

#### 4.2 BOOM OPERATING CHARACTERISTICS AND LIMITATIONS

##### Capacities

The boom can be raised from the transport position with or without any load in platform, if:

- Machine is positioned on a firm surface and outriggers set properly with the outrigger pads on horizontal surfaces.
- Load is within manufacturer's rated capacity.
- All machine systems are functioning properly.

##### Stability

In addition to the conditions listed above under Capacities, machine stability also depends on the following:

- A work surface capable of supporting the machine and a slope within machine leveling specifications.
- Platform is only operated within its work area specification for rated load and boom reach. (See Figure 4-4., Figure 4-5., and Figure 4-7.)

## SECTION 4 - MACHINE OPERATION

### 4.3 ENGINE OPERATION

**NOTE:** Initial starting must always be performed from the ground controls.

The battery disconnect switch must be ON (see Section 4.10 on page 4-30). The main power switch at the ground controls and power/emergency stop buttons at the platform and ground controls must be ON (turned clockwise) to start the engine.

#### Diesel Starting Procedure

**NOTE:** If gas/diesel engine fails to start promptly, do not crank for an extended time. Should engine fail to start again, allow starter to cool off for 2-3 minutes. If engine fails after several attempts, refer to manufacturers engine maintenance manual.

**NOTE:** If engine is diesel, when starting from ground, turn the start key at the engine to the HEAT (glow plug) position for 10 to 15 seconds before attempting to start. Release the key and start the engine.

1. With power on, set the key at the Ground/Emergency Control box in the neutral (vertical) position, then push the appropriate ENGINE START switch (item 4 or 5) until engine starts.

**NOTE:** Allow gas/diesel engine to warm-up for a few minutes at low speed before applying any load.



**Figure 4-1. Ground/Emergency Control Box**

- |  |  |
|--|--|
| 1. Platform/Remote (Center) Platform Position                              | 4. Gas/Diesel Engine Start Button <sup>(1)</sup> (if equipped) |
| 2. Ground Control Position - (Turn ClockWise and Hold)                     | 5. Electric Engine Start Button <sup>(1)</sup>                 |
| 3. Platform/Remote Ground Maintenance Position - (Turned CounterClockWise) | 6. Enable Light  |

**NOTE:** <sup>(1)</sup> Key switch must be set to ON, battery disconnect switch must be ON, and both the ground and platform emergency stop switches must be reset to ON.

## SECTION 4 - MACHINE OPERATION

**NOTE:** At low temperatures start the motor and let it run for a few minutes, so that the hydraulic oil circulates and reaches at least 50°F (10°C) before operating the platform.

### Diesel Engine Shutdown Procedure

1. Remove all load and allow engine to operate at low speed for 3-5 minutes; this allows further reduction of internal engine temperature.
2. Turn off the gas/diesel engine by using the gas/diesel engine button (item 12, Figure 4-6.) on the platform/remote control box.
3. The shutdown procedure takes about 1 minute, wait for complete shut-off (display off).
4. Push POWER/EMERGENCY STOP switches at the platform and ground in, to the off position.
5. Turn engine key to off.

### Electric Engine Starting Procedure - AC Voltage Machine

#### **⚠ CAUTION**

**ENSURE THE ELECTRICAL CIRCUIT BEING USED IS THE SAME VOLTAGE AND FREQUENCY INDICATED ON THE ELECTRIC ENGINE PLATE. USE AN AC EXTENSION CORD WITH SUFFICIENT AMPERAGE CAPACITY TO PROPERLY POWER THE MACHINE.**

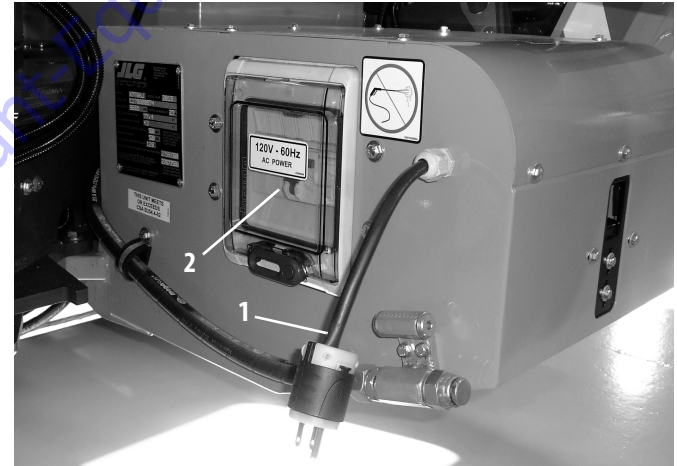

1. Before connecting the machine to the electrical circuit, ensure the key on the gas/diesel engine is in the OFF position.



## **SECTION 4 - MACHINE OPERATION**

---

2. Power the machine using a heavy duty AC power cord with sufficient amperage capacity, through the connector (*item 1* positioned near the electric engine.
3. Turn on the circuit breaker switch (*item 2*) positioned behind the clear plastic cover near the electric engine (— symbol is ON - O symbol is OFF).
4. Start the electric engine using the engine start button at the ground/emergency control box. (*item 5 - Figure 4-1.*) and operate machine.
5. When finished operating with the electric engine, turn off breaker switch (*item 2*), and unhook the electric AC cord from receptacle (*item 1*).

## SECTION 4 - MACHINE OPERATION

### 4.4 BASE AND BOOM/JIB ALIGNMENT

The machine uses a reflector/photocell alignment that checks if the boom assembly is completely lowered and retracted, the jib is lowered, and the turntable is aligned with the base. (see photos)

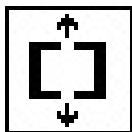

When these conditions are met this symbol will display in position (6) on the Platform/ Remote Control LCD display.

UNLESS THESE CONDITIONS ARE MET, DRIVE, STEER, TRACK WIDTH ADJUSTMENT, AND OUTRIGGER MOVEMENT IS PREVENTED.



Base/Boom Alignment - Visual Indicator

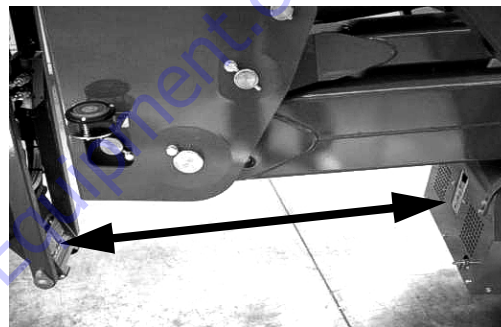

Boom/Jib and Base Alignment - Reflectors/Photocells

### 4.5 TRACKS - DRIVING, STEERING AND TRACK WIDTH ADJUST

#### **⚠ WARNING**

KEEP EVERYONE A DISTANCE OF AT LEAST 6 FT. (1.83 M) FROM THE MACHINE WHEN OPERATING THE TRACKS.

**NOTE:** *The base and boom/jib must be aligned and retracted before this function will operate, see Section 4.4, BASE AND BOOM/JIB ALIGNMENT.*

#### Track width adjust

#### **NOTICE**

DO NOT WIDEN OR NARROW THE TRACKS WIDTH WHEN PARKED WITH THE TRACKS ON THE GROUND. THE MACHINE MUST BE TRAVELLING OR RAISED ON ITS OUTRIGGERS WHEN OPERATING THIS FUNCTION.

Press and hold button 3 for widening or button 9 for narrowing the track.

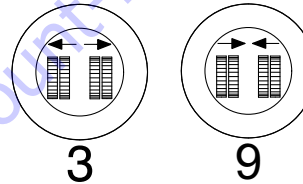

## SECTION 4 - MACHINE OPERATION

---

### Travelling (Drive and Steer)

#### **⚠ WARNING**

USE EXTREME CAUTION WHEN APPROACHING A CREST OF ANY TERRAIN OBSTACLE. CHECK FOR CURBS, LARGE STONES, OR OTHER TERRAIN OBSTACLES INCLUDING OVERHEAD OBSTACLES AS THE MACHINE WILL MAKE UNCONTROLLED PIVOTING MOTIONS WHEN THE CENTER OF GRAVITY (CENTER OF TRACK FRAME) SHIFTS OVER AN EDGE. SLOW DOWN TO MINIMIZE ACCELERATION DURING PIVOTING MOVEMENT.

USE EXTREME CAUTION WHEN DRIVING IN REVERSE.

- To drive straight forward or reverse, move the controllers for both tracks at the same time, direction and position.
- Always fully widen the track prior to driving, if possible, for easier steering and increased stability.
- Always travel in the slow speed setting unless the travel path is firm, level and uniform.

### Travelling (Grades and Side Slopes)

#### **⚠ WARNING**

TO AVOID LOSS OF TRAVEL CONTROL OR "TIP OVER", FULLY WIDEN TRACKS, AND DO NOT DRIVE MACHINE ON GRADES EXCEEDING 25 DEGREES (40%).

USE RAMPS WHEN TRAVELLING ON STEPS OR OTHER SURFACES THAT ARE NOT SMOOTH OR HAVE GOOD TRACTION.

WHEN DRIVING ON SIDESLOPES, FULLY WIDEN THE TRACKS AND EXTEND THE LOW SIDE OUTRIGGERS UNTIL THEY ARE CLOSE TO THE GROUND TO HELP PREVENT A TIP-OVER IF A CHANGE IN SURFACE OCCURS. (SEE FIGURE 4-2.)

DRIVE ON SIDESLOPES WITH THE BOOM STOWED. DO NOT DRIVE ON SIDESLOPES WHICH EXCEED 14 DEGREES.

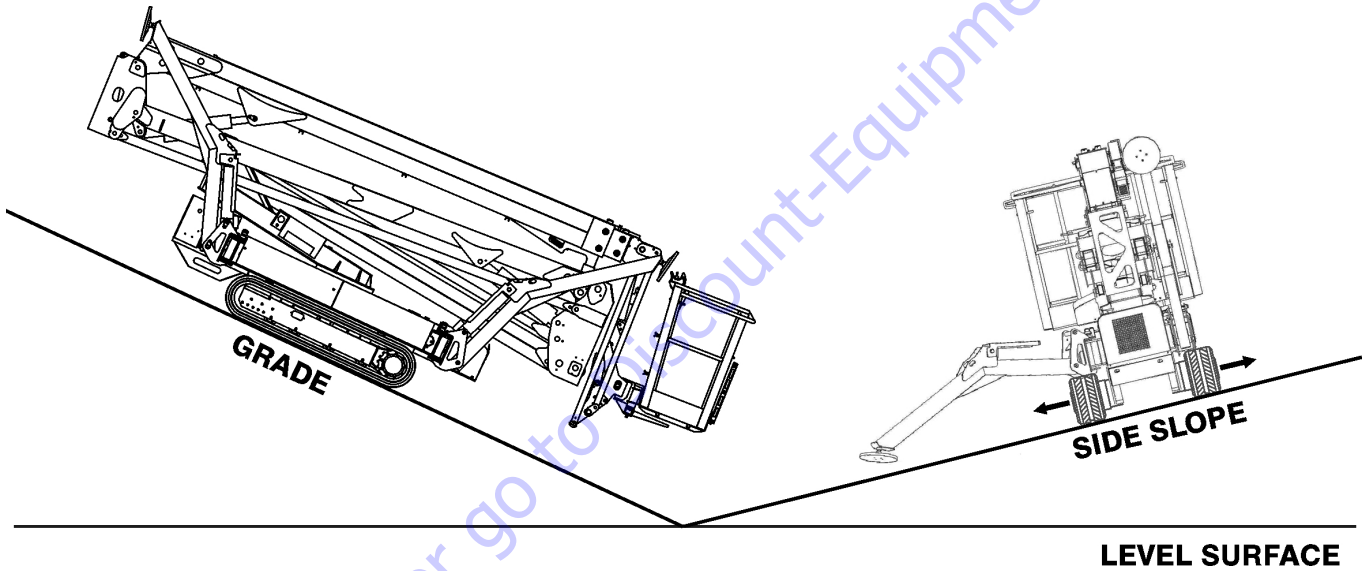

**Figure 4-2. Grade and Side Slope Definition**

## SECTION 4 - MACHINE OPERATION

### Jib Position for Travelling

It is necessary to raise the JIB arm when driving up or down slopes that exceed 10° and but less than the max. 25° to prevent the jib from contacting the ground.

#### NOTICE

**ONLY PERFORM THIS OPERATION WHEN IT IS NECESSARY. IN ALL OTHER SITUATIONS, DRIVE WITH THE BOOM AND JIB FULLY LOWERED AND ALIGNED.**



The permission to use the JIB is indicated by the icon in position 5 on the remote control display panel.

Before lifting the jib arm in the traversing phase, the following conditions must be verified:

- All outriggers must be lifted from the ground
- There must be no operator in the basket
- The platform/remote control box must be removed from the platform and used from the ground.

**NOTE:** *The aerial part safety device by-pass key must not have been activated after the machine has been closed and aligned.*

If any of these conditions have not been met, the use of the JIB is not possible and one of the following error displays appears.

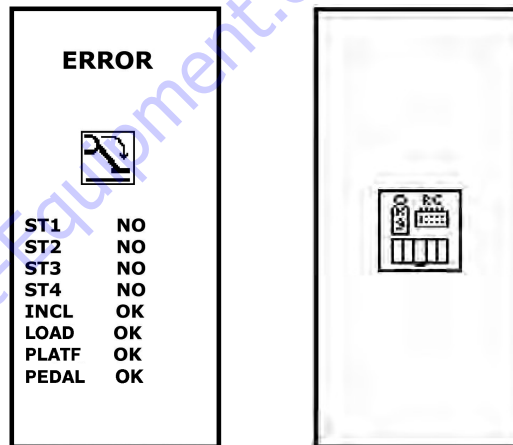

After these conditions have been met, make sure that there are no obstacles in the Jib working area and operate as follows:

- Activate joystick for moving the JIB arm. If a different joystick is activated an error message will appear on the display.



- After slope has been passed, for which the jib had to be raised, fully lower jib and continue travelling.
- With JIB raised, ALWAYS travel at minimum speed and keep JIB as near as possible to the ground.

### 4.6 OUTRIGGER OPERATION

#### **⚠ WARNING**

BE CERTAIN OUTRIGGER PADS ARE SET ON A FIRM AND HORIZONTAL SURFACE. DO NOT SET OUTRIGGER PADS ON INCLINED, VERTICAL, OR SLIPPERY SURFACES.

#### **NOTICE**

THE OUTRIGGERS WILL NOT OPERATE UNLESS THE BOOM AND JIB ARE COMPLETELY LOWERED, RETRACTED AND ALIGNED WITH THE BASE.

**NOTE:** *Base and boom/jib must be aligned and stowed before this function will operate, see Section 4.4, BASE AND BOOM/JIB ALIGNMENT.*

## SECTION 4 - MACHINE OPERATION

### Variable Outrigger Positioning

Position each outrigger from the transport position to the restricted or full area of operation by pulling up on black T handle lock and swinging the outrigger to one of those positions. (see Figure 4-3.) Release the handle and make sure each outrigger locks in the selected position.

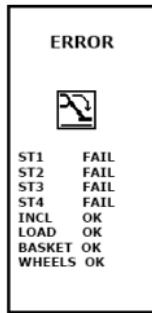

If one of the four outrigger locking pins is lifted or the outrigger position control microswitch is not working properly, all movement will be stopped and an error message will appear on the platform/remote control LCD display.

Operation will be possible when the outrigger position locking pin is properly set and/or the microswitch is in the correct configuration again.

Check correct positioning of the handle and two microswitches at each outrigger before every use, as shown in following illustration.

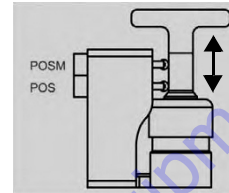

Outrigger In Full Work Area (Rotated to 58°)

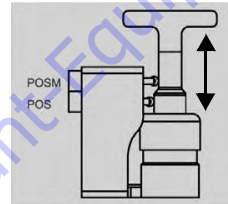

Outrigger In Restricted Work Area (Rotated to 24°)

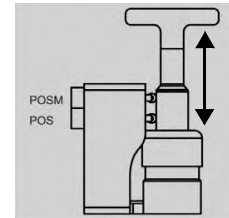

Outrigger in Transport Position



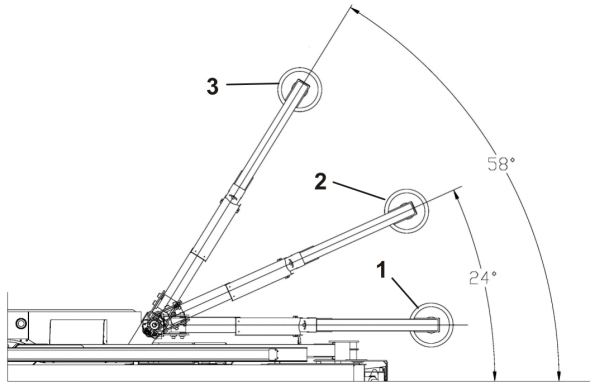

Figure 4-3. Outrigger Positions

- 1. Transport Position
- 2. Restricted Work Area Position
- 3. Full Work Area Position

**Operating with Outriggers Set to 24° - Restricted Work Area Of Operation**

(See Figure 4-4. and Figure 4-5.)

**NOTE:** Swing and jib functions will not be allowed in certain areas.

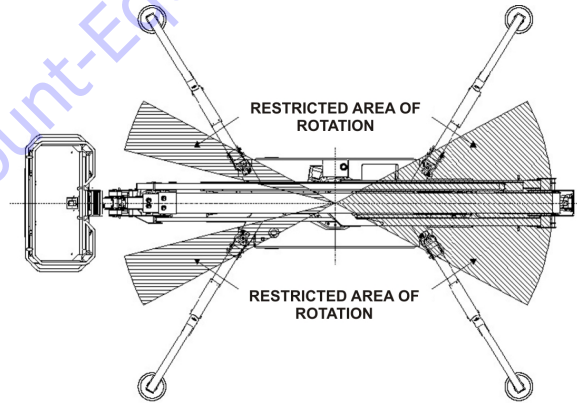

## SECTION 4 - MACHINE OPERATION

---

If at least one of the outriggers is set in the restricted area position (24°), the platform/remote control box LCD will display the symbol for restricted area operation in position 1 which is always visible during the use of the machine in this set up.

### **WARNING**

**DO NOT OPERATE IF SYMBOL FOR RESTRICTED AREA OF OPERATION IS NOT DISPLAYED ON THE LCD SCREEN WHEN ANY OF THE OUTRIGGERS ARE IN THE RESTRICTED AREA POSITION.**

If you try to position the boom outside the allowed working area by rotating the boom, the movement will be stopped and a message on the LCD display will appear indicating that it is necessary to rotate in the opposite direction in order to keep working.

The following illustrations (*Figure 4-4. and Figure 4-5.*) show the various areas of allowable boom rotation and jib extend operation for the different outrigger settings.

Unless all four (4) outriggers are set to "full work area position" jib extend is restricted to the  $\pm 30^\circ$  rotation area shown in (*Figure 4-4. and Figure 4-5.*).

## SECTION 4 - MACHINE OPERATION

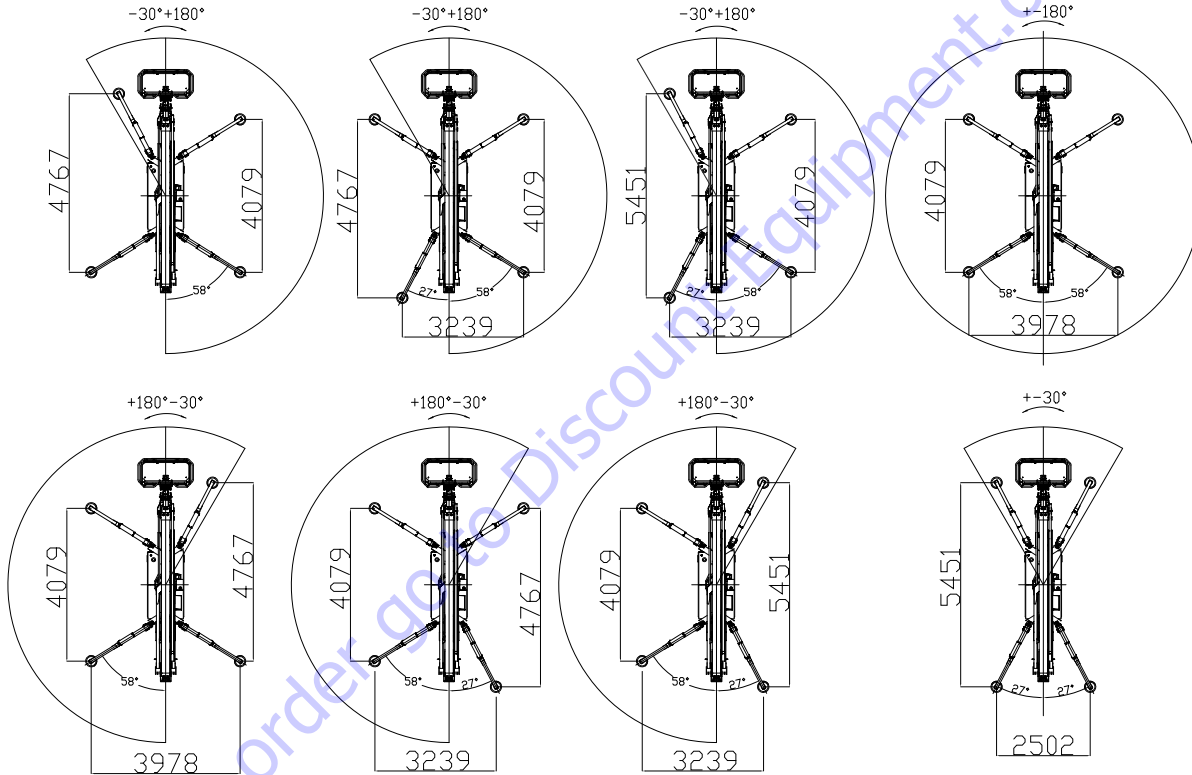

**Figure 4-4. Boom Area of Operation for Various Outrigger Positions (Sheet 1 of 2)**

## SECTION 4 - MACHINE OPERATION

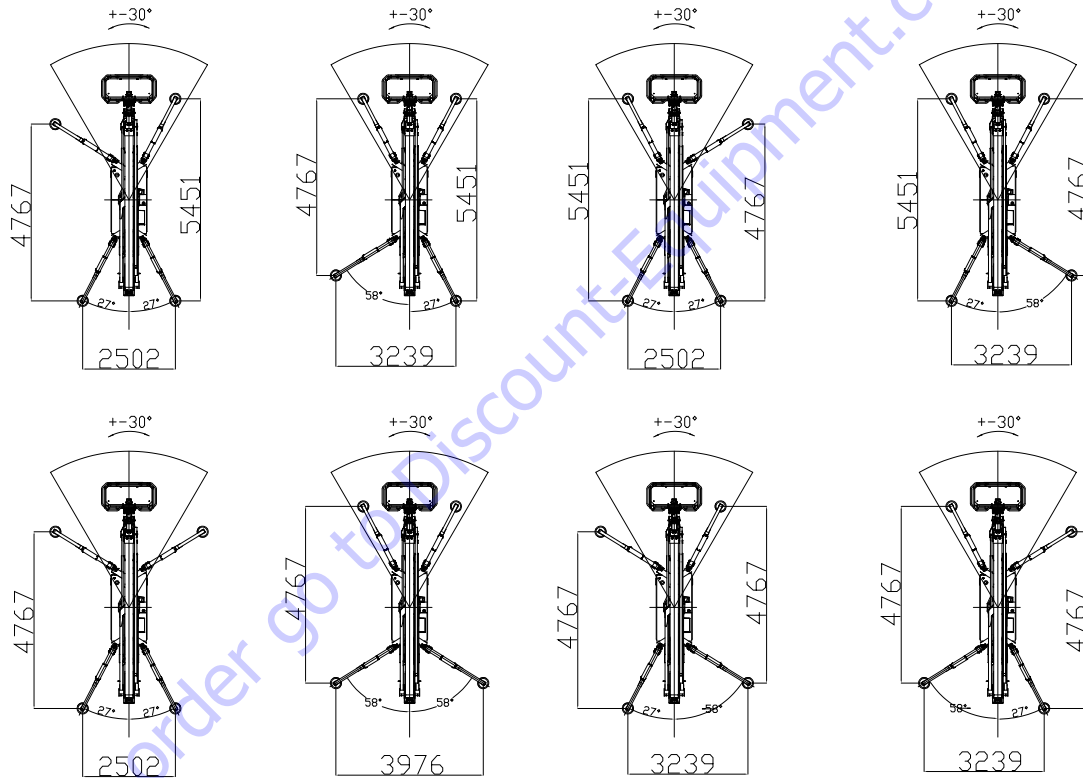
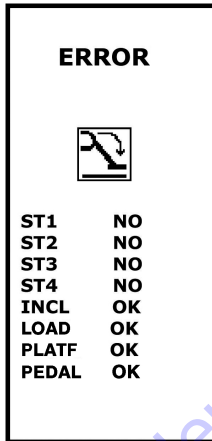

Figure 4-5. Boom Area Of Operation for Various Outrigger Positions (Sheet 2 of 2)

## SECTION 4 - MACHINE OPERATION

---

If one of the outriggers does not come into contact with the ground while being set, the engine will turn off or, the self-levelling attempt will stop. This situation may be due to the slope on which the outriggers are being set up on exceeds the allowed slope for proper set up at the end of the stabilization phase. If the machine is to be lifted even further from the ground after the outriggers are properly set, push and hold the outrigger automatic set and level button.



If the functions are selected when one of the above listed conditions is missing, an error message will appear on the platform/remote control display indicating which of the conditions are OK and which are not. If the condition is that an outrigger is not set properly, the message will also indicate which outrigger is not set properly.

ST1: if OK outrigger 1 is set properly.

ST2: if OK outrigger 2 is set properly.

ST3: if OK outrigger 3 is set properly.

ST4: if OK outrigger 4 is set properly.

INCL: if OK the machine is set up on an accepted slope.

LOAD: if OK the load in the platform is acceptable.

PLATFORM: if OK the platform/remote control box is in the proper location in the platform.

PEDAL: If OK the footswitch is correctly depressed.

## SECTION 4 - MACHINE OPERATION

### Setting Outriggers From the Platform/Remote Console

(Reference Figure 4-6. on page 4-21 for item number location)

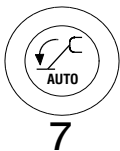

**Either** - Press and hold the outrigger auto-set and level button 7 (item 7) until OK appears on the platform LCD display;

**or**



Operate each outrigger separately by pressing button 2 (item 2) to select which outrigger to control (each outrigger is numbered 1 thru 4, see decal, each press of button 2 displays the outrigger selected on the LCD display). Press button 1 (item 1) to retract or button 7 (item 7) to set that outrigger. The OK will appear on the display when the outriggers are set properly and the unit is level.

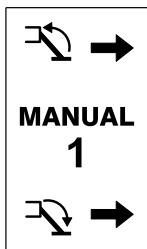

**Note:** To cycle back to outrigger auto-set mode, press button 2 (item 2) until the LCD display shows the normal operating icons.

### **⚠ WARNING**

**CHECK BUBBLE LEVEL INDICATOR TO CONFIRM UNIT IS LEVEL (BUBBLE IS IN THE 1° GREEN (CENTER) AREA) AND TRACKS ARE OFF THE GROUND BEFORE OPERATING THE BOOM FUNCTIONS. IF BUBBLE IN THE LEVEL INDICATOR IS NOT IN THE GREEN AREA, AFTER USING THE AUTO-LEVEL FUNCTION, SHUT DOWN THE MACHINE AND HAVE THE MACHINE REPAIRED BY A QUALIFIED SERVICE TECHNICIAN.**

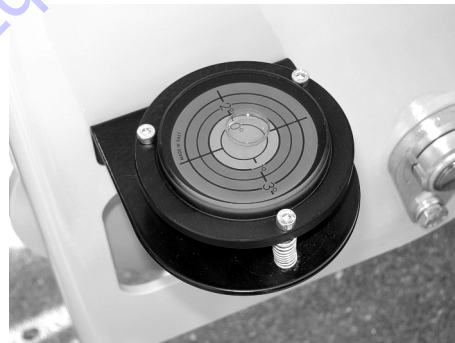

Each outrigger has a yellow light installed. All lights will be on steady if outriggers are positioned to the full operation area. Lights will be flashing if any of the outriggers are positioned in the restricted operation area. No lights will be on if the outriggers are not set properly.

### NOTICE

IF ONE OF THE ORANGE LIGHTS LOCATED ON EACH OUTRIGGER SHOULD FLASH OR REMAIN ON WHEN THAT OUTRIGGER IS LIFTED FROM THE GROUND, STOP THE MACHINE IMMEDIATELY AND CALL A QUALIFIED JLG SERVICE TECHNICIAN AS THIS INDICATES A PROBLEM WITH THE CORRESPONDING OUTRIGGER MICRO SWITCH.

### WARNING

IF SLOPE EXCEEDS 13°, THE MACHINE IS NOT CAPABLE OF PROPERLY SETTING OUTRIGGERS AND LEVELING ITSELF. OPERATION OF BOOM AND PLATFORM FUNCTIONS WILL NOT BE ALLOWED IN THIS CONDITION. THE MACHINE IS CONSIDERED STABILIZED WHEN LEVELED TO LESS THAN 1° AND TRACKS ARE LIFTED AT LEAST 2 IN. (5 CM) FROM THE GROUND. STABILIZING MACHINE WITH AN INCLINATION DEGREE HIGHER THAN THE ONE ALLOWED COULD CAUSE INSTABILITY OF THE MACHINE

If the platform ladder is higher than 16 in. (40 cm) off the ground when the ladder is lowered, when setting the machine on outriggers from the ground position, lower the outriggers until the ladder is less than 16 in. (40 cm) off the ground. Then enter the platform to properly set the machine up on outriggers.

### Retracting The Outriggers

(Reference Figure 4-6. on page 4-21 for item number location)

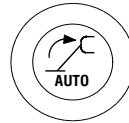

1

**Either** - Press and hold button no. 1 (*item 1*) of the remote control.

The 4 outriggers will all retract at the same time and lower the machine.

**or**



2

Operate each outrigger separately by pressing button 2 (*item 2*) to select which outrigger to control (*each outrigger is numbered 1 thru 4, see decal at each outrigger, each press of button 2 displays the outrigger selected on the LCD display*). Press button 1 (*item 1*) to retract or button 7 (*item 7*) to set that outrigger.

**Note:** To cycle back to outrigger auto-retract mode, press button 2 (*item 2*) until the LCD display shows the normal operating icons.

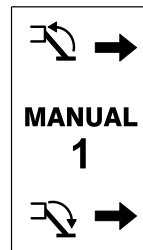

### 4.7 BOOM/PLATFORM OPERATION

#### **NOTICE**

**THE BOOM WILL NOT OPERATE UNTIL THE OUTRIGGERS ARE PROPERLY SET AND MACHINE IS LEVELED.**

**AT PLATFORM/REMOTE CONTROL STATION, TWIST EMERGENCY STOP BUTTON CLOCKWISE TO THE OUT POSITION, START ENGINE, AND ACTIVATE FOOTSWITCH FOR ALL PLATFORM/REMOTE CONTROL FUNCTIONS.**

**ALWAYS STOW (RAISE) THE LADDER AFTER ENTERING OR EXITING THE PLATFORM TO PREVENT IT BEING DAMAGED WHEN OPERATING THE MACHINE.**

If the operator attempts to raise the JIB with more than the allowed capacity in the platform a maximum weight reminder icon appears in the middle of the platform/remote LCD display and the function stops.

If the machine is set up on outriggers for the reduced operating area, the swing function will be stopped if and when you try to go outside the allowed working area. A message on the platform/remote control LCD display will appear informing that it is necessary to swing in the opposite direction to continue operation.

**NOTE:** *At low temperatures start the motor and let it run for a few minutes, so that the hydraulic oil circulates and reaches at least 50°F (10°C) before operating the platform.*

#### **Overload Alarm**

If the platform is overloaded all the boom functions are stopped, the overload icon appears on the platform/remote LCD display and the alarm sounds. To restore the boom functions it is necessary to remove the extra load.

#### **⚠ WARNING**

**TO AVOID SERIOUS INJURY, DO NOT OPERATE MACHINE IF ANY CONTROL LEVER OR SWITCH CONTROLLING PLATFORM MOVEMENT DOES NOT RETURN TO THE 'OFF' OR NEUTRAL POSITION WHEN RELEASED. IF THE PLATFORM DOES NOT STOP WHEN A CONTROL SWITCH OR LEVER IS RELEASED, REMOVE YOUR FOOT FROM THE FOOT SWITCH AND/OR USE EMERGENCY STOP SWITCH TO STOP THE MACHINE.**

If platform is lifted from the proper mounting position during the use of the machine, an alarm will sound and all the movements of the machine will stop. An error message will appear on the LCD display of the platform/remote control.

#### **Platform Level Adjustment** *(Item 14, Figure 4-6.)*

**NOTE:** *During normal operation of the machine, the platform will automatically maintain its position.*

- To manually Level Up, turn select switch clockwise and hold until desired position is reached.
- To manually Level Down, turn the select switch counter clockwise and hold until desired position is reached.



### **⚠ WARNING**

**ONLY USE THE PLATFORM LEVELING OVERRIDE FUNCTION FOR SLIGHT LEVELING OF THE PLATFORM. INCORRECT USE COULD CAUSE THE LOAD/OCCUPANT TO SHIFT OR FALL. FAILURE TO DO SO COULD RESULT IN DEATH OR SERIOUS INJURY.**

#### **Raise And Lower The Tower Boom** *(Item 17, Figure 4-6.)*

- To raise the tower boom, depress the foot switch and move the controller forward.
- To lower the tower boom, depress the foot switch and move the controller backwards.

#### **Raise And Lower The Main Boom** *(Item 18, Figure 4-6.)*

- To raise the main boom, depress the foot switch and move the controller forward.
- To lower the main boom, depress the foot switch and move the controller backwards.

#### **Telescope The Main Boom** *(Item 19, Figure 4-6.)*

- To extend the main boom, depress foot switch and move controller backward.
- To retract the main boom, depress foot switch and move controller forward.

#### **Platform Rotation** *(Item 20, Figure 4-6.)*

- To rotate the platform to the right, depress the footswitch and move the controller forward.

- To rotate the platform to the left, depress the footswitch and move the controller backwards.

#### **Raise And Lower The Jib** *(Item 21, Figure 4-6.)*

- To raise the jib, depress the foot switch and move the controller forward.
- To lower the jib, depress the foot switch and move the controller backwards.

#### **Swinging The Boom** *(Item 22, Figure 4-6.)*

### **⚠ WARNING**

**WHEN SWINGING THE BOOM MAKE SURE THERE IS AMPLE ROOM FOR THE BOOM AND UPRIGHT TO CLEAR SURROUNDING WALLS, PARTITIONS AND EQUIPMENT.**

If the turntable is rotated with tower boom too low or tower boom is lowered near an outrigger, Those functions will stop before contact with an outrigger. The display on the platform/remote control box will indicate to swing in the opposite direction or lift up.

- To swing the boom to the right, depress the foot switch and move the controller forward.
- To swing boom to the left, depress foot switch and move controller backwards.

## SECTION 4 - MACHINE OPERATION

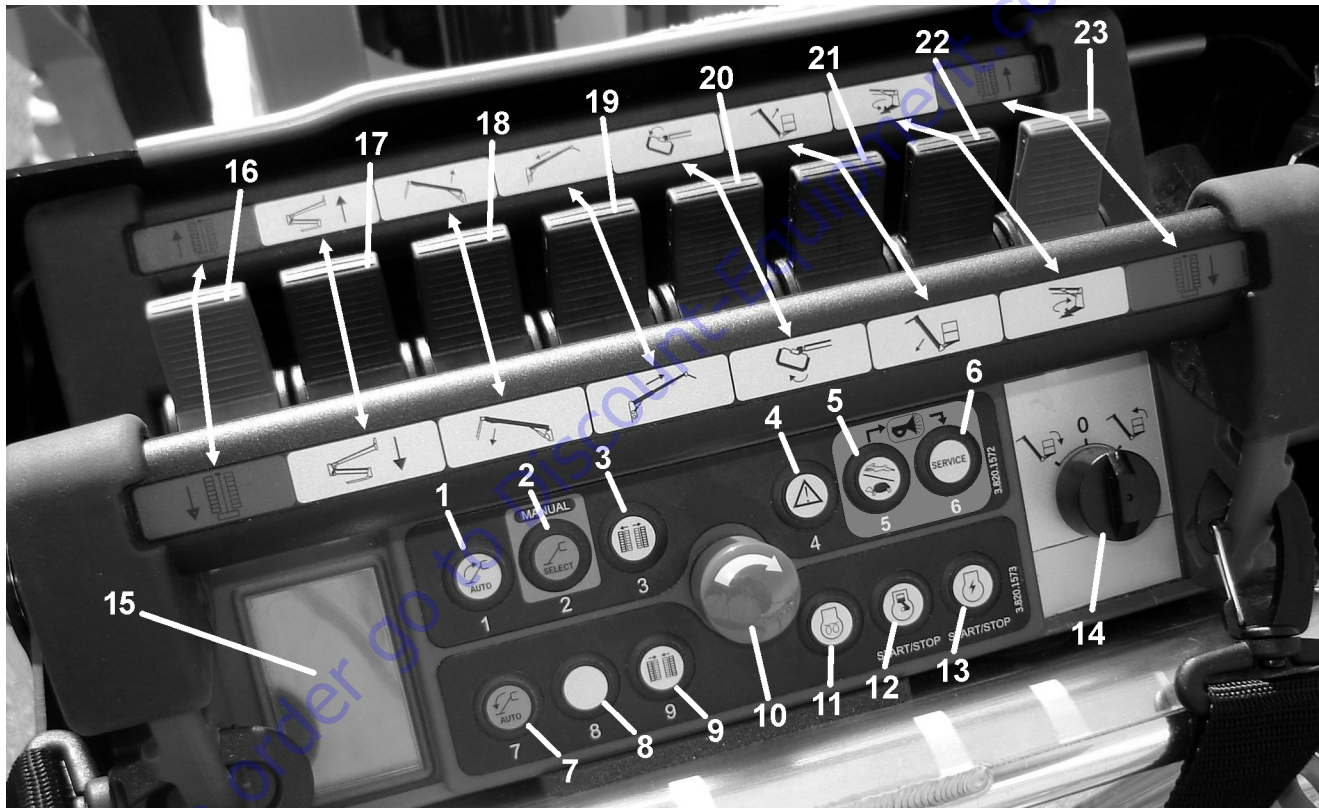
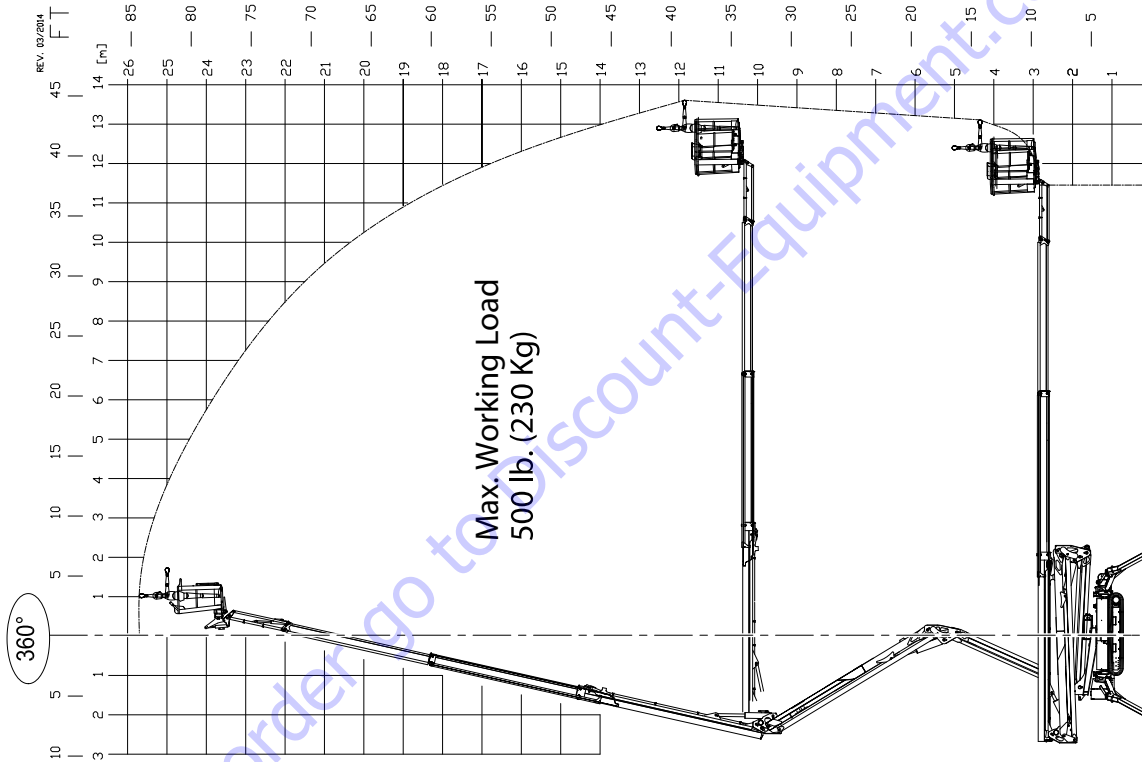

Figure 4-6. Platform/Remote Control Box

# SECTION 4 - MACHINE OPERATION



**Figure 4-7. Platform - Load/Reach Chart - X770AJ**  
 (Full 360° Rotation and Jib Extend ONLY with Outriggers Set to Full Work Area Position)

## SECTION 4 - MACHINE OPERATION

### SkyGuard Operation (If Equipped)

The SkyGuard™ feature is used to provide enhanced control panel protection. When the SkyGuard™ sensor is activated, functions that were in use at the time of actuation will reverse or cutout and the ground alarm will beep. The table below outlines these functions.



**NOTE:** Reverse motion can be stopped by the operator by releasing the footswitch, depressing the emergency stop button, or by releasing pressure on the SkyGuard™ sensor.

If SkyGuard™ remains activated after function reversal or cutout, depress and hold the SkyGuard™ Override Switch (button number 8) to allow normal use of machine functions until the SkyGuard™ sensor is disengaged.

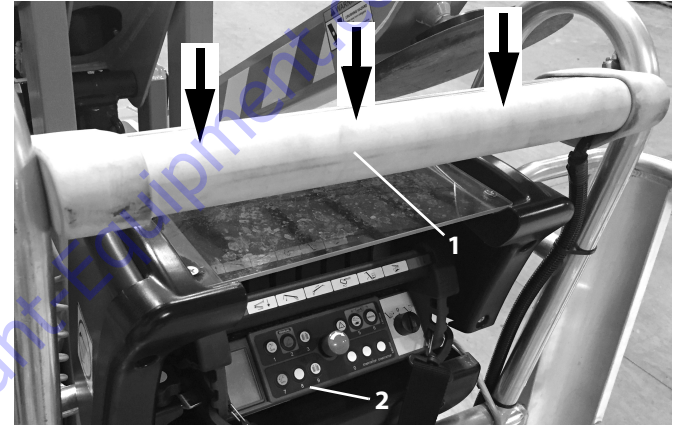

1. SkyGuard™ Sensor                      2. SkyGuard™ Override Switch  
(button number 8)

**Figure 4-8. SkyGuard™ Sensor and Override Switch Location**

**Table 4-1. SkyGuard™ Function Table**

Main Lift Up	Main Lift Dn	Main Tele In	Main Tele Out	Swing	Drive Forward	Drive Reverse	Tower Lift Up	Tower Lift Down	Platform Level	Platform Rotate	Jib Lift
R	C	C	R	R	C	C	R	C	C	C	C
R = Indicates Reversal is Activated											
C = Indicates Cutout is Activated											
N/A Indicates the function does not exist for this model											

## SECTION 4 - MACHINE OPERATION

### Emergency Lowering

The main function of the emergency lowering is to lower the platform in the event of primary power failure.

Some functions will not operate since this is a gravity lowering system and a symbol will appear on the display if one of those functions are selected.

Operate as follows:

1. Ensure the emergency stop button is in the ON position by turning it clockwise
2. Depress the foot switch.
3. Push and hold down button 4 (*item 4*) on the platform/remote control box. The LCD display will show the symbol shown on button 4 in position 8 on the LCD display. (*Items 4 and 15, Figure 4-6.*)
4. Select a boom function to operate by moving the paddle controller in the direction for lowering - (*items 18, and 21 in Figure 4-6.*)
5. When finished, release the emergency lowering switch, controller and foot switch.
6. Position the emergency stop switch to the off position.



Determine the reason for the primary power failure and have the problem corrected by a qualified JLG service technician.

### Platform Removal/Installation

The platform may only be removed to allow passage through areas measuring a minimum of 39 in. (99cm).

**NOTE:** *If the platform is removed, only track movement is allowed.*

#### Platform Removal

1. Remove the platform/remote control box from the mounting support.
2. Loosen and remove the aluminum caps that secure the platform to the jib platform mounting posts.



3. Lift the platform off the mounting posts in an upward direction. Place platform aside for later installation.

## SECTION 4 - MACHINE OPERATION

---

### Platform Installation

1. Lift the platform and align the platform mounts with the jib mounting posts and lower until seated.
2. Secure the platform to the jib mounting posts with the aluminum threaded caps. Do not overtighten.
3. Re-install the platform/remote control box into the mounting support on the platform.

### 4.8 BATTERY CHARGING - DIESEL/AC-ELECTRIC

**NOTE:** *Be sure that the machine is parked in a well ventilated area free of flames and sparks.*

- Only plug the charger into a properly grounded outlet.
- Do not use ground adaptors or modify plug. Do not touch non-insulated portion of output connector or non-insulated battery terminal.
- Always disconnect the AC supply before making or breaking the connections to the battery.
- Do not open or disassemble charger.
- Do not operate charger if the AC supply cord is damaged or if the charger has been damaged in any way.

#### Battery Charging - Daily

#### CAUTION

**BEFORE CONNECTING THE BUILT-IN CHARGER TO THE RECEPTACLE, ENSURE THE KEY ON THE ENGINE IS POSITIONED TO OFF.**

The machine has a built-in battery charger. To activate this feature connect the machine to an appropriately grounded AC receptacle and activate the charging switch behind the clear plastic door. (*See photo*) Verify the battery disconnect switch is on.

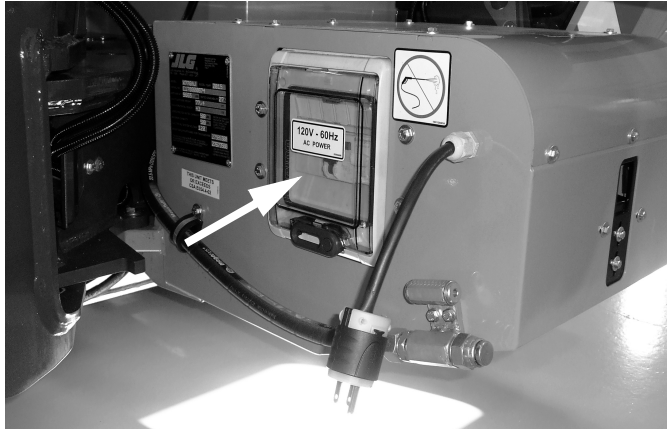

### 4.9 BATTERY CHARGING - LITHIUM-ION MACHINE

To check the battery condition on the lithium ION equipped machine, power up the machine and use the special indicator shown at position 8 on the platform control station LCD display.



or;

Check charge indicator (*item 2*) on top right side of the Lithium-Ion battery pack. This indicator shows the current charge state of the lithium-ion battery pack as follows;



RED LED: shows that the battery is in the initial charging phase.

YELLOW LED: shows that the battery has reached 80% charge.

GREEN LED: shows that the battery has reached 100% of charge.

If machine is powered on while charging, the LCD display on the platform control station also shows the machine charge indicator.



## SECTION 4 - MACHINE OPERATION

### Charging the Battery Pack

#### NOTICE

**DO NOT LEAVE THE MACHINE IN CONTINUOUS CHARGING FOR TIME PERIODS EXCEEDING 24 HOURS.**

**REMEMBER, THE CHARGE WORKS EVEN IF THE ELECTRONIC BOARD OF THE MACHINE IS TURNED OFF. SO THE BATTERIES CAN BE CHARGING EVEN IF THE REMOTE CONTROL IS OFF.**

**CHARGE THE MACHINE USING ONLY THE BATTERY CHARGER INSTALLED ON IT. THE USE OF A CHARGER OTHER THAN THAT PROVIDED VOIDS ANY KIND OF WARRANTY ON BATTERIES.**

Approximate time required to fully recharge the battery pack:

- Full Recharge -8 hrs. - 120V AC or 4 hrs. - 220V AC
- 80% Recharge -4 hrs. - 120V AC or 2 hrs. - 220V AC
- The batteries can be charged during machine operation, (*obviously the charging times in this case will be longer*).
- The batteries can be charged when they are not fully depleted.
- If the charge is less than 20% an audible warning signal will be activated whenever the electric motor is started, to alert the user to charge the machine.

- If the charge is less than 10%, in addition to the audible warning signal, reduced speed is activated and an icon comes on in position 4 on the platform station LCD display.



To start charging the battery connect the main AC power supply to the **AC socket (item 1 - photo)** located on the right rear of the machine next to the electric engine.

After a few seconds the **charge indicator (item 2 - photo)** located on the right hand side of the machine on top of the lithium-ion battery pack turns red, meaning the battery has started charging.

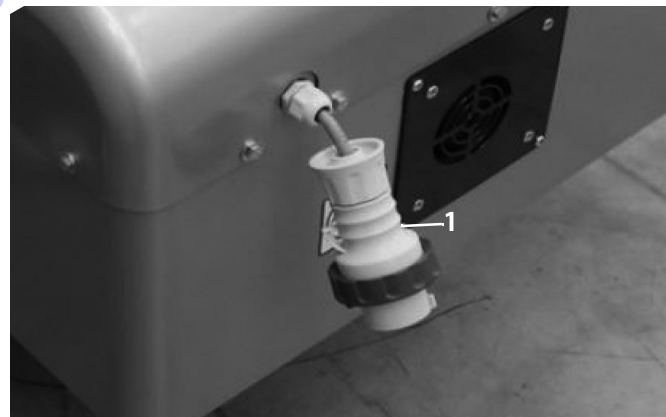



## SECTION 4 - MACHINE OPERATION



### **⚠ WARNING**

**THE BATTERY CHARGER SUPPLIED WITH THE LIFT WAS DESIGNED TO ENSURE SAFE AND RELIABLE PERFORMANCE. IT IS ALREADY FITTED ON THE MACHINE AND DOES NOT NEED ANY ADJUSTMENT OR CONFIGURATION BY THE USER; NONETHELESS, TO AVOID INJURY AND DAMAGE TO THE BATTERY CHARGER, THE FOLLOWING ESSENTIAL PRECAUTIONS MUST BE OBSERVED:**

- Carefully read installation instructions contained in this manual. For future reference, keep manual in a safe place.
- Do not place battery pack near heat sources.

- As battery charger is sealed without forced ventilation, its performance depends on ambient temperature and type of installation.
- Be certain type of power supply available corresponds to voltage specified and indicated on the battery charger rating plate or in this Operation/Maintenance Manual. If any questions, contact your local JLG Service Center or the local electrical company.
- An AC class circuit breaker can be used as a protection device for the battery charger power supply, however it is recommended to use a class A or even better class B device.
- In regard to safety and electromagnetic compatibility, the battery charger features a three pin plug with ground, which can only be plugged into an grounded socket. If the plug does not go into the socket, most probably the socket is old and not grounded. In this case, contact an electrician to have the socket replaced. Do not use adapters to resolve ungrounded circuit plug problems.
- Ensure power cable is undamaged. If cable is worn or damaged, have it replaced immediately.
- If extensions or multiple sockets are used, make sure these support total rated current.

## SECTION 4 - MACHINE OPERATION

- Disconnect power supply before connecting or disconnecting battery.
- Do not use the battery charger to charge the batteries of other vehicles; the battery charger installed was specially designed to charge the type of lithium batteries used on this machine. Do not attempt to charge any other type of batteries.
- Do not attempt to repair the battery charger. Opening the cover may expose the user to the risk of electric shock.
- Do not open battery charger, opening it may affect the index of protection (IP) even after it has been closed again.
- If battery charger is not working correctly or is damaged, disconnect it immediately from power outlet and the battery socket and contact your local JLG Service Center.

### Charge Curve

The battery charger features just one charge curve (IU1a) plus balancing and maintenance, designed specifically for charging the lithium-ion battery pack on this machine.

### Cold Weather Charging

Lithium battery pack discharge and/or recharge with positive lithium battery level (SOC>0) is possible over 14°F (-10°C).

In cold environmental temperature (not lower than -13°F (-25°C), the on-board electric heaters automatically warm up the cells. The heaters are activated by the BMS when the minimum cell temperature is 32°F (0°C). The heaters are automatically switched off when the minimum cell temperature raises over 35.6°F (2°C).

In cases where the battery charger is connected, when the minimum cell temperature is 32°F (0°C), the charger only supplies 3A to supply power to the heaters until a positive minimum cell temperature is reached.

From -13°F (-25°C) to 32°F (0°C) with null lithium battery level (SOC=0) the heaters will only work while the battery charger is connected to the machine.

The battery cold/heater activated icon will be shown on the display when the heaters are enabled. The machine can only be moved in the lower speed while the heater system is active.



### Cooling Fans

In hot environmental temperatures, the cooling fans systems becomes active to cool down the battery cells. This system is automatically activated by the BMS when cell temperature raises over 98.6°F (37°C). The cooling fans system will automatically shut off when cell temperature cools down to 95°F (35°C).

## SECTION 4 - MACHINE OPERATION

### 4.10 SHUT DOWN AND PARK

#### **⚠ CAUTION**

**WHEN PARKING THE MACHINE ON A SLOPE OR UNEVEN GROUND WITH THE OUTRIGGERS RETRACTED, PARK WITH THE TRACKS IN THE FULLY WIDENED POSITION AND BLOCK THE TRACKS USING WEDGES TO PREVENT MACHINE MOVEMENTS.**

1. Drive machine to a reasonably well protected area.
2. Ensure boom and jib are in the stowed (aligned) position.
3. Remove all load and allow engine to operate 3-5 minutes at LOW setting to permit reduction of internal engine temperatures.
4. Shut down gas/diesel/electric engine with the same button on the platform/remote control station used to start it. Complete machine shut down takes approximately 1 minute, LCD display OFF.
5. At ground and platform controls, push-in emergency stop buttons and remove key at the ground controls. Turn off engine and remove the key.
6. Close platform control console lid if necessary to protect instruction placards, warning decals and operating controls from hostile environment, place a cover over this area.
7. If machine is to be shut down for long periods of time, turn battery disconnect switch, RED handle

located on the electrical/battery tray housing, to the POWER OFF position. (see photos below)

#### **POWER ON**

Clockwise  
(As Shown)

#### **POWER OFF**

Counter-  
Clockwise



**BATTERY DISCONNECT SWITCH - GAS/DIESEL/AC-ELECTRIC**

## SECTION 4 - MACHINE OPERATION

### 4.11 LIFTING AND TIE DOWN

#### Lifting

1. Determine gross weight of machine, refer to the serial number tag, or weigh the individual unit to find out the gross vehicle weight.
2. Place the booms in the stowed position and properly aligned. All outriggers are fully retracted and the tracks are fully widened.
3. Remove all loose items from the machine.
4. Properly adjust the rigging to prevent damage to the machine and so the machine remains level.
5. Width of slings must not exceed 2.36 in (60 mm), the width of the chains must not exceed .984 in (25 mm), the diameter of the ropes must not exceed .984 in (25 mm) in order not to exert a pressure in an abnormal direction on the outrigger plate.

#### **NOTICE**

**USE OF ROPES, CHAINS OR SLINGS WITH LENGTH LESS THAN 10 ft (3m) COULD CAUSE PERMANENT DAMAGE TO MACHINE OUTRIGGERS.**

To lift machine, a separate sling must be attached to each outrigger using the appropriate lifting points as indicated in Figure 4-9..

Weight of machine is not spread equally over the four outriggers (See Figure 4-10.). Minimum required capacity of the

four ropes, chains or slings used must be no less than 4,409 lb (2000 kg) and their length no less than 10 ft (3m) and all identical.



**Figure 4-9. Machine Lifting Points**

1. Outrigger Lifting Lug (4 corners)

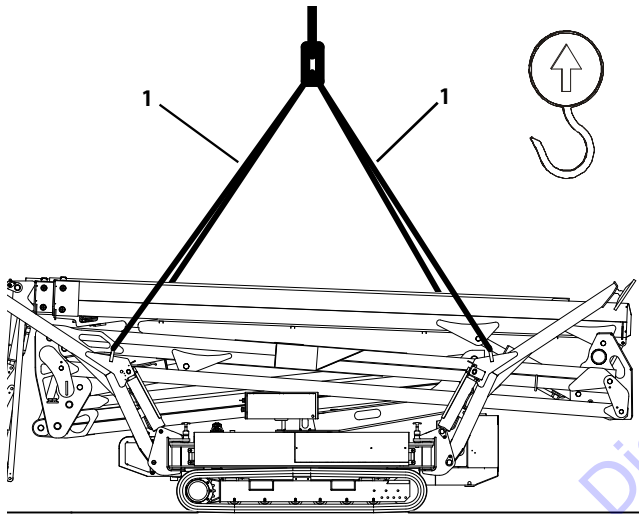

**Figure 4-10. Lifting Machine - Attach Points**

1. Lifting Slings

**Tie Down** (See Figure 4-11.)

### **NOTICE**

**WHEN TRANSPORTING MACHINE, BOOM MUST BE FULLY LOWERED INTO THE BOOM REST.**

- Travel up ramps with platform behind machine.
- Do not contact ground with jib or bottom of platform when loading/unloading. Operate machine from ground remote position and raise jib to prevent contact with the ground. See "Jib Position for Travelling" on page 4-9.
- ALWAYS load/unload the machine with track fully widened.
  1. Place booms in the stowed position.
  2. Remove all loose items from machine.
  3. Secure chassis using straps or chains of adequate strength.

### **⚠ CAUTION**

**DO NOT MAKE CONNECTIONS AT POINTS DIFFERENT THAN THOSE IDENTIFIED BY THE TIE DOWN LOCATION DECAL SHOWN. THIS COULD CAUSE PERMANENT DAMAGE RESULTING IN COLLAPSE OF THE PRODUCT.**

## SECTION 4 - MACHINE OPERATION

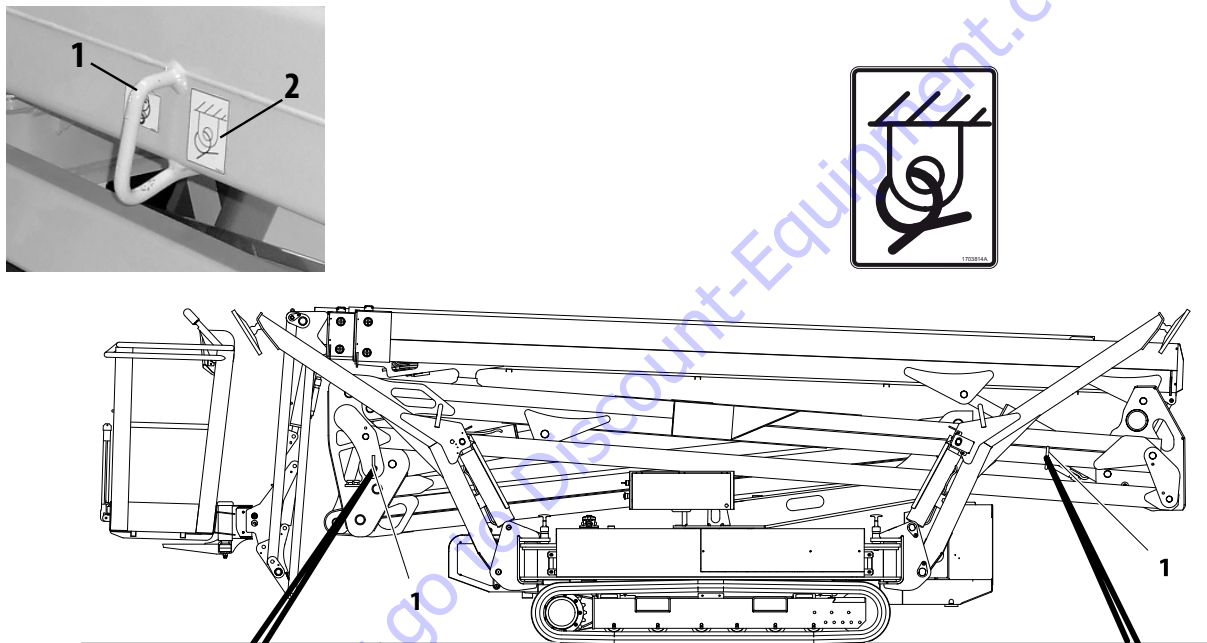

**Figure 4-11. Machine Tie-Down Points (both sides of machine)**

1. Tie-Down Loop

2. Tie-Down Decal

4.12 MACHINE DECALS



Figure 4-12. Decal installation - Left Side



## SECTION 4 - MACHINE OPERATION



Figure 4-13. Decal Installation - Left Side



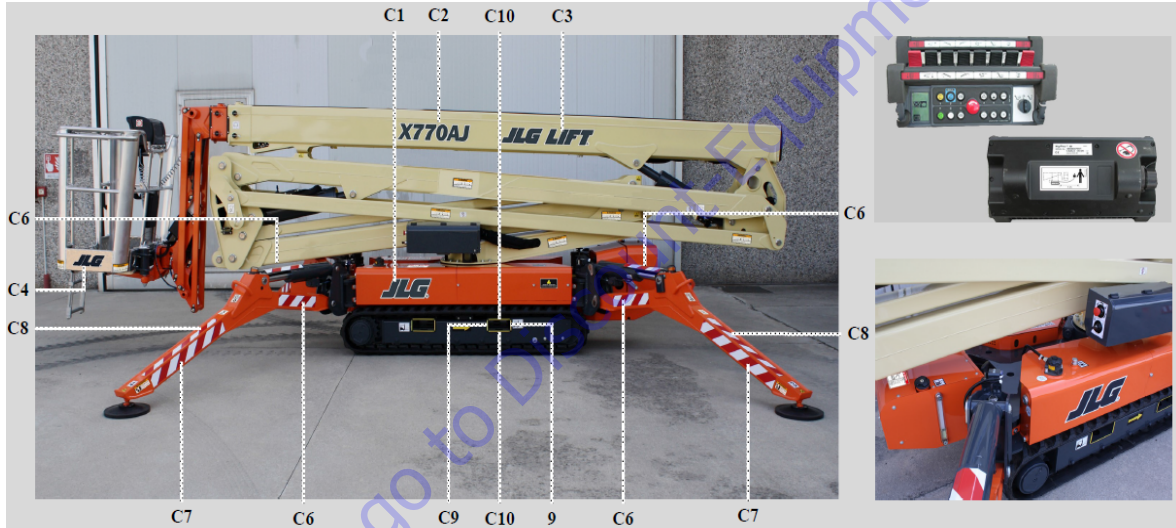

Figure 4-14. Decal installation - Right Side

## SECTION 4 - MACHINE OPERATION

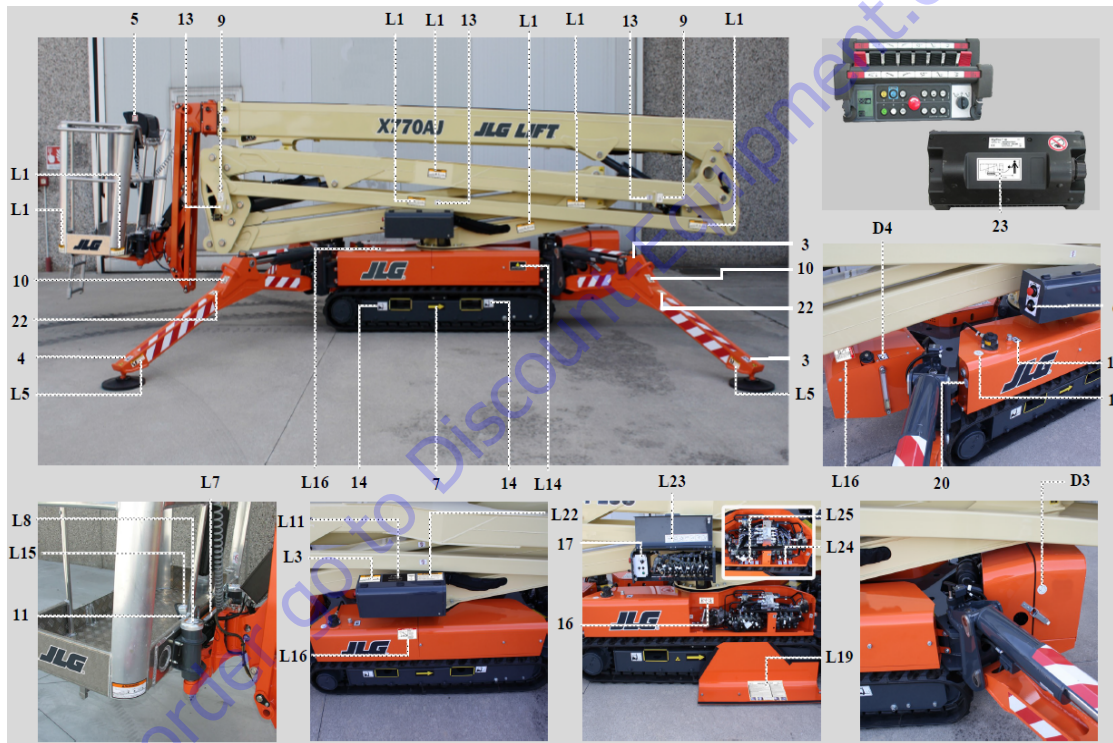

Figure 4-15. Decal installation - Right Side

## SECTION 4 - MACHINE OPERATION

Table 4-2. X770AJ - Decal Installation

ITEM #	PART NUMBER	DESCRIPTION
1	06555500	Decal, Outrigger Number 1
2	06555600	Decal, Outrigger Number 2
3	06555700	Decal, Outrigger Number 3
4	06555800	Decal, Outrigger Number 4
5	1001125483	Decal, No Pressure Washing At This Location
6	07668200	Decal, Emergency Stop and Main Power Key Switch
7	06040500	Decal, Forward Travel Direction
8	1701640	Decal, Manual
9	1703814	Decal, Machine Tie Down Location
10	07071200	Decal, Lift Lug
11	1704277	Decal, Lanyard Attach Point
12	06164700	Decal, Hydraulic Oil Filter
13	07056700	Decal, Not A Machine Lifting Point
14	07350300	Decal, Fork Truck Lifting Pocket
15	06706500	Decals, Boom/Base Alignment Arrow
16	06998800	Decal, Platform Manual Diverter Pump
17	07668300	Decal, Control Selector Switch/Engine Start/Stabilizer Indicator
18	1702155	Decal, Battery Disconnect
19	1701504	Decal, Warning - Hydraulic Fluid Under Pressure
20	06165000	Decal, Hydraulic Oil Tank - Fluid Level Check
21	06136900	Decal, Lubrication Point
22	07678300	Decal, Outrigger, Max. Ground Pressure

## SECTION 4 - MACHINE OPERATION

**Table 4-2. X770AJ - Decal Installation**

ITEM #	PART NUMBER	DESCRIPTION
23	07240300	Decal, Keep 3 ft./1m Away When Operating With Tele /Radio Commands
24	1001223055	Decal, Annual Inspection
25	--	--
26	1704125	Air and Water Attach
C1	07060500	Decal, JLG
C2	07633900	Decal, JLG
C3	07677500	Decal, JLG Lift
C4	07690100	Decal, JLG
C5	07691500	Decal, JLG
C6	06039900	Decal, Safety Strip
C7	06039700	Decal, Safety Strip
C8	06039600	Decal, Safety Strip
C9	07268300	Decal, Warning Fork Lift
C10	07268400	Decal, Warning Fork Lift
D1	07056300	Decal, 220V - 50/60HZ - Electrical
D1	07056400	Decal, Danger - 120V - 60Hz
D2	06214200	Decal, Liquid Refrigerant
D3	06060000	Decal, Engine Oil Level
D4	1701505	Decal, Diesel Fuel Only
D5	06056300	Decal, Danger - Hot Surface
D6	1001228370	Decal, ICES
	1001223453	Decal, ICES

## SECTION 4 - MACHINE OPERATION

**Table 4-2. X770AJ - Decal Installation**

ITEM #	PART NUMBER	DESCRIPTION
L1	07056100	Decal, Warning - Boom Crushing Hazard
L2	1706387	Decal, Warning - Crushing Hazard - Platform
L3	1706099	Decal, Warning - Boom Crushing Hazard - Ground Controls
L4	1702868	Decal, Caution - No Hands or Lanyard - Platform Rail
L5	07056200	Decal, Warning - Crushing Hazard - Outrigger Pad
L6	1706386	Decal, Warning - Fall Hazard - Platform
L7	07051100	Decal, Warning - Fall Hazard - Platform Mounting Caps
L8	07051000	Decal, Warning - Fall Hazard - Platform Mounting Caps
L9	1706133	Decal, Warning - Tip-Over Hazard - Platform
L10	07058700	Decal, Warning - Tip-Over Hazard - Platform
L11	081081GB	Decal, Maximum Platform Capacity
L12	07042100	Decal, Boom Functions Safety System Bypass (Key Switch)
L13	07042200	Decal, Drive Functions Safety System Bypass (Key Switch)
L14	1702901	Decal, Manual Descent Instructions Inside
L15	3252347	Decal, Warning - Platform Foot Switch
L16	1706128	Decal, Danger - Electrocutation Hazard - Maintain Distance From Electric Lines
L17	1703813	Decal, Warning - Battery Charging Ventilation - Explosion/Fire Hazard
L18	1704972	Decal, Warning - Diesel Engine - Explosion/Fire Hazard - Glow Plugs/Starting Fluid
L19	076791GB	Decal, Emergency Lowering
L20	1706385	Decal, Warning - Fall Hazard - Platform Gate
L21	08069800	Decal, Prop 65
L22	1706135	Decal, Warning - Ground Control Instructions

## SECTION 4 - MACHINE OPERATION

---

**Table 4-2. X770AJ - Decal Installation**

<b>ITEM #</b>	<b>PART NUMBER</b>	<b>DESCRIPTION</b>
L23	076787GB	Decal, Boom - Hydraulic Valve Controls, Ground Control Station
L24	072425GB	Decal, Components Left Side - Hydraulic Valve Controls
L25	072426GB	Decal, Components Right Side - Hydraulic Valve Controls

**TO PURCHASE THIS PRODUCT PLEASE CONTACT US**



**Equipment Financing and  
Extended Warranties Available**



**Discount-Equipment.com is your online resource for  
commercial and industrial quality parts and equipment sales.**

**561-964-4949**

**visit us on line @ [www.discount-equipment.com](http://www.discount-equipment.com)**

Select an option below to find your Equipment

**Search by Manufacturer**

**Search by Product Type**

**Request a Quote**

We sell worldwide for the brands: Genie, Terex, JLG, MultiQuip, Mikasa, Essick, Whiteman, Mayco, Toro Stone, Diamond Products, Generac Magnum, Airman, Haulotte, Barreto, Power Blanket, Nifty Lift, Atlas Copco, Chicago Pneumatic, Allmand, Miller Curber, Skyjack, Lull, Skytrak, Tsurumi, Husquvarna Target, Stow, Wacker, Sakai, Mi-T-M, Sullair, Basic, Dynapac, MBW, Weber, Bartell, Bennar Newman, Haulotte, Ditch Runner, Menegotti, Morrison, Contec, Buddy, Crown, Edco, Wyco, Bomag, Laymor, EZ Trench, Bil-Jax, F.S. Curtis, Gehl Pavers, Heli, Honda, ICS/PowerGrit, IHI, Partner, Imer, Clipper, MMD, Koshin, Rice, CH&E, General Equipment, Amida, Coleman, NAC, Gradall, Square Shooter, Kent, Stanley, Tamco, Toku, Hatz, Kohler, Robin, Wisconsin, Northrock, Oztec, Toker TK, Rol-Air, APT, Wylie, Ingersoll Rand / Doosan, Innovatech, Con X, Ammann, Mecalac, Makinex, Smith Surface Prep, Small Line, Wanco, Yanmar

### SECTION 5. EMERGENCY PROCEDURES

#### 5.1 GENERAL

This section explains the steps to be taken in case of an emergency situation while operating.

#### 5.2 INCIDENT NOTIFICATION

JLG Industries, Inc. must be notified immediately of any incident involving a JLG product. Even if no injury or property damage is evident, the factory should be contacted by telephone and provided with all necessary details.

In USA -

JLG Phone: 877-JLG-SAFE (554-7233)  
(8am till 4:45pm EST)

Outside USA: 240-420-2661

E-mail: ProductSafety@JLG.com

Failure to notify the manufacturer of an incident involving a JLG Industries product within 48 hours of such an occurrence may void any warranty consideration on that particular machine.

#### **NOTICE**

**FOLLOWING ANY ACCIDENT, THOROUGHLY INSPECT MACHINE AND TEST ALL FUNCTIONS FIRST FROM GROUND CONTROLS, THEN FROM PLATFORM CONTROLS. DO NOT LIFT ABOVE 10 FT (3 M) UNTIL YOU ARE SURE ALL DAMAGE HAS BEEN REPAIRED, IF REQUIRED, AND ALL CONTROLS ARE OPERATING CORRECTLY.**



## SECTION 5 - EMERGENCY PROCEDURES

### 5.3 EMERGENCY OPERATION

#### Power Main Cut-Off Switch Location

A battery cut-off switch - RED handle (*photo shows power ON*) is located on the inside of the battery/electrical box tray at the left front of the machine just behind the outrigger mount. When switched off - handle turn all the way counter-clockwise - all electrical power to the machine is shut down.

**POWER ON**  
Clockwise  
(As Shown)

**POWER OFF**  
Counter-  
Clockwise

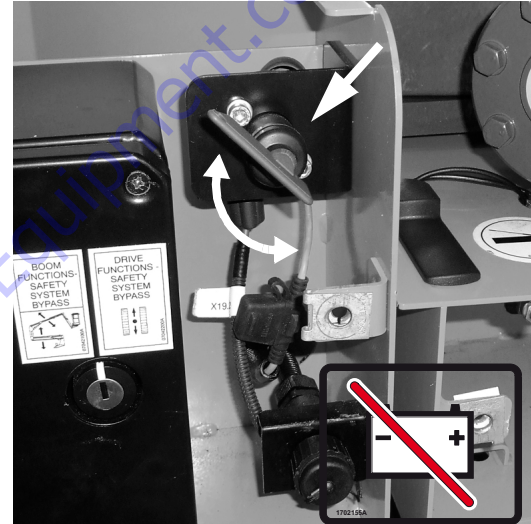

**BATTERY DISCONNECT SWITCH - GAS/DIESEL/AC-ELECTRIC**

## SECTION 5 - EMERGENCY PROCEDURES

---

### Operator Unable to Control Machine

IF PLATFORM OPERATOR IS PINNED, TRAPPED OR UNABLE TO OPERATE OR CONTROL MACHINE:

1. Other personnel should operate the machine from ground controls only as required.
2. Other qualified personnel on the platform may use the platform controls. DO NOT CONTINUE OPERATION IF CONTROLS DO NOT FUNCTION PROPERLY.
3. Cranes, forklift trucks or other equipment can be used to remove platform occupants and stabilize machine motion.

### Platform or Boom Caught Overhead

If platform or boom becomes jammed or snagged in overhead structures or equipment, rescue platform occupants prior to freeing the machine.

**NOTE:** *The engine runs the hydraulic pump which provides hydraulic pressure for the hydraulic system. The electric power provides power for the hydraulic proportional valve solenoids to open and close which operate various solenoids and relays on the hydraulic system. In the event either/or both are not operating properly, the following procedures will allow the lowering of the boom and platform.*

## SECTION 5 - EMERGENCY PROCEDURES

---

### Manual Descent with Engine Running and Electrical Power

#### CAUTION

ENSURE BOOM IS NOT POSITIONED OVER THE OUTRIGGERS OR OVERHEAD OF PERSONNEL BEFORE LOWERING.

#### Using Platform/Remote Control Box from Platform

(See Figure 5-1.)

The manual descent system is provided as an emergency means to lower personnel in the platform.

1. Check emergency stop button (*item 10*) is in the ON position by turning it clockwise.
2. Depress platform foot switch on floor of platform.

3. Press and hold down button 4 (*item 4*) with hazard symbol on platform/remote control box. The LCD display (*item 15*) will indicate the triangle symbol seen on the button in LCD position 8.
4. Select a boom function to operate by moving it's controller in the direction for lowering. (*items 17, 18, and 21*)
5. When finished, release emergency lowering switch (*item 4*), and foot switch.
6. Position (*press*) the emergency stop switch to the OFF position.



## SECTION 5 - EMERGENCY PROCEDURES

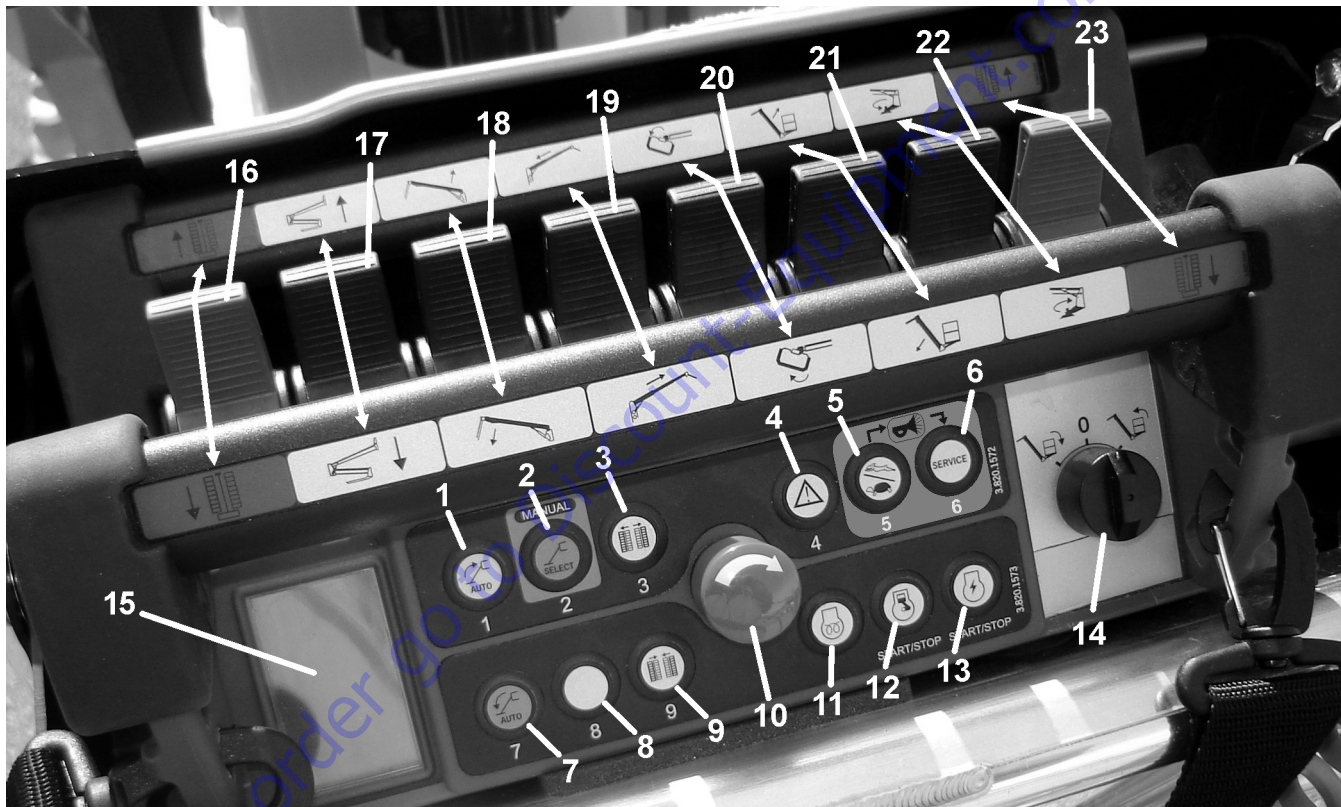

**Figure 5-1. Platform/Remote Control Station**

## SECTION 5 - EMERGENCY PROCEDURES

---

### Using Emergency/Ground Controls from Ground

(See Figure 5-2.)

#### CAUTION

**ENSURE BOOM IS NOT POSITIONED OVER THE OUTRIGGERS OR OVERHEAD OF PERSONNEL BEFORE LOWERING.**

1. Check that the main power key switch (*item 1*) is set to the ON (I) position.
2. Be certain emergency stop button (*item 2*) is in the ON position by turning it clockwise.
3. Start engine, if not already running (*item 4*).
4. At Emergency/Ground Control box, turn mode selector switch (*item 3*) all the way clockwise and hold.
5. Check that the green (*machine stabilized*) indicator light (*item 5*) on the Emergency/Ground Control box is on.
6. Operate the appropriate manual control lever (*item 7 thru 13*) next to its control valve under the cover of the valve distributor. See decal on valve distributor cover for boom component and direction to operate lever for desired movement.
7. When finished, release mode selector switch (*item 3*) back to the neutral position.
8. Position (*press*) emergency stop switch (*item 1*) to the OFF position.

## SECTION 5 - EMERGENCY PROCEDURES

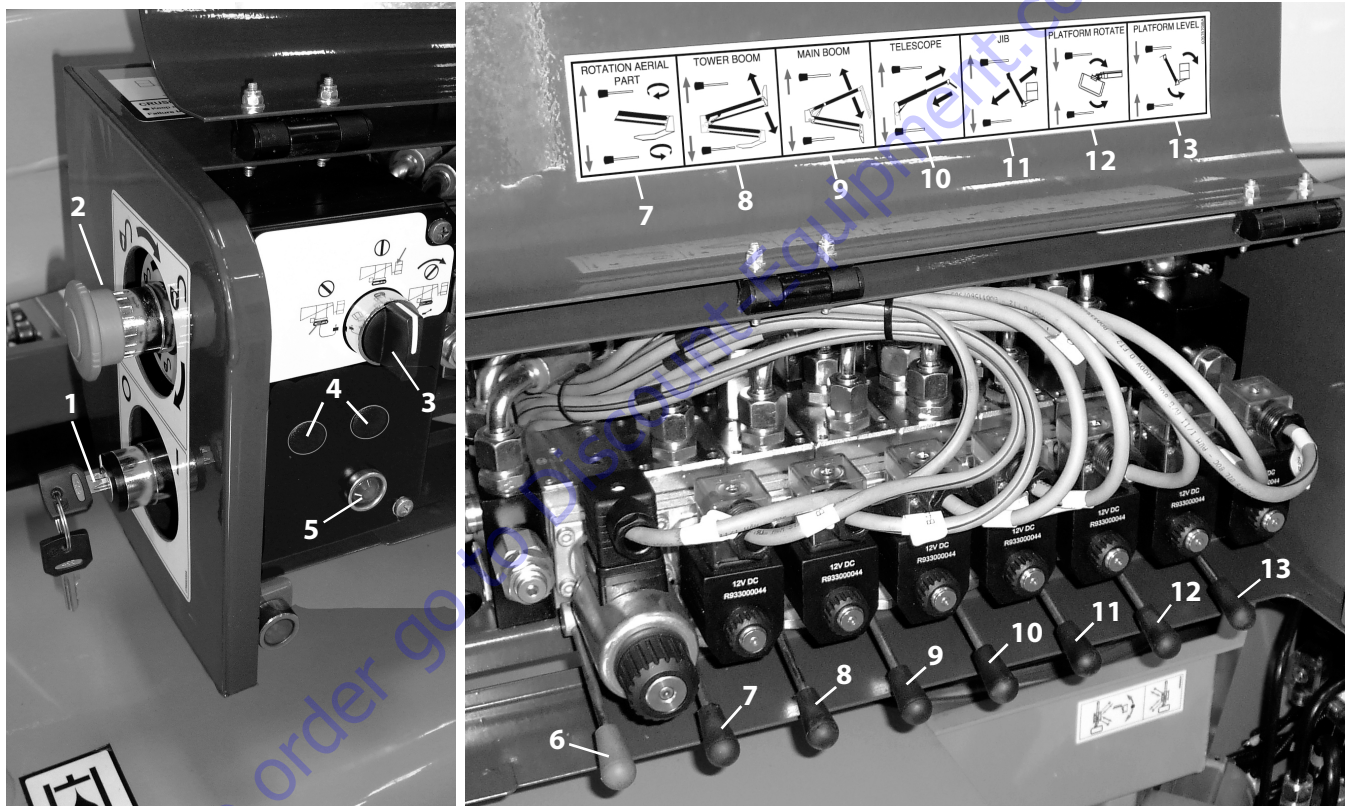

Figure 5-2. Ground Control Station

## SECTION 5 - EMERGENCY PROCEDURES

---

### Manual Descent with Engine Running but without Electrical Power

#### Hand Pump - Proportional Valves Tray on Right Side of Machine

(See Figure 5-3.)

#### CAUTION

**ENSURE BOOM IS NOT POSITIONED OVER THE OUTRIGGERS OR OVERHEAD OF PERSONNEL BEFORE LOWERING.**

1. Remove hand pump compartment cover - proportional valve tray on the right front side of the machine.
2. Locate and remove the proportional valve adjustment knob (*item 1*) from protective plastic bag,
3. Slide the adjustment knob assembly onto the proportional valve stem (*item 2*).

**NOTE:** *The proportional valve adjusts speed of the boom movements (pressure flow) when using boom control valves at the valve distributor on the ground control station in Figure 5-2. Without electrical power you must manually open this valve with the adjustment knob before operating the boom controls.*

4. Turn proportional valve adjustment knob clockwise approximately four turns, the more turns the valve is open the faster the movement of the

boom component. Always carry out movement at the slowest possible speed.

5. At the ground control valve distributor operate the boom control valves as needed. (*see Figure 5-2.*)
6. Make boom movements in the following sequence:
  - fully retract main boom (*item 10, Figure 5-2.*)
  - fully lower jib (*item 11, Figure 5-2.*)
  - fully lower tower boom (*item 8, Figure 5-2.*)
  - fully lower main boom (*item 9, Figure 5-2.*)
7. When emergency operation is complete, loosen knob on the proportional valve completely, remove it and place it back in the protective bag.



## SECTION 5 - EMERGENCY PROCEDURES

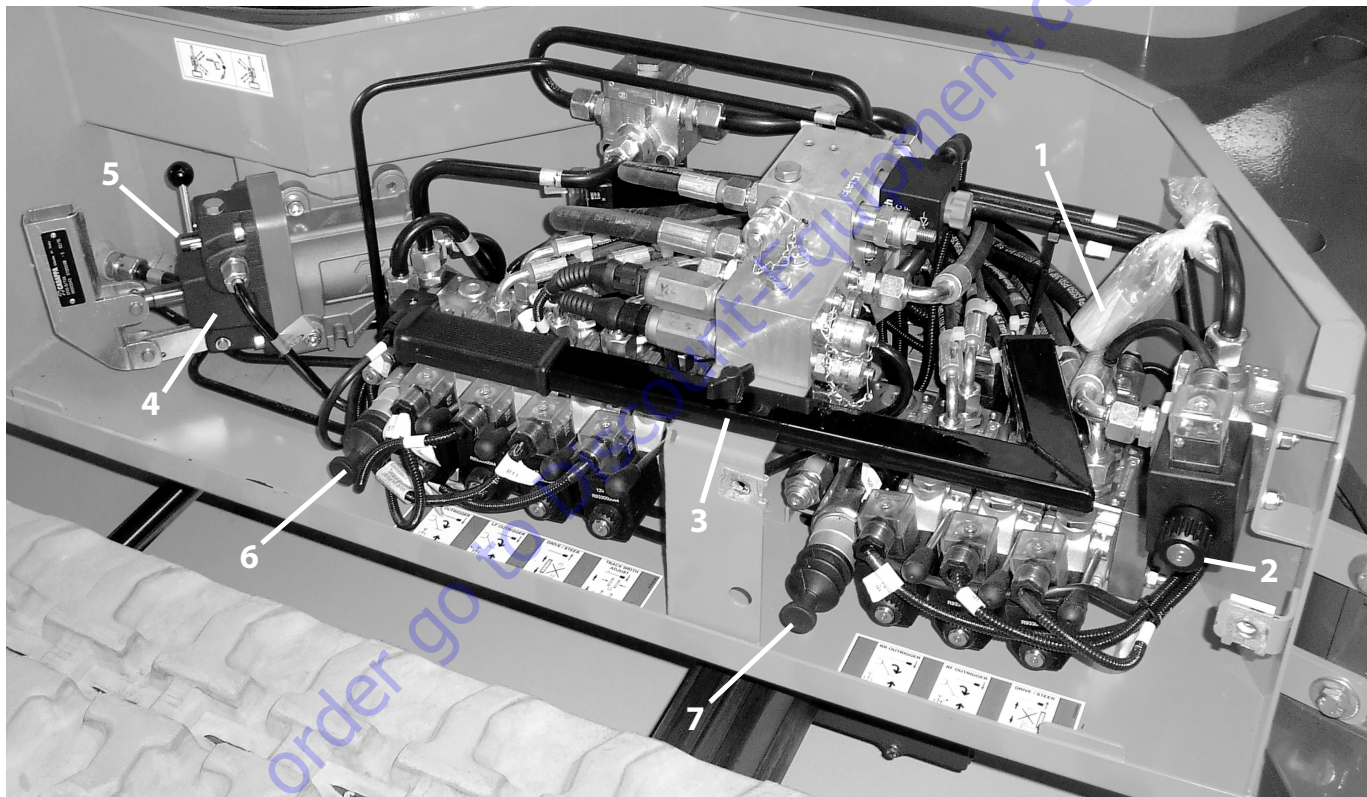

**Figure 5-3. Hand Pump - Chassis Control Valve Tray**



## SECTION 5 - EMERGENCY PROCEDURES

### Manual Descent without Engine or Electrical Power.

#### Using Hand Pump in Hydraulic Compartment on Right side of Machine

(See Figure 5-3.)

1. Platform retrieval sequence.  
Ensure the machine is level and all outriggers are properly deployed on a firm surface.
  - a. Remove the hydraulic panel cover on the right front side of the machine.
  - b. Locate the pump handle (item 3) secured to the bracket inside of the hydraulic compartment.
  - c. Install the pump handle on the pump (item 4) and secure in place with the provided screw. The lever (item 5) on the pump must be set to the left, check decal above pump.

**NOTE:** Always swing turntable inline with the chassis first so that the turntable and base indicator arrows are aligned. This will eliminate possibility of an elevated or extended boom being positioned overhead of personnel at the pump and eliminate the risk of lowering the jib onto an outrigger.



#### **⚠ WARNING**

**NEVER REACH THROUGH, UNDER, OR OVER THE BOOM'S PATH OF TRAVEL TO THE GROUND CONTROL PANEL. IF NO ASSISTANT IS AVAILABLE, PROCEED WITH THE FOLLOWING STEPS.**

#### **NOTICE**

**TO AVOID CONTACT BETWEEN JIB AND OUTRIGERS. DO NOT ATTEMPT MANUAL SWING WITH BOOMS AND JIB FULLY LOWERED.**

2. Lift the function enable lever UP and hold (item 6 - Figure 5-2.), While pumping the hand pump (item 4) and activating the swing control lever (item 7 - Figure 5-2.) in the desired direction of travel, until the turntable is aligned with the chassis.

## SECTION 5 - EMERGENCY PROCEDURES

---

- 3.** Retract the main boom *(if necessary)*.  
Lift the function enable lever UP and hold *(item 6 - Figure 5-2.)*. While pumping the hand pump, activate telescope function lever *(Item 7, Figure 5-2.)* in the appropriate direction to retract the main boom.
- 4.** Lower the jib.  
Lift the function enable lever UP and hold *(item 6 - Figure 5-2.)*, while pumping the handpump, activate the jib lift function lever *(item 8, Figure 5-2.)* in the appropriate direction to lower the jib.
- 5.** Lower Tower Boom  
Lift the function enable lever UP and hold *(item 6 - Figure 5-2.)*, while pumping the handpump, activate the tower boom lift function lever *(item 5, Figure 5-2.)* in the appropriate direction to lower the tower boom.
- 6.** Lower the Main Boom  
Lift the function enable lever UP and hold *(item 6 - Figure 5-2.)*, while pumping the handpump, activate the main boom lift function lever *(item 6, Figure 5-2.)* in the appropriate direction to lower the main boom.
- 7.** Rotate the platform *(if necessary)*.  
Lift the function enable lever UP and hold *(item 6 - Figure 5-2.)*, while pumping the handpump, activate the appropriate platform rotate function lever *(item 12, Figure 5-2.)* to rotate the platform.
- 8.** Level the platform *(if necessary)*.  
Lift the function enable lever UP and hold *(item 6 - Figure 5-2.)*, while pumping the handpump, activate the appropriate platform level function lever *(item 13, Figure 5-2.)* to level the platform.
- 9.** Remove the manual pump handle from the pump and secure to turntable in its original position.

## SECTION 5 - EMERGENCY PROCEDURES

---

### Outrigger/Track Movement Emergency Procedure:

#### Outrigger/Track Movement Using the Hand Pump in Hydraulic Compartment on Right side of Machine

#### **WARNING**

PLACE THE MACHINE INTO TRANSPORT CONFIGURATION ONLY AFTER HAVING ALIGNED AND FULLY LOWERED AND RETRACTED THE BOOM AND JIB.

#### **WARNING**

WHEN RETRACTING THE OUTRIGGERS, THE MACHINE CAN BECOME UNBALANCED IF ONE OR MORE OUTRIGGERS ARE OFF OF THE GROUND AT ANY ONE TIME. RETRACT OUTRIGGERS EQUALLY, TO KEEP MACHINE BALANCED.

**NOTE:** When performing ANY manual operation of outrigger/track functions with hand pump, if available, machine electrical power can be powered ON.

If machine CANNOT be powered ON, then the silver/black knob tool (item 1 - Figure 5-3.) in the plastic bag is needed to screw on to (item 2 - Figure 5-3.). This will allow oil flow to the RIGHT outrigger/track valve set (item 7 - Figure 5-3.).

With NO power and without the tool installed on (item 2) the flow defaults to the LEFT side outrigger/track valve set (item 6 - Figure 5-3.).

### Outrigger Functions: (See Figure 5-3.)

1. Remove the hydraulic valve compartment cover on the right - front of the chassis by removing the thumbscrews. This will provide access to the manual override levers for the right side (item 7) and left side (item 6) outrigger and right and left track function solenoids.
2. Locate pump handle (item 3) secured to the bracket inside of the hydraulic compartment, right side of machine.
3. Install pump handle (item 3) on the pump (item 4) and secure in place with the provided screw. The lever (item 5) on the pump must be set to the left to manually operate right side outrigger and track functions (item 7). If operating with NO power, install the silver/black knob valve tool (item 1) to valve (item 2) (see previous note).

### For right side (operator's perspective) Outrigger and Track Functions:

4. Locate the proportional flow valve attached to the group of three valves (item 7 - Figure 5-3.). Press the knob on the valve in until it stops.
5. While holding the flow valve in, activate the lever in the desired direction on the appropriate valve solenoid (valve description below) while pumping the pump handle to achieve the desired function movement.

## SECTION 5 - EMERGENCY PROCEDURES

---

(Item 7 - Figure 5-3.)

- 1st valve, far left in the group of three operates Right Rear Outrigger.
- 2nd valve, from the left in the group of three operates Right Front Outrigger
- 3rd valve, from the left in the group of three operates the Right Track Drive functions.

### **For left side (operator's perspective) Outrigger and Track Functions**

1. Locate the proportional flow valve attached to the group of four valves (item 6 - Figure 5-3.). Press the knob on the valve in until it stops.
2. The lever on the pump must be set to the right to manually operate left side outrigger and track functions.
3. If operating with NO power, and if still installed from right side operation, remove the valve tool (item 1 - Figure 5-3.) from the flow valve (item 2 - Figure 5-3.)
4. Activate the lever in the desired direction on the appropriate valve solenoid (valve description below), while pumping the handle to achieve the desired function movement.

(Item 6 - Figure 5-3.)

- 1st valve, far left - toward front of machine in the group of four, operates Left Rear Outrigger.

- 2nd valve from the left in the group of four, operates Left Front Outrigger.
  - 3rd valve from the left in the group of four, operates the Left Track Drive functions.
  - 4th valve from the left in the group of four, operates track extension and retraction.
5. Remove (if necessary) valve tool, unscrew the valve black knob and un-install the valve tool from the flow valve.
  6. Remove manual pump handle from the pump and secure it in its original position.
  7. Replace any access panels that were previously removed.

## SECTION 5 - EMERGENCY PROCEDURES

### 5.4 SAFETY DEVICES BYPASS KEY USE

#### **⚠ WARNING**

**THIS FEATURE MUST ONLY BE USED AS DESCRIBED BELOW. THE MACHINE COULD TIP OVER IF THESE DIRECTIONS ARE NOT FOLLOWED.**

The machine has a key for bypassing the platform safety systems. The key used to activate the safety device bypass switch, is fastened to the cover attach screw mounting tab from the factory, on the left side of the electrical components compartment near the battery.

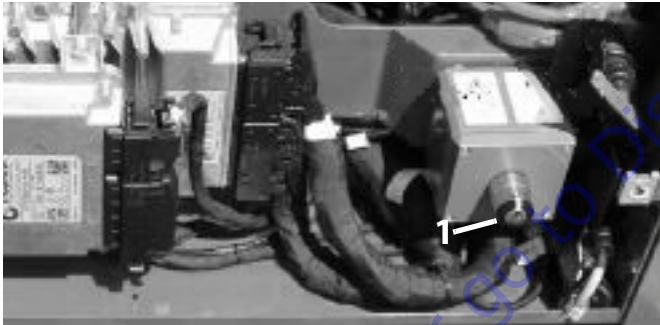

Remove key and insert it into the bypass key switch (item 1 - photo). After using the safety device bypass, a qualified JLG mechanic must be contacted to determine the reason for needing



to use this feature. Return the key to the where you found it and secure it in that location.

The safety device circuit board records every time the safety device bypass key is activated along with the movements made during these operations.

**NOTE:** *In case of machine with restricted area of operation, the bypass of the safety devices does not allow the boom assembly to go out of the safe working area.*

#### **⚠ WARNING**

**SAFETY DEVICE BYPASS ALLOWS OPERATION OF MACHINE WITH AN OVERLOAD IN THE PLATFORM. THE OVERLOAD ALARM WILL SOUND AND THE OVERLOAD ICON WILL BE ON THE PLATFORM/REMOTE CONTROL BOX DISPLAY. REMOVE OVERLOAD FROM THE PLATFORM BEFORE OPERATION.**

## SECTION 5 - EMERGENCY PROCEDURES

---

### Using Emergency Descent In Case Of An Outrigger Losing Contact With The Ground

One or more of the outriggers may lose contact with the ground which will result in the platform/remote control box functions being inoperable except for emergency lowering.

To restore platform/remote control box functions, lower and retract the booms and then reposition the machine and properly set the outriggers.

Use the emergency descent from the platform if possible by using the following sequence, fully retract main boom, fully lower jib, fully lower tower boom, and fully lower main boom.

If this is not possible, have a properly trained person on the ground bypass the platform safety devices and allow the operator in the platform to lower and retract the booms or allow emergency manual operations to bring the platform back to the ground.

1. Locate and use safety device bypass key as stated above.
2. Activate safety device bypass by turning key in a counterclockwise direction and hold it in position (see decal).
3. The safety devices BYPASS icon will appear on the platform/remote control box display.



4. Operate the machine from the platform/remote control ONLY carrying out operations that allow the tower boom lowering, main boom retract and jib lowering. The main boom must be fully retracted prior to operating swing and main boom lowering functions.

### **⚠ WARNING**

**NEVER PERFORM OPERATIONS DIFFERENT TO THOSE LISTED OR THAT CAN IN SOME WAY REDUCE THE STABILITY OF THE MACHINE. THE ORDER OF THE BOOM MOVEMENTS MUST BE DONE IN A WAY TO PREVENT ANY OPERATION THAT REDUCES THE STABILITY OF THE MACHINE.**

5. Once booms and jib are fully lowered and aligned, release the key and follow instructions above to secure the key.

If machine is set up in the reduced stabilization area, bypassing the safety devices does not allow the boom to go out of the working area related to that outrigger configuration.

## SECTION 5 - EMERGENCY PROCEDURES

### Machine Realignment Emergency Procedure

**THIS OPERATION MUST ONLY BE PERFORMED WITH THE BOOMS AND JIB FULLY LOWERED AND RETRACTED.**

During transport, the turntable may swing and become out of alignment with the base. If this occurs, one of the two EMERGENCY PROCEDURES given below can be used:

#### Machine Realignment:

1. Open the electric components compartment;
2. Locate and use the safety device bypass key as described above;
3. Activate the safety device bypass by turning the key in a counterclockwise direction and holding it in position (see sticker);
4. The safety devices BYPASS icon will appear on the platform/remote control box LCD display. 
5. Realign the machine while operating the swing function from the platform/remote control box.
6. Once the machine is aligned, release the key and store it as stated above.

**NOTE:** *In case of machine with restricted work area, the bypass of the safety devices does not allow the boom assembly to go out of the working area related to that outrigger configuration.*

#### Movement Of Tracks With Machine Not Aligned:

**OPERATION ONLY ALLOWED TO GO TO A CONDITION SUITABLE TO CARRY OUT THE PROCEDURE INDICATED IN "MACHINE RE-ALIGNMENT" ABOVE. ALL OTHER USE IS PROHIBITED.**

1. Open the electric components compartment;
2. Locate and use the safety device bypass key as described above;
3. Activate the safety device bypass key by turning it in a clockwise direction and holding it in position (see decal);
4. The safety devices BYPASS icon will appear on the platform/remote control box display. 
5. Operate drive/steer controls with extreme caution.
6. Move machine to a proper location to perform "Machine Realignment" procedure to realign the machine.
7. At the end of the operation release the key and store it as is described above.

The control circuit board records every activation of the safety device bypass key.

## **SECTION 6. GENERAL SPECIFICATIONS AND OPERATOR MAINTENANCE**

### **6.1 INTRODUCTION**

This section of the manual provides additional necessary information to the operator for proper operation and maintenance of this machine.

The maintenance portion of this section is intended as information to assist the machine operator to perform daily maintenance tasks only, and does not replace the more thorough Preventive Maintenance and Inspection Schedule included in the Service and Maintenance Manual.

#### **NOTICE**

**AVOID PRESSURE-WASHING ELECTRICAL/ELECTRONIC COMPONENTS. IF PRESSURE-WASHING THE MACHINE IS NEEDED, ENSURE MACHINE IS SHUT DOWN BEFORE PRESSURE-WASHING. SHOULD PRESSURE WASHING BE UTILIZED TO WASH AREAS CONTAINING ELECTRICAL/ELECTRONIC COMPONENTS, JLG INDUSTRIES, INC. RECOMMENDS A MAXIMUM PRESSURE OF 750 PSI (52 BAR) AT A MINIMUM DISTANCE OF 12 IN (30.5 CM) AWAY FROM THESE COMPONENTS. IF ELECTRICAL/ELECTRONIC COMPONENTS ARE SPRAYED, SPRAYING MUST NOT BE DIRECT AND ONLY FOR BRIEF TIME PERIODS TO AVOID HEAVY SATURATION.**



## SECTION 6 - GENERAL SPECIFICATIONS AND OPERATOR MAINTENANCE

### 6.2 OPERATING SPECIFICATIONS

**Table 6-1. Operating Specifications**

Model	X770AJ
Maximum work load (capacity)	500 lbs (230 kg)
Max. Vertical Platform Height	77 ft (23.6 m)
Max. Horizontal Platform Reach	43.6 ft (13.3 m)

### Dimensional Data

**Table 6-2. Dimensional Data**

Model	X770AJ
Overall Width	without Platform: 3 ft. 2 in (0.972m) with Platform: 4 ft. 10 in. (1.48m)
Outriggers Deployed Width	13 ft 4 in x 13 ft 1 in (4.06 m x 3.96 m)
Stowed Height	6 ft 6 in (1.99m)
Stowed Length	20 ft. 9 in. (6.32 m)
Approach angle	with Jib lowered: 9° with Jib raised: 26°
Departure angle	22°

### Chassis

**Table 6-3. Chassis Data**

Model	X770AJ
Maximum Travel Grade w/ boom in stowed position (gradeability)	16°
Maximum Travel Side Slope w/ boom in stowed position	16° (28.7%)
Turning radius	0°
Maximum ground pressure per track (psi)	7.68 psi (0.54 kg/cm <sup>2</sup> )
Maximum ground pressure per outrigger	63 psi (4.42 kg/cm <sup>2</sup> )
Maximum outrigger pad load	7,020 lb (3,184 kg)
Outrigger pad diameter	11.8 in (300 mm)
Max drive speed (with std. 2nd speed)	Diesel Engine: 0.93 mph (1,5 km/hr) (Lithium) Electric Engine: 0.43 - 0.75 mph (0,7 - 1,2 km/hr)
Max hydraulic system pressure	2,901 psi (200 bar)
Maximum wind speed	28 mph (12.5 m/s)
Maximum manual force	90 lb (400 N)
Electrical system voltage	12V
Gross machine weight (platform empty)	Diesel: 9,623 lbs (4,365 kg) Lithium: 9,665 lbs (4,384 kg)

## SECTION 6 - GENERAL SPECIFICATIONS AND OPERATOR MAINTENANCE

### Capacities

**Table 6-4. Capacities**

Model	X770AJ
Hydraulic Tank	15.85 gal (60L)
Fuel Tank	Diesel: 6.6 gal (25L)
Engine Oil	Diesel: 0.98 gal (3.71L)

### Electric Motor Data

**Table 6-6. Electric Motor Specifications**

Model	X770AJ
Rated Input Voltage	120V
Rated Frequency	50Hz - 50Hz - 60Hz
Rated Power	2.2 Kw - 2.2 Kw - 2.2 Kw

### Engine Data

**Table 6-5. Kubota D902 Specifications**

Model	X770AJ
Type	Liquid cooled
Number of cylinders	3
Displacement	55 cu. in. (898 cm <sup>3</sup> )
Output	21.6 hp (16.1 kW)
High engine speed	3200 RPM
Battery	12V - 70Ah - 760A
Alternator	40A - 3200RPM

## SECTION 6 - GENERAL SPECIFICATIONS AND OPERATOR MAINTENANCE

### Lithium-Ion Battery Pack Specifications

Table 6-7. Lithium Ion Specifications

Model	X770AJ
<b>Battery Pack</b>	
No. of cells in the battery pack:	26 cells
Rated voltage of each cell:	3.2 volt
Max. cell voltage:	3.65 volt
Min. cell voltage:	2.5 volt
Features of complete pack:	83 volt - 100 ampere/h
*Charge cycles:	2000 cycles
Cathode:	Lithium Ion Phosphate (LiFePO4)
Anode:	Graphite
Memory effect:	NO
<b>Battery Charger</b>	
Type:	120V (+/- 30V) - 50/60 Hz
Necessary time to recharge:	4 hrs to 80% of recharge
<b>Electric System</b>	83 volt for the batteries - 12 volt for the machine
<b>Electric Motor</b>	83 volt - three phase - 2000 watt
* The charge cycles have to be considered based on the fact that there is not memory effect in the lithium batteries, i.e. 2000 charges at 100% or 4000 charges at 50%, etc..	

### Major Component Weights

Table 6-8. Major Component Weights

Model	X770AJ
Engine (Dry Weight)	Kubota D902 Diesel: 158 lb. (72 kg)
Boom Sections Combined	4,916 lb. (2,230 kg)
Lift Cylinders	
	Level Cylinder: 16.5 lb. (7.5 kg)
	Jib Cylinder: 26.5 lb. (12 kg)
	3rd boom level cylinder: 16.5 lb. (7.5 kg)
	Lift cylinder: 198.4 lb. (90 kg)
	Upper lift cylinder: 154.3 lb. (70 kg)
	Swing Actuator: 44 lb. (20 kg)
	Telescope cylinder: 209.4 lb. (95 kg)
Platform	1 - occupants: 77.2 lb. (35 kg) 2 - occupants: 110.2 lb (50 kg)
Chassis	Diesel: 4,718 lb. (2,140 kg)

### 6.3 SERVICE/MAINTENANCE

#### Cleaning the Machine

##### **WARNING**

WHEN WASHING THE MACHINE, THE MAIN POWER SWITCH MUST BE DISENGAGED, THE KEY REMOVED AND THE EMERGENCY STOP BUTTON PRESSED.

- Washing the outside of the machine;

Never use flammable liquids. Adopt the above safety measures to prevent sparks due to short-circuits.

If washing the track with a cleaning solution, carefully cover all the vital parts and above all the electrical components. Follow the instructions provided by the manufacturer of the cleaning solution.

Clean the machine using only water-soluble detergents.

The more often the machine is cleaned, the more it will need to be re-greased (*see lubrication chart*).

Do not wet the electric motors and the other electrical components directly.

Do not aim the spray directly onto decals and rating plates.

- Cleaning the electrical system;

##### **WARNING**

NEVER CLEAN THE INVERTER OR THE ELECTRIC MOTOR WITH WATER, AS THIS MAY CAUSE DAMAGE TO THE ELECTRICAL SYSTEM.

##### **NOTICE**

ONLY USE DRY DETERGENTS, IN ACCORDANCE WITH THE MANUFACTURERS' INSTRUCTIONS. NEVER REMOVE COVERS, GUARDS AND THE LIKE.

Clean the electrical system using a dry, non-metallic brush and low pressure air.

- After cleaning

Dry the machine carefully before starting it again (for example using compressed air).

##### **WARNING**

IF, DESPITE ALL THE PRECAUTIONS, MOISTURE HAS PENETRATED INTO THE ELECTRIC MOTOR OR OTHER PARTS OF THE ELECTRIC SYSTEM, THESE MUST BE DRIED USING COMPRESSED AIR TO AVOID THE RISK OF SHORT CIRCUITS.

## SECTION 6 - GENERAL SPECIFICATIONS AND OPERATOR MAINTENANCE

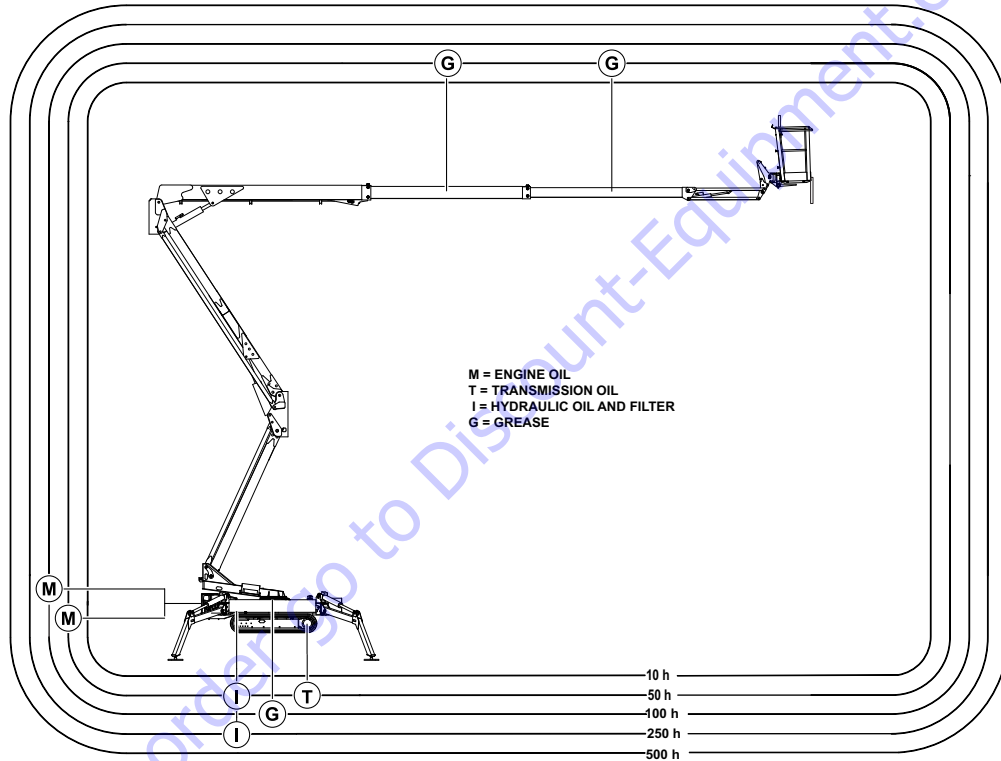

**Figure 6-1. Lubrication and Maintenance Point Locations**

## SECTION 6 - GENERAL SPECIFICATIONS AND OPERATOR MAINTENANCE

### Lubrication

(See Figure 6-1.)

#### Hydraulic Oil

**Table 6-9. Hydraulic Oil Specifications**

Hydraulic System Operating Temperature Range	Viscosity Grade
14deg F (-10 deg C) and 104deg F (+40deg C)	ISOVG 46
14deg F (-10 deg C) or above 104deg F (+40deg C)	ISO 68

**NOTE:** When adding or replacing hydraulic oil only use JLG approved hydraulic oil. Do not mix oils unless directed by JLG.

#### Recommended Gearbox Oils

600 XP 150

EP 150

Blasia 150

Spartan EP150

#### Engine Oil

SAE 10W30

#### Greasing and Lubrication

Recommended lubricants

Contact Grease EP (blue in color) is used to grease the turntable and cylinder pins on the chassis

GR MU EP1 Grease is used to grease the expansion guide of the chassis, the track tension valve, and basket support pins

White EP NLGI 2 Grease is used on the boom extensions

Either MU EP1 or Esso Beacon EP2 is used to grease the coupler and belt tensioner

#### Greasing Locations (See Figure 6-1.)

**NOTE:** Use a brush to spread grease onto telescopic boom wear pad areas.

## SECTION 6 - GENERAL SPECIFICATIONS AND OPERATOR MAINTENANCE

### Hydraulic Oil Specifications

Fluid  Description	Proprieties		Base				Classifications		
	Viscosity at 40°C (cst, Typical)	Viscosity Index	Mineral Oils	Vegetable Oils	Syntetic	Syntetic Polyol Esters	Readily Biodegradable*	Virtually Non-toxic**	Fire Resistant***
Pakelo Hydraulic EP Extra ISO 68	68	180	X						
Pakelo Hydraulic EP Extra ISO 46	46	160	X						
GeolubeECO Hydraulic ISO 46 (P/N 17527700)	47.3	144				X	X		
Pakelo Hydraulic EP Extra ISO 32	32	160	X						
Pakelo Hydraulic EP Extra ISO 22	22	180	X						
SHELL TELLUS S3V 68	68	180	X						
SHELL TELLUS S3V 46	46	160	X						
MobilEAL EnviroSynH46 (P/N2300029)	46	145				X	X		
SHELL TELLUS S3V 32	32	160	X						
SHELL TELLUS S3V 22	22	180	X						

**Figure 6-2. Hydraulic Oil Specifications**

\* Readily biodegradable classification indicates one of the following: CO2 Conversion > 60% per EPA 560/6-82-003 / CO2 Conversion > 80% per CEC-L-33-A-93.

\*\* Virtually Non-toxic classification indicates an LC50 > 5000 per OECD 203.

\*\*\* Fire Resistant classification indicates Factory Mutual Research Corp. (FMRC) Approval.

## SECTION 6 - GENERAL SPECIFICATIONS AND OPERATOR MAINTENANCE

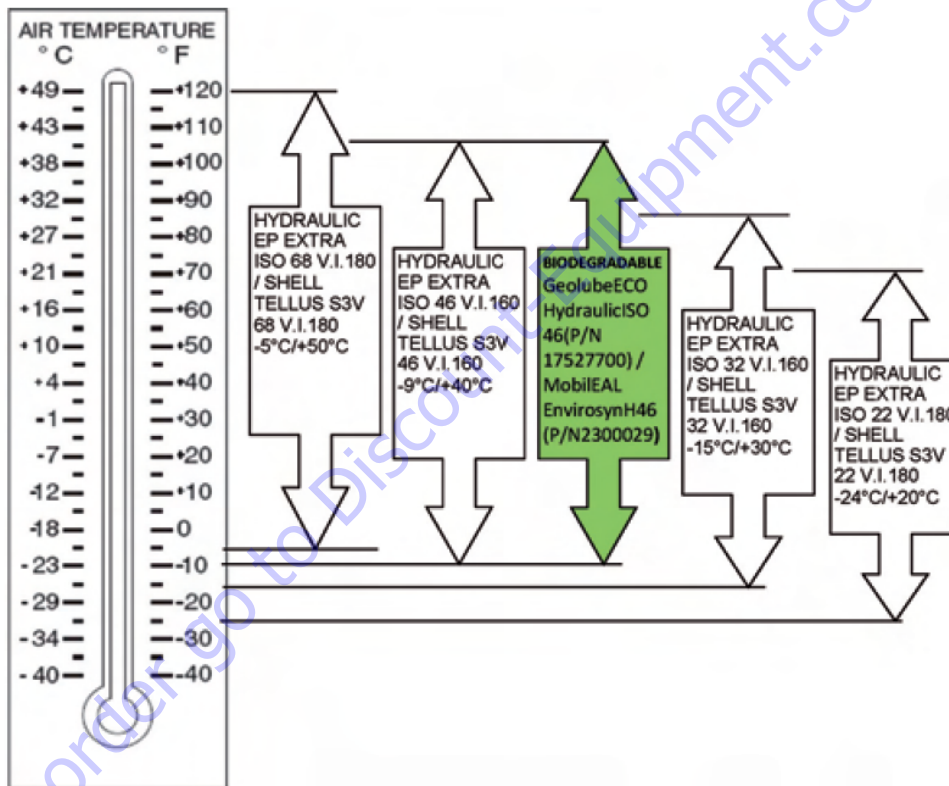

Figure 6-3. Hydraulic Oil Operating Temperatures



## SECTION 6 - GENERAL SPECIFICATIONS AND OPERATOR MAINTENANCE

**Table 6-10. Component Maintenance Intervals - X770AJ - with Diesel Engine**

Component	Operation	Pre-Start	As Needed	Hours						
				10	50	100	250	500	1000	2000
Dry Air Filter(Diesel Engine)	Check/Clean	•								
	Replace							•		
Engine Oil (Diesel Engine)	Check Level	•								
	Replace				•*	•				
Engine Oil Filter (Diesel Engine)	Check/Clean				•					
	Replace						•	•		
Fuel Filter (Diesel Engine)	Clean	•								
	Replace							•		
Cooling System (Diesel Engine)	Check Level	•								
	Liquid Add and Replacement							•		
Water Separator (Diesel Engine)	Clean and Drain Water	•			•*	•				
Hydraulic Oil	Check Level	•								
	Replace								•	
Hydraulic Oil Filter	Replace Cartridge				•*	•				
Articulated Joint Points	Grease				•*	•				
Battery	Check		•							
Reduction Gear Oil	Check Level					•				
	Replace					•*			•	
Machine	General Periodic Check								•	•*

## SECTION 6 - GENERAL SPECIFICATIONS AND OPERATOR MAINTENANCE

**Table 6-10. Component Maintenance Intervals - X770AJ - with Diesel Engine**

Component	Operation	Pre-Start	As Needed	Hours						
				10	50	100	250	500	1000	2000
Extension Arm Internal Sliding Ring (if equipped)	Check Wear						•			
	Replace								•	
Turntable Bolt Tightening	Check						•*	•		
Platform Mount Pin Nuts	Check torque 148 ft. lb. (200 Nm)								•	
Extension Ropes and pulleys (if equipped)	Check Wear								•**	•*
	Replace									•***



- \* 1st time interval then per chart thereafter
- \*\* At least every 3 months or 1000 hrs. of operation
- \*\*\* At lease every 5 years or 2000 hrs of operation. Check every year. If torque is not correct, replace the nuts with new nuts of same specification. Install dry without using grease or oil to specified torque.

## SECTION 6 - GENERAL SPECIFICATIONS AND OPERATOR MAINTENANCE

**Table 6-11. Component Maintenance Intervals - X770AJ - with Lithium-Ion Battery Pack**

Component	Operation	Pre-Start	As Needed	Hours						
				10	50	100	250	500	1000	2000
Hydraulic Oil	Check Level	•								
	Replace								•	
Hydraulic Oil Filter	Replace Cartridge				•*		•			
Articulated Joint Points	Grease				•*	•				
Battery (Auxiliary)	Check		•							
Reduction Gear Oil	Check Level					•				
	Replace					•*			•	
Machine	General Periodic Check								•	•*
Extension Arm Internal Sliding Ring (if equipped)	Check Wear						•			
	Replace								•	
Turntable Bolt Tightening	Check						•*	•		
Platform Mount Pin Nuts	Check torque 148 ft. lb. (200 Nm)								•	
Extension Ropes and pulleys (if equipped)	Check Wear								•**	•*
	Replace									•***



\* 1st time interval then per chart thereafter

\*\* At least every 3 months or 1000 hrs. of operation

\*\*\* At least every 5 years or 2000 hrs of operation. Check every year. If torque is not correct, replace the nuts with new nuts of same specification. Install dry without using grease or oil to specified torque.

## SECTION 6 - GENERAL SPECIFICATIONS AND OPERATOR MAINTENANCE

### Engine Air Filter

Kubota  
D902  
Diesel

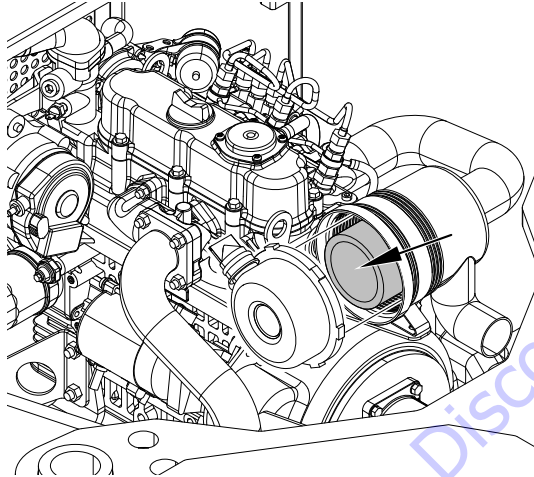

Lube Point(s) - Replaceable Paper Element, or Foam Filter Element

Interval - Check daily. Replace paper element after 500 hrs of operation, sooner if operating in a dusty environment.

The foam element can be washed out in warm soapy water, then rinse and let dry, Dip in clean engine oil and squeeze out the excess oil. If too much oil is left in the foam the engine will smoke when started.

### Engine Oil

Kubota  
D902  
Diesel

DIPSTICK

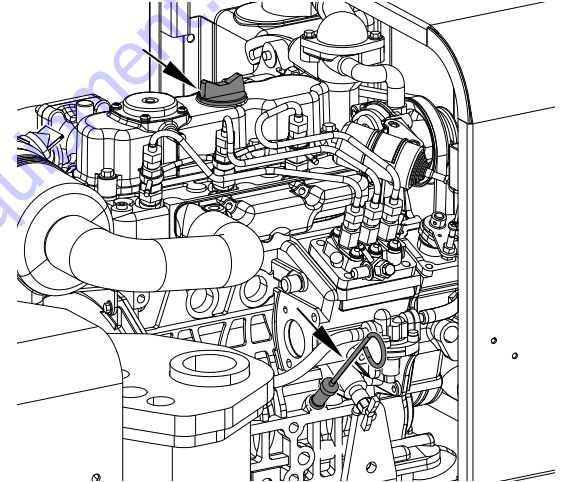

Lube Point(s) - Fill Cap on Valve Cover or Dip Stick Tube

Oil Capacity -Diesel 0.98 gal (3.71L) - API - CC grade or better

Interval - Check fill level on dipstick daily.

Change oil/filter per maintenance interval chart -  
(See Table 6-10 )

## SECTION 6 - GENERAL SPECIFICATIONS AND OPERATOR MAINTENANCE

### Engine Oil Filter (if equipped)

Kubota  
D902  
Diesel

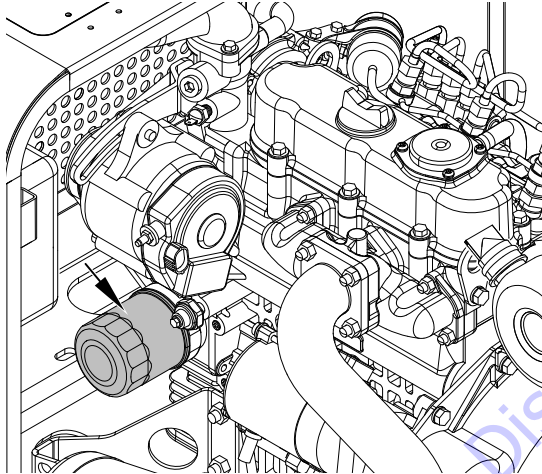

Lube Point(s) - Filter Cartridge/replaceable

Interval - Clean every 100 hours. Replace 500 hours.

### Engine Fuel Filter/Sediment Bowl (if equipped)

Kubota  
D902  
Diesel

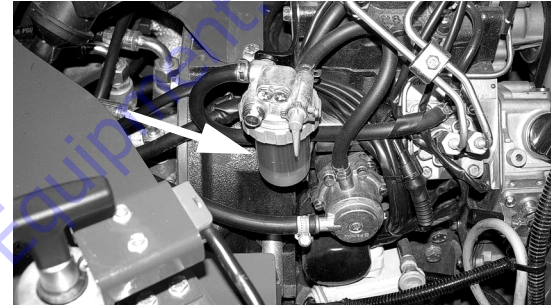

Interval - Clean every 100 hours

### Engine Cooling System and Fluid (if equipped)

Kubota  
D902  
Diesel

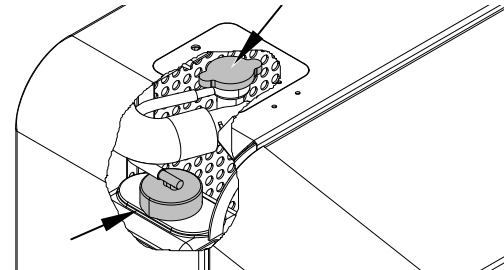

Interval - Check daily. Replace fluid every 500 hours

**NOTE:** Coolant utilized is to be compliant with SAE J 1034

## SECTION 6 - GENERAL SPECIFICATIONS AND OPERATOR MAINTENANCE

### Hydraulic Oil

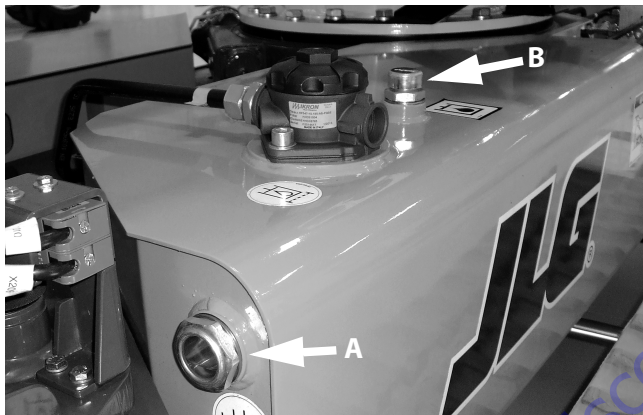

Lube Point(s) - Fill Cap

Capacity - 15.85 gallons (60 liters)

Interval - Check level daily. Change every two years or 1200 hours of operation

**NOTE:** Hydraulic oil levels are to be checked with the machine in transport position while on a firm, level and uniform surface. Oil level must be half-way in the level indicator (Indicator-A). To add hydraulic oil use (cap-B).

### Hydraulic Oil Filter Cartridge



Lube Point(s) - Filter Cap (Indicator A)

Interval - Replace after first 50 hours of use. Replace thereafter every 250 hours and every time the hydraulic oil is replaced.

## SECTION 6 - GENERAL SPECIFICATIONS AND OPERATOR MAINTENANCE

### Rubber Track Maintenance/Replacement

#### Check track tension

Stop the machine on a firm, level, and uniform surface. Raise the machine off the surface using the outriggers. Measure distance A from the bottom of the roller to the inside of the rubber belt. The rubber track tension is to be between 0.4 inches (10mm) and 0.6 inches (15mm).

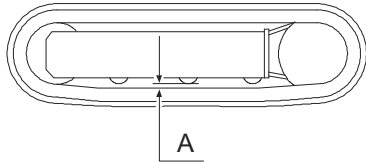

**NOTE:** If the track is out of tolerance immediately discontinue use of the machine

#### **⚠ WARNING**

**THE GREASE CONTAINED WITHIN THE HYDRAULIC TRACK IS PRESSURIZED. NEVER LOOSEN GREASING VALVE 1 MORE THAN ONE (1) TURN. NEVER LOOSEN GREASE VALVE 2.**

1. Ensure all debris has been removed between the wheel teeth and track links.
2. Remove the screws from the adjustment access lid 3.

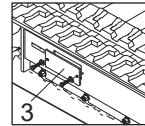
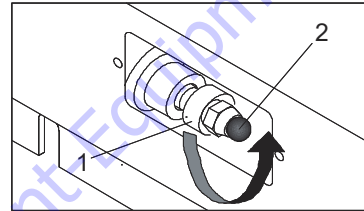

3. Loosening of the track.
4. Slowly unscrew valve 1 in the counterclockwise direction. Do not exceed one (1) screw rotation.
5. If the grease does not begin to drain, slowly rotate the track.
6. Once correct track tension has been achieved, turn grease valve 1 clockwise to tighten valve.
7. Clean area of all trace grease.

## SECTION 6 - GENERAL SPECIFICATIONS AND OPERATOR MAINTENANCE

### Tightening of the track

- Connect a grease gun to grease valve 2 and add grease until belt tension is within the specified values.

**NOTE:** If the track does not return to the specified values by following the above procedure immediately discontinue use and contact service personnel.

### Checking the rubber tracks

- If broken steel ropes are noted discontinue use until damaged components are replaced

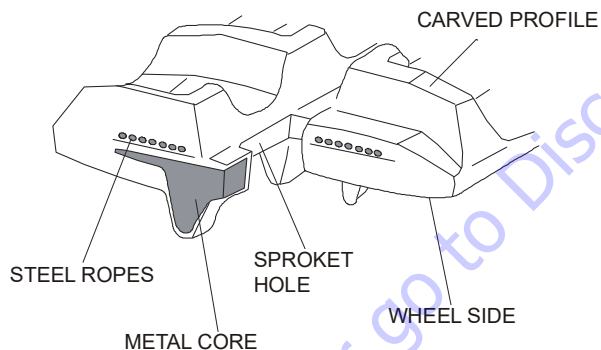

- If broken metal cores are noted discontinue use until damaged components are replaced

- If metal cores are separating discontinue use of the machine until the damaged components are replaced.

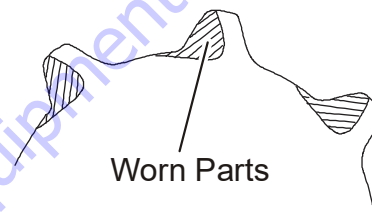

- If abrasive or fatigue cracks are noted it is recommended the machine be removed from service until the components are replaced.



### Track Torque

It is extremely important to apply and maintain proper track mounting torque.

### **⚠ WARNING**

**TRACK NUTS MUST BE INSTALLED AND MAINTAINED AT THE PROPER TORQUE TO PREVENT LOOSENING OF THE TRACK, BROKEN STUDS, AND POSSIBLE DANGEROUS SEPARATION OF THE TRACK FROM THE TEETH.**



## SECTION 6 - GENERAL SPECIFICATIONS AND OPERATOR MAINTENANCE

### Replacing Rubber Tracks

1. Elevate the machine on firm, level and uniform surface utilizing the outriggers.
2. Remove the screws and remove cover 3 as shown in figure.

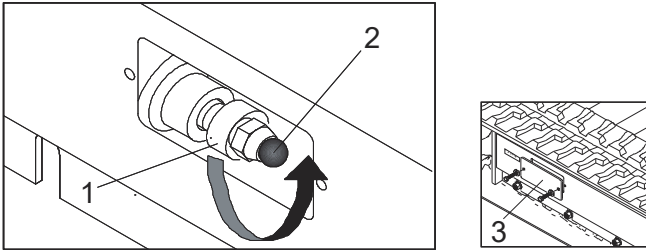

3. To loosen the track, slowly unscrew valve 1 in a counter-clockwise direction. Do NOT exceed one (1) rotation.
4. Allow grease to drain. If grease does not drain, slowly rotate the track.
5. Insert three steel pipes 4 between the rollers of the track. Turn the driving wheel backwards 5 to engage the track tensioning wheel. Apply an outward force 6 to lift the track from the track tensioning wheel.

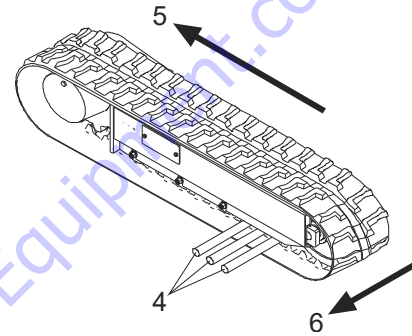

### Installation of Rubber Track

1. Ensure all hydraulic cylinder grease have been removed
2. Align the track links with the wheel teeth. Position the other end of the track on the track tensioning wheel
3. Slowly rotate the drive wheel in reverse while, using one steel pipe, pushing the track plate inside the frame.
4. Verify the track links have engaged the wheel teeth in the track tensioning wheel
5. Adjust track tension (see Loosening/Tightening track section).

## SECTION 6 - GENERAL SPECIFICATIONS AND OPERATOR MAINTENANCE

### Wire Cable Inspection

A qualified technician shall conduct the following:

1. Remove all covers from the third boom section and two boom extensions and inspect the wire ropes and pulleys for any damage.
2. Wire cables when pulled on manually shall not move more than an eighth (1/8) inch.
3. Wire rope torque is 10Nm

### Inspection

**NOTE:** The pictures in this section are just samples to show the replacement criteria of the rope.

1. Inspect ropes for broken wires, particularly valley wire breaks and breaks at end terminations.

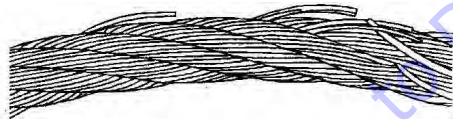

**NOTE:** Flexing a wire rope can often expose broken wires hidden in valleys between strands.

2. Inspect ropes for corrosion.
3. Inspect ropes for kinks or abuse.

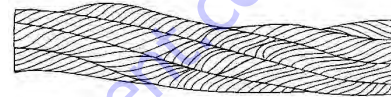

**NOTE:** A kink is caused by pulling down a loop in a slack line during improper handling, installation, or operation.

4. Inspect sheaves for condition of bearings/pins.
5. Inspect sheaves for condition of flanges.
6. Inspect sheaves with a groove wearout gauge for excessive wear.

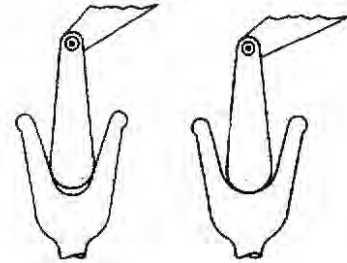

**NOTE:** Observe the groove so that it may be clearly seen whether the contour of the gauge matches the contour of the bottom of the groove.

7. Ropes passing inspection should be lubricated with wire rope lubricant before reassembly.

## SECTION 6 - GENERAL SPECIFICATIONS AND OPERATOR MAINTENANCE

### Wire Cable Adjustment

To check for correct wire cable tension position machine on a firm, level, and uniform surface.

1. Remove the cover on the third boom section
2. Loosen the register counter-nuts allowing for access to the wire cable adjustment nuts
3. Position both boom extensions until approximately 12-15 inches of the inner booms are showing
4. Tighten nuts on the retract cables to a torque of 10Nm (7.4ftlbs)

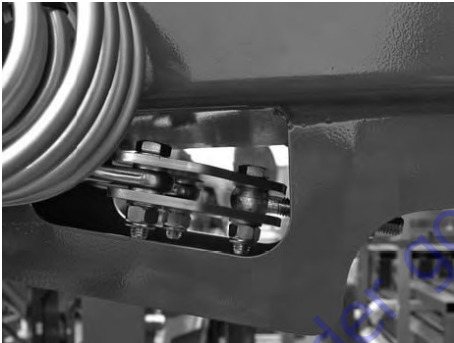

5. Fully extend both boom extensions. Retract the boom extension sections between 12-15 inches.

6. Torque the bolts on the extend cables until the threads extend 2-1/2  $\pm 0.11$  inches (65mm  $\pm 3$ mm) from the boom section. Do not twist cable while tightening.

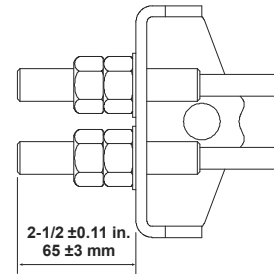
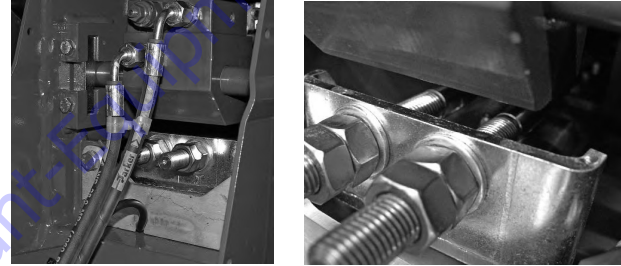

7. Cycle the boom extensions five (5) times and verify the wire cables are at a torque of 10Nm (7.4ft-lbs)
8. Verify during the cycle testing that no rubbing occurs from the wire rope cables

## SECTION 6 - GENERAL SPECIFICATIONS AND OPERATOR MAINTENANCE

---

9. Upon verification tighten the counter-nuts and reattach any removed covers

### Wear Pad Inspection

Check for distance between wear pads and boom sections. Distance is to be no more than 1/32nd inch.

### Turntable Attach Bolts

Ensure the bolts of the coupling elements (turntable) are torqued to 183 ft-lb. (248 Nm)

### Battery Maintenance and Charging - Diesel/AC-Electric

**NOTE:** *The battery is a maintenance free battery. Do NOT attempt to open a maintenance-free sealed battery.*

#### External Battery Charger Use

#### **WARNING**

**WHEN AN EXTERNAL BATTERY CHARGER IS TO BE USED, CHARGING HARNESS MUST BE PLUGGED INTO A GROUNDED RECEPTACLE. IF RECEPTACLE IS NOT GROUNDED AND A MALFUNCTION SHOULD OCCUR, THE MACHINE COULD CAUSE SERIOUS ELECTRICAL SHOCK.**

1. Open battery cover.
2. Disconnect the terminal clamps from the battery poles.
3. Connect the cables of the charger to the battery poles. and turn on the battery charger

**NOTE:** *Re-charge voltage should never exceed 14.7 volts and the load intensity shall be 0.2% of the value indicated below and on the lid of the battery.*

4. When charging is completed turn off the battery charger before disconnecting the cables from the battery poles
5. Return the terminal clamps to the battery poles and lubricate with the appropriate product
6. Close battery cover.

#### **NOTICE**

**IT IS GOOD PRACTICE TO AVOID PRESSURE-WASHING ELECTRICAL/ELECTRONIC COMPONENTS. IN THE EVENT PRESSURE-WASHING THE MACHINE IS NEEDED, ENSURE THE MACHINE IS SHUT DOWN BEFORE PRESSURE-WASHING. SHOULD PRESSURE WASHING BE UTILIZED TO WASH AREAS CONTAINING ELECTRICAL/ELECTRONIC COMPONENTS, JLG INDUSTRIES, INC. RECOMMENDS A MAXIMUM PRESSURE OF 750 PSI (52 BAR) AT A MINIMUM DISTANCE OF 12 INCHES (30.5 CM) AWAY FROM THESE COMPONENTS. IF ELECTRICAL/ELECTRONIC COMPONENTS ARE SPRAYED, SPRAYING MUST NOT BE DIRECT AND BE FOR BRIEF TIME PERIODS TO AVOID HEAVY SATURATION.**

### 6.4 ELECTRIC MOTOR MAINTENANCE

Periodically check the condition of the following electric motor components.

#### Electric Motor

The electric motor is located inside of the rear hydraulic valve distributor support cover.

- POWER SUPPLY TERMINALS

Check tightness of the nuts on the power supply terminals and make sure the insulation is intact.

- FAN

Keep air intakes clean and make sure the fan can rotate freely.

- BEARINGS

Check the condition of the bearings, in the event of noise contact JLG for replacement, the life of the bearings is reduced significantly in heavy duty operating conditions.

**NOTE:** *This motor is "brushless" therefore no brushes need to be checked or replaced.*

### 6.5 PLATFORM/REMOTE CONTROL SERVICE MENU

#### Service Button

*(See Figure 3-3. on page 3-10)*

A SERVICE button (*item 6*) is present on the remote control which allows to view the status of the machine parameters and is an aid in the safety checks of the machine.

By pressing the SERVICE button a numerical menu is displayed on the LCD display (*item 15*), each of these menu items can be accessed by pressing the corresponding platform/remote control buttons (*numbered 1 thru 9*) below the buttons.

1 - INPUT

2 - LANGUAGE

3 - ERRORS

4 - RAMPS

5 - CURRENT

6 - W. HOURS

7 - SETUP

8 - JOYSTICK

9 - EXIT

MENUS 4; 5; CANNOT BE ACCESSED

## SECTION 6 - GENERAL SPECIFICATIONS AND OPERATOR MAINTENANCE

### Menu Input

The signals that arrive at the board from the various sensors mounted on the machine and from the platform/remote control commands are displayed. The status of the input and the following selection to scroll the menu appears for each screen:

- 1 - PREV - access the previous input
- 2 - NEXT - access the successive input
- 9 - ESC - escape from the INPUT menu

LIGHTLIFT SELF-PROPELLED AERIAL PLATFORM - X700AJ	
ST1 GND A	Both ON indicate the stabilizer 1 rests on the ground.
ST1 GND B	
ST2 GND A	Both ON indicate the stabilizer 2 rests on the ground.
ST2 GND B	
ST3 GND A	Both ON indicate the stabilizer 3 rests on the ground.
ST3 GND B	
ST4 GND A	Both ON indicate the stabilizer 4 rests on the ground.
ST4 GND B	
ST1 OPEN A	Both ON indicate the stabilizer 1 is completely open, TOTAL AREA.
ST1 OPEN B	
ST2 OPEN A	Both ON indicate the stabilizer 2 is completely open, TOTAL AREA
ST2 OPEN B	

ST3 OPEN A	Both ON indicate the stabilizer 3 is completely open, TOTAL AREA
ST3 OPEN B	
ST4 OPEN A	Both ON indicate the stabilizer 4 is completely open, TOTAL AREA
ST4 OPEN B	
BYPASAE A	Both ON indicate aerial part safety devices have been disconnected by the specially provided key.
BYPASAE B	
BYPASCB A	Both ON indicate undercarriage part safety devices have been disconnected by the specially provided key.
BYPASCB B	
EM. GRND A	Both ON indicate that emergency stop button isn't pressed (from ground).
EM. GRND B	
FOTO A	Both ON indicate that the photocells are aligned.
FOTO B	
EM R.C. GND	Both ON indicate that the remote control button isn't pressed (from ground).
ST12 CLOSED	ON status indicates the stabilizers 1-2 are completely up and pressurized.
ST34 CLOSED	ON status indicates the stabilizers 3-4 are completely up and pressurized.
TEMP ALRM A	Both ON indicate the external temperature probe is activated (only Russian version).
TEMP ALRM B	
GENERATOR	ON or OFF depending on whether, the engine is ON or OFF.
EMERG. COMM	ON position indicates the emergency buttons are activated.

## SECTION 6 - GENERAL SPECIFICATIONS AND OPERATOR MAINTENANCE

MICROROPE	ON position indicates both cables are working.
START M. TE	ON position indicates the engine start button (from ground) is pressed.
MOTOR TEMP.	OFF position with the engine running indicates the alarm is activated.
MOTOR PRESS.	ON position with the engine running indicates the alarm is activated.
START M. EL	ON position indicates the remote control from ground is activated by the provided key.
MICROJIB A	Both ON indicates the JIB arm is completely closed.
MICROJIB B	
PEDALE	ON position indicates the pedal within the basket is pressed. (only pedal version)
EM BASK. A	Both ON indicates the emergency STOP (of the remote control) within the basket isn't pressed
EM BASK. B	
POSM 1 A	Both ON indicates the stabilizer 1 is in stabilization position.
POSM 1 B	
POSM 2 A	Both ON indicates the stabilizer 2 is in stabilization position.
POSM 2 B	
POSM 3 A	Both ON indicates the stabilizer 3 is in stabilization position.
POSM 3 B	

POSM 4 A	Both ON indicates the stabilizer 4 is in stabilization position.
POSM 4 B	
R.C. PLATFORM	ON position indicates the remote control is in its mount. (in the platform).
INCLIN. X	Indicates the inclination of X axis in tenths of a degree.
INCLIN. Y	Indicates the inclination of Y axis in tenths of a degree.
LOAD	Indicates the weight in the platform in pounds.
POS. 1E2	Indicates 1° and 2° arm cylinder stroke in tenths of a millimeter.
POS. 3	Indicates 3° arm cylinder stroke in tenths of a millimeter.
ROTATION A	Indicates the angular position of the aerial part in degrees (180° - aligned photocells).
MOTOR RPM	Indicates the engine speed.
CURRENT A	Indicates the power to proportional valve.
CURRENT B	Indicates the power to proportional valve.
CURRENT C	Indicates the power to proportional valve.
TEMPERAT.	Indicates the temperature measured by the electrical probe.
SUPPLY (V)	Indicate the voltage (In volts).

## SECTION 6 - GENERAL SPECIFICATIONS AND OPERATOR MAINTENANCE

---

### Errors Menu

Indicates the agreement (OK) or not (FAULT) status of the sensors that have a double control.

The sensors are listed on different screens use:

- 1 - PREV - access the previous input
- 2 - NEXT - access the successive input
- 9 - ESC - escape from the INPUT menu

If the OK symbol appears at the side of the sensor it means that the two elements of the same sensor sent identical information.

If the FAULT symbol appears at the side of the sensor it means that the two elements of the same sensor sent inconsistent information.

The last page of the error menu describes the error code relating to the battery charger system, inverter or battery pack. (See "Lithium-Ion Machine Fault Codes" on page 6-27.)

Errors are indicated by the "spanner" icon in position 7 on the remote control display (See "Platform/Remote Control Station Functions" on page 3-9).



If there are operating problems with the machine and the "spanner" icon is shown on the display, do not operate machine until repaired by a JLG factory trained technician.

### Working Hours Menu

Indicates the number of machine working hours.

### Set-up Menu

The items in this menu cannot normally be accessed.

### Joystick Menu

Displays the signal that each individual Joystick sends to the main board.



### 6.6 LITHIUM-ION MACHINE - MAINTAINANCE

#### Battery Pack System Components and Maintenance

#### **⚠ CAUTION**

**WHEN RECHARGING THE BATTERY PACK AND DURING ANY OTHER MAINTENANCE OPERATION ON THE BATTERY PACK, IT IS NECESSARY TO USE AT LEAST THE PERSONAL PROTECTIVE EQUIPMENT (PPE) LISTED BELOW.**

- Eye protection devices  
Protective glasses, for protection against sprays of hazardous materials.

- Hand protection devices  
Hand protection gloves, for protection and insulation during work on live parts.
- Foot protection devices  
Shoes with antistatic coating able to insulate the worker during work on the electrical parts of the system.

## SECTION 6 - GENERAL SPECIFICATIONS AND OPERATOR MAINTENANCE

### Lithium-Ion Machine Fault Codes

(See "Errors Menu" on page 25 info for display information)

**Table 6-12. Inverter Fault Codes**

CODE	DESCRIPTION
1	Wrong Config Cause - EEPROM memory not configured. Solution - Contact Hinowa after sales service.
8	Watch Dog Cause - Inverter cannot start or stop electric motor. Solution - Check connections and continuity of electric motor. If OK, replace inverter.
13	Eeprom KO Cause - EEPROM hardware or software problem. Solution - Replace inverter.
16	Aux output KO Cause - Problem with electromechanical brake. Solution - This is generally a temporary problem due to certain working conditions. If problem persists, replace inverter.
17	Logic failure #3 Cause - Activated in the event of high inverter current peaks. Solution - This is generally a temporary problem due to certain working conditions. If problem persists, replace inverter.
18	Logic Failure #2 Cause - Internal fault in the inverter. Solution - Replace inverter.

**Table 6-12. Inverter Fault Codes**

CODE	DESCRIPTION
19	Logic failure #1 Cause - Sudden voltage surge or voltage drop. Solution - This is a temporary problem due to certain working conditions. If problem persists, replace inverter.
30	VMN low Cause - Inverter power supply voltage is lower than battery voltage, or alternatively incorrect connection to positive battery pole. Solution - Check connection to positive battery pole. If problem persists, replace inverter.
31	VMN High Cause - One motor phase not connected correctly or faulty. Solution - Check motor phases. If problem persists, replace inverter.
37	Contact closed Cause - Relay remains closed when power to coil is disconnected. Solution - Check relay.
38	Contact Open Cause - Inverter supplies power to relay coil but contact doesn't close. Solution - Check relay and power supply to coil.
49	I=0 Ever Cause - Feedback current from motor sensor not constantly at 0. Solution - Check connection to motor.

## SECTION 6 - GENERAL SPECIFICATIONS AND OPERATOR MAINTENANCE

**Table 6-12. Inverter Fault Codes**

CODE	DESCRIPTION
53	STBY1 high Cause – Internal fault detected in the inverter. Solution – This is generally a temporary problem due to certain working conditions. If problem persists, replace inverter.
60	Capacitor Charge Cause – Internal fault in the inverter. Solution – Check connections and motor phases.
61	High temperature Cause – High temperature inside the inverter. Solution – Improve cooling to inverter. If fault persists, contact JLG after-sales service.
65	Motor temperature Cause – High motor temperature. Solution – Temporarily stop machine to allow motor to cool down.
67	Can Bus KO Cause – Inverter doesn't receive any information from Can Bus line. Solution – Check connections using multifunction tester.
70	Encoder Error Cause – Problem detected with encoder (=motor speed sensor). Solution – Check speed sensor connection. Anomaly may also have been caused by fault with bearing.

**Table 6-12. Inverter Fault Codes**

CODE	DESCRIPTION
73	Thermis sensor KO Cause – Signal from temperature sensor greater than 4.95 Volts or less than 0.1 Volt. Solution – This is generally a temporary problem due to certain working conditions. If problem persists, replace inverter.
74	Driver shorted Cause – Relay power supply fault. Solution – Check relay power supply. This is generally a temporary problem due to certain working conditions. If problem persists, replace inverter.
75	Driver shorted Cause – Relay power supply fault. Solution – Check relay power supply. This is generally a temporary problem due to certain working conditions. If problem persists, replace inverter.
76	Coil shorted Cause – Problem detected with relay coil. Solution – Make sure relay coil is intact.
78	VACC not OK Cause – Solution – This is generally a temporary problem due to certain working conditions. If problem persists, replace inverter.

## SECTION 6 - GENERAL SPECIFICATIONS AND OPERATOR MAINTENANCE

---

**Table 6-12. Inverter Fault Codes**

<b>CODE</b>	<b>DESCRIPTION</b>
<b>79</b>	Incorrect start Cause – Incorrect starting procedure. Solution – Check electrical connections. This is generally a temporary problem due to certain working conditions. If problem persists, replace inverter.
<b>86</b>	Pedal wire KO Cause – Solution – This is generally a temporary problem due to certain working conditions. If problem persists, replace inverter.
<b>93</b>	Wrong set batt Cause – With power connected, battery test detected incorrect batteries fitted. Solution – Replace batteries with the original ones supplied directly by JLG.
<b>94</b>	Current sensor KO Cause – Set up procedure for maximum current in progress. Solution – Contact JLG after-sales service.
<b>99</b>	Check up needed Cause – Solution – Contact Hinowa after sales service.

## SECTION 6 - GENERAL SPECIFICATIONS AND OPERATOR MAINTENANCE

---

### BMS Fault Codes - (Battery Management System)

(See "Errors Menu" on page 25 info for display information)

**NOTE:** The CODE column indicates the CAN CODE in the message sent by the battery charger. The normal mains voltage tolerance is the rated value  $\pm 15\%$ .

#### CODE – TYPE OF ERROR

A99E01 – Configuration error

A99E02 – Incorrect voltage

A99E03 – Incorrect temperature

A99E04 – Excess discharge current

A99E05 – Excess charge current

A99E06 – Pre.charge error

A99E07 – No 12 V power supply

A99E08 – No 12 V power supply

A99E09 – High battery compartment temperature

A99E10 – High electronic board temperature

A99E11 – Incorrect self.protection device temperature

A99E12 – Fault on all temperature sensors

A99E13 – Temperature sensor fault

A99E14 – Earth connection fault

A99E01 – Incorrect system configuration

A99E02 – Incorrect voltage

A99E03 – Incorrect temperature

A99E04 – Excess discharge current

A99E05 – Excess charge current

A99E06 – Pre.charge error

A99E07 – No 12 V power supply

A99E08 – No 12 V power supply

A99E09 – High battery compartment temperature

A99E15 – Boot loader error

A99E16 – Secondary protection

A99E17 – Control device error

A99E18 – Power board error

A99E19 – I2C module not ready

A99E20 – I2C TX error

A99E21 – I2C RX error

A99E22 – I2C RX error 2

A99E23 – AD error

A99E99 – General error

## SECTION 6 - GENERAL SPECIFICATIONS AND OPERATOR MAINTENANCE

### Battery Charger Fault Codes

(See "Errors Menu" on page 25 info for display information)

**Table 6-13. Battery Charger Fault Codes**

CODE	DESCRIPTION	STATUS	ACTION
8	Internal logic fault.	Battery charger stops working.	Contact service dept. or change product.
13	Communication problem with external memory.	Battery charger stops working.	Contact service dept. or change product.
18	Extended shutdown or power failure.	Battery charger stops supplying power. Operation resumes as soon as alarm conditions are no longer present or after restarting.	If problem is a power failure, check battery charger mains power supply.
19	Internal logic fault.	Battery charger stops working.	Contact service dept. or change product.
240	Digital input is open and managed as hardware start-stop.	Battery charger stops charging until digital input closes.	Close digital input.
241	Problem in CANBUS communication with other systems in the network.	The way this is managed may change based on different firmware releases.	Check correct operation of CANBUS system.
242	Error when reading internal memory on micro controller.	Battery charger stops working.	Contact service dept. or change product.
244	Mains voltage lower than maximum operating range tolerance.	Battery charger won't start charging until mains voltage returns within normal operating range.	Make sure mains voltage is within correct operating parameters.
245	Abnormal current draw in primary section.	Battery charger stops supplying power. Operation resumes as soon as alarm conditions are no longer present.	If problem persists, contact service dept. or change product.

## SECTION 6 - GENERAL SPECIFICATIONS AND OPERATOR MAINTENANCE

**Table 6-13. Battery Charger Fault Codes**

CODE	DESCRIPTION	STATUS	ACTION
246	Stage 1 ended by timeout without reaching control voltage.	Battery charger stops working.	Make sure battery capacity is compatible or check that battery is compliant with battery charger. If battery is correct and problem persists, contact service dept.
248	Temperature inside battery charger too high.	If internal temperature exceeds 80°C, battery charger reduces power to 80%, while it stops operating altogether if internal temperature exceeds 90°C. Battery charger starts at full power again when internal temperature falls below 70°C.	
249	Battery temperature too high.	If temperature exceeds 55°C or is less than -20°C, battery charger stops working. When battery temperature falls below 45°C or exceeds -10°C battery charger resumes normal operation.	
251	Power failure detected.	Battery charger stops supplying power. Operation resumes as soon as alarm conditions are no longer present.	If problem persists, check battery charger mains power supply.
252	Short-circuit in battery charger output.	Battery charger stops working.	Turn off battery charger and resolve short circuit at output. If problem persists, contact service dept. or change product.
253	Mains voltage higher than maximum operating range tolerance.	Battery charger won't start charging until mains voltage returns within normal operating range.	Make sure mains voltage is within correct operating parameters.

### 6.7 LITHIUM-ION BATTERY PACK - HANDLING IN DANGEROUS CONDITIONS

Battery cells must be handled correctly in order to ensure proper and safe use. However, if mistakes are made in handling the cells, causing explosion or venting, the user has to be equipped so as to be able to face this emergency.

The purpose of this section is to train the user on safe handling of cells that have been subjected to extreme conditions.

#### ***These Conditions Are As Follows:***

1. Hot cells
2. Cells that have released substances or vented
3. Exploded cells
4. Fire enveloping the lithium batteries

#### **Procedure For Handling Hot Cells**

As soon as it has been established the temperature of a cell has risen considerably, the first action is evacuation of personnel from the affected area. The area has to be isolated and nobody can enter if not strictly necessary.

If possible, before leaving the area, the person who first identified the problem has to check if there is an external short-circuit and resolve it as soon as possible. After the short-circuit has been resolved, the cell will start to cool down. However, the area has to remain isolated until the cell reaches ambient temperature and is removed from the area. The temperature of the cell has to be checked periodically using a remote sensor such as an infrared sensor. If the cell remains hot the following actions must be assessed.

#### ***Minimum Equipment Required:***

- Infrared temperature probe
- Safety glasses
- Hard hat with impact resistant face visor
- Non-conductive pliers
- Hand, arm and body protection



## SECTION 6 - GENERAL SPECIFICATIONS AND OPERATOR MAINTENANCE

---

### Start Procedure;

1. Evacuate the area as soon as abnormal cell temperature has been established.
2. Periodically check temperature of the cell using a remote sensor for the first two hours or until one of the following cases occur:
  - The cell starts to cool down
  - The cell vents
  - The cell explodes
3. If the cell starts cooling, check the temperature every hour until ambient temperature has been reached.
4. If a temperature sensor is not available, do not handle the cell for a minimum of 24 hours.
5. Remove cell from the work area when ambient temperature has been reached and return to normal operations.
6. Dispose of the cell in accordance with existing legislation (in the country in question) on hazardous materials.

*Procedures in cases of venting or explosion are examined in the following paragraphs.*

### Procedure For Handling Vented Cells

In normal conditions a cell does not show leaks or venting, however a cell may vent or release substances if the critical temperature is reached or if the protective glass metal seal breaks due to severe mechanical conditions.

The severity of the leak consequent to venting ranges from slight leak around the seal to a violent leak of substances through the vent. In some cases, if the cell is not plugged, it may behave as a projectile.

Electrolyte inside the cell may cause very serious irritation to the respiratory tract, eyes and skin. In addition, venting may cause emission of highly corrosive vapors in the work environment. In this case, all protective equipment suited to limit exposure to toxic fumes must be available.

### **Minimum Equipment Required;**

- Class D fire extinguisher
- Eye protection or face shield
- Respirator with filter for hydrochloric acid and sulphur dioxide
- Neoprene gloves
- Acid resistant lab coats
- Baking soda, calcium oxide or acid absorbent in kit form
- Vermiculite
- Plastic bags

## **SECTION 6 - GENERAL SPECIFICATIONS AND OPERATOR MAINTENANCE**

---

### **Start Procedure;**

In the event of electrolyte release from the cells, proceed as follows:

1. Evacuate the people exposed to fumes from the area.
2. Air the environment until the complete removal of the cell and until the characteristic pungent odor has disappeared.
3. If the cell is too hot, allow it to cool to ambient temperature before handling it (see "Procedure For Handling Hot Cells" on page 33).
4. Wear safety equipment: coat, gloves, mask and filters, and move the cell to a well-ventilated area.
5. Place every cell in a sealable plastic bag and remove the excess air, then seal the bag.
6. Place a cup of vermiculite in a second bag, place first bag in the second and seal it.
7. Place everything in a third bag with some baking soda and seal the bag.
8. Absorb and collect the leaked electrolyte with absorbent material or baking soda.
9. Place the absorbent material in a bag and seal it.
10. Clean area with plenty of water.
11. Dispose of hazardous material in accordance with the local legislation in force.

### **First Aid In The Event Of Contact With The Electrolyte**

#### **EYES**

Immediately wash the eyes in abundant running water for at least 15 minutes, keeping the eyelids open and flushing the eye and back of the eyelid. Immediately seek medical help.

#### **SKIN**

Wash in cold water under a shower, remove contaminated garments. Continue washing for at least 15 minutes. Seek medical help where necessary.

#### **RESPIRATORY TRACT**

Move person(s) outdoors into the open air. If person(s) has difficulty breathing, have oxygen administered by trained personnel. If breathing stops, apply mouth-to-mouth resuscitation and immediately seek emergency medical help.

## SECTION 6 - GENERAL SPECIFICATIONS AND OPERATOR MAINTENANCE

---

### Procedure For Exploded Cells

Explosion of lithium batteries is not likely, it is a rare event that only occurs when an abnormal condition causes the temperature to rise and reach a critical point. However, in the event of lithium battery explosion the environment will quickly be filled with dense white smoke which will cause serious irritation to the respiratory tract, eyes and skin. Precautions must be taken to limit exposure to these fumes.

#### **Minimum Equipment Required;**

- Class D fire extinguisher
- Class ABC extinguisher for any secondary fires
- Eye protection or face shield
- Respirator with filter for hydrochloric acid and sulphur dioxide
- Neoprene gloves
- Acid.resistant lab coats
- Baking soda, calcium oxide or acid absorbent in kit form
- Vermiculite
- Plastic bags

#### **Start Procedure;**

In the event of cell explosion, proceed as follows:

1. Evacuate personnel from the areas contaminated by smoke.
2. Ventilate the rooms until the cell has been removed from the area and until the characteristic pungent odor has disappeared.
3. Even if this is quite unlikely, there may be fires as a consequence of the explosion. The ways these emergencies are faced are described in the following paragraph.
4. The exploded cell may be hot. Allow it to cool down to ambient temperature before handling it (see Procedure for handling hot cells).
5. Wear safety equipment: coat, gloves, mask and filters.
6. In case of explosion the area around the cell will be covered by a black carbonaceous material which contains metallic parts of the cell. Cover the carbonaceous residues with a 50/50 mixture of baking soda and vermiculite or other absorbent material. Avoid contact between the metallic residues and charged cells, as this condition may cause a short.circuit.
7. Place contaminated material in a sealable plastic bag and remove excess air.
8. Seal the bag.

## SECTION 6 - GENERAL SPECIFICATIONS AND OPERATOR MAINTENANCE

---

9. Place a cup of vermiculite in a second bag, place the first bag in the second and seal it.
10. Clean area with plenty of water and keep cleaning with water and soap.
11. Dispose of hazardous material in accordance with the local legislation in force.

*First Aid In The Event Of Contact With The Electrolyte;*

### **EYES**

Immediately wash eyes in abundant running water for at least 15 minutes, keeping the eyelids open and flushing the eye and back of the eyelid. Immediately seek medical help.

### **SKIN**

Wash in cold water under a shower, remove contaminated garments. Continue washing for at least 15 minutes. Seek medical help where necessary.

### **RESPIRATORY TRACT**

Move casualty outdoors into the open air. If person(s) has difficulty breathing, have oxygen administered by trained personnel. If breathing stops, apply mouth-to-mouth resuscitation and immediately seek emergency medical help.

### **Lithium Battery Fire**

All metals may burn in certain conditions, which depend on certain factors such as: physical state, presence of oxidizing atmospheres and severity of the source of ignition. Alkali metals such as lithium may burn in normal atmospheres. In addition, lithium reacts explosively with water to form hydrogen and the presence of small quantities of water may set fire to the material and the hydrogen gas that is released. Once metal fires start they are very hard to extinguish with ordinary equipment. This is partly due to the strong heat produced by the burning metal, whose temperature may reach 1832° F (1000° C). In addition, lithium may react with certain materials commonly used in fire extinguishers, like water and CO<sub>2</sub>. Special extinguishers are required, designed for controlling and extinguishing lithium fires.

In particular, graphite-based extinguishers (Lith-x) are used. Usually these extinguishers work by forming a crust or a layer of material on the surface of the burning metal. Lith-x, which is a common graphite-based agent, may be used with an extinguisher or spread over the fire. In the event of lithium fire, the room may fill with a dense white smoke, mostly formed by lithium oxide and other metal oxides. This condition may cause serious damage to the respiratory tract, skin and eyes. All precautions needed to limit exposure to these fumes must be adopted. It should be noted that this procedure is applicable only to fires on individual cells. Larger fires have to be managed only by professionally trained personnel.

## SECTION 6 - GENERAL SPECIFICATIONS AND OPERATOR MAINTENANCE

---

Finally, it should be noted that in the presence of combustible materials other than lithium it is advisable to use different types of extinguishers in conjunction to better ensure the extinguishing action of each on the appropriate material, however do not use water or CO2 extinguishers directly on lithium fires.

### **Minimum Equipment Required;**

- Class D fire extinguisher
- Class ABC extinguisher for any secondary fires
- Breathing apparatus
- Fireproof clothing
- Fireproof gloves
- Mask or protective glasses
- Non-conductive pliers
- Dustpan, mineral oil

### **Start Procedure;**

1. In the event of fire on one cell, a team of experienced fire-fighting personnel has to be contacted. The personnel must be properly trained to fight lithium battery fires.
2. Evacuate personnel from all areas and sound the fire alarm.
3. The fire-fighting personnel go to the area where the fire is located and gather all the information regarding the situation and the person who gave the alarm.

4. Quarantine the area. Air the rooms until the burning material has been removed from the area and the characteristic pungent odor has disappeared.
5. Two members of the team enter the area with appropriate safety equipment.

**NOTE:** *Lithium melts at 356° F (180° C). It becomes highly reactive and when it catches fire it may eject molten lithium particles. For this reason the surrounding cells may overheat and cause a violent explosion. The fire-fighting personnel must pay attention to any dangerous materials located near the fire.*

6. Completely cover fire with extinguishing material. Never leave fire unattended as it may develop again.
7. If necessary, extinguish secondary fires with suitable extinguishers.
8. After all material has burned and cooled down, carefully mix residual material to prevent resumption of the fire.
9. Put the material in a metal drum, cover the surface with plenty of extinguishing material.
10. Residual material may contain un-reacted lithium, therefore limit exposure to rain by covering, for example, with mineral oil.
11. Wear safety equipment: coat, gloves, mask and filters.

## SECTION 6 - GENERAL SPECIFICATIONS AND OPERATOR MAINTENANCE

---

12. The area around the cell will be covered by a black carbonaceous deposit which contains metallic parts of the cell. Cover the carbonaceous residue with a 50/50 mixture of baking soda and vermiculite or other absorbent material. Avoid contact between the metallic residue and charged cells as this condition may cause a short.circuit.
13. Place the contaminated material in a sealable plastic bag and remove the excess air.
14. Seal the bag.
15. Place a cup of vermiculite in a second bag, place the first bag in the second and seal it.
16. Clean the area with plenty of water and keep cleaning with water and soap.
17. Dispose of hazardous material in accordance with the local legislation in force.

*First Aid In The Event Of Contact With The Electrolyte;*

### **EYES**

Immediately wash the eyes in abundant running water for at least 15 minutes, keeping the eyelids open and flushing the eye and back of the eyelid. Immediately seek medical help.

### **SKIN**

Wash in cold water under a shower, remove contaminated garments. Continue washing for at least 15 minutes. Seek medical help where necessary.

### **RESPIRATORY TRACT**

Move person(s) outdoors into the open air. If person(s) has difficulty breathing, have oxygen administered by trained personnel. If breathing stops apply mouth-to-mouth resuscitation and immediately seek emergency medical help.

**TO PURCHASE THIS PRODUCT PLEASE CONTACT US**



**Equipment Financing and  
Extended Warranties Available**



**Discount-Equipment.com is your online resource for  
commercial and industrial quality parts and equipment sales.**

**561-964-4949**

**visit us on line @ [www.discount-equipment.com](http://www.discount-equipment.com)**

Select an option below to find your Equipment

**Search by Manufacturer**

**Search by Product Type**

**Request a Quote**

We sell worldwide for the brands: Genie, Terex, JLG, MultiQuip, Mikasa, Essick, Whiteman, Mayco, Toro Stone, Diamond Products, Generac Magnum, Airman, Haulotte, Barreto, Power Blanket, Nifty Lift, Atlas Copco, Chicago Pneumatic, Allmand, Miller Curber, Skyjack, Lull, Skytrak, Tsurumi, Husquvarna Target, Stow, Wacker, Sakai, Mi-T-M, Sullair, Basic, Dynapac, MBW, Weber, Bartell, Bennar Newman, Haulotte, Ditch Runner, Menegotti, Morrison, Contec, Buddy, Crown, Edco, Wyco, Bomag, Laymor, EZ Trench, Bil-Jax, F.S. Curtis, Gehl Pavers, Heli, Honda, ICS/PowerGrit, IHI, Partner, Imer, Clipper, MMD, Koshin, Rice, CH&E, General Equipment, Amida, Coleman, NAC, Gradall, Square Shooter, Kent, Stanley, Tamco, Toku, Hatz, Kohler, Robin, Wisconsin, Northrock, Oztec, Toker TK, Rol-Air, APT, Wylie, Ingersoll Rand / Doosan, Innovatech, Con X, Ammann, Mecalac, Makinex, Smith Surface Prep, Small Line, Wanco, Yanmar

**JLG**<sup>®</sup>

An Oshkosh Corporation Company

**Discount  
Equipment**

[www.Discount-Equipment.com](http://www.Discount-Equipment.com)

To order go to [www.Discount-Equipment.com](http://www.Discount-Equipment.com)