



www.Discount-Equipment.com

---

# Service and Maintenance Manual

***Models***

***TOUCAN 12E***

***TOUCAN 12E Plus***

***TOUCAN 32E***

**31210298**

*May 24, 2017*

CE



# PARTS FINDER

**Search Website  
by Part Number**



**Search Manual  
Library For Parts  
Manual & Lookup Part  
Numbers – Purchase  
or Request Quote**

**Search Manuals**

Enter your information to search for manuals and parts.

\* Brand:

\* Model:

\* Serial:

\* Part Number:

SEARCH

**Can't Find Part or  
Manual? Request Help  
by Manufacturer,  
Model & Description**

**Parts Order Form**

Please fill in the following information:

Manufacturer:

Model:

Description:

Quantity:

Part Number:

Part Name:

Part Description:

Part Location:

Part Condition:

Part Status:

Part Price:

Part Weight:

Part Dimensions:

Part Material:

Part Color:

Part Finish:

Part Notes:

Part Attachments:

Part Images:

Part Videos:

Part Documents:

Part Links:

Part Other:

Part Comments:

Part Status:

Part Price:

Part Weight:

Part Dimensions:

Part Material:

Part Color:

Part Finish:

Part Notes:

Part Attachments:

Part Images:

Part Videos:

Part Documents:

Part Links:

Part Other:

Part Comments:

Part Status:

Part Price:

Part Weight:

Part Dimensions:

Part Material:

Part Color:

Part Finish:

Part Notes:

Part Attachments:

Part Images:

Part Videos:

Part Documents:

Part Links:

Part Other:

Part Comments:

Discount-Equipment.com is your online resource for quality parts & equipment.

Florida: **561-964-4949** Outside Florida TOLL FREE: **877-690-3101**

**Need parts?**

Click on this link: <http://www.discount-equipment.com/category/5443-parts/> and choose one of the options to help get the right parts and equipment you are looking for. Please have the machine model and serial number available in order to help us get you the correct parts. If you don't find the part on the website or on once of the online manuals, please fill out the request form and one of our experienced staff members will get back to you with a quote for the right part that your machine needs.

We sell worldwide for the brands: Genie, Terex, JLG, MultiQuip, Mikasa, Essick, Whiteman, Mayco, Toro Stone, Diamond Products, Generac Magnum, Airman, Haulotte, Barreto, Power Blanket, Nifty Lift, Atlas Copco, Chicago Pneumatic, Allmand, Miller Curber, Skyjack, Lull, Skytrak, Tsurumi, Husquvarna Target, , Stow, Wacker, Sakai, Mi-T- M, Sullair, Basic, Dynapac, MBW, Weber, Bartell, Bennar Newman, Haulotte, Ditch Runner, Menegotti, Morrison, Contec, Buddy, Crown, Edco, Wyco, Bomag, Laymor, Barreto, EZ Trench, Bil-Jax, F.S. Curtis, Gehl Pavers, Heli, Honda, ICS/PowerGrit, IHI, Partner, Imer, Clipper, MMD, Koshin, Rice, CH&E, General Equipment, ,AMida, Coleman, NAC, Gradall, Square Shooter, Kent, Stanley, Tamco, Toku, Hatz, Kohler, Robin, Wisconsin, Northrock, Oztec, Toker TK, Rol-Air, Small Line, Wanco, Yanmar

## **SECTION A. INTRODUCTION - MAINTENANCE SAFETY PRECAUTIONS**

---

### **A GENERAL**

This section contains the general safety precautions which must be observed during maintenance of the aerial platform. It is of utmost importance that maintenance personnel pay strict attention to these warnings and precautions to avoid possible injury to themselves or others, or damage to the equipment. A maintenance program must be followed to ensure that the machine is safe to operate.

#### **⚠ WARNING**

**MODIFICATION OF THE MACHINE WITHOUT CERTIFICATION BY A RESPONSIBLE AUTHORITY THAT THE MACHINE IS AT LEAST AS SAFE AS ORIGINALLY MANUFACTURED, IS A SAFETY VIOLATION.**

The specific precautions to be observed during maintenance are inserted at the appropriate point in the manual. These precautions are, for the most part, those that apply when servicing hydraulic and larger machine component parts.

Your safety, and that of others, is the first consideration when engaging in the maintenance of equipment. Always be conscious of weight. Never attempt to move heavy parts without the aid of a mechanical device. Do not allow heavy objects to rest in an unstable position. When raising a portion of the equipment, ensure that adequate support is provided.

#### **⚠ WARNING**

**SINCE THE MACHINE MANUFACTURER HAS NO DIRECT CONTROL OVER THE FIELD INSPECTION AND MAINTENANCE, SAFETY IN THIS AREA IS THE RESPONSIBILITY OF THE OWNER/OPERATOR.**

---

### **B HYDRAULIC SYSTEM SAFETY**

It should be noted that the machines hydraulic systems operate at extremely high, potentially dangerous pressures. Every effort should be made to relieve any system pressure prior to disconnecting or removing any portion of the system.

---

### **C MAINTENANCE**

#### **⚠ WARNING**

**FAILURE TO COMPLY WITH SAFETY PRECAUTIONS LISTED IN THIS SECTION MAY RESULT IN MACHINE DAMAGE, PERSONNEL INJURY OR DEATH AND IS A SAFETY VIOLATION.**

- REMOVE ALL RINGS, WATCHES AND JEWELRY WHEN PERFORMING ANY MAINTENANCE.
- DO NOT WEAR LONG HAIR UNRESTRAINED, OR LOOSE-FITTING CLOTHING AND NECKTIES WHICH ARE APT TO BECOME CAUGHT ON OR ENTANGLED IN EQUIPMENT.
- OBSERVE AND OBEY ALL DANGER, WARNING, CAUTION AND OTHER INSTRUCTIONS ON MACHINE AND IN SERVICE MANUAL.
- KEEP OIL, GREASE, WATER, ETC. WIPED FROM STANDING SURFACES AND HAND HOLDS.
- NEVER WORK UNDER AN ELEVATED STRUCTURE UNTIL STRUCTURE HAS BEEN SAFELY RESTRAINED FROM ANY MOVEMENT BY BLOCKING OR OVERHEAD SLING.
- BEFORE MAKING ADJUSTMENTS, LUBRICATING OR PERFORMING ANY OTHER MAINTENANCE, SHUT OFF ALL POWER CONTROLS.
- BATTERY SHOULD ALWAYS BE DISCONNECTED DURING REPLACEMENT OF ELECTRICAL COMPONENTS.
- KEEP ALL SUPPORT EQUIPMENT AND ATTACHMENTS STOWED IN THEIR PROPER PLACE.
- USE ONLY APPROVED, NONFLAMMABLE CLEANING SOLVENTS.
- ENSURE REPLACEMENT PARTS OR COMPONENTS ARE IDENTICAL OR EQUIVALENT TO ORIGINAL PARTS OR COMPONENTS.

## **REVISION LOG**

Original Issue - May 24, 2017

Go to [Discount-Equipment.com](http://Discount-Equipment.com) to order your parts

TABLE OF CONTENTS

**SECTION A - INTRODUCTION - MAINTENANCE SAFETY PRECAUTIONS**

A	GENERAL .....	A-1
B	HYDRAULIC SYSTEM SAFETY .....	A-1
C	MAINTENANCE .....	A-1

**SECTION 1 - OPERATING SPECIFICATIONS**

1.1	OPERATING SPECIFICATIONS .....	1-1
1.2	DIMENSIONAL DATA .....	1-1
1.3	PERFORMANCE DATA .....	1-2
1.4	CAPACITIES .....	1-2
1.5	COMPONENTS DATA .....	1-3
	Batteries .....	1-3
	Electric Pump / Electric Motor Assembly .....	1-3
	Drive Motor Assembly .....	1-3
	Swing Drive .....	1-4
	Platform Rotation Drive .....	1-4
	Cylinders .....	1-4
	Tires .....	1-4
1.6	MAJOR COMPONENTS WEIGHTS .....	1-5
1.7	LUBRICATION .....	1-6
	Hydraulic Oil .....	1-6
	Lubrication Chart .....	1-7
	Lube Specifications .....	1-8
1.8	TORQUE REQUIREMENTS .....	1-8
1.9	SERIAL NUMBER LOCATIONS .....	1-9

**SECTION 2 - GENERAL SERVICE INFORMATION**

2.1	MACHINE PREPARATION, INSPECTION AND MAINTENANCE .....	2-1
	General .....	2-1
	Preparation, Inspection and Maintenance .....	2-1
	Pre-Start Inspection .....	2-1
	Pre-Delivery Inspection and Frequent Inspection .....	2-1
	Annual Machine Inspection .....	2-1
	Preventative Maintenance .....	2-1
2.2	PREVENTIVE MAINTENANCE AND INSPECTION SCHEDULE .....	2-2
2.3	SERVICING AND MAINTENANCE GUIDELINES .....	2-6
	General .....	2-6
	Safety and Workmanship .....	2-6
	Cleanliness .....	2-6
	Components Removal and Installation .....	2-6
	Component Disassembly and Reassembly .....	2-6
	Pressure-Fit Parts .....	2-6
	Bearings .....	2-6
	Care and Installation of Teflon Coated Bushings .....	2-6
	Bolt Usage and Torque Application .....	2-7
	Hydraulic Lines and Electrical Wiring .....	2-7
	Hydraulic System .....	2-7
	Welding on Work Platform .....	2-8
	Lubrication .....	2-8
	Battery .....	2-8
2.4	LUBRICATION INFORMATION .....	2-8
	Hydraulic System .....	2-8
	Lubrication Specifications .....	2-8
	Hydraulic Oil .....	2-8
	Changing Hydraulic Oil .....	2-8
2.5	PRESSURE RELIEF VALVE .....	2-9
2.6	HYDRAULIC CARTRIDGE INSTALLATION .....	2-9

# TABLE OF CONTENTS

## SECTION 3 - THEORY OF OPERATION

3.1	OVERVIEW	3-1
3.2	MODES OF OPERATION	3-1
	Ground Mode	3-1
	Platform Mode	3-1
3.3	CAN COMMUNICATIONS	3-1
3.4	JOYSTICKS	3-2
3.5	TRACTION	3-2
3.6	PUMP/STRUCTURE MOVEMENTS	3-3
	Lift Up/Down	3-3
	Swing	3-4
	Steer	3-5
	Telescope	3-5
	Platform Level	3-6
	Interlocks	3-6
	Personality Settings and Calibration	3-7

## SECTION 4 - CHASSIS MOUNTED COMPONENTS

4.1	DRIVE MOTORS	4-1
	Brake - Electrical Characteristics	4-1
	Brake - Dust Cleaning	4-1
	Brake Disassembly	4-1
	Brake Disk Wear Checking	4-1
	Brake Assembly	4-2
	Drive Motor Assembly Removal	4-2
	Drive Motor Assembly Installation	4-3
	Oil Type & Capacity	4-3
	Oil Filling	4-3
4.2	WHEELS AND TIRES	4-4
	Tire Wear and Damage	4-4
	Wheel and Tire Replacement	4-4
	Wheel Installation	4-4
4.3	STEERING LINKAGE	4-5
	Steer Cylinder	4-5
	Steering Linkage - Spindle/Hub Assembly	4-5

## SECTION 5 - TURNTABLE AND VERTICAL MAST

5.1	SWING BEARING	5-1
	Swing Bearing Attach Bolts Check	5-1
	Swing Bearing Lubrication	5-1
	Replacement of Swing Bearing	5-2
5.2	SWING DRIVE	5-4
	Swing Drive Removal	5-4
	Swing Drive Disassembly	5-5
	Swing Drive Assembly	5-5
	Swing Drive Installation	5-5
5.3	ROLLERS	5-5
	Inspection	5-5
	Removal and Installation	5-5
5.4	MAST AND ROLLERS SETTING	5-6
	Introduction	5-6
	Procedure	5-7
5.5	LIFTING CHAINS	5-10
	Safety Accessories and Tooling	5-10
	Lubrication	5-10
	Lifting Chains Inspection	5-11
	Lifting Chains Removal and Installation	5-12
	Chain Tension Adjustment	5-19
5.6	PULLEY - PULLEY SUPPORT	5-19
	Pulley Inspection	5-19
	Removal and Installation	5-20

5.7	MAST CYLINDER .....	5-21
	Mast Cylinder Removal .....	5-21
	Mast Cylinder Disassembly .....	5-23
	Mast Cylinder Installation .....	5-23
5.8	COUNTERWEIGHT .....	5-24
	Counterweight Removal .....	5-24
	Counterweight Installation .....	5-24
 <b>SECTION 6 - TELESCOPIC BOOM AND PLATFORM</b>		
6.1	OVERLOAD SYSTEM .....	6-1
	Overload System Verification (If Equipped) .....	6-1
	Overload System Setting .....	6-1
6.2	PLATFORM .....	6-2
	Platform Removal .....	6-2
	Platform Installation .....	6-2
6.3	PLATFORM SUPPORTS AND SLAVE CYLINDER .....	6-3
	Platform Supports and Slave Cylinder Removal .....	6-3
	Slave Cylinder Disassembly .....	6-5
	Platform Supports and Slave Cylinder Installation .....	6-5
6.4	TELESCOPIC BOOM, BOOM AND MASTER CYLINDERS .....	6-5
	Boom and Cylinders Removal .....	6-5
	Boom and Master Cylinders Disassembly .....	6-6
	Boom Disassembly .....	6-6
	Boom and Cylinders Installation .....	6-6
6.5	TELESCOPE .....	6-6
	Telescope Sections and Cylinder Removal .....	6-6
	Telescope Dual Cylinder Disassembly .....	6-7
	Telescope Sections and Cylinder Installation .....	6-7
	Telescope Sections and Cylinder Removal .....	6-7
	Telescope Cylinder Disassembly .....	6-8
	Telescope Sections and Cylinder Installation .....	6-8
 <b>SECTION 7 - HYDRAULICS</b>		
7.1	HYDRAULIC LINES CONNECTIONS .....	7-1
7.2	HYDRAULIC POWER UNIT .....	7-2
	Ports Identification .....	7-3
	Proportional Pressure Relief Valve .....	7-3
	Hand Pump .....	7-3
	Proportional Flow Control Valve .....	7-3
	Solenoid Valve 4-3 .....	7-4
	Check Valve 0.5 bar .....	7-4
	Electric Motor .....	7-4
7.3	HYDRAULIC TANK .....	7-6
	Oil Level .....	7-6
	Adding Oil to the System .....	7-6
	Tank Draining/Cleaning .....	7-6
	Tank Filling .....	7-6
7.4	SECONDARY MANIFOLD .....	7-7
	Manifold Schematic .....	7-7
	Disassembly .....	7-7
	Inspection .....	7-7
	Assembly .....	7-7
7.5	CYLINDERS HOLDING VALVES .....	7-8
	Mast Cylinder Holding Valve .....	7-8
	Jib Cylinder Holding Valve .....	7-8
	Telescope Cylinder Holding Valve .....	7-10
	Slave Cylinder Holding Valve .....	7-10
7.6	SWING MOTOR .....	7-12
7.7	CYLINDER REPAIR .....	7-13
	Disassembly .....	7-17
	Inspection .....	7-17

# TABLE OF CONTENTS

Assembly	7-17
<b>SECTION 8 - 2CONTROL COMPONENTS</b>	
8.1	CONTROL COMPONENTS OVERVIEW . . . . . 8-1
8.2	CONTROL COMPONENTS - SERVICE . . . . . 8-2
	Battery Maintenance and Safety Practices . . . . . 8-2
	Main Power Contactor Relay . . . . . 8-5
	Power Fuse . . . . . 8-5
	Mast Elevation Limit Switch . . . . . 8-6
	Jib Elevation Limit Switches . . . . . 8-6
	Chain Slack Sensor . . . . . 8-7
	Overload Sensor . . . . . 8-8
	Overload System Setting . . . . . 8-8
	Drive Orientation Switch . . . . . 8-9
	Steering Sensor . . . . . 8-10
	Tilt Sensor . . . . . 8-10
8.3	TRACTION SYSTEM . . . . . 8-12
	Common Traction System Difficulties . . . . . 8-12
8.4	POWER MODULE . . . . . 8-13
	Removal . . . . . 8-13
	Installation . . . . . 8-14
	Power Module Electrical Evaluation . . . . . 8-15
8.5	GROUND CONTROL STATION . . . . . 8-17
	Ground Module . . . . . 8-17
	Membrane Panel . . . . . 8-20
	Printed Circuit Board (PCB) Replacement . . . . . 8-20
8.6	PLATFORM CONTROL STATION . . . . . 8-21
	Printed Circuit Board (PCB) Replacement . . . . . 8-21
	Upper Control Box - Component Replacement . . . . . 8-21
	Upper Control Box - Components Evaluation . . . . . 8-22
<b>SECTION 9 - JLG CONTROL SYSTEM</b>	
9.1	HAND HELD ANALYZER . . . . . 9-1
	Analyzer Menu Structure . . . . . 9-1
	Hand Analyzer . . . . . 9-2
	Using the Analyzer . . . . . 9-2
	Changing the Access Level of the Hand Held Analyzer . . . . . 9-3
	Adjusting Parameters Using the Hand Held Analyzer . . . . . 9-4
	Machine Setup . . . . . 9-5
9.2	ANALYZER SCREEN LAYOUT . . . . . 9-6
9.3	MACHINE SETUP PROGRAMMING INFORMATION . . . . . 9-8
9.4	CALIBRATION INSTRUCTIONS . . . . . 9-10
9.5	CALIBRATING STEERING SENSOR . . . . . 9-10
9.6	CALIBRATING TILT SENSOR . . . . . 9-10
9.7	CALIBRATING THE JOYSTICKS . . . . . 9-10
9.8	CALIBRATING THE PRESSURE RELIEF VALVE . . . . . 9-11
9.9	MACHINE PERSONALITY - ADJUSTMENT SETTINGS . . . . . 9-12
9.10	SYSTEM TEST . . . . . 9-17
<b>SECTION 10 - DIAGNOSTIC TROUBLE CODES</b>	
10.1	INTRODUCTION . . . . . 10-1
10.2	DTC INDEX . . . . . 10-1
10.3	DTC CHECK TABLES . . . . . 10-2
	0-0 Help Comments . . . . . 10-2
<b>SECTION 11 - GENERAL ELECTRICAL INFORMATION &amp; SCHEMATICS</b>	
11.1	GENERAL . . . . . 11-1
11.2	MULTIMETER BASICS . . . . . 11-1
	Grounding . . . . . 11-1
	Backprobing . . . . . 11-1
	Min/Max . . . . . 11-1



	Polarity .....	11-1
	Scale .....	11-1
	Voltage Measurement .....	11-1
	Resistance Measurement .....	11-2
	Continuity Measurement .....	11-2
	Current Measurement .....	11-3
11.3	CHECKING SWITCHES .....	11-3
	Basic Check .....	11-3
	Limit Switches .....	11-3
	Automatic Switches .....	11-4
	Switch Wiring - Low Side, High Side .....	11-4
11.4	APPLYING SILICONE DIELECTRIC COMPOUND TO ELECTRICAL CONNECTIONS .....	11-4
11.5	AMP CONNECTOR .....	11-5
	Applying Silicone Dielectric Compound to AMP Connectors .....	11-5
	Assembly .....	11-5
	Disassembly .....	11-7
	Wedge Lock .....	11-7
	Service - Voltage Reading .....	11-7
11.6	DEUTSCH CONNECTORS .....	11-9
	DT/DTP Series Assembly .....	11-9
	DT/DTP Series Disassembly .....	11-9
	HD30/HDP20 Series Assembly .....	11-10
	HD30/HDP20 Series Disassembly .....	11-10
11.7	CONNECTORS IDENTIFICATION .....	11-11
11.8	ELECTRICAL SCHEMATIC .....	11-14
11.9	HYDRAULIC SCHEMATIC .....	11-20

Go to Discount-Equipment.com to order your parts

**LIST OF FIGURES**

<b>FIGURE NO.</b>	<b>TITLE</b>	<b>PAGE NO.</b>
1-1.	Lubrication Chart . . . . .	1-7
1-2.	Serial Number . . . . .	1-9
3-1.	Drive Motor Schematic . . . . .	3-2
3-2.	Hydraulic Pump Electric Schematic . . . . .	3-3
3-3.	Mast Lift/Lower System - Basic Schematic . . . . .	3-3
3-4.	Jib Lift/Lower System - Basic Schematic . . . . .	3-4
3-5.	Swing System - Basic Schematic . . . . .	3-4
3-6.	Steer System - Basic Schematic . . . . .	3-5
3-7.	Telescope System - Basic Schematic . . . . .	3-5
3-8.	Platform Level System - Basic Schematic . . . . .	3-6
4-1.	Dust Cleaning . . . . .	4-1
4-2.	Brake Disassembly . . . . .	4-1
4-3.	Brake Disk Wear Checking . . . . .	4-1
4-4.	Brake Assembly. . . . .	4-2
4-5.	Drive Motor Removal. . . . .	4-2
4-6.	Drive Motor Installation . . . . .	4-3
4-7.	Oil filling . . . . .	4-3
4-8.	Wheel Lug Nut Tightening Sequence . . . . .	4-4
4-9.	Steering Linkage Assembly . . . . .	4-5
4-10.	Steering Sensor Installation . . . . .	4-6
5-1.	Access Holes. . . . .	5-1
5-2.	Torque Sequence Diagram. . . . .	5-1
5-3.	Swing Bearing Race Lubrication . . . . .	5-1
5-4.	Swing Bearing Teeth Lubrication . . . . .	5-1
5-5.	Swing Bearing Removal - 1 of 6 . . . . .	5-2
5-6.	Swing Bearing Removal - 2 of 6 . . . . .	5-2
5-7.	Swing Bearing Removal - 3 of 6 . . . . .	5-2
5-8.	Swing Bearing Removal - 4 of 6 . . . . .	5-3
5-9.	Swing Bearing Removal - 5 of 6 . . . . .	5-3
5-10.	Swing Bearing Removal - 6 of 6 . . . . .	5-3
5-11.	Swing Bearing Installation. . . . .	5-4
5-12.	Swing Drive Removal . . . . .	5-4
5-13.	Swing Drive Disassembly - 1 of 3 . . . . .	5-5
5-14.	Swing Drive Disassembly - 2 of 3 . . . . .	5-5
5-15.	Swing Drive Disassembly - 3 of 3 . . . . .	5-5
5-16.	Roller Assembly . . . . .	5-5
5-17.	Roller Removal . . . . .	5-6
5-18.	Roller Installation . . . . .	5-6
5-19.	Loosening and Tightening Direction. . . . .	5-6
5-20.	Setting Angles . . . . .	5-6
5-21.	Setting Tool . . . . .	5-7
5-22.	Top Rollers Mast Configuration . . . . .	5-7
5-23.	Top Rollers Mast Centering (Top View-Mast Lowered)5-7	
5-24.	Adjusting Top Roller Play . . . . .	5-7
5-25.	Bottom Rollers Mast Configuration . . . . .	5-8
5-26.	Bottom Rollers Mast Centering (Bottom View - Mast Raised)5-8	
5-27.	Adjusting Bottom Roller Play . . . . .	5-9
5-28.	Mast Vertical Alignment. . . . .	5-9
5-29.	Top and Bottom Rollers . . . . .	5-10
5-30.	Long Hollow Body Socket. . . . .	5-10
5-31.	Cracked Plate . . . . .	5-11
5-32.	Turned Pin . . . . .	5-11
5-33.	Worn Plate . . . . .	5-11
5-34.	Chains Stages and Attachments Description . . . . .	5-12
5-35.	First Chain Stage. . . . .	5-13
5-36.	Second Chain Stage . . . . .	5-13

5-37.	Third Chain Stage . . . . .	5-14
5-38.	Fourth Chain Stage . . . . .	5-14
5-39.	First Chains Stage Removal . . . . .	5-15
5-40.	Second Chains Stage Removal . . . . .	5-16
5-41.	Third Chains Stage Removal . . . . .	5-17
5-42.	Fourth Chains Stage Removal . . . . .	5-18
5-43.	Chain Tension Adjustment . . . . .	5-19
5-44.	Chains Tension Control . . . . .	5-19
5-45.	Slantwise Pulley . . . . .	5-19
5-46.	Pulley Assembly Wear . . . . .	5-20
5-47.	Pulley Support Removal . . . . .	5-20
5-48.	Mast Cylinder Removal - 1 of 8 . . . . .	5-21
5-49.	Mast Cylinder Removal - 2 of 8 . . . . .	5-21
5-50.	Mast Cylinder Removal - 3 of 8 . . . . .	5-21
5-51.	Mast Cylinder Removal - 4 of 8 . . . . .	5-21
5-52.	Mast Cylinder Removal - 5 of 8 . . . . .	5-22
5-53.	Mast Cylinder Removal - 6 of 8 . . . . .	5-22
5-54.	Mast Cylinder Removal - 7 of 8 . . . . .	5-22
5-55.	Mast Cylinder Removal - 8 of 8 . . . . .	5-23
5-56.	Counterweight Removal - 1 of 2 . . . . .	5-24
5-57.	Counterweight Removal - 2 of 2 . . . . .	5-24
6-1.	Overload System Verification . . . . .	6-1
6-2.	Platform Removal-Installation . . . . .	6-2
6-3.	Platform Support and Slave Cylinder Removal - 1 of 4 . . . . .	6-3
6-4.	Platform Rotation Option (If Equipped) . . . . .	6-3
6-5.	Platform Support and Slave Cylinder Removal - 2 of 4 . . . . .	6-3
6-6.	Platform Support and Slave Cylinder Removal - 3 of 4 . . . . .	6-3
6-7.	Platform Support and Slave Cylinder Removal - 4 of 4 . . . . .	6-4
6-8.	Boom and Cylinder Removal - 1 of 2 . . . . .	6-5
6-9.	Boom and Cylinder Removal - 2 of 2 . . . . .	6-6
6-10.	Telescope and Cylinder Removal - 1 of 5 . . . . .	6-6
6-11.	Telescope and Cylinder Removal - 2 of 5 . . . . .	6-6
6-12.	Telescope and Cylinder Removal - 3 of 5 . . . . .	6-6
6-13.	Telescope and Cylinder Removal - 4 of 5 . . . . .	6-7
6-14.	Telescope and Cylinder Removal - 5 of 5 . . . . .	6-7
6-15.	Telescope and Cylinder Removal - 1 of 3 . . . . .	6-7
6-16.	Telescope and Cylinder Removal - 2 of 3 . . . . .	6-7
6-17.	Telescope and Cylinder Removal - 3 of 3 . . . . .	6-8
7-1.	Hydraulic Lines Connections . . . . .	7-1
7-2.	Hydraulic Power Unit . . . . .	7-2
7-3.	Ports Identification . . . . .	7-3
7-4.	Hand Pump . . . . .	7-3
7-5.	Terminal Tightening . . . . .	7-4
7-6.	Dust Cleaning . . . . .	7-4
7-7.	Moving Hydraulic Power Unit Motor . . . . .	7-5
7-8.	Motor Brushes . . . . .	7-5
7-9.	Hydraulic Oil Check . . . . .	7-6
7-10.	Tank Draining/Cleaning . . . . .	7-6
7-11.	Secondary Manifold . . . . .	7-7
7-12.	Secondary Manifold Schematic . . . . .	7-7
7-13.	Mast Cylinder Holding Valve - Removal/Installation . . . . .	7-8
7-14.	Mast Cylinder Holding Valve - Schematic/Exploded View . . . . .	7-8
7-15.	Jib Cylinder Holding Valve - Removal/Installation . . . . .	7-8
7-16.	Jib Cylinder Holding Valve - Schematic/Exploded View	7-9
7-17.	Telescope Cylinder Holding Valve - Removal/Installation . . . . .	7-10
7-18.	Slave Cylinder Holding Valve - Removal/Installation	7-10
7-19.	Adjustment Checking . . . . .	7-11
7-20.	Air Bleeding From Rod Side . . . . .	7-11
7-21.	Air Bleeding From Piston Side . . . . .	7-12
7-22.	Swing Motor . . . . .	7-12

## TABLE OF CONTENTS

7-23.	Steer Cylinder	7-13
7-24.	Master Cylinder	7-13
7-25.	Slave Cylinder	7-14
7-26.	Jib Cylinder	7-14
7-27.	Mast Cylinder	7-15
7-28.	Telescope Cylinder	7-15
7-29.	Telescope Plus Cylinder	7-16
8-1.	Control Components Location	8-1
8-2.	Battery filling	8-2
8-3.	Draining the water	8-3
8-4.	Measuring Electrolyte Specific Gravity	8-3
8-5.	Main Power Contactor Relay	8-5
8-6.	Power Fuse	8-5
8-7.	Mast Elevation Limit Switches	8-6
8-8.	Actuators Setting	8-6
8-9.	Jib Elevation Limit Switches	8-6
8-10.	Jib Actuators Setting	8-6
8-11.	Chain Slack Sensors	8-7
8-12.	Overload Sensor	8-8
8-13.	Overload Sensor Setting	8-8
8-14.	Overload System	8-9
8-15.	Drive Orientation Switch	8-10
8-16.	Steering Sensor	8-10
8-17.	Wheel Straightening	8-10
8-18.	Tilt Sensor	8-10
8-19.	Tilt Sensor Calibration Verification	8-11
8-20.	Main Electrical Power Connections	8-12
8-21.	Power Module Removal - Installation	8-13
8-22.	Power Module Terminals	8-14
8-23.	Cables on Power Module Post Terminal	8-14
8-24.	Ground Control Station Connectors - 1 of 3	8-17
8-25.	Ground Control Station Connectors - 2 of 3	8-18
8-26.	Ground Control Station Connectors - 3 of 3	8-19
8-27.	Ground Control Box Circuit Board - Installation	8-20
8-28.	Upper Control Box Circuit Board - Installation	8-21
8-29.	Joystick Controls - Installation	8-21
8-30.	Enable/Emergency Stop Switches - Installation	8-22
9-1.	Hand Held Analyzer	9-1
9-2.	Hand Held Analyzer Connection	9-2
9-3.	Analyzer Flow Chart - Sheet 1 of 2	9-6
9-4.	Analyzer Flow Chart - Sheet 2 of 2	9-7
9-5.	Wheel Straightening	9-10
9-6.	System Test Flow Chart	9-17
10-1.	DTCs Displays	10-1
11-1.	Voltage Measurement (DC)	11-1
11-2.	Resistance Measurement	11-2
11-3.	Continuity Measurement	11-2
11-4.	Current Measurement (DC)	11-3
11-5.	Connector Assembly Figure 1	11-5
11-6.	AMP Connector	11-5
11-7.	Connector Assembly Figure 2	11-6
11-8.	Connector Assembly Figure 3	11-6
11-9.	Connector Assembly Figure 4	11-6
11-10.	Connector Disassembly	11-7
11-11.	Connector Installation	11-8
11-12.	DT/DTP Contact Installation	11-9
11-13.	DT/DTP Contact Removal	11-9
11-14.	HD/HDP Contact Installation	11-10
11-15.	HD/HDP Locking Contacts Into Position	11-10
11-16.	HD/HDP Contact Removal	11-10
11-17.	HD/HDP Unlocking Contacts	11-10
11-18.	Wiring Harness and Connectors - Sheet 1 of 3	11-11

11-19. Wiring Harness and Connectors - Sheet 2 of 3 .....11-12  
11-20. Wiring harness and Connectors - Sheet 3 of 3. ....11-13  
11-21. Electrical schematic - Drive System .....11-14  
11-22. Electrical Schematic - Turntable .....11-15  
11-23. Electrical Schematic - Lower Control Board.....11-16  
11-24. Electrical Schematic - Mast.....11-17  
11-25. Electrical Schematic - Platform Box .....11-18  
11-26. Electrical Schematic - Batteries .....11-19  
11-27. Hydraulic schematic .....11-20

Go to [Discount-Equipment.com](http://Discount-Equipment.com) to order your parts

## TABLE OF CONTENTS

---

### LIST OF TABLES

TABLE NO.	TITLE	PAGE NO.
1-1	Operating Specifications . . . . .	1-1
1-2	Dimensions . . . . .	1-1
1-3	Performances . . . . .	1-2
1-4	Capacities . . . . .	1-2
1-5	Battery Specifications . . . . .	1-3
1-6	Hydraulic Unit Specifications . . . . .	1-3
1-7	Drive Motor Specifications . . . . .	1-3
1-8	Swing Drive Specifications . . . . .	1-4
1-9	Platform Rotation Drive Specifications . . . . .	1-4
1-10	Cylinders Specifications . . . . .	1-4
1-11	Tires Specifications . . . . .	1-4
1-12	Major Components Weights . . . . .	1-5
1-13	Hydraulic Oil Specifications (Standard) . . . . .	1-6
1-14	Lubrication Chart . . . . .	1-7
1-15	Lube Specifications . . . . .	1-8
1-16	Torque Chart . . . . .	1-8
2-1	Maintenance and Inspection Requirements . . . . .	2-2
2-2	Inspection and Preventive Maintenance Schedule . . . . .	2-3
4-1	Wheel Torque Chart . . . . .	4-4
5-1	Influence of roller setting on mast play . . . . .	5-6
5-2	Top Rollers Tightening . . . . .	5-7
5-3	Bottom Rollers Setting Height . . . . .	5-8
5-4	Maximum Mast Lowering Time . . . . .	5-9
5-5	Maximum Tightening Adjustment . . . . .	5-10
8-1	Battery Troubleshooting . . . . .	8-4
8-2	Mast Limit Switch Conditions . . . . .	8-6
8-3	Main Jib Switch Conditions . . . . .	8-6
8-4	End Of Stroke Jib Limit Switch Conditions . . . . .	8-6
8-5	Slack Chain Connection (x295) Condition . . . . .	8-8
8-6	Sensor Connections Conditions . . . . .	8-8
8-7	Sensor Connections Conditions . . . . .	8-10
8-8	Joysticks wiring . . . . .	8-22
9-1	Machine Setup Programming Information . . . . .	9-8
9-2	Acceptable Pressure Values - T12E/T32E . . . . .	9-11
9-3	Acceptable Pressure Values - T12E Plus . . . . .	9-11
9-4	Machine Personality Adjustment . . . . .	9-12

**SECTION 1. OPERATING SPECIFICATIONS**

**1.1 OPERATING SPECIFICATIONS**

**Table 1-1. Operating Specifications**

Description	Model Toucan 12E	Model Toucan 12E Plus	Model Toucan 32E
Maximum Work Load	200 kg		500 lbs
Maximum Persons	2		
Maximum Horizontal Side Force	400 N		100 lbs
Maximum Operating Wind Speed	12.5 m/s (45 km/h)		28 mph
Maximum Stowed Travel Grade (Gradeability)	25% (14°)		
Maximum Stowed Travel Grade (Side slope)	8.7% (5°)		
Tilt Alarm Triggering Angle Value	3°		
Maximum Tire Load (per wheel)	2 280 kg	2 680 kg	5 030 lbs
Approximate Gross Machine Weight - Global	4 300 kg	4 900 kg	9 480 lbs

**1.2 DIMENSIONAL DATA**

**Table 1-2. Dimensions**

Description	Models Toucan 12E - Toucan 12E Plus	Model Toucan 32E
Overall Stowed Machine Height	1.99 m	6.5'
Overall Machine Length	3.65 m	11.8'
Overall Machine Width	1.20 m	3.9'
Platform Size - Length (Platform base)	0.70 m	27.6"
Platform Size - Width - (Platform base)	1.05 m	41.3"
Wheel Base (Wheels straightened)	1.60 m	5.3'
Ground Clearance (chassis base plate)	10 cm	3.9"

## SECTION 1 - OPERATING SPECIFICATIONS

### 1.3 PERFORMANCE DATA

**Table 1-3. Performances**

Description	Model Toucan 12E	Model Toucan 12E Plus	Model Toucan 32E
Platform Height - Stowed (Platform floor to ground)	0.35 m		1.1 ft
Platform Height - Elevated (Platform floor to ground)	9.83 m	10.65 m	32.3 ft
Platform Height - Mast Elevated / Jib Horizontal (Platform floor to ground)	7.12 m		23.4 ft
Up and Over clearance - Jib Horizontal	6.95 m		22.8 ft
Maximum Horizontal Reach (from centreline)	4.60 m	5.55 m	14.9 ft
Maximum Horizontal Reach (from side edge of chassis)	4.00 m	4.95 m	13.0 ft
Maximum Horizontal Reach (from rear edge of chassis)	3.57 m	4.52 m	11.5 ft
Swinging Angle	345° (not continuous)		
Inside Turning Radius	0.75 m		2.5 ft
Outside Turning Radius	2.60 m		8.5 ft
Gradeability	25% (14°)		
<b>Elevating</b>			
Mast Lift Up Time - W/one person (approx. 80kg)	23 to 27 seconds		
Mast Lift Down Time - W/one person (approx. 80kg)	24 to 28 seconds		
Jib Lift Up Time - W/one person (approx. 80kg)	15 to 21 seconds		
Jib Lift Down Time - W/one person (Approx. 80kg)	21 to 27 seconds		
Telescope In Time - W/one person (Approx. 80kg)	14 to 19 seconds	19 to 24 seconds	14 to 19 seconds
Telescope Out Time - W/one person (Approx. 80kg)	14 to 20 seconds	18 to 24 seconds	14 to 20 seconds
<b>Swinging</b>			
Swinging Time - From rest to rest - Mast stowed	63 to 73 seconds		
Swinging Time - From rest to rest - Mast elevated	87 to 103 seconds		
<b>Driving</b>			
Maximum Drive Speed	Stowed Mast elevated	5.50 km/h 0.75 km/h	

### 1.4 CAPACITIES

**Table 1-4. Capacities**

Component	Models Toucan 12E - Toucan 32E	Model Toucan 12E Plus
Hydraulic Tank	21.8l (18.7 l usable) - 5.8 gal (4.9 gal usable)	
Hydraulic System (Including Tank)	Approx. 20l - (5.28 gal)	Approx. 21.5l - (5.3 gal)



**1.5 COMPONENTS DATA**

**Batteries**

**Table 1-5. Battery Specifications**

Description	Model Toucan 12E - Toucan 12E Plus - Toucan 32E	
Voltage (48VSystem - Series)	8 Packs of 6 Volts (semitraction)	
Amp Hour (Standard battery)	260 Amp Hour @ 20 HR. Rate 215 Amp Hour @ 5 HR. Rate	
Life Cycle Rating	800 Cycles	
Weight - Approx	265 kg	584 lbs

**Electric Pump / Electric Motor Assembly**

**Table 1-6. Hydraulic Unit Specifications**

Description	Model Toucan 12E - Toucan 12E Plus - Toucan 32E	
Motor	Voltage	48 VDC
	Power	3 kW
Pump (Gear pump)	Displacement	4.2 cc/rev (0.26 cu.in/rev)
	Flow rate	13 l/mn @ 11 MPa (3.4 gal/mn@1600 psi)
Max. Operating Pressure		18 MPa (2 600 psi)

**Drive Motor Assembly**

**Table 1-7. Drive Motor Specifications**

Description	Model Toucan 12E - Toucan 12E Plus - Toucan 32E	
Motor	Voltage	48 VDC
	Power	3.5 kW
Brake	Supply Voltage	24 VDC (Nominal)
Sensor Bearing	64 Impulses per rev.	

## SECTION 1 - OPERATING SPECIFICATIONS

### Swing Drive

**Table 1-8. Swing Drive Specifications**

Description	Model Toucan 12E - Toucan 12E Plus - Toucan 32E
Motor Type	Orbital
Displacement	20 cc
Gear Reducer	Wheel and Worm. Ratio 1/50

### Platform Rotation Drive

**Table 1-9. Platform Rotation Drive Specifications**

Description	Model Toucan 12E - Toucan 12E Plus - Toucan 32E	
Electrical Cylinder	Voltage	48 VDC
	Stroke	150 mm

### Cylinders

**Table 1-10. Cylinders Specifications**

Description	Bore DIA.	Stroke	Rod DIA.
Steer Cylinder (Double Action)	50 mm (1.97 in)	171 mm (6.73 in)	25 mm (0.98 in)
Telescope Cylinder Toucan 12E (Double Action)	50 mm (1.97 in)	1240 mm (48.82 in)	30 mm (1.18 in)
Telescope Cylinder Toucan 12E Plus (Double Action)	50 mm (1.97 in)	171 mm (6.73 in)	25 mm (0.98 in)
Master Cylinder (Double Action)	55 mm (2.16 in)	265.5 mm (10.45 in)	35 mm (1.38 in)
Slave Cylinder (Double Action)	55 mm (2.16 in)	265.5 mm (10.45 in)	35 mm (1.38 in)
Mast Cylinder (Single Action)	90 mm (3.54 in)	1005 mm (39.57 in)	80 mm (3.15 in)
Jib Cylinder (Single Action)	70 mm (2.76 in)	755 mm (29.72 in)	65 mm (2.56 in)

### Tires

**Table 1-11. Tires Specifications**

Description	Models Toucan 12E/12E Plus	Toucan 32E
Size	457 x 178 mm	18 x 7 in
Max. Allowable Tire Load	3 265 kg	7 200 lbs
Wheel Bolt Torque	250 N.m	185 ft lb
	210 N.m	155 ft lb

**1.6 MAJOR COMPONENTS WEIGHTS**

**Table 1-12. Major Components Weights**

Description		Models Toucan 12E/12E Plus	Toucan 32E
Platform	(*)	54 kg	119 lbs
Platform Support (Without Rotation)		20 kg	44 lbs
Platform Support (Option Rotation)		11 kg	24 lbs
Level Correction Support (Option Rotation)		15 kg	33 lbs
Boom		54 kg	119 lbs
Telescope Mid Section (Toucan 12E Plus)		28 kg	62 lbs
Telescope Inner Section (Toucan 12E Plus)		22 kg	49 lbs
Telescope (Toucan 12E / Toucan 32E)		32 kg	71 lbs
Boom Cylinder		46 kg	101 lbs
Master Cylinder		11 kg	24 lbs
Slave Cylinder		12 kg	26 lbs
Telescope Cylinder	Toucan 12E Plus	42 kg	93 lbs
	Toucan 12E/Toucan 32E	26 kg	57 lbs
Mast Assembly (5 Mast Sections)		630 kg	1 390 lbs
Mast Cylinder		76 kg	168 lbs
Mast Section #1		290 kg	640 lbs
Swing Bearing		32 kg	71 lbs
Swing Drive		17 kg	37 lbs
Electric Pump		18 kg	40 lbs
Chassis		680 kg	1 500 lbs
Wheel and Tire (each)	(*)	35 kg	77 lbs
Spindle Steering (each)	(*)	19 kg	42 lbs
Drive Motor (each)	(*)	90 kg	200 lbs
Battery Standard (each)	(*)	33 kg	73 lbs
Counterweight	Main (*)	1 395 kg	3 076 lbs
	Additional (*)	575 kg	1 268 lbs

(\*) Items critical for stability

**⚠ WARNING**

**DO NOT REPLACE ITEMS CRITICAL TO STABILITY, SUCH AS BATTERIES OR SOLID TIRES, WITH ITEMS OF DIFFERENT WEIGHT OR SPECIFICATION. DO NOT MODIFY UNIT IN ANY WAY TO AFFECT STABILITY.**

**1.7 LUBRICATION**

**Hydraulic Oil**

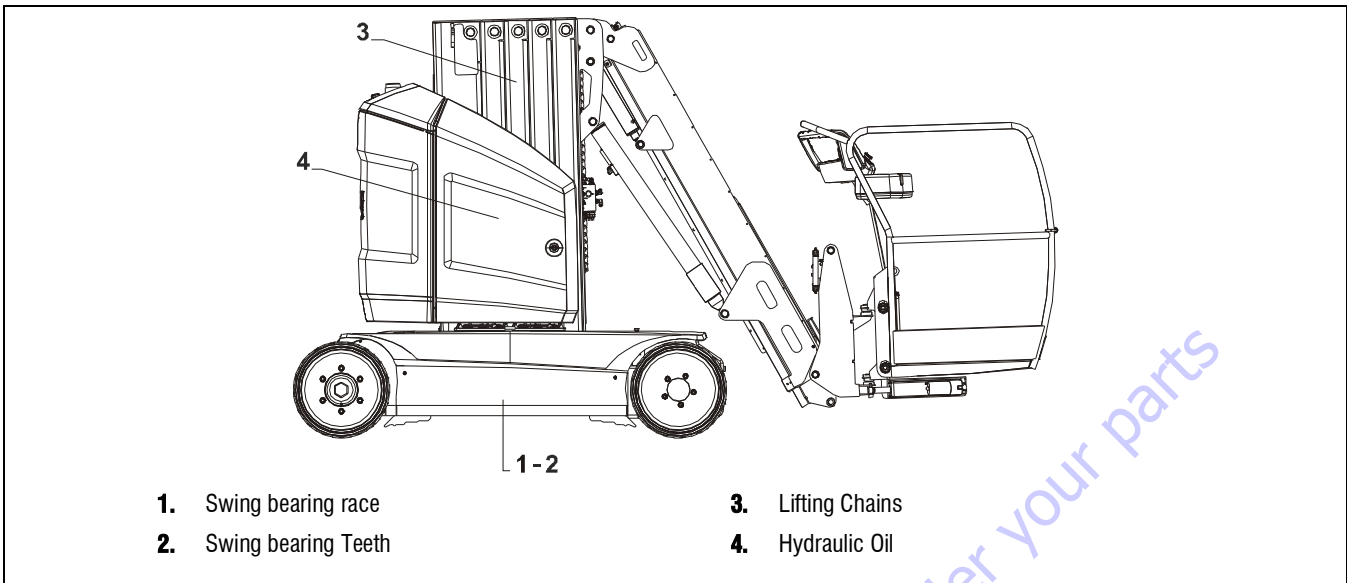
**Table 1-13. Hydraulic Oil Specifications (Standard)**

Specifications	NERVOFLUID 15	MOBIL DTE 10XL 15
ISO Viscosity Grade	15	15
Cinematic Viscosity @ +40°C [104°F]	14.9 mm <sup>2</sup> /s (cSt)	15.8 mm <sup>2</sup> /s (cSt)
Cinematic Viscosity @ 0°C [32°F]	3.8 mm <sup>2</sup> /s (cSt)	4.07 mm <sup>2</sup> /s (cSt)
Pour Point, Max.	-40°C (-40°F)	-54°C (-65°F)
Flash Point, Min.	175°C (347°F)	182°C (359°F)
Viscosity Index	153	168
ISO 6743-4 Classification	HV	-

**NOTE:** Hydraulic oils must have anti-wear qualities and sufficient chemical stability for mobile hydraulic system service. It is not advisable to mix oil of different brands or types, as they may not contain the same required additive or be of comparable viscosities.

Go to Discount-Equipment.com to order your parts

**Lubrication Chart**



**Figure 1-1. Lubrication Chart**

**Table 1-14. Lubrication Chart**

Component	Number/Type Lube Points	Lube	Interval Hours			Comments
			125	250	1000	
1 Swing Bearing Race	2 grease fittings	A		X		
2 Swing Bearing Teeth	By brush	B			X	Remove old grease first
3 Lifting Chains	Spray on or by brush	C	X			Lubricate before first 50 hours of operation
4 Hydraulic Oil	Fill through reservoir cap	D			X	Check level daily. Change at least every 2 years

**NOTE:** Lubrication intervals are based on machine operation under normal condition. For machines used in multi shift operations and/or exposed to hostile environments or conditions, lubrication frequencies must be increased accordingly.

**NOTE:** Refer to the corresponding sections in this manual for specific lubrication procedures.

## SECTION 1 - OPERATING SPECIFICATIONS

### Lube Specifications

**Table 1-15. Lube Specifications**

Key	Specifications	E.g.
A	Extreme Pressure - Multi Purpose Grease	MOBILUX EP2 COMPLEX EP2
B	Open Gear Lube	MOBILTAC 81
C	Non Detergent Mineral Oil (*)	MOBIL DTE 10XL 68
D	Hydraulic Oil	NERVOFLUID 15
E	Synthetic Chain Oil	FUCHS VT800

(\*) To be adapted to the machine's operating conditions. Refer to the corresponding section in this manual.

### 1.8 TORQUE REQUIREMENTS

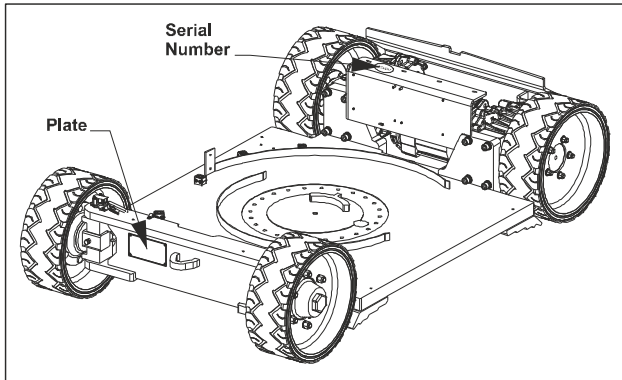
Unless specific torque requirements are given within the text, refer to the following torque chart to determine proper torque values.

**Table 1-16. Torque Chart**

Torque Values for Bolts, Nuts and Studs												
Grade	Unit	M4x70	M5x80	M6x100	M8x125	M10x150	M12x175	M14x200	M16x200	M20x250	M24x300	M30x350
<b>8.8</b>	N.m	2.7	5.2	9.1	22	44	76	121	189	370	637	1280
	lbf.ft	2	3.8	6.7	16.2	32.5	56	89.2	139	272	469	944
<b>10.9</b>	N.m	3.9	7.7	13.4	32	64	111	178	278	544	936	1880
	lbf.ft	2.9	5.7	9.9	23.6	47.2	81.9	131	205	408	690	1386
<b>12.9</b>	N.m	4.6	9	15.7	38	75	130	209	325	637	1095	2200
	lbf.ft	3.4	6.6	11.6	28	55.3	95.9	154	239	469	807	1622
Torque Values for Hydraulic Fittings												
Type	Unit	TORQUE FOR STEEL BODY		TORQUE FOR ALUMINUM BODY								
<b>JIC 9/16"-18</b>	N.m	31		-								
	lbf.ft	22.9										
<b>BSPP 1/4"-19</b>	N.m	35		25								
	lbf.ft	25.8		18.4								
<b>BSPP 3/8"-19</b>	N.m	70		50								
	lbf.ft	51.6		36.9								
<b>Metric M14x150</b>	N.m	45		32								
	lbf.ft	33.2		23.6								
<b>Metric M18x150</b>	N.m	70		50								
	lbf.ft	51.6		36.9								

**1.9 SERIAL NUMBER LOCATIONS**

For machines identification, a serial number plate is affixed at the front side of the chassis. If the serial number plate is damaged or missing, the machine serial number is stamped on the frame at location shown following.



**Figure 1-2. Serial Number**

Go to Discount-Equipment.com to order your parts

# PARTS FINDER

**Search Website  
by Part Number**



**Search Manual  
Library For Parts  
Manual & Lookup Part  
Numbers – Purchase  
or Request Quote**

A screenshot of the "Search Manuals" form. The form has a title "Search Manuals" and a subtitle "Please provide information to help us locate the manual and/or parts you need." It includes fields for "Brand", "Model", "Serial", "Part Number", and "Quantity". There is a "Search" button at the bottom.

**Can't Find Part or  
Manual? Request Help  
by Manufacturer,  
Model & Description**

A screenshot of the "Parts Order Form". The form has a title "Parts Order Form" and a subtitle "Please fill in as much information as possible." It includes fields for "Manufacturer", "Model", "Description", "Part Number", "Quantity", and "Comments". There is a "Submit" button at the bottom.

Discount-Equipment.com is your online resource for quality parts & equipment.

Florida: **561-964-4949** Outside Florida TOLL FREE: **877-690-3101**

**Need parts?**

Click on this link: <http://www.discount-equipment.com/category/5443-parts/> and choose one of the options to help get the right parts and equipment you are looking for. Please have the machine model and serial number available in order to help us get you the correct parts. If you don't find the part on the website or on one of the online manuals, please fill out the request form and one of our experienced staff members will get back to you with a quote for the right part that your machine needs.

We sell worldwide for the brands: Genie, Terex, JLG, MultiQuip, Mikasa, Essick, Whiteman, Mayco, Toro Stone, Diamond Products, Generac Magnum, Airman, Haulotte, Barreto, Power Blanket, Nifty Lift, Atlas Copco, Chicago Pneumatic, Allmand, Miller Curber, Skyjack, Lull, Skytrak, Tsurumi, Husquvarna Target, , Stow, Wacker, Sakai, Mi-T- M, Sullair, Basic, Dynapac, MBW, Weber, Bartell, Bennar Newman, Haulotte, Ditch Runner, Menegotti, Morrison, Contec, Buddy, Crown, Edco, Wyco, Bomag, Laymor, Barreto, EZ Trench, Bil-Jax, F.S. Curtis, Gehl Pavers, Heli, Honda, ICS/PowerGrit, IHI, Partner, Imer, Clipper, MMD, Koshin, Rice, CH&E, General Equipment, ,AMida, Coleman, NAC, Gradall, Square Shooter, Kent, Stanley, Tamco, Toku, Hatz, Kohler, Robin, Wisconsin, Northrock, Oztec, Toker TK, Rol-Air, Small Line, Wanco, Yanmar



## SECTION 2. GENERAL SERVICE INFORMATION

### 2.1 MACHINE PREPARATION, INSPECTION AND MAINTENANCE

#### General

This section provides the necessary information needed by those personnel that are responsible to place the machine in operation readiness and maintain its safe operating condition. For maximum service life and safe operation, ensure that all the necessary inspections and maintenance have been completed before placing the machine into service.

#### Preparation, Inspection and Maintenance

It is important to establish and conform to a comprehensive inspection and preventive maintenance program. The following table outlines the periodic machine inspections and maintenance recommended by JLG Industries, Inc. Consult your national, regional, or local regulations for further requirements for aerial work platforms. The frequency of inspections and maintenance must be increased as environment, severity and frequency of usage requires.

#### Pre-Start Inspection

It is the User's or Operator's primary responsibility to perform a Pre-Start Inspection of the machine prior to use daily or at each change of operator. Reference the Operation and Safety Manual for completion procedures for the Pre-Start Inspection. The Operator and Safety Manual must be read in its entirety and understood prior to performing the Pre-Start Inspection.

#### Pre-Delivery Inspection and Frequent Inspection

The Pre-Delivery Inspection and Frequent Inspection shall be performed by a qualified JLG equipment mechanic. JLG Industries, Inc. recognizes a qualified JLG equipment mechanic as a person who, by possession of a recognized degree, certificate, extensive knowledge, training, or experience, has successfully demonstrated the ability and proficiency to service, repair, and maintain the subject JLG product model.

The Pre-Delivery Inspection and Frequent Inspection procedures are performed in the same manner, but at different times. The Pre-Delivery Inspection shall be performed prior to each sale, lease, or rental delivery. The Frequent Inspection shall be accomplished for each machine in service for 3 months or 150 hours (whichever comes first); out of service for a period of more than 3 months; or when purchased used. The frequency of this inspection must be increased as environment, severity and frequency of usage requires.

Reference the JLG Pre-Delivery and Frequent Inspection Form and the Inspection and Preventative Maintenance Schedule for items requiring inspection during the perfor-

mance of these inspections. Reference the appropriate areas of this manual for servicing and maintenance procedures.

#### Annual Machine Inspection

The annual machine inspection must be performed by a Factory-Trained Service Technician on an annual basis, no later than thirteen (13) months from the date of the prior Annual Machine Inspection. JLG Industries, Inc. recognizes a Factory-Trained Service Technician as a person who has successfully completed the JLG Service Training School for the subject JLG product model. Reference the machine Service and Maintenance Manual and appropriate JLG inspection form for performance of this inspection.

Reference the JLG Annual Machine Inspection Form and the Inspection and Preventative Maintenance Schedule for items requiring inspection during the performance of this inspection. Reference the appropriate areas of this manual for servicing and maintenance procedures.

For the purpose of receiving safety-related bulletins, it is important that JLG Industries, Inc. has updated ownership information for each machine. When performing each Annual Machine Inspection, notify JLG Industries, Inc. of the current machine ownership.

#### Preventative Maintenance

In conjunction with the specified inspections, maintenance shall be performed by a qualified JLG equipment mechanic. JLG Industries, Inc. recognizes a qualified JLG equipment mechanic as a person who, by possession of a recognized degree, certificate, extensive knowledge, training, or experience, has successfully demonstrated the ability and proficiency to service, repair, and maintain the subject JLG product model.

Reference the Preventive Maintenance and Inspection Schedule and the appropriate areas of this manual for servicing and maintenance procedures. The frequency of service and maintenance must be increased as environment, severity and frequency of usage requires.

## SECTION 2 - GENERAL SERVICE INFORMATION

**Table 2-1. Maintenance and Inspection Requirements**

TYPE	FREQUENCY	PRIMARY RESPONSIBILITY	SERVICE QUALIFICATION	REFERENCE
Pre-start Inspection	Prior to use each day; or At each Operator change	User or Operator	User or Operator	Operator and Safety manual
Pre-delivery Inspection	Prior to each sale, lease or rental delivery	Owner, Dealer or User	Qualified JLG Mechanic	Service and Maintenance Manual and applicable JLG inspection form
Frequent Inspection	In service for 3 months; or Out of service for a period of more than 3 months; or Purchased used	Owner, Dealer or User	Qualified JLG Mechanic	Service and Maintenance Manual and applicable JLG inspection form
Annual Machine Inspection	Annually, no later than 13 months from the date of the prior inspection	Owner, Dealer or User	Factory-Trained Service Technician (Recommended)	Service and Maintenance Manual and applicable JLG inspection form
Preventive Maintenance	At intervals as specified in the Service and Maintenance manual	Owner, Dealer or User	Qualified JLG Mechanic	Service and Maintenance Manual

### 2.2 PREVENTIVE MAINTENANCE AND INSPECTION SCHEDULE

The preventive maintenance and inspection checks are listed and defined in Table 2-2. This table is divided into two basic parts, the "AREA" to be inspected and the "INTERVAL" at which the inspection is to take place. Under the "AREA" portion of the table, the various systems along with the components that make up that system are listed. The "INTERVAL" portion of the table is divided into six columns representing the various inspection time periods. The numbers listed within the interval column represent the applicable inspection code for which that component is to be checked.

The checks and services listed in this schedule are not intended to replace any local or regional regulations that may pertain to this type of equipment nor should the lists be considered as all inclusive. Variances in interval times may occur due to climate and/or conditions and depending on the location and use of the machine.

**SECTION 2 - GENERAL SERVICE INFORMATION**

**Table 2-2. Inspection and Preventive Maintenance Schedule**

AREA	INTERVAL					
	Pre-start <sup>1</sup> Inspection	Weekly preventive maintenance	Monthly preventive Maintenance	Pre-delivery <sup>2</sup> or Frequent <sup>3</sup> Inspection	Annual <sup>4</sup> (Yearly) Inspection	Every 2 Years
<b>PLATFORM ASSEMBLY</b>						
Platform	1-2				1-2	
Railing	2				2	
Gate	1-5				1-5	
Floor	7				2	
Lanyard Anchorage Points	2			2-9		
Platform Support (Option Platform Rotation Only)	2			1-2-4	1-2-4	
Level Correction Support	2			1-2-4	1-2-4	
<b>TELESCOPIC BOOM ASSEMBLY</b>						
Boom and Telescope Weldment	2			1-2-4	1-2-4	
Pivot Pins and Pins Retainers	1			1-2	1-2	
Wear Pads				12	3-12	
Hose, Cables Installation, Power Track				1-2-8-11	1-2-8-11	
<b>MAST ASSEMBLY</b>						
Mast Sections	2			2-4	2-3-4	
Roller Pin, Plastic Wear Pad				12	3-12	
Pulleys				2	2	
Chains/Yokes	13			12-13	12-13	
Hose, Cables Installation, Power Track				1-2-8-11	1-2-8-11	
<b>TURNTABLE</b>						
Swing Drive System	5		8	5-8	5-8	
Swing Bearing Bolts					14	
Hose, Cables Installation, Power Track				1-2-8-11	1-2-8-11	
Hoods, Hood Props, Hood Latches				5	1-2-5	
<b>CHASSIS ASSEMBLY</b>						
Chassis Weldment					4	
Tires	1-15	16		15-16-17	15-16-17	
Wheel Bolts	1	14		14	14	
Steering Spindles Weldments				2-4	2-4	

## SECTION 2 - GENERAL SERVICE INFORMATION

Table 2-2. Inspection and Preventive Maintenance Schedule

AREA	INTERVAL					
	Pre-start <sup>1</sup> Inspection	Weekly preventive maintenance	Monthly preventive Maintenance	Pre-delivery <sup>2</sup> or Frequent <sup>3</sup> Inspection	Annual <sup>4</sup> (Yearly) Inspection	Every 2 Years
Steering Knuckles Thrust Washers				12	12	
Steer Components			1			
Drive Motor Brakes					7-12	
Drive Motor Gearbox				8	8	
Hoods, Hood Props				5	1-2-5	
<b>FUNCTIONS/CONTROLS</b>						
Platform Controls	5-6-9			5-6-9	5-6-9	
Ground Controls	5-6-9			5-6-9	5-6-9	
Manual/Breakdown Controls	5-9			5-9	5-9	
Emergency Stop Switches (Ground & Platform)	5			5	5	
Functions Limit or Cutout Switch Systems	5			5	5	
<b>POWER SYSTEM</b>						
Batteries	18	18		1-19		
Battery Fluid		10		10		
Centralized Filling System			5	5	5-8	
Battery Container Draining			22		22	
Electrical Connections		1		20	20	
Battery Charger				5	5	
<b>HYDRAULIC/ELECTRIC SYSTEM</b>						
Hydraulic Power Unit	8		1-8	1-8		
Hydraulic Cylinders	8	1-7-8	2	1-2-8	1-2-8	
Hydraulic Hoses, Lines and Fittings	8	1-8	11	1-2-8-11	1-2-8-11	
Hydraulic Tank/Hydraulic Fluid	10					
Hydraulic Fluid Replacement						22
Electrical Connections		1		20	20	
Instruments, Switches	5	1			7-15	
Lights, Horn	5			5		
Electric Motor Brushes (Hyd. Power Unit)					7-12	
<b>GENERAL</b>						
Operation and Safety manuals in Storage Box	21			21	21	

**SECTION 2 - GENERAL SERVICE INFORMATION**

**Table 2-2. Inspection and Preventive Maintenance Schedule**

AREA	INTERVAL					
	Pre-start <sup>1</sup> Inspection	Weekly preventive maintenance	Monthly preventive Maintenance	Pre-delivery <sup>2</sup> or Frequent <sup>3</sup> Inspection	Annual <sup>4</sup> (Yearly) Inspection	Every 2 Years
ANSI and EMI Manuals/Handbooks Installed					21	
Capacity Decals Installed, Secure, Legible	21			21	21	
All Decals/Placards installed, Secure, Legible	21			21	21	
Walk-Around Inspection Performed	21					
Annual Machine Inspection Due				21	21	
No Unauthorized Modifications or Additions				21	21	
All Relevant Safety Publications Incorporated				21	21	
General Structural Condition and Welds				2-4	2-4	
All Fasteners, Pins, Shields and Covers				1-2	1-2	
Grease and Lubricate to Specifications				22	22	
Function Test of All Systems	21			21	21-22	
Paint and Appearance				7	7	
Stamp Inspection Date on Mast Section #1					22	
Notify JLG of Machine Ownership					22	

**Maintenance and Inspection Table Codes:**

1. Check for proper and secure installation.
2. Visual inspection for damage, cracks, distortion and excessive wear.
3. Check for proper adjustment.
4. Check for cracked or broken welds.
5. Operates properly.
6. Returns to neutral or "off" position when released.
7. Clean and free of debris.
8. Check for sign of leakage.
9. Decals installed and legible.
10. Check for proper fluid level.
11. Check for chafing and proper routing.
12. Check for proper tolerances.
13. Properly lubricated.
14. Torqued to proper specification
15. No worn edges, excessive wear or distorted profiles.
16. Properly seated around the rim.
17. Proper and authorized components.
18. State of charge.
19. Check/record acid gravity and tension.
20. No loose connections, corrosion or abrasion.

21. Verify.
22. Perform.

**Footnotes:**

- 1: Prior to use each day; or at each operator change.
- 2: Prior to each sale, lease or delivery.
- 3: In service for 3 months or 125 hours; or out of service for 3 months or more; or purchased used.
- 4: Annually, not later than 13 months from the date of prior inspection.

### 2.3 SERVICING AND MAINTENANCE GUIDELINES

#### General

---

The following information is provided to assist you in the use and application of servicing and maintenance procedures contained in this book.

#### Safety and Workmanship

---

Your safety and that of others is the first consideration when engaging in the maintenance of equipment. Always be conscious of weight. Never attempt to move heavy parts without the aid of a mechanical device. Do not allow heavy object to rest in an unstable position. When raising a portion of the equipment, ensure that adequate support is provided.

#### WARNING

**NEVER WORK UNDER AN ELEVATED PLATFORM UNTIL PLATFORM HAS BEEN SAFELY RESTRAINED FROM ANY MOVEMENT BY BLOCKING OR OVERHEAD SLING.**

#### Cleanliness

---

The most important single item in preserving the long service life of a machine is to keep dirt and foreign materials out of the vital components. Precautions have been taken to safeguard against this. Shields, covers, seals and filters are provided to keep the wheel bearings, mast sections and oil supply clean; however, these items must be maintained on a scheduled basis in order to function properly.

At any time when hydraulic oil lines are disconnected, clean adjacent areas as well as the openings and fittings themselves. As soon as a line or component is disconnected, cap or cover all opening to prevent entry of foreign matter.

Contaminants in the hydraulic system will affect operation and will result in serious damage to components working parts. Every precaution must be taken to keep hydraulic oil clean, including reserve oil in storage. If the oil must be poured from the original container into another, be sure to clean all contaminants from the service container.

Clean and inspect all parts during servicing or maintenance, and assure that all passages and openings are unobstructed. Cover all parts to keep them clean. Be sure all parts are clean before they are installed. New parts should remain in their containers until they are ready to be used.

#### Components Removal and Installation

---

Use adjustable lifting devices, whenever possible, if mechanical assistance is required. All slings (chains, cables, etc.) should be parallel to each other and as near perpendicular as possible to top of part being lifted.

Should it be necessary to remove a component on an angle, keep in mind that the capacity of an eyebolt or similar bracket lessens, as the angle between the supporting

structure and the component becomes less than 90 degrees.

If a part resists removal, check to see whether all nuts, bolts, cables, brackets, wiring, etc. have been removed and that no adjacent parts are interfering.

#### Component Disassembly and Reassembly

---

When disassembling or reassembling a component, complete the procedural steps in sequence. Do not partially disassemble or assemble one part, then start on another.

Always recheck your work to ensure that nothing has been overlooked. Do not make any adjustments, other than those recommended, without obtaining proper approval.

#### Pressure-Fit Parts

---

When assembling pressure-fit parts, use an "anti-seize" or molybdenum disulfide base compound to lubricate the mating surface.

#### Bearings

---

When a bearing is removed, cover it to keep out dirt and abrasives. Clean bearings in nonflammable cleaning solvent and allow to drip dry. Compressed air can be used but do not spin the bearing.

Discard bearing if the races and balls (or rollers) are pitted, scored or burned.

If bearing is found to be serviceable, apply a light coat of oil and wrap it in clean (waxed) paper. Do not unwrap reusable or new bearing until they are ready to be installed.

Lubricate new or used serviceable bearings before installation. When pressing a bearing into a retainer or bore, apply pressure to the outer race. If the bearing is to be installed on a shaft, apply pressure to the inner race.

#### Care and Installation of Teflon Coated Bushings

---

##### Bushings:

No jiffy wheels or reaming of any kind can be used on teflon coated bushings.

Once the coating on the bushing is damaged, it cannot be used any more and must be replaced.

##### Pins:

Any rough or damaged surface on a pin will cause the teflon coating of the bushing to be damaged.

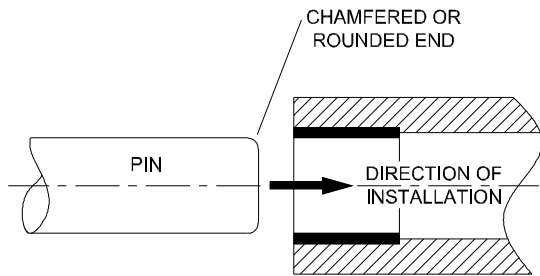
All rust or masking residue must be cleaned from the pin prior to assembly.

Never dry (black colored) "Arcor" treated pins (hot washing, vapor...). This will reduce corrosion resistance property of pin coating.

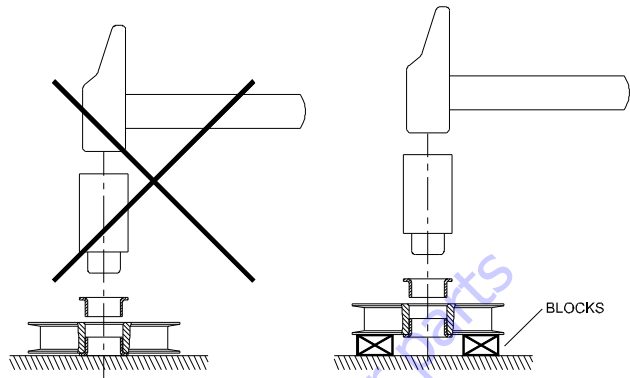
##### Bushings and Pin:

1. Coat inside diameter of bushing with specified lubricant prior to pin installation.
2. Properly align pin and bushing so that the coating does not get damaged when installing the pin.

3. Pins have chamfered or rounded end to prevent damage to the coating of the bushing during pin installation.

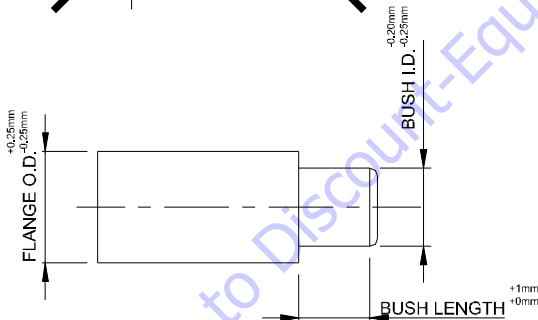
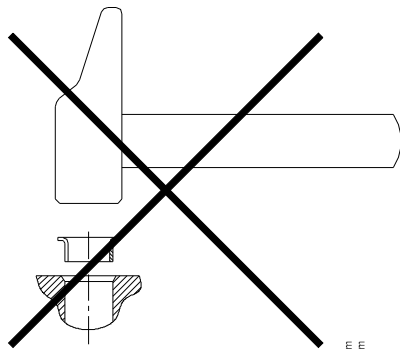


4. Blocking must be used on parts that will receive two flange bushings to prevent damage to the lower bushing flange.



**Bushing Installation:**

1. Use an appropriate driver (soft steel) to insert bushing in its housing.



2. Slightly oil the outside diameter of the bushing to facilitate insertion.
3. Keep driver, bushing and housing correctly aligned during assembly.

**Bolt Usage and Torque Application**

**NOTICE**

SELF LOCKING FASTENERS, SUCH AS NYLON INSERT AND THREAD DEFORMING LOCKNUTS, ARE NOT INTENDED TO BE REINSTALLED AFTER REMOVAL.

Use bolts of proper length. A bolt which is too long will bottom before the head is tight against its related part. If a bolt is too short, there will not be enough thread area to engage and hold the part properly. When replacing bolts, use only those having the same specifications of the original, or one which is equivalent.

Unless specific torque requirements are given within the text, standard torque values should be used on heat treated bolts, studs and steel nuts, in accordance with recommended shop practices or the Torque Chart in Section 1 of this Service Manual.

**Hydraulic Lines and Electrical Wiring**

Clearly mark or tag hydraulic lines and electrical wiring, as well as their receptacles, when disconnecting or removing them from the unit. This will assure that they are correctly reinstalled.

Coat contacts of electrical connectors with silicone dielectric compound (Refer to Section 11).

Always disconnect battery plug (located in the battery compartment) prior to working on the electrical system.

**Hydraulic System**

**⚠ WARNING**

EXERCISE EXTREME CARE AROUND PRESSURIZED HYDRAULIC SYSTEMS WHILE IN OPERATION OR UNTIL ALL PRESSURE IS RELEASED.

### **⚠ WARNING**

**HIGH PRESSURE OIL COULD PENETRATE SKIN AND CAUSE INJURIES OR BURNS. LOOSEN FITTINGS OR COMPONENTS SLOWLY TO ALLOW OIL PRESSURE TO DROP GRADUALLY.**

When servicing the hydraulic system, use a container to collect the oil from hydraulic lines or components and prevent it from spilling on the work platform or on the ground.

**NOTE:** *Used oils and filter cartridges must be disposed of according to regulation in force.*

Before disconnecting a hydraulic line or removing a component, clean fittings and adjacent area. As soon as a line or component is disconnected, cap or cover all opening to prevent entry of foreign matter.

Disassemble and reassemble hydraulic parts on clean work surface. Clean all metal parts with non-flammable cleaning solvent. Lubricate components, as required, to aid assembly.

Keep the system clean. Hydraulic system filter should be replaced at the specified intervals. Examine filter cartridge for evidence of metal or rubber particles. If evidence of metal or rubber particles is found, drain and flush the entire system.

### **Welding on Work Platform**

When welding on the work platform, disconnect battery plug and ALL electronic components. When welding on the chassis, connect the welder ground wire to the machine chassis as close as possible to the area being welded. When welding on the superstructure, connect the welder ground wire to the machine superstructure as close as possible to the area being welded. This is to prevent arcing inside the swing bearing, the lifting chains or the cylinders.

### **NOTICE**

**FAILURE TO COMPLY WITH THE ABOVE REQUIREMENTS MAY RESULT IN COMPONENT DAMAGE (I.E. ELECTRONIC MODULES, SWING BEARING, COLLECTOR RING, BOOM WIRE ROPES ETC.).**

### **Lubrication**

Components and assemblies requiring lubrication and servicing are shown in Section 1.7. Service applicable components with the amount, type, and grade of lubricant are recommended in this manual, at the specified intervals. When recommended lubricants are not available, consult your local supplier for an equivalent that meets or exceeds the specifications listed.

### **Battery**

Clean and dry battery top. Ensure all connections are clean and correctly tight. Coat terminals with a silicone dielectric compound.

Drain the water that can accumulate at the bottom of the batteries container. (Refer to Section 8-2).

## 2.4 LUBRICATION INFORMATION

### **Hydraulic System**

The primary enemy of a hydraulic system is contamination. Contaminants enter the system by various means, e.g., using inadequate hydraulic oil, allowing moisture, grease, filings, sealing components, sand, etc., to enter when performing maintenance, or by permitting the pump to cavitate due to insufficient system warm-up or leaks in the pump supply.

The design and manufacturing tolerances of the component working parts are very close, therefore, even the smallest amount of dirt or foreign matter entering a system can cause wear or damage to the components and generally results in faulty operation. Every precaution must be taken to keep hydraulic oil clean, including reserve oil in storage.

Cloudy oils indicate a high moisture content which permits organic growth, resulting in oxidation or corrosion. If this condition occurs, the system must be drained, flushed, and refilled with clean oil.

It is not advisable to mix oils of different brands or types, as they may not contain the same required additives or be of comparable viscosities. Good grade mineral oils, with viscosities suited to the ambient temperatures in which the machine is operating, are recommended for use.

**NOTE:** *Metal particles may appear in the oil of new machines due to the wear-in of meshing components.*

### **Lubrication Specifications**

Specified lubricants, as recommended by the component manufacturers, are always the best choice, however, multi-purpose greases usually have the qualities which meet a variety of single purpose grease requirements.

Should any question arise regarding the use of greases in maintenance stock, consult your local supplier for evaluation. Refer to Section 1.7 of this Service Manual for an explanation of the lubricant key designations appearing in the Lubrication Chart.

### **Hydraulic Oil**

For best performance, JLG recommends the use of ISO VG 15 oil with a viscosity about 15 cSt at 40 °C. Refer to Section 1.7 of this Service Manual for recommended hydraulic oils.

### **Changing Hydraulic Oil**

Use of any of the recommended hydraulic oils eliminates the need for changing the oil on a regular basis. If it is necessary to change the oil, use only those oils meeting or exceeding the specifications appearing in this manual. If unable to obtain the same type of oil supplied with the machine, consult local supplier for assistance in selecting the proper equivalent. Avoid mixing petroleum and syn-



thetic base oils. JLG Industries recommends changing the hydraulic oil at least every 2 years.

Use every precaution to keep the hydraulic oil clean. If the oil must be poured from the original container into another, be sure to clean all possible contaminants from the service container.

While the unit is shut down, a good preventive maintenance measure is to make a thorough inspection of all hydraulic components, lines, fittings, etc., as well as a functional check of each system, before placing the machine back in service.

coil. Finally, install and tighten the coil nut to the specified torque.

---

### 2.5 PRESSURE RELIEF VALVE

Pressure relieving in the hydraulic circuit is achieved by a proportional electric relief valve installed on the power unit valve body. The valve is adjusted by an electric input.

Pressure relief values of machine functions can be checked by connecting a pressure gauge at port "A2" on the hydraulic main manifold.

Before checking pressure relief values, operate the machine a few minutes to warm the hydraulic oil.

For a correct reading of pressure relief values, the machine must be operated from the platform console at maximum speed (max. travel of the joysticks). Read the pressure values when the cylinders are at end of stroke or when the structure is fully swung either to the left or to the right. When checking pressure relief value of the swing function, the mast and jib must be fully lowered.

In case of noisy operation of the pressure relief valve when cylinders are at end of stroke, bleed the air from the circuit.

Refer to Sections 7 and 9-8 of this manual for further information.

---

### 2.6 HYDRAULIC CARTRIDGE INSTALLATION

Before install a new cartridge, ensure that no external contaminant is present. Inspect O-rings and back-up rings to ensure there is no damage such as cuts or nicks.

Lubricate all seals of the cartridge with a small amount of the same oil that is used on the work platform (Refer to Section 1-7). If the seals are too dry, the back-up ring could spin out of the cage groove and cause seal damage.

Insert the cartridge into the cavity and tighten by hand in a clockwise manner. Continue to screw in the cartridge with a torque wrench and tighten to the specific torque. It is important to use the specified torque for each valve to ensure optimal performance of the cartridge.

Insert the coil and use the specified torque when tightening the coil nut. It is important to use the specified torque for each coil nut to ensure the stainless steel tube is not stretched.

If the valve requires two coils, install them separately. Place the washer on top of first coil then install the second

## SECTION 3. THEORY OF OPERATION

### 3.1 OVERVIEW

The control system is composed of four main electronic modules and a maintenance display.

The Ground Module (UGM), located on the right side of the turntable, is the master system controller.

Most functions are dispatched and coordinated from this module, all other system modules handle sub-tasks.

All characterized information (values) are stored into the UGM (i.e., Personalities, Machine Setups or Calibrations).

If the master module is reprogrammed, this information is lost. The technician should record Personalities and Machine Setups before programming so they can be restored afterwards.

Otherwise, default values can be used as a starting point to restore previous configuration.

The Master Power Module (MPM) and Slave Power module (SPM), located at the rear of the chassis, are controlled by the Ground Module through a bus CAN.

The Ground Module and the Master and Slave Power modules enable the control system (UGM controls the high side of the voting relay, SPM controls the low side of the voting relay, MPM controls the low side of the main contactor).

The Master Power Module controls the right drive motor and its brake and the hydraulic pump motor via commands from the CAN bus. It also measures current applied to these loads and input voltage for fault protection and reporting.

The Slave Power Module controls the left drive motor and its brake via commands from the CAN bus. It also measures current applied to these loads and input voltage for fault protection and reporting.

The PLATFORM MODULE reads linked switches and joysticks positions and relays that information to the UGM.

It uses information from the CAN bus for operator display. It also reports faults pertaining to devices in the Platform Control Station and devices connected to the Platform Control Station.

The Multi Display Indicator (MDI), located at the Ground Control Station, uses information from the CAN bus for operator display.

The machine can be fitted with an optional Rotate Module. This module, located in the platform support, controls the platform rotate actuator via commands from the CAN bus. It also measures current applied to the electric motor of the actuator and input voltage for fault protection and reporting.

For safe operation of the vehicle, the control system will not allow certain functions under certain conditions. These are called interlocks. Specific interlocks are discussed below. The interlocks discussed assume that all control system devices are functioning properly unless indicated. Fault conditions will generate Diagnostic Trouble Codes and additional interlocks.

Some faults only show up at power-up when the control system performs a self-test. All controls should be left

alone during this test.

Note that the market and model of the machine affects what personalities and setups are. The appropriate information is displayed for the given model and market. The market and model must be set properly for safe and lawful operation of the machine.

### 3.2 MODES OF OPERATION

#### Ground Mode

When the machine is powered up in Ground Mode, only the functions at the Ground control station are operational. Functions are controlled by membrane switches (buttons). Whatever the function controlled, the Enable

button [  ] must be pushed-in and held to enable other controls.

#### Platform Mode

In platform mode the Platform Control Box is enabled. It is the primary control station for the vehicle. At power-up, all indicators illuminate for a lamp check.

### 3.3 CAN COMMUNICATIONS

The communications between the different modules is done through two bus CAN.

CAN 1 links the Ground Module to the Platform Module, the Rotate Module (if installed) and the Multi Display Indicator (MDI).

CAN 2 links the Ground Module to both Master and Slave Power modules.

CAN (Controller Area Network) is the type of two-wire differential serial communication link used for control of the vehicle. This type of network has matured since its invention in 1986 and is used extensively in many kinds of machines.

Two-Wire Differential: The signal meaning is derived from the difference in voltage between two wires, usually twisted together in a common "jacket". This jacket can also contain a shield surrounding the wires inside for noise protection. Any noise that does penetrate the shield will affect both wires the same. However, the difference in voltage stays the same, therefore signal meaning is not corrupted. This differs from one-wire signals in that one wire signals derive the signal meaning from the difference between the signal wire and system ground wire. The system ground is the ground for many signals, as well as power. Any noise on either wire will change the signal and may corrupt it.

Serial Communication Link: Modules on the link send messages digitally, bit by bit along the wires where differ-

## SECTION 3 - THEORY OF OPERATION

ent voltage levels represent a "1" or a "0". The 1's and 0's are assembled by the receiver according to the protocol used to determine the messages meaning. Using serial communication allows two wires to replace many more. It also allows use of sensor and switch information in multiple places without duplicating those sensors and switches.

**CAN:** On a bus, all modules on the bus are connected to the same wires. A CAN bus could be represented on a schematic by a long pair of straight lines with multiple modules connected to them by short pairs of lines. It has a termination resistor at both ends of the long lines placed between the two wires. These resistors are approximately 120  $\Omega$ . On a JLG aerial work platform, this is typically in the platform and in the chassis. These resistors may be in the harness or in the module. A complete CAN circuit measures approximately 60  $\Omega$  between the two wires and these wires are open to the shield.

Each module on the CAN bus broadcasts its messages according to a priority assigned to the message. All the other modules will receive the message and determine if it is important to them. Typical message traffic is 300 - 500 messages per second. The high bus speed allows all modules to be constantly updated around 20 times per second. A CAN network also has error detection and handling for robust communications.

### 3.4 JOYSTICKS

The joysticks are used to "command" lift, telescope, swing and drive. Those commands may be modified by the control system based on interlocks and personalities.

The joystick control handle sensors are not simple potentiometers. There is a position sensing element, and signal conditioning circuitry in them to generate the position signal. They are powered by 5VDC supplied from the platform module. When centered a joystick will output approximately 2.5VDC. Fully backward or left, it will output approximately 0.5V DC. Fully forward or right, it will output approximately 4.5V DC.

On the handle of the drive/swing joystick is the trigger switch that must be depressed in order to operate those functions. For the mast, jib and telescope joystick, an enable button (located on the right hand side of the box) must be depressed and held. This prevents unintentional movement.

To pass start-up tests controls must be released and the joysticks must be centered.

No operation from the platform console is possible until the joysticks are centered. If one of the enable device is found triggered at power-up, the emergency stop switch must be re-cycled to clear the fault.

Joysticks personalities to define the centered position (where command is 0%), minimum and maximum forward, as well as minimum and maximum reverse can be altered by performing a calibration of the joysticks.

### 3.5 TRACTION

The traction or drive system, moves the vehicle along the ground by electric asynchronous motors.

Each controller is an inverter which transforms the battery DC voltage in AC voltage, to power the three phases drive motors. The motors are wired in triangle configuration. The rotating speed is directly linked to the voltage frequency applied. The voltage supplied to the motor is modulated below approx. 60 Hz; above 60 Hz, nominal voltage is applied. The nominal voltage between two motor phases is approx. 28 Vrms (will vary depending on battery status and driving conditions). The default frequency range is 0.6Hz to 146 Hz which approximately corresponds to a driving speed of 0km/h to 5.5km/h. The actual rotating frequency of the motors is measured by the encoders; for a proper motor operation, the difference between the actual frequency and the inverter output frequency has to be maintained within few Hz. When a motor is driving the machine, Inverter Freq. > Encoder Freq.; when the motor is braking, Inverter Freq. < Encoder Freq.. The tolerance between the frequency applied and the actual measurement called maximum slip value, is approx. 15Hz (depends on the speed and on the driving conditions).

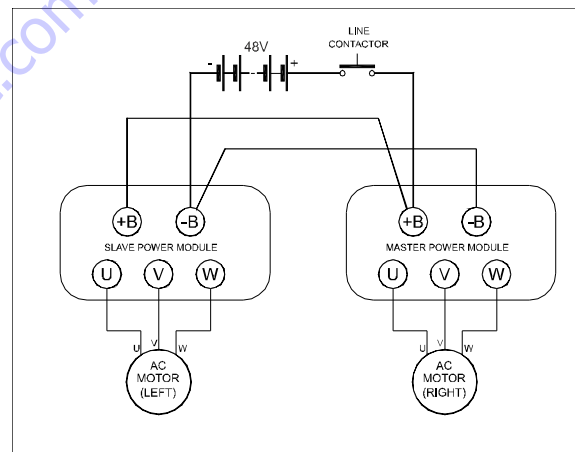


Figure 3-1. Drive Motor Schematic

The parking and emergency brakes are released by the controllers: voltage is approx. 24V at driving start (for 1 second) and approx. 16V after.

### 3.6 PUMP/STRUCTURE MOVEMENTS

An electrically driven hydraulic pump provides hydraulic pressure to actuate the steering and superstructure movements.

The Power Module is essentially a "low-side" switch for the pump motor. The positive terminal of the pump is tied to Battery Positive (+B) after the Line Contactor. The negative terminal of the pump connects to the (-P) Terminal of the Master Power Module, which switches current through MOSFET transistors to the Battery Negative.

For variable speed pump operation, the MOSFET transistors switch On and Off at high frequencies. The Duty Cycle is varied to control the voltage applied to the pump motor. When the MOSFET's spend 50% of the period On and 50% Off, approximately half of the available Battery power will be applied to the pump motor. Similarly, the MOSFET are On continuously (100% Duty Cycle) to apply all available Battery power to the pump motor (i.e. Mast Lift Up at full speed from Platform Mode).

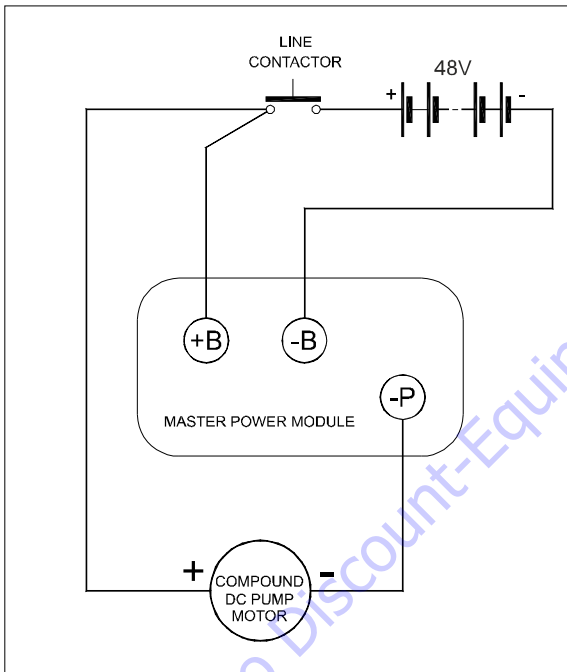


Figure 3-2. Hydraulic Pump Electric Schematic

When the Control System is energized, the voltage at the (- P) Terminal will be approximately +48V (referenced to - B) when the pump is static.

The (-P) Terminal will be approximately at +1V (referenced to -B) when the pump is running at full speed (i.e. Mast Lift Up from Platform Mode).

#### Lift Up/Down

The lift actuators are single acting hydraulic cylinders. Lift down is "powered" by gravity.

To lift the mast, the pump is run and an appropriate signal is sent to the proportional relief valve. Then, after a short delay, the solenoid energizes and opens the mast valve.

The pump speed is set proportional to joystick position. Fluid flows into the mast cylinder and extend the rod. As mast sections are linked to each others by lifting chains, all mast sections elevate simultaneously.

To bring the mast down, appropriate signals are sent for the proportional relief valve for proper pressure settings and flow control valve for pre-activation, and the pump is run for a short period of time to pressurize the circuit. Once the circuit is pressurized, the mast valve opens. Then, the flow control valve opens proportional to joystick position, and allows fluid back to the tank, allowing the mast to retract by gravity.

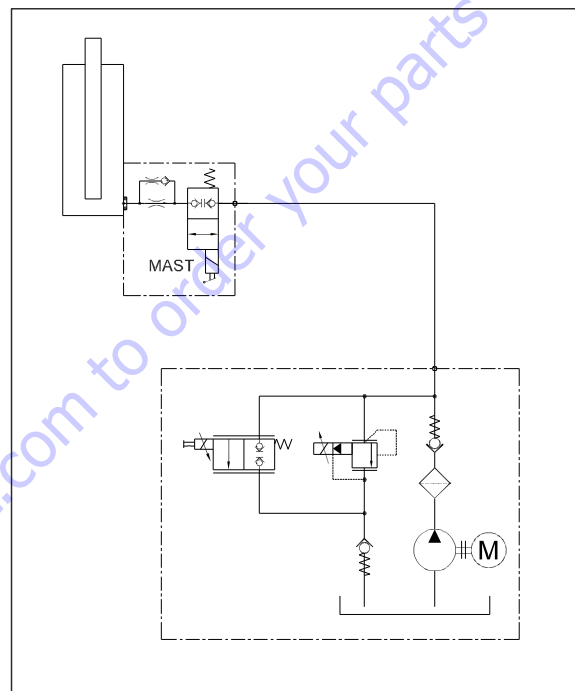


Figure 3-3. Mast Lift/Lower System - Basic Schematic

## SECTION 3 - THEORY OF OPERATION

To lift the jib, the pump is run and an appropriate signal is sent to the proportional relief valve. Then after a short delay, the jib solenoid energizes and opens the jib valve. The pump speed is set proportional to joystick position. Fluid flows into the jib cylinder and extend the rod.

To bring the jib down, appropriate signals are sent, to the proportional relief valve for proper pressure settings and flow control valve for pre-activation, and the pump is run for a short period of time to pressurize the circuit, and to the flow control valve. Once the circuit is pressurized, the jib valve opens. Then, the flow control valve opens proportional to joystick position, and allows fluid back to the tank, allowing the jib to go down by gravity.

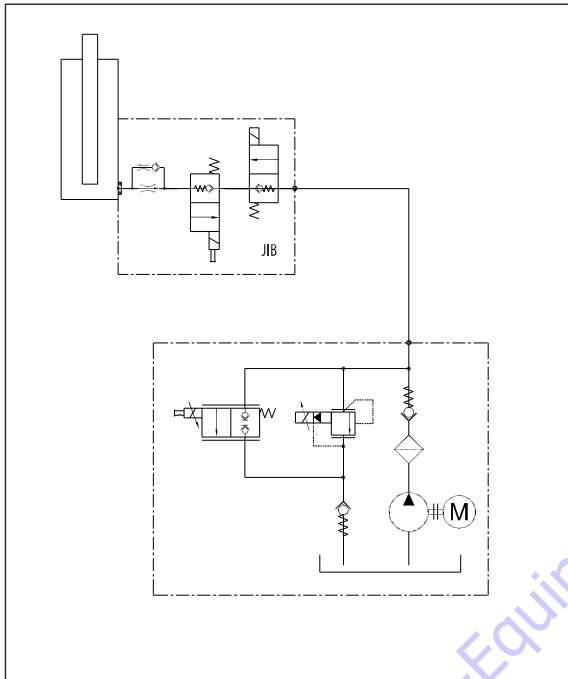


Figure 3-4. Jib Lift/Lower System - Basic Schematic

## Swing

Swing is actuated by a hydraulic motor.

To swing, solenoids of the swing valve energize (right one to swing to the right and left one to swing to the left), an appropriate electric signal is sent to the proportional relief valve and the pump speed is set proportional to joystick position. Pressure is applied to one port of the motor and drained from the other, allowing the motor to turn.

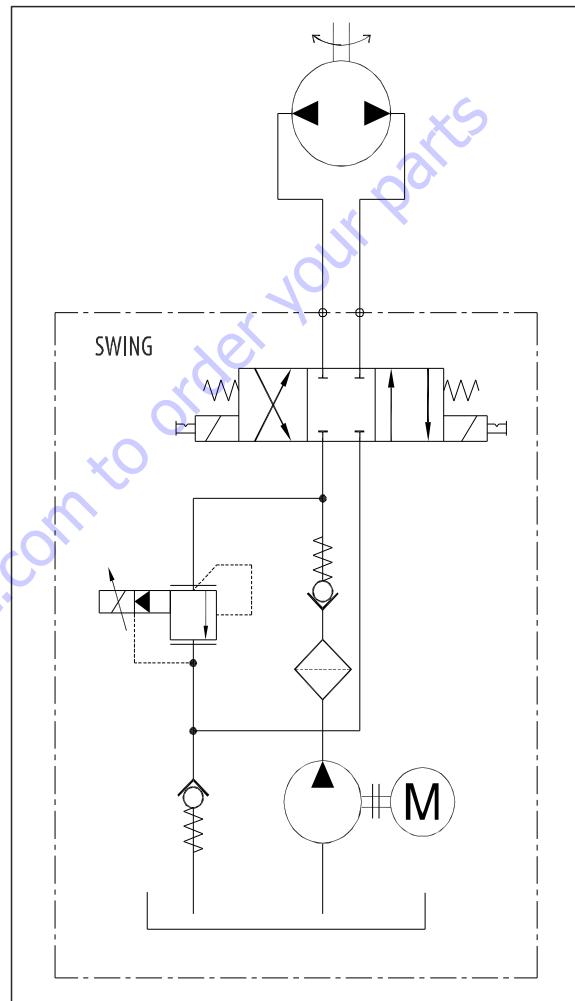


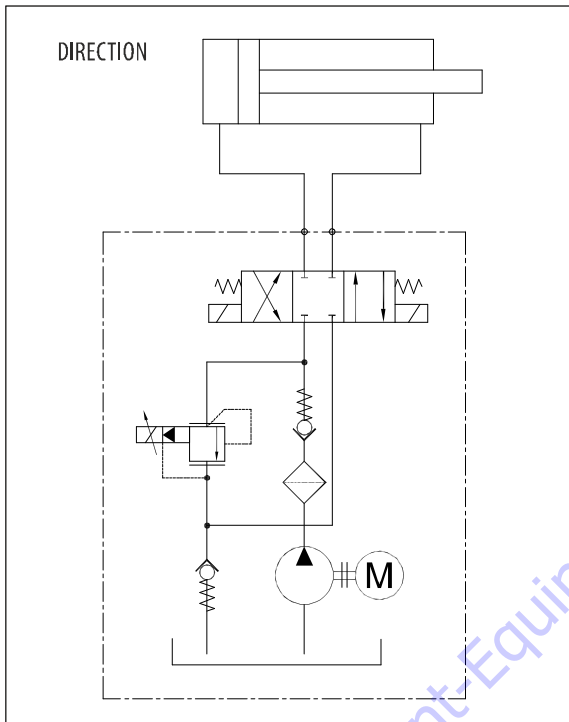
Figure 3-5. Swing System - Basic Schematic

**Steer**

Steering is actuated by a double acting hydraulic cylinder. To change steering angle of the wheels, pressure is applied to one side of the piston and drained from the other.

To steer, solenoids of the steer valve energize (right one to steer to the right and left one to steer to the left), an appropriate electric signal is sent to the proportional relief valve and the pump is run.

The pump speed, and thereby the rate of steering angle change, is adjusted based on drive speed. This adjustment is modified by steer personality settings.



**Figure 3-6. Steer System - Basic Schematic**

The steering sensor is located on the front steering axle. It is key operated by the right spindle attach pin. There is a position sensing element and a signal conditioning circuitry in it to generate the position signal (i.e. the wheel steering angle). It is powered by 4.3 VDC supplied from the master power module.

When the wheels are fully steered to the right, it will output approximately 0.7 VDC.

When the wheels are fully steered to the left, it will output approximately 3.7 VDC.

When the wheels are straight, it will output approximately 2.5 VDC.

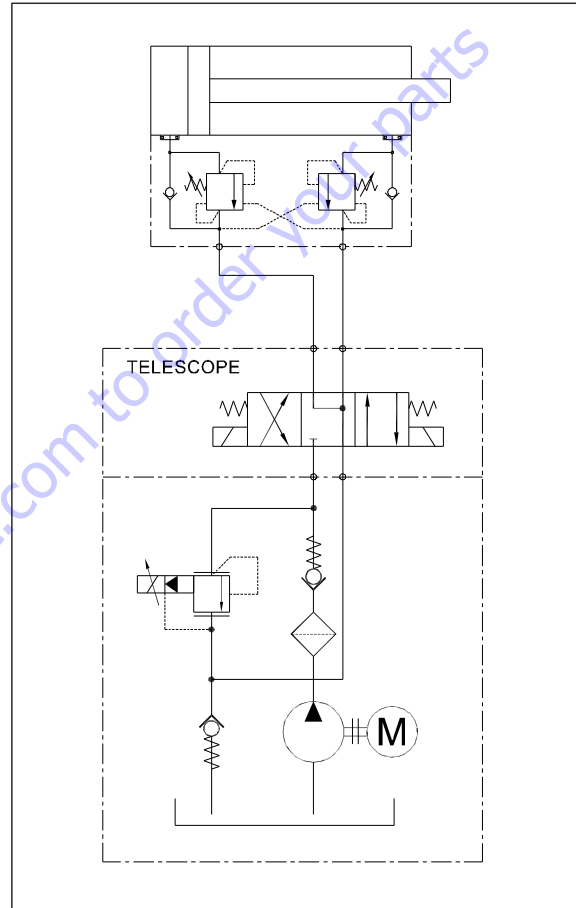
Depending on output signal, the speed of the inner drive motor will be reduced to allow machine to take a curve (like a differential system).

**Telescope**

Telescope movement is activated by a double acting hydraulic cylinder.

To extend or retract the telescope, solenoids of the telescope valve energize (Tele in to retract and tele out to extend), an appropriate electric signal is sent to the proportional relief valve and the pump speed is set proportional to joystick position.

Pressure is applied to one side of the piston and drained from the other.



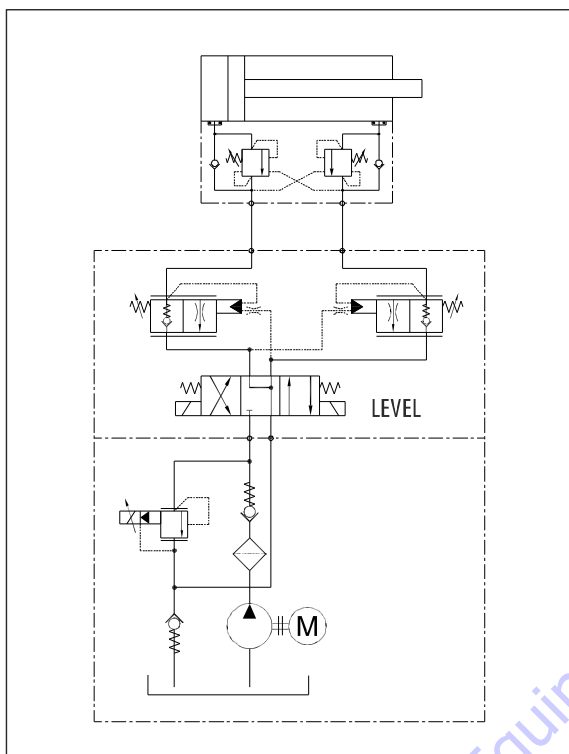
**Figure 3-7. Telescope System - Basic Schematic**

**Platform Level**

Platform level movement is activated by a double acting hydraulic cylinder.

To level the platform, solenoids of the level valve energize (the up one to level up and the down one to level down) and an appropriate electric signal is sent to the proportional relief valve.

Pressure is applied to one side of the piston and drained from the other.



**Figure 3-8. Platform Level System - Basic Schematic**

**Interlocks**

Interlocks are system inputs (limit switches, sensors or internal controller measurement) which affect the system functions.

**NOTE:** For more detailed information concerning system adjustment and operation, refer to section 8 Control Components.

**Overload Switch**

The overload switch senses platform load. In order to avoid false trip, the switch input is delayed.

- The switch must be tripped for more than 1s to consider the platform overloaded.
- The switch must be released for more than 1s to consider the platform not overloaded.

When the platform overloaded:

- All the movements are cut out from both the platform console and the ground console if the MACHINE SETUP, LOAD SYSTEM is set to CUTOUT ALL;

- All the movements are cut out from the platform console if the MACHINE SETUP, LOAD SYSTEM is set to CUTOUT PLATFORM;
- All the movements can be performed at normal speed if the MACHINE SETUP, LOAD SYSTEM is set to NOT INSTALLED;

**Tilt Sensor**

A dual axis tilt sensor is installed on the chassis.

When the platform is fully lowered (mast and jib switches NOT tripped), if the machine is tilted:

- A visual alarm is displayed;
- Mast raising is disallowed;
- Jib raising is restricted to travel height (max. platform floor height approx. 1m (3.3 ft)).
- Other functions are not affected.

When the machine is tilted and above elevation:

- The drive functions are cut-out;
- Telescope out is disallowed;
- Mast Lift Up, Jib Lift Up and Swing are allowed at reduced speed;
- Mast Lift Down and Telescope In are allowed at normal speed;
- Jib Lift Down is allowed at normal speed only if mast is fully lowered;
- Other functions are not affected.

**Chain Slack Switches**

The chain slack switches sense the lifting chains tension. In case of slack chain detected:

- The drive functions are cut out;
- Telescope and Swing functions are cut out;
- Jib Lift Down, Mast Lift Down and Platform Level Down are cut out;
- Mast Lift Up and Jib Lift Up are allowed at reduced speed;

**Drive Orientation Switch**

The drive orientation switch is a proximity switch which trips when the turntable is swung  $\pm 45^\circ$  off center of the normal driving position. This occurs roughly when the jib is swung past the rear tires. When the drive orientation switch is tripped:

- Drive and steer functions can only be performed after the DOS override switch (on the platform console) has been engaged. Drive and steer functions can be operated at normal speed;
- All the structure movements remain unaffected by the DOS.

### **Mast Limit Switch, Main Jib Limit Switch**

The main jib limit switch and the mast limit switch determine if the platform is in Elevated position. When one (at least) of these switches is tripped:

- Max. driving speed is reduced from approx. 5.5 km/h to approx. 0.75 km/h.

### **Secondary Jib Limit Switch (End Of Stroke)**

This switch reduces jib up speed and gives a smoother acceleration ramp (Jib Down) when tripped.

### **Battery Charger Interlock**

When the battery charger is connected to the mains, the information is sent to the control system. If the battery charger is connected to the mains:

- All the movements are cut out from the platform console if the MACHINE SETUP, CHARGER INTERLOC is set to CUTOUT ALL;
- Drive and steer functions are cut out if the MACHINE SETUP, CHARGER INTERLOC is set to DRIVE ONLY.

### **Battery Discharge Indication**

The battery status is continuously monitored. Indication is given to the operator through both the MDI and the platform console panel. Functions limitations are applied depending on three status: charged, discharged (which corresponds to 70% discharge) and deeply discharged (which corresponds to 80% discharged).

If the battery is charged, no function limitation is applied.

If the battery is discharged:

- The max. driving speed, in transport position, is reduced by 50%. Out of transport position, driving speed is not affected;
- Mast Lift Up and Jib Lift Up maximum speeds are reduced;
- Other movements can be operated at normal speed.

If the battery is deeply discharged:

- Mast Lift Up, Jib Lift Up and Telescope OUT are cut out;
- The max. driving speed is limited at 0.4 km/h, whatever the platform position is;
- Mast Lift Down, Jib Lift Down, Telescope IN and Swing (If elevated) can be operated at normal speed.

### **Personality Settings and Calibration**

---

Functions performances may be altered by changing the applicable personality settings or calibrating different elements of the control system.

Refer to Section 9 of this manual for the applicable procedures.



## SECTION 4. CHASSIS MOUNTED COMPONENTS

## 4.1 DRIVE MOTORS

The electric wheel drive assemblies are mounted independent of each other on the base frame at the rear of the machine.

The wheel drive assembly consists of a 28V AC asynchronous electric motor driving a gear box. The assembly also includes a friction disk parking brake assembly. This brake assembly is mounted on the end of the drive motor assembly.

The component parts of the left and right drive motor assemblies are identical.

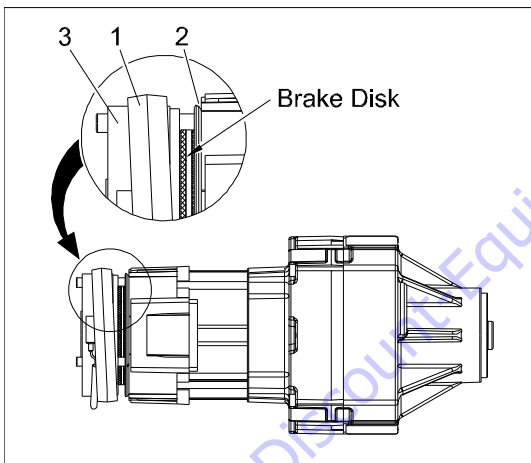
**Brake - Electrical Characteristics**

Coil, nominal voltage: 24 VDC

Coil, resistance:  $13.3 \Omega \pm 0.6 \Omega$

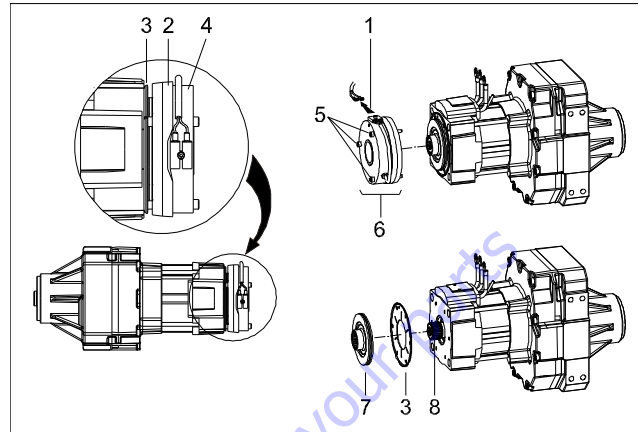
**Brake - Dust Cleaning**

Due to a possible build-up of dust from brake lining wear inside the brake compartment, it is recommended to perform this dust cleaning task on an annual basis using clean, oil free, compressed air.



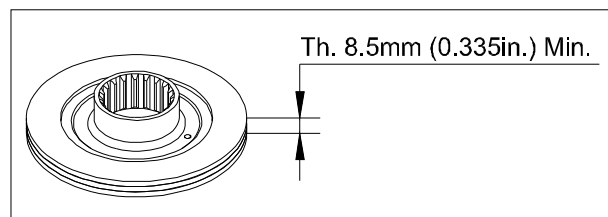
**Figure 4-1. Dust Cleaning**

1. Disconnect battery plug.
2. Remove chassis hoods.
3. Remove the dust protection ring (1) from the friction plate retaining groove (2) and pull it over the magnet body (3).
4. Blow any accumulated dust in brake compartment.
5. Once complete, correctly reposition the dust protection ring.

**Brake Disassembly**

**Figure 4-2. Brake Disassembly**

1. Place the machine on a flat and level surface. Using ground controls fully rotate the turntable either to the left or to the right. Turn power off and disconnect battery plug. Chock both front wheels.
2. Remove chassis hoods. Remove chassis rear shield.
3. Disconnect electric cables from brake terminal block (1).
4. Remove dust protection ring (2) from friction plate retaining groove (3) and pull it over magnet body (4) as shown. The protection ring will help to keep all parts together during brake removal.
5. Loosen the 3 screws (5) securing brake assembly.
6. Remove magnet body and armature plate assembly (6).
7. Remove brake disk (7) from driver (8). Remove friction plate (3).

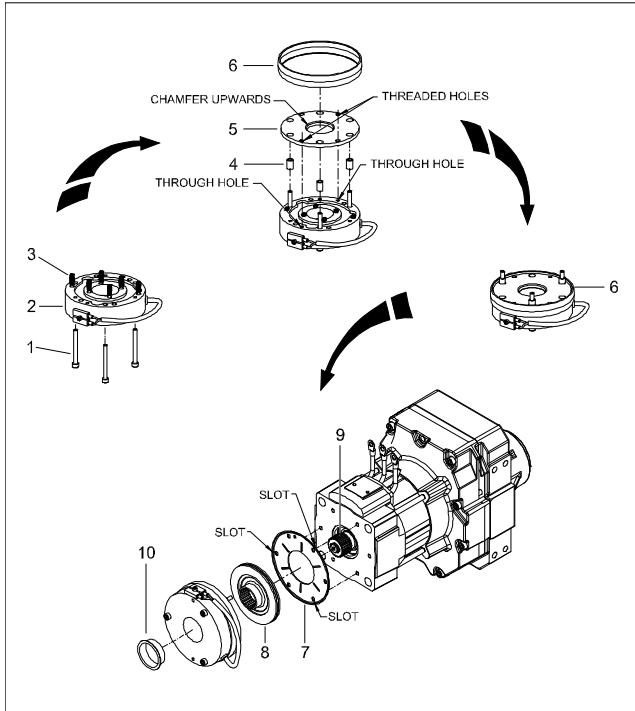
**Brake Disk Wear Checking**

**Figure 4-3. Brake Disk Wear Checking**

Check brake disk thickness on several locations. Replace the disk if its thickness is below 8.5mm (0.335 in.).

**Brake Assembly**

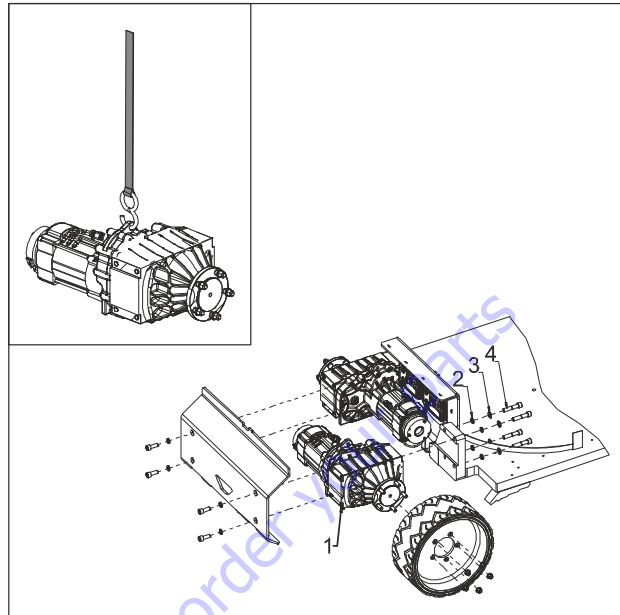
**NOTE:** The brake is only suitable for dry operation. All parts must be free from grease, oil, water or other substances that could affect braking efficiency.



**Figure 4-4. Brake Assembly**

1. Insert the 3 screws (1) in the magnet body (2) mounting holes.
2. Install the 6 springs (3). Locate springs as shown.
3. Install the 3 bushings (4).
4. Install the armature plate (5) taking care to align the threaded holes of the plate with the through holes of the magnet body and to position the chamfer upwards.
5. Install the dust protection ring (6) onto the assembly to keep all parts in place.
6. Install the friction plate (7) on the motor assembly.
7. Install the brake disk (8) on the driver (9).
8. Reposition the friction plate (7) so as the mounting screws will go through the holes that are nearing the slots.
9. Install and secure the brake assembly.
10. Correctly position the dust protection ring (6). Install the dust cap (10).

**Drive Motor Assembly Removal**



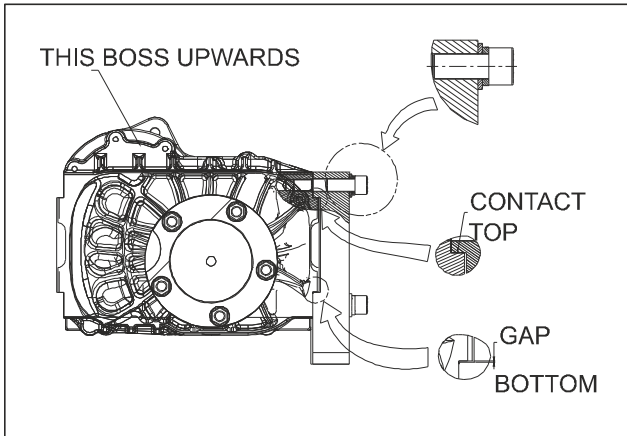
**Figure 4-5. Drive Motor Removal**

- 1- Drive Motor Assembly
- 2- Hardened washer
- 3- Spring Washer
- 4- Socket Head Cap Screw (Grade 10.9)

1. Place the machine on a flat and level surface. Using ground controls fully rotate the turntable either to the left or to the right. Turn power off and disconnect battery plug. Chock both front wheels.
2. Remove chassis hoods. Remove rear and side shields.
3. Using a jack of appropriate capacity, elevate the machine enough to be able to remove the wheel(s) and to place blocks under the chassis.
4. Remove the wheel(s).
5. Disconnect sensor bearing/thermal sensor connector and brake supply cables. Tag and disconnect motor cables from the controller.
6. Attach an adequate lifting device to the drive motor assembly and remove slack.
7. Loosen hardware securing the motor assembly to the chassis. Remove the drive motor assembly.

**Drive Motor Assembly Installation**

Install drive motor assembly in reverse order from removal. Ensure the tenon of the gear box casing contacts the top of the mounting plate slot as shown following.



**Figure 4-6. Drive Motor Installation**

Correctly install the hardened washers and spring washers. Torque the 4 Hex. Head Cap Screws Grade 10.9 to 290 N.m (214 ft.lb).

**Oil Type & Capacity**

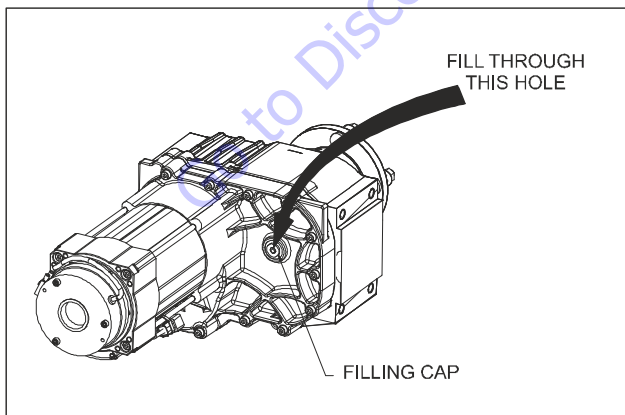
The torque hub unit is designed to utilize the same oil throughout its service life. However, should it need to be serviced the oil could need to be drained and replaced.

When serviced, fill the unit with ISO VG220 oil.

The gearbox will need to be filled with 2 liters (0.53 Gal.) of oil.

**Oil Filling**

Gearbox oil filling is performed through the filling port as shown in figure 4-6, until oil level is flush with the threads (gearbox in horizontal position).



**Figure 4-7. Oil filling**

**4.2 WHEELS AND TIRES**

**Tire Wear and Damage**

Inspect tires periodically for wear or damage. Tires with worn edges or distorted profiles require replacement. Tires with significant damage in the tread area or side wall, require immediate evaluation before replacing machine into service.

**Wheel and Tire Replacement**

Replacement wheels must have the same diameter and profile as the original. Replacement tires must be the same size and rating as the tire being replaced. Use of genuine parts is recommended.

Both tires/wheel on the same axle must be replaced:

- If the overall diameter of the tire is less than 445 mm.
- If any uneven wear is discovered.

A tire with significant damage in the tread area or side-wall requires immediate evaluation before placing the machine into service. If a cut, tear, chunk, or other discrepancy exceeds any one or more of the following dimensions, the tire must be replaced:

76 mm long, 19 mm wide, 19 mm deep

- If the metal wheel is visible at any point through the tread area of the tire.
- If more than one discrepancy exists in any quadrant of the wheel (within 90 degrees of one another).

**Wheel Installation**

It is extremely important to apply and maintain proper mounting torque.

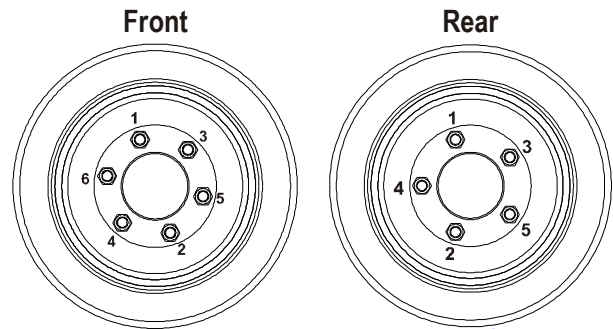
**⚠ WARNING**

**WHEEL LUG NUTS MUST BE INSTALLED AND MAINTAINED AT THE PROPER TORQUE TO PREVENT LOOSE WHEELS, BROKEN LUG NUTS, AND POSSIBLE SEPARATION OF WHEEL FROM THE AXLE. BE SURE TO USE ONLY THE LUG NUTS THAT MATCHED TO THE CONE ANGLE OF THE WHEEL.**

Tighten the lug nuts to the proper torque to prevent wheels from coming loose. Use a torque wrench to tighten the fasteners. Over-tightening will result in breaking the lug nuts or permanently deforming the mounting holes in the wheels. The proper procedure for attaching wheels is as follow:

1. Start all lug nuts by hand to prevent cross threading. DO NOT use a lubricant on threads or nuts.

2. Tighten lug nuts in the following sequence.



**Figure 4-8. Wheel Lug Nut Tightening Sequence**

3. The tightening of the lug nuts should be done in stages. Following the recommended sequence, tighten lug nut per wheel torque.

**Table 4-1. Wheel Torque Chart**

Torque Sequence - Front Wheels		
1 <sup>st</sup> Stage	2 <sup>nd</sup> Stage	3 <sup>rd</sup> Stage
50 N.m (37 lb.ft)	160 N.m (118 lb.ft)	250 N.m (184 lb.ft)

Torque Sequence - Rear Wheels		
1 <sup>st</sup> Stage	2 <sup>nd</sup> Stage	3 <sup>rd</sup> Stage
50 N.m (37 lb.ft)	140 N.m (103 lb.ft)	210 N.m (155 lb.ft)

4. Wheel lug nuts should be torqued after the first 50 hours of operation and after each wheel removal. Check torque every 3 month or 125 hours of operation.

### 4.3 STEERING LINKAGE

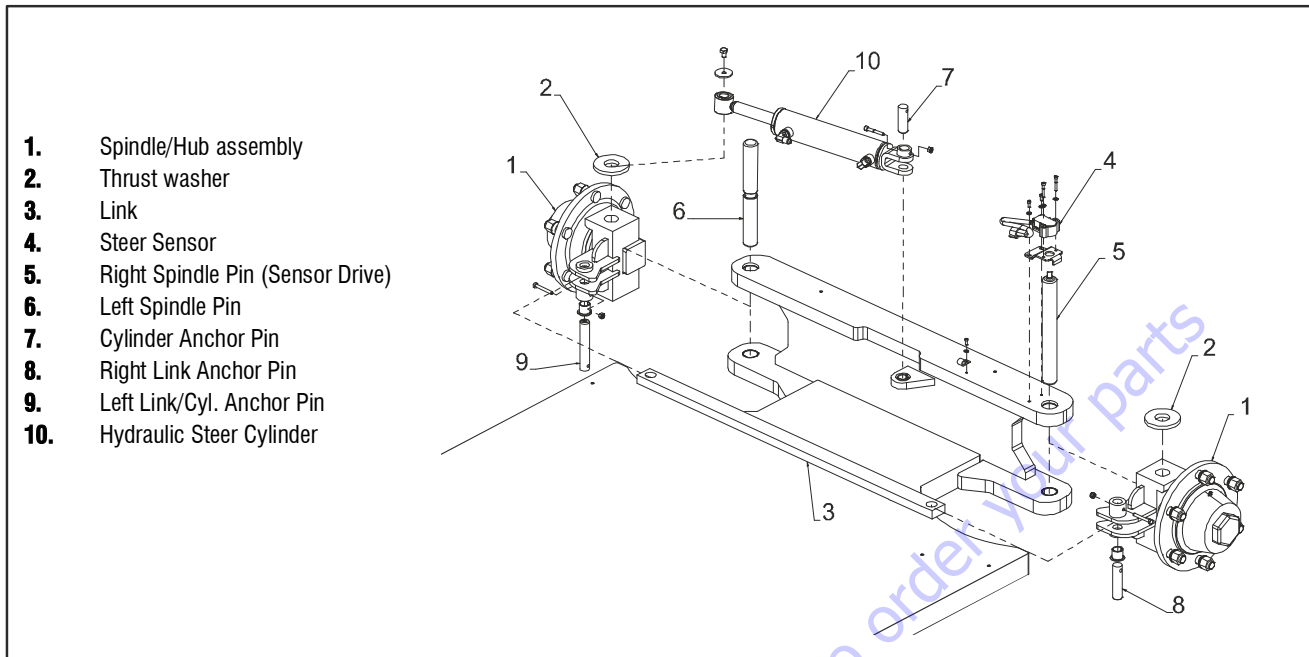


Figure 4-9. Steering Linkage Assembly

#### Steer Cylinder

##### Removal

1. Tag, disconnect and cap steer cylinder hydraulic lines and ports.
2. Remove hardware on top of the left link/cyl. anchor pin (9).
3. Remove the cylinder anchor pin (7).
4. Remove the cylinder.

##### Inspection

Check cylinder flange bushings and flange bushing installed onto chassis for damage or excessive wear. Replace if necessary.

##### Cylinder Disassembly

Refer to Section 7-8.

##### Installation

1. Coat bushings inside diameter with multipurpose grease.
2. Install the rod end onto the left link/cyl. anchor pin (9) and secure with hardware. Apply Loctite #242 to screw threads.
3. Align barrel holes with frame mounting hole. Install cylinder anchor pin and secure with hardware.
4. Remove caps and connect hydraulic lines to cylinder ports.
5. Perform a few steering movements to bleed air from the circuit and to check for proper operation.
6. Check hydraulic fluid level and adjust accordingly.

#### Steering Linkage - Spindle/Hub Assembly

##### Removal

1. Should the spindle(s) require(s) removal, remove the wheel(s).
2. If necessary, remove steer cylinder (10) as previously described.
3. Remove right link anchor pin (8) and left link/cyl. anchor pin (9).
4. Remove the steering link (3).
5. If the right spindle/hub assembly requires removal, remove the steering sensor (4).
6. Loosen locknut and screw securing the spindle pin (5-6) and remove the pin. Remove the spindle (1) and the thrust washer (2).

##### Inspection

Check bushings installed on the chassis axle for damage or excessive wear. Replace if necessary.

Check bushings installed on the steering link for damage or excessive wear. Replace if necessary.

Check pins condition. Replace if necessary.

Check thrust washer thickness. Replace washer if its thickness is less than 5mm (0.20 in.).

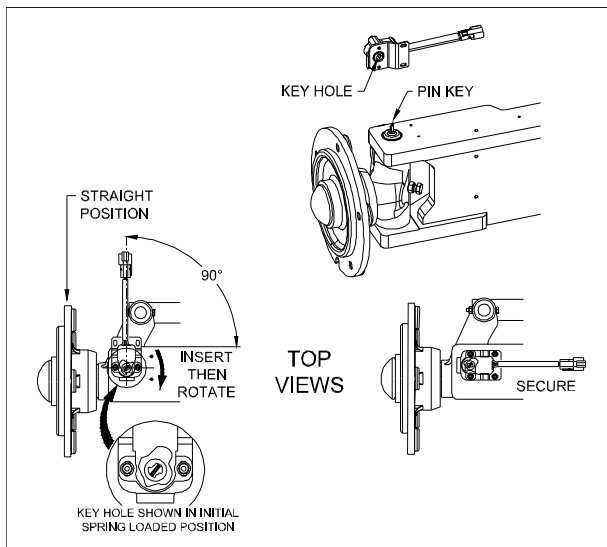
##### Installation

1. Coat chassis axle bushings inside diameter with multipurpose grease.
2. Install thrust washer (2) and spindle/hub assembly (1) between the two plates of the axle. Insert spindle pivot pin (insert right spindle pin (5) so as the blind

## SECTION 4 - CHASSIS MOUNTED COMPONENTS

radial hole of the pin aligns with the threaded hole of the spindle) and secure with hardware.

3. Coat steering link flange bushings inside diameter with multipurpose grease.
4. Install the steering link (3) with flanges downwards. Install anchor pins and secure with hardware.
5. Install steering sensor as shown following.



**Figure 4-10. Steering Sensor Installation**

6. Install steer cylinder if removed.
7. Install wheels: Refer to Section 4-2.

### NOTICE

IF STEERING SENSOR WAS REMOVED/REPLACED, OR SENSOR DRIVING PIN AND/OR SPINDLE WAS REMOVED/REPLACED, IT IS HIGHLY RECOMMENDED TO PERFORM A STEERING SENSOR CALIBRATION PROCEDURE. REFER TO SECTION 9-5.

# PARTS FINDER

**Search Website  
by Part Number**



**Search Manual  
Library For Parts  
Manual & Lookup Part  
Numbers – Purchase  
or Request Quote**

**Can't Find Part or  
Manual? Request Help  
by Manufacturer,  
Model & Description**

Discount-Equipment.com is your online resource for quality parts & equipment.

Florida: **561-964-4949** Outside Florida TOLL FREE: **877-690-3101**

**Need parts?**

Click on this link: <http://www.discount-equipment.com/category/5443-parts/> and choose one of the options to help get the right parts and equipment you are looking for. Please have the machine model and serial number available in order to help us get you the correct parts. If you don't find the part on the website or on once of the online manuals, please fill out the request form and one of our experienced staff members will get back to you with a quote for the right part that your machine needs.

We sell worldwide for the brands: Genie, Terex, JLG, MultiQuip, Mikasa, Essick, Whiteman, Mayco, Toro Stone, Diamond Products, Generac Magnum, Airman, Haulotte, Barreto, Power Blanket, Nifty Lift, Atlas Copco, Chicago Pneumatic, Allmand, Miller Curber, Skyjack, Lull, Skytrak, Tsurumi, Husquvarna Target, , Stow, Wacker, Sakai, Mi-T- M, Sullair, Basic, Dynapac, MBW, Weber, Bartell, Bennar Newman, Haulotte, Ditch Runner, Menegotti, Morrison, Contec, Buddy, Crown, Edco, Wyco, Bomag, Laymor, Barreto, EZ Trench, Bil-Jax, F.S. Curtis, Gehl Pavers, Heli, Honda, ICS/PowerGrit, IHI, Partner, Imer, Clipper, MMD, Koshin, Rice, CH&E, General Equipment, ,AMida, Coleman, NAC, Gradall, Square Shooter, Kent, Stanley, Tamco, Toku, Hatz, Kohler, Robin, Wisconsin, Northrock, Oztec, Toker TK, Rol-Air, Small Line, Wanco, Yanmar

## SECTION 5. TURNTABLE AND VERTICAL MAST

### 5.1 SWING BEARING

#### Swing Bearing Attach Bolts Check

This check must be performed after the first 50 hours of machine operation and every 500 hours of machine operation thereafter. If during this check, bolts are found missing or loose, replace missing or loosen bolts (use Loctite® 270 on bolts installed in threaded holes through swing bearing outer race).

Outer bearing race is attached to the chassis plate.

Inner bearing race is attached to the turntable base plate.

1. Place the machine on a flat and level surface. Fully lower the mast and the jib. Remove chassis hoods and chassis side shields.
2. Using a suitable overhead lifting equipment attached to both lifting rings of mast section #1, lift and place the machine on blocks of a minimum height of 500mm (20") and capable of supporting the weight of the work platform. Position blocks in such a way that the swing bearing attach bolts to the chassis remain accessible and that the machine remain stable on blocks when the structure will be swung.

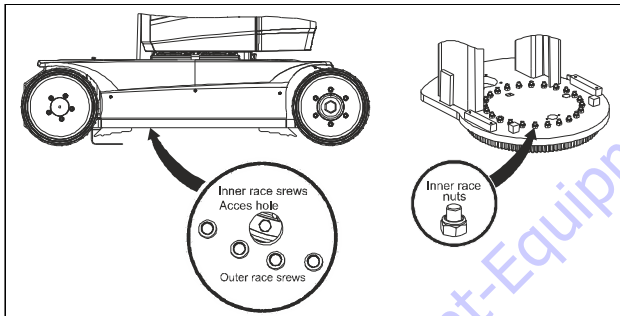


Figure 5-1. Access Holes

3. Check outer race attach screws in sequence for correct torque condition: torque value 117 N.m (86 ft lbs).
4. Check inner race attach screws and nuts in sequence for correct torque condition: torque value 117 N.m (86 ft lbs). Attach screws are accessible through an access hole in the chassis base plate: rotate superstructure using the ground controls (or manual swing devices) to gain access to each screw.

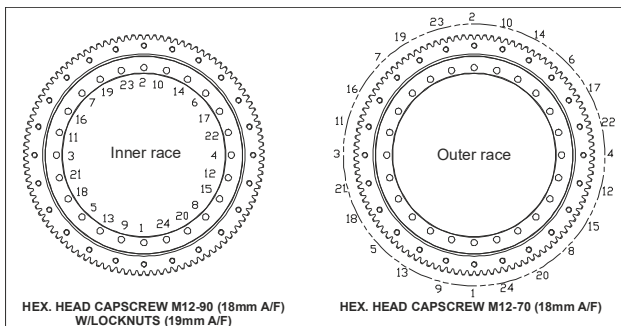


Figure 5-2. Torque Sequence Diagram

#### Swing Bearing Lubrication

##### Bearing Race Lubrication

Lube Points: 2 grease fittings

Capacity: A/R

Lube: A (See Table 1-14)

Interval: Every 250 hours of operation

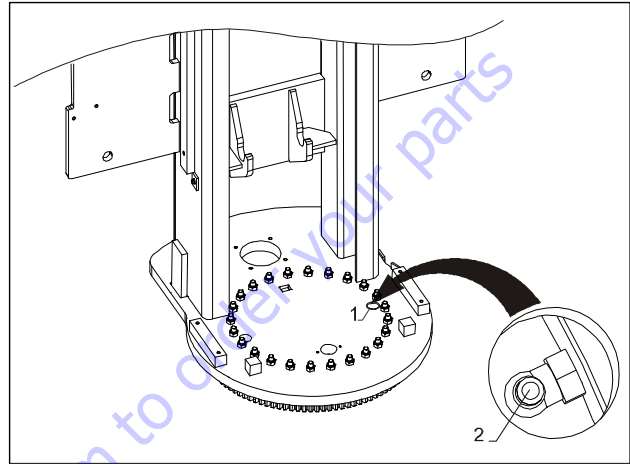


Figure 5-3. Swing Bearing Race Lubrication

1. From ground control station, raise the mast to gain access to the turntable base plate.
2. Locate the two access holes (1) on the turntable plate.
3. Lubricate using a grease gun through the 2 grease fittings (2).

##### Bearing Teeth Lubrication

Lube Points: Coat each tooth

Capacity: A/R

Lube: B (See Table 1-14)

Interval: Every 1000 hours of operation

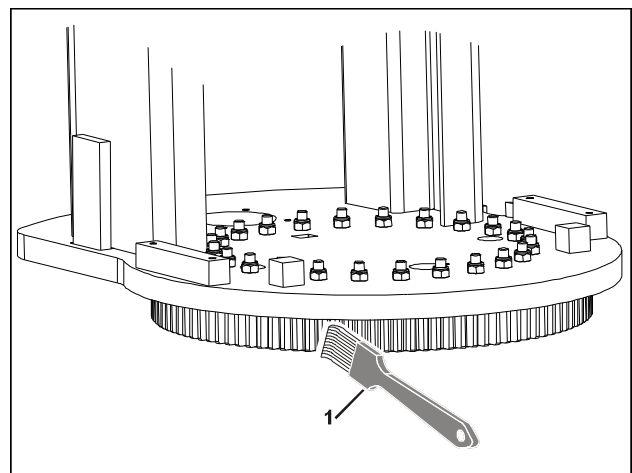


Figure 5-4. Swing Bearing Teeth Lubrication

1. Remove chassis hoods and lateral frame shields.

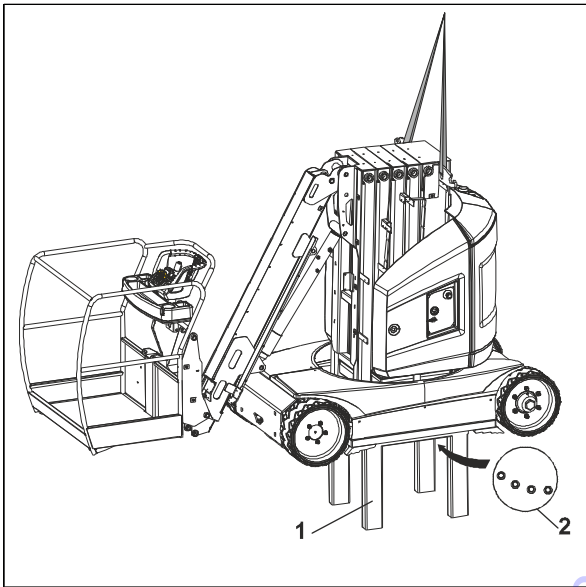


## SECTION 5 - TURNTABLE AND VERTICAL MAST

2. From ground control station, raise the mast to gain access to the turntable plate.
3. Fully swing the structure to the right.
4. Apply grease on the accessible bearing teeth using a **brush (1)**.
5. Fully swing the structure to the left.
6. Complete the operation on the rest of bearing teeth.

### Replacement of Swing Bearing

#### Removal



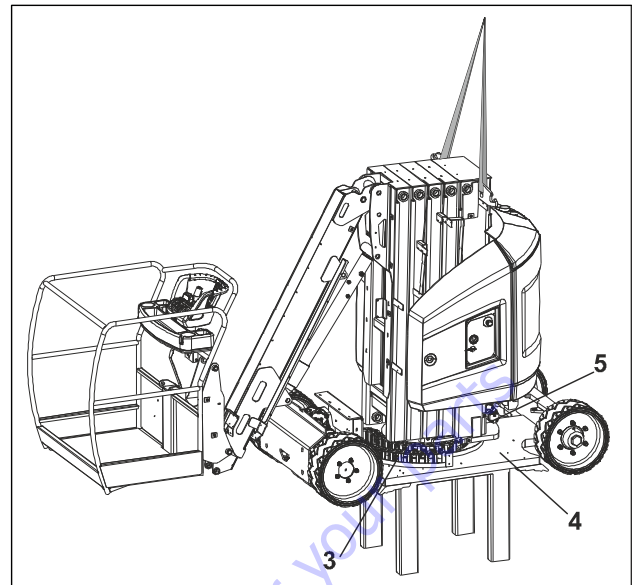
**Figure 5-5. Swing Bearing Removal - 1 of 6**

1. Using a suitable overhead lifting equipment attached to both lifting rings of mast section #1, lift and place the machine on a support (1) with a minimum height of 500 mm (20") and capable of supporting the weight of work platform.

**NOTE:** Toucan 12E/32E weight : 4300 kg / 9480 lbs  
Toucan 12E Plus weight : 4900 kg / 10800 lbs.

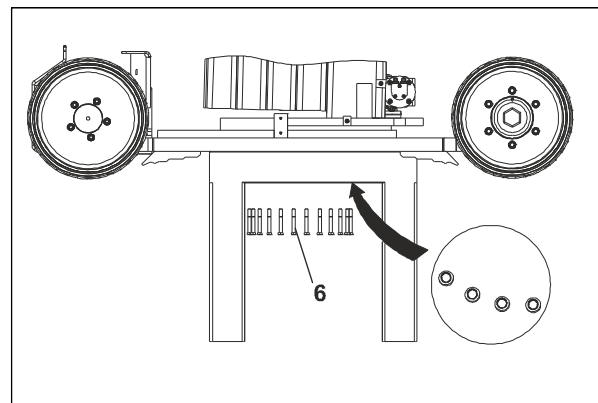
Position the frame such a way that the swing bearing attach bolts under the chassis remain accessible (2). Let the machine secured with the lifting device.

**NOTE:** During the lift up operation, the tilt angle will be about 9° for the Toucan 12E and 7° for the Toucan 12E Plus, in the platform direction.



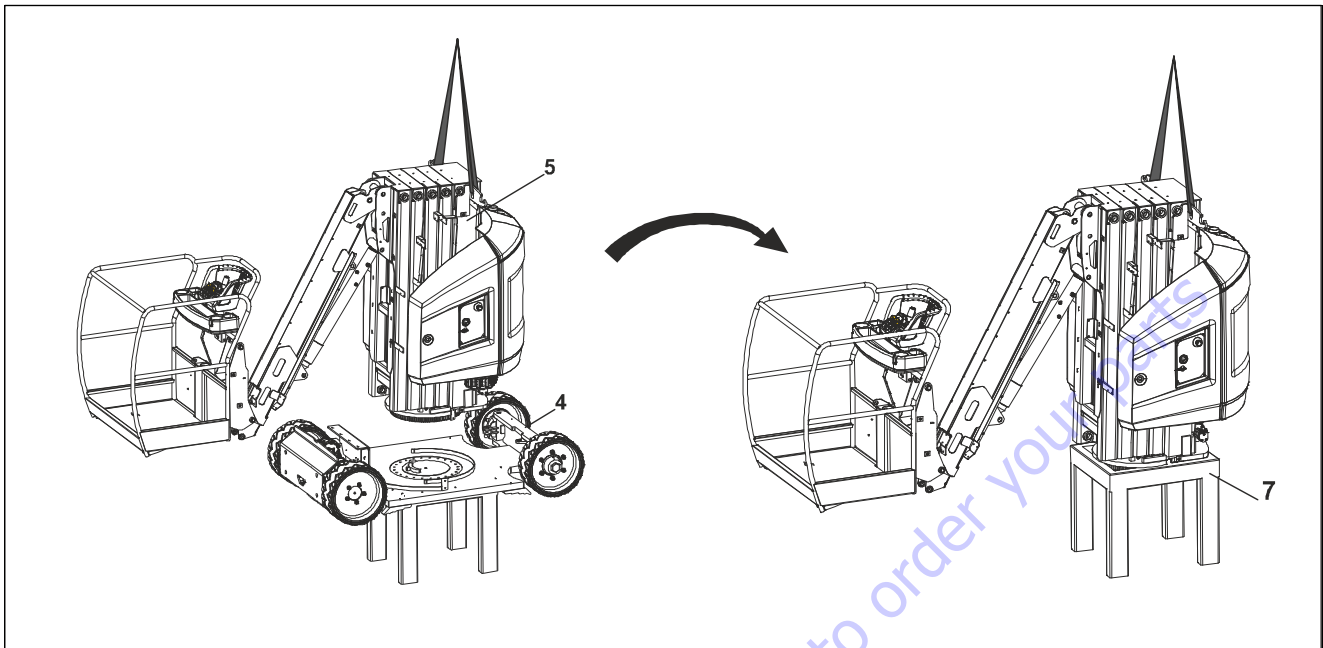
**Figure 5-6. Swing Bearing Removal - 2 of 6**

2. Remove chassis hoods and lateral frame shields.
3. Tag and disconnect power cables from the bottom battery packs.
4. Remove bottom battery packs (Qty 4) and battery supports on both side to gain access to the circular power track (3).
5. Disconnect the power track (3) from the machine frame (4).
6. Tag and disconnect all the cables and hoses that come from the power track and that are connected on frame components (Steering cylinder, controller,...). Cap or plug all openings so no dirt enters the system.
7. Disconnect the power track (3) from the machine turntable (5). Roll the power track around the turntable and store it above the swing drive. Secure it with tie straps to avoid any damages when the turntable will be removed from the frame.



**Figure 5-7. Swing Bearing Removal - 3 of 6**

- Remove and discard the 24 screws and hardened washers (6) securing the swing bearing outer race to the frame.



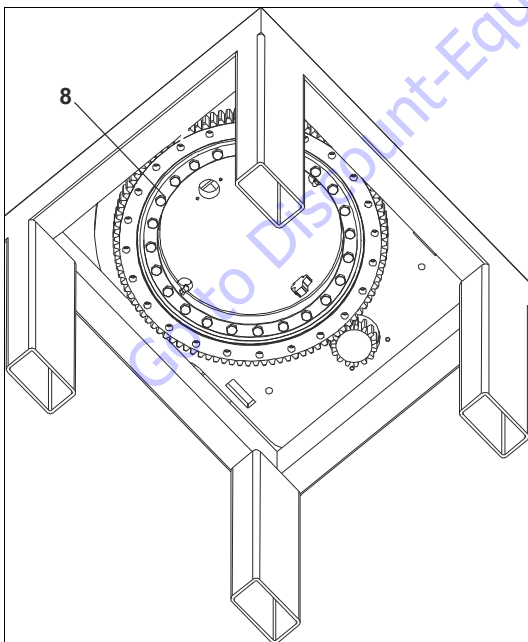
**Figure 5-8. Swing Bearing Removal - 4 of 6**

- Carefully lift the turntable assembly (5) and place it onto a support (7) with a minimum height of 500 mm (20") and capable of supporting the weight of the complete assembly.

Let the turntable be secured with the lifting device.

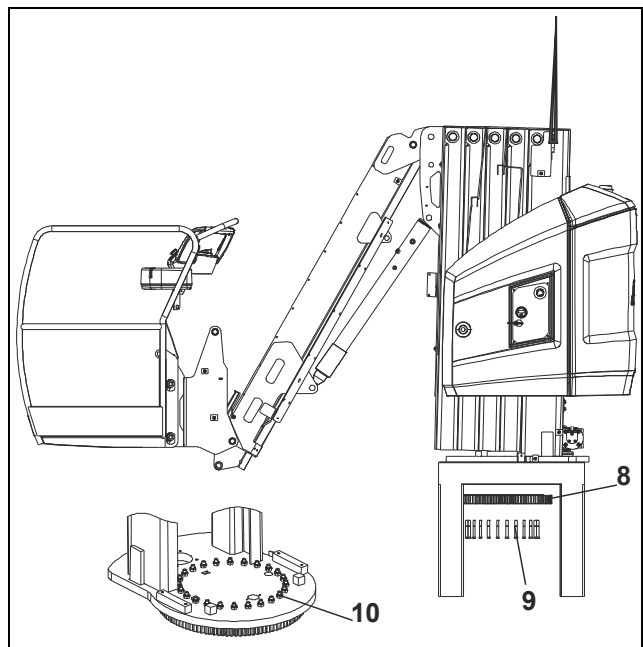
**NOTE:** During the lift up operation, the tilt angle will be about 8° for the Toucan 12E and 7° for the Toucan 12E Plus, in the platform direction.

**NOTE:** Toucan 12E/32E turntable weight: 3000 kg/6615 lbs.  
Toucan 12E Plus turntable weight: 3600 kg/7940 lbs.



**Figure 5-9. Swing Bearing Removal - 5 of 6**

Position the turntable such a way that the swing bearing (8) can be removed.



**Figure 5-10. Swing Bearing Removal - 6 of 6**

- Remove and discard the 24 screws (9) and nuts (10) securing the bearing (8) to the base plate. Use a suitable lifting equipment to support and remove the bearing.

## SECTION 5 - TURNTABLE AND VERTICAL MAST

11. Clean and inspect bearing teeth for damages or excessive wear. Clean bearing seating surfaces on the chassis and on the turntable base plate. Free threaded holes on the swing bearing outer race from dirt, oil or foreign material. Check the functioning of the ball bearing (cracks or hard points).

### Installation of Swing Bearing

#### **CAUTION**

JLG INDUSTRIES RECOMMEND THAT ALL REMOVED BEARING NUTS, BOLTS AND HARDENED WASHER TO BE DISCARDED AND REPLACED WITH NEW PARTS. SINCE THE SWING BEARING IS THE ONLY STRUCTURAL LINK BETWEEN THE CHASSIS AND TURNTABLE, IT IS IMPERATIVE THAT REPLACEMENT HARDWARE MEETS JLG SPECIFICATIONS. USE OF GENUINE JLG HARDWARE IS HIGHLY RECOMMENDED.

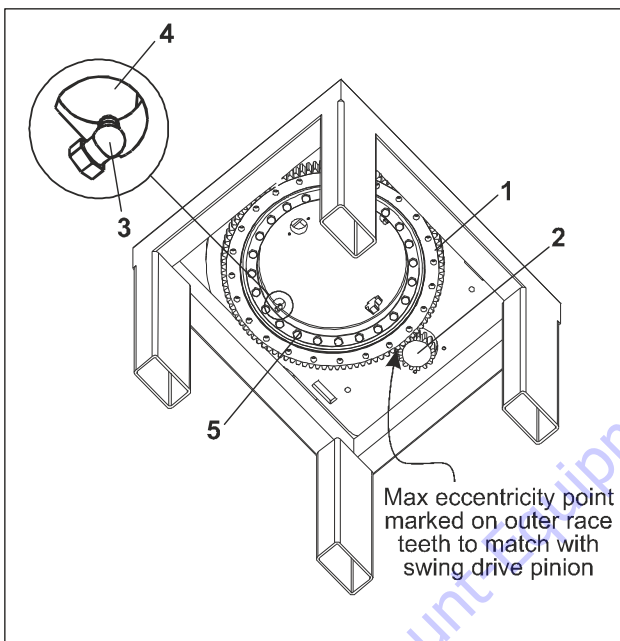


Figure 5-11. Swing Bearing Installation

1. Install the swing bearing (1) in such a way that the maximum eccentricity point (marked by a colored spot on 3 teeth) matches with the pinion (2). Rotate the inner race to align the two inner race greasers (3) with the two turntable base plate holes (4).
2. Loosely install the 24 new screws (5) and locknuts through inner race of bearing and turntable base plate.
3. Move the bearing towards pinion until contact.

#### **CAUTION**

IF COMPRESSED AIR OR ELECTRICALLY OPERATED WRENCH IS USED FOR TIGHTENING THE BEARING ATTACHMENT BOLTS, THE TORQUE SETTING ACCURACY OF THE TOOL SHOULD BE CHECKED PRIOR TO USE.

4. Following the torque sequence diagram (Refer to Torque Sequence Diagram) tighten the bolts to an initial torque of 80 N.m (59 ft.lbs). Then following the same sequence, tighten to a final torque of 117 N.m (86 ft.lbs).
5. Carefully lift the turntable assembly and place it onto the machine frame such a way that the bearing outer race holes are in line with the frame holes.
6. Apply thread locking component Loctite 270 on bearing bolts.
7. Install the bearing bolts and hardened washers.
8. Following the torque sequence diagram (Refer to Torque Sequence Diagram) tighten the bolts to an initial torque of 80 N.m (59 ft.lbs). Then following the same sequence, tighten to a final torque of 117 N.m (86 ft.lbs).
9. Repeat all the removal steps in reverse order.
10. Perform a few swing movements from the ground controls to check for proper operation.
11. Record work platform operating time (hourmeter on ground console). Turntable bearing bolts torque will have to be verified after the next 50 hours of operation.

## 5.2 SWING DRIVE

### Swing Drive Removal

12. Place the machine on a flat and level surface.
13. Remove chassis hoods and right side frame shield.
14. Using ground controls, rotate the turntable 90° to the left.
15. Tag, disconnect and cap swing motor hydraulic lines and ports.

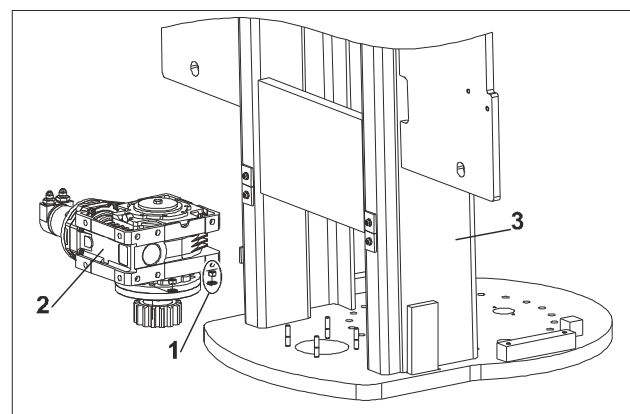
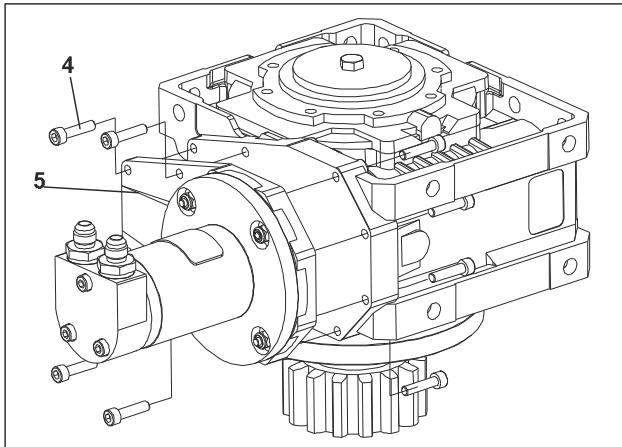


Figure 5-12. Swing Drive Removal

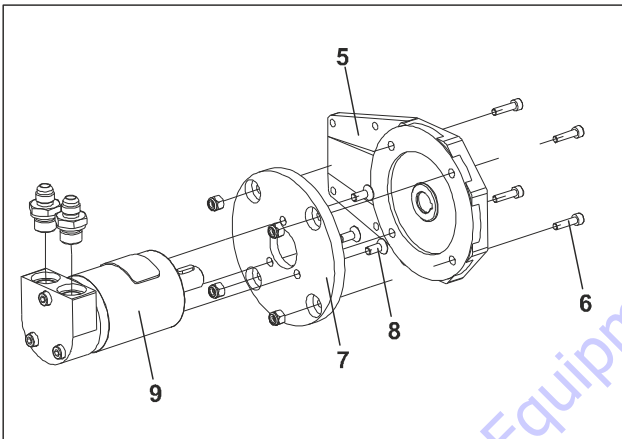
16. Remove the 4 attachments nuts and washers (1) securing the swing drive (2) on the turntable base (3).
17. Lift swing drive upwards and remove it from its mounting hole.

**Swing Drive Disassembly**



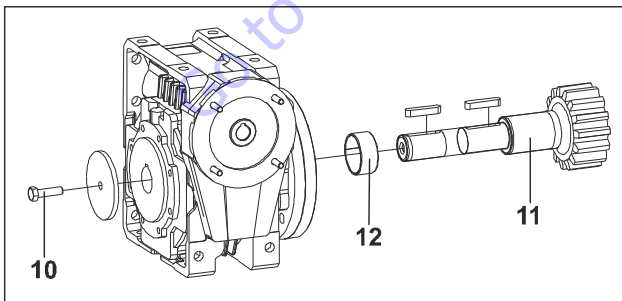
**Figure 5-13. Swing Drive Disassembly - 1 of 3**

1. Remove the screws (4) (Qty 8) to open and remove the gear assembly cover (5).



**Figure 5-14. Swing Drive Disassembly - 2 of 3**

2. Remove the screws (6) (Qty 4) to disconnect the motor flange (7) from the cover (5).
3. Remove the screws (8) (Qty 3) to disconnect the motor (9) from the flange (7).



**Figure 5-15. Swing Drive Disassembly - 3 of 3**

4. Remove the screw (10) and the pinion (11).
5. Clean and inspect the hydraulic motor and the pinion for damage or excessive wear. Replace if necessary.

**Swing Drive Assembly**

1. Coat the bushing (12) with multipurpose grease.
2. Secure the screw (10) with thread locking compound Loctite 243.
3. Repeat all disassembly steps in reverse order.

**Swing Drive Installation**

1. Repeat all removal steps in reverse order.
2. Secure the nuts (1) with thread locking compound Loctite 243.
3. Perform a few swing movements from the ground controls to check for proper operation.
4. Check hydraulic level and adjust accordingly.

**5.3 ROLLERS**

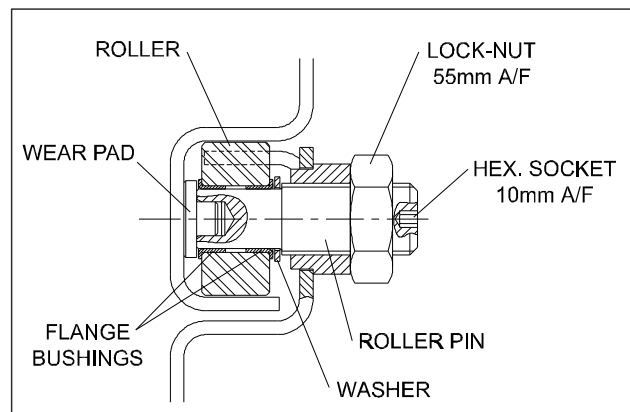
**Inspection**

Check roller pin plastic wear pad thickness. Replace roller pin if the wear pad thickness is less than 3.5 mm (0.13 in).

**Removal and Installation**

**NOTE:** Mast rollers can be removed one by one in turn without dismantling the telescopic mast. Fully lower the mast to remove the upper rollers. Raise the mast as necessary to gain access to the lower rollers. Mast sections alignment must be adjusted after rollers replacement.

**Roller Assembly**



**Figure 5-16. Roller Assembly**

## SECTION 5 - TURNTABLE AND VERTICAL MAST

### Roller Removal

1. Unscrew and remove the locknut from the roller pin.
2. Unscrew the roller pin to release the plastic wear pad and free the wear pad as indicated below:

#### NOTICE

HOLD THE PLASTIC WEAR PAD, THE ROLLER, THEN THE WASHER TO PREVENT THEM FROM FALLING TO THE BOTTOM OF THE MAST PROFILE.

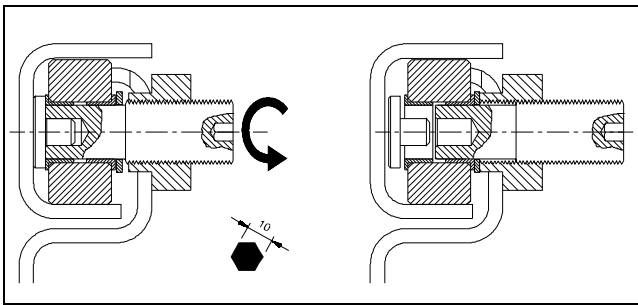


Figure 5-17. Roller Removal

### Roller Installation

**NOTE:** If already assembled, use a locknut to free the plastic wear pad, the roller and the washer from the pin: install the locknut on the pin and tighten it until the wear pad is released.

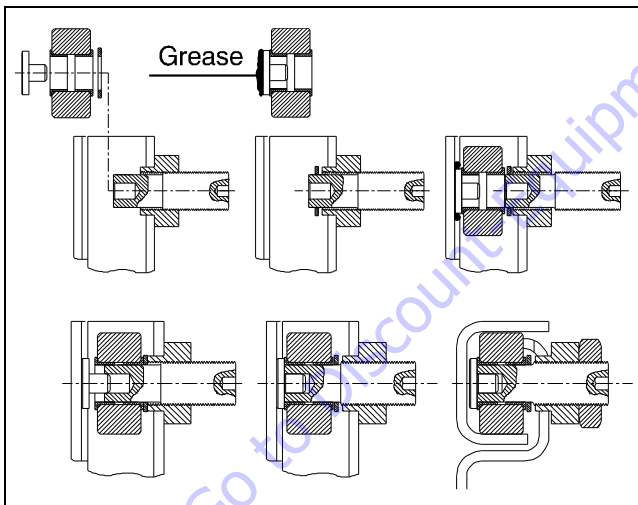


Figure 5-18. Roller Installation

1. Partly tighten the pin on the mast section and slide the washer on the pin.
2. Apply grease to the wear pad so that it sticks to the mast wall and does not fall to the bottom of the mast section.
3. Press the wear pad to the mast wall and slide the roller and the wear pad in line with the pin.
4. Once the roller is in line with the pin, tighten the pin so that the roller slides onto the pin.

5. Reposition the wear pad in line with the pin then tighten the pin until the plastic wear pad is fully inserted.
6. Loosen slightly the pin to prevent the mast from jamming during adjustment. Loosely install the locknut.
7. Repeat operation for the other pin assemblies.
8. Adjust mast transversal play and mast sections alignment.

## 5.4 MAST AND ROLLERS SETTING

### Introduction

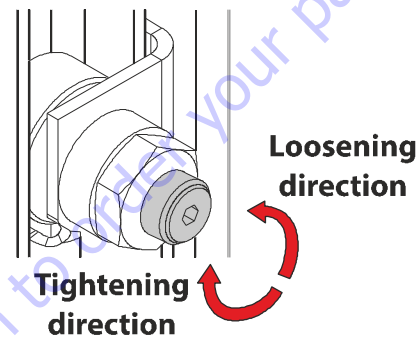


Figure 5-19. Loosening and Tightening Direction

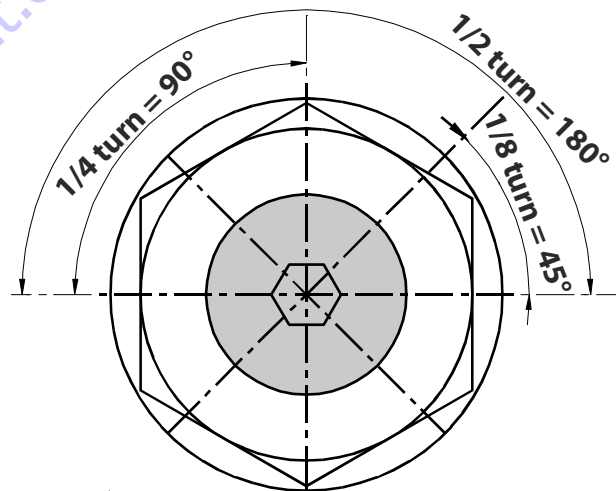


Figure 5-20. Setting Angles

Angular Adjustment		Play Modification (mm) - Action on 1 roller
Turn	Angle (°)	Models 12E-32E
1	360	4.5
1/2	180	2.2
1/4	90	1.1
1/8	45	0.6

Table 5-1. Influence of roller setting on mast play

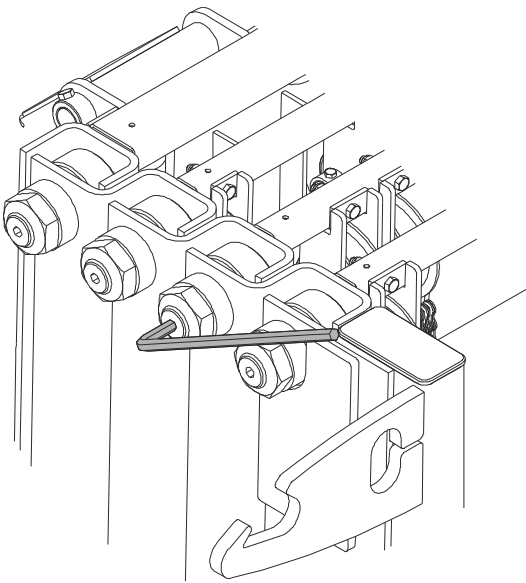


Figure 5-21. Setting Tool

**⚠ WARNING**

NEVER USE MANUAL DESCENT CONTROL WHEN SETTING MAST. NEVER STAND UNDER THE PLATFORM IF THE SLACK CHAIN WARNING ALARM IS ACTIVE.

**NOTE:** Clean the mast surfaces and remove grease before setting operation.

**⚠ CAUTION**

USE ALL APPLICABLE SAFETY PRECAUTIONS WHILE WORKING ON, UNDER OR AROUND ANY MACHINERY.

**Procedure**

**Top Rollers Setting**

1. Ensure mast is fully lowered prior to completing top roller setting procedure. Refer to Top Rollers Mast Configuration for mast configuration/terminology.

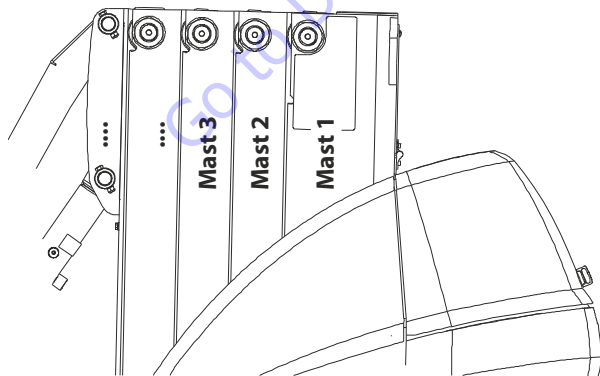


Figure 5-22. Top Rollers Mast Configuration

2. Bring each top roller pad in contact with corresponding mast surfaces and adjust distances so that C1D=C1G; C2D=C2G until last mast section CxD=CxG.

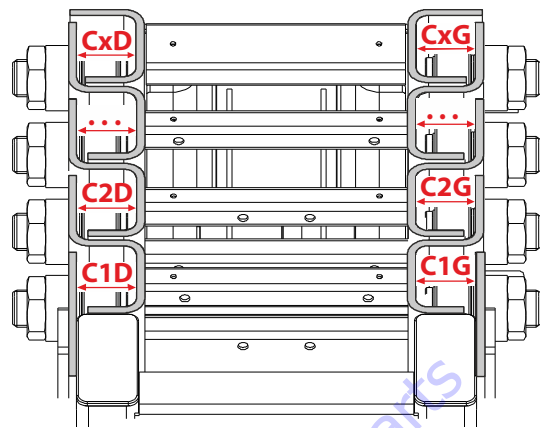


Figure 5-23. Top Rollers Mast Centering (Top View-Mast Lowered)

3. On each top roller, on right side of the machine, loosen roller to be able to insert a 0.5 mm shim (between roller pad and mast profile), see Adjusting Top Roller Play

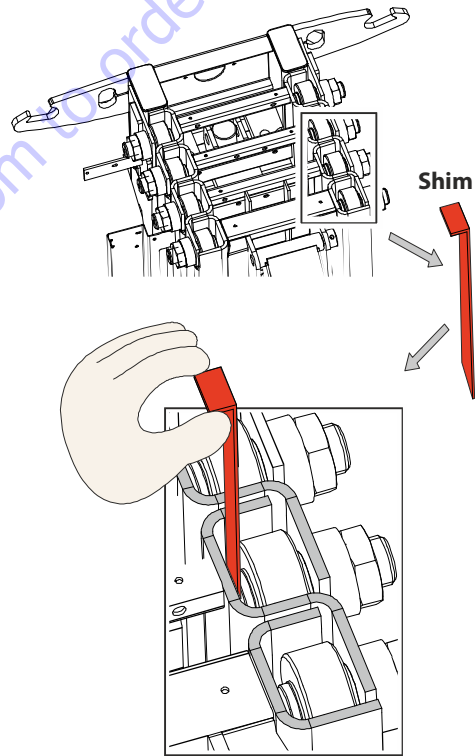


Figure 5-24. Adjusting Top Roller Play

4. Slowly tighten the roller so that it comes just in contact with the shim. Remove the shim and tighten the rollers as indicated in the Table 5-2.

Top Rollers	Tightening (Turn)
	Models 12E-32E
Mast 1	1/4
Mast 2	3/8 (1/4 + 1/8)
Mast 3	3/8 (1/4 + 1/8)

Table 5-2. Top Rollers Tightening

## SECTION 5 - TURNTABLE AND VERTICAL MAST

Top Rollers	Tightening (Turn)
	Models 12E-32E
Mast 4	3/8 (1/4 + 1/8)
Mast 5	3/8 (1/4 + 1/8)

**Table 5-2. Top Rollers Tightening**

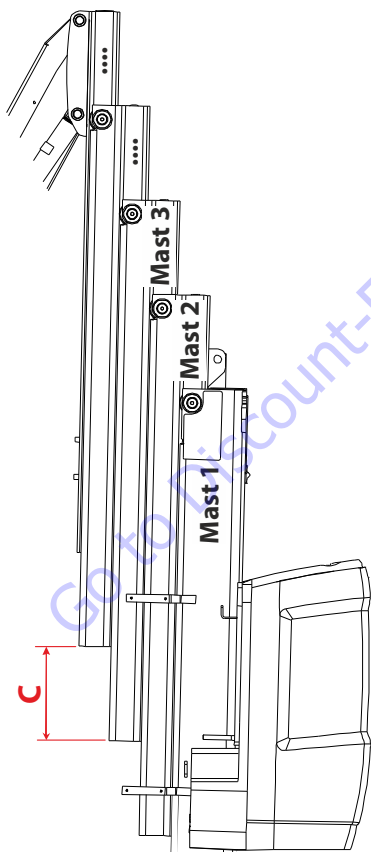
- Tighten lock nuts on each roller.
- Test mast lowering movement through a complete stroke. No mast jamming (slack chain) must appear. In the event of a slack chain occurrence, identify the concerned roller and loosen roller 1/8 turn and recheck mast lowering movement. Complete step 6 until mast lowers without sticking.

### Bottom Rollers Setting

- Bottom rollers setting is done with different mast heights. Raise the mast sections to the measurements shown in table 5-3.

### **⚠ WARNING**

EXERCISE EXTREME CAUTION WHEN WORKING UNDER THE PLATFORM TO PERFORM THIS STEP. NEVER STAND UNDER THE PLATFORM IF THE SLACK CHAIN WARNING ALARM IS ACTIVE.



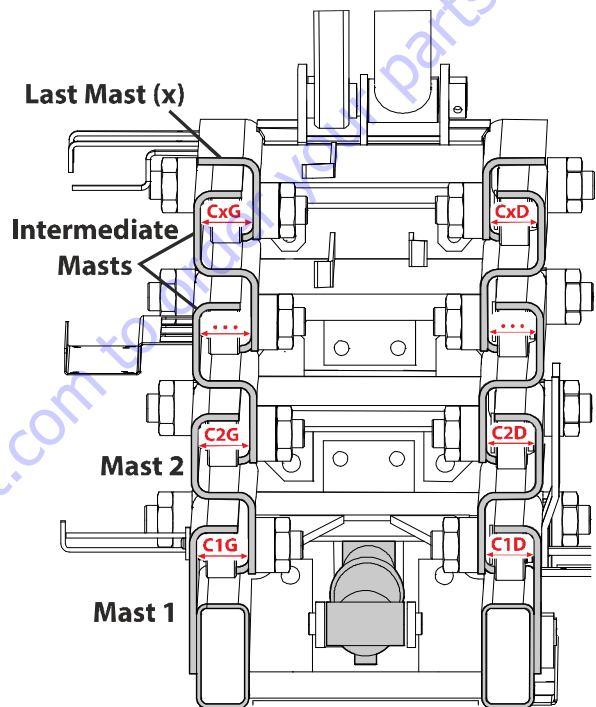
**Figure 5-25. Bottom Rollers Mast Configuration**

- Bring each bottom roller pad in contact with corresponding mast surfaces and adjust distances so

Bottom Rollers	Setting Height = C (mm)
	Models 12E-32E
Mast 2	Maxi
Mast 3	500
Mast 4	350
Mast 5	250
Mast 6	200

**Table 5-3. Bottom Rollers Setting Height**

that C1D=C1G; C2D=C2G until last mast section CxD=CxG.



**Figure 5-26. Bottom Rollers Mast Centering (Bottom View - Mast Raised)**

9. On each bottom roller, on right side of the machine, loosen roller to be able to insert a 0.5 mm shim (between roller pad and mast profile).

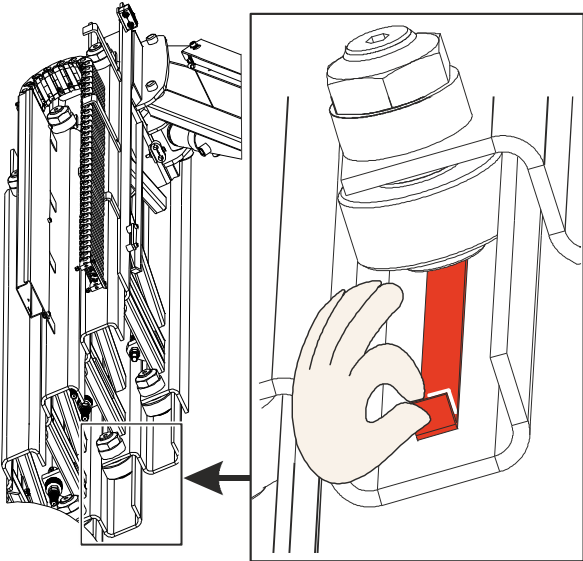


Figure 5-27. Adjusting Bottom Roller Play

10. Slowly tighten the roller so that it comes just in contact with the shim. Remove the shim.
11. Tighten lock nuts on each roller.
12. Test mast lowering movement through a complete stroke. No mast jamming (slack chain) must appear. In the event of a slack chain occurrence, identify the concerned roller and loosen roller 1/8 turn and recheck mast lowering movement. Complete step 12 until mast lowers without sticking.

**Mast Vertical Alignment Setting**

13. Fully raise the mast and use a plumb line to ensure that the vertical alignment of the mast sections is correct (See Mast Vertical Alignment).

**NOTE:** Pay attention to the previous mast play adjustments: If a roller needs to be tightened/loosened, apply the opposite setting on the other side roller.

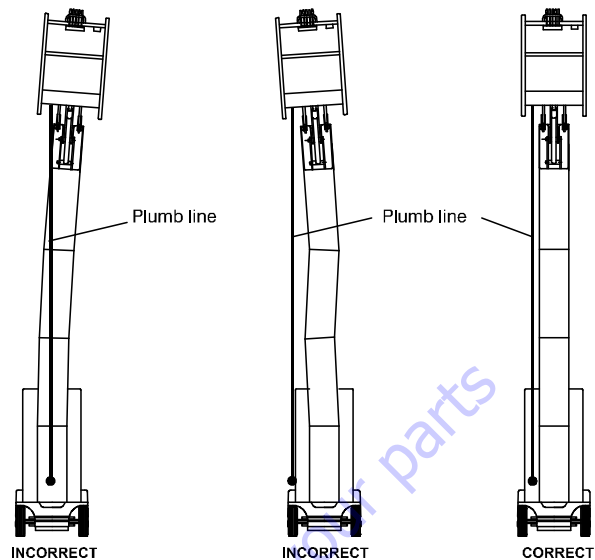


Figure 5-28. Mast Vertical Alignment

**Settings Validation**

14. a). Test mast lowering movement from ground control panel (No load in the platform). The mast must come down without jamming or slack chain warning in the maximum time indicated in Table 5-4.
- b). Test mast lowering movement with platform control box (One operator in the platform). A second operator should be on the ground to assist with rescue in the event of mast sticking. The mast must come down without jamming or slack chain warning in the maximum time indicated in Table 5-4.

Controls	Mast Lowering Time (s)
	Models 12E-32E
Ground Control Panel	50
Platform Control Box	30

Table 5-4. Maximum Mast Lowering Time

- c). If the operator considers that an adjustment is needed (too much play in the mast, mast jamming...), the setting can be modified within following limits:

**- Top rollers:**

Tightening (maximum indicated in Table 5-5) compared to basic setting in step 4 or  
Loosening until correct functioning (No mast jamming).

**- Bottom rollers:**

Tightening (maximum indicated in Table 5-5) compared to basic setting in step 10 or  
Loosening until correct functioning (No mast jamming).



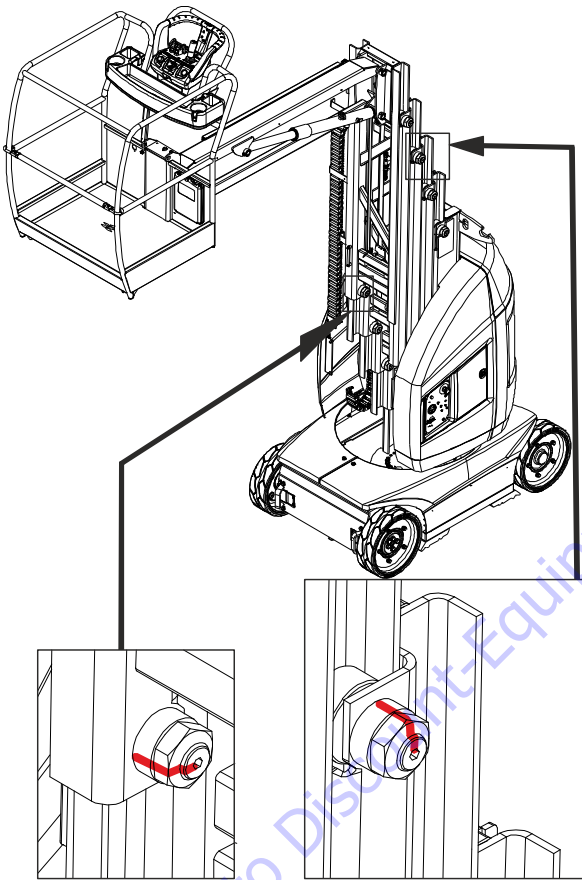
## SECTION 5 - TURNTABLE AND VERTICAL MAST

Rollers	Rollers Setting (Turn)
	Models 12E-32E
Top	1/8
Bottom	1/8

**Table 5-5. Maximum Tightening Adjustment**

**NOTE:** After each tightening operation, it is imperative to ensure that no mast jamming appears. Maximum times for mast lowering are given for a temperature >10°C (50°F).

- Visual marking is required: mark the rollers with a paint mark as shown in (See Figure 5-29.)



**Figure 5-29. Top and Bottom Rollers**

### Final Control

- Complete full function tests of the machine prior to returning the machine to service.

## 5.5 LIFTING CHAINS

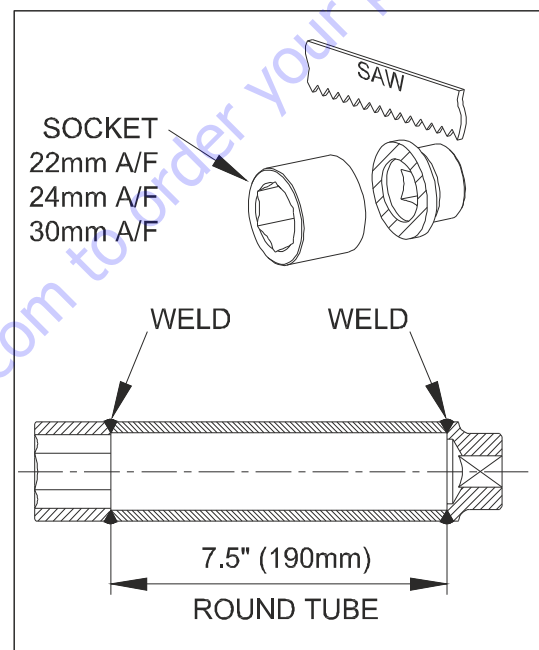
### **⚠ WARNING**

NEVER WORK UNDER AN ELEVATED PLATFORM UNTIL PLATFORM HAS BEEN SAFELY RESTRAINED FROM ANY MOVEMENT BY BLOCKING OR OVERHEAD SLING.

### Safety Accessories and Tooling

Using suitable lifting equipment to support mast section(s) during chain replacement procedure is essential for good working safety condition.

A long hollow body socket is required to allow insertion over the long threaded chain anchors. A box socket can be built using a square drive socket and a tube as follow:



**Figure 5-30. Long Hollow Body Socket**

Use this box socket with a square driver ratchet and appropriate square drive extensions to reach the anchors attachment nuts.

### Lubrication

Lube Points: 8 chains

Capacity: A/R

Lube: C (See Table 1-14)

Interval: After the first 50 hours of operation and every 125 hours of operation (or every 3 months) thereafter.

### **NOTICE**

THE INITIAL LUBRICATION OF THE CHAINS IS ONLY TO PROTECT THEM AGAINST RUST AND TO PROTECT FRICTION SURFACES DURING THE FIRST 50 HOURS OF OPERATION.

**NOTICE**

**AVOID REMOVING THE LUBRICANT FROM THE CHAINS. DO NOT USE ACID OR DETERGENT TO CLEAN THE CHAINS. USE ONLY SPECIFIED LUBRICANT. NEVER USE GREASE TO LUBRICATE THE CHAINS.**

**NOTE:** Chains lubrication intervals must be established depending on the environment in which the work platform is operated or stored (dusty or aggressive environment). The lubricant must be adapted to the machine's operating condition. In general, a non detergent mineral oil is sufficient. Its viscosity must be adapted to the temperature according to the chart below. A too low viscosity will facilitate draining of the lubricant by gravity. A too high viscosity will prevent lubricant from reaching the friction surfaces of the chain.

Operating Temperature °C (°F)	ISO Viscosity grades VG
-15°C to 0°C (5°F to 32°F)	15 to 32 mm <sup>2</sup> /s (cSt)
0°C to 50°C (32°F to 122°F)	46 to 150 mm <sup>2</sup> /s (cSt)

- Using the ground control station, fully raise the mast.
- Lubricate the chains with a specified lubricant using a paint brush or by spraying (if using a paint brush, lubricant must be applied longitudinally to facilitate penetration of lubricant between friction surfaces, then transversely between the plates to enable lubricant to reach the joint).

**NOTE:** If the chains are too clogged for the lubrication to be correctly performed:

- Remove them from the mast.
- Thoroughly clean them with paraffin oil.
- Dry with compressed air while moving the chain.
- IMMEDIATELY** dip in specified lubricant and move the chain.
- Reinstall chain and cycle the mast several times.

**Lifting Chains Inspection**

Inspect thoroughly each chain over its entire length:

- Chains, anchors, clevis pins and splits pins should not be corroded.
- Plates should not be cracked:

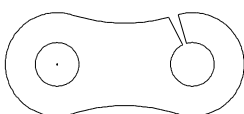


Figure 5-31. Cracked Plate

- The plate clevis pins should not present excessive play.
- Pins should not have turned in their housing (1).

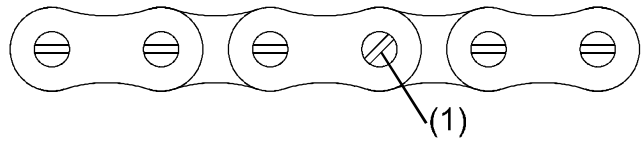


Figure 5-32. Turned Pin

- Plates should not be worn above 5% of their total height.

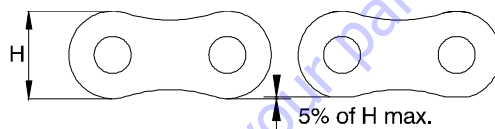
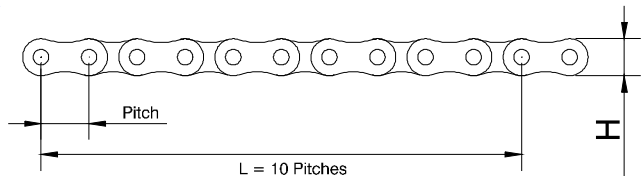


Figure 5-33. Worn Plate

	4th Stage	3rd Stage	1st and 2nd Stage
<b>Pitch</b>	5/8" (15.875 mm)	3/4" (19.05 mm)	
<b>H min.</b>	11.5 mm (0.453 in.)	13.6 mm (0.535 in.)	17.2 mm (0.68 in.)

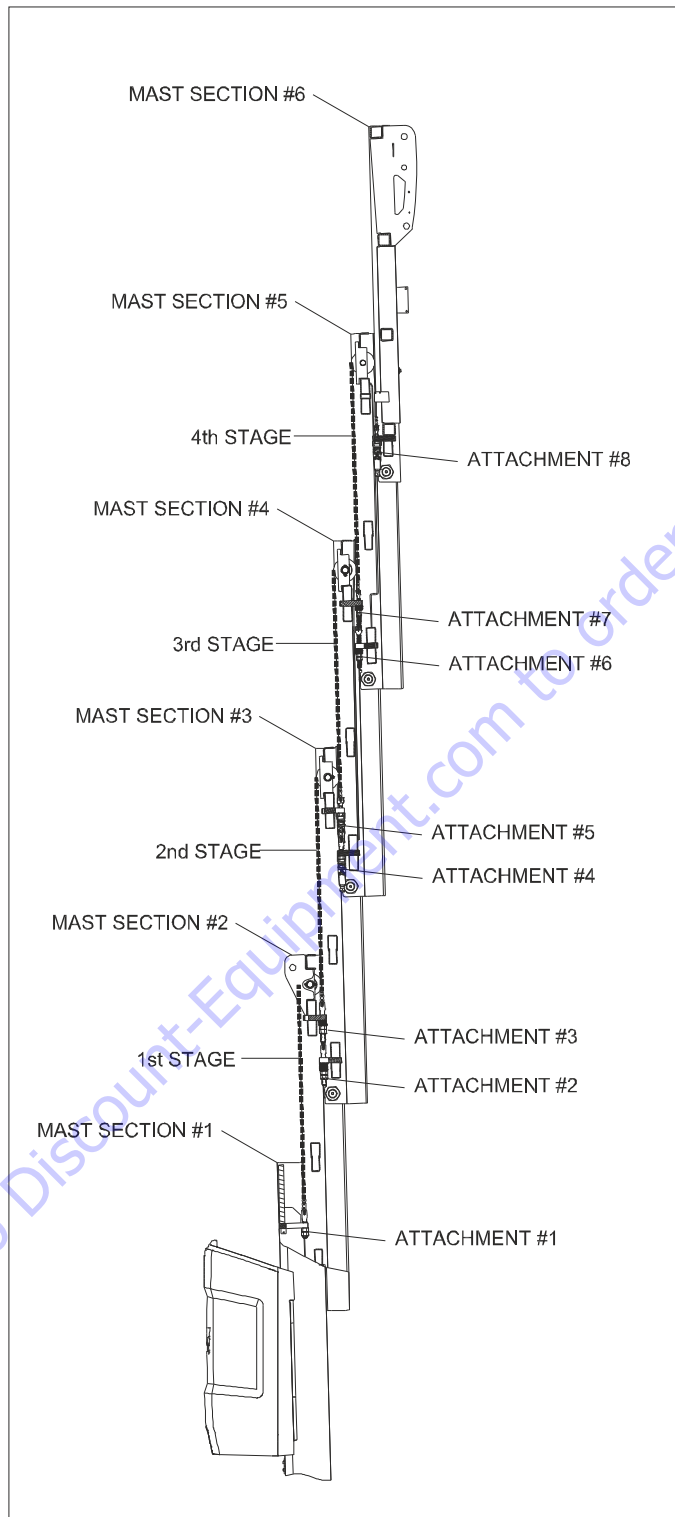
- Chains should not have stretched above the values indicated in the chart below.



Pitch	5/8" (15.875 mm)	3/4" (19.05 mm)
<b>L max.</b>	163.5 mm (6.4 in.)	196 mm (7.7 in.)

All chain appearing faulty or worn must be replaced including chain anchors. Condition of the pulleys, pulley bushings and telescopic mast alignment must be inspected.

**Lifting Chains Removal and Installation**



**Figure 5-34. Chains Stages and Attachments Description**

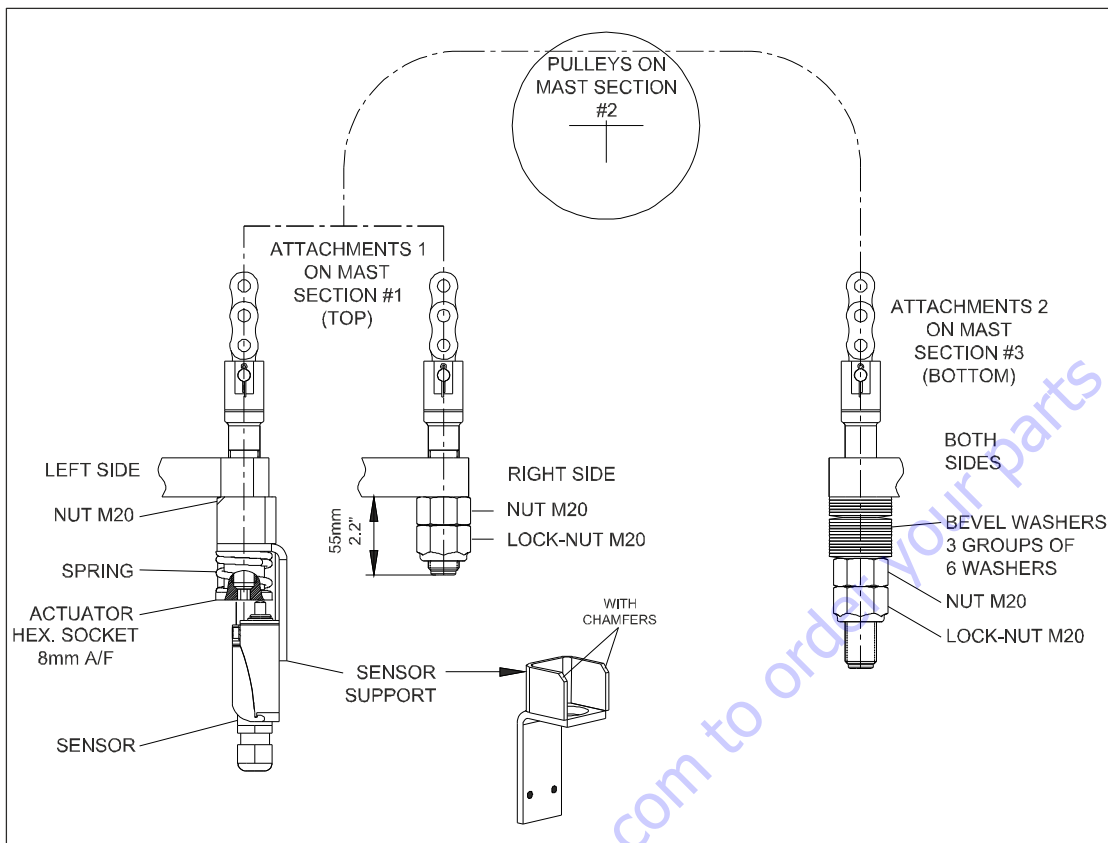


Figure 5-35. First Chain Stage

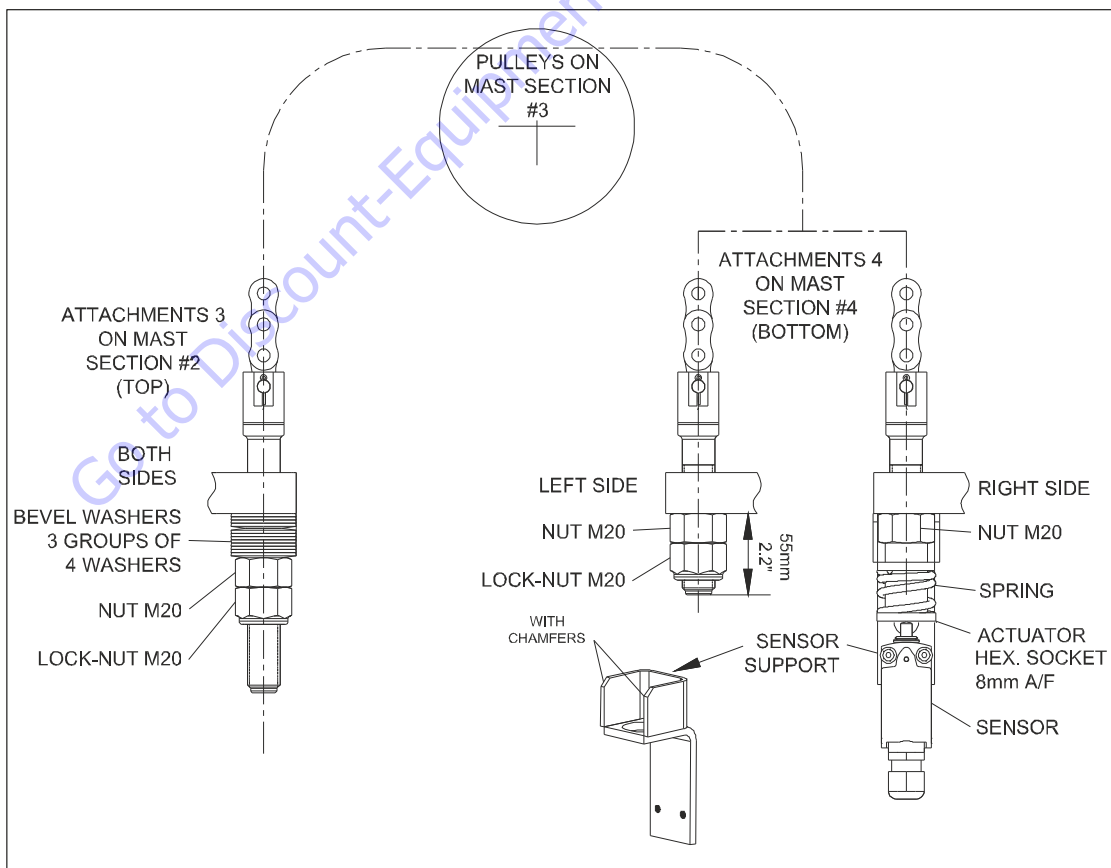
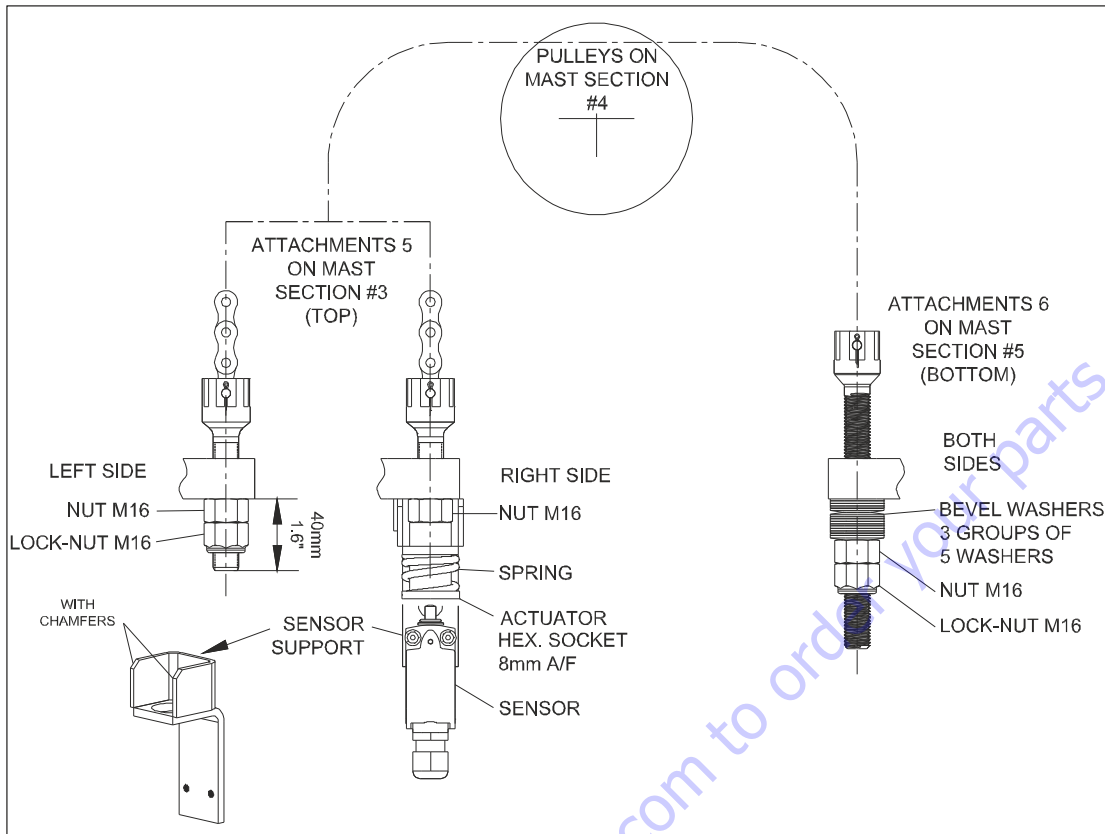
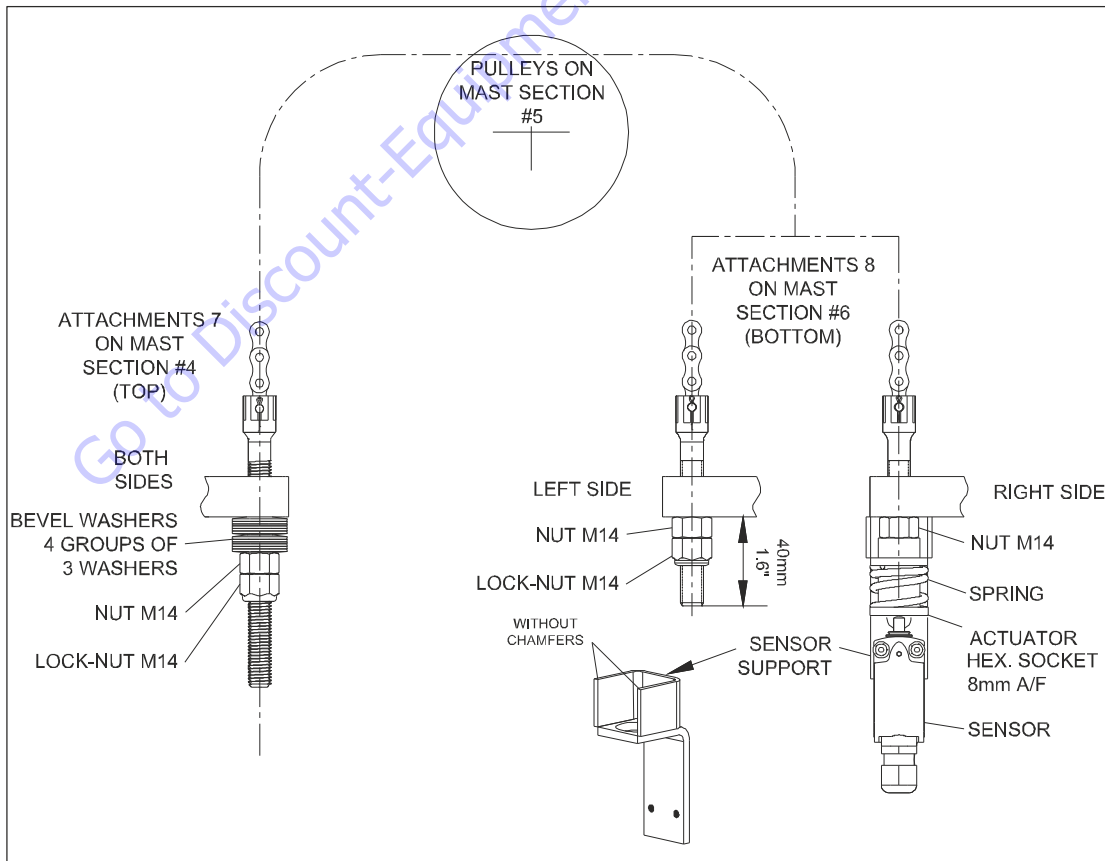


Figure 5-36. Second Chain Stage



**Figure 5-37. Third Chain Stage**



**Figure 5-38. Fourth Chain Stage**

**NOTICE**

REPLACE SYSTEMATICALLY BOTH CHAINS OF A SAME STAGE. CHAIN ANCHORS, CLEVIS PINS, BEVEL WASHERS AND NUTS MUST ALSO BE REPLACED. USE ONLY GENUINE JLG PARTS. REMOVE THE LIFTING CHAINS ONE BY ONE. ALWAYS REPLACE AND TENSION A CHAIN BEFORE REMOVING ANOTHER ONE. IN ADDITION, LIFTING EQUIPMENT SUCH AS CHAINS OR SLINGS SHOULD BE INSTALLED AS REQUIRED TO SUPPORT MAST SECTIONS DURING CHAIN REMOVAL. CORRECTLY TAG AND DISCARD WORN CHAINS AND COMPONENTS SO THAT THEY CANNOT BE INSTALLED ON THE WORK PLATFORM OR ON ANOTHER MACHINE.

**NOTICE**

INSTALLATION OF CHAINS MUST BE DONE IN A CLEAN WORK AREA. DO NOT REMOVE THE LUBRICANT FROM THE CHAIN BEFORE, DURING OR AFTER THEIR INSTALLATION. WHEN UNROLLING OR INSTALLING CHAINS, AVOID TWISTING THEM.

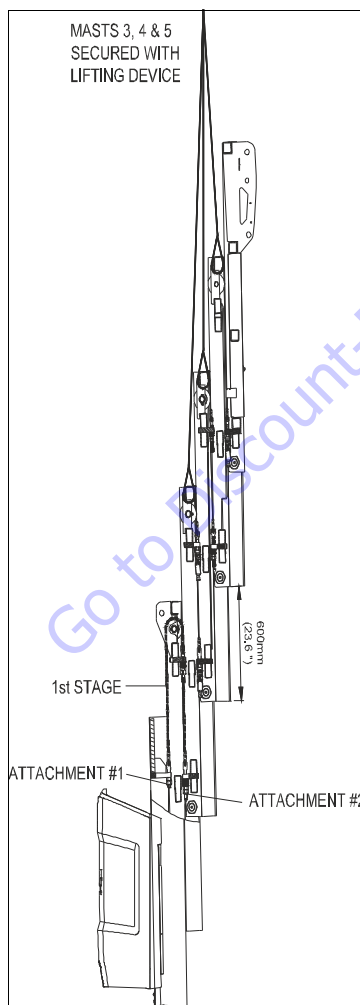
**NOTE:** As part of the lifting chain replacement procedure, inspect condition of the pulley pins and pulleys. Replace all damaged parts.

Remove frame hoods, frame shields and rotate the turntable 90 degrees to get easier access to the mast assembly.

**1<sup>st</sup> Chains Stage Removal**

1. Using the ground controls, raise the mast to gain access to chain attachments #1 and #2.
2. Safely secure mast sections #3, #4 and #5 with adjustable lifting chains as indicated on the figure below.  
Draw all slack from chains.

3. Remove the locknut, attachment nut and the bevel washers from a chain anchor at attachment #2.
4. If installed, remove the chain slack detection assembly from the other end of the chain at attachment #1.  
To remove the detection assembly, first remove the sensor, the actuator, the spring, the sensor support and then the attachment nut.  
If not installed, remove the locknut and the attachment nut from the other end of the chain.
5. Remove the chains from the pulley groove.
6. Install and tension a new chain before removing the other one.



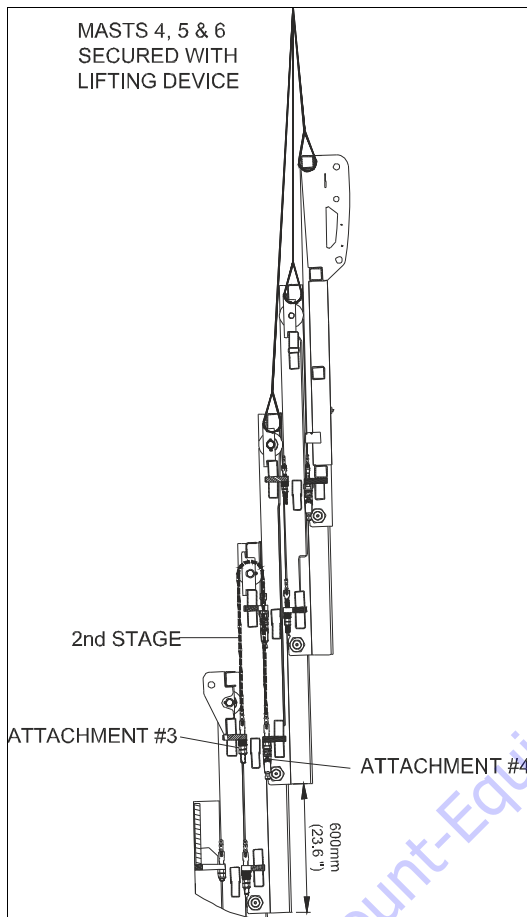
**1<sup>st</sup> Chains Stage Installation**

1. Install the short anchor at one end of the chains. Correctly install the split pins on the clevis pin.
2. Install the long anchor at the other end of the chain. Correctly install the clevis pins on the split pin.
3. Run the chain over the pulley. The short anchor must be on the side of attachment #1.
4. Install the chain slack detection assembly or the attachment nut and locknut (as indicated on the previous figures) at attachment #1.
5. Install the bevel washers and the attachment nut at attachment #2.
6. Check that the chain is correctly positioned in the pulley groove and tighten the attachment nut (on the long anchor) until the chain is under tension. The locknut will be installed after chains tension adjustment procedure.
7. After both chains of the stage have been replaced, adjust lifting chains tension accordingly.

**Figure 5-39. First Chains Stage Removal**

**2<sup>nd</sup> Chains Stage Removal**

1. Using the ground controls, raise the mast to gain access to chain attachment #3 and #4.
2. Safely secure mast sections #4, #5 and #6 with adjustable lifting chains as indicated on the figure below.  
Draw all slack from chains.



**Figure 5-40. Second Chains Stage Removal**

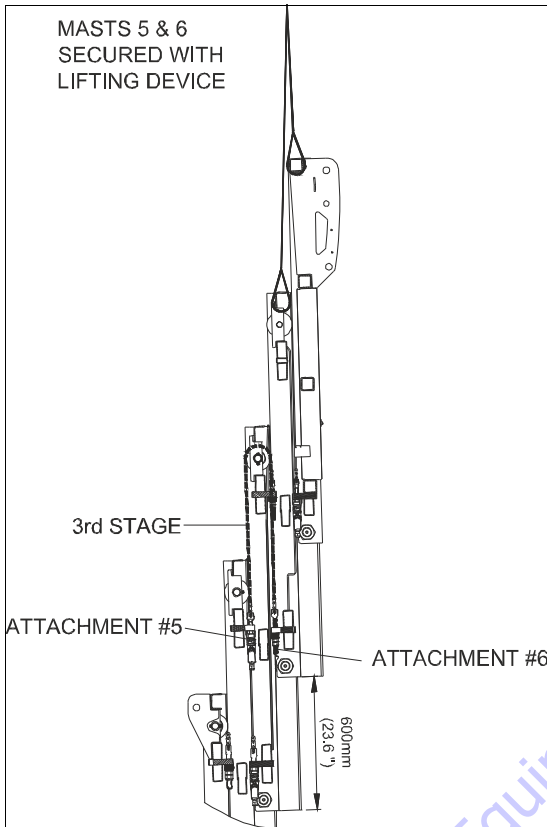
3. Remove the locknut, attachment nut and the bevel washers from a chain anchor at attachment #3.
4. If installed, remove the chain slack detection assembly from the other end of the chain at attachment #4.  
To remove the detection assembly, first remove the sensor, the actuator, the spring, the sensor support and then the attachment nut.  
If not installed, remove the locknut and the attachment nut from the other end of the chain.
5. Remove the chain from the pulley groove.
6. Install and tension a new chain before removing the other one.

**2<sup>nd</sup> Chains Stage Installation**

1. Install a short anchor at one end of the chain. Correctly install the split pins on the clevis pin.
2. Install the long anchor at the other end of the chain. Correctly install the split pins on the clevis pin.
3. Run the chain over the pulley. The short anchor must be on the side of attachment #4.
4. Install the chain slack detection system or the attachment nut and locknut (as indicated on the previous figures) at attachment #4.
5. Install the bevel washers and attachment nut at attachment #3.
6. Check that the chain is correctly positioned in the pulley groove and tighten the attachment nut (on the long anchor) until the chain is under tension. The locknut will be installed after chains tension adjustment procedure.
7. After both chains of the stage have been replaced, adjust lifting chains tension accordingly.

**3<sup>rd</sup> Chains Stage Removal**

1. Using the ground controls, raise the mast to gain access to chain attachment #5 and #6.
2. Safely secure mast sections #5 and #6 with adjustable lifting chains as indicated on figure below. Draw all slack from chains.



**Figure 5-41. Third Chains Stage Removal**

3. Remove the locknut, attachment nut and the bevel washers from a chain anchor at attachment #6.
4. If installed, remove the chain slack detection assembly from the other end of the chain at attachment #5. To remove the detection assembly, first remove the sensor, the actuator, the spring, the sensor support and then the attachment nut. If not installed, remove the locknut and the attachment nut from the other end of the chain.
5. Remove one of the chain anchors so that the chain can be removed from the pulley groove.
6. Install and tension a new chain before removing the other one.

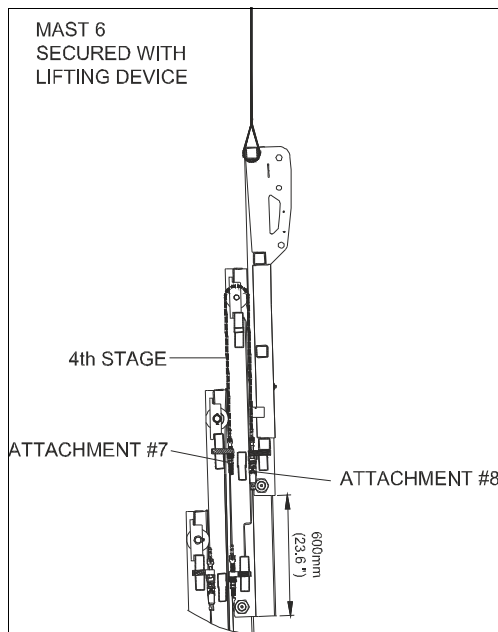
**3<sup>rd</sup> Chains Stage Installation**

1. Install a short anchor at one end of the chain. Correctly install the split pins on the clevis pin.
2. Run the end of the chain (without anchor) over the pulley. The short anchor must be on the side of attachment #5.
3. Install the long anchor at the other end of the chain. Correctly install the split pins on the clevis pin.
4. Install the chain slack detection system or the attachment nut and locknut (as indicated on the previous figures) at attachment #5.
5. Install the bevel washers and attachment nut at attachment #6.
6. Check that the chain is correctly positioned in the pulley groove and tighten the attachment nut (on the long anchor) until the chain is under tension. The locknut will be installed after chains tension adjustment procedure.
7. After both chains of the stage have been replaced, adjust lifting chains tension accordingly.



**4<sup>th</sup> Chains Stage Removal**

1. Using the ground controls, raise the mast to gain access to chain attachment #7 and #8.
2. Safely secure mast section #6 with adjustable lifting chains as indicated on figure below.  
Draw all slack from chains.



**Figure 5-42. Fourth Chains Stage Removal**

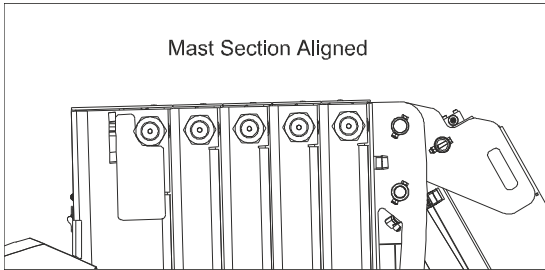
3. Remove the locknut, attachment nut and the bevel washers from a chain anchor at attachment #7.
4. If installed, remove the chain slack detection assembly from the other end of the chain at attachment #8.  
To remove the detection assembly, first remove the sensor, the actuator, the spring, the sensor support and then the attachment nut.  
If not installed, remove the locknut and the attachment nut from the other end of the chain.
5. Remove the chain from the pulley.
6. Install and tension a new chain before removing the other one.

**4<sup>th</sup> Chains Stage Installation**

1. Install a short anchor and a long one on the chain. Correctly install the split pins on the clevis pins.
2. Run the chain over the pulley so that the short anchor is on the side of attachment #8.
3. Install the chain slack detection assembly or the attachment nut and locknut (as indicated on the previous figure) at attachment #8.
4. Install the bevel washers and attachment nut at attachment #7.
5. Check that the chain is correctly positioned in the pulley groove and tighten the attachment nut (on the long anchor) until the chain is under tension. The locknut will be installed after chains tension adjustment procedure.
6. After both chains of the stage have been replaced, adjust lifting chains tension accordingly.

**Chain Tension Adjustment**

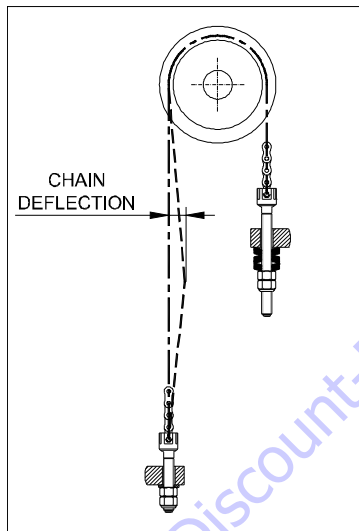
The lifting of a same stage must have an identical tension. In addition, the chains must be tensioned so that the mast sections are aligned (with approx. 80 kg (176 lbs) in the platform).



**Figure 5-43. Chain Tension Adjustment**

**Chains Tension Control**

1. Fully raise the mast then lower it by approximately 50 cm (20 in.).
2. Press on each chain between the pulley and the chain attachment. Each chain of a same stage must have the same deflection.



**Figure 5-44. Chains Tension Control**

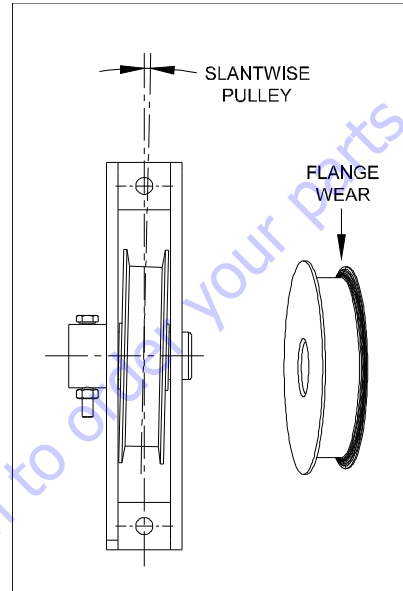
**Chain Tension Adjustment**

1. With the mast fully lowered, check mast sections alignment for reference.
2. Fully raise the mast then lower it by approximately 50 cm (20 in.).
3. Remove the locking nuts from the long anchor of the chains to be adjusted.
4. Press on each chain between the pulley and the chain attachment to estimate chain deflection difference. Tighten the attachment nut on the anchor of the chain which is too slack or loosen the attachment nut on the anchor of the chain which is too tight, so as to ensure the final alignment of the mast sections is kept.
5. Install and tighten the locknut on each anchor.

**5.6 PULLEY - PULLEY SUPPORT**

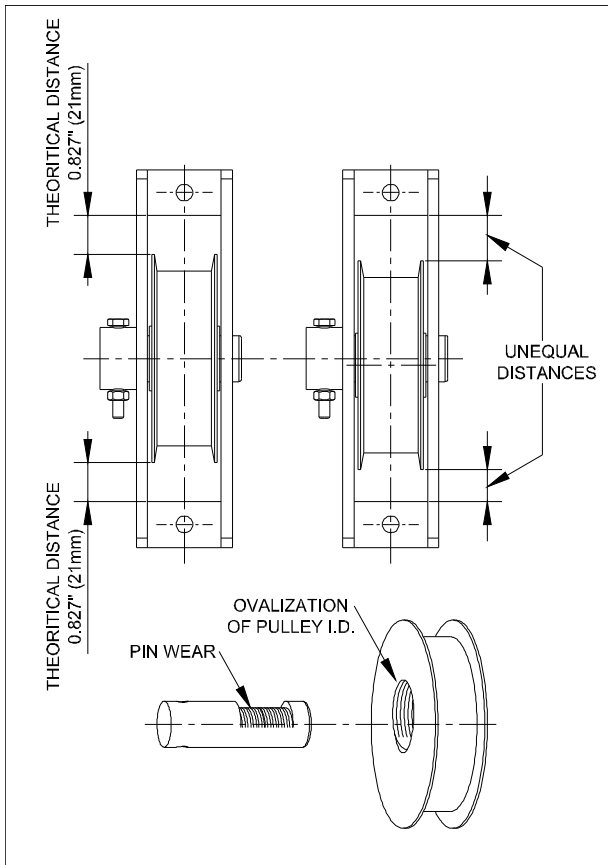
**Pulley Inspection**

1. From ground controls, raise the mast to get pulleys visible.
2. Check for slantwise pulleys. Replace pulley assembly and check mast sections alignment.



**Figure 5-45. Slantwise Pulley**

3. Check for iron filings on turntable circular base plate or on pulley support bottom tube. Presence of iron filings indicates a severe pin and pulley assembly wear. Remove the machine from service until the worn pulley assembly has been replaced. Check mast sections alignment after pulley replacement.
4. Measure distance between the top edge of the pulley and the top of the pulley support, then the distance between the bottom edge of the pulley and the bottom of the pulley support. Unequal distances indicate a severe pin and pulley assembly wear. Remove the machine from service until the worn pulley assembly has been replaced.



**Figure 5-46. Pulley Assembly Wear**

**Removal and Installation**

**NOTICE**

**REMOVE PULLEY SUPPORTS AND/OR PULLEY ONE BY ONE. ALWAYS REPLACE AND SECURE A PULLEY SUPPORT AND/OR A PULLEY BEFORE REMOVING ANOTHER ONE. THE SAME SUITABLE LIFTING DEVICE USED FOR CHAINS REMOVAL SHOULD BE USED TO SUPPORT MAST SECTION DURING DISASSEMBLY.**

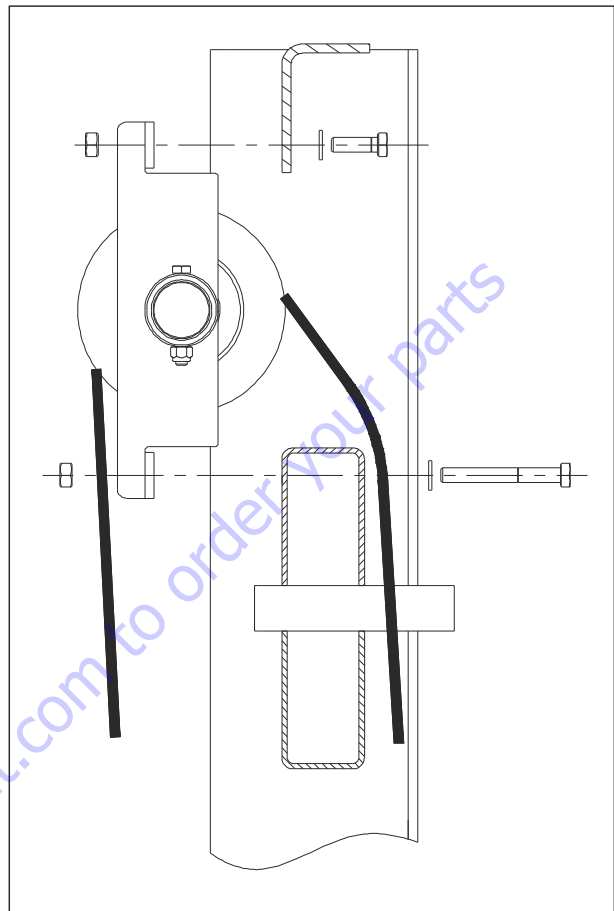
**NOTE:** *Unless the pulley supports need replacing, there is no need to remove the lifting chains for removing the pulleys. If the pulley supports need replacing, follow the lifting chain removal and installation procedure. Once the chains slackened, only remove the long anchor to be able to run the chain out of the pulley support (if necessary).*

Remove frame hoods, frame shields and rotate the turntable 90° to get an easier access to the mast assembly.

**Pulley Removal**

1. Follow the lifting chains removal and installation procedure to secure the appropriate mast section(s).
2. Remove the locknut from a long anchor and loosen the attachment nut to slacken the chain.

3. Remove the hardware securing the pulley support to the mast and slide the pulley support out of the mast.



**Figure 5-47. Pulley Support Removal**

4. Remove the pulley pin locking hardware and drive the pin out while holding the pulley.

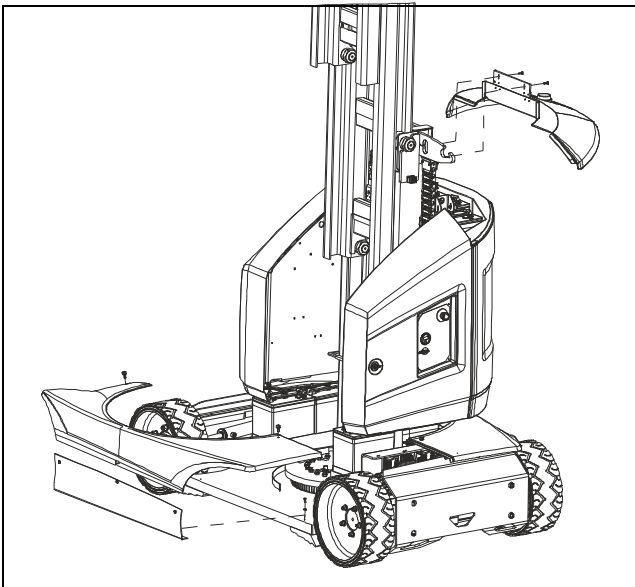
**Pulley Installation**

1. Position the chain over the pulley. Align the pulley with the mounting holes in the pulley support and install the pin. Secure the pin with hardware.
2. Install and secure the pulley support to the mast.
3. Tighten the attachment nut of the long anchor to tension the chain before removing the other pulley support. The locknut will be installed after chains tension adjustment procedure.
4. Adjust chains tension accordingly.

**5.7 MAST CYLINDER**

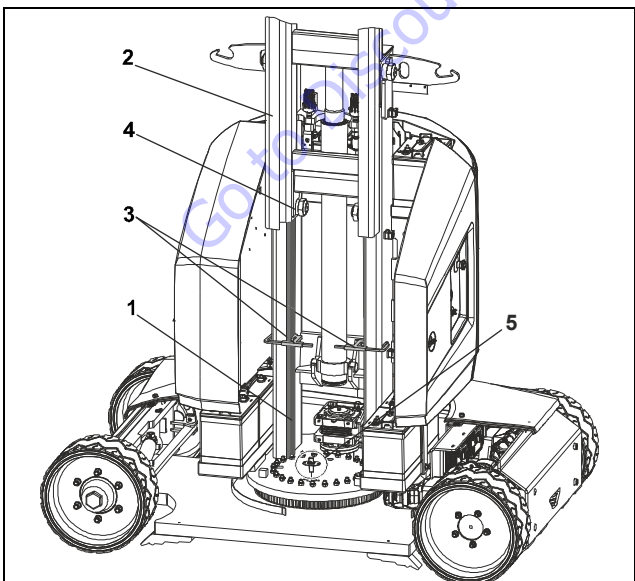
**Mast Cylinder Removal**

1. Place the machine on a flat and level surface. Remove chassis hoods and lateral frame shields. Remove battery top hood. Rotate the superstructure 90°.
2. Using the ground controls, fully raise the mast.



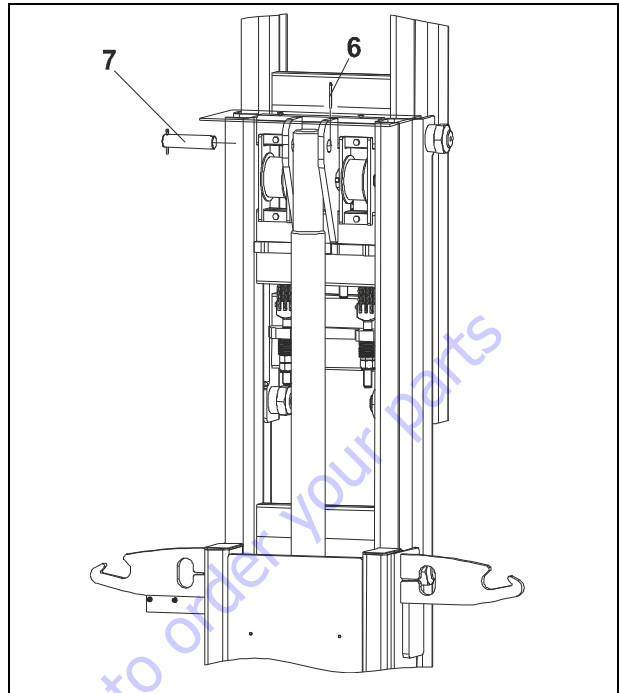
**Figure 5-48. Mast Cylinder Removal - 1 of 8**

3. Install a couple of suitable blockings (1) to support mast section #2 (2) as indicated. The blocking must rest on turntable circular base plate. Secure the blocking with C-clamps (3).
4. Using the ground controls, lower the mast until mast section #2 rollers (4) rest on blockings.
5. Remove the drive orientation switch (5) to avoid damages on next steps.



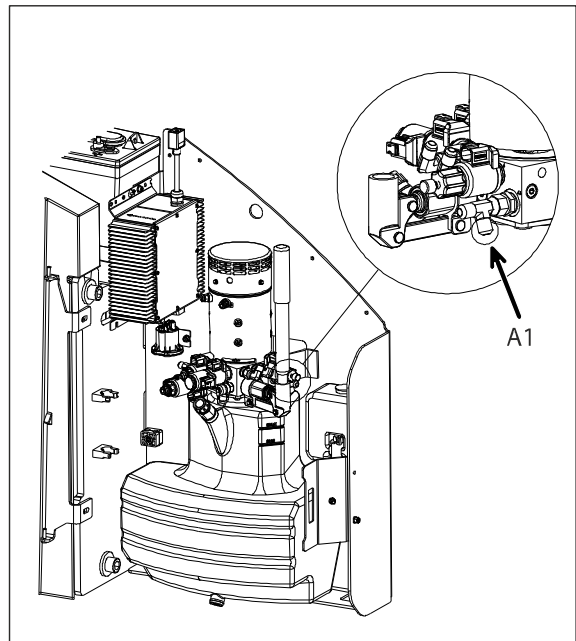
**Figure 5-49. Mast Cylinder Removal - 2 of 8**

6. Remove one cotter pin (6) from cylinder anchor pin. Drive the pin (7) out using a suitable drift.



**Figure 5-50. Mast Cylinder Removal - 3 of 8**

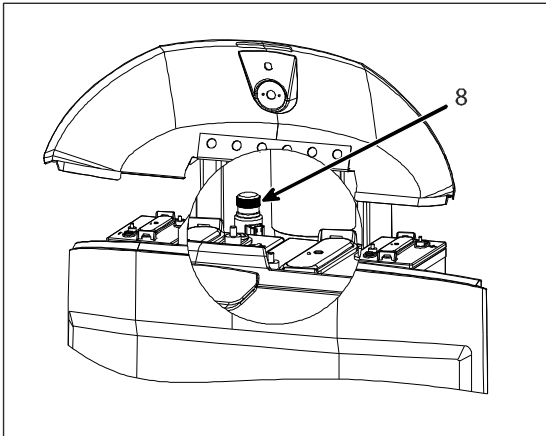
7. Disconnect the mast cylinder hose from port A1 on power unit manifold. Put the hose end into a tank to collect the oil during the next step.



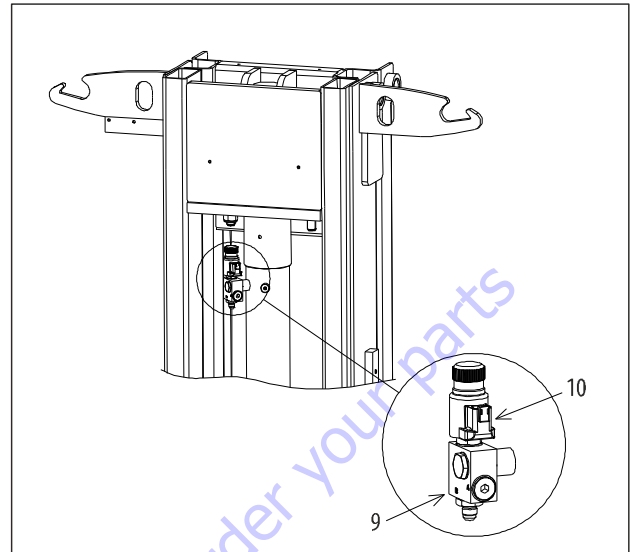
**Figure 5-51. Mast Cylinder Removal - 4 of 8**

**SECTION 5 - TURNTABLE AND VERTICAL MAST**

8. Control the mast lowering using the actuator (8) until the cylinder rod is fully retracted:

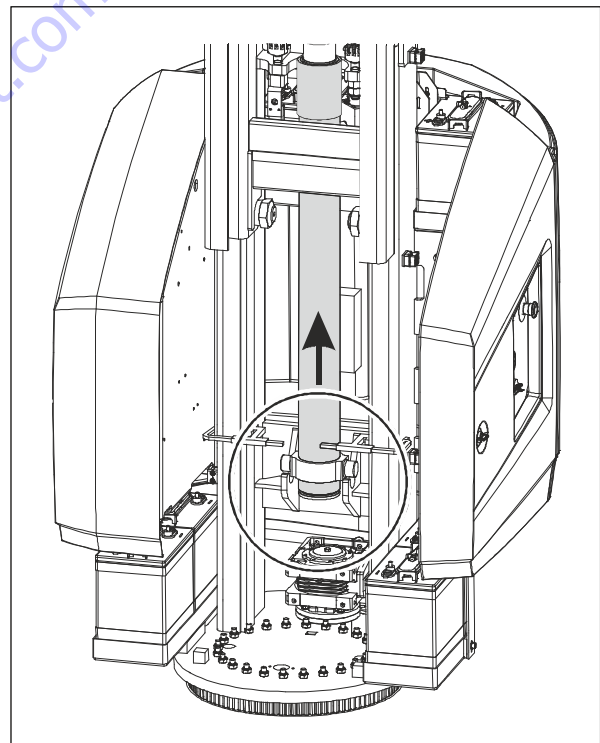


9. Once the rod fully retracted, disconnect mast cylinder hose from holding valve (9) and electric line from the valve coil (10).

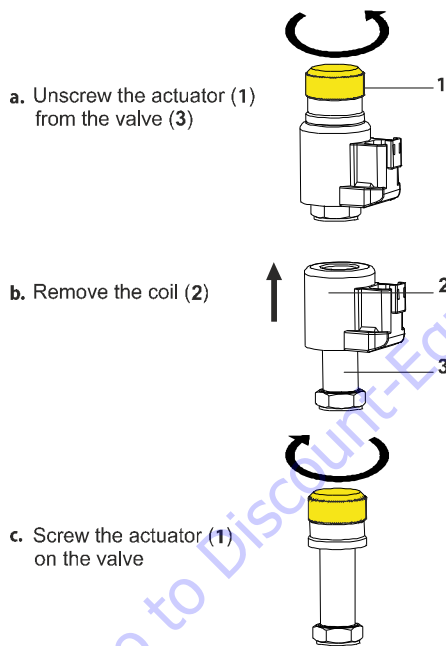


**Figure 5-53. Mast Cylinder Removal - 6 of 8**

10. Using suitable lifting equipment, unhook the mast cylinder from its supports.

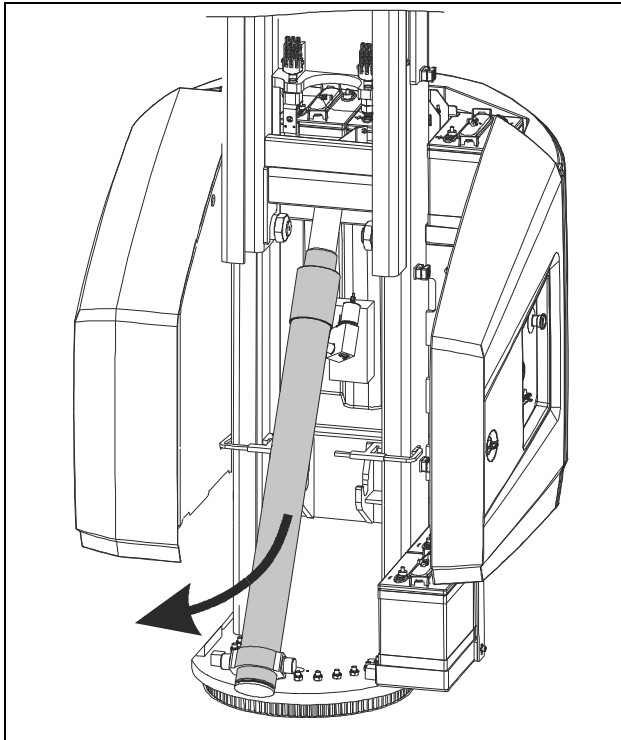


**Figure 5-54. Mast Cylinder Removal - 7 of 8**



**Figure 5-52. Mast Cylinder Removal - 5 of 8**

11. Move the mast cylinder out of the masts.



**Figure 5-55. Mast Cylinder Removal - 8 of 8**

### **Mast Cylinder Disassembly**

Refer to Section 7-8.

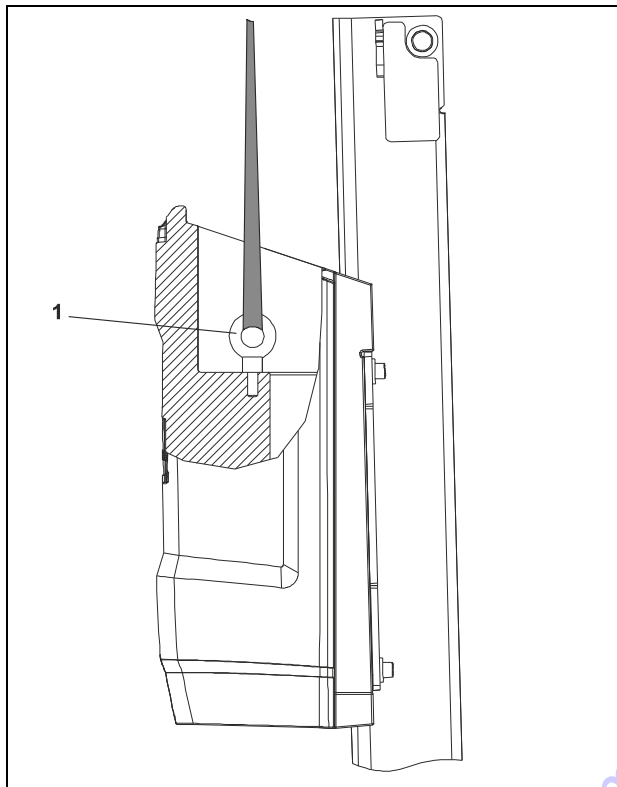
### **Mast Cylinder Installation**

1. Position the mast cylinder fully retracted onto the mast assembly. Install the drive orientation switch.
2. Connect mast cylinder hose on holding valve and electric line on valve coil.
3. Connect the other end of the mast cylinder hose to the port A1 onto the manifold of the power unit.
4. Using the ground controls, extend the cylinder until the hole of the rod aligns with the mounting holes of the mast section #2. Install the anchor pin and the cotter pin.
5. Using the ground controls fully extend the cylinder and remove blocking.
6. From the ground controls, perform a few mast raising/lowering movements to bleed the air from the circuit and to check for proper operation.
7. Check hydraulic fluid level and adjust accordingly. Install hoods and frame shields.

**5.8 COUNTERWEIGHT**

**Counterweight Removal**

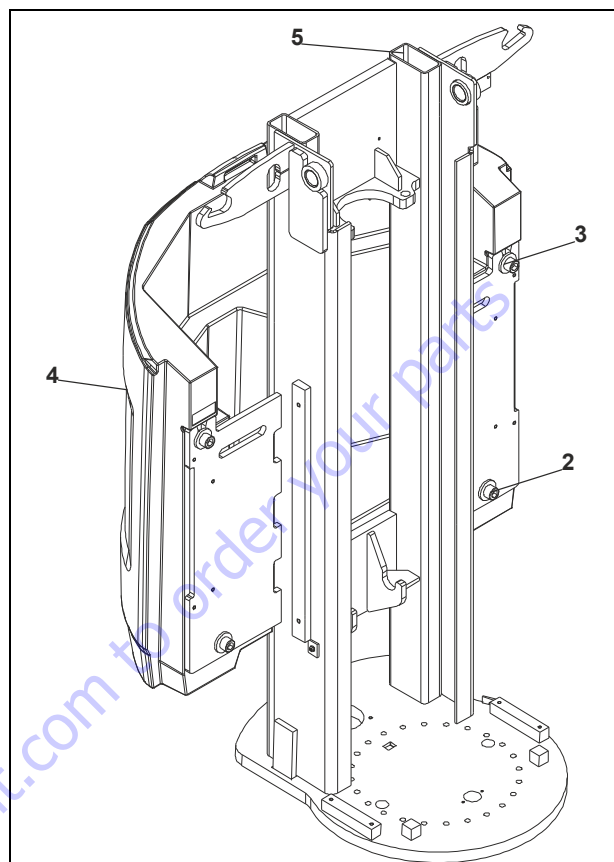
1. Remove all parts above the counterweight.



**Figure 5-56. Counterweight Removal - 1 of 2**

2. Install an eye bolt M20x2.5 thread (1) as shown.

3. Attach a sling to the eye bolt. Use an overhead crane and draw off slack from the sling.



**Figure 5-57. Counterweight Removal - 2 of 2**

4. Remove the 2 bottom bolts (2). Loosen the 2 top bolts (3). Do not remove them from counterweight (4) (it will help for the installation). Lift up the counterweight and remove it from the turntable (5).

**Counterweight Installation**

1. Repeat all removal steps in reverse order.
2. Torque the retaining bolts to 350 N.m (260 ft.lbs).

## SECTION 6. TELESCOPIC BOOM AND PLATFORM

## 6.1 OVERLOAD SYSTEM

## Overload System Verification (If Equipped)

Interval - At least every 6 months of operation.

1. Position the platform/ground select switch to the platform position.
2. Pull out both platform and ground emergency stop switches.
3. Place a 200 kg load evenly distributed on platform floor.
4. Lift the platform with your hands to apply a small upwards force (**F**), then remove the force to let the platform fall.
  - No alarm should be triggered.

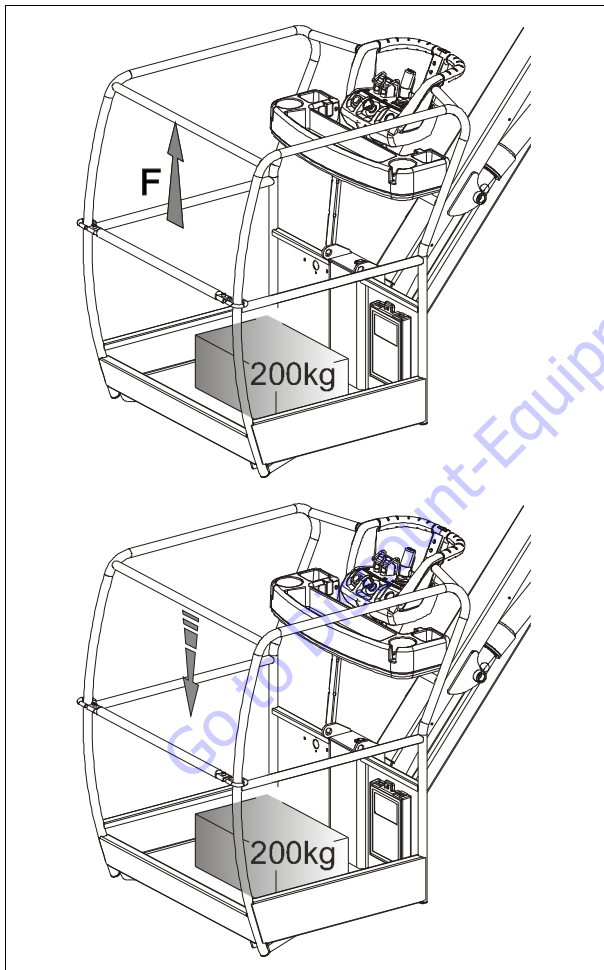


Figure 6-1. Overload System Verification

5. Add an additional weight of 10 kg to the 200 kg load.

6. Lift the platform with your hands to apply a small upwards force (**F**), then remove the force to let the platform fall.
  - RED light indicators at both the ground and the platform control stations blink.
  - An audible alarm sounds.
7. Remove the 10 kg additional load.
8. Lift the platform with your hands to apply a small upwards force (**F**), then remove the force to let the platform fall.
  - No alarm should be triggered.

If the overload system does not activate as instructed, calibrate the overload system as per section 8-2 and then verify the system before placing the machine into service.

## Overload System Setting

Refer to Section 8-2



### 6.2 PLATFORM

#### Platform Removal

1. Place the machine on a flat and level surface. Shut machine down.
2. Attach slings to the platform railings. Use an overhead crane or another lifting equipment, draw all slack from slings.
2. Install platform onto its support. Install lateral ball bearings, pins and retaining rings.
3. Correctly route cables and secure them with clamps. Connect platform console connectors in their casing and install casing cover. Install AC socket and the air line if fitted.
4. Set over load system. Refer to § 8-2.

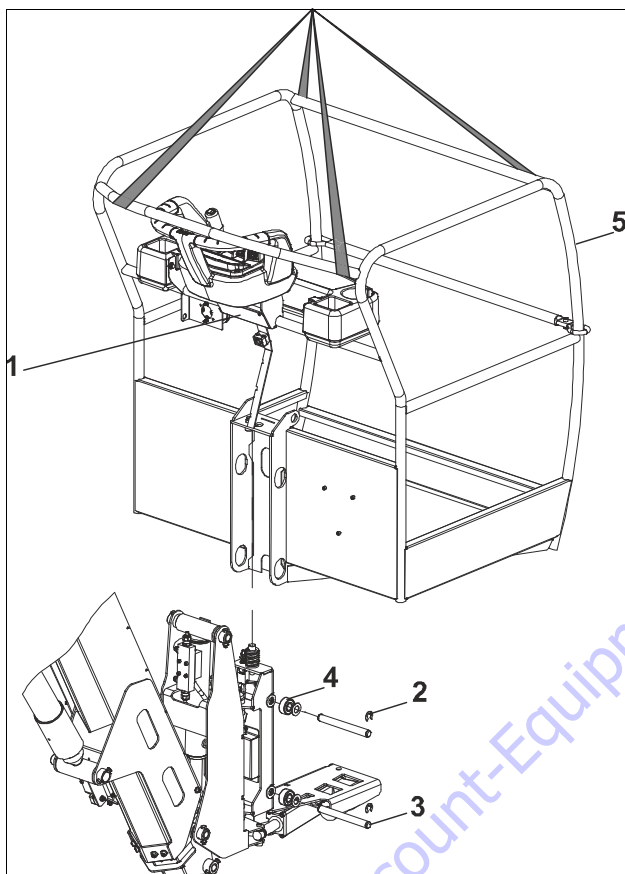


Figure 6-2. Platform Removal-Installation

3. Remove clamp securing electric cables to the platform. If fitted: disconnect AC socket and remove the air line.
4. Remove platform connectors casing cover (1). Disconnect the connector from the platform console.
5. Remove the retaining rings (2). Remove the bearing pins (3) and the 4 lateral ball bearings (4).
6. Lift and remove the platform assembly (5).
7. Check the ball bearings (4 lateral and 2 front) for cracks or hard points. Replace bearings if necessary.

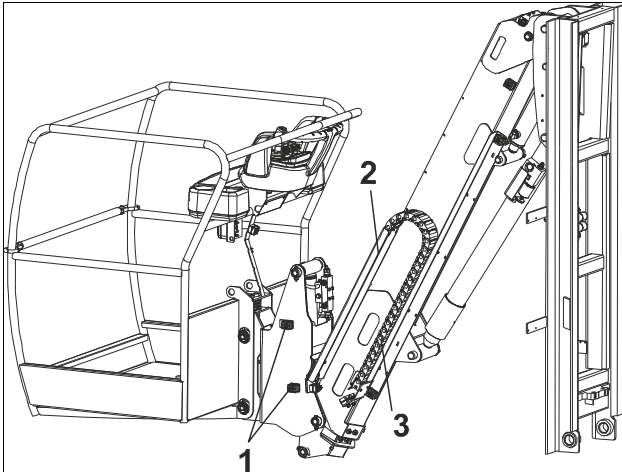
#### Platform Installation

1. If removed, install the 2 front ball bearings on platform support front pins and secure with hardware (Use Loctite®243).

**6.3 PLATFORM SUPPORTS AND SLAVE CYLINDER**

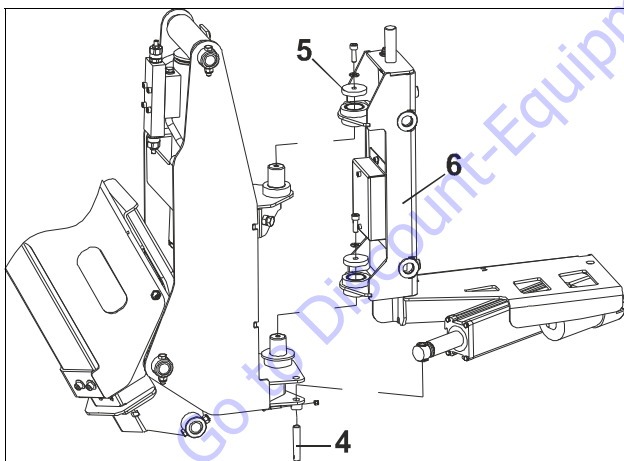
**Platform Supports and Slave Cylinder Removal**

1. Remove the platform: Refer to § 6-2.



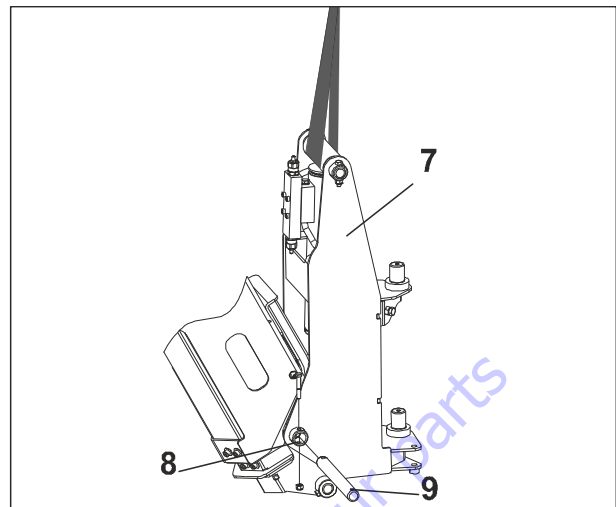
**Figure 6-3. Platform Support and Slave Cylinder Removal - 1 of 4**

2. Tag and disconnect all electric cables and hoses.
3. Remove all the clamps (1), channel (2) and power track (3).



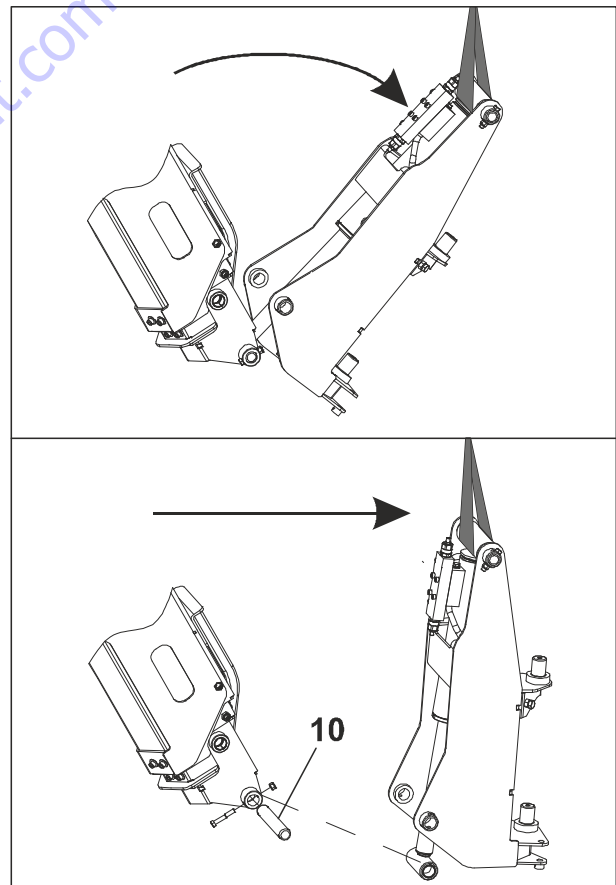
**Figure 6-4. Platform Rotation Option (If Equipped)**

4. Remove electrical cylinder pin (4) and retaining washers (5).
5. Lift and remove platform support (6).



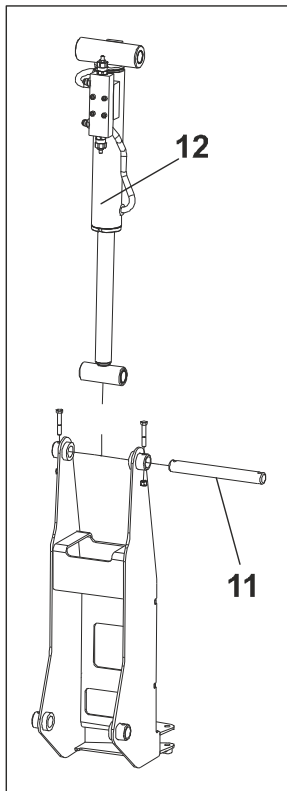
**Figure 6-5. Platform Support and Slave Cylinder Removal - 2 of 4**

6. Secure the level correction support (7) with a sling.
7. Use a special pin (8) (Ø 30 mm length 140 mm) to drive the pin (9) out of the support. Let this special pin into the inner section of the telescope to maintain the telescope cylinder rod in place.



**Figure 6-6. Platform Support and Slave Cylinder Removal - 3 of 4**

8. Tilt the support to gain access and to remove the slave cylinder rod pin (10).



**Figure 6-7. Platform Support and Slave Cylinder Removal - 4  
of 4**

9. Remove the slave cylinder pin (11).
10. Lift and remove the slave cylinder (12).

**NOTE:** *It is not required to remove platform and platform supports to remove the slave cylinder. To remove only the slave cylinder, support the platform with a suitable lifting equipment and remove pins 10 and 11.*

**Slave Cylinder Disassembly**

Refer to Section 7-8.

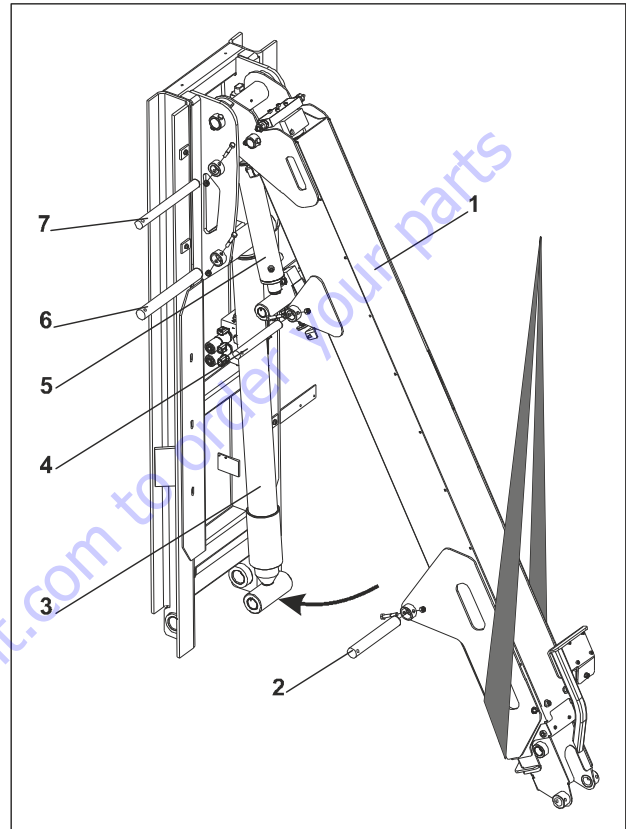
**Platform Supports and Slave Cylinder Installation**

1. Coat inside diameter of bushings with multipurpose grease prior to installing pins. Check for excessive wear of the pins. Replace if necessary.
2. Repeat all removal steps in reverse order.
3. Bleed the air from the slave cylinder: Refer to Section 7-6.
4. Perform a few boom movements from the ground control to check for proper operation.
5. Check hydraulic fluid level and adjust accordingly.

**6.4 TELESCOPIC BOOM, BOOM AND MASTER CYLINDERS**

**Boom and Cylinders Removal**

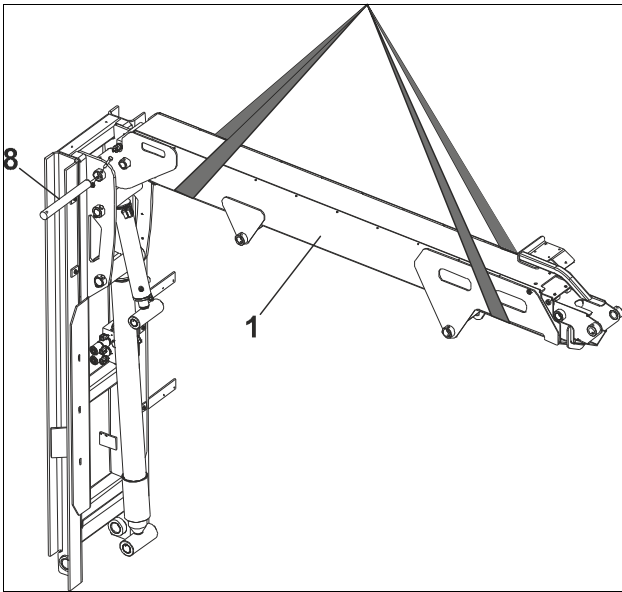
1. Remove platform and platform supports: Refer to Sections 6-2 and 6-3.



**Figure 6-8. Boom and Cylinder Removal - 1 of 2**

2. Secure the boom assembly (1) with a sling.
3. Remove the boom cylinder pin (2) and tilt the boom cylinder (3) along the mast section.
4. Remove the master cylinder pin (4) and tilt the master cylinder (5) along the mast section.
5. Remove the boom cylinder pin (6) and remove the boom cylinder (3). (Use a sling and a lifting equipment if necessary).
6. Remove the master cylinder pin (7) and remove the master cylinder (5).

**NOTE:** It is not required to remove platform and platform supports to remove the boom and master cylinders. To remove boom and master cylinders, support the boom with a sling and remove the cylinders pins (2), (4), (6) and (7).



**Figure 6-9. Boom and Cylinder Removal - 2 of 2**

7. Lift up the boom assembly (1) to the horizontal and secure it with slings as shown.
8. Remove the boom pin (8) and lift down the boom assembly.

**NOTE:** It is not required to remove the boom and master cylinders from the mast to remove the boom assembly.

**Boom and Master Cylinders Disassembly**

Refer to section 7-8.

**Boom Disassembly**

Refer to section 6-5.

**Boom and Cylinders Installation**

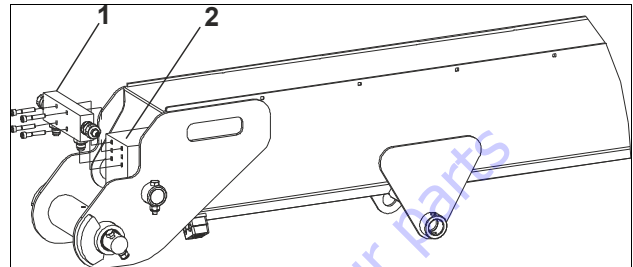
1. Coat inside diameter of bushings with multipurpose grease prior to installing pins. Check for excessive wear of the pins. Replace if necessary.
2. Repeat all removal step in reverse order.
3. Perform a few boom movements from the ground control to check for proper operation.
4. Check hydraulic fluid level and adjust accordingly.

**6.5 TELESCOPE**

**6.5.1 Telescope Toucan 12E Plus**

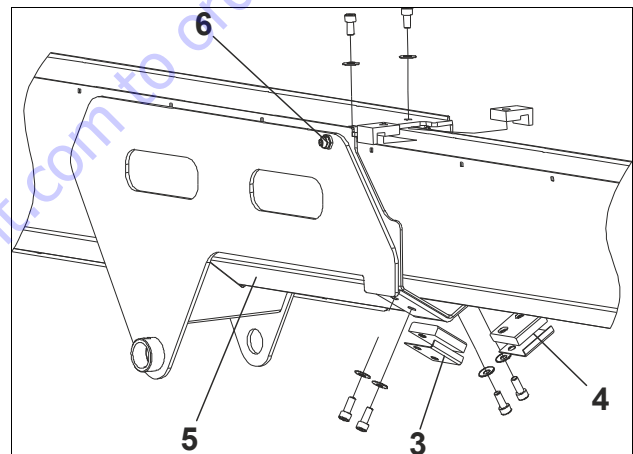
**Telescope Sections and Cylinder Removal**

1. Remove the telescopic boom. Refer to Section 6-4.



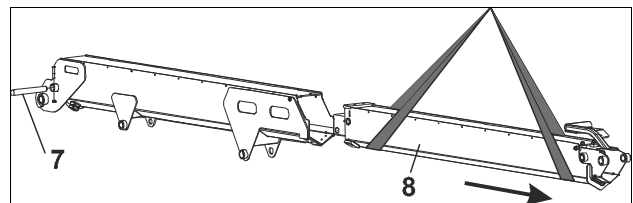
**Figure 6-10. Telescope and Cylinder Removal - 1 of 5**

2. Remove the holding valve block (1) from the telescope dual cylinder (2).



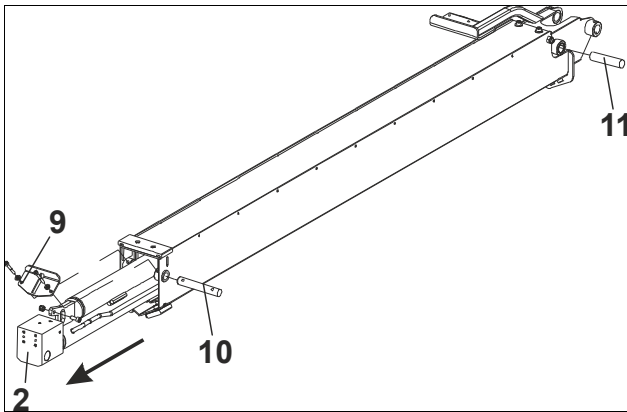
**Figure 6-11. Telescope and Cylinder Removal - 2 of 5**

3. Remove shims (3) and wear pads (4) that are located on the boom section (5). Note the location and the amount of shims to aid in reassembly. Loosen the lateral screws (6).



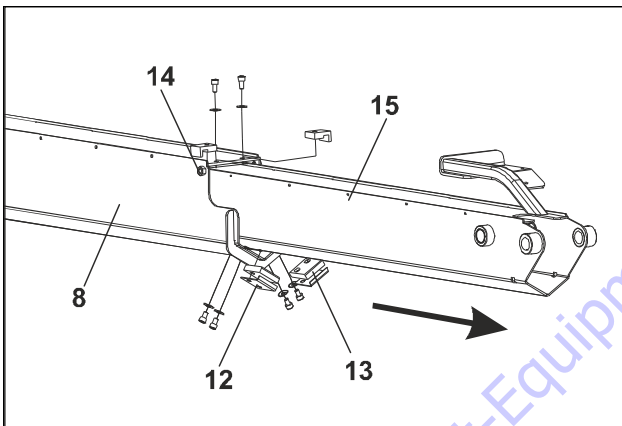
**Figure 6-12. Telescope and Cylinder Removal - 3 of 5**

4. Remove the telescope cylinder pin (7).
5. Secure the mid section (8) with slings and remove it from the boom section (5).



**Figure 6-13. Telescope and Cylinder Removal - 4 of 5**

6. Remove the cylinder bracket (9), the telescope cylinder pin (10) and the pin (11) (Refer to step 7 Section 6-3.).
7. Secure the telescope cylinder (2) with slings and remove it from telescope sections.



**Figure 6-14. Telescope and Cylinder Removal - 5 of 5**

8. Remove shims (12) and wear pads (13) that are located on the mid section (8). Note the location and the amount of shims to aid in reassembly. Loosen the lateral screws (14).
9. Secure inner section (15) with slings if necessary and remove it from mid section (8).
10. Inspect pins, wear pads and bushings for excessive wear. Replace if necessary.

**Telescope Dual Cylinder Disassembly**

Refer to Section 7-8.

**Telescope Sections and Cylinder Installation**

1. Coat inside diameter of bushings with multipurpose greased prior to installing pins.
2. Repeat all removal steps in reverse order.

**NOTE:** Apply multipurpose grease on wear pads sliding faces prior to installing them.

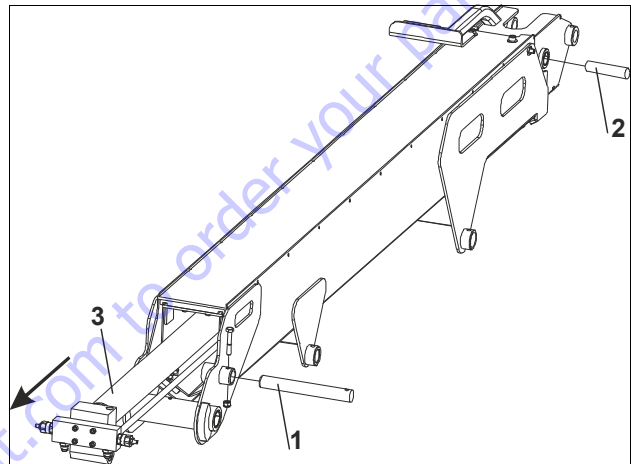
Secure wear pads retaining bolts with thread locking compound Loctite 243. Torque the retaining bolts to 7.5 N.m (5.5 ft.lbs).

3. Perform a few telescope movements from the ground control to check for proper operation.
4. Check hydraulic level and adjust accordingly.

**6.5.2 Telescope Toucan 12E / Toucan 32E**

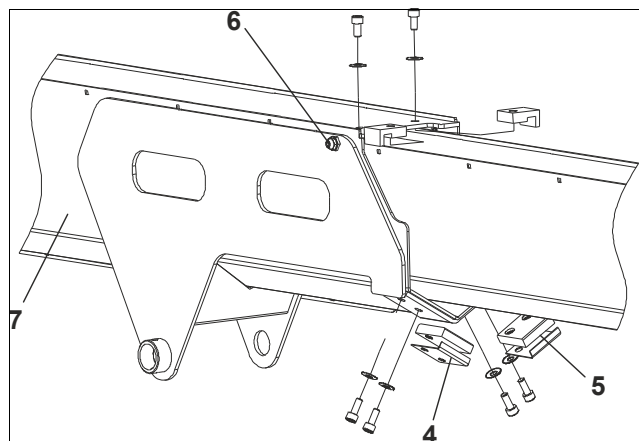
**Telescope Sections and Cylinder Removal**

1. Remove telescopic boom. Refer to section 6-4.



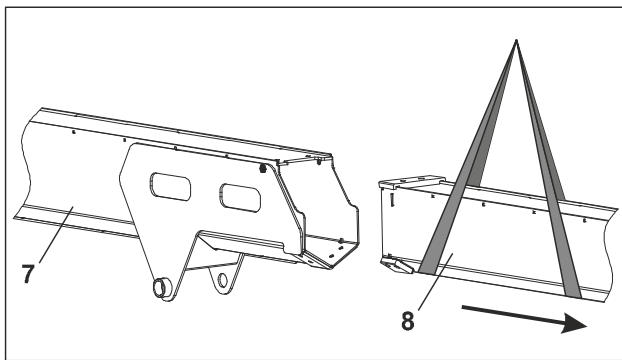
**Figure 6-15. Telescope and Cylinder Removal - 1 of 3**

2. Remove telescope cylinder pins (1) and (2).
3. Remove the telescope cylinder (3) from telescope sections.



**Figure 6-16. Telescope and Cylinder Removal - 2 of 3**

4. Remove shims (4) and wear pads (5) that are located on the boom section (7). Note the location and the amount of shims to aid in reassembly. Loosen the lateral screws (6).



**Figure 6-17. Telescope and Cylinder Removal - 3 of 3**

5. Secure inner section (8) with slings if necessary and remove it from boom section (7).
6. Inspect pins, wear pads and bushings for excessive wear.  
Replace if necessary.

### Telescope Cylinder Disassembly

---

Refer to section 7-8.

### Telescope Sections and Cylinder Installation

---

1. Coat inside diameter of bushings with multipurpose grease prior to installing pins.
2. Repeat all removal steps in reverse order.

**NOTE:** Apply multipurpose grease on wear pads sliding faces prior to installing them.  
Secure wear pads retaining bolt with thread locking compound Loctite 243.  
Torque the retaining bolts to 7.5 N.m (5.5 ft.lbs).

3. Perform a few telescope movements from the ground control to check for proper operation.
4. Check hydraulic level and adjust accordingly.

# PARTS FINDER

**Search Website  
by Part Number**



**Search Manual  
Library For Parts  
Manual & Lookup Part  
Numbers – Purchase  
or Request Quote**

**Search Manuals**

Enter your information to search for manuals and parts.

\* Brand:

\* Model:

\* Serial:

\* Part Number:

\* Category:

**Can't Find Part or  
Manual? Request Help  
by Manufacturer,  
Model & Description**

**Parts Order Form**

Please fill in the following information:

Manufacturer:

Model:

Description:

Quantity:

Part Number:

Part Name:

Part Description:

Part Category:

Part Location:

Part Condition:

Part Status:

Part Price:

Part Weight:

Part Dimensions:

Part Material:

Part Color:

Part Finish:

Part Notes:

Part Reference:

Part Drawing:

Part Photo:

Part Video:

Part Audio:

Part Other:

Discount-Equipment.com is your online resource for quality parts & equipment.

Florida: **561-964-4949** Outside Florida TOLL FREE: **877-690-3101**

**Need parts?**

Click on this link: <http://www.discount-equipment.com/category/5443-parts/> and choose one of the options to help get the right parts and equipment you are looking for. Please have the machine model and serial number available in order to help us get you the correct parts. If you don't find the part on the website or on one of the online manuals, please fill out the request form and one of our experienced staff members will get back to you with a quote for the right part that your machine needs.

We sell worldwide for the brands: Genie, Terex, JLG, MultiQuip, Mikasa, Essick, Whiteman, Mayco, Toro Stone, Diamond Products, Generac Magnum, Airman, Haulotte, Barreto, Power Blanket, Nifty Lift, Atlas Copco, Chicago Pneumatic, Allmand, Miller Curber, Skyjack, Lull, Skytrak, Tsurumi, Husquvarna Target, , Stow, Wacker, Sakai, Mi-T- M, Sullair, Basic, Dynapac, MBW, Weber, Bartell, Bennar Newman, Haulotte, Ditch Runner, Menegotti, Morrison, Contec, Buddy, Crown, Edco, Wyco, Bomag, Laymor, Barreto, EZ Trench, Bil-Jax, F.S. Curtis, Gehl Pavers, Heli, Honda, ICS/PowerGrit, IHI, Partner, Imer, Clipper, MMD, Koshin, Rice, CH&E, General Equipment, ,AMida, Coleman, NAC, Gradall, Square Shooter, Kent, Stanley, Tamco, Toku, Hatz, Kohler, Robin, Wisconsin, Northrock, Oztec, Toker TK, Rol-Air, Small Line, Wanco, Yanmar



SECTION 7. HYDRAULICS

7.1 HYDRAULIC LINES CONNECTIONS

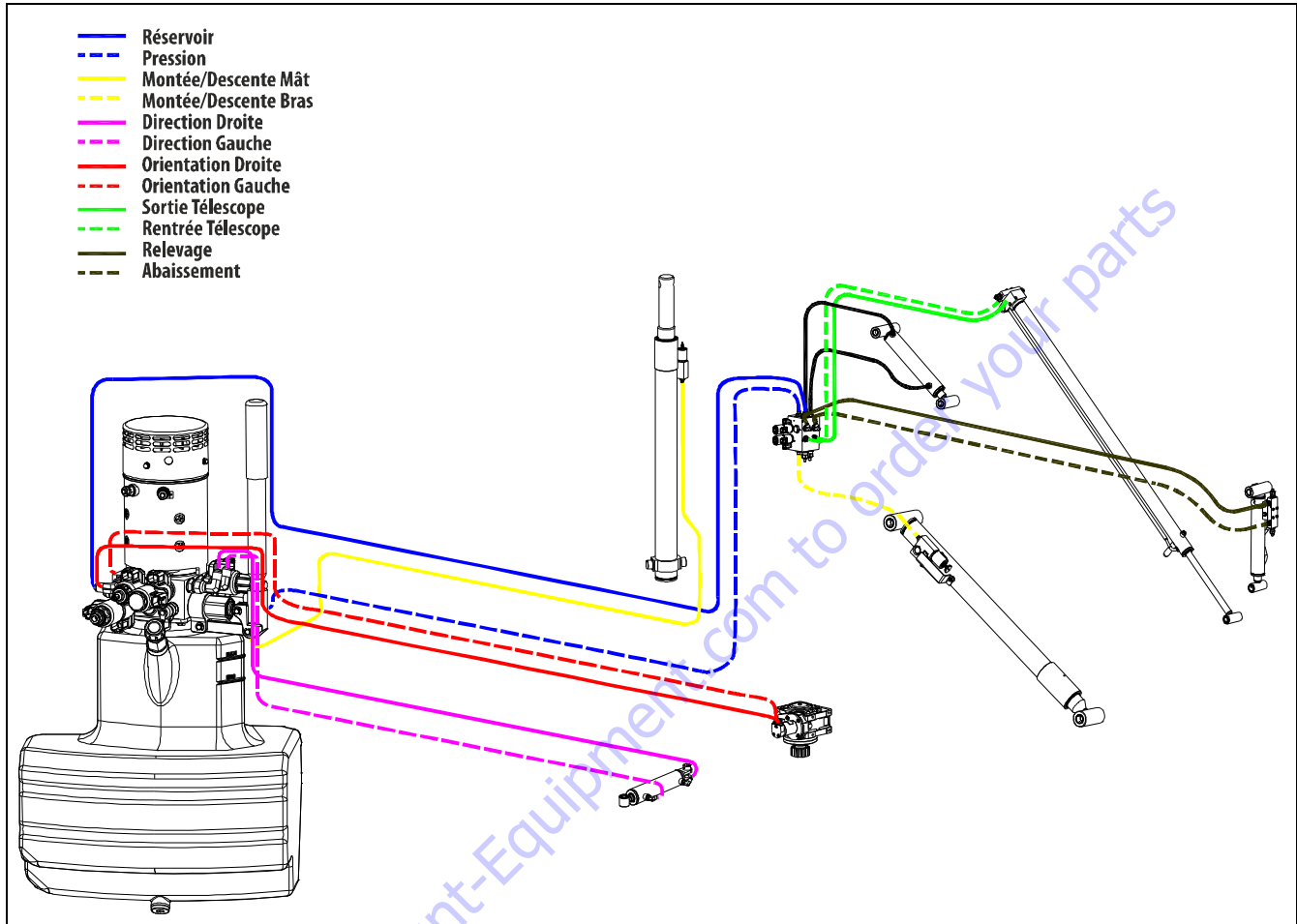


Figure 7-1. Hydraulic Lines Connections

7.2 HYDRAULIC POWER UNIT

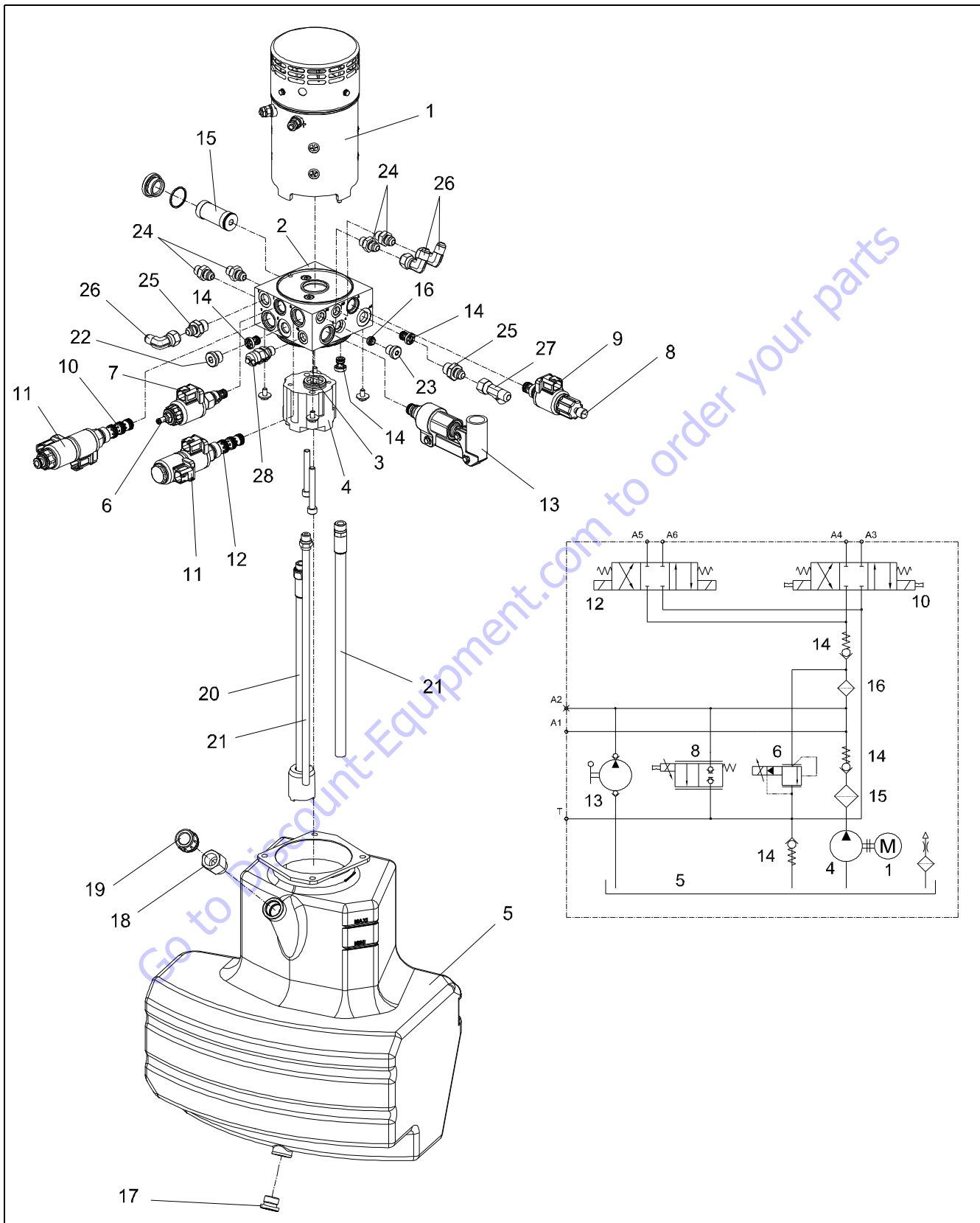
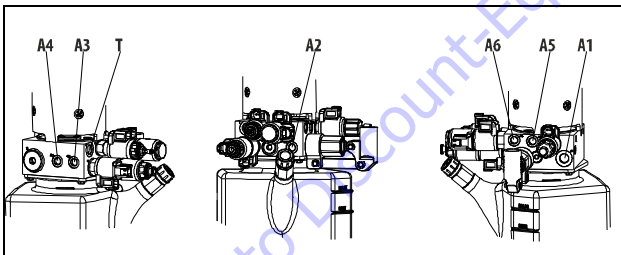


Figure 7-2. Hydraulic Power Unit

1. Electric Motor
2. Valve Body
3. Coupling
4. Pump (Gear pump)
5. Tank
6. Proportional Pressure Relief Valve
7. Proportional Valve Coil
8. Proportional Flow Regulator
9. Proportional Valve Coil
10. Solenoid Valve 4-3 Swing
11. Valve Coil
12. Solenoid Valve 4-3 Steer
13. Hand Pump
14. Check Valve 0.5 bar
15. Filter Pressure
16. Sieve
17. Draining Plug
18. breather Adapter
19. Filler/Breather Cap
20. Suction Pipe
21. Return Pipe
22. Plug - BSPP 3/8"
23. Plug - BSPP 1/4"
24. Union Male 1/4" BSPP - Male JIC 9/16"
25. Union Male 3/8" BSPP - Male JIC 9/16"
26. 90° Elbow JIC 9/16" Swivel
27. Lateral Run Tee JIC 9/16" Swivel
28. Pressure Plug BSPP 1/4"

**Ports Identification**



**Figure 7-3. Ports Identification**

**Port A1, T:** BSPP 3/8"

**Port A2, A3, A4, A5, A6:** BSPP 1/4"

**Proportional Pressure Relief Valve**

A screw-in, cartridge-style, pilot operated, spool-type pressure relief valve (Refer to Figure 7-2). It is infinitely adjusted across a prescribed range using a PWM signal delivered by the master controller. As a function of the electrical control signal, the pressure relief valve changes. Pressure output is inversely proportional to DC current input.

When a machine function is performed, the valve is controlled with a signal corresponding to the appropriate relief pressure. Setting range of the pressure relief valve: 4 to 228 bars.

Pressure relief valve: tightening torque = 25 to 30 N.m

Pressure relief valve coil nut: tightening torque = 4.5 to 5.5 N.m

**NOTICE**

THE COIL OF THE PROPORTIONAL RELIEF VALVE IS SPECIALLY DESIGNED FOR PROPORTIONAL CONTROLS APPLICATIONS. DO NOT INVERT THIS COIL WITH ANOTHER DIRECTIONAL VALVE COIL. THE VOLTAGE INDICATION ON THE PROPORTIONAL COIL IS 12 VDC AND ITS RESISTANCE VALUE IS 2.2 Ω .

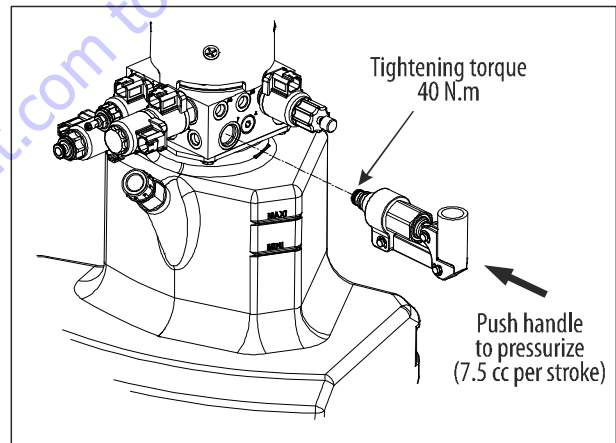
**NOTICE**

AFTER REPLACEMENT OF THE PROPORTIONAL RELIEF VALVE AND/OR THE PROPORTIONAL COIL, ALL PRESSURE RELIEF VALUES MUST BE CHECKED AND ADJUSTED ACCORDINGLY.

Refer to Section 9-7 for proper proportional relief valve adjustment procedure.

**Hand Pump**

Oil supply to the hydraulic circuit of the work platform when using the breakdown controls for slewing and jib raising movements.



**Figure 7-4. Hand Pump**

**Proportional Flow Control Valve**

A solenoid-operated, electrically-variable, pressure-compensated, spool-type, normally closed when de-energized, proportional flow control valve.

Provide proportional movements for mast and jib lowering by regulating flow regardless of system working pressure. With an increasing current applied to the solenoid (corresponding to the position of the lowering movement joystick), the valve will increase output flow.

Manual override to allow (by opening valve at max) the hand pump for breakdown controls.

Tightening torque for the cartridge: 35 N.m

Tightening torque for the coil nut of the cartridge: 4.5 to 5.5 N.m

**NOTICE**

THE COIL OF THE PROPORTIONAL FLOW CONTROL VALVE IS SPECIALLY DESIGNED FOR PROPORTIONAL CONTROLS APPLICATIONS. DO NOT INVERT THIS COIL WITH ANOTHER DIRECTIONAL VALVE COIL. THE VOLTAGE INDICATION ON THE PROPORTIONAL COIL IS 12 VDC AND ITS RESISTANCE VALUE IS 2.2 Ω.

**Solenoid Valve 4-3**

A solenoid-operated, 4 way, 3 positions, direct-acting, spool-type, closed center, screw-in hydraulic cartridge valve.

Coil Nominal Voltage: 12 VDC

Coil Resistance Value: 8 Ω

Tightening torque for the cartridge: 50 N.m

Tightening torque for the coil of the cartridge: 5 N.m

**SLEWING**

Slewing movement right and left, with operation of manual override. To override, push the knurled button and screw to activate right slewing movement, or pull the knurled button and unscrew to activate left slewing movement.

**STEERING**

Steering movement right and left.

**Disassembly:**

1. Remove the cartridge nuts holding the coils (SLEWING and STEERING) and remove the coils.
2. Remove the cartridge valves.

**Inspection:**

1. Clean all parts with an appropriate solvent and dry with compressed air.
2. Check the spool surfaces are not scratched.
3. Check the axial and radial holes on each spool are not blocked.

**NOTE:** If the spool is scratched or if the holes are blocked, the cartridge must be replaced.

**Assembly:**

**CAUTION**

NEVER INTERCHANGE CARTRIDGES. ALL COMPONENTS MUST BE CLEAN BEFORE ASSEMBLY.

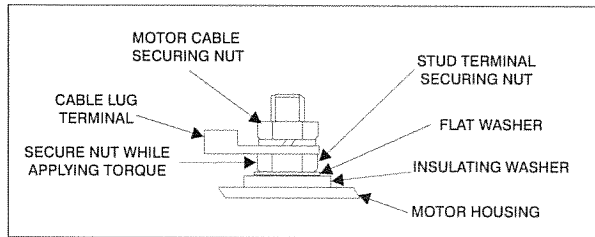
1. Check O-rings are present and not damaged on the cartridge.
2. Install the cartridge in the manifold.
3. Install the coils and torque the nuts to the corresponding tightening torque.

**Check Valve 0.5 bar**

Prevents the return of the oil flow supplied by the hydraulic power unit through the pump, and to revolve motor counter clockwise.

**Electric Motor**

**Terminal Tightening**

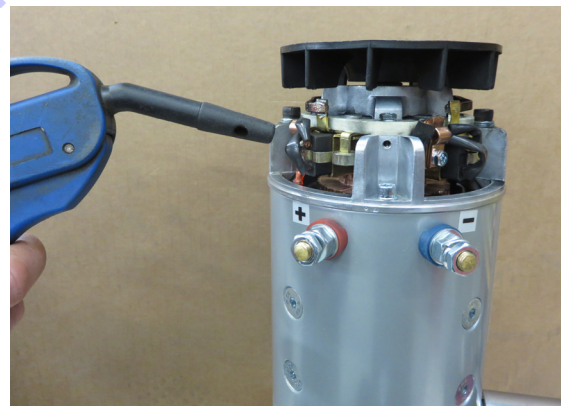


**Figure 7-5. Terminal Tightening**

**Dust Cleaning**

Due to a possible built-up of dust from brush wear inside the pump motor cover around the brushes and armature under heavy usage, it is recommended to perform this dust cleaning task on an annual basis. Use clean, oil free, compressed air.

1. Disconnect the battery plug.
2. Remove the protection cover from the motor (secured with 4 screws).
3. Blow any accumulated brush dust around the brushes and armature commutator.
4. Check brushes for wear, replace if necessary.
5. Once complete, reassemble for operation.



**Figure 7-6. Dust Cleaning**

**Brush Wear Check (Qty 4)**

Replace brushes that are worn below their usable length (16 mm (0.63 in.)), show signs of uneven wear or signs of overheating, such as discolored brush shunts and brush springs. Brushes should always be replaced in complete sets of four. Use identical replacement parts; do not substitute brush grades as the brushes are matched to the motor type and application to provide the best service. Substituting brushes of the wrong grade can cause premature commutator failure and excessive brush wear.

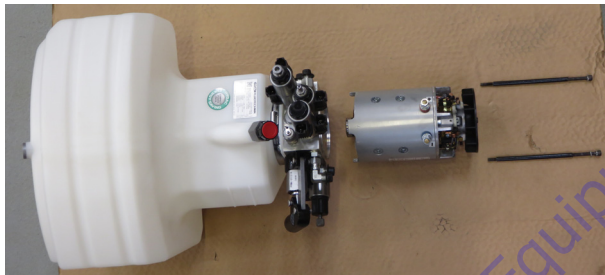
**Brush Removal**

**NOTE:** No hydraulic power unit connections or hydraulic need to be disconnected.

1. Disconnect battery plug.
2. Disconnect both power unit motor cables (+ and -).
3. Remove the protection cover from the motor (secured with 4 screws).
4. Position the motor fan so that the two notches face the two screws.



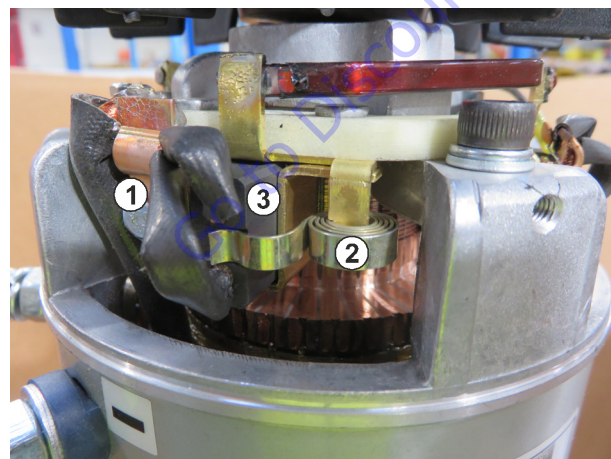
5. Loosen the two screws securing the motor. Lift the motor.



**Figure 7-7. Moving Hydraulic Power Unit Motor**

**Brushes Installation**

1. Lift the spiral spring (2) and slide the brush (3) into its housing.
2. Attach the brush terminal end to the terminal post using the terminal screw (1).
3. Repeat previous steps for each brush.
4. Install the protection cover.
5. Secure the hydraulic power unit to the machine, as originally installed.
6. Connect battery plug and check for proper operation of the machine.



**Figure 7-8. Motor Brushes**

6. Remove the brush terminal screw (1).
7. Lift the spiral spring (2) and remove the brush (3) from its housing.
8. Repeat previous steps for each brush (Qty: 4).

**7.3 HYDRAULIC TANK**

**Tank Capacity: 21.8 liters (5.8 gallons)**

Hydraulic system capacity:

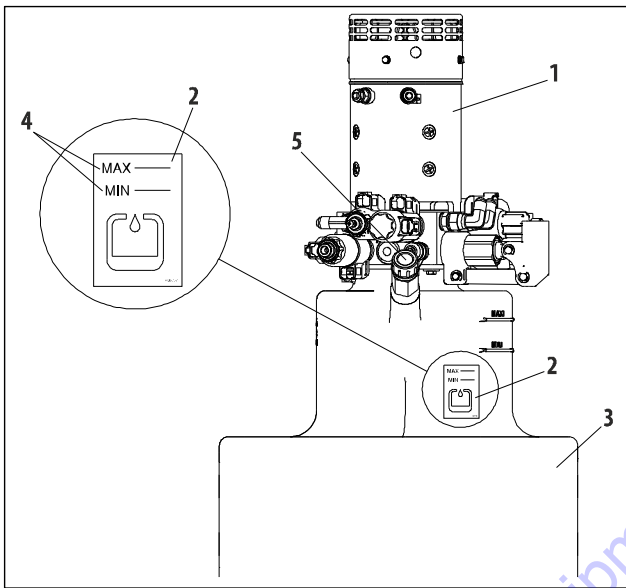
Toucan 12E: approximately 20 liters (5.28 gallons)

Toucan 12E Plus: approximately 21 liters (5.55 gallons)

**Oil Level**

Oil level should be checked daily. Hydraulic oil should be changed every 1000 hours of machine operation or at least every 2 years.

**NOTE:** Check oil level with the wheels straight.



**Figure 7-9. Hydraulic Oil Check**

1. Open the access door to the hydraulic power unit (1).
2. Locate the decal (2) on the tank (3).
3. The oil level in the tank must be within the MIN (minimum) and MAX (maximum) markings (4) of the decal.

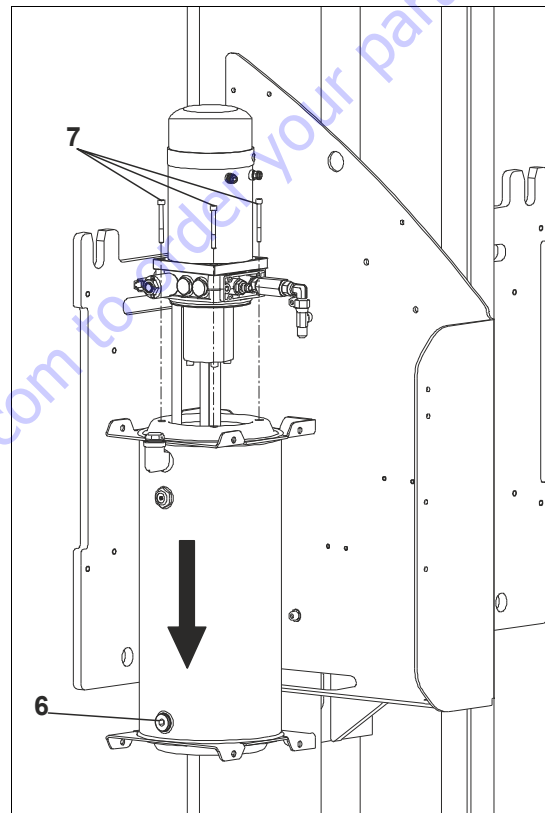
**Adding Oil to the System**

**NOTE:** Care should be taken not to introduce any impurities (dirt, water, etc...) while cap or plug is removed.

1. Wipe all dirt and debris from the filler/breather cap (5) area.
2. Remove (unscrew) the filler/breather cap (5).
3. Add proper grade of oil by using a clean funnel. Fill until oil level is between the MIN and MAX markings (4). Replace the cap.

**Tank Draining/Cleaning**

1. Fully retract the machine (mast, jib, telescope).
2. Place a collecting tank (with a minimum capacity of 15 liters) under the tank (3).
3. Loosen the draining cap (6) and drain the power unit tank.
4. Loosen four motor screws (7) and remove the hardware securing the tank. Remove the tank.
5. Drain and wipe the tank.
6. Drain and wipe oil strainer and pipes.
7. Install and secure the tank to the power unit.



**Figure 7-10. Tank Draining/Cleaning**

**Tank Filling**

1. Remove the filler/breather cap and fill the tank up to the MAX level marking.
2. Using the ground controls, fully raise and lower the mast and the jib and then fully extend and retract the telescope to bleed the air from the circuit.
3. From platform console, fully steer the wheels to the right.
4. Check hydraulic fluid level and adjust accordingly.

## 7.4 SECONDARY MANIFOLD

Hydraulic control for jib, telescope and leveling movements of the work platform.

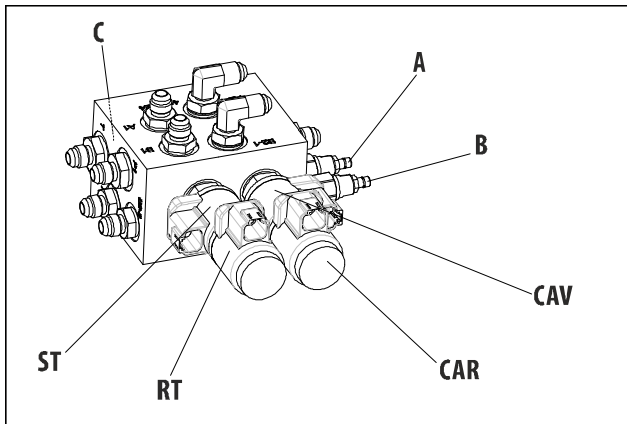


Figure 7-11. Secondary Manifold

### Manifold Schematic

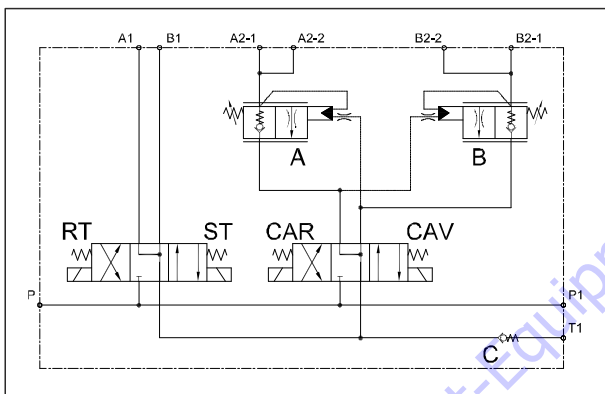


Figure 7-12. Secondary Manifold Schematic

#### A, B: Counterbalance Valve

Prevents mechanical damages in case of platform leveling hydraulic system is misadjusted.

Prevents draining of platform leveling lines after a jib or a platform level movement.

The valve pilot ratio and the check is spring-biased at 3.45 bar to assure holding.

Both valves are factory preset (185 bar for A and 160 bar for B) and cannot be adjusted on the machine.

Tightening torque for the cartridge: 24 N.m

#### C: Check Valve 3 bar

Secures a minimum pressure in the hydraulic lines and allows a proper working.

#### RT-ST/CAV-CAR: Solenoid Valve 4-3

A solenoid-operated, 4-way, 3-positions, direct acting, spool type, motor spool, screw in hydraulic cartridge valve.

Coil Nominal Voltage: 12 VDC

Coil Resistance Value: 8.0 Ω

Tightening torque for the cartridge: 38 to 46 N.m

Tightening torque for the coils nut of the cartridge: 4.5 to 5.5 N.m

**RT-ST:** Telescope movement in and out

**CAV-CAR:** Platform leveling movement forward and backward.

### Disassembly

1. Remove the cartridge nuts holding the coils (RT, ST, CAV, CAR) and remove the coils.
2. Remove the cartridge valves.

### Inspection

3. Clean all parts with an appropriate solvent and dry with compressed air.
4. Check the spool surfaces are not scratched.
5. Check the axial and radial holes on each spool are not blocked.

**NOTE:** If the spool is scratched or if the holes are blocked, the cartridge must be replaced.

### Assembly

#### ⚠ CAUTION

**NEVER INTERCHANGE CARTRIDGES. ALL COMPONENTS MUST BE CLEAN BEFORE ASSEMBLY.**

1. Check O-rings are present and not damaged on the cartridge.
2. Install the cartridge in the manifold.
3. Install the coils and torque the nuts to the corresponding tightening torque.

7.5 CYLINDERS HOLDING VALVES

Mast Cylinder Holding Valve

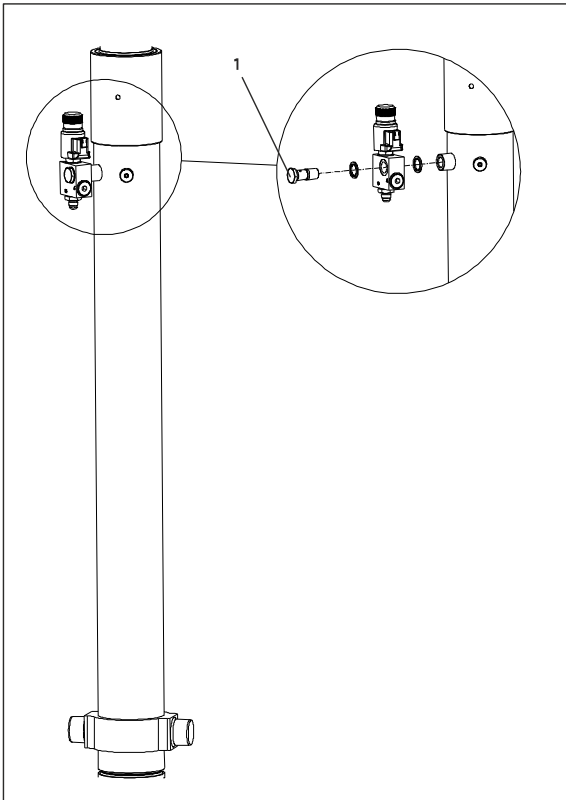


Figure 7-13. Mast Cylinder Holding Valve - Removal/Installation

Valve Removal

**WARNING**

ENSURE THAT THE MAST IS FULLY LOWERED (OR SAFETY SUPPORTED) BEFORE DISMOUNTING THE VALVE. DISCONNECT BATTERY PLUG UNTIL THE REPAIRS ARE COMPLETED.

1. Remove the mast cylinder, with the holding valve. Refer to Section 5-7.
2. Unscrew the valve mounting screw (4) and plug the cylinder port (3/8" BSPP).

Valve Installation

1. Check presence and condition of the two auto-centralized BS rings. Install the valve onto the cylinder. Keep the solenoid valve perpendicular to the cylinder and torque the banjo bolt (4) to 38 N.m.

**CAUTION**

DO NOT OVER-TORQUE THE VALVE BANJO BOLT.

2. Install the mast cylinder on the work platform. Refer to Section 5-7.

3. Perform a few mast raising/lowering movements to bleed air from the circuit and to check for proper operation.
4. Check the mast manual descent for proper operation.
5. Check hydraulic fluid level and adjust accordingly.

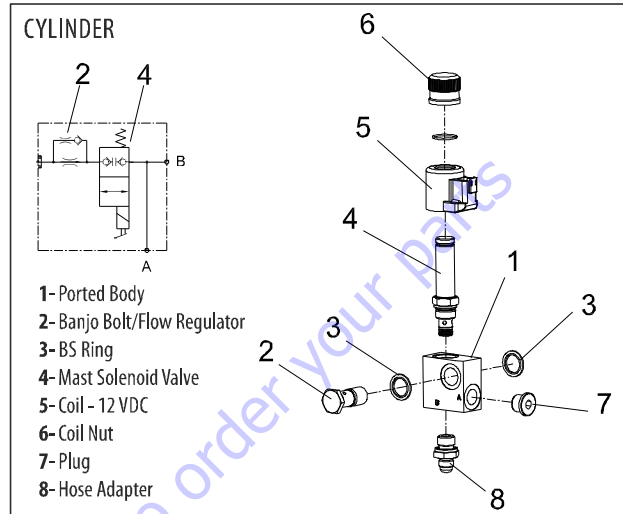


Figure 7-14. Mast Cylinder Holding Valve - Schematic/Exploded View

Mast Solenoid Valve (4)

Holds the platform load in the event of hose failure. A solenoid-operated, 2-way, normally closed, internally piloted, bidirectional blocking, screw-in hydraulic cartridge valve, with operation of manual override. To override, remove the coil (5), screw the nut (6) to activate the mast lower movement.

Coil Nominal Voltage: 12 VDC

Coil Resistance Value: 8 Ω

Tightening torque for the cartridge: 32 to 38 N.m

Tightening torque for the coil nut of the cartridge: 4.5 to 5.5 N.m

Flow Regulator (2)

Ensures a constant and limited lowering speed in the event of hydraulic failure (valves, hoses...).

Jib Cylinder Holding Valve

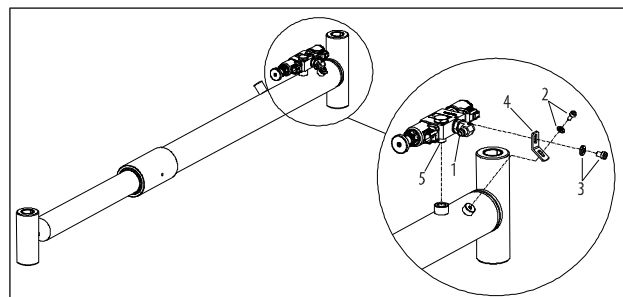


Figure 7-15. Jib Cylinder Holding Valve - Removal/Installation



**Valve Removal****⚠ WARNING**

**ENSURE THAT THE JIB IS FULLY LOWERED (OR SAFELY SUPPORTED) BEFORE DISMOUNTING THE VALVE. DISCONNECT BATTERY PLUG UNTIL THE REPAIRS ARE COMPLETED.**

1. Ensure the jib is lowered (or safely supported - Refer to Section 5). Turn power off at ground controls. Disconnect battery plug.
2. Tag and disconnect electric line from the solenoid valve coil.
3. Disconnect and cap the cylinder hydraulic line and port (1).
4. Unscrew the hardware (2) and (3) securing the valve protector (4) and remove the protector.
5. Unscrew the valve banjo bolt (5) and plug the cylinder port (3/8" BSPP).

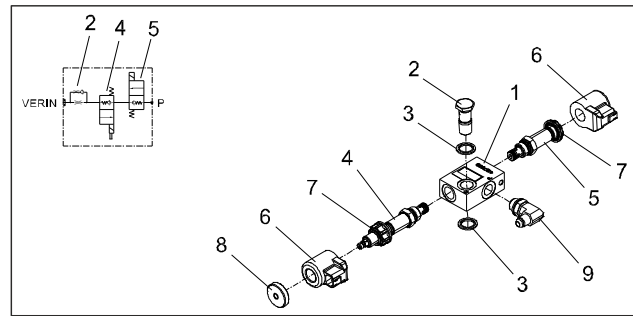
**Valve Installation**

1. Check presence and condition of the two BS rings. Install the valve onto the cylinder. Keep the block in line with the cylinder and torque the banjo bolt (5) to 38 N.m.

**⚠ CAUTION**

**DO NOT OVER-TORQUE THE VALVE BANJO BOLT.**

2. Install the valve protector on the cylinder and the manifold then secure with hardware (2) and (3).
3. Remove port plug and hydraulic line cap. Correctly connect line to valve port.
4. Connect electric line to solenoid valve coil as previously tagged.
5. Connect battery plug.
6. From platform console, perform at least 5 (five) Jib Up/Down movement (full stroke) to bleed the air from the circuit and to check for proper operation.
7. Raise the jib to horizontal position and stop. Perform a Jib Lowering movement. If there is a jerk upwards before the jib begins to go down, the circuit is not correctly bled. Perform additional Jib Up/Down movements (full stroke) and repeat this step until all air is bled from the circuit.
8. Check hydraulic fluid level and adjust accordingly.



**Figure 7-16. Jib Cylinder Holding Valve - Schematic/Exploded View**

1. Ported Body
2. Banjo Bolt/Flow Regulator
3. BS Ring
4. Jib Lowering Solenoid Valve
5. Jib Raising Solenoid Valve
6. Coil 12 VDC
7. Coil Nut
8. Manual Override Boot
9. Hose Adapter

**Jib Lowering Solenoid Valve (4)**

Holds the platform load in the event of hose failure.

A solenoid-operated, 2-way, internally piloted, unidirectional blocking, screw-in hydraulic cartridge valve, with operation of manual override.

To override, pull the screw at the end of the valve to activate the jib lower movement.

Coil Nominal Voltage: 12 VDC

Coil Resistance Value: 8  $\Omega$

Tightening torque for the cartridge: 36 to 44 N.m

Tightening torque for the coil of the cartridge: 4.5 to 5 N.m

**Jib Raising Solenoid Valve (5)**

A solenoid-operated, 2-way, internally piloted, unidirectional blocking, screw-in hydraulic cartridge valve, with operation of manual override.

Coil Nominal Voltage: 12 VDC

Coil Resistance Value: 8  $\Omega$

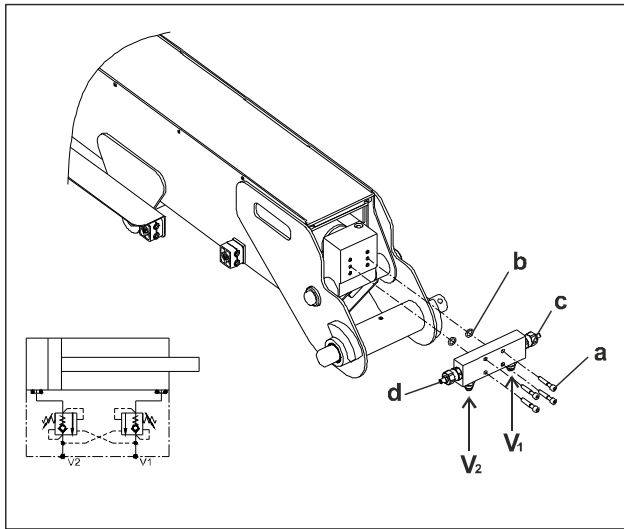
Tightening torque for the cartridge: 36 to 44 N.m

Tightening torque for the coil of the cartridge: 4.5 to 5 N.m

**Flow Regulator (2)**

**Ensures a constant and limited lowering speed in the event of hydraulic failure (valves, hoses...).**

**Telescope Cylinder Holding Valve**



**Figure 7-17. Telescope Cylinder Holding Valve - Removal/Installation**

**Dual Over-center Valve**

Allows to hold the load in the event of hose failure and allows thermal expansion relief of the hydraulic fluid.

Pilot ratio: 4.1:1

**Setting of the Counterbalance Valve (c) Rod Side**

1. Lower the jib and retract the telescope.
2. Fully tighten the valve setting screw.
3. Place a 200 kg load evenly distributed on the work platform floor.
4. Slowly loosen the valve setting screw until the telescope starts to extend, then, tighten the screw again by 3/4 turn. Tighten the locknut.

**Setting of the Counterbalance Valve (d) Piston Side**

1. Place a 200 kg load evenly distributed on the work platform.
2. Fully tighten the valve setting screw.
3. Fully raise the jib and extend the telescope by approximately 50 cm.
4. Slowly loosen the valve setting screw until the telescope starts to retract, then tighten the screw again by 3/4 turn. Tighten the locknut.

**Valve Removal**

**⚠ WARNING**

**ENSURE THE TELESCOPE IS FULLY RETRACTED (OR SAFELY SUPPORTED) BEFORE DISMOUNTING THE VALVE. DISCONNECT BATTERY PLUG UNTIL THE REPAIRS ARE COMPLETED.**

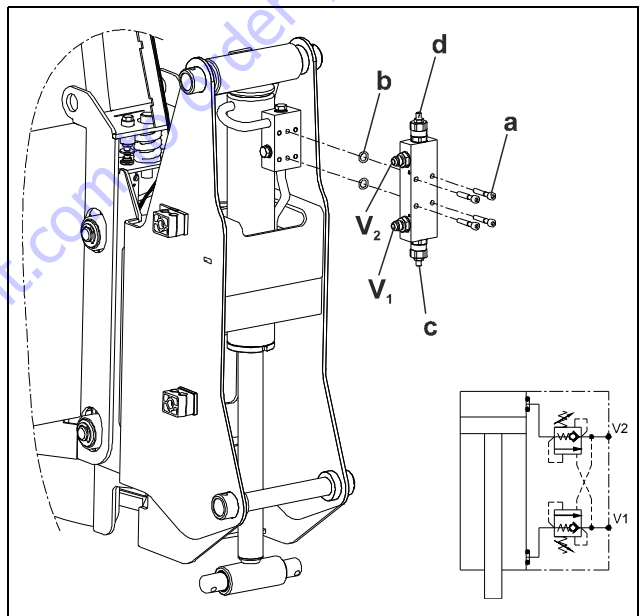
1. Fully lower the jib and retract the telescope completely. Raise the mast and install suitable blockings to support the end of the telescope. Lower the mast until the end of the telescope rests on blockings. Turn power off at ground controls. Disconnect battery plug.

2. Tag, disconnect and cap telescope cylinder hydraulic lines and ports (V<sub>1</sub> and V<sub>2</sub>).
3. Unscrew four valve mounting screws (a), plug the cylinder ports and remove the holding valve.

**Valve Installation**

1. Check presence and position of the two O-rings (b) and install the valve onto the cylinder. Torque four screws (a) to 9.5 N.m.
2. Connect hydraulic lines as previously tagged.
3. Connect battery plug. Using ground controls, raise the mast and remove blockings.
4. Raise jib to horizontal. Perform a few telescope in/out movements to bleed air form the circuit and to check for proper operation.
5. Check hydraulic fluid level and adjust accordingly.

**Slave Cylinder Holding Valve**



**Figure 7-18. Slave Cylinder Holding Valve - Removal/Installation**

**Dual Over-center Valves**

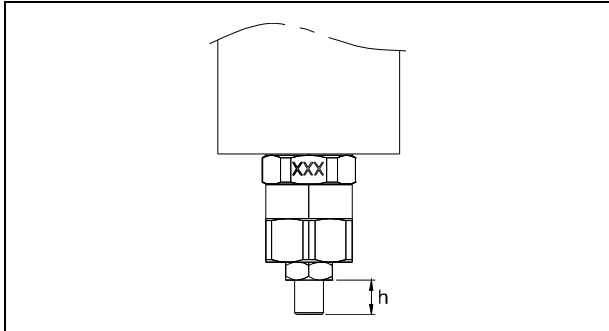
Allows to hold the load in the event of hose failure and allows thermal expansion relief of the hydraulic fluid.

Pilot ratio: 8.5:1

**Setting of the Counterbalance Valve (c) Rod Side**

This valve is factory preset and cannot be adjusted on the machine.

Adjustment checking:  $h=12$  mm



**Figure 7-19. Adjustment Checking**

**Setting of the Counterbalance Valve (d) Piston Side**

1. Fully tighten the valve setting screw.
2. Machine fully retracted, place a 200 kg load evenly distributed on the work platform.
3. Slowly loosen the valve setting screw until the platform starts to move down, then tighten the screw again by 1/8 turn. Tighten the locknut until contact with the valve, then tighten the nut again by 1/8 turn.

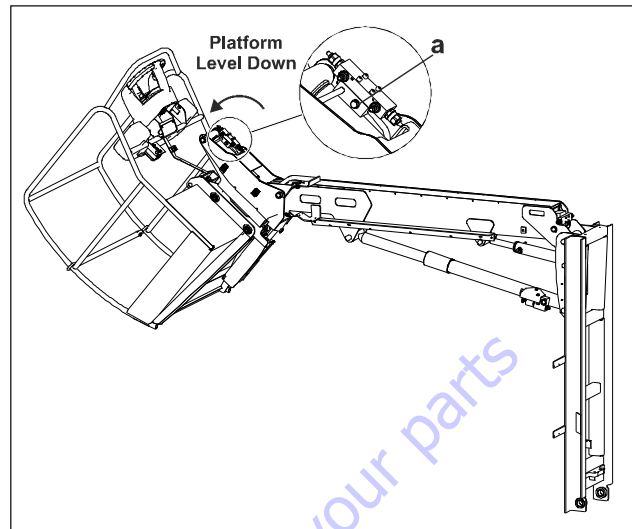
**Valve Removal****⚠ WARNING**

ENSURE THE PLATFORM IS SAFELY SUPPORTED BEFORE DISMOUNTING THE VALVE. DISCONNECT BATTERY PLUG UNTIL THE REPAIRS ARE COMPLETED.

1. Fully retract the machine and ensure work platform is horizontal. Install suitable blockings to support the platform. Turn the power off at ground controls and disconnect battery plug.
2. Tag, disconnect and cap slave cylinder hydraulic lines and ports ( $V_1$  and  $V_2$ ).
3. Unscrew four valve mounting screws (a), plug the cylinder ports and remove the holding valve.

**Valve Installation**

1. Check presence and position of the two O-rings (b) and install the valve onto the cylinder. Torque four screws (a) to 9.5 N.m.
2. Connect hydraulic lines as previously tagged.
3. Connect battery plug. Using ground controls, raise the mast and remove blockings.
4. Perform a few jib raising/lowering movements to check for proper operation then bleed air from the circuit (on the cylinder sides).
5. Check hydraulic fluid level and adjust accordingly.

**Air Bleeding from Rod Side**

**Figure 7-20. Air Bleeding From Rod Side**

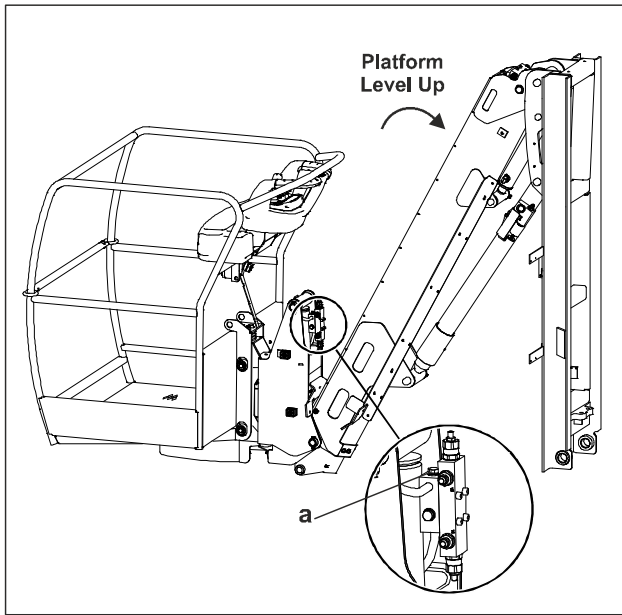
1. Raise the jib to the horizontal position, then fully retract the slave cylinder (platform level down movement).
2. While levelling the platform down, loosen the bleeding screw (a) by half a turn max.

**⚠ DANGER**

DURING THE BLEEDING PROCESS, HYDRAULIC OIL IS UNDER PRESSURE IN THE CYLINDER AND OIL PROJECTIONS CAN HAPPEN.

3. The bleeding process is complete once no more air escapes from the screw (a). Tighten the bleeding screw to 24 N.m.
4. Clean all parts with a solvent and dry with compressed air.
5. Perform a few platform level up/down movements to check for proper operation.
6. Check hydraulic fluid level and adjust accordingly.

**Air Bleeding from Piston Side**



**Figure 7-21. Air Bleeding From Piston Side**

1. Lower the jib, then fully extend the slave cylinder (platform level up movement).
2. While levelling the platform up, loosen the bleeding screw (a) by half a turn max.

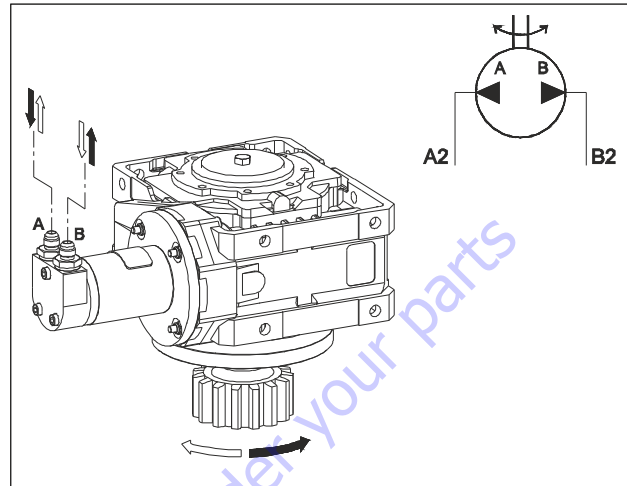
**⚠ DANGER**

**DURING THE BLEEDING PROCESS, HYDRAULIC OIL IS UNDER PRESSURE IN THE CYLINDER AND OIL PROJECTIONS CAN HAPPEN.**

3. The bleeding process is complete once no more air escapes from the screw (a). Tighten the bleeding screw to 24 N.m.
4. Clean all parts with a solvent and dry with compressed air.
5. Perform a few platform level up/down movements to check for proper operation.
6. Check hydraulic fluid level and adjust accordingly.

**7.6 SWING MOTOR**

**NOTE:** Refer to Section 5 of this manual for swing motor removal procedure.



**Figure 7-22. Swing Motor**

**Ports Identification**

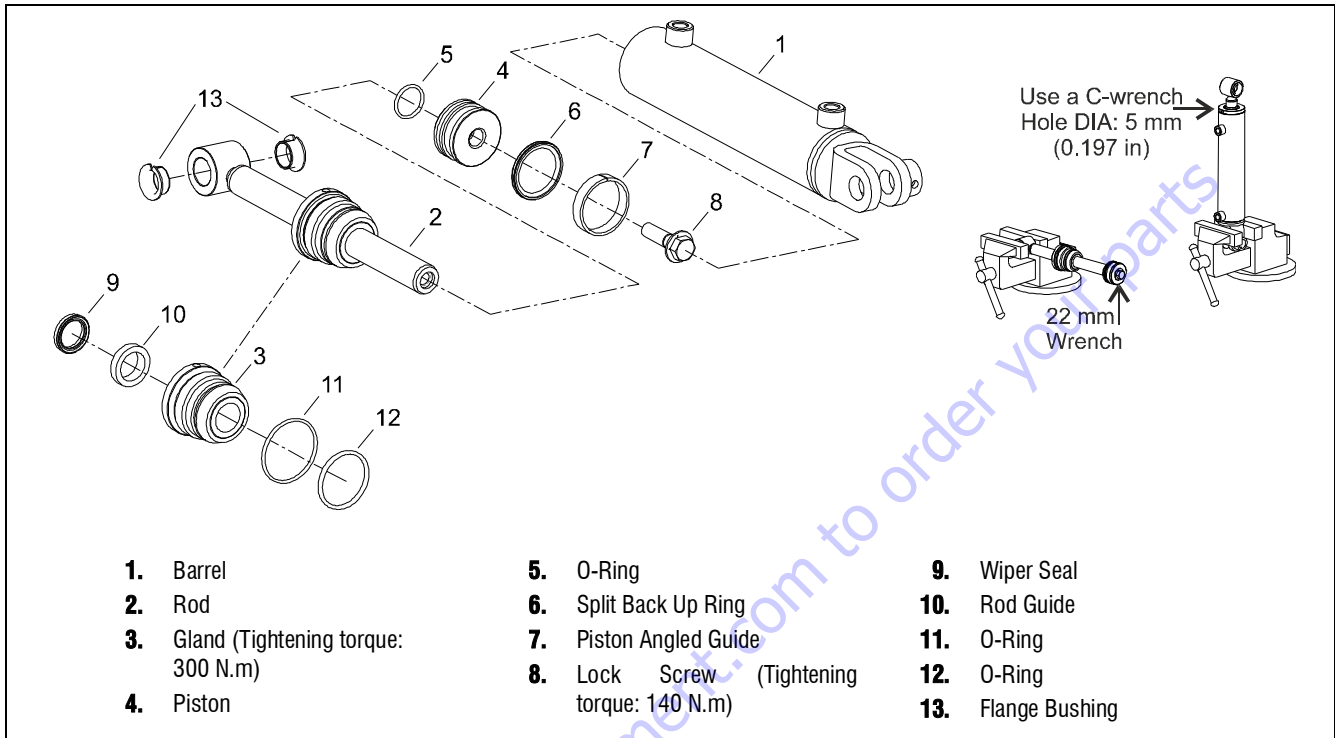
Port A: Swing Right

Port B: Swing Left

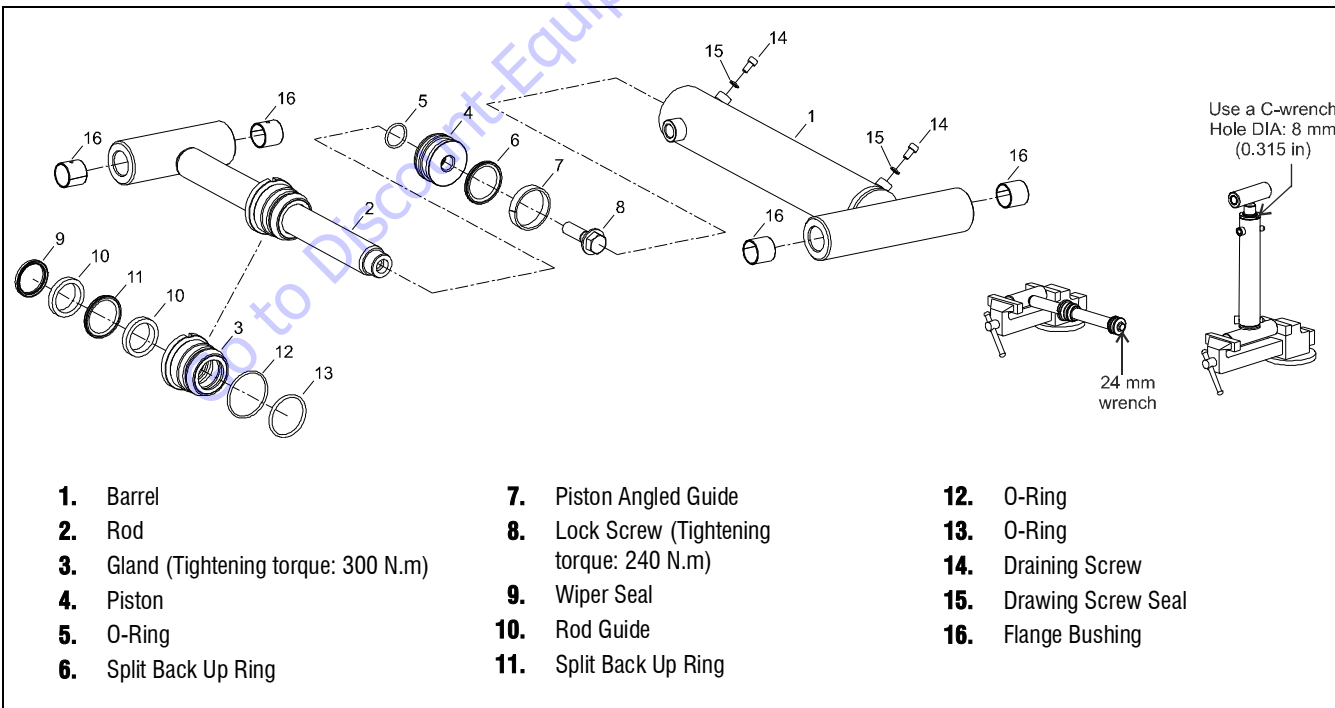
### 7.7 CYLINDER REPAIR

**NOTE:** The following are general procedures that apply to all the cylinders of the machine. Procedures that apply to a specific cylinder will be so noted.

**NOTE:** After cylinder removal, it is recommended to replace bushings (if fitted). Refer to Section 2 for bushings installation procedure.

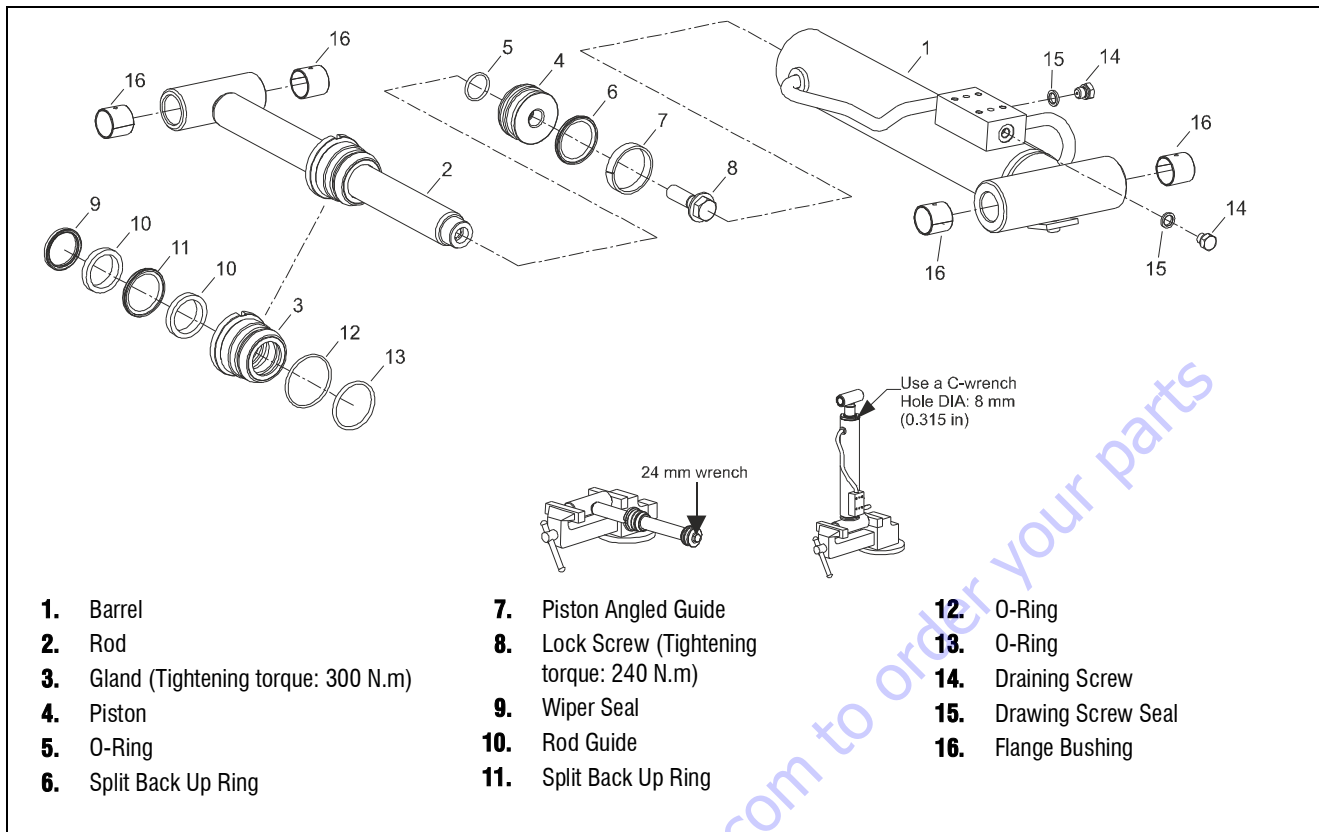


**Figure 7-23. Steer Cylinder**

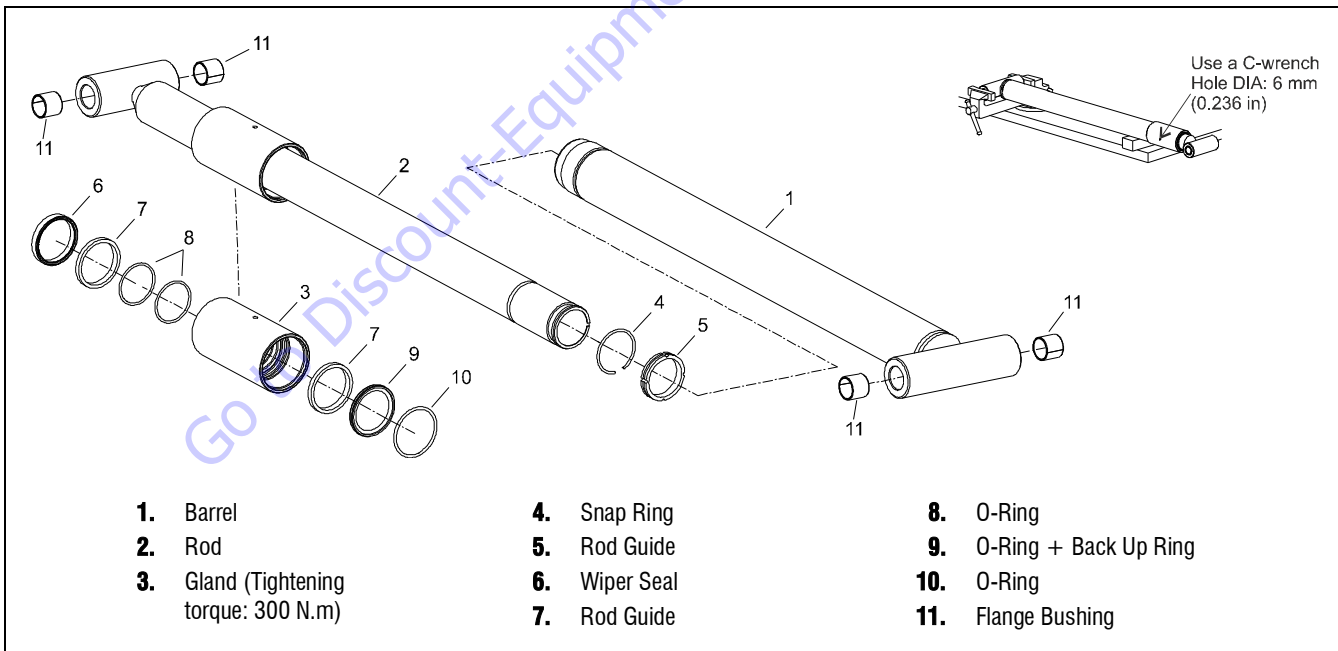


**Figure 7-24. Master Cylinder**

**SECTION 7 - HYDRAULICS**



**Figure 7-25. Slave Cylinder**



**Figure 7-26. Jib Cylinder**

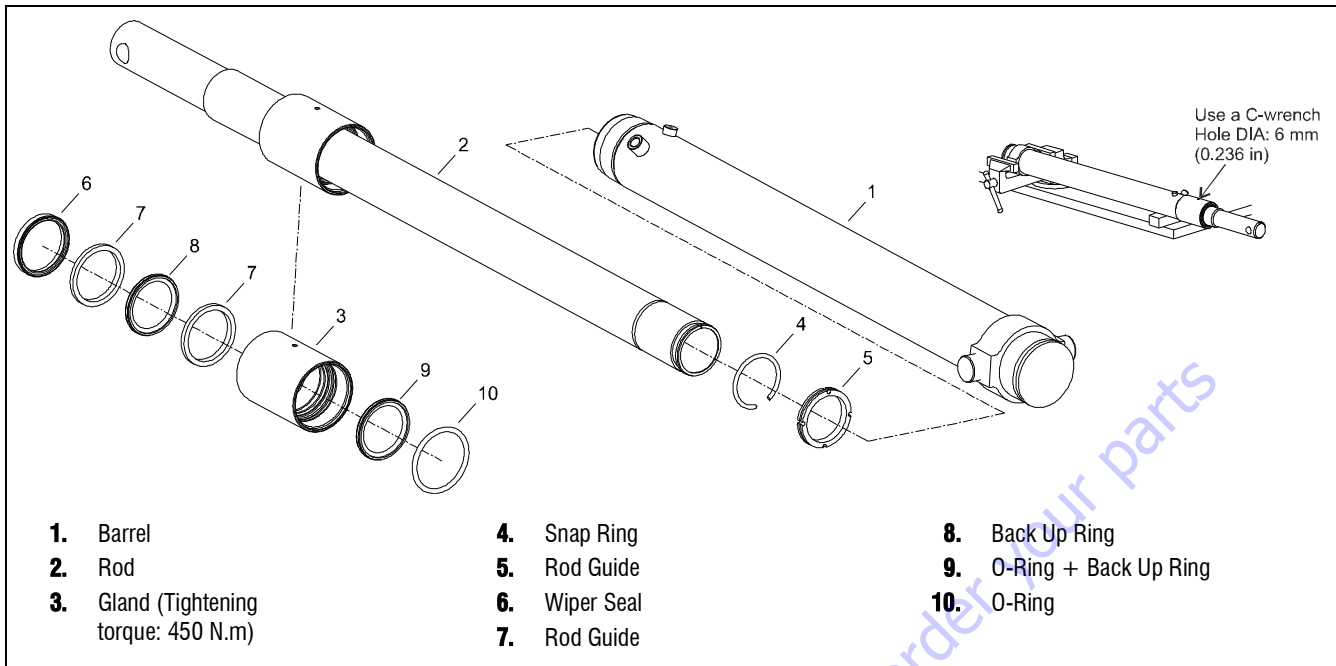


Figure 7-27. Mast Cylinder

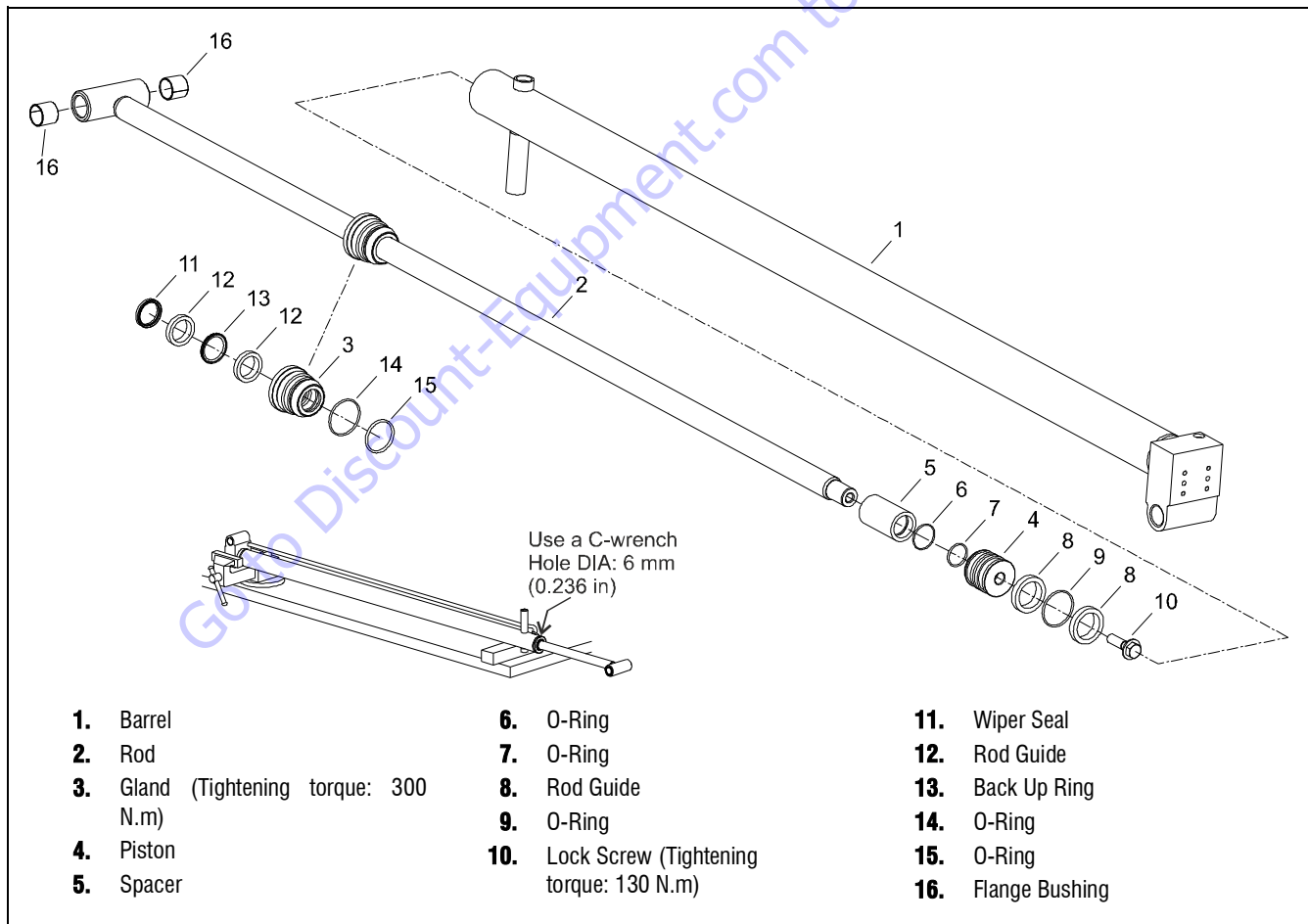
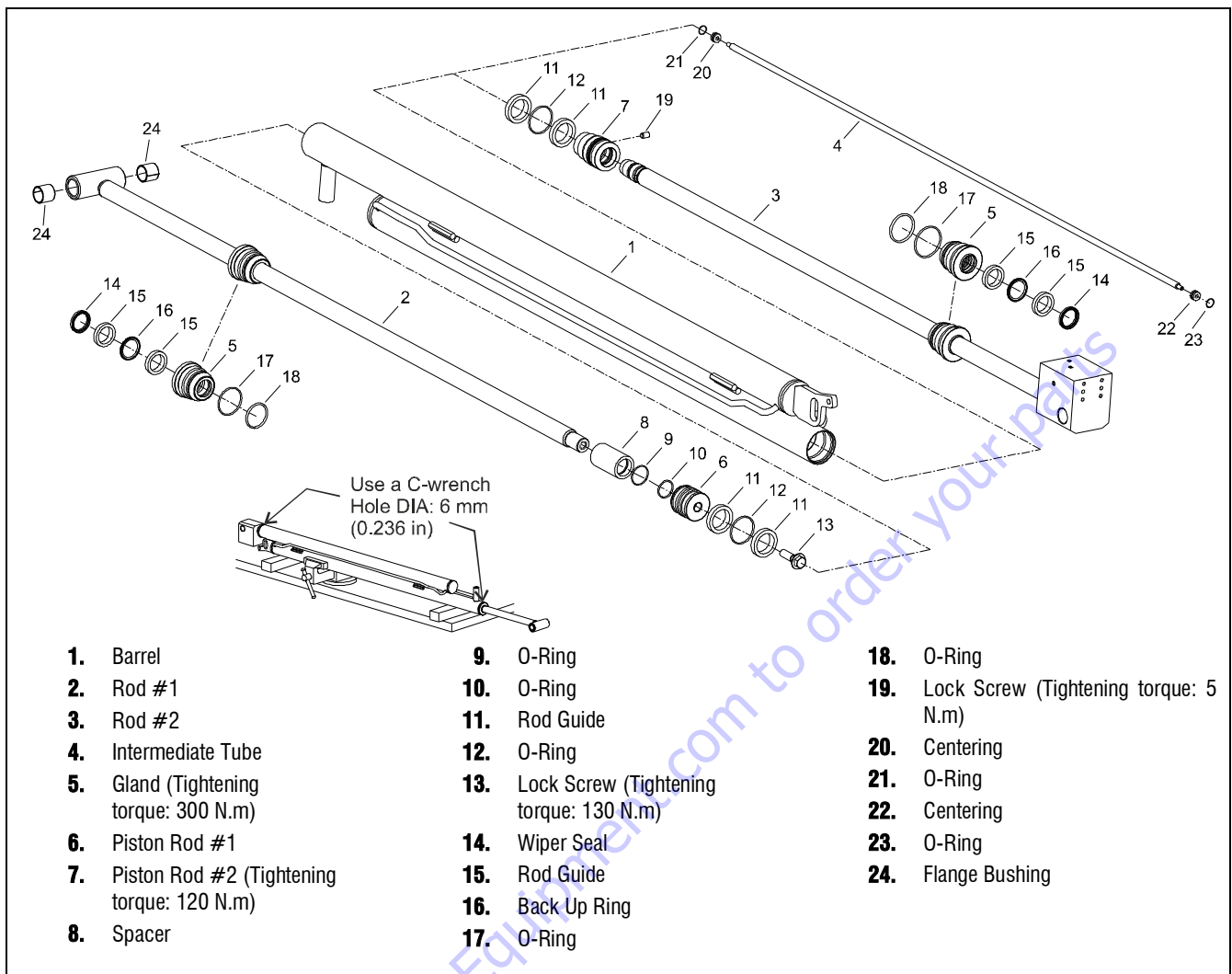


Figure 7-28. Telescope Cylinder



**Figure 7-29. Telescope Plus Cylinder**



## Disassembly

### NOTICE

NEVER USE COMPRESSED AIR TO EXTRACT THE ROD FROM THE BARREL OR TO CYCLE THE CYLINDER.

### NOTICE

DISASSEMBLY OF A CYLINDER SHOULD BE PERFORMED ON A CLEAN WORK SURFACE IN A DIRT FREE WORK AREA.

### NOTICE

IF USING A VISE TO HOLD CYLINDER BARREL, NEVER CLAMP THE BARREL TUBE WITH THE VISE'S JAWS.

1. Drain oil from the cylinder.
2. Place the cylinder barrel into a suitable holding fixture.
3. Using an appropriate tool (C-Wrench), loosen the barrel head gland by turning it in counter-clockwise direction.
4. Withdraw the rod assembly from the barrel taking care not to damage the chrome surface of the rod(s).
5. All cylinder but mast and jib cylinders: place the rod assembly into a suitable holding fixture.
6. All cylinder but mast and jib cylinders: loosen the piston attachment screw. Remove piston parts and withdraw barrel head gland from the rod.  
Mast and Jib Cylinders: remove the rod guide (No need for removing the snap ring from the cylinder rod). Withdraw barrel head gland from the rod.
7. Remove and discard seals, O-rings, back-up rings and guide bands from the piston and the barrel head gland.
8. Align discarded seals and rings in the order of disassembly as reminder for new seals and rings installation.
6. If applicable, inspect piston surface for damage and scoring and for distortion. Dress piston surface as necessary.
7. If applicable, inspect piston grooves for burrs and sharp edges. Dress applicable surface as necessary.
8. Inspect cylinder head gland inside diameter for scoring or other damage and for ovality and tapering. Replace cylinder if necessary.
9. Inspect threaded portion of cylinder head gland for damage. Dress threads as necessary.
10. Inspect seals grooves in head gland for burrs and sharp edges. Dress applicable surfaces as necessary.
11. Inspect cylinder head gland outside diameter for scoring or other damage and ovality and tapering. Replace cylinder if necessary.
12. If applicable, inspect rod and barrel bushings for excessive wear or damage. Replace as necessary.
13. Inspect the oil ports for blockage or the presence of dirt or other foreign material. Repair as necessary.

## Assembly

**NOTE:** Prior to cylinder assembly, ensure that the proper cylinder seal kit is used. See your JLG Parts manual. Apply a light film of hydraulic oil to all components prior to assembly.

1. Install new seal(s), backup ring(s) and guide bands into the applicable cylinder head gland groove(s).
2. Use a soft mallet to tap a new wiper seal into the applicable cylinder head gland groove (the flat part of seal must be facing into head).
3. Place new O-rings and backup rings in the applicable outside diameter grooves of the cylinder head.
4. Carefully install the head gland on the rod, ensuring that the wiper and rod seals are not damaged or dislodged.
5. All cylinder but mast and jib cylinders: install O-ring, piston seal, angled guides and split backup rings on piston parts and install the piston assembly on the rod. Secure the piston assembly with the lock screw. Mast and jib cylinders only: install a new rod guide.
6. Position the barrel in a suitable holding fixture.

### NOTICE

EXTREME CARE SHOULD BE TAKEN WHEN INSTALLING THE CYLINDER ROD, HEAD AND PISTON. AVOID PULLING THE ROD OFF CENTER, WHICH COULD CAUSE DAMAGE TO THE PISTON AND CYLINDER BARREL SURFACES.

7. With the barrel clamped securely, and while adequately supporting the rod, insert the piston end into the cylinder barrel. Ensure that piston seals are not damaged.

## Inspection

1. Clean all parts thoroughly with an approved cleaning solvent.
2. Inspect the cylinder rod for scoring, tapering, ovality or other damage. If necessary, dress rod with Scotch Brite or equivalent. Replace cylinder if necessary.
3. Inspect threaded portion of the rod for excessive damage. Dress threads as necessary.
4. Inspect the inner surface of the cylinder barrel tube for scoring or other damage. Check inside diameter for tapering or ovality. Replace cylinder if necessary.
5. Inspect threaded portion of the barrel for damage. Dress threads as necessary.

## **SECTION 7 - HYDRAULICS**

---

8. Continue pushing the rod into the barrel until the cylinder head gland can be inserted into/onto the barrel cylinder.
9. Secure the cylinder head gland.
10. After the cylinder has been reassembled, the rod should be pushed all the way (fully retracted).

Go to [Discount-Equipment.com](http://Discount-Equipment.com) to order your parts

SECTION 8. 2CONTROL COMPONENTS

8.1 CONTROL COMPONENTS OVERVIEW

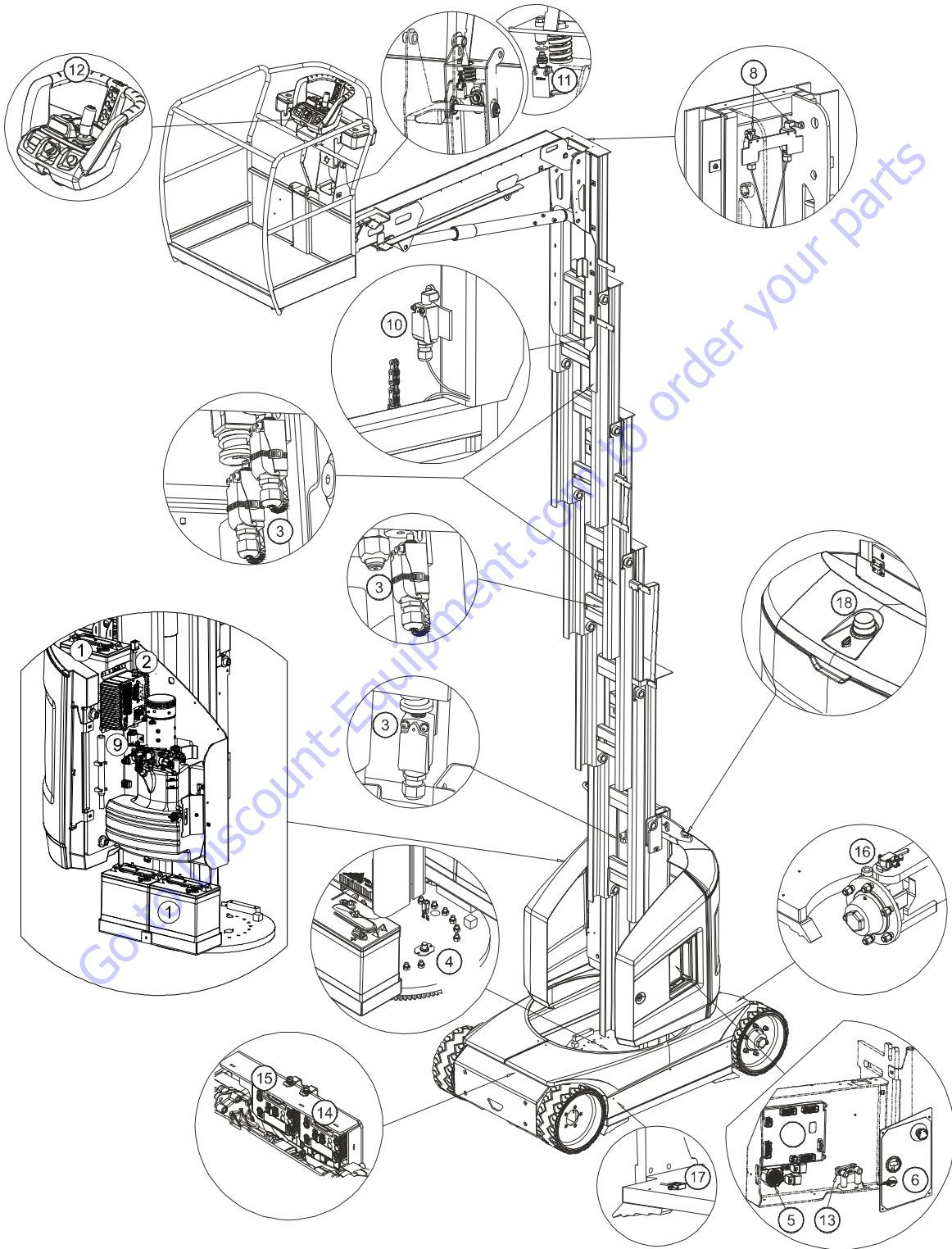


Figure 8-1. Control Components Location

1. Batteries
2. Battery Charger/48 VDC to 12 VDC Converter
3. Chain Slack Sensors
4. Drive Orientation Sensor
5. Ground Alarm
6. Ground Control Station
7. Ground Module
8. Jib Elevation Limit Switches
9. Main Contactor Power Relay
10. Mast Elevation Limit Switch
11. Overload Sensor
12. Platform Control Station
13. Power Fuse
14. Power Module - Master
15. Power Module - Slave
16. Steering Sensor
17. Tilt Sensor
18. Warning Beacon

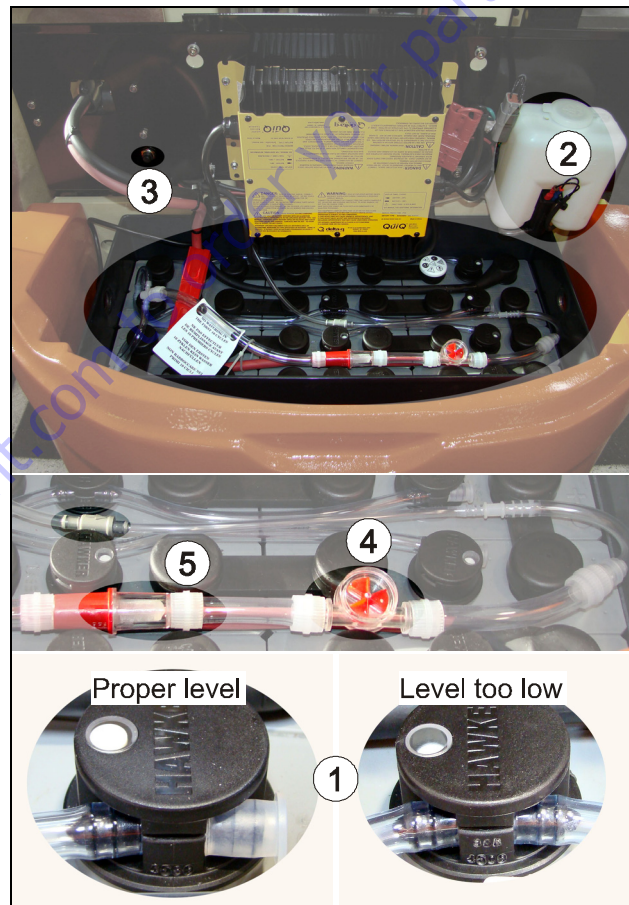
**⚠ WARNING**

**DO NOT REPLACE ITEMS CRITICAL TO STABILITY, SUCH AS BATTERIES, WITH ITEMS OF DIFFERENT WEIGHT OR SPECIFICATION. DO NOT MODIFY UNIT IN ANY WAY TO AFFECT STABILITY.**

**Electrolyte Level:**

Check the electrolyte level of the batteries often and add only distilled water when required:

1. Open access door to the battery compartment.
2. Check proper electrolyte level after charge using the floats (1) in the center of each cell filling cap.



**Figure 8-2. Battery filling**

3. Fill the can (2) with distilled water.
4. Depress and hold the push button (3) to activate the filling pump. Release the button when the flow indicator (4) slows down.
5. Check for proper level in each cell (float on each cell's cap). Actuate the filling pump again if some cells show improper level.

**Battery Cleaning:**

- Regularly clean and dry battery top.
- Ensure all connections are clean and correctly tight.
- Coat terminals with a silicone dielectric compound.

**8.2 CONTROL COMPONENTS - SERVICE**

**NOTICE**

**BEFORE REMOVING ANY COMPONENT FROM THE ELECTRICAL SYSTEM, DISCONNECT THE BATTERIES USING THE QUICK-DISCONNECT LOCATED IN THE BATTERY PACK COMPARTMENT.**

**Battery Maintenance and Safety Practices**

**⚠ WARNING**

**ENSURE THAT BATTERY ACID DOES NOT COME INTO CONTACT WITH SKIN OR CLOTHING. WEAR PROTECTIVE CLOTHING AND EYEWEAR WHEN WORKING WITH BATTERIES. NEUTRALIZE ANY BATTERY ACID SPILLS WITH BAKING SODA AND WATER.**

**RINGS, WATCHES OR ANY OTHER JEWELRY MUST BE REMOVED DURING MAINTENANCE OR ANY SERVICING OPERATION ON THE BATTERY.**

**BATTERY ACID RELEASES AN EXPLOSIVE GAS WHILE CHARGING, ALLOW NO OPEN FLAMES, SPARKS OR LIGHTED TOBACCO PRODUCTS IN THE AREA WHILE CHARGING BATTERIES. CHARGE BATTERIES ONLY IN A WELL VENTILATED AREA.**

**ADD ONLY DISTILLED WATER TO BATTERIES. ADD WATER TO BATTERIES AFTER CHARGING TO AVOID ELECTROLYTE OVERFLOW.**

- Drain the water that can accumulate at the bottom of the batteries container using the bulb supplied with the machine as follow:

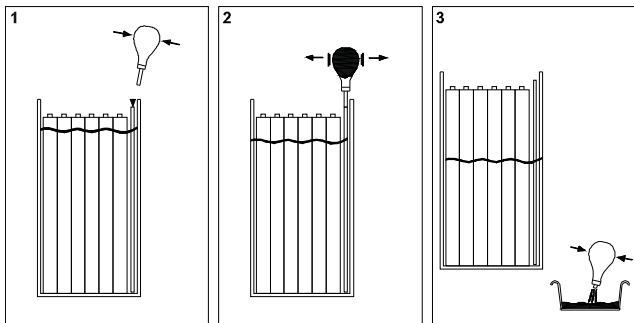


Figure 8-3. Draining the water

**Filling Circuit Inspection and Servicing:**

Battery filling circuit must be serviced once a year. Cleaning frequency must be increased in case of premature clogging of the filter or a reduction of water flow.

- Disconnect and clean the filter (5) (See Figure 8-2) by reversing the water flow from the normal direction.
- Check hoses for flexibility. In case of hardening in the connections area, replace the hose.
- Check every fittings and connections for leakage.
- Check the caps individually. Ensure perfect mobility of the floats. In case of clogging, replace the cap.
- In any case, it is recommended to replace the caps every 2 or 3 years.

**NOTE:** The filling circuit includes a check valve that prevents remaining water in the can from flowing in battery cells by gravity. Never remove this check valve. Doing so will cause excessive electrolyte level in the cells and electrolyte overflow.

**Battery Container Maintenance:**

Keep the metallic container clean. In case of corrosion, clean, neutralize corrosion and apply anti-acid paint on the affected area.

**Battery Voltage and Electrolyte Specific Gravity Recording:**

**NOTE:** Voltage and specific gravity measures should not be performed after battery cells have been filled. These measures must be done after a complete charge, once the charger has been unplugged and after the battery has been standing for at least 15 minutes.

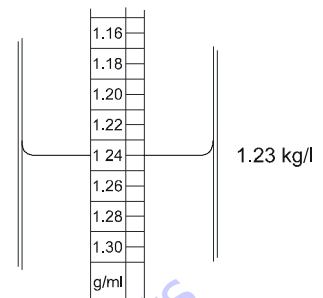


Figure 8-4. Measuring Electrolyte Specific Gravity

- Open the filling cap of the cell where the red cable is connected (B+).
- Using the hydrometer (supplied with the machine), take a quantity of electrolyte sufficient so that the float emerges. Ensure that the float top does not touch the rubber bulb or that the float does not stick by capillarity to the glass wall.
- Read the value as indicated in the previous figure.
- Return electrolyte in the cell and record the value in the battery service log.
- Measure the cell voltage and record the value in the battery service log.
- Repeat operation for each cell in sequence from B+ (Red cable) to B- (Black cable).

**Use of a Battery in a Cold Chamber or in a Cold Climate:**

Low temperatures decrease battery capacity. The battery must be fully charged when the machine is operated in a cold chamber or in cold weather condition.

**Battery Not Working Continuously or Inactive Battery:**

A battery that is not used or used intermittently must be stored charged in a dry area away from freezing temperatures. A charge must be performed once a month.

- Disconnect the battery to insulate it electrically.
- Keep the top of the battery clean and dry to prevent self-discharge.

**NOTICE**

IF THE BATTERY IS NOT USED CONTINUOUSLY, IT MUST BE RECHARGED BEFORE USE AND AT LEAST ONCE A MONTH (EVEN IF THE ELECTROLYTE SPECIFIC GRAVITY MEASURES ARE HIGH).

BEFORE RETURNING TO SERVICE A BATTERY THAT REMAINS INACTIVE FOR A LONG PERIOD OF TIME, CHARGE THE BATTERY AND CHECK ELECTROLYTE LEVEL IN THE CELLS.

## SECTION 8 - 2CONTROL COMPONENTS

### Battery Troubleshooting:

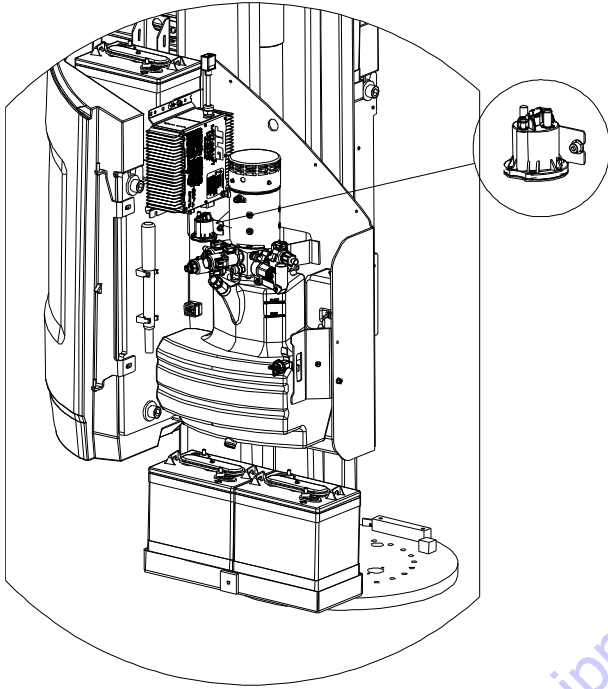
Symptoms	Probable causes	Solutions
Electrolyte overflow.	Filling done before the charge. Cells overfilled.  Overcharge.	Fill battery cells after the charge.  Never charge battery if electrolyte specific gravity is above 1,240 kg/l.
Inequal electrolyte specific gravity or electrolyte specific gravity too low.	Filling done before the charge.  Loss of electrolyte due to overflow.  Stratification of the electrolyte.	Fill battery cells after the charge.  Perform an equalization charge.  Contact your JLG Distributor/Product Support.
Low voltage in the cells in open circuit.	Electrolyte specific gravity too low.  Short-circuit.	Refer to "electrolyte specific gravity too low".  Clean battery top.
Battery cells temperature too high (over 113°F (45°C)).	Problem with the charger.  Bad air circulation during charge.  Cell weak or faulty Cells shorted.	Get the charger checked by a technician.  Open access doors to batteries during charge. Reduce temperature of the area where the battery is charged (artificial ventilation).  Change battery cell.
Battery incapable of supporting regular operation.	Battery under charged.  Cell faulty.  Faulty cable or connection.  Battery at the end of its service life.	Perform an equalization charge.  Replace faulty cell.  Check wire condition and connection.  Replace the battery.

**Table 8-1. Battery Troubleshooting**

**Main Power Contactor Relay**

The main power contactor relay is located on the left side of the mast, inside the hydraulic pump/motor assembly compartments as shown following.

Electrical characteristics:  
 Nominal voltage: 48V DC  
 Coil resistance: 195 Ω  
 Pull in voltage: 32 V DC  
 Hold voltage: 13.9 V DC

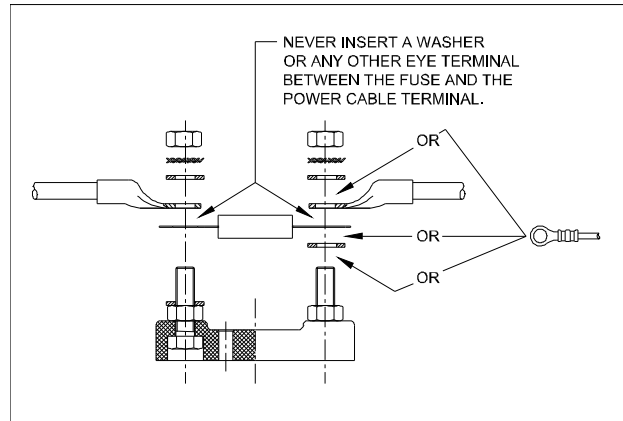
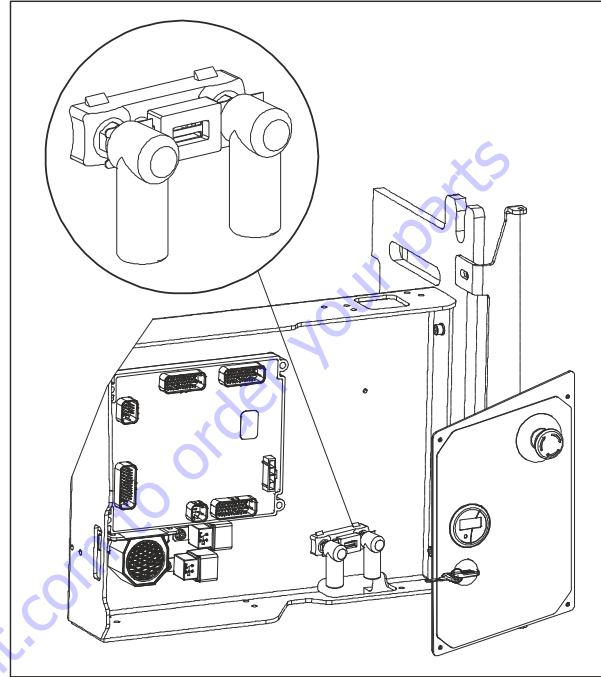


**Figure 8-5. Main Power Contactor Relay**

**Power Fuse**

The power fuse is located on the right side of the mast, inside the ground module compartment as shown following.

Amp. Rating: 250 Amps  
 Type: C20 (DIN 43560)



**Figure 8-6. Power Fuse**

## SECTION 8 - 2 CONTROL COMPONENTS

### Mast Elevation Limit Switch

Elevation limit switch is attached to mast section #6 as shown following. When the mast elevates, cam welded on mast section #5 actuates the switch.

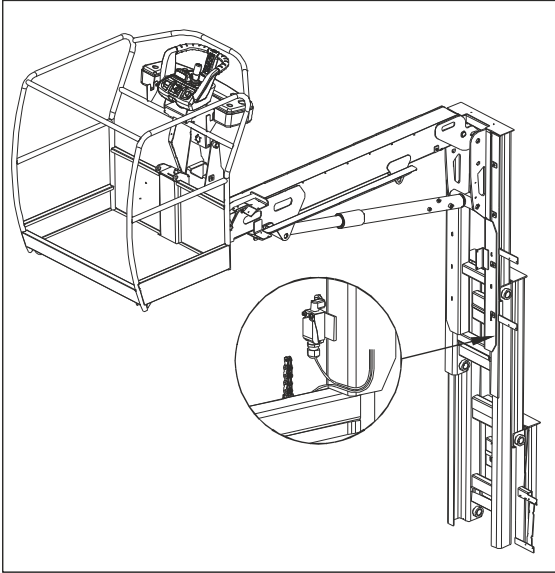


Figure 8-7. Mast Elevation Limit Switches

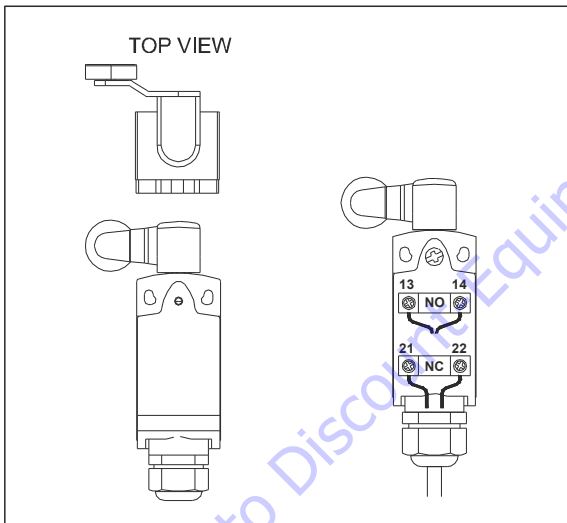


Figure 8-8. Actuators Setting

Mast limit switch conditions:

Table 8-2. Mast Limit Switch Conditions

Contact #	Function	Voltage with Mast Retracted	Voltage with Mast elevated
13	Contact NO	+ V Supply	+ V Supply
14	Contact NO	0	+ V Supply
21	Contact NC	+ V Supply	+ V Supply
22	Contact NC	+ V Supply	0

+ V Supply = 12 to 14 VDC

### Jib Elevation Limit Switches

Jib limit switches are attached to mast section #6.

The main jib switch ① is actuated for a platform elevation (mast retracted) of approx. 1.2 m (4 ft).

The end of stroke switch ② is actuated about 30 cm (1ft) before full jib elevation.

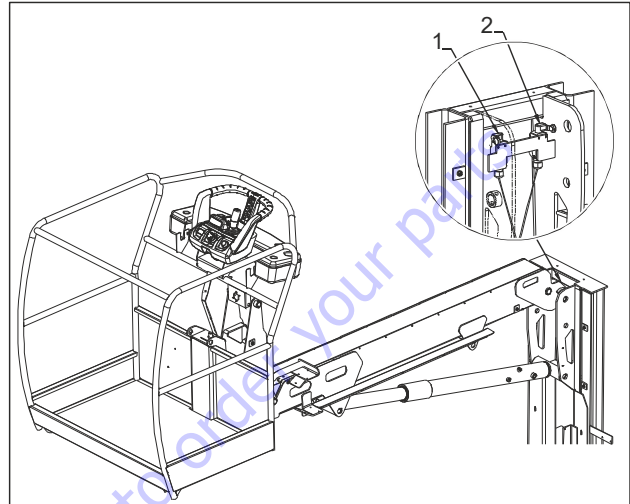


Figure 8-9. Jib Elevation Limit Switches

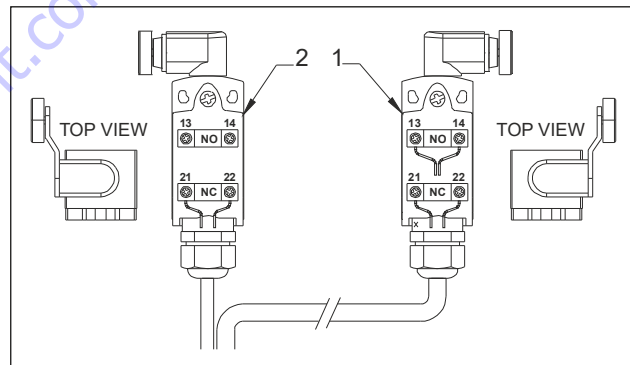


Figure 8-10. Jib Actuators Setting

Table 8-3. Main Jib Switch Conditions

Contact #	Function	Voltage with Jib Down	Voltage with Jib Elevated
13	Contact NO	+ V Supply	+ V Supply
14	Contact NO	0	+ V Supply
21	Contact NC	+ V Supply	+ V Supply
22	Contact NC	+ V Supply	0

+ V Supply = 12 to 14 VDC

Table 8-4. End Of Stroke Jib Limit Switch Conditions

Contact #	Function	Voltage with Jib Down	Voltage with Jib at End Of Stroke
21	Contact NC	+ V Supply	+ V Supply
22	Contact NC	+ V Supply	0

+ V Supply = 12 to 14 VDC



### Chain Slack Sensor

One chain of each lifting chain stage is fitted with a slack detection device. Those 4 switches are wired in series.

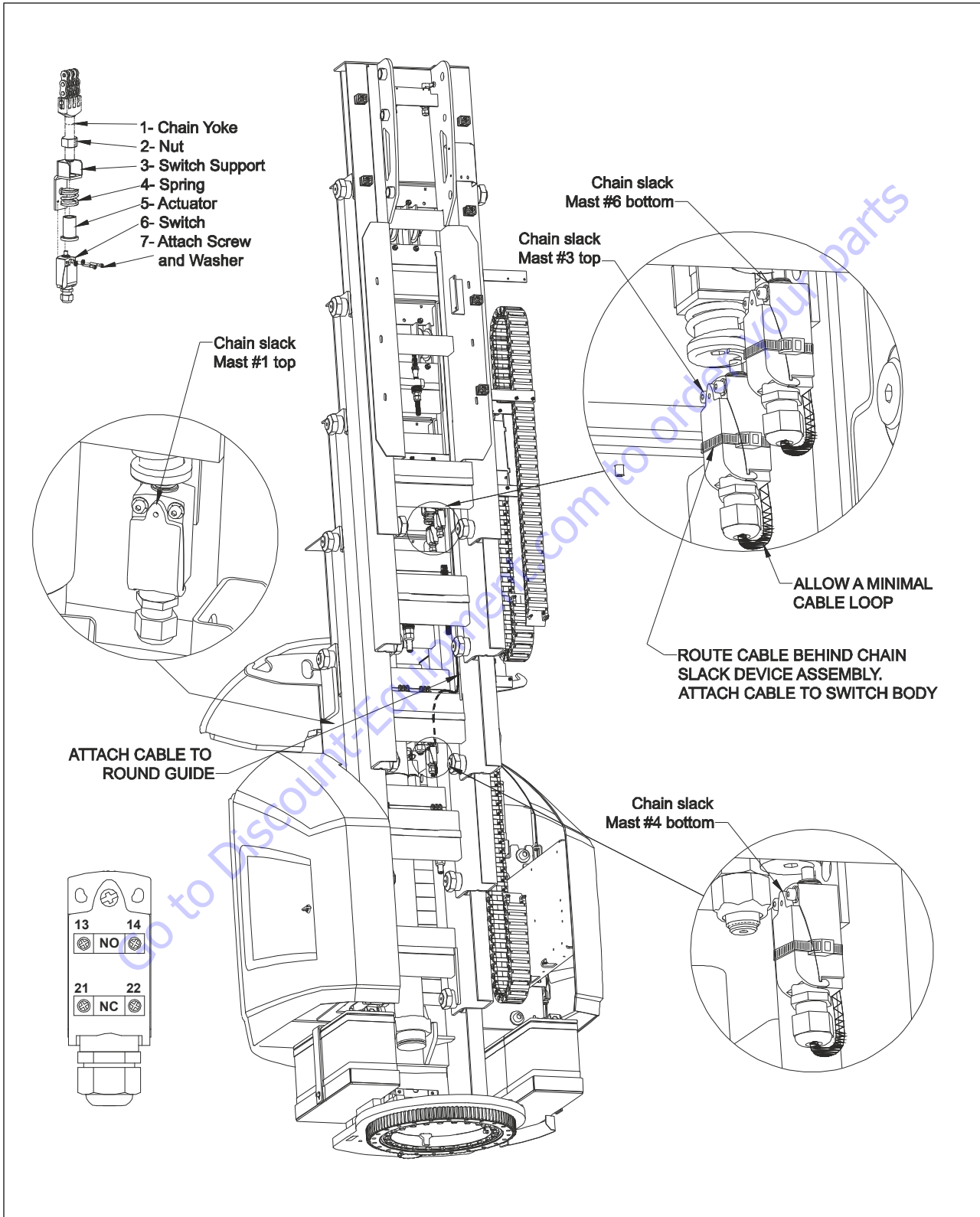


Figure 8-11. Chain Slack Sensors

## SECTION 8 - 2 CONTROL COMPONENTS

Slack chain condition is:

- Generally caused by the platform or the jib coming to rest on an obstacle while lowering.
- More rarely caused by a mast jamming. This can be due to an incorrect adjustment (Refer to Section 5-4) or a foreign body entering the guiding system.

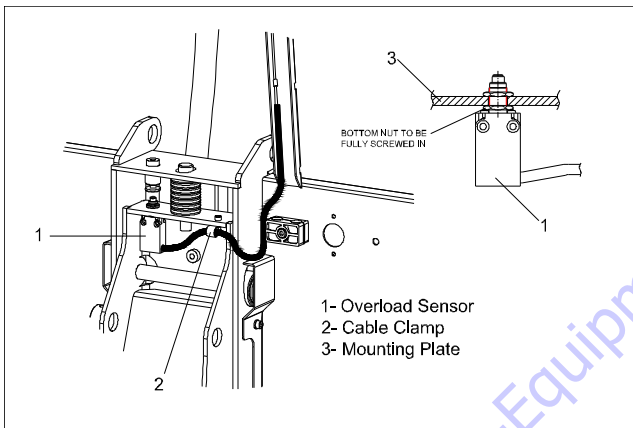
**Table 8-5. Slack Chain Connection (x295) Condition**

Pin #	Function	Voltage with NO Slack Chain	Voltage with Slack Chain
1	Power	+ V Supply	+ V Supply
2	Output	+ V Supply	0

+V Supply = 12 to 14 VDC

### Overload Sensor

When the maximum rated load in the platform is exceeded, the switch is actuated and all machine functions are disabled. The platform must be unloaded until the alarm stops.



**Figure 8-12. Overload Sensor**

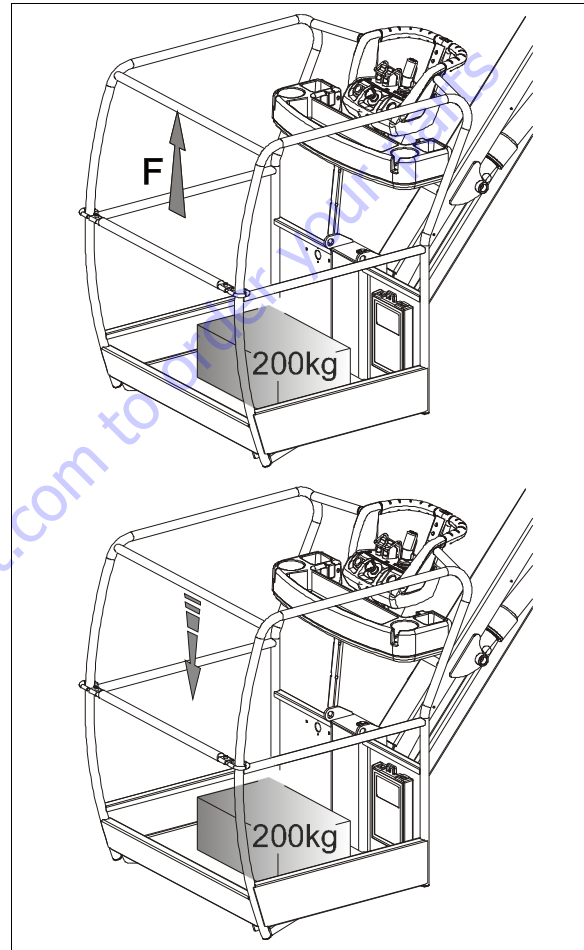
**Table 8-6. Sensor Connections Conditions**

Pin #	Function	Voltage Not Overloaded	Voltage If Overloaded
1	Power	+ V Supply	+ V Supply
2	Power	+ V Supply	+ V Supply
3	Contact NO	0	+ V Supply
4	Contact NC	+ V Supply	0

+V Supply = 12 to 14 VDC

### Overload System Setting

1. Position the machine on a flat level ground. Position the Platform/Ground select switch to the Platform position. Pull out both Platform and Ground Emergency Stop switches.
2. Place a 200 kg load evenly distributed on platform floor.
3. Slightly lift up the platform with the hands then let it fall.



**Figure 8-13. Overload Sensor Setting**

- Remove the cap screw (1).  
Loosen the locknut of the setting screw (2).

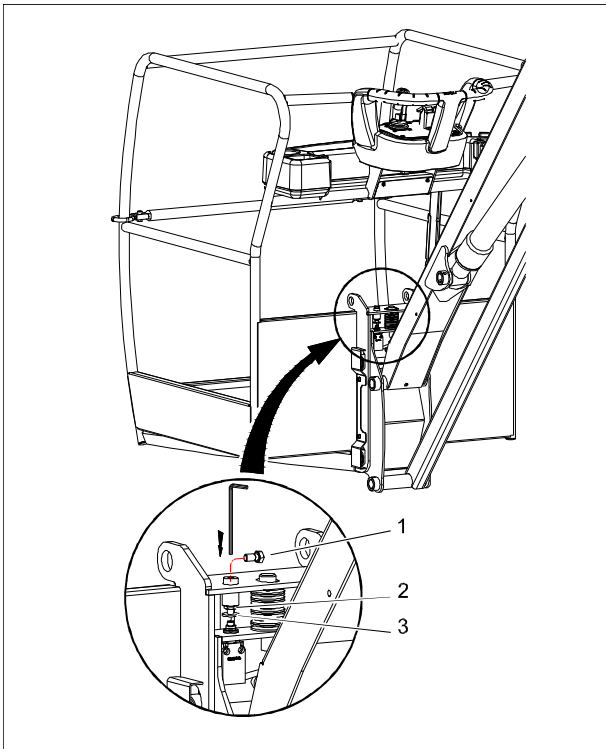
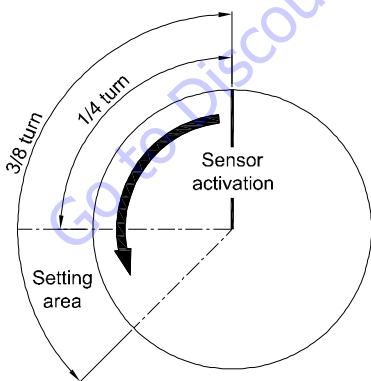


Figure 8-14. Overload System

- Slowly tighten the setting screw (3) until the sensor is activated and the acoustic alarm sounds.

**NOTE:** Depending on the machine type, the acoustic alarm is delayed between 1 and 2 seconds.

- Once the sensor is activated, loosen the setting screw between 1/4 and 3/8 turn.  
- The acoustic alarm should stop.



- Tighten the locknut while maintaining the setting screw.  
Re-install the cap screw.
- Refer to the Operation and Safety Manual to verify the Overload System Setting.

### Drive Orientation Switch

The drive orientation switch is located on the turntable base plate, behind the telescopic mast. This is an inductive switch that detects presence of ferrous material. It must be powered to operate. When the cam welded on chassis base plate is no more present (i.e. the jib is swung beyond the rear tires or further in either direction) the switch will open.

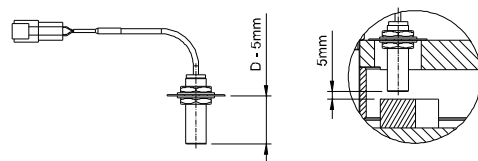
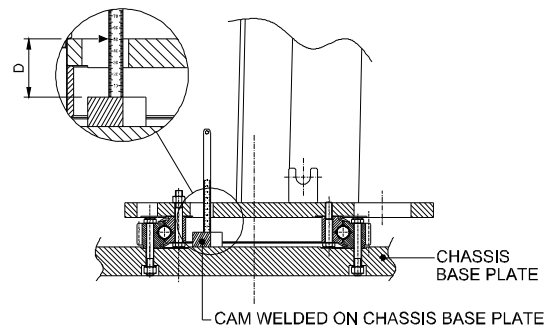
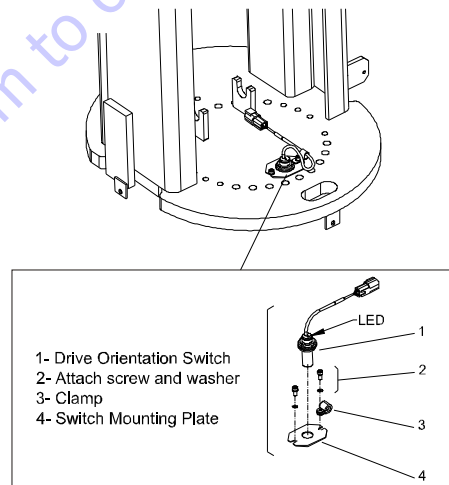
The LED on top of the switch will light up when the cam is present.

Sensor connections conditions:

Pin #	Function	Voltage with Track Present	Voltage with Track Absent
1	Power (+)	+V Supply	+V Supply
2	Output	+V Supply	Open
3	Power (-)	-V Supply	-V Supply

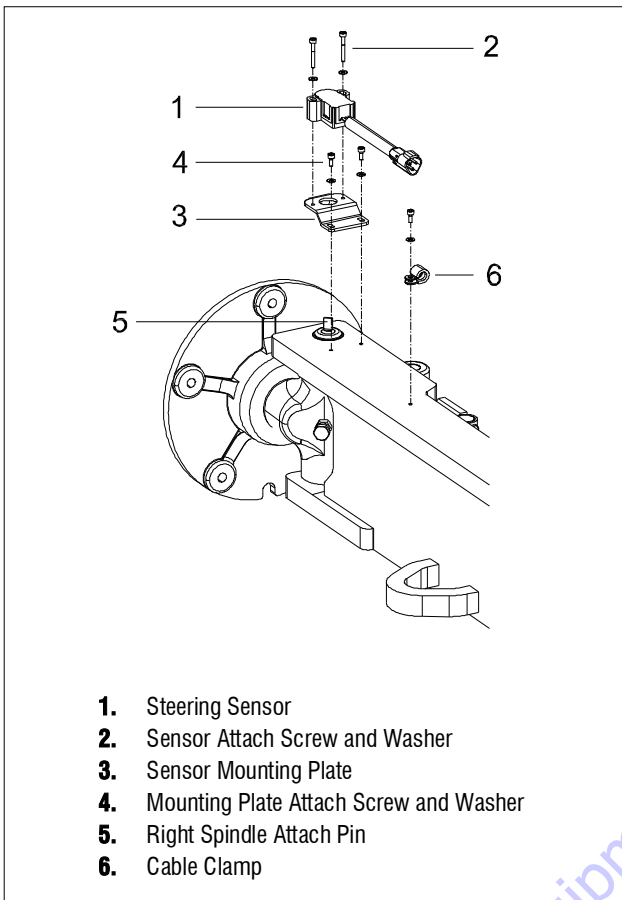
+V Supply = 12 to 14 VDC

The sensor is calibrated mechanically as shown following.



**Figure 8-15. Drive Orientation Switch**

**Steering Sensor**



- 1. Steering Sensor
- 2. Sensor Attach Screw and Washer
- 3. Sensor Mounting Plate
- 4. Mounting Plate Attach Screw and Washer
- 5. Right Spindle Attach Pin
- 6. Cable Clamp

**Figure 8-16. Steering Sensor**

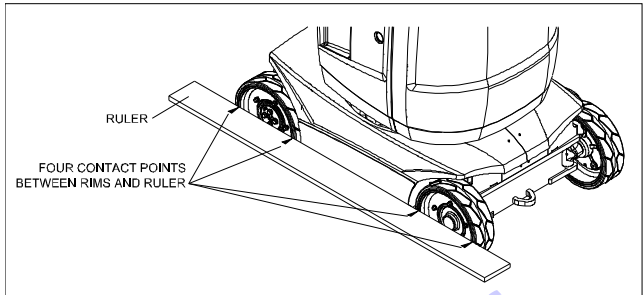
The steering sensor is located on the front steering axle. It is key operated by the right spindle attach pin.

Sensor connections conditions:

Pin #	Function	Voltage Right Stop	Voltage Wheels Straight	Voltage Left Stop
A or 1	Power (+)	4.2V - 4.4V		
B or 2	Output	0.5V - 1.0V	2.2V - 2.8V	3.4V - 3.9V
C or 3	Power (-)	-V <sub>batt</sub>		

If the sensor is dismantled, the output voltage is:  
 $0.1x (\text{Sensor Power Voltage}) = 0.42V - 0.44V$ .

If the sensor is forced on the opposite stop the output voltage is:  
 $0.9x (\text{Sensor Power Voltage}) = 3.78V - 3.96V$ .

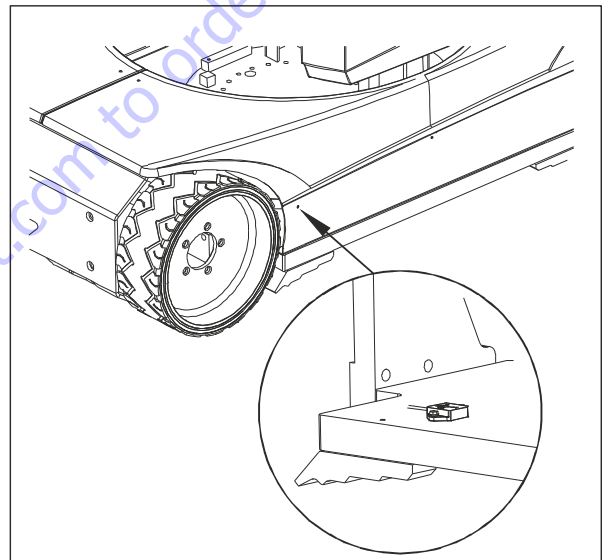


**Figure 8-17. Wheel Straightening**

**NOTE:** Refer to Section 4-3 for Steering Sensor Installation.

**Tilt Sensor**

The tilt sensor is located on the chassis base plate, behind the right rear wheel.



**Figure 8-18. Tilt Sensor**

The control system monitors the tilt sensor to determine if the vehicle is tilted excessively. If the vehicle tilt angle in any direction is greater than 3 degrees, the control system considers the machine tilted.

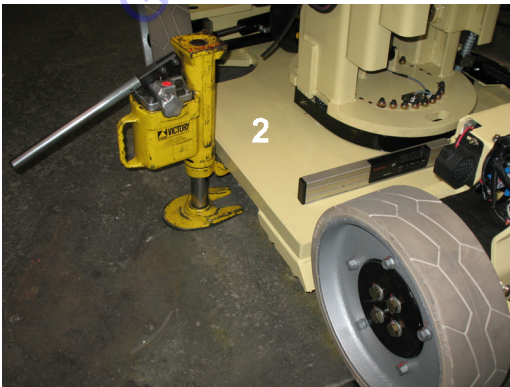
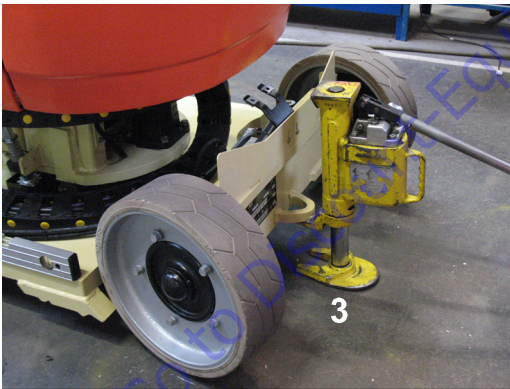
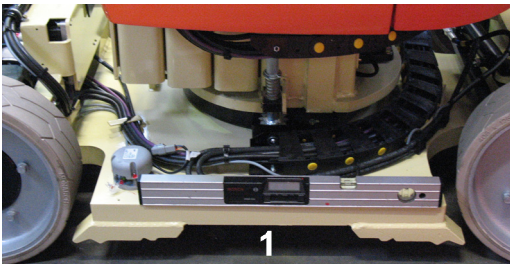
**Table 8-7. Sensor Connections Conditions**

Pin #	Wire Color	Function	Voltage
1	White	Power	5V
2	Yellow	Ground	0
3	Brown	Output X	0.5V to 4.5V
4	Green	Output Y	0.5V to 4.5V

Refer to Section 9-3 for Tilt Sensor Calibration

**Tilt Sensor Calibration Verification:**

1. Power the machine on at ground control station and slightly raise the mast to actuate the main mast limit switch (Refer to Figure 8-8).
2. Place a spirit level (digital display) longitudinally (1) on the chassis (front - rear direction).
3. Using a jack (3) of appropriate capacity, slowly and carefully lift the front of the chassis: the LED under the tilt sensor body should switch off when the chassis angle reaches 3 degrees. The warning alarm should be triggered approx. 1 second later.
4. Place a spirit level (digital display) transversely (2) on the chassis (left - right direction).
5. Using a jack (3) of appropriate capacity, slowly and carefully lift the side of the chassis: the LED under the tilt sensor body should switch off when the chassis angle reaches 3 degrees. The warning alarm should be triggered approx. 1 second later.
6. If the LED switches off before 2.5 degrees or after 3.1 degrees in either direction, perform a new calibration procedure and verify calibration again.



**Figure 8-19. Tilt Sensor Calibration Verification**

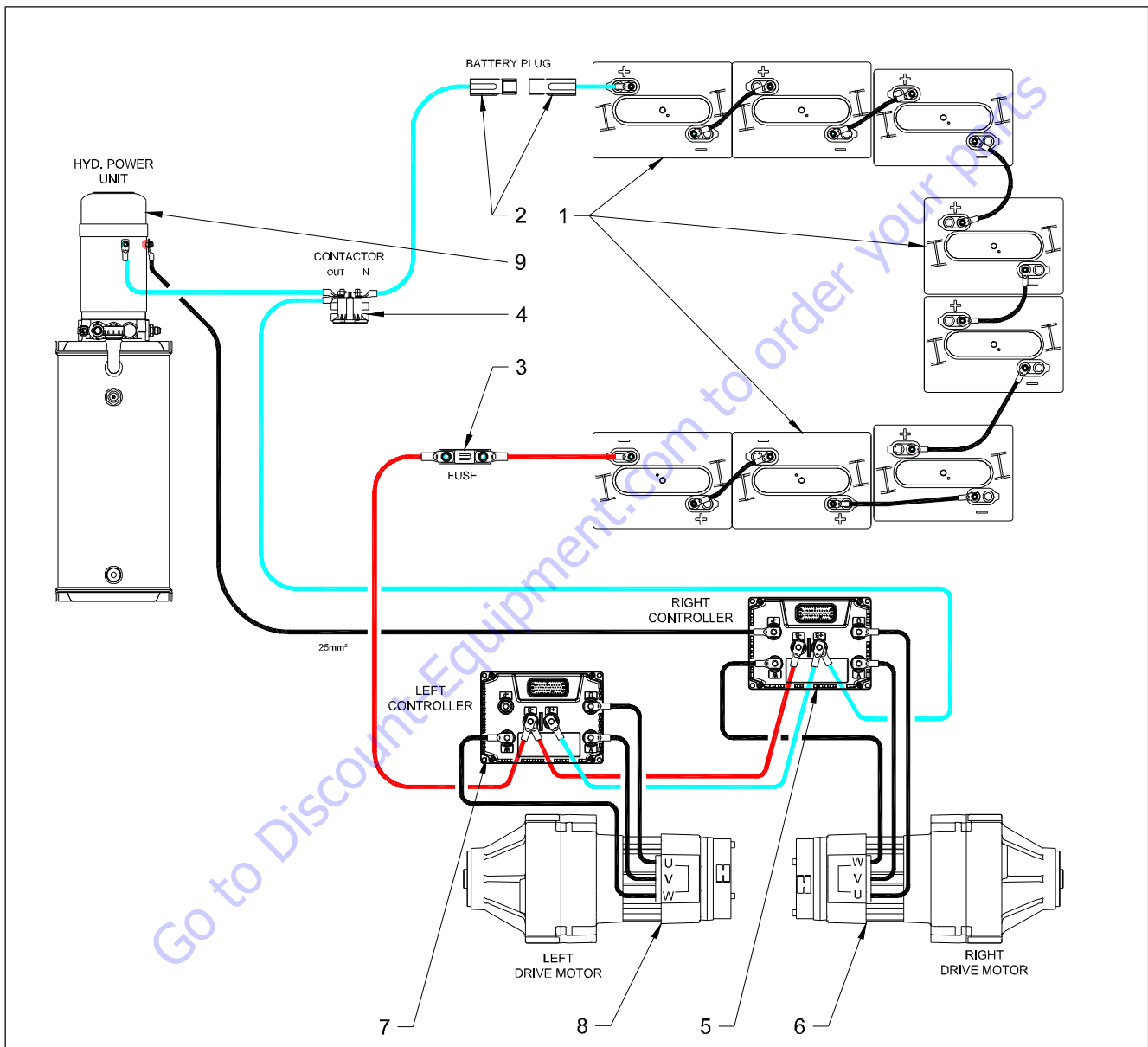
**8.3 TRACTION SYSTEM**

Refer to Section 3-5 TRACTION - Theory of Operation for more detailed information on Traction System.

**Common Traction System Difficulties**

**1. Ground Module Interlocks**

There are a variety of interlocks that prevent Drive due to system events. Before investigating Traction System Issues, examine the JLG Analyser's HELP Menu while attempting to Drive from Platform Mode. Refer to the Section 9 for explanation of the JLG Analyser Help Messages.



- |  |                                |
|--|--------------------------------|
| <b>1.</b> Battery Pack                   | <b>6.</b> Drive Motor - Right  |
| <b>2.</b> Battery Power Quick-Disconnect | <b>7.</b> Power Module - Slave |
| <b>3.</b> Power Fuse                     | <b>8.</b> Drive Motor - Left   |
| <b>4.</b> Power Contactor                | <b>9.</b> Hydraulic Pump Motor |
| <b>5.</b> Power Module - Master          |                                |

**Figure 8-20. Main Electrical Power Connections**

## 8.4 POWER MODULE

The power modules are located at the rear of the chassis between the driving wheels. The master module is mounted on the right side of the chassis and the slave module on the left side.

The master power module controls the right drive motor and the hydraulic pump motor.

The slave power module controls the left drive motor.

Both power modules are identical and share the same software. The master or slave condition of the power modules is defined by the wiring of the inputs: on the master module, the connector pin #6 is energized at power-up.

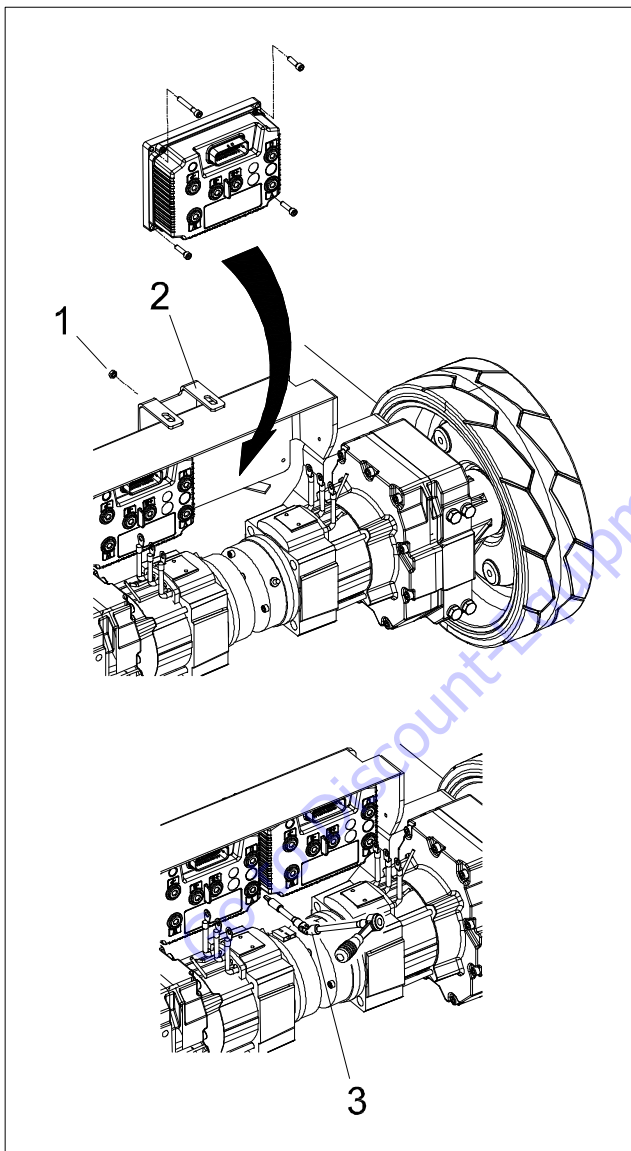


Figure 8-21. Power Module Removal - Installation

## Removal

### ⚠ CAUTION

**PRIOR TO ANY SERVICING OPERATION ON POWER MODULES, DISCONNECT BATTERY PLUG.**

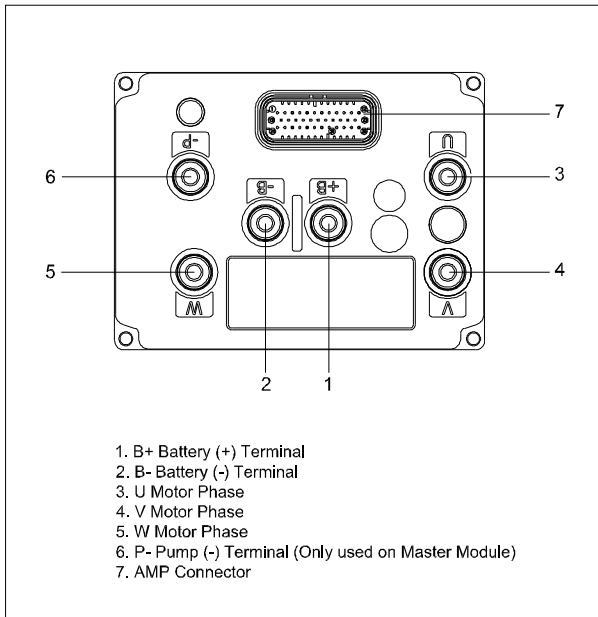
**AFTER MACHINE OPERATION, EVEN WITH THE POWER TURNED OFF AND THE BATTERY DISCONNECTED, INTERNAL CAPACITORS OF THE POWER MODULES MAY REMAIN CHARGED FOR SOME TIMES. REFER TO THE FOLLOWING PROCEDURE TO DISCHARGE THOSE CAPACITORS.**

1. From ground controls, swing the turntable 90° from chassis center line. Shut machine down and disconnect battery plug.
2. Actuate the battery filling pump button: the pump will run for a few seconds till the capacitors are discharged.
3. Remove chassis covers and rear chassis shield.
4. Disconnect AMP connector from the power module: Refer to Section 11.
5. Tag and disconnect power cables from the power module.
6. Loosen the nut (1) securing the chassis cover bracket (2).
7. Remove the four screws securing the power module. Use a ratchet wrench with appropriate extensions and a universal joint (3) to remove the bottom screws. Remove the power module.

**Installation**

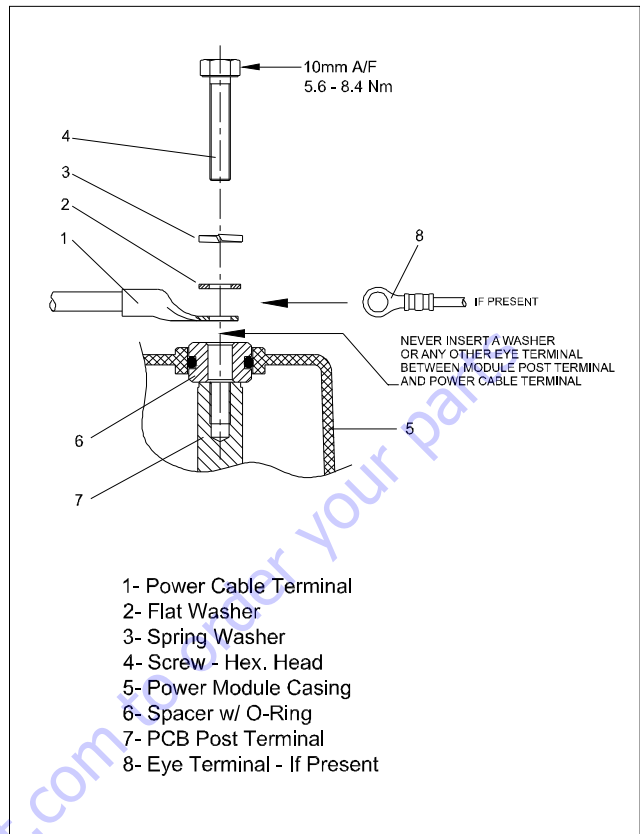
1. Apply a light layer of thermo-conductive grease on the new power module base plate.
2. Install the power module with the AMP connector upwards and secure to the chassis.

**NOTE:** Power module shown as installed on the machine (AMP connector Upwards).



**Figure 8-22. Power Module Terminals**

3. Connect cables and connector back to the power module as previously tagged. Tighten the power cables on controller posts with a torque of 5.6 - 8.4 Nm (4.1 - 6.2 ft lb).



**Figure 8-23. Cables on Power Module Post Terminal**

**NOTICE**

**DO NOT OVERTIGHTEN THE TERMINAL BOLTS, OR DAMAGE TO THE UNIT COULD OCCUR.**

4. After all connections to the power module are made and verified, the battery can be reconnected.
5. Install chassis rear shield and chassis covers.
6. Check software version (Refer to Section 9), if necessary proceed with a software update.
7. Proceed with a steer sensor calibration (Refer to Section 9.3).



**Power Module Electrical Evaluation**

**1. Master Controller Inputs / Outputs List**

Pin	Function	Type	
1	Unused	Digital	Input
2	Electro-Brake Supply (Positive)	Digital	Output
3	+Valves Supply (Positive)	Power	Input
4	Electro-Brake Driver (Negative)	PWM	Output
5	Right Wheel Encoder Ground	Power	Output
6	Master Selection	Digital	Input
7	Unused	Digital	Input
8	Unused	Digital	Output
9	Unused	Digital	Output
10	Master Key Switch (Ignition)	Digital	Input
11	Unused	Digital	Output
12	Main Line Contactor (Negative)	PWM	Output
13	Right Wheel Encoder Pin A	Digital	Input
14	Right Wheel Encoder Pin B	Digital	Input
15	Steer Angle Sensor	Analog	Input
16	Charger Interlock	Digital	Input
17	Unused	Digital	Input
18	Unused	Digital	Input

Pin	Function	Type	
19	Unused	Digital	Input
20	Unused	Unused	Input
21	Unused	Digital	Input
22	Right Wheel Thermal Sensor	Analog	Input
23	Unused	Prop	Output
24	Unused	Prop	Output
25	Right Wheel Encoder Power	Power	Output
26	Unused	Digital	Output
27	Master CAN Low	Com	Input
28	Master CAN High	Com	Input
29	Unused	Digital	Input
30	Unused	Analog	Input
31	Unused	Digital	Input
32	Unused	Digital	Input
33	Unused	Digital	Output
34	Unused	Digital	Output
35	Unused	Digital	Input

## SECTION 8 - 2CONTROL COMPONENTS

### 2. Slave Controller Inputs / Outputs List

Pin	Function	Type	
1	Unused	Digital	Input
2	Electro-Brake Supply (Positive)	Digital	Output
3	Valves Supply (Positive)	Power	Input
4	Electro-Brake Driver (Negative)	PWM	Output
5	Left Wheel Encoder Ground	Power	Output
6	Unused	Digital	Input
7	Unused	Digital	Input
8	Unused	Digital	Output
9	Unused	Digital	Output
10	Slave Key Switch (Ignition)	Digital	Input
11	Unused	Digital	Output
12	Contact Relay (Negative)	PWM	Output
13	Left Wheel Encoder Pin A	Digital	Input
14	Left Wheel Encoder Pin B	Digital	Input
15	Unused	Analog	Input
16	Unused	Digital	Input
17	Unused	Digital	Input
18	Unused	Digital	Input

Pin	Function	Type	
19	Unused	Digital	Input
20	Unused	Digital	Input
21	Unused	Digital	Input
22	Left Wheel Thermal Sensor	Analog	Input
23	Unused	Prop	Output
24	Unused	Prop	Output
25	Left Wheel Encoder Power	Power	Output
26	Unused	Digital	Output
27	Slave CAN Low	Com	Input
28	Slave CAN High	Com	Input
29	Unused	Digital	Input
30	Unused	Analog	Input
31	Unused	Digital	Input
32	Unused	Digital	Input
33	Unused	Digital	Output
34	Unused	Digital	Output
35	Unused	Digital	Input

### 3. Inputs Characteristics

Digital Inputs:

- Switching Threshold: 4.3V ± 0.5V
- Input Impedance: 13.5 kΩ ± 1kΩ

Analog Inputs:

- Acceptable signal range: 0 - 10V
- Machine signal range: 0.5 - 4.5V

Power Inputs:

- V Batt input

### 4. Outputs Characteristics

Digital Outputs:

- Drive to -Vbatt
- Max. Output current: 1.5A

PWM Outputs:

- PWM controlled (Adjustable voltage)
- Drive to -Vbatt
- Max. output current: 2.5A

Proportional Outputs (Prop):

- PWM controlled with current sensing
- Drive to -Vbatt

Power Outputs:

- +5V power supply for the motor encoder (exact value: 4.3V)

8.5 GROUND CONTROL STATION

Ground Module

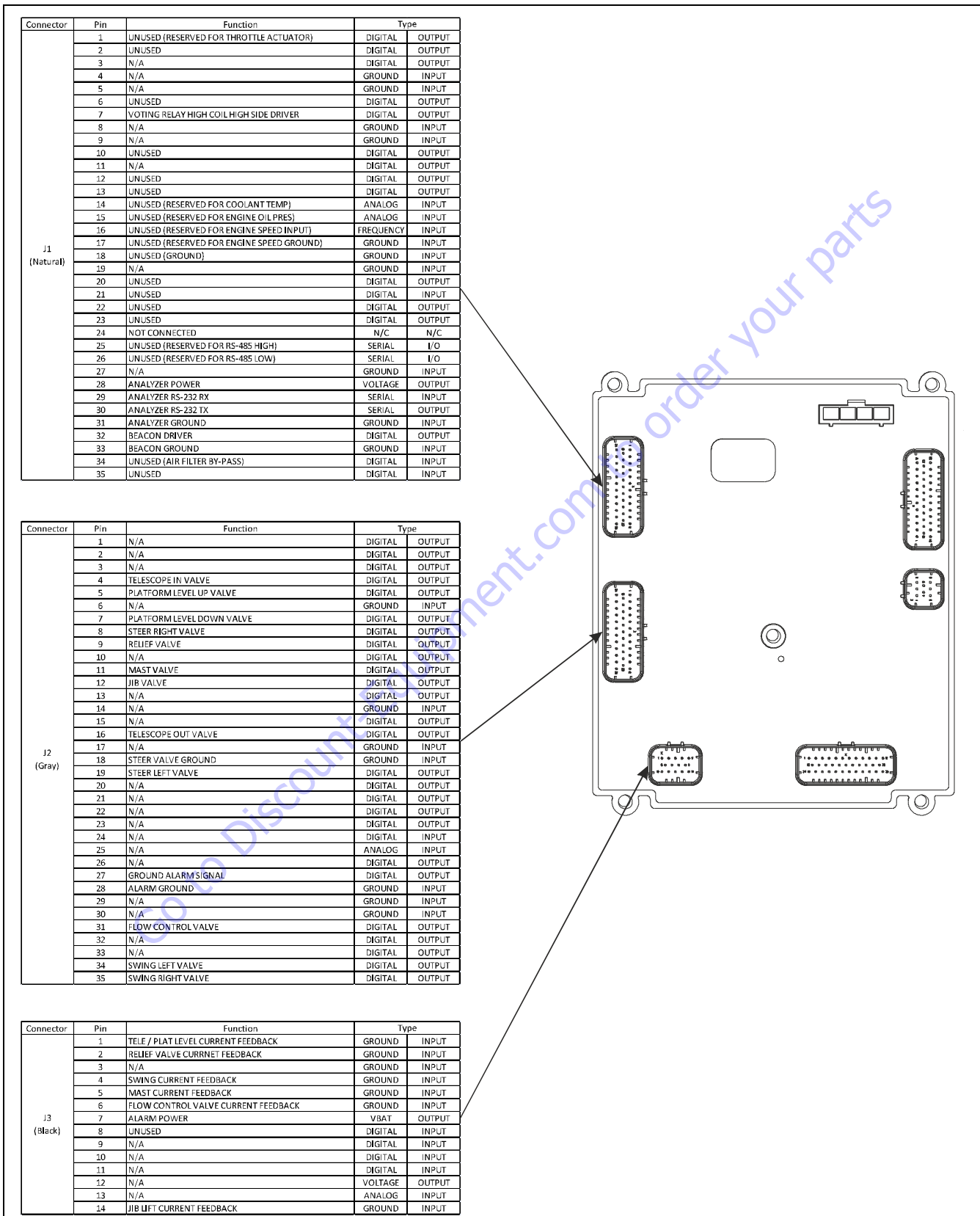
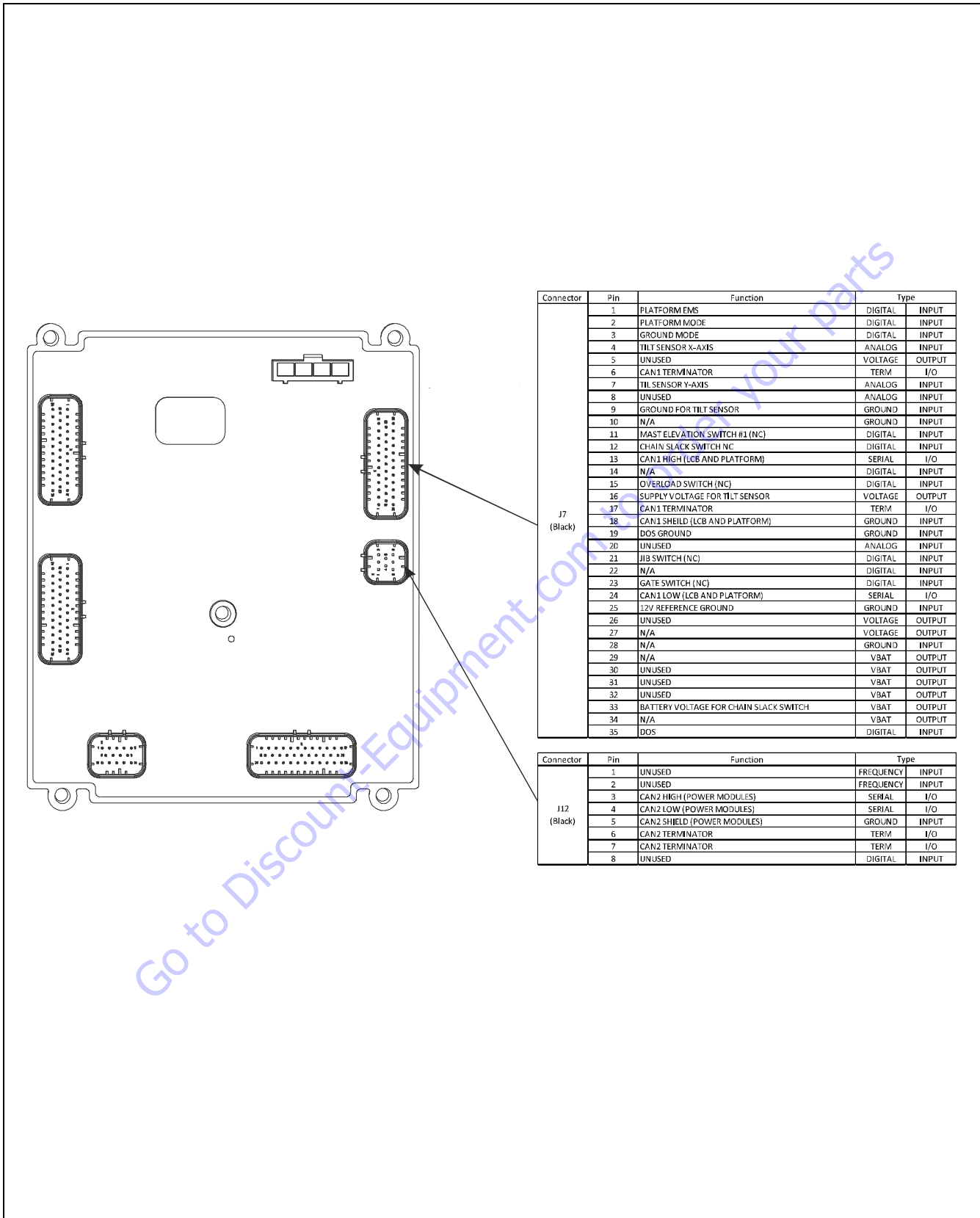


Figure 8-24. Ground Control Station Connectors - 1 of 3

**SECTION 8 - 2CONTROL COMPONENTS**



**Figure 8-25. Ground Control Station Connectors - 2 of 3**

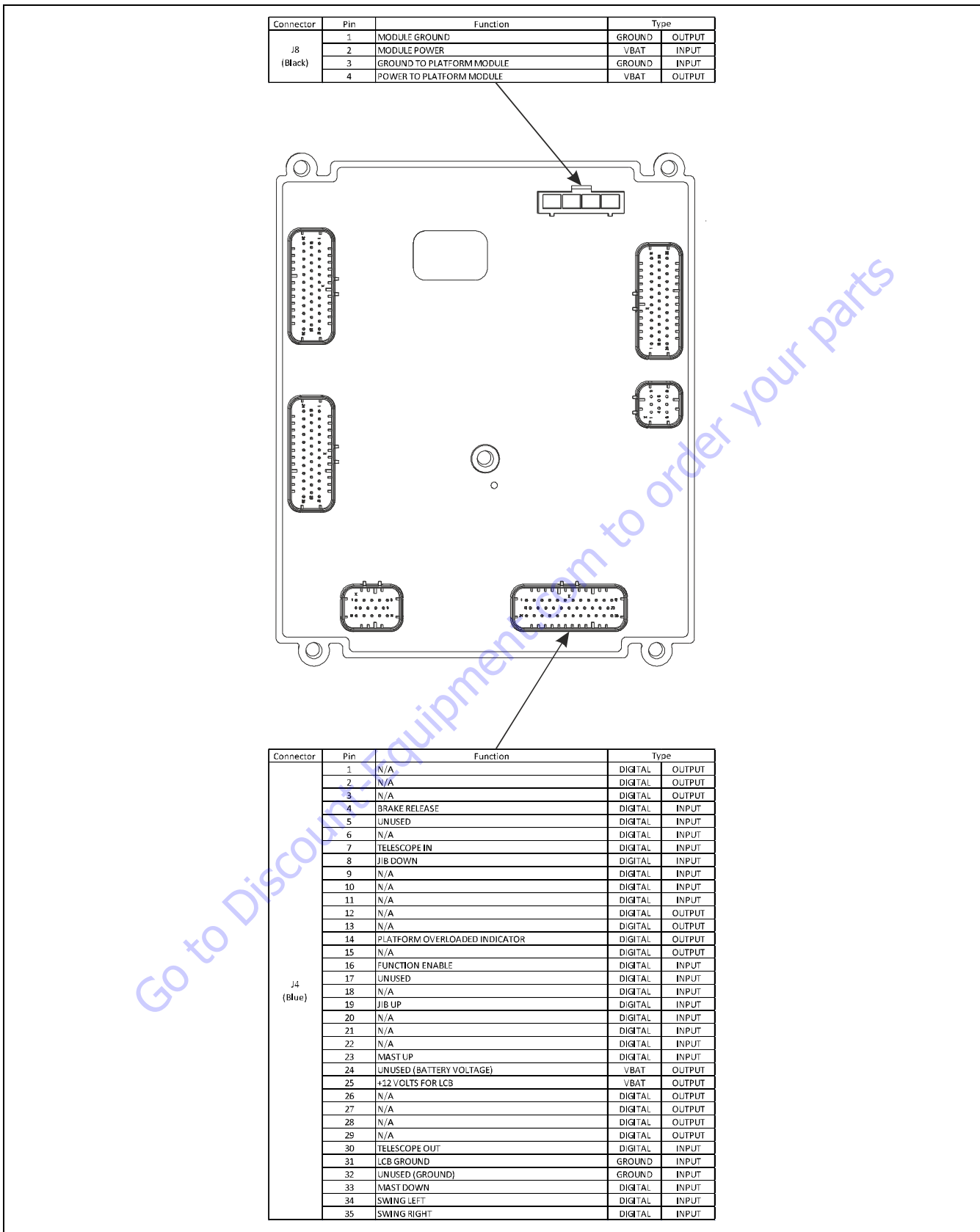


Figure 8-26. Ground Control Station Connectors - 3 of 3

**Membrane Panel**

**1. Electrical Evaluation**

The membrane panel integrates two functions:

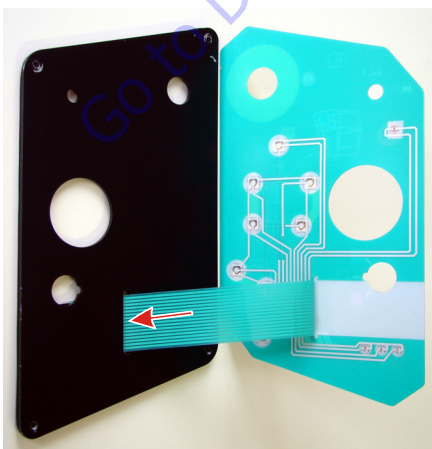
- Indicator LEDs: these are surface mount components with standard LED characteristics;
- Push buttons: each push button is a SPST (Single Pole Single Throw) switch; switch ON = 20 to 40 Ω (circuit impedance, measured on the ribbon connector).

**2. Replacement**

1. Turn machine power down and disconnect battery plug.
2. Remove the control box panel assembly. Unplug both the ribbon cable and the connector from PCB.
3. Remove the following elements from the panel assembly: E-Stop, Multi Display Indicator (MDI), circuit breaker and contact key.
4. Peel the membrane panel.



5. Clean the back plate surface from glue residues;
6. Install the new membrane panel on the back plate, taking into account the following:
  - Insert the ribbon cable into the plate slot.

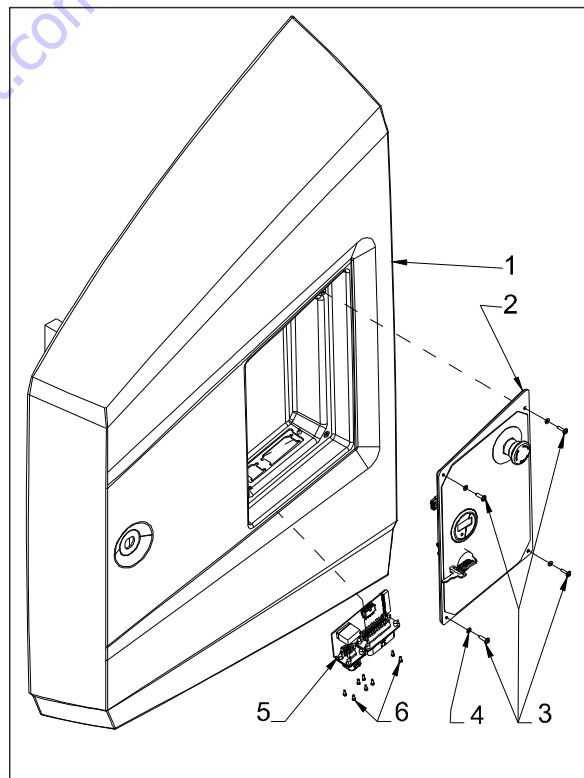


- Align with precision the membrane panel cut out for the contact key with the corresponding hole on the back plate;
- Adjust the membrane panel position to align the other cut out on the corresponding holes on the back plate.



7. Re-install the components on the panel, re-connect the connectors on the PCB and re-install the panel assembly.

**Printed Circuit Board (PCB) Replacement**



**Figure 8-27. Ground Control Box Circuit Board - Installation**

1. Door
2. Control Box Panel Assembly
3. Panel Attach Screws
4. Panel Plastic Washers
5. Circuit Board Assembly
6. Circuit Board Attach Screws

1. Turn machine power off and disconnect battery plug.
2. Disconnect AMP connectors from the circuit board assembly: Refer to Section 11.
3. Remove the control box panel assembly. Unplug both the ribbon cable and the connector from PCB.
4. Remove the eight screws that affix the PCB connectors to the door.
5. Replace PCB and reassemble the upper control box.

2. Face Plate Assembly
3. Face Plate Attach Screws
4. Circuit Board Assembly
5. Circuit Board Attach Screws

1. Remove the upper control box face plate. Unplug ribbon cable and connectors from PCB.
2. Remove the four screws that affix the PCB.
3. Replace PCB, connect ribbon cable and connectors back to the PCB and reassemble the upper control box.

**8.6 PLATFORM CONTROL STATION**

**⚠ CAUTION**

THE PRINTED CIRCUIT BOARD (PCB) INSTALLED IN THE UPPER CONTROL BOX CONTAINS NUMEROUS DELICATE ELECTRONIC CIRCUITS AND COMPONENTS WHICH CAN BECOME DAMAGED AS A RESULT OF ELECTROSTATIC DISCHARGE (ESD).

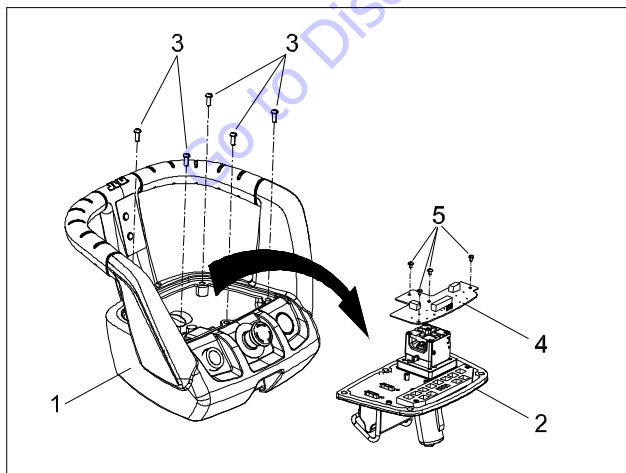
KEEP REPLACEMENT PCB IN ITS ANTISTATIC BAG TILL READY TO INSTALL.

PRIOR TO OPEN THE UPPER CONTROL BOX, TURN MACHINE POWER OFF AND DISCONNECT BATTERY PLUG.

IT IS BEST TO WEAR AN ELECTROSTATIC DISCHARGE (ESD) WRIST STRAP WHEN HANDLING THE PCB, IF YOU DO NOT HAVE AN ESD WRIST STRAP, KEEP YOUR HANDS DRY AND FIRST TOUCH A METAL OBJECT TO ELIMINATE STATIC ELECTRICITY. WHEN HANDLING THE PCB, AVOID TOUCHING ANY METAL LEADS OR CONNECTORS.

DO NOT ALLOW METAL OBJECTS (SCREWS, TOOLS,...) TO COME INTO CONTACT WITH THE CIRCUIT BOARD OR ITS COMPONENTS.

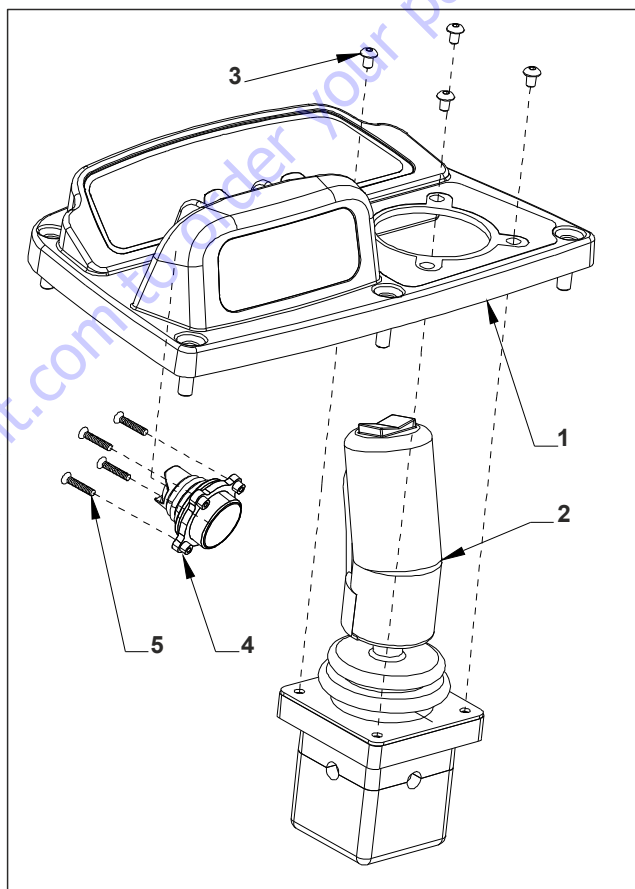
**Printed Circuit Board (PCB) Replacement**



**Figure 8-28. Upper Control Box Circuit Board - Installation**

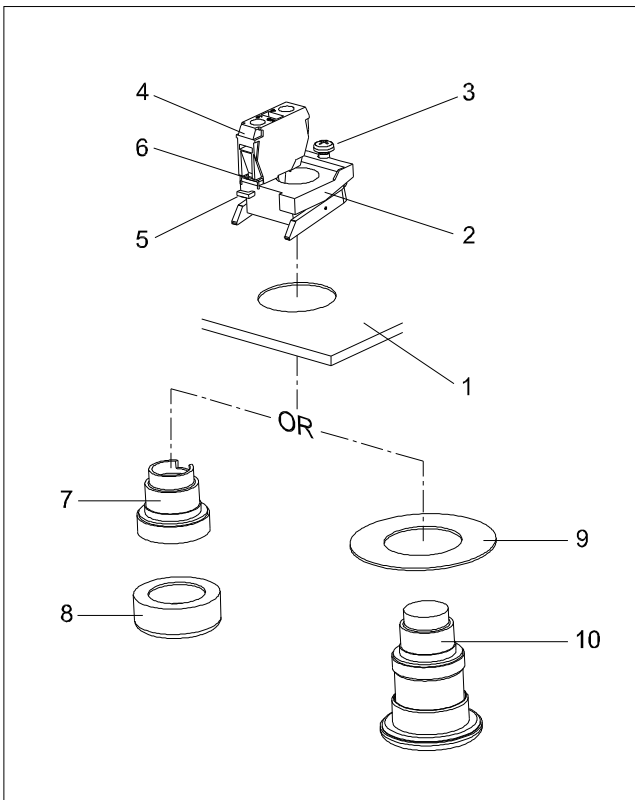
1. Upper Box Assembly

**Upper Control Box - Component Replacement**



**Figure 8-29. Joystick Controls - Installation**

1. Face Plate
2. Drive/Swing Joystick Assembly
3. Drive/Steer Joystick Attach Screws
4. Mast/Jib/Telescope Joysticks Assembly
5. Mast/Jib/Telescope Joystick Attach Screws



**Figure 8-30. Enable/Emergency Stop Switches - Installation**

1. Box Panel
  2. Switch Base
  3. Base Release Screw
  4. Switch
  5. Barrel Release Lever
  6. Switch Release Lever
  7. Enable Button/Barrel
  8. Boot
  9. Decal
  10. Emergency Stop Button/Barrel
1. Loosen the base release screw, then spin the switch base if necessary to access the barrel release lever.
  2. Pull the barrel release lever straight out with the blade of a screwdriver and pull barrel out of the switch base from the front of the control box.
  3. If the switch requires removal, pull the switch release lever out with the blade of a screwdriver and remove the switch.
  4. Reverse steps to install.

**Upper Control Box - Components Evaluation**

**1. Mast, Jib and Telescope Joysticks**

Three single axis mini-joysticks are used for the mast, jib lift and telescope functions. They all have the same characteristics.

Electrical characteristics:

- Output voltage range: 0.5 - 4.5 V

**Table 8-8. Joysticks wiring**

Connector #	Wire Color	Function
1	Blue	Output (0.5 - 4.5 V)
2	Red	Supply (+5V)
3	Black	Supply (0V)
4	N/A	N/A

**2. Drive Joystick**

The drive joystick is a dual axis joystick with a trigger and a rocker switch.

Joystick wiring:

Connector #	Wire Color	Function
1	Orange	Power (+5V)
2	Green	Ground
3	Grey	Signal Output: Swing Axis
4	Blue	Signal Output: Drive Axis
5	Red	Trigger
6	Yellow	Rocker: Steer Left
7	Violet	Rocker: Steer Right
8	Brown	Trigger + Rocker Power (+ V Supply)

*+V Supply = 12 to 14 VDC*

**3. Membrane Switches**

The DOS and Horn switches are made of membrane switches:

Each push button is a SPST switch; switch ON = 15 to 25  $\Omega$  (circuit impedance, measured on the ribbon connector).





## SECTION 9. JLG CONTROL SYSTEM

## 9.1 HAND HELD ANALYZER

The Control System may be accessed by using a custom designed, hand held analyzer (Analyzer Kit, JLG P/N 2901443 or separately, Analyzer JLG P/N 1600244 & Cable, JLG P/N 1600633) which will display two lines of information at a time, by scrolling through the program.

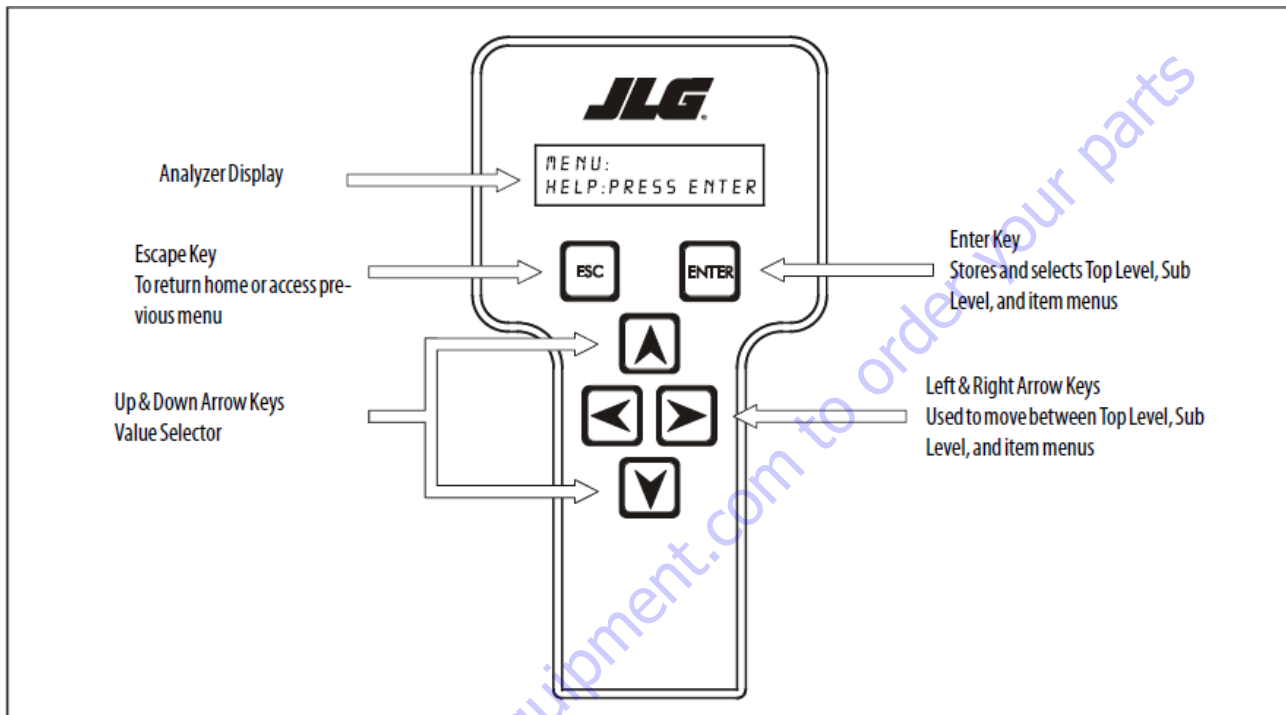


Figure 9-1. Hand Held Analyzer

### Analyzer Menu Structure

There are seven levels within the Analyzer menu structure and they are as follows:

#### 1. HELP: PRESS ENTER

This is the default menu that appears at power up of the Analyzer. This menu displays the current Help (fault) message. This is intended to quickly guide the technician in the event of a fault in the JLG Control System. This menu also displays functional interlocks. Pressing ENTER shows Logged Help which is a record of the last 25 Help (fault) messages. Editing of information in this menu is not possible.

#### 2. DIAGNOSTICS

This menu provides real-time status information about the control system as a diagnostic aid.

#### 3. SYSTEM TEST

This menu is used to activate and then interact with the Control System's self-test functionality. Starting the System Test will cause the functionality of each device to be tested. Outputs are energized to detect short or open circuit conditions and digital inputs are

stimulated to simulate switching conditions. Editing of information in this menu is not possible.

#### 4. ACCESS LEVEL

This menu allows the technician to navigate between access levels; Operator Access or Service Access. To enter the Service access level, a five-digit code must be entered. Powering down returns the Analyzer to Operator Access.

#### 5. PERSONALITIES

This menu contains performance settings specific to the machine. These settings are necessary to maintain functions such as solenoid breakpoints and joystick engagement percentages and are organized in an outline format (see Table 9-4., Analyzer Personalities Menu). These settings can be modified in the Service access level.

#### 6. MACHINE SETUP

This menu contains machine configuration information for the JLG Control System. Selections in this menu can change interlock functionality and cause some Personality and Machine Setup entries to be visible or hidden. These settings can be modified in the Service access level.

### 7. CALIBRATIONS

This menu allows the operator to interact with the sensors on the machine. These settings can be modified in the Service access level.

#### Hand Analyzer

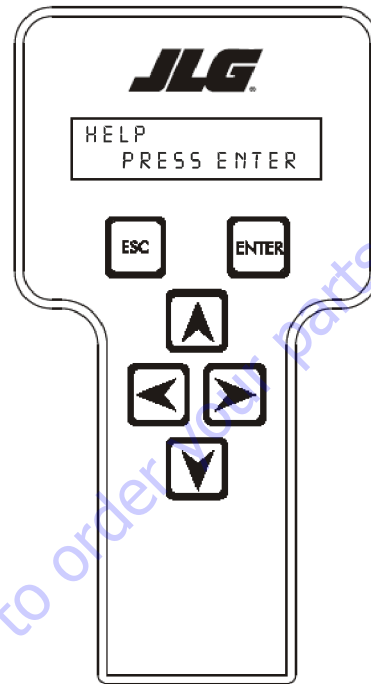
1. Connect the four pin end of cable supplied with the analyzer to the four position connector on the platform console and connect the remaining end of the cable to the analyzer.
2. Power up the Control System by turning the lower key to platform position and pulling both emergency stop buttons on.



Figure 9-2. Hand Held Analyzer Connection

#### Using the Analyzer

With the machine power on and the analyzer connected properly, the analyzer will display the following:



**HELP:**  
**PRESS ENTER**

At this point, using the **RIGHT** and **LEFT** arrow keys, you can move between the top level menu items. To select a displayed menu item, press **ENTER**. To cancel a selected menu item, press **ESC**; then you will be able to scroll using the right and left arrow keys to select a different menu item.

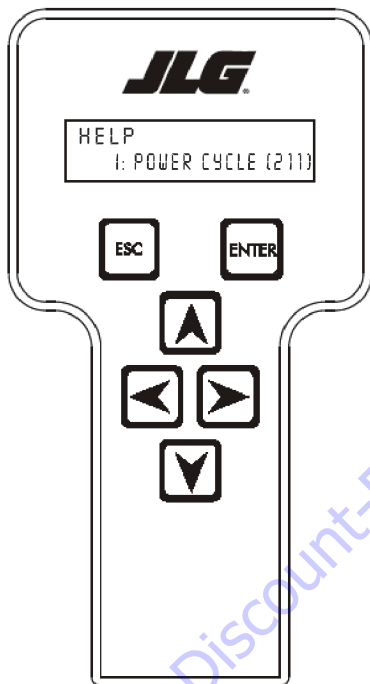
The top level menus are as follows:

- HELP:**
- DIAGNOSTICS**
- SYSTEM TEST**
- OPERATOR ACCESS**
- PERSONALITIES**
- MACHINE SETUP**
- CALIBRATIONS (Service Access only)**

If you press **ENTER**, at the **HELP:PRESS ENTER** displays, and a fault is present, the analyzer display will scroll the fault across the screen. If there was no fault detected, the display will read:

**HELP:EVERYTHING OK.** If powered up at the ground station, the display will read: **GROUND OK.**

If **ENTER** is pressed again, the display moves to the following display:



**LOG(211)  
1:POWER CYCLE**

At this point, the analyzer will display the last fault the system has seen, if any are present. You may scroll through the fault logs to view what the last 25 faults were. Use the right and left arrow keys to scroll through the fault logs. To return to the beginning, Press **ESC** two times. **POWER CYCLE (211)** indicates a power up.

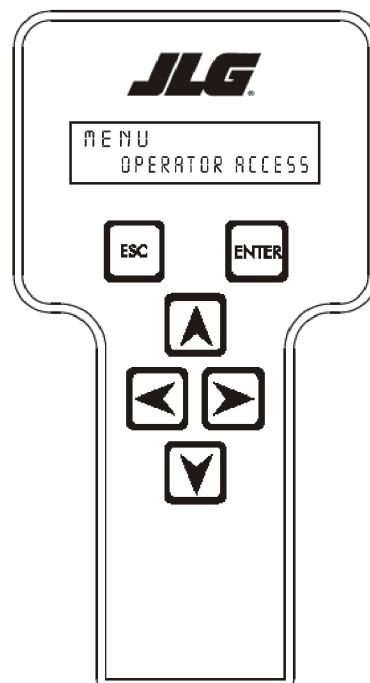
When a top level menu is selected, a new set of menu items may be offered: for example:

- DRIVE**
- STEER**
- SWING**
- MAST**
- .....
- .....

Pressing **ENTER** with any of the above displayed menus, will display additional submenus within the selected menu. In some cases, such as **DRIVE**, the next level is the parameter or information to be changed. Refer to the flow chart for what menus are available within the top level menus. You may only view the personality settings for selected menus while in Operator Access level. Remember, you may always cancel a selected menu item by pressing the **ESC** key.

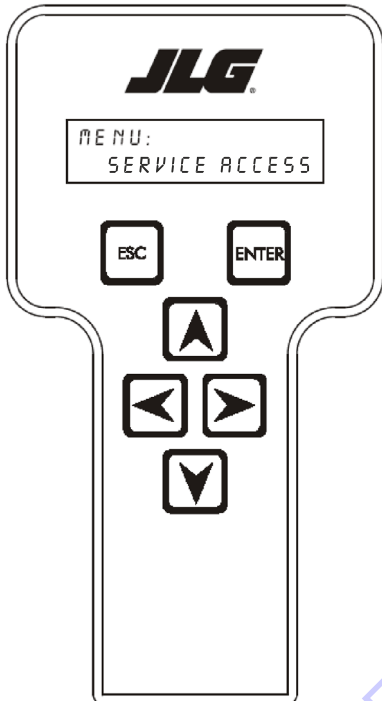
**Changing the Access Level of the Hand Held Analyzer**

When the analyzer is first connected, you will be in Operator Access level which enables you to only view most settings which cannot be changed until you enter a password to advance to a lower level. This ensures that a setting cannot be accidentally altered. To change the access level, the correct password must be entered. To enter the password, scroll to the **OPERATOR ACCESS** level menu. For example:



**ACCESS LEVEL:  
CODE 00000**

Press **ENTER** to select the **ACCESS LEVEL** menu.  
Using the **UP** or **DOWN** arrow keys, enter the first digit of the password, 3.  
Then, using the **RIGHT** arrow key, position the cursor to the right one space to enter the second digit of the password.  
Use the **UP** or **DOWN** arrow key to enter the second digit of the password which is 33271.  
Once the correct password is displayed, press **ENTER**.  
The access level should display the following, if the password was entered correctly:

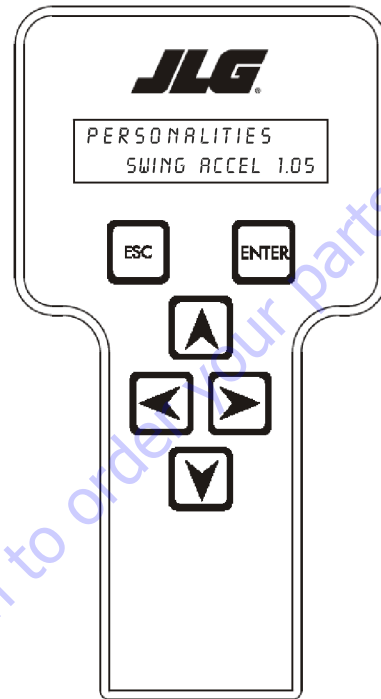


**MENU:  
SERVICE ACCESS**

Repeat the above steps if the correct access level is not displayed or you can not adjust the personality settings.

**Adjusting Parameters Using the Hand Held Analyzer**

Once you have gained Service Access, and a personality item is selected, press the UP and Down arrow keys to adjust its value, for example:

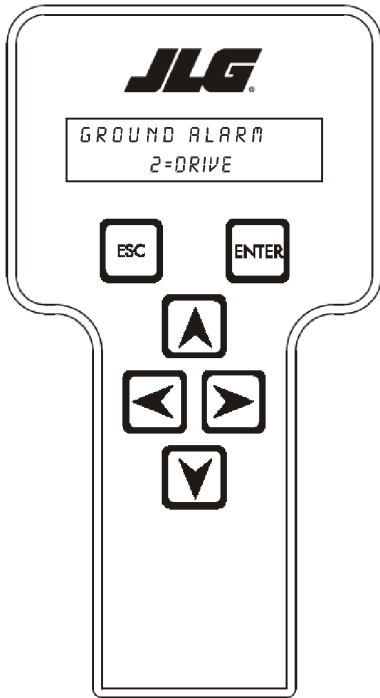


**SWING:  
ACCEL 1.0s**

There will be a minimum and maximum for the value to ensure efficient operation. The Value will not increase if the **UP** arrow is pressed when at the maximum value nor will the value decrease if the **DOWN** arrow is pressed and the value is at the minimum value for any particular personality. If the value does not change when pressing the up and down arrow, check the access level to ensure you are at Service Access.

## Machine Setup

When a machine digit item is selected, press the UP or DOWN arrow keys to adjust its value. For example:



### GROUND ALARM: 2=DRIVE

The effect of the machine digit value is displayed along with its value. The above display would be selected if the machine was equipped with a ground alarm and you wanted it to sound when driving. There are certain settings allowed to install optional features or select the machine model.

When selection the machine model to match the size of the machine, the personality settings will all default to the factory recommended settings.

**NOTE:** Refer to Table 9-3, Machine Personality Adjustments for the recommended factory settings.

**NOTE:** Password 33271 will give you Service Access, which will permit you to change all machine personality settings.

9.2 ANALYZER SCREEN LAYOUT

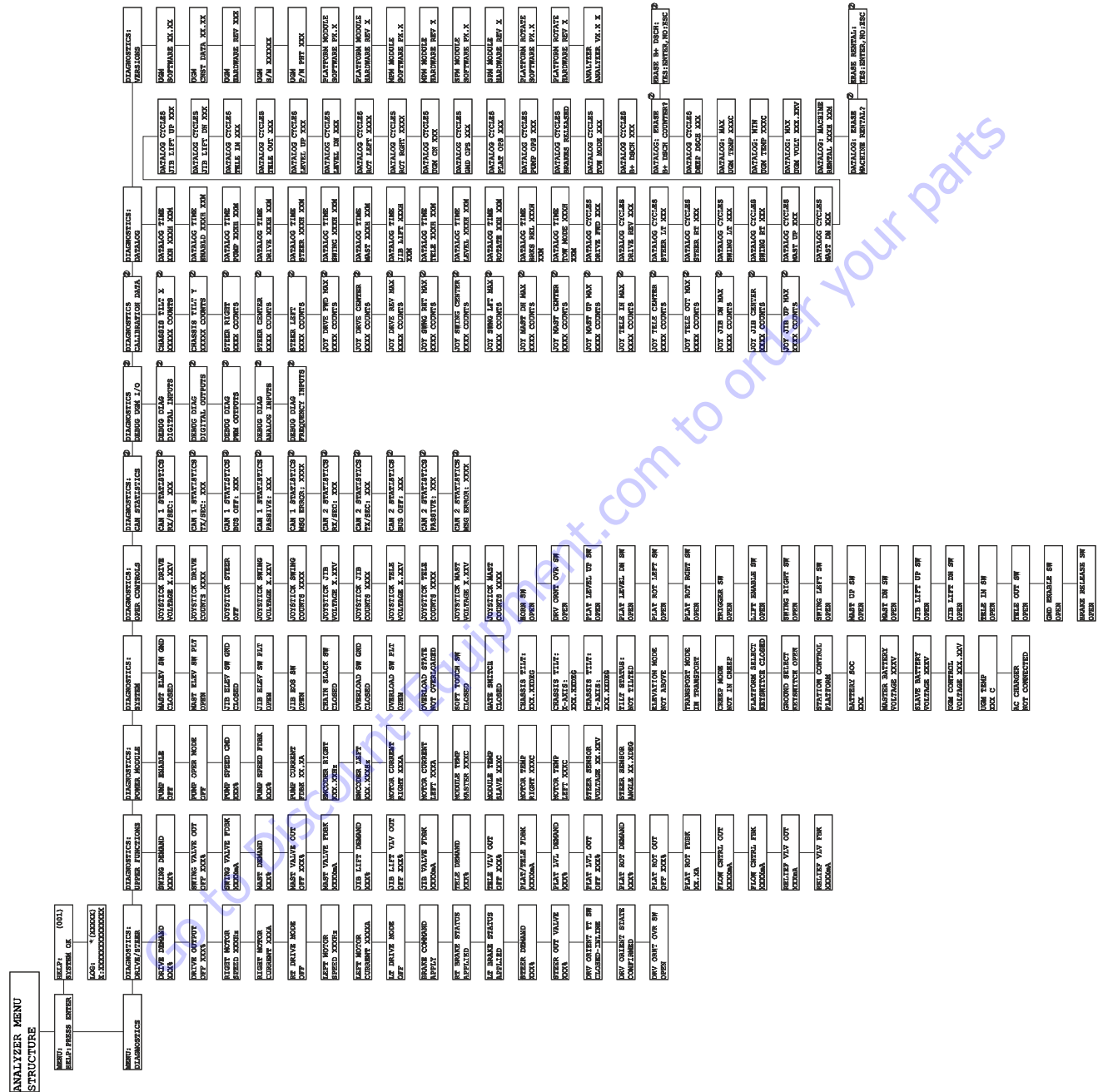


Figure 9-3. Analyzer Flow Chart - Sheet 1 of 2

NOTE: @ - Service only.





**9.3 MACHINE SETUP PROGRAMMING INFORMATION**

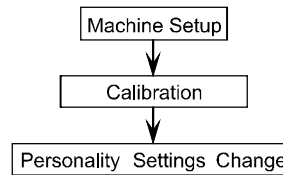
**NOTICE**

WHEN INSTALLING A NEW POWER MODULE CONTROLLER ON THE MACHINE, IT WILL BE NECESSARY TO PROGRAM THE CONTROLLER FOR THE PROPER MACHINE CONFIGURATION, INCLUDING OPTIONS.

**NOTICE**

IT IS A GOOD PRACTICE TO AVOID PRESSURE-WASHING ELECTRICAL/ELECTRONIC COMPONENTS. SHOULD PRESSURE-WASHING BE UTILIZED TO WASH AREAS CONTAINING ELECTRICAL/ELECTRONIC COMPONENTS, JLG INDUSTRIES, INC. RECOMMENDS A MAXIMUM PRESSURE OF 750 PSI (52 BAR) AT A MINIMUM DISTANCE OF 12 INCHES (30.5 CM) AWAY FROM THESE COMPONENTS. IF ELECTRICAL/ELECTRONIC COMPONENTS ARE SPRAYED, SPRAYING MUST NOT BE DIRECT AND BE FOR BRIEF TIME PERIODS TO AVOID HEAVY SATURATION.

The following logic shall be followed:



By changing the Model type, all Personality Settings are reset

Necessary: adjustment of the different sensors settings

If necessary, to achieve optimal performance

Shaded entries are not available for the selected market.

Configuration Digit	Setting Range	Description	Default Number
MODEL NUMBER 1	- 2 3	- Toucan 12E Toucan 12E Plus	1
MARKET 2	1 2 3 4 5 6	CE ANSI USA ANSI EXPORT CSA AUSTRALIA JAPAN	1
DRIVE CUTOUT 3	1 2	NO YES	1
GROUND ALARM 4	1 2 3 4 5	NO DRIVE DESCENT MOTION FAULTS ONLY	4
LOAD SYSTEM 5	1 2 3	*NO CUTOUT PLATFORM #CUTOUT ALL	2
*Only visible in CE, ANSI EXP, Australia, and Japan Markets #Only visible in CE, ANSI EXP, and Japan Markets			
BATTERY 6	1 2	FLOODED AGM	1
SOFT TOUCH 7	1 2	NO YES	1
GATE 8	1 2	NO YES	1
CHARGER INTER-LOCK 9	1 2	DRIVE ONLY CUTOUT ALL	2

**Table 9-1. Machine Setup Programming Information**

Configuration Digit	Setting Range	Description	Default Number
DISPLAY UNITS 10	1 2	METRIC IMPERIAL	1
PLATFORM ROTATE 11	1 2	NO YES	1

**Table 9-1. Machine Setup Programming Information**

Go to Discount-Equipment.com to order your parts

**9.4 CALIBRATION INSTRUCTIONS**

All calibration procedures are menu driven through the use of the standard JLG analyzer. The user is prompted to exercise the machine in a specific order to use the machines physical properties to consistently establish sensor response and the interaction of valves, pump and motors.

The chart below lists the calibrations required and potential reasons for re-calibration.

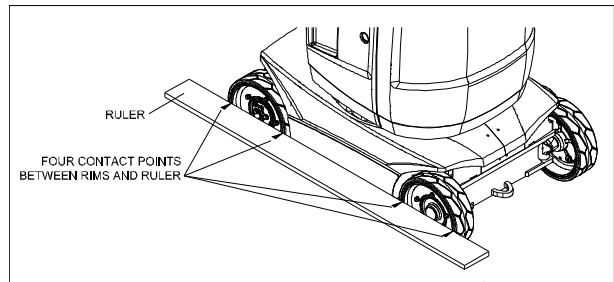
Calibration Procedure	Reasons for Re-calibration
Steer Sensor	Ground module replacement Master or Slave module replacement Steer sensor removal or replacement Steering spindle or steering pin removal or replacement Drive speeds out of tolerances
Tilt Sensor	Ground module replacement Sensor removal or replacement System parameters reset Tilt readings inaccuracy
Joysticks	Ground module replacement Joysticks replacement Platform console inoperative

**NOTE:** If the system is reset (by changing the machine model), the steer sensor, the joysticks and the pressure relief valve must be re-calibrated.

**9.5 CALIBRATING STEERING SENSOR**

1. Position the Platform/Ground select switch to the Platform position.
2. Pull out both Platform and Ground Emergency Stop switches.
3. Position the machine on a flat level ground.
4. Enter Service Access and scroll to the CALIBRATION -> SET STEER SENSOR screen.
5. Press ENTER to enter Steer Sensor calibration sub-menu.
6. Hit ENTER again to begin the calibration process.
7. The screen will indicate 'LEFT TO MAX' : Activate the steer control until the wheels are fully steered to the left (you may drive for a limited distance while steering to ensure the mechanical stop is reached).
8. Hit ENTER to confirm.

9. The screen will indicate 'CENTER' : Activate the steer control until the wheels are straight in relationship with the chassis.



**Figure 9-5. Wheel Straightening**

10. Hit ENTER to confirm.
11. The screen will indicate 'RIGHT TO MAX' : Activate the steer control until the wheels are fully steered to the right (you may drive for a limited distance while steering to ensure the mechanical stop is reached).
12. Hit ENTER to confirm.
13. After completing the Steer Sensor calibration, hit ESC twice to go back to CALIBRATIONS.

**9.6 CALIBRATING TILT SENSOR**

1. Position the Platform/Ground select switch to the Platform position.
2. Pull out both Platform and Ground Emergency Stop switches.
3. Position the machine on flat level ground.
4. Ensure the chassis is level ( $\pm 0.1^\circ$ ), using a spirit level (digital display), both longitudinally and transversely.
5. Ensure the mast is fully retracted, the boom is fully lowered and the turntable is not overswung (boom between the driving wheels).
6. Enter Service Access and scroll to the CALIBRATION/TILT SENSOR screen.
7. Hit ENTER to calibrate the tilt sensor.
8. Check that the tilt sensor is properly calibrated (refer to Section 8-2).

**9.7 CALIBRATING THE JOYSTICKS**

1. Position the Platform/Ground select switch to the Platform position.
2. Pull out both Platform and Ground Emergency Stop switches.
3. Enter Service Access and scroll to the CALIBRATION / JOYSTICK screen.
4. Scroll to the joystick that needs to be calibrated (D/S JOY X-AXIS -> D/S JOY Y-AXIS -> MAST JOYSTICK -> JIB LIFT JOY -> TELE JOY).
5. Hit ENTER to enter Joystick calibration procedure.

6. The screen will indicate 'FWD TO MAX' (or 'LEFT TO MAX'): Tilt and maintain the Joystick fully forward (or fully to the left).
7. Hit ENTER to acquire the joystick position.
8. The screen will indicate 'CENTER'.
9. Release the joystick and allow it to center.
10. Hit ENTER to acquire the joystick position.
11. The screen will indicate 'REV TO MAX' (or 'RIGHT TO MAX') : Tilt and maintain the joystick fully reverse (or fully to the right).
12. Hit ENTER to acquire the joystick position.

11. Repeat steps 6 to 10 for each movement in order to set all pressures. Other personalities to be adjusted are TELE IN RELIEF, TELE OUT RELIEF, JIB UP RELIEF, LEVEL UP RELIEF, LEVEL DN RELIEF, STEER RELIEF LEFT, STEER RELIEF RIGHT, SWING RELIEF. During step 8, movement related to corresponding personality must be controlled at max.
12. After completing the Relief Valves calibrations, hit ESC to go back to PERSONALITIES.

**9.8 CALIBRATING THE PRESSURE RELIEF VALVE**

The PWM Pressure Relief Valve has a setting for each movement. The different settings can be viewed / altered by accessing to the personalities. The aim of the calibration procedure is to set all the pressure personalities.

**NOTE: After a complete reset of the system, setting the maximum pressure for all the movements is mandatory.**

*Before any pressure measurement or adjustment, warm up the system by operating the different movements.*

*Pressure measurement is to be performed with a function operated at maximum speed.*

1. Position the Platform/Ground select switch to the Platform position.
2. Pull out both Platform and Ground Emergency Stop switches.
3. Position the machine on a flat level ground. A minimum up and over clearance of 10m is required.
4. Connect a pressure gauge to the dedicated port (port "M" on the main hydraulic manifold).
5. Connect the Analyzer, Enter Service Access Level 1 (Operator Access menu), scroll to the PERSONALITIES screen and Press ENTER.
6. Using the Left and Right arrows, adjust MAST personality then press ENTER.
7. Using the Left and Right arrows, adjust MAST UP, RELIEF personality.
8. Fully raise the mast; at the end of the stroke of the mast, read the actual maximum pressure.
9. Using the Up and Down arrows, adjust MAST UP, RELIEF personality in order to set the pressure as required in the tables below for the acceptable pressure values. Adjusting the personality setting must be done when the system is idle (no movement is controlled). The allowed tolerance on the pressure setting is ±0.5MPa.
10. When the correct pressure is set, Hit ENTER to complete the Pressure Relief Valve Calibration, then hit ESC to go back to PERSONALITIES menu.

Function	Minimum pressure		Maximum Pressure	
Mast Lift Up	16.5 MPa	2395 psi	18.5 MPa	2685 psi
Jib Lift Up	17 MPa	2465 psi	18 MPa	2610 psi
Telescope Out	9.5 MPa	1380 psi	10.5 MPa	1525 psi
Telescope In	11.5 MPa	1668 psi	12.5 MPa	1815 psi
Swing	5 MPa	725 psi	6.5 MPa	945 psi
Platform Level Up	13.5 MPa	1960 psi	15.5 MPa	2250 psi
Platform Level Down	9 MPa	1305 psi	11 MPa	1595 psi
Steer Right	9 MPa	1305 psi	11 MPa	1595 psi
Steer Left	9 MPa	1305 psi	11 MPa	1595 psi

**Table 9-2. Acceptable Pressure Values - T12E/T32E.**

Function	Minimum pressure		Maximum Pressure	
Mast Lift Up	16.5 MPa	2395 psi	18.5 MPa	2685 psi
Jib Lift Up	17 MPa	2465 psi	18 MPa	2610 psi
Telescope Out	9.5 MPa	1380 psi	10.5 MPa	1525 psi
Telescope In	11 MPa	1595 psi	13 MPa	1885 psi
Swing	5 MPa	725 psi	6.5 MPa	945 psi
Platform Level Up	13.5 MPa	1960 psi	15.5 MPa	2250 psi
Platform Level Down	9 MPa	1305 psi	11 MPa	1595 psi
Steer Right	9 MPa	1305 psi	11 MPa	1595 psi
Steer Left	9 MPa	1305 psi	11 MPa	1595 psi

**Table 9-3. Acceptable Pressure Values - T12E Plus**

**9.9 MACHINE PERSONALITY - ADJUSTMENT SETTINGS**

Personality settings adjustments shall be done when the system is idle (none of the power components, drive or pump motor, is running).

**Table 9-4. Machine Personality Adjustment**

ADJUSTMENT	ADJUSTMENT RANGES	MODEL NUMBER DEFAULT VALUES	
		TOUCAN 12E TOUCAN 32E	TOUCAN 12E PLUS
<b>DRIVE</b>			
ACCEL	0.5-5.0s	2.0	2.0
DECEL	0.3-5.0s	3.0	3.0
DECEL TO STOP	0.3-2.0s	1.0	1.0
MAX SPEED MAX	50-100%	100	100
REDUCED SPEED MAX	40-80%	60	60
ELEV MAX	5-14%	14	14
CREEP MAX	5-14%	10	10
FREQ MIN	0-5Hz	0.6	0.6
FREQ MAX	100-165Hz	146	146
<b>STEER</b>			
ACCEL	0-2.0s	0.2	0.2
DECEL	0-2.0s	0.1	0.1
MIN	1-30%	5	5
LEFT MAX	25-75%	45	45
RIGHT MAX	25-75%	42	42
CREEP	10-40%	20	20
RELIEF LEFT	950-1450mA	1200	1200
RELIEF RIGHT	1000-1500mA	1200	1200
<b>SWING</b>			
ACCEL	0-5.0s	1.0	1.0
DECEL	0-2.0s	1.0	1.0
MIN	1-30%	3	3
MAX	10-50%	18	18
ELEV MAX	5-50%	12	12
CREEP	1-15%	7	7
RELIEF	1200-1800mA	1400	1400

**Table 9-4. Machine Personality Adjustment**

ADJUSTMENT	ADJUSTMENT RANGES	MODEL NUMBER DEFAULT VALUES	
		TOUCAN 12E TOUCAN 32E	TOUCAN 12E PLUS
<b>MAST</b>			
UP ACCEL	0-5.0s	1.5	1.5
UP DECEL	0-2.0s	0.5	0.5
UP MIN	5-30%	20	20
UP MAX	50-100%	100	100
UP REDUCED MAX	30-80%	60	60
UP RELIEF	600-900mA	800	800
UP CREED	20-60%	30	30
DOWN ACCEL	0-5.0s	1.0	1.0
DOWN DECEL	0-2.0s	0.5	0.5
DOWN MIN	100-500mA	350	350
DOWN MAX	800-1500mA	1150	1150
DOWN CREEP	500-1000mA	800	800
<b>TELESCOPE</b>			
ACCEL	0-5.0s	1.0	1.0
DECEL	0-2.0s	0.5	0.5
IN MIN	5-30%	15	15
IN MAX	25-75%	30	50
IN RELIEF	850-1300mA	1100	1100
OUT MIN	5-30%	12	12
OUT MAX	30-80%	42	70
OUT RELIEF	875-1325mA	1150	1150
CREEP	20-60%	20	20

**SECTION 9 - JLG CONTROL SYSTEM**

**Table 9-4. Machine Personality Adjustment**

ADJUSTMENT	ADJUSTMENT RANGES	MODEL NUMBER DEFAULT VALUES	
		TOUCAN 12E TOUCAN 32E	TOUCAN 12E PLUS
<b>JIB LIFT</b>			
UP ACCEL	0-5.0s	1.5	1.5
UP DECEL	0-2.0s	0.6	0.6
UP MIN	5-30%	20	20
UP MAX	40-80%	45	60
UP REDUCED MAX	20-60%	38	38
UP RELIEF	575-875mA	800	800
UP CREEP	20-60%	30	35
DOWN ACCEL	0-5.0s	2.0	2.0
DOWN DECEL	0-2.0s	1.0	1.0
DOWN MIN	100-500mA	350	350
DOWN MAX	850-1540mA	1150	1150
DOWN CREEP	400-800mA	725	700
<b>PLATFORM LEVEL</b>			
ACCEL	0-5.0s	1.0	1.0
DECEL	0-2.0s	0.5	0.5
UP MIN	1-30%	10	10
UP MAX	10-40%	28	28
UP RELIEF	750-1100mA	850	850
DN MIN	1-30%	1	1
DN MAX	10-50%	32	32
DN RELIEF	1000-1500mA	1100	1100
<b>PLATFORM ROTATE</b>			
ACCEL	0-5.0s	1.0	1.0
DECEL	0-2.0s	0.5	0.5
MIN	1-30%	1	1
MAX	50-100%	50*	50*

\*: 50% for SKF Actuator  
80% for Thomson Actuator

**Table 9-4. Machine Personality Adjustment**

ADJUSTMENT	ADJUSTMENT RANGES	MODEL NUMBER DEFAULT VALUES	
		TOUCAN 12E TOUCAN 32E	TOUCAN 12E PLUS
<b>JOYSTICKS</b>			
DRIVE JOY FWD	500-600	550	550
MIN COUNTS			
DRIVE JOY FWD	850-950	915	915
MAX COUNTS			
DRIVE JOY REV	425-525	480	480
MIN COUNTS			
DRIVE JOY REV	75-175	105	105
MAX COUNTS			
SWING JOY RHT	500-600	550	550
MIN COUNTS			
SWING JOY RHT	850-950	915	915
MAX COUNTS			
SWING JOY LEFT	425-525	480	480
MIN COUNTS			
SWING JOY LEFT	75-175	105	105
MAX COUNTS			
MAST JOY DN	500-575	540	540
MIN COUNTS			
MAST JOY DN	850-950	915	915
MAX COUNTS			
MAST JOY UP	450-525	480	480
MIN COUNTS			
MAST JOY UP	75-175	105	105
MAX COUNTS			
TELE JOY IN	500-575	540	540
MIN COUNTS			
TELE JOY IN	850-950	915	915
MAST COUNTS			
TELE JOY OUT	450-525	480	480
MIN COUNTS			



**Table 9-4. Machine Personality Adjustment**

ADJUSTMENT		ADJUSTMENT RANGES	MODEL NUMBER DEFAULT VALUES	
			TOUCAN 12E TOUCAN 32E	TOUCAN 12E PLUS
	TELEJOY OUT	75-175	105	105
	MAXCOUNTS			
	JIBJOY DN	500-575	540	540
	MINCOUNTS			
	JIBJOY DN	850-950	915	915
	MAXCOUNTS			
	JIBJOY UP	450-525	480	480
	MINCOUNTS			
	JIBJOY UP	75-175	105	105
	MAXCOUNTS			
<b>ALARM/HORN</b>				
	HORN VOLUME	25-100%	100	100
	ALARM VOLUME	25-100%	75	75

9.10 SYSTEM TEST

The Control System incorporates a built-in system test to check the system components and functions. To use this function, use the following procedures.

Before proceeding, ensure that the machine is in the following configuration:

- a. Machine on a flat level ground;
- b. Mast and Jib fully lowered;
- c. Telescope fully retracted;
- d. Jib in line with the chassis, counterweight positioned over the steering wheels.

Test procedure

1. Position the Platform/Ground select switch to the Platform position.
2. Pull out both Emergency Stop switches.

3. Plug the analyzer.
4. Enter Service Access and scroll to the SYSTEM TEST screen.
5. Hit ENTER. The analyzer will prompt you asking if you want to activate the system test; hit ENTER again to activate.
6. Follow the flow path in Figure 9-6., System Test Flow Chart and go through the component tests. Hit ESC key during any part of the test to return to the main menu without completing all tests or wait until all tests are complete. During the TEST SWITCHES sequence, the analyzer allows control switches to be operated and shows if they are closed (CL) or open (OP). During the TEST INDICATORS sequence, the operator is prompted to confirm (by pressing ENTER key) that the named lamp is lit.

**NOTE:** Specific test can be directly accessed by scrolling to the desired screen with the horizontal arrows.

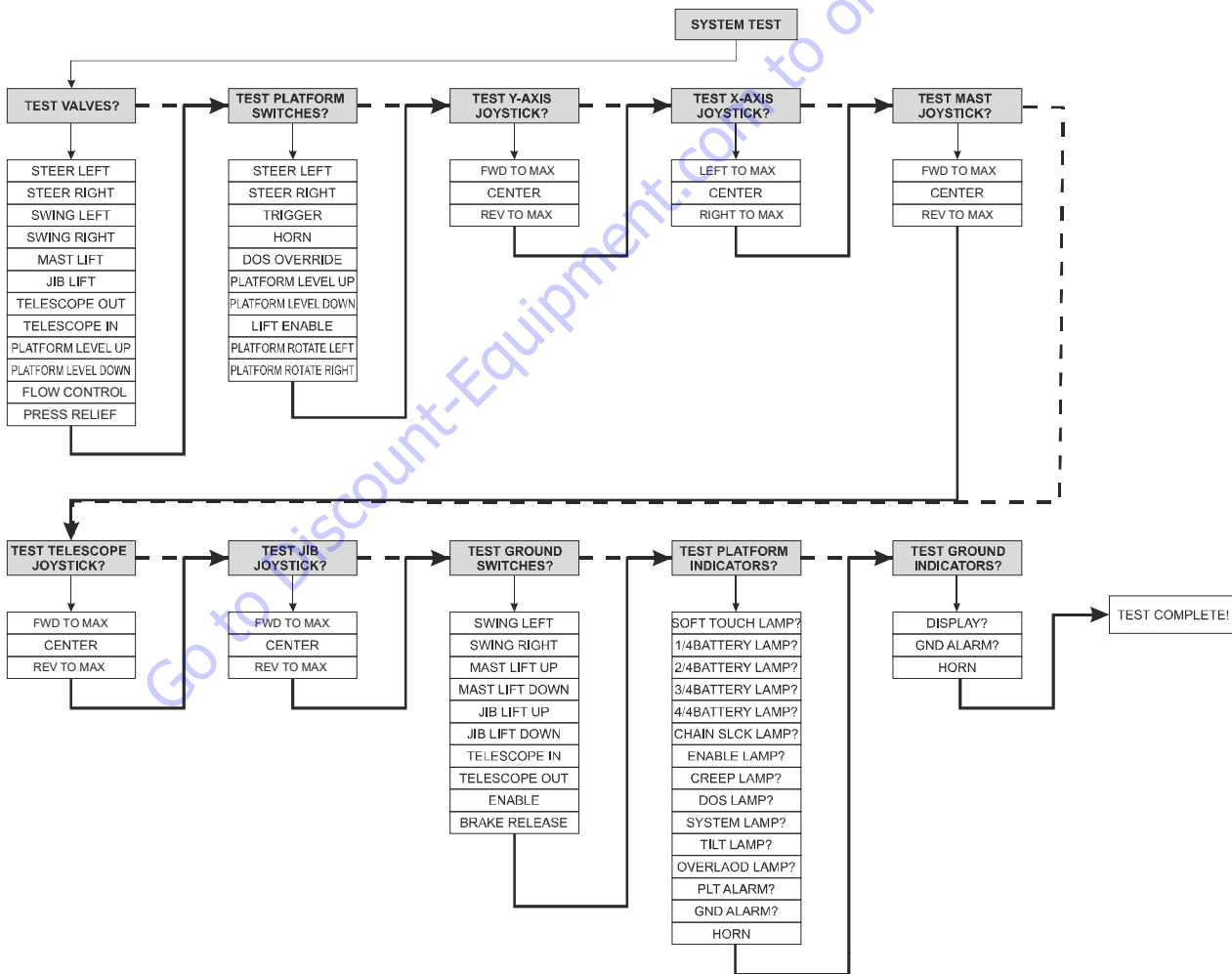


Figure 9-6. System Test Flow Chart



SECTION 10. DIAGNOSTIC TROUBLE CODES

10.1 INTRODUCTION

This section provides a reference for Diagnostic Trouble Codes (DTC) read from the analyzer. DTCs are also displayed on the Multi Display Indicator (MDI, Ground Console) and on the face of the platform console. For more information on any sensors or indicators, refer to the appropriate section for the machine area. Many of the checks below require configuring and using a multimeter. Refer to Section 11, GENERAL ELECTRICAL INFORMATION & SCHEMATICS for multimeter basics. DTCs are sorted in groups by the first two digits, which are also the system distress lamp flash code. To troubleshoot multiple DTCs, start with the DTC with the higher first two digits. To view all active DTCs on the analyzer, view logged help before the first power cycle. The machine is powered by a nominal 48 Volts battery pack, the control system is powered by a 12 V converter.

Some procedures below refer to these nominal voltages: VBatt for the battery; VSupply for the converter. Actual voltage measurements may differ based on the charge of the batteries. **If a correction is made during a check, conclude the check by cycling the machine power, using the emergency stop switch.** It may also be helpful to run a system test, ANALYZER -> SYSTEM TEST for intermittent or difficult problems.

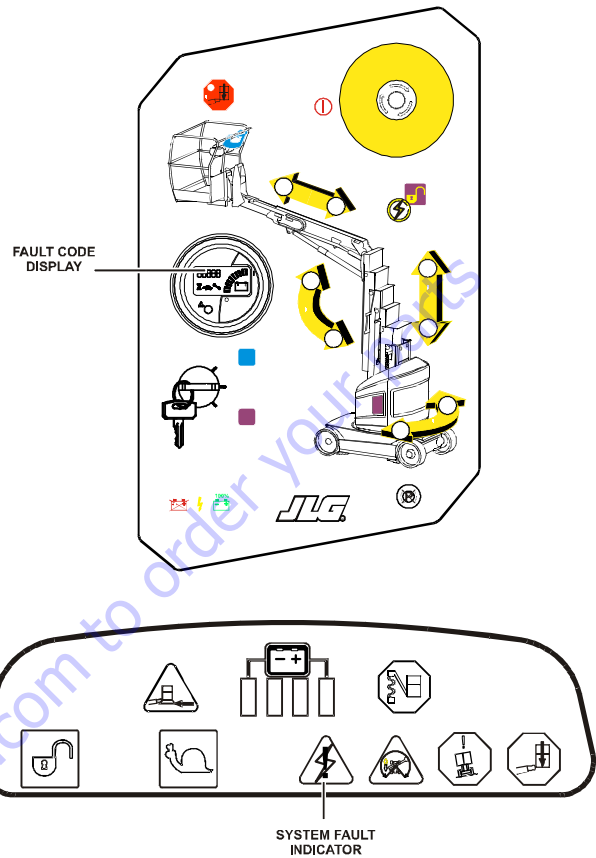


Figure 10-1. DTCs Displays

10.2 DTC INDEX

DTC TABLE	PAGE
0-0 Help Comments	10-2
2-1 Power-Up	10-4
2-2 Platform Controls	10-4
2-3 Ground Controls	10-7
2-5 Function Prevented	10-12
3-1 Line Contactor Open Circuit	10-14
3-2 Line Contactor Short Circuit	10-14
3-3 Ground Output Driver	10-15
4-2 Thermal Limit	10-23
4-4 Battery Supply	10-26
4-6 Transmission and Drive System	10-29
6-6 Communication	10-30
6-7 Accessory	10-33
7-7 Electric Motor	10-33
8-1 Tilt Sensor	10-36
8-2 Platform Load Sense	10-37
8-6 Steering / Axle	10-38
8-7 Safety System Override	10-41
9-9 Hardware	10-41

## SECTION 10 - DIAGNOSTIC TROUBLE CODES

### 10.3 DTC CHECK TABLES

#### 0-0 Help Comments

DTC	Help Message	Condition Producing DTC	Control system Response or Machine Condition	Corrective Action/Operational Requirement for Function Movement and/or to Clear Fault
001	EVERYTHING OK	The normal help message in Platform Mode. Displays on the analyzer only.		
002	GROUND MODE OK	The normal help message in Ground Mode. Displays on the analyzer only.		
008	FUNCTIONS LOCKED OUT - SYSTEM POWERED DOWN	After 2 hours without activity, the Control System enters a low-power state to preserve battery charge. Displays on the analyzer only; the MDI's LED is blinking with the display Off.	<ul style="list-style-type: none"> <li>• Normal operation should resume after a power cycle.</li> <li>• Check battery charge, condition, etc.</li> </ul>	<ul style="list-style-type: none"> <li>• Normal operation should resume after a power cycle. Refer problem to a qualified JLG mechanic.</li> </ul>
0010	RUNNING AT CUTBACK - OUT OF TRANSPORT POSITION	Drive speed is limited while the mast is elevated. Displays on the analyzer only.	<ul style="list-style-type: none"> <li>• Fully stow the platform.</li> <li>• Check that the mast switches are securely mounted.</li> <li>• Check the mast switches wiring with platform fully stowed:                      @ +VSupply: X253A(2), X704B(1), X704B(2), C084-J7(11), C084-J7(21), X761A(2).                      @ -VSupply: X253A(6), X761A(1), X761A(3).</li> </ul>	<ul style="list-style-type: none"> <li>• Fully stow the platform.</li> <li>• Check that the mast switches are securely mounted. Refer problem to a qualified JLG mechanic.</li> </ul>
0022	DIFFERENT FUNCTION SELECTED & IGNORED	Two functions were selected simultaneously	<ul style="list-style-type: none"> <li>• Release joysticks and allow to center.</li> <li>• Release buttons and allow to return to the normal positions.</li> </ul> Refer problem to a qualified JLG mechanic.	<ul style="list-style-type: none"> <li>• Release joysticks and allow to center.</li> <li>• Release buttons and allow to return to the normal positions.</li> </ul> Refer problem to a qualified JLG mechanic.
0023	FUNCTION SELECTED BUT TRIGGER SWITCH OPEN	One of the drive joystick functions was activated, but the trigger switch was not.	<ul style="list-style-type: none"> <li>• Release joystick and allow to center.</li> <li>• Check if the joystick is obstructed or jammed.</li> <li>• Proceed with a joystick calibration.</li> <li>• Check Joystick voltages (refer to Section 8-6).</li> <li>• Check if the trigger switch is damaged.</li> <li>• Check trigger switch output: J2(5).</li> </ul>	<ul style="list-style-type: none"> <li>• Release joystick and allow to center.</li> <li>• Check if the joystick is obstructed or jammed.</li> <li>• Check if the trigger switch is damaged.</li> </ul> Refer problem to a qualified JLG mechanic.

## SECTION 10 - DIAGNOSTIC TROUBLE CODES

DTC	Help Message	Condition Producing DTC	Control system Response or Machine Condition	Corrective Action/Operational Requirement for Function Movement and/or to Clear Fault
0027	FUNCTION SELECTED BUT LIFT ENABLE SWITCH OPEN	Mast, Jib, Telescope, Platform Rotate, or Platform Level was commanded but the enable switch was not activated.	<ul style="list-style-type: none"> <li>• Release joystick and allow to center.</li> <li>• Check if the joystick is obstructed or jammed.</li> <li>• Proceed with a joystick calibration.</li> <li>• Check Joystick voltages (refer to Section 8-6).</li> <li>• Check if the enable switch is damaged.</li> <li>• Check the enable switch output : J1 (18).</li> </ul>	<ul style="list-style-type: none"> <li>• Release joystick and allow to center.</li> <li>• Check if the joystick is obstructed or jammed.</li> <li>• Check if the enable switch is damaged.</li> </ul> <p>Refer problem to a qualified JLG mechanic.</p>
0028	DRIVE PREVENTED - TILTED & ELEVATED	Drive is prevented while the platform is not in transport position and the chassis is not level.	<ul style="list-style-type: none"> <li>• Check that the machine is tilted. If so, lower the platform and reposition the machine to a level surface.</li> <li>• Fully stow the platform.</li> <li>• Check that the tilt sensor is securely mounted</li> <li>• Check the tilt sensor setting</li> </ul>	<ul style="list-style-type: none"> <li>• Check that the machine is tilted. If so, lower the platform and reposition the machine to a level surface.</li> <li>• Fully stow the platform.</li> <li>• Check that the tilt sensor is securely mounted and its wire connected.</li> </ul> <p>Refer problem to a qualified JLG mechanic.</p>
0033	TRACTION MOTOR AT CURRENT LIMIT	The traction motors have exceeded 175 A for 3 seconds. Drive speed is reduced.	<ul style="list-style-type: none"> <li>• Cycle power to clear the fault</li> <li>• Check for Damage to motor leads from Power Modules</li> <li>• Replace Power Modules</li> </ul>	<ul style="list-style-type: none"> <li>• Cycle power to clear the fault.</li> </ul> <p>Refer problem to a qualified JLG mechanic.</p>
0036	FUNCTION PREVENTED - FUNCTION SELECTED BEFORE GROUND ENABLE	One of the functions was activated at the ground station, but the enable was not.	<ul style="list-style-type: none"> <li>• Check if the ground enable switch is damaged, obstructed or jammed.</li> <li>• Disconnect the membrane panel ribbon cable : replace the membrane panel if DTC is no longer present.</li> <li>• Check the switch line voltage @ +V supply: C0170-J3(13)</li> </ul>	<ul style="list-style-type: none"> <li>• Check if the ground enable switch is damaged, obstructed or jammed.</li> </ul> <p>Refer problem to a qualified JLG mechanic.</p>

## SECTION 10 - DIAGNOSTIC TROUBLE CODES

### 2-1 Power-Up

DTC	Help Message	Condition Producing DTC	Control system Response or Machine Condition	Corrective Action/Operational Requirement for Function Movement and/or to Clear Fault
211	POWER CYCLE	The normal help message is issued at each power cycle. Displays on the analyzer only.	Normal operation. No check necessary.	Normal operation. No check necessary.
212	KEYSWITCH FAULTY	Both Platform and Ground modes are selected simultaneously. Defaults to Ground Mode.	<ul style="list-style-type: none"> <li>• Check key switch function.</li> <li>• Replace key switch.</li> </ul>	Refer problem to a qualified JLG mechanic.

### 2-2 Platform Controls

DTC	Help Message	Condition Producing DTC	Control system Response or Machine Condition	Corrective Action/Operational Requirement for Function Movement and/or to Clear Fault
221	FUNCTION PROBLEM - HORN PERMANENTLY SELECTED	The horn switch was closed during power-up in platform mode.	<ul style="list-style-type: none"> <li>• Check if the horn switch is damaged, obstructed or jammed.</li> <li>• Check horn push button output: J4(3).</li> </ul>	<ul style="list-style-type: none"> <li>• Check if the horn switch is damaged, obstructed or jammed.</li> </ul> Refer problem to a qualified JLG mechanic.
224	FUNCTION PROBLEM - STEER LEFT PERMANENTLY SELECTED	The Steer Left Switch was closed during power-up in platform mode."	<ul style="list-style-type: none"> <li>• Check if the steer left switch is obstructed or jammed.</li> <li>• Check the left steer switch output: J2(6).</li> </ul>	<ul style="list-style-type: none"> <li>• Check if the steer left switch is obstructed or jammed.</li> </ul> Refer problem to a qualified JLG mechanic.
225	FUNCTION PROBLEM - STEER RIGHT PERMANENTLY SELECTED	The Steer Right Switch was closed during power-up in platform mode.	<ul style="list-style-type: none"> <li>• Check if the steer right switch is obstructed or jammed.</li> <li>• Check the right steer switch output: J2(7).</li> </ul>	<ul style="list-style-type: none"> <li>• Check if the steer right switch is obstructed or jammed.</li> </ul> Refer problem to a qualified JLG mechanic.
227	STEER SWITCHES FAULTY	The steer left and steer right inputs were closed simultaneously.	<ul style="list-style-type: none"> <li>• Check if the steer switches are damaged, obstructed or jammed.</li> </ul>	<ul style="list-style-type: none"> <li>• Check if the steer switches are damaged, obstructed or jammed.</li> </ul> Refer problem to a qualified JLG mechanic.
229	FUNCTION PROBLEM - TRIGGER PERMANENTLY CLOSED	The trigger switch was closed during power-up in platform mode.	<ul style="list-style-type: none"> <li>• Check if the trigger switch is obstructed or jammed.</li> <li>• Check trigger switch output voltage: J2(5).</li> </ul>	<ul style="list-style-type: none"> <li>• Check if the trigger switch is obstructed or jammed.</li> </ul> Refer problem to a qualified JLG mechanic.
2210	TRIGGER CLOSED TOO LONG WHILE IN NEUTRAL	The trigger switch was closed for more than seven seconds while the joystick was centered.	<ul style="list-style-type: none"> <li>• Check if the trigger switch is obstructed or jammed.</li> <li>• Check trigger switch output voltage: J2(5).</li> </ul>	<ul style="list-style-type: none"> <li>• Check if the trigger switch is obstructed or jammed.</li> </ul> Refer problem to a qualified JLG mechanic.
2240	LIFT ENABLE SWITCH PERMANENTLY SELECTED	The Lift Enable switch was closed during power-up in platform mode.	<ul style="list-style-type: none"> <li>• Check if the lift enable switch is obstructed or jammed.</li> <li>• Check lift enable switch output voltage: J1(18).</li> </ul>	<ul style="list-style-type: none"> <li>• Check if the lift enable switch is obstructed or jammed.</li> </ul> Refer problem to a qualified JLG mechanic.

## SECTION 10 - DIAGNOSTIC TROUBLE CODES

DTC	Help Message	Condition Producing DTC	Control system Response or Machine Condition	Corrective Action/Operational Requirement for Function Movement and/or to Clear Fault
2241	LIFT ENABLE SWITCH CLOSED TOO LONG WHILE IN NEUTRAL	The lift enable switch was closed for more than seven seconds while the joystick was centered.	<ul style="list-style-type: none"> <li>Check if the lift enable switch is obstructed or jammed.</li> <li>Check lift enable switch output voltage: J1 (18).</li> </ul>	<ul style="list-style-type: none"> <li>Check if the lift enable switch is obstructed or jammed.</li> </ul> Refer problem to a qualified JLG mechanic.
2242	FUNCTION LOCKED OUT - MAST JOYSTICK NOT CENTERED	The Mast Joystick was not centered at power-up in platform mode.	<ul style="list-style-type: none"> <li>Release joystick and allow to center.</li> <li>Check if the joystick is obstructed or jammed.</li> <li>Proceed with a calibration.</li> <li>Check the joystick voltages: if the power is not correct, replace the board; if the output is not correct, replace the joystick (refer to Section 8-6).</li> </ul>	<ul style="list-style-type: none"> <li>Release joystick and allow to center.</li> <li>Check if the joystick is obstructed or jammed.</li> </ul> Refer problem to a qualified JLG mechanic.
2243	FUNCTION LOCKED OUT - JIB JOYSTICK NOT CENTERED	The Jib Joystick was not centered at power-up in platform mode.	<ul style="list-style-type: none"> <li>Release joystick and allow to center.</li> <li>Check if the joystick is obstructed or jammed.</li> <li>Proceed with a calibration.</li> <li>Check the joystick voltages: if the power is not correct, replace the board; if the output is not correct, replace the joystick (refer to Section 8-6).</li> </ul>	<ul style="list-style-type: none"> <li>Release joystick and allow to center.</li> <li>Check if the joystick is not obstructed or jammed.</li> </ul> Refer problem to a qualified JLG mechanic.
2247	FUNCTION PROBLEM - PLATFORM ROTATE LEFT PERMANENTLY SELECTED	The Platform Rotate Left switch was closed during power-up in platform mode.	<ul style="list-style-type: none"> <li>Check if the Platform Rotate Left switch is obstructed or jammed.</li> <li>Check the Platform Rotate Left switch output: J1 (11).</li> </ul>	<ul style="list-style-type: none"> <li>Check if the Platform Rotate Left switch is obstructed or jammed.</li> </ul> Refer problem to a qualified JLG mechanic.
2248	FUNCTION PROBLEM - PLATFORM ROTATE RIGHT PERMANENTLY SELECTED	The Platform Rotate Right switch was closed during power-up in platform mode.	<ul style="list-style-type: none"> <li>Check if the Platform Rotate Right switch is obstructed or jammed.</li> <li>Check the Platform Rotate Right switch output: J1 (12).</li> </ul>	<ul style="list-style-type: none"> <li>Check if the Platform Rotate Right switch is obstructed or jammed.</li> </ul> Refer problem to a qualified JLG mechanic.
2262	FUNCTION PROBLEM - PLATFORM LEVEL UP PERMANENTLY SELECTED	The Platform Level Up switch was closed during power-up in platform mode.	<ul style="list-style-type: none"> <li>Check if the Platform Level Up switch is obstructed or jammed.</li> <li>Check the Platform Level Up switch output: J4(4).</li> </ul>	<ul style="list-style-type: none"> <li>Check if the Platform Level Up switch is obstructed or jammed.</li> </ul> Refer problem to a qualified JLG mechanic.
2263	FUNCTION PROBLEM - PLATFORM LEVEL DOWN PERMANENTLY SELECTED	The Platform Level Down switch was closed during power-up in platform mode.	<ul style="list-style-type: none"> <li>Check if the Platform Level Down switch is obstructed or jammed.</li> <li>Check the Platform Level Down switch output: J4(5).</li> </ul>	<ul style="list-style-type: none"> <li>Check if the Platform Level Down switch is obstructed or jammed.</li> </ul> Refer problem to a qualified JLG mechanic.



## SECTION 10 - DIAGNOSTIC TROUBLE CODES

DTC	Help Message	Condition Producing DTC	Control system Response or Machine Condition	Corrective Action/Operational Requirement for Function Movement and/or to Clear Fault
2264	FUNCTION PROBLEM – DOS OVERRIDE PERMANENTLY SELECTED	The machine is in Platform mode and the DOS switch is sending a continual override signal.	<ul style="list-style-type: none"> <li>• Check if the DOS switch is obstructed or jammed.</li> <li>• Check the DOS switch output: J4(2).</li> </ul>	<ul style="list-style-type: none"> <li>• Check if the DOS switch is obstructed or jammed.</li> </ul> Refer problem to a qualified JLG mechanic.
2274	DRIVE/SWING JOYSTICK FAULTY – WIPER OUT OF RANGE	The Drive/Swing joystick wiper signal input is outside the acceptable voltage range.	<ul style="list-style-type: none"> <li>• Center joystick and check to see if a power cycle will clear DTC.</li> <li>• Check joystick wiper voltage: J2(3) for swing, J2(4) for drive. Acceptable range : 0.35V - 4.65V</li> </ul>	<ul style="list-style-type: none"> <li>• Center joystick and check to see if a power cycle will clear DTC.</li> </ul> Refer problem to a qualified JLG mechanic.
2275	FUNCTION LOCKED OUT – DRIVE/SWING JOYSTICK NOT CENTERED	The Drive/Swing joystick was not centered at power-up in platform mode.	<ul style="list-style-type: none"> <li>• Release joystick and allow to center.</li> <li>• Check if the joystick is obstructed or jammed.</li> <li>• Proceed with a calibration.</li> <li>• Check joystick voltages (refer to Section 8-6).</li> </ul>	<ul style="list-style-type: none"> <li>• Release joystick and allow to center.</li> <li>• Check if the joystick is obstructed or jammed.</li> </ul> Refer problem to a qualified JLG mechanic.
2276	FUNCTION LOCKED OUT – TELESCOPE JOYSTICK NOT CENTERED	The Telescope Joystick was not centered at power-up in platform mode."	<ul style="list-style-type: none"> <li>• Release joystick and allow to center.</li> <li>• Check if the joystick is obstructed or jammed.</li> <li>• Proceed with a calibration.</li> <li>• Check the joystick voltages : if the power is not correct, replace the board; if the output is not correct, replace the joystick (refer to Section 8-6).</li> </ul>	<ul style="list-style-type: none"> <li>• Release joystick and allow to center.</li> <li>• Check if the joystick is obstructed or jammed.</li> </ul> Refer problem to a qualified JLG mechanic.
2277	MAST JOYSTICK FAULTY – WIPER OUT OF RANGE	The Mast joystick wiper signal input is outside the acceptable voltage range.	<ul style="list-style-type: none"> <li>• Center joystick and check to see if a power cycle will clear DTC.</li> <li>• Check joystick wiper voltage : J5(6). Acceptable range : 0.5V - 4.5V</li> </ul>	<ul style="list-style-type: none"> <li>• Release joystick and allow to center.</li> <li>• Check if the joystick is obstructed or jammed.</li> </ul> Refer problem to a qualified JLG mechanic.
2278	TELESCOPE JOYSTICK FAULTY – WIPER OUT OF RANGE	The Telescope joystick wiper signal input is outside the acceptable voltage range.	<ul style="list-style-type: none"> <li>• Center joystick and check to see if a power cycle will clear DTC.</li> <li>• Check joystick wiper voltage : J6(1). Acceptable range : 0.5V - 4.5V</li> </ul>	<ul style="list-style-type: none"> <li>• Release joystick and allow to center.</li> <li>• Check if the joystick is obstructed or jammed.</li> </ul> Refer problem to a qualified JLG mechanic.
2279	JIB JOYSTICK FAULTY – WIPER OUT OF RANGE	The Jib joystick wiper signal input is outside the acceptable voltage range.	<ul style="list-style-type: none"> <li>• Center joystick and check to see if a power cycle will clear DTC.</li> <li>• Check joystick wiper voltage : J5(3). Acceptable range : 0.5V - 4.5V</li> </ul>	<ul style="list-style-type: none"> <li>• Release joystick and allow to center.</li> <li>• Check if the joystick is obstructed or jammed.</li> </ul> Refer problem to a qualified JLG mechanic.

 **2-3 Ground Controls**

DTC	Help Message	Condition Producing DTC	Control system Response or Machine Condition	Corrective Action/Operational Requirement for Function Movement and/or to Clear Fault
233	FUNCTION PROBLEM - BRAKE RELEASE PERMANENTLY SELECTED	The Brake Release switch was closed during power-up in ground mode.	<ul style="list-style-type: none"> <li>• Check if the concerned switch is damaged, obstructed or jammed.</li> <li>• Disconnect the membrane panel ribbon cable : replace the membrane panel if DTC is no longer present.</li> <li>• Check the switch line voltage : C0170-J3(3), C0170-J1(4) and C084-J4(4).</li> </ul>	<ul style="list-style-type: none"> <li>• Check if the concerned switch is damaged, obstructed or jammed.</li> </ul> Refer problem to a qualified JLG mechanic.
2310	FUNCTION PROBLEM - GROUND ENABLE PERMANENTLY SELECTED	The Ground Enable switch was closed during power-up in ground mode.	<ul style="list-style-type: none"> <li>• Check if the concerned switch is damaged, obstructed or jammed.</li> <li>• Disconnect the membrane panel ribbon cable : replace the membrane panel if DTC is no longer present.</li> <li>• Check the switch line voltage : C0170-J3(4), C0170-J1(16) and C084-J4(16)."</li> </ul>	<ul style="list-style-type: none"> <li>• Check if the concerned switch is damaged, obstructed or jammed.</li> </ul> Refer problem to a qualified JLG mechanic.
2368	FUNCTION PROBLEM - MAST LIFT UP PERMANENTLY SELECTED	The Mast Lift Up switch was closed during power-up in ground mode.	<ul style="list-style-type: none"> <li>• Check if the concerned switch is damaged, obstructed or jammed.</li> <li>• Disconnect the membrane panel ribbon cable : replace the membrane panel if DTC is no longer present.</li> <li>• Check the switch line voltage : C0170-J3(12), C0170-J1(23) and C084-J4(23).</li> </ul>	<ul style="list-style-type: none"> <li>• Check if the concerned switch is damaged, obstructed or jammed.</li> </ul> Refer problem to a qualified JLG mechanic.
2369	FUNCTION PROBLEM - MAST LIFT DOWN PERMANENTLY SELECTED	The Mast Lift Down switch was closed during power-up in ground mode.	<ul style="list-style-type: none"> <li>• Check if the concerned switch is damaged, obstructed or jammed.</li> <li>• Disconnect the membrane panel ribbon cable : replace the membrane panel if DTC is no longer present.</li> <li>• Check the switch line voltage : C0170-J3(9), C0170-J1(33) and C084-J4(33).</li> </ul>	<ul style="list-style-type: none"> <li>• Check if the concerned switch is damaged, obstructed or jammed.</li> </ul> Refer problem to a qualified JLG mechanic.
2370	FUNCTION PROBLEM - JIB LIFT UP PERMANENTLY SELECTED	The Jib Lift Up Switch was closed during power-up in ground mode.	<ul style="list-style-type: none"> <li>• Check if the concerned switch is damaged, obstructed or jammed.</li> <li>• Disconnect the membrane panel ribbon cable : replace the membrane panel if DTC is no longer present.</li> <li>• Check the switch line voltage : C0170-J3(7), C0170-J1(19) and C084-J4(19).</li> </ul>	<ul style="list-style-type: none"> <li>• Check if the concerned switch is damaged, obstructed or jammed.</li> </ul> Refer problem to a qualified JLG mechanic.

## SECTION 10 - DIAGNOSTIC TROUBLE CODES

DTC	Help Message	Condition Producing DTC	Control system Response or Machine Condition	Corrective Action/Operational Requirement for Function Movement and/or to Clear Fault
2371	FUNCTION PROBLEM - JIB LIFT DOWN PERMANENTLY SELECTED	The Jib Lift Down switch was closed during power-up in ground mode.	<ul style="list-style-type: none"> <li>• Check if the concerned switch is damaged, obstructed or jammed.</li> <li>• Disconnect the membrane panel ribbon cable : replace the membrane panel if DTC is no longer present.</li> <li>• Check the switch line voltage : C0170-J3(8), C0170-J1(8) and C084-J4(8).</li> </ul>	<ul style="list-style-type: none"> <li>• Check if the concerned switch is damaged, obstructed or jammed.</li> </ul> <p>Refer problem to a qualified JLG mechanic.</p>
2372	FUNCTION PROBLEM - SWING LEFT PERMANENTLY SELECTED	The Swing Left switch was closed during power-up in ground mode.	<ul style="list-style-type: none"> <li>• Check if the concerned switch is damaged, obstructed or jammed.</li> <li>• Disconnect the membrane panel ribbon cable : replace the membrane panel if DTC is no longer present.</li> <li>• Check the switch line voltage : C0170-J3(11), C0170-J1(34) and C084-J4(34).</li> </ul>	<ul style="list-style-type: none"> <li>• Check if the concerned switch is damaged, obstructed or jammed.</li> </ul> <p>Refer problem to a qualified JLG mechanic.</p>
2373	FUNCTION PROBLEM - SWING RIGHT PERMANENTLY SELECTED	The Swing Right switch was closed during power-up in ground mode.	<ul style="list-style-type: none"> <li>• Check if the concerned switch is damaged, obstructed or jammed.</li> <li>• Disconnect the membrane panel ribbon cable : replace the membrane panel if DTC is no longer present.</li> <li>• Check the switch line voltage : C0170-J3(14), C0170-J1(35) and C084-J4(35).</li> </ul>	<ul style="list-style-type: none"> <li>• Check if the concerned switch is damaged, obstructed or jammed.</li> </ul> <p>Refer problem to a qualified JLG mechanic.</p>
2374	MAST SWITCH FAULTY	The Mast Lift Up and Down switches are active simultaneously.	<ul style="list-style-type: none"> <li>• Check if one of the concerned switch is damaged, obstructed or jammed.</li> <li>• Disconnect the membrane panel ribbon cable : replace the membrane panel if DTC is no longer present.</li> <li>• Check both switch lines voltage : C0170-J3(12), C0170-J1(23), C084-J4(23) and C0170-J3(9), C0170-J1(33), C084-J4(33).</li> </ul>	<ul style="list-style-type: none"> <li>• Check if one of the concerned switches is damaged, obstructed or jammed.</li> </ul> <p>Refer problem to a qualified JLG mechanic.</p>
2375	JIB SWITCH FAULTY	The Jib Lift Up and Down switches are active simultaneously.	<ul style="list-style-type: none"> <li>• Check if one of the concerned switch is damaged, obstructed or jammed.</li> <li>• Disconnect the membrane panel ribbon cable : replace the membrane panel if DTC is no longer present.</li> <li>• Check both switch lines voltage : C0170-J3(7), C0170-J1(19), C084-J4(19) and C0170-J3(8), C0170-J1(8), C084-J4(8).</li> </ul>	<ul style="list-style-type: none"> <li>• Check if one of the concerned switches is damaged, obstructed or jammed.</li> </ul> <p>Refer problem to a qualified JLG mechanic.</p>

**SECTION 10 - DIAGNOSTIC TROUBLE CODES**

DTC	Help Message	Condition Producing DTC	Control system Response or Machine Condition	Corrective Action/Operational Requirement for Function Movement and/or to Clear Fault
2376	SWING SWITCH FAULTY	The Swing Right Left and Right switches are active simultaneously.	<ul style="list-style-type: none"> <li>• Check if one of the concerned switch is damaged, obstructed or jammed.</li> <li>• Disconnect the membrane panel ribbon cable : replace the membrane panel if DTC is no longer present.</li> <li>• Check both switch lines voltage : C0170-J3(11), C0170-J1(34), C084-J4(34) and C0170-J3(14), C0170-J1(35), C084-J4(35).</li> </ul>	<ul style="list-style-type: none"> <li>• Check if one of the concerned switches is damaged, obstructed or jammed. Refer problem to a qualified JLG mechanic.</li> </ul>
2379	MAIN MAST LIMIT SWITCH - NOT RESPONDING	The status of the Main Mast limit switch does not change while raising the mast.	<p>If the mast is not raising while the function is controlled:</p> <ul style="list-style-type: none"> <li>- Pump not running : check the voltage applied to the pump motor;</li> <li>- Pump running : check the oil level; check the hydraulic pressure and the voltage applied to the pressure relief valve; check mast lift valve; check the mast for obstruction or damages.</li> </ul> <p>• If the mast is raising while the function is controlled :</p> <ul style="list-style-type: none"> <li>- Check if the Main Mast limit switch is damaged, obstructed or jammed;</li> <li>- Check the Main Mast limit switch wiring:</li> </ul> <p>Mast stowed:</p> <ul style="list-style-type: none"> <li>@ +VSupply: X761A(4), X704B(1), C084-J7(11).</li> <li>@ -VSupply: X253A(6), X761A(3), X638A(F).</li> </ul> <p>Mast elevated :</p> <ul style="list-style-type: none"> <li>@ +VSupply: X761A(4), X761A(3), X638A(F).</li> <li>@ -VSupply: X253A(6), X704B(1).</li> <li>@ 6.5 to 7.5 V: C084-J7(11).</li> </ul>	<ul style="list-style-type: none"> <li>• Check if the Main Mast limit switch (left switch) is damaged, obstructed or jammed. Refer problem to a qualified JLG mechanic.</li> </ul>

## SECTION 10 - DIAGNOSTIC TROUBLE CODES

DTC	Help Message	Condition Producing DTC	Control system Response or Machine Condition	Corrective Action/Operational Requirement for Function Movement and/or to Clear Fault
2380	MAIN MAST LIMIT SWITCH - FAULTY	N.O. and N.C. contacts show the same electrical status for more than 1 second.	<p>Check if the Main Mast limit switch is damaged;</p> <ul style="list-style-type: none"> <li>• Check the Main Mast limit switch wiring:</li> </ul> <p>Mast stowed:            @ +VSupply: X253A(2), X704B(1), C084-J7(11).            @ -VSupply: X253A(6), X761A(3), X638A(F).            Mast elevated:            @ +VSupply: X253A(2), X761A(3), X638A(F).            @ -VSupply: X253A(6), X704B(1).            @ 6.5 to 7.5 V: C084-J7(11).</p>	Refer problem to a qualified JLG mechanic
2388	PLATFORM ROTATE SWITCH FAULTY	The Platform Rotate Left and Platform Rotate Right inputs were closed simultaneously.	Check if the platform rotate switches are damaged, obstructed or jammed.	<ul style="list-style-type: none"> <li>• Check if the rotate switches are damaged, obstructed or jammed.</li> </ul> Refer problem to a qualified JLG mechanic.
2390	TELESCOPE SWITCH FAULTY	The Telescope In and Telescope Out inputs were closed simultaneously.	Check if the Telescope switches are damaged, obstructed or jammed.	<ul style="list-style-type: none"> <li>• Check if the Telescope switches are damaged, obstructed or jammed.</li> </ul> Refer problem to a qualified JLG mechanic.
2393	PLATFORM LEVEL SWITCH FAULTY	The Platform Level Up and Platform Level Down inputs were closed simultaneously.	Check if the platform level switches are damaged, obstructed or jammed.	<ul style="list-style-type: none"> <li>• Check if the platform level switches are damaged, obstructed or jammed.</li> </ul> Refer problem to a qualified JLG mechanic.
23109	FUNCTION PROBLEM - TELESCOPE IN PERMANENTLY SELECTED	The Telescope In Switch was closed during power-up in ground mode	<p>Check if the concerned switch is damaged, obstructed or jammed.</p> <p>Disconnect the membrane panel ribbon cable : replace the membrane panel if DTC is no longer present.</p> <p>Check the switch line voltage : C0170-J3(6), C0170-J1(7) and C084-J4(7).</p>	<ul style="list-style-type: none"> <li>• Check if the Telescope In switch is obstructed or jammed.</li> </ul> Refer problem to a qualified JLG mechanic.
23110	FUNCTION PROBLEM - TELESCOPE OUT PERMANENTLY SELECTED	The Telescope Out Switch was closed during power-up in ground mode	<ul style="list-style-type: none"> <li>• Check if the concerned switch is damaged,</li> <li>• obstructed or jammed.</li> <li>• Disconnect the membrane panel ribbon cable : replace the membrane panel if DTC is no longer present.</li> <li>• Check the switch line voltage : C0170-J3(5), C0170-J1(30) and C084-J4(30).</li> </ul>	<ul style="list-style-type: none"> <li>• Check if the Telescope Out switch is obstructed or jammed.</li> </ul> Refer problem to a qualified JLG mechanic.

**SECTION 10 - DIAGNOSTIC TROUBLE CODES**

DTC	Help Message	Condition Producing DTC	Control system Response or Machine Condition	Corrective Action/Operational Requirement for Function Movement and/or to Clear Fault
23121	JIB LIMIT SWITCH - FAULTY	The jib limit switch outputs are reading high or low simultaneously	<ul style="list-style-type: none"> <li>• Check if the Jib limit switch is damaged;</li> <li>• Check the Jib limit switch wiring : Jib stowed: @ +VSupply: X253A(2), X704B(2), C084-J7 (21). @ -VSupply: X253A(6), X761A(1). Jib elevated : @ +VSupply: X253A(2), X761A(1). @ -VSupply : X253A(6), X704B(2). @ 6.5 to 7.5 V: C084-J7 (21).</li> </ul>	Refer problem to a qualified JLG mechanic.
23122	JIB LIMIT SWITCH - NOT RESPONDING	The status of the Jib limit switch does not change while raising the Jib for more than 5000ms.	<ul style="list-style-type: none"> <li>• If the Jib is not raising while the function is controlled: - Pump not running : check the voltage applied to the pump motor; - Pump running : check the oil level; check the hydraulic pressure and the voltage applied to the pressure relief valve; check Jib valve; check the Jib for obstruction or damages.</li> <li>• If the Jib is raising while the function is controlled : - Check if the Jib limit switch (Refer to Section 8-2) is damaged, obstructed or jammed; - Check the Jib limit switch wiring: Jib stowed: @ +VSupply: X253A(2), X704B(2), C084-J7 (21). @ -VSupply: X253A(6), X761A(1). Jib elevated: @ +VSupply: X253A(2), X761A(1). @ -VSupply: X253A(6), X704B(2). @ 6.5 to 7.5 V: C084-J7 (21).</li> </ul>	<ul style="list-style-type: none"> <li>• Check if the Jib limit switch (Refer to Section 8-2) is damaged, obstructed or jammed. Refer problem to a qualified JLG mechanic.</li> </ul>

## SECTION 10 - DIAGNOSTIC TROUBLE CODES

DTC	Help Message	Condition Producing DTC	Control system Response or Machine Condition	Corrective Action/Operational Requirement for Function Movement and/or to Clear Fault
23123	JIB LIMIT SWITCH - DISMOUNTED	Status of Jib Limit Switch conflicts with status of the Jib EOS Limit Switch	<ul style="list-style-type: none"> <li>Check if the Jib EOS Limit Switch (Refer to Section 8-2) is damaged, obstructed, or jammed.</li> <li>Check if the Jib Limit Switch (Refer to Section 8-2) is damaged, obstructed, or jammed.</li> <li>Check the Jib limit switch and Jib EOS limit switch wiring :                      Jib stowed :                      @ +VSupply: X253A(2), X704B(2), C084-J7(21), X761A(2), X638A(H).                      @ -VSupply: X253A(6), X761A(1).                      Jib elevated (Out of transport but below horizontal) :                      @ +VSupply: X253A(2), X761A(1), X761A(2), X638A(H).                      @ -VSupply: X253A(6), X704B(2).                      @ 6.5 to 7.5 V: C084-J7(21).                      Jib elevated (Fully elevated) :                      @ +VSupply: X253A(2), X761A(1).                      @ -VSupply: X253A(6), X704B(2), X761A(2), X638A(H).                      @ 6.5 to 7.5 V: C084-J7(21).</li> </ul>	<ul style="list-style-type: none"> <li>Check if the Jib limit switch (Refer to Section 8-2) is damaged,</li> <li>obstructed or jammed.</li> <li>Check if the Jib EOS limit switch (Refer to Section 8-2) is damaged, obstructed or jammed.</li> </ul> Refer problem to a qualified JLG mechanic.

### 2-5 Function Prevented

DTC	Help Message	Condition Producing DTC	Control system Response or Machine Condition	Corrective Action/Operational Requirement for Function Movement and/or to Clear Fault
253	DRIVE PREVENTED - CHARGER CONNECTED	Drive prevented while the vehicle is charging."	<ul style="list-style-type: none"> <li>Check if the charger is connected to off board power source and disconnect if desired.</li> <li>Check interlock relay wiring :                      @ +Vbatt when the machine is not charging : C0107-J2(8)                      @ -Vbatt when the machine is not charging : C0107-J2(2).</li> </ul>	<ul style="list-style-type: none"> <li>Check if the charger is connected to off board power source and disconnect if desired.</li> </ul> Refer problem to a qualified JLG mechanic.
259	MODEL CHANGED - HYDRAULICS SUSPENDED - CYCLE EMS	The model selection has been changed.	<ul style="list-style-type: none"> <li>Check ANALYZER-&gt;MACHINE SETUP-&gt;MODEL.</li> <li>Refer to Section 9 for proper personality settings and calibrations.</li> </ul>	Refer problem to a qualified JLG mechanic.

## SECTION 10 - DIAGNOSTIC TROUBLE CODES

DTC	Help Message	Condition Producing DTC	Control system Response or Machine Condition	Corrective Action/Operational Requirement for Function Movement and/or to Clear Fault
2516	DRIVE PREVENTED - ABOVE ELEVATION	DRIVE CUTOFF set to 1 (YES), and the mast is elevated.	<ul style="list-style-type: none"> <li>Fully stow the platform.</li> </ul>	<ul style="list-style-type: none"> <li>Fully stow the platform. Refer problem to a qualified JLG mechanic.</li> </ul>
2520	FUNCTIONS LOCKED OUT – CONSTANT DATA VERSION IMPROPER	Constant Data is not compatible with Software	<ul style="list-style-type: none"> <li>Cycle power to clear the fault.</li> <li>Reinstall the most current Production software for the UGM.</li> <li>Replace UGM</li> </ul>	<ul style="list-style-type: none"> <li>Cycle power to clear the fault. Refer problem to a qualified JLG mechanic.</li> </ul>
2538	FUNCTION PREVENTED - CHARGER CONNECTED	Functions are prevented while the vehicle is charging."	<ul style="list-style-type: none"> <li>Check if the charger is connected to off board power source and disconnect if desired.</li> <li>Check interlock relay wiring : @ + Vbatt when the machine is not charging: C0107-J2(8) @ - Vbatt when the machine is not charging: C0107-J2(2).</li> </ul>	<ul style="list-style-type: none"> <li>Check if the charger is connected to off board power source and disconnect if desired. Refer problem to a qualified JLG mechanic.</li> </ul>
2542	FUNCTION PREVENTED - BRAKES ELECTRONICALLY RELEASED FOR TOWING	Manual brake release mode is activated. Drive or lift is not possible."	<ul style="list-style-type: none"> <li>Push manual brake release switch again or cycle power to clear manual brake release mode.</li> <li>Check if the brake release switch is damaged, obstructed or jammed.</li> <li>Check the switch line voltage: C0170-J3(3), C0170-J1(4) and C084-J4(4).</li> </ul>	<ul style="list-style-type: none"> <li>Push manual brake release switch again or cycle power to clear manual brake release mode.</li> <li>Check if the brake release switch is damaged, obstructed or jammed. Refer problem to a qualified JLG mechanic.</li> </ul>
2543	FUNCTION PREVENTED - CHAIN SLACK DETECTED	Slack was detected in the mast chain.	<ul style="list-style-type: none"> <li>Refer to section 5 for the required operations to clear the fault.</li> <li>Check if the Chain Slack limit switches are damaged, obstructed or jammed.</li> <li>Check the chain slack switches wiring: @ + Vsupply: X296A(1), X296A(2), X295A(1), X295A(2).</li> </ul>	<ul style="list-style-type: none"> <li>Refer to section 5 for the required operations to clear the fault.</li> <li>Check if the Chain Slack Limit Switches are damaged, obstructed or jammed. Refer problem to a qualified JLG mechanic.</li> </ul>
2548	SYSTEM TEST MODE ACTIVE	The system is in test mode.	<ul style="list-style-type: none"> <li>Cycle power to clear test mode.</li> </ul>	<ul style="list-style-type: none"> <li>Cycle power to clear test mode. Refer problem to a qualified JLG mechanic.</li> </ul>
2564	DRIVE PREVENTED – LEFT BRAKE NOT RELEASING	Slave Power Module detects brake release drivers are damaged.	<ul style="list-style-type: none"> <li>Cycle power to clear the fault.</li> <li>If the fault is not cleared: Replace the Slave controller.</li> </ul>	<ul style="list-style-type: none"> <li>Cycle power to clear the fault. Refer problem to a qualified JLG mechanic.</li> </ul>



## SECTION 10 - DIAGNOSTIC TROUBLE CODES

DTC	Help Message	Condition Producing DTC	Control system Response or Machine Condition	Corrective Action/Operational Requirement for Function Movement and/or to Clear Fault
2565	DRIVE PREVENTED – RIGHT BRAKE NOT RELEASING	Master Power Module detects brake release drivers are damaged.	<ul style="list-style-type: none"> <li>• Cycle power to clear the fault.</li> <li>• If the fault is not cleared: Replace the Master controller.</li> </ul>	<ul style="list-style-type: none"> <li>• Cycle power to clear the fault. Refer problem to a qualified JLG mechanic.</li> </ul>

### 3-1 Line Contactor Open Circuit

DTC	Help Message	Condition Producing DTC	Control system Response or Machine Condition	Corrective Action/Operational Requirement for Function Movement and/or to Clear Fault
311	OPEN CIRCUIT LINE CONTACTOR	The line contactor is not closing the power circuit properly.	<ul style="list-style-type: none"> <li>• Check the line contactor contacts</li> <li>• Check the line contactor [KM] coil wiring : @ +Vbatt : C0170-J4(6), C0107-J3(1). @ -Vbatt : C0172A-B+, C0173-B+.</li> <li>• Check the line contactor coil.</li> <li>• Replace the line contactor.</li> </ul>	Refer problem to a qualified JLG mechanic.
312	CONTACTOR DRIVER PERMANENTLY OFF	The line contactor driver is out of order.	<ul style="list-style-type: none"> <li>• Replace the Master controller.</li> </ul>	Refer problem to a qualified JLG mechanic.
315	VOTING RELAY DRIVER PERMANENTLY OFF	The voting relay driver is out of order.	<ul style="list-style-type: none"> <li>• Replace the Slave controller.</li> </ul>	Refer problem to a qualified JLG mechanic.

### 3-2 Line Contactor Short Circuit

DTC	Help Message	Condition Producing DTC	Control system Response or Machine Condition	Corrective Action/Operational Requirement for Function Movement and/or to Clear Fault
321	LINE CONTACTOR WELDED OR MISWIRED	The line contactor is welded closed or miswired.	<ul style="list-style-type: none"> <li>• Check the contact of the line contactor.</li> <li>• Replace the line contactor if necessary.</li> </ul>	Refer problem to a qualified JLG mechanic.

**SECTION 10 - DIAGNOSTIC TROUBLE CODES**

DTC	Help Message	Condition Producing DTC	Control system Response or Machine Condition	Corrective Action/Operational Requirement for Function Movement and/or to Clear Fault
322	CONTACTOR DRIVER PERMANENTLY ON	The line contactor driver output is shorted or open circuit.	<ul style="list-style-type: none"> <li>• Check contactor wiring for a short circuit with -Vbatt or open circuit. @ +Vbatt: C0170-J4(1), C0170-J4(6), V across contactor coil. With machine off, check X263A(2), X267A(2), and C0172-J1(12) for continuity with -Vbatt.</li> <li>• If the wiring is correct, the driver circuit is damaged : replace the Master controller.</li> </ul>	Refer problem to a qualified JLG mechanic.
327	VOTING RELAY WELDED OR MISWIRED	Voting Relay miswired or shorted to +VSupply	<ul style="list-style-type: none"> <li>• Check wiring for damage or short circuit with +VSupply @ +VSupply: C0170-J1(24). @ -VSupply: C0170-J4(4), X263A(3), X267A(3), C0173-J1(12)</li> <li>• Replace LCB</li> <li>• If problem continues after LCB Replacement, disconnect connector C084-J1. If fault clears, replace the UGM. If fault remains, Replace the Slave Power Module.</li> </ul>	Refer problem to a qualified JLG mechanic.
328	VOTING RELAY DRIVER PERMANENTLY ON	The Voting Relay driver output is shorted or open circuit.	<ul style="list-style-type: none"> <li>• Check wiring for damage or short to -VSupply @ +VSupply: C0170-J1(24). @ -VSupply: C0170-J4(4), X263A(3), X267A(3), C0173-J1(12)</li> <li>• Replace Slave Power Module</li> </ul>	Refer problem to a qualified JLG mechanic.

## SECTION 10 - DIAGNOSTIC TROUBLE CODES

### 3-3 Ground Output Driver

DTC	Help Message	Condition Producing DTC	Control system Response or Machine Condition	Corrective Action/Operational Requirement for Function Movement and/or to Clear Fault
3311	GROUND ALARM – SHORT TO BATTERY	The Ground Module detects a short to +VSupply at the Ground Alarm Output.	<ul style="list-style-type: none"> <li>• Check the UGM driver output C084-J2(7) for a short circuit with +VSupply.</li> <li>• If the harness is correct: Replace the ground alarm</li> <li>• If the harness and the ground alarm are correct and if the fault appears at start up: Replace the UGM.</li> </ul>	Refer problem to a qualified JLG mechanic.
3382	PLATFORM LEVEL UP VALVE – SHORT TO GROUND	The Ground Module detects a short to -VSupply at the Platform Level Up Valve output.	<ul style="list-style-type: none"> <li>• Check the valve driver output C084-J2(5) and C084-J3(1) for a short circuit with -VSupply.</li> <li>• If the wiring is correct, the driver circuit is damaged : replace the UGM.</li> </ul>	Refer problem to a qualified JLG mechanic.
3383	PLATFORM LEVEL UP VALVE – OPEN CIRCUIT	The Ground Module detects an open circuit at the Platform Level Up Valve output.	<ul style="list-style-type: none"> <li>• Check the valve harness for signs of damage</li> <li>• Check the valve coil connections and wiring for interruptions.</li> <li>• Check the valve coil for correct impedance (refer to Section 7-5).</li> <li>• Replace the UGM if the coil and its harness are correct.</li> </ul>	Refer problem to a qualified JLG mechanic.
3388	PLATFORM LEVEL DOWN VALVE – SHORT TO GROUND	The Ground Module detects a short to -VSupply at the Platform Level Down Valve output.	<ul style="list-style-type: none"> <li>• Check the valve driver output C084-J2(7) and C084-J3(1) for a short circuit with -VSupply.</li> <li>• If the wiring is correct, the driver circuit is damaged : replace the UGM.</li> </ul>	Refer problem to a qualified JLG mechanic.
3389	PLATFORM LEVEL DOWN VALVE – OPEN CIRCUIT	The Ground Module detects an open circuit at the Platform Level Down Valve output.	<ul style="list-style-type: none"> <li>• Check the valve harness for signs of damage</li> <li>• Check the valve coil connections and wiring for interruptions.</li> <li>• Check the valve coil for correct impedance (refer to Section 7-5).</li> <li>• Replace the UGM if the coil and its harness are correct.</li> </ul>	Refer problem to a qualified JLG mechanic.
33118	SWING RIGHT VALVE – SHORT TO GROUND	The Ground Module detects a short to -VSupply at the Swing Right Valve output.	<ul style="list-style-type: none"> <li>• Check the valve driver output C084-J2(35) and C084-J3(4) for a short circuit with -VSupply.</li> <li>• If the wiring is correct, the driver circuit is damaged : replace the UGM."</li> </ul>	Refer problem to a qualified JLG mechanic.

## SECTION 10 - DIAGNOSTIC TROUBLE CODES

DTC	Help Message	Condition Producing DTC	Control system Response or Machine Condition	Corrective Action/Operational Requirement for Function Movement and/or to Clear Fault
33119	SWING RIGHT VALVE – OPEN CIRCUIT	The Ground Module detects an open circuit at the Swing Right Valve output.	<ul style="list-style-type: none"> <li>• Check the valve harness for signs of damage</li> <li>• Check the valve coil connections and wiring for interruptions.</li> <li>• Check the valve coil for correct impedance (refer to Section 7-4).</li> <li>• Replace the UGM if the coil and its harness are correct.</li> </ul>	Refer problem to a qualified JLG mechanic.
33122	SWING LEFT VALVE – SHORT TO GROUND	The Ground Module detects a short to -VSupply at the Swing Left Valve output.	<ul style="list-style-type: none"> <li>• Check the valve driver output C084-J2(34) and C084-J3(4) for a short circuit with -VSupply.</li> <li>• If the wiring is correct, the driver circuit is damaged : replace the UGM.</li> </ul>	Refer problem to a qualified JLG mechanic.
33186	TELESCOPE OUT VALVE – OPEN CIRCUIT	The Ground Module detects an open circuit at the Telescope Out Valve output.	<ul style="list-style-type: none"> <li>• Check the valve harness for signs of damage</li> <li>• Check the valve coil connections and wiring for interruptions.</li> <li>• Check the valve coil for correct impedance (refer to Section 7-5).</li> <li>• Replace the UGM if the coil and its harness are correct.</li> </ul>	Refer problem to a qualified JLG mechanic.
33188	TELESCOPE OUT VALVE – SHORT TO GROUND	The Ground Module detects a short to -VSupply at the Telescope Out Valve output.	<ul style="list-style-type: none"> <li>• Check the valve driver output C084-J2(16) and C084-J3(4) for a short circuit with -VSupply.</li> <li>• If the wiring is correct, the driver circuit is damaged : replace the UGM.</li> </ul>	Refer problem to a qualified JLG mechanic.
33189	TELESCOPE IN VALVE – OPEN CIRCUIT	The Ground Module detects an open circuit at the Telescope In Valve output.	<ul style="list-style-type: none"> <li>• Check the valve harness for signs of damage</li> <li>• Check the valve coil connections and wiring for interruptions.</li> <li>• Check the valve coil for correct impedance (refer to Section 7-5).</li> <li>• Replace the UGM if the coil and its harness are correct.</li> </ul>	Refer problem to a qualified JLG mechanic.
33190	TELESCOPE IN VALVE – SHORT TO GROUND	The Ground Module detects a short to -VSupply at the Telescope In Valve output.	<ul style="list-style-type: none"> <li>• Check the valve driver output C084-J2(4) and C084-J3(4) for a short circuit with -VSupply.</li> <li>• If the wiring is correct, the driver circuit is damaged : replace the UGM.</li> </ul>	Refer problem to a qualified JLG mechanic.

## SECTION 10 - DIAGNOSTIC TROUBLE CODES

DTC	Help Message	Condition Producing DTC	Control system Response or Machine Condition	Corrective Action/Operational Requirement for Function Movement and/or to Clear Fault
33295	SWING LEFT VALVE – OPEN CIRCUIT	The Ground Module detects an open circuit at the Swing Left Valve output.	<ul style="list-style-type: none"> <li>• Check the valve harness for signs of damage</li> <li>• Check the valve coil connections and wiring for interruptions.</li> <li>• Check the valve coil for correct impedance (refer to Section 7-4).</li> <li>• Replace the UGM if the coil and its harness are correct.</li> </ul>	Refer problem to a qualified JLG mechanic.
33297	LEFT BRAKE – SHORT TO GROUND	The left brake positive output supply is detected shorted to -Vbatt.	<ul style="list-style-type: none"> <li>• Check the left brake positive driver output C0173-J1(4) and C0173-J1(2) for a short circuit with -Vbatt.</li> <li>• Check the brake coil for correct impedance (refer to Section 4-1).</li> <li>• If the wiring and the coil are correct, the driver circuit is damaged: replace the Slave controller.</li> </ul>	Refer problem to a qualified JLG mechanic.
33304	RIGHT BRAKE – SHORT TO GROUND	The right brake positive output supply is detected shorted to -Vbatt.	<ul style="list-style-type: none"> <li>• Check the right brake positive driver output C0172-J1(4) and C0172-J1(2) for a short circuit with -Vbatt.</li> <li>• Check the brake coil for correct impedance (refer to Section 4-1).</li> <li>• If the wiring and the coil are correct, the driver circuit is damaged : replace the Master controller.</li> </ul>	Refer problem to a qualified JLG mechanic.
33314	FLOW CONTROL VALVE – OPEN CIRCUIT	The Ground Module detects an open circuit at the Flow Control Valve output.	<ul style="list-style-type: none"> <li>• Check the valve harness for signs of damage</li> <li>• Check the valve coil connections and wiring for interruptions.</li> <li>• Check the valve coil for correct impedance (refer to Section 7-4).</li> <li>• Replace the UGM if the coil and its harness are correct.</li> </ul>	Refer problem to a qualified JLG mechanic.
33315	FLOW CONTROL VALVE – SHORT TO BATTERY	The Ground Module detects a short to +VSupply at the Flow Control Valve output.	<ul style="list-style-type: none"> <li>• Check the UGM driver output C084-J2(31) for a short circuit with +VSupply.</li> <li>• Check the valve coil for correct impedance (refer to Section 7-4).</li> <li>• If the harness and the coil are correct and if the fault appears at start up: Replace the UGM.</li> </ul>	Refer problem to a qualified JLG mechanic.

## SECTION 10 - DIAGNOSTIC TROUBLE CODES

DTC	Help Message	Condition Producing DTC	Control system Response or Machine Condition	Corrective Action/Operational Requirement for Function Movement and/or to Clear Fault
33316	FLOW CONTROL VALVE – SHORT TO GROUND	The Ground Module detects a short -VSupply at the Flow Control Valve output.	<ul style="list-style-type: none"> <li>Check the valve driver output C084-J2(31) and C084-J3(6) for a short circuit with -VSupply.</li> <li>If the wiring is correct, the driver circuit is damaged : replace the UGM.</li> </ul>	Refer problem to a qualified JLG mechanic.
33363	MAST VALVE – SHORT TO BATTERY	The Ground Module detects a short to +VSupply at the Mast Valve output.	<ul style="list-style-type: none"> <li>Check the UGM driver output C084-J2(11) for a short circuit with +VSupply.</li> <li>Check the valve coil for correct impedance (refer to Section 7-6).</li> <li>If the harness and the coil are correct and if the fault appears at start up: Replace the UGM."</li> </ul>	Refer problem to a qualified JLG mechanic.
33365	MAST VALVE - OPEN CIRCUIT	The Mast valve coil is faulty or disconnected or the coil driver is faulty."	<ul style="list-style-type: none"> <li>Check the valve harness for signs of damage</li> <li>Check the valve coil connections and wiring for interruptions.</li> <li>Check the valve coil for correct impedance (refer to Section 7-6).</li> <li>Replace the UGM if the coil and its harness are correct.</li> </ul>	Refer problem to a qualified JLG mechanic.
33469	MAST VALVE – SHORT TO GROUND	The Ground Module detects a short to -VSupply at the Mast Valve output.	<ul style="list-style-type: none"> <li>Check the valve driver output C084-J2(11) and C084-J3(5) for a short circuit with -VSupply.</li> <li>If the wiring is correct, the driver circuit is damaged : replace the UGM.</li> </ul>	Refer problem to a qualified JLG mechanic.
33366	PROPORTIONAL RELIEF VALVE - SHORT TO BATTERY	The Proportional Relief valve driver output is detected short to +VSupply.	<ul style="list-style-type: none"> <li>Check the UGM driver output C084-J2(9) and C084-J3(2) for a short circuit with +VSupply.</li> <li>Check the valve coil for correct impedance (refer to Section 7-2).</li> <li>If the harness and the coil are correct and if the fault appears at start up: Replace the UGM.</li> </ul>	Refer problem to a qualified JLG mechanic.
33367	PROPORTIONAL RELIEF VALVE - SHORT TO GROUND	The Proportional Relief valve driver output is shorted to -VSupply.	<ul style="list-style-type: none"> <li>Check the valve driver output C084-J2(9) and C084-J3(2) for a short circuit with -VSupply.</li> <li>If the wiring is correct, the driver circuit is damaged: replace the UGM.</li> </ul>	Refer problem to a qualified JLG mechanic.

## SECTION 10 - DIAGNOSTIC TROUBLE CODES

DTC	Help Message	Condition Producing DTC	Control system Response or Machine Condition	Corrective Action/Operational Requirement for Function Movement and/or to Clear Fault
33368	PROPORTIONAL RELIEFVALVE - OPEN CIRCUIT	The Proportional Relief valve coil is faulty or disconnected.	<ul style="list-style-type: none"> <li>• Check the valve harness for signs of damage</li> <li>• Check the valve coil connections and wiring for interruptions.</li> <li>• Check the valve coil for correct impedance (refer to Section 7-2).</li> <li>• Replace the UGM if the coil and its harness are correct.</li> </ul>	Refer problem to a qualified JLG mechanic.
33412	SWING VALVES - SHORT TO BATTERY	The Ground Module detects a short to +VSupply at either the Swing Right or Swing Left valve	<ul style="list-style-type: none"> <li>• Check the UGM driver output C084-J2(34), C084-J2(35), and C084-J3(4) for a short circuit with +VSupply.</li> <li>• Check the valve coil for correct impedance (refer to Section 7-4).</li> <li>• If the harness and the coil are correct and if the fault appears at start up: Replace the UGM.</li> </ul>	Refer problem to a qualified JLG mechanic.
33415	FLOW CONTROL VALVE – CURRENT FEEDBACK READING TOO LOW	The Ground Module calls for current greater than 250mA, but the actual current is at least 125mA less than the called for current for more than 1 second	<ul style="list-style-type: none"> <li>• Check the valve harness for signs of damage</li> <li>• Check the valve coil connections and wiring for interruptions.</li> <li>• Check the valve coil for correct impedance (refer to Section 7-4).</li> <li>• Check if correct coil is plugged into the harness</li> <li>• Replace the UGM if the coil and its harness are correct.</li> </ul>	Refer problem to a qualified JLG mechanic.
33419	FLOW CONTROL VALVE – CURRENT FEEDBACK READING LOST	Measured feedback current is less than 225mA while Ground Module output is greater than 40% (Displayed on Analyzer DIAGNOSTICS menu).	<ul style="list-style-type: none"> <li>• Check the valve harness for signs of damage Check the valve coil connections and wiring for interruptions.</li> <li>• Check the valve coil for correct impedance (refer to Section 7-4).</li> <li>• Replace the UGM if the coil and its harness are correct.</li> </ul>	Refer problem to a qualified JLG mechanic.
33468	TELESCOPE/ PLATFORM LEVEL VALVES - SHORT TO BATTERY	A Telescope/Platform Level Valve driver is shorted	<ul style="list-style-type: none"> <li>• Check the valve driver outputs C084-J2(4), C084-J2(16), C084-J2(5), C084-J2(7), and C084-J3(1), for a short circuit with +VSupply.</li> <li>• If the wiring is correct, the driver circuit is damaged: replace the UGM.</li> </ul>	Refer problem to a qualified JLG mechanic.

## SECTION 10 - DIAGNOSTIC TROUBLE CODES

DTC	Help Message	Condition Producing DTC	Control system Response or Machine Condition	Corrective Action/Operational Requirement for Function Movement and/or to Clear Fault
33470	MAST VALVE – CURRENT FEEDBACK READING LOST	The mast valve current measures less than 225 mA while commanding the valve at greater than 40%	<ul style="list-style-type: none"> <li>• Check the valve harness for signs of damage</li> <li>• Check the valve coil connections and wiring for interruptions.</li> <li>• Check the valve coil for correct impedance (refer to Section 7-6).</li> <li>• Replace the UGM if the coil and its harness are correct.</li> </ul>	Refer problem to a qualified JLG mechanic.
33471	SWING VALVES – CURRENT FEEDBACK READING LOST	Current from swing valves measures less than 225 mA while commanding the swing valves at greater than 40%	<ul style="list-style-type: none"> <li>• Check the valve harness for signs of damage</li> <li>• Check the valve coil connections and wiring for interruptions.</li> <li>• Check the valve coil for correct impedance (refer to Section 7-4).</li> <li>• Replace the UGM if the coil and its harness are correct.</li> </ul>	Refer problem to a qualified JLG mechanic.
33472	TELESCOPE / PLATFORM LEVEL VALVES – CURRENT FEEDBACK READING LOST	Current from the telescope/platform level valves measures less than 225 mA while commanding the valve at greater than 40%	<ul style="list-style-type: none"> <li>• Check the valve harness for signs of damage</li> <li>• Check the valve coil connections and wiring for interruptions.</li> <li>• Check the valve coil for correct impedance (refer to Section 7-5).</li> <li>• Replace the UGM if the coil and its harness are correct.</li> </ul>	Refer problem to a qualified JLG mechanic.
33473	JIB VALVE – OPEN CIRCUIT	The Jib valve coil is faulty or disconnected or the coil driver is faulty.	<ul style="list-style-type: none"> <li>• Check the valve harness for signs of damage</li> <li>• Check the valve coil connections and wiring for interruptions.</li> <li>• Check the valve coil for correct impedance (refer to Section 7-6).</li> <li>• Replace the UGM if the coil and its harness are correct.</li> </ul>	Refer problem to a qualified JLG mechanic.
33474	JIB VALVE – SHORT TO GROUND	The Jib valve driver output is detected short to power supply ground.	<ul style="list-style-type: none"> <li>• Check the valve driver output C084-J2(12) and C084-J3(14) for a short circuit with -VSupply.</li> <li>• If the wiring is correct, the driver circuit is damaged: replace the UGM.</li> </ul>	Refer problem to a qualified JLG mechanic.



## SECTION 10 - DIAGNOSTIC TROUBLE CODES

DTC	Help Message	Condition Producing DTC	Control system Response or Machine Condition	Corrective Action/Operational Requirement for Function Movement and/or to Clear Fault
33475	JIB VALVE – SHORT TO BATTERY	The Jib valve driver output is detected short to power supply 12 Volts.	<ul style="list-style-type: none"> <li>• Check the UGM driver output C084-J2(12) for a short circuit with +VSupply.</li> <li>• Check the valve coil for correct impedance (refer to Section 7-6).</li> <li>• If the harness and the coil are correct and if the fault appears at start up: Replace the UGM.</li> </ul>	Refer problem to a qualified JLG mechanic.
33476	JIB VALVE – CURRENT FEEDBACK READING LOST	The Jib valve current measures less than 225 mA while commanding the valve at greater than 40%	<ul style="list-style-type: none"> <li>• Check the valve harness for signs of damage</li> <li>• Check the valve coil connections and wiring for interruptions.</li> <li>• Check the valve coil for correct impedance (refer to Section 7-6).</li> <li>• Replace the UGM if the coil and its harness are correct.</li> </ul>	Refer problem to a qualified JLG mechanic.
33477	PROPORTIONAL RELIEF VALVE – CURRENT FEEDBACK READING LOST	The proportional relief valve current measures less than 225 mA while commanding the valve at greater than 40%	<ul style="list-style-type: none"> <li>• Check the valve harness for signs of damage</li> <li>• Check the valve coil connections and wiring for interruptions.</li> <li>• Check the valve coil for correct impedance (refer to Section 7-2).</li> <li>• Replace the UGM if the coil and its harness are correct.</li> </ul>	Refer problem to a qualified JLG mechanic.
33478	PROPORTIONAL RELIEF VALVE – CURRENT FEEDBACK READING TOO LOW	The Ground Module calls for current greater than 250mA, but the actual current is at least 125mA less than the called for current for more than 1 second	<ul style="list-style-type: none"> <li>• Check the valve harness for signs of damage</li> <li>• Check the valve coil connections and wiring for interruptions.</li> <li>• Check the valve coil for correct impedance (refer to Section 7-2).</li> <li>• Check if correct coil is plugged into the harness</li> <li>• Replace the UGM if the coil and its harness are correct.</li> </ul>	Refer problem to a qualified JLG mechanic.
33479	VOTING RELAY – SHORT TO BATTERY	The UGM detects +VSupply on the driver for the voting relay at startup	<ul style="list-style-type: none"> <li>• Check the harness for signs of damage @ 6.5 to 7.5 V while fault active: C018-J1 (7)</li> <li>• Replace LCB</li> <li>• Replace UGM</li> </ul>	Refer problem to a qualified JLG mechanic.
33480	VOTING RELAY – SHORT TO GROUND	The UGM detects -VSupply on the driver for the voting relay	<ul style="list-style-type: none"> <li>• Check the harness for signs of damage @ 6.5 to 7.5 V while fault active: C018-J1 (7)</li> <li>• Replace LCB</li> <li>• Replace UGM</li> </ul>	Refer problem to a qualified JLG mechanic.

## SECTION 10 - DIAGNOSTIC TROUBLE CODES

DTC	Help Message	Condition Producing DTC	Control system Response or Machine Condition	Corrective Action/Operational Requirement for Function Movement and/or to Clear Fault
33481	LEFT BRAKE - SHORT TO GROUND OR OPEN CIRCUIT	The Slave Power Module detects a short to -Vbatt or open circuit at the left brake output.	<ul style="list-style-type: none"> <li>• Check the harness for signs of damage between the Power Module and the Brake.</li> <li>• Replace the Slave Power Module</li> </ul>	Refer problem to a qualified JLG mechanic.
33482	RIGHT BRAKE - SHORT TO GROUND OR OPEN CIRCUIT	The Master Power Module detects a short to -Vbatt or open circuit at the right brake output.	<ul style="list-style-type: none"> <li>• Check the harness for signs of damage between the Power Module and the Brake.</li> <li>• Replace the Master Power Module</li> </ul>	Refer problem to a qualified JLG mechanic.
33485	THE MASTER POWER MODULE DETECTS A SHORT BETWEEN THE CONTACTOR DRIVER AND THE RIGHT BRAKE OUTPUT.	The Master Power Module detects a short between the contactor driver and the right brake output.	<ul style="list-style-type: none"> <li>• Check the harness for signs of damage</li> <li>• Replace the Master Power Module</li> </ul>	Refer problem to a qualified JLG mechanic.
33486	VOTING RELAY / BRAKE RETURN – SHORT TO BATTERY	The Slave Power Module detects a short between the voting relay driver driver and the left brake output.	<ul style="list-style-type: none"> <li>• Check the harness for signs of damage</li> <li>• Replace the Slave Power Module</li> </ul>	Refer problem to a qualified JLG mechanic.

### 4-2 Thermal Limit

DTC	Help Message	Condition Producing DTC	Control system Response or Machine Condition	Corrective Action/Operational Requirement for Function Movement and/or to Clear Fault
426	MASTER MODULE TEMPERATURE - OUT OF RANGE	The Master Module (right controller) temperature sensor is out of the permitted range.	<ul style="list-style-type: none"> <li>• Change the Master controller.</li> </ul>	Refer problem to a qualified JLG mechanic.
427	SLAVE MODULE TEMPERATURE - OUT OF RANGE	The Slave Module (left controller) temperature sensor is out of the permitted range."	<ul style="list-style-type: none"> <li>• Change the Slave controller.</li> </ul>	Refer problem to a qualified JLG mechanic.

## SECTION 10 - DIAGNOSTIC TROUBLE CODES

DTC	Help Message	Condition Producing DTC	Control system Response or Machine Condition	Corrective Action/Operational Requirement for Function Movement and/or to Clear Fault
428	MASTER MODULE TOO HOT - PLEASE WAIT	The Master Module (right controller) has reached thermal cutout.	<ul style="list-style-type: none"> <li>• Power down and allow to cool.</li> <li>• Do not operate in ambients over 60°C.</li> <li>• Check for jammed or obstructed right drive motor.</li> <li>• Check for excessively high drive motor current consumption while driving on the level ( over 120A).</li> <li>• Check for jammed or obstructed telescopic mast.</li> <li>• Check for excessively high pump motor current consumption while raising the jib with the platform empty (battery output current over 90A).</li> <li>• Check the Master module for proper installation (refer to § 8-4).</li> <li>• If the module is cold when the fault appears: replace the module.</li> </ul>	Refer problem to a qualified JLG mechanic.
429	SLAVE MODULE TOO HOT - PLEASE WAIT	The Slave Module (left controller) has reached thermal cutout.	<ul style="list-style-type: none"> <li>• Power down and allow to cool.</li> <li>• Do not operate in ambients over 60°C.</li> <li>• Check for jammed or obstructed left drive motor.</li> <li>• Check for excessively high drive motor current consumption while driving on the level (over 120A).</li> <li>• Check the Slave module for proper installation (refer to § 8-4).</li> <li>• If the module is cold when the fault appears: replace the module.</li> </ul>	Refer problem to a qualified JLG mechanic.

## SECTION 10 - DIAGNOSTIC TROUBLE CODES

DTC	Help Message	Condition Producing DTC	Control system Response or Machine Condition	Corrective Action/Operational Requirement for Function Movement and/or to Clear Fault
4210	RIGHT DRIVE MOTOR TOO HOT - PLEASE WAIT	The right drive motor temperature is too high.	<ul style="list-style-type: none"> <li>• Power down and allow to cool.</li> <li>• Do not operate in ambients over 60°C.</li> <li>• Check for jammed or obstructed right drive motor.</li> <li>• Check battery charge and recharge if necessary.</li> <li>• Check for damaged battery, power cables and connections.</li> <li>• Using the analyzer, check that the motor temperature sensor information is correct.</li> <li>• Check the sensor wiring and connections.</li> <li>• Check the sensor for correct impedance (refer to Section 8).</li> <li>• If the motor is cold and the fault is still present: replace the Master controller.</li> </ul>	Refer problem to a qualified JLG mechanic.
4211	LEFT DRIVE MOTOR TOO HOT - PLEASE WAIT	The left drive motor temperature is too high.	<ul style="list-style-type: none"> <li>• Power down and allow to cool.</li> <li>• Do not operate in ambients over 60°C.</li> <li>• Check for jammed or obstructed right drive motor.</li> <li>• Check battery charge and recharge if necessary.</li> <li>• Check for damaged battery, power cables and connections.</li> <li>• Using the analyzer, check that the motor temperature sensor information is correct.</li> <li>• Check the sensor wiring and connections.</li> <li>• Check the sensor for correct impedance (refer to Section 8).</li> <li>• If the motor is cold and the fault is still present: replace the Slave controller.</li> </ul>	Refer problem to a qualified JLG mechanic.

## SECTION 10 - DIAGNOSTIC TROUBLE CODES

DTC	Help Message	Condition Producing DTC	Control system Response or Machine Condition	Corrective Action/Operational Requirement for Function Movement and/or to Clear Fault
4212	RIGHT DRIVE MOTOR TEMPERATURE - OUT OF RANGE	The right drive motor sensor is damaged or disconnected.	<ul style="list-style-type: none"> <li>• Check the sensor wiring and connections.</li> <li>• Check the sensor for correct impedance (refer to Section 8).</li> <li>• Replace the motor temperature sensor if necessary.</li> <li>• If the sensor and its wiring are correct: replace the Master controller.</li> </ul>	Refer problem to a qualified JLG mechanic.
4213	LEFT DRIVE MOTOR TEMPERATURE - OUT OF RANGE	The left drive motor sensor is damaged or disconnected.	<ul style="list-style-type: none"> <li>• Check the sensor wiring and connections.</li> <li>• Check the sensor for correct impedance (refer to Section 8).</li> <li>• Replace the motor temperature sensor if necessary.</li> <li>• If the sensor and its wiring are correct: replace the Slave controller.</li> </ul>	Refer problem to a qualified JLG mechanic.

### 4-4 Battery Supply

DTC	Help Message	Condition Producing DTC	Control system Response or Machine Condition	Corrective Action/Operational Requirement for Function Movement and/or to Clear Fault
442	BATTERY VOLTAGE TOO HIGH - SYSTEM SHUT-DOWN	A problem has been detected with the batteries or power module.	<ul style="list-style-type: none"> <li>• May be due to improper battery charging or incorrect voltage batteries being used.</li> </ul>	May be due to improper battery charging or incorrect voltage batteries being used. Refer problem to a qualified JLG mechanic.
4417	BATTERY POWER LOW	The batteries are discharged.	<ul style="list-style-type: none"> <li>• Recharge batteries.</li> <li>• Check for damaged battery, battery cables or connections.</li> <li>• Check battery charger function. Be sure to observe indicators for at least 30 seconds.</li> </ul>	<ul style="list-style-type: none"> <li>• Recharge batteries.</li> <li>• Check for damaged batteries, battery cables or connections.</li> <li>• Check battery charger function. Be sure to observe indicators for at least 30 seconds.</li> </ul> Refer problem to a qualified JLG mechanic.

**SECTION 10 - DIAGNOSTIC TROUBLE CODES**

DTC	Help Message	Condition Producing DTC	Control system Response or Machine Condition	Corrective Action/Operational Requirement for Function Movement and/or to Clear Fault
4418	MASTER MODULE VOLTAGE OUT OF RANGE	The controller detects an overvoltage condition. Overvoltage threshold is 65v	<ul style="list-style-type: none"> <li>• If the fault appears at start up or during standby : check that no external device is connected to the batteries, creating down-going pulses. Refer to a qualified JLG mechanic to know the approved options on the machine.</li> <li>• If no voltage transient is detected on the supply line and the fault appears every time the key is switched ON : Replace the Master controller.</li> <li>• Check if the fault appears during traction acceleration or driving hydraulic functions (undervoltage condition detected) : check battery charge; check for damaged batteries, battery cables and connections</li> <li>• Check if the fault appears during traction braking (overvoltage condition detected): check line contactor contact, battery power cable connection.</li> </ul>	<ul style="list-style-type: none"> <li>• Recharge batteries.</li> <li>• Check for damaged batteries, battery cables or connections.</li> <li>• Check battery charger function. Be sure to observe indicators for at least 30 seconds.</li> </ul> <p>Refer problem to a qualified JLG mechanic.</p>

Go to Discount-Equipment.com to buy your parts

## SECTION 10 - DIAGNOSTIC TROUBLE CODES

DTC	Help Message	Condition Producing DTC	Control system Response or Machine Condition	Corrective Action/Operational Requirement for Function Movement and/or to Clear Fault
4419	SLAVE MODULE VOLTAGEOUTOF RANGE	The controller detects an overvoltage condition. Overvoltage threshold is 65V,	<ul style="list-style-type: none"> <li>• If the fault appears at start up or during standby : check that no external device is connected to the batteries, creating down-going pulses. Refer to a qualified JLG mechanic to know the approved options on the machine.</li> <li>• If no voltage transient is detected on the supply line and the fault appears every time the key is switched ON : Replace the Slave controller.</li> <li>• Check if the fault appears during traction acceleration or driving hydraulic functions (undervoltage condition detected): check battery charge; check for damaged batteries, battery cables and connections</li> <li>• Check if the fault appears during traction braking (overvoltage condition detected) : check line contactor contact, battery power cable connection.</li> </ul>	<ul style="list-style-type: none"> <li>• Recharge batteries.</li> <li>• Check for damaged batteries, battery cables or connections.</li> <li>• Check battery charger function. Be sure to observe indicators for at least 30 seconds.</li> </ul> <p>Refer problem to a qualified JLG mechanic.</p>
4420	BATTERY DEEPLY DISCHARGED	The batteries are deeply discharged.	<ul style="list-style-type: none"> <li>• Recharge batteries.</li> <li>• Check for damaged batteries, battery cables or connections.</li> <li>• Check battery charger function. Be sure to observe indicators for at least 30 seconds.</li> </ul>	<ul style="list-style-type: none"> <li>• Recharge batteries.</li> <li>• Check for damaged batteries, battery cables or connections.</li> <li>• Check battery charger function. Be sure to observe indicators for at least 30 seconds.</li> </ul> <p>Refer problem to a qualified JLG mechanic.</p>
4428	PLATFORM ROTATE MODULE – VOLTAGE OUT OF RANGE	A problem has been detected with the 48 volt supply or the platform rotate module.	<ul style="list-style-type: none"> <li>• Recharge batteries.</li> <li>• Check for damaged batteries, cables or, connections.</li> <li>• Replace the Platform Rotate Module</li> </ul>	Refer problem to a qualified JLG mechanic.
4429	WRONG BATTERY	Battery voltage is incorrect for selected battery	<ul style="list-style-type: none"> <li>• Verify batteries selected in Machine Setup.</li> <li>• Recharge batteries.</li> <li>• Check for damaged batteries, cables or connections.</li> </ul>	Refer problem to a qualified JLG mechanic.

** 4-6 Transmission and Drive System**

DTC	Help Message	Condition Producing DTC	Control system Response or Machine Condition	Corrective Action/Operational Requirement for Function Movement and/or to Clear Fault
4610	RIGHT SPEED SENSOR - NOT RESPONDING PROPERLY	A problem has been detected with the right drive motor speed sensor (encoder).	<ul style="list-style-type: none"> <li>• Check the right motor encoder wiring and connections.</li> <li>• Check the harness for proper installation (refer to Section 11).</li> </ul>	Refer problem to a qualified JLG mechanic.
4611	LEFT SPEED SENSOR - NOT RESPONDING PROPERLY	A problem has been detected with the left drive motor speed sensor (encoder).	<ul style="list-style-type: none"> <li>• Check the left motor encoder wiring and connections.</li> <li>• Check the harness for proper installation (refer to Section 11).</li> </ul>	Refer problem to a qualified JLG mechanic.
4612	RIGHT SPEED SENSOR - RPM HIGH	Machine overspeed has been detected on the right motor.	<ul style="list-style-type: none"> <li>• The machine should be driven at limited speed in ramps.</li> <li>• Check the Personality : Drive, Max and adjust if necessary.</li> </ul>	<ul style="list-style-type: none"> <li>• The machine should be driven at limited speed in ramps.</li> </ul> Refer problem to a qualified JLG mechanic.
4613	LEFT SPEED SENSOR - RPM HIGH	Machine overspeed has been detected on the left motor.	<ul style="list-style-type: none"> <li>• The machine should be driven at limited speed in ramps.</li> <li>• Check the Personality : Drive, Max and adjust if necessary.</li> </ul>	<ul style="list-style-type: none"> <li>• The machine should be driven at limited speed in ramps.</li> </ul> Refer problem to a qualified JLG mechanic.



## SECTION 10 - DIAGNOSTIC TROUBLE CODES

### 6-6 Communication

DTC	Help Message	Condition Producing DTC	Control system Response or Machine Condition	Corrective Action/Operational Requirement for Function Movement and/or to Clear Fault
662	CANBUS FAILURE – PLATFORM MODULE	The UGM determines that CAN communication from the Platform Module is lost.	<ul style="list-style-type: none"> <li>• Check if platform is powered on</li> <li>• Ensure that all the connectors pins are properly in place and the connectors are free of moisture or oxidation.</li> <li>• Check if connector X638A is properly connected to the platform box</li> <li>• Check harnesses for signs of damage</li> <li>• Check if voltage on CAN High or CAN Low exceeds 5 V</li> <li>• Check impedance between CAN High and CAN Low on CAN channel 1 (<math>60\Omega + 5\%</math>)</li> <li>• Replace the platform controller</li> <li>• Replace UGM</li> </ul>	Refer problem to a qualified JLG mechanic.
6613	CANBUS FAILURE – EXCESSIVE CANBUS ERRORS	The UGM determines that excessive CANbus errors have occurred over one or both of the CAN channels	<ul style="list-style-type: none"> <li>• Ensure that all the connectors pins are properly in place and the connectors are free of moisture or oxidation.</li> <li>• Check harnesses for signs of damage</li> <li>• Check if voltage on CAN High or CAN Low exceeds 5 V on both CAN channels. If measured voltage exceeds 36 V, replace the UGM. If measured voltage exceeds 36 V on CAN can channel 1, replace th platform controller and ground display.</li> <li>• Check resistance between CAN High and CAN Low on CAN channel 1 (<math>60\Omega + 5\%</math>)</li> </ul>	Refer problem to a qualified JLG mechanic.

**SECTION 10 - DIAGNOSTIC TROUBLE CODES**

DTC	Help Message	Condition Producing DTC	Control system Response or Machine Condition	Corrective Action/Operational Requirement for Function Movement and/or to Clear Fault
6632	CANBUS FAILURE - MASTER MODULE	The control system failed to receive messages from the Master Module (right controller).	<ul style="list-style-type: none"> <li>• Check the Can Bus connections on the Master power module : C0172-J1 (27) &amp; C0172-J1 (28).</li> <li>• Disconnect C0173-J1 (Slave controller connector) and</li> <li>• measure resistance between C0173-J1 (27) and C0173-J1 (28) on the harness side of the connector. If it is not <math>60\Omega \pm 5\%</math>, check continuity of the bus wires : -C0172-J1 (27) to C0173-J1 (27) &amp; C0172-J1 (28) to C0173-J1 (28); -C0172-J1 (27) to C084-J12(4) &amp; C0172-J1 (28) to C084-J12(3); If continuity is correct, replace the terminating resistor at connection at X59A and recheck resistance.</li> <li>• Ensure that all the connectors pins are properly in place and the connectors are free of moisture or oxidation.</li> <li>• With the terminating resistor removed from X59A, measure the resistance between C084-J12(3) and C084-J12(4) of the UGM: if it is not <math>120\Omega \pm 5\%</math>, replace the the wire connecting C084-J12(6) and C084-J12(7). If resistance is still not correct, replace the UGM</li> </ul>	Refer problem to a qualified JLG mechanic.

## SECTION 10 - DIAGNOSTIC TROUBLE CODES

DTC	Help Message	Condition Producing DTC	Control system Response or Machine Condition	Corrective Action/Operational Requirement for Function Movement and/or to Clear Fault
6634	THE PLATFORM MODULE FAILED TO RECEIVE MESSAGES FROM BOTH THE MASTER AND THE SLAVE MODULES.	The platform module failed to receive messages from both the master and the slave modules.	<ul style="list-style-type: none"> <li>• Check the Can Bus connections on the Slave power module : C0173-J1 (27) &amp; C0173-J1 (28).</li> <li>• Disconnect C0172-J1 (Master controller connector) and measure resistance between C0172-J1 (27) and C0172-J1 (28) on the harness side of the connector. If it is not <math>60\Omega \pm 5\%</math>, check continuity of the bus wires : -C0172-J1 (27) to C0173-J1 (27) &amp; C0172-J1 (28) to C0173-J1 (28); -C0172-J1 (27) to C084-J12(4) &amp; C0172-J1 (28) to C084-J12(3);</li> <li>• If continuity is correct, replace the terminating resistor at connection at X59A and recheck resistance.</li> <li>• Ensure that all the connectors pins are properly in place and the connectors are free of moisture or oxidation.</li> <li>• With the terminating resistor removed from X59A, measure the resistance between C084-J12(3) and C084-J12(4) of the UGM: if it is not <math>120\Omega \pm 5\%</math>, replace the the wire connecting C084-J12(6) and C084-J12(7). If resistance is still not correct, replace the UGM</li> </ul>	Refer problem to a qualified JLG mechanic.
6643	CANBUS FAILURE – PLATFORM ROTATE MODULE	The UGM determines that CAN communication from the Platform Rotate Module is lost or corrupted	<ul style="list-style-type: none"> <li>• Ensure that all the connectors pins are properly in place and the connectors are free of moisture or oxidation.</li> <li>• Check harnesses for signs of damage</li> <li>• Check if voltage on CAN High or CAN Low exceeds 5 V</li> <li>• Check impedance between CAN High X210(1) and CAN Low X210(2) on CAN channel 1 (<math>60\Omega + 5\%</math>)</li> <li>• Replace the platform rotate controller</li> </ul>	Refer problem to a qualified JLG mechanic.

 **6-7 Accessory**

DTC	Help Message	Condition Producing DTC	Control system Response or Machine Condition	Corrective Action/Operational Requirement for Function Movement and/or to Clear Fault
672	FUNCTIONS CUTOUT - SOFT TOUCH DETECTED	An obstacle has been detected by the soft touch device (if equipped).	<ul style="list-style-type: none"> <li>Clear the obstacle.</li> <li>Ensure ANALYZER-&gt;MACHINESETUP-&gt;SOFT TOUCH is set to 0 if not installed.</li> </ul>	<ul style="list-style-type: none"> <li>Clear the obstacle.</li> </ul> Refer problem to a qualified JLG mechanic.
673	FUNCTIONS CUTOUT - GATE OPEN DETECTED	This DTC does not apply to the Toucan 12E.	<ul style="list-style-type: none"> <li>Ensure ANALYZER-&gt;MACHINESETUP-&gt;GATE is set to 0 (Not Installed).</li> </ul>	Refer problem to a qualified JLG mechanic.

 **7-7 Electric Motor**

DTC	Help Message	Condition Producing DTC	Control system Response or Machine Condition	Corrective Action/Operational Requirement for Function Movement and/or to Clear Fault
7712	LEFT DRIVE MOTOR – OPEN CIRCUIT	The Slave Power Module has detected an open circuit on one or more motor phase connections.	<ul style="list-style-type: none"> <li>Check the harness for signs of damage</li> <li>Replace the Slave Power Module</li> </ul>	Refer problem to a qualified JLG mechanic.
7715	RIGHT DRIVE MOTOR OPEN CIRCUIT	The Master Power Module has detected an open circuit on one or more motor phase connections.	<ul style="list-style-type: none"> <li>Check the harness for signs of damage</li> <li>Replace the Master Power Module</li> </ul>	Refer problem to a qualified JLG mechanic.
7718	LEFT DRIVE MOTOR ROTATION OPPOSITE CONTROL	The Slave Power Module detects that the left motor is rotating in the direction opposite of the commanded direction.	<ul style="list-style-type: none"> <li>Check the harness for proper installation</li> <li>Check the motor phase for proper installation</li> <li>Check that the motor is connected to the correct controller</li> </ul>	Refer problem to a qualified JLG mechanic.
7720	RIGHT DRIVE MOTOR ROTATION OPPOSITE CONTROL	The Master Power Module detects that the right motor is rotating in the direction opposite of the commanded direction.	<ul style="list-style-type: none"> <li>Check the harness for proper installation</li> <li>Check the motor phase for proper installation</li> <li>Check that the motor is connected to the correct controller</li> </ul>	Refer problem to a qualified JLG mechanic.
7721	MASTER MODULE CAPACITOR BANK FAULT	The power capacitor bank of the power module is not charging properly at startup.	<ul style="list-style-type: none"> <li>Ensure that no external device is connected to the batteries. Refer to a qualified JLG mechanic to know the approved options on the machine.</li> <li>Check battery, power cables and connections.</li> </ul>	Refer problem to a qualified JLG mechanic.

## SECTION 10 - DIAGNOSTIC TROUBLE CODES

DTC	Help Message	Condition Producing DTC	Control system Response or Machine Condition	Corrective Action/Operational Requirement for Function Movement and/or to Clear Fault
7722	SLAVE MODULE CAPACITOR BANK FAULT	The power capacitor bank of the power module is not charging properly at startup.	<ul style="list-style-type: none"> <li>• Ensure that no external device is connected to the batteries. Refer to a qualified JLG mechanic to know the approved options on the machine.</li> <li>• Check battery, power cables and connections.</li> </ul>	Refer problem to a qualified JLG mechanic.
7723	RIGHT MOTOR FEEDBACK FAILURE	The right motor voltage feedback circuits are damaged (Master Module).	<ul style="list-style-type: none"> <li>• Check the right motor power wiring and connections.</li> </ul>	Refer problem to a qualified JLG mechanic.
7724	LEFT MOTOR FEEDBACK FAILURE	The left motor voltage feedback circuits are damaged (Slave Module).	<ul style="list-style-type: none"> <li>• Check the left motor power wiring and connections.</li> </ul>	Refer problem to a qualified JLG mechanic.
7725	PUMP MOTOR - NOT RESPONDING	The pump motor feedback is not responding when the pump is being driven (by the Master Module).	<ul style="list-style-type: none"> <li>• Check the pump motor power wiring and connections.</li> <li>• Check the pump motor for proper impedance.</li> </ul>	Refer problem to a qualified JLG mechanic.
7726	RIGHT MOTOR OUTPUT - OUT OF RANGE HIGH	The right motor voltage output is higher than expected (Master Module).	<ul style="list-style-type: none"> <li>• Check the right motor power wiring and connections.</li> <li>• Check the motor phase to phase impedance.</li> <li>• Check the motor phases for proper insulation with the chassis.</li> </ul>	Refer problem to a qualified JLG mechanic.
7727	LEFT MOTOR OUTPUT - OUT OF RANGE HIGH	The left motor voltage output is higher than expected (Slave Module).	<ul style="list-style-type: none"> <li>• Check the right motor power wiring and connections.</li> <li>• Check the motor phase to phase impedance.</li> <li>• Check the motor phases for proper insulation with the chassis.</li> </ul>	Refer problem to a qualified JLG mechanic.
7728	RIGHT MOTOR OUTPUT - OUT OF RANGE LOW	The right motor voltage output is lower than expected (Master Module).	<ul style="list-style-type: none"> <li>• Check the right motor power wiring and connections.</li> <li>• Check the motor phase to phase impedance.</li> <li>• Check the motor phases for proper insulation with the chassis.</li> <li>• Check the line contactor contact.</li> </ul>	Refer problem to a qualified JLG mechanic.
7729	LEFT MOTOR OUTPUT - OUT OF RANGE LOW	The left motor voltage output is lower than expected (Slave Module).	<ul style="list-style-type: none"> <li>• Check the left motor power wiring and connections.</li> <li>• Check the motor phase to phase impedance.</li> <li>• Check the motor phases for proper insulation with the chassis.</li> <li>• Check the line contactor contact.</li> </ul>	Refer problem to a qualified JLG mechanic.

## SECTION 10 - DIAGNOSTIC TROUBLE CODES

DTC	Help Message	Condition Producing DTC	Control system Response or Machine Condition	Corrective Action/Operational Requirement for Function Movement and/or to Clear Fault
7730	PUMP MOTOR OUTPUT - OUT OF RANGE HIGH	The pump motor voltage output is higher than expected (driven by the Master Module).	<ul style="list-style-type: none"> <li>• Check the pump motor power wiring and connections.</li> <li>• Check the pump motor for proper impedance.</li> <li>• Check the pump motor connections for proper insulation with the chassis.</li> </ul>	Refer problem to a qualified JLG mechanic.
7731	PUMP MOTOR OUTPUT - OUT OF RANGE LOW	The pump motor voltage output is lower than expected (driven by the Master Module).	<ul style="list-style-type: none"> <li>• Check the pump motor power wiring and connections.</li> <li>• Check the pump motor for proper impedance.</li> <li>• Check the pump motor connections for proper insulation with the chassis.</li> <li>• Check the line contactor contact.</li> </ul>	Refer problem to a qualified JLG mechanic.
7732	STALLED RIGHT MOTOR	The right motor has been detected stalled.	<ul style="list-style-type: none"> <li>• Ensure vehicle is not stuck on something preventing movement.</li> <li>• Check for jammed or obstructed right drive motor.</li> </ul>	Refer problem to a qualified JLG mechanic.
7733	STALLED LEFT MOTOR	The left motor has been detected stalled.	<ul style="list-style-type: none"> <li>• Ensure vehicle is not stuck on something preventing movement.</li> <li>• Check for jammed or obstructed left drive motor.</li> </ul>	Refer problem to a qualified JLG mechanic.
7737	PUMP MOTOR AT CURRENT LIMIT	The Pump Motor current has reached current limit.	<ul style="list-style-type: none"> <li>• Allow motor to cool down if motor is hot</li> <li>• Check to see if mast is obstructed</li> <li>• Check to see if jib is obstructed</li> <li>• Check to see if telescope is obstructed</li> <li>• Check to see if fluid in reservoir is low</li> <li>• Check to see if Pump is obstructed. Refer to Section 7-2 for servicing the pump</li> <li>• Check harnesses for signs of damage</li> <li>• Replace the Master Power Module</li> </ul>	Refer problem to a qualified JLG mechanic.
7745	PLATFORM ROTATE MOTOR POSITIVE – SHORT TO BATTERY	The Platform Rotate Controller has determined that the positive motor terminal is shorted to + Vbatt	<ul style="list-style-type: none"> <li>• Check to see if motor or platform is obstructed.</li> <li>• Check harnesses for signs of damage</li> <li>• Replace the platform rotate controller</li> </ul>	Refer problem to a qualified JLG mechanic.

## SECTION 10 - DIAGNOSTIC TROUBLE CODES

DTC	Help Message	Condition Producing DTC	Control system Response or Machine Condition	Corrective Action/Operational Requirement for Function Movement and/or to Clear Fault
7746	PLATFORM ROTATE MOTOR POSITIVE – SHORT TO GROUND	The Platform Rotate Controller has determined that the positive motor terminal is shorted to -Vbatt	<ul style="list-style-type: none"> <li>Check harnesses for signs of damage</li> <li>Replace the platform rotate controller</li> </ul>	Refer problem to a qualified JLG mechanic.
7747	PLATFORM ROTATE MOTOR NEGATIVE – SHORT TO BATTERY	The Platform Rotate Controller has determined that the negative motor terminal is shorted to +Vbatt	<ul style="list-style-type: none"> <li>Check to see if motor or platform is obstructed.</li> <li>Check harnesses for signs of damage</li> <li>Replace the platform rotate controller</li> </ul>	Refer problem to a qualified JLG mechanic.
7748	PLATFORM ROTATE MOTOR NEGATIVE – SHORT TO GROUND	The Platform Rotate Controller has determined that the negative motor terminal is shorted to -Vbatt	<ul style="list-style-type: none"> <li>Check harnesses for signs of damage</li> <li>Replace the platform rotate controller</li> </ul>	Refer problem to a qualified JLG mechanic.
7749	PLATFORM ROTATE MOTOR – OPEN CIRCUIT	The Platform Rotate Controller has determined that one or both of the motor terminals is disconnected	<ul style="list-style-type: none"> <li>Check harnesses for signs of damage</li> <li>Replace the platform rotate controller</li> </ul>	Refer problem to a qualified JLG mechanic.
7750	PLATFORM ROTATE MOTOR – CURRENT TOO HIGH	The Platform Rotate Controller has determined that the rotate motor current is too high	<ul style="list-style-type: none"> <li>Check to see if motor or platform is obstructed.</li> <li>Check harnesses for signs of damage</li> <li>Replace the platform rotate controller</li> </ul>	Refer problem to a qualified JLG mechanic.

### 8-1 Tilt Sensor

DTC	Help Message	Condition Producing DTC	Control system Response or Machine Condition	Corrective Action/Operational Requirement for Function Movement and/or to Clear Fault
813	CHASSIS TILT SENSOR NOT CALIBRATED	The Chassis Tilt sensor is not Calibrated	<ul style="list-style-type: none"> <li>Go through the calibration procedure in analyzer (refer to section 9-6)</li> <li>Replace the Tilt Sensor</li> <li>Replace the UGM</li> </ul>	Refer problem to a qualified JLG mechanic.
814	CHASSIS TILT SENSOR OUT OF RANGE	The UGM determines the Chassis Tilt sensor is out of range	<ul style="list-style-type: none"> <li>Check to see that the vehicle is on a level surface</li> <li>Check to see that the tilt sensor is mounted properly to the chassis.</li> <li>Check harnesses for damage</li> <li>Replace tilt sensor</li> <li>Replace UGM</li> </ul>	Refer problem to a qualified JLG mechanic.
818	TILT SENSOR STAGNANT	The UGM determines the Chassis Tilt sensor is stagnant	<ul style="list-style-type: none"> <li>Replace tilt sensor</li> <li>Replace UGM</li> </ul>	Refer problem to a qualified JLG mechanic.

 **8-2 Platform Load Sense**

DTC	Help Message	Condition Producing DTC	Control system Response or Machine Condition	Corrective Action/Operational Requirement for Function Movement and/or to Clear Fault
829	FUNCTIONS CUTOUT - PLATFORM OVER-LOADED	The platform is overloaded and functions are restricted.	<ul style="list-style-type: none"> <li>• Unload the platform.</li> <li>• Check if the overload switch is obstructed or jammed.</li> <li>• Check harnesses for signs of damage</li> </ul> When Platform is not overloaded: @ +VSupply: X261 (4), C084-J7(15) @ -VSupply: X261 (3), X638A(J) When Platform is overloaded: @ +VSupply: X261 (3), X638A(J) @ 6.5 to 7.5 V: X261 (4), C084-J7(15)	<ul style="list-style-type: none"> <li>• Unload the platform.</li> <li>• Check if the overload switch is obstructed or jammed.</li> </ul> Refer problem to a qualified JLG mechanic.
8210	OVERLOAD SENSOR ERROR	Inconsistency in the overload sensor information.	<ul style="list-style-type: none"> <li>• Unload the platform.</li> <li>• Check if the overload switch is obstructed or jammed.</li> <li>• Check harnesses for signs of damage</li> </ul> When Platform is not overloaded: @ +VSupply: X261 (4), C084-J7(15) @ -VSupply: X261 (3), X638A(J) When Platform is overloaded: @ +VSupply: X261 (3), X638A(J) @ 6.5 to 7.5 V: X261 (4), C084-J7(15)	<ul style="list-style-type: none"> <li>• Check if the overload switch is damaged.</li> </ul> Refer problem to a qualified JLG mechanic.

 **8-6 Steering/Axle**

DTC	Help Message	Condition Producing DTC	Control system Response or Machine Condition	Corrective Action/Operational Requirement for Function Movement and/or to Clear Fault
8639	FRONT LEFT STEER VALVE – OPEN CIRCUIT	The Ground Module detects an open circuit at the Front Left Steer Valve output.	<ul style="list-style-type: none"> <li>• Check the valve harness for signs of damage</li> <li>• Check the valve coil connections and wiring for interruptions.</li> <li>• Check the valve coil for correct impedance (refer to Section 7-4).</li> <li>• Replace the UGM if the coil and its harness are correct.</li> </ul>	Refer problem to a qualified JLG mechanic.



## SECTION 10 - DIAGNOSTIC TROUBLE CODES

DTC	Help Message	Condition Producing DTC	Control system Response or Machine Condition	Corrective Action/Operational Requirement for Function Movement and/or to Clear Fault
8640	FRONT LEFT STEER VALVE – SHORT TO BATTERY	The Ground Module detects a short to +VSupply at the Front Left Steer Valve output.	<ul style="list-style-type: none"> <li>Check the UGM driver output C084-J2(19) for a short circuit with +VSupply.</li> <li>Check the valve coil for correct impedance (refer to Section 7-4).</li> <li>If the harness and the coil are correct and if the fault appears at start up: Replace the UGM.</li> </ul>	Refer problem to a qualified JLG mechanic.
8641	FRONT LEFT STEER VALVE – SHORT TO GROUND	The Ground Module detects a short -VSupply at the Front Left Steer Valve output.	<ul style="list-style-type: none"> <li>Check the valve driver output C084-J2(19) for a short circuit with -VSupply.</li> <li>If the wiring is correct, the driver circuit is damaged: replace the UGM.</li> </ul>	Refer problem to a qualified JLG mechanic.
8642	FRONT RIGHT STEER VALVE – OPEN CIRCUIT	The Ground Module detects an open circuit at the Front Right Steer Valve output.	<ul style="list-style-type: none"> <li>Check the valve harness for signs of damage</li> <li>Check the valve coil connections and wiring for interruptions.</li> <li>Check the valve coil for correct impedance (refer to Section 7-4).</li> <li>Replace the UGM if the coil and its harness are correct.</li> </ul>	Refer problem to a qualified JLG mechanic.
8643	FRONT RIGHT STEER VALVE – SHORT TO BATTERY	The Ground Module detects a short to +VSupply at the Front Right Steer Valve output.	<ul style="list-style-type: none"> <li>Check the UGM driver output C084-J2(8) for a short circuit with +VSupply.</li> <li>Check the valve coil for correct impedance (refer to Section 7-4).</li> <li>If the harness and the coil are correct and if the fault appears at start up: Replace the UGM.</li> </ul>	Refer problem to a qualified JLG mechanic.
8644	FRONT RIGHT STEER VALVE – SHORT TO GROUND	The Ground Module detects a short -VSupply at the Front Right Steer Valve output.	Check the valve driver output C084-J2(8) for a short circuit with -VSupply. If the wiring is correct, the driver circuit is damaged: replace the UGM.	Refer problem to a qualified JLG mechanic.
8664	STEER SENSOR- OUT OF RANGE HIGH	Invalid signal from the steer sensor.	<p>Check the steer sensor for damage.</p> <p>Check the steer sensor installation.</p> <p>Check the steer sensor connections voltages (refer to Section 8-2).</p>	Refer problem to a qualified JLG mechanic.

**SECTION 10 - DIAGNOSTIC TROUBLE CODES**

DTC	Help Message	Condition Producing DTC	Control system Response or Machine Condition	Corrective Action/Operational Requirement for Function Movement and/or to Clear Fault
8665	STEER SENSOR - OUT OF RANGE LOW	Invalid signal from the steer sensor.	<ul style="list-style-type: none"> <li>• Check the steer sensor for damage.</li> <li>• Check that the steer sensor is securely mounted.</li> <li>• Check the steer sensor connections voltages (refer to Section 8-2).</li> <li>• Check the steering spindle assembly : no abnormal play, king pin securely fasten.</li> <li>• Check that the sensor is positively actuated thru all the steering range : if necessary, proceed with a reset of the sensor, then with a new calibration (refer to Section 9-5).</li> <li>• If the sensor power is correct but its output improper : Replace the sensor and proceed with a calibration (refer to Section 9-5).</li> </ul>	Refer problem to a qualified JLG mechanic.
8666	STEER SENSOR - DECOUPLED	Invalid signal from the steer sensor.	<ul style="list-style-type: none"> <li>• Check the steer sensor for damage.</li> <li>• Check that the steer sensor is securely mounted.</li> <li>• Check the steer sensor connections voltages (refer to Section 8-2).</li> <li>• Check the steering spindle assembly : no abnormal play, king pin securely fasten.</li> <li>• Check that the sensor is positively actuated thru all the steering range : if necessary, proceed with a reset of the sensor, then with a new calibration (refer to Section 9-5).</li> <li>• If the sensor power is correct but its output improper : Replace the sensor and proceed with a calibration (refer to Section 9-5).</li> </ul>	<ul style="list-style-type: none"> <li>• Check the steer sensor for damage.</li> <li>• Check that the steer sensor is securely mounted.</li> </ul> Refer problem to a qualified JLG mechanic.

**SECTION 10 - DIAGNOSTIC TROUBLE CODES**

DTC	Help Message	Condition Producing DTC	Control system Response or Machine Condition	Corrective Action/Operational Requirement for Function Movement and/or to Clear Fault
8667	STEER SENSOR - NOT RESPONDING	Invalid signal from the steer sensor. This fault appears when steering is controlled but the sensor output remains unchanged for more than 1 second.	<ul style="list-style-type: none"> <li>• If the wheels do not steer while the function is controlled:                             <ul style="list-style-type: none"> <li>- Pump not running : check the voltage applied to the pump motor;</li> <li>- Pump running : check the oil level; check the hydraulic pressure and the voltage applied to the pressure relief valve; check the steer and the directional valves; check that the steering wheels are not obstructed nor jammed,</li> </ul> </li> <li>• If the wheels steer properly:                             <ul style="list-style-type: none"> <li>-Check the steer sensor for damage.</li> <li>-Check that the steer sensor is securely mounted.</li> <li>-Check the steer sensor connections voltages (refer to Section 8-2).</li> <li>-If the sensor power is correct but its output improper: Replace the sensor and proceed with a calibration (refer to Section 9-5).</li> </ul> </li> </ul>	<ul style="list-style-type: none"> <li>• Check the steer sensor for damage.</li> <li>• Check that the steer sensor is securely mounted.</li> </ul> Refer problem to a qualified JLG mechanic.
8668	STEER SENSOR - NOT CALIBRATED	The steering sensor has not been calibrated	<ul style="list-style-type: none"> <li>• Proceed with a sensor calibration (refer to Section 9-5).</li> <li>• If the sensor can not be calibrated:                             <ul style="list-style-type: none"> <li>-Check the steer connection voltages (refer to Section 8-2).</li> <li>-If the sensor power is correct but its output improper: Replace the sensor and proceed with a calibrations (refer to Section 9-5).</li> </ul> </li> </ul>	Refer problem to a qualified JLG mechanic.

**8-7 Safety System Override**

DTC	Help Message	Condition Producing DTC	Control system Response or Machine Condition	Corrective Action/Operational Requirement for Function Movement and/or to Clear Fault
873	MACHINE SAFETY SYSTEM OVERRIDE OCCURRED	Machine Safety System Override has Been used to override a Safety System or the Platform Operator station	<ul style="list-style-type: none"> <li>Go into the analyzer under CALIBRATIONS &gt; MSSO &gt; MSSO LOG and record the most recent time stamps</li> <li>Under CALIBRATIONS &gt; MSSO &gt; MSSO RESET, select ENTER to clear the fault</li> </ul>	Refer problem to a qualified JLG mechanic.

**9-9 Hardware**

DTC	Help Message	Condition Producing DTC	Control system Response or Machine Condition	Corrective Action/Operational Requirement for Function Movement and/or to Clear Fault
998	EEPROM FAILURE - CHECK ALL SETTINGS	The UGM has detected an anomaly in EEPROM	<ul style="list-style-type: none"> <li>Cycle power to clear the fault.</li> <li>Reinstall the most current Production software for the UGM.</li> <li>Replace UGM</li> </ul>	<ul style="list-style-type: none"> <li>Cycle power to clear the fault.</li> </ul> Refer problem to a qualified JLG mechanic.
999	FUNCTIONS LOCKED OUT - POWER MODULE SOFTWARE VERSION IMPROPER	The UGM has detected software major versions to be incompatible with software on Power Modules	<ul style="list-style-type: none"> <li>Cycle power to clear the fault.</li> <li>Cycle power to clear the fault.</li> <li>Reinstall the most current Production software on the UGM and Power Modules.</li> </ul>	<ul style="list-style-type: none"> <li>Cycle power to clear the fault.</li> </ul> Refer problem to a qualified JLG mechanic.
9910	FUNCTIONS LOCKED OUT - PLATFORM MODULE SOFTWARE VERSION IMPROPER	The UGM has detected software major versions to be incompatible with software on Platform Module	<ul style="list-style-type: none"> <li>Cycle power to clear the fault.</li> <li>Cycle power to clear the fault.</li> <li>Reinstall the most current Production software on the UGM and Platform Module.</li> </ul>	<ul style="list-style-type: none"> <li>Cycle power to clear the fault.</li> </ul> Refer problem to a qualified JLG mechanic.
9919	GROUND SENSOR REF VOLTAGE OUT OF RANGE	The UGM has detected that the Sensor Reference Voltage Output is out of range	<ul style="list-style-type: none"> <li>Cycle power to clear the fault.</li> <li>Check harnesses for signs of damage @ 5 V: C084-J7(16) @ -VSupply: C084-J7(9)</li> <li>Disconnect Tilt Sensor. If the fault clears, replace the tilt sensor.</li> <li>Replace the UGM</li> </ul>	<ul style="list-style-type: none"> <li>Cycle power to clear the fault.</li> </ul> Refer problem to a qualified JLG mechanic.

## SECTION 10 - DIAGNOSTIC TROUBLE CODES

DTC	Help Message	Condition Producing DTC	Control system Response or Machine Condition	Corrective Action/Operational Requirement for Function Movement and/or to Clear Fault
9920	PLATFORM SENSOR REF VOLTAGE OUT OF RANGE	The Platform Module has detected that the Sensor Reference Voltage Output is out of range	<ul style="list-style-type: none"> <li>• Cycle power to clear the fault.</li> <li>• Check harnesses for signs of damage @ +VSupply: C0651-J5(10) @ 5V: C0651-J2(1), C0651-J5(1), C0651-J5(4), and C0651-J6(2) @ -VSupply: C0651-J2(2), C0651-J5(2), C0651-J5(5), C0651-J5(7), and C0651-J6(3)</li> <li>• Replace the Platform Module</li> </ul>	<ul style="list-style-type: none"> <li>• Cycle power to clear the fault.</li> </ul> Refer problem to a qualified JLG mechanic.
9924	FUNCTIONS LOCKED OUT - MACHINE NOT CONFIGURED	The UGM has detected that the machine was not setup after software installation	<ul style="list-style-type: none"> <li>• Cycle power to clear the fault.</li> <li>• Using the analyzer, go to MACHINE SETUP and toggle the machine model</li> </ul>	<ul style="list-style-type: none"> <li>• Cycle power to clear the fault.</li> </ul> Refer problem to a qualified JLG mechanic.
9944	CURRENT FEED-BACK GAINS OUT OF RANGE	The UGM has detected that its current feedback gains are out of range	<ul style="list-style-type: none"> <li>• Cycle power to clear the fault.</li> <li>• Replace the UGM</li> </ul>	<ul style="list-style-type: none"> <li>• Cycle power to clear the fault.</li> </ul> Refer problem to a qualified JLG mechanic.
9945	CURRENT FEED-BACK CALIBRATION CHECKSUM INCORRECT	The UGM has detected that its current feedback checksum is incorrect	<ul style="list-style-type: none"> <li>• Cycle power to clear the fault.</li> <li>• Reinstall the most current Production software for the UGM.</li> <li>• Replace UGM</li> </ul>	<ul style="list-style-type: none"> <li>• Cycle power to clear the fault.</li> </ul> Refer problem to a qualified JLG mechanic.
9949	MACHINE CONFIGURATION OUT OF RANGE – CHECK ALL SETTINGS	The UGM detects an internal problem	<ul style="list-style-type: none"> <li>• Cycle power to clear the fault.</li> <li>• Reinstall the most current Production software for the UGM.</li> <li>• Replace UGM</li> </ul>	<ul style="list-style-type: none"> <li>• Cycle power to clear the fault.</li> </ul> Refer problem to a qualified JLG mechanic.
9979	FUNCTIONS LOCKED OUT - GROUND MODULE SOFTWARE VERSION IMPROPER	The UGM detects a problem with its software version	<ul style="list-style-type: none"> <li>• Cycle power to clear the fault.</li> <li>• Reinstall the most current Production software for the UGM.</li> <li>• Replace UGM</li> </ul>	<ul style="list-style-type: none"> <li>• Cycle power to clear the fault.</li> </ul> Refer problem to a qualified JLG mechanic.
9986	GROUND MODULE VLOW FET FAILURE	The UGM detects an internal problem	<ul style="list-style-type: none"> <li>• Cycle power to clear the fault.</li> <li>• Reinstall the most current Production software for the UGM.</li> <li>• Replace UGM</li> </ul>	<ul style="list-style-type: none"> <li>• Cycle power to clear the fault.</li> </ul> Refer problem to a qualified JLG mechanic.
9992	MASTER MODULE A/D FAILURE	"There is an internal error in the Master Module (right controller)."	<ul style="list-style-type: none"> <li>• Cycle power to clear the fault.</li> <li>• If the fault is not cleared : Replace the Master controller.</li> </ul>	<ul style="list-style-type: none"> <li>• Cycle power to clear the fault.</li> </ul> Refer problem to a qualified JLG mechanic.
9993	SLAVE MODULE A/D FAILURE	There is an internal error in the Slave Module (left controller)."	<ul style="list-style-type: none"> <li>• Cycle power to clear the fault.</li> <li>• If the fault is not cleared : Replace the Slave controller.</li> </ul>	<ul style="list-style-type: none"> <li>• Cycle power to clear the fault.</li> </ul> Refer problem to a qualified JLG mechanic.
9994	MASTER MODULE EEPROM FAILURE	There is an internal error in the Master Module (right controller).	<ul style="list-style-type: none"> <li>• Cycle power to clear the fault.</li> <li>• If the fault is not cleared : Replace the Master controller.</li> </ul>	<ul style="list-style-type: none"> <li>• Cycle power to clear the fault.</li> </ul> Refer problem to a qualified JLG mechanic.

## SECTION 10 - DIAGNOSTIC TROUBLE CODES

DTC	Help Message	Condition Producing DTC	Control system Response or Machine Condition	Corrective Action/Operational Requirement for Function Movement and/or to Clear Fault
9995	SLAVE MODULE EEPROM FAILURE	There is an internal error in the Slave Module (left controller).	<ul style="list-style-type: none"> <li>• Cycle power to clear the fault.</li> <li>• If the fault is not cleared : Replace the Slave controller.</li> </ul>	<ul style="list-style-type: none"> <li>• Cycle power to clear the fault.</li> <li>Refer problem to a qualified JLG mechanic.</li> </ul>
9998	MASTER MODULE PROTECTION FAILURE	There is an internal error in the Master Module (right controller).	<ul style="list-style-type: none"> <li>• Cycle power to clear the fault.</li> <li>• If the fault is not cleared : Replace the Master controller.</li> </ul>	<ul style="list-style-type: none"> <li>• Cycle power to clear the fault.</li> <li>Refer problem to a qualified JLG mechanic.</li> </ul>
9999	SLAVE MODULE PROTECTION FAILURE	There is an internal error in the Slave Module (left controller)."	<ul style="list-style-type: none"> <li>• Cycle power to clear the fault.</li> <li>• If the fault is not cleared : Replace the Slave controller.</li> </ul>	<ul style="list-style-type: none"> <li>• Cycle power to clear the fault.</li> <li>Refer problem to a qualified JLG mechanic.</li> </ul>
99910	MASTER MODULE FAILURE - CHECK POWER CIRCUITS OR MOSFET SHORT CIRCUIT	A short circuit on the power outputs of the Master Module (right controller) has been detected.	<ul style="list-style-type: none"> <li>• Replace the Master controller.</li> </ul>	<ul style="list-style-type: none"> <li>• Cycle power to clear the fault.</li> <li>Refer problem to a qualified JLG mechanic.</li> </ul>
99101	SLAVE MODULE FAILURE - CHECK POWER CIRCUITS OR MOSFET SHORT CIRCUIT	A short circuit on the power outputs of the Slave Module (left controller) has been detected.	<ul style="list-style-type: none"> <li>• Replace the Slave controller.</li> </ul>	<ul style="list-style-type: none"> <li>• Cycle power to clear the fault.</li> <li>Refer problem to a qualified JLG mechanic.</li> </ul>
99102	MASTER MODULE WATCHDOG RESET	There is an internal error in the Master Module (right controller).	<ul style="list-style-type: none"> <li>• Cycle power to clear the fault.</li> <li>• If the fault is not cleared : Replace the Master controller.</li> </ul>	<ul style="list-style-type: none"> <li>• Cycle power to clear the fault.</li> <li>Refer problem to a qualified JLG mechanic.</li> </ul>
99103	SLAVE MODULE WATCHDOG RESET	There is an internal error in the Slave Module (left controller).	<ul style="list-style-type: none"> <li>• Cycle power to clear the fault.</li> <li>• If the fault is not cleared : Replace the Slave controller.</li> </ul>	<ul style="list-style-type: none"> <li>• Cycle power to clear the fault.</li> <li>Refer problem to a qualified JLG mechanic.</li> </ul>
99104	MASTER MODULE WATCHDOG2 RESET	There is an internal error in the Master Module (right controller).	<ul style="list-style-type: none"> <li>• Cycle power to clear the fault.</li> <li>• If the fault is not cleared : Replace the Master controller.</li> </ul>	<ul style="list-style-type: none"> <li>• Cycle power to clear the fault.</li> <li>Refer problem to a qualified JLG mechanic.</li> </ul>
99105	SLAVE MODULE WATCHDOG2 RESET	There is an internal error in the Slave Module (left controller).	<ul style="list-style-type: none"> <li>• Cycle power to clear the fault.</li> <li>• If the fault is not cleared : Replace the Slave controller.</li> </ul>	<ul style="list-style-type: none"> <li>• Cycle power to clear the fault.</li> <li>Refer problem to a qualified JLG mechanic.</li> </ul>
99106	MASTER MODULE RAM FAILURE	There is an internal error in the Master Module (right controller).	<ul style="list-style-type: none"> <li>• Cycle power to clear the fault.</li> <li>• If the fault is not cleared : Replace the Master controller.</li> </ul>	<ul style="list-style-type: none"> <li>• Cycle power to clear the fault.</li> <li>Refer problem to a qualified JLG mechanic.</li> </ul>
99107	SLAVE MODULE RAM FAILURE	There is an internal error in the Slave Module (left controller).	<ul style="list-style-type: none"> <li>• Cycle power to clear the fault.</li> <li>• If the fault is not cleared : Replace the Slave controller.</li> </ul>	<ul style="list-style-type: none"> <li>• Cycle power to clear the fault.</li> <li>Refer problem to a qualified JLG mechanic.</li> </ul>
99108	MASTER MODULE - INTERNAL ERROR	There is an internal error in the Master Module (right controller).	<ul style="list-style-type: none"> <li>• Cycle power to clear the fault.</li> <li>• If the fault is not cleared : Replace the Master controller.</li> </ul>	<ul style="list-style-type: none"> <li>• Cycle power to clear the fault.</li> <li>Refer problem to a qualified JLG mechanic.</li> </ul>
99109	SLAVE MODULE - INTERNAL ERROR	There is an internal error in the Slave Module (left controller).	<ul style="list-style-type: none"> <li>• Cycle power to clear the fault.</li> <li>• If the fault is not cleared : Replace the Slave controller.</li> </ul>	<ul style="list-style-type: none"> <li>• Cycle power to clear the fault.</li> <li>Refer problem to a qualified JLG mechanic.</li> </ul>
99110	MASTER MODULE - INTERNAL ERROR	There is an internal error in the Master Module (right controller).	<ul style="list-style-type: none"> <li>• Cycle power to clear the fault.</li> <li>• If the fault is not cleared : Replace the Master controller.</li> </ul>	<ul style="list-style-type: none"> <li>• Cycle power to clear the fault.</li> <li>Refer problem to a qualified JLG mechanic.</li> </ul>

## SECTION 10 - DIAGNOSTIC TROUBLE CODES

DTC	Help Message	Condition Producing DTC	Control system Response or Machine Condition	Corrective Action/Operational Requirement for Function Movement and/or to Clear Fault
99111	SLAVE MODULE - INTERNAL ERROR	There is an internal error in the Slave Module (left controller).	<ul style="list-style-type: none"> <li>• Cycle power to clear the fault.</li> <li>• If the fault is not cleared : Replace the Slave controller.</li> </ul>	<ul style="list-style-type: none"> <li>• Cycle power to clear the fault.</li> </ul> Refer problem to a qualified JLG mechanic.
99112	MASTER MODULE - INTERNAL ERROR	There is an internal error in the Master Module (right controller).	<ul style="list-style-type: none"> <li>• Cycle power to clear the fault.</li> <li>• If the fault is not cleared : Replace the Master controller.</li> </ul>	<ul style="list-style-type: none"> <li>• Cycle power to clear the fault.</li> </ul> Refer problem to a qualified JLG mechanic.
99113	SLAVE MODULE - INTERNAL ERROR	There is an internal error in the Slave Module (left controller).	<ul style="list-style-type: none"> <li>• Cycle power to clear the fault.</li> <li>• If the fault is not cleared : Replace the Slave controller.</li> </ul>	<ul style="list-style-type: none"> <li>• Cycle power to clear the fault.</li> </ul> Refer problem to a qualified JLG mechanic.
99114	MASTER MODULE - INTERNAL ERROR	There is an internal error in the Master Module (right controller).	<ul style="list-style-type: none"> <li>• Cycle power to clear the fault.</li> <li>• If the fault is not cleared : Replace the Master controller.</li> </ul>	<ul style="list-style-type: none"> <li>• Cycle power to clear the fault.</li> </ul> Refer problem to a qualified JLG mechanic.
99115	SLAVE MODULE - INTERNAL ERROR	There is an internal error in the Slave Module (left controller).	<ul style="list-style-type: none"> <li>• Cycle power to clear the fault.</li> <li>• If the fault is not cleared : Replace the Slave controller.</li> </ul>	<ul style="list-style-type: none"> <li>• Cycle power to clear the fault.</li> </ul> Refer problem to a qualified JLG mechanic.
99116	MASTER MODULE - INTERNAL ERROR	There is an internal error in the Master Module (right controller).	<ul style="list-style-type: none"> <li>• Cycle power to clear the fault.</li> <li>• If the fault is not cleared : Replace the Master controller.</li> </ul>	<ul style="list-style-type: none"> <li>• Cycle power to clear the fault.</li> </ul> Refer problem to a qualified JLG mechanic.
99117	SLAVE MODULE - INTERNAL ERROR	There is an internal error in the Slave Module (left controller).	<ul style="list-style-type: none"> <li>• Cycle power to clear the fault.</li> <li>• If the fault is not cleared : Replace the Slave controller.</li> </ul>	<ul style="list-style-type: none"> <li>• Cycle power to clear the fault.</li> </ul> Refer problem to a qualified JLG mechanic.
99120	MASTER MODULE - INTERNAL ERROR	There is an internal error in the Master Module (right controller).	<ul style="list-style-type: none"> <li>• Cycle power to clear the fault.</li> <li>• If the fault is not cleared : Replace the Master controller.</li> </ul>	<ul style="list-style-type: none"> <li>• Cycle power to clear the fault.</li> </ul> Refer problem to a qualified JLG mechanic.
99121	SLAVE MODULE - INTERNAL ERROR	There is an internal error in the Slave Module (left controller).	<ul style="list-style-type: none"> <li>• Cycle power to clear the fault.</li> <li>• If the fault is not cleared : Replace the Slave controller.</li> </ul>	<ul style="list-style-type: none"> <li>• Cycle power to clear the fault.</li> </ul> Refer problem to a qualified JLG mechanic.
99164	PLATFORM ROTATE MODULE - INTERNAL ERROR	The Platform rotate module detects a problem	<ul style="list-style-type: none"> <li>• Cycle power to clear the fault.</li> <li>• Replace the platform rotate module</li> </ul>	<ul style="list-style-type: none"> <li>• Cycle power to clear the fault.</li> </ul> Refer problem to a qualified JLG mechanic.
99165	PLATFORM ROTATE MODULE - INTERNAL 12V SUPPLY ERROR	Logic voltage inside the Platform Rotate Module is incorrect.	<ul style="list-style-type: none"> <li>• Cycle power to clear the fault.</li> <li>• Check voltage on X211 (1) to see if voltage is within range of + Vbatt</li> <li>• Charge machine batteries</li> <li>• Replace the platform rotate module</li> </ul>	<ul style="list-style-type: none"> <li>• Cycle power to clear the fault.</li> </ul> Refer problem to a qualified JLG mechanic.
99166	DRIVE COMMAND ERROR	The Power Modules are reporting inconsistent drive command messages	<ul style="list-style-type: none"> <li>• Cycle power to clear the fault.</li> <li>• Reinstall the most current Production software for the UGM and Power Modules.</li> <li>• Replace UGM</li> <li>• Replace the Power Modules</li> </ul>	<ul style="list-style-type: none"> <li>• Cycle power to clear the fault.</li> </ul> Refer problem to a qualified JLG mechanic.

**SECTION 10 - DIAGNOSTIC TROUBLE CODES**

DTC	Help Message	Condition Producing DTC	Control system Response or Machine Condition	Corrective Action/Operational Requirement for Function Movement and/or to Clear Fault
99167	PUMP COMMAND ERROR	The Power Modules are reporting inconsistent Pump command messages	<ul style="list-style-type: none"> <li>• Cycle power to clear the fault.</li> <li>• Reinstall the most current Production software for the UGM and Power Modules.</li> <li>• Replace UGM</li> <li>• Replace the Power Modules</li> </ul>	<ul style="list-style-type: none"> <li>• Cycle power to clear the fault.</li> </ul> Refer problem to a qualified JLG mechanic.
99168	MASTER MODULE – CURRENT MEASUREMENT ERROR	The Master Module determines internal current feedback sensors are out of range	<ul style="list-style-type: none"> <li>• Cycle power to clear the fault.</li> <li>• Replace the Master Power Module</li> </ul>	<ul style="list-style-type: none"> <li>• Cycle power to clear the fault.</li> </ul> Refer problem to a qualified JLG mechanic.
99169	SLAVE MODULE - CURRENT MEASUREMENT ERROR	The Slave Module determines internal current feedback sensors are out of range	<ul style="list-style-type: none"> <li>• Cycle power to clear the fault.</li> <li>• Replace the Slave Power Module</li> </ul>	<ul style="list-style-type: none"> <li>• Cycle power to clear the fault.</li> </ul> Refer problem to a qualified JLG mechanic.
99170	FUNCTIONS LOCKED OUT – PLATFORM ROTATE MODULE SOFTWARE VERSION IMPROPER	The UGM detects the software version on the platform rotate module is incompatible with UGM software.	<ul style="list-style-type: none"> <li>• Cycle power to clear the fault.</li> <li>• If the fault is not cleared : Replace the Platform Rotate Module.</li> </ul>	<ul style="list-style-type: none"> <li>• Cycle power to clear the fault.</li> <li>• If the fault is not cleared : Replace the Platform Rotate Module.</li> </ul>

Go to Discount-Equipment.com to order your parts



## SECTION 11. GENERAL ELECTRICAL INFORMATION & SCHEMATICS

### 11.1 GENERAL

This section contains basic electrical information and schematics to be used for locating and correcting most of the operating problems which may develop. If a problem should develop which is not presented in this section or which is not corrected by listed corrective actions, technical qualified guidance should be obtained before proceeding with any maintenance.

### 11.2 MULTIMETER BASICS

A wide variety of multimeters or Volt Ohm Meters (VOM) can be used for troubleshooting your equipment. This section shows diagrams of a common, digital VOM configured for several different circuit measurements. Instructions for your VOM may vary. Please consult the meter operator's manual for more information.

#### Grounding

"Grounding the meter" means to take the black lead (which is connected to the COM (common) or negative port) and touch it to a good path to the negative side of the Voltage source.

#### Backprobing

To "backprobe" means to take the measurement by accessing a connector's contact on the same side as the wires, the back of the connector. Readings can be done while maintaining circuit continuity this way. If the connector is the sealed type, great care must be taken to avoid damaging the seal around the wire. It is best to use probes or probe tips specifically designed for this technique, especially on sealed connectors. Whenever possible, insert probes into the side of the connector such that the test also checks both terminals of the connection. It is possible to inspect a connection within a closed connector by backprobing both sides of a connector terminal and measuring resistance. Do this after giving each wire a gentle pull to ensure the wires are still attached to the contact and contacts are seated in the connector.

#### Min/Max

Use of the "MIN/MAX" recording feature of some meters can help when taking measurements of intermittent conditions while alone. For example, you can read the Voltage applied to a solenoid when it is only operational while a switch, far from the solenoid and meter, is held down.

#### Polarity

Getting a negative Voltage or current reading when expecting a positive reading frequently means the leads are reversed. Check what reading is expected, the location of the signal and that the leads are connected to the device under test correctly. Also check that the lead on the "COM" port goes to the Ground or negative side of the sig-

nal and the lead on the other port goes to the positive side of the signal.

#### Scale

M = Mega = 1 000 000 x (Displayed Number)

k = kilo = 1 000 x (Displayed Number)

m = milli = (Displayed Number) / 1 000

$\mu$  = micro = (Displayed Number) / 1 000 000

Example: 1.2 k $\Omega$  = 1200  $\Omega$

Example: 50 mA = 0.05 A

#### Voltage Measurement

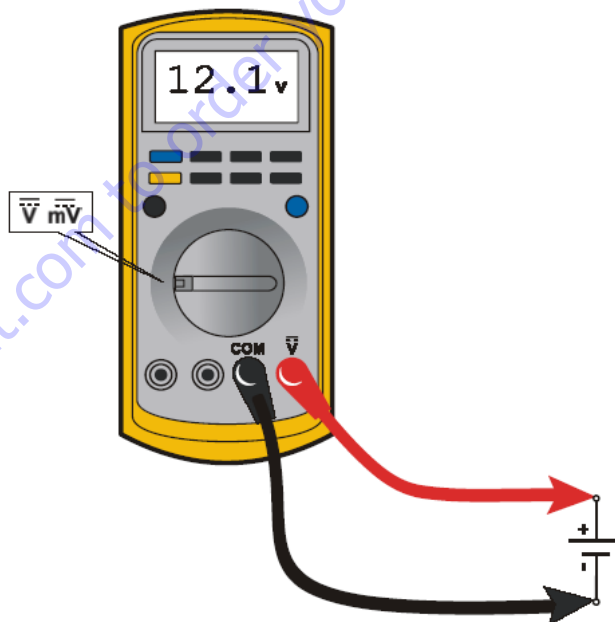
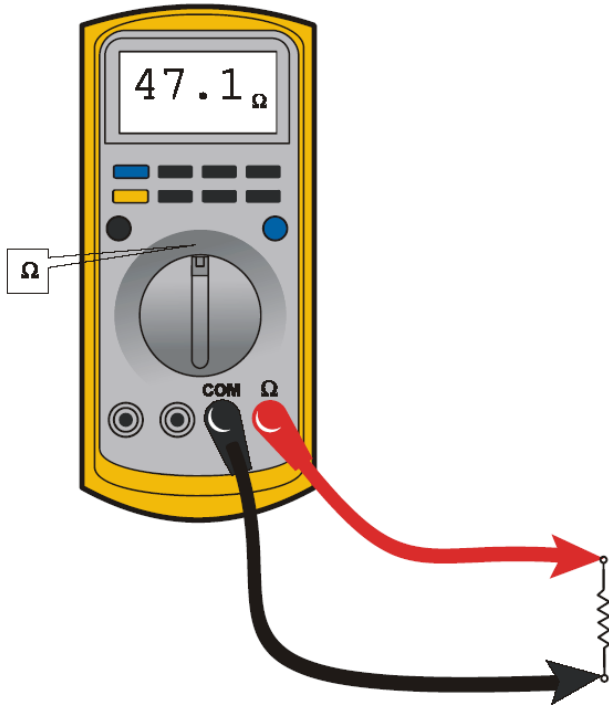


Figure 11-1. Voltage Measurement (DC)

- If meter is not auto ranging, set it to the correct range (See multimeter's operation manual).
- Use firm contact with meter leads.

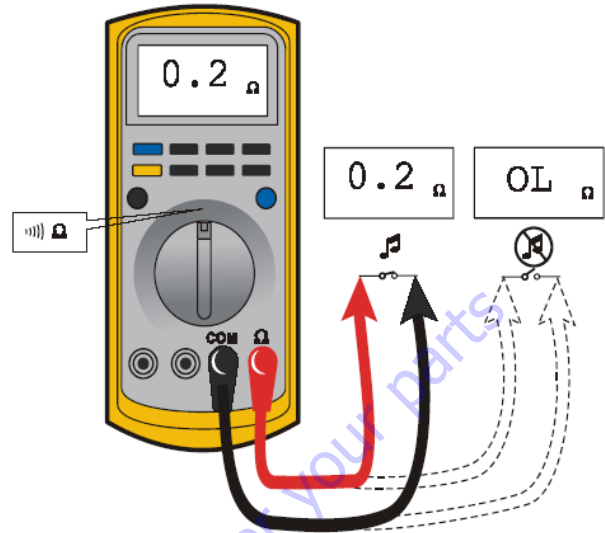
**Resistance Measurement**



**Figure 11-2. Resistance Measurement**

- First test meter and leads by touching leads together. Resistance should read a short circuit (very low resistance).
- Circuit power must be turned OFF before testing resistance.
- Disconnect component from circuit before testing.
- If meter is not auto ranging, set it to the correct range (See multimeter's operation manual).
- Use firm contacts with meter leads.

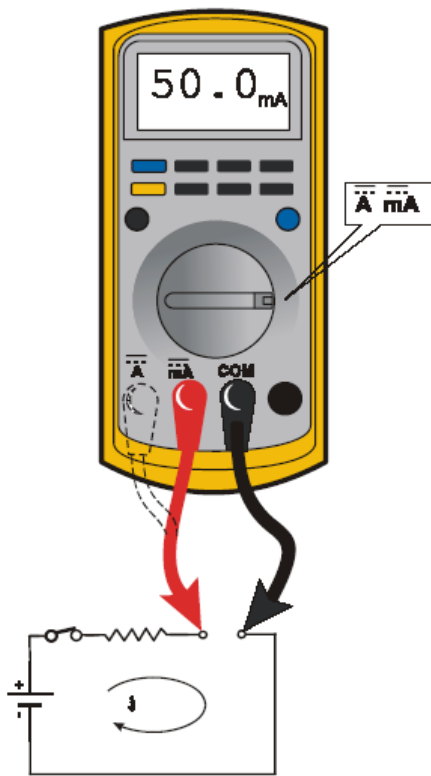
**Continuity Measurement**



**Figure 11-3. Continuity Measurement**

- Some meters require a separate button to enable audible continuity testing.
- Circuit power must be turned OFF before testing continuity.
- Disconnect component from circuit before testing.
- Use firm contact with meter leads.
- First test meter and leads by touching leads together. Meter should produce an audible alarm, indicating continuity.

**Current Measurement**



**Figure 11-4. Current Measurement (DC)**

- Set up meter for the expected current range.
- Be sure to connect the meter leads to the correct jacks for the current range you have selected.
- If meter is not auto ranging, set it to the correct range (See multimeter’s operation manual).
- Use firm contact with meter leads.

- b. Change the switch position.
  - c. Measure resistance again with the leads in the same positions. If the meter was reading short, it should read an open. If the meter was reading open it should read short.
5. If the switch has more than two terminals, consult the schematic or switch diagram to determine what terminals will be connected. The test is similar to testing a switch with two terminals.
    - a. Place one meter lead on the common contact and the other on a different contact in the same circuit.
    - b. Cycle through all positions of the switch. The meter should read short only when the switch connects the two terminals and open otherwise.
    - c. If the switch has more than one common contact repeat the process for that circuit.

**Limit Switches**

Limit switches are used to control movement or indicate position. Mechanical limit switches are just like manually operated switches except that the moving object operates the switch. These switches can be tested the same way as a standard switch by manually operating the sensing arm.

Another type of limit switch used by JLG is the inductive proximity switch, also referred to as a "prox switch". Inductive proximity switches are actuated only by ferrous metal (metal that contains Iron, such as steel) near the switch. They do not require contact, and must be energized to actuate. These types of switches can be used to detect boom or platform position, for example. These switches have a sensing face where the switch can detect ferrous metal close to it. To find the sensing face, take note how the switch is mounted and how the mechanisms meet the switch. Test this type of switch as follow:

1. Remove prox switch from its mount.
2. Reconnect harness if it was disconnected for step a, and turn on machine.
3. Hold switch away from metal and observe switch state in the control system diagnostics using the Analyzer. See vehicle or control system documentation on how to do this.
4. Place sensing face of switch on the object to be sensed by the switch. If that is not available, use a piece of ferrous metal physically similar to it. The switch state in the control system diagnostics should change.
5. When reinstalling or replacing switch be sure to follow mounting instructions and properly set the gap between the switch and object sensed.

**11.3 CHECKING SWITCHES**

**Basic Check**

The following check determines if the switch is functioning properly, not the circuit in which the switch is placed. A switch is functioning properly when there is continuity between the correct terminals or contacts only when selected.

1. De-energize the circuit.
2. Isolate the switch from the rest of the circuit if possible; If not possible, keep in mind it may affect readings.
3. Access the terminals to the switch.
4. If the switch has two terminals:
  - a. Measure resistance across the terminals.

### Automatic Switches

If the switch is actuated automatically, by temperature or pressure for example, find a way to manually actuate the switch to test it. Do this either by applying heat or pressure, for example, to the switch. These switches may need to be energized to actuate.

1. Connect instrumentation to monitor and/or control the parameter the switch is measuring.
2. Observe switch state in control system with the Analyzer. See vehicle or control system documentation on how to do this.
3. Operate system such that the switch actuates. This could be going over a certain pressure or temperature, for example. The state indicated in the control system should change.

### Switch Wiring - Low Side, High Side

When controlling a load, a switch can be wired between the positive side of the power source and the load. This switch is called a "high side" switch. The switch supplies the power to the load. When a switch is wired between the negative side of the power source and the load, it is a "low side" switch. The switch provides the ground to the load.

A low side switch will allow voltage to be present on the load. No power is applied because the switch is stopping current flow. This voltage can be seen if the measurement is taken with one test lead on the load and the other on the battery negative side or grounded to the vehicle. What is actually being measured is the voltage drop across the switch. This could mislead a technician into thinking the load is receiving power but not operating. To produce an accurate picture of power or voltage applied to the load, measure voltage across the load's power terminals. Also the technician can measure the voltage at both power terminals with respect to battery ground. The difference between those two measurements is the voltage applied to the load.

1. To prevent oxidation, silicone grease must be packed completely around male and female pins on the inside of the connector prior to assembly. This is most easily achieved by using a syringe.

**NOTE:** *Over a period of time, oxidation increases electrical resistance at the connection, eventually causing circuit failure.*

2. To prevent shorting, silicone grease must be packed around each wire where they enter the outside of the connector housing. Also, silicone grease must be applied at the joint where the male and female connectors come together. Any other joints (around strain reliefs, etc...) where water could enter the connector should also be sealed.

**NOTE:** *This condition is especially common when machines are pressure washed since the washing solution is much more conductive than water.*

3. Anderson connectors for the battery boxes and battery chargers should have silicone grease applied to the contacts only.

**NOTE:** *Curing-type sealants might also be used to prevent shorting and would be less messy, but would make future pin removal more difficult.*

## 11.4 APPLYING SILICONE DIELECTRIC COMPOUND TO ELECTRICAL CONNECTIONS

Silicone Dielectric Compound must be used on all electrical connections for the following reasons:

- To prevent oxidation at the mechanical joint between male and female pins.
- To prevent electrical malfunction caused by low level conductivity between pins when wet.

Use the following procedure to apply Silicone Dielectric Compound to the electrical connectors. This procedure applies to all plug connections not enclosed in a box. Silicone grease should not be applied to connectors with external seals.

**11.5 AMP CONNECTOR**

**Applying Silicone Dielectric Compound to AMP Connectors**

Silicone Dielectric Compound must be used on the AMP connections for the following reasons:

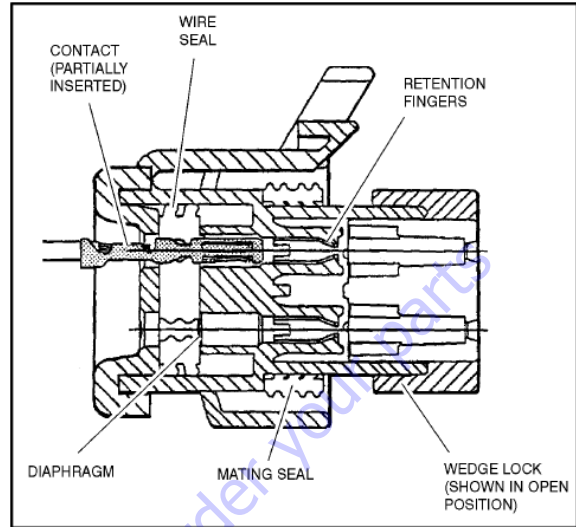
- To prevent oxidation at the mechanical joint between male and female pins.
- To prevent electrical malfunction caused by low level conductivity between pins when wet.

Use the following procedure to apply Silicone Dielectric Compound to the electrical connectors.

1. To prevent oxidation and low level conductivity, silicone dielectric grease must be packed completely around male and female pins on the inside of the connector after the mating of the housing to the header. This is easily achieved by using a syringe to fill the header with silicone dielectric compound, to a point just above the top of the male pins inside the header. When assembling the housing to the header, it is possible that the housing will become air locked, thus preventing the housing latch from engaging.
2. Pierce one of the unused wire seals to allow the trapped air inside the housing to escape.
3. Install a hole plug into this and/or any unused wire seal that has silicone dielectric compound escaping from it.

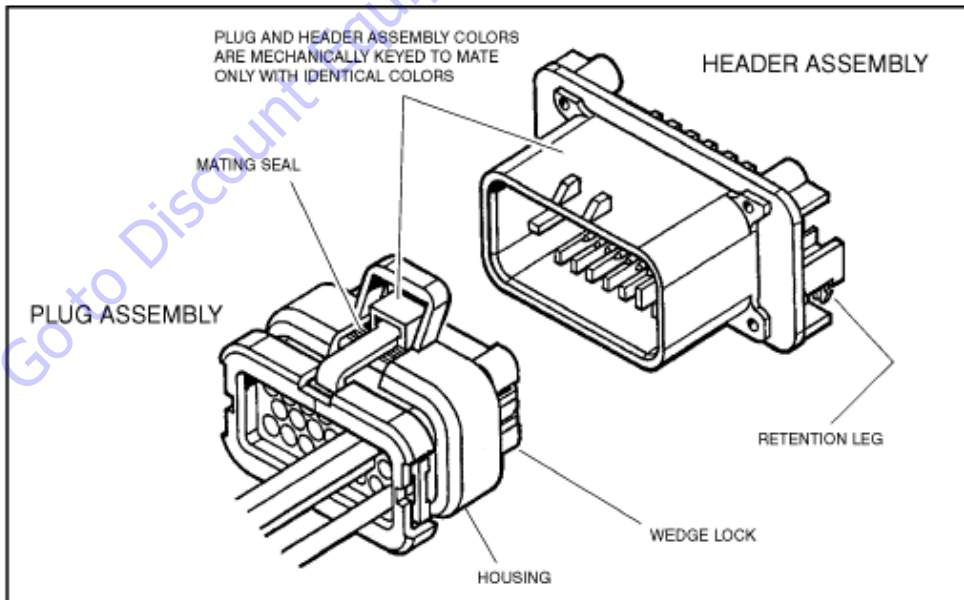
**Assembly**

Check to be sure the wedge lock is in the open, or asshipped, position (See Figure 11-5). Proceed as follow:

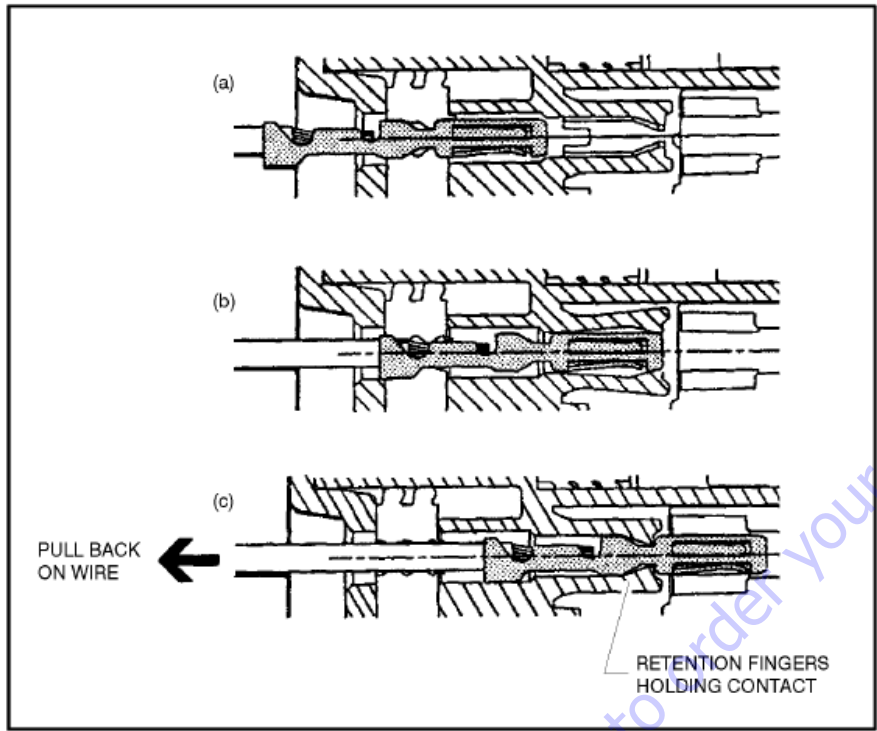


**Figure 11-5. Connector Assembly Figure 1**

1. To insert a contact, push it straight into the appropriate circuit cavity as far as it will go (See Figure 11-7).
2. Pull back on the contact wire with a force of 1 or 2 lbs. to be sure the retention fingers are holding the contact (See Figure 11-7).

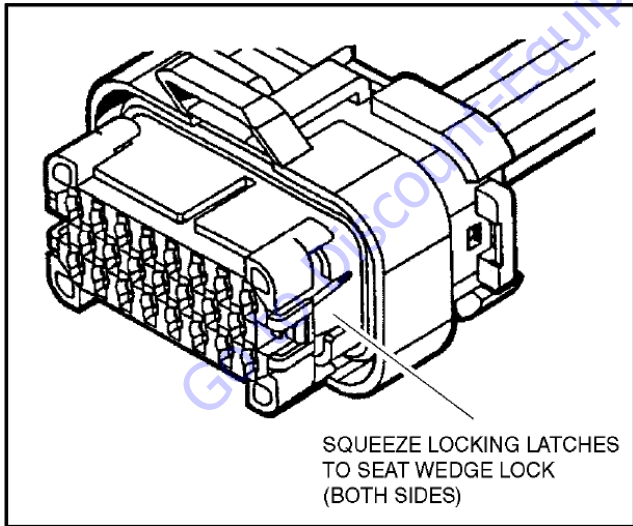


**Figure 11-6. AMP Connector**

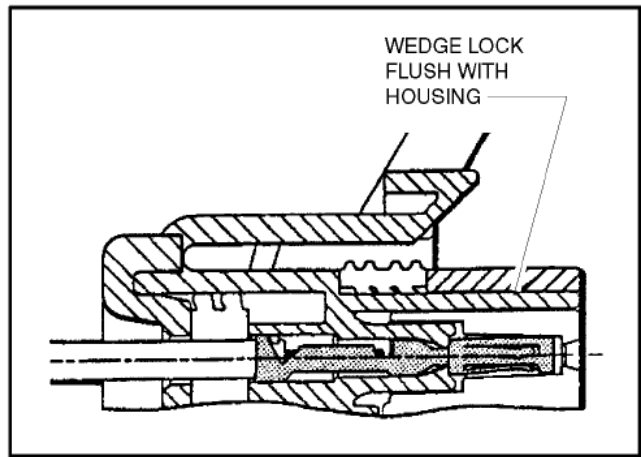


**Figure 11-7. Connector Assembly Figure 2**

3. After all required contacts have been inserted, the wedge lock must be closed to its locked position. Release the locking latches by squeezing them inward (See Figure 11-8).
4. Slide the wedge lock into the housing until it is flush with the housing (See Figure 11-9).



**Figure 11-8. Connector Assembly Figure 3**



**Figure 11-9. Connector Assembly Figure 4**

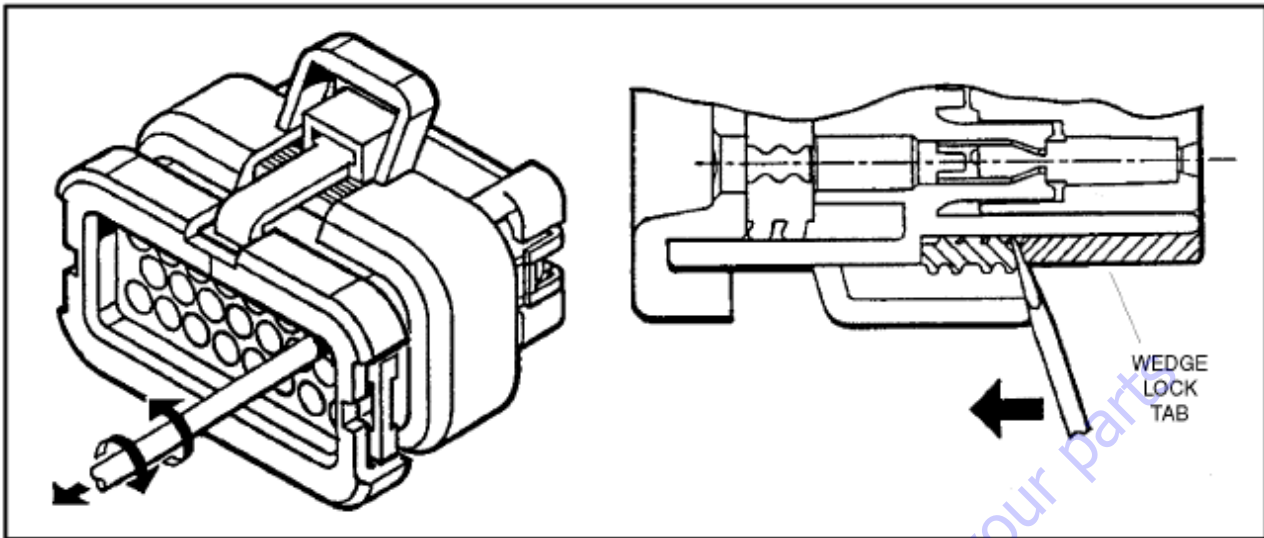


Figure 11-10. Connector Disassembly

### Disassembly

1. Insert a 4.8 mm (3/16") wide screwdriver blade between the mating seal and one of the red wedge lock tabs.
2. Pry open the wedge lock to the open position.
3. While rotating the wire back and forth over a half turn (1/4 turn in each direction), gently pull the wire until the contact is removed.

**NOTE:** The wedge lock should never be removed from the housing for insertion or removal of the contacts.

### Wedge Lock

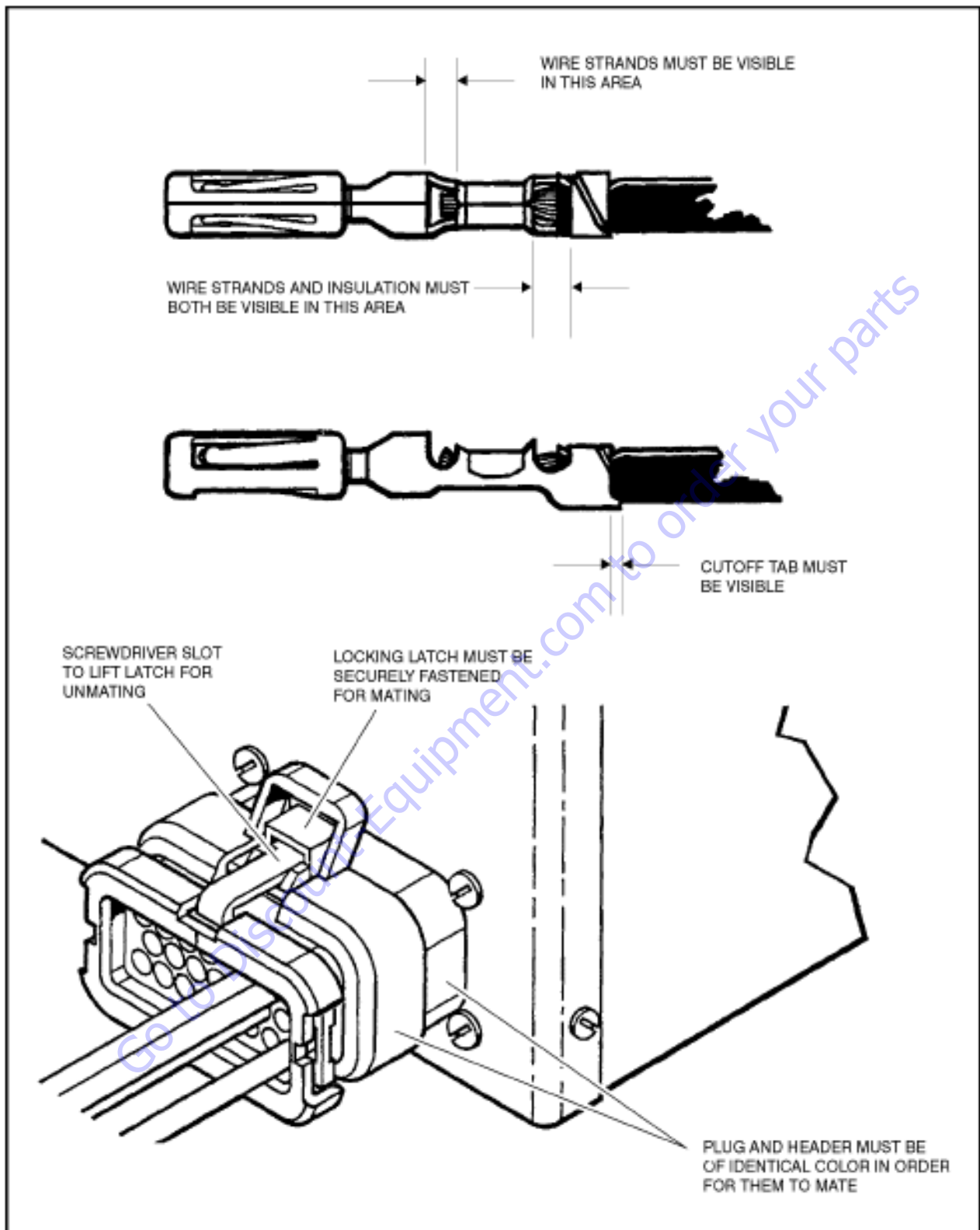
The wedge lock has slotted openings in the forward, or mating end. These slots accommodate circuit testing in the field, by using a flat probe such as a pocket knife. DO NOT use a sharp point such as an ice pick.

### Service - Voltage Reading

#### **⚠ CAUTION**

**DO NOT PIERCE WIRE INSULATION TO TAKE VOLTAGE READINGS.**

It has been common practice in electrical troubleshooting to probe wire by piercing the insulation with a sharp point. This practice should be discouraged when dealing with the AMPSEAL plug assembly, or any other sealed connector system. The resulting pinholes in the insulation will allow moisture to invade the system by traveling along the wire strands. This nullifies the effectiveness of the connector seals and could result in system failure.

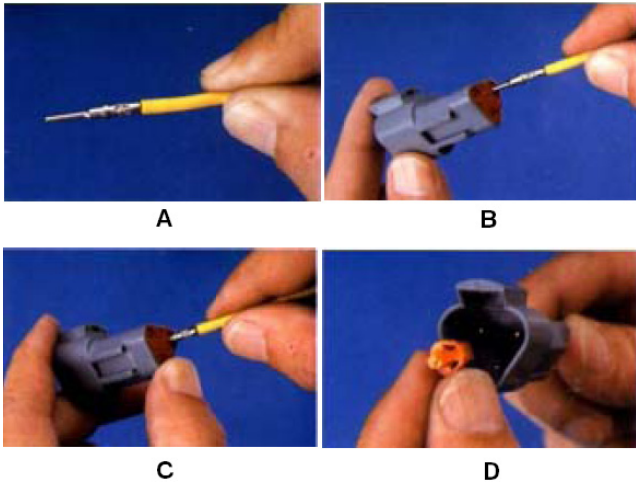


**Figure 11-11. Connector Installation**



## 11.6 DEUTSCH CONNECTORS

### DT/DTP Series Assembly

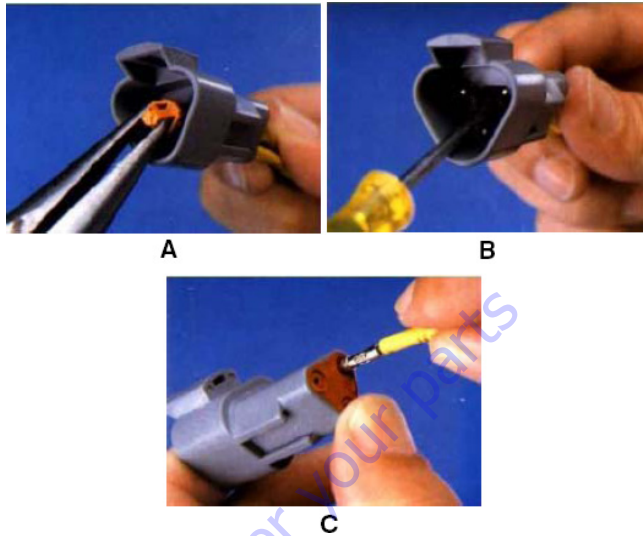


**Figure 11-12. DT/DTP Contact Installation**

1. Grasp crimped contact about 25 mm behind the contact barrel.
2. Hold connector with rear grommet facing you.
3. Push contact straight into connector grommet until a click is felt. A slight tug will confirm that it is properly locked in place.
4. Once all contacts are in place, insert wedgelock with arrow pointing toward exterior locking mechanism. The wedgelock will snap into place. Rectangular wedges are not oriented. They may go in either way.

**NOTE:** The receptacle is shown - use the same procedure for plug.

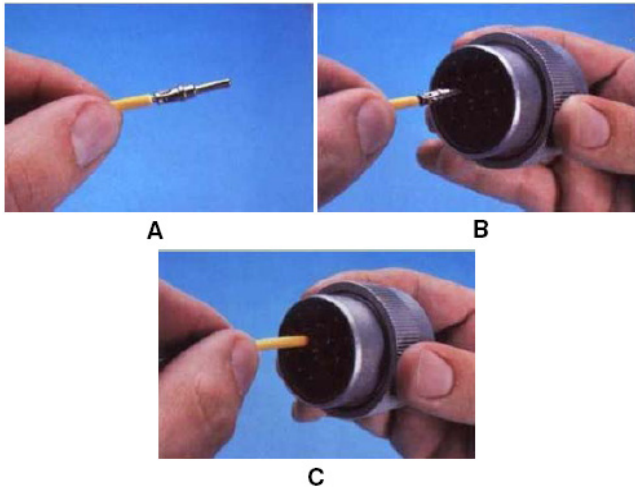
### DT/DTP Series Disassembly



**Figure 11-13. DT/DTP Contact Removal**

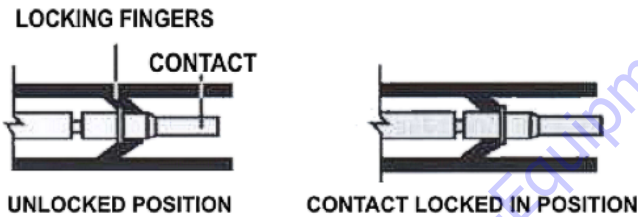
1. Remove wedgelock using needlenose pliers or a hook shaped wire to pull wedge straight out.
2. To remove the contacts, gently pull wire backwards, while at the same time releasing the locking finger by moving it away from the contact with a screwdriver.
3. Hold the rear seal in place, as removing the contact may displace the seal.

**HD30/HDP20 Series Assembly**



**Figure 11-14. HD/HDP Contact Installation**

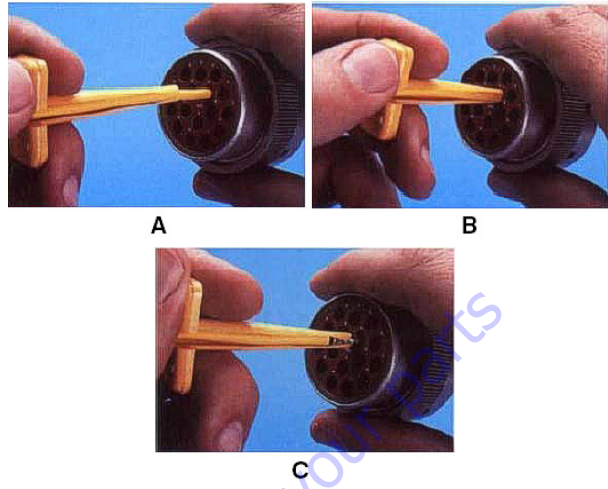
1. Grasp contact about 25 mm behind the contact crimp barrel.
2. Hold connector with rear grommet facing you.
3. Push contact straight into connector grommet until a positive stop is felt. A slight tug will confirm that it is properly locked in place.



**Figure 11-15. HD/HDP Locking Contacts Into Position**

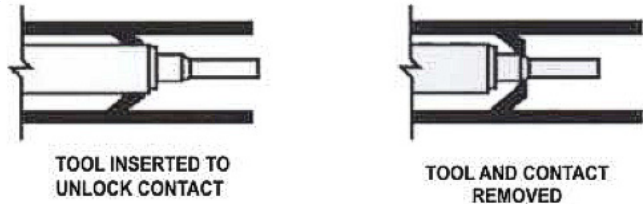
**NOTE:** For unused wire cavities, insert sealing plugs for full environmental sealing.

**HD30/HDP20 Series Disassembly**



**Figure 11-16. HD/HDP Contact Removal**

1. With rear insert toward you, snap appropriate size extractor tool over the wire of contact to be removed.
2. Slide tool along into the insert cavity until it engages contact and resistance is felt.
3. Pull contact-wire assembly out of connector.



**Figure 11-17. HD/HDP Unlocking Contacts**

**NOTE:** Do not twist or insert tool at an angle.

11.7 CONNECTORS IDENTIFICATION

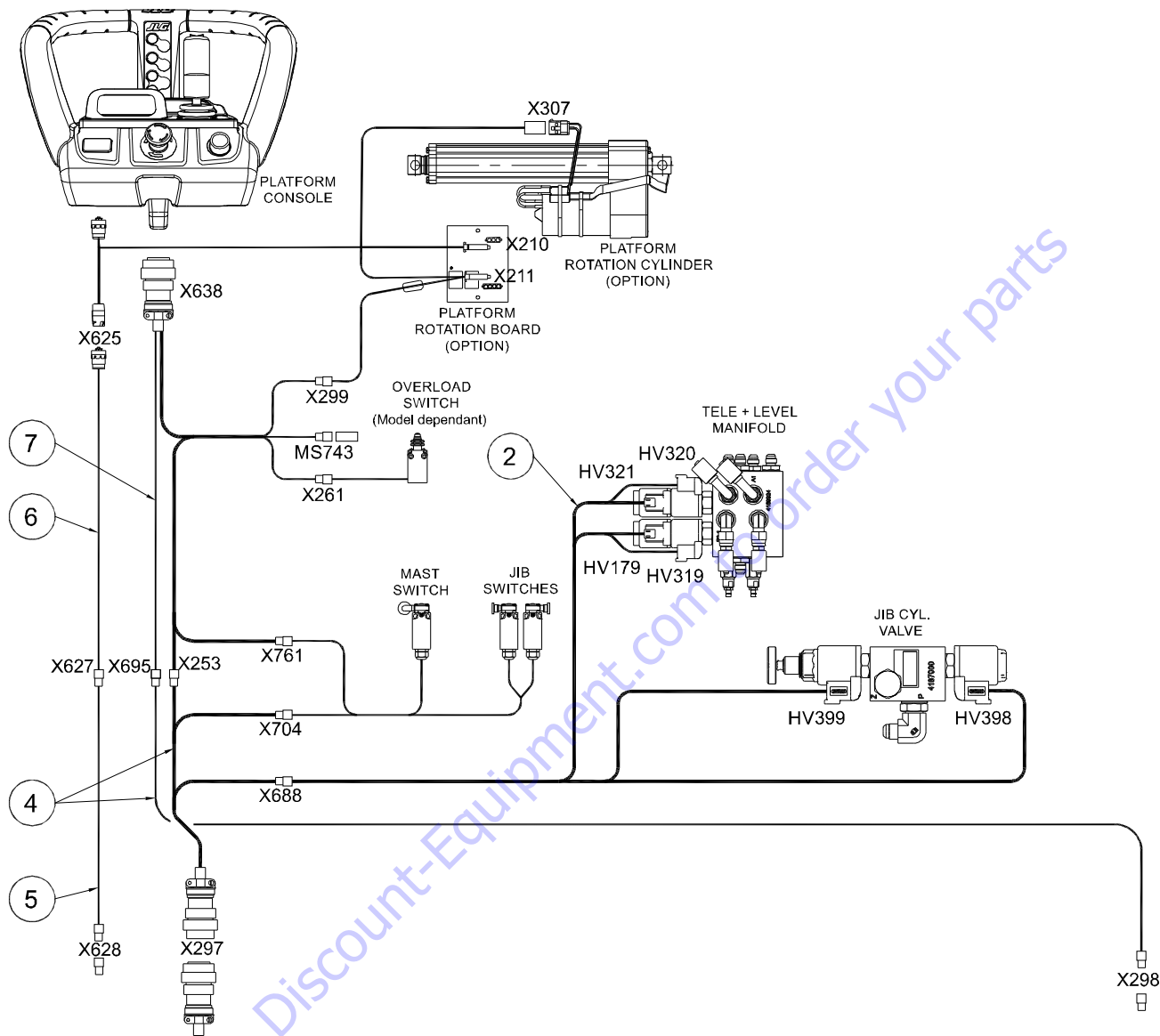
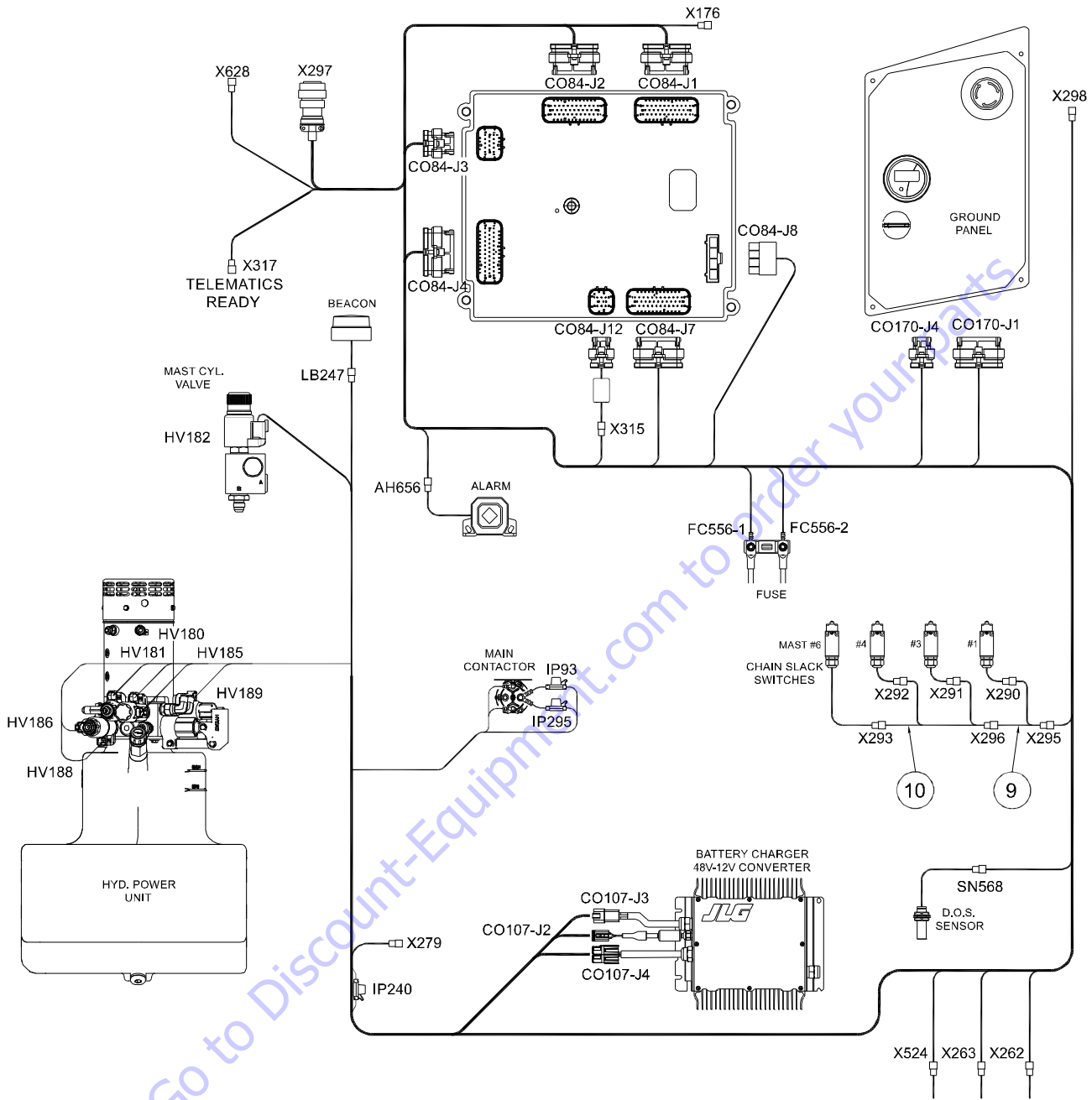
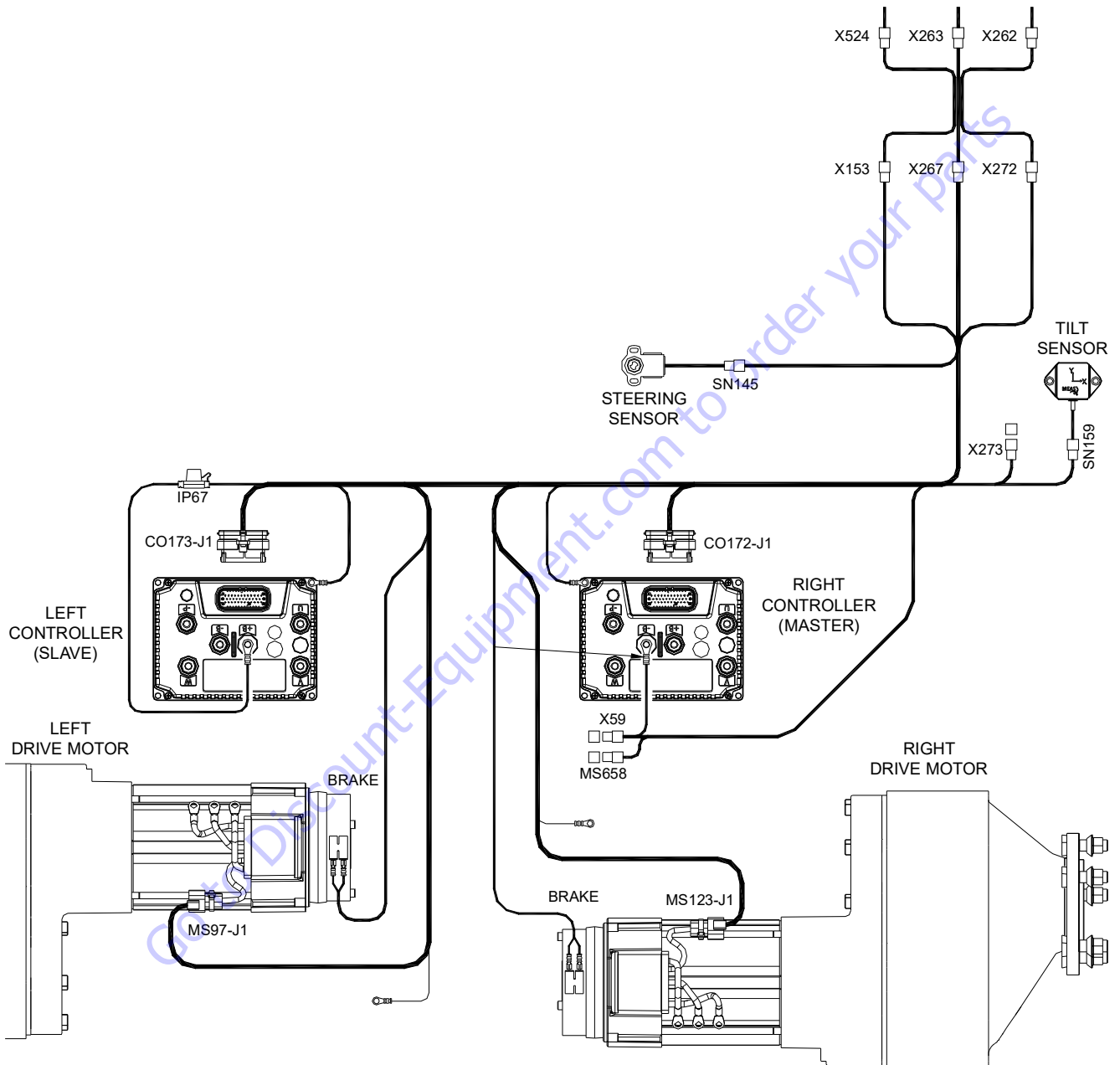


Figure 11-18. Wiring Harness and Connectors - Sheet 1 of 3

**SECTION 11 - GENERAL ELECTRICAL INFORMATION & SCHEMATICS**



**Figure 11-19. Wiring Harness and Connectors - Sheet 2 of 3**



**Figure 11-20. Wiring harness and Connectors - Sheet 3 of 3**

11.8 ELECTRICAL SCHEMATIC

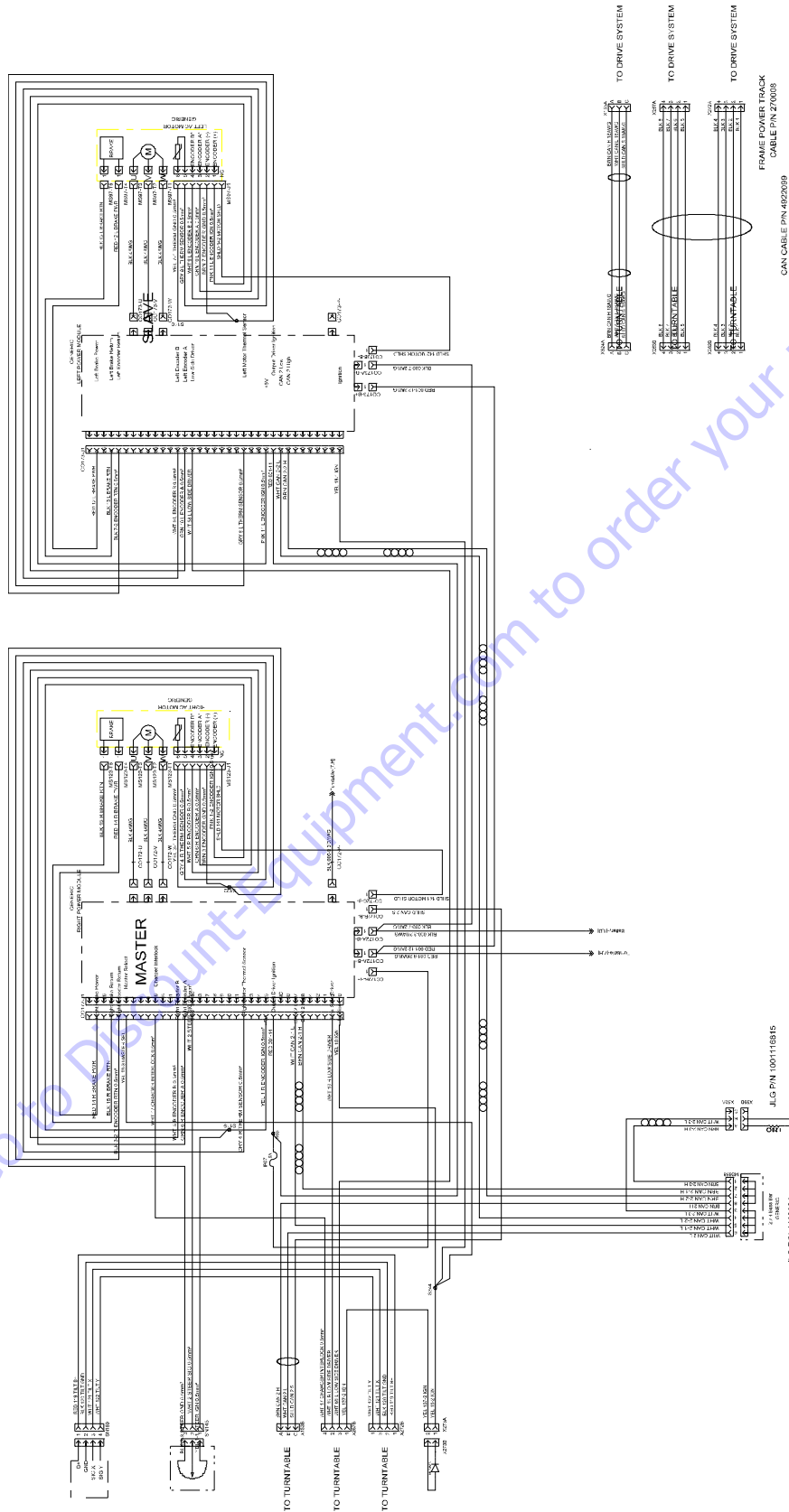


Figure 11-21. Electrical schematic - Drive System

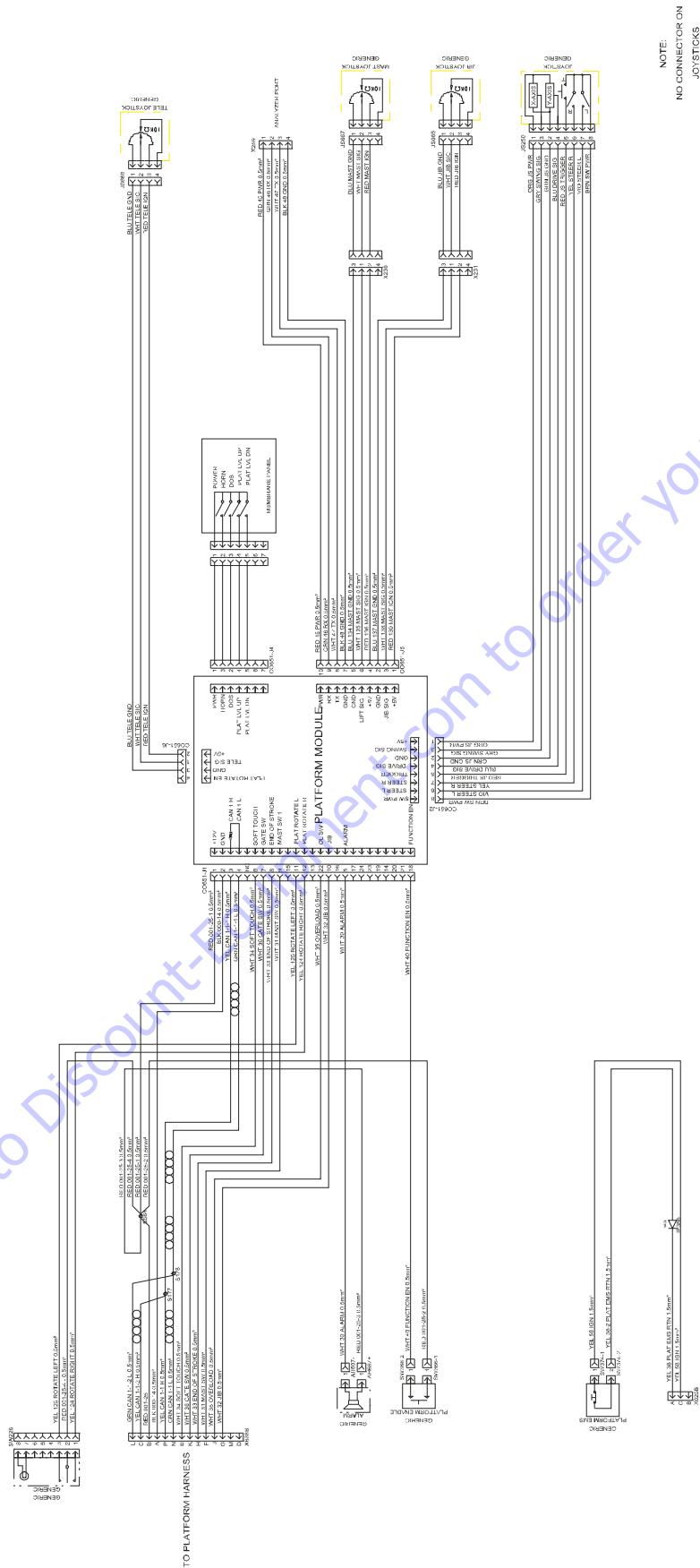








**SECTION 11 - GENERAL ELECTRICAL INFORMATION & SCHEMATICS**



**Figure 11-25. Electrical Schematic - Platform Box**



11.9 HYDRAULIC SCHEMATIC

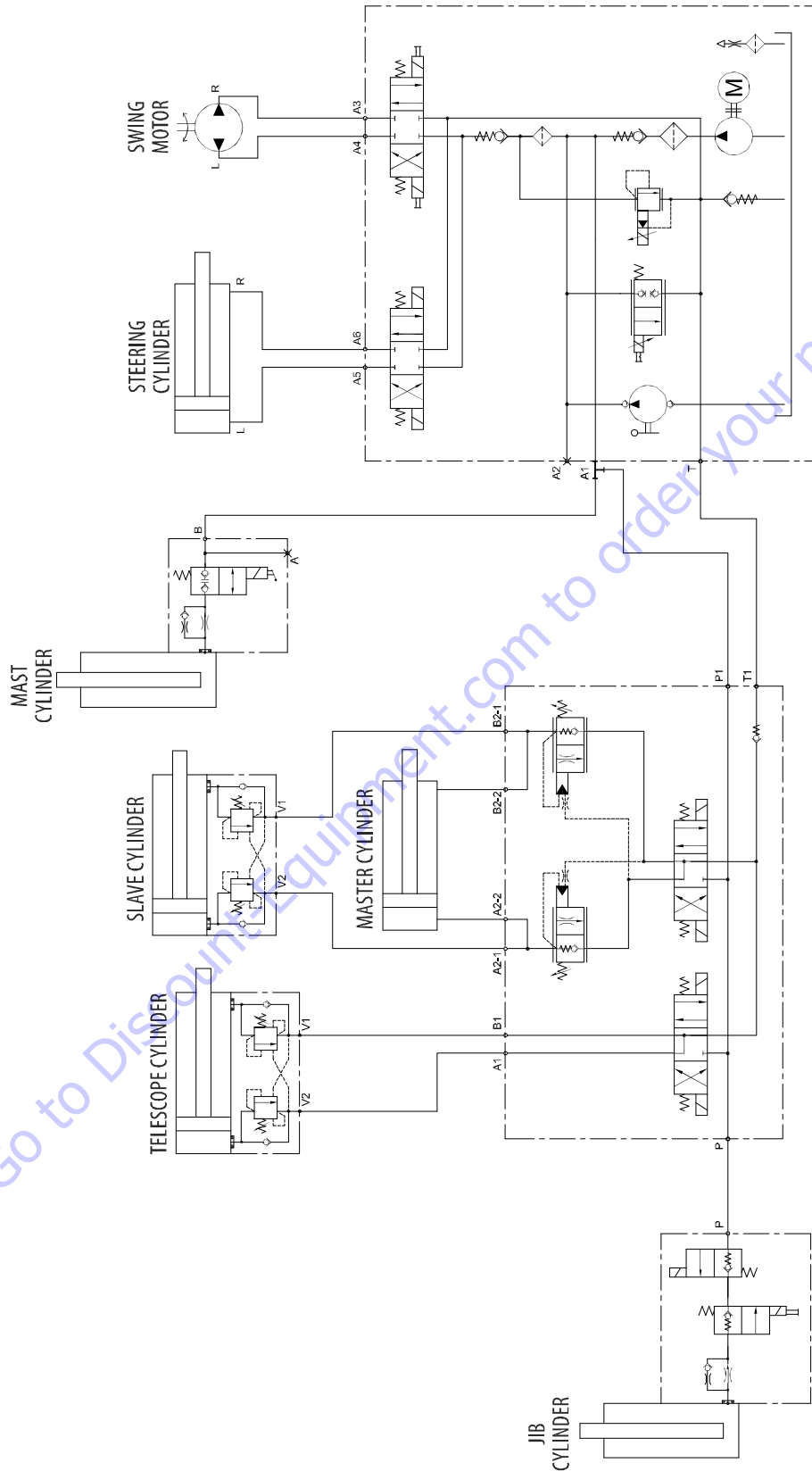


Figure 11-27. Hydraulic schematic

# PARTS FINDER

**Search Website  
by Part Number**



**Search Manual  
Library For Parts  
Manual & Lookup Part  
Numbers – Purchase  
or Request Quote**

A screenshot of the "Search Manuals" form. The form has a title "Search Manuals" and a subtitle "Please provide information to help us locate the manual and/or parts you need." It includes fields for "Brand", "Model", "Serial", "Part Number", and "Quantity". There is a "Search" button at the bottom.

**Can't Find Part or  
Manual? Request Help  
by Manufacturer,  
Model & Description**

A screenshot of the "Parts Order Form". The form has a title "Parts Order Form" and a subtitle "Please fill in as much information as possible." It includes fields for "Manufacturer", "Model", "Description", "Part Number", "Quantity", and "Comments". There is a "Submit" button at the bottom.

Discount-Equipment.com is your online resource for quality parts & equipment.

Florida: **561-964-4949** Outside Florida TOLL FREE: **877-690-3101**

**Need parts?**

Click on this link: <http://www.discount-equipment.com/category/5443-parts/> and choose one of the options to help get the right parts and equipment you are looking for. Please have the machine model and serial number available in order to help us get you the correct parts. If you don't find the part on the website or on once of the online manuals, please fill out the request form and one of our experienced staff members will get back to you with a quote for the right part that your machine needs.

We sell worldwide for the brands: Genie, Terex, JLG, MultiQuip, Mikasa, Essick, Whiteman, Mayco, Toro Stone, Diamond Products, Generac Magnum, Airman, Haulotte, Barreto, Power Blanket, Nifty Lift, Atlas Copco, Chicago Pneumatic, Allmand, Miller Curber, Skyjack, Lull, Skytrak, Tsurumi, Husquvarna Target, , Stow, Wacker, Sakai, Mi-T- M, Sullair, Basic, Dynapac, MBW, Weber, Bartell, Bennar Newman, Haulotte, Ditch Runner, Menegotti, Morrison, Contec, Buddy, Crown, Edco, Wyco, Bomag, Laymor, Barreto, EZ Trench, Bil-Jax, F.S. Curtis, Gehl Pavers, Heli, Honda, ICS/PowerGrit, IHI, Partner, Imer, Clipper, MMD, Koshin, Rice, CH&E, General Equipment, ,AMida, Coleman, NAC, Gradall, Square Shooter, Kent, Stanley, Tamco, Toku, Hatz, Kohler, Robin, Wisconsin, Northrock, Oztec, Toker TK, Rol-Air, Small Line, Wanco, Yanmar

**JLG**<sup>®</sup>



[www.Discount-Equipment.com](http://www.Discount-Equipment.com)

---

*Go to [Discount-Equipment.com](http://Discount-Equipment.com) to order your parts*

---