

TOW-PRO® SERIES

TRAILER MOUNTED BOOM LIFTS



www.Discount-Equipment.com



Performance

Platform Height		
T350	34 ft 5 in.	10.5 m
T500J	50 ft 9.5 in.	15.3 m
Horizontal Outreach		
Working Outreach		
T350	20 ft 2 in.	6.15 m
T500J	31 ft 6 in.	9.6 m
Centerline to Platform Edge		
T350	18 ft 9.5 in.	5.7 m
T500J	29 ft 6 in.	9 m
From Outrigger Pad Edge		
T350	13 ft 6 in.	4.11 m
T500J	23 ft 5 in.	7.14 m
Up and Over Height		
T350	15 ft	4.57 m
T500J	18 ft	5.49 m
Swing		
	410 Degrees Non-Continuous	
Platform Capacity		
	500 lb	227 kg
Platform Capacity w/Rotator (Optional)		
	440 lb	200 kg
Material Hook Capacity		
	500 lb	227 kg
Platform Rotator (Optional)		
	90 Degrees Manual	
Jib Length (T500J only)		
	4 ft	1.22 m
Jib Vertical Motion (T500J only)		
	130 degrees (+75, -55)	
Weight*		
T350	3,400 lb	1,542 kg
T500J	4,800 lb	2,177 kg
Leveling Capability		
	11 Degrees	
Max. Ground Bearing Pressure		
T350	23 psi	1.62 kg/cm ²
T500J	31 psi	2.18 kg/cm ²
Towing Speed Rating		
	65 mph	105 kmph
Tongue Weight*		
T350	250 lb	114 kg
T500J	350 lb	159 kg

*Machine weights may increase with options

Standard Specifications

Power Source

DC Power	24V DC
Batteries	4 x 6V 220 amp-hr
Gasoline Engine (Optional)	Honda GX 270—9 hp

Tires

• T350	ST215/75 R14 Pneumatic
• T500J	ST225/75 R15 Pneumatic

Standard Features

- Telescopic Upper Boom
- 4 ft (1.22 m) Jib (T500J Only)
- Platform, Side Entry: 30 x 48 in. (0.76 x 1.22 m)
- Proportional Controls
- 110V-AC Receptacle in the Platform
- Auto-Leveling Hydraulic Outriggers
- Motion Alarm
- Tilt Alarm/Indicator Light
- Hourmeter
- Four 6V 220 Amp-Hour Batteries
- Battery Condition Indicator
- Parking Brake
- 2 in. Hitch with Adjustable Height Coupler
- Standard Air and Water Lines to Platform



Accessories & Options

- Platform Rotator
- Material Hook — 500 lb (227 kg) Capacity
- Drive and Outrigger Set
- Platform Mounted Glass/Panel Tray
- Non-Marking Outrigger Pads
- Full-Size Spare Tire
- Flashing Amber Beacon
- 3000 Watt Honda Generator

TOW-PRO® SERIES

TRAILER MOUNTED BOOM LIFTS



Dimensions

All dimensions are approximate.

T350

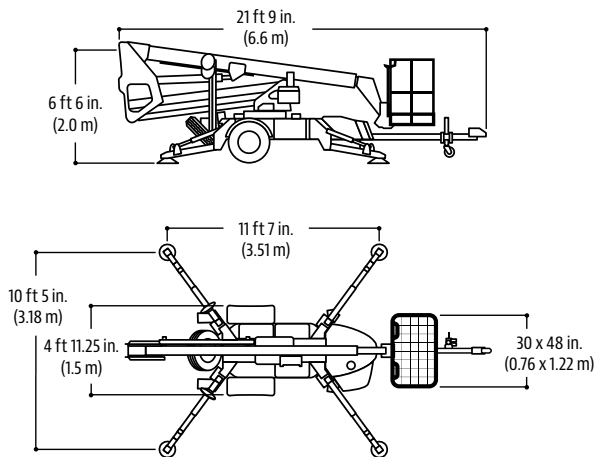

T500J

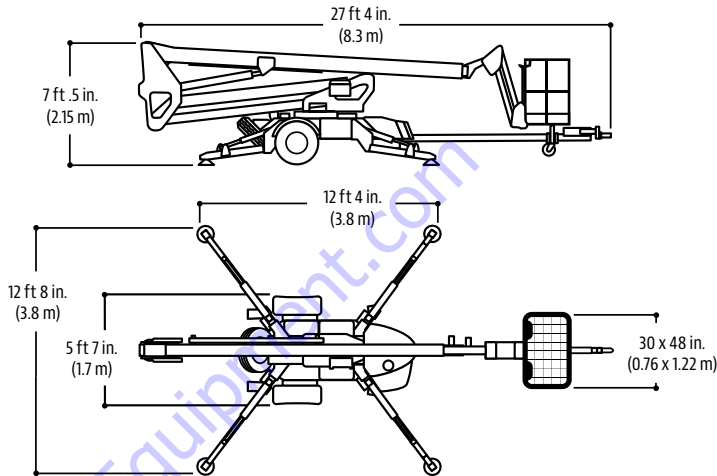

Reach Dimensions

T350

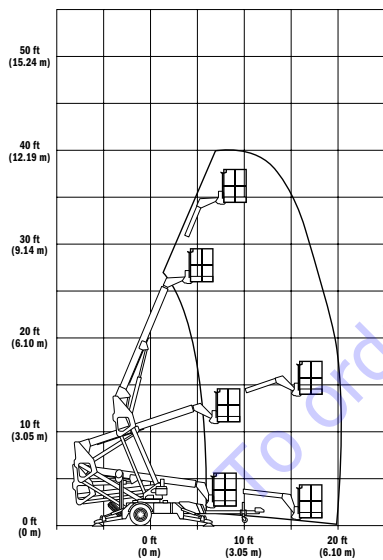

T500J

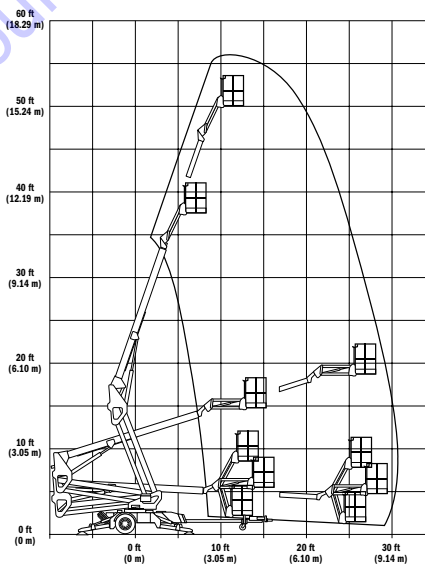

The JLG "1 & 5" Warranty

We provide coverage for one (1) full year, and cover all specified major structural components for five (5) years. Due to continuous product improvements, we reserve the right to make specification and/or equipment changes without prior notification. This machine meets or exceeds applicable ANSI and CSA requirements based on machine configuration as originally manufactured for intended applications. Please reference the serial number plate on the machine for additional information.



www.Discount-Equipment.com

Part No.: 3133001
 RT11708
 Printed in USA