



An Oshkosh Corporation Company



www.Discount-Equipment.com

Service and Maintenance Manual

Model(s)

Ecolift50

Ecolift70

830P

3121741

June 29, 2018 - Rev B



ANSI



PARTS FINDER

Search Website
by Part Number



Search Manual
Library For Parts
Manual & Lookup Part
Numbers – Purchase
or Request Quote

Search Manuals

Enter your information to search our manual library for parts manuals.

* Brand:

* Model:

* Serial:

* Part Number:

SEARCH

Can't Find Part or
Manual? Request Help
by Manufacturer,
Model & Description

Parts Order Form

Please fill in the following information to request help finding a part or manual.

MANUFACTURER:

MODEL:

DESCRIPTION:

DATE:

NAME:

PHONE:

EMAIL:

ADDRESS:

CITY:

STATE:

ZIP:

COUNTRY:

REQUESTOR:

REQUESTOR TITLE:

COMPANY:

PHONE:

EMAIL:

ADDRESS:

CITY:

STATE:

ZIP:

COUNTRY:

REQUESTOR:

REQUESTOR TITLE:

COMPANY:

PHONE:

EMAIL:

ADDRESS:

CITY:

STATE:

ZIP:

COUNTRY:

REQUESTOR:

REQUESTOR TITLE:

COMPANY:

PHONE:

EMAIL:

ADDRESS:

CITY:

STATE:

ZIP:

COUNTRY:

Discount-Equipment.com is your online resource for quality parts & equipment.
Florida: **561-964-4949** Outside Florida TOLL FREE: **877-690-3101**

Need parts?

Click on this link: <http://www.discount-equipment.com/category/5443-parts/> and choose one of the options to help get the right parts and equipment you are looking for. Please have the machine model and serial number available in order to help us get you the correct parts. If you don't find the part on the website or on once of the online manuals, please fill out the request form and one of our experienced staff members will get back to you with a quote for the right part that your machine needs.

We sell worldwide for the brands: Genie, Terex, JLG, MultiQuip, Mikasa, Essick, Whiteman, Mayco, Toro Stone, Diamond Products, Generac Magnum, Airman, Haulotte, Barreto, Power Blanket, Nifty Lift, Atlas Copco, Chicago Pneumatic, Allmand, Miller Curber, Skyjack, Lull, Skytrak, Tsurumi, Husquvarna Target, , Stow, Wacker, Sakai, Mi-T- M, Sullair, Basic, Dynapac, MBW, Weber, Bartell, Bennar Newman, Haulotte, Ditch Runner, Menegotti, Morrison, Contec, Buddy, Crown, Edco, Wyco, Bomag, Laymor, Barreto, EZ Trench, Bil-Jax, F.S. Curtis, Gehl Pavers, Heli, Honda, ICS/PowerGrit, IHI, Partner, Imer, Clipper, MMD, Koshin, Rice, CH&E, General Equipment, ,AMida, Coleman, NAC, Gradall, Square Shooter, Kent, Stanley, Tamco, Toku, Hatz, Kohler, Robin, Wisconsin, Northrock, Oztec, Toker TK, Rol-Air, Small Line, Wanco, Yanmar

INTRODUCTION - MAINTENANCE SAFETY PRECAUTIONS

GENERAL

This section contains the general safety precautions which must be observed during maintenance of the aerial platform. It is of utmost importance that maintenance personnel pay strict attention to these warnings and precautions to avoid possible injury to themselves or others, or damage to the equipment. A maintenance program must be followed to ensure that the machine is safe to operate.

⚠ WARNING

MODIFICATION OR ALTERATION OF AN AERIAL WORK PLATFORM SHALL BE MADE ONLY WITH WRITTEN PERMISSION FROM THE MANUFACTURER.

The specific precautions to be observed during maintenance are inserted at the appropriate point in the manual. These precautions are, for the most part, those that apply when servicing hydraulic and larger machine component parts.

Your safety, and that of others, is the first consideration when engaging in the maintenance of equipment. Always be conscious of weight. Never attempt to move heavy parts without the aid of a mechanical device. Do not allow heavy objects to rest in an unstable position. When raising a portion of the equipment, ensure that adequate support is provided.

⚠ WARNING

SINCE THE MACHINE MANUFACTURER HAS NO DIRECT CONTROL OVER THE FIELD INSPECTION AND MAINTENANCE, SAFETY IN THIS AREA RESPONSIBILITY OF THE OWNER/OPERATOR.

HYDRAULIC SYSTEM SAFETY

It should be noted that the machines hydraulic systems operate at extremely high potentially dangerous pressures. Every effort should be made to relieve any system pressure prior to disconnecting or removing any portion of the system.



MAINTENANCE

⚠ WARNING

FAILURE TO COMPLY WITH SAFETY PRECAUTIONS LISTED IN THIS SECTION COULD RESULT IN MACHINE DAMAGE, PERSONNEL INJURY OR DEATH AND IS A SAFETY VIOLATION.

- ENSURE REPLACEMENT PARTS OR COMPONENTS ARE IDENTICAL OR EQUIVALENT TO ORIGINAL PARTS OR COMPONENTS.
- NO SMOKING IS MANDATORY. NEVER REFUEL DURING ELECTRICAL STORMS. ENSURE THAT FUEL CAP IS CLOSED AND SECURE AT ALL OTHER TIMES.
- REMOVE ALL RINGS, WATCHES AND JEWELRY WHEN PERFORMING ANY MAINTENANCE.
- DO NOT WEAR LONG HAIR UNRESTRAINED, OR LOOSE-FITTING CLOTHING AND NECKTIES WHICH ARE APT TO BECOME CAUGHT ON OR ENTANGLED IN EQUIPMENT.
- OBSERVE AND OBEY ALL WARNINGS AND CAUTIONS ON MACHINE AND IN SERVICE MANUAL.
- KEEP OIL, GREASE, WATER, ETC. WIPED FROM STANDING SURFACES AND HAND HOLDS.
- USE CAUTION WHEN CHECKING A HOT, PRESSURIZED COOLANT SYSTEM.
- NEVER WORK UNDER AN ELEVATED PLATFORM UNTIL IT HAS BEEN SAFELY RESTRAINED FROM ANY MOVEMENT BY BLOCKING OR OVERHEAD SLING, OR SAFETY PROP HAS BEEN ENGAGED.
- BEFORE MAKING ADJUSTMENTS, LUBRICATING OR PERFORMING ANY OTHER MAINTENANCE, SHUT OFF ALL POWER CONTROLS.
- BATTERY SHOULD ALWAYS BE DISCONNECTED DURING REPLACEMENT OF ELECTRICAL COMPONENTS.
- KEEP ALL SUPPORT EQUIPMENT AND ATTACHMENTS STOWED IN THEIR PROPER PLACE.
- USE ONLY APPROVED, NONFLAMMABLE CLEANING SOLVENTS.

REVISION LOG

Original Issue	A - January 20, 2017
Revised	B - June 29, 2018 - Revised Covers

Go to Discount-Equipment.com to order your parts

TABLE OF CONTENTS

SUBJECT - SECTION, PARAGRAPH	PAGE NO.
SECTION - INTRODUCTION - MAINTENANCE SAFETY PRECAUTIONS	
GENERAL	A
HYDRAULIC SYSTEM SAFETY	A
MAINTENANCE	A
REVISION LOG	B
SECTION - TABLE OF CONTENTS	
SECTION 1 - MACHINE SPECIFICATIONS	
1.1 GENERAL SPECIFICATIONS	1-1
Machine Specifications	1-1
1.2 LUBRICATION	1-3
Hydraulic Oil - (830P Only)	1-3
Lubrication Specifications	1-3
1.3 SERIAL NUMBER LOCATIONS	1-3
1.4 TORQUE REQUIREMENTS	1-3
1.5 TORQUE CHARTS	1-5
SECTION 2 - GENERAL SERVICE INFORMATION	
2.1 MACHINE PREPARATION, INSPECTION, AND MAINTENANCE	2-1
General	2-1
Preparation, Inspection, and Maintenance	2-1
Pre-Start Inspection	2-1
Pre-Delivery Inspection and Frequent Inspection	2-1
Annual Machine Inspection	2-1
Preventative Maintenance	2-1
2.2 PREVENTIVE MAINTENANCE AND INSPECTION SCHEDULE	2-2
2.3 SERVICING AND MAINTENANCE GUIDELINES	2-4
General	2-4
Safety and Workmanship	2-4
Cleanliness	2-4
Components Removal and Installation	2-4
Component Disassembly and Reassembly	2-4
Pressure-Fit Parts	2-4
Bearings	2-4
Gaskets	2-4
Bolt Usage and Torque Application	2-5
2.4 HYDRAULIC SYSTEM INFORMATION - (830P ONLY)	2-5
Hydraulic Lines and Electrical Wiring	2-5
Hydraulic System	2-5
Lubrication and Servicing	2-5
Hydraulic Oil	2-5
Changing Hydraulic Oil	2-5
SECTION 3 - COMPONENT SERVICING	
3.1 FRAME COVER INSTALLATION	3-1
Ecolift50	3-1
Ecolift70	3-1
830P	3-2
3.2 TOOL TRAY INSTALLATION	3-3

TABLE OF CONTENTS

Ecolift50	3-3
Ecolift70	3-3
830P	3-3
3.3 CASTOR WHEEL ASSEMBLY	3-4
Ecolift70 and 830P	3-4
Ecolift50	3-4
3.4 REAR AXLE ASSEMBLY	3-5
Ecolift 50/70	3-5
830P	3-6
3.5 PLATFORM INSTALLATION	3-7
Ecolift50/70	3-7
830P	3-7
3.6 ECOLIFT FLYWHEEL CRANK COVER INSTALLATION	3-8
3.7 ECOLIFT50/70 MAST INSTALLATION	3-8
Mast Disassembly	3-8
Mast Re-assembly	3-10
Gas Cylinder Pressurizing	3-12
Flywheel Rotation Force - Testing	3-12
3.8 830P MAST INSTALLATION	3-13
Mast Disassembly	3-13
Mast Assembly Notes	3-13
Hydraulic System - Pressure and Leak Check	3-14
3.9 830P ELECTRICAL/HYDRAULIC COMPONENTS	3-16
Contactor Solenoid Replacement	3-17
Battery Charger Operation	3-17

SECTION 4 - 830P - TROUBLESHOOTING AND SCHEMATICS

4.1 GENERAL	4-1
4.2 TROUBLESHOOTING INFORMATION	4-1
4.3 HYDRAULIC CIRCUIT CHECKS	4-1
4.4 ELECTRICAL SYSTEM - MULTIMETER BASICS	4-1
Grounding	4-1
Backprobing	4-1
Min/Max	4-1
Polarity	4-2
Scale	4-2
Continuity Measurement Over Long Distances	4-2
Requirements:	4-2
Procedure	4-2
4.5 ELECTRICAL SWITCH TESTING	4-5
Basic Check	4-5
Limit Switches	4-5
Automatic Switches	4-5
Switch Wiring - Low Side, High Side	4-5
4.6 830P ELECTRICAL DIAGRAM	4-7
4.7 830P HYDRAULIC DIAGRAM	4-8

LIST OF FIGURES

FIGURE NO.	TITLE	PAGE NO.
1-1.	Operating Specification (EcoLift 50)	1-2
1-2.	Operating Specification (EcoLift 70)	1-2
1-3.	Operating Specification (830P)	1-2
1-4.	Torque Chart (SAE Fasteners - Sheet 1 of 7)	1-5
1-5.	Torque Chart (SAE Fasteners - Sheet 2 of 7))	1-6
1-6.	Torque Chart (SAE Fasteners - Sheet 3 of 7)	1-7
1-7.	Torque Chart (SAE Fasteners - Sheet 4 of 7)	1-8
1-8.	Torque Chart (METRIC Fasteners - Sheet 5 of 7))	1-9
1-9.	Torque Chart (METRIC Fasteners - Sheet 6 of 7)	1-10
1-10.	Torque Chart (METRIC Fasteners - Sheet 7 of 7)	1-11
3-1.	Frame Cover Installation - Ecolift50	3-1
3-2.	Frame Cover Installation - Ecolift50	3-1
3-3.	Frame Cover Installation - 830P	3-2
3-4.	Tool Tray Installation - Ecolift50	3-3
3-5.	Tool Tray Installation - Ecolift70	3-3
3-6.	Tool Tray Installation - 830P	3-3
3-7.	Castor Wheel Installation - Ecolift70 and 830P	3-4
3-8.	Castor Wheel Installation - Ecolift50	3-4
3-9.	Rear Wheel and Brake Installation - Ecolift50/70	3-5
3-10.	Rear Wheel and Brake Installation - 830P	3-6
3-11.	Platform Installation - Ecolift50 and 70	3-7
3-12.	Platform Installation - 830P	3-7
3-13.	Flywheel Crank Cover Installation - Ecolift50 and 70	3-8
3-14.	Mast Top Cap Installation - Ecolift	3-8
3-15.	Ecolift Mast Assembly	3-9
3-16.	Belt Clamp Mounting Bolts - Ecolift	3-10
3-17.	Belt Clamp Assembly - Ecolift	3-11
3-18.	Flywheel Rotation Force - Testing - Ecolift	3-12
3-19.	830P Mast Assembly	3-15
3-20.	830P Electrical/Hydraulic Components	3-16
3-21.	Battery Charger	3-17
3-22.	Charger AC Input Cable	3-17
3-23.	Battery Charge Indicator	3-17
3-24.	Charger LEDs	3-18
4-1.	Voltage Measurement (DC)	4-3
4-2.	Resistance Measurement	4-3
4-3.	Continuity Measurement	4-4
4-4.	Current Measurement (DC)	4-4
4-5.	830P - Electrical Diagram	4-7
4-6.	830P - Hydraulic Diagram	4-8

LIST OF TABLES

TABLE NO.	TITLE	PAGE NO.
1-1.	Machine Specifications	1-1
1-2.	Machine Dimensions	1-1
1-3.	Lubrication Specifications	1-3
1-4.	Lubrication Intervals for Various Components	1-4
2-1.	Inspection and Maintenance	2-2
2-2.	Preventive Maintenance & Inspection Schedule	2-3
3-1.	Ecolift 50 - Gas Cylinder Recharging Pressure	3-12
3-2.	Ecolift 70 - Gas Cylinder Recharging Pressure	3-12
4-1.	830P - Troubleshooting	4-6

PARTS FINDER

**Search Website
by Part Number**



**Search Manual
Library For Parts
Manual & Lookup Part
Numbers – Purchase
or Request Quote**

A screenshot of the "Search Manuals" form. It includes a title "Search Manuals", a subtitle "Please provide information to help us locate the manual and/or parts", and several input fields: "Brand" (dropdown), "Model" (dropdown), "Serial" (text), "Part Number" (text), "Part Name" (text), and "Comments" (text). A "Search" button is at the bottom.

**Can't Find Part or
Manual? Request Help
by Manufacturer,
Model & Description**

A screenshot of the "Parts Order Form". It has a title "Parts Order Form" and a subtitle "Please fill in as much information as possible". The form includes a "Manufacturer" dropdown, a "Model" dropdown, a "Description" text field, and a "Part Number" text field. There are also checkboxes for "Quantity" and "Date Received". A "Submit" button is at the bottom.

Discount-Equipment.com is your online resource for quality parts & equipment.

Florida: **561-964-4949** Outside Florida TOLL FREE: **877-690-3101**

Need parts?

Click on this link: <http://www.discount-equipment.com/category/5443-parts/> and choose one of the options to help get the right parts and equipment you are looking for. Please have the machine model and serial number available in order to help us get you the correct parts. If you don't find the part on the website or on once of the online manuals, please fill out the request form and one of our experienced staff members will get back to you with a quote for the right part that your machine needs.

We sell worldwide for the brands: Genie, Terex, JLG, MultiQuip, Mikasa, Essick, Whiteman, Mayco, Toro Stone, Diamond Products, Generac Magnum, Airman, Haulotte, Barreto, Power Blanket, Nifty Lift, Atlas Copco, Chicago Pneumatic, Allmand, Miller Curber, Skyjack, Lull, Skytrak, Tsurumi, Husquvarna Target, , Stow, Wacker, Sakai, Mi-T- M, Sullair, Basic, Dynapac, MBW, Weber, Bartell, Bennar Newman, Haulotte, Ditch Runner, Menegotti, Morrison, Contec, Buddy, Crown, Edco, Wyco, Bomag, Laymor, Barreto, EZ Trench, Bil-Jax, F.S. Curtis, Gehl Pavers, Heli, Honda, ICS/PowerGrit, IHI, Partner, Imer, Clipper, MMD, Koshin, Rice, CH&E, General Equipment, ,AMida, Coleman, NAC, Gradall, Square Shooter, Kent, Stanley, Tamco, Toku, Hatz, Kohler, Robin, Wisconsin, Northrock, Oztec, Toker TK, Rol-Air, Small Line, Wanco, Yanmar

SECTION 1. MACHINE SPECIFICATIONS

1.1 GENERAL SPECIFICATIONS

Machine Specifications

Table 1-1. Machine Specifications

DESCRIPTION	Ecolift 50	Ecolift 70	830P
Maximum Working Height	11.5 ft. (3.50 m)	14 ft. (4.20 m)	14.76 ft. (4.50 m)
Maximum Platform Height	4.9 ft. (1.50 m)	7.21 ft. (2.20 m)	8.20 ft. (2.50 m)
Platform Dimensions	28.3 in. (L) x 23.6 in. (W) (720 mm (L) x 600 mm (W))	33.4 in. (L) x 25.3 in. (W) (850 mm (L) x 644 mm (W))	3.28 ft. (L) x 2.39 ft. (W) (1m (L) x 0.73m (W))
Working Footprint	38.8 in. x 28.3 in. (985 mm x 700 mm)	50.3 in. x 29.1 in. (1280 mm x 740 mm)	3.90 ft. x 2.46 ft. (1.19m x 0.75m)
Max. Platform Capacity (Platform and Tool Tray Combined)	330 lb. (150 kg) (1 person + tools)		440 lbs. (200 kg) (1 person + tools)
Max. Tool Tray Capacity	33 lb. (15 kg)		
Maximum Manual Side Force	45 Lb. (200 N)		
Maximum Gradient For Operation	0 degrees		
Maximum Wind Force	Indoor use only		
Maximum Wheel Load	260 lb. (118 kg)	320 lb. (145 kg)	345 lb. (157 kg)
Maximum Ground Bearing Pressure	168 psi (11.81 kg/cm ²)	171 psi (12 kg/cm ²)	174 psi (12.23 kg/cm ²)

Table 1-2. Machine Dimensions

DESCRIPTION	Ecolift 50	Ecolift 70	830P
Length	38.8 in. (985mm)	50.3 in. (1280mm)	3.92 ft. (1.195m)
Width	28.3 in. (700mm)	29.1 in. (740mm)	2.46 ft. (0.750m)
Height	61 in. (1550mm)	76.77 in. (1950mm)	5.11 ft. (1.560m)
Weight	397 lb. (180kg)	672 lb. (305 kg)	628 lbs. (285 kg)

SECTION 1 - MACHINE SPECIFICATIONS

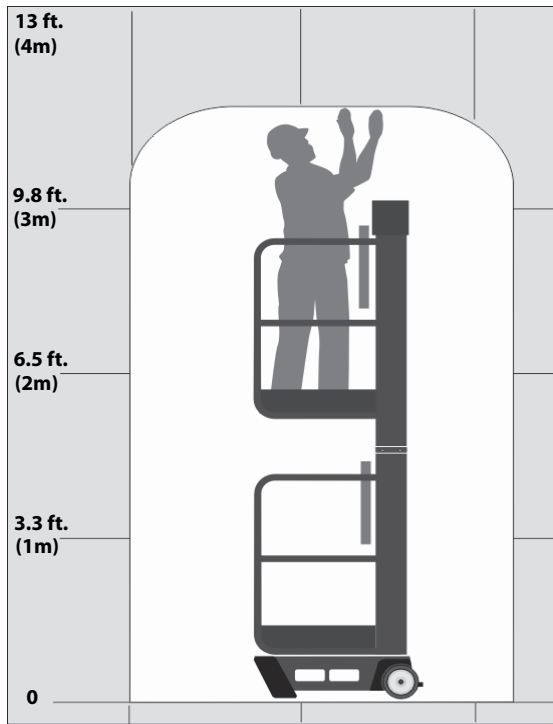

Figure 1-1. Operating Specification (Ecolift 50)

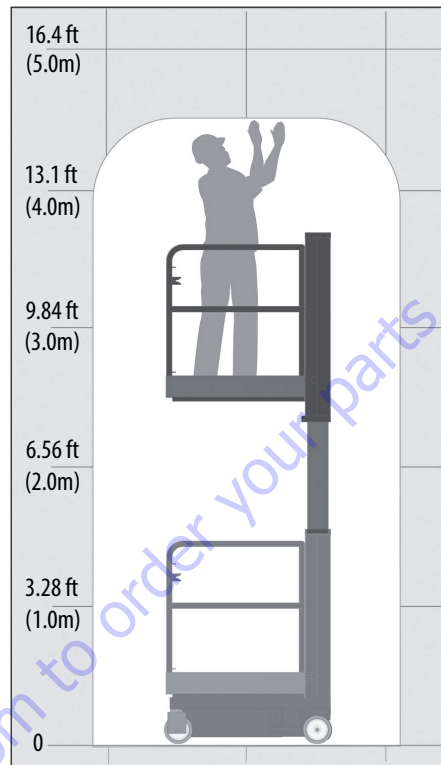

Figure 1-3. Operating Specification (830P)

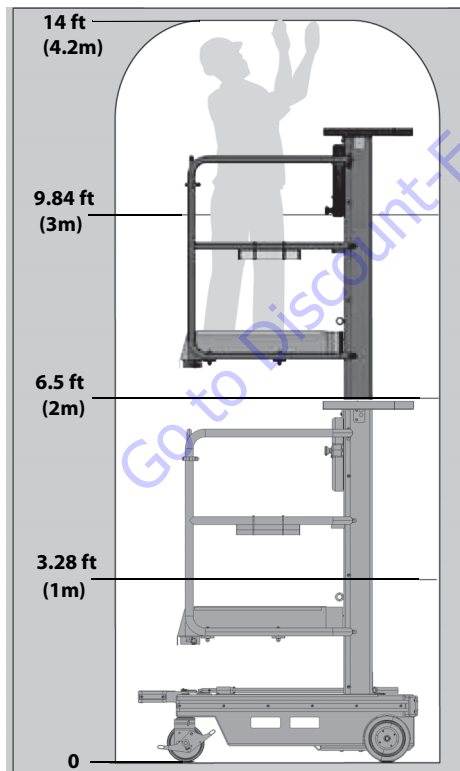

Figure 1-2. Operating Specification (Ecolift 70)

1.2 LUBRICATION

NOTE: Also see Lubrication Interval Chart - Table 1-4, Lubrication Intervals for Various Components in this section of the manual.

Hydraulic Oil - (830P Only)

The hydraulic oil must be replaced on an annual basis. If the oil is not replaced, then premature wear and failure of components will occur.

Refill with grade 32 mineral oil.

Lubrication Specifications

Table 1-3. Lubrication Specifications

KEY	SPECIFICATIONS
MPG -	Multipurpose Grease having a minimum dripping point of 350° F. Excellent water resistance and adhesive qualities, and being of extreme pressure type. (Timken OK 40 pounds minimum.)
EPGL -	Extreme Pressure Gear Lube (oil) meeting API service classification GL-5 or MIL-Spec MIL-L-2105.
HO -	Hydraulic Oil - Grade 32 Mineral Oil

1.3 SERIAL NUMBER LOCATIONS

For machine identification, a serial number plate is affixed to the machine. The plate is located on the mast assembly, just above the mast support column. Ecolift plate is on back of mast, 830P plate is behind platform on front of mast, the platform must be tilted up into maintenance position to see the plate.

1.4 TORQUE REQUIREMENTS

When maintenance becomes necessary or a fastener has loosened, refer to the applicable Torque Charts in this section of the manual, to determine proper torque values for different size fasteners.

SECTION 1 - MACHINE SPECIFICATIONS

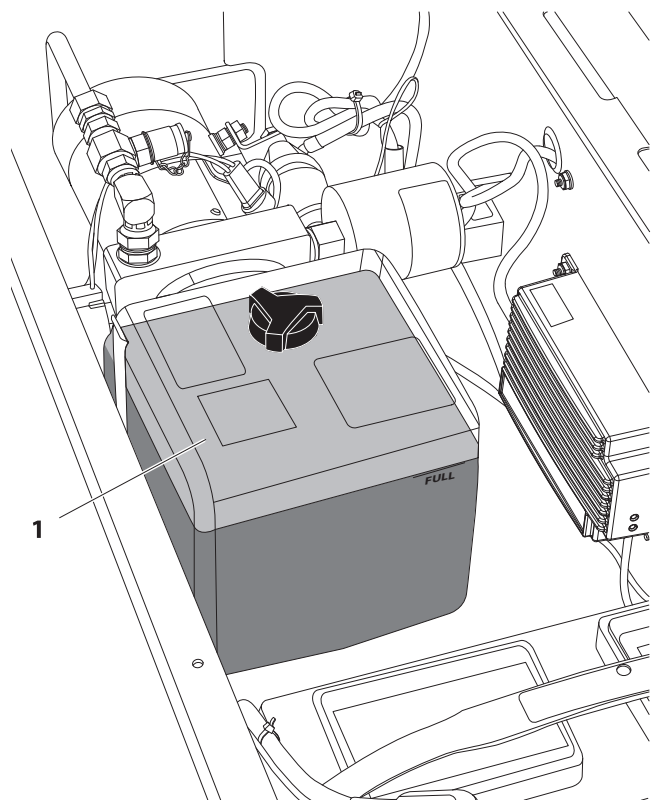

830P

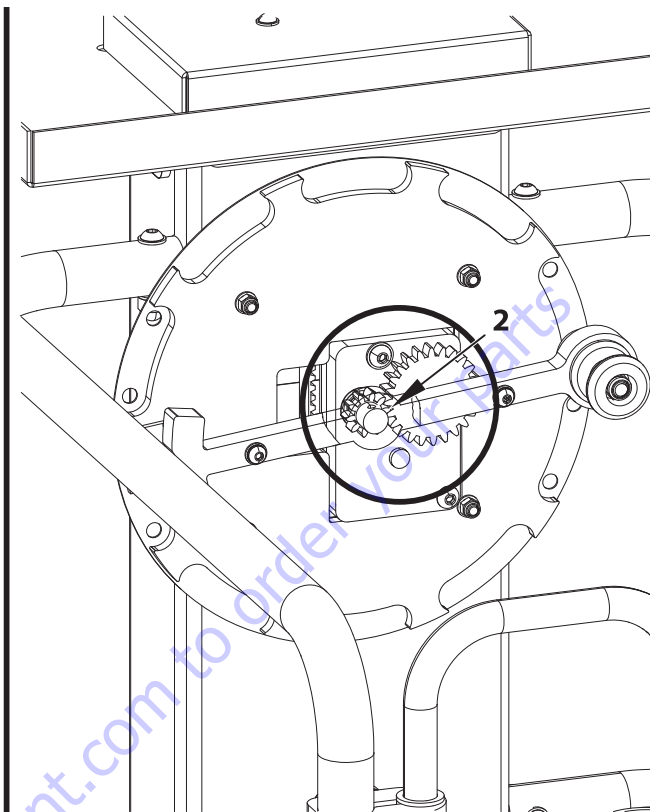

Ecolift 50/70

Table 1-4. Lubrication Intervals for Various Components

ITEM	COMPONENT	NO/TYPE LUBE POINTS	LUBE/METHOD	INTERVAL (a)				COMMENTS
				3 MONTHS	6 MONTHS	1 YEAR	2 YEARS	
1	Hydraulic Oil Capacity: 4.22 Qt. (830P Only)	Fill To Line on Reservoir	HO - Check Hyd. Oil Level HO - Change Hyd. Oil			✓		Check fluid level every day. (b) Change hydraulic oil annually.
2	Mast Flywheel (Ecolift 50/70 Only)	Flywheel Crank - Drive Gears	Open Gear Grease		✓			Inspect and lubricate. Do not use standard gear grease.
Key to Lubricants: OGG - Open Gear Grease, Omega 73 - Grade 2, Harsh Environment Grease HO - Hydraulic Oil - Grade 32, Mineral Oil								
Notes: (a) Recommended lubricating intervals are based on normal use. If machine is subjected to severe operating conditions, such as a high number of cycles, location, corrosive/dirty environment, etc., user must adjust lubricating requirements accordingly. (b) Prior to checking hydraulic oil level, operate machine through one complete cycle of lift function (full up and down). Failure to do so will result in incorrect oil level reading on the hydraulic reservoir.								

1.5 TORQUE CHARTS

Values for Zinc Yellow Chromate Fasteners (Ref 4150707)												
SAE GRADE 5 BOLTS & GRADE 2 NUTS												
Size	TPI	Bolt Dia	Tensile Stress Area	Clamp Load	Torque (Dry)		Torque Lubricated		Torque (Loctite® 242™ or 271™ OR Vibra-TITE™ 111 or 140)		Torque (Loctite® 262™ or Vibra-TITE™ 131)	
					IN-LB	[N.m]	IN-LB	[N.m]	IN-LB	[N.m]	IN-LB	[N.m]
		In	Sq In	LB								
4	40	0.1120	0.00604	380	8	0.9	6	0.7				
	48	0.1120	0.00661	420	9	1.0	7	0.8				
6	32	0.1380	0.00909	580	16	1.8	12	1.4				
	40	0.1380	0.01015	610	18	2.0	13	1.5				
8	32	0.1640	0.01400	900	30	3.4	22	2.5				
	36	0.1640	0.01474	940	31	3.5	23	2.6				
10	24	0.1900	0.01750	1120	43	4.8	32	3.5				
	32	0.1900	0.02000	1285	49	5.5	36	4				
1/4	20	0.2500	0.0318	2020	96	10.8	75	9	105	12		
	28	0.2500	0.0364	2320	120	13.5	86	10	135	15		
		In	Sq In	LB								
5/16	18	0.3125	0.0524	3340	17	23	13	18	19	26	16	22
	24	0.3125	0.0580	3700	19	26	14	19	21	29	17	23
3/8	16	0.3750	0.0775	4940	30	41	23	31	35	48	28	38
	24	0.3750	0.0878	5600	35	47	25	34	40	54	32	43
7/16	14	0.4375	0.1063	6800	50	68	35	47	55	75	45	61
	20	0.4375	0.1187	7550	55	75	40	54	60	82	50	68
1/2	13	0.5000	0.1419	9050	75	102	55	75	85	116	68	92
	20	0.5000	0.1599	10700	90	122	65	88	100	136	80	108
9/16	12	0.5625	0.1820	11600	110	149	80	108	120	163	98	133
	18	0.5625	0.2030	12950	120	163	90	122	135	184	109	148
5/8	11	0.6250	0.2260	14400	150	203	110	149	165	224	135	183
	18	0.6250	0.2560	16300	170	230	130	176	190	258	153	207
3/4	10	0.7500	0.3340	21300	260	353	200	271	285	388	240	325
	16	0.7500	0.3730	23800	300	407	220	298	330	449	268	363
7/8	9	0.8750	0.4620	29400	430	583	320	434	475	646	386	523
	14	0.8750	0.5090	32400	470	637	350	475	520	707	425	576
1	8	1.0000	0.6060	38600	640	868	480	651	675	918	579	785
	12	1.0000	0.6630	42200	700	949	530	719	735	1000	633	858
1 1/8	7	1.1250	0.7630	42300	800	1085	600	813	840	1142	714	968
	12	1.1250	0.8560	47500	880	1193	660	895	925	1258	802	1087
1 1/4	7	1.2500	0.9690	53800	1120	1518	840	1139	1175	1598	1009	1368
	12	1.2500	1.0730	59600	1240	1681	920	1247	1300	1768	1118	1516
1 3/8	6	1.3750	1.1550	64100	1460	1979	1100	1491	1525	2074	1322	1792
	12	1.3750	1.3150	73000	1680	2278	1260	1708	1750	2380	1506	2042
1 1/2	6	1.5000	1.4050	78000	1940	2630	1460	1979	2025	2754	1755	2379
	12	1.5000	1.5800	87700	2200	2983	1640	2224	2300	3128	1974	2676

NO. 5000059 REV. J

- NOTES: 1. THESE TORQUE VALUES DO NOT APPLY TO CADMIUM PLATED FASTENERS
 2. ALL TORQUE VALUES ARE STATIC TORQUE MEASURED PER STANDARD AUDIT METHODS TOLERANCE = ±10%
 3. * ASSEMBLY USES HARDENED WASHER

REFERENCE JLG ANEROBIC THREAD LOCKING COMPOUND				
JLG P/N	Loctite® P/N		ND Industries P/N	Description
0100011	242™		Vibra-TITE™ 121	Medium Strength (Blue)
0100019	271™		Vibra-TITE™ 140	High Strength (Red)
0100071	262™		Vibra-TITE™ 131	Medium - High Strength (Red)

Figure 1-4. Torque Chart (SAE Fasteners - Sheet 1 of 7)

SECTION 1 - MACHINE SPECIFICATIONS

Values for Zinc Yellow Chromate Fasteners (Ref 4150707)

SAE GRADE 8 (HEX HD) BOLTS & GRADE 8 NUTS*

Size	TPI	Bolt Dia	Tensile Stress Area	Clamp Load	Torque (Dry or Loctite® 263) K= 0.20		Torque (Loctite® 242™ or 271™ OR Vibra-TITE™ 111 or 140) K=.18		Torque (Loctite® 262™ or Vibra-TITE™ 131) K=0.15	
					IN-LB	[N.m]	IN-LB	[N.m]	IN-LB	[N.m]
		In	Sq In	LB	FT-LB	[N.m]	FT-LB	[N.m]	FT-LB	[N.m]
4	40	0.1120	0.00604							
	48	0.1120	0.00661							
6	32	0.1380	0.00909							
	40	0.1380	0.01015							
8	32	0.1640	0.01400							
	36	0.1640	0.01474	1320	43	5				
10	24	0.1900	0.01750	1580	60	7				
	32	0.1900	0.02000	1800	68	8				
1/4	20	0.2500	0.0318	2860	143	16	129	15		
	28	0.2500	0.0364	3280	164	19	148	17		
		In	Sq In	LB	FT-LB	[N.m]	FT-LB	[N.m]	FT-LB	[N.m]
5/16	18	0.3125	0.0524	4720	25	35	20	25	20	25
	24	0.3125	0.0580	5220	25	35	25	35	20	25
3/8	16	0.3750	0.0775	7000	45	60	40	55	35	50
	24	0.3750	0.0878	7900	50	70	45	60	35	50
7/16	14	0.4375	0.1063	9550	70	95	65	90	50	70
	20	0.4375	0.1187	10700	80	110	70	95	60	80
1/2	13	0.5000	0.1419	12750	105	145	95	130	80	110
	20	0.5000	0.1599	14400	120	165	110	150	90	120
9/16	12	0.5625	0.1820	16400	155	210	140	190	115	155
	18	0.5625	0.2030	18250	170	230	155	210	130	175
5/8	11	0.6250	0.2260	20350	210	285	190	260	160	220
	18	0.6250	0.2560	23000	240	325	215	290	180	245
3/4	10	0.7500	0.3340	30100	375	510	340	460	280	380
	16	0.7500	0.3730	33600	420	570	380	515	315	430
7/8	9	0.8750	0.4620	41600	605	825	545	740	455	620
	14	0.8750	0.5090	45800	670	910	600	815	500	680
1	8	1.0000	0.6060	51500	860	1170	770	1045	645	875
	12	1.0000	0.6630	59700	995	1355	895	1215	745	1015
1 1/8	7	1.1250	0.7630	68700	1290	1755	1160	1580	965	1310
	12	1.1250	0.8560	77000	1445	1965	1300	1770	1085	1475
1 1/4	7	1.2500	0.9690	87200	1815	2470	1635	2225	1365	1855
	12	1.2500	1.0730	96600	2015	2740	1810	2460	1510	2055
1 3/8	6	1.3750	1.1550	104000	2385	3245	2145	2915	1785	2430
	12	1.3750	1.3150	118100	2705	3680	2435	3310	2030	2760
1 1/2	6	1.5000	1.4050	126500	3165	4305	2845	3870	2370	3225
	12	1.5000	1.5800	142200	3555	4835	3200	4350	2665	3625

- NO. 5000059 REV. J
- NOTES: 1. THESE TORQUE VALUES DO NOT APPLY TO CADMIUM PLATED FASTENERS
 2. ALL TORQUE VALUES ARE STATIC TORQUE MEASURED PER STANDARD AUDIT METHODS TOLERANCE = ±10%
 3. * ASSEMBLY USES HARDENED WASHER

Figure 1-5. Torque Chart (SAE Fasteners - Sheet 2 of 7)

SOCKET HEAD CAP SCREWS										
Magni Coating (Ref 4150701)*										
Size	TPI	Bolt Dia	Tensile Stress Area	Clamp Load See Note 4	Torque (Dry) K = .17		Torque (Loctite® 242™ or 271™ OR Vibra-TITE™ 111 or 140 OR Precoat 85® K=0.16		Torque (Loctite® 262™ or Vibra-TITE™ 131) K=0.15	
					IN-LB	[N.m]	IN-LB	[N.m]	IN-LB	[N.m]
		In	Sq In	LB						
4	40	0.1120	0.00604							
	48	0.1120	0.00661							
6	32	0.1380	0.00909							
	40	0.1380	0.01015							
8	32	0.1640	0.01400							
	36	0.1640	0.01474							
10	24	0.1900	0.01750							
	32	0.1900	0.02000							
1/4	20	0.2500	0.0318	2860	122	14	114	13		
	28	0.2500	0.0364	3280	139	16	131	15		
		In	Sq In	LB	FT-LB	[N.m]	FT-LB	[N.m]	FT-LB	[N.m]
5/16	18	0.3125	0.0524	4720	20	25	20	25	20	25
	24	0.3125	0.0580	5220	25	35	20	25	20	25
3/8	16	0.3750	0.0775	7000	35	50	35	50	35	50
	24	0.3750	0.0878	7900	40	55	40	55	35	50
7/16	14	0.4375	0.1063	9550	60	80	55	75	50	70
	20	0.4375	0.1187	10700	65	90	60	80	60	80
1/2	13	0.5000	0.1419	12750	90	120	85	115	80	110
	20	0.5000	0.1599	14400	100	135	95	130	90	120
9/16	12	0.5625	0.1820	16400	130	175	125	170	115	155
	18	0.5625	0.2030	18250	145	195	135	185	130	175
5/8	11	0.6250	0.2260	20350	180	245	170	230	160	220
	18	0.6250	0.2560	23000	205	280	190	260	180	245
3/4	10	0.7500	0.3340	30100	320	435	300	410	280	380
	16	0.7500	0.3730	33600	355	485	335	455	315	430
7/8	9	0.8750	0.4620	41600	515	700	485	660	455	620
	14	0.8750	0.5090	45800	570	775	535	730	500	680
1	8	1.0000	0.6060	51500	730	995	685	930	645	875
	12	1.0000	0.6630	59700	845	1150	795	1080	745	1015
1 1/8	7	1.1250	0.7630	68700	1095	1490	1030	1400	965	1310
	12	1.1250	0.8560	77000	1225	1665	1155	1570	1085	1475
1 1/4	7	1.2500	0.9690	87200	1545	2100	1455	1980	1365	1855
	12	1.2500	1.0730	96600	1710	2325	1610	2190	1510	2055
1 3/8	6	1.3750	1.1550	104000	2025	2755	1905	2590	1785	2430
	12	1.3750	1.3150	118100	2300	3130	2165	2945	2030	2760
1 1/2	6	1.5000	1.4050	126500	2690	3660	2530	3440	2370	3225
	12	1.5000	1.5800	142200	3020	4105	2845	3870	2665	3625

- NO. 5000059 REV. J
- NOTES: 1. THESE TORQUE VALUES DO NOT APPLY TO CADMIUM PLATED FASTENERS
 2. ALL TORQUE VALUES ARE STATIC TORQUE MEASURED PER STANDARD AUDIT METHODS TOLERANCE = ±10%
 *3. ASSEMBLY USES HARDENED WASHER OR FASTENER IS PLACED AGAINST PLATED STEEL OR RAW ALUMINUM
 4. CLAMP LOAD LISTED FOR SHCS IS SAME AS GRADE 8 OR CLASS 10.9 AND DOES NOT REPRESENT FULL STRENGTH CAPABILITY OF SHCS. IF HIGHER LOAD IS REQUIRED, ADDITIONAL TESTING IS REQUIRED.

Figure 1-6. Torque Chart (SAE Fasteners - Sheet 3 of 7)

SECTION 1 - MACHINE SPECIFICATIONS

SOCKET HEAD CAP SCREWS										
Zinc Yellow Chromate Fasteners (Ref 4150707)*										
Size	TPI	Bolt Dia	Tensile Stress Area	Clamp Load See Note 4	Torque (Dry) K = .20		Torque (Loctite® 242™ or 271™ OR Vibra-TITE™ 111 or 140 OR Precoat 85® K=0.18		Torque (Loctite® 262™ or Vibra-TITE™ 131) K=0.15	
					IN-LB	[N.m]	IN-LB	[N.m]	IN-LB	[N.m]
		In	Sq In	LB						
4	40	0.1120	0.00604							
	48	0.1120	0.00661							
6	32	0.1380	0.00909							
	40	0.1380	0.01015							
8	32	0.1640	0.01400							
	36	0.1640	0.01474							
10	24	0.1900	0.01750							
	32	0.1900	0.02000							
1/4	20	0.2500	0.0318	2860	143	16	129	15		
	28	0.2500	0.0364	3280	164	19	148	17		
		In	Sq In	LB	FT-LB	[N.m]	FT-LB	[N.m]	FT-LB	[N.m]
5/16	18	0.3125	0.0524	4720	25	35	20	25	20	25
	24	0.3125	0.0580	5220	25	35	25	35	20	25
3/8	16	0.3750	0.0775	7000	45	60	40	55	35	50
	24	0.3750	0.0878	7900	50	70	45	60	35	50
7/16	14	0.4375	0.1063	9550	70	95	65	90	50	70
	20	0.4375	0.1187	10700	80	110	70	95	60	80
1/2	13	0.5000	0.1419	12750	105	145	95	130	80	110
	20	0.5000	0.1599	14400	120	165	110	150	90	120
9/16	12	0.5625	0.1820	16400	155	210	140	190	115	155
	18	0.5625	0.2030	18250	170	230	155	210	130	175
5/8	11	0.6250	0.2260	20350	210	285	190	260	160	220
	18	0.6250	0.2560	23000	240	325	215	290	180	245
3/4	10	0.7500	0.3340	30100	375	510	340	460	280	380
	16	0.7500	0.3730	33600	420	570	380	515	315	430
7/8	9	0.8750	0.4620	41600	605	825	545	740	455	620
	14	0.8750	0.5090	45800	670	910	600	815	500	680
1	8	1.0000	0.6060	51500	860	1170	775	1055	645	875
	12	1.0000	0.6630	59700	995	1355	895	1215	745	1015
1 1/8	7	1.1250	0.7630	68700	1290	1755	1160	1580	965	1310
	12	1.1250	0.8560	77000	1445	1965	1300	1770	1085	1475
1 1/4	7	1.2500	0.9690	87200	1815	2470	1635	2225	1365	1855
	12	1.2500	1.0730	96600	2015	2740	1810	2460	1510	2055
1 3/8	6	1.3750	1.1550	104000	2385	3245	2145	2915	1785	2430
	12	1.3750	1.3150	118100	2705	3680	2435	3310	2030	2760
1 1/2	6	1.5000	1.4050	126500	3165	4305	2845	3870	2370	3225
	12	1.5000	1.5800	142200	3555	4835	3200	4350	2665	3625

NO. 500059 REV. J

- NOTES: 1. THESE TORQUE VALUES DO NOT APPLY TO CADMIUM PLATED FASTENERS
 2. ALL TORQUE VALUES ARE STATIC TORQUE MEASURED PER STANDARD AUDIT METHODS TOLERANCE = ±10%
 *3. ASSEMBLY USES HARDENED WASHER OR FASTENER IS PLACED AGAINST PLATED STEEL OR RAW ALUMINUM
 4. CLAMP LOAD LISTED FOR SHCS IS SAME AS GRADE 8 OR CLASS 10.9 AND DOES NOT REPRESENT FULL STRENGTH CAPABILITY OF SHCS. IF HIGHER LOAD IS REQUIRED, ADDITIONAL TESTING IS REQUIRED.

Figure 1-7. Torque Chart (SAE Fasteners - Sheet 4 of 7)

Values for Zinc Yellow Chromate Fasteners (Ref 4150707)							
CLASS 8.8 METRIC BOLTS CLASS 8 METRIC NUTS							
Size	PITCH	Tensile Stress Area	Clamp Load	Torque (Dry or Loctite® 263™)	Torque (Lub)	Torque (Loctite® 262™ OR Vibra-TITE™ 131)	Torque (Loctite® 242™ or 271™ OR Vibra-TITE™ 111 or 140)
		Sq mm	KN	[N.m]	[N.m]	[N.m]	[N.m]
3	0.5	5.03	2.19	1.3	1.0	1.2	1.4
3.5	0.6	6.78	2.95	2.1	1.6	1.9	2.3
4	0.7	8.78	3.82	3.1	2.3	2.8	3.4
5	0.8	14.20	6.18	6.2	4.6	5.6	6.8
6	1	20.10	8.74	11	7.9	9.4	12
7	1	28.90	12.6	18	13	16	19
8	1.25	36.60	15.9	26	19	23	28
10	1.5	58.00	25.2	50	38	45	55
12	1.75	84.30	36.7	88	66	79	97
14	2	115	50.0	140	105	126	154
16	2	157	68.3	219	164	197	241
18	2.5	192	83.5	301	226	271	331
20	2.5	245	106.5	426	320	383	469
22	2.5	303	132.0	581	436	523	639
24	3	353	153.5	737	553	663	811
27	3	459	199.5	1080	810	970	1130
30	3.5	561	244.0	1460	1100	1320	1530
33	3.5	694	302.0	1990	1490	1790	2090
36	4	817	355.5	2560	1920	2300	2690
42	4.5	1120	487.0	4090	3070	3680	4290

NO. 500059 REV. J

- NOTES: 1. THESE TORQUE VALUES DO NOT APPLY TO CADMIUM PLATED FASTENERS
 2. ALL TORQUE VALUES ARE STATIC TORQUE MEASURED PER STANDARD AUDIT METHODS TOLERANCE = ±10%
 *3. ASSEMBLY USES HARDENED WASHER OR FASTENER IS PLACED AGAINST PLATED STEEL OR RAW ALUMINUM
 4. CLAMP LOAD LISTED FOR SHCS IS SAME AS GRADE 8 OR CLASS 10.9 AND DOES NOT REPRESENT FULL STRENGTH CAPABILITY OF SHCS. IF HIGHER LOAD IS REQUIRED, ADDITIONAL TESTING IS REQUIRED.

Figure 1-8. Torque Chart (METRIC Fasteners - Sheet 5 of 7)

SECTION 1 - MACHINE SPECIFICATIONS

Values for Zinc Yellow Chromate Fasteners (Ref 4150707)						
CLASS 10.9 METRIC BOLTS CLASS 10 METRIC NUTS CLASS 12.9 SOCKET HEAD CAP SCREWS M3 - M5*						
Size	PITCH	Tensile Stress Area	Clamp Load	Torque (Dry or Loctite® 263™) K = 0.20	Torque (Lub OR Loctite® 242™ or 271™ OR Vibra-TITE™ 111 or 140) K= 0.18	Torque (Loctite® 262™ OR Vibra-TITE™ 131) K=0.15
		Sq mm	KN	[N.m]	[N.m]	[N.m]
3	0.5	5.03	3.13			
3.5	0.6	6.78	4.22			
4	0.7	8.78	5.47			
5	0.8	14.20	8.85			
6	1	20.10	12.5			
7	1	28.90	18.0	25.2	22.7	18.9
8	1.25	36.60	22.8	36.5	32.8	27.4
10	1.5	58.00	36.1	70	65	55
12	1.75	84.30	52.5	125	115	95
14	2	115	71.6	200	180	150
16	2	157	97.8	315	280	235
18	2.5	192	119.5	430	385	325
20	2.5	245	152.5	610	550	460
22	2.5	303	189.0	830	750	625
24	3	353	222.0	1065	960	800
27	3	459	286.0	1545	1390	1160
30	3.5	561	349.5	2095	1885	1575
33	3.5	694	432.5	2855	2570	2140
36	4	817	509.0	3665	3300	2750
42	4.5	1120	698.0	5865	5275	4395

NO. 500059 REV. J

- NOTES: 1. THESE TORQUE VALUES DO NOT APPLY TO CADMIUM PLATED FASTENERS
 2. ALL TORQUE VALUES ARE STATIC TORQUE MEASURED PER STANDARD AUDIT METHODS TOLERANCE = ±10%
 *3. ASSEMBLY USES HARDENED WASHER OR FASTENER IS PLACED AGAINST PLATED STEEL OR RAW ALUMINUM
 4. CLAMP LOAD LISTED FOR SHCS IS SAME AS GRADE 8 OR CLASS 10.9 AND DOES NOT REPRESENT FULL STRENGTH CAPABILITY OF SHCS. IF HIGHER LOAD IS REQUIRED, ADDITIONAL TESTING IS REQUIRED.

Figure 1-9. Torque Chart (METRIC Fasteners - Sheet 6 of 7)

Magni Coating (Ref 4150701)*						
CLASS 12.9 SOCKET HEAD CAP SCREWS M6 AND ABOVE*						
Size	PITCH	Tensile Stress Area	Clamp Load See Note 4	Torque (Dry or Loctite® 263™) K = .17	Torque (Lub OR Loctite® 242™ or 271™ OR Vibra-TITE™ 111 or 140) K = .16	Torque (Loctite® 262™ OR Vibra-TITE™ 131) K = .15
		Sq mm	kN	[N.m]	[N.m]	[N.m]
3	0.5	5.03				
3.5	0.6	6.78				
4	0.7	8.78				
5	0.8	14.20				
6	1	20.10	12.5	13	12	11
7	1	28.90	18.0	21	20	19
8	1.25	36.60	22.8	31	29	27
10	1.5	58.00	36.1	61	58	54
12	1.75	84.30	52.5	105	100	95
14	2	115	71.6	170	160	150
16	2	157	97.8	265	250	235
18	2.5	192	119.5	365	345	325
20	2.5	245	152.5	520	490	460
22	2.5	303	189.0	705	665	625
24	3	353	220.0	900	845	790
27	3	459	286.0	1315	1235	1160
30	3.5	561	349.5	1780	1680	1575
33	3.5	694	432.5	2425	2285	2140
36	4	817	509.0	3115	2930	2750
42	4.5	1120	698.0	4985	4690	4395

NO. 500059 REV. J

- NOTES: 1. THESE TORQUE VALUES DO NOT APPLY TO CADMIUM PLATED FASTENERS
 2. ALL TORQUE VALUES ARE STATIC TORQUE MEASURED PER STANDARD AUDIT METHODS TOLERANCE = ±10%
 *3. ASSEMBLY USES HARDENED WASHER OR FASTENER IS PLACED AGAINST PLATED STEEL OR RAW ALUMINUM
 4. CLAMP LOAD LISTED FOR SHCS IS SAME AS GRADE 8 OR CLASS 10.9 AND DOES NOT REPRESENT FULL STRENGTH CAPABILITY OF SHCS. IF HIGHER LOAD IS REQUIRED, ADDITIONAL TESTING IS REQUIRED.

Figure 1-10. Torque Chart (METRIC Fasteners - Sheet 7 of 7)

PARTS FINDER

**Search Website
by Part Number**



**Search Manual
Library For Parts
Manual & Lookup Part
Numbers – Purchase
or Request Quote**

Search Manuals

Enter your information to search for manuals and parts.

* Brand:

* Model:

* Serial:

* Part Number:

SEARCH

**Can't Find Part or
Manual? Request Help
by Manufacturer,
Model & Description**

Parts Order Form

Please fill in the following information:

Manufacturer:

Model:

Description:

Quantity:

Part Number:

Part Name:

Part Description:

Part Location:

Part Condition:

Part Status:

Part Price:

Part Weight:

Part Dimensions:

Part Material:

Part Color:

Part Finish:

Part Notes:

Submit

Discount-Equipment.com is your online resource for quality parts & equipment.

Florida: **561-964-4949** Outside Florida TOLL FREE: **877-690-3101**

Need parts?

Click on this link: <http://www.discount-equipment.com/category/5443-parts/> and choose one of the options to help get the right parts and equipment you are looking for. Please have the machine model and serial number available in order to help us get you the correct parts. If you don't find the part on the website or on once of the online manuals, please fill out the request form and one of our experienced staff members will get back to you with a quote for the right part that your machine needs.

We sell worldwide for the brands: Genie, Terex, JLG, MultiQuip, Mikasa, Essick, Whiteman, Mayco, Toro Stone, Diamond Products, Generac Magnum, Airman, Haulotte, Barreto, Power Blanket, Nifty Lift, Atlas Copco, Chicago Pneumatic, Allmand, Miller Curber, Skyjack, Lull, Skytrak, Tsurumi, Husquvarna Target, , Stow, Wacker, Sakai, Mi-T- M, Sullair, Basic, Dynapac, MBW, Weber, Bartell, Bennar Newman, Haulotte, Ditch Runner, Menegotti, Morrison, Contec, Buddy, Crown, Edco, Wyco, Bomag, Laymor, Barreto, EZ Trench, Bil-Jax, F.S. Curtis, Gehl Pavers, Heli, Honda, ICS/PowerGrit, IHI, Partner, Imer, Clipper, MMD, Koshin, Rice, CH&E, General Equipment, ,AMida, Coleman, NAC, Gradall, Square Shooter, Kent, Stanley, Tamco, Toku, Hatz, Kohler, Robin, Wisconsin, Northrock, Oztec, Toker TK, Rol-Air, Small Line, Wanco, Yanmar

SECTION 2. GENERAL SERVICE INFORMATION

2.1 MACHINE PREPARATION, INSPECTION, AND MAINTENANCE

General

This section provides the necessary information needed by those personnel that are responsible to place the machine in operation readiness and maintain its safe operating condition. For maximum service life and safe operation, ensure that all the necessary inspections and maintenance have been completed before placing the machine into service.

Preparation, Inspection, and Maintenance

It is important to establish and conform to a comprehensive inspection and preventive maintenance program. Table 2-1, Inspection and Maintenance outlines the periodic machine inspections and maintenance recommended by JLG Industries, Inc. Consult your national, regional, or local regulations for further requirements for aerial work platforms. The frequency of inspections and maintenance must be increased as environment, severity and frequency of usage requires.

Pre-Start Inspection

It is the User's or Operator's primary responsibility to perform a Pre-Start Inspection of the machine prior to use daily or at each change of operator. Reference the Operator's and Safety Manual for completion procedures for the Pre-Start Inspection. The Operator and Safety Manual must be read in its entirety and understood prior to performing the Pre-Start Inspection.

Pre-Delivery Inspection and Frequent Inspection

The Pre-Delivery Inspection and Frequent Inspection shall be performed by a qualified JLG equipment mechanic. JLG Industries, Inc. recognizes a qualified JLG equipment mechanic as a person who, by possession of a recognized degree, certificate, extensive knowledge, training, or experience, has successfully demonstrated the ability and proficiency to service, repair, and maintain the subject JLG product model.

The Pre-Delivery Inspection and Frequent Inspection procedures are performed in the same manner, but at different times. The Pre-Delivery Inspection shall be performed prior to each sale, lease, or rental delivery. The Frequent Inspection shall be accomplished for each machine in service for 3 months or 150 hrs; out of service for a period of more than 3 months; or when purchased used. The frequency of this inspection must be increased as environment, severity and frequency of usage requires.

Reference the JLG Pre-Delivery and Frequent Inspection Form and the Inspection and Preventative Maintenance Schedule for items requiring inspection during the performance of these inspections. Reference the appropriate areas of this manual for servicing and maintenance procedures.

Annual Machine Inspection

The Annual Machine Inspection must be performed by a Factory Trained Service Technician on an annual basis, no later than thirteen (13) months from the date of the prior Annual Machine Inspection. JLG Industries, Inc. recognizes a qualified JLG equipment mechanic as a person who has successfully completed the JLG Service Training School for the subject JLG product model. Reference the machine Service and Maintenance Manual and appropriate JLG inspection form for performance of this inspection.

Reference the JLG Annual Machine Inspection Form and the Inspection and Preventative Maintenance Schedule for items requiring inspection during the performance of this inspection. Reference the appropriate areas of this manual for servicing and maintenance procedures.

For the purpose of receiving safety-related bulletins, it is important that JLG Industries, Inc. has updated ownership information for each machine. When performing each Annual Machine Inspection, notify JLG Industries, Inc. of the current machine ownership.

Preventative Maintenance

In conjunction with the specified inspections, maintenance shall be performed by a qualified JLG equipment mechanic. JLG Industries, Inc. recognizes a qualified JLG equipment mechanic as a person who, by possession of a recognized degree, certificate, extensive knowledge, training, or experience, has successfully demonstrated the ability and proficiency to service, repair, and maintain the subject JLG product model.

Reference Table 2-2, Preventive Maintenance & Inspection Schedule., and the appropriate areas of this manual for servicing and maintenance procedures. The frequency of service and maintenance must be increased as environment, severity and frequency of usage requires.

Table 2-1. Inspection and Maintenance

TYPE	FREQUENCY	PRIMARY RESPONSIBILITY	SERVICE QUALIFICATION	REFERENCE
Pre-Start Inspection	Prior to use each day; or At each Operator change.	User or Operator	User or Operator	Operator and Safety Manual
Pre-Delivery Inspection	Prior to each sale, lease, or rental delivery.	Owner, Dealer, or User	Qualified JLG Mechanic	Service and Maintenance Manual and applicable JLG inspection form.
Frequent Inspection	In service for 3 months; or Out of service for a period of more than 3 months; or Purchased used.	Owner, Dealer, or User	Qualified JLG Mechanic	Service and Maintenance Manual and applicable JLG inspection form.
Annual Machine Inspection	Annually, no later than 13 months from the date of the prior inspection.	Owner, Dealer, or User	JLG Factory Trained Service Technician (Recommended)	Service and Maintenance Manual and applicable JLG inspection form.
Preventative Maintenance	At intervals as specified in the Service and Maintenance Manual.	Owner, Dealer, or User	Qualified JLG Mechanic	Service and Maintenance Manual

2.2 PREVENTIVE MAINTENANCE AND INSPECTION SCHEDULE

(See Table 2-2.)

The preventive maintenance and inspection checks are listed and defined in the following table. This table is divided into two basic parts, the "AREA" to be inspected and the "INTERVAL" at which the inspection is to take place. Under the "AREA" portion of the table, the various systems along with the components that make up that system are listed. The "INTERVAL" portion of the table is divided into five columns representing the various inspection time periods. The numbers listed within the interval column represent the applicable inspection code for which that component is to be checked.

The checks and services listed in this schedule are not intended to replace any local or regional regulations that may pertain to this type of equipment nor should the lists be considered as all inclusive. Variations in interval times may occur due to climate and/or conditions and depending on the location and use of the machine.

Inspection and Maintenance Codes:

1. Check for proper and secure installation.
2. Visual inspection for damage, cracks, distortion, or excessive wear.
3. Check for proper adjustment.
4. Check for cracked or broken welds.
5. Operates properly.
6. Returns to neutral or "off" position when released.
7. Clean and free of debris.
8. Interlocks function properly.
9. Check for signs of leakage.

10. Decals installed and legible.
11. Check for proper fluid level.
12. Check for chafing and proper routing.
13. Check for proper tolerances.
14. Properly lubricated.
15. Torqued to proper specification.
16. No gouges, excessive wear, or cords showing.
17. Properly inflated and seated around rim.
18. Proper and authorized components.
19. Fully charged.
20. No loose connections, corrosion, or abrasions.
21. Verify.
22. Perform.
23. Sealed properly.
24. Overrides Platform controls.
25. Replace.

Footnotes:

- a. Prior to each sale, lease, or delivery.
- b. In service for 3 months; or Out of service for 3 months or more; or Purchased used.
- c. Annually, no later than 13 months from the date of the prior inspection.
- d. Replace every 3 years.

Table 2-2. Preventive Maintenance & Inspection Schedule.

AREA ON MACHINE	INTERVAL		
	PRE-DELIVERY ^(a) OR FREQUENT ^(b) INSPECTION	6 MONTHS	ANNUAL ^(c)
MAST ASSEMBLY			
Mast Sections	1,2,5		
Belt System (<i>Ecolift Only</i>)	5		16
Slide Pads			2,3
Wear Screws	1	3	
Flywheel Crank Assembly (<i>Ecolift Only</i>)	1,5		14
Tool Tray	1		
PLATFORM ASSEMBLY			
Platform	1,2,4,5		
Guard Rails	1,2,4,5		
Gate Doors	1,2,5		
Floor	1,2		
Lanyard Anchorage Point	1,2		
CHASSIS ASSEMBLY			
Axle Wheels and Brake Assembly	1,5,7		
Front Caster Wheels and Brake	1,4,5,7		
Bubble Level	1		
Emergency Lowering Tool (<i>Ecolift Only</i>)	1,5		
FUNCTIONS/CONTROLS - (830P ONLY)			
Platform Control	1,5		
POWER SYSTEM - (830P ONLY)			
Electrical Connections	1		
Battery and Cables	1,20		
Motor Contactor Solenoids ^(d)		1,5,20	
HYDRAULIC/ELECTRIC SYSTEM - (830P ONLY)			
Hydraulic Pump	1,9		
Hydraulic Cylinder	1,9		
Hydraulic Lines, and Fittings	1,9		1,9
Hydraulic Reservoir, Cap, and Breather	1		
Hydraulic Fluid	11		25
GENERAL			
Operator and Safety Manual in Storage Box	21	21	21
ANSI and EMI Manuals/Handbooks Installed	21	21	21
Capacity Decals Installed, Secure, Legible	21	21	21
All Decals/Placards Installed, Secure, Legible	21	21	21
"Walk-Around" Inspection Performed	22		
Annual Machine Inspection Due			21
No Unauthorized Modifications or Additions		21	21
All Relevant Safety Publications Incorporated		21	21,22
General Structural Condition and Welds		2,4	2,4
All Fasteners, Pins, Shields, and Covers			1,2
Function Test of All Systems	22	22	
Paint and Appearance		7	7
Stamp Inspection Date on Frame			22
Notify JLG of Machine Ownership			22

2.3 SERVICING AND MAINTENANCE GUIDELINES

General

The following information is provided to assist you in the use and application of servicing and maintenance procedures contained in this chapter.

⚠ CAUTION

WHEN AN ABNORMAL CONDITION IS NOTED AND PROCEDURES CONTAINED HEREIN DO NOT SPECIFICALLY RELATE TO THE NOTED IRREGULARITY, WORK SHOULD BE STOPPED AND TECHNICALLY QUALIFIED GUIDANCE OBTAINED BEFORE WORK IS RESUMED.

Safety and Workmanship

Your safety, and that of others, is the first consideration when engaging in the maintenance of equipment. Always be conscious of component weight. Never attempt to move heavy parts without the aid of a mechanical device. Do not allow heavy objects to rest in an unstable position. When raising a portion of the equipment, ensure that adequate support is provided.

⚠ WARNING

NEVER WORK UNDER AN ELEVATED PLATFORM UNTIL PLATFORM HAS BEEN SAFELY RESTRAINED FROM ANY MOVEMENT BY BLOCKING OR OVERHEAD SLING.

Cleanliness

The most important single item in preserving the long service life of a machine is to keep dirt and foreign materials out of the vital components. Precautions have been taken to safeguard against this. Shields, covers, seals, and filters are provided to keep the wheel bearings, mast sections and oil supply clean; however, these items must be maintained on a scheduled basis in order to function properly.

At any time when oil lines are disconnected, clear adjacent areas as well as the openings and fittings themselves. As soon as a line or component is disconnected, cap or cover all openings to prevent entry of foreign matter.

Clean and inspect all parts during servicing or maintenance, and assure that all passages and openings are unobstructed. Cover all parts to keep them clean. Be sure all parts are clean before they are installed. New parts should remain in their containers until they are ready to be used.

Components Removal and Installation

Use adjustable lifting devices, whenever possible, if mechanical assistance is required. All slings (*chains, cables, etc.*) should be parallel to each other and as near perpendicular as possible to top of part being lifted.

Should it be necessary to remove a component on an angle, keep in mind that the capacity of an eyebolt or similar bracket lessens, as the angle between the supporting structure and the component becomes less than 90 degrees.

If a part resists removal, check to see whether all nuts, bolts, cables, brackets, wiring, etc., have been removed and that no adjacent parts are interfering.

Component Disassembly and Reassembly

When disassembling or reassembling a component, complete the procedural steps in sequence. Do not partially disassemble or assemble one part, then start on another. Always recheck your work to assure that nothing has been overlooked. Do not make any adjustments, other than those recommended, without obtaining proper approval.

Pressure-Fit Parts

When assembling pressure-fit parts, use an "anti-seize" or molybdenum disulfide base compound to lubricate the mating surface.

Bearings

When a bearing is removed, cover it to keep out dirt and abrasives. Clean bearings in nonflammable cleaning solvent and allow to drip dry. Compressed air can be used but do not spin the bearing.

Discard bearings if the races and balls (or rollers) are pitted, scored, or burned.

If bearing is found to be serviceable, apply a light coat of oil and wrap it in clean (waxed) paper. Do not unwrap reusable or new bearings until they are ready to install.

Lubricate new or used serviceable bearings before installation. When pressing a bearing into a retainer or bore, apply pressure to the outer race. If the bearing is to be installed on a shaft, apply pressure to the inner race.

Gaskets

Check that holes in gaskets align with openings in the mating parts. If it becomes necessary to hand-fabricate a gasket, use gasket material or stock of equivalent material and thickness. Be sure to cut holes in the right location, as blank gaskets can cause serious system damage.

Bolt Usage and Torque Application

Use bolts of proper length. A bolt which is too long will bottom before the head is tight against its related part. If a bolt is too short, there will not be enough thread area to engage and hold the part properly. When replacing bolts, use only those having the same specifications of the original, or one which is equivalent.

Unless specific torque requirements are given within the text, standard torque values should be used on heat-treated bolts, studs, and steel nuts, in accordance with recommended shop practices. (See *Torque Chart in Section-1 of this manual.*)

2.4 HYDRAULIC SYSTEM INFORMATION - (830P Only)

Hydraulic Lines and Electrical Wiring

Clearly mark or tag hydraulic lines and electrical wiring, as well as their receptacles, when disconnecting or removing them from the unit. This will assure that they are correctly reinstalled.

Hydraulic System

Keep the system clean. If evidence of metal or rubber particles is found in the hydraulic system, drain and flush the entire system.

Disassemble and reassemble parts on clean work surface. Clean all metal parts with non-flammable cleaning solvent. Lubricate components, as required, to aid assembly.

The primary enemy of a hydraulic system is contamination. Contaminants enter the system by various means, e.g., using inadequate hydraulic oil, allowing moisture, grease, filings, sealing components, sand, etc., to enter when performing maintenance, or by permitting the pump to cavitate due to insufficient system warm-up or leaks in the pump supply.

The design and manufacturing tolerances of the component working parts are very close, therefore, even the smallest amount of dirt or foreign matter entering a system can cause wear or damage to the components and generally results in faulty operation. Every precaution must be taken to keep hydraulic oil clean, including reserve oil in storage.

Lubrication and Servicing

Components and assemblies requiring lubrication and servicing are shown in the Lubrication Chart, (See *Section-1*). Service applicable components with the amount, type, and grade of lubricant recommended in this manual, at the specified intervals. When recommended lubricants are not available, consult your local supplier for an equivalent that meets or exceeds the specifications listed.

Cloudy oils indicate a high moisture content which permits organic growth, resulting in oxidation or corrosion. If this condition occurs, the system must be drained, flushed, and refilled with clean oil.

It is not advisable to mix oils of different brands or types, as they may not contain the same required additives or be of comparable viscosities. Good grade mineral oils, with viscosities suited to the ambient temperatures in which the machine is operating, are recommended for use.

NOTE: *Metal particles may appear in the oil of new machines due to the wear-in of meshing components.*

Hydraulic Oil

For best performance, JLG recommends the use of Grade 32, Mineral oil. Refer to Section-1 for recommended hydraulic oils.

Changing Hydraulic Oil

To drain the hydraulic tank, the mast must be in the transport position, and the platform tilted to allow access to the motor/pump unit. The only practical method to remove the oil from the tank is to use a syringe suitable for hydraulic oil, which are easily obtainable, or a vacuum system for hydraulic oil. The hydraulic steel pipe connection to the cylinder must not be disconnected, unless by a competent person. If the connection has been disconnected, then a full pressure test of the system must be conducted prior to placing the machine back into service. See Hydraulic System - Pressure and Leak Check on page 3-14, no leaks must be evident when the pressure test is conducted.

Use every precaution to keep the hydraulic oil clean. If the oil must be poured from the original container into another, be sure to clean all possible contaminants from the service container.

While the unit is shut down, a good preventive maintenance measure is to make a thorough inspection of all hydraulic components, lines, fittings, etc., as well as a functional check of each system, before placing the machine back in service.

SECTION 3. COMPONENT SERVICING

3.1 FRAME COVER INSTALLATION

Ecolift50

NOTE: Do not release the flywheel crank and raise the platform without weight in the platform. The mast contains a charged gas cylinder under constant pressure to help assist the lifting process.

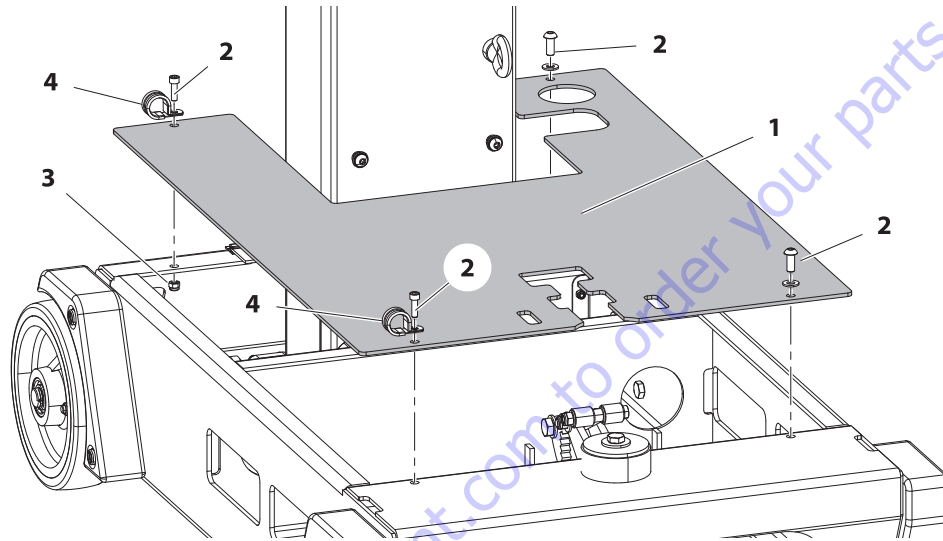

Figure 3-1. Frame Cover Installation - Ecolift50

- | | |
|-----------------------|--|
| 1. Frame Cover | 3. Lock Nut (Qty. 4) |
| 2. Screws and Washers | 4. Emergency Lowering Tool Mounting Clamps |

Ecolift70

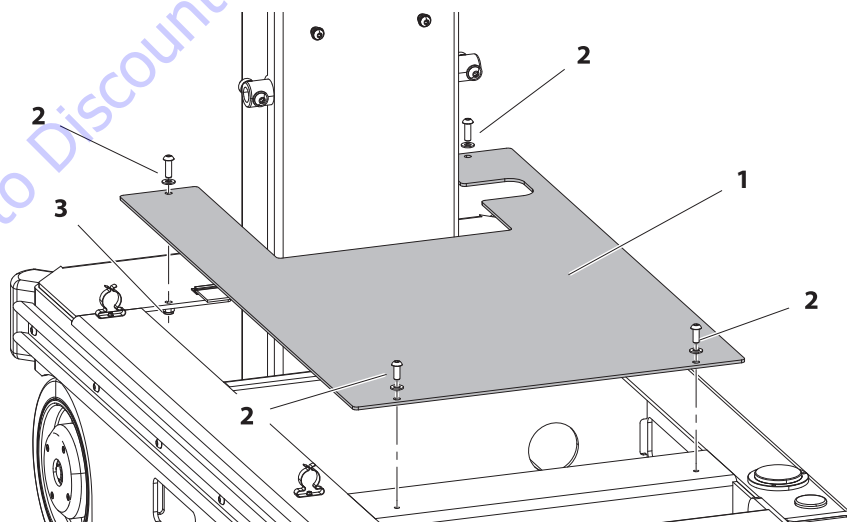

Figure 3-2. Frame Cover Installation - Ecolift50

- | | |
|-----------------------|----------------------|
| 1. Frame Cover | 3. Lock Nut (Qty. 4) |
| 2. Screws and Washers | |

830P

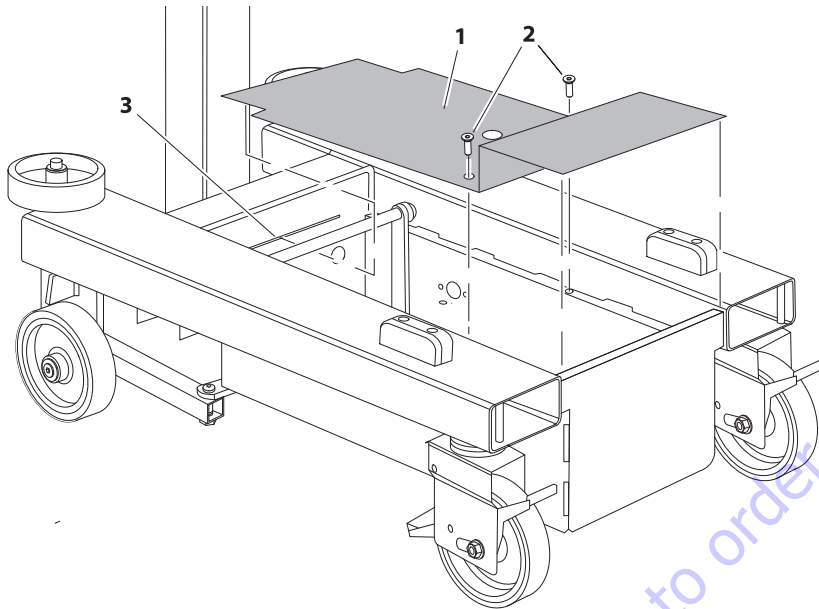

Figure 3-3. Frame Cover Installation - 830P

- 1. Frame Cover
- 2. Screws
- 3. Slot in Frame

Go to Discount-Equipment.com to order your parts

3.2 TOOL TRAY INSTALLATION

830P

Ecolift50

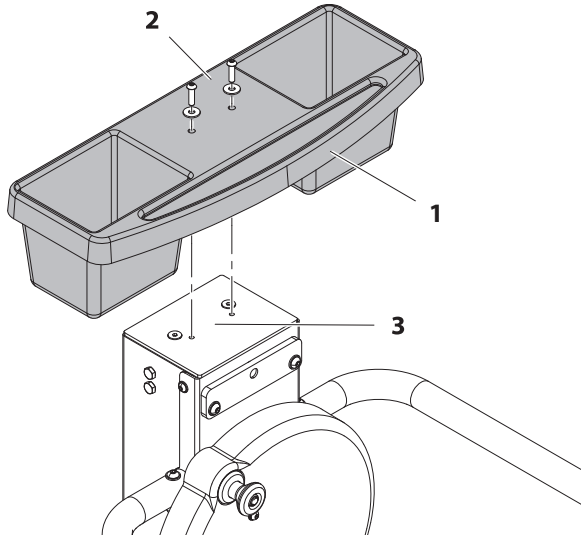

Figure 3-4. Tool Tray Installation - Ecolift50

- 1. Tool Tray
- 2. Attach Screws and Washers
- 3. Top Of Mast Mounting Holes

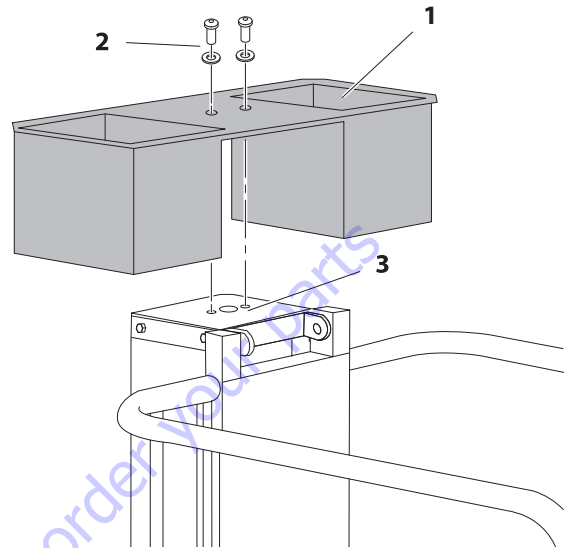

Figure 3-6. Tool Tray Installation - 830P

- 1. Tool Tray
- 2. Attach Screws and Washers
- 3. Top Of Mast Mounting Holes

Ecolift70

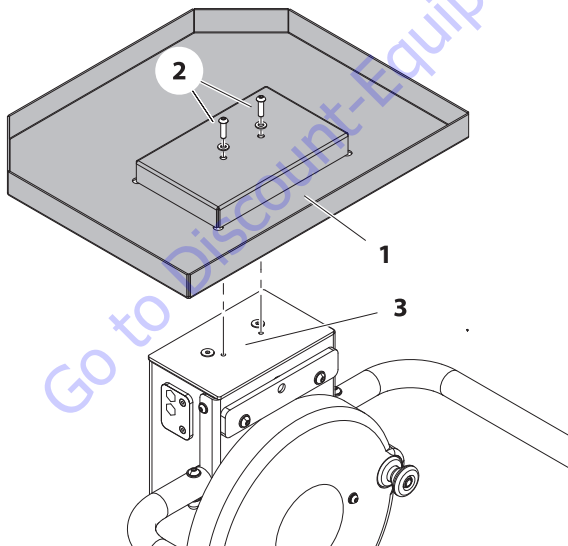

Figure 3-5. Tool Tray Installation - Ecolift70

- 1. Tool Tray
- 2. Attach Screws and Washers
- 3. Top Of Mast Mounting Holes

3.3 CASTOR WHEEL ASSEMBLY

Ecolift70 and 830P

In order to ensure the castors are maintained in serviceable and safe condition, regular inspection is required, especially where arduous conditions are known to be involved or there is suspicion of misuse or abuse.

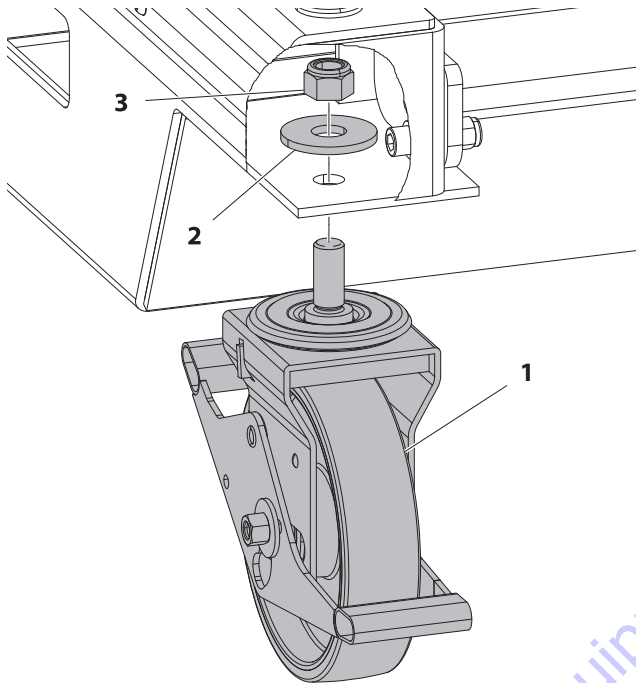

Figure 3-7. Castor Wheel Installation - Ecolift70 and 830P

- | | |
|--------------------------|----------------|
| 1. Castor Wheel Assembly | 3. Locking Nut |
| 2. Washer | |

1. Using suitable lifting equipment raise the front of the machine to allow removal of the castor wheel.
2. Using correct size wrench or socket remove the attaching nut on the top of the castor wheel assembly inside the frame.
3. Slide castor assembly out bottom of frame.

Install in reverse order using the above steps.

Ecolift50

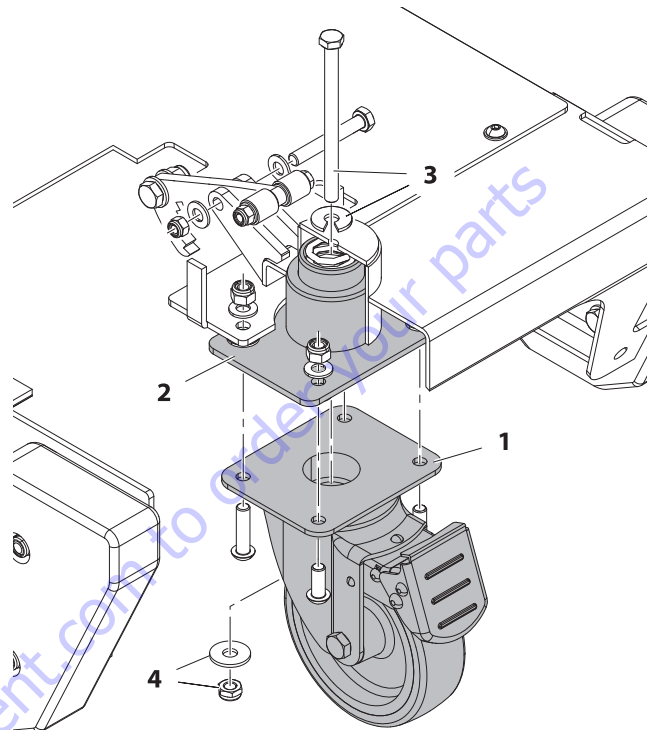

Figure 3-8. Castor Wheel Installation - Ecolift50

- | | |
|--------------------------|-----------------------------|
| 1. Castor Wheel Assembly | 3. Mounting Bolt and Washer |
| 2. Spring Mount | 4. Locking Nut and Washer |

1. Use suitable lifting equipment to raise and support the front of the machine to allow removal of the castor wheel.
2. Be certain the castor is in the down position removing the tension from the internal spring.
3. Using correct size wrench or socket hold the mounting bolt head on the top of the chassis frame housing and remove the locking nut and washer on the bottom of the castor wheel assembly inside the castor wheel frame.
4. Slide castor and mount assembly out bottom of frame.

Install in reverse order using the above steps.

3.4 REAR AXLE ASSEMBLY

Ecolift 50/70

The rear axle assembly includes a locking wheel brake system which is activated when the platform is raised from the stowed position. When activated along with the front castor brake, this helps keep the machine from moving when the platform is raised.

This brake system consists of a disc bolted to the back of the wheel hub assembly, the disc has a series of holes into which a spring loaded pin will engage when the platform is raised. Both rear axle wheels are equipped with the brake system.

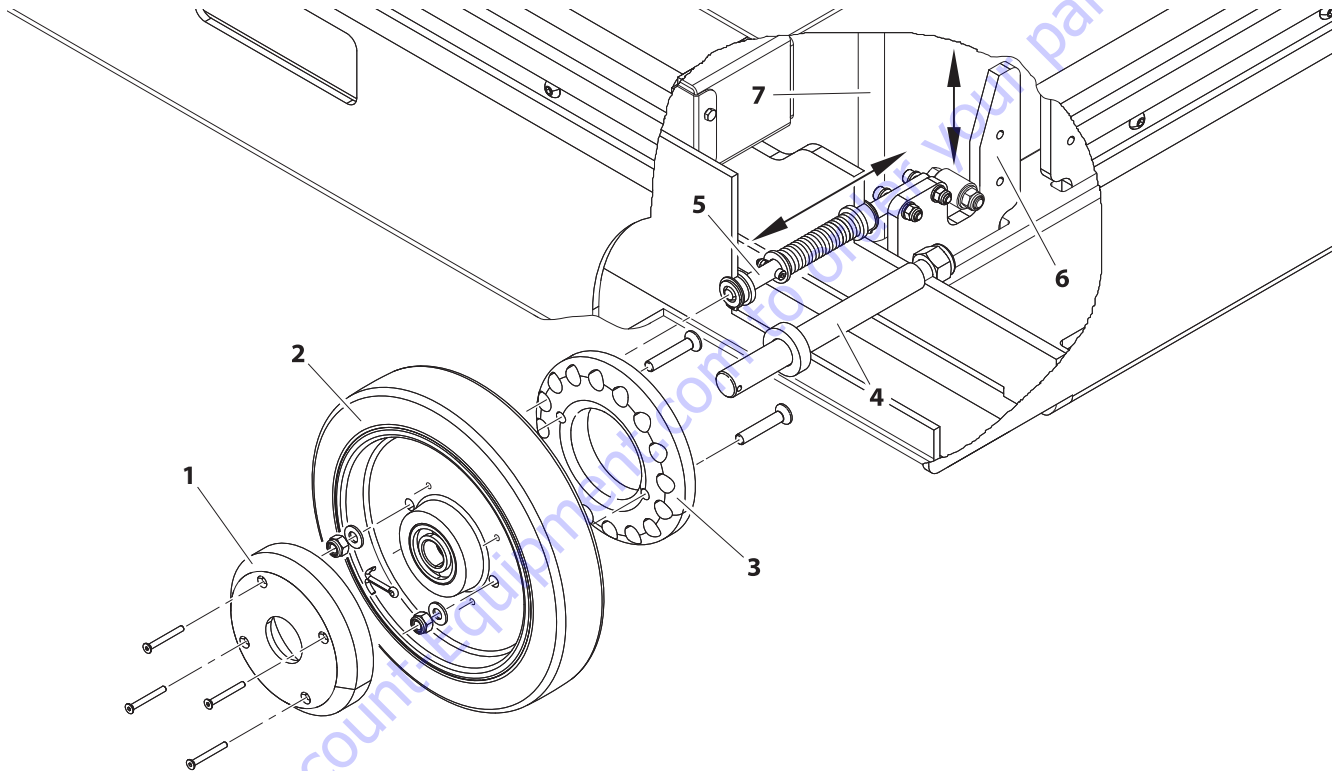

Figure 3-9. Rear Wheel and Brake Installation - Ecolift50/70

- | | |
|---|----------------------|
| 1. Wheel Bearing Cover | 5. Spring Loaded Pin |
| 2. Wheel Assembly | 6. Brake Actuator |
| 3. Wheel Brake Disk | 7. Mast |
| 4. Axle, Spacer and Mounting Nut Assembly | |

830P

The 830P rear axle brake assembly is actuated by a pivoting lever bar. When the platform is raised the lever bar is allowed to raise at the front, this lowers the frame at the rear and pivots the tire up until it makes contact with the stop weldment on the frame. That along with the front caster brakes helps hold the machine in place while the platform is elevated.

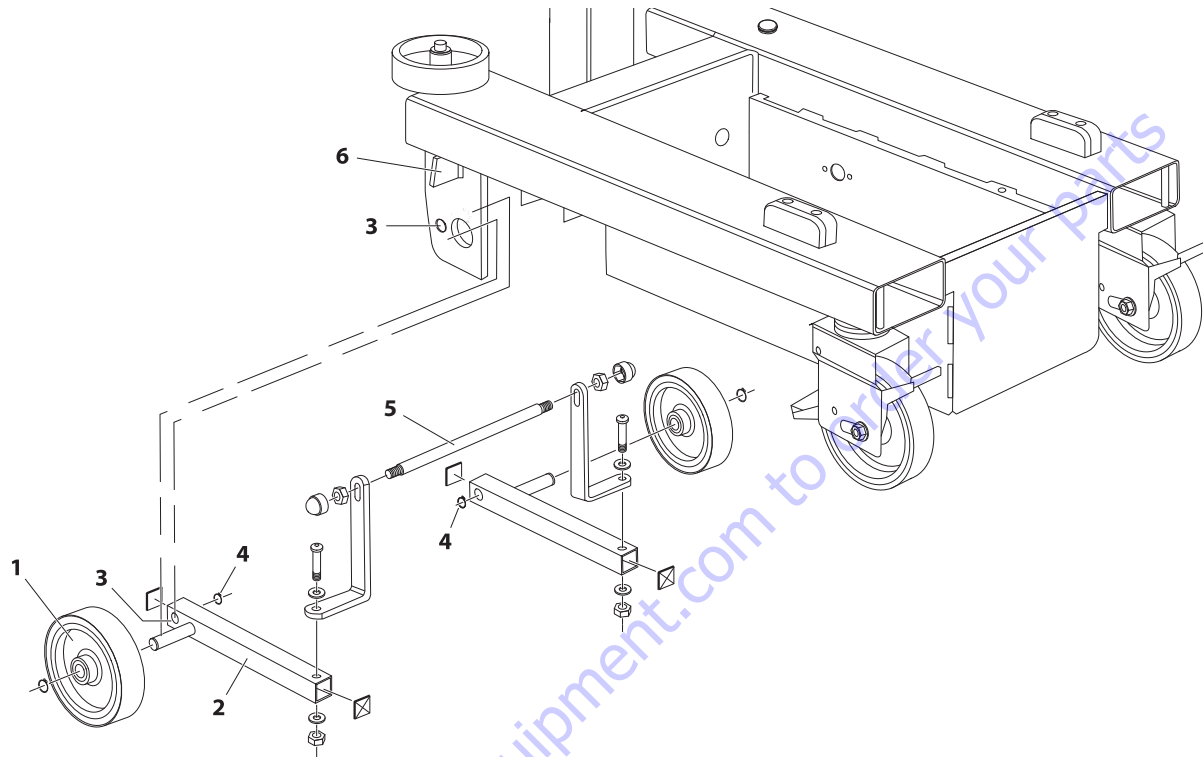

Figure 3-10. Rear Wheel and Brake Installation - 830P

- | | |
|--------------------------|-----------------------------------|
| 1. Wheel Assembly | 4. Lever Bar Pivot Snap Ring |
| 2. Pivoting Lever Bar | 5. Brake Actuator Bar and Bracket |
| 3. Lever Bar Pivot Point | 6. Frame Stop Weldment |

Adjusting the Brake Actuator Bar (5)

The brake actuator bar (5) is adjustable within the slots at the top of the L side brackets. Moving the actuator bar up or down allows the amount of pivoting action of the frame assembly.

This may need adjustment if when moving the machine, the wheel is dragging on the frame stop weldment (6) with the platform fully lowered. Or the frame stop weldment (6) doesn't engage the wheel (1) at all, when the platform is elevated.

Adjusting the actuator bar higher in the L bracket slots pushes the Pivoting Lever Bar (2) down further in the front and raises the frame higher at the rear, thereby increasing the gap between the wheel (1) and the frame stop weldment (6).

Adjusting the actuator bar lower in the L bracket slots raises the Pivoting Lever Bar (2) up in the front and lowers the frame at the rear, thereby decreasing the gap between the wheel (1) and the frame stop weldment (6).

3.5 PLATFORM INSTALLATION

830P

Ecolift50/70

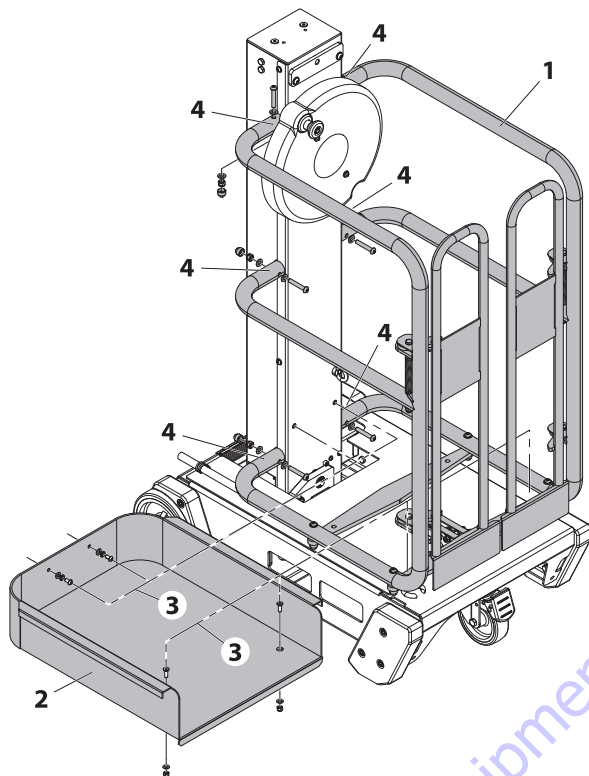

Figure 3-11. Platform Installation - Ecolift50 and 70

- | | |
|-----------------------|---|
| 1. Platform Assembly | 3. Floor Pan Mounting Bolts and Washers |
| 2. Floor Pan Assembly | 4. Platform to Mast Bolts and Washers |

1. Remove the four bolts, nuts and washers securing the floor pan to the platform assembly. Remove floor pan.
2. Remove the six bolts, nuts and washers securing the platform assembly to the mast assembly.
3. Loosen the bolt and nuts on the bottom rail cross-member to allow the platform rails to clear the mast mounting sockets.
4. With the aid of an assistant, remove platform from mast by pulling each rail out from its mast socket then lifting the platform off and setting aside.

NOTE: When assembling apply anti-seize compound to the platform rail attach bolts/nuts (item 4).

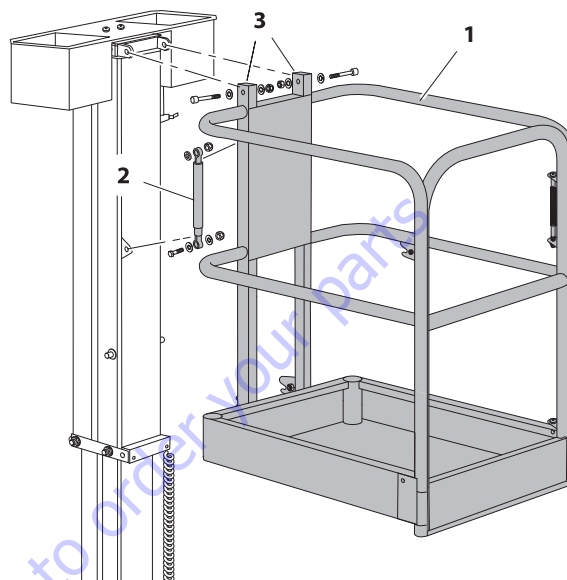

Figure 3-12. Platform Installation - 830P

- | | |
|--------------------------------|---------------------------------------|
| 1. Platform Assembly | 3. Platform to Mast Bolts and Washers |
| 2. Gas Strut w/Catch Mechanism | |

1. Release platform latch lock pin and swing the front of the platform up until it can be supported by the gas strut catch mechanism.
2. Support platform from the top rails using suitable overhead lifting equipment. Lift platform enough to take the weight of the platform off of the gas strut.
3. Unbolt and remove the gas strut.
4. Let the front of the platform down carefully until level. Now move the lifting straps to the center of the platform rails to support the platform.
5. Remove the platform to mast mounting bolts, washers and nuts.
6. Carefully lift the platform off the machine and set aside.

3.6 ECOLIFT FLYWHEEL CRANK COVER INSTALLATION

⚠ CAUTION

DO NOT RELEASE THE FLYWHEEL CRANK AND ATTEMPT TO RAISE THE PLATFORM WITHOUT WEIGHT IN THE PLATFORM. THE MAST CONTAINS A GAS CHARGED CYLINDER UNDER CONSTANT PRESSURE TO HELP ASSIST THE LIFTING PROCESS WHEN THE PLATFORM IS IN THE STOWED POSITION.

⚠ CAUTION

ONCE FLYWHEEL CRANK COVER IS REMOVED KEEP HANDS AND FINGERS AWAY FROM THE CRANK MECHANISM IF RELEASING AND ROTATING THE HANDLE.

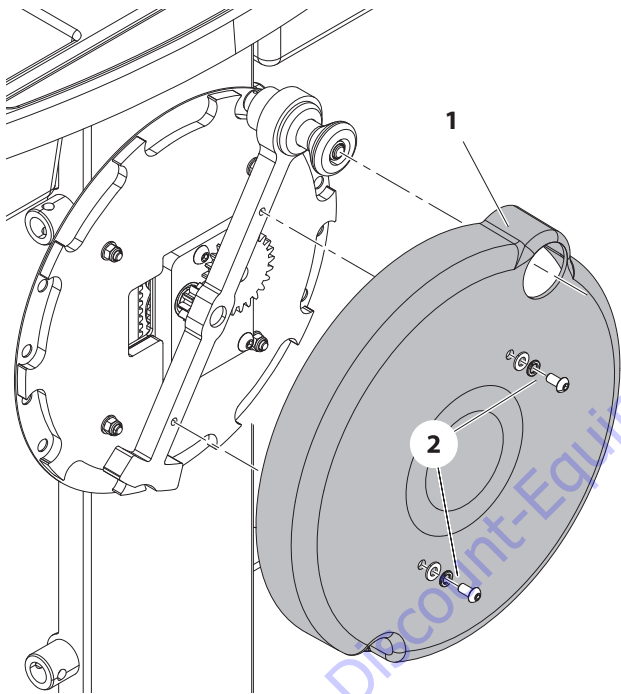

Figure 3-13. Flywheel Crank Cover Installation - Ecolift50 and 70

- 1. Frame Cover
- 2. Mounting Screws/Washers

3.7 ECOLIFT50/70 MAST INSTALLATION

(See Figure 3-15.)

⚠ CAUTION

THE MAST CONTAINS A GAS CHARGED CYLINDER UNDER CONSTANT PRESSURE. WHEN THE PLATFORM IS FULLY LOWERED THE GAS IS UNDER THE MOST PRESSURE.

DO NOT RELEASE THE FLYWHEEL CRANK WITHOUT WEIGHT IN THE PLATFORM DUE TO THE CONSTANT PRESSURE OF THE GAS CYLINDER. IF REMOVING THE MAST ASSEMBLY FROM THE MACHINE, THE GAS MUST BE RELIEVED FROM THE PRESSURIZED GAS CYLINDER.

Mast Disassembly

The mast assembly can be disassembled while on the machine or removed completely from the machine and disassembled.

1. Remove the tool tray from the top of the mast assembly. (See Section 3.2)
2. Remove the frame cover from the base frame. (See Section 3.1)

NOTE: Before performing the next step you must have provisions to refill the gas cylinder once mast is reassembled. See 830P Mast Installation on page 3-13.

3. Remove the mast top cover and using the valve on the top of the gas cylinder, allow all the gas to escape from the cylinder.
4. Remove the platform from the mast. (See Section 3.5).
5. Remove the mast from the base frame. If disassembling off the machine.
6. Remove the flywheel crank cover from the flywheel crank. (See Section 3.6)
7. Remove the mast top cap.

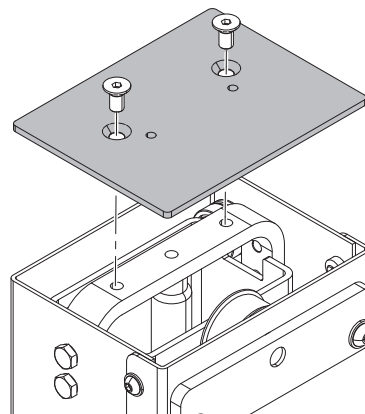

Figure 3-14. Mast Top Cap Installation - Ecolift

- 1. Top Cover
- 2. Mounting Screws

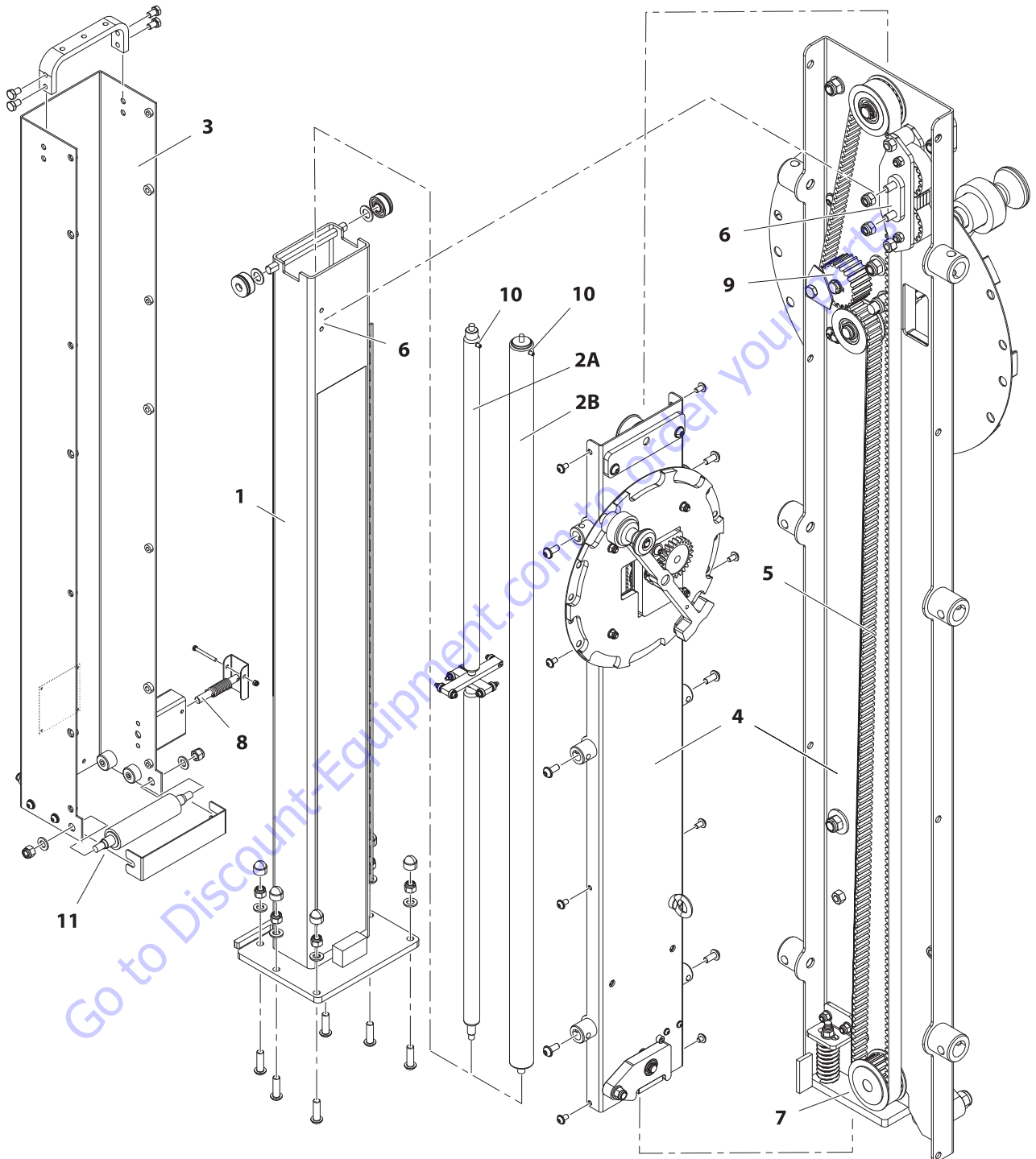

Figure 3-15. Ecolift Mast Assembly

- | | | |
|---|---|---|
| <ul style="list-style-type: none"> 1. Inner Mast Assembly 2. A - Ecolift50 - Pressurized Gas Cylinder 2. B - Ecolift70 - Pressurized Gas Cylinder 3. Outer Mast Section (Rear Half) | <ul style="list-style-type: none"> 4. Outer Mast Section (Front Cover) 5. Belt Drive System 6. Stationary Belt Clamp Assembly and Mounting Holes 7. Belt Spring Tensioner and Interlock Plate | <ul style="list-style-type: none"> 8. Mast Safety Interlock Pin 9. Flywheel Crank Drive Gear 10. Gas Cylinder Fill Valve 11. Mast Guide Roller Assembly |
|---|---|---|

8. With the gas cylinder de-pressurized, loosen, **but do not remove**, the four bolts attaching the gas cylinder mount to the top of the outer mast section.
9. Check that the mount can be moved up and down by hand, and there is not a great amount of pressure on the mount from the gas cylinder. If OK, remove the bolts from the mount and remove the mount from the top of the mast.
10. Remove the safety interlock pin cover and pull the interlock pin out and rotate 90° to lock the pin in the retracted position.
11. Removing the outer mast/front cover assembly from the mast.
 - a. Remove the 14 screws (7 each side) from the front cover assembly.
12. The belt drive system clamp assembly which clamps the belt ends, is anchored to the inner mast section and must be unbolted.
 - a. The head of the belt clamp mounting bolts must first be aligned with the access hole in the flywheel mounting plate on the front of the mast. (See Figure 3-16.) This is so they can be kept from turning while removing the nuts inside the inner mast section.
 - b. At the top of the mast assembly approximately 6 in. down on the inside of the inner mast weldment, remove the two lock nuts attaching the belt clamp assembly to the inner mast weldment.

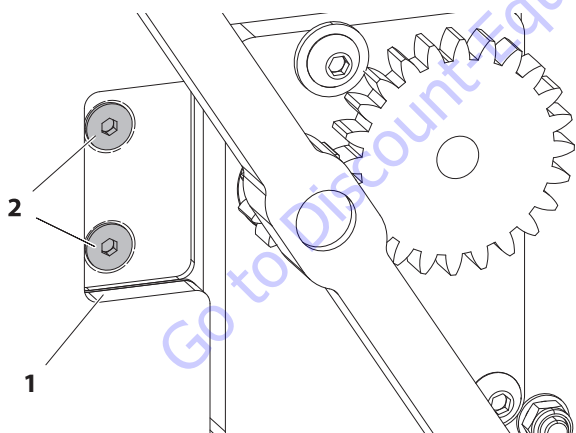

Figure 3-16. Belt Clamp Mounting Bolts - Ecolift

1. Flywheel Plate Access Hole 2. Belt Clamp Mounting Bolts

NOTE: Extend or retract mast assembly to almost stowed position to align with belt clamp bolt heads.

13. Once step 8 and 9 are completed the complete outer mast front cover and flywheel assembly can be lifted off the mast assembly for further disassembly, if required.

14. Remove the mast guide roller from the bottom front of the mast assembly.
15. Using an assistant, lift the outer mast section off the inner mast section and set aside for disassembly, if necessary.
16. If necessary, remove the gas cylinder from the inner mast section. If tight in the mounting hole on the bottom of the inner mast section, you may have to tap the cylinder rod with a flat punch to get it started out of the mounting hole.
17. At the top of the inner mast section carefully pull the gas cylinder out of the inner mast section.
18. If necessary to remove the drive belt assembly from the front cover.
 - a. Compress the spring tensioner enough to allow the belt to be slid off the lower belt cog gear.
 - b. Remove the bolt from the belt guide roller plate beside the drive gear, this will allow the belt to be removed from the drive gear and idler cog gear next to it.
 - c. The belt and clamp assembly should now be free from the front cover assembly.
 - d. If replacing belt, disassemble the belt clamp assembly and install new belt. (See Figure 3-17.)

Mast Re-assembly

(Item numbers refer to Figure 3-15.)

Assemble the mast reversing the steps above.

Mast components requiring lubrication, anti-seize compound, or thread locking compound during assembly:

- Thread Locking Compound Required:
 - Apply to threads of lanyard attach eyelet. (on item 4)
 - Belt tensioner stop - apply to socket head screw and nut just above the pulley block on front panel. (on item 4)
 - Apply to threads of belt guide plate mounting bolt and nut. (item 9)
 - Apply to threads of belt clamp allen head mounting bolts. (item 6)
 - Apply to threads of gas strut support bracket mast bolts. (top of item 3)
- Anti-Seize Compound:
 - Apply to threaded stud on belt spring tensioner. (on item 6)
 - Coat the flat facing surface of the three pulleys and drive gear and the guide plate. (on item 4 and 9)

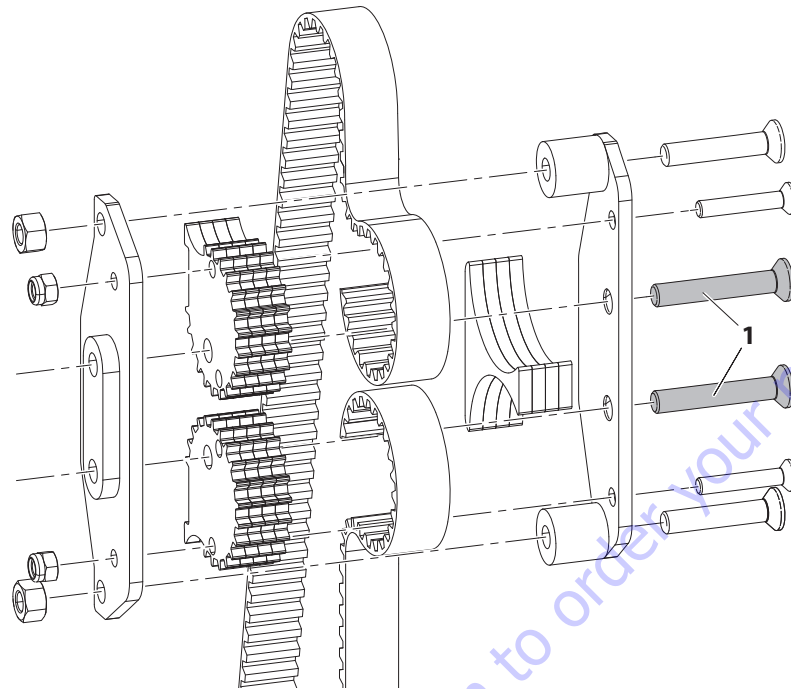

Figure 3-17. Belt Clamp Assembly - Ecolift

1. Belt Clamp to Inner Mast - Mounting Bolts

Gas Cylinder Pressurizing

⚠ CAUTION

BEFORE PRESSURIZING THE GAS CYLINDER BE CERTAIN THE FLYWHEEL CRANK PIN IS ENGAGED WITH ONE OF THE FLYWHEEL BACKING PLATE SLOTS.

Fill each gas cylinder through the valve on the side of the cylinder barrel with nitrogen gas.

⚠ CAUTION

DO NOT EXCEED 1450 PSI (100 BAR) MAXIMUM PRESSURE IN THE GAS STRUT.

Table 3-1. Ecolift 50 - Gas Cylinder Recharging Pressure

AMBIENT TEMPERATURE IN RECHARGING AREA	PRESSURE
5°F to 23°F (-15.0 to -5.1°C)	928 PSI +/- 7 PSI (64 bar +/- 0.5 bar)
23°F to 41°F (-5.0 to +4.9°C)	972 PSI +/- 7 PSI (67 bar +/- 0.5 bar)
41°F to 59°F (+5.0 to +14.9°C)	1015 PSI +/- 7 PSI (70 bar +/- 0.5 bar)
59°F to 77°F (+15.0 to +24.9°C)	1059 PSI +/- 7 PSI (73 bar +/- 0.5 bar)
77°F to 95°F (+25.0 to +34.9°C)	1102 PSI +/- 7 PSI (76 bar +/- 0.5 bar)

Table 3-2. Ecolift 70 - Gas Cylinder Recharging Pressure

AMBIENT TEMPERATURE IN RECHARGING AREA	PRESSURE
5°F to 23°F (-15.0 to -5.1°C)	1001 PSI +/- 7 PSI (69 bar +/- 0.5 bar)
23°F to 41°F (-5.0 to +4.9°C)	1044 PSI +/- 7 PSI (72 bar +/- 0.5 bar)
41°F to 59°F (+5.0 to +14.9°C)	1088 PSI +/- 7 PSI (75 bar +/- 0.5 bar)
59°F to 77°F (+15.0 to +24.9°C)	1031 PSI +/- 7 PSI (78 bar +/- 0.5 bar)
77°F to 95°F (+25.0 to +34.9°C)	1175 PSI +/- 7 PSI (81 bar +/- 0.5 bar)

Flywheel Rotation Force - Testing

(See Figure 3-18.)

When the gas cylinder is pressurized properly, it should take no more than 55 lb. (25 Kg) of force to turn the flywheel handle in the counter-clockwise (lowering) direction, when the platform is close to fully lowered. At this mast position the gas cylinder inside the mast assembly, is almost fully compressed.

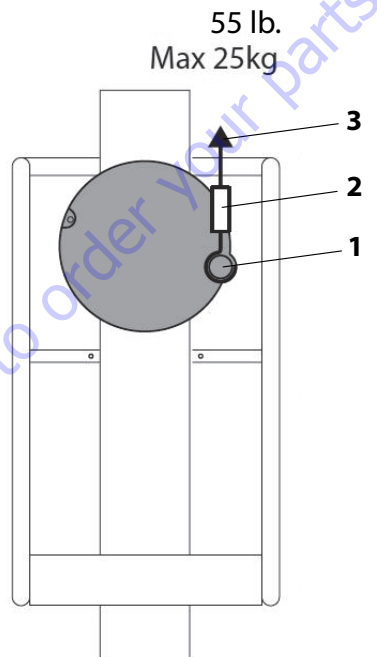

Figure 3-18. Flywheel Rotation Force - Testing - Ecolift

1. Flywheel Crank - Pin Released + Person in Platform
2. Calibrated Digital Spring Balance
3. Rotate in Counter-Clockwise Direction

3.8 830P MAST INSTALLATION

(See Figure 3-19.)

The 830P mast is extended using a hydraulic cylinder pressurized by a hydraulic pump.

The 830P mid and outer mast sections are removable, the inner mast section is stationary and is welded to the base assembly, so therefore not removable.

Mast Disassembly

1. Completely lower the platform to stowed position.
2. Remove the tool tray. (See Section 3.2)
3. Remove the platform assembly. (See Section 3.5)
4. Remove the frame cover. (See Section 3.1)
5. Disconnect the positive (+) battery terminal at the battery.
6. Remove the mast top cap bolts on the sides of the outer mast section. Carefully pull/pry up on the top cap to manually extend the hydraulic cylinder rod.
7. Remove counter sunk hex head screw attaching the hydraulic cylinder rod to the mast top cap. Remove the mast top cap and lay aside.

NOTE: It may be necessary to restrain the cylinder rod from turning when removing the screw attaching it to the mast top cap. If gripping the rod surface, protect it from severe damage, grip as close to the bottom of the top cap as possible, as this area does not retract into the cylinder barrel.

NOTE: If only removing lift cylinder jump to steps 17 and 18 next.

8. Next loosen the lock nuts on all the wear screws around the base of the outer mast section. Loosen wear screws until flush with mast inside surface.
9. Loosen the two slide pads, one each side, at the top of the mast mid section and slide as far rearward as possible and hand tighten in place.
10. Remove the roller guide at the bottom front of the outer mast section.
11. The outer mast section weighs approximately 77 lb., using suitable lifting equipment, carefully and slowly lift the outer mast section off the mid mast section assembly.

NOTE: In order to slide the mid mast section off of the inner mast section, the mid mast section must be pushed rearward to create clearance between the spring dampening bar stop mounted on the inside of the lower half of the mid mast section and the spring dampening assembly mounted three quarters the way up on the outside of the inner mast section.

12. Loosen the lock nuts on all the wear screws around the base of the mid mast section. Loosen wear screws until flush with mast inside surface.
13. Loosen the two slide pads, one each side, at the top of the inner mast section and slide as far rearward as possible and hand tighten in place.
14. Remove the roller guide at the bottom front of the mid mast section.
15. The mid mast section weighs approximately 66 lb., using suitable lifting equipment, carefully and slowly lift the mid mast section off the inner mast assembly.
16. If removing the hydraulic cylinder, remove the access panel at the bottom rear of the mast assembly. Disconnect and cap the hydraulic line attached to the bottom of the cylinder.
17. Carefully remove the cylinder from the inner mast section, protect cylinder rod from damage.

Mast Assembly Notes

(Item numbers refer to Figure 3-19.)

Assemble the mast reversing the steps above.

Mast components requiring lubrication, anti-seize compound, or thread locking compound during assembly:

- Thread Locking Compound Required:
 - Apply to threads of fitting on bottom of lift cylinder. (item 5)
 - Apply to threads of hydraulic line fitting on bottom of lift cylinder. (item 5)
 - Apply to threads of mast cap to cylinder rod screw. (item 4)
 - Apply to threads of mast cap to outer mast section screws. (item 4)
- Anti-Seize Compound:
 - Coat the surface of the spring dampener block and approximately one inch around it. (item 10)
- On a level surface check each mast section is plumb with vertical level as they are assembled. Use the slide pads at the top of the mast section and wear screws at the bottom of the mast section to adjust the sections vertically on the mast.
- Do not overtighten wear screws and slide pads against mast surface. Run in until contact is made to take out any side to side or front to back movement, when plumbed vertical, then tighten large nut. Gap between screw and mast should be no more than .008 in. to .019 in. (0.2mm to 0.5mm).
- Once mast is completely assembled, set machine up for operation and check that mast assembly extends and retracts correctly.

Hydraulic System - Pressure and Leak Check

1. Check that the hydraulic oil level is at the FULL mark on the pump reservoir.
2. Place a pressure gauge on the existing test port at the hydraulic pressure line from pump to the cylinder. Gauge must be capable of reading greater than the set hydraulic pressure.
3. Fully extend and retract the mast through two or three lift cycles. Recheck the pump reservoir oil level.
4. Elevate platform to maximum height and check the pump line pressure while pump is running. Should be approximately 1100 psi @ normal operating temperature.
5. Check the lines and fittings for any hydraulic oil leaks. Repair if needed.
6. Top off the pump reservoir oil level to FULL if needed.

Go to Discount-Equipment.com to order your parts

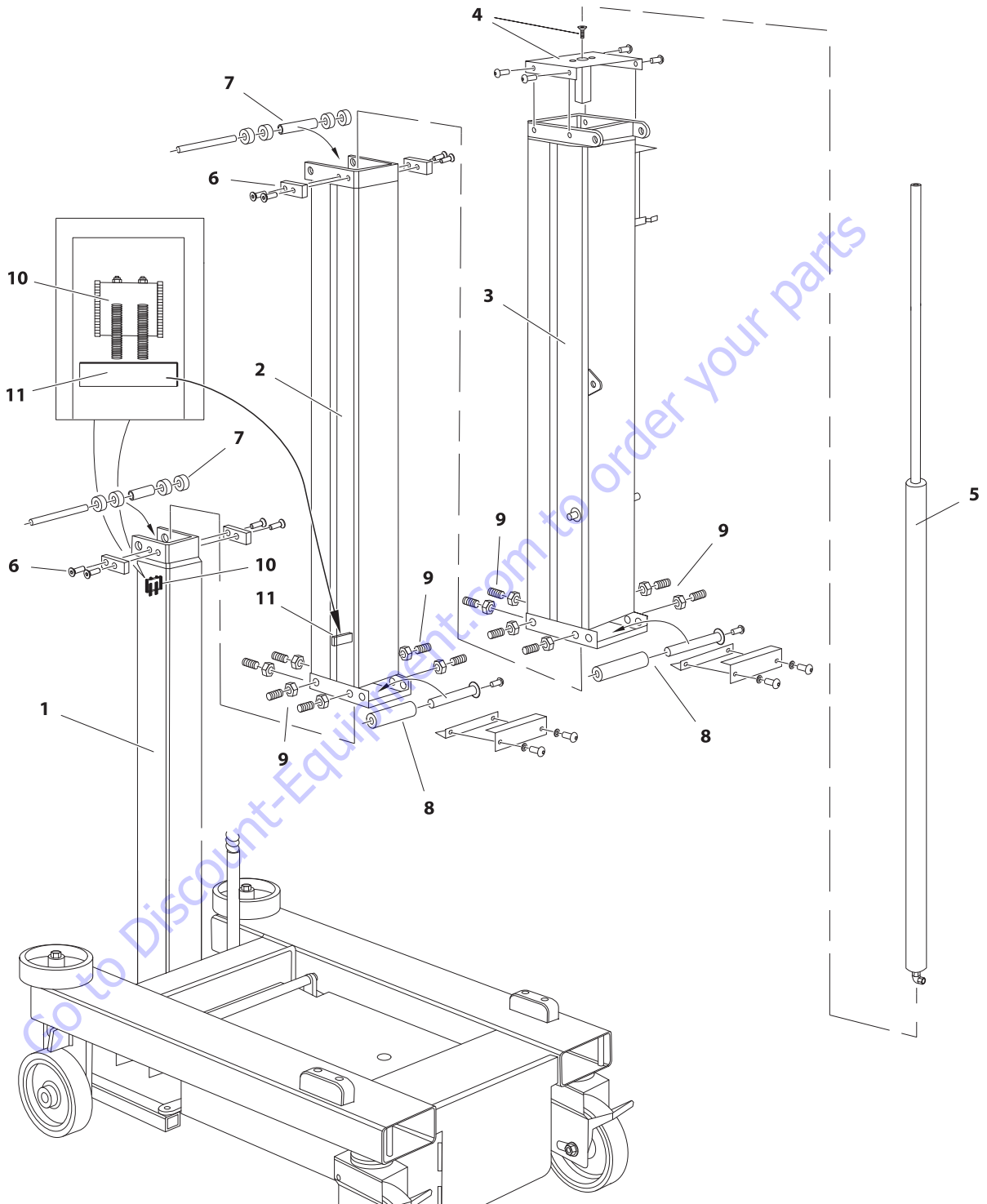

Figure 3-19. 830P Mast Assembly

- | | | |
|---|---|--|
| <ul style="list-style-type: none"> 1. Inner Mast Section (Welded to Base) 2. Mid Mast Section 3. Outer Mast Section 4. Mast Top Cap, Mounting and Cylinder Screws | <ul style="list-style-type: none"> 5. Hydraulic Lift Cylinder 6. Inner and Mid - Mast Slide Pads 7. Inner and Mid - Mast Rear Guide Roller 8. Mid and Outer - Mast Front Guide Roller | <ul style="list-style-type: none"> 9. Wear Screws 10. Spring Damper Assembly 11. Spring Damper Stop |
|---|---|--|

3.9 830P ELECTRICAL/HYDRAULIC COMPONENTS

NOTE: See Hydraulic and Electrical Diagrams in Section 4, 830P - Troubleshooting And Schematics. for complete electrical wiring connections.

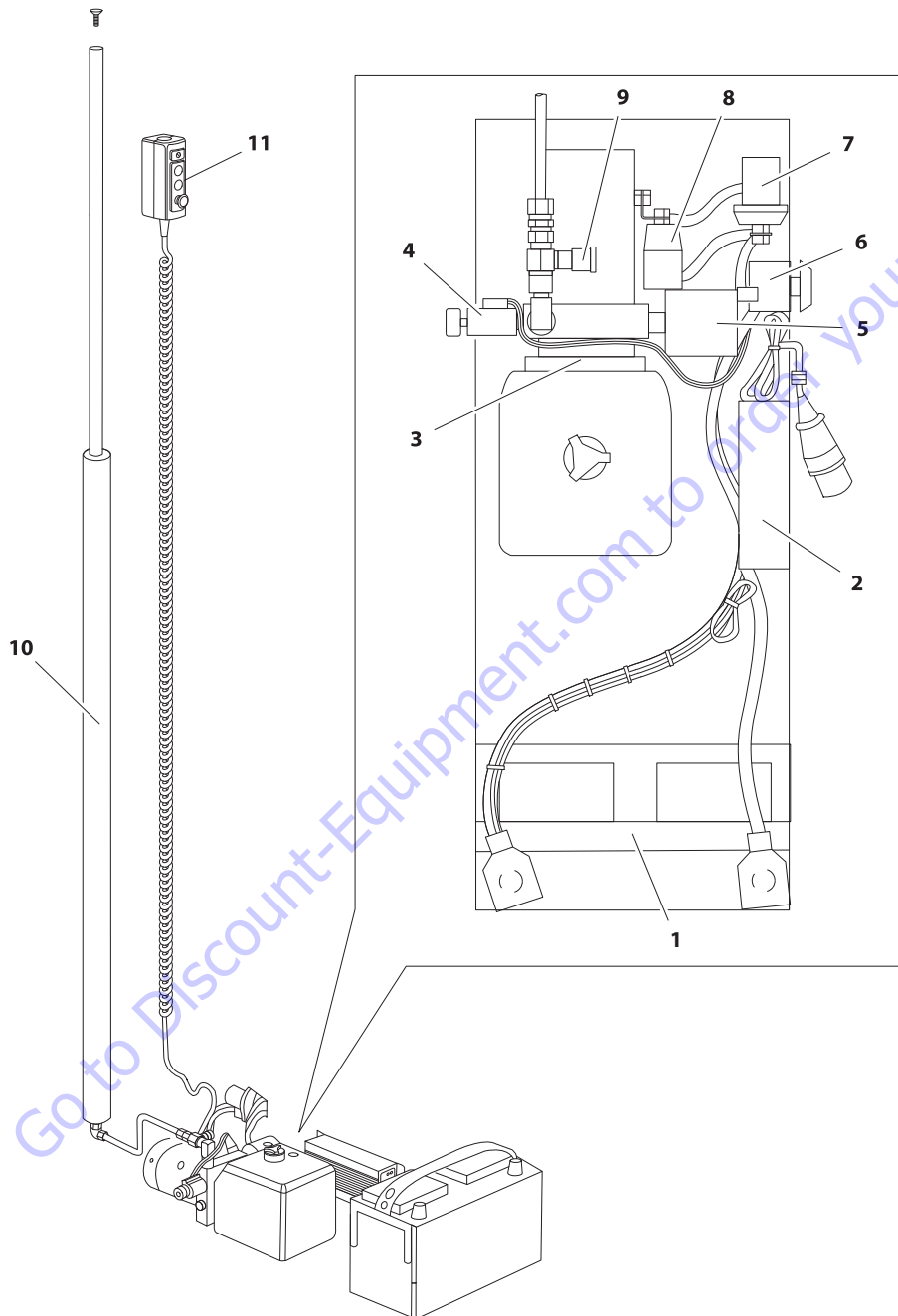

Figure 3-20. 830P Electrical/Hydraulic Components

- | | | |
|-------------------------------------|--------------------------------|---|
| 1. Battery | 5. Lift Valve | 9. Hydraulic Test Port |
| 2. Battery Charger | 6. Emergency Stop Switch w/Key | 10. Hydraulic Lift Cylinder |
| 3. Hydraulic Pump and Reservoir | 7. Safety Solenoid | 11. Platform Control Station with Enable Button |
| 4. Lowering Valve w/Manual Override | 8. Pump Starter Solenoid | |

Contactors Solenoid Replacement

(See Figure 3-20. - Items 7 and 8)

(See Figure 4-5. - motor contactor 1 and motor contactor 2 for wiring connections, if necessary)

1. Place machine in a clear work area.
2. Rotate the platform up into the machine maintenance position and lock the gas strut.
3. Remove the base frame cover.
4. Disconnect machine power by removing the battery (+) positive terminal from the battery (+) positive post.
5. Disconnect the motor contactor 1 and/or motor contactor 2 cables and wiring from the contactor solenoids.
6. Remove the mounting bolts and nuts from the contactor solenoids.
7. Replace the contactor solenoid, install reversing the steps above.

Battery Charger Operation

The battery charger is located under the base frame cover beneath the platform. (See Figure 3-21.). To access the charger, see Figure 5-2.

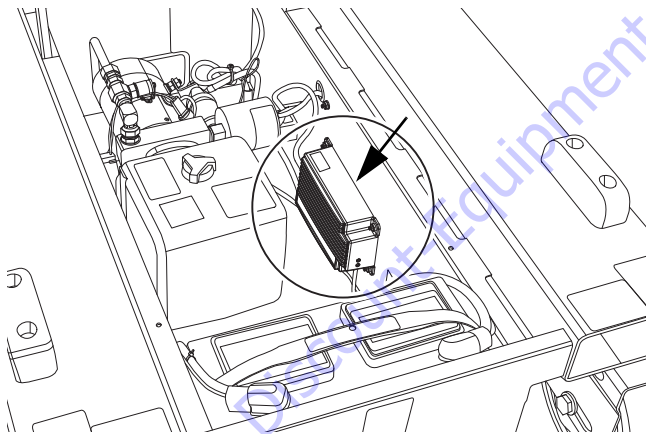

Figure 3-21. Battery Charger

The charging AC input cable is located on the left side of the machine base (see Figure 3-22.). Plug into a compatible AC power supply, see charger specifications in Table 5-3 on page 5-3.

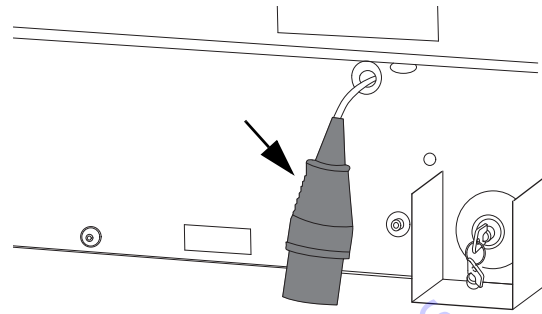

Figure 3-22. Charger AC Input Cable

The battery charge level can be monitored at the platform control box - battery charge indicator see Figure 3-23. or by observing the LEDs on the front of the battery charger, see Figure 3-24.

To display current battery charge status on the platform control - battery charge indicator - both the ground and platform control, emergency stop switches must be set to the ON position, and the enable button on the side of the platform control must be momentarily pressed in. When the indicator is at the top of the GREEN area that indicates a full charge. When the indicator is in the RED area this indicates power is getting low and batteries will soon need recharged.

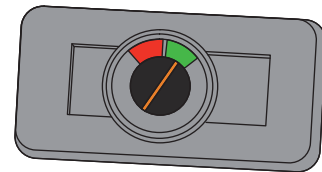

Figure 3-23. Battery Charge Indicator
(Located near the top of the Platform Control Box)

If observing the charger LEDs, ensure the GREEN LED (front of charger) illuminates. and stays lit.

The adjacent AMBER LED has three modes (see Figure 3-24.).

1. Rapid flash, indicates maximum charge rate. (Note, when switching charger on, the amber light must rapid flash. If not, there is a fault, check fuse and connections).
2. Slow pulse, indicates slower charging.
3. Continuous illumination indicates float charge. Both LEDs go "off" when fully charged.

The battery charger can be connected to the AC power supply at any time or left for extended periods.

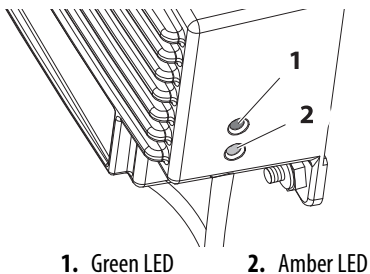

Figure 3-24. Charger LEDs

NOTICE

AC POWER SUPPLY CIRCUIT SHOULD BE PROTECTED WITH A BREAKER CIRCUIT. ONLY CHARGE BATTERY IN A WELL-VENTILATED AREA.

NOTE: *The charger is fitted with a 15A automotive spade fuse (blue). If the fuse has failed, the indicator lights will still operate. The fuse may have failed if the battery is heavily discharged and the motor is run when the charger is switched on. In such an event, the fuse is simple to replace; ensure battery disconnect is switched off and that the positive RED battery cable is disconnected before attempting to check or change fuse.*

Go to Discount-Equipment.com to order your parts

PARTS FINDER

**Search Website
by Part Number**



**Search Manual
Library For Parts
Manual & Lookup Part
Numbers – Purchase
or Request Quote**

Search Manuals

Enter the model number or part number to search for parts.

* Brand:

* Serial Number:

* Model:

Serial:

Part Number:

Quantity:

Submit

**Can't Find Part or
Manual? Request Help
by Manufacturer,
Model & Description**

Parts Order Form

Please fill in the following information:

Manufacturer:

Model:

Serial:

Description:

Quantity:

Submit

Discount-Equipment.com is your online resource for quality parts & equipment.

Florida: **561-964-4949** Outside Florida TOLL FREE: **877-690-3101**

Need parts?

Click on this link: <http://www.discount-equipment.com/category/5443-parts/> and choose one of the options to help get the right parts and equipment you are looking for. Please have the machine model and serial number available in order to help us get you the correct parts. If you don't find the part on the website or on once of the online manuals, please fill out the request form and one of our experienced staff members will get back to you with a quote for the right part that your machine needs.

We sell worldwide for the brands: Genie, Terex, JLG, MultiQuip, Mikasa, Essick, Whiteman, Mayco, Toro Stone, Diamond Products, Generac Magnum, Airman, Haulotte, Barreto, Power Blanket, Nifty Lift, Atlas Copco, Chicago Pneumatic, Allmand, Miller Curber, Skyjack, Lull, Skytrak, Tsurumi, Husquvarna Target, , Stow, Wacker, Sakai, Mi-T- M, Sullair, Basic, Dynapac, MBW, Weber, Bartell, Bennar Newman, Haulotte, Ditch Runner, Menegotti, Morrison, Contec, Buddy, Crown, Edco, Wyco, Bomag, Laymor, Barreto, EZ Trench, Bil-Jax, F.S. Curtis, Gehl Pavers, Heli, Honda, ICS/PowerGrit, IHI, Partner, Imer, Clipper, MMD, Koshin, Rice, CH&E, General Equipment, ,AMida, Coleman, NAC, Gradall, Square Shooter, Kent, Stanley, Tamco, Toku, Hatz, Kohler, Robin, Wisconsin, Northrock, Oztec, Toker TK, Rol-Air, Small Line, Wanco, Yanmar

SECTION 4. 830P - TROUBLESHOOTING AND SCHEMATICS

4.1 GENERAL

This section contains troubleshooting information to be used for locating and correcting most of the operating problems which may develop in the aerial platform. If a problem should develop which is not presented in this section or which is not corrected by listed corrective actions, technically qualified guidance should be obtained before proceeding with any maintenance.

4.2 TROUBLESHOOTING INFORMATION

The troubleshooting procedures applicable to the aerial platform are listed and defined in Table 4-1, 830P - Troubleshooting.

Each malfunction within an individual group or system is followed by a listing of probable causes which will enable determination of the applicable remedial action. The probable causes and the remedial action should, where possible, be checked in the order listed in the tables.

It should be noted that there is no substitute for a thorough knowledge of the equipment and related systems.

It should be recognized that the majority of the problems arising in the machine will be centered in the hydraulic and electrical systems. For this reason, every effort has been made to ensure that all likely problems in these areas are given the fullest possible treatment. In the remaining machine groups, only those problems which are symptomatic of greater problems which have more than one probable cause and remedy are included. This means that problems for which the probable cause and remedy may be immediately obvious are not listed in this section.

The first rule for troubleshooting any circuit that is hydraulically operated and electrically controlled is to determine if the circuit is lacking hydraulic oil and electrical control power. This can be ascertained by overriding the bypass valve (*mechanically or electrically*) so that oil is available to the function valve, then overriding the function valve mechanically. If the function performs satisfactorily, the problem exists with the control circuit.

4.3 HYDRAULIC CIRCUIT CHECKS

The first reference for improper function of a hydraulic system, where the cause is not immediately apparent, should be the Troubleshooting Chart. The best place to begin the problem analysis is at the power source (*pump*). Once it is determined that the pump is serviceable, then a systematic check of the circuit components, beginning with the control, would follow.

NOTE: For aid in Hydraulic troubleshooting, refer to Figure 4-6. HYDRAULIC Schematic at the end of this section. For ELECTRICAL Diagram refer to Figure 4-5. at the end of this chapter.

4.4 ELECTRICAL SYSTEM - MULTIMETER BASICS

A wide variety of multi-meters or Volt Ohm Meters (VOM) can be used for troubleshooting your equipment. A digital meter with reasonable accuracy (within 7%) is recommended for the measurements in these procedures. This section shows diagrams of a common, digital VOM configured for several different circuit measurements. Instructions for your VOM may vary. Please consult the meter operator's manual for more information.

Grounding

"Grounding the meter" means to take the black lead (which is connected to the COM (common) or negative port) and touch it to a good path to the negative side of the voltage source.

Backprobing

To "backprobe" means to take the measurement by accessing a connector's contact on the same side as the wires, the back of the connector. Readings can be done while maintaining circuit continuity this way. If the connector is the sealed type, great care must be taken to avoid damaging the seal around the wire. It is best to use probes or probe tips specifically designed for this technique, especially on sealed connectors. Whenever possible insert probes into the side of the connector such that the test also checks both terminals of the connection. It is possible to inspect a connection within a closed connector by backprobing both sides of a connector terminal and measuring resistance. Do this after giving each wire a gentle pull to ensure the wires are still attached to the contact and contacts are seated in the connector.

Min/Max

Use of the "Min/Max" recording feature of some meters can help when taking measurements of intermittent conditions while alone. For example, you can read the voltage

applied to a solenoid when it is only operational while a switch, far from the solenoid and meter, is held down.

Polarity

Finding a negative voltage or current reading when expecting a positive reading frequently means the leads are reversed. Check what reading is expected, the location of the signal and that the leads are connected to the device under test correctly. Also check that the lead on the "COM" port goes to the ground or negative side of the signal and the lead on the other port goes to the positive side of the signal.

Scale

M = Mega = 1,000,000 * (Displayed Number)

k = kilo = 1,000 * (Displayed Number)

m = milli = (Displayed Number) / 1,000

μ = micro = (Displayed Number) / 1,000,000

Example: 1.2 k Ω = 1200 Ω

Example: 50 mA = 0.05 A

Continuity Measurement Over Long Distances

When trying to determine continuity of a harness or wire, longer than the reach of standard instrument leads, is possible to perform the check without excessively long leads. Using the other wires in the harness one can determine the condition of a particular wire in the harness.

Requirements:

- Harness with at least three separate wires including the wire under test.
- These wires must be able to be isolated from other wires, etc.
- Jumper or method to connect contacts on one side of harness.
- Meter that can measure resistance or continuity.

Procedure

Test multimeter leads resistance. Subtract this value from the measured resistance of the wires to get a more accurate measurement.

Consult the circuit schematic to determine which wires to use in addition to wire under test, here called wire #1 and wire #2, and how to isolate these wires. These wires should appear in the same connectors as the wire under test or are within reach of the jumper.

1. Disconnect all connections associated with the wire under test and the two additional wires. If harness is not completely isolated disconnect battery terminals also, as a precaution.
2. Measure continuity between all three wires, the wire under test, wire #1 and wire #2. These should be open. If not, repair the shorted wires or replace the harness.
3. On one side, jumper from contact of wire #1 and wire #2.
4. Measure continuity between wire #1 and wire #2. If there is continuity, both wires are good and can be used for this test. If there is not continuity, either wire could be bad. Check connections and measurement setup. Redo measurement. If still no continuity, repair wires or consult schematic for other wires to use for test.
5. Jumper from wire under test to wire #1.
6. Measure continuity. If there is continuity, the wire under test is good. Resistance of a wire increases as the length increases and as the diameter decreases.

One can find the continuity of two wires, here #1 and #2, at once by following steps 1 through 4. If there is a problem the third wire is used to troubleshoot the other wires. To find the problem, start at step 1 and use the entire procedure.

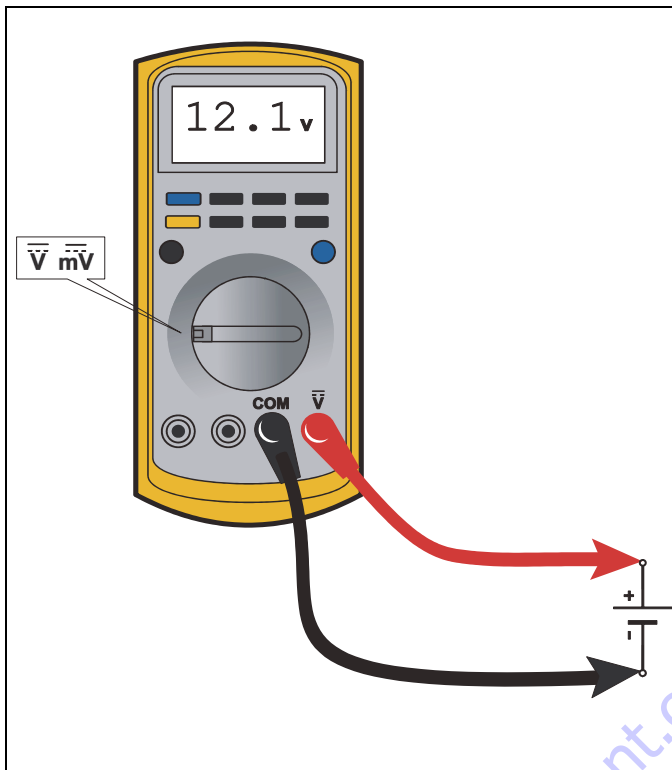
Voltage Measurement**Figure 4-1. Voltage Measurement (DC)**

- If meter is not auto ranging, set it to the correct range (See multimeter's operation manual)
- Use firm contact with meter leads

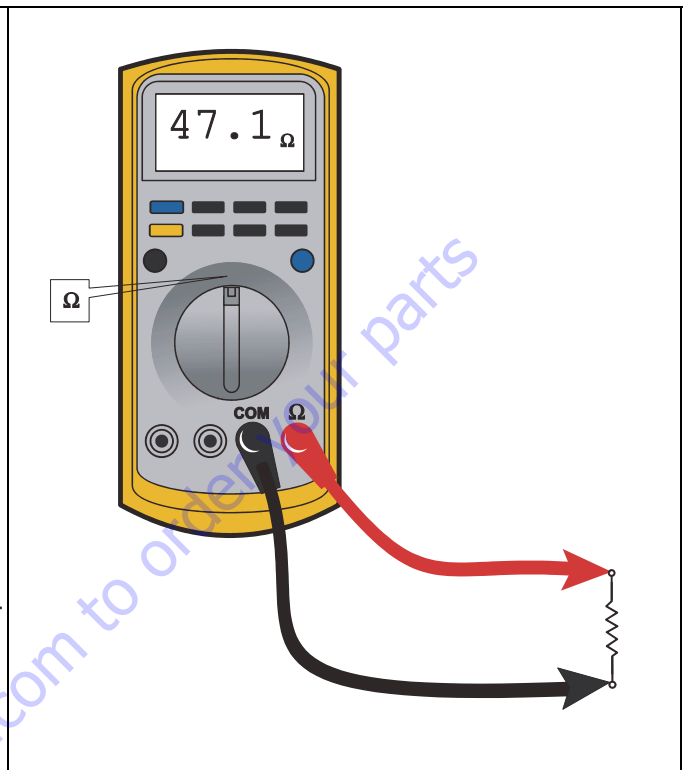
Resistance Measurement**Figure 4-2. Resistance Measurement**

- First test meter and leads by touching leads together. Resistance should read a short circuit (very low resistance)
- Circuit power must be turned OFF before testing resistance
- Disconnect component from circuit before testing
- If meter is not auto ranging, set it to the correct range (See multimeter's operation manual)
- Use firm contact with meter leads

Continuity Measurement

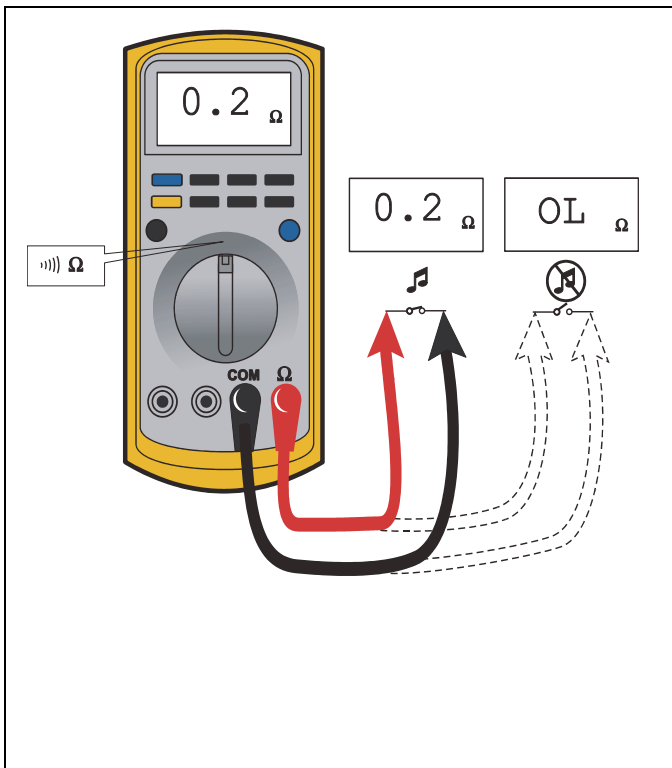

Figure 4-3. Continuity Measurement

Current Measurement

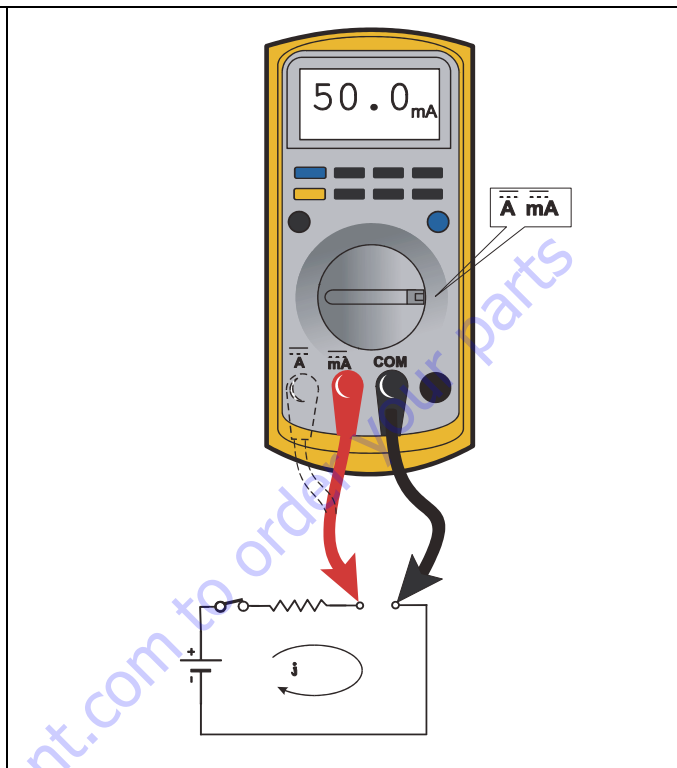

Figure 4-4. Current Measurement (DC)

- Some meters require a separate button press to enable audible continuity testing
- Circuit power must be turned OFF before testing continuity
- Disconnect component from circuit before testing
- Use firm contact with meter leads
- First test meter and leads by touching leads together. Meter should produce an audible alarm, indicating continuity

- Set up the meter for the expected current range
- Be sure to connect the meter leads to the correct jacks for the current range you have selected
- If meter is not auto ranging, set it to the correct range (See multi meter's operation manual)
- Use firm contact with meter leads

4.5 ELECTRICAL SWITCH TESTING

Basic Check

The following check determines if the switch is functioning properly, not the circuit in which the switch is placed. A switch is functioning properly when there is continuity between the correct terminals or contacts only when selected.

1. De-energize the circuit.
2. Isolate the switch from the rest of the circuit if possible. If not possible, keep in mind it may affect readings.
3. Access the terminals to the switch.
4. If the switch has two terminals:
 - a. Measure resistance across the terminals.
 - b. Change the switch position.
 - c. Measure resistance again with the leads in the same positions. If the meter was reading short, it should read an open. If the meter was reading open it should read short.
5. If the switch has more than two terminals, consult the schematic or switch diagram to determine what terminals will be connected. The test is similar to testing a switch with two terminals.
 - a. Place one meter lead on the common contact and the other on a different contact in the same circuit.
 - b. Cycle through all positions of the switch. The meter should read short only when the switch connects the two terminals and open otherwise.
 - c. If the switch has more than one common contact repeat the process for that circuit.

Limit Switches

Limit switches are used to control movement or indicate position. Mechanical limit switches are just like manually operated switches except that the moving object operates the switch. These switches can be tested the same way as a standard switch by manually operating the sensing arm.

Another type of limit switch used by JLG is the inductive proximity switch, also referred to as a "prox switch". Inductive proximity switches are actuated only by ferrous metal (metal that contains Iron, such as steel) near the switch. They do not require contact, and must be energized to actuate. These types of switches can be used to detect boom or platform position, for example. These switches have a sensing face where the switch can detect ferrous metal close to it. To find the sensing face, take note how the switch is mounted and how the mechanisms meet the switch. Test this type of switch as follows:

1. Remove prox switch from its mount.

2. Reconnect harness if it was disconnected for step 1, and turn on machine.
3. Hold switch away from metal and observe switch state in the control system diagnostics using the Analyzer. See vehicle or control system documentation on how to do this.
4. Place sensing face of switch on the object to be sensed by the switch. If that is not available, use a piece of ferrous metal physically similar to it. The switch state in the control system diagnostics should change.
5. When reinstalling or replacing switch be sure to follow mounting instructions and properly set the gap between the switch and object sensed.

Automatic Switches

If the switch is actuated automatically, by temperature or pressure for example, find a way to manually actuate the switch to test it. Do this either by applying heat or pressure, for example, to the switch. These switches may need to be energized to actuate.

1. Connect instrumentation to monitor and/or control the parameter the switch is measuring.
2. Observe switch state in control system with the Analyzer. See vehicle or control system documentation on how to do this.
3. Operate system such that the switch actuates. This could be going over a certain pressure or temperature, for example. The state indicated in the control system should change.

Switch Wiring - Low Side, High Side

When controlling a load, a switch can be wired between the positive side of the power source and the load. This switch is called a "high side" switch. The switch supplies the power to the load. When a switch is wired between the negative side of the power source and the load, it is a "low side" switch. The switch provides the ground to the load.

A low side switch will allow voltage to be present on the load. No power is applied because the switch is stopping current flow. This voltage can be seen if the measurement is taken with one test lead on the load and the other on the battery negative side or grounded to the vehicle. What is actually being measured is the voltage drop across the switch. This could mislead a technician into thinking the load is receiving power but not operating. To produce an accurate picture of power or voltage applied to the load, measure voltage across the load's power terminals. Also, the technician can measure the voltage at both power terminals with respect to battery ground. The difference between those two measurements is the voltage applied to the load.

SECTION 4 - 830P - TROUBLESHOOTING AND SCHEMATICS

Table 4-1. 830P - Troubleshooting

TROUBLE	PROBABLE CAUSE	REMEDY
Platform does not rise.		
	Red emergency stop button is engaged (PUSHED IN) on control station.	Disengage (TURN CLOCKWISE) red emergency button until it pops out.
	Enable button on platform control not pressed in.	Press and hold Enable button while operating platform up or down buttons.
	Control relay not functioning.	Replace control relay.
	Motor start relay not functioning.	Replace motor start relay.
	Unit wiring not properly grounded.	Check all ground connections in the wiring.
Unit lowers by itself.		
	Manual descent valve open.	Close manual descent valve.
	Hydraulic hose and/or fittings loose causing a hydraulic pressure leak.	Tighten hydraulic hose and/or fittings.
	Lift DOWN solenoid valve not functioning.	Replace Lift DOWN solenoid valve.
Unit leaking hydraulic oil.		
	Hydraulic hose and/or fittings loose.	Tighten hydraulic hose and/or fittings.
	Valve and/or plug loose.	Tighten valve and/or plug.
	Breather cap on tank is saturated or clogged with oil.	Replace breather cap on tank.
	Hydraulic oil tank over-filled.	Lower oil level to full mark on dipstick.
Unit lowers very slowly.		
	Lift DOWN solenoid valve not functioning.	Replace Lift DOWN solenoid valve.

4.6 830P ELECTRICAL DIAGRAM

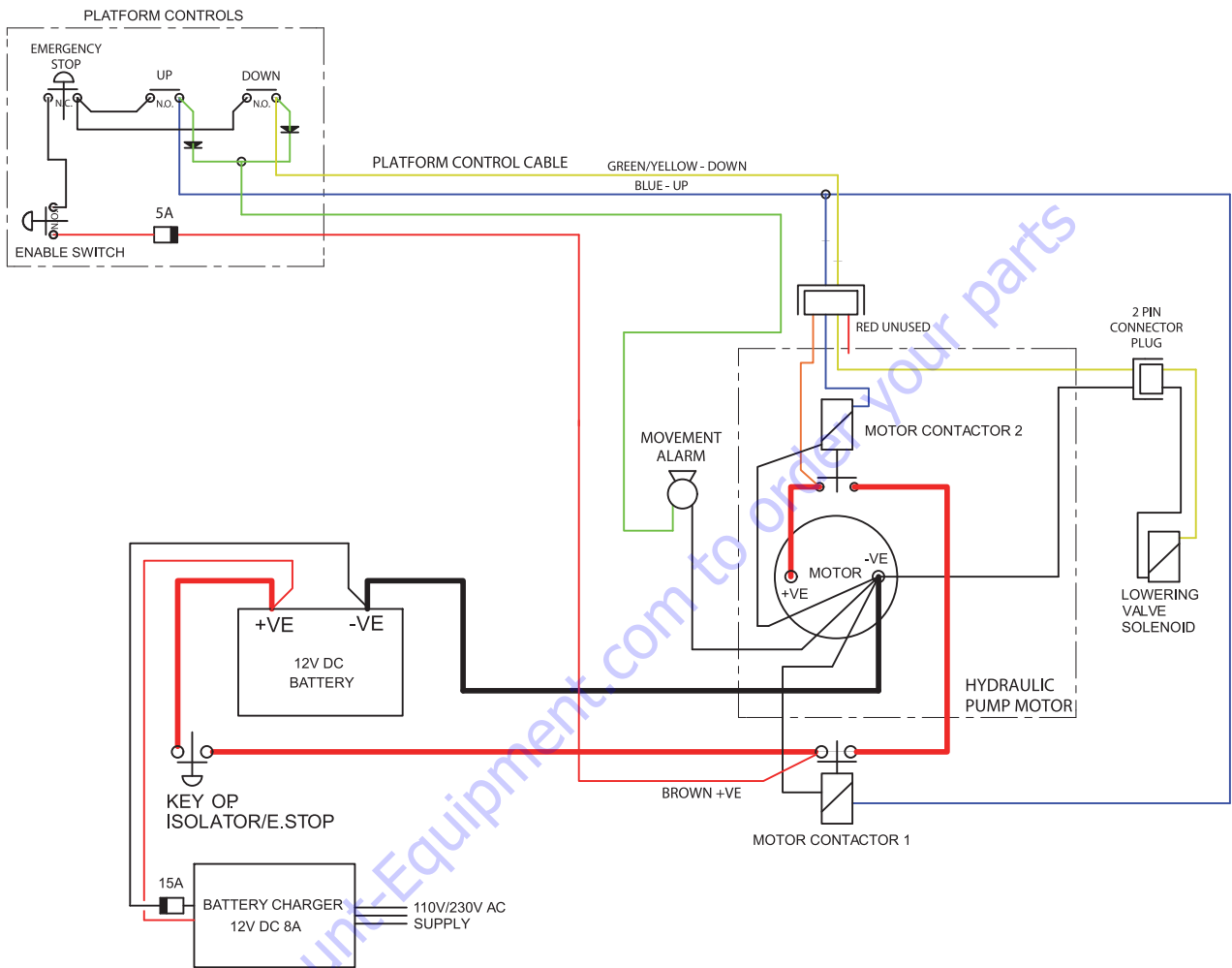

Figure 4-5. 830P - Electrical Diagram.

4.7 830P HYDRAULIC DIAGRAM

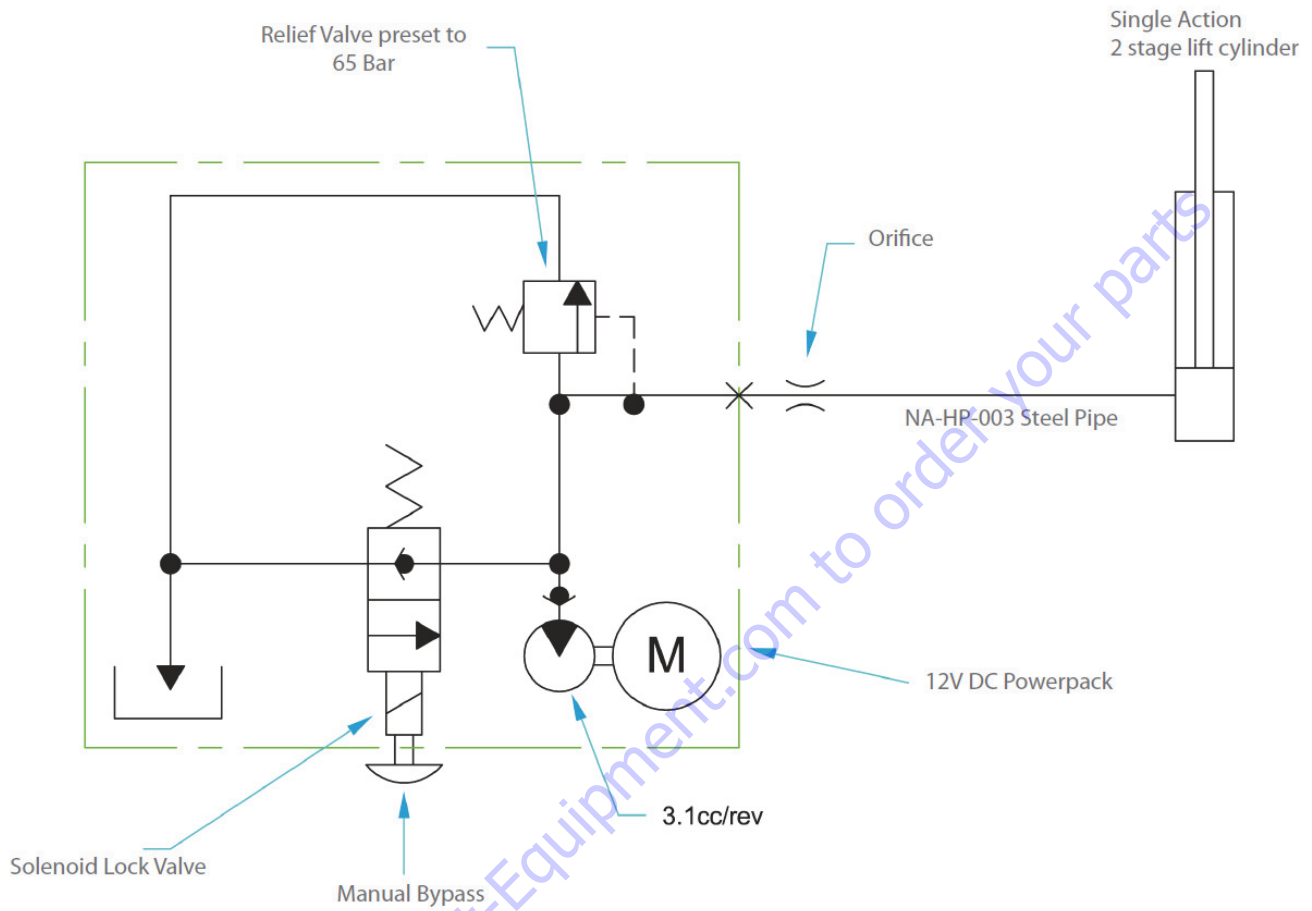

Figure 4-6. 830P - Hydraulic Diagram.

PARTS FINDER

**Search Website
by Part Number**



**Search Manual
Library For Parts
Manual & Lookup Part
Numbers – Purchase
or Request Quote**

Search Manuals

Enter your information to search for manuals and parts.

* Brand:

* Model:

* Serial:

* Part Number:

SEARCH

**Can't Find Part or
Manual? Request Help
by Manufacturer,
Model & Description**

Parts Order Form

Please fill in the following information:

Manufacturer:

Model:

Description:

Quantity:

Part Number:

Part Name:

Part Description:

Part Location:

Part Condition:

Part Status:

Part Material:

Part Color:

Part Weight:

Part Dimensions:

Part Price:

Part Notes:

Submit

Discount-Equipment.com is your online resource for quality parts & equipment.

Florida: **561-964-4949** Outside Florida TOLL FREE: **877-690-3101**

Need parts?

Click on this link: <http://www.discount-equipment.com/category/5443-parts/> and choose one of the options to help get the right parts and equipment you are looking for. Please have the machine model and serial number available in order to help us get you the correct parts. If you don't find the part on the website or on once of the online manuals, please fill out the request form and one of our experienced staff members will get back to you with a quote for the right part that your machine needs.

We sell worldwide for the brands: Genie, Terex, JLG, MultiQuip, Mikasa, Essick, Whiteman, Mayco, Toro Stone, Diamond Products, Generac Magnum, Airman, Haulotte, Barreto, Power Blanket, Nifty Lift, Atlas Copco, Chicago Pneumatic, Allmand, Miller Curber, Skyjack, Lull, Skytrak, Tsurumi, Husquvarna Target, , Stow, Wacker, Sakai, Mi-T- M, Sullair, Basic, Dynapac, MBW, Weber, Bartell, Bennar Newman, Haulotte, Ditch Runner, Menegotti, Morrison, Contec, Buddy, Crown, Edco, Wyco, Bomag, Laymor, Barreto, EZ Trench, Bil-Jax, F.S. Curtis, Gehl Pavers, Heli, Honda, ICS/PowerGrit, IHI, Partner, Imer, Clipper, MMD, Koshin, Rice, CH&E, General Equipment, ,AMida, Coleman, NAC, Gradall, Square Shooter, Kent, Stanley, Tamco, Toku, Hatz, Kohler, Robin, Wisconsin, Northrock, Oztec, Toker TK, Rol-Air, Small Line, Wanco, Yanmar

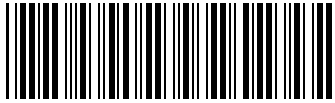

3121741



An Oshkosh Corporation Company

**Discount
Equipment**

www.Discount-Equipment.com

Go to Discount-Equipment.com to order your parts