



An Oshkosh Corporation Company

Operation and Safety Manual

Original Instructions - Keep this manual with the machine at all times.

Model

830P

SN P900004871 to Present



ANSI

31215862

December 12, 2019 - Rev A

TO PURCHASE THIS PRODUCT PLEASE CONTACT US



**Equipment Financing and
Extended Warranties Available**



**Discount-Equipment.com is your online resource for
commercial and industrial quality parts and equipment sales.**

561-964-4949

visit us on line @ www.discount-equipment.com

Select an option below to find your Equipment

Search by Manufacturer

Search by Product Type

Request a Quote

We sell worldwide for the brands: Genie, Terex, JLG, MultiQuip, Mikasa, Essick, Whiteman, Mayco, Toro Stone, Diamond Products, Generac Magnum, Airman, Haulotte, Barreto, Power Blanket, Nifty Lift, Atlas Copco, Chicago Pneumatic, Allmand, Miller Curber, Skyjack, Lull, Skytrak, Tsurumi, Husquvarna Target, Stow, Wacker, Sakai, Mi-T-M, Sullair, Basic, Dynapac, MBW, Weber, Bartell, Bennar Newman, Haulotte, Ditch Runner, Menegotti, Morrison, Contec, Buddy, Crown, Edco, Wyco, Bomag, Laymor, EZ Trench, Bil-Jax, F.S. Curtis, Gehl Pavers, Heli, Honda, ICS/PowerGrit, IHI, Partner, Imer, Clipper, MMD, Koshin, Rice, CH&E, General Equipment, Amida, Coleman, NAC, Gradall, Square Shooter, Kent, Stanley, Tamco, Toku, Hatz, Kohler, Robin, Wisconsin, Northrock, Oztec, Toker TK, Rol-Air, APT, Wylie, Ingersoll Rand / Doosan, Innovatech, Con X, Ammann, Mecalac, Makinex, Smith Surface Prep, Small Line, Wanco, Yanmar



WARNING

Operating, servicing and maintaining this vehicle or equipment can expose you to chemicals including engine exhaust, carbon monoxide, phthalates, and lead, which are known to the State of California to cause cancer and birth defects or other reproductive harm. To minimize exposure, avoid breathing exhaust, do not idle the engine except as necessary, service your vehicle or equipment in a well-ventilated area and wear gloves or wash your hands frequently when servicing. For more information go to www.P65Warnings.ca.gov.

FOREWORD

The Mobile Elevating Work Platform (MEWP) models covered in this manual are designed and tested to meet or exceed various compliance standards. Please refer to the manufacturer's nameplate affixed to the subject MEWP for specific standard compliance information.

This manual is a very important tool! Keep it with the machine at all times.

The purpose of this manual is to provide owners, users, operators, lessors, and lessees with the precautions and operating procedures essential for the safe and proper machine operation for its intended purpose.

Due to continuous product improvements, JLG Industries, Inc. reserves the right to make specification changes without prior notification. Contact JLG Industries, Inc. for updated information.

Refer to www.JLG.com for Warranty, Product Registration, and other machine-related documentation.

SAFETY ALERT SYMBOLS AND SAFETY SIGNAL WORDS



This is the Safety Alert Symbol. It is used to alert you to the potential personal injury hazards. Obey all safety messages that follow this symbol to avoid possible injury or death

DANGER

INDICATES AN IMMINENTLY HAZARDOUS SITUATION. IF NOT AVOIDED, WILL RESULT IN SERIOUS INJURY OR DEATH. THIS DECAL WILL HAVE A RED BACKGROUND.

WARNING

INDICATES A POTENTIALLY HAZARDOUS SITUATION. IF NOT AVOIDED, COULD RESULT IN SERIOUS INJURY OR DEATH. THIS DECAL WILL HAVE AN ORANGE BACKGROUND.

CAUTION

INDICATES A POTENTIALLY HAZARDOUS SITUATION. IF NOT AVOIDED, MAY RESULT IN MINOR OR MODERATE INJURY. IT MAY ALSO ALERT AGAINST UNSAFE PRACTICES. THIS DECAL WILL HAVE A YELLOW BACKGROUND.

NOTICE

INDICATES INFORMATION OR A COMPANY POLICY THAT RELATES DIRECTLY OR INDIRECTLY TO THE SAFETY OF PERSONNEL OR PROTECTION OF PROPERTY.

REVISION LOG

Original Issue - ADecember 12, 2019

To order go to Discount-Equipment.com

SECTION - 1 - SAFETY PRECAUTIONS

1.1 GENERAL 1-1

1.2 PRE-OPERATION 1-1

 Operator Training and Knowledge 1-1

 Workplace Inspection 1-2

 Machine Inspection 1-2

1.3 OPERATION 1-3

 General 1-3

 Trip and Fall Hazard 1-3

 Electrocution Hazard 1-4

 Tipping Hazards 1-5

 Crushing and Collision Hazards 1-7

1.4 TRANSPORTING 1-8

 Tipping Hazards 1-8

1.5 MOVING, LIFTING AND REPOSITIONING 1-10

 General 1-10

 Additional Safety Information 1-10

1.6 MAINTENANCE 1-10

 Maintenance Hazards 1-10

 Battery Hazards 1-11

SECTION - 2 - PREPARATION AND INSPECTION

2.1 PERSONNEL TRAINING 2-1

 Operator Training 2-1

 Training Supervision 2-1

 Operator Responsibility 2-1

Machine Familiarization 2-2

2.2 PREPARATION, INSPECTION, AND MAINTENANCE 2-2

2.3 PRE-START INSPECTION 2-4

2.4 DAILY WALK-AROUND INSPECTION 2-5

 General 2-5

2.5 FUNCTION CHECK 2-7

SECTION - 3 - MACHINE OPERATION

3.1 GENERAL 3-1

3.2 MACHINE DESCRIPTION 3-1

3.3 OPERATING CHARACTERISTICS AND LIMITATIONS 3-2

 Placards 3-2

 Capacities 3-2

 Stability 3-2

3.4 PLATFORM LOADING 3-2

3.5 MACHINE OPERATION 3-3

 Machine Component Locations 3-4

 Battery Charger 3-5

 Ground Control Box 3-7

 Positioning and Leveling Machine 3-8

 Entering/Exiting The Platform 3-8

 Platform Control Box 3-9

TABLE OF CONTENTS

3.6	TRANSPORTING, LIFTING, AND TIE-DOWN PROCEDURES.....	3-10
	Loading or Towing	3-10
	Vehicle Transport.....	3-10
	Storage	3-10
	Transportation Diagram	3-11
3.7	DECAL INSTALLATION	3-12

SECTION - 4 - EMERGENCY PROCEDURES

4.1	GENERAL INFORMATION.....	4-1
4.2	EMERGENCY OPERATION	4-1
	Operator Unable to Control Machine.....	4-1
	Platform Caught Overhead	4-1
	Righting of Tipped Machine.....	4-2
4.3	INCIDENT NOTIFICATION.....	4-2
4.4	EMERGENCY LOWERING OPERATION	4-3

SECTION - 5 - GENERAL SPECIFICATIONS

5.1	INTRODUCTION.....	5-1
5.2	SPECIFICATIONS	5-2
	Working Specifications	5-2
	Operating Specifications.....	5-3
	Power Source	5-3
	Battery Charger	5-3
	Lubrication Specification	5-3

5.3	OPERATOR MAINTENANCE	5-4
	Accessing Hydraulic/Electrical Components In ...	
	Base Frame	5-4
	Hydraulic System Maintenance.....	5-5

SECTION - 6 - INSPECTION AND REPAIR LOG

LIST OF TABLES

1-1	Minimum Approach Distances (M.A.D.)	1-5
2-1	Inspection and Maintenance Table	2-3

SECTION 1. SAFETY PRECAUTIONS

1.1 GENERAL

This section outlines the necessary precautions for proper and safe machine usage and maintenance. In order to promote proper machine usage, it is mandatory that a daily routine is established based on the content of this manual. A maintenance program, using the information provided in the Service and Maintenance section, must also be established by a qualified person and must be followed to ensure that the machine is safe to operate.

The owner/user/operator/lessor/lessee of the machine must not accept operating responsibility until this manual has been read, training is accomplished, and operation of the machine has been completed under the supervision of an experienced and qualified operator.

These sections contain the responsibilities of the owner, user, operator, lessor, and lessee concerning safety, training, inspection, maintenance, application, and operation. If there are any questions with regard to safety, training, inspection, maintenance, application, and operation, please contact JLG Industries, Inc. ("JLG").

WARNING

FAILURE TO COMPLY WITH THE SAFETY PRECAUTIONS LISTED IN THIS MANUAL COULD RESULT IN MACHINE DAMAGE, PROPERTY DAMAGE, PERSONAL INJURY OR DEATH.

1.2 PRE-OPERATION

Operator Training and Knowledge

- Read, understand, and study the Operation and Safety Manual in its entirety before operating the machine. For clarification, questions, or additional information regarding any portions of this manual, contact JLG Industries, Inc.

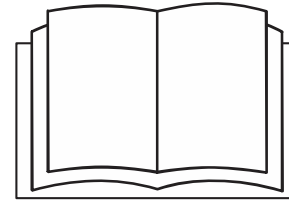

- An operator must not accept operating responsibilities until adequate training has been given by competent and authorized persons.
- Allow only those authorized and qualified personnel to operate the machine who have demonstrated that they understand the safe and proper operation and maintenance of the unit.
- Read, understand, and obey all DANGERS, WARNINGS, CAUTIONS, and operating instructions on the machine and in this manual.
- Ensure that the machine is to be used in a manner which is within the scope of its intended application as determined by JLG.

SECTION 1 - SAFETY PRECAUTIONS

- All operating personnel must be familiar with the emergency controls and emergency operation of the machine as specified in this manual.
- Read, understand, and obey all applicable employer, local, and governmental regulations as they pertain to your utilization and application of the machine.

Workplace Inspection

- Precautions to avoid all hazards in the work area must be taken by the user before and during operation of the machine.
- Do not operate or raise the platform from a position on trucks, trailers, railway cars, floating vessels, scaffolds or other equipment unless the application is approved in writing by JLG.
- Before operation, check work area for overhead hazards such as electric lines, bridge cranes, and other potential overhead obstructions.
- Check operating surfaces for holes, bumps, drop-offs, obstructions, debris, concealed holes, and other potential hazards.
- Check the work area for hazardous locations. Do not operate the machine in hazardous environments unless approved for that purpose by JLG.
- Ensure that the ground conditions are adequate to support the maximum tire load indicated on the tire load decals located on the chassis adjacent to each wheel.

Machine Inspection

- Do not operate this machine until the inspections and functional checks have been performed as specified in Section 2 of this manual.
- Do not operate this machine until it has been serviced and maintained according to the maintenance and inspection requirements as specified in the Service and Maintenance section of this manual.
- Ensure all safety devices are operating properly. Modification of these devices is a safety violation.

WARNING

MODIFICATION OR ALTERATION OF A MEWP SHALL BE MADE ONLY WITH PRIOR WRITTEN PERMISSION FROM THE MANUFACTURER.

- Do not operate any machine on which the safety or instruction placards or decals are missing or illegible.
- Check the machine for modifications to original components. Ensure that any modifications have been approved by JLG.
- Avoid accumulation of debris on platform floor. Keep mud, oil, grease, and other slippery substances from footwear and platform floor.

1.3 OPERATION

General

- Machine operation requires your full attention. Bring the machine to a full stop before using any device, i.e. cell phones, two-way radios, etc. that will distract your attention from safely operating the machine.
- Do not use the machine for any purpose other than positioning personnel, their tools, and equipment.
- Before operation, the user must be familiar with the machine capabilities and operating characteristics of all functions.
- Never operate a malfunctioning machine. If a malfunction occurs, shut down the machine. Remove the unit from service and notify the proper authorities.
- Do not remove, modify, or disable any safety devices.
- Do not allow personnel to tamper with or operate the machine from the ground with personnel in the platform, except in an emergency.
- Do not carry materials directly on platform railing unless approved by JLG.
- Always ensure that power tools are properly stowed and never left hanging by their cord from the platform work area.
- Fully lower platform before leaving machine.
- Remove all rings, watches, and jewelry when operating machine. Do not wear loose fitting clothing or long hair unrestrained which may become caught or entangled in equipment.
- Persons under the influence of drugs or alcohol or who are subject to seizures, dizziness, or loss of physical control must not operate this machine.

Trip and Fall Hazard

- Prior to operation, ensure all gates and rails are fastened and secured in their proper position.

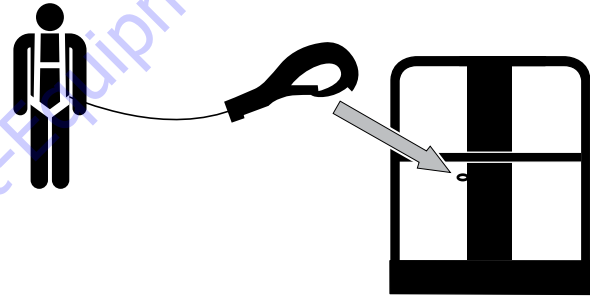

- JLG recommends that the operator utilizes a fall/travel restraint system in the platform with a lanyard attached to an authorized lanyard anchorage point. For further information regarding fall protection requirements on JLG products, contact JLG.
- Identify the designated lanyard anchorage point at the platform and securely attach the lanyard. Attach only one (1) lanyard per lanyard anchorage point.
- Enter and exit only through gate area. Use extreme caution when entering or leaving platform. Ensure that the platform assembly is fully lowered. Face the platform when entering or leaving the platform. Always maintain “three point contact” with the machine, using two hands and one foot or two feet and one hand at all times during entry and exit.

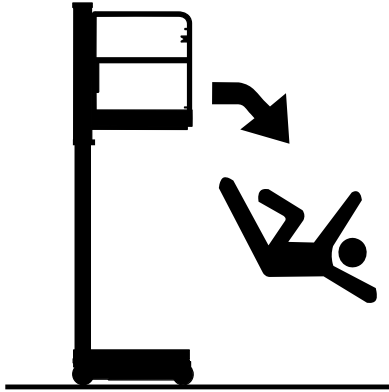

- Keep both feet firmly positioned on the platform floor at all times. Never position ladders, boxes, steps, planks, or similar items on unit to provide additional reach for any purpose.
- Never use the mast assembly to gain access to or leave the platform.
- Keep oil, mud, and slippery substances cleaned from footwear and the platform floor.

Electrocution Hazard

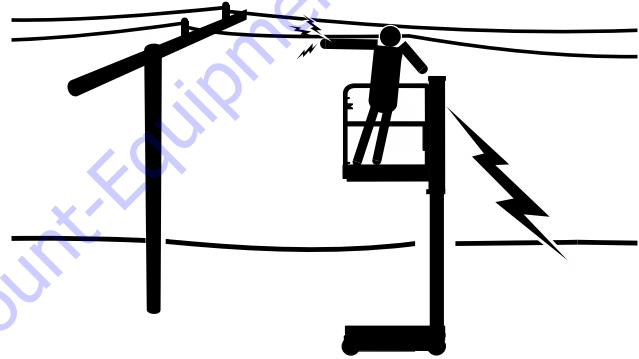

- This machine is not insulated and does not provide protection from contact or proximity to electrical current.
- Maintain distance from electrical lines, apparatus, or any energized (exposed or insulated) parts according to the Minimum Approach Distance (MAD) as shown in Table 1-1.
- Allow for machine movement and electrical line swaying.
- Maintain a clearance of at least 10 ft (3 m) between any part of the machine and its occupants, their tools, and their equipment from any electrical line or apparatus carrying up to 50,000 volts. One foot additional clearance is required for every additional 30,000 volts or less.

Table 1-1. Minimum Approach Distances (M.A.D.)

VOLTAGE RANGE (Phase to Phase)	MINIMUM APPROACH DISTANCE in Feet (Meters)
0 to 50 KV	10 (3)
Over 50KV to 200KV	15 (5)
Over 200 KV to 350 KV	20 (6)
Over 350 KV to 500 KV	25 (8)
Over 500 KV to 750 KV	35 (11)
Over 750 KV to 1000 KV	45 (14)
NOTE: <i>This requirement shall apply except where employer, local or governmental regulations are more stringent.</i>	

- The minimum approach distance may be reduced if insulating barriers are installed to prevent contact, and the barriers are rated for the voltage of the line being guarded. These barriers shall not be part of (or attached to) the machine. The minimum approach distance shall be reduced to a distance within the designed working dimensions of the insulating barrier. This determination shall be made by a qualified person in accordance with the employer, local, or governmental requirements for work practices near energized equipment.

⚠ DANGER

DO NOT MANEUVER MACHINE OR PERSONNEL INSIDE PROHIBITED ZONE (MAD). ASSUME ALL ELECTRICAL PARTS AND WIRING ARE ENERGIZED UNLESS KNOWN OTHERWISE.

Tipping Hazards

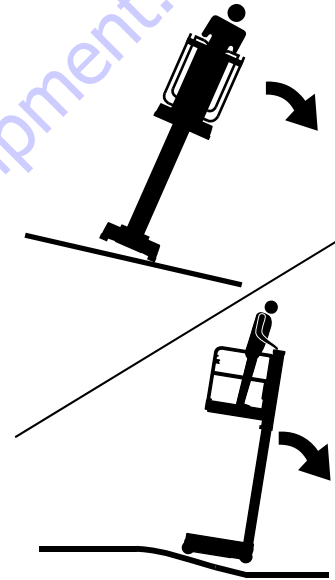

- Ensure that the ground conditions are adequate to support the maximum tire load indicated on the tire load decals located on the chassis adjacent to each wheel. Do not operate machine on unsupported surfaces.

SECTION 1 - SAFETY PRECAUTIONS

- Do not elevate platform while on or near a sloping, uneven, or soft surface. Ensure machine is positioned on a firm, level and smooth surface before elevating platform.
- Before operating on floors, bridges, trucks, and other surfaces, check allowable capacity of the surfaces.
- Never exceed the maximum work load as specified on the platform. Keep all loads within the confines of the platform, unless authorized by JLG.
- Keep the chassis of the machine a minimum of 2 ft. (0.6m) from holes, bumps, drop-offs, obstructions, debris, concealed holes, and other potential hazards at the ground level.
- Never operate machine in high wind, rain or snow.
- Do not perform work that will subject unit to a horizontal force or create a swaying motion of the platform.

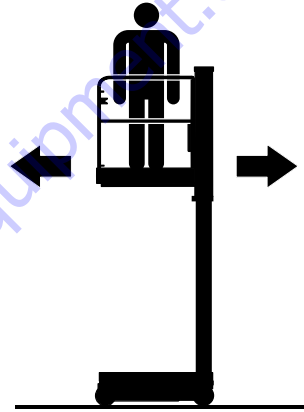

- Never attempt to use the machine as a crane. Do not tie-off machine to any adjacent structure. Never attach wire, cable, or any similar items to platform.
- Do not cover the platform sides or carry large surface-area items in the platform. The addition of such items increases the exposed wind area of the machine.
- Do not increase the platform size with unauthorized deck extensions or attachments.

- If the mast assembly or platform is caught so that one or more wheels are off the ground, platform personnel must be removed before attempting to free the machine. Use cranes, forklift trucks, or other appropriate equipment to stabilize machine and remove personnel.

Crushing and Collision Hazards

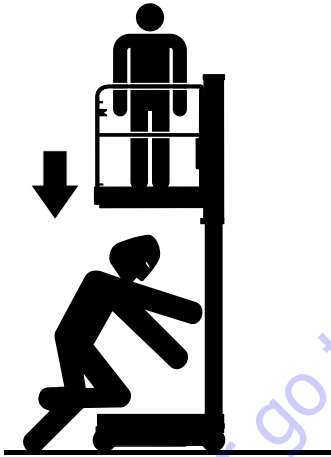

- Approved head gear must be worn by all operating and ground personnel.

- Watch for obstructions around machine and overhead when driving. Check clearances above, on sides, and bottom of platform when lifting or lowering platform.
- During operation, keep all body parts inside platform railing.
- Keep non-operating personnel at least 6 ft. (1.8m) away from machine during all operations.
- When moving the machine, the operator must limit travel speed according to conditions of ground surface, congestion, visibility, slope, location of personnel, and other factors.
- Exercise extreme caution at all times to prevent obstacles from striking or interfering with operating controls and persons in the platform.
- Ensure that operators of other overhead and floor level machines are aware of the aerial work platform's presence. Disconnect power to overhead cranes. Barricade floor area if necessary.
- Do not operate over ground personnel. Warn personnel not to work, stand, or walk under a raised platform. Position barricades on floor as necessary.

1.4 TRANSPORTING

Tipping Hazards

⚠ WARNING

FAILURE TO COMPLY WITH THE FOLLOWING TIPPING HAZARD INSTRUCTIONS COULD CAUSE THE UNIT TO TIP OVER OR BE HARD TO CONTROL WHEN BEING MOVED, WHICH COULD RESULT IN SERIOUS INJURY OR DEATH.

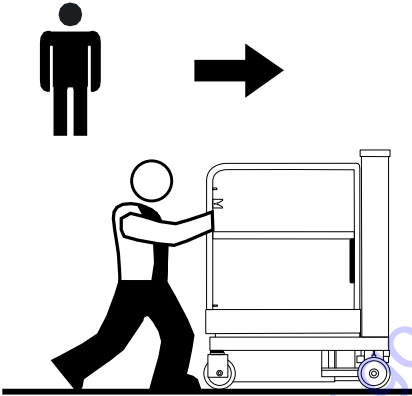

- On a level surface, always push machine from the platform end with the mast end leading the way.
- Watch for obstructions around machine and overhead.
- Check travel path for persons, holes, bumps, drop-offs, obstructions, debris, and coverings which may conceal other hazards.
- Before placing machine on floors, trucks and other surfaces, check allowable capacity of surfaces.

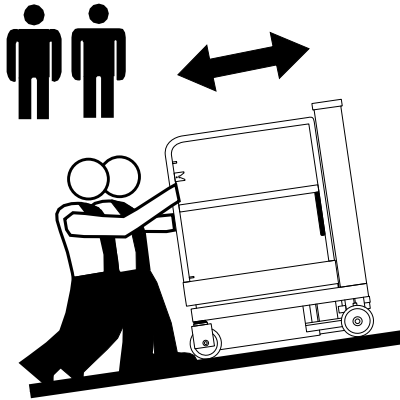

- Two persons are required on slopes up to 5°. A forklift must be used when moving units on slopes greater than 5°.
- Always travel up or down a slope with the platform end of the machine positioned towards the low side of the slope. The operator and assistant must walk side by side to guide the machine.



- Never position the unit sideways on a slope.
- Do not elevate the platform or move the machine on a soft surface.
- Use caution and check clearances when moving machine in restricted or close quarters.
- Always use an assistant when moving machine in areas where vision is obstructed.
- Keep non-operating personnel at least 6 ft. (1.8m) away from machine during moving operations.

1.5 MOVING, LIFTING AND REPOSITIONING

General

- Never allow personnel in platform while moving, lifting or repositioning the machine.
- This machine shall not be towed by a vehicle.
- Do not move assembled unit on wheels over soft or uneven surfaces, or over obstructions, bumps, debris, etc.
- Disassemble unit to transport over uneven or sloped ground, or in a vehicle.
- Ensure platform is fully retracted and completely empty of tools prior to disassembly, lifting or hauling.
- Refer to the Machine Operation section of this manual for lifting information.

Additional Safety Information

- Do not use machine as ground for welding.

1.6 MAINTENANCE

This sub-section contains general safety precautions which must be observed during maintenance of this machine. Additional precautions to be observed during machine maintenance are inserted at the appropriate points in this manual and in the Service and Maintenance section of this manual. It is of utmost importance that maintenance personnel pay strict attention to these precautions to avoid possible injury to personnel or damage to the machine or property. A maintenance program must be established by a qualified person and must be followed to ensure that the machine is safe.

Maintenance Hazards

- Shut off power to all controls and ensure that all moving parts are secured from inadvertent motion prior to performing any adjustments or repairs.
- Never work under an elevated platform until it has been fully lowered to the full down position, if possible, or otherwise supported and restrained from movement with appropriate safety props, blocking, or overhead supports.
- DO NOT attempt to repair or tighten any hydraulic hoses or fittings while the machine is powered on or when the hydraulic system is under pressure.
- Always relieve hydraulic pressure from all hydraulic circuits before loosening or removing hydraulic components.

- DO NOT use your hand to check for leaks. Use a piece of cardboard or paper to search for leaks. Wear gloves to help protect hands from spraying fluid.
- Ensure replacement parts or components are identical or equivalent to original parts or components.
- Ensure that all moving parts are secured from inadvertent motion prior to performing any adjustments or repairs.
- Never attempt to move heavy parts without the aid of a mechanical device. Do not allow heavy objects to rest in an unstable position. Ensure adequate support is provided when raising components of the machine.
- Use only approved non-flammable cleaning solvents.
- Do not replace items critical to stability, such as batteries or solid tires, with items of different weight or specification.
- Do not modify unit in any way to affect stability.
- Reference the Service and Maintenance Manual for the weights of critical stability items.



⚠ WARNING

MODIFICATION OR ALTERATION OF A MEWP SHALL BE MADE ONLY WITH PRIOR WRITTEN PERMISSION FROM THE MANUFACTURER.

Battery Hazards

- Always disconnect batteries when servicing electrical components or when performing welding on the machine.
- Do not allow smoking, open flame, or sparks near battery during charging or servicing.
- Do not contact tools or other metal objects across the battery terminals.
- Always wear hand, eye, and face protection when servicing batteries. Ensure that battery acid does not come in contact with skin or clothing.

⚠ CAUTION

BATTERY FLUID IS HIGHLY CORROSIVE. AVOID CONTACT WITH SKIN AND CLOTHING AT ALL TIMES. IMMEDIATELY RINSE ANY CONTACTED AREA WITH CLEAN WATER AND SEEK MEDICAL ATTENTION.

- Charge batteries only in a well ventilated area.
- Avoid overfilling the battery fluid level. Add distilled water to batteries only after the batteries are fully charged.

SECTION 1 - SAFETY PRECAUTIONS



NOTES:

A large area consisting of two columns of horizontal lines for writing notes. The lines are evenly spaced and extend across most of the page width.

To order go to Discount-Equipment.com

SECTION 2. PREPARATION AND INSPECTION

2.1 PERSONNEL TRAINING

The Mobile Elevating Work Platform (MEWP) is a personnel handling device, so it is necessary that it be operated and maintained only by trained personnel.

Operator Training

Operator training must cover:

1. Reading and understanding the Operation and Safety Manual.
2. Thorough understanding of the intended purpose and function of the MEWP controls, including platform, ground, and emergency descent controls.
3. Control labels, instructions, and warnings on the machine.
4. Applicable regulations, standards, and safety rules.
5. Use of approved fall protection equipment.
6. Enough knowledge of the mechanical operation of the machine to recognize a malfunction or potential malfunction.
7. The safest means to operate the machine where overhead obstructions, other moving equipment, and obstacles, depressions, holes, and drop-offs exist.

8. Means to avoid the hazards of unprotected electrical conductors.
9. Selection of the appropriate MEWPs and available options for the work to be performed considering specific job requirements, with involvement from the MEWP owner, user, and/or supervisor.
10. The responsibility of the operator to ensure all platform occupants have a basic level of knowledge to work safely on the MEWP, and to inform them of applicable regulations, standards, and safety rules.
11. The requirement for familiarization in addition to training.

Training Supervision

Training must be done under the supervision of a qualified person in an open area free of obstructions until the trainee has developed the ability to safely control and operate the machine.

Operator Responsibility

The operator must be instructed that they have the responsibility and authority to shut down the machine in case of a malfunction or other unsafe condition of either the machine or the job site.

Machine Familiarization

NOTE: Responsibilities for familiarization may vary by region.

Only properly trained personnel who have received unit-specific familiarization shall operate a MEWP. The user shall determine if personnel are qualified to operate the MEWP prior to operation. The user shall ensure that after familiarization, the operator operates the MEWP for a sufficient period of time to achieve proficiency. When authorized by the user, self-familiarization can be achieved, if authorized, by a properly trained operator reading, understanding and following the manufacturer's operator's manual.

Prior to users authorization of an operator to use a specific model of MEWP, the user shall ensure the operator is familiarized on the following:

1. Location of the manual storage compartment and the requirement to ensure the required manual(s) are present on the MEWP;
2. Purpose and function of the machine controls and indicators at the platform and ground control stations;
3. Purpose, location, and function of the emergency controls;
4. Operating characteristics and limitations;
5. Features and devices;
6. Accessories and optional equipment.

2.2 PREPARATION, INSPECTION, AND MAINTENANCE

The following table covers the machine inspections and maintenance recommended by JLG Industries, Inc. Consult local regulations for further requirements for aerial work platforms. The frequency of inspections and maintenance must be increased as necessary when the machine is used in a harsh or hostile environment, if the machine is used with increased frequency, or if the machine is used in a severe manner.

Table 2-1. Inspection and Maintenance Table

TYPE	FREQUENCY	PRIMARY RESPONSIBILITY	SERVICE QUALIFICATION	REFERENCE
Pre-Start Inspection	Before using each day; or whenever there's an Operator change.	User or Operator	User or Operator	Operator and Safety Manual
Pre-Delivery Inspection (See Note Below)	Before each sale, lease, or rental delivery.	Owner, Dealer, or User	Qualified JLG Mechanic	Service and Maintenance Manual and applicable JLG inspection form
Frequent Inspection	In service for 3 months or 150 hours, whichever comes first; or Out of service for a period of more than 3 months; or Purchased used.	Owner, Dealer, or User	Qualified JLG Mechanic	Service and Maintenance Manual and applicable JLG inspection form
Annual Machine Inspection	Annually, no later than 13 months from the date of prior inspection.	Owner, Dealer, or User	Factory-Trained Service Technician (Recommended)	Service and Maintenance Manual and applicable JLG inspection form
Preventative Maintenance	At intervals as specified in the Service and Maintenance Manual.	Owner, Dealer, or User	Qualified JLG Mechanic	Service and Maintenance Manual

NOTE: Inspection forms are available from JLG. Use the Service and Maintenance Manual to perform inspections.

NOTICE

JLG INDUSTRIES, INC. RECOGNIZES A FACTORY-TRAINED SERVICE TECHNICIAN AS A PERSON WHO HAS SUCCESSFULLY COMPLETED THE JLG SERVICE TRAINING SCHOOL FOR THE SPECIFIC JLG PRODUCT MODEL.

2.3 PRE-START INSPECTION

The Pre-Start Inspection should include each of the following:

1. **Cleanliness** – Check all surfaces for leakage (oil, fuel, or battery fluid) or foreign objects. Report any leakage to proper maintenance personnel.
2. **Structure** – Inspect the machine structure for dents, damage, weld or parent metal cracks or other discrepancies. Report this to the proper maintenance personnel.

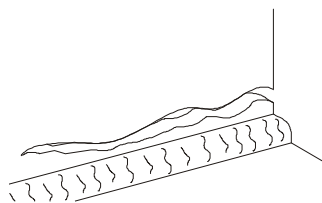

Parent Metal Crack

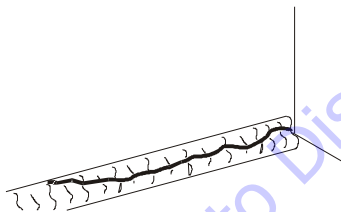

Weld Crack

3. **Decals and Placards** – Check all for cleanliness and legibility. Make sure none of the decals and placards are missing. Make sure all illegible decals and placards are cleaned or replaced.
4. **Operation and Safety Manual** – Make sure a copy of the Operation and Safety Manual, AEM Safety Manual,

and ANSI Manual of Responsibilities is enclosed in the weather resistant manual storage container.

5. **Walk-Around Inspection** – Refer to Section 2.4.
6. **Battery** - Charge is required.
7. **Hydraulic Oil** - Check the hydraulic oil level. Ensure hydraulic oil is added as required.
8. **Function Check** - Once the Walk-Around Inspection is complete, perform a function check of all systems in an area free of overhead and ground level obstructions. Refer to Section 2.5 for more specific instructions.
9. **Platform Gate** – Keep gate and surrounding area clean and unobstructed. Verify the gate closes properly and is not bent or damaged. Keep gate closed at all times except when entering/exiting the platform and loading/unloading materials.
10. **Lanyard Attach Points** – JLG Industries, Inc. recommends personnel in the platform wear a fall/travel restraint system with a lanyard attached to an authorized lanyard attach point.

⚠ WARNING

IF THE MACHINE DOES NOT OPERATE PROPERLY, TURN OFF THE MACHINE IMMEDIATELY! REPORT THE PROBLEM TO THE PROPER MAINTENANCE PERSONNEL. DO NOT OPERATE THE MACHINE UNTIL IT IS DECLARED SAFE FOR OPERATION.

2.4 DAILY WALK-AROUND INSPECTION

General

Begin Walk-Around Inspection at item 1. Continue around machine checking each item in this check list.

NOTICE

DO NOT OVERLOOK VISUAL INSPECTION OF CHASSIS UNDERSIDE. CHECKING THIS AREA MAY RESULT IN DISCOVERY OF CONDITIONS WHICH COULD CAUSE EXTENSIVE MACHINE DAMAGE.

INSPECTION NOTE:

On each item, make sure there are no loose or missing parts, they are securely fastened, no visible damage exists in addition to any other criteria mentioned.

- 1. Rear Wheels - Auto-Locking Brake** - Check for any debris stuck to or around wheels. See Inspection Note.
- 2. Emergency Lowering Valve** - Ensure the emergency lowering valve is closed before machine operation.
- 3. Ground Control Box** - Placard secure and legible, control switches return to neutral position when activated and released, emergency stop switch functions properly. Control markings legible.
- 4. Swivel Castor Wheels** - Properly secured, wheels and castors turn freely. Brakes lock and releases, prevent wheels from rolling when locked.
- 5. Entry Gate** - Platform railings and entry gate in proper working order.
- 6. Platform Control Box** - Ensure the control console is firmly secured in the proper location. Placards secure and legible, control switches return to neutral position when activated and released, emergency stop switch functions properly. Control markings legible.
- 7. Platform** - See Inspection Note.
- 8. Mast Assembly** - Verify lanyard attach point is not bent and is secure to mast. See Inspection Note.
- 9. Bubble Level Indicator** - Check bubble level indicator is clean, secure, and responsive to movement.
- 10. Emergency Stop/Battery Isolator** - Turn key switch in emergency stop button, then pull to release.
- 11. Battery/Charger Assembly/Hydraulic System** - Proper battery electrolyte level (if non-sealed battery), no battery terminal corrosion. Check hydraulic oil level in reservoir, check hydraulic lines for oil leaks.
- 12. Static Strap** - See Inspection Note.

SECTION 2 - PREPARATION AND INSPECTION

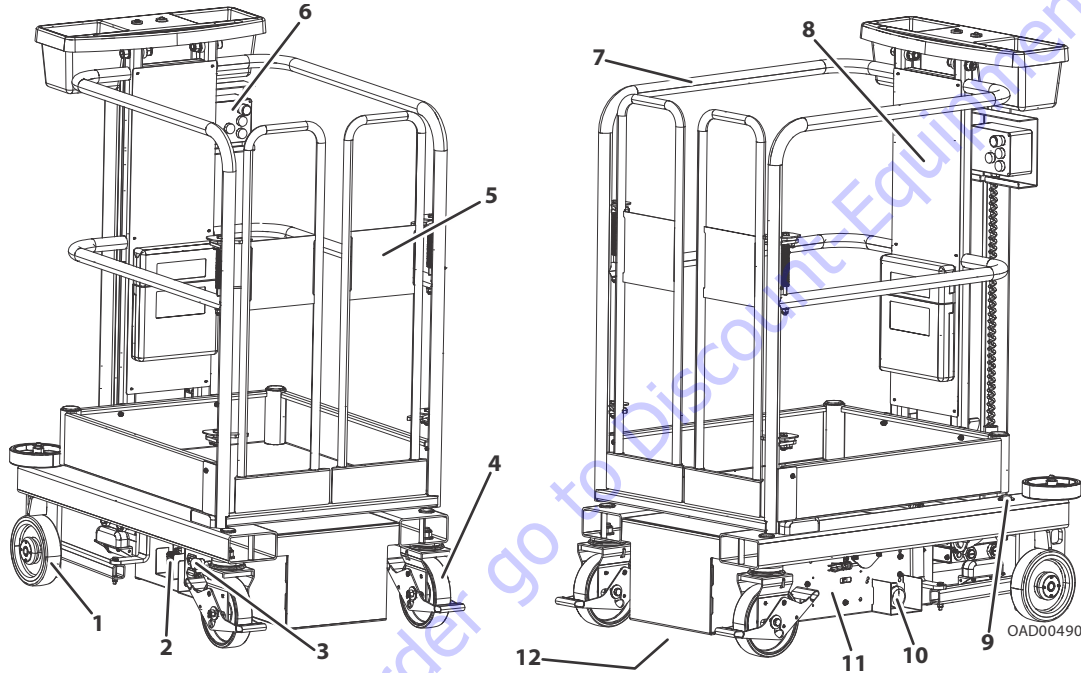

1. Rear Auto-Lock Brake Wheel
2. Emergency Lowering Valve
3. Ground Control Box
4. Swivel Castor
5. Entry Gate
6. Platform Control Box
7. Platform
8. Mast Assembly
9. Bubble Level Indicator
10. Emergency Stop/Battery Isolator
11. Battery/Charger/Hydraulic Pump Assembly
12. Static Strap

2.5 FUNCTION CHECK

The function check of all systems should be performed in an area free of overhead and ground level obstructions. Perform a function check as follows:

1. Set up machine for operation according to instructions in Section 3, Positioning and Leveling Machine.
2. Check that front caster wheel locks, when set, stop all machine rolling movement.
3. Power up machine. Check that the Emergency Stop button, located on the base frame, shuts power off when pressed in.
4. Check that all ground controls operate properly. Check that all platform movement stops immediately when the up or down buttons are released. Check that the emergency stop button stops all platform movement when pressed in.
5. Enter platform check that the platform entry gate automatically closes.
6. Check that the platform controls operate properly. Check that all platform movement stops immediately when the enable, up, or down buttons are released on the platform control box. Check that the emergency stop button stops all platform movement when pressed in.
7. Raise and lower platform 2 ft to 3 ft (0.61 m to 0.92 m) several times. Check for smooth elevation and lowering of platform.
8. With the aid of an assistant, check the operation of the rear wheel auto locking brake mechanism. With the platform elevated and clear of the chassis, observe the action of the rear wheel brake, ensure the wheels fully engage the locking tab weldments above the rear wheels when the platform is elevated, and is released when the platform is fully lowered.
9. To test the Emergency Lowering Valve, raise platform 2 ft to 3 ft (0.61 m to 0.92 m). Open the valve by pulling out the red knob. Release the knob once the machine is at its desired height, which closes the valve.

SECTION 2 - PREPARATION AND INSPECTION



NOTES:

Two columns of horizontal lines for taking notes, separated by a vertical line. The lines are evenly spaced and extend across most of the page width.

To order go to Discount-Equipment.com

TO PURCHASE THIS PRODUCT PLEASE CONTACT US



**Equipment Financing and
Extended Warranties Available**



**Discount-Equipment.com is your online resource for
commercial and industrial quality parts and equipment sales.**

561-964-4949

visit us on line @ www.discount-equipment.com

Select an option below to find your Equipment

Search by Manufacturer

Search by Product Type

Request a Quote

We sell worldwide for the brands: Genie, Terex, JLG, MultiQuip, Mikasa, Essick, Whiteman, Mayco, Toro Stone, Diamond Products, Generac Magnum, Airman, Haulotte, Barreto, Power Blanket, Nifty Lift, Atlas Copco, Chicago Pneumatic, Allmand, Miller Curber, Skyjack, Lull, Skytrak, Tsurumi, Husquvarna Target, Stow, Wacker, Sakai, Mi-T-M, Sullair, Basic, Dynapac, MBW, Weber, Bartell, Bennar Newman, Haulotte, Ditch Runner, Menegotti, Morrison, Contec, Buddy, Crown, Edco, Wyco, Bomag, Laymor, EZ Trench, Bil-Jax, F.S. Curtis, Gehl Pavers, Heli, Honda, ICS/PowerGrit, IHI, Partner, Imer, Clipper, MMD, Koshin, Rice, CH&E, General Equipment, Amida, Coleman, NAC, Gradall, Square Shooter, Kent, Stanley, Tamco, Toku, Hatz, Kohler, Robin, Wisconsin, Northrock, Oztec, Toker TK, Rol-Air, APT, Wylie, Ingersoll Rand / Doosan, Innovatech, Con X, Ammann, Mecalac, Makinex, Smith Surface Prep, Small Line, Wanco, Yanmar

SECTION 3. MACHINE OPERATION

3.1 GENERAL

NOTICE

THE MANUFACTURER HAS NO DIRECT CONTROL OVER MACHINE APPLICATION AND OPERATION. THE USER AND OPERATOR ARE RESPONSIBLE FOR CONFORMING WITH GOOD SAFETY PRACTICES.

This section provides the necessary information needed to understand control function and operation.

⚠ WARNING

DO NOT RAISE PLATFORM UNLESS THE MACHINE IS ON A SMOOTH, FIRM SURFACE, WITHIN THE LIMITS OF THE MAXIMUM OPERATING SLOPE, FREE OF OBSTRUCTIONS AND HOLES.

TO AVOID SERIOUS INJURY, DO NOT OPERATE MACHINE IF ANY CONTROL LEVERS OR TOGGLE SWITCHES CONTROLLING PLATFORM MOVEMENT DO NOT RETURN TO THE OFF OR NEUTRAL POSITION WHEN RELEASED.

IF THE PLATFORM DOES NOT STOP WHEN A CONTROL SWITCH OR LEVER IS RELEASED, USE THE EMERGENCY STOP SWITCH TO STOP THE MACHINE.

3.2 MACHINE DESCRIPTION

This machine is a Mobile Elevating Work Platform (MEWP) used to position personnel along with their necessary tools and materials at work locations.

This MEWP is manually propelled push-a-round machine with a work platform mounted to an elevating mast mechanism. The personnel lift's intended purpose is to provide personnel (with their tools and materials) access to areas above ground level.

When the platform is fully lowered, the machine can be pushed on its wheels between work areas on a smooth, firm surface within the limits of the maximum operating slope. It can also be transported by forklift truck or loaded onto a suitable vehicle.

The machine also has a ground control station that can override the platform control station. Ground controls operate lift up and down functions only. Except for performing inspections and function checks, ground controls are to be used only in an emergency to lower the platform to the ground should the operator in the platform be unable to do so.

3.3 OPERATING CHARACTERISTICS AND LIMITATIONS

Placards

Important points to remember during operation are provided at the control stations by DANGER, WARNING, CAUTION, NOTICE, and INSTRUCTION placards. This information is placed at various locations for the express purpose of alerting personnel of potential hazards constituted by the operating characteristics and limitations of the machine. Refer to the Foreword for definitions of placard safety signal words.

Capacities

Raising platform above horizontal with or without any load in platform is based on the following criteria:

1. Machine is positioned on a smooth, firm surface within the limits of the maximum operating slope.
2. Load is within manufacturer's rated capacity.
3. All machine systems are functioning properly.

Stability

This machine, as originally manufactured by JLG and operated within its rated capacity on a smooth, firm surface, within the limits of the maximum operating slope, provides a stable aerial platform for all platform positions.

3.4 PLATFORM LOADING

The platform maximum rated load capacity is shown on a placard located on the platform billboard and is based upon the machine positioned on a smooth, firm surface, within the limits of the maximum operating slope. Refer to Section 5.1 for the maximum platform capacity.

The platform is entered through an entry gate at the rear of the platform. Keep entry gate closed at all times except when entering/exiting the platform and loading/unloading materials.

NOTE: *It is important to remember that the load should be evenly distributed on the platform. The load should be placed near the center of the platform when possible.*

3.5 MACHINE OPERATION

The following control conditions must be met before elevating the platform:

- Make sure the Pre-Start Inspection (Section 2) has been completed, and the machine is safe to use.
- Check that machine base is level and is set up properly for operation.
- Platform swing-in entry gate must be closed and latched once the operator is in the platform.

- Ensure Emergency lowering valve is closed.
- Batteries contain enough voltage to operate the machine. Check the battery charge indicator located on the ground control box.

NOTICE

JLG RECOMMENDS THAT THE OPERATOR UTILIZES A FALL RESTRAINT SYSTEM IN THE PLATFORM WITH A LANYARD ATTACHED TO THE AUTHORIZED LANYARD ANCHORAGE POINT IN THE PLATFORM.

Machine Component Locations

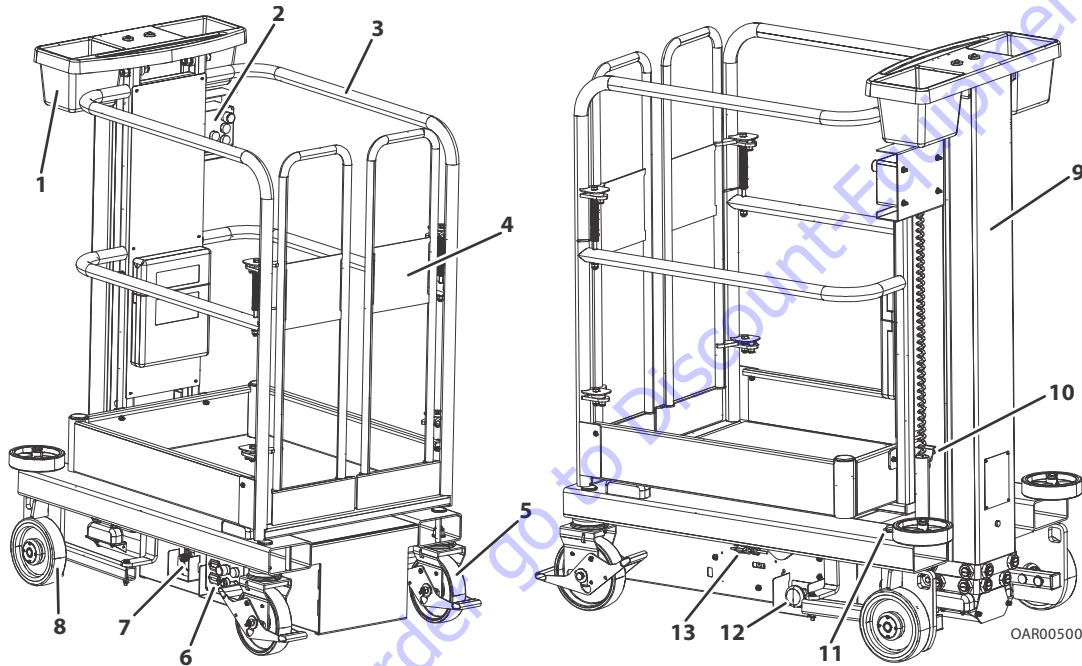

- 1. Tool Tray
- 2. Platform Control Box
- 3. Platform
- 4. Entry Gate
- 5. Front Locking Caster Wheels
- 6. Ground Control Box
- 7. Emergency Lowering Valve
- 8. Rear Wheel (Auto Locking)
- 9. Mast Assembly
- 10. Platform Lift Up Release Latch
- 11. Bubble Level Indicator
- 12. Emergency Stop Switch
- 13. Battery Charger AC Plug

Battery Charger

NOTE: When charging machine, turn off the battery isolator.

The battery charger is located under the base frame cover beneath the platform. To access the charger, refer to Section 5.3.

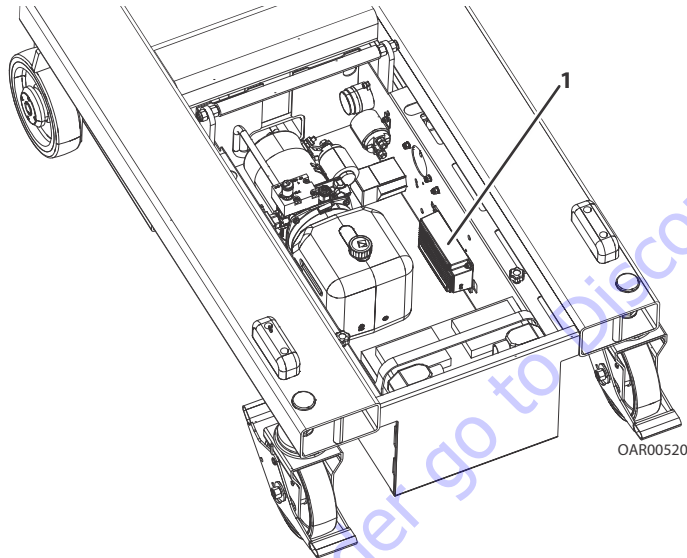

1. Charger Assembly

The charging AC input cable is located on the right side of the machine base. Plug into a compatible AC power supply. Refer to Section 5.2 for charger specifications.

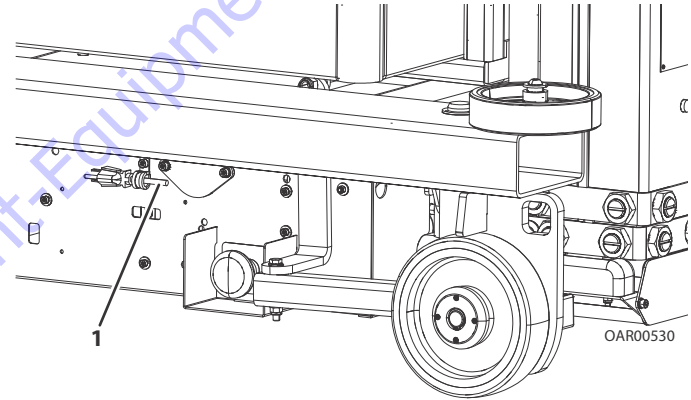

1. AC Input Cable

The battery charge level can be monitored at the ground control box or by observing the LEDs on the front of the battery charger.

SECTION 3 - MACHINE OPERATION

At the ground control box, the battery charge indicator displays a series of red LEDs. One LED is lit at a time to indicate battery charge.

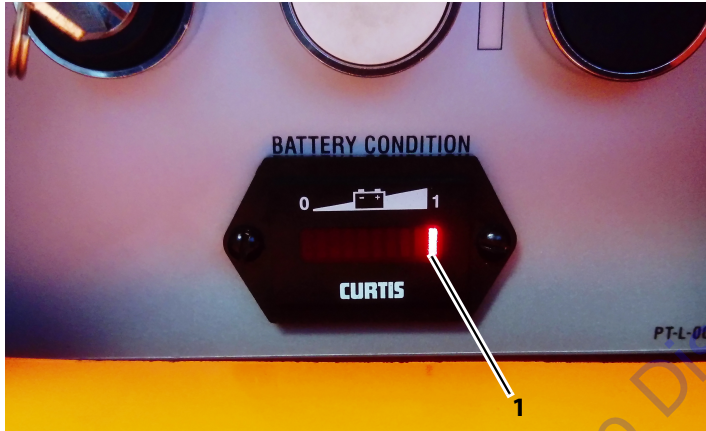

1. Full Battery Charge

On the battery charger inside in the chassis, the charge level can be monitored on the side of the charger.

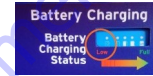

Plug in the charger to an available power supply and ensure the "low" LED illuminates. A flashing LED indicates a fault. Disconnect and reconnect to the power supply. If flashing continues, seek technical support.

The LEDs will illuminate in sequence. When the "full" LED is illuminated, charging is complete.

The battery charger can be connected to the AC power supply at any time or left for extended periods.

NOTICE

AC POWER SUPPLY CIRCUIT SHOULD BE PROTECTED WITH A BREAKER CIRCUIT. ONLY CHARGE BATTERY IN A WELL-VENTILATED AREA.

Ground Control Box

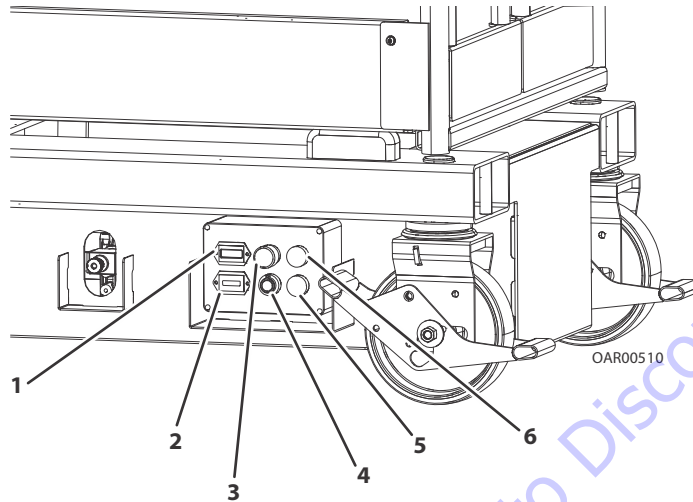

- | | |
|-----------------------------|--|
| 1. Hourmeter | 4. Ground/Off/Platform Key Selector Switch |
| 2. Battery Charge Indicator | 5. Lift Down Switch |
| 3. Emergency Stop Switch | 6. Lift Up Switch |

1. **Hourmeter** - Displays the number of hours the machine has been operated.
2. **Battery Charge Indicator** - Displays the current charge status of onboard batteries.
3. **Emergency Stop Switch** - A red two-position emergency switch that, when positioned to ON furnishes operating power to the ground control key selector. In addition, the switch can be used to turn off power to the function controls in the event of an emergency. Turn on power to the machine by pulling out the red two-position emergency stop switch. Turn off power by depressing switch.
4. **Ground/Off/Platform Key Selector** - When positioned to Ground, power is supplied to the ground control box. When positioned to Platform, power is supplied to the platform control box.
5. **Lift Down Switch** - Press and hold to lower platform.
6. **Lift Up Switch** - Press and hold to raise platform.

SECTION 3 - MACHINE OPERATION

Positioning and Leveling Machine

1. Position machine under work area on a firm, level, and uniform supporting surface.
2. Check that ALL wheels front and rear are in contact with the supporting surface.
3. Check that the bubble level indicator is centered and machine is level.

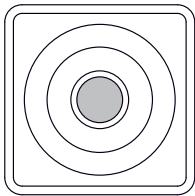

Level

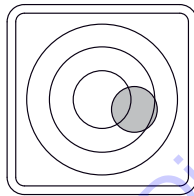

NOT - Level

1. Lock the front castor wheels to prevent the machine from rolling.

Entering/Exiting The Platform

⚠ WARNING

DO NOT EXCEED MAXIMUM PLATFORM CAPACITY. MAXIMUM CAPACITY INCLUDES PERSONNEL IN PLATFORM PLUS WEIGHT IN TOOL TRAY OR ANY OTHER WEIGHT PLACED IN PLATFORM.

1. Always maintain “three point contact” with the machine, using two hands and one foot or two feet and one hand at all times during entry and exit.
2. Attach the lanyard to the lanyard attachment point to the left of the manual box on the mast.
3. Ensure the platform gate is fully closed upon entry.
4. Once in the platform and the entry gate fully closed, the platform is ready for the operation.

⚠ WARNING

BEFORE OPERATING PLATFORM CHECK AROUND AND OVERHEAD FOR ANY OBSTACLES OR PERSONNEL THAT MAY COME INTO CONTACT WITH MACHINE WHILE ELEVATING OR LOWERING THE PLATFORM. IF NECESSARY, EXIT MACHINE AND REPOSITION BEFORE PROCEEDING.

5. Before exiting the platform, be certain platform is fully lowered.

Platform Control Box

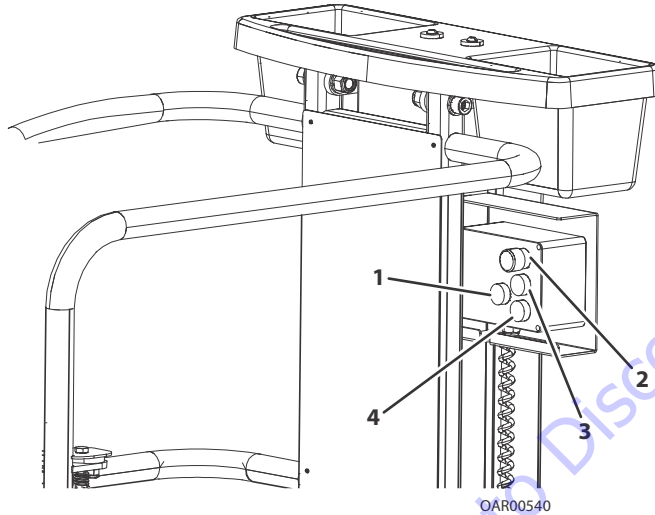

- 1. Enable Switch
- 2. Emergency Stop Switch

- 3. Lift Up Switch
- 4. Lift Down Switch

- 1. Enable Switch** - Press and hold the enable switch in conjunction with the Lift Up or Lift Down switches to enable those function.

NOTE: To operate any function, the enable switch must be depressed and the function selected within five seconds. If a function is not selected within five seconds, the enable switch must be depressed again.

- 2. Emergency Stop Switch** - The Emergency Stop Switch at both the ground control and platform control boxes must be positioned to On in order to allow platform functionality. In case of uncontrolled platform elevation or descent, press in the RED emergency stop button to the OFF position. Twist clockwise to RESET to the ON position.
- 3. Lift Up Switch** - Press Lift Up (**3**) to elevate the platform.
- 4. Lift Down Switch** - Press Lift Down (**4**) to lower the platform.

⚠ WARNING

CRUSHING HAZARD - BE AWARE OF DESCENDING PLATFORM WHEN LOWERING THE PLATFORM. KEEP HANDS OR FEET OFF THE MAST ASSEMBLY AND FROM UNDER THE PLATFORM.

3.6 TRANSPORTING, LIFTING, AND TIE-DOWN PROCEDURES

Loading or Towing

If loading machine up a ramp to the trailer with the aid of a winch, connect the winch cable to the castor/gate end of the chassis using the location holes provided. First run a strap around the front tow/tie down pins mounted inside the fork lift pockets, and then connect the winch cable to the strap.

When towing ensure the castor wheel locks are unlocked, and that the platform is fully lowered in the transport position.

Before disconnecting the machine from the winch cable, engage the castor wheel locks to keep the machine from rolling.

Vehicle Transport

The machine must always be transported in the upright position. Do not lay the machine flat.

The machine can be loaded onto a transport vehicle via a forklift, tail-lift, or winch. Never push the machine up a slope greater than 5° without the aid of a winch or forklift. Ensure the transport vehicle is parked on a level surface.

If using a forklift to transport the machine, engage all castor wheel locks. Adjust the width of the forklift tines to fit the machine's forklift pockets, then fully slide in the tines and lift machine.

If tying down the machine using straps or chains, the platform must be fully lowered to the stowed position with the machine securely tied down to the truck or trailer deck.

NOTICE

NEVER PLACE THE STRAP THROUGH THE PLATFORM OR HANDRAILS THIS COULD RESULT IN MACHINE DAMAGE. DO NOT USE EXCESSIVE FORCE WHEN TIGHTENING STRAPS.

Storage

If the machine is to be taken out of operation for a period longer than one month, take the following precautions:

- Turn on the battery charger. The charger has a programmed maintenance mode and will maintain the battery in good condition indefinitely, although obviously the electrolyte level must still be checked periodically. If this is not practical, then the charger should be switched on once a week for half an hour. This is especially important in cold conditions.
- Replace the hydraulic oil after three months of non-use. Refer to the procedure in Section 5.3.
- If the storage period is for an undetermined period, remove the battery and store in a secure battery storage container. Cover all external electrical and hydraulic connections to prevent corrosion.

Transportation Diagram

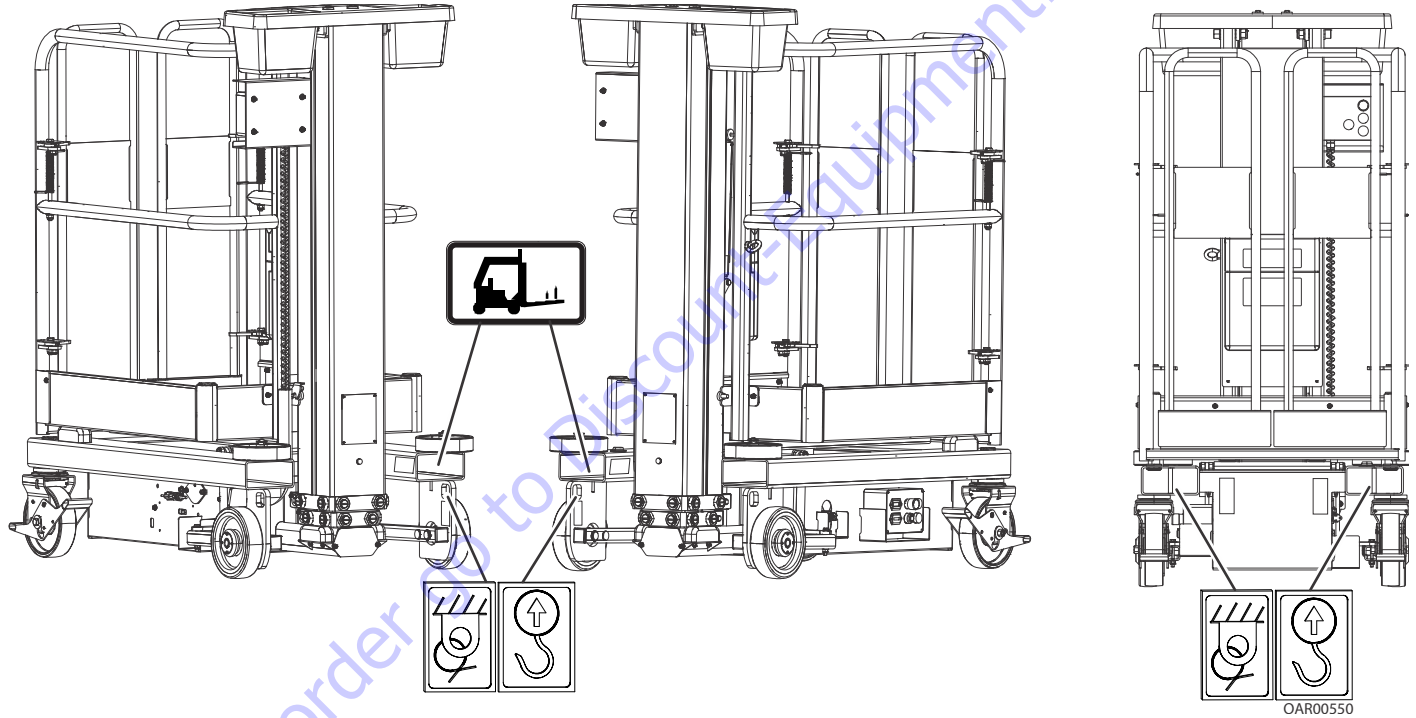

3.7 DECAL INSTALLATION

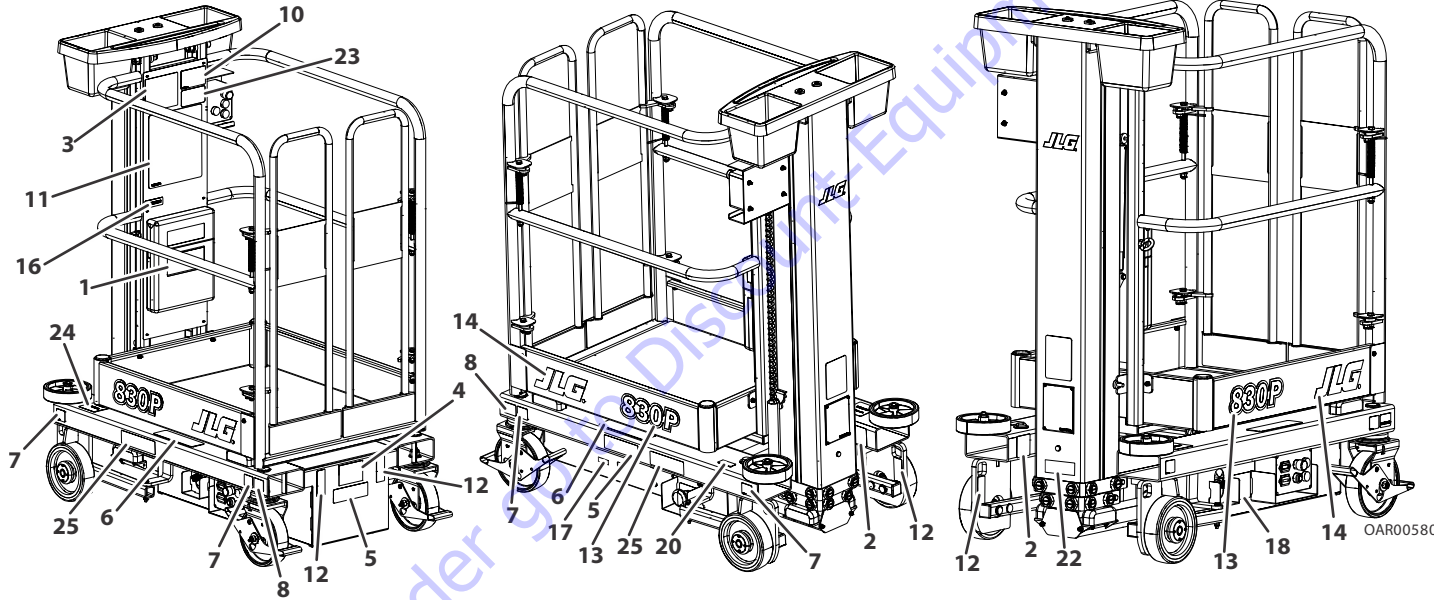

SECTION 3 - MACHINE OPERATION

Item	Part Number			
	ANSI - English (1001251194-B)	CSA - French (1001251195-B)	ANSI - Spanish (1001251196-B)	ANSI - Portuguese (1001251197-B)
1	1701509			
2	1703817			
3	1703781	1704795	1704029	1704021
4	1702391	1001215113	1001241795	1001241805
5	1703813	1001215217	1001241797	1001241806
6	1703786	1704039	1704032	1704024
7	1001213587			
8	1001213208			
9	—			
10	1001213488			
11	1001251170	1001251171	1001251172	1001251173
12	1001213442			
13	1001213551			
14	1001214107			
15	1001214109			
16	1001213582	1001215009	1001241792	1001241802

Item	Part Number			
	ANSI - English (1001251194-B)	CSA - French (1001251195-B)	ANSI - Spanish (1001251196-B)	ANSI - Portuguese (1001251197-B)
17	3251243			
18	1001260980	1001260981	1001260982	1001260983
19	—			
20	1703789	1704041	1704034	1704026
21	—			
22	—	1706351	—	—
23	1001231801	—		
24	1001223055	1001245181	1001245183	1001245185
25	1706832	1001256551	1001256552	1706833

SECTION 3 - MACHINE OPERATION



NOTES:

A series of horizontal lines for taking notes, arranged in two columns. The left column contains 15 lines, and the right column contains 15 lines. A large, light blue watermark is oriented diagonally across the page, reading "To order go to Discount-Equipment.com".

SECTION 4. EMERGENCY PROCEDURES

4.1 GENERAL INFORMATION

This section explains the steps to be taken in case of an emergency situation while operating the machine.

4.2 EMERGENCY OPERATION

Operator Unable to Control Machine

IF THE PLATFORM OPERATOR IS PINNED, TRAPPED OR UNABLE TO OPERATE OR CONTROL THE MACHINE, USE THE FOLLOWING INSTRUCTIONS AS A GUIDELINE.

1. Other personnel should operate the machine from ground controls only as required.
2. Only qualified personnel in the platform may use the platform controls. DO NOT CONTINUE OPERATION IF CONTROLS DO NOT FUNCTION PROPERLY.

Cranes, forklift trucks or other equipment can be used to remove the platform occupant and stabilize motion of the machine.

Platform Caught Overhead

If the platform becomes jammed or snagged in overhead structures or equipment, do the following:

1. Shut off the machine.
2. Rescue all people in the platform before freeing the machine. Personnel must be out of the platform before operating any controls on the machine.
3. Use cranes, forklifts or other equipment to stabilize motion of the machine to prevent a tip over as required.
4. From the ground controls, carefully free the platform from the object.
5. Once clear, restart the machine and return the platform to a safe position.
6. Inspect the machine for damage. If the machine is damaged or does not operate properly, turn off the machine immediately. Report the problem to the proper maintenance personnel. Do not operate the machine until it is declared safe for operation.

Righting of Tipped Machine

Before righting a tipped machine, check machine for any damage which may prevent it from setting properly on its base wheels once in a vertical position, (i.e. base wheels damaged, base frame distorted, etc.). Use a crane, forklift or other suitable lifting equipment and carefully lift the machine to an upright position.

NOTICE

FOLLOWING ANY INCIDENT, THOROUGHLY INSPECT THE MACHINE AND TEST ALL FUNCTIONS. DO NOT ELEVATE PLATFORM UNTIL YOU ARE SURE THAT ALL DAMAGE HAS BEEN REPAIRED, IF REQUIRED AND THAT ALL CONTROLS ARE OPERATING CORRECTLY.

4.3 INCIDENT NOTIFICATION

JLG Industries, Inc. must be notified immediately of any incident involving a JLG product. Even if no injury or property damage is evident, JLG must be contacted by telephone and provided with all necessary details.

- USA: 877-JLG-SAFE (554-7233)
- EUROPE: (32) 0 89 84 82 20
- AUSTRALIA: (61) 2 65 811111
- E-mail: productsafety@jlg.com

Failure to notify the manufacturer of an incident involving a JLG Industries product within 48 hours of such an occurrence may void any warranty consideration on that particular machine.

NOTICE

FOLLOWING ANY INCIDENT, THOROUGHLY INSPECT THE MACHINE. DO NOT ELEVATE PLATFORM UNTIL YOU ARE SURE THAT ALL DAMAGE HAS BEEN REPAIRED, AND THAT ALL CONTROLS ARE OPERATING CORRECTLY. TEST ALL FUNCTIONS FIRST FROM THE GROUND CONTROL STATION, THEN FROM THE PLATFORM CONTROL CONSOLE.

4.4 EMERGENCY LOWERING OPERATION

⚠ WARNING

DO NOT CLIMB OUT OF THE PLATFORM WHILE ELEVATED. THIS MAY AFFECT THE MACHINE'S BALANCE, CAUSING IT TO TIP OVER. ONLY EXIT THE PLATFORM VIA THE PLATFORM GATES. DO NOT ATTEMPT TO CLIMB DOWN MAST.

In case of platform control failure or operator incapacity, use the emergency lowering valve. Before engaging, ensure area beneath the platform is free from obstructions, stay clear of descending structure, and do not force valve knob.

To lower the platform:

1. Locate emergency lowering valve on the frame on the left side of machine.
2. To open valve, pull out red knob in until the platform starts to lower.
3. Once platform is lowered to desired height, release red knob to close valve.

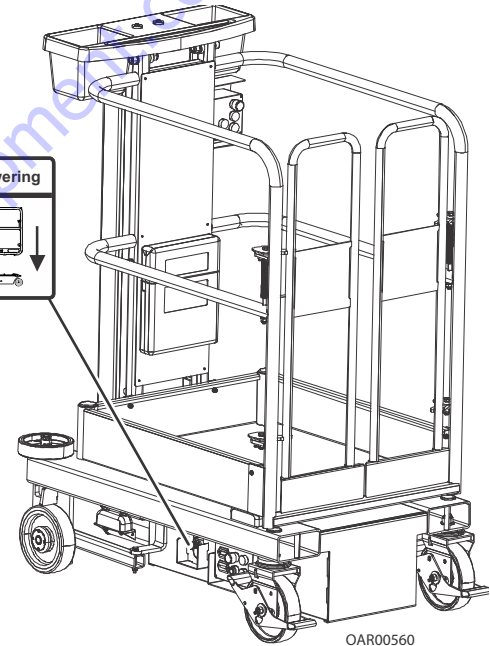
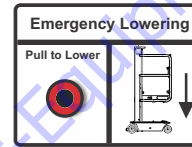

SECTION 4 - EMERGENCY PROCEDURES



NOTES:

A large area consisting of two columns of horizontal lines for taking notes. The left column has 15 lines and the right column has 15 lines, for a total of 30 lines.

To order go to Discount-Equipment.com

SECTION 5. GENERAL SPECIFICATIONS

5.1 INTRODUCTION

This section of the manual provides additional necessary information to the operator for proper operation and maintenance of this machine.

The maintenance portion of this section is intended as information to assist the machine operator to perform daily maintenance tasks only, and does not replace the more thorough Preventive Maintenance and Inspection Schedule included in the Service and Maintenance Manual.

Other Publications Available Specific to this Machine:

- Illustrated Parts Manual - 31215864
- Service and Maintenance Manual - 31215863

SECTION 5 - GENERAL SPECIFICATIONS

5.2 SPECIFICATIONS

Working Specifications

Specification	Value
Maximum Working Height	14.76 ft (4.50 m)
Maximum Platform Height	8.20 ft (2.50 m)
Platform Dimensions	3.28 ft (L) x 2.39 ft (W) (1 m (L) x 0.73 m (W))
Working Footprint	3.90 ft x 2.46 ft (1.19 m x 0.75 m)
Maximum Platform Capacity (Platform and Tool Tray Combined)	440 lb (200 kg) (1 person + tools)
Maximum Manual Side Force	45 lb (200 N)
Maximum Allowable Operating Slope	0 degree
Maximum Wind Force	Indoor use only
Maximum Ground Bearing Pressure	174 psi (12.23 kg/cm ²)
Maximum Wheel Load	345 lb (157 kg)

Dimensions

Specification	Value
Length	3.92 ft (1.195 m)
Width	2.46 ft (0.750 m)
Height	5.11 ft (1.560 m)
Weight	628 lb (285 kg)

Operating Specifications

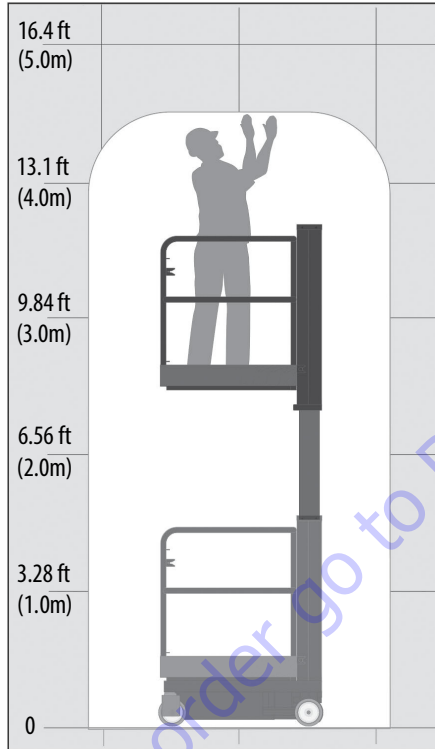

Power Source

- 12V DC Battery
- Electric Motor - Standard 12V DC
- Hydraulic Pump - 3.1cc/rev
- Hydraulic Pressure Relief: 942 psi/65 bar

Battery Charger

AC Input Voltage	90-135V AC
Frequency	45-65 Hz
Output	12V DC, 7A

Lubrication Specification

Hydraulic Oil - Grade 32 Mineral Oil

5.3 OPERATOR MAINTENANCE

Accessing Hydraulic/Electrical Components In Base Frame

1. Raise the platform an inch or two to set the rear wheel brake bar. Engage the front wheel castor locks.

⚠ CAUTION

WHEN REMOVING THE BASE FRAME COVER FOR MAINTENANCE PURPOSES, FIRST SWITCH MACHINE POWER OFF BY DEPRESSING THE EMERGENCY STOP BUTTON LOCATED ON THE BASE OF THE MACHINE. USE APPROPRIATE SAFETY/PERSONAL PROTECTIVE EQUIPMENT WHERE NECESSARY.

2. Lift the platform release latch on the right side of the mast while swinging the platform forward.
3. Tilt the platform up by lifting from gate end. The gas strut mounted on the left of the platform will assist with platform movement.
4. When fully extended, check that the catch mechanism on the gas strut is set and platform is locked in position before working beneath the platform.
5. On the base frame, unscrew the black retaining knobs attaching the frame cover to the base frame. Lift cover off frame.
6. After maintenance is completed, reassemble frame cover on the base frame in reverse order starting at step 4 above. Release gas strut and lower platform.



1. Platform: Maintenance Position
2. Gas Strut with Catch Mechanism
3. Platform Latch Lock Pin
4. Base Frame Cover with Screws

Hydraulic System Maintenance

- Hydraulic Oil Specification - refill with grade 32 mineral oil.
 - Ensure the hydraulic oil reservoir is not overfilled.
 - The oil level must only be checked when the mast is fully lowered.
 - The correct oil level with the mast fully lowered is approximately 3/4 from the base of the reservoir, as indicated by the line on the side of the reservoir.
 - Check that hydraulic connections around the pump and base of cylinder are tight and undamaged.
 - The hydraulic oil must be replaced on an annual basis. If the oil is not replaced, then premature wear and failure of components will occur.
- The only practical method to remove the oil from the tank is to use a syringe suitable for hydraulic oil, which are easily obtainable, or a vacuum system for hydraulic oil. Refill to proper level with fresh oil, and cycle the mast up and down a few full cycles, then recheck oil level.

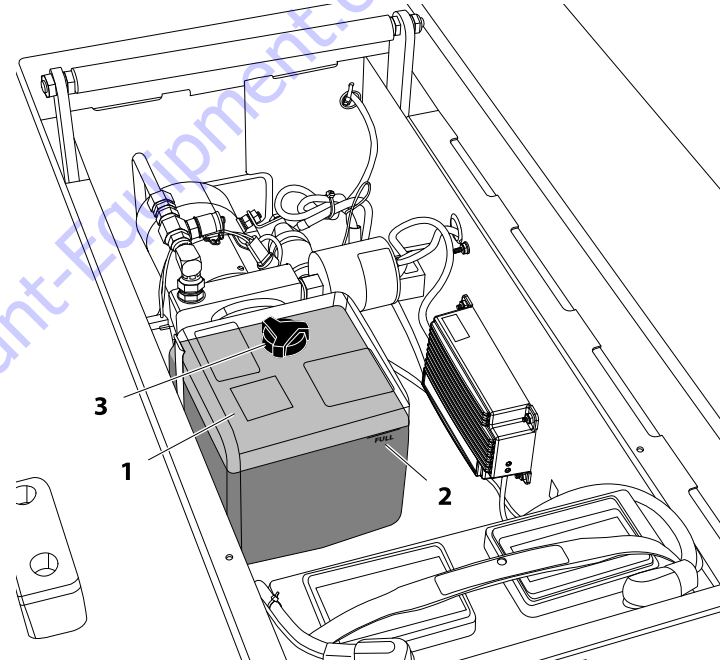

1. Hydraulic Reservoir
2. Full Mark on Reservoir
3. Fill Cap

SECTION 5 - GENERAL SPECIFICATIONS



NOTES:

Two columns of horizontal lines for writing notes.

To order go to Discount-Equipment.com

TO PURCHASE THIS PRODUCT PLEASE CONTACT US



**Equipment Financing and
Extended Warranties Available**



**Discount-Equipment.com is your online resource for
commercial and industrial quality parts and equipment sales.**

561-964-4949

visit us on line @ www.discount-equipment.com

Select an option below to find your Equipment

Search by Manufacturer

Search by Product Type

Request a Quote

We sell worldwide for the brands: Genie, Terex, JLG, MultiQuip, Mikasa, Essick, Whiteman, Mayco, Toro Stone, Diamond Products, Generac Magnum, Airman, Haulotte, Barreto, Power Blanket, Nifty Lift, Atlas Copco, Chicago Pneumatic, Allmand, Miller Curber, Skyjack, Lull, Skytrak, Tsurumi, Husquvarna Target, Stow, Wacker, Sakai, Mi-T-M, Sullair, Basic, Dynapac, MBW, Weber, Bartell, Bennar Newman, Haulotte, Ditch Runner, Menegotti, Morrison, Contec, Buddy, Crown, Edco, Wyco, Bomag, Laymor, EZ Trench, Bil-Jax, F.S. Curtis, Gehl Pavers, Heli, Honda, ICS/PowerGrit, IHI, Partner, Imer, Clipper, MMD, Koshin, Rice, CH&E, General Equipment, Amida, Coleman, NAC, Gradall, Square Shooter, Kent, Stanley, Tamco, Toku, Hatz, Kohler, Robin, Wisconsin, Northrock, Oztec, Toker TK, Rol-Air, APT, Wylie, Ingersoll Rand / Doosan, Innovatech, Con X, Ammann, Mecalac, Makinex, Smith Surface Prep, Small Line, Wanco, Yanmar

JLG[®]

An Oshkosh Corporation Company

**Discount
Equipment**

www.Discount-Equipment.com

To order go to www.Discount-Equipment.com