

BOMAG

FAYAT GROUP

Operating instructions Maintenance instructions

Original operating instructions

BPR 70/70 D

S/N 101 692 26 >

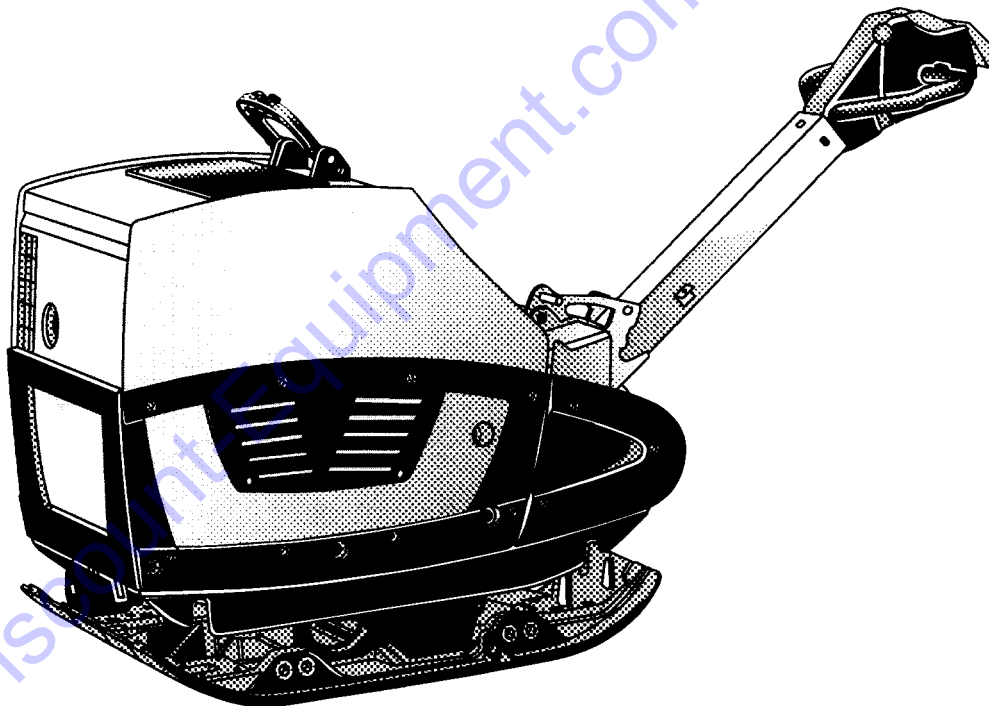

Reversible Vibrating Plate



www.discount-equipment.com

PARTS FINDER

**Search Website
by Part Number**



**Search Manual
Library For Parts
Manual & Lookup Part
Numbers – Purchase
or Request Quote**

Search Manuals

Enter your information to help us find the right parts manual for your machine.

* Brand:

* Model:

* Serial:

* Part Number:

SEARCH

**Can't Find Part or
Manual? Request Help
by Manufacturer,
Model & Description**

Parts Order Form

Please fill in the following information to help us find the right part for your machine.

Manufacturer:	<input type="text"/>
Model:	<input type="text"/>
Description:	<input type="text"/>
Part Number:	<input type="text"/>
Quantity:	<input type="text"/>
Notes:	<input type="text"/>

Submit

Discount-Equipment.com is your online resource for quality parts & equipment.

Florida: **561-964-4949** Outside Florida TOLL FREE: **877-690-3101**

Need parts?

Click on this link: <http://www.discount-equipment.com/category/5443-parts/> and choose one of the options to help get the right parts and equipment you are looking for. Please have the machine model and serial number available in order to help us get you the correct parts. If you don't find the part on the website or on one of the online manuals, please fill out the request form and one of our experienced staff members will get back to you with a quote for the right part that your machine needs.

We sell worldwide for the brands: Genie, Terex, JLG, MultiQuip, Mikasa, Essick, Whiteman, Mayco, Toro Stone, Diamond Products, Generac Magnum, Airman, Haulotte, Barreto, Power Blanket, Nifty Lift, Atlas Copco, Chicago Pneumatic, Allmand, Miller Curber, Skyjack, Lull, Skytrak, Tsurumi, Husquvarna Target, Stow, Wacker, Sakai, Mi-T-M, Sullair, Basic, Dynapac, MBW, Weber, Bartell, Bennar Newman, Haulotte, Ditch Runner, Menegotti, Morrison, Contec, Buddy, Crown, Edco, Wyco, Bomag, Laymor, EZ Trench, Bil-Jax, F.S. Curtis, Gehl Pavers, Heli, Honda, ICS/PowerGrit, IHI, Partner, Imer, Clipper, MMD, Koshin, Rice, CH&E, General Equipment, Amida, Coleman, NAC, Gradall, Square Shooter, Kent, Stanley, Tamco, Toku, Hatz, Kohler, Robin, Wisconsin, Northrock, Oztec, Toker TK, Rol-Air, APT, Wylie, Ingersoll Rand / Doosan, Innovatech, Con X, Ammann, Mecalac, Makinex, Smith Surface Prep, Small Line, Wanco, Yanmar

If the machine is equipped with a battery :

CALIFORNIA
Proposition 65 Warning

Battery posts, terminals and related accessories contain lead and lead compounds, chemicals known to the State of California to cause cancer and birth defects or other reproductive harm.
Wash hands after handling.

If the machine is equipped with a diesel engine :

CALIFORNIA
Proposition 65 Warning

The engine exhaust and some of its constituents are known to the state of California to cause cancer, birth defects, and other reproductive harm.

Go to Discount-Equipment.com to order your parts

These BOMAG machines are products from the wide range of BOMAG machines for earth work, asphalt and refuse compaction as well as stabilizers/recyclers.

BOMAG's vast experience in connection with state-of-the-art production and testing methods, such as lifetime tests of all important components and highest quality demands guarantee maximum reliability of your machine.

Using these instructions will

- help you to become familiar with the machine.
- avoid malfunctions caused by unprofessional operation.

Compliance with the maintenance instructions will

- enhance the reliability of the machine on construction sites,
- prolong the lifetime of the machine,
- reduce repair costs and downtimes.

BOMAG will not assume liability for the function of the machine

- if it is handled in a way not complying with the usual modes of use,
- if it is used for purposes other than those mentioned in these instructions.

No warranty claims can be lodged in case of damage resulting from

- operating errors,
- insufficient maintenance and
- wrong fuels and lubricants.

Please note!

This manual was written for operators and maintenance personnel on construction sites.

You should only operate the machine after you have been instructed and in compliance with these instructions.

Strictly observe the safety regulations.

Please observe also the guidelines of the Civil Engineering Liability Association "Safety Rules for the Operation of Road Rollers and Soil Compactors" and all relevant accident prevention regulations.

For your own personal safety you should only use original spare parts from BOMAG.

In the course of technical development we reserve the right for technical modifications without prior notification.

These operating and maintenance instructions are also available in other languages.

Apart from that, the spare parts catalogue is available from your BOMAG dealer against the serial number of your machine.

Your BOMAG dealer will also supply you with information about the correct use of our machines in soil and asphalt construction.

The above notes do not constitute an extension of the warranty and liability conditions specified in the general terms of business of BOMAG.

We wish you successful work with your BOMAG machine.

BOMAG GmbH

Printed in Germany

Copyright by BOMAG

Foreword

Please fill in

.....

Machine type (Fig. 1)

.....

Serial-number (Fig. 1 and 2)

.....

Engine type (Fig. 3)

.....

Engine number (Fig. 3)

i Note

Supplement the above data together with the commissioning protocol.

During commissioning our organisation will instruct you in the operation and maintenance of the machine.

Please observe strictly the safety regulations and all notes on risks and dangers!

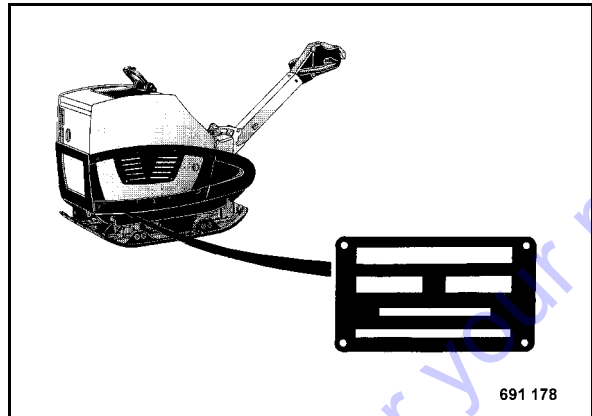

Fig. 1

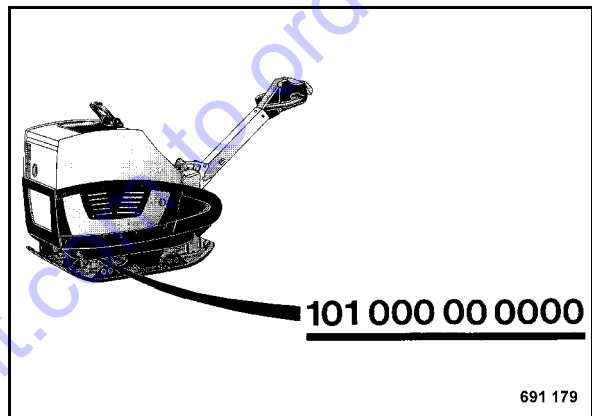

Fig. 2

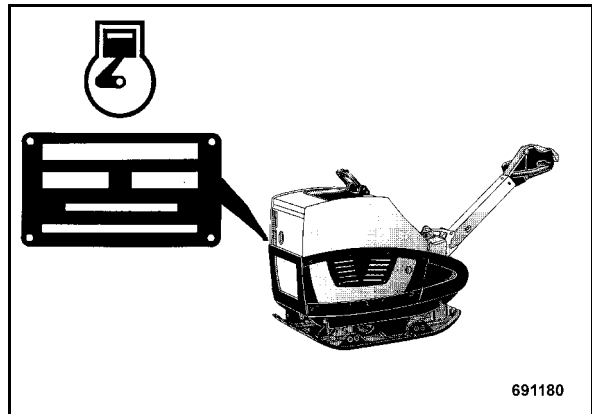

Fig. 3

Technical Data	7
Safety regulations	11
Indicators and Controls	17
3.1 General notes	18
3.2 Description of indicators and control elements	18
3.3 Function of the Economizer	20
Operation	23
4.1 General	24
4.2 Tests before taking into operation	24
4.3 Folding down the steering rod	25
4.4 Operating the low oil level safety device	25
4.5 Starting the engine	26
4.6 Starting with jump wires	27
4.7 Emergency starting with safety crank handle	28
4.8 Operation of Economizer	30
4.9 Work/operation	31
4.10 Backup protection	33
4.11 Stopping the vibratory plate, shutting down the engine	33
4.12 Loading	34
Maintenance	37
5.1 General notes on maintenance	38
5.2 Fuels and lubricants	39
5.3 Table of fuels and lubricants	41
5.4 Running-in instructions	42
5.5 Maintenance table	43
5.6 Cleaning the machine	45
5.7 Check the engine oil level	45
5.8 Checking the fuel level	46
5.9 Check the hydraulic oil level	46
5.10 Checking the air filter service indicator	47
5.11 Clean the cooling fins and the cooling air intake openings	49
5.12 Draining the sludge from the fuel tank	50
5.13 Check the battery condition, grease the poles	51
5.14 Check, adjust the valve clearance	52
5.15 Check the oil level in the vibrator housing	53
5.16 Changing the engine oil	55
5.17 Changing the engine oil filter	56
5.18 Changing the fuel filter	57
5.19 Change the oil in the exciter shaft housing	57
5.20 Check the rubber buffers	58
5.21 Check the V-belt tension, if necessary replace the V-belt	59

Table of Contents

	5.22 Change hydraulic oil and filter	61
	5.23 Check, clean the dry air filter	63
	5.24 Tightening the screws	64
	5.25 Engine conservation	65
Trouble shooting		67
	6.1 General notes	68
	6.2 Engine problems	69
	6.3 Trouble shooting Economizer	72

1 Technical Data

Go to Discount-Equipment.com to order your parts

Technical Data

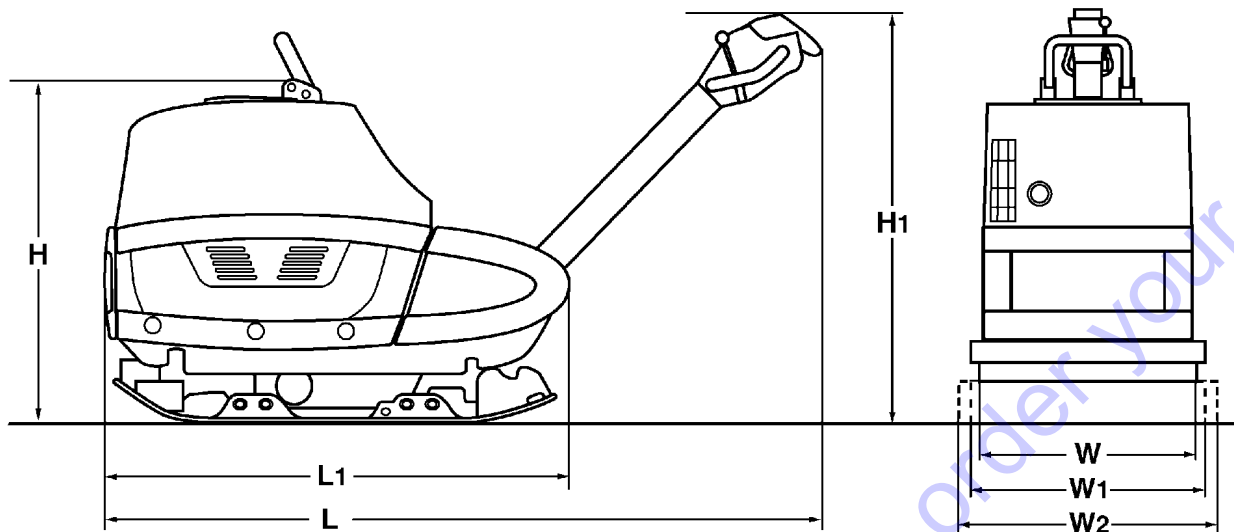

692032

Fig. 4

Dimensions in mm	H	H ₁	L	L ₁	W	W ₁	W ₂
BPR 70/70 D	870	1030	1860	980	550	700	850

*

BPR 70/70 D

Weights

Operating weight (CECE) W	kg	556
Operating weight (CECE) W1	kg	579
Operating weight (CECE) W2	kg	595
Basic weight	kg	570

Travel characteristics

Working speed max.	m/min	28
Max. gradability (depending on soil)	%	35

Drive

Engine manufacturer		Hatz
Type		1D 81
Cooling		Air
Number of cylinders		1
Rated power ISO 9249	kW	9.8
Rated speed	rpm	2700
Drive system		mechanical

*

BPR 70/70 D

Vibration system

Frequency	Hz	68
Centrifugal force	kN	70

Filling capacities

Fuel tank (diesel)	l	10
Engine oil	l	1.9

* The right for technical modifications remains reserved

Go to Discount-Equipment.com to order your parts

Technical Data

The following noise and vibration data acc. to

- EC Machine Regulation edition 2006/42/EC
- the noise regulation 2000/14/EG, noise protection guideline 2003/10/EC
- Vibration Protection Regulation 2002/44/EC

were determined during conditions typical for this type of equipment and by application of harmonized standards.

During operation these values may vary because of the existing operating conditions.

Noise value

Sound pressure level on the place of the operator:

$L_{pA} = 95 \text{ dB(A)}$, determined acc. to ISO 11204 and EN 500

Guaranteed sound power level:

$L_{WA} = 109 \text{ dB(A)}$, determined acc. to ISO 3744 and EN 500

Danger

Loss of hearing!

Wear your personal noise protection means (ear defenders) before starting operation.

Vibration value

Hand-arm vibration:

Vector total of the weighted effective acceleration in three orthogonal directions:

Weighted total vibration value

$a_{hv} = 6.9 \text{ m/s}^2$ on crushed rock determined acc. to ISO 5349 and EN 500

Caution

Observe the daily vibration load (Industrial safety acc. to 2002/44/EEC).

2 Safety regulations

Go to Discount-Equipment.com to order your parts

General

This BOMAG machine has been built in compliance with the latest technical standard and complies with the applicable regulations and technical rules. However, dangers for persons and property may arise from this machine, if:

- it is used for purposes other than the ones it is intended for,
- it is operated by untrained personnel,
- it is changed or converted in an unprofessional way,
- the safety instructions are not observed.

Each person involved in the operation, maintenance and repair of the machine must therefore read and comply with these safety regulations. If necessary, this must be confirmed by obtaining the signature of the customer.

Furthermore, the following obviously also applies:

- applicable accident prevention instructions,
- generally accepted safety and road traffic regulations,
- country specific safety regulations. It is the duty of the operator to be acquainted with these instructions and to apply these accordingly. This applies also for local regulations concerning different types of handling work. Should the recommendations in these instructions be different from the regulations valid in your country, you must comply with the safety regulations valid in your country.

Intended use

This machine must only be used for:

- Compaction of all types of soils
- Repair work on all types of soil
- Paving of walkways
- Work in trenches
- Underfilling and compaction of hard shoulders

Unintended use

Dangers may arise from the machine when it is used for purposes other than the one it is intended for.

Any danger caused by intended use is the sole responsibility of the customer or driver/operator, the manufacturer cannot be made liable.

Examples for unintended use are:

- Dragging the machine along as a measure of transportation
- Throwing the machine off the transport vehicle
- Attaching an additional weight to the machine

It is not permitted to stand on the machine while working.

Any transport ropes fastened to the machine must be removed before operation.

Starting and operation of the machine in explosive environments and in underground mining is prohibited.

Remaining dangers, remaining risks

Despite careful work and compliance with standards and regulations it cannot be ruled out that further dangers may arise when working with and handling the machine.

Both the machine as well as all other system components comply with the currently valid safety regulations. Nevertheless, remaining risks cannot be ruled out completely, even when using the machine for the purpose it is intended for and following all information given in the operating instructions.

A remaining risk can also not be excluded beyond the actual danger zone of the machine. Persons remaining in this area must pay particular attention to the machine, so that they can react immediately in case of a possible malfunction, an incident or failure etc.

All persons remaining in the area of the machine must be informed about the dangers that arise from the operation of the machine.

Regular safety inspections

Have the machine inspected by an expert (properly trained person) once every year.

Who is allowed to work with the machine?

The machine must only be operated by trained and authorized persons who are at least 18 years of age. The responsibilities for the operation of the

machine must be clearly specified and complied with.

Persons under the influence of alcohol, medication or drugs must not operate, service or repair the machine.

Maintenance and repair tasks require specific knowledge and must therefore only be carried out by trained and qualified personnel.

Conversions and alterations to the machine

Unauthorized conversions to the machine are prohibited for safety reasons.

Original parts and accessories have been specially designed for this machine. We wish to make expressly clear that we have not tested or authorized any original parts or special equipment not supplied by us. The installation and/or use of such products can impair the active and/or passive driving safety. The manufacturer expressly excludes any liability for damage resulting from the use of non-original parts or accessories.

Damage, deficiencies, misuse of safety installations

Machines which are not safe to operate must be immediately taken out of service and shall not be used, until these deficiencies have been properly rectified.

Safety installations and switches must neither be removed nor must they be made ineffective.

Notes on safety in the operating and maintenance instructions:

Danger

Paragraphs marked like this highlight possible dangers for persons.

Caution

Paragraphs marked like this highlight possible dangers for machines or parts of the machine.

Note

Paragraphs marked like this contain technical information for the optimal economical use of the machine.

Environment

Paragraphs marked like this point out practices for safe and environmental disposal of fuels and lubricants as well as replacement parts.

Observe environmental regulations.

Loading the machine

Use only safe lifting gear of sufficient load bearing capacity

Fasten the lifting gear only at the specified lifting points.

Check lifting eye for damage before use. Do not use a damaged or in any other way impaired lifting eye.

Secure the machine against tipping or slipping off.

Persons are highly endangered if

- the step under loads being lifted or
- stand under loads being lifted.
- The machine must not swing about when being lifted.

Secure the machine on the transport vehicle against rolling, slipping and turning over.

Starting the machine

Before starting

Become acquainted with the equipment, the control elements, the working principle of the machine and the working area.

Wear your personal protective outfit (hard hat, safety boots, etc.). Wear ear defenders.

Before starting the machine check whether:

- the machine shows any obvious faults
- all guards and safety elements are in place
- the controls are fully functional
- the machine is free of oily and combustible material
- all grips are free of grease, oils, fuel, dirt, snow and ice.

Use only machines which are serviced at regular intervals.

For emergency starting take a correct position to the engine and hold the crank handle correctly.

Do not use any starting aids like start pilot or ether.

Starting and operation of the machine is closed rooms and trenches

Exhaust gases are highly dangerous! Always ensure an adequate supply of fresh air when starting and operating in closed rooms and trenches!

Operation

The machine must only be operated with the steering rod folded down.

Guide the machine in a way that hands do not knock against hard materials. Danger of injury.

Watch out for unusual noises and smoke when operating the plate. Investigate the cause and have the fault corrected.

The vibratory plate must only be operated at full engine speed, as otherwise the centrifugal clutch may be destroyed.

Never leave the plate unattended with the engine running..

Parking the machine

Park the machine on level and firm ground.

Before leaving the machine:

- Park the machine so that it cannot tip over,
- shut the engine down and pull the ignition key out.

Mark machines, which could be in the way, with a clearly visible sign.

Filling in fuel

Do not inhale any fuel fumes.

Refuel only with the engine shut down.

Do not refuel in closed rooms.

No open fire, do not smoke.

Do not spill any fuel. Catch running out fuel, do not let it seep into the ground.

Keep dirt and water away from the fuel.

Maintenance work

Comply with the maintenance work described in the operating and maintenance instructions, including the information concerning the replacement of parts.

Maintenance work must only be performed by qualified and authorized persons.

Keep unauthorized persons away from the machine.

Do not perform maintenance work while the motor is running.

Park the machine on level, firm ground.

Pull the key out of the ignition switch.

Work on hydraulic lines

Relieve hydraulic pressures before working on hydraulic lines. Hydraulic oil escaping under pressure can penetrate the skin and cause severe injury. When being injured by hydraulic oil consult a medical doctor immediately, as otherwise this may cause severe infections.

Do not change the setting of pressure relief valves.

Drain the hydraulic oil at operating temperature – danger of scalding!

Catch running out hydraulic oil and dispose of environmentally.

Always catch and dispose of hydraulic oils separately.

Do not start the engine after draining the hydraulic oil.

Once all work is completed (with the system still depressurized!) check all connections and fittings for leaks.

Changing hydraulic hoses

Hydraulic hoses must be visually inspected at regular intervals.

Hydraulic hoses must be immediately replaced if:

- the outer layer is damaged down to the inlay (e.g. chafing, cuts, cracks)
- the outer layer is brittle (formation of cracks in the hose material)
- the hose shows deformations in pressurized and depressurized condition, which do not comply with the genuine shape of the hydraulic hose
- the hose shows deformations in bends, e.g. squeezing, buckling, layer separation, formation of blisters
- parts of the hose are leaking.
- hoses are not correctly installed
- the hydraulic hose has separated from the fitting

- hoses are mixed up by mistake.
- the fitting shows corrosion that impairs both function and strength.
- fittings are damaged or deformed, whereby the function and strength of the hose/hose connection is impaired.

Only genuine BOMAG replacement hydraulic hoses ensure that the correct hose type (pressure range) is used at the right location.

Working on the engine

Drain the engine oil at operating temperature – danger of scalding!

Wipe off spilled oil, catch running out oil and dispose of environmentally.

Store used filters and other oil contaminated materials in a separate, specially marked container and dispose of environmentally.

Working on electric parts of the machine

Before starting to work on electric parts of the machine disconnect the battery and cover it with insulating material.

Working on the battery

When working on the battery do not smoke, do not use open fire!

Do not let acid come in contact with hands or clothes! When injured by acid flush off with clear water and seek medical advice.

Do not lay any tools on the battery.

For recharging remove the plugs from the battery to avoid an accumulation of highly explosive gases.

Dispose of old batteries according to regulations.

Working on the fuel system

Avoid open fire, do not smoke, do not spill any fuel.

Catch running out fuel, do not let it seep into the ground and dispose off environmentally.

Cleaning work

Do not perform cleaning work while the motor is running.

Do not use gasoline or other easily inflammable substances for cleaning.

When using a steam cleaner for cleaning do not subject electrical parts and insulation material to the direct jet or cover these items beforehand.

Do not guide the water jet directly into air filter and air intake or exhaust muffler.

After maintenance work

After all maintenance work is completed reinstall all guards and safety installations.

Repair

Repair work must only be performed by qualified and authorized persons. Use our repair instructions for this work.

Exhaust gases are highly dangerous! Always ensure an adequate supply of fresh air when starting in closed rooms!

Mark defective machines by attaching a warning note to the steering handle.

Welding

Before starting welding work on the machine disconnect the battery and cover the fuel tank with insulating material.

Safety stickers on the machine

Keep safety stickers in good condition and legible and follow their meaning.

Replace damaged and illegible safety stickers.

Safety regulations

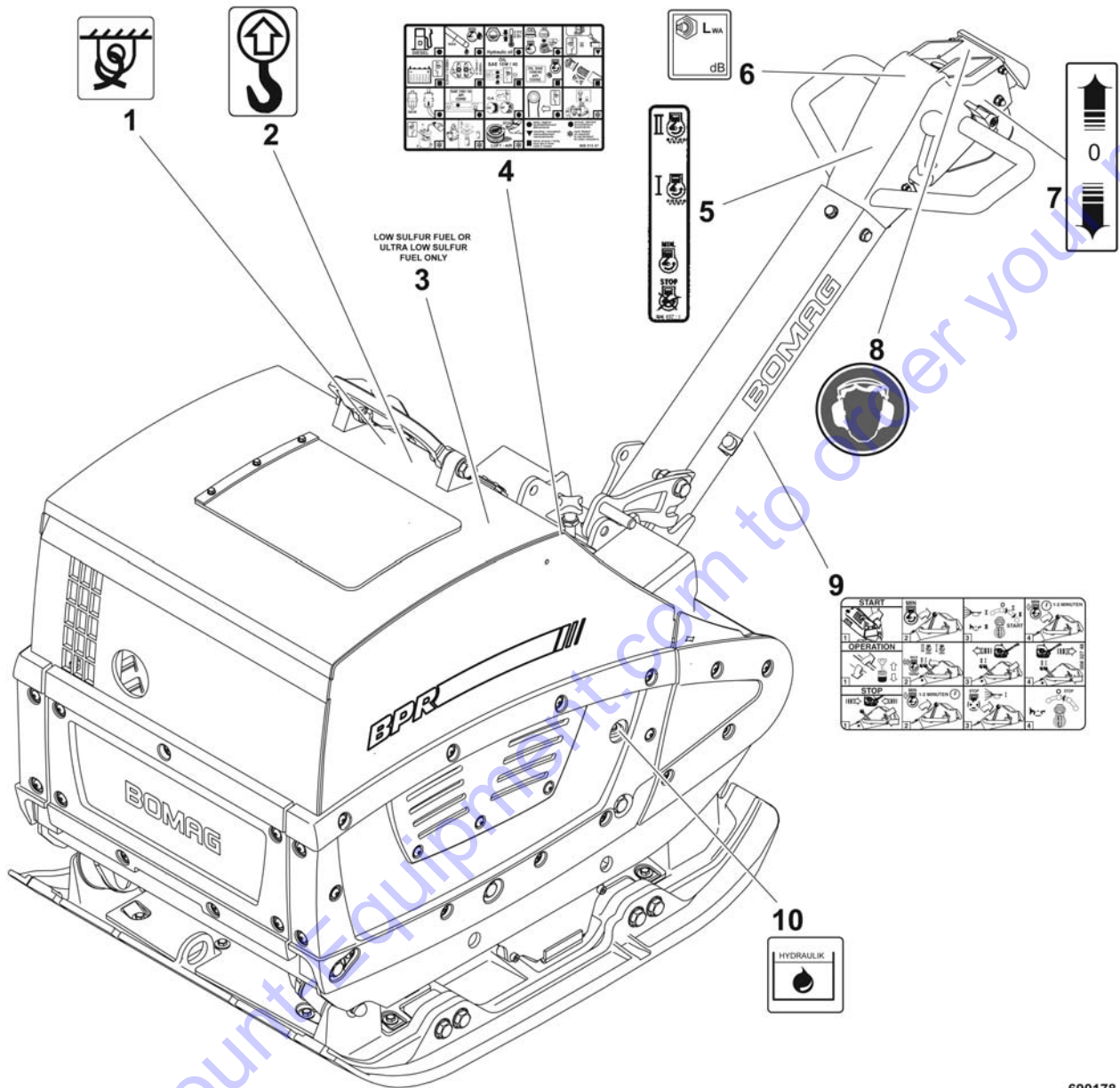

Fig. 5

690178

Stickers and decals

- | | | | |
|---|---|----|--|
| 1 | Information sticker "Lashing point" | 7 | Operation sticker "Travel lever" |
| 2 | Information sticker "Lifting point" | 8 | Instruction sticker "Wear ear defenders" |
| 3 | Instruction sticker "Low sulphur fuel" | 9 | Brief operating instructions |
| 4 | Maintenance sticker | 10 | Information sticker "Hydraulic oil" |
| 5 | Operation sticker "Throttle lever" | | |
| 6 | Information sticker "Guaranteed sound capacity level" | | |

3 Indicators and Controls

Go to Discount-Equipment.com to order your parts

3.1 General notes

Please read this section thoroughly before operating this machine if you are not yet conversant with the indicators and control elements. All functions are described in detail hereunder.

Paragraph 4 Operation contains only concise descriptions of the individual operating steps.

3.2 Description of indicators and control elements

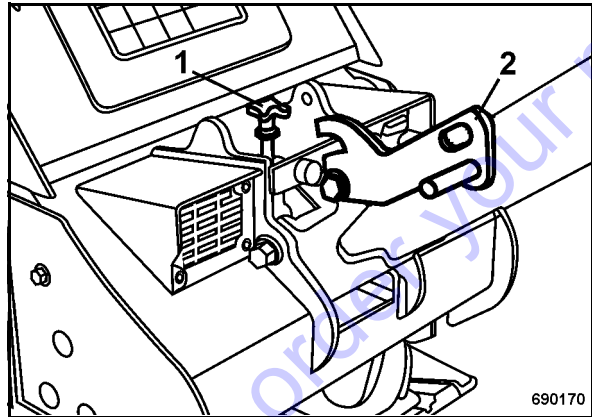

Fig. 6

No. 1 = Steering rod height adjustment

No. 2 = Locking pawl lever

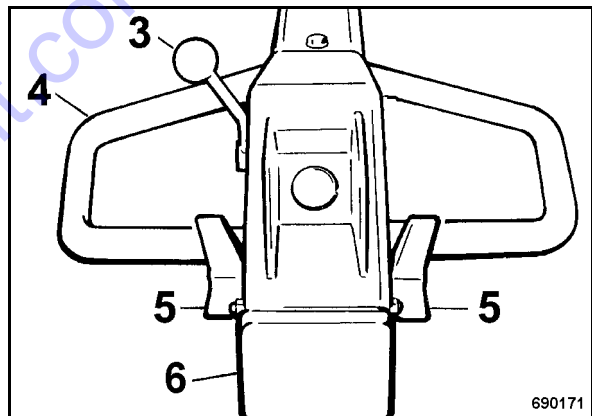

Fig. 7

No. 3 = Throttle lever

No. 4 = Handle

No. 5 = Travel lever (tip switch)

No. 6 = Backup protection

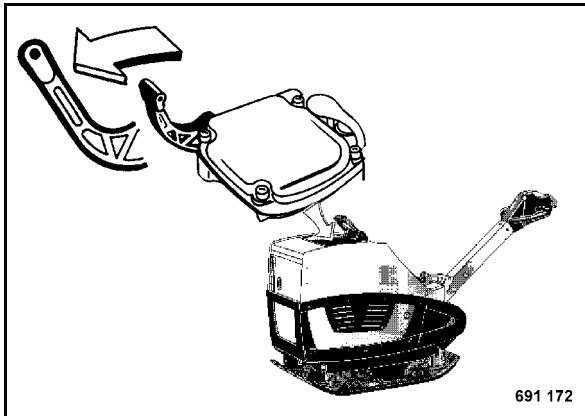

Fig. 8

No. 7 = Decompression lever

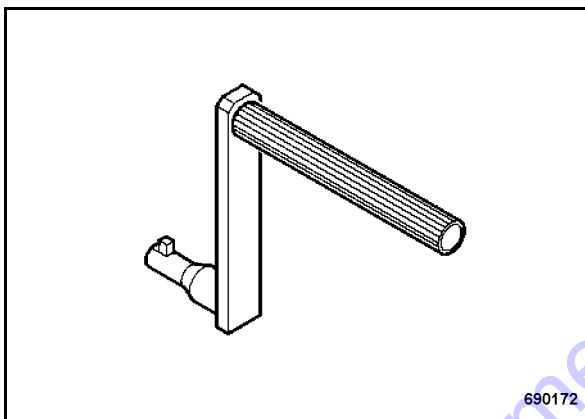

Fig. 9

No. 8 = Safety crankhandle

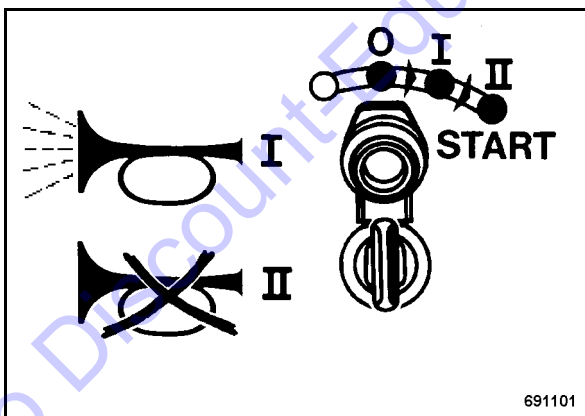

Fig. 10

No. 9 = Ignition switch

i Note

Only machines with electric starter.

- Position "0" = Ignition off, warning buzzer off
- Position "I" = Ignition on, warning buzzer on
- Position "II" = Engine starts, warning buzzer off

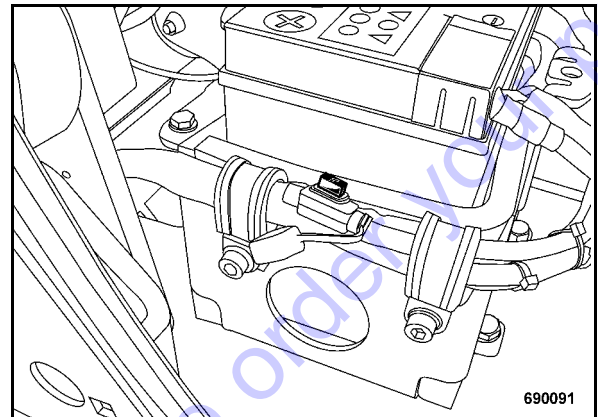

Fig. 11

No. 10 = Fuse (25 A)

i Note

Only machines with electric starter.

⚠ Caution

Always cover the fuse with the protective cover.

Machines with Economizer* are protected by an additional fuse (5 A).

⚠ Danger

Fire hazard!

Do not use fuses with higher ampere ratings and do not bridge fuses.

* Optional equipment

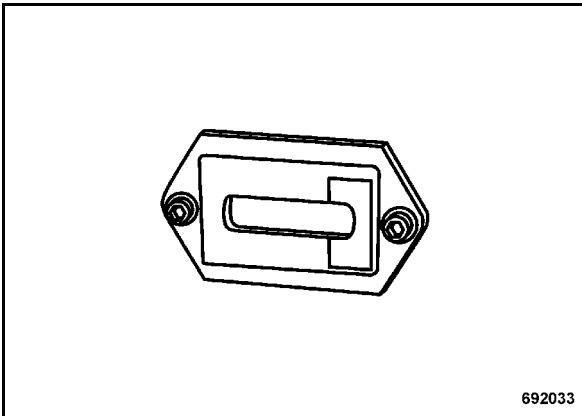

Fig. 12

No. 11 = Operating hour meter*

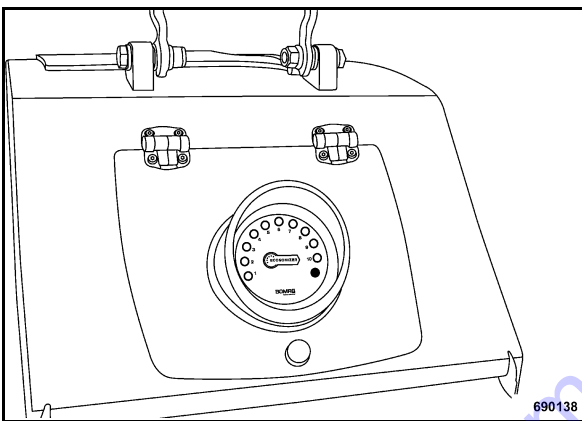

Fig. 13

No. 12 = Economizer display**

3.3 Function of the Economizer

Surface covering compaction control is used to determine the dynamic stiffness of the soil. An acceleration sensor measures the reaction of the soil to the vibrating base plate of the vibratory plate. An LED display shows the soil stiffness measuring value as a non-dimensional value.

This continuous measuring display enables the detection and directed subsequent compaction of possibly arising weak spots.

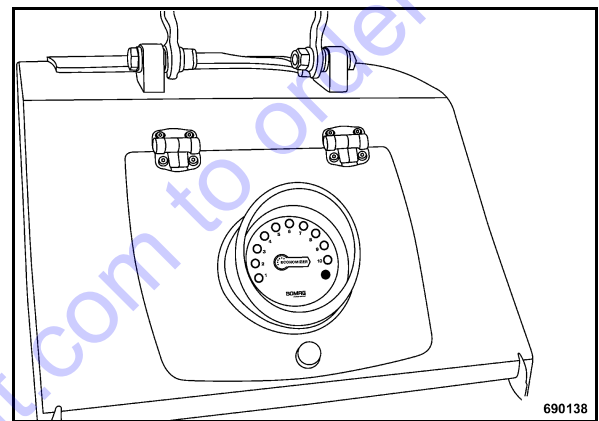

Fig. 14

The Economizer consists of two components:

- the evaluation and display module is integrated in the maintenance flap (within the operator's view). It shows the measuring value measured by the compaction control.
- The acceleration sensor is fastened to the base plate. It converts the accelerations occurring on the base plate into voltage signals.

For the output of the measuring value in the LED display the voltage signal from the acceleration sensor is picked up and processed by the evaluation unit.

In order to achieve the required soil stiffness measured in MN/m^2 , a reference measurement (e.g. dynamic load plate) must be made before the material is compacted.

This is necessary to find out how many LEDs in the Economizer display correspond with the required value in MN/m^2 on the soil being compacted.

* Optional equipment

** Optional equipment

Evaluation and display module

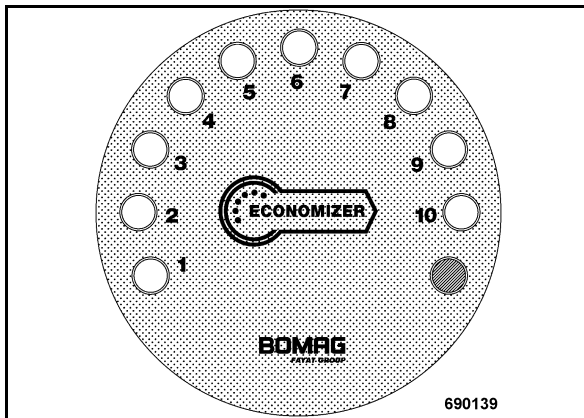

Fig. 15

The yellow LEDs represent the measuring value from the compaction control in 10 stages.

The brightness of the respective last LED varies in order to show intermediate values (example: 4,5: four LEDs are fully on, the fifth LED lights with reduced brightness).

The red LED informs about the system status.

Acceleration sensor

The sensor consists of a sensor element, which is enclosed in a sensor housing, and a connecting cable with plug-in connector. Actual sensor, housing, cable and plug-in connector come as a unit, which cannot be repaired on its own.

The unit is mounted to the base plate of the machine.

i Note

The Economizer is maintenance free.

Do not clean the front screen with hard objects! The material may be destroyed. Possibly disturbing scratches can be removed by polishing, e.g. with lacquer polish.

i Note

Vibrating plates of the same type show identical measuring values when used on the same soil.

The measuring values achieved with different vibratory plates with Economizer from BOMAG can be made comparable by calibration to a reference value.

Go to Discount-Equipment.com to order your parts

4 Operation

Go to Discount-Equipment.com to order your parts

4.1 General

If you are not yet acquainted with the controls and indicating elements on this machine you should thoroughly read chapter 3 "Indicators and control elements" before starting work.

All indicators and control elements are described in detail in this chapter.

4.2 Tests before taking into operation

The following inspections must be carried out before each working day or before a longer working period.

⚠ Danger

Danger of accident!

Please observe strictly the safety regulations in chapter 2 of this instruction manual!

- Park the machine on ground as level as possible.
- Cleaning the machine.

Check:

- condition of engine and machine
- fuel tank and fuel lines for leaks
- screw joints for tight fit

i Note

For a description of the following tasks refer to the chapter "Daily maintenance".

- Engine oil level
- Fuel level
- Hydraulic oil level
- Air filter service indicator

4.3 Folding down the steering rod

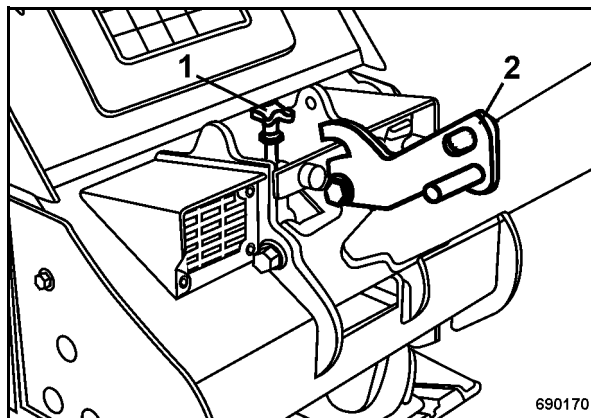

Fig. 16

- Pull the locking pawl lever (2) (Fig. 16) and lower the steering rod, so that it can swing freely.
- Adjust the steering rod with the height adjustment (1) to the height of your body.

4.4 Operating the low oil level safety device

i Note

The engine is equipped with a low oil level safety device, which interrupts the fuel flow to the injection pump. The engine will stop.

If the low oil level safety device has responded or if the fuel tank has been driven empty, the fuel shut-off valve must be opened manually.

⚠ Caution

The low oil level safety device does not release the operator from his duty to check the oil level every day.

Always perform the following work if:

- the low oil level safety device has responded and engine oil has been filled up,
- if the fuel tank has been driven empty.
- the fuel in the supply line has been used up when cranking the engine free during cold starting or by starting faults.

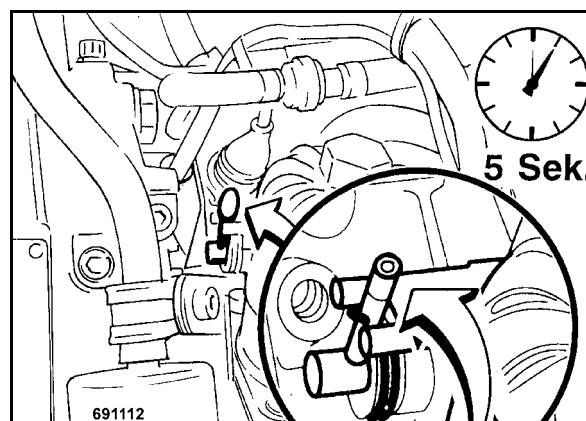

Fig. 17

- Fill in fuel
- Press the hand lever (Fig. 17) for approx. five seconds against the spring.

The engine is ready for starting.

4.5 Starting the engine

▲ Danger

Exhaust gases are highly dangerous!

Always ensure an adequate supply of fresh air when starting and operating in closed rooms and trenches!

▲ Danger

Danger of accident!

Before starting make sure that there are no persons in the danger area of engine or machine and that all safety installations are in place.

Always hold on to the machine.

Always keep an eye on a running machine.

▲ Danger

Loss of hearing!

Wear your personal noise protection means (ear defenders) before starting operation.

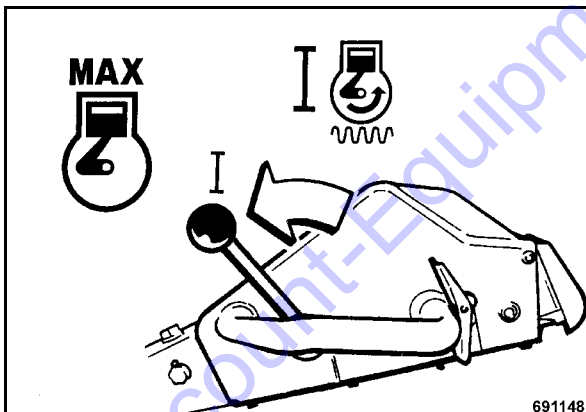

Fig. 18

- Set the throttle lever (Fig. 18) to position "MAX".

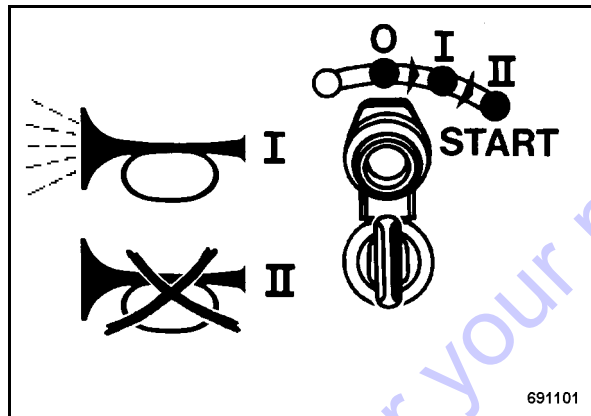

Fig. 19

- Turn the ignition key to position "I" (Fig. 19), the warning buzzer sounds.
- Then turn the ignition key further to position "II" to start the engine.
- As soon as the engine runs, return the ignition key to position "I". The warning buzzer stops.

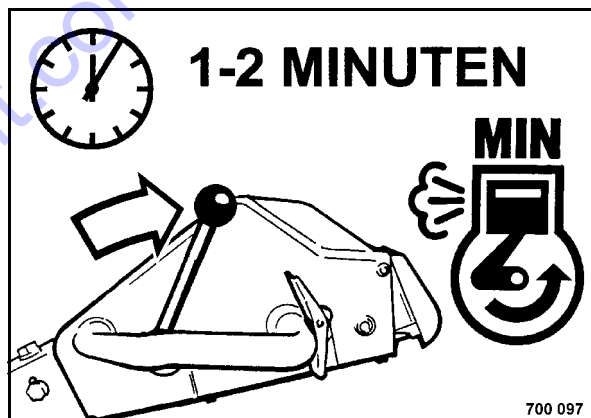

Fig. 20

- After starting take the throttle lever back to position "MIN" (Fig. 20).
- Run the engine warm for approx. 1 to 2 minutes in idle speed.

i Note

Operation of the vibratory plate can be started as soon as the engine responds to short throttle commands.

▲ Caution

When the engine is running leave the ignition key in position "I".

4.6 Starting with jump wires

i Note

Choose this type of starting if the starter battery is exhausted and the machine cannot be started manually with the safety crank handle.

⚠ Caution

A wrong connection will cause severe damage in the electric system.

The auxiliary battery must have the same voltage as the starter battery.

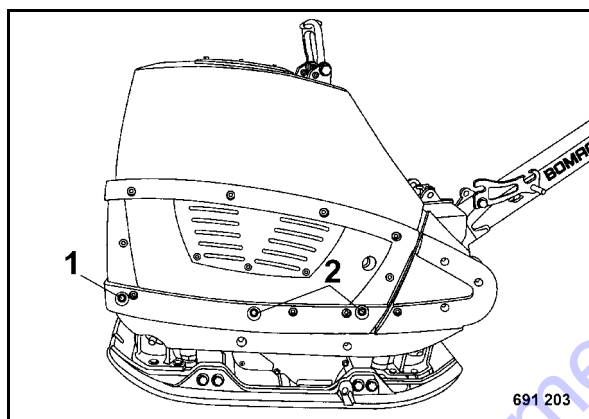

Fig. 21

- Loosen the hood fastening screws (1) on both sides and remove the hood fastening screws (2) on both sides (Fig. 21).
- Fold the hood back to open.
- Remove the battery holder and take off the vibration damping mat.
- Check insulation mats, brackets and screw connections, replace if necessary.

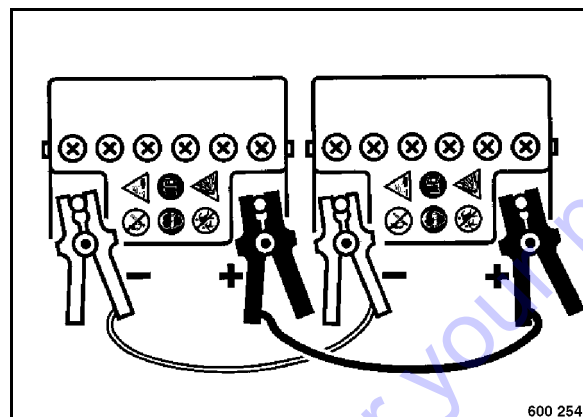

Fig. 22

- Join the plus poles on external battery and starter battery with the jump wire (Fig. 22).
- Use the second jump start cable to connect the negative poles on external battery and starter battery.
- Perform the starting process as described before.
- When the engine is running remove the jump start cable from the two negative poles first and from the positive poles after.

i Note

This work sequence is necessary to avoid short circuit caused by contact between positive and negative cables.

- Close the hood again and fasten it with bolts.

4.7 Emergency starting with safety crank handle

i Note

This starting procedure should only be used in case of a defective, discharged or missing battery.

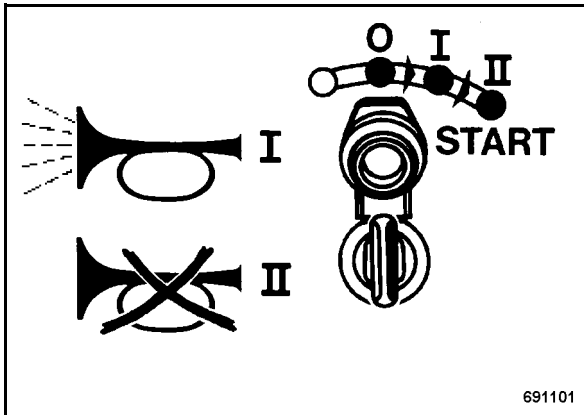

Fig. 23

- Turn the ignition key to position I (Fig. 23), the warning buzzer does not sound.

i Note

With the ignition switch in position I the battery is charged when the engine is running, as long the battery charge level is at least 9 V.

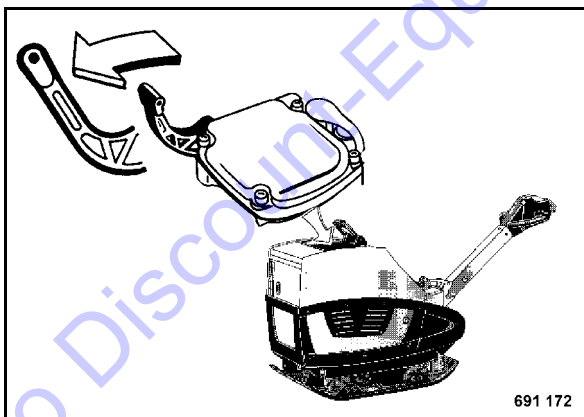

Fig. 24

- Pull the decompression lever (Fig. 24) in direction of arrow to the end stop. The compression lever clicks noticeably into place.

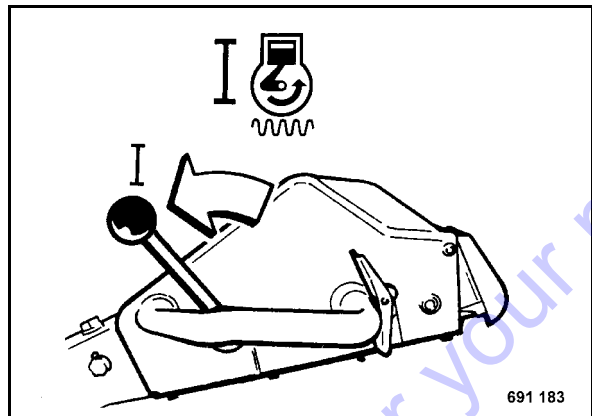

Fig. 25

- Set the throttle lever (Fig. 25) to vibration step 1.

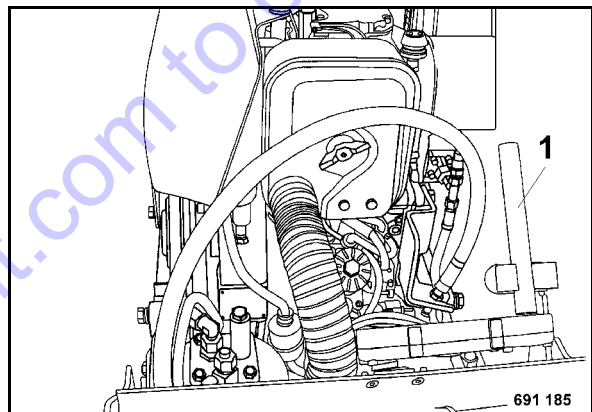

Fig. 26

- Open the rubber cover.
- Take the safety crank handle 1 (Fig. 26) out of the bracket.
- Insert the safety crank handle.

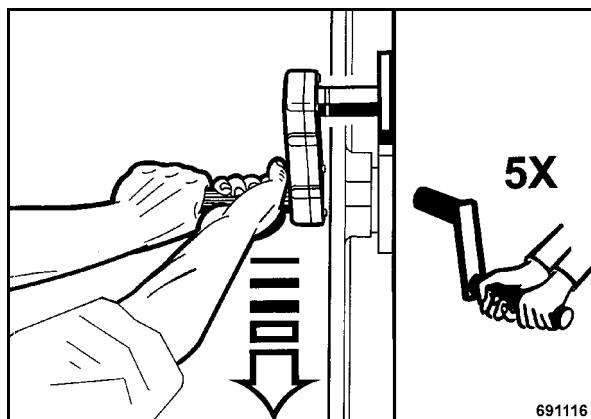

Fig. 27

- Take a correct position to the machine (Fig. 27). Hold the crank handle properly.
- Turn the crank handle with both hands slowly in direction of arrow until it engages.
- Turn the crank handle with increasing speed, until the engine starts.

i Note

The positive engagement between engine and crank handle must be ensured by powerful turning and should by no means be interrupted during the starting process.

When the decompression lever returns to initial position (after five revolutions) the highest speed must be reached.

i Note

If the engine does not start repeat the starting process.

In case of incorrect operation and repeated starting the decompression lever must always be returned to initial position.

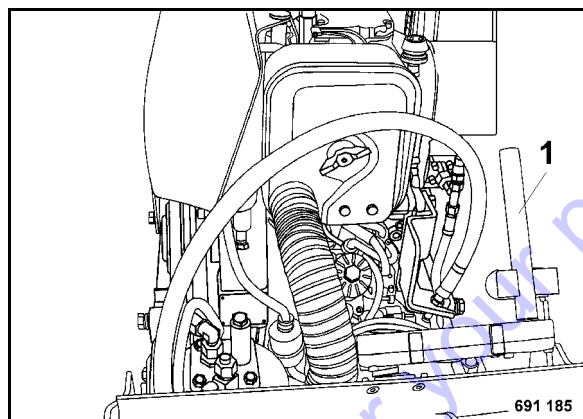

Fig. 28

- Hook the safety crank handle 1 (Fig. 28) back into the bracket.
- Close the plastic cover.

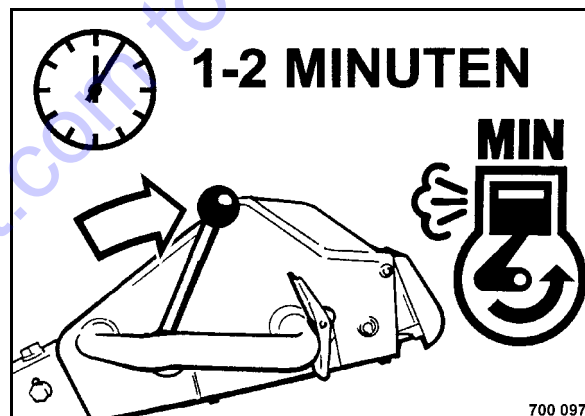

Fig. 29

- After starting take the throttle lever back to position "MIN" (Fig. 29).

i Note

Run the engine warm in idle speed for a short while before starting work.

Operation of the vibratory plate can be started as soon as the engine responds to short throttle commands.

4.8 Operation of Economizer

Meaning of display LEDs/self test

The display LEDs signalize the measuring value of the system. After the corresponding processing by the evaluation module, the display shows a measurement for the compaction of the soil. The number of lighting LEDs symbolizes the increasing compaction of the soil.

The measuring system is automatically started when switching on the machine. The system first of all runs a self test of the LED display.

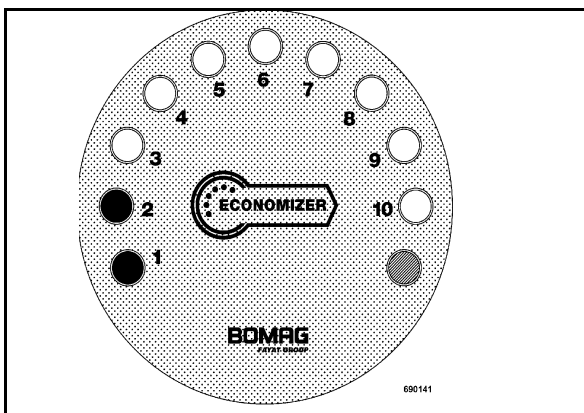

Fig. 30

Self test: the LEDs come on in individual steps from one to ten. Once all LEDs are on, the display goes out again in single steps.

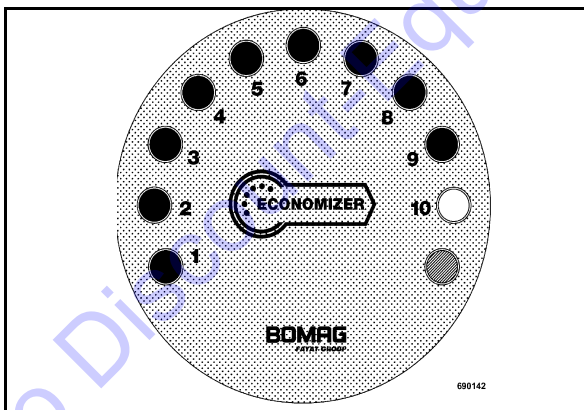

Fig. 31

After completion of the self test the system returns to measuring operation; the status LED (red) first of all lights permanently; this enables the detection of possibly existing system faults.

Notes on operation

- Display values higher during the first pass than during the second pass: the front rounded shape increases the contact area on loose material, a slightly higher measuring value may be displayed.
- The Economizer does not reach the maximum display value, even after many passes: due to different soil stiffness values the maximum value cannot be reached in each case.
- The display varies during a pass by one point up/down: caused by slight fluctuations in material composition and lift height, the mean value indicated during the last pass is decisive.
- The displayed value rises when changing the travel direction: the effective force applied to the soil by the vibratory plate rises when reversing the travel direction. Correct measuring values can only be achieved in forward and reverse travel with maximum speed.
- The display rises to the red section, while all yellow LEDs are on: this signalizes that the maximum possible compaction with this vibratory plate has been reached.
- When the red status LED is permanently on, but no other LED lights, the Economizer does not detect any vibration.
- The red status LED flashes, if the vibration frequency is too low. In order to obtain comparable Economized measuring values, the vibratory plate must work with a predetermined frequency. Measuring values obtained with low frequency cannot be compared with values obtained with high frequency.
- The displayed measuring values are not plausible: weak spots may also be located under the layer to be compacted and thus adversely affect compaction of the layers above. In unfavourable cases an excessively varying material composition or moisture can influence the measuring results.

i Note

*Check the sensor on the base plate for tight fit!
Both screws must be tight.*

- Influence of the water content in the soil on the Economizer: Display of reduced measuring values in case of too dry or too moist material.

- Influence of extension bars on the measuring value: Assembling or removing extension bars changes the contact area and the vibration amplitude. A generally valid statement about the influence on the measuring result cannot be made.
- The measuring values can at present not be saved and documented.

4.9 Work/operation

▲ Danger

Danger of accident!

Operate the machine only with the steering rod folded down.

Guide the machine only by the steering rod.

▲ Caution

Operate the vibratory plate only in one of the three possible engine speed positions, as otherwise the centrifugal clutch may burn.

For short breaks you should always return the throttle lever to idle speed position, this avoids premature wear of the centrifugal clutch.

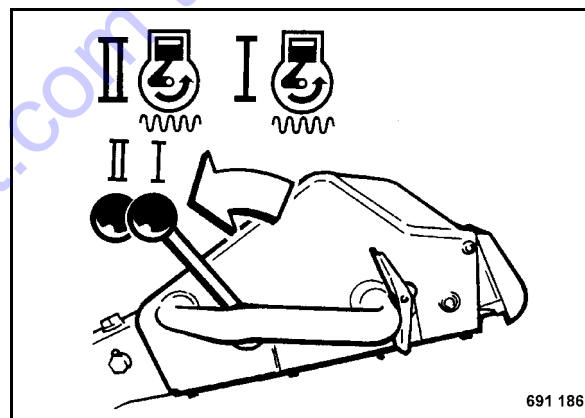

Fig. 32

- Set the throttle lever (Fig. 32) to one of the two possible vibration positions.

Drive forward

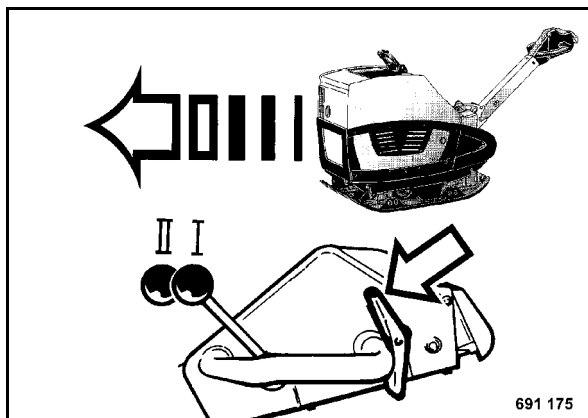

Fig. 33

- Press the upper part of the travel lever (tip switch) (Fig. 33), until the vibratory plate has reached the desired forward travel speed.

The machine drives with a speed which corresponds with the travel lever position.

i Note

The travel lever (tip switch) returns to middle position. The chosen forward speed is maintained.

Drive backwards

⚠ Danger

Danger of accident!

As a measure to avoid injury the machine must only be guided from the side by the steering handle

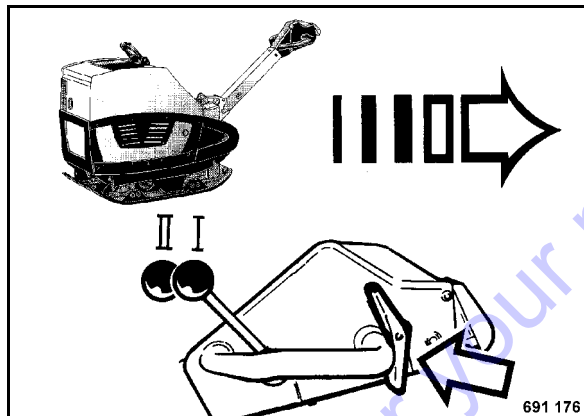

Fig. 34

- Press the upper part of the travel lever (tip switch) (Fig. 34), until the vibratory plate has reached the desired reverse travel speed.

The machine vibrates backwards with a speed which corresponds to the travel lever position.

i Note

The travel lever (tip switch) returns to middle position. The chosen backwards speed is maintained.

If the vibratory plate got stuck

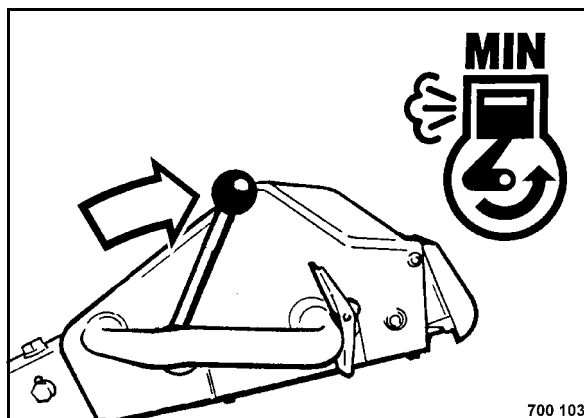

Fig. 35

- Set the throttle lever (Fig. 35) to position "MIN".
- Guide the vibratory plate by the steering rod in accordance the travel lever position, until it is free again.

4.10 Backup protection

▲ Danger

Danger of accident!

As a measure to avoid injury during backwards travel, the machine must only be guided from the side by the steering handle.

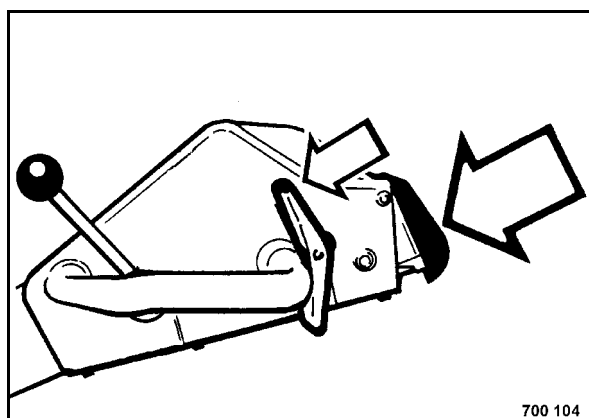

Fig. 36

- When actuating the reversing protection (Fig. 36), the travel lever (tip switch) switches over from backwards to forward travel.

4.11 Stopping the vibratory plate, shutting down the engine

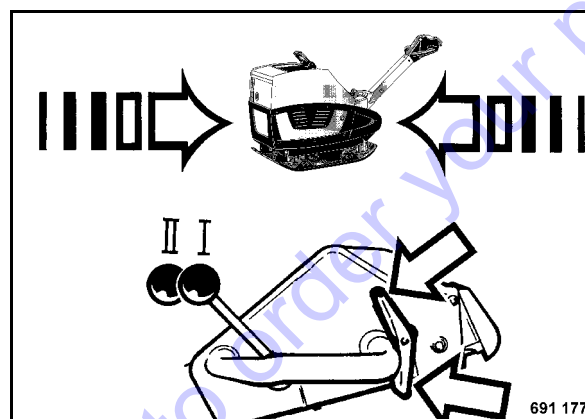

Fig. 37

- Operate the travel lever (tip switch) (Fig. 37), until the vibratory plate vibrates on the spot.

▲ Caution

Do not shut the engine down all of the sudden from full speed, but let it idle for a while for temperature equalization.

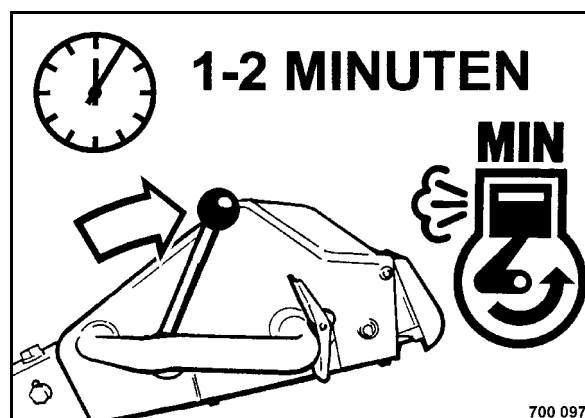

Fig. 38

- Shift the throttle lever to position "MIN" (Fig. 38) and let the engine run with idle speed for a short while.

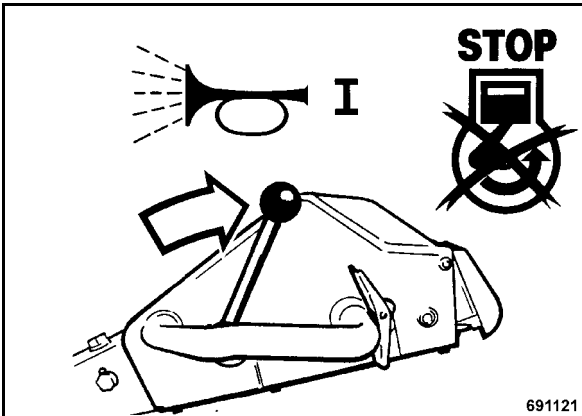

Fig. 39

- Set the throttle lever to position "STOP" (Fig. 39), the warning buzzer sounds.

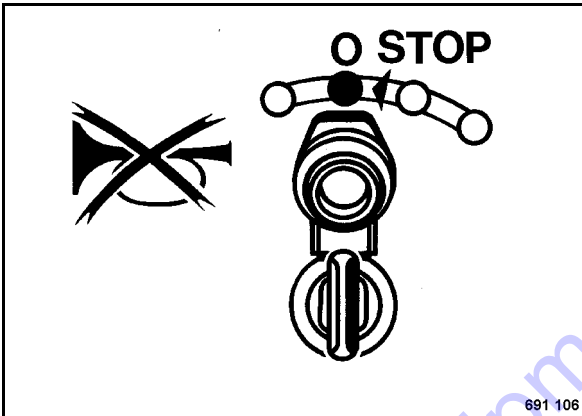

Fig. 40

- Turn the ignition key (Fig. 40) to position "0" and pull it out. The warning buzzer stops.

4.12 Loading

▲ Danger

Danger of accident!

Make sure that persons are not endangered by the machine tipping or sliding off.

Lash the machine down, so that it is secured against rolling, sliding and turning over.

For lifting the machine attach the lifting gear only to the lifting hook.

Check lifting eye for damage before use. Do not use a damaged or in any other way impaired lifting eye.

The machine must not swing about when being lifted.

Do not step or stand under suspended loads.

Use only safe lifting gear of sufficient load bearing capacity

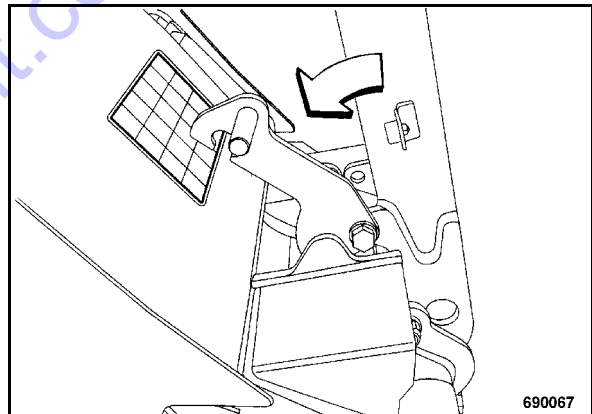

Fig. 41

- Adjust the steering rod upright and engage the locking lever (Fig. 41).

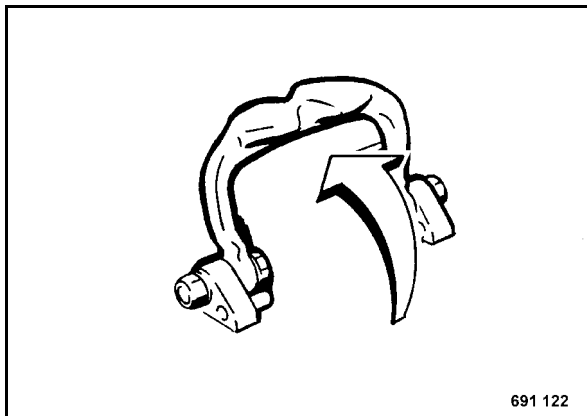

Fig. 42

- Fold the lifting hook (Fig. 42) up.

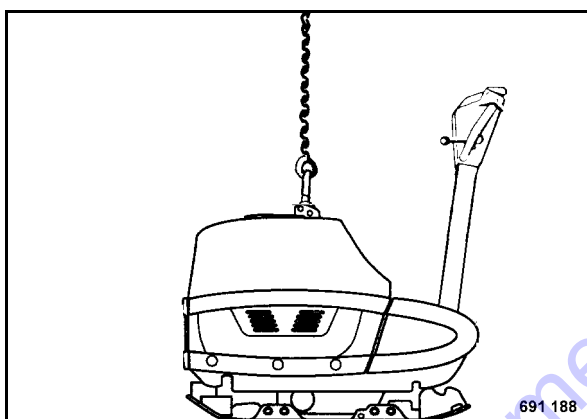

Fig. 43

- Always attach the lifting gear (rope) to the lifting eye to load the vibratory plate (Fig. 43) on a transport vehicle.

⚠ Danger

Danger of accident!

Minimum lifting capacity of lifting gear: see operating weight in chapter "Technical Data".

⚠ Danger

Danger of accident!

Tie the machine down on the transport vehicle, so that it is secured against slipping, sliding and turning over!

Go to Discount-Equipment.com to order your parts

5 Maintenance

Go to Discount-Equipment.com to order your parts

5.1 General notes on maintenance

When performing maintenance work ensure strict compliance with the respective safety instructions and particularly the safety regulations mentioned in chapter 2 of these operating and maintenance instructions.

Thorough maintenance of the machine guarantees far longer safe functioning of the machine and prolongs the lifetime of important components. The effort needed for this work is only little compared with the problems that may arise when not observing this rule.

- Always clean machine and engine thoroughly before starting maintenance work.
- For maintenance work stand the machine on level ground.
- Perform maintenance work only with the motor switched off.

Environment

During maintenance work catch all oils and fuels and do not let them seep into the ground or into the sewage system. Dispose of oils and fuels environmentally.

- Open the hood to perform maintenance work.

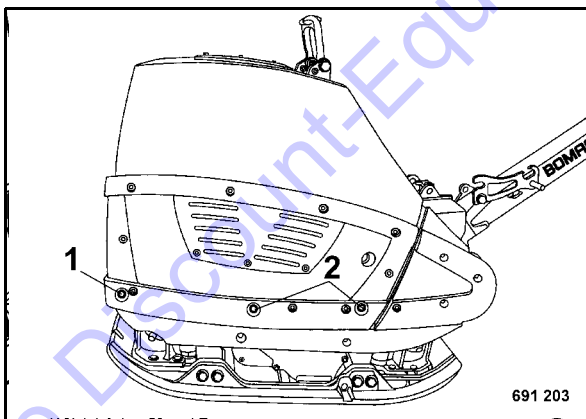

Fig. 44

- Loosen the hood fasteners (1) on both sides and remove the fasteners (2) from both sides (Fig. 44).
- Fold the hood back.

Notes on the fuel system

The lifetime of the diesel engine depends to a great extent on the cleanliness of the fuel.

- Keep fuel free of contaminants and water, since this will damage the injection elements of the engine.
- Drums with inside zinc lining are not suitable to store fuel.
- Keep used filters in a separate waste container and dispose of environmentally.
- The fuel drum must rest for a longer period of time before drawing off fuel.
- Under no circumstances must the drum be rolled to the tapping point just before drawing out fuel.
- When choosing the storage place for fuel make sure that spilled fuel will not harm the environment.
- Do not let the hose stir up the slurry at the bottom of the drum.
- Do not draw off fuel from near the bottom of the drum.
- The rest in the drum is not suitable for the engine and should only be used for cleaning purposes.

Notes on the performance of the engine

On diesel engines both combustion air and fuel injection quantities are thoroughly adapted to each other and determine power, temperature level and exhaust gas quality of the engine.

If your engine has to work permanently in "thin air" (at higher altitudes) and under full load, you should consult the customer service of BOMAG or the customer service of the engine manufacturer.

Frequent causes of faults

- Operating errors
- Incorrect, inadequate maintenance

If you cannot locate the cause of a fault or rectify it yourself by following the trouble shooting chart, you should contact the service departments at our branch offices or dealers.

5.2 Fuels and lubricants

Engine oil

Use winter grade engine oil for winter operation!

In order to assure perfect cold starting it is important to choose the viscosity (SAE-class) of the engine oil according to the ambient temperature.

For winter operation below -10°C the oil change intervals must be shortened.

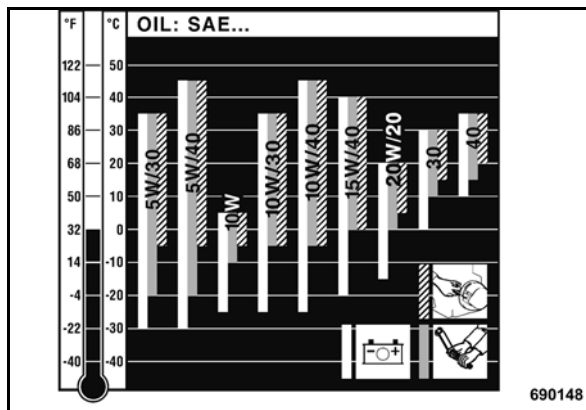

Fig. 45

Lubrication oil with a too high viscosity index causes starting difficulties, the temperature when starting the engine is therefore of highest importance when choosing the viscosity of engine oil for winter operation.

Oil viscosity

Since lubrication oil changes its viscosity with the temperature, the ambient temperature at the operating location of the engine is of utmost importance when choosing the viscosity class (SAE-class) (see diagram (Fig. 45)).

Occasionally falling short of the temperature limit will impair the cold starting ability, but will not cause any engine damage.

Temperature related lubrication oil changes can be avoided by using multi-purpose oils. The following oil change intervals apply also when using multi-purpose oils.

Oil quality

The API-classification is used to classify the oil quality.

The oil manufacturer is solely responsible for assigning a product to a certain quality class.

You should preferably use oils of API quality class CD/CE/CF/CF-4/CG-4 or higher, or ACEA B2/E2. When using oils of API-quality class CC/SE the oil change intervals must be shortened.

Lubrication oil change intervals

API: CD/ CE/CF/

CF-4/CG-4 = 250 operating hours

ACEA B2/E2 = 250 operating hours

i Note

When changing to a higher alloyed oil quality after a longer period of operation, it is recommended to perform the first oil change of the higher quality oil already after 25 operating hours.

⚠ Caution

The longest permissible time a lubrication oil should remain in an engine is 1 year.

Fuels

Quality

You should only use commercially available brand diesel fuel with a sulphur content below 0.5% and ensure strict cleanliness when filling in. A higher sulphur content has a negative effect on the oil change intervals. Use only winter-grade diesel fuel under low ambient temperatures. The fuel provision should always be topped up in due time, so that the tank will not run dry.

The following fuel specifications are permitted:

EN 590 DIN 51601; Nato Codes F-54, F-75, F-76;

BS 2869: A1 and A2; ASTM D 975-78:

1-D and 2-D; VV-F-800 a: DF-A, DF-1 and DF-2.

Winter fuel

For winter operation use only winter diesel fuel, to avoid clogging because of paraffin separation. At very low temperatures disturbing paraffin separation can also be expected when using winter diesel fuel.

Mineral oil based hydraulic oil

The hydraulic system is operated with hydraulic oil HV 32 (ISO) with a kinematic viscosity of $32 \text{ mm}^2/\text{s}$ at 40°C . For topping up or for oil changes use only high-quality hydraulic oil, type HVLP according to DIN 51524, part 3, or hydraulic oils type HV

Maintenance

according to ISO 6743/3. The viscosity index (VI) must be at least 150. (Observe the information of the manufacturer).

Go to Discount-Equipment.com to order your parts

5.3 Table of fuels and lubricants

Assembly	Fuel or lubricant		Quantity approx.
	Summer	Winter	Attention Observe the level marks
Engine - Engine oil	API CD/CE/CF/CF-4/CG-4 SAE 5W/30 (-5 °C to +35 °C) SAE 5W/40 (-5 °C to +45 °C) SAE 10W/30 (-5 °C to +35 °C) SAE 10W/40 (-5 °C to +45 °C) SAE 10W/40 (0 °C to +40 °C)		1.9 l
- Fuel	SAE 30 (+15 °C to +30 °C) SAE 40 (+20 °C to +35 °C)	SAE 10W(-5 °C to +5 °C) Winter diesel fuel (-12 °C) (+10.4 °F)	10 l
Vibrator shaft housing	as engine oil		0.6 l
Hydraulic system	Hydraulic oil (ISO), HV32, kinem. viscosity 32mm ² /s at 40°C		approx. 2.3 l

5.4 Running-in instructions

The following maintenance work must be performed when running in new machines or overhauled engines:

 **Caution**

During the running-in period, up to approx. 200 operating hours, check the engine oil level twice every day.

Depending on the load the engine is subjected to, the oil consumption will drop to the normal level after approx. 100 to 200 operating hours.

After 25 operating hours

- Change the engine oil.
- Check engine and machine for leaks.
- Check the valve clearance, adjust if necessary
- Retighten the fastening screws on air filter exhaust, fuel tank and other attachments.
- Retighten the bolted connections on the machine.
- Check the vibration drive V-belts.
- Check the oil level in the vibrator housing.

5.5 Maintenance table

No.	Maintenance work	Comment	daily	monthly	half-annually	annually	every 2 years	as required
5.6	Clean the machine		X					
5.7	Check the engine oil level	Dipstick mark	X					
5.8	Check the fuel level		X					
5.9	Check the hydraulic oil level	Inspection glass	X					
5.10	Check the air filter service indicator	Rubber spout	X					
5.11	Clean the cooling fins and the cooling air intake openings			X				
5.12	Drain the sludge from the fuel tank			X				
5.13	Check condition of battery, grease poles				X			
5.14	Check, adjust the valve clearance				X			
5.15	Check the oil level in the exciter housing				X			
5.16	Change the engine oil	at least every 250 operating hours				X		
5.17	Change the engine oil filter	at least every 250 operating hours				X		
5.18	Changing the fuel filter					X		
5.19	Change the oil in the exciter shaft housing	at least every 500 operating hours				X		
5.20	Check the rubber buffers					X		
5.21	Check the V-belt tension, if necessary replace the V-belt					X		
5.22	Change hydraulic oil and filter	at least every 500 operating hours					X	
5.23	Check, clean the dry air filter	renew min. 1 x year						X
5.24	Tighten all bolted connections							X
5.25	Engine conservation							X

Go to Discount-Equipment.com to order your parts

5.6 Cleaning the machine

Caution

Perform cleaning work only after the engine has cooled down and with the engine stopped.

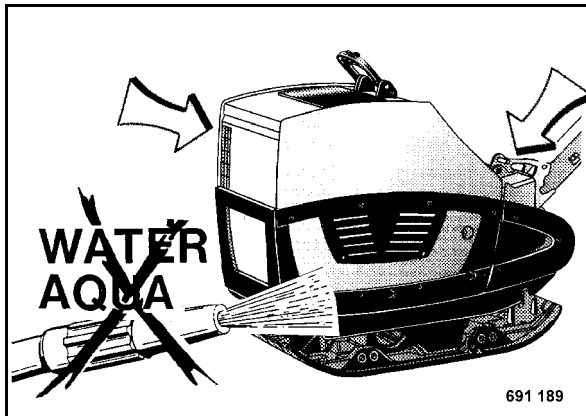

Fig. 46

Caution

Do not guide the water jet directly into the dry air filter intake opening (Fig. 46) and into the opening for the crank handle. Cover the electric equipment against the direct water jet.

- After wet cleaning run the engine warm to evaporate all water residues and to avoid corrosion.

5.7 Check the engine oil level

Note

Park the machine on level ground so that the engine is in horizontal position.

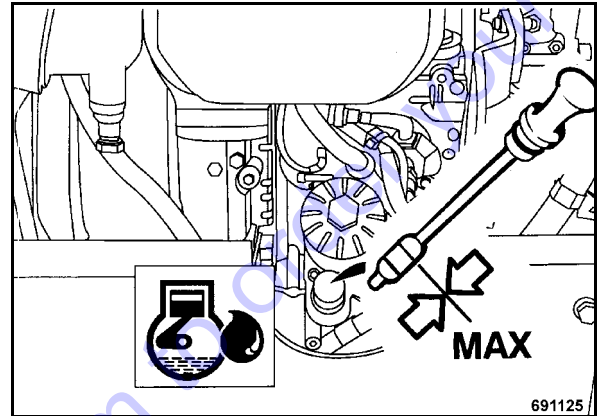

Fig. 47

- Shut down the engine.
- Open the rear rubber cover.
- Pull the dipstick (Fig. 47) out, wipe it off with a lint-free, clean cloth and reinsert it until it bottoms.
- Pull the dipstick back out again.
- The oil level should reach the upper mark on the dipstick.
- If the oil level is too low top up oil immediately.

For quality of oil refer to the table of fuels and lubricants.

- After a running time of approx. 1 min. shut own the engine, wait until all engine oil has run down and check the oil level.

5.8 Checking the fuel level

⚠ Danger

Fire hazard!

When working on the fuel system do not use open fire, do not smoke.

Do not refuel in closed rooms.

Refuel only with the engine stopped.

Do not inhale any fuel fumes.

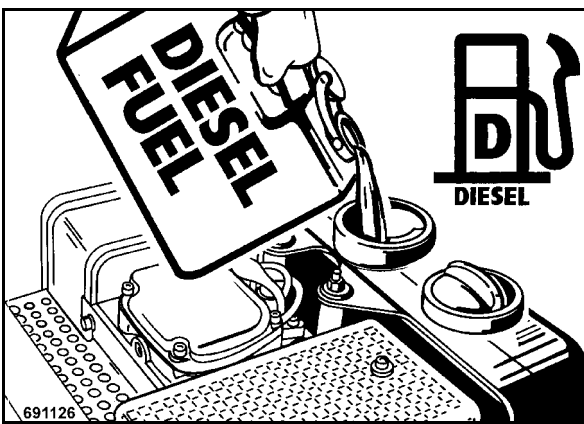

Fig. 48

- Clean the area around the fuel filler neck.
- Open the fuel filler cap and check the fuel level visually.

⚠ Caution

Contaminated fuel can cause malfunction or even damage of the engine.

- If necessary fill in fuel through a funnel with filter screen (Fig. 48).

For quality of fuel refer to the table of fuels and lubricants.

- Close the fuel tank again tightly.

i Note

If the tank was completely empty the mechanical oil pressure monitoring device must be activated. See section "Operating the low oil level safety device"

5.9 Check the hydraulic oil level

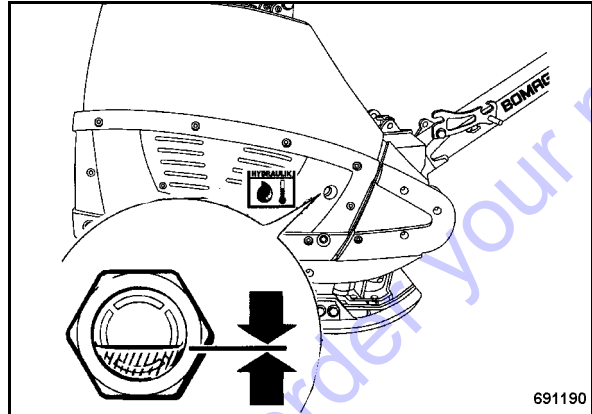

Fig. 49

- Check the oil level in the inspection glass (Fig. 49).

i Note

At room temperature of approx. 20°C the hydraulic oil level should reach approx. the middle of the inspection glass.

Minimum level 1/3 of inspection glass.

⚠ Caution

If, during the daily inspection of the oil level the hydraulic oil level is found to have dropped, check all lines, hoses and components for leaks.

- Top up hydraulic oil, if necessary.

For quality of oil refer to the table of fuels and lubricants.

5.10 Checking the air filter service indicator

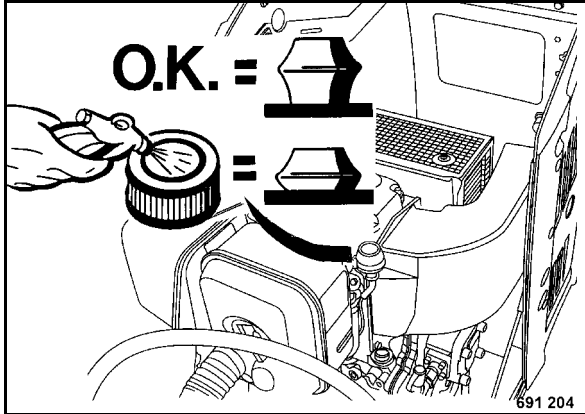

Fig. 50

- Accelerate the engine for a short while to full speed.

i Note

normal rubber bellows = dry air filter o.k. (Fig. 50).

contracted rubber bellows = clean dry air filter.

- Before cleaning pull the rubber bellows up and start the engine.

i Note

If the rubber bellows is contracted again clean the dry air filter.

Under very dusty conditions check the rubber bellows several times every day.

Go to Discount-Equipment.com to order your parts

5.11 Clean the cooling fins and the cooling air intake openings

⚠ Caution

Dirty operating conditions, particularly lubrication oil and fuel deposits on the cooling fins of the engine and the cooling air intake opening have an adverse effect on the cooling of the engine.

You should therefore immediately seal any oil or fuel leaks near fuel tank, cylinder or cooling air intake.

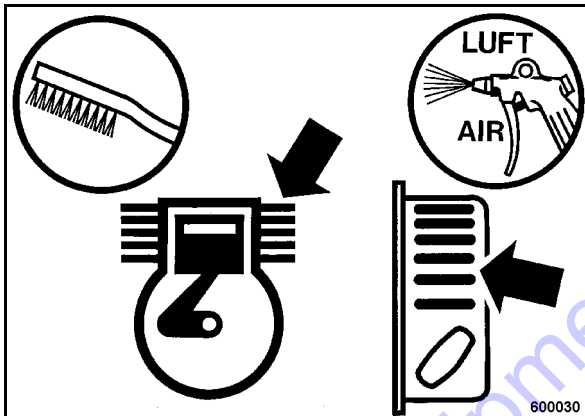

Fig. 51

- Loosen dried on dirt with a suitable brush (Fig. 51) from all cooling fins and cooling air intake openings and blow it off with compressed air.

⚠ Danger

Fire hazard!

Do not use any inflammable solvents.

⚠ Caution

Do not guide the water jet directly into the cooling air openings of the recoil starter, into the dry air filter and on electrical equipment.

- On a oil contaminated engine use a cold cleansing agent for cleaning.

- After a sufficient soaking time clean off with a water or steam jet and blow out with compressed air.
- Run the engine warm for a while to avoid corrosion.

⚠ Caution

Look for the cause of oily contamination and have any leaks sealed by the customer service of BOMAG.

5.12 Draining the sludge from the fuel tank

⚠ Danger

Fire hazard!

When working on the fuel system do not use open fire, do not smoke.

Do not inhale any fuel fumes.

Do not spill any fuel.

♻ Environment

Catch running out fuel and dispose of environmentally.

i Note

For this work the fuel tank should contain only a little quantity of fuel.

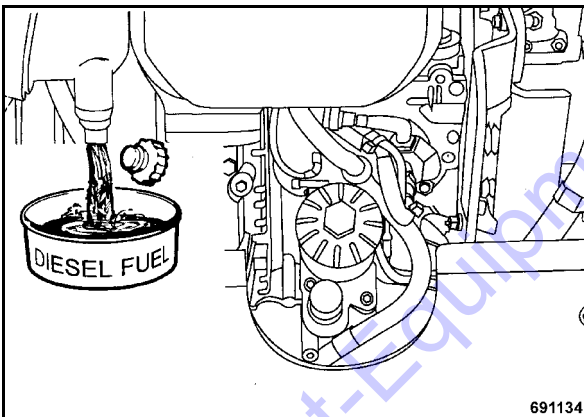

Fig. 52

- Unscrew the drain plug (Fig. 52) underneath the fuel tank, drain off fuel and catch it.
- Once all fuel has run out screw the oil drain plug back in with a new seal ring.

i Note

If the tank was completely empty the mechanical oil pressure monitoring device must be activated. See section "Operating the low oil level safety device"

5.13 Check the battery condition, grease the poles

⚠ Danger

Danger of burning!

When working on the battery do not use open fire, do not smoke!

Do not let acid come in contact with skin or clothes!

Wear safety goggles!

Do not lay any tools on the battery!

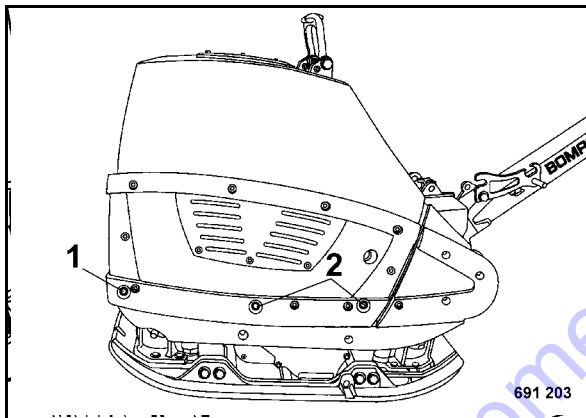

Fig. 53

- Loosen the hood fastening screws (1) on both sides and remove the hood fastening screws (2) on both sides (Fig. 53).
- Fold the hood back to open.

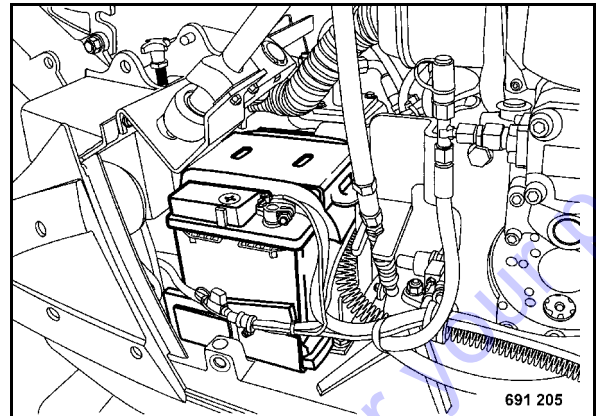

Fig. 54

- Unscrew the battery holder (Fig. 54).
- Remove the vibration damper mat.

Non-maintenance free batteries:

- Clean battery and battery compartment.
- Open plugs and check the acid level.

With control inserts:

- Check whether the acid level reaches the bottom end of the control inserts.

With transparent battery housing:

- Check whether the acid level reaches the level mark on the housing.

Maintenance free batteries:

- Clean the battery
- Grease the poles
- Tighten the terminal clamps

Environment

Dispose of the old batteries environmentally.

⚠ Danger

Development of gas!

For recharging remove the plugs from the battery to avoid the accumulation of highly explosive gases.

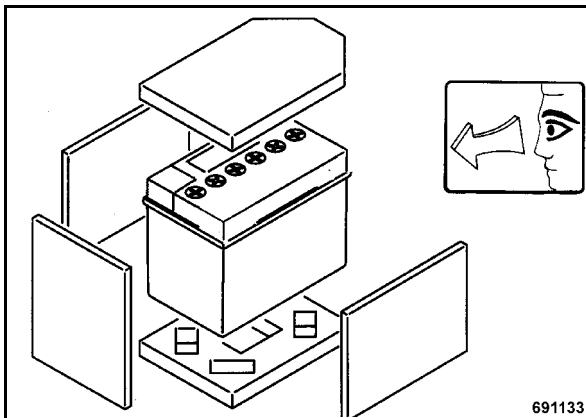

Fig. 55

- Clean the condition of the vibration insulation mats, replace if necessary (Fig. 55).
- Retighten the battery holder.

⚠ Caution

Reinstall the battery compartment cover.

5.14 Check, adjust the valve clearance

⚠ Caution

Check and adjust only when the engine is cold.

The gasket for the cylinder head cover must be generally renewed.

Checking the valve clearance

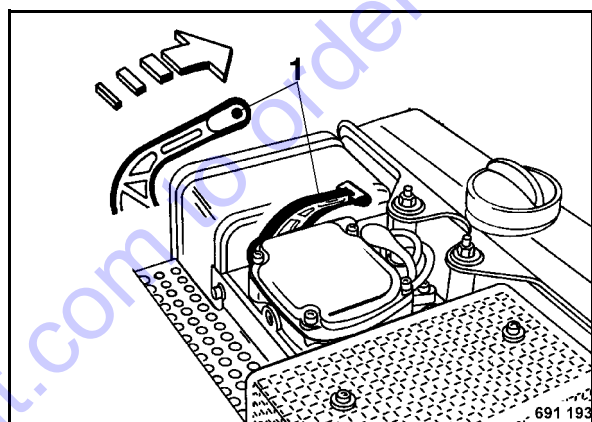

Fig. 56

- Decompression lever 1 (Fig. 56) must be initial position.

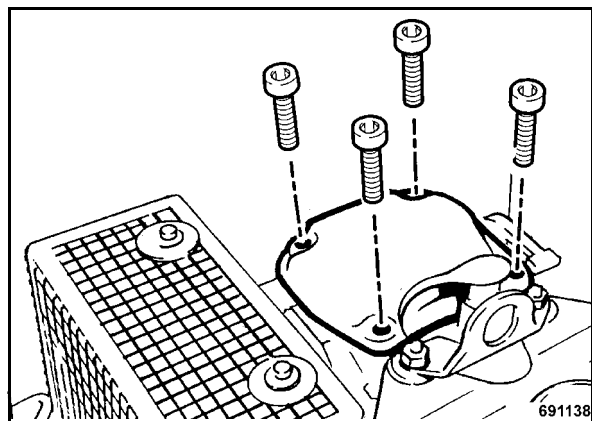

Fig. 57

- Turn the engine in correct direction, until compression resistance can be felt.
- Disassemble the valve cover (Fig. 57).

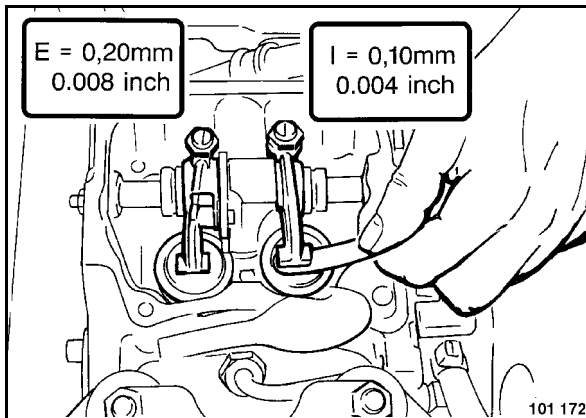

Fig. 58

- Check the valve clearance with a feeler gauge on both valves (Fig. 58).

Nominal value:

Intake valve (I) 0.10 mm (0.004 inch)

Exhaust valve (E) 0.20 mm (0,008 inch)

Adjusting the valve clearance

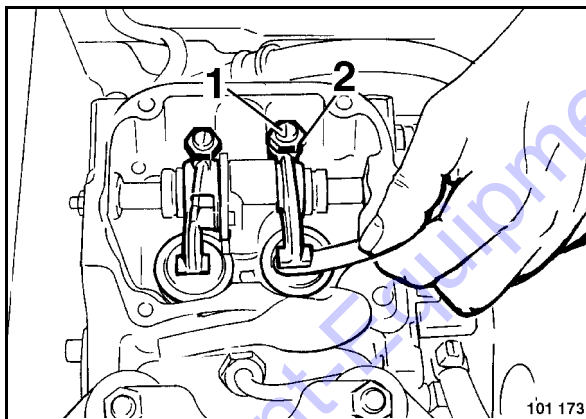

Fig. 59

- Slightly slacken the counter nut 2 (Fig. 59).
- Adjust setscrew (1) with a screwdriver, until the feeler gauge can be inserted and pulled out with little resistance after retightening the counter nut.
- Assemble the cylinder head cover with a new gasket.
- After a short test run check the valve cover for leaks.

5.15 Check the oil level in the vibrator housing

i Note

Park the machine on level ground.

- Clean the area around the level plug.
- Unscrew vent plug (2).

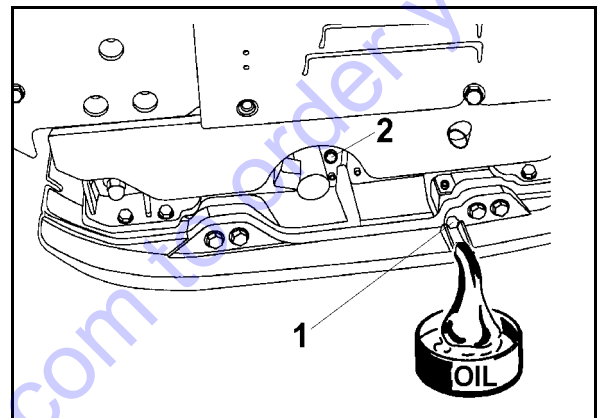

Fig. 60

- Unscrew oil level inspection plug 1 (Fig. 60) and check the oil level.
- The oil level must reach the bottom edge of the level bore, fill in oil if necessary.

For quality and quantity of oil refer to the table of fuels and lubricants.

- Clean level plug (1) and screw in with Omnifit FD 10 BOMAG PIN 00970016.
- Screw vent plug (2) tightly back in.

Go to Discount-Equipment.com to order your parts

5.16 Changing the engine oil

▲ Danger

Danger of scalding!

When draining off hot oil.

♻ Environment

Environmental damage!

Catch old oil and dispose of environmentally.

i Note

Drain the engine oil only when the engine is warm.

Replace the engine oil filter with every oil change.

- Park the machine on level ground so that the engine is in horizontal position.

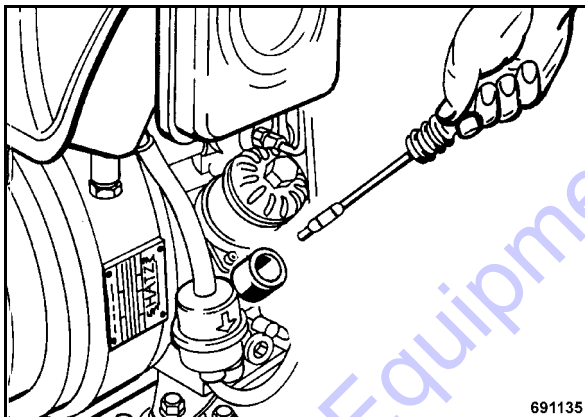

Fig. 61

- Pull the dipstick (Fig. 61) out.

i Note

Clean the drain hose from dust and dirt.

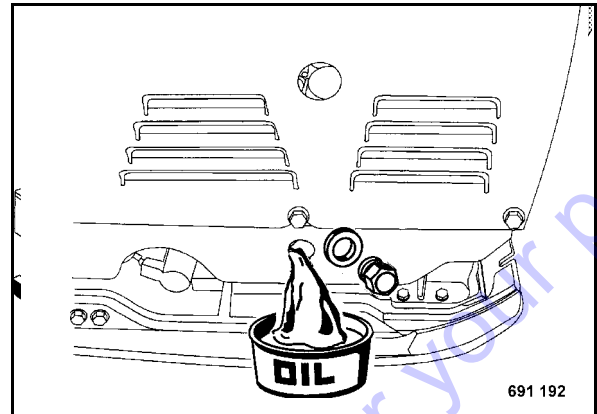

Fig. 62

- Unscrew the drain plug (Fig. 62) and catch running out old oil.
- Clean the drain plug and screw it back in with a new seal ring.

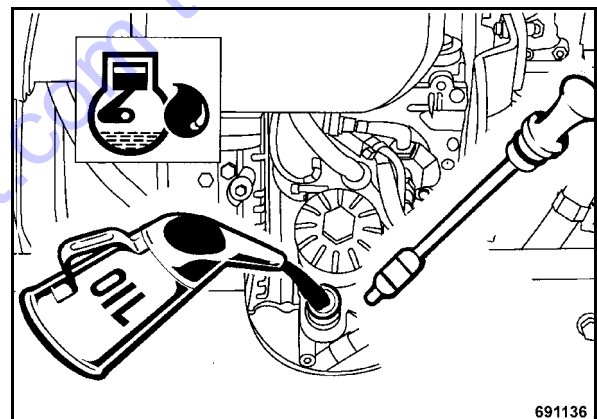

Fig. 63

- Fill in fresh engine oil through the filler opening (Fig. 63).

For quality and quantity of oil refer to the table of fuels and lubricants.

- Push the dipstick back in.

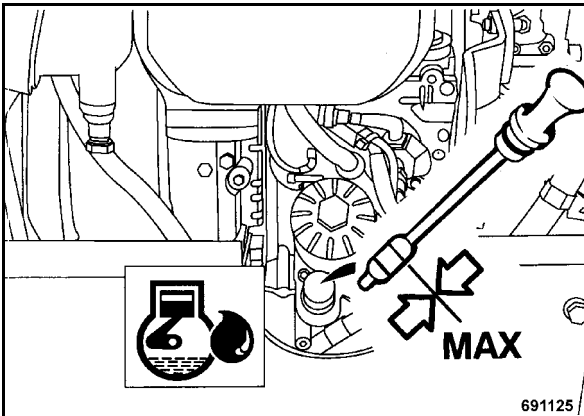

Fig. 64

- After a short test run check the oil level on the dipstick (Fig. 64). The oil level should reach the top level mark, top up oil if necessary.

5.17 Changing the engine oil filter

⚠ Danger

Danger of scalding!

Hot oil when changing the engine oil filter.

♻ Environment

Catch running out oil and dispose of environmentally together with the engine oil filter cartridge.

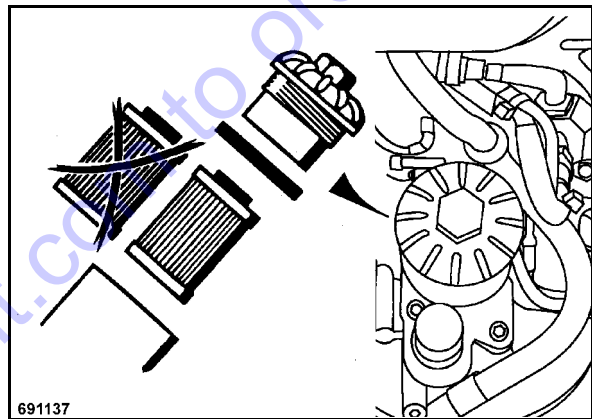

Fig. 65

- Unscrew the cover (Fig. 65).
- Wipe the sealing face on the engine clean.
- Insert the new filter cartridge with the recess facing downwards.
- Check the seal ring in the cover.
- Screw the cover back in oil tight.
- Perform a short test run and inspect the engine for leaks and check the oil level, top up oil if necessary.

5.18 Changing the fuel filter

⚠ Danger

Fire hazard!

When working on the fuel system do not use open fire, do not smoke.

Do not spill any fuel.

Do not inhale any fuel fumes.

♻ Environment

Catch running out fuel and dispose of environmentally together with the fuel filter.

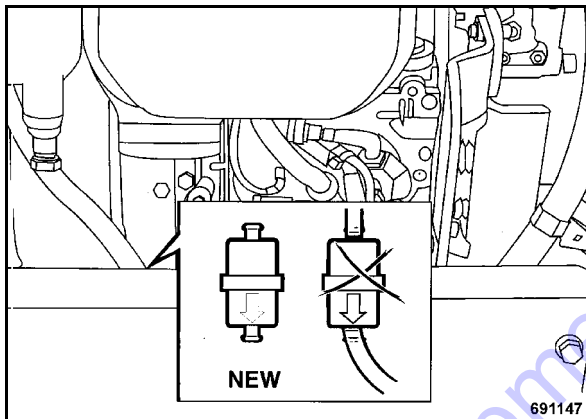

Fig. 66

- Pull the fuel filter (Fig. 66) out of the top and bottom hoses.

i Note

In case of contamination drain off and catch the sludge from the fuel tank, flush out with clean diesel fuel.

- Install the new fuel filter by observing the flow direction.
- Fill the fuel tank again.

i Note

If the tank was completely empty the mechanical oil pressure monitoring device must be activated. See section "Operating the low oil level safety device".

5.19 Change the oil in the exciter shaft housing

♻ Environment

Catch running out old oil, do not let it seep into the ground and dispose off environmentally.

- Clean the area around the level plug.

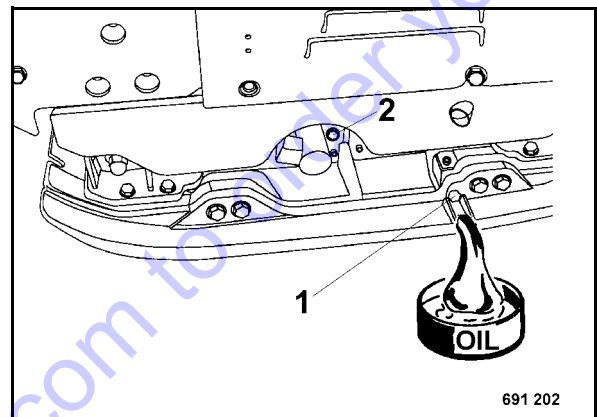

Fig. 67

- Unscrew fastening screws 1 (Fig. 67).
- Unscrew vent plug (2).
- Park the machine under a slight lateral angle and catch the oil.

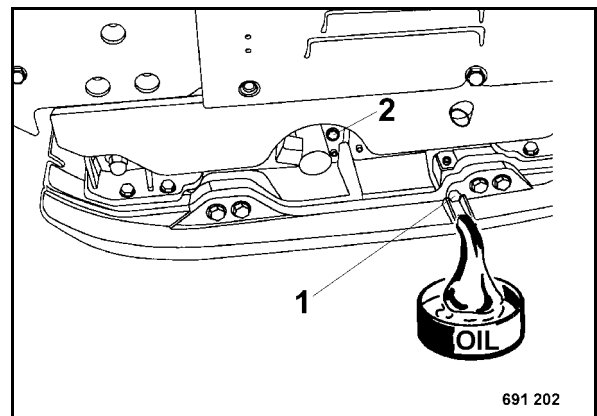

Fig. 68

- Fill in new oil through the oil level inspection bore (Fig. 68), for this purpose park the machine on a slant.

Maintenance every year

i Note

With the machine stopped the oil level must reach the bottom edge of the inspection plug .

For quality and quantity of oil refer to the table of fuels and lubricants.

- Clean level plug (1) and screw in with Omnifit FD 10 BOMAG PIN 00970016.
- Screw vent plug (2) tightly back in.

5.20 Check the rubber buffers

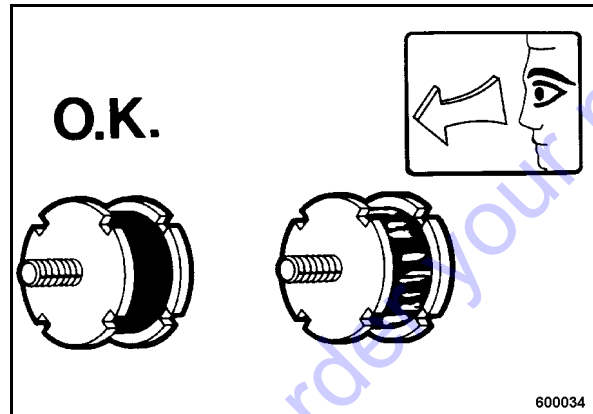

Fig. 69

- Check all rubber buffers (Fig. 69) for tight fit, cracks and damage and replace immediately if damaged.

5.21 Check the V-belt tension, if necessary replace the V-belt

Checking the V-belt

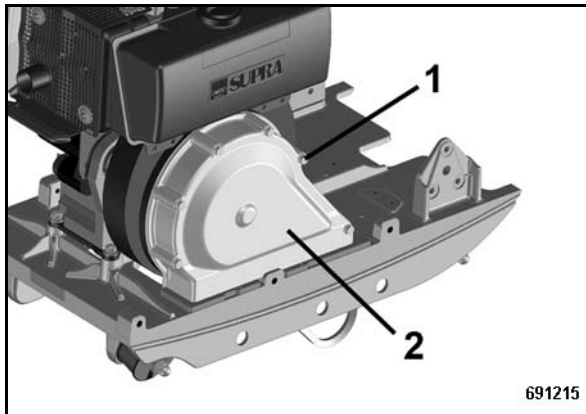

Fig. 70

- Unscrew fastening screws (1) (Fig. 70) for the cover and take off cover (2).

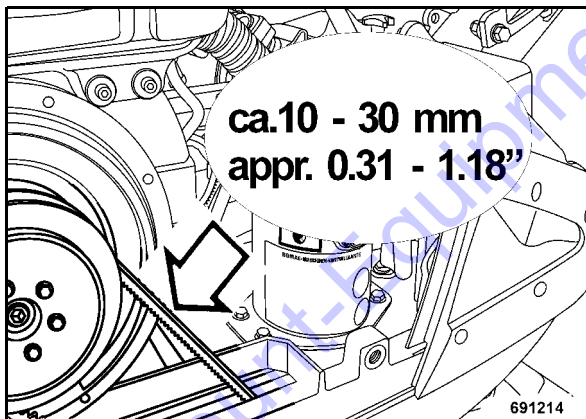

Fig. 71

- Check condition and tightness of V-belt (Fig. 71).

i Note

Compression measurement approx. 10 - 30 mm.

⚠ Caution

Replace a damaged V-belt.

The V-belt cannot be tightened manually. Always replace the V-belt, if the compression measurement is exceeded.

Changing the V-belt

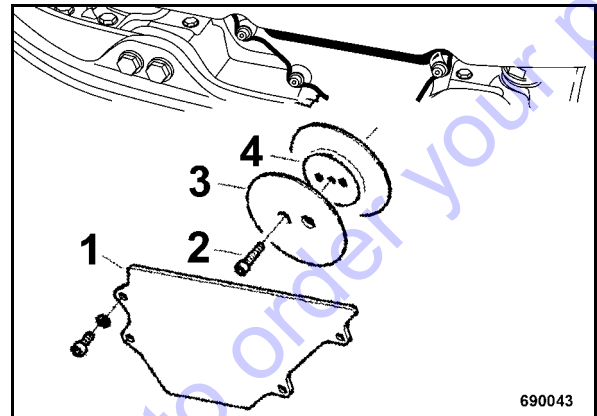

Fig. 72

- Disassemble the safety cover (1) (Fig. 72).
- Loosen the screws (2) and take off the V-belt pulley (3).
- Install the new V-belt.
- Fasten the V-belt pulley and assemble the guard.
- Assemble the cover (2) (Fig. 70).

Maintenance every year

Go to Discount-Equipment.com to order your parts

5.22 Change hydraulic oil and filter

⚠ Danger

Danger of scalding!

Danger of scalding by hot oil.

⚠ Caution

Park the machine on level ground.

Drain off hydraulic oil at operating temperature.

Replace the hydraulic oil filter with every hydraulic oil change.

Change the hydraulic oil at least every 2 years.

For quality and quantity of oil refer to the "table of fuels and lubricants".

♻ Environment

Catch running out oil and dispose of environmentally together with the filter.

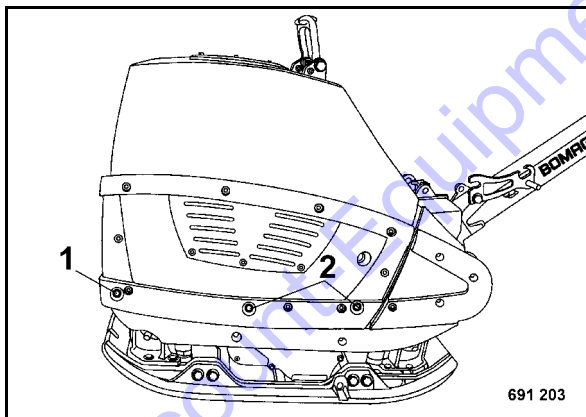

Fig. 73

- Loosen the engine hood fastening (1) (Fig. 73) on both sides and remove the hood fastenings on both sides.
- Fold the engine hood open

Changing the breather filter

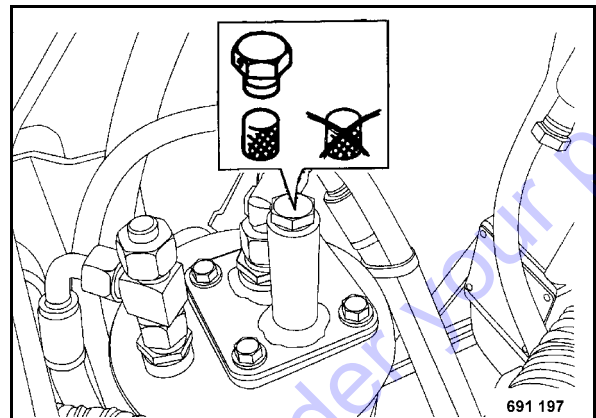

Fig. 74

- Clean the hydraulic oil tank and the area around it.
- Unscrew the plug and take out the breather filter plug (Fig. 74).
- Clean the through bore in the plug.
- Insert a new breather filter plug and screw the plug tightly back in.

Changing hydraulic oil and filter

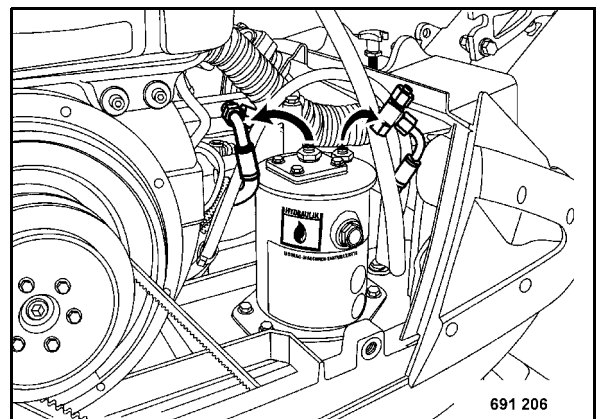

Fig. 75

- Disconnect the connecting hoses (Fig. 75).

Maintenance every 2 years

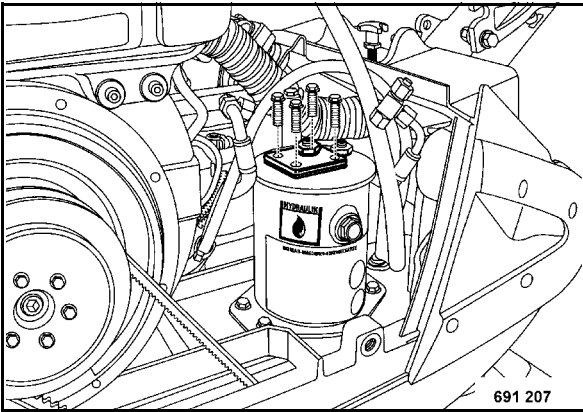

Fig. 76

- Disconnect the connecting flange (Fig. 76).

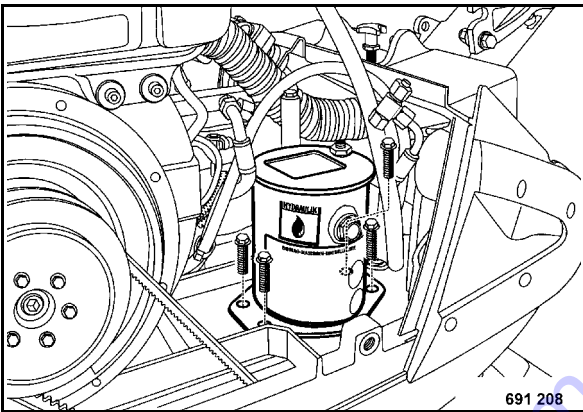

Fig. 77

- Unscrew and empty the hydraulic tank (Fig. 77).
- Reinstall the hydraulic tank after it has been emptied.

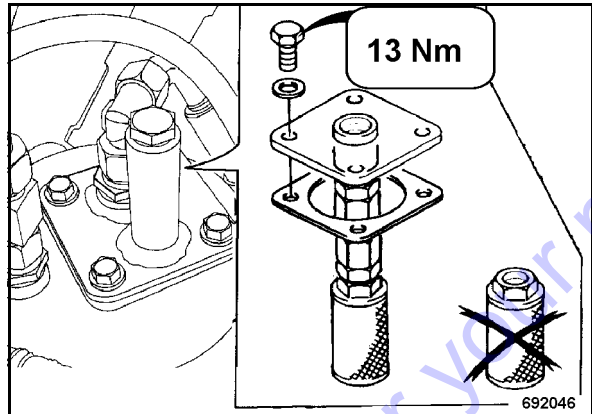

Fig. 78

- Fasten the connecting flange (Fig. 78) with a new gasket on the hydraulic oil tank, tightening torque: 13 Nm.

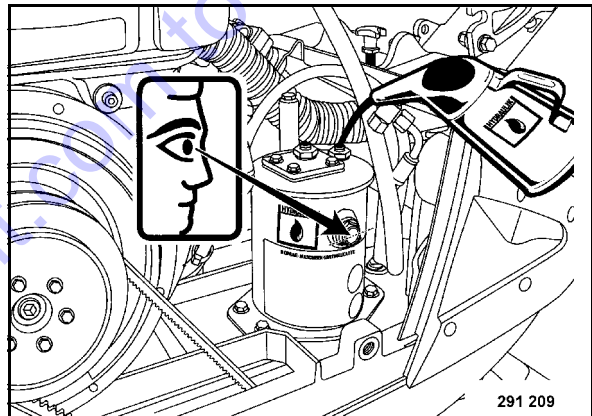

Fig. 79

- Fill in new hydraulic oil (Fig. 79).
- Check the oil level in the inspection glass, top up if necessary.

Nominal value: Middle of inspection glass

- Screw in the filler plug.
- Reconnect the connecting hoses.

5.23 Check, clean the dry air filter

⚠ Caution

Do not use gasoline or hot fluids to clean the filter cartridge.

Dry air filter cartridges with damaged filter element or seal ring must be replaced in any case. It is therefore recommended to keep at least one filter element in stock.

The dry air filter element must be changed after several times cleaning, but at the latest after 1 year.

Each cleaning interval must be marked with a cross on the filter element.

Cleaning does not make sense if the cartridge is covered with a sooty deposit. Use a new filter cartridge.

Incorrectly handled filter cartridges may become ineffective because of damage (e.g. cracks) and cause damage to the engine.

In case of wet or oily dirt replace the filter element.

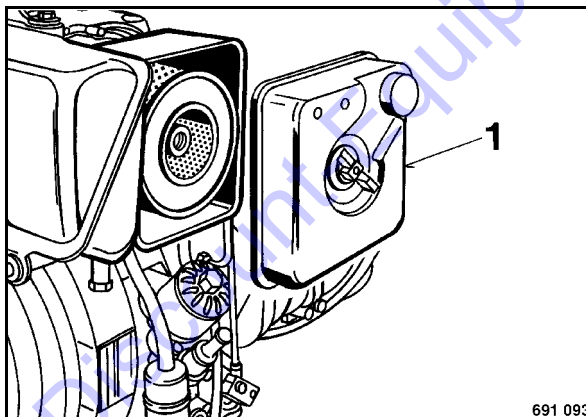

Fig. 80

- Unscrew the wing nut for cover (1) (Fig. 80) and take off the cover.
- Pull out the filter cartridge.

⚠ Danger

Eye injury!

Wear protective clothing (goggles, gloves)

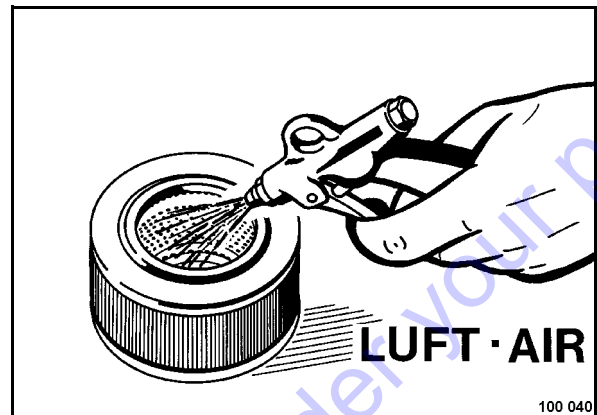

Fig. 81

- Blow the filter cartridge out from inside to outside with dry compressed air (max. 5 bar) (Fig. 81).
- Hold the filter cartridge under an angle to the light or examine it with a lamp for cracks or other signs of damage.

⚠ Caution

The filter cartridge must be replaced if the slightest damage on filter paper or seal lips is found.

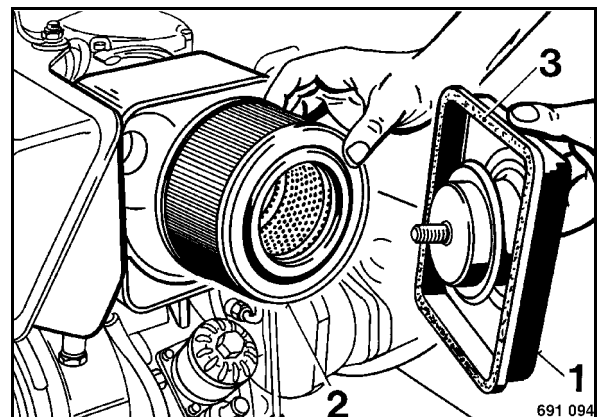

Fig. 82

- Insert the filter cartridge (2) (Fig. 82).
- Check the sealing face (3) on the housing.
- Attach the cover (1) and tighten it with the wing screws.

i Note

When tightening the cover do not damage the seal on the filter housing.

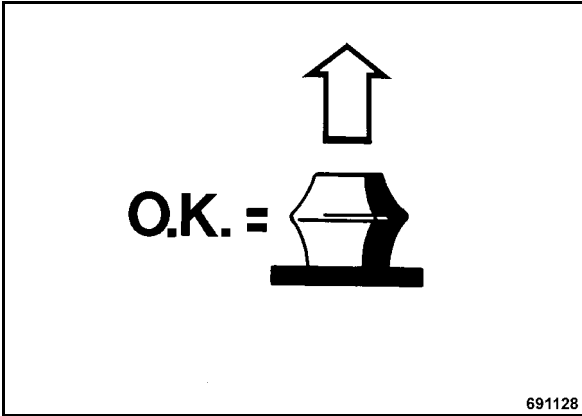

Fig. 83

- Check the air filter service indicator (Fig. 83).

5.24 Tightening the screws

i Note

Self locking nuts must always be replaced by new ones after they have been unscrewed.

Bolt dimensions	Tightening torques* ft - lb		
	8.8	10.9	12.9
M4	2	3	4
M5	4	7	7
M6	7	11	13
M8	18	26	33
M10	37	55	61
M12	65	91	108
M14	101	145	173
M16	156	221	264
M18	213	303	361
M20	304	426	513
M22	413	559	695
M24	524	738	885
M27	774	1092	1308
M30	1047	1482	1770

Fig. 84

*Strength classes for screws with untreated, non-lubricated surfaces. The quality designations are stamped on the screw heads.

8.8 = 8 G

10.9 = 10 K

12.9 = 12 K

The values result in a 90% utilization of the screw's yielding point at a coefficient of friction of $\mu_{\text{total}} = 0.14$.

The compliance with the tightening torques is to be checked with torque wrenches.

The tightening torques are not applicable when using MoS₂ lubricants.

5.25 Engine conservation

If the engine is to be shut down for a longer period of time (e.g. over winter), we recommend the following measures to avoid corrosion:

- Clean engine and cooling system: With cold cleansing agent and water jet or, even better, with steam cleaning equipment.
- Run the engine warm and shut it down.
- Drain the still warm engine oil and fill in anti-corrosion engine oil.
- Drain and catch the fuel from the fuel tank, mix it well with 10% anti-corrosion oil and fill it back in. Instead of mixing the fuel with anti-corrosion oil you may also fill the tank with injection pump testing oil with anti-corrosive properties (e.g. Calibration fluid B).
- Then run the engine for 10 minutes, so that lines, filter, pump and nozzles are filled with the conserving mixture and the new engine oil is distributed to all parts.
- Take the cylinder head cover off, spray the rocker chamber with a mixture of diesel fuel and 10% anti-corrosion oil. Then fasten the cover again.
- Crank the engine several times to spray the combustion chamber (throttle lever in stop position).
- Take the V-belt off and spray the grooves of the V-belt pulleys with anti-corrosion oil. Remove the anti-corrosion oil before taking the machine back into service.
- Close air intake on air filter and exhaust opening tightly.

i Note

Depending on weather conditions these conservation measures will protect the machine for approx. 6 to 12 months.

Before taking the machine back into service you must drain off the conservation oil and replace it with engine oil (see table of fuels and lubricants) according to API-(MIL-) classification.

Anti-corrosion oils are all oils which comply with the specification MIL-L-21260 B or TL 9150-037/2 o Nato Code C640/642.

⚠ Caution

A machine with conserved engine must be clearly marked by attaching a clear warning label.

Go to Discount-Equipment.com to order your parts

6 Trouble shooting

Go to Discount-Equipment.com to order your parts

6.1 General notes

The following work must only be carried out by qualified and trained personnel or by the BOMAG sales service.

Strictly observe the safety regulations.

Malfunctions are frequently caused by incorrect operation of the machine or insufficient maintenance. Whenever a fault occurs you should therefore thoroughly read these instruction on correct operation and maintenance. If you cannot locate the cause of a fault or rectify it yourself by following the trouble shooting chart, you should contact the service departments at our branch offices or dealers.

On the following pages you will find a selection of fault remedies. It goes without saying that not all possible reasons for faults could be listed.

Go to Discount-Equipment.com to order your parts

6.2 Engine problems

Fault	Possible cause	Remedy
Engine does not start or does not start immediately, but can be cranked with the crank handle	<p>Throttle lever in stop or idle speed position</p> <p>no fuel at the injection pump</p> <p>insufficient compression:</p> <ul style="list-style-type: none"> - incorrect valve clearance - Valves worn - Wear on cylinder or piston rings <p>Injection nozzle out of order</p>	<p>Shift the lever to "Start" position</p> <p>Fill in fuel</p> <p>check the entire fuel system systematically.</p> <p>If no result:</p> <ul style="list-style-type: none"> - check supply to engine - check fuel filter - check function of fuel lift pump <p>Check valve clearance, correct if necessary</p> <p>see shop manual</p> <p>see shop manual</p> <p>see shop manual</p>
additionally on engines with mechanical oil pressure monitoring	no oil pressure	<p>Check oil level</p> <p>Activate mechanical oil pressure monitoring</p>
With low temperatures	<p>Temperature below starting limit</p> <p>Fuel slurry caused by insufficient low temperature resistance</p> <p>Starting speed too low:</p> <ul style="list-style-type: none"> - oil with too high viscosity - insufficiently charged battery 	<p>Observe cold start instructions</p> <p>Pull the fuel hose off the fuel lift pump and check whether fuel runs out of the fuel pump clear and without clouds. In case of cloudy fuel you should either warm the engine up or drain the complete fuel supply system. Fill with a temperature resistant fuel mixture.</p> <p>Replace engine oil with oil of correct viscosity</p> <p>Check the battery, if necessary consult a specialist workshop</p>

Trouble shooting

Fault	Possible cause	Remedy
The starter is not switched on or the engine does not crank	Fault in the electric system: <ul style="list-style-type: none"> - Fuse defective - Battery or other cable connections not correctly connected. - Cable terminals loose or oxidised - Battery defective or not charged - Starter defective - insufficiently charged battery 	Check electric equipment and related components or consult the customer service of Bomag
Engine ignites, but does not continue to run when switching the starter motor off.	Fuel filter clogged Fuel supply interrupted Stop signal from monitoring elements connected with the oil pressure monitoring facility: <ul style="list-style-type: none"> - no oil pressure 	Replace the fuel filter check the entire fuel system systematically Check oil level
Engine shuts down by itself during operation	Tank empty Fuel filter clogged The mechanical oil pressure monitoring shuts the engine down because of a lack of oil mechanical defects	Fill in fuel Replace the fuel filter Check the oil level, activate the oil pressure monitoring system
Engine loses power and speed	Fuel supply restricted: <ul style="list-style-type: none"> - Tank empty Fuel filter clogged too much oil in the exciter housing Insufficient tank ventilation Pipe connections leaking Throttle lever does not stay in selected position	Fill in fuel, activate the mechanical oil pressure monitoring system Replace the fuel filter Drain off oil ensure sufficient ventilation of the tank Check line connections for leaks Block the throttle control
Engine loses power and speed, black exhaust smoke	Air filter dirty Incorrect valve clearance Injection nozzle out of order	Clean or replace the air filter Adjusting the valve clearance see shop manual

Fault	Possible cause	Remedy
Engine over-heating	Lubrication oil level in engine too high Insufficient cooling - Dirt in the entire area of the cooling air flow - Air guide plates not completely closed	Drain the engine oil down to the top mark on the dipstick Clean the cooling air duct Check air guide plates for completeness and good sealing

6.3 Trouble shooting Econo- mizer

Fault	Description	Possible cause
Status-LED off	Operation	
Status-LED on	no frequency detected	Engine not running Plug-in connector defective Sensor/cable defective
Status-LED flashing	Frequency detected, but outside permissible range	Engine speed too low Vibration frequency too low Sensor defective atypical soil V-belt slipping incorrect V-belt installed

PARTS FINDER

**Search Website
by Part Number**



**Search Manual
Library For Parts
Manual & Lookup Part
Numbers – Purchase
or Request Quote**

Search Manuals

Enter your information to help us find the right parts manual for your machine.

* Brand:

* Model:

* Serial:

* Part Number:

SEARCH

**Can't Find Part or
Manual? Request Help
by Manufacturer,
Model & Description**

Parts Order Form

Please fill in the following information to help us find the right part for your machine.

Manufacturer:	<input type="text"/>
Model:	<input type="text"/>
Description:	<input type="text"/>
Part Number:	<input type="text"/>
Quantity:	<input type="text"/>
Notes:	<input type="text"/>

Discount-Equipment.com is your online resource for quality parts & equipment.

Florida: **561-964-4949** Outside Florida TOLL FREE: **877-690-3101**

Need parts?

Click on this link: <http://www.discount-equipment.com/category/5443-parts/> and choose one of the options to help get the right parts and equipment you are looking for. Please have the machine model and serial number available in order to help us get you the correct parts. If you don't find the part on the website or on one of the online manuals, please fill out the request form and one of our experienced staff members will get back to you with a quote for the right part that your machine needs.

We sell worldwide for the brands: Genie, Terex, JLG, MultiQuip, Mikasa, Essick, Whiteman, Mayco, Toro Stone, Diamond Products, Generac Magnum, Airman, Haulotte, Barreto, Power Blanket, Nifty Lift, Atlas Copco, Chicago Pneumatic, Allmand, Miller Curber, Skyjack, Lull, Skytrak, Tsurumi, Husquvarna Target, Stow, Wacker, Sakai, Mi-T-M, Sullair, Basic, Dynapac, MBW, Weber, Bartell, Bennar Newman, Haulotte, Ditch Runner, Menegotti, Morrison, Contec, Buddy, Crown, Edco, Wyco, Bomag, Laymor, EZ Trench, Bil-Jax, F.S. Curtis, Gehl Pavers, Heli, Honda, ICS/PowerGrit, IHI, Partner, Imer, Clipper, MMD, Koshin, Rice, CH&E, General Equipment, Amida, Coleman, NAC, Gradall, Square Shooter, Kent, Stanley, Tamco, Toku, Hatz, Kohler, Robin, Wisconsin, Northrock, Oztec, Toker TK, Rol-Air, APT, Wylie, Ingersoll Rand / Doosan, Innovatech, Con X, Ammann, Mecalac, Makinex, Smith Surface Prep, Small Line, Wanco, Yanmar