



BOMAG

FAYAT GROUP

Operating Instruction Maintenance Instruction

Original Operating Instructions

BPR 50/55 D

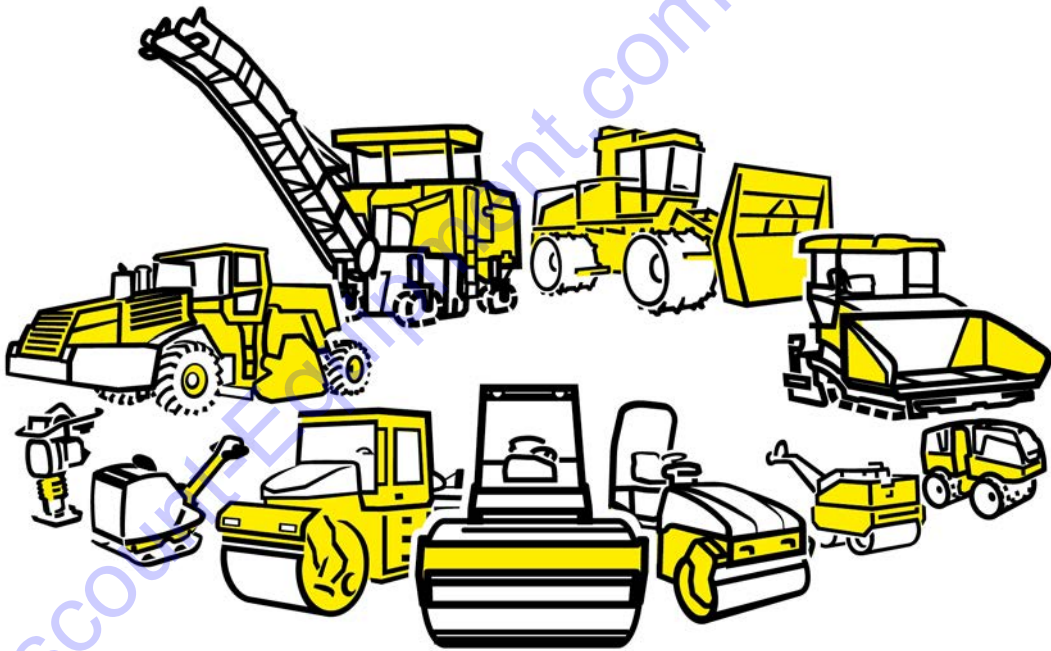

S/N 101 692 89 1001>

Reversible vibratory plate

**Discount
Equipment**

www.discount-equipment.com

008 202 28 EN

© 09/2016

PARTS FINDER

**Search Website
by Part Number**



**Search Manual
Library For Parts
Manual & Lookup Part
Numbers – Purchase
or Request Quote**

Search Manuals

Enter your information to help us find the right parts manual for your machine.

* Brand:

* Model:

* Serial:

* Part Number:

SEARCH

**Can't Find Part or
Manual? Request Help
by Manufacturer,
Model & Description**

Parts Order Form

Please fill in the following information to help us find the right part for your machine.

Manufacturer:	<input type="text"/>
Model:	<input type="text"/>
Description:	<input type="text"/>
Part Number:	<input type="text"/>
Quantity:	<input type="text"/>
Notes:	<input type="text"/>

Discount-Equipment.com is your online resource for quality parts & equipment.

Florida: **561-964-4949** Outside Florida TOLL FREE: **877-690-3101**

Need parts?

Click on this link: <http://www.discount-equipment.com/category/5443-parts/> and choose one of the options to help get the right parts and equipment you are looking for. Please have the machine model and serial number available in order to help us get you the correct parts. If you don't find the part on the website or on one of the online manuals, please fill out the request form and one of our experienced staff members will get back to you with a quote for the right part that your machine needs.

We sell worldwide for the brands: Genie, Terex, JLG, MultiQuip, Mikasa, Essick, Whiteman, Mayco, Toro Stone, Diamond Products, Generac Magnum, Airman, Haulotte, Barreto, Power Blanket, Nifty Lift, Atlas Copco, Chicago Pneumatic, Allmand, Miller Curber, Skyjack, Lull, Skytrak, Tsurumi, Husquvarna Target, Stow, Wacker, Sakai, Mi-T-M, Sullair, Basic, Dynapac, MBW, Weber, Bartell, Bennar Newman, Haulotte, Ditch Runner, Menegotti, Morrison, Contec, Buddy, Crown, Edco, Wyco, Bomag, Laymor, EZ Trench, Bil-Jax, F.S. Curtis, Gehl Pavers, Heli, Honda, ICS/PowerGrit, IHI, Partner, Imer, Clipper, MMD, Koshin, Rice, CH&E, General Equipment, Amida, Coleman, NAC, Gradall, Square Shooter, Kent, Stanley, Tamco, Toku, Hatz, Kohler, Robin, Wisconsin, Northrock, Oztec, Toker TK, Rol-Air, APT, Wylie, Ingersoll Rand / Doosan, Innovatech, Con X, Ammann, Mecalac, Makinex, Smith Surface Prep, Small Line, Wanco, Yanmar

Table of contents

1	Introduction	7
	1.1 Foreword	8
	1.2 Machine type plate and engine type plate	10
2	Technical data	11
	2.1 Noise and vibration data	14
	2.1.1 Noise data.....	14
	2.1.2 Vibration data.....	14
3	Concerning your safety	15
	3.1 Basic prerequisites	16
	3.1.1 General.....	16
	3.1.2 Explanation of warning signs:.....	16
	3.1.3 Personal protective equipment.....	17
	3.1.4 Intended use.....	18
	3.1.5 Improper use.....	18
	3.2 Definition of responsible persons	20
	3.2.1 Operating company.....	20
	3.2.2 Expert / qualified person.....	20
	3.2.3 Driver / operator.....	20
	3.3 Basic safety regulations for safe operation	22
	3.3.1 Remaining dangers, remaining risks.....	22
	3.3.2 Regular safety inspections.....	22
	3.3.3 Modifications and alterations to the machine.....	22
	3.3.4 Damage, defects, misuse of safety devices.....	22
	3.4 Handling fuels and lubricants	23
	3.4.1 Preliminary remarks.....	23
	3.4.2 Safety regulations and environmental protection regulations for handling diesel fuel.....	24
	3.4.3 Safety regulations and environmental protection regulations for handling oil.....	25
	3.4.4 Safety regulations and environmental protection regulations for handling hydraulic oil.....	26
	3.4.5 Safety regulations and environmental protection regulations for handling battery acid.....	27
	3.5 Loading/transporting the machine	28
	3.6 Start-up procedure	29
	3.6.1 Prior to starting up.....	29
	3.6.2 Starting the engine.....	29
	3.7 Operation	30
	3.7.1 Persons in the danger area.....	30
	3.7.2 Operation.....	30
	3.7.3 Parking the machine.....	30
	3.8 Refuelling	31
	3.9 Maintenance work	32
	3.9.1 Preliminary remarks.....	32
	3.9.2 Working on the engine.....	32
	3.9.3 Maintenance work on electric components and battery.....	32
	3.9.4 Cleaning work.....	32
	3.9.5 After maintenance work.....	33

Table of contents

3.10	Repair.....	34
3.11	Signage.....	35
4	Display and control elements.....	39
5	Tests before taking into operation.....	41
5.1	Notes on safety.....	42
5.2	Visual inspections and function tests.....	43
5.3	Checking the engine oil level.....	44
5.4	Checking the fuel level, topping up fuel.....	45
5.5	Checking the rubber buffers.....	46
6	Operation.....	47
6.1	Folding down the steering rod.....	48
6.2	Start the engine.....	49
6.3	Operation.....	51
6.4	Park the machine in secured condition.....	53
6.5	ECONOMIZER.....	54
7	Loading / transporting the machine.....	55
7.1	Loading the machine.....	56
7.2	Lashing the machine to the transport vehicle.....	57
8	Maintenance.....	59
8.1	Preliminary remarks and safety notes.....	60
8.2	Preparations / concluding work.....	61
8.2.1	Open protection hood.....	61
8.3	Fuels and lubricants.....	62
8.3.1	Engine oil.....	62
8.3.2	Fuel.....	62
8.3.3	Mineral oil based hydraulic oil.....	63
8.4	List of fuels and lubricants.....	64
8.5	Running-in instructions.....	65
8.5.1	General.....	65
8.5.2	After 25 operating hours.....	65
8.6	Maintenance table.....	66
8.7	Weekly.....	67
8.7.1	Checking, cleaning the water separator.....	67
8.8	Monthly.....	68
8.8.1	Air filter maintenance.....	68
8.8.2	Cleaning the cooling fins and the cooling air intake openings.....	69
8.8.3	Battery service.....	70
8.9	Semi-annually.....	71
8.9.1	Checking the oil level in the exciter housing.....	71
8.9.2	Servicing the V-belt.....	71
8.9.3	Checking the screw joints on the diesel engine.....	72
8.10	Annually.....	74
8.10.1	Changing the engine oil and cleaning the oil filter.....	74
8.10.2	Replacing the fuel filter.....	76
8.10.3	Replacing the starter rope.....	77

8.10.4	Changing the oil in the exciter housing.....	78
8.10.5	Checking the hydraulic oil level.....	80
8.10.6	Checking, adjusting the valve clearance.....	82
8.11	As required.....	85
8.11.1	Cleaning the machine.....	85
8.11.2	Measures prior to extended shutdown period.....	85
9	Troubleshooting.....	89
9.1	Preliminary remarks.....	90
9.2	Starting the engine with the recoil starter.....	91
9.3	Starting the engine with jump leads.....	94
9.4	Fuse assignment.....	95
9.5	Engine malfunctions.....	96
9.6	Malfunctions during operation.....	98
9.7	Trouble shooting ECONOMIZER.....	99
10	Disposal.....	101
10.1	Final shut-down of machine.....	102

Go to Discount-Equipment.com to order your parts

Go to Discount-Equipment.com to order your parts

1.1 Foreword

BOMAG manufactures machines for earth, asphalt and refuse compaction, stabilizers/recyclers as well as planers and pavers.

BOMAG's vast experience in connection with state-of-the-art production and testing methods, such as lifetime tests of all important components and highest quality demands guarantee maximum reliability of your machine.

These operating and maintenance instructions are part of your machine.

They provide necessary information to operate your machine safely and properly.

They also contain information on required operating, maintenance and repair measures.

Carefully read the operating and maintenance instructions before taking your machine into operation.

Please observe the safety regulations strictly and follow all instructions to ensure safe operation.

If you are not yet acquainted with the controls and indicating elements on this machine, you should thoroughly read the corresponding chapter ↪ *Chapter 4 „Display and control elements“ on page 39.*

The description of the individual operating steps including the notes on safety to be followed can be found in chapter “Operation” ↪ *Chapter 6 „Operation“ on page 47.*

Before every start up, carry out all required visual inspections and function tests ↪ *Chapter 5 „Tests before taking into operation“ on page 41.*

Ensure the compliance with the specified operating, maintenance and repair measures to maintain the functional safety of your machine.

A description of all necessary maintenance work, maintenance intervals as well as information on fuels and lubricants can be found in the chapter “Maintenance” ↪ *Chapter 8 „Maintenance“ on page 59.*

Do not service or repair your machine by yourself to avoid harming persons or damaging material or environment.

The machine must only be serviced and repaired by qualified and authorized personnel.

Contact our Customer Service to carry out the required maintenance work or necessary repairs.

In case of operating errors, inadequate maintenance or the use of unapproved fuels and lubricants all warranty claims will become null and void.

For your own personal safety you should only use original parts from BOMAG.

For your machine we offer service kits to make maintenance easier.

In the course of technical development we reserve the right for technical modifications without prior notification.

These operating and maintenance instructions are also available in other languages.

Apart from that, you can also order the spare parts catalogue against the serial number of your machine.

The above notes do not constitute an extension of the warranty and liability conditions specified in the general sales and delivery conditions of BOMAG GmbH.

We wish you successful work with your BOMAG machine.

Go to Discount-Equipment.com to order your parts

1.2 Machine type plate and engine type plate

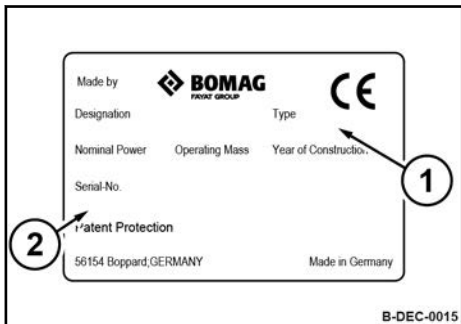

Fig. 1: Machine type plate (example)

Please enter here:	
Machine type (1):	
Serial number (2):	

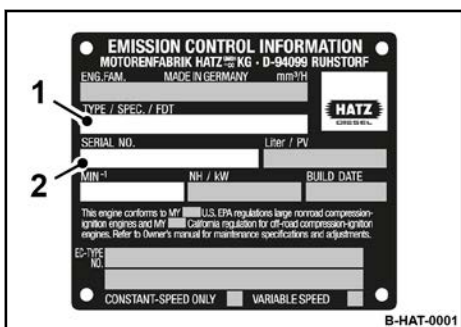

Fig. 2: Engine type plate (example)

Please enter here:	
Engine type (1):	
Engine number (2):	

Go to Discount-Equipment.com to order your parts

Go to Discount-Equipment.com to order your parts

Technical data

Dimensions

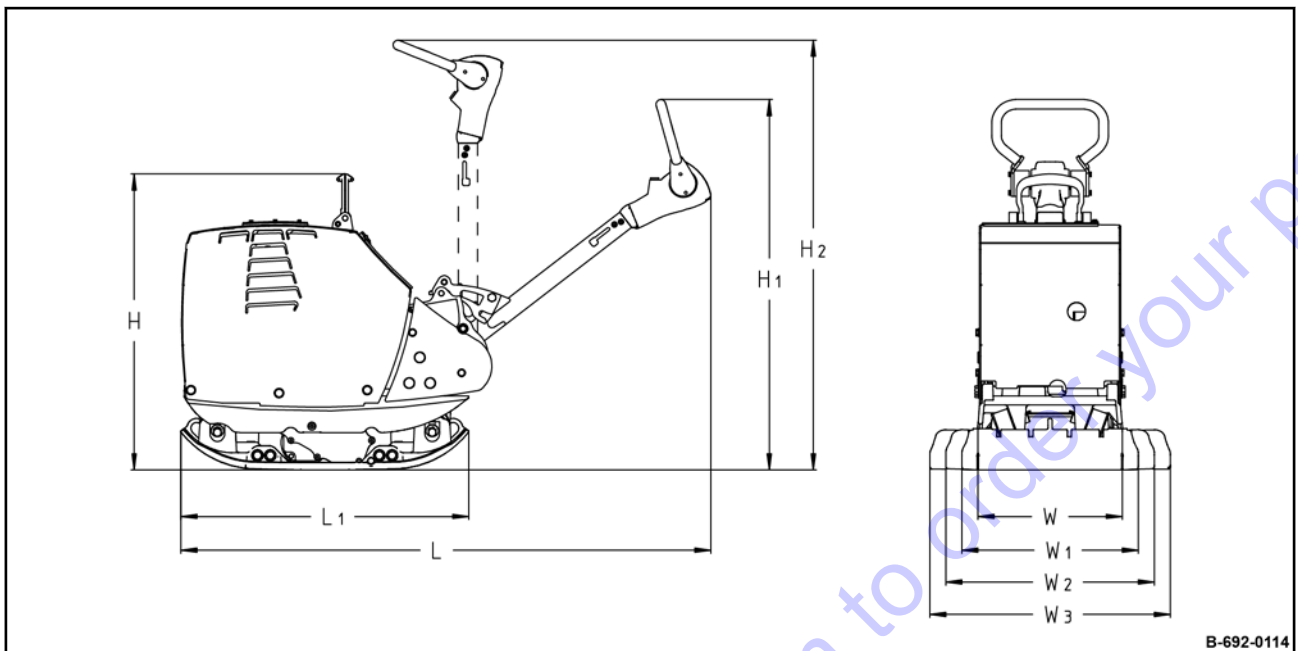

B-692-0114

Fig. 3

H	H ₁	H ₂	L	L ₁	W	W ₁	W ₂	W ₃
Dimensions standard								
921	1153	1338	1653	898	450	550	650	750
(36.3)	(45.4)	(52.7)	(65.1)	(35.4)	(17.7)	(21.7)	(25.6)	(29.5)
Dimensions in millimetres (Dimensions in inch)								

Weights		
Operating weight (CECE) (W)	390	kg
	(860)	(lbs)
Operating weight (CECE) (W ₁)	405	kg
	(893)	(lbs)
Operating weight (CECE) (W ₂)	420	kg
	(926)	(lbs)
Basic weight	400	kg
	(882)	(lbs)

Technical data

Weights		
"STONEGUARD" (special base plate for paving stones) (<i>optional equipment</i>)	+ 35 (+ 77)	kg (lbs)
ECONOMIZER (<i>optional equipment</i>)	+ 5 (+ 11)	kg (lbs)

Travel characteristics		
Max. working speed	28 (92)	m/min (ft/min)
Max. working speed with "STONEGUARD"	25 (82)	m/min (ft/min)
Max. gradability (depending on soil)	35	%

Drive		
Engine manufacturer	Hatz	
Type	1B40	
Cooling	Air	
Number of cylinders	1	
Rated power ISO 3046	6.7 (9.0)	kW (hp)
Rated speed	3000	min ⁻¹
Drive system	mechanical	

Exciter system		
Frequency	66 (3960)	Hz (vpm)
Centrifugal force	50 (11241)	kN (lbf)
Amplitude	1.85 (0,073)	mm (in)

Filling capacities		
Fuel (diesel)	5.0 (1.3)	l (gal us)

2.1 Noise and vibration data

The following noise and vibration data were determined in accordance with the following guidelines under equipment specific conditions and by using harmonized standards:

- EC Machine Directive edition 2006/42/EC
- Noise Emission Directive 2000/14/EC, Noise Protection Directive 2003/10/EC
- Vibration Protection Directive 2002/44/EC

During operation these values may vary because of the prevailing operating conditions.

2.1.1 Noise data

Sound pressure level at the operator's place

$L_{pA} = 95 \text{ dB(A)}$, determined acc. to ISO 11204 and EN 500.



WARNING!

Loss of hearing caused by too high noise burdens!

- Wear your personal protective equipment (ear protection).

Guaranteed sound power level

$L_{WA} = 108 \text{ dB(A)}$, determined acc. to ISO 3744 and EN 500.

2.1.2 Vibration data

Hand-arm vibration

Vector total of the weighted effective acceleration in three orthogonal directions:

Total vibration value $a_{hv} \leq 2.5 \text{ m/s}^2$ on crushed rock determined acc. to ISO 5349 and EN 500.

Associated uncertainty $K = 0.6 \text{ m/s}^2$, determined acc. to EN 12096.

Observe the daily vibration load (work safety acc. to 2002/44/EC).

Go to Discount-Equipment.com to order your parts

3.1 Basic prerequisites

3.1.1 General

This BOMAG machine has been built in compliance with the latest technical standard and complies with the applicable regulations and technical rules.

However, dangers for persons and property may arise from this machine, if:

- it is used for purposes other than the ones it is intended for,
- it is operated by untrained personnel,
- it is changed or converted in an unprofessional way,
- the safety instructions are not observed.

Each person involved in the operation, maintenance and repair of the machine must therefore read and comply with these safety regulations. If necessary, the customer must obtain the relevant signatures as confirmation.

Furthermore, the following obviously also applies:

- applicable accident prevention instructions,
- generally accepted safety and road traffic regulations,
- country specific safety regulations.

It is the duty of the operator to be acquainted with the safety regulations and to apply these accordingly. This also applies for local regulations and regulations concerning different types of handling activities. Should the recommendations in these instructions be different from the regulations valid in your country, you must comply with the safety regulations valid in your country.

3.1.2 Explanation of warning signs:



DANGER!

Danger to life if failing to comply!

Sections marked accordingly indicate an extremely dangerous situation that could lead to fatal or severe injuries, if this warning is disregarded.



WARNING!

Danger to life or danger of severe injuries if failing to comply!

Sections marked accordingly indicate a dangerous situation that could lead to fatal or severe injuries, if this warning is disregarded.

Concerning your safety – Basic prerequisites



CAUTION!

Danger of injury if failing to comply!

Sections marked accordingly indicate a dangerous situation that could lead to fatal or severe injuries, if this warning is disregarded.



NOTICE!

Danger of material damage if failing to comply!

Sections marked accordingly indicate possible dangers for machines or components.



Sections marked accordingly indicate technical information or notes on using the machine or its components.



ENVIRONMENT!

Environmental damage if failing to comply!





Paragraphs marked accordingly indicate practices for safe and environment-friendly disposal of fuels and lubricants as well as replacement parts.

3.1.3 Personal protective equipment

Depending on the work to be carried out, personal protective equipment is required (to be provided by the operating company):

	Working clothes	Tight fitting working clothes with low tear resistance, tight sleeves and without any projecting parts protects against being caught by moving components.
	Safety shoes	To protect against heavy falling parts and slipping on slippery ground.
	Protective gloves	To protect the hands against excoriation, punctures or deep injuries, against irritating and caustic substances as well as against burns.

Concerning your safety – Basic prerequisites

	Safety goggles	To protect the eyes against airborne particles and fluid squirts.
	Face protection	To protect the face against airborne particles and fluid squirts.
	Hard hat	To protect the head against falling parts and to protect against injuries.
	Hearing protection	To protect the hearing against too loud noise.

3.1.4 Intended use

This machine must only be used for:

- Compaction of all types of soils
- Repair work on all types of soil
- Paving of walkways
- Work in trenches
- Underfilling and compaction of hard shoulders

Intended use also includes compliance with the specified operating, maintenance and repair measures.

3.1.5 Improper use

Dangers may arise from the machine when it is used for purposes other than the one it is intended for.

Any danger caused by improper use is the sole responsibility of the operating company or driver/operator, the manufacturer cannot be made liable.

Examples for improper use are:

- dragging the machine along as a measure of transportation
- throwing the machine off the transport vehicle
- attaching an additional weight to the machine

It is not permitted to stand on the machine while working.

Concerning your safety – Basic prerequisites

Lifting tackle must be removed before starting work.

Starting and operating the machine in explosive environments and in underground mining is prohibited.

Go to Discount-Equipment.com to order your parts

3.2 Definition of responsible persons

3.2.1 Operating company

The operating company is the natural or juridical person who uses the machine or in who's name the machine is used.

The operating company must make sure that the machine is only used for the purpose it is intended for and in strict compliance with the safety regulations mentioned in these operating and maintenance instructions.

The operating company must determine and assess the danger in his company. It must then take appropriate action to ensure health and safety at work for his employees and point out any remaining dangers.

The operating company must determine whether there are special operation hazards such as a toxic atmosphere or limiting soil conditions. Such conditions requires special, additional measures to remove or reduce the hazard.

The operating company must make sure that all users read and understand the information concerning safety.

The operating company is responsible for the planning and professional execution of regular safety inspections.

3.2.2 Expert / qualified person

An expert / qualified person is a person who, based on his/her professional education and experience, has profound knowledge in the field of construction equipment and the machine in question in particular.

This person is acquainted with the applicable governmental industrial safety regulations, accident prevention instructions, guidelines and generally acknowledged technical rules and regulations (standards, directives, technical rules of other member states of the European Union or other contractual states concerning the agreement about the European Economic Area) in as far as is necessary to be able to judge the safe condition of these machines.

3.2.3 Driver / operator

This machine must only be operated by trained, instructed persons entrusted by the operating company aged 18 or more.

Observe your local laws and regulations.

Rights, obligations and rules of conduct for driver or operator:

The driver or operator must:

- be instructed about his rights and obligations,
- wear protective equipment as appropriate for the application,
- have read and understood the operating instructions,

Concerning your safety – Definition of responsible persons

- have made himself familiar with the operation of the machine,
- be physically and psychologically able to drive and operate the machine.

Persons under the influence of alcohol, medicine or drugs are not allowed to operate, service or repair the machine.

Maintenance and repair work requires specific knowledge and must therefore only be performed by trained specialists.

Go to Discount-Equipment.com to order your parts

3.3 Basic safety regulations for safe operation

3.3.1 Remaining dangers, remaining risks

Despite careful work and compliance with standards and regulations it cannot be ruled out that further dangers may arise when working with and handling the machine.

Both the machine as well as all other system components comply with the currently valid safety regulations. Nevertheless, remaining risks cannot be ruled out completely, even when using the machine for the purpose it is intended for and following all information given in the operating instructions.

A remaining risk can also not be excluded beyond the actual danger zone of the machine. Persons remaining in this area must pay particular attention to the machine, so that they can react immediately in case of a possible malfunction, an incident or failure etc.

All persons remaining in the area of the machine must be informed about the dangers that arise from the operation of the machine.

3.3.2 Regular safety inspections

Have the machine inspected by an expert (capable person) as required for the conditions the machine is working under, but at least once every year.

3.3.3 Modifications and alterations to the machine

Unauthorized changes to the machine are prohibited for safety reasons.

Original parts and accessories have been specially designed for this machine.

We wish to make explicitly clear that we have not tested or approved any parts or accessories not supplied by us.

The installation and/or use of such products may have an adverse effect on the active and/or passive safety.

3.3.4 Damage, defects, misuse of safety devices

Machines which are not safe to operate or in traffic must be immediately taken out of service and shall not be used, until these deficiencies have been properly rectified.

Safety installations and switches must neither be removed nor must they be made ineffective.

3.4 Handling fuels and lubricants

3.4.1 Preliminary remarks

The operating company must ensure that all professional users have read and follow the corresponding safety data sheets for the individual fuels and lubricants.

Safety data sheets provide valuable information about the following characteristics:

- Name of substance
- Possible dangers
- Composition / information on constituents
- First-Aid measures
- Fire fighting measures
- Measures in case of accidental release
- Handling and storage
- Limitation and monitoring of exposure / personal protective equipment
- physical and chemical properties
- Stability and reactivity
- Toxicological data
- Environmental data
- Notes on waste disposal
- Information on transport
- Legislation
- other data

3.4.2 Safety regulations and environmental protection regulations for handling diesel fuel

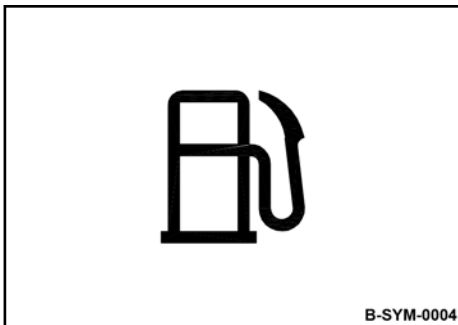

Fig. 4



WARNING!

Danger of burning by ignited diesel fuel!

- Do not allow diesel fuel to come into contact with hot components.
- Smoking and open fire is prohibited!
- Wear your personal protective equipment (protective gloves, protective clothing).



CAUTION!

Health hazard caused by contact with diesel fuel!

- Wear your personal protective equipment (protective gloves, protective clothing).
- Do not inhale any fuel fumes.
- Avoid contact.



CAUTION!

Danger of slipping on spilled diesel fuel!

- Immediately bind spilled diesel fuel with an oil-binding agent.



ENVIRONMENT!

Diesel fuel is an environmentally hazardous substance

- Always keep diesel fuel in proper containers.
- Immediately bind spilled diesel fuel with an oil-binding agent.
- Dispose of diesel fuel and fuel filters according to regulations.

3.4.3 Safety regulations and environmental protection regulations for handling oil

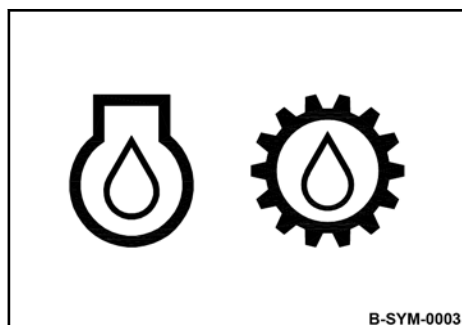

Fig. 5



WARNING!

Danger of burning by ignited oil!

- Do not allow oil to come into contact with hot components.
- Smoking and open fire is prohibited!
- Wear your personal protective equipment (protective gloves, protective clothing).



CAUTION!

Health hazard caused by contact with oil!

- Wear your personal protective equipment (protective gloves, protective clothing).
- Do not inhale any oil vapours.
- Avoid contact.



CAUTION!

Danger of slipping on spilled oil!

- Immediately bind spilled oil with an oil-binding agent.



ENVIRONMENT!

Oil is an environmentally hazardous substance

- Always keep oil in proper containers.
- Immediately bind spilled oil with an oil-binding agent.
- Dispose of oil and oil filter according to regulations.

3.4.4 Safety regulations and environmental protection regulations for handling hydraulic oil

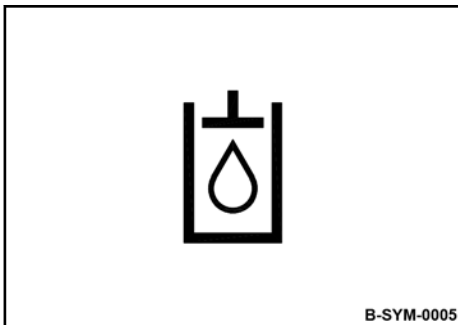

Fig. 6



WARNING!

Danger of injury caused by escaping pressure fluid!

- Always depressurize the hydraulic system before starting work in the hydraulic system.
- Wear your personal protective equipment (protective gloves, protective clothing, goggles).



Should pressure fluid penetrate the skin, immediate medical help is required.



WARNING!

Danger of burning by ignited hydraulic oil!

- Do not allow hydraulic oil to come into contact with hot components.
- Smoking and open fire is prohibited!
- Wear your personal protective equipment (protective gloves, protective clothing).



CAUTION!

Health hazard caused by contact with hydraulic oil!

- Wear your personal protective equipment (protective gloves, protective clothing).
- Do not inhale any oil vapours.
- Avoid contact.



CAUTION!

Danger of slipping on spilled oil!

- Immediately bind spilled oil with an oil-binding agent.



ENVIRONMENT!

Oil is an environmentally hazardous substance

- Always keep oil in proper containers.
- Immediately bind spilled oil with an oil-binding agent.
- Dispose of oil and oil filter according to regulations.

3.4.5 Safety regulations and environmental protection regulations for handling battery acid

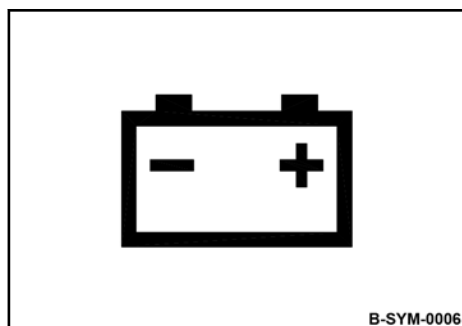

Fig. 7:



WARNING!

Danger of cauterization with acid!

- Wear your personal protective equipment (protective gloves, protective clothing, goggles).
- Do not allow clothes, skin or eyes to come into contact with acid.
- Rinse off spilled battery acid immediately with lots of water.



Rinse acid off clothes, skin or eyes immediately with lots of clear water.

Immediately call for medical advice in case of cauterization.



WARNING!

Danger of injury caused by exploding gas mixture!

- Remove the plugs before starting to recharge the battery.
- Ensure adequate ventilation.
- Smoking and open fire is prohibited!
- Do not lay any tools or other metal objects on the battery.
- Do not wear jewellery (watch, bracelets, etc.) when working on the battery.
- Wear your personal protective equipment (protective gloves, protective clothing, goggles).



ENVIRONMENT!

Battery acid is an environmentally hazardous substance

- Dispose of battery and battery acid according to regulations.

3.5 Loading/transporting the machine

Make sure that persons are not endangered by the machine tipping or sliding off.

Do not use damaged or in any other way impaired lashing points.

Always use appropriate lifting and lashing means on the lifting and lashing points.

Use lifting and lashing gear only in the prescribed direction of load application.

Lifting tackle must not be damaged by machine components.

Secure the machine on the transport vehicle against rolling, slipping and turning over.

Loads must only be attached and hoisted by an expert / capable person.

Use only lifting gear and lifting tackle with sufficient load bearing capacity for the weight to be loaded.

Fasten the lifting gear only at the specified lifting points.

Danger to the life of persons if they step or stand under a suspended load.

When lifting the machine avoid uncontrolled movements of the load. If necessary hold the load with guide ropes.

3.6 Start-up procedure

3.6.1 Prior to starting up

Use only machines which are serviced at regular intervals.

Become acquainted with the equipment, the indicators and control elements, the working principle of the machine and the working area.

Use your personal protective equipment (hard hat, safety boots, if necessary also goggles and ear protection).

Do not take any loose objects with you or fasten them to the machine.

Before start up, check whether:

- persons or obstructions are beside or in front of the machine,
- the machine is free of oily and combustible materials,
- all safety elements are in place,
- all grips are free of grease, oils, fuel, dirt, snow and ice.

Before start up, carry out all required visual inspections and function tests.

If the following tests reveal damages or other faults, the machine must not be operated, until these deficiencies have been corrected.

Do not operate the machine with defective indicators and control elements.

3.6.2 Starting the engine

Do not use any starting aids like start pilot or ether.

The machine must not be operated with damaged, missing or non-functional safety installations.

Before starting and moving the machine, make sure that there is nobody in the danger zone.

Always keep an eye on the machine when the engine is running and hold it by the steering bow.

Do not inhale exhaust fumes, because they contain toxic substances, which could cause damage to health, unconsciousness or even death.

Avoid operation in closed or partly closed rooms, or ensure adequate ventilation when working in trenches.

3.7 Operation

3.7.1 Persons in the danger area

Before taking up work, also after breaks, you should always convince yourself that the danger zone is free of persons or obstructions.

Give warning signals, if necessary. Stop work immediately if persons remain in the danger zone, despite the warning.

3.7.2 Operation

Operate the machine only with the steering rod folded down.

Only use the steering rod to steer the machine.

Guide the machine so that your hands do not hit against solid objects.

When reversing, steer the machine from the side using the steering handle.

Watch out for unusual noises and development of smoke. Perform trouble shooting and have the fault corrected.

Always keep a safe distance to excavation pit borders, embankments and edges.

Refrain from any work that could adversely affect the stability of the machine.

3.7.3 Parking the machine

Park the machine on horizontal, level, firm ground.

Before leaving the machine:

- shut down the engine, pull off the ignition key,
- Secure the machine against accidental tipping over,
- Secure the machine against unauthorized use.

Mark machines, which could be in the way, with a clearly visible sign.

3.8 Refuelling

Do not inhale any fuel fumes.

Refuel only with the engine shut down.

Do not refuel in closed rooms.

No open fire, do not smoke.

Ultra-low sulphur diesel fuel poses a higher risk of combustion caused by the static charging than diesel fuel with a higher sulphur content.

Apply measures against electrostatic charging.

Do not spill any fuel. Catch running out fuel, do not let it seep into the ground.

Wipe off spilled fuel. Keep dirt and water away from the fuel.

A leaking fuel tank can cause an explosion. Ensure tight fit of the fuel tank cover, if necessary replace immediately.

Go to Discount-Equipment.com to order your parts

3.9 Maintenance work

3.9.1 Preliminary remarks

Comply with the maintenance work described in the operating and maintenance instructions, including the information concerning the replacement of parts.

Maintenance work must only be performed by qualified and authorized persons.

Do not touch hot components.

Keep unauthorized persons away from the machine.

Perform maintenance work only with the engine shut down.

Park the machine on horizontal, level, firm ground.

Remove the key from the ignition switch.

3.9.2 Working on the engine

Drain the engine oil at operating temperature – danger of scalding!

Wipe off spilled oil, catch running out oil and dispose of environmentally.

When working on the air filter no dirt should fall into the air duct.

Do not work on the hot exhaust - danger of burning!

Store used filters and other oil contaminated materials in a separate, specially marked container and dispose of environmentally.

3.9.3 Maintenance work on electric components and battery

Before starting to work on electric parts of the machine disconnect the battery and cover it with insulating material.

Do not use fuses with higher ampere ratings and do not bridge fuses.

When working on the battery, smoking or open fire is prohibited!

Do not lay any tools or other metal objects on the battery.

Do not wear jewellery (watch, bracelets, etc.) when working on the battery.

The connection cables of the battery must not touch or rub against machine parts.

3.9.4 Cleaning work

Do not perform cleaning work while the motor is running.

Allow the engine to cool down before starting cleaning work.

Do not use gasoline or other easily inflammable substances for cleaning.

3.9.5 After maintenance work

Reassemble all guards and protections.

Go to Discount-Equipment.com to order your parts

3.10 Repair

Identify a defect machine with a warning sign.

Only operate the machine after it has been repaired.

When replacing safety relevant components, only original spare parts must be used.

Repairs must only be performed by an expert/qualified person.

When performing welding work on the machine you should cover the fuel tank with insulating material.

Go to Discount-Equipment.com to order your parts

3.11 Signage

Keep stickers and decals in good and legible condition and comply with their meaning.

Replace damaged and illegible stickers or decals immediately.

Go to Discount-Equipment.com to order your parts

Concerning your safety – Signage

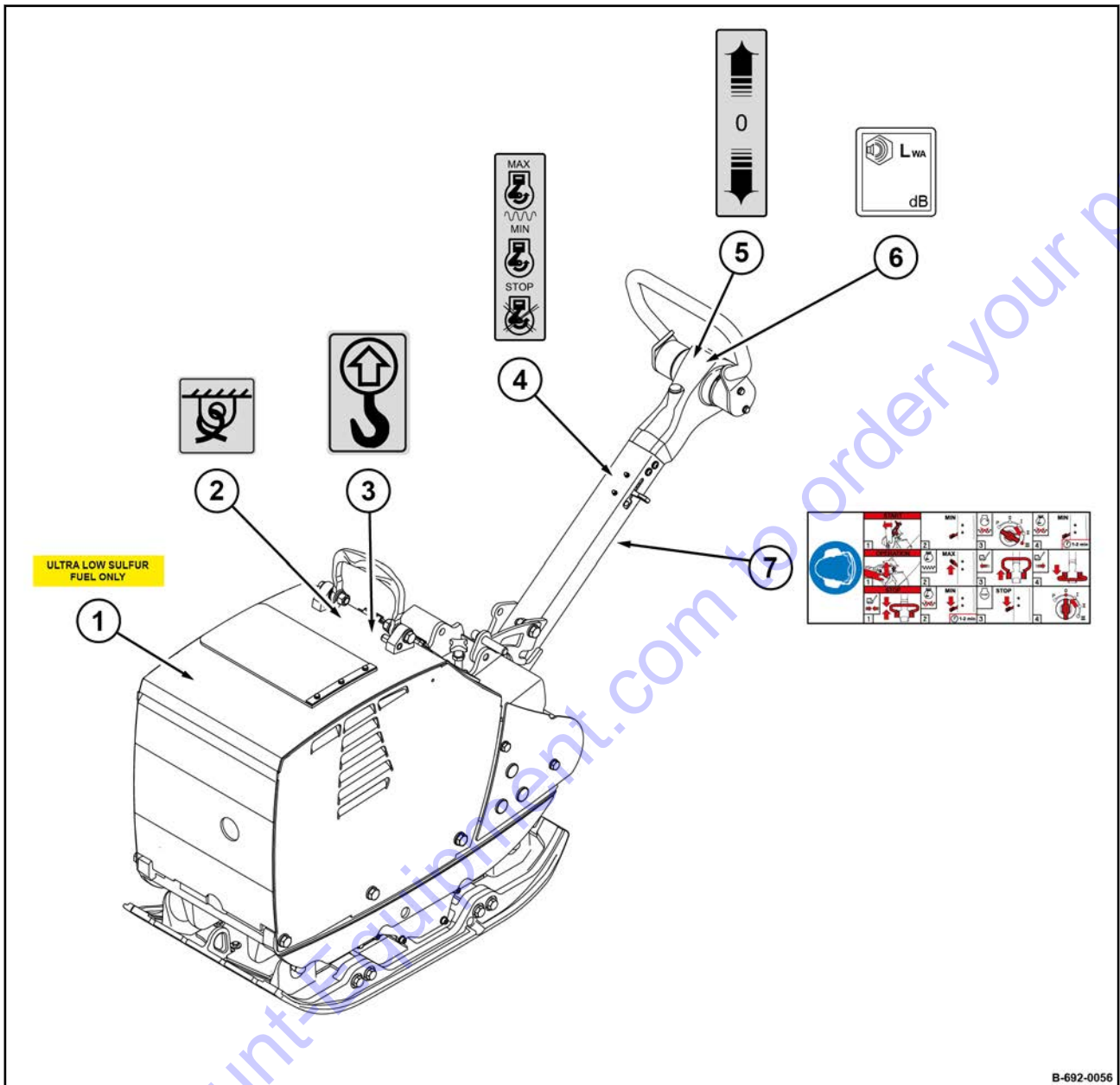

B-692-0056

Fig. 8

- 1 Information sticker - Ultra-low sulphur fuel
- 2 Information sticker - Lashing point
- 3 Information sticker - Lifting point
- 4 Information sticker - Throttle lever
- 5 Information sticker - Handle
- 6 Information sticker - Guaranteed sound capacity level
- 7 Brief operating instructions

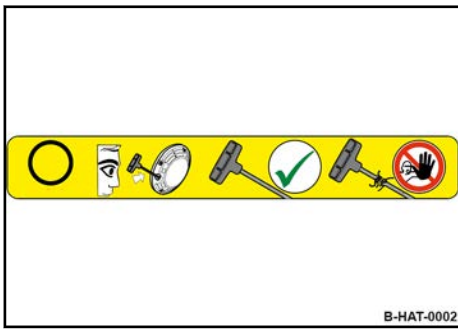

1 Warning sticker - Starter rope

Fig. 9: Stickers on engine

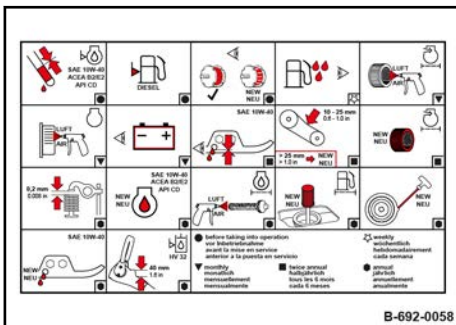

1 Maintenance sticker

Fig. 10: Maintenance sticker

Go to Discount-Equipment.com to order your parts

Go to Discount-Equipment.com to order your parts

Display and control elements

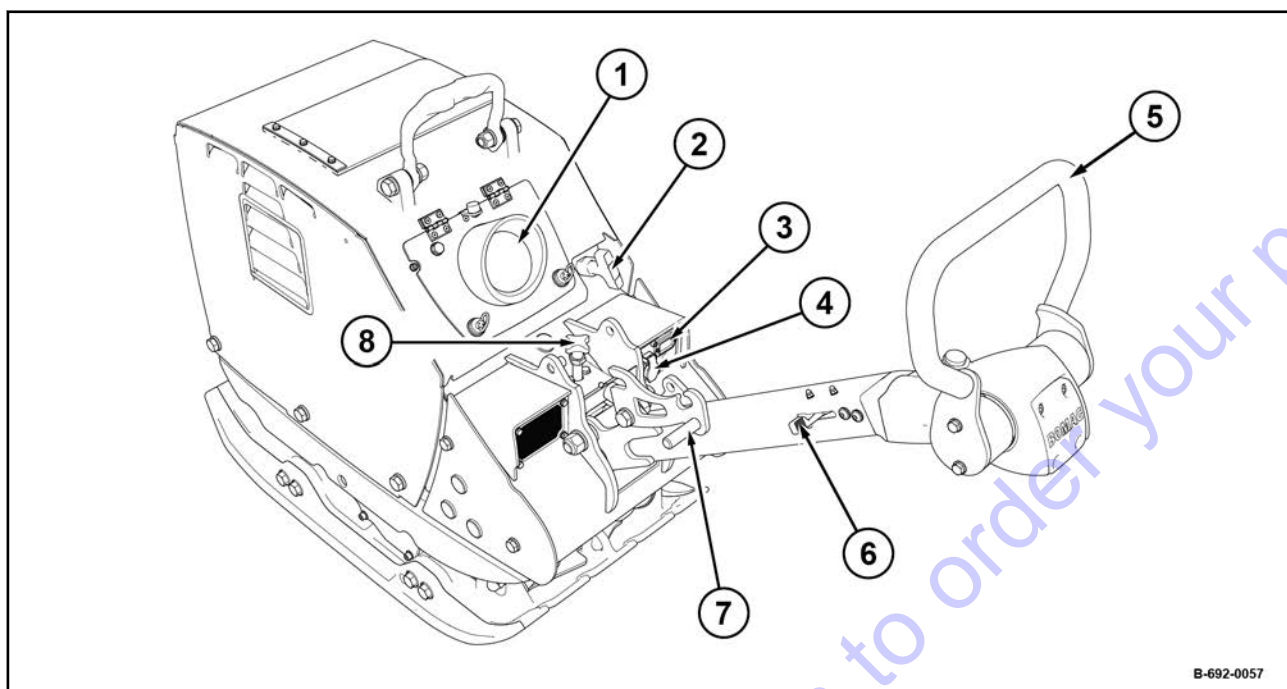

Fig. 11

- 1 Economizer display (*optional equipment*)
- 2 Recoil starter
- 3 Operating hour meter
- 4 Starter switch
- 5 Handle
- 6 Throttle lever
- 7 Locking pawl lever
- 8 Steering rod height adjustment

Go to Discount-Equipment.com to order your parts

5.1 Notes on safety

If the following tests reveal damages or other faults, the machine must not be operated, until these deficiencies have been corrected.

Safety installations and switches must neither be removed nor must they be made ineffective.

Do not change any fixed settings.



WARNING!

Health hazard caused by fuels and lubricants!

- Safety regulations and environmental protection regulations when handling fuels and lubricants must be followed ↪ *Chapter 3.4 „Handling fuels and lubricants“ on page 23.*



WARNING!

Danger of injury caused by rotating parts!

- Before starting work on the machine make sure that the engine can not be started.

1. Park the machine in secured condition ↪ *Chapter 6.4 „Park the machine in secured condition.“ on page 53.*

5.2 Visual inspections and function tests

1. Check fuel tank and lines for condition and leaks.
2. Check bolted connections for tight fit.
3. Check machine for contamination and damage.
4. Check the hydraulic oil cooler for dirt.
5. Check starter rope for chafing.

Go to Discount-Equipment.com to order your parts

5.3 Checking the engine oil level



NOTICE!

Danger of engine damage!

- Use only oil of the permitted specification
↳ Chapter 8.3.1 „Engine oil“ on page 62.

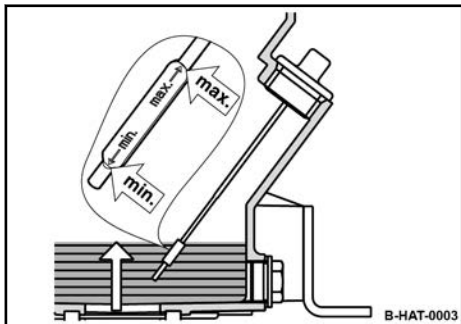

Fig. 12

Protective equipment: ■ Protective gloves

1. Clean the area around the oil dipstick.
2. Pull out the dipstick and wipe it clean with a lint-free, clean cloth.
3. Insert the dipstick and pull it out again to check the oil level.
⇒ The oil level must always be between the "MIN"- and "MAX"-marks.

4.



NOTICE!

Danger of engine damage!

- Do not fill in too much engine oil.

If the oil level is too low, top up oil to the "MAX" mark immediately.

5. Push the dipstick in.

5.4 Checking the fuel level, topping up fuel



NOTICE!

Danger of engine damage!

- Monitor the entire refuelling process.
- Contaminated fuel can cause malfunction or even damage of the engine. If necessary, fill in fuel through a screen filter.
- Use only fuel of the permitted specification
↳ Chapter 8.3.2 „Fuel“ on page 62.

Protective equipment: ■ Working clothes
■ Protective gloves

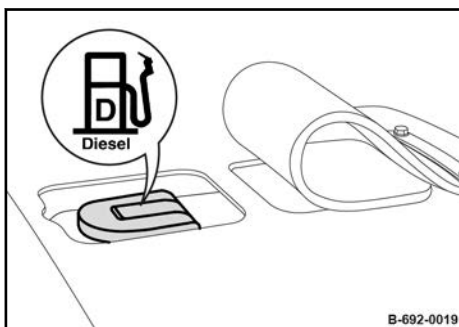

Fig. 13

1. Clean the area around the filler opening.
2. Remove the tank filler cap.
3. Fill in fuel through a funnel with screen filter.
4. Close the fuel tank tightly.

5.5 Checking the rubber buffers

1. Park the machine in secured condition ↪ Chapter 6.4 „Park the machine in secured condition.“ on page 53.
2. Allow the engine to cool down.
3. Check all rubber buffers for tight fit, cracks and tear-offs.
4. Replace damaged rubber buffers immediately.

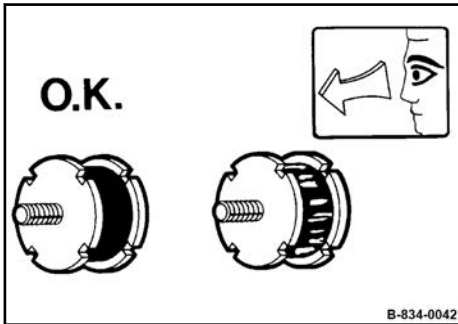

Fig. 14

Go to Discount-Equipment.com to order your parts

Operation – Folding down the steering rod

6.1 Folding down the steering rod

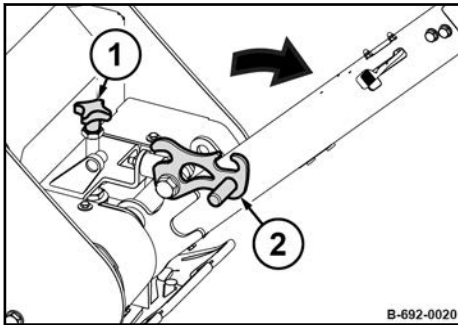

Fig. 15

1. Pull the locking pawl lever (2) and fold down the steering rod.
⇒ The steering rod can swing freely.
2. Adjust the steering rod with the height adjustment (1) to the required height.

Go to Discount-Equipment.com to order your parts

6.2 Start the engine

Exhaust fumes contain toxic substances and can damage your health, cause unconsciousness or even death.



WARNING!

Danger of poisoning by exhaust gases!

- Do not inhale exhaust gases.
- Avoid operation in closed or partly closed rooms, or ensure adequate ventilation when working in trenches.



WARNING!

Loss of hearing caused by too high noise burdens!

- Wear your personal protective equipment (ear protection).

Protective equipment: ■ Hearing protection
 ■ Safety shoes

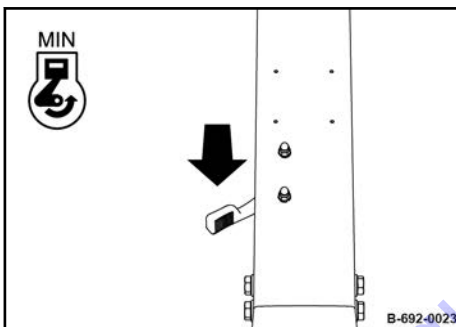

Fig. 16

1. Set the throttle lever to position “MIN”.

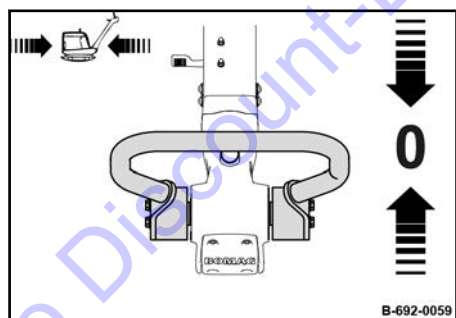

Fig. 17

2. Set the handle to position “0”.

Operation – Start the engine

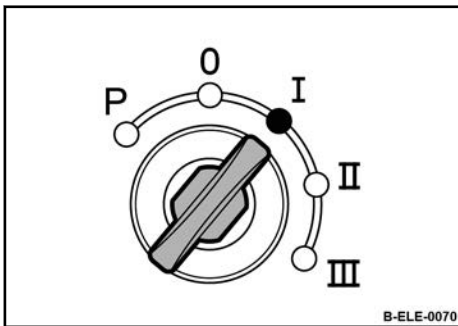

Fig. 18

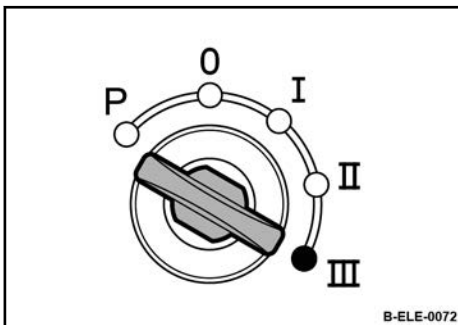

Fig. 19

3. Turn the ignition key to position "I".
⇒ The warning buzzer sounds.

4. **i** *The starter switch is designed with a re-start lock. The ignition key must first be turned back to position "0" before a new starting attempt can be made.*



NOTICE!

Components may get damaged!

- Starting attempts should not exceed 30 seconds uninterrupted or max. 3 times for 10 seconds. Then allow the starter to cool down to ambient temperature.
- If the engine has not started after these attempts, determine the cause.

Turn the ignition key through position "II" to position "III".

⇒ The starter cranks the engine.

The warning buzzer stops.



NOTICE!

Danger of engine damage!

- Run the engine warm for a short while before starting work. Do not operate the engine immediately under full load.

6.3 Operation

Operate the machine only with the steering rod folded down.

Only use the steering rod to steer the machine.

Guide the machine so that your hands do not hit against solid objects.



CAUTION!

Danger of injury caused by uncontrolled machine movement!

- Always hold on to a running machine.
- Always keep an eye on a running machine.

Protective equipment: ■ Hearing protection
 ■ Safety shoes

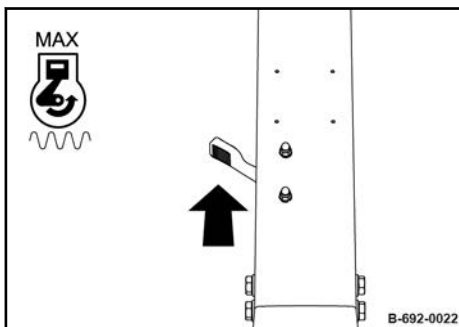

Fig. 20

1.



NOTICE!

The centrifugal clutch may be damaged!

- Operate the machine only with full throttle.

Set the throttle lever to position "MAX".

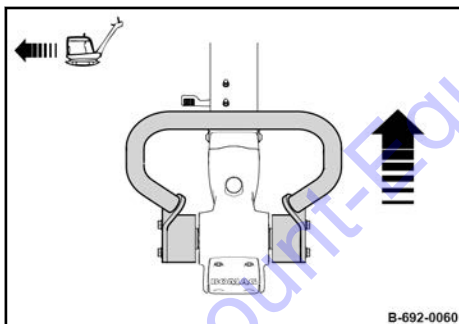

Fig. 21

2.

Shift the handle forwards.

⇒ The machine vibrates forwards with a speed which corresponds with the travel lever position.

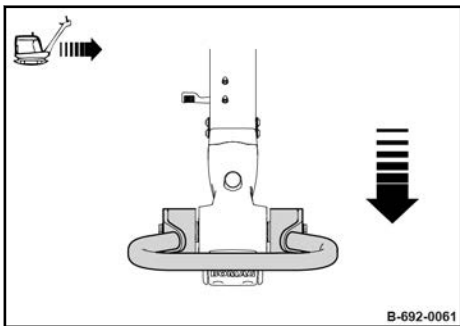

Fig. 22

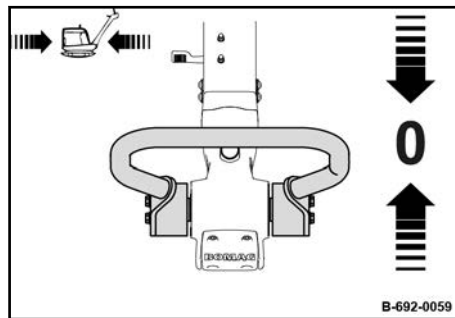

Fig. 23

Help if the machine gets stuck

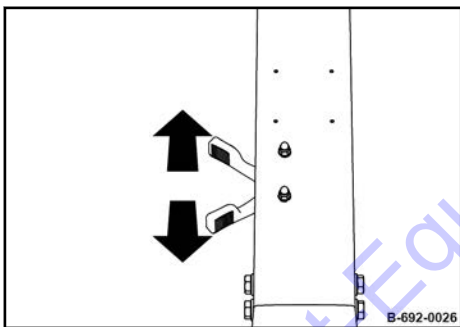

Fig. 24

3.



CAUTION!

Danger of injury caused by the crushing of body parts!

- When reversing, steer the machine from the side using the steering handle.

Pull the handle back.

- ⇒ The machine vibrates backwards with a speed which corresponds with the handle position.

4.

Move the handle back to position "0".

- ⇒ Machine stops and vibrates on the spot.

1.

Keep shifting the throttle lever between "MIN" and "MAX" positions.

At the same time use the steering rod to pull the machine right and left, until it comes free.

6.4 Park the machine in secured condition.

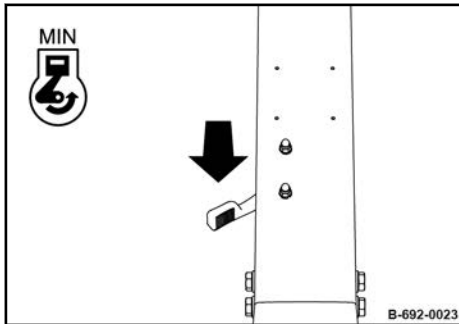

Fig. 25

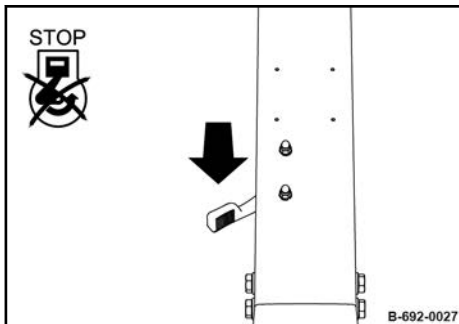

Fig. 26

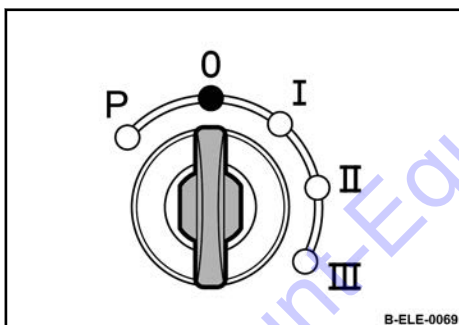

Fig. 27

1. Park the machine on level and firm ground.
2. Set the throttle lever to “MIN” position (idle speed).
⇒ Vibration is shut down.

3. **NOTICE!**
Danger of engine damage!
 - Do not shut down the engine all of a sudden from full load speed, but let it idle for about 2 minutes.

Set the throttle lever to position “Stop”.

⇒ The engine is shut down.

The warning buzzer sounds.

4. Turn the ignition key to position “0” and pull it out.
⇒ The warning buzzer stops.

6.5 ECONOMIZER

The ECONOMIZER informs the driver about the compaction status of the road subbase and enables the detection and selected re-compaction of weak spots.

An acceleration sensor on the base plate measures the reaction of the subsoil to the base plate of the vibratory plate.

Start process

The ECONOMIZER is automatically started by switching the ignition on.

The ECONOMIZER first of all runs an LED test. The LEDs light up one after the other, starting with LED (1). Once all LEDs are on, the display goes out again in single steps.

Measuring operation

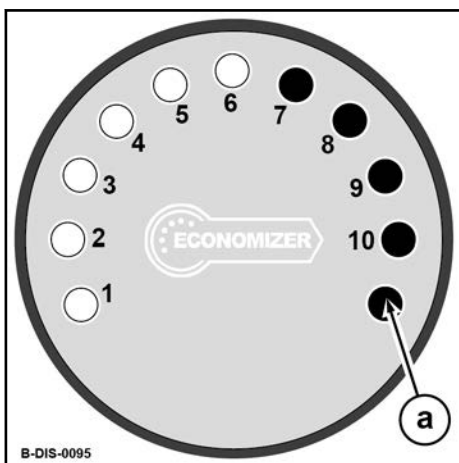

Fig. 28

With the vibration switched on, the measuring value is displayed by the LED display (1-10).

If the displayed value does not increase any further, no further compaction can be achieved with this machine.

The maximum display value (LED display 1-10 and warning display a) is not always reached.



Due to fluctuations in the measuring value, the displayed value can vary by one digit up/down during a pass.

The average of the display reading during the last pass is decisive.

The warning display (a):

- Flashes for 1 - 2 seconds after the vibration has been switched on. The display goes out as soon as the vibration frequency has been reached.
- Flashes if the vibration frequency is too low.
- Lights up, when at the same time the LED displays (1 - 10) have gone out, if no vibration has been detected.

Comparability of measuring values

In order to achieve the desired compaction condition of the road subbase, one must always perform a suitable reference measurement before compaction is started.

The reference measurement is used to determine which display value of the ECONOMIZER corresponds with the measuring value for soil stiffness.

The measuring values achieved with different machines can be made comparable by calibration to a reference value.

7

Loading / transporting the machine

Go to Discount-Equipment.com to order your parts

7.1 Loading the machine

Loads must only be attached and hoisted by an expert / qualified person.

Do not use damaged or in any other way impaired lifting points.

Use only lifting gear and lifting tackle with sufficient load bearing capacity for the weight to be loaded. Minimum load bearing capacity of lifting gear: see operating weight ↪ *Chapter 2 „Technical data“ on page 11.*

Always use appropriate lifting and lashing tackle on the lifting and lashing points.

Use lifting and lashing tackle only in the prescribed direction of load application.

Lifting and lashing tackle must not be damaged by machine components.

When lifting the machine, avoid uncontrolled movements of the load. If necessary, hold the load with guide ropes.

Protective equipment: ■ Protective gloves

1. Park the machine in secured condition ↪ *Chapter 6.4 „Park the machine in secured condition.“ on page 53.*
2. Allow the engine to cool down.
3. Move the steering rod to an upright position and engage the locking lever.

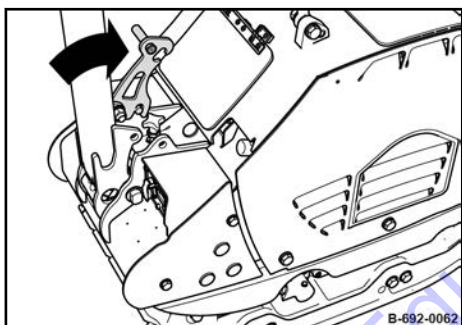

Fig. 29

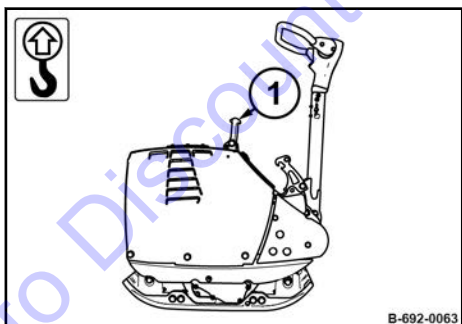

Fig. 30

4. Attach the lifting tackle to the designated lifting eye (1).
- 5.



DANGER!

Danger to life caused by suspended loads!

- Do not step or stand under suspended loads.

Lift the machine carefully and lower it again at the intended location.

7.2 Lashing the machine to the transport vehicle

Do not use damaged or in any other way impaired lifting points.

Always use appropriate lifting and lashing tackle on the lifting and lashing points.

Use lifting and lashing tackle only in the prescribed direction of load application.

Lifting and lashing tackle must not be damaged by machine components.

Protective equipment: ■ Protective gloves

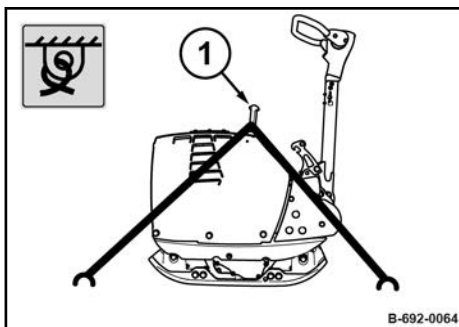

Fig. 31

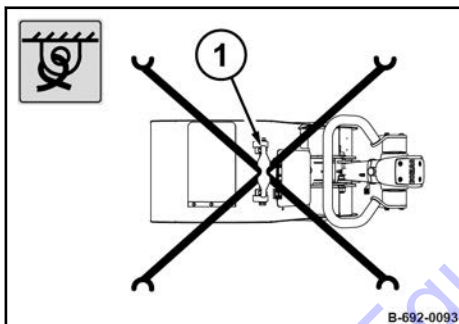

Fig. 32

1. Pull the lashing belts crosswise over the marked lashing point (1).

2. Lash the machine securely to the transport vehicle as shown.

Go to Discount-Equipment.com to order your parts

Go to Discount-Equipment.com to order your parts

8.1 Preliminary remarks and safety notes



DANGER!

Danger to life caused by an operationally unsafe machine!

- The machine must only be serviced by qualified and authorized personnel.
- Follow the safety regulations for maintenance work ↪ *Chapter 3.9 „Maintenance work“ on page 32.*



WARNING!

Health hazard caused by fuels and lubricants!

- Safety regulations and environmental protection regulations when handling fuels and lubricants must be followed ↪ *Chapter 3.4 „Handling fuels and lubricants“ on page 23.*

1. For all maintenance work park the machine in a secured condition ↪ *Chapter 6.4 „Park the machine in secured condition.“ on page 53.*
2. Thoroughly clean machine and engine before starting maintenance work.
3. Wear your personal protective outfit.
4. Do not touch hot engine parts.
5. Perform maintenance work only with the engine shut down.
6. After all maintenance work is completed reinstall all guards and safety installations.

8.2 Preparations / concluding work

Certain maintenance tasks require preparations and concluding activities.

This includes e.g. opening and closing maintenance flaps and maintenance doors as well as securing certain components.

After this work close all maintenance flaps and doors again and return all components to their operating condition.

8.2.1 Open protection hood

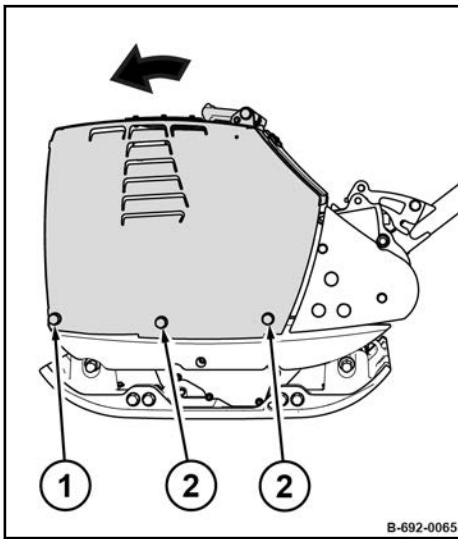

Fig. 33

1. Remove the screws (2) on both sides of the machine.
2. Loosen the screws (1) on both sides and fold the protection hood forwards.
3. Secure the protection hood against unintended closing by tightening the screws (1).

8.3 Fuels and lubricants

8.3.1 Engine oil

8.3.1.1 Oil quality

The following engine oil specifications are permitted:

- API CD/CE/CF/CF-4/CG-4 or higher quality
- ACEA B2/E2 or higher quality

Avoid mixing engine oils.

8.3.1.2 Oil viscosity

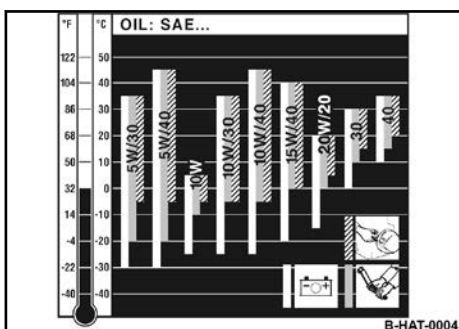

Fig. 34: Oil viscosity diagram

Since engine oil changes its viscosity with the temperature, the ambient temperature at the operating location of the engine is of utmost importance when choosing the viscosity class (SAE-class).

The temperature data of the SAE-class always refers to fresh oils. The engine oil ages during travel operation because of soot and fuel residues. This adversely affects the properties of the engine oil, especially at low ambient temperatures.

Optimal operating conditions can be achieved by using the oil viscosity chart as a reference.

8.3.1.3 Oil change intervals

Annually or every 250 operating hours.



When changing to a higher alloyed oil quality after a longer period of operation, it is recommended to perform the first oil change of the higher quality oil already after 25 operating hours.

8.3.2 Fuel

8.3.2.1 Fuel quality

The following fuel specifications are permitted:

- EN 590
- ASTM D975 Grade-No. 1-D and 2-D
- BS 2869 A1/A2

In order to fulfil national emission regulations one must strictly use the legally required fuels (e.g. sulphur content).

8.3.2.2 Winter fuel

For winter operation use only winter diesel fuel, to avoid clogging because of paraffin separation.

At very low temperatures disturbing paraffin separation can also be expected when using winter diesel fuel.

Diesel fuels suitable for temperatures down to -44 °C (-47 °F) are available for Arctic climates.



NOTICE!

Danger of engine damage!

- The admixture of petroleum and the addition of "flow enhancing additives" (fuel additives) is not permitted.

8.3.2.3 Storage

Even traces of zinc, lead and copper can cause deposits in the injection nozzles, especially in modern Common-Rail injection systems.

Zinc and lead coatings in refuelling systems and fuel lines are not permitted.

Copper containing materials (copper lines, brass items) should be avoided, because they can cause catalytic reactions in the fuel with subsequent depositing in the injection system.

8.3.3 Mineral oil based hydraulic oil

The hydraulic system is operated with hydraulic oil HV 32 (ISO) with a kinematic viscosity of 32 mm²/s at 40 °C (104 °F).

For topping up or for oil changes use only high-quality hydraulic oil, type HVLP according to DIN 51524, part 3, or hydraulic oils type HV according to ISO 6743/3.

The viscosity index (VI) should be at least 150 (observe information of manufacturer).

8.4 List of fuels and lubricants

Assembly group	Fuel or lubricant		Filling quantity
	Summer	Winter	Observe the level mark!
Engine oil	SAE 10W-40		1.5 l (0.4 gal us)
	Specification: ↪ Chapter 8.3.1 „Engine oil“ on page 62		
	SAE 15W-40		
	SAE 10W-30		
	SAE 30	SAE 10W	
Fuel	Diesel	Winter diesel fuel	5.0 l
	Specification: ↪ Chapter 8.3.2 „Fuel“ on page 62		(1.3 gal us)
Exciter shaft housing	as engine oil		0.4 l (0.11 gal us)
Steering rod	Hydraulic oil (ISO), HV 32		0.4 l (0.11 gal us)
	Specification: ↪ Chapter 8.3.3 „Mineral oil based hydraulic oil“ on page 63		

8.5 Running-in instructions

8.5.1 General

The following maintenance work must be performed when running in new machines or overhauled engines.

8.5.2 After 25 operating hours

1. Change the engine oil ↗ *Chapter 8.10.1 „Changing the engine oil and cleaning the oil filter“ on page 74.*
2. Check, adjust the valve clearance ↗ *Chapter 8.10.6 „Checking, adjusting the valve clearance“ on page 82.*
3. Check engine and machine for leaks.
4. Retighten the fastening screws on air filter, exhaust and other attachments.
5. Retighten the bolted connections on the machine.
6. Check the V-belt ↗ *Chapter 8.9.2 „Servicing the V-belt“ on page 71.*
7. Check the oil level in the vibrator housing ↗ *Chapter 8.9.1 „Checking the oil level in the exciter housing“ on page 71.*

Maintenance – Maintenance table

8.6 Maintenance table

No.	Maintenance works	Page
Weekly		
8.7.1	<i>Checking, cleaning the water separator</i>	67
Monthly		
8.8.1	<i>Air filter maintenance</i>	68
8.8.2	<i>Cleaning the cooling fins and the cooling air intake openings</i>	69
8.8.3	<i>Battery service</i>	70
Semi-annually		
8.9.1	<i>Checking the oil level in the exciter housing</i>	71
8.9.2	<i>Servicing the V-belt</i>	71
8.9.3	<i>Checking the screw joints on the diesel engine</i>	72
Annually		
8.10.1	<i>Changing the engine oil and cleaning the oil filter</i>	74
8.10.2	<i>Replacing the fuel filter</i>	76
8.10.3	<i>Replacing the starter rope</i>	77
8.10.4	<i>Changing the oil in the exciter housing</i>	78
8.10.5	<i>Checking the hydraulic oil level</i>	80
8.10.6	<i>Checking, adjusting the valve clearance</i>	82
As required		
8.11.1	<i>Cleaning the machine</i>	85
8.11.2	<i>Measures prior to extended shutdown period</i>	85

8.7 Weekly

8.7.1 Checking, cleaning the water separator



The service intervals for the water separator depend on the water content in the fuel and can therefore not be determined precisely.

After taking the engine into operation you should check for signs of water and dirt initially every day.

Protective equipment: ■ Protective gloves

1. Park the machine in secured condition ↪ Chapter 6.4 „Park the machine in secured condition.“ on page 53.
2. Place the transparent container under the drain plug.
3. Slacken the drain plug and catch running out fluid.
4. Drain the fuel off until there is no water left.
5. Turn the drain plug tightly back in. Ensure leak tightness.
6. Dispose of collected fluid in an environmentally friendly way.

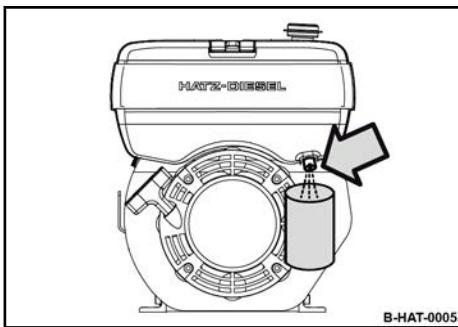

Fig. 35

8.8 Monthly

8.8.1 Air filter maintenance



Contamination of the air filter depends mainly on the proportion of dust in the intake air, if necessary clean several times a day.



NOTICE!

Danger of engine damage!

- Do not start the engine after having removed the air filter.
- If necessary, the air filter may be cleaned up to six times. The air filter must be replaced at the latest after half a year or 500 operating hours respectively.
- Cleaning does not make sense if the air filter element is covered with a sooty deposit.
- Do not use gasoline or hot fluids to clean the filter element.
- After cleaning the air filter must be inspected for damage using a torch.
- Do not continue to use a damaged air filter element. If in doubt use a new air filter.

Protective equipment: ■ Working clothes
■ Protective gloves
■ Safety goggles

1. Park the machine in secured condition ↪ Chapter 6.4 „Park the machine in secured condition.“ on page 53.
2. Allow the engine to cool down.
3. Remove the air filter cover (3).
4. Unscrew the knurled nut (2) and pull out the air filter (1).
5. Clean the air filter cover.
- 6.

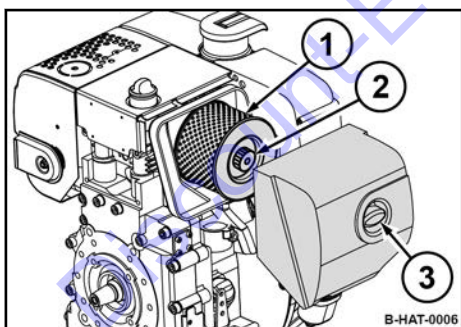

Fig. 36



NOTICE!

Danger of engine damage!

- Avoid the infiltration of dirt into the air intake opening.
- Do not clean the air filter housing with compressed air.

Clean the filter housing with a clean, lint-free cloth.

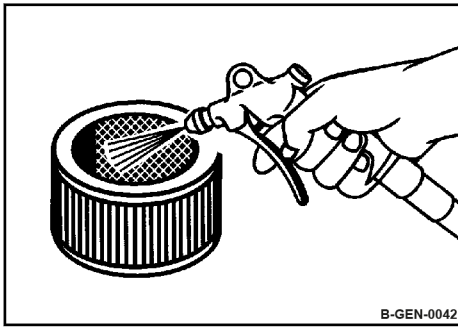

Fig. 37

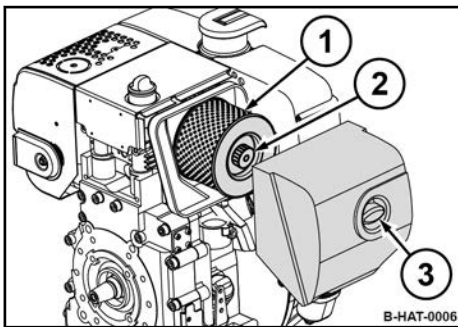

Fig. 38

7.



CAUTION!

Danger of eye injuries caused by particles flying around!

- Wear your personal protective equipment (safety gloves, protective working clothes, goggles).

Blow the air filter out with dry compressed air (max. 5 bar (73 psi)) from inside to outside by moving the gun up and down inside the element, until it is free of dust.

8. Examine the air filter with a torch for cracks and holes.

9. Replace the air filter if it is damaged.

10. Insert the air filter (1) carefully into the filter housing and fasten it with the knurled nut (2).

11.



NOTICE!

Danger of engine damage!

- Ensure correct fit of air filter cover and seal.

Assemble the air filter cover (3).

8.8.2 Cleaning the cooling fins and the cooling air intake openings

- Protective equipment:
- Working clothes
 - Protective gloves
 - Safety goggles

1. Park the machine in secured condition *Chapter 6.4 „Park the machine in secured condition.“ on page 53.*

2. Allow the engine to cool down.

3. Loosen dried on dirt with a suitable brush from all cooling fins and cooling air intake openings.

4.



CAUTION!

Danger of eye injuries caused by particles flying around!

- Wear your personal protective equipment (safety gloves, protective working clothes, goggles).

Blow cooling fins and cooling air intake openings out with compressed air.

5. In case of damp or oily contamination you should consult our customer service department.

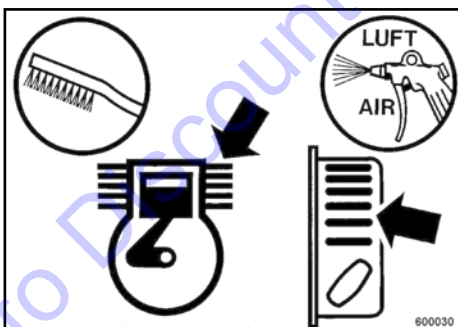

Fig. 39

8.8.3 Battery service



Maintenance free batteries also need care. Maintenance free only means that the fluid level does not need to be checked.

Each battery suffers under self-discharge, which may, if not checked occasionally, even cause damage to the battery as a result of exhaustive discharge.

Exhausted batteries (batteries with formation of sulphate on the plates) are not covered under warranty!

Protective equipment: ■ Working clothes
■ Protective gloves
■ Safety goggles

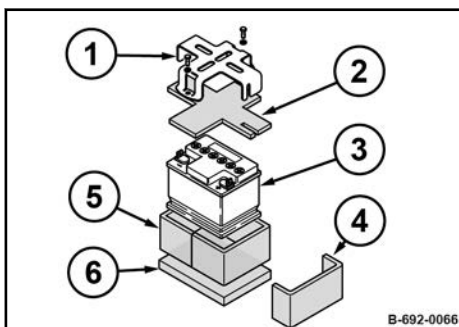

Fig. 40

1. Park the machine in secured condition ↪ Chapter 6.4 „Park the machine in secured condition.“ on page 53.
2. Remove the bracket (1) of the battery.
3. Remove the battery (3) and the vibration damping mats (2, 4, 5, 6).
4. Check the condition of the vibration insulation mats, replace if necessary.
5. Clean the outside of the battery.
6. Clean battery poles and pole clamps and grease them with pole grease (Vaseline).
7. On serviceable batteries check the acid level, if necessary top up to the filling mark with distilled water.
8. Install battery and vibration insulation mats.
9. Install the bracket of the battery.

8.9 Semi-annually

8.9.1 Checking the oil level in the exciter housing



NOTICE!

Components may get damaged!

- Use only oil of the permitted specification
 ↳ Chapter 8.4 „List of fuels and lubricants“ on page 64.

Protective equipment: ■ Working clothes
 ■ Protective gloves

1. Park the machine on level ground.
2. Park the machine in secured condition ↳ Chapter 6.4 „Park the machine in secured condition.“ on page 53.
3. Allow the machine to cool down.
4. Clean the area around oil breather screw (1) and filling/drain plug (2).
5. Unscrew the bleeding screw.
6. Unscrew the filling/drain plug and check the oil level, top up if necessary.
 ⇒ **Nominal value:** Bottom edge of filling/drain bore.
7. Clean bleeding screw and filler / drain plug and install with sealing agent (spare parts number: 00970016).

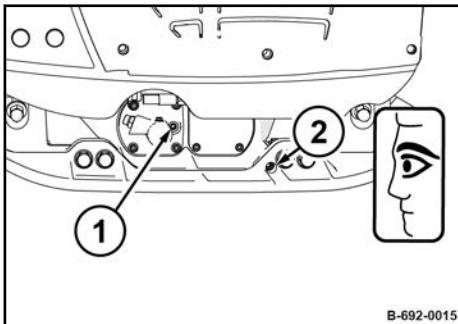

Fig. 41

8.9.2 Servicing the V-belt

Preparations

1. Park the machine in secured condition ↳ Chapter 6.4 „Park the machine in secured condition.“ on page 53.
2. Allow the engine to cool down.
3. Disassemble the V-belt guard (1).

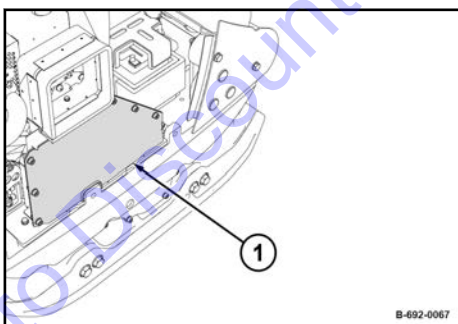

Fig. 42

Checking the V-belt

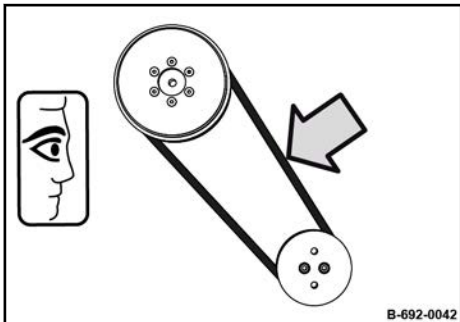

Fig. 43

1. Check condition and tightness of V-belt.
⇒ **Compression measurement:** 10 - 25 mm (0.59 - 0.98 in).

2. **i** The V-belt cannot be re-tightened.

Replace the V-belt if it is damaged or if the compression measurement is exceeded.

Replacing the V-belt

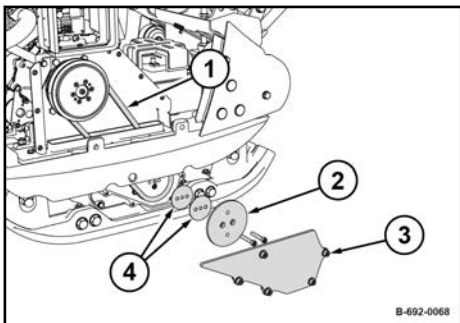

Fig. 44

1. Disassemble the guard (3).
2. Disassemble the V-belt pulley (2).
3. Replace the V-belt (1).
4. If necessary, reassemble the spacers (4) that may have been removed.
5. Assemble the V-belt pulley, tightening torque: 35 Nm (26 ft·lbf).
6. Assemble the guard, tightening torque: 15 Nm (11 ft·lbf).

Final work

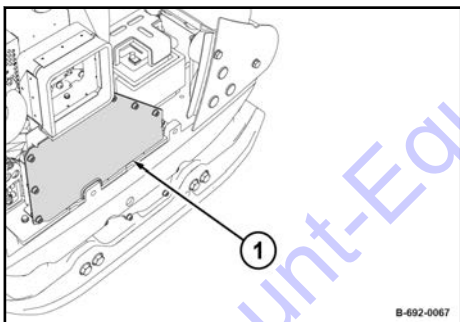

Fig. 45

1. Install the V-belt guard (1).

8.9.3 Checking the screw joints on the diesel engine

1. Park the machine in secured condition ↪ Chapter 6.4 „Park the machine in secured condition.“ on page 53.
2. Allow the engine to cool down.

3.



NOTICE!

Components may get damaged!

- Do not retighten the cylinder head fastening screws.
- Do not retighten or adjust the setscrews on throttle control and injection system.

Check all screw joints on the diesel engine for condition and tight fit, retighten if necessary.

Go to Discount-Equipment.com to order your parts

8.10 Annually

8.10.1 Changing the engine oil and cleaning the oil filter



Change the engine oil at the latest after 250 operating hours.



NOTICE!

Danger of engine damage!

- Change the oil only with the engine at operating temperature.
- Use only oil of the permitted specification ↪ Chapter 8.3.1 „Engine oil“ on page 62.
- Filling quantity: ↪ Chapter 8.4 „List of fuels and lubricants“ on page 64

Protective equipment: ■ Working clothes
■ Protective gloves
■ Safety goggles

Draining off engine oil

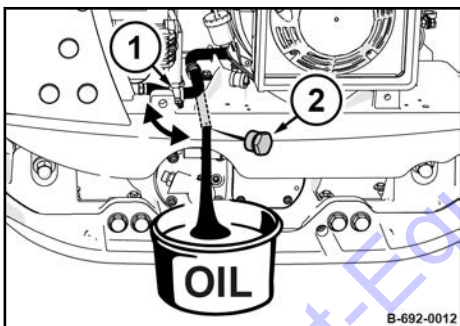

Fig. 46

1. Park the machine in secured condition ↪ Chapter 6.4 „Park the machine in secured condition.“ on page 53.
2. Clean the area around the dipstick and pull the dipstick out.
3. Clean the area around the drain hose.
4. Loosen the hose clamp (1) and route the drain hose to the outside.
- 5.



WARNING!

Danger of burning on hot components!

- Wear your personal protective equipment (protective gloves, protective clothing).
- Avoid touching hot components.

Unscrew the oil drain plug (2) and catch any oil running out.

6. Clean the drain plug and screw it back in.
7. Assemble the drain hose with the hose clamp.

Cleaning the oil filter

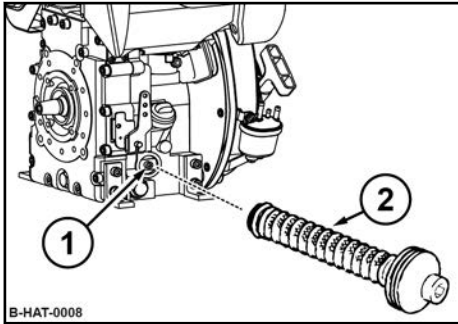

Fig. 47

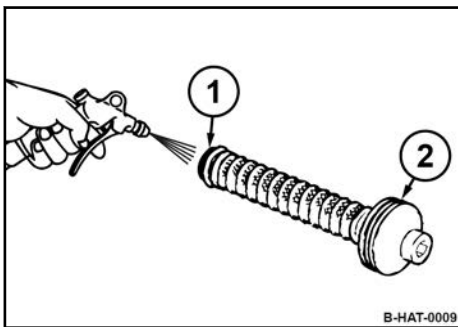

Fig. 48

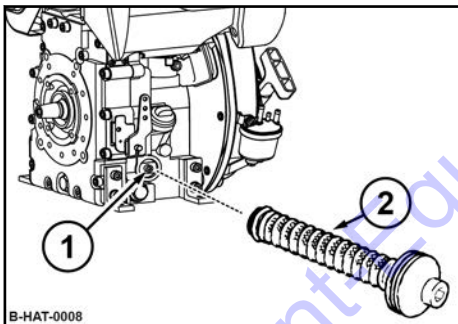

Fig. 49

8. Loosen the screw (1) for approx. five turns and pull the oil filter (2) out of the housing.

9.



CAUTION!

Danger of eye injuries caused by particles flying around!

- Wear your personal protective equipment (safety gloves, protective working clothes, goggles).

Use compressed air to blow the oil filter out from inside to outside.

10. Check the seal ring (2) for damage, change if necessary.
11. Slightly oil the seal rings (1) and (2).
12. Insert the oil filter (2) into the housing and press it against the end stop.
13. Before tightening the screw (1) make sure that the tensioning springs touch the oil filter with both ends.
14. Tighten the screw.

Filling in engine oil

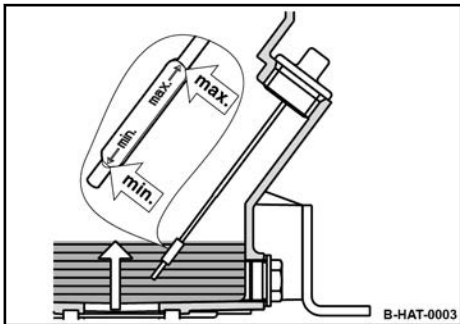

Fig. 50

Final work

15. Fill in fresh engine oil up to the bottom edge of the filling opening.
16. After a short test run check the oil level on the dipstick; if necessary, top up to the top dipstick mark.

17. Check oil filter and drain plug for leaks.
18. Dispose of oil in an environmentally friendly way.

8.10.2 Replacing the fuel filter



NOTICE!

Danger of engine damage!

- Ensure strict cleanliness! Thoroughly clean the area around the fuel tank beforehand.
- Never operate the engine after having removed the fuel filter.

Protective equipment: ■ Working clothes
■ Protective gloves

1. Park the machine in secured condition ↪ Chapter 6.4 „Park the machine in secured condition.“ on page 53.
2. Clean the area around the tank filler cap.
3. Remove the tank filler cap.
4. Pull the fuel filter out of the tank by the string.
5. Pull the fuel hose (3) off the fuel filter (2).
6. Take the fuel filter out of the bracket (1) and replace it with a new one.
7. Plug on the fuel line.
8. Insert the fuel filter into the tank.
9. Close the fuel tank tightly.

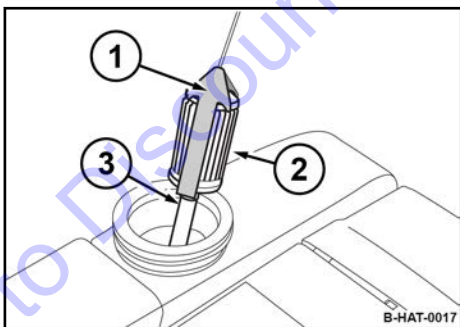

Fig. 51



The fuel system is self-bleeding.

10. Dispose of fuel and filter in an environmentally friendly way.

8.10.3 Replacing the starter rope

- Protective equipment: ■ Working clothes
 ■ Protective gloves

1. Park the machine in secured condition ↪ Chapter 6.4 „Park the machine in secured condition.“ on page 53.
2. Allow the engine to cool down.
3. Unscrew the fastening screws (1) and disassemble the recoil starter (2).

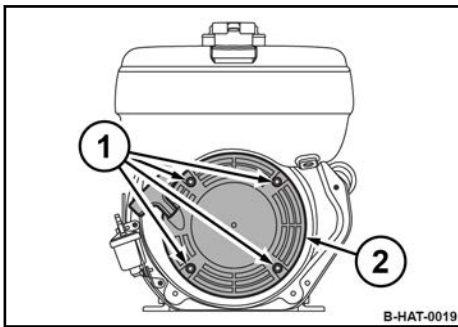

Fig. 52

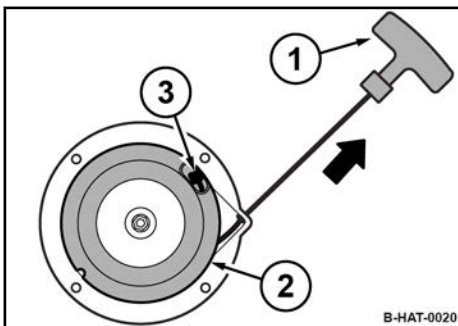

Fig. 53

4. Pull the starter rope with the starter handle (1) out completely.
5. Secure the coil (2) against winding up.
6. Loosen the knot (3) in the starter rope and remove the old starter rope.
7. Carefully turn the coil back, until the recoil spring is relieved.

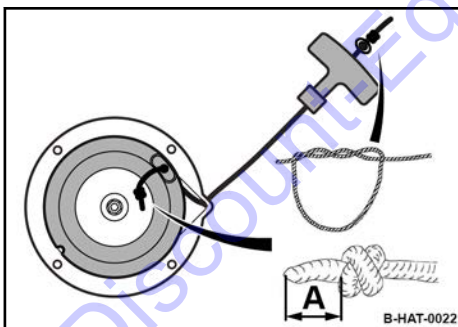

Fig. 54

8. Thread in the new starter rope and fix it with knots on both ends .
A = 15 mm (0.6 in)

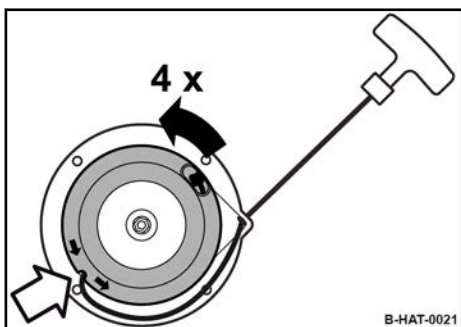

Fig. 55

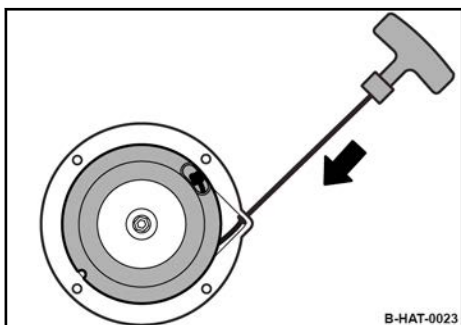

Fig. 56

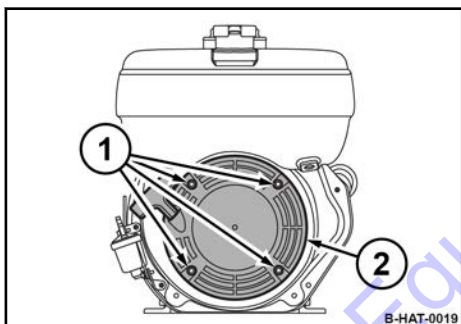

Fig. 57

8.10.4 Changing the oil in the exciter housing

9. Pre-tension the coil by approx. 4 rotations in direction of arrow.
Thereby place the starter rope into the recess in the coil .



CAUTION!

Danger of injury caused by the starter handle hitting against your body!

- Do not let the starter handle hit back.

Slowly guide the starter handle back to initial position .

- 10.
11. Pull the starter handle to check the function and light movement of the recoil starter.
12. Assemble the recoil starter (2) with fastening screws (1).



Perform this maintenance work at the latest after 500 operating hours



NOTICE!

Components may get damaged!

- Use only oil of the permitted specification
↳ Chapter 8.4 „List of fuels and lubricants“ on page 64.

Protective equipment: ■ Working clothes
 ■ Protective gloves

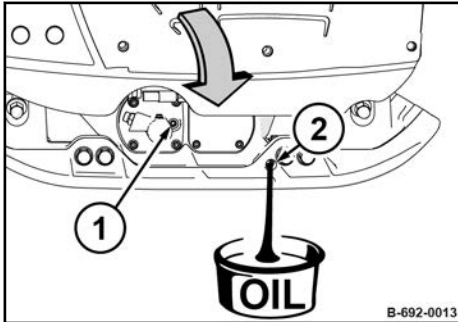

Fig. 58

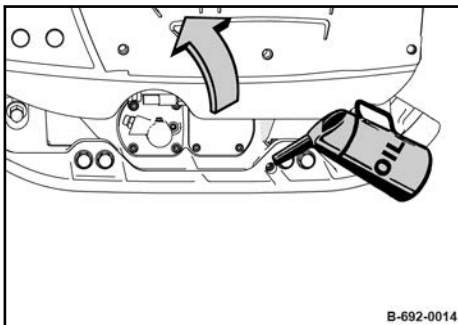

Fig. 59

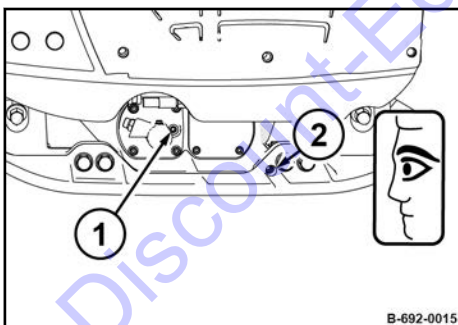

Fig. 60

1. Park the machine on level ground.
2. Park the machine in secured condition ↪ Chapter 6.4 „Park the machine in secured condition.“ on page 53.
3. Clean the area around oil breather screw (1) and filling/drain plug (2).
4. Tilt the machine slightly towards the oil drain side and support it safely.
5. Unscrew the bleeding screw.



WARNING!

Danger of burning on hot components!

- Wear your personal protective equipment (protective gloves, protective clothing).
- Avoid touching hot components.

Unscrew the filling/drain plug and catch any oil running out.

7. Tilt the machine to the opposite side and secure it properly.
8. Fill in new oil.

9. Stand the machine horizontally and check the oil level.

⇒ **Nominal value:** Bottom edge of filling/drain bore.

10. Clean bleeding screw (1) and filling/drain plug (2) and install with sealing agent (spare parts number: 009 700 16).
11. Dispose of oil in an environmentally friendly way.

8.10.5 Checking the hydraulic oil level

Protective equipment: ■ Protective gloves

1. Park the machine in secured condition ↪ *Chapter 6.4 „Park the machine in secured condition.“ on page 53.*
2. Adjust the steering rod with height adjustment so that the area with the filler plug is horizontal.
3. Unscrew the filler plug.

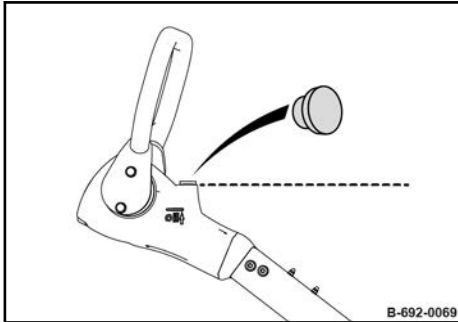

Fig. 61

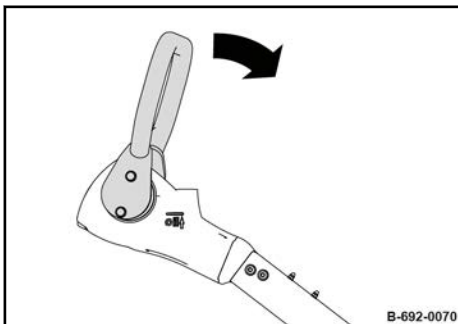

Fig. 62

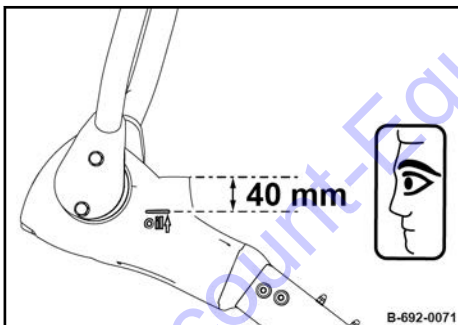

Fig. 63

Filling up hydraulic oil

4. Press the handle forward against the stop and hold it in this position.
5. The oil level must reach the mark on the steering rod head, if necessary fill in hydraulic oil.

Mark: approx. 40 mm (1.6 in) below the filler opening



NOTICE!

Risk of damage!

- Use only hydraulic oil of the permitted specification.

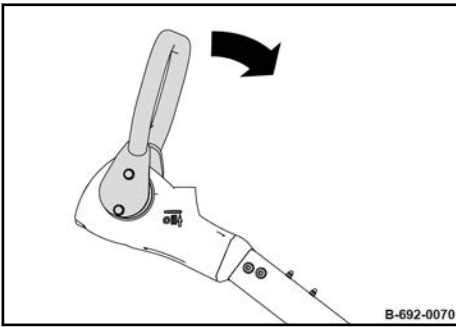

Fig. 64

6. Press the handle forward against the stop and hold it in this position.

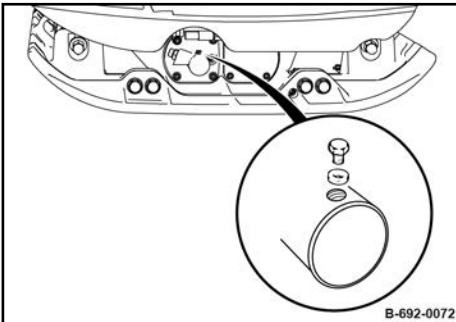

Fig. 65

7. Place a cloth underneath the bleeding screw to catch leaking oil.
8. Slacken the bleeding screw.
9. Wait until all air has escaped and then tighten the bleeding screw.

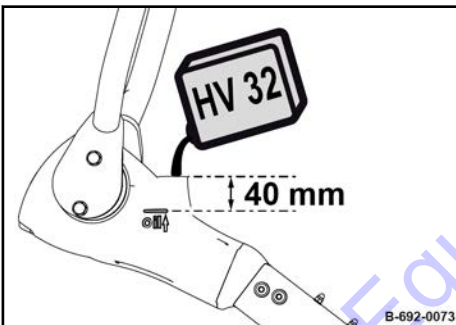

Fig. 66

10. Fill in hydraulic oil up to the mark on the steering rod head.

Final work

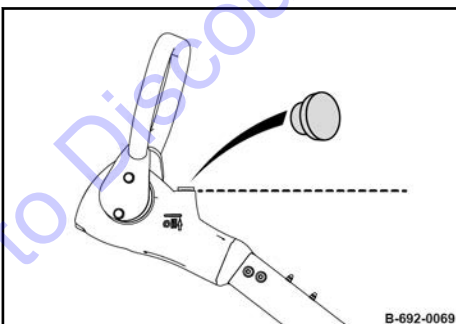

Fig. 67

11. Unscrew the filler plug.

8.10.6 Checking, adjusting the valve clearance



Perform this maintenance work at the latest after 250 operating hours



NOTICE!

Danger of engine damage!

We recommend to have this work carried out by trained personnel or our after sales service.

- Before checking the valve clearance let the engine cool down.

Preparations

Protective equipment: ■ Working clothes
■ Protective gloves

1. Park the machine in secured condition ↪ *Chapter 6.4 „Park the machine in secured condition.“ on page 53.*
2. Let the engine to cool down to ambient temperature.
3. Remove the air filter cover (2).
4. Disassemble the covering (1).

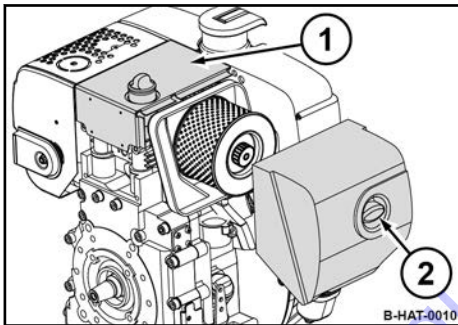

Fig. 68

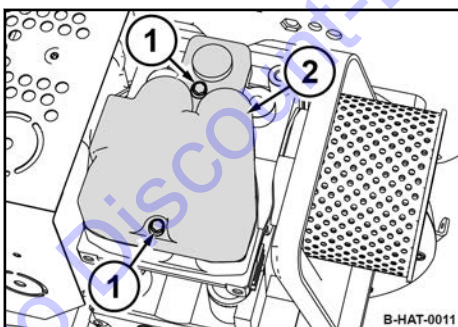

Fig. 69

5. Unscrew the fastening screws (1).
6. Remove the valve cover (2) with gasket.

Checking the valve clearance

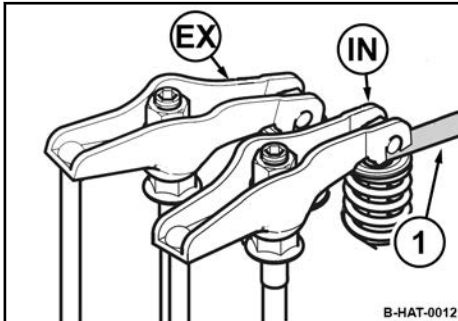

Fig. 70

Valve clearance:

Intake valve (IN)	0.20 mm (0.008 in)
Exhaust valve (EX)	0.20 mm (0.008 in)

1. Crank the engine, until the exhaust valve (EX) is fully open.
2. Check the valve clearance on the intake valve (IN) with a feeler gauge (1), adjust if necessary.
3. Crank the engine further, until the intake valve is fully open.
4. Check the valve clearance on the exhaust valve, adjust if necessary.

Adjusting the valve clearance

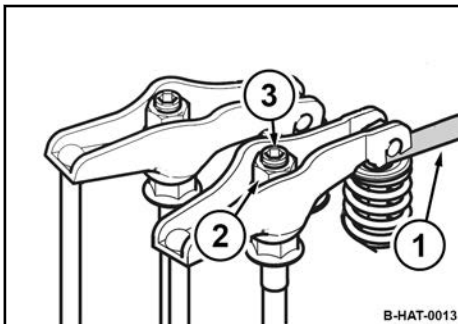

Fig. 71

1. Loosen screw (3) on the rocker arm.
2. Adjust the hexagon nut (2), until the feeler gauge (1) can be inserted and pulled out with noticeable resistance after the screw (3) has been tightened.

Final work

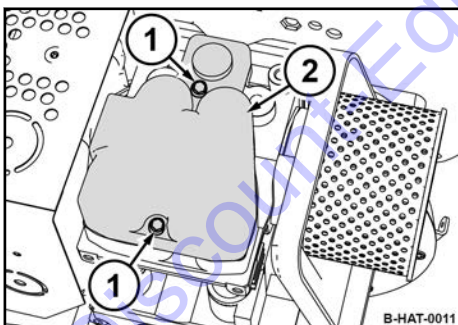

Fig. 72

1. Install the valve cover (2) with a new gasket.
2. Tighten the fastening screws (1) evenly.

Maintenance – Annually

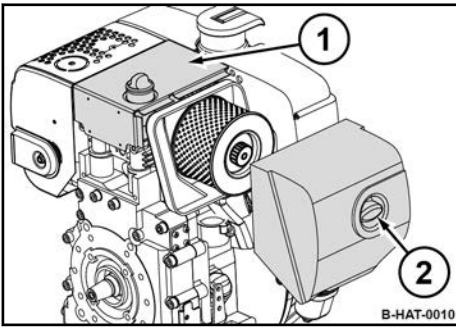

Fig. 73

3. Assemble covering (1) and air filter cover (2).
4. After a short test run check the valve cover for leaks.

Go to Discount-Equipment.com to order your parts

8.11 As required

8.11.1 Cleaning the machine

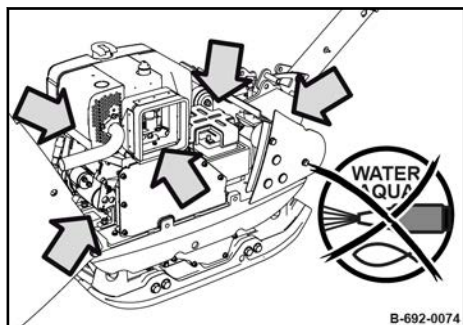

Fig. 74: Cleaning the machine (example)

1. Park the machine in secured condition ↪ Chapter 6.4 „Park the machine in secured condition.“ on page 53.
2. Allow the engine to cool down for at least 30 minutes.
3. Open the protection hood.
- 4.



NOTICE!

Electric components can be damaged by water entering into the system!

- Do not guide the water jet directly into the cooling air openings of the recoil starter, into the dry air filter or onto electrical equipment.

Clean the machine from the outside and inside with a water jet.

5. Close the protection hood.
6. Run the engine warm for a while to avoid corrosion.

8.11.2 Measures prior to extended shutdown period

8.11.2.1 Measures before shutting down

If the machine is shut down for a longer period of time (e.g. winter season), the following work must be carried out:

1. Clean the machine thoroughly.
2. Clean the water separator.
3. Fill the fuel tank with diesel fuel, to prevent the formation of condensation water in the tank.
4. Change engine oil if the oil change had been carried out more than 300 operating hours ago.
5. After shutting down store the machine under cover in a dry and well ventilated room.
6. Cover the cooled down engine to protect it against dust and moisture.

8.11.2.2 Battery service during prolonged machine downtimes



WARNING!

Danger of injury caused by exploding gas mixture!

- Remove the plugs before starting to recharge the battery.
- Ensure adequate ventilation.
- Smoking and open fire is prohibited!
- Do not lay any tools or other metal objects on the battery.
- Do not wear jewellery (watch, bracelets, etc.) when working on the battery.
- Wear your personal protective equipment (protective gloves, protective clothing, goggles).

Protective equipment: ■ Working clothes
■ Protective gloves
■ Safety goggles

1. Switch off all consuming devices (e.g. ignition, light).
2. Measure the open-circuit voltage of the battery at regular intervals (at least 1 x per month).
 - ⇒ Reference values: 12.6 V = fully charged; 12.3 V = discharged to 50%.
3. Recharge the battery immediately after an open-circuit voltage of 12.25 V or less is reached. Do not perform boost charging.
 - ⇒ The open-circuit voltage of the battery occurs approx. 10 hours after the last charging process or one hour after the last discharge.
4. Switch off the charging current before removing the charging clamps.
5. After each charging process allow the battery to rest for one hour before taking it into service.
6. For standstill periods of more than one month you should always disconnect the battery. Do not forget to perform regular open-circuit voltage measurements.

8.11.2.3 Measures before restarting

1. Replace the fuel filter.
2. Replace the air filter.
3. Change the engine oil and clean the oil filter.
4. Check cables, hoses and lines for cracks and leaks.
5. Start the engine and run it for 15 to 30 minutes with idle speed.

6. Check the oil levels.
7. Clean the machine thoroughly.

Go to Discount-Equipment.com to order your parts

Go to Discount-Equipment.com to order your parts

Go to Discount-Equipment.com to order your parts

9.1 Preliminary remarks

Malfunctions are frequently caused by incorrect operation of the machine or insufficient maintenance. Whenever a fault occurs you should therefore thoroughly read these instruction on correct operation and maintenance.

If you cannot locate the cause of a fault or rectify it yourself by following the trouble shooting chart, you should contact our customer service department.

Go to Discount-Equipment.com to order your parts

9.2 Starting the engine with the recoil starter



Start the engine with the recoil starter only if the battery is defective, empty or missing.

Exhaust fumes contain toxic substances and can damage your health, cause unconsciousness or even death.



WARNING!

Danger of poisoning by exhaust gases!

- Do not inhale exhaust gases.
- Avoid operation in closed or partly closed rooms, or ensure adequate ventilation when working in trenches.



WARNING!

Loss of hearing caused by too high noise burdens!

- Wear your personal protective equipment (ear protection).

Protective equipment: ■ Hearing protection
■ Safety shoes

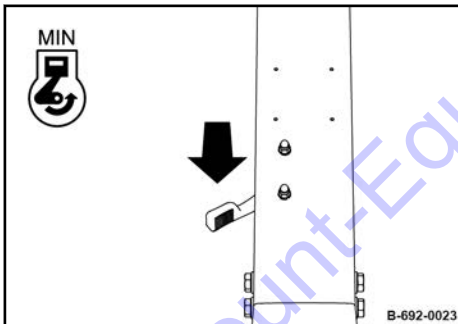

Fig. 75

1. Set the throttle lever to position "MIN".

Troubleshooting – Starting the engine with the recoil starter

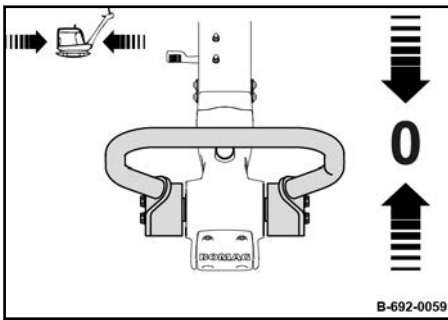

Fig. 76

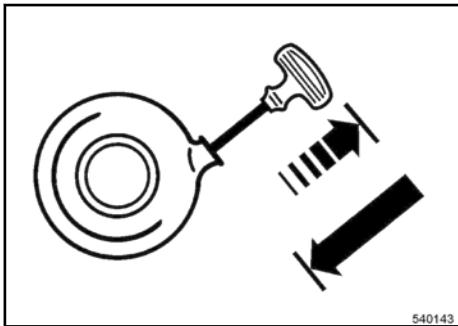

Fig. 77

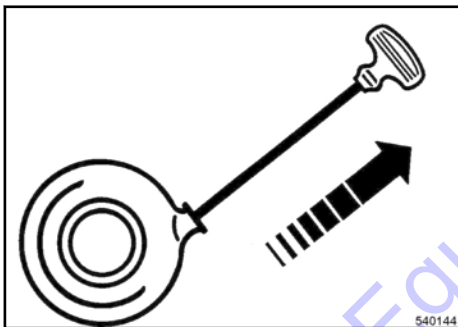

Fig. 78

2. Set the handle to position "0".

3. Lightly pull the rope twice with the starter handle, until resistance can be felt (compression pressure).
4. Guide the starter handle back to initial position.

- 5.



CAUTION!

Danger of injury caused by uncontrolled machine movement!

- Always hold on to a running machine.
- Always keep an eye on a running machine.



NOTICE!

The starter rope may tear off!

- Do not pull the starter rope all the way against the end stop.

Pull the starter handle quickly and with power.

6. Manually guide the starter handle back to initial position.
7. If the engine does not start during the first attempt, repeat the starting process.



NOTICE!

Danger of engine damage!

- Run the engine warm for a short while before starting work. Do not operate the engine immediately under full load.

Go to Discount-Equipment.com to order your parts

9.3 Starting the engine with jump leads



NOTICE!

A wrong connection will cause severe damage in the electric system.

- Bridge the machine only with a 12 Volt auxiliary battery.

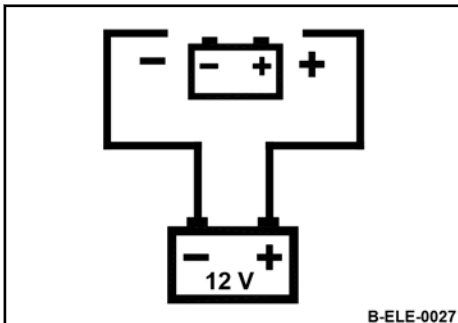

Fig. 79

1. Open the protection hood and secure it to prevent unintended closing.
2. Remove the bracket of the battery.
3. First connect the plus pole of the external battery to the plus pole of the starter battery using the first jump lead.
4. Next, connect the second jump lead to the minus pole of the energizing external battery and then to the minus pole of the starter battery.
5. Start the engine ↪ *Chapter 6.2 „Start the engine“ on page 49.*
6. After starting disconnect the minus poles first and the plus poles after.
7. Install the bracket of the battery.
8. Close the protection hood.

9.4 Fuse assignment



WARNING!

Danger of injury by fire in the machine!

- Do not use fuses with higher ampere ratings and do not bridge fuses.

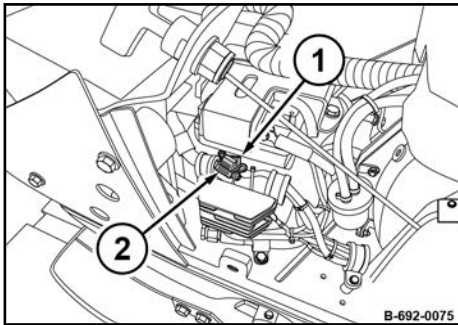

Fig. 80

Pos.	Amperage	Designation
1	5 A	Economizer fuse (<i>optional equipment</i>)
2	25 A	Main fuse

Go to Discount-Equipment.com to order your parts

Troubleshooting – Engine malfunctions

9.5 Engine malfunctions

Malfunction	Possible cause	Remedy
No or poor starting of engine	Fuel tank empty	Check the fuel level, top up if necessary
	Fuel filter clogged	Check the fuel filter, replace if necessary
	Fuel lines leaking	Check the fuel lines
	Incorrect valve clearance	Check, adjust the valve clearance
	Wear on cylinder or piston rings	Have checked by qualified expert personnel
	Injection nozzle out of order	Have checked by qualified expert personnel
Engine does not start or starts poorly at low temperatures	Fuel filter clogged by paraffin separation	Change the fuel filter, use winter fuel
	Engine oil with wrong SAE viscosity class	Change the engine oil
	Insufficiently charged battery	Check the battery or have it checked by qualified expert personnel
Engine does not crank when operating the recoil starter	Recoil starter defective	Replace the recoil starter
	Spring broken	Replace the recoil starter
Starter rope of recoil starter does not return to initial position	Recoil starter dirty	Clean the recoil starter
	Insufficient pre-tension of the spring	Check the pre-tension of the spring, adjust if necessary
	Spring broken	Replace the recoil starter
Engine ignites, but does not run	Fuel filter clogged	Check the fuel filter, replace if necessary
The starter does not switch on or the engine does not crank.	Fault in the electric system: <ul style="list-style-type: none"> ■ Battery or other cable connections not correctly connected. ■ Cable terminals loose or oxidised. ■ Battery defective or not charged. ■ Starter defective. ■ Fuse defective. 	Check
Engine stops	Fuel tank empty	Check the fuel level, top up if necessary
	Fuel filter clogged	Check the fuel filter, replace if necessary
	Tank ventilation blocked	Ensure sufficient ventilation of the tank
	Air in the fuel system	Check the fuel system for air leaks. Check the ventilation valve.
	Mechanical defect	Have checked by qualified expert personnel
Engine loses power and speed	Fuel tank empty	Check the fuel level, top up if necessary
	Fuel system clogged	Check the fuel filter, replace if necessary

Troubleshooting – Engine malfunctions

Malfunction	Possible cause	Remedy
	Tank ventilation blocked	Ensure sufficient ventilation of the tank
	Air in the fuel system	Check the fuel system for air leaks. Check the ventilation valve.
Engine loses power and speed, black exhaust smoke	Air filter dirty	Clean, replace if necessary
	Incorrect valve clearance	Check, adjust the valve clearance
	Injection nozzle out of order	Have checked by qualified expert personnel
Engine overheats	Engine oil level too high	Check, drain off if necessary
	Lack of cooling air	Clean the cooling fins and the cooling air intake openings. Check air guide plates and ducts for completeness and good sealing.
Engine runs with high speed, but no vibration	Centrifugal clutch defective	Have checked by qualified expert personnel
	V-belt broken	Replacing the V-belt

9.6 Malfunctions during operation

Malfunction	Possible cause	Remedy
The machines vibrates forward with a strongly reduced speed	Air in the hydraulic system of the steering rod	Release pressure from the steering rod
	The oil level in the exciter shaft housing is too low	Check the oil level in the exciter shaft housing

Release pressure from the steering rod

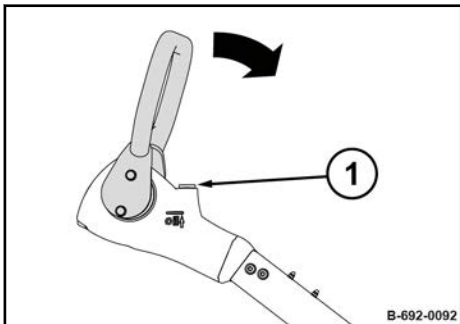

Fig. 81

Protective equipment: ■ Protective gloves

1. Park the machine in secured condition ↪ *Chapter 6.4 „Park the machine in secured condition.“ on page 53.*
2. Press the handle forward against the stop and hold it in this position.
3. Carefully loosen the adjustment screw (1).
⇒ The air makes a slight hissing sound when escaping.
4. Wait until all air has escaped and then tighten the adjustment screw.

9.7 Trouble shooting ECONOMIZER

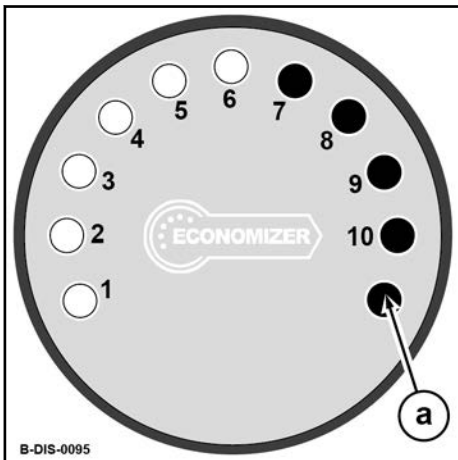

Fig. 82: Economizer display

Malfunction	Possible cause	Remedy
LED (a) flashing	Switching on: The LED (a) flashes for approx 1 - 2 seconds after the vibration has been switched on.	
	Vibration frequency too low	
	Acceleration sensor is not connected	Check the connection of the acceleration sensor
	Cable breakage	Inform our service department
LED (a) lights	No vibration detected	Starting the engine Check the connection of the acceleration sensor
The displayed measuring values are not plausible	The acceleration sensor is not fastened correctly	Shut down the engine and check the fastening screws for the acceleration transducer
	Weak spots in the road subbase	In unfavourable cases an excessively varying material composition or moisture can influence the measuring results. On considerably dry or excessively moist material lower measuring values will be displayed.

Go to Discount-Equipment.com to order your parts

Go to Discount-Equipment.com to order your parts

10.1 Final shut-down of machine

If the machine can no longer be used and needs to be finally shut down you must carry out the following work and have the machine disassembled by an officially recognized specialist workshop.



WARNING!

Health hazard caused by fuels and lubricants!

- Safety regulations and environmental protection regulations when handling fuels and lubricants must be followed ↪ *Chapter 3.4 „Handling fuels and lubricants“ on page 23.*

Protective equipment:

- Working clothes
- Safety shoes
- Protective gloves
- Safety goggles

1. Remove the batteries and dispose of in compliance with legal regulations.
2. Empty the fuel tank.
3. Drain engine oil from engine and exciter housing.
4. Drain off hydraulic oil.

PARTS FINDER

**Search Website
by Part Number**



**Search Manual
Library For Parts
Manual & Lookup Part
Numbers – Purchase
or Request Quote**

Search Manuals

Enter your information to help us find the right parts manual for your machine.

* Brand:

* Model:

* Serial:

* Part Number:

SEARCH

**Can't Find Part or
Manual? Request Help
by Manufacturer,
Model & Description**

Parts Order Form

Please fill in the following information to help us find the right part for your machine.

Manufacturer:	<input type="text"/>
Model:	<input type="text"/>
Description:	<input type="text"/>
Part Number:	<input type="text"/>
Quantity:	<input type="text"/>
Notes:	<input type="text"/>

Submit

Discount-Equipment.com is your online resource for quality parts & equipment.

Florida: **561-964-4949** Outside Florida TOLL FREE: **877-690-3101**

Need parts?

Click on this link: <http://www.discount-equipment.com/category/5443-parts/> and choose one of the options to help get the right parts and equipment you are looking for. Please have the machine model and serial number available in order to help us get you the correct parts. If you don't find the part on the website or on one of the online manuals, please fill out the request form and one of our experienced staff members will get back to you with a quote for the right part that your machine needs.

We sell worldwide for the brands: Genie, Terex, JLG, MultiQuip, Mikasa, Essick, Whiteman, Mayco, Toro Stone, Diamond Products, Generac Magnum, Airman, Haulotte, Barreto, Power Blanket, Nifty Lift, Atlas Copco, Chicago Pneumatic, Allmand, Miller Curber, Skyjack, Lull, Skytrak, Tsurumi, Husquvarna Target, Stow, Wacker, Sakai, Mi-T-M, Sullair, Basic, Dynapac, MBW, Weber, Bartell, Bennar Newman, Haulotte, Ditch Runner, Menegotti, Morrison, Contec, Buddy, Crown, Edco, Wyco, Bomag, Laymor, EZ Trench, Bil-Jax, F.S. Curtis, Gehl Pavers, Heli, Honda, ICS/PowerGrit, IHI, Partner, Imer, Clipper, MMD, Koshin, Rice, CH&E, General Equipment, Amida, Coleman, NAC, Gradall, Square Shooter, Kent, Stanley, Tamco, Toku, Hatz, Kohler, Robin, Wisconsin, Northrock, Oztec, Toker TK, Rol-Air, APT, Wylie, Ingersoll Rand / Doosan, Innovatech, Con X, Ammann, Mecalac, Makinex, Smith Surface Prep, Small Line, Wanco, Yanmar