



An Oshkosh Corporation Company



www.Discount-Equipment.com

Operation and Safety Manual

Original Instructions - Keep this manual with the machine at all times.

TOUCAN 12E

TOUCAN 32E

ANSI   **AS**

31210136

October 16, 2014

English - Operation & Safety

TO PURCHASE THIS PRODUCT PLEASE CONTACT US



**Equipment Financing and
Extended Warranties Available**



**Discount-Equipment.com is your online resource for
commercial and industrial quality parts and equipment sales.**

561-964-4949

visit us on line @ www.discount-equipment.com

Select an option below to find your Equipment

Search by Manufacturer

Search by Product Type

Request a Quote

We sell worldwide for the brands: Genie, Terex, JLG, MultiQuip, Mikasa, Essick, Whiteman, Mayco, Toro Stone, Diamond Products, Generac Magnum, Airman, Haulotte, Barreto, Power Blanket, Nifty Lift, Atlas Copco, Chicago Pneumatic, Allmand, Miller Curber, Skyjack, Lull, Skytrak, Tsurumi, Husquvarna Target, Stow, Wacker, Sakai, Mi-T-M, Sullair, Basic, Dynapac, MBW, Weber, Bartell, Bennar Newman, Haulotte, Ditch Runner, Menegotti, Morrison, Contec, Buddy, Crown, Edco, Wyco, Bomag, Laymor, EZ Trench, Bil-Jax, F.S. Curtis, Gehl Pavers, Heli, Honda, ICS/PowerGrit, IHI, Partner, Imer, Clipper, MMD, Koshin, Rice, CH&E, General Equipment, Amida, Coleman, NAC, Gradall, Square Shooter, Kent, Stanley, Tamco, Toku, Hatz, Kohler, Robin, Wisconsin, Northrock, Oztec, Toker TK, Rol-Air, APT, Wylie, Ingersoll Rand / Doosan, Innovatech, Con X, Ammann, Mecalac, Makinex, Smith Surface Prep, Small Line, Wanco, Yanmar

FOREWORD

This manual is a very important tool! Keep it with the machine at all times.

The purpose of this manual is to provide owners, users, operators, lessors, and lessees with the precautions and operating procedures essential for the safe and proper machine operation for its intended purpose.

Due to continuous product improvements, JLG Industries, Inc. reserves the right to make specification changes without prior notification. Contact JLG Industries, Inc. for updated information.

SAFETY ALERT SYMBOLS AND SAFETY SIGNAL WORDS



This is the Safety Alert Symbol. It is used to alert you to the potential personal injury hazards. Obey all safety messages that follow this symbol to avoid possible injury or death.

DANGER

INDICATES AN IMMINENTLY HAZARDOUS SITUATION. IF NOT AVOIDED, WILL RESULT IN SERIOUS INJURY OR DEATH. THIS DECAL WILL HAVE A RED BACKGROUND.

WARNING

INDICATES A POTENTIALLY HAZARDOUS SITUATION. IF NOT AVOIDED, COULD RESULT IN SERIOUS INJURY OR DEATH. THIS DECAL WILL HAVE AN ORANGE BACKGROUND.

CAUTION

INDICATES A POTENTIALLY HAZARDOUS SITUATION. IF NOT AVOIDED, MAY RESULT IN MINOR OR MODERATE INJURY. IT MAY ALSO ALERT AGAINST UNSAFE PRACTICES. THIS DECAL WILL HAVE A YELLOW BACKGROUND.

NOTICE

INDICATES INFORMATION OR A COMPANY POLICY THAT RELATES DIRECTLY OR INDIRECTLY TO THE SAFETY OF PERSONNEL OR PROTECTION OF PROPERTY.

⚠ WARNING

THIS PRODUCT MUST COMPLY WITH ALL SAFETY RELATED BULLETINS. CONTACT JLG INDUSTRIES, INC. OR THE LOCAL AUTHORIZED JLG REPRESENTATIVE FOR INFORMATION REGARDING SAFETY-RELATED BULLETINS WHICH MAY HAVE BEEN ISSUED FOR THIS PRODUCT.

NOTICE

JLG INDUSTRIES, INC. SENDS SAFETY RELATED BULLETINS TO THE OWNER OF RECORD OF THIS MACHINE. CONTACT JLG INDUSTRIES, INC. TO ENSURE THAT THE CURRENT OWNER RECORDS ARE UPDATED AND ACCURATE.

NOTICE

JLG INDUSTRIES, INC. MUST BE NOTIFIED IMMEDIATELY IN ALL INSTANCES WHERE JLG PRODUCTS HAVE BEEN INVOLVED IN AN ACCIDENT INVOLVING BODILY INJURY OR DEATH OF PERSONNEL OR WHEN SUBSTANTIAL DAMAGE HAS OCCURRED TO PERSONAL PROPERTY OR THE JLG PRODUCT.

For:

- Accident Reporting
- Product Safety Publications
- Current Owner Updates
- Questions Regarding Product Safety
- Standards and Regulations Compliance Information
- Questions Regarding Special Product Applications
- Questions Regarding Product Modifications

Contact:

Product Safety and Reliability Department
JLG Industries, Inc.
13224 Fountainhead Plaza
Hagerstown, MD 21742
USA
or Your Local JLG Office
(See addresses on inside of manual cover)

In USA:

Toll Free: 877-JLG-SAFE (877-554-7233)

Outside USA:

Phone: +1-240-420-2661
Fax: 301-745-3713
E-mail: ProductSafety@JLG.com

REVISION LOG

Original Issue	- February 01, 2013
Revised	- August 27, 2013
Revised	- May 27, 2014
Revised	- October 16, 2014

Go to Discount-Equipment.com to order your parts

SECTION - PARAGRAPH, SUBJECT	PAGE
SECTION - 1 - SAFETY PRECAUTIONS	
1.1 GENERAL	1-1
1.2 PRE-OPERATION	1-1
Operator Training and Knowledge	1-1
Workplace Inspection	1-2
Machine Inspection	1-3
1.3 OPERATION	1-3
General	1-3
Trip and Fall Hazards	1-5
Electrocution Hazards	1-6
Tipping Hazards	1-7
Crushing and Collision Hazards	1-10
1.4 TOWING, LIFTING, AND HAULING	1-11
1.5 MAINTENANCE	1-11
Maintenance Hazards	1-11
Battery Hazards	1-12

SECTION - 2 - USER RESPONSIBILITIES, MACHINE PREPARATION, AND INSPECTION

2.1 PERSONNEL TRAINING	2-1
Operator Training	2-1
Training Supervision	2-2
Operator Responsibility	2-2

SECTION - PARAGRAPH, SUBJECT	PAGE
2.2 PREPARATION, INSPECTION, AND MAINTENANCE	2-2
2.3 PRE-START INSPECTION	2-4
2.4 DAILY WALK-AROUND INSPECTION	2-5
2.5 FUNCTION CHECK	2-7
Overload Sensor Check (If Equipped)	2-9
SECTION - 3 - MACHINE CONTROLS, INDICATORS AND OPERATION	
3.1 GENERAL	3-1
3.2 DESCRIPTION	3-1
3.3 OPERATING CHARACTERISTICS AND LIMITATIONS	3-2
General	3-2
Placards	3-2
Capacities	3-2
3.4 PLATFORM LOADING	3-2
Stability	3-3
3.5 MACHINE CONTROL LOCATIONS	3-5
3.6 CONTROLS AND INDICATORS	3-6
3.7 GROUND CONTROL STATION	3-6
Platform Manual Descent Valves	3-10
Flow Control Valve	3-10
Mast Manual Descent Valve and Actuator ..	3-11

TABLE OF CONTENTS

SECTION - PARAGRAPH, SUBJECT	PAGE
Boom Manual Descent Valve	3-12
Manual Swinging Operating Devices	3-13
3.8 PLATFORM CONTROL STATION	3-14
Grade and Side Slope	3-18
3.9 OPERATION	3-20
3.10 STEERING AND TRAVELLING (DRIVING)	3-20
Steering	3-21
Travelling (driving)	3-21
Drive Orientation System (DOS)	3-22
3.11 PLATFORM	3-22
Platform Level Adjustment	3-22
Platform Rotation (If equipped)	3-22
3.12 RAISING AND LOWERING THE PLATFORM	3-23
Raising and lowering the mast	3-23
Raising and lowering the boom	3-23
Telescoping the Boom	3-23
3.13 SWINGING	3-24
3.14 ALARMS	3-24
Overload Warning Light/Alarm (If equipped)	3-24
Tilt Warning Light/Alarm	3-24
Slack Chain Warning Light/Alarm	3-25
3.15 SHUT DOWN AND PARK	3-26
3.16 BATTERY CHARGING	3-27
Battery Charger Fault Code	3-28

SECTION - PARAGRAPH, SUBJECT	PAGE
3.17 TIE-DOWN/LIFT LUGS	3-29
Tie Down	3-29
Lifting	3-30
3.18 TOWING	3-30
Electric Brake Release	3-31

SECTION - 4 - EMERGENCY PROCEDURES

4.1 GENERAL INFORMATION	4-1
4.2 EMERGENCY OPERATION	4-1
Operator Unable to Control Machine	4-1
Platform or Boom Caught Overhead	4-1
4.3 EMERGENCY CONTROL	4-2
Operator Unable to Control Machine in Overload Condition	4-3
4.4 PLATFORM MANUAL DESCENT	4-3
4.5 INCIDENT NOTIFICATION	4-3
4.6 EMERGENCY TOWING	4-4

SECTION - 5 - GENERAL SPECIFICATIONS AND MAINTENANCE

5.1 INTRODUCTION	5-1
Other Publications Available Specific to this machine:	5-1

SECTION - PARAGRAPH, SUBJECT	PAGE
5.2 OPERATING SPECIFICATIONS	5-2
5.3 OPERATOR MAINTENANCE	5-10
5.4 CHASSIS HOOD REMOVAL	5-11
5.5 BATTERY MAINTENANCE	5-11
Battery Maintenance and Safety Practices . . .	5-11
Battery Voltage and Electrolyte Specific Gravity	5-14
Filling System Maintenance	5-15
Use of a Battery in a Cold Environment	5-15
Battery Not Working Continuously or Inactive	
Battery	5-15
Battery Troubleshooting	5-16
5.6 OIL LEVEL	5-17
Hydraulic Oil Check	5-17
Hydraulic Oil Replacement	5-17
5.7 TIRES & WHEELS	5-18
Tire Wear and Damage	5-18
Wheel and Tire Replacement	5-18
Wheel Installation	5-18
5.8 DECAL INSTALLATION	5-20
5.9 LUBRICATION	5-24
Swing Bearing Race	5-24
Swing Bearing Teeth	5-25
Lifting Chains	5-26

SECTION - PARAGRAPH, SUBJECT	PAGE
5.10 OVERLOAD SYSTEM VERIFICATION (IF EQUIPPED)	5-27
5.11 TILT SENSOR VERIFICATION	5-28
5.12 SLACK CHAIN SENSORS CHECK	5-29
5.13 SUPPLEMENTAL INFORMATION	5-30

SECTION - 6 - INSPECTION AND REPAIR LOG

TABLE OF CONTENTS

SECTION - PARAGRAPH, SUBJECT	PAGE
------------------------------	------

LIST OF TABLES

1-1	Minimum Approach Distance (M.A.D.)	1-6
1-2	Beaufort Scale (For Reference Only)	1-8
2-1	Inspection and Maintenance Table.	2-3
3-1	Battery Charger Fault Code	3-28
5-1	Operating Specifications And Dimensions	5-2
5-2	Dimensions	5-6
5-3	Tires Specifications	5-6
5-4	Drive Motors - Hydraulic Power Unit.	5-7
5-5	Battery Specifications	5-8
5-6	Lubrication Specifications	5-8
5-7	Hydraulic Oil Specifications - Standard	5-8
5-8	Hydraulic Oil Specifications - Optional	5-9
5-9	Wheel Torque Chart	5-19
5-10	Machine Decal Installation Chart	5-23
5-11	Recommended Viscosity Grade	5-26
6-1	Inspection and Repair Log	6-1

SECTION - PARAGRAPH, SUBJECT PAGE

LIST OF FIGURES

2-1. Daily Walk-Around Inspection 2-6
 2-2. Overload Sensor 2-9
 3-1. Position of Least BACKWARD stability 3-4
 3-2. Position of Least FORWARD stability 3-4
 3-3. Basic Nomenclature - Machine Control Locations 3-5
 3-4. Ground Control Station 3-7
 3-5. Flow Control Valve 3-10
 3-6. Mast Manual Descent Valve 3-11
 3-7. Boom Manual Descent Valve 3-12
 3-8. Manual Swinging Operating Devices 3-13
 3-9. Platform Control Station 3-14
 3-10. Platform Control Indicator Panel 3-15
 3-11. Grade and Side Slope 3-19
 3-12. Steer/Drive Controls 3-21
 3-13. Drive Orientation System (DOS) 3-22
 3-14. Machine Tie-Down 3-29
 3-15. Lifting the Machine 3-30
 3-16. Electric Brake Release 3-31
 4-1. Emergency Controls 4-2
 5-1. Range Diagram T12E - T32E 5-4
 5-2. Range Diagram T12E Plus 5-5
 5-3. Operator Maintenance & Lubrication Diagram . . 5-10
 5-4. Chassis Hood Removal 5-11
 5-5. Level Indicators 5-12

5-6. Adding Water to Batteries 5-12
 5-7. Draining the Water 5-13
 5-8. Measuring Electrolyte Specific Gravity 5-14
 5-9. Hydraulic Oil Check 5-17
 5-10. Wheel Lug Nut Tightening Sequence 5-19
 5-11. Decal Installation - Sheet 1 5-20
 5-12. Decal Installation - Sheet 2 5-21
 5-13. Decal Installation - Sheet 3 5-22
 5-14. Swing Bearing Race Lubrication 5-24
 5-15. Swing Bearing Teeth Lubrication 5-25
 5-16. Overload System Verification 5-27
 5-17. Jacking Points 5-28
 5-18. Slack/Broken Chain Sensors 5-29

TO PURCHASE THIS PRODUCT PLEASE CONTACT US



**Equipment Financing and
Extended Warranties Available**



**Discount-Equipment.com is your online resource for
commercial and industrial quality parts and equipment sales.**

561-964-4949

visit us on line @ www.discount-equipment.com

Select an option below to find your Equipment

Search by Manufacturer

Search by Product Type

Request a Quote

We sell worldwide for the brands: Genie, Terex, JLG, MultiQuip, Mikasa, Essick, Whiteman, Mayco, Toro Stone, Diamond Products, Generac Magnum, Airman, Haulotte, Barreto, Power Blanket, Nifty Lift, Atlas Copco, Chicago Pneumatic, Allmand, Miller Curber, Skyjack, Lull, Skytrak, Tsurumi, Husquvarna Target, Stow, Wacker, Sakai, Mi-T-M, Sullair, Basic, Dynapac, MBW, Weber, Bartell, Bennar Newman, Haulotte, Ditch Runner, Menegotti, Morrison, Contec, Buddy, Crown, Edco, Wyco, Bomag, Laymor, EZ Trench, Bil-Jax, F.S. Curtis, Gehl Pavers, Heli, Honda, ICS/PowerGrit, IHI, Partner, Imer, Clipper, MMD, Koshin, Rice, CH&E, General Equipment, Amida, Coleman, NAC, Gradall, Square Shooter, Kent, Stanley, Tamco, Toku, Hatz, Kohler, Robin, Wisconsin, Northrock, Oztec, Toker TK, Rol-Air, APT, Wylie, Ingersoll Rand / Doosan, Innovatech, Con X, Ammann, Mecalac, Makinex, Smith Surface Prep, Small Line, Wanco, Yanmar

SECTION 1. SAFETY PRECAUTIONS

1.1 GENERAL

This section outlines the necessary precautions for proper and safe machine operation and maintenance. In order to promote proper machine usage, it is mandatory that a daily routine is established based on the content of this manual. A maintenance program, using the information provided in this manual and the Service and Maintenance Manual, must also be established by a qualified person and must be followed to ensure that the machine is safe to operate.

The owner/user/operator/lessor/lessee of the machine must not accept operating responsibility until this manual has been read, training is accomplished, and operation of the machine has been completed under the supervision of an experienced and qualified operator.

These sections contain the responsibilities of the owner, user, operator, lessor, and lessee concerning safety, training, inspections, maintenance, application, and operation. If there are any questions with regard to safety, training, inspection, maintenance, application, and operation, please contact JLG Industries, Inc. ("JLG").

⚠ WARNING

FAILURE TO COMPLY WITH THE SAFETY PRECAUTIONS LISTED IN THIS MANUAL COULD RESULT IN MACHINE DAMAGE, PROPERTY DAMAGE, PERSONAL INJURY OR DEATH.

1.2 PRE-OPERATION

Operator Training and Knowledge

- The Operation and Safety Manual must be read and understood in its entirety before operating the machine. For clarification, questions, or additional information regarding any portions of this manual, contact JLG Industries, Inc.

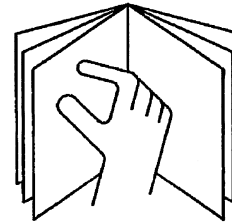

SECTION 1 – SAFETY PRECAUTIONS

- An operator must not accept operating responsibilities until adequate training has been given by competent and authorized persons.
- Allow only those authorized and qualified personnel to operate the machine who have demonstrated that they understand the safe and proper operation and maintenance of the unit.
- Read, understand, and obey all DANGERS, WARNINGS, CAUTIONS, and operating instructions on the machine and in this manual.
- Ensure that the machine is to be used in a manner which is within the scope of its intended application as determined by JLG.
- All operating personnel must be familiar with the emergency controls and emergency operation of the machine as specified in this manual.
- Read, understand, and obey all applicable employer, local, and governmental regulations as they pertain to your utilization and application of the machine.

Workplace Inspection

- Precautions to avoid all hazards in the work area must be taken by the user before and during operation of the machine.
- Do not operate or raise the platform from a position on trucks, trailers, railway cars, floating vessels, scaffolds or other equipment unless the application is approved in writing by JLG.
- Before operation, check work area for overhead hazards such as electric lines, bridge cranes, and other potential overhead obstructions.
- Check floor surfaces for holes, bumps, drop-offs, obstructions, debris, concealed holes, and other potential hazards.
- Check the work area for hazardous locations. Do not operate the machine in hazardous environments unless approved for that purpose by JLG.
- Be sure that the ground conditions are able to support the maximum load shown on the decals located on the machine.
- This machine can be operated in nominal ambient temperatures of -20° C to 40° C (0° F to 104° F). Consult JLG to optimize operation outside of this temperature range.
- This machine must be used in a sufficient ambient light.

Machine Inspection

- Do not operate this machine until the inspections and functional checks have been performed as specified in Section 2 of this manual.
- Do not operate this machine until it has been serviced and maintained according to the maintenance and inspection requirements as specified in the machine's Service and Maintenance Manual.
- Ensure all safety devices are operating properly. Modification of these devices is a safety violation.

WARNING

MODIFICATION OR ALTERATION OF AN AERIAL WORK PLATFORM SHALL BE MADE ONLY WITH PRIOR WRITTEN PERMISSION FROM THE MANUFACTURER.

- Do not operate any machine on which the safety or instruction placards or decals are missing or illegible.
- Check the machine for modifications to original components. Ensure that any modifications have been approved by JLG.
- Avoid accumulation of debris on platform deck. Keep mud, oil, grease, and other slippery substances from footwear and platform deck.

1.3 OPERATION

General

- Machine operation requires your full attention. Bring the machine to a full stop before using any device, i.e. cell phones, two-way radios, etc. that will distract your attention from safely operating the machine.
- Do not use the machine for any purpose other than positioning personnel, their tools, and equipment.
- Before operation, the user must be familiar with the machine capabilities and operating characteristics of all functions.
- Never operate a malfunctioning machine. If a malfunction occurs, shut down the machine. Remove the unit from service and notify the proper authorities.
- Do not remove, modify, or disable any safety devices.
- Never slam a control switch or lever through neutral to an opposite direction. Always return switch to neutral and stop before moving the switch to the next function. Operate controls with slow and even pressure.
- Do not allow personnel to tamper with or operate the machine from the ground with personnel in the platform, except in an emergency.

SECTION 1 – SAFETY PRECAUTIONS

- Do not carry materials directly on platform railing unless approved by JLG.
- When two or more persons are in the platform, the operator shall be responsible for all machine operations.
- Always ensure that power tools are properly stowed and never left hanging by their cord from the platform work area.
- Do not assist a stuck or disabled machine by pushing or pulling except by pulling at the chassis tie-down lugs.
- Fully lower platform and shut off all power before leaving machine.
- Remove all rings, watches, and jewelry when operating machine. Do not wear loose fitting clothing or long hair unrestrained which may become caught or entangled in equipment.
- Persons under the influence of drugs or alcohol or who are subject to seizures, dizziness or loss of physical control must not operate this machine.

Trip and Fall Hazards

- Prior to operation, ensure all gates are fastened and secured in their proper position.

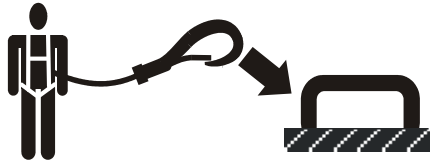

- During operation, occupants in the platform must wear a full body harness with a lanyard attached to an authorized lanyard anchorage point. Attach only one (1) lanyard per lanyard anchorage point.
- Identify the designated lanyard anchorage point(s) at the platform and securely attach the lanyard. Attach only one (1) lanyard per lanyard anchorage point.
- Enter and exit only through gate area. Use extreme caution when entering or leaving platform. Ensure that the platform assembly is fully lowered. Face the machine when entering or leaving the platform. Always maintain “three point contact” with the machine, using two hands

and one foot or two feet and one hand at all times during entry and exit.

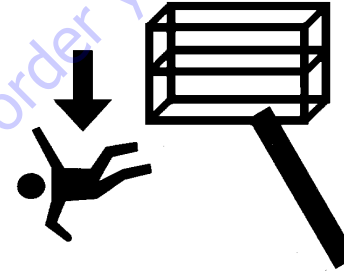

- Keep both feet firmly positioned on the platform floor at all times. Never position ladders, boxes, steps, planks, or similar items on unit to provide additional reach for any purpose.
- Never use extending structure to gain access to or leave the platform.
- Keep oil, mud, and slippery substances cleaned from footwear and the platform floor.

Electrocution Hazards

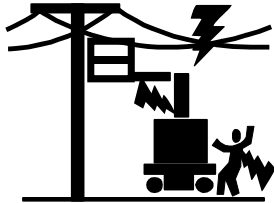
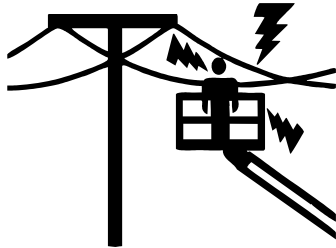

- This machine is not insulated and does not provide protection from contact or proximity to electrical current.
- Maintain distance from electrical lines, apparatus, or any energized (exposed or insulated) parts according to the Minimum Approach Distance (MAD) as shown in Table 1-1.
- Allow for machine movement and electrical line swaying.

- Maintain a clearance of at least 3 m (10 ft.) between any part of the machine and its occupants, their tools and their equipment from any electrical line or apparatus carrying up to 50 000 volts. A 0,3 m (1 ft.) additional clearance is required for every additional 30 000 volts or less.

Table 1-1. Minimum Approach Distance (M.A.D.)

Voltage Range (Phase to Phase)	MINIMUM APPROACH DISTANCE in Meters (Feet)
0 to 50 kV	3 (10)
Over 50 kV to 200 kV	5 (15)
Over 200kV to 350 kV	6 (20)
Over 350 kV to 500 kV	8 (25)
Over 500 kV to 750 kV	11 (35)
Over 750 kV to 1000 kV	14 (45)
NOTE: <i>This requirement shall apply except where employer, local or governmental regulations are more stringent.</i>	

- The minimum approach distance may be reduced if insulating barriers are installed to prevent contact and the barriers are rated for the voltage of the line being guarded. These barriers shall not be part of (or attached to) the machine. The minimum approach distance shall be reduced to a distance within the designed working dimen-

sions of the insulating barrier. This determination shall be made by a qualified person in accordance with the employer, local or governmental requirements for work practices near energized equipment.

DANGER

DO NOT MANEUVER MACHINE OR PERSONNEL INSIDE PROHIBITED ZONE (MAD). ASSUME ALL ELECTRICAL PARTS AND WIRING ARE ENERGIZED UNLESS KNOWN OTHERWISE.

Tipping Hazards

- Ensure that the ground conditions are adequate to support the maximum tire load indicated on the tire load decal located on the chassis. Do not travel on unsupported surfaces.
- The user must be familiar with the driving surface before driving. Do not exceed the allowable sideslope and grade while driving.
- Do not elevate platform or drive with platform elevated while on or near a sloping, uneven, or soft surface. Ensure machine is positioned on a firm, level and smooth surface before elevating platform or driving with the platform in the elevated position.
- Never exceed the maximum work load as specified on the platform. Keep all loads within the confines of the platform, unless authorized by JLG.
- Keep the chassis of the machine a minimum of 0.6 m (2 ft.) from holes, bumps, drop-offs, obstructions, debris, concealed holes, and other potential hazards at the ground level.
- Do not operate the machine when wind conditions exceed 12.5 m/s (28 mph).

SECTION 1 – SAFETY PRECAUTIONS

NOTICE

DO NOT OPERATE THE MACHINE WHEN WIND CONDITIONS EXCEED 28 MPH (12,5 M/S OR 45 KM/H).

Table 1-2. Beaufort Scale (For Reference Only)

Beaufort Number	Wind Speed		Description	Land Conditions
	mph	m/s		
0	0	0-0.2	Calm	Calm. Smoke rises vertically.
1	1-3	0.3-1.5	Light air	Wind motion visible in smoke.
2	4-7	1.6-3.3	Light breeze	Wind felt on exposed skin. Leaves rustle.
3	8-12	3.4-5.4	Gentle breeze	Leaves and smaller twigs in constant motion.
4	13-18	5.5-7.9	Moderate breeze	Dust and loose paper raised. Small branches begin to move.
5	19-24	8.0-10.7	Fresh breeze	Smaller trees sway.
6	25-31	10.8-13.8	Strong breeze	Large branches in motion. Flags waving near horizontal. Umbrella use becomes difficult.
7	32-38	13.9-17.1	Near Gale/Moderate Gale	Whole trees in motion. Effort needed to walk against the wind.
8	39-46	17.2-20.7	Fresh Gale	Twigs broken from trees. Cars veer on road.
9	47-54	20.8-24.4	Strong gale	Light structure damage.

SECTION 1 – SAFETY PRECAUTIONS

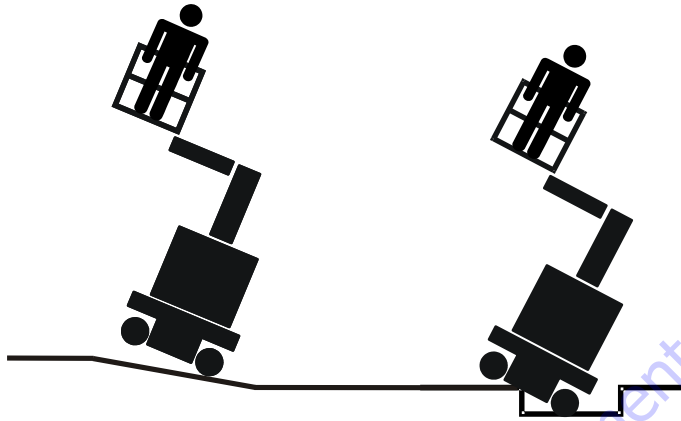

- Never attempt to use the machine as a crane. Do not tie-off machine to any adjacent structure. Never attach wire, cable, or any similar items to platform.
- Do not cover the platform sides or carry large surface-area items in the platform when operating outdoors. The addition of such items increases the exposed wind area of the machine.
- Do not increase the platform size with unauthorized deck extensions or attachments.

- If the extending structure assembly or platform is caught so that one or more wheels are off the ground, all persons must be removed before attempting to free the machine. Use cranes, forklift trucks, or other appropriate equipment to stabilize machine and remove personnel.

SECTION 1 – SAFETY PRECAUTIONS

Crushing and Collision Hazards

- Approved head gear must be worn by all operating and ground personnel.
- Check work area for clearances overhead, on sides, and bottom of platform when lifting, swinging or lowering platform, and driving.
- During operation, keep all body parts inside platform railing.

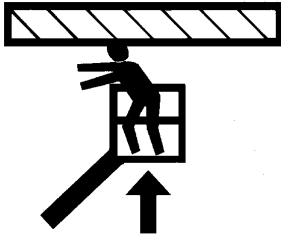

- Always post a lookout when driving in areas where vision is obstructed.
- Keep non-operating personnel at least 2m (6 ft.) away from machine during all operations.
- Limit travel speed according to conditions of ground surface, congestion, visibility, slope, location of personnel,

and other factors which may cause hazard of collision or injury to personnel.

- Be aware of stopping distances in all drive speeds. When driving in high speed, slow down the machine using the controller before stopping.
- Do not use high speed drive in restricted or close quarters or when driving in reverse.
- Exercise extreme caution at all times to prevent obstacles from striking or interfering with operating controls and persons in the platform.
- Ensure that operators of other overhead and floor level machines are aware of the aerial work platform's presence. Disconnect power to overhead cranes. Barricade floor area if necessary.
- Do not operate over ground personnel. Warn personnel not to work, stand, or walk under a raised platform. Position barricades on floor as necessary.

1.4 TOWING, LIFTING, AND HAULING

- Never allow personnel in platform while towing, lifting, or hauling.
- This machine should not be towed, except in the event of emergency, malfunction, power failure, or loading/unloading. Refer to Emergency Towing Procedures.
- Ensure extending structure is fully retracted and that the platform and the tool tray are completely empty of tools prior to towing, lifting or hauling.
- Refer to Section 3 for lifting information.

1.5 MAINTENANCE

This sub-section contains general safety precautions which must be observed during maintenance of this machine. Additional precautions to be observed during machine maintenance are inserted at the appropriate points in this manual and in the Service and Maintenance Manual. It is of utmost importance that maintenance personnel pay strict attention to these precautions to avoid possible injury to personnel or damage to the machine or property. A maintenance program must be established by a qualified person and must be followed to ensure that the machine is safe.

Maintenance Hazards

- Shut off power to all controls and ensure that all moving parts are secured from inadvertent motion prior to performing any adjustments or repairs.
- Never work under an elevated platform until it has been fully lowered to the full down position, if possible, or otherwise supported and restrained from movement with appropriate safety props, blocking, or overhead supports.
- DO NOT attempt to repair or tighten any hydraulic hoses or fittings while the machine is powered on or when the hydraulic system is under pressure.
- Always relieve hydraulic pressure from all hydraulic circuits before loosening or removing hydraulic components.
- DO NOT use your hand to check for leaks. Use a piece of cardboard or paper to search for leaks. Wear gloves to help protect hands from spraying fluid.

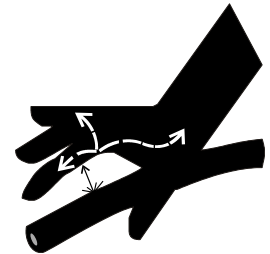

SECTION 1 – SAFETY PRECAUTIONS

- Ensure replacement parts or components are identical or equivalent to original parts or components.
- Never attempt to move heavy parts without the aid of a mechanical device. Do not allow heavy objects to rest in an unstable position. Ensure adequate support is provided when raising components of the machine.
- Use only approved non-flammable cleaning solvents.
- Do not replace items critical to stability, such as batteries or solid tires, with items of different weight or specification. Do not modify unit in any way to affect stability.
- Reference the Service and Maintenance Manual for the weights of critical stability items.

WARNING

MODIFICATION OR ALTERATION OF AN AERIAL WORK PLATFORM SHALL BE MADE ONLY WITH PRIOR WRITTEN PERMISSION FROM THE MANUFACTURER.

Battery Hazards

- Always disconnect batteries when servicing electrical components or when performing welding on the machine.
- Do not allow smoking, open flame, or sparks near battery during charging or servicing.

- Do not contact tools or other metal objects across the battery terminals.

CAUTION

BATTERY FLUID IS HIGHLY CORROSIVE. AVOID CONTACT WITH SKIN AND CLOTHING AT ALL TIMES. IMMEDIATELY RINSE ANY CONTACTED AREA WITH CLEAN WATER AND SEEK MEDICAL ATTENTION.

- Charge batteries only in a well ventilated area.
- Avoid overfilling the battery fluid level. Add distilled water to batteries only after the batteries are fully charged.

TO PURCHASE THIS PRODUCT PLEASE CONTACT US



**Equipment Financing and
Extended Warranties Available**



**Discount-Equipment.com is your online resource for
commercial and industrial quality parts and equipment sales.**

561-964-4949

visit us on line @ www.discount-equipment.com

Select an option below to find your Equipment

Search by Manufacturer

Search by Product Type

Request a Quote

We sell worldwide for the brands: Genie, Terex, JLG, MultiQuip, Mikasa, Essick, Whiteman, Mayco, Toro Stone, Diamond Products, Generac Magnum, Airman, Haulotte, Barreto, Power Blanket, Nifty Lift, Atlas Copco, Chicago Pneumatic, Allmand, Miller Curber, Skyjack, Lull, Skytrak, Tsurumi, Husquvarna Target, Stow, Wacker, Sakai, Mi-T-M, Sullair, Basic, Dynapac, MBW, Weber, Bartell, Bennar Newman, Haulotte, Ditch Runner, Menegotti, Morrison, Contec, Buddy, Crown, Edco, Wyco, Bomag, Laymor, EZ Trench, Bil-Jax, F.S. Curtis, Gehl Pavers, Heli, Honda, ICS/PowerGrit, IHI, Partner, Imer, Clipper, MMD, Koshin, Rice, CH&E, General Equipment, Amida, Coleman, NAC, Gradall, Square Shooter, Kent, Stanley, Tamco, Toku, Hatz, Kohler, Robin, Wisconsin, Northrock, Oztec, Toker TK, Rol-Air, APT, Wylie, Ingersoll Rand / Doosan, Innovatech, Con X, Ammann, Mecalac, Makinex, Smith Surface Prep, Small Line, Wanco, Yanmar

SECTION 2. USER RESPONSIBILITIES, MACHINE PREPARATION, AND INSPECTION

2.1 PERSONNEL TRAINING

The aerial platform is a personnel handling device; so it is necessary that it be operated and maintained only by trained personnel.

Operator Training

Operator training must cover:

- Use and limitations of the controls in the platform and at the ground, emergency controls and safety systems.
- Control labels, instructions, and warnings on the machine.
- Rules of the employer and government regulations.
- Use of approved fall protection device.
- Enough knowledge of the mechanical operation of the machine to recognize a malfunction or potential malfunction.
- The safest means to operate the machine where overhead obstructions, other moving equipment, and obstacles, depressions, holes or drop-offs exist.
- Means to avoid the hazards of unprotected electrical conductors.
- Specific job requirements or machine application.
- Reading and understanding the Operation and Safety manual.

Training Supervision

Training must be done under the supervision of a qualified person in an open area free of obstructions until the trainee has developed the ability to safely control and operate the machine.

Operator Responsibility

The operator must be instructed that he/she has the responsibility and authority to shut down the machine in case of a malfunction or other unsafe condition of either the machine or the job site.

NOTE: *The Manufacturer or Distributor will provide qualified people for training assistance with the first unit(s) delivered and from that time forward as requested by the user or his/her personnel.*

2.2 PREPARATION, INSPECTION, AND MAINTENANCE

Table 2-1 explains the periodic machine inspections and maintenance required by JLG Industries, Inc. Consult local regulations for further requirements for aerial work platforms. The frequency of inspections and maintenance must be increased as necessary when the machine is used in a harsh or hostile environment, if the machine is used with increased frequency, or if the machine is used in a severe manner.

SECTION 2 – USER RESPONSIBILITIES, MACHINE PREPARATION, AND INSPECTION

Table 2-1. Inspection and Maintenance Table

Type	Frequency	Primary Responsibility	Service Qualification	Reference
Pre-Start Inspection	Before using each day; or whenever there's an Operator change.	User or Operator	User or Operator	Operation and Safety Manual
Pre-Delivery Inspection (See Note)	Before each sale, lease, or rental delivery.	Owner, Dealer or User	Qualified JLG Mechanic	Service and Maintenance Manual and applicable JLG inspection form
Frequent Inspection (See Note)	In service for 3 months or 150 hours, whichever comes first; or Out of service for a period of more than 3 months; or Purchased used.	Owner, Dealer or User	Qualified JLG Mechanic	Service and Maintenance Manual and applicable JLG inspection form
Annual Machine Inspection (See Note)	Annually, no later than 13 months from the date of prior inspection.	Owner, Dealer or User	Factory-Trained Service Technician (Recommended)	Service and Maintenance Manual and applicable JLG inspection form
Preventative Maintenance	At intervals as specified in the Service and Maintenance Manual.	Owner, Dealer or User	Qualified JLG Mechanic	Service and Maintenance Manual

NOTE: Inspection forms are available from JLG. Use the Service and Maintenance Manual to perform inspections.

NOTICE

JLG INDUSTRIES, INC. RECOGNIZES A FACTORY-TRAINED SERVICE TECHNICIAN AS A PERSON WHO HAS SUCCESSFULLY COMPLETED THE JLG SERVICE TRAINING SCHOOL FOR THE SPECIFIC JLG PRODUCT MODEL.

SECTION 2 – USER RESPONSIBILITIES, MACHINE PREPARATION, AND INSPECTION

2.3 PRE-START INSPECTION

The Pre-Start Inspection should include each of the following:

1. **Cleanliness** – Check all surfaces for leakage (oil or battery fluid) or foreign objects. Report this to the proper maintenance personnel.
2. **Structure** – Inspect the machine structure for dents, damage, weld or parent metal cracks or other discrepancies. Report this to the proper maintenance personnel.

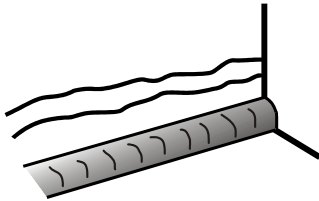

Parent Metal Crack

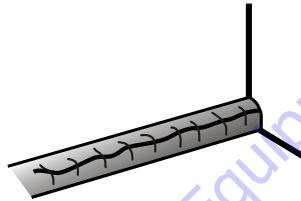

Weld Crack

3. **Decals and Placards** – Check all for cleanliness and legibility. Ensure none of the decals and placards are missing. Ensure all illegible decals and placards are cleaned or replaced. (See Section 5-8 - DECAL INSTALLATION)

4. **Operation and Safety Manuals** – Ensure that a copy of the Operation and Safety manual, AEM Safety Manual (ANSI markets only), and ANSI Manual of Responsibility (ANSI markets only) is enclosed in the weather resistant storage container.
5. **“Walk-Around” Inspection** – Refer to Figure 2-1.
6. **Battery** – Charge as required.
7. **Hydraulic Oil** – Check the hydraulic oil level in the reservoir, add as required.
8. **Accessories/Attachments** - Reference the Operation and Safety Manual of each attachment or accessory installed upon the machine for specific inspection, operation, and maintenance instructions.
9. **Function Check** – Once the “Walk-Around” Inspection is complete, perform a functional check of all systems in an area free of overhead and ground level obstructions. Refer to Section 3 for more specific instructions on the operation of each function.

2.4 DAILY WALK-AROUND INSPECTION

Begin the "Walk-Around Inspection" at Item 1, see Figure 2-1. Continue checking each item in sequence for the conditions listed in the following checklist.

WARNING

TO AVOID POSSIBLE INJURY, BE SURE MACHINE POWER IS OFF. DO NOT OPERATE MACHINE UNTIL ALL MALFUNCTIONS HAVE BEEN CORRECTED.

INSPECTION NOTE: *On all components, make sure there are no loose or missing parts, that they are securely fastened, and no visible damage, leaks or excessive wear exists in addition to any other criteria mentioned.*

- 1. Hood Assemblies** - See *inspection note*.
- 2. Ground Controls** - Placards secure and legible, control switches return to neutral position, emergency stop switches function properly. Control markings legible.
- 3. Hydraulic Pump/Motor, Control Valve Installation/Oil Level in Reservoir** - No unsupported wires or hoses; no damaged or broken wires - See *inspection note*.
- 4. Steering Assembly** - See *inspection note*.
- 5. Wheel/Tire Assemblies** - Properly secured, no missing lug nuts. Inspect for worn tread, cuts, tears or other discrepancies. See *inspection note*.
- 6. Drive Motor and Hub** - No evidence of leakage - See *inspection note*.
- 7. Battery Trays** - See *Inspection Note*.
- 8. Manual Descent Control** - See *Inspection Note*.
- 9. Beacon** - See *Inspection Note*.
- 10. Hydraulic Cylinders** - No visible damage, pivot pins and hydraulic hoses undamaged, no leakage (hose connections - valve block).
- 11. Limit Switches** - Mast and Jib limit switches, chain slack limit switches and overload sensor (if equipped) are properly installed and fastened. See *inspection note*.
- 12. Platform Assembly and Gate** - Gate opens and closes properly. Manual in storage container. See *Inspection Note*.
- 13. Platform Control Console** - Ensure that the control console is firmly secured in the proper location. Placards secure and legible, control lever and switches return to neutral, and emergency stop switch functions properly.
- 14. Lifting chains, Chain Yokes and Clevis Pins** - Must be installed and in good condition. Chains must be correctly tensioned and lubricated.
- 15. Extending Structure** - See *inspection note*.

SECTION 2 – USER RESPONSIBILITIES, MACHINE PREPARATION, AND INSPECTION

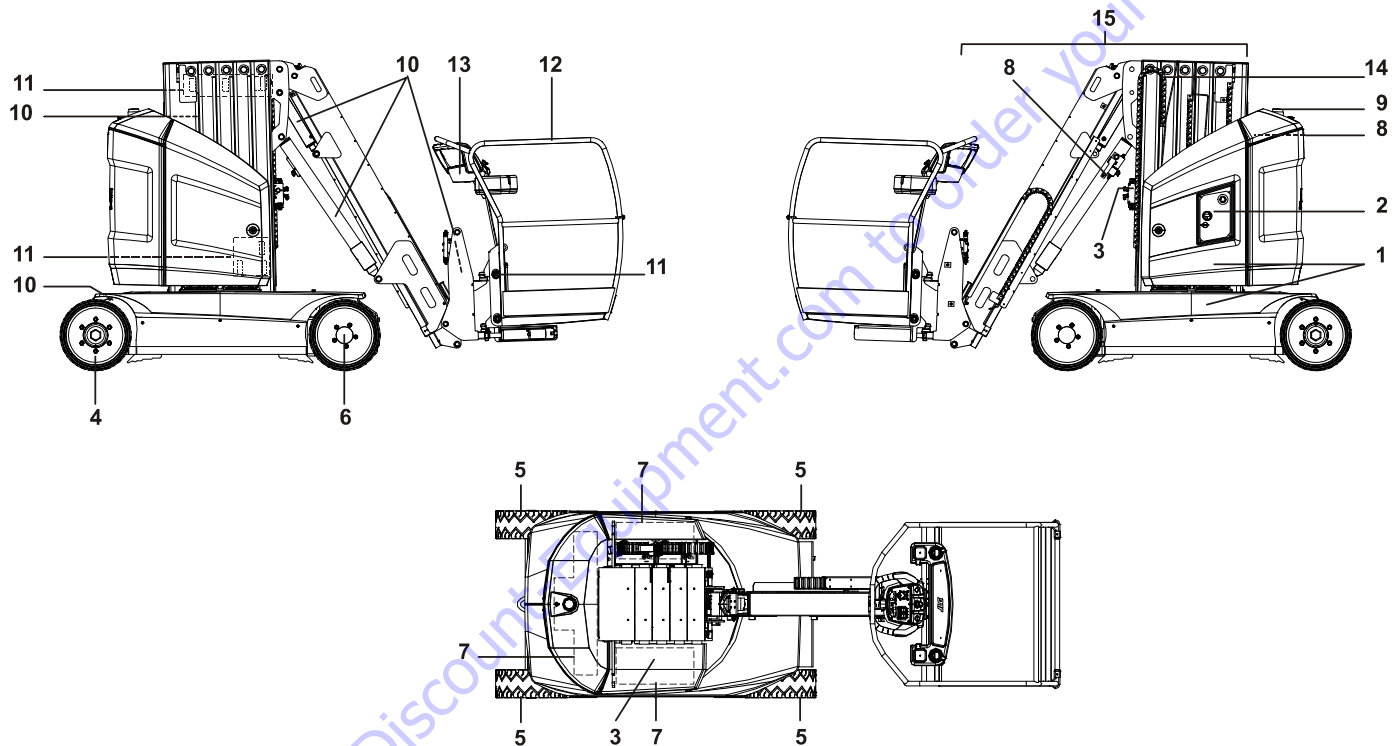

Figure 2-1. Daily Walk-Around Inspection

2.5 FUNCTION CHECK

Refer to Section 3 for description and operation of machine functions.

1. From the **Ground Control Panel** with no load in the platform:
 - a. Operate all functions to ensure proper operation.
 - b. While operating a mast lift-up movement, push in all other function buttons. Mast lift-up movement should continue and no other movement should occur.
 - c. Ensure that all machine functions are disabled when the emergency stop button is depressed.
 - d. Ensure all mast, jib, telescope, manual platform level adjustment and platform rotation (if equipped) functions stop when the function enable button is released.
 - e. Raise the mast about one meter (3 ft.), check if the manual descent valve lowers the mast properly (refer to Figure 3-6. for mast manual descent valve location).
 - f. Raise the jib about half a meter (2 ft.), check if the manual descent valve lowers the jib properly (Refer to Figure 3-7).

2. From the **Platform Control Console**:

- a. Operate all functions including horn button to ensure proper operation.
- b. Ensure that all machine functions are disabled when the emergency stop button is depressed.
- c. Ensure all mast, jib, telescope, manual platform level adjustment and platform rotation (if equipped) functions stop when the function enable button is released.
- d. Ensure all drive functions stop when joystick trigger is released.
- e. With the mast elevated half a meter (2 ft.), on a smooth, firm and level surface, drive the machine to check if the high drive cutout speed-limit is engaged. Drive speed will be reduced from a top speed of 5.5 km/h to 0.75 km/h (3.40 mph to 0.45 mph) (Approx.).

SECTION 2 – USER RESPONSIBILITIES, MACHINE PREPARATION, AND INSPECTION

- 3.** With the platform in the transport (stowed) position:
 - a.** Swing the boom over either of the rear tires and ensure that the Drive Orientation indicator illuminates and that the Drive Orientation Override switch must be used for the drive function to operate. Reposition the platform in line with the chassis.
 - b.** Drive the machine on a grade, not to exceed the rated gradeability, and stop to ensure the brakes hold;
 - c.** Check that the tilt indicator is illuminated to ensure proper operation.

Overload Sensor Check (If Equipped)

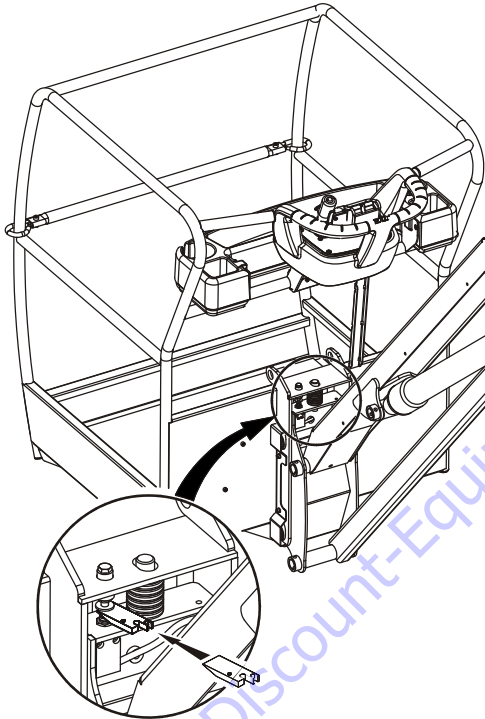

Figure 2-2. Overload Sensor

Check the overload indicator light/alarm to ensure proper operation. Wedge a block (P/N: ST2741 - located in the manual storage container) to activate the overload sensor and keep it activated. Refer to Figure 2-2.

1. From the Platform Control Console:
 - a. Confirm an audible alarm sounds.
 - b. Verify the overload indicator (Red) blinks.
 - c. Check that all functions are disabled.
2. From the Ground Control Panel:
 - a. Confirm an audible alarm sounds.
 - b. Verify the overload indicator (Red) blinks.

TO PURCHASE THIS PRODUCT PLEASE CONTACT US



**Equipment Financing and
Extended Warranties Available**



**Discount-Equipment.com is your online resource for
commercial and industrial quality parts and equipment sales.**

561-964-4949

visit us on line @ www.discount-equipment.com

Select an option below to find your Equipment

Search by Manufacturer

Search by Product Type

Request a Quote

We sell worldwide for the brands: Genie, Terex, JLG, MultiQuip, Mikasa, Essick, Whiteman, Mayco, Toro Stone, Diamond Products, Generac Magnum, Airman, Haulotte, Barreto, Power Blanket, Nifty Lift, Atlas Copco, Chicago Pneumatic, Allmand, Miller Curber, Skyjack, Lull, Skytrak, Tsurumi, Husquvarna Target, Stow, Wacker, Sakai, Mi-T-M, Sullair, Basic, Dynapac, MBW, Weber, Bartell, Bennar Newman, Haulotte, Ditch Runner, Menegotti, Morrison, Contec, Buddy, Crown, Edco, Wyco, Bomag, Laymor, EZ Trench, Bil-Jax, F.S. Curtis, Gehl Pavers, Heli, Honda, ICS/PowerGrit, IHI, Partner, Imer, Clipper, MMD, Koshin, Rice, CH&E, General Equipment, Amida, Coleman, NAC, Gradall, Square Shooter, Kent, Stanley, Tamco, Toku, Hatz, Kohler, Robin, Wisconsin, Northrock, Oztec, Toker TK, Rol-Air, APT, Wylie, Ingersoll Rand / Doosan, Innovatech, Con X, Ammann, Mecalac, Makinex, Smith Surface Prep, Small Line, Wanco, Yanmar

SECTION 3. MACHINE CONTROLS, INDICATORS AND OPERATION

3.1 GENERAL

NOTICE

THE MANUFACTURER HAS NO DIRECT CONTROL OVER MACHINE APPLICATION AND OPERATION, THE USER AND OPERATOR ARE RESPONSIBLE FOR CONFORMING WITH GOOD SAFETY PRACTICES.

This section provides the necessary information needed to understand controls and their functions.

⚠ WARNING

DO NOT RAISE PLATFORM EXCEPT ON A SMOOTH, FIRM AND LEVEL SURFACE FREE OF OBSTRUCTIONS AND HOLES.

TO AVOID SERIOUS INJURY, DO NOT OPERATE MACHINE IF ANY CONTROL LEVERS OR TOGGLE SWITCHES CONTROLLING PLATFORM MOVEMENT DO NOT RETURN TO THE OFF OR NEUTRAL POSITION WHEN RELEASED.

IF THE PLATFORM DOES NOT STOP WHEN A CONTROL SWITCH OR LEVER IS RELEASED, USE THE EMERGENCY STOP SWITCH TO STOP THE MACHINE.

3.2 DESCRIPTION

This machine is a self-propelled hydraulic lift equipped with a work platform on the end of an elevating and rotating mast.

The primary operator control station is in the platform. From this control station, the operator can drive and steer the machine in both forward and reverse directions. The operator can raise or lower the mast and the boom, or extend/retract the telescope or swing the mast to the left or right. Standard mast swing is 172.5 degree left and right of the stowed position. The machine has a Ground Control Station which will override the Platform Control Station. Ground Controls operate mast, boom, telescope and swing and are to be used in an emergency to lower the platform to the ground should the operator in the platform be unable to do so. The Ground Control is also to be used in Pre-Start Inspection.

3.3 OPERATING CHARACTERISTICS AND LIMITATIONS

General

A thorough knowledge of the operating characteristics and limitations of the machine is always the first requirement for any user, regardless of user's experience with similar types of equipment.

Placards

Important points to remember during operation are provided at the control stations by DANGER, WARNING, CAUTION, NOTICE, and INSTRUCTION placards. This information is placed at various locations for the express purpose of alerting personnel of potential hazards constituted by the operating characteristics and limitations of the machine. See foreword for definitions of placard safety signal words.

Capacities

The mast and the boom can be raised above horizontal with or without any load in the platform if:

1. Machine is positioned on a smooth, firm and level surface.
2. Load is within manufacturer's rated design capacity.
3. All machine systems are functioning properly.
4. Machine is as originally equipped from JLG.

3.4 PLATFORM LOADING

The platform maximum rated load capacity is shown on a placard located on the platform billboard and ground control station and is based upon the machine positioned on a smooth, firm, and level surface. Refer to Section 5 for the maximum platform capacity.

The platform is entered through an entry gate at the rear of the platform. Keep entry gate closed during machine operation.

Stability

Machine stability is based on two (2) conditions which are called FORWARD and BACKWARD stability. The machine's position of least FORWARD stability is shown in Figure 3-2. and its position of least BACKWARD stability is shown in Figure 3-1.

WARNING

TO AVOID FORWARD OR BACKWARD TIPPING, DO NOT OVERLOAD MACHINE OR OPERATE THE MACHINE ON AN OUT-OF-LEVEL SURFACE

SECTION 3 – MACHINE CONTROLS, INDICATORS AND OPERATION

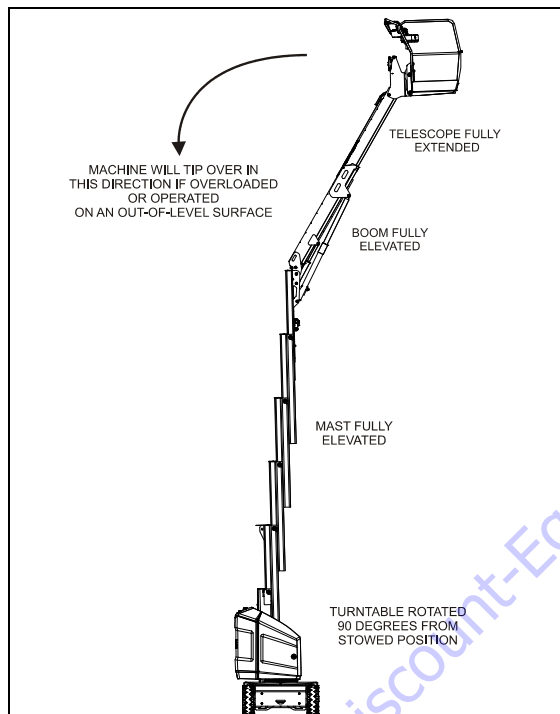

Figure 3-1. Position of Least BACKWARD stability

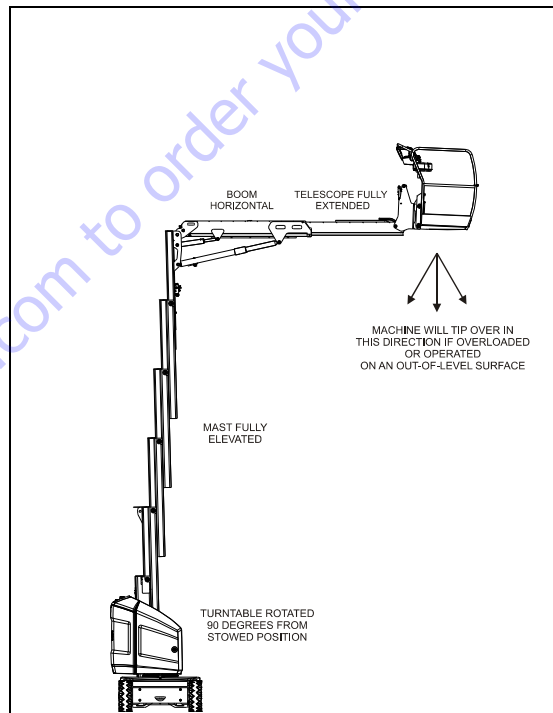
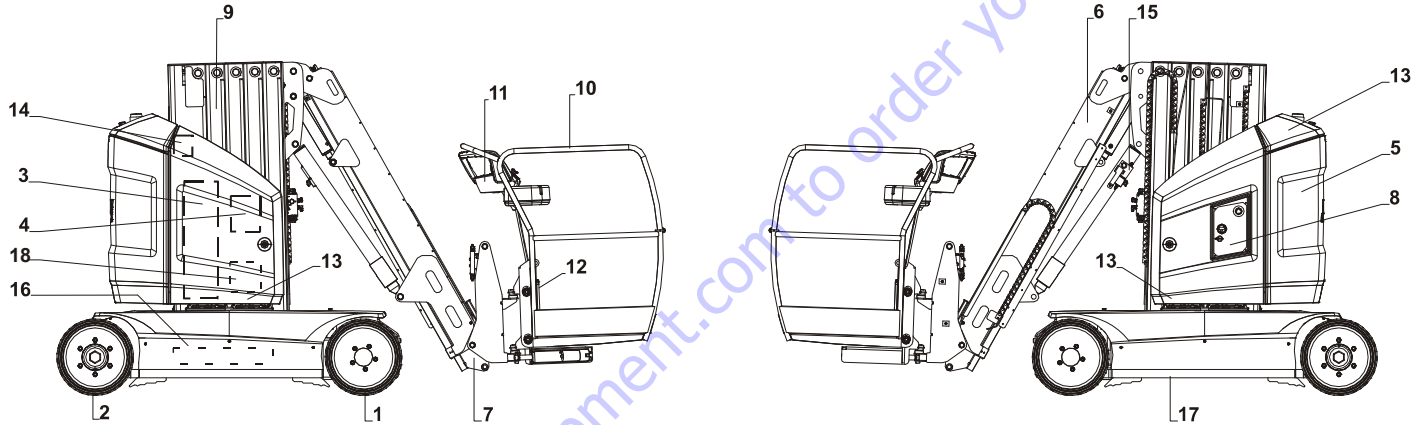

Figure 3-2. Position of Least FORWARD stability

3.5 MACHINE CONTROL LOCATIONS



- | | | |
|------------------------------|------------------------------|-------------------------------|
| 1. Driving Wheels | 7. Fly Boom Section | 13. Access Door to batteries |
| 2. Steering Wheels | 8. Ground Control Panel | 14. Mast Manual Descent Valve |
| 3. Pump/Motor | 9. Telescopic Mast | 15. Jib manual descent Valve |
| 4. Control Valves, Hand Pump | 10. Platform | 16. Turntable |
| 5. Counterweight | 11. Platform Control Console | 17. Chassis |
| 6. Boom | 12. Manual Storage Container | 18. Charger |

Figure 3-3. Basic Nomenclature - Machine Control Locations

3.6 CONTROLS AND INDICATORS

⚠ WARNING

TO AVOID SERIOUS INJURY, DO NOT OPERATE MACHINE IF ANY CONTROL LEVERS OR TOGGLE SWITCHES CONTROLLING PLATFORM MOVEMENT DO NOT RETURN TO THE OFF POSITION WHEN RELEASED.

NOTE: The indicator panels uses different shaped symbols to alert the operator to different types of operational situations that could arise. The meaning of those symbols are explained below.



Indicates a potentially hazardous situation, which if not corrected, could result in serious injury or death. This indicator will be red.



Indicates an abnormal operating condition, which if not corrected, may result in machine interruption or damage. This indicator will be yellow.



Indicates important information regarding the operating condition, i.e. procedures essential for safe operation. This indicator will be green.

3.7 GROUND CONTROL STATION

⚠ WARNING

DO NOT OPERATE FROM GROUND CONTROL STATION WITH PERSONNEL IN THE PLATFORM EXCEPT IN AN EMERGENCY.

NOTICE

WHEN THE MACHINE IS SHUT DOWN FOR OVERNIGHT PARKING OR BATTERY CHARGING, THE PLATFORM/OFF/GROUND SELECTOR AND THE EMERGENCY STOP SWITCHES MUST BE POSITIONED TO OFF TO PREVENT DRAINING THE BATTERIES.

SECTION 3 – MACHINE CONTROLS, INDICATORS AND OPERATION

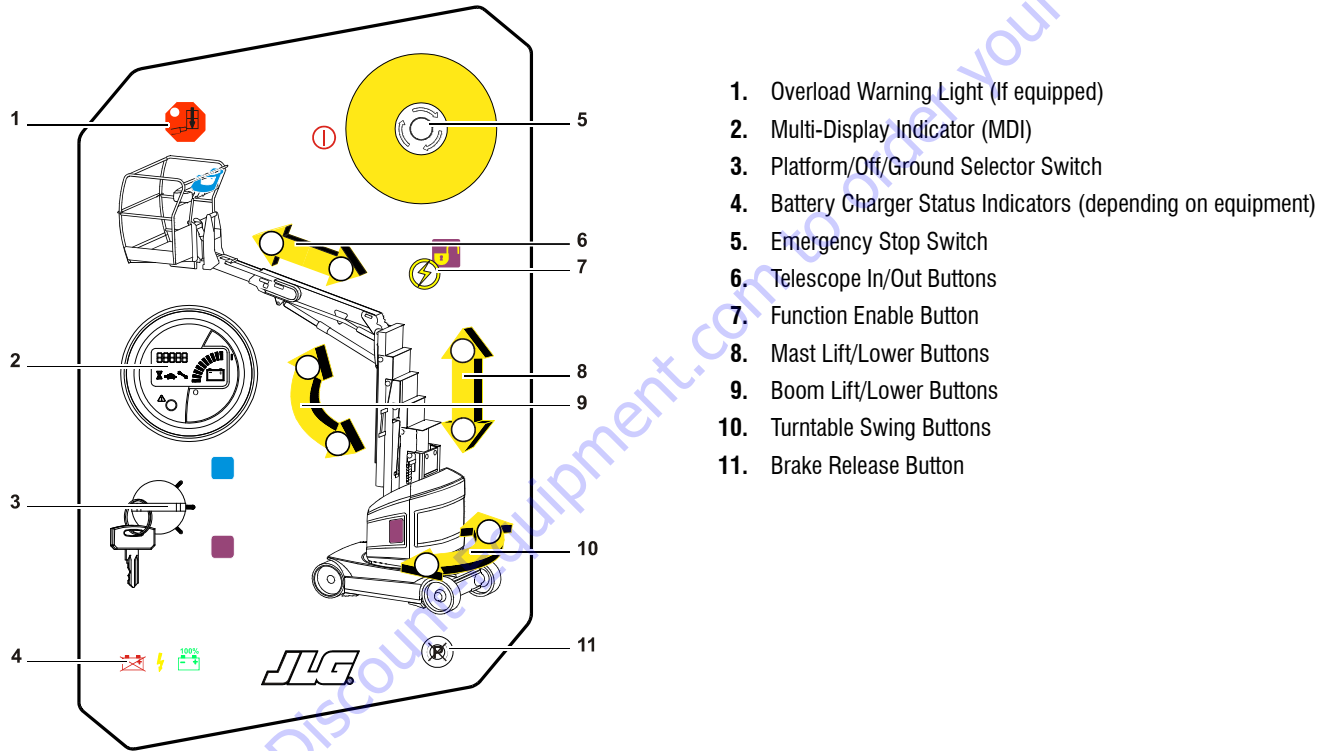

Figure 3-4. Ground Control Station

SECTION 3 – MACHINE CONTROLS, INDICATORS AND OPERATION

1. **Overload Warning Light (If equipped)** - This lamp (red), when blinking, indicates that the maximum rated load in the platform is exceeded. The platform must be safely unloaded until the alarm stops.

2. Multi-Display Indicator (MDI)



Hourmeter - The hourmeter symbol is lit when the number of operated hours is displayed.



Speed reduction - Indicates that the maximum drive speed is reduced when the platform is out of transport position.



The wrench symbol is lit when a DTC (Diagnosis Troubleshooting Code) is displayed.



Five Digits Display

In normal operating condition, displays the total amount of machine operation time accumulated. In abnormal operating condition, displays a DTC (Diagnosis Troubleshooting Code).



Alarm LED

Illuminates in abnormal operating condition (when a DTC, other than 00xx DTC's exists).

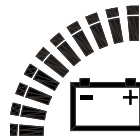

Battery Discharge Indicator (BDI).

This bar-graph is designed to let the operator know the condition of the battery before starting to use the machine.

The last bar flashes when the level of charge is less than 10%. The bar-graph is not displayed when the batteries are completely discharged.

SECTION 3 – MACHINE CONTROLS, INDICATORS AND OPERATION

- 3. Platform/Off/Ground Selector Switch** - A three-position, key-operated power select switch supplies power to the platform or ground controls and powers machine down in the off position.
- 4. Battery Charger Status Indicators** - This panel is designed to give the operator an accurate reading on the status of the battery charger. DEPENDING ON THE CHARGER INSTALLED ON THE MACHINE THESE LIGHTS MAY NOT BE USED. REFER TO SECTION 3-16 OF THIS MANUAL FOR FURTHER INFORMATION.



GREEN- Charge complete



YELLOW- Charging in process



RED- Charging abnormal

- 5. Emergency Stop Switch** - Depress the switch to stop all functions of the machine. The switch must be turned clockwise to restore the machine functions.
- 6. Telescope In/Out Buttons** - Membrane switches that provide extension and retraction of the boom (with the Function Enable Switch (7) pushed in).

- 7. Function Enable Button** - A membrane switch that must be pushed in and held to enable the controls of the ground control station.
- 8. Mast Lift/Lower Buttons** - Membrane switches that provide raising or lowering of the mast (with the Function Enable Switch (7) pushed in).
- 9. Boom Lift/Lower Buttons** - Membrane switches that provide raising or lowering of the boom (with the Function Enable Switch (7) pushed in).
- 10. Turntable Swing Buttons** - Membrane switches that provide swinging of the superstructure to the right or to the left (with the Function Enable Switch (7) pushed in).
- 11. Brake Release Switch**

⚠ WARNING

DO NOT MANUALLY DISENGAGE THE BRAKES UNLESS THE MACHINE:

- IS IN TRANSPORT (STOWED) POSITION.
- IS ON A SMOOTH, FIRM AND LEVEL SURFACE.
- WHEELS CHOCKED OR MACHINE POSITIVELY CONNECTED TO TOW VEHICLE.

The machine must be powered ON to Ground Control Mode at the Platform/Off/Ground selector switch to operate the brake release switch. Refer to section 3-18 of this manual for further information.

Platform Manual Descent Valves

The platform manual descent valves are used in the event of total power failure to lower the platform using gravity.

These devices are composed of:

- a flow control valve located on the main control valves assembly.
- a mast manual descent valve.
- a boom manual descent valve.

⚠ WARNING

DO NOT USE THE MANUAL DESCENT CONTROLS IF THE SLACK CHAIN WARNING IS ACTIVE. REFER TO SECTION 4 FOR SPECIFIC RECOVERY PROCEDURES.

1. Fully screw the flow control valve knob (clockwise).
2. To lower the mast:
 - a. Install the actuator on the remote push bar.
 - b. Push on the actuator. Release the actuator when the platform is lowered to the desired level.
 - c. Return the actuator behind the access door to the pump/motor assembly after use.
3. To lower the boom once the mast is fully retracted, pull the manual descent valve, override button. Release the button when the platform is lowered to the desired level.

4. Fully unscrew the flow control valve knob (counter-clockwise).

⚠ WARNING

KEEP BODY, HANDS AND ARMS OUT OF THE PATH OF THE MAST, THE JIB AND THE PLATFORM WHILE LOWERING.

Flow Control Valve

The flow control valve is located on the main control valves assembly, behind the access door to the pump/motor assembly. A red knob (1) allows to manually open/close the valve.

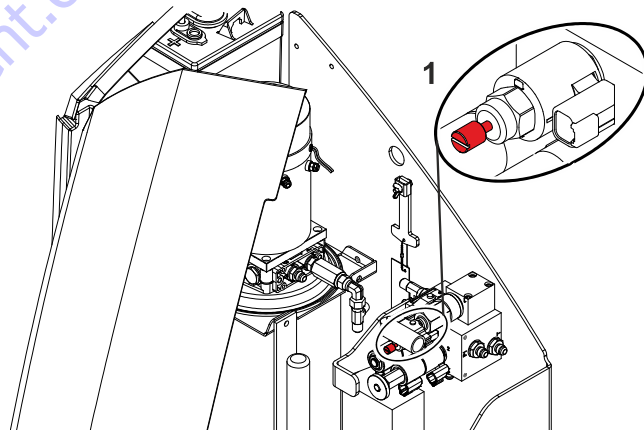

Figure 3-5. Flow Control Valve

Mast Manual Descent Valve and Actuator

- The mast manual descent valve **actuator (3)** is located behind the access door to the pump/motor assembly.
- The mast manual descent valve remote **push bar (2)** (red) is located behind the access door to the batteries.

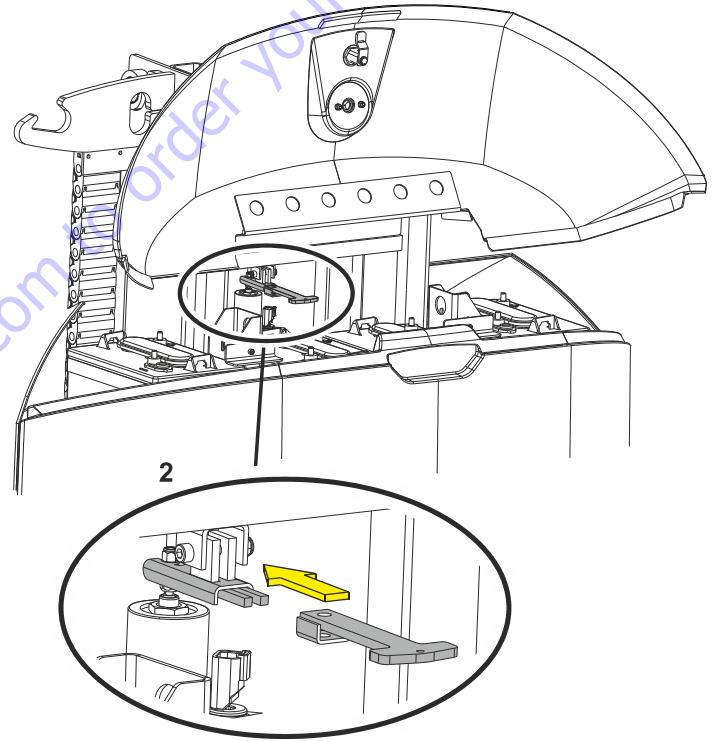
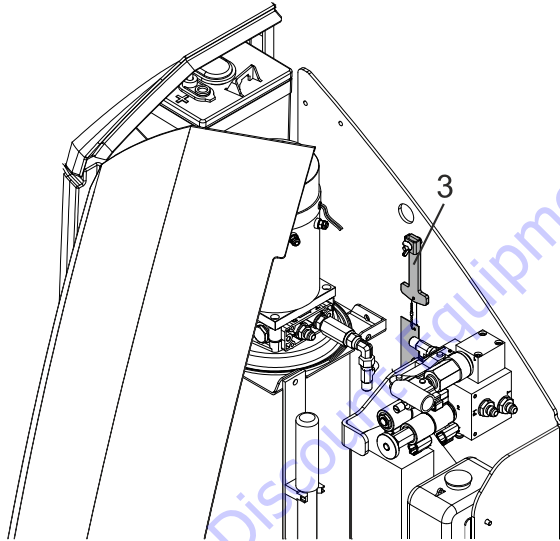

Figure 3-6. Mast Manual Descent Valve

Boom Manual Descent Valve

- The boom manual **descent button (3)** is located on the boom cylinder valve.

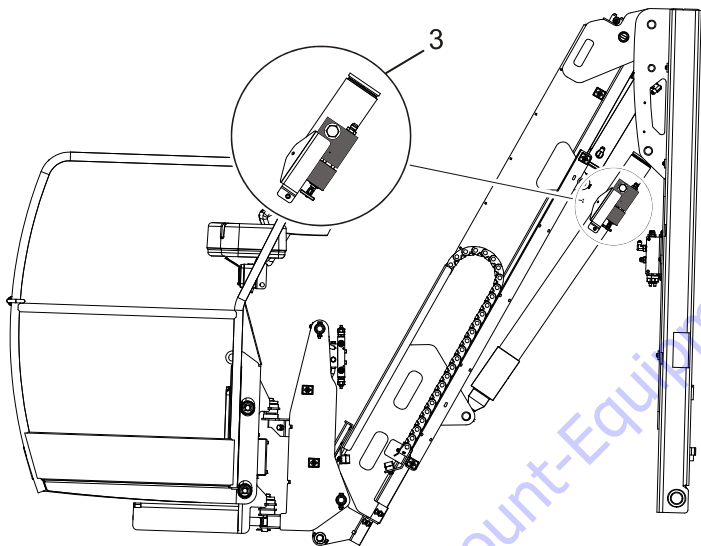

Figure 3-7. Boom Manual Descent Valve

Manual Swinging Operating Devices

The manual swinging operating devices are used in the event of total power failure to manually swing the superstructure. Those devices are composed of:

- a flow control valve (1) located on the main control valves assembly (Refer to Figure 3-5).
 - control valve (2) located on the main control valves assembly (Refer to Figure 3-8).
 - a hand pump (3), located on the main control valves assembly (Refer to Figure 3-8).
1. Fully screw the flow control valve knob.
 2. Push (pull) and hold the control valve knob while activating the hand pump to swing the turntable to the left (right).
 3. Fully unscrew the flow control valve knob.

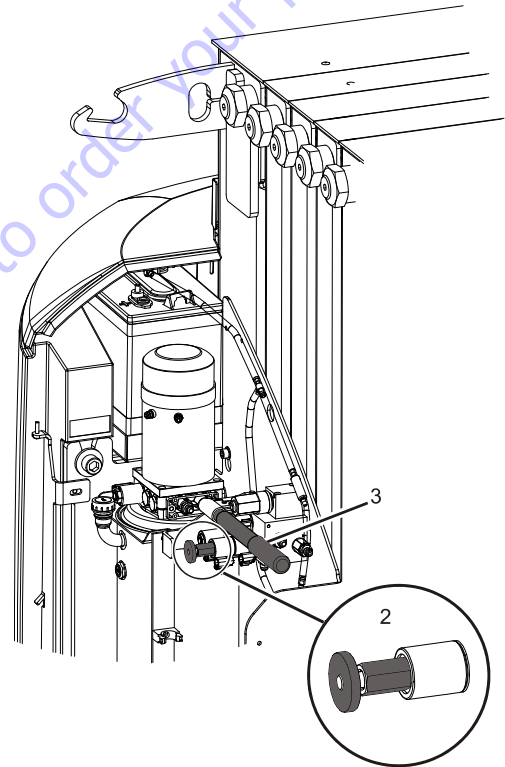

Figure 3-8. Manual Swinging Operating Devices

3.8 PLATFORM CONTROL STATION

⚠ WARNING

TO AVOID SERIOUS INJURY, DO NOT OPERATE MACHINE IF ANY CONTROL LEVERS OR SWITCHES CONTROLLING PLATFORM MOVEMENT DO NOT RETURN TO THE OFF OR NEUTRAL POSITION WHEN RELEASED.

1. Indicator Panel
2. Emergency Stop Switch
3. Trigger Switch
4. Drive/Swing Functions Controller
5. Steer Switch
6. Function Enable Button
7. Mast Lift Up/Down Joystick Controller
8. Telescope In/Out Joystick Controller
9. Boom Lift Up/Down Joystick Controller
10. Platform Rotation Switches (if equipped)
11. Platform Levelling Override Buttons
12. Drive Orientation System (DOS) Override Button
13. Horn

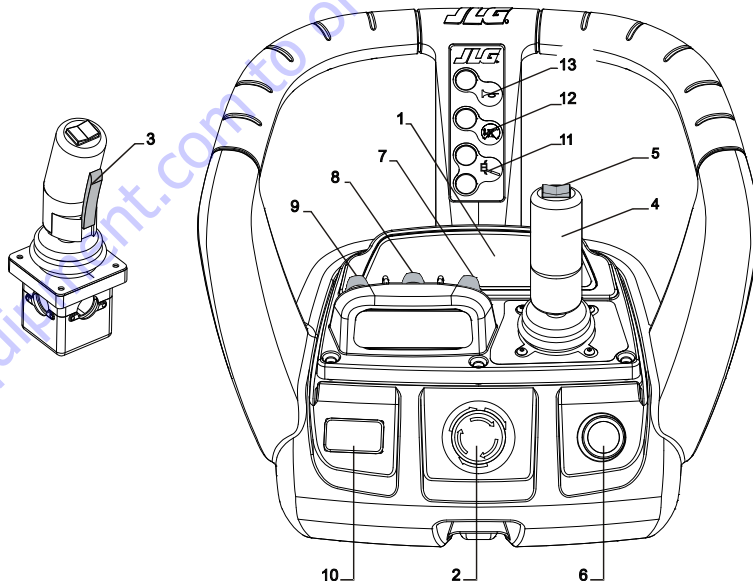

Figure 3-9. Platform Control Station

1. Indicator Panel

NOTE: The indicator lights will illuminate for approximately 1 second when the key is positioned to the ON position to act as a self test.

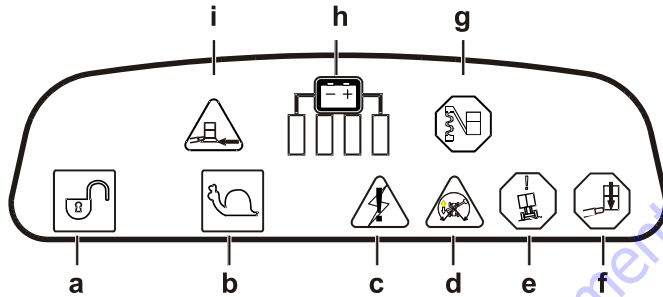
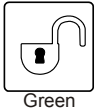

Figure 3-10. Platform Control Indicator Panel

- a-** Control Enable Indicator
- b-** Creep Speed Indicator
- c-** System Distress Indicator
- d-** Drive Orientation Indicator
- e-** Tilt Indicator Warning Light
- f-** Overload Indicator Warning Light (If equipped)
- g-** Slack Chain Indicator Warning Light
- h-** Battery Discharge Indicator (BDI)
- i-** Soft Touch Indicator (Optional)

SECTION 3 – MACHINE CONTROLS, INDICATORS AND OPERATION



Green

- a. When lit, indicates that the controls are enabled. If a function is not actuated within seven seconds, or a seven seconds lapse between ending one function and beginning the next function occurs, the enable light will go out and the enable must be released and activated again to enable the controls.

When blinking, indicates that the machine is in a configuration where the current activated function is not permitted.



Green

- b. Indicates that the high drive cutout limit-speed is engaged (the machine is out of transport (stowed) position).



Yellow

- c. This light indicates that the control system has detected an abnormal condition. This lamp when actuated is flashing a DTC (Diagnostic Troubleshooting Code). For an explanation of these codes and items, the operator can or cannot correct, see Service Manual.



Yellow

- d. When the structure is swung beyond the rear tires or further in either direction, the Drive Orientation indicator will illuminate. This is a signal for the operator to verify that the drive control is being operated in the proper direction (i.e. controls reversed situations).



Red

- e. Indicates that the chassis is out of level (refer to machine specifications for max. allowable slope angle). If the machine is out of the transport (stowed) position and the chassis is out of level, an audible alarm will sound.



Red

- f. (If equipped) - Indicates that the maximum rated load in the platform is exceeded. In addition to the warning indicator, an audible alarm sounds. The platform must be unloaded until the alarm stops.



Red

- g. Indicates that a slack chain condition has been detected. In addition to the warning indicator, an audible alarm will sound as long as the chain slack condition exists.



- h. This set of lights indicates the charge level of the battery.



Yellow

- i. (If equipped) - Indicates the Soft Touch frame is against an obstacle. In addition to the warning indicator, an audible alarm sounds. Once illuminated, only the reverse movement to the one that caused the contact with the obstacle can be operated in Creep mode.

SECTION 3 – MACHINE CONTROLS, INDICATORS AND OPERATION

2. **Emergency Stop Switch** - A two-position, red, emergency stop switch, when positioned to ON furnishes operating power to the platform control station. In addition, the switch can be used to turn off power to the function controls in the event of an emergency. Power is turned off by depressing the switch and power is turned on by turning the switch clockwise to pull it out.
3. **Trigger Switch** - This switch located at the front of the controller acts as an enable and must be depressed before operating the drive, steer and swinging functions. When released, the function being operated will stop.
4. **Drive/Swing Functions Controller** - This dual axis joystick controls drive and swinging functions. The speed of both functions is proportionally controlled by the distance of travel of the hand joystick.
Drive - Engage the trigger switch lever (3) with the joystick in neutral position then move the control handle forward to drive the machine forward or move the control handle backward to drive the machine backward.
Swing - Engage the trigger switch lever (3) with the joystick in neutral position then toggle the control handle to the left to swing the superstructure to the left or toggle the control handle to the right to swing to the right.
5. **Steer Switch** - The thumb-operated steer switch on top of the control handle activates the steer wheels in the direction activated (right or left).
6. **Function Enable Button** - This button is used to enable mast, boom, telescope, platform levelling and rotation (if equipped) functions. It must be depressed and held before actuating a boom, telescope, platform levelling or rotation (if equipped) function. When released, the function being operated will stop.
7. **Mast Lift Up/Down Joystick Controller** - This fingertip, single axis, joystick controller operates Mast Lift Up and Lift Down functions.
With the joystick controller in neutral position, push-in and hold the Function Enable Button (6), moving the joystick Up will raise the mast and moving the joystick Down will lower the mast. The speed of the movements is proportionally controlled by the distance of travel of the joystick.

SECTION 3 – MACHINE CONTROLS, INDICATORS AND OPERATION

- 8. Telescope In/Out Joystick Controller** - This fingertip, single axis, joystick controller operates Telescope In and Telescope Out functions.

With the joystick controller in neutral position, push-in and hold the Function Enable Button (6), moving the joystick Up will extend the telescope and moving the joystick Down will retract the telescope. The speed of the movements is proportionally controlled by the distance of travel of the joystick.

- 9. Boom Lift Up/Down Joystick Controller** - This fingertip, single axis, joystick controller operates Boom Lift Up and Boom Lift Down functions.

With the joystick controller in neutral position, push-in and hold the Function Enable Button (6), moving the joystick Up will raise the boom and moving the joystick Down will lower the boom. The speed of the movements is proportionally controlled by the distance of travel of the joystick.

- 10. Platform Rotation Switch (if equipped)** - A rocker switch allows the operator to swing the platform. Push-in and hold the Function Enable Button (6); pushing-in the Platform Rotation Switch will swing the platform in the corresponding direction.

- 11. Platform Levelling Override Buttons** - Two membrane switches allow the operator to adjust the automatic self levelling system. Push-in and hold the Function Enable

Button (6); pushing-in the upper button will tilt the platform forward and pushing-in the lower button will tilt the platform backward.

- 12. Drive Orientation Override Button** - When the jib is swung beyond the rear tires or further in either direction, the Drive Orientation indicator will illuminate. Before driving, locate the black/white orientation arrows on both the chassis and the platform controls. Push and release the override switch and within 3 seconds slowly move the Drive/Steer control to actuate drive or steer. Move the drive control toward the arrow matching the intended direction of machine travel.

- 13. Horn** - This button, when activated, permits the operator to warn job site personnel when the machine is operating in the area.

Grade and Side Slope

See Figure 3-11., Grade and Side Slope

NOTE: Refer to the Operating Specifications table for Gradeability and Sideslope ratings.

With the machine in transport mode, travelling is limited by two factors: gradeability and side slope. Gradeability is the percent of grade of the incline the machine can climb. Side slope is the angle of the surface the machine can be driven across. Refer to Table 5-1.

SECTION 3 – MACHINE CONTROLS, INDICATORS AND OPERATION

When the machine is out of transport (stowed) position, the machine must not be operated on grade or side slopes greater than that is specified in Table 5-1.

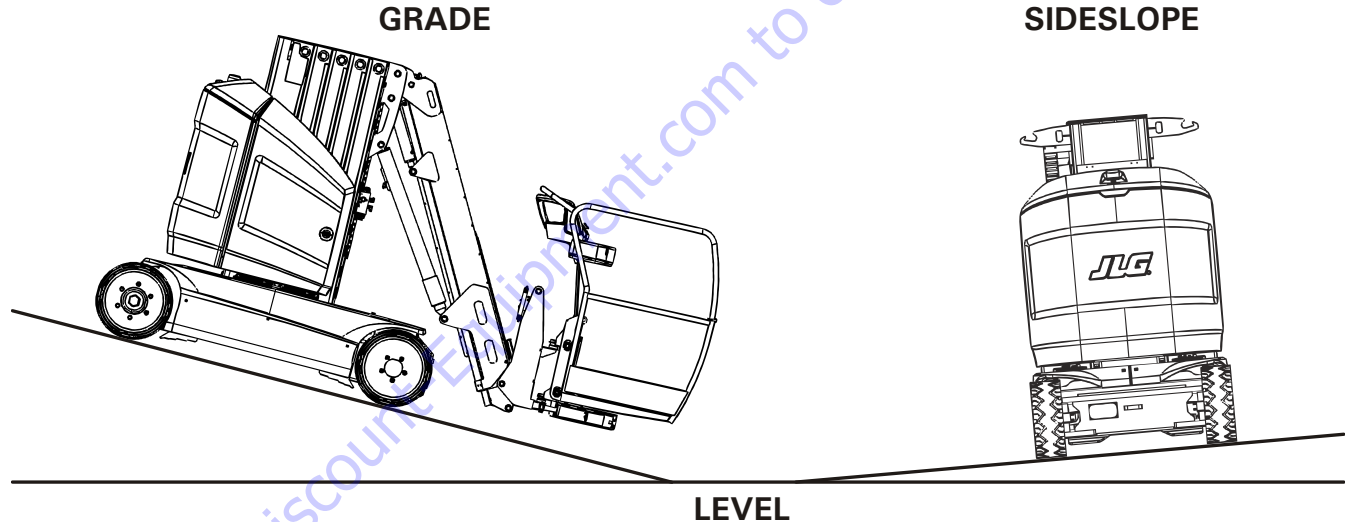

Figure 3-11. Grade and Side Slope

3.9 OPERATION

1. At ground control station, position the key-select switch to PLATFORM.
2. Position the emergency stop switch to the on (out) position by turning it clockwise.
3. At platform control station, position the emergency stop switch to the on (out) position by turning it clockwise.

NOTE: *If at any time during operation, the machine remains idle for a period exceeding 2 hours, machine power will be shut down. The emergency stop switch(es) must be recycled to start machine again.*

⚠ WARNING

TO AVOID SERIOUS INJURY, DO NOT OPERATE MACHINE IF ANY CONTROL LEVERS OR SWITCHES CONTROLLING THE PLATFORM MOVEMENT DOES NOT RETURN TO THE OFF OR NEUTRAL POSITION WHEN RELEASED.

IF THE PLATFORM DOES NOT STOP WHEN CONTROL LEVER OR THE ENABLE BUTTON/TRIGGER SWITCH IS RELEASED, USE THE EMERGENCY STOP SWITCH TO STOP THE MACHINE.

3.10 STEERING AND TRAVELLING (DRIVING)

⚠ WARNING

DO NOT DRIVE WITH MAST OR BOOM OUT OF TRANSPORT (STOWED) POSITION EXCEPT ON A SMOOTH, FIRM AND LEVEL SURFACE FREE OF OBSTRUCTIONS AND HOLES.

TO AVOID LOSS OF TRAVEL CONTROL OR "TIP OVER", DO NOT DRIVE MACHINE ON GRADES OR SIDE SLOPES EXCEEDING THOSE SPECIFIED IN SECTION 5.

USE EXTREME CAUTION WHEN DRIVING IN REVERSE AND AT ALL TIMES WHEN THE PLATFORM IS ELEVATED.

BEFORE DRIVING, LOCATE THE BLACK/WHITE ORIENTATION ARROWS ON BOTH THE CHASSIS AND THE PLATFORM CONTROLS. MOVE THE DRIVE CONTROLS IN A DIRECTION MATCHING THE DIRECTIONAL ARROW FOR THE INTENDED DIRECTION OF TRAVEL.

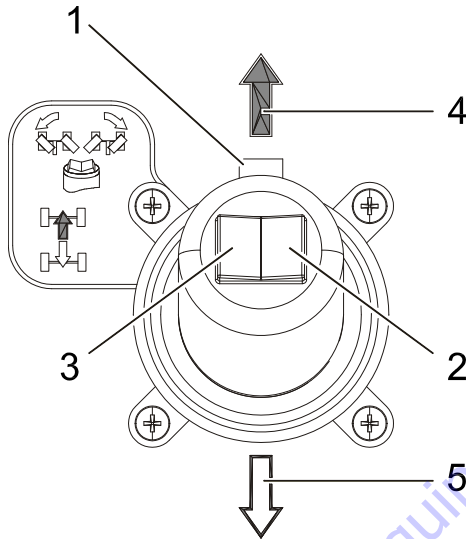

Figure 3-12. Steer/Drive Controls

Steering

1. Squeeze and hold the **trigger switch (1)** on front of the joystick.
2. Activate the thumb switch on top of the joystick to **right (2)** for travelling right or to **left (3)** for travelling left. When released, the thumb switch will return to the center-off position and the wheels will remain in the previously selected position. To return the wheels to the straightened position, the switch must be activated in the opposite direction until the wheels are centered.

Travelling (driving)

1. With all control levers in neutral position, squeeze and hold the **trigger switch (1)** on front of the joystick.
2. Move the joystick **forward (4)** (within 7 seconds after the trigger has been actuated) to drive forward or move the joystick **backward (5)** to drive in reverse. The speed of the movement is proportionally controlled by the distance of travel of the joystick.
3. Return the controller to its centered (neutral) position to stop, then release the trigger.

⚠ WARNING

IF THE TILT INDICATOR WARNING LIGHT/ALARM IS ACTIVATED WHILE DRIVING WITH THE MAST OR THE BOOM RAISED, LOWER THE MAST COMPLETELY, RETRACT THE TELESCOPE, LOWER THE BOOM AND DRIVE TO A SMOOTH, FIRM AND LEVEL SURFACE.

Drive Orientation System (DOS)

When the structure is swung beyond the rear wheels or further in either direction, the **drive orientation indicator (1)** will illuminate and drive will be disabled.

1. Push and release the **override button (2)**, and within 3 seconds move the drive/steer controls to activate drive or steer.
2. Before driving, locate the black/white directional arrows on both the chassis and the platform controls (3). Move the drive control joystick in a direction matching the directional arrow, for the intended direction of travel.

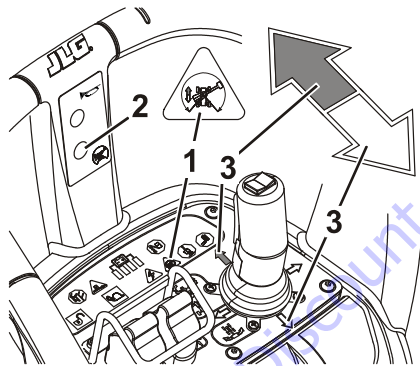

Figure 3-13. Drive Orientation System (DOS)

3.11 PLATFORM

⚠ WARNING

ONLY USE THE PLATFORM LEVELING OVERRIDE FUNCTION FOR SLIGHT LEVELING OF THE PLATFORM. INCORRECT USE COULD CAUSE THE LOAD/OCCUPANTS TO SHIFT OR FALL. FAILURE TO DO SO COULD RESULT IN DEATH OR SERIOUS INJURY.

Platform Level Adjustment

To manually Level Up or Down - Push and hold the Function Enable Button, push the Platform/Level control switch Up or Down and hold until the desired platform position is obtained.

Platform Rotation (If equipped)

To rotate the platform to the left or right, push and hold the Function Enable Button, use the Platform Rotate control switch to select the direction and hold until desired position is reached.

3.12 RAISING AND LOWERING THE PLATFORM

WARNING

DO NOT RAISE THE PLATFORM EXCEPT ON A SMOOTH, FIRM AND LEVEL SURFACE FREE OF OBSTRUCTIONS AND HAZARDS. ENSURE THE AREA BENEATH THE PLATFORM IS FREE FROM PERSONNEL PRIOR TO LOWERING THE PLATFORM.

Raising and lowering the mast

1. With all control levers in neutral position, push in and hold the **Function Enable Button**.
2. To raise or lower the mast, move the mast controller in the desired movement direction. The speed of the movement is proportionally controlled by the distance of travel of the joystick.
3. Return the controller to its centered (neutral) position to stop.

Raising and lowering the boom

1. With all control levers in neutral position, push in and hold the **Function Enable Button**.
2. To raise or lower the boom, move the boom controller in the desired movement direction. The speed of the movement is proportionally controlled by the distance of travel of the joystick.
3. Return the controller to its centered (neutral) position to stop.

Telescoping the Boom

1. With all control levers in neutral position, push in and hold the **Function Enable Button**.
2. To extend or retract the boom, move the telescope controller Up (extension) or Down (retraction). The speed of the movement is proportionally controlled by the distance of travel of the joystick.
3. Return the controller to its centered (neutral) position to stop.

3.13 SWINGING

WARNING

DO NOT SWING THE SUPERSTRUCTURE EXCEPT ON A SMOOTH, FIRM AND LEVEL SURFACE, FREE OF OBSTRUCTIONS AND HOLES.

CAUTION

WHEN SWINGING, MAKE SURE THERE IS AMPLE ROOM FOR THE JIB TO CLEAR SURROUNDING WALLS, PARTITIONS AND EQUIPMENT.

1. With all control levers in neutral position, squeeze and hold the **trigger switch** on front of the joystick.
2. Move the joystick to the desired direction: **right** or **left**. The speed of the movement is proportionally controlled by the distance of travel of the joystick.
3. Return the controller to its centered (neutral) position to stop, then release the trigger.

3.14 ALARMS

Overload Warning Light/Alarm (If equipped)

When the maximum rated load in the platform is exceeded, RED light indicators at both the ground and the platform control stations will blink and an audible alarm will sound. When the overload indicator warning is activated, all machine functions are disabled. The platform must be safely unloaded until the alarm stops.

Tilt Warning Light/Alarm

When the chassis is out of level (Refer to Table 5-1), the RED light indicator at platform control station will illuminate. If the machine is out of transport (stowed) position, and the chassis is out of level an audible alarm will sound.

WARNING

TO AVOID TIP OVER IF RED TILT WARNING LIGHT LIGHTS WHEN MACHINE IS OUT OF TRANSPORT POSITION, LOWER THE PLATFORM TO GROUND LEVEL. THEN REPOSITION MACHINE SO THAT CHASSIS IS LEVEL BEFORE RAISING BOOM.

When the tilt indicator warning is activated, the following functions are affected:

- The Drive function is disabled out of stowed position.
- Mast/Jib Lift and Swinging movements switch to Creep

mode.

- The telescope extension is disabled.
- The retraction functions properly.

When the tilt indicator warning is activated, control the machine as follows:

1. Lower the mast.
2. Retract the telescope.
3. Return the platform in line with the chassis.
4. Lower the boom.
5. Drive the machine to a smooth, firm and level surface.

WARNING

AVOID RAISING THE MAST, EXTENDING THE TELESCOPE, OPERATING THE BOOM OR SWINGING WITH THE MACHINE OUT OF TRANSPORT POSITION WHEN THE CHASSIS IS OUT OF LEVEL. ALWAYS LOWER THE MAST AND RETRACT THE TELESCOPE AS MUCH AS POSSIBLE BEFORE OPERATING THE BOOM OR SWINGING.

Slack Chain Warning Light/Alarm

When the system detects a slack chain condition, the RED light indicator at platform control station will illuminate and an audible alarm will sound.

Slack chain condition is generally caused by the platform or the boom coming to rest on an obstacle while lowering. When the slack chain indicator warning is activated, all machine functions, except mast and boom raising movements are disabled.

Procedure to follow in case the slack chain indicator warning is activated:

1. Raise the mast or the boom (generally the reverse movement to the one that caused the alarm to be activated). This will re-tension the chain(s) and stop the alarm.
2. Examine surroundings to identify the cause.
3. Perform the movement which will clear the machine and prevent contact with the obstacle.

WARNING

IF THE EXAMINATION OF THE SURROUNDINGS DOES NOT REVEAL ANY POSSIBLE OBSTACLE, DISCONTINUE OPERATION IMMEDIATELY. DO NOT USE MANUAL DESCENT CONTROLS. PLATFORM OCCUPANTS MUST BE RESCUED AND THE MAST MECHANISM SERVICED BY A QUALIFIED TECHNICIAN.

3.15 SHUT DOWN AND PARK

Shut down and park the machine as follows:

1. Drive the machine to a reasonably well-protected and well-ventilated area.
2. Ensure the platform is fully lowered.
3. Turn the platform/ground selector switch to off and remove the key to disable the machine and prevent unauthorized use.
4. At the ground control station, position the emergency stop switch to the off (pushed in) position.
5. If necessary, cover the platform console, the instruction placards, caution and warning decals so that they will be protected from hostile environment.
6. If necessary, charge the battery.

3.16 BATTERY CHARGING

NOTE: Be sure that the machine is parked in a well-ventilated area before charging begins.

⚠ WARNING

ONLY PLUG THE CHARGER INTO A PROPERLY INSTALLED AND GROUNDED OUTLET. DO NOT USE GROUND ADAPTORS OR MODIFY PLUG. DO NOT TOUCH NON-INSULATED PORTION OF OUTPUT CONNECTOR OR NON-INSULATED BATTERY TERMINAL.

DO NOT OPERATE CHARGER IF THE AC SUPPLY CORD IS DAMAGED OR IF THE CHARGER HAS RECEIVED A SHARP BLOW, BEEN DROPPED OR OTHERWISE DAMAGED IN ANY WAY.

ALWAYS DISCONNECT THE AC SUPPLY BEFORE MAKING OR BREAKING THE (POS/NEG) CONNECTIONS TO THE BATTERY.

DO NOT OPEN OR DISASSEMBLE CHARGER.

NOTE: It is not necessary to charge the battery if the electrolyte specific gravity has not dropped under 1.240kg/l. Doing so regularly will greatly reduce battery life.

The battery charger **AC input plug (1)** is located on the battery compartment.

1. Connect the **AC input plug (1)** to a grounded outlet.



2. When first powered up, the charger will go through a short LED indicator self-test. The battery charger light's on the Ground Control Station will flash in sequence for two seconds.
3. The batteries are fully charged when the green light on the battery charger status panel (Ground Control Station) is illuminated.

NOTE: If the charger is left plugged in, the charger will automatically restart a complete charge cycle if the batteries voltage drops below a minimum voltage or 30 days has elapsed.

SECTION 3 – MACHINE CONTROLS, INDICATORS AND OPERATION

Battery Charger Fault Code

If a fault occurred during charging, the red (Fault LED located on the Ground Control Station panel) will flash with a code corresponding to the error. Refer to the table following for the flash codes and their removal.

If required, further general and troubleshooting information about the battery charger can be found in the charger manufacturer's Owner's Guide included in the manual storage box mounted on the machine.

Table 3-1. Battery Charger Fault Code

Flash(s)	Fault	Remedy
1	Battery voltage high	Auto-recover - Indicates a high battery pack voltage.
2	Battery voltage low	Auto-recover - Indicates either a battery pack failure, battery pack not connected to charger or battery volts per cell is less than 0.5 VDC. Check the battery pack and connections.
3	Charge time-out	Indicates the batteries did not charge in the allowed time. This could occur if the batteries are a larger capacity than the algorithm is intended for or if the batteries are damaged, old, or in poor condition.
4	Check battery	Indicates the batteries could not be trickle charged up to the minimum voltage per cell level required for the charge to be started.
5	Over-temperature	Auto-recover - Indicates charger has shut down due to high internal temp.
6	Charger Internal Fault	Indicates that the battery will not accept charge current, or an internal fault has been detected in the charger. This fault will nearly always be set within the first 30 seconds of operation. Once it has been determined that the batteries and connections are not faulty and fault 6 is again displayed after interrupting AC power for at least 10 seconds, the charger must be brought to a qualified service depot.

3.17 TIE-DOWN/LIFT LUGS

Tie Down

When transporting the machine:

- Platform must be fully lowered in the stowed position.
- Remove all loose items from the machine.
- Machine must be tied down to the truck bed or trailer deck as shown in Figure 3-14.

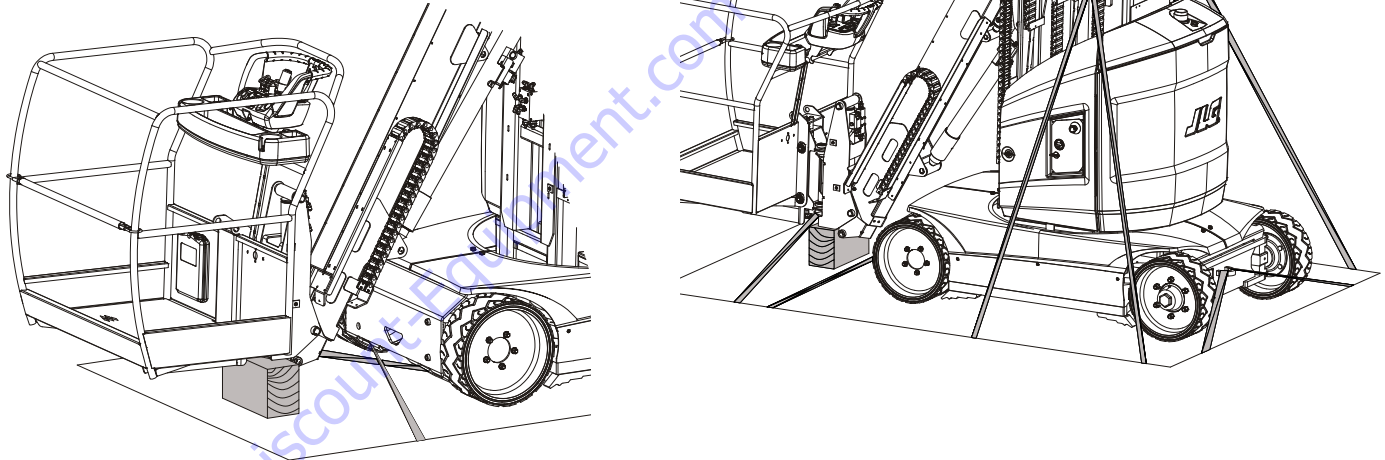

Figure 3-14. Machine Tie-Down

Lifting

When lifting the machine:

- Platform must be fully lowered in the stowed position.
- Remove all loose items from the machine.
- Attach lifting straps/chains at BOTH lifting lugs as shown in Figure 3-15.

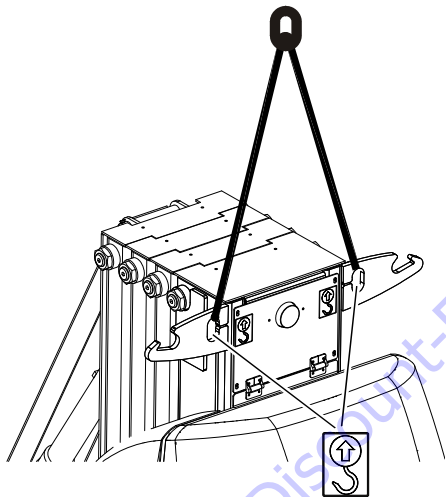

Figure 3-15. Lifting the Machine

3.18 TOWING

It is not recommended that this machine be towed, except in the event of an emergency or a machine power failure.

NOTICE

THE ALLOWABLE TOWING SPEED IS 3 KM/H (1.9 MPH). THE MAXIMUM ALLOWABLE TOWING DISTANCE IS 500 M (0.3 MILES).

Electric Brake Release

NOTE: Electrical release of the brakes requires enough battery power to hold the brakes in released mode until destination is reached.

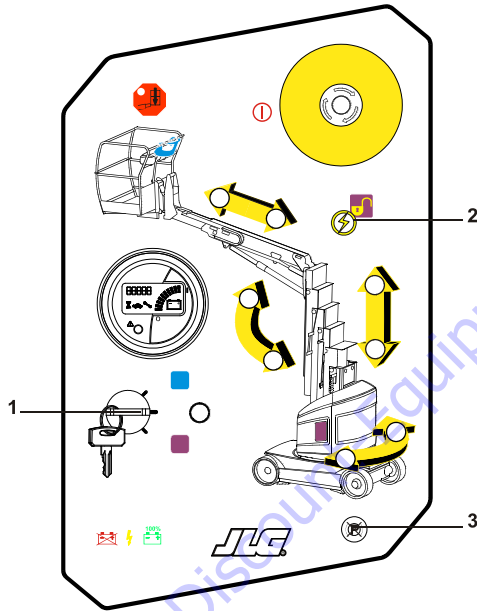

Figure 3-16. Electric Brake Release

1. Chock wheels or secure machine with tow vehicle.
2. Position the key-select-switch to **ground control station (1)**.
3. Push and hold the **enable push button (2)**.
4. Depress the **brake release button (3)** for one second to release the brakes. Once the brakes are released, an acoustic (discontinuous sound) alarm is triggered.
5. When finished towing depress and hold both the **enable push button (2)** and the **brake release button (3)** again or power the machine down at the ground control station to re-engage the brakes.

NOTE: Any action to remove electrical power from the brakes such as, depressing the ground control emergency stop switch, or switching the key switch to OFF or PLATFORM MODE will re-engage the brakes.

SECTION 4. EMERGENCY PROCEDURES

4.1 GENERAL INFORMATION

This section explains the steps to be taken in case of an emergency situation during operation.

4.2 EMERGENCY OPERATION

Operator Unable to Control Machine

IF THE PLATFORM OPERATOR IS UNABLE TO OPERATE OR CONTROL THE MACHINE:

1. Other personnel should operate the machine from ground controls only as required.
2. Only qualified personnel in the platform may use the platform controls. DO NOT CONTINUE OPERATION IF CONTROLS DO NOT FUNCTION PROPERLY.
3. Rescue equipment can be used to remove the platform occupant(s). Cranes and forklift can be used to stabilize motion of the machine.

Platform or Boom Caught Overhead

If the platform or the boom becomes jammed or snagged in overhead structures or equipment, rescue the platform occupant(s) prior to freeing the machine.

4.3 EMERGENCY CONTROL

The machine has a Ground Control Station which will override the Platform Control Station. Ground controls operate Lift and Swing, and are to be used in an emergency to lower the platform to the ground, should the operator in the platform be unable to do so.

⚠ WARNING

DO NOT OPERATE FROM GROUND CONTROL STATION WITH PERSONNEL IN THE PLATFORM EXCEPT IN AN EMERGENCY. ENSURE THE AREA BENEATH THE PLATFORM IS FREE OF PERSONNEL OR OBSTACLES PRIOR TO LOWERING.

1. Position the **key-select switch (1)** to GROUND.
2. Push and hold the **enable button (2)**.
3. Actuate the appropriate **function button (3)** until the desired elevation or position of the platform is achieved.

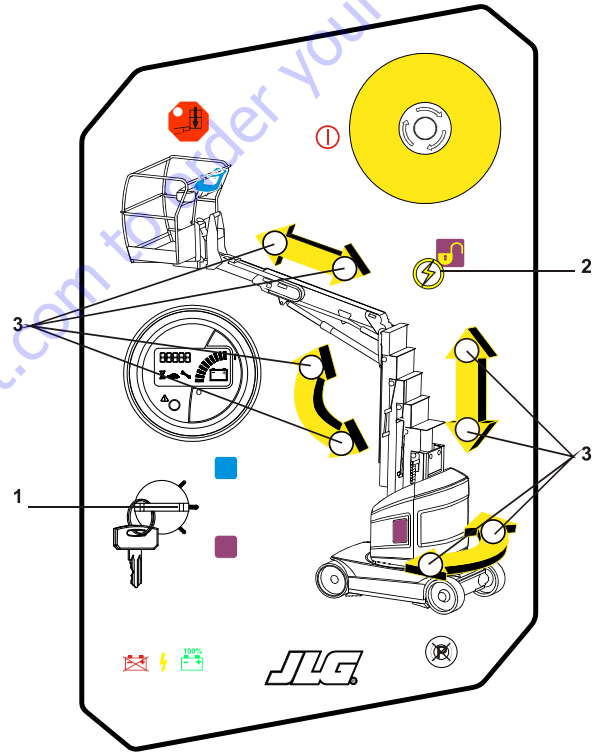

Figure 4-1. Emergency Controls

Operator Unable to Control Machine in Overload Condition

Position the key selector switch to Ground.

1. The overload condition is indicated with :
 - The acoustic alarm
 - The red flashing overload indicator
 - The error code #829 displayed on the Multifunction Digital Indicator (MDI).

The ground control functions are cut.

2. To restore ground control functions :
 - Press three (3) times on the Enable button and while maintaining the Enable button on the third press, then press on the appropriate function.

The alarm stops and the movement is performed.

3. Repeat the above sequence to perform new movements until the overload condition is removed.
4. When the overload condition is no longer remaining :
 - The Ground control console and the Platform control console are functioning properly.

- The error code #843 is permanently displayed on the Multifunction Digital Indicator (MDI) to indicate that the Ground control console has been operated in overload condition.

To reset the machine and clear the #843 error code, contact a qualified JLG equipment mechanic or refer to the Service and Maintenance manual.

4.4 PLATFORM MANUAL DESCENT

The platform manual descent valves are used in the event of a total power failure to retract and lower the platform using gravity. Refer to Section 3 PLATFORM MANUAL DESCENT.

4.5 INCIDENT NOTIFICATION

JLG Industries, Inc. must be notified immediately of any incident involving a JLG product. Even if no injury or property damage is evident, the factory should be contacted by telephone and provided with all necessary details.

In USA:

JLG Phone: 877-JLG-SAFE (554-7233)

EUROPE: (44) 1 698 811005

AUSTRALIA: (61) 2 65 811111

SECTION 4 – EMERGENCY PROCEDURES

E-mail: ProductSafety@JLG.com

Failure to notify the manufacturer of an incident involving a JLG Industries product within 48 hours of such an occurrence may void any warranty consideration on that particular machine.

NOTICE

FOLLOWING ANY INCIDENT, THOROUGHLY INSPECT THE MACHINE. DO NOT ELEVATE PLATFORM UNTIL YOU ARE SURE THAT ALL DAMAGE HAS BEEN REPAIRED, AND THAT ALL CONTROLS ARE OPERATING CORRECTLY. TEST ALL FUNCTIONS FIRST FROM THE GROUND CONTROL STATION, THEN FROM THE PLATFORM CONTROL CONSOLE.

4.6 EMERGENCY TOWING

Towing this machine is discouraged. However provisions for towing the machine in emergency situations have been incorporated. Refer to Section 3-18 TOWING.

TO PURCHASE THIS PRODUCT PLEASE CONTACT US



**Equipment Financing and
Extended Warranties Available**



**Discount-Equipment.com is your online resource for
commercial and industrial quality parts and equipment sales.**

561-964-4949

visit us on line @ www.discount-equipment.com

Select an option below to find your Equipment

Search by Manufacturer

Search by Product Type

Request a Quote

We sell worldwide for the brands: Genie, Terex, JLG, MultiQuip, Mikasa, Essick, Whiteman, Mayco, Toro Stone, Diamond Products, Generac Magnum, Airman, Haulotte, Barreto, Power Blanket, Nifty Lift, Atlas Copco, Chicago Pneumatic, Allmand, Miller Curber, Skyjack, Lull, Skytrak, Tsurumi, Husquvarna Target, Stow, Wacker, Sakai, Mi-T-M, Sullair, Basic, Dynapac, MBW, Weber, Bartell, Bennar Newman, Haulotte, Ditch Runner, Menegotti, Morrison, Contec, Buddy, Crown, Edco, Wyco, Bomag, Laymor, EZ Trench, Bil-Jax, F.S. Curtis, Gehl Pavers, Heli, Honda, ICS/PowerGrit, IHI, Partner, Imer, Clipper, MMD, Koshin, Rice, CH&E, General Equipment, Amida, Coleman, NAC, Gradall, Square Shooter, Kent, Stanley, Tamco, Toku, Hatz, Kohler, Robin, Wisconsin, Northrock, Oztec, Toker TK, Rol-Air, APT, Wylie, Ingersoll Rand / Doosan, Innovatech, Con X, Ammann, Mecalac, Makinex, Smith Surface Prep, Small Line, Wanco, Yanmar

SECTION 5. GENERAL SPECIFICATIONS AND MAINTENANCE

5.1 INTRODUCTION

This section of the manual provides additional necessary information to the operator for proper operation and maintenance of this machine.

The maintenance portion of this section is intended as information to assist the machine operator to perform daily maintenance tasks only, and does not replace the more thorough Preventive Maintenance and Inspection Schedule included in the Service and Maintenance Manual.

Other Publications Available Specific to this machine:

Service and Maintenance Manual.....	31210149
Illustrated Parts Manual.....	31210150

SECTION 5 – GENERAL SPECIFICATIONS AND MAINTENANCE

5.2 OPERATING SPECIFICATIONS

Table 5-1. Operating Specifications And Dimensions

Model	TOUCAN 12E	TOUCAN 12E Plus	TOUCAN 32E
Maximum Work Load	200 kg (2 persons + 40 kg material)		500 lbs (227 kg)
Maximum Manual Side Force	400 N		100 lbf (445 N)
Maximum Operating Wind Speed	45 km/h (12.5 m/s)		28 mph
Maximum Elevated Travel Grade (Gradeability and Side slope)	5.2% (3°)		0°
Maximum Stowed Travel Grade (Gradeability) (Reference Figure 4.3)	25% (14°)		25% (14°)
Maximum Stowed Travel Grade (Side slope) (Reference Figure 4.3)	8.7% (5°)		8.7% (5°)
Maximum Drive Speed	Stowed Mast Elevated	5.50 km/h 0.75 km/h	3.4 mph (5.5 km/h) 0.47 mph (0.75 km/h)
Inside Turning Radius	0.75 m		2.5' (0.75 m)
Outside Turning Radius	2.60 m		8.5' (2.60 m)
Maximum Platform Height	9.83 m	10.65 m	32.3' (9.83 m)
Horizontal Reach			
From centerline of machine	4.60 m	5.55 m	14.9' (4.55 m)
From rear wheel edge	3.57 m	4.52 m	11.5' (3.52 m)
From side wheel edge	4.00 m	4.95 m	13.0' (3.95 m)
Up and Over Clearance	6.95 m		22.8' (6.95 m)
Approximate Gross Machine Weight	4300 kg	4900 kg	9480 lbs (4300 kg)

SECTION 5 – GENERAL SPECIFICATIONS AND MAINTENANCE

Table 5-1. Operating Specifications And Dimensions

Model	TOUCAN 12E	TOUCAN 12E Plus	TOUCAN 32E
Maximum Tire Load (per wheel)	2280 kg	2680 kg	5027 lbs (2280 kg)
Maximum Hydraulic Pressure	18 MPa		2600 psi (18 MPa)
Maximum Ground Bearing Pressure	12.5 kg/cm ²	14 kg/cm ²	178 psi (12.5 kg/cm ²)
Electrical System Voltage	48V		

SECTION 5 – GENERAL SPECIFICATIONS AND MAINTENANCE

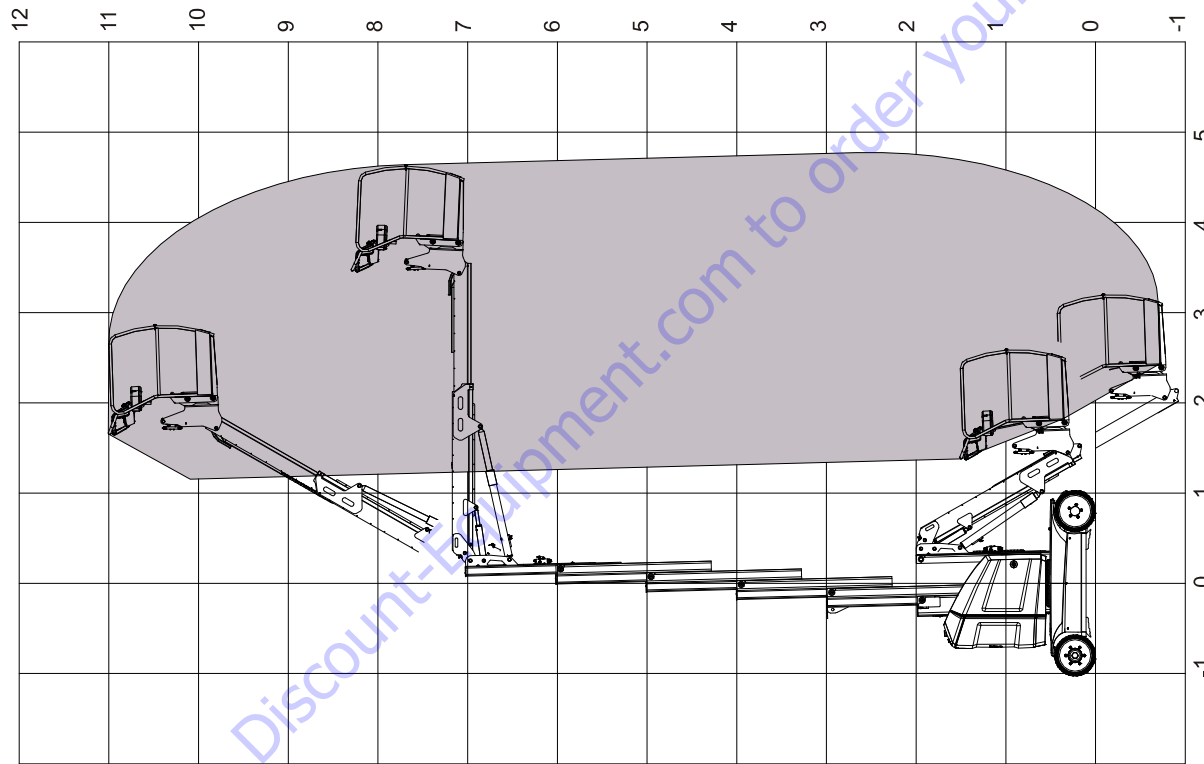

Figure 5-1. Range Diagram T12E - T32E

SECTION 5 – GENERAL SPECIFICATIONS AND MAINTENANCE

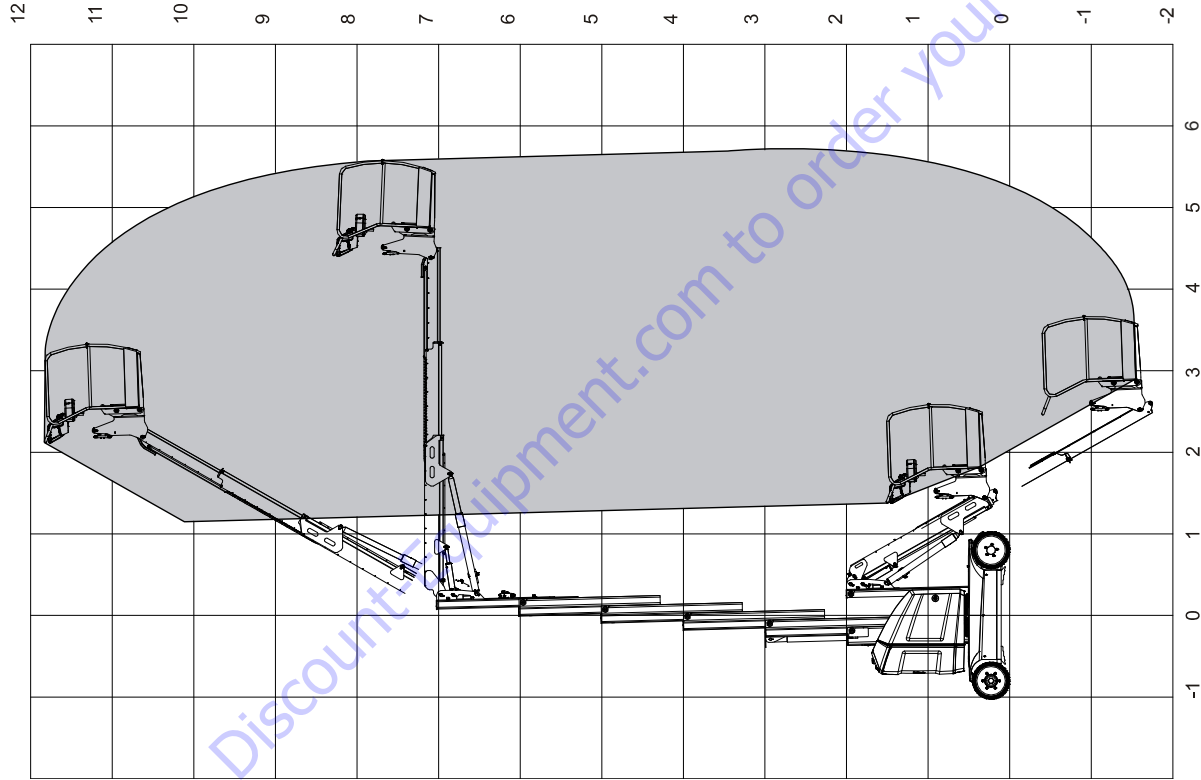

Figure 5-2. Range Diagram T12E Plus

SECTION 5 – GENERAL SPECIFICATIONS AND MAINTENANCE

Table 5-2. Dimensions

DESCRIPTION	Model TOUCAN 12E TOUCAN 12E Plus	Model TOUCAN 32E
Platform Height - Stowed	0.35 m	13.8" (0.35 m)
Overall Stowed Machine Height	1.99 m	6.5' (1.99 m)
Overall Machine Width	1.20 m	3.9' (1.20 m)
Overall Machine Length	3.65 m	11.8' (3.60 m)
Platform Size - Length	0.70 m	2.3' (0.70 m)
Platform Size - Width	1.05 m	3.4' (1.05 m)

Table 5-3. Tires Specifications

DESCRIPTION	All Models	
Size	Ø457 x 178 mm	
Wheel Bolts Torque	Front	250 N.m (184 lb.ft)
	Rear	210 N.m (155 lb.ft)

SECTION 5 – GENERAL SPECIFICATIONS AND MAINTENANCE

Table 5-4. Drive Motors - Hydraulic Power Unit

DESCRIPTION			All Models		
Drive Motor			Voltage	28 VAC	
			Power	2 kW	
Hydraulic Power Unit	Motor			48 VDC	
				3.5 kW	
	Pump	Displacement		4.2 cc/rev - (0.26 cu.in/rev)	
		Flow Rate		11.5 l/mn @ 13 MPa - (3.04 gal/min @ 1900 psi)	
	Capacity	Tank		15 l (11.5 l usable) - (3.96 gal (3.04 gal usable))	
		Hydraulic System (1)		TOUCAN 12E - TOUCAN32E Approx. 20 l - (5.28 gal)	TOUCAN 12E Plus Approx. 21.5 l - (5.68 gal)

(1) - Including Tank

SECTION 5 – GENERAL SPECIFICATIONS AND MAINTENANCE

Table 5-5. Battery Specifications

DESCRIPTION	All Models
Voltage (48 VDC)	8 packs of 6V
Amp Hour (Standard battery)	215 Amp Hour @ 5 HR. Rate 260 Amp Hour @ 20HR. Rate
Battery Weight (Approx.)	265 kg (584 lbs)

Table 5-6. Lubrication Specifications

KEY	SPECIFICATIONS	e.g.
A	Extreme Pressure - Multi Purpose Grease	MOBILUX EP2 COMPLEX EP2
B	Open Gear Lube	MOBILTAC 81
C	Non Detergent Mineral Oil (*)	MOBIL DTE 16M
D	Synthetic Chain Oil	Fuchs VT 800

(*) To be adapted to the machine's operating conditions. See Table 5-11

NOTE: Aside from JLG recommendations, it is not advisable to mix oils of different brands or types, as they may not contain the same required additives or be of comparable viscosities.

Table 5-7. Hydraulic Oil Specifications - Standard

SPECIFICATION	NERVOFLUID VG 15
ISO Viscosity grade	15
Cinematic Viscosity @ -20°C (-4°F)	214 mm ² /s (cSt)
Cinematic Viscosity @ 0°C (32°F)	68 mm ² /s (cSt)
Cinematic Viscosity @ +40°C (104°F)	14.9 mm ² /s (cSt)
Pour Point, Max.	-40°C (-40°F)
Flash Point, Min.	175°C (347°F)
Viscosity Index	153
ISO 6743-4 Classification	HV

SECTION 5 – GENERAL SPECIFICATIONS AND MAINTENANCE

Table 5-8. Hydraulic Oil Specifications - Optional

SPECIFICATIONS	PANOLIN HLP SYNTH 3504	NERVOL AGROFLUID 32
Oil Type	Synthetic Biodegradable	Synthetic Food Compatible
ISO Viscosity Grade	32 cSt	32 cSt
Cinematic Viscosity @ -20°C (-4°F)	1150 cSt	795 cSt
Cinematic Viscosity @ 0°C (32°F)	280 cSt	198 cSt
Cinematic Viscosity @ +40°C (104°F)	30.6 cSt	31 cSt
Pour Point, Max.	-58°C (-72.4°F)	-60°C (-76°F)
Flash Point, Min.	240°C (464°F)	230°C (446°F)
Viscosity Index	140	143
ISO 6743-4 Classification	-	-

5.3 OPERATOR MAINTENANCE

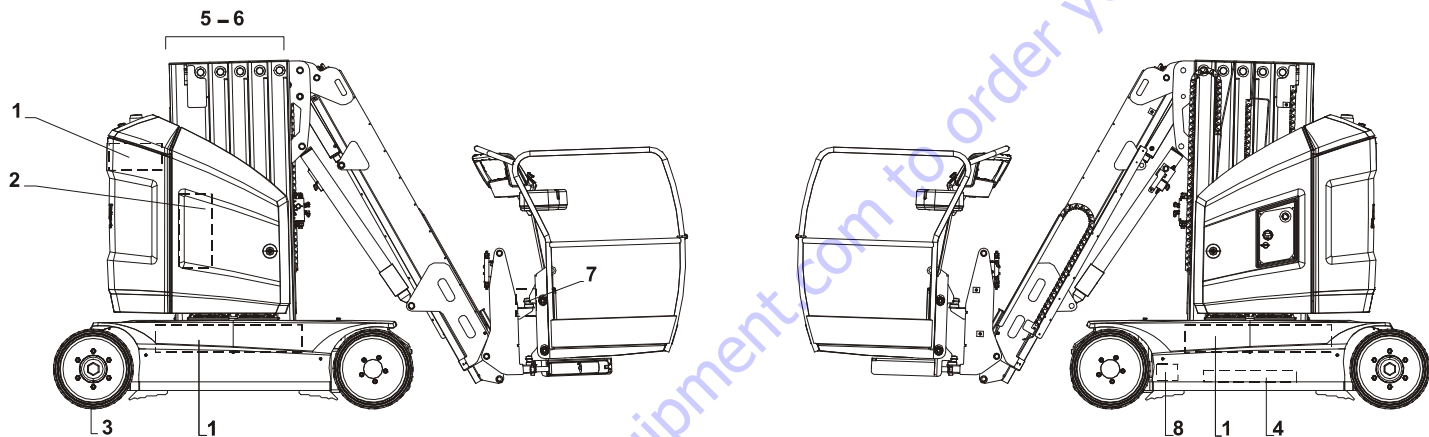

- 1. Battery
- 2. Oil Level / Oil Filter
- 3. Tires & Wheels
- 4. Turntable Bearing Lubrication

- 5. Telescopic Mast Lubrication
- 6. Lifting Chains Lubrication
- 7. Overload System Verification (If Equipped)
- 8. Tilt Sensor Verification

Figure 5-3. Operator Maintenance & Lubrication Diagram

5.4 CHASSIS HOOD REMOVAL

- Unscrew the four (4) retaining screws (a);
- Remove first the left chassis cover (b) : Slide the cover to the rear of the machine (1) by approx. 20 mm (1”), then lift the covers (2) to remove it completely;
- Remove the right chassis cover (c) : Proceed as for the left cover.

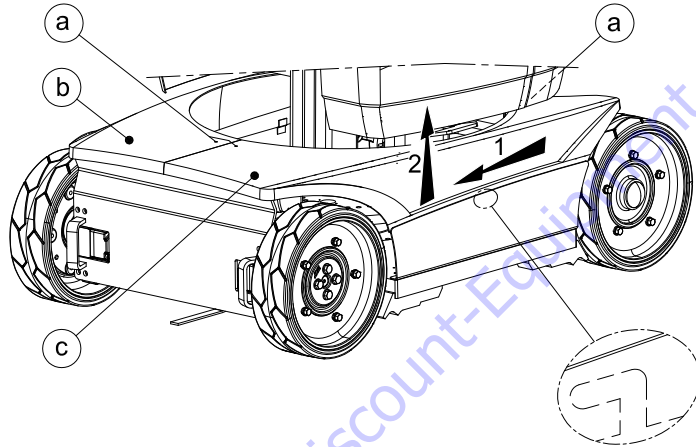

Figure 5-4. Chassis Hood Removal

5.5 BATTERY MAINTENANCE

Battery Maintenance and Safety Practices

⚠ CAUTION

ENSURE THAT BATTERY ACID DOES NOT COMES INTO CONTACT WITH SKIN OR CLOTHING. WEAR PROTECTIVE CLOTHING AND EYEWEAR WHEN WORKING WITH BATTERIES. NEUTRALIZE ANY BATTERY ACID SPILLS WITH BAKING SODA AND WATER.

BATTERY ACID RELEASES AN EXPLOSIVE GAS WHILE CHARGING, ALLOW NO OPEN FAMES, SPARKS OR LIGHTED TOBACCO PRODUCTS IN THE AREA WHILE CHARGING BATTERIES. CHARGE BATTERIES ONLY IN A WELL VENTILATED AREA.

SECTION 5 – GENERAL SPECIFICATIONS AND MAINTENANCE

As with any wet cell battery, check the electrolyte level of the batteries often, using the floats in the center of each cell filling.

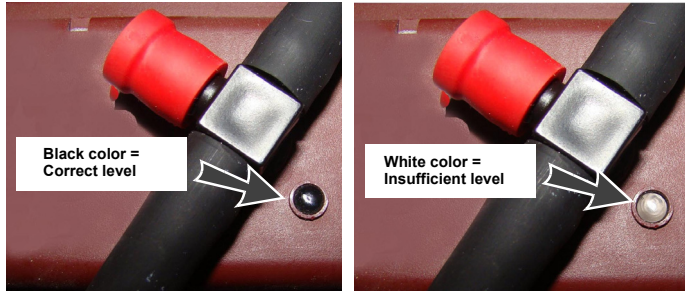

Figure 5-5. Level Indicators

Add only distilled water when required.

NOTICE

ADD ONLY DISTILLED WATER TO BATTERIES. FILL BATTERIES ONLY AFTER CHARGING (DURING CHARGE, ELECTROLYTE LEVEL INCREASES AND CAN OVERFLOW).

- Fill the **reservoir (1)** with distilled water.
- Depress and hold the filling **pump activation button (2)**.
- Release the button when the **flow indicator (3)** slows down.

- Ensure the level is correct in each cell.

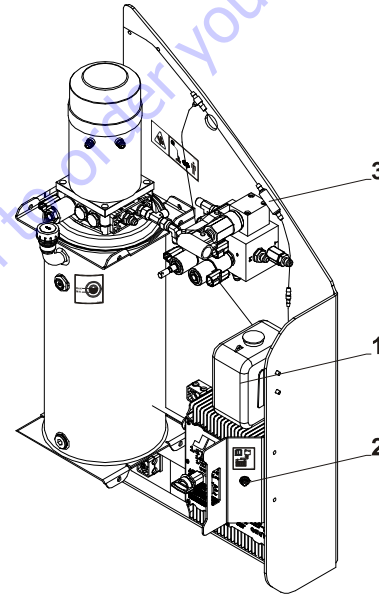

Figure 5-6. Adding Water to Batteries

1. Water Reservoir
2. Pump Activation Button
3. Flow Indicator + Filter

SECTION 5 – GENERAL SPECIFICATIONS AND MAINTENANCE

Regularly:

- Clean and dry the battery top.
- Ensure the connections are clean and tight.
- Drain the water that can accumulate at the bottom of the container (electrolyte overflow, leak in the filling circuit, battery cleaning...).

⚠ CAUTION

DRAINED WATER MAY HAVE BEEN IN CONTACT WITH ACID AND MAY HAVE BECOME CORROSIVE. ENSURE THAT DRAINED WATER DOES NOT COME INTO CONTACT WITH SKIN OR CLOTHING. WEAR PROTECTIVE CLOTHING AND EYEWEAR WHEN WORKING WITH BATTERIES. NEUTRALIZE ANY BATTERY ACID SPILLS WITH BAKING SODA AND WATER.

NOTE: *The water that contacted a battery is classified as industrial waste and must be disposed of according to regulations in force.*

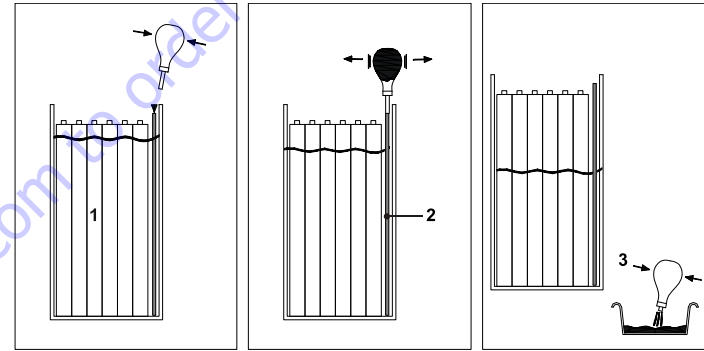

Figure 5-7. Draining the Water

1. Battery Container
2. Plunger
3. Bulb

SECTION 5 – GENERAL SPECIFICATIONS AND MAINTENANCE

Battery Voltage and Electrolyte Specific Gravity

NOTE: Voltage and specific gravity measures should not be performed after battery cells have been filled. These measures must be done after a complete charge, once the charger has been unplugged and after the battery has been standing for at least 15 minutes.

- Open the filling cap of the cell on which the red cable is connected (B+).
- Using the hydrometer (supplied with the machine), take a quantity of electrolyte sufficient so that the float emerges. Ensure that the float top does not touch the rubber bulb or that the float does not stick by capillarity to the glass wall.
- Read the value as indicated in Figure 5-8.
- Return electrolyte in the cell and record the value in the battery service log.
- Measure the cell voltage and record the value in the battery service log.
- Repeat operation for each cell in sequence from B+ (Red Cable) to B- (Black cable).

NOTE: If important disparities are noticed between gravity/voltage of different cells or if the gravity values are lower than 1.240kg/l (after a complete charge) contact JLG Product Support.

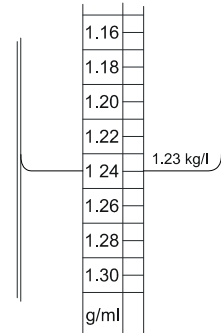

Figure 5-8. Measuring Electrolyte Specific Gravity

Filling System Maintenance

Batteries filling circuit must be serviced once a year. Cleaning frequency must be increased in case of premature clogging of the filter or a reduction of water flow.

- Disconnect and clean the **filter (3)** (See Figure 5-6.) by reversing the water flow from the normal direction.
- Check hoses for flexibility. In case of hardening in the connections area, replace the hose.
- Check every fittings and connections for leakage.
- Check the caps individually. Ensure perfect mobility of the floats. In case of clogging, replace the cap.

Use of a Battery in a Cold Environment

Low temperatures decrease battery capacity. The battery must be fully charged when the machine is operated in a cold environment.

Battery Not Working Continuously or Inactive Battery

A battery that is not used or used intermittently must be stored charged in a dry area away from freezing temperatures. A charge must be performed once a month.

- Disconnect the battery to insulate it electrically.
- Keep the top of the battery clean and dry to prevent self-discharge.

NOTICE

IF THE BATTERY IS NOT USED CONTINUOUSLY, IT MUST BE RECHARGED BEFORE USE AND AT LEAST ONCE A MONTH (EVEN IF THE ELECTROLYTE SPECIFIC GRAVITY MEASURES ARE HIGH).

BEFORE RETURNING TO SERVICE A BATTERY THAT REMAIN INACTIVE FOR A LONG PERIOD OF TIME, CHARGE THE BATTERY AND CHECK ELECTROLYTE LEVEL IN THE CELLS.

SECTION 5 – GENERAL SPECIFICATIONS AND MAINTENANCE

Battery Troubleshooting

Symptoms	Probable causes	Solutions
Electrolyte overflow.	Filling done before the charge. Cells overfilled.	Fill battery cells after the charge.
	Overcharge.	Never charge battery if electrolyte specific gravity is above 1,240 kg/l.
Inequal electrolyte specific gravity or electrolyte specific gravity too low.	Filling done before the charge.	Fill battery cells after the charge.
	Loss of electrolyte due to overflow. <u>Stratification of the electrolyte.</u>	Perform an equalization charge. <u>Contact your JLG Distributor/Product Support.</u>
Low voltage in the cells in open circuit.	Electrolyte specific gravity too low.	Refer to "electrolyte specific gravity too low".
	Short-circuit.	Clean battery top.
Battery cells temperature too high (over 113°F (45°C)).	Problem with the charger.	Get the charger checked by a technician.
	Bad air circulation during charge. Cell weak or faulty <u>Cells shorted.</u>	Open access doors to batteries during charge. Reduce temperature of the area where the battery is charged (artificial ventilation). <u>Change battery cell.</u>
Battery incapable of supporting regular operation.	Battery under charged.	Perform an equalization charge.
	Cell faulty.	Replace faulty cell.
	Faulty cable or connection. Battery at the end of its service life.	Check wire condition and connection. Replace the battery.

5.6 OIL LEVEL

NOTE: Care should be taken not to introduce any impurities (dirt, water etc.) while cap or plug is removed.

Hydraulic Oil Check

Lube Point - Hydraulic Tank

Reservoir Capacity: 15 liters

Lube - Hydraulic Oil (See Table 5-7)

Interval - Check Daily

NOTE: Check oil level with the wheels fully steered to the left.

1. Open the access door to the **hydraulic power unit (1)**.
2. Locate the **decals (2)** on the **tank (3)**.
3. The oil level in the tank must be within the MIN (minimum) and Max (maximum) **markings (4)** of the decal.
4. If additional oil is required, wipe all dirt and debris from the **filler/breather cap (5)** area, add proper grade of oil by using a funnel. Fill until oil level is between the MIN and MAX **markings (4)**.

Hydraulic Oil Replacement

Interval - After first 50 hours of operation and every 250 hours thereafter.

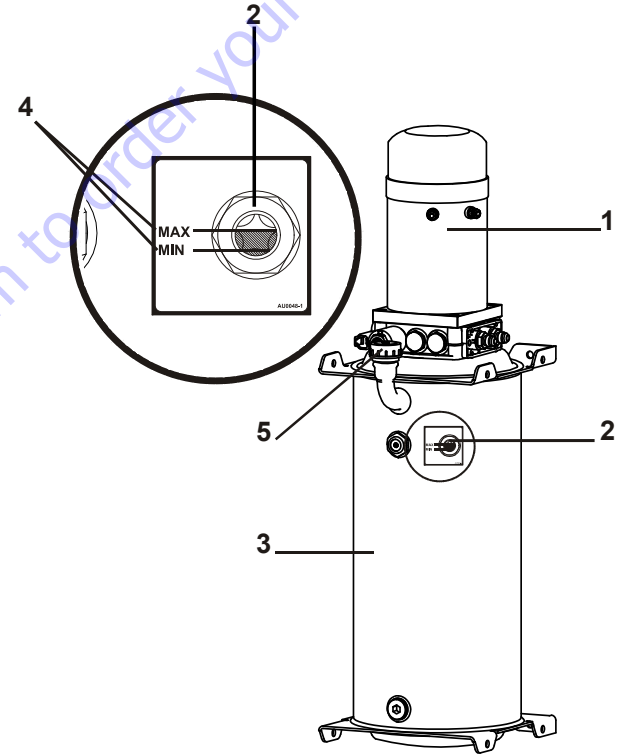

Figure 5-9. Hydraulic Oil Check

5.7 TIRES & WHEELS

Tire Wear and Damage

Inspect tires periodically for wear or damage. Tires with worn edges or distorted profiles require replacement. Tires with significant damage in the tread area or side wall, require immediate evaluation before replacing machine into service.

Wheel and Tire Replacement

Replacement wheels must have the same diameter and profile as the original. Replacement tires must be the same size and rating as the tire being replaced.

Use of genuine parts is recommended.

Both tires/wheel on the same axle must be replaced:

- If the overall diameter of the tire is less than 445 mm.
- If any uneven wear is discovered.

A tire with significant damage in the tread area or sidewall requires immediate evaluation before placing the machine into service. If a cut, tear, chunk, or other discrepancy exceeds any one or more of the following dimensions, the tire must be replaced:

76 mm long, 19 mm wide, 19 mm deep

- If the metal wheel is visible at any point through the tread area of the tire.
- If more than one discrepancy exists in any quadrant of the wheel (within 90 degrees of one another).

Wheel Installation

It is extremely important to apply and maintain proper mounting torque.

⚠ WARNING

WHEEL LUG NUTS MUST BE INSTALLED AND MAINTAINED AT THE PROPER TORQUE TO PREVENT LOOSE WHEELS, BROKEN LUG NUTS, AND POSSIBLE SEPARATION OF WHEEL FROM THE AXLE. BE SURE TO USE ONLY THE LUG NUTS THAT MATCHED TO THE CONE ANGLE OF THE WHEEL.

Tighten the lug nuts to the proper torque to prevent wheels from coming loose. Use a torque wrench to tighten the fasteners. Over-tightening will result in breaking the lug nuts or permanently deforming the mounting holes in the wheels. The proper procedure for attaching wheels is as follow:

1. Start all lug nuts by hand to prevent cross threading. DO NOT use a lubricant on threads or nuts.

SECTION 5 – GENERAL SPECIFICATIONS AND MAINTENANCE

2. Tighten lug nuts in the following sequence.

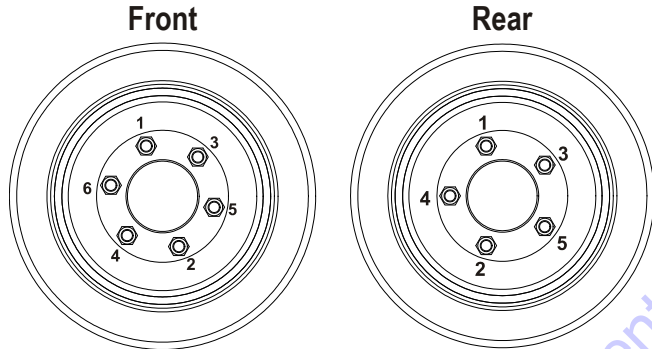

Figure 5-10. Wheel Lug Nut Tightening Sequence

3. The tightening of the lug nuts should be done in stages. Following the recommended sequence, tighten lug nut per wheel torque.

Table 5-9. Wheel Torque Chart

Torque Sequence - Front Wheels		
1 st Stage	2 nd Stage	3 rd Stage
50 N.m (37 lb.ft)	160 N.m (118 lb.ft)	250 N.m (184 lb.ft)

Torque Sequence - Rear Wheels		
1 st Stage	2 nd Stage	3 rd Stage
50 N.m (37 lb.ft)	140 N.m (103 lb.ft)	210 N.m (155 lb.ft)

4. Wheel lug nuts should be torqued after the first 50 hours of operation and after each wheel removal. Check torque every 3 month or 125 hours of operation.

5.8 DECAL INSTALLATION

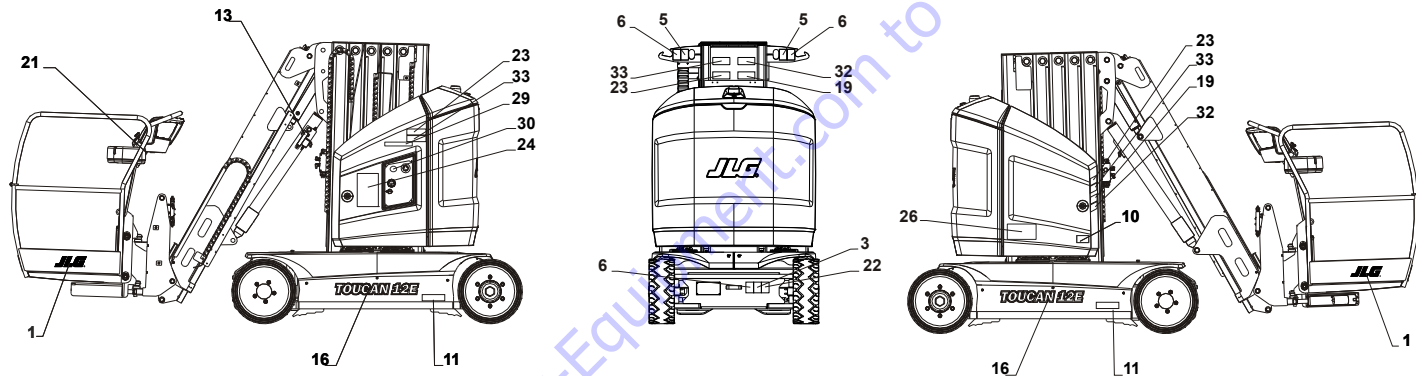

Figure 5-11. Decal Installation - Sheet 1

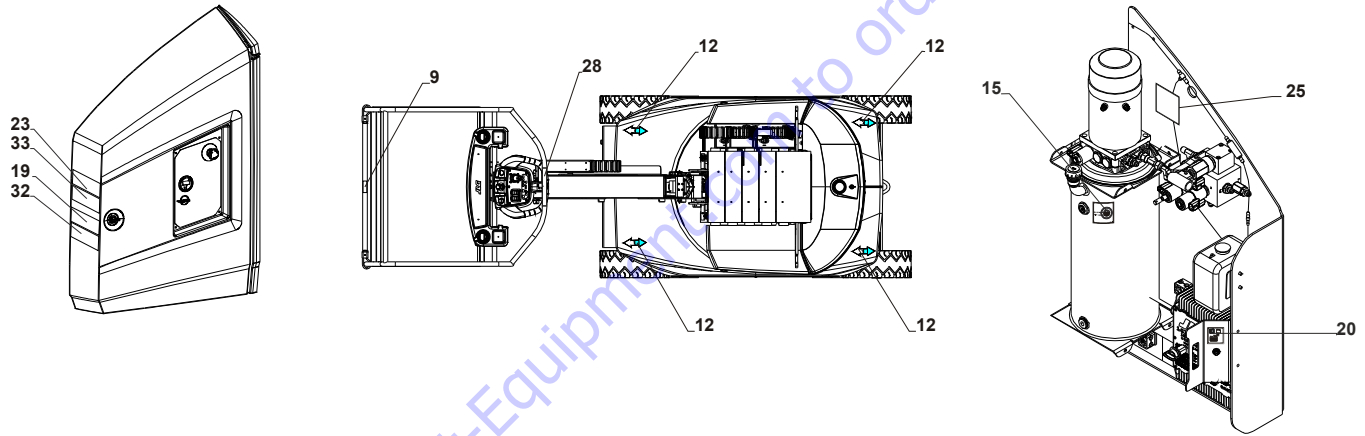

Figure 5-12. Decal Installation - Sheet 2

SECTION 5 – GENERAL SPECIFICATIONS AND MAINTENANCE

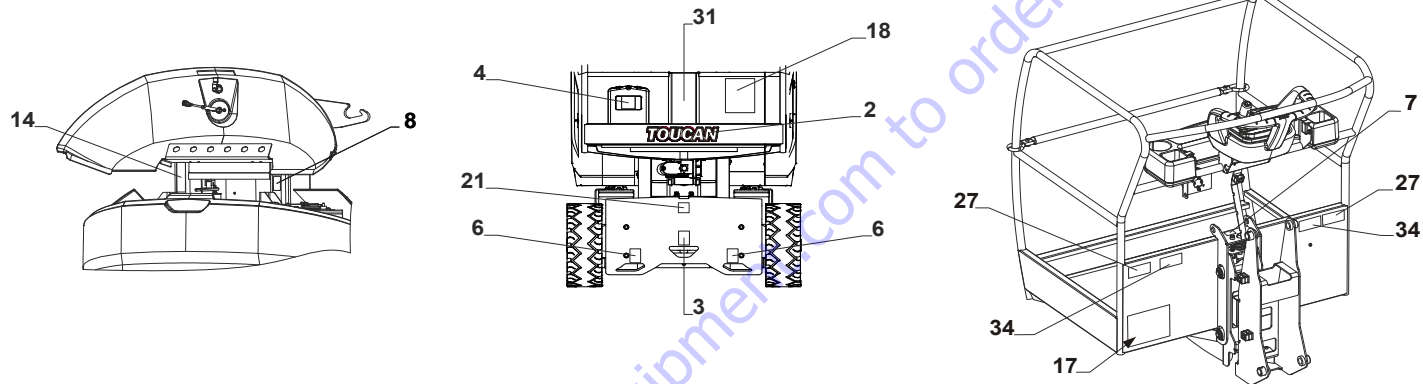

Figure 5-13. Decal Installation - Sheet 3

SECTION 5 – GENERAL SPECIFICATIONS AND MAINTENANCE

Table 5-10. Machine Decal Installation Chart

Item #	T12E	T12E Plus	T32E	T32E CAN	T32E LAT	T32E DOM2	Item #	T12E	T12E Plus	T32E	T32E CAN	T32E LAT	T32E DOM2
1	1705781	1705781	1705781	1705781	1705781	1705781	18	AU2102	AU2102	AU2120	AU2141	AU2148	AU2148
2	AU1825	AU1825	AU1825	AU1825	AU1825	AU1825	19	AU2103	AU2103	AU2118	AU2144	AU2150	AU2150
3	1701499	1701499	1701499	1701499	1701499	1701499	20	AU2104	AU2104	AU2104	AU2104	AU2104	AU2104
4	1701640	1701640	1701640	1701640	1701640	1701640	21	AU2105	AU2105	AU2105	AU2105	AU2105	AU2105
5	1703811	1703811	1703811	1703811	1703811	1703811	22	AU2193	AU2194	AU2199	AU2199	AU2199	AU2199
6	1703814	1703814	1703814	1703814	1703814	1703814	23	AU2108	AU2108	AU2117	AU2117	AU2149	AU2149
7	1704277	1704277	1704277	1704277	1704277	1704277	24	AU2109	AU2109	AU2121	AU2205	AU2203	AU2204
8	1705803	1705803	1705803	1705803	1705803	1705803	25	AU2195	AU2195	AU2195	AU2195	AU2195	AU2195
9	1706493	1706493	-	1703785	1703785	1703785	26	AU2196	AU2196	AU2196	AU2196	AU2196	AU2196
10	1706740	1706740	1706740	1706740	1706740	1706740	27	-	-	AU2119	AU2119	AU2147	AU2147
11	1706764	1706764	1704885	1704885	1704885	1704885	28	-	-	AU2201	AU2201	AU2201	AU2201
12	AU0149	AU0149	AU0149	AU0149	AU0149	AU0149	29	-	-	AU2202	AU2202	AU2202	AU2202
13	AU2191	AU2191	AU2191	AU2191	AU2191	AU2191	30	-	-	AU2206	AU2206	AU2206	AU2206
14	AU2192	AU2192	AU2192	AU2192	AU2192	AU2192	31	-	-	-	AU2120	AU2153	AU2120
15	AU0048	AU0048	AU0048	AU0048	AU0048	AU0048	32	-	-	-	AU2118	AU2155	AU2118
16	AU2190	AU2197	AU2198	AU2198	AU2198	AU2198	33	-	-	-	AU2143	AU2154	AU2117
17	AU2101	AU2101	AU2101	AU2101	AU2101	AU2101	34	-	-	-	AU2140	AU2152	AU2119

5.9 LUBRICATION

NOTE: Recommended lubricating intervals are based on machine operation under normal conditions. For machines used in multi-shift operations and/or exposed to hostile environments or conditions, lubrication frequencies must be increased accordingly.

Swing Bearing Race

Lube Points - 2 grease fittings
Capacity: A/R
Lube - A (See Table 5-6)
Interval - Every 250 hours of operation

1. Remove chassis hoods.
2. From ground control station, raise the mast to gain access to the turntable plate.
3. Locate the **access holes (1)** on the turntable plate.
4. Lubricate using a grease gun through both grease fittings (2).

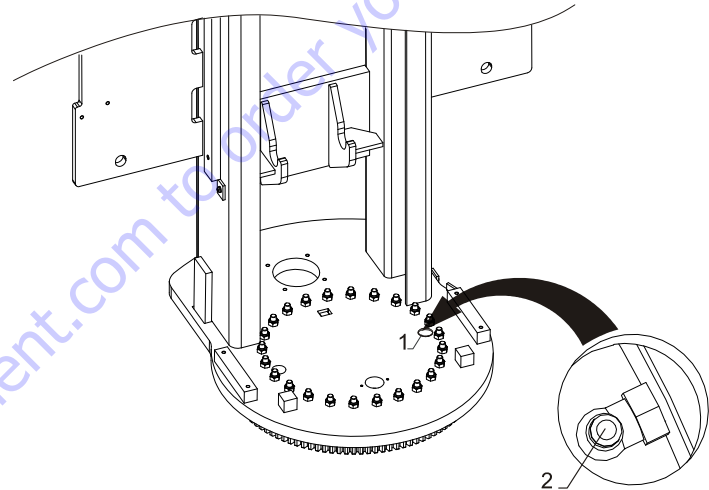

Figure 5-14. Swing Bearing Race Lubrication

Swing Bearing Teeth

Lube Points - Coat each tooth

Capacity: A/R

Lube - B (See Table 5-6)

Interval - Every 1000 hours of operation

1. Remove chassis hoods and lateral frame shields.
2. From ground control station, raise the mast to gain access to the turntable plate.
3. Fully swing the structure to the right.
4. Apply grease on the accessible bearing teeth using a **brush (1)**.
5. Fully swing the structure to the left.
6. Complete the operation on the rest of bearing teeth.

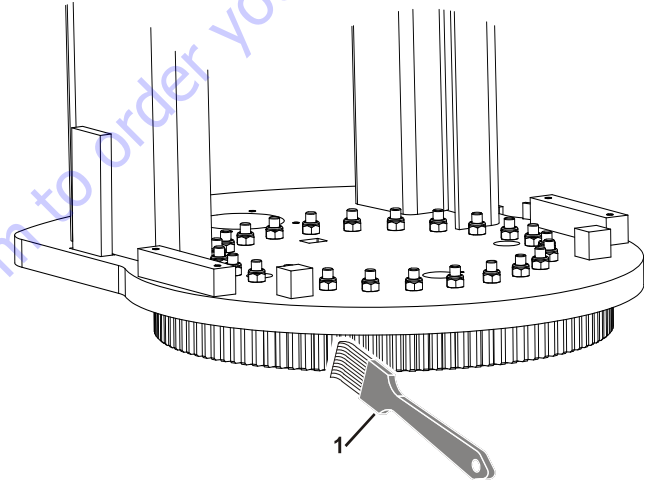

Figure 5-15. Swing Bearing Teeth lubrication

Lifting Chains

Lube Points - 8 chains

Capacity: A/R

Lube - C (See Table 5-6)

Interval - After the first 50 hours of operation and every 125 hours of operation (or every 30 days) thereafter.

Lubricant can be applied manually with a brush or by spraying. Apply lubricant longitudinally and transversally for the lubricant to reach the joints between the plates.

Table 5-11. Recommended Viscosity Grade

TEMPERATURE	ISO VISCOSITY GRADE
-15°C to 0°C (5° to 32°F)	15 to 32 mm ² /s (cSt)
0°C to 50°C (32°F to 122°F)	46 to 150 mm ² /s (cSt)

5.10 OVERLOAD SYSTEM VERIFICATION (IF EQUIPPED)

Interval - At least every 6 months of operation.

1. Turn machine power on at ground control station.
2. Place a 200kg load evenly distributed on platform floor:
 - No alarm should be triggered.
3. Add weight on platform (additional load not to exceed 10kg) until the overload warning is activated:
 - RED light indicators at both the ground and the platform control stations blink.
 - An audible alarm sounds.
 - All functions are disabled.
4. Remove additional load. Apply a slight force (**F**) on the platform:
 - Alarms stop.
5. If the overload warning is not activated after the addition of 10kg, have the overload system calibrated by a qualified technician before placing machine into service.

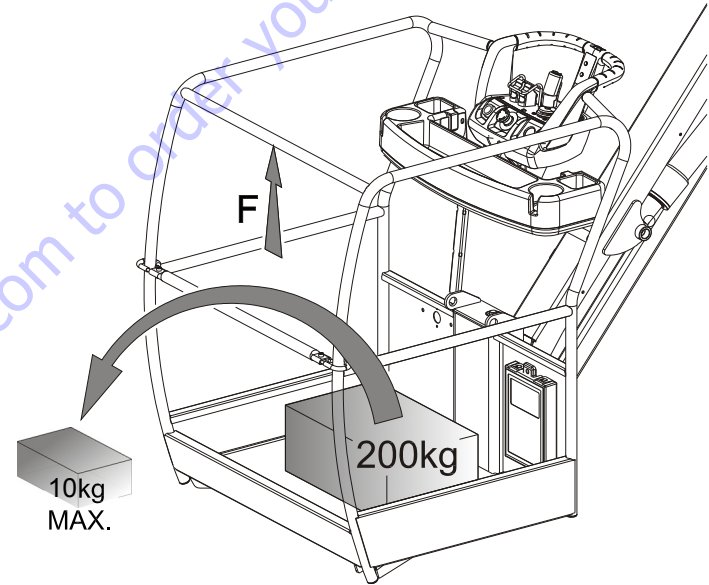

Figure 5-16. Overload System Verification

5.11 TILT SENSOR VERIFICATION

Interval - At least every 6 months of operation.

1. Drive the machine on a known level surface.
2. Chock both rear wheels.
3. Remove chassis hoods and place a level on the chassis positioned in line w/chassis.
4. Using a jack of appropriate capacity, lift the front on the chassis. The tilt alarm must be activated within 0.3° below the value in Table 5-1.
5. Place the spirit level perpendicular to the chassis and lift either the left or the right side of the chassis. The tilt alarm must be activated within 0.3° below the value in Table 5-1.
6. If the tilt warning is not activated within the indicated angle values, the tilt sensor must be recalibrated by a qualified technician before placing machine into service.

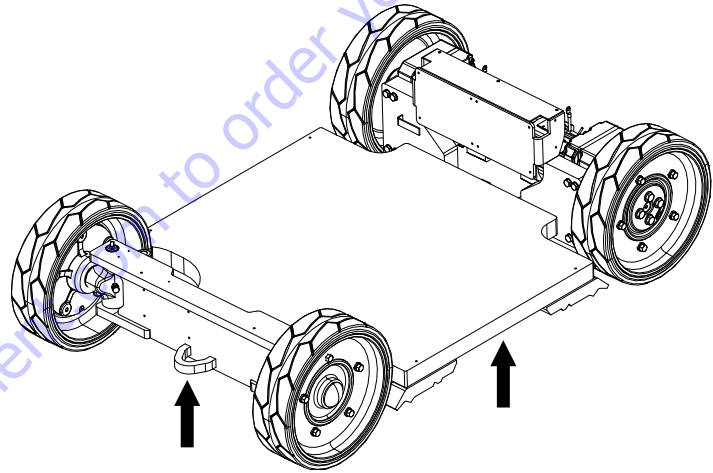

Figure 5-17. Jacking Points

5.12 SLACK CHAIN SENSORS CHECK

Interval - Check after every 6 months of operation.

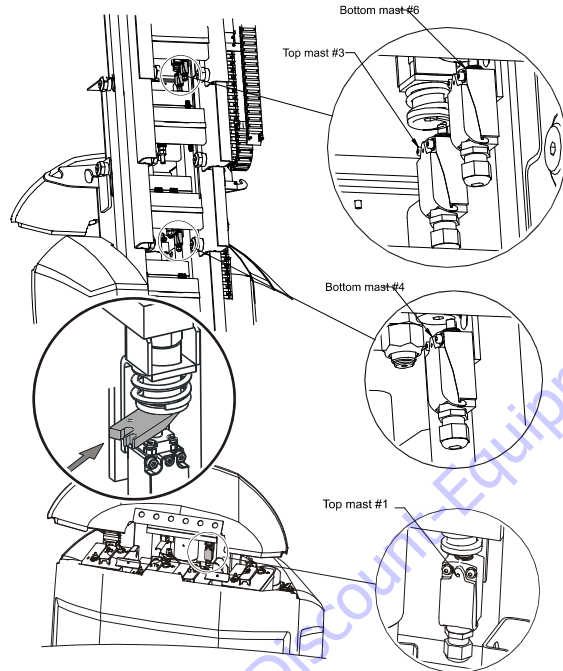

Figure 5-18. Slack/Broken Chain Sensors

Check the 4 slack chain sensors to ensure proper operation.
Location : one at the top of mast 1, one at the top of mast 3, one at the bottom of mast 4 and one at the bottom of mast 6 (see opposite).

Wedge a block (P/N : ST2741) as illustrated opposite to activate the slack chain sensor and keep it activated. The system is functioning properly if :

1. From the Platform Control Console :

- An acoustic alarm sounds.
- The red slack chain indicator lights up on the Platform Control Panel.
- All functions are disabled except boom and mast raising functions.
- Prohibited movements are indicated by the orange light indicator on the platform control panel.

2. From the Ground Control Console :

- An acoustic alarm sounds.

Repeat steps 1 to 2 for each slack chain sensor.

5.13 SUPPLEMENTAL INFORMATION

The equivalent continuous A-weighted sound pressure level at the work platform is less than 70dB(A).

The weighed root mean square acceleration value to which the arms are subjected (control levers) is inferior to 2.5 m/s/s.

The weighed root mean square acceleration value to which the feet are subjected (platform floor) is inferior to 0.5 m/s/s.

Go to Discount-Equipment.com to order your parts

PROPOSITION 65 WARNING

- **Battery posts, terminals and related accessories contain lead and lead compounds, chemicals known to the State of California to cause cancer and reproductive harm.**
- **Batteries also contain other chemicals known to the State of California to cause cancer.**
- **Wash hands after handling.**

TO PURCHASE THIS PRODUCT PLEASE CONTACT US



**Equipment Financing and
Extended Warranties Available**



**Discount-Equipment.com is your online resource for
commercial and industrial quality parts and equipment sales.**

561-964-4949

visit us on line @ www.discount-equipment.com

Select an option below to find your Equipment

Search by Manufacturer

Search by Product Type

Request a Quote

We sell worldwide for the brands: Genie, Terex, JLG, MultiQuip, Mikasa, Essick, Whiteman, Mayco, Toro Stone, Diamond Products, Generac Magnum, Airman, Haulotte, Barreto, Power Blanket, Nifty Lift, Atlas Copco, Chicago Pneumatic, Allmand, Miller Curber, Skyjack, Lull, Skytrak, Tsurumi, Husquvarna Target, Stow, Wacker, Sakai, Mi-T-M, Sullair, Basic, Dynapac, MBW, Weber, Bartell, Bennar Newman, Haulotte, Ditch Runner, Menegotti, Morrison, Contec, Buddy, Crown, Edco, Wyco, Bomag, Laymor, EZ Trench, Bil-Jax, F.S. Curtis, Gehl Pavers, Heli, Honda, ICS/PowerGrit, IHI, Partner, Imer, Clipper, MMD, Koshin, Rice, CH&E, General Equipment, Amida, Coleman, NAC, Gradall, Square Shooter, Kent, Stanley, Tamco, Toku, Hatz, Kohler, Robin, Wisconsin, Northrock, Oztec, Toker TK, Rol-Air, APT, Wylie, Ingersoll Rand / Doosan, Innovatech, Con X, Ammann, Mecalac, Makinex, Smith Surface Prep, Small Line, Wanco, Yanmar



An Oshkosh Corporation Company



www.Discount-Equipment.com



Go to Discount-Equipment.com to order JLG parts