



Service and Maintenance Manual

Models

TOUCAN 8E/20E

TOUCAN 10E/26E

P/N - 31210090

February 16, 2017



CE ANSI AS



PARTS FINDER

**Search Website
by Part Number**



**Search Manual
Library For Parts
Manual & Lookup Part
Numbers – Purchase
or Request Quote**

Search Manuals

Enter your information to help us locate the right manual for your parts.

* Brand:

* Model:

* Serial:

* Part Number:

SEARCH

**Can't Find Part or
Manual? Request Help
by Manufacturer,
Model & Description**

Parts Order Form

Please fill in the following information to help us locate the right part for your machine.

Manufacturer:	<input type="text"/>
Model:	<input type="text"/>
Description:	<input type="text"/>
Part Number:	<input type="text"/>
Quantity:	<input type="text"/>
Notes:	<input type="text"/>

Discount-Equipment.com is your online resource for quality parts & equipment.

Florida: **561-964-4949** Outside Florida TOLL FREE: **877-690-3101**

Need parts?

Click on this link: <http://www.discount-equipment.com/category/5443-parts/> and choose one of the options to help get the right parts and equipment you are looking for. Please have the machine model and serial number available in order to help us get you the correct parts. If you don't find the part on the website or on one of the online manuals, please fill out the request form and one of our experienced staff members will get back to you with a quote for the right part that your machine needs.

We sell worldwide for the brands: Genie, Terex, JLG, MultiQuip, Mikasa, Essick, Whiteman, Mayco, Toro Stone, Diamond Products, Generac Magnum, Airman, Haulotte, Barreto, Power Blanket, Nifty Lift, Atlas Copco, Chicago Pneumatic, Allmand, Miller Curber, Skyjack, Lull, Skytrak, Tsurumi, Husquvarna Target, , Stow, Wacker, Sakai, Mi-T- M, Sullair, Basic, Dynapac, MBW, Weber, Bartell, Bennar Newman, Haulotte, Ditch Runner, Menegotti, Morrison, Contec, Buddy, Crown, Edco, Wyco, Bomag, Laymor, Barreto, EZ Trench, Bil-Jax, F.S. Curtis, Gehl Pavers, Heli, Honda, ICS/PowerGrit, IHI, Partner, Imer, Clipper, MMD, Koshin, Rice, CH&E, General Equipment, ,AMida, Coleman, NAC, Gradall, Square Shooter, Kent, Stanley, Tamco, Toku, Hatz, Kohler, Robin, Wisconsin, Northrock, Oztec, Toker TK, Rol-Air, Small Line, Wanco, Yanmar

SECTION A. INTRODUCTION - MAINTENANCE SAFETY PRECAUTIONS

A GENERAL

This section contains the general safety precautions which must be observed during maintenance of the aerial platform. It is of utmost importance that maintenance personnel pay strict attention to these warnings and precautions to avoid possible injury to themselves or others, or damage to the equipment. A maintenance program must be followed to ensure that the machine is safe to operate.

⚠ WARNING

MODIFICATION OF THE MACHINE WITHOUT CERTIFICATION BY A RESPONSIBLE AUTHORITY THAT THE MACHINE IS AT LEAST AS SAFE AS ORIGINALLY MANUFACTURED, IS A SAFETY VIOLATION.

The specific precautions to be observed during maintenance are inserted at the appropriate point in the manual. These precautions are, for the most part, those that apply when servicing hydraulic and larger machine component parts.

Your safety, and that of others, is the first consideration when engaging in the maintenance of equipment. Always be conscious of weight. Never attempt to move heavy parts without the aid of a mechanical device. Do not allow heavy objects to rest in an unstable position. When raising a portion of the equipment, ensure that adequate support is provided.

⚠ WARNING

SINCE THE MACHINE MANUFACTURER HAS NO DIRECT CONTROL OVER THE FIELD INSPECTION AND MAINTENANCE, SAFETY IN THIS AREA IS THE RESPONSIBILITY OF THE OWNER/OPERATOR.

B HYDRAULIC SYSTEM SAFETY

It should be noted that the machines hydraulic systems operate at extremely high, potentially dangerous pressures. Every effort should be made to relieve any system pressure prior to disconnecting or removing any portion of the system.

C MAINTENANCE

⚠ WARNING

FAILURE TO COMPLY WITH SAFETY PRECAUTIONS LISTED IN THIS SECTION MAY RESULT IN MACHINE DAMAGE, PERSONNEL INJURY OR DEATH AND IS A SAFETY VIOLATION.

- REMOVE ALL RINGS, WATCHES AND JEWELRY WHEN PERFORMING ANY MAINTENANCE.
- DO NOT WEAR LONG HAIR UNRESTRAINED, OR LOOSE-FITTING CLOTHING AND NECKTIES WHICH ARE APT TO BECOME CAUGHT ON OR ENTANGLED IN EQUIPMENT.
- OBSERVE AND OBEY ALL DANGER, WARNING, CAUTION AND OTHER INSTRUCTIONS ON MACHINE AND IN SERVICE MANUAL.
- KEEP OIL, GREASE, WATER, ETC. WIPED FROM STANDING SURFACES AND HAND HOLDS.
- NEVER WORK UNDER AN ELEVATED STRUCTURE UNTIL STRUCTURE HAS BEEN SAFELY RESTRAINED FROM ANY MOVEMENT BY BLOCKING OR OVERHEAD SLING.
- BEFORE MAKING ADJUSTMENTS, LUBRICATING OR PERFORMING ANY OTHER MAINTENANCE, SHUT OFF ALL POWER CONTROLS.
- BATTERY SHOULD ALWAYS BE DISCONNECTED DURING REPLACEMENT OF ELECTRICAL COMPONENTS.
- KEEP ALL SUPPORT EQUIPMENT AND ATTACHMENTS STOWED IN THEIR PROPER PLACE.
- USE ONLY APPROVED, NONFLAMMABLE CLEANING SOLVENTS.
- ENSURE REPLACEMENT PARTS OR COMPONENTS ARE IDENTICAL OR EQUIVALENT TO ORIGINAL PARTS OR COMPONENTS.

REVISION LOG

Original Issue	- August 28, 2009
Revision	- January 27, 2014
Revision	- September 17, 2015
Revision	- June 08, 2016
Revision	- February 16, 2017

Go to Discount-Equipment.com to order your parts

TABLE OF CONTENTS

SUBJECT - SECTION, PARAGRAPH	PAGE NO.
SECTION A - INTRODUCTION - MAINTENANCE SAFETY PRECAUTIONS	
A General	A-1
B Hydraulic System Safety	A-1
C Maintenance	A-1
SECTION 1 - OPERATING SPECIFICATIONS	
1.1 OPERATING SPECIFICATIONS	1-1
1.2 DIMENSIONAL data	1-1
1.3 PERFORMANCE DATA	1-2
1.4 CAPACITIES	1-3
1.5 COMPONENTS DATA	1-3
Batteries	1-3
Electric Pump / Electric Motor Assembly	1-3
Drive Motor Assembly	1-3
Swing Motor	1-4
Cylinders	1-4
Tires	1-4
1.6 MAJOR COMPONENTS WEIGHTS	1-5
1.7 LUBRICATION	1-6
Hydraulic Oil	1-6
Lubrication Chart	1-7
Lube Specifications	1-8
1.8 TORQUE REQUIREMENTS	1-8
1.9 SERIAL NUMBER LOCATIONS	1-9
SECTION 2 - GENERAL SERVICE INFORMATION	
2.1 Machine preparation, inspection and maintenance	2-1
General	2-1
Preparation, Inspection and Maintenance	2-1
Pre-Start Inspection	2-1
Pre-Delivery Inspection and Frequent Inspection	2-1
Annual Machine Inspection	2-1
Preventative Maintenance	2-1
2.2 preventive maintenance and inspection schedule	2-2
2.3 Servicing and maintenance guidelines	2-5
General	2-5
Safety and Workmanship	2-5
Cleanliness	2-6
Components Removal and Installation	2-6
Component Disassembly and Reassembly	2-6
Pressure-Fit Parts	2-6
Bearings	2-6
Care and Installation of Teflon Coated Bushings	2-6
Bolt Usage and Torque Application	2-7
Hydraulic Lines and Electrical Wiring	2-7
Hydraulic System	2-7
Welding on Work Platform	2-8
Lubrication	2-8
Battery	2-8
2.4 Lubrication Information	2-8
Hydraulic System	2-8
Lubrication Specifications	2-8
Hydraulic Oil	2-8
Changing Hydraulic Oil	2-8
2.5 Pressure Relief Valve	2-8
SECTION 3 - THEORY OF OPERATION	

TABLE OF CONTENTS

3.1	OVERVIEW	3-1
3.2	Modes of operation	3-1
	Ground Mode	3-1
	Platform Mode	3-1
3.3	Can Communications	3-1
3.4	Joysticks	3-3
3.5	Traction	3-3
3.6	Pump/structure movements	3-4
	Lift Up/Down	3-4
	Swing	3-5
	Steer	3-6
	Interlocks	3-6
	Personality Settings and Calibration	3-7
SECTION 4 - CHASSIS MOUNTED COMPONENTS		
4.1	DRIVE MOTORS	4-1
	Brake - Dust Cleaning	4-1
	Brake Disassembly	4-1
	Brake Disk Wear Checking	4-1
	Brake Assembly	4-2
	Drive Motor Assembly Removal	4-2
	Drive Motor Assembly Installation	4-3
	Wheel Motor Disassembly	4-3
	Wheel Motor Assembly	4-4
	Oil Filling	4-6
4.2	Wheels and Tires	4-6
	Tire wear and damage	4-6
	Wheel and Tire Replacement	4-6
	Wheel Installation	4-6
4.3	Steering Linkage	4-7
	Steer Cylinder	4-8
	Steering Linkage - Spindle/Hub Assembly	4-8
	Hoses and Cables Routing	4-9
4.4	Front Wheel Hub	4-9
SECTION 5 - TURNTABLE AND VERTICAL MAST		
5.1	SWING BEARING	5-1
	Swing Bearing Attach Bolts Check	5-1
	Swing Bearing Lubrication	5-1
	Replacement of Swing Bearing	5-2
5.2	Swing Motor	5-6
5.3	Mast Profile Lubrication	5-7
5.4	Rollers	5-7
	Inspection	5-7
	Removal and Installation	5-7
5.5	Mast and Rollers Setting	5-9
	Introduction	5-9
	Procedure	5-9
5.6	Lifting chains	5-13
	Safety Accessories and Tooling	5-13
	Lubrication	5-13
	Lifting Chains Inspection	5-14
	Lifting Chains Removal and Installation	5-15
	Chain Tension Adjustment	5-23
5.7	Pulley - Pulley Support	5-24
	Pulley Inspection	5-24
	Removal and Installation	5-25
5.8	Mast Cylinder Removal and Installation	5-25
	Mast Cylinder Removal	5-25
	Mast Cylinder Disassembly	5-26
	Mast Cylinder Installation	5-26

SECTION 6 - JIB AND PLATFORM

6.1 PLATFORM 6-1
 Platform Removal 6-1
 Platform Installation 6-1
 6.2 OVERLOAD SYSTEM 6-1
 Bevel Washers Lubrication 6-1
 Overload System Verification 6-2
 Overload System Setting 6-2
 6.3 Jib Cylinder Removal and Installation 6-2
 Jib Cylinder Removal 6-2
 Jib Cylinder Disassembly 6-3
 Jib Cylinder Installation 6-3

SECTION 7 - HYDRAULICS

7.1 HYDRAULIC TANK 7-1
 Oil Level 7-1
 Oil Level if Decal is Missing 7-1
 Adding Oil to the System 7-1
 Tank Draining/Cleaning 7-1
 Tank Filling 7-2
 7.2 Hydraulic Filter Replacement 7-2
 7.3 Hydraulic Power Unit 7-3
 Ports Identification 7-3
 Hydraulic Lines Connections 7-4
 Proportional Pressure Relief Valve 7-4
 Air Bleeding 7-4
 Flow Directional Valve 7-5
 Steer Valve 7-5
 Swing Valve 7-5
 Swing Motor By-Pass Valve 7-5
 Electric Motor 7-5
 7.4 SWING MOTOR 7-6
 Ports Identification 7-6
 7.5 CYLINDERS HOLDING VALVES 7-7
 Mast Cylinder Holding Valve 7-7
 Jib Cylinder Holding Valve 7-8
 7.6 CYLINDER REPAIR 7-9
 Disassembly 7-10
 Inspection 7-10
 Assembly 7-11

SECTION 8 - CONTROL COMPONENTS

8.1 Control components overview 8-1
 8.2 Control Components - Service 8-3
 Battery Maintenance and Safety Practices 8-3
 Main Power Contactor Relay 8-6
 Power Fuse 8-6
 Mast Elevation Limit Switches 8-7
 Chain Slack Sensor 8-8
 Overload Sensor (If equipped) 8-10
 Drive Orientation Switch 8-10
 Steering Sensor 8-11
 Tilt Sensor 8-11
 Ground Alarm 8-13
 Warning Beacon 8-13
 Descent/Motion Alarm (Optional) 8-14
 8.3 Traction System 8-15
 Common Traction System Difficulties 8-15
 8.4 Power Module 8-16
 Removal 8-16
 Installation 8-17

TABLE OF CONTENTS

	Power Module Electrical Evaluation	8-18
8.5	Ground Control Station	8-20
	Membrane Panel	8-20
	Printed Circuit Board (PCB) Replacement	8-20
8.6	Platform Control Station	8-21
	Printed Circuit Board (PCB) Replacement	8-21
	Upper Control Box - Component Replacement	8-21
	Upper Control Box - Components Evaluation	8-22
SECTION 9 - JLG CONTROL SYSTEM		
9.1	HAND HELD ANALYZER	9-1
	To Connect the Hand Analyzer	9-1
	Using the Analyzer	9-1
	Changing the Access Level of the Hand Held Analyzer	9-2
	Machine Setup	9-3
9.2	Analyzer screen layout	9-4
9.3	MACHINE SETUP PROGRAMMING INFORMATION	9-9
9.4	CALIBRATION INSTRUCTIONS	9-10
9.5	CALIBRATING STEERING SENSOR	9-10
9.6	CALIBRATING OVERLOAD SYSTEM	9-10
9.7	CALIBRATING THE JOYSTICKS	9-11
9.8	Calibrating the pressure relief valve	9-11
9.9	MACHINE PERSONALITY - ADJUSTMENT SETTINGS	9-12
9.10	SYSTEM TEST	9-15
SECTION 10 - DIAGNOSTIC TROUBLE CODES		
10.1	INTRODUCTION	10-1
10.2	DTC INDEX	10-1
10.3	DTC CHECK TABLES	10-2
	0-0 Help Comments	10-2
	8-7 Safety System Override	10-20
SECTION 11 - GENERAL ELECTRICAL INFORMATION & SCHEMATICS		
11.1	GENERAL	11-1
11.2	Multimeter Basics	11-1
	Grounding	11-1
	Backprobing	11-1
	Min/Max	11-1
	Polarity	11-1
	Scale	11-1
	Voltage Measurement	11-1
	Resistance Measurement	11-2
	Continuity Measurement	11-2
	Current Measurement	11-3
11.3	Checking Switches	11-3
	Basic Check	11-3
	Limit Switches	11-3
	Automatic Switches	11-4
	Switch Wiring - Low Side, High Side	11-4
11.4	Applying Silicone Dielectric Compound to Electrical Connections	11-4
11.5	AMP Connector	11-5
	Applying Silicone Dielectric Compound to AMP Connectors	11-5
	Assembly	11-5
	Disassembly	11-7
	Wedge Lock	11-7
	Service - Voltage Reading	11-7
11.6	Deutsch Connectors	11-9
	DT/DTP Series Assembly	11-9
	DT/DTP Series Disassembly	11-9
	HD30/HDP20 Series Assembly	11-10
	HD30/HDP20 Series Disassembly	11-10

11.7 CONNECTORS IDENTIFICATION11-11
11.8 ELECTRICAL SCHEMATIC11-14
11.9 Hydraulic schematic11-20

Go to Discount-Equipment.com to order your parts

LIST OF FIGURES

FIGURE NO.	TITLE	PAGE NO.
1-1.	Lubrication Chart	1-7
1-2.	Serial Number	1-9
3-1.	Basic Electronic Module Connections	3-2
3-2.	Drive Motor Schematic	3-3
3-3.	Hydraulic Pump Electric Schematic	3-4
3-4.	Mast Lift System - Basic Schematic	3-4
3-5.	Jib Lift System - Basic Schematic	3-5
3-6.	Swing System - Basic Schematic	3-5
3-7.	Steer System - Basic Schematic	3-6
4-1.	Dust Cleaning	4-1
4-2.	Brake Disassembly	4-1
4-3.	Brake Disk Wear Checking	4-1
4-4.	Brake Assembly	4-2
4-5.	Drive Motor Removal	4-2
4-6.	Drive Motor Installation	4-3
4-7.	Motor Disassembly	4-3
4-8.	Motor Connector	4-3
4-9.	Stator Disassembly	4-3
4-10.	Rotor Disassembly	4-4
4-11.	Extraction du Rotor	4-4
4-12.	Encoder Disassembly	4-4
4-13.	Encoder Assembly	4-4
4-14.	Rotor Assembly	4-5
4-15.	Motor Sealing	4-5
4-16.	Motor Positioning	4-5
4-17.	Oil Filling	4-6
4-18.	Wheel Lug Nut Tightening Sequence	4-6
4-19.	Steering Linkage Assembly	4-7
4-20.	Steering Sensor Installation	4-8
4-21.	Hoses and Cables Routing	4-9
4-22.	Front Wheel Hub - Installation	4-9
5-1.	Access Holes	5-1
5-2.	Torque Sequence Diagram	5-1
5-3.	Swing Bearing Race Lubrication	5-1
5-4.	Swing Bearing Teeth Lubrication	5-2
5-5.	Counterweight Removal (T10E/T26E)	5-2
5-6.	Counterweight Removal (T8E/T20E)	5-3
5-7.	Mast Assembly Lifting	5-3
5-8.	Mast Section #1 Set on Blockings	5-4
5-9.	Bearing Alignment T10E/T26E	5-4
5-10.	Bearing Alignment T8E/T20E	5-4
5-11.	Backlash Adjustment	5-5
5-12.	Chain Slack Detection System - Sensor Cable	5-6
5-13.	Drive Orientation Switch Harness Routing	5-6
5-14.	Mast Profiles Lubrication	5-7
5-15.	Roller Assembly	5-8
5-16.	Roller Removal	5-8
5-17.	Roller Installation	5-8
5-18.	Loosening and Tightening Direction	5-9
5-19.	Setting Angles	5-9
5-20.	Setting Tool	5-9
5-21.	Top Rollers Mast Configuration	5-9
5-22.	Top Rollers Mast Centering (Top View-Mast Lowered)5-10	
5-23.	Adjusting Top Roller Play	5-10
5-24.	Bottom Rollers Mast Configuration	5-10
5-25.	Bottom Rollers Mast Centering (Bottom View - Mast Raised)5-11	

5-26.	Adjusting Bottom Roller Play	5-11
5-27.	Mast Vertical Alignment	5-11
5-28.	Top and Bottom Rollers	5-12
5-29.	Supporting Mast Sections	5-13
5-30.	Long Hollow Body Socket	5-13
5-31.	Cracked Plate	5-14
5-32.	Turned Pin	5-14
5-33.	Worn Plate	5-14
5-34.	Chains Stages and Attachments Description - T10E/T26E	5-15
5-35.	Chains Stages and Attachments Description (T8E/T20E)	5-16
5-36.	First Chain Stage	5-17
5-37.	Second Chain Stage (T10E/T26E)	5-18
5-38.	Third Chain Stage (T10E/T26E) Second Chain Stage (T8E/T20E)	5-19
5-39.	Supporting Mast Sections	5-20
5-40.	Supporting Mast Sections	5-21
5-41.	Supporting Mast Sections	5-22
5-42.	Supporting Mast Sections	5-23
5-43.	Chain Tension Adjustment	5-23
5-44.	Chains Tension Control	5-24
5-45.	Slantwise Pulley	5-24
5-46.	Pulley Assembly Wear	5-25
5-47.	Pulley Support Removal	5-25
5-48.	Supporting Mast Sections for Mast Cylinder Removal	5-26
5-49.	Mast Cylinder Removal	5-26
6-1.	Platform Removal-Installation	6-1
6-2.	Bevel Washer Lubrication	6-1
6-3.	Jib Cylinder Removal - Figure 1 of 2	6-2
6-4.	Jib Cylinder Removal - Figure 2 of 2	6-2
7-1.	Hydraulic Oil Check	7-1
7-2.	Oil Level if Decal is Missing	7-1
7-3.	Tank Draining/Cleaning	7-2
7-4.	Oil Filter Replacement	7-2
7-5.	Hydraulic Power Unit	7-3
7-6.	Ports Identification	7-3
7-7.	Hydraulic Lines Connections	7-4
7-8.	Air Bleeding	7-4
7-9.	Terminal Tightening	7-5
7-10.	Dust Cleaning	7-5
7-11.	Moving Hydraulic Power Unit	7-5
7-12.	Motor Brushes	7-6
7-13.	Swing Motors	7-6
7-14.	Mast Cylinder Holding Valve - Removal/Installation	7-7
7-15.	Mast Cylinder Holding Valve - Schematic/Exploded View	7-8
7-16.	Jib Cylinder Holding Valve - Removal/Installation	7-8
7-17.	Jib Cylinder Holding Valve - Schematic/Exploded View	7-9
7-18.	Steer Cylinder	7-9
7-19.	Jib Cylinder	7-10
7-20.	Mast Cylinder	7-10
8-1.	Control Components Location - T8E/T20E	8-1
8-2.	Control Components Location - T10E/T26E	8-2
8-3.	Battery filling	8-3
8-4.	Draining the water	8-4
8-5.	Measuring Electrolyte Specific Gravity	8-4
8-6.	Main Power Contactor Relay	8-6
8-7.	Power Fuse	8-6
8-8.	Mast Elevation Limit Switches	8-7
8-9.	Actuators Setting	8-7
8-10.	Chain Slack Sensors - T8E/T20E	8-8
8-11.	Chain Slack Sensors - T10E/T26E	8-9
8-12.	Overload Sensor	8-10
8-13.	Drive Orientation Switch	8-10

TABLE OF CONTENTS

8-14.	Steering Sensor	8-11
8-15.	Wheel Straightening	8-11
8-16.	Tilt Sensor	8-11
8-17.	Tilt Sensor Check	8-12
8-18.	Tilt Sensor Calibration	8-12
8-19.	Tilt Sensor Calibration Verification	8-12
8-20.	Ground Alarm	8-13
8-21.	Warning Beacons	8-13
8-22.	Descent/Motion Alarm	8-14
8-23.	Main Electrical Power Connections	8-15
8-24.	Power Module Removal - Installation	8-16
8-25.	Power Module Terminals	8-17
8-26.	Cables on Power Module Post Terminal	8-17
8-27.	Ground Control Box Circuit Board - Installation	8-20
8-28.	Upper Control Box Circuit Board - Installation	8-21
8-29.	Joystick Controls - Installation	8-21
8-30.	Enable/Emergency Stop Switches - Installation	8-22
9-1.	Hand Held Analyzer Connection	9-1
9-2.	Analyzer Flow Chart - Sheet 1 of 5	9-4
9-3.	Analyzer Flow Chart - Sheet 2 of 5	9-5
9-4.	Analyzer Flow Chart - Sheet 3 of 5	9-6
9-5.	Analyzer Flow Chart - Sheet 4 of 5	9-7
9-6.	Analyzer Flow Chart - Sheet 5 of 5	9-8
9-7.	Wheel Straightening	9-10
9-8.	Overload System	9-11
9-9.	System Test Flow Chart	9-15
10-1.	DTCs Displays	10-1
11-1.	Voltage Measurement (DC)	11-1
11-2.	Resistance Measurement	11-2
11-3.	Continuity Measurement	11-2
11-4.	Current Measurement (DC)	11-3
11-5.	Connector Assembly Figure 1	11-5
11-6.	AMP Connector	11-5
11-7.	Connector Assembly Figure 2	11-6
11-8.	Connector Assembly Figure 3	11-6
11-9.	Connector Assembly Figure 4	11-6
11-10.	Connector Disassembly	11-7
11-11.	Connector Installation	11-8
11-12.	DT/DTP Contact Installation	11-9
11-13.	DT/DTP Contact Removal	11-9
11-14.	HD/HDP Contact Installation	11-10
11-15.	HD/HDP Locking Contacts Into Position	11-10
11-16.	HD/HDP Contact Removal	11-10
11-17.	HD/HDP Unlocking Contacts	11-10
11-18.	Wiring Harness and Connectors - Sheet 1 of 3	11-11
11-19.	Wiring Harness and Connectors - Sheet 2 of 3	11-12
11-20.	Wiring harness and Connectors - Sheet 3 of 3	11-13
11-21.	Electrical schematic caption	11-14
11-22.	Electrical Schematic ELE251 - Sheet 1 of 2	11-16
11-23.	Electrical Schematic Toucan ELE251 - Sheet 2 of 2	11-17
11-24.	Electrical Schematic ELE259 - Sheet 1 of 2	11-18
11-25.	Electrical Schematic ELE259 - Sheet 2 of 2	11-19
11-26.	Hydraulic schematic Toucan 10E/Toucan 26E	11-20
11-27.	Hydraulic schematic Toucan 8E/Toucan 20E	11-21

LIST OF TABLES

TABLE NO.	TITLE	PAGE NO.
1-1	Operating Specifications	1-1
1-2	Dimensions	1-1
1-3	Performances	1-2
1-4	Capacities	1-3
1-5	Battery Specifications	1-3
1-6	Hydraulic Unit Specifications	1-3
1-7	Drive Motor Specifications	1-3
1-8	Swing Motor Specifications	1-4
1-9	Cylinders Specifications	1-4
1-10	Tires Specifications	1-4
1-11	Major Components Weights	1-5
1-12	Hydraulic Oil Specifications (Standard)	1-6
1-13	Lubrication Chart	1-7
1-14	Lube Specifications	1-8
1-15	Torque Chart	1-8
2-1	Maintenance and Inspection Requirements	2-2
2-2	Inspection and Preventive Maintenance Schedule	2-3
4-1	Wheel Torque Chart	4-7
5-1	Influence of roller setting on mast play	5-9
5-2	Top Rollers Tightening	5-10
5-3	Bottom Rollers Setting Height	5-10
5-4	Bottom Rollers Tightening	5-11
5-5	Maximum Mast Lowering Time	5-12
5-6	Maximum Tightening Adjustment	5-12
8-1	Battery Troubleshooting	8-5
9-1	Machine Setup Programming Information	9-9
9-2	Acceptable Pressure Values	9-12
9-3	Machine Personality Adjustment	9-13

Go to Discount-Equipment.com to order your parts

SECTION 1. OPERATING SPECIFICATIONS

1.1 OPERATING SPECIFICATIONS

Table 1-1. Operating Specifications

Description	Toucan 8E	Toucan 8E XL	Toucan 20E	Toucan 10E	Toucan 26E
Maximum Work Load	200 kg		500 lbs (227 kg)	200 kg	500 lbs (227 kg)
Maximum Persons	2				
Maximum Horizontal Side Force	400 N		100 lbf (445 N)	400 N	100 lbf (445 N)
Maximum Operating Wind Speed	12.5 m/s (45 km/h)		28 mph	12.5 m/s (45 km/h)	28 mph
Maximum Stowed Travel Grade (Gradeability)	25% (14°)				
Maximum Stowed Travel Grade (Side slope)	8.7% (5°)				
Tilt Alarm Triggering Angle Value	3.5% (2°)				
Maximum Tire Load (per wheel)	1 280 kg	1 280 kg	3043 lbs (1380 kg)	1 680 kg	3 485 lbs (1 580 kg)
Maximum Ground Bearing Pressure	18.2 kg/cm ²		270 psi	21 kg/cm ²	285 psi
Approximate Gross Machine Weight - Global	2 120 kg	2 340 kg	5 360 lbs (2 430 kg)	2 990 kg	6 834 lbs (3 100 kg)

1.2 DIMENSIONAL DATA

Table 1-2. Dimensions

Description	Toucan 8E	Toucan 8E XL	Toucan 20E	Toucan 10E	Toucan 26E
Overall Stowed Machine Height	1.99 m		6.59 ft (2.01m)	1.99 m	6.53 ft (1.99 m)
Overall Machine Length	2.09 m	2.35 m	6.86 ft (2.09 m)	2.82 m	9.25 ft (2.82 m)
Overall Machine Width	0.99 m		3.25 ft (0.99 m)	0.99 m	3.75 ft (1.14 m)
Platform Size - Length (Platform base)	0.85 m	1.10 m	2.79 ft (0.85 m)	0.70 m	2.30 ft (0.70m)
Platform Size - Width - (Platform base)	0.90 m		2.95 ft (0.90 m)	0.90 m	2.95 ft (0.90 m)
Wheel Base (Wheels straightened)	1.20 m		3.94 ft (1.20 m)	1.20 m	3.94 ft (1.20 m)
Ground Clearance (chassis base plate)	105 mm		2.95 in (75 mm)	105 mm	4.13 in (105 mm)
Ground Clearance (drive motors gear box area)	75 mm		2.95 in (75 mm)	75 mm	2.95 in (75 mm)

SECTION 1 - OPERATING SPECIFICATIONS

1.3 PERFORMANCE DATA

Table 1-3. Performances

Description	Toucan 8E	Toucan 8E XL	Toucan 20E	Toucan 10E	Toucan 26E
Platform Height - Stowed (Platform floor to ground)	0.62 m		2.06 ft (0.63 m)	0.37 m	1.21 ft (0.37 m)
Platform Height - Elevated (Platform floor to ground)	6.15 m		20.21 ft (6.16 m)	8.10 m	26.5 ft (8.10 m)
Platform Height - Mast Elevated / Jib Horizontal (Platform floor to ground)	5.37 m		17.65 ft (5.38 m)	6.60 m	21.6 ft (6.60 m)
Up and Over clearance - Jib Horizontal	5.10 m		16.76 ft (5.11 m)	6.50 m	21.3 ft (6.50 m)
Maximum Horizontal Reach (from centreline)	1.89 m	2.15 m	6.56 ft (2.00 m)	2.58 m	8.67 ft (2.64 m)
Maximum Horizontal Reach (from side edge of chassis)	1.39 m	1.65 m	4.92 ft (1.50 m)	2.08 m	6.76 ft (2.06 m)
Maximum Horizontal Reach (from rear edge of chassis)	1.09 m	1.35 m	3.94 ft (1.20 m)	1.78 m	6.04 ft (1.84 m)
Swinging Angle	345° (non continuous)				
Inside Turning Radius	0.55 m		1.8 ft (0.55 m)	0.55 m	1.8 ft (0.55 m)
Outside Turning Radius	1.99 m		6.5 ft (1.99 m)	1.99 m	6.89 ft (2.10 m)
Gradeability	25% (14°)				
Elevating					
Mast Lift Up Time - W/one person (approx. 80kg)	20 to 25 seconds			22 to 27 seconds	
Mast Lift Down Time - W/one person (approx. 80kg)	24 to 29 seconds			22 to 27 seconds	
Jib Lift Up Time - W/one person (approx. 80kg)	7 to 12 seconds			11 to 16 seconds	
Jib Lift Down Time - W/one person (Approx. 80kg)	9 to 14 seconds			11 to 16 seconds	
Swinging					
Swinging Time - From rest to rest - Mast stowed	47 to 52 seconds			35 to 40 seconds	
Swinging Time - From rest to rest - Mast elevated	47 to 52 seconds			55 to 60 seconds	
Driving					
Maximum Drive Speed					
	Stowed	5.50 km/h	3.40 mph	5.50 km/h	3.40 mph
	Mast elevated (1)	0.75 km/h	0.47 mph	0.75 km/h	0.47 mph
	Mast fully elevated (2)			0.40 km/h	0.47 mph

(1) Up to 7.20 m (23.62 ft) - Platform height w / jib stowed (Toucan 10E and Toucan 26E models only)

(2) Above 7.20 m (23.62 ft) - Platform height w / jib stowed (Toucan 10E and Toucan 26E models only)

1.4 CAPACITIES

Table 1-4. Capacities

Component	Models Toucan 8E - Toucan 10E	Models Toucan 20E - Toucan 26E
Hydraulic Tank	6l (5.5 l usable)	1.59 Gal. (1.45 Gal. usable)
Hydraulic System (Including Tank)	Approx. 9l	Approx. 2.38 Gal.

1.5 COMPONENTS DATA

Batteries

Table 1-5. Battery Specifications

Description	Model Toucan 8E	Model Toucan 20E	Models Toucan 10E - Toucan 26E
Voltage (24V System - Series)	4 batteries of 6V	4 batteries of 6V (AGM)	12 cells of 2 Volts
Amp Hour (Standard battery)	225 Amp Hour @ 20 HR. Rate	213 Amp Hour @ 20 HR. Rate	240 Amp Hour @ 5 HR. Rate
Life Cycle Rating	1 200 Cycles	1200 Cycles	1200 Cycles
Weight - Approx	112 kg	275 lb - 125 kg	220 kg - 485 lbs

Electric Pump / Electric Motor Assembly

Table 1-6. Hydraulic Unit Specifications

Description	All models	
Motor	Voltage	24 VDC
	Power	3 kW
Pump (Gear pump)	Displacement	3.1 cc/rev (0.19 ci/rev)
	Flow rate	9.6 l/mn @ 13 MPa (2.5 gpm @ 1885 psi)
Max. Operating Pressure	18 MPa (2610 psi)	

Drive Motor Assembly

Table 1-7. Drive Motor Specifications

Description	Models Toucan 8E - Toucan 20E - Toucan 10E - Toucan 26E	
Motor	Voltage	15 VAC
	Power	0.85 kW
Brake	Supply Voltage	24 VDC (Nominal)
Sensor Bearing	64 Impulses per rev.	

SECTION 1 - OPERATING SPECIFICATIONS

Swing Motor

Table 1-8. Swing Motor Specifications

Description	Model Toucan 8E - Toucan 20E	Model Toucan 10E - Toucan 26E
Motor Type	Orbital	Orbital
Displacement	12.5 cc	314.9 cc
Chock Valves Setting (@ 10 l/mn)		5.0-6.5 MPa (725-942 psi)

Cylinders

Table 1-9. Cylinders Specifications

Description	Bore DIA.	Stroke	Rod DIA.
Steer Cylinder (Double Action)	40 mm (1.57 in)	145 mm (5.71 in)	20 mm (0.79 in)
Mast Cylinder (Single Action)	65 mm (2.56 in)	1220 mm (48 in)	60 mm (2.36 in)
Jib Cylinder (Single Action) (Toucan 10E - Toucan 26E)	60 mm (2.36 in)	535 mm (21.1 in)	50 mm (1.97 in)
Jib Cylinder (Single Action) (Toucan 8E - Toucan 20E)	60 mm (2.36 in)	425 mm (16.7 in)	50 mm (1.97 in)

Tires

Table 1-10. Tires Specifications

Description	Model Toucan 8E - Toucan 20E - Toucan 10E - Toucan 26E	
Size	406 x 125 mm	16 x 4.9 in
Max. Allowable Tire Load	1 815 kg	4 000 lb
Wheel Bolt Torque	163 Nm	120 ft lb

1.6 MAJOR COMPONENTS WEIGHTS

Table 1-11. Major Components Weights

Description		Model Toucan 8E - Toucan 20E		Model Toucan 10E - Toucan 26E	
		kg	lb	kg	lb
Platform (Standard)	(*)	80 kg	176 lb	74 kg	163 lb
Platform (XL)	(*)	92 kg	203 lb	-	-
Platform Support		9 kg	20 lb	12.5 kg	27.6 lb
Upper Jib		19 kg	42 lb	25 kg	55 lb
Lower Jib		7 kg	15 lb	11 kg	24.3 lb
Jib Cylinder		19 kg	42 lb	20 kg	44 lb
Mast Assembly (4 mast sections - Toucan 10E/Toucan 26E) (3 mast sections - Toucan 8E/Toucan 20E)		240 kg	529 lb	390 kg	860 lb
Mast Cylinder		48 kg	106 lb	48 kg	106 lb
Mast Section #1		135 kg	298 lb	182 kg	401 lb
Chassis Assembly		630 kg	1 389 lb	630 kg	1 389 lb
Wheel and Tire Assembly (each)	(*)	18.5 kg	40.8 lb	18.5 kg	40.8 lb
Drive Motor (each)	(*)	30 kg	66 lb	30 kg	66 lb
Battery - Standard	(*)	4x28 kg = 112 kg	247 lb	220 kg	485 lb
Counterweight (Standard Platform)	(*)	610 kg	1345 lb	1 270 kg	2 800 lb
Additional Counterweight (XL Platform)	(*)	200 kg	441 lb	-	-

(*) Items critical for stability

WARNING

DO NOT REPLACE ITEMS CRITICAL TO STABILITY, SUCH AS BATTERIES OR SOLID TIRES, WITH ITEMS OF DIFFERENT WEIGHT OR SPECIFICATION. DO NOT MODIFY UNIT IN ANY WAY TO AFFECT STABILITY.

1.7 LUBRICATION

Hydraulic Oil

Table 1-12. Hydraulic Oil Specifications (Standard)

Specifications	NERVOFLUID VG32	MOBIL DTE 10XL 32
ISO Viscosity Grade	32	32
Cinematic Viscosity @ +40°C [104°F]	34 mm ² /s (cSt)	32.7 mm ² /s (cSt)
Cinematic Viscosity @ +100°C [212°F]	6.5 mm ² /s (cSt)	6.6 mm ² /s (cSt)
Pour Point, Max.	-38°C (-36°F)	-54°C (-65°F)
Flash Point, Min.	225°C (437°F)	250°C (482°F)
Viscosity Index	148	164
ISO6743-4 Classification	HV	HV

NOTE: Hydraulic oils must have anti-wear qualities and sufficient chemical stability for mobile hydraulic system service. It is not advisable to mix oil of different brands or types, as they may not contain the same required additive or be of comparable viscosities.

Go to Discount-Equipment.com to order your parts

Lubrication Chart

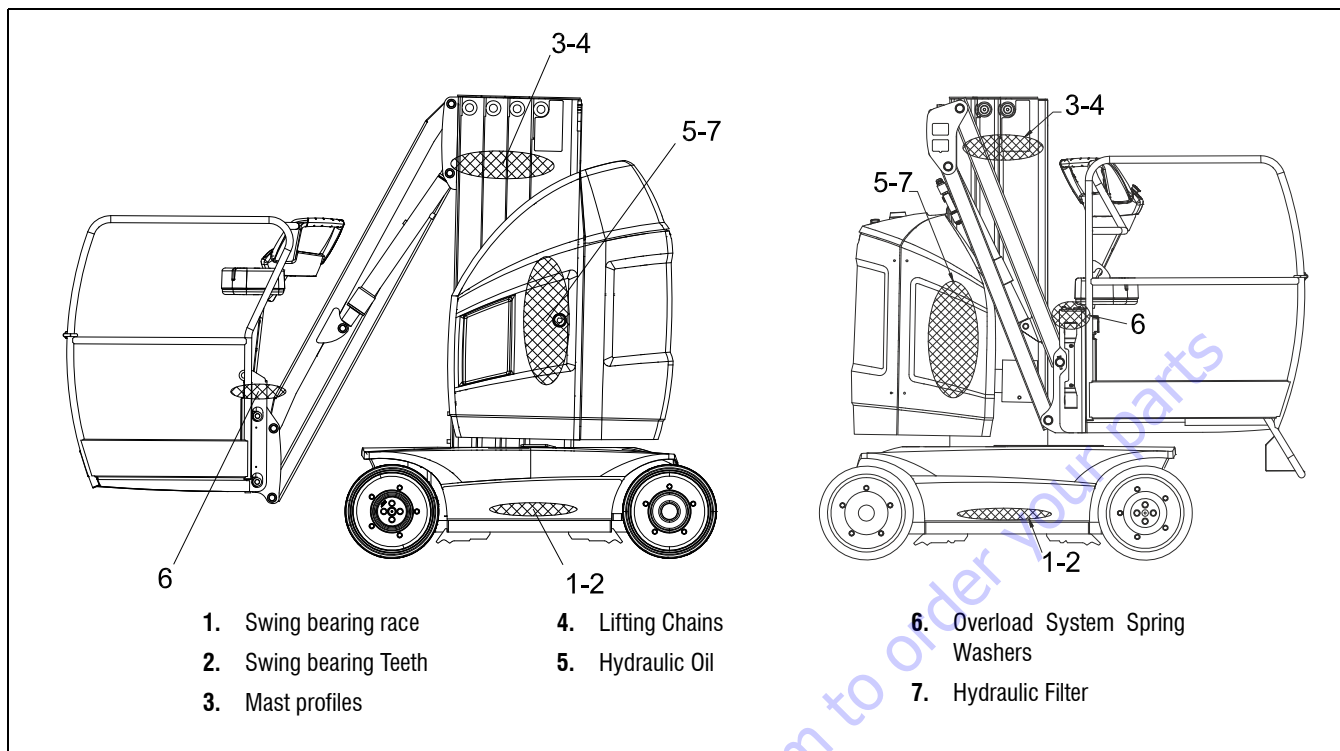

Figure 1-1. Lubrication Chart

Table 1-13. Lubrication Chart

Component	Number/Type Lube Points	Lube	Interval Hours			Comments
			125	250	1000	
1 Swing Bearing Race	2 grease fittings	A		X		
2 Swing Bearing Teeth	By brush	B			X	Remove old grease first
3 Mast Profiles	By brush	A	X			Remove old grease first
4 Lifting Chains	Spray on or by brush	C	X			Lubricate before first 50 hours of operation
5 Hydraulic Oil	Fill through reservoir cap	D			X	Check level daily. Change at least every 2 years
6 Overload System Spring Washers	By brush	E	X			
7 Hydraulic Filter	N/A	N/A		X		Change after first 50 hours of operation

NOTE: Lubrication intervals are based on machine operation under normal condition. For machines used in multi shift operations and/or exposed to hostile environments or conditions, lubrication frequencies must be increased accordingly.

NOTE: Refer to the corresponding sections in this manual for specific lubrication procedures.

SECTION 1 - OPERATING SPECIFICATIONS

Lube Specifications

Table 1-14. Lube Specifications

Key	Specifications	E.g.
A	Extreme Pressure - Multi Purpose Grease	MOBILUX EP2 COMPLEX EP2
B	Open Gear Lube	MOBILTAC 81
C	Non Detergent Mineral Oil (*)	MOBIL DTE 10XL 68
D	Hydraulic Oil	NERVOFLUID VG32 MOBIL DTE 10XL 32
E	Synthetic Chain Oil	FUCHS VT800

(*) To be adapted to the machine's operating conditions. Refer to the corresponding section in this manual.

1.8 TORQUE REQUIREMENTS

Unless specific torque requirements are given within the text, refer to the following torque chart to determine proper torque values.

Table 1-15. Torque Chart

Torque Values for Bolts, Nuts and Studs												
Grade	Unit	M4x70	M5x80	M6x100	M8x125	M10x150	M12x175	M14x200	M16x200	M20x250	M24x300	M30x350
8.8	Nm	2.7	5.2	9.1	22	44	76	121	189	370	637	1280
	lbf.ft	2	3.8	6.7	16.2	32.5	56	89.2	139	272	469	944
10.9	Nm	3.9	7.7	13.4	32	64	111	178	278	544	936	1880
	lbf.ft	2.9	5.7	9.9	23.6	47.2	81.9	131	205	408	690	1386
12.9	Nm	4.6	9	15.7	38	75	130	209	325	637	1095	2200
	lbf.ft	3.4	6.6	11.6	28	55.3	95.9	154	239	469	807	1622
Torque Values for Hydraulic Fittings												
Type	Unit	TORQUE FOR STEEL BODY		TORQUE FOR ALUMINUM BODY								
JIC 9/16"-18	N.m	31		-								
	lbf.ft	22.9										
BSPP 1/4"-19	N.m	35		25								
	lbf.ft	25.8		18.4								
BSPP 3/8"-19	N.m	70		50								
	lbf.ft	51.6		36.9								
Metric M14x150	N.m	45		32								
	lbf.ft	33.2		23.6								
Metric M18x150	N.m	70		50								
	lbf.ft	51.6		36.9								

1.9 SERIAL NUMBER LOCATIONS

For machines identification, a serial number plate is affixed at the front side of the chassis. If the serial number plate is damaged or missing, the machine serial number is stamped on the frame at location shown following.

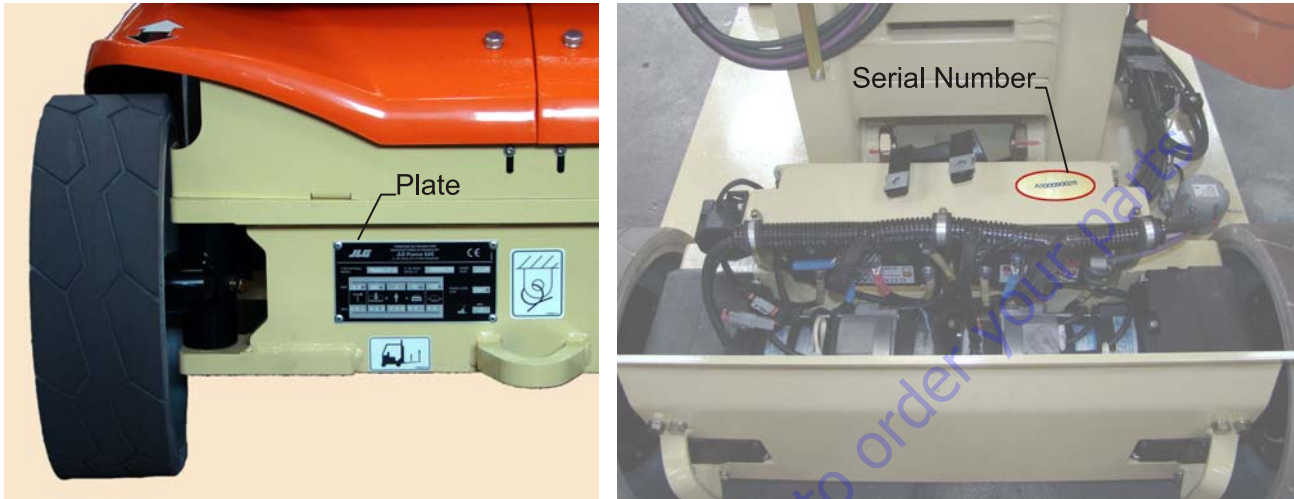

Figure 1-2. Serial Number

PARTS FINDER

**Search Website
by Part Number**



**Search Manual
Library For Parts
Manual & Lookup Part
Numbers – Purchase
or Request Quote**

Search Manuals

Enter your information to search for manuals and parts.

* Brand:

* Model:

* Serial:

* Part Number:

SEARCH

**Can't Find Part or
Manual? Request Help
by Manufacturer,
Model & Description**

Parts Order Form

Please fill in the following information:

Manufacturer:

Model:

Description:

Quantity:

Part Number:

Part Name:

Part Description:

Part Category:

Part Location:

Part Status:

Part Condition:

Part Material:

Part Color:

Part Weight:

Part Dimensions:

Part Price:

Part Notes:

Submit

Discount-Equipment.com is your online resource for quality parts & equipment.

Florida: **561-964-4949** Outside Florida TOLL FREE: **877-690-3101**

Need parts?

Click on this link: <http://www.discount-equipment.com/category/5443-parts/> and choose one of the options to help get the right parts and equipment you are looking for. Please have the machine model and serial number available in order to help us get you the correct parts. If you don't find the part on the website or on once of the online manuals, please fill out the request form and one of our experienced staff members will get back to you with a quote for the right part that your machine needs.

We sell worldwide for the brands: Genie, Terex, JLG, MultiQuip, Mikasa, Essick, Whiteman, Mayco, Toro Stone, Diamond Products, Generac Magnum, Airman, Haulotte, Barreto, Power Blanket, Nifty Lift, Atlas Copco, Chicago Pneumatic, Allmand, Miller Curber, Skyjack, Lull, Skytrak, Tsurumi, Husquvarna Target, , Stow, Wacker, Sakai, Mi-T- M, Sullair, Basic, Dynapac, MBW, Weber, Bartell, Bennar Newman, Haulotte, Ditch Runner, Menegotti, Morrison, Contec, Buddy, Crown, Edco, Wyco, Bomag, Laymor, Barreto, EZ Trench, Bil-Jax, F.S. Curtis, Gehl Pavers, Heli, Honda, ICS/PowerGrit, IHI, Partner, Imer, Clipper, MMD, Koshin, Rice, CH&E, General Equipment, ,AMida, Coleman, NAC, Gradall, Square Shooter, Kent, Stanley, Tamco, Toku, Hatz, Kohler, Robin, Wisconsin, Northrock, Oztec, Toker TK, Rol-Air, Small Line, Wanco, Yanmar

SECTION 2. GENERAL SERVICE INFORMATION

2.1 MACHINE PREPARATION, INSPECTION AND MAINTENANCE

General

This section provides the necessary information needed by those personnel that are responsible to place the machine in operation readiness and maintain its safe operating condition. For maximum service life and safe operation, ensure that all the necessary inspections and maintenance have been completed before placing the machine into service.

Preparation, Inspection and Maintenance

It is important to establish and conform to a comprehensive inspection and preventive maintenance program. The following table outlines the periodic machine inspections and maintenance recommended by JLG Industries, Inc. Consult your national, regional, or local regulations for further requirements for aerial work platforms. The frequency of inspections and maintenance must be increased as environment, severity and frequency of usage requires.

Pre-Start Inspection

It is the User's or Operator's primary responsibility to perform a Pre-Start Inspection of the machine prior to use daily or at each change of operator. Reference the Operator's and Safety Manual for completion procedures for the Pre-Start Inspection. The Operator and Safety Manual must be read in its entirety and understood prior to performing the Pre-Start Inspection.

Pre-Delivery Inspection and Frequent Inspection

The Pre-Delivery Inspection and Frequent Inspection shall be performed by a qualified JLG equipment mechanic. JLG Industries, Inc. recognizes a qualified JLG equipment mechanic as a person who, by possession of a recognized degree, certificate, extensive knowledge, training, or experience, has successfully demonstrated the ability and proficiency to service, repair, and maintain the subject JLG product model.

The Pre-Delivery Inspection and Frequent Inspection procedures are performed in the same manner, but at different times. The Pre-Delivery Inspection shall be performed prior to each sale, lease, or rental delivery. The Frequent Inspection shall be accomplished for each machine in service for 3 months; out of service for a period of more than 3 months; or when purchased used. The frequency of this inspection must be increased as environment, severity and frequency of usage requires.

Reference the JLG Pre-Delivery and Frequent Inspection Form and the Inspection and Preventative Maintenance Schedule for items requiring inspection during the performance of these inspections. Reference the appropriate

areas of this manual for servicing and maintenance procedures.

Annual Machine Inspection

The annual machine inspection must be performed by a Factory-Trained Service Technician on an annual basis, no later than thirteen (13) months from the date of the prior Annual Machine Inspection. JLG Industries, Inc. recognizes a Factory-Trained Service Technician as a person who has successfully completed the JLG Service Training School for the subject JLG product model. Reference the machine Service and Maintenance Manual and appropriate JLG inspection form for performance of this inspection.

Reference the JLG Annual Machine Inspection Form and the Inspection and Preventative Maintenance Schedule for items requiring inspection during the performance of this inspection. Reference the appropriate areas of this manual for servicing and maintenance procedures.

For the purpose of receiving safety-related bulletins, it is important that JLG Industries, Inc. has updated ownership information for each machine. When performing each Annual Machine Inspection, notify JLG Industries, Inc. of the current machine ownership.

Preventative Maintenance

In conjunction with the specified inspections, maintenance shall be performed by a qualified JLG equipment mechanic. JLG Industries, Inc. recognizes a qualified JLG equipment mechanic as a person who, by possession of a recognized degree, certificate, extensive knowledge, training, or experience, has successfully demonstrated the ability and proficiency to service, repair, and maintain the subject JLG product model.

Reference the Preventive Maintenance and Inspection Schedule and the appropriate areas of this manual for servicing and maintenance procedures. The frequency of service and maintenance must be increased as environment, severity and frequency of usage requires.

SECTION 2 - GENERAL SERVICE INFORMATION

Table 2-1. Maintenance and Inspection Requirements

TYPE	FREQUENCY	PRIMARY RESPONSIBILITY	SERVICE QUALIFICATION	REFERENCE
Pre-start Inspection	Prior to use each day; or At each Operator change	User or Operator	User or Operator	Operator and Safety manual
Pre-delivery Inspection	Prior to each sale, lease or rental delivery	Owner, Dealer or User	Qualified JLG Mechanic	Service and Maintenance Manual and applicable JLG inspection form
Frequent Inspection	In service for 3 months; or Out of service for a period of more than 3 months; or Purchased used	Owner, Dealer or User	Qualified JLG Mechanic	Service and Maintenance Manual and applicable JLG inspection form
Annual Machine Inspection	Annually, no later than 13 months from the date of the prior inspection	Owner, Dealer or User	Factory-Trained Service Technician (Recommended)	Service and Maintenance Manual and applicable JLG inspection form
Preventive Maintenance	At intervals as specified in the Service and Maintenance manual	Owner, Dealer or User	Qualified JLG Mechanic	Service and Maintenance Manual

2.2 PREVENTIVE MAINTENANCE AND INSPECTION SCHEDULE

The preventive maintenance and inspection checks are listed and defined in Table 2-2. This table is divided into two basic parts, the "AREA" to be inspected and the "INTERVAL" at which the inspection is to take place. Under the "AREA" portion of the table, the various systems along with the components that make up that system are listed. The "INTERVAL" portion of the table is divided into six columns representing the various inspection time periods. The numbers listed within the interval column represent the applicable inspection code for which that component is to be checked.

The checks and services listed in this schedule are not intended to replace any local or regional regulations that may pertain to this type of equipment nor should the lists be considered as all inclusive. Variances in interval times may occur due to climate and/or conditions and depending on the location and use of the machine.

SECTION 2 - GENERAL SERVICE INFORMATION

Table 2-2. Inspection and Preventive Maintenance Schedule

AREA	INTERVAL					
	Pre-start ¹ Inspection	Weekly preventive maintenance	Monthly preventive Maintenance	Pre-delivery ² or Frequent ³ Inspection	Annual ⁴ (Yearly) Inspection	Every 2 Years
PLATFORM ASSEMBLY						
Platform	1-2				1-2	
Railing	2				2	
Gate	1-5				1-5	
Floor	7				2	
Lanyard Anchorage Points	2			2-9		
JIB ASSEMBLY						
Jibs Weldments	2			1-2-4	1-2-4	
Pivot Pins and Pins Retainers	1			1-2	1-2	
Hose, Cables Installation				2-8-11	2-8-11	
MAST ASSEMBLY						
Mast Sections	2			2-4-13	2-3-4-13	
Roller Pin, Bronze Spacer				12	12	
Pulleys				2	2	
Chains/Yokes	13			12-13	12-13	
Power Tracks/Hose/Cable Installation				1-2-8-11	1-2-8-11	
TURNTABLE						
Swing Drive System	5		8	5-8	5-8	
Swing Bearing Bolts					14	
Hoods, Hood Props, Hood Latches				5	1-2-5	
CHASSIS ASSEMBLY						
Chassis Weldment					4	
Tires	1-15	16		15-16-17	15-16-17	
Wheel Bolts	1	14		14	14	
Steering Spindles Weldments (if welded)				2-4	2-4	
Hubs				1	1	
Steering Knuckles Thrust Washers				12	12	
Steer Components			1			
Drive Motor Brakes					7-12	
Drive Motor Gearbox				8	8	

SECTION 2 - GENERAL SERVICE INFORMATION

Table 2-2. Inspection and Preventive Maintenance Schedule

AREA	INTERVAL					
	Pre-start ¹ Inspection	Weekly preventive maintenance	Monthly preventive Maintenance	Pre-delivery ² or Frequent ³ Inspection	Annual ⁴ (Yearly) Inspection	Every 2 Years
Hoods, Hood Props				5	1-2-5	
FUNCTIONS/CONTROLS						
Platform Controls	5-6-9			5-6-9	5-6-9	
Ground Controls	5-6-9			5-6-9	5-6-9	
Manual/Breakdown Controls	5-9			5-9	5-9	
Emergency Stop Switches (Ground & Platform)	5			5	5	
Functions Limit or Cutout Switch Systems	5			5	5	
POWER SYSTEM						
Batteries	18	18		1-19		
Battery Fluid		10		10		
Centralized Filling System			5	5	5-8	
Battery Container Draining			22		22	
Electrical Connections		1		20	20	
Battery Charger				5	5	
HYDRAULIC/ELECTRIC SYSTEM						
Hydraulic Power Unit	8		1-8	1-8		
Hydraulic Cylinders	8	1-7-8	2	1-2-8	1-2-8	
Hydraulic Hoses, Lines and Fittings	8	1-8	11	1-2-8-11	1-2-8-11	
Hydraulic Tank/Hydraulic Fluid	10					
Hydraulic Fluid Replacement						22
Electrical Connections		1		20	20	
Instruments, Switches	5	1			7-15	
Lights, Horn	5			5		
Electric Motor Brushes (Hyd. Power Unit)					7-12	
GENERAL						
Operation and Safety manuals in Storage Box	21			21	21	
ANSI and EMI Manuals/Handbooks Installed (ANSI Market)					21	
Capacity Decals Installed, Secure, Legible	21			21	21	
All Decals/Placards installed, Secure, Legible	21			21	21	

Table 2-2. Inspection and Preventive Maintenance Schedule

AREA	INTERVAL					
	Pre-start ¹ Inspection	Weekly preventive maintenance	Monthly preventive Maintenance	Pre-delivery ² or Frequent ³ Inspection	Annual ⁴ (Yearly) Inspection	Every 2 Years
Walk-Around Inspection Performed	21					
Annual Machine Inspection Due				21	21	
No Unauthorized Modifications or Additions				21	21	
All Relevant Safety Publications Incorporated				21	21	
General Structural Condition and Welds				2-4	2-4	
All Fasteners, Pins, Shields and Covers				1-2	1-2	
Grease and Lubricate to Specifications				22	22	
Function Test of All Systems	21			21	21-22	
Paint and Appearance				7	7	
Stamp Inspection Date on Mast Section #1					22	
Notify JLG of Machine Ownership					22	

Maintenance and Inspection Table Codes:

1. Check for proper and secure installation.
2. Visual inspection for damage, cracks, distortion and excessive wear.
3. Check for proper adjustment.
4. Check for cracked or broken welds.
5. Operates properly.
6. Returns to neutral or "off" position when released.
7. Clean and free of debris.
8. Check for sign of leakage.
9. Decals installed and legible.
10. Check for proper fluid level.
11. Check for chafing and proper routing.
12. Check for proper tolerances.
13. Properly lubricated.
14. Torqued to proper specification
15. No worn edges, excessive wear or distorted profiles.
16. Properly seated around the rim.
17. Proper and authorized components.
18. State of charge.
19. Check/record acid gravity and tension.
20. No loose connections, corrosion or abrasion.
21. Verify.
22. Perform.

Footnotes:

- 1: Prior to use each day; or at each operator change.
- 2: Prior to each sale, lease or delivery.
- 3: In service for 3 months or 125 hours; or out of service for 3 months or more; or purchased used.
- 4: Annually, not later than 13 months from the date of prior inspection.

2.3 SERVICING AND MAINTENANCE GUIDELINES

General

The following information is provided to assist you in the use and application of servicing and maintenance procedures contained in this book.

Safety and Workmanship

Your safety and that of others is the first consideration when engaging in the maintenance of equipment. Always be conscious of weight. Never attempt to move heavy parts without the aid of a mechanical device. Do not allow heavy object to rest in an unstable position. When raising a portion of the equipment, ensure that adequate support is provided.



NEVER WORK UNDER AN ELEVATED PLATFORM UNTIL PLATFORM HAS BEEN SAFELY RESTRAINED FROM ANY MOVEMENT BY BLOCKING OR OVERHEAD SLING.

Cleanliness

The most important single item in preserving the long service life of a machine is to keep dirt and foreign materials out of the vital components. Precautions have been taken to safeguard against this. Shields, covers, seals and filters are provided to keep the wheel bearings, mast sections and oil supply clean; however, these items must be maintained on a scheduled basis in order to function properly.

At any time when hydraulic oil lines are disconnected, clean adjacent areas as well as the openings and fittings themselves. As soon as a line or component is disconnected, cap or cover all opening to prevent entry of foreign matter.

Contaminants in the hydraulic system will affect operation and will result in serious damage to components working parts. Every precaution must be taken to keep hydraulic oil clean, including reserve oil in storage. If the oil must be poured from the original container into another, be sure to clean all contaminants from the service container.

Clean and inspect all parts during servicing or maintenance, and assure that all passages and openings are unobstructed. Cover all parts to keep them clean. Be sure all parts are clean before they are installed. New parts should remain in their containers until they are ready to be used.

Components Removal and Installation

Use adjustable lifting devices, whenever possible, if mechanical assistance is required. All slings (chains, cables, etc.) should be parallel to each other and as near perpendicular as possible to top of part being lifted.

Should it be necessary to remove a component on an angle, keep in mind that the capacity of an eyebolt or similar bracket lessens, as the angle between the supporting structure and the component becomes less than 90 degrees.

If a part resists removal, check to see whether all nuts, bolts, cables, brackets, wiring, etc. have been removed and that no adjacent parts are interfering.

Component Disassembly and Reassembly

When disassembling or reassembling a component, complete the procedural steps in sequence. Do not partially disassemble or assemble one part, then start on another.

Always recheck your work to ensure that nothing has been overlooked. Do not make any adjustments, other than those recommended, without obtaining proper approval.

Pressure-Fit Parts

When assembling pressure-fit parts, use an "anti-seize" or molybdenum disulfide base compound to lubricate the mating surface.

Bearings

When a bearing is removed, cover it to keep out dirt and abrasives. Clean bearings in nonflammable cleaning solvent and allow to drip dry. Compressed air can be used but do not spin the bearing.

Discard bearing if the races and balls (or rollers) are pitted, scored or burned.

If bearing is found to be serviceable, apply a light coat of oil and wrap it in clean (waxed) paper. Do not unwrap reusable or new bearing until they are ready to be installed.

Lubricate new or used serviceable bearings before installation. When pressing a bearing into a retainer or bore, apply pressure to the outer race. If the bearing is to be installed on a shaft, apply pressure to the inner race.

Care and Installation of Teflon Coated Bushings

Bushings:

No jiffy wheels or reaming of any kind can be used on teflon coated bushings.

Once the coating on the bushing is damaged, it cannot be used any more and must be replaced.

Pins:

Any rough or damaged surface on a pin will cause the teflon coating of the bushing to be damaged.

All rust or masking residue must be cleaned from the pin prior to assembly.

Never dry (black colored) "Arcor" treated pins (hot washing, vapor...). This will reduce corrosion resistance property of pin coating.

Bushings and Pin:

1. Coat inside diameter of bushing with specified lubricant prior to pin installation.
2. Properly align pin and bushing so that the coating does not get damaged when installing the pin.
3. Pins have chamfered or rounded end to prevent damage to the coating of the bushing during pin installation.

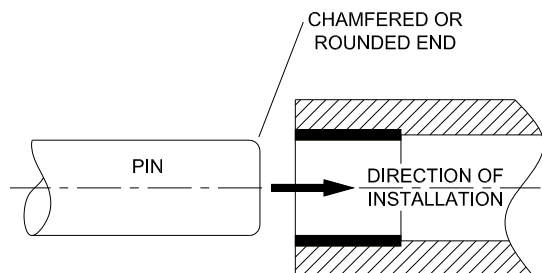

Bushing Installation:

1. Use an appropriate driver (soft steel) to insert bushing in its housing.

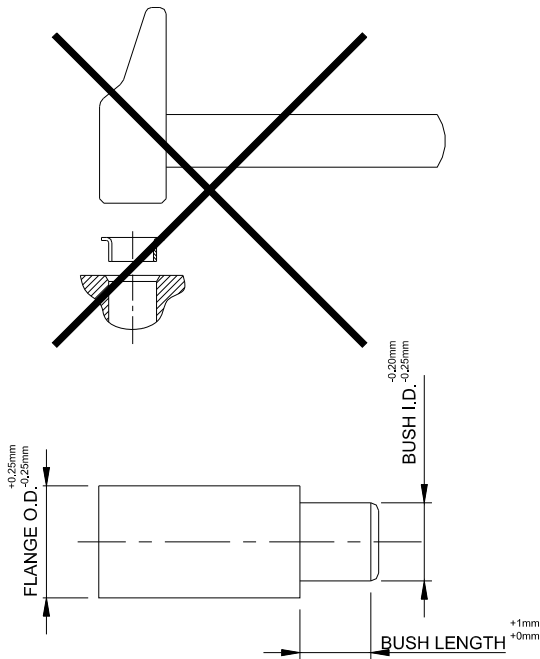

2. Slightly oil the outside diameter of the bushing to facilitate insertion.
3. Keep driver, bushing and housing correctly aligned during assembly.
4. Blocking must be used on parts that will receive two flange bushings to prevent damage to the lower bushing flange.

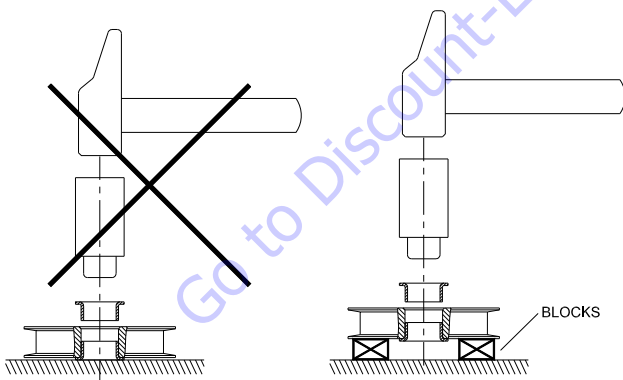

Bolt Usage and Torque Application

NOTICE

SELF LOCKING FASTENERS, SUCH AS NYLON INSERT AND THREAD DEFORMING LOCKNUTS, ARE NOT INTENDED TO BE REINSTALLED AFTER REMOVAL.

Use bolts of proper length. A bolt which is too long will bottom before the head is tight against its related part. If a bolt is too short, there will not be enough thread area to engage and hold the part properly. When replacing bolts, use only those having the same specifications of the original, or one which is equivalent.

Unless specific torque requirements are given within the text, standard torque values should be used on heat treated bolts, studs and steel nuts, in accordance with recommended shop practices or the Torque Chart in Section 1 of this Service Manual.

Hydraulic Lines and Electrical Wiring

Clearly mark or tag hydraulic lines and electrical wiring, as well as their receptacles, when disconnecting or removing them from the unit. This will assure that they are correctly reinstalled.

Coat contacts of electrical connectors with silicone dielectric compound (Refer to Section 11).

Always disconnect battery plug (located in the battery compartment) prior to working on the electrical system.

Hydraulic System

⚠ WARNING

EXERCISE EXTREME CARE AROUND PRESSURIZED HYDRAULIC SYSTEMS WHILE IN OPERATION OR UNTIL ALL PRESSURE IS RELEASED.

⚠ WARNING

HIGH PRESSURE OIL COULD PENETRATE SKIN AND CAUSE INJURIES OR BURNS. LOOSEN FITTINGS OR COMPONENTS SLOWLY TO ALLOW OIL PRESSURE TO DROP GRADUALLY.

When servicing the hydraulic system, use a container to collect the oil from hydraulic lines or components and prevent it from spilling on the work platform or on the ground.

NOTE: Used oils and filter cartridges must be disposed of according to regulation in force.

Before disconnecting a hydraulic line or removing a component, clean fittings and adjacent area. As soon as a line or component is disconnected, cap or cover all opening to prevent entry of foreign matter.

Disassemble and reassemble hydraulic parts on clean work surface. Clean all metal parts with non-flammable cleaning solvent. Lubricate components, as required, to aid assembly.

Keep the system clean. Hydraulic system filter should be replaced at the specified intervals. Examine filter cartridge for evidence of metal or rubber particles. If evidence of metal or rubber particles is found, drain and flush the entire system.

Welding on Work Platform

When welding on the work platform, disconnect battery plug and ALL electronic components. When welding on the chassis, connect the welder ground wire to the machine chassis as close as possible to the area being welded. When welding on the superstructure, connect the welder ground wire to the machine superstructure as close as possible to the area being welded. This is to prevent arcing inside the swing bearing, the lifting chains or the cylinders.

NOTICE

FAILURE TO COMPLY WITH THE ABOVE REQUIREMENTS MAY RESULT IN COMPONENT DAMAGE (I.E. ELECTRONIC MODULES, SWING BEARING, COLLECTOR RING, BOOM WIRE ROPES ETC.).

Lubrication

Components and assemblies requiring lubrication and servicing are shown in Section 1.7. Service applicable components with the amount, type, and grade of lubricant are recommended in this manual, at the specified intervals. When recommended lubricants are not available, consult your local supplier for an equivalent that meets or exceeds the specifications listed.

Battery

Clean and dry battery top. Ensure all connections are clean and correctly tight. Coat terminals with a silicone dielectric compound.

Drain the water that can accumulate at the bottom of the batteries container. (Refer to Section 8-2).

2.4 LUBRICATION INFORMATION

Hydraulic System

The primary enemy of a hydraulic system is contamination. Contaminants enter the system by various means, e.g., using inadequate hydraulic oil, allowing moisture, grease, filings, sealing components, sand, etc., to enter when performing maintenance, or by permitting the pump to cavitate due to insufficient warm-up or leaks in the pump supply.

The design and manufacturing tolerances of the component working parts are very close, therefore, even the smallest amount of dirt or foreign matter entering a system can cause wear or damage to the components and generally results in faulty operation. Every precaution must be taken to keep hydraulic oil clean, including reserve oil in storage.

Replace hydraulic filter at recommended intervals.

Cloudy oils indicate a high moisture content which permits organic growth, resulting in oxidation or corrosion. If this condition occurs, the system must be drained, flushed, and refilled with clean oil.

It is not advisable to mix oils of different brands or types, as they may not contain the same required additives or be of comparable viscosities. Good grade mineral oils, with viscosities suited to the ambient temperatures in which the machine is operating, are recommended for use.

NOTE: *Metal particles may appear in the oil of new machines due to the wear-in of meshing components.*

Lubrication Specifications

Specified lubricants, as recommended by the component manufacturers, are always the best choice, however, multi-purpose greases usually have the qualities which meet a variety of single purpose grease requirements.

Should any question arise regarding the use of greases in maintenance stock, consult your local supplier for evaluation. Refer to Section 1.7 of this Service Manual for an explanation of the lubricant key designations appearing in the Lubrication Chart.

Hydraulic Oil

For best performance, JLG recommends the use of ISO VG 32 oil with a viscosity of 32 cSt at 40 °C. Refer to Section 1.7 of this Service Manual for recommended hydraulic oils.

Changing Hydraulic Oil

Use of any of the recommended hydraulic oils eliminates the need for changing the oil on a regular basis. If it is necessary to change the oil, use only those oils meeting or exceeding the specifications appearing in this manual. If unable to obtain the same type of oil supplied with the machine, consult local supplier for assistance in selecting the proper equivalent. Avoid mixing petroleum and synthetic base oils. JLG Industries recommends changing the hydraulic oil at least every 2 years.

Use every precaution to keep the hydraulic oil clean. If the oil must be poured from the original container into another, be sure to clean all possible contaminants from the service container.

While the unit is shut down, a good preventive maintenance measure is to make a thorough inspection of all hydraulic components, lines, fittings, etc., as well as a functional check of each system, before placing the machine back in service.

2.5 PRESSURE RELIEF VALVE

Pressure relieving in the hydraulic circuit is achieved by a proportional electric relief valve installed on the power unit valve body. The valve is adjusted by an electric input.

Pressure relief values of machine functions can be checked by connecting a pressure gauge at port "2" on the hydraulic power unit valve body.

Before checking pressure relief values, operate the machine a few minutes to warm the hydraulic oil.

For a correct reading of pressure relief values, the machine must be operated from the platform console at maximum speed (max. travel of the joysticks). Read the pressure values when the cylinders are at end of stroke or when the structure is fully swung either to the left or to the right. When checking pressure relief value of the swing function, the mast must be fully lowered.

In case of noisy operation of the pressure relief valve when cylinders are at end of stroke, bleed the air from the valve.

Refer to Sections 7 and 9-8 of this manual for further information.

Go to Discount-Equipment.com to order your parts

SECTION 3. THEORY OF OPERATION

3.1 OVERVIEW

The MASTER MODULE (or master controller) mounted on the right side of the chassis is the master system controller. Most functions are dispatched and coordinated from this module, all other system modules handle sub-tasks. All characterized information (values) are stored into the master module (i.e., Personalities, Machine Setups or Calibrations). If the master module is reprogrammed, this information is lost.

Once set, all characterized information are copied to the SLAVE MODULE (or slave controller) via the CAN bus.

The technician should record Personalities and Machine Setups before programming so they can be restored afterwards. Otherwise, default values can be used as a starting point to restore previous configuration.

The PLATFORM MODULE reads linked switches and joysticks positions and relays that information to the MASTER and SLAVE MODULES. It uses information from the CAN bus for operator display. It also reports faults pertaining to devices in the Platform Control Station and devices connected to the Platform Control Station.

The MASTER MODULE controls the main contactor, the right drive motor and its brake and the hydraulic pump motor via commands from the CAN bus. It also measures current applied to these loads and input voltage for fault protection and reporting.

The SLAVE MODULE controls the left drive motor and its brake and all the hydraulic valves (lift up/down, swing, steer and the proportional pressure relief valve) via commands from the CAN bus. It also measures current applied to these loads and input voltage for fault protection and reporting.

For safe operation of the vehicle, the control system will not allow certain functions under certain conditions. These are called interlocks. Specific interlocks are discussed below. The interlocks discussed assume that all control system devices are functioning properly unless indicated. Fault conditions will generate Diagnostic Trouble Codes and additional interlocks.

Some faults only show up at power-up when the control system performs a self-test. All controls should be left alone during this test.

Note that the market and model of the machine affects what personalities and setups are. The appropriate information is displayed for the given model and market. The market and model must be set properly for safe and lawful operation of the machine.

3.2 MODES OF OPERATION

Ground Mode

When the machine is powered up in Ground Mode, only the functions at the Ground control station are opera-

tional. Functions are controlled by membrane switches (buttons). Whatever the function controlled, the Enable button [] must be pushed-in and held to enable other controls.

Platform Mode

In platform mode the Platform Control Box is enabled. It is the primary control station for the vehicle. At power-up, all indicators illuminate for a lamp check.

3.3 CAN COMMUNICATIONS

CAN (Controller Area Network) is the type of two-wire differential serial communication link used between the platform board, the Multi Display Indicator (MDI) and the ground modules (master and slave controllers) for control of the vehicle. This type of network has matured since its invention in 1986 and is used extensively in many kinds of machines.

Two-Wire Differential: The signal meaning is derived from the difference in voltage between two wires, usually twisted together in a common "jacket". This jacket can also contain a shield surrounding the wires inside for noise protection. Any noise that does penetrate the shield will affect both wires the same. However, the difference in voltage stays the same, therefore signal meaning is not corrupted. This differs from one-wire signals in that one wire signals derive the signal meaning from the difference between the signal wire and system ground wire. The system ground is the ground for many signals, as well as power. Any noise on either wire will change the signal and may corrupt it.

Serial Communication Link: Modules on the link send messages digitally, bit by bit along the wires where different voltage levels represent a "1" or a "0". The 1's and 0's are assembled by the receiver according to the protocol used to determine the messages meaning. Using serial communication allows two wires to replace many more. It also allows use of sensor and switch information in multiple places without duplicating those sensors and switches.

CAN: On a bus, all modules on the bus are connected to the same wires. A CAN bus could be represented on a schematic by a long pair of straight lines with multiple modules connected to them by short pairs of lines. It has a termination resistor at both ends of the long lines placed between the two wires. These resistors are approximately 120 Ω . On a JLG aerial work platform, this is typically in the platform and in the chassis. These resistors may be in the harness or in the module. A complete CAN circuit measures approximately 60 Ω between the two wires and these wires are open to the shield.

Each module on the CAN bus broadcasts its messages according to a priority assigned to the message. All the other modules will receive the message and determine if it

SECTION 3 - THEORY OF OPERATION

is important to them. Typical message traffic is 300 - 500 messages per second. The high bus speed allows all modules to be constantly updated around 20 times per

second. A CAN network also has error detection and handling for robust communications.

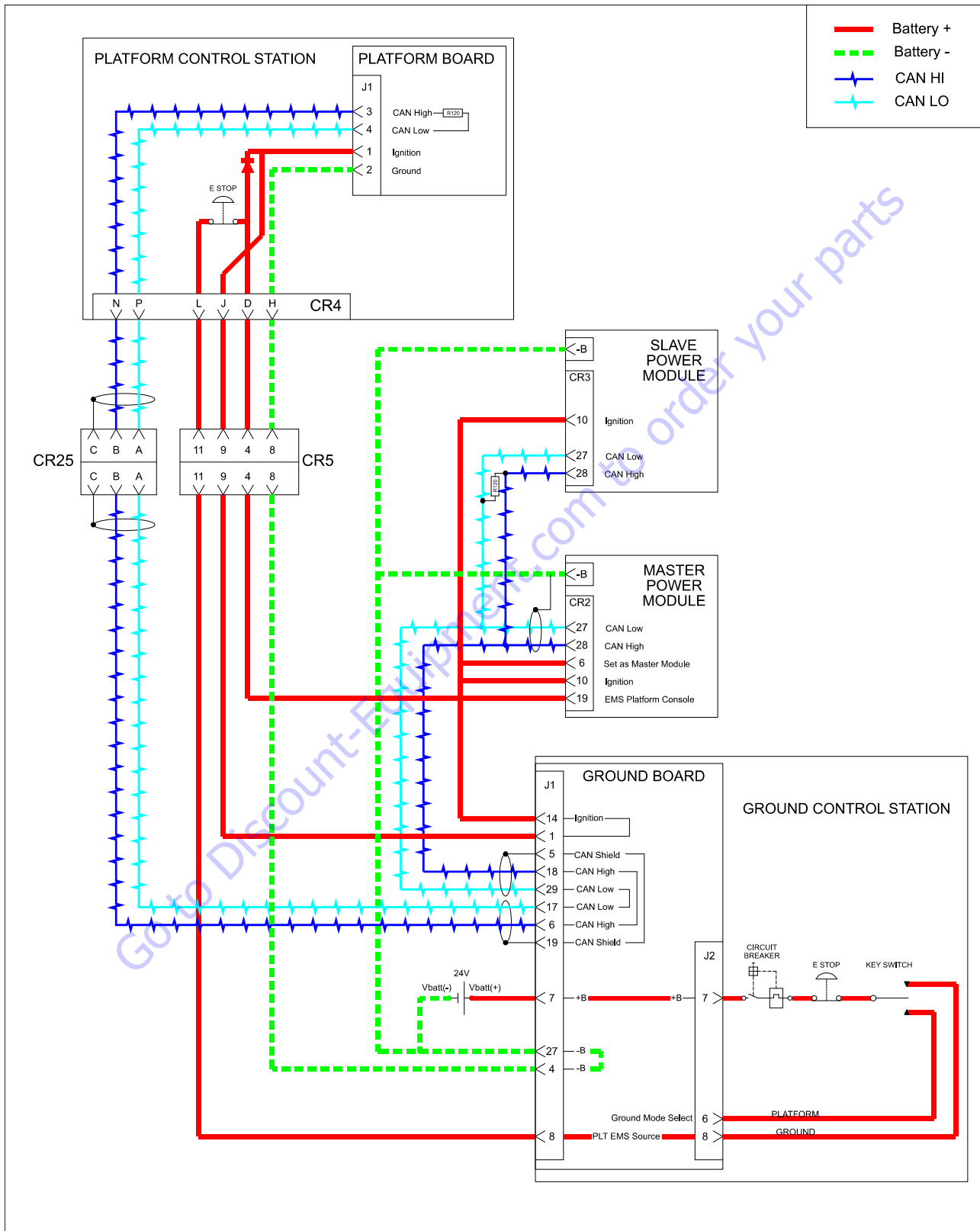

Figure 3-1. Basic Electronic Module Connections

3.4 JOYSTICKS

The joysticks are used to "command" lift, swing and drive. Those commands may be modified by the control system based on interlocks and personalities.

The joystick control handle sensors are not simple potentiometers. There is a position sensing element, and signal conditioning circuitry in them to generate the position signal. They are powered by 5VDC supplied from the platform module. When centered a joystick will output approximately 2.5VDC. Fully backward or left, it will output approximately 0.5VDC. Fully forward or right, it will output approximately 4.5VDC.

On the handle of the drive/swing joystick is the trigger switch that must be depressed in order to operate those functions. For the mast and jib joystick, an enable button (located on the left hand side of the box) must be depressed and held. This prevents unintentional movement.

To pass start-up tests controls must be released and the joysticks must be centered.

No operation from the platform console is possible until the joysticks are centered. If one of the enable device is found triggered at power-up, the emergency stop switch must be re-cycled to clear the fault.

Joysticks personalities to define the centered position (where command is 0%), minimum and maximum forward, as well as minimum and maximum reverse can be altered by performing a calibration of the joysticks.

3.5 TRACTION

The traction or drive system, moves the vehicle along the ground by electric asynchronous motors.

Each controller is an inverter which transforms the battery DC voltage in AC voltage, to power the three phases drive motors. The motors are wired in triangle configuration. The rotating speed is directly linked to the voltage frequency applied. The voltage supplied to the motor is modulated below approx. 60 Hz; above 60 Hz, nominal voltage is applied. The nominal voltage between two motor phases is approx. 15 Vrms to 19 Vrms (will vary depending on battery status and driving conditions). The default frequency range is 0.6Hz to 170 Hz which approximately corresponds to a driving speed of 0km/h to 5.5km/h. The actual rotating frequency of the motors is measured by the encoders; for a proper motor operation, the difference between the actual frequency and the inverter output frequency has to be maintained within few Hz. When a motor is driving the machine, Inverter Freq.>Encoder Freq.; when the motor is braking, Inverter Freq.<Encoder Freq.. The tolerance between the frequency applied and the actual measurement called maximum slip value, is approx. 15Hz (depends on the speed and on the driving conditions).

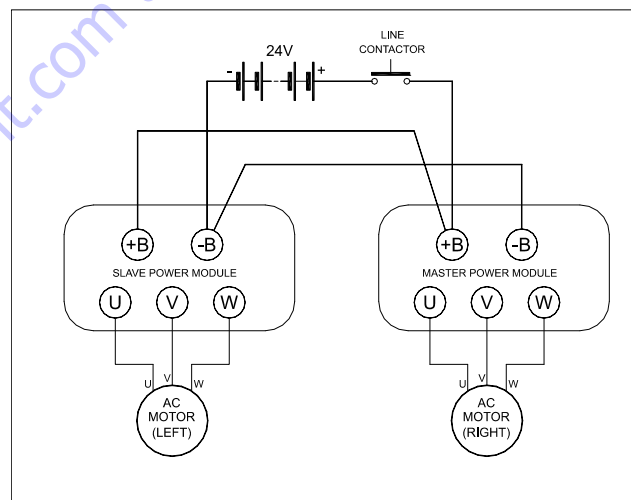

Figure 3-2. Drive Motor Schematic

3.6 PUMP/STRUCTURE MOVEMENTS

An electrically driven hydraulic pump provides hydraulic pressure to actuate the steering and superstructure movements.

The Power Module is essentially a "low-side" switch for the pump motor. The positive terminal of the pump is tied to Battery Positive (+B) after the Line Contactor. The negative terminal of the pump connects to the (-P) Terminal of the Master Power Module, which switches current through MOSFET transistors to the Battery Negative.

For variable speed pump operation, the MOSFET transistors switch On and Off at high frequencies. The Duty Cycle is varied to control the voltage applied to the pump motor. When the MOSFET's spend 50% of the period On and 50% Off, approximately half of the available Battery power will be applied to the pump motor. Similarly, the MOSFET are On continuously (100% Duty Cycle) to apply all available Battery power to the pump motor (i.e. Mast Lift Up at full speed from Platform Mode).

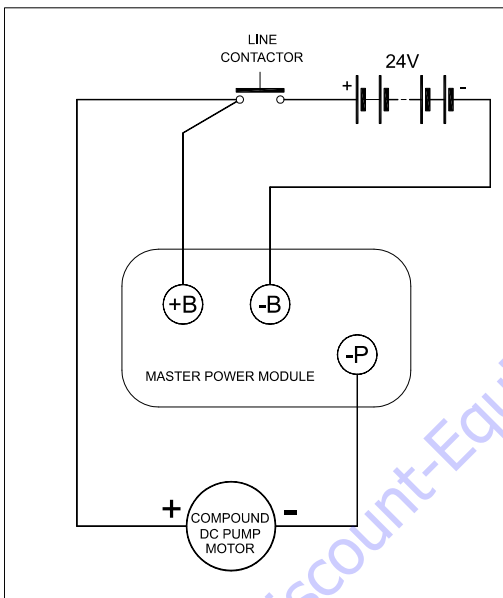

Figure 3-3. Hydraulic Pump Electric Schematic

When the Control System is energized, the voltage at the (-P) Terminal will be approximately +24V (referenced to -B) when the pump is static.

The (-P) Terminal will be approximately at +1V (referenced to -B) when the pump is running at full speed (i.e. Mast Lift Up from Platform Mode).

Lift Up/Down

The lift actuators are single acting hydraulic cylinders. Cylinders do not have sealed pistons but only rod guides. The area of the guide that fluid touches on both sides does not provide lift because the forces on both sides cancel each other. Only the area of the rod provides the lifting.

Lift down is "powered" by gravity.

To lift the mast, the pump is run and an appropriate signal is sent to the proportional relief valve. Then, after a short delay, the solenoid energizes and opens the mast valve. The pump speed is set proportional to joystick position. Fluid flows into the mast cylinder and extend the rod. As mast sections are linked to each others by lifting chains, all mast sections elevate simultaneously.

To bring down the mast, an appropriate electric signal is sent for the proportional relief valve to close and the pump is run for a short period of time to pressurize the circuit. Once the circuit is pressurized, the mast valve opens and the load is held by the proportional pressure relief valve. Then, the pressure relief valve opens proportional to joystick position, and allows fluid back to the tank, allowing the mast to retract by gravity.

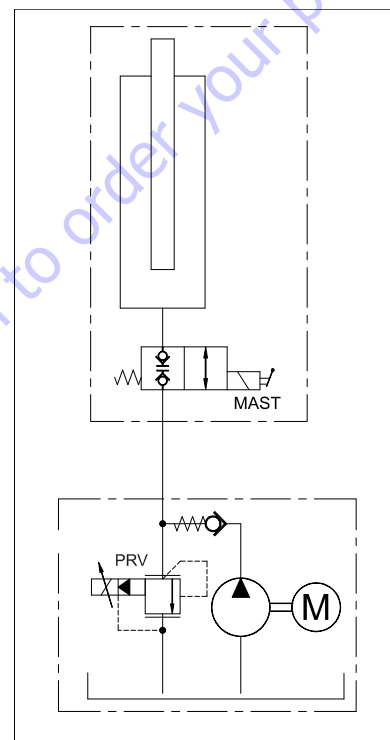

Figure 3-4. Mast Lift System - Basic Schematic

To lift the jib, the pump is run and an appropriate signal is sent to the proportional relief valve. Then after a short delay, the jib up solenoid energizes and opens the jib up valve. The pump speed is set proportional to joystick position. Fluid flows into the jib cylinder and extend the rod.

To bring down the jib, an appropriate electric signal is sent for the proportional relief valve to close and the pump is run for a short period of time to pressurize the circuit. Once the circuit is pressurized, the jib down valve opens and the load is held by the proportional pressure relief valve. Then, the pressure relief valve opens proportional to joystick position, and allows fluid back to the tank, allowing the jib to go down by gravity.

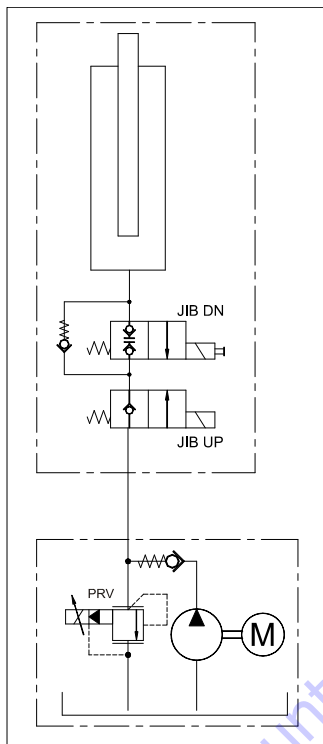

Figure 3-5. Jib Lift System - Basic Schematic

Swing

Swing is actuated by a hydraulic motor.

To swing to the right, the solenoid of the swing valve energizes, an appropriate electric signal is sent to the proportional relief valve and the pump speed is set proportional to joystick position. Pressure is applied to one port of the motor and drained from the other, allowing the motor to turn.

To swing to the left, the solenoids of both the swing and the flow directional valve energize, an appropriate electric signal is sent to the proportional relief valve and the pump speed is set proportional to joystick position. Pressure is applied to one port of the motor and drained from the other, allowing the motor to turn.

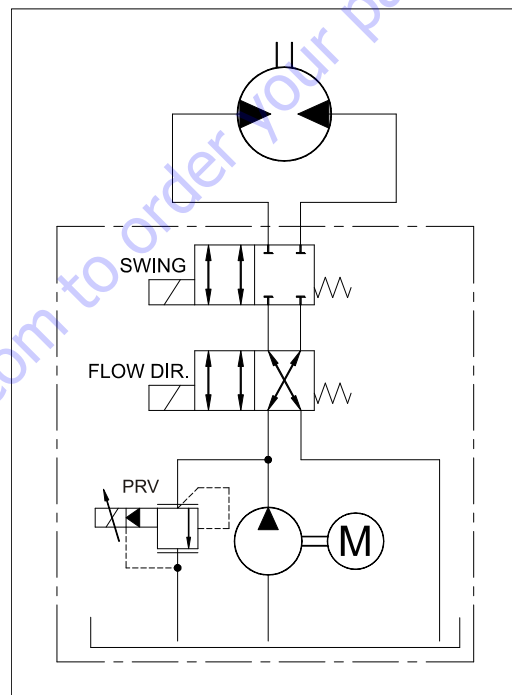

Figure 3-6. Swing System - Basic Schematic

Steer

Steering is actuated by a double acting hydraulic cylinder. To change steering angle of the wheels, pressure is applied to one side of the piston and drained from the other.

To steer to the right, the solenoids of both the steer and the flow directional valve energize, an appropriate electric signal is sent to the proportional relief valve and the pump is run.

To steer to the left, the solenoid of the steer valve energizes, an appropriate electric signal is sent to the proportional relief valve and the pump is run.

The pump speed, and thereby the rate of steering angle change, is adjusted based on drive speed. This adjustment is modified by steer personality settings.

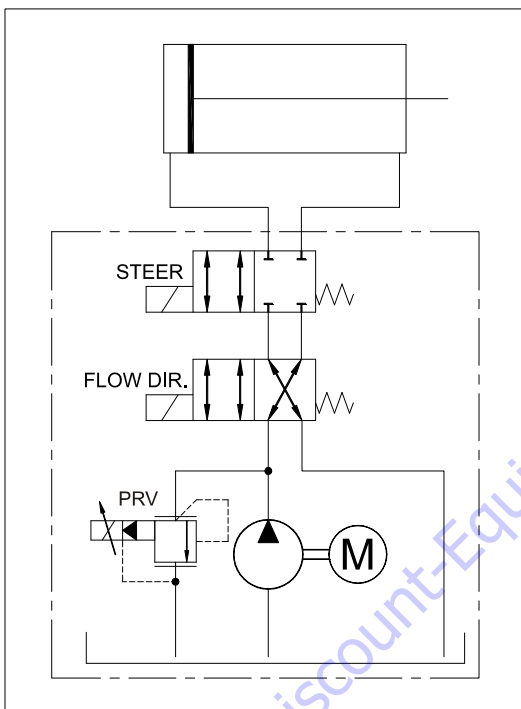

Figure 3-7. Steer System - Basic Schematic

The steering sensor is located on the front steering axle. It is key operated by the right spindle attach pin. There is a position sensing element and a signal conditioning circuitry in it to generate the position signal (i.e. the wheel steering angle). It is powered by 4.3 VDC supplied from the master power module.

When the wheels are fully steered to the right, it will output approximately 0.7 VDC.

When the wheels are fully steered to the left, it will output approximately 3.7 VDC.

When the wheels are straight, it will output approximately 2.5 VDC.

Depending on output signal, the speed of the inner drive motor will be reduced to allow machine to take a curve (like a differential system).

Interlocks

Interlocks are system inputs (limit switches, sensors or internal controller measurement) which affect the system functions.

NOTE: For more detailed information concerning system adjustment and operation, refer to section 8 Control Components.

Overload Switch

The overload switch senses platform load. In order to avoid false trip, the switch input is delayed.

- The switch must be tripped for more than 3s to consider the platform overloaded.
- The switch must be released for more than 5s to consider the platform not overloaded.

When the platform overloaded:

- All the movements are cut out from both the platform console and the ground console if the MACHINE SETUP, LOAD is set to CUTOUT ALL;
- All the movements are cut out from the platform console if the MACHINE SETUP, LOAD is set to CUTOUT PLATFORM;
- All the movements can be performed at normal speed if the MACHINE SETUP, LOAD is set to NOT INSTALLED;

Tilt Switch

The tilt switch senses the chassis tilt angle. In order to avoid false trip, the switch is internally delayed:

- The switch must be tripped for more than 1s to consider the machine tilted.

When the platform is in transport position (none of the mast switches is tripped), a visual alarm is displayed in case of machine tilted but the functions are not affected.

When the machine is tilted and out of transport position:

- The drive functions are cut out;
- Jib Lift Up, Mast Lift Up and Swing are allowed at reduced speed;
- Jib Lift Down and Mast Lift Down are allowed at normal speed.

Chain Slack Switch

The chain slack switches sense the lifting chains tension. In case of slack chain detected:

- The drive functions are cut out;
- Jib Lift Down, Mast Lift Down and Swing are cut out;
- Mast Lift Up is allowed at reduced speed;
- Jib Lift Up is allowed at normal speed.

Drive Orientation Switch

The drive orientation switch is a proximity switch which trips when the turntable is swung $\pm 45^\circ$ off center of the normal driving position. This occurs roughly when the jib is swung past the rear tires. When the drive orientation switch is tripped:

- Drive and steer functions can only be performed after the DOS override switch (on the platform console) has been engaged. Drive and steer functions can be operated at normal speed;
- All the structure movements (Mast and Jib Lift, Swing) remain unaffected by the DOS.

Main Mast Limit Switch

The main mast limit switch determines whether the platform is in Transport position (mast fully lowered) or in Elevated position. When the main mast limit switch is tripped:

- Max. driving speed is reduced from approx. 5.5 km/h to approx. 0.75 km/h.

Secondary Mast Limit Switch (Toucan 10E only)

The secondary mast limit switch is used to detect when the mast is close to the max. elevation. When the secondary mast limit switch is tripped:

Max. driving speed is reduced from approx. 0.75 km/h to approx 0.4 km/h.

Platform Gate Switches (If equipped)

Two gate switches are used to detect when a gate is opened. When one of the switches is tripped:

- All the movements are cut out from the platform console.

Battery Charger Interlock

When the battery charger is connected to the mains, the information is sent to the control system. If the battery charger is connected to the mains:

- All the movements are cut out from the platform console if the MACHINE SETUP, CHARGER INTERLOC is set to CUTOFF ALL;
- Drive and steer functions are cut out if the MACHINE SETUP, CHARGER INTERLOC is set to DRIVE ONLY.

Battery Discharge Indication

The battery status is continuously monitored by the MASTER MODULE. Indication is given to the operator through both the MDI and the platform console panel. Functions limitations are applied depending on three status: charged, discharged (which corresponds to 70% discharge) and deeply discharged (which corresponds to 80% discharged).

If the battery is charged, no function limitation is applied.

If the battery is discharged:

- The max. driving speed, in transport position, is reduced by 50%. Out of transport position, driving speed is not affected;
- Mast Lift Up, Jib Lift Up and Swing maximum speeds are reduced (same parameter as for tilted condition is used);
- Mast Lift Down and Jib Lift Down can be operated at normal speed.

If the battery is deeply discharged:

- Mast Lift Up and Jib Lift Up are cut out;
- The max. driving speed is limited at 0.4 km/h, whatever the platform position is;

- Max. swing speed is reduced;
- Mast Lift Down and Jib Lift Down can be operated at normal speed.

Personality Settings and Calibration

Functions performances may be altered by changing the applicable personality settings or calibrating different elements of the control system.

Refer to Section 9 of this manual for the applicable procedures.

PARTS FINDER

**Search Website
by Part Number**



**Search Manual
Library For Parts
Manual & Lookup Part
Numbers – Purchase
or Request Quote**

Search Manuals

Enter your information to search for manuals and parts.

* Brand:

* Model:

* Serial:

* Part Number:

SEARCH

**Can't Find Part or
Manual? Request Help
by Manufacturer,
Model & Description**

Parts Order Form

Please fill in the following information:

Manufacturer:

Model:

Description:

Quantity:

Part Number:

Part Name:

Part Description:

Part Location:

Part Condition:

Part Status:

Part Color:

Part Material:

Part Weight:

Part Dimensions:

Part Price:

Part Notes:

Submit

Discount-Equipment.com is your online resource for quality parts & equipment.

Florida: **561-964-4949** Outside Florida TOLL FREE: **877-690-3101**

Need parts?

Click on this link: <http://www.discount-equipment.com/category/5443-parts/> and choose one of the options to help get the right parts and equipment you are looking for. Please have the machine model and serial number available in order to help us get you the correct parts. If you don't find the part on the website or on one of the online manuals, please fill out the request form and one of our experienced staff members will get back to you with a quote for the right part that your machine needs.

We sell worldwide for the brands: Genie, Terex, JLG, MultiQuip, Mikasa, Essick, Whiteman, Mayco, Toro Stone, Diamond Products, Generac Magnum, Airman, Haulotte, Barreto, Power Blanket, Nifty Lift, Atlas Copco, Chicago Pneumatic, Allmand, Miller Curber, Skyjack, Lull, Skytrak, Tsurumi, Husquvarna Target, , Stow, Wacker, Sakai, Mi-T- M, Sullair, Basic, Dynapac, MBW, Weber, Bartell, Bennar Newman, Haulotte, Ditch Runner, Menegotti, Morrison, Contec, Buddy, Crown, Edco, Wyco, Bomag, Laymor, Barreto, EZ Trench, Bil-Jax, F.S. Curtis, Gehl Pavers, Heli, Honda, ICS/PowerGrit, IHI, Partner, Imer, Clipper, MMD, Koshin, Rice, CH&E, General Equipment, ,AMida, Coleman, NAC, Gradall, Square Shooter, Kent, Stanley, Tamco, Toku, Hatz, Kohler, Robin, Wisconsin, Northrock, Oztec, Toker TK, Rol-Air, Small Line, Wanco, Yanmar

SECTION 4. CHASSIS MOUNTED COMPONENTS

4.1 DRIVE MOTORS

The electric wheel drive assemblies are mounted independent of each other on the base frame at the rear of the machine.

The wheel drive assembly consists of a 15V AC asynchronous electric motor driving a gear box. The assembly also includes a friction disk parking brake assembly. This brake assembly is mounted on the end of the drive motor assembly.

The component parts of the left and right drive motor assemblies are identical.

Brake - Dust Cleaning

Due to a possible build-up of dust from brake lining wear inside the brake compartment, it is recommended to perform this dust cleaning task on an annual basis using clean, oil free, compressed air.

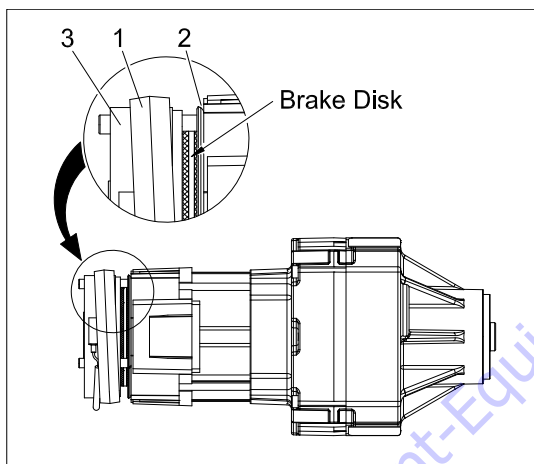

Figure 4-1. Dust Cleaning

1. Disconnect battery plug.
2. Remove chassis hoods.
3. Remove the dust protection ring (1) from the friction plate retaining groove (2) and pull it over the magnet body (3).
4. Blow any accumulated dust in brake compartment.
5. Once complete, correctly reposition the dust protection ring.

Brake Disassembly

Figure 4-2. Brake Disassembly

1. Place the machine on a flat and level surface. Using ground controls fully rotate the turntable either to the left or to the right. Turn power off and disconnect battery plug. Chock both front wheels in both directions.
2. Remove chassis hoods. Remove chassis rear shield.
3. Disconnect electric cables from brake terminal block (1).
4. Remove dust protection ring (2) from friction plate retaining groove (3) and pull it over magnet body (4) as shown. The protection ring will help to keep all parts together during brake removal.
5. Loosen the 3 screws (5) securing brake assembly.
6. Remove magnet body and armature plate assembly (6).
7. Remove brake disk (7) from driver (8). Remove friction plate (3).

Brake Disk Wear Checking

Figure 4-3. Brake Disk Wear Checking

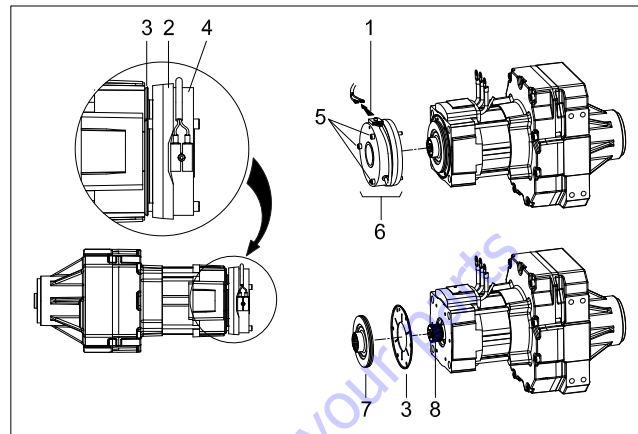
Check brake disk thickness on several locations.

Replace the disk if its thickness is below 8.5mm (0.335 in.).

Brake Assembly

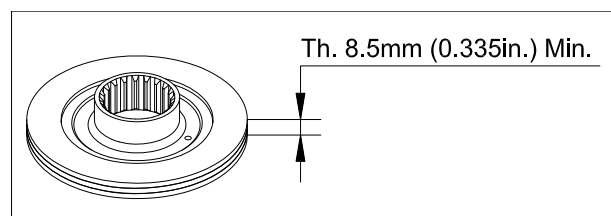
NOTE: The brake is only suitable for dry operation. All parts must be free from grease, oil, water or other substances that could affect braking efficiency.

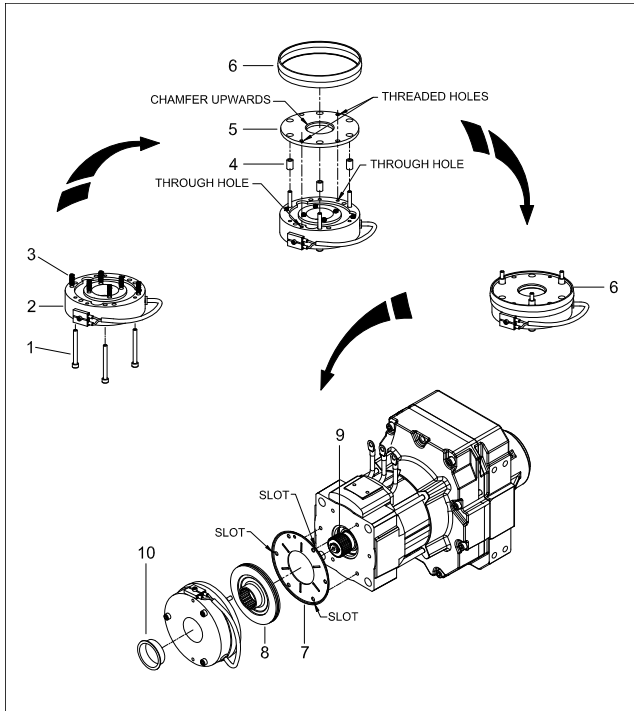

Figure 4-4. Brake Assembly

1. Insert the 3 screws (1) in the magnet body (2) mounting holes.
2. Install the 6 springs (3). Locate springs as shown.
3. Install the 3 bushings (4).
4. Install the armature plate (5) taking care to align the threaded holes of the plate with the through holes of the magnet body and to position the chamfer upwards.
5. Install the dust protection ring (6) onto the assembly to keep all parts in place.
6. Install the friction plate (7) on the motor assembly.
7. Install the brake disk (8) on the driver (9).
8. Reposition the friction plate (7) so as the mounting screws will go through the holes that are nearing the slots.
9. Install and secure the brake assembly.
10. Correctly position the dust protection ring (6). Install the dust cap (10).

Drive Motor Assembly Removal

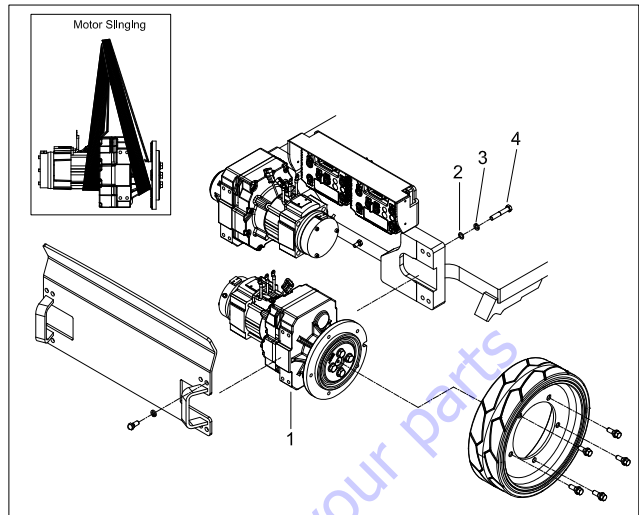

Figure 4-5. Drive Motor Removal

- 1- Drive Motor Assembly
- 2- Hardened washer
- 3- Spring Washer
- 4- Hex. Head Cap Screw (Grade 10.9)

1. Place the machine on a flat and level surface. Using ground controls fully rotate the turntable either to the left or to the right. Turn power off and disconnect battery plug. Chock both front wheels in both directions.
2. Remove chassis hoods. Remove rear and side shields.
3. Using a jack of appropriate capacity, elevate the machine enough to be able to remove the wheel(s) and to place blocks under the chassis.
4. Remove the wheel(s).
5. Disconnect sensor bearing/thermal sensor connector and brake supply cables. Tag and disconnect motor cables from the controller.
6. Attach an adequate lifting device to the drive motor assembly and remove slack.
7. Loosen hardware securing the motor assembly to the chassis. Remove the drive motor assembly.

Drive Motor Assembly Installation

Install drive motor assembly in reverse order from removal. Ensure the tenon of the gear box casing contacts the top of the mounting plate slot as shown following.

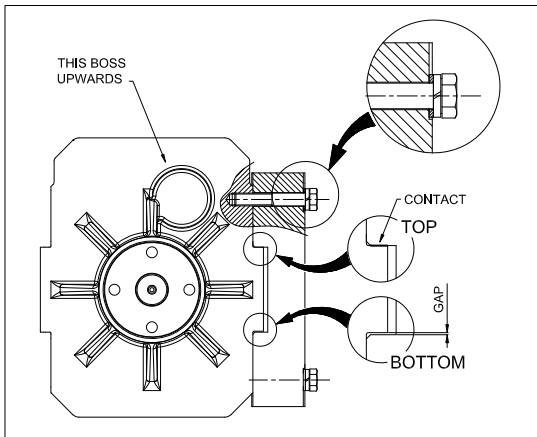

Figure 4-6. Drive Motor Installation

Correctly install the hardened washers and spring washers. Torque the 4 Hex. Head Cap Screws Grade 10.9 to 102 Nm (75 ft.lb).

Wheel Motor Disassembly

Brake disassembly

(see procedure in the previous paragraph).

Motor disassembly

1. Place the wheel motor vertically, on 2 wooden blocks, brake towards the top.

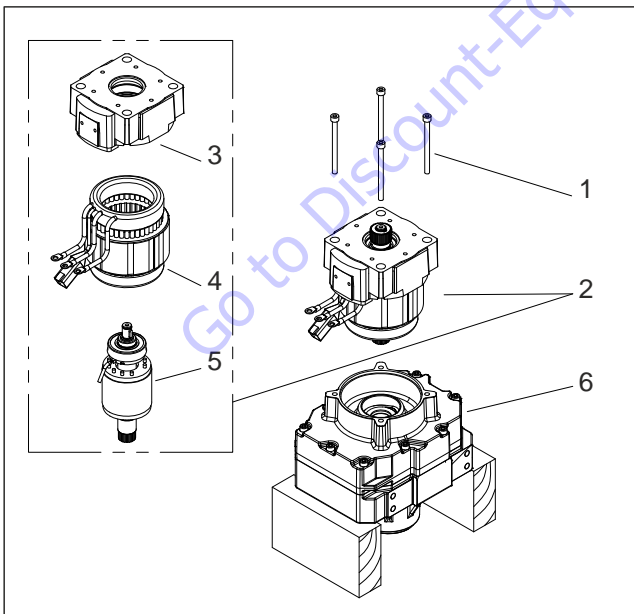

Figure 4-7. Motor Disassembly

2. Unscrew the 4 screws M8 (1).

3. Extract the motor assembly (2), rear casing (3), stator (4) and rotor (5), by pulling the stator (do not pull the rear casing).

It can be necessary to give light mallets hits on the stator body to disengage the motor assembly (2) from the gearbox (6).

4. To change the encoder, disconnect the encoder cable from the 6 points connector. (See Section #11 for information on connectors).

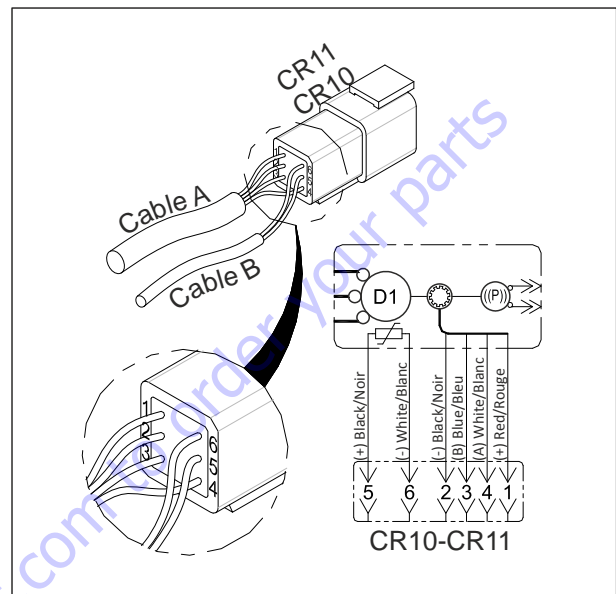

Figure 4-8. Motor Connector

Cable A: Encoder cable

Cable B: Sheathed wires of the temperature sensor

5. Extract the stator (4) with its cable seal (17) from the rear casing and rotor assembly (7).

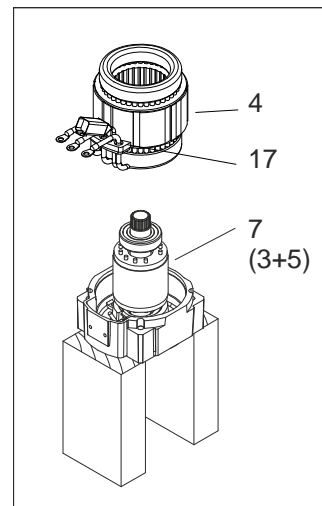

Figure 4-9. Stator Disassembly

It can be necessary to give light mallets hits on the stator body to disengage it from the rear casing.

Slide the encoder cable through the rubber cable seal (17) when extracting the stator.

Rotor Disassembly

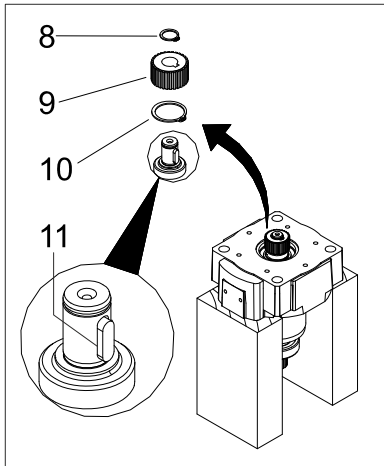

Figure 4-10. Rotor Disassembly

1. Remove the retaining ring (8) of the gear (9).
2. Extract the gear using a extractor and remove the key (11).
3. Remove the retaining ring (10).
4. Position the rear casing and rotor assembly on 2 wooden blocks.

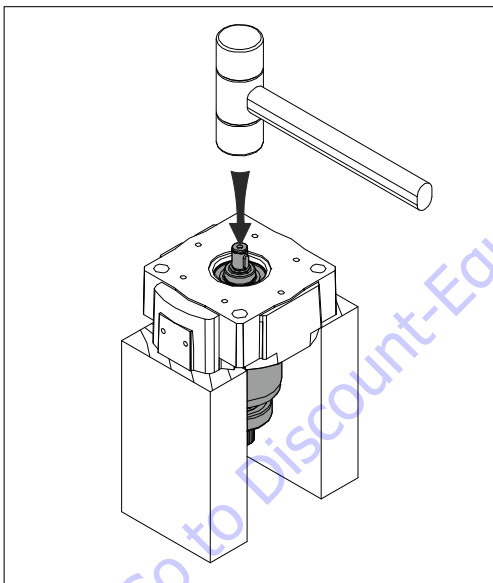

Figure 4-11. Extraction du Rotor

Extract the rotor tapping with a mallet on the rotor axle while maintaining the rotor.

Encoder Disassembly

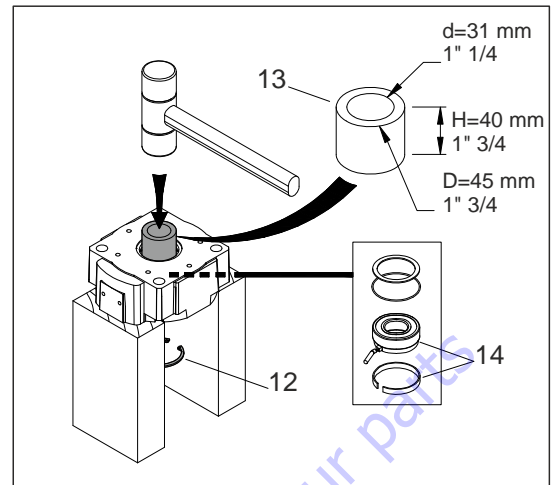

Figure 4-12. Encoder Disassembly

1. Remove the retaining ring (12).
2. Position a sleeve (13) on the encoder (14) and tap it to extract it.

Wheel Motor Assembly

Encoder Assembly

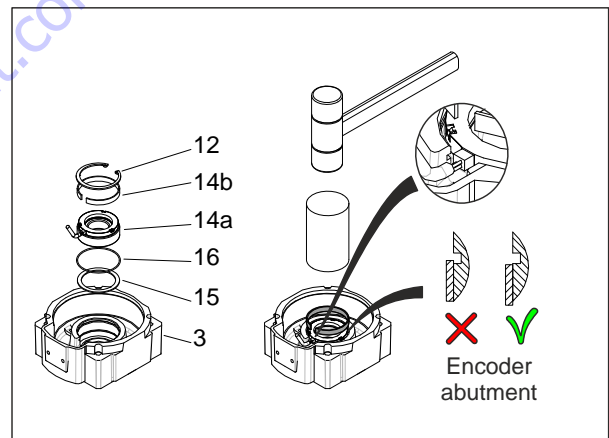

Figure 4-13. Encoder Assembly

1. Install the shim washer (15) and the O ring (16) well back in its groove.
2. Position the encoder (14a) with the cable in the middle of the rear casing housing (3) notch.
3. Position the centering (14b) on the encoder with the slot centered on the cable.
4. Using a drill $\text{\O} 62 \text{ mm}$ ($2'' \frac{7}{16}$) and a mallet, tap on the centering (14b) to the encoder (14) abutment.
5. Install the retaining ring (12).

Rotor Assembly

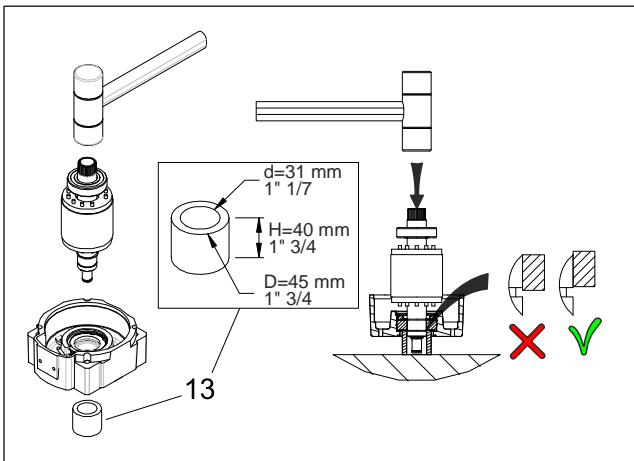

Figure 4-14. Rotor Assembly

1. Position a sleeve (13) on the encoder.
2. Install the rotor until its abutment in the housing using a mallet.
3. Install the retaining ring (10), the key (11) the gear (9) and the retaining ring (8).
(See Figure 4-10. Rotor Disassembly)
4. Position the encoder cable into the cable seal.

Stator Assembly

1. Place the stator (4) on the rear casing and rotor assembly (7) and insert the cable encoder into the cable seal (17).
(See Figure 4-9. Stator Disassembly)
2. Position the cable seal (17) into the casing (3) housing.
3. Complete the stator (4) installation.

Motor Assembly:

NOTE: Prior to install the motor, see the following paragraph "Oil Filling".

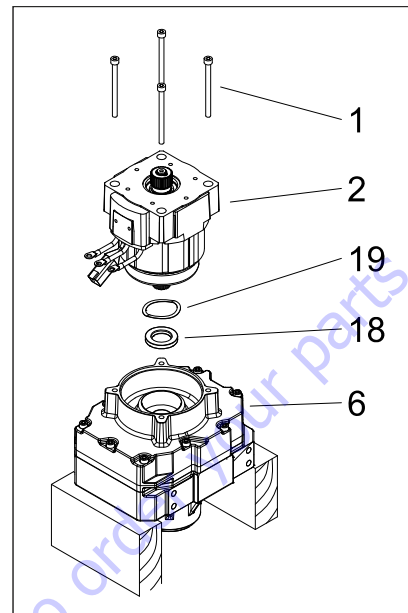

Figure 4-15. Motor Sealing

1. Insert the spring washer (19) above the lip seal (18) and grease with Mobilux EP2.
2. Turn the motor so that the cables are on the same side as the gearbox boss.

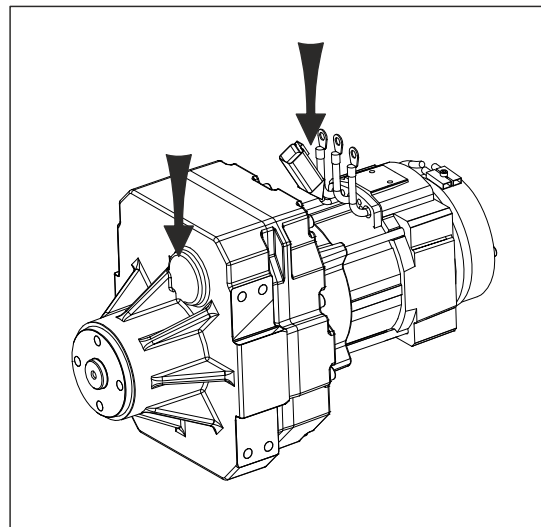

Figure 4-16. Motor Positioning

3. To authorize insertion, turn the motor or the brake drive gear so that the gears intermesh.
4. Screw staggered the 4 screws (1) of the motor (torque value: 16 N.m ± 2.4 N.m).
5. The new encoder should be equipped with contacts Deutsch JLG P/N 4460917. Re-wire the encoder connector (See Fig. 4-8).

Brake Assembly:

1. (see procedure on the previous paragraph "Brake Assembly").

Oil Filling

Oil Type & Capacity:

The gearbox is designed to utilize the same oil throughout its service life. However, should it need to be serviced the oil could need to be drained and replaced.

When serviced, fill the unit with ISO VG220 oil.

The gearbox will need to be filled with 2 liters (0.53 Gal.) of oil.

NOTE: Prior 02/2016, the oil filling procedure requires the drive motor disassembly. Since 02/2016, the gearbox is equipped with a filler cap.

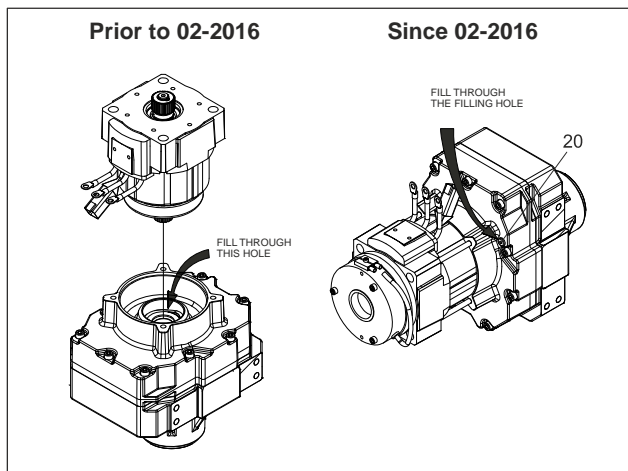

Figure 4-17. Oil Filling

1. Prior 02/2016: Drain and flush the gearbox, position it vertically and fill with the required amount of oil. Since 02/2016: Filling the gear is carried by the filling hole until the oil reaches the tapping hole (gearbox in horizontal position). Put the filler cap (20).

Sealing between the gearbox and the motor is ensured by the lip seal (18) located under the spring washer (19). Replace if necessary. When changing the seal, lubricate with grease SKF LGHT or LGPH 2, MOBILUX EP 2 or Esso Unirex N3. Properly install the seal to abutment using a sleeve external diameter 50 to 52 mm (2").

4.2 WHEELS AND TIRES

Tire wear and damage

Inspect tires daily for wear or damage. Tires with worn edges or distorted profiles require replacement.

Tires with significant damage in the tread area or side wall, require immediate evaluation before replacing the machine into service.

Wheel and Tire Replacement

Replacement wheels must have the same diameter and profile as the original. Replacement tires must be the same size and rating as the tire being replaced. Use of genuine JLG parts is highly recommended.

Wheel Installation

It is extremely important to apply and maintain proper wheel mounting torque.



WHEEL LUG NUTS MUST BE INSTALLED AND MAINTAINED AT THE PROPER TORQUE TO PREVENT LOOSE WHEELS, BROKEN LUG NUTS, AND POSSIBLE SEPARATION OF WHEEL FROM THE AXLE. BE SURE TO USE ONLY THE LUG NUTS MATCHED TO THE CONE ANGLE OF THE WHEEL.

Tighten the lug nuts to the proper torque to prevent wheels from coming loose. Use a torque wrench to tighten the fasteners. DO NOT use impact wrench. If you do not have a torque wrench, tighten the fasteners with a lug wrench, then immediately have a service garage or dealer tighten the lug nuts to the proper torque. Over-tightening will result in breaking the lug nuts or permanently deforming the mounting holes in the wheels. The proper procedure for attaching wheels is as follows:

1. Start all lug nuts by hand to prevent cross threading. DO NOT use a lubricant on threads or nuts.
2. Tighten lug nuts in the following sequence.

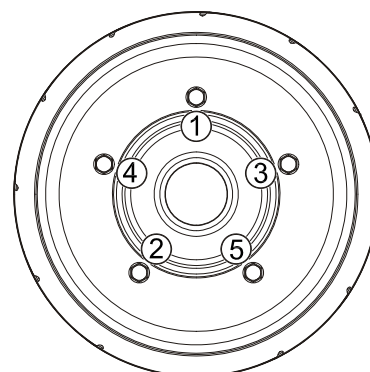

Figure 4-18. Wheel Lug Nut Tightening Sequence

- The tightening of the lug nuts should be done in stages. Following the recommended sequence, tighten lug nuts per wheel torque.

Torque Sequence		
1 st Stage	2 nd Stage	3 rd Stage
28-42 Nm	91-112 Nm	142-163 Nm

Table 4-1. Wheel Torque Chart

- Wheels lug nuts should be torqued after the first 50 hours of operation and after each wheel removal. Check torque every 3 months or 125 hours of operation.

4.3 STEERING LINKAGE

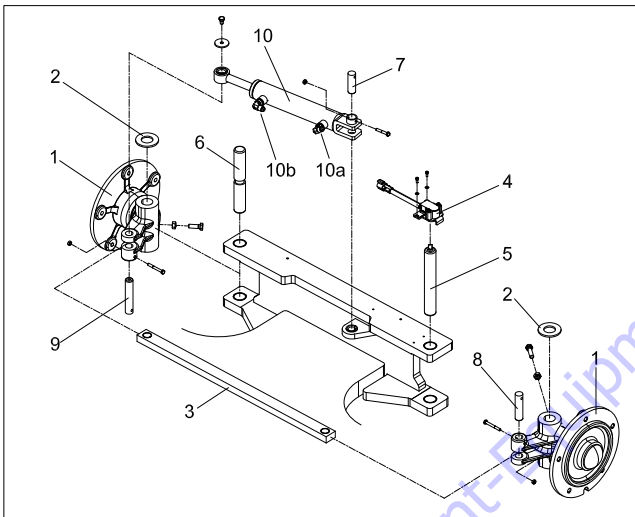

Figure 4-19. Steering Linkage Assembly

- Spindle/Hub assembly
- Thrust washer
- Link
- Steer Sensor
- Right Spindle Pin (Sensor Drive)
- Left Spindle Pin
- Cylinder Anchor Pin
- Right Link Anchor Pin
- Left Link/Cyl. Anchor Pin
- Hydraulic Steer Cylinder
- Steer Cylinder-Steer Right Port
- Steer Cylinder-Steer Left Port

Steer Cylinder

Removal

1. Tag, disconnect and cap steer cylinder hydraulic lines and ports.
2. Remove hardware on top of the left link/cyl. anchor pin (9).
3. Remove the cylinder anchor pin (7).
4. Remove the cylinder.

Inspection

Check cylinder flange bushings and flange bushing installed onto chassis for damage or excessive wear. Replace if necessary.

Cylinder Repair

Refer to Section 7-5.

Installation

1. Coat bushings inside diameter with multipurpose grease.
2. Install the rod end onto the left link/cyl. anchor pin (9) and secure with hardware. Apply Loctite #242 to screw threads.
3. Align barrel holes with frame mounting hole. Install cylinder anchor pin and secure with hardware.
4. Remove caps and connect hydraulic lines to cylinder ports. The Yellow/Blue tagged hose is to be connected to the steer right port (10a).
5. Perform a few steering movements to bleed air from the circuit and to check for proper operation.
6. Check hydraulic fluid level and adjust accordingly.

Steering Linkage - Spindle/Hub Assembly

Removal

1. Should the spindle(s) require(s) removal, remove the wheel(s).
2. If necessary, remove steer cylinder (10) as previously described.
3. Remove right link anchor pin (8) and left link/cyl. anchor pin (9).
4. Remove the steering link (3).
5. If the right spindle/hub assembly requires removal, remove the steering sensor (4).
6. Loosen locknut and screw securing the spindle pin (5-6) and remove the pin. Remove the spindle (1) and the thrust washer (2).

Inspection

Check bushings installed on the chassis axle for damage or excessive wear. Replace if necessary.

Check bushings installed on the steering link for damage or excessive wear. Replace if necessary.

Check pins condition. Replace if necessary.

Check thrust washer thickness. Replace washer if its thickness is less than 3mm (0.12 in.).

Installation

1. Coat chassis axle bushings inside diameter with multipurpose grease.
2. Install thrust washer (2) and spindle/hub assembly (1) between the two plates of the axle. Insert spindle pivot pin (insert right spindle pin (5) so as the blind radial hole of the pin aligns with the threaded hole of the spindle) and secure with hardware.
3. Coat steering link flange bushings inside diameter with multipurpose grease.
4. Install the steering link (3) with flanges downwards. Install anchor pins and secure with hardware.
5. Install steering sensor as shown following.

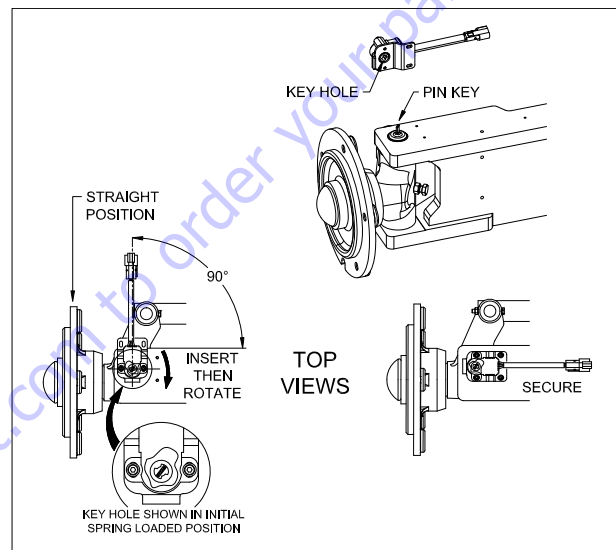

Figure 4-20. Steering Sensor Installation

6. Install steer cylinder if removed.
7. Install wheels: Refer to Section 4-2.

NOTICE

IF STEERING SENSOR WAS REMOVED/REPLACED, OR SENSOR DRIVING PIN AND/OR SPINDLE WAS REMOVED/REPLACED, IT IS HIGHLY RECOMMENDED TO PERFORM A STEERING SENSOR CALIBRATION PROCEDURE. REFER TO SECTION 9-5.

Hoses and Cables Routing

CAUTION

ROUTE AND STRAP STEERING SENSOR HARNESS AS SHOWN ON FIGURE 4-13. THIS IS TO PREVENT THE CABLE FROM BEING PINCHED/DAMAGED BY THE WHEEL WHEN FULLY STEERED TO THE RIGHT.

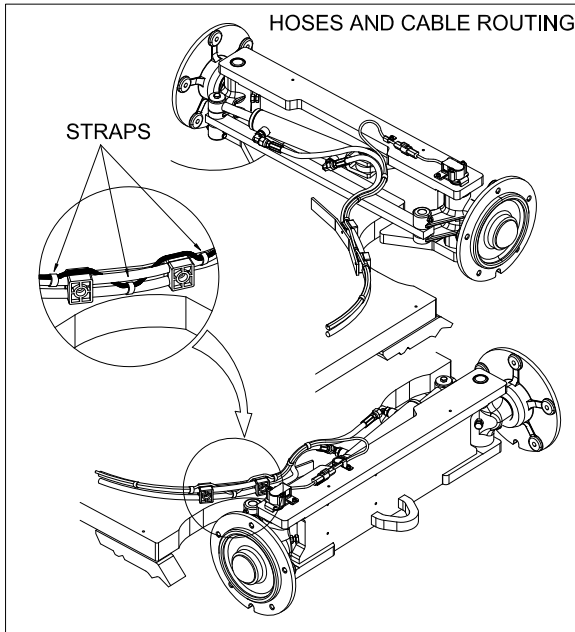

Figure 4-21. Hoses and Cables Routing

4.4 FRONT WHEEL HUB

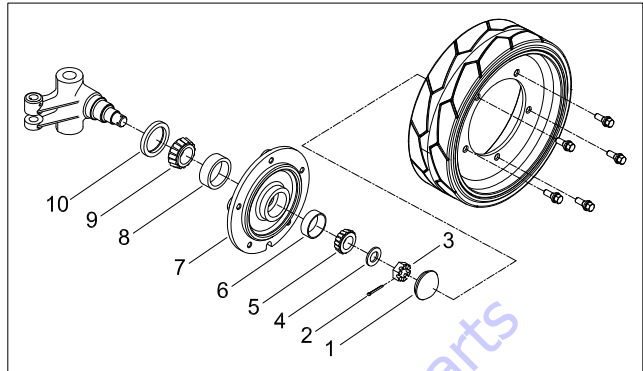

Figure 4-22. Front Wheel Hub - Installation

1. Hub Cap
2. Cotter Pin
3. Spindle Nut
4. Washer
5. Outer Tapered Roller Bearing (a)
6. Outer Bearing Race (a)
7. Wheel Mounting Hub (a)
8. Inner Bearing Race (a)
9. Inner Tapered Roller Bearing (a)
10. Hub Seal

NOTE: (a) Bearing race (6, 8) are press fitted to wheel mounting hub (7) and are only available for service as a complete hub assembly.

Also before installing or re-installing the inner and outer taper roller bearings, be certain they are lubricated (packed) with multipurpose grease.

1. Tighten spindle nut to 40-54 Nm (30-40 ft. lbs.) to properly seat bearings.
2. Loosen spindle nut completely until it can be turned by hand.
3. Then finger tighten spindle nut by hand without rotating the wheel mounting hub.
4. Install cotter pin, if necessary nut may be backed off to nearest slot, if more than 1/2 of the cotter pin hole is visible, the nut may be tightened slightly to get the cotter pin installed.
5. Before installing the hub cap, check wheel hub for excessive end play.
 - a. Rotate hub by hand, hub should rotate freely, if too tight, back the nut off to the next cotter pin hole.
 - b. Hub should not be noticeably loose when moved parallel with spindle centerline.
6. Install wheel, torque wheel per specification in Section 4.2.

PARTS FINDER

**Search Website
by Part Number**



**Search Manual
Library For Parts
Manual & Lookup Part
Numbers – Purchase
or Request Quote**

Search Manuals

Enter your information to help us locate the right manual for your machine.

* Brand:

* Model:

* Serial:

* Part Number:

SEARCH

**Can't Find Part or
Manual? Request Help
by Manufacturer,
Model & Description**

Parts Order Form

Please fill in the information below to help us locate the right part for your machine.

MANUFACTURER:

MODEL:

DESCRIPTION:

SEARCH

Discount-Equipment.com is your online resource for quality parts & equipment.

Florida: **561-964-4949** Outside Florida TOLL FREE: **877-690-3101**

Need parts?

Click on this link: <http://www.discount-equipment.com/category/5443-parts/> and choose one of the options to help get the right parts and equipment you are looking for. Please have the machine model and serial number available in order to help us get you the correct parts. If you don't find the part on the website or on one of the online manuals, please fill out the request form and one of our experienced staff members will get back to you with a quote for the right part that your machine needs.

We sell worldwide for the brands: Genie, Terex, JLG, MultiQuip, Mikasa, Essick, Whiteman, Mayco, Toro Stone, Diamond Products, Generac Magnum, Airman, Haulotte, Barreto, Power Blanket, Nifty Lift, Atlas Copco, Chicago Pneumatic, Allmand, Miller Curber, Skyjack, Lull, Skytrak, Tsurumi, Husquvarna Target, , Stow, Wacker, Sakai, Mi-T- M, Sullair, Basic, Dynapac, MBW, Weber, Bartell, Bennar Newman, Haulotte, Ditch Runner, Menegotti, Morrison, Contec, Buddy, Crown, Edco, Wyco, Bomag, Laymor, Barreto, EZ Trench, Bil-Jax, F.S. Curtis, Gehl Pavers, Heli, Honda, ICS/PowerGrit, IHI, Partner, Imer, Clipper, MMD, Koshin, Rice, CH&E, General Equipment, ,AMida, Coleman, NAC, Gradall, Square Shooter, Kent, Stanley, Tamco, Toku, Hatz, Kohler, Robin, Wisconsin, Northrock, Oztec, Toker TK, Rol-Air, Small Line, Wanco, Yanmar

SECTION 5. TURNTABLE AND VERTICAL MAST

5.1 SWING BEARING

Swing Bearing Attach Bolts Check

This check must be performed after the first 50 hours of machine operation and every 500 hours of machine operation thereafter. If during this check, bolts are found missing or loose, replace missing or loosen bolts (use Loctite®270 on bolts installed in threaded holes through turntable base plate).

Outer bearing race is attached to the chassis plate.

Inner bearing race is attached to the turntable base plate.

1. Place the machine on a flat and level surface. Fully lower the mast and the jib. Remove chassis hoods and chassis side shields. Remove bearing teeth covers.
2. Using a suitable overhead lifting equipment attached to both lifting rings of mast section #1, lift and place the machine on blocks of a minimum height of 300mm (12") and capable of supporting the weight of the work platform. Position blocks in such a way that the swing bearing attach bolts to the chassis remain accessible and that the machine remain stable on blocks when the structure will be swung.

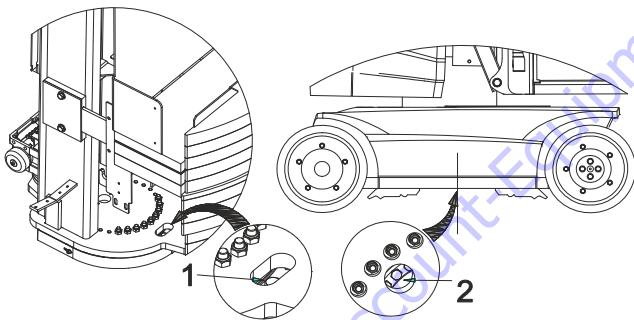

Figure 5-1. Access Holes

3. Check outer race attach screws and nuts in sequence for correct torque condition: torque value 117 Nm (86 ft lbs). If needed, attach screws are accessible through an access hole (1) in the turntable base plate: rotate superstructure using the ground controls (or manual swinging devices) to gain access to each screw.
4. Check inner race attach screws and nuts in sequence for correct torque condition: torque value 117 Nm (86 ft lbs). Attach screws are accessible through an access hole (2) in the chassis base plate: rotate superstructure using the ground controls (or

manual swinging devices) to gain access to each screw.

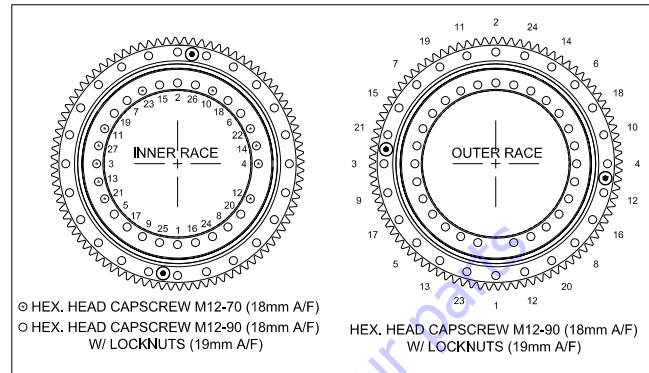

Figure 5-2. Torque Sequence Diagram

Swing Bearing Lubrication

Bearing Race Lubrication

Lube Points: 2 grease fittings

Capacity: A/R

Lube: A (See Table 1-14)

Interval: Every 250 hours of operation

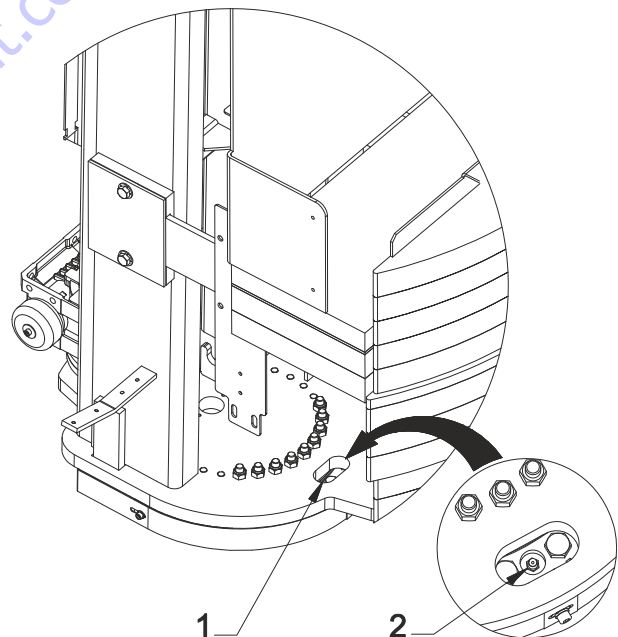

Figure 5-3. Swing Bearing Race Lubrication

1. From ground control station, raise the mast to gain access to the turntable base plate.
2. Locate the access hole (1) on the turntable plate.
3. Swing the structure to the right to gain access to the first grease fitting (2).
4. Lubricate using a grease gun.
5. Swing the structure 180° to the left to gain access to the second grease fitting and lubricate.

Bearing Teeth Lubrication

Lube Points: Coat each tooth

Capacity: A/R

Lube: B (See Table 1-14)

Interval: Every 1000 hours of operation

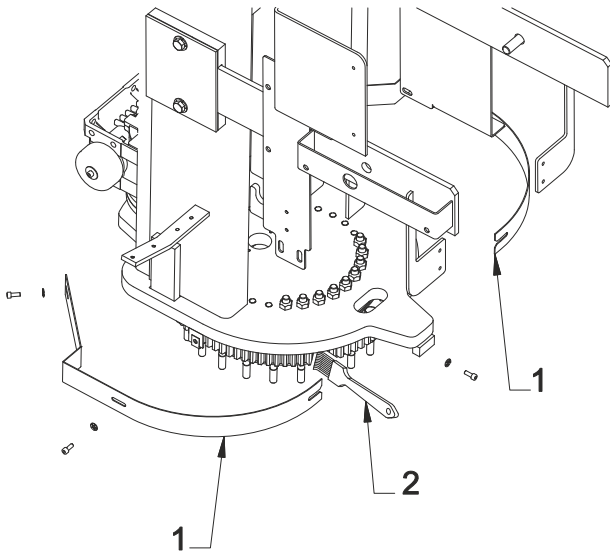

Figure 5-4. Swing Bearing Teeth Lubrication

1. Remove chassis hoods.
2. From ground control station, raise the mast to gain access to the turntable plate.
3. Remove bearing teeth covers (1).
4. Remove used grease from bearing teeth with a cloth. Using the manual slewing mechanism, rotate superstructure to reach all the teeth.
5. Using a brush (2), apply a generous coating of specified lubricant on bearing teeth. Rotate superstructure to reach all the teeth.
6. Install bearing teeth covers. Install chassis hoods.

Replacement of Swing Bearing

Removal

1. Place the machine on a flat and level surface. Fully lower the mast and the jib. Remove chassis hoods and chassis side shields. Swing the turntable 90° from chassis centre line. Shut machine down and disconnect battery plug.
2. Remove battery cover assembly. Tag and disconnect electric connector from the beacon.
3. Unplug the connector from the ground console. Remove the right access door.
4. Remove left access door (8E/20E).
5. Tag and disconnect electric lines and power cables from line contactor and power fuse. Disconnect charger interlock connector. Disconnect hose from the centralized filling unit (if equipped).
6. Remove charger and accessories mounting plate assembly (10E/26E).
7. Disconnect battery cables and pipes and remove the four battery cells (8E/20E).
8. Using an adequate lifting equipment and slings, remove battery pack (10E/26E).
9. Attach a suitable eyebolt and an adequate lifting device to the counterweight and draw all slack from sling (or chain). Remove the hardware securing the counterweight. Ensure the electrical cables, battery cables and hydraulic lines will not get pinched during counterweight removal. Remove the counterweight support bracket (8E/20E).

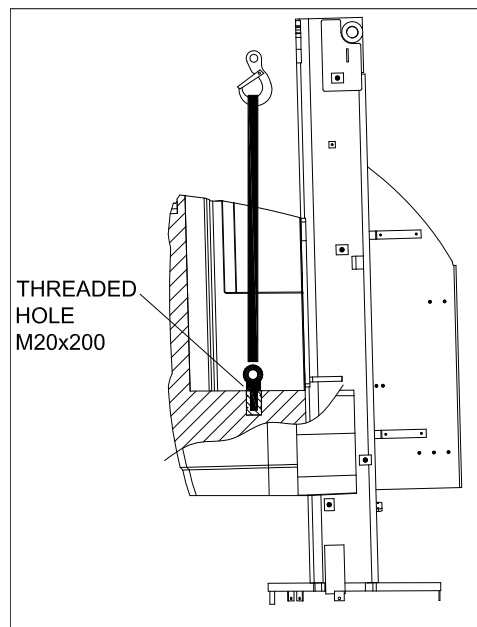

Figure 5-5. Counterweight Removal (T10E/T26E)

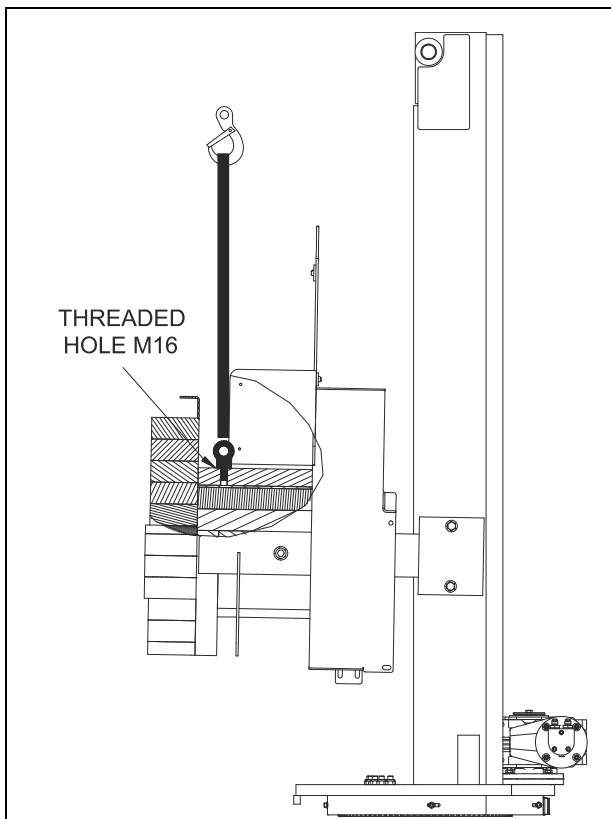

Figure 5-6. Counterweight Removal (T8E/T20E)

10. Tag and disconnect all connectors of the harness coming from the chassis (harness coming out from the rotary power track). Disconnect the power cable (BLACK TAGGED) from the hydraulic unit motor. Remove all clamps securing hoses and harnesses on the left hand side of the hydraulic power unit. Tag, disconnect and cap hydraulic lines from ports 5 and 6 of the hydraulic power unit valve body. Remove hardware securing the rotary power track to the turntable.
11. Tag, disconnect and cap hydraulic lines from the mast cylinder valve. Unscrew coil nut, remove the manual override device, the O-ring and the coil. Remove mast cylinder valve from cylinder port (Refer to Section 7).
12. Remove hardware securing the mast lateral power track to mast section #1. Remove all clamps securing hoses and harnesses on the left hand side (T10E/T26E), right hand side/right hand side (T8E/T20E) of mast section #1.
13. Tag and disconnect chain slack harness connector (harness coming out from the mast inside power track). Remove hardware securing the mast inside power track to mast section #1.
14. Attach suitable sling(s) to mast sections as shown following and draw all slack from sling(s). Remove the locknut, attachment nut and chain slack detection system from chains attachments on mast section #1.

tion #1. Attach chain anchor with plastic straps to prevent the chains from running over the pulleys.

15. Loosen the roller pin locknuts at the top of mast section #1 and slightly unscrew roller pins to allow clearance. Lift the mast sections assembly by a maximum of 300mm (12") to gain access to the mast cylinder anchor pin on mast section #2.

NOTICE

WHEN MAST SECTIONS ASSEMBLY IS LIFTED, MAST CYLINDER WILL NORMALLY EXTEND. IF NOT, PUSH THE CYLINDER BARREL DOWN (TO EXTEND THE CYLINDER) TO RETURN THE STUDS OF THE BARREL BOTTOM END TO THEIR SUPPORT ON BASE PLATE.

16. Plug mast cylinder port (3/8"BSPP). This is to prevent the cylinder from retracting suddenly when the anchor pin on mast section #2 will be removed.
17. Remove one cotter pin from mast cylinder anchor pin. Using a suitable drift, drive the pin out. Tie the cylinder to mast section #1 with a rope and protect the chrome surface of the rod.
18. Carefully lift the mast sections assembly until the roller pins at the bottom of mast section #2 are accessible. Remove the roller pin locknuts and slightly unscrew roller pins to allow clearance. Lift the mast sections assembly as shown following.

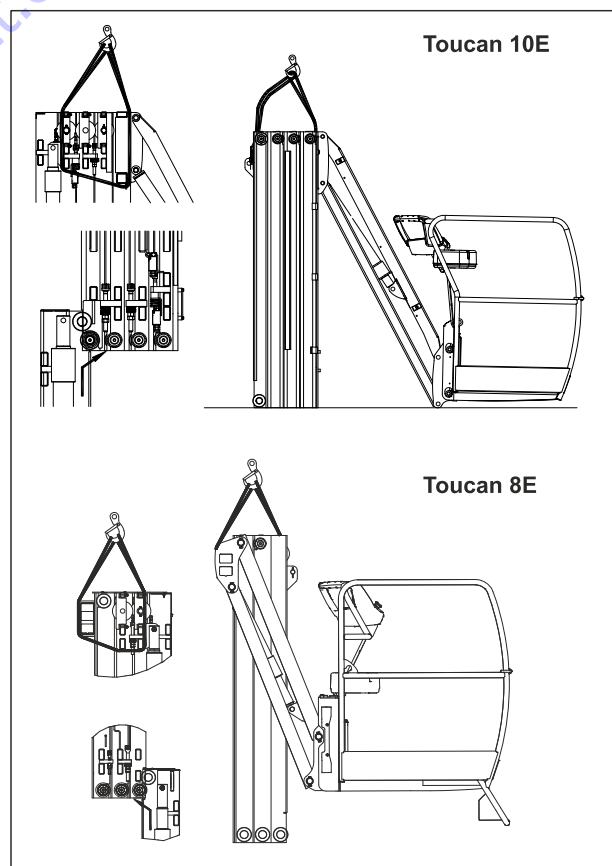

Figure 5-7. Mast Assembly Lifting

SECTION 5 - TURNTABLE AND VERTICAL MAST

19. Carefully place the mast sections assembly vertically on a flat and level surface near the chassis
20. Tag, disconnect and remove the drive orientation switch.
21. Remove the cylinder from mast section #1 using a suitable sling attached to the barrel. Move the cylinder to a clean area.
22. Using a suitable overhead lifting equipment attached to both lifting rings of mast section #1, lift and place the unit on blocks of a minimum height of 300mm (12") and capable of supporting the weight of the work platform. Position the blocks in such a way that the swing bearing attach screws remain accessible and that the machine is stable on blocks.
23. Keep lifting equipment attached to both lifting rings and draw all slack from slings/chains.
24. Remove bearing teeth covers to gain access to the heads of the screws securing the bearing to the chassis. Remove and discard the 24 nuts and hardened washers securing the swing bearing outer race to the chassis. Carefully lift mast section #1 assembly and set it as shown following.

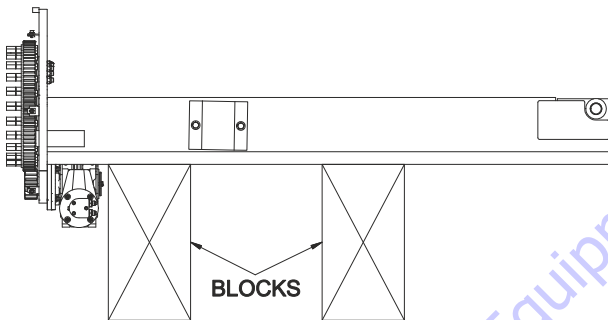

Figure 5-8. Mast Section #1 Set on Blockings

25. Remove and discard the hardware securing the bearing to the base plate. Use suitable lifting equipment to remove the bearing. Remove and discard the 24 hex. head screws from the bearing outer race.
26. Clean and inspect pinion teeth for damage or excessive wear. Replace swing motor if necessary. Clean bearing seating surfaces on the chassis and on the turntable base plate. Free threaded holes of turntable base plate from dirt, oil or foreign material.

Installation

CAUTION

SINCE THE SWING BEARING IS THE ONLY STRUCTURAL LINK BETWEEN THE CHASSIS AND TURNTABLE, USE A GENUINE JLG PART IS HIGHLY RECOMMENDED.

1. Install swing motor assembly if removed.
2. Rotate the inner race of the new bearing in such a way that the maximum eccentricity point (marked by a green spot on 3 teeth) matches with the pinion of

the swing motor and that the area of the inner race where a hole is missing (ball loading plug area) aligns with the area where a hole is missing on the turntable base plate. See Figure below:

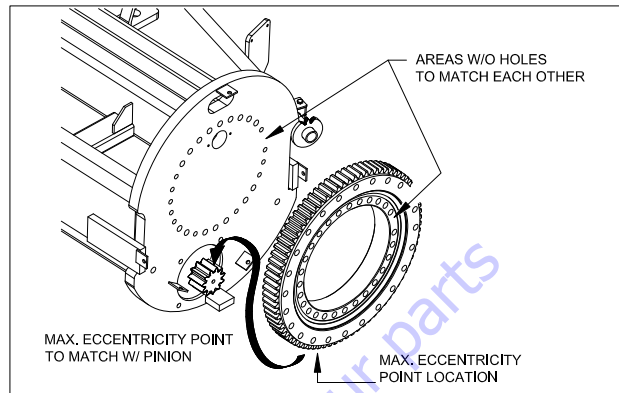

Figure 5-9. Bearing Alignment T10E/T26E

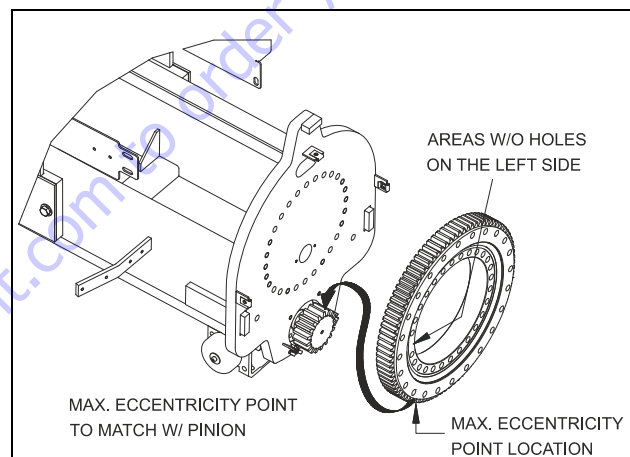

Figure 5-10. Bearing Alignment T8E/T20E

CAUTION

JLG INDUSTRIES RECOMMEND THAT ALL REMOVED BEARING NUTS, BOLTS AND HARDENED WASHER TO BE DISCARDED AND REPLACED WITH NEW PARTS. SINCE THE SWING BEARING IS THE ONLY STRUCTURAL LINK BETWEEN THE CHASSIS AND TURNTABLE, IT IS IMPERATIVE THAT REPLACEMENT HARDWARE MEETS JLG SPECIFICATIONS. USE OF GENUINE JLG HARDWARE IS HIGHLY RECOMMENDED.

3. Insert the 24 new hex. head screws M12-90 into the outer bearing race mounting holes prior to install the bearing on the turntable base plate.
4. Place bearing onto the turntable base plate with the maximum eccentricity point aligned with the pinion. Loosely install new M12x90 hex. head cap screws and locknuts through inner race of bearing and turntable base plate. Apply a light coating of Loctite®270 to the new M12x70 hex. head cap screws and loosely install screws through inner race of bearing.
5. Insert a feeler gauge of 0.20 mm (0.008 in) between the bearing and the pinion teeth as shown below to

adjust backlash in the gear. Torque bearing bolts 30 to 35 Nm (22 to 25 lb ft). Remove the feeler gauge and recheck backlash.

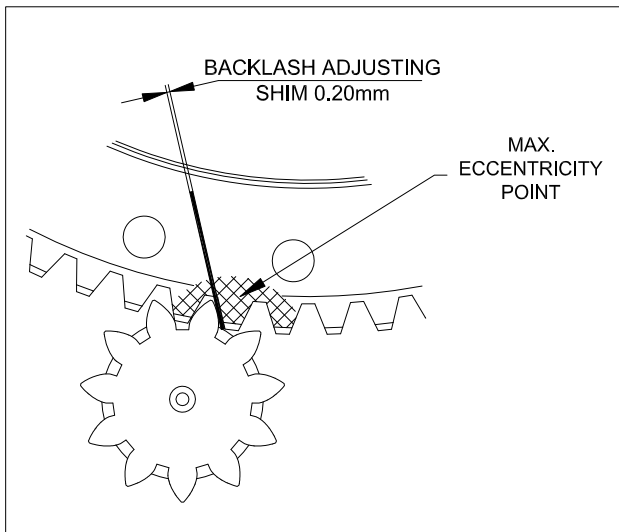

Figure 5-11. Backlash Adjustment

⚠ CAUTION

IF COMPRESSED AIR OR ELECTRICALLY OPERATED WRENCH IS USED FOR TIGHTENING THE BEARING ATTACHMENT BOLTS, THE TORQUE SETTING ACCURACY OF THE TOOL SHOULD BE CHECKED PRIOR TO USE.

6. Following the torque sequence diagram (refer to Figure 5-2.), tighten the bolts to an initial torque of 80 Nm (59 ft lbs). Then, following the same sequence, tighten to a final torque of 117 Nm (86 ft lbs).

7. Taking care not to damage the outer race bolts, carefully lift and position the mast section #1 assembly above the machine chassis so as the grease fittings of the bearing are positioned 90° from chassis centerline. Align bolts with the chassis holes and carefully lower mast section assembly. Loosely install 3 hardened washers, new screws, nuts and locknuts to correctly position the assembly. Lower the mast section #1 assembly onto the chassis. Slightly slack the slings/chains but keep them in place until the assembly is correctly secured to the chassis.
8. Loosely install all hardened washers and locknuts. Following the torque sequence diagram (refer to Figure 5-2.), tighten the nuts to an initial torque of 80 Nm (59 ft lbs). Then, following the same sequence, tighten to a final torque of 117 Nm (86 ft lbs).
9. Apply a generous coating of specified lubricant on bearing teeth with a brush and install teeth covers.
10. Secure the rotary power track to the turntable.
11. Lift the machine using suitable overhead lifting equipment attached to both lifting rings of mast section #1 lifting rings and remove blocks.
12. Using a suitable sling attached to the barrel, install the mast cylinder onto mast section #1, tie cylinder to mast section #1 with a rope and protect the chrome surface of the rod. The cylinder must be enough extended to be able to insert the pin.
13. Route sling(s) through mast sections assembly as indicated in the previous removal procedure. Position sling(s) and overhead lifting equipment accessory in such a way that the mast sections assembly remains in a vertical position when lifted.
14. Engage mast sections assembly in mast section #1 profiles till being able to install mast cylinder anchor pin. Install and correctly bend the cotter pins.
15. Loosely install the roller pin locknuts at the bottom of mast section #2.
16. Remove the plug from the cylinder port. Slowly and carefully lower the mast assembly to be able to run the chain anchors through attachment holes on mast section #1 and to install attachment nuts. Once attachment nuts are installed, continue lowering the mast assembly until the cylinder is fully retracted.
17. Tighten attachment nuts until the required distance between the top of the chain attachment plate and the top end of the chain anchor is obtained (Refer to Section 5-5). Slack and remove sling(s) from mast sections assembly.
18. Install chain slack detection system and locknut. Secure mast inner power track with hardware (10E/26E). Attach chain slack sensor cable to cylinder barrel with plastic straps.

SECTION 5 - TURNTABLE AND VERTICAL MAST

Re-plug chain slack sensor harness connector as previously tagged.

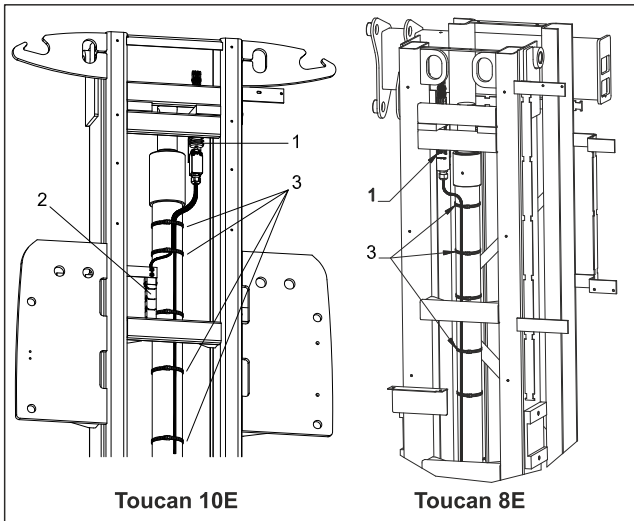

Figure 5-12. Chain Slack Detection System - Sensor Cable

- 1- Chain slack Detection System
- 2- Mast Inner Power Track (T10E/T26E).
- 3- Plastic Straps

19. Secure mast lateral power track. Correctly route hoses and cables along mast section #1 and install clamps.
20. Install and connect the drive orientation switch as previously tagged. Route the switch harness between the two cylinder supports as shown below.

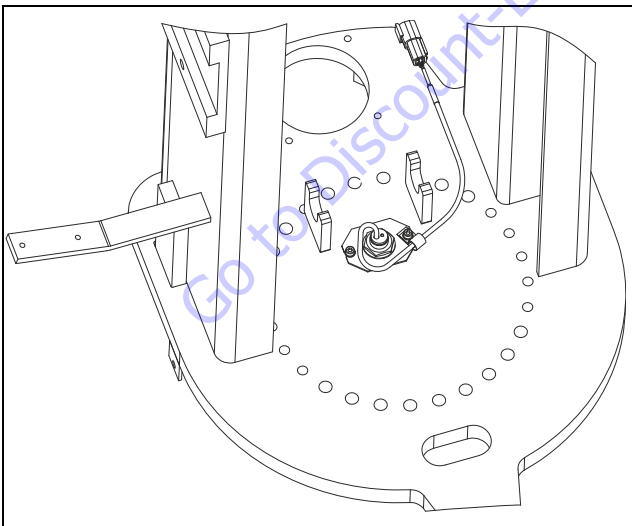

Figure 5-13. Drive Orientation Switch Harness Routing

21. Install mast cylinder valve and connect hydraulic lines. Install the coil, the O-ring and the manual override device (Refer to Section 7).

22. Connect hydraulic lines to ports 5 and 6 of the hydraulic power unit valve body (Connect Yellow/Blue tagged hose to port 5).
23. Correctly route hoses and cables on the left hand side of the hydraulic power unit and install clamps.
24. Connect the power cable (Black Tagged) to the hydraulic unit motor. Re-plug all connectors of the harness coming from the chassis (harness coming out from the rotary power track) as previously tagged.
25. Install and secure the counterweight taking care not to pinch cables or hoses. Install battery pack onto the counterweight.
26. Install and secure charger and accessories mounting plate assembly. Connect electric lines and power cables to the line contactor and to the power fuse as previously tagged. Re-plug charger interlock connector. Connect the battery centralized filling unit hose.
27. Re-plug the beacon. Install battery cover assembly.
28. Install right access door and re-plug the connector to the ground console.
29. Connect battery plug. Using ground controls, check swing system for proper operation.
30. Adjust mast section alignment (Refer to Section 5.4). Adjust chains tension if necessary (Refer to Section 5.5). Check hydraulic fluid level and adjust accordingly. Lubricate bearing track as specified.
31. Check all machine functions for proper and safe operation (Including mast manual descent). Install chassis shields and hoods. Record work platform operating time (hour meter on ground console); turntable bearing bolts torque will have to be verified after the next 50 hours of operation.

5.2 SWING MOTOR

Removal

1. Place the machine on a FLAT AND LEVEL SURFACE. Remove chassis hoods and right side shield. Using ground controls (or manual swinging operating device), rotate the turntable 90° to the right, fully raise the mast and install suitable blockings to support mast section #2 (Refer to Section 5.5). Lower the mast until mast section#2 rests on blockings. Turn power off at ground controls. Disconnect battery plug.
2. Tag, disconnect and cap swing motor hydraulic lines and ports.
3. Remove the mast cylinder holding valve (Refer to Section 7).
4. Remove the 4 attachment screws and washers securing the motor to the turntable base plate.
5. Lift the motor upwards and remove it from its mounting hole.

- Clean and inspect pinion teeth for damage or excessive wear. Replace the motor if necessary.

Installation

- Install the swing motor in its mounting hole and secure with hardware.
- Install ports fittings on the motor (Refer to Section 7-4) and torque them to 50 N.m (36.9 ft.lbs).
- Connect hydraulic lines to motor ports as previously tagged.
- Install mast cylinder holding valve and the manual override device (Refer to Section 7).
- Connect battery plug. Using ground controls, raise the mast and remove blockings. Check swing system from proper and safety operation.
- Check the mast manual descent for proper operation.
- Check hydraulic fluid level and adjust accordingly. Install chassis shield and hoods.

5.3 MAST PROFILE LUBRICATION

Lube Points: Bronze spacers tracks

Capacity: A/R

Lube: A (See Table 1-14)

Interval: Every 125 hours of operation or after each cleaning.

- Using ground control station, fully raise the mast.
- Clean the inside wall of the mast sections to remove the old grease.
- Using a brush, lubricate the roller pin bronze wear pad track with specified lubricant.
- Cycle the mast and complete lubrication as necessary.

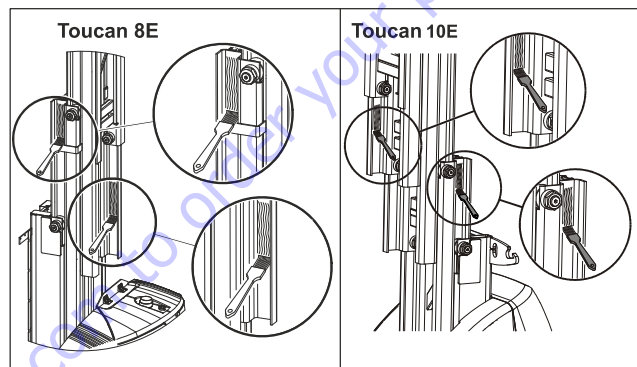

Figure 5-14. Mast Profiles Lubrication

5.4 ROLLERS

Inspection

Check roller pin bronze wear pad thickness. Replace roller pin if the wear pad thickness is less than 3.5 mm (0.13 in).

Removal and Installation

NOTE: Mast rollers can be removed one by one in turn without dismantling the telescopic mast. Fully lower the mast to remove the upper rollers. Raise the mast as necessary to gain access to the lower rollers. Mast sections alignment must be adjusted after rollers replacement.

Roller Assembly

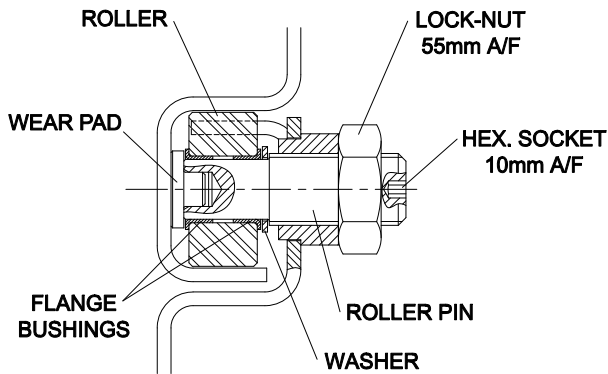

Figure 5-15. Roller Assembly

Roller Removal

1. Unscrew and remove the locknut from the roller pin.
2. Unscrew the roller pin to release the bronze wear pad and free the wear pad as indicated below:

NOTICE

HOLD THE BRONZE WEAR PAD, THE ROLLER, THEN THE WASHER TO PREVENT THEM FROM FALLING TO THE BOTTOM OF THE MAST PROFILE.

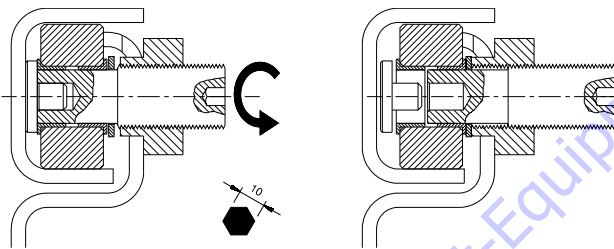

Figure 5-16. Roller Removal

Roller Installation

NOTE: If already assembled, use a locknut to free the bronze wear pad, the roller and the washer from the

pin: install the locknut on the pin and tighten it until the wear pad is released.

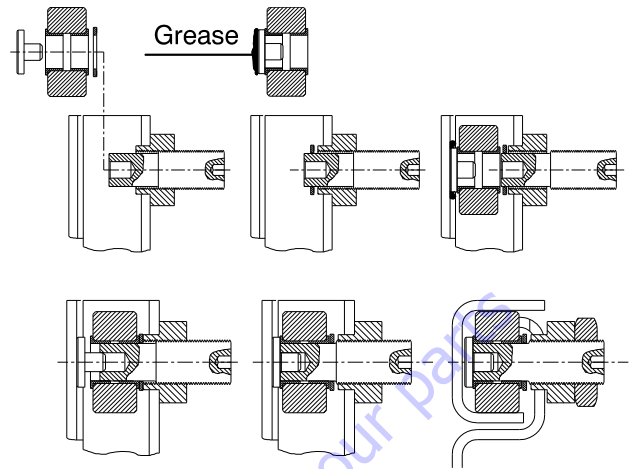

Figure 5-17. Roller Installation

1. Partly tighten the pin on the mast section and slide the washer on the pin.
2. Apply grease to the wear pad so that it sticks to the mast wall and does not fall to the bottom of the mast section.
3. Press the wear pad to the mast wall and slide the roller and the wear pad in line with the pin.
4. Once the roller is in line with the pin, tighten the pin so that the roller slides onto the pin.
5. Reposition the wear pad in line with the pin then tighten the pin until the bronze wear pad is fully inserted.
6. Loosen slightly the pin to prevent the mast from jamming during adjustment. Loosely install the locknut.
7. Repeat operation for the other pin assemblies.
8. Adjust mast transversal play and mast sections alignment.

5.5 MAST AND ROLLERS SETTING

Introduction

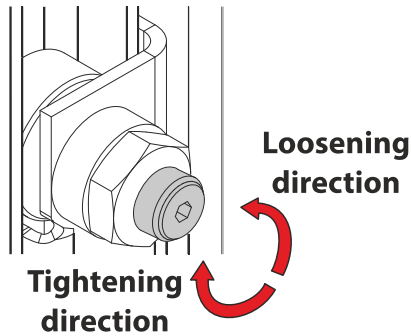

Figure 5-18. Loosening and Tightening Direction

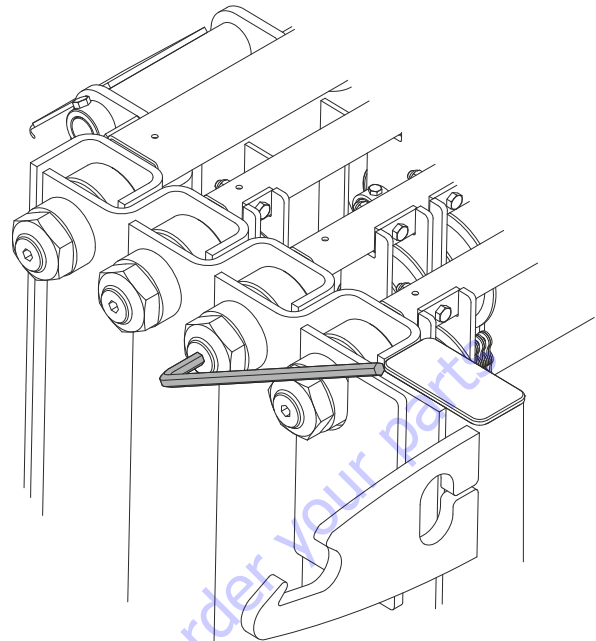

Figure 5-20. Setting Tool

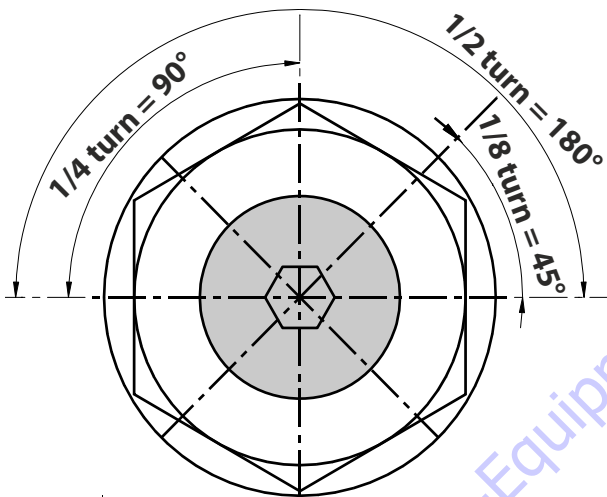

Figure 5-19. Setting Angles

⚠ WARNING

NEVER USE MANUAL DESCENT CONTROL WHEN SETTING MAST. NEVER STAND UNDER THE PLATFORM IF THE SLACK CHAIN WARNING ALARM IS ACTIVE.

NOTE: Clean the mast surfaces and remove grease before setting operation.

⚠ CAUTION

USE ALL APPLICABLE SAFETY PRECAUTIONS WHILE WORKING ON, UNDER OR AROUND ANY MACHINERY.

Procedure

Top Rollers Setting

1. Ensure mast is fully lowered prior to completing top roller setting procedure. Refer to figure 5-21 for mast configuration/terminology.

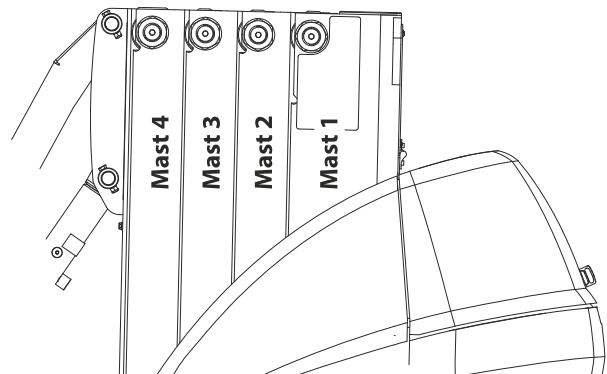

Figure 5-21. Top Rollers Mast Configuration

Angular Adjustment		Play Modification (mm) - Action on 1 roller
Turn	Angle (°)	Models 8E-10E-20E-26E
1	360	4
1/2	180	2
1/4	90	1
1/8	45	0.5

Table 5-1. Influence of roller setting on mast play

SECTION 5 - TURNTABLE AND VERTICAL MAST

- Bring each top roller pad in contact with corresponding mast surfaces and adjust distances so that $C1D=C1G$; $C2D=C2G$ until last mast section $CxD=CxG$.

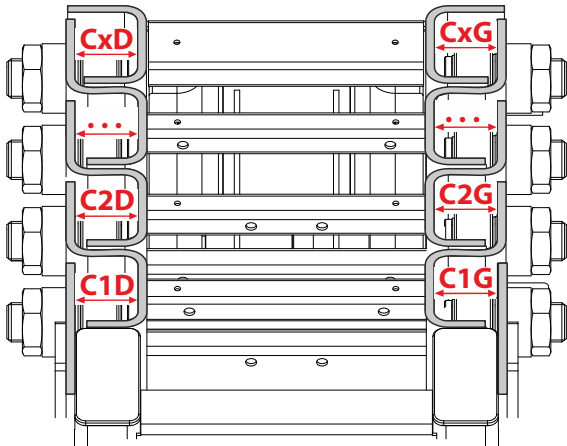

Figure 5-22. Top Rollers Mast Centering (Top View-Mast Lowered)

- On each top roller, on right side of the machine, loosen roller to be able to insert a 0.5 mm shim (between roller pad and mast profile), see Figure 5-23.

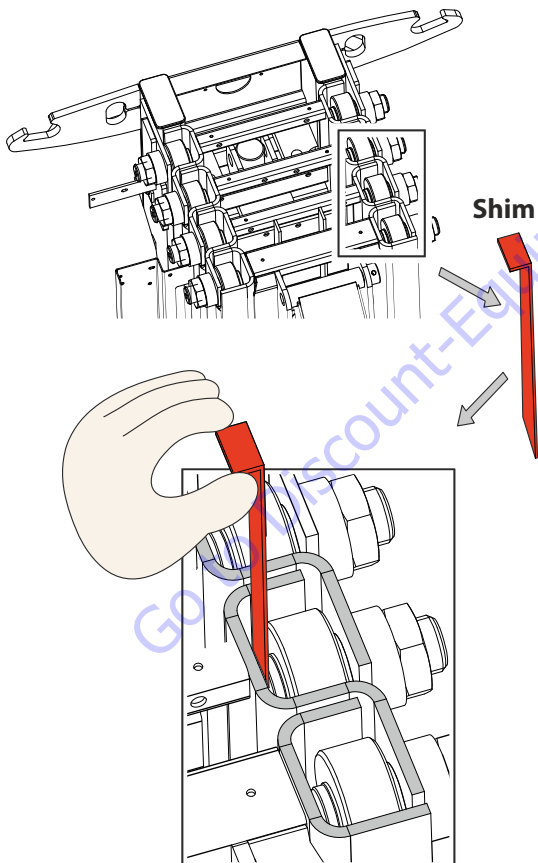

Figure 5-23. Adjusting Top Roller Play

- Slowly tighten the roller so that it comes just in contact with the shim. Remove the shim and tighten the rollers as indicated in the Table 5-2.

Top Rollers	Tightening (Turn)	
	Models 8E-20E	Models 10E-26E
Mast 1	$3/8 (1/4 + 1/8)$	$1/2$
Mast 2	$3/8 (1/4 + 1/8)$	$1/2$
Mast 3	0	$3/8 (1/4 + 1/8)$
Mast 4		$1/4$

Table 5-2. Top Rollers Tightening

- Tighten lock nuts on each roller.
- Test mast lowering movement through a complete stroke. No mast jamming (slack chain) must appear. In the event of a slack chain occurrence, identify the concerned roller and loosen roller $1/8$ turn and recheck mast lowering movement. Complete step 6 until mast lowers without sticking.

Bottom Rollers Setting

- Bottom rollers setting is done with different mast heights. Raise the mast sections to the measurements shown in table 5-3.

⚠ WARNING

EXERCISE EXTREME CAUTION WHEN WORKING UNDER THE PLATFORM TO PERFORM THIS STEP. NEVER STAND UNDER THE PLATFORM IF THE SLACK CHAIN WARNING ALARM IS ACTIVE.

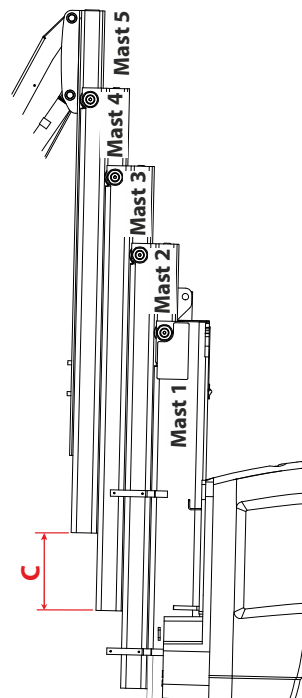

Figure 5-24. Bottom Rollers Mast Configuration

Bottom Rollers	Setting Height = C (mm)	
	Models 8E-20E	Models 10E-26E
Mast 2	Maxi	Maxi
Mast 3	Maxi	600
Mast 4	800	300
Mast 5		300

Table 5-3. Bottom Rollers Setting Height

- Bring each bottom roller pad in contact with corresponding mast surfaces and adjust distances so that $C1D=C1G$; $C2D=C2G$ until last mast section $CxD=CxG$.

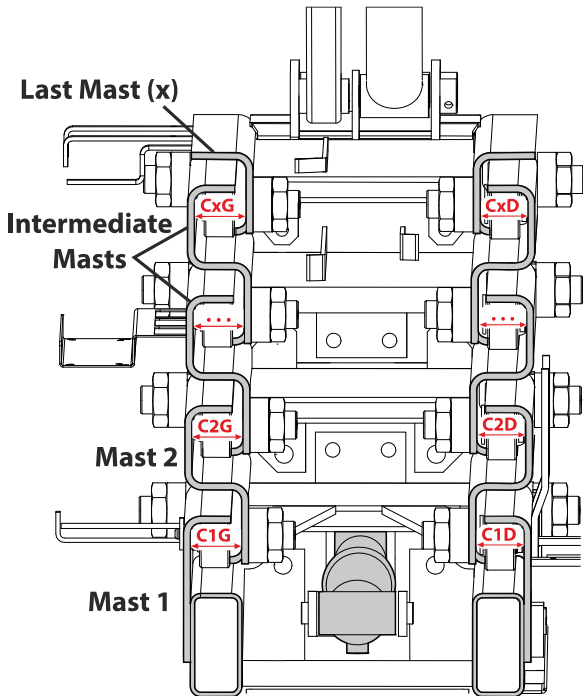

Figure 5-25. Bottom Rollers Mast Centering (Bottom View - Mast Raised)

- On each bottom roller, on right side of the machine, loosen roller to be able to insert a 0.5 mm shim (between roller pad and mast profile).

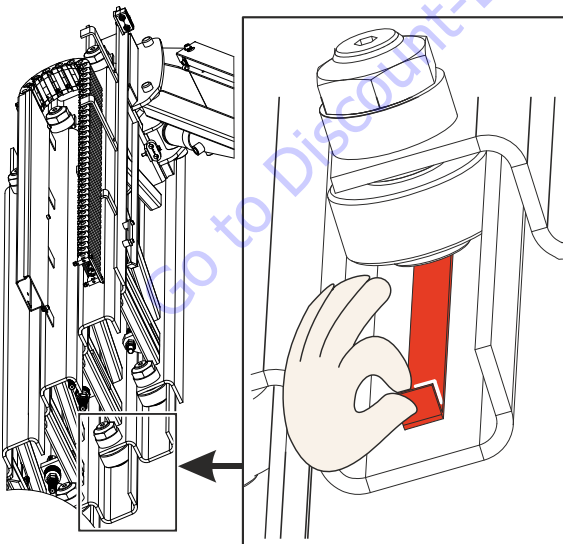

Figure 5-26. Adjusting Bottom Roller Play

- Slowly tighten the roller so that it comes just in contact with the shim. Remove the shim and tighten the rollers as indicated in the Table 5-4.

Bottom Rollers	Tightening (Turn)	
	Models 8E-20E	Models 10E-26E
Mast2	1/8	1/4
Mast3	1/8	1/4
Mast4	0	1/4
Mast5		0

Table 5-4. Bottom Rollers Tightening

- Tighten lock nuts on each roller.
- Test mast lowering movement through a complete stroke. No mast jamming (slack chain) must appear. In the event of a slack chain occurrence, identify the concerned roller and loosen roller 1/8 turn and recheck mast lowering movement. Complete step 12 until mast lowers without sticking.

Mast Vertical Alignment Setting

- Fully raise the mast and use a plumb line to ensure that the vertical alignment of the mast sections is correct (See Figure 5-27).

NOTE: Pay attention to the previous mast play adjustments: If a roller needs to be tightened/loosened, apply the opposite setting on the other side roller.

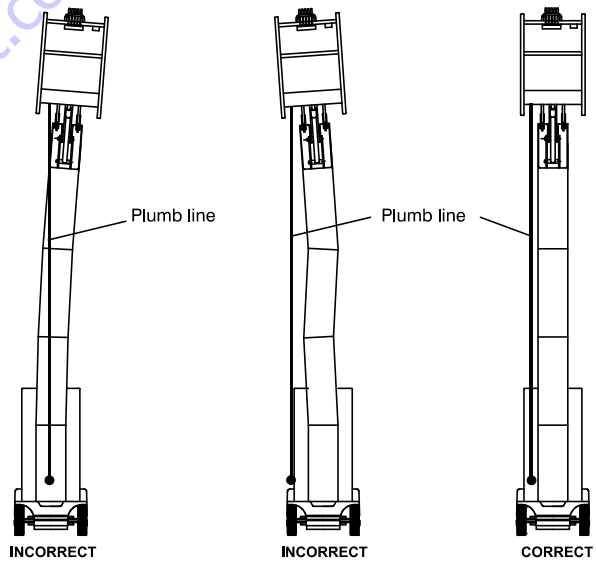

Figure 5-27. Mast Vertical Alignment

SECTION 5 - TURNTABLE AND VERTICAL MAST

Settings Validation

14. a). Test mast lowering movement from ground control panel (No load in the platform).
The mast must come down without jamming or slack chain warning in the maximum time indicated in Table 5-5.
- b). Test mast lowering movement with platform control box (One operator in the platform).
A second operator should be on the ground to assist with rescue in the event of mast sticking.
The mast must come down without jamming or slack chain warning in the maximum time indicated in Table 5-5.

Controls	Mast Lowering Time (s)	
	Models 8E-20E	Models 10E-26E
Ground Control Panel	45	45
Platform Control Box	30	30

Table 5-5. Maximum Mast Lowering Time

c). If the operator considers that an adjustment is needed (too much play in the mast, mast jamming...), the setting can be modified within following limits:

- Top rollers:

Tightening (maximum indicated in Table 5-6) compared to basic setting in step 4 or
Loosening until correct functioning (No mast jamming).

- Bottom rollers:

Tightening (maximum indicated in Table 5-6) compared to basic setting in step 10 or
Loosening until correct functioning (No mast jamming).

Rollers	Rollers Setting (Turn)	
	Models 8E-20E	Models 10E-26E
Top	1/8	1/8
Bottom	1/8	1/4

Table 5-6. Maximum Tightening Adjustment

NOTE: After each tightening operation, it is imperative to ensure that no mast jamming appears.
Maximum times for mast lowering are given for a temperature >10°C (50°F).

15. Visual marking is required: mark the rollers with a paint mark as shown in Figure 5-28.

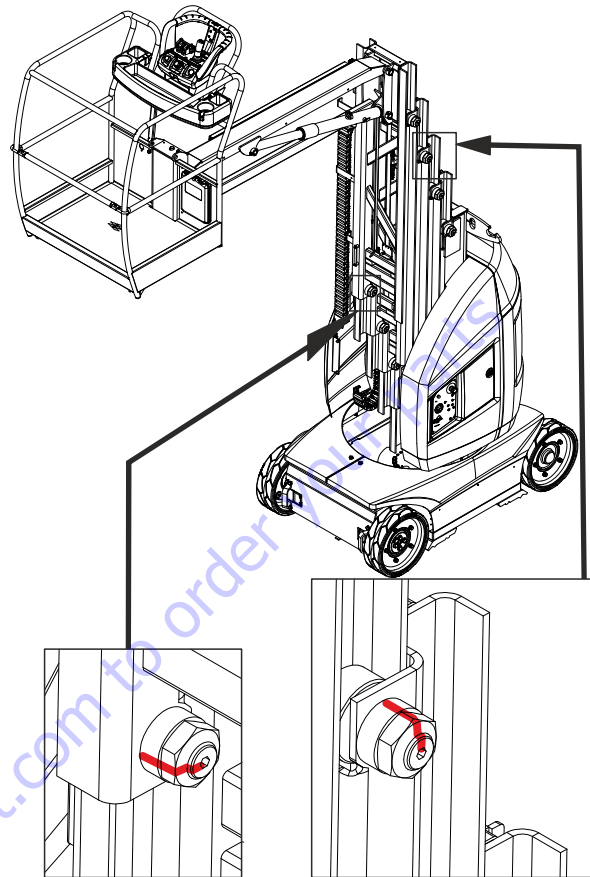

Figure 5-28. Top and Bottom Rollers

Mast Lubrication

16. Using ground control panel, fully raise the mast.
Using a brush, lubricate the roller pin wear pad track with specified lubricant. Avoid greasing the roller track.
Clean roller track if necessary.

Final Control

17. Complete full function tests of the machine prior to returning the machine to service.

5.6 LIFTING CHAINS

WARNING

NEVER WORK UNDER AN ELEVATED PLATFORM UNTIL PLATFORM HAS BEEN SAFELY RESTRAINED FROM ANY MOVEMENT BY BLOCKING OR OVERHEAD SLING.

Safety Accessories and Tooling

Distance "A": mast cylinder stroke required to gain access to chains attachments. See chart below:

1 st Stage chains attachment	A=800 mm (31.5 in)
2 nd Stage chains attachment	A=800 mm (31.5 in)
3 rd Stage chains attachment (T10E/T26E)	A=650 mm (25.6 in)

Using suitable couples of blockings to support mast section(s) during chain replacement procedure is essential for good working safety condition. Blockings could be strong wooden blocks or steel tubes with obturated ends. Blockings should be inserted in mast section roller track and secured with C-clamps as shown following:

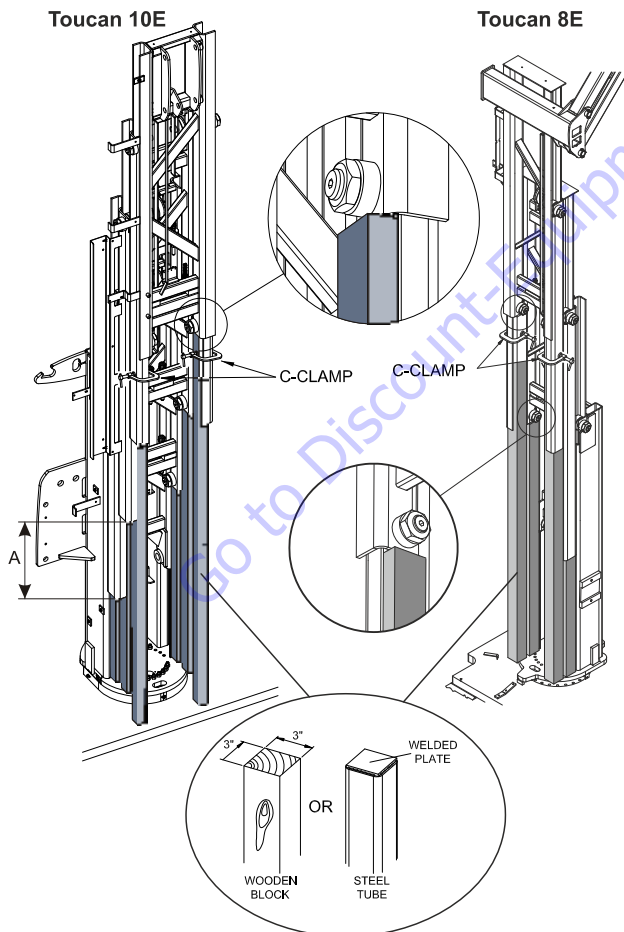

Figure 5-29. Supporting Mast Sections

A long hollow body socket is required to allow insertion over the long threaded chain anchors. A box socket can be built using a square drive socket and a tube as follow:

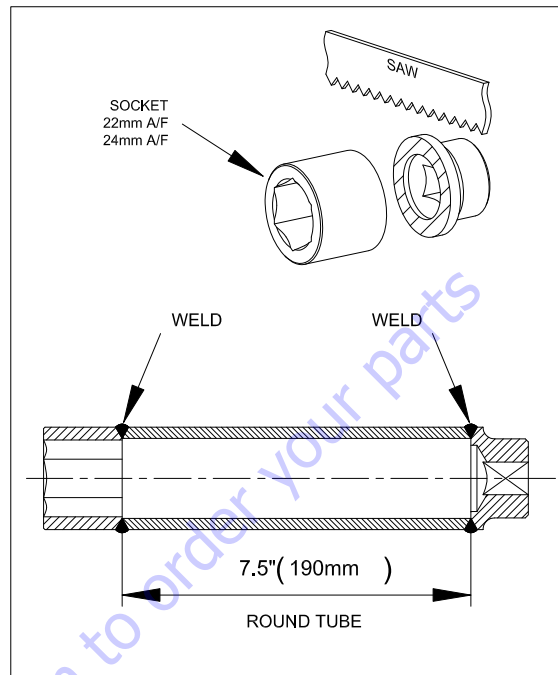

Figure 5-30. Long Hollow Body Socket

Use this box socket with a square driver ratchet and appropriate square drive extensions to reach the anchors attachment nuts.

Lubrication

Lube Points: 6 chains (10E/26E) or 4 (8E/20E)
 Capacity: A/R
 Lube: C (See Table 1-14)
 Interval: After the first 50 hours of operation and every 125 hours of operation (or every 3 months) thereafter.

NOTICE

THE INITIAL LUBRICATION OF THE CHAINS IS ONLY TO PROTECT THEM AGAINST RUST AND TO PROTECT FRICTION SURFACES DURING THE FIRST 50 HOURS OF OPERATION.

NOTICE

AVOID REMOVING THE LUBRICANT FROM THE CHAINS. DO NOT USE ACID OR DETERGENT TO CLEAN THE CHAINS. USE ONLY SPECIFIED LUBRICANT. NEVER USE GREASE TO LUBRICATE THE CHAINS.

NOTE: Chains lubrication intervals must be established depending on the environment in which the work platform is operated or stored (dusty or aggressive environment). The lubricant must be adapted to the machine's operating condition. In general, a non detergent mineral oil is sufficient. Its viscosity must be adapted to the temperature according to the

SECTION 5 - TURNTABLE AND VERTICAL MAST

chart below. A too low viscosity will facilitate draining of the lubricant by gravity. A too high viscosity will prevent lubricant from reaching the friction surfaces of the chain.

Operating Temperature °C (°F)	ISO Viscosity grades VG
-15°C to 0°C (5°F to 32°F)	15 to 32 mm ² /s (cSt)
0°C to 50°C (32°F to 122°F)	46 to 150 mm ² /s (cSt)

- Using the ground control station, fully raise the mast.
- Lubricate the chains with a specified lubricant using a paint brush or by spraying (if using a paint brush, lubricant must be applied longitudinally to facilitate penetration of lubricant between friction surfaces, then transversely between the plates to enable lubricant to reach the joint).

NOTE: If the chains are too clogged for the lubrication to be correctly performed:

- Remove them from the mast.
- Thoroughly clean them with paraffin oil.
- Dry with compressed air while moving the chain.
- IMMEDIATELY** dip in specified lubricant and move the chain.
- Reinstall chain and cycle the mast several times.

Lifting Chains Inspection

Inspect thoroughly each chain over its entire length:

- Chains, anchors, clevis pins and splits pins should not be corroded.
- Plates should not be cracked:

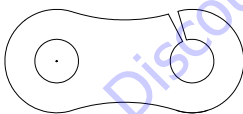

Figure 5-31. Cracked Plate

- The plate clevis pins should not present excessive play.
- Pins should not have turned in their housing (1).

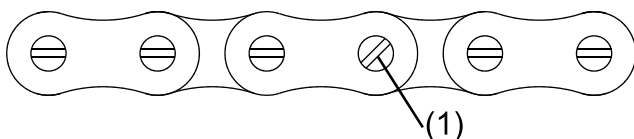

Figure 5-32. Turned Pin

- Plates should not be worn above 5% of their total height.

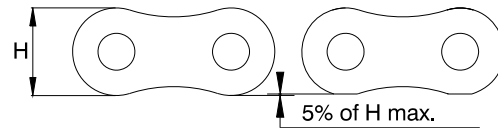
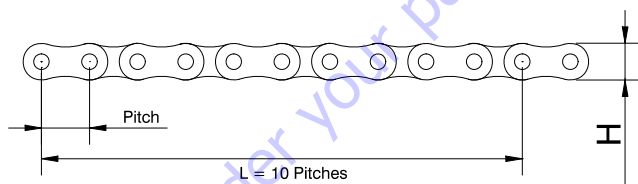

Figure 5-33. Worn Plate

Pitch	5/8" (15.875 mm)	3/4" (19.05 mm)
Hmin.	11.5 mm (0.453 in.)	13.6 mm (0.535 in.)

- Chains should not have stretched above the values indicated in the chart below.



Pitch	5/8" (15.875 mm)	3/4" (19.05 mm)
L max.	163.5 mm (6.4 in.)	196 mm (7.7 in.)

All chain appearing faulty or worn must be replaced including chain anchors. Condition of the pulleys, pulley bushings and telescopic mast alignment must be inspected.

Lifting Chains Removal and Installation

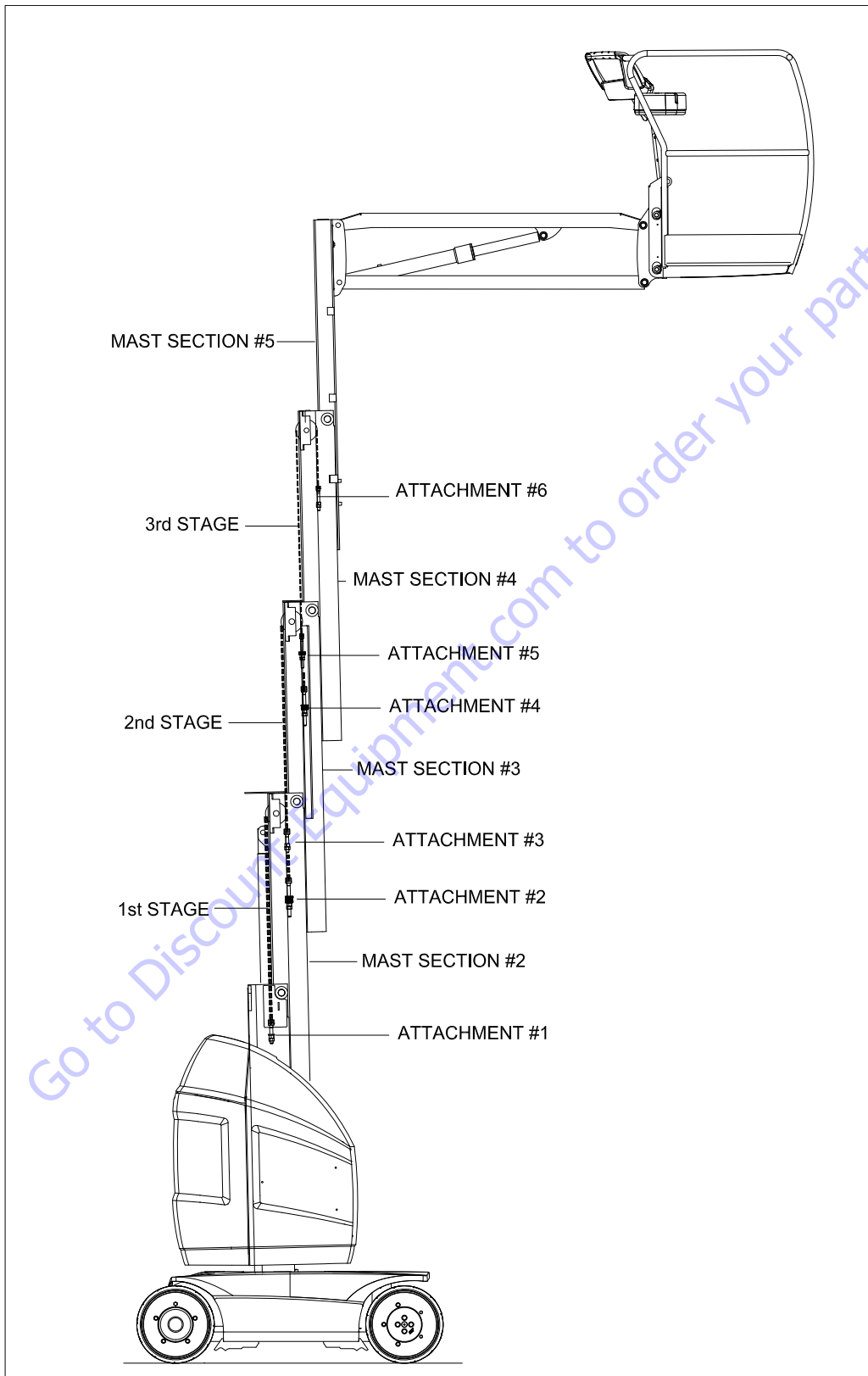

Figure 5-34. Chains Stages and Attachments Description - T10E/T26E

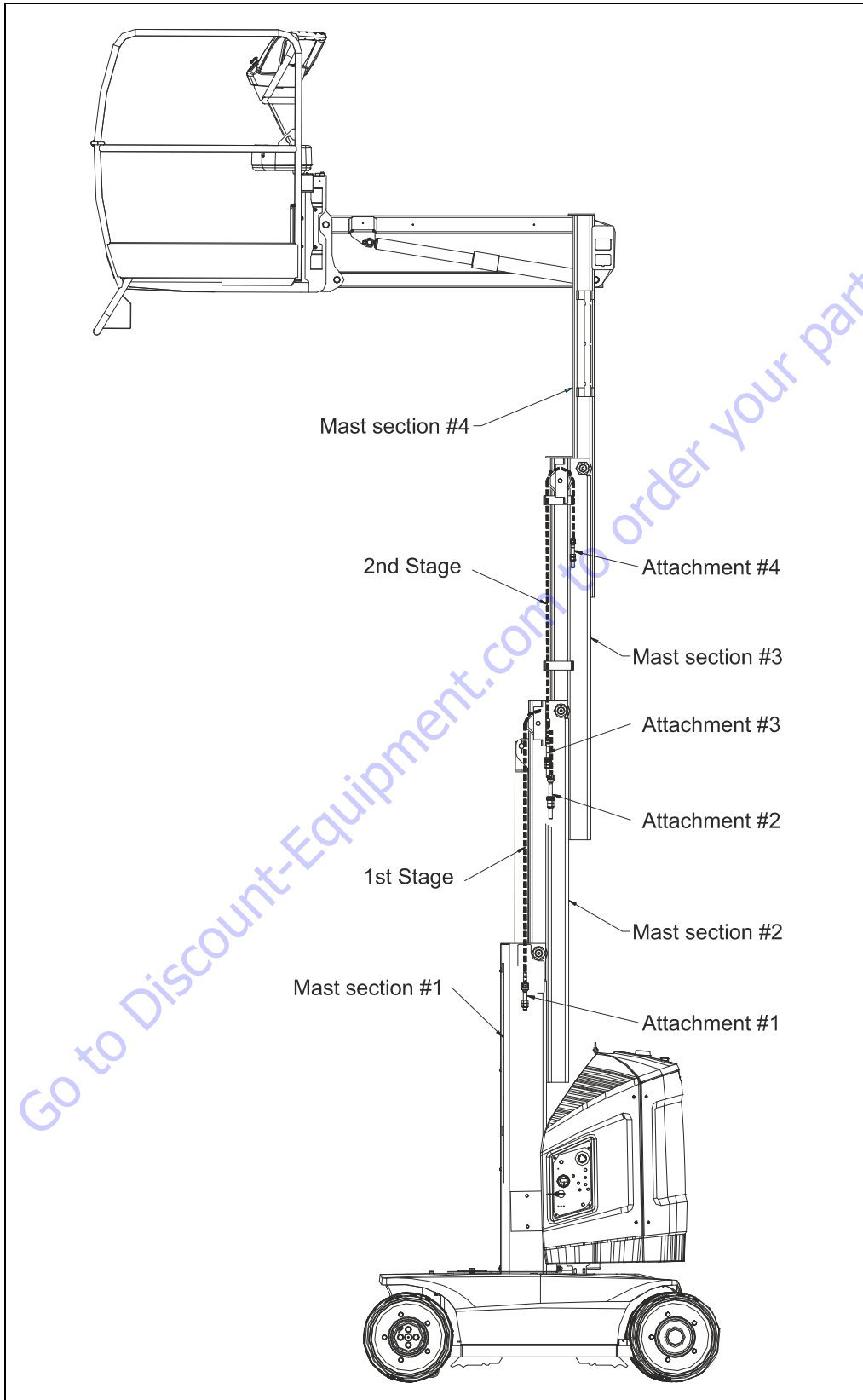

Figure 5-35. Chains Stages and Attachments Description (T8E/T20E)

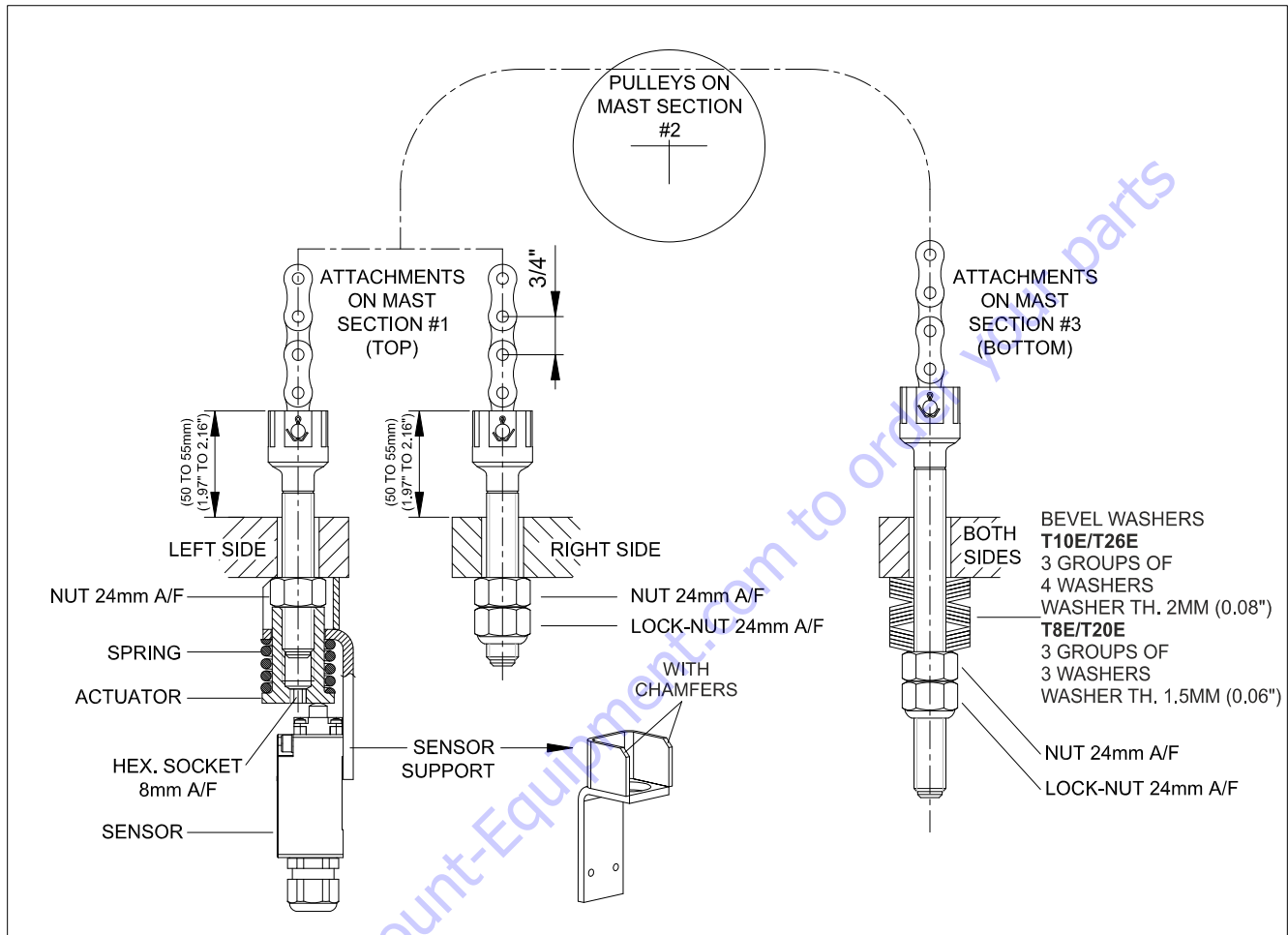

Figure 5-36. First Chain Stage

SECTION 5 - TURNTABLE AND VERTICAL MAST

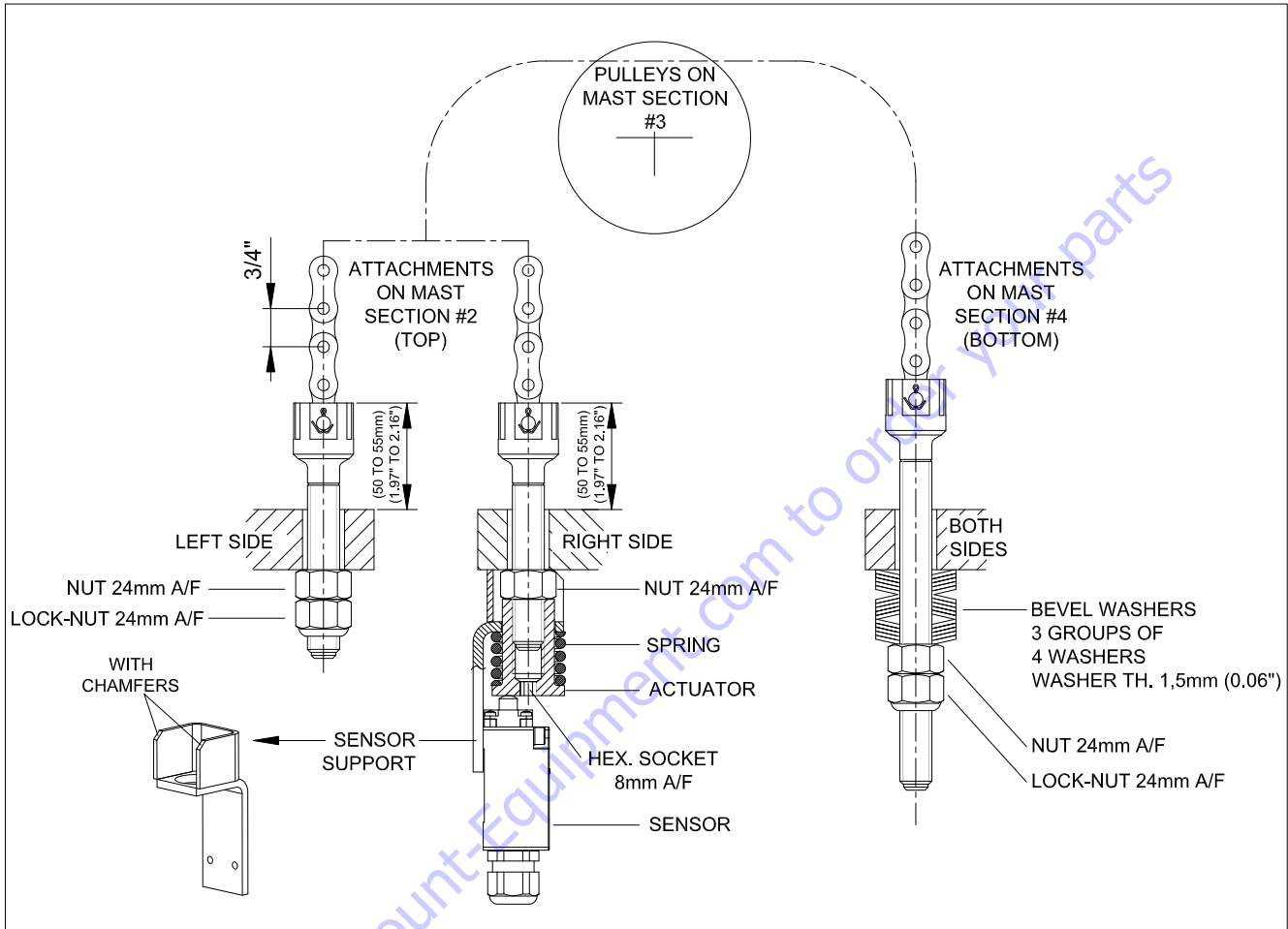

Figure 5-37. Second Chain Stage (T10E/T26E)

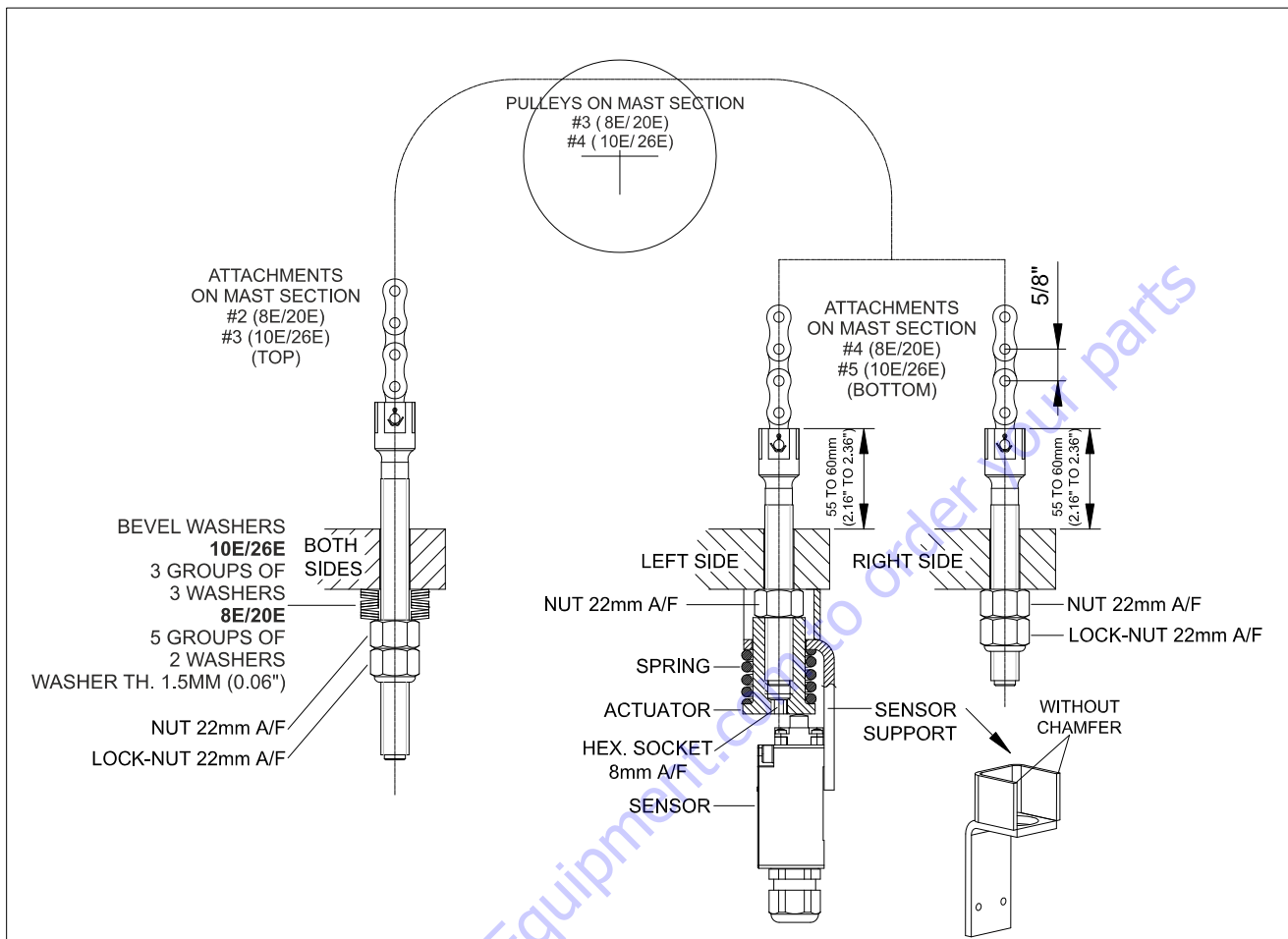

Figure 5-38. Third Chain Stage (T10E/T26E)
Second Chain Stage (T8E/T20E)

NOTICE

REPLACE SYSTEMATICALLY BOTH CHAINS OF A SAME STAGE. CHAIN ANCHORS, CLEVIS PINS, BEVEL WASHERS AND NUTS MUST ALSO BE REPLACED. USE ONLY GENUINE JLG PARTS. REMOVE THE LIFTING CHAINS ONE BY ONE. ALWAYS REPLACE AND TENSION A CHAIN BEFORE REMOVING ANOTHER ONE. IN ADDITION, BLOCKING SHOULD BE INSTALLED AS REQUIRED TO SUPPORT MAST SECTIONS DURING CHAIN REMOVAL. CORRECTLY TAG AND DISCARD WORN CHAINS AND COMPONENTS SO THAT THEY CANNOT BE INSTALLED ON THE WORK PLATFORM OR ON ANOTHER MACHINE.

NOTICE

INSTALLATION OF CHAINS MUST BE DONE IN A CLEAN WORK AREA. DO NOT REMOVE THE LUBRICANT FROM THE CHAIN BEFORE, DURING OR AFTER THEIR INSTALLATION. WHEN UNROLLING OR INSTALLING CHAINS, AVOID TWISTING THEM.

NOTE: As part of the lifting chain replacement procedure, inspect condition of the pulley pins and pulleys. Replace all damaged parts.

Rotate the turntable 90 degrees to the left to get easier access to the mast assembly and to be able to install supports for the mast sections.

1st Chains Stage Removal

1. Using the ground controls, raise the mast to gain access to chain attachments #1 and #2.
2. Safely support mast sections #3, #4 and #5 with 3 couples of suitable blockings as indicated on the figure below (T10E/T26E).
Safely support mast sections #3 and #4 with 2 couples of suitable blockings as indicated on the figure below (T8E/T20E).
The blockings must rest on the turntable circular base plate or on the chassis plate as applicable.

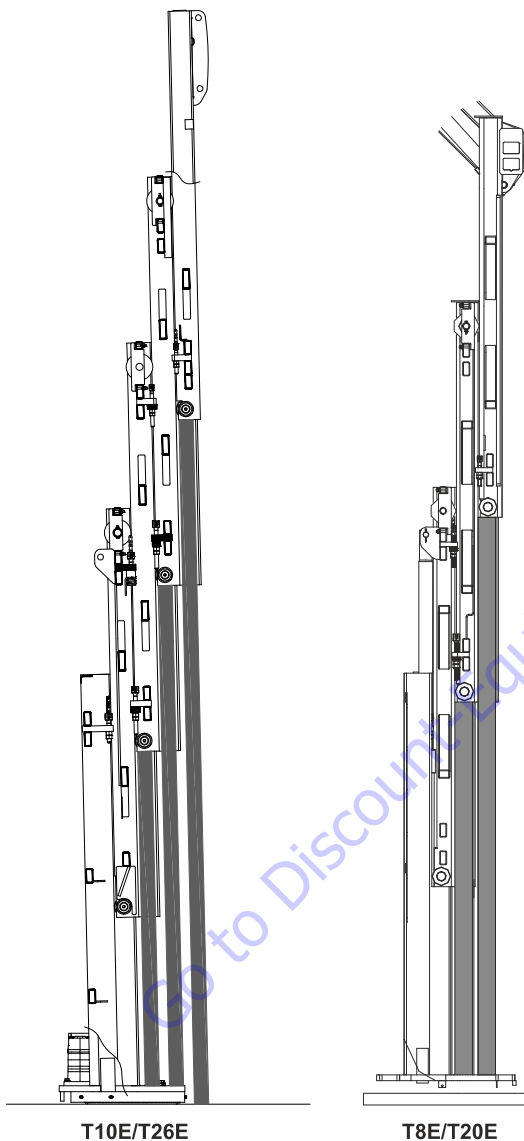

Figure 5-39. Supporting Mast Sections

3. Using the ground controls, lower the mast until the mast sections rest on blockings. Secure the blockings in place with C-clamps.
4. Remove the locknut, attachment nut and bevel washers from a chain anchor at attachment #2.
5. If installed, remove the chain slack detection assembly from the other end of the chain. If not installed,

remove the locknut and the attachment nut from the other end of the chain. If necessary, remove mast inside power track from mast section #2 attach plate to facilitate access to the chain anchor.

6. Remove one of the chains anchors so that the chain can be removed from the pulley groove (if necessary).
7. Install and tension a new chain before removing the other one.

1st Chains Stage Installation

1. Install the short anchor at one end of the chains. Correctly install the split pins on the clevis pin.
2. Run the end of the chain (without anchor) over the pulley. The short anchor must be on the side of attachment #1.
3. Install the long anchor at the other end of the chain. Correctly install the clevis pins on the split pin.
4. Install the chain slack detection assembly or the attachment nut and locknut (as indicated on the previous figures) at attachment #1.
5. Install the bevel washers and the attachment nut at attachment #2.
6. Check that the chain is correctly positioned in the pulley groove and tighten the attachment nut (on the long anchor) until the chain is under tension. The locknut will be installed after chains tension adjustment procedure.
7. After both chains of the stage have been replaced, slightly raise the mast using the ground controls. Remove C-clamps and blockings.
8. Adjust lifting chains tension accordingly.

2nd Chains Stage Removal (T10E/T26E)

1. Using the ground controls, raise the mast to gain access to chain attachment #3 and #4.
2. Support efficiently mast section #4 and #5 with 2 couples of suitable blockings as indicated on the figure below.
The blockings must rest on the turntable circular base plate or on the chassis plate as applicable.

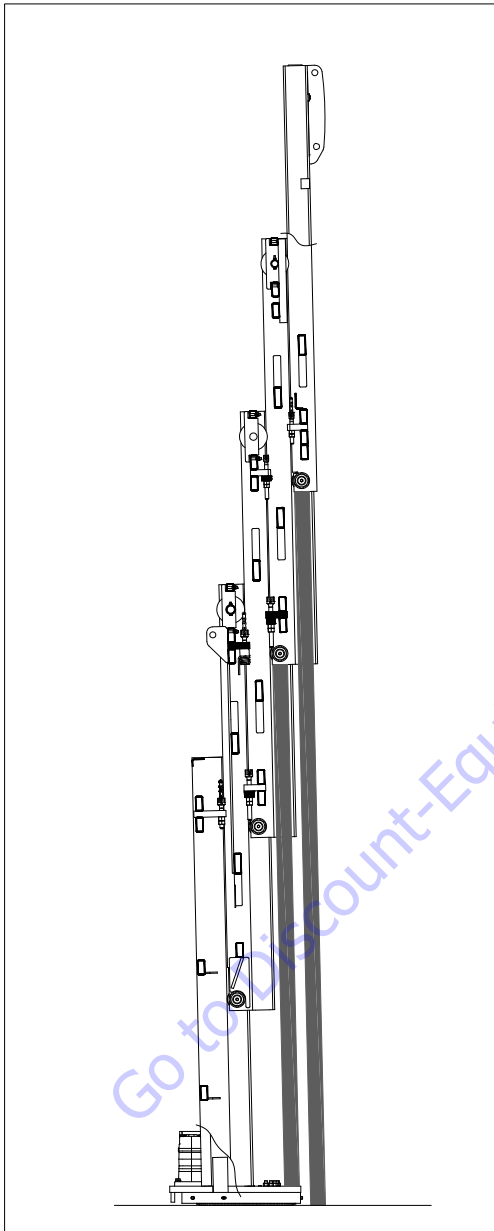

Figure 5-40. Supporting Mast Sections

3. Using the ground controls, lower the mast until the mast sections rest on blockings. Secure the blockings with C-clamps.
4. Remove the locknut, attachment nut and bevel washers from a chain anchor at attachment #4.

5. If installed, remove the chain slack detection system from the other end of the chain. If not installed, remove the locknut and the attachment nut.
6. Remove one of the chain anchors so that the chain can be removed from the pulley groove (if necessary).
7. Install and tension a new chain before removing the other one.

2nd Chains Stage Installation (T10E/T26E)

1. Install a short anchor at one end of the chain. Correctly install the split pins on the clevis pin.
2. Run the end of the chain (without anchor) over the pulley. The short anchor must be on the side of attachment #3.
3. Install the long anchor at the other end of the chain. Correctly install the split pins on the clevis pin.
4. Install the chain slack detection system or the attachment nut and locknut (as indicated on the previous figures) at attachment #3.
5. Install the bevel washers and attachment nut at attachment #4.
6. Check that the chain is correctly positioned in the pulley groove and tighten the attachment nut (on the long anchor) until the chain is under tension. The locknut will be installed after chains tension adjustment procedure.
7. After both chains of the stage have been replaced, slightly raise the mast using the ground controls. Remove C-clamps and blockings.
8. Adjust lifting chains tension accordingly.

2nd Chains Stage Removal (T8E/T20E)

1. Using the ground controls, raise the mast to gain access to chain attachment #3 and #4.
2. Support efficiently mast section #4 with a couple of suitable blockings as indicated on the figure below. The blockings must rest on the turntable circular base plate.

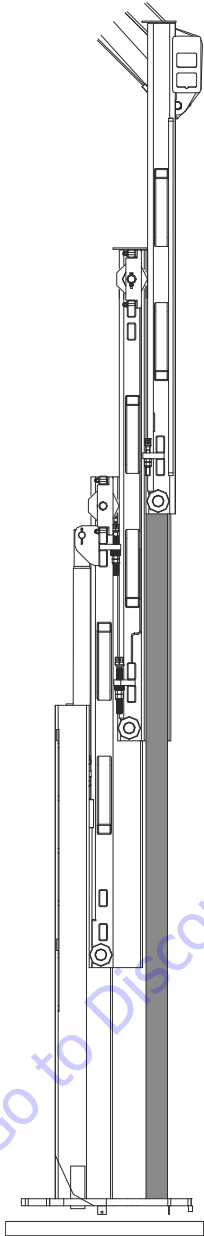

Figure 5-41. Supporting Mast Sections

3. Using the ground controls, lower the mast until the mast section rests on blockings. Secure the blockings with C-clamps.
4. Remove the locknut, the attachment nut and the bevel washers from a chain anchor at attachment #3.

5. If installed, remove the chain slack detection system from the other end of the chain. If not installed, remove the locknut and the attachment nut from the other end of the chain;
6. Remove the chain from the pulley. Install and tension a new chain before removing the other one.

2nd Chains Stage Installation (T8E/T20E)

1. Install a short anchor and a long one on the chain. Correctly install the split pins on the clevis pins.
2. Run the chain over the pulley so that the short anchor is on the side of attachment #4.
3. Install the chain slack detection assembly or the attachment nut and locknut (as indicated on the previous figure) at attachment #4.
4. Install the bevel washers and the attachment nut at attachment #3.
5. Check that the chain is correctly positioned in the pulley groove and tighten the attachment nut (on the long anchor) until the chain is under tension. The locknut will be installed after chains tension adjustment procedure.
6. After both chains of the stage have been replaced, slightly raise the mast using the ground controls. Remove C-clamps and blockings.
7. Adjust lifting chains tension accordingly.

3rd Chains Stage Removal (T10E/T26E)

1. Using the ground controls, raise the mast to gain access to chain attachment #5 and #6.
2. Support efficiently mast section #5 with a couple of suitable blockings as indicated on the figure below. The blockings must rest on the chassis plate.

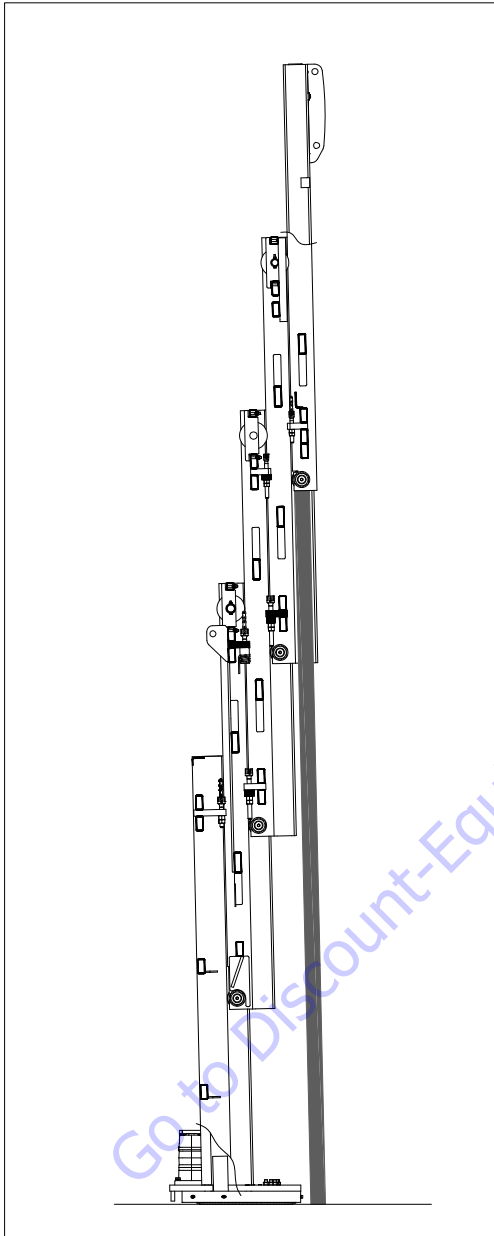

Figure 5-42. Supporting Mast Sections

3. Using the ground controls, lower the mast until the mast section rests on blockings. Secure the blockings with C-clamps.
4. Remove the locknut, the attachment nut and the bevel washers from a chain anchor at attachment #5.
5. If installed, remove the chain slack detection system from the other end of the chain. If not installed,

remove the locknut and the attachment nut from the other end of the chain;

6. Remove the chain from the pulley. Install and tension a new chain before removing the other one.

3rd Chains Stage Installation (T10E/T26E)

1. Install a short anchor and a long one on the chain. Correctly install the split pins on the clevis pins.
2. Run the chain over the pulley so that the short anchor is on the side of attachment #6.
3. Install the chain slack detection assembly or the attachment nut and locknut (as indicated on the previous figure) at attachment #6.
4. Install the bevel washers and the attachment nut at attachment #5.
5. Check that the chain is correctly positioned in the pulley groove and tighten the attachment nut (on the long anchor) until the chain is under tension. The locknut will be installed after chains tension adjustment procedure.
6. After both chains of the stage have been replaced, slightly raise the mast using the ground controls. Remove C-clamps and blockings.
7. Adjust lifting chains tension accordingly.

Chain Tension Adjustment

The lifting of a same stage must have an identical tension. In addition, the chains must be tensioned so that the mast sections are aligned (with approx. 80 kg (176 lb) in the platform).

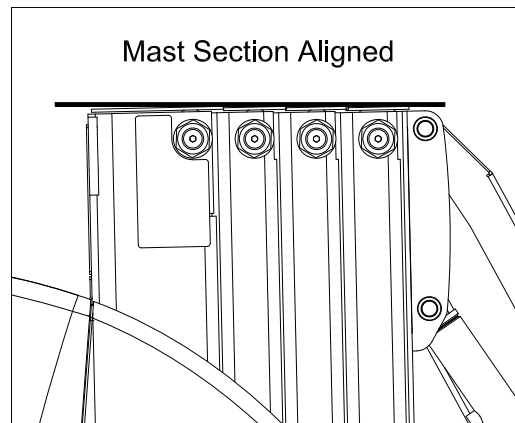

Figure 5-43. Chain Tension Adjustment

Chains Tension Control

1. Fully raise the mast then lower it by approximately 50 cm (20 in.).

2. Press on each chain between the pulley and the chain attachment. Each chain of a same stage must have the same deflection.

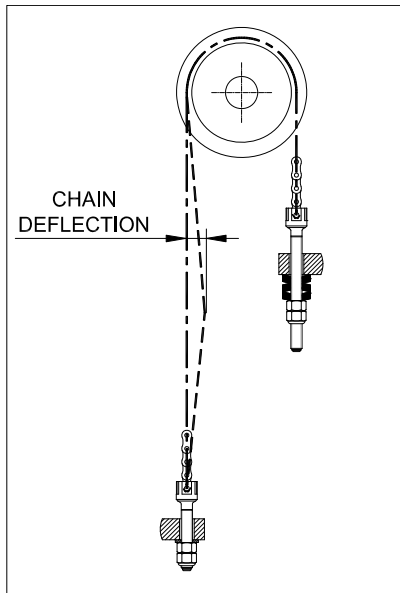

Figure 5-44. Chains Tension Control

Chain Tension Adjustment

1. With the mast fully lowered, check mast sections alignment for reference.
2. Fully raise the mast then lower it by approximately 50 cm (20 in.).
3. Remove the locking nuts from the long anchor of the chains to be adjusted.
4. Press on each chain between the pulley and the chain attachment to estimate chain deflection difference. Tighten the attachment nut on the anchor of the chain which is too slack or loosen the attachment nut on the anchor of the chain which is too tight, so as to ensure the final alignment of the mast sections is kept.
5. Install and tighten the locknut on each anchor.

5.7 PULLEY - PULLEY SUPPORT

Pulley Inspection

1. From ground controls, raise the mast to get pulleys visible.
2. Check for slantwise pulleys. Replace pulley assembly and check mast sections alignment.

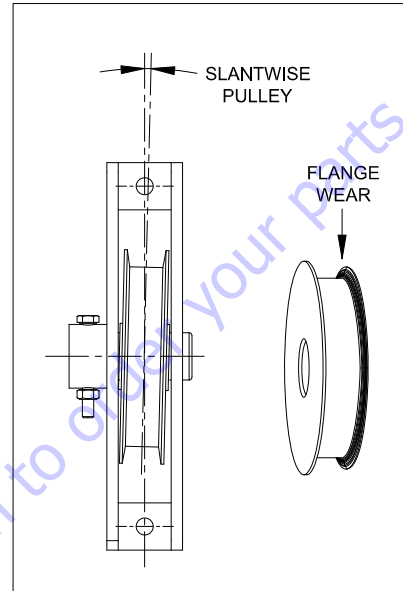

Figure 5-45. Slantwise Pulley

3. Check for iron filings on turntable circular base plate or on pulley support bottom tube. Presence of iron filings indicates a severe pin and pulley assembly wear. Remove the machine from service until the worn pulley assembly has been replaced. Check mast sections alignment after pulley replacement.
4. Measure distance between the top edge of the pulley and the top of the pulley support, then the distance between the bottom edge of the pulley and the bottom of the pulley support. Unequal distances indicate a severe pin and pulley assembly wear. Remove the machine from service until the worn pulley assembly has been replaced.

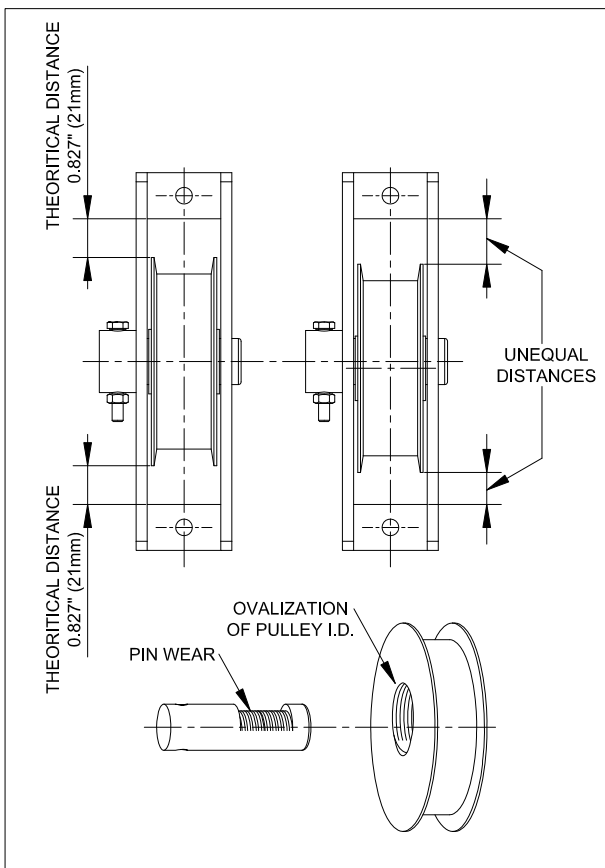

Figure 5-46. Pulley Assembly Wear

Removal and Installation

NOTICE

REMOVE PULLEY SUPPORTS AND/OR PULLEY ONE BY ONE. ALWAYS REPLACE AND SECURE A PULLEY SUPPORT AND/OR A PULLEY BEFORE REMOVING ANOTHER ONE. THE SAME SUITABLE BLOCKINGS USED FOR CHAINS REMOVAL SHOULD BE USED TO SUPPORT MAST SECTION DURING DISASSEMBLY.

NOTE: Unless the pulley supports need replacing, there is no need to remove the lifting chains for removing the pulleys. If the pulley supports need replacing, follow the lifting chain removal and installation procedure. Once the chains slackened, only remove the long anchor to be able to run the chain out of the pulley support (if necessary).

Rotate the turntable to the left to get an easier access to the mast assembly and to be able to install supports for the mast sections.

Pulley Removal

1. Follow the lifting chains removal and installation procedure to install blockings under the appropriate mast section(s).
2. Remove the locknut from a long anchor and loosen the attachment nut to slacken the chain.

3. Remove the hardware securing the pulley support to the mast and slide the pulley support out of the mast.

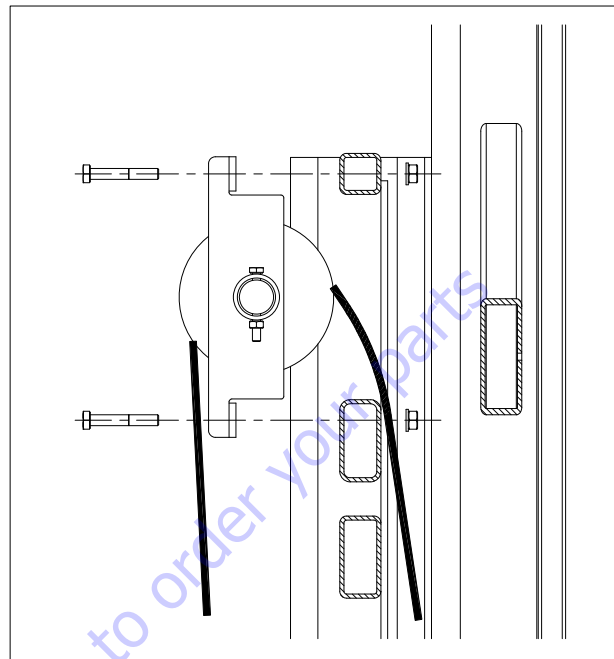

Figure 5-47. Pulley Support Removal

4. Remove the pulley pin locking hardware and drive the pin out while holding the pulley.

Pulley Installation

1. Position the chain over the pulley. Align the pulley with the mounting holes in the pulley support and install the pin. Secure the pin with hardware.
2. Install and secure the pulley support to the mast.
3. Tighten the attachment nut of the long anchor to tension the chain before removing the other pulley support. The locknut will be installed after chains tension adjustment procedure.
4. Remove blocking as described in the lifting chains installation procedure and adjust chains tension accordingly.

5.8 MAST CYLINDER REMOVAL AND INSTALLATION

Mast Cylinder Removal

1. Place the machine on a flat and level surface. Remove chassis hoods and chassis side shield. Rotate the superstructure 90° to the right.
2. Using the ground controls, fully raise the mast.
3. Install a couple of suitable blocking to support mast section #2 as indicated below.

The blockings must rest on turntable circular base plate. Secure the blockings with C-clamps.

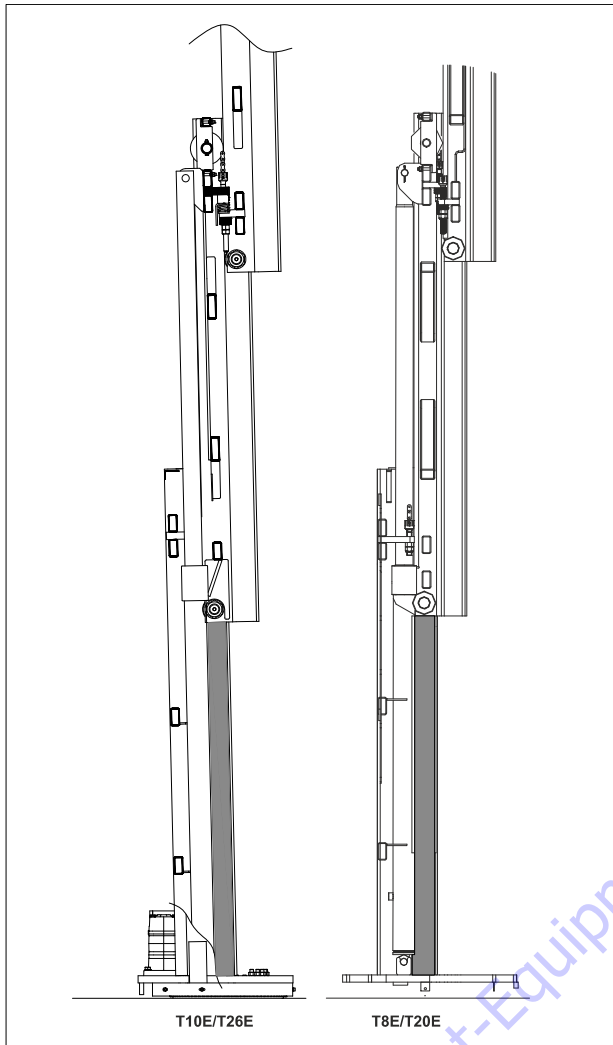

Figure 5-48. Supporting Mast Sections for Mast Cylinder Removal

4. Using the ground controls, lower the mast until mast section #2 bottom rests on blockings.
5. Remove one cotter pin from the mast cylinder anchor pin. Drive the pin out using a suitable drift.
6. While controlling a mast lowering movement from ground controls (or manual descent), manually help the cylinder rod to retract (use a mallet if necessary). Fully retract the rod.
7. Once fully retracted, remove cylinder holding valve: Refer to Section 7.
(T10E/T26E): Unhook the cylinder from its supports. Move the cylinder out of the mast.

T8E/T20E: Using an adequate lifting equipment and slings, remove the mast cylinder.

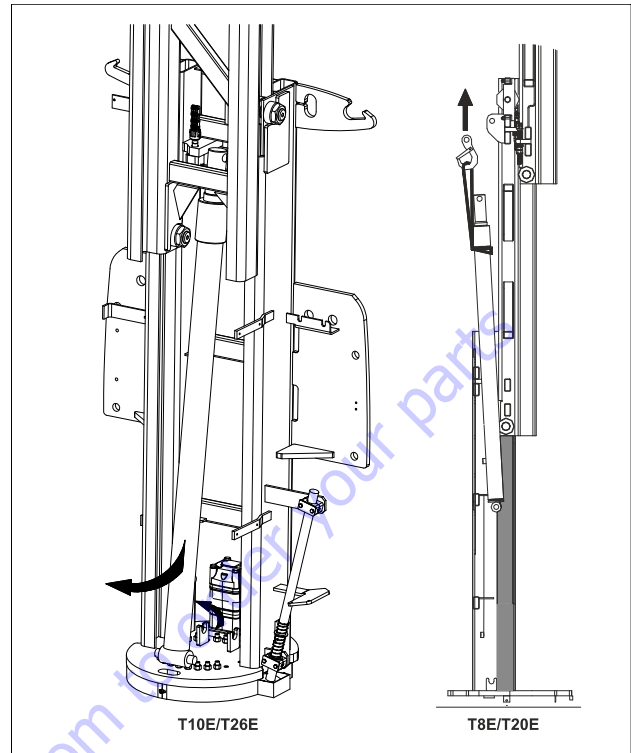

Figure 5-49. Mast Cylinder Removal

NOTE: Care should be taken not to damage the Drive Orientation Switch. Remove the switch if necessary, but do not disconnect. Refer to Section 8-2.

Mast Cylinder Disassembly

Refer to Section 7.

Mast Cylinder Installation

1. Position the cylinder (fully retracted) onto the mast assembly.

NOTE: Route the Drive Orientation Switch harness between the two cylinder supports on turntable base plate (T10E/T26E).

2. Install cylinder holding valve: Refer to Section 7.
3. Using the ground controls, extend the cylinder until the hole of the rod aligns with the mounting holes of the mast section #2. Install the anchor pin and the cotter pin.
4. Using the ground controls, fully extend the cylinder and remove blockings.
5. From ground controls, perform a few mast raising/lowering movements to bleed air from the circuit and to check for proper operation.
6. Check hydraulic fluid level and adjust accordingly. Install chassis shield and hoods.

SECTION 6. JIB AND PLATFORM

6.1 PLATFORM

Platform Removal

1. Place the machine on a flat and level surface. From ground controls, swing the turntable 90° from chassis center line and raise slightly the jib. Shut machine down.
2. Attach slings to the platform railings. Using an overhead crane or another suitable lifting equipment, draw all slack from slings.

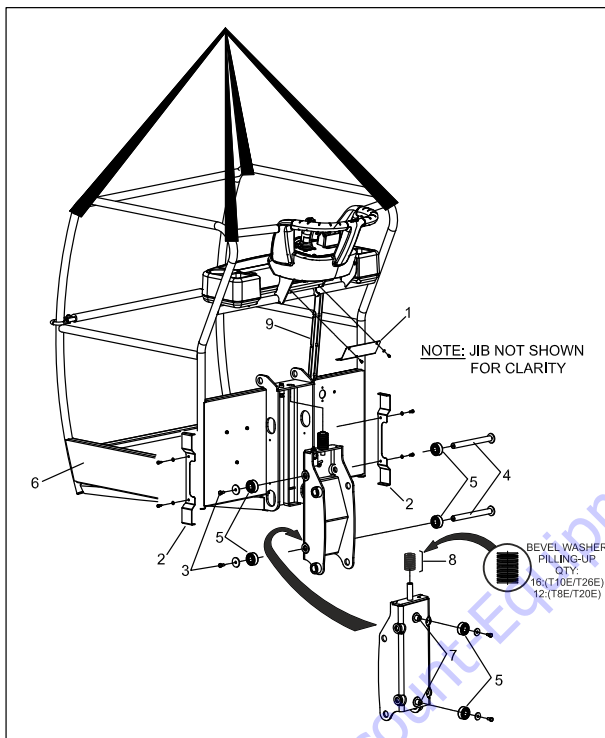

Figure 6-1. Platform Removal-Installation

3. Remove clamp securing electric cables to the platform. If fitted: disconnect AC socket. If fitted: remove clamp securing the air line.
4. Remove platform connectors casing cover (1). Disconnect the connector from the platform console.
5. Remove both side bearings covers (2).
6. Remove one screw (3) from each bearing pin (4). Remove the bearing pins (4). Remove the ball bearings (5).
7. Lift and remove the platform assembly (6).
8. Check the ball bearings (Qty:6) for cracks or hard points. Replace bearings if necessary.

Platform Installation

1. If removed, install ball bearings (5) on platform support front pins (7) and secure with hardware (Use Loctite®243).
2. If removed, install the 16 (T10E/T26E)/12 (T8E/T20E) bevel washers (8) on platform support top pin.
3. Install platform onto its support. Install side ball bearings and pins. Secure with hardware (Use Loctite®243).
4. Install side bearings covers.
5. Correctly route cables (and air hose if fitted) on platform and install clamp(s). Attach cables to platform channel (9) with plastic straps. Insert harness connectors in their casing and install casing cover (1). Plug the connector to platform console. (Connect AC line to socket if fitted).
6. Set overload system: Refer to Section 8-2.

6.2 OVERLOAD SYSTEM

Bevel Washers Lubrication

Bevel washer piling up lubrication is important to maintain overload system accuracy. Coat the spring washers using a brush or by spraying.

Lube Points - Spring Washers

Capacity: A/R

Lube - D (See Table 1-14)

Interval - Every 125 hours of operation or after each cleaning

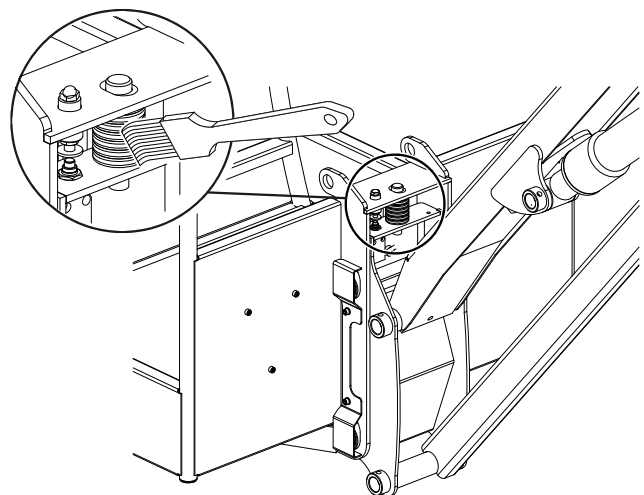

Figure 6-2. Bevel Washer Lubrication

Overload System Verification

Interval - At least every 6 months of operation

1. Turn machine power on at ground control station.
2. Place a 200 kg load evenly distributed on platform floor:
 - No alarm should be triggered.
3. Add weight on platform (additional load not to exceed 30 kg) until the overload warning is activated.
 - RED light indicators at both the ground and the platform control stations blink.
 - An audible alarm sounds.

NOTE: Overload alarm actuation is delayed (Approx. 3 seconds).

4. Remove additional load. Apply a slight force (**F**) on the platform:
 - Alarms stop.

NOTE: Overload alarm stop is delayed (Approx. 5 seconds).

5. If the overload warning is not activated after the addition of 30 kg, set overload system as indicated below before replacing machine into service.

Overload System Setting

Refer to Section 8-2

6.3 JIB CYLINDER REMOVAL AND INSTALLATION

Jib Cylinder Removal

1. Place the machine on a flat and level surface. Swing the turntable 90° from chassis center line. From ground controls, raise the jib to gain access to the cylinder. Just support the platform with an overhead crane or another suitable lifting equipment.

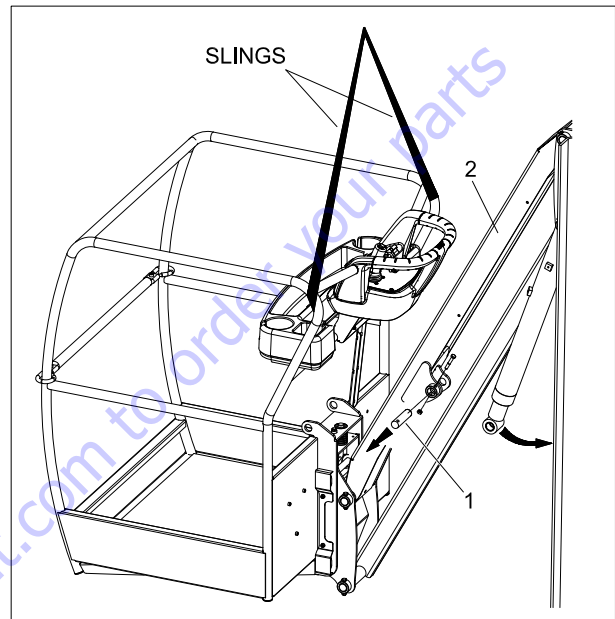

Figure 6-3. Jib Cylinder Removal - Figure 1 of 2

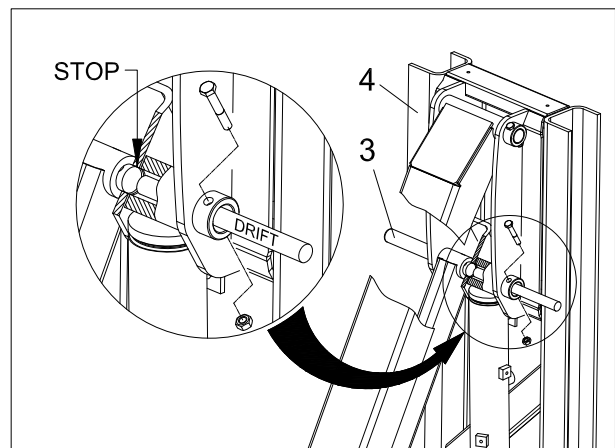

Figure 6-4. Jib Cylinder Removal - Figure 2 of 2

2. Remove cylinder holding valve: Refer to Section 7. Plug cylinder port (3/8" BSPP). Remove hoses clamp from cylinder barrel.
3. Secure the cylinder with suitable slings or supports as required.
4. Remove the hardware securing the cylinder anchor pin (1) to the upper jib (2). Using a suitable brass drift, drive the pin out.

5. Remove the hardware securing the cylinder anchor pin (3) to the mast section #5 (4). Using a suitable brass drift, slowly drive the pin out, just enough to release the cylinder. The pin must stay engaged to hold the lower jib.
6. Remove the cylinder and place in a suitable area.

Jib Cylinder Disassembly

Refer to Section 7.

Jib Cylinder Installation

NOTE: Coat inside diameter of bushings with multi-purpose grease prior to installing pins.

1. Position the jib cylinder using suitable slings or supports. Align barrel end and pin mounting holes on the mast.
2. Using a mallet, drive the pin (3) through the barrel end until being able to install the pin securing hardware.
3. Repeat step 2 for the cylinder rod pin (2). Lift or lower the platform to align rod end and pin mounting holes.
4. Install hose clamp on cylinder barrel. Remove cylinder port plugs and install cylinder holding valve: Refer to Section 7.
5. Perform a few jib movements from the ground control station to bleed the air from the circuit and to check for proper operation.
6. Check hydraulic fluid level and adjust accordingly.

Go to Discount-Equipment.com to order your parts

PARTS FINDER

**Search Website
by Part Number**



**Search Manual
Library For Parts
Manual & Lookup Part
Numbers – Purchase
or Request Quote**

A screenshot of the "Search Manuals" form on the website. The form has a title "Search Manuals" and a subtitle "Please provide information to help us locate the right manual for your parts." It includes several input fields: "Brand" (a dropdown menu), "Model Number" (a text field), "Year" (a dropdown menu), "Serial" (a text field), "Part Number" (a text field), and "Quantity" (a text field). There is a "Search" button at the bottom of the form.

**Can't Find Part or
Manual? Request Help
by Manufacturer,
Model & Description**

A screenshot of the "Parts Order Form" on the website. The form has a title "Parts Order Form" and a subtitle "Please fill in as much information as possible." It includes several input fields: "Manufacturer" (a dropdown menu), "Model" (a text field), "Year" (a dropdown menu), "Description" (a text field), "Part Number" (a text field), "Quantity" (a text field), and "Comments" (a text area). There is a "Submit" button at the bottom of the form.

Discount-Equipment.com is your online resource for quality parts & equipment.

Florida: **561-964-4949** Outside Florida TOLL FREE: **877-690-3101**

Need parts?

Click on this link: <http://www.discount-equipment.com/category/5443-parts/> and choose one of the options to help get the right parts and equipment you are looking for. Please have the machine model and serial number available in order to help us get you the correct parts. If you don't find the part on the website or on once of the online manuals, please fill out the request form and one of our experienced staff members will get back to you with a quote for the right part that your machine needs.

We sell worldwide for the brands: Genie, Terex, JLG, MultiQuip, Mikasa, Essick, Whiteman, Mayco, Toro Stone, Diamond Products, Generac Magnum, Airman, Haulotte, Barreto, Power Blanket, Nifty Lift, Atlas Copco, Chicago Pneumatic, Allmand, Miller Curber, Skyjack, Lull, Skytrak, Tsurumi, Husquvarna Target, , Stow, Wacker, Sakai, Mi-T- M, Sullair, Basic, Dynapac, MBW, Weber, Bartell, Bennar Newman, Haulotte, Ditch Runner, Menegotti, Morrison, Contec, Buddy, Crown, Edco, Wyco, Bomag, Laymor, Barreto, EZ Trench, Bil-Jax, F.S. Curtis, Gehl Pavers, Heli, Honda, ICS/PowerGrit, IHI, Partner, Imer, Clipper, MMD, Koshin, Rice, CH&E, General Equipment, ,AMida, Coleman, NAC, Gradall, Square Shooter, Kent, Stanley, Tamco, Toku, Hatz, Kohler, Robin, Wisconsin, Northrock, Oztec, Toker TK, Rol-Air, Small Line, Wanco, Yanmar

SECTION 7. HYDRAULICS

7.1 HYDRAULIC TANK

Tank Capacity: 6 liters (1.59 gallons)
 Hydraulic system capacity: approximately 9 liters (2.38 gallons)

Oil Level

Oil level should be checked daily. Hydraulic oil should be changed every 1000 hours of machine operation or at least every 2 years.

NOTE: Check oil level with the wheels fully steered to the left.

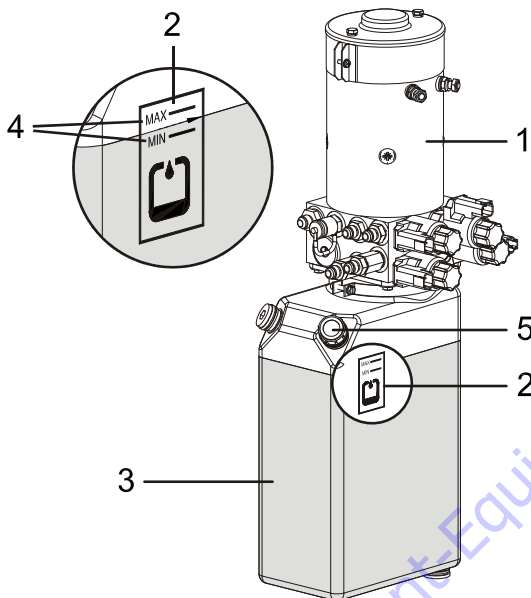

Figure 7-1. Hydraulic Oil Check

1. Open the access door to the hydraulic power unit (1).
2. Locate the decal (2) on the tank (3).
3. The oil level in the tank must be within the MIN (minimum) and MAX (maximum) markings (4) of the decal.

Oil Level if Decal is Missing

Figure 7-2. Oil Level if Decal is Missing

Adding Oil to the System

NOTE: Care should be taken not to introduce any impurities (dirt, water, etc...) while cap or plug is removed.

1. Wipe all dirt and debris from the filler/breather cap (5) area.
2. Remove (pull) the filler/breather cap (5).
3. Add proper grade of oil by using a clean funnel. Fill until oil level is between the MIN and MAX markings (4). Replace the cap.

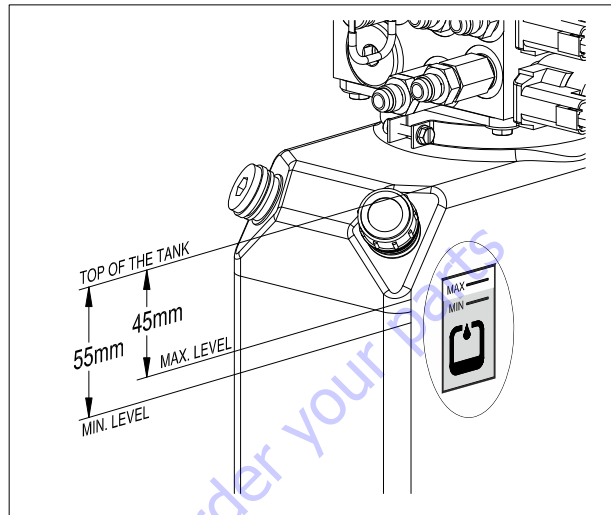
Tank Draining/Cleaning

1. Using the ground controls, fully raise the mast and the jib.
2. Disconnect hydraulic line from port 1 of the hydraulic power unit.
3. Place the hose in a collecting tank.
4. Using the manual descent, fully lower the mast and the jib to collect oil from the circuit.
5. Reconnect hydraulic line to port 1. Using the ground controls, raise the jib till pump unpriming.
6. Disconnect hydraulic line from port 1. Place the hose in the collecting tank. Fully lower the jib using the manual descent.
7. Cap/Plug hydraulic line and valve body port.

- Loosen the two bolts securing the hydraulic power unit.

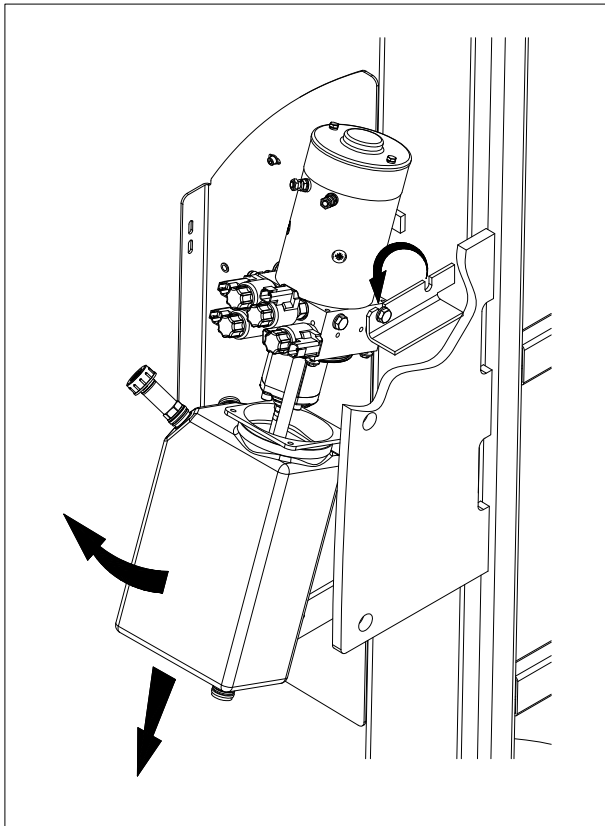

Figure 7-3. Tank Draining/Cleaning

- Lift, slide and tilt the power unit.
- Loosen the tank clamp screw. Remove the hardware securing the tank. Remove the tank.
- Drain and wipe the tank.
- Remove and wipe the oil strainer.
- Install the oil strainer on the suction pipe. Install and secure the tank to the power unit. Secure the hydraulic power unit to the machine.
- Replace the hydraulic filter. Refer to Section 7-2.
- Connect hydraulic line to port 1.

Tank Filling

- Remove the filler/breather cap and fill the tank up to the MAX level marking.
- Using the ground controls, fully raise and lower the mast and the jib to bleed the air from the circuit.
- Bleed the proportional pressure relief valve. Refer to Chapter 7-3 of this manual.
- From platform console, fully steer the wheels to the right.
- Check hydraulic fluid level and adjust accordingly.

7.2 HYDRAULIC FILTER REPLACEMENT

Lube Point: Replaceable Element.

Interval: After first 50 hours of operation and every 250 hours thereafter.

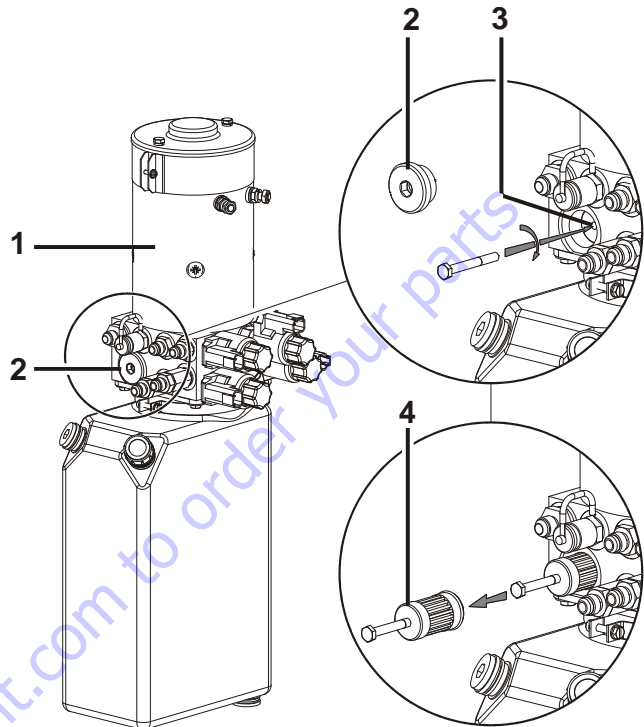

Figure 7-4. Oil Filter Replacement

- Turn machine power off at ground control station.
- Open the access door to the hydraulic power unit (1).
- Wipe all dirt and debris from the filter plug (2) area.
- Unscrew the filter plug (2).
- Install a screw (M6) in the threaded hole (3) of the filter and extract the filter (4). Use a container to collect oil that can spill from the filter cavity.
- Install a new filter (oil the filter O-ring before insertion) and the filter plug.
- Turn machine power on and perform a few swinging movements from the ground control station to bleed the air from the circuit.

7.3 HYDRAULIC POWER UNIT

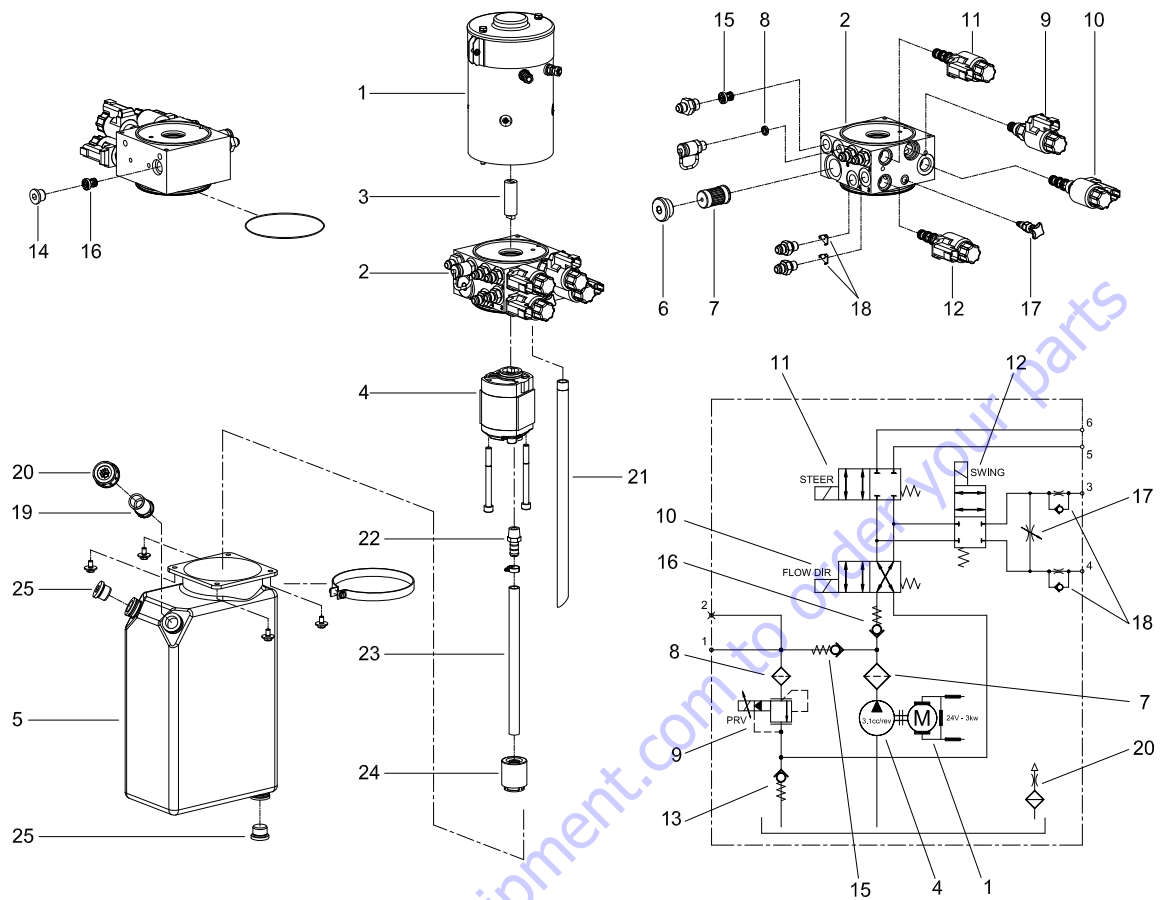

Figure 7-5. Hydraulic Power Unit

- 1- Electric Motor
- 2- Valve Body
- 3- Coupling
- 4- Pump (Gear pump)
- 5- Tank
- 6- Filter Plug
- 7- Filter
- 8- Filter Screen
- 9- Proportional Pressure Relief Valve
- 10- Flow Directional Valve
- 11- Steer Valve
- 12- Swing Valve
- 13- Check Valve (Built-in)
- 14- Plug - 3/8" BSPP
- 15- Check Valve
- 16- Check Valve
- 17- Swing Motor By-Pass Valve (Needle Valve)
- 18- Flow Regulator (Jet)
- 19- Adapter
- 20- Filler/Breather Cap
- 21- Return Pipe
- 22- Adapter
- 23- Suction Pipe
- 24- Strainer
- 25- Plug - 1/2" BSPP (plastic)

Ports Identification

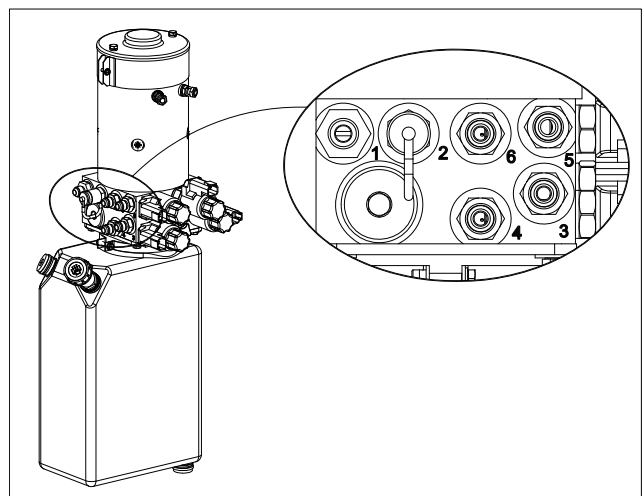

Figure 7-6. Ports Identification

SECTION 7 - HYDRAULICS

Port 1: Mast and Jib Lift Up/Down

Port 2: Pressure Plug

Port 3: Swing Right

Port 4: Swing Left

Port 5: Steer Left

Port 6: Steer Right

Hydraulic Lines Connections

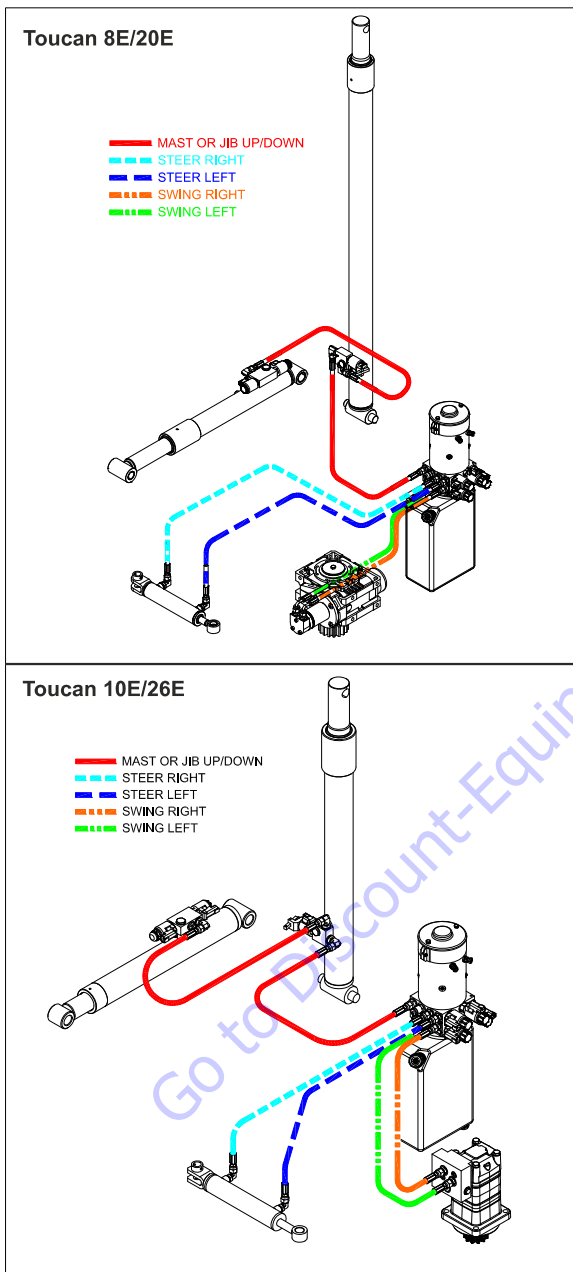

Figure 7-7. Hydraulic Lines Connections

Proportional Pressure Relief Valve

This two stage spool type proportional relief valve (9) (Refer to Figure 7-5.) is controlled by a PWM signal delivered by the master controller. As a function of the electrical control signal, the pressure relief value changes. When

a machine function is performed, the valve is controlled with a signal corresponding to the appropriate relief pressure.

NOTICE

THE COIL OF THE PROPORTIONAL RELIEF VALVE IS SPECIALLY DESIGNED FOR PROPORTIONAL CONTROLS APPLICATIONS. DO NOT INVERT THIS COIL WITH ANOTHER DIRECTIONAL VALVE COIL. THE VOLTAGE INDICATION ON THE PROPORTIONAL COIL IS 24 "VADC" AND ITS RESISTANCE VALUE IS 8.8 OHMS.

NOTICE

AFTER REPLACEMENT OF THE PROPORTIONAL RELIEF VALVE AND/OR THE PROPORTIONAL COIL, ALL PRESSURE RELIEF VALUES MUST BE CHECKED AND ADJUSTED ACCORDINGLY.

Refer to Section 9.4 for proper proportional relief valve adjustment procedure.

Air Bleeding

Air entrapped in the valve pole tube can cause noisy operation of the valve when relieving the pressure. This can be due to an insufficient fluid level in the hydraulic reservoir. Check oil level as previously indicated. This can also appear after the hydraulic circuit has been serviced.

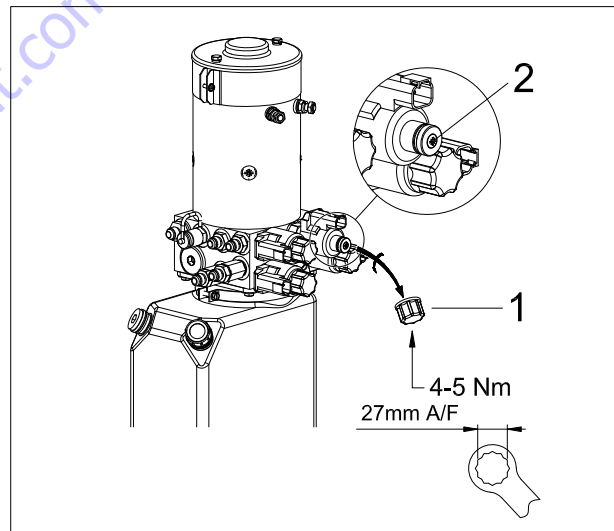

Figure 7-8. Air Bleeding

1. From ground controls, operate a jib lift up movement till the jib is fully raised.
2. Unscrew and remove the valve coil nut (1).
3. Using a screw driver of appropriate dimension, loosen the bleeding screw (2) from about 3 turns (Do not remove the screw).
4. Continue jib operation (with the jib cylinder fully extended). Once a continuous and regular oil flow comes out from the valve bleeding orifice, tighten the bleeding screw to 1 N.m.
5. Install coil nut (1).

Flow Directional Valve

This 4-Way, 2-Position Solenoid Valve (10) (Refer to Figure 7-5.) allows flow direction change for Steering and Swinging movements.

The coil of the valve is supplied when a RIGHT Steering or LEFT Swinging movement is controlled.

Steer Valve

This 4-Way, 2-Position Solenoid Valve (11) (Refer to Figure 7-5.) is supplied each time a Steering movement is controlled.

Swing Valve

This 4-Way, 2-Position Solenoid Valve (12) (Refer to Figure 7-5.) is supplied each time a Swing movement is controlled.

Swing Motor By-Pass Valve

This Needle Valve (17) (Refer to Figure 7-5.) allows swing motor by-passing for manual swinging operation. In normal operation, this valve must be closed (fully screwed in).

Electric Motor

Terminal Tightening:

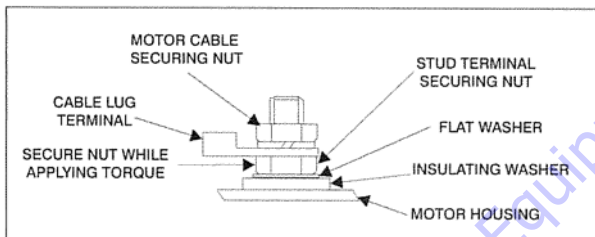

Figure 7-9. Terminal Tightening

Dust Cleaning:

Due to a possible built-up of dust from brush wear inside the pump motor cover around the brushes and armature under heavy usage, it is recommended to perform this dust cleaning task on an annual basis. Use clean, oil free, compressed air.

1. Disconnect the battery plug.
2. Remove the protection cover from the motor.
3. Blow any accumulated brush dust around the brushes and armature commutator.
4. Check brushes for wear, replace if necessary.

5. Once complete, reassemble for operation.



Figure 7-10. Dust Cleaning

Brush Wear Check (Qty 4):

Replace brushes that are worn below their usable length (10 mm (0.40 in.)), show signs of uneven wear or signs of overheating, such as discolored brush shunts and brush springs. Brushes should always be replaced in complete sets of four. Use identical replacement parts; do not substitute brush grades as the brushes are matched to the motor type and application to provide the best service. Substituting brushes of the wrong grade can cause premature commutator failure and excessive brush wear.

Brush Removal:

NOTE: No hydraulic power unit connections, hydraulic or electrical need to be disconnected.

1. Disconnect battery plug.
2. Loosen the two bolts securing the hydraulic power unit. Lift and slide the power unit.

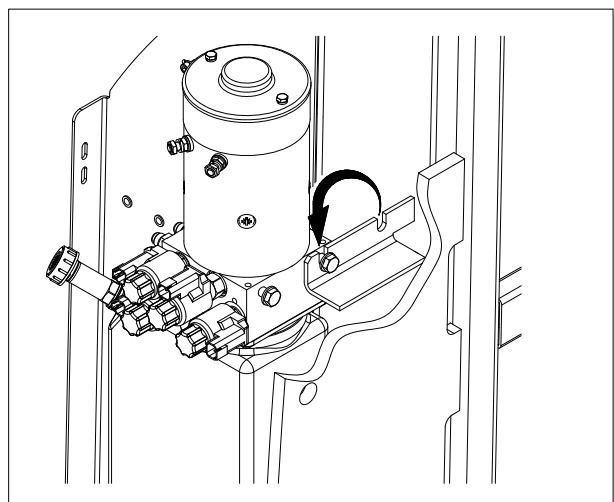

Figure 7-11. Moving Hydraulic Power Unit

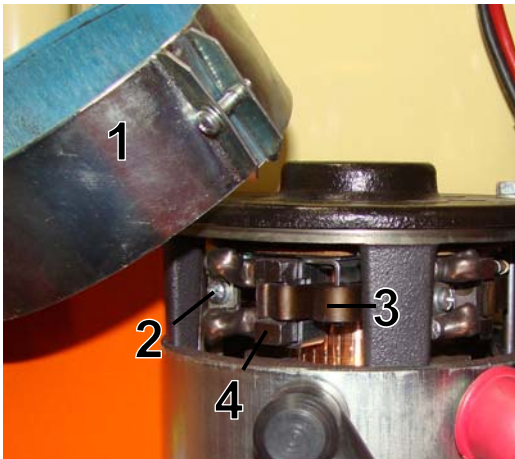

Figure 7-12. Motor Brushes

3. Remove the protection cover from the motor (1).
4. Remove the brush terminal screw (2).
5. Lift the spiral spring (3) and remove the brush (4) from its housing.
6. Repeat previous steps for each brush (Qty: 4).

Brushes Installation:

1. Lift the spiral spring (3) and slide the brush (4) into its housing.
2. Attach the brush terminal end to the terminal post using the terminal screw (2).
3. Repeat previous steps for each brush.
4. Install the protection cover (1).
5. Secure the hydraulic power unit to the machine, as originally installed.
6. Connect battery plug and check for proper operation of the machine.

7.4 SWING MOTOR

NOTE: Refer to Section 5 of this manual for swing motor removal procedure.

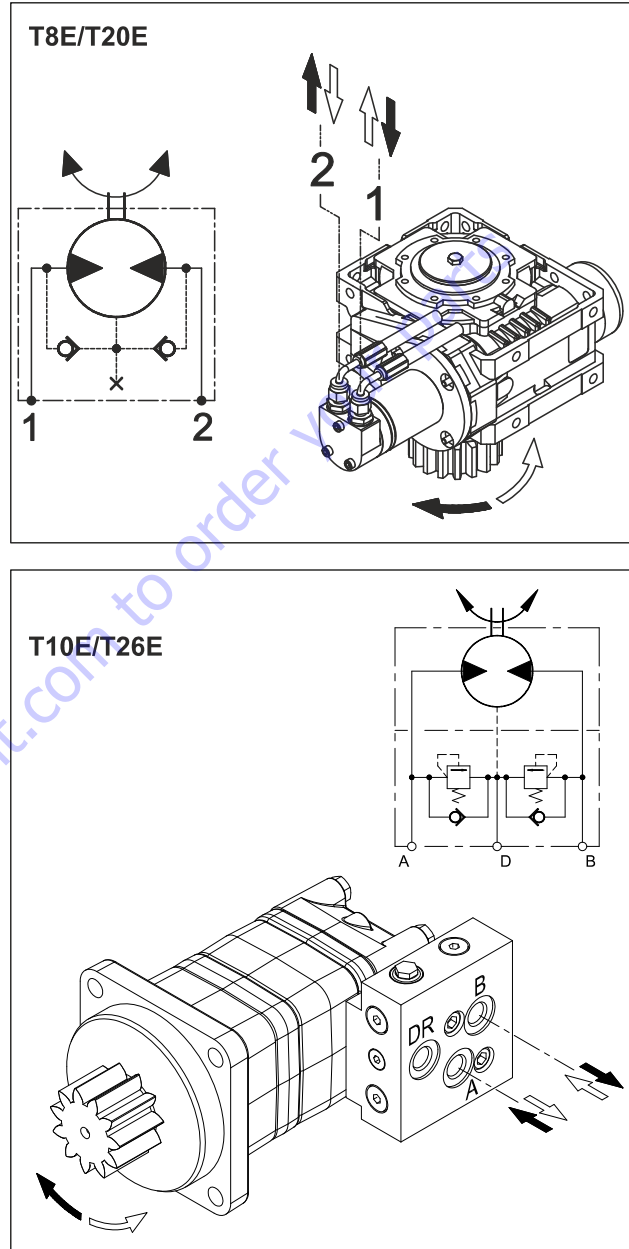

Figure 7-13. Swing Motors

Ports Identification

Toucan 8E/Toucan 20E

- Port 1: Swing Right
- Port 2: Swing Left

Toucan 10E/Toucan 26E

- Port A: Swing Left
- Port B: Swing Right
- Port DR: Drain Port - Plugged

7.5 CYLINDERS HOLDING VALVES

Mast Cylinder Holding Valve

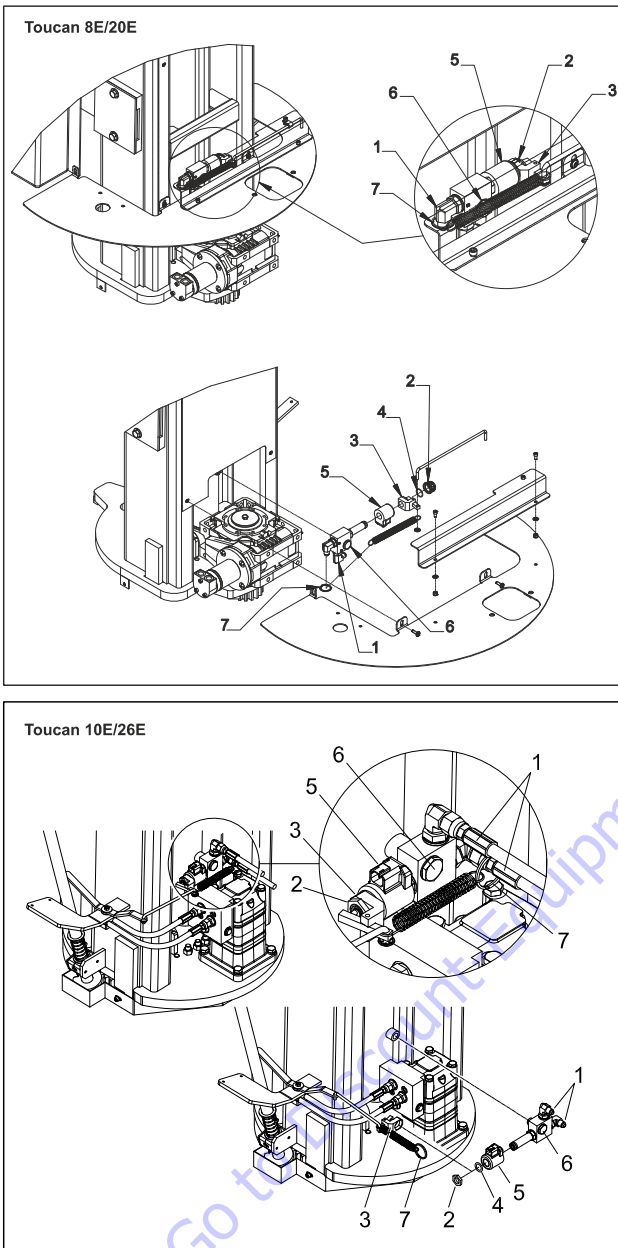

Figure 7-14. Mast Cylinder Holding Valve - Removal/Installation

Valve Removal

⚠ WARNING

ENSURE THAT THE MAST IS FULLY LOWERED (OR SAFELY SUPPORTED) BEFORE DISMOUNTING THE VALVE. DISCONNECT BATTERY PLUG UNTIL THE REPAIRS ARE COMPLETED.

1. Remove chassis hoods. Swing the structure 90° to the right. Fully raise the mast and install suitable blockings to support mast section #2 (Refer to Sec-

tion 5). Lower the mast until mast section #2 rests on blockings. Turn power off at ground controls. Disconnect battery plug.

2. Remove the carter and the seal cover plate (T8E/T20E).
3. Tag, disconnect and cap mast cylinder hydraulic lines and ports (1).
4. Remove the spring ring (7) from the elbow adapter.
5. Unscrew coil nut (2), remove the manual override device (3), the O-ring (4) and the coil (5).
6. Unscrew the valve mounting screw (6) and plug the cylinder port (3/8" BSPP).

Valve Installation

1. Check presence and condition of the two BS rings. Install the valve onto the cylinder. Keep the solenoid valve perpendicular to the cylinder and torque the banjo bolt (6) 38 to 42 Nm (28 to 31 ft lbs).

CAUTION

DO NOT OVER-TORQUE THE VALVE BANJO BOLT.

2. Install the coil (5), the O-ring (4), the manual override device (3) and tighten the coil nut (2).
3. Attach the spring ring (7) to the elbow adapter and connect hydraulic and electric lines as previously tagged.
4. Connect battery plug. Using ground controls, raise the mast and remove blockings.
5. Perform a few mast raising/lowering movements to bleed air from the circuit and to check for proper operation.
6. Check the mast manual descent for proper operation.
7. Install chassis hoods.
8. Check hydraulic fluid level and adjust accordingly.

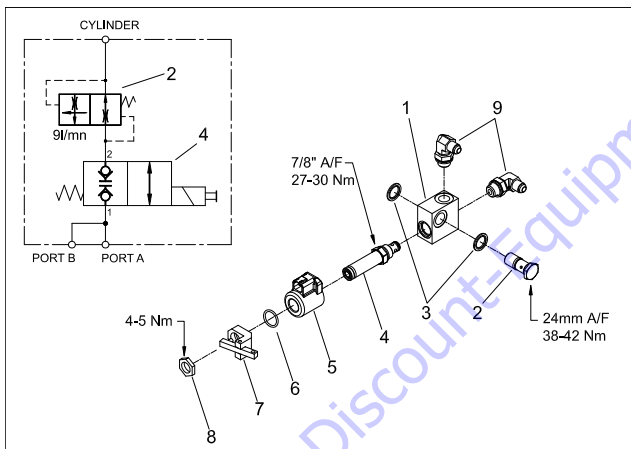

Figure 7-15. Mast Cylinder Holding Valve - Schematic/Exploded View

1. Ported Body
2. Banjo Bolt w/ Built-in Flow Regulator
3. BS Ring
4. Mast Solenoid Valve
5. Coil - 24 VDC
6. O-Ring
7. Manual Override Device
8. Coil Nut
9. Elbow Adapter

Jib Cylinder Holding Valve

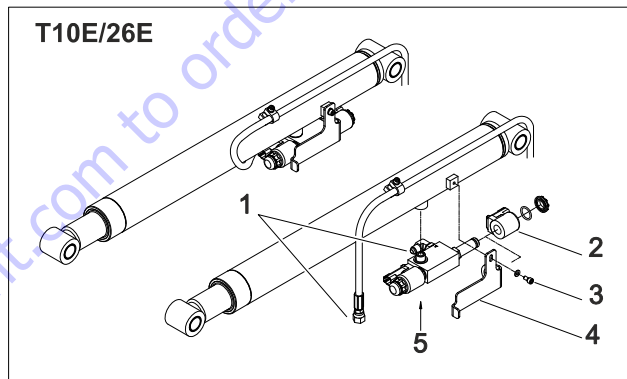
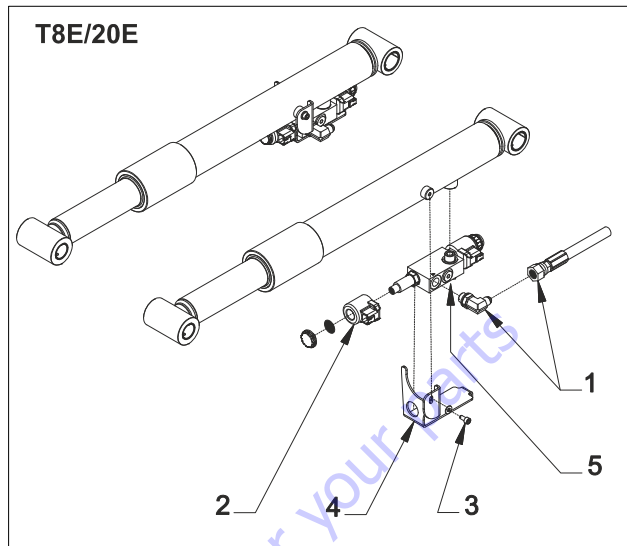

Figure 7-16. Jib Cylinder Holding Valve - Removal/Installation

Valve Removal

WARNING

ENSURE THAT THE JIB IS FULLY LOWERED (OR SAFELY SUPPORTED) BEFORE DISMOUNTING THE VALVE. DISCONNECT BATTERY PLUG UNTIL THE REPAIRS ARE COMPLETED.

1. Ensure the jib is lowered (or safely supported - Refer to Section 5). Turn power off at ground controls. Disconnect battery plug.
2. Tag and disconnect electric lines from the solenoid valve coils.
3. Disconnect and cap the cylinder hydraulic line and port (1).
4. Remove the coil from the Jib Up solenoid valve (2).
5. Unscrew the hardware (3) securing the valve protector (4) and remove the protector.
6. Unscrew the valve banjo bolt (5) and plug the cylinder port (3/8" BSPP).

Valve Installation

1. Remove the coil from the Jib Up solenoid valve (2).
2. Check presence and condition of the two BS rings. Install the valve onto the cylinder. Keep the block in line with the cylinder and torque the banjo bolt (5) 38 to 42 Nm (28 to 31 ft lbs).

CAUTION

DO NOT OVER-TORQUE THE VALVE BANJO BOLT.

3. Slide the valve protector onto the Jib Up solenoid valve (2) and secure with hardware (3).
4. Install the coil onto the solenoid valve. Install the O-ring and tighten the coil nut 4 to 5 Nm (2.8 to 3.7 ft lbs).
5. Remove port plug and hydraulic line cap. Correctly connect line to valve port.
6. Connect electric lines to solenoid valve coils as previously tagged.
7. Connect battery plug.
8. From platform console, perform at least 5 (five) Jib Up/Down movement (full stroke) to bleed the air from the circuit and to check for proper operation.
9. Raise the jib to horizontal position and stop. Perform a Jib Lowering movement. If there is a jerk upwards before the jib begins to go down, the circuit is not correctly bled. Perform additional Jib Up/Down movements (full stroke) and repeat this step until all air is bled from the circuit.
10. Check hydraulic fluid level and adjust accordingly.

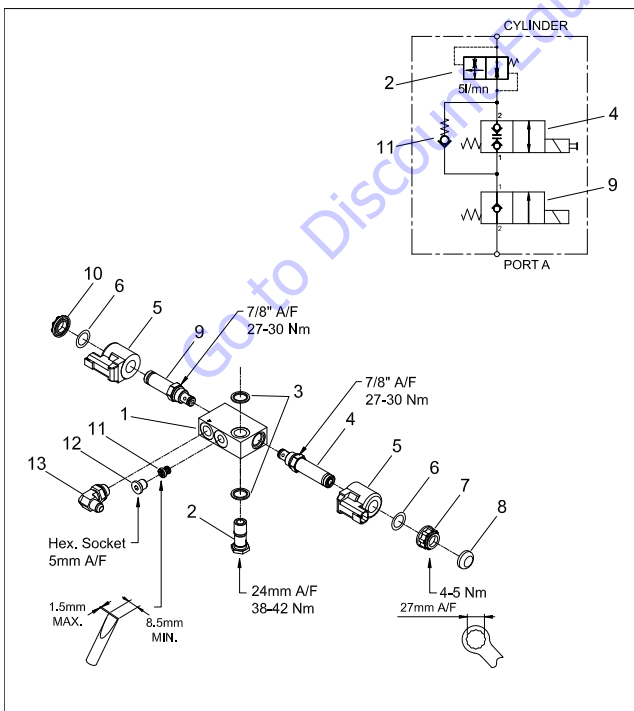

Figure 7-17. Jib Cylinder Holding Valve - Schematic/Exploded View

1. Ported Body
2. Banjo Bolt w/ Built-in Flow Regulator
3. BS Ring
4. Jib Down Solenoid Valve
5. Coil - 24 VDC
6. O-Ring
7. Coil Nut
8. Manual Override Boot
9. Jib Up Solenoid Valve
10. Coil Nut
11. Check Valve
12. Plug - 1/4" BSPP
13. Elbow Adapter

7.6 CYLINDER REPAIR

NOTE: The following are general procedures that apply to all the cylinders of the machine. Procedures that apply to a specific cylinder will be so noted.

NOTE: After cylinder removal, it is recommended to replace bushings (if fitted). Refer to Section 1 for bushings installation procedure.

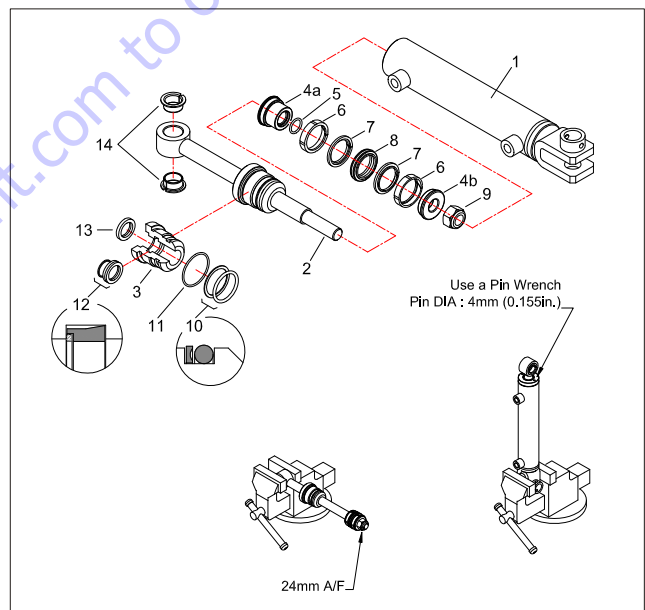

Figure 7-18. Steer Cylinder

1. Barrel
2. Rod
3. Gland
4. Piston (a-b)
5. O-Ring
6. Piston Angled guide
7. Split Back-up Ring
8. O-Ring
9. Locknut
10. O-Ring + Back-up Ring
11. O-Ring
12. Rod Seal
13. Wiper Seal
14. Flange Bushing

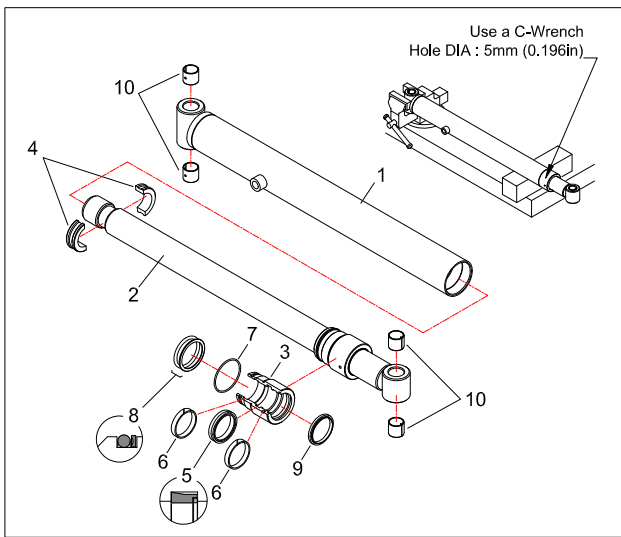

Figure 7-19. Jib Cylinder

1. Barrel
2. Rod
3. Gland
4. Rod Guide
5. Rod Seal
6. Guide Band
7. O-Ring
8. O-Ring + Back-up Ring
9. Wiper Seal
10. Bushing

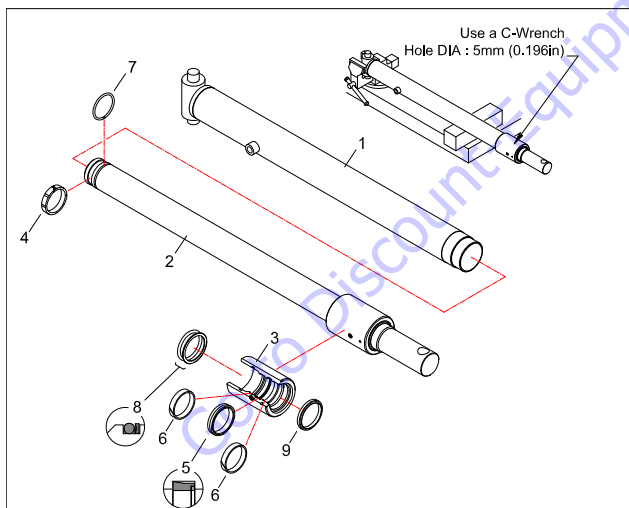

Figure 7-20. Mast Cylinder

1. Barrel
2. Rod
3. Gland
4. Rod Guide
5. Rod Seal
6. Guide Band
7. Snap Ring
8. O-Ring + Back-up Ring
9. Wiper Seal

Disassembly

NOTICE

NEVER USE COMPRESSED AIR TO EXTRACT THE ROD FROM THE BARREL OR TO CYCLE THE CYLINDER.

NOTICE

DISASSEMBLY OF A CYLINDER SHOULD BE PERFORMED ON A CLEAN WORK SURFACE IN A DIRT FREE WORK AREA.

NOTICE

IF USING A VISE TO HOLD CYLINDER BARREL, NEVER CLAMP THE BARREL TUBE WITH THE VISE'S JAWS.

1. Drain oil from the cylinder.
2. Place the cylinder barrel into a suitable holding fixture.
3. Using an appropriate tool (Pin Wrench or C-Wrench), loosen the barrel head gland by turning it in counter-clockwise direction.
4. Withdraw the rod assembly from the barrel taking care not to damage the chrome surface of the rod(s).
5. Steer cylinder only: place the rod assembly into a suitable holding fixture.
6. Steer cylinder only: loosen the piston attachment locknut. Remove piston parts and withdraw barrel head gland from the rod.
Mast and Jib Cylinders: remove the rod guide (No need for removing the snap ring from the mast cylinder rod). Withdraw barrel head gland from the rod.
7. Remove and discard seals, O-rings, back-up rings and guide bands from the piston and the barrel head gland.
8. Align discarded seals and rings in the order of disassembly as reminder for new seals and rings installation.

Inspection

1. Clean all parts thoroughly with an approved cleaning solvent.
2. Inspect the cylinder rod for scoring, tapering, ovality or other damage. If necessary, dress rod with Scotch Brite or equivalent. Replace cylinder if necessary.
3. Inspect threaded portion of the rod for excessive damage. Dress threads as necessary.
4. Inspect the inner surface of the cylinder barrel tube for scoring or other damage. Check inside diameter for tapering or ovality. Replace cylinder if necessary.
5. Inspect threaded portion of the barrel for damage. Dress threads as necessary.

6. If applicable, inspect piston surface for damage and scoring and for distortion. Dress piston surface as necessary.
 7. If applicable, inspect piston grooves for burrs and sharp edges. Dress applicable surface as necessary.
 8. Inspect cylinder head gland inside diameter for scoring or other damage and for ovality and tapering. Replace cylinder if necessary.
 9. Inspect threaded portion of cylinder head gland for damage. Dress threads as necessary.
 10. Inspect seals grooves in head gland for burrs and sharp edges. Dress applicable surfaces as necessary.
 11. Inspect cylinder head gland outside diameter for scoring or other damage and ovality and tapering. Replace cylinder if necessary.
 12. If applicable, inspect rod and barrel bushings for excessive wear or damage. Replace as necessary.
 13. Inspect the oil ports for blockage or the presence of dirt or other foreign material. Repair as necessary.
- the cylinder barrel. Ensure that piston seals are not damaged or dislodged when entering the threaded area of the barrel (Steer cylinder).
8. Continue pushing the rod into the barrel until the cylinder head gland can be inserted into/onto the barrel cylinder.
 9. Secure the cylinder head gland.
 10. After the cylinder has been reassembled, the rod should be pushed all the way (fully retracted).

Assembly

NOTE: Prior to cylinder assembly, ensure that the proper cylinder seal kit is used. See your JLG Parts manual. Apply a light film of hydraulic oil to all components prior to assembly.

1. Install new seal(s), backup ring(s) and guide bands into the applicable cylinder head gland groove(s). Mast and Jib cylinder only: install guide bands so that the splits are not in alignment with each other.
2. Use a soft mallet to tap a new wiper seal into the applicable cylinder head gland groove (the flat part of seal must be facing into head).
3. Jib and steer cylinders only: place new O-rings and backup rings in the applicable outside diameter grooves of the cylinder head.
4. Carefully install the head gland on the rod, ensuring that the wiper and rod seals are not damaged or dislodged.
5. Steer cylinder only: install O-ring, piston seal, angled guides and split backup rings on piston parts and slide the piston assembly on the rod. Secure the piston assembly with the locknut. Mast cylinder only: install a new rod guide.
6. Position the barrel in a suitable holding fixture.

NOTICE

EXTREME CARE SHOULD BE TAKEN WHEN INSTALLING THE CYLINDER ROD, HEAD AND PISTON. AVOID PULLING THE ROD OFF CENTER, WHICH COULD CAUSE DAMAGE TO THE PISTON AND CYLINDER BARREL SURFACES.

7. With the barrel clamped securely, and while adequately supporting the rod, insert the piston end into

PARTS FINDER

**Search Website
by Part Number**



**Search Manual
Library For Parts
Manual & Lookup Part
Numbers – Purchase
or Request Quote**

**Can't Find Part or
Manual? Request Help
by Manufacturer,
Model & Description**

Discount-Equipment.com is your online resource for quality parts & equipment.

Florida: **561-964-4949** Outside Florida TOLL FREE: **877-690-3101**

Need parts?

Click on this link: <http://www.discount-equipment.com/category/5443-parts/> and choose one of the options to help get the right parts and equipment you are looking for. Please have the machine model and serial number available in order to help us get you the correct parts. If you don't find the part on the website or on once of the online manuals, please fill out the request form and one of our experienced staff members will get back to you with a quote for the right part that your machine needs.

We sell worldwide for the brands: Genie, Terex, JLG, MultiQuip, Mikasa, Essick, Whiteman, Mayco, Toro Stone, Diamond Products, Generac Magnum, Airman, Haulotte, Barreto, Power Blanket, Nifty Lift, Atlas Copco, Chicago Pneumatic, Allmand, Miller Curber, Skyjack, Lull, Skytrak, Tsurumi, Husquvarna Target, , Stow, Wacker, Sakai, Mi-T- M, Sullair, Basic, Dynapac, MBW, Weber, Bartell, Bennar Newman, Haulotte, Ditch Runner, Menegotti, Morrison, Contec, Buddy, Crown, Edco, Wyco, Bomag, Laymor, Barreto, EZ Trench, Bil-Jax, F.S. Curtis, Gehl Pavers, Heli, Honda, ICS/PowerGrit, IHI, Partner, Imer, Clipper, MMD, Koshin, Rice, CH&E, General Equipment, ,AMida, Coleman, NAC, Gradall, Square Shooter, Kent, Stanley, Tamco, Toku, Hatz, Kohler, Robin, Wisconsin, Northrock, Oztec, Toker TK, Rol-Air, Small Line, Wanco, Yanmar

SECTION 8. CONTROL COMPONENTS

8.1 CONTROL COMPONENTS OVERVIEW

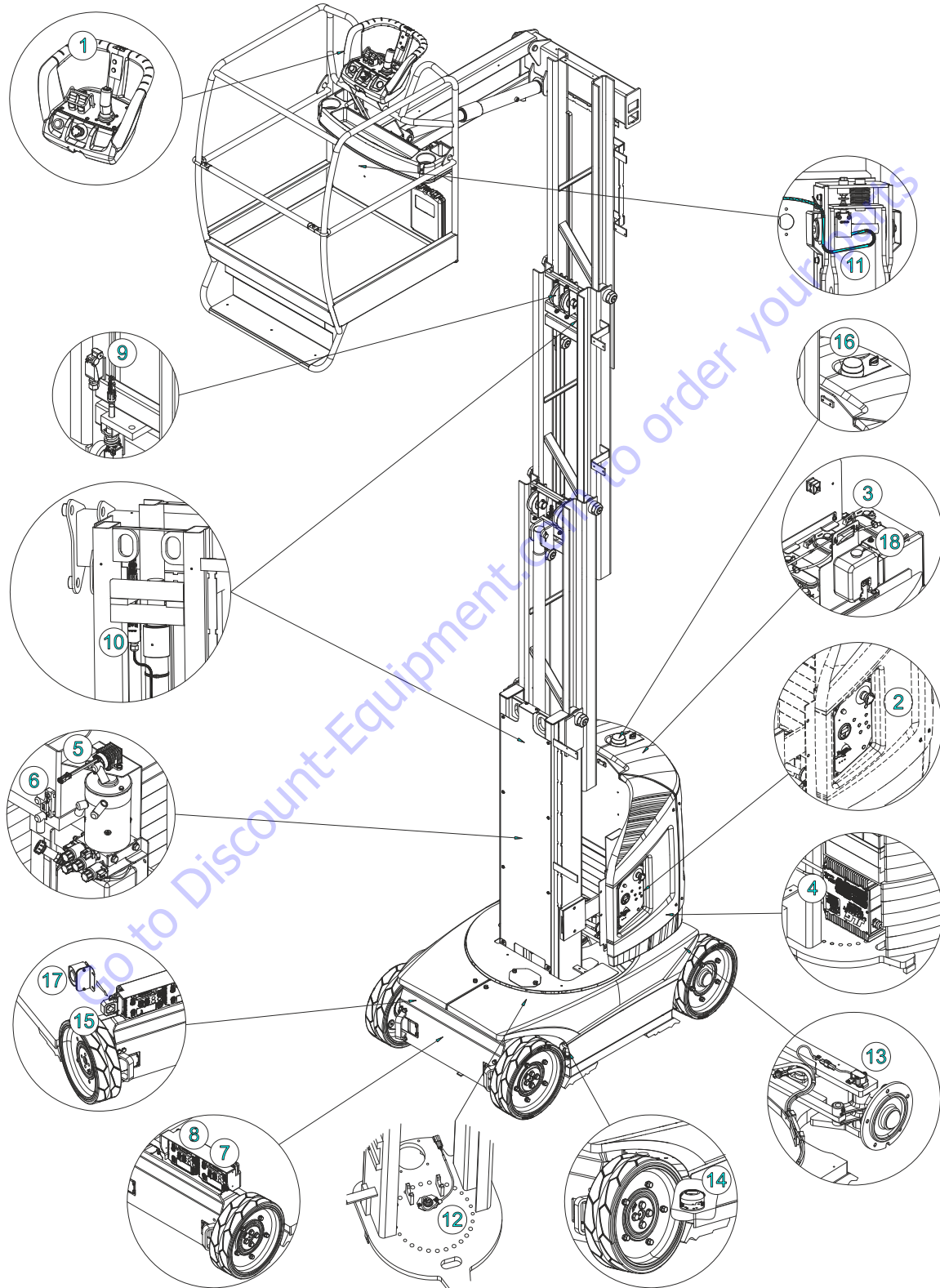

Figure 8-1. Control Components Location - T8E/T20E

SECTION 8 - CONTROL COMPONENTS

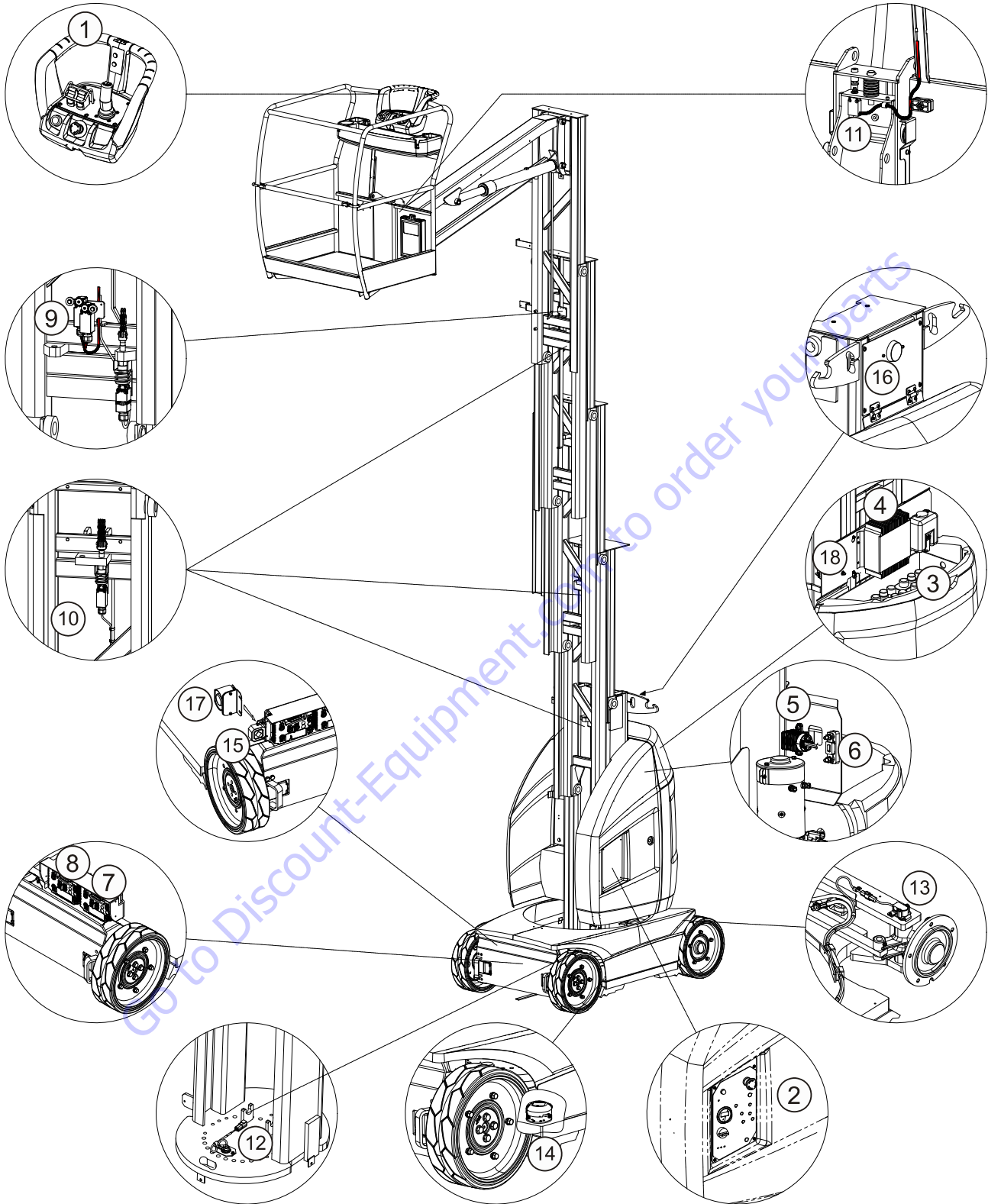

Figure 8-2. Control Components Location - T10E/T26E

1. Platform Control Station
2. Ground Control Station
3. Battery Pack
4. Battery Charger
5. Main Contactor Power Relay
6. Power Fuse
7. Power Module - Master
8. Power Module - Slave
9. Mast Elevation Limit Switch(es)
10. Chain Slack Sensors
11. Overload Sensor
12. Drive Orientation Switch
13. Steering Sensor
14. Tilt Sensor
15. Ground Alarm
16. Warning Beacon
17. Descent/Motion Alarm (Optional)
18. Battery Centralized Filling Switch

8.2 CONTROL COMPONENTS - SERVICE

NOTICE

BEFORE REMOVING ANY COMPONENT FROM THE ELECTRICAL SYSTEM, DISCONNECT THE BATTERIES USING THE QUICK-DISCONNECT LOCATED IN THE BATTERY PACK COMPARTMENT.

Battery Maintenance and Safety Practices

WARNING

ENSURE THAT BATTERY ACID DOES NOT COME INTO CONTACT WITH SKIN OR CLOTHING. WEAR PROTECTIVE CLOTHING AND EYEWEAR WHEN WORKING WITH BATTERIES. NEUTRALIZE ANY BATTERY ACID SPILLS WITH BAKING SODA AND WATER.

RINGS, WATCHES OR ANY OTHER JEWELRY MUST BE REMOVED DURING MAINTENANCE OR ANY SERVICING OPERATION ON THE BATTERY.

BATTERY ACID RELEASES AN EXPLOSIVE GAS WHILE CHARGING, ALLOW NO OPEN FLAMES, SPARKS OR LIGHTED TOBACCO PRODUCTS IN THE AREA WHILE CHARGING BATTERIES. CHARGE BATTERIES ONLY IN A WELL VENTILATED AREA.

ADD ONLY DISTILLED WATER TO BATTERIES. ADD WATER TO BATTERIES AFTER CHARGING TO AVOID ELECTROLYTE OVERFLOW.

WARNING

DO NOT REPLACE ITEMS CRITICAL TO STABILITY, SUCH AS BATTERIES, WITH ITEMS OF DIFFERENT WEIGHT OR SPECIFICATION. DO NOT MODIFY UNIT IN ANY WAY TO AFFECT STABILITY.

Electrolyte Level:

Check the electrolyte level of the batteries often and add only distilled water when required:

1. Open access door to the battery compartment.
2. Check proper electrolyte level after charge using the floats (1) in the center of each cell filling cap.

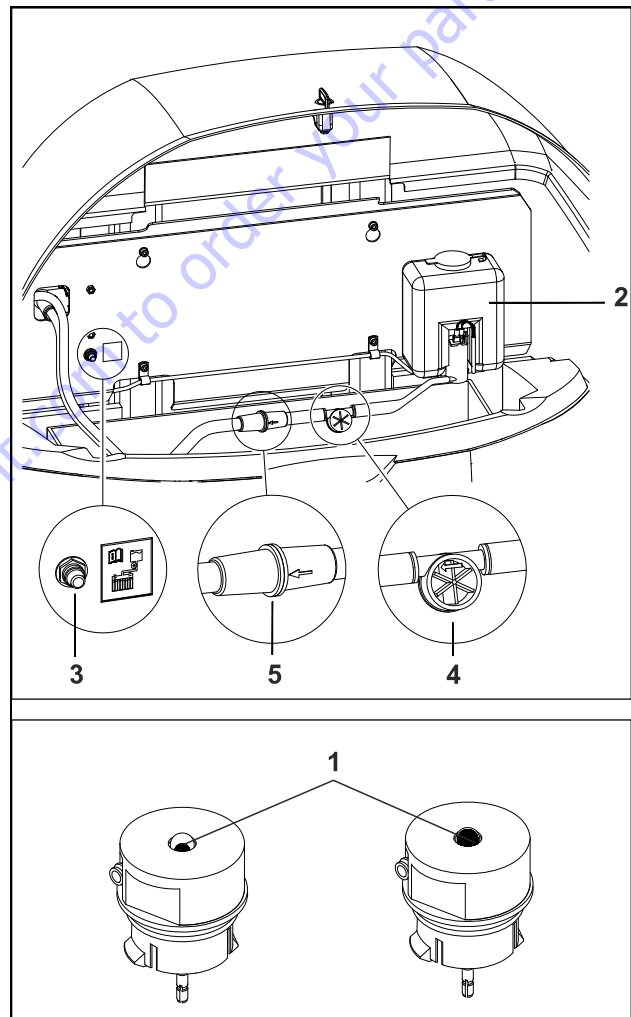

Figure 8-3. Battery filling

3. Fill the can (2) with distilled water.
4. Depress and hold the push button (3) to activate the filling pump. Release the button when the flow indicator (4) slows down.
5. Check for proper level in each cell (float on each cell's cap). Actuate the filling pump again if some cells show improper level.

SECTION 8 - CONTROL COMPONENTS

Battery Cleaning:

- Regularly clean and dry battery top.
- Ensure all connections are clean and correctly tight.
- Coat terminals with a silicone dielectric compound.
- Drain the water that can accumulate at the bottom of the batteries container using a bulb as follow:

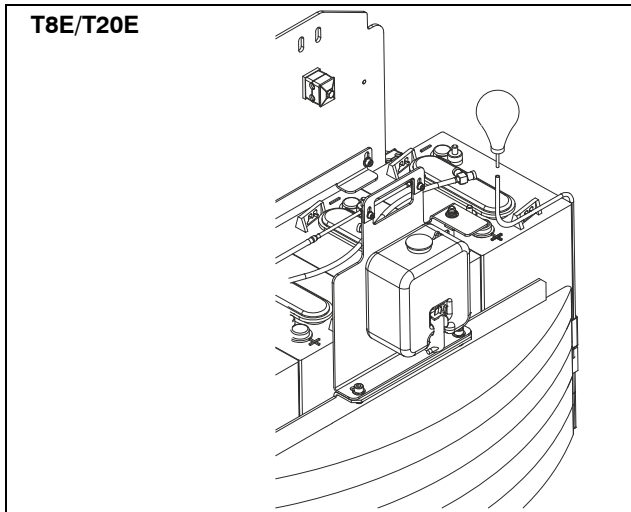

T8E/T20E

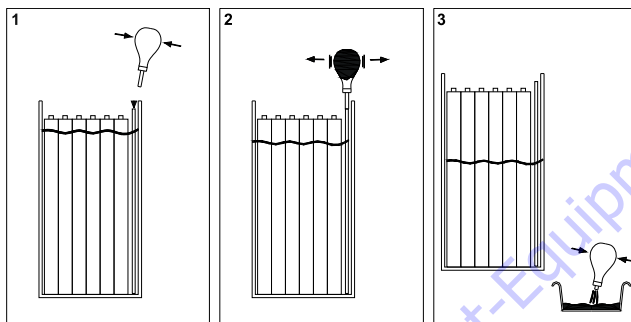

Figure 8-4. Draining the water

Filling Circuit Inspection and Servicing:

Battery filling circuit must be serviced once a year. Cleaning frequency must be increased in case of premature clogging of the filter or a reduction of water flow.

- Disconnect and clean the filter (5) (See Figure 8-2) by reversing the water flow from the normal direction.
- Check hoses for flexibility. In case of hardening in the connections area, replace the hose.
- Check every fittings and connections for leakage.
- Check the caps individually. Ensure perfect mobility of the floats. In case of clogging, replace the cap.
- In any case, it is recommended to replace the caps every 2 or 3 years.

NOTE: The filling circuit includes a check valve that prevents remaining water in the can from flowing in battery cells by gravity. Never remove this check valve. Doing so will cause excessive electrolyte level in the cells and electrolyte overflow.

Battery Container Maintenance:

Keep the metallic container clean. In case of corrosion, clean, neutralize corrosion and apply anti-acid paint on the affected area.

Battery Voltage and Electrolyte Specific Gravity Recording:

NOTE: Voltage and specific gravity measures should not be performed after battery cells have been filled. These measures must be done after a complete charge, once the charger has been unplugged and after the battery has been standing for at least 15 minutes.

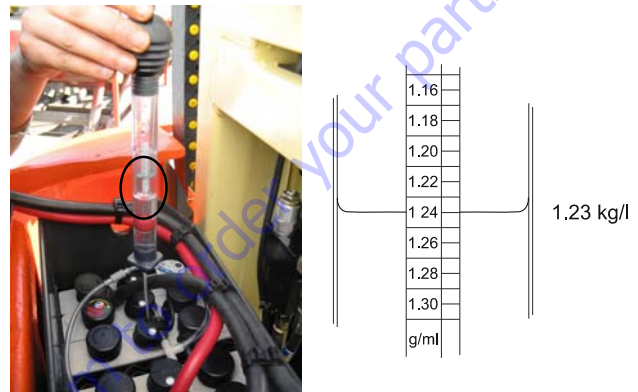

Figure 8-5. Measuring Electrolyte Specific Gravity

- Open the filling cap of the cell where the red cable is connected (B+).
- Using an hydrometer, take a quantity of electrolyte sufficient so that the float emerges. Ensure that the float top does not touch the rubber bulb or that the float does not stick by capillarity to the glass wall.
- Read the value as indicated in the previous figure.
- Return electrolyte in the cell and record the value in the battery service log.
- Measure the cell voltage and record the value in the battery service log.
- Repeat operation for each cell in sequence from B+ (Red cable) to B- (Black cable).

Use of a Battery in a Cold Chamber or in a Cold Climate:

Low temperatures decrease battery capacity. The battery must be fully charged when the machine is operated in a cold chamber or in cold weather condition.

Battery Not Working Continuously or Inactive Battery:

A battery that is not used or used intermittently must be stored charged in a dry area away from freezing temperatures. A charge must be performed once a month.

- Disconnect the battery to insulate it electrically.
- Keep the top of the battery clean and dry to prevent self-discharge.

NOTICE

IF THE BATTERY IS NOT USED CONTINUOUSLY, IT MUST BE RECHARGED BEFORE USE AND AT LEAST ONCE A MONTH (EVEN IF THE ELECTROLYTE SPECIFIC GRAVITY MEASURES

ARE HIGH).

BEFORE RETURNING TO SERVICE A BATTERY THAT REMAINS INACTIVE FOR A LONG PERIOD OF TIME, CHARGE THE BATTERY AND CHECK ELECTROLYTE LEVEL IN THE CELLS.

Battery Troubleshooting:

Symptoms	Probable causes	Solutions
Electrolyte overflow.	Filling done before the charge. Cells overfilled. Overcharge.	Fill battery cells after the charge. Never charge battery if electrolyte specific gravity is above 1,240 kg/l.
Inequal electrolyte specific gravity or electrolyte specific gravity too low.	Filling done before the charge. Loss of electrolyte due to overflow. Stratification of the electrolyte.	Fill battery cells after the charge. Perform an equalization charge. Contact your JLG Distributor/Product Support.
Low voltage in the cells in open circuit.	Electrolyte specific gravity too low. Short-circuit.	Refer to "electrolyte specific gravity too low". Clean battery top.
Battery cells temperature too high (over 113°F (45°C)).	Problem with the charger. Bad air circulation during charge. Cell weak or faulty Cells shorted.	Get the charger checked by a technician. Open access doors to batteries during charge. Reduce temperature of the area where the battery is charged (artificial ventilation). Change battery cell.
Battery incapable of supporting regular operation.	Battery under charged. Cell faulty. Faulty cable or connection. Battery at the end of its service life.	Perform an equalization charge. Replace faulty cell. Check wire condition and connection. Replace the battery.

Table 8-1. Battery Troubleshooting

SECTION 8 - CONTROL COMPONENTS

Main Power Contactor Relay

The main power contactor relay is located on the left (T8E/T20E), on the bulkhead on the right (T10E/T26E) side of the mast, inside the hydraulic pump/motor assembly compartments as shown following.

Electrical characteristics:

Nominal voltage: 24V

Coil resistance: 52 Ω

See Figure 8-21 for electrical wiring connections.



Figure 8-6. Main Power Contactor Relay

Power Fuse

The power fuse is located on the left (T8E/T20E), on the bulkhead on the right (T10E/T26E) side of the mast, inside the hydraulic pump/motor assembly compartment as shown following.

Amp. Rating: 325 Amps

Type: C20 (DIN 43560)

See Figure 8-21 for electrical wiring connections.

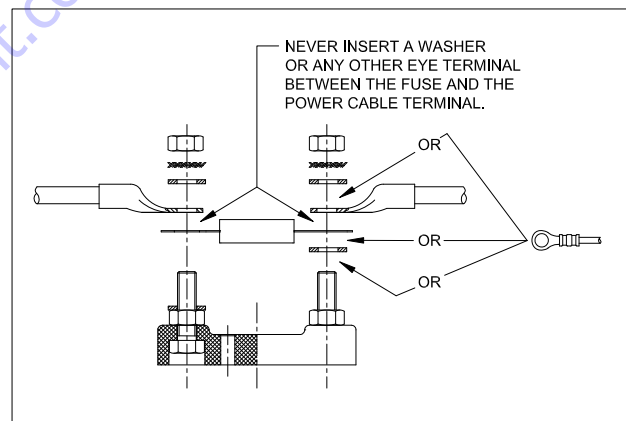

Figure 8-7. Power Fuse

Mast Elevation Limit Switches

Elevation limit switches are attached to mast section #5 (10E/26E), #4 (8E/20E) as shown following. When the mast elevates, cams welded on mast section #4 actuate the switches.

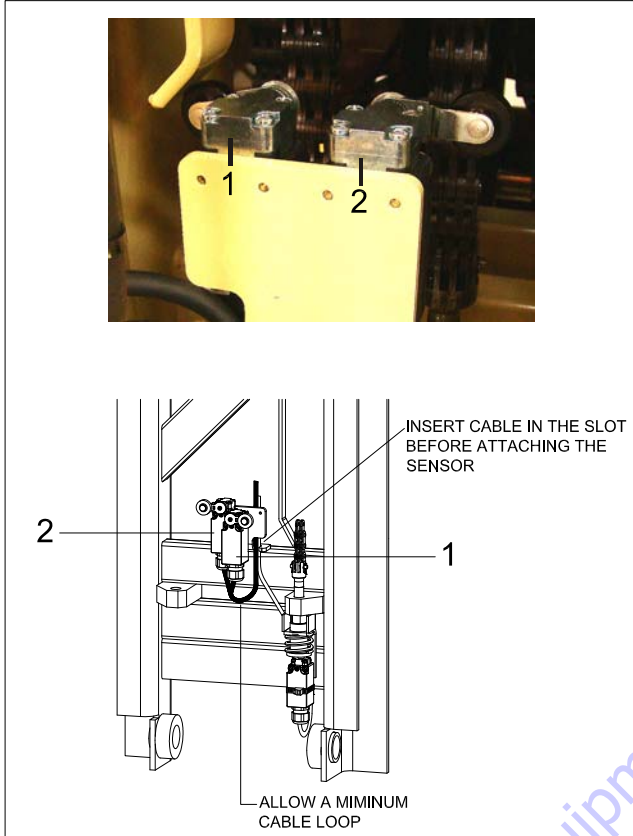

Figure 8-8. Mast Elevation Limit Switches

The main mast limit switch (1) is the first to be actuated (at the beginning of mast travel).

The secondary mast limit switch (2) is actuated about 0.9 meter (2.95 ft) before mast full elevation.

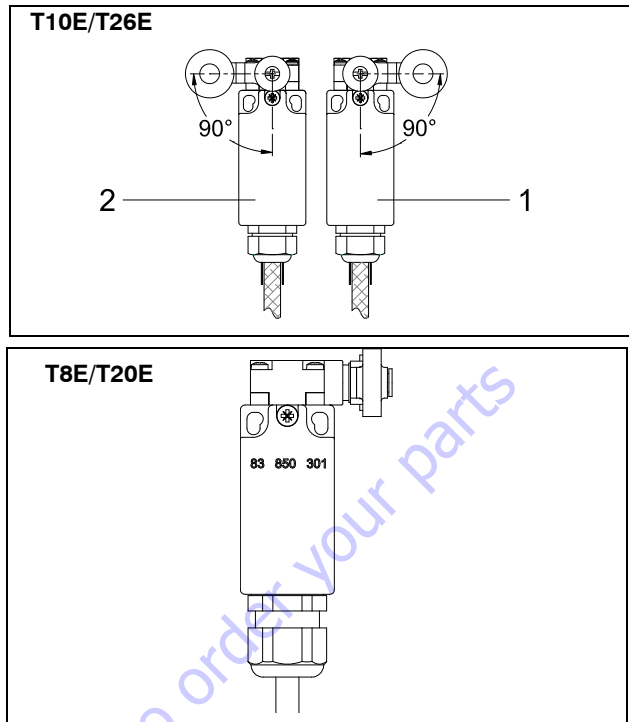

Figure 8-9. Actuators Setting

Chain Slack Sensor

One chain of each lifting chain stage is fitted with a slack detection device. Those 3 (T10E/T26E) / 2 (T8E/T20E) switches are wired in series.

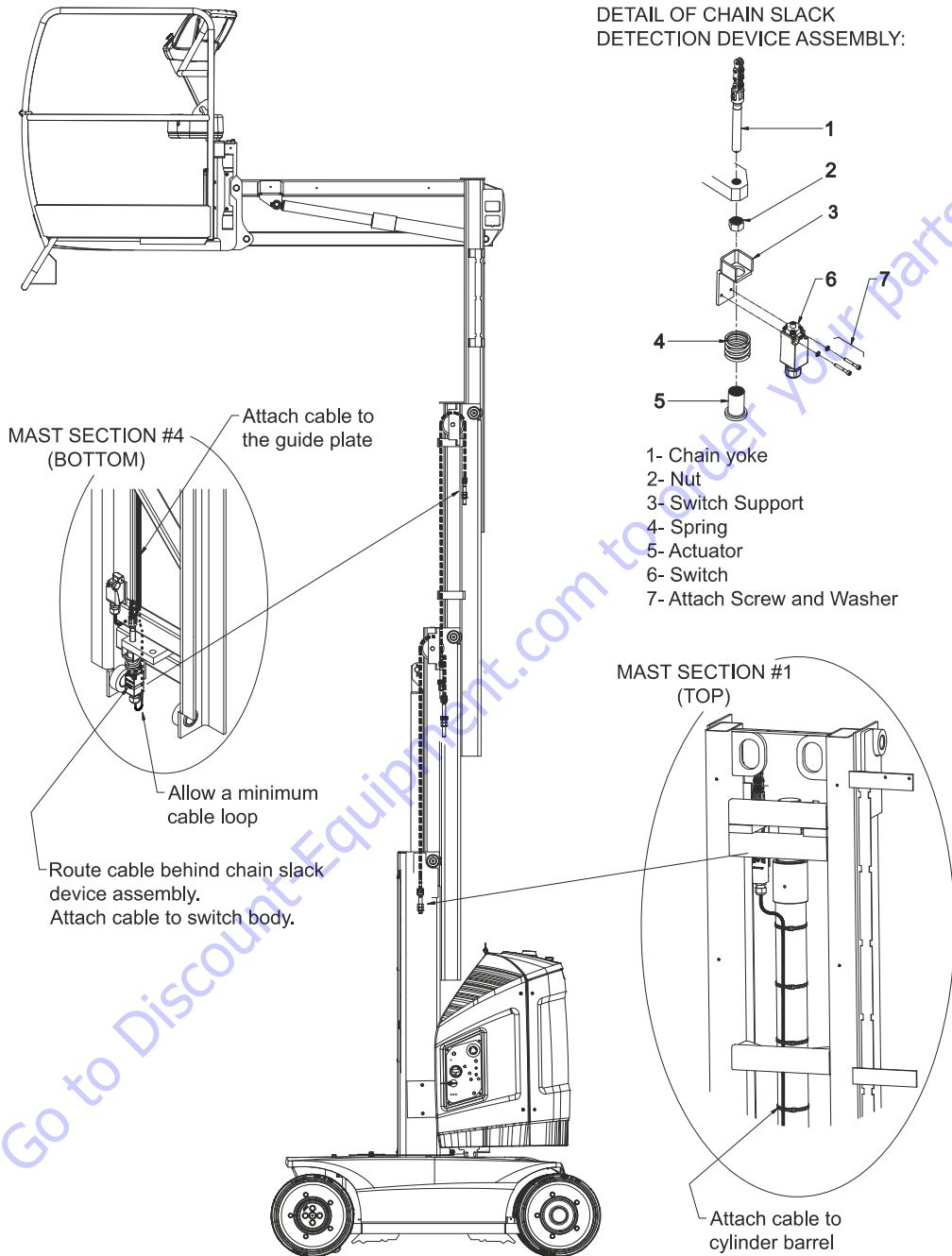

Figure 8-10. Chain Slack Sensors - T8E/T20E

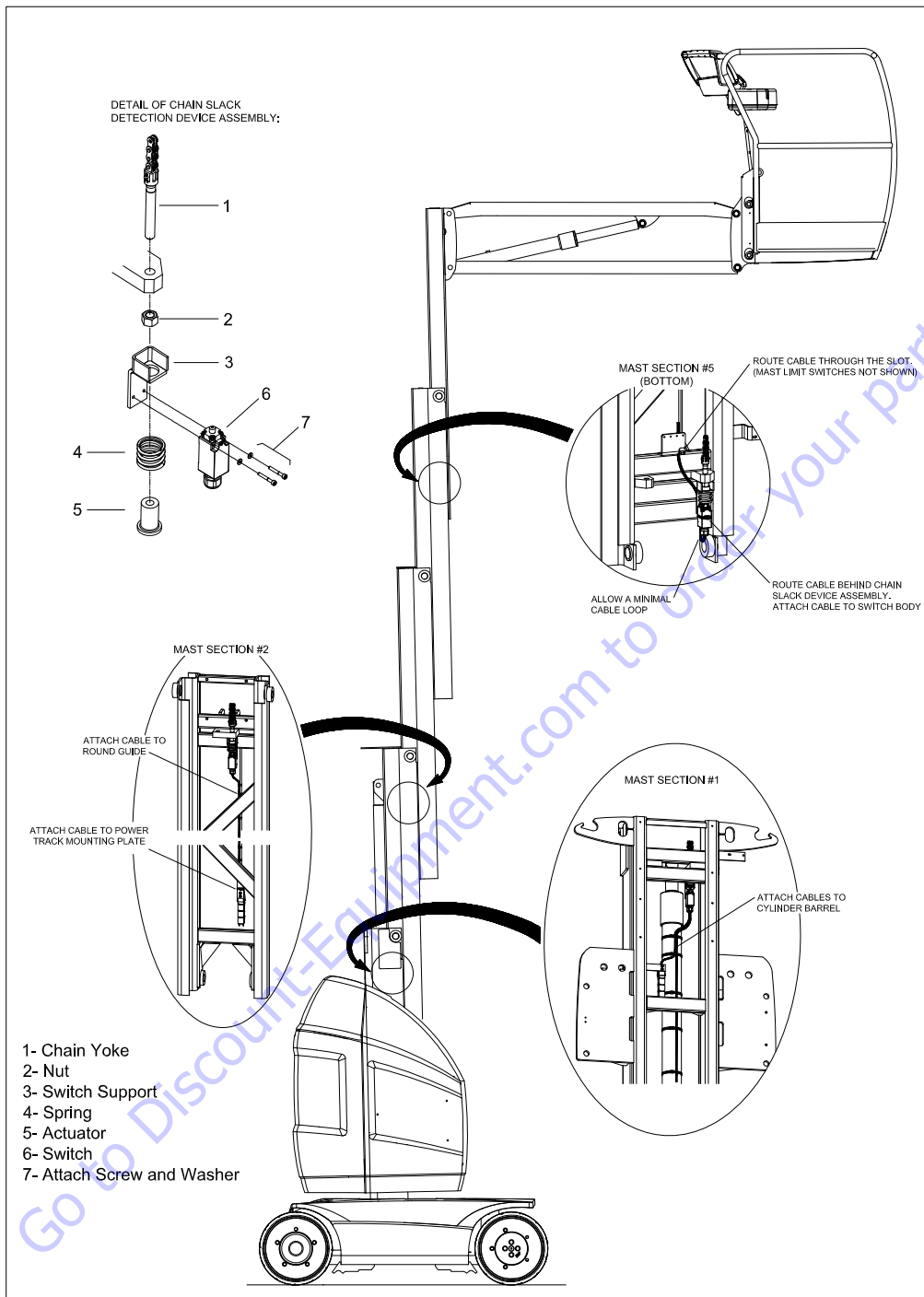

Figure 8-11. Chain Slack Sensors - T10E/T26E

Slack chain condition is:

- Generally caused by the platform or the jib coming to rest on an obstacle while lowering.
- More rarely caused by a mast jamming. This can be due to a lack of lubrication (Refer to Section 5-3), an incorrect adjustment (Refer to Section 5-4) or a foreign body entering the guiding system.

Overload Sensor (If equipped)

When the maximum rated load in the platform is exceeded, the switch is actuated and all machine functions are disabled. The platform must be unloaded until the alarm stops.

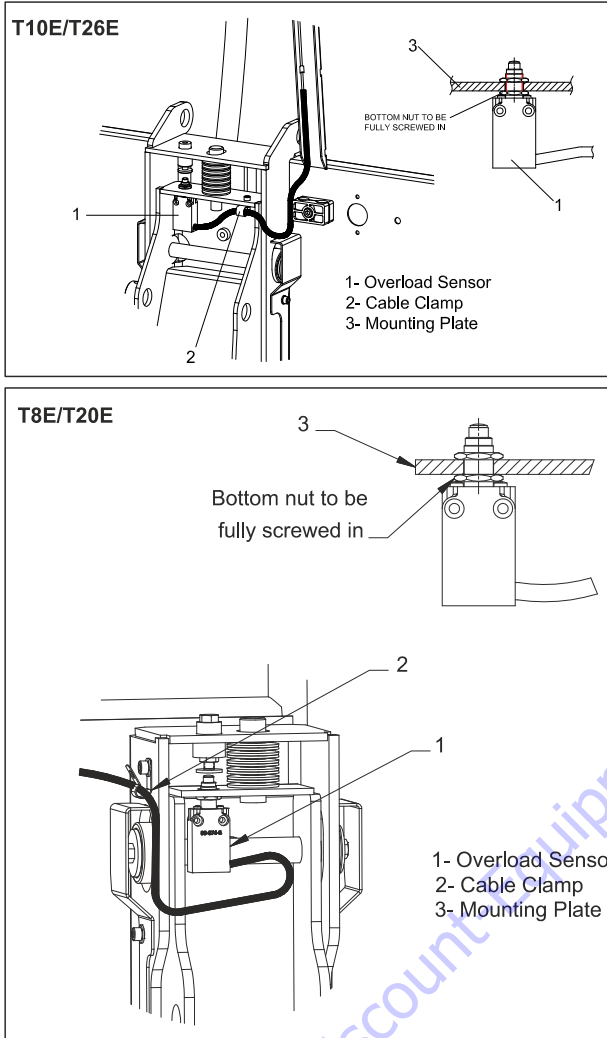

Figure 8-12. Overload Sensor

Refer to Section 9-6 for Overload System Calibration.

Drive Orientation Switch

The drive orientation switch is located on the turntable base plate, behind the telescopic mast. This is an inductive switch that detects presence of ferrous material. It must be powered to operate. When the cam welded on chassis base plate is no more present (i.e. the jib is swung beyond the rear tires or further in either direction) the switch will open.

The LED on top of the switch will light up when the cam is present.

Sensor connections conditions:

Pin #	Function	Voltage with track present	Voltage with track absent
1	Power (+)	+Vbatt	+Vbatt
2	Output	+Vbatt	Open
3	Power (-)	-Vbatt	-Vbatt

The sensor is calibrated mechanically as shown following.

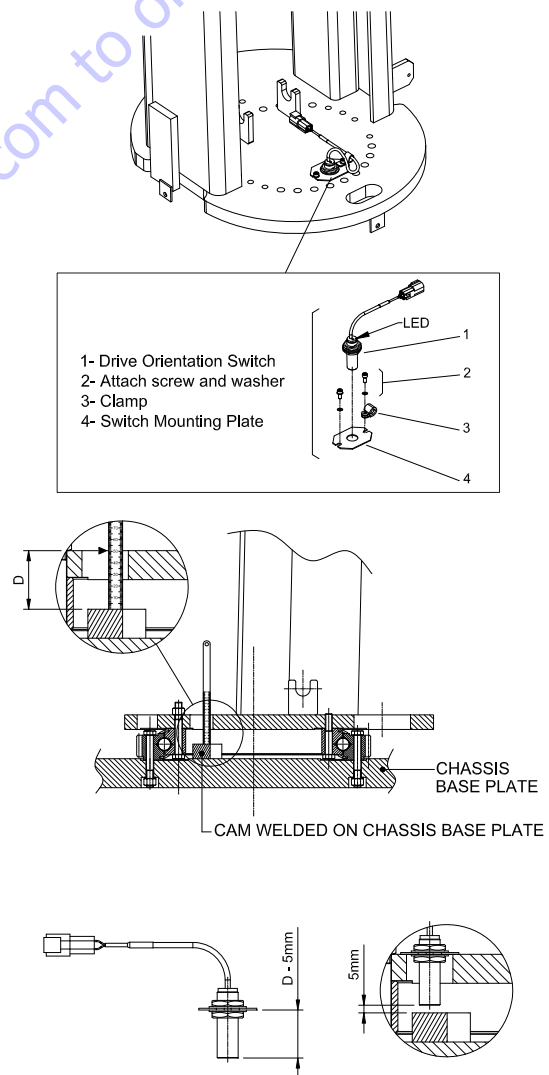
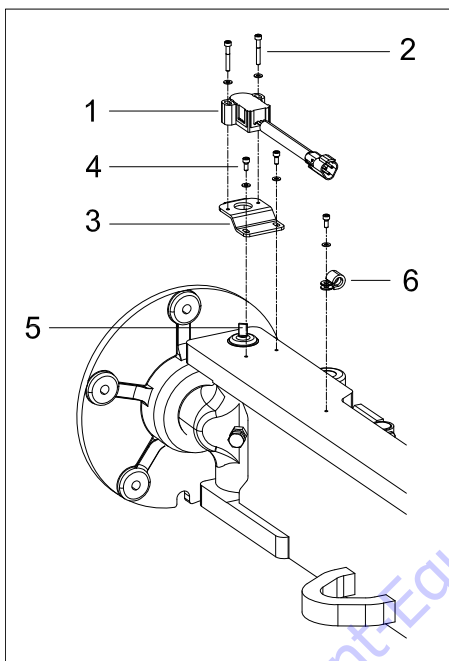
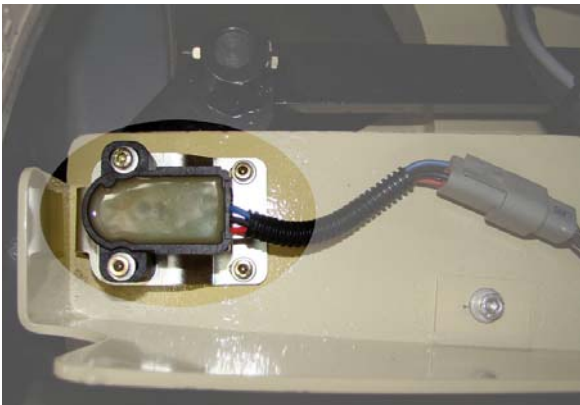

Figure 8-13. Drive Orientation Switch

Steering Sensor



1. Steering Sensor
2. Sensor Attach Screw and Washer
3. Sensor Mounting Plate
4. Mounting Plate Attach Screw and Washer
5. Right Spindle Attach Pin
6. Cable Clamp

Figure 8-14. Steering Sensor

The steering sensor is located on the front steering axle. It is key operated by the right spindle attach pin.

Sensor connections conditions:

Pin #	Function	Voltage Right Stop	Voltage Wheels Straight	Voltage Left Stop
A or 1	Power (+)	4.2V - 4.4V		
B or 2	Output	0.5V - 1.0V	2.2V - 2.8V	3.4V - 3.9V
C or 3	Power (-)	-Vbatt		

If the sensor is dismantled, the output voltage is:
 $0.1x$ (Sensor Power Voltage) = 0.42V - 0.44V).
 If the sensor is forced on the opposite stop the output voltage is: $0.9x$ (Sensor Power Voltage) = 3.78V - 3.96V).

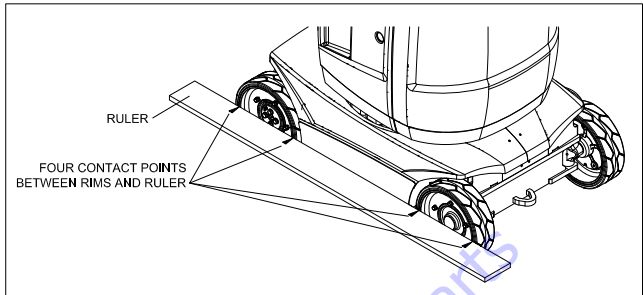

Figure 8-15. Wheel Straightening

NOTE: Refer to Section 4-3 for Steering Sensor Installation.

Tilt Sensor

The tilt sensor is located on the chassis base plate, in front of the right rear wheel.

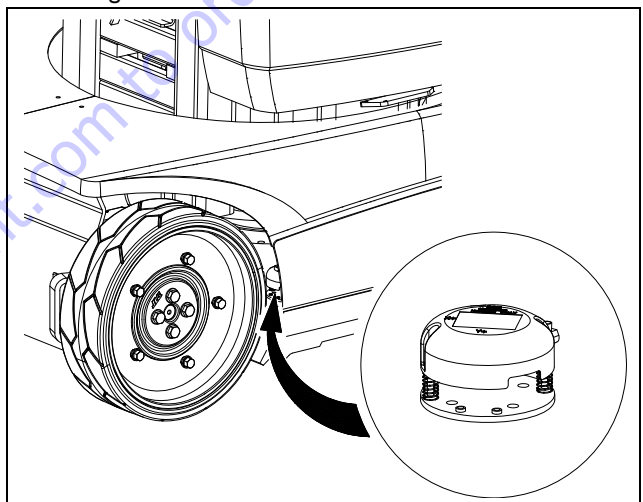

Figure 8-16. Tilt Sensor

The control system monitors the tilt sensor to determine if the vehicle is tilted excessively. If the vehicle tilt angle in any direction is greater than 2 degrees, the control system considers the machine tilted.

Sensor connections conditions:

Pin #	Function	Voltage with Machine NOT tilted	Voltage with Machine tilted
1	Power (-)	-Vbatt	-Vbatt
2	Power (+)	+Vbatt	+Vbatt
3	Output	+Vbatt	Open

SECTION 8 - CONTROL COMPONENTS

Tilt Sensor Check:

Wedge a block (P/N:ST2741 - located in the manual storage container) to activate the tilt sensor and keep it tilted as shown following.

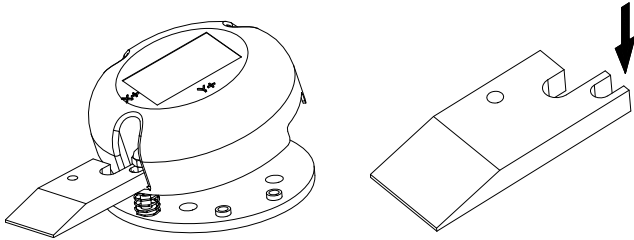

Figure 8-17. Tilt Sensor Check

NOTE: When tilted, the green LED at the bottom of the sensor body switches off indicating that the output signal has been cutout. Tilt sensor output signal cutout is delayed (Approx. 1 second).

From the platform control station, raise the mast by approximately 1m.

- Confirm an audible alarm sounds.
- Verify the tilt indicator (red) blinks.
- Check the following functions are affected:
 - Drive function disabled.
 - Mast/Jib lift-up and swinging movements can be performed only in creep mode.

Tilt Sensor Calibration:

Set the machine on a known leveled surface. Position a spirit level (digital display recommended) longitudinally and transversely on the chassis base plate to confirm the machine is leveled.

With the machine powered on, use an electrical wire to connect the battery NEG. (i.e. [B-] post of a power module) to the terminal block of the tilt sensor. The LED at the bottom of the sensor body will blink, indicating the new 0 degree position has been defined.

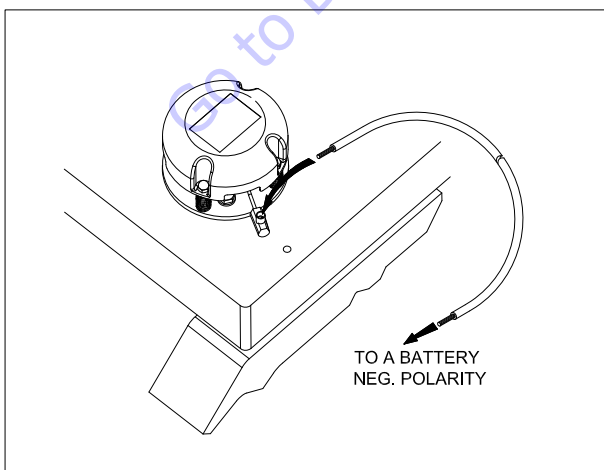

Figure 8-18. Tilt Sensor Calibration

Tilt Sensor Calibration Verification:

1. Power the machine on at ground control station and slightly raise the mast to actuate the main mast limit switch (Refer to Figure 8-8).
2. Place a spirit level (digital display) longitudinally (1) on the chassis (front - rear direction).
3. Using a jack (3) of appropriate capacity, slowly and carefully lift the front of the chassis: the LED under the tilt sensor body should switch off when the chassis angle reaches 2 degrees. The warning alarm should be triggered approx. 1 second later.
4. Place a spirit level (digital display) transversely (2) on the chassis (left - right direction).
5. Using a jack (3) of appropriate capacity, slowly and carefully lift the side of the chassis: the LED under the tilt sensor body should switch off when the chassis angle reaches 2 degrees. The warning alarm should be triggered approx. 1 second later.
6. If the LED switches off before 1.8 degrees or after 2.1 degrees in either direction, perform a new calibration procedure and verify calibration again.

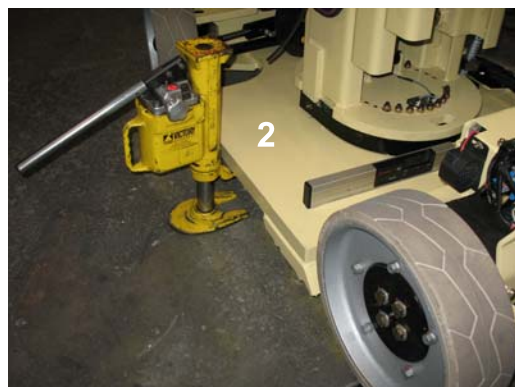
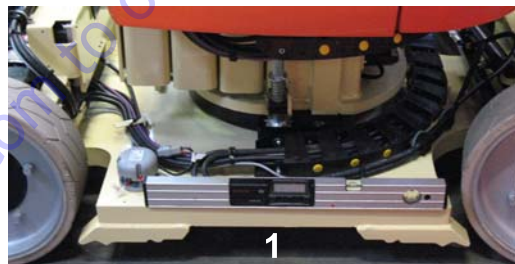

Figure 8-19. Tilt Sensor Calibration Verification

Ground Alarm

The ground alarm is located at the left side of the power modules, on the chassis.

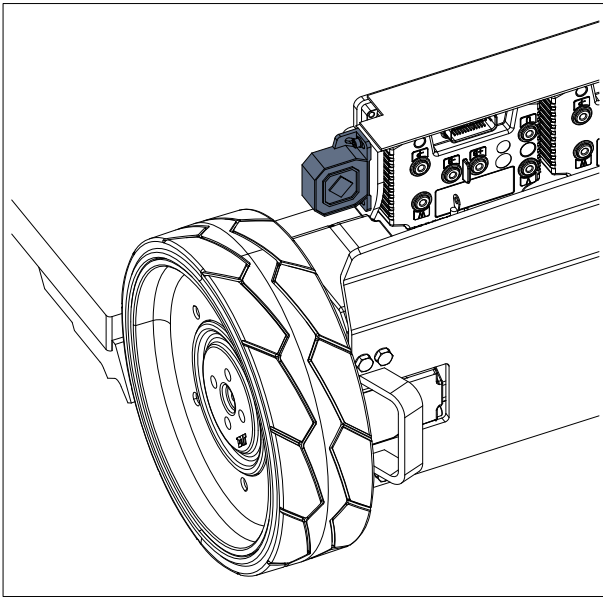

Figure 8-20. Ground Alarm

Warning Beacon

The warning beacon is located at the top of the mast, above the battery compartment door.

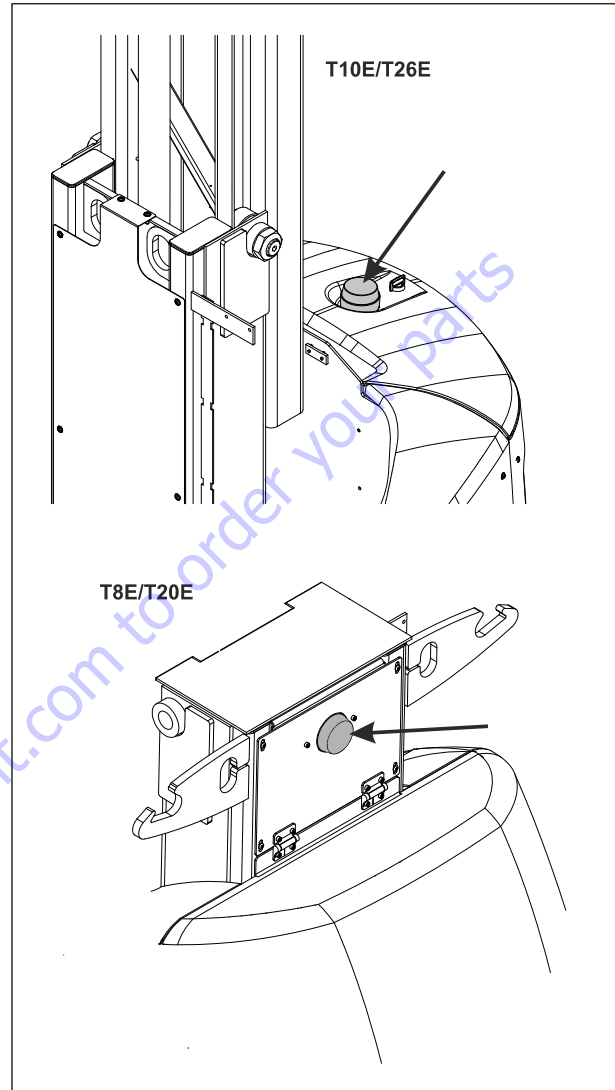

Figure 8-21. Warning Beacons

Descent/Motion Alarm (Optional)

An optional acoustic alarm can be installed on the chassis at the left side of the power modules.

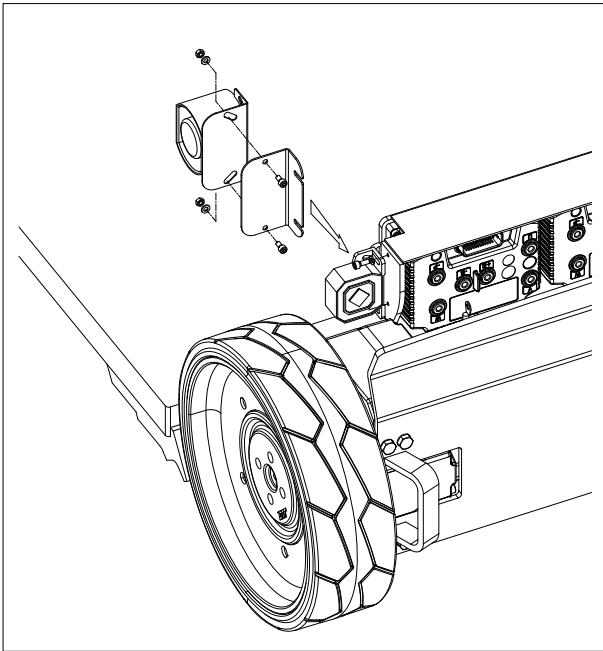

Figure 8-22. Descent/Motion Alarm

Acoustic alarm personalities to define operating mode can be access via analyzer menu: refer to Section 9 JLG CONTROL SYSTEM.

Go to Discount-Equipment.com to order your parts

8.3 TRACTION SYSTEM

Refer to Section 3-5 TRACTION - Theory of Operation for more detailed information on Traction System.

Common Traction System Difficulties

1. Ground Module Interlocks

There are a variety of interlocks that prevent Drive due to system events. Before investigating Traction System Issues, examine the JLG Analyser's HELP Menu while attempting to Drive from Platform Mode. Refer to the Section 9 for explanation of the JLG Analyser Help Messages.

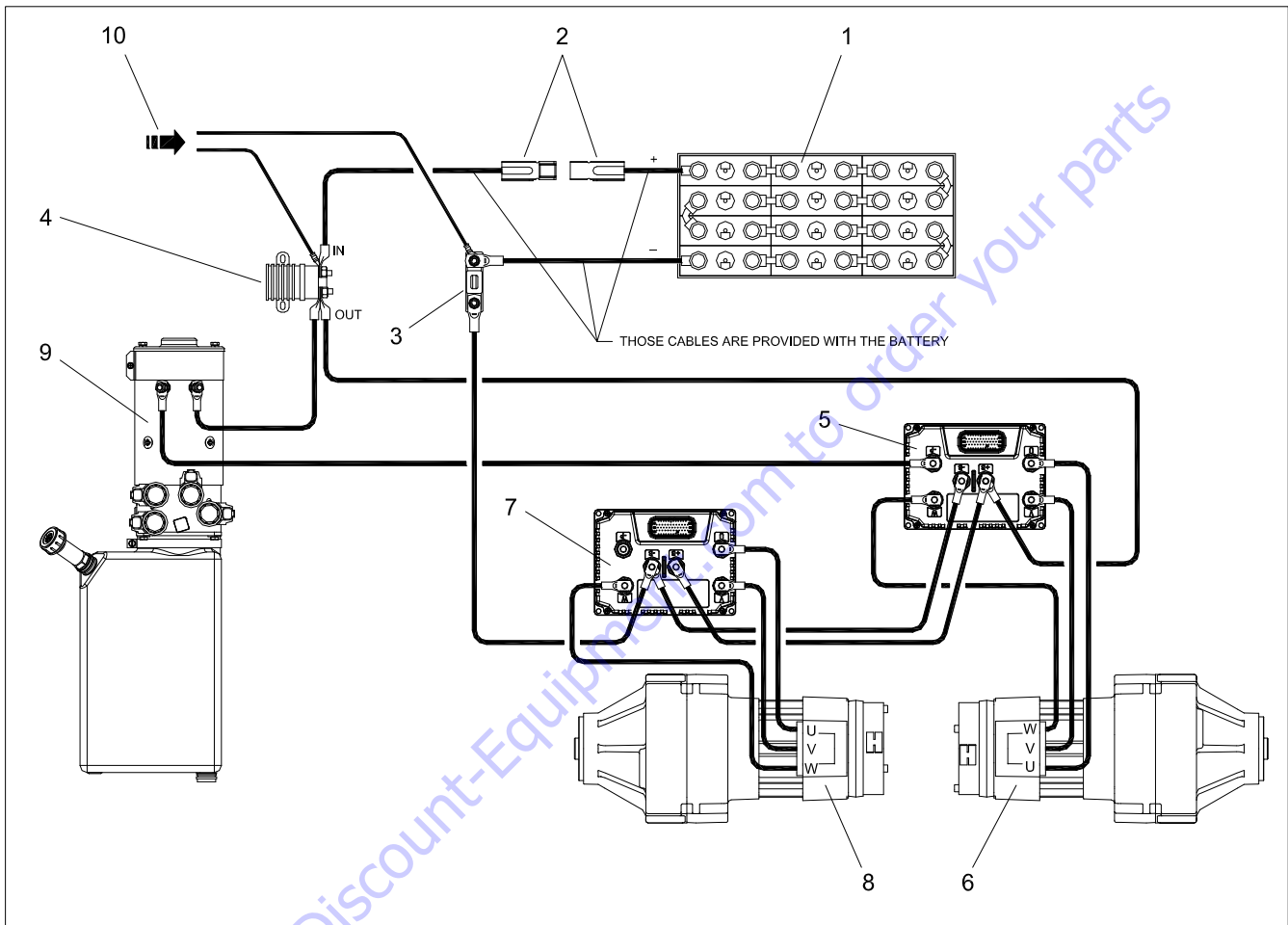

1. Battery Pack
2. Battery Power Quick-Disconnect
3. Power Fuse
4. Power Contactor
5. Power Module - Master
6. Drive Motor - Right
7. Power Module - Slave
8. Drive Motor - Left
9. Hydraulic Pump Motor
10. Cables from Battery Charger

Figure 8-23. Main Electrical Power Connections

8.4 POWER MODULE

The power modules are located at the rear of the chassis between the driving wheels. The master module is mounted on the right side of the chassis and the slave module on the left side.

The master power module controls the right drive motor and the hydraulic pump motor.

The slave power module controls the left drive motor.

Both power modules are identical and share the same software. The master or slave condition of the power modules is defined by the wiring of the inputs: on the master module, the connector pin #6 is energized at power-up.

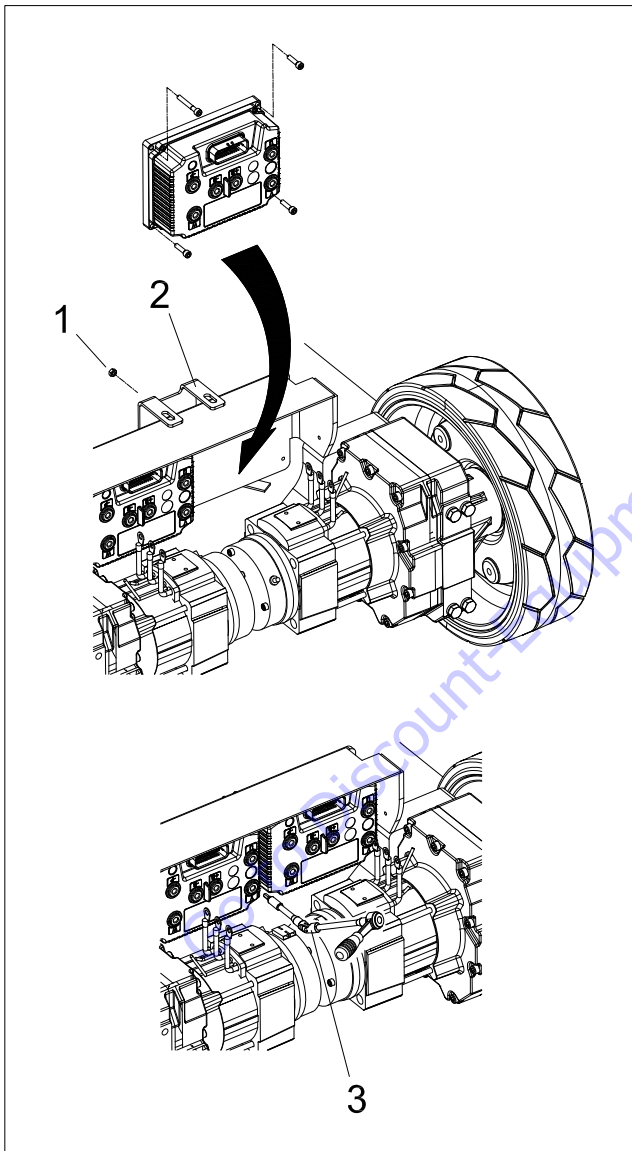

Figure 8-24. Power Module Removal - Installation

Removal

CAUTION

PRIOR TO ANY SERVICING OPERATION ON POWER MODULES, DISCONNECT BATTERY PLUG.

AFTER MACHINE OPERATION, EVEN WITH THE POWER TURNED OFF AND THE BATTERY DISCONNECTED, INTERNAL CAPACITORS OF THE POWER MODULES MAY REMAIN CHARGED FOR SOME TIMES. REFER TO THE FOLLOWING PROCEDURE TO DISCHARGE THOSE CAPACITORS.

1. From ground controls, swing the turntable 90° from chassis center line. Shut machine down and disconnect battery plug.
2. Actuate the battery filling pump button: the pump will run for a few seconds till the capacitors are discharged.
3. Remove chassis covers and rear chassis shield.
4. Disconnect AMP connector from the power module: Refer to Section 11.
5. Tag and disconnect power cables from the power module.
6. Loosen the nut (1) securing the chassis cover bracket (2).
7. Remove the four screws securing the power module. Use a ratchet wrench with appropriate extensions and a universal joint (3) to remove the bottom screws. Remove the power module.

Installation

1. Apply a light layer of thermo-conductive grease on the new power module base plate.
2. Install the power module with the AMP connector upwards and secure to the chassis.

NOTE: Power module shown as installed on the machine (AMP connector Upwards).

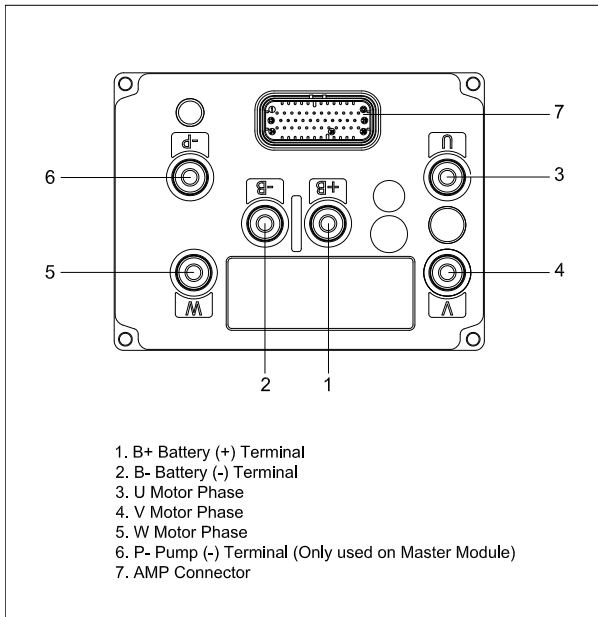

Figure 8-25. Power Module Terminals

3. Connect cables and connector back to the power module as previously tagged. Tighten the power cables on controller posts with a torque of 5.6 - 8.4 Nm (4.1 - 6.2 ft lb).

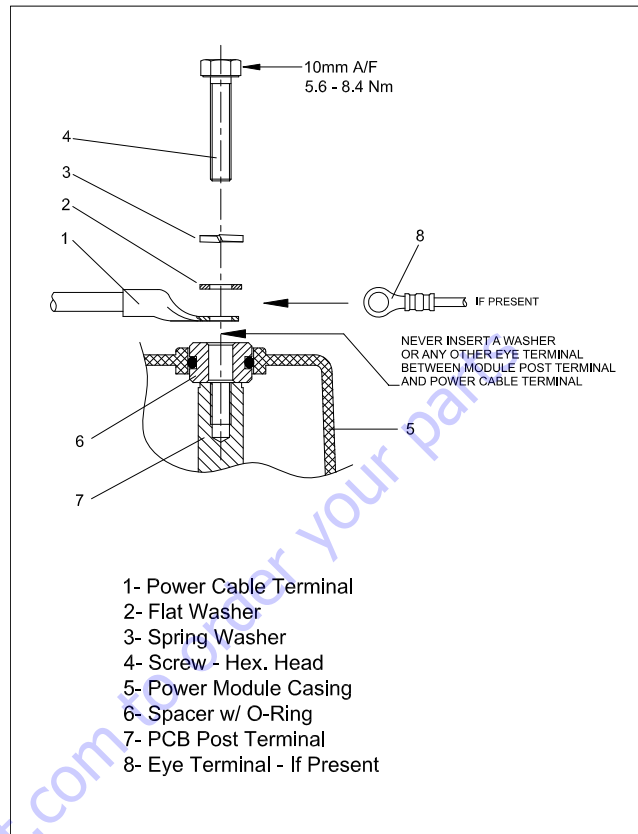

Figure 8-26. Cables on Power Module Post Terminal

NOTICE

DO NOT OVERTIGHTEN THE TERMINAL BOLTS, OR DAMAGE TO THE UNIT COULD OCCUR.

4. After all connections to the power module are made and verified, the battery can be reconnected.
5. Install chassis rear shield and chassis covers.
6. Check software version (Refer to Section 9), if necessary proceed with a software update.
7. Proceed with a system setup and calibration (Refer to Section 9.3).

SECTION 8 - CONTROL COMPONENTS

Power Module Electrical Evaluation

1. Master Controller Inputs / Outputs List

Pin	Function	Type	
1	Drive Orientation Switch	Digital	Input
2	Electro-Brake Supply (Positive)	Digital	Output
3	+ Valves	Power	Input
4	Electro-Brake Driver (Negative)	PWM	Output
5	Right Wheel Encoder Ground	Power	Output
6	Master Selection	Digital	Input
7	Tilt Switch	Digital	Input
8	Main Line Contactor	Digital	Output
9	Unused	Digital	Output
10	Master Key Switch (Ignition)	Digital	Input
11	Beacon Control	Digital	Output
12	Unused	PWM	Output
13	Right Wheel Encoder Pin A	Digital	Input
14	Right Wheel Encoder Pin B	Digital	Input
15	Steer Angle Sensor	Analog	Input
16	Charger Interlock	Digital	Input
17	Manual Brake Release	Digital	Input
18	Unused	Digital	Input

Pin	Function	Type	
19	Platform E-Stop	Digital	Input
20	Mast Limit Switch 2 (N.C.)	Digital	Input
21	Unused	Digital	Input
22	Right Wheel Thermal Sensor	Analog	Input
23	Unused	Prop	Output
24	Overload Indication Light	Prop	Output
25	Right Wheel Encoder Power	Power	Output
26	Horn	Digital	Output
27	Master CAN Low	Com	Input
28	Master CAN High	Com	Input
29	Gate Limit Switch (N.C.)	Digital	Input
30	Unused	Analog	Input
31	Main Mast Limit Switch (N.C.)	Digital	Input
32	Overload Switch (N.C.)	Digital	Input
33	Unused	Digital	Output
34	Unused	Digital	Output
35	Chain Slack Switch	Digital	Input

2. Slave Controller Inputs / Outputs List

Pin	Function	Type	
1	Unused	Digital	Input
2	Electro-Brake Supply (Positive)	Digital	Output
3	+Valves	Power	Input
4	Electro-Brake Driver (Negative)	PWM	Output
5	Left Wheel Encoder Ground	Power	Output
6	Unused	Digital	Input
7	Redundant Tilt Switch Input	Digital	Input
8	Swing Control Solenoid	Digital	Output
9	Mast Control Solenoid	Digital	Output
10	Slave Key Switch (Ignition)	Digital	Input
11	Steer Control Solenoid	Digital	Output
12	Slave Negative Contactor Relay	PWM	Output
13	Left Wheel Encoder Pin A	Digital	Input
14	Left Wheel Encoder Pin B	Digital	Input
15	Unused	Analog	Input
16	Jib Command Down Input	Digital	Input
17	Jib Command Up Input	Digital	Input
18	Unused	Digital	Input

3. Inputs Characteristics

Digital Inputs:

- Switching Threshold: $4V \pm 0.5V$
- Input Impedance: $4.5\text{ k}\Omega \pm 500\ \Omega$

Analog Inputs:

- Acceptable signal range: 0 - 10V
- Toucan 10E signal range: 0.5 - 4.5V

Power Inputs:

- 24V input, taken after the voting relay.

Pin	Function	Type	
19	Ground Enable	Digital	Input
20	Mast Command Up Input	Digital	Input
21	Unused	Digital	Input
22	Left Wheel Thermal Sensor	Analog	Input
23	Proportional Relief Solenoid Valve	Prop	Output
24	Jib Up Control Solenoid	Prop	Output
25	Left Wheel Encoder Power	Power	Output
26	Motion Alarm	Digital	Output
27	Slave CAN Low	Com	Input
28	Slave CAN High	Com	Input
29	Swing Command Left Input	Digital	Input
30	Unused	Analog	Input
31	Swing Command Right Input	Digital	Input
32	Mast Command Down Input	Digital	Input
33	Jib Down Control Solenoid	Digital	Output
34	Flow Direction Solenoid	Digital	Output
35	Redundant Chain Slack Input	Digital	Input

4. Outputs Characteristics

Digital Outputs:

- Drive to -Vbatt
- Max. Output current: 1.5A

PWM Outputs:

- PWM controlled (Adjustable voltage)
- Drive to -Vbatt
- Max. output current: 2.5A

Proportional Outputs (Prop):

- PWM controlled with current sensing
- Drive to -Vbatt

Power Outputs:

- +5V power supply for the motor encoder (exact value: 4.3V)

8.5 GROUND CONTROL STATION

Membrane Panel

1. Electrical Evaluation

The membrane panel integrates two functions:

- Indicator LEDs: these are surface mount components with standard LED characteristics;
- Push buttons: each push button is a SPST (Single Pole Single Throw) switch; switch ON = 20 to 40 Ω (circuit impedance, measured on the ribbon connector).

2. Replacement

1. Turn machine power down and disconnect battery plug.
2. Remove the control box panel assembly. Unplug both the ribbon cable and the connector from PCB.
3. Remove the following elements from the panel assembly: E-Stop, Multi Display Indicator (MDI), circuit breaker and contact key.
4. Peel the membrane panel.



5. Clean the back plate surface from glue residues;
6. Install the new membrane panel on the back plate, taking into account the following:
 - Insert the ribbon cable into the plate slot.

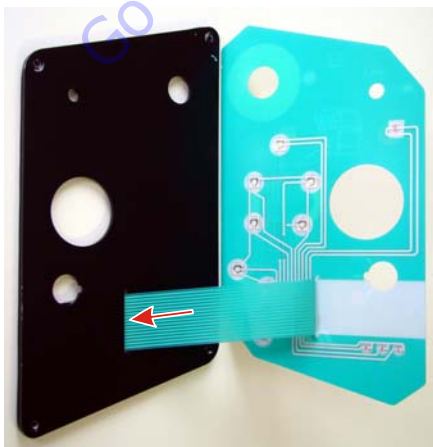

- Align with precision the membrane panel cut out for the contact key with the corresponding hole on the back plate;
- Adjust the membrane panel position to align the other cut out on the corresponding holes on the back plate.



7. Re-install the components on the panel, re-connect the connectors on the PCB and re-install the panel assembly.

Printed Circuit Board (PCB) Replacement

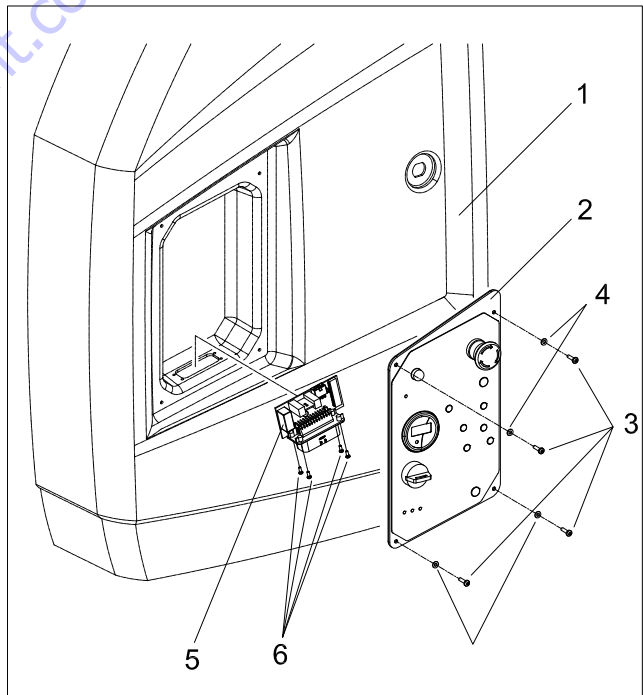

Figure 8-27. Ground Control Box Circuit Board - Installation

1. Door
2. Control Box Panel Assembly
3. Panel Attach Screws
4. Panel Plastic Washers
5. Circuit Board Assembly
6. Circuit Board Attach Screws

1. Turn machine power off and disconnect battery plug.
2. Disconnect AMP connector from the circuit board assembly: Refer to Section 11.
3. Remove the control box panel assembly. Unplug both the ribbon cable and the connector from PCB.
4. Remove the four screws that affix the PCB connector to the door.
5. Replace PCB and reassemble the upper control box.

1. Upper Box Assembly
2. Face Plate Assembly
3. Face Plate Attach Screws
4. Circuit Board Assembly
5. Circuit Board Attach Screws

1. Remove the upper control box face plate. Unplug ribbon cable and connectors from PCB.
2. Remove the four screws that affix the PCB.
3. Replace PCB, connect ribbon cable and connectors back to the PCB and reassemble the upper control box.

8.6 PLATFORM CONTROL STATION

⚠ CAUTION

THE PRINTED CIRCUIT BOARD (PCB) INSTALLED IN THE UPPER CONTROL BOX CONTAINS NUMEROUS DELICATE ELECTRONIC CIRCUITS AND COMPONENTS WHICH CAN BECOME DAMAGED AS A RESULT OF ELECTROSTATIC DISCHARGE (ESD).

KEEP REPLACEMENT PCB IN ITS ANTISTATIC BAG TILL READY TO INSTALL.

PRIOR TO OPEN THE UPPER CONTROL BOX, TURN MACHINE POWER OFF AND DISCONNECT BATTERY PLUG.

IT IS BEST TO WEAR AN ELECTROSTATIC DISCHARGE (ESD) WRIST STRAP WHEN HANDLING THE PCB, IF YOU DO NOT HAVE AN ESD WRIST STRAP, KEEP YOUR HANDS DRY AND FIRST TOUCH A METAL OBJECT TO ELIMINATE STATIC ELECTRICITY. WHEN HANDLING THE PCB, AVOID TOUCHING ANY METAL LEADS OR CONNECTORS.

DO NOT ALLOW METAL OBJECTS (SCREWS, TOOLS,...) TO COME INTO CONTACT WITH THE CIRCUIT BOARD OR ITS COMPONENTS.

Printed Circuit Board (PCB) Replacement

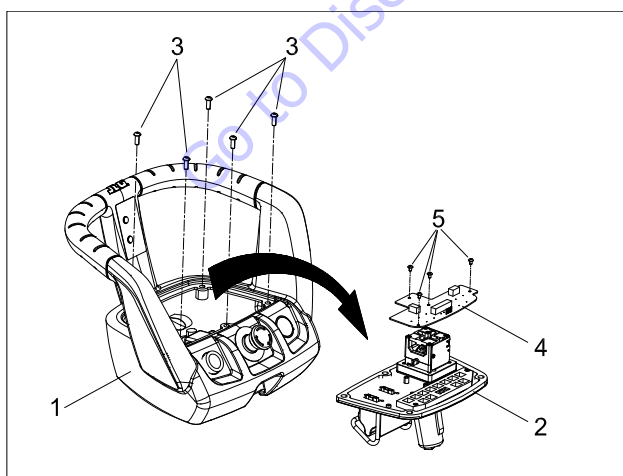

Figure 8-28. Upper Control Box Circuit Board - Installation

Upper Control Box - Component Replacement

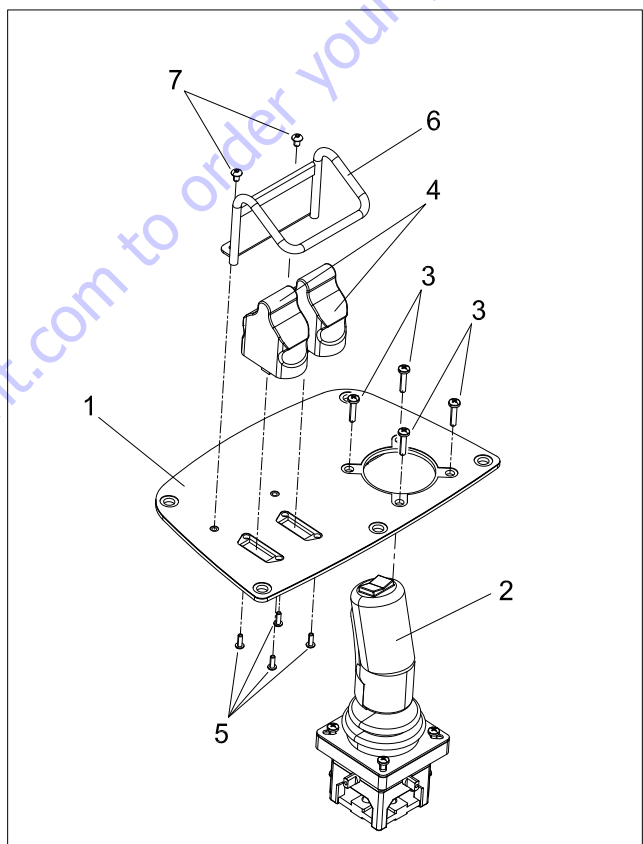

Figure 8-29. Joystick Controls - Installation

1. Face Plate
2. Drive/Swing Joystick Assembly
3. Drive/Steer Joystick Attach Screws
4. Mast/Jib Joysticks Assembly
5. Mast/Jib Joystick Attach Screws
6. Guard
7. Guard Attach Screws

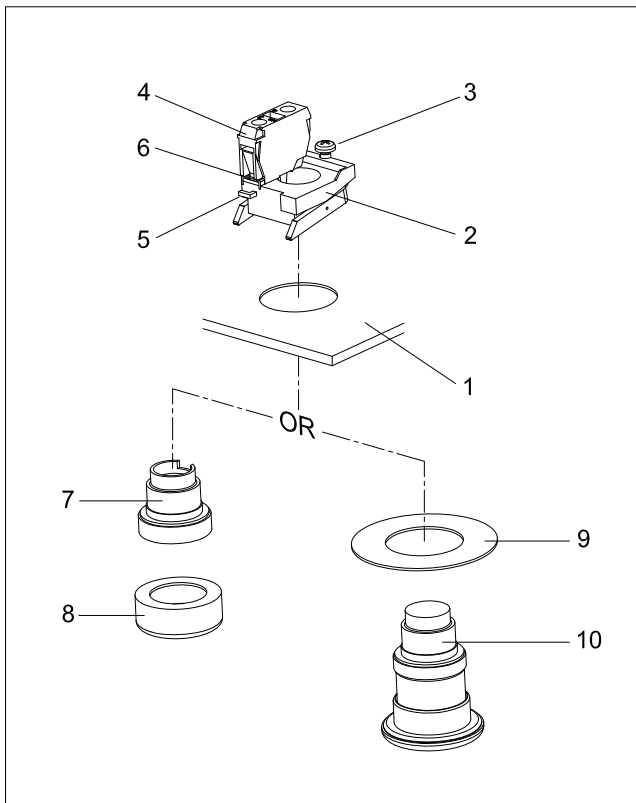

Figure 8-30. Enable/Emergency Stop Switches - Installation

1. Box Panel
2. Switch Base
3. Base Release Screw
4. Switch
5. Barrel Release Lever
6. Switch Release Lever
7. Enable Button/Barrel
8. Boot
9. Decal
10. Emergency Stop Button/Barrel

1. Loosen the base release screw, then spin the switch base if necessary to access the barrel release lever.
2. Pull the barrel release lever straight out with the blade of a screwdriver and pull barrel out of the switch base from the front of the control box.
3. If the switch requires removal, pull the switch release lever out with the blade of a screwdriver and remove the switch.
4. Reverse steps to install.

Upper Control Box - Components Evaluation

1. Mast and Jib Joysticks

Two single axis mini-joysticks are used for the mast and jib lift functions. Both have the same characteristics.

Electrical characteristics:

- Track resistance: $5k\Omega \pm 20\%$
- Output voltage range: 10-90% of input ($\pm 2\%$)

Joysticks wiring:

- Yellow wire: Power from the board (+5V)
- Blue wire: Ground
- Green wire: Signal output

Joystick signal output for system interpretation:

Description	Default Value	Calibrated Value
Voltage for the minimum mast/jib forward position (+1%)	2.65V	CENTER +0.15V
Voltage for the maximum mast/jib forward position (+100%)	4.45V	FWD TO MAX -0.05V
Voltage for the minimum mast/jib reverse position (-1%)	2.35V	CENTER -0.15V
Voltage for the maximum mast/jib reverse position (-100%)	0.55V	REV TO MAX +0.05V

2. Drive Joystick

The drive joystick is a dual axis joystick with a trigger and a rocker switch.

Joystick wiring:

CONNECTOR PIN #	WIRE COLOR	FUNCTION
1	Orange	Power (+5V)
2	Green	Ground
3	Grey	Signal Output: Swing Axis
4	Blue	Signal Output: Drive Axis
5	Red	Trigger
6	Yellow	Rocker: Steer Left
7	Violet	Rocker: Steer Right
8	Brown	Trigger + Rocker Power (+24V)

Joystick signal output for system interpretation:

Description	Default Value	Calibrated Value
Voltage for the minimum drive forward / swing right position (+1%)	2.65V	CENTER + 0.15V
Voltage for the maximum drive forward / swing right position (+100%)	4.45V	FWD TO MAX - 0.05V
Voltage for the minimum drive reverse / swing left position (-1%)	2.35V	CENTER - 0.15V
Voltage for the maximum drive reverse / swing left position (-100%)	0.55V	REV TO MAX + 0.05V

3. Membrane Switches

The DOS and Horn switches are made of membrane switches:

Each push button is a SPST switch; switch ON = 15 to 25 Ω (circuit impedance, measured on the ribbon connector).

Go to Discount-Equipment.com to order your parts

SECTION 9. JLG CONTROL SYSTEM

9.1 HAND HELD ANALYZER

To Connect the Hand Analyzer

1. Connect the four pin end of cable supplied with the analyzer to the four position connector on the platform console and connect the remaining end of the cable to the analyzer.
2. Power up the Control System by turning the lower key to platform position and pulling both emergency stop buttons on.



Figure 9-1. Hand Held Analyzer Connection

Using the Analyzer

With the machine power on and the analyzer connected properly, the analyzer will display the following:

HELP:
PRESS ENTER

At this point, using the **RIGHT** and **LEFT** arrow keys, you can move between the top level menu items. To select a displayed menu item, press **ENTER**. To cancel a selected menu item, press **ESC**; then you will be able to scroll using the right and left arrow keys to select a different menu item.

The top level menus are as follow:
(Also see § 9-2 Analyzer Screen Layout).

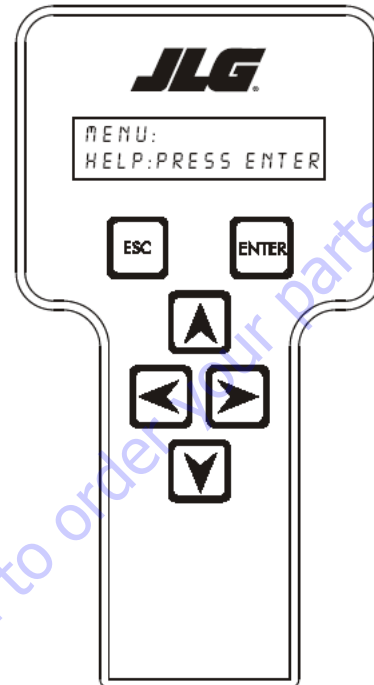

HELP:
DIAGNOSTICS
SYSTEM TEST
ACCESS LEVEL 2
PERSONALITIES (See Table 9-4)
MACHINE SETUP (See Table 9-1)

If you press **ENTER**, at the **HELP:PRESS ENTER** displays, and a fault is present during power up, the analyzer display will scroll the fault across the screen. If there was no fault detected during power up, the display will read:

- In platform mode,
HELP:(001)
EVERYTHING OK,

- In ground mode,
HELP:(002)
GROUND MODE OK,

If **ENTER** is pressed again, the display moves to the following display:

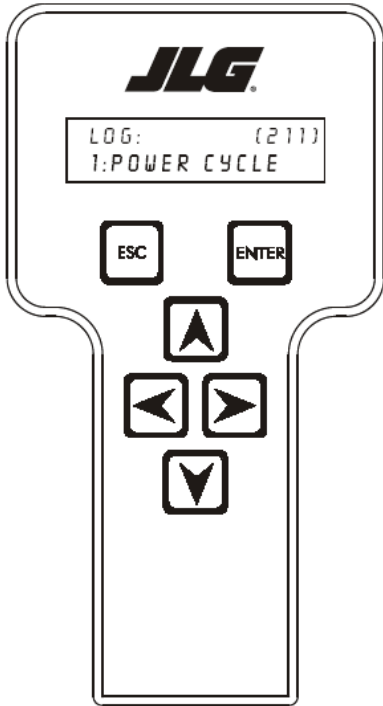

LOGGED HELP

LOG:211

1: Power Cycle (Or last recorded fault)

At this point, the analyzer will display the current fault, if any are present. You may scroll through the fault logs to view what the last fifteen faults were. Use the right and left arrow keys to scroll through the fault logs. To return to the beginning, Press **ESC** two times.

When a top level menu is selected, a new set of menu items may be offered; If for example you choose Personalities:

- DRIVE**
- STEER**
- MAST LIFT**
- JIB LIFT**
- SWING**
- GROUND**

Pressing **ENTER** with any of the above displayed menus, will display additional submenus within the selected menu. In some cases the next level is the parameter or information to be changed. Refer to the flow chart for what menus are available within the top level menus. You may only view the personality settings for selected menus while in access level 2. Remember, you may always cancel a selected menu item by pressing the **ESC** key.

Changing the Access Level of the Hand Held Analyzer

When the analyzer is first connected, you will be in access level 2 which enables you to only view most configuration settings which cannot be changed until you enter a password to advance to a lower level. This ensures that a setting cannot be accidentally altered. To change the access level, the correct password must be entered. To enter the password, scroll to the **ACCESS LEVEL** menu.

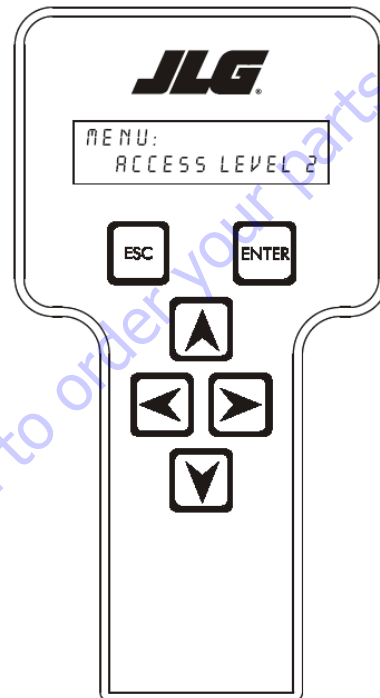

For example:

**MENU:
ACCESS LEVEL 2**

Press **ENTER** to select the **ACCESS LEVEL** menu. Using the **UP** or **DOWN** arrow keys, enter the first digit of the password, 3. Then, using the **RIGHT** arrow key, position the cursor to the right one space to enter the second digit of the password. Use the **UP** or **DOWN** arrow key to enter the second digit of the password which is 3. Repeat this process until you have entered all five digits of the password which is 33271.

Once the correct password is displayed, press **ENTER**. The access level should display the following, if the password was entered correctly:

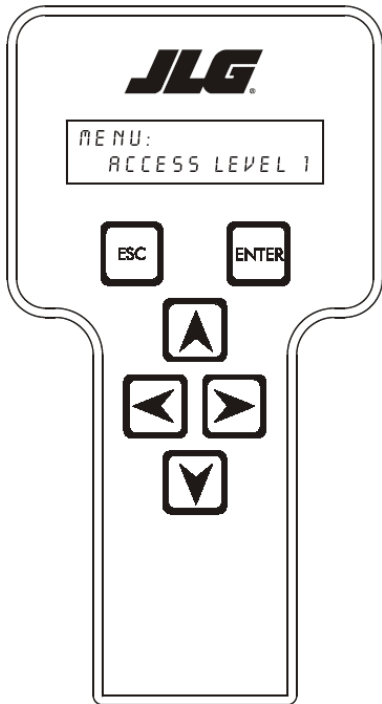

MENU:
ACCESS LEVEL 1

Repeat the above steps if the correct access level is not displayed or you can not adjust the personality settings.

Machine Setup

When a machine digit item is selected, press the **UP** or **DOWN** arrow keys to adjust its value.

⚠ WARNING

FAILURE TO MAKE THE PROPER SETTINGS FOR THE PARTICULAR MACHINE CAN RESULT IN IMPROPER OPERATION.

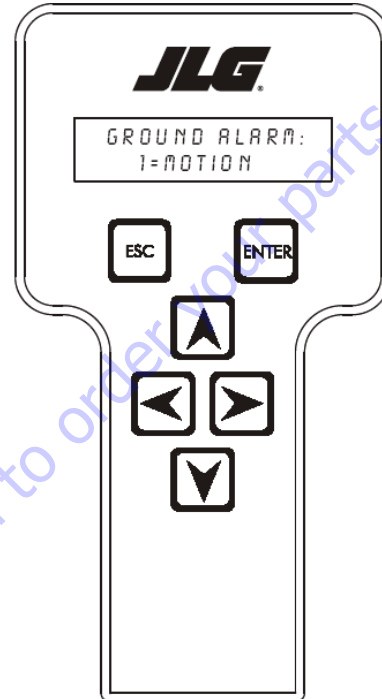

For example:

GROUND ALARM:
1=MOTION

The effect of the machine digit value is displayed along with its value. The above display would be selected if the machine was equipped with a ground alarm and you wanted it to sound when driving. There are certain settings allowed to install optional features or select the machine model.

NOTE: When selecting the machine model to match the type of the machine, the personality settings will return to default settings.

NOTE: Refer to the appropriate Machine Personality Settings Table, and the Machine Setup Table on the following pages in this Service Manual for the default settings.

Password 33271 will give you access to level 1, which will permit you to change all machine personality and/or machine setup settings.

⚠ WARNING

CHANGING THESE SETTINGS MAY ADVERSELY AFFECT THE PERFORMANCE OF YOUR MACHINE.

9.2 ANALYZER SCREEN LAYOUT

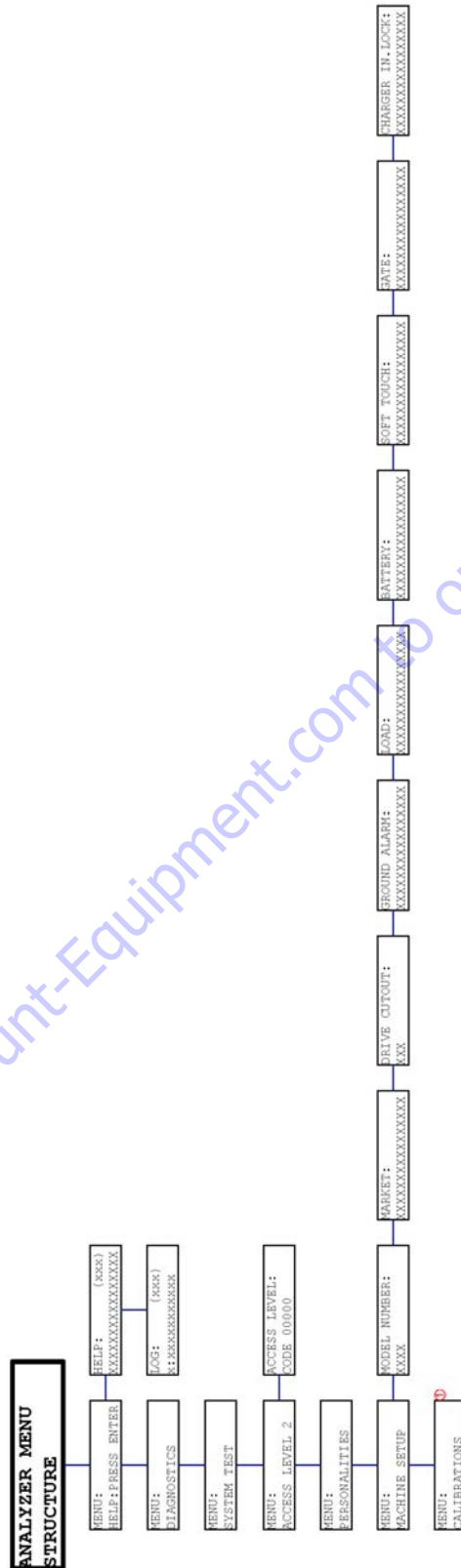

Figure 9-2. Analyzer Flow Chart - Sheet 1 of 5

NOTE: Ⓣ - Only available in access level 1.

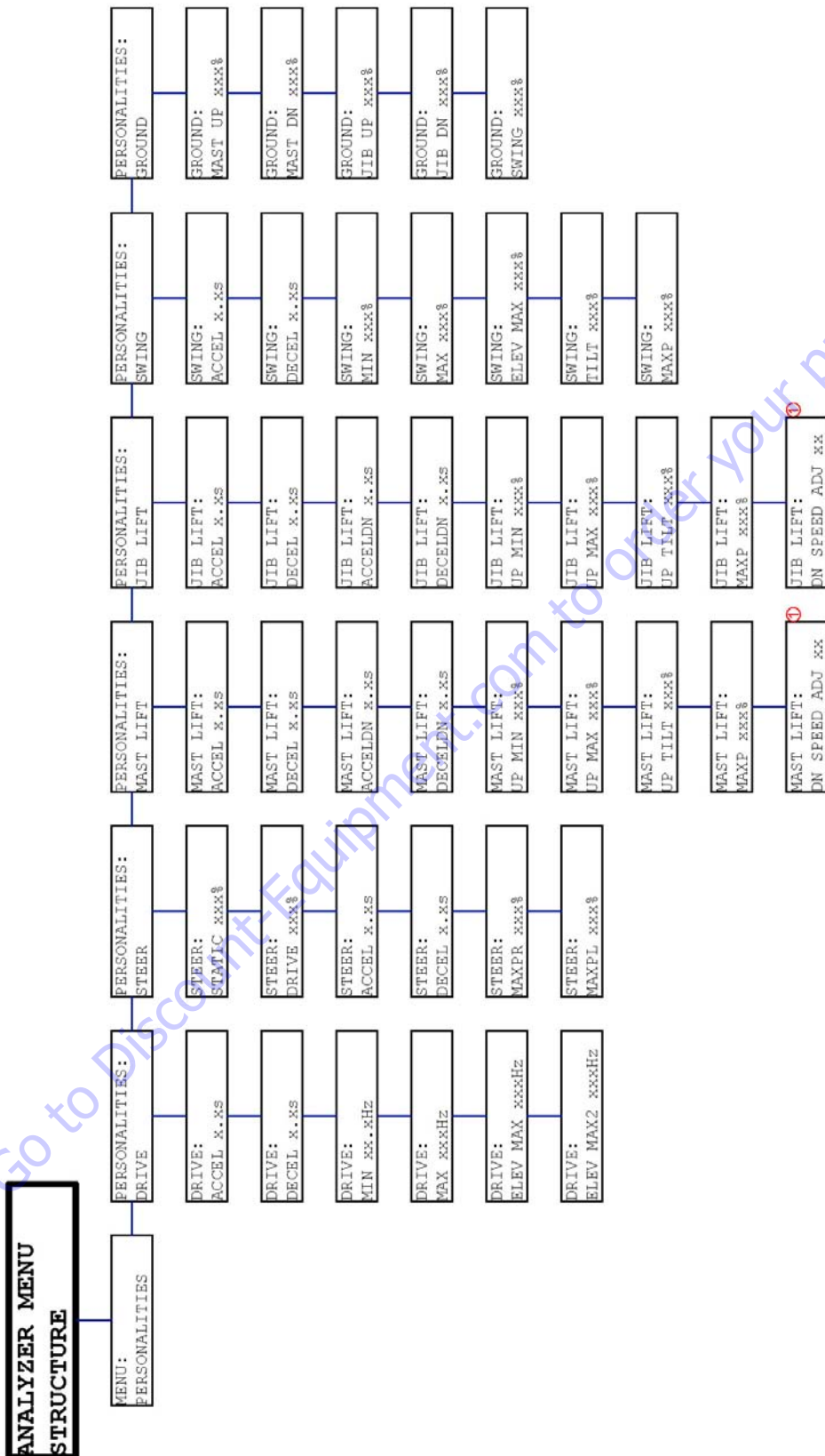

Figure 9-5. Analyzer Flow Chart - Sheet 4 of 5

NOTE: Ⓣ - Only available in access level 1.

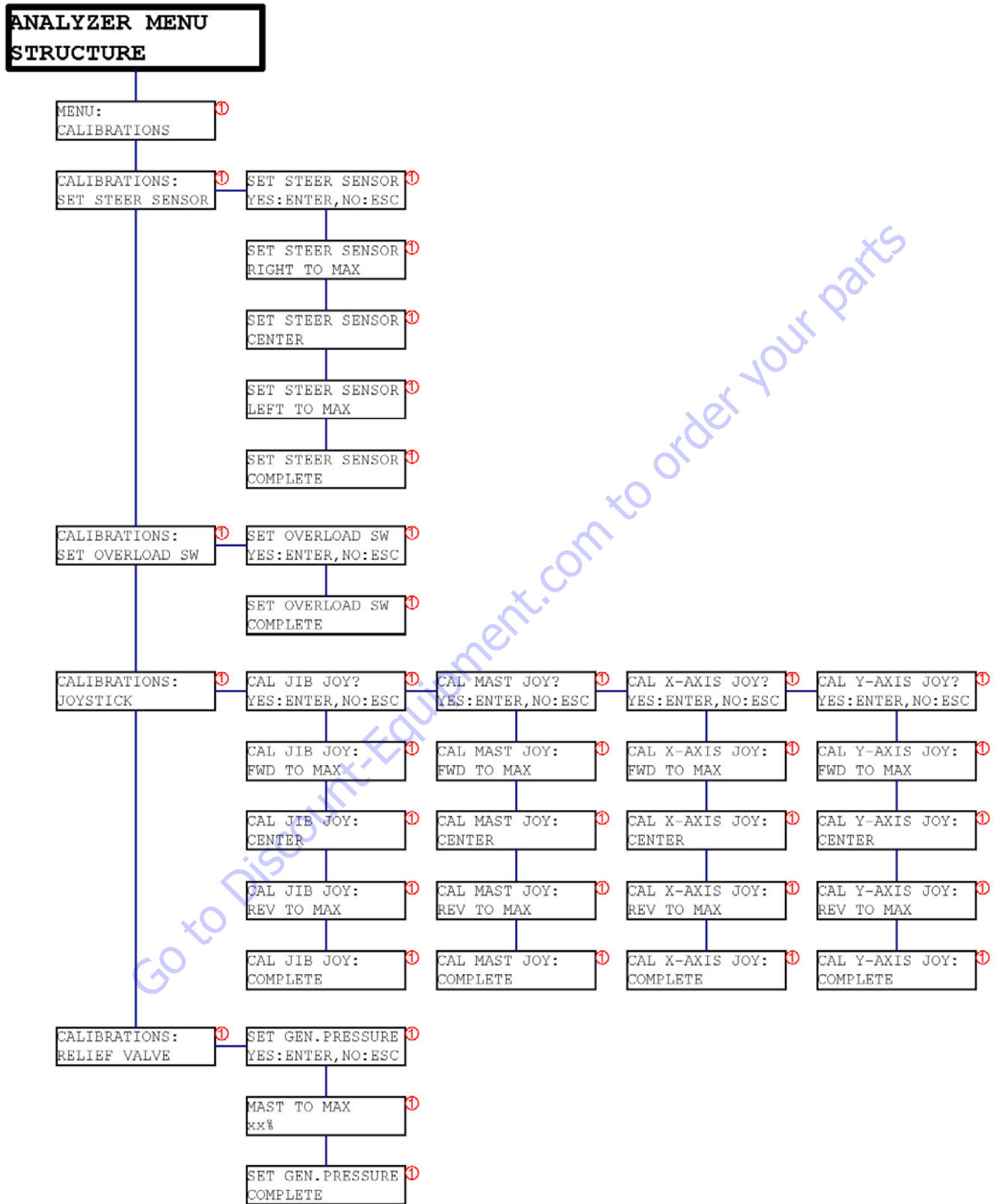
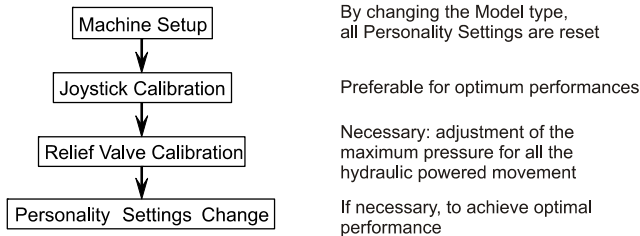

Figure 9-6. Analyzer Flow Chart - Sheet 5 of 5

NOTE: Ⓛ - Only available in access level 1.

9.3 MACHINE SETUP PROGRAMMING INFORMATION

In case of complete system reset (Controller change, Personality settings reset), the following logic shall be followed:



Shaded entries are not available for the selected market.

Configuration Digit	Setting Range	Description	Default Setting
1 (Model #)	0 1	Toucan 10E (26E) Toucan 8E (20E)	0
2 (Market)	0 1 2 3 4 5	CE ANSI USA ANSI EXPORT CSA AUSTRALIA JAPAN	0
3 (Drive Cutout)	0 1	0=NO - Drive NOT PREVENTED while elevated. 1=YES - Drive Prevented while elevated.	0
4 (Ground Alarm)	0 1 2	0=NOT INSTALLED 1=DESCENT - Vehicle alarm will function during lift down motions. 2=MOTION - Vehicle alarm will function during drive and all motions.	0
5 (Load)	0 1 2	0=NOT INSTALLED - Load sensing system (LSS) is not fitted to the vehicle 1=CUTOOUT PLT - Load sensing system (LSS) is fitted, and Platform Controls are prevented in the event of an overload. Ground Controls remain functional. 2=CUTOOUT ALL - Load sensing system (LSS) is fitted. Platform and Ground Controls are prevented in the event of an overload.	1
6 (Soft Touch)	0 1	0=NOT INSTALLED - Soft touch frame is not fitted to the vehicle. 1=INSTALLED - Soft touch frame is fitted to the vehicle. In the event of soft touch device actuation during a motion, only the reverse movement will be allowed.	0
7 (Gate)	0 1	0=NOT INSTALLED - Articulated gate is not fitted to the platform. 1=INSTALLED - Platform is fitted with an articulated gate. Platform and Ground Controls are prevented when gate is open.	0
8 (Charger Interlock)	0 1	0=DRIVE ONLY - Drive motion prevented when vehicle is charging. 1=CUTOOUT ALL - All motions are prevented while vehicle is charging.	1

Table 9-1. Machine Setup Programming Information

9.4 CALIBRATION INSTRUCTIONS

All calibration procedures are menu driven through the use of the standard JLG analyzer (connected to the control system on the bottom of the platform control box). The user is prompted to exercise the machine in a specific order to use the machines physical properties to consistently establish sensor response and the interaction of valves, pump and motors.

The chart below lists the calibrations required and potential reasons for re-calibration.

Calibration Procedure	Reasons for Re-calibration
Steer Sensor	Master or Slave module replacement Steer sensor removal or replacement Steering spindle or steering pin removal or replacement Drive speeds out of tolerances
Overload Switch	Switch removal or replacement Platform replacement Rollers replacement System parameters reset Load control inaccuracy
Joysticks	Master or Slave module replacement Joysticks replacement Platform console inoperative
Relief Valve	Master or Slave module replacement Pressure Relief Valve replacement Hydraulic power pack replacement Movement speeds out of range

NOTE: If the system is reset (by changing the machine model), the steer sensor, the joysticks and the pressure relief valve must be re-calibrated.

NOTE: The tilt sensor is not calibrated using the analyzer (Refer to Section 8-2 for the appropriate procedure).

9.5 CALIBRATING STEERING SENSOR

1. Position the Platform/Ground select switch to the Platform position.
2. Pull out both Platform and Ground Emergency Stop switches.
3. Position the machine on a flat level ground.
4. Enter Access Level 1 and scroll to the CALIBRATION -> SET STEER SENSOR screen.
5. Press ENTER to enter Steer Sensor calibration sub-menu.
6. Hit ENTER again to begin the calibration process.
7. The screen will indicate 'LEFT TO MAX' : Activate the steer control until the wheels are fully steered to the left (you may drive for a limited distance while steering to ensure the mechanical stop is reached).
8. Hit ENTER to confirm.

9. The screen will indicate 'CENTER' : Activate the steer control until the wheels are straight in relationship with the chassis.

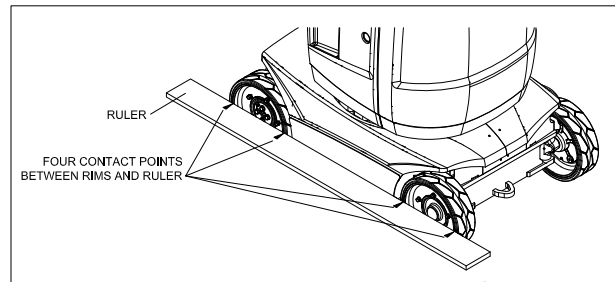

Figure 9-7. Wheel Straightening

10. Hit ENTER to confirm.
11. The screen will indicate 'RIGHT TO MAX' : Activate the steer control until the wheels are fully steered to the right (you may drive for a limited distance while steering to ensure the mechanical stop is reached).
12. Hit ENTER to confirm.
13. After completing the Steer Sensor calibration, hit ESC twice to go back to CALIBRATIONS.

9.6 CALIBRATING OVERLOAD SYSTEM

Calibrating the overload system is a mechanical operation. The procedure through the analyzer is established to help the technician by removing the delay timers in the system : the alarm will directly give the overload switch status. Calibrating the overload system will clear the fault 'LSS HAS NOT BEEN CALIBRATED' : this fault is, by default, present on all new system.

1. Position the Platform/Ground select switch to the Platform position.
2. Pull out both Platform and Ground Emergency Stop switches.
3. Position the machine on a flat level ground.
4. Enter Access Level 1 and scroll to the CALIBRATION -> SET OVERLOAD SW screen.
5. Press ENTER to enter Overload Switch calibration sub-menu.
6. Position a 220kg load evenly distributed on platform floor.

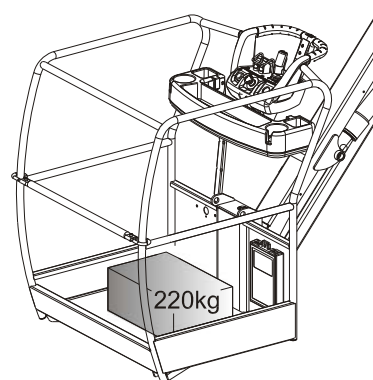

7. Remove the cap screw (1).
8. Loosen the locknut of the setting screw (2).
9. Screw the setting screw (3) until the sensor is activated and the acoustic alarm sounds.
10. Tighten the locknut of the setting screw while maintaining the setting screw.
11. Re-install the cap screw.
12. Hit ENTER to complete the calibration.
13. After completing the Overload switch calibration, hit ESC twice to go back to CALIBRATIONS.
14. Refer to the Operator's and Safety Manual to verify the Overload System setting.

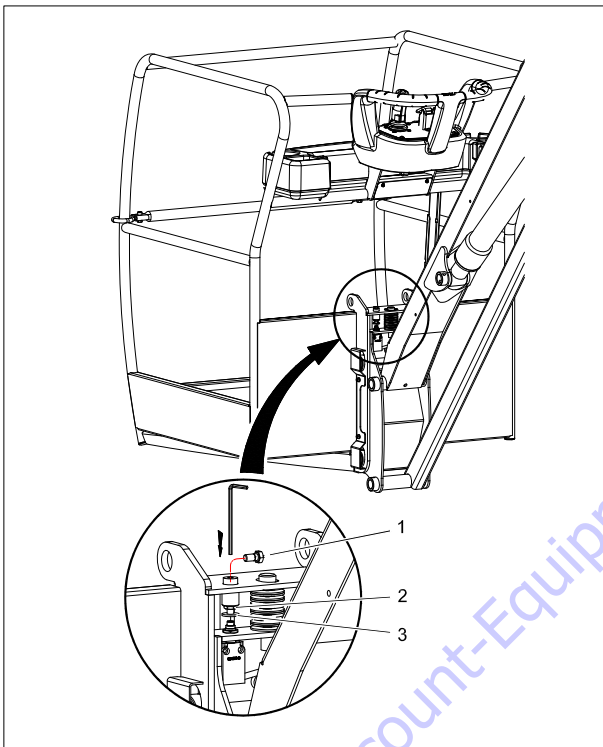

Figure 9-8. Overload System

9.7 CALIBRATING THE JOYSTICKS

1. Position the Platform/Ground select switch to the Platform position.
2. Pull out both Platform and Ground Emergency Stop switches.
3. Enter Access Level 1 and scroll to the CALIBRATION / JOYSTICK screen.
4. Scroll to the joystick that needs to be calibrated (JIB JOY -> MAST JOY -> X-AXIS JOY -> Y-AXIS JOY).
5. Hit ENTER to enter Joystick calibration procedure.
6. The screen will indicate 'FWD TO MAX' (or 'LEFT TO MAX') : Tilt and maintain the Joystick fully forward (or fully to the left).
7. Hit ENTER to acquire the joystick position.
8. The screen will indicate 'CENTER'.
9. Release the joystick and allow it to center.
10. Hit ENTER to acquire the joystick position.
11. The screen will indicate 'REV TO MAX' (or 'RIGHT TO MAX') : Tilt and maintain the joystick fully reverse (or fully to the right).
12. Hit ENTER to acquire the joystick position.

9.8 CALIBRATING THE PRESSURE RELIEF VALVE

The PWM Pressure Relief Valve has a setting for each movement. The different settings can be viewed / altered by accessing to the personalities. The aim of the calibration procedure is to set all the pressure personalities in one operation.

NOTE: After a complete reset of the system, setting the maximum pressure for all the movements is mandatory. Calibrating the Pressure Relief Valve is the recommended practice: it does not only set the maximum pressure for all the hydraulic powered movements but adjusts the response curves of the valve. Although it is possible to set all the maximum pressures by adjusting all the MAXP personality settings, this will not adjust the response curves. Before any pressure measurement or adjustment, warm up the system by operating the different movements. Pressure measurement is to be performed with a function operated at maximum speed.

1. Position the Platform/Ground select switch to the Platform position.
2. Pull out both Platform and Ground Emergency Stop switches.
3. Position the machine on a flat level ground. A minimum up and over clearance of 7m is required.
4. Connect a pressure gauge to the dedicated port (port "2" on the hydraulic power unit valve body).
5. Connect the Analyzer, Enter Access Level 1 and scroll to the CALIBRATION / RELIEF VALVE screen.
6. Press ENTER to enter Relief Valve calibration sub-menu.
7. The screen will indicate 'SET GEN PRESSURE' : Hit ENTER.
8. The screen will indicate 'MAST TO MAX' and display MAST, MAXP personality.
9. Fully raise the mast; at the end of the stroke of the mast, read the actual maximum pressure.
10. Using the Up and Down arrows, adjust MAST, MAXP personality in order to set the pressure at 17MPa (± 0.5 MPa). Adjusting the personality must be done when the system is idle (no movement is controlled).
11. When the correct pressure is set, Hit ENTER to complete the Pressure Relief Valve Calibration (the sys-

tem will calculate and overwrite all MAXP personalities).

12. After completing the Relief Valve calibration, hit ESC twice to go back to CALIBRATIONS.
13. Control the different pressures and adjust the personality settings if required (refer to § 9-9 for personality settings adjustment procedures): see Table 9-2 for the acceptable pressure values.

Toucan 10E & Toucan 26E				
Function	Minimum pressure		Maximum Pressure	
Mast Lift Up	16 MPa	2320 psi	17 MPa	2465 psi
Jib Lift Up	14 MPa	2030 psi	16 MPa	2320 psi
Swing Right / Left	4 MPa	580 psi	5 MPa	725 psi
Steer Right	7 MPa	1015 psi	9 MPa	1305 psi
Steer Left	10 MPa	1450 psi	12 MPa	1740 psi

Toucan 8E & Toucan 20E				
Function	Minimum pressure		Maximum Pressure	
Mast Lift Up	14 MPa	2030 psi	15 MPa	2175 psi
Jib Lift Up	14 MPa	2030 psi	15 MPa	2175 psi
Swing Right / Left	5.5 MPa	800 psi	6.5 MPa	945 psi
Steer Right	7 MPa	1015 psi	9 MPa	1305 psi
Steer Left	10 MPa	1450 psi	12 MPa	1740 psi

Table 9-2. Acceptable Pressure Values

9.9 MACHINE PERSONALITY - ADJUSTMENT SETTINGS

Personality settings adjustments shall be done when the system is idle (none of the power components, drive or pump motor, is running).

Each time the Up or Down arrow is hit to modify a personality setting, the value is modified in the Master Module memory and written in the Slave Module memory. If a personality value is changed by maintaining the Up or Down arrow, the value set in the Master Module is the value displayed but the value written in the Slave Module may differ: in this situation, the altered movement speed or pressure will NOT be consistent with the displayed value. In order to ensure that the verification of the modified setting is valid:

- Values should be changed step by step, or
- The last value adjustment should be a single step adjustment, or
- The power should be cycled.

Table 9-3. Machine Personality Adjustment

Submenu (Displayed on Analyzer 1st line)	Parameter (Displayed on Analyzer 2nd line)	Description	Adjustment Range	Default Values (0)
DRIVE				
	ACCEL	Displays/adjusts drive acceleration	0.5 - 5.0 sec	2.0
	DECEL	Displays/adjusts drive deceleration	0.5 - 5.0 sec	1.2
	MIN	Displays/adjusts minimum drive speed	0.5 - 4.0 Hz	0.6
	MAX	Displays/adjusts maximum drive speed	1 - 170 Hz	170
	ELEV MAX	Displays/adjusts maximum drive speed when the platform is elevated (Main mast switch is triggered)	1 - 22 Hz	22
	ELEV MAX2 (3)	Displays/adjusts maximum drive speed when the platform is fully elevated (Mast switch 2 is triggered)	1 - 12 Hz	12
STEER				
	STATIC	Displays/adjusts maximum steer speed when the machine is not driving	1 - 100%	50
	DRIVE	Displays/adjusts maximum steer speed when the machine is driving	1 - 100%	18
	ACCEL	Displays/adjusts steer acceleration	0.1 - 5.0 sec	0.1
	DECEL	Displays/adjusts steer deceleration	0.0 - 5.0 sec	0.0
	MAXPR	Displays/adjusts steer right maximum pressure	1 - 55%	38
	MAXPL	Displays/adjusts steer left maximum pressure	1 - 55%	43
MAST LIFT				
	ACCEL	Displays/adjusts mast lift up acceleration	0.1 - 5.0 sec	1.0
	DECEL	Displays/adjusts mast lift up deceleration	0.1 - 5.0 sec	0.5
	ACCEL DN	Displays/adjusts mast lift down acceleration	0.1 - 5.0 sec	0.5
	DECEL DN	Displays/adjusts mast lift down deceleration	0.1 - 5.0 sec	0.1
	UP MIN	Displays/adjusts mast lift up minimum speed	1 - 50%	25
	UP MAX	Displays/adjusts mast lift up maximum speed	25 - 100%	100
	UP TILT (1)	Displays/adjusts mast lift up speed when machine is tilted	25 - 70%	50
	MAXP	Displays/adjusts mast lift up maximum pressure	1 - 65%	58
	DN SPEED ADJ (2)	Displays/adjusts mast lift down speed	0 - 10	5
JIB LIFT				
	ACCEL	Displays/adjusts jib lift up acceleration	0.1 - 5.0 sec	2.5
	DECEL	Displays/adjusts jib lift up deceleration	0.1 - 5.0 sec	0.5

Table 9-3. Machine Personality Adjustment

Submenu (Displayed on Analyzer 1st line)	Parameter (Displayed on Analyzer 2nd line)	Description	Adjustment Range	Default Values (0)
	ACCEL DN	Displays/adjusts jib lift down acceleration	0.1 - 5.0 sec	0.5
	DECEL DN	Displays/adjusts jib lift down deceleration	0.1 - 5.0 sec	0.1
	UP MIN	Displays/adjusts jib lift up minimum speed	10 - 50%	10
	UP MAX	Displays/adjusts jib lift up maximum speed	10 - 100%	50
	UP TILT (1)	Displays/adjusts jib lift up speed when machine is tilted	15 - 60%	60
	MAXP	Displays/adjusts jib lift up maximum pressure	1 - 65%	52
	DN SPEED ADJ (2)	Displays/adjusts jib lift down speed	0 - 10	5
SWING				
	ACCEL	Displays/adjusts swing acceleration	0.1 - 5.0 sec	2.0
	DECEL	Displays/adjusts swing deceleration	0.1 - 5.0 sec	2.0
	MIN	Displays/adjusts minimum swing speed	1 - 50%	5
	MAX	Displays/adjusts maximum swing speed	1 - 100%	26
	ELEV MAX (1)	Displays/adjusts maximum swing speed when the platform is elevated	1 - 100%	67
	TILT (1)	Displays/adjusts maximum swing speed when the machine is tilted	5 - 50%	45
	MAXP	Displays/adjusts swing maximum pressure	1 - 40%	29
GROUND				
	MAST UP (1)	Displays/adjusts fixed mast lift up speed	1 - 80%	70
	MAST DN (1)	Displays/adjusts fixed mast lift down speed	1 - 80%	70
	JIB UP (1)	Displays/adjusts fixed jib lift up speed	1 - 80%	60
	JIB DN (1)	Displays/adjusts fixed jib lift down speed	1 - 90%	80
	SWING (1)	Displays/adjusts fixed swing speed	1 - 80%	50

NOTE: (0) These settings may change in order to achieve optimal performance on a machine by machine basis.

(1) These personalities are a percentage of the maximum speed setting of the considered movement.

NOTE: (2) Mast and jib lift down speed parameters are automatically set when the general pressure is calibrated. Depending on the machine applica-

tion, it may be necessary to adjust the movements's response curve: decreasing DN SPEED ADJ will lower the lift down speed for a constant input, increasing the parameter will increase the lift down speed for a constant input.

(3) Toucan 10E

9.10 SYSTEM TEST

The Control System incorporates a built-in system test to check the system components and functions. To use this function, use the following procedures.

Before proceeding, ensure that the machine is in the following configuration:

- a. Machine on a flat level ground;
- b. Mast and Jib fully lowered;
- c. Jib in line with the chassis, counterweight positioned over the steering wheels.

Test from the platform console

1. Position the Platform/Ground select switch to the Platform position.
2. Pull out both Emergency Stop switches.
3. Plug the analyzer into the connector at the base of the platform control box.
4. Enter Access Level 1 and scroll to the SYSTEM TEST screen.

5. Hit ENTER. The analyzer will prompt you asking if you want to activate the system test; hit ENTER again to activate.
6. Follow the flow path in Figure 9-9., System Test Flow Chart and go through the component tests. Hit ESC key during any part of the test to return to the main menu without completing all tests or wait until all tests are complete. During the TEST SWITCHES sequence, the analyzer allows control switches to be operated and shows if they are closed (CL) or open (OP). During the TEST INDICATORS sequence, the operator is prompted to confirm (by pressing ENTER key) that the named lamp is lit.

NOTE: Specific test can be directly accessed by scrolling to the desired screen with the horizontal arrows.

Test from the ground console

1. Position the Platform/Ground select switch to the Ground position.
2. Follow the 'Test from the platform console' procedure, selecting the tests referring to the ground console (TEST GROUND SWITCHES & TEST GROUND INDICATORS).

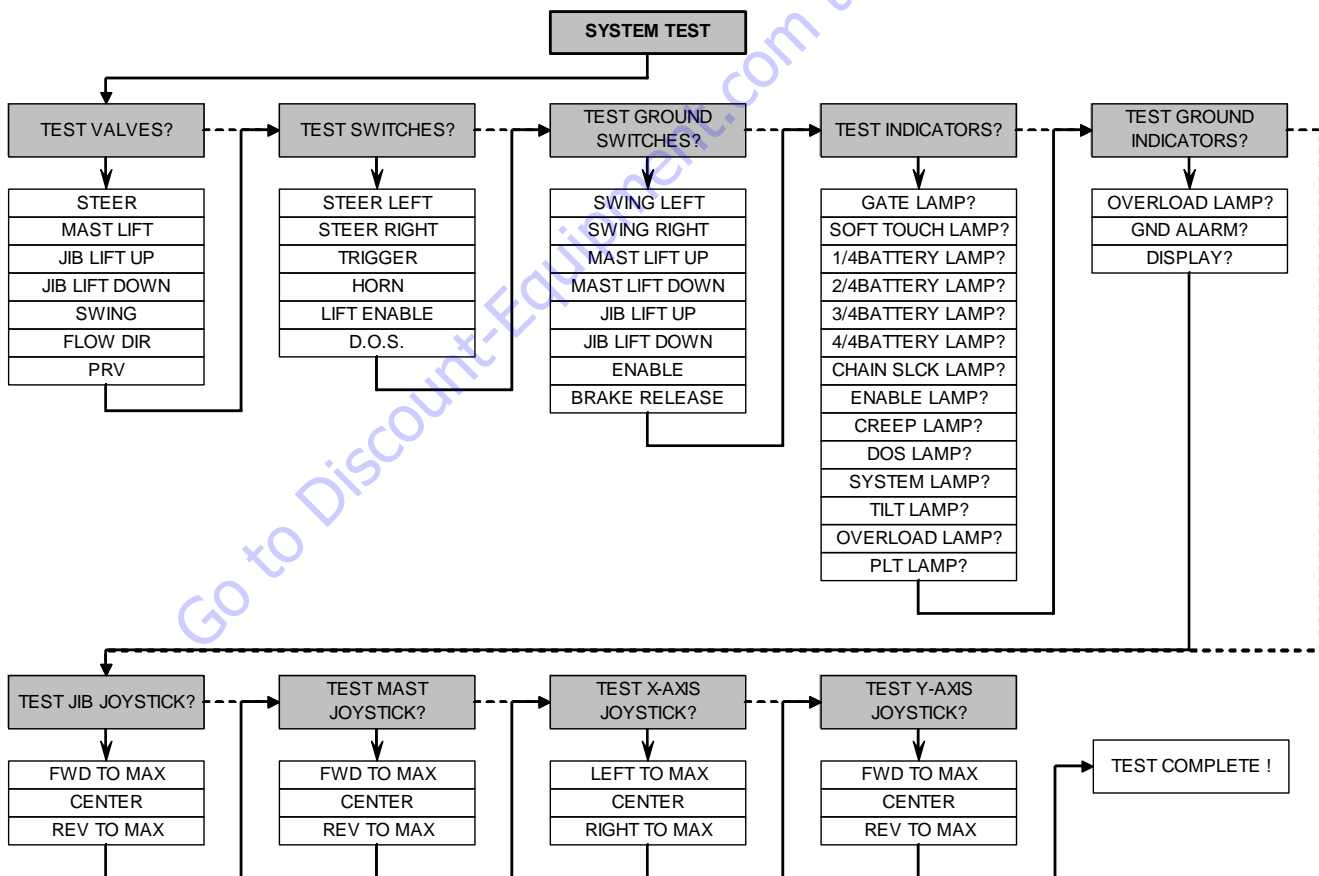

Figure 9-9. System Test Flow Chart

PARTS FINDER

**Search Website
by Part Number**



**Search Manual
Library For Parts
Manual & Lookup Part
Numbers – Purchase
or Request Quote**

Search Manuals

Enter your information to search for manuals and parts.

* Brand:

* Model:

* Serial:

* Part Number:

SEARCH

**Can't Find Part or
Manual? Request Help
by Manufacturer,
Model & Description**

Parts Order Form

Please fill in the following information:

Manufacturer:

Model:

Description:

Quantity:

Part Number:

Part Name:

Part Description:

Part Location:

Part Condition:

Part Status:

Part Price:

Part Weight:

Part Dimensions:

Part Material:

Part Color:

Part Finish:

Part Notes:

Part Images:

Part Attachments:

Part Specifications:

Part Certifications:

Part Compliance:

Part Safety:

Part Environmental:

Part Other:

Submit

Discount-Equipment.com is your online resource for quality parts & equipment.

Florida: **561-964-4949** Outside Florida TOLL FREE: **877-690-3101**

Need parts?

Click on this link: <http://www.discount-equipment.com/category/5443-parts/> and choose one of the options to help get the right parts and equipment you are looking for. Please have the machine model and serial number available in order to help us get you the correct parts. If you don't find the part on the website or on once of the online manuals, please fill out the request form and one of our experienced staff members will get back to you with a quote for the right part that your machine needs.

We sell worldwide for the brands: Genie, Terex, JLG, MultiQuip, Mikasa, Essick, Whiteman, Mayco, Toro Stone, Diamond Products, Generac Magnum, Airman, Haulotte, Barreto, Power Blanket, Nifty Lift, Atlas Copco, Chicago Pneumatic, Allmand, Miller Curber, Skyjack, Lull, Skytrak, Tsurumi, Husquvarna Target, , Stow, Wacker, Sakai, Mi-T- M, Sullair, Basic, Dynapac, MBW, Weber, Bartell, Bennar Newman, Haulotte, Ditch Runner, Menegotti, Morrison, Contec, Buddy, Crown, Edco, Wyco, Bomag, Laymor, Barreto, EZ Trench, Bil-Jax, F.S. Curtis, Gehl Pavers, Heli, Honda, ICS/PowerGrit, IHI, Partner, Imer, Clipper, MMD, Koshin, Rice, CH&E, General Equipment, ,AMida, Coleman, NAC, Gradall, Square Shooter, Kent, Stanley, Tamco, Toku, Hatz, Kohler, Robin, Wisconsin, Northrock, Oztec, Toker TK, Rol-Air, Small Line, Wanco, Yanmar

SECTION 10. DIAGNOSTIC TROUBLE CODES

10.1 INTRODUCTION

This section provides a reference for Diagnostic Trouble Codes (DTC) read from the analyzer. DTCs are also displayed on the Multi Display Indicator (MDI, Ground Console) and on the face of the platform console. For more information on any sensors or indicators, refer to the appropriate section for the machine area. Many of the checks below require configuring and using a multimeter. Refer to Section 11, GENERAL ELECTRICAL INFORMATION & SCHEMATICS for multimeter basics. DTCs are sorted in groups by the first two digits, which are also the system distress lamp flash code. To troubleshoot multiple DTCs, start with the DTC with the higher first two digits. To view all active DTCs on the analyzer, view logged help before the first power cycle. The machine is powered by a nominal 24 Volts battery pack.

Some procedures below refer to this nominal voltage as 24V. Actual voltage measurements may differ based on the charge of the batteries. **If a correction is made during a check, conclude the check by cycling the machine power, using the emergency stop switch.** It may also be helpful to run a system test, ANALYZER -> SYSTEM TEST for intermittent or difficult problems.

10.2 DTC INDEX

DTC TABLE	PAGE
0-0 Help Comments	10-1
2-1 Power-Up	10-2
2-2 Platform Controls	10-3
2-3 Ground Controls	10-4
2-5 Function Prevented	10-5
3-1 Line Contactor Open Circuit	10-6
3-2 Line Contactor Short Circuit	10-7
3-3 Ground Output Driver	10-8
4-2 Thermal Limit	10-9
4-4 Battery Supply	10-10
4-6 Transmission and Drive System	10-11
6-6 Communication	10-12
6-7 Accessory	10-13
7-7 Electric Motor	10-14
8-1 Tilt Sensor	10-15
8-2 Platform Load Sense	10-16
8-6 Steering / Axle	10-17
8-7 Safety System Override	10-17
9-9 Hardware	10-18

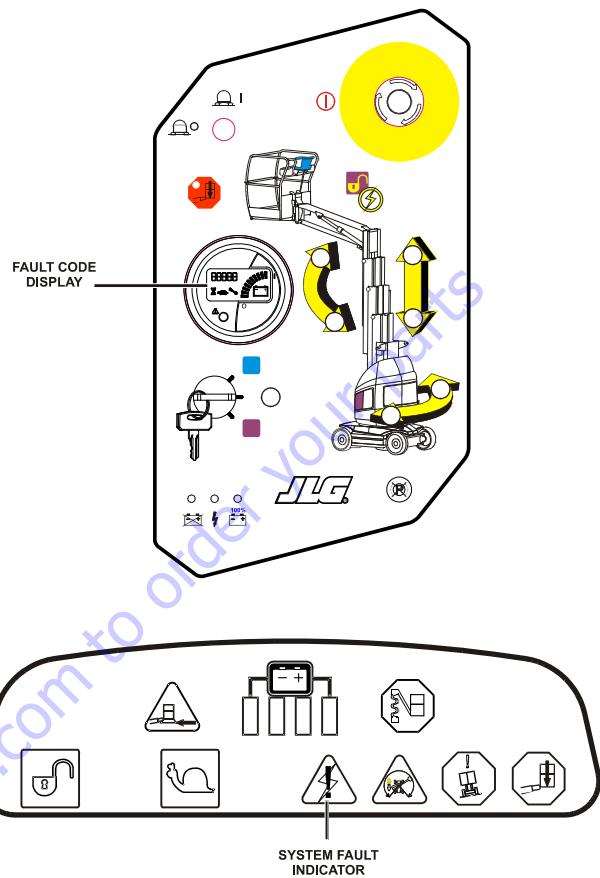

Figure 10-1. DTCs Displays

SECTION 10 - DIAGNOSTIC TROUBLE CODES

10.3 DTC CHECK TABLES

0-0 Help Comments

DTC	FAULT MESSAGE	DESCRIPTION	CHECK
001	EVERYTHING OK	The normal help message in Platform Mode. Displays on the analyzer only.	
002	GROUND MODE OK	The normal help message in Ground Mode. Displays on the analyzer only.	If Ground Mode is active with selector on Platform Mode : <ul style="list-style-type: none"> • Check integrity of wire #14 from CR5(4) to CR2(19) • Check keyswitch for stuck contacts
008	FUNCTIONS LOCKED OUT - SYSTEM POWERED DOWN	After 2 hours without activity, the Control System enters a low-power state to preserve battery charge. Displays on the analyzer only; the MDI's LED is blinking with the display Off.	<ul style="list-style-type: none"> • Normal operation should resume after a power cycle. • Check battery charge, condition, etc.
0010	RUNNING AT CUTBACK - OUT OF TRANSPORT POSITION	Drive speed is limited while the mast is elevated. Displays on the analyzer only.	<ul style="list-style-type: none"> • Fully stow the platform. • Check that the mast switches are securely mounted. • Check the mast switches wiring : @ +Vbatt : CR4(A), CR23(1), CR23(4), CR23(3), CR23(6), CR5(3), CR5(5), CR2(31), CR2(20). @ -Vbatt : CR4(B), CR4(C), CR23(2), CR23(5).
0022	DIFFERENT FUNCTION SELECTED & IGNORED	Two hydraulically powered movements commanded simultaneously.	<ul style="list-style-type: none"> • Release the joysticks and allow to center. • Check if one of the joysticks is obstructed or jammed. • Proceed with a joystick calibration. • Check Joystick voltages (refer to §8-6).
0023	FUNCTION SELECTED BUT TRIGGER SWITCH OPEN	One of the drive joystick functions was activated, but the trigger switch was not.	<ul style="list-style-type: none"> • Release joystick and allow to center. • Check if the joystick is obstructed or jammed. • Proceed with a joystick calibration. • Check joystick connections • Check Joystick voltages (refer to §8-6). • Check if the trigger switch is damaged. • Check trigger switch output : J2(5).
0027	FUNCTION SELECTED BUT LIFT ENABLE SWITCH OPEN	The Mast or the Jib joystick was activated, but the enable switch was not.	<ul style="list-style-type: none"> • Release joystick and allow to center. • Check if the joystick is obstructed or jammed. • Proceed with a joystick calibration. • Check joystick connections • Check Joystick voltages (refer to §8-6). • Check if the enable switch is damaged. • Check the enable switch output: J1(18).
0028	DRIVE PREVENTED - TILTED & ELEVATED	Drive is prevented while the platform is not in transport position and the chassis is not level.	<ul style="list-style-type: none"> • Check that the machine is tilted. If so, lower the platform and reposition the machine to a level surface. • Fully stow the platform. • Check that the tilt sensor is securely mounted and its wire connected. • Check the tilt sensor wiring : @ +Vbatt : CR9(B), CR9(C), CR2(7), CR3(7). @ -Vbatt : CR9(A). • Check the tilt sensor setting; if necessary, proceed with a sensor calibration.

SECTION 10 - DIAGNOSTIC TROUBLE CODES

DTC	FAULT MESSAGE	DESCRIPTION	CHECK
0029	RUNNING AT CREEP - MAX ELEVATION	Drive speed is limited while the mast is fully extended. Displays on the analyzer only.	<ul style="list-style-type: none"> Fully stow the platform. Check that the mast switches are securely mounted. Check the mast switches wiring : @ +Vbatt : CR4(A), CR23(1), CR23(4), CR23(3), CR23(6), CR5(3), CR5(5), CR2(31), CR2(20). @ -Vbatt : CR4(B), CR4(C), CR23(2), CR23(5).

2-1 Power-Up

DTC	FAULT MESSAGE	DESCRIPTION	CHECK
211	POWER CYCLE	The normal help message is issued at each power cycle. Displays on the analyzer only.	Normal operation. No check necessary.
212	KEYSWITCH FAULTY	Both Platform and Ground modes are selected simultaneously. Defaults to Ground Mode.	<ul style="list-style-type: none"> Check key switch function. Replace key switch.

2-2 Platform Controls

DTC	FAULT MESSAGE	DESCRIPTION	CHECK
221	FUNCTION PROBLEM - HORN PERMANENTLY SELECTED	The horn switch was closed during power-up in platform mode.	<ul style="list-style-type: none"> Check if the horn switch is damaged, obstructed or jammed. Check horn push button output : J4(3).
224	FUNCTION PROBLEM - STEER LEFT PERMANENTLY SELECTED	The Steer Left Switch was closed during power-up in platform mode.	<ul style="list-style-type: none"> Check if the steer left switch is obstructed or jammed. Check the left steer switch output : J2(6).
225	FUNCTION PROBLEM - STEER RIGHT PERMANENTLY SELECTED	The Steer Right Switch was closed during power-up in platform mode.	<ul style="list-style-type: none"> Check if the steer right switch is obstructed or jammed. Check the right steer switch output : J2(7).
226	ACCELERATOR FAULTY - WIPER OUT OR RANGE	The joystick wiper signal input is outside the acceptable voltage range.	<ul style="list-style-type: none"> Center joystick and check to see if a power cycle will clear DTC. Check joystick wiper voltage : J2(3) for swing, J2(4) for drive. Acceptable range : 0,35V - 4,65V.
227	STEER SWITCHES FAULTY	The steer left and steer right inputs were closed simultaneously.	<ul style="list-style-type: none"> Check if the steer switches are damaged, obstructed or jammed.
228	FUNCTION LOCKED OUT - ACCELERATOR NOT CENTERED	The Joystick was not centered at power-up in platform mode.	<ul style="list-style-type: none"> Release joystick and allow to center. Check if the joystick is obstructed or jammed. Proceed with a calibration. Check joystick voltages (refer to Section 8).
229	FUNCTION PROBLEM - TRIGGER PERMANENTLY CLOSED	The trigger switch was closed during power-up in platform mode.	<ul style="list-style-type: none"> Check if the trigger switch is obstructed or jammed. Check trigger switch output voltage : J2(5).
2210	TRIGGER CLOSED TOO LONG WHILE IN NEUTRAL	The trigger switch was closed for more than seven seconds while the joystick was centered.	<ul style="list-style-type: none"> Check if the trigger switch is obstructed or jammed. Check trigger switch output voltage : J2(5).

SECTION 10 - DIAGNOSTIC TROUBLE CODES

DTC	FAULT MESSAGE	DESCRIPTION	CHECK
2233	FUNCTION ENABLE RELAY - INVALID SIGNAL	Before driving the relay coil, the controller checks if the relay contacts are stuck.	<ul style="list-style-type: none"> Check the N.O. contact of the voting relay (installed on the interface board - ground console). Check the voting relay output for short to +Vbatt condition: CR1 (24), CR1 (25), CR1 (26) & CR1 (28) and the connected lines. Check connections between the voting relay and the main contactor: CR19(1) & CR7(8)
2240	LIFT ENABLE SWITCH PERMANENTLY SELECTED	The Lift Enable switch was closed during power-up in platform mode.	<ul style="list-style-type: none"> Check if the lift enable switch is obstructed or jammed. Check lift enable switch output voltage : J1 (18).
2241	LIFT ENABLE SWITCH CLOSED TOO LONG WHILE IN NEUTRAL	The Lift Enable switch was closed for more than seven seconds while the mast and jib joysticks were centered.	<ul style="list-style-type: none"> Check if the lift enable switch is obstructed or jammed. Check lift enable switch output voltage : J1 (18).
2242	FUNCTION LOCKED OUT - MAST JOYSTICK NOT CENTERED	The Mast Joystick was not centered at power-up in platform mode.	<ul style="list-style-type: none"> Release joystick and allow to center. Check if the joystick is obstructed or jammed. Proceed with a calibration. Check the joystick voltages : if the power is not correct, replace the board; if the output is not correct, replace the joystick (refer to Section 8).
2243	FUNCTION LOCKED OUT - JIB JOYSTICK NOT CENTERED	The Jib Joystick was not centered at power-up in platform mode.	<ul style="list-style-type: none"> Release joystick and allow to center. Check if the joystick is obstructed or jammed. Proceed with a calibration. Check the joystick voltages : if the power is not correct, replace the board; if the output is not correct, replace the joystick (refer to Section 8).
2244	GATE LIMIT SWITCH - FAULTY	N.O. and N.C. contacts show the same electrical status for more than 1 second. (If Equipped)	<p>If machine is NOT equipped with Gate Limit Switches :</p> <ul style="list-style-type: none"> Check machine configuration with the analyser. <p>If the machine is equipped with Gate Limit Switch(es) :</p> <ul style="list-style-type: none"> Check if the Gate limit switch(es) is (are) damaged; Check the limit switch(es) for proper (complete) actuation Check the limit switch(es) wiring : Gate(s) closed : @ +Vbatt : CR32(A), CR32(B), CR33(A), CR33(B). @ -Vbatt : CR32(C), CR33(C).

2-3 Ground Controls

DTC	FAULT MESSAGE	DESCRIPTION	CHECK
233	FUNCTION PROBLEM - BRAKE RELEASE PERMANENTLY SELECTED	The Brake Release switch was closed during power-up in ground mode.	<ul style="list-style-type: none"> Check if the concerned switch is damaged, obstructed or jammed. Disconnect the membrane panel ribbon cable : replace the membrane panel if DTC is no longer present. Check the switch line voltage : J3(12), CR1(34) and CR2(17).

SECTION 10 - DIAGNOSTIC TROUBLE CODES

DTC	FAULT MESSAGE	DESCRIPTION	CHECK
2310	FUNCTION PROBLEM - GROUND ENABLE PERMANENTLY SELECTED	The Ground Enable switch was closed during power-up in ground mode.	<ul style="list-style-type: none"> • Check if the concerned switch is damaged, obstructed or jammed. • Disconnect the membrane panel ribbon cable : replace the membrane panel if DTC is no longer present. • Check the switch line voltage : J3(4), CR1(9) and CR3(19).
2368	FUNCTION PROBLEM - MAST LIFT UP PERMANENTLY SELECTED	The Mast Lift Up switch was closed during power-up in ground mode.	<ul style="list-style-type: none"> • Check if the concerned switch is damaged, obstructed or jammed. • Disconnect the membrane panel ribbon cable : replace the membrane panel if DTC is no longer present. • Check the switch line voltage : J3(6), CR1(21) and CR3(20).
2369	FUNCTION PROBLEM - MAST LIFT DOWN PERMANENTLY SELECTED	The Mast Lift Down switch was closed during power-up in ground mode.	<ul style="list-style-type: none"> • Check if the concerned switch is damaged, obstructed or jammed. • Disconnect the membrane panel ribbon cable : replace the membrane panel if DTC is no longer present. • Check the switch line voltage : J3(7), CR1(22) and CR3(32).
2370	FUNCTION PROBLEM - JIB LIFT UP PERMANENTLY SELECTED	The Jib Lift Up Switch was closed during power-up in ground mode.	<ul style="list-style-type: none"> • Check if the concerned switch is damaged, obstructed or jammed. • Disconnect the membrane panel ribbon cable : replace the membrane panel if DTC is no longer present. • Check the switch line voltage : J3(8), CR1(30) and CR3(17).
2371	FUNCTION PROBLEM - JIB LIFT DOWN PERMANENTLY SELECTED	The Jib Lift Down switch was closed during power-up in ground mode.	<ul style="list-style-type: none"> • Check if the concerned switch is damaged, obstructed or jammed. • Disconnect the membrane panel ribbon cable : replace the membrane panel if DTC is no longer present. • Check the switch line voltage : J3(9), CR1(31) and CR3(16).
2372	FUNCTION PROBLEM - SWING LEFT PERMANENTLY SELECTED	The Swing Left switch was closed during power-up in ground mode.	<ul style="list-style-type: none"> • Check if the concerned switch is damaged, obstructed or jammed. • Disconnect the membrane panel ribbon cable : replace the membrane panel if DTC is no longer present. • Check the switch line voltage : J3(11), CR1(33) and CR3(29).
2373	FUNCTION PROBLEM - SWING RIGHT PERMANENTLY SELECTED	The Swing Right switch was closed during power-up in ground mode.	<ul style="list-style-type: none"> • Check if the concerned switch is damaged, obstructed or jammed. • Disconnect the membrane panel ribbon cable : replace the membrane panel if DTC is no longer present. • Check the switch line voltage : J3(10), CR1(32) and CR3(31).

SECTION 10 - DIAGNOSTIC TROUBLE CODES

DTC	FAULT MESSAGE	DESCRIPTION	CHECK
2374	MAST SWITCH FAULTY	The Mast Lift Up and Down switches are active simultaneously.	<ul style="list-style-type: none"> • Check if one of the concerned switch is damaged, obstructed or jammed. • Disconnect the membrane panel ribbon cable : replace the membrane panel if DTC is no longer present. • Check both switch lines voltage : J3(6), CR1(21), CR3(20) and J3(7), CR1(22), CR2(32).
2375	JIB SWITCH FAULTY	The Jib Lift Up and Down switches are active simultaneously.	<ul style="list-style-type: none"> • Check if one of the concerned switch is damaged, obstructed or jammed. • Disconnect the membrane panel ribbon cable : replace the membrane panel if DTC is no longer present. • Check both switch lines voltage : J3(8), CR1(30), CR3(17) and J3(9), CR1(31), CR2(16).
2376	SWING SWITCH FAULTY	The Swing Left and Right switches are active simultaneously.	<ul style="list-style-type: none"> • Check if one of the concerned switch is damaged, obstructed or jammed. • Disconnect the membrane panel ribbon cable : replace the membrane panel if DTC is no longer present. • Check both switch lines voltage : J3(11), CR1(33), CR3(29) and J3(10), CR1(32), CR2(31).
2377	CHAIN SLACK SWITCH DIS-AGREEMENT	Chain slack switch controllers' inputs are not the same for more than 1 second.	<ul style="list-style-type: none"> • Check the wiring between the two controllers CR2(35) to CR3(35)) and the connections.
2378	MAIN MAST LIMIT SWITCH - DECOUPLED	The information from the Mast Limit switches is not consistent.	<ul style="list-style-type: none"> • Check if one of the concerned limit switches is damaged, obstructed or jammed. • Check the mast switches wiring : Mast stowed : @ +Vbatt : CR4(A), CR23(1), CR23(4), CR23(3), CR23(6), CR5(3), CR5(5), CR2(31), CR2(20). @ -Vbatt : CR4(B), CR4(C), CR23(2), CR23(5). Mast elevated : @ +Vbatt : CR4(A), CR4(B), CR23(1), CR23(2), CR23(4), CR23(6), CR5(5), CR2(20). @ -Vbatt : CR4(C), CR23(3), CR23(5), CR5(3), CR2(31). Mast fully elevated : @ +Vbatt : CR4(A), CR4(B), CR4(C), CR23(1), CR23(2), CR23(4), CR23(5). @ -Vbatt : CR23(3), CR23(6), CR5(3), CR5(5), CR2(20), CR2(31).

SECTION 10 - DIAGNOSTIC TROUBLE CODES

DTC	FAULT MESSAGE	DESCRIPTION	CHECK
2379	MAIN MAST LIMIT SWITCH - NOT RESPONDING	The status of the Main Mast limit switch does not change while raising the mast.	<ul style="list-style-type: none"> If the mast is not raising while the function is controlled : <ul style="list-style-type: none"> Pump not running : check the voltage applied to the pump motor; Pump running : check the oil level; check the hydraulic pressure and the voltage applied to the pressure relief valve; check mast lift valve; check the mast for obstruction or damages. If the mast is raising while the function is controlled : <ul style="list-style-type: none"> Check if the Main Mast limit switch (left switch) is damaged, obstructed or jammed; Check the Main Mast limit switch wiring : <p>Mast stowed :</p> <p>@ +Vbatt : CR4(A), CR23(1), CR23(3), CR5(3), CR2(31). @ -Vbatt : CR4(B), CR23(2).</p> <p>Mast elevated :</p> <p>@ +Vbatt : CR4(A), CR4(B), CR23(1), CR23(2). @ -Vbatt : CR23(3), CR5(3), CR2(31).</p>
2380	MAIN MAST LIMIT SWITCH - FAULTY	N.O. and N.C. contacts show the same electrical status for more than 1 second.	<ul style="list-style-type: none"> Check if the Main Mast limit switch (left switch) is damaged; Check the Main Mast limit switch wiring : <p>Mast stowed :</p> <p>@ +Vbatt : CR4(A), CR23(1), CR23(3), CR5(3), CR2(31). @ -Vbatt : CR4(B), CR23(2).</p> <p>Mast elevated :</p> <p>@ +Vbatt : CR4(A), CR4(B), CR23(1), CR23(2). @ -Vbatt : CR23(3), CR5(3), CR2(31).</p>
2381	MAST LIMIT SWITCH 2 - FAULTY	N.O. and N.C. contacts show the same electrical status for more than 1 second.	<ul style="list-style-type: none"> Check if the Main Mast limit switch (left switch) is damaged; Check the Main Mast limit switch wiring : <p>Mast stowed :</p> <p>@ +Vbatt : CR4(A), CR23(4), CR23(6), CR5(5), CR2(20). @ -Vbatt : CR4(C), CR23(5).</p> <p>Mast elevated :</p> <p>@ +Vbatt : CR4(A), CR4(C), CR23(4), CR23(5). @ -Vbatt : CR23(6), CR5(5), CR2(20).</p>
2382	FUNCTION PREVENTED - OVERSWING DETECTED	The structure is swung beyond the rear tires or further in either direction.	<ul style="list-style-type: none"> If the structure is in line with the chassis, check the Drive Orientation switch (on the turntable) for damage. Check the switch setting (refer to Section 8) Check the switch wiring : <p>Structure in line with the chassis :</p> <p>@ +Vbatt : CR21(1), CR21(2); @ -Vbatt : CR21(3).</p> <p>Structure swung :</p> <p>@ +Vbatt : CR21(1); @ -Vbatt : CR21(3); Insulated : CR21(2).</p>

SECTION 10 - DIAGNOSTIC TROUBLE CODES

2-5 Function Prevented

DTC	FAULT MESSAGE	DESCRIPTION	CHECK
259	MODEL CHANGED - HYDRAULIC SUSPENDED - CYCLE EMS	The model selection has been changed.	<ul style="list-style-type: none"> Check ANALYZER->MACHINE SETUP->MODEL. Refer to §9 for adapted personality settings and calibration.
2516	DRIVE PREVENTED - ABOVE ELEVATION	DRIVE CUTOUT set to 1 (YES), and the mast is elevated.	<ul style="list-style-type: none"> Fully stow the platform.
2538	FUNCTION PREVENTED - CHARGER CONNECTED	Functions are prevented while the vehicle is charging.	<ul style="list-style-type: none"> Check if the charger is connected to off board power source and disconnect if desired. Check interlock relay wiring : @ +Vbatt when the machine is not charging : CR26(2), CR2(16).
2542	FUNCTION PREVENTED - BRAKES ELECTRONICALLY RELEASED FOR TOWING	Manual brake release mode is activated. Drive or lift is not possible.	<ul style="list-style-type: none"> Push manual brake release switch again or cycle power to clear manual brake release mode. Check if the brake release switch is damaged, obstructed or jammed. Check the switch line voltage : J3(12), CR1(34) and CR2(17).
2543	FUNCTION PREVENTED - CHAIN SLACK DETECTED	Slack was detected in the mast chain.	<ul style="list-style-type: none"> Refer to section 4 for the required operations to clear the fault. Check if the Chain Slack limit switches are damaged, obstructed or jammed. Check the chain slack switches wiring : @ +Vbatt : CR27(2), CR6(2), CR2(35), CR3(35).
2544	ALL FUNCTIONS PREVENTED - FAULTY MASTER VALVE ENABLE	The valve enable input on the Master controller is not energized : no outputs can be operated from the Master controller.	Check the wiring of the input : CR2(3) must be at +Vbatt when one of the control console is energized.
2545	ALL FUNCTIONS PREVENTED - FAULTY SLAVE VALVE ENABLE	The valve enable input on the Slave controller is not energized : no outputs can be operated from the Slave controller.	Check the wiring of the input : CR3(3) must be at +Vbatt when one of the control console is energized.
2548	(SYSTEM TEST MODE) SYSTEM TEST MODE ACTIVE	The system is in test mode.	<ul style="list-style-type: none"> Cycle power to clear test mode.

3-1 Line Contactor Open Circuit

DTC	FAULT MESSAGE	DESCRIPTION	CHECK
311	OPEN CIRCUIT LINE CONTACTOR	The line contactor is not closing the power circuit properly.	<ul style="list-style-type: none"> Check the power connections of the line contactor to the battery Check the power connections of the line contactor to the power controllers Check the line contactor [KM] coil wiring : @ -Vbatt : CR19(2), CR17(6), CR2(8). @ +Vbatt : CR19(1), CR17(8), CR1(25). Check the line contactor coil. Replace the line contactor.
312	CONTACTOR DRIVER PERMANENTLY OFF	The line contactor driver is out of order.	<ul style="list-style-type: none"> Replace the Master controller.

3-2 Line Contactor Short Circuit

DTC	FAULT MESSAGE	DESCRIPTION	CHECK
321	LINE CONTACTOR MISWIRED ON OR WELDED	The line contactor [KM] contact is miswired or welded.	<ul style="list-style-type: none"> Check the contact of the line contactor. Replace the line contactor if necessary.
322	CONTACTOR DRIVER PERMANENTLY ON	The line contactor driver output is shorted.	<ul style="list-style-type: none"> Check the driver output CR2(12) for a short circuit with -Vbatt. If the wiring is correct, the driver circuit is damaged : replace the Master controller.
324	VALVE ENABLE DRIVER PERMANENTLY ON	The voting relay driver output is shorted.	<ul style="list-style-type: none"> Check the driver output CR3(12) for a short circuit with -Vbatt. If the wiring is correct, the driver circuit is damaged : replace the Slave controller.

3-3 Ground Output Driver

DTC	FAULT MESSAGE	DESCRIPTION	CHECK
3312	LEFT BRAKE - SHORT TO BATTERY	The left brake positive output supply is detected at high level while no drive function is controlled.	<ul style="list-style-type: none"> Check the left brake positive driver output CR3(2) for a short circuit with +Vbatt. If the wiring is correct, the driver circuit is damaged : replace the Slave controller.
3313	RIGHT BRAKE - SHORT TO BATTERY	The right brake positive output supply is detected at high level while no drive function is controlled.	<ul style="list-style-type: none"> Check the right brake positive driver output CR2(2) for a short circuit with +Vbatt. If the wiring is correct, the driver circuit is damaged : replace the Slave controller.
3314	LEFT BRAKE - OPEN CIRCUIT	There is no positive supply to the left brake while a drive function is active.	<ul style="list-style-type: none"> Check the left brake positive driver output CR3(2) for a short circuit with -Vbatt. If the wiring is correct, the driver circuit is damaged : replace the Slave controller.
3315	RIGHT BRAKE - OPEN CIRCUIT	There is no positive supply to the right brake while a drive function is active.	<ul style="list-style-type: none"> Check the right brake positive driver output CR2(2) for a short circuit with -Vbatt. If the wiring is correct, the driver circuit is damaged : replace the Slave controller.
33100	JIB LIFT UP VALVE - SHORT TO GROUND	The Jib Lift Up valve driver is shorted.	<ul style="list-style-type: none"> Check the valve driver output CR3(24) for a short circuit with -Vbatt. If the wiring is correct, the driver circuit is damaged : replace the Slave controller.
33101	JIB LIFT UP VALVE - OPEN CIRCUIT	The Jib Lift Up valve coil is faulty or disconnected.	<ul style="list-style-type: none"> Check the valve coil connections and wiring for interruptions. Check the valve coil for correct impedance (refer to Section 8). Replace the Slave controller if the coil and its harness are correct.
33102	JIB LIFT UP VALVE - SHORT TO BATTERY	The Jib Lift Up valve coil driver output is shorted to +Vbatt.	<ul style="list-style-type: none"> Check the valve coil connections and wiring for short to +Vbatt. Check the valve coil for correct impedance (refer to Section 8).

SECTION 10 - DIAGNOSTIC TROUBLE CODES

DTC	FAULT MESSAGE	DESCRIPTION	CHECK
33103	JIB LIFT DOWN VALVE - SHORT TO GROUND	The Jib Lift Down valve driver is shorted or the valve coil is faulty (open) or disconnected.	<ul style="list-style-type: none"> • Check the valve driver output CR3(33) for a short circuit with -Vbatt. • Check the valve coil connections and wiring for interruptions. • Check the valve coil for correct impedance (refer to Section 8). • If the wiring is correct, the driver circuit is damaged : replace the Slave controller.
33104	JIB LIFT DOWN VALVE - OPEN CIRCUIT	The Jib Lift Down valve coil is faulty or disconnected or the coil driver is faulty.	<ul style="list-style-type: none"> • Check the valve coil connections and wiring for interruptions. • Check the valve coil for correct impedance (refer to Section 8). • Replace the Slave controller if the coil and its harness are correct.
33105	JIB LIFT DOWN VALVE - SHORT TO BATTERY	The Jib Lift Down valve coil driver output is shorted to +Vbatt.	<ul style="list-style-type: none"> • Check the valve coil connections and wiring for short to +Vbatt. • Check the valve coil for correct impedance (refer to Section 8).
33297	LEFT BRAKE - SHORT TO GROUND	The left brake positive output supply is detected shorted to -Vbatt.	<ul style="list-style-type: none"> • Check the left brake positive driver output CR3(2) for a short circuit with -Vbatt. • Check the brake coil for correct impedance (refer to Section 8). • If the wiring and the coil are correct, the driver circuit is damaged : replace the Slave controller.
33300	LINE CONTACTOR COIL - OPEN CIRCUIT	The EV1 valve driver is not able to drive the load (cannot close).	<ul style="list-style-type: none"> • The device or its driving circuit is damaged, replace the controller.
33304	RIGHT BRAKE - SHORT TO GROUND	The right brake positive output supply is detected shorted to -Vbatt.	<ul style="list-style-type: none"> • Check the right brake positive driver output CR2(2) for a short circuit with -Vbatt. • Check the brake coil for correct impedance (refer to Section 8). • If the wiring and the coil are correct, the driver circuit is damaged : replace the Master controller.
33355	STEER VALVE - SHORT TO GROUND	The Steer valve driver is shorted or the valve coil is faulty (open) or disconnected.	<ul style="list-style-type: none"> • Check the valve driver output CR3(11) for a short circuit with -Vbatt. • Check the valve coil connections and wiring for interruptions. • Check the valve coil for correct impedance (refer to Section 8). • If the wiring is correct, the driver circuit is damaged : replace the Slave controller.
33356	STEER VALVE - OPEN CIRCUIT	The Steer valve coil is faulty or disconnected or the coil driver is faulty.	<ul style="list-style-type: none"> • Check the valve coil connections and wiring for interruptions. • Check the valve coil for correct impedance (refer to Section 8). • Replace the Slave controller if the coil and its harness are correct.

SECTION 10 - DIAGNOSTIC TROUBLE CODES

DTC	FAULT MESSAGE	DESCRIPTION	CHECK
33358	FLOW DIRECTION VALVE - SHORT TO GROUND	The Flow Direction valve driver is shorted or the valve coil is faulty (open) or disconnected.	<ul style="list-style-type: none"> • Check the valve driver output CR3(34) for a short circuit with -Vbatt. • Check the valve coil connections and wiring for interruptions. • Check the valve coil for correct impedance (refer to Section 8). • If the wiring is correct, the driver circuit is damaged : replace the Slave controller.
33359	FLOW DIRECTION VALVE - OPEN CIRCUIT	The Flow Direction valve coil is faulty or disconnected or the coil driver is faulty.	<ul style="list-style-type: none"> • Check the valve coil connections and wiring for interruptions. • Check the valve coil for correct impedance (refer to Section 8). • Replace the Slave controller if the coil and its harness are correct.
33362	SWING VALVE - OPEN CIRCUIT	The Swing valve coil is faulty or disconnected or the coil driver is faulty.	<ul style="list-style-type: none"> • Check the valve coil connections and wiring for interruptions. • Check the valve coil for correct impedance (refer to Section 8). • Replace the Slave controller if the coil and its harness are correct.
33365	MAST VALVE - OPEN CIRCUIT	The Mast valve coil is faulty or disconnected or the coil driver is faulty.	<ul style="list-style-type: none"> • Check the valve coil connections and wiring for interruptions. • Check the valve coil for correct impedance (refer to Section 8). • Replace the Slave controller if the coil and its harness are correct.
33366	PROPORTIONAL RELIEF VALVE - SHORT TO BATTERY	The Proportional Relief valve driver output is detected short to +Vbatt.	<ul style="list-style-type: none"> • Check the following Slave controller driver output CR3(23) for a short circuit with +Vbatt. • Check the valve coil for correct impedance (refer to Section 8). • If the harness and the coil are correct and if the fault appears at start up : Replace the Slave controller.
33367	PROPORTIONAL RELIEF VALVE - SHORT TO GROUND	The Proportional Relief valve driver output is shorted.	<ul style="list-style-type: none"> • Check the valve driver output CR3(23) for a short circuit with -Vbatt. • If the wiring is correct, the driver circuit is damaged : replace the Slave controller.
33368	PROPORTIONAL RELIEF VALVE - OPEN CIRCUIT	The Proportional Relief valve coil is faulty or disconnected.	<ul style="list-style-type: none"> • Check the valve coil connections and wiring for interruptions. • Check the valve coil for correct impedance (refer to Section 8). • Replace the Slave controller if the coil and its harness are correct.
33381	MASTER MODULE OUTPUTS - SHORT TO BATTERY	One of the Master module On/Off outputs is detected short to +Vbatt.	<ul style="list-style-type: none"> • Check the following Master controller driver outputs for a short circuit with +Vbatt : Beacon CR2(11), Line Contactor CR2(8). • Check the line contactor coil for correct impedance (refer to Section 8). • If the harness and the devices are correct and if the fault appears at start up : Replace the Master controller.

SECTION 10 - DIAGNOSTIC TROUBLE CODES

DTC	FAULT MESSAGE	DESCRIPTION	CHECK
33382	SLAVE MODULE OUTPUTS - SHORT TO BATTERY	One of the Slave module On/Off outputs is detected short to +Vbatt.	<ul style="list-style-type: none"> Check the following Slave controller driver outputs for a short circuit with +Vbatt : Swing CR3(8), Mast CR3(9), Steer CR3(11), Jib Lift Down CR3(33), Flow Direction CR3(34). Check each of the valve coils for correct impedance (refer to Section 8). If the harness and the devices are correct and if the fault appears at start up : Replace the Slave controller.
33383	BEACON LIGHT - OPEN CIRCUIT	The Beacon light is faulty or disconnected or the coil driver is faulty.	<ul style="list-style-type: none"> Check the beacon connections and wiring for interruptions. Replace the Slave controller if the beacon and its harness are correct.
33384	BEACON LIGHT - SHORT TO GROUND	The Beacon light driver is shorted or the beacon is faulty (open) or disconnected.	<ul style="list-style-type: none"> Check the valve driver output CR2(11) for a short circuit with -Vbatt. Check the beacon connections and wiring for interruptions. If the wiring is correct, the driver circuit is damaged : replace the Slave controller.
33386	SLAVE MODULE OUTPUTS - SHORT TO GROUND	One of the following Slave module outputs is detected short to -Vbatt : Swing or Mast.	<ul style="list-style-type: none"> Check the valve driver output CR3(8) for a short circuit with -Vbatt. Check the valve driver output CR3(9) for a short circuit with -Vbatt. If the wiring is correct, the driver circuit is damaged : replace the Slave controller.
33387	OVERLOAD LIGHT - SHORT TO GROUND	The Overload Light driver output is shorted.	<ul style="list-style-type: none"> Check the valve driver output CR2(24) for a short circuit with -Vbatt. If the wiring is correct, the driver circuit is damaged : replace the Master controller.
33388	OVERLOAD LIGHT - OPEN CIRCUIT	The Overload Light is faulty or disconnected.	<ul style="list-style-type: none"> Check the overload light connections and wiring for interruptions. Replace the Master controller if the light and its harness are correct.
33389	RIGHT BRAKE RETURN - SHORT TO GROUND	The output of the Right Brake low side driver is shorted to -Vbatt.	<ul style="list-style-type: none"> Check the valve driver output CR2(4) for a short circuit with -Vbatt. If the wiring is correct, the driver circuit is damaged : replace the Master controller.
33390	LEFT BRAKE RETURN - SHORT TO GROUND	The output of the Left Brake low side driver is shorted to -Vbatt.	<ul style="list-style-type: none"> Check the valve driver output CR3(4) for a short circuit with -Vbatt. If the wiring is correct, the driver circuit is damaged : replace the Slave controller.
33391	RIGHT BRAKE RETURN - SHORT TO BATTERY	The output of the Right Brake low side driver is shorted to +Vbatt.	<ul style="list-style-type: none"> Check the right brake low side driver output CR2(4) for a short circuit with +Vbatt. Check the brake coil for correct impedance (refer to Section 8). If the wiring and the coil are correct, the driver circuit is damaged : replace the Master controller.

DTC	FAULT MESSAGE	DESCRIPTION	CHECK
33392	LEFT BRAKE RETURN - SHORT TO BATTERY	The output of the Left Brake low side driver is shorted to +Vbatt.	<ul style="list-style-type: none"> • Check the left brake low side driver output CR3(4) for a short circuit with +Vbatt. • Check the brake coil for correct impedance (refer to Section 8). • If the wiring and the coil are correct, the driver circuit is damaged : replace the Slave controller.

 4-2 Thermal Limit

DTC	FAULT MESSAGE	DESCRIPTION	CHECK
426	MASTER MODULE TEMPERATURE - OUT OF RANGE	The Master Module (right controller) temperature sensor is out of the permitted range.	<ul style="list-style-type: none"> • Change the Master controller.
427	SLAVE MODULE TEMPERATURE - OUT OF RANGE	The Slave Module (left controller) temperature sensor is out of the permitted range.	<ul style="list-style-type: none"> • Change the Slave controller.
428	MASTER MODULE TOO HOT - PLEASE WAIT	The Master Module (right controller) has reached thermal cutout.	<ul style="list-style-type: none"> • Power down and allow to cool. • Do not operate in ambients over 60°C. • Check for jammed or obstructed right drive motor. • Check for excessively high drive motor current consumption while driving on the level (over 120A). • Check for jammed or obstructed telescopic mast. • Check for excessively high pump motor current consumption while raising the jib with the platform empty (battery output current over 90A). • Check the Master module for proper installation (refer to § 8-4). • If the module is cold when the fault appears : replace the module.
429	SLAVE MODULE TOO HOT - PLEASE WAIT	The Slave Module (left controller) has reached thermal cutout.	<ul style="list-style-type: none"> • Power down and allow to cool. • Do not operate in ambients over 60°C. • Check for jammed or obstructed left drive motor. • Check for excessively high drive motor current consumption while driving on the level (over 120A). • Check the Slave module for proper installation (refer to § 8-4). • If the module is cold when the fault appears : replace the module.
4210	RIGHT DRIVE MOTOR TOO HOT - PLEASE WAIT	The right drive motor temperature is too high.	<ul style="list-style-type: none"> • Power down and allow to cool. • Do not operate in ambients over 60°C. • Check for jammed or obstructed right drive motor. • Check battery charge and recharge if necessary. • Check for damaged battery, power cables and connections. • Using the analyzer, check that the motor temperature sensor information is correct. • Check the sensor wiring and connections. • Check the sensor for correct impedance (refer to Section 8). • If the motor is cold and the fault is still present : replace the Master controller.

SECTION 10 - DIAGNOSTIC TROUBLE CODES

DTC	FAULT MESSAGE	DESCRIPTION	CHECK
4211	LEFT DRIVE MOTOR TOO HOT - PLEASE WAIT	The left drive motor temperature is too high.	<ul style="list-style-type: none"> Power down and allow to cool. Do not operate in ambients over 60°C. Check for jammed or obstructed right drive motor. Check battery charge and recharge if necessary. Check for damaged battery, power cables and connections. Using the analyzer, check that the motor temperature sensor information is correct. Check the sensor wiring and connections. Check the sensor for correct impedance (refer to Section 8). If the motor is cold and the fault is still present : replace the Slave controller.
4212	RIGHT DRIVE MOTOR TEMPERATURE - OUT OF RANGE	The right drive motor sensor is damaged or disconnected.	<ul style="list-style-type: none"> Check the sensor wiring and connections. Check the sensor for correct impedance (refer to Section 8). Replace the motor temperature sensor if necessary. If the sensor and its wiring are correct : replace the Master controller.
4213	LEFT DRIVE MOTOR TEMPERATURE - OUT OF RANGE	The left drive motor sensor is damaged or disconnected.	<ul style="list-style-type: none"> Check the sensor wiring and connections. Check the sensor for correct impedance (refer to Section 8). Replace the motor temperature sensor if necessary. If the sensor and its wiring are correct : replace the Slave controller.

4-4 Battery Supply

DTC	FAULT MESSAGE	DESCRIPTION	CHECK
441	BATTERY VOLTAGE TOO LOW - SYSTEM SHUTDOWN	A problem has been detected with the batteries or power module.	<ul style="list-style-type: none"> Recharge batteries. Check for damaged batteries, battery cables or connections. Check voltage drop across line contactor (Max 25mV idle or 100mV during Mast Up) Check battery charger function. Be sure to observe indicators for at least 30 seconds. Refer to Section 8 for Battery / Charger installation.
442	BATTERY VOLTAGE TOO HIGH - SYSTEM SHUTDOWN	A problem has been detected with the batteries or power module.	<ul style="list-style-type: none"> May be due to improper battery charging or incorrect voltage batteries being used. May appear just after battery charge and clear automatically after few minutes.
4417	BATTERY POWER LOW	The batteries are discharged.	<ul style="list-style-type: none"> Recharge batteries. Check for damaged battery, battery cables or connections. Check battery charger function. Be sure to observe indicators for at least 30 seconds.

DTC	FAULT MESSAGE	DESCRIPTION	CHECK
4418	MASTER MODULE VOLTAGE OUT OF RANGE	The controller detects an overvoltage or undervoltage condition. Overvoltage threshold is 35V, undervoltage threshold is 9,5V .	<ul style="list-style-type: none"> • Check for Ground and Platform Emergency Stop connections • If the fault appears at start up or during standby : check that no external device is connected to the batteries, creating down-going pulses. Refer to a qualified JLG mechanic to know the approved options on the machine. • If no voltage transient is detected on the supply line and the fault appears every time the key is switched ON : Replace the Master controller. • Check if the fault appears during traction acceleration or driving hydraulic functions (undervoltage condition detected) : check battery charge; check for damaged batteries, battery cables and connections • Check if the fault appears during traction braking (overvoltage condition detected) : check line contactor contact, battery power cable connection.
4419	SLAVE MODULE VOLTAGE OUT OF RANGE	The controller detects an overvoltage or undervoltage condition. Overvoltage threshold is 35V, undervoltage threshold is 9,5V .	<ul style="list-style-type: none"> • Check for Ground and Platform Emergency Stop connections • If the fault appears at start up or during standby : check that no external device is connected to the batteries, creating down-going pulses. Refer to a qualified JLG mechanic to know the approved options on the machine. • If no voltage transient is detected on the supply line and the fault appears every time the key is switched ON : Replace the Slave controller. • Check if the fault appears during traction acceleration or driving hydraulic functions (undervoltage condition detected) : check battery charge; check for damaged batteries, battery cables and connections • Check if the fault appears during traction braking (overvoltage condition detected) : check line contactor contact, battery power cable connection.
4420	(MASTER MODULE BATTERY VOLTAGE DEEPLY DISCHARGED) BATTERY DEEPLY DISCHARGED	The batteries are deeply discharged.	<ul style="list-style-type: none"> • Recharge batteries. • Check for damaged batteries, battery cables or connections. • Check battery charger function. Be sure to observe indicators for at least 30 seconds.

 **4-6 Transmission and Drive System**

DTC	FAULT MESSAGE	DESCRIPTION	CHECK
4610	RIGHT SPEED SENSOR - NOT RESPONDING PROPERLY	A problem has been detected with the right drive motor speed sensor (encoder).	<ul style="list-style-type: none"> • Check the right motor encoder wiring and connections. • Check the harness for proper installation (refer to Section 11).
4611	LEFT SPEED SENSOR - NOT RESPONDING PROPERLY	A problem has been detected with the left drive motor speed sensor (encoder).	<ul style="list-style-type: none"> • Check the left motor encoder wiring and connections. • Check the harness for proper installation (refer to Section 11).

SECTION 10 - DIAGNOSTIC TROUBLE CODES

DTC	FAULT MESSAGE	DESCRIPTION	CHECK
4612	(RIGHT MOTOR - RPM HIGH) RIGHT SPEED SENSOR - RPM HIGH	Machine overspeed has been detected on the right motor.	<ul style="list-style-type: none"> The machine should be driven at limited speed in ramps. Check the Personality : Drive, Max and adjust if necessary.
4613	(LEFT MOTOR - RPM HIGH) LEFT SPEED SENSOR - RPM HIGH	Machine overspeed has been detected on the left motor.	<ul style="list-style-type: none"> The machine should be driven at limited speed in ramps. Check the Personality : Drive, Max and adjust if necessary.

6-6 Communication

DTC	FAULT MESSAGE	DESCRIPTION	CHECK
6632	CANBUS FAILURE - MASTER MODULE	The control system failed to receive messages from the Master Module (right controller).	<ul style="list-style-type: none"> Check the Can Bus connections on the Master controller : CR2(27) & CR2(28). Disconnect CR3 (Slave controller connector) and measure resistance between CR3(27) and CR3(28). If it is not $60\ \Omega \pm 5\%$, check continuity of the bus wires : <ul style="list-style-type: none"> -CR2(27) to CR3(27) & CR2(28) to CR3(28); -CR2(27) to CR1(29) & CR2(28) to CR1(18); -ground panel board : CR1(29) to CR1(17) & CR1(18) to CR1(6); -CR1(6) to CR25(A) & CR1(17) to CR25(B); -CR25(A) to CR4(P) & CR25(B) to CR4(N); -Platform console : CR4(P) to J1(3) & CR4(N) to J1(4). Ensure that all the connectors pins are properly in place and the connectors are free of moisture or oxidation. Measure the resistance between J1(3) and J1(4) of the platform board : if it is not $120\ \Omega \pm 5\%$, replace the board.
6633	CANBUS FAILURE - SLAVE MODULE	The control system failed to receive messages from the Slave Module (left controller).	<ul style="list-style-type: none"> Check the Can Bus connections on the Slave controller : CR3(27) & CR3(28). Disconnect CR3 (Slave controller connector) and measure resistance between CR3(27) and CR3(28). If it is not $60\ \Omega \pm 5\%$, check continuity of the bus wires : <ul style="list-style-type: none"> -CR2(27) to CR3(27) & CR2(28) to CR3(28); -CR2(27) to CR1(29) & CR2(28) to CR1(18); -ground panel board : CR1(29) to CR1(17) & CR1(18) to CR1(6); -CR1(6) to CR25(A) & CR1(17) to CR25(B); -CR25(A) to CR4(P) & CR25(B) to CR4(N); -Platform console : CR4(P) to J1(3) & CR4(N) to J1(4). Ensure that all the connectors pins are properly in place and the connectors are free of moisture or oxidation. Measure the resistance between J1(3) and J1(4) of the platform board : if it is not $120\ \Omega \pm 5\%$, replace the board.

SECTION 10 - DIAGNOSTIC TROUBLE CODES

DTC	FAULT MESSAGE	DESCRIPTION	CHECK
6634	CANBUS COMM LOST	The platform module failed to receive messages from both the master and the slave modules.	<ul style="list-style-type: none"> Disconnect CR3 (Slave controller connector) and measure resistance between CR3(27) and CR3(28). If it is not $60\Omega \pm 5\%$, check continuity of the bus wires : <ul style="list-style-type: none"> -CR2(27) to CR3(27) & CR2(28) to CR3(28); -CR2(27) to CR1(29) & CR2(28) to CR1(18); -ground panel board : CR1(29) to CR1(17) & CR1(18) to CR1(6); -CR1(6) to CR25(A) & CR1(17) to CR25(B); -CR25(A) to CR4(P) & CR25(B) to CR4(N); -Platform console : CR4(P) to J1(3) & CR4(N) to J1(4). Ensure that all the connectors pins are properly in place and the connectors are free of moisture or oxidation. Measure the resistance between J1(3) and J1(4) of the platform board : if it is not $120\Omega \pm 5\%$, replace the board.

6-7 Accessory

DTC	FAULT MESSAGE	DESCRIPTION	CHECK
672	FUNCTIONS CUTOFF - SOFT TOUCH DETECTED	An obstacle has been detected by the soft touch device (if equipped).	<ul style="list-style-type: none"> Clear the obstacle. Ensure ANALYZER->MACHINE SETUP->SOFT TOUCH is set to 0 if not installed.
673	FUNCTIONS CUTOFF - GATE OPEN DETECTED	Platform entry gate is detected open.	<ul style="list-style-type: none"> Ensure ANALYZER->MACHINE SETUP->GATE is set to 0 (If Not Installed). <p>If Gate limit switch(es) is (are) installed :</p> <ul style="list-style-type: none"> Check if the Gate limit switch(es) is (are) damaged; Check the limit switch(es) for proper (complete) actuation Check the limit switch(es) wiring : <p>Gate(s) closed :</p> <ul style="list-style-type: none"> @ +Vbatt : CR32(A), CR32(B), CR33(A), CR33(B). @ -Vbatt : CR32(C), CR33(C).

7-7 Electric Motor

DTC	FAULT MESSAGE	DESCRIPTION	CHECK
7721	MASTER MODULE CAPACITOR BANK FAULT	The power capacitor bank of the power module is not charging properly at startup.	<ul style="list-style-type: none"> Ensure that no external device is connected to the batteries. Refer to a qualified JLG mechanic to know the approved options on the machine. Check battery, power cables and connections.
7722	SLAVE MODULE CAPACITOR BANK FAULT	The power capacitor bank of the power module is not charging properly at startup.	<ul style="list-style-type: none"> Ensure that no external device is connected to the batteries. Refer to a qualified JLG mechanic to know the approved options on the machine. Check battery, power cables and connections.
7723	RIGHT MOTOR FEEDBACK FAILURE	The right motor voltage feedback circuits are damaged (Master Module).	<ul style="list-style-type: none"> Check the right motor power wiring and connections.

SECTION 10 - DIAGNOSTIC TROUBLE CODES

DTC	FAULT MESSAGE	DESCRIPTION	CHECK
7724	LEFT MOTOR FEEDBACK FAILURE	The left motor voltage feedback circuits are damaged (Slave Module).	<ul style="list-style-type: none"> Check the left motor power wiring and connections.
7725	PUMP MOTOR - NOT RESPONDING	The pump motor feedback is not responding when the pump is being driven (by the Master Module).	<ul style="list-style-type: none"> Check the pump motor power wiring and connections. Check the pump motor for proper impedance.
7726	RIGHT MOTOR OUTPUT - OUT OF RANGE HIGH	The right motor voltage output is higher than expected (Master Module).	<ul style="list-style-type: none"> Check the right motor power wiring and connections. Check the motor phase to phase impedance. Check the motor phases for proper insulation with the chassis.
7727	LEFT MOTOR OUTPUT - OUT OF RANGE HIGH	The left motor voltage output is higher than expected (Slave Module).	<ul style="list-style-type: none"> Check the right motor power wiring and connections. Check the motor phase to phase impedance. Check the motor phases for proper insulation with the chassis.
7728	RIGHT MOTOR OUTPUT - OUT OF RANGE LOW	The right motor voltage output is lower than expected (Master Module).	<ul style="list-style-type: none"> Check the right motor power wiring and connections. Check the motor phase to phase impedance. Check the motor phases for proper insulation with the chassis. Check the line contactor contact.
7729	LEFT MOTOR OUTPUT - OUT OF RANGE LOW	The left motor voltage output is lower than expected (Slave Module).	<ul style="list-style-type: none"> Check the left motor power wiring and connections. Check the motor phase to phase impedance. Check the motor phases for proper insulation with the chassis. Check the line contactor contact.
7730	PUMP MOTOR OUTPUT - OUT OF RANGE HIGH	The pump motor voltage output is higher than expected (driven by the Master Module).	<ul style="list-style-type: none"> Check the pump motor power wiring and connections. Check the pump motor for proper impedance. Check the pump motor connections for proper insulation with the chassis.
7731	PUMP MOTOR OUTPUT - OUT OF RANGE LOW	The pump motor voltage output is lower than expected (driven by the Master Module).	<ul style="list-style-type: none"> Check the pump motor power wiring and connections. Check the pump motor for proper impedance. Check the pump motor connections for proper insulation with the chassis. Check the line contactor contact.
7732	STALLED RIGHT MOTOR	The right motor has been detected stalled.	<ul style="list-style-type: none"> Ensure vehicle is not stuck on something preventing movement. Check for jammed or obstructed right drive motor.
7733	STALLED LEFT MOTOR	The left motor has been detected stalled.	<ul style="list-style-type: none"> Ensure vehicle is not stuck on something preventing movement. Check for jammed or obstructed left drive motor.

8-1 Tilt Sensor

DTC	FAULT MESSAGE	DESCRIPTION	CHECK
815	CHASSIS TILT SENSOR DIS-AGREEMENT	Tilt sensor inputs to the control system are not the same state.	<ul style="list-style-type: none"> Check the wiring between the two controllers and the connections : CR2(7) to CR3(7).

8-2 Platform Load Sense

DTC	FAULT MESSAGE	DESCRIPTION	CHECK
825	LSS HAS NOT BEEN CALIBRATED	The Load Sensing System has not been calibrated	<ul style="list-style-type: none"> Perform a load sensing system calibration.
829	FUNCTIONS CUTOFF - PLATFORM OVERLOADED	The platform is overloaded and functions are restricted.	<ul style="list-style-type: none"> Unload the platform. Check if the overload switch is obstructed or jammed. Control the overload switch actuator setting; if necessary proceed with a calibration. Check the switch wiring : @ +Vbatt : CR4(A), CR24(1), CR24(2), CR24(4), CR5(7) @ -Vbatt : CR4(E), CR24(3).
8210	OVERLOAD SENSOR ERROR	Inconsistency in the overload sensor information.	<ul style="list-style-type: none"> Check if the overload switch is damaged. Check the switch wiring and connections: @ +Vbatt : CR4(A), CR24(1), CR24(2), CR24(4), CR5(7) @ -Vbatt : CR4(E), CR24(3), CR2(32).

8-6 Steering/Axle

DTC	FAULT MESSAGE	DESCRIPTION	CHECK
8664	STEER SENSOR - OUT OF RANGE HIGH	Invalid signal from the steer sensor.	<ul style="list-style-type: none"> Check the steer sensor for damage. Check the steer sensor installation. Check the steer sensor connections voltages (refer to Section 8).
8665	STEER SENSOR - OUT OF RANGE LOW	Invalid signal from the steer sensor.	<ul style="list-style-type: none"> Check the steer sensor for damage. Check that the steer sensor is securely mounted. Check the steer sensor connections voltages (refer to Section 8). Check the steering spindle assembly : no abnormal play, king pin securely fasten. Check that the sensor is positively actuated thru all the steering range : if necessary, proceed with a reset of the sensor, then with a new calibration (refer to § 9-3). If the sensor power is correct but its output improper : Replace the sensor and proceed with a calibration (refer to § 4-3 & 9-3).
8666	STEER SENSOR - DECOUPLED	Invalid signal from the steer sensor.	<ul style="list-style-type: none"> Check the steer sensor for damage. Check that the steer sensor is securely mounted. Check the steer sensor connections voltages (refer to Section 8). Check the steering spindle assembly : no abnormal play, king pin securely fasten. Check that the sensor is positively actuated thru all the steering range : if necessary, proceed with a reset of the sensor, then with a new calibration (refer to § 9-3). If the sensor power is correct but its output improper : Replace the sensor and proceed with a calibration (refer to § 4-3 & 9-3).

SECTION 10 - DIAGNOSTIC TROUBLE CODES

DTC	FAULT MESSAGE	DESCRIPTION	CHECK
8667	STEER SENSOR - NOT RESPONDING	Invalid signal from the steer sensor. This fault appears when steering is controlled but the sensor output remains unchanged for more than 1 second.	<ul style="list-style-type: none"> If the wheels do not steer while the function is controlled : <ul style="list-style-type: none"> Pump not running : check the voltage applied to the pump motor; Pump running : check the oil level; check the hydraulic pressure and the voltage applied to the pressure relief valve; check the steer and the directional valves; check that the steering wheels are not obstructed nor jammed, If the wheels steer properly : <ul style="list-style-type: none"> Check the steer sensor for damage, Check that the steer sensor is securely mounted. Check the steer sensor connections voltages (refer to Section 8). If the sensor power is correct but its output improper: Replace the sensor and proceed with a calibration (refer to § 4-3 & 9-3).
8668	STEER SENSOR - NOT CALIBRATED	The steering sensor has not been calibrated	<ul style="list-style-type: none"> Proceed with a sensor calibration (refer to §4-3 and 9-3). If the sensor can not be calibrated : <ul style="list-style-type: none"> Check the steer connection voltages (refer to Section 8). If the sensor power is correct but its output improper: Replace the sensor and proceed with a calibrations (refer to § 9-3).

8-7 Safety System Override

DTC	FAULT MESSAGE	DESCRIPTION	CHECK
873	MACHINE SAFETY SYSTEM OVERRIDE OCCURED	Machine Safety System Override (MSSO) has been used to override a Safety System or the Platform Operator station.	<ul style="list-style-type: none"> The record of the use of MSSO must be cleared. Fault should be retentive through power cycled; Can only be reset by the analyzer with CALIBRATIONS>MSSO>MSSO RESET.

9-9 Hardware

DTC	FAULT MESSAGE	DESCRIPTION	CHECK
9992	MASTER MODULE A/D FAILURE	There is an internal error in the Master Module (right controller).	<ul style="list-style-type: none"> Cycle power to clear the fault. If the fault is not cleared : Replace the Master controller.
9993	SLAVE MODULE A/D FAILURE	There is an internal error in the Slave Module (left controller).	<ul style="list-style-type: none"> Cycle power to clear the fault. If the fault is not cleared : Replace the Slave controller.
9994	MASTER MODULE EEPROM FAILURE	There is an internal error in the Master Module (right controller).	<ul style="list-style-type: none"> Cycle power to clear the fault. If the fault is not cleared : Replace the Master controller.
9995	SLAVE MODULE EEPROM FAILURE	There is an internal error in the Slave Module (left controller).	<ul style="list-style-type: none"> Cycle power to clear the fault. If the fault is not cleared : Replace the Slave controller.

SECTION 10 - DIAGNOSTIC TROUBLE CODES

DTC	FAULT MESSAGE	DESCRIPTION	CHECK
9996	MASTER MODULE MEMORY FAILURE	There is an internal error in the Master Module (right controller).	<ul style="list-style-type: none"> • Cycle power to clear the fault. • If the fault is not cleared : Replace the Master controller.
9997	SLAVE MODULE MEMORY FAILURE	There is an internal error in the Slave Module (left controller).	<ul style="list-style-type: none"> • Cycle power to clear the fault. • If the fault is not cleared : Replace the Slave controller.
9998	MASTER MODULE PROTECTION FAILURE	There is an internal error in the Master Module (right controller).	<ul style="list-style-type: none"> • Cycle power to clear the fault. • If the fault is not cleared : Replace the Master controller.
9999	SLAVE MODULE PROTECTION FAILURE	There is an internal error in the Slave Module (left controller).	<ul style="list-style-type: none"> • Cycle power to clear the fault. • If the fault is not cleared : Replace the Slave controller.
99100	MASTER MODULE FAILURE - CHECK POWER CIRCUITS OR MOSFET SHORT CIRCUIT	A short circuit on the power outputs of the Master Module (right controller) has been detected.	<ul style="list-style-type: none"> • Replace the Master controller.
99101	SLAVE MODULE FAILURE - CHECK POWER CIRCUITS OR MOSFET SHORT CIRCUIT	A short circuit on the power outputs of the Slave Module (left controller) has been detected.	<ul style="list-style-type: none"> • Replace the Slave controller.
99102	MASTER MODULE WATCHDOG RESET	There is an internal error in the Master Module (right controller).	<ul style="list-style-type: none"> • Cycle power to clear the fault. • If the fault is not cleared : Replace the Master controller.
99103	SLAVE MODULE WATCHDOG RESET	There is an internal error in the Slave Module (left controller).	<ul style="list-style-type: none"> • Cycle power to clear the fault. • If the fault is not cleared : Replace the Slave controller.
99104	MASTER MODULE WATCHDOG2 RESET	There is an internal error in the Master Module (right controller).	<ul style="list-style-type: none"> • Cycle power to clear the fault. • If the fault is not cleared : Replace the Master controller.
99105	SLAVE MODULE WATCHDOG2 RESET	There is an internal error in the Slave Module (left controller).	<ul style="list-style-type: none"> • Cycle power to clear the fault. • If the fault is not cleared : Replace the Slave controller.
99106	MASTER MODULE RAM FAILURE	There is an internal error in the Master Module (right controller).	<ul style="list-style-type: none"> • Cycle power to clear the fault. • If the fault is not cleared : Replace the Master controller.
99107	SLAVE MODULE RAM FAILURE	There is an internal error in the Slave Module (left controller).	<ul style="list-style-type: none"> • Cycle power to clear the fault. • If the fault is not cleared : Replace the Slave controller.
99108	MASTER MODULE - INTERNAL ERROR	There is an internal error in the Master Module (right controller).	<ul style="list-style-type: none"> • Cycle power to clear the fault. • If the fault is not cleared : Replace the Master controller.
99109	SLAVE MODULE - INTERNAL ERROR	There is an internal error in the Slave Module (left controller).	<ul style="list-style-type: none"> • Cycle power to clear the fault. • If the fault is not cleared : Replace the Slave controller.
99110	MASTER MODULE - INTERNAL ERROR	There is an internal error in the Master Module (right controller).	<ul style="list-style-type: none"> • Cycle power to clear the fault. • If the fault is not cleared : Replace the Master controller.
99111	SLAVE MODULE - INTERNAL ERROR	There is an internal error in the Slave Module (left controller).	<ul style="list-style-type: none"> • Cycle power to clear the fault. • If the fault is not cleared : Replace the Slave controller.

SECTION 10 - DIAGNOSTIC TROUBLE CODES

DTC	FAULT MESSAGE	DESCRIPTION	CHECK
99112	MASTER MODULE - INTERNAL ERROR	There is an internal error in the Master Module (right controller).	<ul style="list-style-type: none"> • Cycle power to clear the fault. • If the fault is not cleared : Replace the Master controller.
99114	MASTER MODULE - INTERNAL ERROR	There is an internal error in the Master Module (right controller).	<ul style="list-style-type: none"> • Cycle power to clear the fault. • If the fault is not cleared : Replace the Master controller.
99115	SLAVE MODULE - INTERNAL ERROR	There is an internal error in the Slave Module (left controller).	<ul style="list-style-type: none"> • Cycle power to clear the fault. • If the fault is not cleared : Replace the Slave controller.
99116	MASTER MODULE - INTERNAL ERROR	There is an internal error in the Master Module (right controller).	<ul style="list-style-type: none"> • Cycle power to clear the fault. • If the fault is not cleared : Replace the Master controller.
99117	SLAVE MODULE - INTERNAL ERROR	There is an internal error in the Slave Module (left controller).	<ul style="list-style-type: none"> • Cycle power to clear the fault. • If the fault is not cleared : Replace the Slave controller.
99118	MASTER MODULE - INTERNAL ERROR	There is an internal error in the Master Module (right controller).	<ul style="list-style-type: none"> • Cycle power to clear the fault. • If the fault is not cleared : Replace the Master controller.
99119	SLAVE MODULE - INTERNAL ERROR	There is an internal error in the Slave Module (left controller).	<ul style="list-style-type: none"> • Cycle power to clear the fault. • If the fault is not cleared : Replace the Slave controller.
99120	MASTER MODULE - INTERNAL ERROR	There is an internal error in the Master Module (right controller).	<ul style="list-style-type: none"> • Cycle power to clear the fault. • If the fault is not cleared : Replace the Master controller.
99121	SLAVE MODULE - INTERNAL ERROR	There is an internal error in the Slave Module (left controller).	<ul style="list-style-type: none"> • Cycle power to clear the fault. • If the fault is not cleared : Replace the Slave controller.
99122	MASTER MODULE - INTERNAL ERROR	There is an internal error in the Master Module (right controller).	<ul style="list-style-type: none"> • Cycle power to clear the fault. • If the fault is not cleared : Replace the Master controller.
99123	SLAVE MODULE - INTERNAL ERROR	There is an internal error in the Slave Module (left controller).	<ul style="list-style-type: none"> • Cycle power to clear the fault. • If the fault is not cleared : Replace the Slave controller.
99124	MASTER KO - TRIGGER	There is an internal error in the Master Module (right controller).	<ul style="list-style-type: none"> • Cycle power to clear the fault. • If the fault is not cleared : Replace the Master controller.
99125	MASTER KO - TILT AND ELEV	There is an internal error in the Master Module (right controller).	<ul style="list-style-type: none"> • Cycle power to clear the fault. • If the fault is not cleared : Replace the Master controller.
99126	MASTER KO - DRIVE CUTOUT	There is an internal error in the Master Module (right controller).	<ul style="list-style-type: none"> • Cycle power to clear the fault. • If the fault is not cleared : Replace the Master controller.
99127	MASTER KO - MAST LIMIT	There is an internal error in the Master Module (right controller).	<ul style="list-style-type: none"> • Cycle power to clear the fault. • If the fault is not cleared : Replace the Master controller.
99128	MASTER KO - MAST LIMIT2	There is an internal error in the Master Module (right controller).	<ul style="list-style-type: none"> • Cycle power to clear the fault. • If the fault is not cleared : Replace the Master controller.

SECTION 10 - DIAGNOSTIC TROUBLE CODES

DTC	FAULT MESSAGE	DESCRIPTION	CHECK
99129	MASTER KO - OVERLOAD	There is an internal error in the Master Module (right controller).	<ul style="list-style-type: none"> • Cycle power to clear the fault. • If the fault is not cleared : Replace the Master controller.
99130	MASTER KO - CHAINSLACK	There is an internal error in the Master Module (right controller).	<ul style="list-style-type: none"> • Cycle power to clear the fault. • If the fault is not cleared : Replace the Master controller.
99131	MASTER KO - MAST LIFT VALVE	There is an internal error in the Master Module (right controller).	<ul style="list-style-type: none"> • Cycle power to clear the fault. • If the fault is not cleared : Replace the Master controller.
99132	MASTER KO - JIB UP/DOWN VALVE	There is an internal error in the Master Module (right controller).	<ul style="list-style-type: none"> • Cycle power to clear the fault. • If the fault is not cleared : Replace the Master controller.
99133	MASTER KO - SWING VALVE	There is an internal error in the Master Module (right controller).	<ul style="list-style-type: none"> • Cycle power to clear the fault. • If the fault is not cleared : Replace the Master controller.

Go to Discount-Equipment.com to order your parts

PARTS FINDER

**Search Website
by Part Number**



**Search Manual
Library For Parts
Manual & Lookup Part
Numbers – Purchase
or Request Quote**

A screenshot of the "Search Manuals" form. The form has a title "Search Manuals" and a subtitle "Please provide information to help us locate the manual and/or parts you need." It includes fields for "Brand", "Model", "Serial", "Part Number", and "Quantity". There is a "Search" button at the bottom.

**Can't Find Part or
Manual? Request Help
by Manufacturer,
Model & Description**

A screenshot of the "Parts Order Form". The form has a title "Parts Order Form" and a subtitle "Please fill in as much information as possible." It includes fields for "Manufacturer", "Model", "Description", "Part Number", "Quantity", and "Comments". There is a "Submit" button at the bottom.

Discount-Equipment.com is your online resource for quality parts & equipment.

Florida: **561-964-4949** Outside Florida TOLL FREE: **877-690-3101**

Need parts?

Click on this link: <http://www.discount-equipment.com/category/5443-parts/> and choose one of the options to help get the right parts and equipment you are looking for. Please have the machine model and serial number available in order to help us get you the correct parts. If you don't find the part on the website or on one of the online manuals, please fill out the request form and one of our experienced staff members will get back to you with a quote for the right part that your machine needs.

We sell worldwide for the brands: Genie, Terex, JLG, MultiQuip, Mikasa, Essick, Whiteman, Mayco, Toro Stone, Diamond Products, Generac Magnum, Airman, Haulotte, Barreto, Power Blanket, Nifty Lift, Atlas Copco, Chicago Pneumatic, Allmand, Miller Curber, Skyjack, Lull, Skytrak, Tsurumi, Husquvarna Target, , Stow, Wacker, Sakai, Mi-T- M, Sullair, Basic, Dynapac, MBW, Weber, Bartell, Bennar Newman, Haulotte, Ditch Runner, Menegotti, Morrison, Contec, Buddy, Crown, Edco, Wyco, Bomag, Laymor, Barreto, EZ Trench, Bil-Jax, F.S. Curtis, Gehl Pavers, Heli, Honda, ICS/PowerGrit, IHI, Partner, Imer, Clipper, MMD, Koshin, Rice, CH&E, General Equipment, ,AMida, Coleman, NAC, Gradall, Square Shooter, Kent, Stanley, Tamco, Toku, Hatz, Kohler, Robin, Wisconsin, Northrock, Oztec, Toker TK, Rol-Air, Small Line, Wanco, Yanmar

SECTION 11. GENERAL ELECTRICAL INFORMATION & SCHEMATICS

11.1 GENERAL

This section contains basic electrical information and schematics to be used for locating and correcting most of the operating problems which may develop. If a problem should develop which is not presented in this section or which is not corrected by listed corrective actions, technical qualified guidance should be obtained before proceeding with any maintenance.

11.2 MULTIMETER BASICS

A wide variety of multimeters or Volt Ohm Meters (VOM) can be used for troubleshooting your equipment. This section shows diagrams of a common, digital VOM configured for several different circuit measurements. Instructions for your VOM may vary. Please consult the meter operator's manual for more information.

Grounding

"Grounding the meter" means to take the black lead (which is connected to the COM (common) or negative port) and touch it to a good path to the negative side of the Voltage source.

Backprobing

To "backprobe" means to take the measurement by accessing a connector's contact on the same side as the wires, the back of the connector. Readings can be done while maintaining circuit continuity this way. If the connector is the sealed type, great care must be taken to avoid damaging the seal around the wire. It is best to use probes or probe tips specifically designed for this technique, especially on sealed connectors. Whenever possible, insert probes into the side of the connector such that the test also checks both terminals of the connection. It is possible to inspect a connection within a closed connector by backprobing both sides of a connector terminal and measuring resistance. Do this after giving each wire a gentle pull to ensure the wires are still attached to the contact and contacts are seated in the connector.

Min/Max

Use of the "MIN/MAX" recording feature of some meters can help when taking measurements of intermittent conditions while alone. For example, you can read the Voltage applied to a solenoid when it is only operational while a switch, far from the solenoid and meter, is held down.

Polarity

Getting a negative Voltage or current reading when expecting a positive reading frequently means the leads are reversed. Check what reading is expected, the location of the signal and that the leads are connected to the device under test correctly. Also check that the lead on the "COM" port goes to the Ground or negative side of the sig-

nal and the lead on the other port goes to the positive side of the signal.

Scale

M = Mega = 1 000 000 x (Displayed Number)

k = kilo = 1 000 x (Displayed Number)

m = milli = (Displayed Number) / 1 000

μ = micro = (Displayed Number) / 1 000 000

Example: 1.2 k Ω = 1200 Ω

Example: 50 mA = 0.05 A

Voltage Measurement

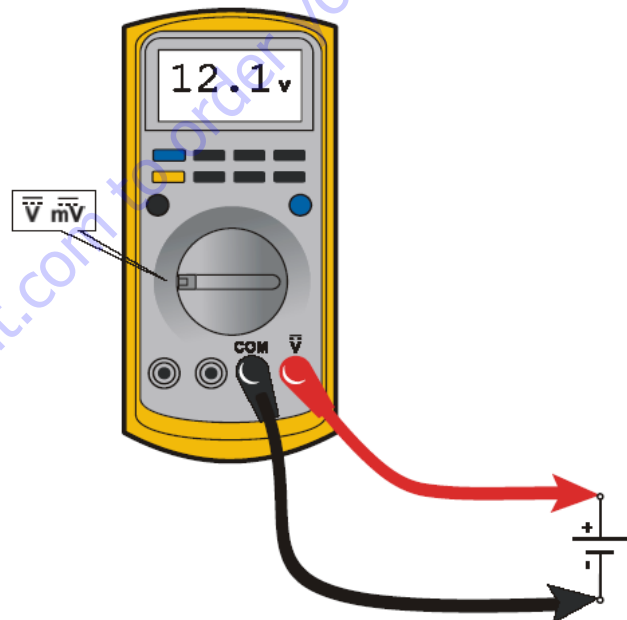

Figure 11-1. Voltage Measurement (DC)

- If meter is not auto ranging, set it to the correct range (See multimeter's operation manual).
- Use firm contact with meter leads.

Resistance Measurement

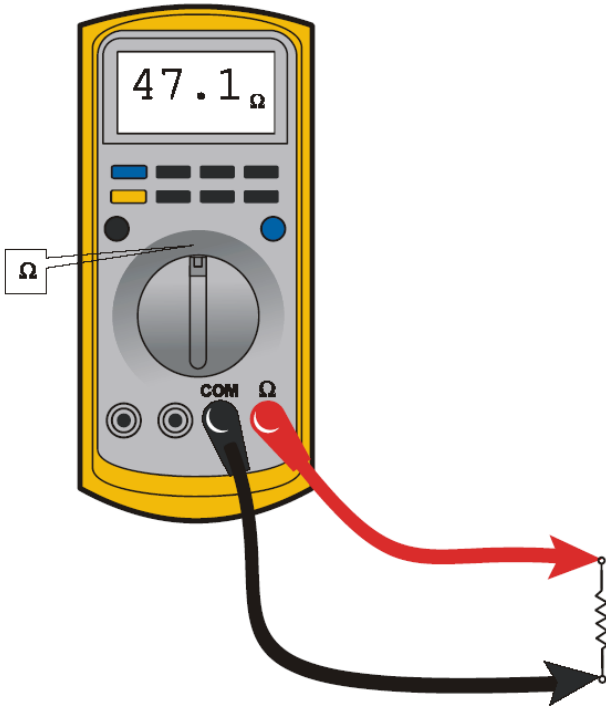

Figure 11-2. Resistance Measurement

- First test meter and leads by touching leads together. Resistance should read a short circuit (very low resistance).
- Circuit power must be turned OFF before testing resistance.
- Disconnect component from circuit before testing.
- If meter is not auto ranging, set it to the correct range (See multimeter's operation manual).
- Use firm contacts with meter leads.

Continuity Measurement

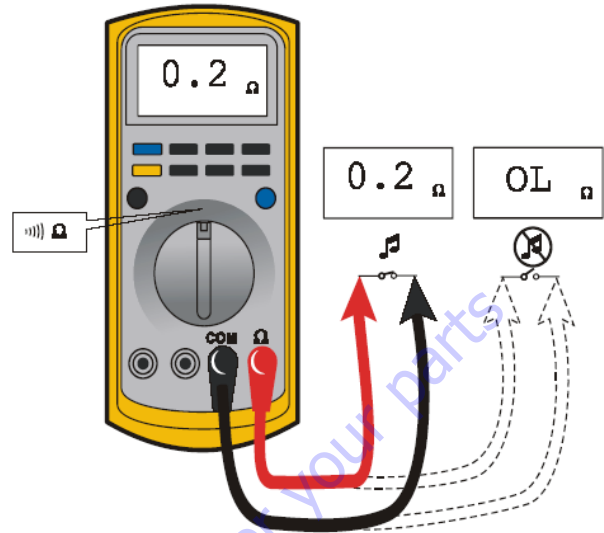

Figure 11-3. Continuity Measurement

- Some meters require a separate button to enable audible continuity testing.
- Circuit power must be turned OFF before testing continuity.
- Disconnect component from circuit before testing.
- Use firm contact with meter leads.
- First test meter and leads by touching leads together. Meter should produce an audible alarm, indicating continuity.

Current Measurement

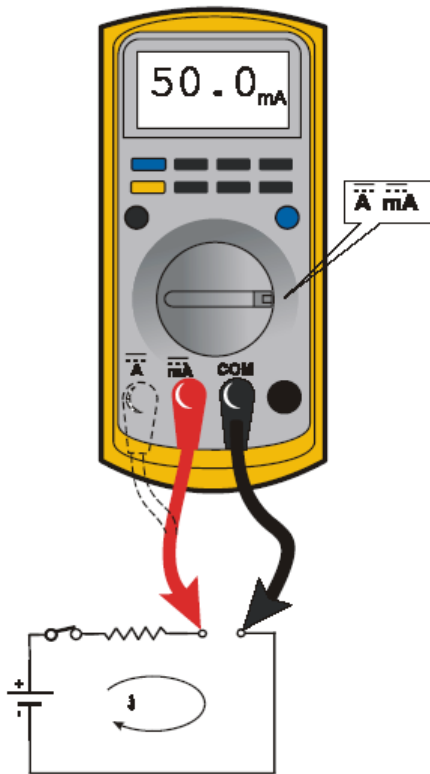

Figure 11-4. Current Measurement (DC)

- Set up meter for the expected current range.
- Be sure to connect the meter leads to the correct jacks for the current range you have selected.
- If meter is not auto ranging, set it to the correct range (See multimeter's operation manual).
- Use firm contact with meter leads.

11.3 CHECKING SWITCHES

Basic Check

The following check determines if the switch is functioning properly, not the circuit in which the switch is placed. A switch is functioning properly when there is continuity between the correct terminals or contacts only when selected.

1. De-energize the circuit.
2. Isolate the switch from the rest of the circuit if possible; If not possible, keep in mind it may affect readings.
3. Access the terminals to the switch.
4. If the switch has two terminals:
 - a. Measure resistance across the terminals.

- b. Change the switch position.
 - c. Measure resistance again with the leads in the same positions. If the meter was reading short, it should read an open. If the meter was reading open it should read short.
5. If the switch has more than two terminals, consult the schematic or switch diagram to determine what terminals will be connected. The test is similar to testing a switch with two terminals.
 - a. Place one meter lead on the common contact and the other on a different contact in the same circuit.
 - b. Cycle through all positions of the switch. The meter should read short only when the switch connects the two terminals and open otherwise.
 - c. If the switch has more than one common contact repeat the process for that circuit.

Limit Switches

Limit switches are used to control movement or indicate position. Mechanical limit switches are just like manually operated switches except that the moving object operates the switch. These switches can be tested the same way as a standard switch by manually operating the sensing arm.

Another type of limit switch used by JLG is the inductive proximity switch, also referred to as a "prox switch". Inductive proximity switches are actuated only by ferrous metal (metal that contains Iron, such as steel) near the switch. They do not require contact, and must be energized to actuate. These types of switches can be used to detect boom or platform position, for example. These switches have a sensing face where the switch can detect ferrous metal close to it. To find the sensing face, take note how the switch is mounted and how the mechanisms meet the switch. Test this type of switch as follow:

1. Remove prox switch from its mount.
2. Reconnect harness if it was disconnected for step 1, and turn on machine.
3. Hold switch away from metal and observe switch state in the control system diagnostics using the Analyzer. See vehicle or control system documentation on how to do this.
4. Place sensing face of switch on the object to be sensed by the switch. If that is not available, use a piece of ferrous metal physically similar to it. The switch state in the control system diagnostics should change.
5. When reinstalling or replacing switch be sure to follow mounting instructions and properly set the gap between the switch and object sensed.

Automatic Switches

If the switch is actuated automatically, by temperature or pressure for example, find a way to manually actuate the switch to test it. Do this either by applying heat or pressure, for example, to the switch. These switches may need to be energized to actuate.

1. Connect instrumentation to monitor and/or control the parameter the switch is measuring.
2. Observe switch state in control system with the Analyzer. See vehicle or control system documentation on how to do this.
3. Operate system such that the switch actuates. This could be going over a certain pressure or temperature, for example. The state indicated in the control system should change.

Switch Wiring - Low Side, High Side

When controlling a load, a switch can be wired between the positive side of the power source and the load. This switch is called a "high side" switch. The switch supplies the power to the load. When a switch is wired between the negative side of the power source and the load, it is a "low side" switch. The switch provides the ground to the load.

A low side switch will allow voltage to be present on the load. No power is applied because the switch is stopping current flow. This voltage can be seen if the measurement is taken with one test lead on the load and the other on the battery negative side or grounded to the vehicle. What is actually being measured is the voltage drop across the switch. This could mislead a technician into thinking the load is receiving power but not operating. To produce an accurate picture of power or voltage applied to the load, measure voltage across the load's power terminals. Also the technician can measure the voltage at both power terminals with respect to battery ground. The difference between those two measurements is the voltage applied to the load.

1. To prevent oxidation, silicone grease must be packed completely around male and female pins on the inside of the connector prior to assembly. This is most easily achieved by using a syringe.

NOTE: *Over a period of time, oxidation increases electrical resistance at the connection, eventually causing circuit failure.*

2. To prevent shorting, silicone grease must be packed around each wire where they enter the outside of the connector housing. Also, silicone grease must be applied at the joint where the male and female connectors come together. Any other joints (around strain reliefs, etc...) where water could enter the connector should also be sealed.

NOTE: *This condition is especially common when machines are pressure washed since the washing solution is much more conductive than water.*

3. Anderson connectors for the battery boxes and battery chargers should have silicone grease applied to the contacts only.

NOTE: *Curing-type sealants might also be used to prevent shorting and would be less messy, but would make future pin removal more difficult.*

11.4 APPLYING SILICONE DIELECTRIC COMPOUND TO ELECTRICAL CONNECTIONS

Silicone Dielectric Compound must be used on all electrical connections for the following reasons:

- To prevent oxidation at the mechanical joint between male and female pins.
- To prevent electrical malfunction caused by low level conductivity between pins when wet.

Use the following procedure to apply Silicone Dielectric Compound to the electrical connectors. This procedure applies to all plug connections not enclosed in a box. Silicone grease should not be applied to connectors with external seals.

11.5 AMP CONNECTOR

Applying Silicone Dielectric Compound to AMP Connectors

Silicone Dielectric Compound must be used on the AMP connections for the following reasons:

- To prevent oxidation at the mechanical joint between male and female pins.
- To prevent electrical malfunction caused by low level conductivity between pins when wet.

Use the following procedure to apply Silicone Dielectric Compound to the electrical connectors.

1. To prevent oxidation and low level conductivity, silicone dielectric grease must be packed completely around male and female pins on the inside of the connector after the mating of the housing to the header. This is easily achieved by using a syringe to fill the header with silicone dielectric compound, to a point just above the top of the male pins inside the header. When assembling the housing to the header, it is possible that the housing will become air locked, thus preventing the housing latch from engaging.
2. Pierce one of the unused wire seals to allow the trapped air inside the housing to escape.
3. Install a hole plug into this and/or any unused wire seal that has silicone dielectric compound escaping from it.

Assembly

Check to be sure the wedge lock is in the open, or asshipped, position (See Figure 11-5). Proceed as follow:

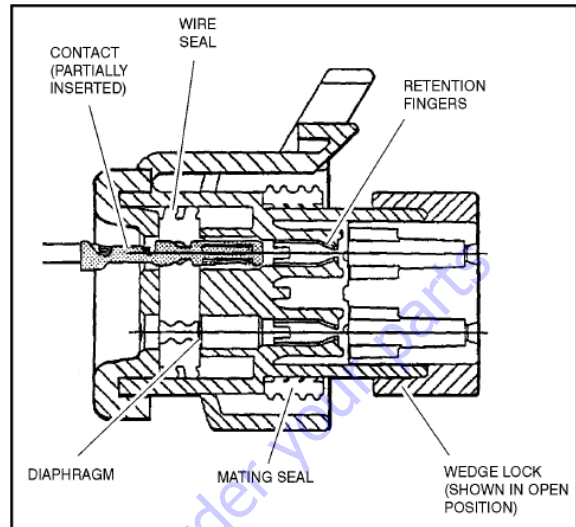

Figure 11-5. Connector Assembly Figure 1

1. To insert a contact, push it straight into the appropriate circuit cavity as far as it will go (See Figure 11-7).
2. Pull back on the contact wire with a force of 1 or 2 lbs. to be sure the retention fingers are holding the contact (See Figure 11-7).

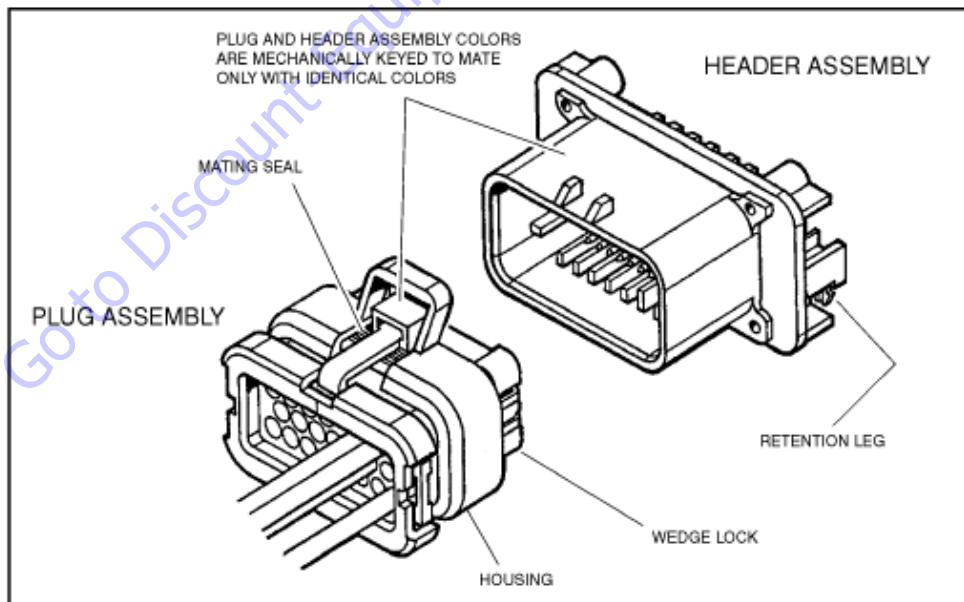

Figure 11-6. AMP Connector

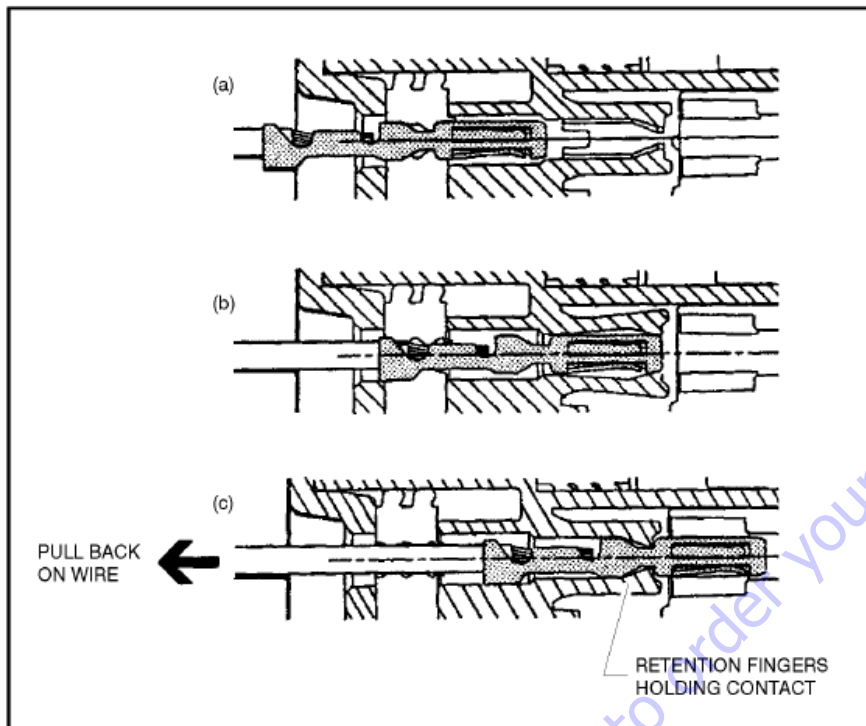

Figure 11-7. Connector Assembly Figure 2

3. After all required contacts have been inserted, the wedge lock must be closed to its locked position. Release the locking latches by squeezing them inward (See Figure 11-8).
4. Slide the wedge lock into the housing until it is flush with the housing (See Figure 11-9).

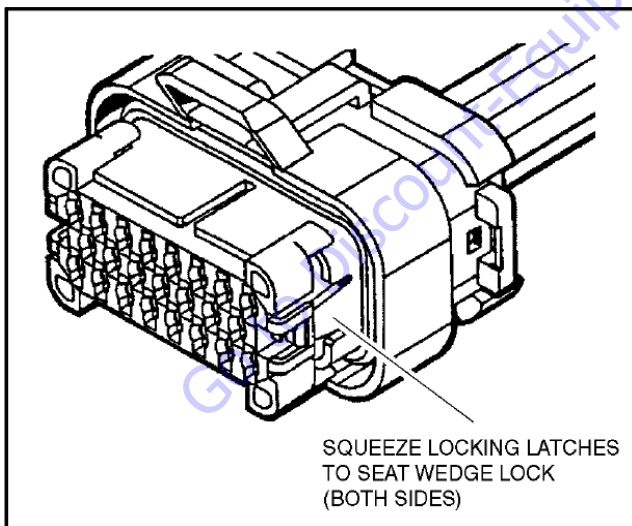

Figure 11-8. Connector Assembly Figure 3

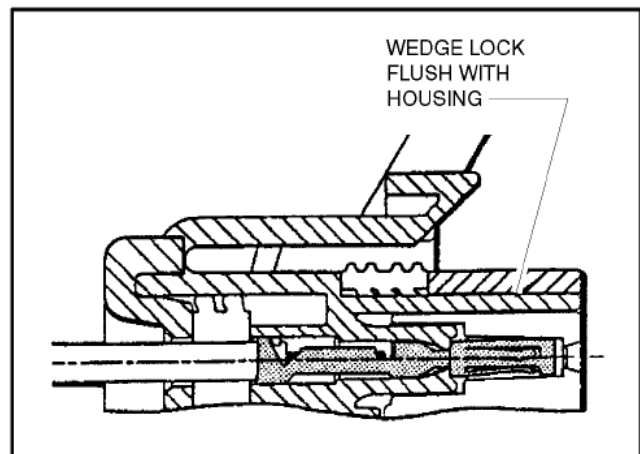

Figure 11-9. Connector Assembly Figure 4

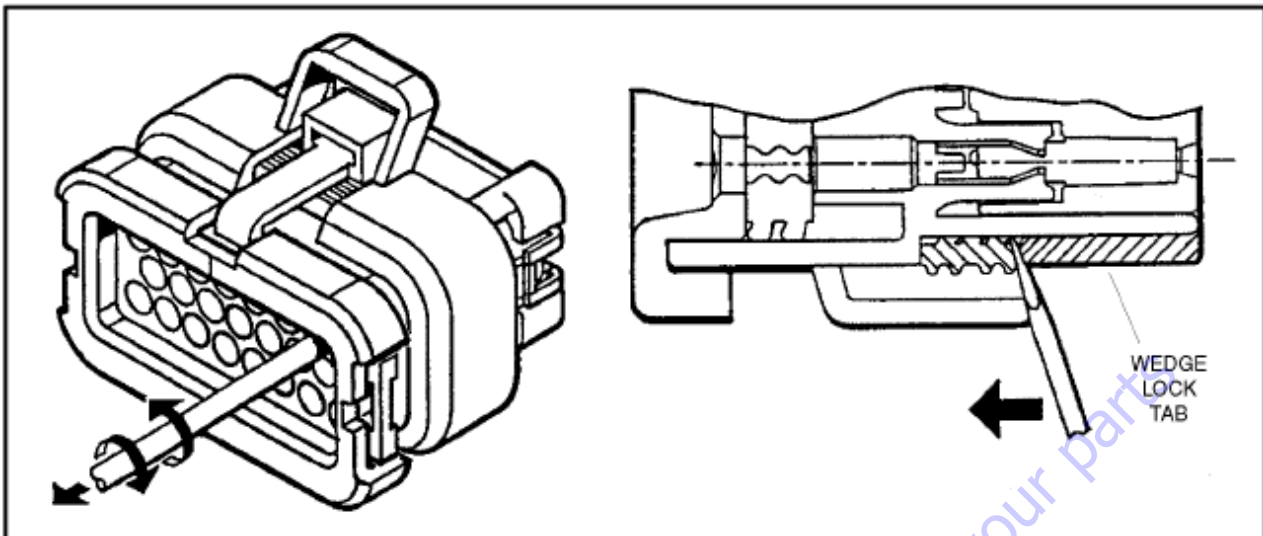

Figure 11-10. Connector Disassembly

Disassembly

1. Insert a 4.8 mm (3/16") wide screwdriver blade between the mating seal and one of the red wedge lock tabs.
2. Pry open the wedge lock to the open position.
3. While rotating the wire back and forth over a half turn (1/4 turn in each direction), gently pull the wire until the contact is removed.

NOTE: The wedge lock should never be removed from the housing for insertion or removal of the contacts.

Wedge Lock

The wedge lock has slotted openings in the forward, or mating end. These slots accommodate circuit testing in the field, by using a flat probe such as a pocket knife. DO NOT use a sharp point such as an ice pick.

Service - Voltage Reading

⚠ CAUTION

DO NOT PIERCE WIRE INSULATION TO TAKE VOLTAGE READINGS.

It has been common practice in electrical troubleshooting to probe wire by piercing the insulation with a sharp point. This practice should be discouraged when dealing with the AMPSEAL plug assembly, or any other sealed connector system. The resulting pinholes in the insulation will allow moisture to invade the system by traveling along the wire strands. This nullifies the effectiveness of the connector seals and could result in system failure.

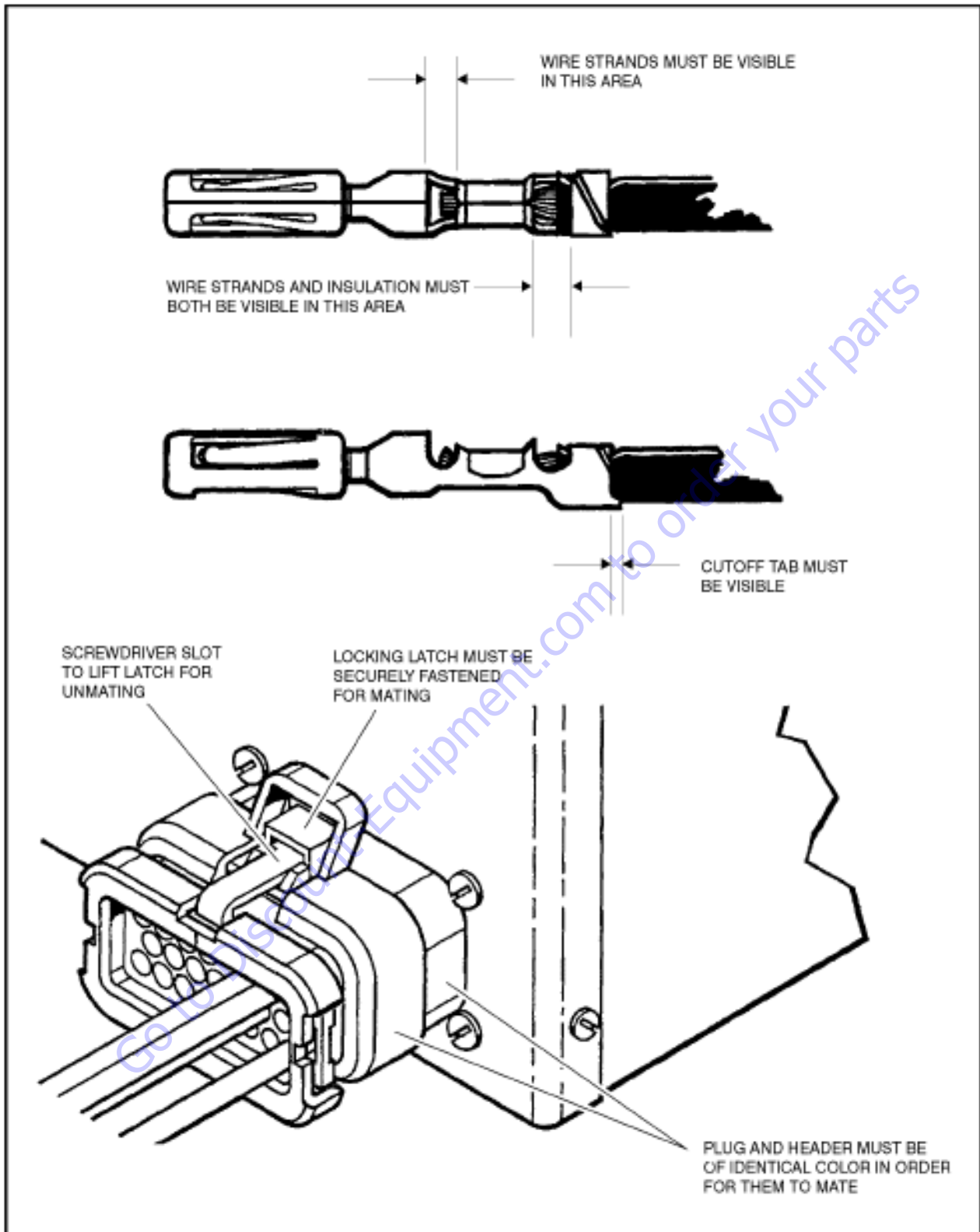

Figure 11-11. Connector Installation

11.6 DEUTSCH CONNECTORS

DT/DTP Series Assembly

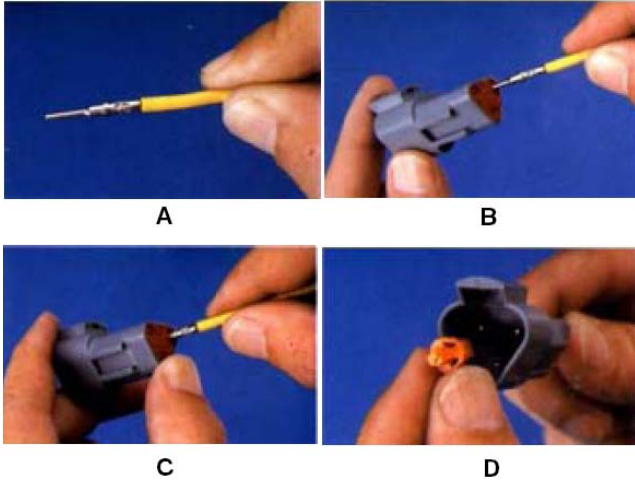

Figure 11-12. DT/DTP Contact Installation

1. Grasp crimped contact about 25 mm behind the contact barrel.
2. Hold connector with rear grommet facing you.
3. Push contact straight into connector grommet until a click is felt. A slight tug will confirm that it is properly locked in place.
4. Once all contacts are in place, insert wedgelock with arrow pointing toward exterior locking mechanism. The wedgelock will snap into place. Rectangular wedges are not oriented. They may go in either way.

NOTE: The receptacle is shown - use the same procedure for plug.

DT/DTP Series Disassembly

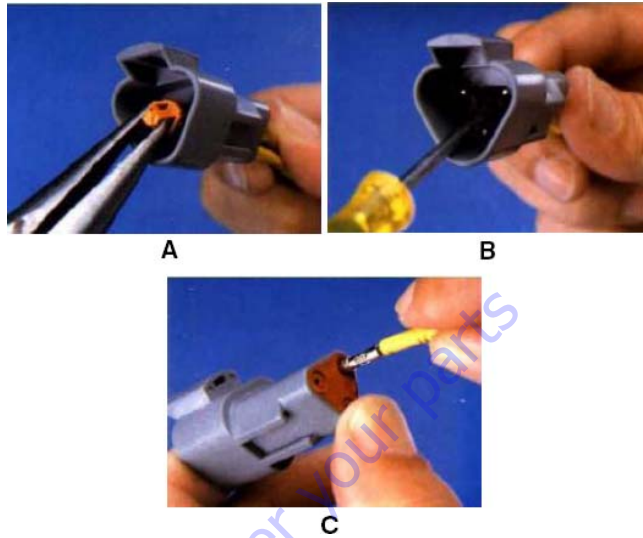

Figure 11-13. DT/DTP Contact Removal

1. Remove wedgelock using needle-nose pliers or a hook shaped wire to pull wedge straight out.
2. To remove the contacts, gently pull wire backwards, while at the same time releasing the locking finger by moving it away from the contact with a screwdriver.
3. Hold the rear seal in place, as removing the contact may displace the seal.

HD30/HDP20 Series Assembly

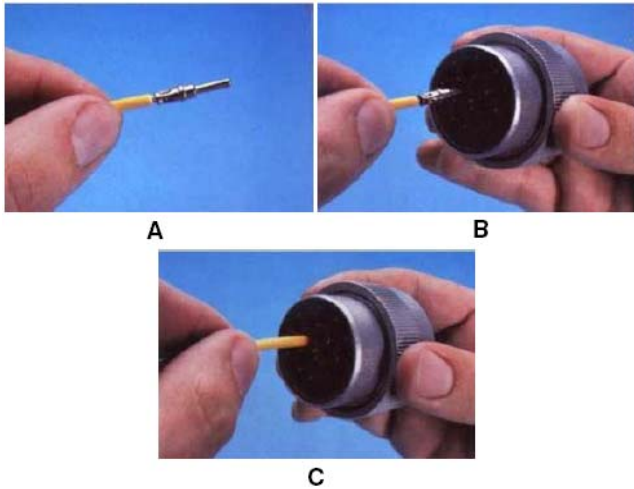

Figure 11-14. HD/HDP Contact Installation

1. Grasp contact about 25 mm behind the contact crimp barrel.
2. Hold connector with rear grommet facing you.
3. Push contact straight into connector grommet until a positive stop is felt. A slight tug will confirm that it is properly locked in place.

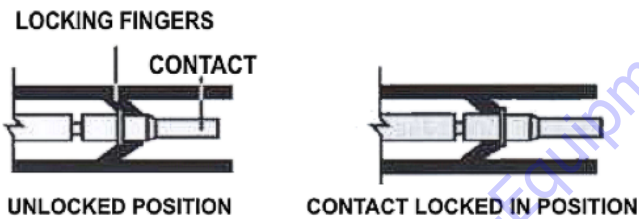

Figure 11-15. HD/HDP Locking Contacts Into Position

NOTE: For unused wire cavities, insert sealing plugs for full environmental sealing.

HD30/HDP20 Series Disassembly

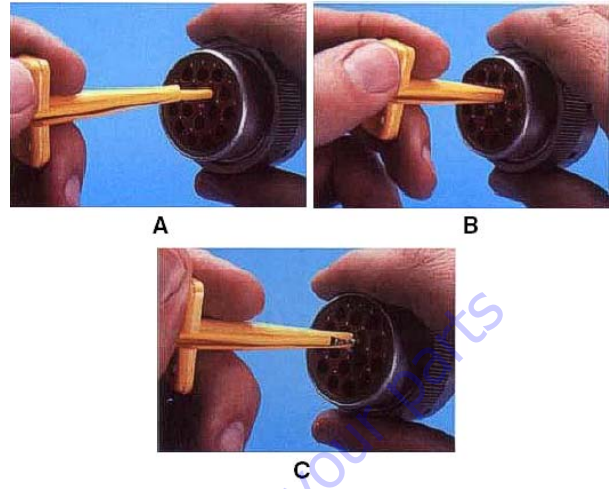

Figure 11-16. HD/HDP Contact Removal

1. With rear insert toward you, snap appropriate size extractor tool over the wire of contact to be removed.
2. Slide tool along into the insert cavity until it engages contact and resistance is felt.
3. Pull contact-wire assembly out of connector.

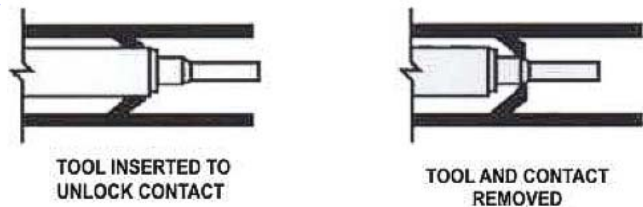

Figure 11-17. HD/HDP Unlocking Contacts

NOTE: Do not twist or insert tool at an angle.

11.7 CONNECTORS IDENTIFICATION

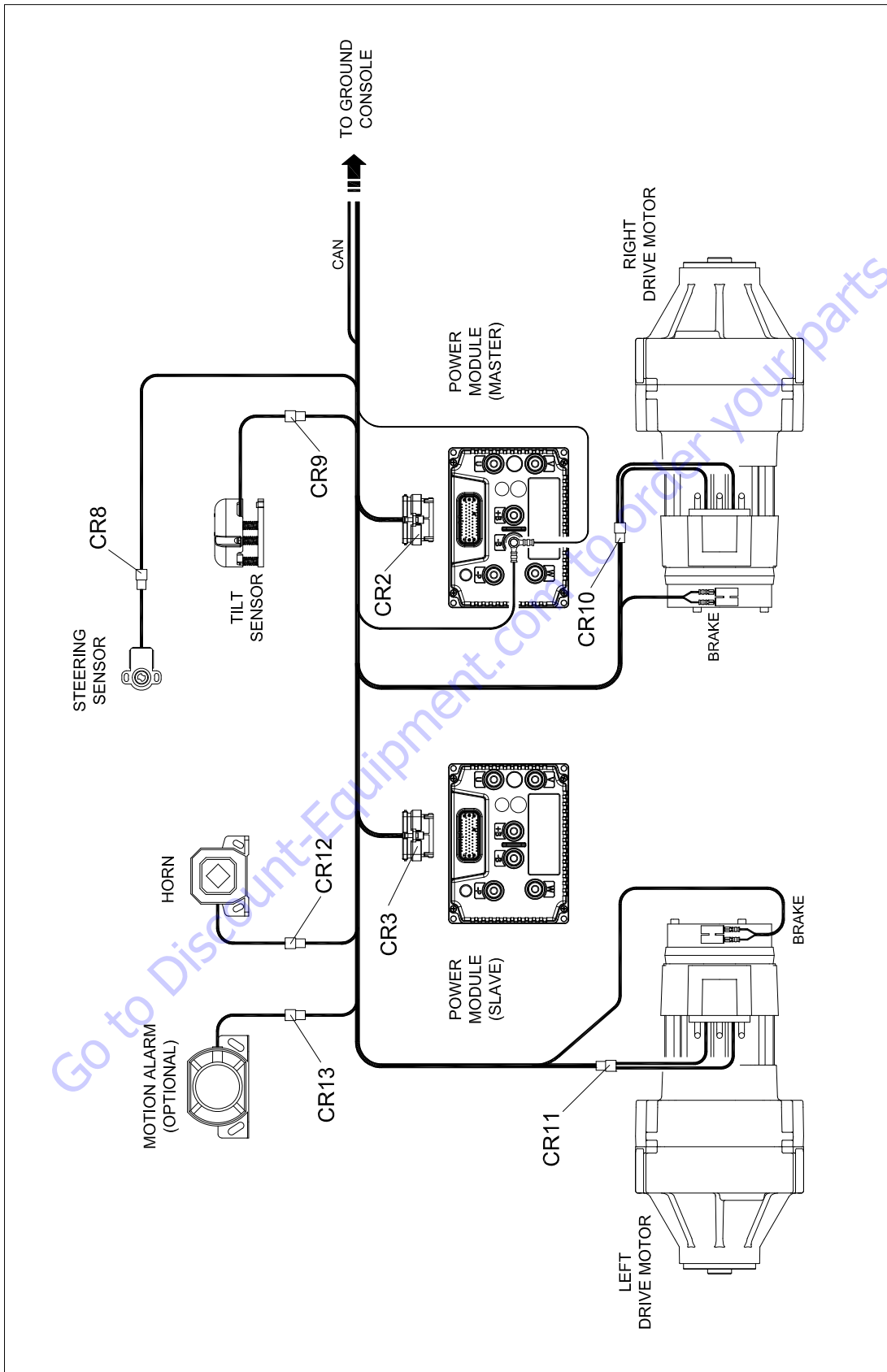

Figure 11-18. Wiring Harness and Connectors - Sheet 1 of 3

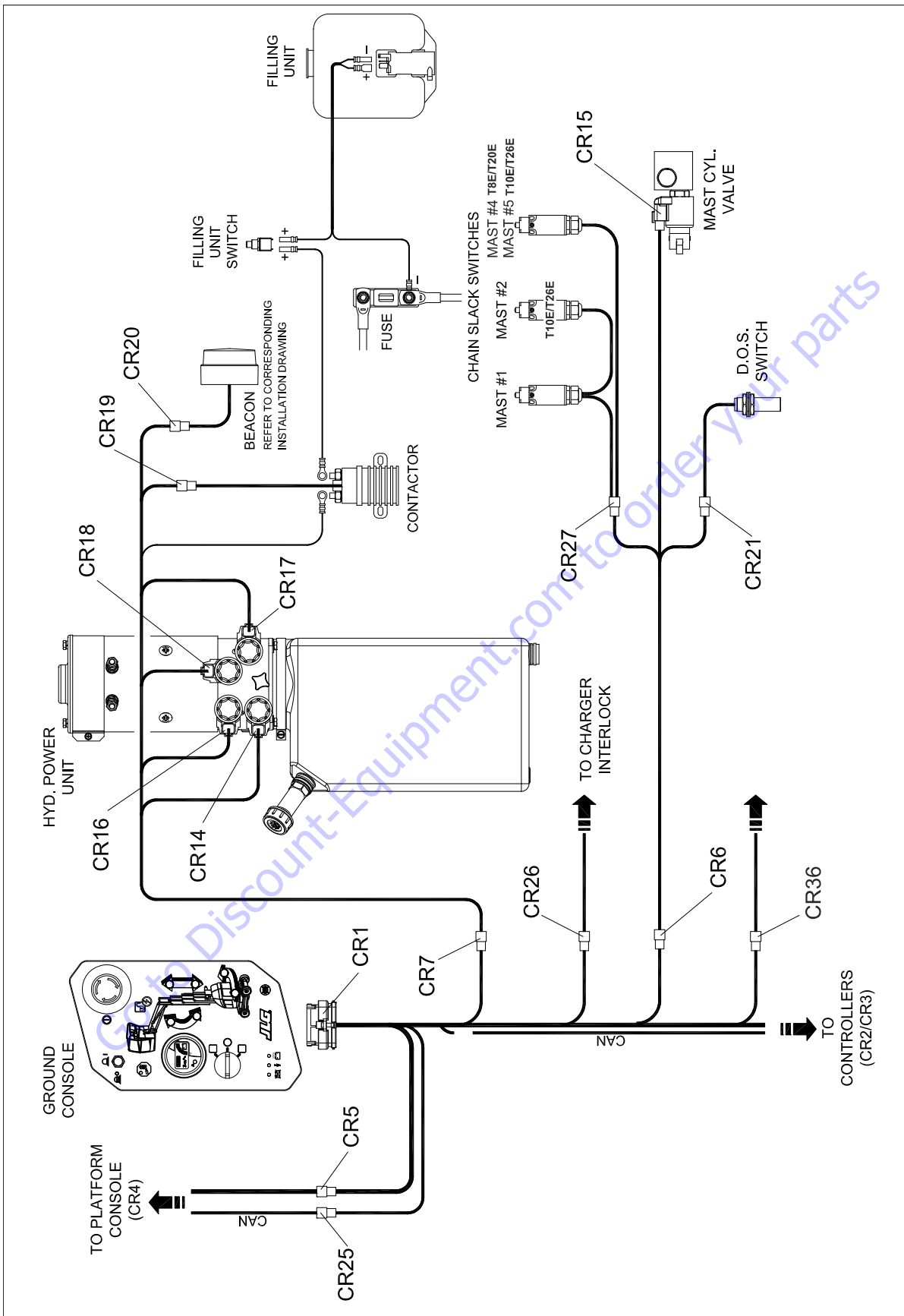

Figure 11-19. Wiring Harness and Connectors - Sheet 2 of 3

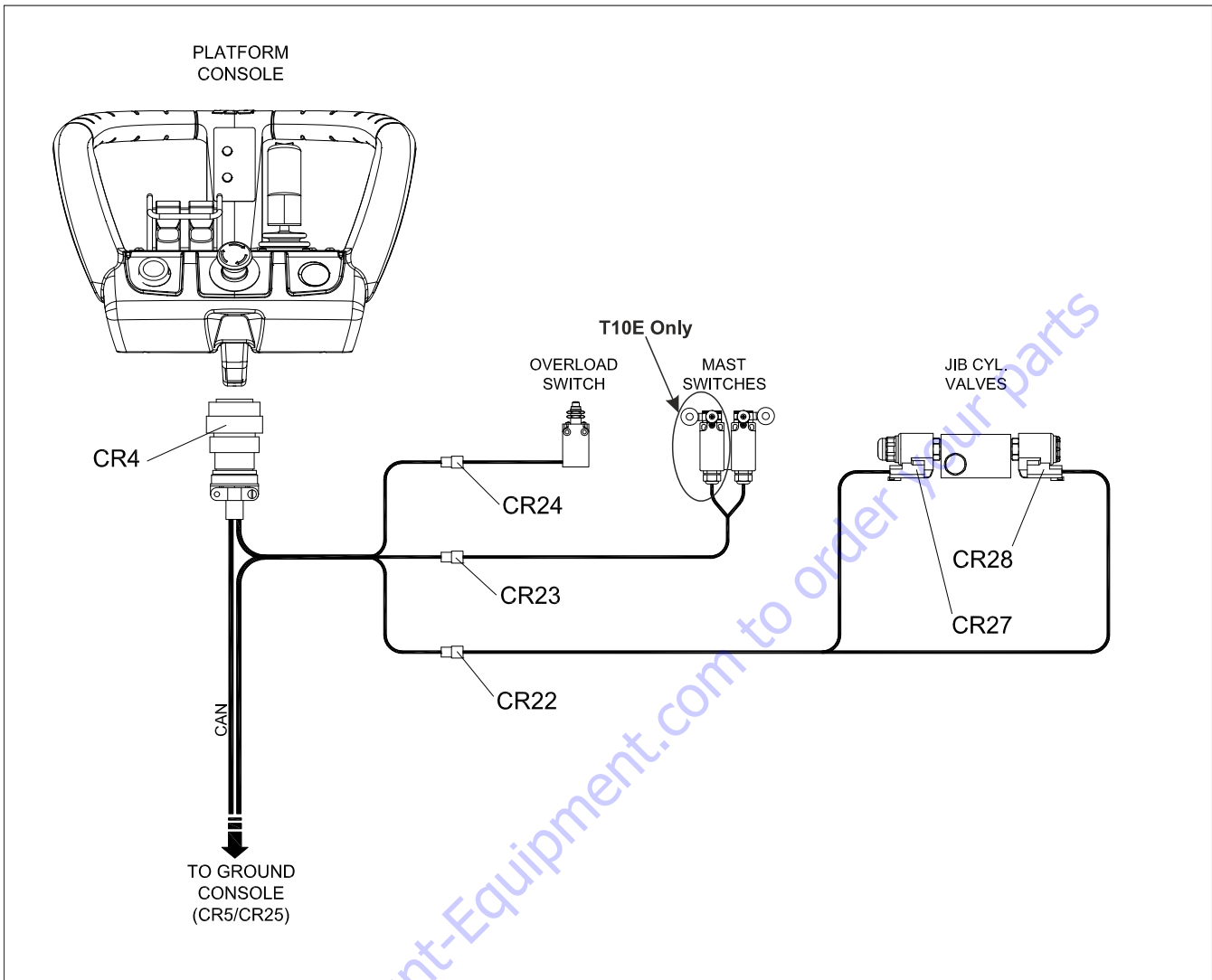

Figure 11-20. Wiring harness and Connectors - Sheet 3 of 3

11.8 ELECTRICAL SCHEMATIC

Wire Identification :

xx-yy : xx = wire # , yy = total wire number of the cable

Example

12-18 : Wire #12 of the 18 wires cable

Marking (every 100mm approx) : 

xxy : xx = pin # , y = connector # (values : 0, 1, 2, 3 with 0=common line between CR2 and CR3)

Examples

263 : Wire connected to pin #26 of connector CR3

070 : Wire connected to pin #7, common to both Master and Slave controllers (CR2 & CR3)

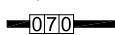
Marking (at wire ends only) : 

White - Brown : CAN cable, twisted pair, coloured wires

Depending on cable : White = Green - Brown = Yellow.

Figure 11-21. Electrical schematic caption

This page has been left blank intentionally

Go to Discount-Equipment.com to order your parts

SECTION 11 - GENERAL ELECTRICAL INFORMATION & SCHEMATICS

ELE251 - Sans MSSO

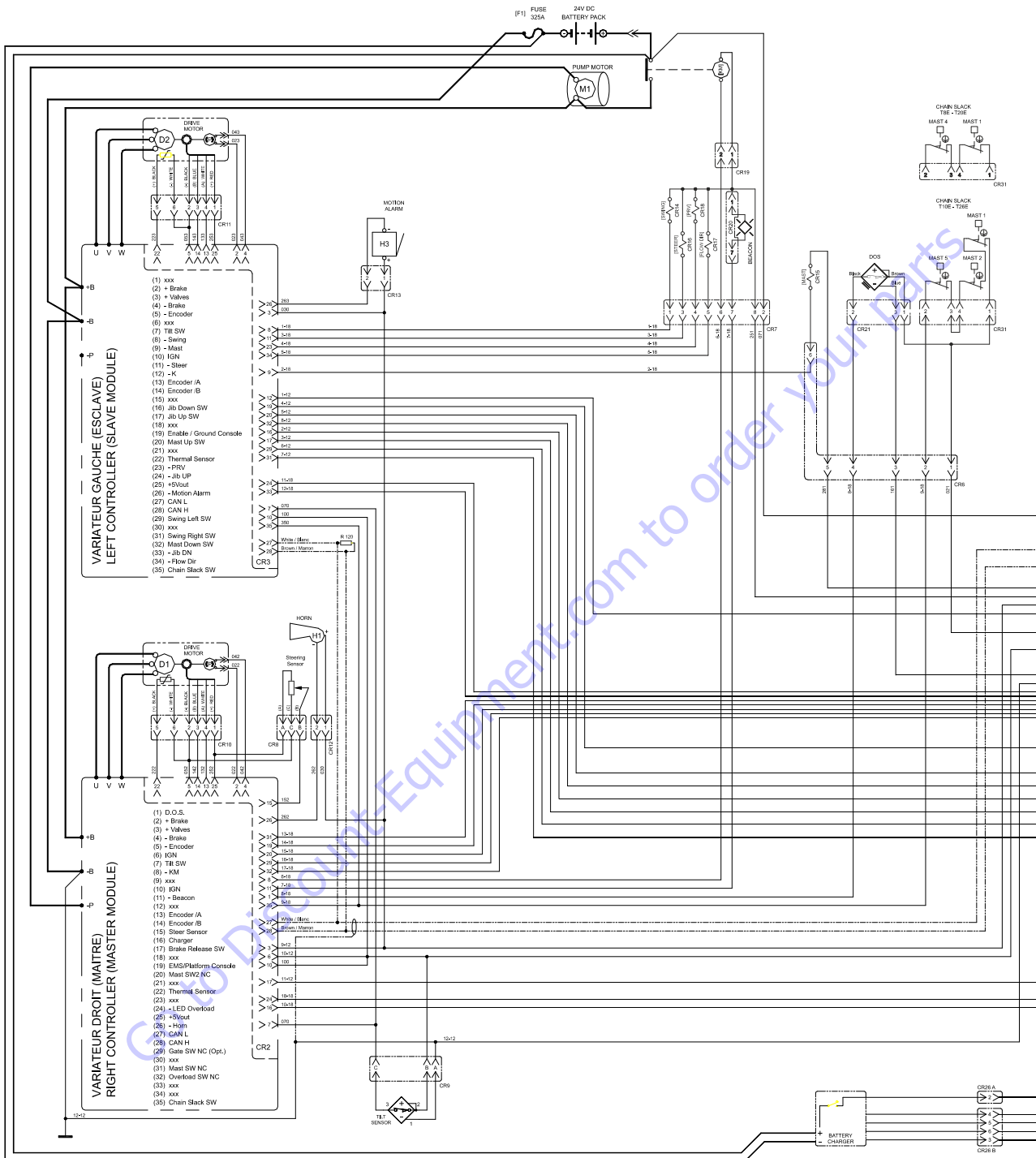

Figure 11-22. Electrical Schematic ELE251 - Sheet 1 of 2

SECTION 11 - GENERAL ELECTRICAL INFORMATION & SCHEMATICS

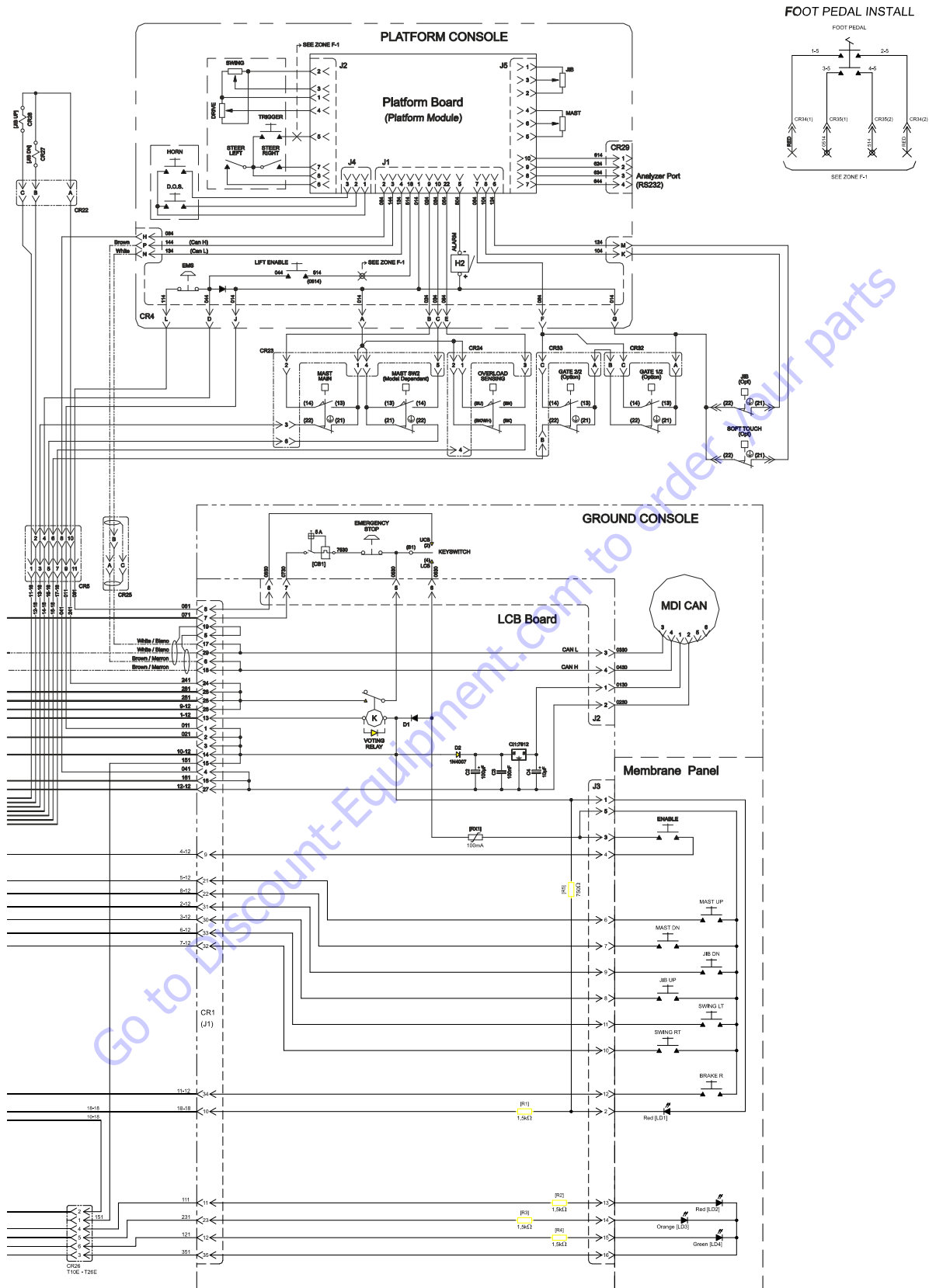

Figure 11-23. Electrical Schematic Toucan ELE251 - Sheet 2 of 2

SECTION 11 - GENERAL ELECTRICAL INFORMATION & SCHEMATICS

ELE259 - Avec MSSO

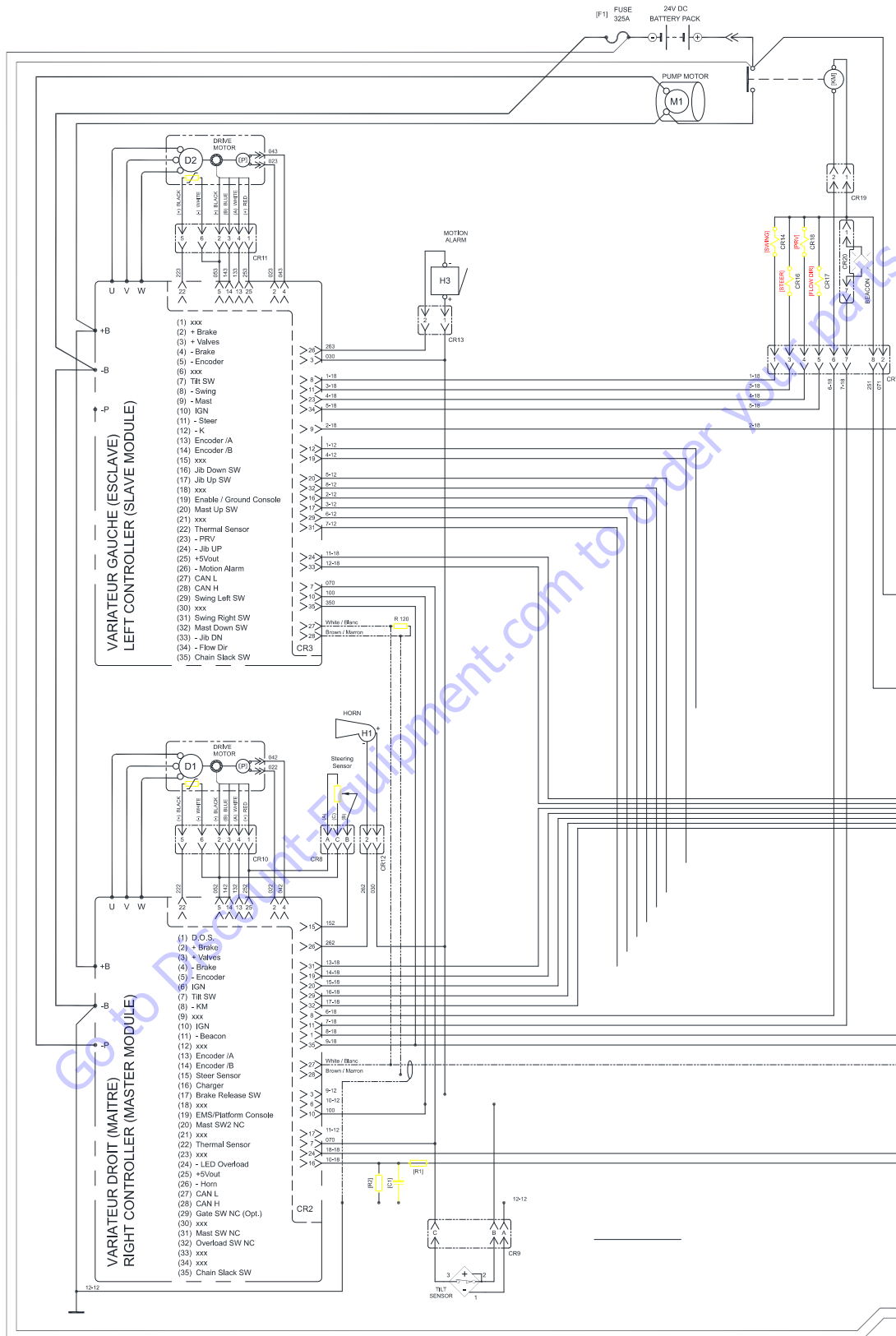

Figure 11-24. Electrical Schematic ELE259 - Sheet 1 of 2

11.9 HYDRAULIC SCHEMATIC

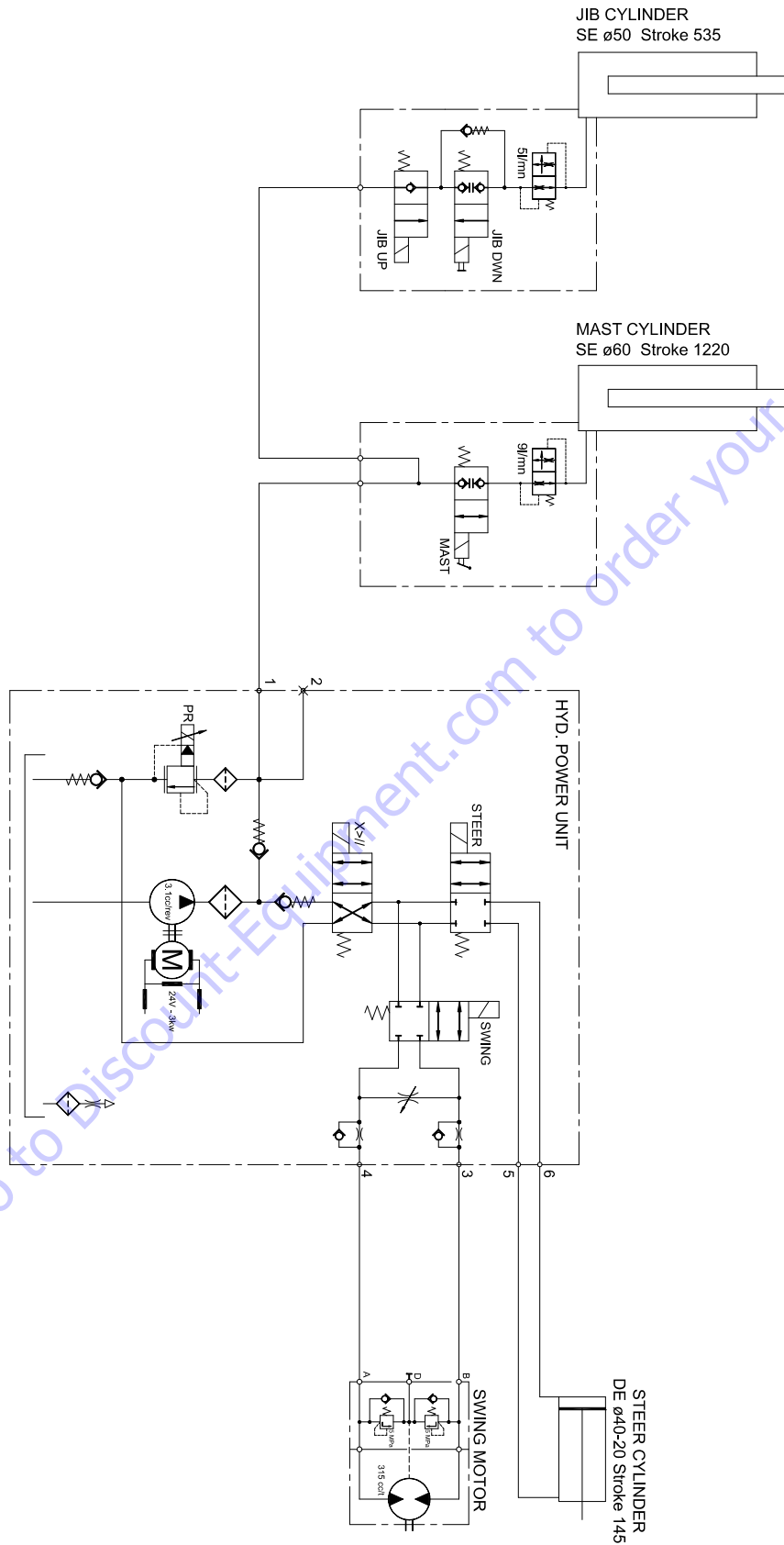

Figure 11-26. Hydraulic schematic Toucan 10E/Toucan 26E

SECTION 11 - GENERAL ELECTRICAL INFORMATION & SCHEMATICS

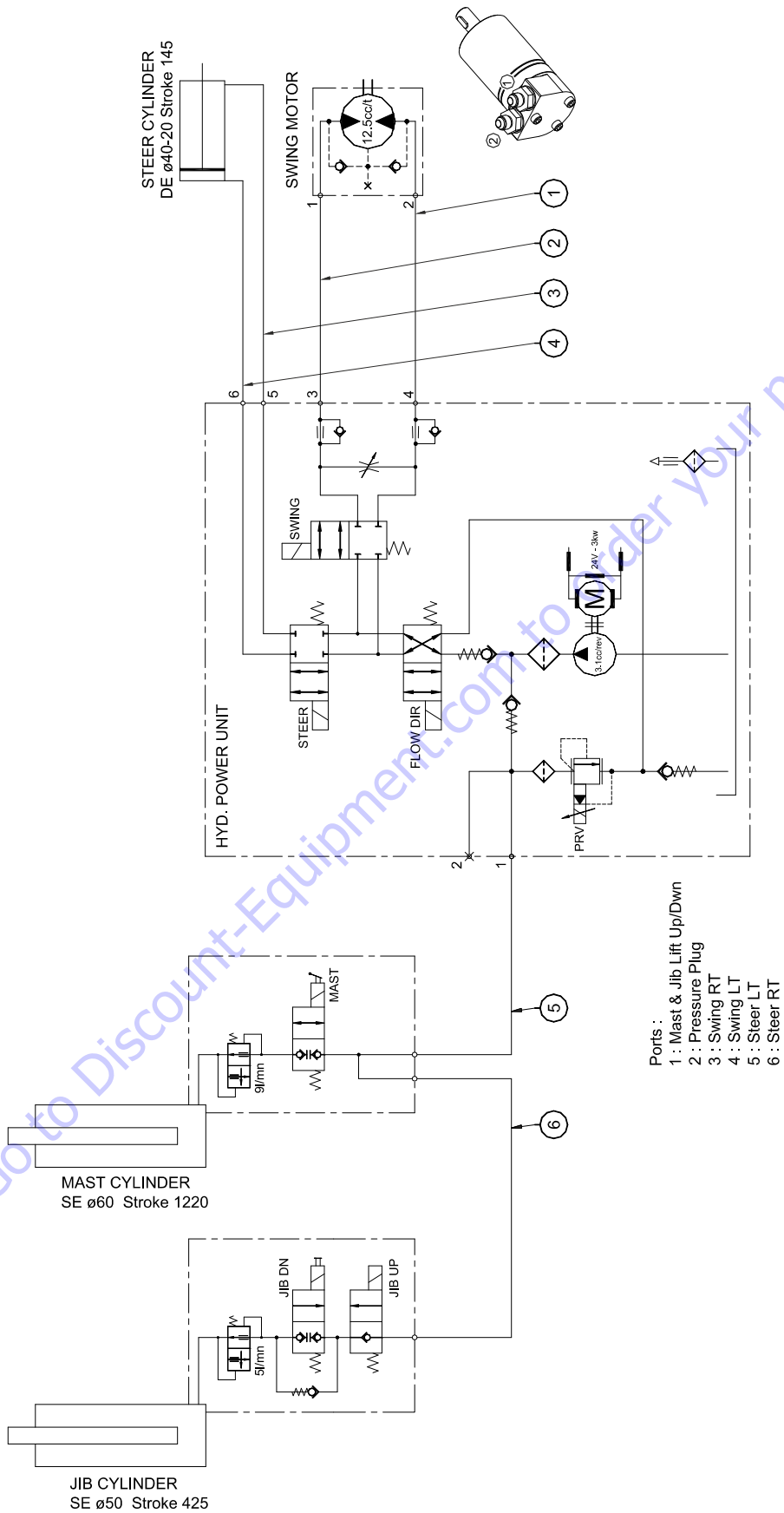

Figure 11-27. Hydraulic schematic Toucan 8E/Toucan 20E

JLG[®]



www.Discount-Equipment.com

Go to Discount-Equipment.com to order your parts
