

# Model M450AJ

## ARTICULATING BOOM LIFTS



www.Discount-Equipment.com



### MORE ECONOMIC

- Electric power for zero emissions and near-silent running indoors.

### MORE PRODUCTIVE

- Stay up and running longer with onboard charging.

### MORE ACCESS

- Get great access to hard-to-reach places with near-vertical jib positioning and 180-degree side-to-side movement.

### SMART DESIGN

- Enjoy industry leading upcycles so you can work longer with higher productivity.



### Standard Features

- 0.76 m x 1.52 m low mount platform
- Side entry with drop bar mid rail
- Multiple function operation
- Full proportional drive joystick control with integral thumb steer switch
- Full proportional main boom and swing joystick control
- Multiple speed control for lower boom, telescope and jib
- Selectable creep speed on drive / lift and swing functions
- 1.22 m articulating jib
- 180 degree powered platform rotator
- Platform console machine status light panel <sup>1</sup>
- Load sensing system
- AC power cable to platform
- Two Wheel Direct Electric Drive
- Automatic traction control
- Programmable "Personality" settings
- On-board self-diagnostic testing
- Enclosed battery / electrical compartment
- 20 amp automatic battery charger
- Automatic rear wheel brakes
- Sculptured ABS hoods
- 3 degree tilt alarm and indicator light
- Lifting/tie down lugs
- Ground control selector switch with key lock
- Battery condition indicator
- Hour meter
- Horn
- Platform tool tray
- Manual descent system
- 1.75 m narrow frame
- JLG Skyguard active system

<sup>1</sup> Provides indicator lights at platform control console for system distress, low battery, tilt light, and foot switch status.

### Standard Specifications

Power Source	48V DC
• Electrical System	8 x 6V 370 A/hr
• Batteries - deep cycle	Dual AC Traction
• Drive Motors	
Hydraulic System	
• Hydraulic Motor	Perm. Magnet
Tyres	240/55-17.5 Foam Filled
Generator Set	Kubota OC60 Air-cooled 5 kW

### Accessories & Options

- 0.76 m x 1.22 m slide bar side entry platform
- 0.76 m x 1.22 m Self closing inward swing gate
- 13 mm air line to platform
- 240/55 - 17.5 non marking foam filled tyres
- 305 A/hr AGM Batteries
- All motion alarm
- Alarm package <sup>2</sup>
- Platform worklights
- Head and tail lights
- Light package <sup>3</sup>
- Amber strobe light
- Euro Plug & Socket
- Acrylic console shield
- Cylinder bellows
- Skyguard beacon (ILOS)
- Synthetic Biodegradable Hydraulic Oil
- Special paint colour

<sup>2</sup> Includes all-motion alarm and amber strobe light.

<sup>3</sup> Includes head & tail lights and platform work lights.

# Model M450AJ

## ARTICULATING BOOM LIFTS

### Performance

- Working Height 15.72 m
- Working Outreach 7.89 m
- Up and Over Height 7.70 m
- Swing (non-continuous) 360°
- Platform Capacity – Unrestricted 230 kg
- Platform Rotator (Hydraulic) 180°
- Jib – Overall Length 1.24 m
- Jib – Range of articulation 144° (+84°/ -60°)
  - A. Platform Size 0.76 m x 1.52 m
  - B. Overall Width 1.75 m
  - C. Tailswing (working condition) Zero
  - D. Stowed Height 2.01 m
  - E. Stowed Length 6.45 m
  - F. Wheelbase 2.01 m
  - G. Ground Clearance 0.20 m
- Machine weight <sup>1</sup> 6,700 kg
- Maximum Ground Bearing Pressure 5.3 kg/cm<sup>2</sup>
- Drive Speed 5.2 km/h
- Gradeability 30%
- Turning Radius – Inside 0.61 m
- Turning Radius – Outside 3.15 m

<sup>1</sup> Certain options or country standards may increase weight and/or dimensions.



### Reach Diagram

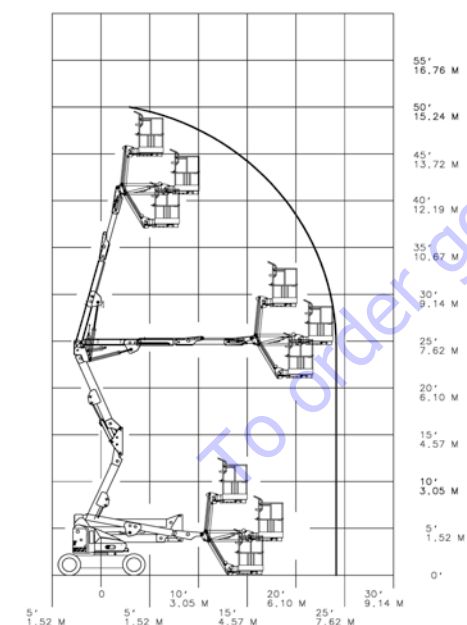

### Dimensions

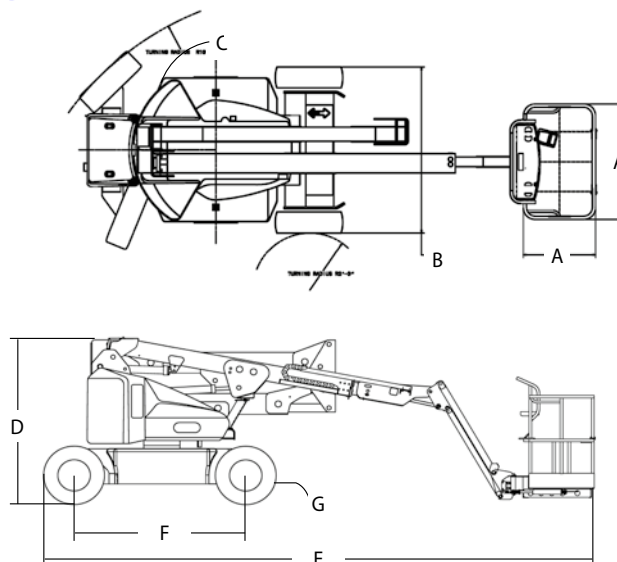

### IMPORTANT

JLG is continually researching and developing products and reserves the right to make modifications without prior notice. All data in this document is indicative. Certain options or country standards will increase weight. Specifications may change to meet country standards or with the addition of optional equipment.

Due to continuous product improvements, JLG Industries reserves the right to make specification and/or equipment changes without prior notification

[www.Discount-Equipment.com](http://www.Discount-Equipment.com)