

5.7 FUNCTION PUMP

Removal

1. Place machine on level surface and allow the engine and system fluids to cool.
2. Properly relieve any pressure in hydraulic system.
3. Tag and disconnect the hydraulic lines and fittings from the function pump. Use a suitable container to retain any residual hydraulic fluid. Immediately cap lines and ports.

NOTE: The function pump weighs approximately 35 lbs. (16 kg).

4. Use a suitable device to support the function pump.
5. Remove two bolts and washers attaching the function pump to the drive pump. Remove function pump from the machine as shown.

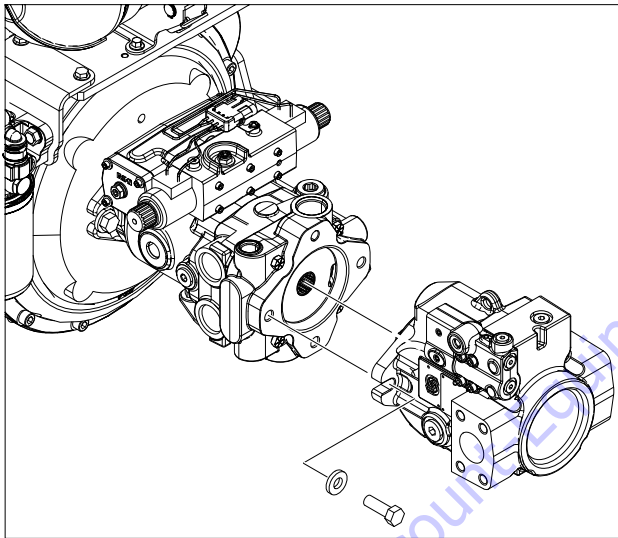

6. Remove and discard o-ring, if applicable.
7. Place function pump in the clean work area.

Installation

NOTE: The function pump weighs approximately 35 lbs. (16 kg).

1. Use a suitable device to support the function pump.
2. If applicable, install the o-ring on to the function pump.
3. Align and install the function pump to the drive pump.

NOTE: Make sure that the pump shaft is properly aligned.

CAUTION

INCORRECT SHAFT ALIGNMENT MAY RESULT IN DAMAGE TO DRIVE SHAFT, BEARINGS, OR SEAL WHICH CAN CAUSE EXTERNAL OIL LEAKAGE.

4. Secure function pump with two bolts and washers as shown. Apply JLG Threadlocker P/N 0100011 to the bolts before installation. Torque bolts to 85 ft. lbs. (116Nm).

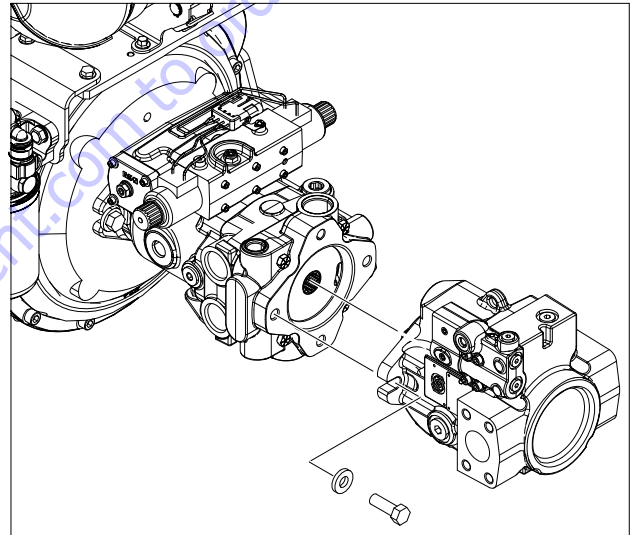

5. Remove tag and reconnect the hydraulic lines to the function pump.
6. Reconnect the battery power and make sure for proper working of the function pump.

Table 5-33. Symbols Used

Symbol	Meaning	Symbol	Meaning
	Non-reusable part, use a new part		Inspect for wear or damage
	Option - either part may exist		Note correct orientation
	Internal hex head		Torque specification
	O-ring boss port		Pull out with tool - press fit
	Lubricate with hydraulic fluid		Cover splines with installation sleeve
	Apply grease/petroleum jelly		Pressure measurement / gauge location or specification

The symbols above can be found in the pump illustrations. The legend above is provided to define each symbol and explain its purpose.

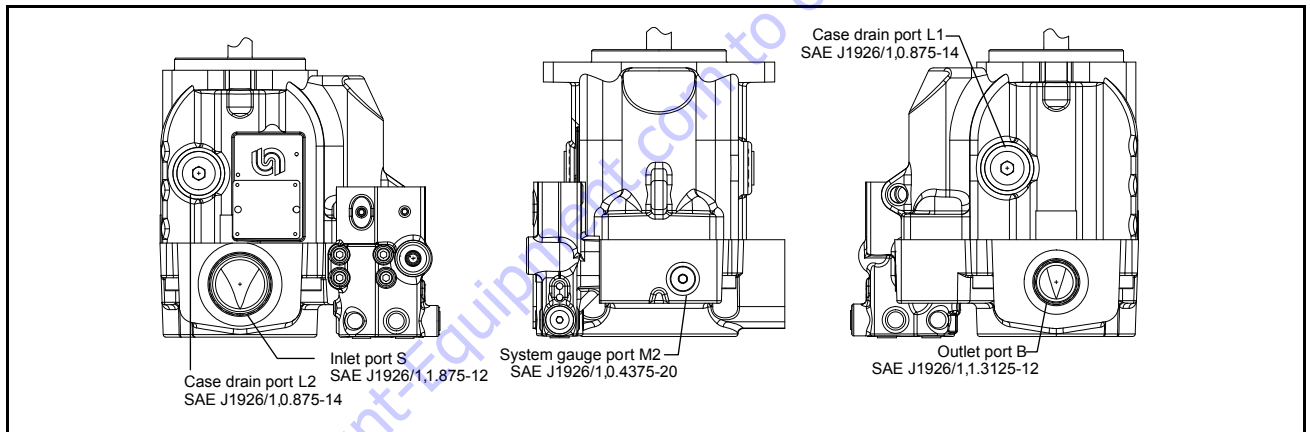

Figure 5-149. Gauge Port Locations

Table 5-34. Gauge and Port information

Port	Purpose	Range of Pump	Fitting
M2	System pressure	0-5000 psi [0-300 bar]	7/16 - 20 o-ring fitting
M4	Servo pressure	0-5000 psi [0-300 bar]	7/16 - 20 o-ring fitting
L1,L2	Case pressure	0-100 psi [0-10 bar]	7/8 - 14 o-ring fitting
X1	Load Sense signal	0-5000 psi [0-300 bar]	7/16 - 20 o-ring fitting (tee into Load Sense signal line)

Initial Start-up Procedures

Follow this procedure when starting-up a new pump or when the pump has been removed.

1. Install the pump on the engine. Ensure the pump shaft is properly aligned.

⚠ CAUTION

INCORRECT SHAFT ALIGNMENT MAY RESULT IN DAMAGE TO DRIVE SHAFT, BEARINGS, OR SEAL WHICH CAN CAUSE EXTERNAL OIL LEAKAGE.

2. Fill the main pump housing with clean hydraulic fluid. Pour filtered oil directly into the main most case drain port.
3. Fill the inlet line leading from the pump to the reservoir. Check the inlet line for properly tightened fittings and be certain it is free of restrictions and air leaks.
4. To ensure the pump stays filled with oil, install the case drain line in the main most case drain port.
5. Install a gauge at port M2 to monitor system pressure during start up.

6. While watching the pressure gauge installed at M2, jog the engine or run at the lowest possible speed until system pressure builds to normal levels (minimum 160 psi [11 bar]). Once system pressure is established, increase to full operating speed. If system pressure is not maintained, shutdown the engine, determine cause, and take corrective action. Refer to Troubleshooting.
7. Operate the hydraulic system for at least fifteen minutes under light load conditions.
8. Check and adjust control settings as necessary after installation. Refer to Adjustments.
9. Shut down the engine and remove the pressure gauge. Replace plug at port M2.
10. Check the fluid level in the reservoir; add clean filtered fluid if necessary. The pump is now ready for operation.

Go to Discount-Equipment.com to order your parts

Troubleshooting

Table 5-35. Excessive Noise and/ or Vibration

Item	Description	Action
Check fluid level in reservoir.	Insufficient hydraulic fluid will cause cavitation.	Fill the reservoir to proper level.
Check for air in system.	Air in system will cause noisy, erratic control.	Purge air and tighten fittings. Check inlet for leaks.
Check pump inlet pressure / vacuum.	Improper inlet conditions will cause erratic behavior and low output flow.	Correct pump inlet pressure / vacuum conditions. Refer to Hydraulic parameters.
Inspect shaft couplings.	A loose or incorrect shaft coupling will cause excessive noise and/or vibration.	Repair or replace coupling and ensure that correct coupling is being used.
Check shaft alignment.	Misaligned shafts will create excessive noise and/or vibration.	Correct shaft misalignment.
Hydraulic fluid viscosity above acceptable limits.	Hydraulic fluid viscosity above acceptable limits or low fluid temperature will not allow the pump to fill or control to operate properly.	Allow system to warm up before operation or use fluid with the appropriate viscosity grade for expected operating temperatures.

Table 5-36. Actuator Response Is Sluggish

Item	Description	Action
Check external system relief valve setting.	Low external relief valve setting will slow down system.	Adjust external relief valve setting per manufacturer's recommendations. External relief setting must be above Pressure Compensator setting for proper operation.
Check Pressure Compensator and LS control setting.	Low Pressure Compensator setting will prevent the pump from achieving full stroke. Low Load Sense setting will limit output flow.	Adjust Pressure Compensator and Load Sense setting. Refer to Adjustments.
Check Load Sense control signal pressures.	Incorrect Load Sense signal will not allow pump to operate correctly.	Inspect system, ensure that proper Load Sense signal is transmitted to the pump.
Internal system leaks.	Worn internal parts will not allow the pump to operate properly.	Refer to Authorized Service Center for repairs as required.
Hydraulic fluid viscosity above acceptable limits.	Hydraulic fluid viscosity above acceptable limits or low fluid temperature will not allow the pump to fill or control to operate properly.	Allow system to warm up before operation or use fluid with the appropriate viscosity grade for expected operating temperatures.
Check external system valving.	Malfunctioning valving may not allow system to respond properly.	Repair or replace system valving as required.
Check pump case pressure.	High case pressure will cause the system to be sluggish.	Correct case drain line restrictions.
Check pump inlet pressure / vacuum.	High inlet vacuum will cause low output flow.	Correct inlet pressure conditions.

SECTION 5 - BASIC HYDRAULIC INFORMATION & HYDRAULIC SCHEMATICS

Table 5-37. System Operating Hot

Item	Description	Action
Check fluid level in reservoir.	Insufficient volume of hydraulic fluid will not meet cooling demands of system.	Fill reservoir to proper level. Verify proper size of reservoir.
Inspect heat exchanger. Check air flow and input air temperature for the heat exchanger.	Insufficient air flow, high input air temperature, or under-sized heat exchanger will not meet cooling demands of the system.	Clean, repair, or replace heat exchanger as required. Verify proper size of heat exchanger.
Check external system relief valve setting.	Fluid passing through relief valve adds heat to system.	Adjust external system relief valve setting per manufacturer's recommendations. External relief valve setting must be above Pressure Compensator setting for proper operation.
Check pump inlet pressure / vacuum.	High inlet vacuum adds heat to system.	Correct inlet pressure / vacuum conditions.

Table 5-38. Low Pump Output Flow

Item	Description	Action
Check fluid level in reservoir.	Insufficient hydraulic fluid will limit output flow and cause internal damage to pump.	Fill the reservoir to proper level.
Hydraulic fluid viscosity above acceptable limits.	Fluid viscosity above acceptable limits or low fluid temperature will not allow the pump to fill or control to operate properly.	Allow system to warm up before operation or use fluid with the appropriate viscosity grade for expected operating temperatures.
Check external system relief valve setting.	External relief valve set below Pressure Compensator setting will cause low output flow.	Adjust external relief valve per manufacturer's recommendation. External relief valve setting must be above Pressure Compensator setting for proper operation.
Check Pressure Compensator and Load Sense control setting.	Low Pressure Compensator setting will prevent the pump from achieving full stroke. Low Load Sense setting will limit output flow.	Adjust Pressure Compensator and Load Sense setting. Refer to Adjustments.
Check pump inlet pressure / vacuum.	High inlet vacuum will cause low output flow.	Correct inlet pressure conditions.
Check input speed.	Low input speeds decrease flow.	Adjust input speed.
Check pump rotation.	Incorrect rotational configuration will cause low flow.	Use pump with appropriate rotational configuration.

Table 5-39. Pressure or Flow Instability

Item	Description	Action
Check for air in system.	Air in system will cause erratic operation.	Activate Pressure Compensator, allowing system to bleed air. Check inlet line for leaks and eliminate source of air ingress.
Check control spools.	Sticking control spools will cause erratic operation.	Inspect spools for free movement in bore. Clean or replace as needed.
Check Load Sense setting.	Low Load Sense setting may cause instability.	Adjust Load Sense setting to proper level. See Adjustments.
Check Load Sense signal line.	Blocked Load Sense signal line will interfere with proper Load Sense operation.	Remove blockage.
Check external relief valve and Pressure Compensator setting.	Insufficient pressure differential between Pressure Compensator Pressure Compensator setting and external relief valve.	Adjust external relief valve or Pressure Compensator control settings to appropriate level. Relief valve setting must be above Pressure Compensator setting for proper operation.
Check external relief valve.	Chattering external relief valve may cause unstable feedback to pump control.	Adjust or replace relief valve.

Table 5-40. System Pressure Not Reaching Pressure Compensator Setting

Item	Description	Action
Check Pressure Compensator control setting.	System pressure will not rise above Pressure Compensator setting.	Adjust Pressure Compensator to appropriate setting.
Check external relief valve.	External relief valve setting below Pressure Compensator setting will prevent pressure compensation.	Adjust external relief valve per manufacturer's recommendations. External relief valve must be set above Pressure Compensator setting for proper operation.
Inspect Pressure Compensator control spring.	Broken, damaged, or missing spring will cause erratic operation.	Replace spring as required.
Inspect Pressure Compensator spool for wear.	Wear of the Pressure Compensator spool will cause internal leakage in the control.	Replace the spool as required.
Inspect Pressure Compensator spool for proper orientation.	Improper orientation will result in poor operation.	Correct orientation of spool.
Check Pressure Compensator control for contamination.	Contamination may interfere with movement of the Pressure Compensator Spool.	Clean Pressure Compensator control components, take appropriate action to eliminate contamination.

Table 5-41. High Inlet Vacuum

Item	Description	Action
<p>⚠ CAUTION</p> <p>HIGH INLET VACUUM CAUSES CAVITATION WHICH CAN DAMAGE INTERNAL PUMP COMPONENTS.</p>		
Check fluid temperature.	Low temperature increases viscosity. High fluid viscosity causes high inlet vacuum.	Allow system to warm up before operation.
Inspect inlet screen.	Blocked or restricted inlet screen will cause high inlet vacuum.	Clean screen / remove blockage.
Check inlet piping.	Too many fittings, bends, or long piping will cause high inlet vacuum.	Eliminate fittings to make path more direct.
Hydraulic fluid viscosity above acceptable limits.	High fluid viscosity causes high inlet vacuum.	Select fluid with appropriate viscosity for expected operating temperature.

Go to Discount-Equipment.com to order your parts

Shaft Seal Replacement

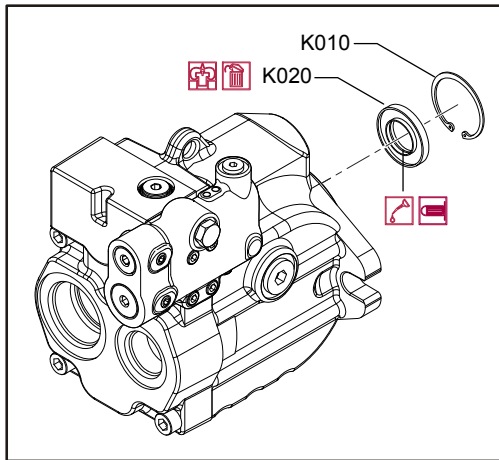

Figure 5-150. Shaft Seal and Retaining Ring

A lip type shaft seal is used in the pump and can be replaced without major disassembly of the unit. Replacement of the shaft seal requires removal of the pump from the machine.

REMOVAL

1. Using the appropriate snap-ring pliers, remove the retaining ring (K010) from the housing.
2. Remove the shaft seal (K020) from the bore in the pump housing and discard. Avoid damaging the pump housing or shaft. Puncture the face of the seal with a packing hook, or use a slide-hammer type puller to remove the seal.

INSTALLATION

1. Inspect the pump housing and new seal for damage. Inspect the sealing area on the shaft for rust, wear, or contamination. Polish the sealing area on the shaft if necessary.
2. Lubricate the lip of the new shaft seal with clean hydraulic fluid. Place a protective sleeve over the shaft end to prevent damage to the seal during installation.

CAUTION

PREMATURE BEARING FAILURE CAN RESULT IF THE SHAFT SEAL CONTACTS THE SHAFT BEARING. PRESS THE SEAL INTO THE HOUSING ONLY FAR ENOUGH TO CLEAR THE RETAINING RING GROOVE.

3. Keeping the seal perpendicular to the shaft, press the new seal into the housing just far enough to clear the retaining ring groove. Install seal with the cupped side toward the shaft bearing. Do not damage the seal during installation.
4. Using the appropriate snap ring pliers, install the seal retaining ring.
5. Remove the installation sleeve.

Control Assembly

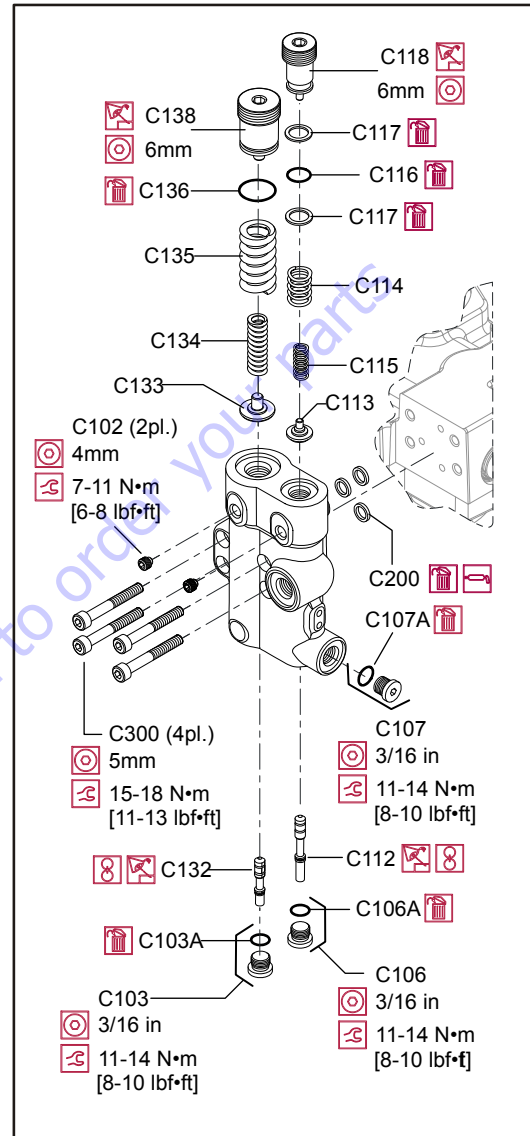

Figure 5-151. Control Assembly

DISASSEMBLY

1. Remove the four screws (C300) holding the control housing onto the end cap.
2. Remove the control and discard the three interface o-rings (C200).
3. Remove the Pressure Compensator set screw (C102), Pressure Compensator adjustment screw (C138), o-ring (C136), springs (C135, C134), and seat (C133). Discard the o-ring.
4. Remove the plug (C103), o-ring (C103A), and Pressure Compensator spool (C132) from the control housing; discard the o-ring. Note orientation of the spool for reassembly.
5. Remove the plug (C107) and o-ring (C107A); discard the o-ring.

NOTE: For Pressure Compensator only controls, skip steps 6 and 7.

6. Remove the Load Sense set screw (C102), Load Sense adjustment screw (C118), o-ring (C116), backup rings (C117), springs (C114, C115), and seat (C113); discard the o-ring.
7. Remove the plug (C106), o-ring (C106A), and Load Sense spool (C112) from the control housing; discard the o-ring. Note orientation of the spool for reassembly.

INSPECTION

1. Inspect the adjustment screws for wear at the tips and where they contact the springs; replace as necessary.
2. Inspect the springs and spring guides for wear or damage; replace as necessary.
3. Carefully inspect the spools. Ensure the sealing lands are free of nicks and scratches. Check the ends that contact the spring guides for wear. Replace spools as necessary.
4. Inspect the control housing for damage. Check the spool bores for excessive wear.
5. Clean all parts and lubricate spools, springs, guides and new o-rings with clean hydraulic fluid.

REASSEMBLY

1. Install the Pressure Compensator spool, spherical end first, into the Pressure Compensator bore. The Pressure Compensator spool is the shorter of the two. Using a new o-ring, install the plug (C103). Torque to 8-10 ft.lb. [11-14 Nm].
2. Place the two Pressure Compensator springs onto the spring guide and install into the Pressure Compensator bore. Place a new o-ring onto the Pressure Compensator adjustment screw and thread it into the Pressure Compensator bore until flush, then make another full turn. Install and torque the set screw to 6-8 ft.lb. [7-11 Nm].

NOTE: For Pressure Compensator only controls, skip steps 15 and 16.

3. Install the Load Sense spool, spherical end first, into the Load Sense bore. The Load Sense spool is the longer of the two. Using a new o-ring, install the plug (C106). Torque to 8-10 ft.lb. [11-14 Nm].
4. Place the two Load Sense springs onto the spring guide and install into the Load Sense bore. Place a new o-ring and backup rings onto the Load Sense adjustment screw and thread it into the Load Sense bore until flush, then make another full turn. Install and torque the set screw to 6-8 ft.lb. [7-11 Nm].
5. Using a new o-ring, install the plug (C107). Torque to 8-10 ft.lb. [11-14 Nm].
6. Using petroleum jelly to retain them, install the three interface o-rings (C200) in the recesses on the control housing.
7. Install the control assembly onto the endcap using the four screws (C300). Torque to 11-13 ft.lb. [15-18 Nm]. Torque screws in a criss-cross pattern and re-torque the first screw to ensure proper torque retention.

Plug and Fitting Sizes and Torques

If any plugs or fittings are removed from the unit during service, install and torque as indicated here. This drawing is a

composite. Your configuration may differ but the appropriate wrench size and torque can be found here.

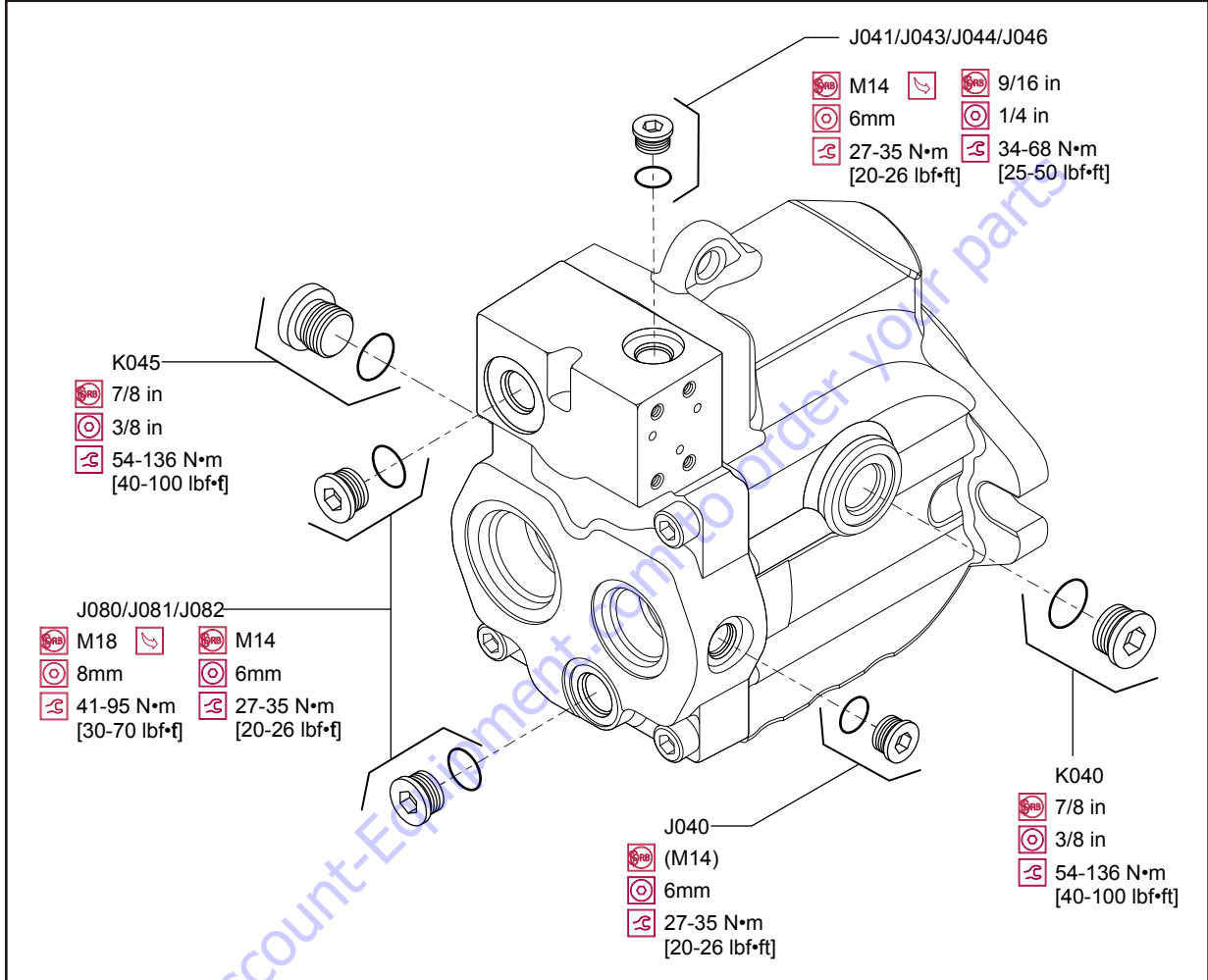

Figure 5-152. Plug Locations, Sizes, and Torques

5.8 DRIVE PUMP

Removal

NOTE: Remove the function pump from the machine first, refer Section 5.7, Function Pump.

1. Tag and disconnect the hydraulic lines and fittings from the drive pump. Use a suitable container to retain any residual hydraulic fluid. Immediately cap lines and ports.

NOTE: The drive pump weighs approximately 62 lbs. (28 kg).

2. Use a suitable device to support the drive pump.
3. Remove two bolts and washers attaching the drive pump to the engine assembly. Remove drive pump from the machine as shown.

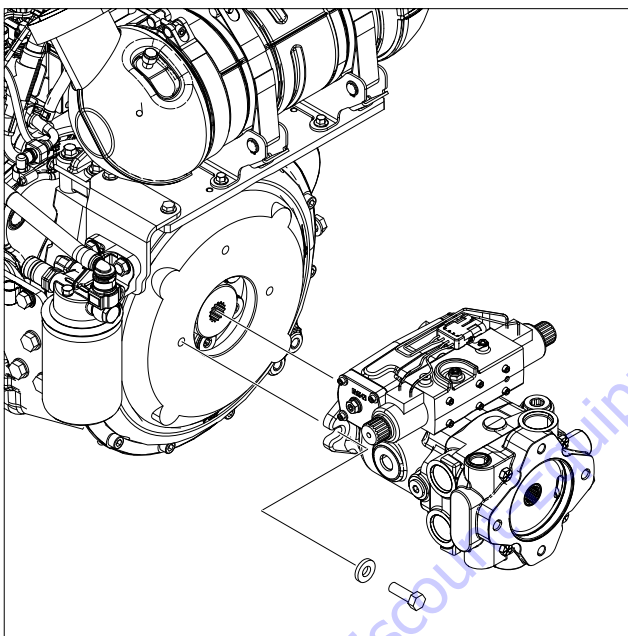

4. Remove and discard o-ring from the drive pump groove.
5. Place drive pump in the clean work area.

Installation

NOTE: The drive pump weighs approximately 62 lbs. (28 kg).

1. Use a suitable device to support the drive pump.
2. Install the new o-ring in to the drive pump groove.
3. Align and install the drive pump to the engine assembly.

NOTE: Make sure that the pump shaft is properly aligned.

CAUTION

INCORRECT SHAFT ALIGNMENT MAY RESULT IN DAMAGE TO DRIVE SHAFT, BEARINGS, OR SEAL WHICH CAN CAUSE EXTERNAL OIL LEAKAGE.

4. Secure drive pump with two bolts and washers as shown.

NOTE: Apply JLG Threadlocker P/N 0100011 to the bolts before installation.

5. Torque bolt to 46-56 ft.lbs. (62-76 Nm)

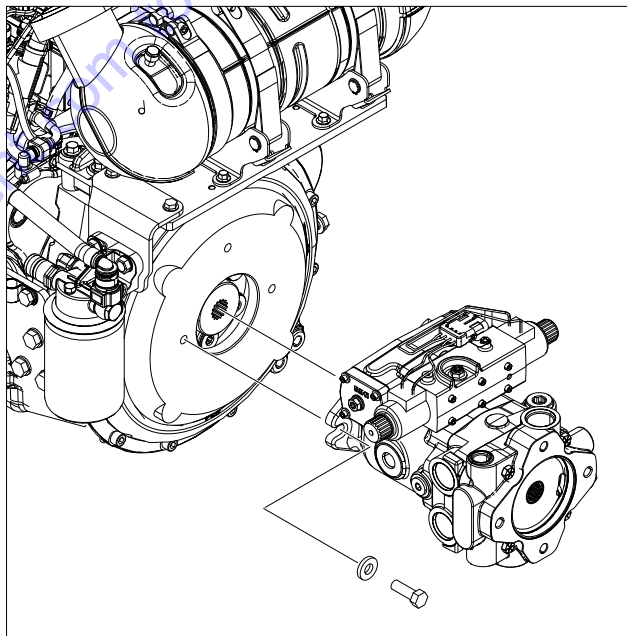

6. Remove tag and reconnect the hydraulic lines and fittings to the drive pump.

Servo Controlled Piston Pump

DISASSEMBLY

The following instructions apply to a single servo controlled piston pump with or without a gerotor charge pump. A tandem pump assembly should be separated into individual pumps before disassembly.

1. Position the pump into a protected jaw vise, clamping onto the outer portion of the flange, with the Capscrews up. Mark the relationship of the working ports (for assembly identification) to the servo control assembly with a scribe. Remove the four Capscrews retaining endcover.
2. Lift the charge pump adapter assembly straight up off endcover, shaft and gerotor. Gerotor may stay in adapter or on endcover.
3. Remove o-ring from charge pump adapter.
4. Remove outer gerotor ring from either the charge pump adapter or the inner gerotor ring.

NOTE: Refer to "Charge Pump Adapter Assembly" for disassembly and inspection of charge pump adapter assembly.

5. Remove the inner gerotor ring and key from drive shaft or inner gerotor ring and coupler assembly from shaft.
6. Lift endcover straight up off shaft and housing. Remove valve plate from endcover or from rotating kit assembly, still in housing.
7. From endcover, remove bypass valve or plug, and relief valve assemblies. Note: Mark the relief valve in relationship to the cavity it was removed, for reassembly purposes.

Endcover Inspection

- Check the bearing (press fit) in endcover. If needles remain in cage, move freely, and setting is at the dimension shown in Figure 5-153. removal not required.
- Check roll pin in endcover. If tight and set to the dimension shown in Figure 5-153. removal not required.

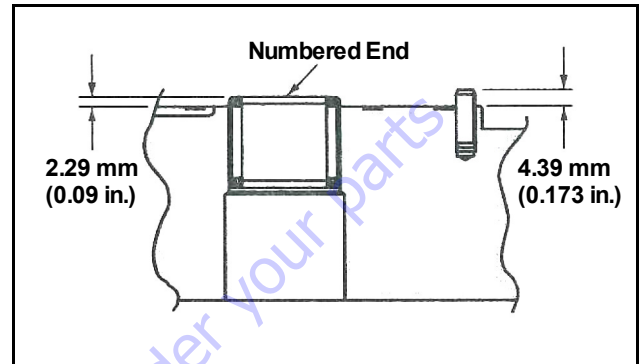

Figure 5-153. Endcover Inspection

1. Remove housing gasket from housing or endcover.
2. With pump still in vise, remove the six Capscrews retaining the manual servo control assembly. Remove the control assembly and control housing gasket from the housing. Remove orifice plates, noting location for reassembly. Remove nut and lock washer from control arm, remove arm. Note position of control arm for reassembly.

NOTE: Refer to "Manual Servo Control Basic Assembly" for disassembly and inspection of control assembly.

3. To remove rotating kit assembly from housing, first remove pump from vise holding the rotating kit assembly in position. Lower pump so that the shaft end (flange end) is up. Set the rear of housing onto table with housing flat and rotating kit assembly at rest on table. (Hole in table, for protruding shaft, is required.) Lift and remove the housing and shaft from rotating kit assembly, and swashplate.
4. Remove swash plate from rotating kit assembly and servo piston follower from swashplate.

NOTE: Refer to "Rotating Kit Assembly" for disassembly and inspection of rotating kit.

Swashplate Inspection

- The finish on the piston shoe surfaces of the swash plate should show no signs of scoring.
 - Inspect swashplate bushing surface for wear and surface for coating transfer from bushing.
1. To remove servo piston assembly from housing, start with the four each Capscrews and washers retaining each cover plate.
 2. In removing the cover plate from the servo piston bolt, remove jam nut, washer, and seal washer. Hold the servo piston bolt with hex key and unscrew cover plate off of bolt.
 3. Remove servo piston assembly and seal sub-assemblies (two sets) from housing.

NOTE: Disassembly of servo piston assembly is not required.

4. Remove retaining ring from the front of housing. Press the shaft, shaft seal or spacer, and washer from housing. Remove retaining ring, thrust washer, thrust bearing, second thrust washer, and second retaining ring from shaft.

Housing Inspection

- Check the bearing (press fit) in housing. If needles remain in cage, move freely, and setting at the dimension shown in Figure 5-154., removal not required.

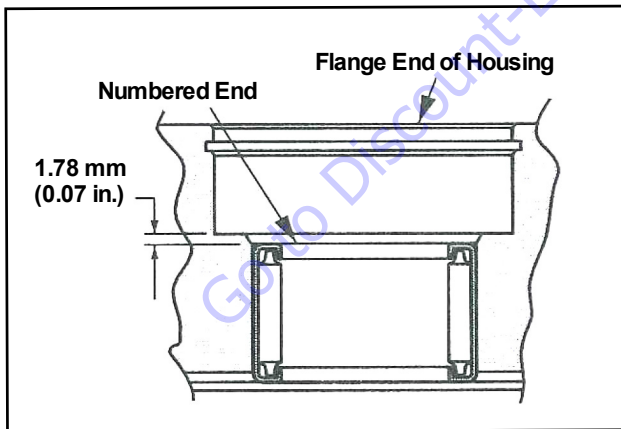

Figure 5-154. Housing Inspection

1. To remove cradle sub-assembly, remove the two Capscrews retaining cradle inside housing. Removing cradle subassembly from housing.
2. Remove button head Capscrews (2 Qty.) to remove bushing from cradle.

Bushing Inspection

- Inspect bushing for contamination embedment within coating of bushing surface coming in contact with swash-plate.
1. Remove all plugs from housing.
 2. Discard the shaft seal, gaskets, and o-rings from all assemblies. Replace with new seals upon reassembly.

ASSEMBLY

1. All parts should be cleaned and critical moving parts lubricated before reassembly.
2. If necessary, press new bearing in housing to dimension shown in Figure 5-154. with the numbered end of bearing outward.
3. Install the two new seal sub-assemblies into the servo piston cavity of housing.
4. Screw the cover plate onto the servo piston assembly. Install new cover plate gasket in place on housing. Install servo piston assembly and cover plate into servo piston bore in right side of housing (as shown in Figure 5-155. Retain cover plate with four each washers and Capscrews. Torque Capscrews 40 to 48 in.lbs (4.5 to 5.4 Nm). To obtain neutral, centering the servo piston assembly is required. Measure in from the left side and set servo piston 0.5 in. (12.7 mm) from surface of housing servo bore as shown in Figure 5-155.

NOTE: Re-adjustment may be required for neutral at unit start-up.

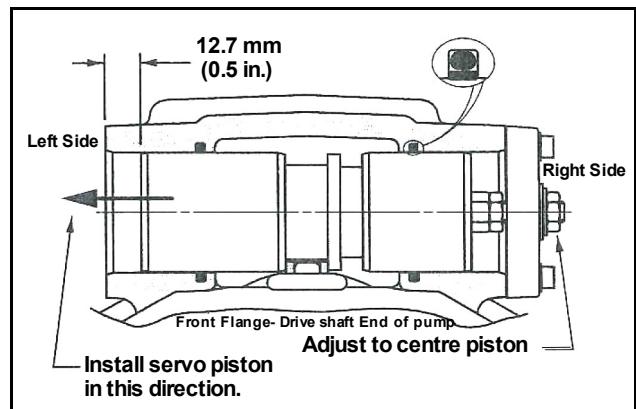

Figure 5-155. Servo Piston Installation

5. Install new seal washer, washer, and jam nut to servo piston bolt. Holding servo piston bolt with hex key wrench Torque jam nut (150 to 160 in.lbs) 17 to 18 Nm. Check the centering of servo piston assembly. Install new cover plate gasket and cover plate to left side of servo piston and retain with four each washers and #10-24 Capscrews. Torque Capscrews 40 to 48 in.lbs (4.5 to 5.4 Nm).

6. To assemble cradle sub-assembly, install bushing onto cradle retaining with button head Capscrews. Torque button head Capscrew 14 to 16 in.lbs (1.6 to 1.8 Nm).
7. Place cradle sub-assembly into housing making sure cradle is completely seated into housing. Retain cradle sub-assembly with two Capscrews. Torque Capscrews 20 to 24 ft.lbs (27 to 33 Nm).
8. To install shaft, place exterior retaining ring, thrust race, thrust bearing, second thrust race, and second retaining ring onto shaft. Position washer and shaft seal or spacer onto shaft.
9. Install shaft assembly into front of housing for units with spacer, retain with interior retaining ring and go on to step 10. For units with shaft seal, seat seal into position with seal driver and retain with interior retaining ring.
10. Install servo piston follower onto swashplate dowel pin. Install swashplate carefully onto bushing (coat bushing surface with hydraulic oil), aligning servo piston follower with slot in servo piston assembly.

NOTE: Refer to "Rotating Kit Assembly" for reassembly of rotating kit assembly.

11. To install rotating kit assembly, leave housing and shaft in the horizontal position. Holding swashplate into position with screw driver thru controller linkage passage-way at the top of housing. place rotating kit assembly over shaft and into housing until pistons are in against swashplate. Make sure all parts are in housing completely and properly positioned. Return the pump to the vise with open end of housing up. clamping housing on the outer portion of the flange.
12. Install gasket on to housing.
13. If necessary, press new bearing and roll pin in endcover to dimension shown in figure 1-3. Bearing installed with the numbered end outward. Roll pin installed with split oriented away from bearing.
14. Install new o-ring on relief valves. Install relief valve in its original cavity in endcover that it was removed. Torque 100 to 110 ft.lbs (136 to 149 Nm).
15. Install new o-ring on bypass valve or plug. Install bypass valve or plug into endcover. Note: Make sure paddle of bypass valve is perpendicular to relief valve axis prior to installing or damage could result.
16. Apply a small amount of petroleum jelly to the steel side of valve plate to hold in place for installation. Aligning the index pin, place the valve plate in position onto the endcover, with steel side against endcover.
17. Install endcover assembly onto housing assembly. Make sure ports are positioned correctly, valve plate and gasket stay in place.

18. Install key and inner ring gerotor onto shaft or coupler assembly. Lubricate inner ring gerotor.

NOTE: Refer to "Charge Pump Adapter Assembly" for assembly of charge relief valve in adapter plate.

19. Install o-ring and outer ring gerotor onto adapter plate. Lubricate both a-ring and outer ring to hold in position during assembly of adapter plate. Install adapter plate onto endcover. Make sure o-ring and gerotor ring stay in place.
20. Retain endcover and adapter plate (when used) with four Capscrews, Torque 27 to 31 ft.lbs (37 to 42 Nm).

NOTE: Refer to "Manual Servo Control Basic Assembly" for reassembly of manual servo control assembly.

21. Install control housing gasket onto housing. Install orifices into control assembly and retain in position with petroleum jelly. Position the feedback link at 90 degrees from control housing. Install manual servo control assembly onto housing making sure feedback link entered small groove in servo piston assembly.
22. Retain control assembly with six Capscrews, torque 40 to 48 in.lbs (4.5 to 5.4 Nm).
23. Install control arm onto control assembly input arm. Retain with lock washer and nut, torque 4 to 6 ft.lbs (5 to 8 Nm).
24. Install new o-rings on all plugs. Install plugs into housing. Torque 3/4 in. plug 21 to 24 ft.lbs (28 to 32 Nm). Torque 1-1/4 in. plug 40 to 45 ft.lbs (54 to 61 Nm).
25. Refer to "Start-up Procedure".

Charge Pump Adapter Assembly

DISASSEMBLY

1. Remove plug, shims, spring, and poppet from adapter assembly as shown in Figure 5-157.

Inspection

- Inspect the charge pump relief valve seat inside the charge pump adapter. Check to insure that seat is smooth and free of burrs or other defects.
- Inspect the charge pump relief valve spring.
- Inspect the bearing or bushing inside the charge pump adapter. The bearing needles must remain in the bearing cage and bearing at dimension shown in Figure 5-156. The bushing must have no excessive scoring.
- Inspect the gerotor pocket inside the charge pump adapter assembly. It should not be scored excessively.

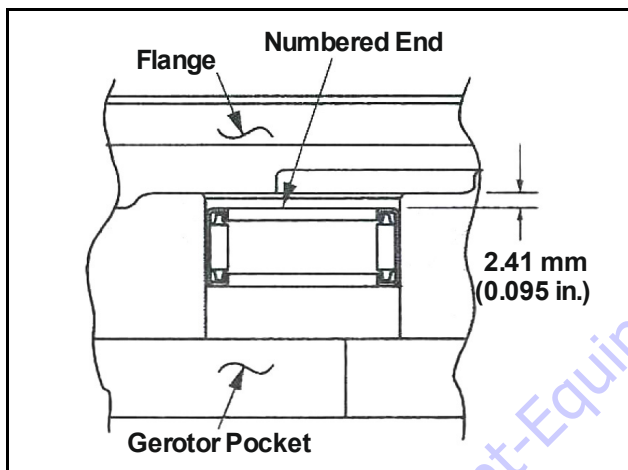
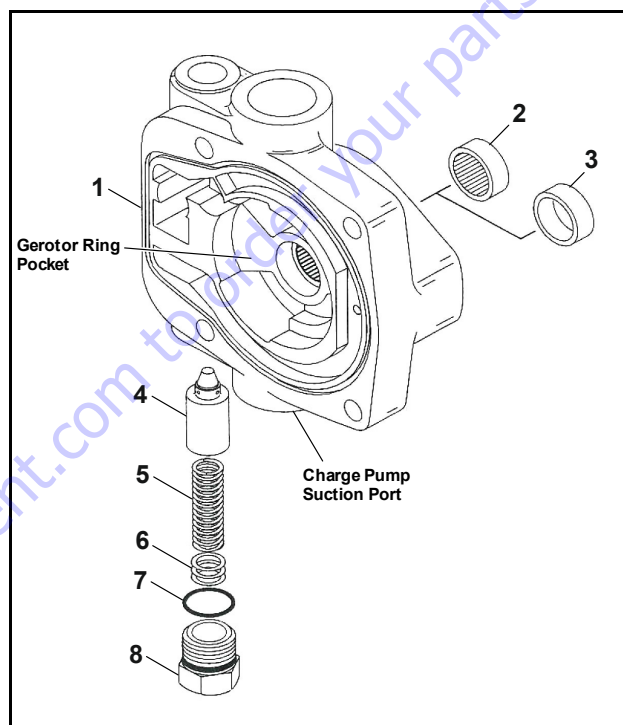

Figure 5-156. bearing or bushing inspection

ASSEMBLY

1. If necessary, press new bearing or bushing in adapter assembly. The bearing to dimension shown in Figure 5-156. with the numbered end of bearing outward and closest to mounting flange. The bushing is to be pressed flush to 0.254 mm [0.010 in.] recessed.
2. Install poppet, spring, shims, new o-ring on plug, and plug into adapter assembly. Torque plug 30 to 27 ft.lbs. (40.7 to 36.6 Nm).



- | | |
|------------------------|-----------|
| 1. Charge Pump Adapter | 5. Spring |
| 2. Bearing | 6. Shims |
| 3. Bushing | 7. O-ring |
| 4. Poppet | 8. Plug |

Figure 5-157. Charge Pump Adapter Assembly

Manual Servo Control Basic Assembly

DISASSEMBLY

1. Remove wiper seal with screw driver. Remove set screw retaining input shaft and remove input shaft from control housing.
2. Remove set screw from plug retaining valve spool and remove plug.
3. Remove E-ring from pin retaining feedback link and valve spool. Remove pin, feedback link, valve spool, and bell crank from control housing.
4. Compress spring and remove E-ring, spring retainer, spring, and second spring retainer from valve spool.
5. Remove o-rings from plug and input shaft. Clean all parts and lubricate in prep for reassembly.

ASSEMBLY

1. Install spring retainer, spring, and second spring retainer onto spool. Compress spring with retainer and retain with E-ring onto valve spool.

2. Install valve spool into control housing making sure that metering notches on valve spool can be seen in the metering ports. Notches shown in Figure 5-158.
3. Position bell crank in housing. Slide feedback link into position between clevis on valve spool, aligning holes, and install dowel pin retaining with E-ring.
4. Install new o-ring onto input shaft. Hold bell crank in position with feedback link slot and align splined hole of bell crank with input shaft cavity. Install input shaft into control housing and bell crank.
5. JLG Threadlocker P/N 0100011 or equivalent to set screw and install, retaining input shaft. Adjust set screw until it bottoms out on input shaft and back out one-quarter turn.
6. Install wiper seal on input shaft as shown in Figure 5-158. Install new o-ring onto plug, retaining valve spool, and install plug. Adjust plug until there is no play in the valve spool with input shaft held stationary. Lock in place with set screw. Torque set screw 17 to 25 in.lbs (2 to 3 Nm).

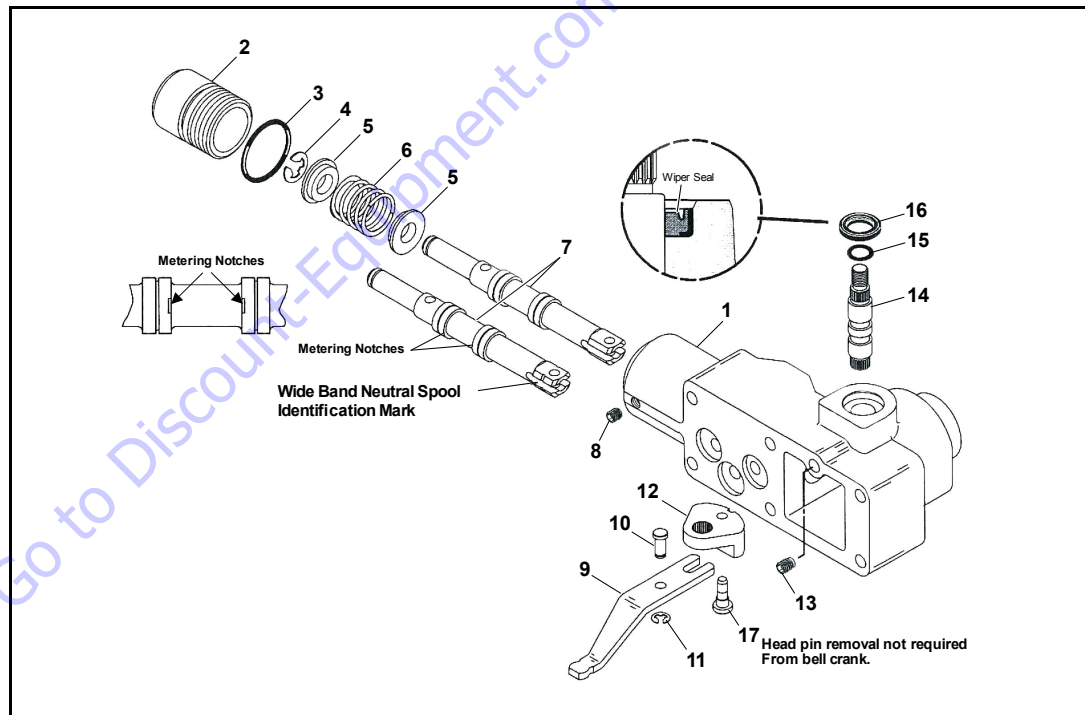

- | | | | |
|--------------------|---------------------------|--------------------|-----------------|
| 1. Control Housing | 6. Spool Centering Spring | 10. Dowel Pin | 14. Input Shaft |
| 2. Plug | 7. Valve Spool | 11. Retaining Ring | 15. O-ring |
| 3. O-ring | 8. Set Screw | 12. Bell Crank | 16. Wiper Seal |
| 4. Retaining Ring | 9. Feedback Link | 13. Set Screw | 17. Head Pin |
| 5. Spring Retainer | | | |

Figure 5-158. Manual Servo Control Basic Assembly

Manual Servo Control Assembly Options

DISASSEMBLY - DESTROKE VALVE ASSEMBLY OPTION

1. Remove the two Capscrews and lock washers from manifold. Removing destroke valve assembly and two a-rings.
2. Remove destroke valve from manifold in order to remove o-rings and backup washers. Note: in order to remove destroke valve the solenoid may need to be removed from core first (not shown).

ASSEMBLY - DESTROKE VALVE ASSEMBLY OPTION

1. Install new o-rings and backup washers onto destroke valve.
2. Install destroke valve into manifold by hand until top o-ring is met by manifold. Then wrench tighten to 25 ft.lbs. (34 Nm) max. Loosen Nut retaining coil to reposition if necessary and re-torque 4 to 5 ft.lbs. (5.4 to 7 Nm).
3. Lubricate the two o-rings and install onto manifold. Install destroke valve assembly onto control assembly. Retain with lock washers and Capscrews. Torque 2.2 to 2.6 ft.lbs. (3 to 3.5 Nm).

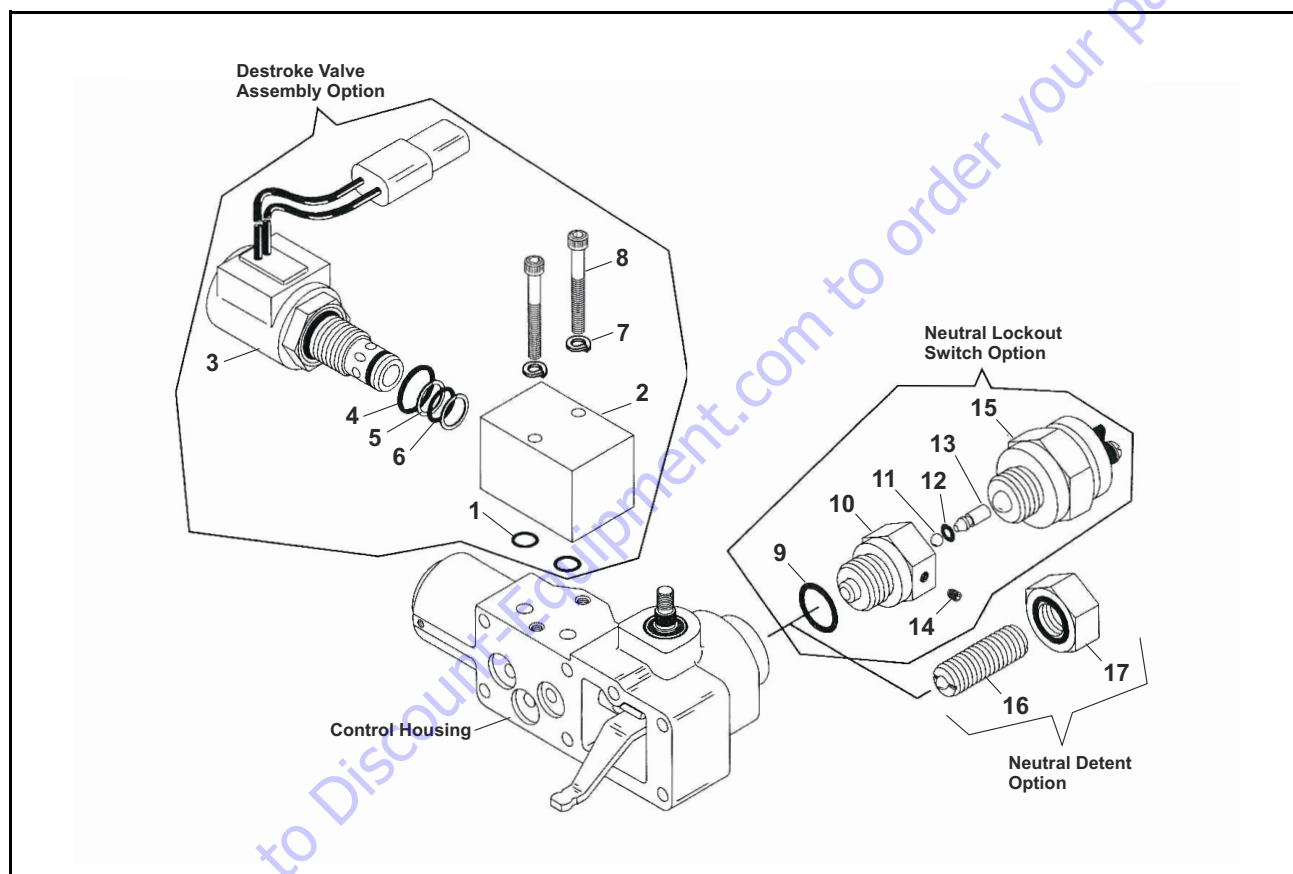

- | | | | |
|-------------------|----------------|-----------------------------|----------------------------|
| 1. O-ring | 6. O-ring | 10. Neutral Lockout Adapter | 14. Set Screw |
| 2. manifold | 7. Lock Washer | 11. Ball | 15. Neutral Lockout Switch |
| 3. Destroke Valve | 8. Capscrew | 12. O-ring | 16. Ball Plunger |
| 4. O-ring | 9. O-ring | 13. Pin | 17. Nut Seal |
| 5. Backup Washer | | | |

Figure 5-159. Manual Servo Control Basic Assembly Option

DISASSEMBLY - NEUTRAL LOCKOUT SWITCH ASSEMBLY OPTION

1. Loosen set screw in adapter and remove neutral lockout switch from adapter.
2. Remove neutral lockout adapter from control assembly.
3. Remove pin, ball, and a-rings from adapter.

ASSEMBLY - NEUTRAL LOCKOUT SWITCH ASSEMBLY OPTION

1. Install new a-ring onto adapter and new o-ring onto pin.
2. Install ball and pin into adapter. Lubricate with petroleum jelly to hold in place during installation.
3. Install adapter into control assembly. Torque 44 to 53 ft.lbs. (60 to 70 Nm).
4. Apply Loctite #222 or equivalent to threads of switch and install neutral lockout switch into adapter. The adjustment procedures for the switch are as follows.
 - a. Install switch, while moving control arm back and forth, until "detent" action is detected. Back out the switch until the "detent" action is very slight.
 - b. Obtain a test light or use a multimeter. Attach the leads from the test light to the switch or the wiring connector.
 - c. Move the control arm out of the detent position. The test light will go on. Screw in the switch until the light goes off. Mark this as position "A". See Figure 5-160. Move the control arm to the detent position and the test light should come back on.
 - d. Leaving the control arm in the detent position, the light will remain on. Screw in the switch until the light goes off. Mark this position "B".
 - e. Unscrew the switch one third of the distance between "B" and "A". Install and tighten the hex socket head set screw in one of the main quadrants of the hex of the switch adapter. See Figure 5-160. Torque set screw 2.3 to 2.8 in.lbs (3.2 to 3.8 Nm).
5. Test the switch by moving the control arm to the detent position, the light should be on. Move the control arm out of detent, the light should go off.
6. Remove test light and put servo control assembly into operation.

DISASSEMBLY - NEUTRAL DETENT OPTION

1. Loosen seal nut and remove ball plunger from control housing.

ASSEMBLY- NEUTRAL DETENT OPTION

1. Install ball plunger into control housing until contact with bell crank detent is detected. After contact screw in 1/2 turn and retain with seal nut. Torque nut 10 to 22 ft.lbs. (14 to 30 Nm).

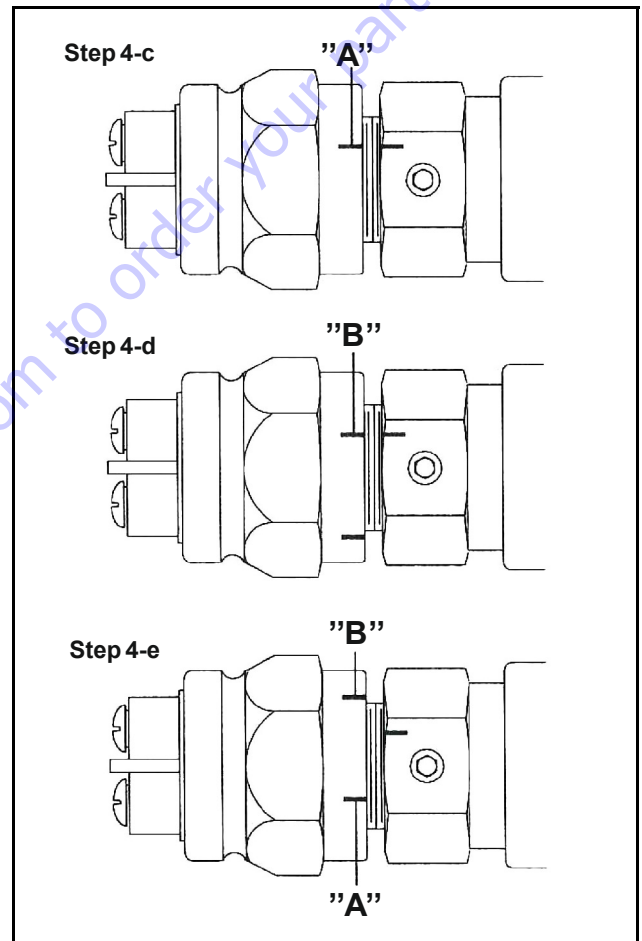

Figure 5-160. Neutral Lockout Switch Assembly

Rotating Kit Assembly

DISASSEMBLY

Disassembly of rotating assembly is required for inspection only.

1. Remove the nine piston assemblies, shoe retainer, and shoe retainer pivot from cylinder barrel.

Inspection

- Examine the O.D. of the pistons for finish condition. They should not show wear or deep scratches. Inspect the shoes for a snug fit on the ball end of the pistons and a flat smooth surface that comes in contact with the swashplate. **Do not lap piston shoes.**
 - Examine the shoe retainer for wear in the pivot area.
 - Examine the pivot to insure smoothness and no signs of wear.
 - Inspect the cylinder barrel surface that makes contact with valve plate. This surface should be smooth and free of deep scratches. Do not lap piston block.
 - The pistons should move freely in the cylinder barrel bore. If they are sticky in the bore, examine the bore for scoring or contamination.
2. To inspect pins and spring caution should be taken in removing spring. The spring is highly compressed and the retaining ring should not be removed without compressing the spring safely.

The following parts are required to disassemble the cylinder barrel:

- 2 ea. 3/8 in. I.D. x 1-1/8 in. O.D. flat washers
- 1 ea. 3/8 in. x 3-1/4 in. N.C. Capscrew, and
- 1 ea. 3/8 in. N.C. nut

To remove spring, place one of the flat washers over the 3/8 in. x 3-1/4 in. Capscrew. Put Capscrew through the center of the cylinder barrel and apply the second washer. Let washer rest on the three pins and retain with nut. Turning nut and compressing spring inside the barrel. Use a pair of retaining ring pliers and remove the internal retaining ring. Remove nut, bolt, and the two washers from barrel. Remove the washer, spring, second washer, three pins, and pin keeper at the same time.

ASSEMBLY

1. To reassemble the rotating kit assembly complete the following: Compress the pin keeper and install in the spline of the cylinder barrel. Install the three pins with head end to the inside of the barrel and position in the special grooves of the cylinder barrel spline.
2. Install the washer, spring, and second washer into the cylinder barrel. Use the two 3/8 in. I. D. washers, nut, and 3/8 in. x 3-1/4 in. Capscrew to compress the spring and retain with retaining ring. Remove the nut, Capscrew, and the two washers.
3. Install the pivot onto the three pins, shoe retainer on the pivot, and piston assemblies thru the shoe retainer and into cylinder barrel. resting on shoe retainer.

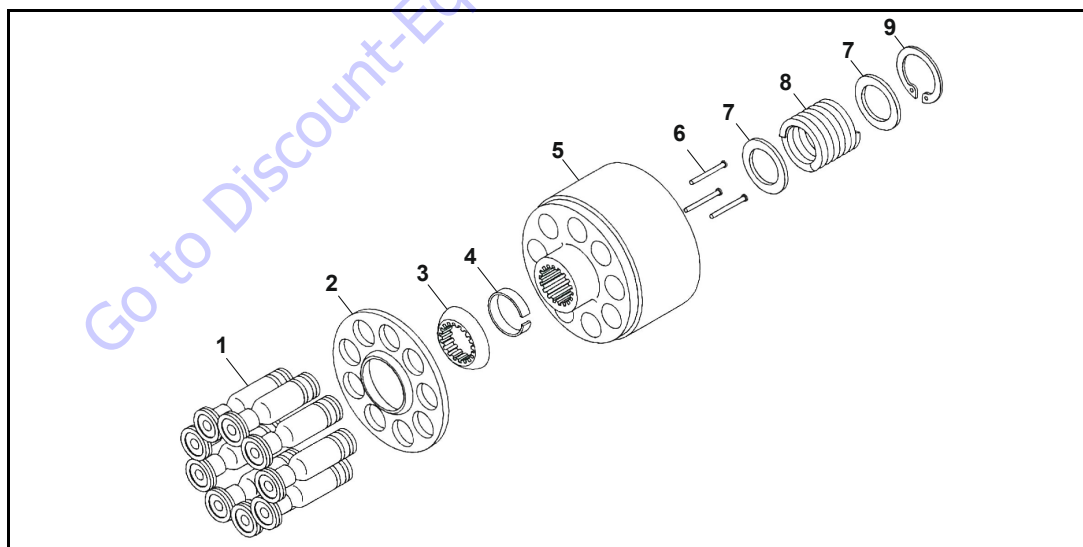

- | | | | |
|------------------------|--------------------|-----------|-------------------|
| 1. Piston assemblies | 4. Retainer | 6. Pins | 8. Spring |
| 2. Shoe Retainer | 5. Cylinder Barrel | 7. Washer | 9. Retaining Ring |
| 3. Shoe Retainer Pivot | | | |

Figure 5-161. Rotating Kit Assembly

Fault-logic Trouble Shooting

Match the transmission symptoms with the problem statements and follow the action steps shown in the box diagrams. This will give expedient aid in correcting minor problems eliminating unnecessary machine down time.

Following the fault - logic diagrams are diagram action comments of the action steps shown in the diagrams. Where applicable, the comment number of the statement appears in the action block of the diagrams.

RECOMMENDED GAUGE LOCATIONS

Gauges Recommended

Inlet vacuum gauge: 30 PSI to 14.8 PSI (2 bar to 1 bar)

System pressure gauge: 10,000 PSI (700 bar)

Charge pressure gauge: 0 to 600 PSI (0 to 50 bar)

Case pressure gauge: 0 to 300 PSI (0 to 25 bar)

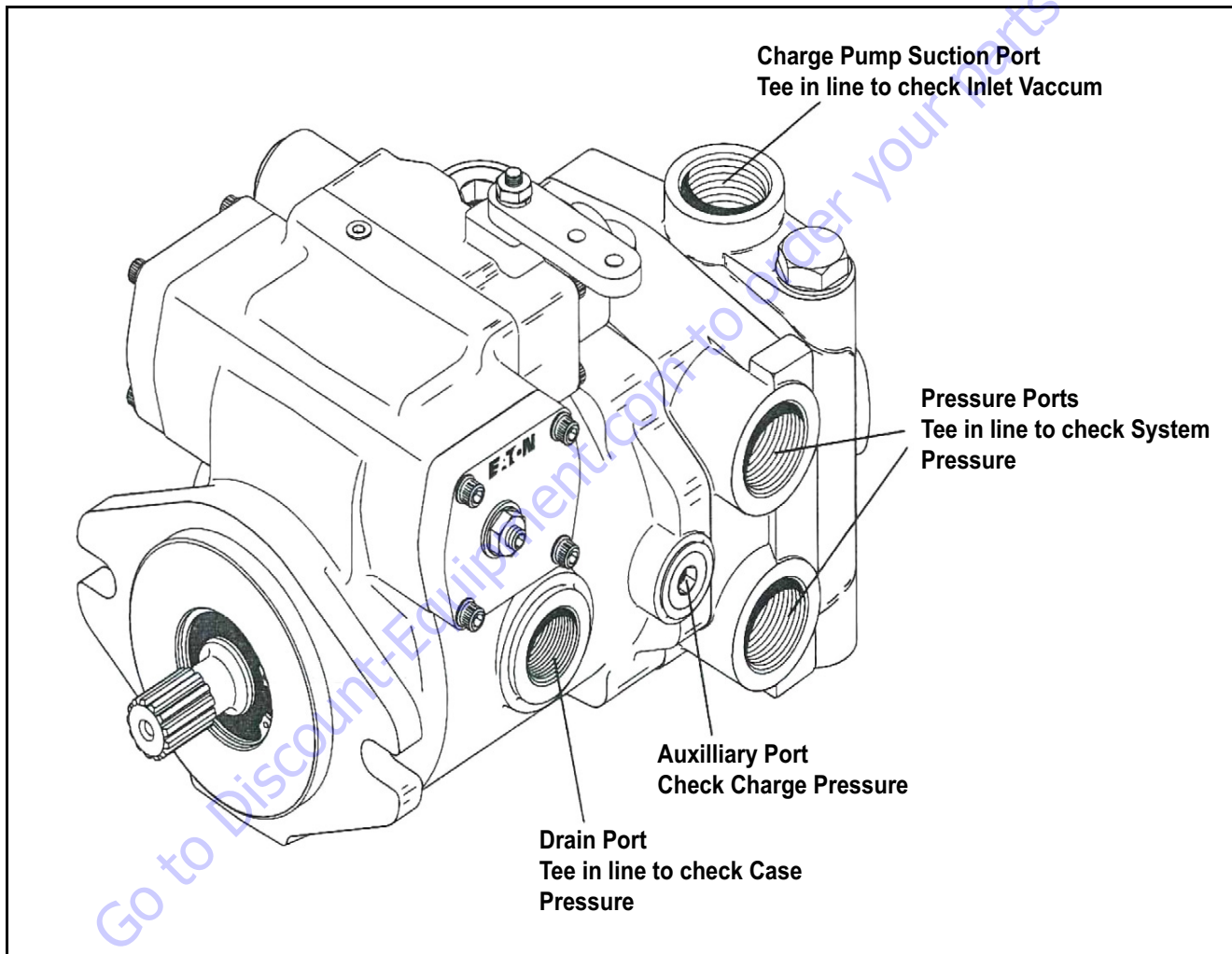

Figure 5-162. Gauge Locations

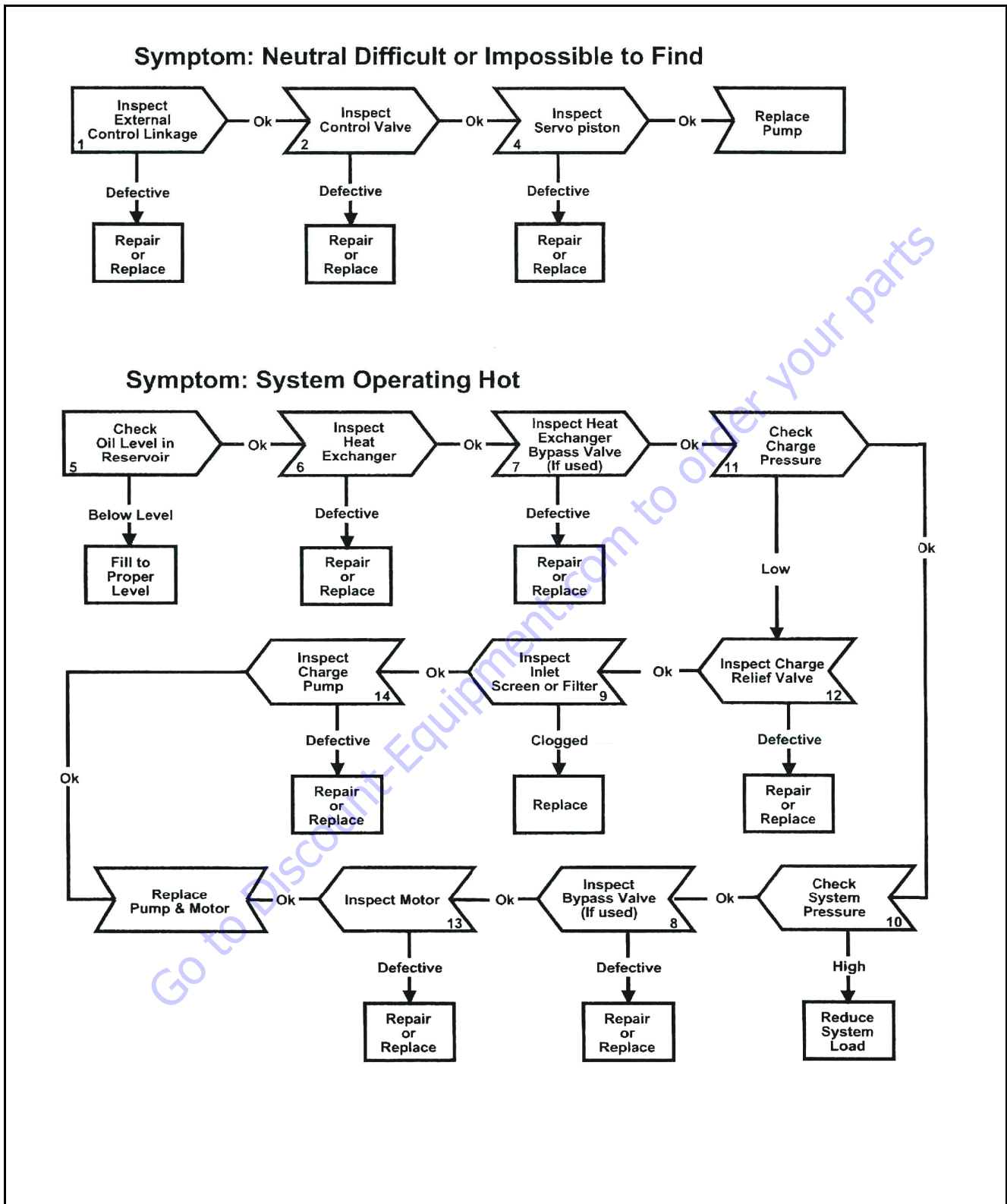

Figure 5-163. Fault-logic Troubleshooting

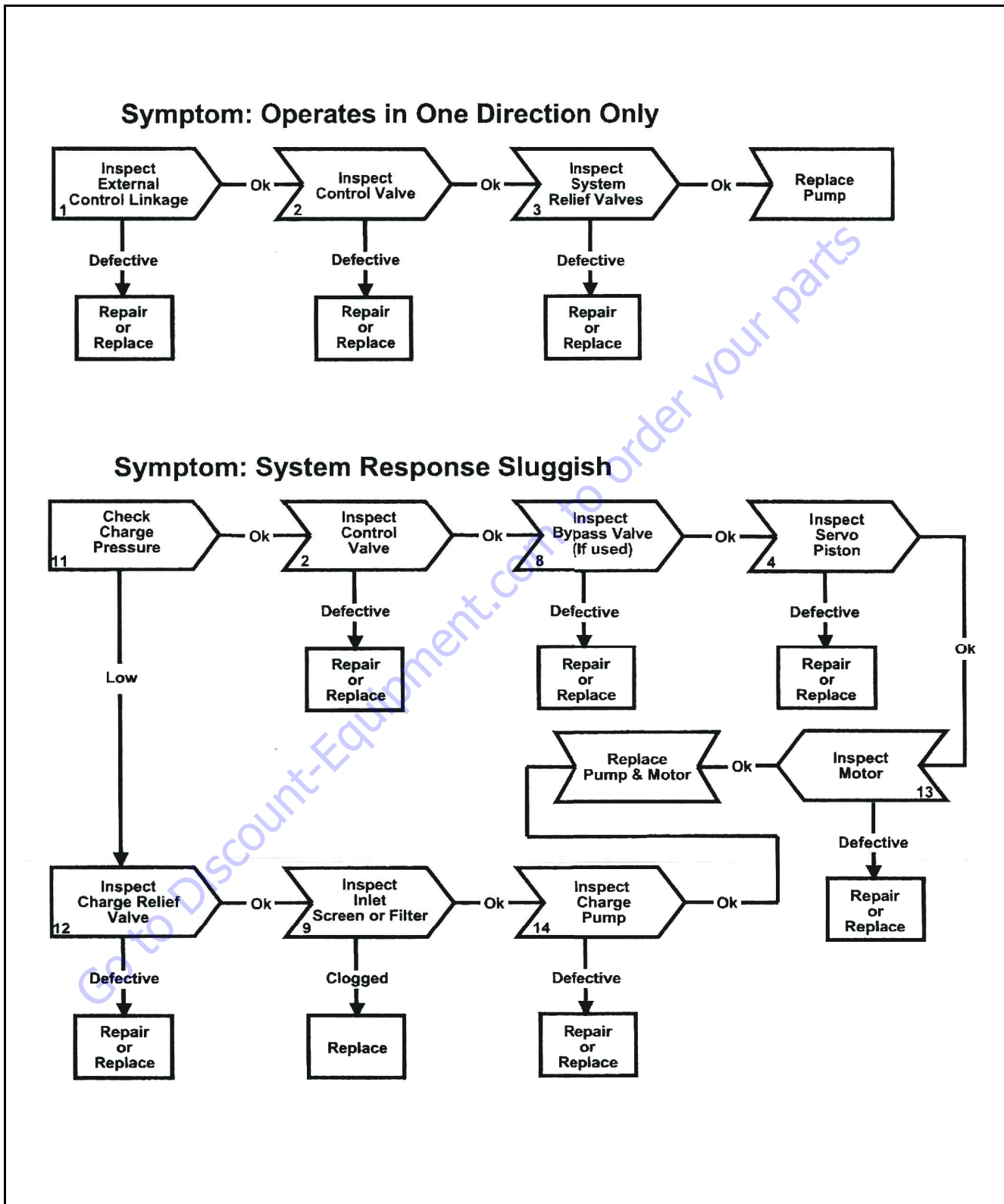

Figure 5-164. Fault-logic Troubleshooting

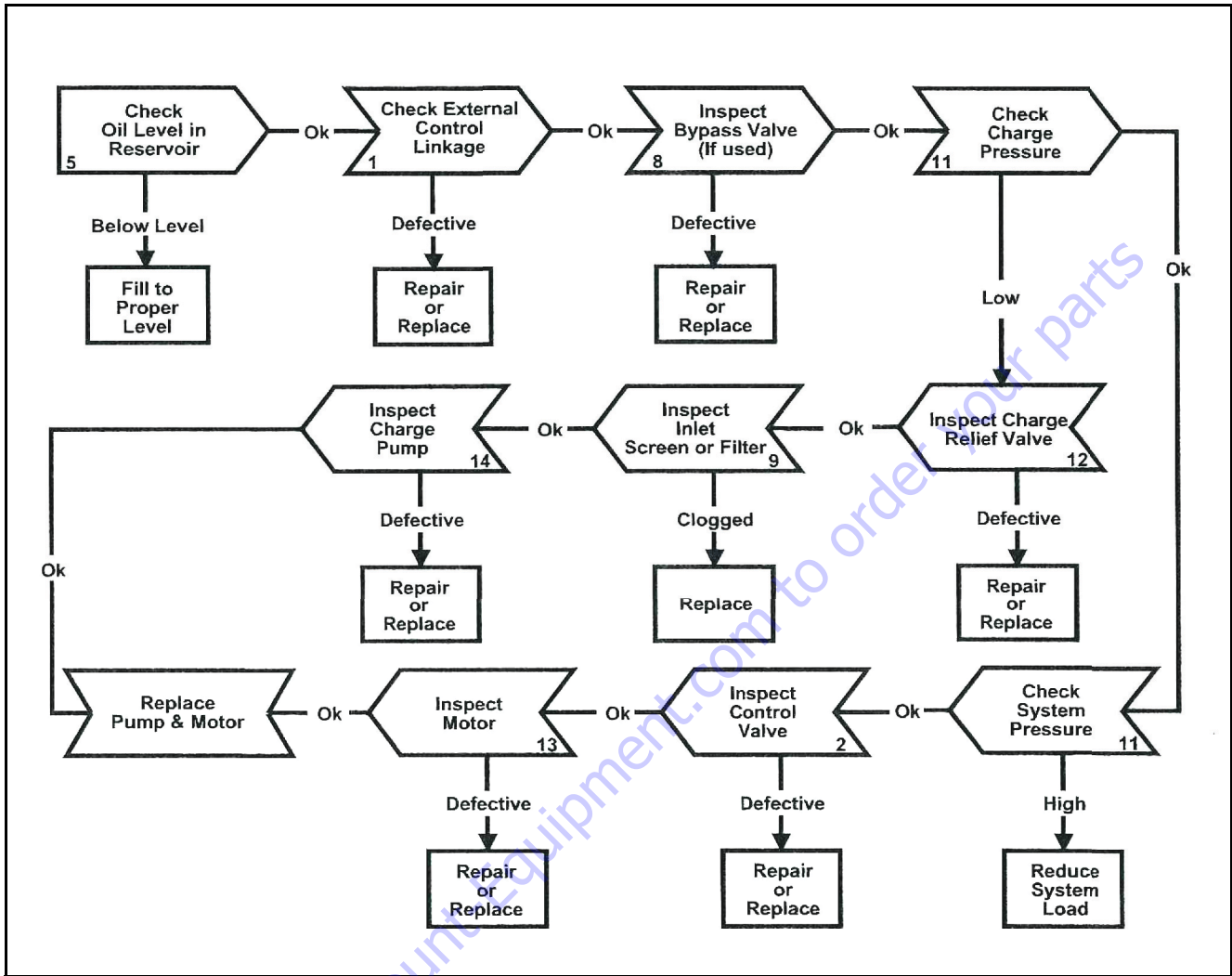

Figure 5-165. Fault-logic Troubleshooting

DIAGRAM ACTION STEP COMMENTS

- 1. Inspect External Control Linkage for:**
 - a. Misadjusted or disconnected
 - b. Binding, bent or broken
- 2. Inspect Control Valve for:**
 - a. Plugged control orifice(s)
 - b. Damaged mounting gasket
 - c. Misadjusted, damaged or broken neutral return spring
 - d. Broken control connector pin
 - e. Faulty destroke valve (if used)
 - f. Galled or stuck control spool
 - g. Neutral detent or lockout switch misadjusted (if used)
- 3. Inspect System Relief Valves for:**
 - a. Improper pressure relief setting
 - b. Damaged or broken spring
 - c. Valve held off seat
 - d. Damaged valve seat
- 4. Inspect Servo Piston for:**
 - a. Misadjusted, damaged or broken neutral return spring assembly
 - b. Galled or stuck servo piston
 - c. Damaged or missing o-ring and/or backup ring
- 5. Check Oil Level in Reservoir:**
 - a. Consult owner/operators manual for the proper type fluid and level
- 6. Inspect Heat Exchanger for:**
 - a. Obstructed air flow (air cooled)
 - b. Obstructed water flow (water cooled)
 - c. Improper plumbing (inlet to outlet)
 - d. Obstructed fluid flow
- 7. Inspect Heat Exchanger Bypass Valve for:**
 - a. Improper pressure adjustment
 - b. Stuck or broken valve
- 8. Inspect Bypass Valve for: (if used)**
 - a. Held in a partial or full open position
- 9. Inspect Inlet Screen or Filter for:**
 - a. Plugged or clogged screen or filter element
 - b. Obstructed inlet or outlet
 - c. Open inlet to charge pump

10. Check System Pressure:

- a. See Figure 5-162. for location of pressure gauge installation
- b. Consult owner/operators manual for maximum system relief valve settings

11. Check Charge Pressure:

- a. See Figure 5-162. for location of charge pressure gauge installation
- b. Consult owner/operators manual for maximum charge relief valve settings

12. Inspect Charge Relief Valve for:

- a. Improper charge relief pressure setting
- b. Damaged or broken spring
- c. Poppet valve held off seat

13. Inspect Motor for:

- a. Consult owner/operator manual for motor operation and trouble shooting

14. Inspect Charge Pump for:

- a. Broken or missing drive key
- b. Damaged or missing o-ring
- c. Excessive gerotor clearance
- d. Galled or broken gerotor set

System/Charge Relief Valve Pressure Settings

Inlet Vacuum	2.94 PSI (0.203 bar) max.
Case Pressure	25 PSI (1.7 bar) maximum
Charge Pressure	250 to 300 PSI (17.24 to 20.68 bar)
System Pressure	5000 PSI (345 bar) maximum 3000 PSI (207 bar) continuous

The high pressure relief valves are all factory preset and cannot be readjusted.

The pressure setting is stamped on each valve with a three digit number. To identify, multiply the noted number by 10 to get the valves pressure setting.

Example: 10 x 500 = 5000 PSI (345 bar)

Start-up Procedure

When initially starting a new or a rebuilt transmission system, it is extremely important that the start-up procedure be followed. It prevents the chance of damaging the unit which might occur if the system was not properly purged of air before start-up.

1. After the transmission components have been properly installed, fill the servo pump housing at least half full with filtered system oil. Connect all hydraulic lines and check to be sure they are tight.
2. Install and adjust all control linkage.
3. Fill the reservoir with an approved oil that has been filtered through a 10 micron filter. Refer to Eaton Hydraulics Technical Data sheet number 3-401 titled Hydraulic Fluid Recommendations.
4. Gasoline or L.P. engines: remove the coil wire and turn the engine over for 15 seconds. Diesel engines: shut off the fuel flow to the injectors and turn the engine over for 15 seconds.
5. Replace the coil wire or return the fuel flow to the injectors. Place the transmission unit in the neutral position, start the engine and run it at a low idle. The charge pump should immediately pick up oil and fill the system. If there is no indication of fill in 30 seconds, stop engine and determine the cause.
6. After the system starts to show signs of fill, slowly move pump swashplate to a slight cam angle. Continue to operate system slowly with no load on motors until system responds fully.
7. Check fluid level in the reservoir and refill if necessary to the proper level with an approved filtered oil.
8. Check all line connections for leaks and tighten if necessary.
9. The machine is now ready to be put into operation.
10. Frequent filter changes are recommended for the first two changes after placing the machine back into operation. Change the first filter in 3-5 hours and the second at approximately 50 hours. Routinely scheduled filter changes are recommended for maximum life of the hydraulic system.

Go to Discount-Equipment.com to order your parts

This Page Left Blank Intentionally

5.9 HYDRAULIC SCHEMATIC

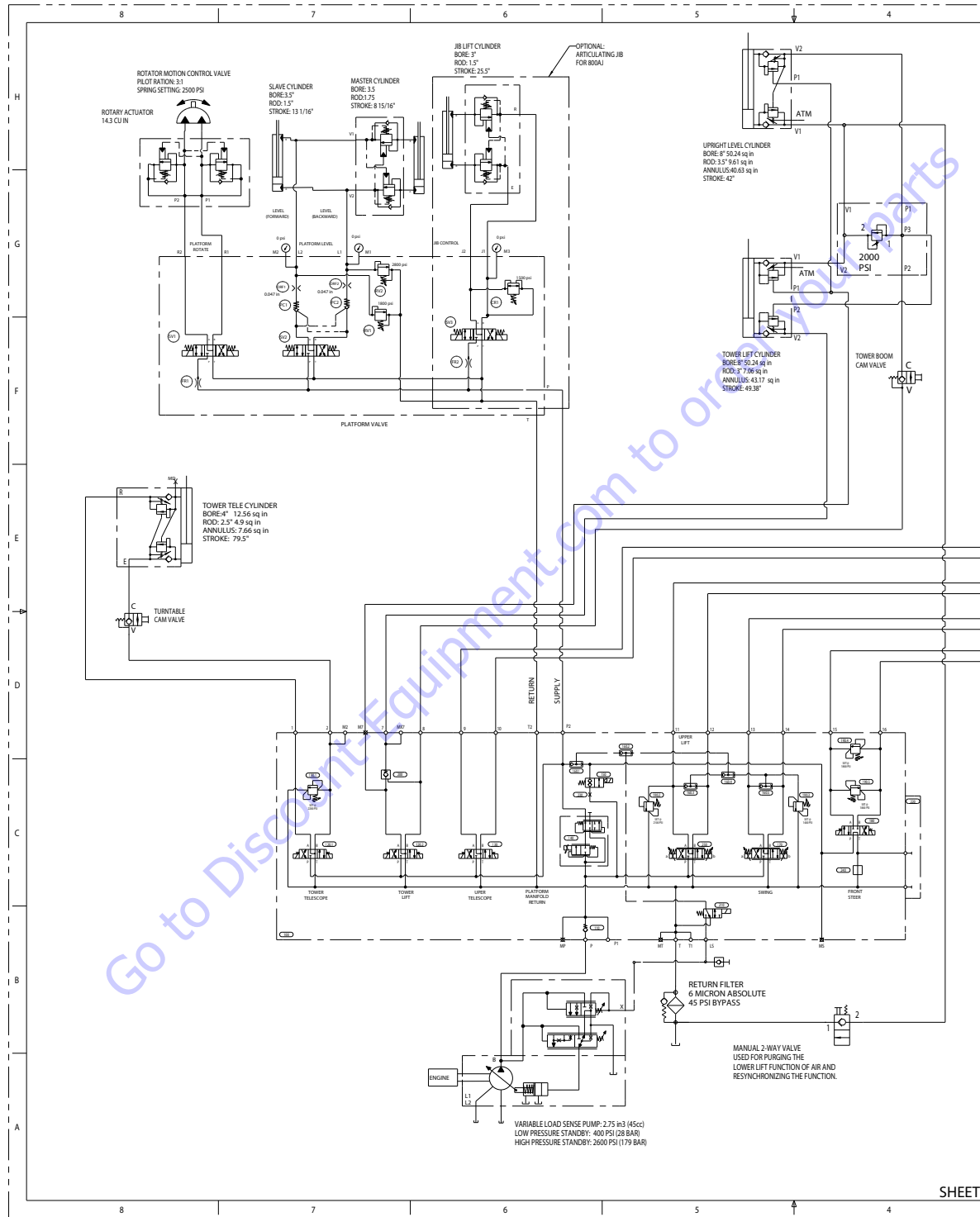

Figure 5-166. Hydraulic Schematic - Sheet 1 of 4

SECTION 5 - BASIC HYDRAULIC INFORMATION & HYDRAULIC SCHEMATICS

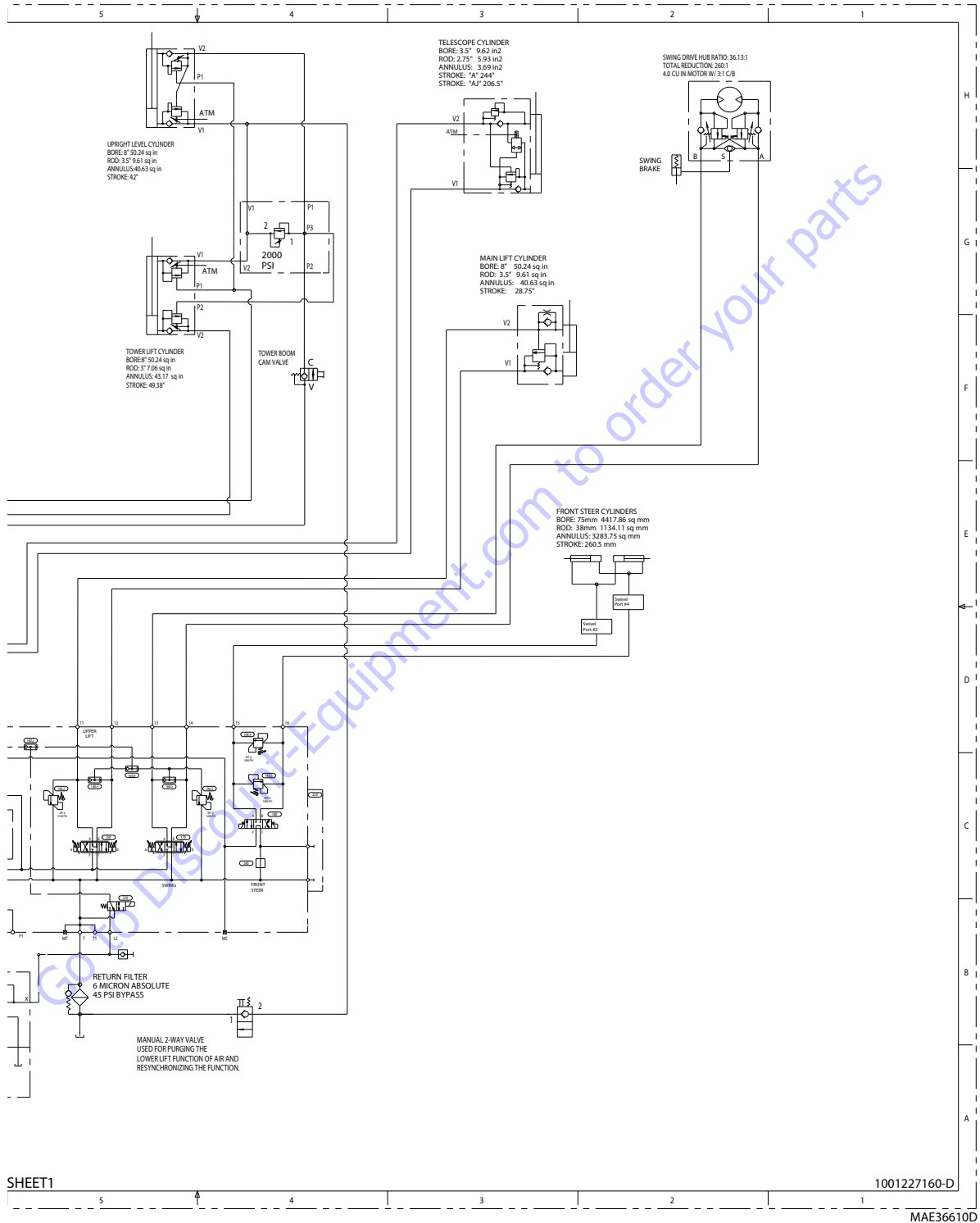

Figure 5-167. Hydraulic Schematic - Sheet 2 of 4

SECTION 5 - BASIC HYDRAULIC INFORMATION & HYDRAULIC SCHEMATICS

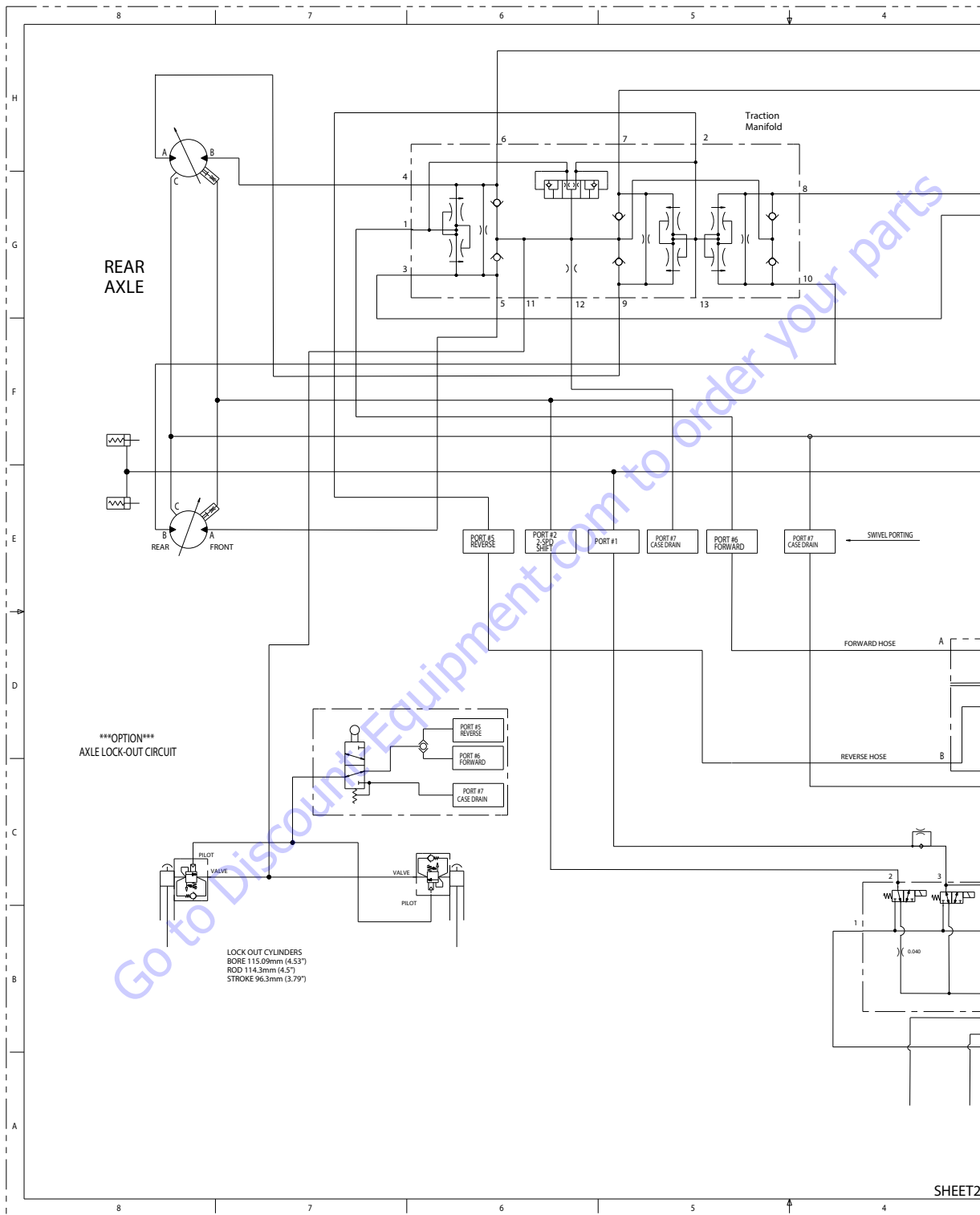
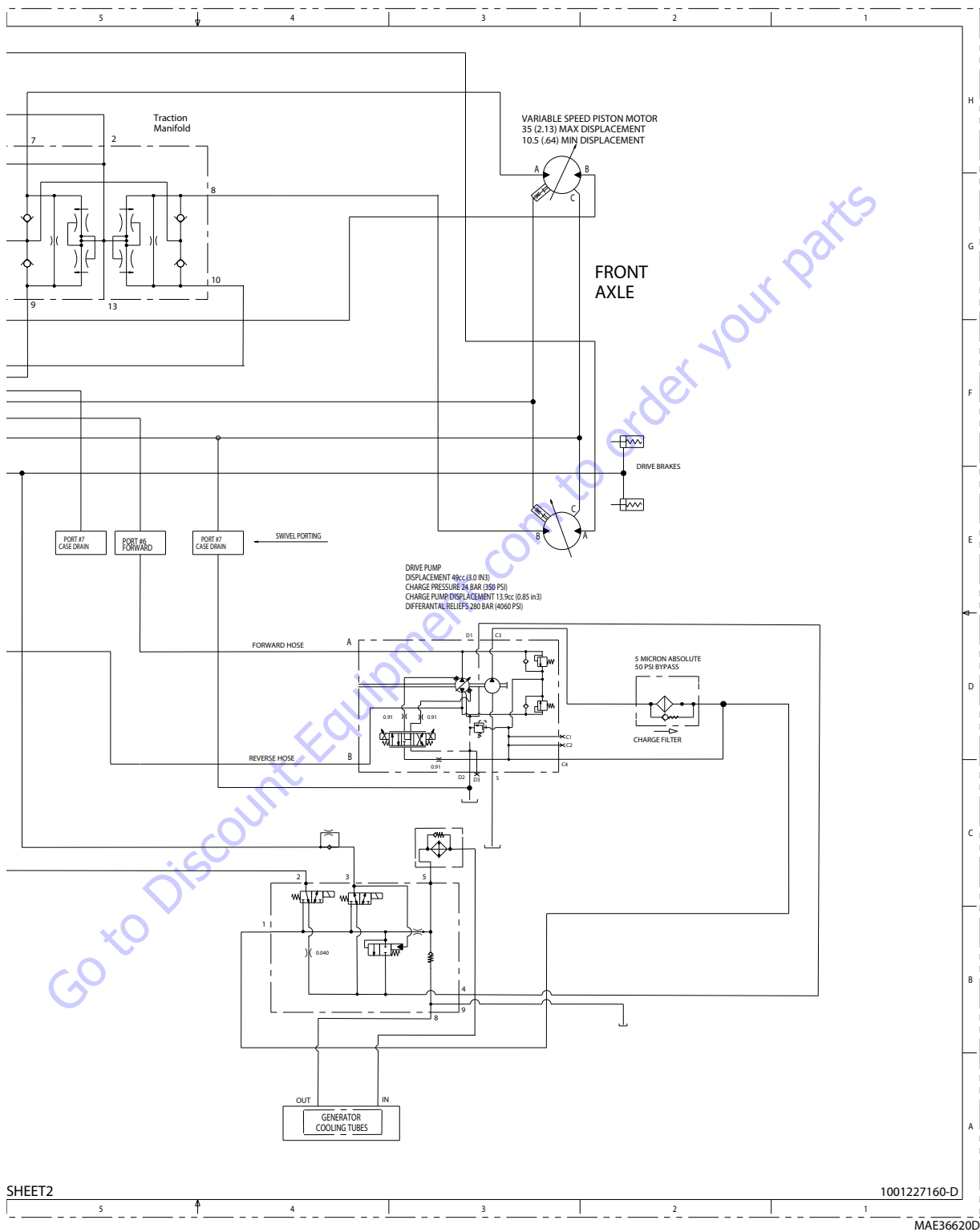

Figure 5-168. Hydraulic Schematic - Sheet 3 of 4

SECTION 5 - BASIC HYDRAULIC INFORMATION & HYDRAULIC SCHEMATICS



SHEET2

1001227160-D

MAE36620D

Figure 5-169. Hydraulic Schematic - Sheet 4 of 4

SECTION 6. JLG CONTROL SYSTEM

6.1 INTRODUCTION

NOTICE

THIS MACHINE IS POWERED BY AN 84VDC (NOMINAL) ELECTRICAL SYSTEM THAT CAN RANGE UP TO 105VDC DURING NORMAL OPERATION, AND BY A 48VAC (NOMINAL) ELECTRICAL MOTOR SYSTEM THAT CAN RANGE UP TO 60VAC. BASED ON EMPLOYER, LOCAL, AND GOVERNMENTAL REGULATIONS AS THEY PERTAIN TO THIS MACHINE, SPECIFIC ELECTRICAL TRAINING AND CERTIFICATIONS MAY BE REQUIRED BEFORE SERVICING OR TROUBLESHOOTING.

The machine has two separate battery systems, 12 Volt and 84 Volt.

The 12 Volt system powers the control modules (e.g., UGM), hydraulic valves, clutch actuation, fans, and the engine start/alternator system.

The 84 Volt system powers the Integrated Motor Generator (IMG) and the mobile battery charging system, which includes the battery boxes, IMG control enclosure, 84V/12V DC/DC converter. The two battery chargers are powered by AC mains power in the range 85-245 VAC, 45-65 Hz.

The JLG designed Control System is the 12 volt based control system installed on the boom lift and includes Universal Ground Module (UGM), Platform and HEC modules.

The JLG Control System provides simplicity in viewing and adjusting the various personality settings for smooth control of: acceleration, deceleration, creep, min speed, and max.-speed for all boom, drive, and steering functions.

The main lift, swing, and drive are controlled by individual joysticks, with steering being controlled by a rocker switch built into the top the drive joystick. To activate Drive, Lift, and Swing simply pull up on the slide lock location on the joystick and move the handle into the direction desired.

The control system will control the voltage output to the valves and pump, as programmed for smooth operation and maximum cycle time. Ground control speeds for all boom functions can also be programmed into the control system.

The JLG Control System ground control module has a built in LED to indicate any faults. The system stores recent faults which may be accessed for troubleshooting. Optional equipment may be added later but must be programmed into the control system when installed.

The HEC module is responsible for commanding Hybrid control functions and processing Hybrid related feedback signals.

6.2 JLG CONTROL SYSTEM ANALYZER KIT INSTRUCTIONS

NOTICE

WHEN INSTALLING A NEW POWER MODULE CONTROLLER ON THE MACHINE, IT WILL BE NECESSARY TO PROGRAM THE CONTROLLER FOR THE PROPER MACHINE CONFIGURATION, INCLUDING OPTIONS.

NOTICE

IT IS A GOOD PRACTICE TO AVOID PRESSURE-WASHING ELECTRICAL/ELECTRONIC COMPONENTS. SHOULD PRESSURE-WASHING BE UTILIZED TO WASH AREAS CONTAINING ELECTRICAL/ELECTRONIC COMPONENTS, JLG INDUSTRIES, INC. RECOMMENDS A MAXIMUM PRESSURE OF 750 PSI (52 BAR) AT A MINIMUM DISTANCE OF 12 INCHES (30.5 CM) AWAY FROM THESE COMPONENTS. IF ELECTRICAL/ELECTRONIC COMPONENTS ARE SPRAYED, SPRAYING MUST NOT BE DIRECT AND BE FOR BRIEF TIME PERIODS TO AVOID HEAVY SATURATION.

The Control System may be accessed utilizing a custom designed, hand held analyzer (Analyzer Kit, JLG part no. 2901443) which will display two lines of information at a time, by scrolling through the program.

This Analyzer kit can be plugged into the UGM and also the HEC.

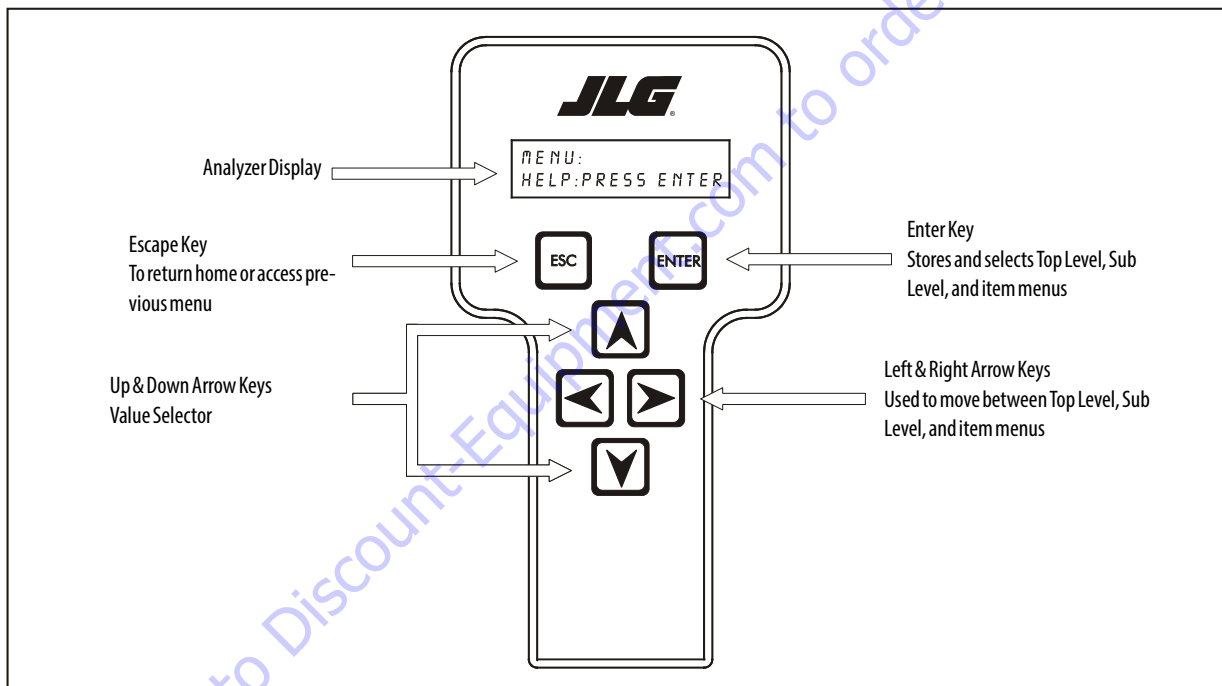

Figure 6-1. Hand Held Analyzer

To Connect the JLG Control System Analyzer

1. Connect the four pin end of the cable supplied with the analyzer, to the control module located in the platform box or at the HEC module and connect the remaining end of the cable to the analyzer.

NOTE: The cable has a four pin connector at each end of the cable; the cable cannot be connected backwards.



2. Power up the Control System by turning the lower key to the platform or ground position and pulling both emergency stop buttons on.

Using the Analyzer

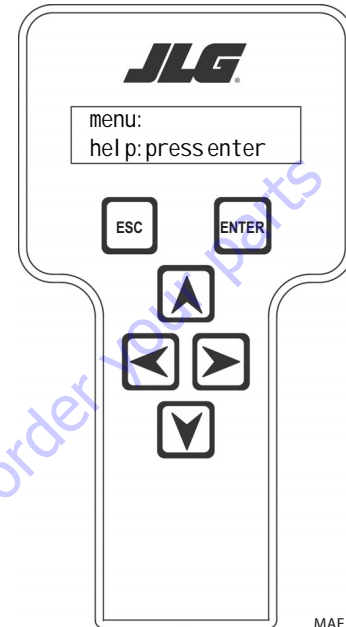
With the machine power on and the analyzer connected properly, the analyzer will display the following:



HELP: PRESS ENTER

At this point, using the RIGHT  and LEFT  arrow keys, you can move between the top level menu items. To

select a displayed menu item, press ENTER . To cancel a

selected menu item, press Escape ; then you will be able to scroll using the right and left arrow keys to select a different menu item.

SECTION 6 - JLG CONTROL SYSTEM

The top level UGM menus are as follows:

HELP
DIAGNOSTICS
ACTIVATE TEST
ACCESS LEVEL
PERSONALITIES
MACHINE SETUP
LEVEL VEHICLE (level 1 only)
CALIBRATIONS (view only)

The top level HEC menus are as follows:

HELP
DIAGNOSTICS
ACCESS LEVEL
PERSONALITIES
MACHINE SETUP

If you press **ENTER** , at the **HELP: PRESS ENTER** display, and a fault is present, the analyzer display will scroll the fault across the screen. If there was no fault detected, the display will read: **HELP: EVERYTHING OK**. If powered up at the ground station, the display will read: **GROUND OK**.

If **ENTER**  is pressed again, the display moves to the following display:

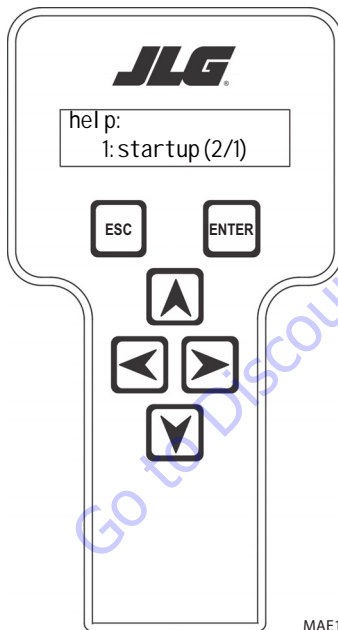

MAE19060

LOGGED HELP 1: STARTUP (2/1)

At this point, the analyzer will display the last fault the system has seen, if any are present. You may scroll through the fault logs to view what the last 25 faults were. Use the right and left arrow keys to scroll through the fault logs. To return to the

beginning, press **ESCAPE**  two times. **STARTUP (2/1)** indicates a power up.

When a top level menu is selected, a new set of menu items may be offered: for example:

DRIVE
BOOM
SYSTEM
DATALOG
VERSIONS

Pressing **ENTER**  with any of the above displayed menus, will display additional sub-menus within the selected menu. In some cases, such as **DRIVE**, the next level is the parameter or information to be changed. Refer to the flow chart for what menus are available within the top level menus. You may only view the personality settings for selected menus while in **OPERATOR ACCESS**. Remember, you may always cancel a

selected menu item by pressing the **ESCAPE**  key.

Changing the Access Level of the Hand Held Analyzer

When the analyzer is first connected, you will be in Operator Access which enables you to only view most settings which cannot be changed until you enter a password to advance to a lower level. This ensures that a setting cannot be accidentally altered. To change the access level, the correct password must be entered. To enter the password, scroll to the **ACCESS LEVEL** menu. For example:

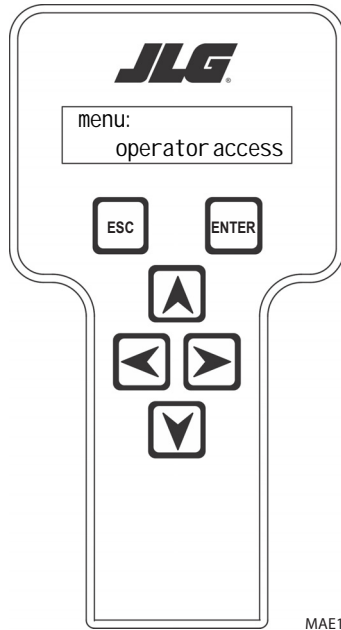

Press **ENTER**  to select the **ACCESS LEVEL** menu.

Using the **UP**  or **DOWN**  arrow keys, enter the first digit of the password, 3.

Then using the **RIGHT**  arrow key, position the cursor to the right one space to enter the second digit of the password.

Use the **UP**  or **DOWN**  arrow key to enter the second digit of the password which is 33271.

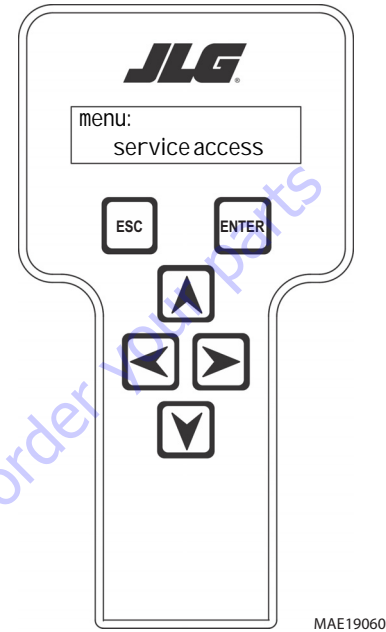

Once the correct password is displayed, press **ENTER** . The access level should display the following, if the password was entered correctly:



MENU: SERVICE ACCESS

Repeat the above steps if the correct access level is not displayed or you can not adjust the personality settings.

Adjusting Parameters Using the Hand Held Analyzer

Once you have gained access to level 1, and a personality item is selected, press the **UP**  or **DOWN**  arrow keys to adjust its value, for example:

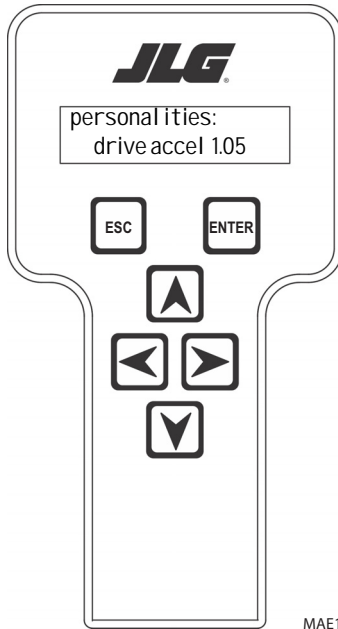



MAE19060

DRIVE: ACCEL 1.5s

There will be a minimum and maximum for the value to ensure efficient operation. The Value will not increase if the **UP**  arrow is pressed when at the maximum value nor will

the value decrease if the **DOWN**  arrow is pressed and the value is at the minimum value for any particular personality. If the value does not change when pressing the up and down arrows, check the access level to ensure you are at access level 1.

Machine Setup

When a machine digit item is selected, press the **UP**  or **DOWN**  arrow keys to adjust its value, for example:

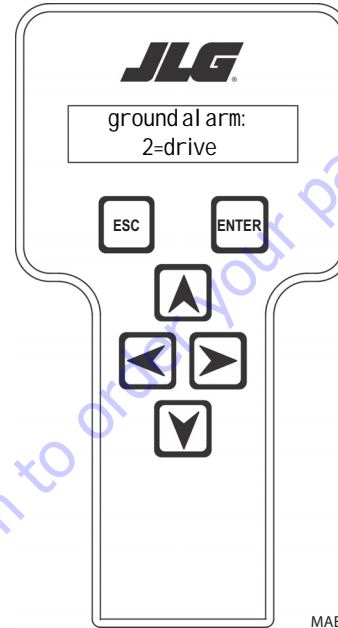

MAE19060

GROUND ALARM: 2 = DRIVE

The effect of the machine digit value is displayed along with its value. The above display would be selected if the machine was equipped with a ground alarm and you wanted it to sound when driving. There are certain settings allowed to install optional features or select the machine model.

When selection the machine model to match the size of the machine, the personality settings will all default to the factory recommended setting.

NOTE: Refer to *Personality Ranges/Defaults for the recommended factory settings.*

NOTE: Password 33271 will give you access to level 1, which will permit you to change all machine personality settings.

There is a setting that JLG strongly recommends that you do not change. This setting is so noted below:

ELEVATION CUTBACK

⚠ WARNING

CHANGING THIS SETTING MAY ADVERSELY AFFECT THE PERFORMANCE OF YOUR MACHINE.

NOTICE

ITS IS A GOOD PRACTICE TO AVOID PRESSURE-WASHING ELECTRICAL/ELECTRONIC COMPONENTS. SHOULD PRESSURE-WASHING BE UTILIZED TO WASH AREAS CONTAINING ELECTRICAL/ELECTRONIC COMPONENTS, JLG INDUSTRIES INC. RECOMMENDS A MAXIMUM PRESSURE OF 750 PSI (52 BAR) AT A MINIMUM DISTANCE OF 12 INCHES (30.5CM) AWAY FROM THESE COMPONENTS. IF ELECTRICAL/ELECTRONIC COMPONENTS ARE SPRAYED, SPRAYING MUST NOT BE DIRECT AND BE FOR BRIEF TIME PERIODS TO AVOID HEAVY SATURATION.

Level Vehicle Description

⚠ WARNING

DO NOT LEVEL VEHICLE EXCEPT ON A LEVEL SURFACE.

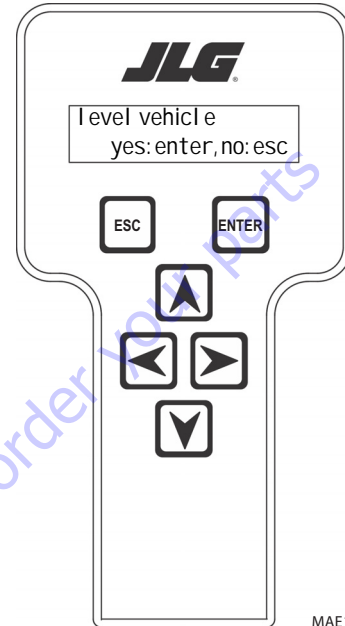

MAE19060

LEVEL VEHICLE
YES:ENTER, NO:ESC

Not available at password level 2 ENTER  confirms that vehicle is currently level, and zeroes the tilt sensor measurements

Ground Control Console Display Gauge

(See Figure 6-5., Ground Control Console Display Gauge)

The Display Gauge shows engine hours, fuel level or battery level (if applicable), and Diagnostic Trouble Codes (DTCs) from both the JLG Control System. During machine start up, with no active DTCs in the control system, the splash screen will show for 3 seconds and then switch to main screen. If there is an active DTC while powering up the machine, the splash screen will show for 3 seconds, and then launch the Diagnostics Screen. The indicator lamp will light when there is an active DTC in the Fault Log.



Figure 6-2. Splash Screen

The Diagnostic Screen will show active and inactive faults from the JLG Control System on the screen. An asterisk (*) will be displayed to show active faults.

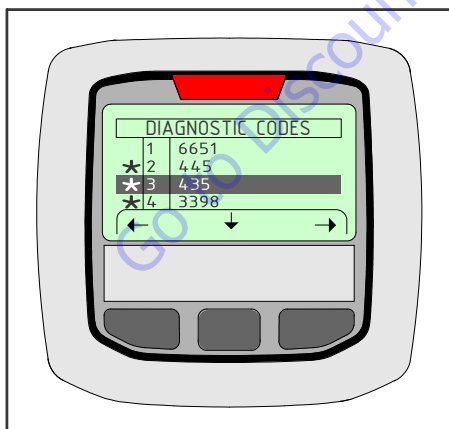

Figure 6-3. Diagnostic Screen

The Engine Diagnostics Screen will show SPN (Suspect Parameter Number), FMI (Failure Mode Identifier), and Occurrence count information. Engine SPN text is not scrollable. If there is more than one engine trouble code, the operator must exit from the Engine DTC Screen to see other SPN and FMI information.

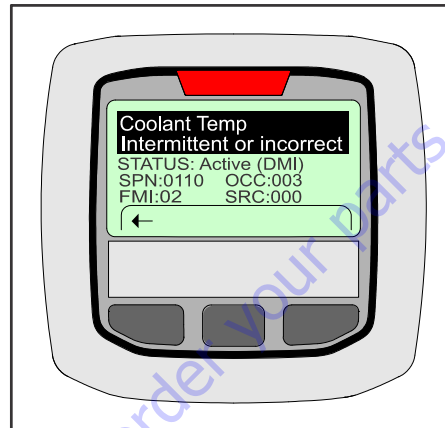

Figure 6-4. Engine Diagnostic Screen

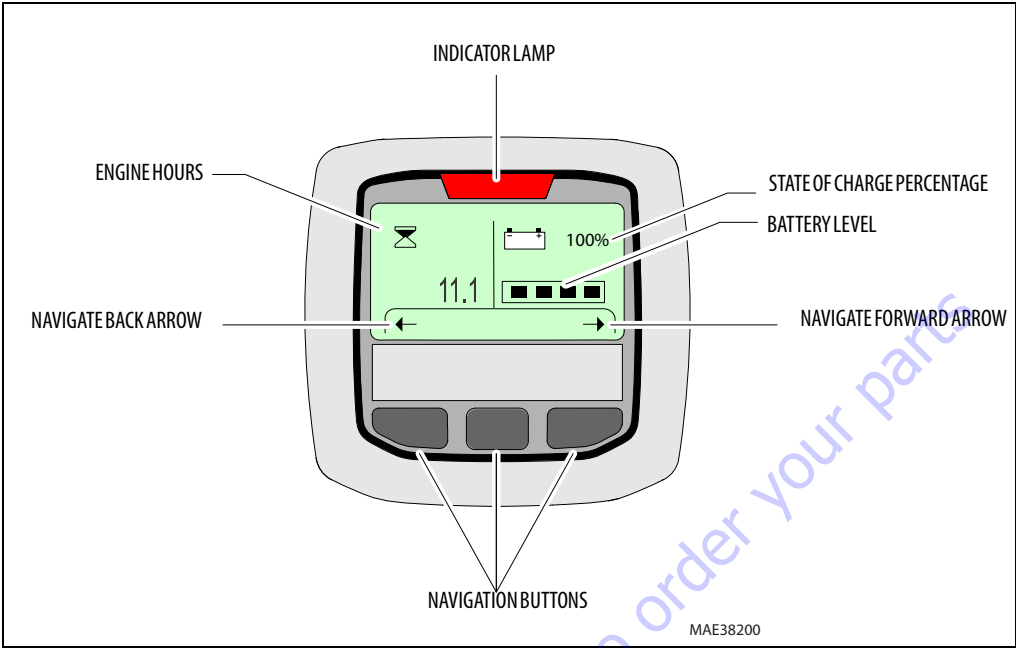

Figure 6-5. Ground Control Console Display Gauge

Go to Discount-Equipment.com to order your parts

SECTION 6 - JLG CONTROL SYSTEM

Table 6-1. Analyzer Abbreviations

ABBREVIATION	MEANING
ACCEL	ACCELERATE
ACT	ACTIVE
A/D	ANALOG DIGITAL CONVERTER COUNT
AMB.	AMBIENT
ANG	ANGLE
AUX	AUXILIARY
BCS	BOOM CONTROL SYSTEM
BM	BOOM LENGTH ANGLE MODULE
BLAM	BOOM LENGTH ANGLE MODULE
BR	BROKEN
BSK	BASKET
CAL	CALIBRATION
CL	CLOSED
CM	CHASSIS MODULE
CNTL	CONTROL
CNTRL	CONTROL
C/O	CUTOUT
CONT(S)	CONTRACTOR(S)
COOR	COORDINATED
CRKPT	CRACK POINT
CRP	CREEP
CUT	CUTOUT
CYL	CYLINDER
DECEL	DECELERATE
D	DOWN
DN	DOWN
DWN	DOWN
DEG.	DEGREE
DOS	DRIVE ORIENTATION SYSTEM
DRV	DRIVE
E	ERROR
E&T	ELEVATED & TILTED
ELEV	ELEVATION
ENG	ENGINE
EXT	EXTEND
F	FRONT
FL	FLOW
FNT	FRONT
FOR	FORWARD
FWD	FORWARD
FSW	FOOT SWITCH
FUNC	FUNCTION
G	GROUND

Table 6-1. Analyzer Abbreviations

ABBREVIATION	MEANING
GND	GROUND
GRN	GREEN
GM	GROUND MODULE
H	HOURS
HW	HARDWARE
HWFS	HARDWARE FAILSAFE
I	IN or CURRENT
JOY	JOYSTICK
L	LEFT
LB	POUND
LEN	LENGTH
LIM	LIMIT
LT	LEFT
LVL	LEVEL
M	MINUTES
MIN	MINIMUM
MAX	MAXIMUM
M	MAIN
MN	MAIN
NO	NORMALLY OPEN or NO
NC	NORMALLY CLOSED
O	OUT
O/C	OPEN CIRCUIT
OP	OPEN
O/R	OVERRIDE or OUTRIGGER
O//R	OVERRIDE
OSC	OSCILLATING
OVRD	OVERRIDE
P	PLATFORM
P	PRESSURE
PCV	PROPORTIONAL CONTROL VALVE
PLAT	PLATFORM
PLT	PLATFORM
PM	PLATFORM MODULE
POT	POTENTIOMETER
PRES	PRESSURE
PRS	PRESSURE
PT	POINT
R	REAR or RIGHT
REV	REVERSE or REVISION
RET	RETRACT
ROT.	ROTATE
RT	RIGHT

Table 6-1. Analyzer Abbreviations

ABBREVIATION	MEANING
S/C	SHORT CIRCUIT
SEL	SELECTOR
SN	SERIAL NUMBER
SPD	SPEED
STOW	STOWED
STOWD	STOWED
SW	SWITCH or SOFTWARE
TELE	TELESCOPE
TEMP	TEMPERATURE
TORQ.	TORQUE
TRN	TRANSPORT
T/T	TURNTABLE
T	TOWER
TURNTBL	TURNTABLE
TWR	TOWER
U	UPPER or UP
V	VOLT
VER	VERSION
VLV	VALVE
WIT	WITNESS
YEL	YELLOW

6.3 PLATFORM LOAD SENSING SYSTEM

The Platform Load Sensing (LSS) System consists of a single load cell mounted within the platform support. This system compares the designed capacity (500 lb (230 kg)) to the measured weight in the platform.

If the actual platform load exceeds the selected Rated Load, the following will occur:

1. The Overload Visual Warning Indicator will flash at the selected control position (platform or ground).
2. The Platform and Ground Alarms will sound 5 seconds On, and 2 seconds Off.
3. All normal movement will be prevented from the platform control position (optional - ground control functions may be prevented).
4. Further movement is permitted by:
 - a. Removing the excess platform load until actual platform load is less than Rated Load.
 - b. Operation of the overriding emergency system (Auxiliary Power Unit).
 - c. By an authorized person at the ground control position (optional - ground control functions may be prevented).



NOTICE

THE LOAD SENSING SYSTEM MUST BE CALIBRATED WHEN ONE OR MORE OF THE FOLLOWING CONDITIONS OCCUR:

- a. LSS Sensor removal or replacement
- b. Addition or removal of certain platform mounted accessories. (Refer to Calibration)
- c. Platform is removed, replaced, repaired or shows evidence of impact.

NOTICE



THE LOAD SENSING SYSTEM REQUIRES PERIODIC FUNCTION VERIFICATION NOT TO EXCEED 6 MONTHS FROM PREVIOUS VERIFICATION. REFER TO TESTING & EVALUATION.

All calibration procedures are menu driven through the use of a JLG Analyzer.

Diagnostic Menu

The Diagnostic Menu is another troubleshooting tool for the Load Sensing System. Sensor and status information is pre-

sented in real-time for the technician. Several sub-menus exist to organize the data.

To access the Diagnostic Menu, use the LEFT  and RIGHT  Arrow keys to select DIAGNOSTICS from the Top Level

Menu. Press the ENTER key  to view the menu.

Press the LEFT and RIGHT Arrow keys to view the displays and select the various sub-menus. To access a sub-menu, press the ENTER key. Once in a sub-menu, press the LEFT and RIGHT Arrow keys to view the various displays (just like a Top Level

menu). To exit a sub-menu, press the ESC key .

Table 6-2, Diagnostic Menu Descriptions details the structure of the Diagnostic Menu, and describes the meaning of each piece of information presented.

Table 6-2. Diagnostic Menu Descriptions

Diagnostics Menu (Displayed on Analyzer 1 st Line)	Parameter (Displayed on Analyzer 2 nd Line)	Parameter Value (Displayed on Analyzer 2 nd Line)	Description
PLATFORM LOAD	STATE:	OK / OVERLOAD	LSS Status.
PLATFORM LOAD	ACTUAL:	XXX.X KG	Calibrated weight of the platform. ??? if Platform Load is Unhealthy**.
PLATFORM LOAD (service*)	GROSS:	XXX.X KG	Gross weight of the platform. ??? if both Cells are Unhealthy**.
PLATFORM LOAD (service*)	OFFSET 1:	XXX.X KG	Stored offset weight of Cell 1. ??? if LSS is not calibrated.
PLATFORM LOAD (service*)	OFFSET 2:	XXX.X KG	Stored offset weight of Cell 1. ??? if LSS is not calibrated.
PLATFORM LOAD (service*)	ACCESSORY	XXX.X KG	Stored accessory weight. ??? if LSS is not calibrated.
PLATFORM LOAD (service*)	UNRESTRICT	XXX.X KG	UGM will set Unrestricted Rated Load as defined by Machine Configuration.
PLATFORM LOAD (service*)	RESTRICT	XXX.X KG	UGM will set Restricted Rated Load as defined by Machine Configuration.
PLATFORM LOAD (service*)	RAW 1:	XXX.X KG	Gross value from Cell 1. ??? if Unhealthy**.
PLATFORM LOAD (service*)	RAW 2:	XXX.X KG	Gross value from Cell 2. ??? if Unhealthy**.

* Indicates only visible in service view mode
 ** Typically indicates a DTC is active

Calibration Procedure

1. Remove everything from the platform, except permanently fixed JLG Accessories, to allow the Load Sensing System to record its' weight during calibration. This includes all tools, debris, and customer-installed devices.
2. Plug the JLG Analyzer into the Machine at the Ground Station and enter Service Access Password 33271.
3. The platform should be approximately level for calibration. Level the platform from ground control (if necessary) to within +/- 5°.
4. To access the Calibration Menu, use the LEFT and RIGHT Arrow keys to select CALIBRATION from the Top Level Menu. The screen will read:

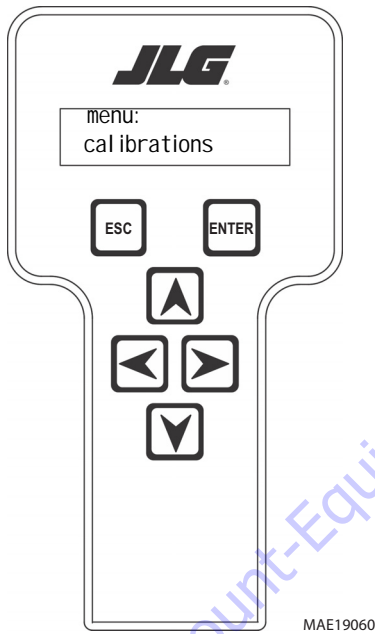

NOTE: The Calibration Menu is not available in OPERATOR ACCESS.

5. Press the ENTER key  to view the menu. Upon entry to the Calibration Menu, the JLG Control System will link to the Analyzer and the screen will read:

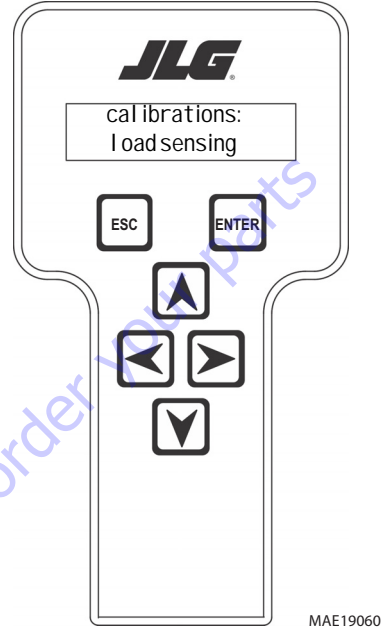

6. Press Enter . The Screen will read:

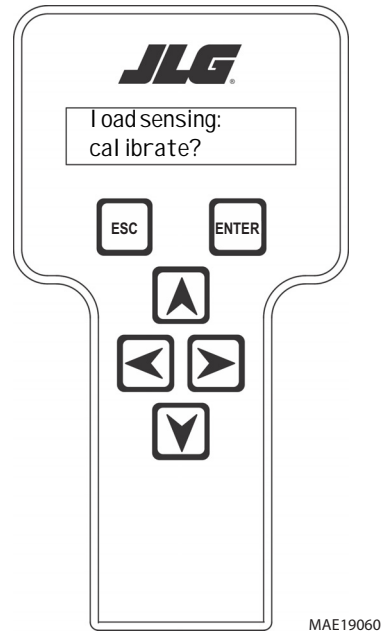

NOTE: Calibration will auto fail if LSS DTC's are active (443, 444, 4479, 4480, 663, 821, 822, 823, 824, 8218, 8222 -> 8238, 991, 992, 993, 994 or 99285).

Pressing the ESC key  after starting calibration and before calibration is complete will display the CAL FAILED message. This will not disturb the prior calibration information.

7. Press ENTER . The analyzer screen will read:

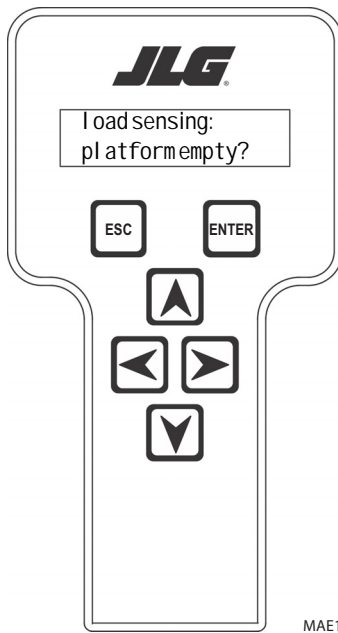

MAE19060

8. If the platform is empty, press ENTER . The screen will read:

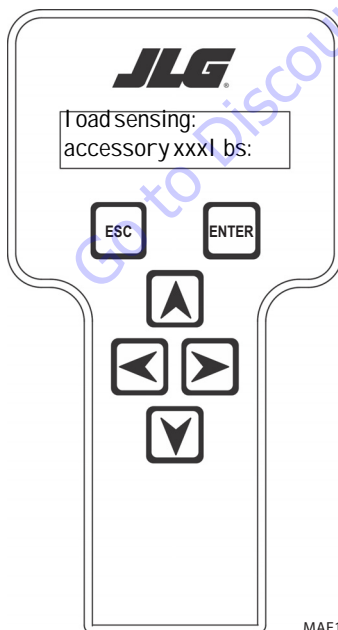

MAE19060

NOTE: Accessory weight will reset to 0 lbs. each time the machine is re-calibrated and will need to be re-entered.

NOTE: The Accessory weight will be temporarily stored in the Control System until calibration has been completed successfully.

Refer to Table 6-3, Accessory Weights. Use the up and down analyzer keys to enter the accessory weight(s) (in lbs). When all the accessory weights are entered, press

ENTER . The screen will read:

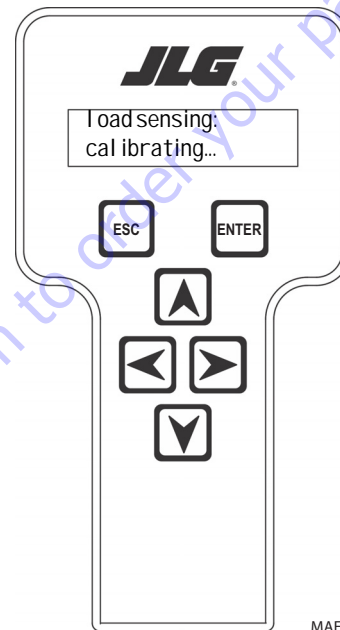

MAE19060

Table 6-3. Accessory Weights

Accessory	Weight
SkyWelder (stick welder)	70 lb (32 kg)
SkyWelder Prep	Prep only = 15 lb (7 kg) Full install = 70 lb (32 kg)
SkyCutter (plasma cutter)	70 lb (32 kg)
SkCutter / SkyWelder Combo	140 lb (64 kg)
Fire Extinguisher	45 lb (20 kg)
Overhead SoftTouch	80 lb (36 kg)
Work Surface	20 lb (9 kg)

NOTE: Not all Accessories are available on every JLG model. Some Accessory combinations are prohibited due to excessive weight and/or load restriction. If any installed JLG Accessories are labeled with weight decals but are not listed in the table above, include their weight when entering the ACC WEIGHT value.

- The control system will calculate the load cell readings and ensure it is greater than 130 lbs. (59 kg), but less than 575 lbs.(261 kg).

If the platform weight is not within the allowed range, the calibration attempt will be unsuccessful and the Analyzer will show the following:

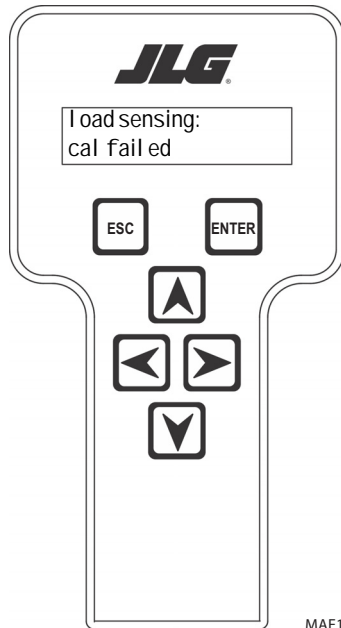

MAE19060

- Use the analyzer keys to select N for no or Y for yes. Press

ENTER . The screen will read:

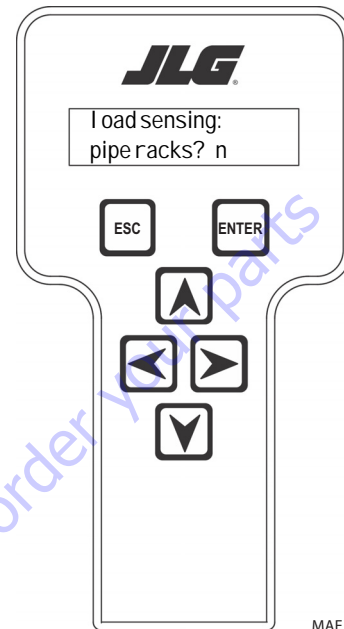

MAE19060

- Press ENTER . The control system will ask for installed accessories. The screen will show the following:

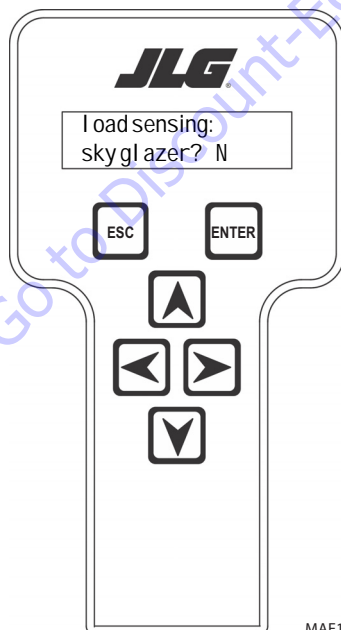

MAE19060

SECTION 6 - JLG CONTROL SYSTEM

12. Use the analyzer keys to select N for no or Y for yes. Press

ENTER . The control system will default to an estimate of unrestricted capacity, which can be adjusted if necessary. Refer to Table 6-4, SkyGlazier Capacity Reductions and Table 6-5, Pipe Rack Capacity Reductions.

The screen will read:

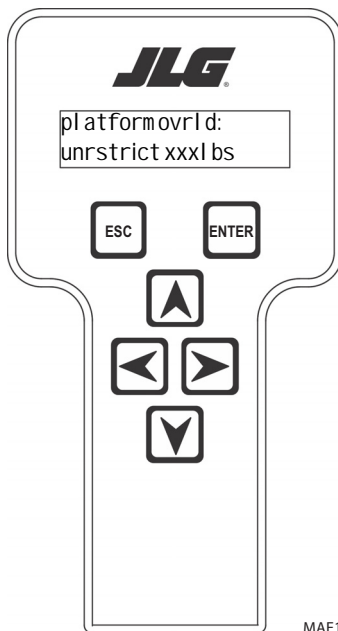

MAE19060

Table 6-4. SkyGlazier Capacity Reductions

Capacity	PLATFORM OVRLD	PLATFORM OVRLD RESTRICT
500 lb (227 kg)	400 lb (181 kg)	n/a
550 lb (250 kg)	400 lb (181 kg)	n/a
600 lb (272 kg)	400 lb (181 kg)	n/a
750 lb (340 kg)	n/a	590 lb (268 kg)
1000 lb (454 kg)	n/a	750 lb (340 kg)

Note: If both SkyGlazier and Pipe Racks are configured, capacity will be the lower of the two values.

Table 6-5. Pipe Rack Capacity Reductions

Capacity	PLATFORM OVRLD	PLATFORM OVRLD RESTRICT
500 lb (227 kg)	400 lb (181 kg)	n/a
550 lb (250 kg)	450 lb (204 kg)	n/a
600 lb (272 kg)	500 lb (227 kg)	n/a
750 lb (340 kg)	n/a	650 lb (295 kg)
1000 lb (454 kg)	n/a	900 lb (408 kg)

Note: If both SkyGlazier and Pipe Racks are configured, capacity will be the lower of the two values.

13. Press ENTER . The following screen will be displayed for restricted capacity, which can be adjusted if necessary. Refer to Table 6-4, SkyGlazier Capacity Reductions and Table 6-5, Pipe Rack Capacity Reductions.

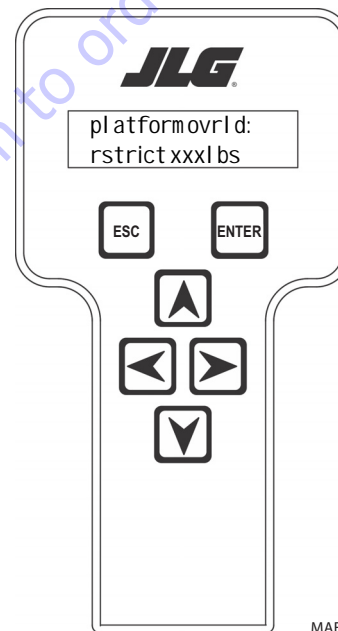

MAE19060

14. Press ENTER . If calibration is successful, the screen will read:

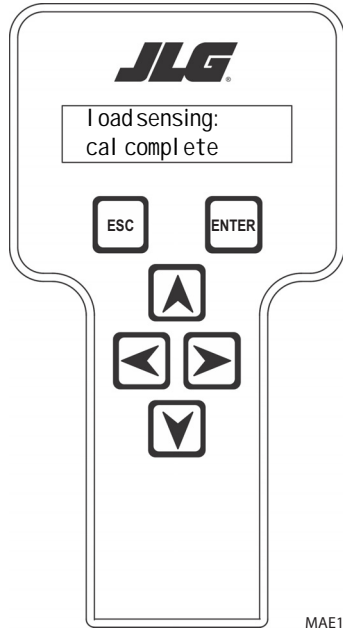

MAE19060

Go to Discount-Equipment.com to order your parts

Testing & Evaluation

Refer to Troubleshooting if the Load Sensing System fails to meet these guidelines.

1. Connect the JLG Analyzer.
2. Level the Platform. The platform should be approximately level for analysis, or the guidelines below will not be applicable. Level the platform from Ground Control (if necessary) to within ± 5 degrees.
3. Observe the Empty Platform Weight. Proceed to the DIAGNOSTICS, PLTLOAD sub-menu and observe the measured platform load. All tools, debris, and customer-installed devices shall be removed during evaluation. Ideally, the PLTLOAD should be zero but can vary ± 15 lbs (± 7 kg). Further, the reading should be stable and should not vary by more than ± 2 lbs (± 1 kg) (unless there is heavy influence from wind or vibration).
4. Use the Technician's Weight to Evaluate. The technician should enter the platform and record the PLTLOAD reading while standing in the center of the platform.
5. Confirm Control System Warnings and Interlocks. Using the keyswitch, select Platform Mode and power-up. Start the vehicle's engine and ensure that all controls are functional and the Load Sensing System's Overload Visual and Audible Warnings are not active. Simulate an Overload by unplugging the Shear Beam Load Cell. The Overload Visual Warning should flash, and the Audible Warning (at Platform and Ground) should sound for 5 seconds On, and 2 seconds Off. With the engine running, all control should be prevented. Cycle the Platform EMS to stop the engine and then power-up again. The Overload Visual and Audible Warning should continue. Confirm that controls are responsive when using the Auxiliary Power Unit for emergency movement. Reconnect the Load Cell. The Overload Visual and Audible Warnings should cease and normal control function should return. Switch the vehicle's keyswitch to Ground Mode and repeat the above procedure. The Overload Visual Warning at the Ground Controls should flash, and the Audible Warning (at Platform and Ground) should sound for 5 seconds On, 2 seconds Off. However, the controls should remain functional when using the engine and the Auxiliary Power Unit (if the Control System's MACHINE SETUP, LOAD is set to "2=CUTOUT PLT". If set to "3=CUTOUT ALL", then Ground Controls will be prevented when using the engine as in the platform).
6. Confirm Control System Capacity Indication (optional for vehicles with Dual Capacity Ratings). For vehicles equipped with a Capacity Select switch on the Platform Console Box, it is necessary to examine an additional interface between the Load Sensing System and the Control System. Using the keyswitch, select Platform Mode and power-up. If necessary, put the boom in the transport position (completely stowed) and center the Jib Plus (if equipped). Place the Capacity Select switch in the unrestricted position and ensure that the proper indicator illuminates on the Platform Console Box. Plug the JLG Analyzer into the Analyzer connection and proceed to the DIAGNOSTICS, SYSTEM submenu. Ensure that the CAPACITY displays indicate OFF. Place the Capacity Select switch in the unrestricted position (if so equipped) and ensure that the proper indicator illuminates on the Platform Console Box (but does not flash). For vehicles with unrestricted capacity, ensure that the unrestricted CAPACITY display indicates ON but the restricted CAPACITY indicates OFF. For vehicles with restricted capacity, ensure that the unrestricted CAPACITY display indicates OFF but the restricted CAPACITY indicates ON.
7. Confirm Load Sensing System Performance with Calibrated Weights. Operate the vehicle from Ground Control and place the boom in the transport position (fully stowed) for safety. Plug the JLG Analyzer into the control system connection and proceed to the DIAGNOSTICS, PLTLOAD display. Place 500lbs (230kg) in the platform and ensure that PLTLOAD is with $\pm 5\%$ of the actual weight. For Dual Capacity vehicles, do the same for the alternate capacity (unrestricted or restricted).

Troubleshooting

The following tables are furnished to provide possible resolutions for common difficulties. Difficulties are classified as General, Calibration, Measurement Performance, and Host System Functionality.

Table 6-6. LSS Troubleshooting Chart

Difficulty	Possible Resolution
<p>Empty Platform Weight (DIAGNOSTICS, PLATFORM LOAD) is not within $\pm 15\text{lbs}$ ($\pm 7\text{kg}$) of zero.</p> <p>or</p> <p>Platform Load readings (DIAGNOSTICS, PLATFORM LOAD) are unstable by more than $\pm 2\text{lbs}$ ($\pm 1\text{kg}$) (without the influence of vibration or wind).</p> <p>or</p> <p>There are large variations in Platform Load (DIAGNOSTICS, PLATFORM LOAD) based on the location of the load. Tolerance to variations is 20lbs for an evaluation using the technician's weight, and $\pm 5\%$ of Rated Load when using calibrated weights.</p>	<p>The LSS System is unable to properly measure the platform weight.</p> <ol style="list-style-type: none"> The Load Cell is not properly plugged into the LSS Harness. It is possible poor electrical contact is made. Wiring leading to the Load Cell is damaged. Carefully inspect sensor wiring where it passes through cable clamps for signs of damage. Inspect wiring where damage to the channel is apparent. The Load Cell was not assembled properly during installation. Examine the sensor's reading using the JLG Analyzer. Proceed to the DIAGNOSTICS, CELL, LOAD displays and determine if the readings are reasonable. It is often helpful to apply slight downward pressure above the sensor and observe that its output increases (increasing force measurement; decreasing means the sensor is mounted upside-down). The Load Cell is contaminated by debris or moisture. Examine the sensor's reading using the JLG Analyzer. Proceed to the DIAGNOSTICS, CELL, LOAD displays and determine if the readings are reasonable and stable (not changing by more than $\pm 2\text{lbs}$ ($\pm 1\text{kg}$) (without the influence of vibration or wind). Lack of measurement stability is a key indication of contamination. Unplug the connector and inspect for dirt or moisture. Look carefully into the female connector on the sensor's cordset for evidence of contamination. Debris should be brushed away with a soft bristle brush (do not introduce any cleaners as they will leave conductive residue). Moisture should be allowed to evaporate or accelerated with a heat-gun (use low heat and be carefully to not melt connector materials). Moisture intrusion into the molded portion of the connector (capillary action into the wire bundle) or the Shear Beam Load Cell itself will require replacement of the sensor. The Load Cell has been mechanically damaged. If the Load Cell is physically deformed or has damage to the cover it should be replaced immediately. It is also possible to have invisible mechanical damage resulting from an extreme overload ($>6000\text{lbs}$ [$>2722\text{kg}$]).
<p>The Visual and Audible Overload Warnings fail to sound when platform is loaded beyond Rated Load, or when simulated by unplugging the Load Cell. Controls remain functional at Platform and Ground Control positions.</p>	<p>The Control System is failing to regard the overload signal from the LSS System, or the signal is shorted.</p> <ol style="list-style-type: none"> The Load Sensing System must be enabled within the Control System. Plug the JLG Analyzer into the Control System, enter the Access Level 1 password (33271), and examine the MACHINE SETUP, LOAD sub-menu. The selection "2=CUTOUT PLT" should be displayed (platform controls prevented during overload, ground controls remain operational). In country- or customer-specific circumstance, the selection "3=CUTOUT ALL" is used (platform and ground controls prevented during overload).
<p>The Ground Audible Warning fails to sound, but the Platform Audible Warning sounds properly.</p>	<p>The Ground Alarm is missing or improperly installed. Verify that the device is mounted. Verify wiring from the Main Terminal Box and Ground Module.</p>
<p>Controls remain functional at the Ground Control position during an overload, or when simulated by unplugging the Load Cell. The Controls at the Platform Control position are prevented when using the engine, but not when using the Auxiliary Power Unit.</p>	<p>The JLG Control System is configured to prevent platform controls only in the event of overload. Alternately, the Host Control System can be configured to prevent ground and platform controls for country- or customer-specific circumstances.</p> <p>Using the JLG Analyzer, enter the Access Level 1 password (33271). Proceed to the MACHINE SETUP, LOAD sub-menu. Set this parameter to "2=CUTOUT PLT" to prevent platform controls in the event of overload. Set this parameter to "3=CUTOUT ALL" to prevent platform and ground controls in the event of overload.</p>

6.4 RESETTING THE MSSO SYSTEM

1. Use the following procedure to reset the MSSO system.
2. Position the Platform/Ground select switch to the desired position.
3. Plug the analyzer into the connector coming from the ground control module or from the platform console.

NOTE: If performing the procedure from the platform console, the Emergency Stop switch on the ground console must also be pulled out.

4. Pull out the Emergency Stop switch.
5. The analyzer screen should read:

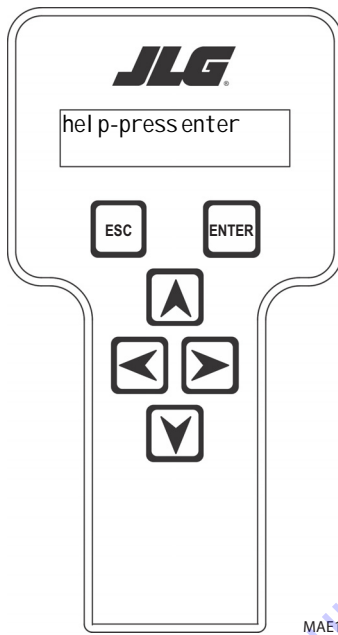

6. Use the arrow button to reach OPERATOR ACCESS. Press



7. Enter the Access Code, 33271.

8. Use the right Arrow key to reach MENU: CALIBRATIONS.



9. Use the arrow keys to reach the LOAD SENSING menu. The screen should read:

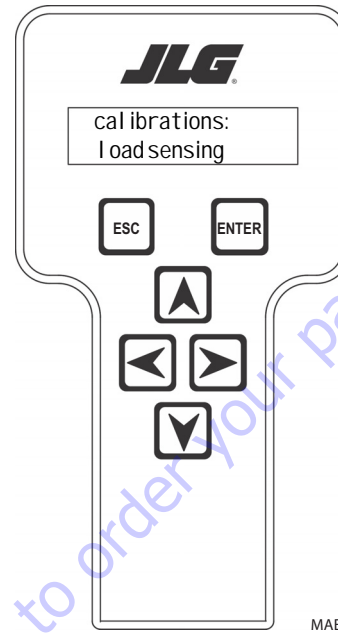



10. Press ENTER .

11. Use the Down  arrow to reach MSSO RESET.

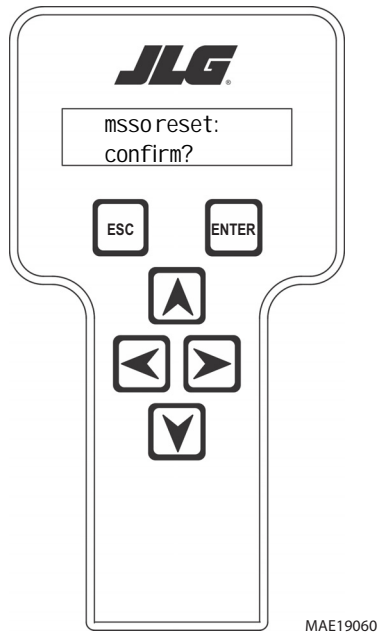
12. Press Enter . The screen will read:



13. Press Enter . The JLG Control System will reset an active 873 DTC and the MSSO System will be reset. Press Escape  to return to the CALIBRATIONS menu.

6.5 MACHINE CONFIGURATION PROGRAMMING INFORMATION

Table 6-7. Machine Configuration Programming Information (Software Version P1.1)

Configuration Digit	Number	Description	Default Number
<p>NOTE: The machine configuration must be completed before any personality settings can be changed. Changing the personality settings first and then changing the model number of the machine configuration will cause the personality settings to return to default values.</p>			
MODEL NUMBER: 1	1	H800A	1
MARKET: 2	<p>0</p> <p>1</p> <p>2</p> <p>3</p> <p>4</p> <p>5</p> <p>6</p>	<p>ANSI USA</p> <p>ANSI EXPORT</p> <p>CSA</p> <p>CE</p> <p>AUSTRALIA</p> <p>JAPAN</p> <p>GB</p>	0

Go to Discount-Equipment.com to order your parts

Table 6-7. Machine Configuration Programming Information (Software Version P1.1)

Configuration Digit	Number	Description	Default Number
ENGINE: 3* * Engine selections vary depending on model selection.	1	FORD EFI GAS: Ford LRG425 EFI Gas (Tier 1)	18
	2	FORD EFI D/F: Ford LRG425 EFI dual fuel (Tier 1)	
	3	DEUTZ F4 TIER1: Deutz F4M1011F Diesel (Tier 1)	
	4	DEUTZ F3 TIER1: Deutz F3M1011F Diesel (Tier 1)	
	5	CAT. 3024C: CAT 3024C Diesel (Tier 2)	
	6	CAT. 3044C: CAT 3044C Diesel (Tier 2)	
	7	PERKINS 404C (Tier 2)	
	8	DEUTZ F4 TIER2: Deutz F4M2011 Diesel (Tier 2)	
	9	DEUTZ F3 TIER2: Deutz F3M2011 Diesel (Tier 2)	
	10	FORD GASTIER2: Ford LRG425 EFI Gas (Tier 2)	
	11	FORD D/F TIER2: Ford LRG425 EFI Dual Fuel (Tier 2)	
	12	DEUTZ ECM: Engine Control Module - ECM (Tier 2 and Tier 3)	
	13	DUAL FUEL ECM: GM/PSI 3.0L Dual Fuel (Tier 2)	
	14	PERKINS ECM	
	15	CAT ECM	
	16	DEUTZ EMR4: Deutz Engine Control Module (Tier 4 Final)	
	17	FORD DUAL FUEL	
	18	KUBOTA D1305	
FLYWHEEL TEETH: 4	0	133 TEETH: 133 flywheel teeth.	2
	1	110 TEETH: 110 flywheel teeth.	
	2	23 Teeth.	

SECTION 6 - JLG CONTROL SYSTEM

Table 6-7. Machine Configuration Programming Information (Software Version P1.1)

Configuration Digit	Number	Description	Default Number
GLOW PLUG: 5	0	NO GLOW PLUGS: No glow plugs installed.	2
	1	AIR INTAKE: Glow plugs installed in the air intake on the manifold.	
	2	IN-CYLINDER: Glow plugs installed in each cylinder.	
STARTER LOCKOUT: 6	0	DISABLED: Automatic pre-glow time determined by ambient air temperature; engine start can be attempted at any time during pre-glow.	0
	1	ENABLED: Automatic pre-glow time determined by ambient air temperature; engine start is NOT permitted until pre-glow is finished.	
ENGINE SHUTDOWN: 7	0	DISABLED: No engine shutdown.	1
	1	ENABLED: Shutdown engine when coolant temperature is greater than 110 deg. C or the oil pressure is less than 8 PSI.	
FUEL CUTOUT 8 *This menu item is only visible if non dual fuel engines are selected.	0	RESTART: Engine allowed to be restarted multiple times when very low fuel level is reached.	0
	1	ONE RESTART: Engine allowed to be restarted once for 2 minutes when very low fuel level is reached.	
	2	ENGINE STOP: Engine not able to restart when very low fuel level is reached.	

Table 6-7. Machine Configuration Programming Information (Software Version P1.1)

Configuration Digit	Number	Description	Default Number
TILT: 9* *Certain market selections will limit tilt options and alter default setting. <i>Note: Any of the selections above will light the tilt lamp when a tilted condition occurs and will sound the platform alarm when the machine is also above elevation.</i>	1	5 DEGREES: Reduces the maximum speed of all boom functions to creep when tilted more than 5 degrees and above elevation; also reduces drive speed to creep.	7
	2	4 DEGREES: Reduces the maximum speed of all boom functions to creep when tilted more than 4 degrees and above elevation; also reduces drive speed to creep.	
	3	3 DEGREES: Reduces the maximum speed of all boom functions to creep when tilted more than 3 degrees and above elevation; also reduces drive speed to creep.	
	4	4 DEGREES + CUT: Reduces the maximum speed of all boom functions to creep when tilted more than 4 degrees and above elevation; also disallows tower lift up, tower telescope out, drive, main telescope out and main lift up.	
	5	3 DEGREES + CUT: Reduces the maximum speed of all boom functions to creep when tilted more than 3 degrees and above elevation; also disallows tower lift up, tower telescope out, drive, main telescope out and main lift up.	
	6	5 DEGREES + CUT: Reduces the maximum speed of all boom functions to creep when tilted more than 5 degrees and above elevation; also disallows tower lift up, tower telescope out, drive, main telescope out and main lift up.	
	7	5 DEG + DRV CUT Reduces the maximum speed of all boom functions to creep when tilted more than 5 degrees and above elevation; also reduces drive speed to creep when drive reversal is allowed, drive is disallowed otherwise.	
	8	4 DEG + DRV CUT Reduces the maximum speed of all boom functions to creep when tilted more than 4 degrees and above elevation; also reduces drive speed to creep when drive reversal is allowed, drive is disallowed otherwise.	
	9	3 DEG + DRV CUT Reduces the maximum speed of all boom functions to	
JIB: 10* *Only visible under certain model selections.	0	NO: No jib installed.	1
	1	YES: Jib installed which has up and down movements only.	
4 WHEEL STEER: 11* *Only visible under certain model selections.	0	NO: No four-wheel steer installed.	0
	1	YES: Four-wheel steer installed.	
ST TOUCH / SKYGUARD: 12	0	NONE: No soft touch or skyguard system installed.	2
	1	SOFT TOUCH - Soft touch only installed.	
	2	SKYGUARD - Skyguard only installed.	
	3	BOTH (CUTOUT) - Soft touch and Skyguard installed.	

SECTION 6 - JLG CONTROL SYSTEM

Table 6-7. Machine Configuration Programming Information (Software Version P1.1)

Configuration Digit	Number	Description	Default Number
GENSET/WELDER: 13	0	NO: No generator installed.	0
	1	BELT DRIVE: Belt driven setup.	
H & T LIGHTS: 14	0	NO: No head and tail lights installed.	0
	1	YES: Head and tail lights installed.	
LOAD SYSTEM: 15* *Certain market selectors will limit load system options or alter default settings.	1	NO: No load sensor installed.	1
	2	WARN ONLY: Functions in creep, overload lamp lit, platform alarm beeps (5 sec ON, 2 sec OFF).	
	3	CUTOUT PLATFORM: All functions cutout, overload lamp lit, platform alarm beeps (5 sec ON, 2 sec OFF).	
	4	CUTOUT ALL: All functions cutout, flash overload light (500mS on, 500mS off), platform alarm beeps (5 sec ON, 2 sec OFF).	
	5	SPECIAL 1: Functions in creep, overload lamp lit, disables main telescope out & main lift up, platform alarm beeps (5 sec ON, 2 sec OFF).	
LOAD SENSOR: 16* *Only visible if Load Sensor Menu selection is not 0 and under certain market selections. *Certain market selections will limit load sensor options.	0	1 ON ROTATOR: Use the on-board load sensor for all models except those which use the Leveling Platform Module.	2
	1	4 UNDER PLATFORM: Use the EIM for load sensing.	
	2	SINGLE CELL: Single Cell, CANbus based sensor.	
FUNCTION CUTOUT: 17* *Only visible under certain market selections. *Certain market selections will limit function cutout options or alter default setting.	0	NO: No drive cutout.	0
	1	BOOM CUTOUT: Boom function cutout while driving above elevation.	
	2	DRIVE CUTOUT: Drive & steer cutout above elevation.	
	3	DRIVE CUTE&T: Drive & steer cutout above elevation and tilted.	

Table 6-7. Machine Configuration Programming Information (Software Version P1.1)

Configuration Digit	Number	Description	Default Number
GROUND ALARM: 18* *Certain market selections will alter default setting.	0	NO: No ground alarm installed.	3
	1	DRIVE: Travel alarm sounds when the drive function is active (Option).	
	2	DESCENT: Descent alarm sounds when lift down is active (Option).	
	3	MOTION: Motion alarm sounds when any function is active (Option).	
DRIVE: 19* *Only visible under certain model selections.	0	4WD: Four wheel drive.	0
	1	2WD: Two wheel drive.	
	2	2WD W/ 2-SPEED: Two wheel drive with 2-speed valve.	
DISPLAY UNITS: 20* *Certain market selections will alter default setting.	0	IMPERIAL: DEG F, PSI, LBS.	0
	1	METRIC: DEG C, KPA, KGS	
DRIVE CONTROL: 21	0	NORMAL: Drive coils are energized from the Ground Module.	2
	1	PROPULSION: Drive coils are energized from the Propulsion Module.	
	2	ENHANCED: Drive coils are energized from the Ground Module and the ground side of the drive coils are brought back to current feedback returns.	
DRIVE PUMP 22 *Only visible on 600A, 600S, and 800S models, H800AJ	0	SAUER DANFOSS: Machine equipped with Sauer Danfoss drive pump	1
	1	EATON: Machine equipped with Eaton drive pump	
	2	M46 - XXXX: Machine equipped with M46 - XXXX drive pump	
	3	830XXXXX: Machine equipped with 830XXXXX: drive pump	
BOOM CONTROL: 23	0	NORMAL: Boom function coils are energized from the Ground Module.	1
	1	ENHANCED: Boom function are energized from the Ground Module and the ground side of the drive coils and brought back to current feedback returns.	
FUNCTION SPEED KNOB 24	0	YES: Machine is equipped with Function Speed Knob.	0
	1	NO: Machine is equipped with Operation Speed Switch.	

SECTION 6 - JLG CONTROL SYSTEM

Table 6-7. Machine Configuration Programming Information (Software Version P1.1)

Configuration Digit	Number	Description	Default Number
CLEARSKY: 25	0	NO: Clearsky (telematics) option is disabled.	0
	1	YES: Clearsky (telematics) option is enabled.	
CRIBBING OPTION: 26	0	NO: Cribbing Option is disabled.	0
	1	YES: Cribbing Option is enabled.	
ALARM / HORN: 27	0	SEPERATE: Separate alarm and horn.	0
	1	COMBINED: Combination alarm / horn.	
ALERT / BEACON: 28	0	OFF FOR CREEP: Alert beacon will not flash while in Creep.	0
	1	20FPS FOR CREEP: Alert beacon will flash at 20FPS while in Creep.	
TEMP CUTOUT: 29	0	NO: Temp Cutout is Disabled	0
	1	YES: Temp Cutout is Enabled	
PLAT LVL OVR CUT: 30	0	NO: Platform Level Override will always be functional.	0
	1	YES: Platform Level Override will only be functional when In Transport.	

4150364-Z

Table 6-8. H800A Machine Configuration Programming Settings (Software Version P1.1)

	ANSI USA	ANSI Export	CSA	CE	Australia	Japan	GB
Model Number	1	1	1	1	1	1	1
Market	0	1	2	3	4	5	6
Engine	18	18	18	18	18	18	
Flywheel Teeth	2	2	2	2	2	2	
Glow Plugs	2	2	2	2	2	2	
Starter Lockout	0	0	0	0	0	0	
Engine Shutdown	1	1	1	1	1	1	
Fuel Cutout	0	0	0	0	0	0	
Tilt	1	1	1	X	X	1	
	2	2	2	X	2	2	
	3	3	3	X	3	3	
	4	4	4	4	4	4	
	5	5	5	5	5	5	
	6	6	6	X	X	6	
	7	7	7	X	X	7	
	8	8	8	8	8	8	
	9	9	9	9	9	9	
Jib	1	1	1	1	1	1	
4 Wheel Steer	0	0	0	0	0	0	
Soft Touch/Skyguard	2	2	2	2	2	2	
Gen Set / Welder	0	0	0	0	0	0	
	1	1	1	1	1	1	
Head & Taillights	0	0	0	0	0	0	
	1	1	1	1	1	1	
Load System	1	1	1	1	1	1	
	X	X	X	X	X	X	
	X	3	X	3	3	3	
	X	4	X	4	X	4	
	X	X	X	X	X	X	
Load Sensor	X	X	X	X	X	X	
	X	X	X	X	X	X	
	2	2	2	2	2	2	
Function Cutout	0	0	0	0	0	0	
	X	1	1	1	1	1	
	2	2	2	X	2	2	
	X	X	X	X	X	X	
Ground Alarm	0	0	0	0	0	0	
	1	1	1	1	1	1	
	2	2	2	2	2	2	
	3	3	3	3	3	3	
Drive Type	0	0	0	0	0	0	

Table 6-8. H800A Machine Configuration Programming Settings (Software Version P1.1)

	ANSI USA	ANSI Export	CSA	CE	Australia	Japan	GB
Display Units	0	0	0	0	0	0	
	1	1	1	1	1	1	
Drive Control	2	2	2	2	2	2	
Drive Pump	1	1	1	1	1	1	
Boom Control	1	1	1	1	1	1	
Function Speed Knob	0	0	0	0	0	0	
Clearsky	0	0	0	0	0	0	
	1	1	1	1	1	1	
Cribbing Option	0	0	0	0	0	0	
	1	1	1	1	1	1	
Alarm / Horn	0	0	0	0	0	0	
	1	1	1	1	1	1	
Alert Beacon	0	0	0	0	0	0	
	1	1	1	1	1	1	
Temp Cutout	0	0	0	0	0	0	
	X	1	X	1	X	X	
Plat Lvl Ovr Cut	0	0	0	0	0	0	
	1	1	1	1	1	1	

BOLD TEXT indicates the default setting. Plain text indicates another available selection. **ITALIC TEXT** indicates the default when option is factory installed. SHADED CELLS indicate hidden menu or selection.

4150364-Z

6.6 MACHINE PERSONALITY SETTINGS AND FUNCTION SPEEDS

NOTE: Personality settings can be adjusted within the adjustment range in order to achieve optimum machine performance.

Table 6-9. Machine Personality Settings

SUBMENU (DISPLAYED ON ANALYZER 1ST LINE)	PERSONALITY ADJUSTMENT	RANGE	DEFAULTS
DRIVE:	ACCEleration	0.0 to 5.0s	3.5
	DECEleration	0.0 to 3.0s	2
	FORward MINimum speed	1 to 35%	30
	FORward MAXimum speed	1 to 100%	75
	REVerse MINimum speed	1 to 35%	30
	REVerse MAXimum speed	1 to 100%	75
	ELEVATED MAXimum speed	1 to 100%	34
	CREEP MAXimum speed	1 to 90%	32
STEER:	MAXimum speed	1 to 100%	100
MAIN LIFT:	ACCEleration	0.0 to 5.0s	2.5
	DECEleration	0.0 to 3.0s	1.0
	MINimum Up speed	1 to 60%	40
	MAXimum Up speed	1 to 100%	80
	CREEP maximum Up speed	1 to 65%	53
	MINimum Down speed	1 to 60%	40
	MAXimum Down speed	1 to 100%	85
	CREEP maximum Down speed	1 to 75%	53
TOWER LIFT:	ACCEleration	0.0 to 5.0s	2.2
	DECEleration	0.0 to 3.0s	0.7
	MINimum UP speed	1 to 60%	35
	MAXimum UP speed	1 to 100%	87
	MINimum DOWN speed	1 to 60%	35
	MAXimum DOWN speed	1 to 100%	81

Table 6-9. Machine Personality Settings

SUBMENU (DISPLAYED ON ANALYZER 1ST LINE)	PERSONALITY ADJUSTMENT	RANGE	DEFAULTS
SWING	ACCEleration	0.0 to 5.0s	2.8
	DECEleration	0.0 to 3.0s	1.5
	MINimum LEFT speed	1 to 50%	40
	MAXimum LEFT speed	1 to 100%	69
	CREEP maximum LEFT speed	1 to 65%	60
	MINimum RIGHT speed	1 to 50%	55
	MAXimum RIGHT speed	1 to 100%	69
	CREEP maximum RIGHT speed	1 to 65%	58
MAIN TELESCOPE:	ACCEleration	0.0 to 5.0s	2.5
	DECEleration	0.0 to 3.0s	1.0
	MINimum IN speed	1 to 65%	40
	MAXimum IN speed	1 to 100%	75
	MINimum OUT speed	1 to 65%	40
	MAXimum OUT speed	1 to 100%	75
TELESCOPE TOWER:	ACCEleration	0.0 to 5.0s	1.0
	DECEleration	0.0 to 3.0s	0.5
	MINimum IN speed	1 to 65%	35
	MAXimum IN speed	1 to 100%	70
	MINimum OUT speed	1 to 65%	50
	MAXimum OUT speed	1 to 100%	85
PLATFORM LEVEL:	ACCEleration	0.0 to 5.0s	1.5
	DECEleration	0.0 to 3.0s	0.0
	MINimum UP speed	1 to 65%	26
	MAXimum UP speed	1 to 100%	40
	MINimum DOWN speed	1 to 65%	25
	MAXimum DOWN speed	1 to 100%	40
	Medium Speed	0.01 to 1.00	0.60
PLATFORM ROTATE:	ACCEleration	0.0 to 5.0s	1.5
	DECEleration	0.0 to 3.0s	0.0
	MINimum LEFT speed	1 to 100%	24
	MAXimum LEFT speed	1 to 100%	35
	MINimum RIGHT speed	1 to 100%	24
	MAXimum RIGHT speed	1 to 100%	35

Table 6-9. Machine Personality Settings

SUBMENU (DISPLAYED ON ANALYZER 1ST LINE)	PERSONALITY ADJUSTMENT	RANGE	DEFAULTS
JIB LIFT	Lift ACCEleration	0.0 to 5.0s	3.5
	Lift DECEleration	0.0 to 3.0s	0.5
	MINimum UP speed	1 to 65%	26
	MAXimum UP speed	1 to 100%	42
	MINimum down	1 to 65%	26
	Max Down	1 to 100%	35
GROUND MODE	Tower LIFT UP speed	1 to 100%	86
	Tower LIFT DOWN speed	1 to 100%	80
	Main LIFT UP speed	1 to 100%	79
	Main LIFT DOWN speed	1 to 100%	84
	SWING speed	1 to 100%	68
	Main TELEscope speed	1 to 100%	74
	Tower TELEscope speed	1 to 100%	69
	PLATFORM ROTATE speed	1 to 100%	34
	PLATFORM LEVEL speed	1 to 100%	39
	JIB LIFT speed	1 to 100%	34
<i>Note: Ground Mode speed are automatically limited to being lower than platform speed for a given function.</i>			

4150365-K

6.7 MACHINE ORIENTATION WHEN SETTING FUNCTION SPEEDS

Tower Lift: Main Boom Horizontal, Telescoped In. Tower Lift Up, Record Time. Tower Lift Down, Record Time.

Tower Telescope: Tower Lift Fully Elevated, Main Boom Horizontal, Telescoped In. Tower Tele Out, Record Time. Tower Tele In, Record Time.

Lift: Tower Lift Fully Elevated, Tower Telescope Fully Extended, Main Telescope Fully Retracted.

Swing: Boom at Full Elevation. Telescope Retracted. Swing the Turntable off center and stop. Swing the opposite direction and start the test when the turntable is centered up. This eliminates ramp up and down on the controller affecting times.

Telescope: Boom at Full Elevation; Telescope Retracted; Telescope Out, Record Time. Telescope In, Record Time.

Drive (Forward/Reverse): Test should be done on a smooth level surface. Drive Select Switch should be set to high speed. Start approximately 25 ft. (7.62 m) from the starting point so that the unit is at maximum speed when starting the test. Results should be recorded for a 200 ft. (60.96 m) course. Drive Forward, Record Time. Drive Reverse, Record Time.

Drive (Above Horizontal): Test should be done on a smooth, level surface. Drive Select Switch should be set to Low Engine, Low Drive. The Platform Speed Control Knob should be positioned to Creep Speed. This simulates machine speed when the boom is above horizontal. Results should be recorded for a 50 ft. (15.2 m) course. Drive Forward, Record Time. Drive Reverse, Record Time.

Platform Rotate: Platform level and completely rotated one direction. Rotate the opposite direction, Record Time. Rotate the other direction, Record Time.

Articulating Jib: Platform level and centered with the boom. Start with the Jib down. Jib Up, Record Time. Jib Down, Record Time.

Test Notes

1. Stop watch should be started with the function, not with the controller or switch.
2. Drive test results reflect 15x19.5 or 18x19.5 tires, pneumatic or foam filled.
3. All speed tests are run from the platform. These speeds do not reflect the ground control operation.
4. The platform speed knob control must be at full speed (turned clockwise completely).
5. Function speeds may vary due to cold, thick hydraulic oil. Test should be run with the oil temperature above 100° F (38° C).
6. Some flow control functions may not work with the speed knob clicked into the creep position.

Table 6-10. Function Speeds

Function	Speed Tolerance Hybrid Mode (In Seconds)	Speed Tolerance Electric Mode (In Seconds)
Main Lift Up	45-50	45-50
Main Lift Down	45-50	45-50
Swing Right & Left	79-101	79-101
NOTE: No more than 10% difference between swing left and swing right.		
Main Telescope Out	30-40	30-40
Main Telescope In	24-34	24-34
Platform Rotate Right & Left	19-30	19-30
NOTE: No more than 15% difference between rotator left and rotator right.		
Jib Up	20-30	20-30
Jib Down	30-40	30-40
Tower Lift Up	60-75	60-75
Tower Lift Down	44-53	44-53
Tower Telescope Out	24-32	24-32
Tower Telescope In	15-25	15-25
Drive (4WD) Forward & Reverse	33-45 (FWD) 115-125 (Rev)	46-63 (FWD) 179-189 (Rev)
Drive Horizontal Above Elevation (4WD) Forward & Reverse (CE)	122 Min	122 Min
Drive Horizontal Above Elevation 4WD Forward & Reverse (ANSI)	122 Min	122 Min

4150241-1

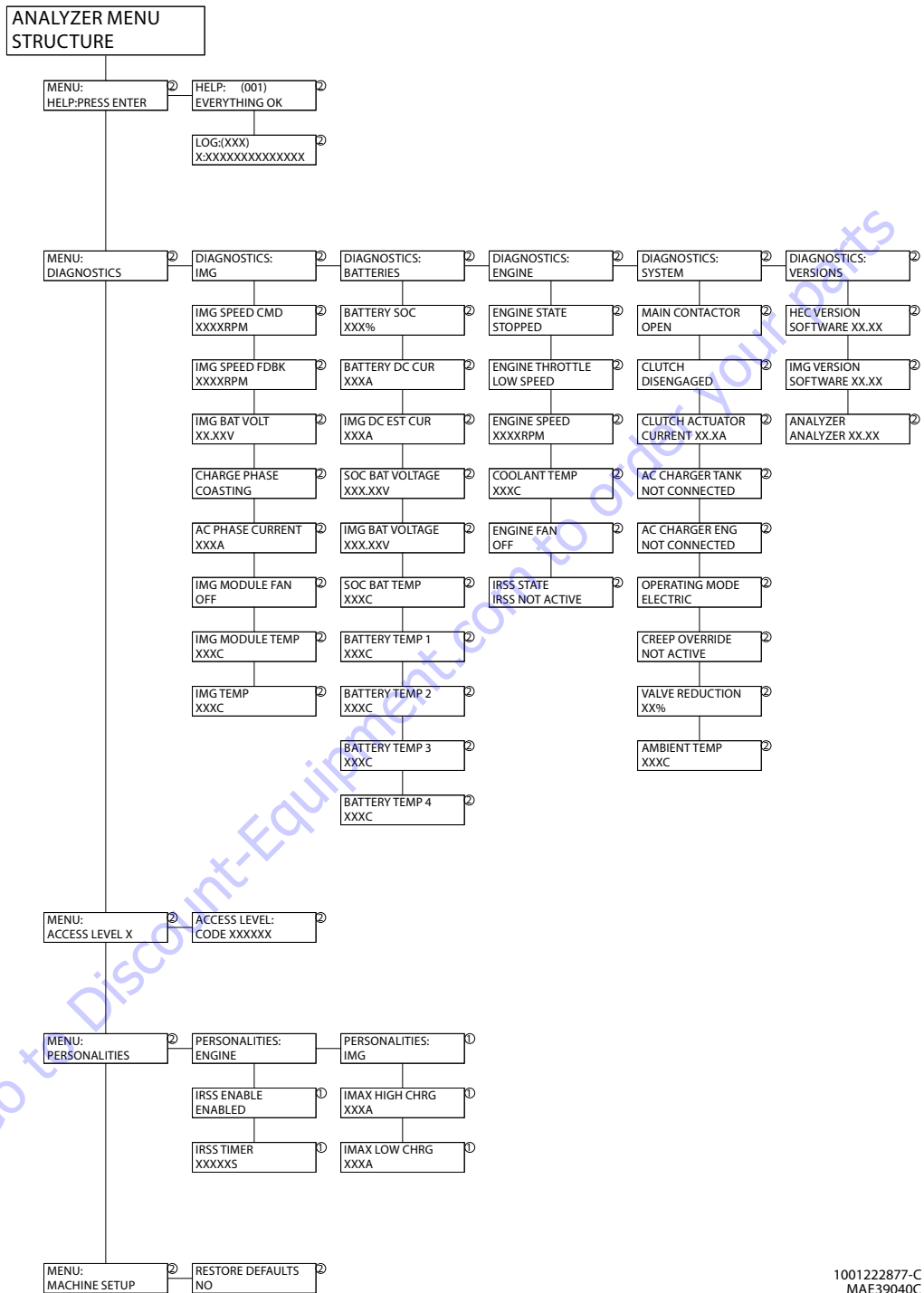

1001222877-C
MAE39040C

Figure 6-6. Analyzer Flow Chart (Software Version P1.1)

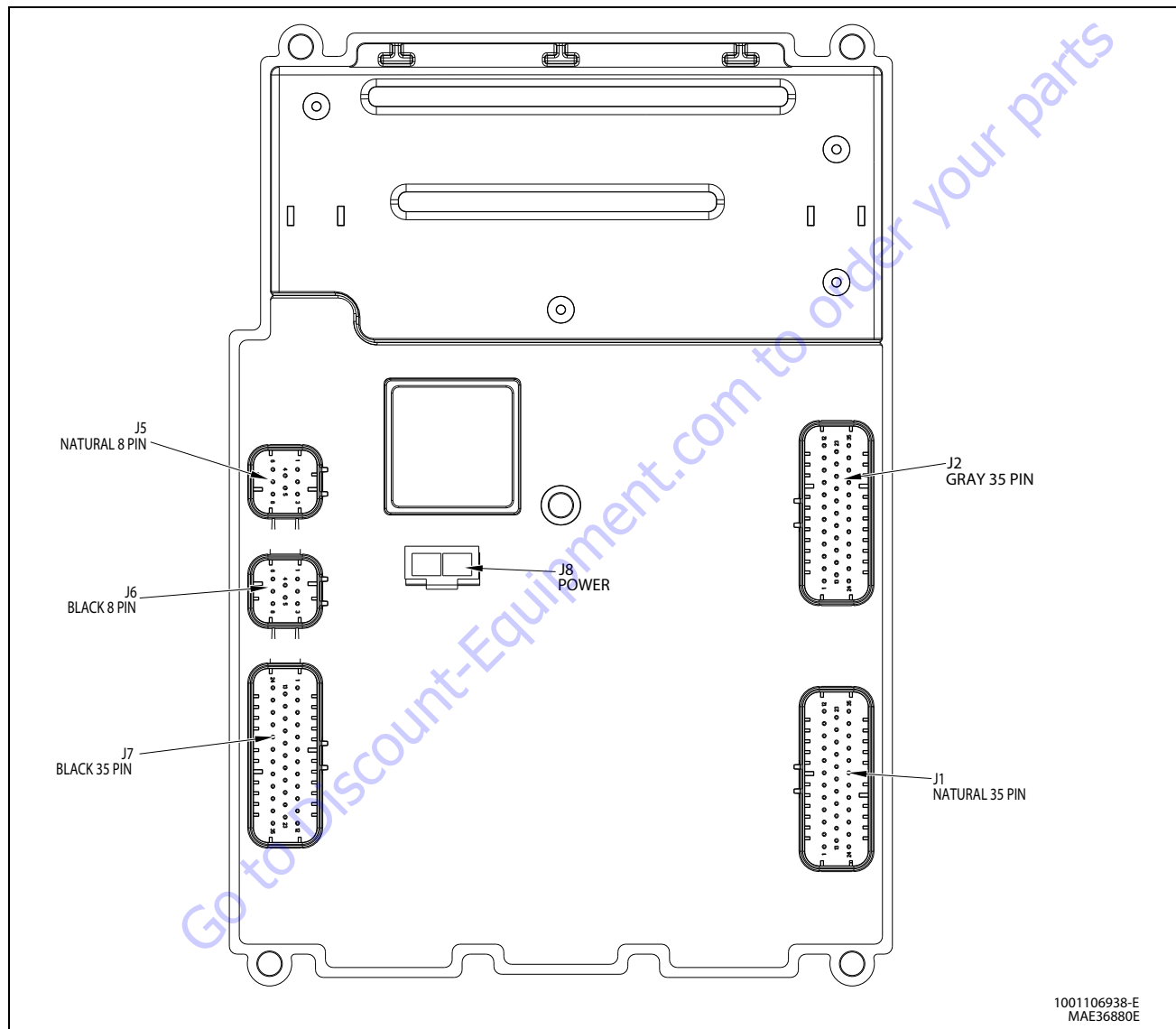

Figure 6-7. Platform Control Module

Connector	Pin	Assignment	Function
J1 NATURAL	1	TOWER LIFT UP	DIGITAL INPUT
	2	TOWER LIFT DOWN	DIGITAL INPUT
	3	TOWER TELESCOPE IN	DIGITAL INPUT
	4	TOWER TELESCOPE OUT	DIGITAL INPUT
	5	MAIN TELESCOPE IN	DIGITAL INPUT
	6	MAIN TELESCOPE OUT	DIGITAL INPUT
	7	PLATFORM ROTATE RIGHT	DIGITAL INPUT
	8	PLATFORM ROTATE LEFT	DIGITAL INPUT
	9	PLATFORM LEVEL UP	DIGITAL INPUT
	10	PLATFORM LEVEL DOWN	DIGITAL INPUT
	11	JIB UP	DIGITAL INPUT
	12	JIB DOWN	DIGITAL INPUT
	13	SPEED PUMP POTENTIOMETER GROUND	GROUND
	14	ENGINE START	DIGITAL INPUT
	15	ELEC MODE	DIGITAL INPUT
	16	CRAB STEER SELECT	DIGITAL INPUT
	17	COORDINATED STEER SELECT	DIGITAL INPUT
	18	SWITCH POWER	BATTERY VOLTAGE
	19	UNALLOCATED	DIGITAL INPUT
	20	UNALLOCATED	DIGITAL INPUT
	21	UNALLOCATED	DIGITAL INPUT
	22	DRIVE ORIENTATION SYSTEM FEATURE ENABLE	DIGITAL INPUT
	23	SKYGUARD INPUT #2	DIGITAL INPUT
	24	UNALLOCATED	DIGITAL INPUT
	25	UNALLOCATED	DIGITAL INPUT
	26	UNALLOCATED	DIGITAL INPUT
	27	TWO SPEED VALVE (HIGHENGINE)	DIGITAL INPUT
	28	TORQUE MODE	DIGITAL INPUT
	29	SOFT TOUCH OVER RIDE	DIGITAL INPUT
	30	HEAD/TAIL LIGHT	DIGITAL INPUT
	31	HORN	DIGITAL INPUT
	32	CREEP MODE	DIGITAL INPUT
	33	UNALLOCATED	DIGITAL INPUT
	34	SPEED PUMP POTENTIOMETER REFERENCE VOLTAGE	+7 REFERENCE VOLTAGE
	35	SPEED PUMP POTENTIOMETER	DIGITAL INPUT

Connector	Pin	Assignment	Function
J5 NATURAL	1	LIFT/SWING JOYSTICK SUPPLY VOLTAGE	SUPPLY VOLTAGE
	2	LIFT CENTER TAP	INPUT
	3	LIFT SIGNAL	INPUT
	4	SWING SIGNAL	INPUT
	5	SWING CENTER TAP	INPUT
	6	NOT CONNECTED	INPUT
	7	LIFT/SWING JOYSTICK RETURN	GROUND
	8	GROUND RETURN	GROUND

Connector	Pin	Assignment	Function
J6 BLACK	1	DRIVE/STEER JOYSTICK SUPPLY VOLTAGE	SUPPLY VOLTAGE
	2	DRIVE CENTER TAP	INPUT
	3	DRIVE SIGNAL	INPUT
	4	STEER SIGNAL	INPUT
	5	STEER LEFT	INPUT
	6	STEER RIGHT	INPUT
	7	DRIVE/STEER JOYSTICK RETURN	GROUND
	8	GROUND RETURN	GROUND

Connector	Pin	Assignment	Function
J8	1	MODULE GROUND	GROUND
	2	MODULE POWER	BATTERY VOLTAGE

SECTION 6 - JLG CONTROL SYSTEM

Connector	Pin	Assignment	Function
J2 GRAY	1	UNALLOCATED	DIGITAL INPUT
	2	UNALLOCATED	DIGITAL INPUT
	3	BATTERY VOLTAGE	BATTERY VOLTAGE
	4	DRIVE ORIENTATION SYSTEM OVERRIDE SWITCH	HS DIGITAL INPUT
	5	UNALLOCATED	LAMP OUTPUT
	6	CHASSIS TILTED INDICATOR	LAMP OUTPUT
	7	FUNCTION ENABLE INDICATOR	LAMP OUTPUT
	8	VEHICLE SYSTEM DISTRESS INDICATOR	LAMP OUTPUT
	9	CREEP SPEED INDICATOR	LAMP OUTPUT
	10	UNALLOCATED	LAMP OUTPUT
	11	PLATFORM OVER LOADED INDICATOR	LAMP OUTPUT
	12	UNALLOCATED	LAMP OUTPUT
	13	UNALLOCATED	LAMP OUTPUT
	14	DRIVE ORIENTATION SYSTEM INDICATOR	LAMP OUTPUT
	15	GENERATOR ON INDICATOR	LAMP OUTPUT
	16	SOFT TOUCH TRIGGERED INDICATOR	LAMP OUTPUT
	17	GLOW PLUG ENGAGED INDICATOR	LAMP OUTPUT
	18	LAMP RETURN	GROUND
	19	LOW FUEL	LAMP OUTPUT
	20	UPRIGHT TILTED INDICATOR	LAMP OUTPUT
	21	BATTERY SOC	LAMP OUTPUT
	22	BATTERY SOC	LAMP OUTPUT
	23	BATTERY SOC	LAMP OUTPUT
	24	BATTERY SOC	LAMP OUTPUT
	25	BATTERY LEVEL INDICATORS RETURN	GROUND
	26	ANALYZER POWER	ANALYZER POWER
	27	ANALYZER GROUND	ANALYZER GROUND
	28	ANALYZER RX	ANALYZER RX
	29	ANALYZER TX	ANALYZER TX
	30	BATTERY VOLTAGE	BATTERY VOLTAGE
	31	BATTERY VOLTAGE	BATTERY VOLTAGE
	32	BATTERY VOLTAGE	BATTERY VOLTAGE
	33	BATTERY VOLTAGE	BATTERY VOLTAGE
	34	SWITCH POWER	BATTERY VOLTAGE
	35	FULL BATTERY SOC INDICATOR	LAMP OUTPUT

Connector	Pin	Assignment	Function
J7 BLACK	1	GROUND MODE	GROUND MODE
	2	PLATFORM EMS	PLATFORM EMS
	3	PLATFORM EMS TO GROUND MODULE	PLATFORM MODE
	4	FOOTSWITCH (FUNCTIONENABLESWITCH) POWER	BATTERY VOLTAGE
	5	GENERATOR SWITCH POWER	BATTERY VOLTAGE
	6	UNALLOCATED	BATTERY VOLTAGE
	7	LSS	BATTERY VOLTAGE
	8	FOOTSWITCH SIGNAL	DIGITAL INPUT
	9	GENERATOR ON SIGNAL	DIGITAL INPUT
	10	+7 REFERENCE VOLTAGE	+7 REFERENCE VOLTAGE
	11	UNALLOCATED	ANALOG INPUT
	12	UNALLOCATED	ANALOG INPUT
	13	UNALLOCATED	ANALOG INPUT
	14	GROUND RETURN	GROUND
	15	+7 REFERENCE VOLTAGE	+7 REFERENCE VOLTAGE
	16	UNALLOCATED	GROUND
	17	UNALLOCATED	HSDIGITALINPUT
	18	SKYGUARD INPUT #1	HS DIGITAL INPUT
	19	PLATFORM ALARM	LAMP OUTPUT
	20	ALARM RETURN	GROUND
	21	PLATFORM LEVEL UP	ME DIGITAL OUTPUT
	22	PLATFORM LEVEL DOWN	ME DIGITAL OUTPUT
	23	GROUND RETURN	GROUND
	24	GROUND RETURN	GROUND
	25	JIB UP	ME DIGITAL OUTPUT
	26	JIB DOWN	ME DIGITAL OUTPUT
	27	UNALLOCATED	ME DIGITAL OUTPUT
	28	UNALLOCATED	ME DIGITAL OUTPUT
	29	GROUND RETURN	GROUND
	30	CAN LOW (CAN 1)	CAN LOW
	31	CAN HIGH (CAN 1)	CAN HIGH
	32	UNALLOCATED (CAN 1)	CAN SHIELD
	33	PLATFORM ROTATE LEFT	ME DIGITAL OUTPUT
	34	PLATFORM ROTATE RIGHT	ME DIGITAL OUTPUT
	35	GROUND RETURN	GROUND

Go to Discount-Equipment.com to order your parts

This Page Left Blank Intentionally

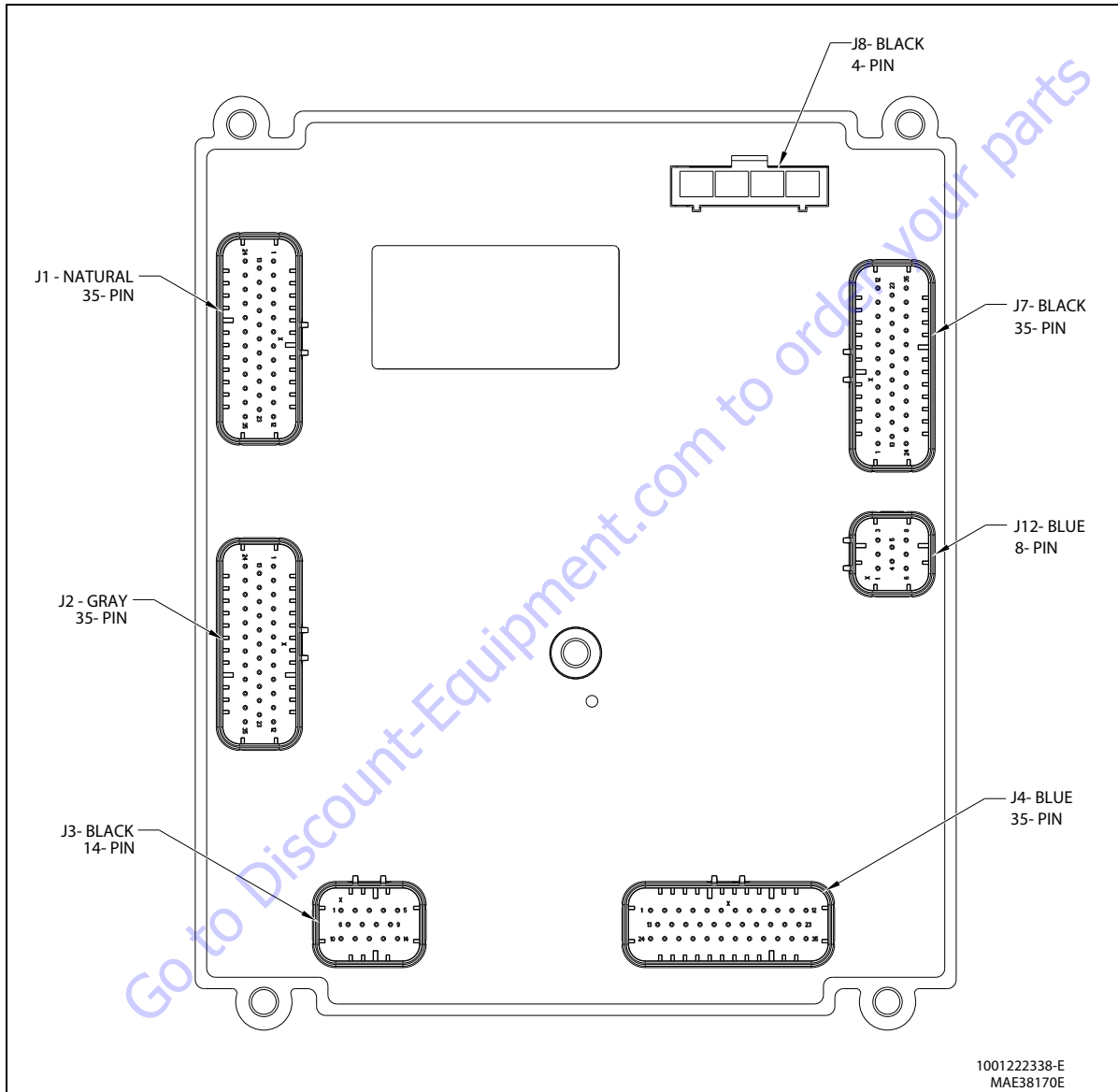

Figure 6-8. Ground Control Module

Connector	Pin	Function	Type
J1 (Natural)	1	THROTTLEACTUATOR(2-SPEED)RELAY	DIGITAL OUTPUT
	2	FUELPUMPRELAY	DIGITAL OUTPUT
	3	DRIVEFORWARDVALVE	DIGITAL OUTPUT
	4	ENGINESPEEDSENSORGROUND	GROUND INPUT
	5	PARKBRAKE/2-SPEEDVALVESGROUND	GROUND INPUT
	6	DRIVEREVERSEVALVE	DIGITAL OUTPUT
	7	RUN/STOPACTUATORRELAY	DIGITAL OUTPUT
	8	COOLANTTEMPSENSORGROUND	GROUND INPUT
	9	GLOWPLUG/STARTERGROUND	GROUND INPUT
	10	RUN/STOPACTUATORHOLDSIGNAL	DIGITAL OUTPUT
	11	ENGINESTARTERSOLENOIDRELAY	DIGITAL OUTPUT
	12	GLOWPLUGsRELAY	DIGITAL OUTPUT
	13	UNUSED	DIGITAL OUTPUT
	14	ENGINECOOLANTTEMPERATURESENSOR	ANALOG INPUT
	15	ENGINEOILPRESSURESWITCH	ANALOG INPUT
	16	ENGINESPEEDSENSOR	FREQUENCY INPUT
	17	RUN/STOP/FUELPUMPRELAYGROUND	GROUND INPUT
	18	SKYPOWER(OPTION)GROUND	GROUND INPUT
	19	FANRELAYGROUND(ENGINE/IMG/IMGCONTROLLER)	GROUND INPUT
	20	2SPEEDVALVE	DIGITAL OUTPUT
	21	UNUSED	DIGITAL INPUT
	22	SKYPOWER(OPTION)EXCITATION	DIGITAL OUTPUT
	23	PRARKINGBRAKEVALVE	DIGITAL OUTPUT
	24	UNUSED	N/C N/C
	25	UNUSED(REERVEDFORRS-485HIGH)	SERIAL I/O
	26	UNUSED(REERVEDFORRS-485LOW)	SERIAL I/O
	27	THROTTLEACTUATOR(2-SPEED)/HEAD/TAILLIGHTRELAYGROUND	GROUND INPUT
	28	ANALYZERPOWER	VOLTAGE OUTPUT
	29	ANALYZERRS-232RX	SERIAL INPUT
	30	ANALYZERRS-232TX	SERIAL OUTPUT
	31	ANALYZERGROUND	GROUND INPUT
	32	ENGINEALTERNATOREXCITATION	DIGITAL OUTPUT
	33	THROTTLEACTUTOR(2-SPEED)GROUND	GROUND INPUT
	34	UNUSED	DIGITAL INPUT
	35	UNUSED	DIGITAL INPUT

Connector	Pin	Function	Type
J2 (Gray)	1	STEER DUMP VALVE	DIGITAL OUTPUT
	2	GROUND ALARM	DIGITAL OUTPUT
	3	TOWER TELESCOPE IN VALVE	DIGITAL OUTPUT
	4	MAIN TELESCOPE IN VALVE	DIGITAL OUTPUT
	5	UNUSED	DIGITAL OUTPUT
	6	FUEL LEVEL SENSOR GROUND	GROUND INPUT
	7	UNUSED	DIGITAL OUTPUT
	8	RIGHT FRONT STEERVALVE	DIGITAL OUTPUT
	9	REAR RIGHT STEER VALVE	DIGITAL OUTPUT
	10	UNUSED	DIGITAL OUTPUT
	11	MAIN LIFTUP VALVE	DIGITAL OUTPUT
	12	UNUSED	DIGITAL OUTPUT
	13	MAIN DUMP VALVE	DIGITAL OUTPUT
	14	ALARM/STEERDUMPGROUND	GROUND INPUT
	15	TOWERTELESCOPEOUTVALVE	DIGITAL OUTPUT
	16	MAINTELESCOPEOUTVALVE	DIGITAL OUTPUT
	17	MAINDUMP/TELE/LEFT/TOWERVALVESGROUND	GROUND INPUT
	18	UNUSED	GROUND INPUT
	19	LEFTFRONT STEER VALVE	DIGITAL OUTPUT
	20	REAR LEFT STEERVALVE	DIGITAL OUTPUT
	21	UNUSED	DIGITAL OUTPUT
	22	MAIN LIFT DOWNVALVE	DIGITAL OUTPUT
	23	UNUSED	DIGITAL OUTPUT
	24	UNUSED	DIGITAL INPUT
	25	FUELSENSOR	ANALOG INPUT
	26	HEAD/TAILLIGHTENABLERELAY	DIGITAL OUTPUT
	27	HORN/GROUNDALARMOUTPUT	DIGITAL OUTPUT
	28	MSSOCONFIGURATIONPOWER	GROUND INPUT
	29	UNUSED	GROUND INPUT
	30	STEER/STEERDUMPVALVESGROUND	GROUND INPUT
	31	FLOWCONTROLVALVE	DIGITAL OUTPUT
	32	TOWERLIFTDOWNVALVE	DIGITAL OUTPUT
	33	TOWERLIFTUPVALVE	DIGITAL OUTPUT
	34	SWINGLEFTVALVE	DIGITAL OUTPUT
	35	SWINGRIGHTVALVE	DIGITAL OUTPUT

SECTION 6 - JLG CONTROL SYSTEM

Connector	Pin	Function	Type	
J4 (Blue)	1	CRIBBINGENABLEDINDICATOR	DIGITAL	OUTPUT
	2	UNRESTRICTEDINDICATOR	DIGITAL	OUTPUT
	3	GLOWPLUGINDICATOR	DIGITAL	OUTPUT
	4	ENGINESTARTSWITCH	DIGITAL	INPUT
	5	PLATFORMLEVELDOWNSWITCH	DIGITAL	INPUT
	6	PLATFORMROTATELEFTSWITCH	DIGITAL	INPUT
	7	MAINTELESCOPEINSWITCH	DIGITAL	INPUT
	8	JIBLIFTDOWNSWITCH	DIGITAL	INPUT
	9	UNUSED	DIGITAL	INPUT
	10	TOWERLIFTUPSWITCH	DIGITAL	INPUT
	11	TOWERTELEINSWITCH	DIGITAL	INPUT
	12	UNUSED	DIGITAL	OUTPUT
	13	LOWFUELINDICATOR	DIGITAL	OUTPUT
	14	PLATFORMOVERLOADEDINDICATOR	DIGITAL	OUTPUT
	15	BOOMMALFUNCTIONINDICATOR	DIGITAL	OUTPUT
	16	EMERGENCYDESCENT/FUNCTIONENABLESWITCH	DIGITAL	INPUT
	17	PLATFORMLEVELUPSWITCH	DIGITAL	INPUT
	18	PLATFORMROTATERIGHTSWITCH	DIGITAL	INPUT
	19	JIBLIFTUPSWITCH	DIGITAL	INPUT
	20	UNUSED	DIGITAL	INPUT
	21	TOWERLIFTDOWNSWITCH	DIGITAL	INPUT
	22	TOWERTELEOUTSWITCH	DIGITAL	INPUT
	23	MAINLIFTUPSWITCH	DIGITAL	INPUT
	24	UNUSED	VBAT	OUTPUT
	25	SWITCHESPOWER	VBAT	OUTPUT
	26	BATTERYLOW/NOTCHARGINGINDICATOR	DIGITAL	OUTPUT
	27	RESTRICTEDINDICATOR	DIGITAL	OUTPUT
	28	CHECKENGINEINDICATOR	DIGITAL	OUTPUT
	29	SYSTEMDISTRESSINDICATOR	DIGITAL	OUTPUT
	30	MAINTELESCOPEOUTSWITCH	DIGITAL	INPUT
	31	INDICATORSGROUND	GROUND	INPUT
	32	UNUSED	GROUND	INPUT
	33	MAINLIFTDOWNSWITCH	DIGITAL	INPUT
	34	SWINGLEFTSWITCH	DIGITAL	INPUT
	35	SWINGRIGHTSWITCH	DIGITAL	INPUT

Connector	Pin	Function	Type	
J7 (Black)	1	PLATFORMMEMS	DIGITAL	INPUT
	2	PLATFORMMODE	DIGITAL	INPUT
	3	GROUNDMODE	DIGITAL	INPUT
	4	CAPACITYANGLESWITCH	ANALOG	INPUT
	5	UNUSED	VOLTAGE	OUTPUT
	6	UNUSED	TERM	I/O
	7	CAPACITYLENGTHSWITCH	ANALOG	INPUT
	8	UNUSED	ANALOG	INPUT
	9	UNUSED	GROUND	INPUT
	10	UNUSED	GROUND	INPUT
	11	ELEVATIONSWITCH	DIGITAL	INPUT
	12	UNUSED	DIGITAL	INPUT
	13	CAN1HIGH	SERIAL	I/O
	14	GROUNDMODEPOWERTOPLATFORM	DIGITAL	INPUT
	15	FOOTSWITCH	DIGITAL	INPUT
	16	CAPACITYANGLESWITCHPOWER	VOLTAGE	OUTPUT
	17	UNUSED	TERM	I/O
	18	UNUSED	GROUND	INPUT
	19	TOWERSWITCHESGROUND	GROUND	INPUT
	20	UNUSED	ANALOG	INPUT
	21	TOWERTELESCOPERETRACTEDSWITCH	DIGITAL	INPUT
	22	TOWERLIFTSWITCH	DIGITAL	INPUT
	23	JUMPER	DIGITAL	INPUT
	24	CAN1LOW	SERIAL	I/O
	25	UNUSED	GROUND	INPUT
	26	CAPACITYLENGTHSWITCHPOWER	VOLTAGE	OUTPUT
	27	UNUSED	VOLTAGE	OUTPUT
	28	UNUSED	GROUND	INPUT
	29	BOOMELEVATIONSWITCHPOWER	VBAT	OUTPUT
	30	JUMPERPOWER	VBAT	OUTPUT
	31	UNUSED	VBAT	OUTPUT
	32	UNUSED	VBAT	OUTPUT
	33	TOWERTELESCOPERETRACTEDSWITCHPOWER	VBAT	OUTPUT
	34	TOWERLIFTSWITCHPOWER	VBAT	OUTPUT
	35	DOSSWITCH	DIGITAL	INPUT

Connector	Pin	Function	Type	
J3 (Black)	1	DRIVEVALVESCURRENTFEEDBACK	GROUND	INPUT
	2	THROTTLECURRENTFEEDBACK	GROUND	INPUT
	3	UMSENSORGROUND	GROUND	INPUT
	4	SWINGVALVESCURRENTFEEDBACK	GROUND	INPUT
	5	UNUSED	GROUND	INPUT
	6	FLOWCONTROLVALVESCURRENTFEEDBACK	GROUND	INPUT
	7	ENGINESPEEDSENSOR/UMSENSORPOWER	VBAT	OUTPUT
	8	UMSENSOR	DIGITAL	INPUT
	9	CRIBBINGENABLESWITCH	DIGITAL	INPUT
	10	UNUSED	DIGITAL	INPUT
	11	MSSOCONFIGURATION	DIGITAL	INPUT
	12	UNUSED	VOLTAGE	OUTPUT
	13	UNUSED	ANALOG	INPUT
	14	MAINLIFTVALVESCURRENTFEEDBACK	GROUND	INPUT

Connector	Pin	Function	Type	
J12 (Blue)	1	UNUSED	FREQUENCY	INPUT
	2	UNUSED	FREQUENCY	INPUT
	3	CAN2HIGH(ISOLATED)	SERIAL	I/O
	4	CAN2LOW(ISOLATED)	SERIAL	I/O
	5	MSSOSWITCHGROUND	GROUND	INPUT
	6	UNUSED	SERIAL	I/O
	7	UNUSED	SERIAL	I/O
	8	MSSOSWITCH	DIGITAL	INPUT

Connector	Pin	Function	Type	
J8 (Black)	1	MODULEGROUND	GROUND	OUTPUT
	2	MODULEPOWER	VBAT	INPUT
	3	UNSED	GROUND	INPUT
	4	UNSED	VBAT	OUTPUT

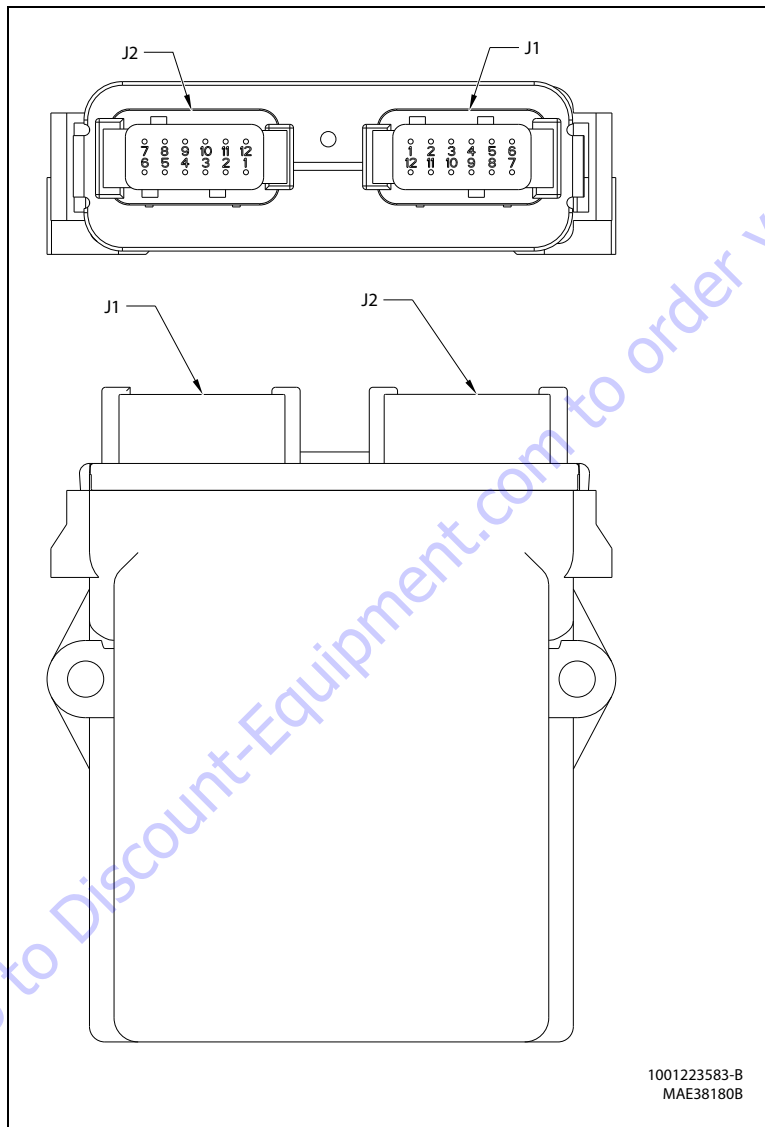

Figure 6-9. HEC Module

CONNECTOR	PIN	TAGNAME	DESCRIPTION	TYPE	
J1(BLACK)	1	12VSYSTEMIGN	IGNITION	POWER	INPUT
	2	12VSYSTEMGND	ACCESSORYMODULEGROUND	POWER	INPUT
	3	SPARE		DIGITAL	INPUT
	4	SPARE		DIGITAL	INPUT
	5	SPARE		DIGITAL	INPUT
	6	SPARE		DIGITAL	INPUT
	7	IMGCONTROLLER COOLING FAN	IMGCONTROLLERFAN	DIGITAL	OUTPUT
	8	SPARE		DIGITAL	OUTPUT
	9	SPARE		DIGITAL	OUTPUT
	10	ENGINE COOLING FAN	ENGINEFAN	DIGITAL	OUTPUT
	11	SPARE		DIGITAL	OUTPUT
	12	SPARE		DIGITAL	OUTPUT
J2(GREY)	1	SPARE		POWER	OUTPUT
	2	SPARE		ANALOG	INPUT
	3	SPARE		POWER	OUTPUT
	4	SPARE		POWER	OUTPUT
	5	SPARE		ANALOG	INPUT
	6	SPARE		POWER	OUTPUT
	7	SPARE		ANALOG	INPUT
	8	SPARE		ANALOG	INPUT
	9	CANH	CANBUSHIGH	SERIAL	I/O
	10	CANL	CANBUSLOW	SERIAL	I/O
	11	TX_ANALYZER	RS-232TRANSMIT	SERIAL	OUTPUT
	12	RX_ANALYZER	RS-232RECEIVE	SERIAL	INPUT

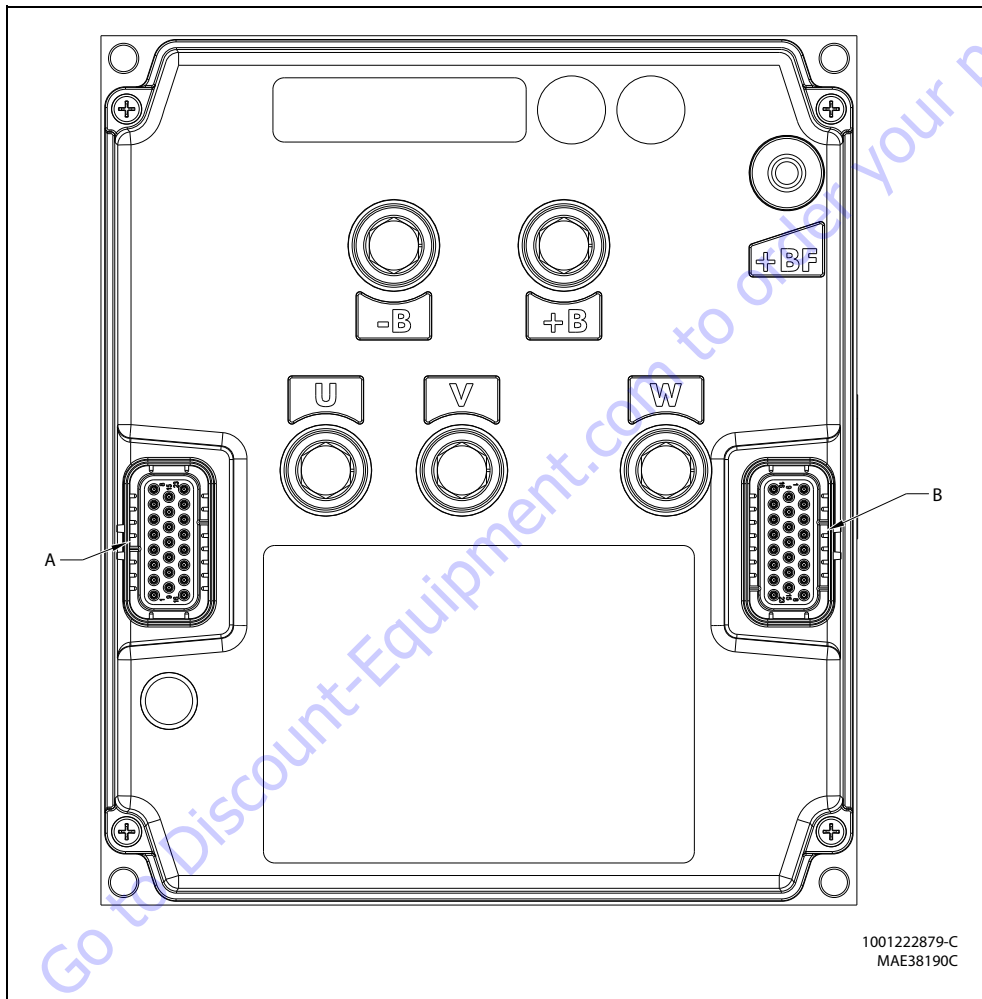

Figure 6-10. IMG Controller

CONNECTOR	PIN	FUNCTION	TYPE	
A	1	IMG_CONTROLLER_IGN	LOGICPOWERIN	POWER
	2	SPARE	POWEROUT	POWER
	3	SPARE	ANALOGIN	INPUT
	4	SPARE	HSDIGITALIN	INPUT
	5	SPARE	HSDIGITALIN	INPUT
	6	CHARGER1_INTERLOCK_A	LSDIGITALIN	INPUT
	7	SPARE	ENCODERCHA	INPUT
	8	SPARE	ENCODERPWR	POWER
	9	BATT_ANALOG_SENSE_GND	ANALOGGND	POWER
	10	SPARE	ANALOGIN	INPUT
	11	SPARE	HSDIGITALIN	INPUT
	12	SPARE	CAN1TERMINATOR	COMMUNICATION
	13	CHARGER2_INTERLOCK_B	LSDIGITALIN	INPUT
	14	SPARE	ENCODERCHB	INPUT
	15	LS_DIG/IMG_TEMP_GND	ENCODERGND	POWER
	16	MAIN_CONTACTOR_LS_DRV	PWMDIGITALOUT	OUTPUT
	17	SPARE	POWERIN	POWER
	18	SPEED_CONVERTER_PULSE	LSDIGITALOUT	OUTPUT
	19	SPEED_CONVERTER_CHARGE	LSDIGITALOUTPWM	OUTPUT
	20	CAN2-L	CAN1SIGNAL	COMMUNICATION
	21	CAN2-H	CAN1SIGNAL	COMMUNICATION
	22	N/C	CAN1GROUND	POWER
	23	IMG_TEMP+	ANALOG/DIGITALTEMP	INPUT

6.8 CANBUS COMMUNICATIONS

CANbus: CAN (Control Area Network) is a two wire differential serial link between the Platform Module, Universal Ground Module (UGM) and HEC module providing bi-directional communications. This machine has two CANbus communications. CAN1 connects ground display, HEC module and clutch control module. CAN2 connects Universal Ground Module (UGM), IMG module and SoC device.

Two-wire: One wire (YEL) is driven high (5v) and the other low (GRN) (0v) to send a signal; both wires "float" (2.5v) when no signal is being sent.

Differential: Any electrical line noise can affect the high or the low wires but never both, so communications is not corrupted.

Serial Link: Messages are being sent bit by bit along the wires; the high bus speed allow all modules to be constantly updated around 20 times per second. Typical traffic is 300 - 500 messages per second.

A complete CANbus circuit is approximately 60 ohms, which can be verified at the "T" fitting inside the ground station or below the BLAM. Each individual circuit from the modules is approximately 120 ohms.

The UGM is the master system controller. Most functions are dispatched and coordinated from this module, The PLATFORM MODULE handle sub-tasks. All characterized information (values) are stored into the ground module (i.e., Personalities or Calibrations).

Interlocks: Any device that sends an electrical input. (For an example a limit switch, proximity switch, etc;)

Platform Level: The UGM stores the default values and handles interlocks. The PLATFORM MODULE reads the sensors mounted on the platform assembly and controls the Level Up / Down valves to maintain set point sent from the UGM.

Steer: The UGM stores crack points and sends desired drive direction, steering mode and axle extend/retract commands. The PLATFORM MODULE reports the steering switch position to the UGM.

Drive: The UGM stores crack points, sends commands for each drive pump. (Command is computed from drive joystick input, interlocks, wheel angle, etc).

Lift, Tele, & Swing: The UGM stores default values and handles interlocks and calibration information. Lift, Telescope and Swing commands are dependent upon interlocks through out the machine. Boom angle, length and swing are controlled by the UGM.

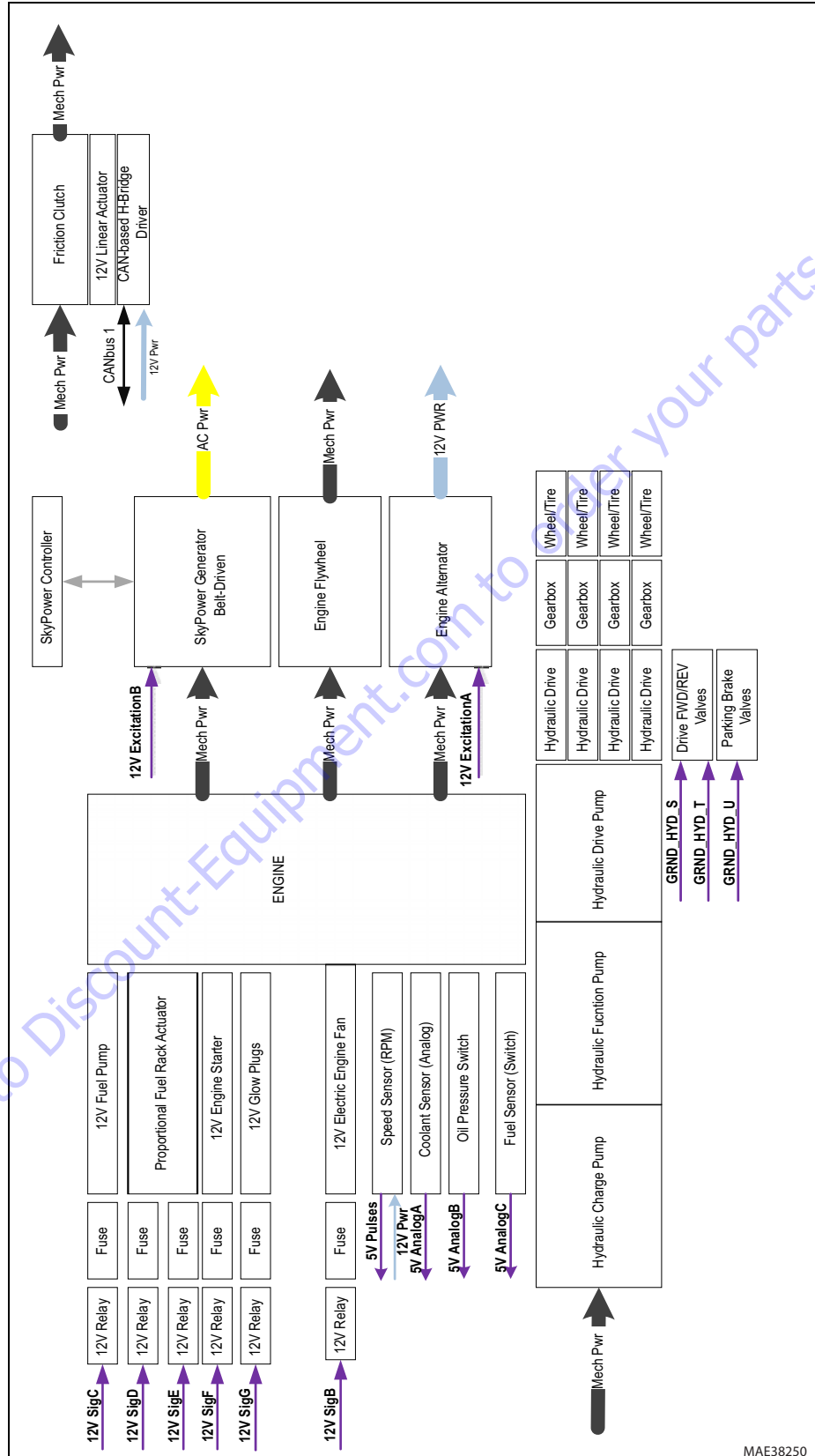

Figure 6-11. Control System Block Diagram - Sheet 1 of 4

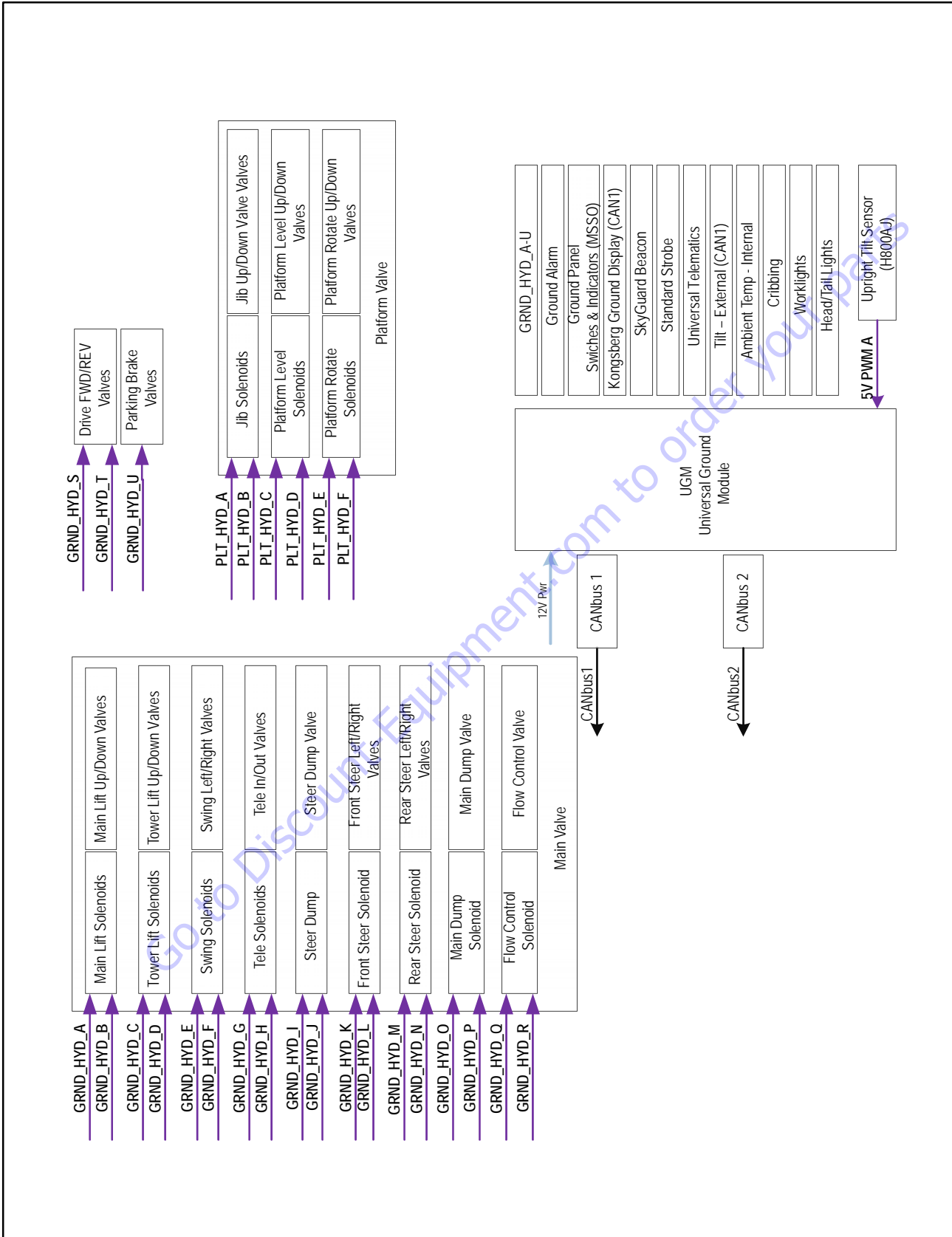

Figure 6-12. Control System Block Diagram - Sheet 2 of 4

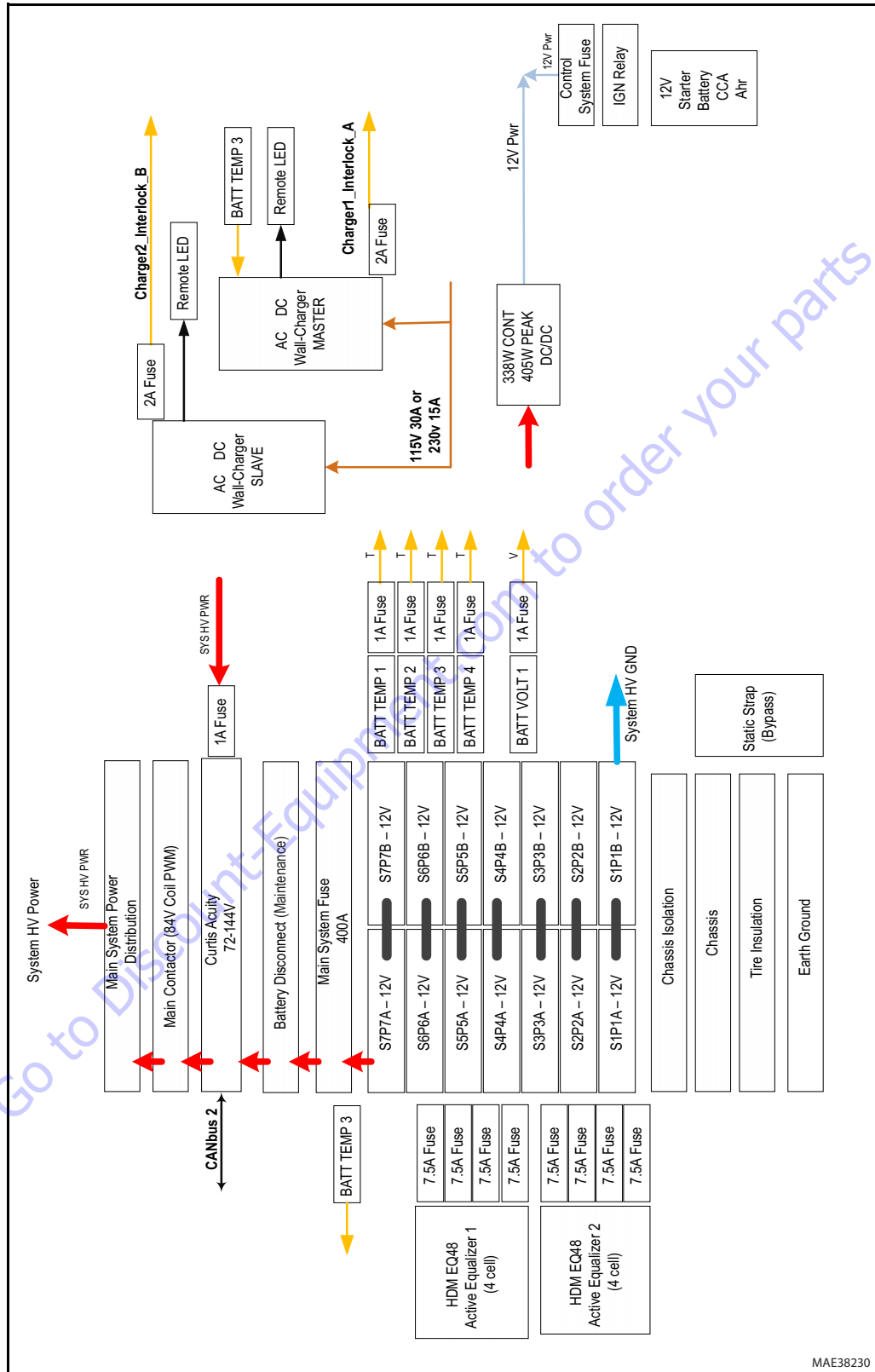

Figure 6-13. Control System Block Diagram - Sheet 3 of 4

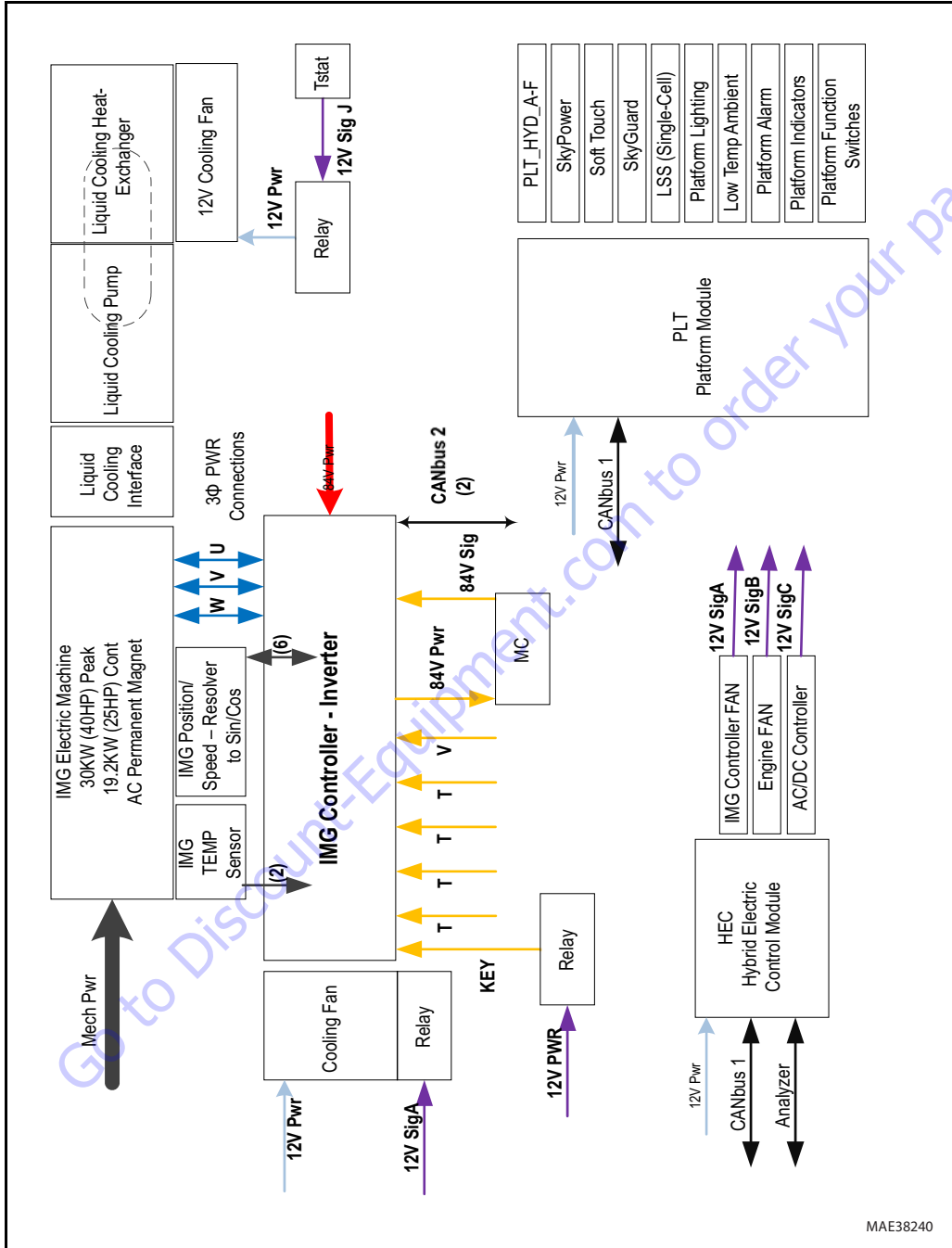

Figure 6-14. Control System Block Diagram - Sheet 4 of 4

6.9 DIAGNOSTIC TROUBLE CODE CHART

Table 6-11. Diagnostic Trouble Code Chart

DTC	Flash Code	Sequence	Fault Message	Fault Description	Check
001	00	1	EVERYTHING OK	The normal help message in Platform Mode.	No response required for this DTC.
002	00	2	GROUND MODE OK	The normal help message in Platform Mode.	No response required for this DTC.
0010	00	10	RUNNING AT CUTBACK - OUT OF TRANSPORT POSITION	Drive speed is limited to "ELEVATED MAX" while the vehicle is out of transport position. The normal help message in Ground Mode.	Response described in Drive Modes section.
000	00	0	<<< HELP COMMENT >>>		
0011	00	11	FSW OPEN (Foot switch open)	A drive / boom function was selected with the Footswitch open.	The UGM shall not Enable the Machine.
0012	00	12	RUNNING AT CREEP - CREEP SWITCH OPEN	All functions at creep while the Creep Switch is open.	The UGM shall limit the machine to Creep speed.
0013	00	13	RUNNING AT CREEP - TILTED AND ABOVE ELEVATION	All functions at creep while the Platform is elevated and the Chassis is tilted.	
0014	00	14	CHASSIS TILT SENSOR OUT OF RANGE	The Chassis is tilted > 19 degrees for more than 4 seconds.	Not reported during power-up.
0015	00	15	LOAD SENSOR READING UNDER WEIGHT	The Load Sensing System indicates > 20% under calibrated zero point.	
0031	00	31	FUEL LEVEL LOW - ENGINE SHUTDOWN	Engine Shutdown has occurred due to Fuel Level = EMPTY condition.	Response described in Fuel Shutdown section.
0035	00	35	APU ACTIVE	Auxiliary Power/Emergency Descent Mode is active.	Response described in Auxiliary Power/Emergency Descent Mode section.
0039	00	39	SKYGUARD ACTIVE - FUNCTIONS CUTOFF	Response described in Auxiliary Power/Emergency Descent Mode section.	Response described in Sky-Guard section.
0040	00	40	RUNNING AT CREEP - CREEP SWITCH CLOSED	All Function speeds are limited to creep because the creep switch is closed.	
210	21	0	<<< POWER-UP >>>		
211	21	1	POWER CYCLE	The normal help message is issued at each power cycle.	
212	21	2	KEYSWITCH FAULTY	Both Platform and Ground modes are selected simultaneously.	The UGM shall assume a station selection of Ground.
213	21	3	FSW FAULTY	Both Footswitches are closed for more than one second.	The UGM shall not Enable the Machine.
220	22	0	<<< PLATFORM CONTROLS >>>		
227	22	7	STEER SWITCHES FAULTY	Both Steer Left and Steer Right inputs are closed simultaneously.	The UGM shall prohibit Steer; The UGM shall limit Drive to Creep The Steer Left switch input = Low; The Steer Right switch input = Low; Steer and full Drive speed permitted after controls are initialized

SECTION 6 - JLG CONTROL SYSTEM

Table 6-11. Diagnostic Trouble Code Chart

DTC	Flash Code	Sequence	Fault Message	Fault Description	Check
2211	22	11	FSW INTERLOCK TRIPPED	The Footswitch was closed for more than seven seconds.	Can be reported during power-up.
2212	22	12	DRIVE LOCKED - JOYSTICK MOVED BEFORE FOOTSWITCH	A drive function was selected with Footswitch open.	Can be reported during power-up.
2213	22	13	STEER LOCKED - SELECTED BEFORE FOOTSWITCH	A steer function was selected with Footswitch open.	The UGM shall not Enable the Machine.
2214	22	14	DRIVE/STEER LOCKED - JOYSTICK MOVED BEFORE ENABLE	Drive/Steer was selected before Enable switch activated.	
2216	22	16	D/S JOY. OUT OF RANGE HIGH	The D/S Joystick reference voltage is > 8.1V.	Resistive joysticks. If the reference voltage is > 7.7V then the reference voltage is out of tolerance of a short to battery has occurred.
2217	22	17	D/S JOY. CENTER TAP BAD	The D/S Joystick center tap voltage is < 3.08V or > 3.83V.	Resistive joysticks. - There is a +/- .1V range around these values due to resistor tolerances.
2219	22	19	L/S JOY. OUT OF RANGE HIGH	The L/S Joystick reference voltage is > 8.1V.	Resistive joysticks. - If the reference voltage is > 7.7V then the reference voltage is out of tolerance of a short to battery has occurred.
2220	22	20	L/S JOY. CENTER TAP BAD	The L/S Joystick center tap voltage is < 3.08V or > 3.83V.	Resistive joysticks. - There is a +/- .1V range around these values due to resistor tolerances.
2221	22	21	LIFT/SWING LOCKED - JOYSTICK MOVED BEFORE FOOTSWITCH	A lift / swing function was selected with Footswitch open.	If triggered by the Lift and/or Swing joystick not being in the neutral position at Startup, the UGM shall prohibit Lift and Swing. If triggered by Lift and/or Swing joystick is not in the neutral position when Footswitch becomes active or while DTC 2212, 2213 or 2223 is active, the UGM shall not Enable the Machine.
2222	22	22	WAITING FOR FSW TO BE OPEN	The Footswitch was closed during Platform selection.	Can be reported during power-up.
2223	22	23	FUNCTION SWITCHES LOCKED - SELECTED BEFORE ENABLE	A boom function was selected with Footswitch open.	The UGM shall not Enable the Machine.
2224	22	24	FOOTSWITCH SELECTED BEFORE START	The Footswitch was closed during engine start.	The UGM shall prohibit Engine Start.
2269	22	69	FUNCTION PROBLEM - HIGH SPEED & CREEP ACTIVE TOGETHER		

Table 6-11. Diagnostic Trouble Code Chart

DTC	Flash Code	Sequence	Fault Message	Fault Description	Check
234	23	4	FUNCTION SWITCHES FAULTY - CHECK DIAGNOSTICS/BOOM	A boom function has both directions selected together.	Disable whichever boom functions whose boom control inputs are triggering the fault. If Engine Start/Aux at fault, disable Engine Start but permit Auxiliary Power/ Emergency Descent.
235	23	5	FUNCTION SWITCHES LOCKED - SELECTED BEFORE AUX POWER	A boom function was selected before aux power.	
236	23	6	FUNCTION SWITCHES LOCKED - SELECTED BEFORE START SWITCH	A boom function was selected before engine start.	
237	23	7	START SWITCH LOCKED - SELECTED BEFORE KEYSWITCH	The Start Switch was closed during power-up.	The UGM shall prohibit Engine Start.
23163	23	163	FUNCTION PROBLEM - MSSO PERMANENTLY SELECTED	The MSSO switch input = Low at Startup.	No response required for this DTC Power Cycled.
240	24	0	<<< OTHER CONTROLS >>>		
241	24	1	AMBIENT TEMPERATURE SENSOR - OUT OF RANGE LOW	MACHINE SETUP > TEMP CUTOUT = YES; Ambient Temperature sensor reading - 50C.	The UGM shall set Low Temperature Cutout state = Faulty If the Machine is in Platform Mode and if the Boom is Above Elevation; The UGM shall suspend motion; If the Machine is in Ground Mode; No response required for this DTC.
242	24	2	AMBIENT TEMPERATURE SENSOR - OUT OF RANGE HIGH	Ambient Temperature sensor reading \geq 85C.	Check Ambient Temperature sensor reading < 85C.
250	25	0	<<< FUNCTION PREVENTED >>>		
259	25	9	MODEL CHANGED - HYDRAULICS SUSPENDED - CYCLE EMS	The model selection has been changed.	Disable all machine and engine functions (i.e., command engine shutdown and do not permit start).
2513	25	13	GENERATOR MOTION CUTOUT ACTIVE	Driving is not possible while the vehicle generator is running AND is configured to prevent drive.	The UGM shall not Enable the Machine.
2514	25	14	BOOM PREVENTED - DRIVE SELECTED	Boom functions are not possible while the vehicle is being driven AND is configured to not allow simultaneous drive & boom operation.	The UGM shall prohibit all boom functions.
2516	25	16	DRIVE PREVENTED - ABOVE ELEVATION	Driving is not possible while Boom functions are selected AND is configured to not allow simultaneous drive & boom operation.	The UGM shall prohibit Drive and Steer.
2517	25	17	DRIVE PREVENTED - TILTED & ABOVE ELEVATION	Driving is not possible while the vehicle is tilted and above elevation AND is configured to prevent drive while tilted and above elevation.	The UGM shall prohibit Drive and Steer.

SECTION 6 - JLG CONTROL SYSTEM

Table 6-11. Diagnostic Trouble Code Chart

DTC	Flash Code	Sequence	Fault Message	Fault Description	Check
2518	25	18	DRIVE PREVENTED - BOOM SELECTED	MACHINE SETUP > FUNCTION CUTOUT = BOOM CUTOUT The boom is Above Elevation Any boom function is already active The operator attempts to activate Drive or Steer.	The UGM shall prohibit Drive and Steer.
2519	25	19	DRIVE PREVENTED - TILTED & EXTENDED OR HIGH ANGLE	Drive Selected while tilted and extended and tilt is configured to cutout drive.	
2520	25	20	FUNCTIONS LOCKED OUT - CONSTANT DATA VERSION IMPROPER		
2530	25	30	UMS SENSOR FORWARD LIMIT REACHED	The Upright angle relative to the turntable is less than -4.0 degree.	
2531	25	31	UMS SENSOR OUT OF USABLE RANGE	Both the turntable tilt sensor and the UMS sensor read greater then +/-10 degree in the same direction.	
2532	25	32	UMS SENSOR BACKWARD LIMIT REACHED	The Upright angle relative to the turntable is greater than +2.5 degree.	
2563	25	63	SKYGUARD SWITCH - DISAGREEMENT	MACHINE SETUP > SKYGUARD = YES; Machine is in Platform Mode; [(SkyGuard input #1 Platform Module J7-18) ≠ (SkyGuard input #2 Platform Module J1-23)] > 160ms	Response detailed in Sky-Guard section.
2568	25	68	TEMPERATURE CUTOUT ACTIVE - AMBIENT TEMPERATURE TOO LOW	Low Temperature Cutout = Active	If the Boom is Above Elevation; The UGM shall suspend motion; The UGM shall limit the machine to Creep speed after controls initialized If the Machine is in Platform Mode and if the Boom is not Above Elevation.
2576	25	76	PLATFORM LEVEL PREVENTED - ABOVE ELEVATION	Platform Level Override Cutout = Enabled; The Platform Level Up or Down switch input = High; Footswitch is active.	The UGM shall suspend Platform Level Up and Down commands; The UGM shall prohibit Platform Level Up and Down
2577	25	77	DRIVE PREVENTED - START BATTERY CONNECTED	Start battery is connected	Check the battery.
330	33	0	<<< GROUND OUTPUT DRIVER >>>		
331	33	1	BRAKE - SHORT TO BATTERY	There is a Short to Battery to the Brake Valve.	Check Harness for damage.
332	33	2	BRAKE - OPEN CIRCUIT	There is an Open Circuit to the Brake Valve.	Check Harness for damage.
3311	33	11	GROUND ALARM - SHORT TO BATTERY	There is a Short to Battery to the Ground Alarm.	Ground Alarm equipped vehicles only.
3336	33	36	ALTERNATOR POWER - SHORT TO GROUND	There is a Short to Ground to the Alternator/ECM.	Check Harness for damage.
3340	33	40	AUX POWER - SHORT TO GROUND	There is a Short to Ground to the Auxiliary Power Pump Relay.	Check Harness for damage.
3341	33	41	AUX POWER - OPEN CIRCUIT	There is an Open Circuit to the Auxiliary Power Pump Relay.	Check Harness for damage.
3342	33	42	AUX POWER - SHORT TO BATTERY	There is a Short to Battery to the Auxiliary Power Pump Relay.	Check Harness for damage.

Table 6-11. Diagnostic Trouble Code Chart

DTC	Flash Code	Sequence	Fault Message	Fault Description	Check
3346	33	46	ELECTRIC FAN - SHORT TO GROUND	There is a short to ground to the Electric Fan.	Check Harness for damage.
3347	33	47	ELECTRIC FAN - OPEN CIRCUIT	There is an Open Circuit to the Electric Fan.	Check Harness for damage.
3348	33	48	ELECTRIC FAN - SHORT TO BATTERY	There is a Short to Battery to the Electric Pump.	Check Harness for damage.
3349	33	49	ELECTRIC PUMP - SHORT TO GROUND	There is a Short to Ground to the Pump Relay.	Check Harness for damage.
3350	33	50	ELECTRIC PUMP - OPEN CIRCUIT	There is an Open Circuit to the Pump Relay.	Check Harness for damage.
3351	33	51	ELECTRIC PUMP - SHORT TO BATTERY	There is a Short to Battery to the Pump Relay.	Check Harness for damage.
3352	33	52	LP LOCK - SHORT TO GROUND	There is an Open Circuit to the LP Lock.	Check Harness for damage.
3353	33	53	LP LOCK - OPEN CIRCUIT	There is an Open Circuit to the LP Lock.	Check Harness for damage.
3354	33	54	LP LOCK - SHORT TO BATTERY	There is a short to Battery to the LP Lock.	Check Harness for damage.
3355	33	55	LP START ASSIST - SHORT TO GROUND	There is a short to ground to the LP Start Assist.	Check Harness for damage.
3356	33	56	LP START ASSIST - OPEN CIRCUIT	There is an Open Circuit to the LP Start Assist.	Check Harness for damage.
3357	33	57	LP START ASSIST - SHORT TO BATTERY	There is a short to battery to the LP Start Assist.	Check Harness for damage.
3358	33	58	MAIN DUMP VALVE - SHORT TO GROUND	There is a Short to Ground to the Main Dump Valve.	Check Harness for damage.
3359	33	59	MAIN DUMP VALVE - OPEN CIRCUIT	There is an Open Circuit to the Main Dump Valve.	Check Harness for damage.
3360	33	60	MAIN DUMP VALVE - SHORT TO BATTERY	There is a Short to Battery to the Main Dump Valve.	Check Harness for damage.
3361	33	61	BRAKE - SHORT TO GROUND	There is a Short to Ground to the Brake Valve.	Check Harness for damage.
3362	33	62	START SOLENOID - SHORT TO GROUND	There is a Short to Ground to the Start Relay.	Check Harness for damage.
3363	33	63	START SOLENOID - OPEN CIRCUIT	There is an Open Circuit to the Start Relay.	Check Harness for damage.
3364	33	64	START SOLENOID - SHORT TO BATTERY	There is a Short to Battery to the Start Relay.	Check Harness for damage.
3365	33	65	STEER DUMP VALVE - SHORT TO GROUND	There is a Short to Ground to the Steer Dump Valve.	Check Harness for damage.
3366	33	66	STEER DUMP VALVE - OPEN CIRCUIT	There is an Open Circuit to the Steer Dump Valve.	Check Harness for damage.
3367	33	67	STEER DUMP VALVE - SHORT TO BATTERY	There is a Short to Battery to the Steer Dump Valve.	Check Harness for damage.
3368	33	68	TWO SPEED VALVE - SHORT TO GROUND	There is a Short to Ground to the Two Speed Valve.	Check Harness for damage.
3369	33	69	TWO SPEED VALVE - OPEN CIRCUIT	There is an Open Circuit to the Two Speed Valve.	Check Harness for damage.
3370	33	70	TWO SPEED VALVE - SHORT TO BATTERY	There is a Short to Battery to the Two Speed Valve.	Check Harness for damage.

SECTION 6 - JLG CONTROL SYSTEM

Table 6-11. Diagnostic Trouble Code Chart

DTC	Flash Code	Sequence	Fault Message	Fault Description	Check
3371	33	71	GROUND ALARM - SHORT TO GROUND	There is a Short to Ground to the Ground Alarm.	Check Harness for damage.
3372	33	72	GROUND ALARM - OPEN CIRCUIT	There is an Open Circuit to the Ground Alarm.	Check Harness for damage.
3373	33	73	GEN SET/WELDER - SHORT TO GROUND	There is a Short to Ground to the Generator Relay.	Check Harness for damage.
3374	33	74	GEN SET/WELDER - OPEN CIRCUIT	There is an Open Circuit to the Generator Relay.	Check Harness for damage.
3375	33	75	GEN SET/WELDER - SHORT TO BATTERY	There is a Short to Battery to the Generator Relay.	Check Harness for damage.
3376	33	76	HEAD TAIL LIGHT - SHORT TO GROUND	There is a Short to Ground to the Head Light Relay.	Check Harness for damage.
3377	33	77	HEAD TAIL LIGHT - OPEN CIRCUIT	There is an Open Circuit to the Head Light Relay.	Check Harness for damage.
3378	33	78	HEAD TAIL LIGHT - SHORT TO BATTERY	There is a Short to Battery to the Head Light Relay.	Check Harness for damage.
3379	33	79	HOOR METER - SHORT TO GROUND	There is a Short to Ground to the Hour Meter.	Check Harness for damage.
3382	33	82	PLATFORM LEVEL UP VALVE - SHORT TO GROUND	There is a Short to Ground to the Platform Level Up Valve	Check Harness for damage.
3383	33	83	PLATFORM LEVEL UP VALVE - OPEN CIRCUIT	There is an Open Circuit to the Platform Level Up Valve.	Check Harness for damage.
3384	33	84	PLATFORM LEVEL UP VALVE - SHORT TO BATTERY	There is a Short to Battery to the Platform Level Up Valve	Check Harness for damage.
3388	33	88	PLATFORM LEVEL DOWN VALVE - SHORT TO GROUND	There is a Short to Ground to the Platform Level Down Valve	Check Harness for damage.
3389	33	89	PLATFORM LEVEL DOWN VALVE - OPEN CIRCUIT	There is an Open Circuit to the Platform Level Down Valve.	Check Harness for damage.
3390	33	90	PLATFORM LEVEL DOWN VALVE - SHORT TO BATTERY	There is a Short to Battery to the Platform Level Down Valve	Check Harness for damage.
3394	33	94	PLATFORM ROTATE LEFT VALVE - SHORT TO GROUND	There is a Short to Ground to the Platform Rotate Left Valve.	Check Harness for damage.
3395	33	95	PLATFORM ROTATE LEFT VALVE - OPEN CIRCUIT	There is an Open Circuit to the Platform Rotate Left Valve.	Check Harness for damage.
3396	33	96	PLATFORM ROTATE LEFT VALVE - SHORT TO BATTERY	There is a Short to Battery to the Platform Rotate Left Valve.	Check Harness for damage.
3397	33	97	PLATFORM ROTATE RIGHT VALVE - SHORT TO GROUND	There is a Short to Ground to the Platform Rotate Right Valve.	Check Harness for damage.
3398	33	98	PLATFORM ROTATE RIGHT VALVE - OPEN CIRCUIT	There is an Open Circuit to the Platform Rotate Right Valve.	Check Harness for damage.
3399	33	99	PLATFORM ROTATE RIGHT VALVE - SHORT TO BATTERY	There is a Short to Battery to the Platform Rotate Right Valve.	Check Harness for damage.
33100	33	100	JIB LIFT UP VALVE - SHORT TO GROUND	There is a Short to Ground to the JIB Lift Up Valve.	Check Harness for damage.
33101	33	101	JIB LIFT UP VALVE - OPEN CIRCUIT	There is an Open Circuit to the JIB Lift Up Valve.	Check Harness for damage.
33102	33	102	JIB LIFT UP VALVE - SHORT TO BATTERY	There is a Short to Battery to the JIB Lift Up Valve.	Check Harness for damage.

Table 6-11. Diagnostic Trouble Code Chart

DTC	Flash Code	Sequence	Fault Message	Fault Description	Check
33103	33	103	JIB LIFT DOWN VALVE - SHORT TO GROUND	There is a Short to Ground to the JIB Lift Down Valve.	Check Harness for damage.
33104	33	104	JIB LIFT DOWN VALVE - OPEN CIRCUIT	There is an Open Circuit to the JIB Lift Down Valve.	Check Harness for damage.
33105	33	105	JIB LIFT DOWN VALVE - SHORT TO BATTERY	There is a Short to Battery to the JIB Lift Down Valve.	Check Harness for damage.
33106	33	106	TOWER LIFT UP VALVE - SHORT TO GROUND	There is a Short to Ground to the Tower Lift Up Valve.	Check Harness for damage.
33107	33	107	TOWER LIFT UP VALVE - OPEN CIRCUIT	There is an Open Circuit to the Tower Lift Up Valve.	Check Harness for damage.
33108	33	108	TOWER LIFT UP VALVE - SHORT TO BATTERY	There is a Short to Battery to the Tower Lift Up Valve.	Check Harness for damage.
33109	33	109	TOWER LIFT DOWN VALVE - SHORT TO GROUND	There is a Short to Ground to the Tower Lift Down Valve.	Check Harness for damage.
33110	33	110	TOWER LIFT DOWN VALVE - OPEN CIRCUIT	There is an Open Circuit to the Tower Lift Down Valve.	Check Harness for damage.
33111	33	111	TOWER LIFT DOWN VALVE - SHORT TO BATTERY	There is a Short to Battery to the Tower Lift Down Valve.	Check Harness for damage.
33112	33	112	TOWER TELESCOPE IN VALVE - SHORT TO GROUND	There is a Short to Ground to the Tower Telescope In Valve.	Check Harness for damage.
33113	33	113	TOWER TELESCOPE IN VALVE - OPEN CIRCUIT	There is an Open Circuit to the Tower Telescope In Valve.	Check Harness for damage.
33114	33	114	TOWER TELESCOPE IN VALVE - SHORT TO BATTERY	There is a Short to Battery to the Tower Telescope In Valve.	Check Harness for damage.
33115	33	115	TOWER TELESCOPE OUT VALVE - SHORT TO GROUND	There is a Short to Ground to the Tower Telescope Out Valve.	Check Harness for damage.
33116	33	116	TOWER TELESCOPE OUT VALVE - OPEN CIRCUIT	There is an Open Circuit to the Tower Telescope Out Valve.	Check Harness for damage.
33117	33	117	TOWER TELESCOPE OUT VALVE - SHORT TO BATTERY	There is a Short to Battery to the Tower Telescope Out Valve.	Check Harness for damage.
33118	33	118	SWING RIGHT VALVE - SHORT TO GROUND	There is a Short to Ground to the Swing Right Valve.	Check Harness for damage.
33119	33	119	SWING RIGHT VALVE - OPEN CIRCUIT	There is an Open Circuit to the Swing Right Valve.	Check Harness for damage.
33120	33	120	TELESCOPE IN VALVE - SHORT TO BATTERY	There is a Short to Battery to the Main Telescope In Valve.	Check Harness for damage.
33121	33	121	SWING RIGHT VALVE - SHORT TO BATTERY	There is a Short to Battery to the Swing Right Valve.	Check Harness for damage.
33122	33	122	SWING LEFT VALVE - SHORT TO GROUND	There is a Short to Ground to the Swing Left Valve.	Check Harness for damage.
33123	33	123	TELESCOPE OUT VALVE - SHORT TO BATTERY	There is a Short to Battery to the Main Telescope Out Valve.	Check Harness for damage.
33130	33	130	THROTTLE ACTUATOR - SHORT TO GROUND	There is a Short to Ground to the Throttle Actuator.	Check Harness for damage.
33131	33	131	THROTTLE ACTUATOR - OPEN CIRCUIT	There is an Open Circuit to the Throttle Actuator.	Check Harness for damage.
33132	33	132	THROTTLE ACTUATOR - SHORT TO BATTERY	There is a Short to Battery to the Throttle Actuator.	Check Harness for damage.

SECTION 6 - JLG CONTROL SYSTEM

Table 6-11. Diagnostic Trouble Code Chart

DTC	Flash Code	Sequence	Fault Message	Fault Description	Check
33170	33	170	LIFT DOWN VALVE - OPEN CIRCUIT	There is a Short to Ground to the Lift Down Valve.	Check Harness for damage.
33171	33	171	LIFT DOWN VALVE - SHORT TO BATTERY	There is an Open Circuit to the Lift Down Valve.	Check Harness for damage.
33172	33	172	LIFT DOWN VALVE - SHORT TO GROUND	There is a Short to Battery to the Lift Down Valve.	Check Harness for damage.
33175	33	175	JIB ROTATE LEFT VALVE - OPEN CIRCUIT	There is an Open Circuit to the JIB Rotate Left Valve.	Check Harness for damage.
33176	33	176	JIB ROTATE LEFT VALVE - SHORT TO BATTERY	There is a Short to Battery to the JIB Rotate Left Valve.	Check Harness for damage.
33177	33	177	JIB ROTATE LEFT VALVE - SHORT TO GROUND	There is a Short to Ground to the JIB Rotate Left Valve.	Check Harness for damage.
33178	33	178	JIB ROTATE RIGHT VALVE - OPEN CIRCUIT	There is an Open Circuit to the JIB Rotate Right Valve.	Check Harness for damage.
33179	33	179	JIB ROTATE RIGHT VALVE - SHORT TO BATTERY	There is a Short to Battery to the JIB Rotate Right Valve.	Check Harness for damage.
33180	33	180	JIB ROTATE RIGHT VALVE - SHORT TO GROUND	There is a Short to Ground to the JIB Rotate Right Valve.	Check Harness for damage.
33182	33	182	LIFT VALVES - SHORT TO BATTERY	There is a Short to Battery to the Lift Valves.	Check Harness for damage.
33186	33	186	TELESCOPE OUT VALVE - OPEN CIRCUIT	There is an Open Circuit to the Main Telescope Out Valve.	Check Harness for damage.
33188	33	188	TELESCOPE OUT VALVE - SHORT TO GROUND	There is a Short to Ground to the Main Telescope Out Valve.	Check Harness for damage.
33189	33	189	TELESCOPE IN VALVE - OPEN CIRCUIT	There is an Open Circuit to the Main Telescope In Valve.	Check Harness for damage.
33190	33	190	TELESCOPE IN VALVE - SHORT TO GROUND	There is a Short to Ground to the Main Telescope In Valve.	Check Harness for damage.
33207	33	207	HORN - OPEN CIRCUIT	There is an Open Circuit to the Horn.	Check Harness for damage.
33208	33	208	HORN - SHORT TO BATTERY	There is a Short to Battery to the Horn.	Check Harness for damage.
33209	33	209	HORN - SHORT TO GROUND	There is a Short to Ground to the Horn.	Check Harness for damage.
33279	33	279	GLOWPLUG - OPEN CIRCUIT	There is an Open Circuit to the Glow Plugs.	Check Harness for damage.
33280	33	280	GLOWPLUG - SHORT TO BATTERY	There is a Short to Battery to the Glow Plugs.	Check Harness for damage.
33281	33	281	GLOWPLUG - SHORT TO GROUND	There is a Short to Ground to the Glow Plugs.	Check Harness for damage.
33287	33	287	LIFT - CURRENT FEEDBACK READING TOO LOW	The Engine State = ENGINE RUNNING; The UGM commanded current > 250mA; The difference between the commanded current and the measured feedback current > [(the larger of (125mA) or (15% of the commanded function Max))] for longer than 1 second	The UGM shall suspend Lift Up and Down command and revert to Open Loop Current control for Lift; The UGM shall limit Lift Up and Down to Creep speed after controls initialized
33295	33	295	SWING LEFT VALVE - OPEN CIRCUIT	There is an Open Circuit to the Swing Left Valve.	Check Harness for damage.

Table 6-11. Diagnostic Trouble Code Chart

DTC	Flash Code	Sequence	Fault Message	Fault Description	Check
33306	33	306	SWING LEFT VALVE - SHORT TO BATTERY	There is short to Battery to the Swing Left Valve.	Check Harness for damage.
33314	33	314	FLOW CONTROL VALVE - OPEN CIRCUIT	There is an Open Circuit to the Flow Control Valve.	Check Harness for damage.
33315	33	315	FLOW CONTROL VALVE - SHORT TO BATTERY	There is short to Battery to the Flow Control Valve	Check Harness for damage.
33316	33	316	FLOW CONTROL VALVE - SHORT TO GROUND	There is short to Ground to the Flow Control Valve	Check Harness for damage.
33317	33	317	DRIVE FORWARD VALVE - OPEN CIRCUIT	There is an Open Circuit to the Drive Forward Valve.	Check Harness for damage.
33318	33	318	DRIVE FORWARD VALVE - SHORT TO BATTERY	There is short to Battery to the Drive Forward Valve.	Check Harness for damage.
33319	33	319	DRIVE FORWARD VALVE - SHORT TO GROUND	There is short to Ground to the Drive Forward Valve.	Check Harness for damage.
33320	33	320	DRIVE REVERSE VALVE - OPEN CIRCUIT	There is an Open Circuit to the Drive Reverse Valve.	Check Harness for damage.
33321	33	321	DRIVE REVERSE VALVE - SHORT TO BATTERY	There is a short to Battery to the Drive Reverse Valve.	Check Harness for damage.
33322	33	322	DRIVE REVERSE VALVE - SHORT TO GROUND	There is a short to Ground to the Drive Reverse Valve.	Check Harness for damage.
33323	33	323	LIFT UP VALVE - OPEN CIRCUIT	There is an Open Circuit to the Lift Up Valve.	Check Harness for damage.
33324	33	324	LIFT UP VALVE - SHORT TO BATTERY	There is a short to Battery to the Lift Up Valve.	Check Harness for damage.
33325	33	325	LIFT UP VALVE - SHORT TO GROUND	There is a Short to Ground to the Lift Up Valve.	Check Harness for damage.
33331	33	331	DRIVE - CURRENT FEEDBACK READING TOO LOW	The Engine State = ENGINE RUNNING; The UGM commanded current > 250mA; The difference between the commanded current and the measured feedback current > [the larger of (125mA) or (15% of the commanded function Max)] for longer than 1 second	The UGM shall suspend Drive Forward and Reverse command and revert to Open Current loop control for Drive; The UGM shall limit Drive Forward and Reverse to Creep speed after controls initialized
33410	33	410	DRIVE - CURRENT FEEDBACK READING LOST	Measured feedback current < 225mA while PWM output > 40% for a period of 100ms.	The UGM shall suspend Drive Forward and Reverse command and revert to Open Current loop control for Drive; The UGM shall limit Drive Forward and Reverse to Creep speed after controls initialized
33412	33	412	SWING VALVES - SHORT TO BATTERY	There is a short to Battery to the Swing Valves.	Check Harness for damage.
33414	33	414	SWING - CURRENT FEEDBACK READING TOO LOW	Current feedback into controller is below threshold value.	Check wiring and coil.

SECTION 6 - JLG CONTROL SYSTEM

Table 6-11. Diagnostic Trouble Code Chart

DTC	Flash Code	Sequence	Fault Message	Fault Description	Check
33415	33	415	FLOW CONTROL VALVE - CURRENT FEEDBACK READING TOO LOW	The Engine State = ENGINE RUNNING; The UGM commanded current > 250mA; The difference between the commanded current and the measured feedback current > [the larger of (125mA) or (15% of the commanded function Max)] for longer than 1 second.	The UGM shall suspend Flow Control and revert to Open Current loop control for Flow Control.
33417	33	417	LIFT - CURRENT FEEDBACK READING LOST	Measured feedback current < 225mA while PWM output > 40% for a period of 100ms.	The UGM shall suspend Lift Up and Down command and revert to Open Loop Current control for Lift; The UGM shall limit Lift Up and Down to Creep speed after controls initialized.
33418	33	418	SWING - CURRENT FEEDBACK READING LOST	Current feedback into controller not detected.	Check wiring and coil.
33419	33	419	FLOW CONTROL VALVE - CURRENT FEEDBACK READING LOST	Measured feedback current < 225mA while PWM output > 40% for a period of 100ms.	The UGM shall suspend Flow Control and revert to Open Current loop control for Flow Control.
33488	33	488	SWING FLOW CONTROL VALVE - SHORT TO GROUND	There is a short to the Ground to the Swing Flow Control Valve.	Check Harness for damage.
33575	33	575	ECM PULL DOWN RESISTOR - OPEN CIRCUIT	There is an Open Circuit to the ECM Pull Down Resistor.	Check Harness for damage.
340	34	0	<<< PLATFORM OUTPUT DRIVER >>>		
341	34	1	PLATFORM LEVEL UP VALVE - OPEN CIRCUIT	There is an Open Circuit to the Platform Level Up Valve.	Check Harness for damage.
342	34	2	PLATFORM LEVEL UP VALVE - SHORT TO BATTERY	There is a Short to Battery to the Platform Level Up Valve.	Check Harness for damage.
343	34	3	PLATFORM LEVEL UP VALVE - SHORT TO GROUND	There is a Short to Ground to the Platform Level Up Valve.	Check Harness for damage.
344	34	4	PLATFORM LEVEL UP VALVE - SHORT TO BATTERY OR OPEN CIRCUIT	There is a Short to Battery or an Open Circuit to the Platform Level Up Valve.	Check Harness for damage.
345	34	5	PLATFORM LEVEL DOWN VALVE - OPEN CIRCUIT	There is an Open Circuit to the Platform Level Down Valve.	Check Harness for damage.
346	34	6	PLATFORM LEVEL DOWN VALVE - SHORT TO BATTERY	There is a short to Battery to the Platform Level Down Valve.	Check Harness for damage.
347	34	7	PLATFORM LEVEL DOWN VALVE - SHORT TO GROUND	There is a short to the Ground to the Platform Level Down Valve.	Check Harness for damage.
348	34	8	PLATFORM LEVEL DOWN VALVE - SHORT TO BATTERY OR OPEN CIRCUIT	There is a Short to Battery or an Open Circuit to the Platform Level Down Valve.	Check Harness for damage.
349	34	9	PLATFORM ROTATE LEFT VALVE - OPEN CIRCUIT	There is an Open Circuit to the Platform Rotate Left Valve.	Check Harness for damage.
3410	34	10	PLATFORM ROTATE LEFT VALVE - SHORT TO BATTERY	There is a short to Battery to the Platform Rotate Left Valve.	Check Harness for damage.
3411	34	11	PLATFORM ROTATE LEFT VALVE - SHORT TO GROUND	There is a short to Ground to the Platform Rotate Left Valve.	Check Harness for damage.
3412	34	12	PLATFORM ROTATE RIGHT VALVE - OPEN CIRCUIT	There is an Open Circuit to the Platform Rotate Right Valve.	Check Harness for damage.

Table 6-11. Diagnostic Trouble Code Chart

DTC	Flash Code	Sequence	Fault Message	Fault Description	Check
3413	34	13	PLATFORM ROTATE RIGHT VALVE - SHORT TO BATTERY	There is a short to Battery to the Platform Rotate Right Valve.	Check Harness for damage.
3414	34	14	PLATFORM ROTATE RIGHT VALVE - SHORT TO GROUND	There is a short to Ground to the Platform Rotate Right Valve.	Check Harness for damage.
3415	34	15	JIB LIFT UP VALVE - OPEN CIRCUIT	There is an Open Circuit to the JIB Lift Up Valve.	Check Harness for damage.
3416	34	16	JIB LIFT UP VALVE - SHORT TO BATTERY	There is a Short to Battery to the JIB Lift Up Valve.	Check Harness for damage.
3417	34	17	JIB LIFT UP VALVE - SHORT TO GROUND	There is a short to Ground to the JIB Lift Up Valve.	Check Harness for damage.
3418	34	18	JIB LIFT DOWN VALVE - OPEN CIRCUIT	There is an Open Circuit to the JIB Lift Down Valve.	Check Harness for damage.
3419	34	19	JIB LIFT DOWN VALVE - SHORT TO BATTERY	There is a Short to Battery to the JIB Lift Down Valve.	Check Harness for damage.
3420	34	20	JIB LIFT DOWN VALVE - SHORT TO GROUND	There is a Short to Ground to the JIB Lift Down Valve.	Check Harness for damage.
3421	34	21	JIB ROTATE LEFT VALVE - OPEN CIRCUIT	There is an Open Circuit to the JIB Rotate Left Valve.	Check Harness for damage.
3422	34	22	JIB ROTATE LEFT VALVE - SHORT TO BATTERY	There is a Short to Battery to the JIB Rotate Left Valve.	Check Harness for damage.
3423	34	23	JIB ROTATE LEFT VALVE - SHORT TO GROUND	There is a Short to Ground to the JIB Rotate Left Valve.	Check Harness for damage.
3424	34	24	JIB ROTATE RIGHT VALVE - OPEN CIRCUIT	There is an Open Circuit to the JIB Rotate Right Valve.	Check Harness for damage.
3425	34	25	JIB ROTATE RIGHT VALVE - SHORT TO BATTERY	There is a Short to Battery to the JIB Rotate Right Valve.	Check Harness for damage.
3426	34	26	JIB ROTATE RIGHT VALVE - SHORT TO GROUND	There is a Short to Ground to the JIB Rotate Right Valve.	Check Harness for damage.
430	43	0	<<< ENGINE >>>		
431	43	1	FUEL SENSOR - SHORT TO BATTERY OR OPEN CIRCUIT	The Fuel Sensor reading is > 4.3V.	Energize fuel sensor per System Indicators
432	43	2	FUEL SENSOR - SHORT TO GROUND	The Fuel Sensor reading is < 0.2V.	Energize fuel sensor per System Indicators
433	43	3	OIL PRESSURE - SHORT TO BATTERY	The Oil Pressure Sensor reading is > 6.6V.	Deutz engine only.
434	43	4	OIL PRESSURE - SHORT TO GROUND	The Oil Pressure Sensor reading is < 0.1V for more then 5 seconds.	Deutz engine only. - Not reported during engine start.
435	43	5	COOLANT TEMPERATURE - SHORT TO GROUND	The Coolant Temperature Sensor reading is < 0.1V.	Deutz engine only.
436	43	6	FORD FAULT CODE ##	All ford fault codes except 63 are simply passed through from the Ford ECM. They only occur if a Ford Engine is selected in the machine configuration digits. Can be reported during power-up sequence.	

SECTION 6 - JLG CONTROL SYSTEM

Table 6-11. Diagnostic Trouble Code Chart

DTC	Flash Code	Sequence	Fault Message	Fault Description	Check
437	43	7	ENGINE TROUBLE CODE	Displays engine SPN/FMI code.	Report and log in Help If [(MACHINE SETUP > DEUTZ EMR2) or (MACHINE SETUP > DEUTZ EMR4) and SPN:FMI = 535:7], prohibit engine cranking.
438	43	8	HIGH ENGINE TEMP	(Ford engine only) The engine temperature is > 117 C. (Deutz engine only) The engine temperature is > 130 C.	Ford / Deutz engine only.
439	43	9	AIR FILTER BYPASSED	The Air Filter is clogged.	Check Airfilter for clogging
4310	43	10	NO ALTERNATOR OUTPUT	Battery voltage is < 11.5 volts for more then 15 seconds after engine start.	Activate the No Charge indicator J4-26 per System Indicators.
4311	43	11	LOW OIL PRESSURE	(Ford engine only) The ECM has reported a low oil pressure fault. (Deutz engine only) Oil pressure is < 8 PSI for more then 10 seconds after engine start.	Ford / Deutz engine only.
4312	43	12	485 COMMUNICATIONS LOST	This fault only occurs with a Ford Engine. It occurs when no response are received from the ECM for 2.5 seconds. Can be reported during power-up sequence.	
4313	43	13	THROTTLE ACTUATOR FAILURE	The engine RPM is > XXX for more then XX seconds.	
4314	43	14	WRONG ENGINE SELECTED - ECM DETECTED	A ECM was detected with a non- ECM type engine selected.	
4322	43	22	LOSS OF ENGINE SPEED SENSOR	The engine RPM sensor indicates 0 RPM AND the Oil Pressure Sensor indicates > 8 PSI for three seconds.	Diesel engine only.
4323	43	23	SPEED SENSOR READING INVALID SPEED	The engine RPM sensor indicates > 4000 RPM.	Diesel engine only.
4331	43	31	SOOT LOAD WARNING - LOW	SPN/FMI 3719 / 16 3703 / 31	Check Engine.
4332	43	32	SOOT LOAD WARNING - HIGH	SPN/FMI 3719 / 0 3714 / 31	Check Engine.
4333	43	33	SOOT LOAD WARNING - SEVERE	SPN/FMI 3715 / 31	Check Engine.
4334	43	34	ENGINE COOLANT - LOW LEVEL	MACHINE SETUP > ENGINE = DEUTZ EMR4; ECM transmits a J1939 DM1 message for an engine coolant low level fault (SPN:FMI 111:1) on CAN2 or uses the J1939 Transport Protocol every one second to send this information if multiple engine faults exist.	MACHINE SETUP > ENGINE SHUTDOWN = ENABLED then shutdown the engine; Activate High Engine Temperature indicator J4-28.
440	44	0	<<< BATTERY SUPPLY >>>		
441	44	1	BATTERY VOLTAGE TOO LOW - SYSTEM SHUTDOWN	Battery voltage is < 9V.	
442	44	2	BATTERY VOLTAGE TOO HIGH - SYSTEM SHUTDOWN	Battery voltage is > 16V.	
445	44	5	BATTERY VOLTAGE LOW	Battery voltage is < 11V for more then 5 seconds.	

Table 6-11. Diagnostic Trouble Code Chart

DTC	Flash Code	Sequence	Fault Message	Fault Description	Check
660	66	0	<<<COMMUNICATION>>>		
662	66	2	CANBUS FAILURE - PLATFORM MODULE	Platform Module CAN communication lost.	
664	66	4	CANBUS FAILURE - ACCESSORY MODULE	The accessory module is not receiving CAN messages. This is probably due to wiring problem.	Check the Wiring.
666	66	6	CANBUS FAILURE - ENGINE CONTROLLER	Engine Control Module CAN	ECM equipped engine only.
6620	66	20	CANBUS FAILURE - UMS SENSOR	communication lost.	
6622	66	22	CANBUS FAILURE - TCU MODULE	Machine Setup/ Telematics=YES, No device heartbeat for 30 sec	
6623	66	23	CANBUS FAILURE - GATEWAY MODULE	Machine Setup/ Telematics=YES, No device heartbeat for 30 sec	
6629	66	29	CANBUS FAILURE - TELEMATICS CANBUS LOADING TOO HIGH		
6657	66	57	CANBUS FAILURE - TEMPERATURE SENSOR	MACHINE SETUP > TEMP CUTOUT = YES; UGM does not receive any CAN messages from the Ambient Temperature sensor in 250ms	The UGM shall set Low Temperature Cutout state = Faulty If the Machine is in Platform Mode and if the Boom is Above Elevation; The UGM shall suspend motion; The UGM shall limit the machine to Creep speed after controls initialized If the Machine is in Platform Mode and if the Boom is not Above Elevation.
671	67	1	ACCESSORY FAULT		
680	68	0	<<<TELEMATICS>>>		
681	68	1	REMOTE CONTRACT MANAGEMENT OVERRIDE - ALL FUNCTIONS IN CREEP		
810	81	0	<<<TILT SENSOR>>>		
813	81	3	CHASSIS TILT SENSOR NOT CALIBRATED	The Chassis Tilt Sensor has not been calibrated.	
815	81	5	CHASSIS TILT SENSOR DISAGREEMENT		
816	81	6	UMS SENSOR NOT CALIBRATED	The Control System detects a sensor out of range condition or a not calibrated fault with UMS angle sensor	
817	81	7	UMS SENSOR FAULT	The system detects that the UMS sensor frequency outside the 100Hz +/- 5Hz range or the duty cycle is outside 50% +/- 21% Range	
820	82	0	<<<PLATFORM LOAD SENSE>>>		
825	82	5	LSS HAS NOT BEEN CALIBRATED	The Load Sensing System Module has not been calibrated.	UGM to set Platform Load State = Overloaded

SECTION 6 - JLG CONTROL SYSTEM

Table 6-11. Diagnostic Trouble Code Chart

DTC	Flash Code	Sequence	Fault Message	Fault Description	Check
826	82	6	RUNNING AT CREEP - PLATFORM OVERLOADED	All functions at creep, the Load Sensing System indicates the Platform is overloaded AND is configured to warn only while the Platform is overloaded.	
827	82	7	DRIVE & BOOM PREVENTED - PLATFORM OVERLOADED	Driving and boom functions are not possible while the Load Sensing System indicates the Platform is overloaded AND is configured to prevent drive and boom functions while the Platform is overloaded.	
828	82	8	LIFT UP & TELE OUT PREVENTED - PLATFORM OVERLOADED	Lift up and telescope out are not possible while the Load Sensing System indicates the Platform is overloaded AND is configured to prevent Lift up and telescope out while the Platform is overloaded.	
8639	86	39	FRONT LEFT STEER VALVE - OPEN CIRCUIT	There is an open circuit to the Front Left Steer Valve	Check Harness for damage.
8640	86	40	FRONT LEFT STEER VALVE - SHORT TO BATTERY	There is a short to Battery to the Front Left Steer Valve	Check Harness for damage.
8641	86	41	FRONT LEFT STEER VALVE - SHORT TO GROUND	There is a short to Ground to the Front Left Steer Valve	Check Harness for damage.
8642	86	42	FRONT RIGHT STEER VALVE - OPEN CIRCUIT	There is an open circuit to the Front Right Steer Valve	Check Harness for damage.
8643	86	43	FRONT RIGHT STEER VALVE - SHORT TO BATTERY	There is a short to Battery to the Front Right Steer Valve	Check Harness for damage.
8644	86	44	FRONT RIGHT STEER VALVE - SHORT TO GROUND	There is a short to Ground to the Front Right Steer Valve	Check Harness for damage.
8645	86	45	REAR LEFT STEER VALVE - OPEN CIRCUIT	There is an open circuit to the Rear Left Steer Valve	Check Harness for damage.
8646	86	46	REAR LEFT STEER VALVE - SHORT TO BATTERY	There is a short to Battery to the Rear Left Steer Valve	Check Harness for damage.
8647	86	47	REAR LEFT STEER VALVE - SHORT TO GROUND	There is a short to Ground to the Rear Left Steer Valve	Check Harness for damage.
8648	86	48	REAR RIGHT STEER VALVE - OPEN CIRCUIT	There is an open circuit to the Rear Right Steer Valve	Check Harness for damage.
8649	86	49	REAR RIGHT STEER VALVE - SHORT TO BATTERY	There is a short to Battery to the Rear Right Steer Valve	Check Harness for damage.
8650	86	50	REAR RIGHT STEER VALVE - SHORT TO GROUND	There is a short to Ground to the Rear Right Steer Valve	Check Harness for damage.
871	87	1	RETURN FILTER BYPASSED	Hydraulic Return Filter Clogged	Check Hydraulic Return Filter.
872	87	2	CHARGE PUMP FILTER BYPASSED	Charge Pump Filter Clogged	Check Charge Pump Filter.
873	87	3	MACHINE SAFETY SYSTEM OVERRIDE OCCURRED	MSSO = Active	Response described in MSSO Influence on Machine Operation section.

Table 6-11. Diagnostic Trouble Code Chart

DTC	Flash Code	Sequence	Fault Message	Fault Description	Check
998	99	8	EEPROM FAILURE - CHECK ALL SETTINGS	The Ground Module has reported an EEPROM failure.	Disable all machine and engine functions (i.e., command engine shutdown and do not permit start); reset the section of EEPROM where the failure occurred to defaults.
9910	99	10	FUNCTIONS LOCKED OUT - PLATFORM MODULE SOFTWARE VERSION IMPROPER	The Platform Module software version is not compatible with the rest of the system.	Activate the platform alarm continuously Creep mode is active If Platform Mode is active, disable all Drive, Steer, and Boom functions and do not permit Machine Enable.
9914	99	14	PLATFORM MODULE SOFTWARE UPDATE REQUIRED	The Platform Module software requires an update.	
9915	99	15	CHASSIS TILT SENSOR NOT GAIN CALIBRATED	The Chassis Tilt Sensor gain calibration has been lost.	
9916	99	16	CHASSIS TILT SENSOR GAIN OUT OF RANGE	The Chassis Tilt Sensor gain calibration has become corrupted.	
9919	99	19	GROUND SENSOR REF VOLTAGE OUT OF RANGE	The Ground Module has reported that its sensor reference voltage is outside acceptable range.	Not reported during power-up.
9920	99	20	PLATFORM SENSOR REF VOLTAGE OUT OF RANGE	The Platform Module has reported that its sensor reference voltage is outside acceptable range.	Not reported during power-up.
9921	99	21	GROUND MODULE FAILURE - HIGH SIDE DRIVER CUTOUT FAULTY	The Ground Module has reported that its high side driver cutout failed.	
9922	99	22	PLATFORM MODULE FAILURE - HWFS CODE 1	The Platform Module has reported that the V(Low) FET has failed.	
9923	99	23	GROUND MODULE FAILURE - HWFS CODE 1	The Ground Module has reported that the V(Low) FET has failed.	
9924	99	24	FUNCTIONS LOCKED OUT - MACHINE NOT CONFIGURED	The machine is powered up and no model has been selected yet in the MACHINE SETUP menu	Display ??? or NO MODEL at Analyzer MACHINE SETUP menu MACHINE SETUP->MODEL NUMBER Do not report any other faults Disable all machine and engine functions (i.e., command engine shutdown and do not permit start).
9944	99	44	CURRENT FEEDBACK GAINS OUT OF RANGE	The factory set current feedback gains are out of range.	A gain of 1 is used for the factory gain(s) that was out of range; all functions shall be placed in Creep mode.

Table 6-11. Diagnostic Trouble Code Chart

DTC	Flash Code	Sequence	Fault Message	Fault Description	Check
9945	99	45	CURRENT FEEDBACK CALIBRATION CHECKSUM INCORRECT	The factory set current feedback checksum is not correct.	
9979	99	79	FUNCTIONS LOCKED OUT - GROUND MODULE SOFTWARE VERSION IMPROPER	Temporary fault for the telematics project. The model needs to be a 600S or 1350S if not this fault will be generated and Platform controls will be prevented. This fault was to ensure that the software will only work for these two models.	Disable all machine and engine functions (i.e., command engine shutdown and do not permit start).

Go to Discount-Equipment.com to order your parts

6.10 DIAGNOSTIC TROUBLE CODE CHART- ADDITIONAL HEC FAULTS

Table 6-12. Diagnostic Trouble Code Chart - Additional HEC Faults

DTC	JLG Help Message	Required Control Response or State Assignment ^{2,3}	Conditions Required for Movement and/or to Clear Fault	Corrective Action
008	FUNCTIONS LOCKED OUT - SYSTEM POWERED DOWN	After 5 minutes, the HEC shall enable the Platform Alarm/Annunciation via UGM and display at HEC analyzer as active. After 10 additional minutes, the HEC shall open Main Contactor and trigger DTC008 via the UGM and Ground Display; the HEC shall also prohibit all functions; the HEC shall also command Engine Shutdown and prevent Engine Start	Machine is enabled or the engine is started within 10 minutes of the platform alarm being initially triggered; Power Cycle after 15 minutes	Activate function if < 15 minutes or cycle power to reset unattended alarm
0054	IMG MODULE - AT CURRENT LIMIT	HEC shall limit the machine to Creep speed	HEC detects that the IMG Current is < 540 Arms for 15000ms (reported by IMG Module); Full speed permitted after controls are initialized	Determine if any wheel resistance exists that could contribute to maximum current draw (i.e. locked hub) or if environmental factors are contributing (i.e. steep grade, cold oil in hubs or hydraulic system)
23204	CHARGE INTERLOCK - INVALID SIGNAL	No response required	Power Cycled	Check that both Chargers are plugged in. Check wiring for both Charger interlock signals. Check interlock relay in both Chargers.
2538	FUNCTION PREVENTED - CHARGER CONNECTED	HEC shall prohibit all functions per Charger Interlock section	Not all of the trigger conditions are met	Check that both Chargers are plugged in. Check wiring for both Charger interlock signals. Check X314 & X314B and C04-8-2 & C05-8-2 for proper mating. Check interlock relay in both Chargers for proper functionality.
2589	TOWER PREVENTED - DRIVE SELECTED IN ELECTRIC MODE	HEC shall implement a hydraulic valve reduction of 50%	Not all of the trigger conditions are met	Verify that Drive is selected or if there is a faulty signal from the Joystick or Tower Switch.

Table 6-12. Diagnostic Trouble Code Chart - Additional HEC Faults

DTC	JLG Help Message	Required Control Response or State Assignment ^{2,3}	Conditions Required for Movement and/or to Clear Fault	Corrective Action
319	MAIN CONTACTOR - PERMANENTLY OFF	<p>If (Hybrid Mode = Electric or Hybrid), HEC shall suspend all functions;</p> <p>If (Hybrid Mode = Electric or Hybrid), the HEC shall prohibit all functions;</p> <p>HEC / IMG Module shall command the Main Contactor open;</p> <p>If (Hybrid Mode = Engine), the HEC shall limit the machine to Creep speed after Controls initialized and trigger DTC 4378</p>	Power Cycled	<p>Verify Main Contactor is not damaged.</p> <p>Verify that Main Contactor is properly connected, both coil (RL269) and power contacts (RL269-1 and RL269-2).</p> <p>Verify Main 84V fuse is intact (X265-X266).</p> <p>Verify auxiliary contacts in battery maintenance disconnect (SW269 & X542) that breaks the driver signal @ RL269-Pin 1.</p>
3110	MAIN CONTACTOR - SHORT TO GROUND OR OPEN CIRCUIT	<p>If (Hybrid Mode = Electric or Hybrid), HEC shall suspend all functions;</p> <p>If (Hybrid Mode = Electric or Hybrid), the HEC shall prohibit all functions;</p>	Power Cycled	<p>Verify Main Contactor coil is properly connected (RL269=Pins 1 & 2).</p> <p>With power off and coil disconnected, check if there is a short or a low impedance from A16 to 84V B- (of IMG Controller) with battery maintenance disconnect On.</p> <p>Verify that coil resistance is approx. 1Kohm.</p> <p>If coil is properly connected and impedance is OK, Internal failure, replace module.</p>
3111	MAIN CONTACTOR - SHORT TO BATTERY	<p>HEC / IMG Module shall command the Main Contactor open;</p> <p>If (Hybrid Mode = Engine), the HEC shall limit the machine to Creep speed after Controls initialized and trigger DTC 4378</p> <p>If (Hybrid Mode = Electric or Hybrid), HEC / IMG Module shall command the Main Contactor open;</p> <p>If (Hybrid Mode = Engine), the HEC shall limit the machine to Creep speed after Controls initialized and trigger DTC 4378</p>	Power Cycled	<p>Verify wiring and that no fault exists that would short 84V to the low-side of the contactor coil (RL269-Pin 1 & C06-A-16). 84V should be present on the high-side of the contactor coil (RL269-Pin 2).</p>

Table 6-12. Diagnostic Trouble Code Chart - Additional HEC Faults

DTC	JLG Help Message	Required Control Response or State Assignment ^{2,3}	Conditions Required for Movement and/or to Clear Fault	Corrective Action
3112	MAIN CONTACTOR – WAITING FOR MOTOR RPM TO BE ZERO	<p>If (Hybrid Mode = Electric or Hybrid), HEC shall suspend all functions, and command engine shutdown</p> <p>If (Hybrid Mode = Electric or Hybrid), the HEC shall prohibit all functions;</p> <p>HEC / IMG Module shall command the Main Contactor open;</p> <p>If (Hybrid Mode = Engine), the HEC shall limit the machine to Creep speed after Controls initialized and trigger DTC 4378</p>	IMG Module not reporting 159	<p>Exists if rotation is detected on the IMG before the Main Contactor is closed.</p> <p>Check that engine is not rotating before Main Contactor is closed.</p> <p>Check that IMG sensor cable is not disconnected at the IMG (X483) or at the Resolver Converter input (XCNA).</p>
3212	MAIN CONTACTOR – WELDED OR MISWIRED	<p>If (Hybrid Mode = Electric or Hybrid), HEC shall suspend all functions;</p> <p>If (Hybrid Mode = Electric or Hybrid), the HEC shall prohibit all functions;</p> <p>HEC / IMG Module shall command the Main Contactor open;</p> <p>If (Hybrid Mode = Engine), the HEC shall limit the machine to Creep speed after Controls initialized and trigger DTC 4378</p>	Power Cycled	<p>Verify that Main Contactor is properly connected at power contacts (RL269-1 and RL269-2) and that nothing is bridging across the contacts.</p> <p>With contactor disconnected, verify that internal contacts are not welded (reading short); High impedance should exist between the two power contacts (open-circuit).</p>
4237	IMG MODULE TEMPERATURE – OUT OF RANGE	<p>If (Hybrid Mode = Electric or Hybrid), HEC shall suspend all functions;</p> <p>If (Hybrid Mode = Electric or Hybrid), the HEC shall prohibit all functions;</p> <p>HEC / IMG Module shall command the Main Contactor open;</p> <p>If (Hybrid Mode = Engine), the HEC shall limit the machine to Creep speed after Controls initialized and trigger DTC 4378</p>	<p>HEC no longer detects Zapi code;</p> <p>Full speed permitted after controls are initialized</p>	Internal failure of IMG Controller temperature sensor. Replace Controller.

Table 6-12. Diagnostic Trouble Code Chart - Additional HEC Faults

DTC	JLG Help Message	Required Control Response or State Assignment ^{2,3}	Conditions Required for Movement and/or to Clear Fault	Corrective Action
4238	IMG MODULE - TEMPERATURE TOO HIGH	<p>If Not Charging Battery (HECFLGChrgMde = 0)</p> <p>HEC shall set machine to CREEP @ 95°C; If IMG Temp is $\geq 105^\circ\text{C}$ suspend all functions (Machine Enable = 0)</p> <p>IMG Module shall decrease allowed IMG Max Traction Current (0x203F) linearly between 85°C (100%) and 105°C (0%)</p> <p>If Charging Battery (HECFLGChrgMde = 1)</p> <p>HEC shall decrease allowed charge current [HECCTLIMGBatCurLmt] by 5% for every 1°C over 85°C; If IMG Temp is $\geq 105^\circ\text{C}$ disable charging.</p> <p>IMG Module shall decrease allowed IMG Max Braking Current [from 252Arms] linearly between 85°C (100%) and 105°C (0%).</p>	[HEC no longer detects Zapi code and [HEC detects IGM Module temperature $< 85^\circ\text{C}$ for 500ms (reported by IMG Module) and Controls Initialized]]	<p>Verify that IMG MODULETEMP diagnostic temperature is displaying a reasonable temperature for the activity in process. Typically not $> 85^\circ\text{C}$.</p> <p>Check IMG Fan Fuse (Position 5, 15A)</p> <p>Check IMG FAN is operating properly: ON @ $65^\circ\text{C}/149^\circ\text{F}$ OFF @ $55^\circ\text{C}/131^\circ\text{F}$</p> <p>Check IMG FAN wiring and relay, driven by HEC output CO3-J1-7.</p>
4335	ENGINE RPM TOO HIGH	<p>If (Hybrid Mode = Engine or Hybrid), HEC shall suspend all functions;</p> <p>If (Hybrid Mode = Engine or Hybrid), the HEC shall prohibit all functions;</p> <p>If (Hybrid Mode = Engine or Hybrid), the HEC shall command Engine Shutdown and prevent Engine Start;</p>	Power Cycled	<p>Typically triggered when IMG is braking against the engine while driving downhill and engine over speeds due to braking load.</p> <p>Check diagnostic feedback from IMG Speed Sensor (IMG SPEED FDBK) & Engine Speed Sensor (ENGINE SPEED)</p>
4378	ENGINE ONLY MODE ACTIVE	<p>HEC shall disable Hybrid System.</p> <p>Place machine in CREEP</p>	Power Cycled OR Hybrid Mode = Electric	<p>Check HEC for Hybrid related DTCs when UGM reports DTC 674.</p> <p>Engine-Only Mode is response to a number of Hybrid related faults. This will point to another HEC triggered DTC that is simultaneously active.</p>
4417	BATTERY POWER LOW	No response required	Not all of the trigger conditions are met	<p>Verify that SOC% reading is $< 20\%$. This is a normal response to Low SOC and is designed to notify the operator that the 84V battery is in need of charging, either by IMG or Wall-Charger.</p>

Table 6-12. Diagnostic Trouble Code Chart - Additional HEC Faults

DTC	JLG Help Message	Required Control Response or State Assignment ^{2,3}	Conditions Required for Movement and/or to Clear Fault	Corrective Action
4420	BATTERY DEEPLY DISCHARGED	No response required	Not all of the trigger conditions are met	Verify that SOC% reading is <5%. This is a normal response to VERY Low SOC and is designed to notify the operator that the 84V battery is in need of charging, either by IMG or Wall-Charger.
4431	BATTERY TEMPERATURE - TOO HIGH	<p>If (Hybrid Mode = Electric or Hybrid), HEC shall suspend all functions;</p> <p>If (Hybrid Mode = Electric or Hybrid), the HEC shall prohibit all functions;</p> <p>HEC / IMG Module shall command the Main Contactor open;</p> <p>If (Hybrid Mode = Engine), the HEC shall limit the machine to Creep speed after Controls initialized and trigger DTC 4378</p>	<p>Battery temperature returns to within acceptable range, BATT HITEMP – 5 degrees</p> <p>Note: BATT HITEMP defined in High Battery Temperature section in SRD</p>	<p>Verify that the top of the 84V stack battery is > 55? using SOC BAT TEMP diagnostic temperature reading.</p> <p>Verify SOC device temperature sensor wiring.</p> <p>Battery temperature increases with heavy charge and discharge currents. In high ambient temperatures < 40?, the battery temperature is expected to be > 55? with heavy usage.</p>
4434	ENGINE START FAILED - TOO MANY ATTEMPTS	<p>If (Hybrid Mode = Engine or Hybrid), HEC shall suspend all functions;</p> <p>If (Hybrid Mode = Engine or Hybrid), the HEC shall prohibit all functions;</p> <p>If (Hybrid Mode = Engine or Hybrid), the HEC shall command Engine Shutdown and prevent Engine Start;</p>	Power Cycled	Cycle power and resume engine start process.

Table 6-12. Diagnostic Trouble Code Chart - Additional HEC Faults

DTC	JLG Help Message	Required Control Response or State Assignment ^{2,3}	Conditions Required for Movement and/or to Clear Fault	Corrective Action
4466	CONTROL VOLTAGE TOO LOW - SYSTEM SHUTDOWN	<p>If (Hybrid Mode = Electric or Hybrid), HEC shall suspend all functions;</p> <p>If (Hybrid Mode = Electric or Hybrid), the HEC shall prohibit all functions;</p> <p>HEC / IMG Module shall command the Main Contactor open;</p> <p>If (Hybrid Mode = Engine), the HEC shall limit the machine to Creep speed after Controls initialized and trigger DTC 4378</p>	Power Cycled	<p>Verify that 12V starter battery is properly charged and that the DC/DC converter output is 13.5V while in Electric Mode. Check DC/DC fuse (FC456-1 & FC456-2) if no DC/DC output.</p> <p>Check 12V starter battery wiring.</p> <p>Check alternator output in Hybrid Mode</p> <p>Check DC/DC wiring in Electric Mode.</p>
4467	CONTROL VOLTAGE TOO HIGH - SYSTEM SHUTDOWN	<p>If (Hybrid Mode = Electric or Hybrid), HEC shall suspend all functions;</p> <p>If (Hybrid Mode = Electric or Hybrid), the HEC shall prohibit all functions;</p> <p>HEC / IMG Module shall command the Main Contactor open;</p> <p>If (Hybrid Mode = Engine), the HEC shall limit the machine to Creep speed after Controls initialized and trigger DTC 4378</p>	Power Cycled	<p>Verify that 12V starter battery is properly charged and that the DC/DC converter output is 13.5V while in Electric Mode. Check DC/DC fuse (FC456-1 & FC456-2) if no DC/DC output.</p> <p>Check 12V starter battery wiring.</p> <p>Check alternator output in Hybrid Mode</p> <p>Check DC/DC wiring in Electric Mode.</p>
4468	CONTROL VOLTAGE TOO LOW	No response required	Power Cycled	<p>Verify that 12V starter battery is properly charged and that the DC/DC converter output is 13.5V while in Electric Mode. Check DC/DC fuse (FC456-1 & FC456-2) if no DC/DC output.</p> <p>Check 12V starter battery wiring.</p> <p>Check alternator output in Hybrid Mode</p> <p>Check DC/DC wiring in Electric Mode.</p>

Table 6-12. Diagnostic Trouble Code Chart - Additional HEC Faults

DTC	JLG Help Message	Required Control Response or State Assignment ^{2,3}	Conditions Required for Movement and/or to Clear Fault	Corrective Action
4487	IMG TEMPERATURE - OUT OF RANGE	<p>If (Hybrid Mode = Electric or Hybrid), HEC shall suspend all functions;</p> <p>If (Hybrid Mode = Electric or Hybrid), the HEC shall prohibit all functions;</p> <p>HEC / IMG Module shall command the Main Contactor open;</p> <p>If (Hybrid Mode = Engine), the HEC shall limit the machine to Creep speed after Controls initialized and trigger DTC 4378</p>	Power Cycled	<p>Verify that diagnostic reading IMG Temp is reporting a temperature out of range > 170°C. Check IMG Temperature sensor wiring with cable disconnected. Internal IMG sensor may be damaged. Check Ohm reading with DMM at X483B (IMG bell housing connector) Pins G & H:</p> <p>498 ohms @ 0C/32F 538 ohms @ 10C/50F 603 ohms @ 25C/77F 635 ohms @ 32C/89.6F 663 ohms @ 38C/100.4F</p>
4488	IMG TEMPERATURE - TOO HIGH	<p>If Not Charging Battery (HECFLGChrgMde = 0):</p> <p>HEC shall set machine to CREEP @ 150C); If IMG Temp is >= 160°C suspend all functions (Machine Enable = 0).</p> <p>IMG Module shall decrease allowed IMG Max Traction Current (0x203F) linearly between 150°C (100%) and 170°C (0%)</p> <p>If Charging Battery (HECFLGChrgMde = 1):</p> <p>HEC shall decrease allowed charge current [HECCTLIMGBatCurLmt] by 5% for every 1°C over 140°C; If IMG Temp is >= 160°C disable charging until < 140°C.</p> <p>IMG Module shall decrease allowed IMG Max Braking Current [from 252Arms] linearly between 150°C (100%) and 170°C (0%).</p>	[HEC no longer detects Zapi code and [HEC detects IGM temperature < 140°C for 500ms and Controls Initialized]]	<p>Verify that IMG TEMP diagnostic temperature is displaying a reasonable temperature for the activity in process (i.e. ambient, long IMG run time in traction, charging, etc).</p> <p>Long-term Traction and Charging is typically in the range of 100-120°. Temperatures > 140° are possible on steep grades.</p>

Table 6-12. Diagnostic Trouble Code Chart - Additional HEC Faults

DTC	JLG Help Message	Required Control Response or State Assignment ^{2,3}	Conditions Required for Movement and/or to Clear Fault	Corrective Action
4489	IMG MODULE - VOLTAGE OUT OF RANGE	<p>If (Hybrid Mode = Electric or Hybrid), HEC shall suspend all functions;</p> <p>If (Hybrid Mode = Electric or Hybrid), the HEC shall prohibit all functions;</p> <p>HEC / IMG Module shall command the Main Contactor open;</p> <p>If (Hybrid Mode = Engine), the HEC shall limit the machine to Creep speed after Controls initialized and trigger DTC 4378</p>	<p>HEC no longer detects Zapi code;</p> <p>Full speed permitted after controls are initialized</p>	<p>Verify diagnostic voltage IMG BAT VOLT or Measure DC voltage @ A1 (with DMM) with respect to 84V B- on IMG Controller during operation that caused this DTC to trigger; verify voltage spike to $\geq 116Vdc$ or voltage dip to $\leq 30C$. Verify 84Vdc battery stack voltage.</p>
4490	IMG SPEED SENSOR - NOT RESPONDING PROPERLY	<p>If (Hybrid Mode = Electric or Hybrid), HEC shall suspend all functions;</p> <p>If (Hybrid Mode = Electric or Hybrid), the HEC shall prohibit all functions;</p> <p>HEC / IMG Module shall command the Main Contactor open;</p> <p>If (Hybrid Mode = Engine), the HEC shall limit the machine to Creep speed after Controls initialized and trigger DTC 4378</p>	Power Cycled	<p>Verify diagnostic IMG SPEED FDBK to see if it matches IMG SPEED CMD.</p> <p>If DTC is triggered at startup with no rotation, verify that Resolver Converter connections are properly made and wiring is correct and not damaged (X346B, XCNB & XCNC).</p>
4491	IMG SPEED SENSOR - RPM NOT AS EXPECTED	<p>If (Hybrid Mode = Electric or Hybrid), HEC shall suspend all functions;</p> <p>If (Hybrid Mode = Electric or Hybrid), the HEC shall prohibit all functions;</p> <p>HEC / IMG Module shall command the Main Contactor open;</p> <p>If (Hybrid Mode = Engine), the HEC shall limit the machine to Creep speed after Controls initialized and trigger DTC 4378</p>	Power Cycled	<p>Verify diagnostic IMG SPEED FDBK to see if it matches IMG SPEED CMD.</p> <p>IMG Speed should never be > 2600 RPM for all functions and applications. Functions will be 1800 or 2600 RPM.</p>

Table 6-12. Diagnostic Trouble Code Chart - Additional HEC Faults

DTC	JLG Help Message	Required Control Response or State Assignment ^{2,3}	Conditions Required for Movement and/or to Clear Fault	Corrective Action
4492	IMG OUTPUT - OUT OF RANGE LOW	<p>If (Hybrid Mode = Electric or Hybrid), HEC shall suspend all functions;</p> <p>If (Hybrid Mode = Electric or Hybrid), the HEC shall prohibit all functions;</p> <p>HEC / IMG Module shall command the Main Contactor open;</p> <p>If (Hybrid Mode = Engine), the HEC shall limit the machine to Creep speed after Controls initialized and trigger DTC 4378</p>	Power Cycled	<p>Check IMG Phase connections U, V, W to the IMG Control Module for shorts, opens, loose connection or improper connection.</p> <p>Check disconnected cables for U, V, W short-circuit from center conduction to shield.</p> <p>If not a connection issue, Internal failure, replace module</p>
4493	IMG OUTPUT - OUT OF RANGE HIGH	<p>If (Hybrid Mode = Electric or Hybrid), HEC shall suspend all functions;</p> <p>If (Hybrid Mode = Electric or Hybrid), the HEC shall prohibit all functions;</p> <p>HEC / IMG Module shall command the Main Contactor open;</p> <p>If (Hybrid Mode = Engine), the HEC shall limit the machine to Creep speed after Controls initialized and trigger DTC 4378</p>	Power Cycled	<p>Check IMG Phase connections U, V, W to the IMG Control Module for shorts or improper connection.</p> <p>If not a connection issue, Internal failure, replace module.</p>

Table 6-12. Diagnostic Trouble Code Chart - Additional HEC Faults

DTC	JLG Help Message	Required Control Response or State Assignment ^{2,3}	Conditions Required for Movement and/or to Clear Fault	Corrective Action
4494	IMG MOTOR - STALLED	<p>If (Hybrid Mode = Electric or Hybrid), HEC shall suspend all functions;</p> <p>If (Hybrid Mode = Electric or Hybrid), the HEC shall prohibit all functions;</p> <p>HEC / IMG Module shall command the Main Contactor open;</p> <p>If (Hybrid Mode = Engine), the HEC shall limit the machine to Creep speed after Controls initialized and trigger DTC 4378</p>	Power Cycled	<p>Check for any impediment that could cause the IMG to not freely rotate.</p> <p>Check for hydraulic issues that would load down the IMG in Electric Mode or IMG/Engine in Hybrid Mode.</p> <p>Check for IMG SPEED FDBK to make sure it is not 0 RPM. If 0 RPM, check Resolver Converter and wiring (XCNA, XCNB, XCNC), as well as IMG Resolver wiring (X483).</p> <p>This results in high AC phase current with rotation not matching commanded speed.</p>
4495	IMG MOTOR - ROTATION OPPOSITE CONTROL	<p>If (Hybrid Mode = Electric or Hybrid), HEC shall suspend all functions;</p> <p>If (Hybrid Mode = Electric or Hybrid), the HEC shall prohibit all functions;</p> <p>HEC / IMG Module shall command the Main Contactor open;</p> <p>If (Hybrid Mode = Engine), the HEC shall limit the machine to Creep speed after Controls initialized and trigger DTC 4378</p>	Power Cycled	<p>Check IMG and IMG Controller Phase wiring for proper U, V, W phasing.</p> <p>This is typically caused by two phases that are swapped.</p>
4496	IMG MOTOR - OPEN CIRCUIT	<p>If (Hybrid Mode = Electric or Hybrid), HEC shall suspend all functions;</p> <p>If (Hybrid Mode = Electric or Hybrid), the HEC shall prohibit all functions;</p> <p>HEC / IMG Module shall command the Main Contactor open;</p> <p>If (Hybrid Mode = Engine), the HEC shall limit the machine to Creep speed after Controls initialized and trigger DTC 4378</p>	Power Cycled	<p>Check IMG Phase connections U, V, W to the IMG Control Module for opens or loose connection.</p>

Table 6-12. Diagnostic Trouble Code Chart - Additional HEC Faults

DTC	JLG Help Message	Required Control Response or State Assignment ^{2,3}	Conditions Required for Movement and/or to Clear Fault	Corrective Action
44100	WRONG BATTERY STACK VOLTAGE	<p>If (Hybrid Mode = Electric or Hybrid), HEC shall suspend all functions;</p> <p>If (Hybrid Mode = Electric or Hybrid), the HEC shall prohibit all functions;</p> <p>HEC / IMG Module shall command the Main Contactor open;</p> <p>If (Hybrid Mode = Engine), the HEC shall limit the machine to Creep speed after Controls initialized and trigger DTC 4378</p>	Power Cycled	<p>Check 84V battery state of charge, BATTERY SOC diagnostic.</p> <p>Check 84V Battery Voltage, SOC BAT VOLTAGE diagnostic.</p> <p>Check all 84V battery stack wiring.</p>
44101	IMG MOTOR - FEEDBACK FAILURE	<p>If (Hybrid Mode = Electric or Hybrid), HEC shall suspend all functions;</p> <p>If (Hybrid Mode = Electric or Hybrid), the HEC shall prohibit all functions;</p> <p>HEC / IMG Module shall command the Main Contactor open;</p> <p>If (Hybrid Mode = Engine), the HEC shall limit the machine to Creep speed after Controls initialized and trigger DTC 4378</p>	Power Cycled	Internal controller failure. Replace controller.
44102	UNCOMMANED ENGINE RPM	<p>If (Hybrid Mode = Electric), HEC shall suspend all functions & remove machine enable;</p> <p>If (Hybrid Mode = Electric), the HEC shall prohibit all functions, including machine enable;</p>	Power Cycled	<p>Check clutch position to make sure it is not engaged in Electric Mode.</p> <p>Verify operation of H-bridge controller that drives the linear actuator to engage and disengage the clutch to make sure there is not impingement or binding of the linear actuator.</p> <p>Check linear actuator connections at H-bridge module (X387) and actuator (X389).</p> <p>Check H-bridge fuse, Position 19, 5A.</p>

Table 6-12. Diagnostic Trouble Code Chart - Additional HEC Faults

DTC	JLG Help Message	Required Control Response or State Assignment^{2,3}	Conditions Required for Movement and/or to Clear Fault	Corrective Action
44103	BATTERY TEMPERATURE SENSOR #1 - OUT OF RANGE	No response required	Not all of the trigger conditions are met;	Verify connection at SN309 & X403. Verify fuse at FC419, 1A. Verify that battery temperature sensor @ 84V battery is properly connected and not damaged. 10K @ 25C, NTC, so as temperature goes down, resistance goes up and as temperature goes up, resistance goes down. Range: 674 ohms - 176Kohms (-30? to 60?/-22°F to 140°F).
44104	BATTERY TEMPERATURE SENSOR #2 - OUT OF RANGE	No response required	Not all of the trigger conditions are met;	Verify connection at SN310. Verify fuse at FC420, 1A. Verify that battery temperature sensor @ 48V battery is properly connected and not damaged. 10K @ 25C, NTC, so as temperature goes down, resistance goes up and as temperature goes up, resistance goes down. Range: 674 ohms - 176Kohms (-30? to 60?/-22°F to 140°F).
44105	BATTERY TEMPERATURE SENSOR #3 - OUT OF RANGE	No response required	Not all of the trigger conditions are met;	Verify connection at SN311. Verify fuse at FC422, 1A. Verify that battery temperature sensor @ 36V battery is properly connected and not damaged. 10K @ 25C, NTC, so as temperature goes down, resistance goes up and as temperature goes up, resistance goes down. Range: 674 ohms - 176Kohms (-30? to 60?/-22°F to 140°F).
44106	BATTERY TEMPERATURE SENSOR #4 - OUT OF RANGE	No response required	Not all of the trigger conditions are met;	Verify connection at SN312. Verify fuse at FC423, 1A. Verify that battery temperature sensor @ 24V battery is properly connected and not damaged. 10K @ 25C, NTC, so as temperature goes down, resistance goes up and as temperature goes up, resistance goes down. Range: 674 ohms - 176Kohms
44108	CLUTCH ACTUATOR - SHORT TO BATTERY	HEC shall disable the Clutch Actuator; HEC shall limit the machine to Creep speed	Power Cycled	Verify wiring between H-Bridge controller and linear actuator, between connectors X387 and X389.
44109	CLUTCH ACTUATOR - SHORT TO GROUND	HEC shall disable the Clutch Actuator HEC shall limit the machine to Creep speed	Power Cycled	Verify wiring between H-Bridge controller and linear actuator, between connectors X387 and X389.
44110	CLUTCH ACTUATOR - OPEN CIRCUIT	HEC shall disable the Clutch Actuator; HEC shall limit the machine to Creep speed	Power Cycled	Verify wiring between H-Bridge controller and linear actuator, between connectors X387 and X389. Verify internal limit switches of linear actuator, at both end stops, are not damaged.

Table 6-12. Diagnostic Trouble Code Chart - Additional HEC Faults

DTC	JLG Help Message	Required Control Response or State Assignment ^{2,3}	Conditions Required for Movement and/or to Clear Fault	Corrective Action
44111	CLUTCH ACTUATOR-CURRENT TOO HIGH	HEC shall disable the Clutch Actuator HEC shall limit the machine to Creep speed	Power Cycled	Verify that clutch actuator and clutch arm is not binding up. Verify that clutch actuator can move easily from extended to retracted and from retracted to extended. Verify CLUTCH ACTUATOR CURRENT in diagnostic is < 5A.
44112	ENGINE/IMG SPEED DISAGREEMENT	If (Hybrid Mode = Hybrid), HEC shall suspend all functions; If (Hybrid Mode = Hybrid), the HEC shall prohibit all functions; If (Hybrid Mode = Hybrid), the HEC shall command Engine Shutdown and prevent Engine Start;	Power Cycled	Verify that clutch is not slipping. Verify that clutch is not partially engaged.
44113	IMG OUTPUT - PHASE SHORT	If (Hybrid Mode = Electric or Hybrid), HEC shall suspend all functions; If (Hybrid Mode = Electric or Hybrid), the HEC shall prohibit all functions; HEC / IMG Module shall command the Main Contactor open; If (Hybrid Mode = Engine), the HEC shall limit the machine to Creep speed after Controls initialized and trigger DTC 4378	Power Cycled	Verify IMG phase cables U, V, W and terminals are not shorted to each other or anything else.
44114	IMG MODULE - OVERLOAD	If (Hybrid Mode = Electric or Hybrid), HEC shall suspend all functions; If (Hybrid Mode = Electric or Hybrid), the HEC shall prohibit all functions; HEC / IMG Module shall command the Main Contactor open; If (Hybrid Mode = Engine), the HEC shall limit the machine to Creep speed after Controls initialized and trigger DTC 4378	Power Cycled	Verify that hydraulic functions are not encountering additional resistance.

Table 6-12. Diagnostic Trouble Code Chart - Additional HEC Faults

DTC	JLG Help Message	Required Control Response or State Assignment ^{2,3}	Conditions Required for Movement and/or to Clear Fault	Corrective Action
44115	IMG MODULE – WAITING FOR POWER BRIDGE TO CLOSE	<p>If (Hybrid Mode = Electric or Hybrid), HEC shall suspend all functions;</p> <p>If (Hybrid Mode = Electric or Hybrid), the HEC shall prohibit all functions;</p> <p>HEC / IMG Module shall command the Main Contactor open;</p> <p>If (Hybrid Mode = Engine), the HEC shall limit the machine to Creep speed after Controls initialized and trigger DTC 4378</p>	Power Cycled	Verify that engine/IMG is not rotating before the Main Contactor is closed.
44116	SYSTEM VOLTAGE TOO LOW – SYSTEM SHUTDOWN	<p>If (Hybrid Mode = Hybrid, HEC shall put all functions in Creep.</p> <p>If (Hybrid Mode = Electric, the HEC shall suspend and prohibit all functions;</p> <p>HEC / IMG Module shall command the Main Contactor open;</p> <p>If (Hybrid Mode = Engine), the HEC shall limit the machine to Creep speed after Controls initialized and trigger DTC 4378</p>	Power Cycled	Verify 84V BATTERY SOC diagnostic. Recharge 84V Battery.
44117	STATE OF CHARGE SENSOR – FAULTY TEMPERATURE READING	<p>HEC shall limit machine to creep speed;</p> <p>HEC shall prohibit charge and shutdown the engine (enable engine only mode);</p> <p>HEC shall assign SOC% to 'error / unknown'.</p>	Power Cycled	Verify SOC BAT TEMP diagnostic. Potential internal SOC Device error. The difference between diagnostics BATTERY TEMP 1 and SOC BAT TEMP must be less than 15C for 20 sec.
44118	STATE OF CHARGE SENSOR – FAULTY VOLTAGE READING	<p>HEC shall limit machine to creep speed;</p> <p>HEC shall prohibit charge and shutdown the engine (enable engine only mode);</p> <p>HEC shall assign SOC% to 'error / unknown'.</p>	Power Cycled	Verify SOC BAT VOLTAGE diagnostic. Potential internal SOC Device error. The difference between diagnostics IMG BAT VOLT and SOC BAT VOLTAGE must be less than 5V for 20 sec.

Table 6-12. Diagnostic Trouble Code Chart - Additional HEC Faults

DTC	JLG Help Message	Required Control Response or State Assignment ^{2,3}	Conditions Required for Movement and/or to Clear Fault	Corrective Action
44119	STATE OF CHARGE SENSOR – FAULTY CURRENT READING	HEC shall limit machine to creep speed; HEC shall prohibit charge and shutdown the engine (enable engine only mode); HEC shall assign SOC% to 'error / unknown'.	Power Cycled	Verify SOC BAT TEMP diagnostic. Potential internal SOC Device error. The difference between diagnostics BATTERY TEMP 1 and SOC BAT TEMP must be less than 15C for 20 sec.
6665	CANBUS FAILURE - CLUTCH ACTUATOR MODULE	HEC shall limit the machine to Creep speed	HEC receives CAN messages from the Clutch Actuator Module.	Verify CAN 1 bus connector @ X387 and impedance of 60 ohms across CAN H and CAN L. If not connection issue, internal H-Bridge Module failure. If this persists or causes the machine to not function properly, replace the module.
6666	CANBUS FAILURE - HYBRID ELECTRIC CONTROL MODULE		Not all of the trigger conditions are met.	Verify the CAN 1 bus connector C03-J2 Pins 9 & 10. Verify all connections at MS-385 CAN-T. Also verify impedance of 60 ohms across CAN H and CAN L.
6668	CANBUS FAILURE - INTEGRATED MOTOR GENERATOR MODULE	If (Hybrid Mode = Electric or Hybrid), HEC shall suspend all functions; If (Hybrid Mode = Electric or Hybrid), the HEC shall prohibit all functions; HEC / IMG Module shall command the Main Contactor open; If (Hybrid Mode = Engine), the HEC shall limit the machine to Creep speed after Controls initialized and trigger DTC 4378	HEC receives CAN messages from the IMG Module; Full speed permitted after controls are initialized IMG Module shall recover if CAN communication is re-established.	Verify the CAN 2 bus connections at C06-A Pins 20 & 21. Verify connections at MS331 CAN-T. Verify impedance of 60 ohms across CAN H and CAN L. Verify battery maintenance disconnect is On. Verify 84V Enable fuse at FC457, 10A, located below battery maintenance switch. Verify signal at MiniTactor RL272 that feeds 84V logic power to C06-A Pin 1.

Table 6-12. Diagnostic Trouble Code Chart - Additional HEC Faults

DTC	JLG Help Message	Required Control Response or State Assignment ^{2,3}	Conditions Required for Movement and/or to Clear Fault	Corrective Action
6669	CANBUS FAILURE - STATE OF CHARGE SENSOR	<p>HEC shall limit machine to creep speed;</p> <p>HEC shall prohibit charge and shutdown the engine (enable engine only mode);</p> <p>HEC shall assign SOC% to 'error / unknown'.</p>	<p>Not all of the trigger conditions are met;</p> <p>Engine only mode available upon restart.</p>	<p>Verify fuse at FC356, 1A and power to the module X322 Pins 1 & 2.</p> <p>Verify the CAN 2 bus connections at X344 Pins G & H.</p> <p>Verify CAN 2 bus connection at X403.</p> <p>Verify CAN 2 bus connections X323 Pins A & B.</p> <p>Verify impedance of 60 ohms across CAN H and CAN L.</p> <p>Verify all connections at MS331.</p>
99281	HYBRID FUNCTIONS LOCKED OUT - IMPROPER MOTOR PARAMETERS	<p>If (HybridMode = Electric or Hybrid), HEC shall suspend all functions;</p> <p>If (Hybrid Mode = Electric or Hybrid), the HEC shall prohibit all functions;</p> <p>HEC / IMG Module shall command the Main Contactor open;</p> <p>If (Hybrid Mode = Engine), the HEC shall limit the machine to Creep speed after Controls initialized and trigger DTC 4378</p>	Power Cycled	Internal EEPROM error, replace module or reprogram motor parameters if proper tools are available.
99298	IMG MODULE - EEPROM FAILURE	<p>If (Hybrid Mode = Electric or Hybrid), HEC shall suspend all functions;</p> <p>If (Hybrid Mode = Electric or Hybrid), the HEC shall prohibit all functions;</p> <p>HEC / IMG Module shall command the Main Contactor open;</p> <p>If (Hybrid Mode = Engine), the HEC shall limit the machine to Creep speed after Controls initialized and trigger DTC 4378</p>	Power Cycled	Internal EEPROM error, replace module or reprogram motor parameters.
99299	IMG MODULE - PROTECTION FAILURE	<p>If (Hybrid Mode = Electric or Hybrid), HEC shall suspend all functions;</p> <p>If (HybdMode = Electric or Hybrid), the HEC shall prohibit all functions;</p> <p>HEC / IMG Module shall command the Main Contactor open;</p> <p>If (Hybrid Mode = Engine), the HEC shall limit the machine to Creep speed after Controls initialized and trigger DTC 4378</p>	Power Cycled	Internal Module Logic Board Error, replace module.

Table 6-12. Diagnostic Trouble Code Chart - Additional HEC Faults

DTC	JLG Help Message	Required Control Response or State Assignment ^{2,3}	Conditions Required for Movement and/or to Clear Fault	Corrective Action
99300	FUNCTIONS LOCKED OUT - IMG MODULE SOFTWARE VERSION IMPROPER	<p>HEC shall suspend all functions;</p> <p>HEC shall prohibit all functions;</p> <p>HEC / IMG Module shall command the Main Contactor open;</p> <p>HEC shall command Engine Shutdown and prevent Engine Start</p>	Power Cycled	Reprogram modules as required..
99301	IMG MODULE - CONTACTOR DRIVER FAILURE	<p>If (Hybrid Mode = Electric or Hybrid), HEC shall suspend all functions;</p> <p>If (Hybrid Mode = Electric or Hybrid), the HEC shall prohibit all functions;</p> <p>HEC / IMG Module shall command the Main Contactor open;</p> <p>If (Hybrid Mode = Engine), the HEC shall limit the machine to Creep speed after Controls initialized and trigger DTC 4378</p>	Power Cycled	Internal Module Error, replace module.
99302	IMG MODULE - WATCHDOG RESET	<p>If (Hybrid Mode = Electric or Hybrid), HEC shall suspend all functions;</p> <p>If (Hybrid Mode = Electric or Hybrid), the HEC shall prohibit all functions;</p> <p>HEC / IMG Module shall command the Main Contactor open;</p> <p>If (Hybrid Mode = Engine), the HEC shall limit the machine to Creep speed after Controls initialized and trigger DTC 4378</p>	Power Cycled	Internal Module Error, replace module.
99303	IMG MODULE - RAM FAILURE	<p>If (Hybrid Mode = Electric or Hybrid), HEC shall suspend all functions;</p> <p>If (Hybrid Mode = Electric or Hybrid), the HEC shall prohibit all functions;</p> <p>HEC / IMG Module shall command the Main Contactor open;</p> <p>If (Hybrid Mode = Engine), the HEC shall limit the machine to Creep speed after Controls initialized and trigger DTC 4378</p>	Power Cycled	Internal Module Error, replace module.

Table 6-12. Diagnostic Trouble Code Chart - Additional HEC Faults

DTC	JLG Help Message	Required Control Response or State Assignment ^{2,3}	Conditions Required for Movement and/or to Clear Fault	Corrective Action
99304	IMG MODULE - CHECK POWER CIRCUITS OR MOSFET SHORT CIRCUIT	<p>If (Hybrid Mode = Electric or Hybrid), HEC shall suspend all functions;</p> <p>If (Hybrid Mode = Electric or Hybrid), the HEC shall prohibit all functions;</p> <p>HEC / IMG Module shall command the Main Contactor open;</p> <p>If (Hybrid Mode = Engine), the HEC shall limit the machine to Creep speed after Controls initialized and trigger DTC 4378</p>	Power Cycled	Internal Module Error, replace module.
99305	IMG MODULE - DATA ACQUISITION ERROR	<p>If (Hybrid Mode = Electric or Hybrid), HEC shall suspend all functions;</p> <p>If (Hybrid Mode = Electric or Hybrid), the HEC shall prohibit all functions;</p> <p>HEC / IMG Module shall command the Main Contactor open;</p> <p>If (Hybrid Mode = Engine), the HEC shall limit the machine to Creep speed after Controls initialized and trigger DTC 4378</p>	Power Cycled	Internal Module Error, replace module.
99306	IMG MODULE - CURRENT FEEDBACK OUT OF RANGE	<p>If (Hybrid Mode = Electric or Hybrid), HEC shall suspend all functions;</p> <p>If (Hybrid Mode = Electric or Hybrid), the HEC shall prohibit all functions;</p> <p>HEC / IMG Module shall command the Main Contactor open;</p> <p>If (Hybrid Mode = Engine), the HEC shall limit the machine to Creep speed after Controls initialized and trigger DTC 4378</p>	Power Cycled	Internal Module Error, replace module.
99307	IMG MODULE - WRONG LOGIC VOLTAGE AT POWER-ON	<p>If (Hybrid Mode = Electric or Hybrid), HEC shall suspend all functions;</p> <p>If (Hybrid Mode = Electric or Hybrid), the HEC shall prohibit all functions;</p> <p>HEC / IMG Module shall command the Main Contactor open;</p> <p>If (Hybrid Mode = Engine), the HEC shall limit the machine to Creep speed after Controls initialized and trigger DTC 4378</p>	Power Cycled	Internal Module Error, replace module.

Table 6-12. Diagnostic Trouble Code Chart - Additional HEC Faults

DTC	JLG Help Message	Required Control Response or State Assignment ^{2,3}	Conditions Required for Movement and/or to Clear Fault	Corrective Action
99308	IMG MODULE - CAPACITOR BANK FAULT	<p>If (Hybrid Mode = Electric or Hybrid), HEC shall suspend all functions;</p> <p>If (Hybrid Mode = Electric or Hybrid), the HEC shall prohibit all functions;</p> <p>HEC / IMG Module shall command the Main Contactor open;</p> <p>If (Hybrid Mode = Engine), the HEC shall limit the machine to Creep speed after Controls initialized and trigger DTC 4378</p>	Power Cycled	<p>Verify that no other path/load can sink current from the A1 pin on IMG Controller.</p> <p>If Internal Module Error, replace module.</p>
99309	IMG MODULE - A/D FAILURE	<p>If (Hybrid Mode = Electric or Hybrid), HEC shall suspend all functions;</p> <p>If (Hybrid Mode = Electric or Hybrid), the HEC shall prohibit all functions;</p> <p>HEC / IMG Module shall command the Main Contactor open;</p> <p>If (Hybrid Mode = Engine), the HEC shall limit the machine to Creep speed after Controls initialized and trigger DTC 4378</p>	Power Cycled	Internal Module Error, replace module.
99310	IMG MODULE - INTERNAL CANBUS FAILURE	<p>If (Hybrid Mode = Electric or Hybrid), HEC shall suspend all functions;</p> <p>If (Hybrid Mode = Electric or Hybrid), the HEC shall prohibit all functions;</p> <p>HEC / IMG Module shall command the Main Contactor open;</p> <p>If (Hybrid Mode = Engine), the HEC shall limit the machine to Creep speed after Controls initialized and trigger DTC 4378</p>	Power Cycled	Internal Module Error, replace module.
99311	IMG MODULE - HARDWARE FAULT	<p>If (Hybrid Mode = Electric or Hybrid), HEC shall suspend all functions;</p> <p>If (Hybrid Mode = Electric or Hybrid), the HEC shall prohibit all functions;</p> <p>HEC / IMG Module shall command the Main Contactor open;</p> <p>If (Hybrid Mode = Engine), the HEC shall limit the machine to Creep speed after Controls initialized and trigger DTC 4378</p>	Power Cycled	Internal Module Error, replace module.

Table 6-12. Diagnostic Trouble Code Chart - Additional HEC Faults

DTC	JLG Help Message	Required Control Response or State Assignment ^{2,3}	Conditions Required for Movement and/or to Clear Fault	Corrective Action
99312	IMG MODULE - CURRENT MEASUREMENT ERROR	<p>If (Hybrid Mode = Electric or Hybrid), HEC shall suspend all functions;</p> <p>If (Hybrid Mode = Electric or Hybrid), the HEC shall prohibit all functions;</p> <p>HEC / IMG Module shall command the Main Contactor open;</p> <p>If (Hybrid Mode = Engine), the HEC shall limit the machine to Creep speed after Controls initialized and trigger DTC 4378</p>	Power Cycled	Internal Module Error, replace module.
99313	IMG MODULE - CURRENT FEEDBACK GAIN OUT OF RANGE	<p>If (Hybrid Mode = Electric or Hybrid), HEC shall suspend all functions;</p> <p>If (Hybrid Mode = Electric or Hybrid), the HEC shall prohibit all functions;</p> <p>HEC / IMG Module shall command the Main Contactor open;</p> <p>If (Hybrid Mode = Engine), the HEC shall limit the machine to Creep speed after Controls initialized and trigger DTC 4378</p>	Power Cycled	Internal Module Error, replace module.
99314	IMG MODULE - INTERNAL ERROR	<p>If (Hybrid Mode = Electric or Hybrid), HEC shall suspend all functions;</p> <p>If (Hybrid Mode = Electric or Hybrid), the HEC shall prohibit all functions;</p> <p>HEC / IMG Module shall command the Main Contactor open;</p> <p>If (Hybrid Mode = Engine), the HEC shall limit the machine to Creep speed after Controls initialized and trigger DTC 4378</p>	Power Cycled	Internal Module Error, replace module.
99315	IMG MODULE - POWER MEASUREMENT ERROR	<p>If (Hybrid Mode = Electric or Hybrid), HEC shall suspend all functions;</p> <p>If (Hybrid Mode = Electric or Hybrid), the HEC shall prohibit all functions;</p> <p>HEC / IMG Module shall command the Main Contactor open;</p> <p>If (Hybrid Mode = Engine), the HEC shall limit the machine to Creep speed after Controls initialized and trigger DTC 4378</p>	Power Cycled	Internal Module Error, replace module.

Table 6-12. Diagnostic Trouble Code Chart - Additional HEC Faults

DTC	JLG Help Message	Required Control Response or State Assignment ^{2,3}	Conditions Required for Movement and/or to Clear Fault	Corrective Action
99316	CLUTCH ACTUATOR MODULE - INTERNAL ERROR	HEC shall disable the Clutch Actuator; HEC shall limit machine to CREEP speed.	Power Cycled	Internal Module Error, replace module.
99318	IMG MODULE - VDC SHORTED	If (Hybrid Mode = Electric or Hybrid), HEC shall suspend all functions; If (Hybrid Mode = Electric or Hybrid), the HEC shall prohibit all functions; HEC / IMG Module shall command the Main Contactor open; If (Hybrid Mode = Engine), the HEC shall limit the machine to Creep speed after Controls initialized and trigger DTC 4378	Power Cycled	Internal Module Error, replace module.
99319	IMG MODULE - POSITIVE LC OPEN	If (Hybrid Mode = Electric or Hybrid), HEC shall suspend all functions; If (Hybrid Mode = Electric or Hybrid), the HEC shall prohibit all functions; HEC / IMG Module shall command the Main Contactor open; If (Hybrid Mode = Engine), the HEC shall limit the machine to Creep speed after Controls initialized and trigger DTC 4378	Power Cycled	Internal Module Error, replace module.
99320	IMG MODULE - LC COIL OPEN	If (Hybrid Mode = Electric or Hybrid), HEC shall suspend all functions; If (Hybrid Mode = Electric or Hybrid), the HEC shall prohibit all functions; HEC / IMG Module shall command the Main Contactor open; If (Hybrid Mode = Engine), the HEC shall limit the machine to Creep speed after Controls initialized and trigger DTC 4378	Power Cycled	Internal Module Error, replace module.

Table 6-12. Diagnostic Trouble Code Chart - Additional HEC Faults

DTC	JLG Help Message	Required Control Response or State Assignment ^{2,3}	Conditions Required for Movement and/or to Clear Fault	Corrective Action
99321	IMG MODULE - EEPROM PARAMETER RESTORE	<p>If (Hybrid Mode = Electric or Hybrid), HEC shall suspend all functions;</p> <p>If (Hybrid Mode = Electric or Hybrid), the HEC shall prohibit all functions;</p> <p>HEC / IMG Module shall command the Main Contactor open;</p> <p>If (Hybrid Mode = Engine), the HEC shall limit the machine to Creep speed after Controls initialized and trigger DTC 4378</p>	Power Cycled	Result of clearing EEPROM so that values are set to default values.
99322	IMG MODULE - SIN COS FAILURE	<p>If (Hybrid Mode = Electric or Hybrid), HEC shall suspend all functions;</p> <p>If (Hybrid Mode = Electric or Hybrid), the HEC shall prohibit all functions;</p> <p>HEC / IMG Module shall command the Main Contactor open;</p> <p>If (Hybrid Mode = Engine), the HEC shall limit the machine to Creep speed after Controls initialized and trigger DTC 4378</p>	Power Cycled	TBD Internal Module Error, replace module.
99323	IMG MODULE - SIN COS SHORTED	<p>If (Hybrid Mode = Electric or Hybrid), HEC shall suspend all functions;</p> <p>If (Hybrid Mode = Electric or Hybrid), the HEC shall prohibit all functions;</p> <p>HEC / IMG Module shall command the Main Contactor open;</p> <p>If (Hybrid Mode = Engine), the HEC shall limit the machine to Creep speed after Controls initialized and trigger DTC 4378</p>	Power Cycled	TBD Internal Module Error, replace module.
99324	IMG MODULE - SIN COS OVERLOAD	<p>If (Hybrid Mode = Electric or Hybrid), HEC shall suspend all functions;</p> <p>If (Hybrid Mode = Electric or Hybrid), the HEC shall prohibit all functions;</p> <p>HEC / IMG Module shall command the Main Contactor open;</p> <p>If (Hybrid Mode = Engine), the HEC shall limit the machine to Creep speed after Controls initialized and trigger DTC 4378</p>	Power Cycled	TBD Internal Module Error, replace module.

Table 6-12. Diagnostic Trouble Code Chart - Additional HEC Faults

DTC	JLG Help Message	Required Control Response or State Assignment ^{2,3}	Conditions Required for Movement and/or to Clear Fault	Corrective Action
99325	IMG MODULE - SIN COS OPEN	<p>If (Hybrid Mode = Electric or Hybrid), HEC shall suspend all functions;</p> <p>If (Hybrid Mode = Electric or Hybrid), the HEC shall prohibit all functions;</p> <p>HEC / IMG Module shall command the Main Contactor open;</p> <p>If (Hybrid Mode = Engine), the HEC shall limit the machine to Creep speed after Controls initialized and trigger DTC 4378</p>	Power Cycled	TBD Internal Module Error, replace module.
99326	IMG MODULE - SOFTWARE IMPROPER	<p>If (Hybrid Mode = Electric or Hybrid), HEC shall suspend all functions;</p> <p>If (Hybrid Mode = Electric or Hybrid), the HEC shall prohibit all functions;</p> <p>HEC / IMG Module shall command the Main Contactor open;</p> <p>If (Hybrid Mode = Engine), the HEC shall limit the machine to Creep speed after Controls initialized and trigger DTC 4378</p>	Power Cycled	Reprogram modules as required..
99327	IMG MODULE - REDUNDANT SOFTWARE VERSION MISMATCH	<p>If (Hybrid Mode = Electric or Hybrid), HEC shall suspend all functions;</p> <p>If (Hybrid Mode = Electric or Hybrid), the HEC shall prohibit all functions;</p> <p>HEC / IMG Module shall command the Main Contactor open;</p> <p>If (Hybrid Mode = Engine), the HEC shall limit the machine to Creep speed after Controls initialized and trigger DTC 4378</p>	Power Cycled	Reprogram modules as required.
99331	IMG MODULE - SPEED CALCULATION MISMATCH	<p>If (Hybrid Mode = Electric or Hybrid), HEC shall suspend all functions;</p> <p>If (Hybrid Mode = Electric or Hybrid), the HEC shall prohibit all functions;</p> <p>HEC / IMG Module shall command the Main Contactor open;</p> <p>If (Hybrid Mode = Engine), the HEC shall limit the machine to Creep speed after Controls initialized and trigger DTC 4378</p>	Power Cycled	Internal Module Error, replace module.

6.11 DIAGNOSTIC TROUBLE CODE CHART - HYBRID UGM

Table 6-13. Diagnostic Trouble Code Chart - Hybrid UGM

DTC	JLG Help Message	Required Control Response or State Assignment	Conditions Required for Movement and/or Clear Fault	Corrective Action
11	EVERYTHING OK	No response required for this DTC	N/A	
21	GROUND MODE OK	No response required for this DTC	N/A	
8	FUNCTIONS LOCKED OUT-SYSTEM POWERED DOWN	UGM shall activate Unattended Audible alarm and issue DTC. HEC shall issue DTC.	HECFLGUnAtndAlrm=0	
101	RUNNING AT CUTBACK - OUT OF TRANSPORT POSITION	UGM shall apply requirements in Drive/Steer Speed Reductions section. Drive speed is limited to "ELEVATED MAX" while the vehicle is out of transport position	Machine is not Out of Transport	
111	FSW OPEN	The UGM shall not Enable the Machine	Controls initialized	
121	RUNNING AT CREEP - CREEP SWITCH OPEN	The UGM shall limit the machine to Creep speed	Platform creep switch input = Low	
131	RUNNING AT CREEP - TILTED AND ABOVE ELEVATION	UGM shall limit the machine to Creep speed	Not all of the trigger conditions are met	
15	LOAD SENSOR READING UNDER WEIGHT	If the UGM determines that CLCPitfmLd > -22.7kg (-50lbs) for 5 seconds the fault is set not active. If 1-cell LSS Configured AND If [(DTC 0015 is active AND PitfmOvrLd_Wght == TRUE) AND (APUactive == FALSE AND HydCMDActive == TRUE)] Then SET all (Functions)OK_LSS = FALSE Else SET all (Functions)OK_LSS = TRUE End If	Not all of the trigger conditions are met	
31	FUEL LEVEL LOW - ENGINE SHUTDOWN	Interlock requirements specified in Fuel Shutdown section.	Power Cycle	
39	SKYGUARD ACTIVE - FUNC- TIONS CUTOUT	Refer to SkyGuard System Detailed Requirements and Logic section for machine response	Not all of the trigger conditions are met	
40	RUNNING AT CREEP - CREEP SWITCH CLOSED	All functions are limited to CREEP Speed	Not all of the trigger conditions are met	
211	POWER CYCLE	No response required	N/A	
212	KEYSWITCH FAULTY	The UGM assumes a station selection of Ground Mode	J7-3 or J7-2 = LOW	

Table 6-13. Diagnostic Trouble Code Chart - Hybrid UGM

DTC	JLG Help Message	Required Control Response or State Assignment	Conditions Required for Movement and/or to Clear Fault	Corrective Action
213	FSW FAULTY	Machine is not allowed to enter the Machine Enabled state	Power Cycle	
227	STEER SWITCHES FAULTY	UGM prohibits Steer Left and Right; Drive speed limited to Creep	UGM detects that both steer switches are not active at the same time; steer and full Drive speed permitted after controls are initialized	
2211	FSW INTERLOCK TRIPPED	The Machine Enabled state is disabled	The footswitch is released	
2212	DRIVE LOCKED - JOYSTICK MOVED BEFORE FOOTSWITCH	If triggered by the drive joystick not being in the neutral position immediately following the startup period, then disable drive and steer. If triggered by a proper machine enable signal being received while the drive joystick is not in the neutral position, then do not allow the machine to enter the Machine Enabled state (7-second timer does not begin)	If triggered by the drive joystick not being in the neutral position immediately following Start Up, then when Drive joystick is returned to its neutral position and the machine is not in the Enabled state. If triggered by proper machine enable signal being received while the drive joystick is not in the neutral position then when the Drive joystick is returned to neutral or the footswitch is released	
2213	STEER LOCKED - SELECTED BEFORE FOOTSWITCH	UGM shall prohibit the machine from entering the Machine Enabled state (7-second timer does not begin)	When the steer controls are returned to neutral or the footswitch is released	
2214	DRIVE/STEER LOCKED - JOYSTICK MOVED BEFORE ENABLE			
2216	D/S JOY. OUT OF RANGE HIGH	UGM shall prohibit Drive; Steer still permitted	The PM no longer reports the fault	
2217	D/S JOY. CENTER TAP BAD	UGM shall prohibit Drive; Steer still permitted	The PM detects that the drive/steer center tap voltage is between 3.31 and 3.75 volts and no longer reports the fault to the UGM	
2219	L/S JOY. OUT OF RANGE HIGH	UGM shall disable Lift and Swing in Platform Mode.	The PM no longer reports the fault	
2220	L/S JOY. CENTER TAP BAD	UGM shall disable Lift and Swing in Platform Mode.	The PM detects that the lift/swing center tap voltage is between 3.31 and 3.75 volts and no longer reports the fault to the UGM	
2221	LIFT/SWING LOCKED - JOYSTICK MOVED BEFORE FOOTSWITCH	If fault occurs at startup, disable Lift and Swing in Platform Mode If fault occurs by receipt of a proper enable signal, then machine is not permitted to enter the Machine Enabled state (7-second timer does not begin).	If triggered by the Lift/Swing controls not being in the neutral position immediately following Start Up, then when Lift/Swing controls are returned to neutral and the machine is not in the Enabled state. If triggered by proper machine enable signal being received while the Lift/Swing controls are not in the neutral position, then when the Lift/Swing controls are returned to neutral or the footswitch is released.	
2222	WAITING FOR FSW TO BE OPEN	UGM shall prohibit the machine from entering the Machine Enabled state	Footswitch is disengaged	
2223	FUNCTION SWITCHES LOCKED - SELECTED BEFORE ENABLE	Machine is not allowed to enter the Machine Enabled state (7-second timer does not begin)	None of the boom controls that trigger this fault are engaged or the Footswitch is disengaged.	

SECTION 6 - JLG CONTROL SYSTEM

Table 6-13. Diagnostic Trouble Code Chart - Hybrid UGM

DTC	JLG Help Message	Required Control Response or State Assignment	Conditions Required for Movement and/or to Clear Fault	Corrective Action
2224	FOOTSWITCH SELECTED BEFORE START			
2269	FUNCTION PROBLEM - HIGH SPEED & CREEP ACTIVE TOGETHER			
2286	FUNCTION PROBLEM - SOFT TOUCH/SKYGUARD OVERRIDE PERMANENTLY SELECTED	No response required for this DTC	The Soft Touch / SkyGuard Override switch input = Low	
234	FUNCTION SWITCHES FAULTY - CHECK DIAGNOSTICS/BOOM	Disable whichever boom functions whose boom control inputs are triggering the fault. If Engine Start/Aux at fault, disable Manual Engine Start but permit Auxiliary Power/Emergency Descent.	None of the boom controls that trigger this fault have both of their direction inputs engaged at the same time	
236	FUNCTION SWITCHES LOCKED - SELECTED BEFORE START SWITCH			
237	START SWITCH LOCKED - SELECTED BEFORE KEYSWITCH	UGM shall prevent engine start	Not all of the trigger conditions are met	
23163	FUNCTION PROBLEM - MSSO PERMANENTLY SELECTED	No inhibits required; MSSO permitted if requirements of MSSO section are met	Function switch returns to neutral and the machine is not in the Enabled state.	
241	AMBIENT TEMPERATURE SENSOR - OUT OF RANGE LOW	If the machine is in Platform Mode and above Elevation, UGM shall suspend motion and set Low Temperature Cutout state = Faulty; all functions limited to Creep speed after controls initialized If the Machine is in Platform Mode and Not Above Elevation, UGM shall suspend motion; all functions except Drive/Steer limited to Creep speed after controls initialized If the machine is in Ground Mode, no response required.	Ambient Temperature sensor reading > -50 °C; speed restrictions removed after controls are initialized	
242	AMBIENT TEMPERATURE SENSOR - OUT OF RANGE HIGH	If the machine is in Platform Mode and above Elevation, UGM shall suspend motion and set Low Temperature Cutout state = Faulty; all functions limited to Creep speed after controls initialized If the Machine is in Platform Mode and Not Above Elevation, UGM shall suspend motion; all functions except Drive/Steer limited to Creep speed after controls initialized If the machine is in Ground Mode, no response required.	Ambient Temperature sensor reading < 85 °C; speed restrictions removed after controls are initialized	
259	MODEL CHANGED - HYDRAULICS SUSPENDED - CYCLE EMS	UGM shall suspend all machine functions and disable all outputs and prevent engine start.	Power Cycle	
2514	BOOM PREVENTED - DRIVE SELECTED	UGM shall disable all boom functions	Not all of the trigger conditions are met	
2516	DRIVE PREVENTED - ABOVE ELEVATION	UGM shall disable Drive and Steer	Not all of the trigger conditions are met	
2517	DRIVE PREVENTED - TILTED & ABOVE ELEVATION	UGM shall provide functionality as they pertain to Drive and Steer	At least one of the trigger conditions is not met; then non-Creep function speed permitted after controls initialized.	
2518	DRIVE PREVENTED - BOOM SELECTED	UGM shall disable Drive and Steer	Not all of the trigger conditions are met	
2520	FUNCTIONS LOCKED OUT - CONSTANT DATA VERSION IMPROPER	All functions prohibited	Not all trigger conditions met	

Table 6-13. Diagnostic Trouble Code Chart - Hybrid UGM

DTC	JLG Help Message	Required Control Response or State Assignment	Conditions Required for Movement and/or to Clear Fault	Corrective Action
2530	UMS SENSOR FORWARD LIMIT REACHED			
2531	UMS SENSOR OUT OF USABLE RANGE			
2532	UMS SENSOR BACKWARD LIMIT REACHED			
2549	DRIVE & BOOM PREVENTED – SOFT TOUCH ACTIVE	Refer to Soft Touch System Detailed Requirements and Logic section for machine response	Not all trigger conditions met	
2563	SKYGUARD SW - DISAGREEMENT	Response detailed in SkyGuard section.	{{SkyGuard inputs (Platform Module J7-18 = High) and (Platform Module J1-23 = High)} and (Footswitch State = Not Depressed)}	
2568	TEMPERATURE CUTOUT ACTIVE - AMBIENT TEMPERATURE TOO LOW	If the machine is in Platform Mode and Above Elevation, UGM shall suspend motion and set Low Temperature Cutout state = Active; all functions limited to Creep speed after controls initialized If the Machine is in Platform Mode and Not Above Elevation, UGM shall suspend motion; all functions except Drive/Steer limited to Creep speed after controls initialized	Low Temperature Cutout = Inactive; speed restrictions removed after controls are initialized	
2576	PLATFORM LEVEL PREVENTED - ABOVE ELEVATION	The UGM shall prohibit Platform Level Up and Down override leveling	Not all of the trigger conditions are met	
2578	FUNCTION PREVENTED - TILTED & ABOVE ELEVATION	UGM shall provide functionality as they pertain to the hydraulic functions.	Not all trigger conditions met	
331	BRAKE - SHORT TO BATTERY			
332	BRAKE - OPEN CIRCUIT			
3311	GROUND ALARM - SHORT TO BATTERY			
3358	MAIN DUMP VALVE - SHORT TO GROUND	UGM shall suspend and prohibit UGM High Flow Dump, Swing, Tower Lift Up, and Lift Up.	Power Cycle	
3359	MAIN DUMP VALVE - OPEN CIRCUIT	UGM shall suspend and prohibit UGM High Flow Dump, Swing, Tower Lift Up, and Lift Up.	Power Cycle	
3360	MAIN DUMP VALVE - SHORT TO BATTERY	UGM shall suspend and prohibit UGM High Flow Dump, Swing, Tower Lift Up, and Lift Up.	Power Cycle	
3361	BRAKE - SHORT TO GROUND			
3362	START SOLENOID - SHORT TO GROUND	UGM shall disable starter output, disable charging, and prevent engine start	Power Cycle	
3363	START SOLENOID - OPEN CIRCUIT	No response required.	UGM no longer detects open circuit	
3364	START SOLENOID - SHORT TO BATTERY	UGM shall disable starter output, disable charging, command engine shutdown, and prevent engine start	Power Cycle	
3365	STEER DUMP VALVE - SHORT TO GROUND	UGM shall suspend Drive/Steer and shall limit Drive to Creep speed after controls initialized. UGM shall suspend and prohibit Steer (Low Flow) Dump, Steer, Flow Control, Tele, Jib Up, Platform Level, and Platform Rotate functions.	Power Cycle	

SECTION 6 - JLG CONTROL SYSTEM

Table 6-13. Diagnostic Trouble Code Chart - Hybrid UGM

DTC	JLG Help Message	Required Control Response or State Assignment	Conditions Required for Movement and/or to Clear Fault	Corrective Action
3366	STEER DUMP VALVE - OPEN CIRCUIT	UGM shall suspend Drive/Steer and shall limit Drive to Creep speed after controls initialized. UGM shall suspend and prohibit Steer (Low Flow) Dump, Steer, Flow Control, Tele, Jib Up, Platform Level, and Platform Rotate functions.	Power Cycle	
3367	STEER DUMP VALVE - SHORT TO BATTERY	UGM shall suspend Drive/Steer and shall limit Drive to Creep speed after controls initialized. UGM shall suspend prohibit Steer (Low Flow) Dump, Steer, Flow Control, Tele, Jib Up, Platform Level, and Platform Rotate functions.	Power Cycle	
3368	TWO SPEED VALVE - SHORT TO GROUND			
3369	TWO SPEED VALVE - OPEN CIRCUIT			
3370	TWO SPEED VALVE - SHORT TO BATTERY			
3371	GROUND ALARM - SHORT TO GROUND	MACHINE SETUP → ALARM/HORN = SEPARATE: UGM shall prohibit J2-2 output.	Power Cycle	
3372	GROUND ALARM - OPEN CIRCUIT	MACHINE SETUP → ALARM/HORN = SEPARATE: No response required for this DTC.	Power Cycle	
3373	GEN SET/WELDER - SHORT TO GROUND			
3374	GEN SET/WELDER - OPEN CIRCUIT			
3375	GEN SET/WELDER - SHORT TO BATTERY			
3376	HEAD TAIL LIGHT - SHORT TO GROUND	UGM shall disable H&T Light relay output	Power Cycle	
3377	HEAD TAIL LIGHT - OPEN CIRCUIT	No response required.	The UGM no longer detects open circuit	
3378	HEAD TAIL LIGHT - SHORT TO BATTERY	UGM shall disable H&T Light relay output	Power Cycle	
3382	PLATFORM LEVEL UP VALVE - SHORT TO GROUND	UGM shall disable Platform Level Up; Level Down speed shall be limited to Creep	Power Cycle	
3383	PLATFORM LEVEL UP VALVE - OPEN CIRCUIT	UGM shall suspend Platform Level; UGM shall limit Platform Level speed to Creep after controls initialized	UGM no longer detects open circuit; speed restrictions removed after controls are initialized	
3384	PLATFORM LEVEL UP VALVE - SHORT TO BATTERY	UGM shall disable UGM Platform Level and Flow Control valves	Power Cycle	
3388	PLATFORM LEVEL DOWN VALVE - SHORT TO GROUND	UGM shall disable UGM Platform Level	Power Cycle	

Table 6-13. Diagnostic Trouble Code Chart - Hybrid UGM

DTC	JLG Help Message	Required Control Response or State Assignment	Conditions Required for Movement and/or to Clear Fault	Corrective Action
3389	PLATFORM LEVEL DOWN VALVE - OPEN CIRCUIT	UGM shall suspend Platform Level; UGM shall prohibit Platform Level Up and limit Platform Level Down speed to Creep after controls initialized	UGM no longer detects open circuit; Platform Level Up permitted and speed restrictions removed after controls are initialized	
3390	PLATFORM LEVEL DOWN VALVE - SHORT TO BATTERY	UGM disables Platform Level Up, Level Down, and Flow Control Valve outputs	Power Cycle	
3394	PLATFORM ROTATE LEFT VALVE - SHORT TO GROUND			
3395	PLATFORM ROTATE LEFT VALVE - OPEN CIRCUIT			
3396	PLATFORM ROTATE LEFT VALVE - SHORT TO BATTERY			
3397	PLATFORM ROTATE RIGHT VALVE - SHORT TO GROUND			
3398	PLATFORM ROTATE RIGHT VALVE - OPEN CIRCUIT			
3399	PLATFORM ROTATE RIGHT VALVE - SHORT TO BATTERY			
33100	JIB LIFT UP VALVE - SHORT TO GROUND			
33101	JIB LIFT UP VALVE - OPEN CIRCUIT			
33102	JIB LIFT UP VALVE - SHORT TO BATTERY			
33103	JIB LIFT DOWN VALVE - SHORT TO GROUND			
33104	JIB LIFT DOWN VALVE - OPEN CIRCUIT			
33105	JIB LIFT DOWN VALVE - SHORT TO BATTERY			
33106	TOWER LIFT UP VALVE - SHORT TO GROUND	UGM disables Tower Lift Up output; Tower Lift Down speed limited to Creep after controls initialized	Power Cycle	
33107	TOWER LIFT UP VALVE - OPEN CIRCUIT	The UGM detects an open circuit at this output J2-33	The UGM shall suspend Tower Lift and revert to Open Loop Current control for Tower Lift; UGM shall limit Tower Lift speed to Creep after controls initialized	
33108	TOWER LIFT UP VALVE - SHORT TO BATTERY			
33109	TOWER LIFT DOWN VALVE - SHORT TO GROUND	UGM shall disable Tower Lift Up and Down	Power Cycle	
33110	TOWER LIFT DOWN VALVE - OPEN CIRCUIT	The UGM shall suspend Tower Lift and revert to Open Loop Current control for Tower Lift; UGM shall prohibit Tower Lift Up and shall limit Tower Lift Down speed to Creep after controls initialized	UGM no longer detects open circuit; Tower Lift Up permitted and speed restriction removed for Tower Lift Down after controls are initialized	
33111	TOWER LIFT DOWN VALVE - SHORT TO BATTERY			

SECTION 6 - JLG CONTROL SYSTEM

Table 6-13. Diagnostic Trouble Code Chart - Hybrid UGM

DTC	JLG Help Message	Required Control Response or State Assignment	Conditions Required for Movement and/or to Clear Fault	Corrective Action
33112	TOWER TELESCOPE IN VALVE - SHORT TO GROUND			
33113	TOWER TELESCOPE IN VALVE - OPEN CIRCUIT			
33114	TOWER TELESCOPE IN VALVE - SHORT TO BATTERY			
33115	TOWER TELESCOPE OUT VALVE - SHORT TO GROUND			
33116	TOWER TELESCOPE OUT VALVE - OPEN CIRCUIT			
33117	TOWER TELESCOPE OUT VALVE - SHORT TO BATTERY			
33118	SWING RIGHT VALVE - SHORT TO GROUND	UGM shall disable Swing Left and Right	Power Cycle	
33119	SWING RIGHT VALVE - OPEN CIRCUIT	The UGM shall suspend Swing and revert to Open Loop Current control for Swing; UGM shall limit Swing speed to Creep after controls initialized	UGM no longer detects open circuit; speed restriction removed after controls are initialized	
33120	MAIN TELESCOPE IN VALVE - SHORT TO BATTERY	UGM shall disable Telescope and Flow Control valves	Power Cycle	
33121	SWING RIGHT VALVE - SHORT TO BATTERY			
33122	SWING LEFT VALVE - SHORT TO GROUND	UGM shall disable Swing Left and Right	Power Cycle	
33123	MAIN TELESCOPE OUT VALVE - SHORT TO BATTERY	UGM shall disable Telescope and Flow Control valves	Power Cycle	
33170	MAIN LIFT DOWN VALVE - OPEN CIRCUIT			
33171	MAIN LIFT DOWN VALVE - SHORT TO BATTERY			
33172	MAIN LIFT DOWN VALVE - SHORT TO GROUND			
33182	MAIN LIFT VALVES - SHORT TO BATTERY			
33186	MAIN TELESCOPE OUT VALVE - OPEN CIRCUIT			
33188	MAIN TELESCOPE OUT VALVE - SHORT TO GROUND			
33189	MAIN TELESCOPE IN VALVE - OPEN CIRCUIT			
33190	MAIN TELESCOPE IN VALVE - SHORT TO GROUND			
33207	HORN - OPEN CIRCUIT			
33208	HORN - SHORT TO BATTERY			

Table 6-13. Diagnostic Trouble Code Chart - Hybrid UGM

DTC	JLG Help Message	Required Control Response or State Assignment	Conditions Required for Movement and/or to Clear Fault	Corrective Action
33209	HORN - SHORT TO GROUND			
33267	ENGINE FUEL RELAY – OPEN CIRCUIT	UGM shall disable this output, command engine shutdown and prevent engine start UGM shall flash the Engine Distress Lamp at 3Hz	Power Cycle	
33268	ENGINE FUEL RELAY - SHORT TO BATTERY	Only detected at Startup UGM shall disable this output, command engine shutdown and prevent engine start; UGM shall flash the Engine Distress Lamp at 3Hz	Power Cycle	
33269	ENGINE FUEL RELAY - SHORT TO GROUND	UGM shall disable this output, command engine shutdown and prevent engine start; UGM shall flash the Engine Distress Lamp at 3Hz	Power Cycle	
33279	GLOWPLUG - OPEN CIRCUIT	No response required. Engine start will proceed without glow.	Power Cycle	
33280	GLOWPLUG - SHORT TO BATTERY	UGM shall disable Glow Plug relay output	Power Cycle	
33281	GLOWPLUG - SHORT TO GROUND	Before Start: UGM shall disable Glow Plug relay output and prohibit glow plug cycle. After	Power Cycle	
33287	LIFT - CURRENT FEEDBACK READING TOO LOW	UGM shall suspend Lift Up/Down command and revert to Open Loop Current control for Lift; Lift speed limited to Creep after both Lift Up/Down controls have been returned to neutral and machine is not Enabled	Power Cycle	
33295	SWING LEFT VALVE - OPEN CIRCUIT	The UGM shall suspend Swing command and revert to Open Loop Current control for Swing; UGM shall limit Swing speed to Creep after controls initialized	UGM no longer detects open circuit; restrictions on Swing speed shall be removed after controls are initialized	
33306	SWING LEFT VALVE - SHORT TO BATTERY			
33314	FLOW CONTROL VALVE - OPEN CIRCUIT			
33315	FLOW CONTROL VALVE - SHORT TO BATTERY			
33316	FLOW CONTROL VALVE - SHORT TO GROUND			
33317	DRIVE FORWARD VALVE - OPEN CIRCUIT			
33318	DRIVE FORWARD VALVE - SHORT TO BATTERY			
33319	DRIVE FORWARD VALVE - SHORT TO GROUND			
33320	DRIVE REVERSE VALVE - OPEN CIRCUIT			
33321	DRIVE REVERSE VALVE - SHORT TO BATTERY			
33322	DRIVE REVERSE VALVE - SHORT TO GROUND			
33323	MAIN LIFT UP VALVE - OPEN CIRCUIT			

SECTION 6 - JLG CONTROL SYSTEM

Table 6-13. Diagnostic Trouble Code Chart - Hybrid UGM

DTC	JLG Help Message	Required Control Response or State Assignment	Conditions Required for Movement and/or to Clear Fault	Corrective Action
33324	MAIN LIFT UP VALVE - SHORT TO BATTERY			
33325	MAIN LIFT UP VALVE - SHORT TO GROUND			
33331	DRIVE - CURRENT FEEDBACK READING TOO LOW			
33410	DRIVE - LOSS OF CURRENT FEEDBACK			
33412	SWING VALVES - SHORT TO BATTERY			
33414	SWING - CURRENT FEEDBACK READING TOO LOW	The UGM commanded current > 250mA The difference between the commanded current and the measured feedback current > [the larger of (125mA) or (15% of the commanded function Max)] for longer than 1 second	UGM shall suspend Swing Left/Right command and revert to Open Loop Current control for Swing; Swing speed limited to Creep after both Swing Left/Right have been returned to neutral and machine is not Enabled	
33415	FLOW CONTROL - CURRENT FEEDBACK READING TOO LOW	UGM shall suspend and revert to Open Current loop control for Flow Control Valve; Tele In/Out, Jib Up, Rotate Right/Left, and Level Up/Down speed limited to Creep after controls for those functions have all been simultaneously returned to neutral and machine is not Enabled	Power Cycle	
33417	LIFT - LOSS OF CURRENT FEEDBACK	UGM shall suspend Lift Up/Down command and revert to Open Loop Current control for Lift; Lift speed limited to Creep after both Lift Up/Down controls have been returned to neutral and machine is not Enabled	Power Cycle	
33418	SWING - LOSS OF CURRENT FEEDBACK	UGM shall suspend Swing Left/Right command and revert to Open Loop Current control for Swing; Swing speed limited to Creep after both Swing Left/Right have been returned to neutral and machine is not Enabled	Power Cycle	
33419	FLOW CONTROL - LOSS OF CURRENT FEEDBACK	UGM shall suspend and revert to Open Current loop control for Flow Control Valve; Tele In/Out, Jib Up, Rotate Right/Left, and Level Up/Down speed limited to Creep after controls for those functions have all been simultaneously returned to neutral and machine is not Enabled	Power Cycle	
33488	DRIVE VALVES - SHORT TO BATTERY			
341	PLATFORM LEVEL UP VALVE - OPEN CIRCUIT			
342	PLATFORM LEVEL UP VALVE - SHORT TO BATTERY			
343	PLATFORM LEVEL UP VALVE - SHORT TO GROUND			
344	PLATFORM LEVEL UP VALVE - SHORT TO BATTERY OR OPEN CIRCUIT			

Table 6-13. Diagnostic Trouble Code Chart - Hybrid UGM

DTC	JLG Help Message	Required Control Response or State Assignment	Conditions Required for Movement and/or to Clear Fault	Corrective Action
345	PLATFORM LEVEL DOWN VALVE - OPEN CIRCUIT			
346	PLATFORM LEVEL DOWN VALVE - SHORT TO BATTERY			
347	PLATFORM LEVEL DOWN VALVE - SHORT TO GROUND			
348	PLATFORM LEVEL DOWN VALVE - SHORT TO BATTERY OR OPEN CIRCUIT			
349	PLATFORM ROTATE LEFT VALVE - OPEN CIRCUIT	The UGM shall suspend commands to PM for Platform Rotate; UGM shall limit Platform Rotate speed to Creep after controls are initialized	The PM no longer detects open circuit; speed restrictions shall be removed after controls are initialized	
3410	PLATFORM ROTATE LEFT VALVE - SHORT TO BATTERY	UGM shall disable commands to Platform Module for Platform Rotate and Flow Control valve outputs	Power Cycle	
3411	PLATFORM ROTATE LEFT VALVE - SHORT TO GROUND	UGM shall disable commands to Platform Module for Platform Rotate Left	Power Cycle	
3412	PLATFORM ROTATE RIGHT VALVE - OPEN CIRCUIT	The UGM shall suspend commands to PM for Platform Rotate; UGM shall limit Platform Rotate speed to Creep after controls are initialized	The PM no longer detects open circuit; speed restrictions shall be removed after controls are initialized	
3413	PLATFORM ROTATE RIGHT VALVE - SHORT TO BATTERY	UGM shall disable commands to Platform Module for Platform Rotate and Flow Control valve outputs	Power Cycle	
3414	PLATFORM ROTATE RIGHT VALVE - SHORT TO GROUND	UGM shall disable commands to Platform Module for Platform Rotate Right	Power Cycle	
3415	JIB LIFT UP VALVE - OPEN CIRCUIT	The UGM shall command Platform Module to suspend Jib Lift; UGM shall limit Jib Lift speed to Creep after controls are initialized	The PM no longer detects open circuit; speed restrictions shall be removed after controls are initialized	
3416	JIB LIFT UP VALVE - SHORT TO BATTERY	UGM shall disable Jib Lift Up and Flow Control valve outputs; Jib Lift Down speed limited to Creep	Power Cycle	
3417	JIB LIFT UP VALVE - SHORT TO GROUND	The UGM shall command Platform Module to suspend Jib Lift outputs; UGM shall disable Jib Lift Up.	Power Cycle	
3418	JIB LIFT DOWN VALVE - OPEN CIRCUIT	UGM shall command PM to suspend Jib Lift; UGM shall prohibit Jib Lift Up and limit Jib Lift Down speed to Creep after controls are initialized	The PM no longer detects open circuit; speed restrictions shall be removed and motion permitted after controls are initialized	
3419	JIB LIFT DOWN VALVE - SHORT TO BATTERY	UGM shall command Platform Module to disable Jib Lift outputs	Power Cycle	
3420	JIB LIFT DOWN VALVE - SHORT TO GROUND	UGM shall command to Platform Module to disable Jib Lift outputs	Power Cycle	
431	FUEL SENSOR - SHORT TO BATTERY OR OPEN CIRCUIT	UGM shall respond with functionality detailed in the System Indicators and GenSet/Fuel sections	Power Cycle	

SECTION 6 - JLG CONTROL SYSTEM

Table 6-13. Diagnostic Trouble Code Chart - Hybrid UGM

DTC	JLG Help Message	Required Control Response or State Assignment	Conditions Required for Movement and/or to Clear Fault	Corrective Action
432	FUEL SENSOR - SHORT TO GROUND	UGM shall respond with functionality detailed in the System Indicators and GenSet/Fuel sections	Power Cycle	
433	OIL PRESSURE - SHORT TO BATTERY	UGM shall illuminate the Engine Distress Lamp; If MACHINE SETUP -> ENGINE SHUTDOWN = ENABLED; UGM shall command engine shutdown and prevent engine start; UGM shall flash the Engine Distress Lamp at 3Hz	Power Cycle	
435	COOLANT TEMPERATURE SHORT TO GROUND	UGM assumes maximum temperature exceeded; UGM shall illuminate the Engine Distress Lamp; If MACHINE SETUP -> ENGINE SHUTDOWN = ENABLED; UGM shall command engine shutdown and prevent engine start; UGM shall flash the Engine Distress Lamp at 3Hz	All trigger conditions have been cleared	
438	HIGH ENGINE TEMP	UGM assumes maximum temperature exceeded; UGM shall illuminate the Engine Distress Lamp; If MACHINE SETUP -> ENGINE SHUTDOWN = ENABLED; UGM shall command engine shutdown and prevent engine start; UGM shall flash the Engine Distress Lamp at 3Hz	Power Cycle	
4310	NO ALTERNATOR OUTPUT			
4311	LOW OIL PRESSURE	UGM shall illuminate the Engine Distress Lamp; If MACHINE SETUP -> ENGINE SHUTDOWN = ENABLED; UGM shall command engine shutdown and prevent engine start; UGM shall flash the Engine Distress Lamp at 3Hz	Power Cycle	
4313	THROTTLE ACTUATOR FAILURE			
4322	LOSS OF ENGINE SPEED SENSOR	UGM shall command engine shutdown and prevent engine start; UGM shall flash the Engine Distress Lamp at 3Hz	Power Cycle	
4323	ENGINE SPEED SENSOR READING - INVALID	UGM shall command engine shutdown and prevent engine start; UGM shall flash the Engine Distress Lamp at 3Hz	Power Cycle	
4326	FUEL ACTUATOR - SHORT TO GROUND	Only detected at Startup UGM shall disable this output, command engine shutdown and prevent engine start; UGM shall flash the Engine Distress Lamp at 3Hz	Power Cycle	
4327	FUEL ACTUATOR - OPEN CIRCUIT	UGM shall disable this output, command engine shutdown and prevent engine start; UGM shall flash the Engine Distress Lamp at 3Hz	Power Cycle	
4328	FUEL ACTUATOR - SHORT TO BATTERY	UGM shall disable this output and open low side FET. UGM shall command engine shutdown and prevent engine start; UGM shall flash the Engine Distress Lamp at 3Hz	Power Cycle	

Table 6-13. Diagnostic Trouble Code Chart - Hybrid UGM

DTC	JLG Help Message	Required Control Response or State Assignment	Conditions Required for Movement and/or to Clear Fault	Corrective Action
4330		UGM shall disable this output, command engine shutdown and prevent engine start	Power Cycle	
4353	ENGINE COOLANT TEMPERATURE SENSOR – OUT OF RANGE LOW	If MACHINE SETUP → ENGINE SHUTDOWN = ENABLED, UGM shall shut down engine and not permit engine start	Power Cycle	
4376	FUNCTIONS PREVENTED – ENGINE OIL WARM-UP ACTIVE	UGM shall display DTC upon HEC request; No further system response	HECFLGEngWrmUp=0	
4377	FUEL ACTUATOR FAILURE	UGM shall command engine shutdown and prevent engine start; UGM shall flash the Engine Distress Lamp at 3Hz	Power Cycle	
441	BATTERY VOLTAGE TOO LOW – SYSTEM SHUTDOWN	UGM shall command engine shutdown and prevent engine start; UGM shall prevent all functions; UGM shall disable the IMG	Power Cycle	
442	BATTERY VOLTAGE TOO HIGH – SYSTEM SHUTDOWN	UGM shall command engine shutdown and prevent engine start; UGM shall prevent all functions; UGM shall disable the IMG	Power Cycle	
443	LSS BATTERY VOLTAGE TOO HIGH	SET PltfmOvrLd_DTC = TRUE	Not all of the trigger conditions are met	
444	LSS BATTERY VOLTAGE TOO LOW	SET PltfmOvrLd_DTC = TRUE	Not all of the trigger conditions are met	
445	BATTERY VOLTAGE LOW			
4434	ENGINE START FAILED – TOO MANY ATTEMPTS			
4479	LSS BATTERY VOLTAGE – INITIALIZATION ERROR	SET PltfmOvrLd_DTC = TRUE	Power Cycle	
4480	LSS BATTERY VOLTAGE – NOT CALIBRATED	SET PltfmOvrLd_DTC = TRUE	Power Cycle	
662	CANBUS FAILURE – PLATFORM MODULE			
663	CANBUS FAILURE – LOAD SENSING SYSTEM MODULE	SET PltfmOvrLd_DTC = TRUE SET PltfmGrs1SnsrOK = FALSE SET PltfmGrs2SnsrOK = FALSE	Not all of the trigger conditions are met	
664	CANBUS FAILURE – ACCESSORY MODULE	If in Platform mode, UGM shall suspend all machine functions and disable all outputs. Jib Lift and Platform Rotate also disable in Ground Mode. If MACHINE SETUP → POWER INVERTER = YES, UGM to retain state of Inverter switch and GenSet Enable switch at the state prior to CAN1 loss until CAN1 is restored or Power Cycle.	CAN1 messages are received from the PM and controls are initialized	

SECTION 6 - JLG CONTROL SYSTEM

Table 6-13. Diagnostic Trouble Code Chart - Hybrid UGM

DTC	JLG Help Message	Required Control Response or State Assignment	Conditions Required for Movement and/or to Clear Fault	Corrective Action
6620	UMS SENSOR COMMUNICATIONS LOST			
6622	CANBUS FAILURE – TCU MODULE	No function inhibits required	Not all of the trigger conditions are met	
6623	CANBUS FAILURE – GATEWAY MODULE	No function inhibits required	Not all of the trigger conditions are met	
6629	CANBUS FAILURE – TELEMATICS CANBUS LOADING TOO HIGH	No function inhibits required	Zero Configuration Status (Status Byte = 00) sent on first byte	
6635	CANBUS FAILURE – CHASSIS TILT SENSOR	For Tilt and Grade considerations (machine tilted), display ?? on Analyzer for X/Y axes, and externally report X and Y axes = 20°	CAN1 messages are received from the sensor and controls are initialized	
6651	CANBUS FAILURE – GROUND DISPLAY	No response required	CAN1 messages are received from the sensor and controls are initialized	
6657	CANBUS FAILURE – TEMPERATURE SENSOR	No response required	CAN1 messages are received from the sensor and controls are initialized	
6666	CANBUS FAILURE – HYBRID ELECTRIC CONTROL MODULE	UGM shall suspend all functions; If Engine State = Running, the UGM shall limit the machine to Creep speed after Controls initialized	CAN1 messages are received from the HEC and controls are initialized	
6666	CANBUS FAILURE – STATE OF CHARGE SENSOR	UGM Shall assign SOC% to an “unknown value” UGM shall flash all 4 bar displays (PLT and GND) and display ‘???’ in place of GND SOC reading.	CAN1 messages are received from the sensor	
674	HYBRID ELECTRIC CONTROL DTC ACTIVE	No response required	Not all of the trigger conditions are met	
681	REMOTE CONTRACT MANAGEMENT OVERRIDE - ALL FUNCTIONS IN CREEP	UGM shall limit all machine function speeds to Creep and lock in Transport position	Cleared by ClearSky TCU	
813	CHASSIS TILT SENSOR NOT CALIBRATED	UGM shall consider the Chassis Tilt reading to be unhealthy	Chassis Tilt sensor calibrated	
814	CHASSIS TILT SENSOR OUT OF RANGE	UGM shall consider the Chassis Tilt reading to be unhealthy	Not all of the trigger conditions are met	
816	UMS SENSOR NOT CALIBRATED			
817	UMS SENSOR FAULT			
818	TILT SENSOR STAGNANT	UGM shall consider the Chassis Tilt reading to be unhealthy	Power Cycle	
825	LSS HAS NOT BEEN CALIBRATED	SET PItfmOvrLd_DTC = TRUE SET PItfmLdSnsrOK_DTC = TRUE	Not all of the trigger conditions are met	
826	RUNNING AT CREEP - PLATFORM OVERLOADED	The UGM shall set Platform Load State = Overloaded and provide the operation/interlocks described Load Sensing System section	UGM determines that the Platform is not Overloaded; motion restrictions removed after controls initialized	
827	DRIVE & BOOM PREVENTED - PLATFORM OVERLOADED	The Platform is Overloaded and Machine Setup → LOAD SYSTEM = CUTOUT PLATFORM, Platform Mode is active, and conditions of Table 6-7 apply. -or- The Platform is Overloaded and Machine Setup → LOAD SYSTEM = CUTOUT ALL and conditions of Table 6-7 apply.	Refer to Table 6-7 for machine response.	

Table 6-13. Diagnostic Trouble Code Chart - Hybrid UGM

DTC	JLG Help Message	Required Control Response or State Assignment	Conditions Required for Movement and/or to Clear Fault	Corrective Action
828	LIFT UP & TELEOUT PRE-VENTED - PLATFORM OVER-LOADED			
8211	LSS READING UNDER WEIGHT	SET PltfmOvrLd_DTC = TRUE	Power Cycle	
8218	LSS SENSOR DISAGREEMENT	If {PltfmOvrLd_Wght == FALSE and MachineConfigLdSysActive == TRUE} Then SET LSSCreep_DTC = TRUE End If	Power Cycle	
8222	LSS STRAIN GAUGE 1 - STAGNANT	If {PltfmOvrLd_Wght == FALSE and MachineConfigLdSysActive == TRUE} Then SET LSSCreep_DTC = TRUE End If If [(DTC 8218 - LSS SENSOR DISAGREEMENT or DTC 8223 - LSS STRAIN GAUGE 2 - STAGNANT is active) or (PltfmGrs2SnsrOK == FALSE)] Then SET PltfmOvrLd_DTC = TRUE End If	Power Cycle	
8223	LSS STRAIN GAUGE 2 - STAGNANT	If {PltfmOvrLd_Wght == FALSE and MachineConfigLdSysActive == TRUE} Then SET LSSCreep_DTC = TRUE End If If [(DTC 8218 - LSS SENSOR DISAGREEMENT or DTC 8222 - LSS STRAIN GAUGE 1 - STAGNANT is active) or (PltfmGrs1SnsrOK == FALSE)] Then SET PltfmOvrLd_DTC = TRUE End If	Power Cycle	
8224	LSS STRAIN GAUGE 1 - OUT OF RANGE LOW	SET PltfmGrs1SnsrOK = FALSE If {PltfmOvrLd_Wght == FALSE and MachineConfigLdSysActive == TRUE} Then SET LSSCreep_DTC = TRUE End If If [(DTC 8218 - LSS SENSOR DISAGREEMENT or DTC 8223 - LSS STRAIN GAUGE 2 - STAGNANT is active) or (PltfmGrs2SnsrOK == FALSE)] Then SET PltfmOvrLd_DTC = TRUE End If	Power Cycle	

SECTION 6 - JLG CONTROL SYSTEM

Table 6-13. Diagnostic Trouble Code Chart - Hybrid UGM

DTC	JLG Help Message	Required Control Response or State Assignment	Conditions Required for Movement and/or to Clear Fault	Corrective Action
8225	LSS STRAIN GAUGE 2 - OUT OF RANGE LOW	SET PltfmGrs2SnsrOK = FALSE If {PltfmOvrLd_Wght == FALSE and MachineConfigLdSysActive == TRUE} Then SET LSSCreep_DTC = TRUE End If If {(DTC 8218 – LSS SENSOR DISAGREEMENT or DTC 8222 – LSS STRAIN GAUGE 1 - STAGNANT is active) or (PltfmGrs1SnsrOK == FALSE)} Then SET PltfmOvrLd_DTC = TRUE End If	Power Cycle	
8226	LSS STRAIN GAUGE 1 - OUT OF RANGE HIGH	SET PltfmGrs2SnsrOK = FALSE If {PltfmOvrLd_Wght == FALSE and MachineConfigLdSysActive == TRUE} Then SET LSSCreep_DTC = TRUE End If If {(DTC 8218 – LSS SENSOR DISAGREEMENT or DTC 8222 – LSS STRAIN GAUGE 1 - STAGNANT is active) or (PltfmGrs1SnsrOK == FALSE)} Then SET PltfmOvrLd_DTC = TRUE End If	Power Cycle	
8227	LSS STRAIN GAUGE 2 - OUT OF RANGE HIGH	SET PltfmGrs2SnsrOK = FALSE If {PltfmOvrLd_Wght == FALSE and MachineConfigLdSysActive == TRUE} Then SET LSSCreep_DTC = TRUE End If If {(DTC 8218 – LSS SENSOR DISAGREEMENT or DTC 8222 – LSS STRAIN GAUGE 1 - STAGNANT is active) or (PltfmGrs1SnsrOK == FALSE)} Then SET PltfmOvrLd_DTC = TRUE End If	Power Cycle	
8228	LSS STRAIN GAUGE 1 - INITIALIZATION ERROR	SET PltfmGrs1SnsrOK = FALSE If {PltfmOvrLd_Wght == FALSE and MachineConfigLdSysActive == TRUE} Then SET LSSCreep_DTC = TRUE End If If {(DTC 8218 – LSS SENSOR DISAGREEMENT or DTC 8223 – LSS STRAIN GAUGE 2 - STAGNANT is active) or (PltfmGrs2SnsrOK == FALSE)} Then SET PltfmOvrLd_DTC = TRUE End If	Power Cycle	

Table 6-13. Diagnostic Trouble Code Chart - Hybrid UGM

DTC	JLG Help Message	Required Control Response or State Assignment	Conditions Required for Movement and/or to Clear Fault	Corrective Action
8229	LSS STRAIN GAUGE 2 - INITIALIZATION ERROR	SET PltfmGrS2SnsrOK = FALSE If {PltfmOvrLd_Wght == FALSE and MachineConfigLdSysActive == TRUE} Then SET LSSCreep_DTC = TRUE End If If [(DTC 8218 – LSS SENSOR DISAGREEMENT or DTC 8222 – LSS STRAIN GAUGE 1 - STAGNANT is active) or (PltfmGrS1SnsrOK == FALSE)] Then SET PltfmOvrLd_DTC = TRUE End If	Power Cycle	
8230	LSS STRAIN GAUGE 1 - NOT CALIBRATED	SET PltfmGrS1SnsrOK = FALSE If {PltfmOvrLd_Wght == FALSE and MachineConfigLdSysActive == TRUE} Then SET LSSCreep_DTC = TRUE End If If [(DTC 8218 – LSS SENSOR DISAGREEMENT or DTC 8223 – LSS STRAIN GAUGE 2 - STAGNANT is active) or (PltfmGrS2SnsrOK == FALSE)] Then SET PltfmOvrLd_DTC = TRUE End If	Power Cycle	
8231	LSS STRAIN GAUGE 2 - NOT CALIBRATED	SET PltfmGrS2SnsrOK = FALSE If {PltfmOvrLd_Wght == FALSE and MachineConfigLdSysActive == TRUE} Then SET LSSCreep_DTC = TRUE End If If [(DTC 8218 – LSS SENSOR DISAGREEMENT or DTC 8222 – LSS STRAIN GAUGE 1 - STAGNANT is active) or (PltfmGrS1SnsrOK == FALSE)] Then SET PltfmOvrLd_DTC = TRUE End If	Power Cycle	
8232	LSS STRAIN GAUGE 1 - SENSOR DEFECT	SET PltfmGrS1SnsrOK = FALSE If {PltfmOvrLd_Wght == FALSE and MachineConfigLdSysActive == TRUE} Then SET LSSCreep_DTC = TRUE End If If [(DTC 8218 – LSS SENSOR DISAGREEMENT or DTC 8223 – LSS STRAIN GAUGE 2 - STAGNANT is active) or (PltfmGrS2SnsrOK == FALSE)] Then SET PltfmOvrLd_DTC = TRUE End If	Power Cycle	

SECTION 6 - JLG CONTROL SYSTEM

Table 6-13. Diagnostic Trouble Code Chart - Hybrid UGM

DTC	JLG Help Message	Required Control Response or State Assignment	Conditions Required for Movement and/or to Clear Fault	Corrective Action
8233	LSS STRAIN GAUGE 2 - SENSOR DEFECT	SET PltfmGrs2SnsrOK = FALSE If {PltfmOvrLd_Wght == FALSE and MachineConfigLdSysActive == TRUE} Then SET LSSCreep_DTC = TRUE End If If [(DTC 8218 – LSS SENSOR DISAGREEMENT or DTC 8222 – LSS STRAIN GAUGE 1 - STAGNANT is active) or (PltfmGrs1SnsrOK == FALSE)] Then SET PltfmOvrLd_DTC = TRUE End If	Power Cycle	
8234	LSS STRAIN GAUGE 1 - NOT INSTALLED	SET PltfmGrs1SnsrOK = FALSE If {PltfmOvrLd_Wght == FALSE and MachineConfigLdSysActive == TRUE} Then SET LSSCreep_DTC = TRUE End If If [(DTC 8218 – LSS SENSOR DISAGREEMENT or DTC 8223 – LSS STRAIN GAUGE 2 - STAGNANT is active) or (PltfmGrs2SnsrOK == FALSE)] Then SET PltfmOvrLd_DTC = TRUE End If	Power Cycle	
8235	LSS STRAIN GAUGE 2 - NOT INSTALLED	SET PltfmGrs2SnsrOK = FALSE If {PltfmOvrLd_Wght == FALSE and MachineConfigLdSysActive == TRUE} Then SET LSSCreep_DTC = TRUE End If If [(DTC 8218 – LSS SENSOR DISAGREEMENT or DTC 8222 – LSS STRAIN GAUGE 1 - STAGNANT is active) or (PltfmGrs1SnsrOK == FALSE)] Then SET PltfmOvrLd_DTC = TRUE End If	Power Cycle	
8236	LSS NOT DETECTING CHANGE	SET PltfmOvrLd_DTC == TRUE	Power Cycle	
8237	LSS STRAIN GAUGE 1 - A/D DEFECT	SET PltfmGrs1SnsrOK = FALSE If {PltfmOvrLd_Wght == FALSE and MachineConfigLdSysActive == TRUE} Then SET LSSCreep_DTC = TRUE End If If [(DTC 8218 – LSS SENSOR DISAGREEMENT or DTC 8223 – LSS STRAIN GAUGE 2 - STAGNANT is active) or (PltfmGrs2SnsrOK == FALSE)] Then SET PltfmOvrLd_DTC = TRUE End If	Power Cycle	

Table 6-13. Diagnostic Trouble Code Chart - Hybrid UGM

DTC	JLG Help Message	Required Control Response or State Assignment	Conditions Required for Movement and/or to Clear Fault	Corrective Action
8238	LSS STRAIN GAUGE 2 - A/D DEFECT	<p>SET PltfmGrs2SnsrOK = FALSE</p> <p>If {PltfmOvrLd_Wght == FALSE and MachineConfigLdSysActive == TRUE}</p> <p>Then SET LSSCreep_DTC = TRUE</p> <p>End If</p> <p>If [(DTC 8218 – LSS SENSOR DISAGREEMENT or DTC 8222 – LSS STRAIN GAUGE 1 - STAGNANT is active) or (PltfmGrs1SnsrOK == FALSE)]</p> <p>Then SET PltfmOvrLd_DTC = TRUE</p> <p>End If</p>	Power Cycle	
8639	FRONT LEFT STEER VALVE - OPEN CIRCUIT	UGM shall limit Drive and Steer speed to Creep	UGM no longer detects open circuit; Creep restriction removed after fault clears and controls initialized	
8640	FRONT LEFT STEER VALVE - SHORT TO BATTERY	UGM shall disable Drive and Steer	Power Cycle	
8641	FRONT LEFT STEER VALVE - SHORT TO GROUND	UGM shall disable Steer Left and Right outputs and limit Drive to Creep	Power Cycle	
8642	FRONT RIGHT STEER VALVE - OPEN CIRCUIT	UGM shall limit Drive and Steer speed to Creep	UGM no longer detects open circuit; Creep restriction removed after fault clears and controls initialized	
8643	FRONT RIGHT STEER VALVE - SHORT TO BATTERY	UGM shall disable Drive and Steer	Power Cycle	
8644	FRONT RIGHT STEER VALVE - SHORT TO GROUND	UGM shall disable Steer Left and Right outputs and limit Drive to Creep	Power Cycle	
8645	REAR LEFT STEER VALVE - OPEN CIRCUIT			
8646	REAR LEFT STEER VALVE - SHORT TO BATTERY			
8647	REAR LEFT STEER VALVE - SHORT TO GROUND			
8648	REAR RIGHT STEER VALVE - OPEN CIRCUIT			
8649	REAR RIGHT STEER VALVE - SHORT TO BATTERY			
8650	REAR RIGHT STEER VALVE - SHORT TO GROUND			
873	MACHINE SAFETY SYSTEM OVERRIDE OCCURRED	Machine response as described in the MSSO section	Fault shall be considered active and retained through power cycle; reset only via Analyzer/Calibrations	
998	EEPROM FAILURE - CHECK ALL SETTINGS	UGM shall suspend all machine functions and disable all outputs and reset the section of EEPROM where the failure occurred to defaults (if occurs to MACHINE SETUP, reset to NO MODEL???)	Power Cycle	
9910	FUNCTIONS LOCKED OUT - PLATFORM MODULE SOFTWARE VERSION IMPROPER	UGM shall suspend all machine functions and disable all outputs and activate the platform alarm continuously. If in Platform mode, disable all Drive, Steer, and Boom functions; otherwise, restrict functions to Creep	Not all of the trigger conditions are met	
9914	PLATFORM MODULE SOFTWARE UPDATE REQUIRED			
9919	GROUND SENSOR REF VOLTAGE OUT OF RANGE	UGM shall command engine shutdown and disable engine start operations; otherwise, no interlocks required.	Power Cycle	
9920	PLATFORM SENSOR REF VOLTAGE OUT OF RANGE	UGM shall suspend motion. If in Platform mode, all function speeds shall be limited to Creep	Power Cycle	

SECTION 6 - JLG CONTROL SYSTEM

Table 6-13. Diagnostic Trouble Code Chart - Hybrid UGM

DTC	JLG Help Message	Required Control Response or State Assignment	Conditions Required for Movement and/or to Clear Fault	Corrective Action
9921	GROUND MODULE FAILURE: HIGH SIDE DRIVER CUT-OUT FAULTY	UGM shall suspend all machine functions and disable all outputs. UGM shall prohibit the machine from entering the Machine Enabled state (7-second timer does not begin)	Power Cycle	
9922	PLATFORM MODULE FAILURE: HWFS CODE 1	No response required.	Power Cycle	
9923	GROUND MODULE FAILURE: HWFS CODE 1			
9924	FUNCTIONS LOCKED OUT - MACHINE NOT CONFIGURED	UGM shall suspend all machine functions and disable all outputs. UGM shall display ??? or NO MODEL at Analyzer MACHINE SETUP menu MACHINE SETUP → MODEL NUMBER; UGM shall not report any other faults and shall disable all machine functions	Power Cycle	
9944	CURRENT FEEDBACK GAINS OUT OF RANGE	A gain of 1 is used for the factory gain(s) that was out of range; all functions shall be placed in Creep mode.	Power Cycle	
9945	CURRENT FEEDBACK CALIBRATION CHECKSUM INCORRECT	UGM shall suspend all machine functions and disable all outputs	Power Cycle	
9979	FUNCTIONS LOCKED OUT - GROUND MODULE SOFTWARE VERSION IMPROPER	UGM shall suspend all machine functions and disable all outputs. (i.e., command engine shutdown and do not permit start)	Power Cycle	
99285	LSS - FACTORY CALIBRATION ERROR	SET PItfmOvrLd_DTC == TRUE	Power Cycle	

PARTS FINDER

**Search Website
by Part Number**



**Search Manual
Library For Parts
Manual & Lookup Part
Numbers – Purchase
or Request Quote**

A screenshot of the "Search Manuals" form. The form has a title "Search Manuals" and a subtitle "Please provide information to help us locate the manual and/or parts you need." It includes fields for "Brand", "Model", "Serial", "Part Number", and "Quantity". There is a "Search" button at the bottom.

**Can't Find Part or
Manual? Request Help
by Manufacturer,
Model & Description**

A screenshot of the "Parts Order Form". The form has a title "Parts Order Form" and a subtitle "Please fill in as much information as possible." It includes fields for "Manufacturer", "Model", "Description", "Part Number", "Quantity", and "Comments". There is a "Submit" button at the bottom.

Discount-Equipment.com is your online resource for quality parts & equipment.

Florida: **561-964-4949** Outside Florida TOLL FREE: **877-690-3101**

Need parts?

Click on this link: <http://www.discount-equipment.com/category/5443-parts/> and choose one of the options to help get the right parts and equipment you are looking for. Please have the machine model and serial number available in order to help us get you the correct parts. If you don't find the part on the website or on once of the online manuals, please fill out the request form and one of our experienced staff members will get back to you with a quote for the right part that your machine needs.

We sell worldwide for the brands: Genie, Terex, JLG, MultiQuip, Mikasa, Essick, Whiteman, Mayco, Toro Stone, Diamond Products, Generac Magnum, Airman, Haulotte, Barreto, Power Blanket, Nifty Lift, Atlas Copco, Chicago Pneumatic, Allmand, Miller Curber, Skyjack, Lull, Skytrak, Tsurumi, Husquvarna Target, , Stow, Wacker, Sakai, Mi-T- M, Sullair, Basic, Dynapac, MBW, Weber, Bartell, Bennar Newman, Haulotte, Ditch Runner, Menegotti, Morrison, Contec, Buddy, Crown, Edco, Wyco, Bomag, Laymor, Barreto, EZ Trench, Bil-Jax, F.S. Curtis, Gehl Pavers, Heli, Honda, ICS/PowerGrit, IHI, Partner, Imer, Clipper, MMD, Koshin, Rice, CH&E, General Equipment, ,AMida, Coleman, NAC, Gradall, Square Shooter, Kent, Stanley, Tamco, Toku, Hatz, Kohler, Robin, Wisconsin, Northrock, Oztec, Toker TK, Rol-Air, Small Line, Wanco, Yanmar

SECTION 7. BASIC ELECTRICAL INFORMATION & ELECTRICAL SCHEMATICS

7.1 GENERAL

This section contains basic electrical information and schematics to be used for locating and correcting most of the operating problems which may develop. If a problem should develop which is not presented in this section or which is not corrected by listed corrective actions, technically qualified guidance should be obtained before proceeding with any maintenance.

NOTE: Some of the procedures/connectors shown in this section may not be applicable to all models.

7.2 MULTIMETER BASICS

A wide variety of multimeters or Volt Ohm Meters (VOM) can be used for troubleshooting your equipment. This section shows diagrams of a common, digital VOM configured for several different circuit measurements. Instructions for your VOM may vary. Please consult the meter operator's manual for more information.

Grounding

"Grounding the meter" means to take the black lead (which is connected to the COM (common) or negative port) and touch it to a good path to the negative side of the Voltage source.

Backprobing

To "backprobe" means to take the measurement by accessing a connector's contact on the same side as the wires, the back of the connector. Readings can be done while maintaining circuit continuity this way. If the connector is the sealed type, great care must be taken to avoid damaging the seal around the wire. It is best to use probes or probe tips specifically designed for this technique, especially on sealed connectors. Whenever possible insert probes into the side of the connector such that the test also checks both terminals of the connection. It is possible to inspect a connection within a closed connector by backprobing both sides of a connector terminal and measuring resistance. Do this after giving each wire a gentle pull to ensure the wires are still attached to the contact and contacts are seated in the connector.

Min/Max

Use of the "Min/Max" recording feature of some meters can help when taking measurements of intermittent conditions while alone. For example, you can read the Voltage applied to a solenoid when it is only operational while a switch, far from the solenoid and meter, is held down.

Polarity

Getting a negative Voltage or current reading when expecting a positive reading frequently means the leads are reversed. Check what reading is expected, the location of the signal and that the leads are connected to the device under test correctly. Also check that the lead on the "COM" port goes to the Ground or negative side of the signal and the lead on the other port goes to the positive side of the signal.

Scale

M = Mega = 1,000,000 * (Displayed Number)

k = kilo = 1,000 * (Displayed Number)

m = milli = (Displayed Number) / 1,000

μ = micro = (Displayed Number) / 1,000,000

Example: 1.2 kW = 1200 W

Example: 50 mA = 0.05 A

Voltage Measurement

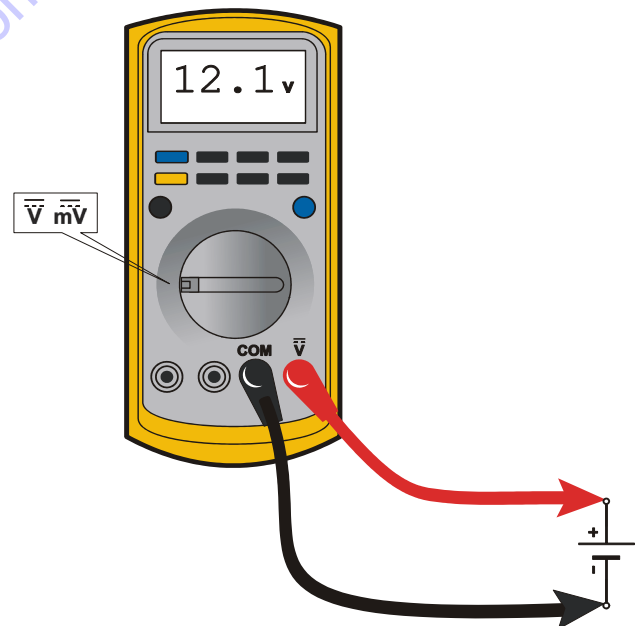

Figure 7-1. Voltage Measurement (DC)

- If meter is not auto ranging, set it to the correct range (See multimeter's operation manual)
- Use firm contact with meter leads

Resistance Measurement

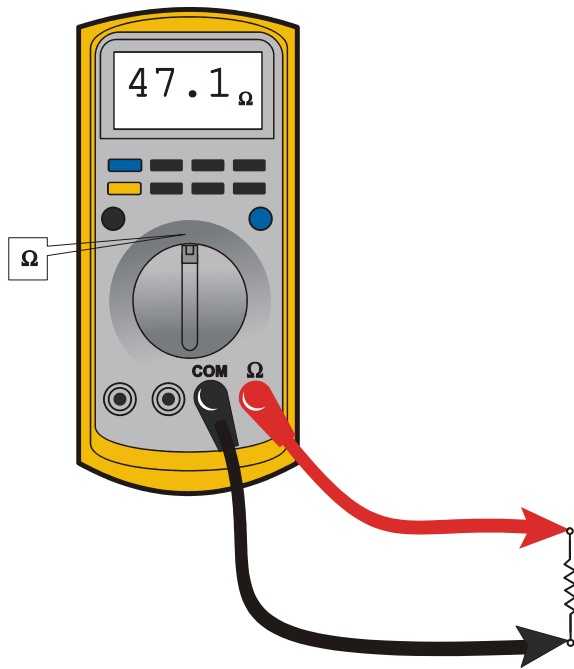

Figure 7-2. Resistance Measurement

- First test meter and leads by touching leads together. Resistance should read a short circuit (very low resistance)
- Circuit power must be turned OFF before testing resistance
- Disconnect component from circuit before testing
- If meter is not auto ranging, set it to the correct range (See multimeter's operation manual)
- Use firm contact with meter leads

Continuity Measurement

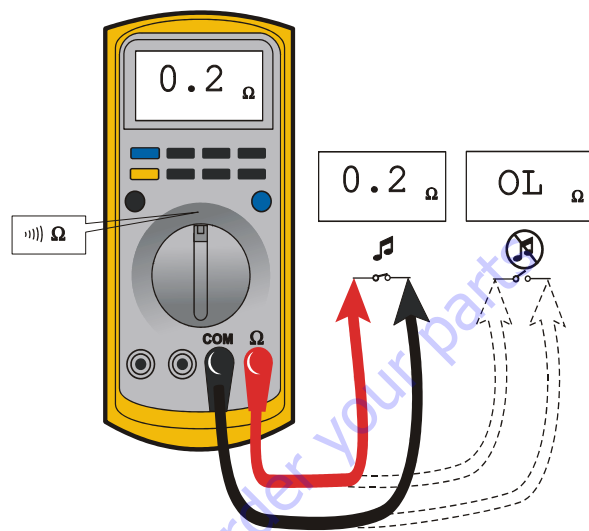

Figure 7-3. Continuity Measurement

- Some meters require a separate button press to enable audible continuity testing
- Circuit power must be turned OFF before testing continuity
- Disconnect component from circuit before testing
- Use firm contact with meter leads
- First test meter and leads by touching leads together. Meter should produce an audible alarm, indicating continuity

Current Measurement

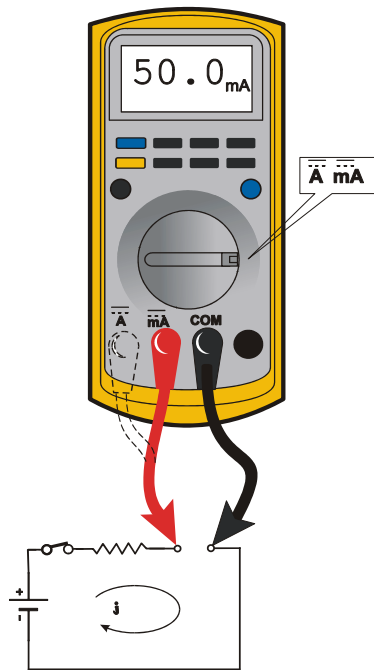

Figure 7-4. Current Measurement (DC)

- Set up the meter for the expected current range
- Be sure to connect the meter leads to the correct jacks for the current range you have selected
- If meter is not auto ranging, set it to the correct range (See multi meter's operation manual)
- Use firm contact with meter leads.

7.3 APPLYING SILICONE DIELECTRIC COMPOUND TO ELECTRICAL CONNECTIONS

NOTE: This section is not applicable for battery terminals.

NOTICE

JLG P/N 0100048 DIELECTRIC GREASE (NOVAGARD G661) IS THE ONLY MATERIAL APPROVED FOR USE AS A DIELECTRIC GREASE.

NOTE: Do NOT apply dielectric grease to the following connections:

- Main Boom Rotary sensor connections (on Celesco Sensor),
- LSS Modules connections,
- Deutz EMR 2 ECM connection.

Silicone Dielectric Compound must be used on all electrical connections except for those mentioned above for the following reasons:

- To prevent oxidation at the mechanical joint between male and female pins.
- To prevent electrical malfunction caused by low level conductivity between pins when wet.

Use the following procedure to apply Silicone Dielectric Compound to the electrical connectors. This procedure applies to all plug connections not enclosed in a box. Silicone grease should not be applied to connectors with external seals.

1. To prevent oxidation, silicone grease must be packed completely around male and female pins on the inside of the connector prior to assembly. This is most easily achieved by using a syringe.

NOTE: Over a period of time, oxidation increases electrical resistance at the connection, eventually causing circuit failure.

2. To prevent shorting, silicone grease must be packed around each wire where they enter the outside of the connector housing. Also, silicone grease must be applied at the joint where the male and female connectors come together. Any other joints (around strain reliefs, etc.) where water could enter the connector should also be sealed.

NOTE: This condition is especially common when machines are pressure washed since the washing solution is much more conductive than water.

- Anderson connectors for the battery boxes and battery chargers should have silicone grease applied to the contacts only.

NOTE: *Curing-type sealants might also be used to prevent shorting and would be less messy, but would make future pin removal more difficult.*

When applied to electrical connections, dielectric grease helps to prevent corrosion of electrical contacts and improper conductivity between contacts from moisture intrusion. Open and sealed connectors benefit from the application of dielectric grease.

Dielectric grease shall be applied to all electrical connectors at the time of connection (except those noted under Exclusions).

Installation of Dielectric Grease

Before following these instructions, refer to excluded connector types (See Exclusions below).

- Use dielectric grease in a tube for larger connection points or apply with a syringe for small connectors.
- Apply dielectric grease to plug/male connector housing which typically contains sockets contact/female terminals (fill it approximately 1/2 full; see example below).
- Leave a thin layer of dielectric grease on the face of the connector
- Assemble the connector system immediately to prevent moisture ingress or dust contamination
- Pierce one of the unused wire seals prior to assembly if the connector system tends to trap air (i.e. AMP Seal) and then install a seal plug.

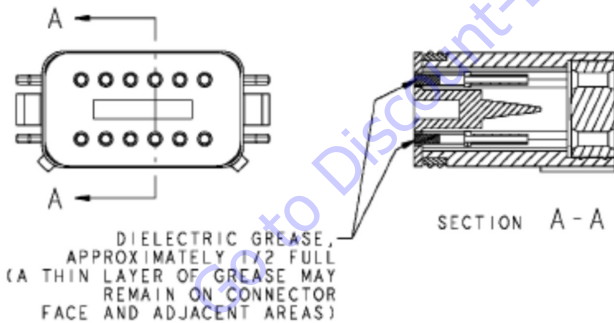

Deutsch HD, DT, DTM, DRC Series

The Deutsch connector system is commonly used for harsh environment interconnect. Follow the installation instructions.



AMP Seal

The AMP Seal connector system is used on the Control ADE Platform and Ground Modules.

Apply dielectric grease to the male contact. If trapped air prevents the connector from latching, pierce one of the unused wire seals. After assembly, install a seal plug (JLG #4460905) to prevent moisture ingress.

Note that seal plugs may be installed by the wire harness manufacturer if an unused wire seal becomes compromised (wire inserted in the wrong cavity during assembly and then corrected).



Figure 7-5. Application to plug/male connector housing

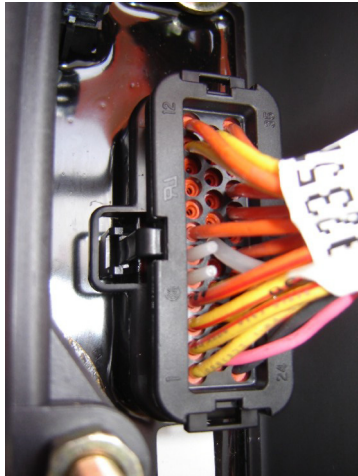

Figure 7-6. Use of Seal Plugs

DIN Connectors

This connector is typically used on hydraulic valves. Follow the installation instructions.



AMP Mate-N-Lok

Follow the installation instructions.

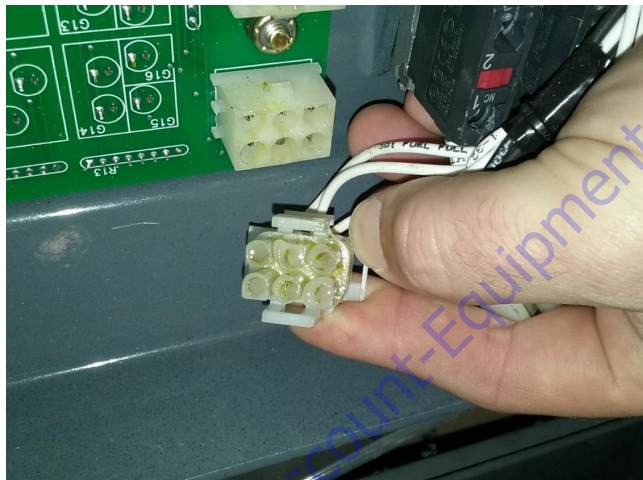

Exclusions

A limited number of connectors do not benefit from dielectric grease, or may be permanently damaged by application. Dielectric grease may not be required in properly sealed enclosures.

Brad Harrison / Phoenix Contact M12

The connector uses gold contact material to resist corrosion and an o-ring seal for moisture integrity. If dielectric grease is mistakenly applied to this connector system, the low-force contacts cannot displace the grease to achieve electrical contact. Once contaminated, there is no practical way to remove the dielectric grease (replacement of female contacts required). The JLG Load Sensing System and 1250AJP Rotary Angle Sensors are examples of components with the M12 connector system.



Figure 7-7. Brad-Harrison M12



Figure 7-8. Phoenix Contact M12

Engine Control Unit Connectors

This type of connector uses back-seals for moisture integrity. However, the low-force contacts cannot displace dielectric grease and create electrical contact. It is possible to use solvents (i.e. contact cleaner or mineral spirits) for the removal of improperly applied dielectric grease. The EMR2 engine control module from Deutz employs this connector system (for example).



Sealed Enclosures

Application of dielectric grease is not required in properly sealed enclosures. To meet criteria, the enclosure must be rated to at least IP66 (dust tight; protected from powerful jets of water). The enclosure must be fitted with a high quality, continuous gasket and all wiring must pass through cable entrances.



MIL-C-5015 Spec Connector's

Crown Connector Inc's recommendation is to not use dielectric grease for this series connector. For similar model series connectors, the manufacturer should be contacted for confirmation before applying dielectric grease. A typical application for this connector is on David Clark Intercom connections in Aerial Work Platforms.



Molex CMC Series Connectors

The CMC connector family is a sealed, high-density connection system using matte-seal technology for CP 0.635 and 1.50 mm terminals. To guarantee IP6K7 and IP6K9 sealing, a seal plug option is used. However, the low-force contacts cannot displace dielectric grease and create electrical contact. It is possible to use solvents (i.e. contact cleaner or mineral spirits) for the removal of improperly applied dielectric grease. The flexbox control modules from JDES employ this connector system (for example).



7.4 AMP CONNECTOR

Applying Silicone Dielectric Compound to AMP Connectors

Silicone Dielectric Compound must be used on the AMP connections for the following reasons:

- To prevent oxidation at the mechanical joint between male and female pins.
- To prevent electrical malfunction caused by low level conductivity between pins when wet.

Use the following procedure to apply Silicone Dielectric Compound to the electrical connectors.

1. To prevent oxidation and low level conductivity, silicone dielectric grease must be packed completely around male and female pins on the inside of the connector after the mating of the housing to the header. This is easily achieved by using a syringe to fill the header with silicone dielectric compound, to a point just above the top of the male pins inside the header. When assembling the housing to the header, it is possible that the housing will become air locked, thus preventing the housing latch from engaging.
2. Pierce one of the unused wire seals to allow the trapped air inside the housing to escape.
3. Install a hole plug into this and/or any unused wire seal that has silicone dielectric compound escaping from it.

Assembly

Check to be sure the wedge lock is in the open, or as-shipped, position (See Figure 7-9.). Proceed as follows:

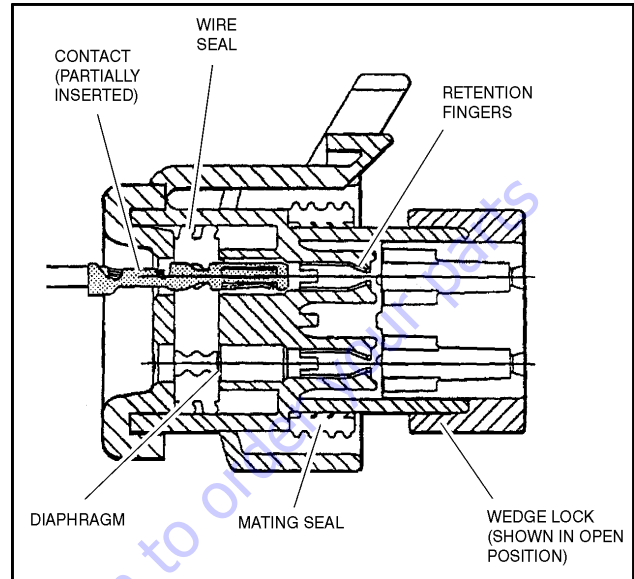

Figure 7-9. Connector Assembly Figure 1

1. To insert a contact, push it straight into the appropriate circuit cavity as far as it will go (See Figure 7-11.).
2. Pull back on the contact wire with a force of 1 or 2 lbs. to be sure the retention fingers are holding the contact (See Figure 7-11.).

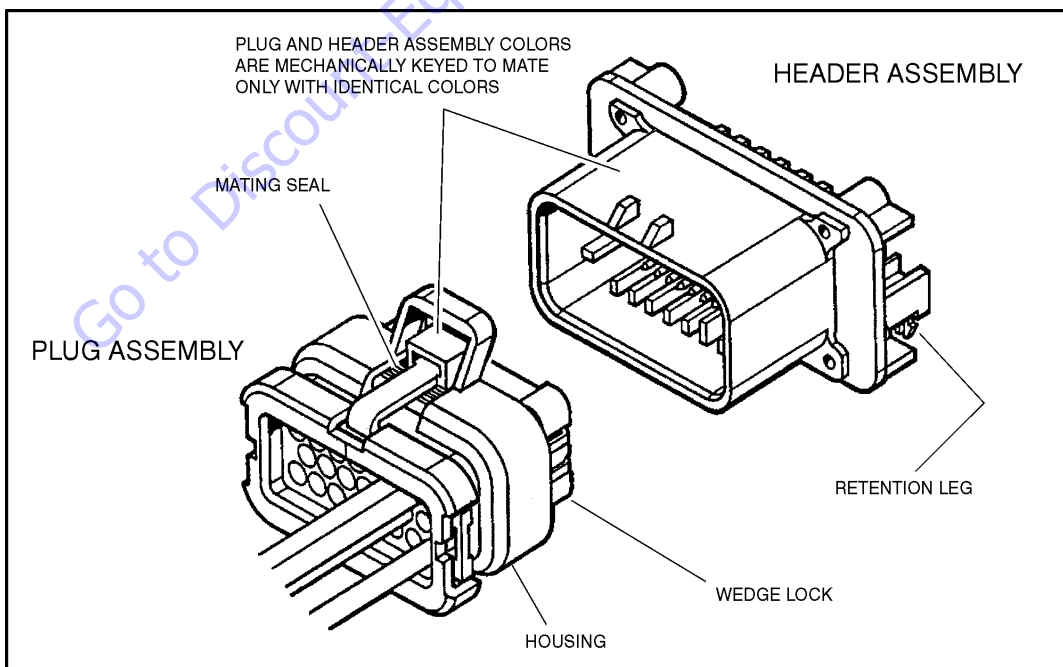

Figure 7-10. AMP Connector

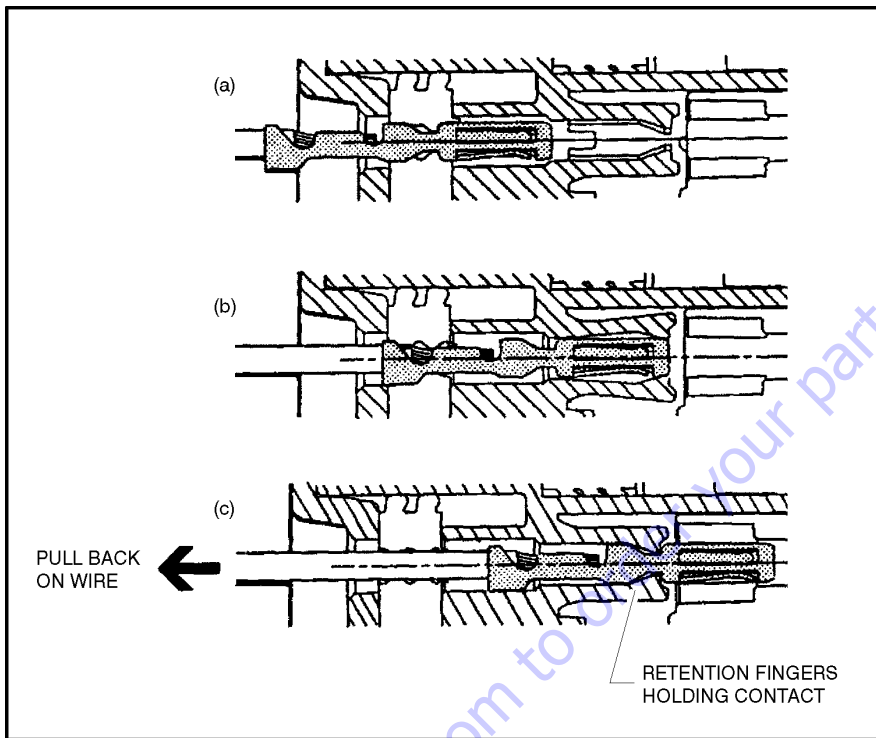

Figure 7-11. Connector Assembly Figure 2

3. After all required contacts have been inserted, the wedge lock must be closed to its locked position. Release the locking latches by squeezing them inward (See Figure 7-12.).

4. Slide the wedge lock into the housing until it is flush with the housing (See Figure 7-13.).

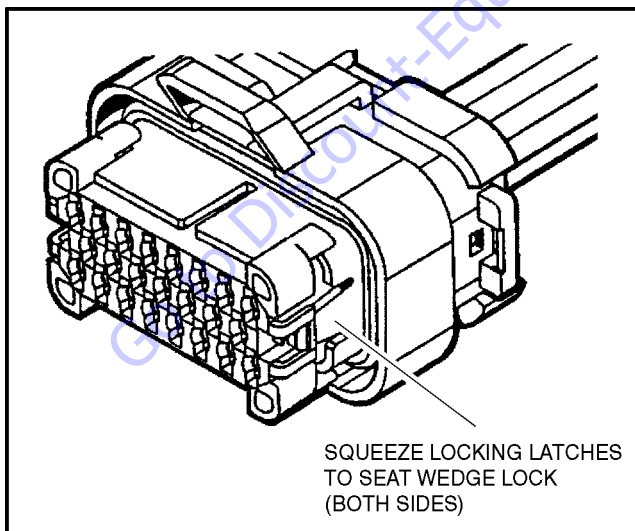

Figure 7-12. Connector Assembly Figure 3

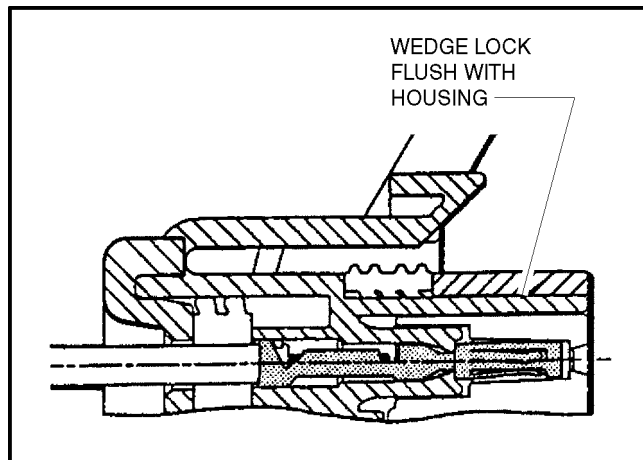

Figure 7-13. Connector Assembly Figure 4

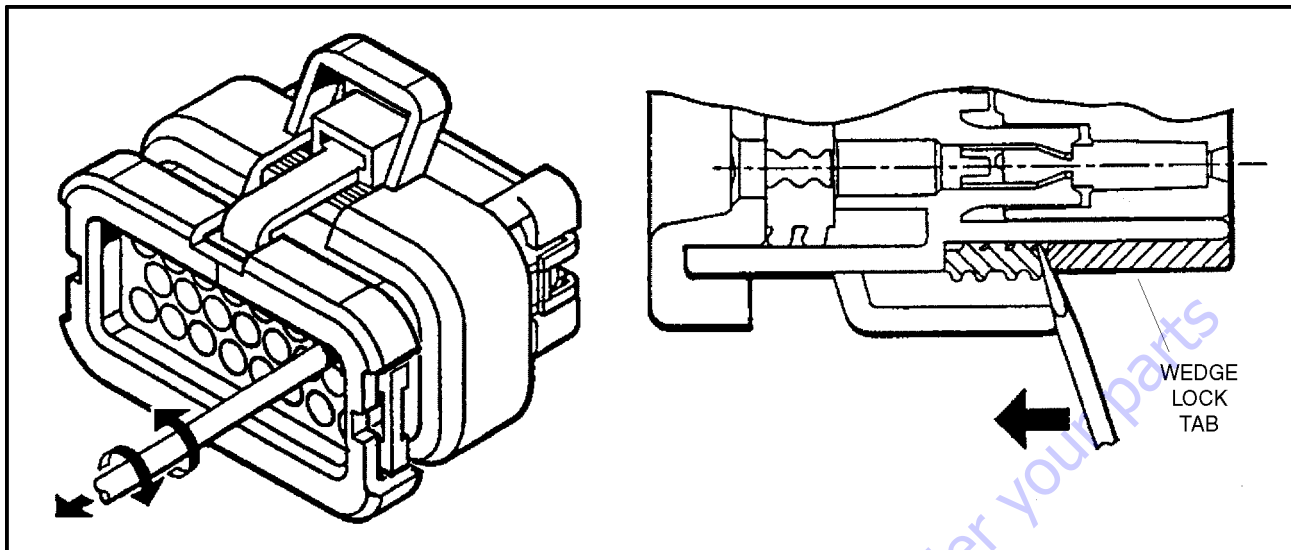

Figure 7-14. Connector Disassembly

Disassembly

5. Insert a 4.8 mm (3/16") wide screwdriver blade between the mating seal and one of the red wedge lock tabs.
6. Pry open the wedge lock to the open position.
7. While rotating the wire back and forth over a half turn (1/4 turn in each direction), gently pull the wire until the contact is removed.

NOTE: The wedge lock should never be removed from the housing for insertion or removal of the contacts.

Wedge Lock

The wedge lock has slotted openings in the forward, or mating end. These slots accommodate circuit testing in the field, by using a flat probe such as a pocket knife. DO NOT use a sharp point such as an ice pick.

Service - Voltage Reading

NOTICE

DO NOT PIERCE WIRE INSULATION TO TAKE VOLTAGE READINGS.

It has been common practice in electrical troubleshooting to probe wires by piercing the insulation with a sharp point. This practice should be discouraged when dealing with the AMPSEAL plug assembly, or any other sealed connector system. The resulting pinholes in the insulation will allow moisture to invade the system by traveling along the wire strands. This nullifies the effectiveness of the connector seals and could result in system failure.

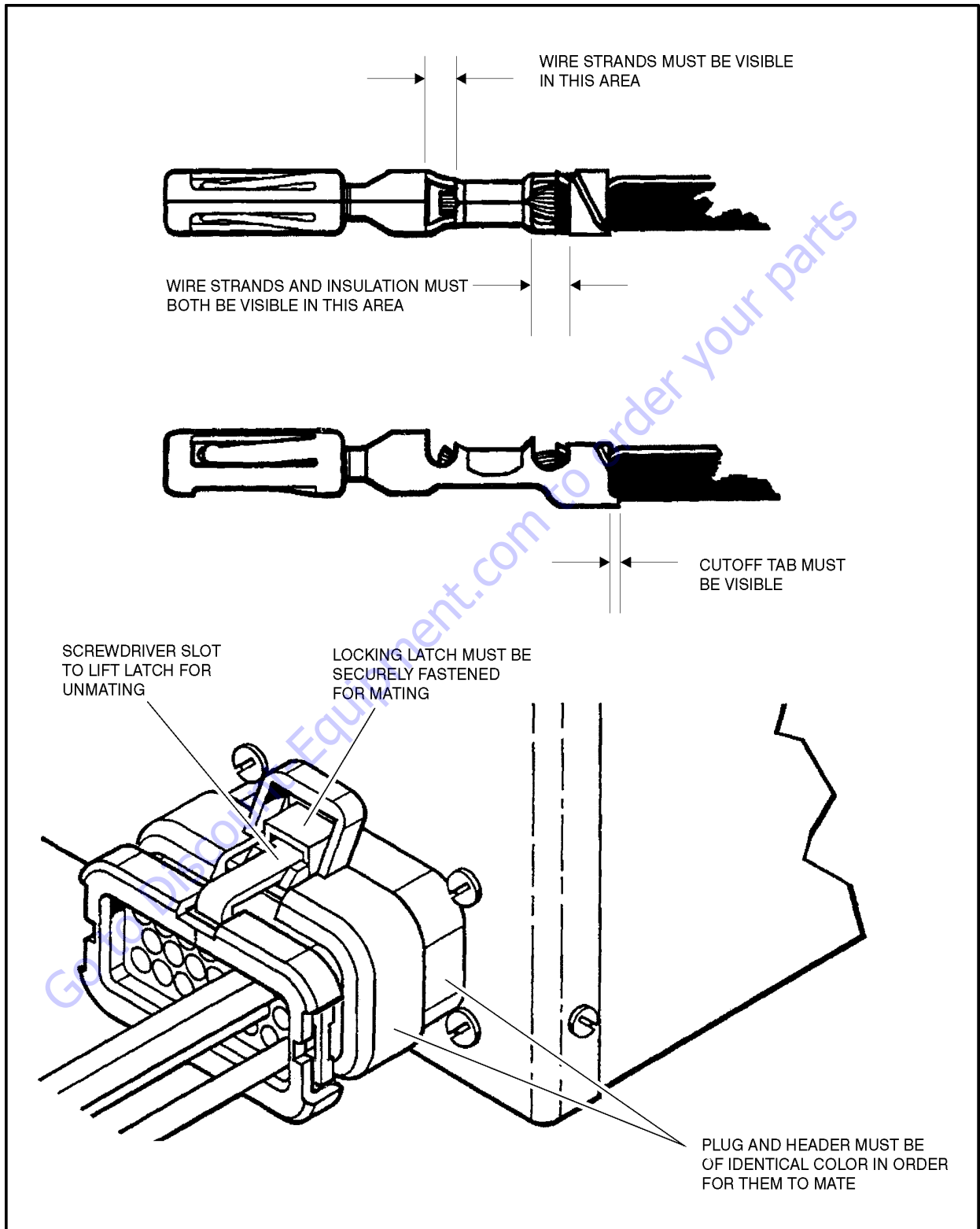

Figure 7-15. Connector Installation

7.5 DEUTSCH CONNECTORS

DT/DTP Series Assembly

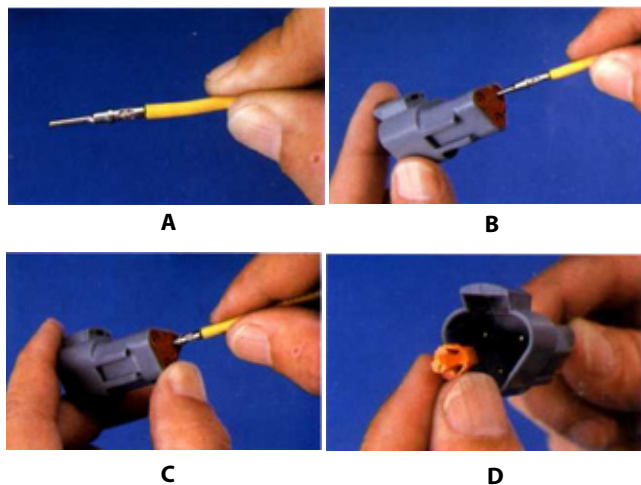

Figure 7-16. DT/DTP Contact Installation

1. Grasp crimped contact about 25mm behind the contact barrel.
2. Hold connector with rear grommet facing you.
3. Push contact straight into connector grommet until a click is felt. A slight tug will confirm that it is properly locked in place.
4. Once all contacts are in place, insert wedgelock with arrow pointing toward exterior locking mechanism. The wedgelock will snap into place. Rectangular wedges are not oriented. They may go in either way.

NOTE: The receptacle is shown - use the same procedure for plug.

DT/DTP Series Disassembly

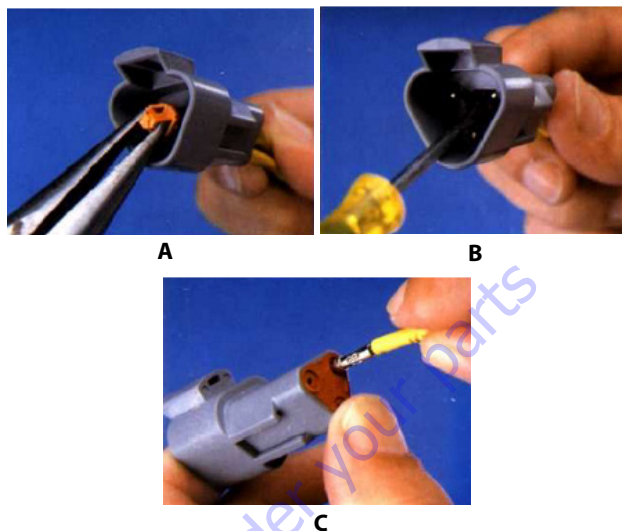

Figure 7-17. DT/DTP Contact Removal

5. Remove wedgelock using needlenose pliers or a hook shaped wire to pull wedge straight out.
6. To remove the contacts, gently pull wire backwards, while at the same time releasing the locking finger by moving it away from the contact with a screwdriver.
7. Hold the rear seal in place, as removing the contact may displace the seal.

HD30/HDP20 Series Assembly

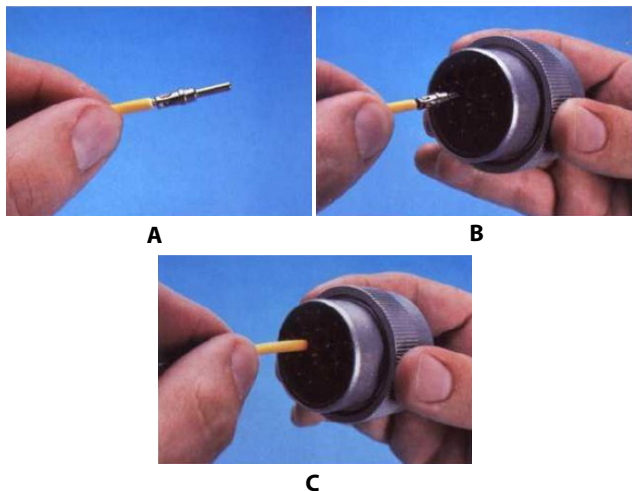

Figure 7-18. HD/HDP Contact Installation

8. Grasp contact about 25mm behind the contact crimp barrel.
9. Hold connector with rear grommet facing you.
10. Push contact straight into connector grommet until a positive stop is felt. A slight tug will confirm that it is properly locked in place.

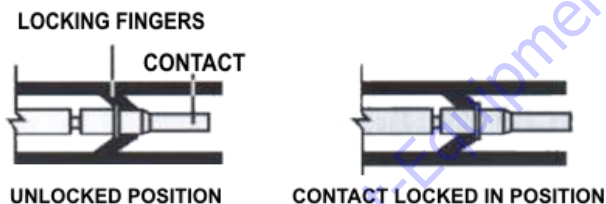

Figure 7-19. HD/HDP Locking Contacts Into Position

NOTE: For unused wire cavities, insert sealing plugs for full environmental sealing

HD30/HDP20 Series Disassembly

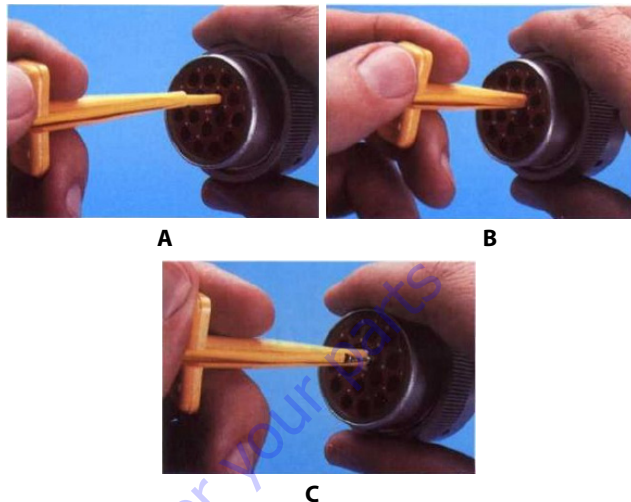

Figure 7-20. HD/HDP Contact Removal

11. With rear insert toward you, snap appropriate size extractor tool over the wire of contact to be removed.
12. Slide tool along into the insert cavity until it engages contact and resistance is felt.
13. Pull contact-wire assembly out of connector.

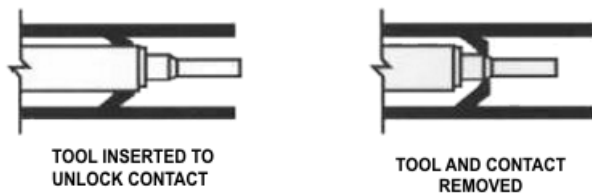

Figure 7-21. HD/HDP Unlocking Contacts

NOTE: Do Not twist or insert tool at an angle.

7.6 DC POWER SYSTEMS

NOTICE

THIS MACHINE IS POWERED BY AN 84VDC (NOMINAL) ELECTRICAL SYSTEM THAT CAN RANGE UP TO 105VDC DURING NORMAL OPERATION, AND BY A 48VAC (NOMINAL) ELECTRICAL MOTOR SYSTEM THAT CAN RANGE UP TO 60VAC. BASED ON EMPLOYER, LOCAL, AND GOVERNMENTAL REGULATIONS AS THEY PERTAIN TO THIS MACHINE, SPECIFIC ELECTRICAL TRAINING AND CERTIFICATIONS MAY BE REQUIRED BEFORE SERVICING OR TROUBLESHOOTING.

The machine has two (2) separate battery systems: 12V and 84V.

The 12V system powers the control modules (e.g., UGM), hydraulic valves, clutch actuation, fans, and engine start/alternator system. The 84V system powers the IMG and the battery charging system, which includes the battery boxes, IGM control enclosure, 84V/12V DC/DC converter, and the two battery chargers.

With a fully assembled and connected machine, all energized points in the 84V system are inaccessible, so the JLG Analyzer must be used to perform diagnostics on the 84V system.

NOTICE

ALL THE COVERS MUST REMAIN INSTALLED ON THE MACHINE UNTIL THE POWER IN THE 84V SYSTEM IS REDUCED.

⚠ WARNING

DEATH OR SERIOUS INJURY MAY RESULT IF THESE INSTRUCTIONS ARE NOT FOLLOWED.

⚠ DANGER

DEATH OR SERIOUS INJURY MAY RESULT IF THESE INSTRUCTIONS ARE NOT FOLLOWED.

7.7 HOT WEATHER OPERATION

Machine also has multiple sensors to monitor temperatures of the Integrated Motor/Generator (IMG), IMG Controller, battery pack, and engine coolant. If temperatures are over their respective pre-set values, distress signals will be displayed. Machine will cut back in power available and eventually be disabled if high component temperatures persistent. This will prevent permanent damage to power components.

7.8 COLD WEATHER OPERATION

The battery capacity will decrease as ambient temperature drops. Typically the battery will decrease to 50% of its specification capacity when temperature is around -20°C / -4°F, even though the analyzer or battery gauge may still show 100% State of Charge (SOC).

Under low ambient temperature, charging the machine with wall AC power may not return the battery pack to 100% charge even though the charger stops charging automatically and displays a green light. It is recommended to charge the machine in warmer ambient conditions. The optional cold weather package could improve the charging capability under this condition.

When the IMG temperature is below 0°C / 32°F, the software will reduce power available to prevent large current spikes from tripping the fuses. When the IMG temperature returns to normal due to operation, the power level will be return to normal.

The machine is available with a Cold Weather Package for environments below freezing temperature. With Cold Weather Package and proper operational practices, machine shall be operational properly down to -20°C / -4°F, though may require special considerations beyond general guidelines in operation and maintenance.

Operation below -20°C / -4°F is not recommended at this point of time due to concerns on reductions in battery capacity.

7.9 DISCONNECTING BATTERY BOX CONNECTORS

The following steps need to be followed in order to properly disconnect the battery box cable connectors.

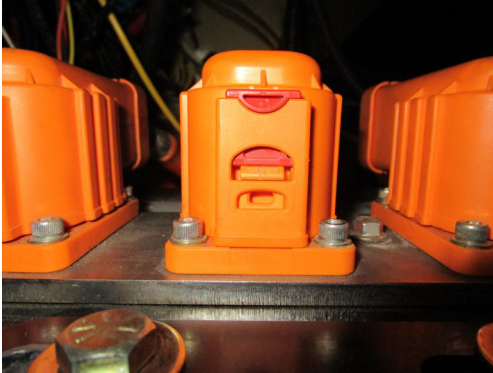

1. Release CPA to pre-lock position. Pull up on the red tab on the cable end of the connector.

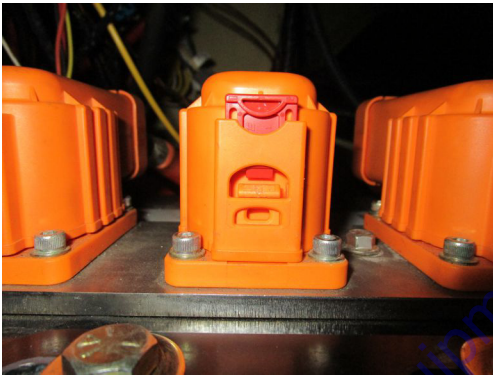

2. At same time press lock latch in pre lock area with finger or tool. Pull the connector up to the first notch.

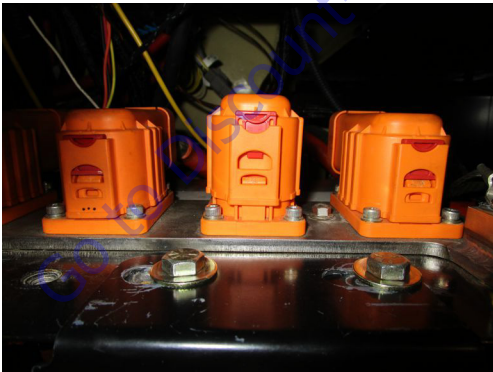

NOTE: When the connector is pulled up to the first notch, it is still connected and current will still flow through it.

3. Press lock latch in second area with finger or small tool. Using a screwdriver or similar device, press in on the tab to release the cable end of the connector from the box end of the connector.

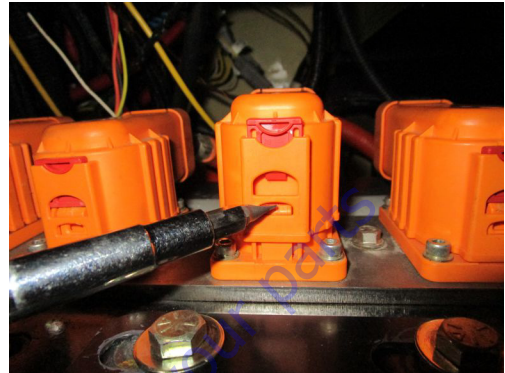

4. At same time completely pull the cable end of the connector away from the box end of the connector to ensure no power will flow through it.

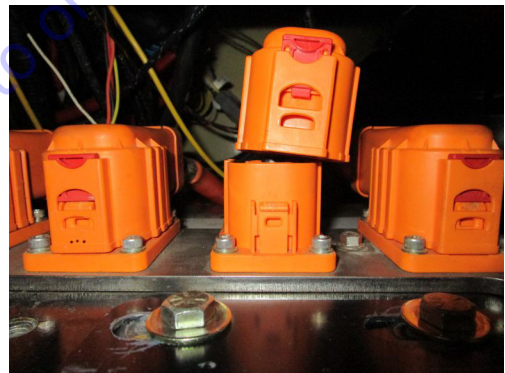

7.10 BATTERY PACK

The battery pack consists of fourteen 12V, sealed AGM maintenance free batteries. The batteries are packed in two banks in parallel, with each pack consisting of seven batteries connected in series to become an 84 VDC system. Each battery bank is 48V when separated.

Reducing System Voltage

This procedure is to be performed for work on compartments at the battery boxes and IGM control box.

Refer to the following procedure to reduce system voltage

At the IGM control box (tank side of machine):



NOTE: Use above image as a reference for connector name.

NOTE: Refer to Section 7.9, Disconnecting Battery Box Connectors for connector disconnecting procedure.



1. Disconnect connector D.
2. Disconnect connector E.

Tank front side of machine

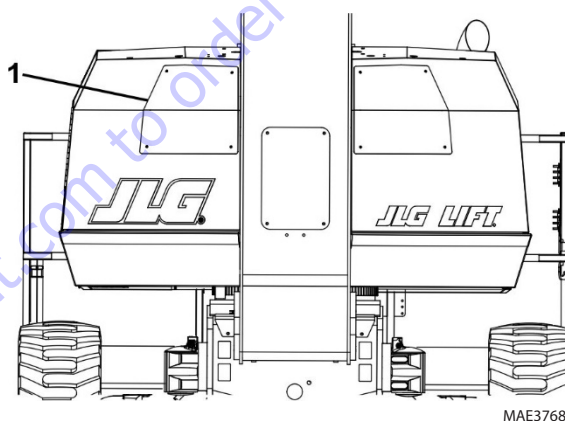

3. Remove cover (1) using a 5/32 allen wrench.



4. Disconnect connector C.
5. Disconnect connector B.

NOTE: Connector "C" must be disconnected before connector "B".



MAE37700

Figure 7-22. 84V hybrid round connector on tank side



MAE37710

Figure 7-23. 84V hybrid round connector on engine side



MAE37720

- a. Check voltage between connectors D and E (on tank side of machine). This check should yield a result of 0V.



MAE37730

- b. Check voltage between connectors B and C (at front of machine). This check should yield a result of 12V-13V.

NOTE: The tank and engine side battery stack will still be roughly 48V depending on battery charge level. The 12V system will still be at full power.

Restoring System Voltage

To restore system voltage back to 84V, reverse the Reducing System Voltage procedure.

Battery Pack Charging System

The machine offers two methods of charging the battery stack. The primary method of charging the battery pack is the diesel engine, which powers the Integrated Motor Generator (IMG) which in turn charges the battery stack. When the diesel engine is running, the Hybrid Electric Control system determines how and when the IMG would charge the battery depending on State of Charge (SOC) of the battery pack, and the available power from diesel engine for charging at the point of the time. The second method to recharge the battery stack is the onboard battery chargers. The chargers are located on the turntable and work with a 120VAC or 240VAC external power source. The chargers are set up as primary and secondary chargers. Both chargers work in tandem through the Bulk Charging phase (up to approximately 90% SOC). Above 90%, a single charger will perform the Absorption and Float Charging phases.

Long Term Storage Guidelines

When the machine is stored for more than 45 days, to prevent a permanent loss of battery capacity, it is important to recharge the battery pack using the machine's wall AC charger before use.

Go to Discount-Equipment.com to order your parts

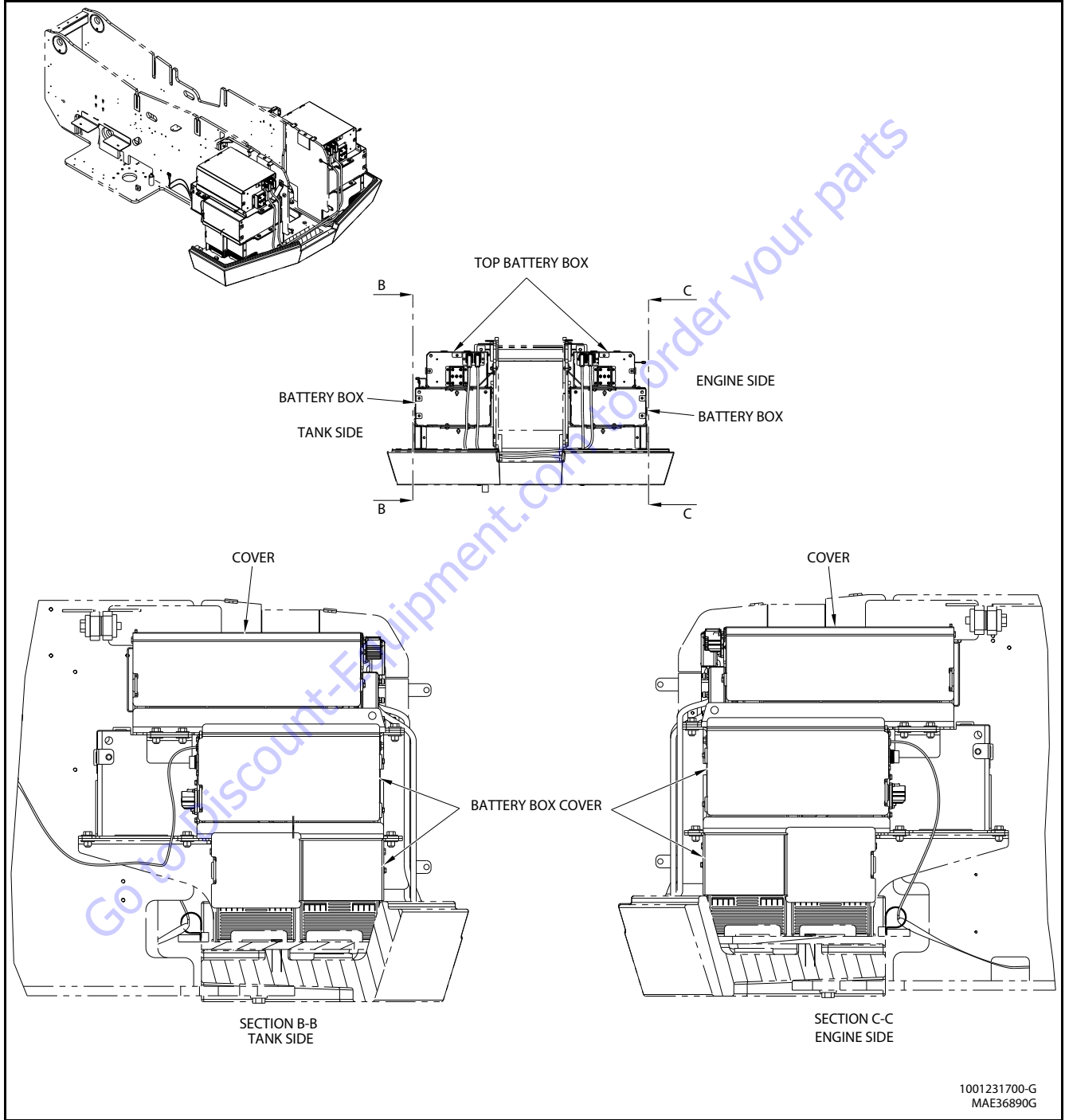

Figure 7-24. Battery Box - Sheet 1 of 15

SECTION 7 - BASIC ELECTRICAL INFORMATION & ELECTRICAL SCHEMATICS

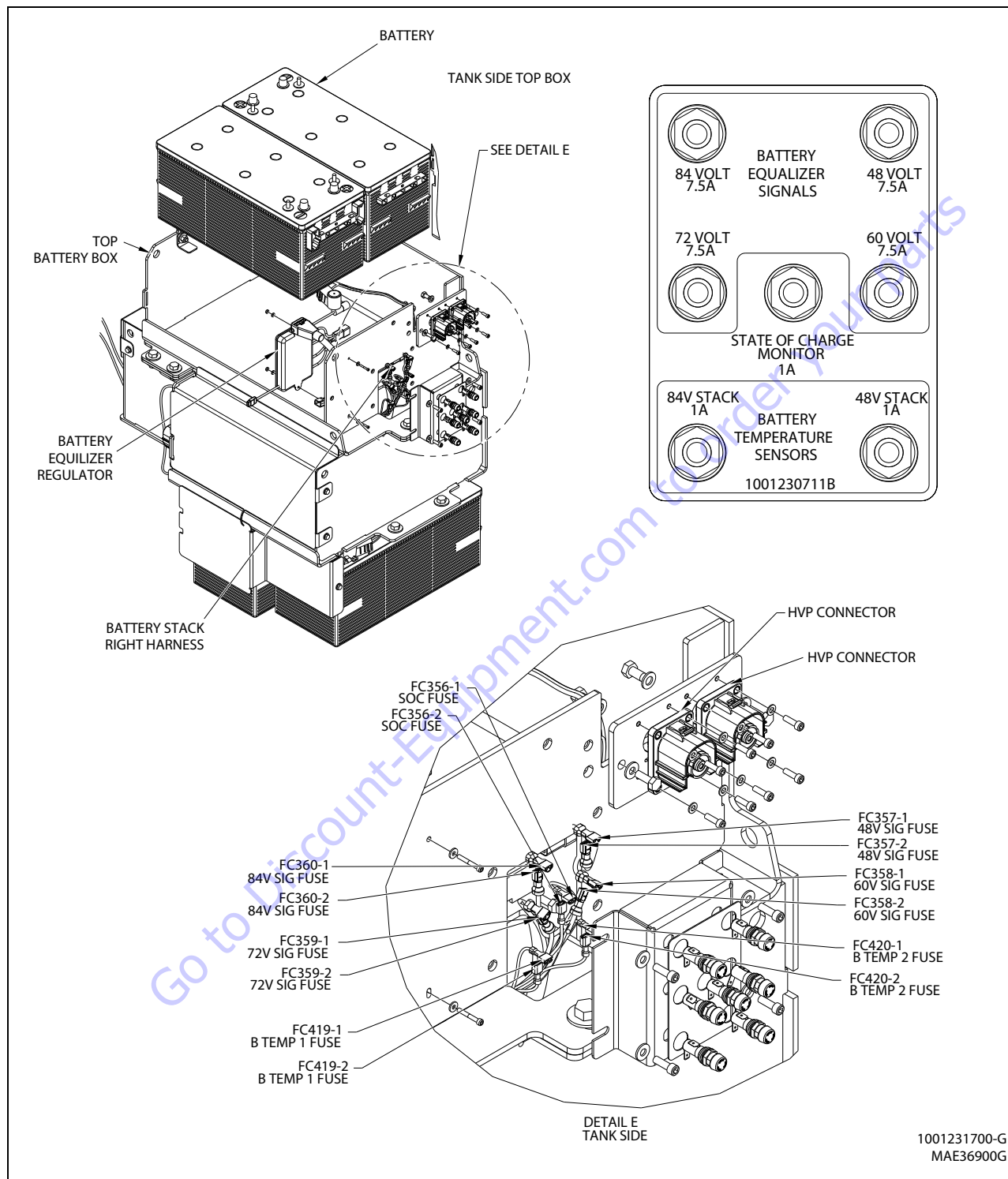

Figure 7-25. Battery Box - Sheet 2 of 15

SECTION 7 - BASIC ELECTRICAL INFORMATION & ELECTRICAL SCHEMATICS

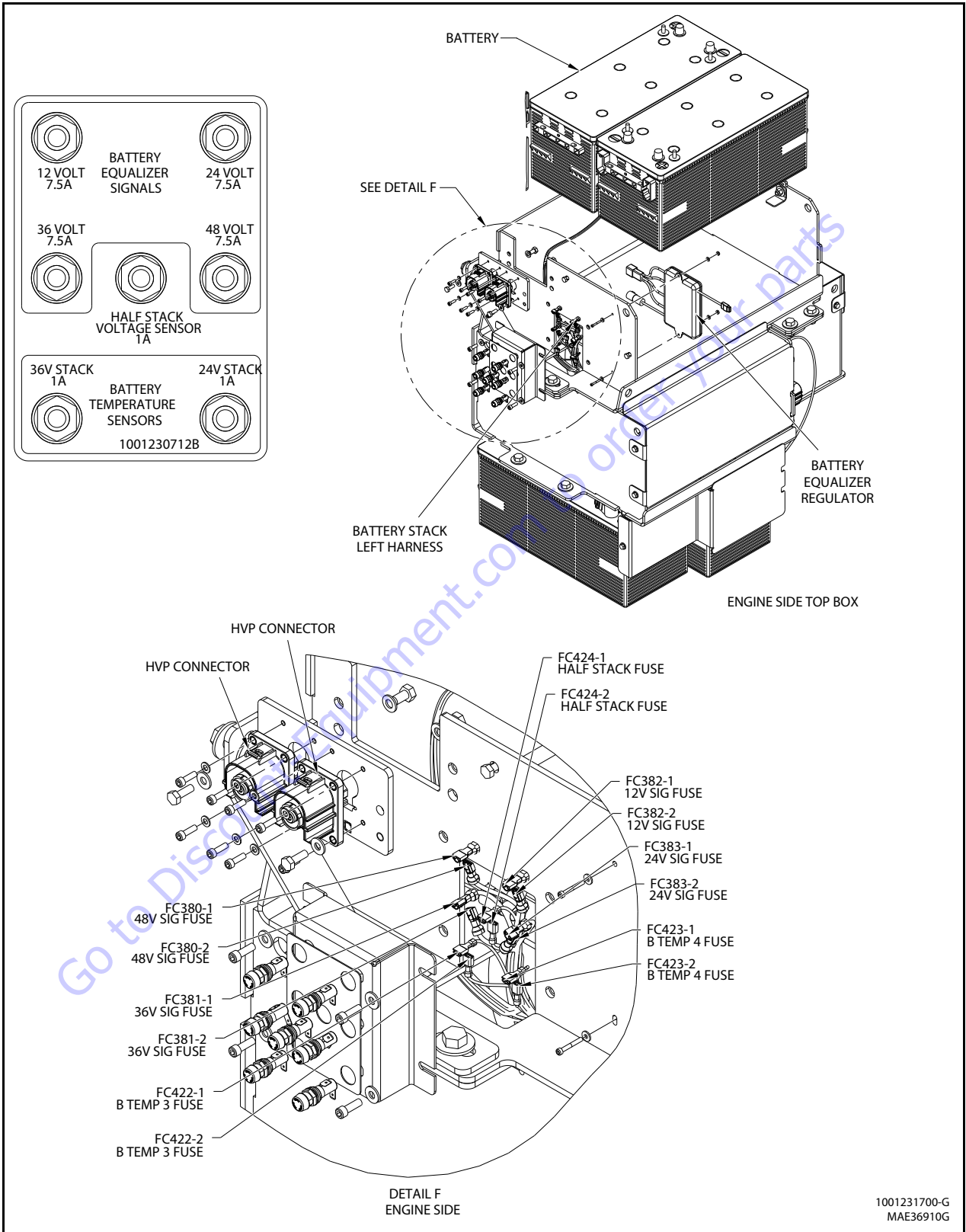

Figure 7-26. Battery Box - Sheet 3 of 15

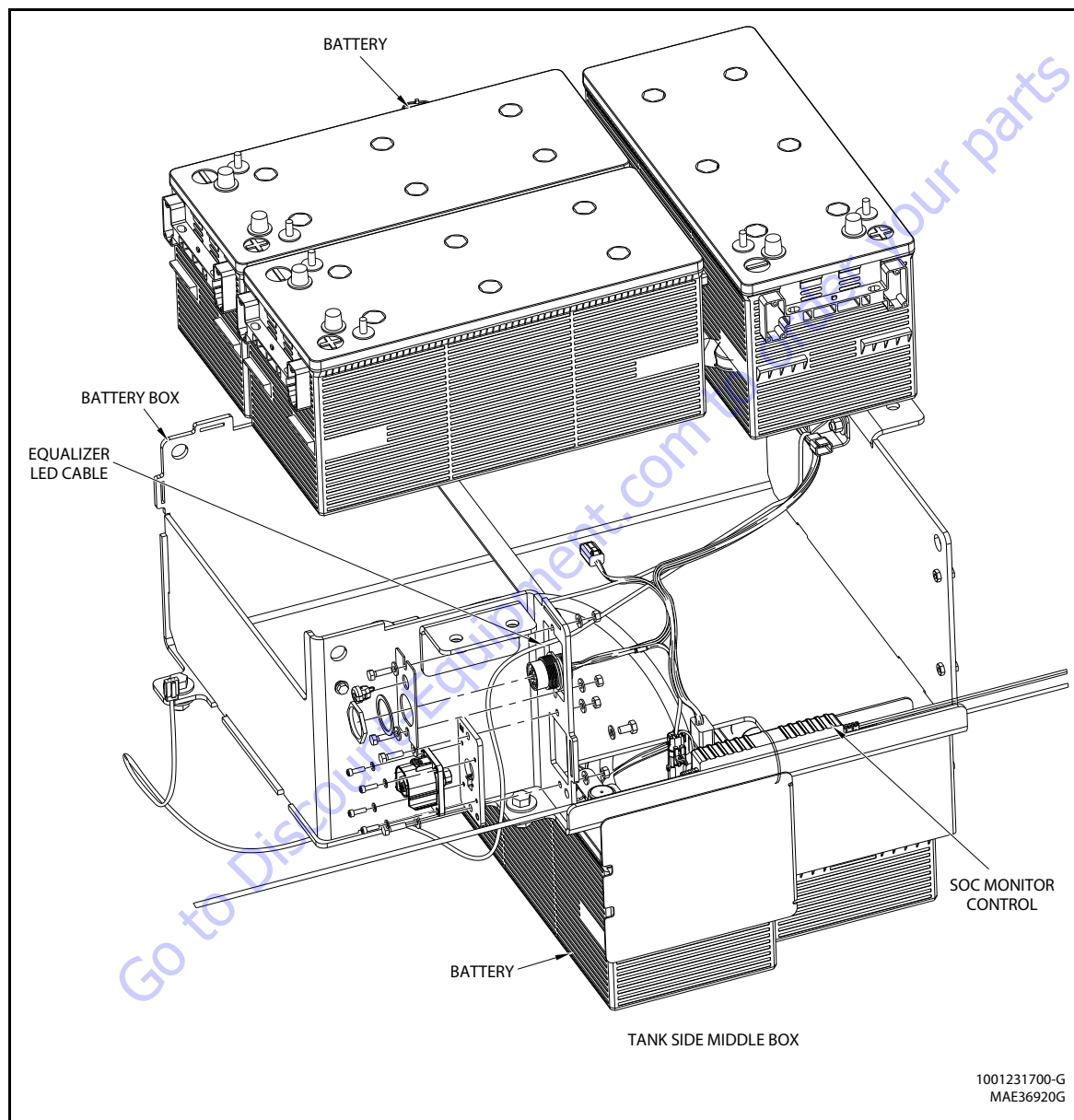
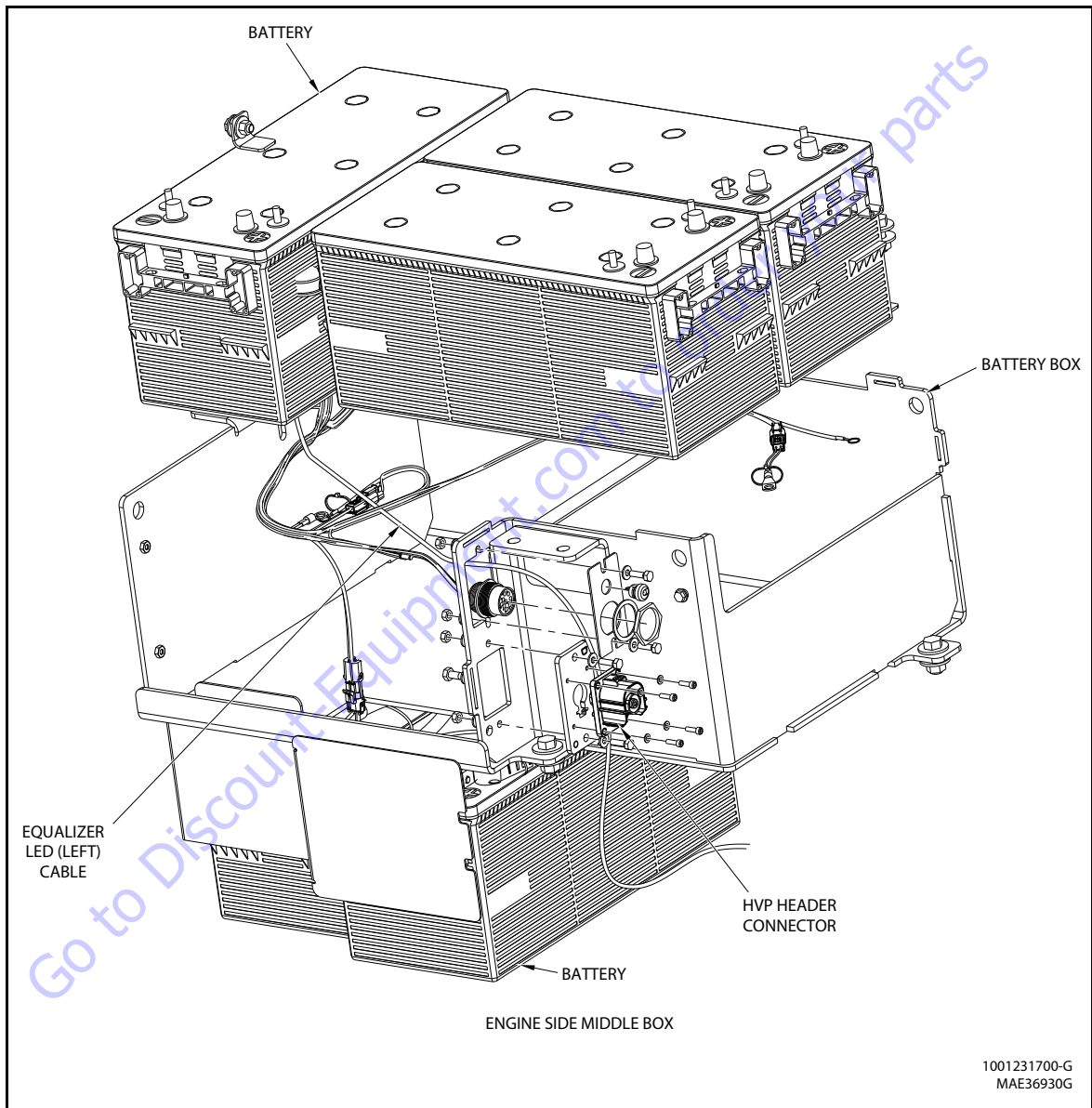

Figure 7-27. Battery Box - Sheet 4 of 15



1001231700-G
MAE36930G

Figure 7-28. Battery Box - Sheet 5 of 15

SECTION 7 - BASIC ELECTRICAL INFORMATION & ELECTRICAL SCHEMATICS

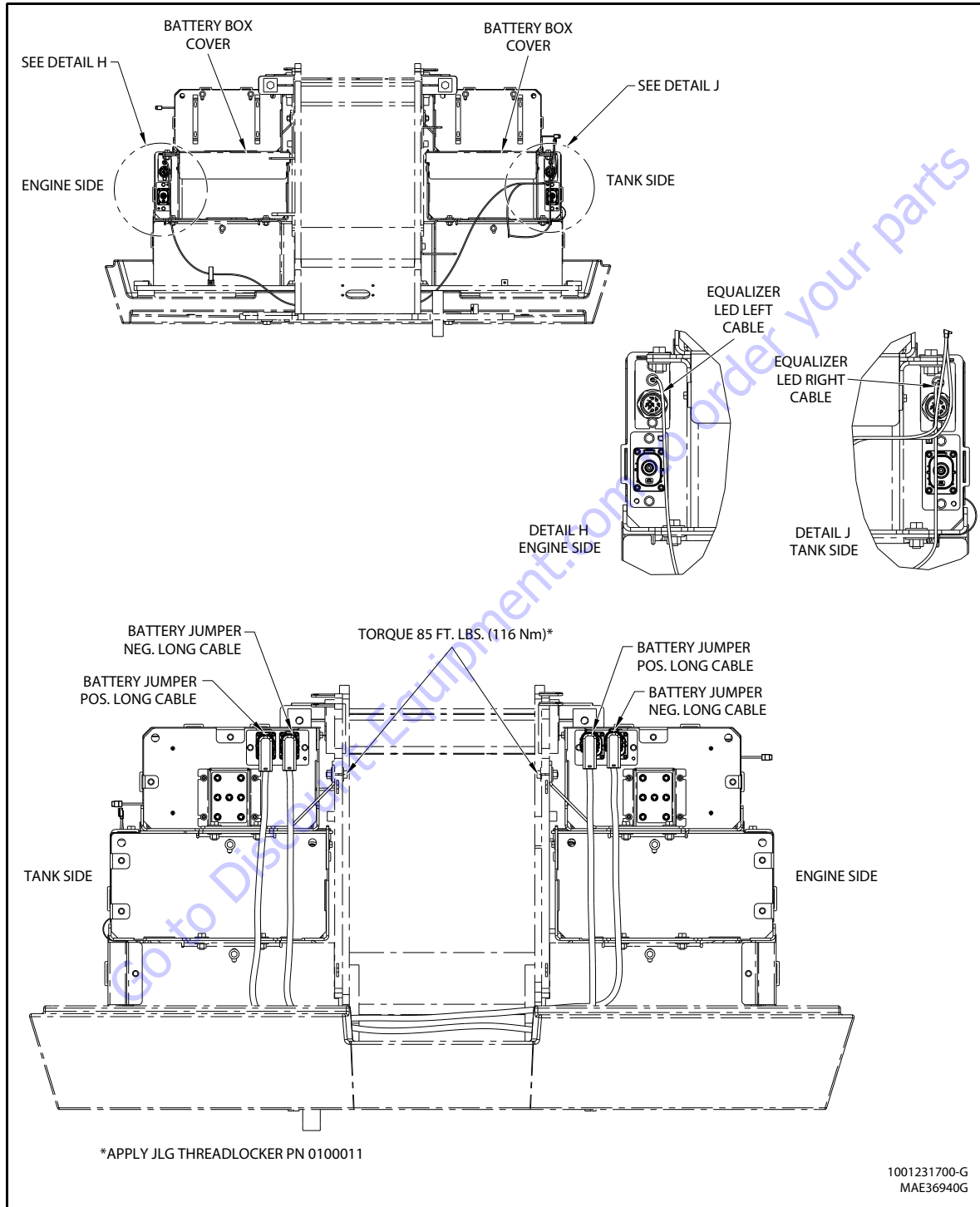

Figure 7-29. Battery Box - Sheet 6 of 15

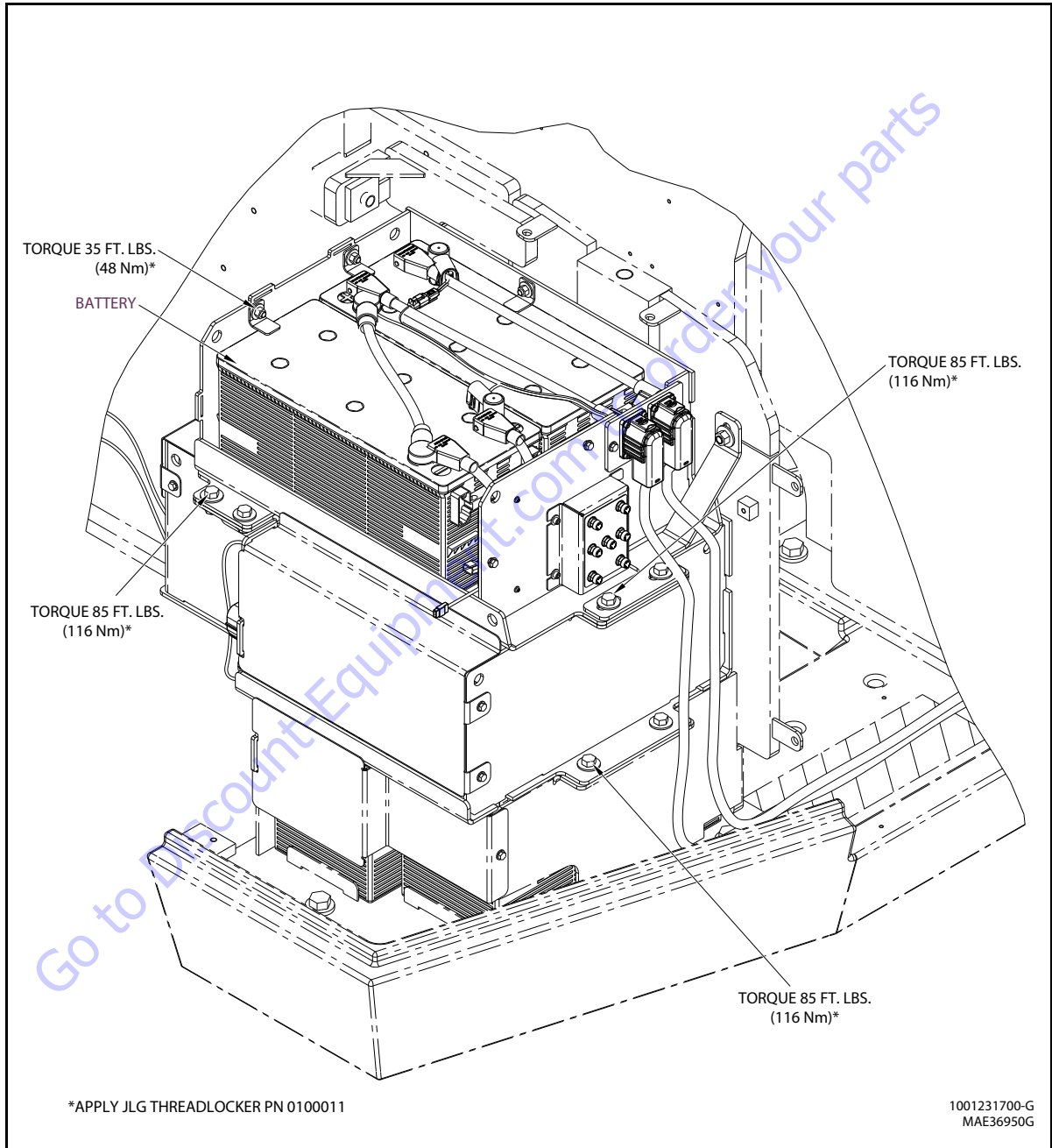

Figure 7-30. Battery Box - Sheet 7 of 15

SECTION 7 - BASIC ELECTRICAL INFORMATION & ELECTRICAL SCHEMATICS

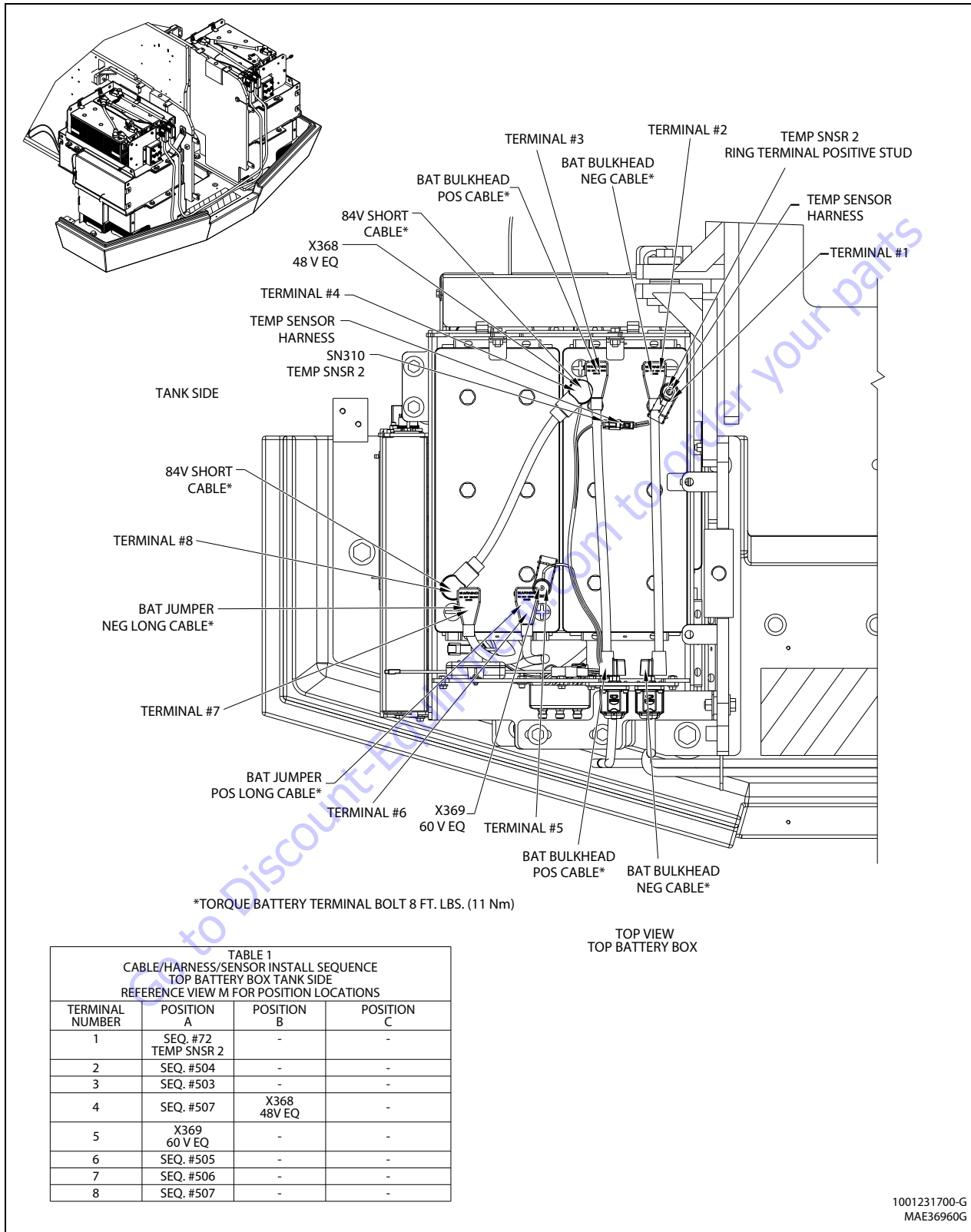

Figure 7-31. Battery Box - Sheet 8 of 15

SECTION 7 - BASIC ELECTRICAL INFORMATION & ELECTRICAL SCHEMATICS

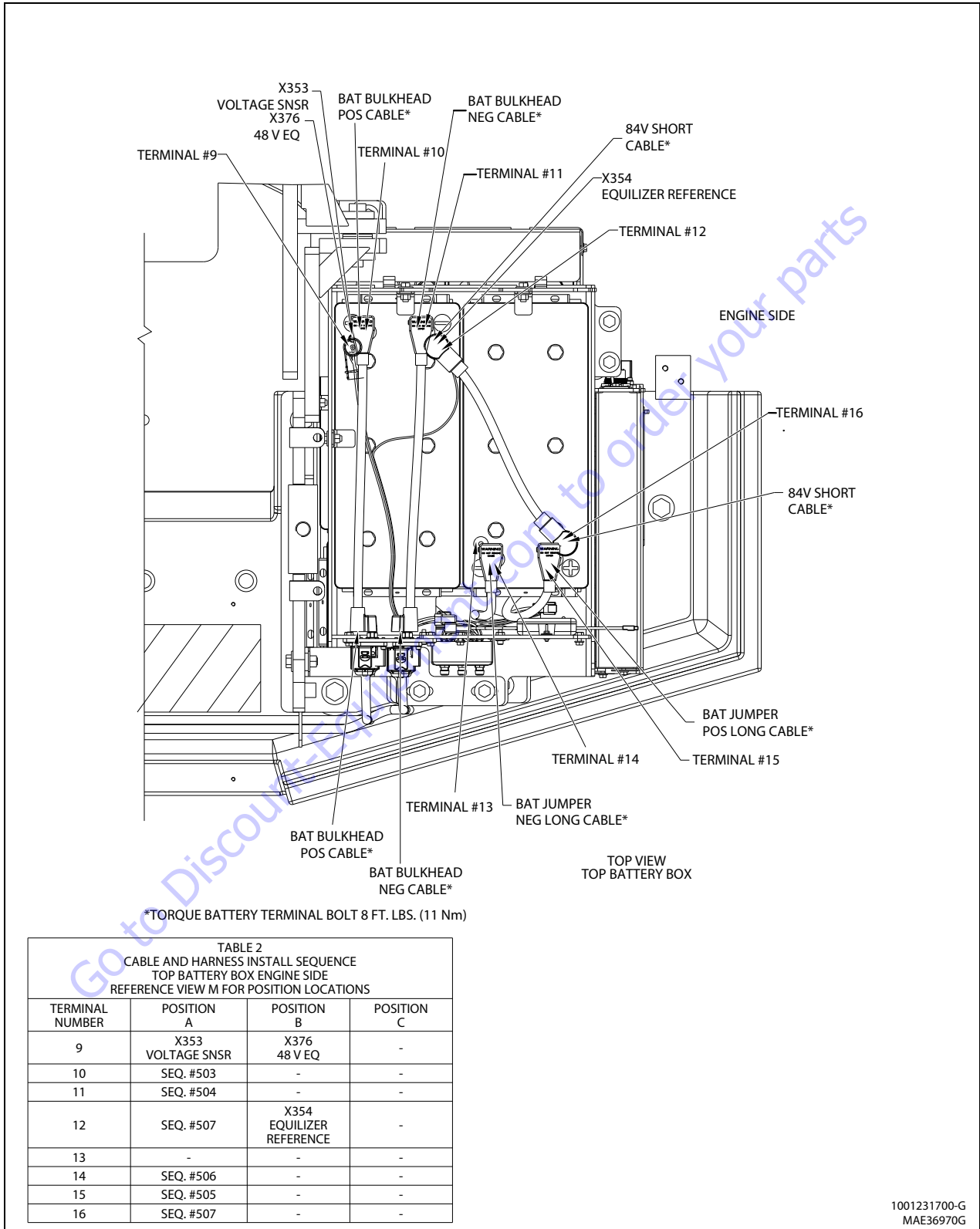

Figure 7-32. Battery Box - Sheet 9 of 15

SECTION 7 - BASIC ELECTRICAL INFORMATION & ELECTRICAL SCHEMATICS

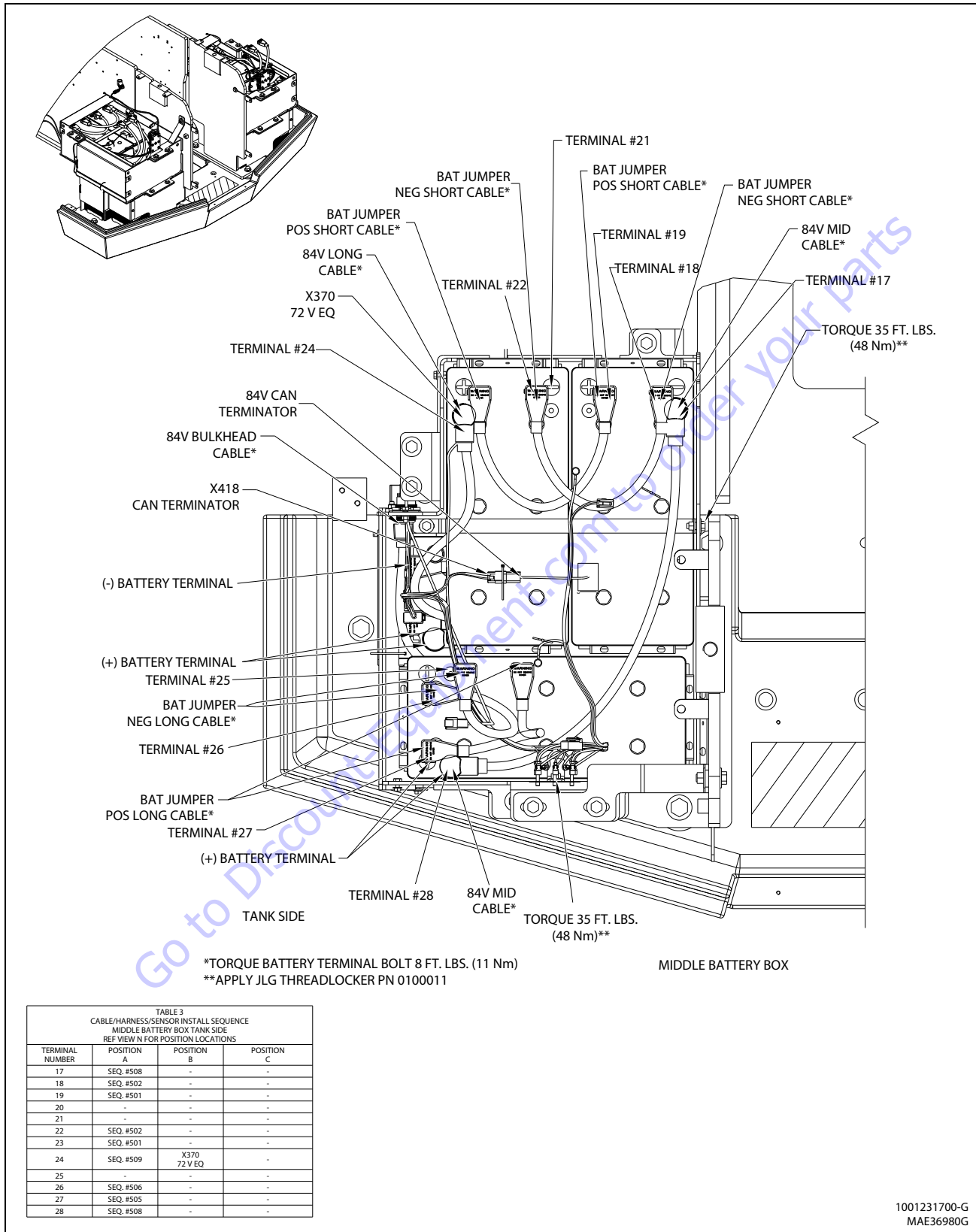

Figure 7-33. Battery Box - Sheet 10 of 15

SECTION 7 - BASIC ELECTRICAL INFORMATION & ELECTRICAL SCHEMATICS

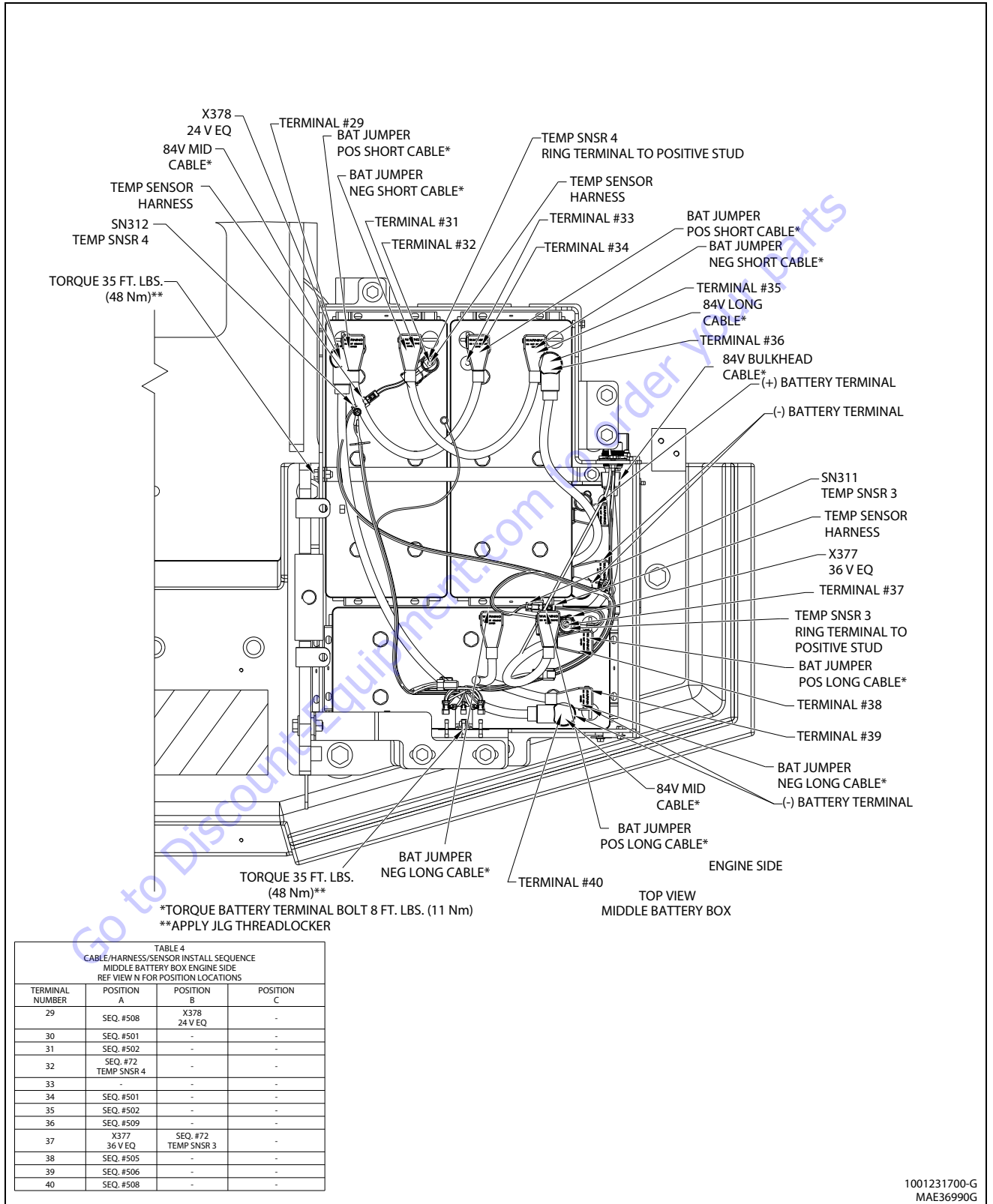

TABLE 4
CABLE/HARNESS/SENSOR INSTALL SEQUENCE
MIDDLE BATTERY BOX ENGINE SIDE
REF VIEW N FOR POSITION LOCATIONS

TERMINAL NUMBER	POSITION A	POSITION B	POSITION C
29	SEQ. #508	X378 24 V EQ	-
30	SEQ. #501	-	-
31	SEQ. #502	-	-
32	SEQ. #72 TEMP SNSR 4	-	-
33	-	-	-
34	SEQ. #501	-	-
35	SEQ. #502	-	-
36	SEQ. #509	-	-
37	X377 36 V EQ	SEQ. #72 TEMP SNSR 3	-
38	SEQ. #505	-	-
39	SEQ. #506	-	-
40	SEQ. #508	-	-

1001231700-G
MAE36990G

Figure 7-34. Battery Box - Sheet 11 of 15

SECTION 7 - BASIC ELECTRICAL INFORMATION & ELECTRICAL SCHEMATICS

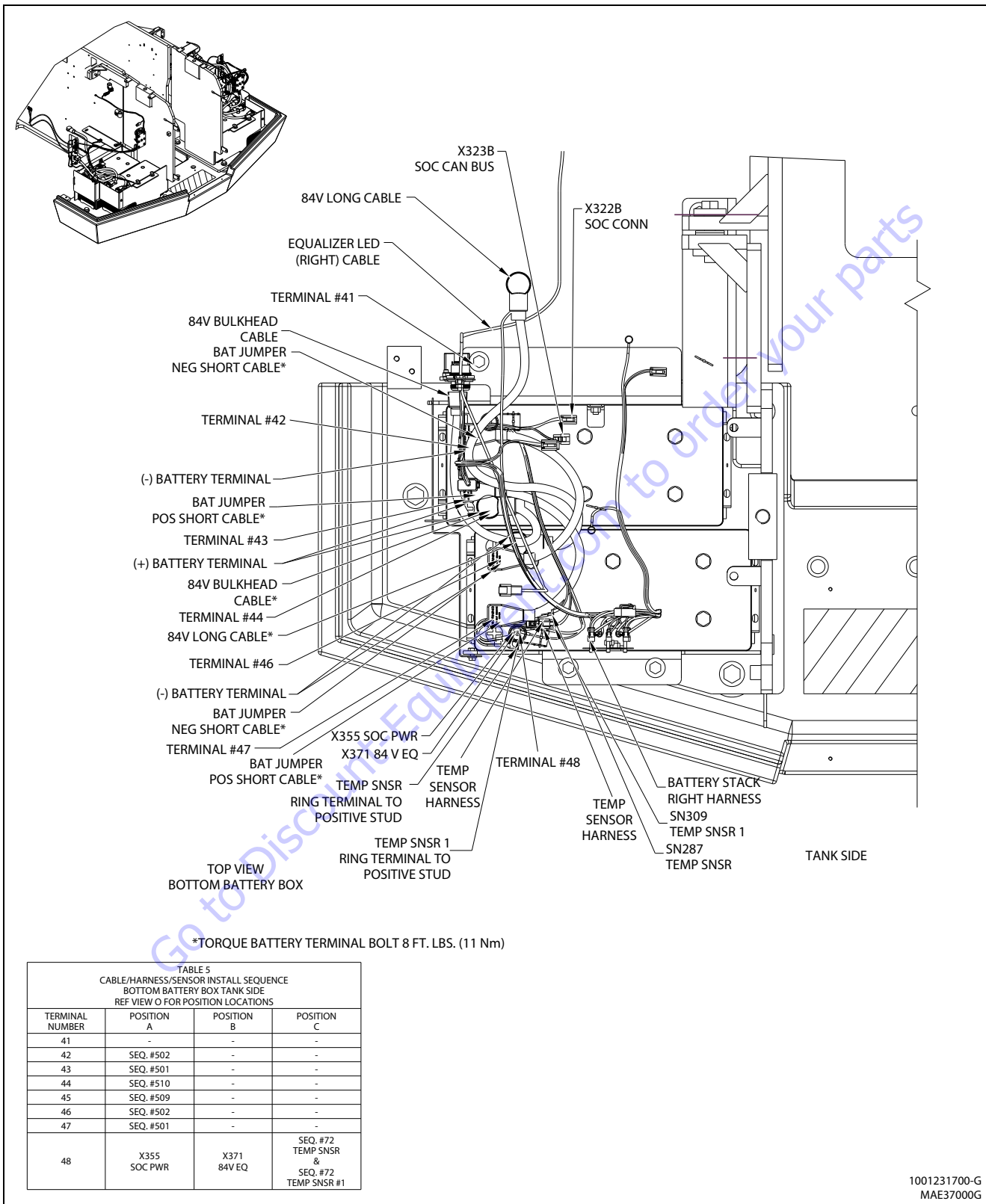

Figure 7-35. Battery Box - Sheet 12 of 15

SECTION 7 - BASIC ELECTRICAL INFORMATION & ELECTRICAL SCHEMATICS

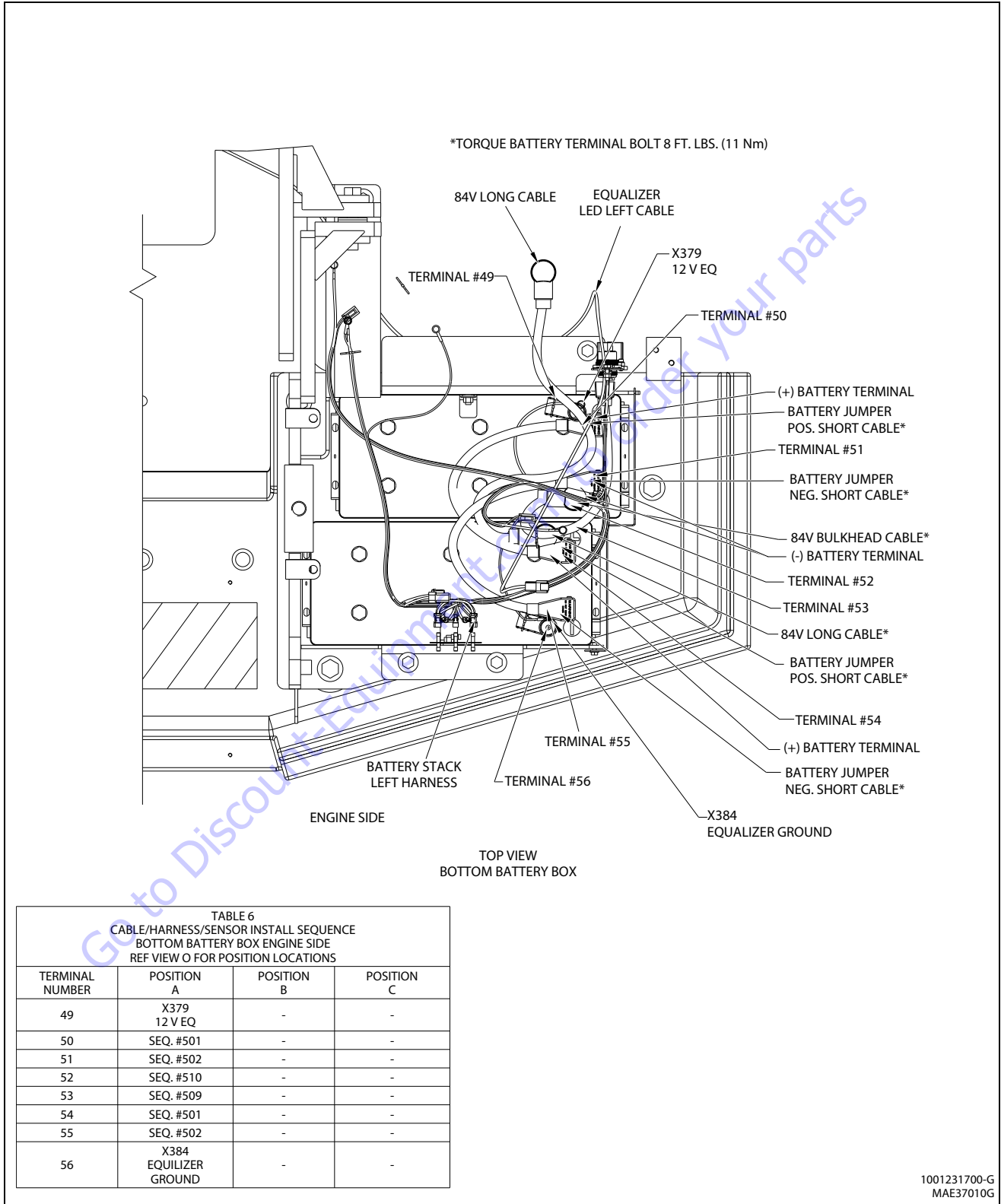

Figure 7-36. Battery Box - Sheet 13 of 15

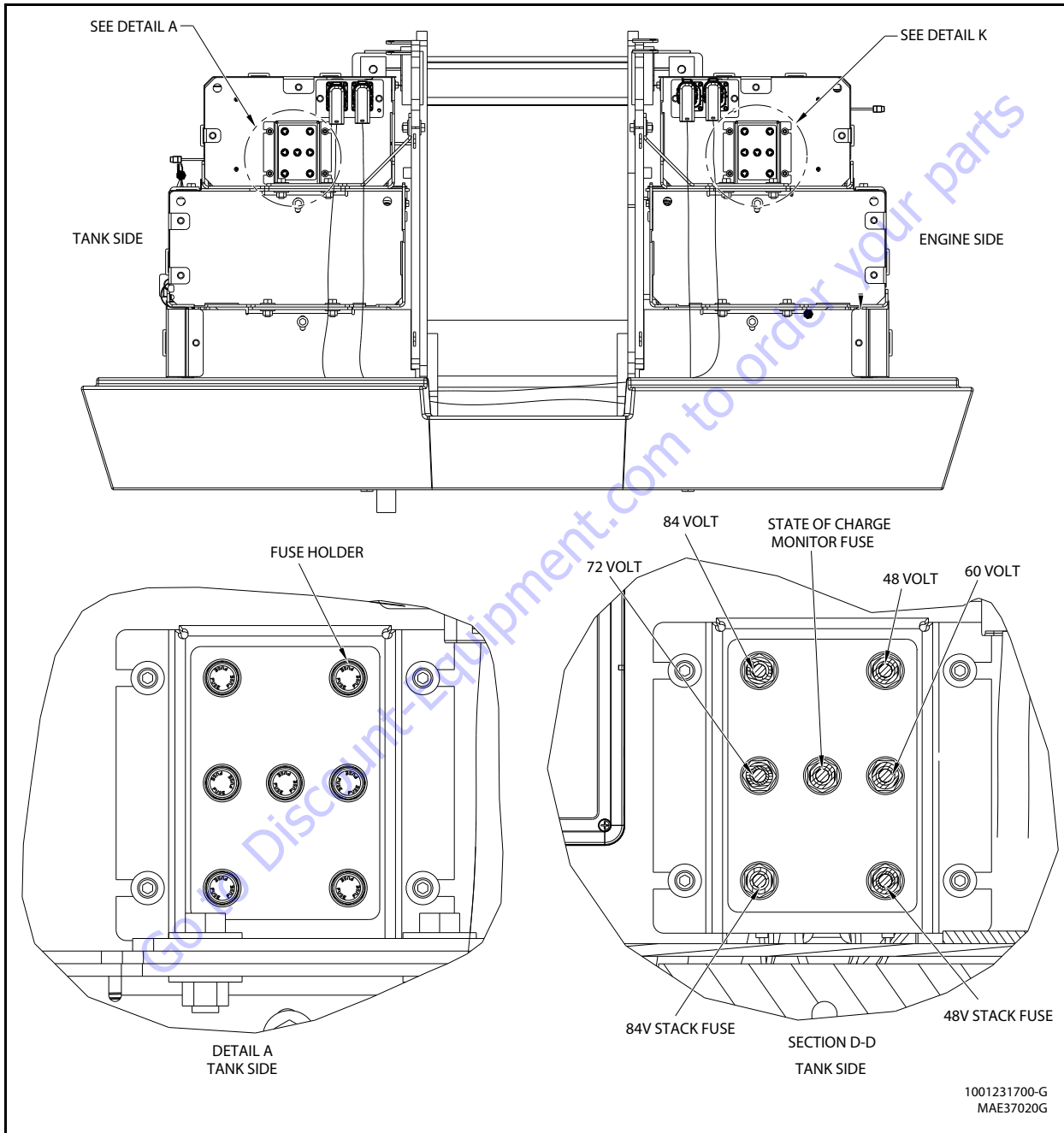

Figure 7-37. Battery Box - Sheet 14 of 15

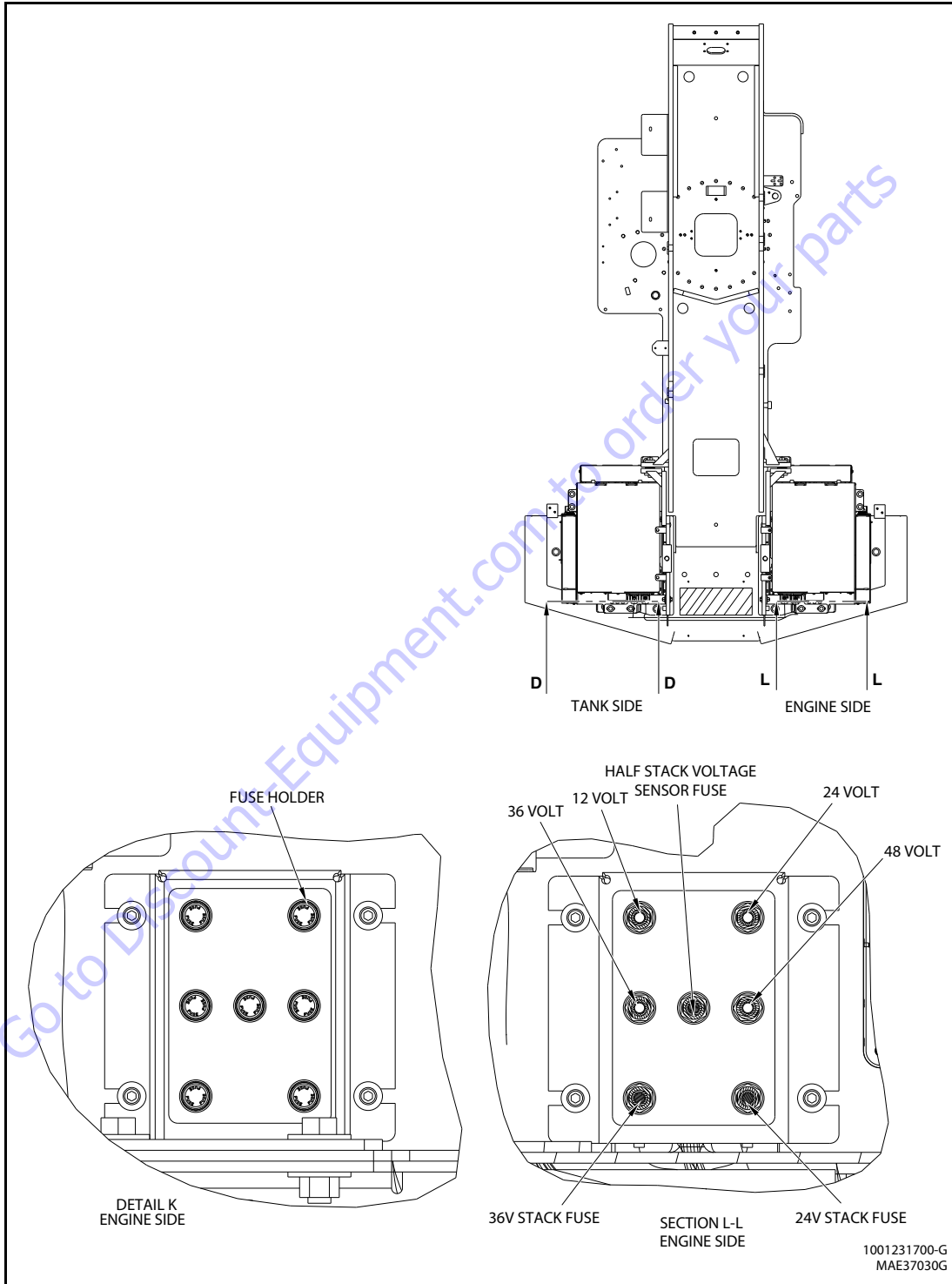

Figure 7-38. Battery Box - Sheet 15 of 15

7.11 IMG BOX

Within the IMG Box, there is both 84V AC and DC current present. The Rotary Disconnect (to be used for maintenance) is DPST to enable 84V isolation.

The Main Contactor is controlled by controllers and the Emergency Stop Switch.

The IMG controller converts DC to AC and back to power the IMG or charge batteries. It also monitors battery and IMG health.

When running in hybrid or electric mode, the IMG uses power from the battery stack.

When engine is running and no function is operating, IMG is charging batteries

If service is needed on the IMG;

1. Turn power off at the rotary disconnect and lock it out.

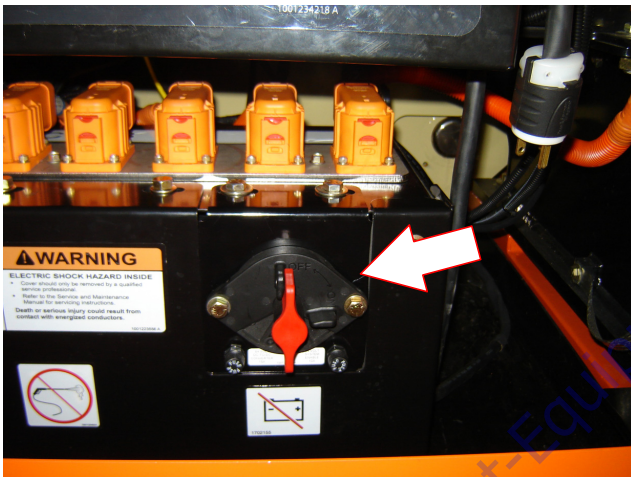

2. Disconnect the IMG sensor cable

Partially Isolating System Voltage

This procedure is to be performed for work on IMG/IMG control components. The disconnect steps below will reduce the System Voltage for working on the following components "downstream" of IMG box:

- on the IMG electrical connections
- on the cabling between IMG control enclosure and IMG
- within the IMG control enclosure

1. Turn the Maintenance disconnect switch to the "OFF" position.

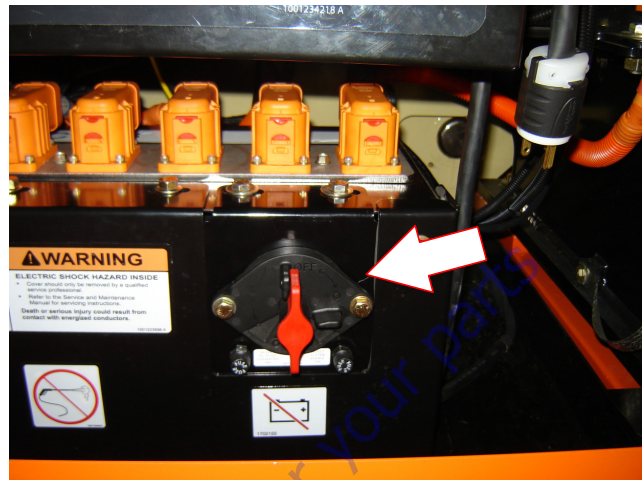

2. Disconnect the B- cable, "D" keyed (Green).

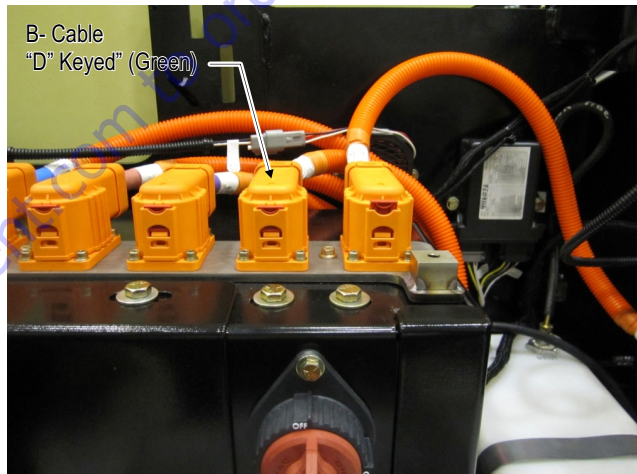

3. Disconnect the B+ cable, "E" keyed (Orange).



4. Disconnect the 84V hybrid harness (round connector) located on each battery box.

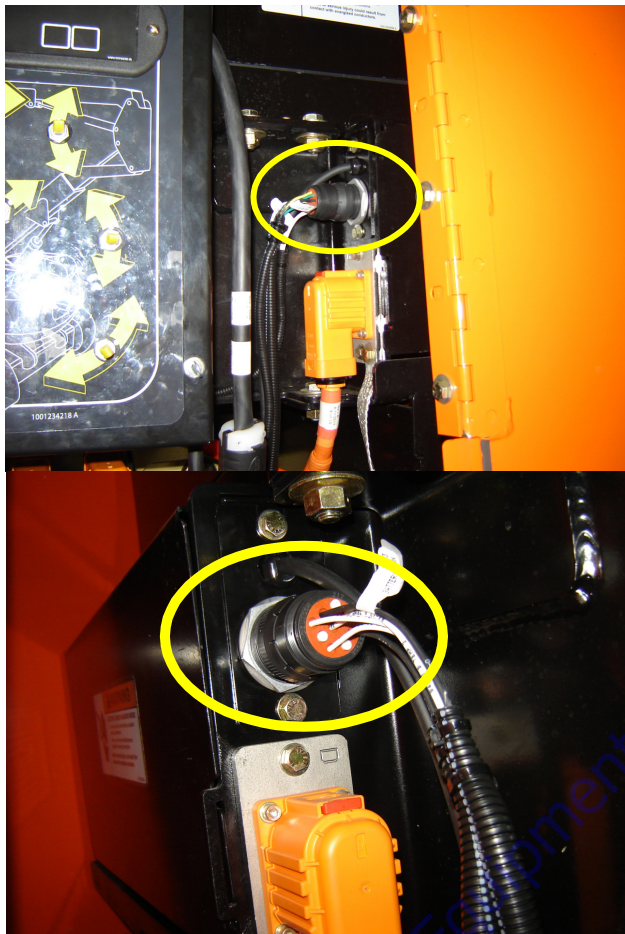

5. Check the voltage at the IMG connectors and verify the reading = 0V.

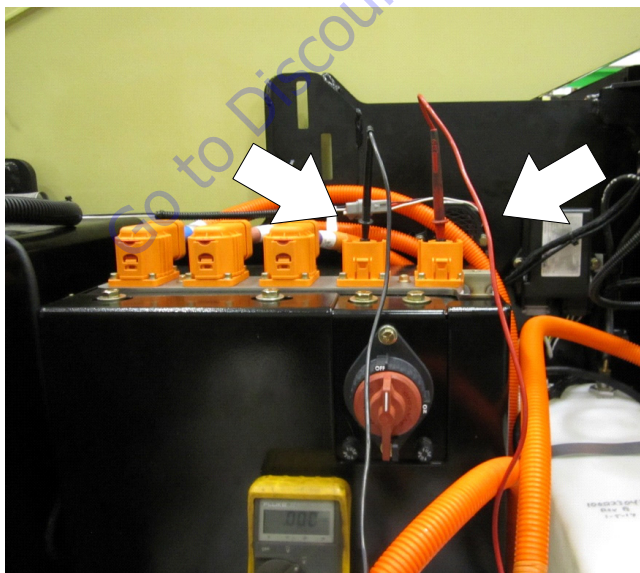

The battery stack and the charging system will still be energized with 84V, but the components above will be isolated to permit work

Remember: Nothing in this procedure affects the power available in the 12V system, so that system will still be fully energized

7.12 IMG CONTROLLER

Refer to Figure 7-43. thru Figure 7-48.

The IMG Controller monitors the battery stacks through voltage sensors, temperature probes and State of Charge device (SOC). It also converts DC to AC and vice versa. In addition, it monitors the IMG sensors and has an isolated CAN 2 channel that is 84V.

Removal

At the IGM control box (tank side of machine):



MAE37660

NOTE: Use above image as a reference for connector name.

NOTE: Refer to Section 7.9, Disconnecting Battery Box Connectors for connector disconnecting procedure.



MAE37670

SECTION 7 - BASIC ELECTRICAL INFORMATION & ELECTRICAL SCHEMATICS

1. Disconnect the "D" keyed connector.
2. Disconnect the "E" keyed connector.



MAE37700

Figure 7-39. 84V hybrid round connector on tank side



MAE37710

Figure 7-40. 84V hybrid round connector on engine side

3. Disconnect the 84V hybrid round connector (1) located on each side of the machine

4. Turn off the power at the maintenance disconnect switch.



5. Disconnect and completely remove the B- cable, "D" keyed (Green) from the IMG box.

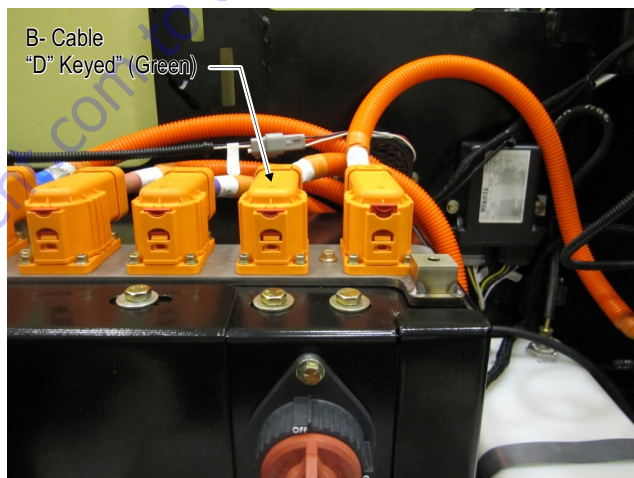

6. Disconnect and completely remove the B+ cable, "E" keyed (Orange) from the IMG box.



7. Remove the hood section that covers the IMG Box.



10. Remove the bolts that secure the IMG Box to the turntable side tray.

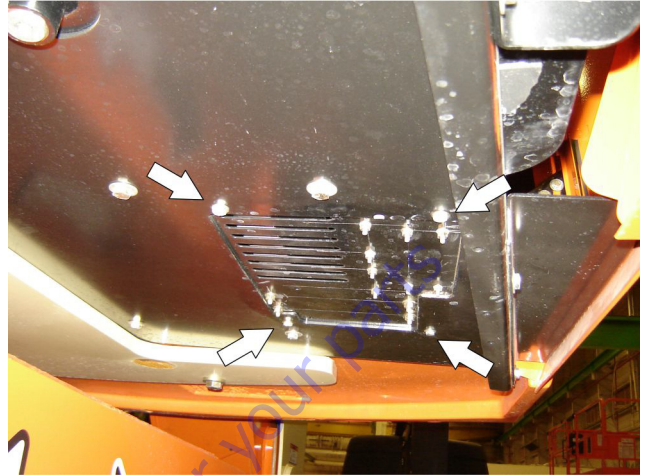

8. Remove the front cover from the box.

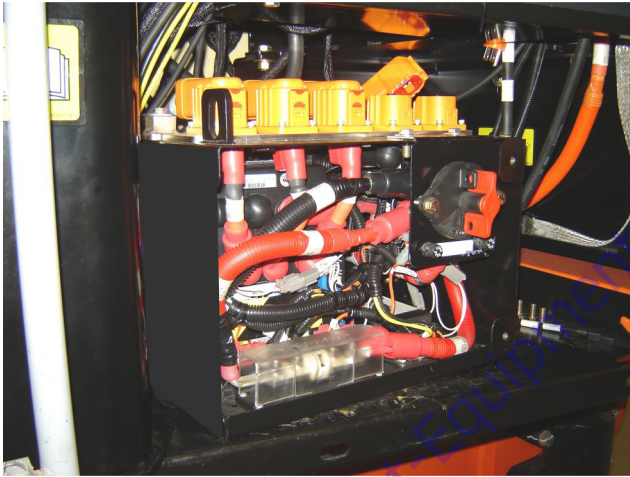

11. Remove the plastic cover from the fuse holder.

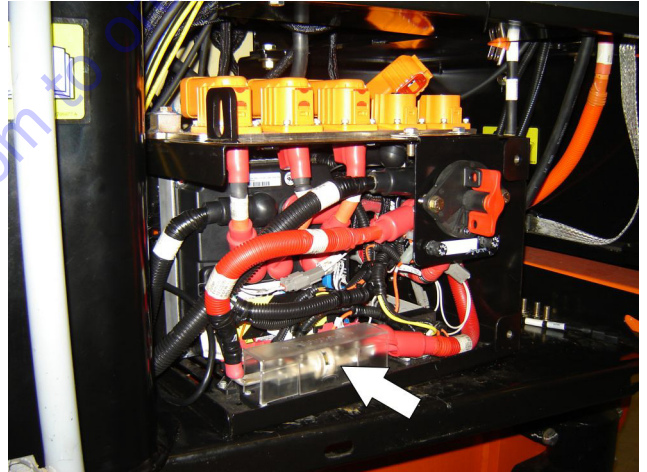

9. Remove the left hand side cover from the box.

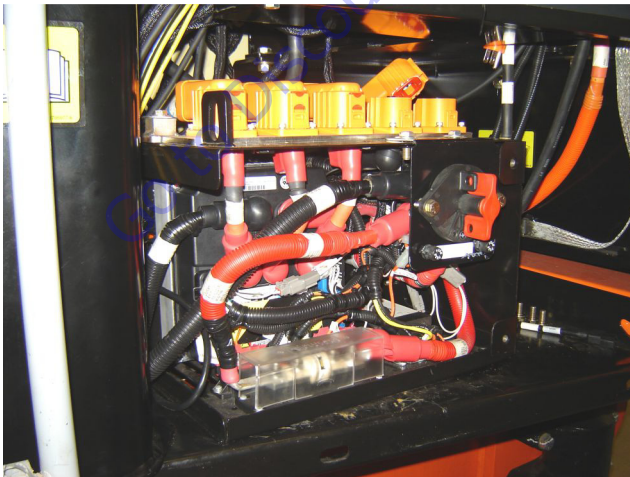

12. Tag and disconnect the Left Hand cable coming from the fuse.

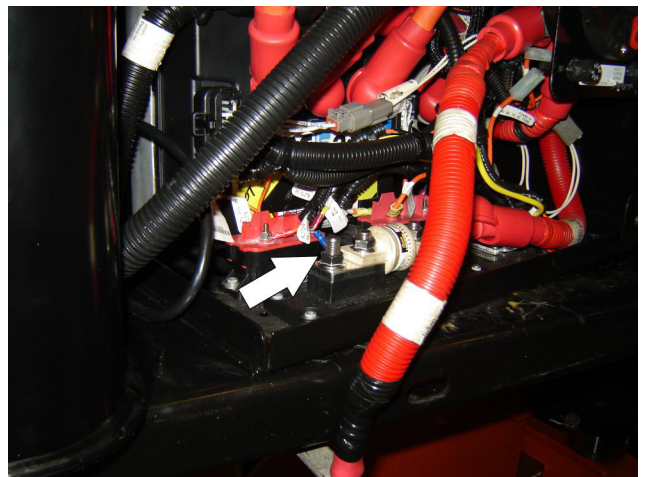

SECTION 7 - BASIC ELECTRICAL INFORMATION & ELECTRICAL SCHEMATICS

13. Remove the bolts securing the maintenance disconnect switch mounting bracket to the box. Pull the switch and bracket assembly away from the box.

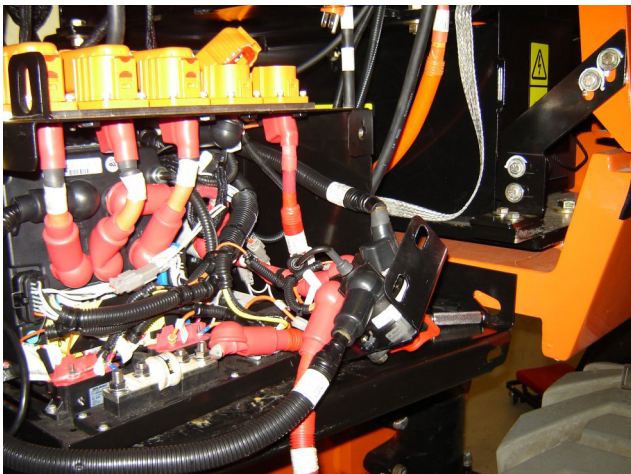

14. Tag and disconnect the connection for the battery charger and the control harnesses from the IMG Controller.

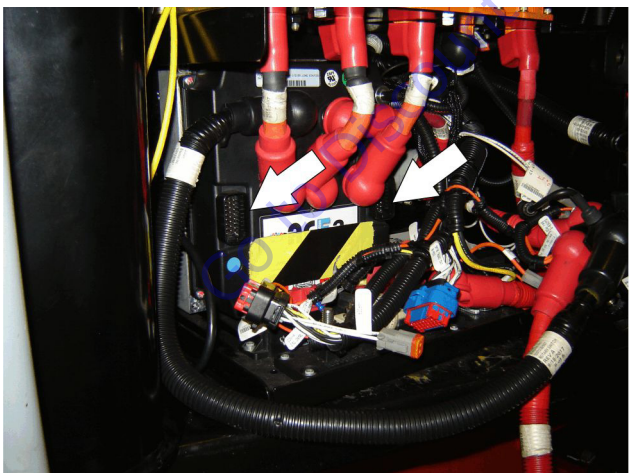
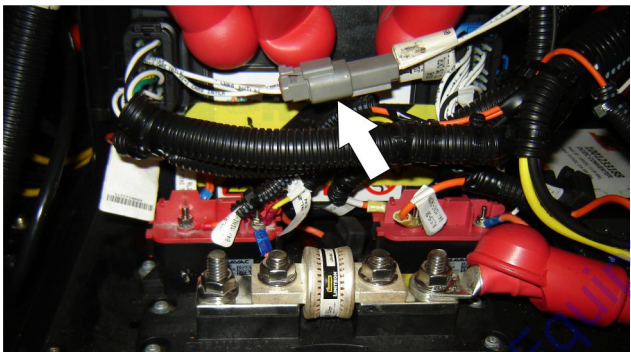

15. Tag, disconnect, and remove the power cables from the connectors and controller for clearance.

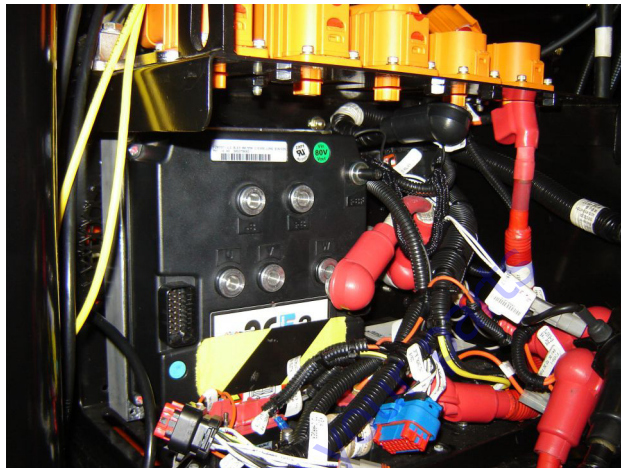

16. Remove the allen screws that secure the IMG Controller to the box. Pull the box out enough to gain access to the retaining nuts at the back of the box.

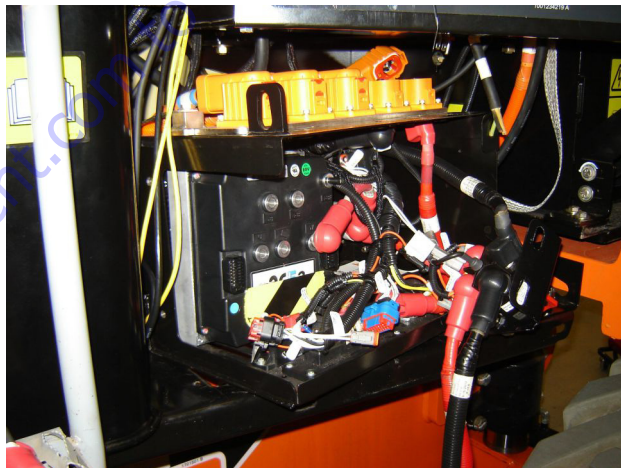

17. Remove the IMG Controller.

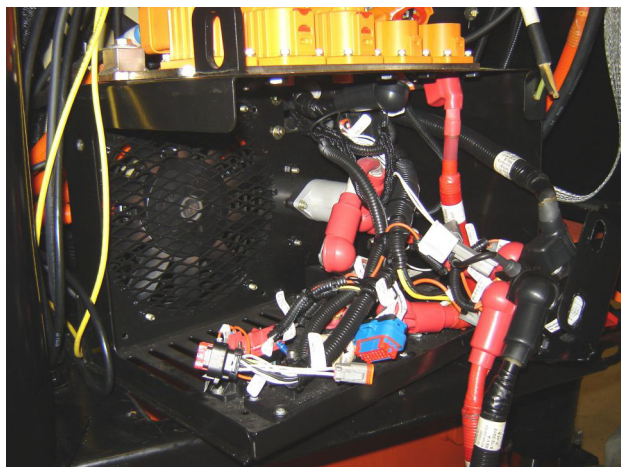

Installation

1. Install the IMG Controller to the box using the allen screws and retaining nuts. If installing a new controller, make sure to remove the standoffs from the old controller for proper installation. Push the box back in place.

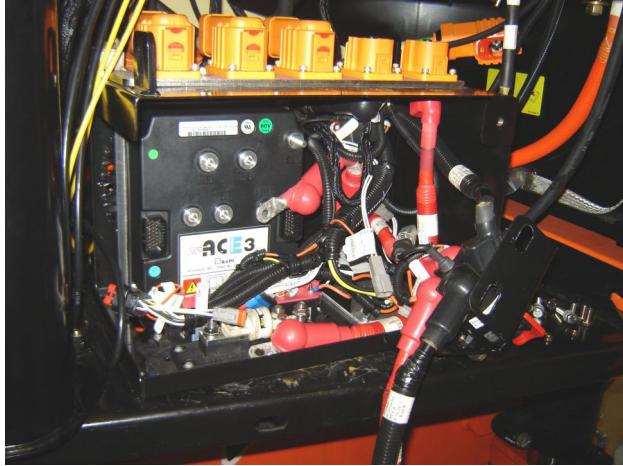

2. Install the power cables to the controller as tagged during removal. Torque all fasteners 9.5 to 11 ft. lbs. (13 to 15 Nm).

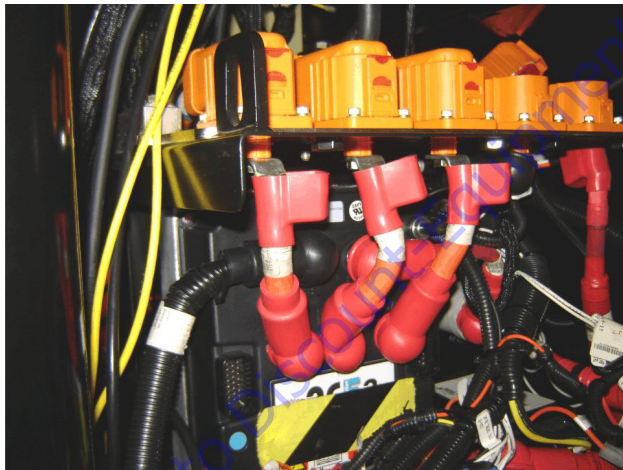

3. Plug the connectors back into the controller as tagged during removal. Reconnect the harness for the battery charger.

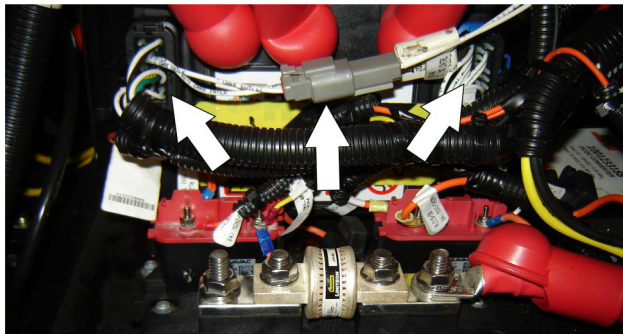

4. Position the maintenance disconnect and bracket assembly in place and secure with the attaching bolts.
5. Install the bolts that secure the IMG box to the turntable side tray.

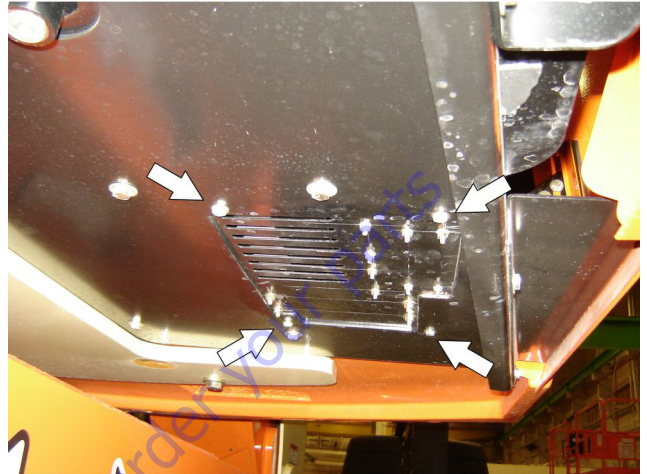

6. Install the power cable onto the fuse as tagged during removal.

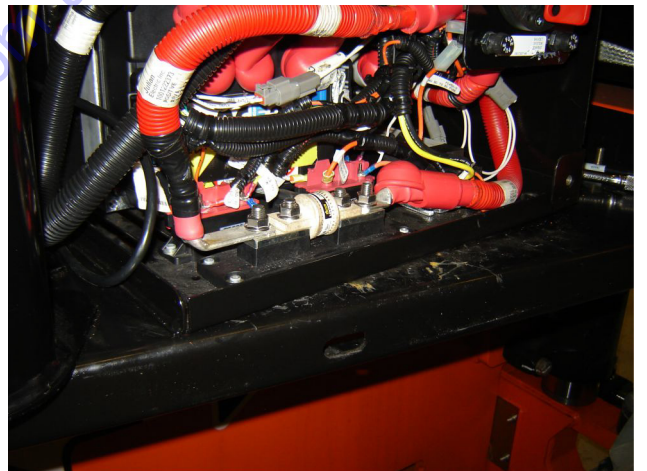

SECTION 7 - BASIC ELECTRICAL INFORMATION & ELECTRICAL SCHEMATICS

7. Install the plastic cover back onto the fuse holder.

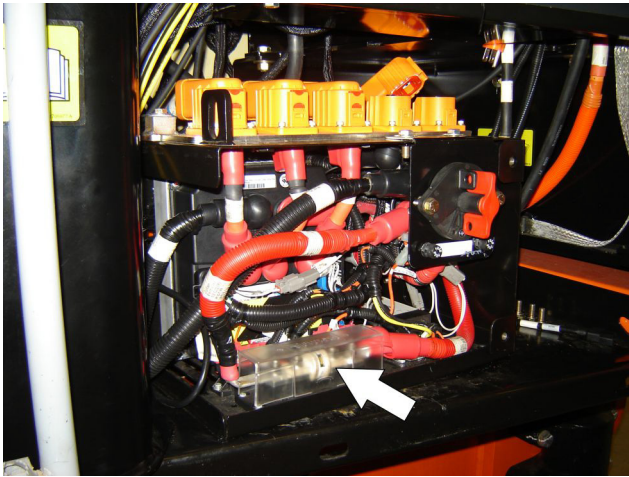

8. Install the left side cover onto the box.

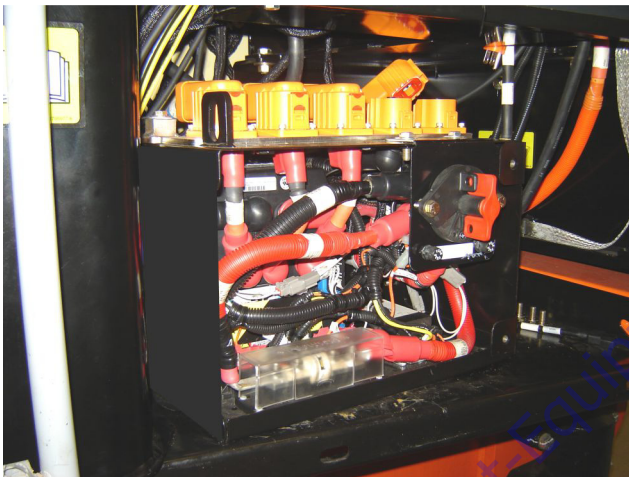

9. Install the front cover onto the box.

10. Install the hood.

11. Connect the B+ cable, "E" keyed (Orange) as tagged during removal.



12. Connect the B- cable, "D" keyed (Green) as tagged during removal.

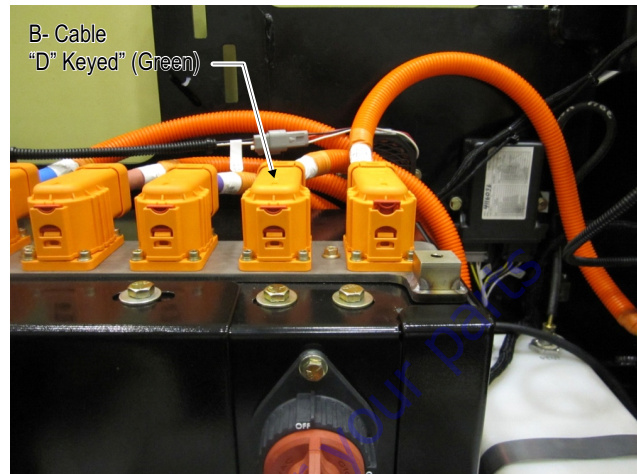

13. Turn the power on at the maintenance disconnect switch.



14. Connect the 84V hybrid round connector (1) located on each side of the machine.



MAE37710

Figure 7-41. 84V hybrid round connector on engine side



MAE37670



MAE37660



MAE37700

Figure 7-42. 84V hybrid round connector on tank side

15. Connect connector E.
16. Disconnect connector D.

SECTION 7 - BASIC ELECTRICAL INFORMATION & ELECTRICAL SCHEMATICS

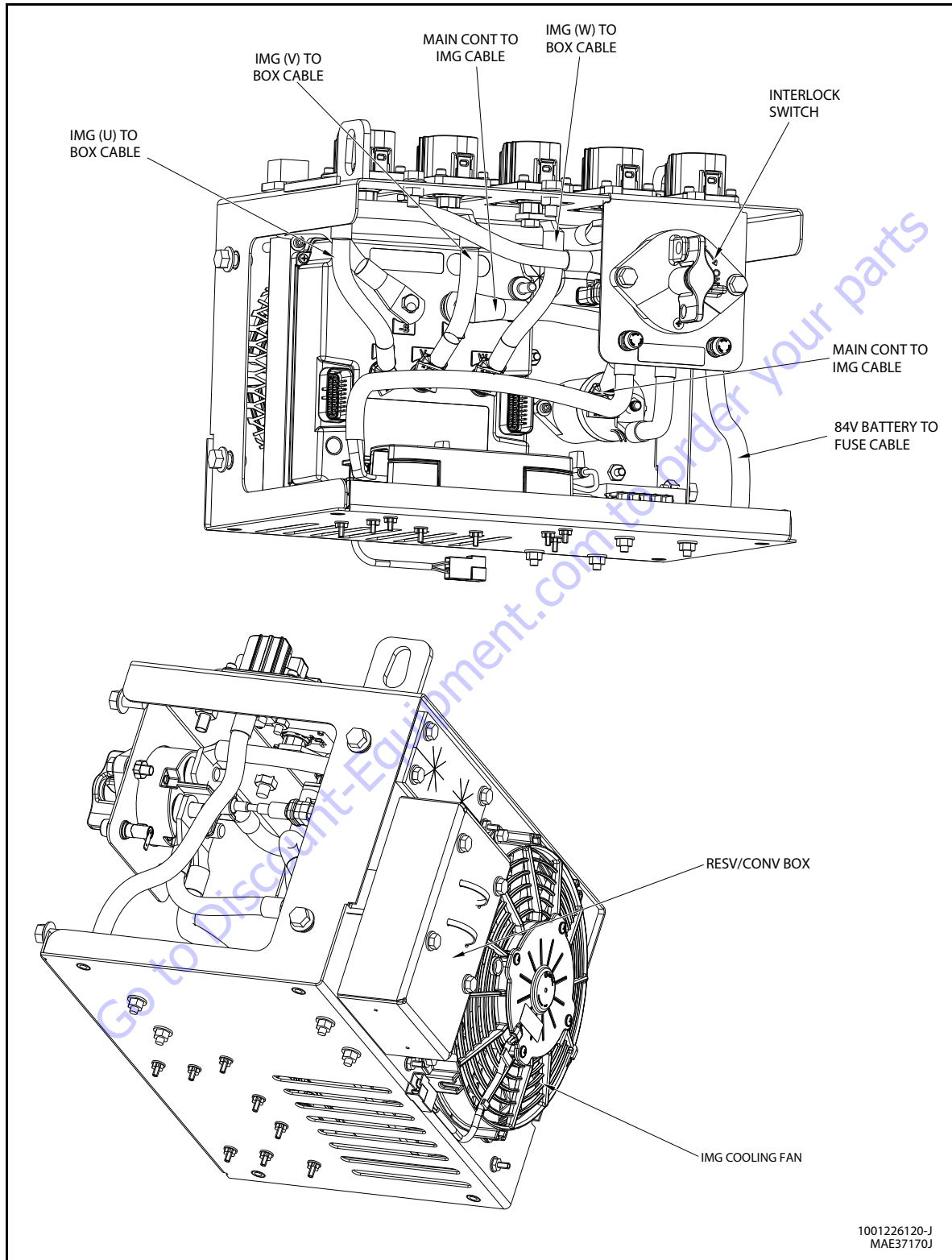

Figure 7-43. IMG Box - Sheet 1 of 6

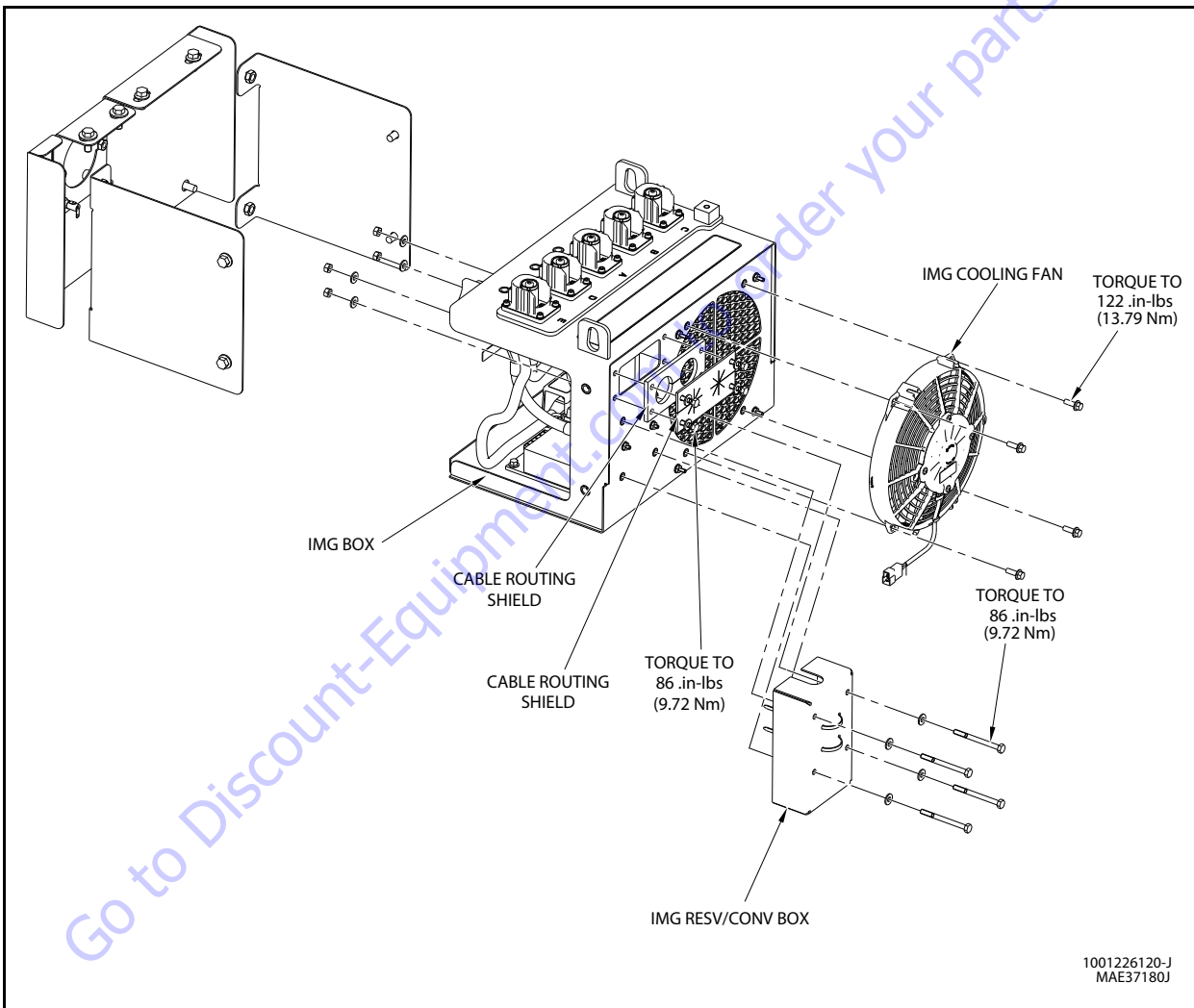

Figure 7-44. IMG Box - Sheet 2 of 6

SECTION 7 - BASIC ELECTRICAL INFORMATION & ELECTRICAL SCHEMATICS

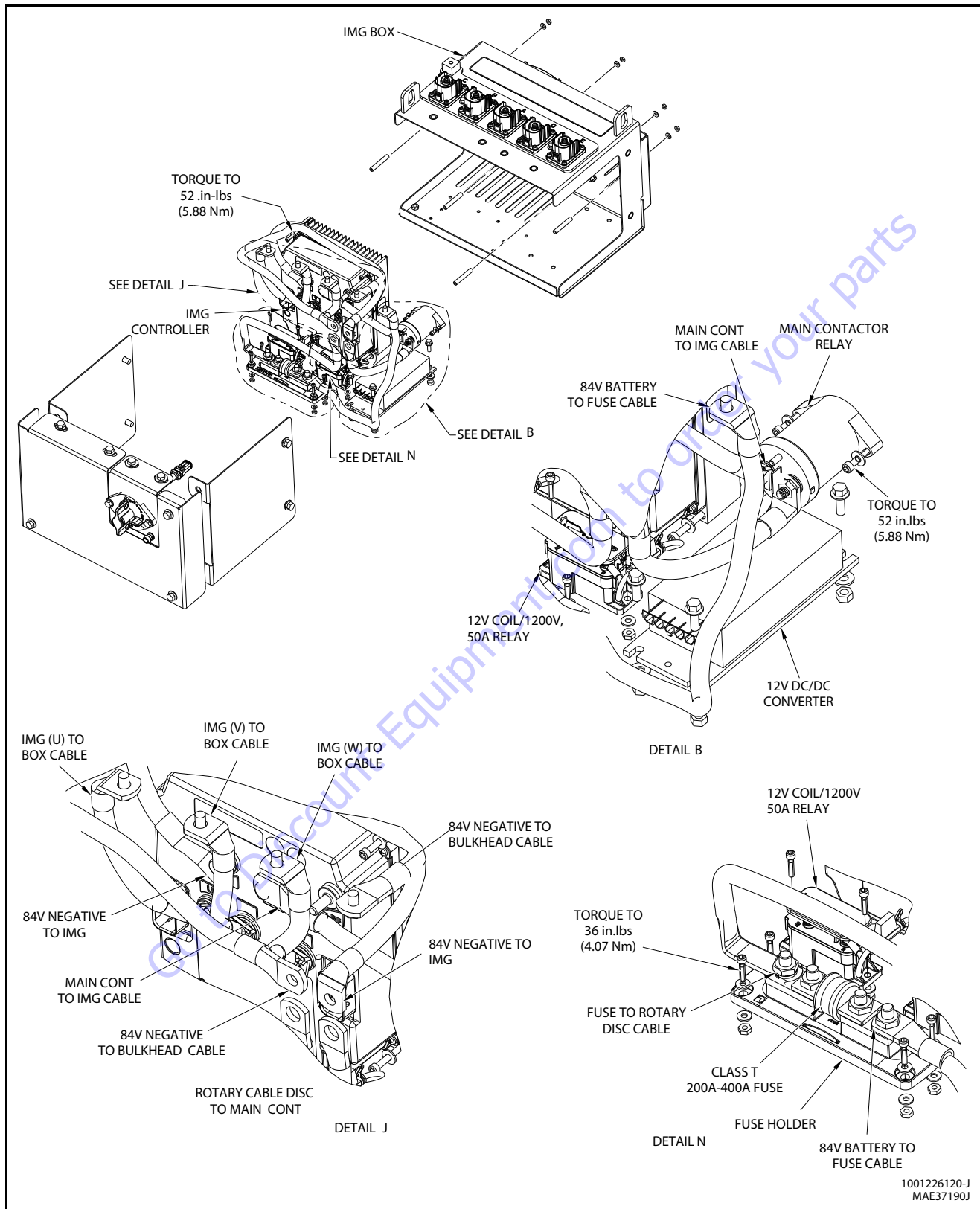

Figure 7-45. IMG Box - Sheet 3 of 6

SECTION 7 - BASIC ELECTRICAL INFORMATION & ELECTRICAL SCHEMATICS

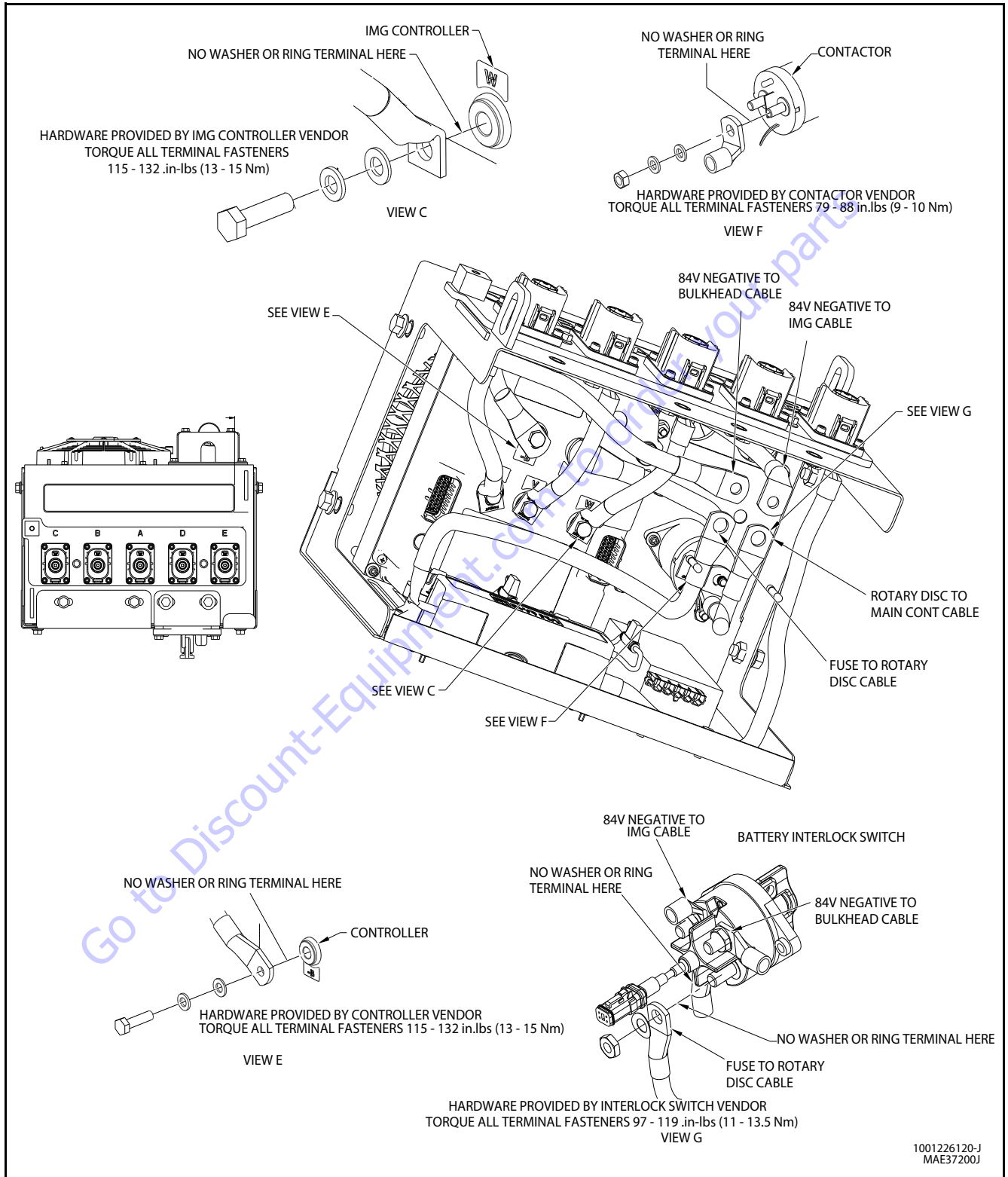

Figure 7-46. IMG Box - Sheet 4 of 6

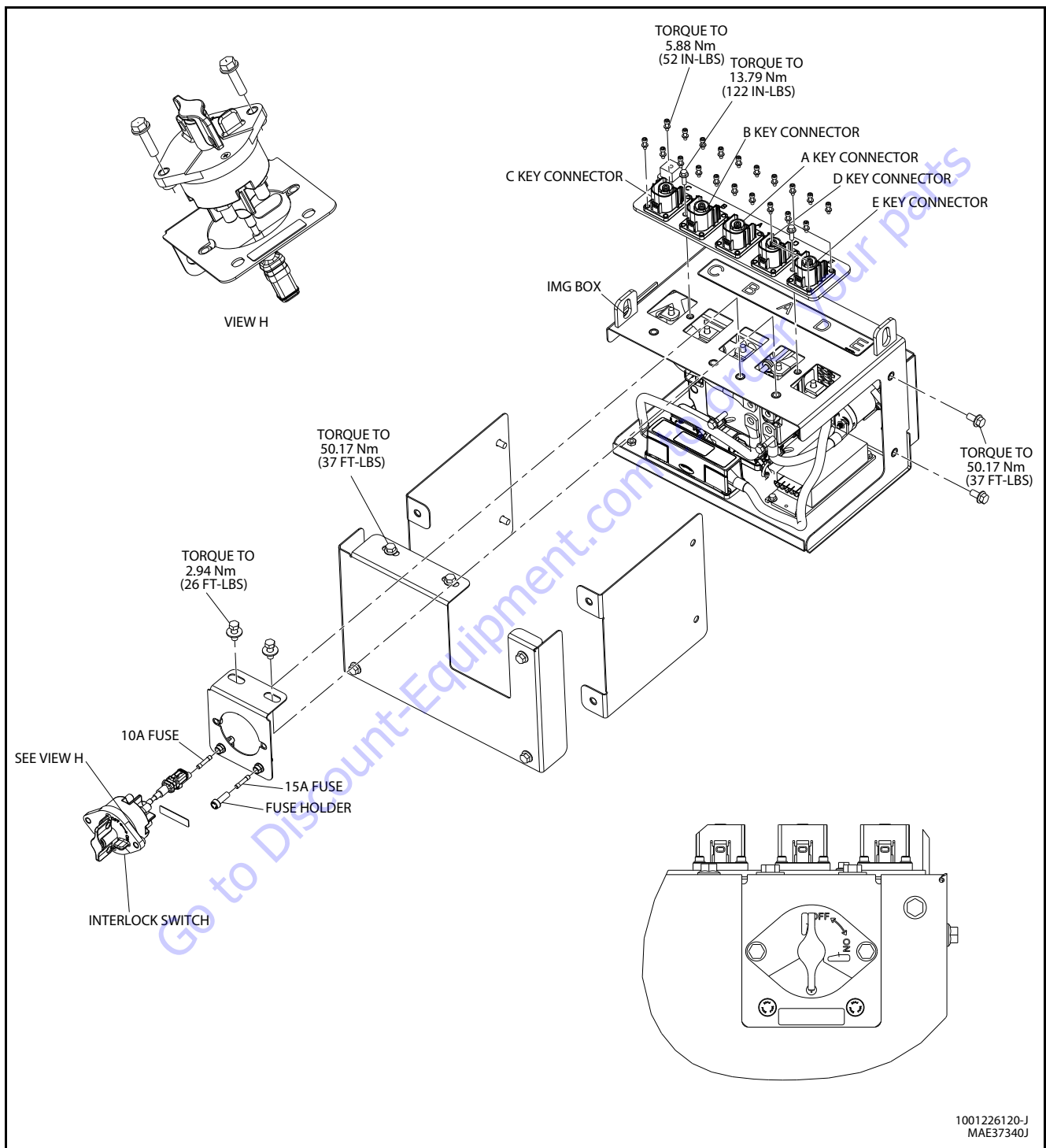
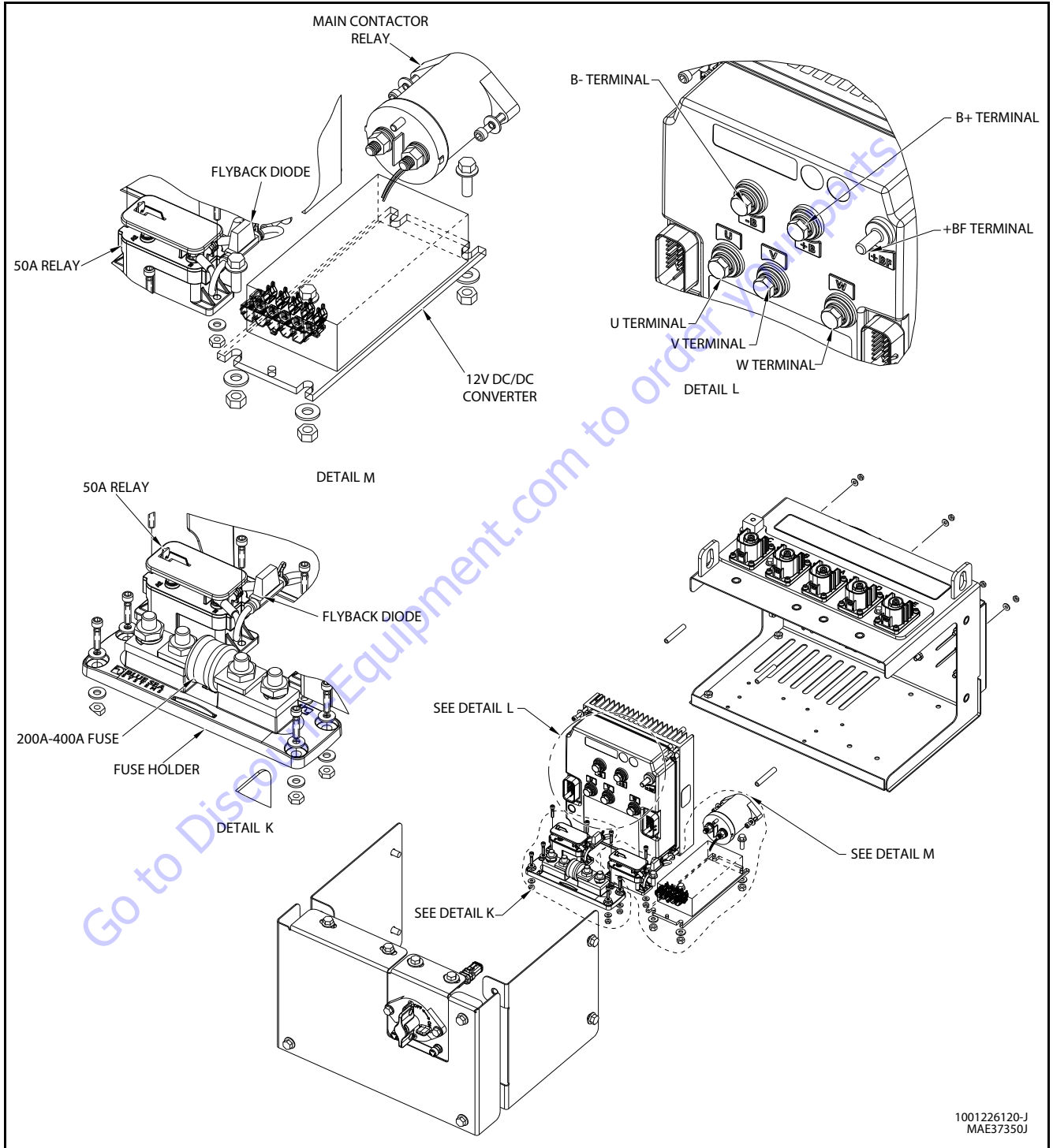

Figure 7-47. IMG Box - Sheet 5 of 6



1001226120-J
MAE37350J

Figure 7-48. IMG Box - Sheet 6 of 6

7.13 HYBRID ELECTRIC CONTROLLER

The Hybrid Electric Controller (HEC) Monitors the hybrid systems and controls the following:

- Controls fans
- Controls DC/DC converter
- DC/DC converter
- Converts 84V to 12V
- Charges 12V battery when engine is not running

7.14 RESOLVER/CONVERTER

The Resolver/Converter translates the IMG signals so the IMG controller can understand them. It is located behind the IMG box.

7.15 STATE OF CHARGE DEVICE

The State of Charge Device (SOC) monitors current to and from batteries, battery stack voltage, and temperature. It communicates to the IMG controller by way of the CAN 2 circuit.

7.16 BATTERY EQUALIZER

There is one battery equalizer for each battery stack. The equalizer monitors the health of the battery stacks. If one pair drops too much, it will take power from a stronger pair to charge them up. Each lead is fused and an LED on the Ground control box shows the status of the batteries. The Battery Balance Indicator displays the state of charge balance of the battery packs. The lights will glow a steady green when the battery pack is balanced or a steady red when the batteries are too far out of balance, resulting in a system shutdown condition. For conditions in between, the light will be green and blink orange at different rates depending upon how far from the normal range the battery packs are (for example, the further out of balance the battery pack is, the faster it will blink. When the battery pack is close to being balanced and is equalizing, the light will blink green.

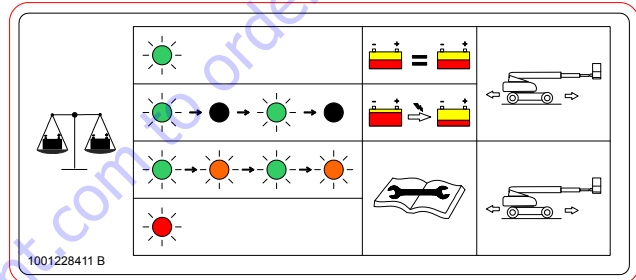
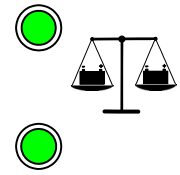

Table 7-1. Battery Equalizer LEDs

MODE	LED	LED INDICATOR	CONDITION
Balanced		Steady Green	Voltage Differential <math>< 0.4V (+/-0.4)</math>
Equalizing		Blink Green 1 Sec On/1 Sec Off	Voltage Differential >math>> 0.6V (+/-0.4)</math>
Battery #1 Low/Over Warning (Gnd~12V Connection)		Green / Blink Orange 1x Per 4 Sec	Gnd~12V Conn When Battery #1 Exceeded Normal Range <math>< 10.5V</math> or $> 16.5V (+/-0.4)$
Battery #2 Low/Over Warning (12V~24V Connection)		Green / Blink Orange 2x Per 4 Sec	12V~24V Conn When Battery #2 Exceeded Normal Range <math>< 10.5V</math> or $> 16.5V (+/-0.4)$
Battery #3 Low/Over Warning (24V~36V Connection)		Green / Blink Orange 3x Per 4 Sec	24V~36V Conn When Battery #3 Exceeded Normal Range <math>< 10.5V</math> or $> 16.5V (+/-0.4)$
Battery #4 Low/Over Warning (36V~48V Connection)		Green / Blink Orange 4x Per 4 Sec	36V~48V Conn When Battery #4 Exceeded Normal Range <math>< 10.5V</math> or $> 16.5V (+/-0.4)$
Auto Shutdown		Steady Red	1) Diff Voltage >math>> 4V (+/-0.4)</math> - or - 2) Any 12V, 24V, 36V, or 48V Lead Disconnected

7.17 BATTERY CHARGERS

The machine incorporates two battery chargers (primary and a secondary) which operate on 220V or 110V. Both chargers operate initially and the primary does the finish charging. 220V charging is the preferred voltage for charging the batteries.

NOTICE

JLG MACHINES EQUIPPED WITH DELTA Q BATTERY CHARGERS ARE DESIGNED FOR THE BEST PERFORMANCE WITH OEM FACTORY APPROVED BATTERIES.

APPROVED JLG REPLACEMENT BATTERIES ARE AVAILABLE THROUGH JLG'S AFTERMARKET PARTS DISTRIBUTION CENTERS OR JLG'S AFTERMARKET PROGRAMS. FOR ASSISTANCE WITH PROPER BATTERY REPLACEMENT, PLEASE CONTACT YOUR LOCAL JLG SUPPORT OFFICE.

BATTERIES APPROVED BY JLG HAVE BEEN TESTED FOR COMPATIBILITY WITH THE ALGORITHM PROGRAMMING OF THE DELTA Q BATTERY CHARGER TO OPTIMIZE BATTERY LIFE AND MACHINE CYCLE TIMES. THE USE OF NON APPROVED BATTERIES IN YOUR JLG EQUIPMENT MAY RESULT IN PERFORMANCE ISSUES OR BATTERY CHARGER FAULT CODES. JLG ASSUMES NO RESPONSIBILITY FOR SERVICE OR PERFORMANCE ISSUES ARISING FROM THE USE OF NON APPROVED BATTERIES.

Battery Charging

IF CHARGING THE MACHINE USING STANDARD 110V 15 OR 20A OUTLETS, EACH CHARGER MUST BE PLUGGED INTO A SEPARATE CIRCUIT. FOR EXAMPLE, EACH OUTLET USED TO PLUG EACH CHARGER INTO MUST BE CONTROLLED BY AN INDIVIDUAL CIRCUIT BREAKER IN THE ELECTRICAL SERVICE PANEL. THE CHARGERS CANNOT BOTH BE PLUGGED INTO MULTIPLE OUTLETS CONTROLLED BY ONLY ONE CIRCUIT BREAKER. IF USING 220V TO CHARGE, A STANDARD 220V 15A CIRCUIT MAY BE USED.

NOTE: Be sure that machine is parked in a well ventilated area before charging begins.

CAUTION

ONLY PLUG THE CHARGER INTO A PROPERLY INSTALLED AND GROUNDED OUTLET. DO NOT USE GROUND ADAPTORS OR MODIFY PLUG. DO NOT TOUCH NON-INSULATED PORTION OF OUTPUT CONNECTOR OR NON-INSULATED BATTERY TERMINAL. DO NOT OPERATE CHARGER IF THE AC SUPPLY CORD IS DAMAGED OR IF THE CHARGER HAS BEEN DAMAGED IN ANY WAY.

1. The battery charger AC input plug is located near the ground control console.
2. Connect the charger AC input plug to a grounded outlet using a 3 wire heavy duty extension cord.
3. After connecting the charger to an AC outlet at the start of the charging cycle, check the Charger Status and Battery Balance indicators on the Ground Control console.

Ground Panel Indicators

BATTERY BALANCE INDICATOR

The Battery Balance Indicator displays the state of charge balance of the battery packs. The lights will glow a steady green when the battery pack is balanced or a steady red when the batteries are too far out of balance, resulting in a system shut-down condition. For conditions in between, the light will be green and blink orange at different rates depending upon how far from the normal range the battery packs are (for example, the further out of balance the battery pack is, the faster it will blink). When the battery pack is close to being balanced and is equalizing, the light will blink green.

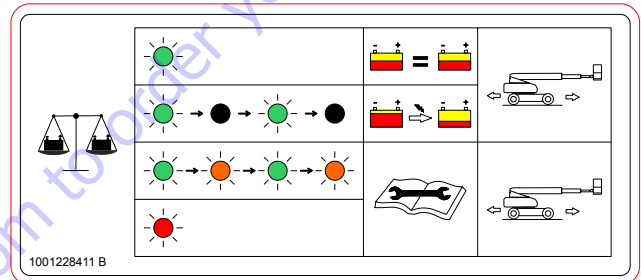
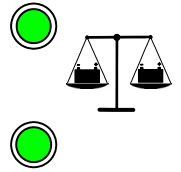

CHARGER STATUS

The Charger Status LEDs give a visual indicator of the status of the battery charger. The red LED indicates Charging Abnormal. The yellow LED indicates charging in progress. The green LED indicates charging is complete. There is one set of LEDs for each battery pack.

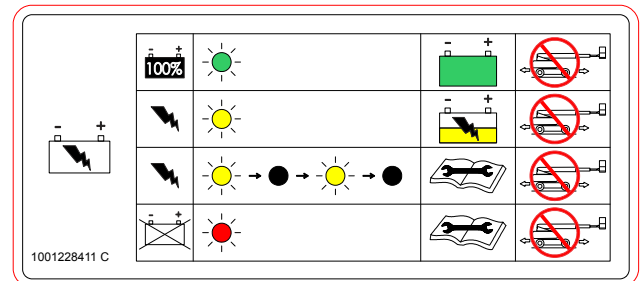
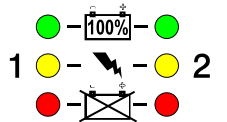

Indications on the Charger 3-LED Display

The charger may become hot during charging. Use hand protection to safely handle the charger during charging.

Extension cords must be 3-wire cord no longer than 30m (100') at 10 AWG or 7.5m (25') at 16 AWG per UL guidelines.

Only connect one QuiQ Charger to a single 120VAC 15A circuit, or the circuit may become overloaded.

The charger will conduct a self-test after being powered on, visible by flashing all of its LEDs in sequence.

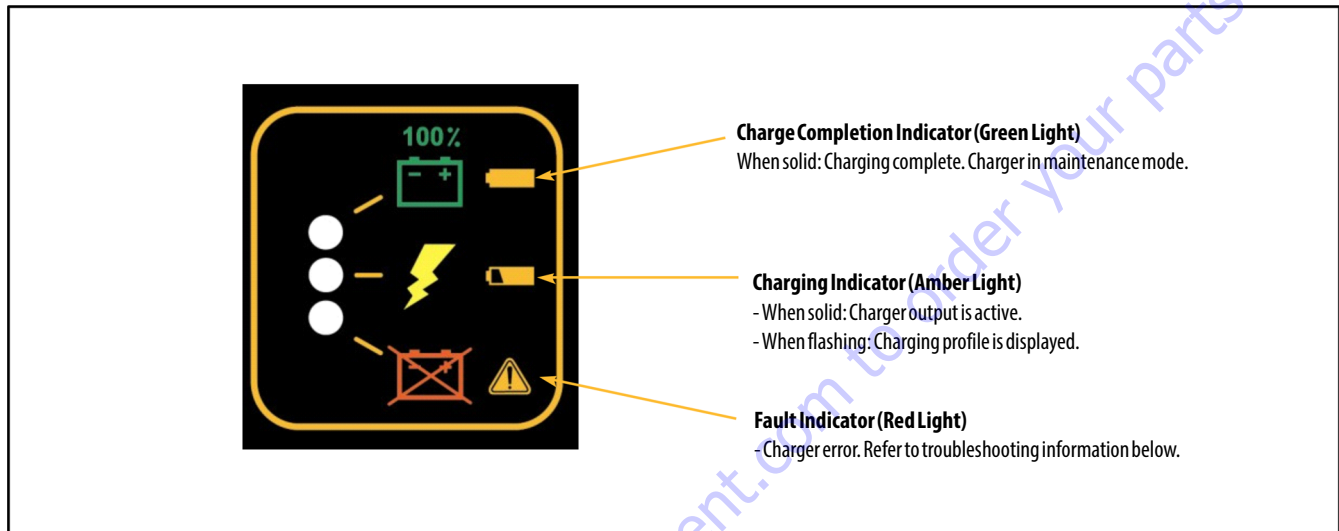

Figure 7-49. Battery Charger LED Display

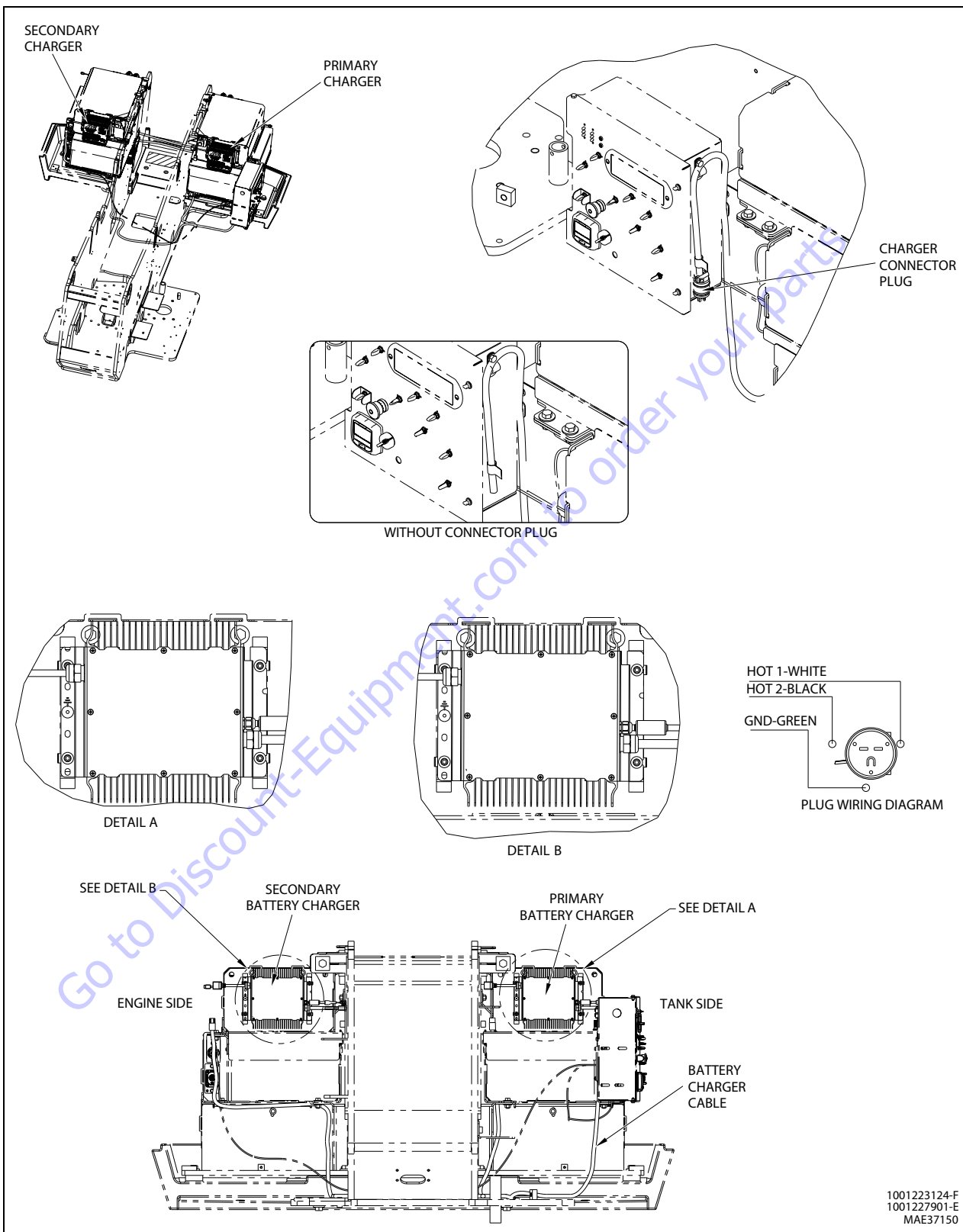

Figure 7-50. Battery Charger Installation

Troubleshooting Instructions (Wall - Charge)

If a fault occurs, count the number of red flashes between pauses and refer to the table below.

Table 7-2. LED Flashes







Flashes	Cause	Solution
	Battery high voltage	Check battery size and condition. This fault will clear automatically once the condition has been corrected.
	Battery low voltage	Check battery size and condition. This fault will clear automatically once the condition has been corrected.
	Charge timeout caused by battery pack not reaching required voltage; or charger output reduced due to high temperatures.	Check connections, that battery type matches selected charge profile and operate the charger at a lower ambient temperature. Reset the charger by interrupting AC power for 15+ seconds.
	Battery could not be trickle charged up to minimum voltage.	Check for shorted or damaged cells. Reset the charger by interrupting AC power for 15+ seconds.
	Charger shutdown due to high internal temperature.	Ensure sufficient cooling airflow. Reset the charger by interrupting AC power for 15+ seconds.
	Internal charger fault	Reset the charger by interrupting AC power for 15+ seconds. Return to service depot if fault persists.

Table 7-3. Detailed LED Fault Indications

Flashes	Explanation and Solution
	<p>High Battery Voltage Detected - starting voltage above 2.5V/cell or voltage during charge rose above 2.7V/cell (algorithm dependent).</p> <ul style="list-style-type: none"> - Check that the battery charger voltage is consistent with the battery pack voltage. - Check for wiring errors. - Occasionally a new, fully charged battery pack may cause this condition. Use this pack before charging it again. - Disconnect any other sources during charging. - If this problem does not clear after the battery voltage is measured to be less than 2.5V per cell, contact Delta-Q. - This fault will automatically clear and the charger will restart charging when the voltage drops to within operating range.
	<p>Low Battery Voltage Detected - starting voltage below 0.5V/cell</p> <ul style="list-style-type: none"> - Check the battery and connections to the battery. - Check the nominal battery voltage. Confirm that the nominal battery voltage is the same as the charger voltage. - If this problem does not clear after the battery voltage is measured to be higher than 1V per cell and all connections are good, contact Delta-Q. - This fault will clear automatically when the returns within range.
	<p>Charge Timeout - Indicates the battery failed to charge within the time allowed by the charge algorithm. This could occur if the battery is of larger capacity than the algorithm is intended for. In unusual cases it could mean charger output is reduced due to high ambient temperature. It can also occur if the battery is damaged, old, or in poor condition.</p> <ul style="list-style-type: none"> - Check the battery for damage such as shorted cells and insufficient water. Try the charger on a good battery. - If the same fault occurs on a good battery, check the connections on the battery and connection to AC power, and AC voltage. - Confirm that the nominal battery pack voltage is the same as the battery charger voltage. - If a charger displays this fault on a battery pack, and the pack is of questionable status, reset the charger by disconnecting AC power for 30 seconds, and then reconnect the AC to start a new charge cycle. After a few charge cycles this problem could stop occurring as the pack "recovers." - This fault must be cleared manually by unplugging the AC, waiting 30 seconds and reconnecting the ac power.
	<p>Check Battery - This fault indicates the battery pack could not be trickle charged up to the minimum level required for the normal charge cycle to be started.</p> <ul style="list-style-type: none"> - Check that none of the battery pack connections between modules are reversed or incorrectly connected. - Check that one or more cells in the battery are not shorted. - Confirm that the nominal battery pack voltage is the same as the battery charger voltage. - Try the charger on a good battery. - If this fault occurs the battery pack is likely in poor condition. Try to recover the pack with a charger that can charge the individual batteries - such as an automotive charger. Be sure to set this charger to the appropriate voltage - 6V per 6V battery, 12V per 12V string/battery.
	<p>Over-Temperature: This fault indicates the charger has become too hot during operation and has shut down. This extra fault indication (as opposed to the flashing ammeter described above), indicates an even higher temperature was reached inside the charger. Though not damaging to the charger, charge time will be extended significantly</p> <ul style="list-style-type: none"> - This fault indication will not clear automatically, but the charger will restart charging automatically when the temperature drops. The fault indication must be cleared manually by unplugging the AC power, waiting 30 seconds and reconnecting the AC. - If possible, install the charger in a cooler location or increase cooling airflow to the cooling fins. - Confirm that dirt or mud is not blocking the cooling fins of the charger. If required, clean the charger by rinsing it with a low-pressure hose.
	<p>QuiQ Internal Fault: This fault indicates that the batteries will not accept charge current, or an internal fault has been detected in the charger. This fault will nearly always be set within the first 30 seconds of operation. If it occurs after the charger has started charging normally, be sure to make a note of it.</p> <ul style="list-style-type: none"> - Try to clear the fault by unplugging AC power, waiting 30 seconds and reconnecting the AC. - Check all battery connections. Look for a high resistance connection. The most likely reason for this fault is a fault in the battery such as a bad battery connection, an open cell, or insufficient water. - Other electrical hardware such as contactors, switches, etc. which are badly wired may also cause this fault. - This fault will occur if an internal fuse inside the charger blows. If the green wire is shorted to ground even momentarily this fuse will blow. To check the fuse, measure with an ohmmeter between the green and red wires with the AC disconnected. If a short circuit is not measured, the fuse has blown. Contact Delta-Q - If this fault occurs after battery charging has started, confirm that AC power was not interrupted and that all battery connections are good. - If all battery connections are good, an internal fault has been detected. Contact Delta-Q.

SECTION 7 - BASIC ELECTRICAL INFORMATION & ELECTRICAL SCHEMATICS

Table 7-4. Charger/Converter Troubleshooting

Symptom	Possible Causes and Solutions
No or low output	<ul style="list-style-type: none"> - Input voltage out of range: - 35 - 87V for the 48V model - 50 - 130V for the 72V model - Unit overheating - increase cooling air flow - Short circuit detected - Poor connections - Inspect connections - Converter damaged
No switched output	<ul style="list-style-type: none"> - Switched input voltage out of range: - 8 - 87V for the 48V model - 8 - 130V for the 72V model - Switching input circuit damaged from high voltage - Poor connections - Inspect connections
Turn-on or turn-off delay greater than 3 seconds	<ul style="list-style-type: none"> - Switched input circuit variability - no action required
Wiring or connectors overheating	<ul style="list-style-type: none"> - Wire gauge too small (minimum 18AWG) - More than 18A drawn from single connector

Table 7-5. Other Conditions

Indication	Explanation and Solution
AC on LED lit, charger won't start charging.	<p>Charger has detected a condition that does not allow it to charge</p> <ul style="list-style-type: none"> - This condition is generally corrected by resetting the charger by removing AC power for 30 seconds and reconnecting it.
Excessive battery watering or strong sulphur (rotten egg) smell	<p>Overcharging or high battery temperature. These symptoms are unlikely to be caused by too high a charge current since the maximum charge current of the charger will be small compared to even a moderately sized battery pack. The most likely cause for this problem is incorrect charge algorithm setting and/or high ambient temperatures.</p> <ul style="list-style-type: none"> - Confirm that the battery pack is not too small - Delta-Q chargers are usually used with batteries larger than 50Ah. - Confirm that the nominal battery voltage matches the charger output voltage. - Confirm the correct battery charge algorithm. If the battery pack is new, the algorithm will need to be changed if the pack is not the same as the old one. Refer to the Product Manual for instructions on how to determine and change the battery charge algorithm. - If the pack is older, it is possible sulphation has taken root. Increased resistance of the battery pack due to this will cause excessive heat and water usage.
Charger operates at low current only	<p>Delta-Q charge algorithms only operate at a low current, usually 2-5A if the battery voltage is less than 2.0V/cell. This is to slowly recharge an over discharged battery to avoid damaging it.</p> <ul style="list-style-type: none"> - Check the battery pack voltage, if it is <2.0V/cell then this low current is normal.
Charger restarts automatically	<p>There are two features of algorithms that may cause this:</p> <ul style="list-style-type: none"> - Maintenance Mode - charger automatically restarts after 14d or 30d, or when the battery voltage falls below 2.08V/cell or 1.5V/cell. These settings are algorithm dependent. - Battery overvoltage - If the battery is very resistive, sometimes in new batteries, the voltage may rise so quickly the charger trips off due to overvoltage. It will then restart the charge cycle when the voltage falls back into range.
Difficulty changing the default battery charge algorithm	<ul style="list-style-type: none"> - The mode to change the battery charge algorithm can only be selected during the first 10 seconds of operation. Refer to the Product Manual for instructions. - If the 10 second window is missed, cycle AC power by unplugging the charger, waiting 30 seconds, and reconnecting AC power. - To extend Battery Charge Algorithm Change Mode by 30 seconds (120 seconds on newer models), connect the charger output to a good battery for approximately 1 second and then disconnect the battery again.

Table 7-6. Part Number Reference

JLG Part Number	Factory Set Algorithm	Delta-Q Part Number
1001222359	143	912-8400-04
1001222360	222	912-8400-05

Table 7-7. Charging Profile (Algorithm) Matrix

	Description	Optimized Battery	JLG Part Number	Approved Battery Manufacturers	Other Tested Batteries	May be Compatible with*
#143	Discover AGM (200-400Ah), temperature compensated	Discover AGM	1001102534	DISCOVER EVL16A-A	N/A	200-400Ah AGM
#222	Discover EV4DA-A battery	Discover AGM	1001231249	Discover EV4DA-A	N/A	

Go to Discount-Equipment.com to order your parts

Instructions for using the Delta-Q QuiQ Programmer CT QuiQ Programming Kit



CONTENTS OF THE QUIQ PROGRAMMING KIT (JLG PART NUMBER: 2915230)

- - QuiQ USB Interface Module
- - QuiQ Programmer CT Installation CD
- - USB Cable
- - Wire Assembly
- - QuiQ Programmer CT Instructions

Figure 7-51. QuiQ Programming Kit

With QuiQ Programmer CT you can:

- - Add a battery charge algorithm
- - Select a different algorithm for battery charging
- - Delete a battery charge algorithm
- - Upgrade the software in your QuiQ or QuiQ-dci charger
- - View charge tracking data from charger
- - Upload Charge Events to Delta-Q's Online Charge Event Database

INSTALLING QUIQ PROGRAMMER CT SOFTWARE AND DRIVERS

You will find the QuiQ Programmer CT application on the QuiQ Programmer CT installation CD. QuiQ Programmer CT requires a PC with a minimum of 512 MB of RAM, running 32-bit or 64-bit edition of Windows XP, Vista, or 7.

To install QuiQ Programmer CT Insert the QuiQ Programmer Installation CT CD into the CD or DVD drive of your PC (label must be facing up). If the setup application does not launch the QuiQ Programmer CT installer automatically (this will depend on your computer's security settings and configuration), click the Start button (or  icon) on the taskbar; click My Computer; double click the drive labeled QuiQ Programmer CT; double click Setup.exe to launch the installer. You may also use Windows Explorer to navigate to Setup.exe. Then follow the instructions on your screen to complete the software installation.

NOTE: If your computer is running Windows XP Professional 64-bit, you must install x64 .NET Framework 2.0 before installing QuiQ Programmer CT. You will find x64 .NET Framework 2.0 on the CD in the subfolder Net64Fx. Double click Net64Fx.exe to start installing the software.

Connecting a QuiQ Charger to your Computer

⚠ WARNING

CHARGER OUTPUTS GREATER THAN 40VDC POSE AN ENERGY AND/OR SHOCK HAZARD UNDER NORMAL USE. DO NOT ENERGIZE CHARGER WITH AC UNTIL WIRE ASSEMBLY CLIPS ARE SECURELY CONNECTED TO CHARGER OUTPUT, AND ALL LEADS ARE SECURED AGAINST MOVEMENT.

⚠ WARNING

ENSURE THE BATTERY LEADS FROM THE USB INTERFACE MODULE ARE PROTECTED FROM SOURCES OF ELECTROSTATIC DISCHARGE THAT MAY DAMAGE THE UNIT.

To connect a QuiQ charger to your computer:

NOTE: QuiQ Programmer CT must be installed on your computer before you connect a QuiQ charger.

1. Disconnect AC power from the QuiQ charger.
2. Disconnect the QuiQ charger from all batteries.
3. Connect the Wire Assembly red clip to the charger positive wire (red).

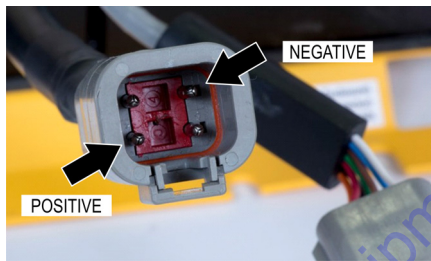

4. Connect the Wire Assembly black clip to the charger negative wire (black).



5. Connect the Wire Assembly to the QuiQ USB Interface Module.



6. Connect the USB cable upstream end to an open USB port on your PC.



7. Connect the USB cable downstream end to the QuiQ USB Interface Module.



8. Upon connection, Windows will detect the QuiQ USB Interface Module and install drivers for it. If Windows does not detect the QuiQ Module you will need to reinstall QuiQ Programmer CT. See section Installing QuiQ Programmer CT Software and Drivers.
9. Connect the QuiQ charger to AC power.

NOTE: For a reliable connection, ensure that the bare leads do not touch each other or other metallic objects.

Starting QuiQ Programmer CT

START APPLICATION IN USER MODE

1. To start QuiQ Programmer CT, select Program/QuiQ Programmer CT/QuiQ Programmer CT from the Start Menu.
2. If your installation has not been registered with a license key, starting the application in User Mode is the only option. First select the Dongle you wish to connect in the COM Setting dialog.

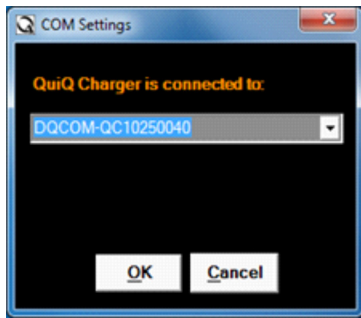

3. Then, the QuiQ Programmer CT starts. If your installation has been registered with a license key, then upon starting the application the login dialog appears:



Click on "Cancel" to start the application in User Mode.

4. The QuiQ Programmer CT interface will appear. The connection status area at the bottom of the window will indicate if the QuiQ USB Interface Module is properly connected to your PC and the QuiQ charger.



If the connection area displays Status: No Connection, then QuiQ Programmer is unable to communicate with your charger. This may be due to one of the following:



- The charger is not connected to the PC. Ensure that all wires are connected (see section Connecting a QuiQ Charger to your Computer).
- The wrong COM port was chosen. Exit QuiQ Programmer CT; restart QuiQ Programmer CT and choose the correct COM port (see step 2 above).
- The USB connection may be temporarily disabled. Exit QuiQ Programmer CT; disconnect the USB cable from your PC; wait 5 seconds, then re-connect the USB cable to your PC. Start QuiQ Programmer CT and choose the correct COM port. See Starting QuiQ Programmer step 2.
- The charger is not connected to an AC power source. Ensure that the charger is connected to AC.
- The QuiQ USB Interface Module driver was installed incorrectly. Exit QuiQ Programmer CT. Disconnect the QuiQ USB Interface Module USB cable from your PC. Remove QuiQ Programmer software from your computer. Reinstall QuiQ Programmer CT.

Programming Delta-Q QuiQ and QuiQ-dci Chargers

Click on the Charger Status tab to activate the Charger Status tab. Then click Browse, to select the folder on your PC containing the QuiQ charger software and algorithms.

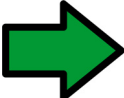

Table 7-8. Programming Delta-Q QuiQ and QuiQ-dci Chargers

What do you want to do?	Icon	Action
Add a charge algorithm to the charger		In the Battery Charge Algorithms list, on the QuiQ Programmer CT user interface, select the algorithms that you want to add to the charger; click the Add to Charger icon.
Upgrade the charger software		In the Charger Software Versions list, on the QuiQ Programmer CT user interface, select the software version that you want to add to the charger; click the Add to Charger icon. Software may take up to 90 seconds to load.
Select a different default algorithm		In the Algorithms Present list on the QuiQ Programmer CT user interface, select the algorithm that you want to set as the default charge algorithm; click Set as Default icon.
Delete an algorithm from the charger		In the Algorithms Present list on the QuiQ Programmer CT user interface, select the algorithms that you want to delete from the charger; click the Delete from Charger icon. Note: You cannot undo an algorithm deletion.
Tip: To select two or more items one after the other in a list, select the first item, press and hold down the SHIFT key on your keyboard, then select the last item. To select two or more items in a list that may not be one after the other, press and hold down the CTRL key, and select the items.		

View Charge Tracking Data with QuiQ Programmer CT

Requirement: To view the charge tracking data in your charger, your charger must have version 3.X software. Note that only chargers with serial number beginning with "DQCM" may have version 3.X software programmed in it.

Start Application in User Mode

- Click on the Charge Event Database tab. This will display the Charger Summary Dialog for that summarizes charge data for the connected charger.

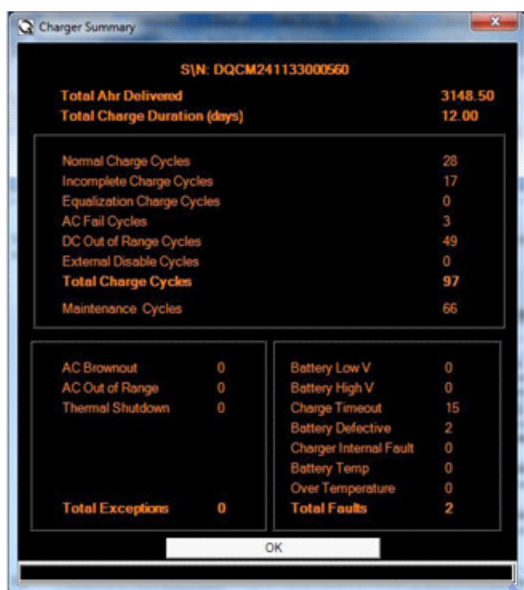

Selecting a Charge Profile

Delta-Q's QuiQ Charger can store up to 10 charging profiles, also called charge algorithms. This section shows how to identify the default profile and select a new profile using the "tap method."

QuiQ chargers are reprogrammable using the QuiQ Programmer supplied by Delta-Q to its OEM partners. Pre-2006 QuiQ chargers with serial number prefix DQCP allow pre-loaded profiles to be selected, but cannot be reprogrammed with new profiles.

IDENTIFY THE DEFAULT PROFILE

1. Required supplies include an insulated wrench, eye protection and gloves.



2. Disconnect the AC power source from the charger, either from the wall outlet, or from the IEC320 connector on the charger.
3. Disconnect power from the batteries using the battery disconnect on the side of the machine.
4. Reconnect AC power.
5. For 11 seconds after the self-test, the charger will display its default charge profile. Profiles are indicated by the number of consecutive flashes followed by a pause

(e.g. #2 = ).

5b. Charge profiles in the double digits will display in the same way, by one or more flashes, a pause, then one or more flashes

(e.g. #42 = )

6. After 11 seconds the red fault light will then blink.

SELECT A NEW PROFILE

1. Disconnect the AC power source from the charger, either from the wall outlet, or from the IEC320 connector on the charger.
2. Reconnect AC power.
3. Touch the positive lead to the positive terminal for 3 seconds (+/- 0.5 seconds), then remove the lead. You will see the next profile displayed on the charger's display. Repeat this step until you reach the desired charge profile.
4. When the charger displays the desired charge profile, apply the positive lead to the positive battery terminal for 10 seconds. When the charge profile is locked, you will hear a click from the charger.
5. Disconnect AC power, wait for the LED indicator display to turn off, then reconnect AC power.
6. Check the LED display to ensure that the desired charge profile is selected.
7. Disconnect the charger from AC power and wait for the LED indicator display to turn off.
8. Reconnect the positive lead to the positive battery terminal.

Battery Testing

As part of regular maintenance, battery testing using a discharge tester or calibrated load is recommended. Battery condition can be determined by comparing actual discharge capacity versus a battery manufacturer's stated reserve capacity (RC). Discharge testing can also help identify defective batteries or cells in battery packs which need attention. Industry standard battery discharge machines use the following rates of discharge to measure battery capacity:

Battery Pack Size (Nominal)	24V	36V	48V
Discharge Rate (Amps)	75	75	56
Cutoff Voltage (1.75Vpc)	21	31.5	42

PROCEDURE:

- Using Delta-Q charger, fully charge the battery pack (indicated by solid green 100% LED)
- Using a discharge tester/load rated for the nominal battery pack size, discharge the pack at a rate appropriate for the type of battery modules in use (see chart above) until the pack voltage reaches 1.75 volts per cell (see chart above)
- Compare the duration of the discharge test (in minutes) to the manufacturer's rated reserve capacity for your specific battery make and model. A Trojan T-105 battery reserve capacity specification @75A is shown as an example:

PRODUCT SPECIFICATIONS

BCI GROUP SIZE	TYPE	CAPACITY ¹ Minutes		CAPACITY ² Amp-Hours		
		@25 Amps	@75 Amps	5-Hr Rate	10-Hr Rate	20-Hr Rate
6 VOLT DEEP CYCLE						
GC2	T-105	447	115	185	207	2

There is no set pass/fail criteria for battery discharge times but use the following results as a guide:

- 80 - 100 % rated capacity minutes - Good
- 50 - 80 % rated minutes - Acceptable
- Under 50 % - One or more defective batteries. Battery service recommended

A method used to identify a battery with a weak or shorted cell(s) is to restart a discharge tester after reaching the cutoff voltage. Measure the voltage of each battery with the discharge tester running (or under load). A battery with a weak cell under load will have a lower voltage compared to other batteries in a pack.

7.18 CLEARSKY™ / TELEMATICS GATEWAY

ClearSky™ is a system that communicates with relevant data points on the machine and transmits real-time machine data via cellular for viewing access through the internet. The system consists of a control unit and a GPS antenna. If not equipped, the machine is ClearSky™ ready with locations existing for the control unit and the antenna, as well as wiring connections available for "plug and play" operation.

SECTION 7 - BASIC ELECTRICAL INFORMATION & ELECTRICAL SCHEMATICS

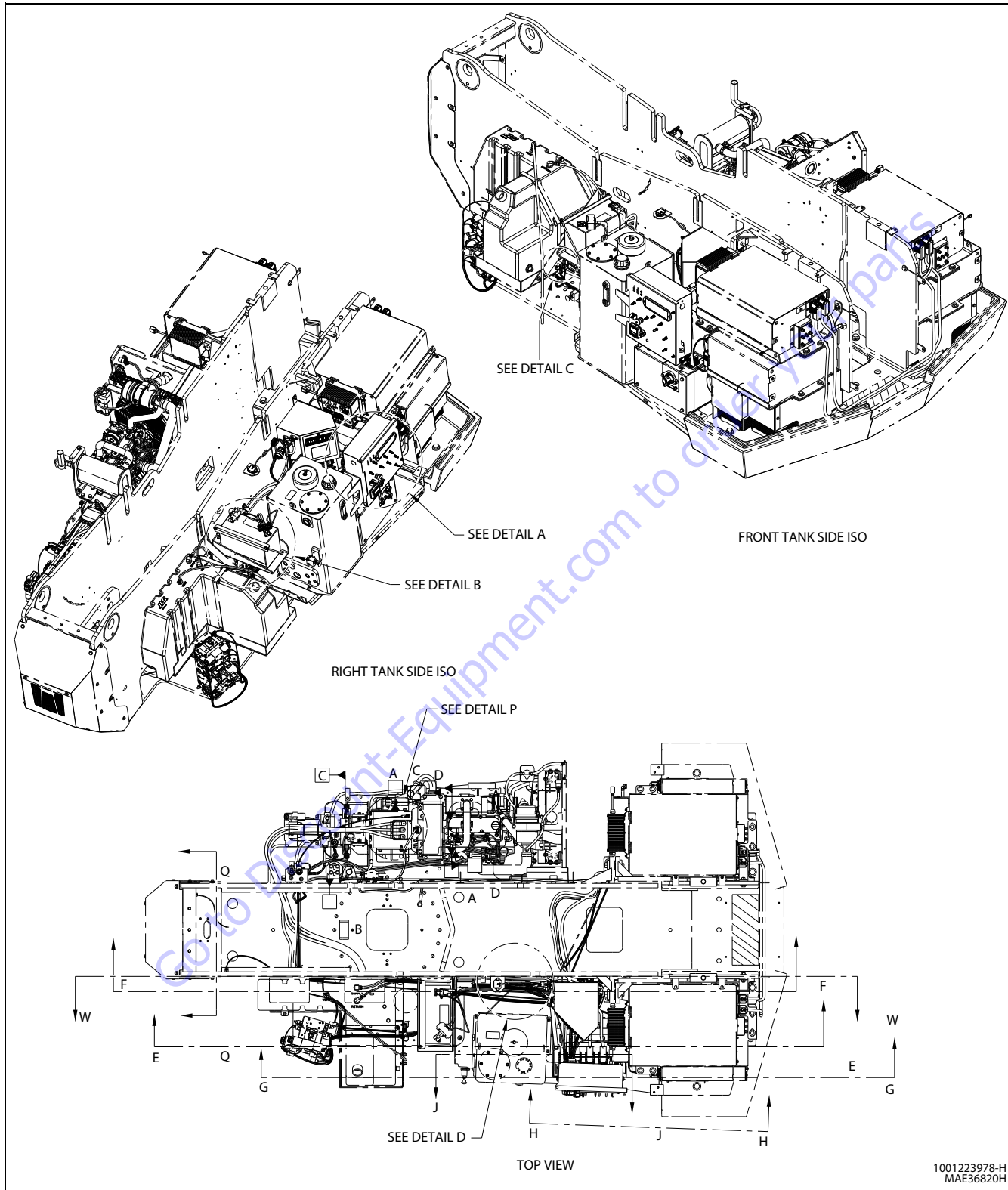

Figure 7-52. Electrical Installation - Sheet 1 of 8

1001223978-H
MAE36820H

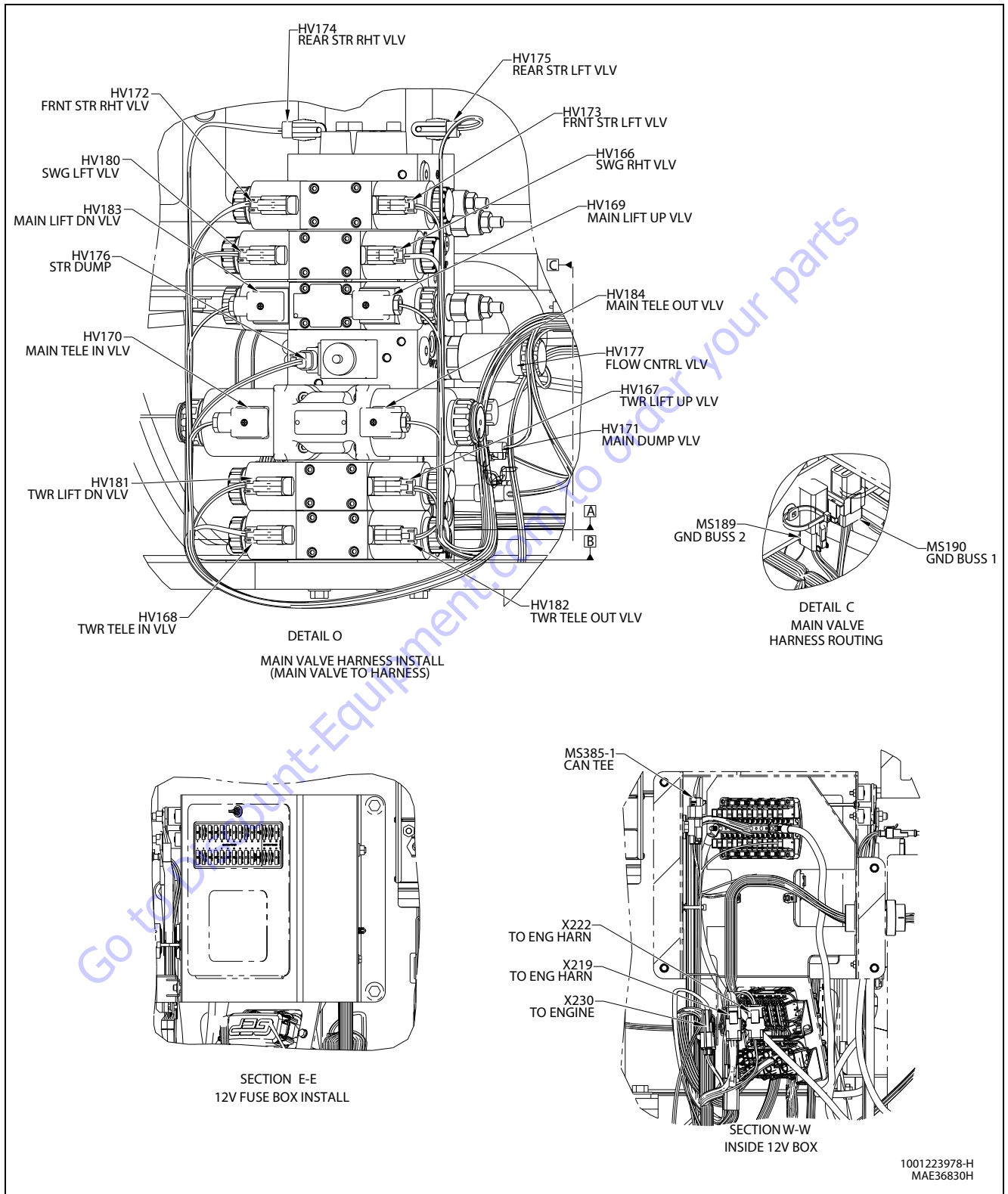

Figure 7-53. Electrical Installation - Sheet 2 of 8

SECTION 7 - BASIC ELECTRICAL INFORMATION & ELECTRICAL SCHEMATICS

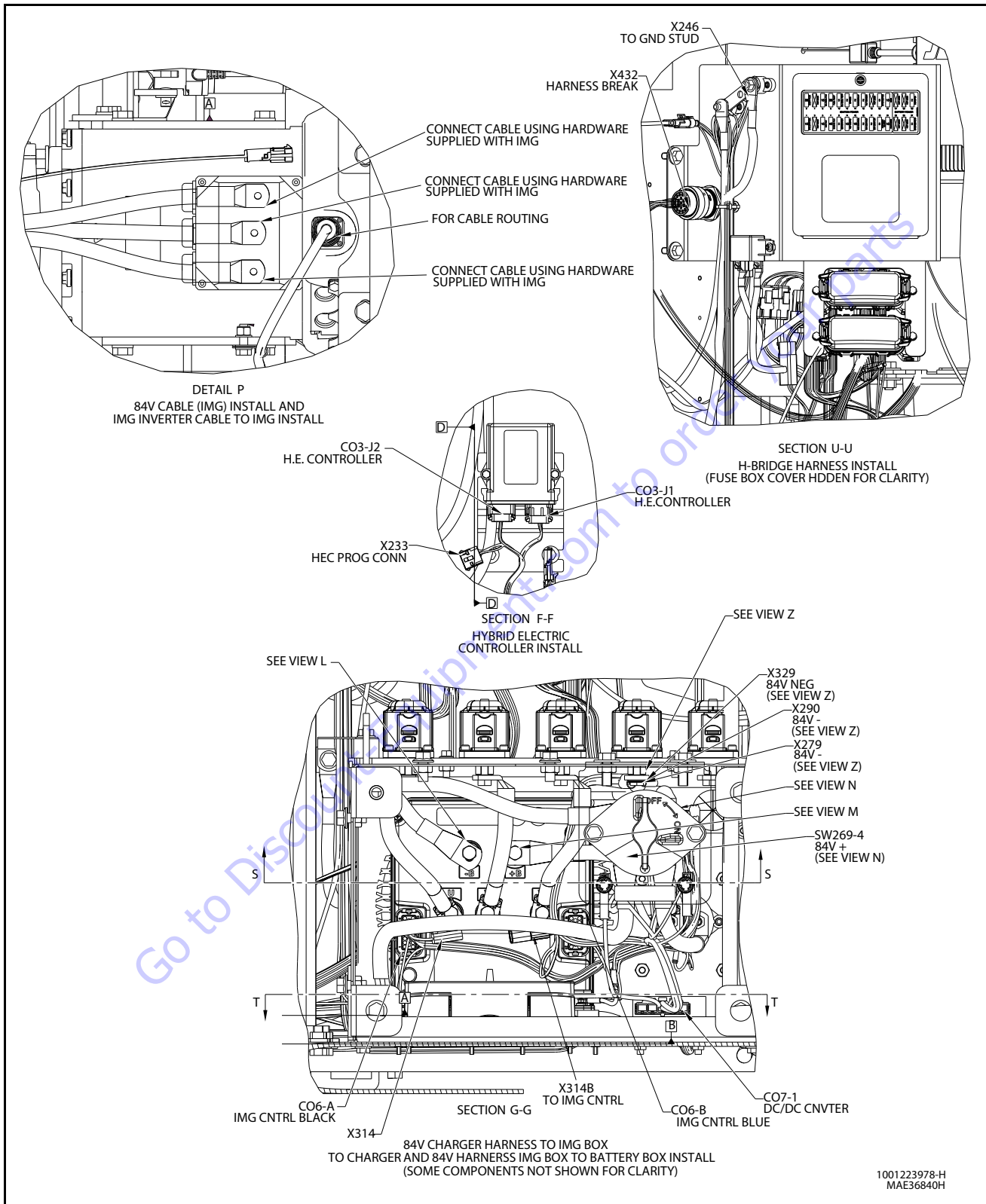

Figure 7-54. Electrical Installation - Sheet 3 of 8

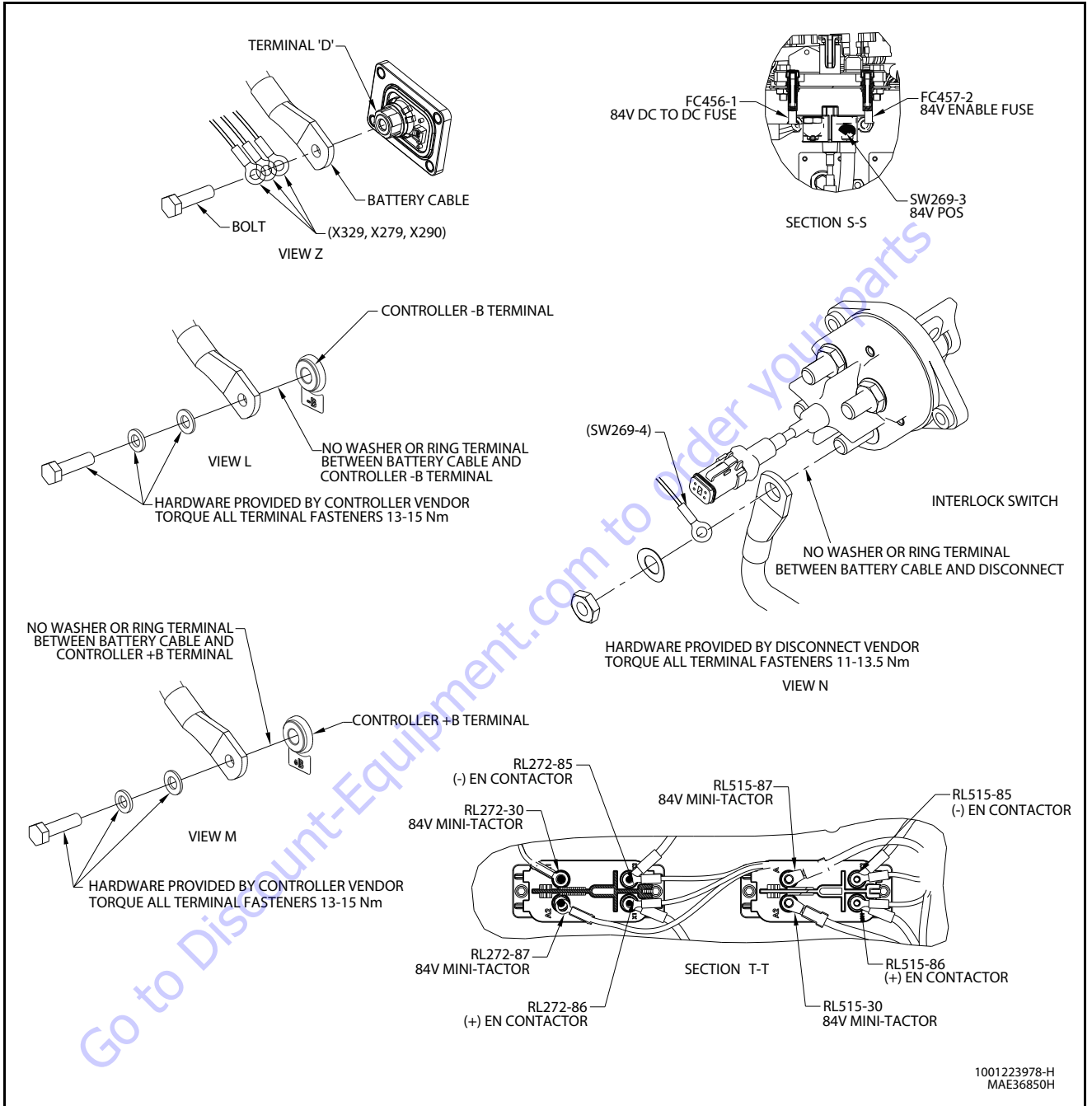

Figure 7-55. Electrical Installation - Sheet 4 of 8

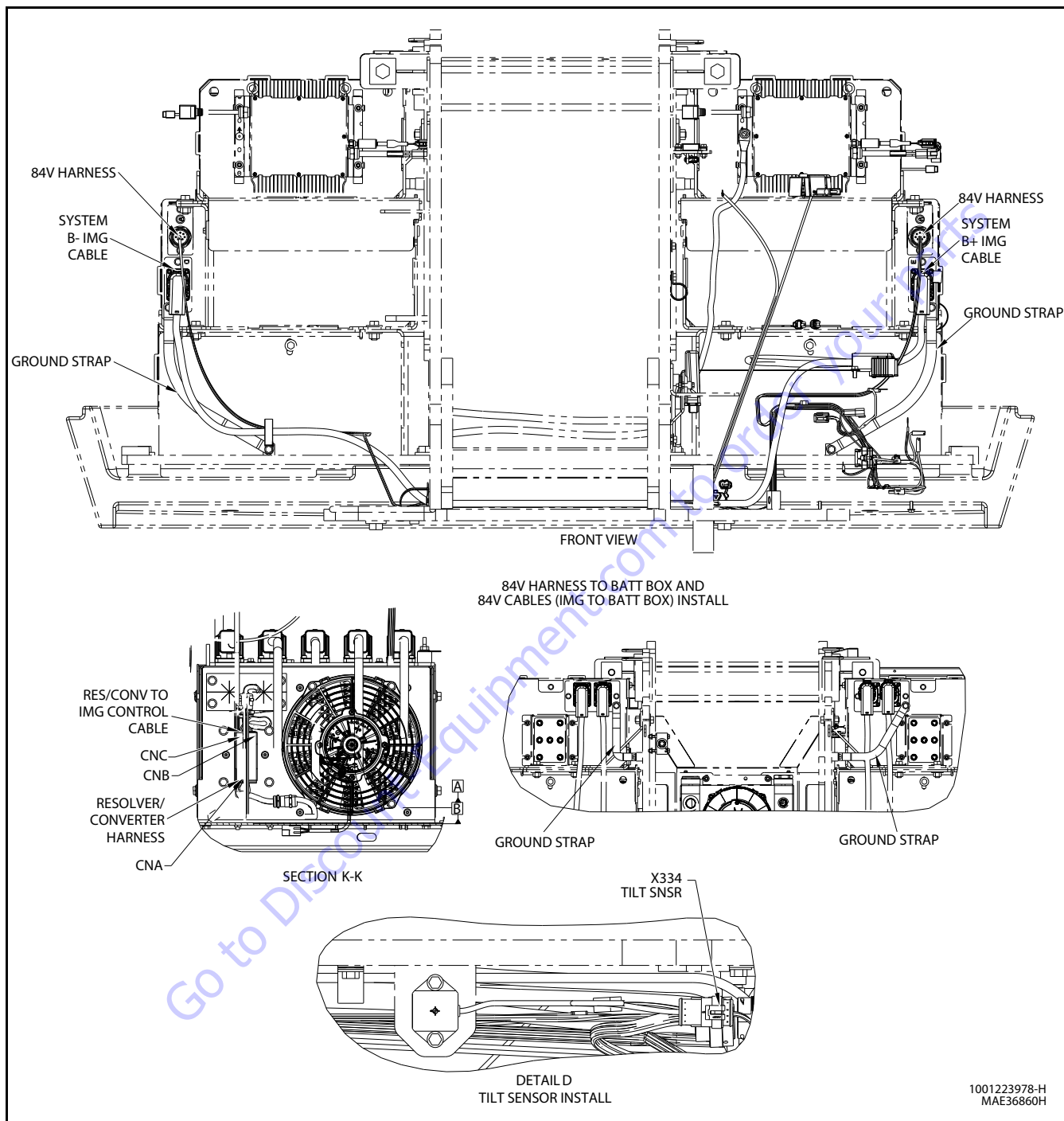

Figure 7-56. Electrical Installation - Sheet 5 of 8

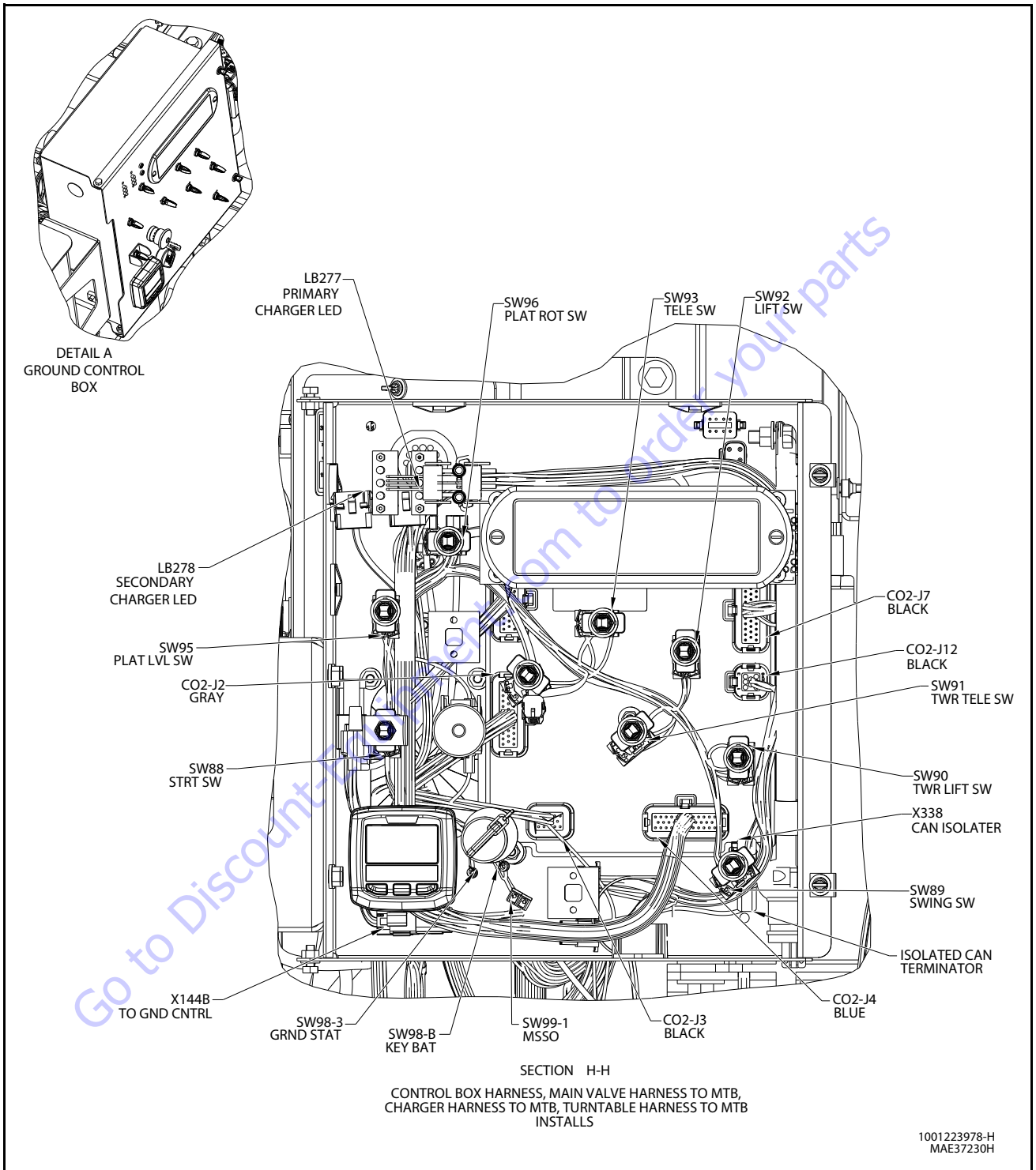

Figure 7-57. Electrical Installation - Sheet 6 of 8

SECTION 7 - BASIC ELECTRICAL INFORMATION & ELECTRICAL SCHEMATICS

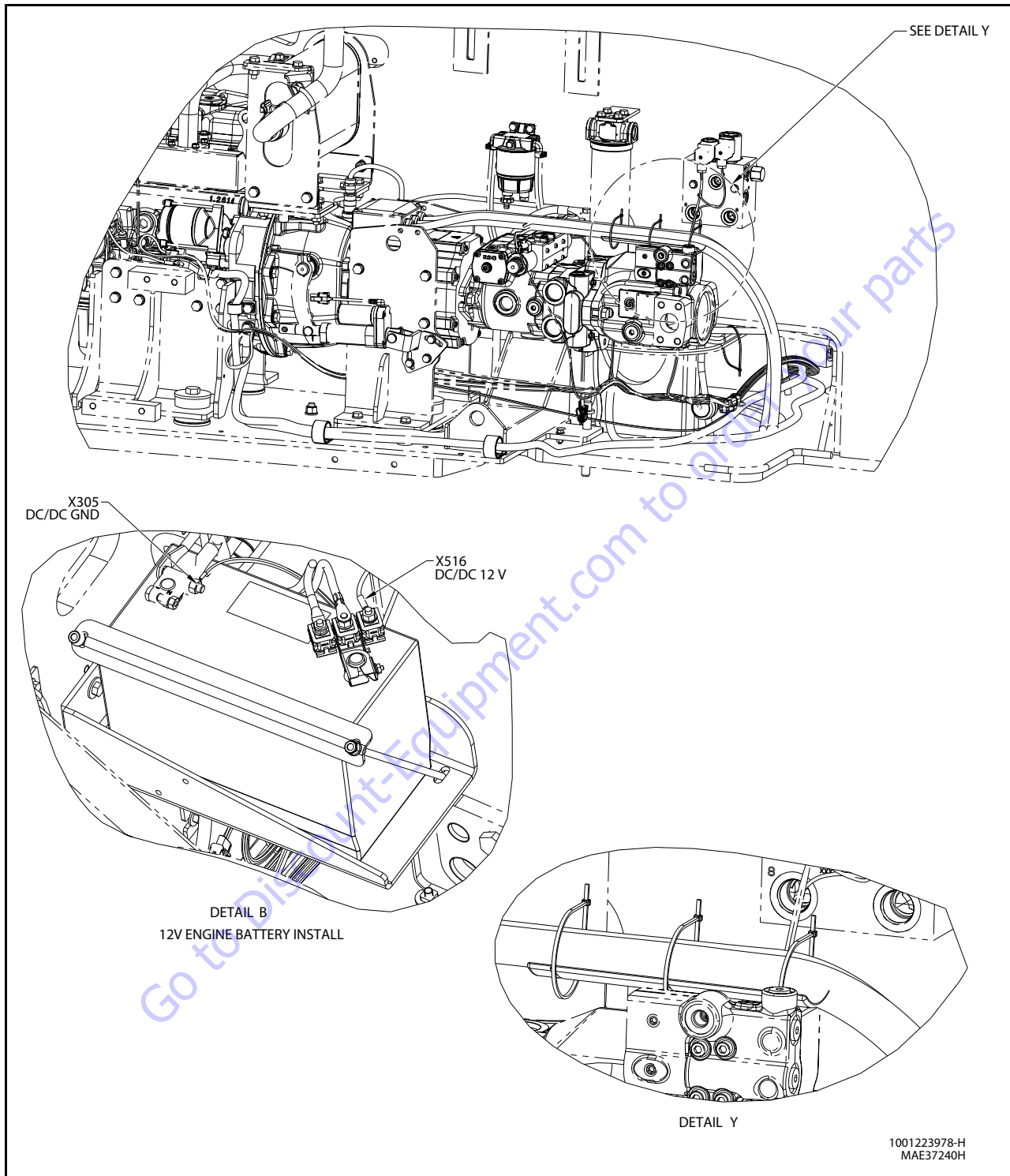

Figure 7-58. Electrical Installation - Sheet 7 of 8

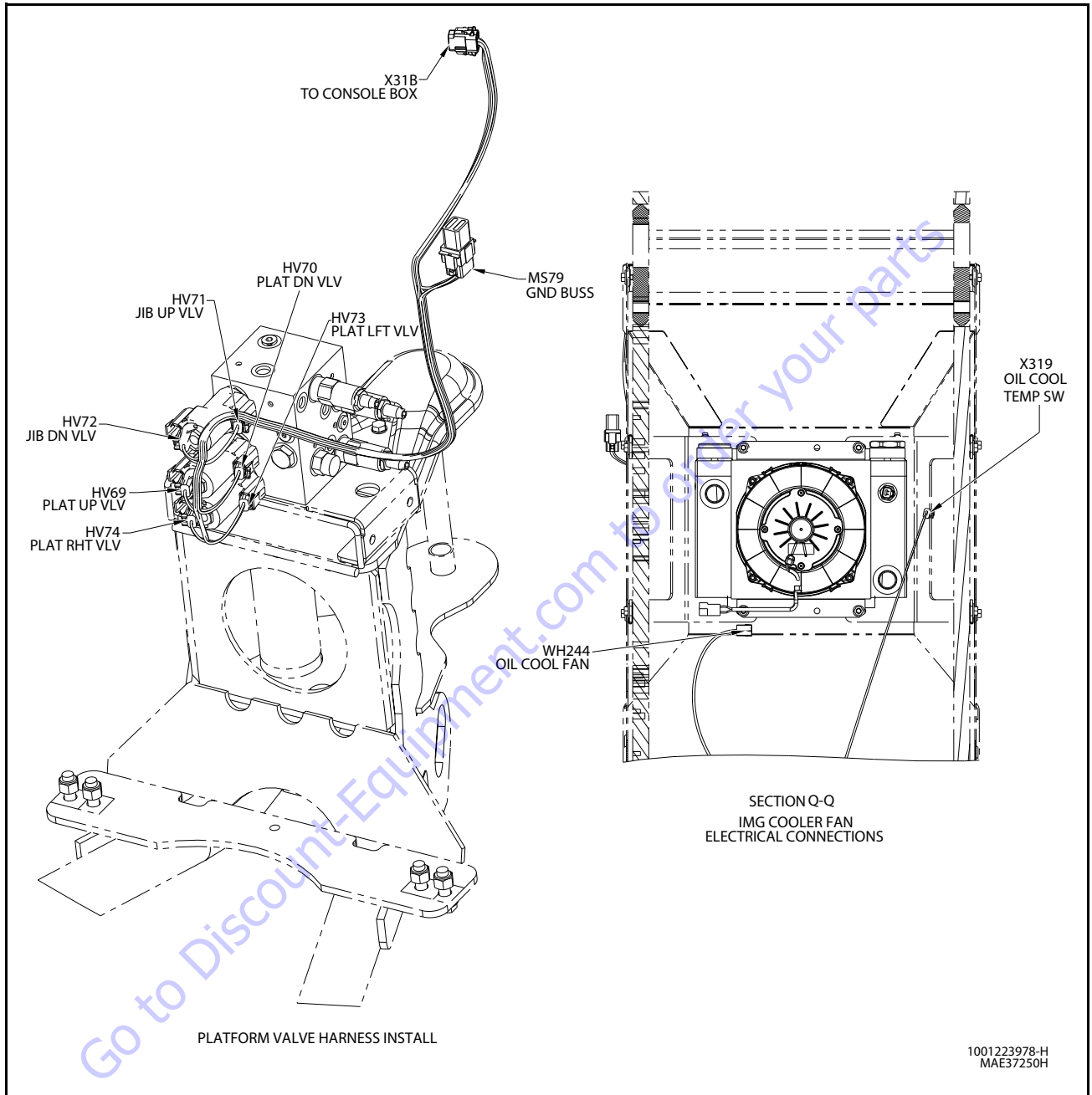

Figure 7-59. Electrical Installation - Sheet 8 of 8

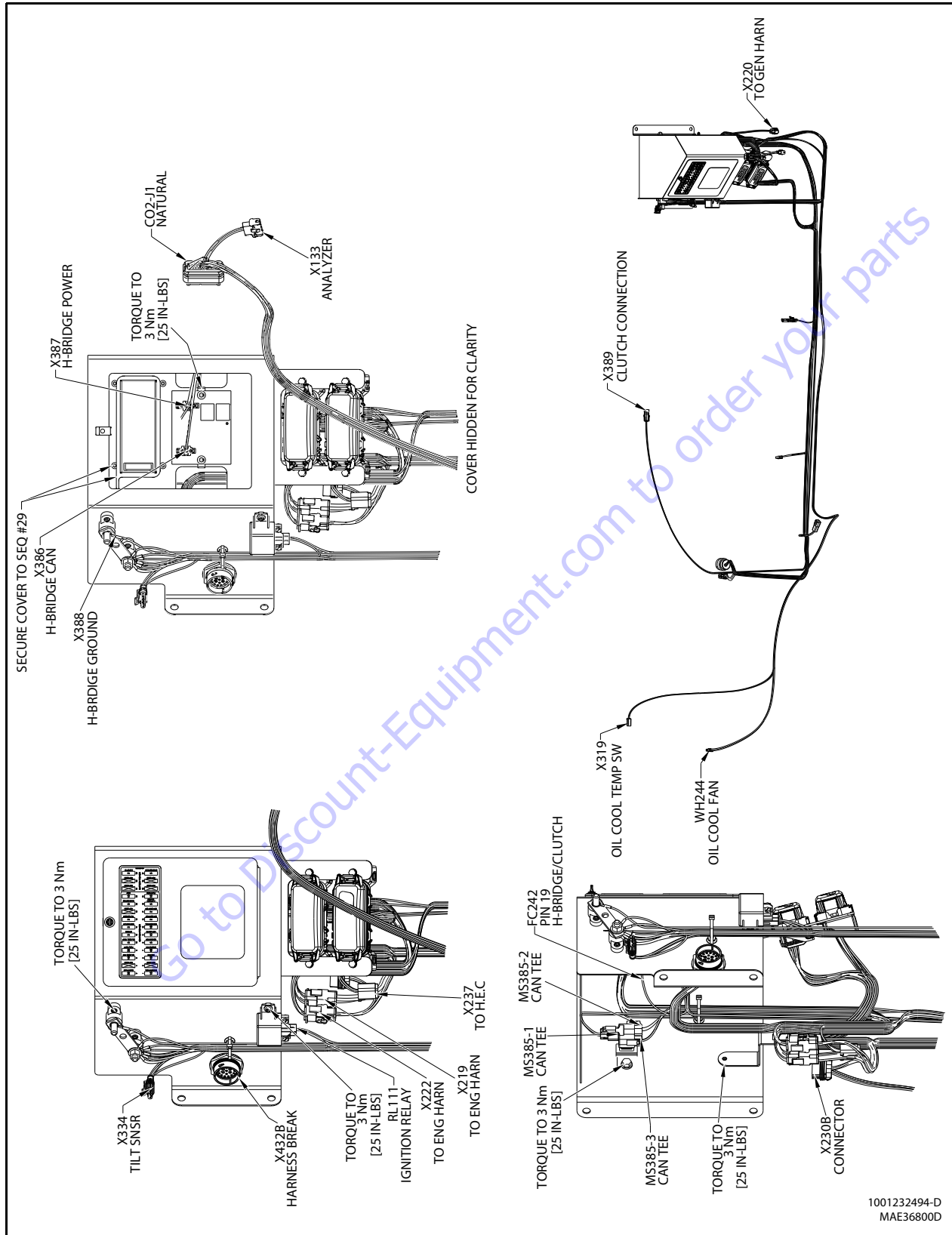

Figure 7-60. Fuse Panel - Sheet 1 of 2

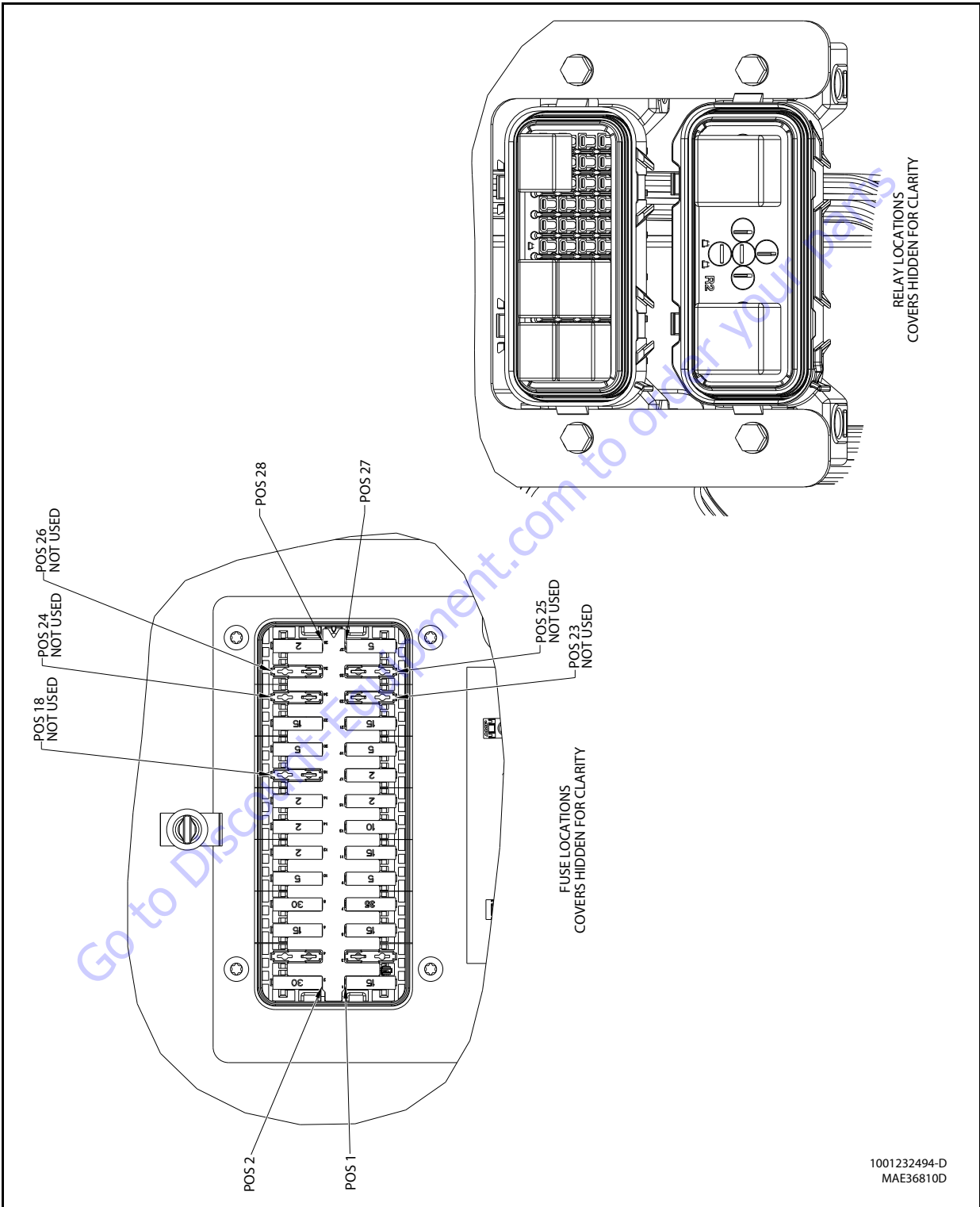

Figure 7-61. Fuse Panel - Sheet 2 of 2

7.19 WIRING HARNESS CONNECTOR LABELS AND WIRING HARNESSES

Connector Labels

Connectors between harnesses are identified by the prefix "X" and a sequentially assigned number. An optional suffix (letters & numbers) may be added when multiple terminations occur at one device or when there are optional connections.

Examples:

X25 connects to X25 in another harness.

X65A, X65B connect to different portions of one device

X163 connects to X163A in ANSI and X163B in CE machines

Component Labels

Every component on the vehicle has a unique identification. A standard prefix letter is assigned according to the table below, followed by a unique sequential number. An optional suffix (letters & numbers) may be added when multiple terminations occur at one device.

Terminals that are not loaded into connectors are considered independent components and labeled in the same fashion.

Table 7-9. Wiring Harness Connector Labels

Component	Category	Label
Audible	Alarms	AH
	Horns	
Battery	Batteries	BT
	Battery Terminals	
Control Module	Ground	CO
	LSS	
	Platform	
Engine	Alternator	EC
	Cold Start	
	Controller	
	Coolant Temp	
	Fuel Pump	
	Fuel Solenoid	
	Glow Plugs	
	Oil Pressure	
Starter		
Fuse & CB Fuse FC	Fuse	FC
	Fusible Link	FC
	Circuit Breaker	CB
Gauge & Display	Board	GD
	Cluster	
	Hour meter	
	LMI	
	Speedometer	
Inline	Resistor	R
	Diode	D
Joystick & Steering	Electronic	JS
	Hydraulic	
Lights	Dome	LB
	Headlights	
	Simple	
	Taillights	
Membrane Panel		MP
Miscellaneous	Radio	MS
	Speakers	
	Splice Blocks	
	T-Connectors	

Table 7-9. Wiring Harness Connector Labels

Component	Category	Label
Other Switches	Disconnect	SW
	EMS	
	Foot	
	HVAC	WH
	Key	SW
	Park brake	
	Pump pot	
	Push	
	Shifter	
	Turn signal	
Relay	5 Pin	RL
	4 Pin	
	Contactors	
	Power module	
Rocker Switch		SW
Sensor	Angle	SN
	Fuel	
	Length	
	Limit	
	Load	
	Pressure	
	Proximity	
	Speed	
	Temperature	
	Terminals	
Sockets		
Male Blades		
Female Blades		
Rings		
Forks		
Toggle Switch	DPDT	SW
	DPST	
	SPDT	
	SPST	
	Special	
Valves	Simple	HV
	Suppression	

Examples:

T67 is a ring terminal connected during installation.
 C01-J3 is the J3 connector for a UGM control module.
 EC9 is a glow plug supplied with the engine

This Page Left Blank Intentionally

Go to Discount-Equipment.com to order your parts

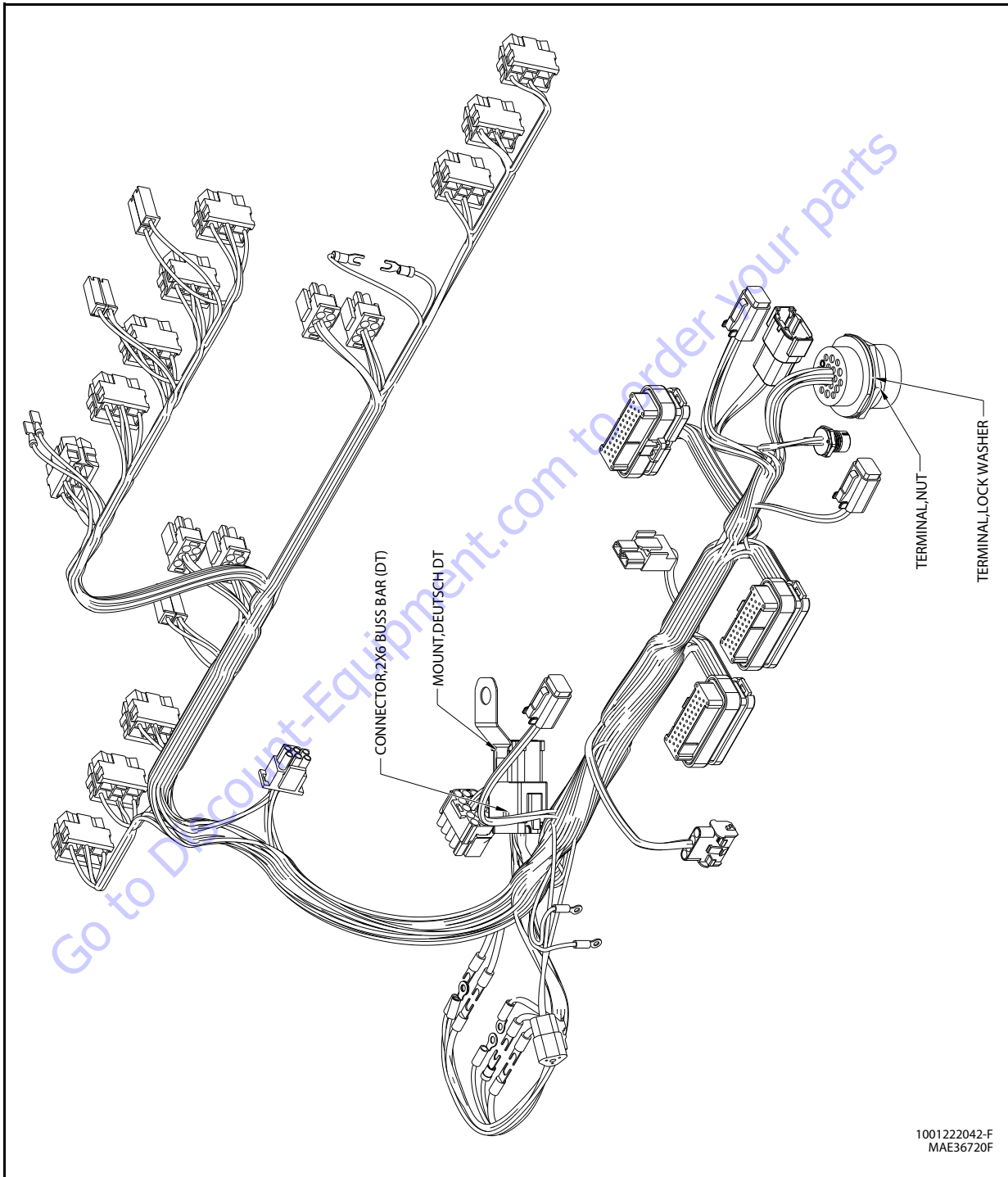

Figure 7-62. Console Box Harness - Sheet 1 of 4

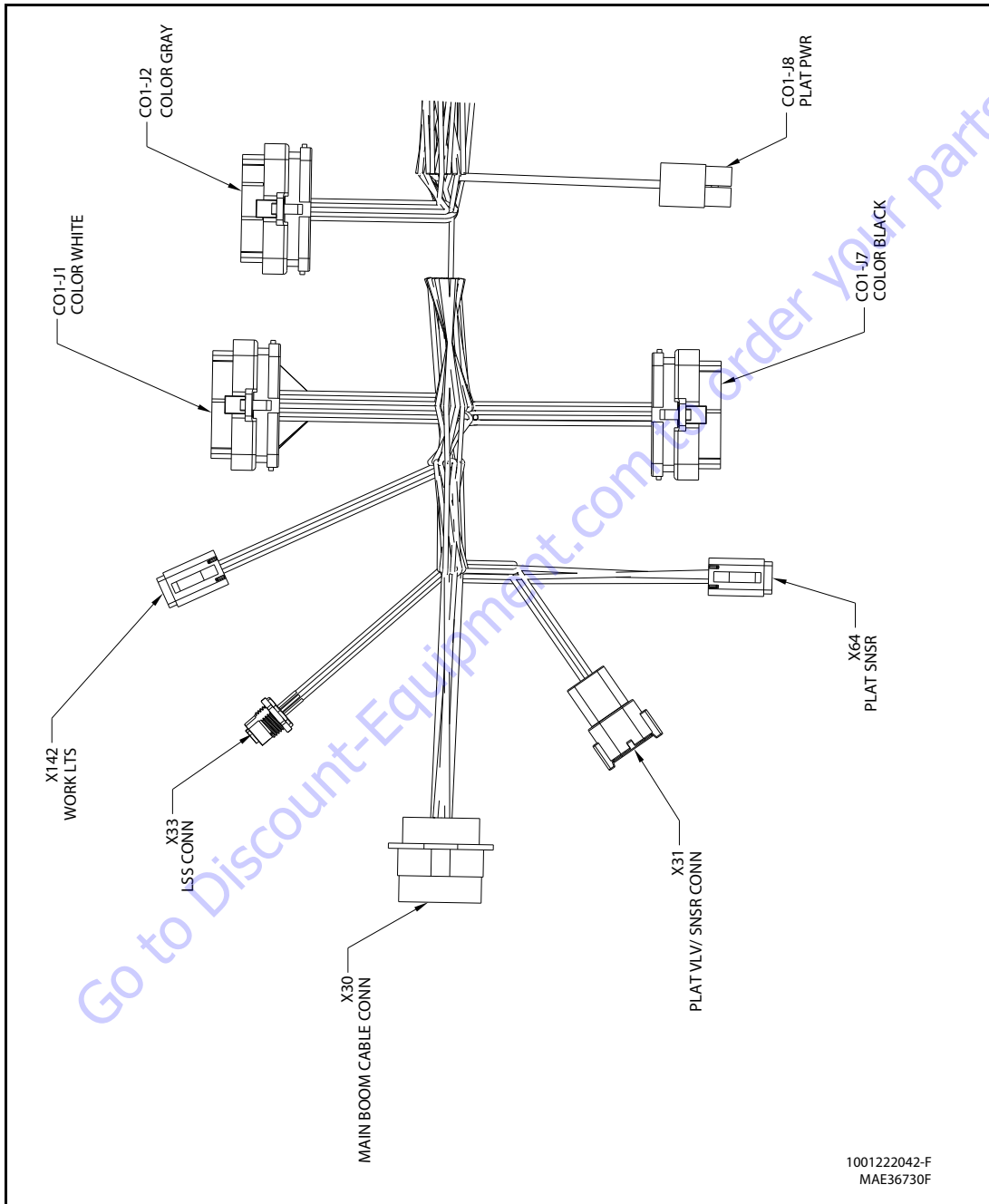

Figure 7-63. Console Box Harness - Sheet 2 of 4

SECTION 7 - BASIC ELECTRICAL INFORMATION & ELECTRICAL SCHEMATICS

C01-J1 COLOR WHITE					
CONN POS	WIRE COLOR	WIRE LABEL	GAUGE	JACKET	TO
1	WHT	5-1TWRUP	18AWG	GXL	SW08(3)
2	WHT	6-1TWRDN	18AWG	GXL	SW08(1)
3	WHT	7-1TWRIN	18AWG	GXL	SW09(1)
4	WHT	8-1TWR0UT	18AWG	GXL	SW09(3)
5	WHT	9-1TELEIN	18AWG	GXL	SW10(3)
6	WHT	10-1TELEOUT	18AWG	GXL	SW10(1)
7	WHT	11-1PLATRHT	18AWG	GXL	SW11(3)
8	WHT	12-1PLATLFT	18AWG	GXL	SW11(1)
9	WHT	13-1PLATUP	18AWG	GXL	SW12(3)
10	WHT	14-1PLATDN	18AWG	GXL	SW12(1)
11	WHT	15-1JIBUP	18AWG	GXL	SW13(3)
12	WHT	16-1JIBDN	18AWG	GXL	SW13(1)
13	BLK	0-1	18AWG	GXL	SW24(5)
14	WHT	48-1ENGSTRT	18AWG	GXL	SW14(1)
15	WHT	48-29HYBSYSEN	18AWG	GXL	SW14(3)
16	WHT	17-1CRBSTR	18AWG	GXL	SW21(1)
17	WHT	18-1COORSTR	18AWG	GXL	SW21(3)
18	YEL	2-1	18AWG	GXL	SW16(2)
19					
20	WHT	55-6SOFTTOUCH	18AWG	GXL	X64(6)
21	WHT	49-31RESTRICTED	18AWG	GXL	SW17(3)
22	WHT	50-2DOSENABLE	18AWG	GXL	C01-J2(30)
23	WHT	65-2PLATINPUT2	18AWG	GXL	X64(5)
24					
25					
26					
27	WHT	46-1MAXSPD	18AWG	GXL	SW22(3)
28	WHT	46-2MAXTORQ	18AWG	GXL	SW22(1)
29	WHT	55-1S.T./SKYG	18AWG	GXL	SW45-2(1)
30	WHT	55-2HEAD/TAILLT	18AWG	GXL	SW26-2(1)
31	WHT	19-1HORN	18AWG	GXL	SW25-2(1)
32	WHT	20-1CREEP	18AWG	GXL	SW24(2)
33					
34	WHT	20-37VPWR	18AWG	GXL	SW24(4)
35	WHT	20-2FUNCSPD	18AWG	GXL	SW24(6)

X30 MAIN BOOM CABLE CONN					
CONN POS	WIRE COLOR	WIRE LABEL	GAUGE	JACKET	TO
1					
2	GRN	CH1TOMS29	18AWG	GXL	MS29(6)
3	YEL	CH1TOMS29	18AWG	GXL	MS29(3)
4	YEL	2-12-1-1	18AWG	GXL	C01-J7(3)
5	YEL	2-13	18AWG	GXL	SW18-2(2)
6					
7					
8					
9					
10	YEL	2-14-2-2	12AWG	GXL	X53(1)
11	WHT	49-11GNDMODE	18AWG	GXL	C01-J7(1)
12	YEL	2-14-2-1	12AWG	GXL	X54(1)
13					
14					
15					
16	BLK	0-6-2	12AWG	GXL	X50(1)
17					
18	BLK	0-6-1	12AWG	GXL	X49(1)
19					

SECTION 7 - BASIC ELECTRICAL INFORMATION & ELECTRICAL SCHEMATICS

C01-J2 COLOR GRAY					
CONN POS	WIRE COLOR	WIRE LABEL	GAUGE	JACKET	TO
1					
2					
3					
4	WHT	50-1 DOS	18AWG	GXL	SW16(1)
5					
6	WHT	49-1 TILT LT	18AWG	GXL	GD20-J4(5)
7	WHT	49-2 ENABLE LT	18AWG	GXL	GD20-J2(2)
8	WHT	49-3 SYS FAIL	18AWG	GXL	GD20-J3(6)
9	WHT	20-4 CREEP LT	18AWG	GXL	GD20-J2(1)
10					
11	WHT	49-5 OVER LOAD LT	18AWG	GXL	GD20-J4(3)
12					
13					
14	WHT	50-3 DOS LT	18AWG	GXL	GD20-J3(3)
15	WHT	55-3 GEN LT	18AWG	GXL	GD20-J4(2)
16	WHT	55-4 S.T/SKYG LT	18AWG	GXL	LB27+(1)
17	WHT	48-2 GLOW LT	18AWG	GXL	GD20-J4(6)
18	BLK	0-2	18AWG	GXL	GD20-J2(6)
19	WHT	48-35 LOW FUEL	18AWG	GXL	GD20-J3(1)
20	WHT	49-4 BOOM MALF	18AWG	GXL	GD20-J3(5)
21	WHT	48-3 LOW BATT LT	18AWG	GXL	GD20-J2(3)
22	WHT	48-4 1/4 BATT	18AWG	GXL	GD20-J1(1)
23	WHT	48-5 3/4 BATT	18AWG	GXL	GD20-J1(3)
24	WHT	48-6 1/2 BATT	18AWG	GXL	GD20-J1(2)
25	BLK	0-3	18AWG	GXL	GD20-J1(4)
26	WHT	4-1 9.5 VPWR	18AWG	GXL	X28(1)
27	BLK	0-4	18AWG	GXL	X28(4)
28	WHT	4-2 RX	18AWG	GXL	X28(2)
29	WHT	4-3 TX	18AWG	GXL	X28(3)
30	WHT	50-2 DOS ENABLE	18AWG	GXL	C01-J1(22)
31					
32					
33					
34					
35	WHT	48-7 BATT FULL	18AWG	GXL	GD20-J1(6)

X33 LSS CONN					
CONN POS	WIRE COLOR	WIRE LABEL	GAUGE	JACKET	TO
1					
2	WHT	2-7	20AWG	CABLE	C01-J7(7)
3	BLU	0-9	20AWG	CABLE	C01-J7(14)
4	BLK	CH1 TO X33	20AWG	CABLE	MS29(2)
5	GRY	CH1 TO X33	20AWG	CABLE	MS29(5)

X64 PLAT SNSR					
CONN POS	WIRE COLOR	WIRE LABEL	GAUGE	JACKET	TO
1	YEL	2-3-4	18AWG	GXL	X57(1)
2	BLK	0-6-3	18AWG	GXL	X60(1)
3	WHT	55-6-1 SOFT TOUCH	18AWG	GXL	X47(13)
4	WHT	65-1 PLAT INPUT1	18AWG	GXL	C01-J7(18)
5	WHT	65-2 PLAT INPUT2	18AWG	GXL	C01-J1(23)
6	WHT	55-6 SOFT TOUCH	18AWG	GXL	C01-J1(20)

SECTION 7 - BASIC ELECTRICAL INFORMATION & ELECTRICAL SCHEMATICS

C01-J8 PLATPWR					
CONN POS	WIRE COLOR	WIRE LABEL	GAUGE	JACKET	TO
1	BLK	0-6	12AWG	GXL	X59(1)
2	YEL	2-3	12AWG	GXL	X55(1)

X142 WORKLTS					
CONN POS	WIRE COLOR	WIRE LABEL	GAUGE	JACKET	TO
1	BLK	0-6-5	18AWG	GXL	X51(1)
2	YEL	2-3-6	18AWG	GXL	X52(1)
3	BLK	0-6-6	18AWG	GXL	X51(1)
4	YEL	2-3-7	18AWG	GXL	X52(1)

X31 PLATVLV/SNSRCONN					
CONN POS	WIRE COLOR	WIRE LABEL	GAUGE	JACKET	TO
1	WHT	16-2JIBDNV LV	18AWG	GXL	C01-J7(26)
2	WHT	12-2PLATLFTV LV	18AWG	GXL	C01-J7(33)
3	WHT	11-2PLATRHTV LV	18AWG	GXL	C01-J7(34)
4					
5	BLK	0-12	16AWG	GXL	C01-J7(23)
6	WHT	14-2PLATDNV LV	18AWG	GXL	C01-J7(22)
7	WHT	13-2PLATUPV LV	18AWG	GXL	C01-J7(21)
8	WHT	15-2JIBUPV LV	18AWG	GXL	C01-J7(25)

C01-J7 COLORBLACK					
CONN POS	WIRE COLOR	WIRE LABEL	GAUGE	JACKET	TO
1	WHT	49-11GN DMODE	18AWG	GXL	X30(11)
2	YEL	2-13	18AWG	GXL	SW18-1(1)
3	YEL	2-12-1-1	18AWG	GXL	X30(4)
4	YEL	2-5	18AWG	GXL	X47(8)
5	YEL	2-4	18AWG	GXL	X47(2)
6					
7	WHT	2-7	20AWG	CABLE	X33(2)
8	WHT	49-9PLATFTSW	18AWG	GXL	X47(7)
9	WHT	55-5GEN	18AWG	GXL	X47(1)
10					
11					
12					
13					
14	BLU	0-9	20AWG	CABLE	X33(3)
15					
16					
17					
18	WHT	65-1PLATINP UT1	18AWG	GXL	X64(4)
19	WHT	49-8ALARM	18AWG	GXL	AH48+(1)
20	BLK	0-5	18AWG	GXL	AH48-(1)
21	WHT	13-2PLATUPV LV	18AWG	GXL	X31(7)
22	WHT	14-2PLATDNV LV	18AWG	GXL	X31(6)
23	BLK	0-12	16AWG	GXL	X31(5)
24					
25	WHT	15-2JIBUPV LV	18AWG	GXL	X31(8)
26	WHT	16-2JIBDNV LV	18AWG	GXL	X31(1)
27					
28					
29					
30	GRN	CH1TOC01-J7	18AWG	GXL	MS29(8)
31	YEL	CH1TOC01-J7	18AWG	GXL	MS29(11)
32					
33	WHT	12-2PLATLFTV LV	18AWG	GXL	X31(2)
34	WHT	11-2PLATRHTV LV	18AWG	GXL	X31(3)
35	BLK	0-7	18AWG	GXL	LB27-(1)

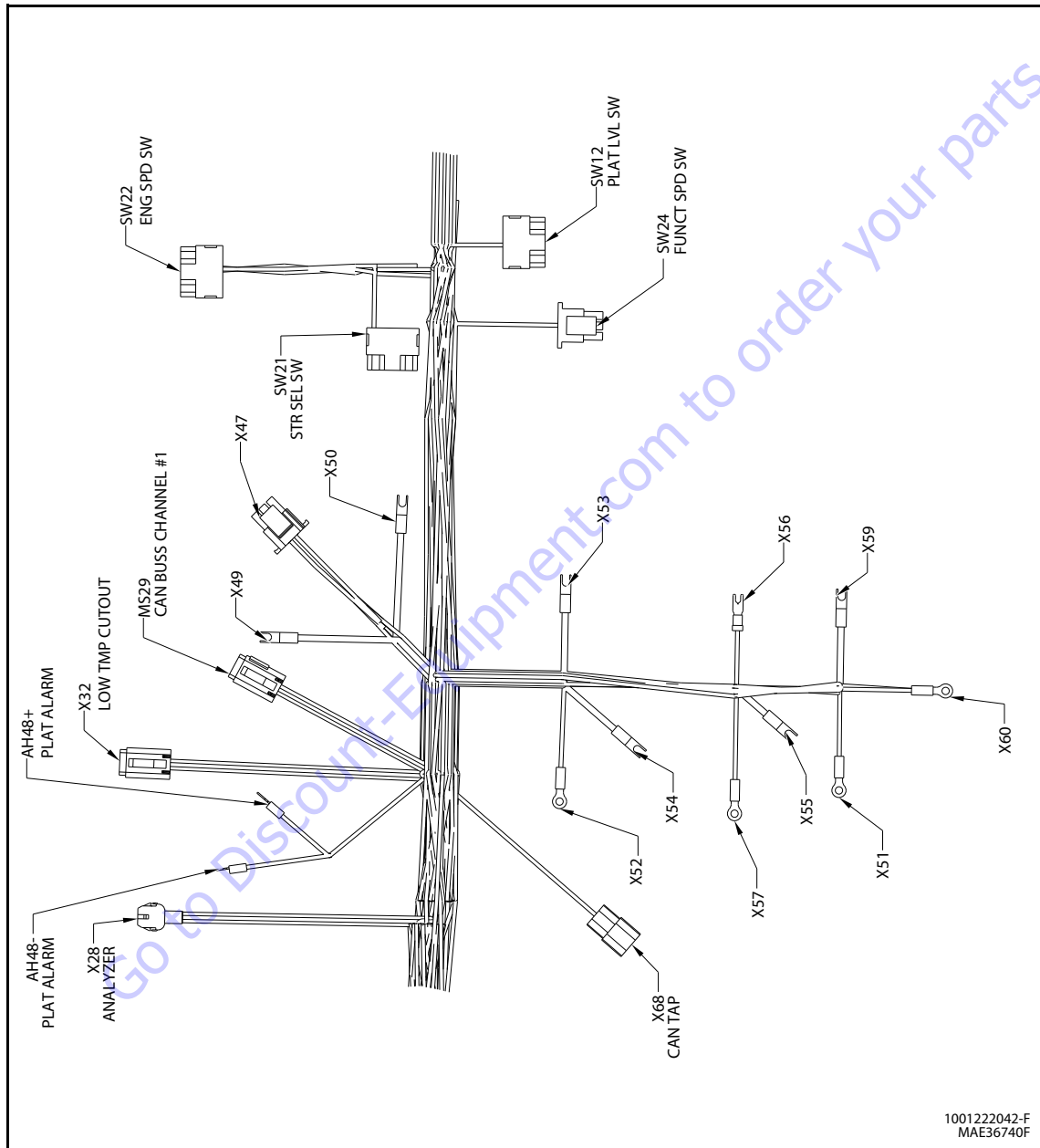

1001222042-F
MAE36740F

Figure 7-64. Console Box Harness - Sheet 3 of 4

SECTION 7 - BASIC ELECTRICAL INFORMATION & ELECTRICAL SCHEMATICS

X28 ANALYZER					
CONN POS	WIRE COLOR	WIRE LABEL	GAUGE	JACKET	TO
1	WHT	4-19.5 VPWR	18AWG	GXL	C01-J2(26)
2	WHT	4-2 RX	18AWG	GXL	C01-J2(28)
3	WHT	4-3 TX	18AWG	GXL	C01-J2(29)
4	BLK	0-4	18AWG	GXL	C01-J2(27)

X59 TO GND					
CONN POS	WIRE COLOR	WIRE LABEL	GAUGE	JACKET	TO
1	BLK	0-6	12AWG	GXL	C01-J8(1)

AH48- PLAT ALARM					
CONN POS	WIRE COLOR	WIRE LABEL	GAUGE	JACKET	TO
1	BLK	0-5	18AWG	GXL	C01-J7(20)

X53 TO IGN					
CONN POS	WIRE COLOR	WIRE LABEL	GAUGE	JACKET	TO
1	YEL	2-14-2-2	12AWG	GXL	X30(10)

AH48+ PLAT ALARM					
CONN POS	WIRE COLOR	WIRE LABEL	GAUGE	JACKET	TO
1	WHT	49-8 ALARM	18AWG	GXL	C01-J7(19)

X51 TO GND					
CONN POS	WIRE COLOR	WIRE LABEL	GAUGE	JACKET	TO
1	BLK	0-6-5	18AWG	GXL	X142(1)
1	BLK	0-6-6	18AWG	GXL	X142(3)

X49 TO GND					
CONN POS	WIRE COLOR	WIRE LABEL	GAUGE	JACKET	TO
1	BLK	0-6-1	12AWG	GXL	X30(18)

MS29 CANBUSS CHANNEL#1					
CONN POS	WIRE COLOR	WIRE LABEL	GAUGE	JACKET	TO
1	YEL	CH1TOX68	18AWG	GXL	X68(A)
2	BLK	CH1TOX33	20AWG	CABLE	X33(4)
3	YEL	CH1TOMS29	18AWG	GXL	X30(3)
4	GRN	CH1TOX68	18AWG	GXL	X68(B)
5	GRY	CH1TOX33	20AWG	CABLE	X33(5)
6	GRN	CH1TOMS29	18AWG	GXL	X30(2)
7					
8	GRN	CH1TOC01-J7	18AWG	GXL	C01-J7(30)
9	GRN	CH1TOX32	18AWG	GXL	X32(3)
10					
11	YEL	CH1TOC01-J7	18AWG	GXL	C01-J7(31)
12	YEL	CH1TOX32	18AWG	GXL	X32(4)

X54 TO IGN					
CONN POS	WIRE COLOR	WIRE LABEL	GAUGE	JACKET	TO
1	YEL	2-14-2-1	12AWG	GXL	X30(12)

X60 TO GND					
CONN POS	WIRE COLOR	WIRE LABEL	GAUGE	JACKET	TO
1	BLK	0-6-3	18AWG	GXL	X64(2)
1	BLK	0-6-4	18AWG	GXL	X32(2)

SECTION 7 - BASIC ELECTRICAL INFORMATION & ELECTRICAL SCHEMATICS

X47 PLAT SW/SNSR					
CONN POS	WIRE COLOR	WIRE LABEL	GAUGE	JACKET	TO
1	WHT	55-5GEN	18AWG	GXL	C01-J7(9)
2	YEL	2-4	18AWG	GXL	C01-J7(5)
3					
4					
5					
6					
7	WHT	49-9PLATFTSW	18AWG	GXL	C01-J7(8)
8	YEL	2-5	18AWG	GXL	C01-J7(4)
9					
10					
11					
12					
13	WHT	55-6-15OFTTOUCH	18AWG	GXL	X64(3)
14					
15					

X55 TO IGN					
CONN POS	WIRE COLOR	WIRE LABEL	GAUGE	JACKET	TO
1	YEL	2-3	12AWG	GXL	C01-J8(2)

SW22 ENG SPD SW					
CONN POS	WIRE COLOR	WIRE LABEL	GAUGE	JACKET	TO
1	WHT	46-2 MAX TORQ	18AWG	GXL	C01-J1(28)
2	YEL	2-1-7	18AWG	GXL	SW21(2)
2	YEL	2-1-8	18AWG	GXL	SW24(3)
3	WHT	46-1 MAX SPD	18AWG	GXL	C01-J1(27)
4					
5					
6					

X50 TO GND					
CONN POS	WIRE COLOR	WIRE LABEL	GAUGE	JACKET	TO
1	BLK	0-6-2	12AWG	GXL	X30(16)

SW21 STR SEL SW					
CONN POS	WIRE COLOR	WIRE LABEL	GAUGE	JACKET	TO
1	WHT	17-1 CRB STR	18AWG	GXL	C01-J1(16)
2	YEL	2-1-6	18AWG	GXL	SW12(2)
2	YEL	2-1-7	18AWG	GXL	SW22(2)
3	WHT	18-1 COOR STR	18AWG	GXL	C01-J1(17)
4					
5					
6					

X52 TO IGN					
CONN POS	WIRE COLOR	WIRE LABEL	GAUGE	JACKET	TO
1	YEL	2-3-6	18AWG	GXL	X142(2)
1	YEL	2-3-7	18AWG	GXL	X142(4)

SW24 FUNCT SPD SW					
CONN POS	WIRE COLOR	WIRE LABEL	GAUGE	JACKET	TO
1					
2	WHT	20-1 CREEP	18AWG	GXL	C01-J1(32)
3	YEL	2-1-8	18AWG	GXL	SW22(2)
3	YEL	2-1-9	18AWG	GXL	SW11(2)
4	WHT	20-37V PWR	18AWG	GXL	C01-J1(34)
5	BLK	0-1	18AWG	GXL	C01-J1(13)
6	WHT	20-2 FUN CSPD	18AWG	GXL	C01-J1(35)

X57 TO IGN					
CONN POS	WIRE COLOR	WIRE LABEL	GAUGE	JACKET	TO
1	YEL	2-3-4	18AWG	GXL	X64(1)

SECTION 7 - BASIC ELECTRICAL INFORMATION & ELECTRICAL SCHEMATICS

SW12 PLAT LVL SW					
CONN POS	WIRE COLOR	WIRE LABEL	GAUGE	JACKET	TO
1	WHT	13-1 PLAT UP	18AWG	GXL	C01-J1(9)
2	YEL	2-1-4	18AWG	GXL	SW25-1(1)
2	YEL	2-1-6	18AWG	GXL	SW21(2)
3	WHT	14-1 PLAT DN	18AWG	GXL	C01-J1(10)
4					
5					
6					

X68CANTAP					
CONN POS	WIRE COLOR	WIRE LABEL	GAUGE	JACKET	TO
A	YEL	CH1 TO X68	18AWG	GXL	MS29(1)
B	GRN	CH1 TO X68	18AWG	GXL	MS29(4)
C					

X56TOIGN					
CONN POS	WIRE COLOR	WIRE LABEL	GAUGE	JACKET	TO
1	YEL	2-3-3	18AWG	GXL	X32(1)

X32 LOWTMP CUTOUT					
CONN POS	WIRE COLOR	WIRE LABEL	GAUGE	JACKET	TO
1	YEL	2-3-3	18AWG	GXL	X56(1)
2	BLK	0-6-4	18AWG	GXL	X60(1)
3	GRN	CH1 TO X32	18AWG	GXL	MS29(9)
4	YEL	CH1 TO X32	18AWG	GXL	MS29(12)

Go to Discount-Equipment.com to order your parts

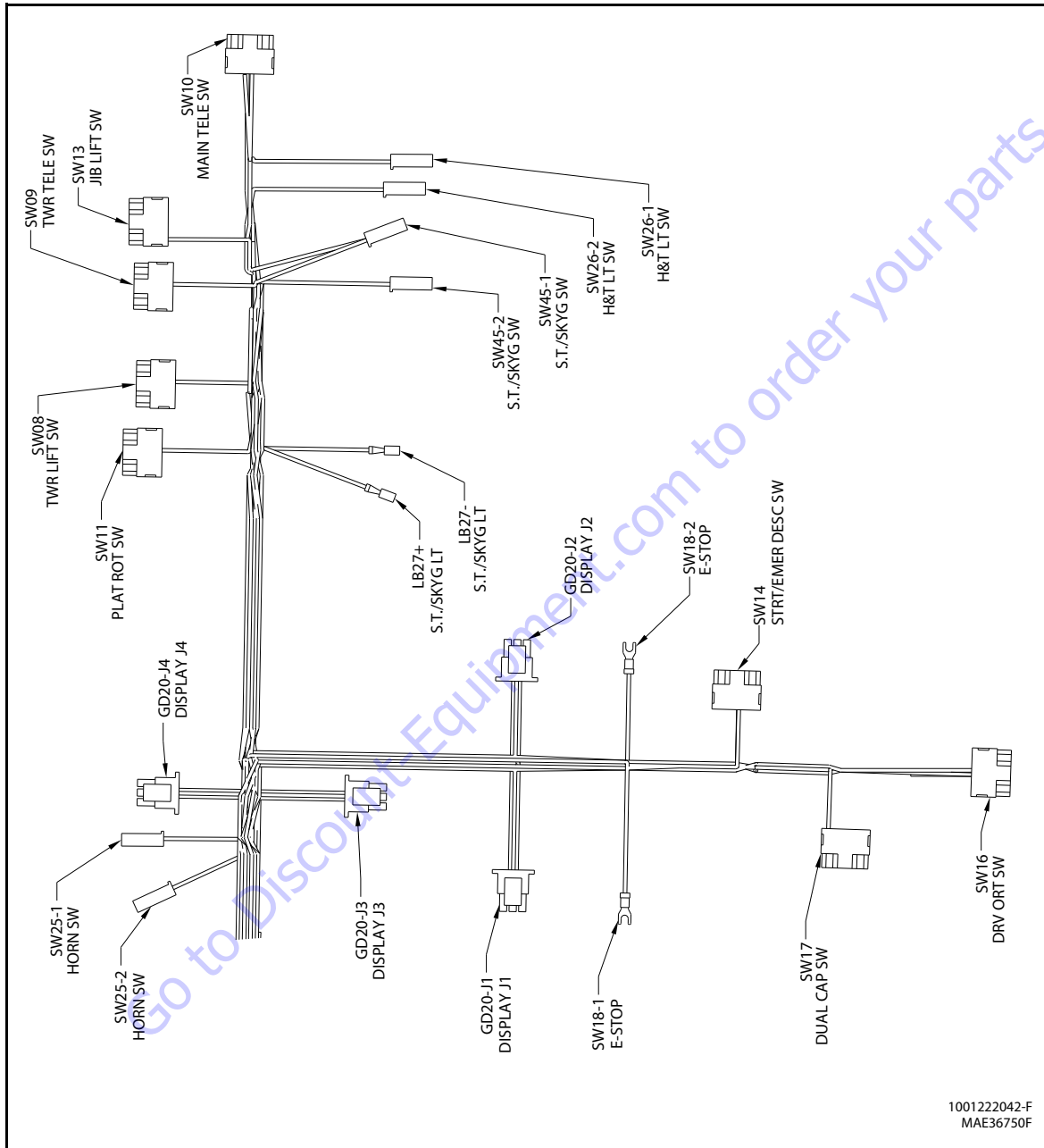

Figure 7-65. Console Box Harness - Sheet 4 of 4

SECTION 7 - BASIC ELECTRICAL INFORMATION & ELECTRICAL SCHEMATICS

SW17 DUAL CAPSW					
CONN POS	WIRE COLOR	WIRE LABEL	GAUGE	JACKET	TO
1					
2	YEL	2-1-1	18AWG	GXL	SW16(2)
2	YEL	2-1-2	18AWG	GXL	SW14(2)
3	WHT	49-31 RESTRICTED	18AWG	GXL	C01-J1(21)
4					
5					
6					

GD20-J1 DISPLAY J1					
CONN POS	WIRE COLOR	WIRE LABEL	GAUGE	JACKET	TO
1	WHT	48-4 1/4 BATT	18AWG	GXL	C01-J2(22)
2	WHT	48-6 1/2 BATT	18AWG	GXL	C01-J2(24)
3	WHT	48-5 3/4 BATT	18AWG	GXL	C01-J2(23)
4	BLK	0-3	18AWG	GXL	C01-J2(25)
5					
6	WHT	48-7 BATT FULL	18AWG	GXL	C01-J2(35)

SW16 DRV ORT SW					
CONN POS	WIRE COLOR	WIRE LABEL	GAUGE	JACKET	TO
1	WHT	50-1 DOS	18AWG	GXL	C01-J2(4)
2	YEL	2-1	18AWG	GXL	C01-J1(18)
2	YEL	2-1-1	18AWG	GXL	SW17(2)
3					
4					
5					
6					

SW14 STRT/EMER DESC SW					
CONN POS	WIRE COLOR	WIRE LABEL	GAUGE	JACKET	TO
1	WHT	48-1 ENG STRT	18AWG	GXL	C01-J1(14)
2	YEL	2-1-2	18AWG	GXL	SW17(2)
2	YEL	2-1-3	18AWG	GXL	SW25-1(1)
3	WHT	48-29 HYB SYS EN	18AWG	GXL	C01-J1(15)
4					
5					
6					

SW18-1 E-STOP					
CONN POS	WIRE COLOR	WIRE LABEL	GAUGE	JACKET	TO
1	YEL	2-13	18AWG	GXL	C01-J7(2)

SW18-2 E-STOP					
CONN POS	WIRE COLOR	WIRE LABEL	GAUGE	JACKET	TO
2	YEL	2-13	18AWG	GXL	X30(5)

GD20-J2 DISPLAY J2					
CONN POS	WIRE COLOR	WIRE LABEL	GAUGE	JACKET	TO
1	WHT	20-4 CREEP LT	18AWG	GXL	C01-J2(9)
2	WHT	49-2 ENABLE LT	18AWG	GXL	C01-J2(7)
3	WHT	48-3 LOW BATT LT	18AWG	GXL	C01-J2(21)
4					
5					
6	BLK	0-2	18AWG	GXL	C01-J2(18)

SECTION 7 - BASIC ELECTRICAL INFORMATION & ELECTRICAL SCHEMATICS

SW08 TWR LIFT SW					
CONN POS	WIRE COLOR	WIRE LABEL	GAUGE	JACKET	TO
1	WHT	5-1TWR UP	18AWG	GXL	C01-J1(1)
2	YEL	2-1-10	18AWG	GXL	SW11(2)
2	YEL	2-1-11	18AWG	GXL	SW09(2)
3	WHT	6-1TWR DN	18AWG	GXL	C01-J1(2)
4					
5					
6					

LB27+ S.T./SKYG LT					
CONN POS	WIRE COLOR	WIRE LABEL	GAUGE	JACKET	TO
1	WHT	55-4 S.T./SKYG LT	18AWG	GXL	C01-J2(16)

GD20-J4 DISPLAY J4					
CONN POS	WIRE COLOR	WIRE LABEL	GAUGE	JACKET	TO
1					
2	WHT	55-3 GEN LT	18AWG	GXL	C01-J2(15)
3	WHT	49-5 OVER LOAD LT	18AWG	GXL	C01-J2(11)
4					
5	WHT	49-1 TILT LT	18AWG	GXL	C01-J2(6)
6	WHT	48-2 GLOW LT	18AWG	GXL	C01-J2(17)

SW25-2 HORN SW					
CONN POS	WIRE COLOR	WIRE LABEL	GAUGE	JACKET	TO
1	WHT	19-1 HORN	18AWG	GXL	C01-J1(31)

LB27- S.T./SKYG LT					
CONN POS	WIRE COLOR	WIRE LABEL	GAUGE	JACKET	TO
1	BLK	0-7	18AWG	GXL	C01-J7(35)

SW25-1 HORNSW					
CONN POS	WIRE COLOR	WIRE LABEL	GAUGE	JACKET	TO
1	YEL	2-1-3	18AWG	GXL	SW14(2)
1	YEL	2-1-4	18AWG	GXL	SW12(2)

SW45-2 S.T./SKYG SW					
CONN POS	WIRE COLOR	WIRE LABEL	GAUGE	JACKET	TO
1	WHT	55-1 S.T./SKYG	18AWG	GXL	C01-J1(29)

SW45-1 S.T./SKYG SW					
CONN POS	WIRE COLOR	WIRE LABEL	GAUGE	JACKET	TO
1	YEL	2-1-12	18AWG	GXL	SW09(2)
1	YEL	2-1-13	18AWG	GXL	SW13(2)

SECTION 7 - BASIC ELECTRICAL INFORMATION & ELECTRICAL SCHEMATICS

SW26-1 H&T LT SW					
CONN POS	WIRE COLOR	WIRE LABEL	GAUGE	JACKET	TO
1	YEL	2-1-15	18AWG	GXL	SW10(2)

SW45-2 S.T./SKYG SW					
CONN POS	WIRE COLOR	WIRE LABEL	GAUGE	JACKET	TO
1	WHT	55-1 S.T./SKYG	18AWG	GXL	C01-J1(29)

SW26-2 H&T LT SW					
CONN POS	WIRE COLOR	WIRE LABEL	GAUGE	JACKET	TO
1	WHT	55-2 HEAD/TAIL LT	18AWG	GXL	C01-J1(30)

SW45-1 S.T./SKYG SW					
CONN POS	WIRE COLOR	WIRE LABEL	GAUGE	JACKET	TO
1	YEL	2-1-12	18AWG	GXL	SW09(2)
1	YEL	2-1-13	18AWG	GXL	SW13(2)

GD20-J4 DISPLAY J4					
CONN POS	WIRE COLOR	WIRE LABEL	GAUGE	JACKET	TO
1					
2	WHT	55-3 GEN LT	18AWG	GXL	C01-J2(15)
3	WHT	49-5 OVER LOADLT	18AWG	GXL	C01-J2(11)
4					
5	WHT	49-1 TILT LT	18AWG	GXL	C01-J2(6)
6	WHT	48-2 GLOW LT	18AWG	GXL	C01-J2(17)

SW26-1 H&T LT SW					
CONN POS	WIRE COLOR	WIRE LABEL	GAUGE	JACKET	TO
1	YEL	2-1-15	18AWG	GXL	SW10(2)

SW26-2 H&T LT SW					
CONN POS	WIRE COLOR	WIRE LABEL	GAUGE	JACKET	TO
1	WHT	55-2 HEAD/TAIL LT	18AWG	GXL	C01-J1(30)

LB27- S.T./SKYG LT					
CONN POS	WIRE COLOR	WIRE LABEL	GAUGE	JACKET	TO
1	BLK	0-7	18AWG	GXL	C01-J7(35)

GD20-J3 DISPLAY J3					
CONN POS	WIRE COLOR	WIRE LABEL	GAUGE	JACKET	TO
1	WHT	48-35 LOW FUEL	18AWG	GXL	C01-J2(19)
2					
3	WHT	50-3 DOS LT	18AWG	GXL	C01-J2(14)
4					
5	WHT	49-4 BOOM MALF	18AWG	GXL	C01-J2(20)
6	WHT	49-3 SYS FAIL	18AWG	GXL	C01-J2(8)

SECTION 7 - BASIC ELECTRICAL INFORMATION & ELECTRICAL SCHEMATICS

SW11 PLAT ROT SW					
CONN POS	WIRE COLOR	WIRE LABEL	GAUGE	JACKET	TO
1	WHT	11-1 PLAT RHT	18AWG	GXL	C01-J1(7)
2	YEL	2-1-10	18AWG	GXL	SW08(2)
2	YEL	2-1-9	18AWG	GXL	SW24(3)
3	WHT	12-1 PLAT LFT	18AWG	GXL	C01-J1(8)
4					
5					
6					

SW10 MAIN TELE SW					
CONN POS	WIRE COLOR	WIRE LABEL	GAUGE	JACKET	TO
1	WHT	9-1 TELE IN	18AWG	GXL	C01-J1(5)
2	YEL	2-1-14	18AWG	GXL	SW13(2)
2	YEL	2-1-15	18AWG	GXL	SW26-1(1)
3	WHT	10-1 TELE OUT	18AWG	GXL	C01-J1(6)
4					
5					
6					

SW09 TWR TELE SW					
CONN POS	WIRE COLOR	WIRE LABEL	GAUGE	JACKET	TO
1	WHT	7-1 TWR IN	18AWG	GXL	C01-J1(3)
2	YEL	2-1-11	18AWG	GXL	SW08(2)
2	YEL	2-1-12	18AWG	GXL	SW45-1(1)
3	WHT	8-1 TWR OUT	18AWG	GXL	C01-J1(4)
4					
5					
6					

SW13 JIBLIFTSW					
CONN POS	WIRE COLOR	WIRE LABEL	GAUGE	JACKET	TO
1	WHT	15-1 JIB UP	18AWG	GXL	C01-J1(11)
2	YEL	2-1-13	18AWG	GXL	SW45-1(1)
2	YEL	2-1-14	18AWG	GXL	SW10(2)
3	WHT	16-1 JIB DN	18AWG	GXL	C01-J1(12)
4					
5					
6					

Go to Discount-Equipment.com to order your parts

This Page Left Blank Intentionally

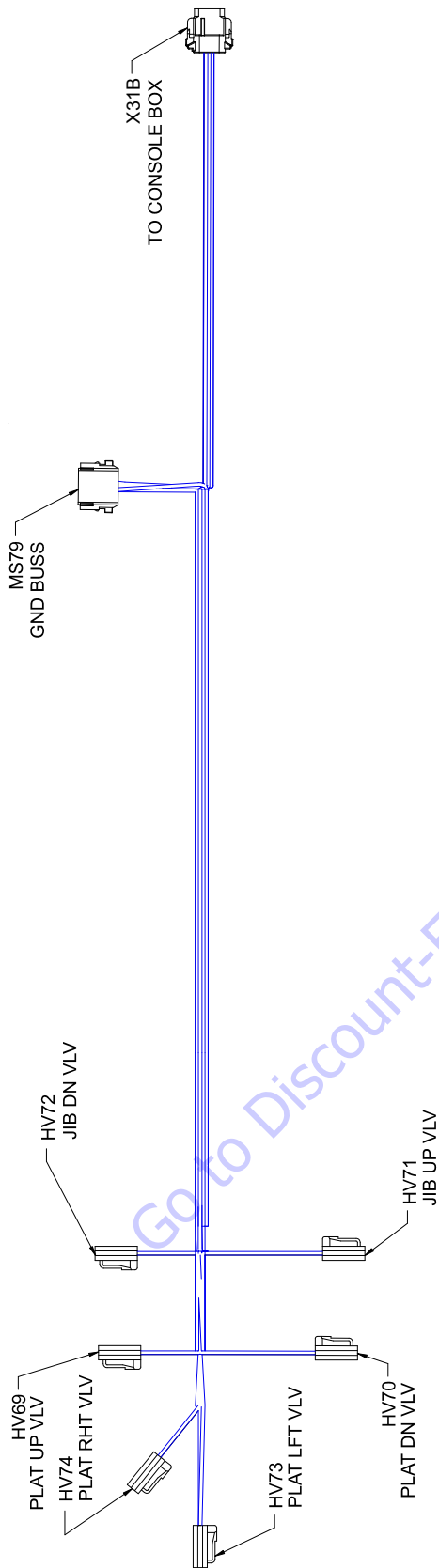

WIRE NO	COLOR	WIRE GAUGE	JACKET	LENGTH (mm)	FROM		TO	
					REFERENCE	PIN	REFERENCE	PIN
0-12-2	BLK	18	GXL	622	HV72	2	MS79	2
0-12-3	BLK	18	GXL	728	HV74	2	MS79	3
0-12-4	BLK	18	GXL	766	HV73	2	MS79	4
0-12-5	BLK	18	GXL	723	HV70	2	MS79	5
0-12-6	BLK	18	GXL	691	HV69	2	MS79	6
0-12-7	BLK	18	GXL	665	HV71	2	MS79	8
0-12	BLK	16	GXL	359	X31B	5	MS79	7
11-2	WHT	18	GXL	987	X31B	3	HV74	1
12-2	WHT	18	GXL	1034	X31B	2	HV73	1
13-2-1	WHT	18	GXL	945	X31B	7	HV69	1
14-2-1	WHT	18	GXL	993	X31B	6	HV70	1
15-2	WHT	18	GXL	919	X31B	8	HV71	1
16-2	WHT	18	GXL	876	X31B	1	HV72	1

1001222047 B

Figure 7-66. Platform Valve Harness

SECTION 7 - BASIC ELECTRICAL INFORMATION & ELECTRICAL SCHEMATICS

MS79 GND BUSS					
CONN POS	WIRE COLOR	WIRE LABEL	GAUGE	JACKET	TO
1					
2	BLK	0-12-2	18AWG	GXL	HV72(2)
3	BLK	0-12-3	18AWG	GXL	HV74(2)
4	BLK	0-12-4	18AWG	GXL	HV73(2)
5	BLK	0-12-5	18AWG	GXL	HV70(2)
6	BLK	0-12-6	18AWG	GXL	HV69(2)
7	BLK	0-12	16AWG	GXL	X31B(5)
8	BLK	0-12-7	18AWG	GXL	HV71(2)

HV73 PLAT LF TVLV					
CONN POS	WIRE COLOR	WIRE LABEL	GAUGE	JACKET	TO
1	WHT	12-2 PLAT LFT VLV	18AWG	GXL	X31B(2)
2	BLK	0-12-4	18AWG	GXL	MS79(4)

HV74 PLAT RHT VLV					
CONN POS	WIRE COLOR	WIRE LABEL	GAUGE	JACKET	TO
1	WHT	11-2PLATRHTVLV	18AWG	GXL	X31B(3)
2	BLK	0-12-3	18AWG	GXL	MS79(3)

X31B TO PLAT HARN					
CONN POS	WIRE COLOR	WIRE LABEL	GAUGE	JACKET	TO
1	WHT	16-2 JIB DN VLV	18AWG	GXL	HV72(1)
2	WHT	12-2 PLAT LFT VLV	18AWG	GXL	HV73(1)
3	WHT	11-2 PLAT RHT VLV	18AWG	GXL	HV74(1)
4					
5	BLK	0-12	16AWG	GXL	MS79(7)
6	WHT	14-2-1 PLAT DN VLV	18AWG	GXL	HV70(1)
7	WHT	13-2-1 PLAT UP VLV	18AWG	GXL	HV69(1)
8	WHT	15-2 JIB UP VLV	18AWG	GXL	HV71(1)

HV69 PLAT UP VLV					
CONN POS	WIRE COLOR	WIRE LABEL	GAUGE	JACKET	TO
1	WHT	13-2-1 PLAT UP VLV	18AWG	GXL	X31B(7)
2	BLK	0-12-6	18AWG	GXL	MS79(6)

HV72 JIB DN VLV					
CONN POS	WIRE COLOR	WIRE LABEL	GAUGE	JACKET	TO
1	WHT	16-2JIBDNVLV	18AWG	GXL	X31B(1)
2	BLK	0-12-2	18AWG	GXL	MS79(2)

HV71 JIB UP VLV					
CONN POS	WIRE COLOR	WIRE LABEL	GAUGE	JACKET	TO
1	WHT	15-2 JIB UP VLV	18AWG	GXL	X31B(8)
2	BLK	0-12-7	18AWG	GXL	MS79(8)

HV70 PLAT DN VLV					
CONN POS	WIRE COLOR	WIRE LABEL	GAUGE	JACKET	TO
1	WHT	14-2-1 PLAT DN VLV	18AWG	GXL	X31B(6)
2	BLK	0-12-5	18AWG	GXL	MS79(5)

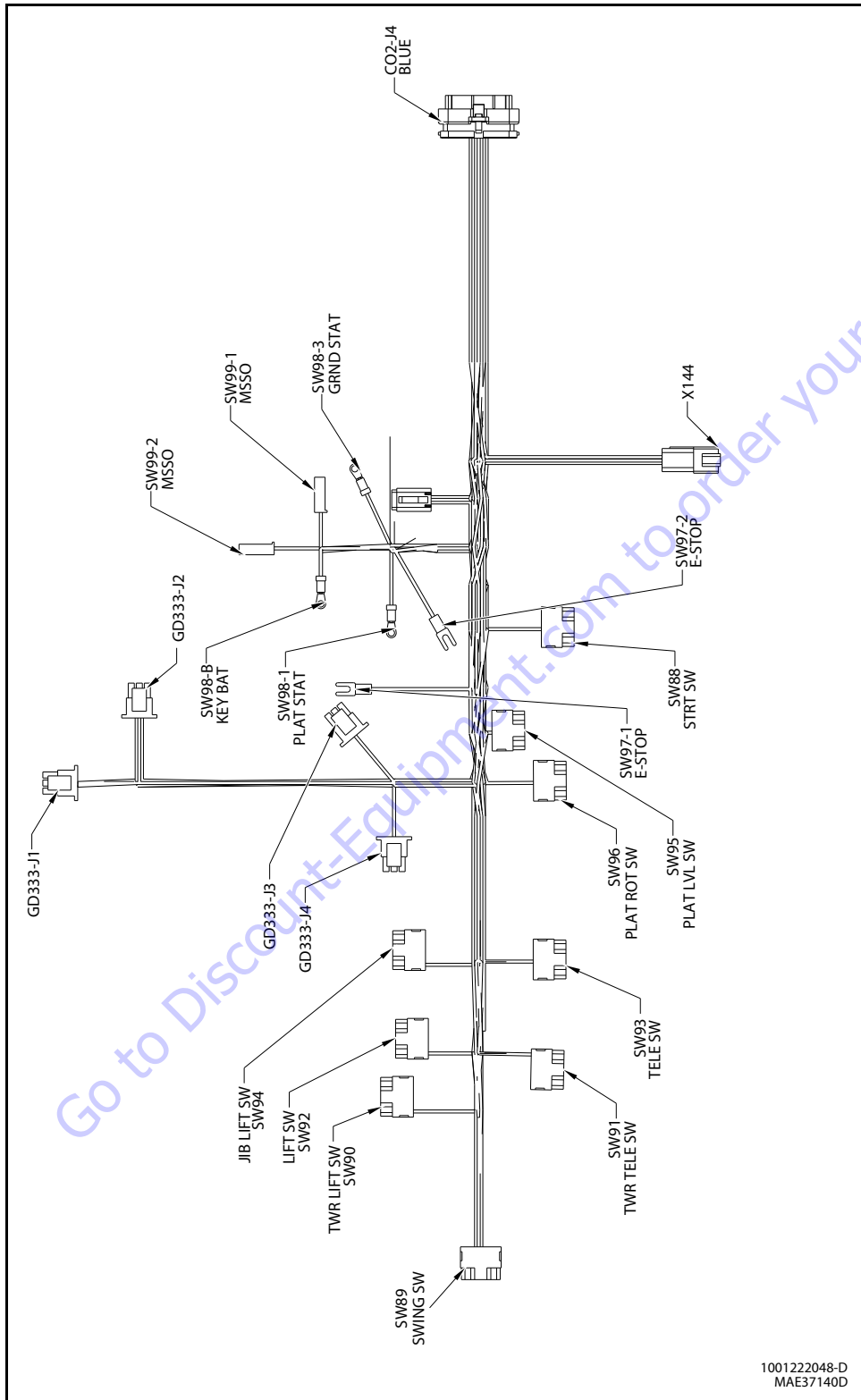

Figure 7-67. Ground Control Harness

SECTION 7 - BASIC ELECTRICAL INFORMATION & ELECTRICAL SCHEMATICS

C02-J4 BLUE					
CONN POS	WIRE COLOR	WIRE LABEL	GAUGE	JACKET	TO
1	WHT	49-14 CRIBBING LT	18AWG	GXL	GD333-J3(1)
2					
3	WHT	48-9 GLOW LT	18AWG	GXL	GD333-J2(3)
4	WHT	48-8 ENG STRT	18AWG	GXL	SW88(1)
5	WHT	14-3 PLAT DN	18AWG	GXL	SW95(3)
6	WHT	12-3 PLAT LFT	18AWG	GXL	SW96(3)
7	WHT	9-2 TELE IN	18AWG	GXL	SW93(1)
8	WHT	16-3 JIB DN	18AWG	GXL	SW94(3)
9					
10	WHT	5-2 TWR UP	18AWG	GXL	SW90(1)
11	WHT	7-2 TWR IN	18AWG	GXL	SW91(3)
12					
13	WHT	48-37 LOW FUEL	18AWG	GXL	GD333-J1(5)
14	WHT	49-13 OVER LOAD LT	18AWG	GXL	GD333-J3(6)
15	WHT	49-10 BM MALF LT	18AWG	GXL	GD333-J2(1)
16	WHT	48-34 EMER DESC	18AWG	GXL	SW88(3)
17	WHT	13-3 PLAT UP	18AWG	GXL	SW95(1)
18	WHT	11-3 PLAT RHT	18AWG	GXL	SW96(1)
19	WHT	15-3 JIB UP	18AWG	GXL	SW94(1)
20					
21	WHT	6-2 TWR DN	18AWG	GXL	SW90(3)
22	WHT	8-2 TWR OUT	18AWG	GXL	SW91(1)
23	WHT	23-1 LIFT UP	18AWG	GXL	SW92(1)
24					
25	YEL	2-11	18AWG	GXL	SW88(2)
26					
27					
28	WHT	48-10 ENG DEST LT	18AWG	GXL	GD333-J4(2)
29	WHT	48-11 SYS DEST	18AWG	GXL	GD333-J4(3)
30	WHT	10-2 TELE OUT	18AWG	GXL	SW93(3)
31	BLK	0-13	18AWG	GXL	GD333-J1(4)
32					
33	WHT	24-1 LIFT DN	18AWG	GXL	SW92(3)
34	WHT	22-1 SWG LFT	18AWG	GXL	SW89(3)
35	WHT	21-1 SWG RHT	18AWG	GXL	SW89(1)

X144					
CONN POS	WIRE COLOR	WIRE LABEL	GAUGE	JACKET	TO
1	YEL	2-13	18AWG	GXL	SW98-1(1)
2	YEL	2-12-2	18AWG	GXL	SW98-3(1)
3	YEL	2-12-3	18AWG	GXL	SW98-3(1)
4	RED	1-1	16AWG	GXL	SW97-1(1)
5	BLK	0-14-2	18AWG	GXL	X101(1)
6	YEL	2-14-3	18AWG	GXL	X101(2)
7	GRN	CH#1 TO DISPLAY	18AWG	GXL	X101(4)
8	YEL	CH#1 TO DISPLAY	18AWG	GXL	X101(3)
9	WHT	49-16 MSSO	18AWG	GXL	SW99-2(1)
10					
11					
12	YEL	55-7 PLAT STAT SEL	18AWG	GXL	SW98-1(1)

X101 DISPLAY					
CONN POS	WIRE COLOR	WIRE LABEL	GAUGE	JACKET	TO
1	BLK	0-14-2	18AWG	GXL	X144(5)
2	YEL	2-14-3	18AWG	GXL	X144(6)
3	YEL	CH#1 TO DISPLAY	18AWG	GXL	X144(8)
4	GRN	CH#1 TO DISPLAY	18AWG	GXL	X144(7)
5					
6					

SW98-3 GRND STAT					
CONN POS	WIRE COLOR	WIRE LABEL	GAUGE	JACKET	TO
1	YEL	2-12-2	18AWG	GXL	X144(2)
1	YEL	2-12-3	18AWG	GXL	X144(3)

SW99-1 MSSO					
CONN POS	WIRE COLOR	WIRE LABEL	GAUGE	JACKET	TO
1	BLK	0-20	18AWG	GXL	GD333-J2(6)

SECTION 7 - BASIC ELECTRICAL INFORMATION & ELECTRICAL SCHEMATICS

SW99-2 MSSO					
CONN POS	WIRE COLOR	WIRE LABEL	GAUGE	JACKET	TO
1	WHT	49-16MSSO	18AWG	GXL	X144(9)

SW97-1 E-STOP					
CONN POS	WIRE COLOR	WIRE LABEL	GAUGE	JACKET	TO
1	RED	1-1	16AWG	GXL	X144(4)

SW98-B KEYBAT					
CONN POS	WIRE COLOR	WIRE LABEL	GAUGE	JACKET	TO
1	RED	1-1	16AWG	GXL	SW97-2(2)

SW95 PLAT LVL SW					
CONN POS	WIRE COLOR	WIRE LABEL	GAUGE	JACKET	TO
1	WHT	13-3 PLAT UP	18AWG	GXL	C02-J4(17)
2	YEL	2-11-7	18AWG	GXL	SW94(2)
2	YEL	2-11-8	18AWG	GXL	SW96(2)
3	WHT	14-3 PLAT DN	18AWG	GXL	C02-J4(5)
4					
5					
6					

SW98-1 PLAT STAT					
CONN POS	WIRE COLOR	WIRE LABEL	GAUGE	JACKET	TO
1	YEL	2-13	18AWG	GXL	X144(1)
1	YEL	55-7 PLAT STAT SEL	18AWG	GXL	X144(12)

SW96 PLAT ROT SW					
CONN POS	WIRE COLOR	WIRE LABEL	GAUGE	JACKET	TO
1	WHT	11-3 PLAT RHT	18AWG	GXL	C02-J4(18)
2	YEL	2-11-8	18AWG	GXL	SW95(2)
3	WHT	12-3 PLAT LFT	18AWG	GXL	C02-J4(6)
4					
5					
6					

SW97-2 E-STOP					
CONN POS	WIRE COLOR	WIRE LABEL	GAUGE	JACKET	TO
2	RED	1-1	16AWG	GXL	SW98-B(1)

SW88 STRT SW					
CONN POS	WIRE COLOR	WIRE LABEL	GAUGE	JACKET	TO
1	WHT	48-8 ENG STRT	18AWG	GXL	C02-J4(4)
2	YEL	2-11	18AWG	GXL	C02-J4(25)
2	YEL	2-11-1	18AWG	GXL	SW89(2)
3	WHT	48-34 EMER DESC	18AWG	GXL	C02-J4(16)
4					
5					
6					

SW93 TELE SW					
CONN POS	WIRE COLOR	WIRE LABEL	GAUGE	JACKET	TO
1	WHT	9-2 TELE IN	18AWG	GXL	C02-J4(7)
2	YEL	2-11-5	18AWG	GXL	SW92(2)
2	YEL	2-11-6	18AWG	GXL	SW94(2)
3	WHT	10-2 TELE OUT	18AWG	GXL	C02-J4(30)
4					
5					
6					

SECTION 7 - BASIC ELECTRICAL INFORMATION & ELECTRICAL SCHEMATICS

SW94 JIB LIFT SW					
CONN POS	WIRE COLOR	WIRE LABEL	GAUGE	JACKET	TO
1	WHT	15-3 JIB UP	18AWG	GXL	C02-J4(19)
2	YEL	2-11-6	18AWG	GXL	SW93(2)
2	YEL	2-11-7	18AWG	GXL	SW95(2)
3	WHT	16-3 JIB DN	18AWG	GXL	C02-J4(8)
4					
5					
6					

GD333-J2					
CONN POS	WIRE COLOR	WIRE LABEL	GAUGE	JACKET	TO
1	WHT	49-10 BM MALF LT	18AWG	GXL	C02-J4(15)
2					
3	WHT	48-9 GLOW LT	18AWG	GXL	C02-J4(3)
4					
5					
6	BLK	0-20	18AWG	GXL	SW99-1(1)
6	BLK	0-13-1	18AWG	GXL	GD333-J1(4)

GD333-J1					
CONN POS	WIRE COLOR	WIRE LABEL	GAUGE	JACKET	TO
1					
2					
3					
4	BLK	0-13	18AWG	GXL	C02-J4(31)
4	BLK	0-13-1	18AWG	GXL	GD333-J2(6)
5	WHT	48-37 LOW FUEL	18AWG	GXL	C02-J4(13)
6					

GD333-J4					
CONN POS	WIRE COLOR	WIRE LABEL	GAUGE	JACKET	TO
1					
2	WHT	48-10 ENG DEST LT	18AWG	GXL	C02-J4(28)
3	WHT	48-11 SYS DEST	18AWG	GXL	C02-J4(29)
4					
5					
6					

GD333-J3					
CONN POS	WIRE COLOR	WIRE LABEL	GAUGE	JACKET	TO
1	WHT	49-14 CRIBBING LT	18AWG	GXL	C02-J4(1)
2					
3					
4					
5					
6	WHT	49-13 OVER LOAD LT	18AWG	GXL	C02-J4(14)

SW92 LIFT SW					
CONN POS	WIRE COLOR	WIRE LABEL	GAUGE	JACKET	TO
1	WHT	23-1 LIFT UP	18AWG	GXL	C02-J4(23)
2	YEL	2-11-4	18AWG	GXL	SW91(2)
2	YEL	2-11-5	18AWG	GXL	SW93(2)
3	WHT	24-1 LIFT DN	18AWG	GXL	C02-J4(33)
4					
5					
6					

SECTION 7 - BASIC ELECTRICAL INFORMATION & ELECTRICAL SCHEMATICS

SW91 TWR TELE SW					
CONN POS	WIRE COLOR	WIRE LABEL	GAUGE	JACKET	TO
1	WHT	8-2 TWR OUT	18AWG	GXL	C02-J4(22)
2	YEL	2-11-3	18AWG	GXL	SW90(2)
2	YEL	2-11-4	18AWG	GXL	SW92(2)
3	WHT	7-2 TWR IN	18AWG	GXL	C02-J4(11)
4					
5					
6					

SW89 SWING SW					
CONN POS	WIRE COLOR	WIRE LABEL	GAUGE	JACKET	TO
1	WHT	21-1 SWG RHT	18AWG	GXL	C02-J4(35)
2	YEL	2-11-1	18AWG	GXL	SW88(2)
2	YEL	2-11-2	18AWG	GXL	SW90(2)
3	WHT	22-1 SWG LFT	18AWG	GXL	C02-J4(34)
4					
5					
6					

SW90 TWR LIFT SW					
CONN POS	WIRE COLOR	WIRE LABEL	GAUGE	JACKET	TO
1	WHT	5-2 TWR UP	18AWG	GXL	C02-J4(10)
2	YEL	2-11-2	18AWG	GXL	SW89(2)
2	YEL	2-11-3	18AWG	GXL	SW91(2)
3	WHT	6-2 TWR DN	18AWG	GXL	C02-J4(21)
4					
5					
6					

Go to Discount-Equipment.com to order your parts

Go to Discount-Equipment.com to order your parts

This Page Left Blank Intentionally

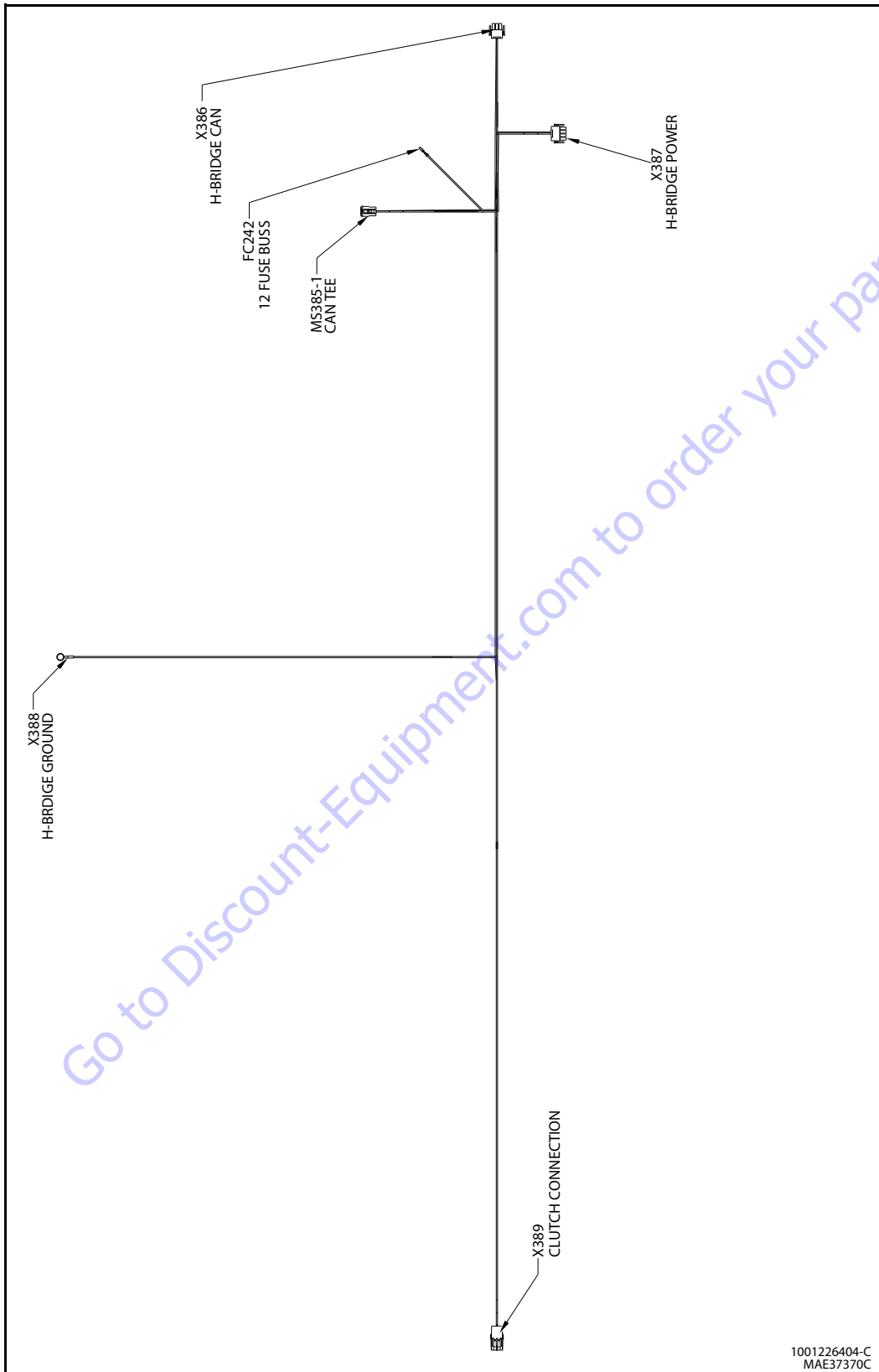

Figure 7-68. H-Bridge/Clutch Harness

SECTION 7 - BASIC ELECTRICAL INFORMATION & ELECTRICAL SCHEMATICS

X389 CLUTCH CONNECTION					
CONN POS	WIRE COLOR	WIRE LABEL	GAUGE	JACKET	TO
A	BLK	CLUTCH	18AWG	GXL	X387(2)
B	RED	CLUTCH	18AWG	GXL	X387(3)

X386 H-BRIDGE CAN					
CONN POS	WIRE COLOR	WIRE LABEL	GAUGE	JACKET	TO
1	YEL	CH#1 TO H-BRIDGE	18AWG	GXL	MS385-1(A)
2	GRN	CH#1 TO H-BRIDGE	18AWG	GXL	MS385-1(B)
3					

X388 H-BRIDGE GROUND					
CONN POS	WIRE COLOR	WIRE LABEL	GAUGE	JACKET	TO
1	BLK	047	18AWG	GXL	X387(4)

MS385-1 CAN TEE					
CONN POS	WIRE COLOR	WIRE LABEL	GAUGE	JACKET	TO
A	YEL	CH#1 TO H-BRIDGE	18AWG	GXL	X386(1)
B	GRN	CH#1 TO H-BRIDGE	18AWG	GXL	X386(2)
C					

FC242 12 FUSE BUSS					
CONN POS	WIRE COLOR	WIRE LABEL	GAUGE	JACKET	TO
19	YEL	2-14-19	18AWG	GXL	X387(1)

X387 H-BRIDGE POWER					
CONN POS	WIRE COLOR	WIRE LABEL	GAUGE	JACKET	TO
1	YEL	2-14-19	18AWG	GXL	FC242(19)
2	BLK	CLUTCH	18AWG	GXL	X389(A)
3	RED	CLUTCH	18AWG	GXL	X389(B)
4	BLK	047	18AWG	GXL	X388(1)

This Page Left Blank Intentionally

Go to Discount-Equipment.com to order your parts

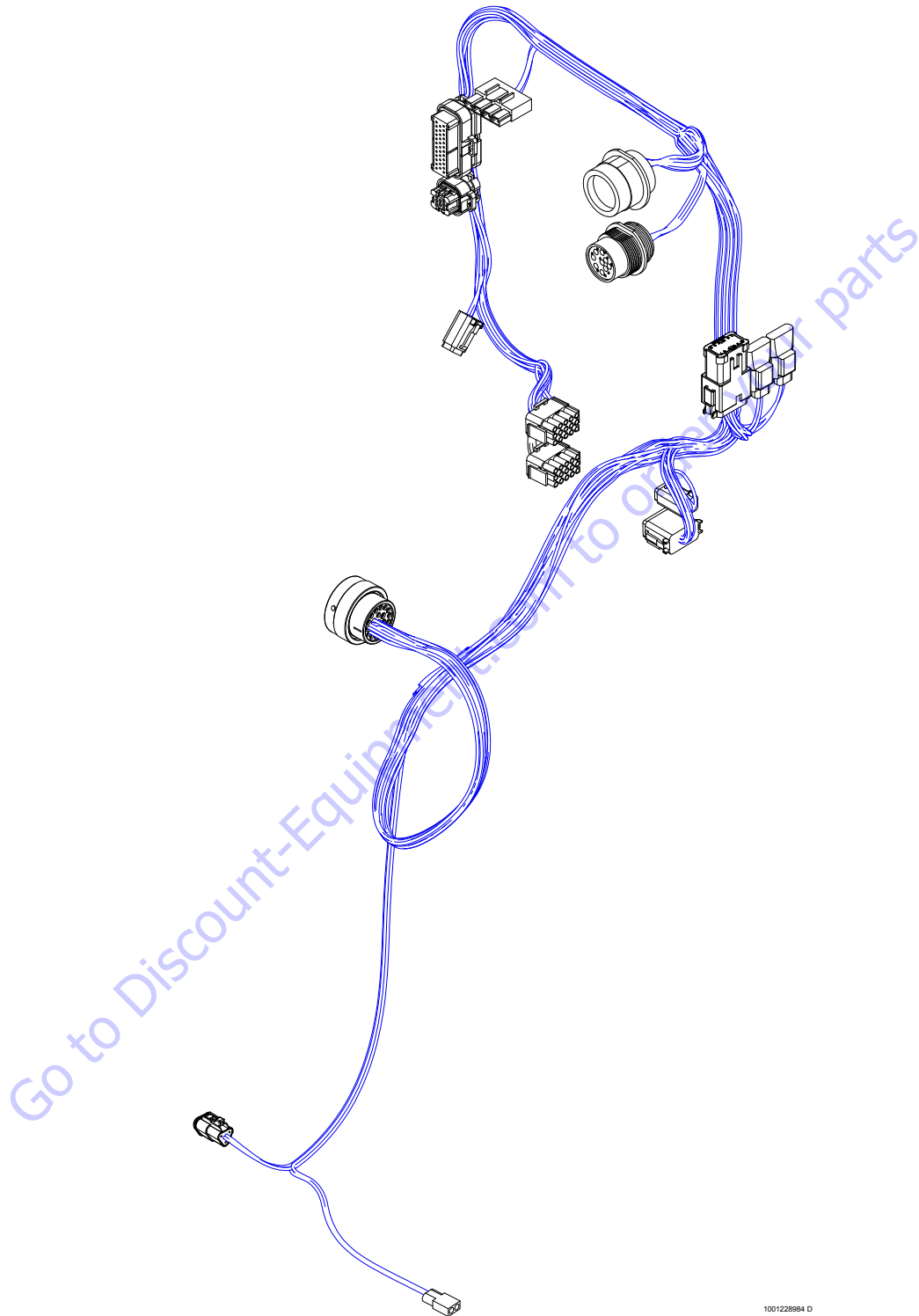
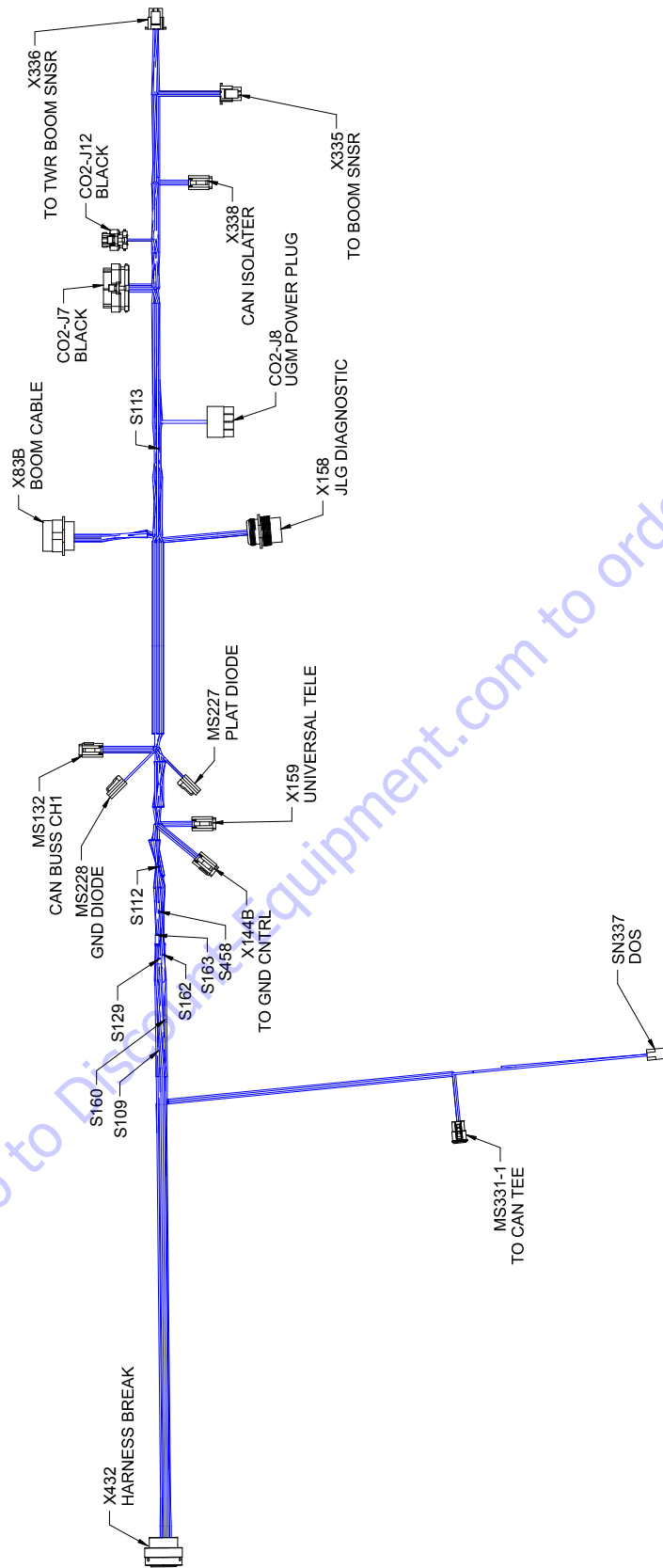

Figure 7-69. Turntable Harness - Sheet 1 of 2

1001228864 D



100122894A.D

Figure 7-70. Turntable Harness - Sheet 2 of 2

SECTION 7 - BASIC ELECTRICAL INFORMATION & ELECTRICAL SCHEMATICS

X432 HARNES BREAK					
CONN POS	WIRE COLOR	WIRE LABEL	GAUGE	JACKET	TO
A	RED	1-1	16AWG	GXL	X144B(4)
B	YEL	2-14-21	12AWG	GXL	S109(2)
C	YEL	2-14-14	18AWG	GXL	X144B(6)
D	YEL	2-14-22	12AWG	GXL	C02-J8(2)
E	BLK	0-14-4	12AWG	GXL	C02-J8(1)
F	BLK	0-14-2	18AWG	GXL	X144B(5)
G	BLK	0-14-3	10AWG	GXL	S129(2)
H	YEL	2-14-11	18AWG	GXL	S458(2)
J	BLK	0-14-7	18AWG	GXL	X336(15)
K	RED	1-3	18AWG	GXL	S160(1)
L	YEL	2-14-20	18AWG	GXL	S163(2)
M	BLK	0-14-6	18AWG	GXL	S162(2)
N	GRN	CH#1 TO MS385	18AWG	GXL	MS132(9)
P	YEL	CH#1 TO MS385	18AWG	GXL	MS132(12)
R	YEL	2-14-17	18AWG	GXL	SN337(2)
S	YEL	CH#1 TO TILT SNSR	18AWG	GXL	MS132(2)
T	GRN	CH#1 TO TILT SNSR	18AWG	GXL	MS132(5)
U	YEL	2-12	18AWG	GXL	S112(2)
V					
W					
X					

S109					
CONN POS	WIRE COLOR	WIRE LABEL	GAUGE	JACKET	TO
1	YEL	2-14-21-1	12AWG	GXL	X83B(12)
1	YEL	2-14-21-2	12AWG	GXL	X83B(10)
2	YEL	2-14-21	12AWG	GXL	X432(B)

MS227 PLAT DIODE					
CONN POS	WIRE COLOR	WIRE LABEL	GAUGE	JACKET	TO
1	YEL	2-12-1	18AWG	GXL	S112(1)
2	YEL	2-12-1	18AWG	GXL	S113(1)

S160					
CONN POS	WIRE COLOR	WIRE LABEL	GAUGE	JACKET	TO
1	RED	1-3	18AWG	GXL	X432(K)
2	RED	1-3-1	18AWG	GXL	X159(1)
2	RED	1-3-2	18AWG	GXL	X158(B)

S129					
CONN POS	WIRE COLOR	WIRE LABEL	GAUGE	JACKET	TO
1	BLK	0-14-3-1	12AWG	GXL	X83B(16)
1	BLK	0-14-3-2	12AWG	GXL	X83B(18)
2	BLK	0-14-3	10AWG	GXL	X432(G)

MS331-1 TO CAN TEE					
CONN POS	WIRE COLOR	WIRE LABEL	GAUGE	JACKET	TO
A	YEL	CH#2 TO IMG CNTRL	18AWG	GXL	X338(2)
B	GRN	CH#2 TO IMG CNTRL	18AWG	GXL	X338(1)
C	BLK	0-50	18AWG	GXL	C02-J12(5)

S162					
CONN POS	WIRE COLOR	WIRE LABEL	GAUGE	JACKET	TO
1	BLK	0-14-6-1	18AWG	GXL	X159(2)
1	BLK	0-14-6-2	18AWG	GXL	X158(A)
2	BLK	0-14-6	18AWG	GXL	X432(M)

SN337 DOS					
CONN POS	WIRE COLOR	WIRE LABEL	GAUGE	JACKET	TO
1	WHT	49-17 DRV ORNT	18AWG	GXL	C02-J7(35)
2	YEL	2-14-17	18AWG	GXL	X432(R)

S163					
CONN POS	WIRE COLOR	WIRE LABEL	GAUGE	JACKET	TO
1	YEL	2-14-5-1	18AWG	GXL	X159(3)
1	YEL	2-14-5-2	18AWG	GXL	X158(H)
2	YEL	2-14-20	18AWG	GXL	X432(L)

SECTION 7 - BASIC ELECTRICAL INFORMATION & ELECTRICAL SCHEMATICS

S458					
CONN POS	WIRE COLOR	WIRE LABEL	GAUGE	JACKET	TO
1	YEL	2-14-11-1	18AWG	GXL	X336(14)
1	YEL	2-14-11-2	18AWG	GXL	X336(12)
2	YEL	2-14-11	18AWG	GXL	X432(H)

S112					
CONN POS	WIRE COLOR	WIRE LABEL	GAUGE	JACKET	TO
1	YEL	2-12-1	18AWG	GXL	MS227(1)
1	YEL	2-12-2	18AWG	GXL	MS228(1)
2	YEL	2-12	18AWG	GXL	X432(U)

MS228 GND DIODE					
CONN POS	WIRE COLOR	WIRE LABEL	GAUGE	JACKET	TO
1	YEL	2-12-2	18AWG	GXL	S112(1)
2	YEL	2-12-2	18AWG	GXL	X144B(2)

X159 UNIVERSAL TELE					
CONN POS	WIRE COLOR	WIRE LABEL	GAUGE	JACKET	TO
1	RED	1-3-1	18AWG	GXL	S160(2)
2	BLK	0-14-6-1	18AWG	GXL	S162(1)
3	YEL	2-14-5-1	18AWG	GXL	S163(1)
4	YEL	55-7 PLAT STAT SEL	18AWG	GXL	X144B(12)

X144B TO GND CNTRL					
CONN POS	WIRE COLOR	WIRE LABEL	GAUGE	JACKET	TO
1	YEL	2-13	18AWG	GXL	X83B(5)
2	YEL	2-12-2	18AWG	GXL	MS228(2)
3	YEL	2-12-3	18AWG	GXL	C02-J7(3)
4	RED	1-1	16AWG	GXL	X432(A)
5	BLK	0-14-2	18AWG	GXL	X432(F)
6	YEL	2-14-14	18AWG	GXL	X432(C)
7	GRN	CH#1 TO DISPLAY	18AWG	GXL	MS132(8)
8	YEL	CH#1 TO DISPLAY	18AWG	GXL	MS132(11)
9	WHT	49-16 MSSO	18AWG	GXL	C02-J12(8)
10					
11					
12	YEL	55-7 PLAT STAT SEL	18AWG	GXL	X159(4)

MS132 CAN BUSS CH1					
CONN POS	WIRE COLOR	WIRE LABEL	GAUGE	JACKET	TO
1	YEL	CH#1 TO J7-13	18AWG	GXL	C02-J7(13)
2	YEL	CH#1 TO TILT SNSR	18AWG	GXL	X432(S)
3	YEL	CH#1 TO JLG DIAG	18AWG	GXL	X158(C)
4	GRN	CH#1 TO J7-24	18AWG	GXL	C02-J7(24)
5	GRN	CH#1 TO TILT SNSR	18AWG	GXL	X432(T)
6	GRN	CH#1 TO JLG DIAG	18AWG	GXL	X158(D)
7	GRN	CH#1 TO PLATFORM	18AWG	GXL	X83B(2)
8	GRN	CH#1 TO DISPLAY	18AWG	GXL	X144B(7)
9	GRN	CH#1 TO MS385	18AWG	GXL	X432(N)
10	YEL	CH#1 TO PLATFORM	18AWG	GXL	X83B(3)
11	YEL	CH#1 TO DISPLAY	18AWG	GXL	X144B(8)
12	YEL	CH#1 TO MS385	18AWG	GXL	X432(P)

SECTION 7 - BASIC ELECTRICAL INFORMATION & ELECTRICAL SCHEMATICS

X158 JLG DIAGNOSTIC					
CONN POS	WIRE COLOR	WIRE LABEL	GAUGE	JACKET	TO
A	BLK	0-14-6-2	18AWG	GXL	S162(1)
B	RED	1-3-2	18AWG	GXL	S160(2)
C	YEL	CH#1 TO JLG DIAG	18AWG	GXL	MS132(3)
D	GRN	CH#1 TO JLG DIAG	18AWG	GXL	MS132(6)
E					
F					
G					
H	YEL	2-14-5-2	18AWG	GXL	S163(1)
J					

S113					
CONN POS	WIRE COLOR	WIRE LABEL	GAUGE	JACKET	TO
1	YEL	2-12-1	18AWG	GXL	MS227(2)
1	YEL	2-12-1-1	18AWG	GXL	X83B(4)
2	YEL	2-12-1-2	18AWG	GXL	CO2-J7(1)
2	YEL	2-12-1-3	18AWG	GXL	CO2-J7(2)

X83B BOOM CABLE					
CONN POS	WIRE COLOR	WIRE LABEL	GAUGE	JACKET	TO
1					
2	GRN	CH#1 TO PLATFORM	18AWG	GXL	MS132(7)
3	YEL	CH#1 TO PLATFORM	18AWG	GXL	MS132(10)
4	YEL	2-12-1-1	18AWG	GXL	S113(1)
5	YEL	2-13	18AWG	GXL	X144B(1)
6	WHT	49-15 FOOT SW	18AWG	GXL	CO2-J7(15)
7					
8					
9	BLK	0-57	18AWG	GXL	CO2-J7(10)
10	YEL	2-14-21-2	12AWG	GXL	S109(1)
11	WHT	49-11 GND MODE	18AWG	GXL	CO2-J7(14)
12	YEL	2-14-21-1	12AWG	GXL	S109(1)
13					
14					
15					
16	BLK	0-14-3-1	12AWG	GXL	S129(1)
17					
18	BLK	0-14-3-2	12AWG	GXL	S129(1)
19					

CO2-J8 UGM POWER PLUG					
CONN POS	WIRE COLOR	WIRE LABEL	GAUGE	JACKET	TO
1	BLK	0-14-4	12AWG	GXL	X432(E)
2	YEL	2-14-22	12AWG	GXL	X432(D)
3					
4					

CO2-J12 BLACK					
CONN POS	WIRE COLOR	WIRE LABEL	GAUGE	JACKET	TO
1					
2					
3	YEL	CH#2 TO TERMINATOR	18AWG	GXL	X338(4)
4	GRN	CH#2 TO TERMINATOR	18AWG	GXL	X338(3)
5	BLK	0-50	18AWG	GXL	MS331-1(C)
6					
7					
8	WHT	49-16 MSSO	18AWG	GXL	X144B(9)

X338 CAN ISOLATER					
CONN POS	WIRE COLOR	WIRE LABEL	GAUGE	JACKET	TO
1	GRN	CH#2 TO IMG CNTRL	18AWG	GXL	MS331-1(B)
2	YEL	CH#2 TO IMG CNTRL	18AWG	GXL	MS331-1(A)
3	GRN	CH#2 TO TERMINATOR	18AWG	GXL	CO2-J12(4)
4	YEL	CH#2 TO TERMINATOR	18AWG	GXL	CO2-J12(3)

SECTION 7 - BASIC ELECTRICAL INFORMATION & ELECTRICAL SCHEMATICS

X335 TO BOOM SNSR					
CONN POS	WIRE COLOR	WIRE LABEL	GAUGE	JACKET	TO
1	WHT	49-33 ELEV CUTBK SW	18AWG	GXL	C02-J7(11)
2					
3					
4					
5					
6	WHT	49-32 ELEV SW SUP	18AWG	GXL	C02-J7(29)
7	WHT	49-31CAP LNTH SUP	18AWG	GXL	C02-J7(26)
8	WHT	49-30 CAP LNTH SW	18AWG	GXL	C02-J7(7)
9	WHT	49-29 CAP ANG SUP	18AWG	GXL	C02-J7(16)
10	WHT	49-28 CAP ANG SW	18AWG	GXL	C02-J7(4)
11					
12					
13					
14					
15					

C02-J7 BLACK					
CONN POS	WIRE COLOR	WIRE LABEL	GAUGE	JACKET	TO
1	YEL	2-12-1-2	18AWG	GXL	S113(2)
2	YEL	2-12-1-3	18AWG	GXL	S113(2)
3	YEL	2-12-3	18AWG	GXL	X144B(3)
4	WHT	49-28 CAP ANG SW	18AWG	GXL	X335(10)
5					
6					
7	WHT	49-30 CAP LNTH SW	18AWG	GXL	X335(8)
8					
9					
10	BLK	0-57	18AWG	GXL	X83B(9)
11	WHT	49-33 ELEV CUTBK SW	18AWG	GXL	X335(1)
12					
13	YEL	CH#1 TO J7-13	18AWG	GXL	MS132(1)
14	WHT	49-11 GND MODE	18AWG	GXL	X83B(11)
15	WHT	49-15 FOOT SW	18AWG	GXL	X83B(6)
16	WHT	49-29 CAP ANG SUP	18AWG	GXL	X335(9)
17	WHT	49-40 CAN TERM JUMPER	18AWG	GXL	C02-J7(6)
18					
19	BLK	0-42	18AWG	GXL	X336(4)
20					
21	WHT	49-34 TWR TELE PROX	18AWG	GXL	X336(6)
22	WHT	49-36 TWR LFT PROX	18AWG	GXL	X336(3)
23	YEL	2-11-9	18AWG	GXL	C02-J7(30)
24	GRN	CH#1 TO J7-24	18AWG	GXL	MS132(4)
25					
26	WHT	49-31 CAP LNTH SUP	18AWG	GXL	X335(7)
27					
28					
29	WHT	49-32 ELEV SW SUP	18AWG	GXL	X335(6)
30					
31					
32					
33	WHT	49-35 TWR TELE PROX	18AWG	GXL	X336(5)
34	WHT	49-37 TWR LIFT PROX	18AWG	GXL	X336(2)
35	WHT	49-17 DRV ORNT	18AWG	GXL	SN337(1)

X336 TO TWR BOOM SNSR					
CONN POS	WIRE COLOR	WIRE LABEL	GAUGE	JACKET	TO
1	BLK	0-42-1	18AWG	GXL	X336(4)
2	WHT	49-37 TWR LIFT PROX	18AWG	GXL	C02-J7(34)
3	WHT	49-36 TWR LFT PROX	18AWG	GXL	C02-J7(22)
4	BLK	0-42	18AWG	GXL	C02-J7(19)
5	WHT	49-35 TWR TELE PROX	18AWG	GXL	C02-J7(33)
6	WHT	49-34 TWR TELE PROX	18AWG	GXL	C02-J7(21)
7					
8					
9					
10					
11					
12	YEL	2-14-11-2	18AWG	GXL	S458(1)
13					
14	YEL	2-14-11-1	18AWG	GXL	S458(1)
15	BLK	0-14-7	18AWG	GXL	X432(J)

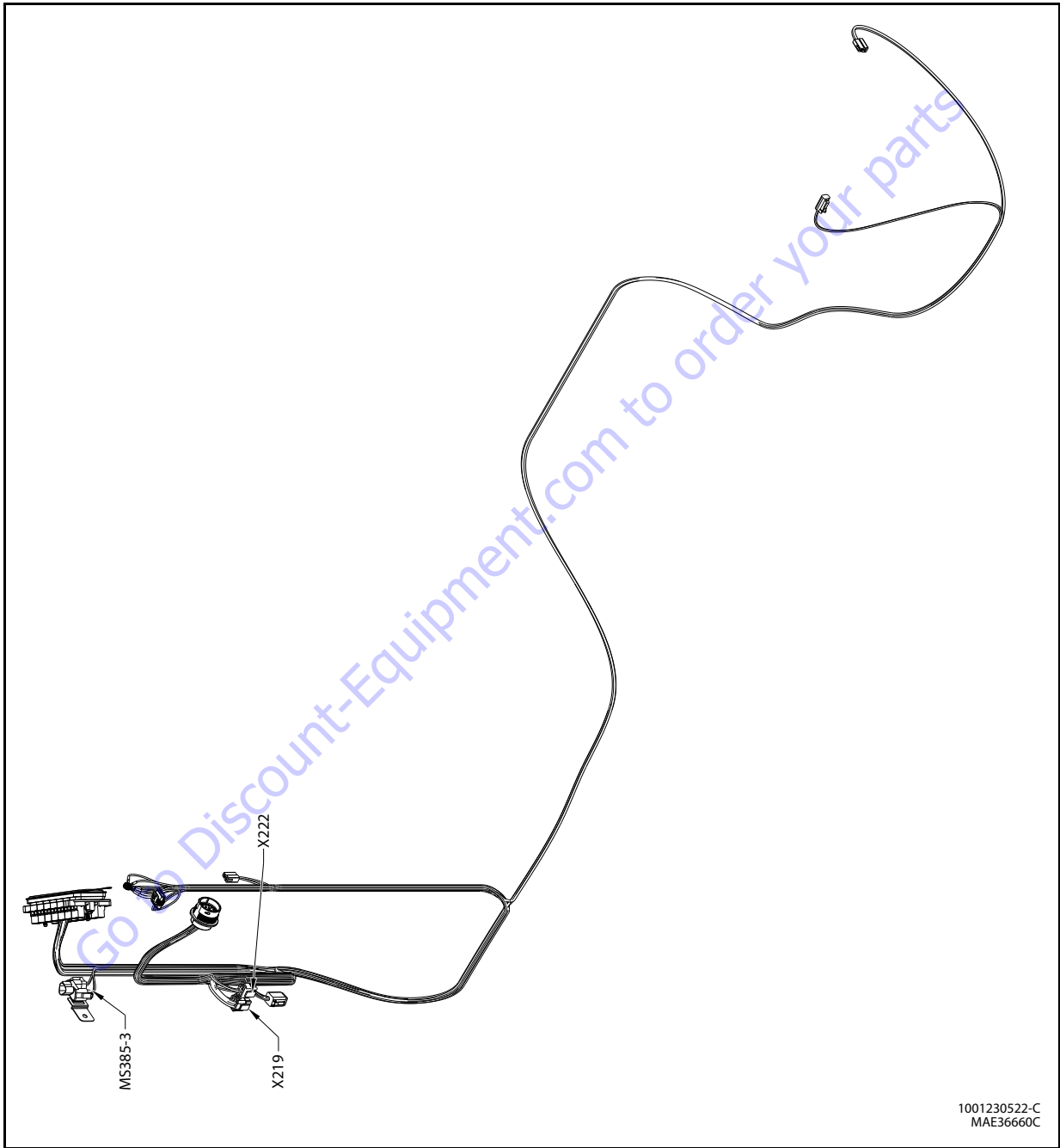

Figure 7-71. Turntable Fuse Panel Harness - Sheet 1 of 3

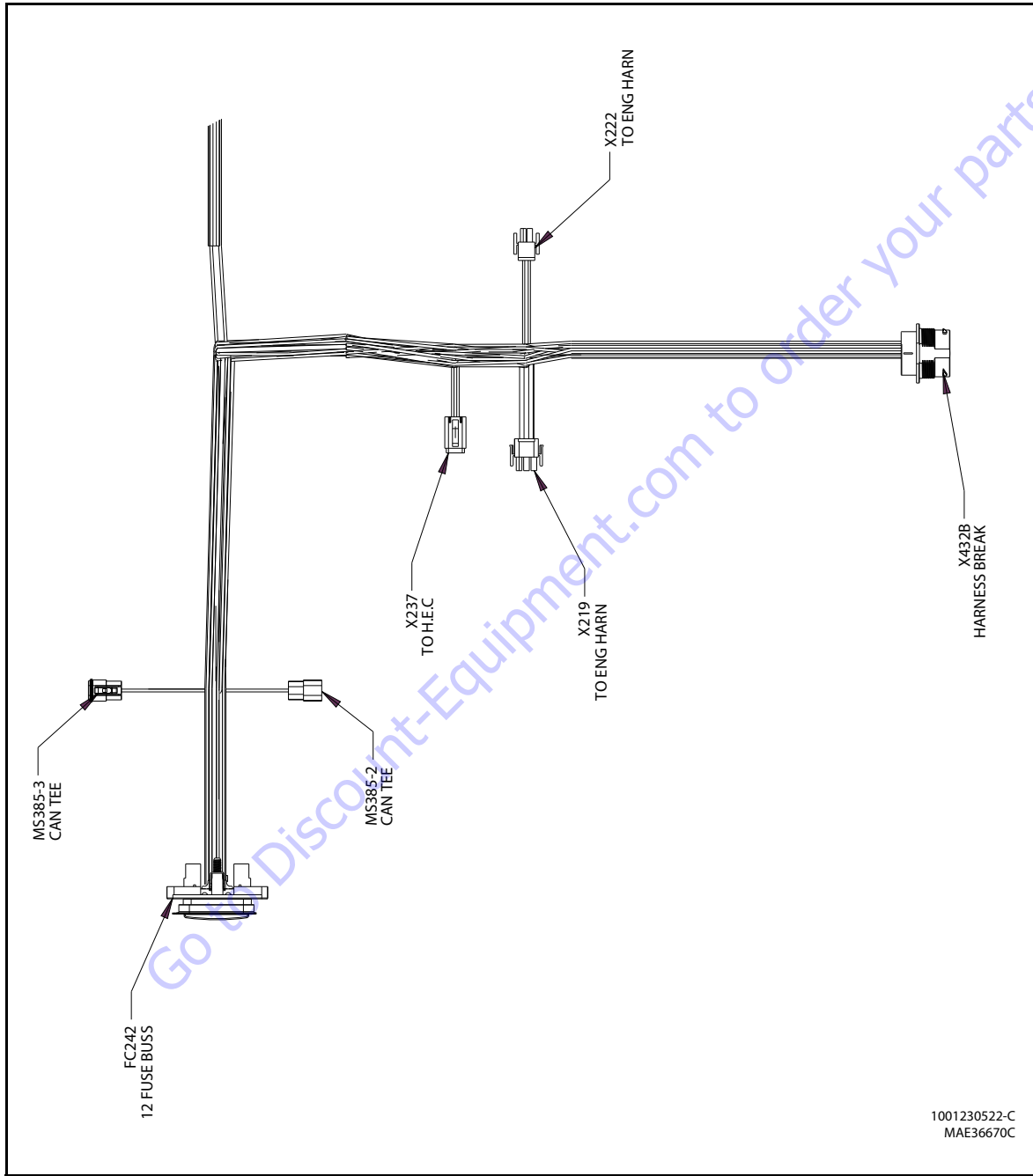

Figure 7-72. Turntable Fuse Panel Harness - Sheet 2 of 3

SECTION 7 - BASIC ELECTRICAL INFORMATION & ELECTRICAL SCHEMATICS

FC242 12 FUSE BUSS					
CONN POS	WIRE COLOR	WIRE LABEL	GAUGE	JACKET	TO
1	YEL	2-14-1	10AWG	GXL	X219(4)
2	YEL	2-14-2	10AWG	GXL	X219(5)
3	YEL	2-14-4	12AWG	GXL	X219(7)
4	YEL	2-14-5	12AWG	GXL	X219(8)
5	YEL	2-14-7	12AWG	GXL	X219(2)
6	YEL	2-14-8	12AWG	GXL	X219(3)
7	YEL	2-14-9	10AWG	GXL	X219(6)
8	YEL	2-14-3	16AWG	GXL	X222(4)
9	YEL	2-14-6	18AWG	GXL	X222(3)
10	YEL	2-14-10	18AWG	GXL	X319(1)
11	YEL	2-14-15	14AWG	GXL	X222(2)
12	YEL	2-14-11	18AWG	GXL	X432B(H)
13	YEL	2-14-12	18AWG	GXL	X237(1)
14	YEL	2-14-14	18AWG	GXL	X432B(C)
15	YEL	2-14-13	18AWG	GXL	X237(4)
16	YEL	2-14-16	18AWG	GXL	X334(1)
17	YEL	2-14-17	18AWG	GXL	X432B(R)
18					
19					
20	YEL	2-14-20	18AWG	GXL	X432B(L)
21	YEL	2-14-21	12AWG	GXL	X432B(B)
22	YEL	2-14-22	12AWG	GXL	X432B(D)
23					
24					
25					
26					
27	RED	1-3	18AWG	GXL	X432B(K)
28	RED	1-1	16AWG	GXL	X432B(A)

MS385-2 CAN TEE					
CONN POS	WIRE COLOR	WIRE LABEL	GAUGE	JACKET	TO
A	YEL	CH#1 TO HEC	18AWG	GXL	X237(5)
B	GRN	CH#1 TO HEC	18AWG	GXL	X237(6)
C					

MS385-3 CAN TEE					
CONN POS	WIRE COLOR	WIRE LABEL	GAUGE	JACKET	TO
A	YEL	CH#1 TO MS385	18AWG	GXL	X432B(P)
B	GRN	CH#1 TO MS385	18AWG	GXL	X432B(N)
C					

X237 TO H.E.C					
CONN POS	WIRE COLOR	WIRE LABEL	GAUGE	JACKET	TO
1	YEL	2-14-12	18AWG	GXL	FC242(13)
2	BLK	0-14-5	18AWG	GXL	X127(1)
3					
4	YEL	2-14-13	18AWG	GXL	FC242(15)
5	YEL	CH#1 TO HEC	18AWG	GXL	MS385-2(A)
6	GRN	CH#1 TO HEC	18AWG	GXL	MS385-2(B)

SECTION 7 - BASIC ELECTRICAL INFORMATION & ELECTRICAL SCHEMATICS

X219 TO ENG HARN					
CONN POS	WIRE COLOR	WIRE LABEL	GAUGE	JACKET	TO
1	WHT	49-27 OIL COOL FAN	12AWG	GXL	WH244(2)
2	YEL	2-14-7	12AWG	GXL	FC242(5)
3	YEL	2-14-8	12AWG	GXL	FC242(6)
4	YEL	2-14-1	10AWG	GXL	FC242(1)
5	YEL	2-14-2	10AWG	GXL	FC242(2)
6	YEL	2-14-9	10AWG	GXL	FC242(7)
7	YEL	2-14-4	12AWG	GXL	FC242(3)
8	YEL	2-14-5	12AWG	GXL	FC242(4)
9					

X222 TO ENG HARN					
CONN POS	WIRE COLOR	WIRE LABEL	GAUGE	JACKET	TO
1	WHT	49-21 OIL COOL FAN	18AWG	GXL	X319(2)
2	YEL	2-14-15	14AWG	GXL	FC242(11)
3	YEL	2-14-6	18AWG	GXL	FC242(9)
4	YEL	2-14-3	16AWG	GXL	FC242(8)
5					
6					

X432B HARNES BREAK					
CONN POS	WIRE COLOR	WIRE LABEL	GAUGE	JACKET	TO
A	RED	1-1	16AWG	GXL	FC242(28)
B	YEL	2-14-21	12AWG	GXL	FC242(21)
C	YEL	2-14-14	18AWG	GXL	FC242(14)
D	YEL	2-14-22	12AWG	GXL	FC242(22)
E	BLK	0-14-4	12AWG	GXL	X124(1)
F	BLK	0-14-2	18AWG	GXL	X126(1)
G	BLK	0-14-3	10AWG	GXL	X125(1)
H	YEL	2-14-11	18AWG	GXL	FC242(12)
J	BLK	0-14-7	18AWG	GXL	X165(1)
K	RED	1-3	18AWG	GXL	FC242(27)
L	YEL	2-14-20	18AWG	GXL	FC242(20)
M	BLK	0-14-6	18AWG	GXL	X161(1)
N	GRN	CH#1 TO MS385	18AWG	GXL	MS385-3(B)
P	YEL	CH#1 TO MS385	18AWG	GXL	MS385-3(A)
R	YEL	2-14-17	18AWG	GXL	FC242(17)
S	YEL	CH#1 TO TILT SNSR	18AWG	GXL	X334(3)
T	GRN	CH#1 TO TILT SNSR	18AWG	GXL	X334(4)
U	YEL	2-12	18AWG	GXL	RL111(1)
V					
W					
X					

Go to Discount-Equipment.com to order your parts

This Page Left Blank Intentionally

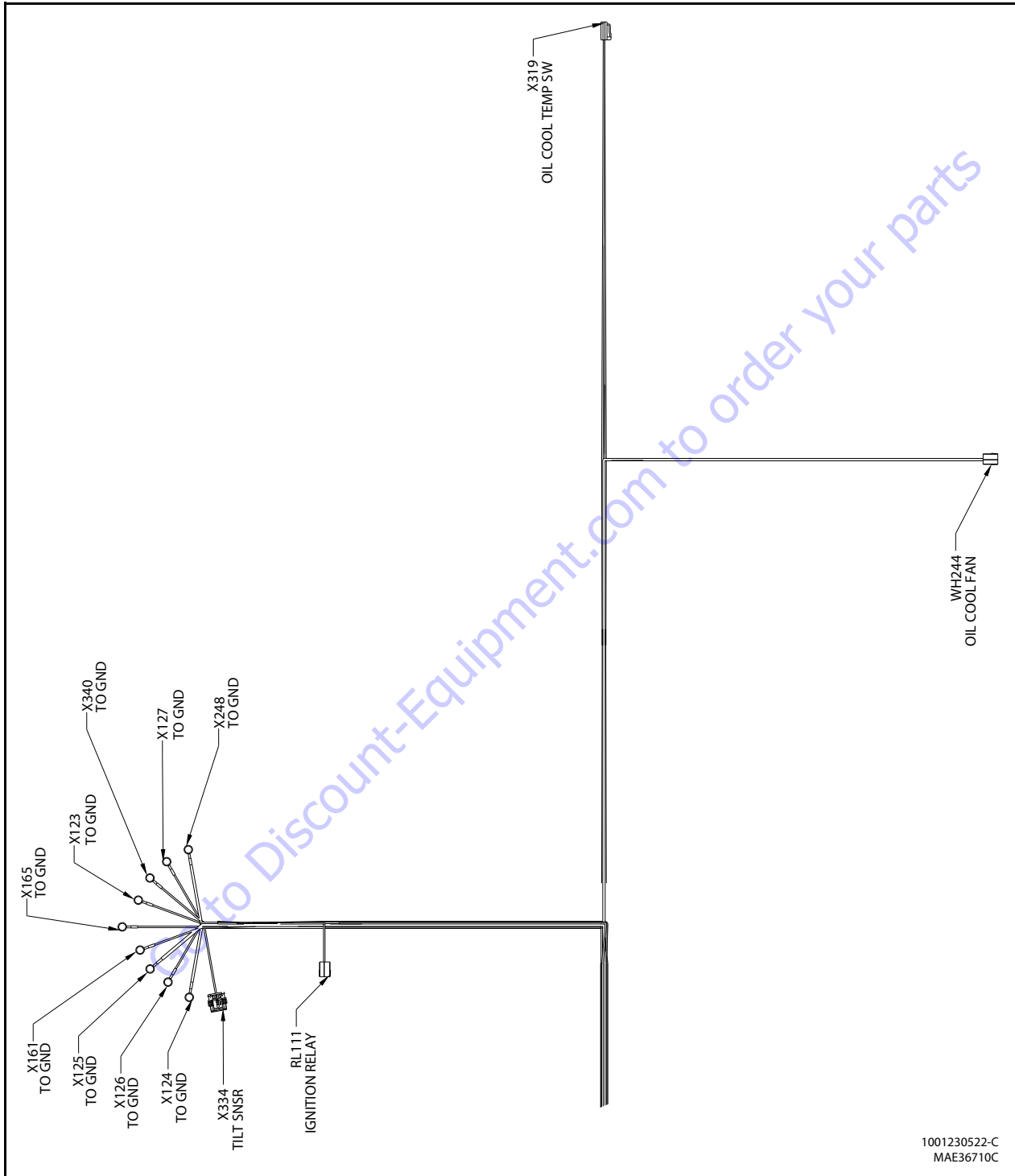

Figure 7-73. Turntable Fuse Panel Harness - Sheet 3 of 3

SECTION 7 - BASIC ELECTRICAL INFORMATION & ELECTRICAL SCHEMATICS

RL111 IGNITION RELAY					
CONN POS	WIRE COLOR	WIRE LABEL	GAUGE	JACKET	TO
1	YEL	2-12	18AWG	GXL	X432B(U)
2	BLK	0-14-1	18AWG	GXL	X123(1)

X125 TO GND					
CONN POS	WIRE COLOR	WIRE LABEL	GAUGE	JACKET	TO
1	BLK	0-14-3	10AWG	GXL	X432B(G)

X334 TILT SNSR					
CONN POS	WIRE COLOR	WIRE LABEL	GAUGE	JACKET	TO
1	YEL	2-14-16	18AWG	GXL	FC242(16)
2	BLK	0-40	18AWG	GXL	X340(1)
3	YEL	CH#1 TO TILT SNSR	18AWG	GXL	X432B(S)
4	GRN	CH#1 TO TILT SNSR	18AWG	GXL	X432B(T)

X161 TO GND					
CONN POS	WIRE COLOR	WIRE LABEL	GAUGE	JACKET	TO
1	BLK	0-14-6	18AWG	GXL	X432B(M)

X124 TO GND					
CONN POS	WIRE COLOR	WIRE LABEL	GAUGE	JACKET	TO
1	BLK	0-14-4	12AWG	GXL	X432B(E)

X165 TO GND					
CONN POS	WIRE COLOR	WIRE LABEL	GAUGE	JACKET	TO
1	BLK	0-14-7	18AWG	GXL	X432B(J)

X126 TO GND					
CONN POS	WIRE COLOR	WIRE LABEL	GAUGE	JACKET	TO
1	BLK	0-14-2	18AWG	GXL	X432B(F)

X123 TO GND					
CONN POS	WIRE COLOR	WIRE LABEL	GAUGE	JACKET	TO
1	BLK	0-14-1	18AWG	GXL	RL111(2)

SECTION 7 - BASIC ELECTRICAL INFORMATION & ELECTRICAL SCHEMATICS

X340 TO GND					
CONN POS	WIRE COLOR	WIRE LABEL	GAUGE	JACKET	TO
1	BLK	0-40	18AWG	GXL	X334(2)

WH244 OILCOOL FAN					
CONN POS	WIRE COLOR	WIRE LABEL	GAUGE	JACKET	TO
1	BLK	0-40-1	12AWG	GXL	X248(1)
2	WHT	49-27 OIL COOL FAN	12AWG	GXL	X219(1)

X127 TO GND					
CONN POS	WIRE COLOR	WIRE LABEL	GAUGE	JACKET	TO
1	BLK	0-14-5	18AWG	GXL	X237(2)

X319 OIL COOLT EMP SW					
CONN POS	WIRE COLOR	WIRE LABEL	GAUGE	JACKET	TO
1	YEL	2-14-10	18AWG	GXL	FC242(10)
2	WHT	49-21 OIL COOL FAN	18AWG	GXL	X222(1)

X248 TO GND					
CONN POS	WIRE COLOR	WIRE LABEL	GAUGE	JACKET	TO
1	BLK	0-40-1	12AWG	GXL	WH244(1)

Go to Discount-Equipment.com to order your parts

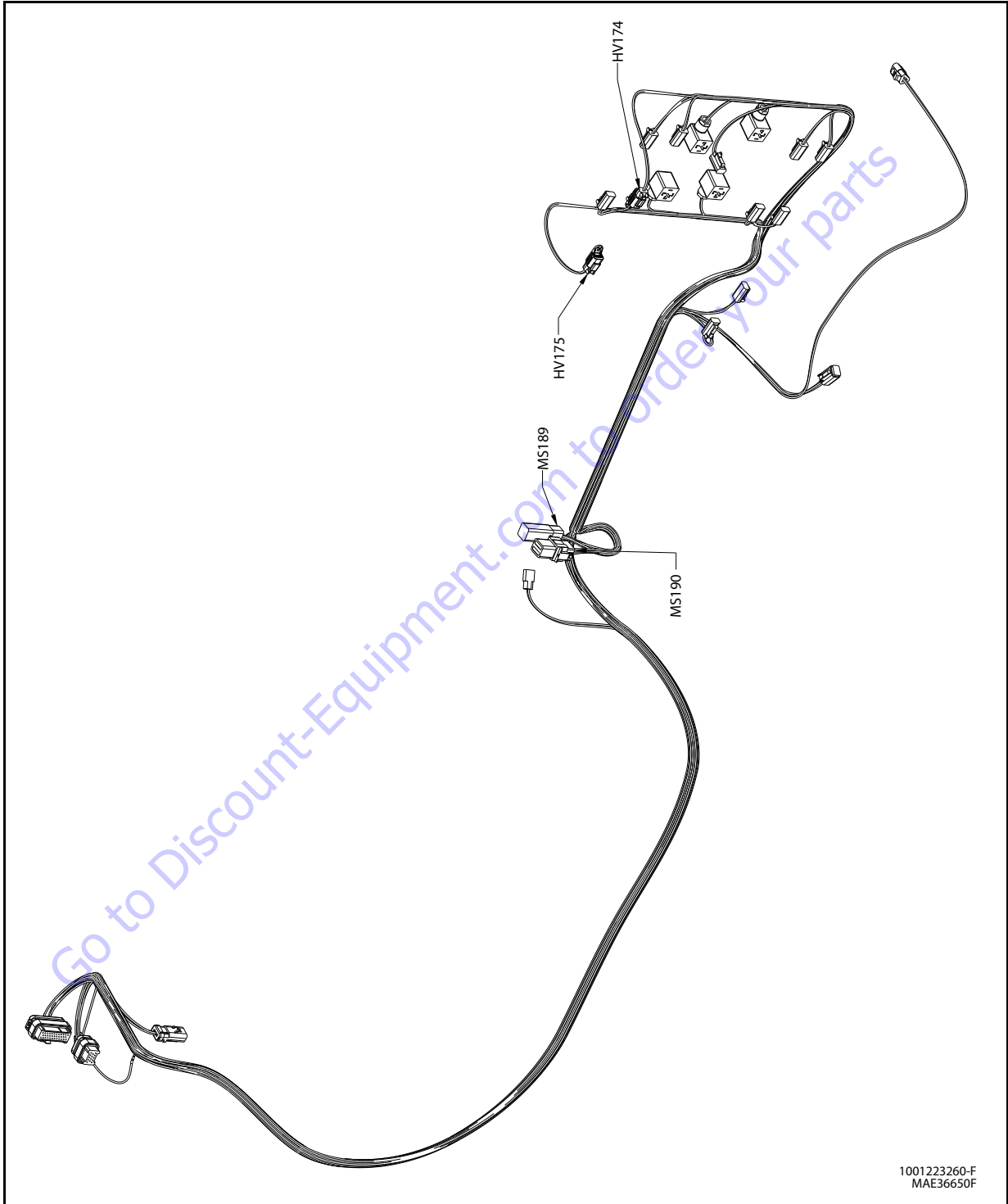

Figure 7-74. Main Valve Harness - Sheet 1 of 2

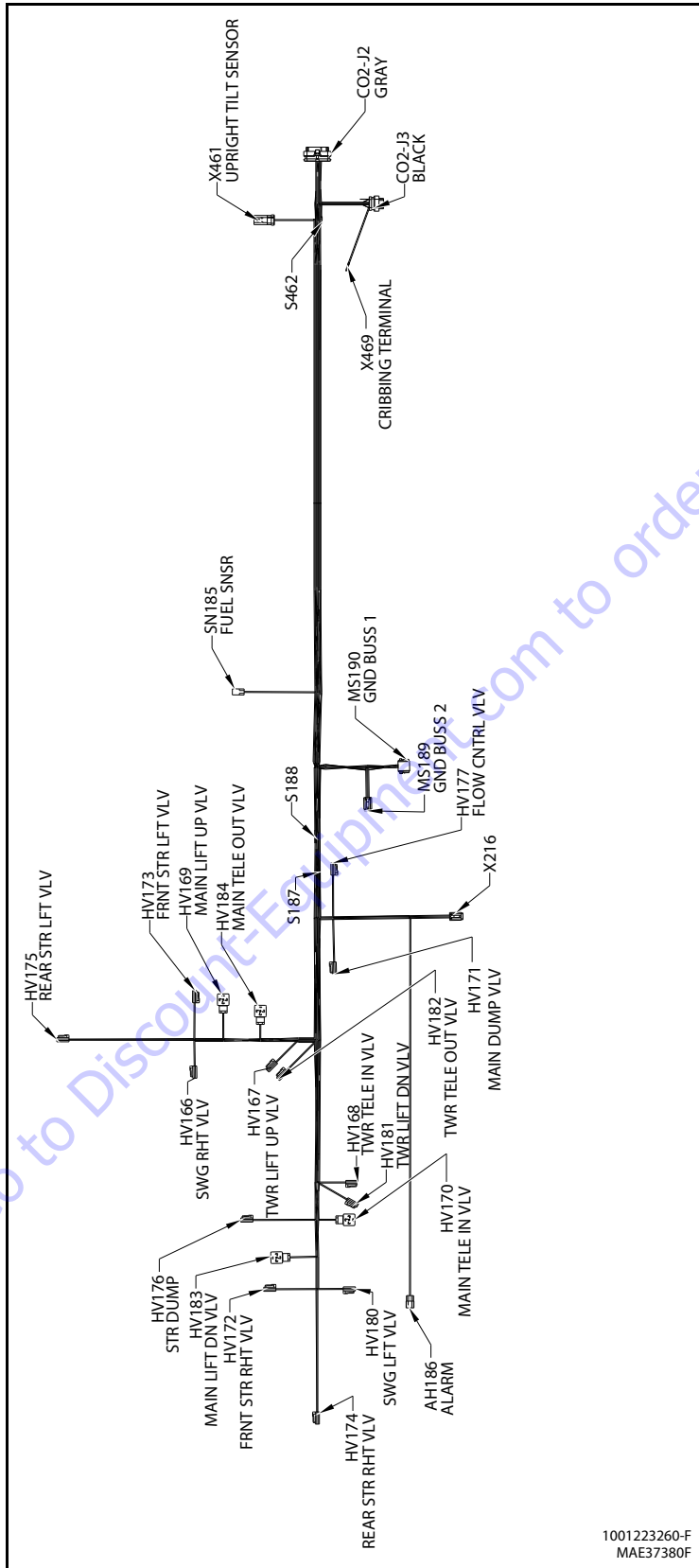

Figure 7-75. Main Valve Harness - Sheet 2 of 2

SECTION 7 - BASIC ELECTRICAL INFORMATION & ELECTRICAL SCHEMATICS

HV174- REAR STR RHT VLV					
CONN POS	WIRE COLOR	WIRE LABEL	GAUGE	JACKET	TO
1	WHT	26-3 REAR STR RHT VLV	18AWG	GXL	CO2-J2(9)
2	BLK	0-23-3	18AWG	GXL	MS189(3)

HV181 TWR LIFT DN VLV					
CONN POS	WIRE COLOR	WIRE LABEL	GAUGE	JACKET	TO
1	WHT	6-3 TWR DN VLV	18AWG	GXL	CO2-J2(32)
2	BLK	0-24-2	18AWG	GXL	MS190(6)

HV172 FRNT STR RHT VLV					
CONN POS	WIRE COLOR	WIRE LABEL	GAUGE	JACKET	TO
1	WHT	26-1 FRNT STR RHT VLV	18AWG	GXL	CO2-J2(8)
2	BLK	0-23-1	18AWG	GXL	MS189(5)

S462					
CONN POS	WIRE COLOR	WIRE LABEL	GAUGE	JACKET	TO
1	YEL	2-16	18AWG	GXL	CO2-J3(7)
2	YEL	2-16-1	18AWG	GXL	X216(2)
2	YEL	2-16-2	18AWG	GXL	X461(1)

HV180 SWG LFT VLV					
CONN POS	WIRE COLOR	WIRE LABEL	GAUGE	JACKET	TO
1	WHT	22-2 SWG LFT VLV	18AWG	GXL	CO2-J2(34)
2	WHT	60-1-1 SWING RTN	18AWG	GXL	S187(2)

HV168 TWR TELE IN VLV					
CONN POS	WIRE COLOR	WIRE LABEL	GAUGE	JACKET	TO
1	WHT	7-3 TWR IN VLV	18AWG	GXL	CO2-J2(3)
2	BLK	0-24-3	18AWG	GXL	MS190(5)

HV183- MAIN LIFT DN VLV					
CONN POS	WIRE COLOR	WIRE LABEL	GAUGE	JACKET	TO
1	WHT	24-2 LIFT DN VLV	18AWG	GXL	CO2-J2(22)
2	WHT	60-2-1 MAIN LIFT RTN	18AWG	GXL	S188(2)

HV175 REAR STR LFT VLV					
CONN POS	WIRE COLOR	WIRE LABEL	GAUGE	JACKET	TO
1	WHT	26-4 REAR STR LFT VLV	18AWG	GXL	CO2-J2(20)
2	BLK	0-23-4	18AWG	GXL	MS189(2)

HV176 STR DUMP					
CONN POS	WIRE COLOR	WIRE LABEL	GAUGE	JACKET	TO
1	WHT	3-4 STR DUMP VLV	18AWG	GXL	CO2-J2(1)
2	BLK	0-23-5	18AWG	GXL	MS189(1)

HV166 SWG RHT VLV					
CONN POS	WIRE COLOR	WIRE LABEL	GAUGE	JACKET	TO
1	WHT	21-2 SWG RHT VLV	18AWG	GXL	CO2-J2(35)
2	WHT	60-1-2 SWG RTN	18AWG	GXL	S187(2)

HV170 MAIN TELE IN VLV					
CONN POS	WIRE COLOR	WIRE LABEL	GAUGE	JACKET	TO
1	WHT	9-3TELEINVLV	18AWG	GXL	CO2-J2(4)
2	BLK	0-24-5	18AWG	GXL	MS190(3)

HV173 FRNT STR LFT VLV					
CONN POS	WIRE COLOR	WIRE LABEL	GAUGE	JACKET	TO
1	WHT	26-2 FRNT STR LFT VLV	18AWG	GXL	CO2-J2(19)
2	BLK	0-23-2	18AWG	GXL	MS189(4)

SECTION 7 - BASIC ELECTRICAL INFORMATION & ELECTRICAL SCHEMATICS

HV169 MAIN LIFT UP VLV					
CONN POS	WIRE COLOR	WIRE LABEL	GAUGE	JACKET	TO
1	WHT	23-2 LIFT UP VLV	18AWG	GXL	C02-J2(11)
2	WHT	60-2-2 MAIN LIFT RTN	18AWG	GXL	S188(2)

HV177 FLOW CNTRL VLV					
CONN POS	WIRE COLOR	WIRE LABEL	GAUGE	JACKET	TO
1	WHT	3-3 FLOW CNTRL VLV	18AWG	GXL	C02-J2(31)
2	WHT	60-3 FLOW CNTRL RTN	18AWG	GXL	C02-J3(6)

HV184- MAIN TELE OUT VLV					
CONN POS	WIRE COLOR	WIRE LABEL	GAUGE	JACKET	TO
1	WHT	10-3 TELE OUT VLV	18AWG	GXL	C02-J2(16)
2	BLK	0-24-6	18AWG	GXL	MS190(2)

AH186 ALARM					
CONN POS	WIRE COLOR	WIRE LABEL	GAUGE	JACKET	TO
A	WHT	49-18 ALARM/HORN	18AWG	GXL	C02-J2(27)
B					
C	BLK	0-22	18AWG	GXL	C02-J2(14)

HV167 TWR LIFT UP VLV					
CONN POS	WIRE COLOR	WIRE LABEL	GAUGE	JACKET	TO
1	WHT	5-3 TWR UP VLV	18AWG	GXL	C02-J2(33)
2	BLK	0-24-1	18AWG	GXL	MS190(7)

X469 CRIBBING TERMINAL					
CONN POS	WIRE COLOR	WIRE LABEL	GAUGE	JACKET	TO
1	WHT	52-75 CRIBBING	18AWG	GXL	C02-J3(9)

X461 UP RIGHT TILT SENSOR					
CONN POS	WIRE COLOR	WIRE LABEL	GAUGE	JACKET	TO
1	YEL	2-16-2	18AWG	GXL	S462(2)
2	WHT	49-40 UP RIGHT TILT	18AWG	GXL	C02-J3(8)
3	BLK	0-57	18AWG	GXL	C02-J3(3)

X216					
CONN POS	WIRE COLOR	WIRE LABEL	GAUGE	JACKET	TO
1	WHT	60-4 DRIVE RTN	18AWG	GXL	C02-J3(1)
2	YEL	2-16-1	18AWG	GXL	S462(2)
3	WHT	60-5 THROTTLE RTN	18AWG	GXL	C02-J3(2)
4	WHT	55-9 H&T LT SIG	18AWG	GXL	C02-J2(26)

HV182 TWR TELE OUT VLV					
CONN POS	WIRE COLOR	WIRE LABEL	GAUGE	JACKET	TO
1	WHT	8-3 TWR OUT VLV	18AWG	GXL	C02-J2(15)
2	BLK	0-24-4	18AWG	GXL	MS190(4)

S188					
CONN POS	WIRE COLOR	WIRE LABEL	GAUGE	JACKET	TO
1	WHT	60-2 MAIN LIFT RTN	18AWG	GXL	C02-J3(14)
2	WHT	60-2-1 MAIN LIFT RTN	18AWG	GXL	HV183(2)
2	WHT	60-2-2 MAIN LIFT RTN	18AWG	GXL	HV169(2)

HV171 MAIN DUMP VLV					
CONN POS	WIRE COLOR	WIRE LABEL	GAUGE	JACKET	TO
1	WHT	3-2 MAIN DUMP VLV	18AWG	GXL	C02-J2(13)
2	BLK	0-24-7	18AWG	GXL	MS190(1)

SECTION 7 - BASIC ELECTRICAL INFORMATION & ELECTRICAL SCHEMATICS

S187					
CONN POS	WIRE COLOR	WIRE LABEL	GAUGE	JACKET	TO
1	WHT	60-1 SWG RTN	18AWG	GXL	CO2-J3(4)
2	WHT	60-1-1 SWING RTN	18AWG	GXL	HV180(2)
2	WHT	60-1-2 SWG RTN	18AWG	GXL	HV166(2)

SN185 FUEL SNSR					
CONN POS	WIRE COLOR	WIRE LABEL	GAUGE	JACKET	TO
1	WHT	48-30 FUEL SNSR	18AWG	GXL	CO2-J2(25)
2	BLK	0-21	18AWG	GXL	CO2-J2(6)

CO2-J2 GRAY					
CONN POS	WIRE COLOR	WIRE LABEL	GAUGE	JACKET	TO
1	WHT	3-4 STR DUMP VLV	18AWG	GXL	HV176(1)
2					
3	WHT	7-3 TWR IN VLV	18AWG	GXL	HV168(1)
4	WHT	9-3 TELE IN VLV	18AWG	GXL	HV170(1)
5					
6	BLK	0-21	18AWG	GXL	SN185(2)
7					
8	WHT	26-1 FRNT STR RHT VLV	18AWG	GXL	HV172(1)
9	WHT	26-3 REAR STR RHT VLV	18AWG	GXL	HV174(1)
10					
11	WHT	23-2 LIFT UP VLV	18AWG	GXL	HV169(1)
12					
13	WHT	3-2 MAIN DUMP VLV	18AWG	GXL	HV171(1)
14	BLK	0-22	18AWG	GXL	AH186(C)
15	WHT	8-3 TWR OUT VLV	18AWG	GXL	HV182(1)
16	WHT	10-3 TELE OUT VLV	18AWG	GXL	HV184(1)
17	BLK	0-24	16AWG	GXL	MS190(8)
18					
19	WHT	26-2 FRNT STR LFT VLV	18AWG	GXL	HV173(1)
20	WHT	26-4 REAR STR LFT VLV	18AWG	GXL	HV175(1)
21					
22	WHT	24-2 LIFT DN VLV	18AWG	GXL	HV183(1)
23					
24					
25	WHT	48-30 FUEL SNSR	18AWG	GXL	SN185(1)
26	WHT	55-9 H&T LT SIG	18AWG	GXL	X216(4)
27	WHT	49-18 ALARM/HORN	18AWG	GXL	AH186(A)
28	WHT	49-50 MSSO CONFIG	18AWG	GXL	CO2-J3(11)
29					
30	BLK	0-23	16AWG	GXL	MS189(6)
31	WHT	3-3 FLOW CNTRL VLV	18AWG	GXL	HV177(1)
32	WHT	6-3 TWR DN VLV	18AWG	GXL	HV181(1)
33	WHT	5-3 TWR UP VLV	18AWG	GXL	HV167(1)
34	WHT	22-2 SWG LFT VLV	18AWG	GXL	HV180(1)
35	WHT	21-2 SWG RHT VLV	18AWG	GXL	HV166(1)

SECTION 7 - BASIC ELECTRICAL INFORMATION & ELECTRICAL SCHEMATICS

MS189 GND BUSS 2					
CONN POS	WIRE COLOR	WIRE LABEL	GAUGE	JACKET	TO
1	BLK	0-23-5	18AWG	GXL	HV176(2)
2	BLK	0-23-4	18AWG	GXL	HV175(2)
3	BLK	0-23-3	18AWG	GXL	HV174(2)
4	BLK	0-23-2	18AWG	GXL	HV173(2)
5	BLK	0-23-1	18AWG	GXL	HV172(2)
6	BLK	0-23	16AWG	GXL	C02-J2(30)

MS190 GND BUSS 1					
CONN POS	WIRE COLOR	WIRE LABEL	GAUGE	JACKET	TO
1	BLK	0-24-7	18AWG	GXL	HV171(2)
2	BLK	0-24-6	18AWG	GXL	HV184(2)
3	BLK	0-24-5	18AWG	GXL	HV170(2)
4	BLK	0-24-4	18AWG	GXL	HV182(2)
5	BLK	0-24-3	18AWG	GXL	HV168(2)
6	BLK	0-24-2	18AWG	GXL	HV181(2)
7	BLK	0-24-1	18AWG	GXL	HV167(2)
8	BLK	0-24	16AWG	GXL	C02-J2(17)

C02-J3 BLACK					
CONN POS	WIRE COLOR	WIRE LABEL	GAUGE	JACKET	TO
1	WHT	60-4 DRIVE RTN	18AWG	GXL	X216(1)
2	WHT	60-5 THROTTLE RTN	18AWG	GXL	X216(3)
3	BLK	0-57	18AWG	GXL	X461(3)
4	WHT	60-1 SWG RTN	18AWG	GXL	S187(1)
5					
6	WHT	60-3 FLOW CNTRL RTN	18AWG	GXL	HV177(2)
7	YEL	2-16	18AWG	GXL	S462(1)
8	WHT	49-40 UP RIGHT TILT	18AWG	GXL	X461(2)
9	WHT	52-75 CRIBBING	18AWG	GXL	X469(1)
10					
11	WHT	49-50 MSSO CONFIG	18AWG	GXL	C02-J2(28)
12					
13					
14	WHT	60-2 MAIN LIFT RTN	18AWG	GXL	S188(1)

Go to Discount-Equipment.com to order your parts

This Page Left Blank Intentionally

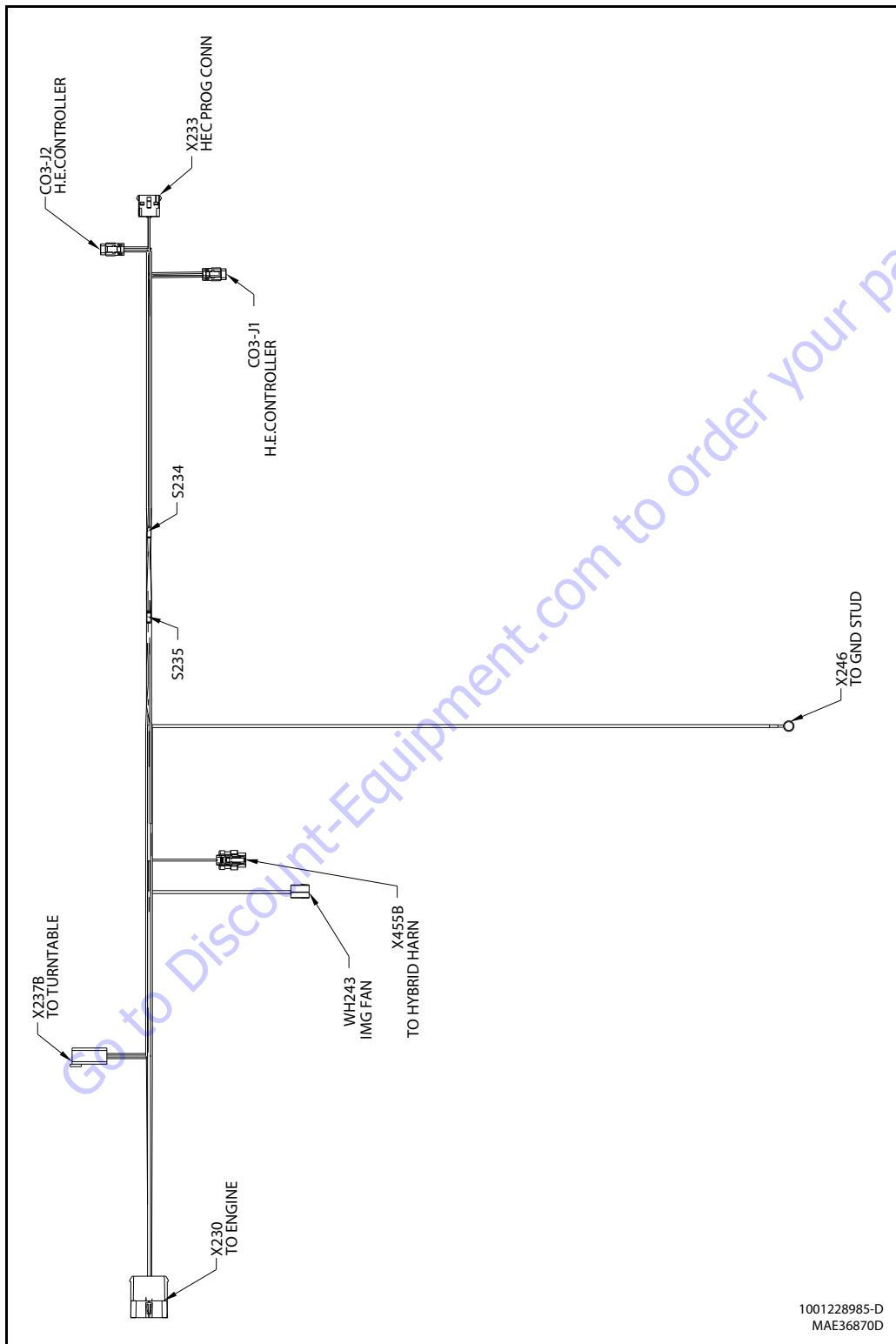

Figure 7-76. Controller Harness

SECTION 7 - BASIC ELECTRICAL INFORMATION & ELECTRICAL SCHEMATICS

WH243					
CONN POS	WIRE COLOR	WIRE LABEL	GAUGE	JACKET	TO
1	BLK	0-14-8-1	12AWG	GXL	X246(1)
2	WHT	49-25 IMG FAN	12AWG	GXL	X230(E)

S235					
CONN POS	WIRE COLOR	WIRE LABEL	GAUGE	JACKET	TO
1	BLK	0-14-5	18AWG	GXL	X237B(2)
2	BLK	0-14-5-1	18AWG	GXL	C03-J1(2)
2	BLK	0-14-5-2	18AWG	GXL	X233(4)

X455B-TOHYBRIDHARN					
CONN POS	WIRE COLOR	WIRE LABEL	GAUGE	JACKET	TO
1	YEL	2-14-13	18AWG	GXL	X237B(4)
2	BLK	0-14-8-2	18AWG	GXL	X246(1)
3	WHT	49-57 DC/DC CONT	18AWG	GXL	C03-J1(8)

C03-J1 H.E.CONTROLLER					
CONN POS	WIRE COLOR	WIRE LABEL	GAUGE	JACKET	TO
1	YEL	2-14-12-1	18AWG	GXL	S234(2)
2	BLK	0-14-5-1	18AWG	GXL	S235(2)
3					
4					
5					
6					
7	WHT	49-20 IMG FAN	18AWG	GXL	X230(A)
8	WHT	49-57 DC/DC CONT	18AWG	GXL	X455B(3)
9					
10	WHT	49-23 ENG FAN	18AWG	GXL	X230(D)
11					
12					

X237B TO TURN TABLE					
CONN POS	WIRE COLOR	WIRE LABEL	GAUGE	JACKET	TO
1	YEL	2-14-12	18AWG	GXL	S234(1)
2	BLK	0-14-5	18AWG	GXL	S235(1)
3					
4	YEL	2-14-13	18AWG	GXL	X455B(1)
5	YEL	CH#1 TO HEC CONT	18AWG	GXL	C03-J2(9)
6	GRN	CH#1 TO HEC CONT	18AWG	GXL	C03-J2(10)

X230 TO ENGINE					
CONN POS	WIRE COLOR	WIRE LABEL	GAUGE	JACKET	TO
A	WHT	49-20 IMG FAN	18AWG	GXL	C03-J1(7)
B					
C					
D	WHT	49-23 ENG FAN	18AWG	GXL	C03-J1(10)
E	WHT	49-25 IMG FAN	12AWG	GXL	WH243(2)

X246					
CONN POS	WIRE COLOR	WIRE LABEL	GAUGE	JACKET	TO
1	BLK	0-14-8-1	12AWG	GXL	WH243(1)
1	BLK	0-14-8-2	18AWG	GXL	X455B(2)

SECTION 7 - BASIC ELECTRICAL INFORMATION & ELECTRICAL SCHEMATICS

C03-J2 H.E.CONTROLLER					
CONN POS	WIRE COLOR	WIRE LABEL	GAUGE	JACKET	TO
1					
2					
3					
4					
5					
6					
7					
8					
9	YEL	CH#1 TO HEC CONT	18AWG	GXL	X237B(5)
10	GRN	CH#1 TO HEC CONT	18AWG	GXL	X237B(6)
11	WHT	4-7 TX	18AWG	GXL	X233(3)
12	WHT	4-8 RX	18AWG	GXL	X233(2)

S234					
CONN POS	WIRE COLOR	WIRE LABEL	GAUGE	JACKET	TO
1	YEL	2-14-12	18AWG	GXL	X237B(1)
2	YEL	2-14-12-1	18AWG	GXL	C03-J1(1)
2	YEL	2-14-12-2	18AWG	GXL	X233(1)

X233 HEC PROG CONN					
CONN POS	WIRE COLOR	WIRE LABEL	GAUGE	JACKET	TO
1	YEL	2-14-12-2	18AWG	GXL	S234(2)
2	WHT	4-8 RX	18AWG	GXL	C03-J2(12)
3	WHT	4-7 TX	18AWG	GXL	C03-J2(11)
4	BLK	0-14-5-2	18AWG	GXL	S235(2)

Go to Discount-Equipment.com to order your parts

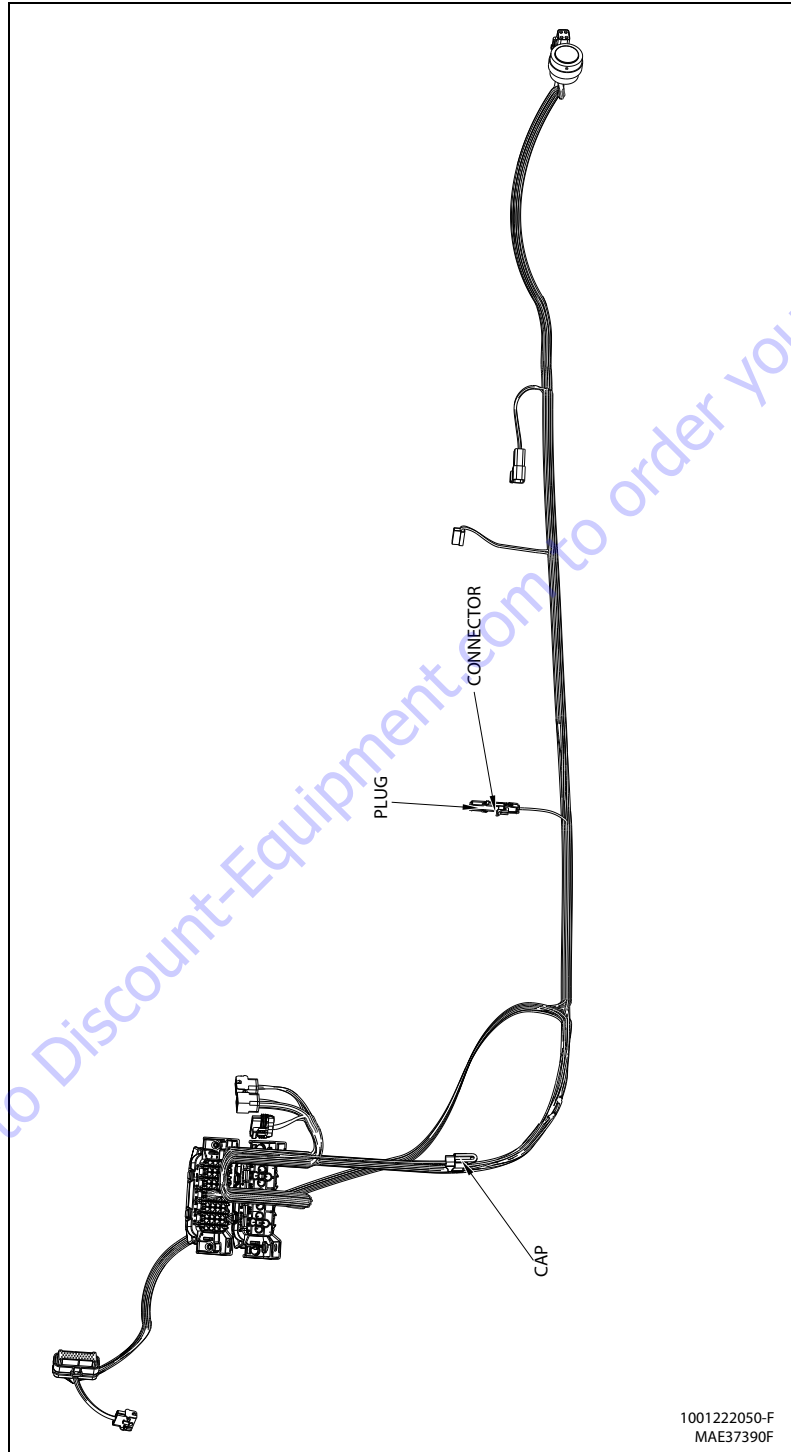

Figure 7-77. Engine Harness - Sheet 1 of 2

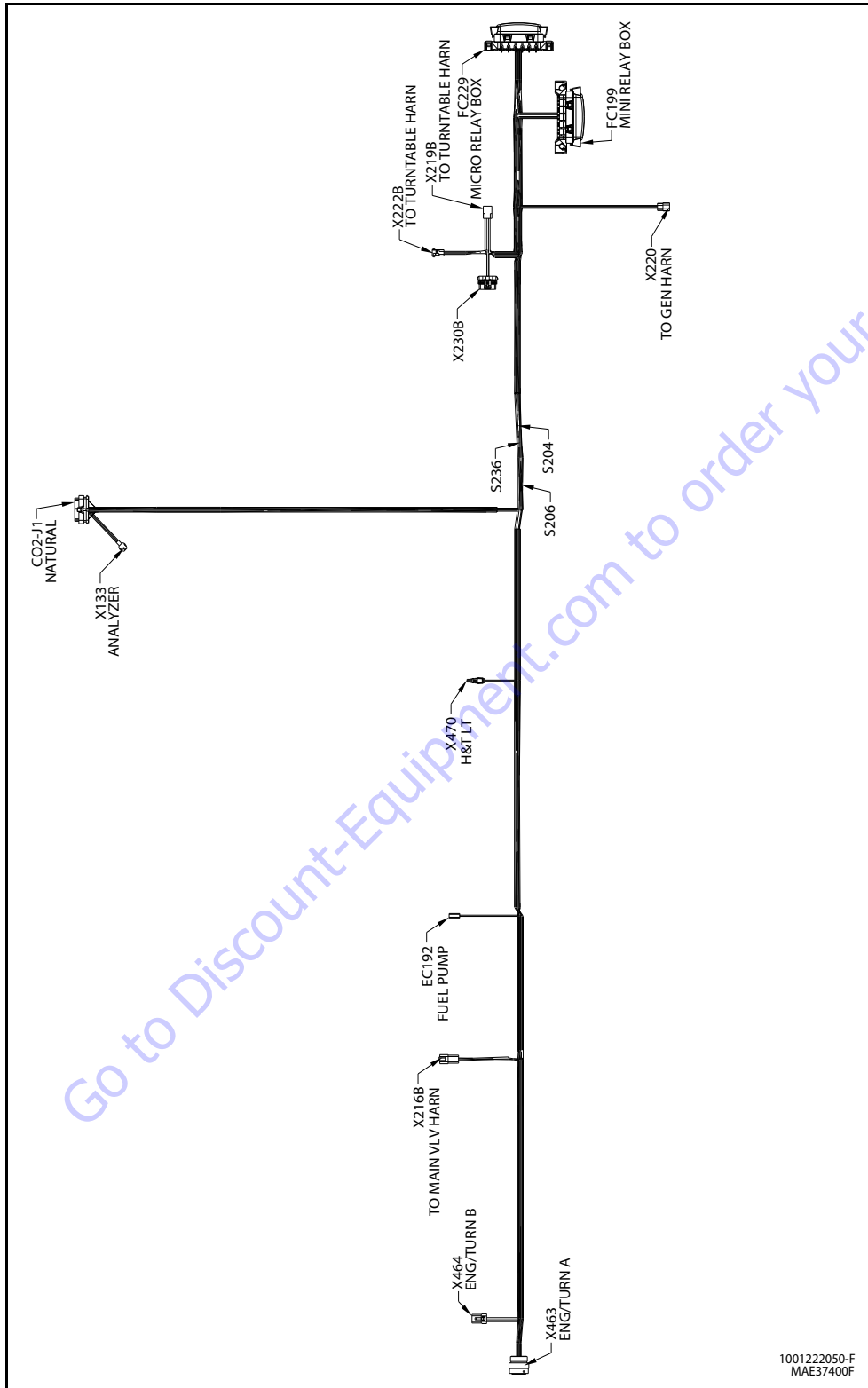

Figure 7-78. Engine Harness - Sheet 2 of 2

SECTION 7 - BASIC ELECTRICAL INFORMATION & ELECTRICAL SCHEMATICS

X463 ENG/TURN A					
CONN POS	WIRE COLOR	WIRE LABEL	GAUGE	JACKET	TO
A	WHT	60-4 DRIVE RTN	18AWG	GXL	X216B(1)
B	WHT	25-2 DRV REV	18AWG	GXL	C02-J1(6)
C	WHT	25-1 DRV FWD	18AWG	GXL	C02-J1(3)
D	WHT	25-32 SPD	18AWG	GXL	C02-J1(20)
E	BLK	0-18	18AWG	GXL	C02-J1(5)
F	WHT	25-4 PRK BRK	18AWG	GXL	C02-J1(23)
G					
H					
J					
K					
L					
M					
N	WHT	60-5 THROTTLE RTN	18AWG	GXL	X216B(3)
O	BLK	0-27	16AWG	GXL	EC192(2)
P	WHT	48-13 THR ACT	18AWG	GXL	C02-J1(1)
Q	WHT	48-16 ALT EXC	18AWG	GXL	C02-J1(32)
R	YEL	2-16-1	18AWG	TXL	X216B(2)
S	WHT	48-21 ENG SPD SNSR	18AWG	TXL	C02-J1(16)
T	BLK	0-16	18AWG	TXL	C02-J1(4)
U					
V	WHT	48-20 OIL PRS	18AWG	GXL	C02-J1(15)
W	WHT	48-19 TEMP SNSR	18AWG	GXL	C02-J1(14)
X	BLK	0-19	18AWG	GXL	C02-J1(8)

X464 ENG/TURN B					
CONN POS	WIRE COLOR	WIRE LABEL	GAUGE	JACKET	TO
1	WHT	49-26 ENG FAN	10AWG	GXL	FC199(12)
2					
3	WHT	48-23 GLOW	10AWG	GXL	FC199(2)
4	WHT	48-22 START	10AWG	TXL	FC229(14)

X216B TO MAIN VLV HARN					
CONN POS	WIRE COLOR	WIRE LABEL	GAUGE	JACKET	TO
1	WHT	60-4 DRIVE RTN	18AWG	GXL	X463(A)
2	YEL	2-16-1	18AWG	TXL	X463(R)
3	WHT	60-5 THROTTLE RTN	18AWG	GXL	X463(N)
4	WHT	55-9 H&T LT SIG	18AWG	GXL	FC229(37)

EC192 TO MAIN VALVE					
CONN POS	WIRE COLOR	WIRE LABEL	GAUGE	JACKET	TO
1	WHT	48-24 FUL PMP	16AWG	GXL	FC229(2)
2	BLK	0-27	16AWG	GXL	X463(O)

X470 H&T LT					
CONN POS	WIRE COLOR	WIRE LABEL	GAUGE	JACKET	TO
1	WHT	55-10 HEAD & TAIL	16AWG	GXL	FC229(38)

X133 ANALYZER					
CONN POS	WIRE COLOR	WIRE LABEL	GAUGE	JACKET	TO
1	WHT	4-49.5 V PWR	18AWG	GXL	C02-J1(28)
2	WHT	4-5 RX	18AWG	GXL	C02-J1(29)
3	WHT	4-6 TX	18AWG	GXL	C02-J1(30)
4	BLK	0-15	18AWG	GXL	C02-J1(31)

SECTION 7 - BASIC ELECTRICAL INFORMATION & ELECTRICAL SCHEMATICS

C02-J1 NATURAL					
CONN POS	WIRE COLOR	WIRE LABEL	GAUGE	JACKET	TO
1	WHT	48-13 THR ACT	18AWG	GXL	X463(P)
2	WHT	48-14 FUL RLY	18AWG	GXL	FC229(1)
3	WHT	25-1 DRV FWD	18AWG	GXL	X463(C)
4	BLK	0-16	18AWG	TXL	X463(T)
5	BLK	0-18	18AWG	GXL	X463(E)
6	WHT	25-2 DRV REV	18AWG	GXL	X463(B)
7					
8	BLK	0-19	18AWG	GXL	X463(X)
9	BLK	0-25	18AWG	GXL	S204(2)
10					
11	WHT	48-17 STRT RLY	18AWG	GXL	FC229(13)
12	WHT	48-18 GLOW RLY	18AWG	GXL	FC199(5)
13					
14	WHT	48-19 TEMP SNSR	18AWG	GXL	X463(W)
15	WHT	48-20 OIL PRS	18AWG	GXL	X463(V)
16	WHT	48-21 ENG SPD SNSR	18AWG	TXL	X463(S)
17	BLK	0-26	18AWG	GXL	S206(2)
18	BLK	0-28	18AWG	GXL	X220(C)
19	BLK	0-30	16AWG	GXL	S236(2)
20	WHT	25-32 SPD	18AWG	GXL	X463(D)
21					
22	WHT	48-24 GEN	18AWG	GXL	X220(B)
23	WHT	25-4 PRK BRK	18AWG	GXL	X463(F)
24					
25					
26					
27	BLK	0-17	18AWG	GXL	FC229(46)
28	WHT	4-49.5 V PWR	18AWG	GXL	X133(1)
29	WHT	4-5 RX	18AWG	GXL	X133(2)
30	WHT	4-6 TX	18AWG	GXL	X133(3)
31	BLK	0-15	18AWG	GXL	X133(4)
32	WHT	48-16 ALT EXC	18AWG	GXL	X463(Q)
33					
34					
35					

S206 TO TURN TABLE					
CONN POS	WIRE COLOR	WIRE LABEL	GAUGE	JACKET	TO
1	BLK	0-26-1	18AWG	GXL	FC229(10)
1	BLK	0-26-2	18AWG	GXL	FC229(22)
2	BLK	0-26	18AWG	GXL	C02-J1(17)

S236 TO TURN TABLE					
CONN POS	WIRE COLOR	WIRE LABEL	GAUGE	JACKET	TO
1	BLK	0-30-1	18AWG	GXL	FC229(12)
1	BLK	0-30-2	18AWG	GXL	FC229(24)
2	BLK	0-30	16AWG	GXL	C02-J1(19)

S204					
CONN POS	WIRE COLOR	WIRE LABEL	GAUGE	JACKET	TO
1	BLK	0-25-1	18AWG	GXL	FC199(6)
1	BLK	0-25-2	18AWG	GXL	FC199(1)
1	BLK	0-30-3	18AWG	GXL	FC199(11)
2	BLK	0-25	18AWG	GXL	C02-J1(9)

X230B					
CONN POS	WIRE COLOR	WIRE LABEL	GAUGE	JACKET	TO
A	WHT	49-20 IMG FAN	18AWG	GXL	FC229(3)
B					
C					
D	WHT	49-23 ENG FAN	18AWG	GXL	FC199(15)
E	WHT	49-25 IMG FAN	12AWG	GXL	FC229(4)

SECTION 7 - BASIC ELECTRICAL INFORMATION & ELECTRICAL SCHEMATICS

X222B TO TURN TABLE HARN					
CONN POS	WIRE COLOR	WIRE LABEL	GAUGE	JACKET	TO
1	WHT	49-21 OIL COOL FAN	18AWG	GXL	FC229(15)
2	YEL	2-14-15	14AWG	GXL	FC229(45)
3	YEL	2-14-6	18AWG	GXL	X220(A)
4	YEL	2-14-3	16AWG	GXL	FC229(9)
5					
6					

FC199 MINI RELAY BOX					
CONN POS	WIRE COLOR	WIRE LABEL	GAUGE	JACKET	TO
1	BLK	0-25-2	18AWG	GXL	S204(1)
2	WHT	48-23 GLOW	10AWG	GXL	X464(3)
3					
4	YEL	2-14-2	10AWG	GXL	X219B(5)
5	WHT	48-18 GLOW RLY	18AWG	GXL	CO2-J1(12)
6	BLK	0-25-1	18AWG	GXL	S204(1)
7					
8					
9					
10					
11	BLK	0-30-3	18AWG	GXL	S204(1)
12	WHT	49-26 ENG FAN	10AWG	GXL	X464(1)
13					
14	YEL	2-14-9	10AWG	GXL	X219B(6)
15	WHT	49-23 ENG FAN	18AWG	GXL	X230B(D)

X219B TO TURN TABLE HARN					
CONN POS	WIRE COLOR	WIRE LABEL	GAUGE	JACKET	TO
1	WHT	49-27OILCOOLFAN	12AWG	GXL	FC229(16)
2	YEL	2-14-7	12AWG	GXL	FC229(11)
3	YEL	2-14-8	12AWG	GXL	FC229(23)
4	YEL	2-14-1	10AWG	TXL	FC229(21)
5	YEL	2-14-2	10AWG	GXL	FC199(4)
6	YEL	2-14-9	10AWG	GXL	FC199(14)
7					
8					
9					

X220 TO H.E.CONTROLLER					
CONN POS	WIRE COLOR	WIRE LABEL	GAUGE	JACKET	TO
A	YEL	2-14-6	18AWG	GXL	X222B(3)
B	WHT	48-24 GEN	18AWG	GXL	CO2-J1(22)
C	BLK	0-28	18AWG	GXL	CO2-J1(18)

SECTION 7 - BASIC ELECTRICAL INFORMATION & ELECTRICAL SCHEMATICS

FC229 MICRO RELAY BOX					
CONN POS	WIRE COLOR	WIRE LABEL	GAUGE	JACKET	TO
1	WHT	48-14 FUL RLY	18AWG	GXL	C02-J1(2)
2	WHT	48-24 FUL PMP	16AWG	GXL	EC192(1)
3	WHT	49-20 IMG FAN	18AWG	GXL	X230B(A)
4	WHT	49-25 IMG FAN	12AWG	GXL	X230B(E)
6					
8					
9	YEL	2-14-3	16AWG	GXL	X222B(4)
10	BLK	0-26-1	18AWG	GXL	S206(1)
11	YEL	2-14-7	12AWG	GXL	X219B(2)
12	BLK	0-30-1	18AWG	GXL	S236(1)
13	WHT	48-17 STRT RLY	18AWG	GXL	C02-J1(11)
14	WHT	48-22 START	10AWG	TXL	X464(4)
15	WHT	49-21 OIL COOL FAN	18AWG	GXL	X222B(1)
16	WHT	49-27 OIL COOL FAN	12AWG	GXL	X219B(1)
18					
20					
21	YEL	2-14-1	10AWG	TXL	X219B(4)
22	BLK	0-26-2	18AWG	GXL	S206(1)
23	YEL	2-14-8	12AWG	GXL	X219B(3)
24	BLK	0-30-2	18AWG	GXL	S236(1)
25					
26					
27					
28					
30					
32					
33					
34					
35					
36					
37	WHT	55-9 H&T LT SIG	18AWG	GXL	X216B(4)
38	WHT	55-10 HEAD&TAIL	16AWG	GXL	X470(1)
39					
40					
42					
44					
45	YEL	2-14-15	14AWG	GXL	X222B(2)
46	BLK	0-17	18AWG	GXL	C02-J1(27)
47					
48					

Go to Discount-Equipment.com to order your parts

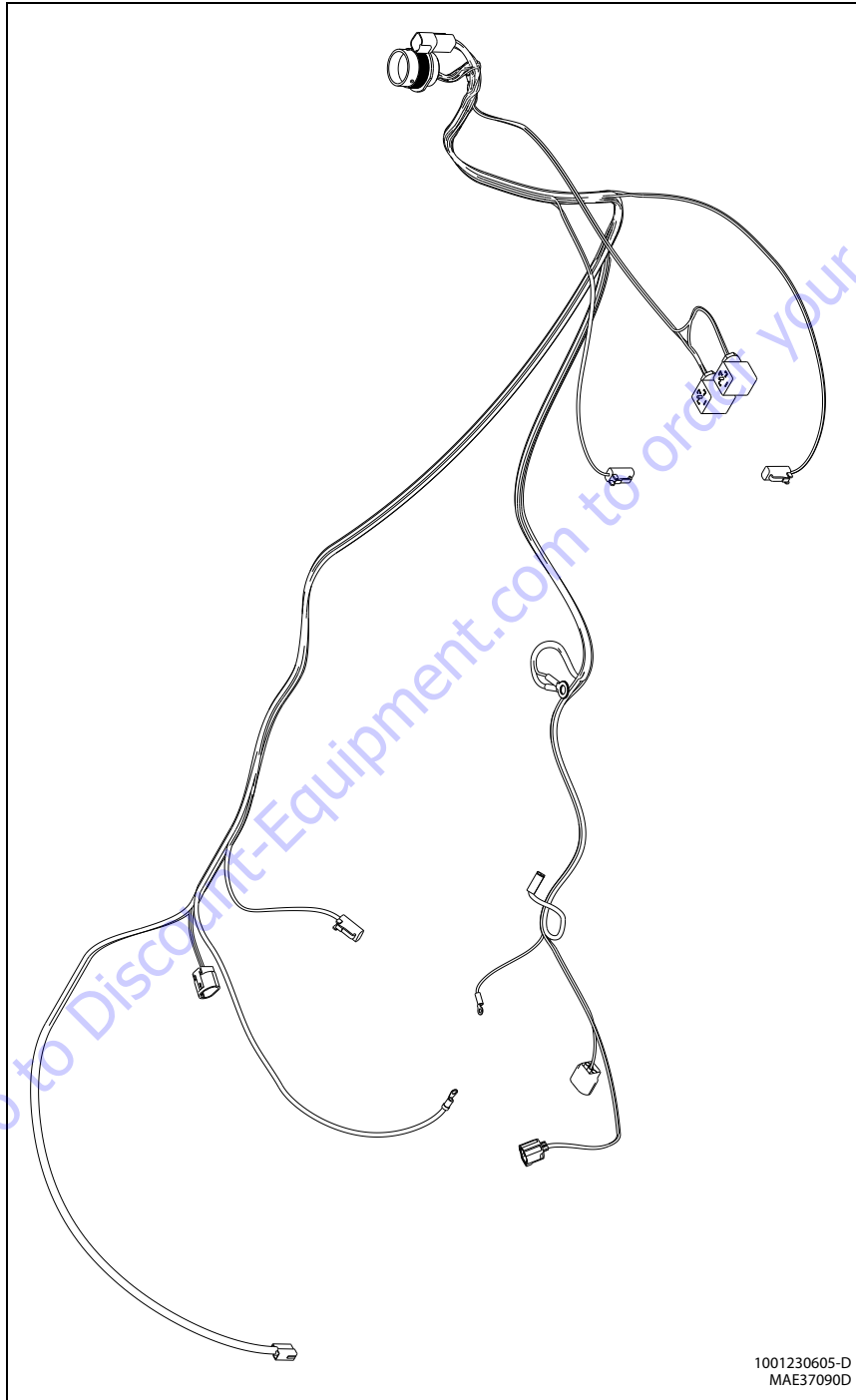

Figure 7-79. Engine Tray Harness - Sheet 1 of 2

SECTION 7 - BASIC ELECTRICAL INFORMATION & ELECTRICAL SCHEMATICS

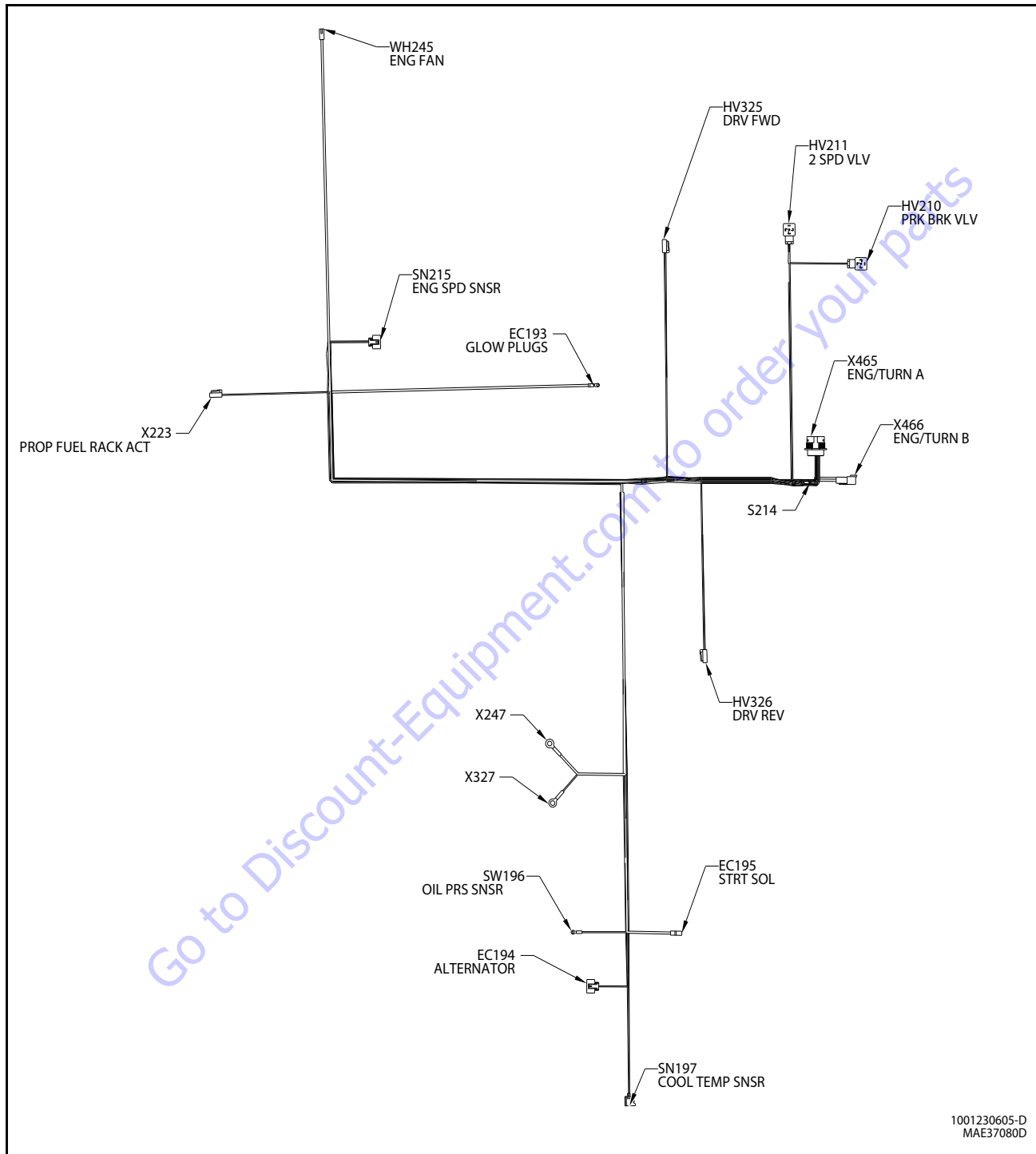

Figure 7-80. Engine Tray Harness - Sheet 2 of 2

SECTION 7 - BASIC ELECTRICAL INFORMATION & ELECTRICAL SCHEMATICS

WH245 ENG FAN					
CONN POS	WIRE COLOR	WIRE LABEL	GAUGE	JACKET	TO
1	BLK	0-14-9	10AWG	GXL	X247(1)
2	WHT	49-26 ENG FAN	10AWG	GXL	X466(1)

SW196 OIL PRS SNSR					
CONN POS	WIRE COLOR	WIRE LABEL	GAUGE	JACKET	TO
1	WHT	48-20 OIL PRS	18AWG	GXL	X465(V)

SN215 ENG SPD SNSR					
CONN POS	WIRE COLOR	WIRE LABEL	GAUGE	JACKET	TO
1	YEL	2-16-1	18AWG	TXL	X465(R)
2	WHT	48-21 ENG SPD SNSR	18AWG	TXL	X465(S)
3	BLK	0-16	18AWG	TXL	X465(T)

EC194 ALTERNATOR					
CONN POS	WIRE COLOR	WIRE LABEL	GAUGE	JACKET	TO
1					
2	WHT	48-16 ALT EXC	18AWG	GXL	X465(Q)
3					

X223 PROP FUEL RACK ACT					
CONN POS	WIRE COLOR	WIRE LABEL	GAUGE	JACKET	TO
1	WHT	60-5 THROTTLE RTN	18AWG	GXL	X465(N)
2	WHT	48-13 THR ACT	18AWG	GXL	X465(P)

SN197 COOL TEMP SNSR					
CONN POS	WIRE COLOR	WIRE LABEL	GAUGE	JACKET	TO
1	WHT	48-19 TEMP SNSR	18AWG	GXL	X465(W)
2	BLK	0-19	18AWG	GXL	X465(X)

X247 TO GROUND					
CONN POS	WIRE COLOR	WIRE LABEL	GAUGE	JACKET	TO
1	BLK	0-14-9	10AWG	GXL	WH245(1)

HV325 DRV FWD					
CONN POS	WIRE COLOR	WIRE LABEL	GAUGE	JACKET	TO
1	WHT	25-1 DRV FWD	18AWG	GXL	X465(C)
2	WHT	60-4-1 DRIVE RTN	18AWG	GXL	S214(1)

X327 TO GROUND					
CONN POS	WIRE COLOR	WIRE LABEL	GAUGE	JACKET	TO
1	BLK	0-27	16AWG	GXL	X465(O)

HV326 DRV REV					
CONN POS	WIRE COLOR	WIRE LABEL	GAUGE	JACKET	TO
1	WHT	25-2DRVREV	18AWG	GXL	X465(B)
2	WHT	60-4-2DRIVERTN	18AWG	GXL	S214(1)

EC193 GLOW PLUGS					
CONN POS	WIRE COLOR	WIRE LABEL	GAUGE	JACKET	TO
1	WHT	48-23GLOW	10AWG	GXL	X466(3)

SECTION 7 - BASIC ELECTRICAL INFORMATION & ELECTRICAL SCHEMATICS

HV211 2 SPD VLV					
CONN POS	WIRE COLOR	WIRE LABEL	GAUGE	JACKET	TO
1	WHT	25-32 SPD	18AWG	GXL	X465(D)
2	BLK	0-18	18AWG	GXL	X465(E)
2	BLK	0-18-1	18AWG	GXL	HV210(2)

HV210 PRK BRK VLV					
CONN POS	WIRE COLOR	WIRE LABEL	GAUGE	JACKET	TO
1	WHT	25-4 PRK BRK	18AWG	GXL	X465(F)
2	BLK	0-18-1	18AWG	GXL	HV211(2)

EC195 STRT SOL					
CONN POS	WIRE COLOR	WIRE LABEL	GAUGE	JACKET	TO
1	WHT	48-22 START	10AWG	GXL	X466(4)

S214					
CONN POS	WIRE COLOR	WIRE LABEL	GAUGE	JACKET	TO
1	WHT	60-4-1DRIVERTN	18AWG	GXL	HV325(2)
1	WHT	60-4-2DRIVERTN	18AWG	GXL	HV326(2)
2	WHT	60-4DRIVERTN	18AWG	GXL	X465(A)

X466 ENG/TURN B					
CONN POS	WIRE COLOR	WIRE LABEL	GAUGE	JACKET	TO
1	WHT	49-26 ENG FAN	10AWG	GXL	WH245(2)
2					
3	WHT	48-23 GLOW	10AWG	GXL	EC193(1)
4	WHT	48-22 START	10AWG	GXL	EC195(1)

X465 ENG/TURN A					
CONN POS	WIRE COLOR	WIRE LABEL	GAUGE	JACKET	TO
A	WHT	60-4 DRIVE RTN	18AWG	GXL	S214(2)
B	WHT	25-2 DRV REV	18AWG	GXL	HV326(1)
C	WHT	25-1 DRV FWD	18AWG	GXL	HV325(1)
D	WHT	25-3 2 SPD	18AWG	GXL	HV211(1)
E	BLK	0-18	18AWG	GXL	HV211(2)
F	WHT	25-4 PRK BRK	18AWG	GXL	HV210(1)
G					
H					
J					
K					
L					
M					
N	WHT	60-5 THROTTLE RTN	18AWG	GXL	X223(1)
O	BLK	0-27	16AWG	GXL	X327(1)
P	WHT	48-13 THR ACT	18AWG	GXL	X223(2)
Q	WHT	48-16 ALT EXC	18AWG	GXL	EC194(2)
R	YEL	2-16-1	18AWG	GXL	SN215(1)
S	WHT	48-21 ENG SPD SNSR	18AWG	GXL	SN215(2)
T	BLK	0-16	18AWG	GXL	SN215(3)
U					
V	WHT	48-20 OIL PRS	18AWG	GXL	SW196(1)
W	WHT	48-19 TEMP SNSR	18AWG	GXL	SN197(1)
X	BLK	0-19	18AWG	GXL	SN197(2)

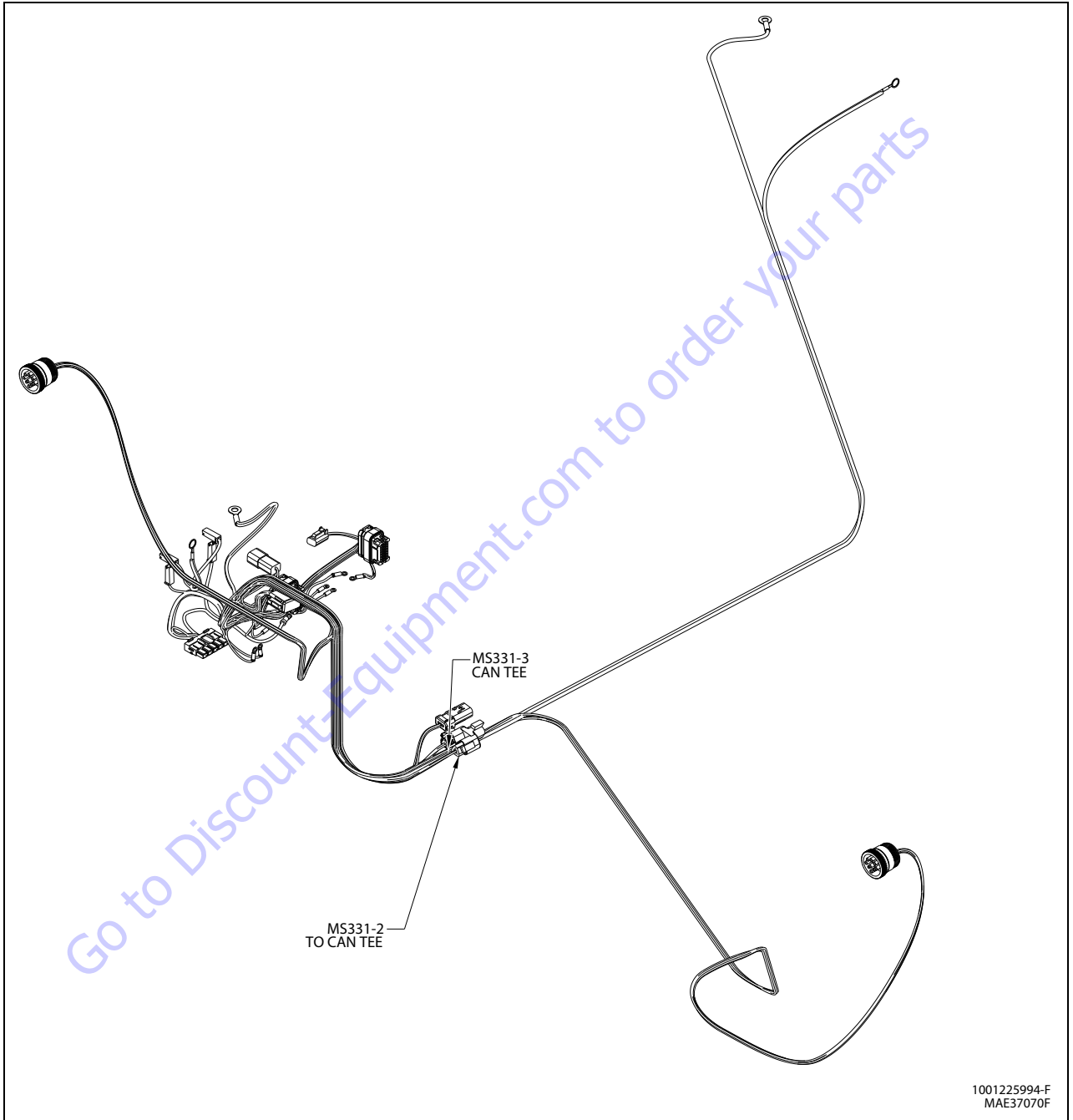

Figure 7-81. Hybrid Harness - Sheet 1 of 3

SECTION 7 - BASIC ELECTRICAL INFORMATION & ELECTRICAL SCHEMATICS

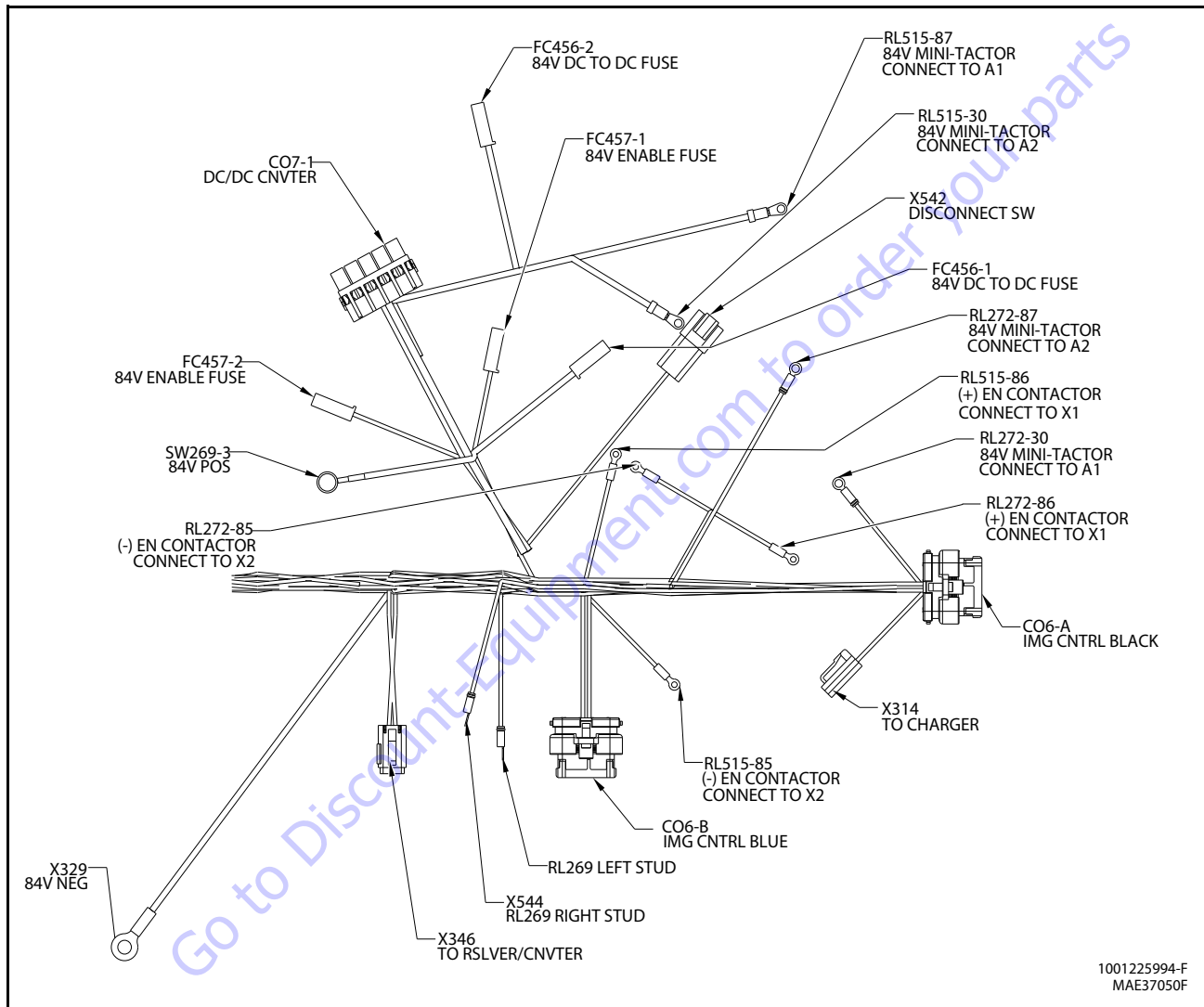

Figure 7-82. Hybrid Harness - Sheet 2 of 3

SECTION 7 - BASIC ELECTRICAL INFORMATION & ELECTRICAL SCHEMATICS

X329 84V NEG					
CONN POS	WIRE COLOR	WIRE LABEL	GAUGE	JACKET	TO
1	BLK	0-36 84V GND	12AWG	GXL	C07-1(3)
1	BLK	0-46	16AWG	GXL	X344(A)

SW269-3 84V POS					
CONN POS	WIRE COLOR	WIRE LABEL	GAUGE	JACKET	TO
1	ORG	84-1	16AWG	GXL	FC457-2(1)
1	ORG	84-5	12AWG	GXL	FC456-1(1)

X346 TO RSLVER/CNVTER					
CONN POS	WIRE COLOR	WIRE LABEL	GAUGE	JACKET	TO
1	BLK	0-46	18AWG	GXL	C06-A(15)
2					
3	WHT	84-22 SPD PULSE	18AWG	GXL	C06-A(18)
4	WHT	84-18 IMG SPD SIN	18AWG	GXL	C06-B(7)
5	WHT	84-16 IMG SPD COS	18AWG	GXL	C06-B(14)
6	WHT	84-19 SPD VFB	18AWG	GXL	C06-B(3)
7	WHT	84-17 IMG SPD PWR	18AWG	GXL	C06-B(8)
8					
9	WHT	84-20 SPD CHRГ	18AWG	GXL	C06-A(19)
10	BLK	0-39-3	18AWG	GXL	S345(2)
11					
12	WHT	84-21 IMG TEMP	18AWG	GXL	C06-A(23)

RL515-85 (-)EN CONTACTOR					
CONN POS	WIRE COLOR	WIRE LABEL	GAUGE	JACKET	TO
1	BLK	0-35-1 12V GND	18AWG	GXL	X305(1)

FC457-2 84V ENABLE FUSE					
CONN POS	WIRE COLOR	WIRE LABEL	GAUGE	JACKET	TO
1	ORG	84-1	16AWG	GXL	SW269-3(1)

FC457-1 84V ENABLE FUSE					
CONN POS	WIRE COLOR	WIRE LABEL	GAUGE	JACKET	TO
1	ORG	84-1	16AWG	GXL	RL272-87(1)

X544 RL269 RIGHT STUD					
CONN POS	WIRE COLOR	WIRE LABEL	GAUGE	JACKET	TO
1	ORG	84-1-2	18AWG	GXL	RL272-30(1)

FC456-1 84V DC TO DC FUSE					
CONN POS	WIRE COLOR	WIRE LABEL	GAUGE	JACKET	TO
1	ORG	84-5	12AWG	GXL	SW269-3(1)

X543 RL269 LEFT STUD					
CONN POS	WIRE COLOR	WIRE LABEL	GAUGE	JACKET	TO
1	WHT	84-3-2 MAIN CONT	18AWG	GXL	X542(3)

C07-1 DC/DC CNVTER					
CONN POS	WIRE COLOR	WIRE LABEL	GAUGE	JACKET	TO
1	BLK	0-35 12V GND	10AWG	GXL	X305(1)
2	YEL	2-15	10AWG	GXL	X516(1)
3	BLK	0-36 84V GND	12AWG	GXL	X329(1)
4	ORG	84-5 DC TO DC PWR	12AWG	GXL	RL515-87(1)
5					

SECTION 7 - BASIC ELECTRICAL INFORMATION & ELECTRICAL SCHEMATICS

X542 DISCONNECT SW					
CONN POS	WIRE COLOR	WIRE LABEL	GAUGE	JACKET	TO
1					
2					
3	WHT	84-3-2 MAIN CONT	18AWG	GXL	X543(1)
4	WHT	84-3 MAIN CONT	18AWG	GXL	C06-A(16)

FC456-2 84V DC TO DC FUSE					
CONN POS	WIRE COLOR	WIRE LABEL	GAUGE	JACKET	TO
1	ORG	84-5 DC TO DC PWR	12AWG	GXL	RL515-30(1)

RL515-87 84V MINI-TACTOR					
CONN POS	WIRE COLOR	WIRE LABEL	GAUGE	JACKET	TO
1	ORG	84-5DCTODCPWR	12AWG	GXL	C07-1(4)

RL515-30 84V MINI-TACTOR					
CONN POS	WIRE COLOR	WIRE LABEL	GAUGE	JACKET	TO
1	ORG	84-5 DC TO DC PWR	12AWG	GXL	FC456-2(1)

RL515-86 (+) EN CONTACTOR					
CONN POS	WIRE COLOR	WIRE LABEL	GAUGE	JACKET	TO
1	WHT	49-57 DC/DC CONT	18AWG	GXL	X455(3)

C06-B IMG CNTRL BLUE					
CONN POS	WIRE COLOR	WIRE LABEL	GAUGE	JACKET	TO
1					
2	WHT	84-11 HALF STACK V	18AWG	GXL	X343(D)
3	WHT	84-19 SPD V FB	18AWG	GXL	X346(6)
4					
5					
6					
7	WHT	84-18 IMG SPD SIN	18AWG	GXL	X346(4)
8	WHT	84-17 IMG SPD PWR	18AWG	GXL	X346(7)
9					
10					
11					
12					
13					
14	WHT	84-16 IMG SPD COS	18AWG	GXL	X346(5)
15	BLK	0-39	18AWG	GXL	S345(2)
16	WHT	84-15 B TEMP 1	18AWG	GXL	X344(B)
17	WHT	84-14 B TEMP 2	18AWG	GXL	X344(C)
18	WHT	84-13 B TEMP 3	18AWG	GXL	X343(A)
19	WHT	84-12 B TEMP 4	18AWG	GXL	X343(B)
20					
21					
22					
23					

RL272-85 (-) EN CONTACTOR					
CONN POS	WIRE COLOR	WIRE LABEL	GAUGE	JACKET	TO
1	BLK	0-14-8-2	18AWG	GXL	X455(2)

SECTION 7 - BASIC ELECTRICAL INFORMATION & ELECTRICAL SCHEMATICS

RL272-86 (+)EN CONTACTOR					
CONN POS	WIRE COLOR	WIRE LABEL	GAUGE	JACKET	TO
1	YEL	2-14-13	18AWG	GXL	X455(1)

RL272-30 84V MINI-TACTOR					
CONN POS	WIRE COLOR	WIRE LABEL	GAUGE	JACKET	TO
1	ORG	84-1	18AWG	GXL	C06-A(1)
1	ORG	84-1-2	18AWG	GXL	X544(1)

X314 TO CHARGER					
CONN POS	WIRE COLOR	WIRE LABEL	GAUGE	JACKET	TO
1	WHT	82-1 CHRGR INTLK	18AWG	GXL	C06-A(13)
2	WHT	82-2 CHRGR INTLK	18AWG	GXL	C06-A(6)

RL272-87 84V MINI-TACTOR					
CONN POS	WIRE COLOR	WIRE LABEL	GAUGE	JACKET	TO
1	ORG	84-1	16AWG	GXL	FC457-1(1)

C06-A IMG CNTRL BLACK					
CONN POS	WIRE COLOR	WIRE LABEL	GAUGE	JACKET	TO
1	ORG	84-1	18AWG	GXL	RL272-30(1)
2					
3					
4					
5					
6	WHT	82-2 CHRGR INTLK	18AWG	GXL	X314(2)
7					
8					
9					
10					
11					
12					
13	WHT	82-1 CHRGR INTLK	18AWG	GXL	X314(1)
14					
15	BLK	0-46	18AWG	GXL	X346(1)
16	WHT	84-3 MAIN CONT	18AWG	GXL	X542(4)
17					
18	WHT	84-22 SPD PULSE	18AWG	GXL	X346(3)
19	WHT	84-20 SPD CHRGR	18AWG	GXL	X346(9)
20	GRN	CH#2 TO IMG	18AWG	GXL	MS331-3(B)
21	YEL	CH#2 TO IMG	18AWG	GXL	MS331-3(A)
22	BLK	0-50	18AWG	GXL	MS331-3(C)
23	WHT	84-21 IMG TEMP	18AWG	GXL	X346(12)

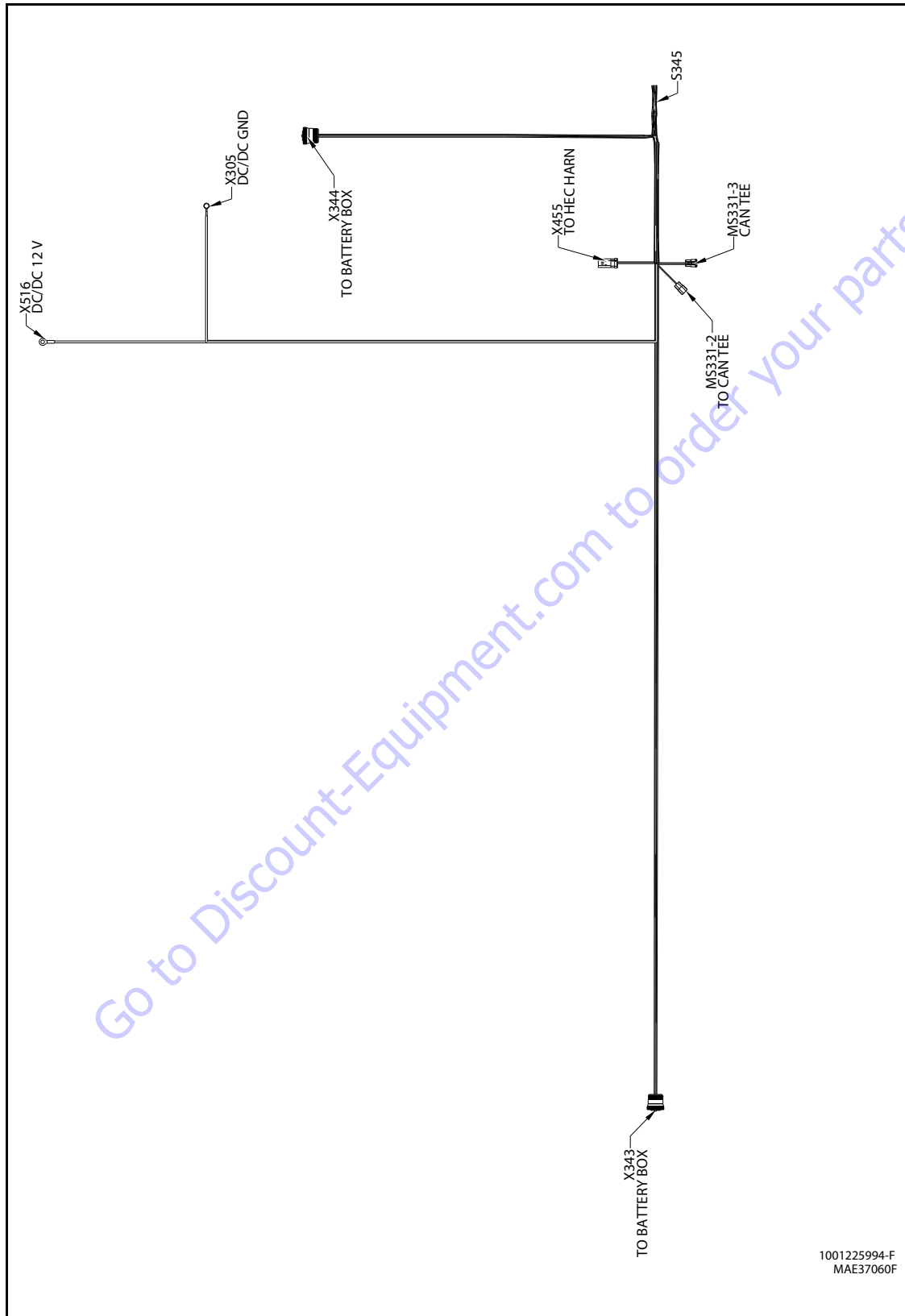

Figure 7-83. Hybrid Harness - Sheet 3 of 3

SECTION 7 - BASIC ELECTRICAL INFORMATION & ELECTRICAL SCHEMATICS

X343 TO BATTERY BOX					
CONN POS	WIRE COLOR	WIRE LABEL	GAUGE	JACKET	TO
A	WHT	84-13 B TEMP 3	18AWG	GXL	C06-B(18)
B	WHT	84-12 B TEMP 4	18AWG	GXL	C06-B(19)
C					
D	WHT	84-11 HALF STACK V	18AWG	GXL	C06-B(2)
E					
F	BLK	0-39-2	18AWG	GXL	S345(1)
G					
H					
J	BLK	0-45	16AWG	GXL	X344(J)

X305 DC/DC GND					
CONN POS	WIRE COLOR	WIRE LABEL	GAUGE	JACKET	TO
1	BLK	0-35 12V GND	10AWG	GXL	C07-1(1)
1	BLK	0-35-1 12V GND	18AWG	GXL	RL515-85(1)

X516 DC/DC 12V					
CONN POS	WIRE COLOR	WIRE LABEL	GAUGE	JACKET	TO
1	YEL	2-15	10AWG	GXL	C07-1(2)

X344 TO BATTERY BOX					
CONN POS	WIRE COLOR	WIRE LABEL	GAUGE	JACKET	TO
A	BLK	0-46	16AWG	GXL	X329(1)
B	WHT	84-15 B TEMP 1	18AWG	GXL	C06-B(16)
C	WHT	84-14 B TEMP 2	18AWG	GXL	C06-B(17)
D					
E					
F	BLK	0-39-1	18AWG	GXL	S345(1)
G	GRN	CH#2 TO SOC	18AWG	GXL	MS331-2(B)
H	YEL	CH#2 TO SOC	18AWG	GXL	MS331-2(A)
J	BLK	0-45	16AWG	GXL	X343(J)

MS331-2 TO CAN TEE					
CONN POS	WIRE COLOR	WIRE LABEL	GAUGE	JACKET	TO
A	YEL	CH#2 TO SOC	18AWG	GXL	X344(H)
B	GRN	CH#2 TO SOC	18AWG	GXL	X344(G)
C					

S345					
CONN POS	WIRE COLOR	WIRE LABEL	GAUGE	JACKET	TO
1	BLK	0-39-1	18AWG	GXL	X344(F)
1	BLK	0-39-2	18AWG	GXL	X343(F)
2	BLK	0-39	18AWG	GXL	C06-B(15)
2	BLK	0-39-3	18AWG	GXL	X346(10)

MS331-3 CAN TEE					
CONN POS	WIRE COLOR	WIRE LABEL	GAUGE	JACKET	TO
A	YEL	CH#2 TO IMG	18AWG	GXL	C06-A(21)
B	GRN	CH#2 TO IMG	18AWG	GXL	C06-A(20)
C	BLK	0-50	18AWG	GXL	C06-A(22)

X455 TO HEC HARN					
CONN POS	WIRE COLOR	WIRE LABEL	GAUGE	JACKET	TO
1	YEL	2-14-13	18AWG	GXL	RL272-86(1)
2	BLK	0-14-8-2	18AWG	GXL	RL272-85(1)
3	WHT	49-57 DC/DC CONT	18AWG	GXL	RL515-86(1)

RL515-85 (-)EN CONTACTOR					
CONN POS	WIRE COLOR	WIRE LABEL	GAUGE	JACKET	TO
1	BLK	0-35-1 12V GND	18AWG	GXL	X305(1)

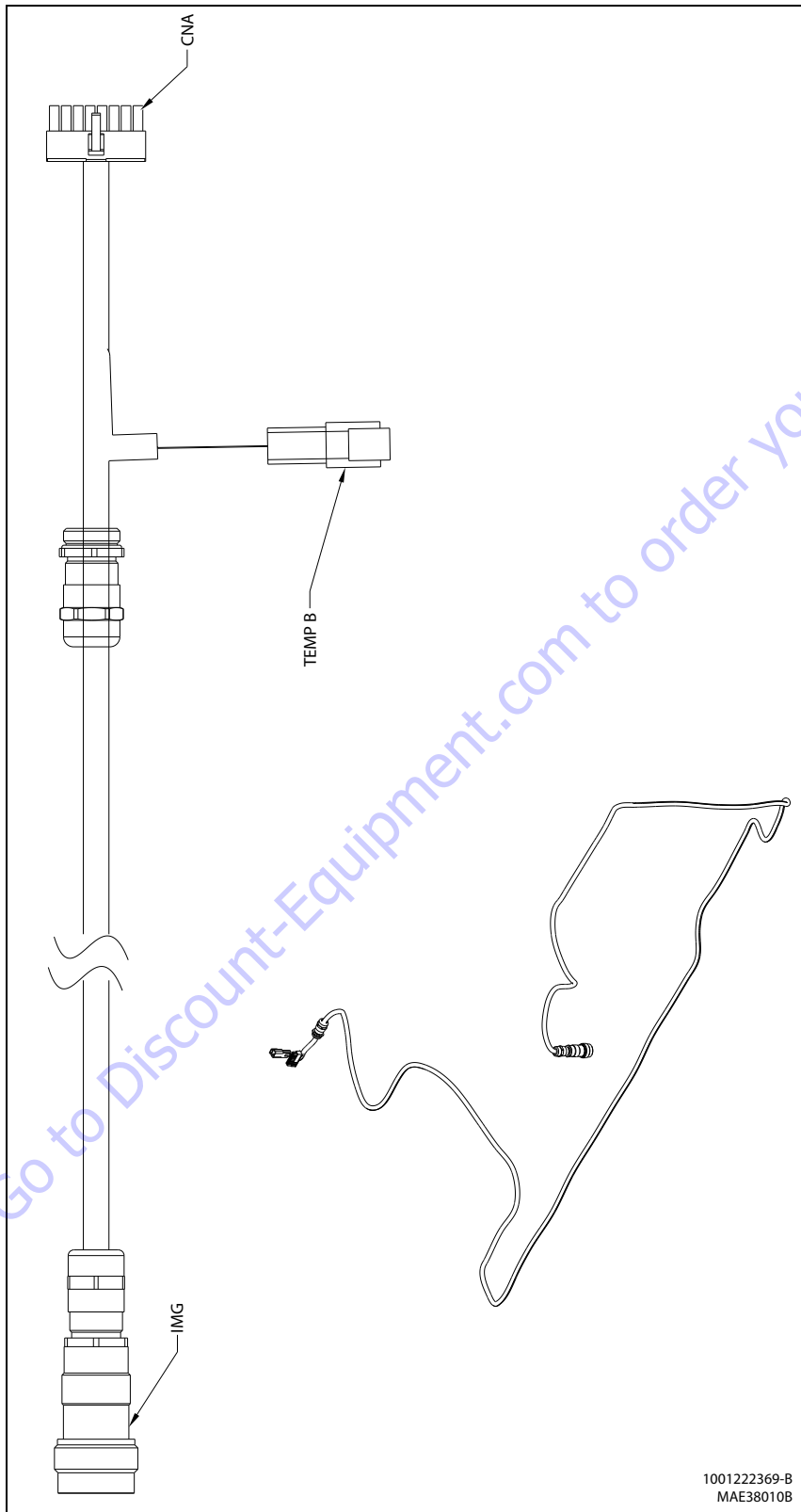

Figure 7-84. Battery Converter Harness

SECTION 7 - BASIC ELECTRICAL INFORMATION & ELECTRICAL SCHEMATICS

IMG					
CONN POS	WIRE COLOR	WIRELABEL	GAUGE	JACKET	TO
A	BLU	SIN+,S2	22AWG	CABLE	CNA(9)
B	VIO	SIN-,S4	22AWG	CABLE	CNA(1)
C	BLK	THERM	22AWG	CABLE	NC
D	BWN	THERM	22AWG	CABLE	NC
E	YEL	COS+,S1	22AWG	CABLE	CNA(12)
F	GRN	COS-,S3	22AWG	CABLE	CNA(4)
G	GRY	THERM	22AWG	CABLE	TEMPB(1)
H	WHT	THERM	22AWG	CABLE	TEMPB(2)
J	RED	REF+,R1	22AWG	CABLE	CNA(16)
K	ORN	REF-,R2	22AWG	CABLE	CNA(8)
L					
M					
N					
P					
R					
S					
T					
U					
V					

CNA					
CONN POS	WIRE COLOR	WIRELABEL	GAUGE	JACKET	TO
1	VIO	SIN-,S4	22AWG	CABLE	IMG(B)
2					
3					
4	GRN	COS-,S3	22AWG	CABLE	IMG(F)
5					
6					
7					
8	ORN	REF-,R2	22AWG	CABLE	IMG(K)
9	BLU	SIN+,S2	22AWG	CABLE	IMG(A)
10					
11					
12	YEL	COS+,S1	22AWG	CABLE	IMG(E)
13					
14					
15					
16	RED	REF+,R1	22AWG	CABLE	IMG(J)

TEMPB					
CONN POS	WIRE COLOR	WIRELABEL	GAUGE	JACKET	TO
1	GRY	THERM	22AWG	CABLE	IMG(G)
2	WHT	THERM	22AWG	CABLE	IMG(H)

This Page Left Blank Intentionally

Go to Discount-Equipment.com to order your parts

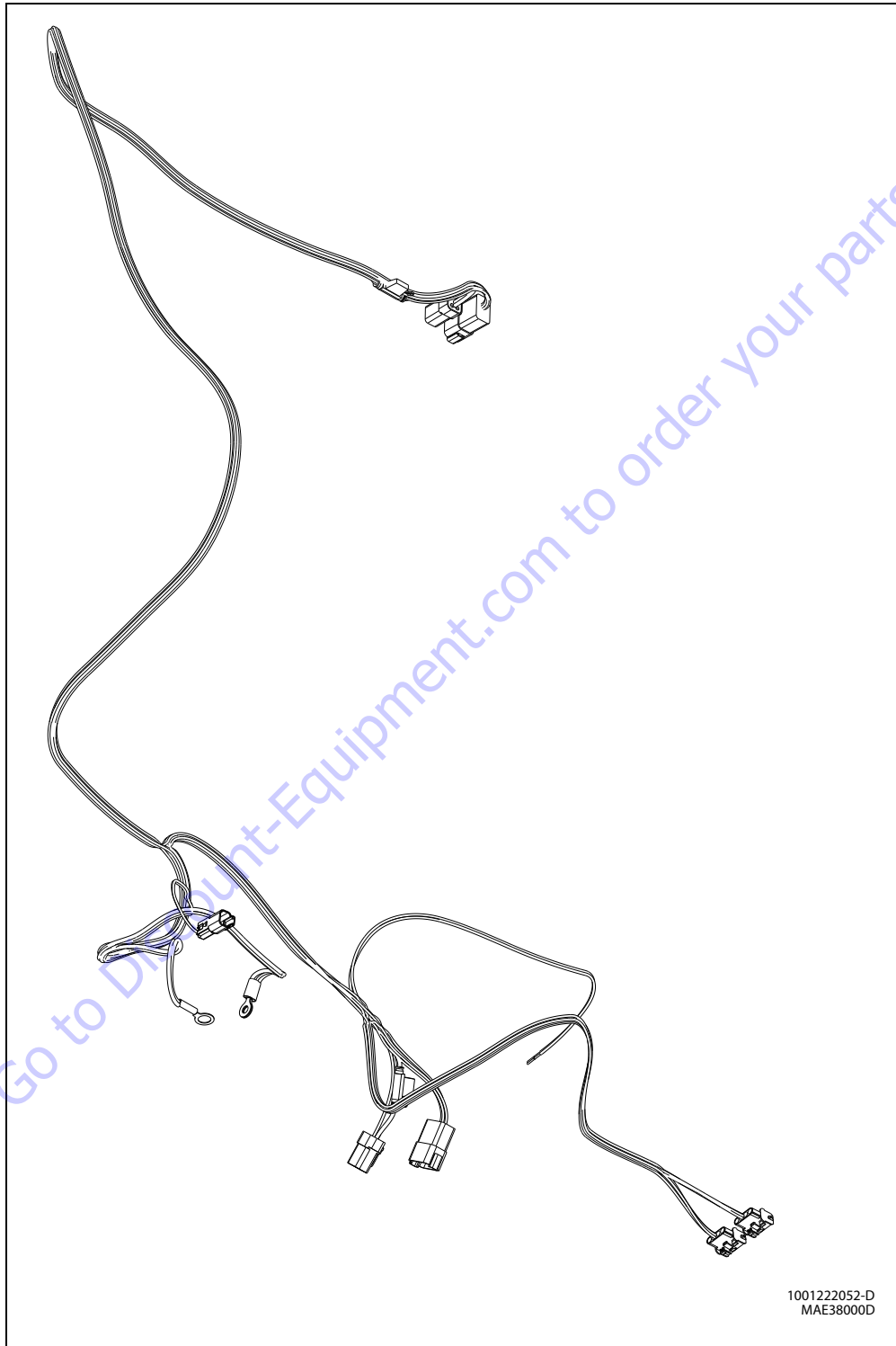

Figure 7-85. Battery Charger Harness - Sheet 1 of 2

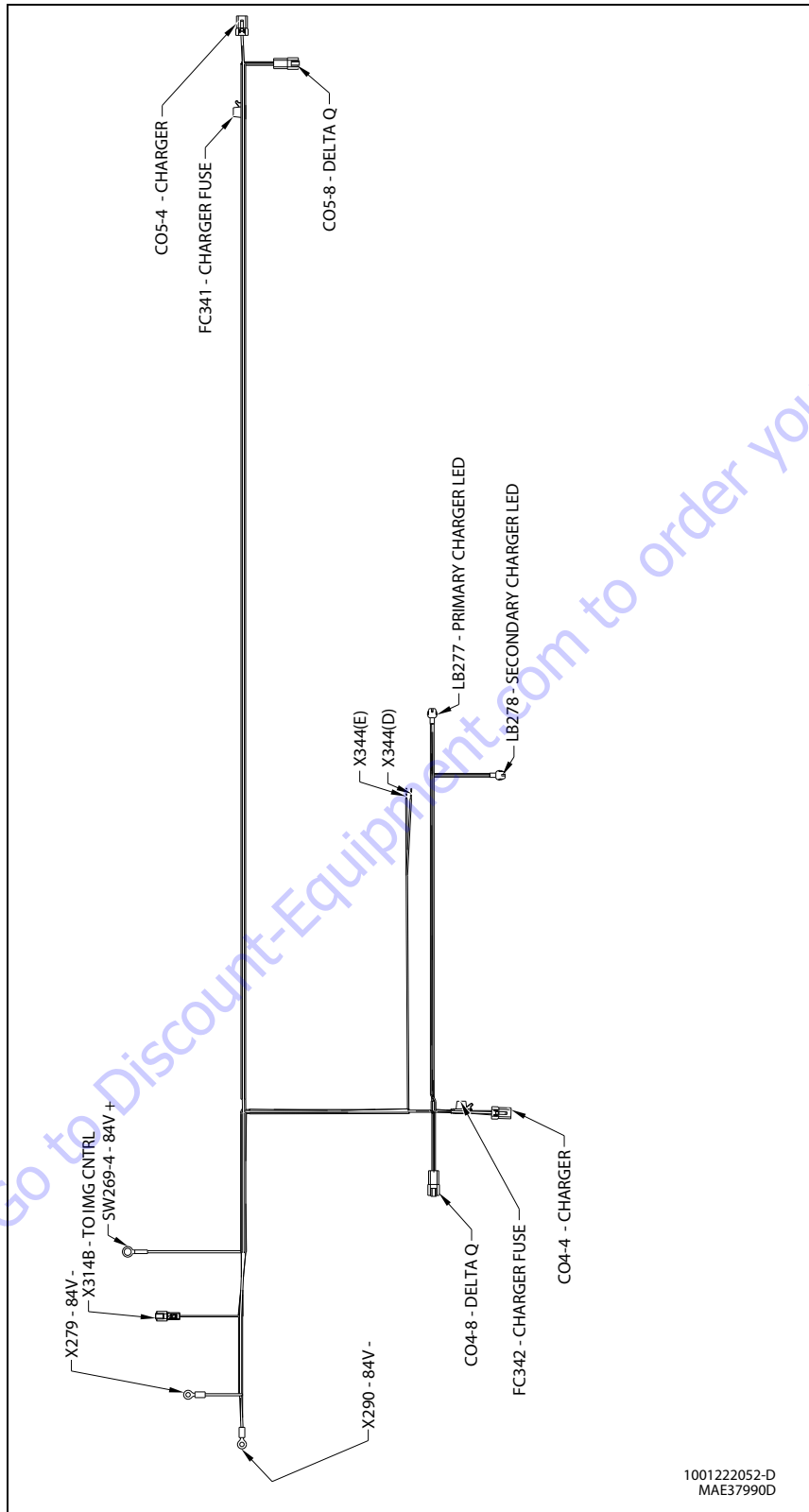

Figure 7-86. Battery Charger Harness - Sheet 2 of 2

SECTION 7 - BASIC ELECTRICAL INFORMATION & ELECTRICAL SCHEMATICS

X290-84V-					
CONN POS	WIRE COLOR	WIRELABEL	GAUGE	JACKET	TO
1	BLK	0-37	12AWG	GXL	C05-4(1)
1	BLK	0-33-1	18AWG	GXL	C05-8(8)

SW269-4-84V+					
CONN POS	WIRE COLOR	WIRELABEL	GAUGE	JACKET	TO
1	ORG	84-6	12AWG	GXL	FC341(1)
1	ORG	84-7	12AWG	GXL	FC342(1)

X279-84V-					
CONN POS	WIRE COLOR	WIRELABEL	GAUGE	JACKET	TO
1	BLK	0-33	18AWG	GXL	C04-8(8)
1	BLK	0-38	12AWG	GXL	C04-4(1)

FC341-CHARGERFUSE					
CONN POS	WIRE COLOR	WIRELABEL	GAUGE	JACKET	TO
1	ORG	84-6	12AWG	GXL	SW269-4(1)
2	ORG	84-6	12AWG	GXL	C05-4(2)

X344(D)-					
CONN POS	WIRE COLOR	WIRELABEL	GAUGE	JACKET	TO
1	WHT	81-1TEMPSEN	16AWG	GXL	C04-4(3)

C04-4-CHARGEROUTPUT					
CONN POS	WIRE COLOR	WIRELABEL	GAUGE	JACKET	TO
1	BLK	0-38	12AWG	GXL	X279(1)
2	ORG	84-7	12AWG	GXL	FC342(2)
3	WHT	81-1TEMPSEN	16AWG	GXL	X344(D)(1)
4	WHT	81-2TEMPRTN	16AWG	GXL	X344(E)(1)

X344(E)-					
CONN POS	WIRE COLOR	WIRELABEL	GAUGE	JACKET	TO
1	WHT	81-2TEMPRTN	16AWG	GXL	C04-4(4)

C05-8-DELTAQ					
CONN POS	WIRE COLOR	WIRELABEL	GAUGE	JACKET	TO
1					
2	WHT	82-1CHRGINTLK	18AWG	GXL	X314B(1)
3	WHT	80-6REDLED	18AWG	GXL	LB278(4)
4	WHT	80-4YELLED	18AWG	GXL	LB278(2)
5	BLK	0-32	18AWG	GXL	LB278(1)
6	WHT	80-2GRNLED	18AWG	GXL	LB278(3)
7					
8	BLK	0-33-1	18AWG	GXL	X290(1)

FC342-CHARGERFUSE					
CONN POS	WIRE COLOR	WIRELABEL	GAUGE	JACKET	TO
1	ORG	84-7	12AWG	GXL	SW269-4(1)
2	ORG	84-7	12AWG	GXL	C04-4(2)

X314B - TOIMGCNTRL					
CONN POS	WIRE COLOR	WIRELABEL	GAUGE	JACKET	TO
1	WHT	82-1CHRGINTLK	18AWG	GXL	C05-8(2)
2	WHT	82-2CHRGINTLK	18AWG	GXL	C04-8(2)

SECTION 7 - BASIC ELECTRICAL INFORMATION & ELECTRICAL SCHEMATICS

C05-4-CHARGEROUTPUT					
CONN POS	WIRE COLOR	WIRELABEL	GAUGE	JACKET	TO
1	BLK	0-37	12AWG	GXL	X290(1)
2	ORG	84-6	12AWG	GXL	FC341(2)
3					
4					

LB277-PRIMARYCHARGERLED					
CONN POS	WIRE COLOR	WIRELABEL	GAUGE	JACKET	TO
1	BLK	0-31	18AWG	GXL	C04-8(5)
2	WHT	80-3YELLED	18AWG	GXL	C04-8(4)
3	WHT	80-1GRNLED	18AWG	GXL	C04-8(6)
4	WHT	80-5REDLED	18AWG	GXL	C04-8(3)

C04-8-DELTAQ					
CONN POS	WIRE COLOR	WIRELABEL	GAUGE	JACKET	TO
1					
2	WHT	82-2CHRGINTLK	18AWG	GXL	X314B(2)
3	WHT	80-5REDLED	18AWG	GXL	LB277(4)
4	WHT	80-3YELLED	18AWG	GXL	LB277(2)
5	BLK	0-31	18AWG	GXL	LB277(1)
6	WHT	80-1GRNLED	18AWG	GXL	LB277(3)
7					
8	BLK	0-33	18AWG	GXL	X279(1)

Go to Discount-Equipment.com to order your parts

Go to Discount-Equipment.com to order your parts

This Page Left Blank Intentionally

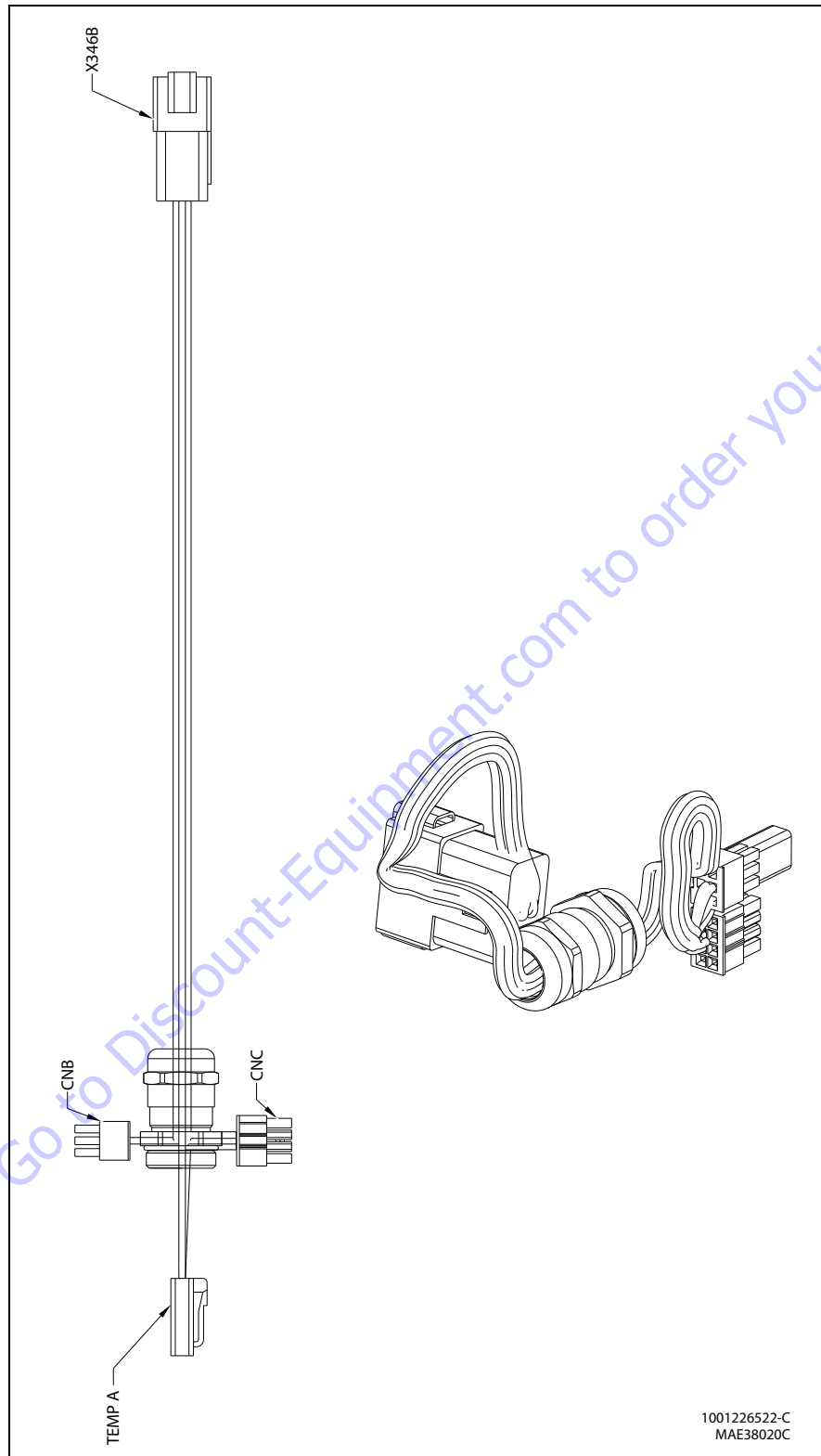

Figure 7-87. Battery Converter cable

SECTION 7 - BASIC ELECTRICAL INFORMATION & ELECTRICAL SCHEMATICS

CNB					
CONN POS	WIRE COLOR	WIRELABEL	GAUGE	JACKET	TO
1	BRN	84-17IMGSPDPWR	18AWG	CABLE	X346B(7)
2	BLU/ BLK	0-44	18AWG	CABLE	X346B(10)
3					
4					
5					
6					

TEMPA					
CONN POS	WIRE COLOR	WIRELABEL	GAUGE	JACKET	TO
1	BLK/ RED	84-21IMGTEMP	18AWG	CABLE	X346B(12)
2	BLK	0-46	18AWG	CABLE	X346B(1)

CNC					
CONN POS	WIRE COLOR	WIRELABEL	GAUGE	JACKET	TO
1	BLU	84-18IMGSPDSIN	18AWG	CABLE	X346B(4)
2	YEL	84-19SPDVFB	18AWG	CABLE	X346B(6)
3					
4	RED	84-22SPDPULSE	18AWG	CABLE	X346B(3)
5	ORN	84-16IMGSPDCOS	18AWG	CABLE	X346B(5)
6					
7					
8	RED/ BLK	84-20SPDCHRG	18AWG	CABLE	X346B(9)

X346B					
CONN POS	WIRE COLOR	WIRELABEL	GAUGE	JACKET	TO
1	BLK	0-46	18AWG	CABLE	TEMPA(2)
2					
3	RED	84-22SPDPULSE	18AWG	CABLE	CNC(4)
4	BLU	84-18IMGSPDSIN	18AWG	CABLE	CNC(1)
5	ORN	84-16IMGSPDCOS	18AWG	CABLE	CNC(5)
6	YEL	84-19SPDVFB	18AWG	CABLE	CNC(2)
7	BRN	84-17IMGSPDPWR	18AWG	CABLE	CNB(1)
8					
9	RED/ BLK	84-20SPDCHRG	18AWG	CABLE	CNC(8)
10	BLU/ BLK	0-44	18AWG	CABLE	CNB(2)
11					
12	BLK/ RED	84-21IMGTEMP	18AWG	CABLE	TEMPA(1)

This Page Left Blank Intentionally

Go to Discount-Equipment.com to order your parts

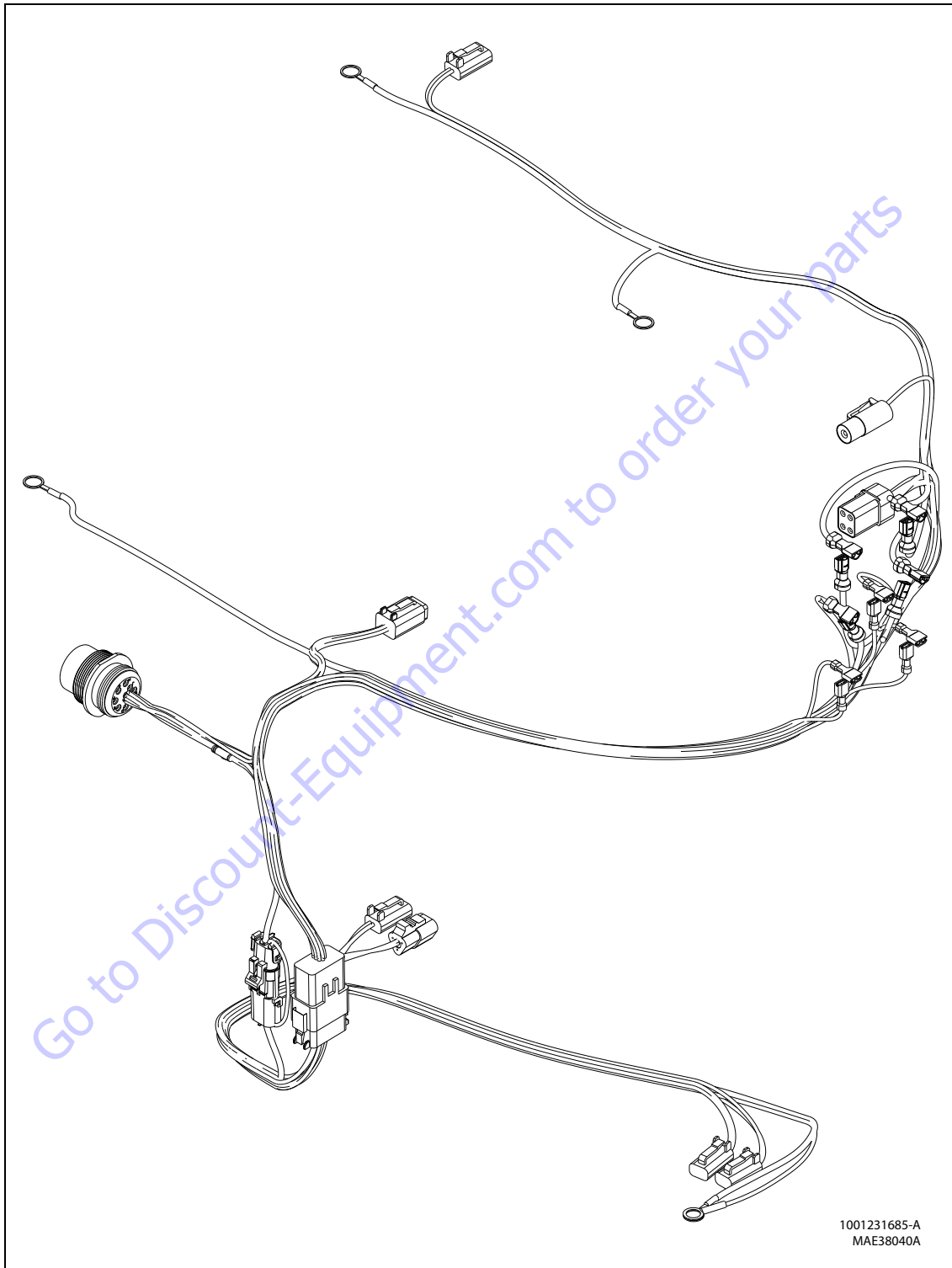
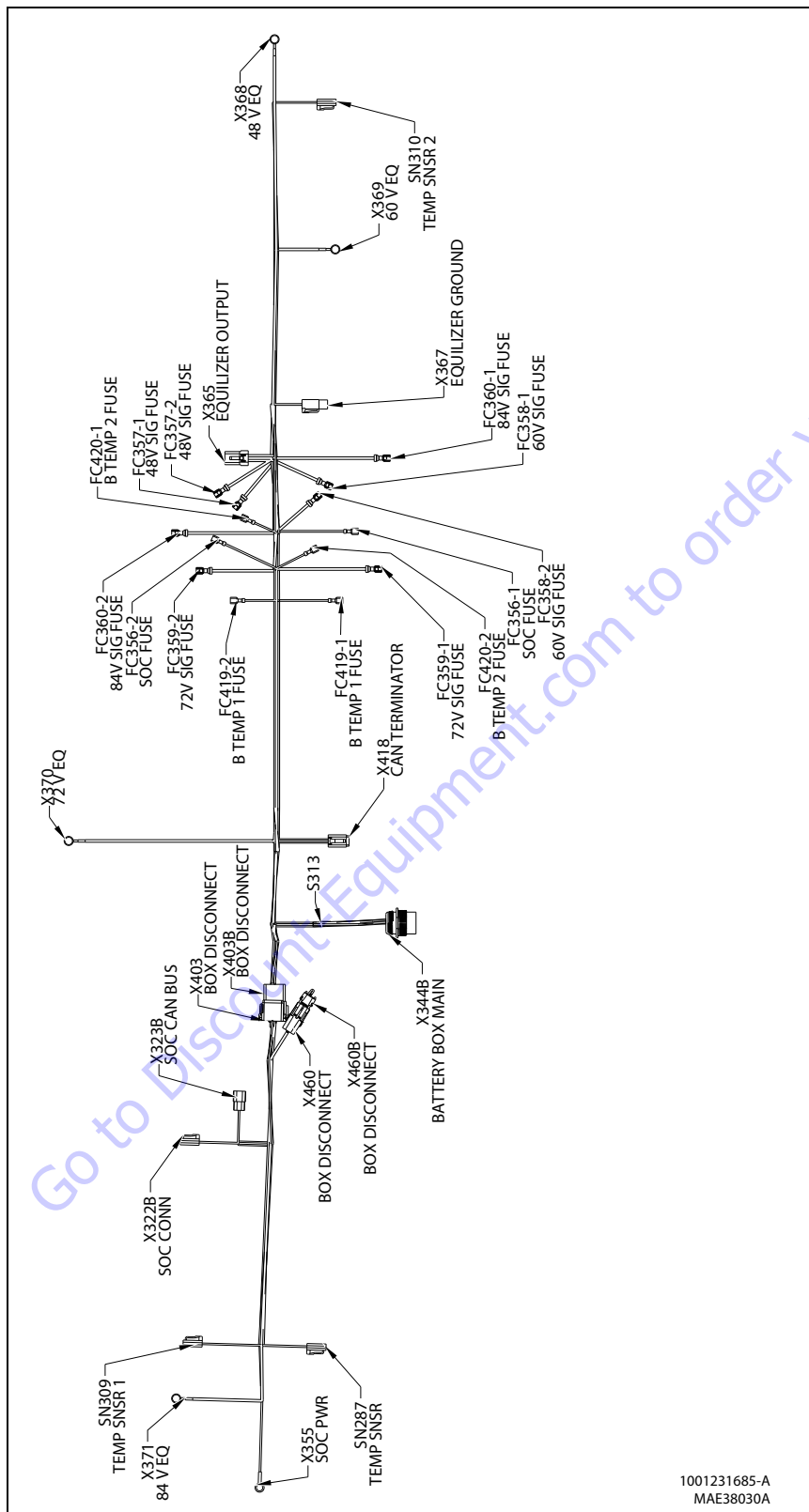

Figure 7-88. Battery Stack Harness (RH) - Sheet 1 of 2



1001231685-A
MAE38030A

Figure 7-89. Battery Stack Harness (RH) - Sheet 2 of 2

SECTION 7 - BASIC ELECTRICAL INFORMATION & ELECTRICAL SCHEMATICS

X355-SOCPWR					
CONN POS	WIRE COLOR	WIRELABEL	GAUGE	JACKET	TO
1	ORG	84-29SOCPWR	16AWG	GXL	X403(11)

X322B-SOCCONN					
CONN POS	WIRE COLOR	WIRELABEL	GAUGE	JACKET	TO
1	ORG	84-29SOCPWR	16AWG	GXL	X403(8)
2	BLK	0-46	16AWG	GXL	X403(7)

X371-84VEQ					
CONN POS	WIRE COLOR	WIRELABEL	GAUGE	JACKET	TO
1	ORG	84-2884VOLT	12AWG	GXL	X460(2)

X323B-SOC CAN BUS					
CONN POS	WIRE COLOR	WIRELABEL	GAUGE	JACKET	TO
A	YEL	CH#2TOSOC	18AWG	GXL	X403(5)
B	GRN	CH#2TOSOC	18AWG	GXL	X403(6)
C					

SN309-					
CONN POS	WIRE COLOR	WIRELABEL	GAUGE	JACKET	TO
1	WHT	84-15BTEMP1	18AWG	GXL	X403(9)
2	BLK	0-39-1-1	18AWG	GXL	X403(10)

X403-BOXDISCONNECT					
CONN POS	WIRE COLOR	WIRELABEL	GAUGE	JACKET	TO
2					
3	WHT	81-1TEMPSEN	16AWG	GXL	SN287(2)
4	WHT	81-2TEMPRTN	16AWG	GXL	SN287(1)
5	YEL	CH#2TOSOC	18AWG	GXL	X323B(A)
6	GRN	CH#2TOSOC	18AWG	GXL	X323B(B)
7	BLK	0-46	16AWG	GXL	X322B(2)
8	ORG	84-29SOCPWR	16AWG	GXL	X322B(1)
9	WHT	84-15BTEMP1	18AWG	GXL	SN309(1)
10	BLK	0-39-1-1	18AWG	GXL	SN309(2)
11	ORG	84-29SOCPWR	16AWG	GXL	X355(1)
12					

SN287-TEMPSNR					
CONN POS	WIRE COLOR	WIRELABEL	GAUGE	JACKET	TO
1	WHT	81-2TEMPRTN	16AWG	GXL	X403(4)
2	WHT	81-1TEMPSEN	16AWG	GXL	X403(3)

X460-BOXDISCONNECT					
CONN POS	WIRE COLOR	WIRELABEL	GAUGE	JACKET	TO
2	ORG	84-2884VOLT	12AWG	GXL	X371(1)

X460B-BOXDISCONNECT					
CONN POS	WIRE COLOR	WIRELABEL	GAUGE	JACKET	TO
2	ORG	84-2884VOLT	12AWG	GXL	FC360-1(1)

SECTION 7 - BASIC ELECTRICAL INFORMATION & ELECTRICAL SCHEMATICS

X403- BOX DISCONNECT					
CONN POS	WIRE COLOR	WIRELABEL	GAUGE	JACKET	TO
2					
3	WHT	81-1TEMPSEN	16AWG	GXL	X344B(D)
4	WHT	81-2TEMPRTN	16AWG	GXL	X344B(E)
5	YEL	CH#2TOSOC	18AWG	GXL	X418(4)
6	GRN	CH#2TOSOC	18AWG	GXL	X418(3)
7	BLK	0-46	16AWG	GXL	X344B(A)
8	ORG	84-29SOCPWR	16AWG	GXL	FC356-1(1)
9	WHT	84-15BTEMP1	18AWG	GXL	FC419-1(1)
10	BLK	0-39-1-1	18AWG	GXL	S313(1)
11	ORG	84-29SOCPWR	16AWG	GXL	FC356-2(1)
12					

X370-72VEQ					
CONN POS	WIRE COLOR	WIRELABEL	GAUGE	JACKET	TO
1	ORG	84-2772VOLT	12AWG	GXL	FC359-1(1)

FC419-1-BTEMP1FUSE					
CONN POS	WIRE COLOR	WIRELABEL	GAUGE	JACKET	TO
1	WHT	84-15BTEMP1	18AWG	GXL	X403B(9)

FC359-1-72VSIGFUSE					
CONN POS	WIRE COLOR	WIRELABEL	GAUGE	JACKET	TO
1	ORG	84-2772VOLT	12AWG	GXL	X370(1)

S313					
CONN POS	WIRE COLOR	WIRELABEL	GAUGE	JACKET	TO
1	BLK	0-39-1-1	18AWG	GXL	X403B(10)
1	BLK	0-39-1-2	18AWG	GXL	SN310(2)
2	BLK	0-39-1	18AWG	GXL	X344B(F)

FC420-2-BTEMP2FUSE					
CONN POS	WIRE COLOR	WIRELABEL	GAUGE	JACKET	TO
1	WHT	84-14BTEMP2	18AWG	GXL	X344B(C)

X344B-BATTERYBOXMAIN					
CONN POS	WIRE COLOR	WIRELABEL	GAUGE	JACKET	TO
A	BLK	0-46	16AWG	GXL	X403B(7)
B	WHT	84-15BTEMP1	18AWG	GXL	FC419-2(1)
C	WHT	84-14BTEMP2	18AWG	GXL	FC420-2(1)
D	WHT	81-1TEMPSEN	16AWG	GXL	X403B(3)
E	WHT	81-2TEMPRTN	16AWG	GXL	X403B(4)
F	BLK	0-39-1	18AWG	GXL	S313(2)
G	GRN	CH#2TOSOC	18AWG	GXL	X418(1)
H	YEL	CH#2TOSOC	18AWG	GXL	X418(2)
J	BLK	0-45	16AWG	GXL	X367(1)

FC356-1-SOCFUSE					
CONN POS	WIRE COLOR	WIRELABEL	GAUGE	JACKET	TO
1	ORG	84-29SOCPWR	16AWG	GXL	X403B(8)

FC358-2-60V SIGFUSE					
CONN POS	WIRE COLOR	WIRELABEL	GAUGE	JACKET	TO
1	ORG	84-2660VOLT	12AWG	GXL	X365(2)

X418-CANTERMINATOR					
CONN POS	WIRE COLOR	WIRELABEL	GAUGE	JACKET	TO
1	GRN	CH#2TOSOC	18AWG	GXL	X344B(G)
2	YEL	CH#2TOSOC	18AWG	GXL	X344B(H)
3	GRN	CH#2TOSOC	18AWG	GXL	X403B(6)
4	YEL	CH#2TOSOC	18AWG	GXL	X403B(5)

FC358-1-60V SIGFUSE					
CONN POS	WIRE COLOR	WIRELABEL	GAUGE	JACKET	TO
1	ORG	84-2660VOLT	12AWG	GXL	X369(1)

SECTION 7 - BASIC ELECTRICAL INFORMATION & ELECTRICAL SCHEMATICS

FC360-1-84VSIGFUSE					
CONN POS	WIRE COLOR	WIRELABEL	GAUGE	JACKET	TO
1	ORG	84-2884VOLT	12AWG	GXL	X460B(2)

FC420-1-BTEMP2FUSE					
CONN POS	WIRE COLOR	WIRELABEL	GAUGE	JACKET	TO
1	WHT	84-14BTEMP2	18AWG	GXL	SN310(1)

X367-EQUILIZERGROUND					
CONN POS	WIRE COLOR	WIRELABEL	GAUGE	JACKET	TO
1	BLK	0-45	16AWG	GXL	X344B(J)

FC357-1-48VSIGFUSE					
CONN POS	WIRE COLOR	WIRELABEL	GAUGE	JACKET	TO
1	ORG	84-2548VOLT	12AWG	GXL	X368(1)

FC419-2-BTEMP1FUSE					
CONN POS	WIRE COLOR	WIRELABEL	GAUGE	JACKET	TO
1	WHT	84-15BTEMP1	18AWG	GXL	X344B(B)

FC357-2-48VSIGFUSE					
CONN POS	WIRE COLOR	WIRELABEL	GAUGE	JACKET	TO
1	ORG	84-2548VOLT	12AWG	GXL	X365(1)

FC359-2-72VSIGFUSE					
CONN POS	WIRE COLOR	WIRELABEL	GAUGE	JACKET	TO
1	ORG	84-2772VOLT	12AWG	GXL	X365(3)

X365-EQUILIZEROUTPUT					
CONN POS	WIRE COLOR	WIRELABEL	GAUGE	JACKET	TO
1	ORG	84-2548VOLT	12AWG	GXL	FC357-2(1)
2	ORG	84-2660VOLT	12AWG	GXL	FC358-2(1)
3	ORG	84-2772VOLT	12AWG	GXL	FC359-2(1)
4	ORG	84-2884VOLT	12AWG	GXL	FC360-2(1)

FC356-2-SOCFUSE					
CONN POS	WIRE COLOR	WIRELABEL	GAUGE	JACKET	TO
1	ORG	84-29SOCPWR	16AWG	GXL	X403B(11)

SN310-TEMPSNSR2					
CONN POS	WIRE COLOR	WIRELABEL	GAUGE	JACKET	TO
1	WHT	84-14BTEMP2	18AWG	GXL	FC420-1(1)
2	BLK	0-39-1-2	18AWG	GXL	S313(1)

X368-48VEQ					
CONN POS	WIRE COLOR	WIRELABEL	GAUGE	JACKET	TO
1	ORG	84-2548VOLT	12AWG	GXL	FC357-1(1)

X369-60VEQ					
CONN POS	WIRE COLOR	WIRELABEL	GAUGE	JACKET	TO
1	ORG	84-2660VOLT	12AWG	GXL	FC358-1(1)

FC360-2-84VSIGFUSE					
CONN POS	WIRE COLOR	WIRELABEL	GAUGE	JACKET	TO
1	ORG	84-2884VOLT	12AWG	GXL	X365(4)

This Page Left Blank Intentionally

Go to Discount-Equipment.com to order your parts

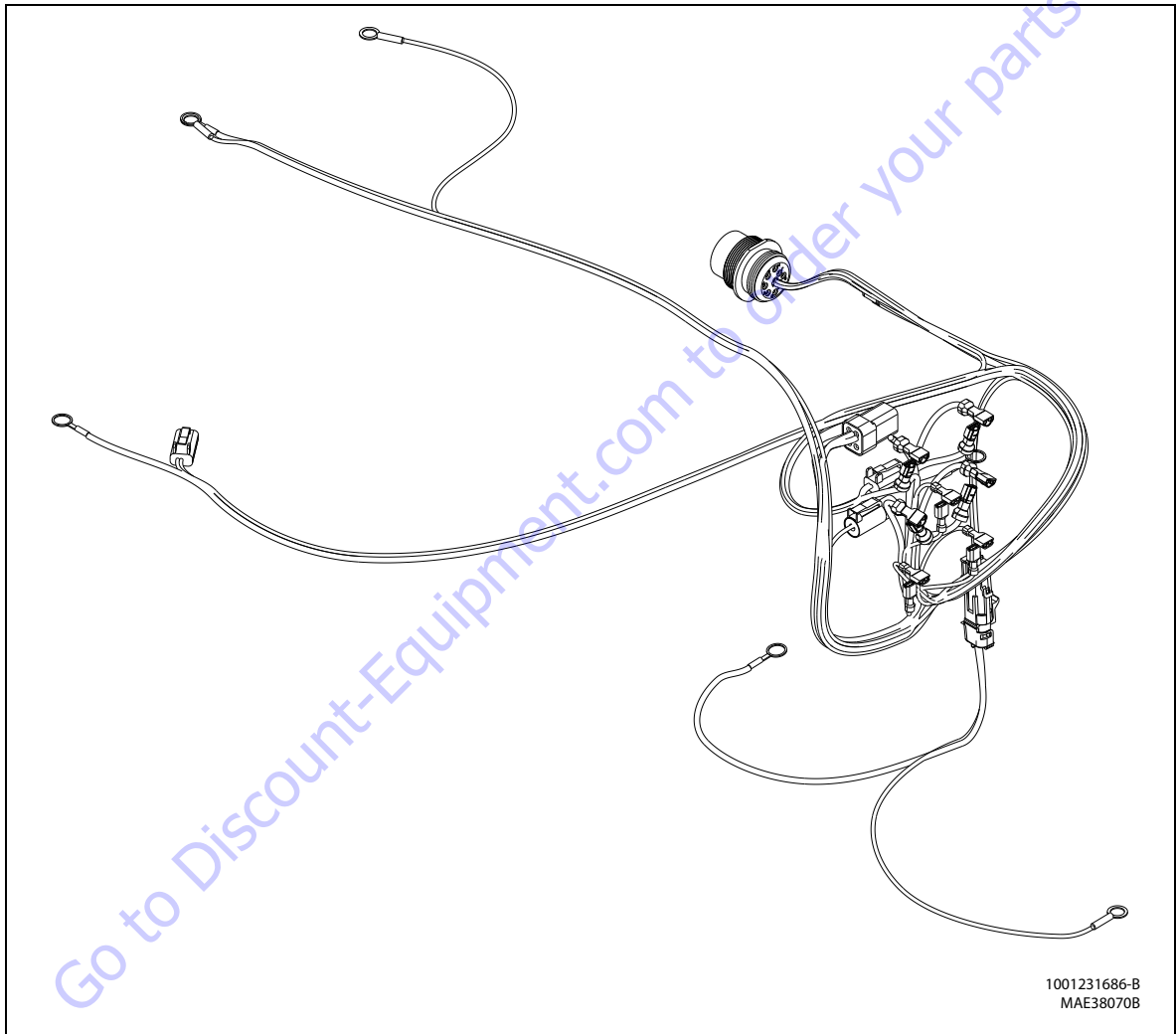

Figure 7-90. Battery Stack Harness (LH) - Sheet 1 of 3

SECTION 7 - BASIC ELECTRICAL INFORMATION & ELECTRICAL SCHEMATICS

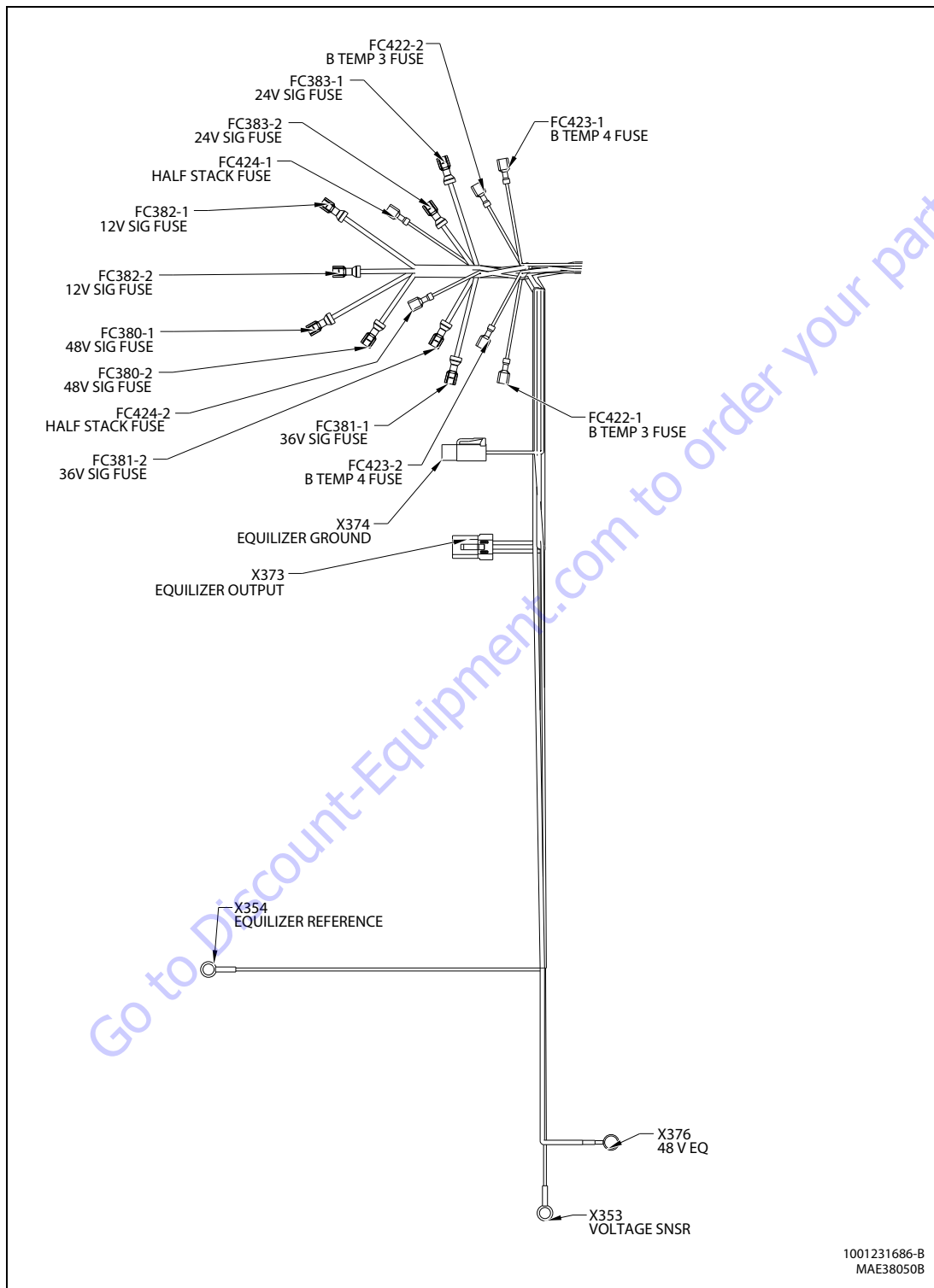

Figure 7-91. Battery Stack Harness (LH) - Sheet 2 of 3

1001231686-B
MAE38050B

SECTION 7 - BASIC ELECTRICAL INFORMATION & ELECTRICAL SCHEMATICS

X374-EQUILIZERGROUND					
CONN POS	WIRE COLOR	WIRELABEL	GAUGE	JACKET	TO
1	BLK	0-47	16AWG	GXL	X425B(1)

FC381-2-36V SIGFUSE					
CONN POS	WIRE COLOR	WIRELABEL	GAUGE	JACKET	TO
1	ORG	84-3236VOLT	12AWG	GXL	X373(3)

X373-EQUILIZEROUTPUT					
CONN POS	WIRE COLOR	WIRELABEL	GAUGE	JACKET	TO
1	ORG	84-3012VOLT	12AWG	GXL	FC382-2(1)
2	ORG	84-3124VOLT	12AWG	GXL	FC383-2(1)
3	ORG	84-3236VOLT	12AWG	GXL	FC381-2(1)
4	ORG	84-3348VOLT	12AWG	GXL	FC380-2(1)

FC424-2-HALFSTACKFUSE					
CONN POS	WIRE COLOR	WIRELABEL	GAUGE	JACKET	TO
1	WHT	84-11HALFSTACKV	18AWG	GXL	X353(1)

X354-EQUILIZERREFERENCE					
CONN POS	WIRE COLOR	WIRELABEL	GAUGE	JACKET	TO
1	BLK	0-45	16AWG	GXL	X343B(J)

FC380-2-48V SIGFUSE					
CONN POS	WIRE COLOR	WIRELABEL	GAUGE	JACKET	TO
1	ORG	84-3348VOLT	12AWG	GXL	X373(4)

X353-VOLTAGESNSR					
CONN POS	WIRE COLOR	WIRELABEL	GAUGE	JACKET	TO
1	WHT	84-11HALFSTACKV	18AWG	GXL	FC424-2(1)

FC380-1-48VSIGFUSE					
CONN POS	WIRE COLOR	WIRELABEL	GAUGE	JACKET	TO
1	ORG	84-3348VOLT	12AWG	GXL	X376(1)

FC422-1-BTEMP3FUSE					
CONN POS	WIRE COLOR	WIRELABEL	GAUGE	JACKET	TO
1	WHT	84-13BTEMP3	18AWG	GXL	SN311(1)

X376-48VEQ					
CONN POS	WIRE COLOR	WIRELABEL	GAUGE	JACKET	TO
1	ORG	84-3348VOLT	12AWG	GXL	FC380-1(1)

FC423-2-BTEMP4FUSE					
CONN POS	WIRE COLOR	WIRELABEL	GAUGE	JACKET	TO
1	WHT	84-12BTEMP4	18AWG	GXL	SN312(1)

FC382-2-12VSIGFUSE					
CONN POS	WIRE COLOR	WIRELABEL	GAUGE	JACKET	TO
1	ORG	84-3012VOLT	12AWG	GXL	X373(1)

FC381-1-36VSIGFUSE					
CONN POS	WIRE COLOR	WIRELABEL	GAUGE	JACKET	TO
1	ORG	84-3236VOLT	12AWG	GXL	X377(1)

FC382-1-12VSIGFUSE					
CONN POS	WIRE COLOR	WIRELABEL	GAUGE	JACKET	TO
1	ORG	84-3012VOLT	12AWG	GXL	X425B(2)

SECTION 7 - BASIC ELECTRICAL INFORMATION & ELECTRICAL SCHEMATICS

FC424-1-HALFSTACKFUSE					
CONN POS	WIRE COLOR	WIRELABEL	GAUGE	JACKET	T0
1	WHT	84-11HALFSTACKV	18AWG	GXL	X343B(D)

FC422-2-BTEMP3FUSE					
CONN POS	WIRE COLOR	WIRELABEL	GAUGE	JACKET	T0
1	WHT	84-13BTEMP3	18AWG	GXL	X343B(A)

FC383-2-24VSIGFUSE					
CONN POS	WIRE COLOR	WIRELABEL	GAUGE	JACKET	T0
1	ORG	84-3124VOLT	12AWG	GXL	X373(2)

FC423-1-BTEMP4FUSE					
CONN POS	WIRE COLOR	WIRELABEL	GAUGE	JACKET	T0
1	WHT	84-12BTEMP4	18AWG	GXL	X343B(B)

FC383-1-24VSIGFUSE					
CONN POS	WIRE COLOR	WIRELABEL	GAUGE	JACKET	T0
1	ORG	84-3124VOLT	12AWG	GXL	X378(1)

Go to Discount-Equipment.com to order your parts

Go to Discount-Equipment.com to order your parts

This Page Left Blank Intentionally

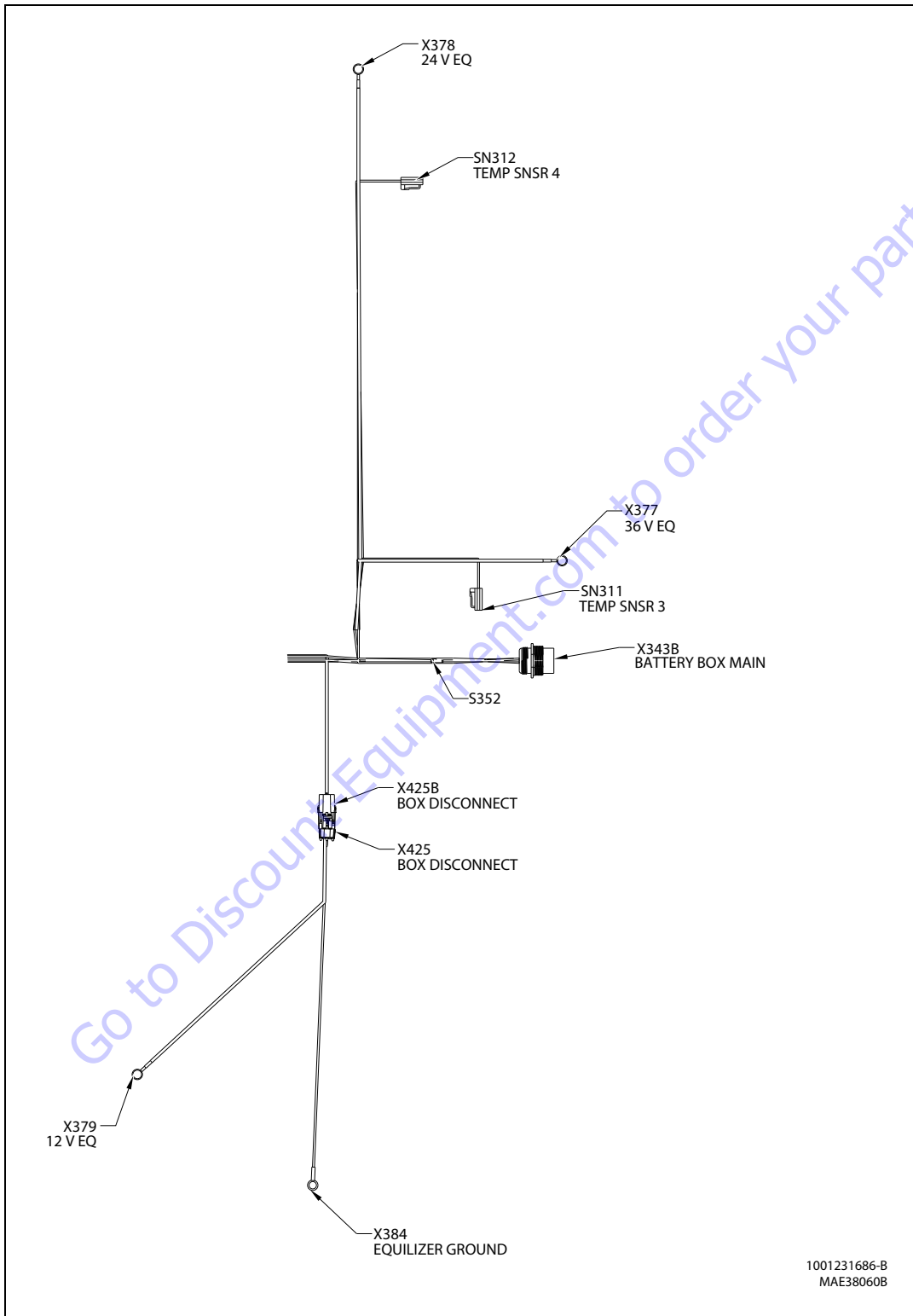

Figure 7-92. Battery Stack Harness (LH) - Sheet 3 of 3

1001231686-B
MAE38060B

SECTION 7 - BASIC ELECTRICAL INFORMATION & ELECTRICAL SCHEMATICS

X378-24VEQ					
CONN POS	WIRE COLOR	WIRELABEL	GAUGE	JACKET	TO
1	ORG	84-3124VOLT	12AWG	GXL	FC383-1(1)

S352					
CONN POS	WIRE COLOR	WIRELABEL	GAUGE	JACKET	TO
1	BLK	0-39-2	18AWG	GXL	X343B(F)
2	BLK	0-39-2-1	18AWG	GXL	SN311(2)
2	BLK	0-39-2-2	18AWG	GXL	SN312(2)

SN312-TEMPSNSR4					
CONN POS	WIRE COLOR	WIRELABEL	GAUGE	JACKET	TO
1	WHT	84-12BTEMP4	18AWG	GXL	FC423-2(1)
2	BLK	0-39-2-2	18AWG	GXL	S352(2)

X425B-BOXDISCONNECT					
CONN POS	WIRE COLOR	WIRELABEL	GAUGE	JACKET	TO
1	BLK	0-47	16AWG	GXL	X374(1)
2	ORG	84-3012VOLT	12AWG	GXL	FC382-1(1)

X377-36VEQ					
CONN POS	WIRE COLOR	WIRELABEL	GAUGE	JACKET	TO
1	ORG	84-3236VOLT	12AWG	GXL	FC381-1(1)

SN311-TEMPSNSR3					
CONN POS	WIRE COLOR	WIRELABEL	GAUGE	JACKET	TO
1	WHT	84-13BTEMP3	18AWG	GXL	FC422-1(1)
2	BLK	0-39-2-1	18AWG	GXL	S352(2)

X343B-BATTERYBOXMAIN					
CONN POS	WIRE COLOR	WIRELABEL	GAUGE	JACKET	TO
A	WHT	84-13BTEMP3	18AWG	GXL	FC422-2(1)
B	WHT	84-12BTEMP4	18AWG	GXL	FC423-1(1)
C					
D	WHT	84-11HALFSTACKV	18AWG	GXL	FC424-1(1)
E					
F	BLK	0-39-2	18AWG	GXL	S352(1)
G					
H					
J	BLK	0-45	16AWG	GXL	X354(1)

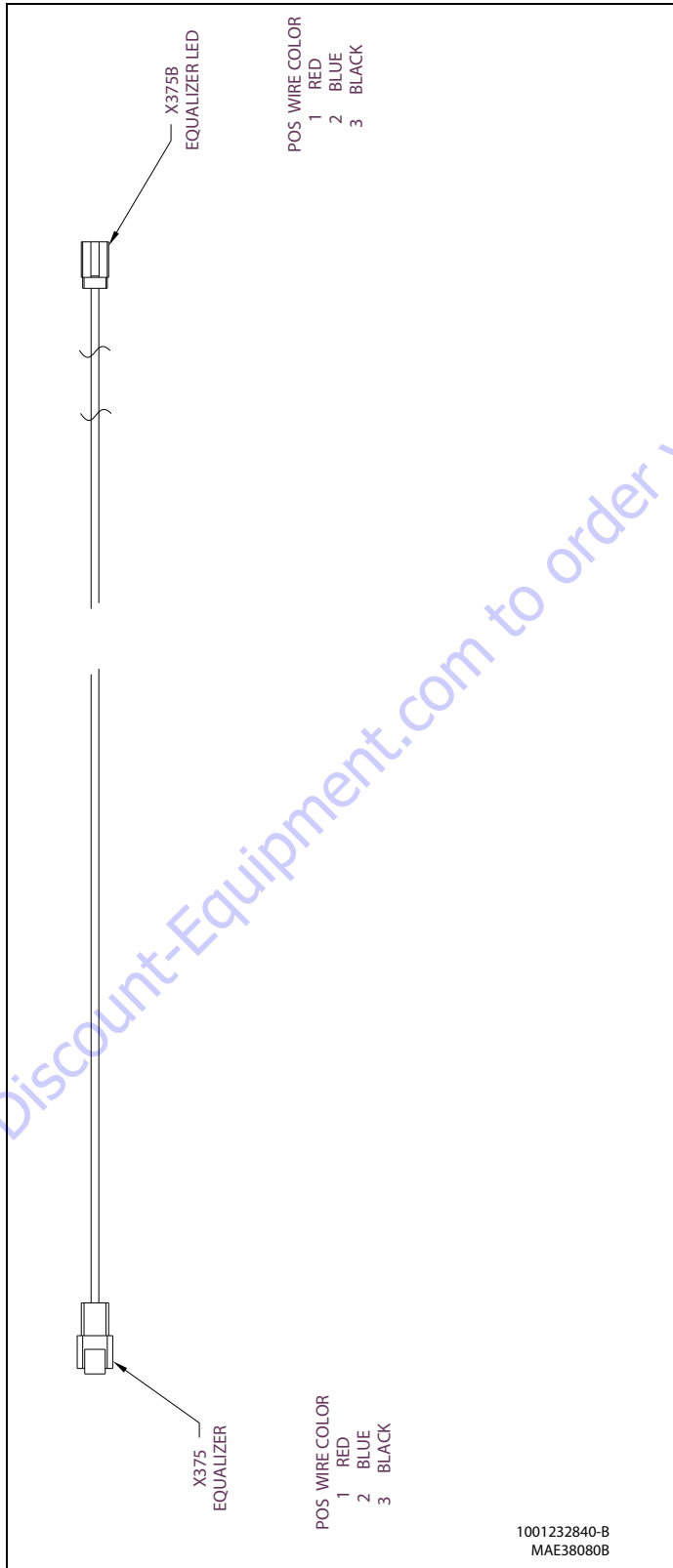

Figure 7-93. Equalizer Cable (LT)

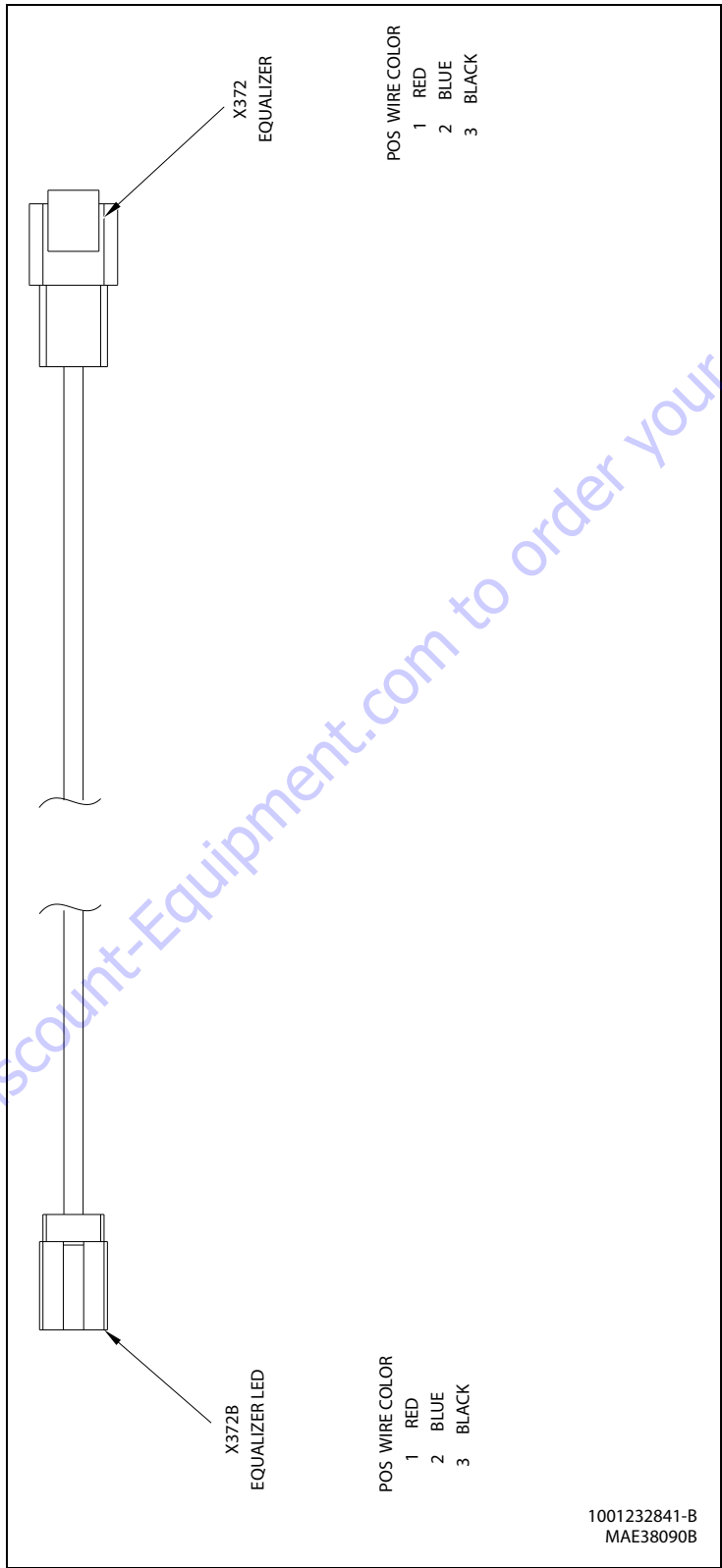
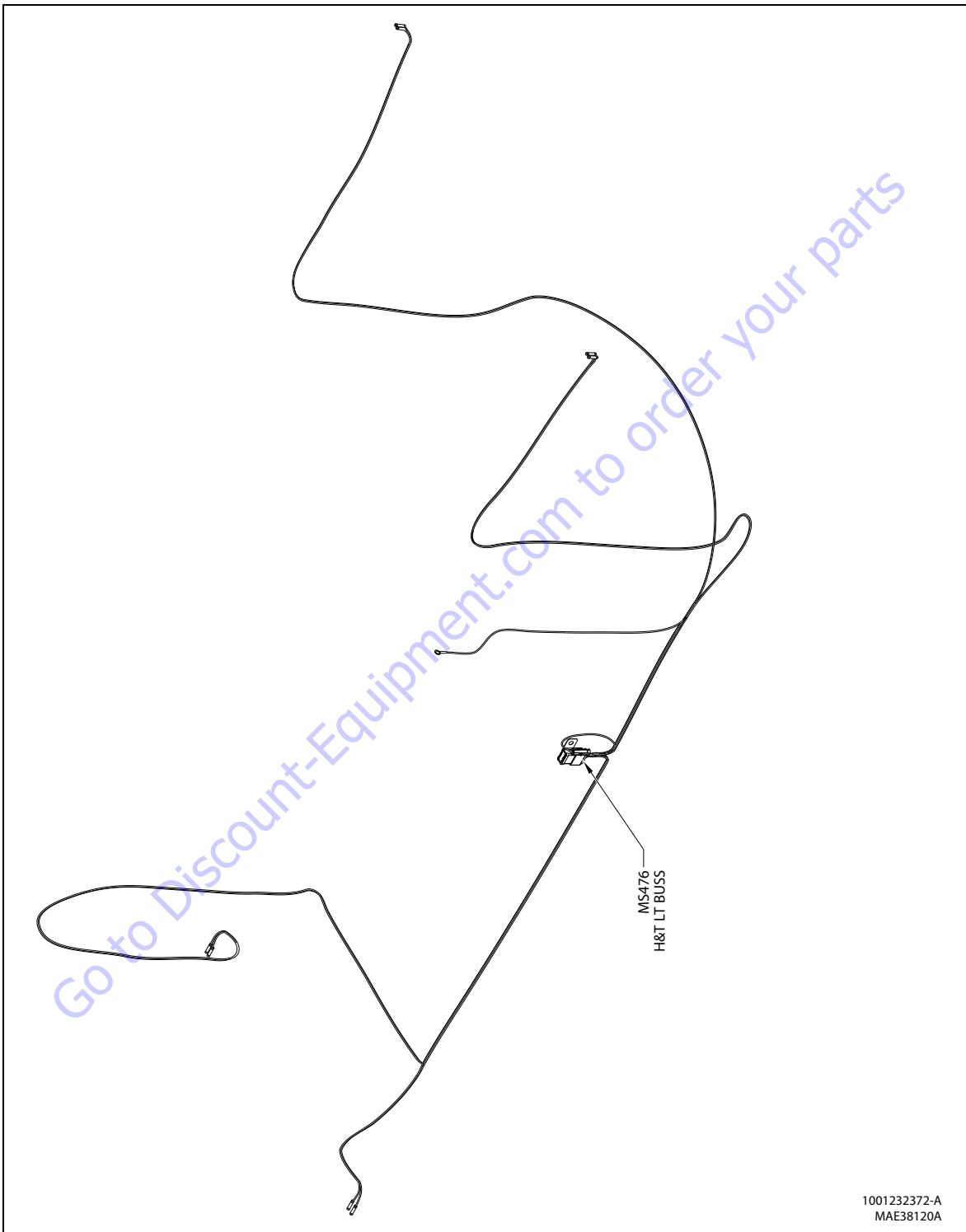

Figure 7-94. Equalizer Cable (RT)

This Page Left Blank Intentionally

Go to Discount-Equipment.com to order your parts



1001232372-A
MAE38120A

Figure 7-95. HRT Light Harness - Sheet 1 of 2

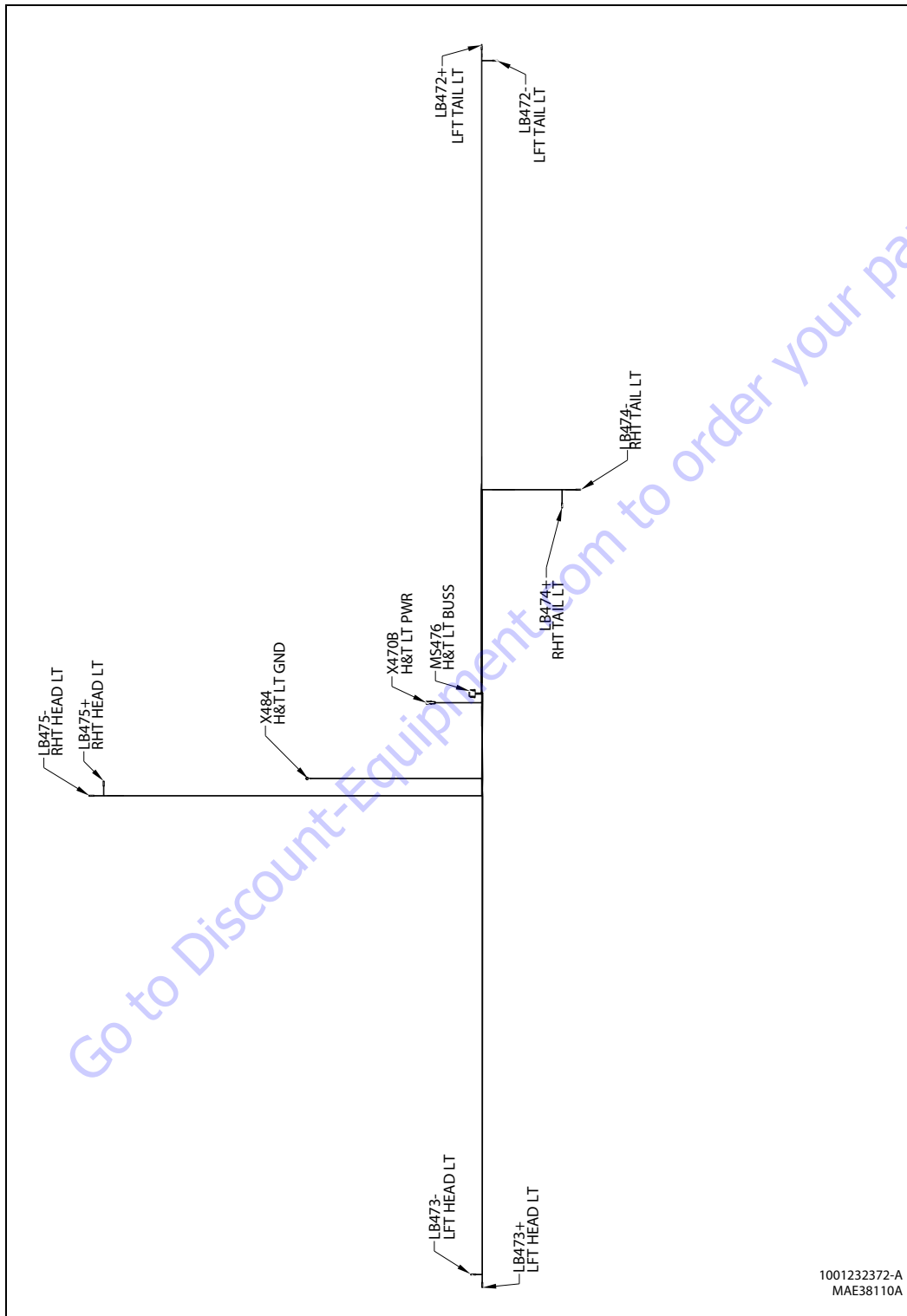

Figure 7-96. HRT Light Harness - Sheet 2 of 2

SECTION 7 - BASIC ELECTRICAL INFORMATION & ELECTRICAL SCHEMATICS

LB473+ - LFT HEAD LT					
CONN POS	WIRE COLOR	WIRE LABEL	GAUGE	JACKET	TO
1	WHT	16/2-1060341	16AWG	CABLE	MS476(6)

LB472--LFTTAILT					
CONN POS	WIRE COLOR	WIRE LABEL	GAUGE	JACKET	TO
1	BLK	16/2-1060341	16AWG	CABLE	MS476(1)

LB473- - LFT HEAD LT					
CONN POS	WIRE COLOR	WIRE LABEL	GAUGE	JACKET	TO
1	BLK	16/2-1060341	16AWG	CABLE	MS476(2)

LB474- - RHTTAIL LT					
CONN POS	WIRE COLOR	WIRE LABEL	GAUGE	JACKET	TO
1	BLK	16/2-1060341	16AWG	CABLE	MS476(11)

LB475- - RHT HEAD LT					
CONN POS	WIRE COLOR	WIRE LABEL	GAUGE	JACKET	TO
1	BLK	16/2-1060341	16AWG	CABLE	MS476(10)

LB474+ - RHTTAIL LT					
CONN POS	WIRE COLOR	WIRE LABEL	GAUGE	JACKET	TO
1	WHT	16/2-1060341	16AWG	CABLE	MS476(9)

LB475+ - RHT HEAD LT					
CONN POS	WIRE COLOR	WIRE LABEL	GAUGE	JACKET	TO
1	WHT	16/2-1060341	16AWG	CABLE	MS476(8)

MS476 - H&T LT BUSS					
CONN POS	WIRE COLOR	WIRE LABEL	GAUGE	JACKET	TO
1	BLK	16/2-1060341	16AWG	CABLE	LB472-(1)
2	BLK	16/2-1060341	16AWG	CABLE	LB473-(1)
3					
4	WHT	49-45H&TLT	16AWG	GXL	X470B(1)
5	WHT	16/2-1060341	16AWG	CABLE	LB472+(1)
6	WHT	16/2-1060341	16AWG	CABLE	LB473+(1)
7					
8	WHT	16/2-1060341	16AWG	CABLE	LB475+(1)
9	WHT	16/2-1060341	16AWG	CABLE	LB474+(1)
10	BLK	16/2-1060341	16AWG	CABLE	LB475-(1)
11	BLK	16/2-1060341	16AWG	CABLE	LB474-(1)
12	BLK	0-00	16AWG	GXL	X484(1)

X484- H&T LT GND					
CONN POS	WIRE COLOR	WIRE LABEL	GAUGE	JACKET	TO
1	BLK	0-00	16AWG	GXL	MS476(12)

X470B-H&TLTPWR					
CONN POS	WIRE COLOR	WIRE LABEL	GAUGE	JACKET	TO
1	WHT	49-45H&TLT	16AWG	GXL	MS476(4)

LB472+- LFTTAIL LT					
CONN POS	WIRE COLOR	WIRE LABEL	GAUGE	JACKET	TO
1	WHT	16/2-1060341	16AWG	CABLE	MS476(5)

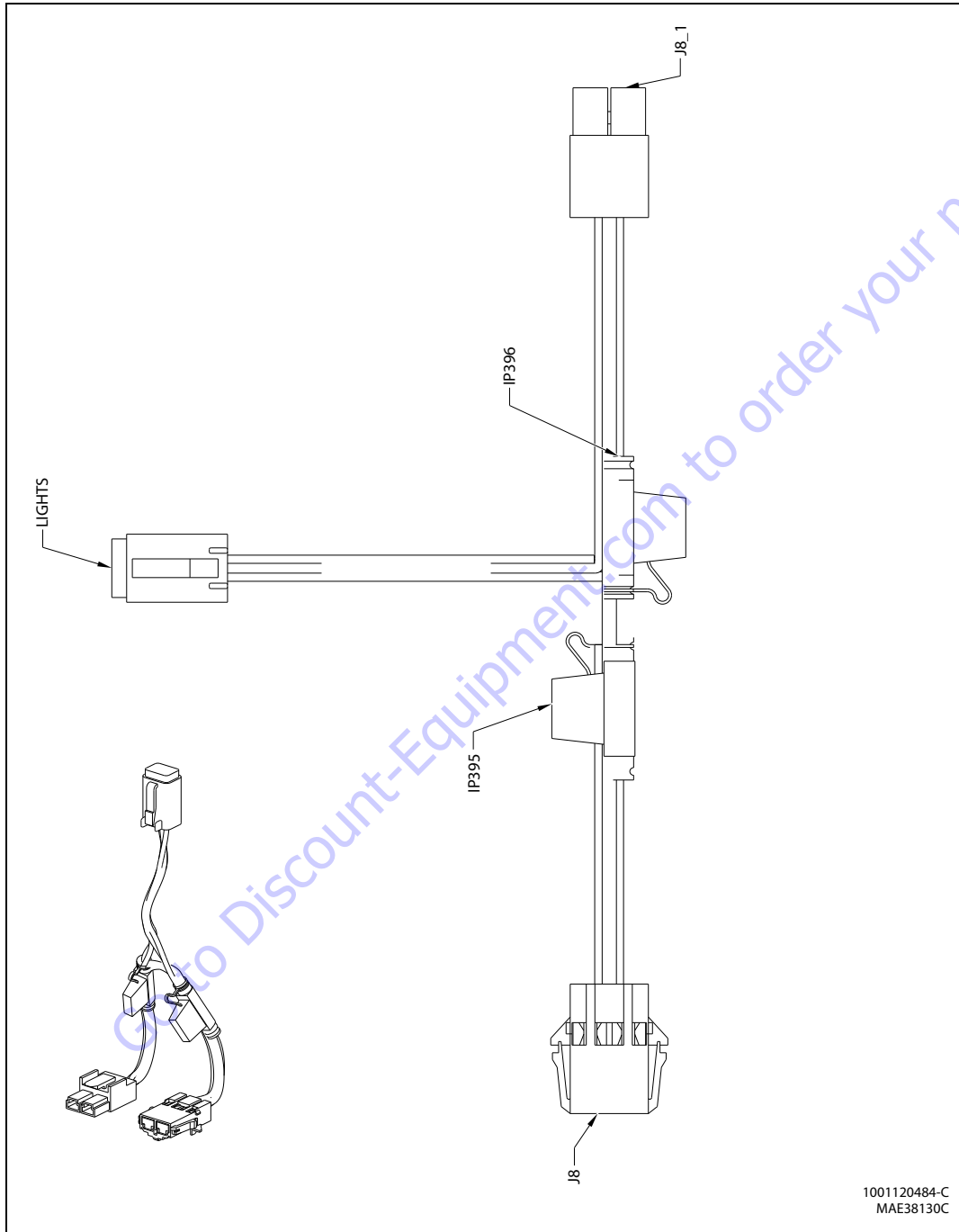

Figure 7-97. PLT Work Light Harness

1001120484-C
MAE38130C

SECTION 7 - BASIC ELECTRICAL INFORMATION & ELECTRICAL SCHEMATICS

J8_1					
CONN POS	WIRE COLOR	WIRELABEL	GAUGE	JACKET	TO
1	BLK	-	12AWG	GXL	J8(1)
1	BLK	-	16AWG	GXL	LIGHTS(3)
2	YEL/RED	-	12AWG	GXL	J8(2)
2	-	SEENOTE3			IP396(2)

IP395					
CONN POS	WIRE COLOR	WIRELABEL	GAUGE	JACKET	TO
1	-	SEENOTE3			LIGHTS(2)
2	-	SEENOTE3			J8(2)

IP396					
CONN POS	WIRE COLOR	WIRELABEL	GAUGE	JACKET	TO
1	-	SEENOTE3			LIGHTS(4)
2	-	SEENOTE3			J8_1(2)

J8					
CONN POS	WIRE COLOR	WIRELABEL	GAUGE	JACKET	TO
1	BLK	-	12AWG	GXL	J8_1(1)
1	BLK	-	16AWG	GXL	LIGHTS(1)
2	YEL/RED	-	12AWG	GXL	J8_1(2)
2	-	SEENOTE3			IP395(2)

LIGHTS					
CONN POS	WIRE COLOR	WIRELABEL	GAUGE	JACKET	TO
1	BLK	-	16AWG	GXL	J8(1)
2	-	SEENOTE3			IP395(1)
3	BLK	-	16AWG	GXL	J8_1(1)
4	-	SEENOTE3			IP396(1)

Go to Discount-Equipment.com to order your parts

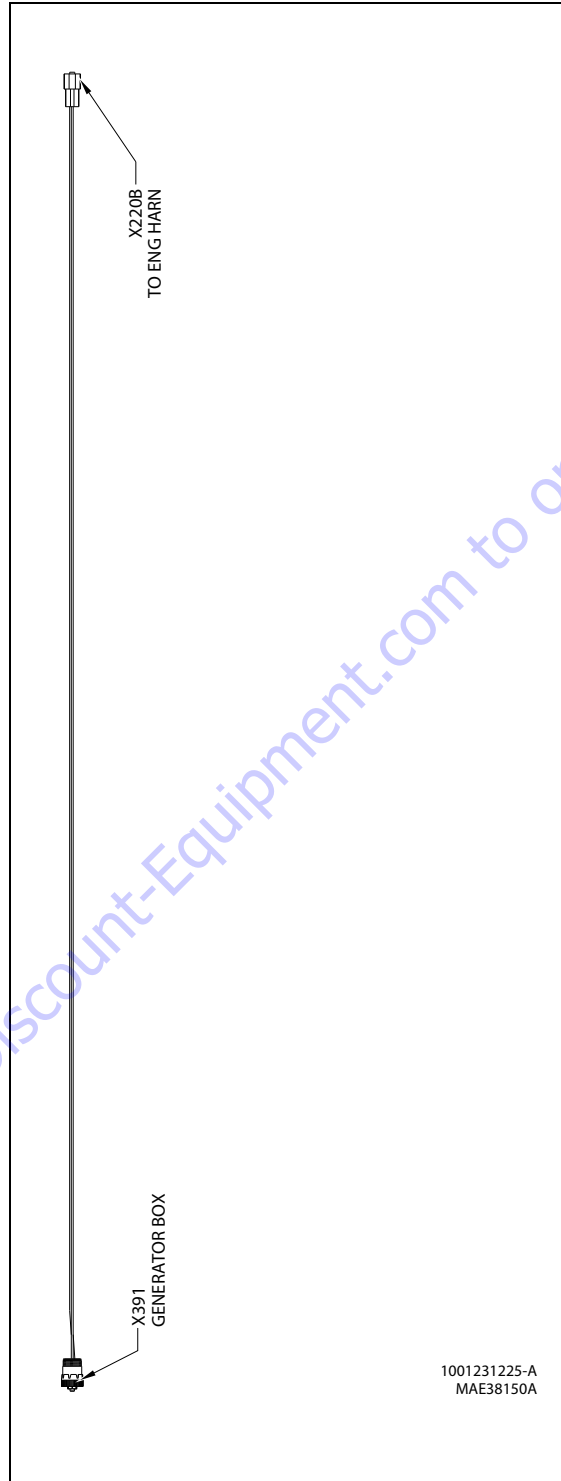

Figure 7-98. Generator Light Harness

SECTION 7 - BASIC ELECTRICAL INFORMATION & ELECTRICAL SCHEMATICS

X391GENERATORBOX					
CONN POS	WIRE COLOR	WIRELABEL	GAUGE	JACKET	TO
A	YEL	2-14-6	18AWG	GXL	X220B(A)
B	WHT	48-24GEN	18AWG	GXL	X220B(B)
C	BLK	0-28	18AWG	GXL	X220B(C)

X220B TOENGHARN					
CONN POS	WIRE COLOR	WIRELABEL	GAUGE	JACKET	TO
A	YEL	2-14-6	18AWG	GXL	X391(A)
B	WHT	48-24GEN	18AWG	GXL	X391(B)
C	BLK	0-28	18AWG	GXL	X391(C)

Go to Discount-Equipment.com to order your parts

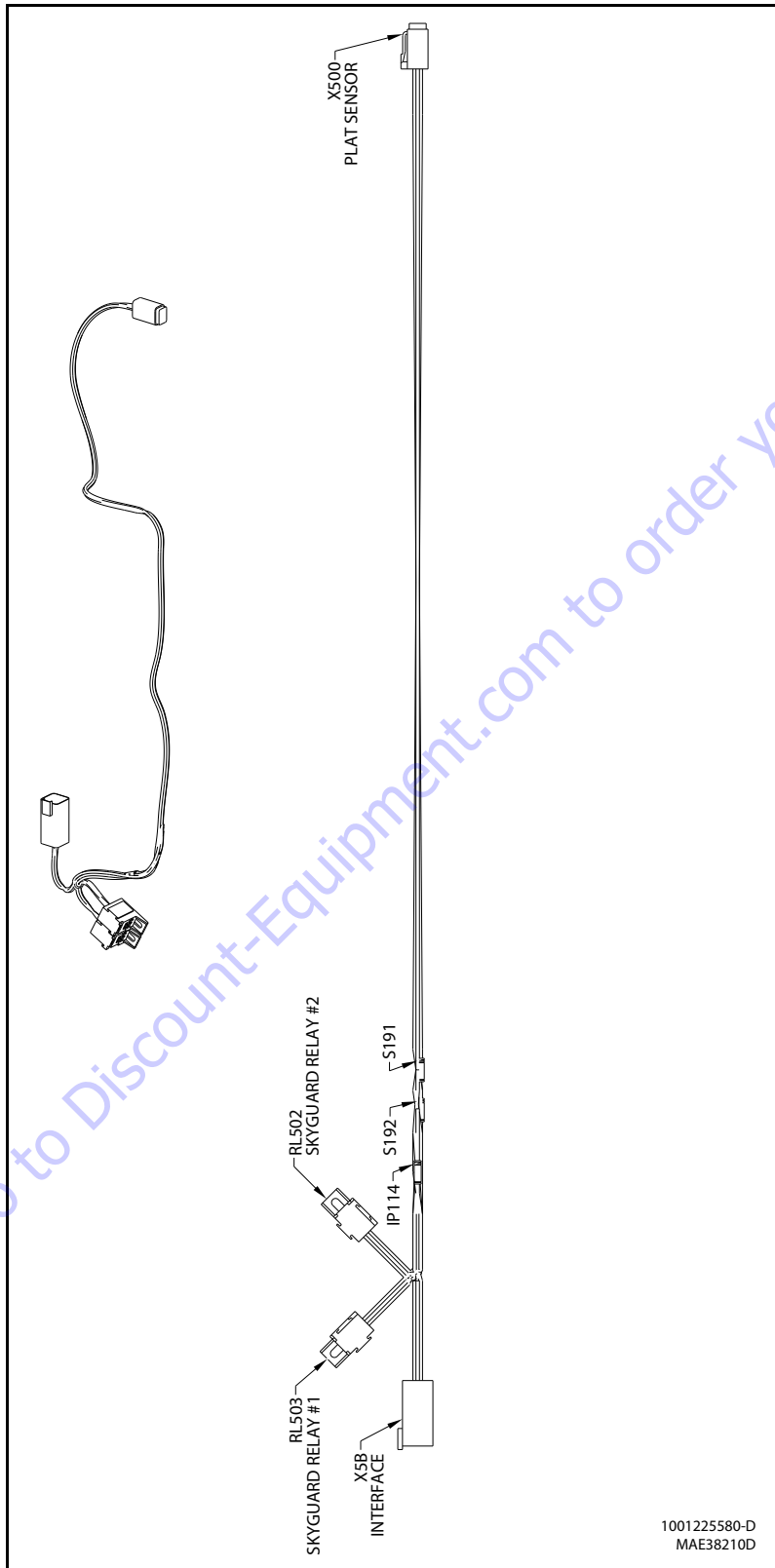

Figure 7-99. Skyguard Harness

SECTION 7 - BASIC ELECTRICAL INFORMATION & ELECTRICAL SCHEMATICS

X5B- INTERFACE					
CONN POS	WIRE COLOR	WIRELABEL	GAUGE	JACKET	T0
1	WHT	P2	18AWG	GXL	IP114(1)
2	WHT	P6	18AWG	GXL	X500(2)
3					
4	WHT	P1	18AWG	GXL	RL503(87)
5	WHT	P3	18AWG	GXL	RL502(87)
6					

S191					
CONN POS	WIRE COLOR	WIRELABEL	GAUGE	JACKET	T0
1	WHT	P5-1	18AWG	GXL	RL503(85)
1	WHT	P5-2	18AWG	GXL	RL502(85)
2	WHT	P5	18AWG	GXL	X500(4)

RL503-SKYGUARDRELAY#1					
CONN POS	WIRE COLOR	WIRELABEL	GAUGE	JACKET	T0
30	WHT	P9-1	18AWG	GXL	IP114(1)
85	WHT	P5-1	18AWG	GXL	S191(1)
86	WHT	P4-1	18AWG	GXL	S192(1)
87	WHT	P1	18AWG	GXL	X5B(4)
87A					

X500 - PLATSENSOR					
CONN POS	WIRE COLOR	WIRELABEL	GAUGE	JACKET	T0
1	WHT	P10	18AWG	GXL	IP114(2)
2	WHT	P6	18AWG	GXL	X5B(2)
3	WHT	P4	18AWG	GXL	S192(2)
4	WHT	P5	18AWG	GXL	S191(2)

RL502-SKYGUARDRELAY#2					
CONN POS	WIRE COLOR	WIRELABEL	GAUGE	JACKET	T0
30	WHT	P9-2	18AWG	GXL	IP114(1)
85	WHT	P5-2	18AWG	GXL	S191(1)
86	WHT	P4-2	18AWG	GXL	S192(1)
87	WHT	P3	18AWG	GXL	X5B(5)
87a					

IP114					
CONN POS	WIRE COLOR	WIRELABEL	GAUGE	JACKET	T0
1	WHT	P2	18AWG	GXL	X5B(1)
1	WHT	P9-1	18AWG	GXL	RL503(30)
1	WHT	P9-2	18AWG	GXL	RL502(30)
2	WHT	P10	18AWG	GXL	X500(1)

S192					
CONN POS	WIRE COLOR	WIRELABEL	GAUGE	JACKET	T0
1	WHT	P4-1	18AWG	GXL	RL503(86)
1	WHT	P4-2	18AWG	GXL	RL502(86)
2	WHT	P4	18AWG	GXL	X500(3)

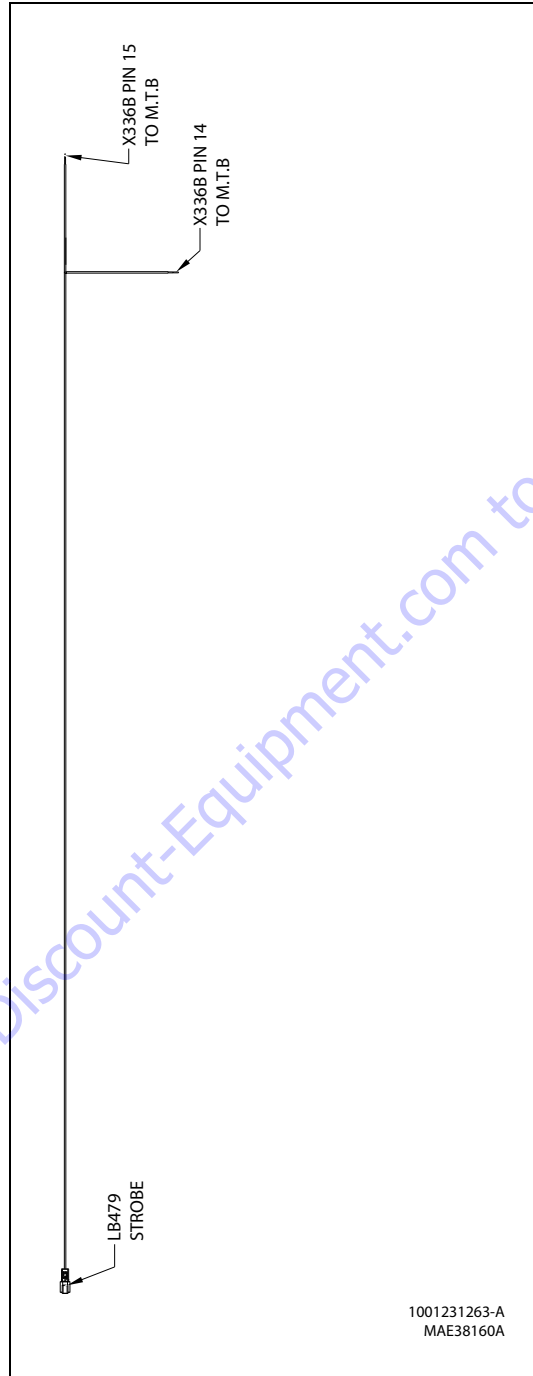

Figure 7-100. Strobe Harness

SECTION 7 - BASIC ELECTRICAL INFORMATION & ELECTRICAL SCHEMATICS

LB479STROBE					
CONN POS	WIRE COLOR	WIRELABEL	GAUGE	JACKET	TO
1	WHT	16/2-1060341	16AWG	CABLE	X336BPIN14(1)
2	BLK	16/2-1060341	16AWG	CABLE	X336BPIN15(1)

X336BPIN14TOM.T.B					
CONN POS	WIRE COLOR	WIRELABEL	GAUGE	JACKET	TO
1	WHT	16/2-1060341	16AWG	CABLE	LB479(1)

X336BPIN15TOM.T.B					
CONN POS	WIRE COLOR	WIRELABEL	GAUGE	JACKET	TO
1	BLK	16/2-1060341	16AWG	CABLE	LB479(2)

Go to Discount-Equipment.com to order your parts

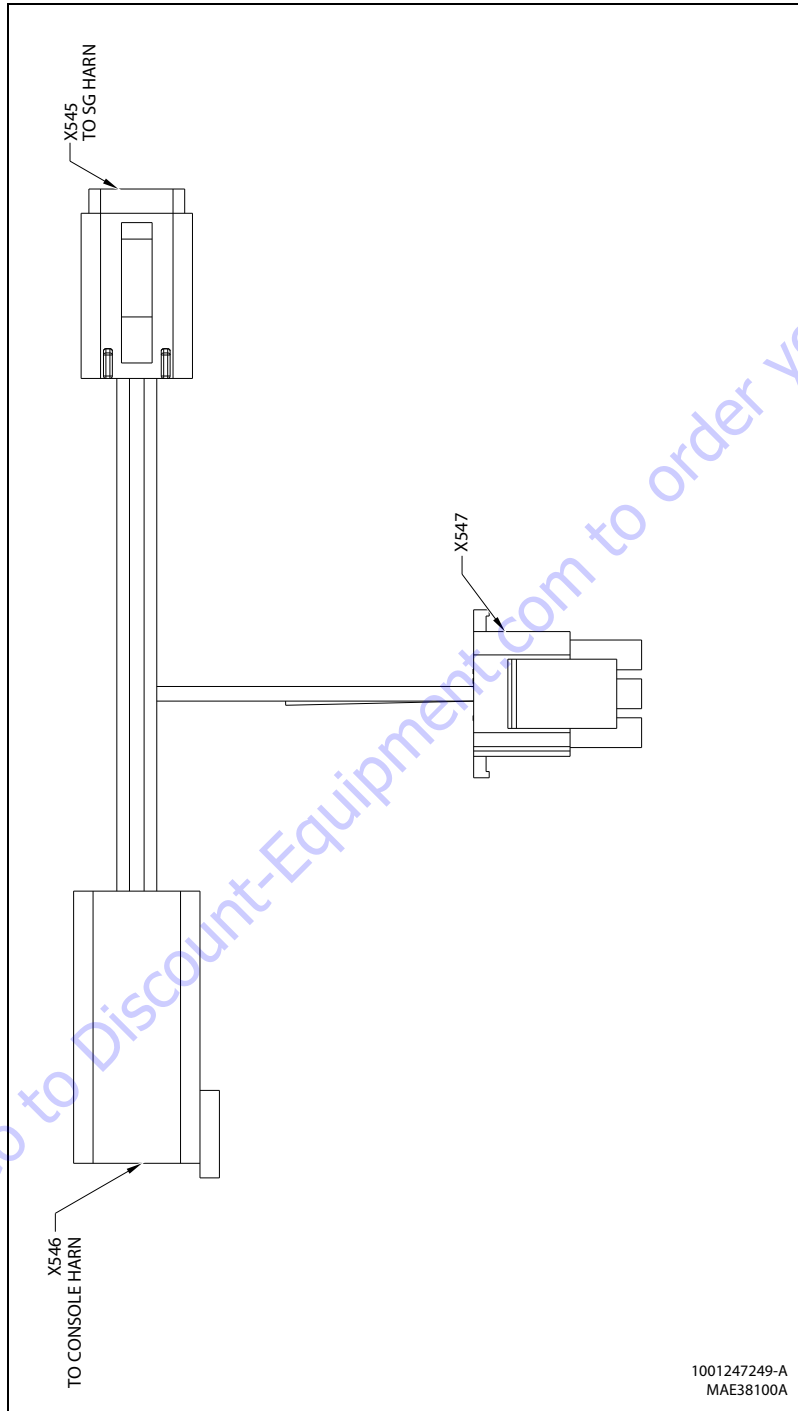

Figure 7-101. Soft Touch Harness

SECTION 7 - BASIC ELECTRICAL INFORMATION & ELECTRICAL SCHEMATICS

X546					
CONN POS	WIRE COLOR	WIRELABEL	GAUGE	JACKET	T0
1	YEL	2-3-4	18AWG	GXL	X547(6)
2	BLK	0-6-3	18AWG	GXL	X545(2)
3	WHT	55-6-1	18AWG	GXL	X545(3)
4	WHT	65-1	18AWG	GXL	X545(4)
5	WHT	65-2	18AWG	GXL	X545(5)
6	WHT	55-6	18AWG	GXL	X545(6)

X545					
CONN POS	WIRE COLOR	WIRELABEL	GAUGE	JACKET	T0
1	YEL	2-3-4-3	18AWG	GXL	X547(3)
2	BLK	0-6-3	18AWG	GXL	X546(2)
3	WHT	55-6-1	18AWG	GXL	X546(3)
4	WHT	65-1	18AWG	GXL	X546(4)
5	WHT	65-2	18AWG	GXL	X546(5)
6	WHT	55-6	18AWG	GXL	X546(6)

X547					
CONN POS	WIRE COLOR	WIRELABEL	GAUGE	JACKET	T0
1					
2					
3	YEL	2-3-4-3	18AWG	GXL	X545(1)
4					
5	YEL	2-3-4-2	18AWG	GXL	X547(4)
6	YEL	2-3-4	18AWG	GXL	X546(1)
7					
8					
9					
10					
11					
12					
13					
14					
15					

Go to Discount-Equipment.com to order your parts

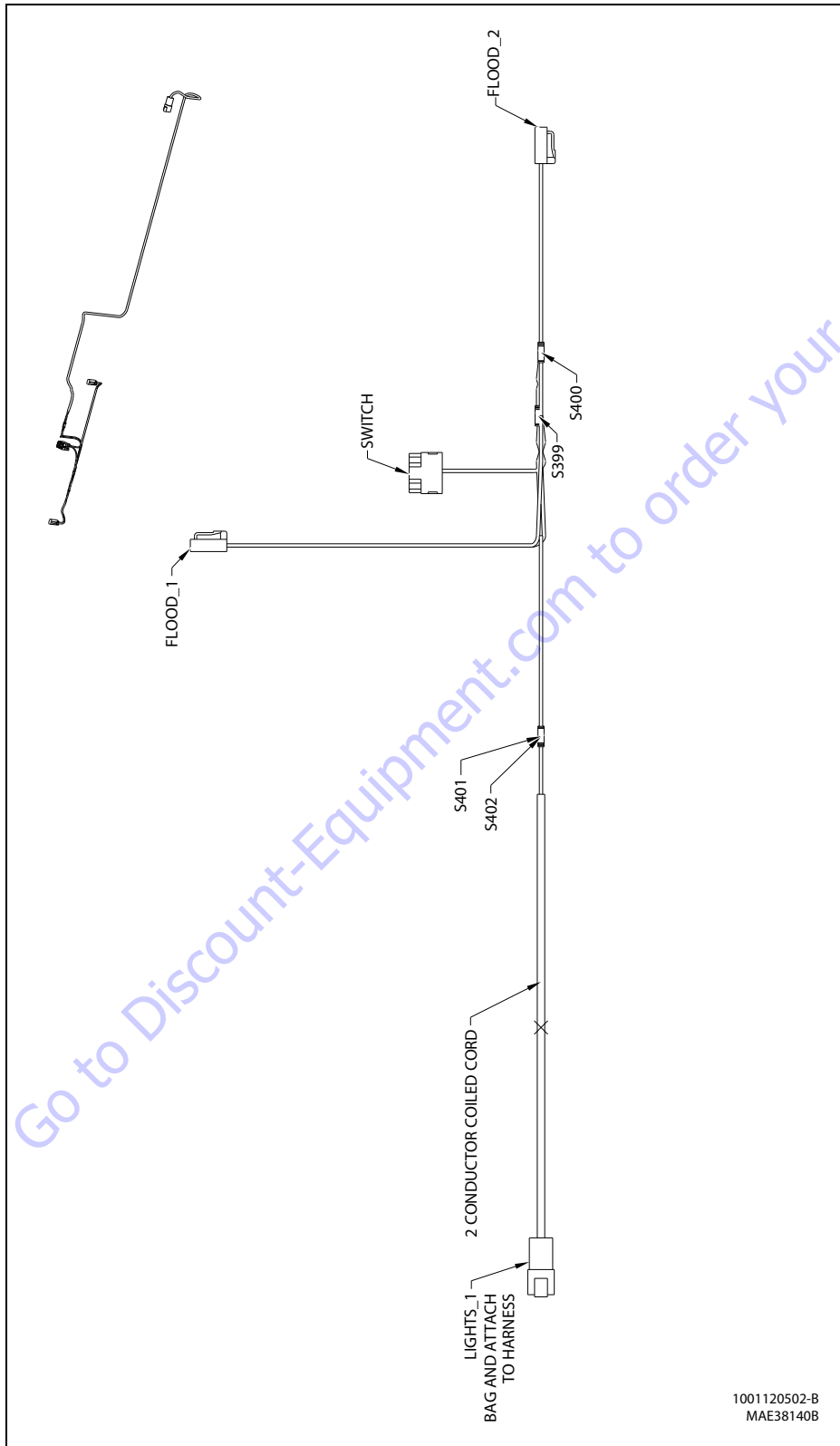

Figure 7-102. PLT Flood Light Harness

SECTION 7 - BASIC ELECTRICAL INFORMATION & ELECTRICAL SCHEMATICS

LIGHTS_1					
CONN POS	WIRE COLOR	WIRELABEL	GAUGE	JACKET	TO
1	BLK	SEENOTE4	16AWG	CABLE	S401(2)
2	WHT	SEENOTE4	16AWG	CABLE	S402(2)
3					
4					

S399					
CONN POS	WIRE COLOR	WIRELABEL	GAUGE	JACKET	TO
1	BLK	--	16AWG	GXL	FLOOD_1(2)
1	BLK	--	16AWG	GXL	S401(1)
2	BLK	--	16AWG	GXL	FLOOD_2(2)

S402					
CONN POS	WIRE COLOR	WIRELABEL	GAUGE	JACKET	TO
1	YEL/RED	--	16AWG	GXL	SWITCH(2)
2	WHT	SEENOTE4	16AWG	CABLE	LIGHTS_1(2)

S400					
CONN POS	WIRE COLOR	WIRELABEL	GAUGE	JACKET	TO
1	YEL/RED	--	16AWG	GXL	FLOOD_1(1)
1	YEL/RED	--	16AWG	GXL	SWITCH(3)
2	YEL/RED	--	16AWG	GXL	FLOOD_2(1)

S401					
CONN POS	WIRE COLOR	WIRELABEL	GAUGE	JACKET	TO
1	BLK	--	16AWG	GXL	S399(1)
2	BLK	SEENOTE4	16AWG	CABLE	LIGHTS_1(1)

FLOOD_2					
CONN POS	WIRE COLOR	WIRELABEL	GAUGE	JACKET	TO
1	YEL/RED	--	16AWG	GXL	S400(2)
2	BLK	--	16AWG	GXL	S399(2)

FLOOD_1					
CONN POS	WIRE COLOR	WIRELABEL	GAUGE	JACKET	TO
1	YEL/RED	--	16AWG	GXL	S400(1)
2	BLK	--	16AWG	GXL	S399(1)

SWITCH					
CONN POS	WIRE COLOR	WIRELABEL	GAUGE	JACKET	TO
1					
2	YEL/RED	--	16AWG	GXL	S402(1)
3	YEL/RED	--	16AWG	GXL	S400(1)
4					
5					
6					

This Page Left Blank Intentionally

Go to Discount-Equipment.com to order your parts

7.20 ELECTRICAL SCHEMATICS

2 CONSOLE BOX

CONSOLE BOX ASSEMBLY
CONSOLE BOX HARNESS

3 PLATFORM VALVE

PLATFORM VALVE HARNESS

4 TURNTABLE

GROUND CONTROL HARNESS
H-BRIDGE/CLUTCH HARNESS
TURNTABLE HYBRID HARNESS
TURNTABLE-FUSE PANEL HARNESS

5 HYDRAULICS & ENGINE

MAIN VALVE H800 HARNESS
KUBOTA ENGINE HARNESS
HYBRID ENGINE TRAY HARNESS

6 HYBRID/ELECTRIC & IMG CONTROLLERS

H.E.CONTROLLER HARNESS
HYBRID 84V H800 HARNESS
BATTERY CHARGER HARNESS

7 RESOLVER/CONVERTER & IMG

RESOLVER CONVERTER HARNESS
RES/CONV TO IMG CONT CABLE
3-PHASE MOTOR CABLE (U)
3-PHASE MOTOR CABLE (V)
3-PHASE MOTOR CABLE (W)
IMG (U) TO BOX
IMG (V) TO BOX
IMG (W) TO BOX

8 BATTERY BOXES

BATTERY STACK RIGHT HARNESS
BATTERY STACK LEFT HARNESS
EQUALIZER LED (LEFT) CABLE
EQUALIZER LED (RIGHT) CABLE

9 OPTIONS

HEAD & TAIL LTS HARNESS
HYBRID STROBE CABLE
GENERATOR ENABLE HARNESS
SKYGUARD, GEN 2 PLAT INTERFACE

10 GENERATOR

Figure 7-103. Electrical Schematics - Sheet 1 of 19

SECTION 7 - BASIC ELECTRICAL INFORMATION & ELECTRICAL SCHEMATICS

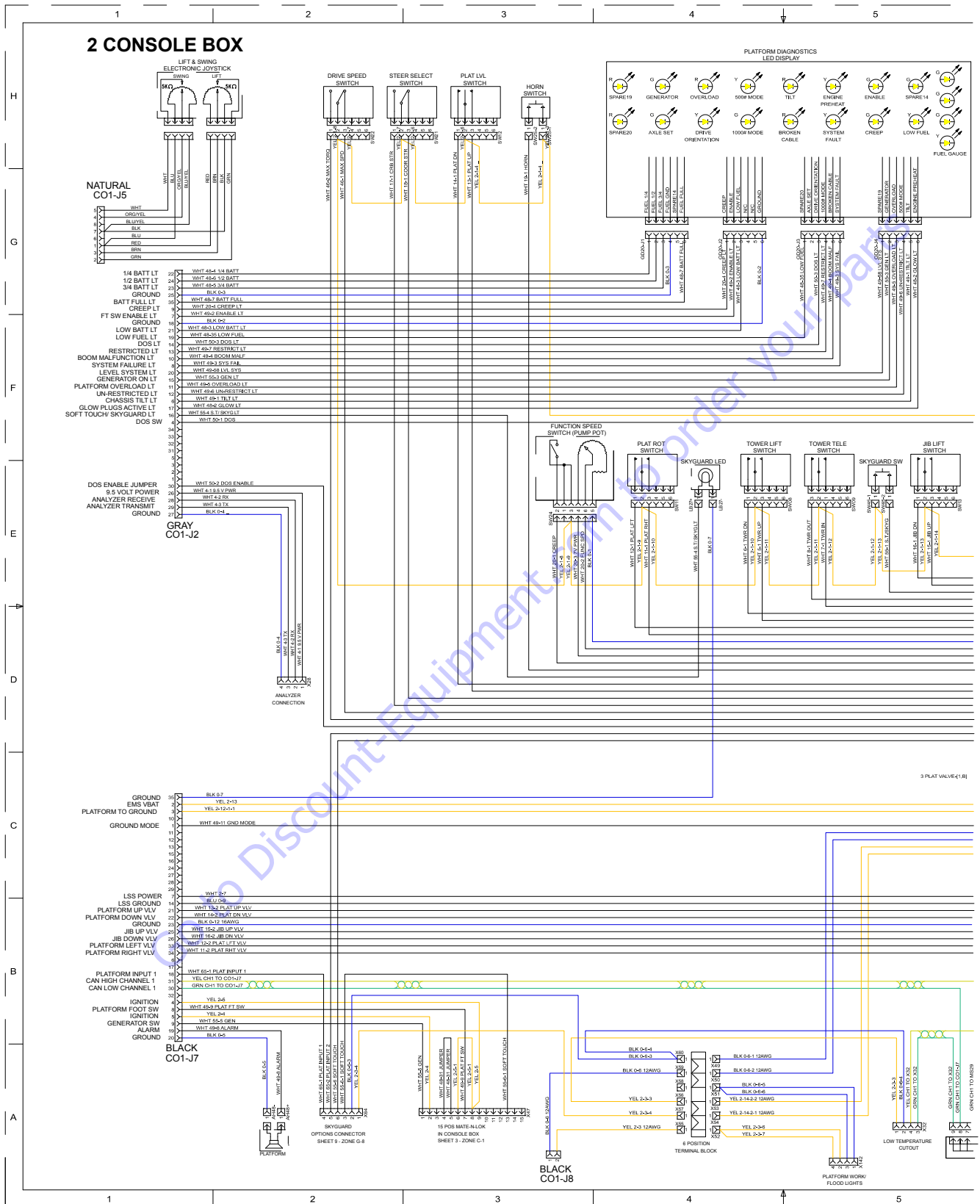

Figure 7-104. Electrical Schematics - Sheet 2 of 19

SECTION 7 - BASIC ELECTRICAL INFORMATION & ELECTRICAL SCHEMATICS

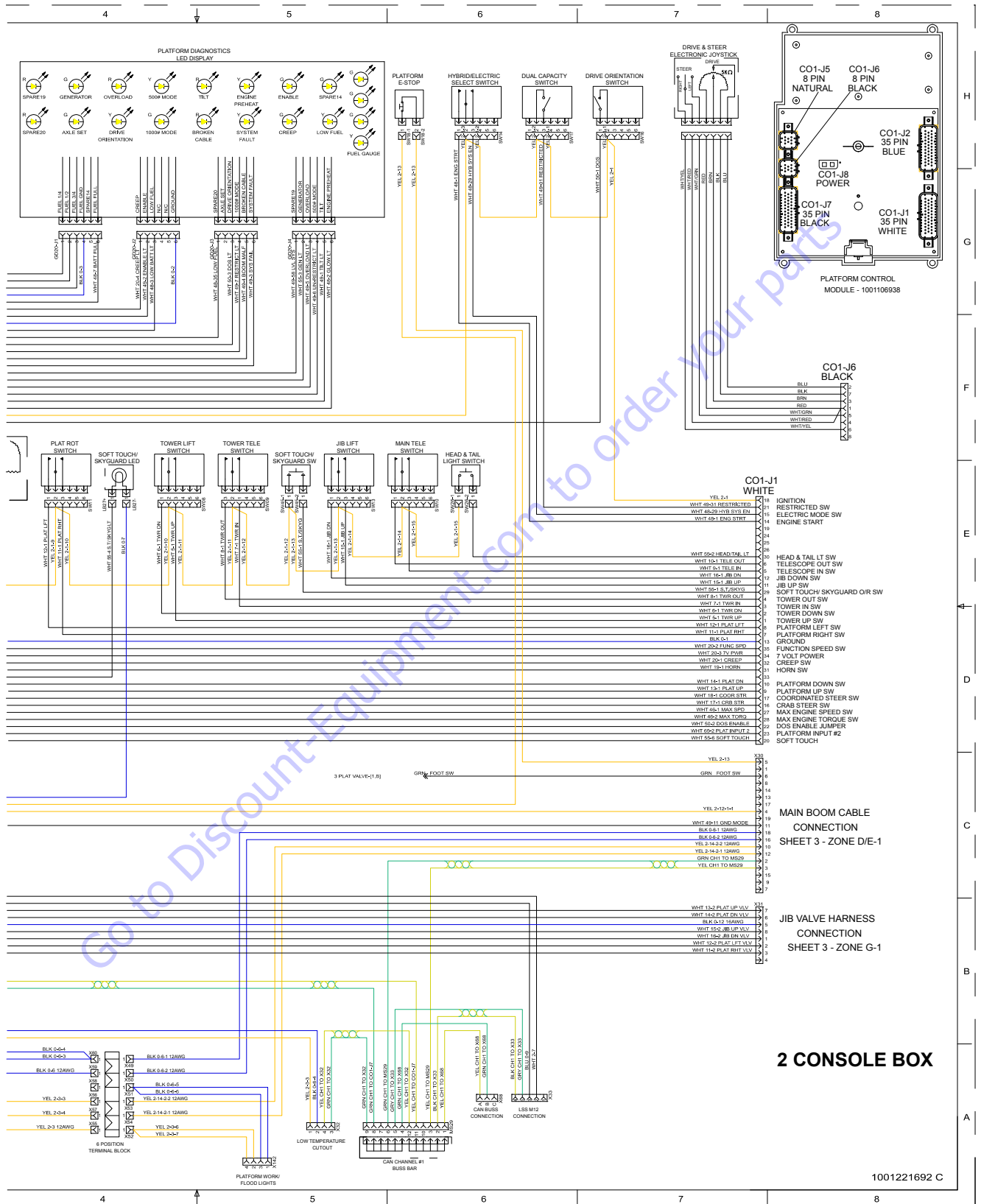

Figure 7-105. Electrical Schematics - Sheet 3 of 19

SECTION 7 - BASIC ELECTRICAL INFORMATION & ELECTRICAL SCHEMATICS

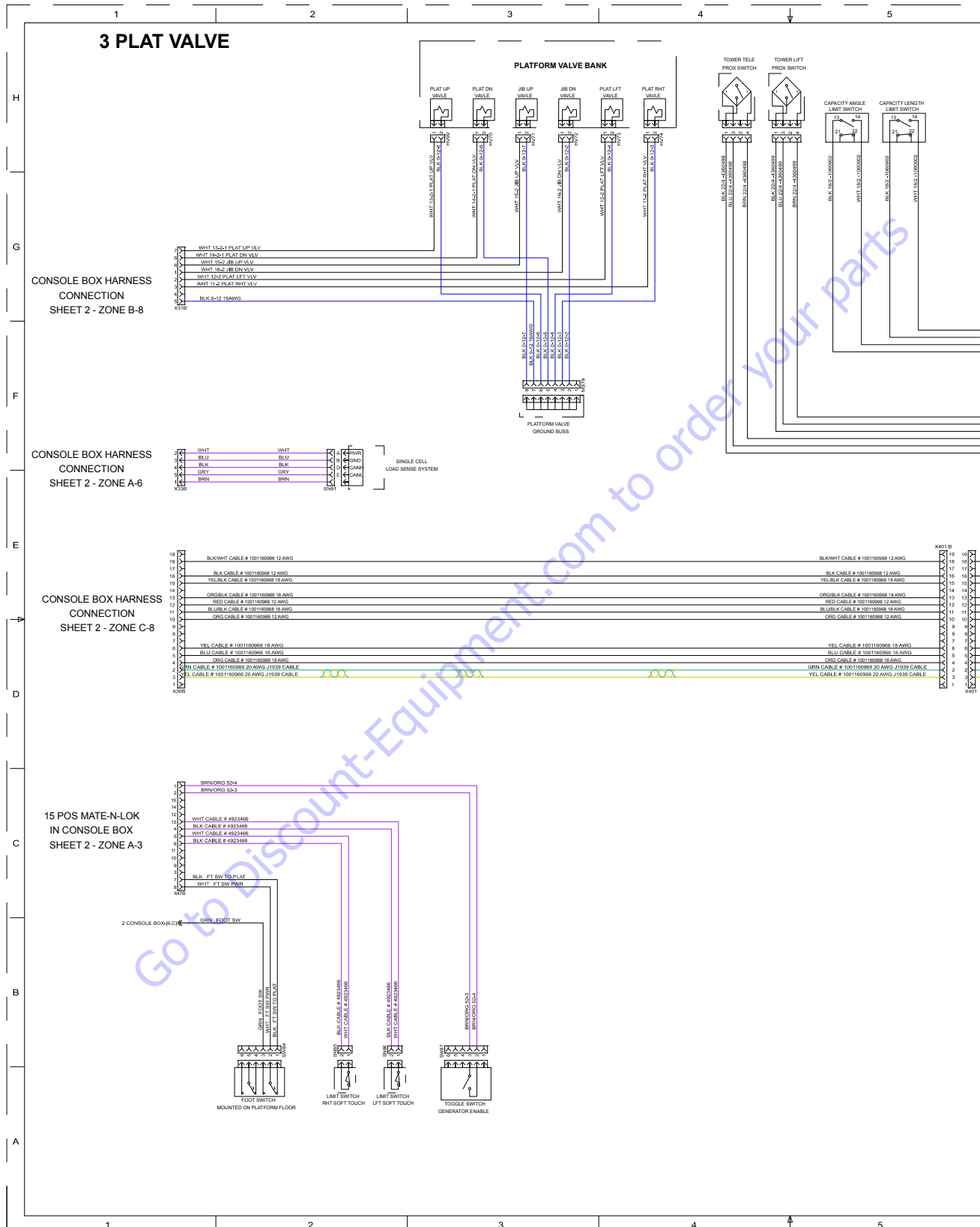

Figure 7-106. Electrical Schematics - Sheet 4 of 19

SECTION 7 - BASIC ELECTRICAL INFORMATION & ELECTRICAL SCHEMATICS

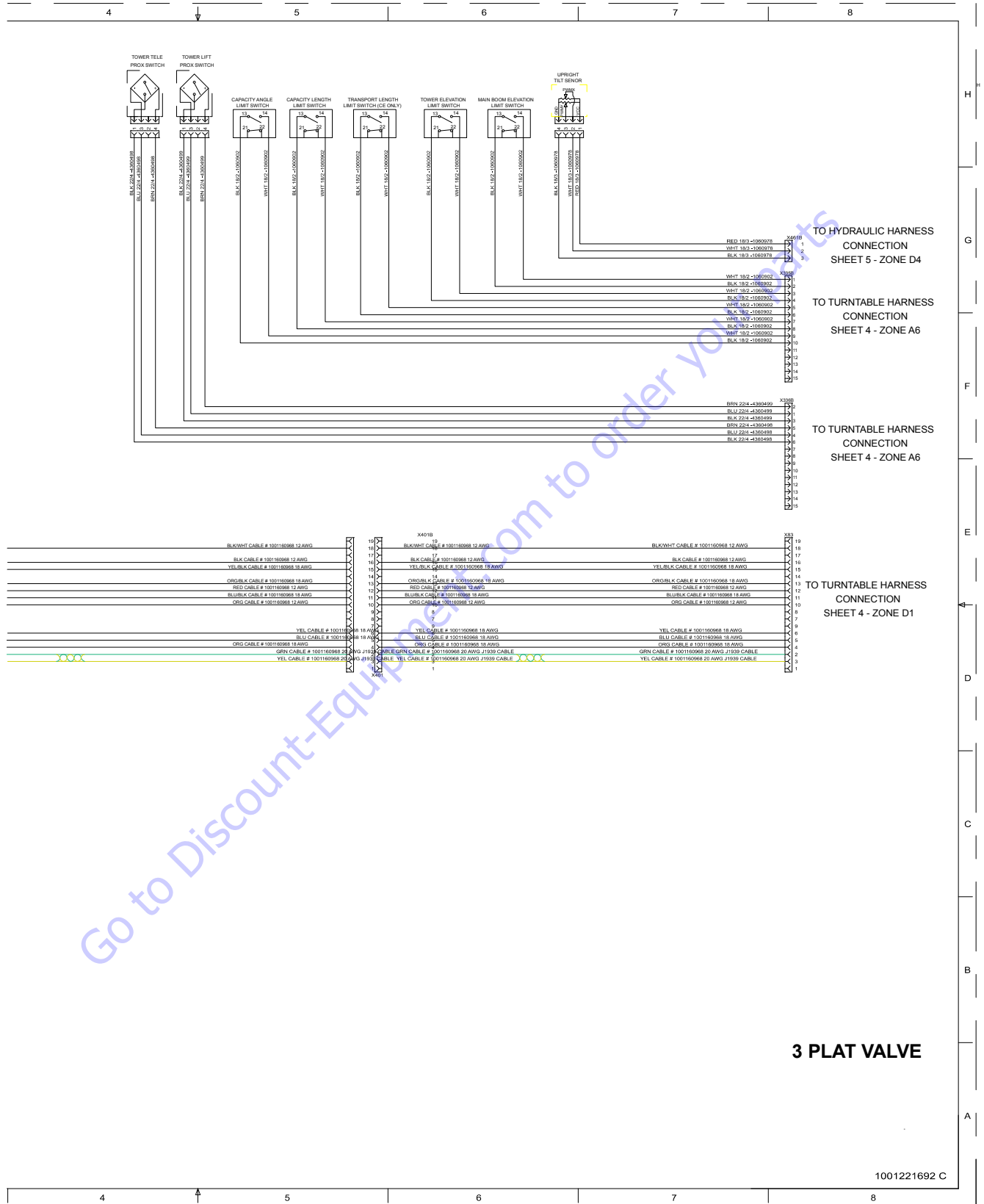

Figure 7-107. Electrical Schematics - Sheet 5 of 19

SECTION 7 - BASIC ELECTRICAL INFORMATION & ELECTRICAL SCHEMATICS

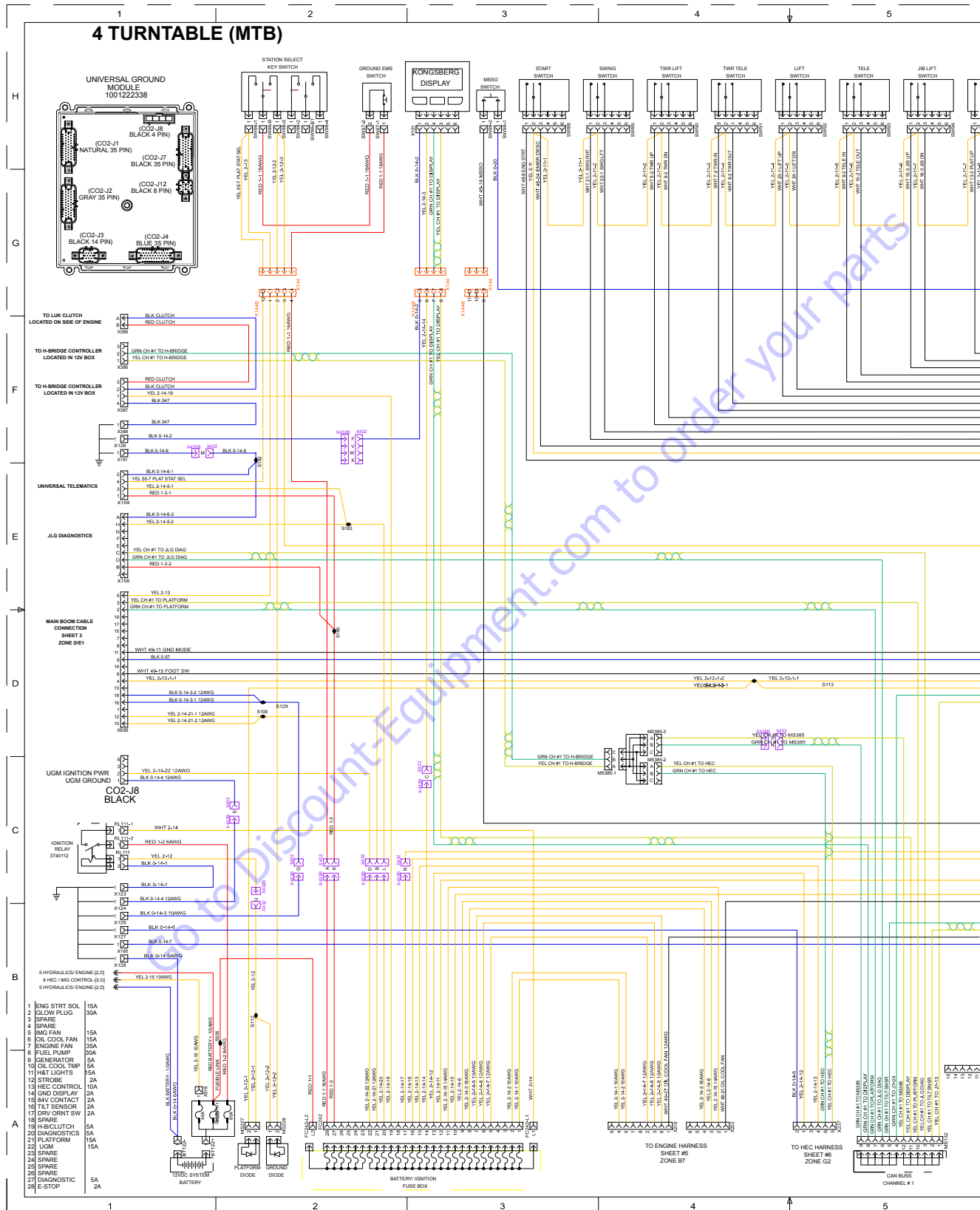

Figure 7-108. Electrical Schematics - Sheet 6 of 19

SECTION 7 - BASIC ELECTRICAL INFORMATION & ELECTRICAL SCHEMATICS

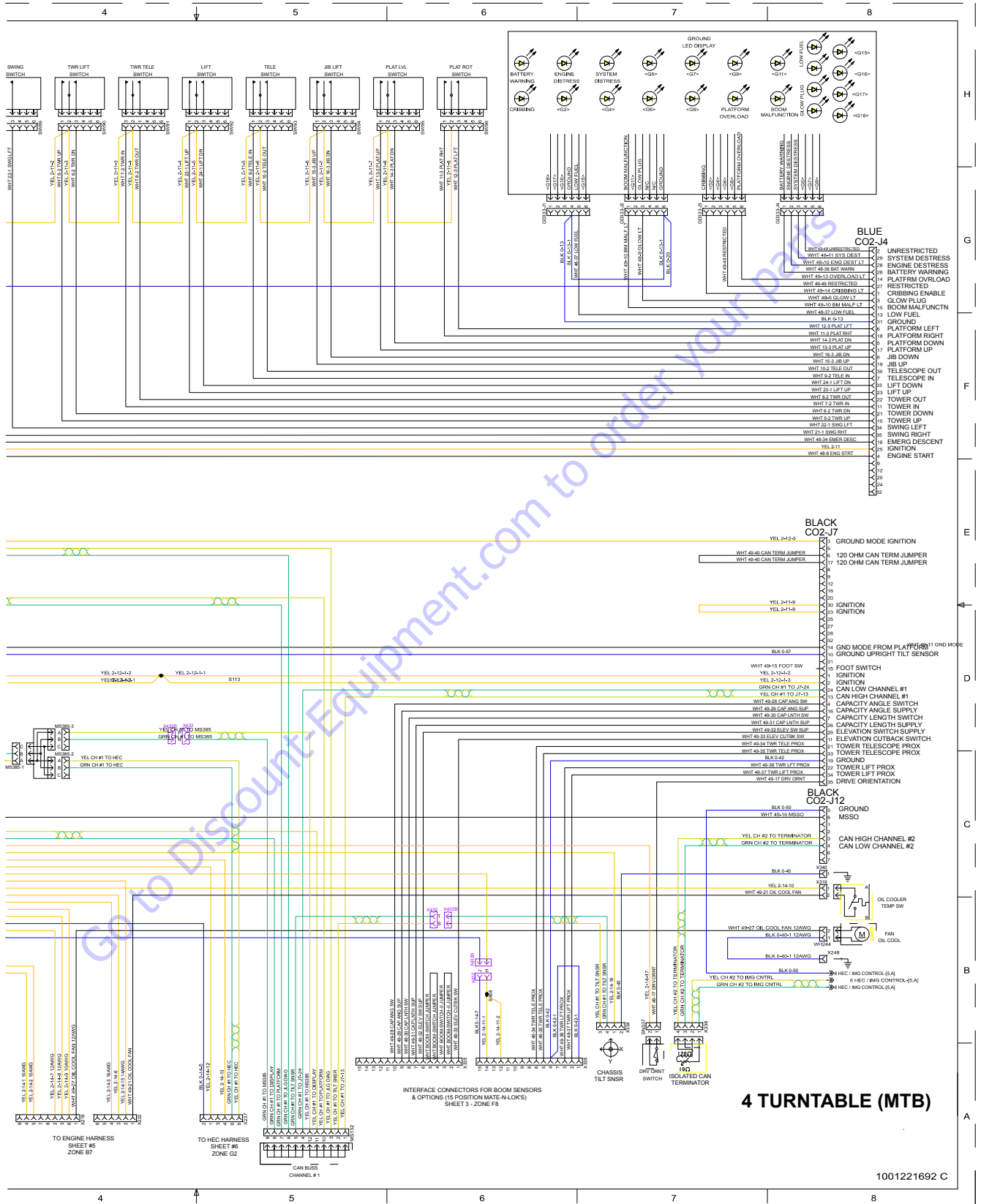

Figure 7-109. Electrical Schematics - Sheet 7 of 19

SECTION 7 - BASIC ELECTRICAL INFORMATION & ELECTRICAL SCHEMATICS

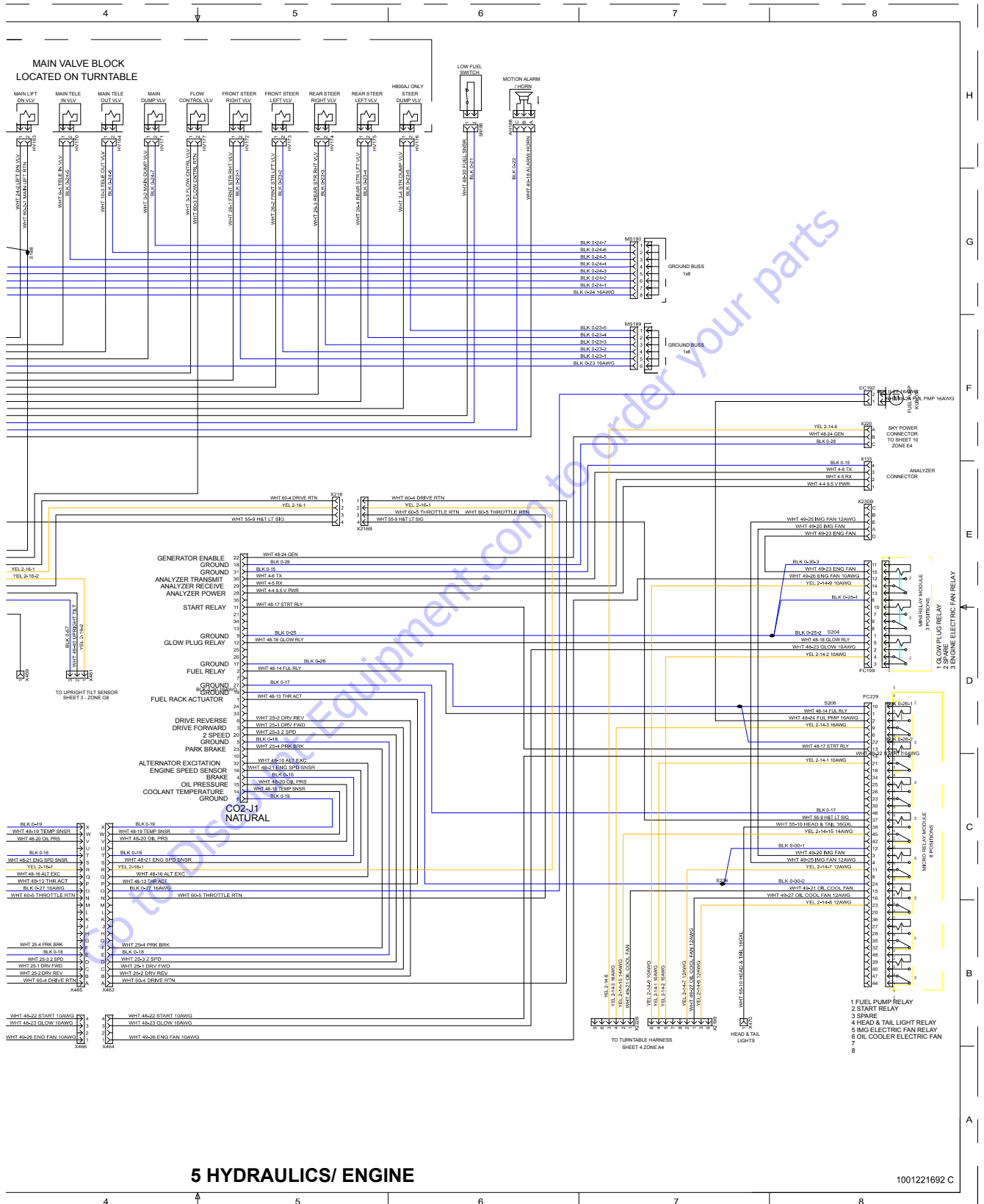

Figure 7-111. Electrical Schematics - Sheet 9 of 19

SECTION 7 - BASIC ELECTRICAL INFORMATION & ELECTRICAL SCHEMATICS

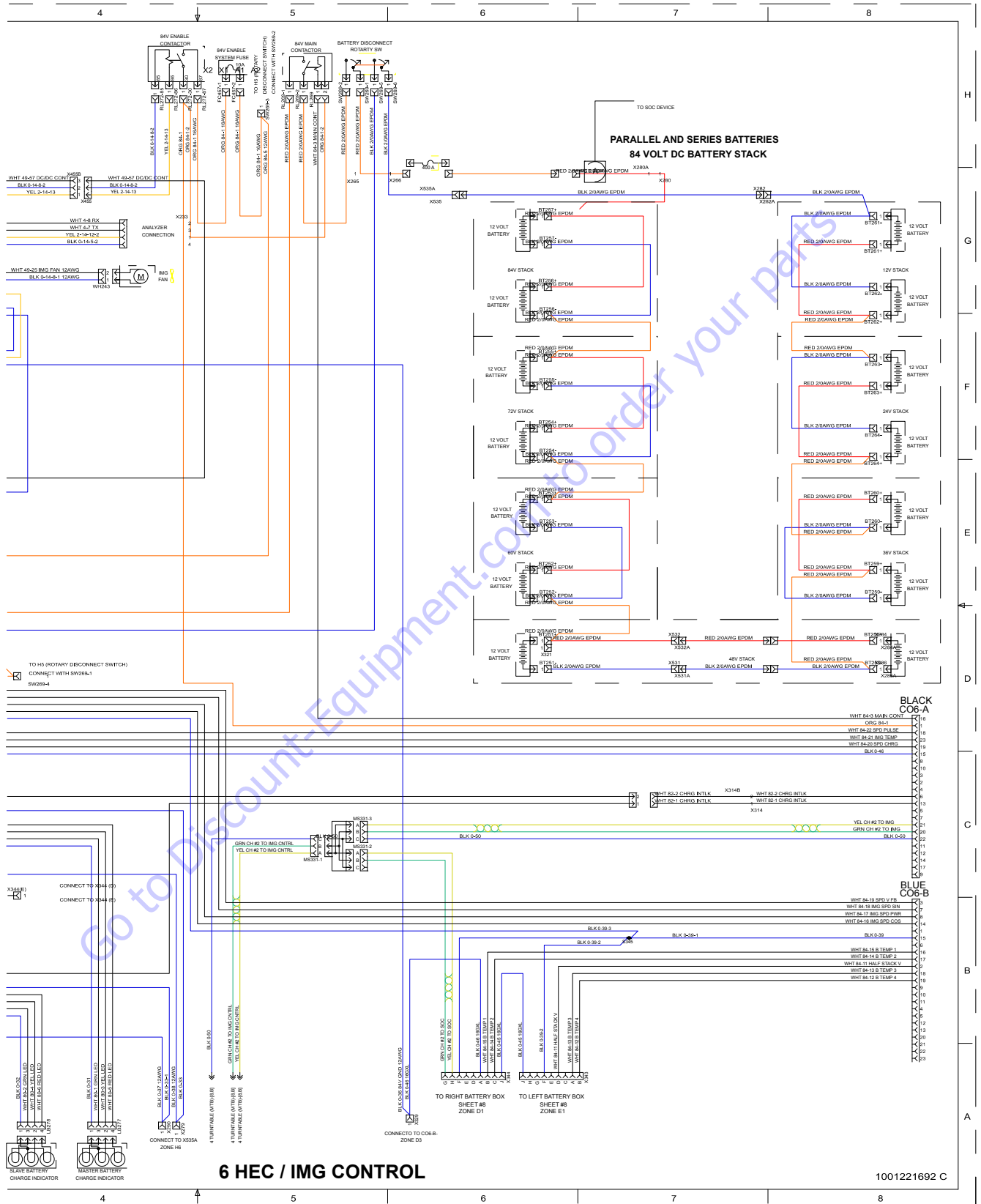

Figure 7-113. Electrical Schematics - Sheet 11 of 19

SECTION 7 - BASIC ELECTRICAL INFORMATION & ELECTRICAL SCHEMATICS

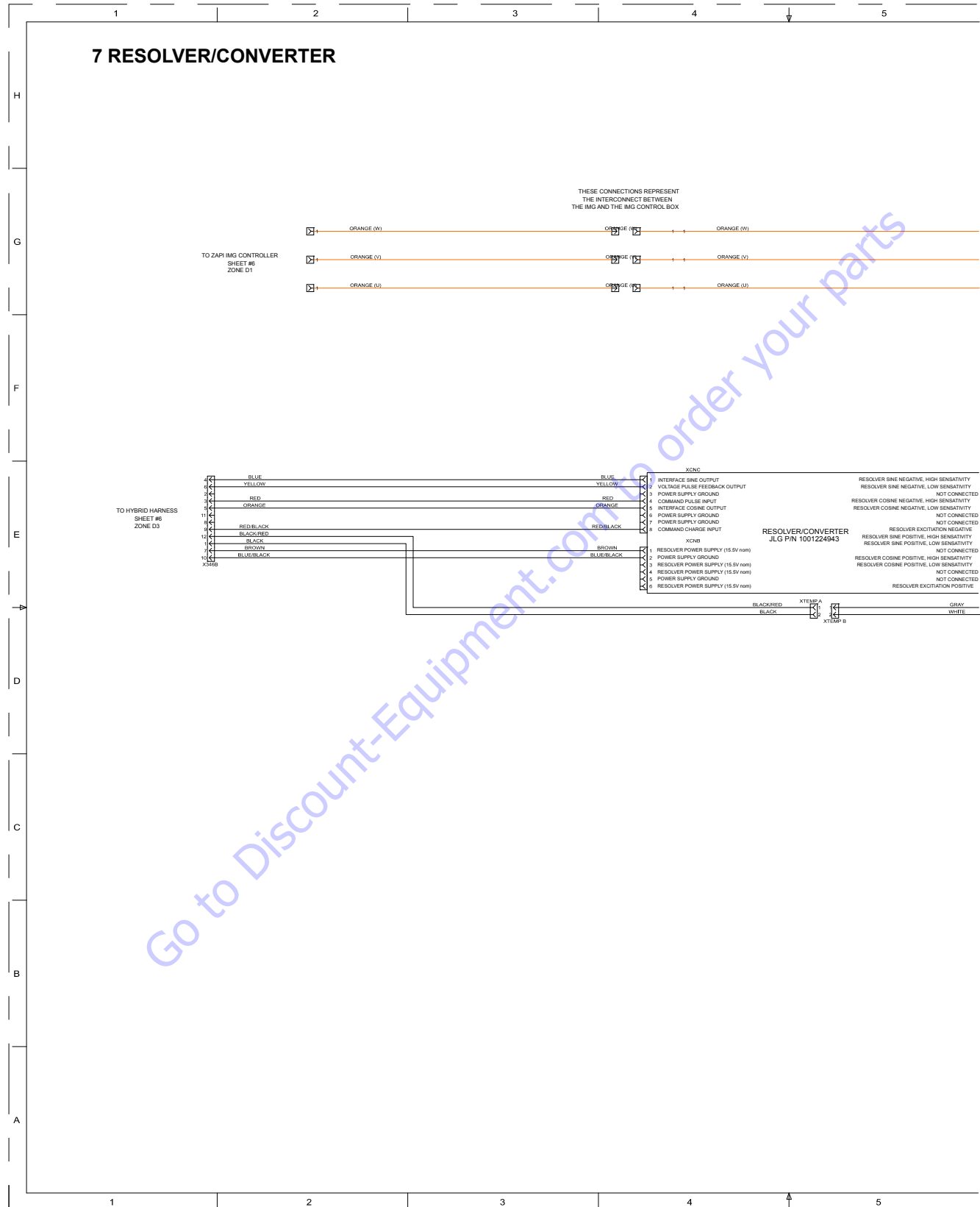

Figure 7-114. Electrical Schematics - Sheet 12 of 19

SECTION 7 - BASIC ELECTRICAL INFORMATION & ELECTRICAL SCHEMATICS

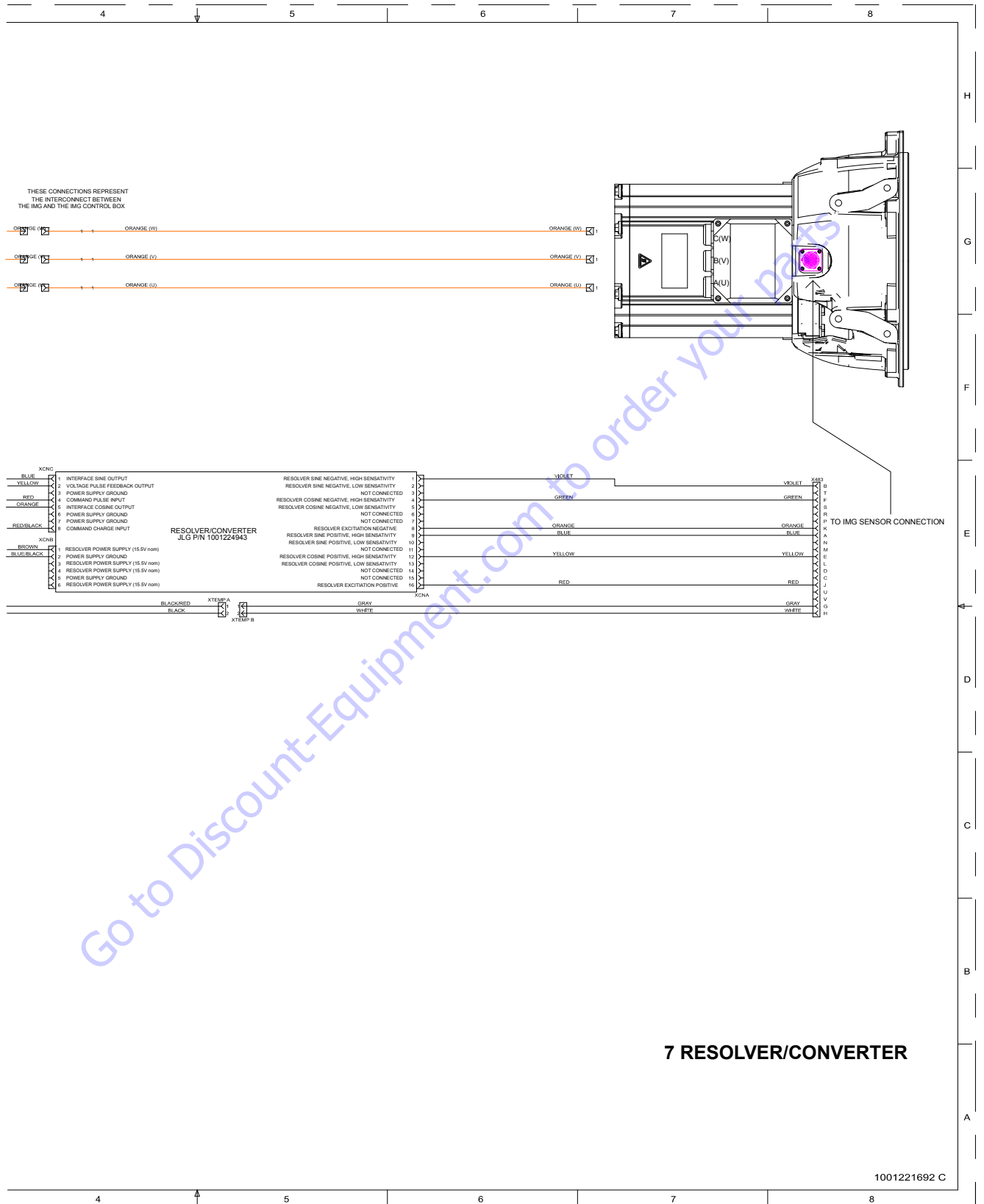

Figure 7-115. Electrical Schematics - Sheet 13 of 19

SECTION 7 - BASIC ELECTRICAL INFORMATION & ELECTRICAL SCHEMATICS

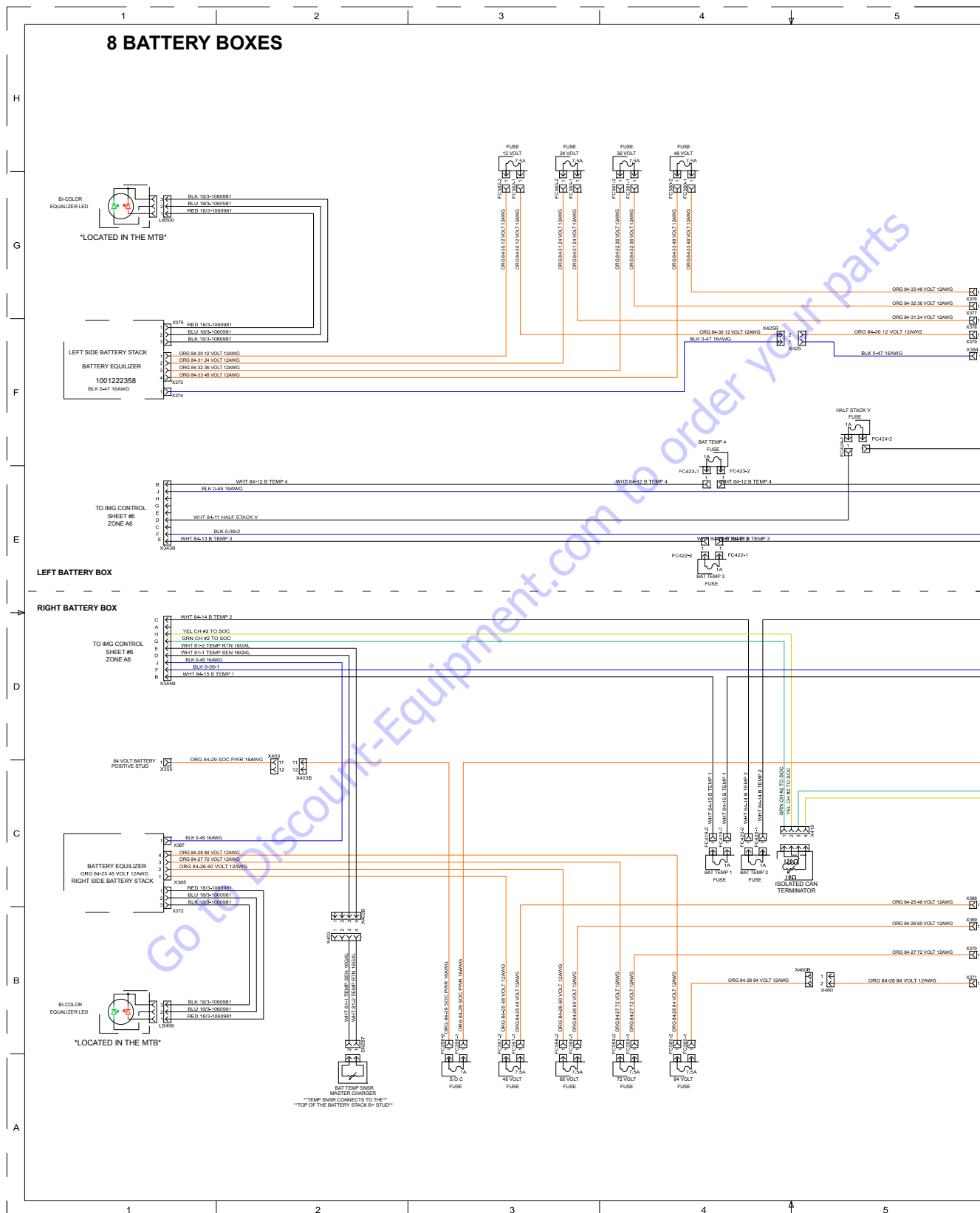

Figure 7-116. Electrical Schematics - Sheet 14 of 19

SECTION 7 - BASIC ELECTRICAL INFORMATION & ELECTRICAL SCHEMATICS

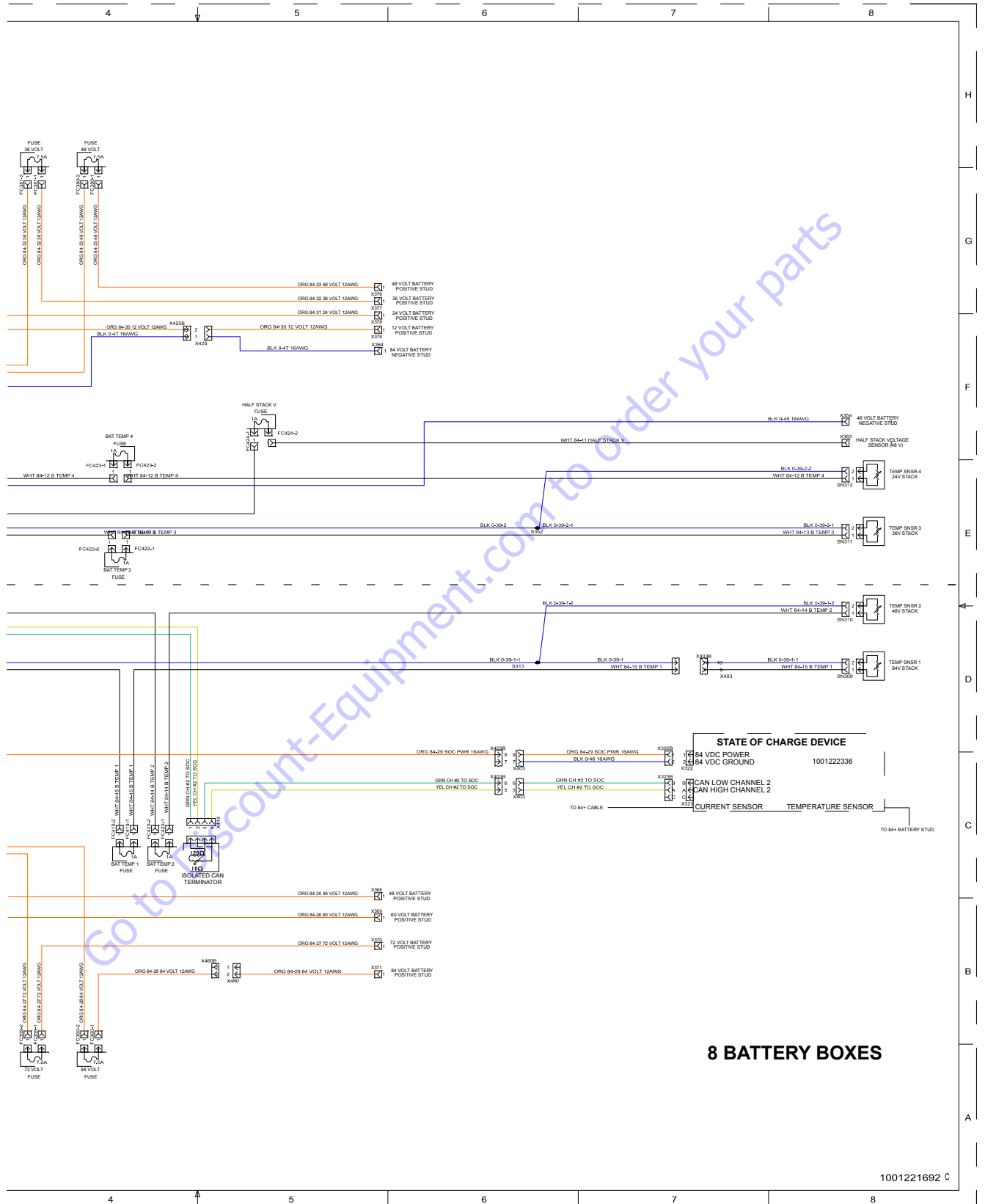

Figure 7-117. Electrical Schematics - Sheet 15 of 19

SECTION 7 - BASIC ELECTRICAL INFORMATION & ELECTRICAL SCHEMATICS

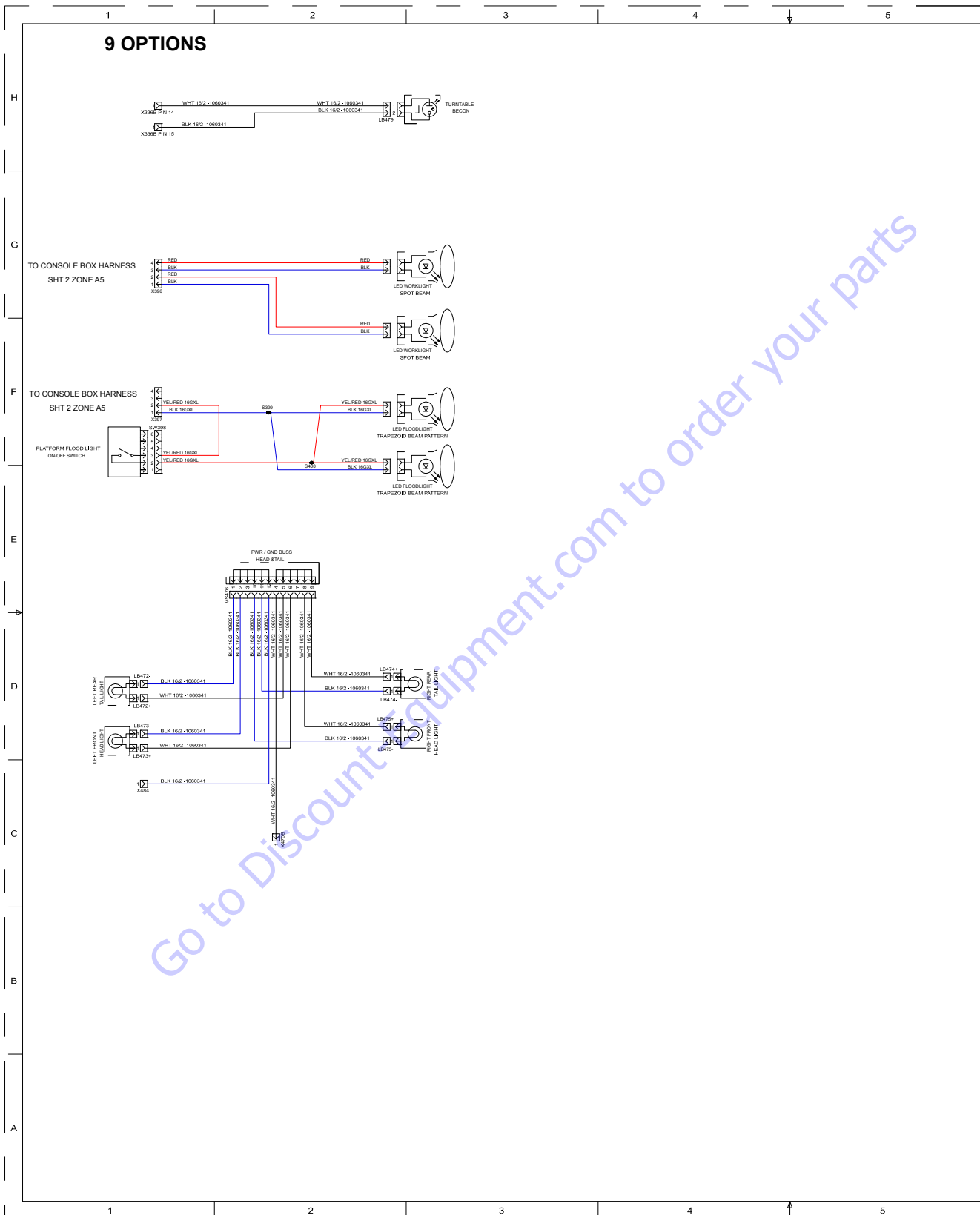

Figure 7-118. Electrical Schematics - Sheet 16 of 19

SECTION 7 - BASIC ELECTRICAL INFORMATION & ELECTRICAL SCHEMATICS

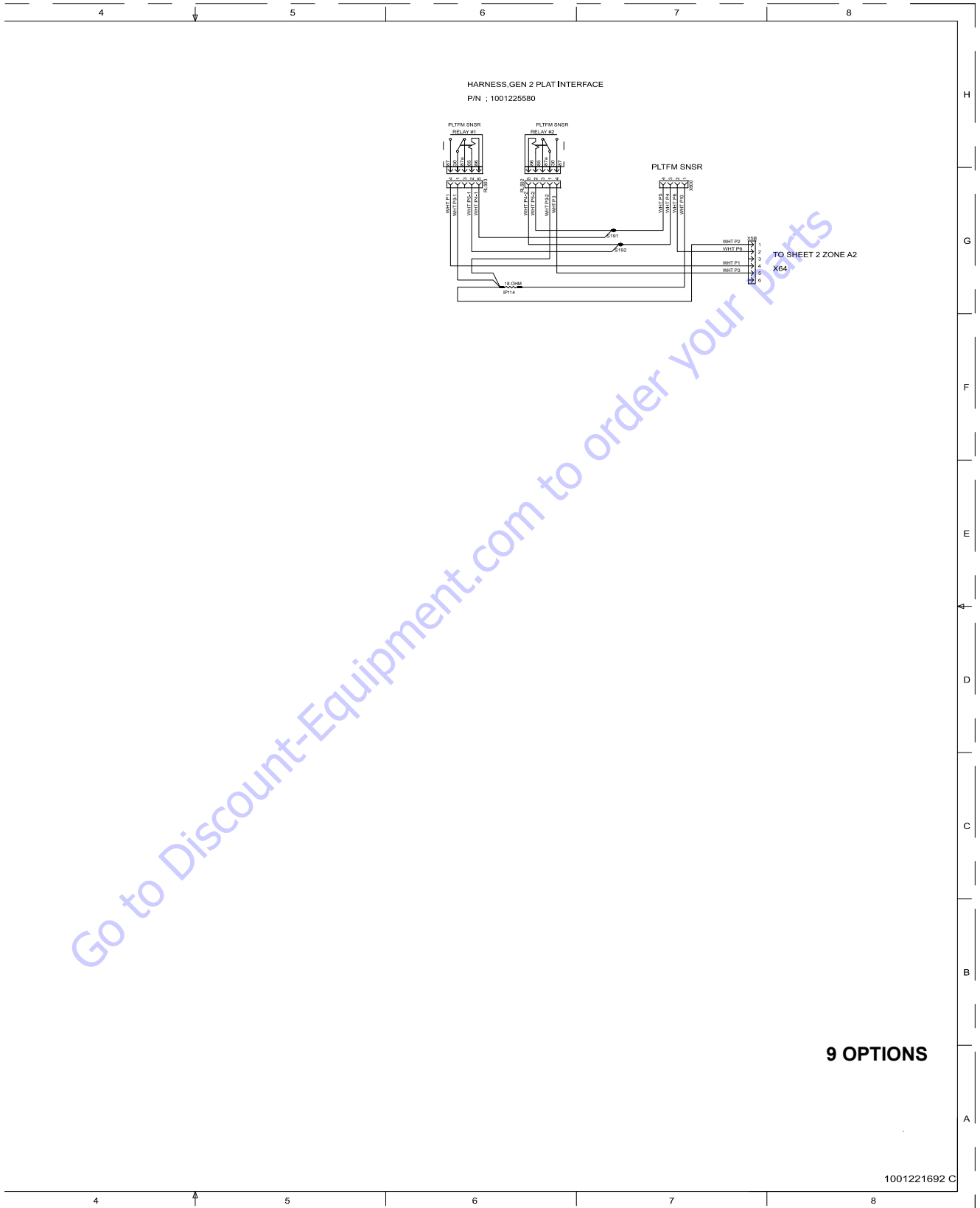

Figure 7-119. Electrical Schematics - Sheet 17 of 19

SECTION 7 - BASIC ELECTRICAL INFORMATION & ELECTRICAL SCHEMATICS

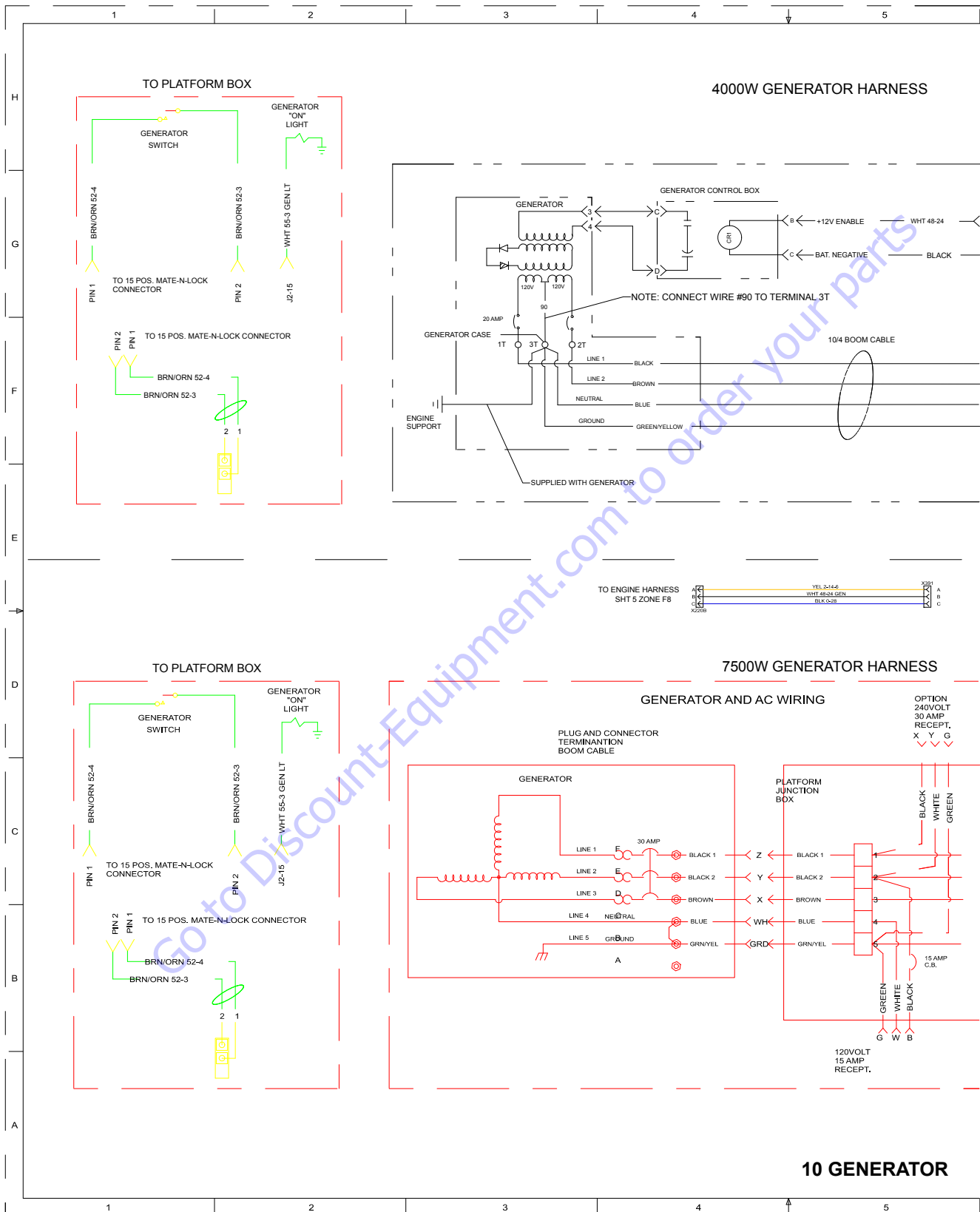

Figure 7-120. Electrical Schematics - Sheet 18 of 19

SECTION 7 - BASIC ELECTRICAL INFORMATION & ELECTRICAL SCHEMATICS

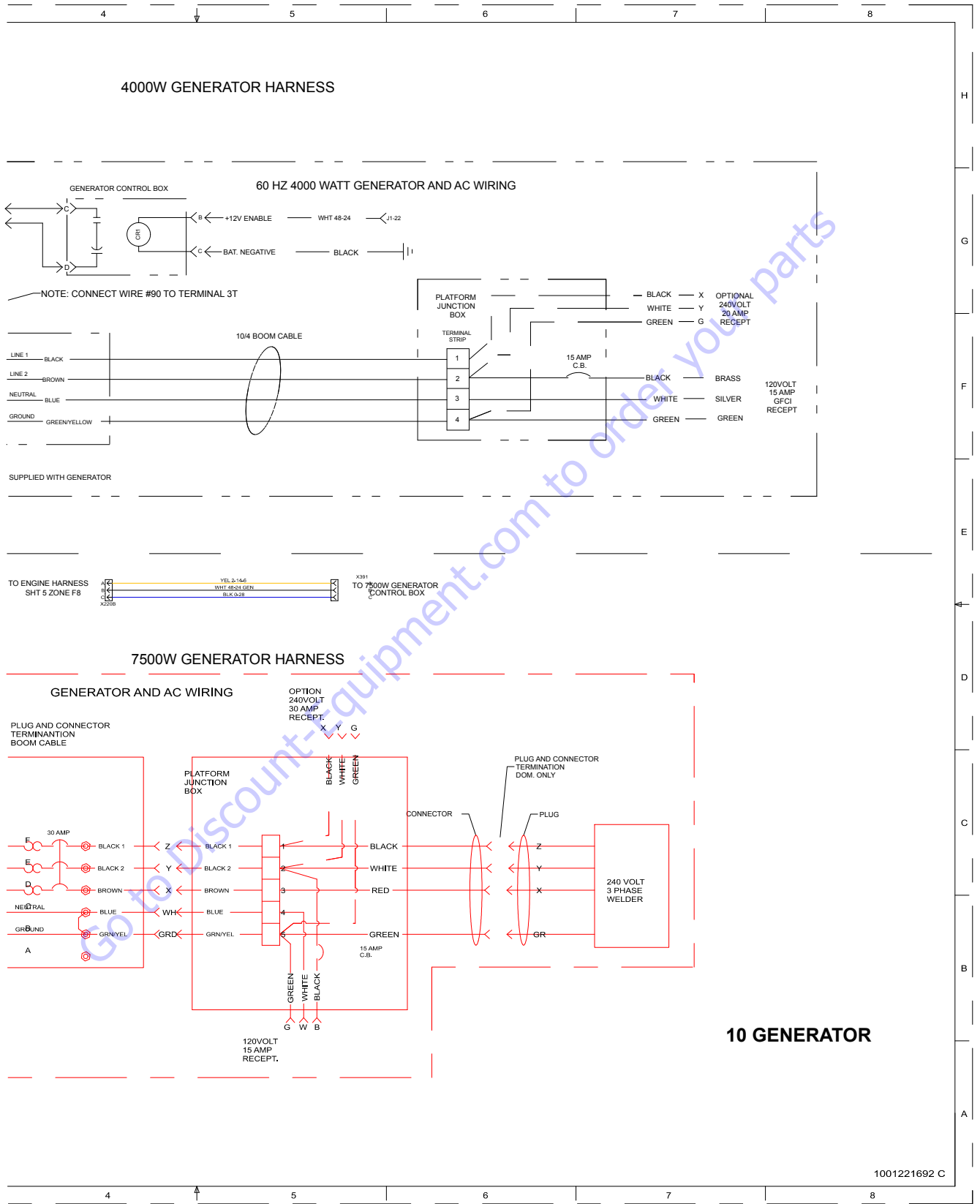

Figure 7-121. Electrical Schematics - Sheet 19 of 19

PARTS FINDER

**Search Website
by Part Number**



**Search Manual
Library For Parts
Manual & Lookup Part
Numbers – Purchase
or Request Quote**

A screenshot of the "Search Manuals" form. The form has a title "Search Manuals" and a subtitle "Please provide information to help us locate the manual and/or parts you need." It includes several input fields: "Brand" (a dropdown menu), "Model Number" (a text field), "Serial Number" (a text field), "Year" (a dropdown menu), "Serial" (a text field), "Part Number" (a text field), "Part Name" (a text field), and "Comments" (a text area). A "Search" button is located at the bottom of the form.

**Can't Find Part or
Manual? Request Help
by Manufacturer,
Model & Description**

A screenshot of the "Parts Order Form". The form has a title "Parts Order Form" and a subtitle "Please fill in as much information as possible." It includes several input fields: "Manufacturer" (a dropdown menu), "Model" (a text field), "Year" (a dropdown menu), "Description" (a text area), "Part Number" (a text field), "Part Name" (a text field), "Quantity" (a text field), "Comments" (a text area), and "Submit" (a button).

Discount-Equipment.com is your online resource for quality parts & equipment.

Florida: **561-964-4949** Outside Florida TOLL FREE: **877-690-3101**

Need parts?

Click on this link: <http://www.discount-equipment.com/category/5443-parts/> and choose one of the options to help get the right parts and equipment you are looking for. Please have the machine model and serial number available in order to help us get you the correct parts. If you don't find the part on the website or on once of the online manuals, please fill out the request form and one of our experienced staff members will get back to you with a quote for the right part that your machine needs.

We sell worldwide for the brands: Genie, Terex, JLG, MultiQuip, Mikasa, Essick, Whiteman, Mayco, Toro Stone, Diamond Products, Generac Magnum, Airman, Haulotte, Barreto, Power Blanket, Nifty Lift, Atlas Copco, Chicago Pneumatic, Allmand, Miller Curber, Skyjack, Lull, Skytrak, Tsurumi, Husquvarna Target, , Stow, Wacker, Sakai, Mi-T- M, Sullair, Basic, Dynapac, MBW, Weber, Bartell, Bennar Newman, Haulotte, Ditch Runner, Menegotti, Morrison, Contec, Buddy, Crown, Edco, Wyco, Bomag, Laymor, Barreto, EZ Trench, Bil-Jax, F.S. Curtis, Gehl Pavers, Heli, Honda, ICS/PowerGrit, IHI, Partner, Imer, Clipper, MMD, Koshin, Rice, CH&E, General Equipment, ,AMida, Coleman, NAC, Gradall, Square Shooter, Kent, Stanley, Tamco, Toku, Hatz, Kohler, Robin, Wisconsin, Northrock, Oztec, Toker TK, Rol-Air, Small Line, Wanco, Yanmar



3121770



An Oshkosh Corporation Company



www.Discount-Equipment.com

Go to Discount-Equipment.com to order your parts