



An Oshkosh Corporation Company



[www.Discount-Equipment.com](http://www.Discount-Equipment.com)

---

# ***Operation and Safety Manual***

*Original Instructions - Keep this manual with the machine at all times.*

***Model  
H800AJ  
PVC 2001***

**ANSI**   **AS/NZS**

**31215042**

November 27, 2019 - Rev A

---

**TO PURCHASE THIS PRODUCT PLEASE CONTACT US**



**Equipment Financing and  
Extended Warranties Available**



**Discount-Equipment.com is your online resource for  
commercial and industrial quality parts and equipment sales.**

**561-964-4949**

**visit us on line @ [www.discount-equipment.com](http://www.discount-equipment.com)**

Select an option below to find your Equipment

**Search by Manufacturer**

**Search by Product Type**

**Request a Quote**

We sell worldwide for the brands: Genie, Terex, JLG, MultiQuip, Mikasa, Essick, Whiteman, Mayco, Toro Stone, Diamond Products, Generac Magnum, Airman, Haulotte, Barreto, Power Blanket, Nifty Lift, Atlas Copco, Chicago Pneumatic, Allmand, Miller Curber, Skyjack, Lull, Skytrak, Tsurumi, Husquvarna Target, Stow, Wacker, Sakai, Mi-T-M, Sullair, Basic, Dynapac, MBW, Weber, Bartell, Bennar Newman, Haulotte, Ditch Runner, Menegotti, Morrison, Contec, Buddy, Crown, Edco, Wyco, Bomag, Laymor, EZ Trench, Bil-Jax, F.S. Curtis, Gehl Pavers, Heli, Honda, ICS/PowerGrit, IHI, Partner, Imer, Clipper, MMD, Koshin, Rice, CH&E, General Equipment, Amida, Coleman, NAC, Gradall, Square Shooter, Kent, Stanley, Tamco, Toku, Hatz, Kohler, Robin, Wisconsin, Northrock, Oztec, Toker TK, Rol-Air, APT, Wylie, Ingersoll Rand / Doosan, Innovatech, Con X, Ammann, Mecalac, Makinex, Smith Surface Prep, Small Line, Wanco, Yanmar



## **WARNING**

Operating, servicing and maintaining this vehicle or equipment can expose you to chemicals including engine exhaust, carbon monoxide, phthalates, and lead, which are known to the State of California to cause cancer and birth defects or other reproductive harm. To minimize exposure, avoid breathing exhaust, do not idle the engine except as necessary, service your vehicle or equipment in a well-ventilated area and wear gloves or wash your hands frequently when servicing. For more information go to [www.P65Warnings.ca.gov](http://www.P65Warnings.ca.gov).

## **FOREWORD**

The Mobile Elevating Work Platform (MEWP) models covered in this manual are designed and tested to meet or exceed various compliance standards. Please refer to the manufacturer's nameplate affixed to the subject MEWP for specific standard compliance information.

This manual is a very important tool! Keep it with the machine at all times.

The purpose of this manual is to provide owners, users, operators, lessors, and lessees with the precautions and operating procedures essential for the safe and proper machine operation for its intended purpose.

Due to continuous product improvements, JLG Industries, Inc. reserves the right to make specification changes without prior notification. Contact JLG Industries, Inc. for updated information.

Refer to [www.JLG.com](http://www.JLG.com) for Warranty, Product Registration, and other machine-related documentation.

## **SAFETY ALERT SYMBOLS AND SAFETY SIGNAL WORDS**



This is the Safety Alert Symbol. It is used to alert you to the potential personal injury hazards. Obey all safety messages that follow this symbol to avoid possible injury or death

### **⚠ DANGER**

INDICATES AN IMMINENTLY HAZARDOUS SITUATION. IF NOT AVOIDED, WILL RESULT IN SERIOUS INJURY OR DEATH. THIS DECAL WILL HAVE A RED BACKGROUND.

### **⚠ WARNING**

INDICATES A POTENTIALLY HAZARDOUS SITUATION. IF NOT AVOIDED, COULD RESULT IN SERIOUS INJURY OR DEATH. THIS DECAL WILL HAVE AN ORANGE BACKGROUND.

### **⚠ CAUTION**

INDICATES A POTENTIALLY HAZARDOUS SITUATION. IF NOT AVOIDED, MAY RESULT IN MINOR OR MODERATE INJURY. IT MAY ALSO ALERT AGAINST UNSAFE PRACTICES. THIS DECAL WILL HAVE A YELLOW BACKGROUND.

### **NOTICE**

INDICATES INFORMATION OR A COMPANY POLICY THAT RELATES DIRECTLY OR INDIRECTLY TO THE SAFETY OF PERSONNEL OR PROTECTION OF PROPERTY.

**⚠ WARNING**

THIS PRODUCT MUST COMPLY WITH ALL SAFETY RELATED BULLETINS. CONTACT JLG INDUSTRIES, INC. OR THE LOCAL AUTHORIZED JLG REPRESENTATIVE FOR INFORMATION REGARDING SAFETY-RELATED BULLETINS WHICH MAY HAVE BEEN ISSUED FOR THIS PRODUCT.

**NOTICE**

JLG INDUSTRIES, INC. SENDS SAFETY RELATED BULLETINS TO THE OWNER OF RECORD OF THIS MACHINE. CONTACT JLG INDUSTRIES, INC. TO ENSURE THAT THE CURRENT OWNER RECORDS ARE UPDATED AND ACCURATE.

**NOTICE**

JLG INDUSTRIES, INC. MUST BE NOTIFIED IMMEDIATELY IN ALL INSTANCES WHERE JLG PRODUCTS HAVE BEEN INVOLVED IN AN ACCIDENT INVOLVING BODILY INJURY OR DEATH OR WHEN SUBSTANTIAL DAMAGE HAS OCCURRED TO PERSONAL PROPERTY OR THE JLG PRODUCT.

**For:**

- Accident Reporting
- Product Safety Publications
- Current Owner Updates
- Questions Regarding Product Safety
- Standards and Regulations Compliance Information
- Questions Regarding Special Product Applications
- Questions Regarding Product Modifications

**Contact:**

Product Safety and Reliability Department  
JLG Industries, Inc.  
13224 Fountainhead Plaza  
Hagerstown, MD 21742  
USA

or Your Local JLG Office  
(See addresses on inside of manual cover)

**In USA:**

Toll Free: 877-JLG-SAFE (877-554-7233)

**Outside USA:**

Phone: 240-420-2661  
Fax: 301-745-3713  
E-mail: ProductSafety@JLG.com

**REVISION LOG**

Original Issue      A - November 27, 2019

To order go to [Discount-Equipment.com](http://Discount-Equipment.com)

**SECTION - 1 - SAFETY PRECAUTIONS**

1.1 GENERAL ..... 1-1

1.2 PRE-OPERATION ..... 1-1

    Operator Training and Knowledge ..... 1-1

    Workplace Inspection ..... 1-2

    Machine Inspection ..... 1-3

1.3 OPERATION ..... 1-3

    General ..... 1-3

    Trip and Fall Hazards ..... 1-4

    Electrocution Hazards ..... 1-5

    Tipping Hazards ..... 1-7

    Crushing and Collision Hazards ..... 1-10

1.4 TOWING, LIFTING, AND HAULING ..... 1-11

1.5 MAINTENANCE ..... 1-11

    Maintenance Hazards ..... 1-11

    Battery Hazards ..... 1-12

**SECTION - 2 - USER RESPONSIBILITIES, MACHINE PREPARATION, AND INSPECTION**

2.1 PERSONNEL TRAINING ..... 2-1

    Operator Training ..... 2-1

    Training Supervision ..... 2-1

    Operator Responsibility ..... 2-2

    Machine Familiarization ..... 2-2

2.2 PREPARATION, INSPECTION, AND MAINTENANCE ..... 2-2

    Pre-Start Inspection ..... 2-5

    Walk-Around Inspection ..... 2-8

2.3 FUNCTION CHECK ..... 2-9

    SkyGuard Function Test ..... 2-14

2.4 OSCILLATING AXLE LOCKOUT TEST (IF EQUIPPED) ..... 2-16

**SECTION - 3 - MACHINE CONTROLS AND INDICATORS**

3.1 GENERAL ..... 3-1

3.2 CONTROLS AND INDICATORS ..... 3-1

    Ground Control Console ..... 3-3

    Ground Control Indicator Panel ..... 3-8

    Ground Control Console Display Gauge ..... 3-10

    Platform Console ..... 3-14

    Platform Console Indicator Panel ..... 3-19

**SECTION - 4 - MACHINE OPERATION**

4.1 DESCRIPTION ..... 4-1

4.2 OPERATING CHARACTERISTICS AND LIMITATIONS ..... 4-1

    Capacities ..... 4-1

    Platform Load Sensing System (LSS) ..... 4-2

    Stability ..... 4-2

4.3 ENGINE OPERATION ..... 4-6

    Starting Procedure ..... 4-6

    Shutdown Procedure ..... 4-7

    Engine Warmup ..... 4-8

4.3 POWERTRAIN OPERATING MODES ..... 4-8

    HYBRID Mode ..... 4-8

    ELECTRIC Mode ..... 4-9

    Switching Between Modes ..... 4-10



## TABLE OF CONTENTS

|      |                                                          |      |
|------|----------------------------------------------------------|------|
| 4.4  | TRAVELING (DRIVING) .....                                | 4-12 |
|      | Traveling Forward and Reverse .....                      | 4-13 |
|      | Traveling on a Grade .....                               | 4-14 |
| 4.4  | STEERING .....                                           | 4-14 |
| 4.5  | PLATFORM .....                                           | 4-14 |
|      | Platform Level Adjustment .....                          | 4-14 |
|      | Platform Rotation .....                                  | 4-14 |
| 4.6  | BOOM .....                                               | 4-15 |
|      | Swinging the Boom .....                                  | 4-15 |
|      | Raising and Lowering the Tower Boom .....                | 4-15 |
|      | Raising and Lowering the Main Boom .....                 | 4-17 |
|      | Telescoping the Main Boom .....                          | 4-17 |
| 4.5  | BATTERY CHARGING .....                                   | 4-17 |
| 4.9  | MACHINE SAFETY SYSTEM OVERRIDE (MSSO)<br>(CE ONLY) ..... | 4-18 |
| 4.10 | SKYGUARD OPERATION .....                                 | 4-18 |
|      | SkyGuard .....                                           | 4-18 |
|      | SkyGuard - SkyLine .....                                 | 4-18 |
|      | SkyGuard - SkyEye .....                                  | 4-19 |
| 4.7  | SHUT DOWN AND PARK .....                                 | 4-20 |
| 4.11 | LIFTING AND TIE DOWN .....                               | 4-20 |
|      | Lifting .....                                            | 4-20 |
|      | Tie Down .....                                           | 4-21 |
| 4.8  | TOWING .....                                             | 4-24 |
| 4.9  | TOW BAR (IF EQUIPPED) .....                              | 4-24 |
| 4.10 | RE-SYNCHRONIZE UPRIGHT .....                             | 4-24 |
|      | Releveling Valve .....                                   | 4-24 |

## SECTION - 5 - EMERGENCY PROCEDURES

|     |                                                          |     |
|-----|----------------------------------------------------------|-----|
| 5.1 | GENERAL .....                                            | 5-1 |
| 5.2 | INCIDENT NOTIFICATION .....                              | 5-1 |
| 5.3 | EMERGENCY OPERATION .....                                | 5-1 |
|     | Operator Unable to Control Machine .....                 | 5-1 |
|     | Platform or Boom Caught Overhead .....                   | 5-2 |
| 5.4 | EMERGENCY TOWING PROCEDURES .....                        | 5-2 |
| 5.5 | MACHINE SAFETY SYSTEM OVERRIDE (MSSO)<br>(CE ONLY) ..... | 5-3 |

## SECTION - 6 - ACCESSORIES

|     |                                  |     |
|-----|----------------------------------|-----|
| 6.1 | FALL ARREST PLATFORM .....       | 6-3 |
|     | Safety Precautions .....         | 6-3 |
| 6.2 | SKYGLAZIER™ .....                | 6-3 |
|     | Capacity Specifications .....    | 6-4 |
|     | Safety Precautions .....         | 6-4 |
|     | Preparation and Inspection ..... | 6-5 |
|     | Operation .....                  | 6-5 |
| 6.3 | SKYPOWER™ .....                  | 6-5 |
|     | Generator Output .....           | 6-6 |
|     | Safety Precautions .....         | 6-6 |
|     | Preparation and Inspection ..... | 6-7 |
|     | Operation .....                  | 6-7 |
| 6.4 | SKYWELDER™ .....                 | 6-7 |
|     | Generator Output .....           | 6-8 |
|     | Welding Accessories .....        | 6-8 |
|     | Accessory Ratings .....          | 6-9 |
|     | Safety Precautions .....         | 6-9 |

Preparation and Inspection ..... 6-10  
 Operation ..... 6-10  
 6.5 SOFT TOUCH..... 6-10

**SECTION - 7 - GENERAL SPECIFICATIONS & OPERATOR  
 MAINTENANCE**

7.1 INTRODUCTION ..... 7-1  
 7.2 OPERATING SPECIFICATIONS AND PERFORMANCE  
 DATA ..... 7-1  
 Operating Specifications ..... 7-1  
 Tires..... 7-2  
 Batteries ..... 7-2  
 Capacities..... 7-3  
 Engine Data ..... 7-3  
 Hydraulic Oil ..... 7-4  
 Critical Stability Weights ..... 7-7  
 7.3 MAINTENANCE AND LUBRICATION ..... 7-12  
 7.4 TIRES & WHEELS..... 7-18  
 Tire Damage..... 7-18  
 Tire Replacement ..... 7-18  
 Wheel Replacement ..... 7-18  
 Wheel Installation ..... 7-19  
 7.5 SUPPLEMENTAL INFORMATION ..... 7-20

**SECTION - 8 - INSPECTION AND REPAIR LOG**

To order go to [Discount-Equipment.com](http://Discount-Equipment.com)

|       |                                                          |      |       |                                                                               |      |
|-------|----------------------------------------------------------|------|-------|-------------------------------------------------------------------------------|------|
| 2-1.  | Basic Nomenclature.....                                  | 2-4  | 4-15. | Decal Installation - Sheet 7 of 11.....                                       | 4-32 |
| 2-2.  | Daily Walk-Around Inspection.....                        | 2-7  | 4-16. | Decal Installation - Sheet 8 of 11.....                                       | 4-33 |
| 2-3.  | Tower Boom Vertical Limit Switch.....                    | 2-10 | 4-17. | Decal Installation - Sheet 9 of 11.....                                       | 4-34 |
| 2-4.  | Tower Boom Horizontal Limit Switch.....                  | 2-11 | 4-18. | Decal Installation - Sheet 10 of 11.....                                      | 4-35 |
| 2-5.  | Boom Upright Positioning - Correct.....                  | 2-12 | 4-19. | Decal Installation - Sheet 11 of 11.....                                      | 4-36 |
| 2-6.  | Boom Upright Positioning - Incorrect.....                | 2-13 | 6-1.  | Soft Touch.....                                                               | 6-11 |
| 3-1.  | Ground Control Console.....                              | 3-2  | 7-1.  | Engine Oil Operating Specifications.....                                      | 7-8  |
| 3-2.  | Ground Control Indicator Panel.....                      | 3-7  | 7-2.  | Hydraulic Oil Operating Temperature Specifications - ....<br>Sheet 1 of 27-9  | .... |
| 3-3.  | Splash Screen.....                                       | 3-10 | 7-3.  | Hydraulic Oil Operating Temperature Specifications - ....<br>Sheet 2 of 27-10 | .... |
| 3-4.  | Diagnostic Screen.....                                   | 3-11 | 7-4.  | Maintenance and Lubrication Diagram.....                                      | 7-11 |
| 3-5.  | Engine Diagnostic Screen.....                            | 3-11 |       |                                                                               |      |
| 3-6.  | Ground Control Console Display Gauge.....                | 3-12 |       |                                                                               |      |
| 3-7.  | Platform Control Console.....                            | 3-13 |       |                                                                               |      |
| 3-8.  | Platform Console Indicator Panel.....                    | 3-18 |       |                                                                               |      |
| 4-1.  | Position of Least Forward Stability.....                 | 4-3  |       |                                                                               |      |
| 4-2.  | Positions of Least Backward Stability (Sheet 1 of 2).... | 4-4  |       |                                                                               |      |
| 4-3.  | Positions of Least Backward Stability (Sheet 2 of 2).... | 4-5  |       |                                                                               |      |
| 4-4.  | Grade and Sideslopes.....                                | 4-11 |       |                                                                               |      |
| 4-5.  | Traveling on a Grade.....                                | 4-14 |       |                                                                               |      |
| 4-6.  | Lifting Chart.....                                       | 4-22 |       |                                                                               |      |
| 4-7.  | Tow Bar.....                                             | 4-23 |       |                                                                               |      |
| 4-8.  | Releveling Valve.....                                    | 4-25 |       |                                                                               |      |
| 4-9.  | Decal Installation - Sheet 1 of 11.....                  | 4-26 |       |                                                                               |      |
| 4-10. | Decal Installation - Sheet 2 of 11.....                  | 4-27 |       |                                                                               |      |
| 4-11. | Decal Installation - Sheet 3 of 11.....                  | 4-28 |       |                                                                               |      |
| 4-12. | Decal Installation - Sheet 4 of 11.....                  | 4-29 |       |                                                                               |      |
| 4-13. | Decal Installation - Sheet 5 of 11.....                  | 4-30 |       |                                                                               |      |
| 4-14. | Decal Installation - Sheet 6 of 11.....                  | 4-31 |       |                                                                               |      |

---

|      |                                             |      |
|------|---------------------------------------------|------|
| 1-1  | Minimum Approach Distances (M.A.D.) .....   | 1-6  |
| 1-2  | Beaufort Scale (For Reference Only).....    | 1-9  |
| 2-1  | Inspection and Maintenance Table .....      | 2-3  |
| 4-1  | SkyGuard Function Table.....                | 4-19 |
| 4-2  | Decal Legend .....                          | 4-37 |
| 6-1  | Available Accessories .....                 | 6-1  |
| 6-2  | Options/Accessories Relationship Table..... | 6-2  |
| 7-1  | Operating Specifications .....              | 7-1  |
| 7-2  | Tire Specifications.....                    | 7-2  |
| 7-3  | Battery Specifications .....                | 7-2  |
| 7-4  | Capacities .....                            | 7-3  |
| 7-5  | Kubota D1305 .....                          | 7-3  |
| 7-6  | Hydraulic Oil .....                         | 7-4  |
| 7-7  | Mobilfluid 424 Specs .....                  | 7-4  |
| 7-8  | Mobil DTE 10 Excel 32 Specs.....            | 7-5  |
| 7-9  | UCon Hydrolube HP-5046 .....                | 7-5  |
| 7-10 | Mobil EAL 224H Specs.....                   | 7-6  |
| 7-11 | Exxon Univis HVI 26 Specs.....              | 7-6  |
| 7-12 | Critical Stability Weights.....             | 7-7  |
| 7-13 | Lubrication Specifications .....            | 7-12 |
| 7-14 | Wheel Torque Chart.....                     | 7-20 |
| 8-1  | Inspection and Repair Log.....              | 8-1  |

**TO PURCHASE THIS PRODUCT PLEASE CONTACT US**



**Equipment Financing and  
Extended Warranties Available**



**Discount-Equipment.com is your online resource for  
commercial and industrial quality parts and equipment sales.**

**561-964-4949**

**visit us on line @ [www.discount-equipment.com](http://www.discount-equipment.com)**

Select an option below to find your Equipment

**Search by Manufacturer**

**Search by Product Type**

**Request a Quote**

We sell worldwide for the brands: Genie, Terex, JLG, MultiQuip, Mikasa, Essick, Whiteman, Mayco, Toro Stone, Diamond Products, Generac Magnum, Airman, Haulotte, Barreto, Power Blanket, Nifty Lift, Atlas Copco, Chicago Pneumatic, Allmand, Miller Curber, Skyjack, Lull, Skytrak, Tsurumi, Husquvarna Target, Stow, Wacker, Sakai, Mi-T-M, Sullair, Basic, Dynapac, MBW, Weber, Bartell, Bennar Newman, Haulotte, Ditch Runner, Menegotti, Morrison, Contec, Buddy, Crown, Edco, Wyco, Bomag, Laymor, EZ Trench, Bil-Jax, F.S. Curtis, Gehl Pavers, Heli, Honda, ICS/PowerGrit, IHI, Partner, Imer, Clipper, MMD, Koshin, Rice, CH&E, General Equipment, Amida, Coleman, NAC, Gradall, Square Shooter, Kent, Stanley, Tamco, Toku, Hatz, Kohler, Robin, Wisconsin, Northrock, Oztec, Toker TK, Rol-Air, APT, Wylie, Ingersoll Rand / Doosan, Innovatech, Con X, Ammann, Mecalac, Makinex, Smith Surface Prep, Small Line, Wanco, Yanmar

## SECTION 1. SAFETY PRECAUTIONS

### 1.1 GENERAL

This section outlines the necessary precautions for proper and safe machine usage and maintenance. It is mandatory that a daily routine is established based on the content of this manual to promote proper machine usage. A maintenance program, using the information provided in this manual and the Service and Maintenance Manual, must also be established by a qualified person and must be followed to ensure that the machine is safe to operate.

The owner/user/operator/lessor/lessee of the machine must not accept operating responsibility until this manual has been read, training is accomplished, and operation of the machine has been completed under the supervision of an experienced and qualified operator.

This section contains the responsibilities of the owner, user, operator, lessor, and lessee concerning safety, training, inspection, maintenance, application, and operation. If there are any questions with regard to safety, training, inspection, maintenance, application, and operation, please contact JLG Industries, Inc. ("JLG").

### WARNING

**FAILURE TO COMPLY WITH THE SAFETY PRECAUTIONS LISTED IN THIS MANUAL COULD RESULT IN MACHINE DAMAGE, PROPERTY DAMAGE, PERSONAL INJURY OR DEATH.**

### 1.2 PRE-OPERATION

#### Operator Training and Knowledge

- Read, understand, and study the Operation and Safety Manual in its entirety before operating the machine. For clarification, questions, or additional information regarding any portions of this manual, contact JLG Industries, Inc.

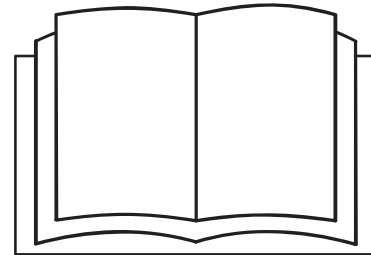

## **SECTION 1 - SAFETY PRECAUTIONS**

---

- Only personnel who have received proper training regarding the inspection, application and operation of MEWPs (including recognition and avoiding hazards associated with their operation) shall be authorized to operate a MEWP.
- Only properly trained personnel who have received unit-specific familiarization shall operate a MEWP. The user shall determine if personnel are qualified to operate the MEWP prior to operation.
- Read, understand, and obey all DANGERS, WARNINGS, CAUTIONS, and operating instructions on the machine and in this manual.
- Ensure that the machine is to be used in a manner which is within the scope of its intended application as determined by JLG.
- All operating personnel must have a thorough understanding of the intended purpose and function of the MEWP controls, including platform, ground and emergency descent controls.
- Read, understand, and obey all applicable employer, local, and governmental regulations as they pertain to your utilization and application of the machine.

### **Workplace Inspection**

- Precautions to avoid all hazards in the work area must be taken by the user before and during operation of the machine.
- Do not operate or raise the platform from a position on trucks, trailers, railway cars, floating vessels, scaffolds or other equipment unless the application is approved in writing by JLG.
- Before operation, check work area for overhead hazards such as electric lines, bridge cranes, and other potential overhead obstructions.
- Check operating surfaces for holes, bumps, drop-offs, obstructions, debris, concealed holes, and other potential hazards.
- Check the work area for hazardous locations. Do not operate the machine in hazardous environments unless approved for that purpose by JLG.
- Ensure that the ground conditions are adequate to support the maximum tire load indicated on the tire load decals located on the chassis adjacent to each wheel. Do not travel on unsupported surfaces.



## Machine Inspection

- Do not operate this machine until the inspections and functional checks as specified in Section 2 of this manual have been performed.
- Do not operate this machine until it has been serviced and maintained according to the maintenance and inspection requirements as specified in the machine's Service and Maintenance Manual.
- Ensure all safety devices are operating properly. Modification of these devices is a safety violation.

### **WARNING**

**MODIFICATION OR ALTERATION OF A MEWP SHALL BE MADE ONLY WITH PRIOR WRITTEN PERMISSION FROM THE MANUFACTURER.**

- Do not operate any machine on which the safety or instruction placards or decals are missing or illegible.
- Check the machine for modifications to original components. Ensure that any modifications have been approved by JLG.
- Avoid accumulation of debris on platform floor. Keep mud, oil, grease, and other slippery substances from footwear and platform floor.

## 1.3 OPERATION

### General

- Machine operation requires your full attention. Bring the machine to a full stop before using any device, i.e. cell phones, two-way radios, etc. that will distract your attention from safely operating the machine.
- Do not use the machine for any purpose other than positioning personnel, their tools, and equipment.
- Before operation, the user must be familiar with the machine capabilities and operating characteristics of all functions.
- Never operate a malfunctioning machine. If a malfunction occurs, shut down the machine. Remove the unit from service and notify the proper authorities.
- Do not remove, modify, or disable any safety devices.
- Never slam a control switch or lever through neutral to an opposite direction. Always return switch to neutral and stop before moving the switch to the next function. Operate controls with slow and even pressure.
- Do not allow personnel to tamper with or operate the machine from the ground with personnel in the platform, except in an emergency.

## SECTION 1 - SAFETY PRECAUTIONS

---

- Do not carry materials directly on platform railing unless approved by JLG.
- When two or more persons are in the platform, the operator shall be responsible for all machine operations.
- Always ensure that power tools are properly stowed and never left hanging by their cord from the platform work area.
- When driving, always position boom over rear axle in line with the direction of travel. Remember, if boom is over the front axle, steer and drive functions will be reversed.
- Do not assist a stuck or disabled machine by pushing or pulling except by pulling at the chassis tie-down lugs.
- Fully lower platform and shut off all power before leaving machine.
- Remove all rings, watches, and jewelry when operating machine. Do not wear loose fitting clothing or long hair unrestrained which may become caught or entangled in equipment.
- Persons under the influence of drugs or alcohol or who are subject to seizures, dizziness or loss of physical control must not operate this machine.

- Hydraulic cylinders are subject to thermal expansion and contraction. This may result in changes to the platform position while the machine is stationary. Factors affecting thermal movement can include the length of time the machine will remain stationary, hydraulic oil temperature, ambient air temperature, and platform position.

### Trip and Fall Hazards

- Prior to operation, ensure all gates are closed and fastened in their proper position.
- During operation, occupants in the platform must wear a full body harness with a lanyard attached to an authorized lanyard anchorage point. Attach only one (1) lanyard per lanyard anchorage point.

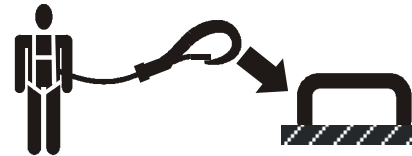

- Enter and exit only through gate area. Use extreme caution when entering or leaving platform. Ensure that the platform assembly is fully lowered. Face the platform when entering or leaving the platform. Always maintain three points of contact with the machine, using two hands and one foot or two feet and one hand at all times during entry and exit.

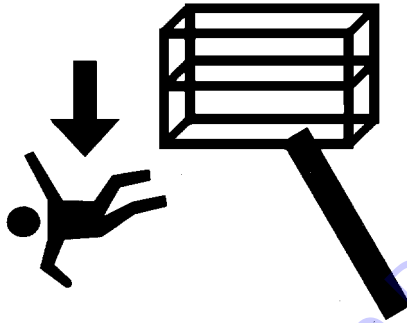

- Keep both feet firmly positioned on the platform floor at all times. Never position ladders, boxes, steps, planks, or similar items on unit to provide additional reach for any purpose.
- Keep oil, mud, and slippery substances cleaned from footwear and the platform floor.

### **Electrocution Hazards**

- This machine is not insulated and does not provide protection from contact or proximity to electrical current.

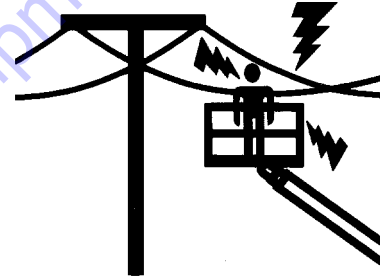

## SECTION 1 - SAFETY PRECAUTIONS

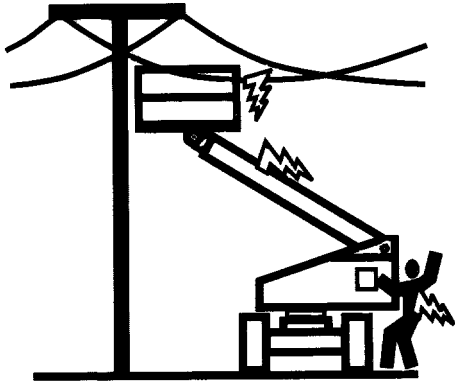

- Maintain distance from electrical lines, apparatus, or any energized (exposed or insulated) parts according to the Minimum Approach Distance (MAD) as shown in Table 1-1.
- Allow for machine movement and electrical line swaying.

**Table 1-1. Minimum Approach Distances (M.A.D.)**

| <b>Voltage Range<br/>(Phase to Phase)</b> | <b>MINIMUM APPROACH DISTANCE<br/>in Feet (Meters)</b> |
|-------------------------------------------|-------------------------------------------------------|
| 0 to 50 KV                                | 10 (3)                                                |
| Over 50KV to 200 KV                       | 15 (5)                                                |
| Over 200 KV to 350 KV                     | 20 (6)                                                |
| Over 350 KV to 500 KV                     | 25 (8)                                                |
| Over 500 KV to 750 KV                     | 35 (11)                                               |
| Over 750 KV to 1000 KV                    | 45 (14)                                               |

**NOTE:** *This requirement shall apply except where employer, local or governmental regulations are more stringent.*

- Maintain a clearance of at least 10 ft. (3m) between any part of the machine and its occupants, their tools, and their equipment from any electrical line or apparatus carrying up to 50,000 volts. One foot additional clearance is required for every additional 30,000 volts or less.

- The minimum approach distance may be reduced if insulating barriers are installed to prevent contact, and the barriers are rated for the voltage of the line being guarded. These barriers shall not be part of (or attached to) the machine. The minimum approach distance shall be reduced to a distance within the designed working dimensions of the insulating barrier. This determination shall be made by a qualified person in accordance with the employer, local, or governmental requirements for work practices near energized equipment.

**⚠ DANGER**

**DO NOT MANEUVER MACHINE OR PERSONNEL INSIDE PROHIBITED ZONE (MAD). ASSUME ALL ELECTRICAL PARTS AND WIRING ARE ENERGIZED UNLESS KNOWN OTHERWISE.**

**Tipping Hazards**

- Ensure that the ground conditions are adequate to support the maximum tire load indicated on the tire load decals located on the chassis adjacent to each wheel. Do not travel on unsupported surfaces.
- The user must be familiar with the operating surface before driving. Do not exceed the allowable sideslope and grade while driving.

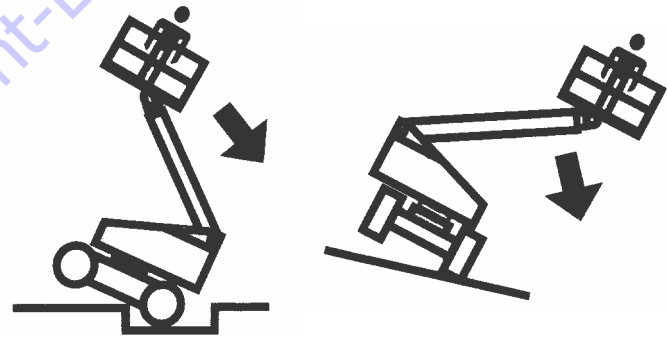

- Do not elevate platform or drive with platform elevated while on or near a sloping, uneven, or soft surface. Ensure machine is positioned on a firm, level and smooth surface before elevating platform or driving with the platform in the elevated position.

## **SECTION 1 - SAFETY PRECAUTIONS**

---

- Before driving on floors, bridges, trucks, and other surfaces, check allowable capacity of the surfaces.
- Never exceed the maximum platform capacity as specified on the platform. Keep all loads within the confines of the platform, unless authorized by JLG.
- Keep the chassis of the machine a minimum of 2 ft. (0.6m) from holes, bumps, drop-offs, obstructions, debris, concealed holes, and other potential hazards at the ground level.
- Do not push or pull any object with the boom.
- Never attempt to use the machine as a crane. Do not tie-off machine to any adjacent structure. Never attach wire, cable, or any similar items to platform.
- If boom assembly or platform is in a position that one or more wheels are off the ground, all persons must be removed before attempting to stabilize the machine. Use cranes, forklift trucks, or other appropriate equipment to stabilize machine.
- Do not operate the machine when wind conditions exceed specifications shown in Section 7-2 of this manual or as shown on the capacity placard of the platform billboard. Factors affecting wind speed are; platform elevation, surrounding structures, local weather events, and approaching storms.
- Wind speed can be significantly greater at height than at ground level.
- Wind speed can change rapidly. Always consider approaching weather events, the time required to lower the platform, and methods to monitor current and potential wind conditions.
- Do not cover or increase surface area of the platform or the load. Do not carry large surface area items in the platform when operating outdoors. The addition of such items increases the exposed wind area of the machine. Increased areas exposed to wind will decrease stability.
- Do not increase the platform size with unauthorized modifications or attachments.

**NOTICE**

**DO NOT OPERATE THE MACHINE WHEN WIND CONDITIONS EXCEED SPECIFICATIONS SHOWN IN SECTION 7.2 OR AS SHOWN ON THE CAPACITY PLACARD ON THE PLATFORM BILLBOARD.**

**Table 1-2. Beaufort Scale (For Reference Only)**

| Beaufort Number | Wind Speed |           | Description             | Land Conditions                                                                         |
|-----------------|------------|-----------|-------------------------|-----------------------------------------------------------------------------------------|
|                 | mph        | m/s       |                         |                                                                                         |
| 0               | 0          | 0-0.2     | Calm                    | Calm. Smoke rises vertically                                                            |
| 1               | 1-3        | 0.3-1.5   | Light air               | Wind motion visible in smoke                                                            |
| 2               | 4-7        | 1.6-3.3   | Light breeze            | Wind felt on exposed skin. Leaves rustle                                                |
| 3               | 8-12       | 3.4-5.4   | Gentle breeze           | Leaves and smaller twigs in constant motion                                             |
| 4               | 13-18      | 5.5-7.9   | Moderate breeze         | Dust and loose paper raised. Small branches begin to move.                              |
| 5               | 19-24      | 8.0-10.7  | Fresh breeze            | Smaller trees sway.                                                                     |
| 6               | 25-31      | 10.8-13.8 | Strong breeze           | Large branches in motion. Flags waving near horizontal. Umbrella use becomes difficult. |
| 7               | 32-38      | 13.9-17.1 | Near Gale/Moderate Gale | Whole trees in motion. Effort needed to walk against the wind.                          |
| 8               | 39-46      | 17.2-20.7 | Fresh Gale              | Twigs broken from trees. Cars veer on road.                                             |
| 9               | 47-54      | 20.8-24.4 | Strong Gale             | Light structure damage.                                                                 |

### Crushing and Collision Hazards

- Approved head gear must be worn by all operating and ground personnel.
- Watch for obstructions around machine and overhead when driving. Check clearances above, on sides, and bottom of platform during all operations.

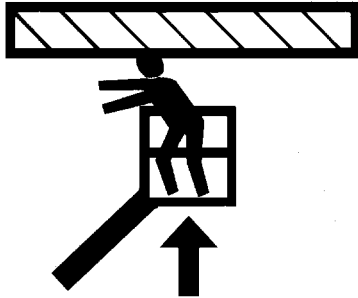

- During operation, keep all body parts inside platform railing.
- Use the boom functions, not the drive function, to position the platform close to obstacles.
- Always post a lookout when driving in areas where vision is obstructed.

- Keep non-operating personnel at least 6 ft. (1.8m) away from machine during all operations.
- Under all travel conditions, the operator must limit travel speed according to conditions of ground surface, congestion, visibility, slope, location of personnel, and other factors.
- Be aware of stopping distances in all drive speeds. When driving in high speed, reduce drive speed before stopping. Travel grades in low speed only.
- Do not use high speed drive in restricted or close quarters or when driving in reverse.
- Exercise extreme caution at all times to prevent obstacles from striking or interfering with operating controls and persons in the platform.
- Ensure that operators of other overhead and floor level machines are aware of the MEWP's presence. Disconnect power to overhead cranes.
- Do not operate over ground personnel. Warn personnel not to work, stand, or walk under a raised boom or platform. Position barricades on floor if necessary.



## **1.4 TOWING, LIFTING, AND HAULING**

- Never allow personnel in platform while towing, lifting, or hauling.
- This machine should not be towed, except in the event of emergency, malfunction, power failure, or loading/unloading. Refer to the Emergency Procedures section of this manual for emergency towing procedures.
- Ensure boom is in the stowed position and the turntable locked prior to towing, lifting or hauling. The platform must be completely empty of tools.
- When lifting machine, lift only at designated areas of the machine. Lift the unit with equipment of adequate capacity.
- Refer to the Machine Operation section of this manual for lifting information.

## **1.5 MAINTENANCE**

This sub-section contains general safety precautions which must be observed during maintenance of this machine. Additional precautions to be observed during machine maintenance are inserted at the appropriate points in this manual and in the Service and Maintenance Manual. It is of utmost importance that maintenance personnel pay strict attention to these precautions to avoid possible injury to personnel or damage to the machine or property. A maintenance program must be established by a qualified person and must be followed to ensure that the machine is safe.

### **Maintenance Hazards**

- Shut off power to all controls and ensure that all moving parts are secured from inadvertent motion prior to performing any adjustments or repairs.
- Never work under an elevated platform until it has been fully lowered to the full down position, if possible, or otherwise supported and restrained from movement with appropriate safety props, blocking, or overhead supports.
- DO NOT attempt to repair or tighten any hydraulic hoses or fittings while the machine is powered on or when the hydraulic system is under pressure.
- Always relieve hydraulic pressure from all hydraulic circuits before loosening or removing hydraulic components.

## SECTION 1 - SAFETY PRECAUTIONS

- DO NOT use your hand to check for leaks. Use a piece of cardboard or paper to search for leaks. Wear gloves to help protect hands from spraying fluid.



- Use only replacement parts or components that are approved by JLG. To be considered approved, replacement parts or components must be identical or equivalent to original parts or components.
- Never attempt to move heavy parts without the aid of a mechanical device. Do not allow heavy objects to rest in an unstable position. Ensure adequate support is provided when raising components of the machine.
- Do not use machine as a ground for welding.
- When performing welding or metal cutting operations, precautions must be taken to protect the chassis from direct exposure to weld and metal cutting spatter.
- Do not refuel the machine with the engine running.
- Use only approved non-flammable cleaning solvents.
- Do not replace items critical to stability, such as batteries or solid tires, with items of different weight or specification. Do not modify the MEWP in any way to affect stability.
- Refer to the Service and Maintenance Manual for the weights of critical stability items.

### **⚠ WARNING**

**MODIFICATION OR ALTERATION OF A MEWP SHALL BE MADE ONLY WITH PRIOR WRITTEN PERMISSION FROM THE MANUFACTURER.**

### **Battery Hazards**

- Always disconnect batteries when servicing electrical components or when performing welding on the machine.
- Do not allow smoking, open flame, or sparks near battery during charging or servicing.
- Do not contact tools or other metal objects across the battery terminals.
- Always wear hand, eye, and face protection when servicing batteries. Ensure that battery acid does not come in contact with skin or clothing.

### **⚠ CAUTION**

**BATTERY FLUID IS HIGHLY CORROSIVE. AVOID CONTACT WITH SKIN AND CLOTHING AT ALL TIMES. IMMEDIATELY RINSE ANY CONTACTED AREA WITH CLEAN WATER AND SEEK MEDICAL ATTENTION.**

- Charge batteries only in a well ventilated area.
- Avoid overfilling the battery fluid level. Add distilled water to batteries only after the batteries are fully charged.

**TO PURCHASE THIS PRODUCT PLEASE CONTACT US**



**Equipment Financing and  
Extended Warranties Available**



**Discount-Equipment.com is your online resource for  
commercial and industrial quality parts and equipment sales.**

**561-964-4949**

**visit us on line @ [www.discount-equipment.com](http://www.discount-equipment.com)**

Select an option below to find your Equipment

**Search by Manufacturer**

**Search by Product Type**

**Request a Quote**

We sell worldwide for the brands: Genie, Terex, JLG, MultiQuip, Mikasa, Essick, Whiteman, Mayco, Toro Stone, Diamond Products, Generac Magnum, Airman, Haulotte, Barreto, Power Blanket, Nifty Lift, Atlas Copco, Chicago Pneumatic, Allmand, Miller Curber, Skyjack, Lull, Skytrak, Tsurumi, Husquvarna Target, Stow, Wacker, Sakai, Mi-T-M, Sullair, Basic, Dynapac, MBW, Weber, Bartell, Bennar Newman, Haulotte, Ditch Runner, Menegotti, Morrison, Contec, Buddy, Crown, Edco, Wyco, Bomag, Laymor, EZ Trench, Bil-Jax, F.S. Curtis, Gehl Pavers, Heli, Honda, ICS/PowerGrit, IHI, Partner, Imer, Clipper, MMD, Koshin, Rice, CH&E, General Equipment, Amida, Coleman, NAC, Gradall, Square Shooter, Kent, Stanley, Tamco, Toku, Hatz, Kohler, Robin, Wisconsin, Northrock, Oztec, Toker TK, Rol-Air, APT, Wylie, Ingersoll Rand / Doosan, Innovatech, Con X, Ammann, Mecalac, Makinex, Smith Surface Prep, Small Line, Wanco, Yanmar

## **SECTION 2. USER RESPONSIBILITIES, MACHINE PREPARATION, AND INSPECTION**

### **2.1 PERSONNEL TRAINING**

The Mobile Elevating Work Platform (MEWP) is a personnel handling device; so it is necessary that it be operated and maintained only by trained personnel.

#### **Operator Training**

Operator training must cover:

1. Reading and understanding the Operation and Safety Manual.
2. Thorough understanding of the intended purpose and function of the MEWP controls, including platform, ground, and emergency descent controls.
3. Control labels, instructions, and warnings on the machine.
4. Applicable regulations, standards, and safety rules.
5. Use of approved fall protection equipment.
6. Enough knowledge of the mechanical operation of the machine to recognize a malfunction or potential malfunction.
7. The safest means to operate the machine where overhead obstructions, other moving equipment, and obstacles, depressions, holes, and drop-offs exist.
8. Means to avoid the hazards of unprotected electrical conductors.
9. Selection of the appropriate MEWP and available options for the work to be performed considering specific job requirements, with involvement from the MEWP owner, user, and/or supervisor.
10. The responsibility of the operator to ensure all platform occupants have a basic level of knowledge to work safely on the MEWP, and to inform them of applicable regulations, standards, and safety rules.
11. The requirement for familiarization in addition to training.

#### **Training Supervision**

Training must be delivered by a qualified person in an open area, free of hazards until the trainee has demonstrated the ability to safely control and operate the machine.

### **Operator Responsibility**

The operator must be instructed they have the responsibility and authority to shut down the machine in case of a malfunction or other unsafe condition of either the machine or the job site.

### **Machine Familiarization**

**NOTE:** *Responsibilities for familiarization may vary by region.*

Only properly trained personnel who have received unit-specific familiarization shall operate a MEWP. The user shall determine if personnel are qualified to operate the MEWP prior to operation. The user shall ensure that after familiarization, the operator operates the MEWP for a sufficient period of time to achieve proficiency. When authorized by the user, self-familiarization can be achieved, if authorized, by a properly trained operator reading, understanding and following the manufacturer's operator's manual.

Prior to users authorization of an operator to use a specific model of MEWP, the user shall ensure the operator is familiarized on the following:

1. Location of the manual storage compartment and the requirement to ensure the required manual(s) are present on the MEWP;
2. Purpose and function of the machine controls and indicators at the platform and ground control stations;
3. Purpose, location, and function of the emergency controls;

4. Operating characteristics and limitations;
5. Features and devices;
6. Accessories and optional equipment.

### **2.2 PREPARATION, INSPECTION, AND MAINTENANCE**

The following table covers machine inspections and maintenance required by JLG Industries, Inc. Consult local regulations for further requirements for MEWPs. Frequency of inspections and maintenance must be increased as necessary when machine is used in a harsh or hostile environment, if machine is used with increased frequency, or if machine is used in a severe manner.

## SECTION 2 - USER RESPONSIBILITIES, MACHINE PREPARATION, AND INSPECTION

**Table 2-1. Inspection and Maintenance Table**

| Type                                 | Frequency                                                                                                                                   | Primary Responsibility | Service Qualification                            | Reference                                                         |
|--------------------------------------|---------------------------------------------------------------------------------------------------------------------------------------------|------------------------|--------------------------------------------------|-------------------------------------------------------------------|
| Pre-Start Inspection                 | Before using each day; or whenever there's an Operator change.                                                                              | User or Operator       | User or Operator                                 | Operation and Safety Manual                                       |
| Pre-Delivery Inspection (See Note)   | Before each sale, lease, or rental delivery.                                                                                                | Owner, Dealer, or User | Qualified JLG Mechanic                           | Service and Maintenance Manual and applicable JLG inspection form |
| Frequent Inspection (See Note)       | In service for 3 months or 150 hours, whichever comes first; or<br>Out of service for a period of more than 3 months; or<br>Purchased used. | Owner, Dealer, or User | Qualified JLG Mechanic                           | Service and Maintenance Manual and applicable JLG inspection form |
| Annual Machine Inspection (See Note) | Annually, no later than 13 months from the date of prior inspection.                                                                        | Owner, Dealer, or User | Factory Trained Service Technician (Recommended) | Service and Maintenance Manual and applicable JLG inspection form |
| Preventative Maintenance             | At intervals as specified in the Service and Maintenance Manual.                                                                            | Owner, Dealer, or User | Qualified JLG Mechanic                           | Service and Maintenance Manual                                    |

**NOTE:** Inspection forms are available from JLG. Use the Service and Maintenance Manual to perform inspections.

### NOTICE

**JLG INDUSTRIES, INC. RECOGNIZES A FACTORY TRAINED SERVICE TECHNICIAN AS A PERSON WHO HAS SUCCESSFULLY COMPLETED THE JLG SERVICE TRAINING SCHOOL FOR THE SPECIFIC JLG PRODUCT MODEL.**

## SECTION 2 - USER RESPONSIBILITIES, MACHINE PREPARATION, AND INSPECTION

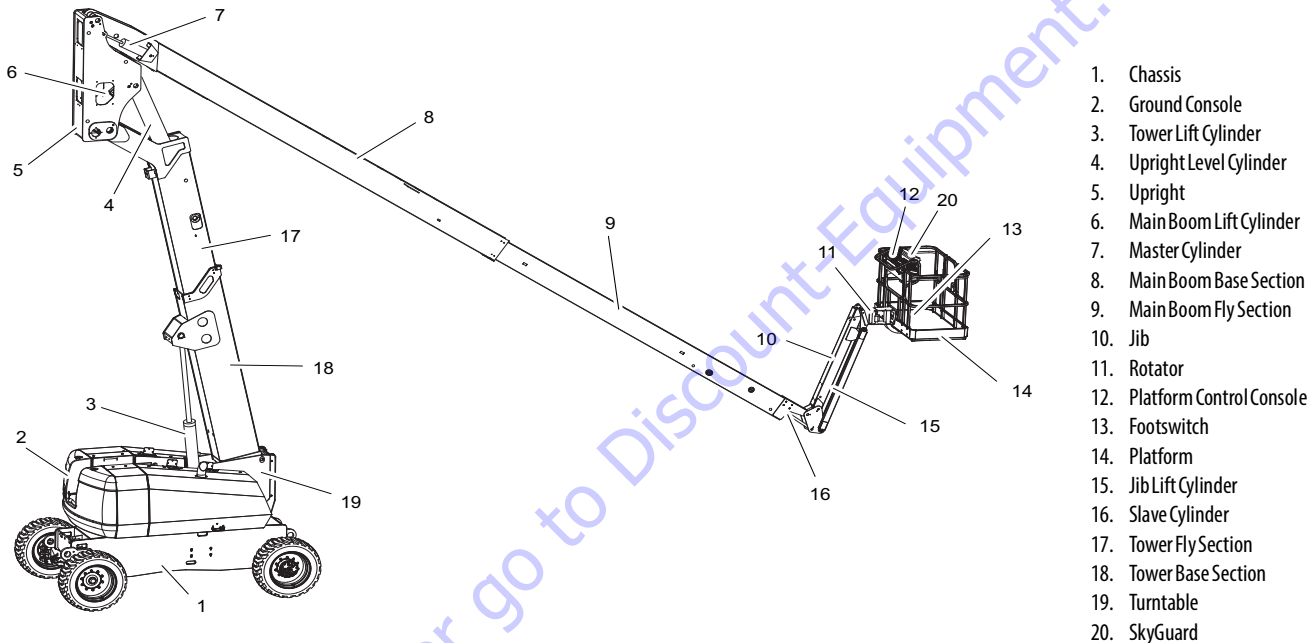
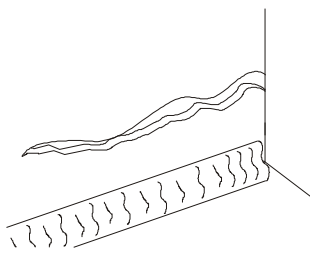

Figure 2-1. Basic Nomenclature

### Pre-Start Inspection

The Pre-Start Inspection should include each of the following:

1. **Cleanliness** – Check all surfaces for leakage (oil, fuel, or battery fluid) or foreign objects. Report any leakage to the proper maintenance personnel.
2. **Structure** - Inspect the machine structure for dents, damage, weld or parent metal cracks or other discrepancies.



Parent Metal Crack

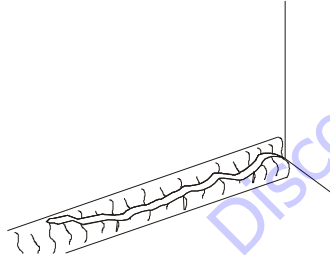

Weld Crack

3. **Decals and Placards** – Check all for cleanliness and legibility. Make sure none of the decals and placards are missing. Make sure all illegible decals and placards are cleaned or replaced.

4. **Operation and Safety Manuals** – Make sure a copy of the Operation and Safety Manual, AEM Safety Manual (ANSI markets only), and ANSI Manual of Responsibilities (ANSI markets only) is enclosed in the weather resistant storage container.
5. **Walk-Around Inspection** – Refer to Figure 2-2.
6. **Battery** – Charge as required.
7. **Fuel** (Combustion Engine Powered Machines) – Add the proper fuel as necessary.
8. **Engine Oil Supply** - Ensure the engine oil level is at the Full mark on the dipstick and the filler cap is secure.
9. **Hydraulic Oil** – Check the hydraulic oil level. Ensure hydraulic oil is added as required.
10. **Accessories/Attachments** - Refer to the Accessories section in this manual or accessory installed upon the machine for specific inspection, operation, and maintenance instructions.
11. **Function Check** – Once the Walk-Around Inspection is complete, perform a functional check of all systems in an area free of overhead and ground level obstructions. Refer to Section 4 for more specific operating instructions.



## **SECTION 2 - USER RESPONSIBILITIES, MACHINE PREPARATION, AND INSPECTION**

---

12. **Platform Gate** – Keep gate and surrounding area clean and unobstructed. Verify the gate closes properly and is not bent or damaged. Keep gate closed at all times except when entering/exiting the platform and loading/unloading materials.
13. **Lanyard Attach Points** – During operation, occupants in the platform must wear a full body harness with a lanyard attached to an authorized lanyard anchorage point. Attach only one (1) lanyard per lanyard anchorage point.

### **WARNING**

**IF THE MACHINE DOES NOT OPERATE PROPERLY, TURN OFF THE MACHINE IMMEDIATELY! REPORT THE PROBLEM TO THE PROPER MAINTENANCE PERSONNEL. DO NOT OPERATE THE MACHINE UNTIL IT IS DECLARED SAFE FOR OPERATION.**

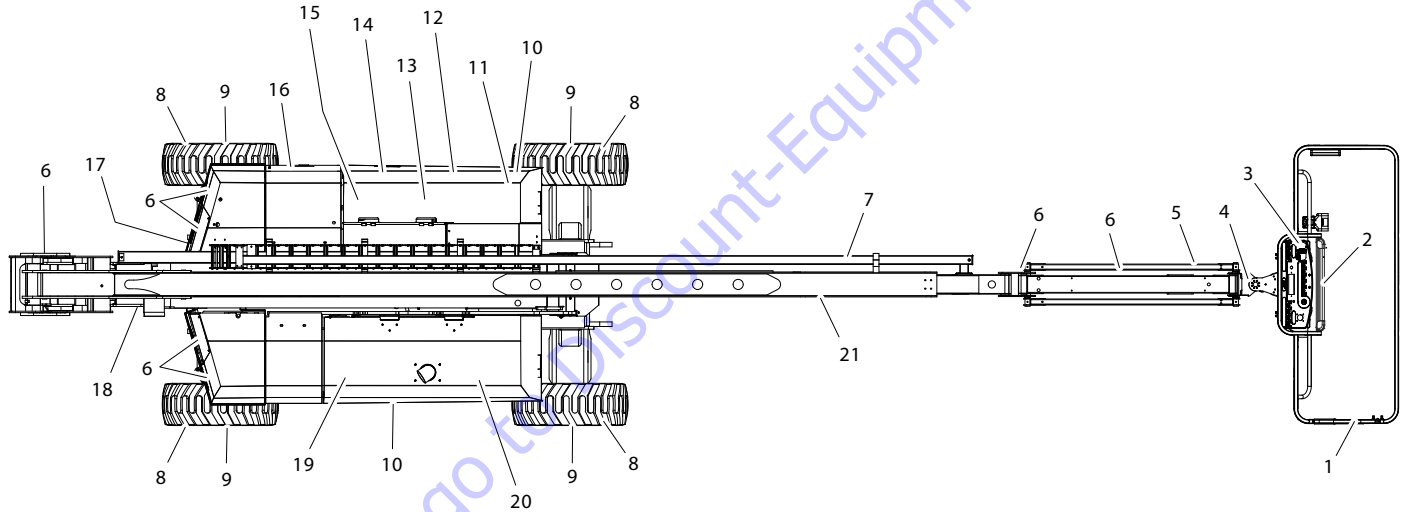

OXCB100

Figure 2-2. Daily Walk-Around Inspection

### Walk-Around Inspection

Begin the Walk-Around Inspection at Item 1, as noted on the diagram. Continue to the right (counterclockwise viewed from top) checking each item in sequence for the conditions listed in the following checklist.

#### **WARNING**

**TO AVOID POSSIBLE INJURY, BE SURE MACHINE POWER IS OFF. DO NOT OPERATE MACHINE UNTIL ALL MALFUNCTIONS HAVE BEEN CORRECTED.**

#### **NOTICE**

**DO NOT OVERLOOK VISUAL INSPECTION OF CHASSIS UNDERSIDE. CHECKING THIS AREA MAY RESULT IN DISCOVERY OF CONDITIONS WHICH COULD CAUSE EXTENSIVE MACHINE DAMAGE.**

***INSPECTION NOTE:** On all components, make sure there are no loose or missing parts, that they are securely fastened, and no visible damage, leaks or excessive wear exists in addition to any other criteria mentioned.*

- 1. Platform Assembly and Gate** - Footswitch works properly, not modified, disabled, or blocked. Gate latches and hinges in working condition.
- 2. SkyGuard** - See Inspection Note.
- 3. Platform Control Console** - Switches and levers return to neutral when activated and released, decals/placards secure and legible, control markings legible.
- 4. Platform Rotator** - See Inspection Note.
- 5. Jib** - See Inspection Note.
- 6. All Hydraulic Cylinders** - See Inspection Note.
- 7. Power Track** - See Inspection Note.
- 8. Wheel/Tire Assemblies** - Properly secured, no missing lug nuts. Inspect for worn tread, cuts, tears or other discrepancies. Inspect wheels for damage and corrosion.
- 9. Drive Motor, Brake, and Hub** - See Inspection Note.
- 10. Hood Assemblies** - See Inspection Note.
- 11. Main Control Valve** - See Inspection Note.
- 12. Fuel Tank** - See Inspection Note.
- 13. Turntable Bearing** - Evidence of proper lubrication. No evidence of loose bolts or looseness between bearing and structure.
- 14. Swing Drive Motor and Brake** - See Inspection Note.

## SECTION 2 - USER RESPONSIBILITIES, MACHINE PREPARATION, AND INSPECTION

15. **Engine Battery** - Proper electrolyte levels; cables tight, no visible damage or corrosion.
16. **Ground Control Console** - Switches and levers return to neutral when activated and released, decals/placards secure and legible, control markings legible.
17. **Tie Rod and Steering Linkage** - See Inspection Note.
18. **Tower Boom** - No visible damage; wear pads secure. All cylinders - rod end pins and barrel-end pins properly secured.
19. **Engine, Clutch Linkage, Integrated Motor Generator** - See Inspection Note.
20. **Hydraulic Pumps** - See Inspection Note.
21. **Main Boom Sections** - No visible damage; wear pads secure. All cylinders - rod end shafts and barrel-end shafts properly secured.

### 2.3 FUNCTION CHECK

#### **WARNING**

TO AVOID SERIOUS INJURY, DO NOT OPERATE MACHINE IF ANY CONTROL LEVERS OR TOGGLE SWITCHES CONTROLLING PLATFORM MOVEMENTS DO NOT RETURN TO THE OFF POSITION WHEN RELEASED.

#### **WARNING**

TO AVOID A COLLISION AND INJURY IF PLATFORM DOES NOT STOP WHEN A CONTROL SWITCH OR LEVER IS RELEASED, REMOVE FOOT FROM FOOTSWITCH OR USE EMERGENCY STOP TO STOP MACHINE.

Perform the Function Check as follows:

1. From the ground control console with no load in the platform:
  - a. Ensure that all machine functions are disabled when the Emergency Stop Button is pushed in.
  - b. Ensure all functions stop when the function switch is released.
  - c. Operate all functions and ensure proper operation;
  - d. Ensure proper operation of the manual descent controls, as described in Section 5.3 of this manual.

## SECTION 2 - USER RESPONSIBILITIES, MACHINE PREPARATION, AND INSPECTION

2. Test the tower boom assembly sequencing as follows:
  - a. Place machine on level ground with the tower boom assembly in the stowed position. Identify the tower boom vertical limit switch adjacent to the tower lift cylinder at the bottom end (rear) of the tower base boom. Open the left side hood and perform a visual check that the plunger on the tower boom vertical limit switch is fully extended. The plunger is shown fully extended in Figure 2-3.



Figure 2-3. Tower Boom Vertical Limit Switch

### **⚠ WARNING**

**DISCONTINUE OPERATION IF PLUNGER IS NOT FULLY EXTENDED**

- b. Attempt to extend the tower fly boom. The tower fly boom should not extend and the red boom malfunction light in the ground control panel should illuminate when pressing the tower telescope switch.

### **⚠ WARNING**

**DISCONTINUE OPERATION IF THE TOWER FLY BOOM EXTENDS OR THE BOOM MALFUNCTION LIGHT DOES NOT ILLUMINATE.**

- c. Raise the tower base boom to approximately 40 degrees, then lower the tower boom back to the below horizontal position. While raising and lowering the tower boom assembly, observe the position of the upright. Ensure that the upright remains vertical relative to the chassis. Refer to Figure 2-5. and Figure 2-6.

### **⚠ WARNING**

**DISCONTINUE OPERATION IF THE UPRIGHT IS OUT OF ALIGNMENT OR THE BOOM MALFUNCTION LIGHT IS FLASHING OR ON STEADY.**

## SECTION 2 - USER RESPONSIBILITIES, MACHINE PREPARATION, AND INSPECTION

- d. Raise the tower base boom to full height. Extend the tower fly boom a few feet. Check that the plunger on the tower boom horizontal limit switch at the end of the tower base boom section is fully extended. The plunger is shown fully extended in Figure 2-4.



Figure 2-4. Tower Boom Horizontal Limit Switch

**⚠ WARNING**

DISCONTINUE OPERATION IF PLUNGER IS NOT FULLY EXTENDED

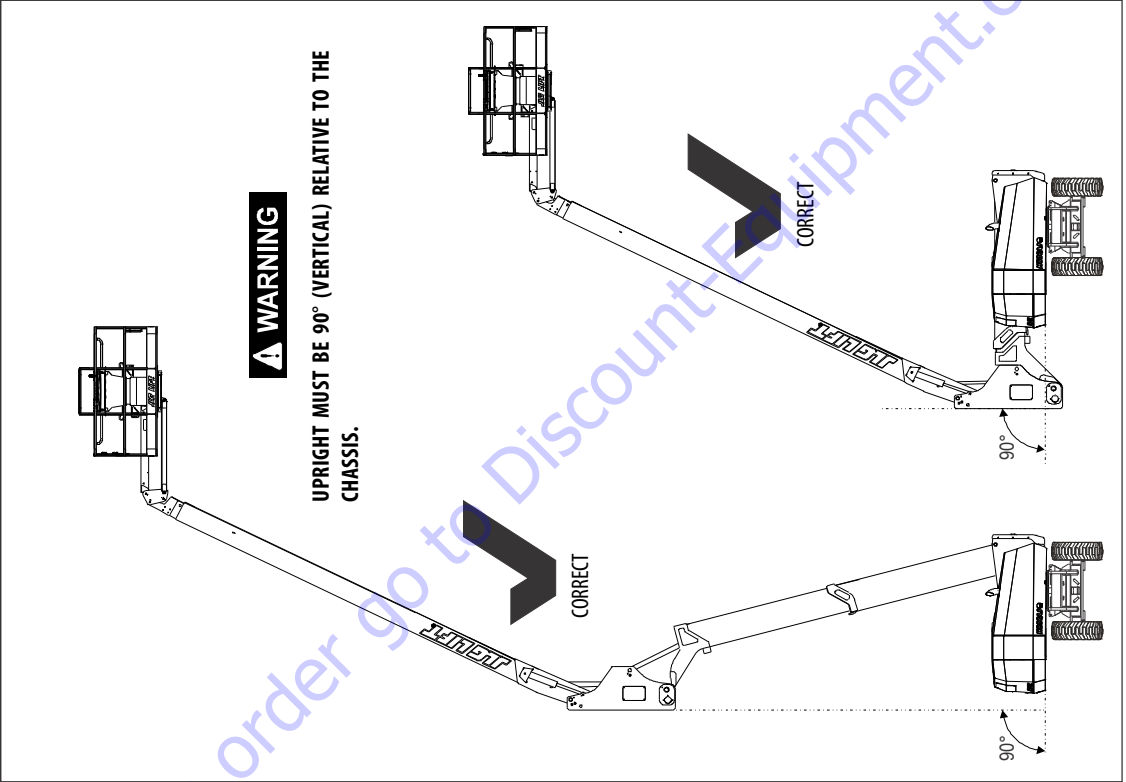

Figure 2-5. Boom Upright Positioning - Correct

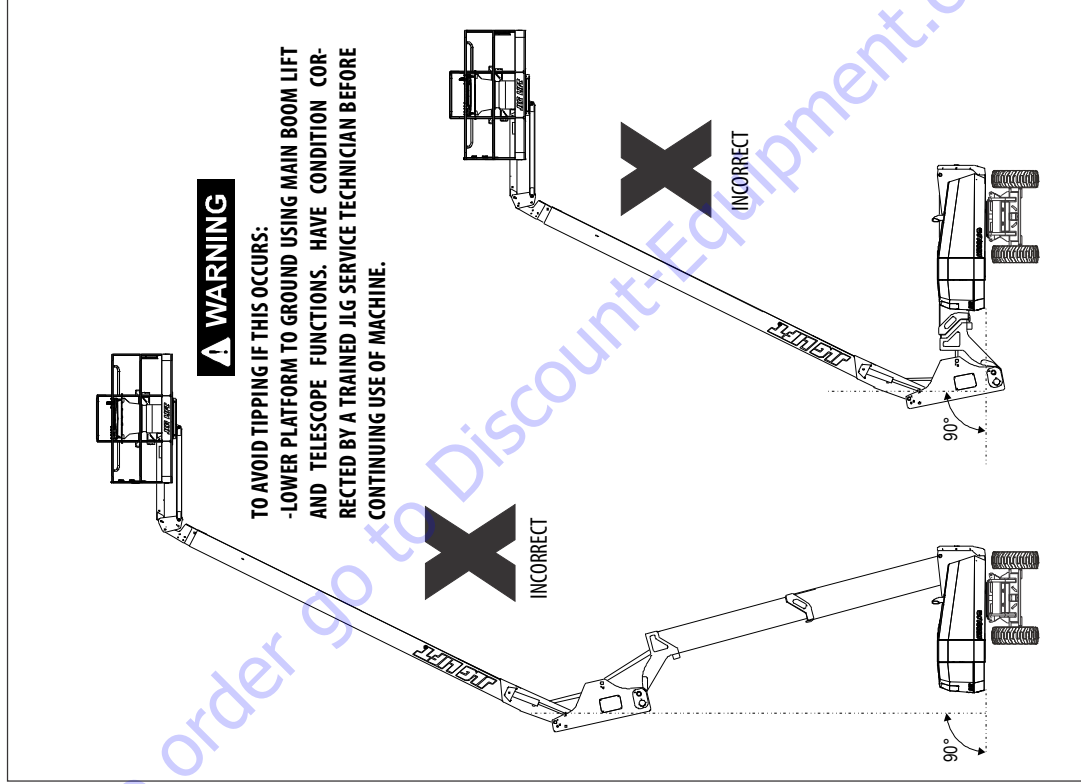

Figure 2-6. Boom Upright Positioning - Incorrect



## SECTION 2 - USER RESPONSIBILITIES, MACHINE PREPARATION, AND INSPECTION

- e. Attempt to lower the tower base boom while the tower fly boom is extended. The tower base boom should not lower and the red boom malfunction light should illuminate when pressing the tower down switch.

### **WARNING**

**DISCONTINUE OPERATION IF THE TOWER BASE BOOM LOWERS OR THE BOOM MALFUNCTION LIGHT DOES NOT ILLUMINATE.**

- 3. From the platform control console:
  - a. Ensure that the control console is firmly secured in the proper location
  - b. Check that all guards protecting the switches or locks are in place.
  - c. Ensure that all machine functions are disabled when the Emergency Stop Button is pushed in.
  - d. Ensure that all machine functions stop when the footswitch is released.
  - e. Operate all functions and ensure proper operation.
- 4. With the platform in the stowed position:
  - a. Drive the machine on a grade, not to exceed the rated gradeability, and stop to ensure the brakes hold;
  - b. Check that the tilt indicator is illuminated to ensure proper operation.

- 5. Swing the boom over either of the rear tires and ensure that the Drive Orientation indicator illuminates and that the Drive Orientation Override switch must be used for the drive function to operate.
- 6. With the machine positioned on a smooth, firm surface within the limits of the maximum operating slope, elevate the boom above 4 degrees of horizontal; Select high speed drive mode. Carefully attempt to drive and ensure the drive speed is reduced.

### **SkyGuard Function Test**

**NOTE:** Refer to Section 4.10, Skyguard Operation for additional information on SkyGuard operation.

From the Platform Console in an area free from obstructions:

- 1. Operate the telescope function.
- 2. Activate the SkyGuard sensor:
  - a. **SkyGuard** - Apply approximately 50 lb (222 Nm) of force to yellow bar.
  - b. **SkyGuard - SkyLine** - Press cable to break magnetic connection between the cable and right bracket.
  - c. **SkyGuard - SkyEye** - Put arm or hand in path of sensor beam.

## SECTION 2 - USER RESPONSIBILITIES, MACHINE PREPARATION, AND INSPECTION

---

3. Once the sensor has been activated, verify the following conditions:
  - a. Telescope out function stops and telescope in function operates for a short duration.
  - b. The horn sounds.
  - c. If equipped with a SkyGuard beacon, the beacon illuminates.
4. Disengage the SkyGuard sensor, release controls, then recycle the footswitch. Ensure normal operation is available.

**NOTE:** *On machines equipped with SkyLine, reattach magnetic end of the cable to the bracket.*

If SkyGuard remains activated after function reversal or cutout, depress and hold the SkyGuard Override Switch to allow normal use of machine functions until the sensor is disengaged.

### 2.4 OSCILLATING AXLE LOCKOUT TEST (IF EQUIPPED)

#### **NOTICE**

**LOCKOUT SYSTEM TEST MUST BE PERFORMED QUARTERLY, ANY TIME A SYSTEM COMPONENT IS REPLACED, OR WHEN IMPROPER SYSTEM OPERATION IS SUSPECTED.**

**NOTE:** *Ensure boom is fully retracted, lowered, and centered between drive wheels prior to beginning lockout cylinder test.*

1. Place a 6 inch (15.2 cm) high block with ascension ramp in front of left front wheel.
2. From platform control console, start engine.
3. Position Drive Speed/Torque Select switch to Slow.
4. Place Drive control lever to Forward position and carefully drive machine up ascension ramp until left front wheel is on top of block.
5. Carefully activate Swing control lever and position boom over Right side of machine.
6. With boom over right side of machine, place Drive control lever to Reverse and drive machine off of block and ramp.
7. Have an assistant check to see that left front or right rear wheel remains elevated in position off of ground.
8. Carefully activate Swing control lever and return boom to stowed position (centered between drive wheels). When boom reaches center, stowed position, lockout cylinders should release and allow wheel to rest on ground, it may be necessary to activate Drive to release cylinders.
9. Place the 6 inch (15.2 cm) high block with ascension ramp in front of right front wheel.
10. Place Drive control lever to Forward and carefully drive machine up ascension ramp until right front wheel is on top of block.
11. Carefully activate Swing control lever and position boom over left side of machine.
12. With boom over left side of machine, place Drive control lever to Reverse and drive machine off of block and ramp.
13. Have an assistant check to see that right front or left rear wheel remains elevated in position off of ground.
14. Carefully activate Swing control lever and return boom to stowed position (centered between drive wheels). When boom reaches center, stowed position, lockout cylinders should release and allow wheel to rest on ground, it may be necessary to activate Drive to release cylinders.
15. If lockout cylinders do not function properly, have qualified personnel correct the malfunction prior to any further operation.

**TO PURCHASE THIS PRODUCT PLEASE CONTACT US**



**Equipment Financing and  
Extended Warranties Available**



**Discount-Equipment.com is your online resource for  
commercial and industrial quality parts and equipment sales.**

**561-964-4949**

**visit us on line @ [www.discount-equipment.com](http://www.discount-equipment.com)**

Select an option below to find your Equipment

**Search by Manufacturer**

**Search by Product Type**

**Request a Quote**

We sell worldwide for the brands: Genie, Terex, JLG, MultiQuip, Mikasa, Essick, Whiteman, Mayco, Toro Stone, Diamond Products, Generac Magnum, Airman, Haulotte, Barreto, Power Blanket, Nifty Lift, Atlas Copco, Chicago Pneumatic, Allmand, Miller Curber, Skyjack, Lull, Skytrak, Tsurumi, Husquvarna Target, Stow, Wacker, Sakai, Mi-T-M, Sullair, Basic, Dynapac, MBW, Weber, Bartell, Bennar Newman, Haulotte, Ditch Runner, Menegotti, Morrison, Contec, Buddy, Crown, Edco, Wyco, Bomag, Laymor, EZ Trench, Bil-Jax, F.S. Curtis, Gehl Pavers, Heli, Honda, ICS/PowerGrit, IHI, Partner, Imer, Clipper, MMD, Koshin, Rice, CH&E, General Equipment, Amida, Coleman, NAC, Gradall, Square Shooter, Kent, Stanley, Tamco, Toku, Hatz, Kohler, Robin, Wisconsin, Northrock, Oztec, Toker TK, Rol-Air, APT, Wylie, Ingersoll Rand / Doosan, Innovatech, Con X, Ammann, Mecalac, Makinex, Smith Surface Prep, Small Line, Wanco, Yanmar

## SECTION 3. MACHINE CONTROLS AND INDICATORS

### 3.1 GENERAL

#### **NOTICE**

**THE MANUFACTURER HAS NO DIRECT CONTROL OVER MACHINE APPLICATION AND OPERATION. THE USER AND OPERATOR ARE RESPONSIBLE FOR CONFORMING WITH GOOD SAFETY PRACTICES.**

This section provides the necessary information needed to understand control functions.

### 3.2 CONTROLS AND INDICATORS

**NOTE:** *The indicator panels use different shaped symbols to alert the operator to different types of operational situations that could arise. The meaning of those symbols are explained below.*



*Indicates a potentially hazardous situation, which if not corrected, could result in serious injury or death. This indicator will be red.*



*Indicates an abnormal operating condition, which if not corrected, may result in machine interruption or damage. This indicator will be yellow.*



*Indicates important information regarding the operating condition, i.e. procedures essential for safe operation. This indicator will be green with the exception of the capacity indicator which will be green or yellow depending upon platform position.*

## SECTION 3 - MACHINE CONTROLS AND INDICATORS

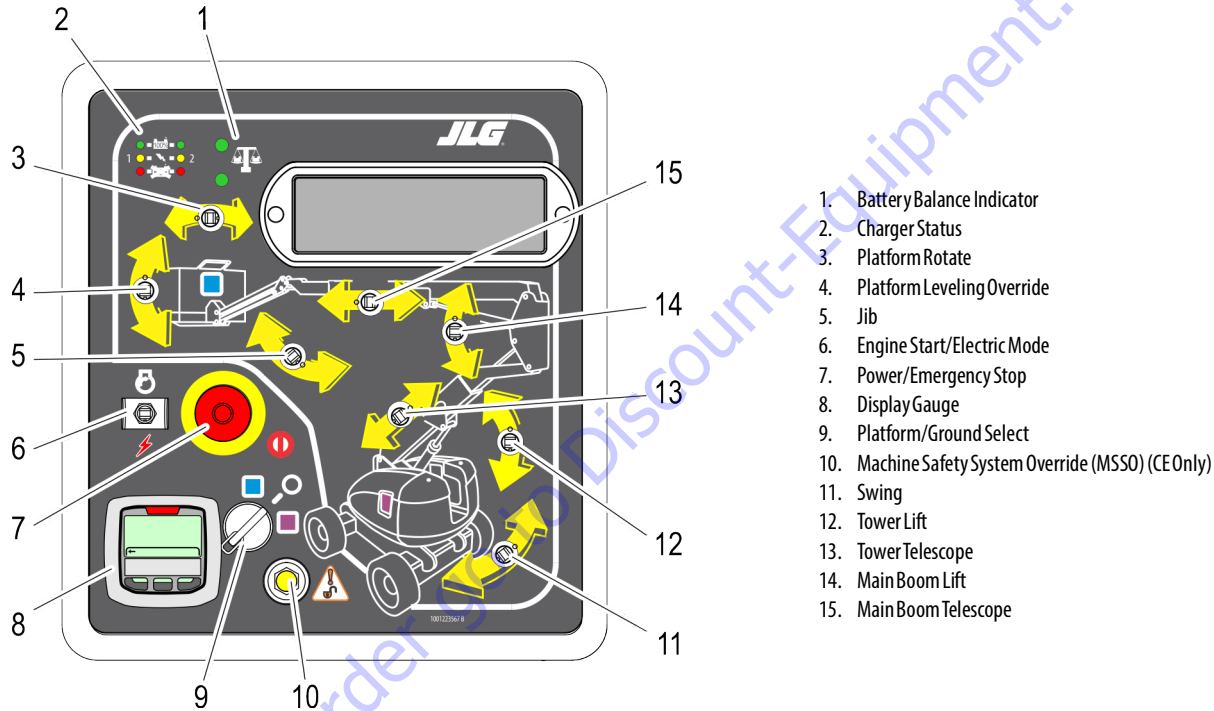

Figure 3-1. Ground Control Console

## Ground Control Console

See Figure 3-1., Ground Control Console.

### **⚠ WARNING**

**TO AVOID SERIOUS INJURY, DO NOT OPERATE MACHINE IF ANY CONTROL LEVERS OR TOGGLE SWITCHES CONTROLLING PLATFORM MOVEMENT DO NOT RETURN TO THE OFF POSITION WHEN RELEASED.**

#### 1. Battery Balance Indicator

The Battery Balance Indicator displays the state of charge balance of the battery packs. The lights will glow a steady green when the battery pack's charge is balanced or a steady red when the battery pack's charge is too far out of balance, resulting in a system shutdown condition. For conditions in between, the light will be green and blink orange at different rates depending upon how far from the normal range the battery packs are (for example, the further out of balance the battery packs are, the faster it will blink). When the battery packs are close to being balanced and is equalizing, the light will blink green.

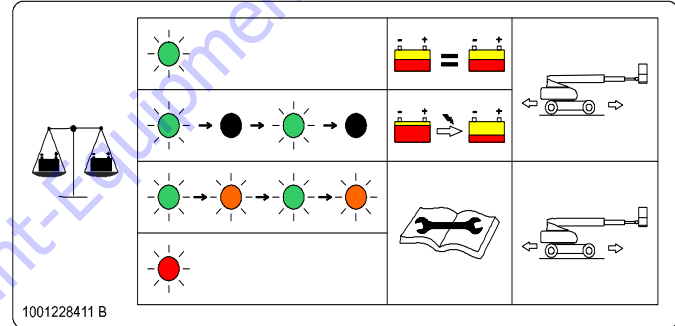

#### 2. Charger Status

The Charger Status LEDs give a visual indicator of the status of each battery charger. The red LED indicates Charging Abnormal. The yellow LED indicates charging in progress. The green LED indicates

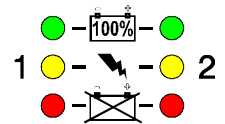

## SECTION 3 - MACHINE CONTROLS AND INDICATORS

charging is complete. There is one set of LEDs for each battery charger.

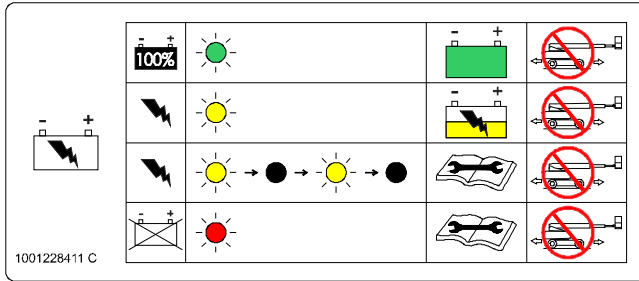

### 3. Platform Rotate

Provides rotation of the platform.

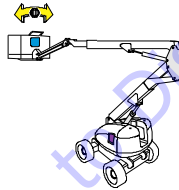

## **⚠ WARNING**

**TO AVOID SERIOUS INJURY, DO NOT OPERATE MACHINE IF ANY CONTROL LEVERS OR TOGGLE SWITCHES CONTROLLING PLATFORM MOVEMENT DO NOT RETURN TO THE OFF POSITION WHEN RELEASED.**

## **⚠ WARNING**

**ONLY USE THE PLATFORM LEVELING OVERRIDE FUNCTION FOR SLIGHT LEVELING OF THE PLATFORM. INCORRECT USE COULD CAUSE THE LOAD/OCCUPANT TO SHIFT OR FALL. FAILURE TO DO SO COULD RESULT IN DEATH OR SERIOUS INJURY.**

### 4. Platform Leveling Override

A three position switch allows the operator to adjust the automatic self leveling system. This switch is used to adjust platform level in situations such as ascending/descending a grade.

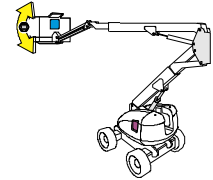

### 5. Jib

Provides raising and lowering of the jib.

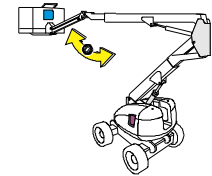



## SECTION 3 - MACHINE CONTROLS AND INDICATORS

**NOTE:** When Glow Plug Indicator is lighted (Yellow), wait until light goes out before cranking engine.

### 6. Engine Start/Electric Mode



To start the engine, the switch must be held Up until the engine starts.

Hold Down for electric mode.



**WHEN THE MACHINE IS SHUT DOWN THE MASTER/EMERGENCY STOP SWITCH MUST BE POSITIONED TO THE "OFF" POSITION TO PREVENT DRAINING THE BATTERY.**

### 7. Power/Emergency Stop Switch

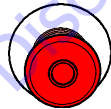

A two-position red mushroom shaped switch supplies power to Platform/Ground Select switch when pulled out (on). When pushed in (off), power is shut off to the Platform/Ground Select switch.

### 8. Display Gauge



Registers engine hours, fuel level (if applicable), and Diagnostic Trouble Codes (DTCs) from both the JLG Control System and the engine control system.

**NOTE:** When the Platform/Ground Select Switch is in the center position, power is shut off to the controls at both operating consoles. Remove the key to prevent the controls from being actuated.



### 9. Platform/Ground Select Switch

The three position, key operated switch supplies power to the platform control console when positioned to Platform. With the switch key turned to the Ground position only ground controls are operable.

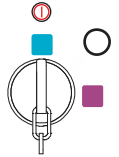

### 10. Machine Safety System Override (MSSO) (CE Only)

Provides emergency override of function controls that are locked out in the event of Load Sense System activation.



**NOTE:** Main Lift, Tower Lift, Swing, Platform Level, Main Telescope, Tower Telescope, and Platform Rotate control switches are spring-loaded and will automatically return to neutral (Off) when released.

## SECTION 3 - MACHINE CONTROLS AND INDICATORS

### 11. Swing Control

Provides 360 degrees continuous turntable rotation.

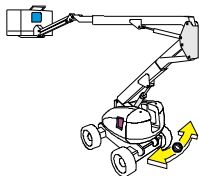

### 12. Tower Lift

Provides raising and lowering of the tower boom. This function works only when the tower boom is fully retracted.

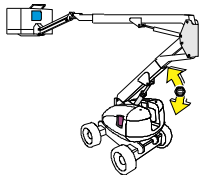

### 13. Tower Telescope

Provides extending and retracting of the tower boom. This function works only when the tower boom is fully elevated (lift up).

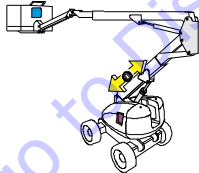

## **⚠ WARNING**

**TO AVOID UPSET AND SERIOUS INJURY, DO NOT OPERATE MACHINE IF TOWER LIFT AND TELESCOPE FUNCTIONS DO NOT OPERATE IN THE ABOVE SEQUENCE.**

## **⚠ WARNING**

**WHEN OPERATING THE BOOM ENSURE THERE ARE NO PERSONNEL AROUND OR UNDER PLATFORM.**

### 14. Main Boom Lift Control

Provides raising and lowering of the main boom.

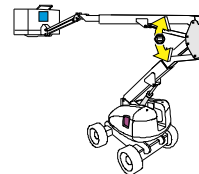

### 15. Main Telescope Control

Provides extension and retraction of the main boom.

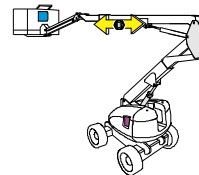

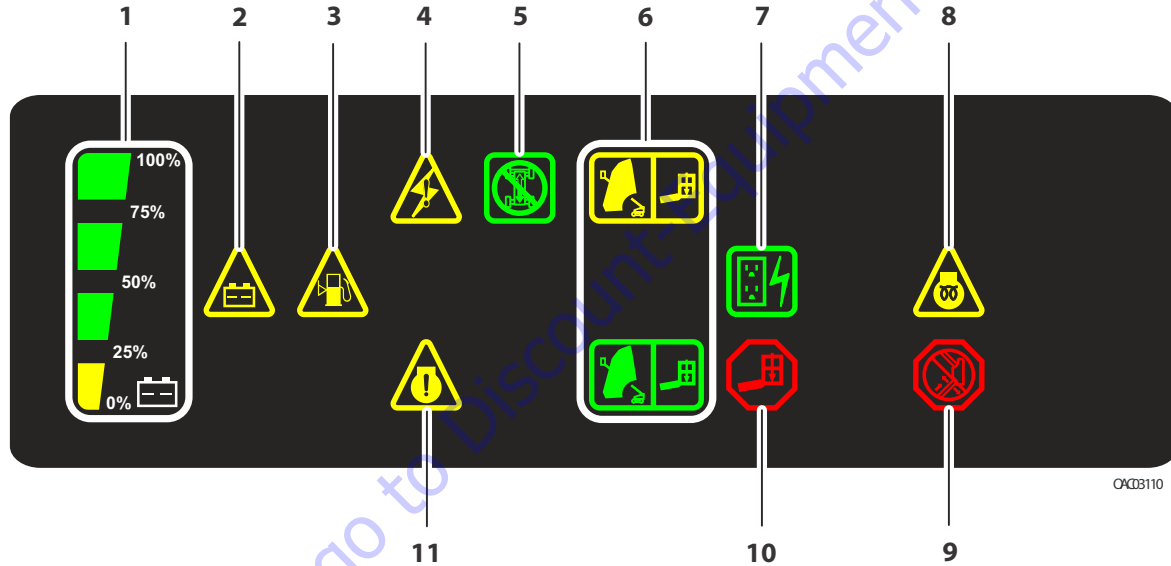

OX03110

- |                        |                            |                     |                       |
|------------------------|----------------------------|---------------------|-----------------------|
| 1. Battery Level Gauge | 4. System Distress         | 7. Generator        | 10. Platform Overload |
| 2. Battery Charge      | 5. Drive Steer Disable     | 8. Glow Plugs       | 11. Engine Error      |
| 3. Low Fuel            | 6. Capacity Zone Indicator | 9. Boom Malfunction |                       |

**Figure 3-2. Ground Control Indicator Panel**

### Ground Control Indicator Panel

(See Figure 3-2., Ground Control Indicator Panel)

1. Battery Charge Level Indicator

Indicates the state-of-charge of the battery pack.

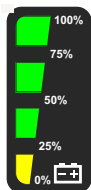

2. Battery Charge Indicator

Indicates a problem in the battery or charging circuit, and service is required.



3. Low Fuel Warning Indicator

Indicates the fuel in the fuel tank is low.



4. System Distress Indicator

The light indicates that the JLG Control System has detected an abnormal condition and a Diagnostic Trouble Code has been set in the system memory. Refer to the Service Manual for instructions concerning the trouble codes and trouble code retrieval.



The system distress indicator light will illuminate for 2-3 seconds when the key is positioned to the ON position to act as a self test.

5. Drive and Steer Disable Indicator

Indicates the Drive and Steer Disable function has been activated.



6. Capacity Zone Indicator

Indicates the platform capacity zone for the current position of the platform. Restricted capacities are permitted at restricted platform positions (shorter boom lengths and higher boom angles).



**NOTE:** Refer to the capacity decals on the machine for restricted and unrestricted platform capacities.

7. AC Generator Indicator

Indicates the generator is in operation.



8. Glow Plug Indicator

Indicates the glow plugs are on. The glow plugs are automatically turned on with the ignition circuit and remain on for approximately seven seconds. Start the engine only after the light goes out.



9. Boom Malfunction Indicator

When an audible alarm sounds and the Boom Malfunction Indicator illuminates when attempting to activate a tower boom function, the function is being cutout by tower boom limit switch. This function is not permitted at the current boom configuration.



When an audible alarm sounds and the Boom Malfunction Indicator illuminates steady without a boom function attempt, the upright is out of alignment.

**WARNING**

**DISCONTINUE OPERATION IF THE UPRIGHT IS OUT OF ALIGNMENT OR THE BOOM MALFUNCTION LIGHT REMAINS ILLUMINATED.**

**WARNING**

**IF THE UPRIGHT IS OUT OF ALIGNMENT WITH THE PLATFORM RAISED, LOWER THE MAIN BOOM AND TELESCOPE OUT UNTIL THE PLATFORM REACHES THE GROUND. THE TOWER BOOM DOWN FUNCTION IS CUT OUT IN THIS CONDITION. REPORT THE PROBLEM TO THE PROPER SERVICE PERSONNEL. DO NOT OPERATE THE MACHINE UNTIL THE CONDITION IS CORRECTED.**

10. Platform Overload Indicator

Indicates the platform has been overloaded.



11. Engine Error Indicator

Indicates a fault with the engine and service is required.



### Ground Control Console Display Gauge

*(See Figure 3-6., Ground Control Console Display Gauge)*

The Display Gauge shows engine hours, fuel level (if applicable), and Diagnostic Trouble Codes (DTCs) from both the JLG Control System and the engine control system. During machine start up, with no active DTCs in the control system, the splash screen will show for 3 seconds and then switch to main screen. If there is an active DTC while powering up the machine, the splash screen will show for 3 seconds, and then launch the Diagnostics Screen. The indicator lamp will light when there is an active DTC in the Fault Log.



**Figure 3-3. Splash Screen**

## SECTION 3 - MACHINE CONTROLS AND INDICATORS

The Diagnostic Screen will show active and inactive faults from the JLG Control System on the screen. An asterisk (\*) will be displayed to show active faults.

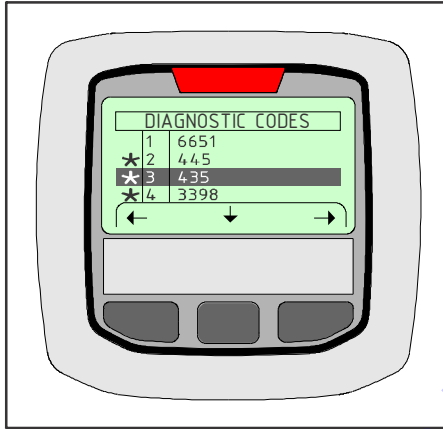

Figure 3-4. Diagnostic Screen

The Engine Diagnostics Screen will show SPN (Suspect Parameter Number), FMI (Failure Mode Identifier), and Occurrence count information. Engine SPN text is not scrollable. If there is more than one engine trouble code, the operator must exit from the Engine DTC Screen to see other SPN and FMI information.

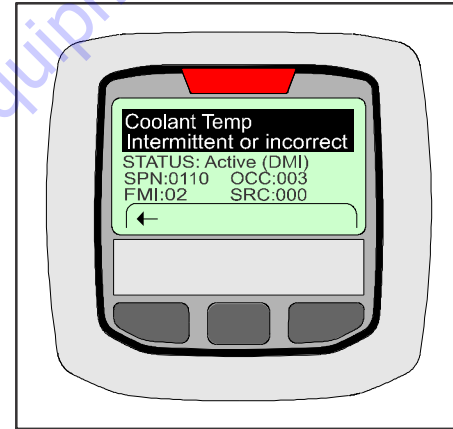

Figure 3-5. Engine Diagnostic Screen

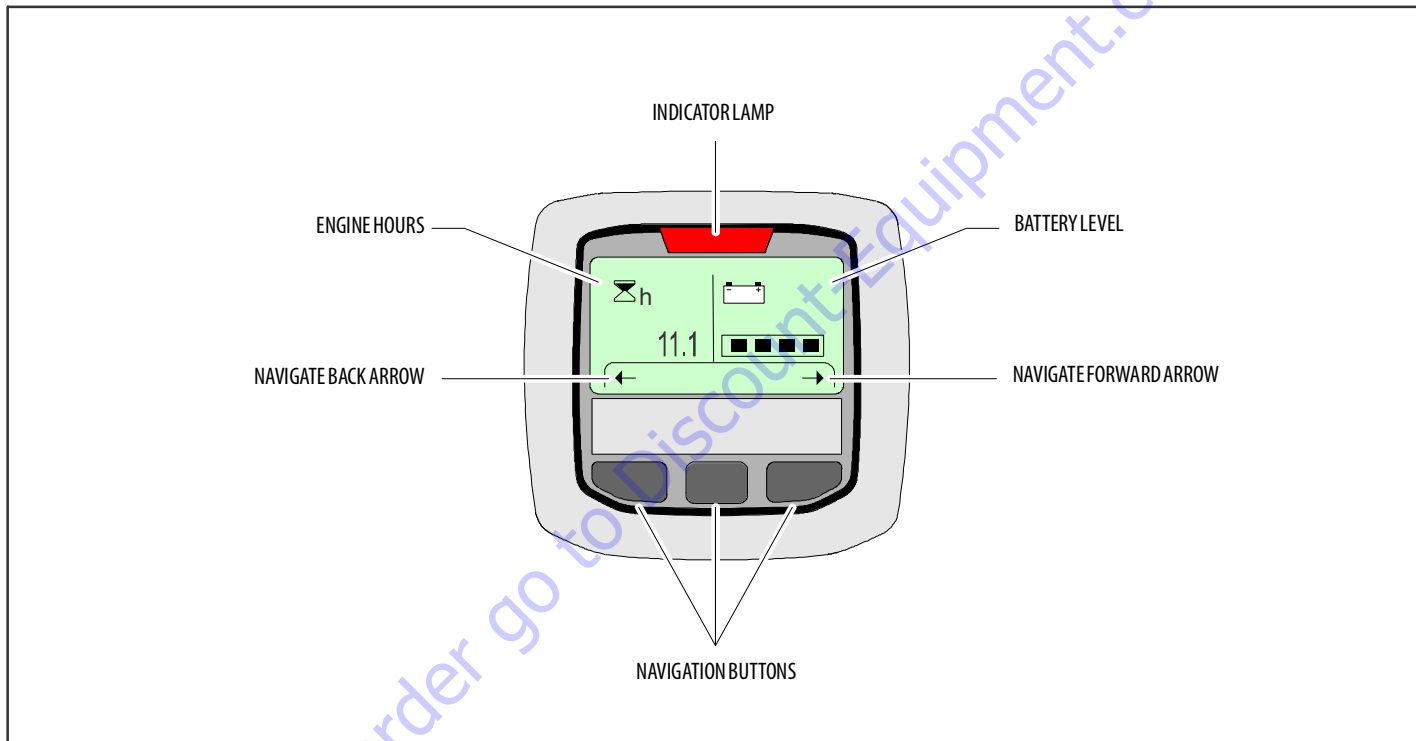
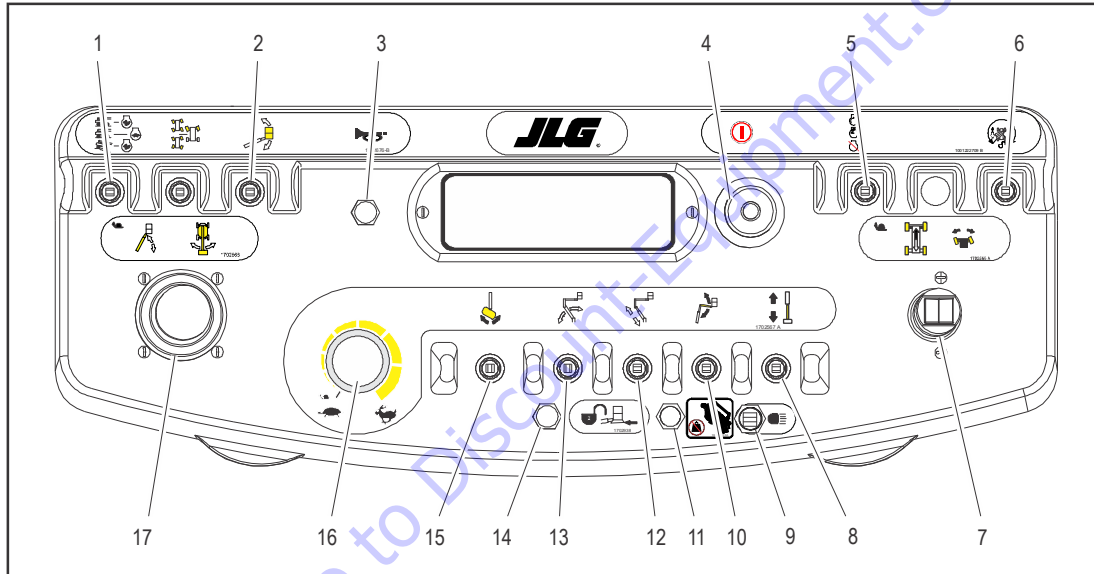

Figure 3-6. Ground Control Console Display Gauge





- |                                |                               |                                  |                                   |
|--------------------------------|-------------------------------|----------------------------------|-----------------------------------|
| 1. Drive Speed / Torque Select | 6. Drive Orientation Override | 10. Jib                          | 14. Soft Touch/SkyGuard Indicator |
| 2. Platform Level Override     | 7. Drive/Steer                | 11. Soft Touch/SkyGuard Override | 15. Platform Rotate               |
| 3. Horn                        | 8. Telescope                  | 12. Tower Telescope              | 16. Function Speed Control        |
| 4. Power/Emergency Stop        | 9. Lights                     | 13. Tower Lift                   | 17. Main Lift / Swing             |
| 5. Engine Start / Mode Select  |                               |                                  |                                   |

Figure 3-7. Platform Control Console

### Platform Console

(See Figure 3-7.)

#### **⚠ WARNING**

**TO AVOID SERIOUS INJURY, DO NOT OPERATE MACHINE IF ANY CONTROL LEVERS OR TOGGLE SWITCHES CONTROLLING PLATFORM MOVEMENT DO NOT RETURN TO THE OFF OR NEUTRAL POSITION WHEN RELEASED.**

#### 1. Drive Speed/Torque Select

The machine has a two position switch - The forward position gives maximum drive speed. The back position gives maximum torque for rough terrain and climbing grades.

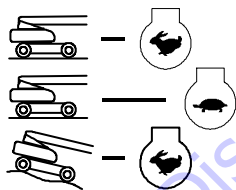

#### 2. Platform Leveling Override

A three position switch allows the operator to adjust the automatic self leveling system. This switch is used to adjust platform level in situations such as ascending/descending a grade.

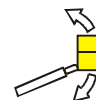

#### 3. Horn

A push-type Horn switch supplies electrical power to an audible warning device when pressed.



#### 4. Power/Emergency Stop Switch

A two-position red mushroom shaped switch furnishes power to Platform Controls when pulled out (On). When pushed in (Off), power is shut off to the platform functions.

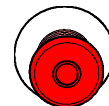

## SECTION 3 - MACHINE CONTROLS AND INDICATORS

### 5. Engine Start/Mode Select

When pushed forward, the switch energizes the starter motor to start the engine. The middle position selects Hybrid Mode. In this mode, the machine will run on a combination of electric and engine power, depending upon machine operation. The bottom position selects Electric Only Mode. In this mode, the machine operates only on electric power.

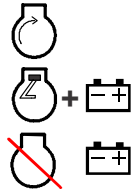

### 6. Drive Orientation Override

When the boom is swung over the rear tires or further in either direction, the Drive Orientation indicator will illuminate when the drive function is selected. Push and release the switch, and within 3 seconds move the Drive/Steer control to activate drive or steer. Before driving, locate the black/white orientation arrows on both the chassis and the platform controls. Move the drive controls in a direction matching the directional arrows for the intended direction of travel.



**NOTE:** Lift, Swing, and Drive control levers are spring-loaded and will automatically return to neutral (off) position when released.

**NOTE:** To operate the Drive joystick, pull up on the locking ring below the handle.

**NOTE:** The Drive joystick is spring loaded and will automatically return to neutral (off) position when released.

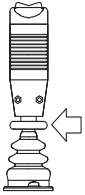

### 7. Drive/Steer

Push forward to drive forward, pull back to drive in reverse. Steering is accomplished via a thumb-activated rocker switch on the end of the steer handle.

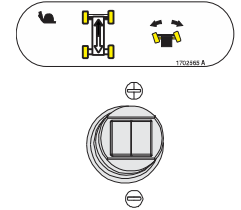

### 8. Main Boom Telescope

Provides extension and retraction of the main boom.

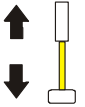

### 9. Lights (If Equipped)

This switch operates the accessory lights package if the machine is so equipped.



## SECTION 3 - MACHINE CONTROLS AND INDICATORS

### 10. Jib

Provides for raising or lowering of the jib.



### 11. Soft Touch/SkyGuard Override Switch

For machines equipped with SkyGuard:

The SkyGuard override switch enables functions cut out by the Skyguard system to be operated again, allowing the operator to resume use of machine functions.



For machines equipped with both SkyGuard and Soft Touch:

The switch operates like the SkyGuard override switch as described above. The switch also enables the functions cut out by the Soft Touch system to operate again at creep speed, allowing the operator to move the platform away from the obstacle that caused the shut-down situation.



### 12. Tower Telescope

Provides for extending and retracting of the tower boom. Tower Telescope must be fully retracted before operating Tower Lift. (Tower Telescope should not function when Tower Lift is not fully elevated up).

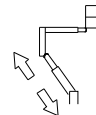

## **⚠ WARNING**

**TO AVOID UPSET AND SERIOUS INJURY, DO NOT OPERATE MACHINE IF TOWER LIFT AND TELESCOPE DO NOT OPERATE IN THE ORDER DESCRIBED ABOVE.**

### 13. Tower Lift

Provides for raising and lowering of the tower boom. Tower Lift must be fully elevated up before operating Tower Telescope. (Tower Lift should not function when Tower Telescope is extended).

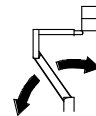

### 14. Soft Touch/SkyGuard Indicator

Indicates the Soft Touch bumper is against an object or the SkyGuard sensor has been activated. All controls are cut out until the override button is pushed. For Soft Touch, controls are then active in the Creep Mode or for SkyGuard, controls will work normally.

### 15. Platform Rotate

Provides rotation of the platform.



### 16. Function Speed Control

This control affects the speed of Telescope and Platform Rotate. Turning the knob all the way counterclockwise until it clicks puts Drive, Main Lift and Swing into Creep mode.



**NOTE:** To operate the Main Boom Lift/Swing joystick, pull up on the locking ring below the handle.

**NOTE:** The Main Boom Lift/Swing joystick is spring loaded and will automatically return to neutral (off) position when released.



### 17. Main Lift/Swing Controller

Provides main lift and swing. Push forward to lift up, pull backward to boom down. Move right to swing right, move left to swing left. Moving the joystick activates switches to provide the functions selected.

**NOTE:** Main boom lift and swing functions may be selected in combination. Maximum speed is reduced when multiple functions are selected.

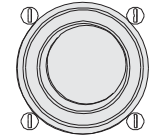

## SECTION 3 - MACHINE CONTROLS AND INDICATORS

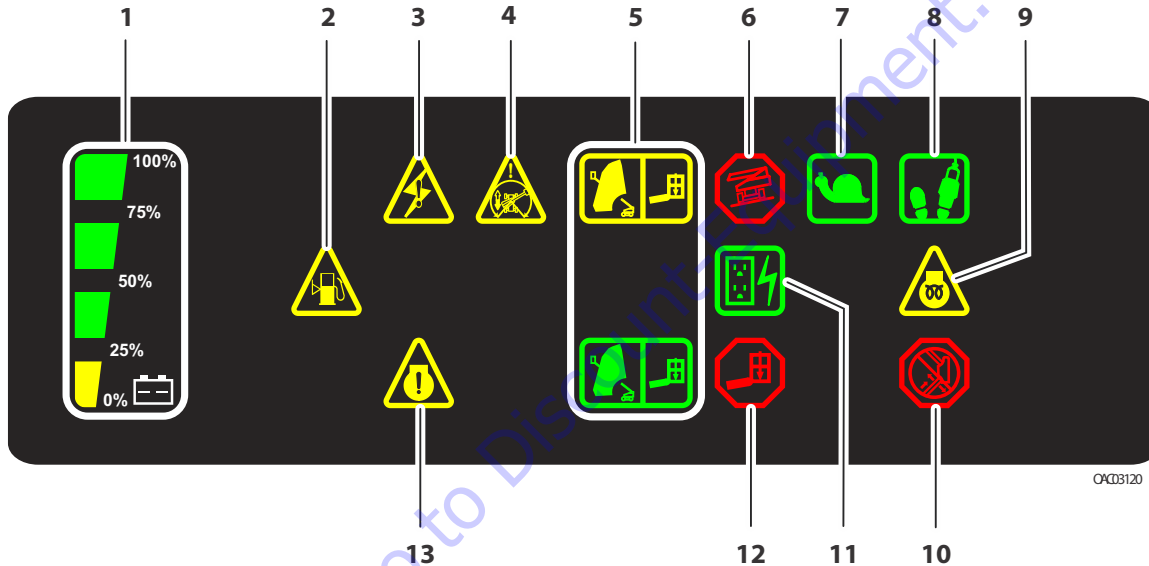

- |                        |                            |                      |                       |
|------------------------|----------------------------|----------------------|-----------------------|
| 1. Battery Level Gauge | 4. Drive Orientation       | 7. Creep             | 10. Boom Malfunction  |
| 2. Low Fuel Indicator  | 5. Capacity Zone Indicator | 8. Footswitch Enable | 11. Generator         |
| 3. System Distress     | 6. Tilt Alarm/Warning      | 9. Glow Plugs        | 12. Platform Overload |
|                        |                            |                      | 13. Engine Error      |

**Figure 3-8. Platform Console Indicator Panel**

### Platform Console Indicator Panel

(See Figure 3-8., Platform Console Indicator Panel)

#### 1. Battery Charge Level Indicator

Indicates the state-of-charge of the battery pack.

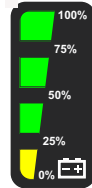

#### 2. Low Fuel Warning Indicator

Indicates the fuel in the fuel tank is low.



#### 3. System Distress Indicator

The light indicates that the JLG Control System has detected an abnormal condition and a Diagnostic Trouble Code has been set in the system memory. Refer to the Service Manual for instructions concerning the trouble codes and trouble code retrieval.



The system distress indicator light will illuminate for 2-3 seconds when the key is positioned to the ON position to act as a self test.

#### 4. Drive Orientation Indicator

When the boom is swung beyond the rear drive tires or further in either direction, the Drive Orientation indicator will illuminate when the drive function is selected. This is a signal for the operator to verify that the drive control is being operated in the proper direction (i.e. controls reversed situations)



#### 5. Capacity Zone Indicator

Indicates the platform capacity zone for the current position of the platform. Restricted capacities are permitted at restricted platform positions (shorter boom lengths and higher boom angles).

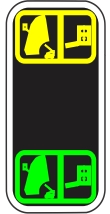

**NOTE:** Refer to the capacity decals on the machine for restricted and unrestricted platform capacities.

## SECTION 3 - MACHINE CONTROLS AND INDICATORS

### 6. Tilt Warning Light and Alarm Indicator



This red illuminator indicates that the chassis is on a slope. If the boom is above horizontal and the machine is on a slope, the tilt alarm warning light will illuminate, an alarm will sound, available functions are placed in Creep speed, and drive is cut out in direction of travel. Drive in the opposite direction may be allowed under certain conditions.

| Tilt Angle | Market      |
|------------|-------------|
| 4°         | All Markets |

#### **⚠ WARNING**

**IF TILT WARNING LIGHT IS ILLUMINATED WHEN BOOM IS RAISED OR EXTENDED, RETRACT AND LOWER TO BELOW HORIZONTAL THEN REPOSITION MACHINE SO THAT IT IS WITHIN THE LIMITS OF THE MAXIMUM OPERATING SLOPE BEFORE EXTENDING BOOM OR RAISING BOOM ABOVE HORIZONTAL.**

### 7. Creep Speed Indicator



When the Function Speed Control is turned to the creep position, the indicator acts as a reminder that all functions are set to the slowest speed.

### 8. Footswitch/Enable Indicator



To operate any function, the footswitch must be depressed and the function selected within seven seconds. The enable indicator shows that the controls are enabled. If a function is not selected within seven seconds, or if a seven second lapse between ending one function and beginning the next function, the enable light will go out and the footswitch must be released and depressed again to enable the controls.

Releasing the footswitch removes power from all controls and applies the drive brakes.

#### **⚠ WARNING**

**TO AVOID SERIOUS INJURY, DO NOT REMOVE, MODIFY OR DISABLE THE FOOTSWITCH BY BLOCKING OR ANY OTHER MEANS.**

### 9. Glow Plug Indicator



Indicates the glow plugs are on. The glow plugs are automatically turned on with the ignition circuit and remain on for approximately seven seconds. Start the engine only after the light goes out.



### 10. Boom Malfunction Indicator



When an audible alarm sounds and the Boom Malfunction Indicator illuminates when attempting to activate a tower boom function, the function is being cutout by tower boom limit switch. This function is not permitted at the current boom configuration.

When an audible alarm sounds and the Boom Malfunction Indicator illuminates steady without a boom function attempt, the upright is out of alignment.

#### **⚠ WARNING**

**DISCONTINUE OPERATION IF THE UPRIGHT IS OUT OF ALIGNMENT OR THE BOOM MALFUNCTION LIGHT REMAINS ILLUMINATED.**

#### **⚠ WARNING**

**IF THE UPRIGHT IS OUT OF ALIGNMENT WITH THE PLATFORM RAISED, LOWER THE MAIN BOOM AND TELESCOPE OUT UNTIL THE PLATFORM REACHES THE GROUND. THE TOWER BOOM DOWN FUNCTION IS CUT OUT IN THIS CONDITION. REPORT THE PROBLEM TO THE PROPER SERVICE PERSONNEL. DO NOT OPERATE THE MACHINE UNTIL THE CONDITION IS CORRECTED.**

### 11. AC Generator Indicator



Indicates the generator is in operation.

### 12. Platform Overload Indicator



Indicates the platform has been overloaded.

### 13. Engine Error Indicator



Indicates a fault with the engine and service is required.

**TO PURCHASE THIS PRODUCT PLEASE CONTACT US**



**Equipment Financing and  
Extended Warranties Available**



**Discount-Equipment.com is your online resource for  
commercial and industrial quality parts and equipment sales.**

**561-964-4949**

**visit us on line @ [www.discount-equipment.com](http://www.discount-equipment.com)**

Select an option below to find your Equipment

**Search by Manufacturer**

**Search by Product Type**

**Request a Quote**

We sell worldwide for the brands: Genie, Terex, JLG, MultiQuip, Mikasa, Essick, Whiteman, Mayco, Toro Stone, Diamond Products, Generac Magnum, Airman, Haulotte, Barreto, Power Blanket, Nifty Lift, Atlas Copco, Chicago Pneumatic, Allmand, Miller Curber, Skyjack, Lull, Skytrak, Tsurumi, Husquvarna Target, Stow, Wacker, Sakai, Mi-T-M, Sullair, Basic, Dynapac, MBW, Weber, Bartell, Bennar Newman, Haulotte, Ditch Runner, Menegotti, Morrison, Contec, Buddy, Crown, Edco, Wyco, Bomag, Laymor, EZ Trench, Bil-Jax, F.S. Curtis, Gehl Pavers, Heli, Honda, ICS/PowerGrit, IHI, Partner, Imer, Clipper, MMD, Koshin, Rice, CH&E, General Equipment, Amida, Coleman, NAC, Gradall, Square Shooter, Kent, Stanley, Tamco, Toku, Hatz, Kohler, Robin, Wisconsin, Northrock, Oztec, Toker TK, Rol-Air, APT, Wylie, Ingersoll Rand / Doosan, Innovatech, Con X, Ammann, Mecalac, Makinex, Smith Surface Prep, Small Line, Wanco, Yanmar

## SECTION 4. MACHINE OPERATION

### 4.1 DESCRIPTION

This machine is a mobile elevating work platform used to position personnel, along with their necessary tools and materials at work locations.

The primary operator control station is in the platform. From this control console, the operator can drive and steer the machine in both forward and reverse directions. The operator can raise or lower the boom or swing the boom to the left or right. Standard boom swing is 360 degree continuous rotation. The machine has a Ground Control Console which will override the Platform Control Console. Ground Controls operate all functions except drive and steer. Except for performing inspections and the Function Check, the ground controls are to be used in an emergency to lower the platform to the ground should the operator in the platform be unable to do so.

### 4.2 OPERATING CHARACTERISTICS AND LIMITATIONS

#### Capacities

Raising boom above horizontal with or without any load in platform, is based on the following criteria:

1. Machine is positioned on a smooth, firm surface within the limits of the maximum operating slope.
2. Load is within manufacturer's rated capacity.
3. All machine systems are functioning properly.
4. Machine is as originally equipped from JLG

### Platform Load Sensing System (LSS)

The Platform Load Sensing System provides the platform capacity to the control system.

If the LSS system senses an overload condition, boom functions will be disabled, the overload indicator is illuminated at both control stations, and the overload alarm will sound. Reduce the weight in the platform to not exceed the rated workload indicated on the capacity decal, then the controls will work again.

### Stability

Machine stability is based on two positions which are called FORWARD STABILITY and BACKWARD STABILITY. The machine position of least forward stability is shown in Figure 4-1. and its positions of least backward stability is shown in Figure 4-2. and Figure 4-3.

#### **WARNING**

**TO AVOID FORWARD OR BACKWARD TIPPING, DO NOT OVERLOAD MACHINE OR OPERATE THE MACHINE BEYOND THE LIMIT OF THE MAXIMUM OPERATING SLOPE.**

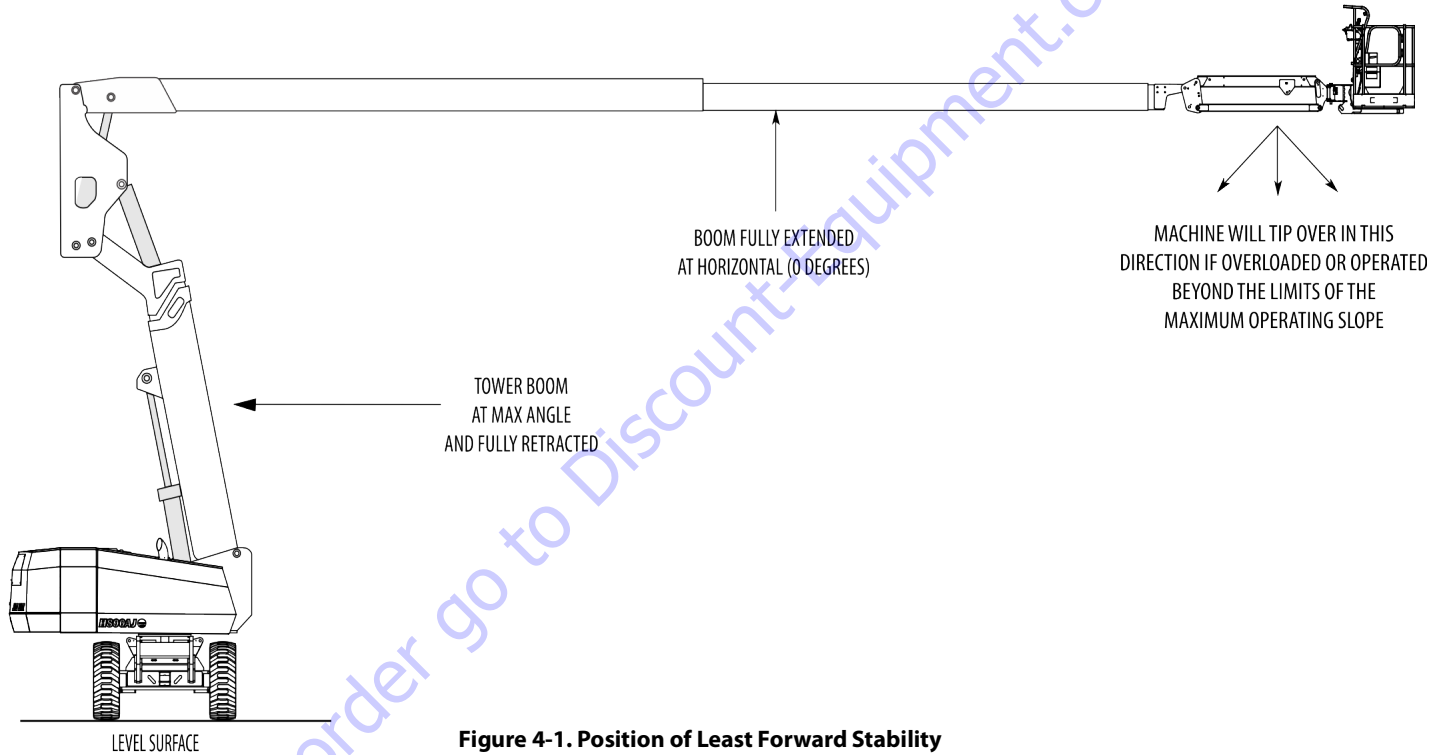
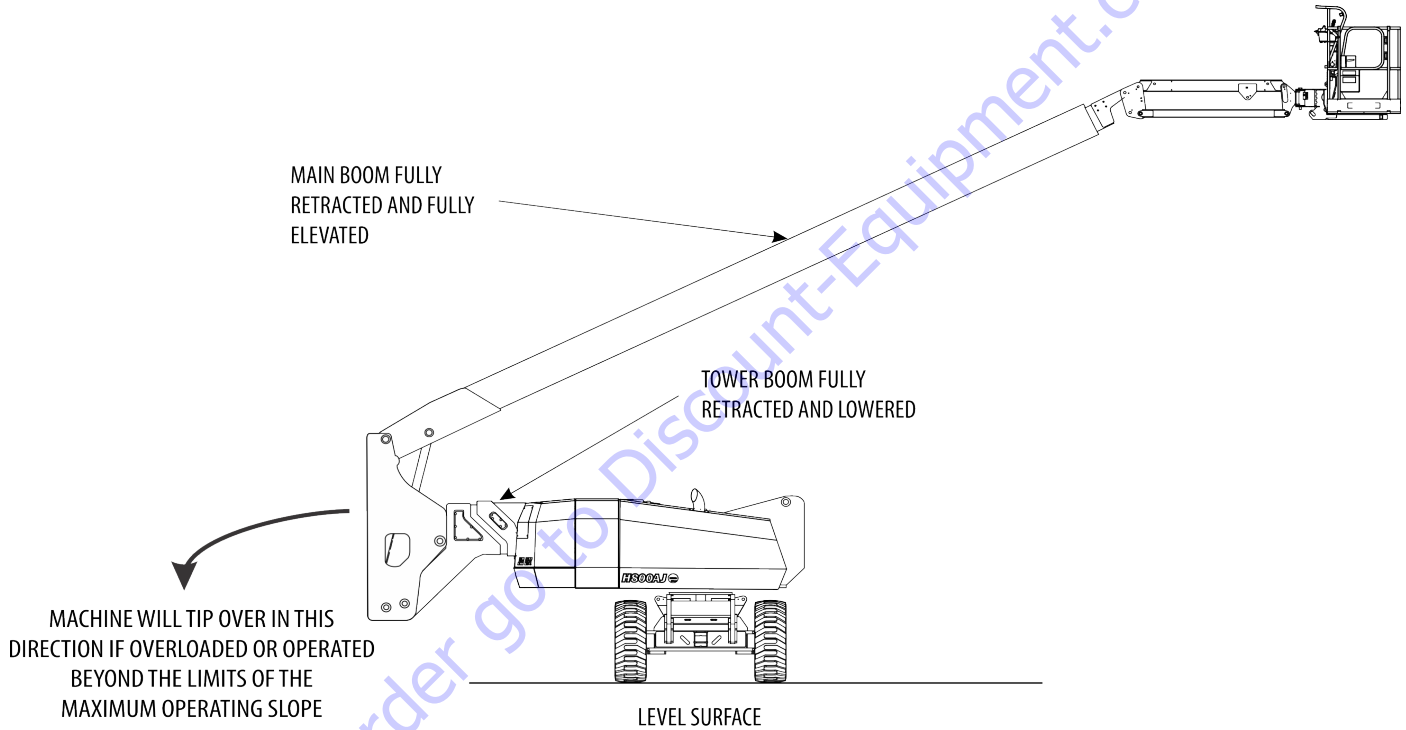

Figure 4-1. Position of Least Forward Stability



**Figure 4-2. Positions of Least Backward Stability (Sheet 1 of 2)**

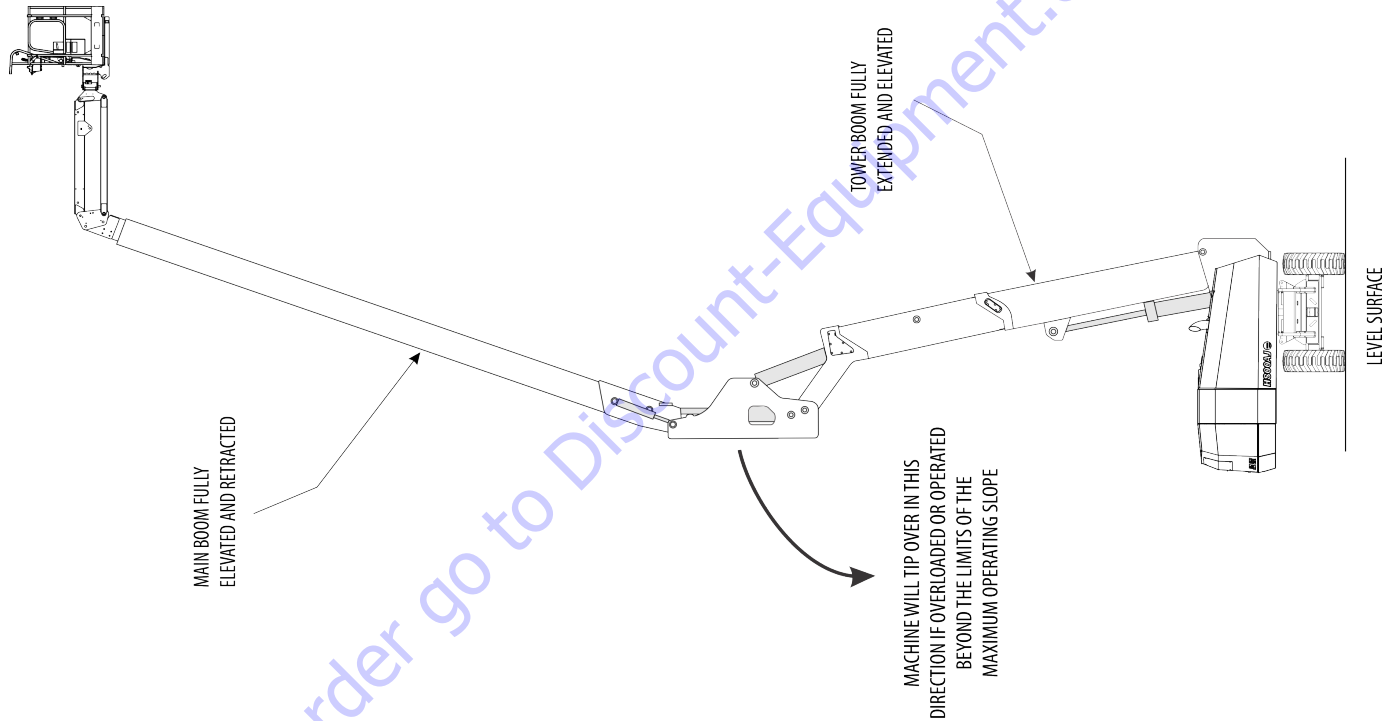

Figure 4-3. Positions of Least Backward Stability (Sheet 2 of 2)

### 4.3 ENGINE OPERATION

**NOTE:** When operating a machine at high altitudes, a decrease in machine performance may occur due to a decrease in air density.

**NOTE:** When operating a machine at high ambient temperatures, a decrease in machine performance and an increase in engine coolant temperature may occur.

**NOTE:** Contact JLG Customer Service for operation under abnormal conditions.

**NOTE:** Initial starting should always be performed from the Ground Control console.

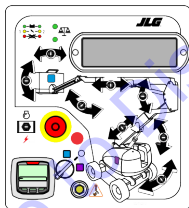

### Starting Procedure

#### **⚠ CAUTION**

**IF ENGINE FAILS TO START PROMPTLY, DO NOT CRANK FOR AN EXTENDED TIME. SHOULD ENGINE FAIL TO START AGAIN, ALLOW STARTER TO "COOL OFF" FOR 2-3 MINUTES. IF ENGINE FAILS AFTER SEVERAL ATTEMPTS, REFER TO ENGINE MAINTENANCE MANUAL.**

**NOTE:** After turning on ignition, operator must wait until glow plug indicator light goes out before cranking engine.

1. Turn key of Platform/Ground Select switch to Ground.
2. Pull the Power/Emergency Stop switch to On.
3. Push the Engine Start switch until engine starts.

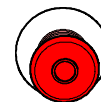



**⚠ CAUTION**

**ALLOW ENGINE TO WARM-UP FOR A FEW MINUTES AT LOW SPEED BEFORE APPLYING ANY LOAD.**

4. After engine has had sufficient time to warm up, push in the Power/Emergency Stop switch and shut engine off.

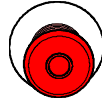

5. Turn Platform/Ground Select switch to Platform.



6. From Ground Control Console, pull Power/Emergency Stop switch out.

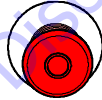

7. From Platform Control Console, pull Power/Emergency Stop switch out.

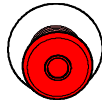

8. Push the Engine Start switch until engine starts.



**NOTE:** Footswitch must be in released (up) position before starter will operate. If starter operates with footswitch in the depressed position, DO NOT OPERATE MACHINE.

**Shutdown Procedure**

**⚠ CAUTION**

**IF AN ENGINE MALFUNCTION CAUSES AN UNSCHEDULED SHUTDOWN, DETERMINE THE CAUSE AND CORRECT IT BEFORE RESTARTING THE ENGINE.**

1. Remove all load and allow engine to operate at low speed for 3-5 minutes; this allows further reduction of internal engine temperature.
2. Push Power/Emergency Stop switch in.

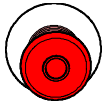

3. Turn Platform/Ground Select switch to Off.

Refer to Engine Manufacturer's manual for detailed information.



### Engine Warmup

When it is below 32°F (0°C), the clutch is disengaged from the engine when started. When engine operating temperature reaches 86°F (30°C), the Integrated Motor Generator (IMG) will spin at 1800 rpm for 10 seconds. After the 10 second period, the clutch (also spinning at 1800 rpm) will engage with the IMG.

**NOTE:** *When in Engine Warmup, after turning on ignition, operator must wait until glow plug indicator light goes out before cranking engine. As soon as the operator begins to crank the engine to start, the indicator will come on steady and an Engine Warmup DTC will be set. When the engine reaches an operating temperature of 86°F (30°C) and the clutch engages, the light will go out and the DTC will go away.*



### 4.3 POWERTRAIN OPERATING MODES

The powertrain system consists of the engine, clutch, Integrated Motor Generator (IMG), and hydraulic pumps. When the clutch is engaged, the diesel engine power transmits through the clutch to the shaft of the IMG, then to the hydraulic pumps.

There are two operation modes for the powertrain system – HYBRID Mode and ELECTRIC Mode. These modes can be selected through the Engine Start/Mode Select switch.

#### HYBRID Mode

Under this mode, the engine is started with engine start switch. Once started, the engine runs continually until either the Power/Emergency Stop is pressed down, or the mode selection switch is flipped to ELECTRIC Mode position. The clutch is engaged under this mode so engine, clutch, IMG, hydraulic pump turn at the same RPM.

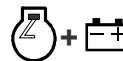

The engine drives the IMG to generate electricity to charge the battery pack and also drive the hydraulic pumps to provide energy needed to operate boom functions and drive functions.

Some functions need additional power provided by the IMG to achieve maximum performance. The Hybrid Electric Control system can sense if the engine power is enough to operate the commanded function. The IMG will then utilize stored energy from the batteries to provide the additional power required for that function.

The IMG does not do any charging if a function is active or if SkyPower is turned on.

The engine will run continuously until stopped whether it is being used for charging or not.

## **ELECTRIC Mode**

In Electric mode, the engine does not run and the clutch is disengaged. The machine operates all functions using battery power only to drive the IMG, which in turn drives the hydraulic pumps.

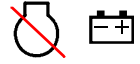

If operated in this mode until the battery stack State of Charge (SOC) reaches a Discharged state, the Low Battery indicator will warn the operator that HYBRID mode must be reactivated or the battery charger plugged into an external AC source. If the operation of the machine continues, the machine will eventually reach a Deeply Discharged state (Approximately 10% SOC). In this condition, all functions are cut back in speed. In the event the battery stack is not recharged after the warning indicators are illuminated and the machine is stored, the Low Battery warning indicator will resume flashing after the Emergency Stop is reset.

### Switching Between Modes

If the selection switch is changed from HYBRID Mode to ELECTRIC Mode position while the engine is running, the clutch will disengage and the engine will stop automatically. The operator can continue operation under ELECTRIC Mode after the footswitch is recycled.

If the selection switch is changed from ELECTRIC Mode to HYBRID Mode position, the machine will engage the clutch. The operator must release the foot switch and press the HYBRID/ELECTRIC Mode Switch into the Engine Start position to start the engine. If the switch is in the HYBRID mode position and the engine is not running, the machine will not operate and will notify the operator with an alarm.

**NOTE:** *When switching between modes, there is a momentary transition period for clutch engagement/disengagement.*

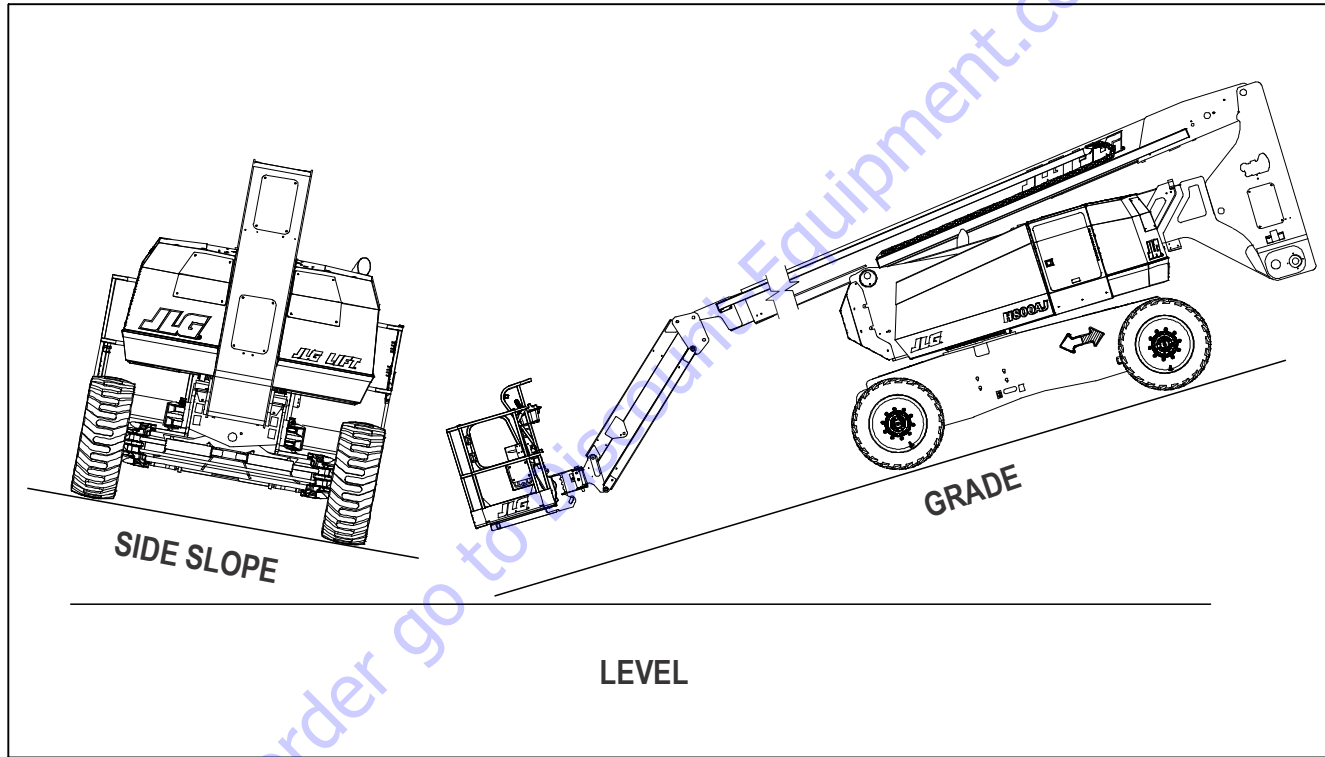

Figure 4-4. Grade and Sideslopes

## SECTION 4 - MACHINE OPERATION

### 4.4 TRAVELING (DRIVING)

See Figure 4-4., Grade and Sideslopes

**NOTE:** Refer to the Operating Specifications table for Gradeability and Sideslope ratings.

All ratings for Gradeability and Sideslope are based upon the machine's boom being in the stowed position, fully lowered, and retracted.

Traveling is limited by two factors:

1. Gradeability, which is the percent of grade of the incline the machine can climb.
2. Sideslope, which is the angle of the slope the machine can be driven across.

#### **⚠ WARNING**

**DO NOT DRIVE THE MEWP OUT OF TRANSPORT MODE EXCEPT ON A SMOOTH, FIRM SURFACE WITHIN THE LIMITS OF THE MAXIMUM OPERATING SLOPE.**

**TO AVOID LOSS OF TRAVEL CONTROL OR TIP OVER, DO NOT DRIVE MACHINE ON GRADES EXCEEDING THOSE SPECIFIED IN THE OPERATING SPECIFICATIONS SECTION OF THIS MANUAL.**

**BE SURE THE TURNABLE LOCK IS ENGAGED BEFORE ANY EXTENDED TRAVELING.**

**DO NOT DRIVE ON SIDESLOPES WHICH EXCEED 4 DEGREES.**

**USE EXTREME CAUTION WHEN DRIVING IN REVERSE AND AT ALL TIMES WHEN THE PLATFORM IS ELEVATED.**

**BEFORE DRIVING, MAKE SURE BOOM IS POSITIONED OVER REAR DRIVE AXLE. IF BOOM IS OVER FRONT WHEELS, STEER AND DRIVE CONTROLS WILL BE REVERSED. LOCATE THE BLACK/WHITE ORIENTATION ARROWS ON BOTH THE CHASSIS AND THE PLATFORM CONTROLS. MOVE THE DRIVE CONTROLS IN A DIRECTION MATCHING THE DIRECTIONAL ARROWS FOR THE INTENDED DIRECTION OF TRAVEL.**

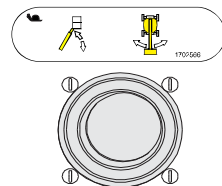
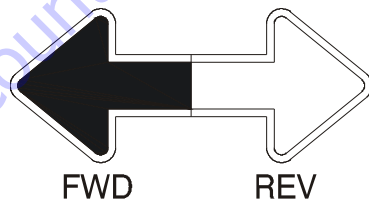

## Traveling Forward and Reverse

1. At Platform Controls, pull out Emergency Stop switch and activate footswitch.

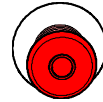

2. Position Drive controller to FORWARD or REVERSE as desired.

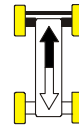

This machine is equipped with a Drive Orientation Indicator. The yellow light on the platform control console indicates that the boom is swung beyond the rear drive tires and the machine may Drive/Steer in the opposite direction from the movement of the controls. If the indicator is illuminated, operate the Drive function in the following manner:

1. Match the black and white direction arrows on both platform control panel and the chassis to determine the direction the machine will travel.

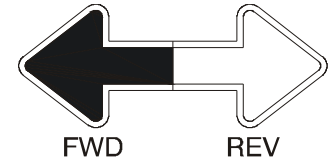

2. Push and release the Drive Orientation Override switch. Within 3 seconds, slowly move the Drive control toward the arrow matching the intended direction of machine travel. The indicator light will flash during the 3 second interval until the drive function is selected.



### Traveling on a Grade

When traveling a grade, maximum braking and traction are obtained with the boom stowed, in position over the rear (drive) axle, and in line with the direction of travel. Drive the machine forward when climbing a grade, and in reverse when descending a grade. Do not exceed the machine's maximum rated gradability.

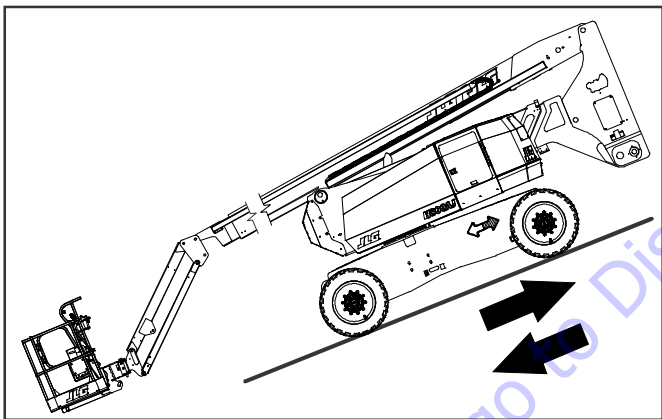

Figure 4-5. Traveling on a Grade

#### NOTICE

IF THE BOOM IS OVER THE FRONT (STEER) AXLE, DIRECTION OF STEER AND DRIVE MOVEMENT WILL BE OPPOSITE FROM THE MOVEMENT OF THE CONTROLS.

### 4.4 STEERING

Position thumb switch on Drive/Steer controller to Right for steering right, or to Left for steering left.



### 4.5 PLATFORM

#### Platform Level Adjustment

#### ⚠ WARNING

ONLY USE THE PLATFORM LEVELING OVERRIDE FUNCTION FOR SLIGHT LEVELING OF THE PLATFORM. INCORRECT USE COULD CAUSE THE LOAD/OCCUPANTS TO SHIFT OR FALL. FAILURE TO DO SO COULD RESULT IN DEATH OR SERIOUS INJURY.

To Level Up or Down - Position the Platform/Level control switch Up or Down and hold until the platform is level.

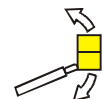

#### Platform Rotation

To rotate the platform to the left or right, use the Platform Rotate control switch to select the direction and hold until the platform is level.





## 4.6 BOOM

### **⚠ WARNING**

A RED TILT WARNING LIGHT IS LOCATED ON THE PLATFORM CONTROL INDICATOR PANEL WHICH LIGHTS WHEN THE CHASSIS IS ON AN EXCESSIVE SLOPE. DO NOT SWING OR RAISE BOOM ABOVE HORIZONTAL WHEN INDICATOR IS LIT.

DO NOT DEPEND ON THE TILT WARNING LIGHT AS A LEVEL INDICATOR FOR THE CHASSIS. THE TILT WARNING LIGHT INDICATES CHASSIS IS ON AN EXCESSIVE SLOPE (4 DEGREES OR GREATER). CHASSIS MUST BE LEVEL BEFORE SWINGING OR RAISING BOOM ABOVE HORIZONTAL OR DRIVING WITH THE BOOM ELEVATED.

TO AVOID TIP OVER IF RED TILT WARNING LIGHT LIGHTS WHEN THE BOOM IS RAISED ABOVE HORIZONTAL, LOWER PLATFORM TO GROUND LEVEL. THEN REPOSITION MACHINE SO THAT CHASSIS IS LEVEL BEFORE RAISING BOOM.

IF THE PLATFORM DOES NOT STOP WHEN A CONTROL SWITCH OR LEVER IS RELEASED, REMOVE FOOT FROM FOOTSWITCH OR USE EMERGENCY STOP SWITCH TO STOP THE MACHINE.

### **⚠ WARNING**

TO AVOID SERIOUS INJURY, DO NOT OPERATE MACHINE IF ANY CONTROL LEVER OR TOGGLE SWITCH CONTROLLING PLATFORM MOVEMENT DOES NOT RETURN TO THE 'OFF' OR NEUTRAL POSITION WHEN RELEASED.

### **⚠ CAUTION**

TO AVOID A COLLISION AND INJURY IF PLATFORM DOES NOT STOP WHEN A CONTROL SWITCH OR LEVER IS RELEASED, REMOVE FOOT FROM FOOTSWITCH OR USE EMERGENCY STOP TO STOP THE MACHINE.

### Swinging the Boom

To swing boom, use Swing control switch to select Right or Left direction.



### **NOTICE**

WHEN SWINGING THE BOOM MAKE SURE THERE IS AMPLE ROOM FOR THE BOOM TO CLEAR SURROUNDING WALLS, PARTITIONS AND EQUIPMENT.

**NOTE:** On CE Market machines, when boom functions are being operated there is an interlock that prevents the use of Drive and Steer functions.

### Raising and Lowering the Tower Boom

This machine has two controls for the tower boom (two toggle switches), one controls tower lift, the other tower telescope. The switching system will sequence its Lift and Telescope functions as follows:

## SECTION 4 - MACHINE OPERATION

1. Sequence while raising the Tower Boom from the fully lowered position.

- a. The Tower Boom must be fully elevated Up (approximately 12 degrees from vertical) before the Tower Boom can be extended from the fully retracted position.

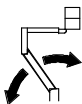

- b. The Tower Telescope Out or In will only be operable when the Tower Boom is fully elevated Up.

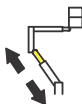

2. Sequence while lowering the Tower Boom from the fully elevated Up position.

- a. Operate Tower Telescope In until Tower Boom is fully retracted. (Tower must not lift down until boom is telescoped In or Up fully.)



- b. The Tower lift Down will only operate when the Tower Boom is fully retracted.

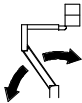

### **⚠ WARNING**

**TO AVOID TILTING THE MACHINE WHILE TOWER BOOM SWITCHING MALFUNCTIONS:**

**LOWER PLATFORM TO GROUND USING MAIN BOOM LIFT AND TELESCOPE FUNCTIONS. HAVE CONDITION CORRECTED BY A QUALIFIED JLG MECHANIC BEFORE CONTINUING USE OF MACHINE.**

### **⚠ WARNING**

**DISCONTINUE OPERATION IF THE UPRIGHT IS OUT OF ALIGNMENT OR THE BOOM MALFUNCTION LIGHT REMAINS ILLUMINATED.**

### **NOTICE**

**IF THE UPRIGHT IS OUT OF ALIGNMENT WITH THE PLATFORM RAISED, LOWER THE MAIN BOOM AND TELESCOPE OUT UNTIL THE PLATFORM REACHES THE GROUND. THE TOWER BOOM DOWN FUNCTION IS CUT OUT IN THIS CONDITION. REPORT THE PROBLEM TO THE PROPER SERVICE PERSONNEL. DO NOT OPERATE THE MACHINE UNTIL THE CONDITION IS CORRECTED.**

## Raising and Lowering the Main Boom

To raise or lower the Main Boom, position the Main Boom Lift switch to Up or Down until the desired height is reached.



## Telescoping the Main Boom

To extend or retract the main boom, use the Main Telescope Control Switch to select In or Out movement.

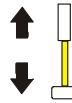

## 4.5 BATTERY CHARGING

The machine incorporates two battery chargers (primary and a secondary) which operate on 220V or 110V. Both chargers operate initially and the primary does the finish charging. 220V charging is the preferred voltage for charging the batteries.

**NOTE:** *The most efficient way to charge the batteries is by running the diesel engine during operation.*

### NOTICE

**IF CHARGING THE MACHINE USING STANDARD 110V 15A OR 20A OUTLETS, EACH CHARGER MUST BE PLUGGED INTO A SEPARATE CIRCUIT. FOR EXAMPLE, EACH OUTLET USED TO PLUG EACH CHARGER INTO MUST BE CONTROLLED BY AN INDIVIDUAL CIRCUIT BREAKER IN THE ELECTRICAL SERVICE PANEL. THE CHARGERS CANNOT BOTH**

**BE PLUGGED INTO MULTIPLE OUTLETS CONTROLLED BY ONLY ONE CIRCUIT BREAKER. IF USING 220V TO CHARGE, A STANDARD 220V 15A CIRCUIT MAY BE USED.**

**NOTE:** *When the battery chargers are plugged in, no machine functions can be performed. DTCs will be set if a function is attempted when the chargers are plugged in.*

**NOTE:** *Be sure that machine is parked in a well ventilated area before charging begins.*

### CAUTION

**ONLY PLUG THE CHARGER INTO A PROPERLY INSTALLED AND GROUNDED OUTLET. DO NOT USE GROUND ADAPTORS OR MODIFY PLUG. DO NOT TOUCH NON-INSULATED PORTION OF OUTPUT CONNECTOR OR NON-INSULATED BATTERY TERMINAL. DO NOT OPERATE CHARGER IF THE AC SUPPLY CORD IS DAMAGED OR IF THE CHARGER HAS BEEN DAMAGED IN ANY WAY.**

1. The battery charger AC input plug(s) is/are located near the ground control console.
2. Connect the charger AC input plug to a grounded outlet using a 3 wire heavy duty extension cord.
3. After connecting the charger to an AC outlet at the start of the charging cycle, check the Charger Status and Battery Balance indicators on the Ground Control console.

### 4.9 MACHINE SAFETY SYSTEM OVERRIDE (MSSO) (CE ONLY)

The Machine Safety System Override (MSSO) is used to override function controls for Emergency Platform Retrieval only. Refer to Section 5.5, MACHINE SAFETY SYSTEM OVERRIDE (MSSO) (CE ONLY) for operating procedures.



### 4.10 SKYGUARD OPERATION

SkyGuard provides enhanced control panel protection. When the SkyGuard sensor is activated, functions in use at the time of actuation will reverse or cutout. The SkyGuard Function Table provides more details on these functions.

During activation, the horn will sound and, if equipped with a SkyGuard beacon, the beacon will illuminate until sensor and footswitch are disengaged.

If the SkyGuard sensor remains activated after function reversal or cutout, depress and hold the SkyGuard Override Switch to allow normal functions until the sensor is disengaged.

Consult the following illustrations to determine which type of SkyGuard the machine has and how it is activated. Regardless of type, SkyGuard function according to the SkyGuard Function Table does not change.

### SkyGuard

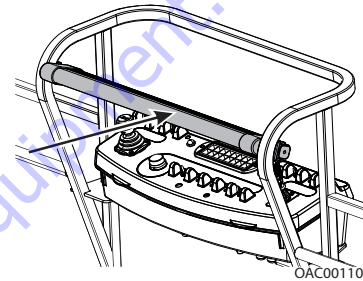

Approximately 50 lb (222 Nm) of force applied to yellow bar.

### SkyGuard - SkyLine

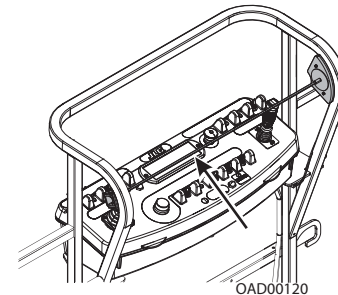

Cable is pressed, breaking the magnetic connection between the cable and right bracket.

Reattach magnetic end of cable to bracket if it becomes disconnected.

**SkyGuard - SkyEye**

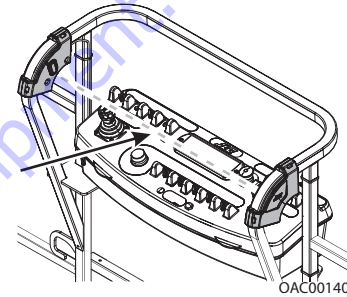
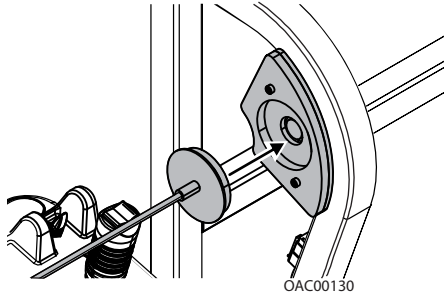

Operator passes through path of sensor beam.

**Table 4-1. SkyGuard Function Table**

| Drive Fwd                                                                                                                                                 | Drive Rev | Steer | Swing | Tower Lift Up | Tower Tele Out | Tower Lift Down | Tower Tele In | Boom Lift Up | Boom Lift Down | Boom Tele Out | Boom Tele In | Jib Lift | Basket Level | Basket Rotate |
|-----------------------------------------------------------------------------------------------------------------------------------------------------------|-----------|-------|-------|---------------|----------------|-----------------|---------------|--------------|----------------|---------------|--------------|----------|--------------|---------------|
| R*/C**                                                                                                                                                    | R         | C     | R     | R             | C              | C               | C             | R            | R              | R             | C            | C        | C            | C             |
| R = Indicates Reversal is Activated                                                                                                                       |           |       |       |               |                |                 |               |              |                |               |              |          |              |               |
| C = Indicates Cutout is Activated                                                                                                                         |           |       |       |               |                |                 |               |              |                |               |              |          |              |               |
| * If SkyGuard has been activated before Soft Touch the function will reverse, if Soft Touch has been activated before SkyGuard the function will cut out. |           |       |       |               |                |                 |               |              |                |               |              |          |              |               |

### 4.7 SHUT DOWN AND PARK

To shut down and park the machine, the procedures are as follows:

1. Drive machine to a reasonably well protected area.
2. Ensure boom is fully retracted and lowered over rear axle.
3. Shut down Emergency Stop at Platform Controls.
4. Shut down Emergency Stop at Ground Controls. Position Platform/Ground Select switch to center Off (center position).
5. If necessary, cover Platform Controls to protect instruction placards, warning decals, and operating controls from hostile environment.

#### **NOTICE**

**IF PARKING A MEWP WITH THE BOOM ELEVATED IN AN EFFORT TO CONSERVE SPACE, BOOMS MAY BE ELEVATED, BUT SHALL NOT BE EXTENDED. IT IS THE OPERATOR'S RESPONSIBILITY TO ENSURE ALL SAFETY PRECAUTIONS IN SECTION 1 OF THIS MANUAL ARE FOLLOWED FOR EACH UNIQUE SITUATION.**

### 4.11 LIFTING AND TIE DOWN

*See Figure 4-6.*

#### **Lifting**

1. Refer to the Serial Number Plate, refer to the Specifications section of this manual, or weigh the individual unit to find out the Gross Vehicle Weight.
2. Place the boom in the stowed position with the turntable locked.
3. Remove all loose items from the machine.
4. Attach lifting device and equipment only to the designated lifting points.
5. Properly adjust the rigging to prevent damage to the machine and so the machine remains level.

## Tie Down

### **NOTICE**

**WHEN TRANSPORTING THE MACHINE, THE BOOM MUST BE FULLY LOWERED INTO THE BOOM REST.**

**NOTE:** *Putting the platform in certain positions for transporting may cause an LSS activation that restricts normal boom functions. Use of the MSSO will result in a MSSO fault.*

1. Place the boom in the stowed position with the turntable locked.
2. Remove all loose items from the machine.
3. Secure the chassis and the platform using straps or chains of adequate strength and attached to the designated tie down points.

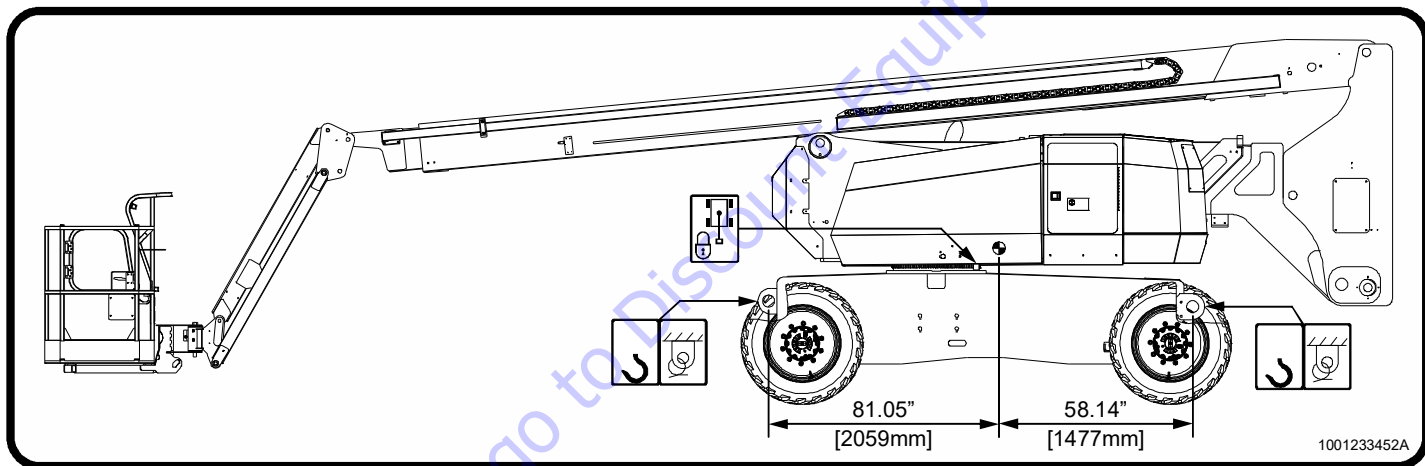

Figure 4-6. Lifting Chart



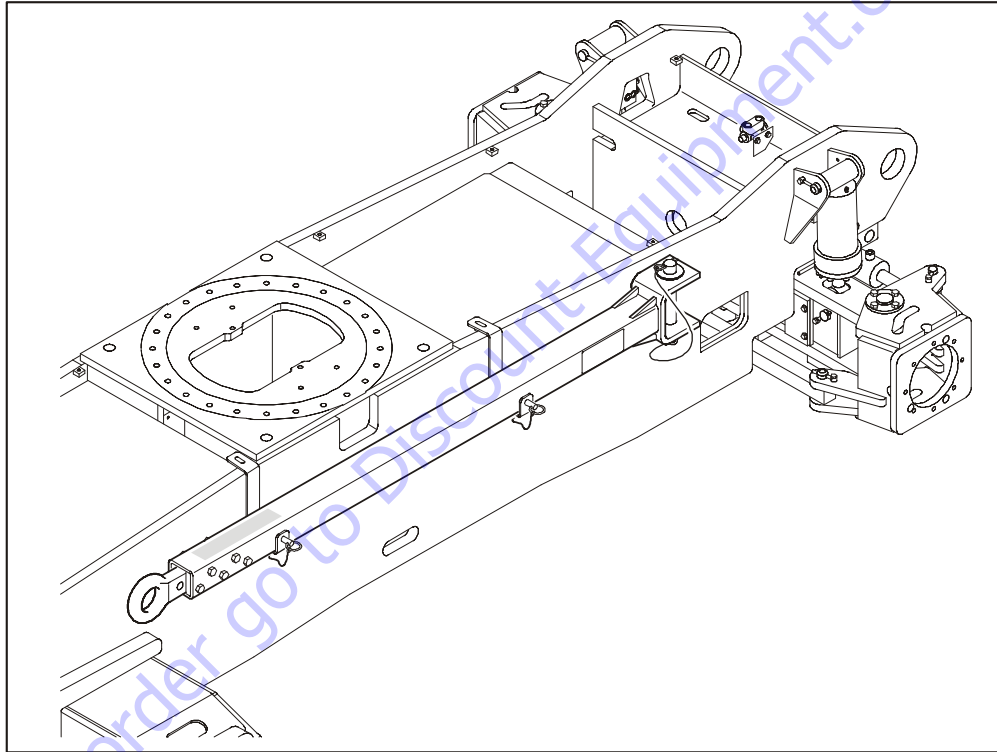

Figure 4-7. Tow Bar

## SECTION 4 - MACHINE OPERATION

### 4.8 TOWING

The machine is not equipped with a tow package. Refer to Section 5 for emergency towing procedures.

### 4.9 TOW BAR (IF EQUIPPED)

#### WARNING

**RUNAWAY VEHICLE/MACHINE HAZARD. MACHINE HAS NO TOWING BRAKES. TOWING VEHICLE MUST BE ABLE TO CONTROL MACHINE AT ALL TIMES. ON-HIGHWAY TOWING NOT PERMITTED. FAILURE TO FOLLOW INSTRUCTIONS COULD CAUSE SERIOUS INJURY OR DEATH.**

MAXIMUM TOWING SPEED 5 MPH (8 KM/H)

MAXIMUM TOWING GRADE 25%.

#### CAUTION

**DO NOT TOW MACHINE WITH ENGINE OPERATING OR DRIVE HUBS ENGAGED.**

**Prior to towing the machine, complete the following:**

1. Retract, lower and position boom in travel position; lock turntable.
2. Lower tow bar and connect to towing vehicle

3. Disconnect drive hubs by inverting disconnect cap.
4. Position steer/tow selector valve for towing; pull valve knob out for towing. The machine is now in the towing mode.

**After towing the machine, complete the following:**

1. Actuate steer/tow selector valve for steering; push valve knob in to the actuated position.
2. Reconnect drive hubs by inverting disconnect cap.
3. Disconnect tow bar from towing vehicle and place it in the stowed position as shown in Figure 4-7. The machine is now in the driving mode.

### 4.10 RE-SYNCHRONIZE UPRIGHT

#### Releveling Valve

A pull type control valve allows the operator to adjust the upright level cylinder if the upright is not 90° (vertical) relative to the chassis (Refer to Figure 2.9 and Figure 2.10). This valve is located in the tank compartment area.

Perform the following steps with the aid of an assistant:

1. Turn the key switch to the ground control position.



2. Start the engine.



3. Pull and hold the red releval knob located next to the main control valve. Refer to Figure 4-8.

4. Raise the tower boom 6 feet (1.8 m).

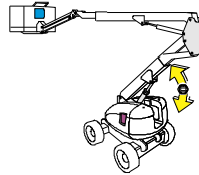

5. Release the red releval knob.

6. Lower the tower boom fully and continue to hold down the switch to Tower Down for an additional 20 seconds.

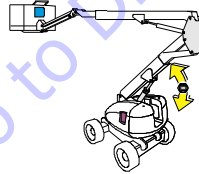

7. Repeat steps 3 thru 6 as necessary until the upright is 90° (vertical) relative to the chassis.

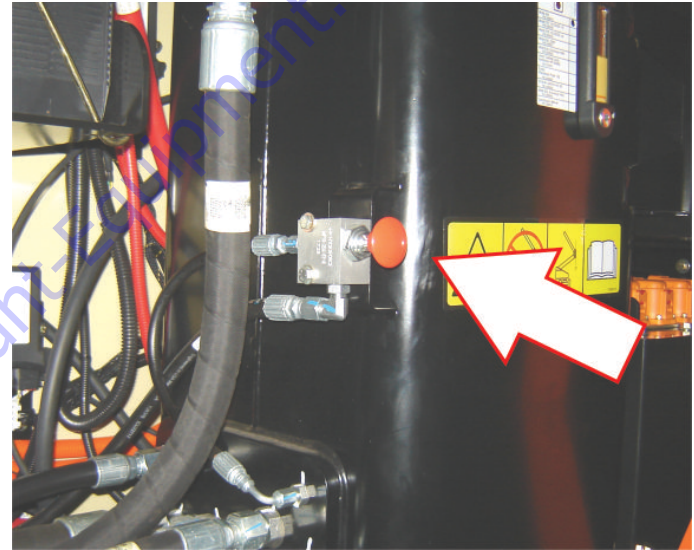

**Figure 4-8. Releveling Valve**

## SECTION 4 - MACHINE OPERATION

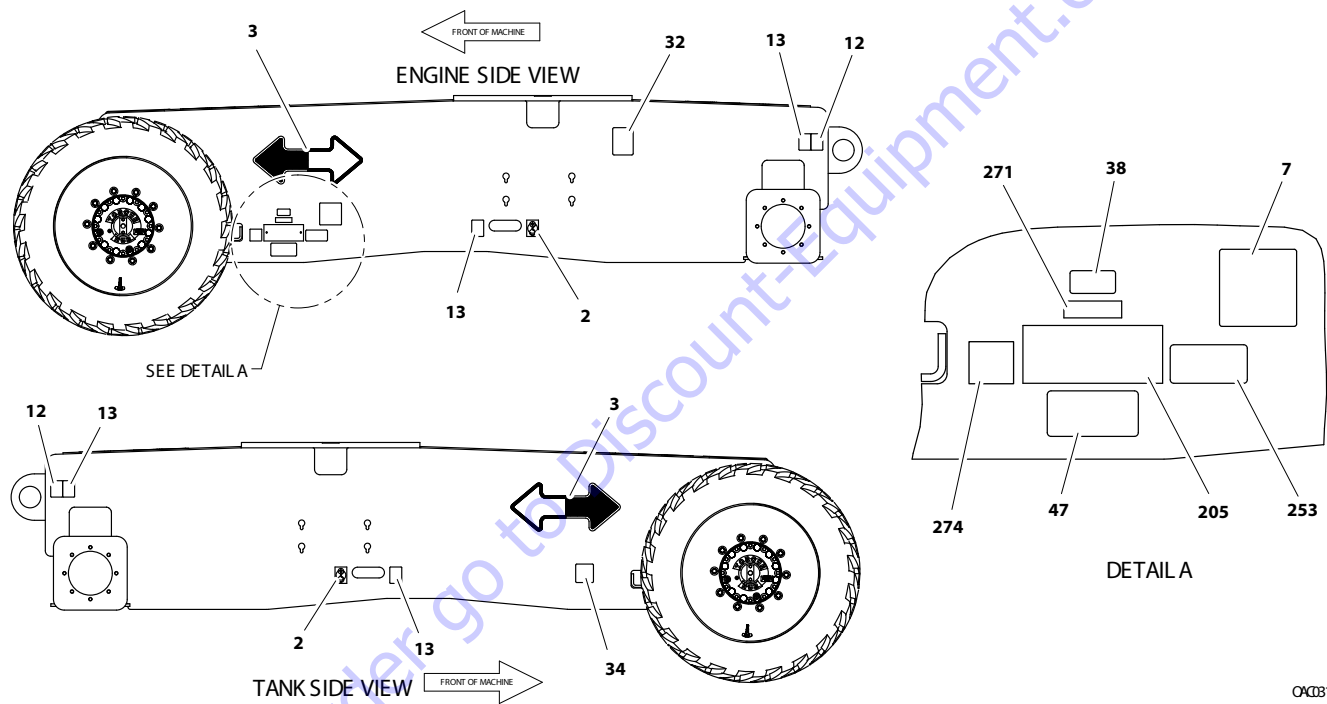

Figure 4-9. Decal Installation - Sheet 1 of 11

OXCB130

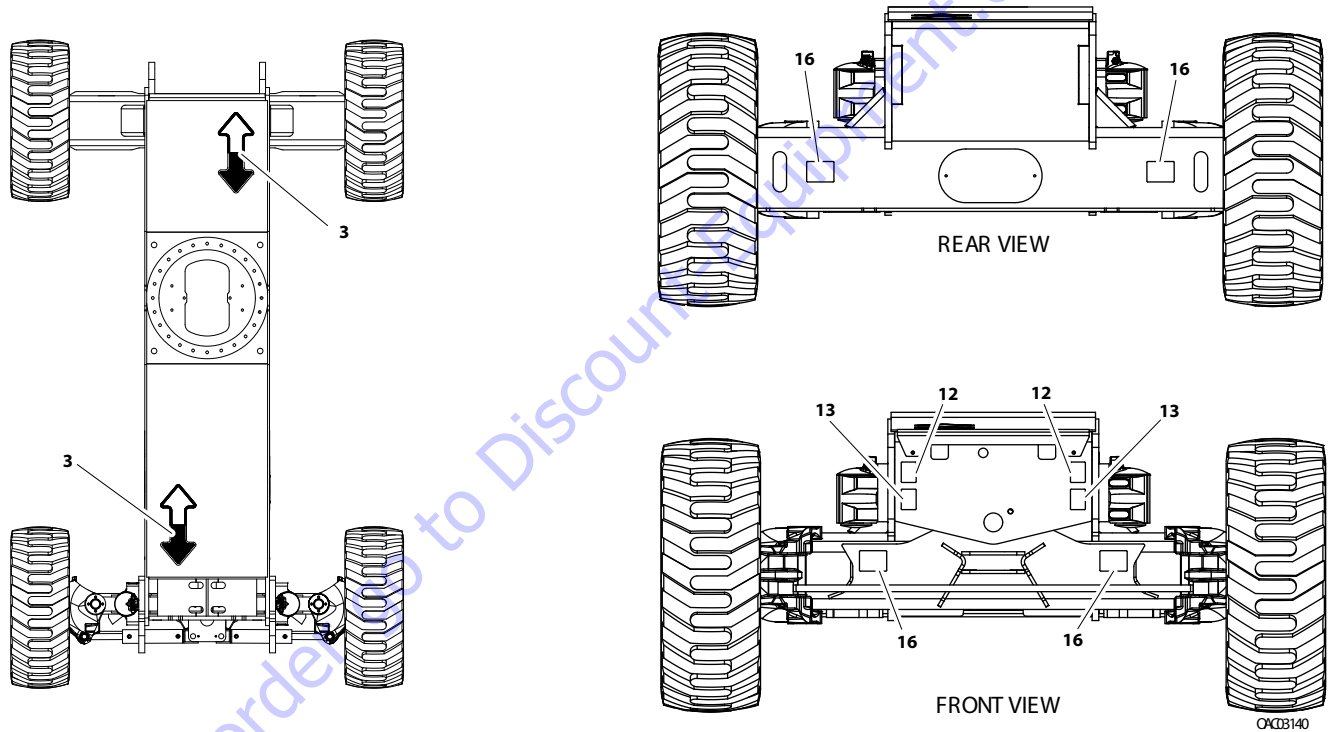

Figure 4-10. Decal Installation - Sheet 2 of 11

## SECTION 4 - MACHINE OPERATION

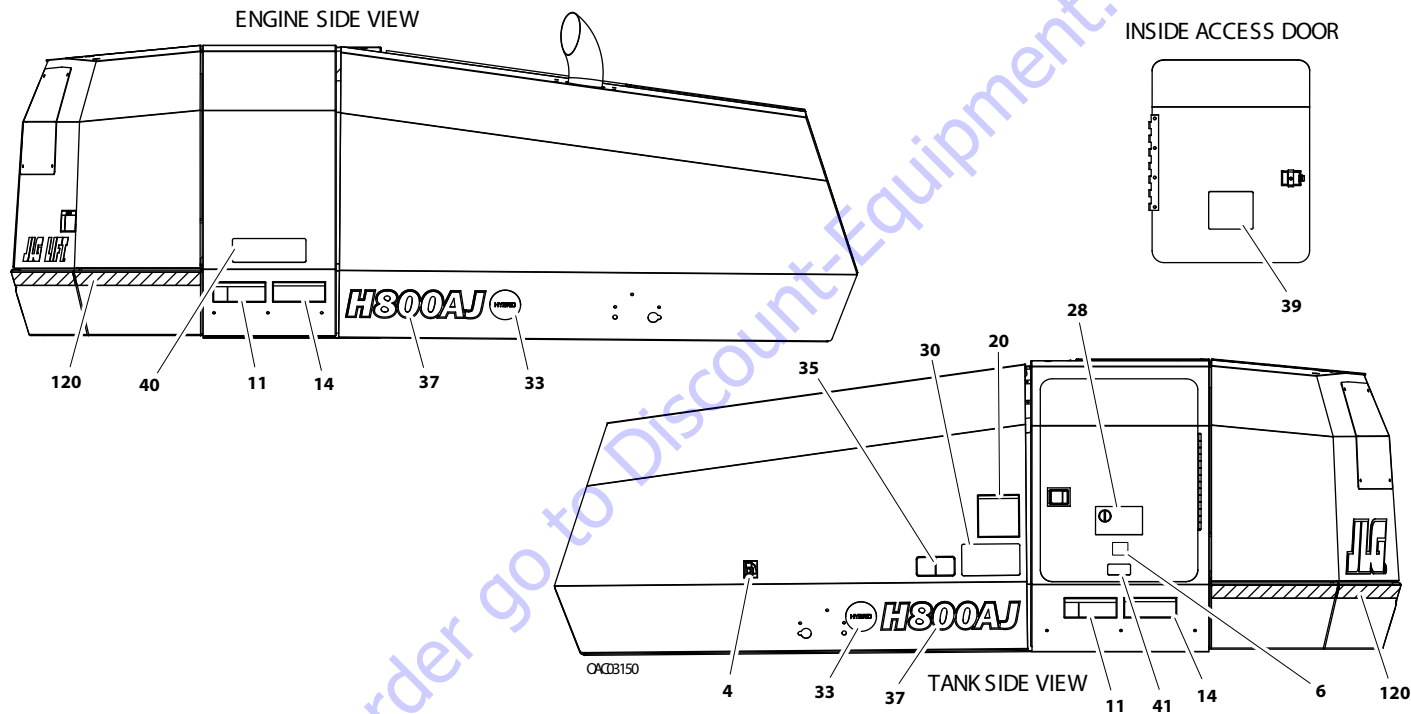

Figure 4-11. Decal Installation - Sheet 3 of 11

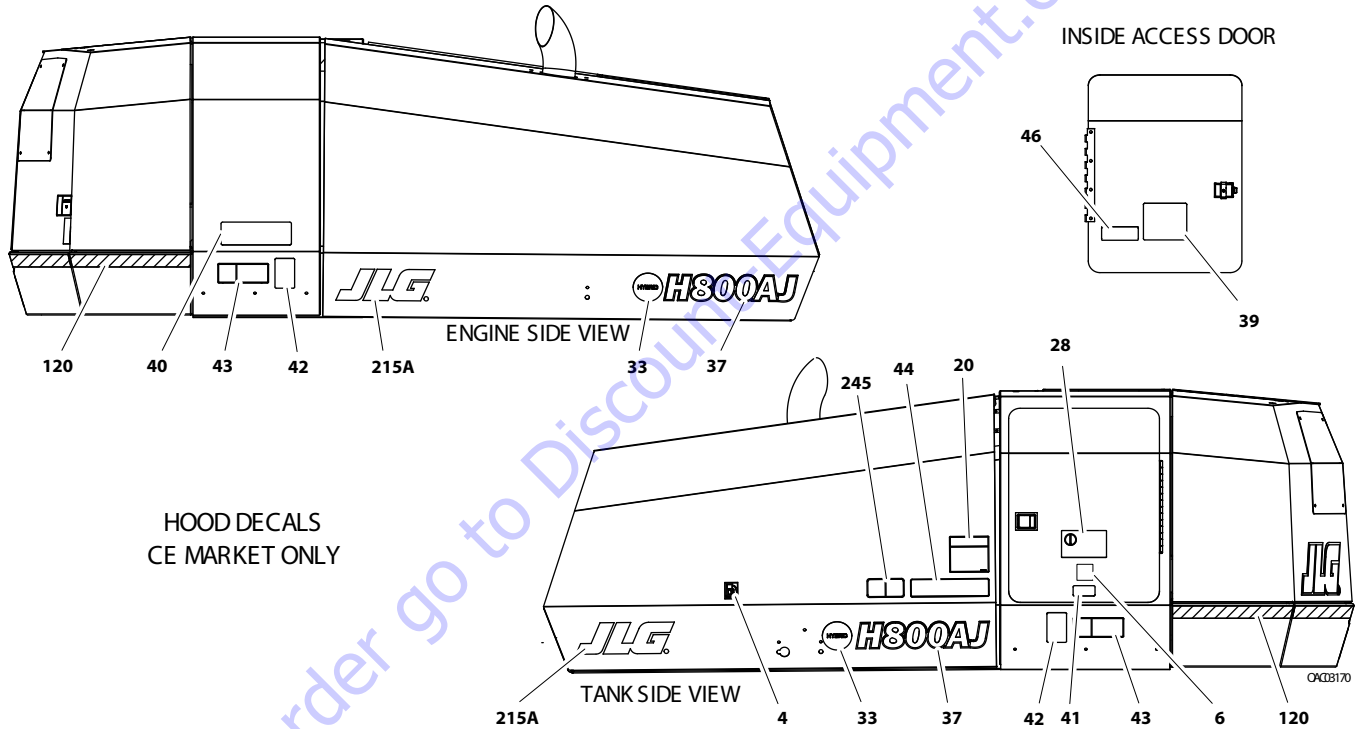
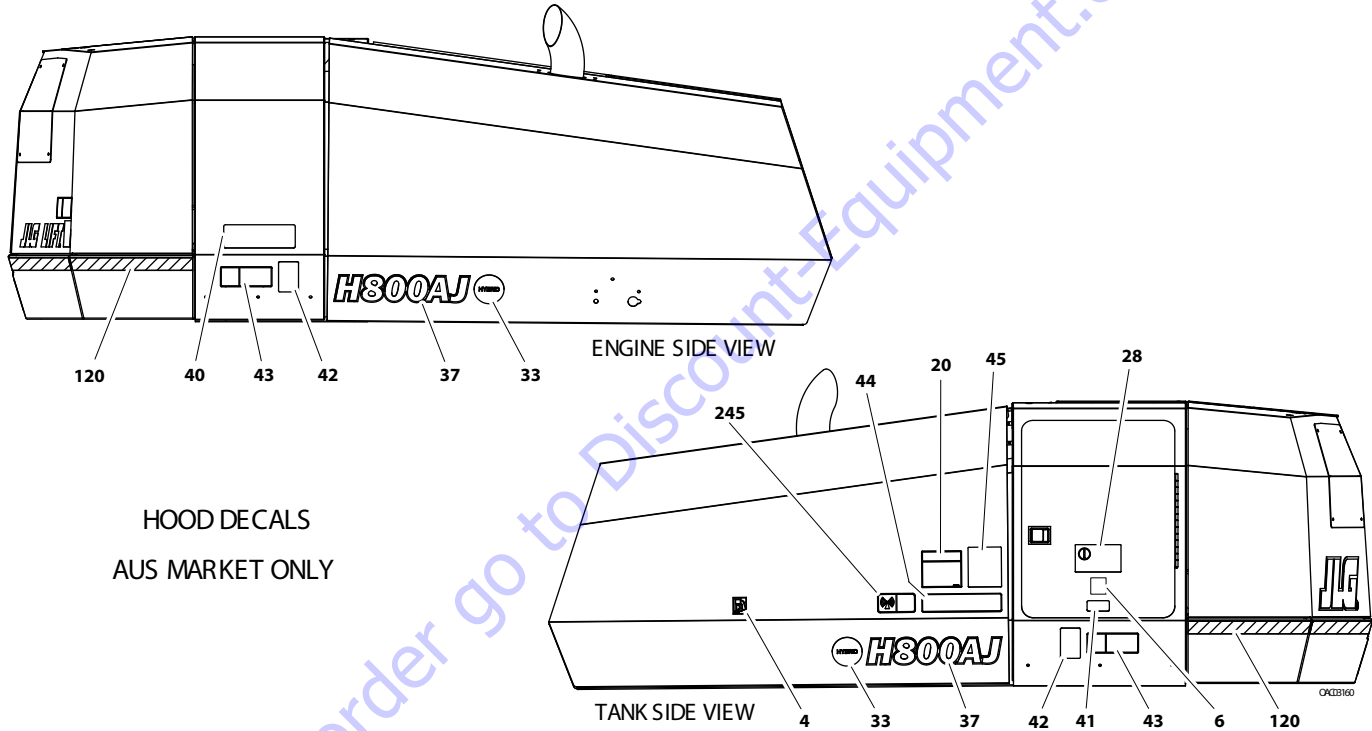

Figure 4-12. Decal Installation - Sheet 4 of 11

**SECTION 4 - MACHINE OPERATION**



**Figure 4-13. Decal Installation - Sheet 5 of 11**



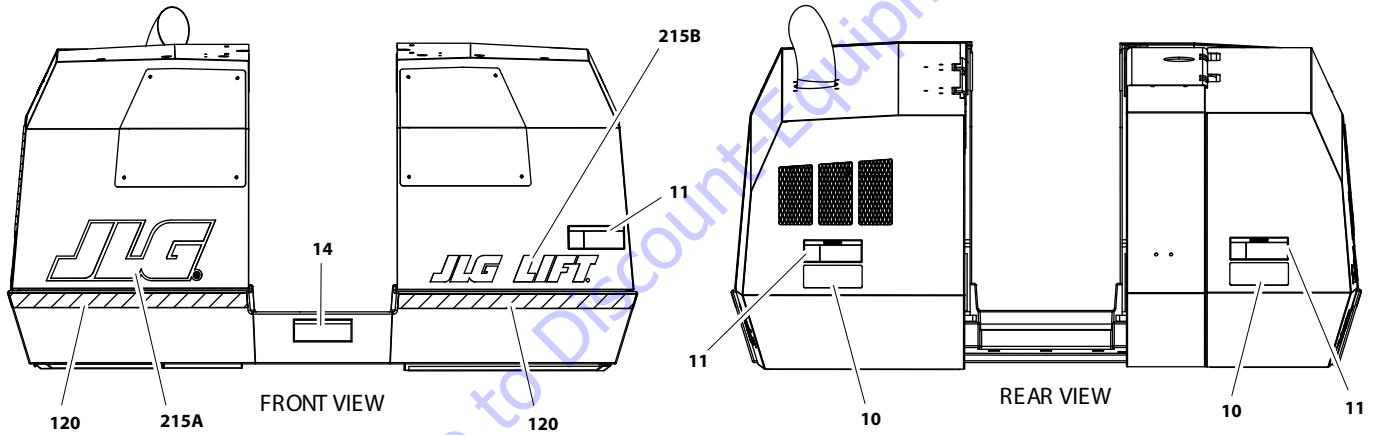
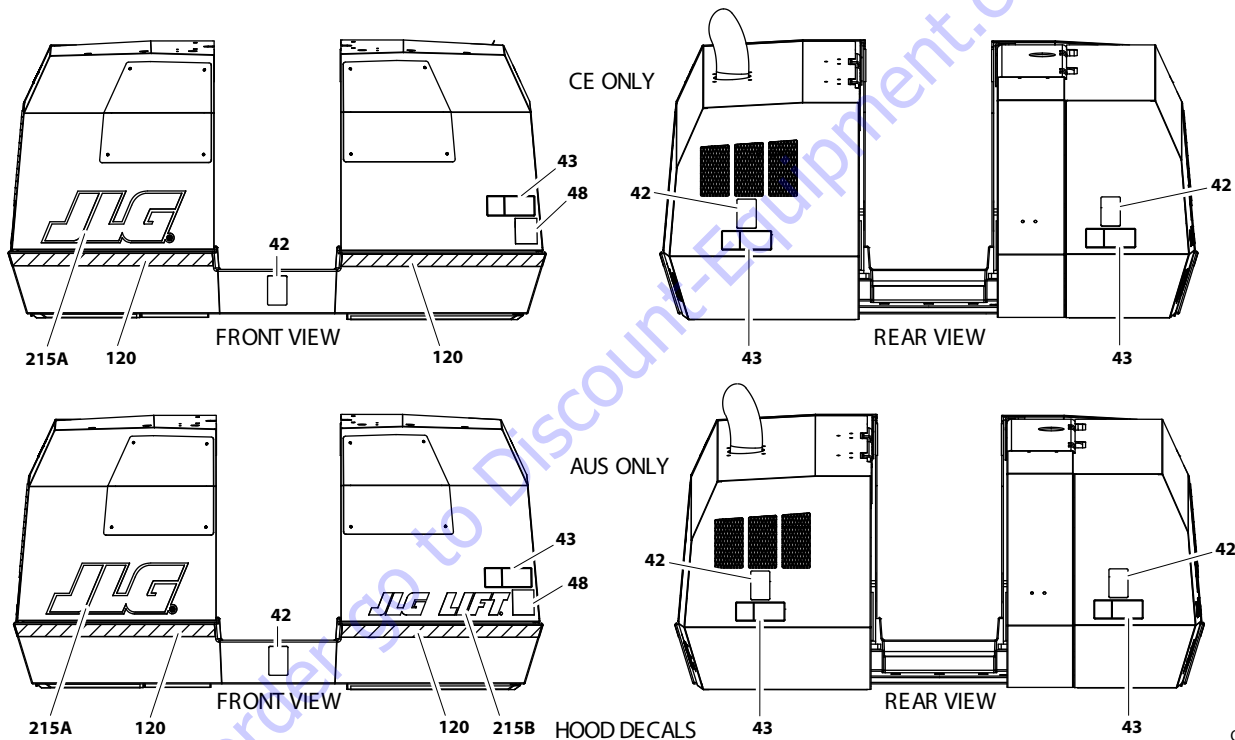

Figure 4-14. Decal Installation - Sheet 6 of 11

**SECTION 4 - MACHINE OPERATION**



**Figure 4-15. Decal Installation - Sheet 7 of 11**

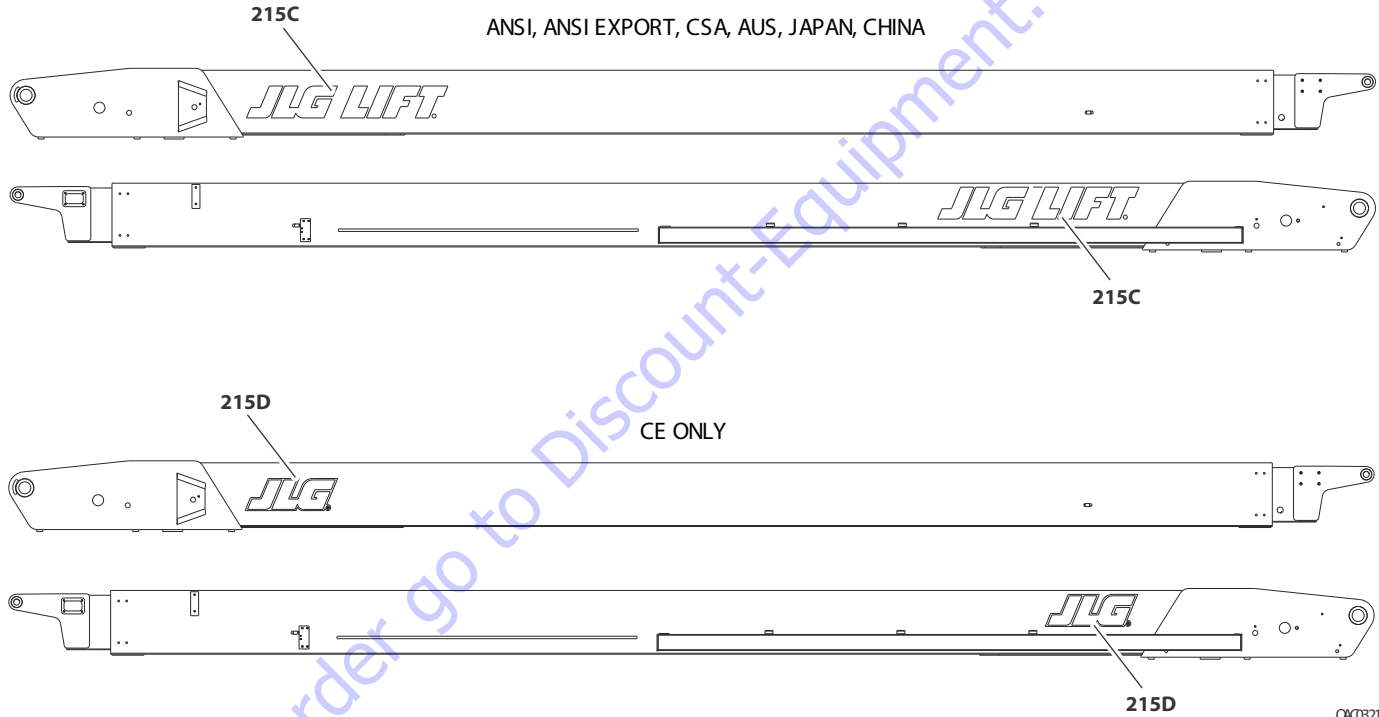

Figure 4-16. Decal Installation - Sheet 8 of 11

## SECTION 4 - MACHINE OPERATION

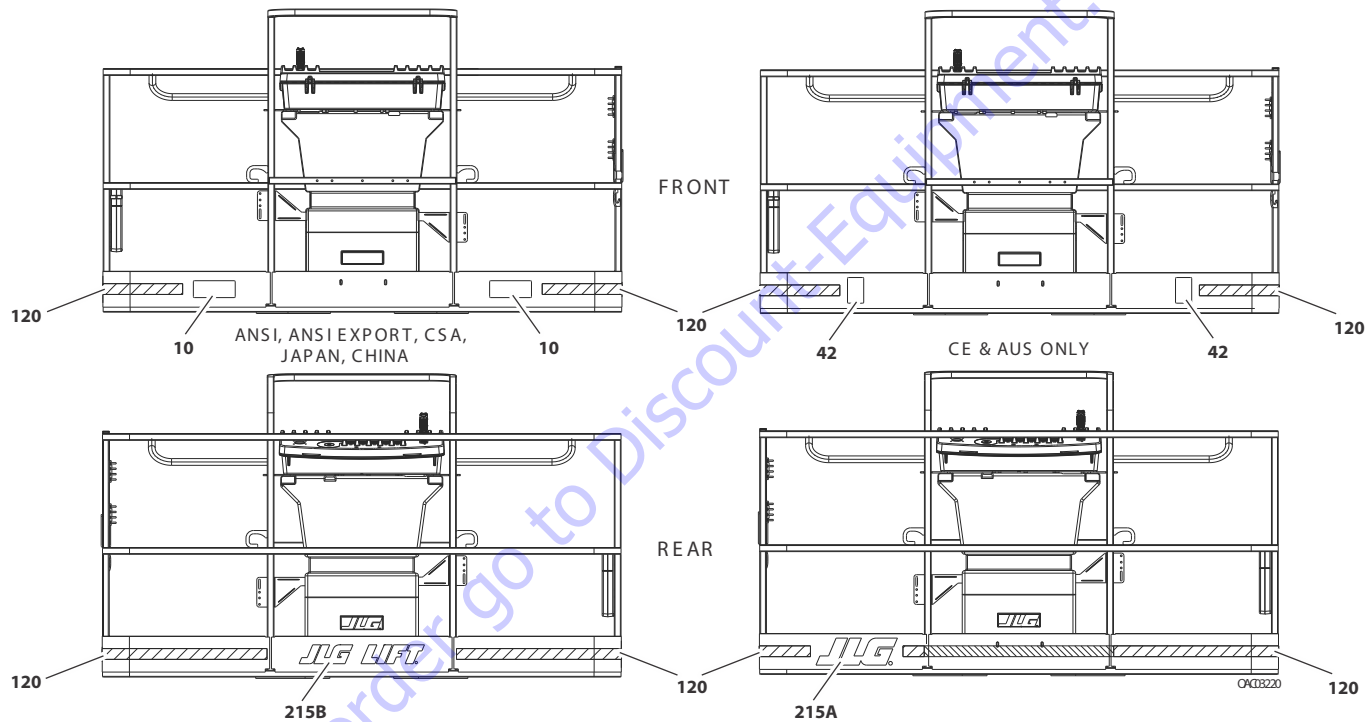

Figure 4-17. Decal Installation - Sheet 9 of 11

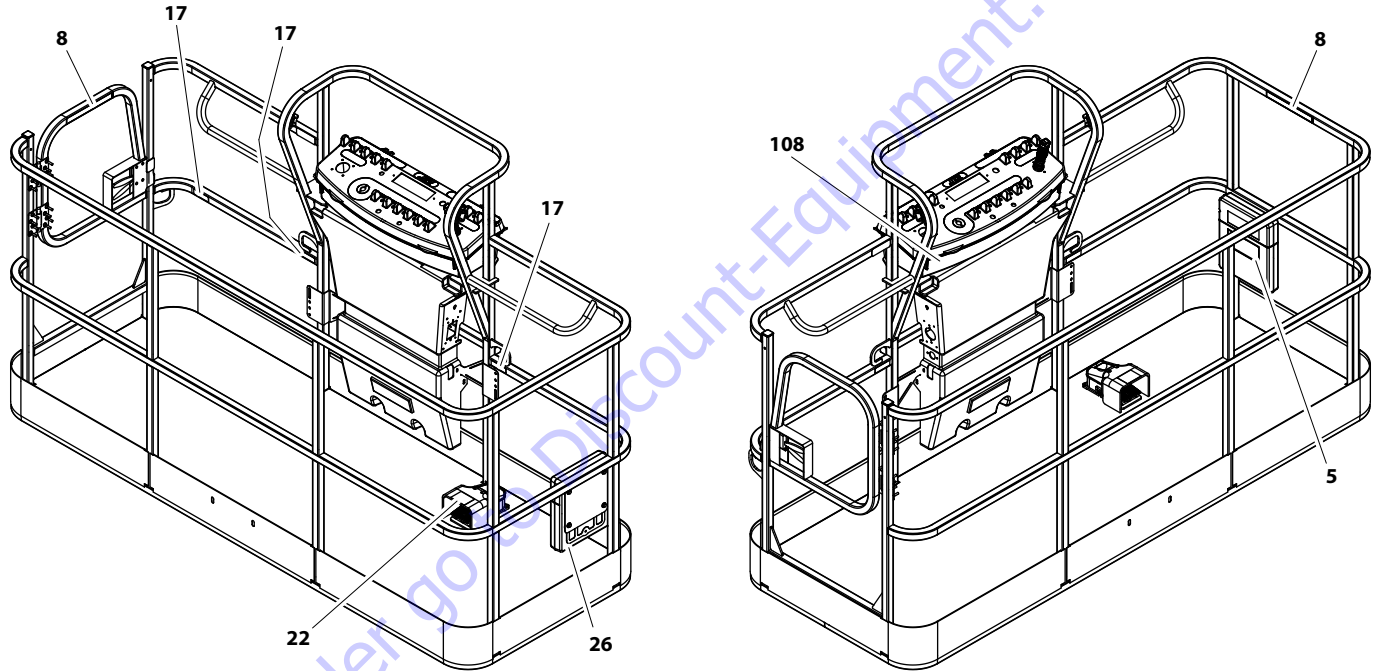

Figure 4-18. Decal Installation - Sheet 10 of 11

## SECTION 4 - MACHINE OPERATION

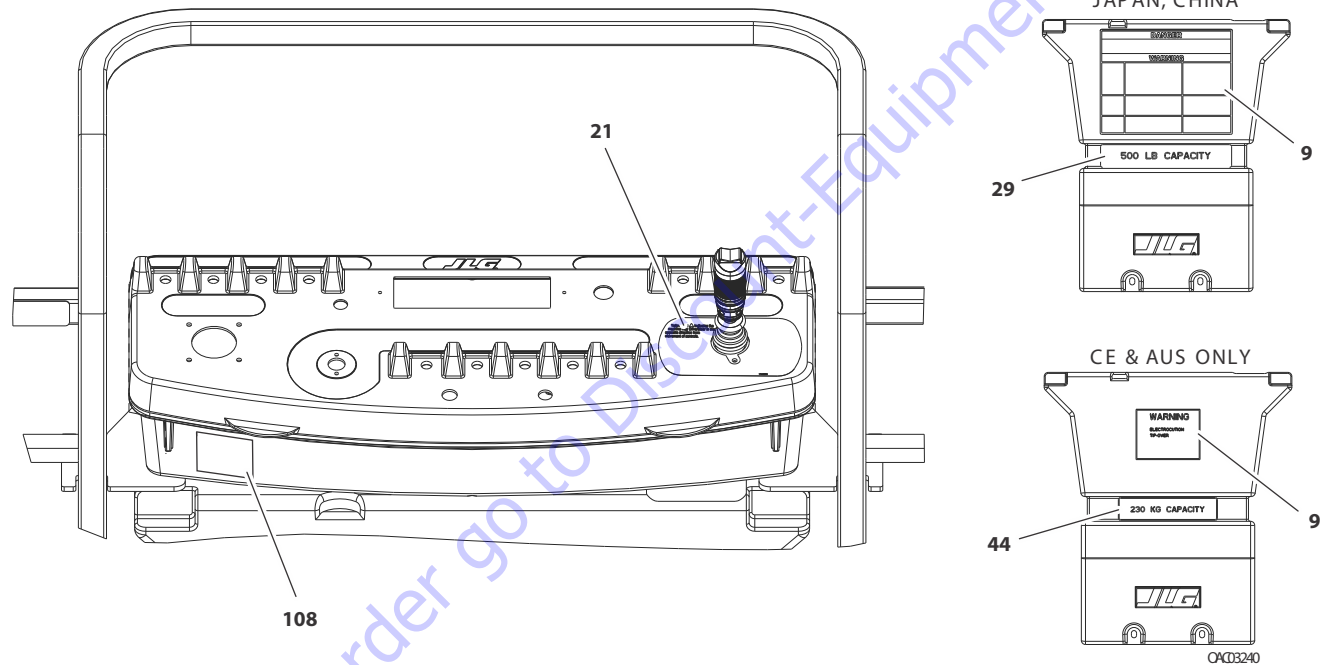

Figure 4-19. Decal Installation - Sheet 11 of 11

Table 4-2. Decal Legend

| Item # | ANSI<br>1001249006-B | Korean<br>1001249008-B | Chinese<br>1001249010-B | Spanish<br>1001249011-B | Portuguese<br>1001249012-B | French<br>1001249009-B | CE<br>1001249549-A | Japanese<br>1001249007-B | Aus<br>1001249548-A |
|--------|----------------------|------------------------|-------------------------|-------------------------|----------------------------|------------------------|--------------------|--------------------------|---------------------|
| 2      | 1701499              | 1701499                | 1701499                 | 1701499                 | 1701499                    | 1701499                | 1701499            | 1701499                  | 1701499             |
| 3      | 1701501              | 1701501                | 1701501                 | 1701501                 | 1701501                    | 1701501                | 1701501            | 1701501                  | 1701501             |
| 4      | 1701505              | 1701505                | 1701505                 | 1701505                 | 1701505                    | 1701505                | 1701505            | 1701505                  | 1701505             |
| 5      | 1701509              | 1701509                | 1701509                 | 1701509                 | 1701509                    | 1701509                | 1701509            | 1701509                  | 1701509             |
| 6      | 1702155              | 1702155                | 1702155                 | 1702155                 | 1702155                    | 1702155                | 1702155            | 1702155                  | 1702155             |
| 7      | 1702631              | 1702631                | 1702631                 | 1702631                 | 1702631                    | 1702631                | 1702631            | 1702631                  | 1702631             |
| 8      | 1702868              | 1705969                | 1001116846              | 1704001                 | 1705967                    | 1704000                | --                 | --                       | --                  |
| 9      | 1703797              | 1703927                | 1703925                 | 1703923                 | 1705895                    | 1703924                | 1705921            | 1703926                  | 1705921             |
| 10     | 1703804              | 1703951                | 1703949                 | 1703947                 | 1705898                    | 1703948                | --                 | 1703950                  | --                  |
| 11     | 1703805              | 1703939                | 1001116851              | 1703935                 | 1705897                    | 1703936                | --                 | 1703938                  | --                  |
| 12     | 1703811              | 1703811                | 1703811                 | 1703811                 | 1703811                    | 1703811                | 1703811            | 1703811                  | 1703811             |
| 13     | 1703814              | 1703814                | 1703814                 | 1703814                 | 1703814                    | 1703814                | 1703814            | 1703814                  | 1703814             |
| 14     | 1703953              | 1703945                | 1703943                 | 1703941                 | 1705903                    | 1703942                | --                 | 1703944                  | --                  |
| 15     | 1703959              | 1703959                | 1703959                 | 1703959                 | 1703959                    | 1703959                | 1703959            | 1703959                  | 1703959             |
| 16     | 1703960              | 1703960                | 1703960                 | 1703960                 | 1703960                    | 1703960                | 1703960            | 1703960                  | 1703960             |
| 17     | 1704277              | 1704277                | 1704277                 | 1704277                 | 1704277                    | 1704277                | 1704277            | 1704277                  | 1704277             |

## SECTION 4 - MACHINE OPERATION

**Table 4-2. Decal Legend**

| Item # | ANSI<br>1001249006-B | Korean<br>1001249008-B | Chinese<br>1001249010-B | Spanish<br>1001249011-B | Portuguese<br>1001249012-B | French<br>1001249009-B | CE<br>1001249549-A | Japanese<br>1001249007-B | Aus<br>1001249548-A |
|--------|----------------------|------------------------|-------------------------|-------------------------|----------------------------|------------------------|--------------------|--------------------------|---------------------|
| 18     | 1704412              | 1704412                | 1704412                 | 1704412                 | 1704412                    | 1704412                | 1704412            | 1704412                  | 1704412             |
| 19     | 1704972              | 1706061                | 1706060                 | 1706063                 | 1706059                    | 1706064                | 1706098            | 1706062                  | 1706098             |
| 20     | 1705336              | 1705345                | 100116849               | 1705917                 | 1705896                    | 1705347                | 1705822            | 1705344                  | 1705822             |
| 21     | 1705351              | 1705427                | 1705430                 | 1705910                 | 1705905                    | 1705429                | --                 | 1705426                  | --                  |
| 22     | 3252347              | 1703981                | 1703982                 | 1703983                 | 1705902                    | 1703984                | 1705828            | 1703980                  | 1705828             |
| 26     | 91403230             | 91403230               | 91403230                | 914403230               | 91403230                   | 91403230               | 914403230          | 91403230                 | 91403230            |
| 27     | 1001096141           | 1705977                | 1705977                 | 1705977                 | 1705977                    | 1705977                | 1705977            | 1705977                  | 1705977             |
| 28     | 1001117307           | 1001117307             | 1001117307              | 1001117307              | 1001117307                 | 1001117307             | 1001117307         | 1001117307               | 1001117307          |
| 29     | 1001253920           | 1001253924             | 1001253926              | 1001253930              | 1001253936                 | 1001253922             | --                 | 1001253932               | --                  |
| 30     | 1001253921           | 1001253925             | 1001253927              | 1001253931              | 1001253937                 | 1001253923             | --                 | 1001253933               | --                  |
| 31     | 1001125483           | 1001125483             | 1001125483              | 1001125483              | 1001125483                 | 1001125483             | 1001125483         | 1001125483               | 1001125483          |
| 32     | 1001131269           | --                     | --                      | --                      | --                         | 1001131269             | --                 | --                       | --                  |
| 33     | 1001174449           | 1001174449             | 1001174449              | 1001174449              | 1001174449                 | 1001174449             | 1001174449         | 1001174449               | 1001174449          |
| 34     | 1001223055           | 1001224048             | 1001224050              | 1001224049              | 1001224052                 | 1001223971             | --                 | 1001224053               | --                  |
| 35     | 1001223554           | 1001233064             | 1001233065              | 1001233067              | 1001233066                 | 1001233063             | 1001223560         | 1001233068               | 1001223560          |
| 36     | 1001223556           | 1001233009             | 1001233010              | 1001233012              | 1001233011                 | 1001233008             | 1001223561         | 1001233013               | 1001223561          |
| 37     | 1001223558           | 1001223558             | 1001223558              | 1001223558              | 1001223558                 | 1001223558             | 1001223558         | 1001223558               | 1001223558          |



Table 4-2. Decal Legend

| Item # | ANSI<br>1001249006-B | Korean<br>1001249008-B | Chinese<br>1001249010-B | Spanish<br>1001249011-B | Portuguese<br>1001249012-B | French<br>1001249009-B | CE<br>1001249549-A | Japanese<br>1001249007-B | Aus<br>1001249548-A |
|--------|----------------------|------------------------|-------------------------|-------------------------|----------------------------|------------------------|--------------------|--------------------------|---------------------|
| 38     | 1001228370           | --                     | --                      | --                      | --                         | 1001228370             | --                 | --                       | --                  |
| 39     | 1001228411           | 1001228411             | 1001228411              | 1001228411              | 1001228411                 | 1001228411             | 1001228411         | 1001228411               | 1001228411          |
| 40     | 1001233452           | 1001233452             | 1001233452              | 1001233452              | 1001233452                 | 1001233452             | 1001233452         | 1001233452               | 1001233452          |
| 41     | 1001233785           | 1001233785             | 1001233785              | 1001233785              | 1001233785                 | 1001233785             | 1001233785         | 1001233785               | 1001233785          |
| 42     | --                   | --                     | --                      | --                      | --                         | --                     | 1701518            | --                       | 1701518             |
| 43     | --                   | --                     | --                      | --                      | --                         | --                     | 1705961            | --                       | 1705961             |
| 44     | --                   | --                     | --                      | --                      | --                         | --                     | 1705978            | --                       | 1705978             |
| 45     | --                   | --                     | --                      | --                      | --                         | --                     | --                 | --                       | 1001112551          |
| 46     | --                   | --                     | --                      | --                      | --                         | --                     | 1001189882         | --                       | --                  |
| 47     | --                   | --                     | --                      | --                      | --                         | --                     | --                 | --                       | 1001232893          |
| 48     | --                   | --                     | --                      | --                      | --                         | --                     | 1001237844         | --                       | 1001237844          |
| 108    | 1001231801           | --                     | --                      | --                      | --                         | --                     | --                 | --                       | --                  |
| 120    | 4420051              | 4420051                | 4420051                 | 4420051                 | 4420051                    | 4420051                | 4420051            | 4420051                  | 4420051             |
| 205    | 1001253997           | 1001253997             | 1001253997              | 1001253997              | 1001253997                 | 1001253997             | 1001253993         | 1001253997               | 1001253999          |
| 215A   | 1702773              | 1702773                | 1702773                 | 1702773                 | 1702773                    | 1702773                | 1702773            | 1702773                  | 1702773             |
| 215B   | 1702774              | 1702774                | 1702774                 | 1702774                 | 1702774                    | 1702774                | --                 | 1702774                  | 1702774             |
| 215C   | 1702861              | 1702861                | 1702861                 | 1702861                 | 1702861                    | 1702861                | --                 | 1702861                  | 1702861             |

## SECTION 4 - MACHINE OPERATION

Table 4-2. Decal Legend

| Item # | ANSI<br>1001249006-B | Korean<br>1001249008-B | Chinese<br>1001249010-B | Spanish<br>1001249011-B | Portuguese<br>1001249012-B | French<br>1001249009-B | CE<br>1001249549-A | Japanese<br>1001249007-B | Aus<br>1001249548-A |
|--------|----------------------|------------------------|-------------------------|-------------------------|----------------------------|------------------------|--------------------|--------------------------|---------------------|
| 215D   | 1001159323           | 1001159323             | 1001159323              | 1001159323              | 1001159323                 | 1001159323             | 1001159323         | 1001159323               | 1001159323          |
| 245    | 1001120989           | 1001120989             | 1001120989              | 1001120989              | 1001120989                 | 1001120989             | 1001120989         | 1001120989               | 1001120989          |
| 253    | --                   | 1001143852             | 1001143852              | 1001143852              | 1001143852                 | 1001143852             | 1001143852         | 1001143852               | 1001143852          |
| 274    | --                   | --                     | --                      | --                      | --                         | --                     | 1001214030         | --                       | --                  |

**TO PURCHASE THIS PRODUCT PLEASE CONTACT US**



**Equipment Financing and  
Extended Warranties Available**



**Discount-Equipment.com is your online resource for  
commercial and industrial quality parts and equipment sales.**

**561-964-4949**

**visit us on line @ [www.discount-equipment.com](http://www.discount-equipment.com)**

Select an option below to find your Equipment

**Search by Manufacturer**

**Search by Product Type**

**Request a Quote**

We sell worldwide for the brands: Genie, Terex, JLG, MultiQuip, Mikasa, Essick, Whiteman, Mayco, Toro Stone, Diamond Products, Generac Magnum, Airman, Haulotte, Barreto, Power Blanket, Nifty Lift, Atlas Copco, Chicago Pneumatic, Allmand, Miller Curber, Skyjack, Lull, Skytrak, Tsurumi, Husquvarna Target, Stow, Wacker, Sakai, Mi-T-M, Sullair, Basic, Dynapac, MBW, Weber, Bartell, Bennar Newman, Haulotte, Ditch Runner, Menegotti, Morrison, Contec, Buddy, Crown, Edco, Wyco, Bomag, Laymor, EZ Trench, Bil-Jax, F.S. Curtis, Gehl Pavers, Heli, Honda, ICS/PowerGrit, IHI, Partner, Imer, Clipper, MMD, Koshin, Rice, CH&E, General Equipment, Amida, Coleman, NAC, Gradall, Square Shooter, Kent, Stanley, Tamco, Toku, Hatz, Kohler, Robin, Wisconsin, Northrock, Oztec, Toker TK, Rol-Air, APT, Wylie, Ingersoll Rand / Doosan, Innovatech, Con X, Ammann, Mecalac, Makinex, Smith Surface Prep, Small Line, Wanco, Yanmar

## SECTION 5. EMERGENCY PROCEDURES

### 5.1 GENERAL

This section explains the steps to be taken in case of an emergency situation while operating.

### 5.2 INCIDENT NOTIFICATION

JLG Industries, Inc. must be notified immediately of any incident involving a JLG product. Even if no injury or property damage is evident, the factory should be contacted by telephone and provided with all necessary details.

USA: 877-JLG-SAFE (554-7233)

EUROPE: (32) 0 89 84 82 20

AUSTRALIA: (61) 2 65 811111

E-mail: ProductSafety@JLG.com

Failure to notify the manufacturer of an incident involving a JLG Industries product within 48 hours of such an occurrence may void any warranty consideration on that particular machine.

### NOTICE

**FOLLOWING ANY ACCIDENT, THOROUGHLY INSPECT THE MACHINE AND TEST ALL FUNCTIONS FIRST FROM THE GROUND CONTROLS, THEN FROM THE PLATFORM CONTROLS. DO NOT LIFT ABOVE 3 M (10 FT.) UNTIL YOU ARE SURE THAT ALL DAMAGE HAS BEEN REPAIRED, IF REQUIRED, AND THAT ALL CONTROLS ARE OPERATING CORRECTLY.**

### 5.3 EMERGENCY OPERATION

#### Operator Unable to Control Machine

IF THE PLATFORM OPERATOR IS PINNED, TRAPPED OR UNABLE TO OPERATE OR CONTROL MACHINE:

1. Other personnel should operate the machine from ground controls only as required.
2. Other qualified personnel on the platform may use the platform controls. DO NOT CONTINUE OPERATION IF CONTROLS DO NOT FUNCTION PROPERLY.
3. Cranes, forklift trucks or other equipment can be used to remove platform occupants and stabilize motion of the machine.

### Platform or Boom Caught Overhead

If the platform or boom becomes jammed or snagged in overhead structures or equipment, do the following:

1. Shut off the machine.
2. Rescue all people in the platform before freeing the machine. Personnel must be out of the platform before operating any controls on the machine.
3. Use cranes, forklifts, or other equipment to stabilize motion of the machine to prevent a tip over as required.
4. From the ground controls, use the Auxiliary Power System (if equipped) to carefully free the platform or boom from the object.
5. Once clear, restart the machine and return the platform to a safe position.
6. Inspect the machine for damage. If the machine is damaged or does not operate properly, turn off the machine immediately. Report the problem to the proper maintenance personnel. Do not operate the machine until it is declared safe for operation.

### 5.4 EMERGENCY TOWING PROCEDURES

Towing this machine is prohibited, unless properly equipped. However, provisions for moving the machine have been incorporated. For specific procedures, refer to Section 4.

## 5.5 MACHINE SAFETY SYSTEM OVERRIDE (MSSO) (CE ONLY)

The Machine Safety System Override (MSSO) is only to be used to retrieve an operator that is pinned, trapped, or unable to operate the machine and function controls are locked out from the platform due to a platform overload situation.



**NOTE:** *If the MSSO functionality is used, a fault code is set in the JLG Control System which must be reset by a qualified JLG Service Technician.*

**NOTE:** *No functional checks of the MSSO system are necessary. The JLG Control system will set a Diagnostic Trouble Code if the control switch is faulty.*

To operate the MSSO:

1. From the ground control console, place the Platform/ Ground Select switch in the Ground position.
2. Pull out the Power/Emergency Stop control.
3. Start the engine.
4. Press and hold the MSSO switch and the control switch for the desired function.

**TO PURCHASE THIS PRODUCT PLEASE CONTACT US**



**Equipment Financing and  
Extended Warranties Available**



**Discount-Equipment.com is your online resource for  
commercial and industrial quality parts and equipment sales.**

**561-964-4949**

**visit us on line @ [www.discount-equipment.com](http://www.discount-equipment.com)**

Select an option below to find your Equipment

**Search by Manufacturer**

**Search by Product Type**

**Request a Quote**

We sell worldwide for the brands: Genie, Terex, JLG, MultiQuip, Mikasa, Essick, Whiteman, Mayco, Toro Stone, Diamond Products, Generac Magnum, Airman, Haulotte, Barreto, Power Blanket, Nifty Lift, Atlas Copco, Chicago Pneumatic, Allmand, Miller Curber, Skyjack, Lull, Skytrak, Tsurumi, Husquvarna Target, Stow, Wacker, Sakai, Mi-T-M, Sullair, Basic, Dynapac, MBW, Weber, Bartell, Bennar Newman, Haulotte, Ditch Runner, Menegotti, Morrison, Contec, Buddy, Crown, Edco, Wyco, Bomag, Laymor, EZ Trench, Bil-Jax, F.S. Curtis, Gehl Pavers, Heli, Honda, ICS/PowerGrit, IHI, Partner, Imer, Clipper, MMD, Koshin, Rice, CH&E, General Equipment, Amida, Coleman, NAC, Gradall, Square Shooter, Kent, Stanley, Tamco, Toku, Hatz, Kohler, Robin, Wisconsin, Northrock, Oztec, Toker TK, Rol-Air, APT, Wylie, Ingersoll Rand / Doosan, Innovatech, Con X, Ammann, Mecalac, Makinex, Smith Surface Prep, Small Line, Wanco, Yanmar

## SECTION 6. ACCESSORIES

Table 6-1. Available Accessories

| Accessory                       | Market             |      |     |    |     |       |       |
|---------------------------------|--------------------|------|-----|----|-----|-------|-------|
|                                 | ANSI<br>(USA Only) | ANSI | CSA | CE | AUS | Japan | China |
| Fall Arrest Platform (36" x96") | √                  | √    | √   | √  |     |       | √     |
| Fall Arrest Platform (36" x72") | √                  | √    | √   |    |     |       | √     |
| SkyGlazier™                     | √                  | √    | √   |    | √   |       | √     |
| SkyPower™                       | √                  | √    | √   | √  | √   | √     | √     |
| SkyWelder™                      | √                  | √    | √   | √  | √   | √     | √     |
| SoftTouch                       | √                  | √    | √   | √  | √   | √     | √     |



**SECTION 6 - ACCESSORIES**

**Table 6-2. Options/Accessories Relationship Table**

| ACCESSORY                                                                                                | REQUIRED ITEM | COMPATIBLE WITH<br>(Note 1)            | INCOMPATIBLE WITH                      | INTERCHANGABLE WITH (Note 2) |
|----------------------------------------------------------------------------------------------------------|---------------|----------------------------------------|----------------------------------------|------------------------------|
| SkyGlazier™                                                                                              |               | SkyPower™                              | 4'Platform, Soft Touch                 | SkyCutter™, SkyWelder™       |
| SkyPower™                                                                                                |               | SkyCutter™, SkyGlazier™,<br>SkyWelder™ |                                        |                              |
| SkyWelder™                                                                                               | SkyPower™     | SkyCutter™                             | 4'Platform, Soft Touch                 | SkyGlazier™                  |
| Soft Touch                                                                                               |               |                                        | SkyCutter™,<br>SkyGlazier™, SkyWelder™ |                              |
| <b>Note 1:</b> Any non-"Sky" accessory not listed under "INCOMPATIBLE WITH" is assumed to be compatible. |               |                                        |                                        |                              |
| <b>Note 2:</b> Can be used on same unit but not simultaneously.                                          |               |                                        |                                        |                              |

4150459 M

## 6.1 FALL ARREST PLATFORM

**NOTE:** See the JLG External Fall Arrest System manual (PN 3128935) for more detailed information.

The external fall arrest system is designed to provide a lanyard attach point while allowing the operator to access areas outside the platform. Exit/enter the platform through the gate area only. The system is designed for use by one person.

Personnel must use fall protection at all times. A full body harness is required with lanyard not to exceed 6 ft (1.8 m) in length, that limits the maximum arrest force to 900 lb (408 kg) for the transfaster type and 1350 lb (612 kg) for the shuttle type fall arrest system.

### Safety Precautions

#### **⚠ WARNING**

**DO NOT OPERATE ANY MACHINE FUNCTIONS WHILE OUTSIDE THE PLATFORM. USE CAUTION WHEN ENTERING/EXITING THE PLATFORM AT ELEVATION.**

## 6.2 SKYGLAZIER™

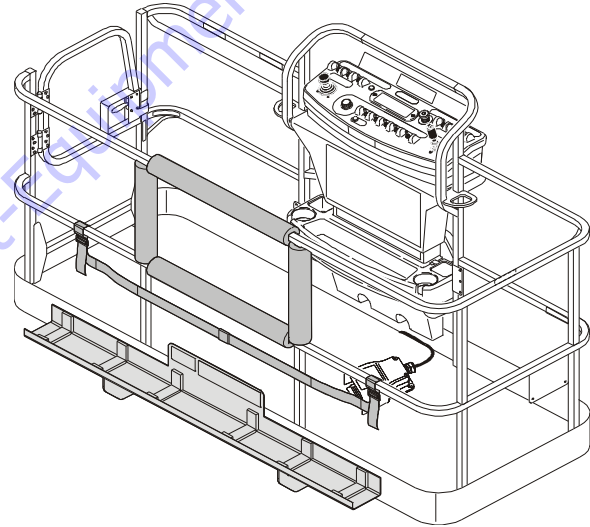

SkyGlazier™ allows glaziers to position panels efficiently. The glazier package consists of a tray that attaches the bottom of the platform. The panel rests on the tray and against top-rail of the platform, which is padded to prevent damage. SkyGlazier™ includes a strap to secure the panel to the platform rail.

## Capacity Specifications

| Capacity Zone *                                                                        | Max. Tray Capacity | Max. Platform Capacity<br>(With Max. Weight in Tray) |
|----------------------------------------------------------------------------------------|--------------------|------------------------------------------------------|
| 500lb<br>(227 kg)                                                                      | 150lb<br>(68 kg)   | 250lb<br>(113 kg)                                    |
| 550lb<br>(250 kg)                                                                      | 150lb<br>(68 kg)   | 250lb<br>(113 kg)                                    |
| 600lb<br>(272 kg)                                                                      | 150lb<br>(68 kg)   | 250lb<br>(113 kg)                                    |
| 750lb<br>(340 kg)                                                                      | 150lb<br>(68 kg)   | 440lb<br>(200 kg)                                    |
| 1000lb<br>(454 kg)                                                                     | 250lb<br>(113 kg)  | 500lb<br>(227 kg)                                    |
| * Refer to the capacity decals installed on the machine for capacity zone information. |                    |                                                      |
| <b>Required Platform Type:</b> Side-Entry                                              |                    |                                                      |
| <b>Max. Dimensions of Panel:</b> 32 sq.ft. (3 sq.m.)                                   |                    |                                                      |

## Safety Precautions

**⚠ WARNING**

ENSURE PANEL IS SECURED WITH STRAP.

**⚠ WARNING**

DO NOT OVERLOAD TRAY OR PLATFORM. TOTAL MACHINE CAPACITY IS REDUCED WHEN TRAY IS INSTALLED.

**⚠ WARNING**

WITH SKYGLAZIER™ INSTALLED, THE ORIGINAL PLATFORM CAPACITY RATINGS ARE REDUCED AS SPECIFIED IN THE CAPACITY SPECIFICATIONS TABLE. DO NOT EXCEED NEW PLATFORM CAPACITY RATINGS. REFER TO CAPACITY DECAL LOCATED ON TRAY.

**⚠ WARNING**

AN INCREASE OF THE AREA EXPOSED TO THE WIND WILL DECREASE STABILITY. LIMIT PANEL AREA TO 32 SQ.FT. (3 SQ.M).

- Ensure no personnel are beneath platform.
- Do not exit platform over rails or stand on rails.
- Remove tray when not in use.
- Use this option only on approved models.

## Preparation and Inspection

- Check for cracked welds and damage to tray.
- Ensure tray is properly secured to platform.
- Ensure strap is not torn or frayed.

## Operation

1. Load SkyGlazier™ tray with panel.
2. Route the adjustable strap around the panel and tighten until secure.
3. Position panel to its desired location.

## 6.3 SKYPOWER™

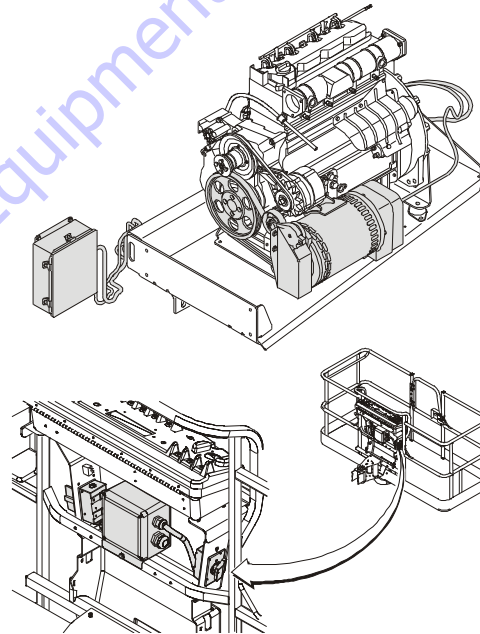

The SkyPower™ system supplies AC power to the platform through an AC receptacle to run tools, lights, cutting, and welding equipment.

## SECTION 6 - ACCESSORIES

---

All power regulation components are located in a watertight box connected by cable to the generator. The generator supplies power when running at the specified speed with the power switch on (switch is located on platform). A three-pole, 30 Amp circuit breaker protects the generator from overload.

### Generator Output

#### ANSI Specifications:

- 3-phase: 240 V, 60 Hz, 7.5 kW
- 1-phase: 240 V/120 V, 60 Hz, 6 kW

#### CE Specifications:

- 3-phase: 240 V, 7.5 kW, 18.3 A, 1.0-pf
- 1-phase: 240 V, 6.0 kW, 26 A, 1.0-pf
- 1-phase: 120 V, 6.0 kW, 50 A, 1.0-pf

#### Peak:

- 3-phase: 8.5 kW
- 1-phase: 6.0 kW

### Safety Precautions

 **WARNING**

**DO NOT OVERLOAD PLATFORM.**

- Ensure no personnel are beneath platform.
- This factory-installed option is available only on specified models.
- Keep lanyard attached at all times.
- Do not use electrical tools in water.
- Use correct voltage for tool being used.
- Do not overload circuit.

## Preparation and Inspection

- Ensure generator is secure.
- Check condition of belt and wiring.

## Operation

Start the engine, then turn on the generator.

See the Miller Generator Technical Manual (PN 3121677) for more information.

## 6.4 SKYWELDER™

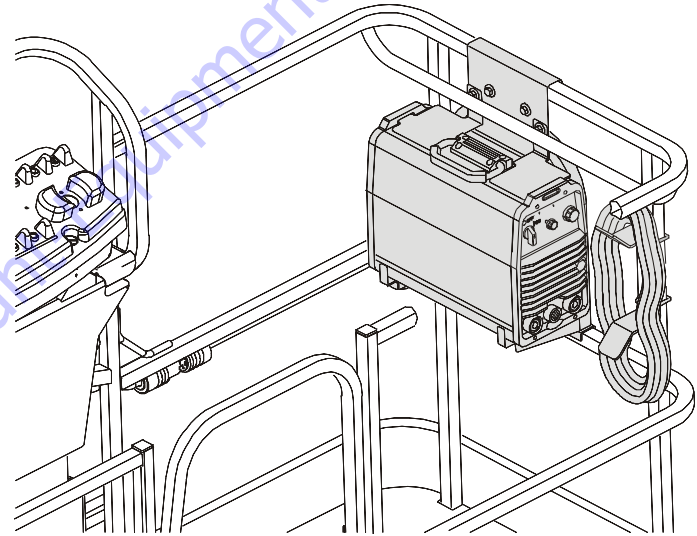

SkyWelder™ is capable of TIG and Stick welding, producing 200 Amps at 100% duty cycle or 250 Amps at 50% duty cycle. This accessory receives power from the SkyPower™ system.

## **Generator Output**

Engine Speed of 1800 rpm +/- 10%.

### **ANSI Specifications:**

- 3-phase: 240 V, 60 Hz, 7.5 kW
- 1-phase: 240 V/120 V, 60 Hz, 6 kW

### **CE Specifications:**

- 3-phase: 400 V, 50 Hz, 7.5 kW
- 1-phase: 220 V, 50 Hz, 6 kW

## **Welding Accessories**

- 12 ft welding leads with clamp and stinger (stored in the platform)
- Fire extinguisher

## Accessory Ratings

| Welding Mode               | Input Power | Rated Output                        | Welding Amperage Range | Maximum Open Circuit Voltage | Amps Input At Rated Load Output (50/60 Hz) |       |       |      |     |
|----------------------------|-------------|-------------------------------------|------------------------|------------------------------|--------------------------------------------|-------|-------|------|-----|
|                            |             |                                     |                        |                              | 230 V                                      | 460 V | 575 V | kVa  | kW  |
| Stick (SMAW)<br>TIG (GTAW) | 3-phase     | 280 Amp at 31.2V,<br>35% Duty Cycle | 5-250 A                | 79VDC                        | 32                                         | 17    | 13    | 15.7 | 10  |
|                            |             | 200 Amp at 28V,<br>100% Duty Cycle  |                        |                              | 20                                         | 11    | 8     | 10.3 | 6.4 |
|                            | 1-phase     | 200 Amp at 28V,<br>50% Duty Cycle   | 5-200 A                | 79VDC                        | 35                                         | ----- | ----- | 9.8  | 6.5 |
|                            |             | 150 Amp at 28V,<br>100% Duty Cycle  |                        |                              | 34                                         | ----- | ----- | 6.9  | 4.4 |

## Safety Precautions

### WARNING

DO NOT OVERLOAD PLATFORM.

### WARNING

DE-RATE THE PLATFORM BY 70 LB (32 KG) WHEN WELDER IS IN THE PLATFORM.

- Check for cracked welds and damage to welder supports.
- Check for proper and secure installation of welder and bracket.
- Ensure no personnel are beneath platform.
- Do not exit platform over rails or stand on rails.
- Use this option only on approved models.
- Keep lanyard attached at all times.
- Ensure correct polarity of leads.
- Wear proper welding apparel.



## SECTION 6 - ACCESSORIES

---

- Use correct rod size and current settings.
- Do not use electrical cords without ground.
- Do not use electrical tools in water.
- Do not weld to the platform.
- Do not ground through the platform.
- Do not use a high frequency arc starter with TIG welder.

### Preparation and Inspection

- Connect ground clamp to metal being welded.
- Ensure there is a good ground connection and observe proper polarity.

### Operation

Start the engine, turn on the generator, then turn on the welder.

See the Miller Welder Owner's Manual (PN 3128957) for more information.

### 6.5 SOFT TOUCH

A padding kit is mounted to the platform rails and to a frame suspended below the platform. Limit switches deactivate platform functions when the padded framework contacts an adjacent structure. A button on the platform console allows override of the system.

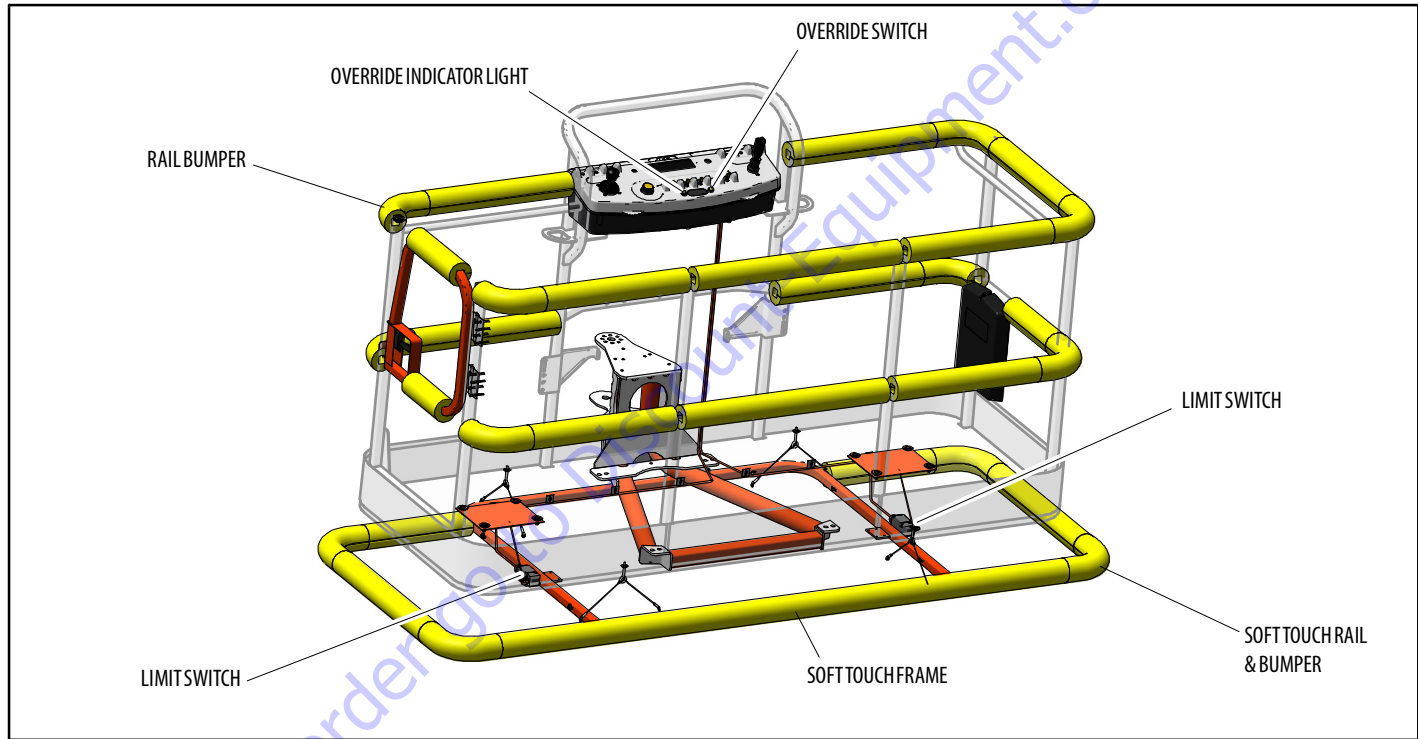

Figure 6-1. Soft Touch

**TO PURCHASE THIS PRODUCT PLEASE CONTACT US**



**Equipment Financing and  
Extended Warranties Available**



**Discount-Equipment.com is your online resource for  
commercial and industrial quality parts and equipment sales.**

**561-964-4949**

**visit us on line @ [www.discount-equipment.com](http://www.discount-equipment.com)**

Select an option below to find your Equipment

**Search by Manufacturer**

**Search by Product Type**

**Request a Quote**

We sell worldwide for the brands: Genie, Terex, JLG, MultiQuip, Mikasa, Essick, Whiteman, Mayco, Toro Stone, Diamond Products, Generac Magnum, Airman, Haulotte, Barreto, Power Blanket, Nifty Lift, Atlas Copco, Chicago Pneumatic, Allmand, Miller Curber, Skyjack, Lull, Skytrak, Tsurumi, Husquvarna Target, Stow, Wacker, Sakai, Mi-T-M, Sullair, Basic, Dynapac, MBW, Weber, Bartell, Bennar Newman, Haulotte, Ditch Runner, Menegotti, Morrison, Contec, Buddy, Crown, Edco, Wyco, Bomag, Laymor, EZ Trench, Bil-Jax, F.S. Curtis, Gehl Pavers, Heli, Honda, ICS/PowerGrit, IHI, Partner, Imer, Clipper, MMD, Koshin, Rice, CH&E, General Equipment, Amida, Coleman, NAC, Gradall, Square Shooter, Kent, Stanley, Tamco, Toku, Hatz, Kohler, Robin, Wisconsin, Northrock, Oztec, Toker TK, Rol-Air, APT, Wylie, Ingersoll Rand / Doosan, Innovatech, Con X, Ammann, Mecalac, Makinex, Smith Surface Prep, Small Line, Wanco, Yanmar

## SECTION 7. GENERAL SPECIFICATIONS & OPERATOR MAINTENANCE

### 7.1 INTRODUCTION

This section of the manual provides additional necessary information to the operator for proper operation and maintenance of this machine.

The maintenance portion of this section is intended as information to assist the machine operator to perform daily maintenance tasks only, and does not replace the more thorough Preventive Maintenance and Inspection Schedule included in the Service and Maintenance Manual.

#### Other Publications Available:

Service and Maintenance Manual ..... 31215043  
 Illustrated Parts Manual ..... 31215044

### 7.2 OPERATING SPECIFICATIONS AND PERFORMANCE DATA

#### Operating Specifications

Table 7-1. Operating Specifications

|                                                             |                                              |
|-------------------------------------------------------------|----------------------------------------------|
| Rated Capacity                                              | 500 lb (230 kg)                              |
| Max. Manual Force                                           | ANSI - 100 lb (445 N)<br>AUS - 90 lb (400 N) |
| Travel Speed                                                | 3.0 MPH (4.83 km/h.)                         |
| Maximum Operating Slope                                     | 4°                                           |
| Maximum Travel Grade, Stowed Position (Gradeability)<br>4WD | 45%                                          |
| Maximum Travel Grade, Stowed Position (Sideslope)           | 4°                                           |
| Turning Radius (Outside)<br>2WS                             | 19'8" (6.02 m)                               |
| Turning Radius (Inside)<br>2WS                              | 12'6" (3.8 m)                                |
| Overall Width                                               | 8'2" (2.48 m)                                |

## SECTION 7 - GENERAL SPECIFICATIONS & OPERATOR MAINTENANCE

**Table 7-1. Operating Specifications**

|                               |                                   |
|-------------------------------|-----------------------------------|
| Tailswing                     | 8'4" (2.56 m)                     |
| Ground Clearance              | 11" (28 cm)                       |
| Machine Height Stowed         | 9ft. 9.5in. (2.98 m)              |
| Machine Length (Stowed)       | 36 ft.-6 in. (11.13 m)            |
| Wheel base                    | 10 ft.-0 in. (3.05 m)             |
| Boom Elevation - 800AJ        |                                   |
| Above Grade                   | +80 ft. (24.38 m)                 |
| Below Grade                   | -13 ft.- 1 in. (3.99 m)           |
| Max. Ground Bearing Pressure  | 76 psi. (5.3 kg/cm <sup>2</sup> ) |
| Max. Tire Load                | 17,755 lb (8054 kg)               |
| Machine Weight approximately* | 35,500 lb (16,103 kg)             |

\* Certain options or country standards can increase weight.

## Batteries

The machine has two (2) separate battery systems: 12V and 84V.

The 12V system powers the control modules (e.g., UGM), hydraulic valves, clutch actuation, fans, and engine start/alternator system. The 84V system powers the IMG and the battery charging system, which includes the battery boxes, IGM control enclosure, 84V/12V DC/DC converter, and the two battery chargers.

**Table 7-3. Battery Specifications**

| System | Type      | Quantity | Voltage | Cold Cranking Amps | Weight         |
|--------|-----------|----------|---------|--------------------|----------------|
| 12V    | lead-acid | 1        | 12V     | 950 @ 0°F (-18°C)  | 66 lb (30 kg)  |
| 84V    | AGM       | 14       | 12V     | 1190 @ 0°F (-18°C) | 138 lb (63 kg) |

## Tires

**Table 7-2. Tire Specifications**

| Size   | Type        | Ply Rating | Load Range | Pressure |
|--------|-------------|------------|------------|----------|
| 15-625 | foam-filled | 16         | H          | N/A      |
| 18-625 | foam-filled | 16         | H          | N/A      |

**Capacities**

**Table 7-4. Capacities**

|                                   |                                   |
|-----------------------------------|-----------------------------------|
| Fuel Tank                         | Approx. 25 gallons (94.6 liters)  |
| Hydraulic Tank                    | Approx. 40 gallons (151.4 liters) |
| Hydraulic System (Including Tank) | 65 Gal. (246 L)                   |
| Drive Hub                         | 44 ounces (1.3 L)                 |
| Drive Brake                       | 2.7 ounces (80 ml)                |

**Engine Data**

**Table 7-5. Kubota D1305**

|                                                                         |                              |
|-------------------------------------------------------------------------|------------------------------|
| Fuel                                                                    | Diesel                       |
| No. of Cylinders                                                        | 3                            |
| Max Rated Gross Output                                                  | 24.8 hp (18.5 kW) @ 2600 rpm |
| High RPM                                                                | 2600                         |
| Low RPM                                                                 | 1800                         |
| Oil Capacity w/filter                                                   | 6 qts. (5.7 L)               |
| Coolant Capacity (Engine Only)                                          | 0.45 gal. (1.7 L)            |
| Engine Dry Weight                                                       | 247 lb (112 kg)              |
| <b>Acceptable Fuel Grades</b>                                           |                              |
| Low Sulfur (<500 ppm) or Ultra Low Sulfur (15 ppm) strongly recommended |                              |
| Up to 5% BioDiesel                                                      |                              |

## SECTION 7 - GENERAL SPECIFICATIONS & OPERATOR MAINTENANCE

### Hydraulic Oil

**Table 7-6. Hydraulic Oil**

| Hydraulic System Operating Temperature Range | S.A.E. Viscosity Grade |
|----------------------------------------------|------------------------|
| +0° to +180°F (-18° to +83°C)                | 10W                    |
| +0° to +210°F (-18° to +99°C)                | 10W-20, 10W30          |
| +50° to +210°F (+10° to +99°C)               | 20W-20                 |

**NOTE:** Hydraulic oils must have anti-wear qualities at least to API Service Classification GL-3, and sufficient chemical stability for mobile hydraulic system service. JLG Industries recommends Mobilfluid 424 hydraulic oil, which has an SAE viscosity index of 152.

**NOTE:** When temperatures remain consistently below 20 degrees F. (-7 degrees C.), JLG Industries recommends the use of standard UTTO.

Aside from JLG recommendations, it is not advisable to mix oils of different brands or types, as they may not contain the same required additives or be of comparable viscosities. If use of hydraulic oil other than standard UTTO is desired, contact JLG Industries for proper recommendations.

**Table 7-7. Mobilfluid 424 Specs**

| SAE Grade               | 10W30         |
|-------------------------|---------------|
| ISO Grade               | 55            |
| Gravity, API            | 29.0          |
| Density, Lb/Gal. 60°F   | 7.35          |
| Pour Point, Max         | -46°F (-43°C) |
| Flash Point, Min.       | 442°F (228°C) |
| Viscosity               |               |
| Brookfield, cP at -18°C | 2700          |
| at 40°C                 | 55 cSt        |
| at 100°C                | 9.3 cSt       |
| Viscosity Index         | 152           |

**SECTION 7 - GENERAL SPECIFICATIONS & OPERATOR MAINTENANCE**

**Table 7-8. Mobil DTE 10 Excel 32 Specs**

|                     |               |
|---------------------|---------------|
| ISO Viscosity Grade | #32           |
| Specific Gravity    | 0.877         |
| Pour Point, Max     | -40°F (-40°C) |
| Flash Point, Min.   | 330°F (166°C) |
| <b>Viscosity</b>    |               |
| at 40°C             | 33cSt         |
| at 100°C            | 6.6cSt        |
| at 100°F            | 169SUS        |
| at 210°F            | 48SUS         |
| cp at -20°F         | 6,200         |
| Viscosity Index     | 140           |

**Table 7-9. UCon Hydrolube HP-5046**

|                  |                         |
|------------------|-------------------------|
| Type             | Synthetic Biodegradable |
| Specific Gravity | 1.082                   |
| Pour Point, Max  | -58°F (-50°C)           |
| pH               | 9.1                     |
| <b>Viscosity</b> |                         |
| at 0°C (32°F)    | 340 cSt (1600SUS)       |
| at 40°C (104°F)  | 46 cSt (215SUS)         |
| at 65°C (150°F)  | 22 cSt (106SUS)         |
| Viscosity Index  | 170                     |



## SECTION 7 - GENERAL SPECIFICATIONS & OPERATOR MAINTENANCE

**Table 7-10. Mobil EAL 224H Specs**

|                                               |                                        |
|-----------------------------------------------|----------------------------------------|
| Type                                          | Synthetic Biodegradable                |
| ISO Viscosity Grade                           | 32/46                                  |
| Specific Gravity                              | .922                                   |
| Pour Point, Max                               | -25°F (-32°C)                          |
| Flash Point, Min.                             | 428°F (220°C)                          |
| Operating Temp.                               | 0 to 180°F (-17 to 162°C)              |
| Weight                                        | 7.64 lb per gal.<br>(0.9 kg per liter) |
| <b>Viscosity</b>                              |                                        |
| at 40°C                                       | 37 cSt                                 |
| at 100°C                                      | 8.4 cSt                                |
| Viscosity Index                               | 213                                    |
| <b>NOTE:</b> Must be stored above 32°F (14°C) |                                        |

**Table 7-11. Exxon Univis HVI 26 Specs**

|                                                                                               |               |
|-----------------------------------------------------------------------------------------------|---------------|
| Specific Gravity                                                                              | 32.1          |
| Pour Point                                                                                    | -76°F (-60°C) |
| Flash Point                                                                                   | 217°F (103°C) |
| <b>Viscosity</b>                                                                              |               |
| at 40°C                                                                                       | 25.8 cSt      |
| at 100°C                                                                                      | 9.3 cSt       |
| Viscosity Index                                                                               | 376           |
| <b>NOTE:</b> Mobil/Exxon recommends that this oil be checked on a yearly basis for viscosity. |               |

## Critical Stability Weights

### WARNING

DO NOT REPLACE ITEMS CRITICAL TO STABILITY WITH ITEMS OF DIFFERENT WEIGHT OR SPECIFICATION (FOR EXAMPLE: BATTERIES, FILLED TIRES, COUNTER WEIGHT, ENGINE, AND PLATFORM) DO NOT MODIFY UNIT IN ANY WAY TO EFFECT STABILITY.

**Table 7-12. Critical Stability Weights**

| COMPONENTS                              |                | LB      | KG.      |
|-----------------------------------------|----------------|---------|----------|
| Tire & Wheel Size<br>(Foam Filled Only) | 15-625         | 544     | 247      |
|                                         | 18-625         | 601     | 273      |
| Engine (No added components)            |                | 247     | 112      |
| Counterweight                           | Turntable      | 1700±68 | 771.5±31 |
| Wheel Hubs                              |                | 218     | 99       |
| Platform                                | 6 FT. (1.83 M) | 205     | 93       |
|                                         | 8 FT. (2.44 M) | 230     | 105      |

## SECTION 7 - GENERAL SPECIFICATIONS & OPERATOR MAINTENANCE

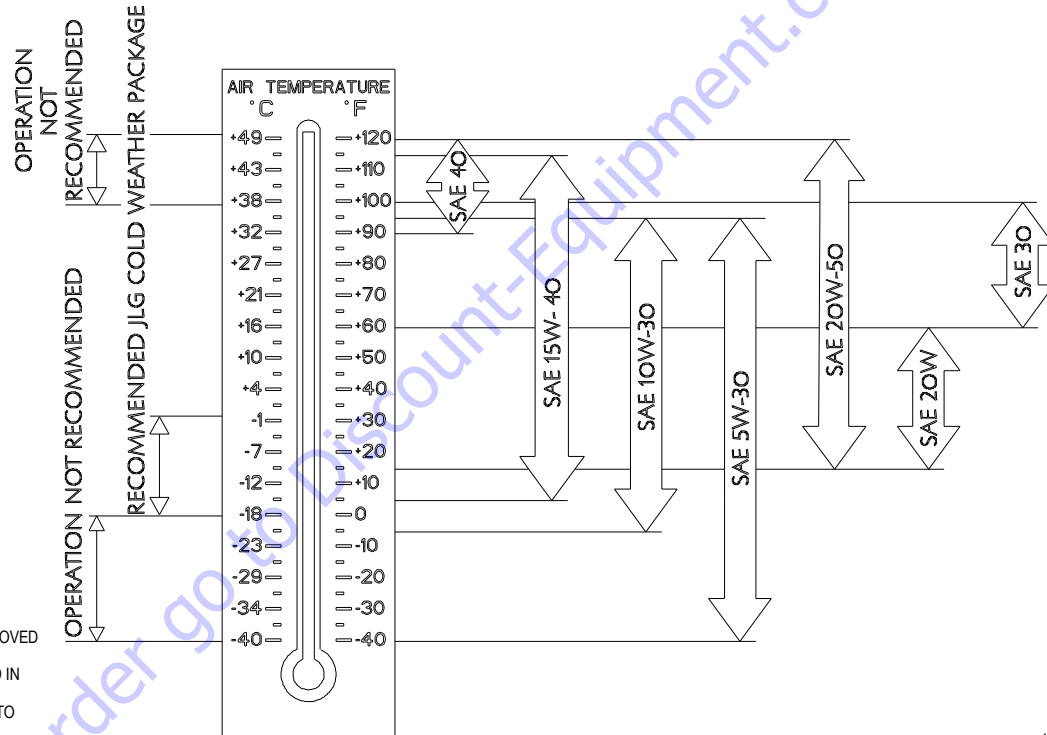

**NOTICE:**

MACHINE OPERATION USING NON-JLG APPROVED ENGINE OIL OR OPERATION OUTSIDE OF THE TEMPERATURE BOUNDARIES OUTLINED IN THE "ENGINE OIL OPERATION CHART" MAY RESULT IN PREMATURE WEAR OR DAMAGE TO COMPONENTS OF THE ENGINE.

**Figure 7-1. Engine Oil Operating Specifications**

1001222023 B

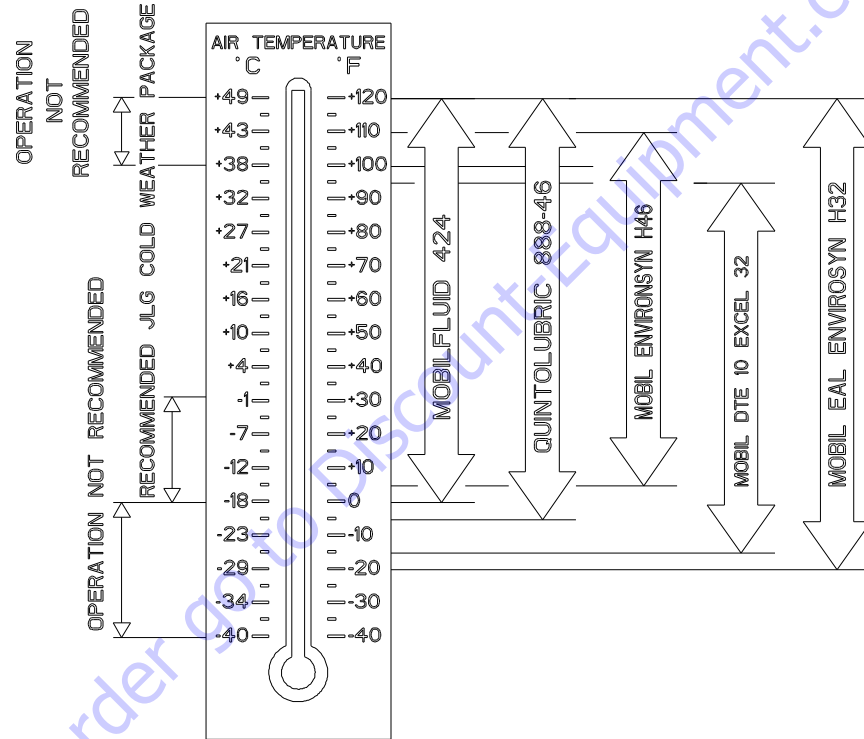

Figure 7-2. Hydraulic Oil Operating Temperature Specifications - Sheet 1 of 2

1001228397 B

## SECTION 7 - GENERAL SPECIFICATIONS & OPERATOR MAINTENANCE

| Fluid                    | Properties                          |            | Base         |                |           |                         | Classification         |                       |                   |
|--------------------------|-------------------------------------|------------|--------------|----------------|-----------|-------------------------|------------------------|-----------------------|-------------------|
|                          | Viscosity @40 °C<br>(Cs.T, Typical) | Visc Index | Mineral Oils | Vegetable Oils | Synthetic | Synthetic Polyol Esters | Readily Biodegradable* | Virtually Non-toxic** | Fire Resistant*** |
| Mobilfluid 424           | 55                                  | 152        | X            |                |           |                         |                        |                       |                   |
| Mobil DTE 10 Excel 32    | 32.7                                | 164        | X            |                |           |                         |                        |                       |                   |
| Mobil EAL EnviroSyn H 32 | 33.1                                | 147        |              |                | X         |                         | X                      |                       |                   |
| Mobil EnviroSyn H 46     | 48.8                                | 145        |              |                | X         |                         | X                      | X                     |                   |
| Quintolubric 888-46      | 47.5                                | 190        |              |                |           | X                       | X                      | X                     | X                 |

NOTICE:  
MACHINE OPERATION USING NON-JLG APPROVED HYDRAULIC FLUIDS OR OPERATION OUTSIDE OF THE TEMPERATURE BOUNDARIES OUTLINED IN THE "HYDRAULIC FLUID OPERATION CHART" MAY RESULT IN PREMATURE WEAR OR DAMAGE TO COMPONENTS OF THE HYDRAULIC SYSTEM.

MACHINE OPERATION TEMPERATURE BOUNDARIES CONTAINED IN THIS DOCUMENT APPLY TO THE FOLLOWING MODELS:  
H800AJ

\* Readily biodegradable classification indicates one of the following:  
CO2 Conversion >60% per EPA 560/6-82-003  
CO2 Conversion >80% per CEC-L-33-A-93

\*\* Virtually Non-toxic classification indicates an LC50 >5000 ppm per OECD 203

\*\*\* Fire Resistant classification indicates Factory Mutual Research Corp. (FMRC) Approval

Figure 7-3. Hydraulic Oil Operating Temperature Specifications - Sheet 2 of 2

1001228397 B

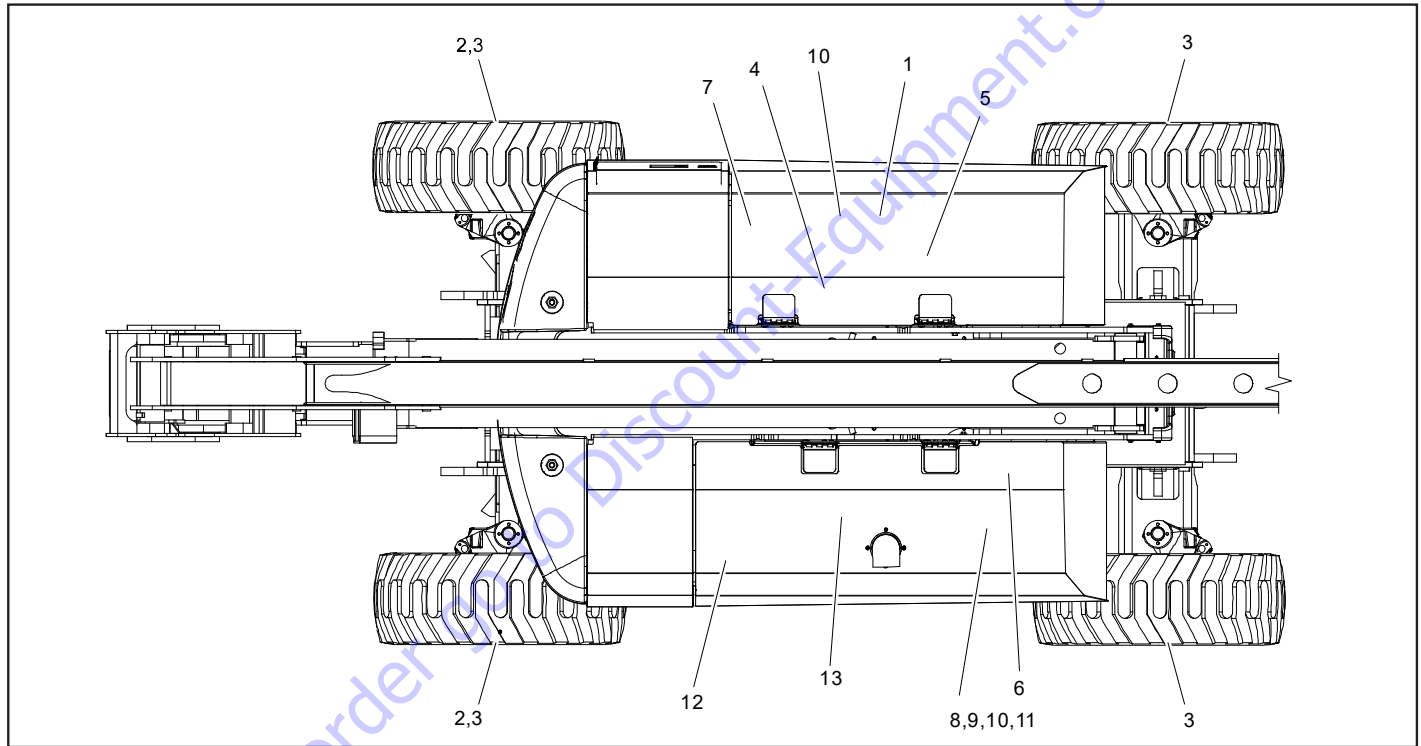

Figure 7-4. Maintenance and Lubrication Diagram

## SECTION 7 - GENERAL SPECIFICATIONS & OPERATOR MAINTENANCE

### 7.3 MAINTENANCE AND LUBRICATION

**NOTE:** The following numbers correspond to those in Figure 7-4., Maintenance and Lubrication Diagram.

**Table 7-13. Lubrication Specifications**

| KEY  | SPECIFICATIONS                                                                                                                                                                              |
|------|---------------------------------------------------------------------------------------------------------------------------------------------------------------------------------------------|
| MPG  | Multipurpose Grease having a minimum dripping point of 350°F (177°C). Excellent water resistance and adhesive qualities, and being of extreme pressure type. (Timken OK 40 pounds minimum.) |
| EPGL | Extreme Pressure Gear Lube (oil) meeting API service classification GL-5 or MIL-Spec MIL-L-2105                                                                                             |
| HO   | Hydraulic Oil. API service classification GL-3, e.g. Mobilfluid 424                                                                                                                         |
| EO   | Engine (crankcase) Oil. Gas - API SF, SH, SG class, MIL-L-2104. Diesel - API CC/CD class, MIL-L-2104B/MIL-L-2104C                                                                           |

#### **NOTICE**

**LUBRICATION INTERVALS ARE BASED ON MACHINE OPERATION UNDER NORMAL CONDITIONS. FOR MACHINES USED IN MULTI-SHIFT OPERATIONS AND/OR EXPOSED TO HOSTILE ENVIRONMENTS OR CONDITIONS, LUBRICATION FREQUENCIES MUST BE INCREASED ACCORDINGLY.**

**NOTE:** It is recommended as a good practice to replace all filters at the same time.

#### 1. Swing Bearing - Internal Ball Bearing



Lube Point(s) - 2 Grease Fittings

Capacity - A/R

Lube - MPG

Interval - Every 3 months or 150 hrs of operation

Comments - Remote Access

## SECTION 7 - GENERAL SPECIFICATIONS & OPERATOR MAINTENANCE

### 2. Wheel Drive Hub

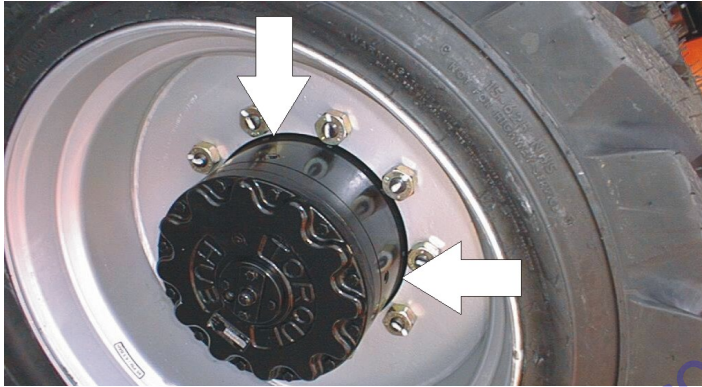

Lube Point(s) - Level/Fill Plug

Capacity - 17 oz. (0.5 L) - 1/2 Full

Lube - EPGL

Interval - Check level every 3 months or 150 hrs of operation;  
change every 2 years or 1200 hours of operation

Comments - Place Fill port at 12 o'clock position and Check  
port at 3 o'clock position. Pour lubricant into fill port until it  
just starts to flow out of check port.

### 3. Oil Change w/Filter

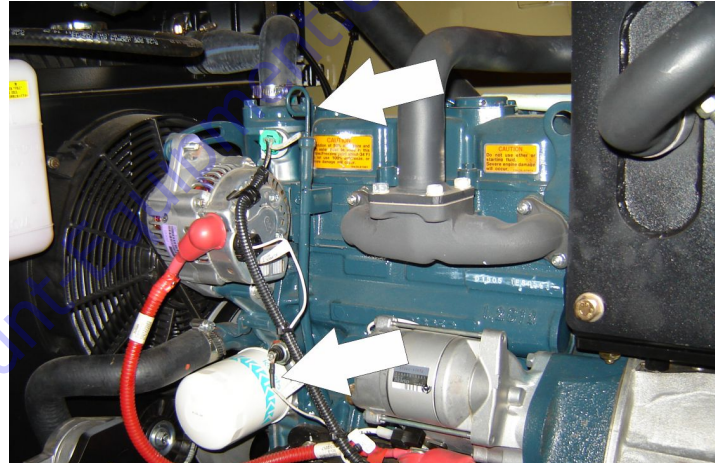

Lube Point(s) - Fill Cap/Spin-on Element

Capacity - 6 qt. (5.7 L) w/filter

Lube - EO

Interval - Change in accordance with engine manual

Comments - Check level daily/Adjust full level by mark on dip-  
stick.



## SECTION 7 - GENERAL SPECIFICATIONS & OPERATOR MAINTENANCE

### 4. Fuel Filter/Water Separator

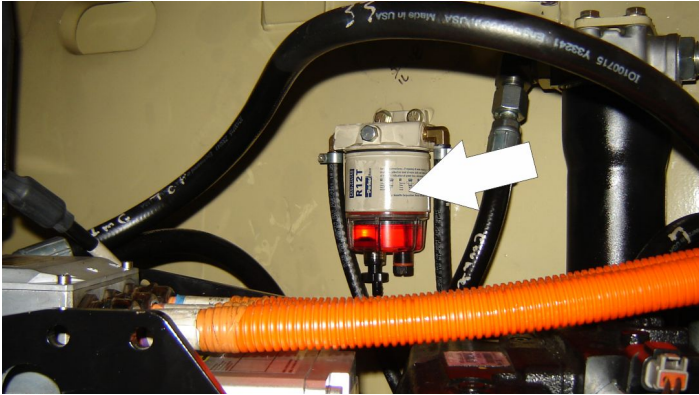

Lube Point(s) - Replaceable Element  
Interval - Drain water daily; Change every year or 600 hours of operation

### 5. Fuel Strainer

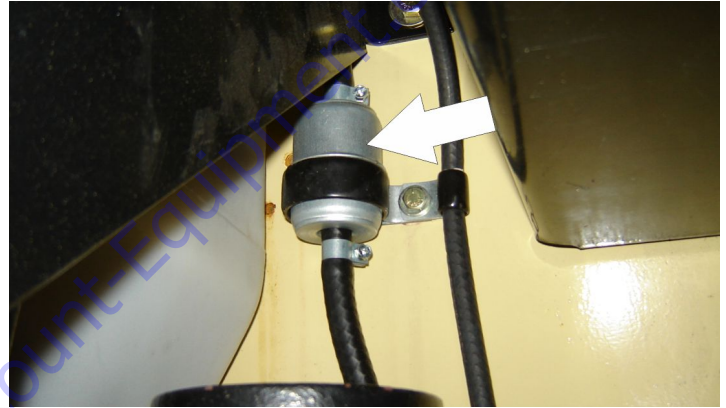

Lube Point(s) - Replaceable Element  
Interval - Change every year or 600 hours of operation

## SECTION 7 - GENERAL SPECIFICATIONS & OPERATOR MAINTENANCE

### 6. Radiator

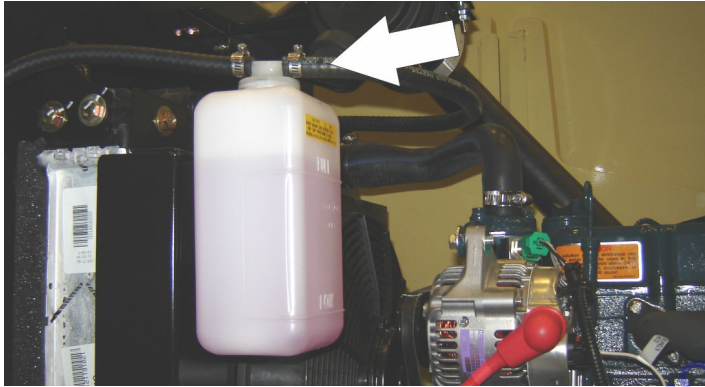

Lube Point(s) - Fill Cap

Lube - Anti-Freeze Coolant (Refer to Engine Manual for compatible coolants)

Capacity - 6 qt. (5.7 L)

### 7. Swing Drive Hub

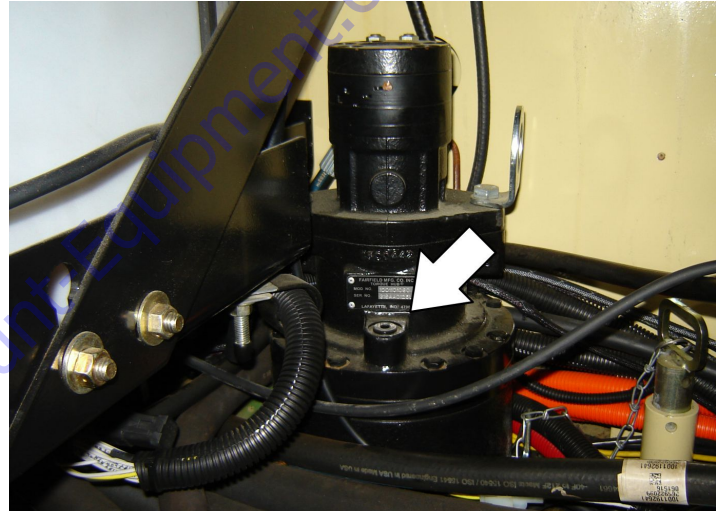

Lube Point(s) - Level/Fill Plug

Capacity - 43 oz. (1.3 L)

Lube - 90w80 Gear Oil

Interval - Check level every 3 months or 150 hrs of operation;  
change every 2 years or 1200 hours of operation

## SECTION 7 - GENERAL SPECIFICATIONS & OPERATOR MAINTENANCE

### 8. Hydraulic Return Filter

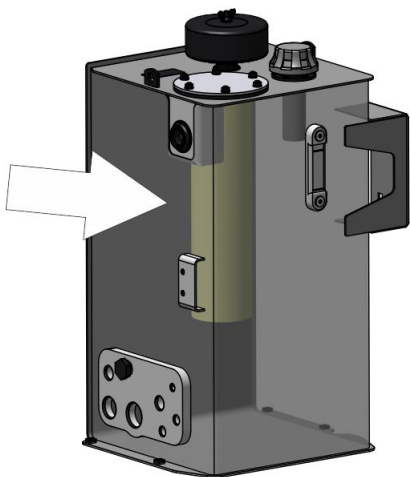

Interval - Change after first 50 hrs. and every 6 months or 300 hrs. thereafter or as indicated by Condition Indicator.

### 9. Hydraulic Charge Filter

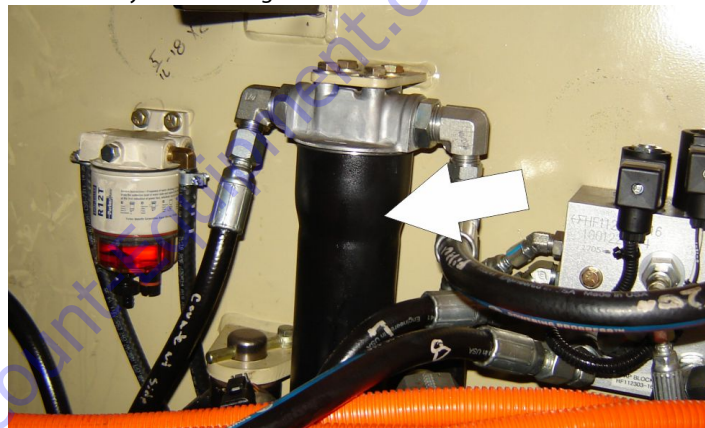

Interval - Change after first 50 hrs. and every 6 months or 300 hrs. thereafter or as indicated by Condition Indicator.

**10. Hydraulic Tank**

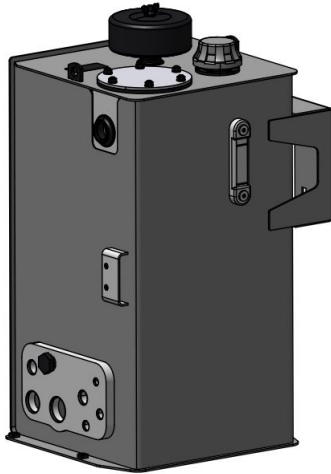

Lube Point(s) - Fill Cap

Capacity - 25 gallons (94.5 L) total capacity, 21 gallons (79.5 L) to Full Mark on Sight Gauge; 59 gallons (223 L) System

Lube - HO

Interval - Check Level daily; Change every 2 years or 1200 hours of operation.

**11. Air Filter**

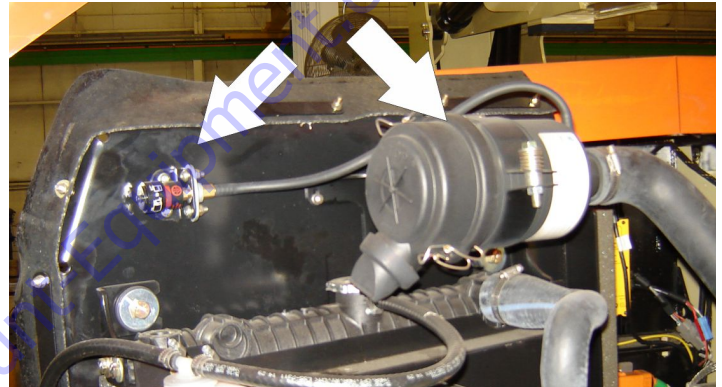

Lube Point(s) - Replaceable Element

Interval - Every 6 months or 300 hours of operation or as indicated by the condition indicator

### 7.4 TIRES & WHEELS

#### Tire Damage

For polyurethane foam filled tires, JLG Industries, Inc. recommends that when any of the following are discovered, measures must be taken to remove the JLG product from service immediately and arrangements must be made for replacement of the tire or tire assembly.

- a smooth, even cut through the cord plies which exceeds 3 inches (7.5 cm) in total length
- any tears or rips (ragged edges) in the cord plies which exceeds 1 inch (2.5 cm) in any direction
- any punctures which exceed 1 inch in diameter
- any damage to the bead area cords of the tire

If a tire is damaged but is within the above noted criteria, the tire must be inspected on a daily basis to insure the damage has not propagated beyond the allowable criteria.

#### Tire Replacement

JLG recommends a replacement tire be the same size, ply and brand as originally installed on the machine. Please refer to the JLG Parts Manual for the part number of the approved tires for a particular machine model. If not using a JLG approved replacement tire, we

recommend that replacement tires have the following characteristics:

- Equal or greater ply/load rating and size of original
- Tire tread contact width equal or greater than original
- Wheel diameter, width, and offset dimensions equal to the original
- Approved for the application by the tire manufacturer (including inflation pressure and maximum tire load)

Unless specifically approved by JLG Industries Inc. do not replace a foam filled or ballast filled tire assembly with a pneumatic tire. When selecting and installing a replacement tire, ensure that all tires are inflated to the pressure recommended by JLG. Due to size variations between tire brands, both tires on the same axle should be the same.

#### Wheel Replacement

The rims installed on each product model have been designed for stability requirements which consist of track width, tire pressure, and load capacity. Size changes such as rim width, center piece location, larger or smaller diameter, etc., without written factory recommendations, may result in an unsafe condition regarding stability.

### Wheel Installation

It is extremely important to apply and maintain proper wheel mounting torque.

#### **⚠ WARNING**

**WHEEL NUTS MUST BE INSTALLED AND MAINTAINED AT THE PROPER TORQUE TO PREVENT LOOSE WHEELS, BROKEN STUDS, AND POSSIBLE DANGEROUS SEPARATION OF WHEEL FROM THE AXLE. BE SURE TO USE ONLY THE NUTS MATCHED TO THE CONE ANGLE OF THE WHEEL.**

Tighten the lug nuts to the proper torque to prevent wheels from coming loose. Use a torque wrench to tighten the fasteners. If you do not have a torque wrench, tighten the fasteners with a lug wrench, then immediately have a service garage or dealer tighten the lug nuts to the proper torque. Over-tightening will result in breaking the studs or permanently deforming the mounting stud holes in the wheels. The proper procedure for attaching wheels is as follows:

1. Start all nuts by hand to prevent cross threading. DO NOT use a lubricant on threads or nuts.

2. Tighten nuts in the following sequence:

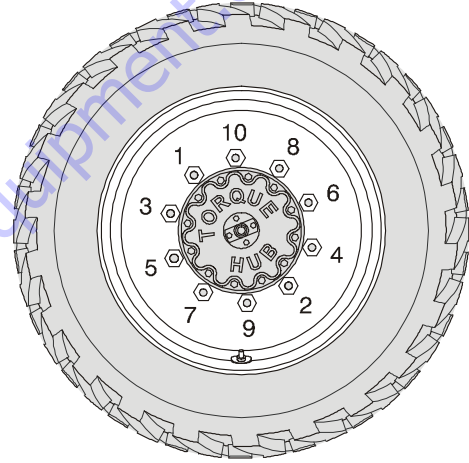

3. The tightening of the nuts should be done in stages. Following the recommended sequence, tighten nuts per wheel torque chart.
4. Wheel nuts should be torqued after first 50 hours of operation and after each wheel removal. Check torque every 3 months or 150 hours of operation.

**Table 7-14. Wheel Torque Chart**

| TORQUE SEQUENCE        |                          |                          |
|------------------------|--------------------------|--------------------------|
| 1st Stage              | 2nd Stage                | 3rd Stage                |
| 70 ft. lbs.<br>(95 Nm) | 170 ft. lbs.<br>(225 Nm) | 300 ft. lbs.<br>(405 Nm) |

### 7.5 SUPPLEMENTAL INFORMATION

The following information is provided in accordance with the requirements of the European Machinery Directive 2006/42/EC and is only applicable to CE machines.

For electric powered machines, the equivalent continuous A-Weighted sound pressure level at the work platform is less than 70dB(A)

For combustion engine powered machines, guaranteed Sound Power Level (LWA) per European Directive 2000/14/EC (Noise Emission in the Environment by Equipment for Use Outdoors) based on test methods in accordance with Annex III, Part B, Method 1 and 0 of the directive, is 102 dB.

The vibration total value to which the hand-arm system is subjected does not exceed  $2,5 \text{ m/s}^2$ . The highest root mean square value of weighted acceleration to which the whole body is subjected does not exceed  $0,5 \text{ m/s}^2$ .

**TO PURCHASE THIS PRODUCT PLEASE CONTACT US**



**Equipment Financing and  
Extended Warranties Available**



**Discount-Equipment.com is your online resource for  
commercial and industrial quality parts and equipment sales.**

**561-964-4949**

**visit us on line @ [www.discount-equipment.com](http://www.discount-equipment.com)**

Select an option below to find your Equipment

**Search by Manufacturer**

**Search by Product Type**

**Request a Quote**

We sell worldwide for the brands: Genie, Terex, JLG, MultiQuip, Mikasa, Essick, Whiteman, Mayco, Toro Stone, Diamond Products, Generac Magnum, Airman, Haulotte, Barreto, Power Blanket, Nifty Lift, Atlas Copco, Chicago Pneumatic, Allmand, Miller Curber, Skyjack, Lull, Skytrak, Tsurumi, Husquvarna Target, Stow, Wacker, Sakai, Mi-T-M, Sullair, Basic, Dynapac, MBW, Weber, Bartell, Bennar Newman, Haulotte, Ditch Runner, Menegotti, Morrison, Contec, Buddy, Crown, Edco, Wyco, Bomag, Laymor, EZ Trench, Bil-Jax, F.S. Curtis, Gehl Pavers, Heli, Honda, ICS/PowerGrit, IHI, Partner, Imer, Clipper, MMD, Koshin, Rice, CH&E, General Equipment, Amida, Coleman, NAC, Gradall, Square Shooter, Kent, Stanley, Tamco, Toku, Hatz, Kohler, Robin, Wisconsin, Northrock, Oztec, Toker TK, Rol-Air, APT, Wylie, Ingersoll Rand / Doosan, Innovatech, Con X, Ammann, Mecalac, Makinex, Smith Surface Prep, Small Line, Wanco, Yanmar



**JLG**<sup>®</sup>

An Oshkosh Corporation Company

**Discount  
Equipment**

[www.Discount-Equipment.com](http://www.Discount-Equipment.com)

To order go to [www.Discount-Equipment.com](http://www.Discount-Equipment.com)