



An Oshkosh Corporation Company



www.Discount-Equipment.com

Operation and Safety Manual

Original Instructions - Keep this manual with the machine at all times.

Model(s)

X1000AJ

X33JP



P/N - 3121783
February, 2019 - Rev A

TO PURCHASE THIS PRODUCT PLEASE CONTACT US



**Equipment Financing and
Extended Warranties Available**



**Discount-Equipment.com is your online resource for
commercial and industrial quality parts and equipment sales.**

561-964-4949

visit us on line @ www.discount-equipment.com

Select an option below to find your Equipment

Search by Manufacturer

Search by Product Type

Request a Quote

We sell worldwide for the brands: Genie, Terex, JLG, MultiQuip, Mikasa, Essick, Whiteman, Mayco, Toro Stone, Diamond Products, Generac Magnum, Airman, Haulotte, Barreto, Power Blanket, Nifty Lift, Atlas Copco, Chicago Pneumatic, Allmand, Miller Curber, Skyjack, Lull, Skytrak, Tsurumi, Husquvarna Target, Stow, Wacker, Sakai, Mi-T-M, Sullair, Basic, Dynapac, MBW, Weber, Bartell, Bennar Newman, Haulotte, Ditch Runner, Menegotti, Morrison, Contec, Buddy, Crown, Edco, Wyco, Bomag, Laymor, EZ Trench, Bil-Jax, F.S. Curtis, Gehl Pavers, Heli, Honda, ICS/PowerGrit, IHI, Partner, Imer, Clipper, MMD, Koshin, Rice, CH&E, General Equipment, Amida, Coleman, NAC, Gradall, Square Shooter, Kent, Stanley, Tamco, Toku, Hatz, Kohler, Robin, Wisconsin, Northrock, Oztec, Toker TK, Rol-Air, APT, Wylie, Ingersoll Rand / Doosan, Innovatech, Con X, Ammann, Mecalac, Makinex, Smith Surface Prep, Small Line, Wanco, Yanmar



WARNING

Operating, servicing and maintaining this vehicle or equipment can expose you to chemicals including engine exhaust, carbon monoxide, phthalates, and lead, which are known to the State of California to cause cancer and birth defects or other reproductive harm. To minimize exposure, avoid breathing exhaust, do not idle the engine except as necessary, service your vehicle or equipment in a well-ventilated area and wear gloves or wash your hands frequently when servicing. For more information go to www.P65Warnings.ca.gov.

FOREWORD

The Mobile Elevating Work Platform (MEWP) models covered in this manual are designed and tested to meet or exceed various compliance standards. Please refer to the manufacturer's nameplate affixed to the subject MEWP for specific standard compliance information.

This manual is a very important tool! Keep it with the machine at all times.

The purpose of this manual is to provide owners, users, operators, lessors, and lessees with the precautions and operating procedures essential for the safe and proper machine operation for its intended purpose.

Due to continuous product improvements, JLG Industries, Inc. reserves the right to make specification changes without prior notification. Contact JLG Industries, Inc. for updated information.

SAFETY ALERT SYMBOLS AND SAFETY SIGNAL WORDS



This is the Safety Alert Symbol. It is used to alert you to the potential personal injury hazards. Obey all safety messages that follow this symbol to avoid possible injury or death.

⚠ DANGER

INDICATES AN IMMINENTLY HAZARDOUS SITUATION. IF NOT AVOIDED, WILL RESULT IN SERIOUS INJURY OR DEATH. THIS DECAL WILL HAVE A RED BACKGROUND.

⚠ WARNING

INDICATES A POTENTIALITY HAZARDOUS SITUATION. IF NOT AVOIDED, COULD RESULT IN SERIOUS INJURY OR DEATH. THIS DECAL WILL HAVE AN ORANGE BACKGROUND.

⚠ CAUTION

INDICATES A POTENTIALITY HAZARDOUS SITUATION. IF NOT AVOIDED, MAY RESULT IN MINOR OR MODERATE INJURY. IT MAY ALSO ALERT AGAINST UNSAFE PRACTICES. THIS DECAL WILL HAVE A YELLOW BACKGROUND.

NOTICE

INDICATES INFORMATION OR A COMPANY POLICY THAT RELATES DIRECTLY OR INDIRECTLY TO THE SAFETY OF PERSONNEL OR PROTECTION OF PROPERTY.

⚠ WARNING

THIS PRODUCT MUST COMPLY WITH ALL SAFETY RELATED BULLETINS. CONTACT JLG INDUSTRIES, INC. OR THE LOCAL AUTHORIZED JLG REPRESENTATIVE FOR INFORMATION REGARDING SAFETY RELATED BULLETINS WHICH MAY HAVE BEEN ISSUED FOR THIS PRODUCT.

NOTICE

JLG INDUSTRIES, INC. SENDS SAFETY RELATED BULLETINS TO THE OWNER OF RECORD OF THIS MACHINE. CONTACT JLG INDUSTRIES, INC. TO ENSURE THAT THE CURRENT OWNER RECORDS ARE UPDATED AND ACCURATE.

NOTICE

JLG INDUSTRIES, INC. MUST BE NOTIFIED IMMEDIATELY IN ALL INSTANCES WHERE JLG PRODUCTS HAVE BEEN INVOLVED IN AN ACCIDENT INVOLVING BODILY INJURY OR DEATH OF PERSONNEL OR WHEN SUBSTANTIAL DAMAGE HAS OCCURRED TO PERSONAL PROPERTY OR THE JLG PRODUCT.

For :

- Accident Reporting
- Product Safety Publications
- Current Owner Updates
- Questions Regarding Product Safety
- Standards and Regulations Compliance Information
- Questions Regarding Special Product Applications
- Questions Regarding Product Modifications

Contact :

Product Safety and Reliability Department
JLG Industries, Inc.
13224 Fountainhead Plaza
Hagerstown, MD 21742
USA

or Your Local JLG Office
(See addresses on inside of manual cover)

In USA:

Toll Free: 877-JLG-SAFE (877-554-7233)

Outside USA:

Phone: 240-420-2661

E-mail: ProductSafety@JLG.com

REVISION LOG

Original Issue of Manual..... February, 2019

To order go to Discount-Equipment.com

SECTION - PARAGRAPH, SUBJECT	PAGE	SECTION - PARAGRAPH, SUBJECT	PAGE
FOREWORD.....	1-A	Operator Training.....	2-1
SAFETY ALERT SYMBOLS AND SAFETY SIGNAL		Training Supervision.....	2-1
WORDS.....	1-B	Operator Responsibility.....	2-1
Contact :.....	1-c	2.2 PREPARATION, INSPECTION, AND	
In USA:.....	1-c	MAINTENANCE.....	2-2
Outside USA:.....	1-c	Pre-Start Inspection.....	2-4
REVISION LOG.....	1-D	Daily Walk-Around Inspection.....	2-5
		Function Check.....	2-7
SECTION - 1 - SAFETY PRECAUTIONS		SECTION - 3 - MACHINE CONTROLS, INDICATORS AND	
1.1 GENERAL.....	1-1	OPERATION	
1.2 PRE-OPERATION.....	1-1	3.1 GROUND CONTROL STATION.....	3-3
Operator Training and Knowledge.....	1-1	Menu Screens:.....	3-7
Workplace Inspection.....	1-2	3.2 PLATFORM CONTROL STATION.....	3-11
Machine Inspection.....	1-3	Installing the Platform Control Station:.....	3-11
1.3 OPERATION.....	1-3	Platform Control Functions:.....	3-12
General.....	1-3	Platform/Remote Control Station LCD Display.....	3-15
Trip and Fall Hazards.....	1-4		
Electrocution Hazards.....	1-5	SECTION - 4 - MACHINE OPERATION	
Tipping Hazards.....	1-6	4.1 DESCRIPTION.....	4-1
Crushing and Collision Hazards.....	1-10	4.2 BOOM OPERATING CHARACTERISTICS AND	
1.4 TOWING, LIFTING, AND HAULING.....	1-11	LIMITATIONS.....	4-1
1.5 MAINTENANCE.....	1-11	Capacities.....	4-1
Maintenance Hazards.....	1-11	Stability.....	4-1
Battery Hazards.....	1-13	4.3 ENGINE OPERATION.....	4-2
		Diesel Starting Procedure.....	4-2
SECTION - 2 - PREPARATION AND INSPECTION		Diesel Engine Shutdown Procedure.....	4-2
2.1 PERSONNEL TRAINING.....	2-1		

TABLE OF CONTENTS

SECTION - PARAGRAPH, SUBJECT	PAGE	SECTION - PARAGRAPH, SUBJECT	PAGE
Electric Engine Starting Procedure - AC Voltage Machine	4-3	Platform Removal/Installation.	4-23
4.4 BASE AND BOOM/JIB ALIGNMENT	4-4	4.8 BATTERY CHARGING - DIESEL/AC-ELECTRIC.	4-24
4.5 TRACKS - DRIVING, STEERING AND TRACK WIDTH ADJUST	4-5	Battery Charging - Daily	4-25
Track width adjust.	4-5	4.9 BATTERY CHARGING - LITHIUM-ION MACHINE	4-25
Travelling (Drive and Steer)	4-6	Charging the Battery Pack	4-26
Travelling (Grades and Side Slopes)	4-6	Charge Curve	4-28
Jib Position for Travelling	4-8	Cold Weather Charging	4-28
4.6 OUTRIGGER OPERATION.	4-9	Cooling Fans	4-28
Variable Outrigger Positioning	4-9	4.10 SHUT DOWN AND PARK	4-29
Operating with Outriggers Set to 32° - Restricted Work Area Of Operation	4-11	4.11 LIFTING AND TIE DOWN	4-30
Setting Outriggers From the Platform/Remote Console	4-17	Lifting with a Forklift.	4-30
Retracting The Outriggers	4-18	Lifting with Slings or Chains.	4-30
4.7 BOOM/PLATFORM OPERATION.	4-18	Tie Down.	4-32
Overload Alarm	4-19	4.12 MACHINE DECALS (X1000AJ)	4-34
Platform Level Adjustment	4-19	4.13 MACHINE DECALS (X33JP)	4-47
Raise And Lower The Tower Boom	4-20	SECTION - 5 - EMERGENCY PROCEDURES	
Raise And Lower The Main Boom	4-20	5.1 GENERAL	5-1
Extend/Retract The Main Boom.	4-20	5.2 INCIDENT NOTIFICATION	5-1
Platform Rotation	4-20	5.3 EMERGENCY OPERATION	5-2
Raise And Lower The Jib	4-20	Power Main Cut-Off Switch Location	5-2
Swinging The Boom	4-20	Operator Unable to Control Machine.	5-3
SkyGuard Operation	4-22	Platform or Boom Caught Overhead	5-3
		Emergency Descent.	5-4
		Using Platform Control Box from Platform	5-6

SECTION - PARAGRAPH, SUBJECT	PAGE	SECTION - PARAGRAPH, SUBJECT	PAGE
5.4 BYPASS KEY	5-7	Hydraulic Oil Filter Cartridge	6-14
Using Emergency Descent In Case Of An		Rubber Track Maintenance/Replacement	6-15
Outrigger Losing Contact With The Ground	5-8	Wire Cable Inspection	6-18
Machine Realignment Emergency Procedure ..	5-9	Wire Cable Adjustment	6-19
		Wear Pad Inspection	6-20
SECTION - 6 - GENERAL SPECIFICATIONS AND OPERA-		Turntable Attach Bolts	6-20
TOR MAINTENANCE		Battery Maintenance and Charging -	
6.1 INTRODUCTION	6-1	Diesel/AC-Electric	6-20
6.2 OPERATING SPECIFICATIONS	6-2	6.4 ELECTRIC MOTOR MAINTENANCE	6-21
Dimensional Data	6-2	Electric Motor	6-21
Chassis	6-2	6.5 PLATFORM/REMOTE CONTROL SERVICE	
Capacities	6-3	MENU	6-21
Engine Data	6-3	Service Button	6-21
Electric Motor Data	6-3	Menu Input	6-22
Lithium-Ion Battery Pack Specifications	6-4	Errors Menu	6-24
Major Component Weights	6-4	Working Hours Menu	6-24
6.3 SERVICE/MAINTENANCE	6-5	Set-up Menu	6-24
Cleaning the Machine	6-5	Joystick Menu	6-24
Lubrication	6-5	6.6 LITHIUM-ION MACHINE - MAINTAINANCE	6-25
Hydraulic Oil Specifications	6-7	Battery Pack System Components and	
Engine Air Filter	6-12	Maintenance	6-25
Engine Oil	6-12	Lithium-Ion Machine Fault Codes	6-26
Engine Oil Filter (if equipped)	6-13	BMS Fault Codes - (Battery Management	
Engine Fuel Filter/Sediment Bowl (if equipped)	6-13	System)	6-29
Engine Cooling System and Fluid (if equipped)	6-13		
Hydraulic Oil	6-14		

TABLE OF CONTENTS

SECTION - PARAGRAPH, SUBJECT	PAGE
Battery Charger Fault Codes	6-30
6.7 LITHIUM-ION BATTERY PACK - HANDLING IN DANGEROUS CONDITIONS	6-32
Procedure For Handling Hot Cells	6-32
Procedure For Handling Vented Cells	6-33
Procedure For Exploded Cells	6-35
Lithium Battery Fire	6-36

SECTION - 7 - INSPECTION AND REPAIR LOG

SECTION - PARAGRAPH, SUBJECT	PAGE
LIST OF FIGURES	
2-1. Daily Walk-Around Inspection	2-6
2-2. SkyGuard™ Sensor and Override Switch Location	2-8
3-1. Basic Machine Component Locations	3-1
3-2. Ground Control Station	3-4
3-3. Platform Control Station	3-13
4-1. Grade and Side Slope Definition	4-7
4-2. Outrigger Positions	4-10
4-3. Outrigger Positions (Sheet 1 of 2)	4-12
4-4. Outrigger Positions (Sheet 2 of 2)	4-13
4-5. Platform - Load/Reach Chart	4-14
4-6. Platform/Remote Control Box	4-21
4-7. SkyGuard™ Sensor and Override Switch Location	4-22
4-8. Machine Lifting Points	4-31
4-9. Lifting Machine - Attach Points	4-32
4-10. Machine Tie-Down Points	4-33
4-11. X1000AJ - Decal Installation - Sheet 1.	4-34
4-12. X1000AJ - Decal Installation - Sheet 2.	4-35
4-13. X1000AJ - Decal Installation - Sheet 3.	4-36
4-14. X1000AJ - Decal Installation - Sheet 4.	4-37
4-15. X1000AJ - Decal Installation - Sheet 5.	4-38
4-16. X1000AJ - Decal Installation - Sheet 6.	4-39
4-17. X1000AJ - Decal Installation - Sheet 7.	4-40

SECTION - PARAGRAPH, SUBJECT	PAGE
4-18. X1000AJ - Decal Installation - Sheet 8.	4-41
4-19. X1000AJ - Decal Installation - Sheet 9.	4-42
4-20. X33JP - Decal Installation - Sheet 1.	4-47
4-21. X33JP - Decal Installation - Sheet 2.	4-48
4-22. X33JP - Decal Installation - Sheet 3.	4-49
4-23. X33JP - Decal Installation - Sheet 4.	4-50
4-24. X33JP - Decal Installation - Sheet 5.	4-51
4-25. X33JP - Decal Installation - Sheet 6.	4-52
4-26. X33JP - Decal Installation - Sheet 7.	4-53
4-27. X33JP - Decal Installation - Sheet 8.	4-54
4-28. X33JP - Decal Installation - Sheet 9.	4-55
4-29. X33JP - Decal Installation - Sheet 10	4-56
5-1. Platform/Remote Control Station.	5-6
6-1. Hydraulic Oil Specifications	6-7
6-2. Hydraulic Oil Operating Temperatures	6-8

SECTION - PARAGRAPH, SUBJECT	PAGE
-------------------------------------	-------------

LIST OF TABLES

1-1	Minimum Approach Distances (M.A.D.)	1-6
1-2	Beaufort Scale (For Reference Only)	1-9
2-1	Inspection and Maintenance Table	2-3
3-1	LCD Display Icon Descriptions.	3-18
3-2	LCD Display Error Descriptions	3-20
4-1	SkyGuard™ Function Table	4-22
4-2	X1000AJ - Decal Installation - Standard	4-43
4-3	X33JP - Decal Installation - Standard	4-57
6-1	Operating Specifications.	6-2
6-2	Dimensional Data	6-2
6-3	Chassis Data	6-2
6-4	Capacities	6-3
6-5	Kubota D902 Specifications	6-3
6-6	Electric Motor Specifications	6-3
6-7	Lithium Ion Specifications.	6-4
6-8	Major Component Weights	6-4
6-9	Hydraulic Oil Specifications	6-6
6-10	Component Maintenance Intervals - X1000AJ/X33JP - with Diesel Engine	6-9
6-11	Component Maintenance Intervals - X1000AJ/X33JP with Lithium-Ion Battery Pack .	6-11
6-12	Inverter Fault Codes	6-26
6-13	Battery Charger Fault Codes	6-30

TO PURCHASE THIS PRODUCT PLEASE CONTACT US



**Equipment Financing and
Extended Warranties Available**



**Discount-Equipment.com is your online resource for
commercial and industrial quality parts and equipment sales.**

561-964-4949

visit us on line @ www.discount-equipment.com

Select an option below to find your Equipment

Search by Manufacturer

Search by Product Type

Request a Quote

We sell worldwide for the brands: Genie, Terex, JLG, MultiQuip, Mikasa, Essick, Whiteman, Mayco, Toro Stone, Diamond Products, Generac Magnum, Airman, Haulotte, Barreto, Power Blanket, Nifty Lift, Atlas Copco, Chicago Pneumatic, Allmand, Miller Curber, Skyjack, Lull, Skytrak, Tsurumi, Husquvarna Target, Stow, Wacker, Sakai, Mi-T-M, Sullair, Basic, Dynapac, MBW, Weber, Bartell, Bennar Newman, Haulotte, Ditch Runner, Menegotti, Morrison, Contec, Buddy, Crown, Edco, Wyco, Bomag, Laymor, EZ Trench, Bil-Jax, F.S. Curtis, Gehl Pavers, Heli, Honda, ICS/PowerGrit, IHI, Partner, Imer, Clipper, MMD, Koshin, Rice, CH&E, General Equipment, Amida, Coleman, NAC, Gradall, Square Shooter, Kent, Stanley, Tamco, Toku, Hatz, Kohler, Robin, Wisconsin, Northrock, Oztec, Toker TK, Rol-Air, APT, Wylie, Ingersoll Rand / Doosan, Innovatech, Con X, Ammann, Mecalac, Makinex, Smith Surface Prep, Small Line, Wanco, Yanmar

SECTION 1. SAFETY PRECAUTIONS

1.1 GENERAL

This section outlines the necessary precautions for proper and safe machine usage and maintenance. It is mandatory that a daily routine is established based on the content of this manual to promote proper machine usage. A maintenance program, using the information provided in this manual and the Service and Maintenance Manual, must also be established by a qualified person and must be followed to ensure that the machine is safe to operate.

The owner/user/operator/lessor/lessee of the machine must not accept operating responsibility until this manual has been read, training is accomplished, and operation of the machine has been completed under the supervision of an experienced and qualified operator.

This section contains the responsibilities of the owner, user, operator, lessor, and lessee concerning safety, training, inspection, maintenance, application, and operation. If there are any questions with regard to safety, training, inspection, maintenance, application, and operation, please contact JLG Industries, Inc. ("JLG").

WARNING

FAILURE TO COMPLY WITH THE SAFETY PRECAUTIONS LISTED IN THIS MANUAL COULD RESULT IN MACHINE DAMAGE, PROPERTY DAMAGE, PERSONAL INJURY OR DEATH.

1.2 PRE-OPERATION

Operator Training and Knowledge

- Read, understand, and study the Operation and Safety Manual in its entirety before operating the machine. For clarification, questions, or additional information regarding any portions of this manual, contact JLG Industries, Inc.

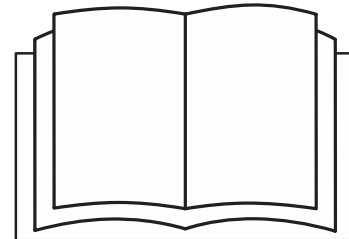

SECTION 1 - SAFETY PRECAUTIONS

- Only personnel who have received proper training regarding the inspection, application and operation of MEWPs (including recognition and avoiding hazards associated with their operation) shall be authorized to operate a MEWP.
- Only properly trained personnel who have received unit-specific familiarization shall operate a MEWP. The user shall determine if personnel are qualified to operate the MEWP prior to operation.
- Read, understand, and obey all DANGERS, WARNINGS, CAUTIONS, and operating instructions on the machine and in this manual.
- Ensure that the machine is to be used in a manner which is within the scope of its intended application as determined by JLG.
- All operating personnel must have a thorough understanding of the intended purpose and function of the MEWP controls, including platform, ground and emergency descent controls.
- Read, understand, and obey all applicable employer, local, and governmental regulations as they pertain to your utilization and application of the machine.

Workplace Inspection

- Precautions to avoid all hazards in the work area must be taken by the user before and during operation of the machine.
- Do not operate or raise the platform from a position on trucks, trailers, railway cars, floating vessels, scaffolds or other equipment unless the application is approved in writing by JLG.
- Before operation, check work area for overhead hazards such as electric lines, bridge cranes, and other potential overhead obstructions.
- Check operating surfaces for holes, bumps, drop-offs, obstructions, debris, concealed holes, and other potential hazards.
- Check the work area for hazardous locations. Do not operate the machine in hazardous environments unless approved for that purpose by JLG.
- Ensure that the ground conditions are adequate to support the maximum outrigger load indicated on the outrigger load decals located on the machine.

Machine Inspection

- Do not operate this machine until the inspections and functional checks as specified in Section 2 of this manual have been performed.
- Do not operate this machine until it has been serviced and maintained according to the maintenance and inspection requirements as specified in the machine's Service and Maintenance Manual.
- Ensure all safety devices are operating properly. Modification of these devices is a safety violation.

WARNING

MODIFICATION OR ALTERATION OF A MEWP SHALL BE MADE ONLY WITH PRIOR WRITTEN PERMISSION FROM THE MANUFACTURER.

- Do not operate any machine on which the safety or instruction placards or decals are missing or illegible.
- Check the machine for modifications to original components. Ensure that any modifications have been approved by JLG.
- Avoid accumulation of debris on platform floor. Keep mud, oil, grease, and other slippery substances from footwear and platform floor.

1.3 OPERATION

General

- Machine operation requires your full attention. Bring the machine to a full stop before using any device, i.e. cell phones, two-way radios, etc. that will distract your attention from safely operating the machine.
- Do not use the machine for any purpose other than positioning personnel, their tools, and equipment.
- Before operation, the user must be familiar with the machine capabilities and operating characteristics of all functions.
- Never operate a malfunctioning machine. If a malfunction occurs, shut down the machine. Remove the unit from service and notify the proper authorities.
- Do not remove, modify, or disable any safety devices.
- Never slam a control switch or lever through neutral to an opposite direction. Always return switch to neutral and stop before moving the switch to the next function. Operate controls with slow and even pressure.

SECTION 1 - SAFETY PRECAUTIONS

- Do not allow personnel to tamper with or operate the machine from the ground with personnel in the platform, except in an emergency.
- Do not carry materials directly on platform railing unless approved by JLG.
- When two or more persons are in the platform, the operator shall be responsible for all machine operations.
- Always ensure that power tools are properly stowed and never left hanging by their cord from the platform work area.
- When driving, always position boom over rear axle in line with the direction of travel. Remember, if boom is over the front axle, steer and drive functions will be reversed.
- Do not assist a stuck or disabled machine by pushing or pulling except by pulling at the chassis tie-down lugs.
- Fully lower platform and shut off all power before leaving machine.
- Remove all rings, watches, and jewelry when operating machine. Do not wear loose fitting clothing or long hair unrestrained which may become caught or entangled in equipment.

- Persons under the influence of drugs or alcohol or who are subject to seizures, dizziness or loss of physical control must not operate this machine.
- Hydraulic cylinders are subject to thermal expansion and contraction. This may result in changes to the platform position while the machine is stationary. Factors affecting thermal movement can include the length of time the machine will remain stationary, hydraulic oil temperature, ambient air temperature and platform position.

Trip and Fall Hazards

- Prior to operation, ensure all gates are closed and fastened in their proper position.
- During operation, occupants in the platform must wear a full body harness with a lanyard attached to an authorized lanyard anchorage point. Attach only one (1) lanyard per lanyard anchorage point.

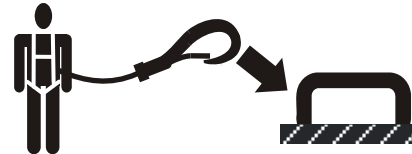

- Enter and exit only through gate area. Use extreme caution when entering or leaving platform. Ensure

that the platform assembly is fully lowered. Face the machine when entering or leaving the platform. Always maintain "three point contact" with the machine, using two hands and one foot or two feet and one hand at all times during entry and exit.

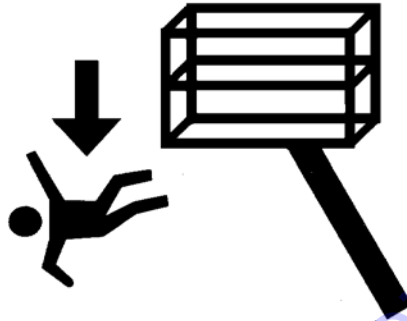

- Keep both feet firmly positioned on the platform floor at all times. Never position ladders, boxes, steps, planks, or similar items on unit to provide additional reach for any purpose.
- Keep oil, mud, and slippery substances cleaned from footwear and the platform floor.

Electrocution Hazards

- This machine is not insulated and does not provide protection from contact or proximity to electrical current.

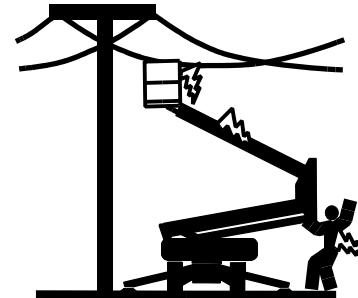
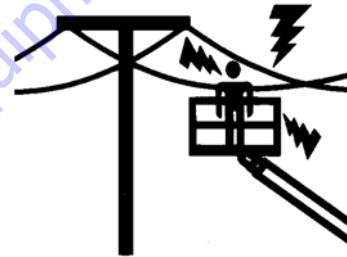

SECTION 1 - SAFETY PRECAUTIONS

- Maintain distance from electrical lines, apparatus, or any energized (exposed or insulated) parts according to the Minimum Approach Distance (MAD) as shown in Table 1-1.
- Allow for machine movement and electrical line swaying.

Table 1-1. Minimum Approach Distances (M.A.D.)

Voltage Range (Phase to Phase)	MINIMUM APPROACH DISTANCE in Feet (Meters)
0 to 50 KV	10 (3)
Over 50KV to 200 KV	15 (5)
Over 200KV to 350 KV	20 (6)
Over 350KV to 500 KV	25 (8)
Over 500KV to 750 KV	35 (11)
Over 750 KV to 1000 KV	45 (14)

NOTE: *This requirement shall apply except where employer, local or governmental regulations are more stringent.*

- Maintain a clearance of at least 10 ft. (3m) between any part of the machine and its occupants, their tools, and their equipment from any electrical line or apparatus carrying up to 50,000 volts. One foot addi-

tional clearance is required for every additional 30,000 volts or less.

- The minimum approach distance may be reduced if insulating barriers are installed to prevent contact, and the barriers are rated for the voltage of the line being guarded. These barriers shall not be part of (or attached to) the machine. The minimum approach distance shall be reduced to a distance within the designed working dimensions of the insulating barrier. This determination shall be made by a qualified person in accordance with the employer, local, or governmental requirements for work practices near energized equipment



DO NOT MANEUVER MACHINE OR PERSONNEL INSIDE PROHIBITED ZONE (MAD). ASSUME ALL ELECTRICAL PARTS AND WIRING ARE ENERGIZED UNLESS KNOWN OTHERWISE.

Tipping Hazards

- Ensure that the ground conditions are adequate to support the maximum outrigger load indicated on the outrigger load decals located on the machine. Do not travel on unsupported surfaces.

SECTION 1 - SAFETY PRECAUTIONS

- The user must be familiar with the operating surface before driving. Do not exceed the allowable sideslope and grade while driving.

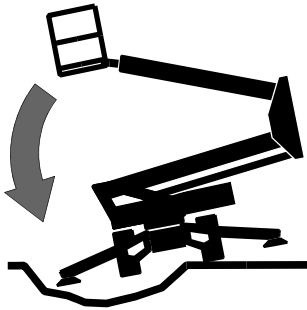

- Do not elevate platform while on or near a sloping, uneven, or soft surface. Ensure machine is positioned on a smooth, firm surface within the limits of the maximum operating slope before elevating platform.
- Before driving on floors, bridges, trucks, and other surfaces, check allowable capacity of the surfaces.
- Do not elevate the platform unless the machine is on a firm operating surface and outriggers are properly set.

- Never exceed the maximum platform capacity as specified on the platform. Keep all loads within the confines of the platform, unless authorized by JLG.
- Keep the chassis and outriggers of the machine a minimum of 2 ft. (0.6m) from holes, bumps, drop-offs, obstructions, debris, concealed holes, and other potential hazards at the ground level.
- Do not push or pull any object with the boom.
- Never attempt to use the machine as a crane. Do not tie-off machine to any adjacent structure. Never attach wire, cable, or any similar items to platform.
- Do not operate the machine when wind conditions exceed 28 mph (12.5 m/s). Refer to Table 1-2, Beaufort Scale (For Reference Only). Factors affecting wind speed are; platform elevation, surrounding structures, local weather events, and approaching storms.
- Wind speed can be significantly greater at height than at ground level.
- Wind speed can change rapidly. Always consider approaching weather events, the time required to lower the platform, and methods to monitor current and potential wind conditions.
- Do not increase the surface area of the platform or the load. Increase of the area exposed to the wind will decrease stability.

SECTION 1 - SAFETY PRECAUTIONS

- Do not increase the platform size with unauthorized deck extensions or attachments.
- If boom assembly or platform is in a position that one or more outriggers are off the ground, all persons must be removed before attempting to stabilize the machine. Use cranes, forklift trucks, or other appropriate equipment to stabilize machine.

⚠ WARNING

DO NOT OPERATE THE MACHINE WHEN WIND CONDITIONS EXCEED SPECIFICATIONS SHOWN IN FIGURE 1-2 BEAUFORT SCALE.

To order go to Discount-Equipment.com

Table 1-2. Beaufort Scale (For Reference Only)

Beaufort Number	Wind Speed		Description	Land Conditions
	mph	m/s		
0	0	0-0.2	Calm	Calm. Smoke rises vertically
1	1-3	0.3-1.5	Light air	Wind motion visible in smoke
2	4-7	1.6-3.3	Light breeze	Wind felt on exposed skin. Leaves rustle
3	8-12	3.4-5.4	Gentle breeze	Leaves and smaller twigs in constant motion
4	13-18	5.5-7.9	Moderate breeze	Dust and loose paper raised. Small branches begin to move.
5	19-24	8.0-10.7	Fresh breeze	Smaller trees sway.
6	25-31	10.8-13.8	Strong breeze	Large branches in motion. Flags waving near horizontal. Umbrella use becomes difficult.
7	32-38	13.9-17.1	Near Gale/Moderate Gale	Whole trees in motion. Effort needed to walk against the wind.
8	39-46	17.2-20.7	Fresh Gale	Twigs broken from trees. Cars veer on road.
9	47-54	20.8-24.4	Strong Gale	Light structure damage.

SECTION 1 - SAFETY PRECAUTIONS

Crushing and Collision Hazards

- Approved head gear must be worn by all operating and ground personnel.
- Watch for obstructions around machine and overhead when driving. Check clearances above, on sides, and bottom of platform when lifting or lowering platform.

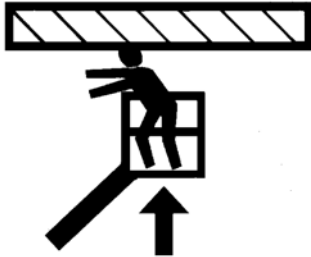

- During operation, keep all body parts inside platform railing.
- Use the boom functions, not the drive function, to position the platform close to obstacles.
- Always post a lookout when driving in areas where vision is obstructed.
- Keep non-operating personnel at least 6 ft. (1.8m) away from machine during all operations.

- Under all travel conditions, the operator must limit travel speed according to conditions of ground surface, congestion, visibility, slope, location of personnel, and other factors which may cause collision or injury to personnel.
- Be aware of stopping distances in all drive speeds. When driving in high speed, switch to low speed before stopping. Travel grades in low speed only.
- Do not use high speed drive in restricted or close quarters or when driving in reverse.
- Exercise extreme caution at all times to prevent obstacles from striking or interfering with operating controls and persons in the platform.
- Ensure that operators of other overhead and floor level machines are aware of the MEWP's presence. Disconnect power to overhead cranes.
- Warn personnel not to work, stand, or walk under a raised boom or platform. Position barricades on floor if necessary.

1.4 TOWING, LIFTING, AND HAULING

- Never allow personnel in platform while towing, lifting, or hauling.
- Ensure boom is in the stowed position and the turntable locked prior to towing, lifting or hauling. The platform must be completely empty of tools.
- When lifting machine, lift only at designated areas of the machine. Lift the unit with equipment of adequate capacity.
- Refer to the Machine Operation section of this manual for lifting information.

1.5 MAINTENANCE

This sub-section contains general safety precautions which must be observed during maintenance of this machine. Additional precautions to be observed during machine maintenance are inserted at the appropriate points in this manual and in the Service and Maintenance Manual. It is of utmost importance that maintenance personnel pay strict attention to these precautions to avoid possible injury to personnel or damage to the machine or property. A maintenance program must be established by a qualified person and must be followed to ensure that the machine is safe.

Maintenance Hazards

- Shut off power to all controls and ensure that all moving parts are secured from inadvertent motion prior to performing any adjustments or repairs.
- Never work under an elevated platform until it has been fully lowered to the full down position, if possible, or otherwise supported and restrained from movement with appropriate safety props, blocking, or overhead supports.
- DO NOT attempt to repair or tighten any hydraulic hoses or fittings while the machine is powered on or when the hydraulic system is under pressure.

SECTION 1 - SAFETY PRECAUTIONS

- Always relieve hydraulic pressure from all hydraulic circuits before loosening or removing hydraulic components.
- DO NOT use your hand to check for leaks. Use a piece of cardboard or paper to search for leaks. Wear gloves to help protect hands from spraying fluid.



- Use only replacement parts or components that are approved by JLG. To be considered approved, replacement parts or components must be identical or equivalent to original parts or components.
- Never attempt to move heavy parts without the aid of a mechanical device. Do not allow heavy objects to rest in an unstable position. Ensure adequate support is provided when raising components of the machine.

- Do not use machine as a ground for welding.
- When performing welding or metal cutting operations, precautions must be taken to protect the chassis from direct exposure to weld and metal cutting spatter.
- Do not refuel the machine with the engine running.
- Use only approved non-flammable cleaning solvents.
- Do not replace items critical to stability, such as batteries or solid tires, with items of different weight or specification. Do not modify the MEWP in any way to affect stability.
- Refer to the Service and Maintenance Manual for the weights of critical stability items.

⚠ WARNING

MODIFICATION OR ALTERATION OF A MEWP SHALL BE MADE ONLY WITH PRIOR WRITTEN PERMISSION FROM THE MANUFACTURER.

Battery Hazards

- Always disconnect batteries when servicing electrical components or when performing welding on the machine.
- Do not allow smoking, open flame, or sparks near battery during charging or servicing.
- Do not contact tools or other metal objects across the battery terminals.
- Always wear hand, eye, and face protection when servicing batteries. Ensure that battery acid does not come in contact with skin or clothing.

CAUTION

BATTERY FLUID IS HIGHLY CORROSIVE. AVOID CONTACT WITH SKIN AND CLOTHING AT ALL TIMES. IMMEDIATELY RINSE ANY CONTACTED AREA WITH CLEAN WATER AND SEEK MEDICAL ATTENTION.

- Charge batteries only in a well ventilated area.
- Avoid overfilling the battery fluid level. Add distilled water to batteries only after the batteries are fully charged.

SECTION 1 - SAFETY PRECAUTIONS

To order go to Discount-Equipment.com

SECTION 2. PREPARATION AND INSPECTION

2.1 PERSONNEL TRAINING

The MEWP (mobile elevating work platform) is a personnel handling device; so it is necessary that it be operated and maintained only by trained personnel.

Operator Training

Operator training must cover:

1. Reading and understanding the Operation and Safety Manual.
2. Thorough understanding of the intended purpose and function of the MEWP controls, including platform, ground, and emergency descent controls.
3. Control labels, instructions, and warnings on the machine.
4. Applicable regulations, standards, and safety rules.
5. Use of approved fall protection equipment.
6. Enough knowledge of the mechanical operation of the machine to recognize a malfunction or potential malfunction.
7. The safest means to operate the machine where overhead obstructions, other moving equipment, and obstacles, depressions, holes, and drop-offs exist.

8. Means to avoid the hazards of unprotected electrical conductors.
9. Selection of the appropriate MEWPs and available options for the work to be performed considering specific job requirements, with involvement from the MEWP owner, user, and/or supervisor.
10. The responsibility of the operator to ensure all platform occupants have a basic level of knowledge to work safely on the MEWP, and to inform them of applicable regulations, standards, and safety rules.
11. The requirement for familiarization in addition to training.

Training Supervision

Training must be delivered by a qualified person in an open area free of hazards until the trainee has demonstrated the ability to safely control and operate the machine.

Operator Responsibility

The operator must be instructed that he/she has the responsibility and authority to shut down the machine in case of a malfunction or other unsafe condition of either the machine or the job site.

SECTION 2 - PREPARATION AND INSPECTION

2.2 PREPARATION, INSPECTION, AND MAINTENANCE

The following table covers periodic machine inspections and maintenance required by JLG Industries, Inc. Consult local regulations for further requirements for MEWPs. Frequency of inspections and maintenance must be increased as necessary when machine is used in a harsh or hostile environment, if machine is used with increased frequency, or if machine is used in a severe manner.

To order go to Discount-Equipment.com

SECTION 2 - PREPARATION AND INSPECTION

Table 2-1. Inspection and Maintenance Table

Type	Frequency	Primary Responsibility	Service Qualification	Reference
Pre-Start Inspection	Before using each day; or whenever there's an Operator change.	User or Operator	User or Operator	Operation and Safety Manual
Pre-Delivery Inspection (See Note)	Before each sale, lease, or rental delivery.	Owner, Dealer, or User	Qualified JLG Mechanic	Service and Maintenance Manual and applicable JLG inspection form
Frequent Inspection	In service for 3 months or 150 hours, whichever comes first; or Out of service for a period of more than 3 months; or Purchased used.	Owner, Dealer, or User	Qualified JLG Mechanic	Service and Maintenance Manual and applicable JLG inspection form
Annual Machine Inspection	Annually, no later than 13 months from the date of prior inspection.	Owner, Dealer, or User	Factory Trained Service Technician (Recommended)	Service and Maintenance Manual and applicable JLG inspection form
Preventative Maintenance	At intervals as specified in the Service and Maintenance Manual.	Owner, Dealer, or User	Qualified JLG Mechanic	Service and Maintenance Manual

NOTE: Inspection forms are available from JLG. Refer to Section 6 - Operators Maintenance when performing inspections.

NOTICE

JLG INDUSTRIES, INC. RECOGNIZES A FACTORY TRAINED SERVICE TECHNICIAN AS A PERSON WHO HAS SUCCESSFULLY COMPLETED THE JLG SERVICE TRAINING SCHOOL FOR THE SPECIFIC JLG PRODUCT MODEL.

SECTION 2 - PREPARATION AND INSPECTION

Pre-Start Inspection

The Pre-Start Inspection should include each of the following:

1. **Cleanliness** – Check all surfaces for leakage (oil, fuel, or battery fluid) or foreign objects. Report any leakage to the proper maintenance personnel.
2. **Structure** - Inspect the machine structure for dents, damage, weld or parent metal cracks or other discrepancies.

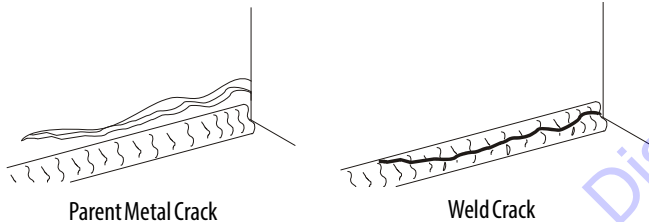

3. **Decals and Placards** – Check all for cleanliness and legibility. Make sure none of the decals and placards are missing. Make sure all illegible decals and placards are cleaned or replaced.

4. **Operation and Safety Manuals** – Make sure a copy of the Operation and Safety Manual, AEM Safety Manual (ANSI markets only), and ANSI Manual of Responsibilities (ANSI markets only) is enclosed in the weather resistant storage container.
5. **Walk-Around Inspection** – Refer to Figure 2-1.
6. **Battery** – Charge as required.
7. **Fuel** (Combustion Engine Powered Machines) – Add the proper fuel as necessary.
8. **Engine Oil Supply** (Combustion Engine Powered Machines) - Ensure the engine oil level is at the Full mark on the dipstick and the filler cap is secure.
9. **Hydraulic Oil** – Check the hydraulic oil level. Ensure hydraulic oil is added as required.
10. **Function Check** – Once the “Walk-Around” Inspection is complete, perform a functional check of all systems in an area free of overhead and ground level obstructions. Refer to Section 4 for more specific operating instructions.

⚠ WARNING

IF THE MACHINE DOES NOT OPERATE PROPERLY, TURN OFF THE MACHINE IMMEDIATELY! REPORT THE PROBLEM TO THE PROPER MAINTENANCE PERSONNEL. DO NOT OPERATE THE MACHINE UNTIL IT IS DECLARED SAFE FOR OPERATION.

SECTION 2 - PREPARATION AND INSPECTION

Walk-Around Inspection

General

Begin the "Walk-Around Inspection" at Item 1, as noted on the diagram. Continue checking each item in sequence for the conditions listed in the following checklist.

WARNING

TO AVOID POSSIBLE INJURY, BE SURE MACHINE POWER IS OFF. DO NOT OPERATE MACHINE UNTIL ALL MALFUNCTIONS HAVE BEEN CORRECTED.

INSPECTION NOTE: *On all components, make sure there are no loose or missing parts, that they are securely fastened, and no visible damage, leaks or excessive wear exists in addition to any other criteria mentioned.*

- 1. Platform Assembly, Foot Switch, Ladder and Gate** - Foot switch in good working order, not modified, disabled or blocked. Manual(s) in storage container, access bar slides up and down properly, platform properly installed and with both caps screwed on. See Inspection Note.
- 2. Control Stations** - Switches and buttons return to neutral, decals/placards secure and legible, control markings legible.
- 3. Outriggers** - See Inspection Note; pads pivot freely.
- 4. Electrical & Hydraulic Cover Assemblies** - See Inspection Note.
- 5. Boom Sections & Turntable** - See Inspection Note.
- 6. Drive Tracks** - Properly Adjusted. See Inspection Note.
- 7. Diesel Engine or Lithium ION Battery Pack** - Free of debris and See Inspection Note.
- 8. Swing Drive & Turntable Bearing** - Check for proper lubrication. See Inspection Note.
- 9. Hydraulic Tank** - Hydraulic oil level correct and See Inspection Note.
- 10. Electric Engine and Hydraulic Pump** - See Inspection Note.
- 11. Platform Rotator & Machine Bubble Level** - See Inspection Note.

SECTION 2 - PREPARATION AND INSPECTION

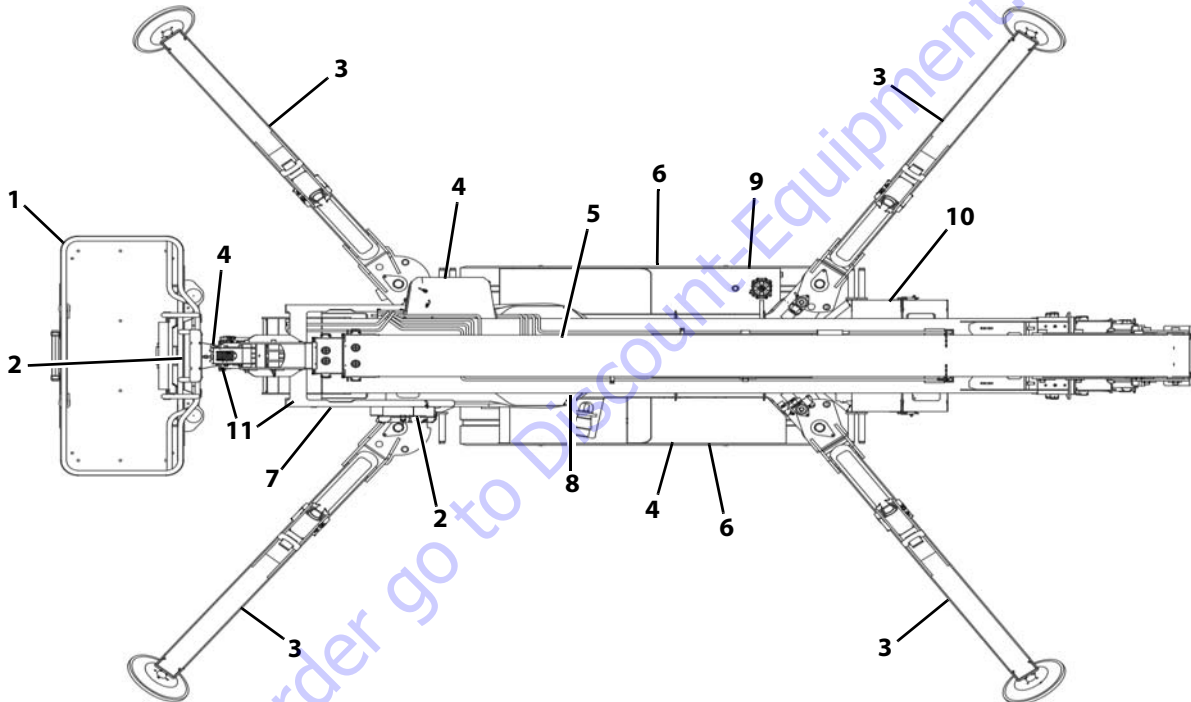

OL00380

Figure 2-1. Daily Walk-Around Inspection

SECTION 2 - PREPARATION AND INSPECTION

Function Check



ENSURE NO FUNCTIONS (EXCEPT TRACK FUNCTIONS) OPERATE WHEN OUT-RIGGERS ARE NOT PROPERLY SET.

After properly setting up on outriggers, perform the function check as follows:

1. From the ground control console with no load in the platform:
 - a. Check all guards protecting function control switches and controllers are in place.
 - b. Operate all functions.
 - c. Ensure all machine functions are disabled when Emergency Stop Button is pushed in.
 - d. Ensure all boom functions stop when function switch is released.
 - e. Ensure main lift down, tower lift down, swing and jib lift down, work properly when using the emergency lowering controls.
2. From the platform control console:
 - a. Ensure that the control console is firmly secured in the proper location.
 - b. Check that all guards protecting the function control switches and controllers are in place;
 - c. Operate all functions.
3. SkyGuard™ Function Test
 - a. From the platform controls, test the SkyGuard™ feature by setting up machine and operating the telescope out functions and then activating the SkyGuard™ sensor. The telescope out function will stop and the telescope in function will operate for a short duration, also the ground alarm will sound until the SkyGuard™ sensor or footswitch is disengaged.
 - b. Disengage the SkyGuard™ sensor, release controls, cycle the power OFF and ON, make sure normal operation is available.
 - c. If SkyGuard™ remains activated after function reversal or cutout, depress and hold the SkyGuard™ Override Switch (button number 8) to allow normal use of machine functions until the SkyGuard™ sensor is disengaged.
- d. Ensure all boom functions stop when the foot switch is released.
- e. Ensure that all machine functions are disabled when the Emergency Stop Button is pushed in.
- f. Ensure main lift down, tower lift down, and jib lift down, work properly when using the emergency lowering controls.

SECTION 2 - PREPARATION AND INSPECTION

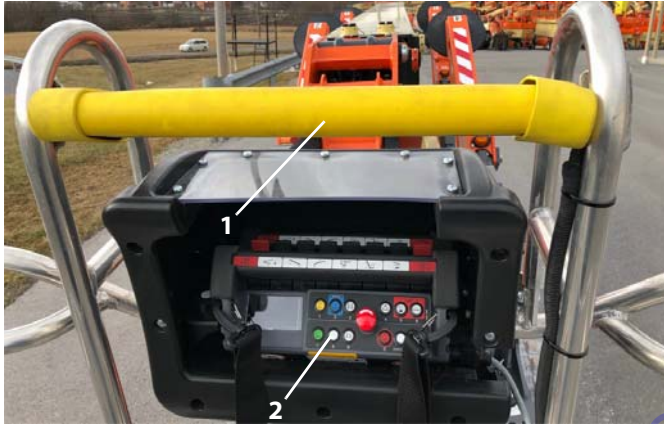

OL00550

1. SkyGuard™ Sensor
2. SkyGuard™ Override Switch
(button number 8)

Figure 2-2. SkyGuard™ Sensor and Override Switch Location

TO PURCHASE THIS PRODUCT PLEASE CONTACT US



**Equipment Financing and
Extended Warranties Available**



**Discount-Equipment.com is your online resource for
commercial and industrial quality parts and equipment sales.**

561-964-4949

visit us on line @ www.discount-equipment.com

Select an option below to find your Equipment

Search by Manufacturer

Search by Product Type

Request a Quote

We sell worldwide for the brands: Genie, Terex, JLG, MultiQuip, Mikasa, Essick, Whiteman, Mayco, Toro Stone, Diamond Products, Generac Magnum, Airman, Haulotte, Barreto, Power Blanket, Nifty Lift, Atlas Copco, Chicago Pneumatic, Allmand, Miller Curber, Skyjack, Lull, Skytrak, Tsurumi, Husquvarna Target, Stow, Wacker, Sakai, Mi-T-M, Sullair, Basic, Dynapac, MBW, Weber, Bartell, Bennar Newman, Haulotte, Ditch Runner, Menegotti, Morrison, Contec, Buddy, Crown, Edco, Wyco, Bomag, Laymor, EZ Trench, Bil-Jax, F.S. Curtis, Gehl Pavers, Heli, Honda, ICS/PowerGrit, IHI, Partner, Imer, Clipper, MMD, Koshin, Rice, CH&E, General Equipment, Amida, Coleman, NAC, Gradall, Square Shooter, Kent, Stanley, Tamco, Toku, Hatz, Kohler, Robin, Wisconsin, Northrock, Oztec, Toker TK, Rol-Air, APT, Wylie, Ingersoll Rand / Doosan, Innovatech, Con X, Ammann, Mecalac, Makinex, Smith Surface Prep, Small Line, Wanco, Yanmar

SECTION 3. MACHINE CONTROLS, INDICATORS AND OPERATION

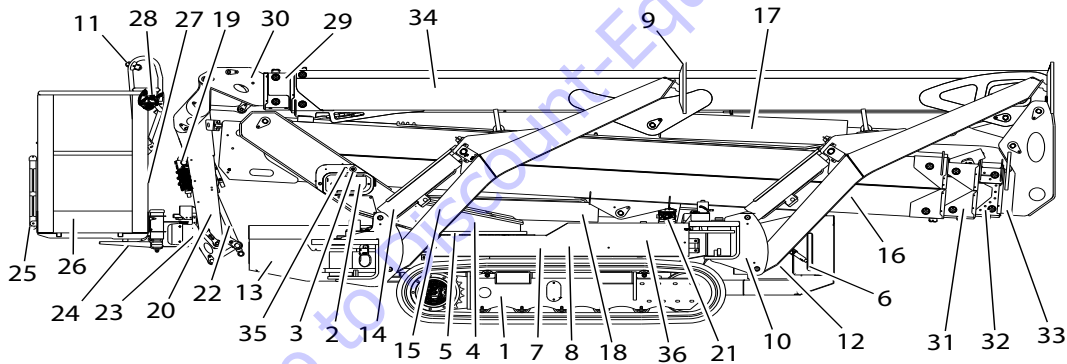

OL00010

Figure 3-1. Basic Machine Component Locations

SECTION 3 - MACHINE CONTROLS, INDICATORS AND OPERATION

Basic Machine Component Locations

1. Extendible Track Undercarriage
2. Ground Control Station
3. Ground Emergency Stop
4. Rotating Turret (inside)
5. Turntable
6. Fuel Tank (Diesel only)
7. Frame
8. Ground Hydraulics Compartment
9. Stabilizer Plate
10. Outrigger Joint
11. SkyGuard™ Sensor
12. Diesel Engine or Electric Motor
13. Lithium Battery Pack (If equipped)
14. Stabilizer Cylinder
15. Stabilizer
16. Tower Boom
17. Main Cylinder
18. Tower Cylinder
19. JIB Hydraulic block
20. JIB Arm
21. Hydraulic Oil Filter
22. Platform Leveling Cylinder
23. Platform Swing Actuator
24. Platform Support
25. Platform Access Ladder
26. Platform
27. Manual Compartment
28. Platform Remote Control
29. Main Boom Extension 1
30. Main Boom Extension 2
31. Tower Boom Extension 1
32. Tower Boom Extension 2
33. Tower Boom Extension 3
34. Main Boom
35. Main Power Keyswitch
36. Battery Disconnect Switch & Battery Compartment

SECTION 3 - MACHINE CONTROLS, INDICATORS AND OPERATION

⚠ WARNING

TO AVOID SERIOUS INJURY, DO NOT OPERATE MACHINE IF ANY CONTROL LEVERS OR SWITCHES CONTROLLING PLATFORM MOVEMENT DO NOT RETURN TO THE OFF POSITION WHEN RELEASED.

3.1 GROUND CONTROL STATION

See Figure 3-2. Ground Control Station

NOTICE

FOR PROLONGED SHUTDOWN OR WHILE PERFORMING MAINTENANCE/ REPAIRS, TURN OFF THE BATTERY DISCONNECT SWITCH.

1. Main Power Key Switch

This switch must be turned to the ON (**I**) position before power is supplied to the Power/Emergency Stop switch. When machine is not in use, the key can be removed in the OFF (**O**) position.

2. Power/Emergency Stop Switch

This two-position red switch removes power from the ground controls when pushed in. Twist the switch clockwise to allow for machine operation at the ground control station.

3. Platform/Ground Selector Switch

This selector switch allows the operator to control the machine from the platform control box when in the counter-clockwise position.

This selector switch allows the operator to control the machine from the ground control station when in the clockwise position.

4. Bypass Key Switch

See Section 5.4, Bypass Key for more information.

5. In the Controls menu, this button is used to switch between machine control functions.

6. Controls machine movement in the UP or RIGHT direction.

7. Controls machine movement in the DOWN or LEFT direction.

SECTION 3 - MACHINE CONTROLS, INDICATORS AND OPERATION

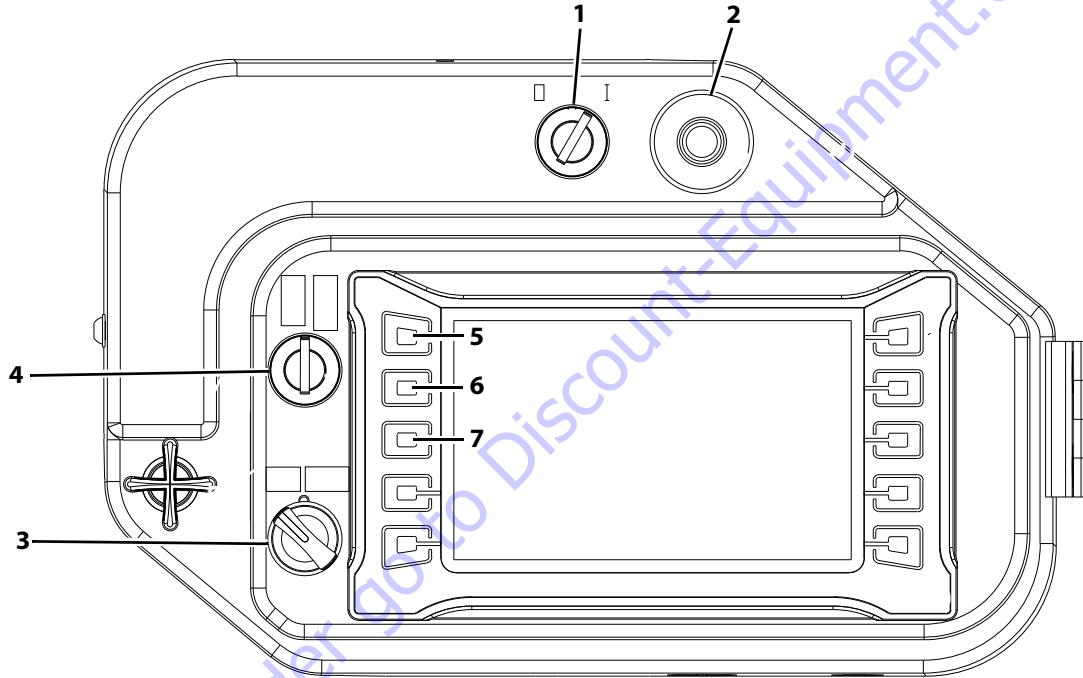

L0410

Figure 3-2. Ground Control Station

SECTION 3 - MACHINE CONTROLS, INDICATORS AND OPERATION

MENU SCREENS

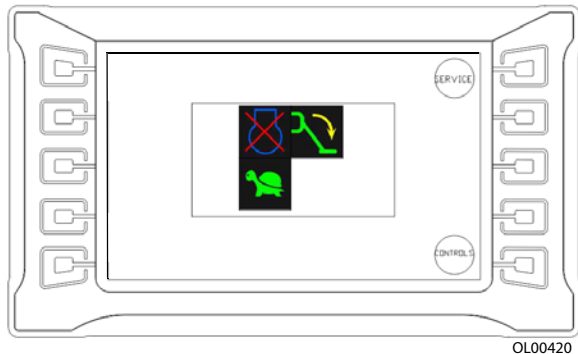

OL00420

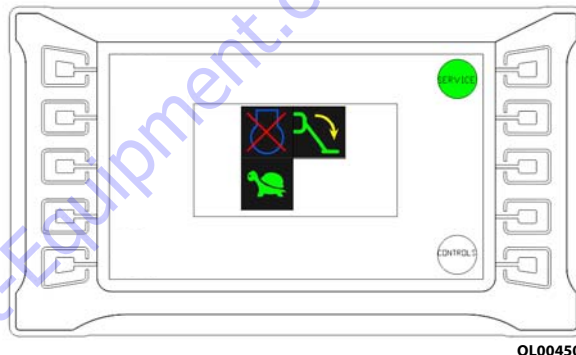

OL00450

Main Menu

The main menu displays the menu functions. This screen also displays machine stabilization status and selected speed. The main menu also displays the menu functions.

Service

Press this button for service related items. Press the ESC button to go back to the main menu.

NOTE: Refer to service manual for further information.

SECTION 3 - MACHINE CONTROLS, INDICATORS AND OPERATION

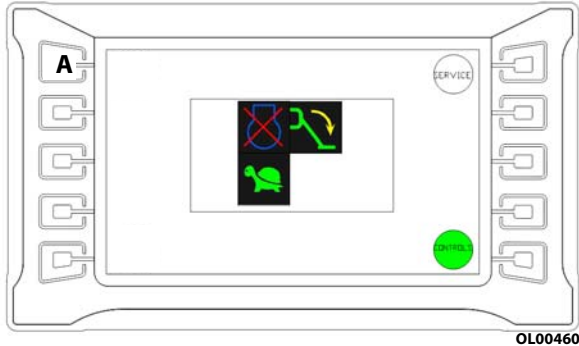

Controls

Press this button to go to the machine control functions screen. Machine functions possible in this menu are:

- Tower Boom (TOWER)
- Main Boom (MAIN)
- Extend/Retract Main Boom (EX-MAIN)
- Jib (JIB)
- Platform Rotate (ROTATE)
- Turn Table Rotate (SWING)

Press button **(A)** to cycle through functions 1 through 6. The machine will cycle to the next function every time button **(A)** is pressed.

- Go Home
- Operating Speed
- Diesel Engine (Diesel only)
- Electric Engine (Diesel only)
- Emergency Descent

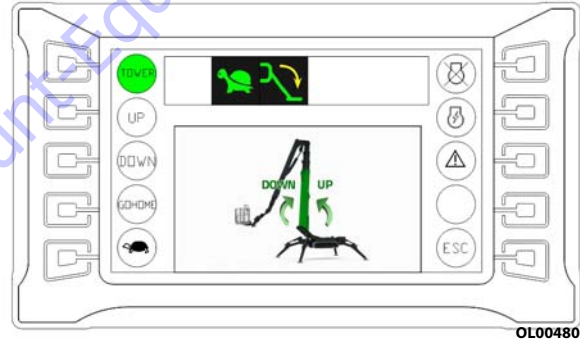

Tower Boom (TOWER)

Use this function to raise and lower the tower boom. Use the Up and Down buttons to perform operations.

SECTION 3 - MACHINE CONTROLS, INDICATORS AND OPERATION

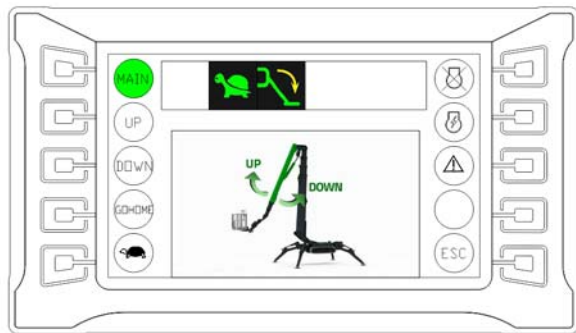

OL00470

Main Boom (MAIN)

Use this function to raise and lower the main boom. Use the Up and Down buttons to perform operations.

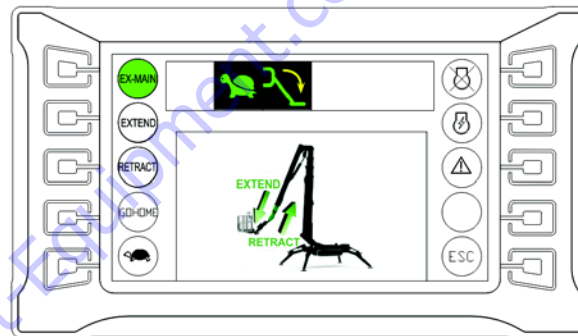

OL00490

Extend/Retract Main Boom (EX-MAIN)

Use this function to extend and retract the main boom. Use the EXTEND and RETRACT buttons to perform operations.

SECTION 3 - MACHINE CONTROLS, INDICATORS AND OPERATION

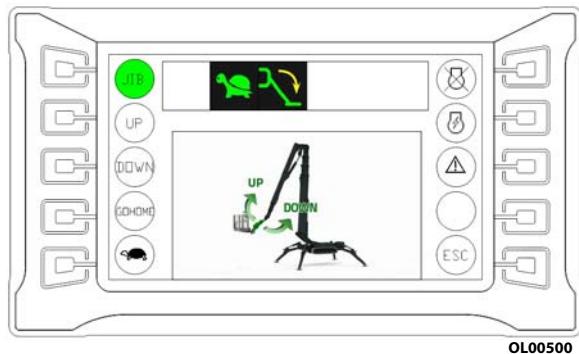

Jib (JIB)

Use this function to raise and lower the Jib. Use the Up and Down buttons to perform operations.

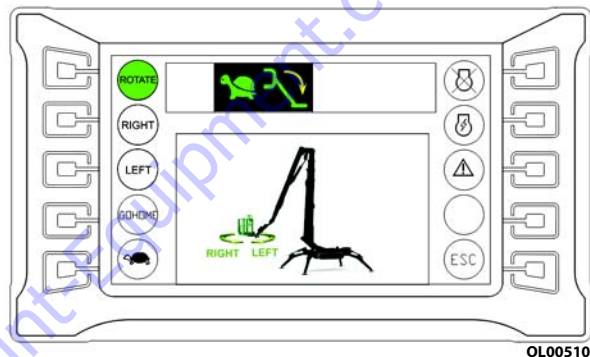

Platform Rotate (ROTATE)

Use this function to rotate the platform. Use the RIGHT and LEFT buttons to perform operations.

SECTION 3 - MACHINE CONTROLS, INDICATORS AND OPERATION

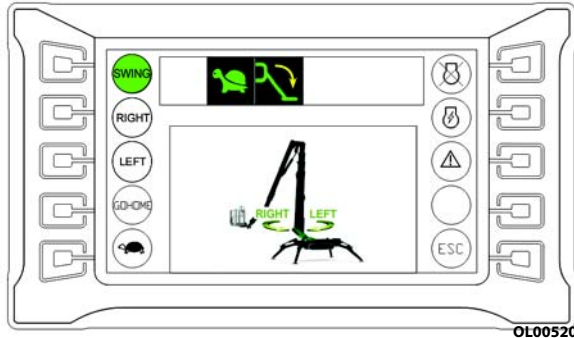

Turn Table Rotate (SWING)

Use this function to rotate the turn table. Use the RIGHT and LEFT buttons to perform operations.

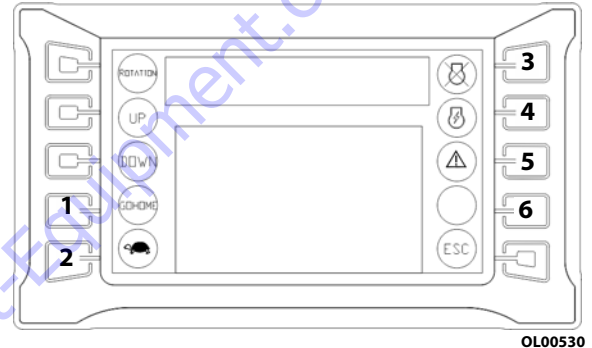

Go Home (1)

Use this function to bring the machine to fully closed position. Press and hold to perform operation. Machine will stop closing once returned to working position, continue to hold button until the "auto icon" goes away. After a slight delay, machine will close completely.

Operating Speed (2)

Use this function to switch between slow and normal speeds for aerial operations.

Diesel Engine (3)

Use this function to operate diesel engine (if equipped).

Electric Engine (4)

Use this function to activate electric motor (if equipped).

Emergency Descent (5)

Use this function to bring the platform to the ground in case of main power failure. See Section 5.3, Emergency Operation for more information.

Bypass Button (6)

In the event the Bypass Key Switch is needed, this button must be pressed to enter and acknowledge Bypass mode has been initiated. The Bypass icon will be displayed by the button when the Bypass Key Switch is activated. See Section 5.4, Bypass Key for more information.

SECTION 3 - MACHINE CONTROLS, INDICATORS AND OPERATION

3.2 PLATFORM CONTROL STATION

The platform control station is connected to the machine at the platform using a flexible cable.

NOTE: Before removing or connecting the flex cable, the machine must be turned OFF.

Installing the Platform Control Station

1. Connect the flexible control cable at the platform to the Platform Control Station box connector on the right side of the control box.

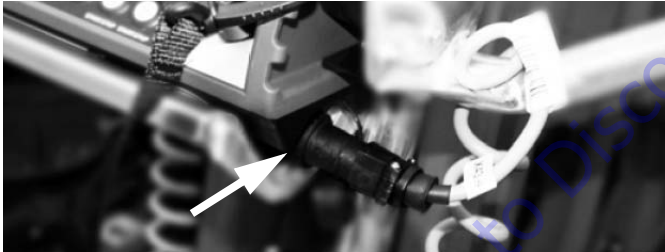

2. In the platform, slide the remote control station assembly into the storage box and place the rib on the right side of the control station assembly under the metal tab attached to the storage box assembly.

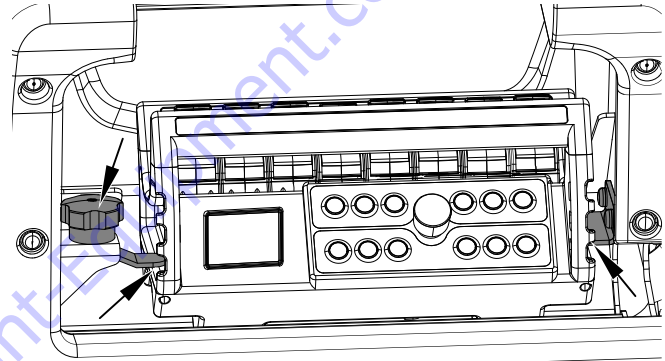

OL00030

3. Lower remote control station assembly into the storage box, ensure the attached flexible cable slides into the slot also on the right side of the box.
4. On the left side of the control station secure the box by turning the handle on the locking tab clockwise locking the rib of the control station under the rotating metal tab of the handle assembly.
5. To remove the control station assembly, reverse the four steps above.

SECTION 3 - MACHINE CONTROLS, INDICATORS AND OPERATION

Platform Control Functions

Platform Foot Switch (see photo below)

To operate any function, the footswitch must be depressed and a function selected within seven seconds. If a function is not selected within seven seconds, or if a seven second lapse between ending one function and beginning the next function, the footswitch must be released and depressed again to enable the controls.



OL00560

See Figure 3-3. on page 3-13, Platform Control Console for remaining items.

NOTE: Buttons 1, 2, 3, 4, 5, 6, 7, 8, 9, serve a double function - they can be used to operate a machine function (icon on button) or used as numerical keys (per number

below the button) when the SERVICE button (6) sub-menu is activated on the LCD display.

1. Outrigger - Automatic Retract
This control allows the operator to control the retraction of all 4 outriggers at one time.
2. Outrigger - Manual
This control allows the operator to control the extension or retraction of one outrigger at a time.
3. Track Width Adjust
This control allows the operator to widen the track.
4. Emergency Lowering
This button allows the operator to lower the boom if main power is not working.

NOTE: Buttons 5 and 6 when pressed simultaneously also activate the horn.

5. Speed Selector/Horn
This button allows the operator to select the desired engine speed for operation.
6. Service Menu/Horn
This button allows the operator to access the Service Menu.
7. Outrigger - Automatic Set And Level
This control allows the operator to control the extension of all 4 outriggers at one time.

SECTION 3 - MACHINE CONTROLS, INDICATORS AND OPERATION

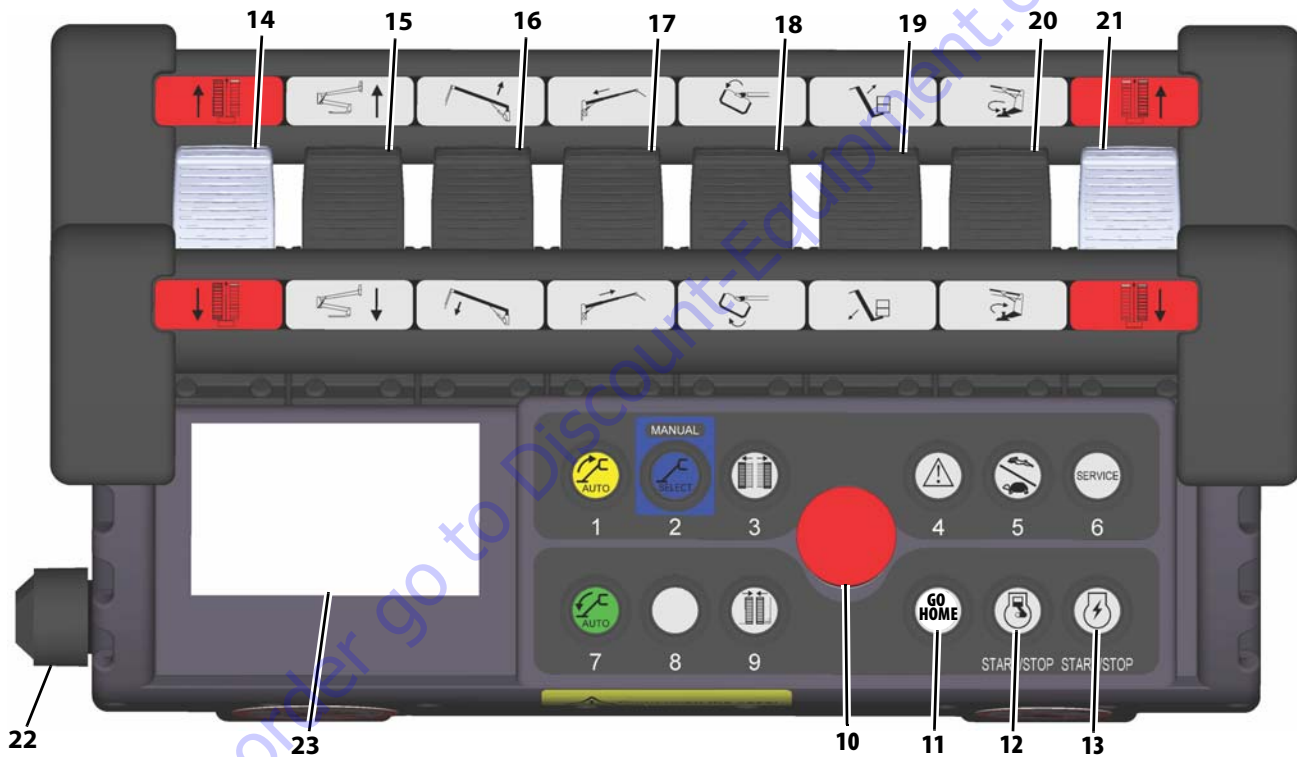

Figure 3-3. Platform Control Station

SECTION 3 - MACHINE CONTROLS, INDICATORS AND OPERATION

8. Selector Button

Used for selecting an item when the Service Menu button (6) is pressed.

This button is also used as the SkyGuard™ Override switch. When the SkyGuard™ system is engaged, press this button to override and disengage SkyGuard™.

9. Track Width Adjust

This control allows the operator to narrow the track.

10. Power/Emergency Stop

A two-position red switch removes power from the ground controls when pushed in. Twist the switch clockwise to allow for machine operation at the ground control station.

11. Go Home

Holding this button in allows the operator to return the MEWP to the fully closed position. The machine will determine and perform the necessary maneuvers to bring to boom down to the closed position.

12. Diesel Engine Starter

This button allows the operator to start or stop the diesel engine. Holding this button in allows the operator to pre-heat the diesel engine in cold climates.

13. Electric Engine Start

This button allows the operator to start or stop the electric engine.

NOTE: *Controllers (14 through 21), the speed of component movement is proportional to the controller distance from the center neutral position.*

ERROR



Movement of a controller without first pressing the platform footswitch is indicated by the depress footswitch error icon on the platform/remote LCD display.

14. Left Side Track Drive And Steer

This control when moved forward or rearward simultaneously with the right side track control (21), allows the operator to move the machine in a straight forward or reverse direction. If each control is moved individually, different amounts or in opposite directions steering the machine occurs.

15. Tower Boom Lift

This control allows the operator to raise and lower the tower boom.

16. Main Boom Lift

This control allows the operator to raise and lower the main boom.

SECTION 3 - MACHINE CONTROLS, INDICATORS AND OPERATION

17. Main Boom Telescope

This switch allows the operator to extend and retract the main boom.

18. Platform Rotate

This switch allows the operator to rotate the platform to the right or left.

19. Jib

This control allows the operator to raise and lower the jib.

20. Swing

This control allows the operator to swing the boom assembly to the right or left.

21. Right Side Track Drive And Steer

This control when moved forward or rearward simultaneously with the left side track control (14), allows the operator to move the machine in a straight forward or reverse direction or, if each control is moved individually or in opposite directions, to steer the machine.

22. Platform Level Switch

NOTE: *The platform will auto-correct to level once another function is activated. The platform will auto-correct to level before the requested function is performed.*

To manually Level Up, turn switch counter-clockwise and hold until desired position is reached. To manually Level Down, turn switch clockwise and hold until desired position is reached.

23. Display

Display shows status of machine and operating information. Wait until a display screen appears before starting operation.

Platform/Remote Control Station LCD Display

At machine start-up and during machine operation the main LCD display screen (item 23 - Figure 3-3.) is activated. There are eight (8) display positions which indicate machine status during various stages of operation.

1	3	5	7
2	4	6	8

SECTION 3 - MACHINE CONTROLS, INDICATORS AND OPERATION

Position 1 Reduced operating area if all outriggers are not fully deployed.

1	3	5	7
2	4	6	8



Position 2 Currently Unused.

1	3	5	7
2	4	6	8

Position 3 Displays if selected engine (gas/diesel or electric) is on or off. The X on the icon indicates the engine is off.

1	3	5	7
2	4	6	8



Position 4 Displays selected engine speed.

1	3	5	7
2	4	6	8



Position 5

1	3	5	7
2	4	6	8

- Displays outriggers are properly set and boom functions are allowed. No display indicates outriggers are not properly set and boom functions are not allowed.
- Displays overload icon when load sensor exceeds allowed work load.



Position 6

1	3	5	7
2	4	6	8

Indicates boom, jib, turntable, and base are aligned. Drive, steer, track width adjustment and outrigger functions are operational if this symbol below is present. No symbol indicates these functions are not operational. Drive and steer are operational if all 4 outriggers are not contacting the ground.



SECTION 3 - MACHINE CONTROLS, INDICATORS AND OPERATION

Position 7 Can indicate any of the following situations:

1	3	5	7
2	4	6	8

- An emergency stop is pushed in (off).
- A low battery. Batteries need charging by running the gas/diesel engine or connecting to a power source.
- Tower boom sensor is faulty.
- Main boom sensor is faulty. Boom functions are cut out.
- Swing sensor is faulty.
- CANBUS communication is faulty.
- Electronic fault.
- Lithium ION - Signals an error in the BMS - Battery Management System
- Skyguard™ sensor has been activated.
- Battery cold/heater activated system is enabled.
- Safety by-pass activated

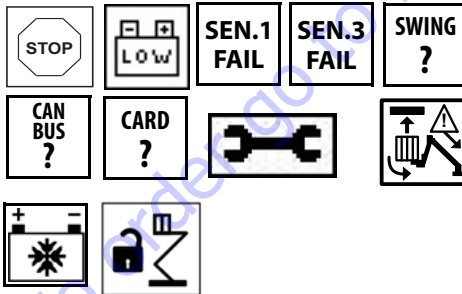

or:

- 50 Hr. - 1st Service Interval - See Section 6 - Table 6-10 and Table 6-11, Component Maintenance Intervals.



Position 8























1	3	5	7
2	4	6	8

- Indicates emergency lowering has been selected.
- Lithium ION - Battery Charge Status and Battery Charger Plugged In.
- Low Lithium charge - Machine reduced speed, must charge Lithium system.





















SECTION 3 - MACHINE CONTROLS, INDICATORS AND OPERATION

Table 3-1. LCD Display Icon Descriptions

	Gas/Diesel engine running		Electric motor running		Remove weight or remote control from platform		Machine Maximum Tilt Angle Exceeded
	Minimum speed		Standard speed		Lower and Retract Boom		Rotate outrigger
	Emergency lowering		Battery voltage low		Machine in prohibited area		RPM signal missing
	Overload in platform		Weight in platform too low		Cables sensor fault		Electric motor OFF
	Safety bypass active		Tower Boom cylinder sensor fault		Gas/Diesel engine OFF		Machine stabilized
	Battery cold/heater activated system enabled				Boom retracted and aligned		

SECTION 3 - MACHINE CONTROLS, INDICATORS AND OPERATION

Table 3-1. LCD Display Icon Descriptions (Continued)

	Maximum speed		Emergency stop pressed		Turntable bearing sensor signal missing		CAN BUS signal missing
	Press footswitch		Select a control		Board or software wrong		Close the jib arm.
	Swing to the right or left		Raise tower boom arms		Wrong remote control connection (on the basket, at the ground)		Stabilization from basket with remote control not placed
	Tower cylinder sensor missing		Cables sensor missing				
	Reduced operating area active		It is possible to only operate the jib				
	Raise outrigger		Double line sensor error, check error menu				

SECTION 3 - MACHINE CONTROLS, INDICATORS AND OPERATION

Table 3-2. LCD Display Error Descriptions

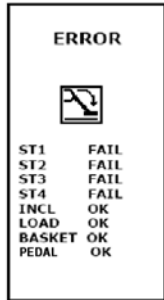

One of the most important error displays in regard to boom movements; this visualization displays why boom movement has been prohibited; in regard to outrigger set, inclination (tilt) platform load, platform/remote control box and footswitch status.

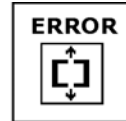

Retract and align the machine



Error in sensor on tower boom cylinder

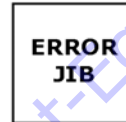

Retract the JIB to work with 200kg



Overload in platform



It is necessary to raise the tower boom



An emergency stop is pressed



Platform/ Remote Control Box is not connected properly



Lift the outriggers to move the tracks

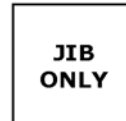

It is possible to only operate the JIB



It is necessary to swing the turntable

SECTION 3 - MACHINE CONTROLS, INDICATORS AND OPERATION

Table 3-2. LCD Display Error Descriptions (Continued)

<p>ERROR</p>	<p>Error in sensor on main boom cylinder</p>	<p>ERROR</p>	<p>Press the footswitch to operate the controls</p>
<p>ERROR</p>	<p>Error in sensor on main boom</p>	<p>ERROR ROTATE STAB</p>	<p>Retract the outrigger to rotate it</p>
<p>NO</p>	<p>Operation not permitted with emergency lowering</p>	<p>OIL</p>	<p>Oil pressure missing = engine turns off <i>Diesel Only</i></p>
	<p>Engine temperature too high = Motor remains at min. <i>Diesel Only</i></p>	<p>ERROR</p>	<p>Too much weight on platform</p>

TO PURCHASE THIS PRODUCT PLEASE CONTACT US



**Equipment Financing and
Extended Warranties Available**



**Discount-Equipment.com is your online resource for
commercial and industrial quality parts and equipment sales.**

561-964-4949

visit us on line @ www.discount-equipment.com

Select an option below to find your Equipment

Search by Manufacturer

Search by Product Type

Request a Quote

We sell worldwide for the brands: Genie, Terex, JLG, MultiQuip, Mikasa, Essick, Whiteman, Mayco, Toro Stone, Diamond Products, Generac Magnum, Airman, Haulotte, Barreto, Power Blanket, Nifty Lift, Atlas Copco, Chicago Pneumatic, Allmand, Miller Curber, Skyjack, Lull, Skytrak, Tsurumi, Husquvarna Target, Stow, Wacker, Sakai, Mi-T-M, Sullair, Basic, Dynapac, MBW, Weber, Bartell, Bennar Newman, Haulotte, Ditch Runner, Menegotti, Morrison, Contec, Buddy, Crown, Edco, Wyco, Bomag, Laymor, EZ Trench, Bil-Jax, F.S. Curtis, Gehl Pavers, Heli, Honda, ICS/PowerGrit, IHI, Partner, Imer, Clipper, MMD, Koshin, Rice, CH&E, General Equipment, Amida, Coleman, NAC, Gradall, Square Shooter, Kent, Stanley, Tamco, Toku, Hatz, Kohler, Robin, Wisconsin, Northrock, Oztec, Toker TK, Rol-Air, APT, Wylie, Ingersoll Rand / Doosan, Innovatech, Con X, Ammann, Mecalac, Makinex, Smith Surface Prep, Small Line, Wanco, Yanmar

SECTION 4. MACHINE OPERATION

4.1 DESCRIPTION

This machine is a Mobile Elevating Work Platform (MEWP) used to position personnel, along with their necessary tools and materials at work locations.

This MEWP has a primary operator control station in the platform. The operator can control drive, steer, boom/platform functions and outriggers. The machine has a Ground Control Station which will override the Platform Control Station. Ground Controls operate boom and platform functions. They are to be used in an emergency to lower the platform to the ground should the operator in the platform be unable to do so. The ground control station is to be used for a Pre-Start Inspection too.

This machine is equipped with an ALL MOTION alarm warning system to alert other personnel in the work area of any machine movement during operation. The motion alarm system is activated during machine function movement such as track, boom, or outrigger operation.

4.2 BOOM OPERATING CHARACTERISTICS AND LIMITATIONS

Capacities

Raising platform above horizontal with or without any load in platform, is based on the following criteria:

- Machine is positioned on a firm surface with outriggers set properly with the outrigger pads on horizontal surfaces.
- Load is within manufacturer's rated capacity.
- All machine systems are functioning properly.

Stability

In addition to the conditions listed above under Capacities, machine stability also depends on the following:

- A work surface capable of supporting the machine and a slope within machine leveling specifications.
- Platform is only operated within its work area specification for rated load and boom reach. (See Figure 4-3., Figure 4-4., and Figure 4-7.)

SECTION 4 - MACHINE OPERATION

4.3 ENGINE OPERATION

The battery disconnect switch must be ON (see Section 4.10 on page 4-29). The emergency stop switch at the ground control station and platform control box must be ON (turned clockwise) to start the engine.

Diesel Starting Procedure



1. With power on, set the platform/ground control select switch to the platform control box (counter-clockwise) position, then press and hold the diesel engine START/STOP button (1) on the platform control box until engine starts.

NOTE: Holding the diesel engine START/STOP button in will allow the glow plugs to come to an appropriate tem-

perature for starting. When they are at temperature, the engine will start.

NOTE: If engine fails to start promptly, do not crank for an extended time. Should engine fail to start again, allow starter to cool off for 2-3 minutes. If engine fails after several attempts, refer to manufacturer's engine maintenance manual.

NOTE: Allow engine to warm-up for a few minutes at low speed before applying any load.

NOTE: At low temperatures start the motor and let it run for a few minutes, so that the hydraulic oil circulates and reaches at least 50°F (10°C) before operating the platform.

Diesel Shutdown Procedure

1. Remove all load and allow engine to operate at low speed for 3-5 minutes; this allows further reduction of internal engine temperature.
2. Turn off the diesel engine by pressing the diesel engine START/STOP button on the platform control box.
3. The shutdown procedure takes about 1 minute, wait for complete shut-off (display off).
4. Push EMERGENCY STOP switches at the platform and ground in, to the off position.
5. Turn engine key and main power key to off.

SECTION 4 - MACHINE OPERATION

Electric Engine Starting Procedure - AC Voltage Machine

⚠ CAUTION

ENSURE THE ELECTRICAL CIRCUIT BEING USED IS THE SAME VOLTAGE AND FREQUENCY INDICATED ON THE ELECTRIC ENGINE PLATE. USE AN AC EXTENSION CORD WITH SUFFICIENT AMPERAGE CAPACITY TO PROPERLY POWER THE MACHINE.



1. Before connecting the machine to the electrical circuit, ensure the key on the diesel engine is in the OFF position.
2. Power the machine using a heavy duty AC power cord with sufficient amperage capacity, through

- the connector (1) positioned near the electric engine.
3. Turn on the circuit breaker switch (2) positioned behind the clear plastic cover near the electric engine (— symbol is ON, O symbol is OFF).
4. Start the electric engine using the electrical engine start button on the platform control box. (item 5 - Figure 4-1.) and operate machine.
5. When finished operating with the electric engine, turn off breaker switch (2), and unhook the electric AC cord from connector (1).

SECTION 4 - MACHINE OPERATION

4.4 BASE AND BOOM/JIB ALIGNMENT

The machine uses internal cylinder sensors to calculate the position of the boom. Using these sensors, the machine can determine if the boom assembly is completely lowered and retracted, the jib is lowered, and the turntable is aligned with the base.

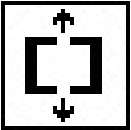

When these conditions are met this symbol will display in position (6) on the Platform/Remote Control LCD display.

UNLESS THESE CONDITIONS ARE MET, DRIVE, STEER, TRACK WIDTH ADJUSTMENT, AND OUTRIGGER MOVEMENT IS PREVENTED.



1. Base/Boom Alignment - Visual Indicator

SECTION 4 - MACHINE OPERATION

4.5 TRACKS - DRIVING, STEERING AND TRACK WIDTH ADJUST

⚠ WARNING

KEEP EVERYONE A DISTANCE OF AT LEAST 6 FT. (1.83 M) FROM THE MACHINE WHEN OPERATING THE TRACKS.

NOTE: *The base and boom/jib must be aligned and retracted before this function will operate, see Section 4.4, BASE AND BOOM/JIB ALIGNMENT.*

Track width adjust

NOTICE

DO NOT WIDEN OR NARROW THE TRACKS WIDTH WHEN PARKED WITH THE TRACKS ON THE GROUND. THE MACHINE MUST BE TRAVELLING OR RAISED ON ITS OUTRIGGERS WHEN OPERATING THIS FUNCTION.

Press and hold button 3 for widening or button 9 for narrowing the track.

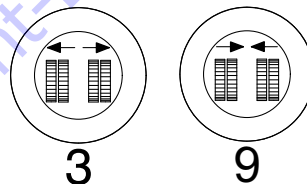

Traveling (Drive and Steer)

⚠ WARNING

USE EXTREME CAUTION WHEN APPROACHING A CREST OF ANY TERRAIN OBSTACLE. CHECK FOR CURBS, LARGE STONES, OR OTHER TERRAIN OBSTACLES INCLUDING OVERHEAD OBSTACLES AS THE MACHINE WILL MAKE UNCONTROLLED PIVOTING MOTIONS WHEN THE CENTER OF GRAVITY (*CENTER OF TRACK FRAME*) SHIFTS OVER AN EDGE. SLOW DOWN TO MINIMIZE ACCELERATION DURING PIVOTING MOVEMENT.

USE EXTREME CAUTION WHEN DRIVING IN REVERSE.

- To drive straight forward or reverse, move the controllers for both tracks at the same time, direction and position.
- Always fully widen the track prior to driving, if possible, for easier steering and increased stability.
- Always travel in the slow speed setting unless the travel path is firm, level and uniform.

Traveling (Grades and Side Slopes)

⚠ WARNING

TO AVOID LOSS OF TRAVEL CONTROL OR "TIP OVER", FULLY WIDEN TRACKS, AND DO NOT DRIVE MACHINE ON GRADES EXCEEDING 16 DEGREES (29%).

USE RAMPS WHEN TRAVELLING ON STEPS OR OTHER SURFACES THAT ARE NOT SMOOTH OR HAVE GOOD TRACTION.

WHEN DRIVING ON SIDESLOPES, FULLY WIDEN THE TRACKS AND EXTEND THE LOW SIDE OUTRIGGERS UNTIL THEY ARE CLOSE TO THE GROUND TO HELP PREVENT A TIP-OVER IF A CHANGE IN SURFACE OCCURS. (SEE FIGURE 4-1.)

DRIVE ON SIDESLOPES WITH THE BOOM STOWED. DO NOT DRIVE ON SIDESLOPES WHICH EXCEED 14 DEGREES.

SECTION 4 - MACHINE OPERATION

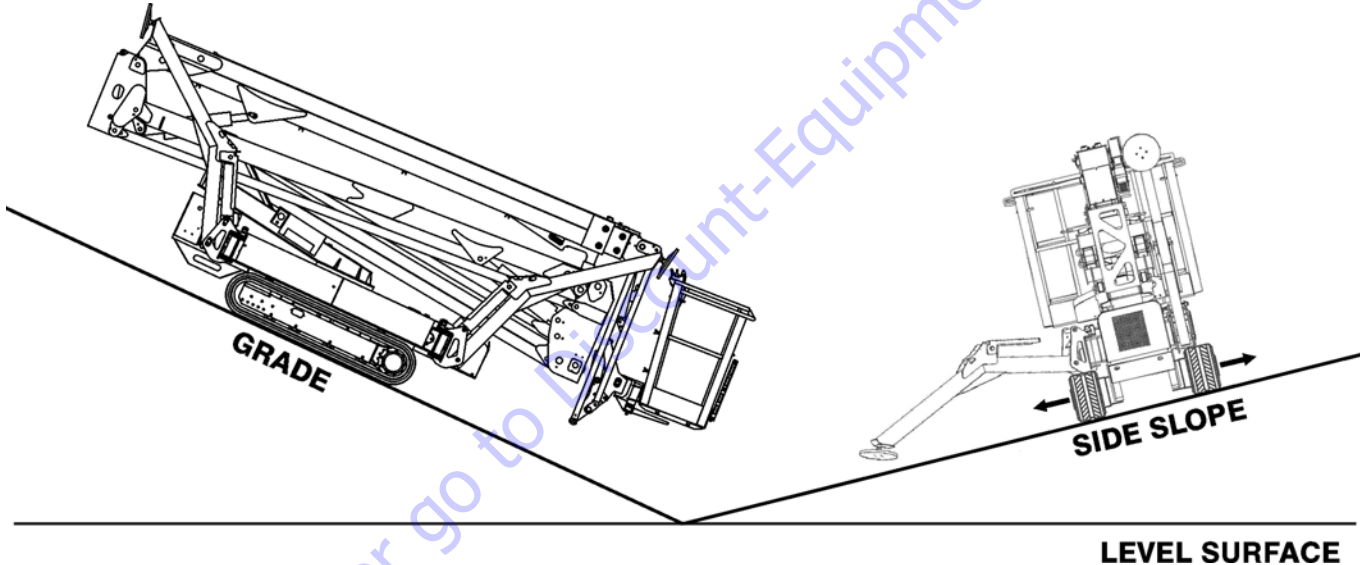

Figure 4-1. Grade and Side Slope Definition

SECTION 4 - MACHINE OPERATION

Jib Position for Traveling

It is necessary to raise the JIB arm when driving up or down slopes that exceed 10° and but less than the max. 15° to prevent the jib from contacting the ground.

NOTICE

ONLY PERFORM THIS OPERATION WHEN IT IS NECESSARY. IN ALL OTHER SITUATIONS, DRIVE WITH THE BOOM AND JIB FULLY LOWERED AND ALIGNED.



Permission to use the JIB is indicated by the icon in position 5 on the remote control display panel.

Before lifting the jib arm in the traversing phase, the following conditions must be verified:

- All outriggers must be lifted from the ground.
- There must be no operator in the platform.

NOTE: *The aerial part safety device by-pass key must not have been activated after the machine has been closed and aligned.*

If any of these conditions have not been met, the use of the JIB is not possible and one of the following error displays appears.



OL00160

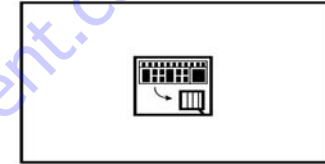

OL00170

After these conditions have been met, make sure that there are no obstacles in the Jib working area and operate as follows:

- Activate joystick for moving the JIB arm. If a different joystick is activated an error message will appear on the display.

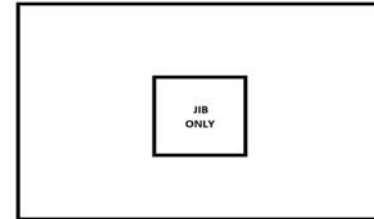

OL00180

- After slope has been passed, for which the jib had to be raised, fully lower jib and continue traveling.
- With JIB raised, ALWAYS travel at minimum speed and keep JIB as near as possible to the ground.

SECTION 4 - MACHINE OPERATION

4.6 OUTRIGGER OPERATION

⚠ WARNING

BE CERTAIN OUTRIGGER PADS ARE SET ON A FIRM AND HORIZONTAL SURFACE. DO NOT SET OUTRIGGER PADS ON INCLINED, VERTICAL, OR SLIPPERY SURFACES.

NOTICE

THE OUTRIGGERS WILL NOT OPERATE UNLESS THE BOOM AND JIB ARE COMPLETELY LOWERED, RETRACTED AND ALIGNED WITH THE BASE.

NOTE: *Base and boom/jib must be aligned and stowed before this function will operate, see Section 4.4, BASE AND BOOM/JIB ALIGNMENT.*

Variable Outrigger Positioning

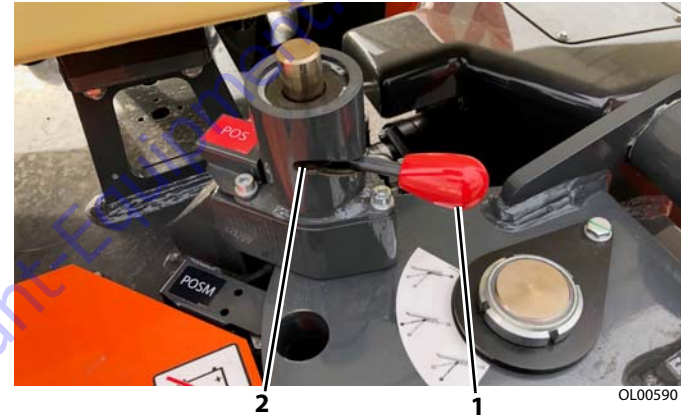

The outrigger joints have locking pins to secure the outriggers while in operational and transport positions.

To position each outrigger from the transport position to the restricted or full area of operation, follow these steps:

1. Pull the outrigger lock handle (1) upward to the locked open position (2) of the groove.
2. Swing outrigger to the desired position.
3. Pull the handle downward toward the locked position and make sure each outrigger locks in the selected position. Make sure that the handle fully closes into the locked position.
4. Ensure all four pins have dropped into their seats for each outrigger.

SECTION 4 - MACHINE OPERATION

ERROR	ST1	FAIL
	ST2	FAIL
	ST3	FAIL
	ST4	FAIL
	INCL	OK
LOAD	OK	
PLATF	OK	
WHEELS	OK	

If one of the four outrigger locking pins is lifted or the outrigger position control microswitch is not working properly, all movement will be stopped and an error message will appear on the platform/remote control LCD display.

Operation will be possible when the outrigger position locking pin is properly set and/or the microswitch is in the correct configuration again.

Check correct positioning of the outrigger lock handle and two microswitches at each outrigger before every use, as shown in following illustration.

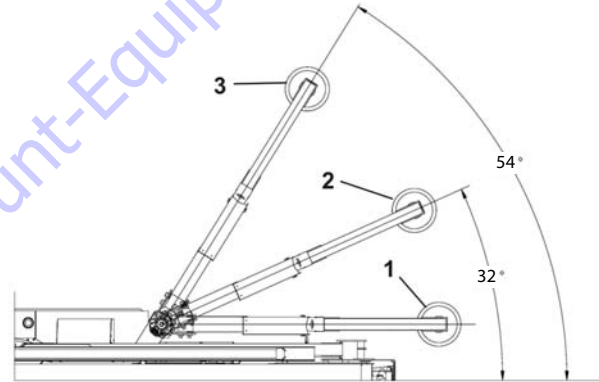

Figure 4-2. Outrigger Positions

1. Transport Position
2. Restricted Work Area Position
3. Full Work Area Position

SECTION 4 - MACHINE OPERATION

Operating with Outriggers Set to 32° - Restricted Work Area Of Operation

(See Figure 4-3. and Figure 4-4.)

NOTE: Swing and jib functions will not be allowed in certain areas.

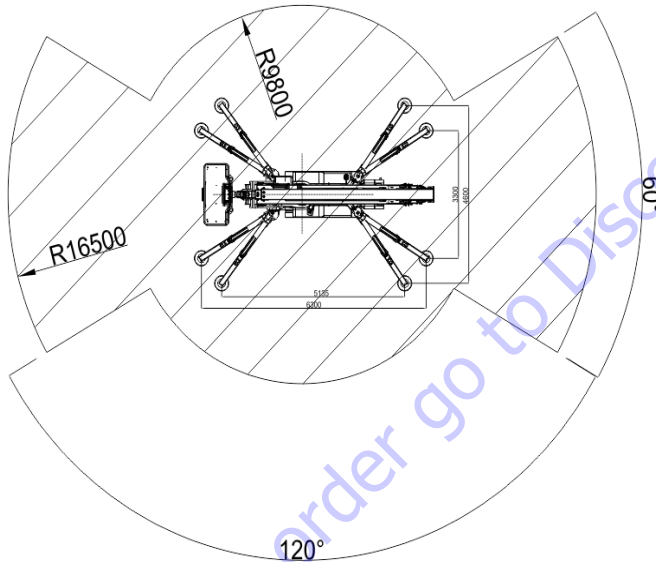

If at least one of the outriggers is set in the restricted area position (32°), the platform/remote control box LCD will display the symbol for restricted area operation in position 1 which is always visible during the use of the machine in this set up.

⚠ WARNING

DO NOT OPERATE IF SYMBOL FOR RESTRICTED AREA OF OPERATION IS NOT DISPLAYED ON THE LCD SCREEN WHEN ANY OF THE OUTRIGGERS ARE IN THE RESTRICTED AREA POSITION.

If you try to position the boom outside the allowed working area by rotating the boom, the movement will be stopped and a message on the LCD display will appear indicating that it is necessary to rotate in the opposite direction in order to keep working.

The following illustrations (*Figure 4-3. and Figure 4-4.*) show the various areas of allowable boom rotation and jib extend operation for the different outrigger settings.

SECTION 4 - MACHINE OPERATION

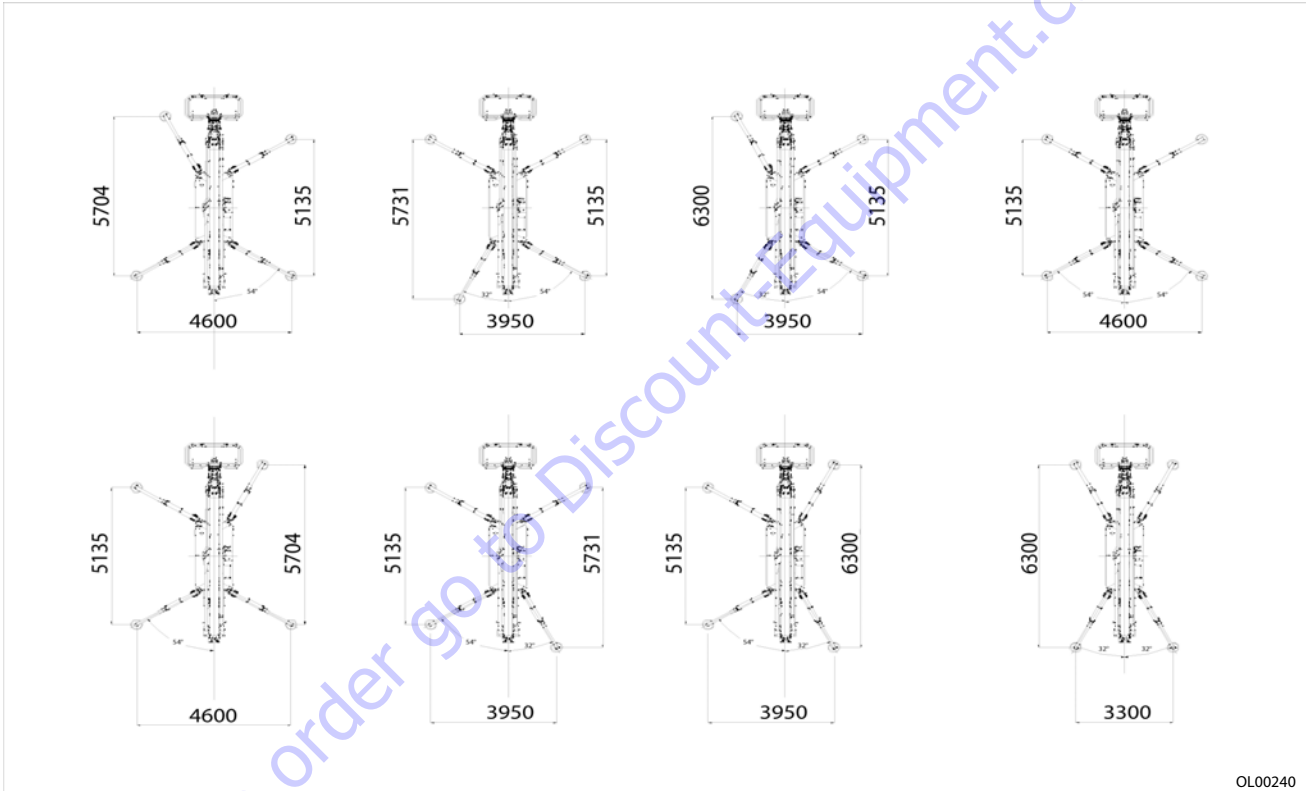

Figure 4-3. Outrigger Positions (Sheet 1 of 2)

OL00240

SECTION 4 - MACHINE OPERATION

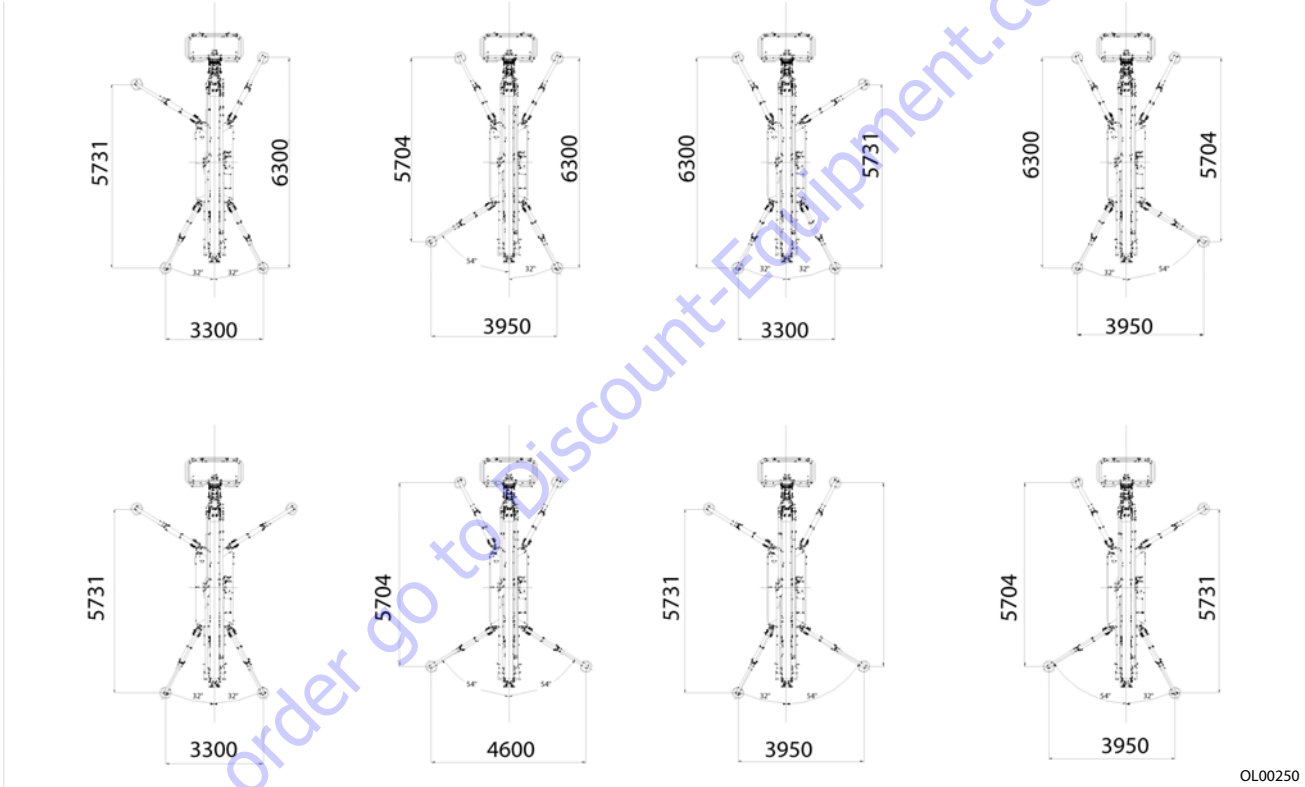



Figure 4-4. Outrigger Positions (Sheet 2 of 2)

SECTION 4 - MACHINE OPERATION

If one of the outriggers does not come into contact with the ground while being set, the engine will turn off or, the self-leveling attempt will stop. This situation may be due to the slope on which the outriggers are being set up on exceeds the allowed slope for proper set up at the end of the stabilization phase. If the machine is to be lifted even further from the ground after the outriggers are properly set, push and hold the outrigger automatic set and level button.

	ST1	NO
	ST2	NO
	ST3	NO
	ST4	NO
	INCL	OK
	LOAD	OK
	PLATF	OK
	PEDAL	OK

If the functions are selected when one of the above listed conditions is missing, an error message will appear on the platform/remote control display indicating which of the conditions are OK and which are not. If the condition is that an outrigger is not set properly, the message will also indicate which outrigger is not set properly.

ST1: if OK outrigger 1 is set properly.

ST2: if OK outrigger 2 is set properly.

ST3: if OK outrigger 3 is set properly.

ST4: if OK outrigger 4 is set properly.

INCL: if OK the machine is set up on an accepted slope.

LOAD: if OK the load in the platform is acceptable.

PLATFORM: if OK the platform/remote control box is in the proper location in the platform.

PEDAL: If OK the footswitch is correctly depressed.

SECTION 4 - MACHINE OPERATION

Setting Outriggers From the Platform/Remote Console

(Reference Figure 4-6. on page 4-21 for item number location)



7

Either - Press and hold the outrigger auto-set and level button 7 (item 7) until OK appears on the platform LCD display;

or

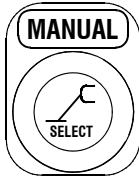

2

Operate each outrigger separately by pressing button 2 (item 2) to select which outrigger to control (each outrigger is numbered 1 thru 4, see decal, each press of button 2 displays the outrigger selected on the LCD display). Press button 7 (item 7) to set that outrigger. The OK will appear on the display when the outriggers are set properly and the unit is level.

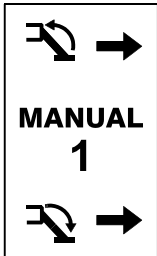

Note: To cycle back to outrigger auto-set mode, press button 2 (item 2) until the LCD display shows the normal operating icons.

⚠ WARNING

CHECK BUBBLE LEVEL INDICATOR TO CONFIRM UNIT IS LEVEL (BUBBLE IS IN THE 1° GREEN (CENTER) AREA) AND TRACKS ARE OFF THE GROUND BEFORE OPERATING THE BOOM FUNCTIONS. IF BUBBLE IN THE LEVEL INDICATOR IS NOT IN THE GREEN AREA, AFTER USING THE AUTO-LEVEL FUNCTION, SHUT DOWN THE MACHINE AND HAVE THE MACHINE REPAIRED BY A QUALIFIED SERVICE TECHNICIAN.



OL00600

SECTION 4 - MACHINE OPERATION

Each outrigger has an orange light installed. All lights will be on steady if outriggers are positioned to the full operation area. Lights will be flashing if any of the outriggers are positioned in the restricted operation area. No lights will be on if the outriggers are not set properly.



OL00610

NOTICE

IF ONE OF THE ORANGE LIGHTS LOCATED ON EACH OUTRIGGER SHOULD FLASH OR REMAIN ON WHEN THAT OUTRIGGER IS LIFTED FROM THE GROUND, STOP THE MACHINE IMMEDIATELY AND CALL A QUALIFIED JLG SERVICE TECHNICIAN AS THIS INDICATES A PROBLEM WITH THE CORRE-

SPONDING OUTRIGGER MICRO SWITCH.

⚠ WARNING

IF SLOPE EXCEEDS 13°, THE MACHINE IS NOT CAPABLE OF PROPERLY SETTING OUTRIGGERS AND LEVELING ITSELF. OPERATION OF BOOM AND PLATFORM FUNCTIONS WILL NOT BE ALLOWED IN THIS CONDITION. THE MACHINE IS CONSIDERED STABILIZED WHEN LEVELED TO LESS THAN 1° AND TRACKS ARE LIFTED AT LEAST 2 IN. (5 CM) FROM THE GROUND. STABILIZING MACHINE WITH AN INCLINATION DEGREE HIGHER THAN THE ONE ALLOWED COULD CAUSE INSTABILITY OF THE MACHINE

If the platform ladder is higher than 16 in. (40 cm) off the ground when the ladder is lowered, when setting the machine on outriggers from the ground position, lower the outriggers until the ladder is less than 16 in. (40 cm) off the ground. Then enter the platform to properly set the machine up on outriggers.

Retracting The Outriggers

(Reference Figure 4-6. on page 4-21 for item number location)

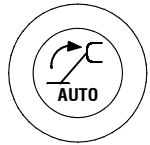

1

Either - Press and hold button no. 1 (*item 1*) of the remote control.

The 4 outriggers will all retract at the same time and lower the machine.

or

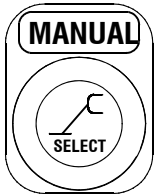

2

Operate each outrigger separately by pressing button 2 (*item 2*) to select which outrigger to control (*each outrigger is numbered 1 thru 4, see decal at each outrigger, each press of button 2 displays the outrigger selected on the LCD display*). Press button 1 (*item 1*) to retract that outrigger.

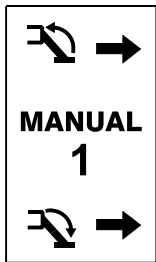

Note: To cycle back to outrigger auto-retract mode, press button 2 (*item 2*) until the LCD display shows the normal operating icons.

4.7 BOOM/PLATFORM OPERATION

NOTICE

THE BOOM WILL NOT OPERATE UNTIL THE OUTRIGGERS ARE PROPERLY SET AND MACHINE IS LEVELED.

AT PLATFORM/REMOTE CONTROL STATION, TWIST EMERGENCY STOP BUTTON CLOCKWISE TO THE OUT POSITION, START ENGINE, AND ACTIVATE FOOTSWITCH FOR ALL PLATFORM/ REMOTE CONTROL FUNCTIONS.

ALWAYS STOW (RAISE) THE LADDER AFTER ENTERING OR EXITING THE PLATFORM TO PREVENT IT BEING DAMAGED WHEN OPERATING THE MACHINE.

If the operator attempts to raise the JIB with more than the allowed capacity in the platform a maximum weight reminder icon appears in the middle of the platform LCD display and the function stops.

If the machine is set up on outriggers for the reduced operating area, the swing function will be stopped if and when you try to go outside the allowed working area. A message on the platform LCD display will appear informing that it is necessary to swing in the opposite direction to continue operation.

NOTE: *At low temperatures start the motor and let it run for a few minutes, so that the hydraulic oil circulates and reaches at least 50°F (10°C) before operating the platform.*

SECTION 4 - MACHINE OPERATION

Overload Alarm

If the platform is overloaded all the boom functions are stopped, the overload icon appears on the platform/remote LCD display and the alarm sounds. To restore the boom functions it is necessary to remove the extra load.

WARNING

TO AVOID SERIOUS INJURY, DO NOT OPERATE MACHINE IF ANY CONTROL LEVER OR SWITCH CONTROLLING PLATFORM MOVEMENT DOES NOT RETURN TO THE 'OFF' OR NEUTRAL POSITION WHEN RELEASED.

IF THE PLATFORM DOES NOT STOP WHEN A CONTROL SWITCH OR LEVER IS RELEASED, REMOVE YOUR FOOT FROM THE FOOT SWITCH AND/OR USE EMERGENCY STOP SWITCH TO STOP THE MACHINE.

If platform is lifted from the proper mounting position during the use of the machine, an alarm will sound and all the movements of the machine will stop. An error message will appear on the LCD display of the platform control.

Platform Level Adjustment *(Item 22, Figure 4-6.)*

NOTE: *The platform will auto-correct to level once another function is activated. The platform will auto-correct to level before the requested function is performed.*

- To manually Level Up, turn switch counter-clockwise and hold until desired position is reached.
- To manually Level Down, turn switch clockwise and hold until desired position is reached.

WARNING

ONLY USE THE PLATFORM LEVELING OVERRIDE FUNCTION FOR SLIGHT LEVELING OF THE PLATFORM. INCORRECT USE COULD CAUSE THE LOAD/OCCUPANT TO SHIFT OR FALL. FAILURE TO DO SO COULD RESULT IN DEATH OR SERIOUS INJURY.

Raise And Lower The Tower Boom (Item 15, Figure 4-6.)

- To raise the tower boom, depress the foot switch and move the controller forward.
- To lower the tower boom, depress the foot switch and move the controller backwards.

NOTE: Tower down will retract the main boom if main boom angle is 15 degrees less than horizontal. Above 15 degrees, tower down function will bring the tower down.

Raise And Lower The Main Boom (Item 16, Figure 4-6.)

- To raise the main boom, depress the foot switch and move the controller forward.
- To lower the main boom, depress the foot switch and move the controller backwards.

Extend/Retract The Main Boom (Item 17, Figure 4-6.)

- To extend the main boom, depress foot switch and move controller backward.
- To retract the main boom, depress foot switch and move controller forward.

Platform Rotation (Item 18, Figure 4-6.)

- To rotate the platform to the right, depress the foot-switch and move the controller forward.
- To rotate the platform to the left, depress the footswitch and move the controller backwards.

Raise And Lower The Jib (Item 19, Figure 4-6.)

- To raise the jib, depress the foot switch and move the controller forward.
- To lower the jib, depress the foot switch and move the controller backwards.

Swinging The Boom (Item 20, Figure 4-6.)

WARNING

WHEN SWINGING THE BOOM MAKE SURE THERE IS AMPLE ROOM FOR THE BOOM AND UPRIGHT TO CLEAR SURROUNDING WALLS, PARTITIONS AND EQUIPMENT.

If the turntable is swung with tower boom too low or tower boom is lowered near an outrigger, Those functions will stop before contact with an outrigger. The display on the platform/remote control box will indicate to swing in the opposite direction or lift up.

- To swing the boom to the right, depress the foot switch and move the controller forward.
- To swing boom to the left, depress foot switch and move controller backwards.

SECTION 4 - MACHINE OPERATION

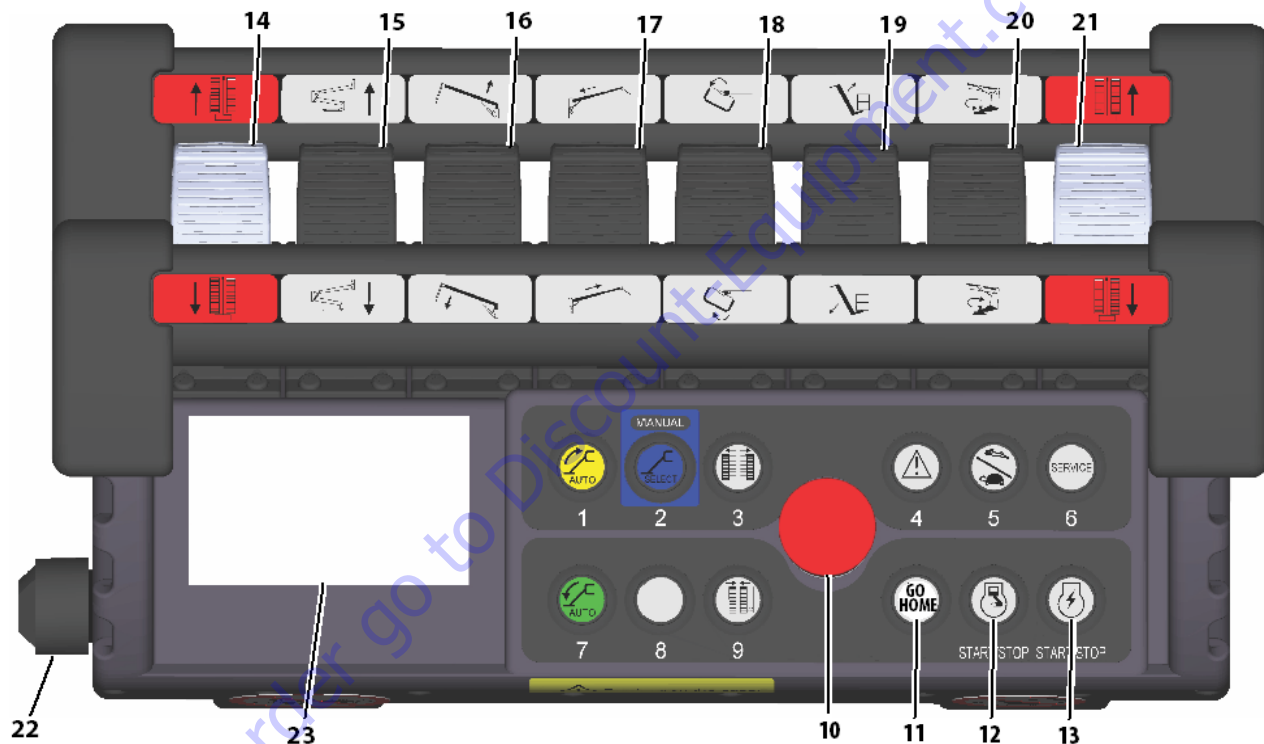

Figure 4-6. Platform/Remote Control Box

SECTION 4 - MACHINE OPERATION

SkyGuard Operation

The SkyGuard™ feature is used to provide enhanced control panel protection. When the SkyGuard™ sensor is activated, functions that were in use at the time of actuation will reverse or cutout and the ground alarm will beep. The table below outlines these functions.



NOTE: Reverse motion can be stopped by the operator by releasing the footswitch, depressing the emergency stop button, or by releasing pressure on the SkyGuard™ sensor.

If SkyGuard™ remains activated after function reversal or cutout, depress and hold the SkyGuard™ Override Switch (button number 8) to allow normal use of machine functions until the SkyGuard™ sensor is disengaged.

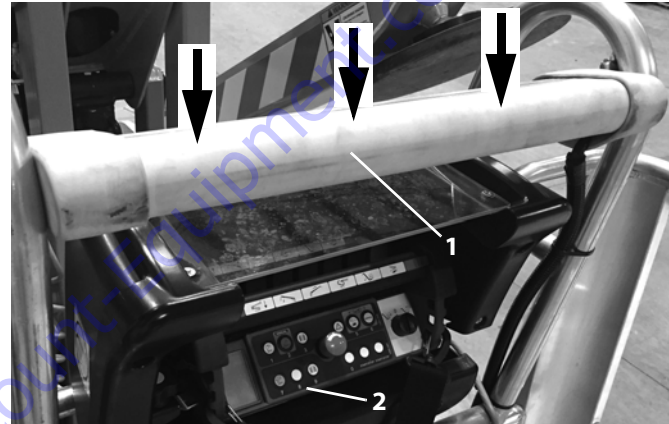

1. SkyGuard™ Sensor

2. SkyGuard™ Override Switch
(button number 8)

Figure 4-7. SkyGuard™ Sensor and Override Switch Location

Table 4-1. SkyGuard™ Function Table

Main Lift Up	Main Lift Dn	Main Tele In	Main Tele Out	Swing	Drive Forward	Drive Reverse	Tower Lift Up	Tower Lift Down	Platform Level	Platform Rotate	Jib Lift	Go Home (All Functions)
R	C	C	R	C	C	C	R	C	C	C	C	C
R= Indicates Reversal is Activated												
C= Indicates Cutout is Activated												
N/A Indicates the function does not exist for this model												

SECTION 4 - MACHINE OPERATION

Platform Removal/Installation

The platform may only be removed to allow passage through areas measuring a minimum of 39 in. (99cm).

NOTE: *If the platform is removed, only track movement is allowed.*

Platform Removal

1. Remove the platform control box from the mounting support.
2. Loosen and remove the aluminum caps (1) that secure the platform to the jib platform mounting posts.

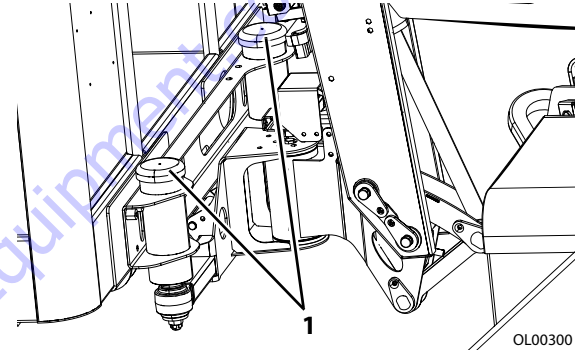

3. Lift the platform off the mounting posts in an upward direction. Place platform aside for later installation.

Platform Installation

1. Lift the platform and align the platform mounts with the jib mounting posts and lower until seated.
2. Secure the platform to the jib mounting posts with the aluminum threaded caps. Do not overtighten.
3. Re-install the platform control box into the mounting support on the platform.

4.8 BATTERY CHARGING - DIESEL/AC-ELECTRIC

NOTE: *Be sure that the machine is parked in a well ventilated area free of flames and sparks.*

- Only plug the charger into a properly grounded outlet.
- Do not use ground adaptors or modify plug. Do not touch non-insulated portion of output connector or non-insulated battery terminal.
- Always disconnect the AC supply before making or breaking the connections to the battery.
- Do not open or disassemble charger.
- Do not operate charger if the AC supply cord is damaged or if the charger has been damaged in any way.

SECTION 4 - MACHINE OPERATION

Battery Charging - Daily

⚠ CAUTION

BEFORE CONNECTING THE BUILT-IN CHARGER TO THE RECEPTACLE, ENSURE THE KEY ON THE ENGINE IS POSITIONED TO OFF.

The machine has a built-in battery charger. To activate this feature connect the machine to an appropriately grounded AC receptacle and activate the charging switch behind the clear plastic door. (See photo) Verify the battery disconnect switch is on.



4.9 BATTERY CHARGING - LITHIUM-ION MACHINE

To check the battery condition on the lithium ION equipped machine, power up the machine and use the special indicator shown at position 8 on the platform control station LCD display.



or;

Check charge indicator on top right side of the Lithium-Ion battery pack. While charging, this indicator shows the current charge state of the lithium-ion battery pack as follows;



RED LED: shows that the battery is in the initial charging phase.

BLINKING GREEN LED: shows that the batteries are balancing.

GREEN LED: shows that the battery has reached 100% of charge.

If machine is powered on while charging, the LCD display on the platform control station also shows the machine charge indicator.

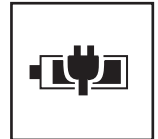

SECTION 4 - MACHINE OPERATION

Charging the Battery Pack

NOTICE

DO NOT LEAVE THE MACHINE IN CONTINUOUS CHARGING FOR TIME PERIODS EXCEEDING 24 HOURS.

REMEMBER, THE CHARGE WORKS EVEN IF THE ELECTRONIC BOARD OF THE MACHINE IS TURNED OFF. SO THE BATTERIES CAN BE CHARGING EVEN IF THE REMOTE CONTROL IS OFF.

CHARGE THE MACHINE USING ONLY THE BATTERY CHARGER INSTALLED ON IT. THE USE OF A CHARGER OTHER THAN THAT PROVIDED VOIDS ANY KIND OF WARRANTY ON BATTERIES.

Approximate time required to fully recharge the battery pack:

- Full Recharge -8 hrs. - 120V AC or 4 hrs. - 220V AC
- 80% Recharge -4 hrs. - 120V AC or 2 hrs. - 220V AC
- The batteries can be charged during machine operation, (*obviously the charging times in this case will be longer*).
- The batteries can be charged when they are not fully depleted.
- If the charge is less than 20% an audible warning signal will be activated whenever the electric motor is started, to alert the user to charge the machine.

- If the charge is less than 10%, in addition to the audible warning signal, reduced speed is activated and an icon comes on in position 4 on the platform station LCD display.



To start charging the battery connect the main AC power supply to the AC socket (1) located on the left rear of the machine next to the electric engine.

After a few seconds the charge indicator (2) located on the right hand side of the machine on top of the lithium-ion battery pack turns red, meaning the battery has started charging.



1

OL00620

SECTION 4 - MACHINE OPERATION



⚠ WARNING

THE BATTERY CHARGER SUPPLIED WITH THE LIFT WAS DESIGNED TO ENSURE SAFE AND RELIABLE PERFORMANCE. IT IS ALREADY FITTED ON THE MACHINE AND DOES NOT NEED ANY ADJUSTMENT OR CONFIGURATION BY THE USER; NONETHELESS, TO AVOID INJURY AND DAMAGE TO THE BATTERY CHARGER, THE FOLLOWING ESSENTIAL PRECAUTIONS MUST BE OBSERVED:

- Carefully read installation instructions contained in this manual. For future reference, keep manual in a safe place.
- Do not place battery pack near heat sources.

- As battery charger is sealed without forced ventilation, its performance depends on ambient temperature and type of installation.
- Be certain type of power supply available corresponds to voltage specified and indicated on the battery charger rating plate or in this Operation and Safety Manual. If any questions, contact your local JLG Service Center or the local electrical company.
- An AC class circuit breaker can be used as a protection device for the battery charger power supply, however it is recommended to use a class A or even better class B device.
- In regard to safety and electromagnetic compatibility, the battery charger features a three pin plug with ground, which can only be plugged into an grounded socket. If the plug does not go into the socket, most probably the socket is old and not grounded. In this case, contact an electrician to have the socket replaced. Do not use adapters to resolve ungrounded circuit plug problems.
- Ensure power cable is undamaged. If cable is worn or damaged, have it replaced immediately.
- If extensions or multiple sockets are used, make sure these support total rated current.

SECTION 4 - MACHINE OPERATION

- Disconnect power supply before connecting or disconnecting battery.
- Do not use the battery charger to charge the batteries of other vehicles; the battery charger installed was specially designed to charge the type of lithium batteries used on this machine. Do not attempt to charge any other type of batteries.
- Do not attempt to repair the battery charger. Opening the cover may expose the user to the risk of electric shock.
- Do not open battery charger, opening it may affect the index of protection (IP) even after it has been closed again.
- If battery charger is not working correctly or is damaged, disconnect it immediately from power outlet and the battery socket and contact a qualified JLG equipment mechanic.

Charge Curve

The battery charger features just one charge curve (IUA) plus balancing and maintenance, designed specifically for charging the lithium-ion battery pack on this machine.

Cold Weather Charging

Lithium battery pack discharge and/or recharge with positive lithium battery level (SOC>0) is possible over 14°F (-10°C).

In cold environmental temperature (not lower than -13°F (-25°C), the on-board electric heaters automatically warm up the cells. The heaters are activated by the BMS when the minimum cell temperature is 32°F (0°C). The heaters are automatically switched off when the minimum cell temperature raises over 35.6°F (2°C).

In cases where the battery charger is connected, when the minimum cell temperature is 32°F (0°C), the charger only supplies 3A to supply power to the heaters until a positive minimum cell temperature is reached.

From -13°F (-25°C) to 32°F (0°C) with null lithium battery level (SOC=0) the heaters will only work while the battery charger is connected to the machine.

The battery cold/heater activated icon will be shown on the display when the heaters are enabled. The machine can only be moved in the lower speed while the heater system is active.



Cooling Fans

In hot environmental temperatures, the cooling fans systems becomes active to cool down the battery cells. This system is automatically activated by the BMS when cell temperature raises over 98.6°F (37°C). The cooling fans system will automatically shut off when cell temperature cools down to 95°F (35°C).

SECTION 4 - MACHINE OPERATION

4.10 SHUT DOWN AND PARK

CAUTION

WHEN PARKING THE MACHINE ON A SLOPE OR UNEVEN GROUND WITH THE OUTRIGGERS RETRACTED, PARK WITH THE TRACKS IN THE FULLY WIDENED POSITION AND BLOCK THE TRACKS USING WEDGES TO PREVENT MACHINE MOVEMENTS.

1. Drive machine to a reasonably well protected area.
2. Ensure machine in the closed position.
3. Remove all load and allow engine to operate 3-5 minutes at LOW setting to permit reduction of internal engine temperatures.
4. Shut down diesel/electric engine with the same button on the platform remote control box used to start it. Complete machine shut down takes approximately 1 minute, LCD display OFF.
5. At ground and platform controls, push-in emergency stop buttons, turn power switch to OFF and remove key at the ground control station. Turn off engine and remove the key.
6. If machine is to be shut down for long periods of time, turn battery disconnect switch (1), RED handle located on the electrical/battery tray housing, to the POWER OFF position.

POWER ON

Clockwise
(As Shown)

POWER OFF

Counter-
Clockwise

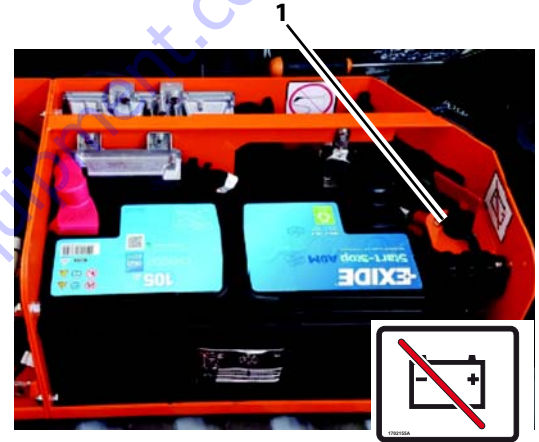

OL00220

BATTERY DISCONNECT SWITCH - DIESEL/AC-ELECTRIC

4.11 LIFTING AND TIE DOWN

Lifting with a forklift

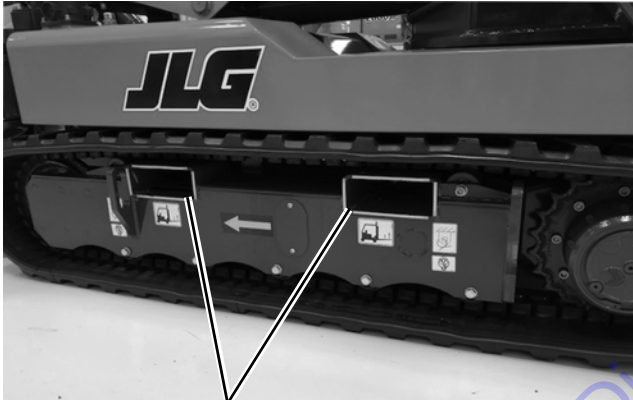

⚠ WARNING

DO NOT LIFT MEWP WITH A FORKLIFT UNLESS MEWP IS IN THE CLOSED, TRANSPORT POSITION WITH THE TRACKS IN THE EXTENDED POSITION. THE BOOM MUST BE ALIGNED AND CLOSED COMPLETELY. THE OUTRIGGERS MUST BE RETRACTED AND LOCKED.

1. Determine gross weight of the MEWP, refer to the serial number tag, or weigh the individual unit to find out the gross vehicle weight. Choose a forklift capable of lifting the MEWP.

2. Make sure that the boom is closed and properly aligned. All outriggers are fully retracted and the tracks are fully extended.
3. Remove all loose items from the MEWP.
4. Slide forks into the forklift lifting points (1) of the MEWP.

NOTE: *This procedure requires qualified personnel to operate the forklift. You must comply with all local government regulations and regulations or requirements identified by the forklift manufacturer.*

Lifting with slings or chains

⚠ WARNING

DO NOT LIFT MEWP WITH SLINGS OR CHAINS UNLESS MEWP IS IN THE CLOSED, TRANSPORT POSITION WITH THE TRACKS IN THE EXTENDED POSITION. THE BOOM MUST BE ALIGNED AND CLOSED COMPLETELY. THE OUTRIGGERS MUST BE RETRACTED AND LOCKED.

1. Determine gross weight of machine, refer to the serial number tag, or weigh the individual unit to find out the gross vehicle weight.
2. Make sure that the boom is closed and properly aligned. All outriggers are fully retracted and the tracks are fully extended.
3. Remove all loose items from the machine.
4. Properly adjust the rigging to prevent damage to the machine and so the machine remains level.

SECTION 4 - MACHINE OPERATION

5. Width of slings must not exceed 2.36 in (60 mm), the width of the chains must not exceed .984 in (25 mm), the diameter of the ropes must not exceed .984 in (25 mm) in order not to exert a pressure in an abnormal direction on the outrigger plate.

NOTICE

USE OF ROPES, CHAINS OR SLINGS WITH LENGTH LESS THAN 10 ft (3m) COULD CAUSE PERMANENT DAMAGE TO MACHINE OUTRIGGERS.

To lift machine, a separate sling must be attached to each outrigger using the appropriate lifting points as indicated in Figure 4-8..

Weight of machine is not spread equally over the four outriggers (See Figure 4-9.). Minimum required capacity of the four ropes, chains or slings used must be no less than 4,409 lb (2000 kg) and their length no less than 10 ft (3m) and all identical.

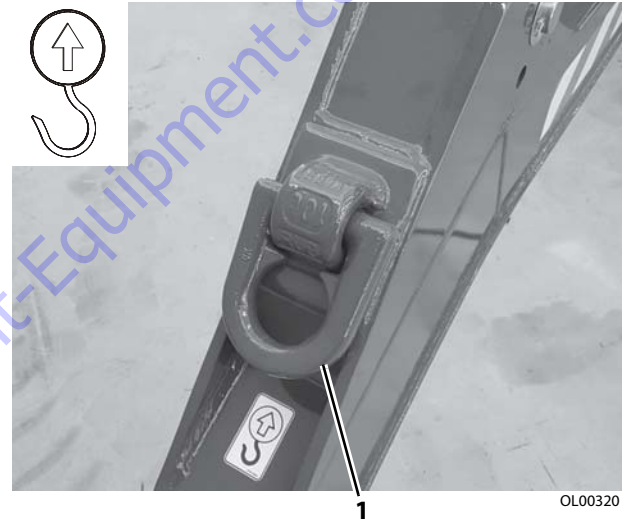

Figure 4-8. Machine Lifting Points

1. Outrigger Lifting Lug

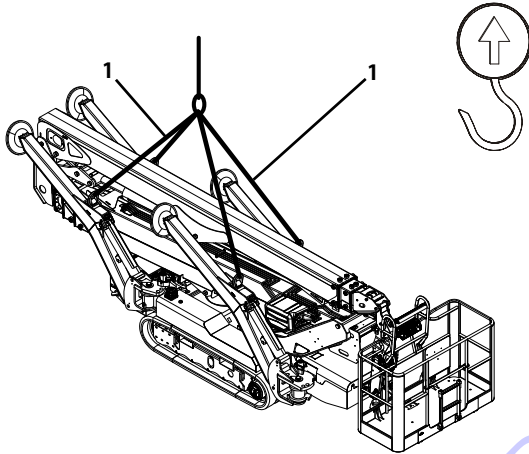

Figure 4-9. Lifting Machine - Attach Points

1. Lifting Slings

Tie Down (See Figure 4-10.)

NOTICE

WHEN TRANSPORTING MACHINE, BOOM MUST BE FULLY LOWERED INTO THE BOOM REST.

- Travel up ramps with platform behind machine.
- Do not contact ground with jib or bottom of platform when loading/unloading. Operate machine from ground using the platform controls detached from platform box. Raise jib to prevent contact with the ground. See "Jib Position for Traveling" on page 4-8.
- ALWAYS load/unload the machine with track fully extended.
 1. Place booms in the stowed position.
 2. Remove all loose items from machine.
 3. Secure chassis using straps or chains of adequate strength.

⚠ CAUTION

DO NOT MAKE CONNECTIONS AT POINTS DIFFERENT THAN THOSE IDENTIFIED BY THE TIE DOWN LOCATION DECAL SHOWN. THIS COULD CAUSE PERMANENT DAMAGE RESULTING IN COLLAPSE OF THE PRODUCT.

SECTION 4 - MACHINE OPERATION

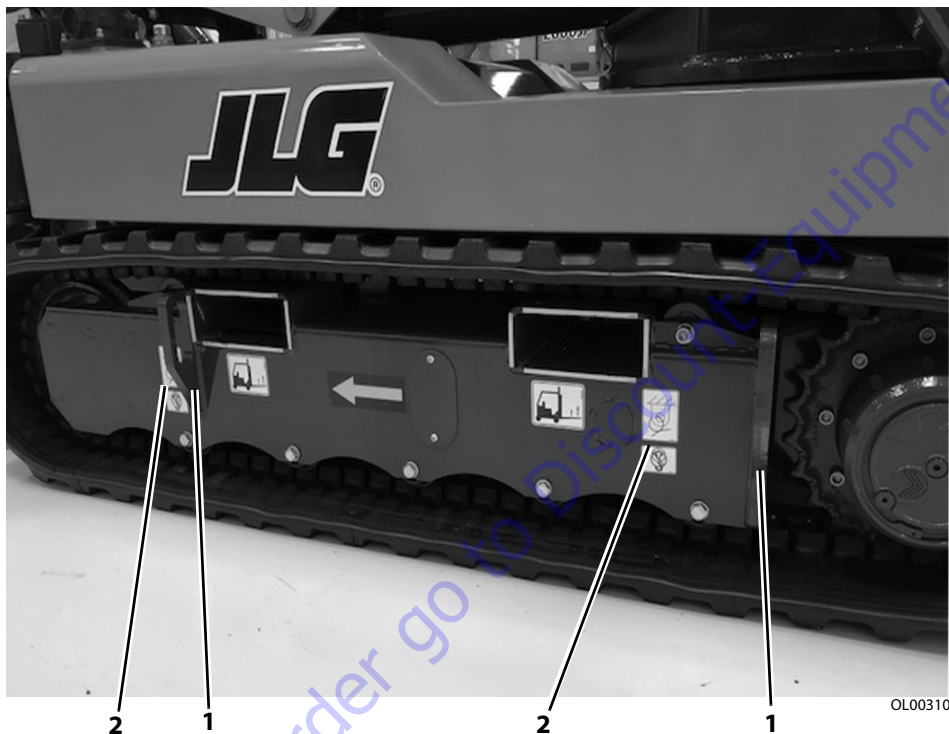

Figure 4-10. Machine Tie-Down Points (both sides of machine)

1. Tie-Down Loop

2. Tie-Down Decal

SECTION 4 - MACHINE OPERATION

4.12 MACHINE DECALS (X1000AJ)



OL00660

Figure 4-11. X1000AJ - Decal installation - Sheet 1

SECTION 4 - MACHINE OPERATION



OL00670

Figure 4-12. X1000AJ - Decal Installation - Sheet 2

SECTION 4 - MACHINE OPERATION



OL00680

Figure 4-13. X1000AJ - Decal Installation - Sheet 3

SECTION 4 - MACHINE OPERATION



OL00690

Figure 4-14. X1000AJ - Decal Installation - Sheet 4

SECTION 4 - MACHINE OPERATION



Figure 4-15. X1000AJ - Decal Installation - Sheet 5

SECTION 4 - MACHINE OPERATION



Figure 4-16. X1000AJ - Decal Installation - Sheet 6

SECTION 4 - MACHINE OPERATION

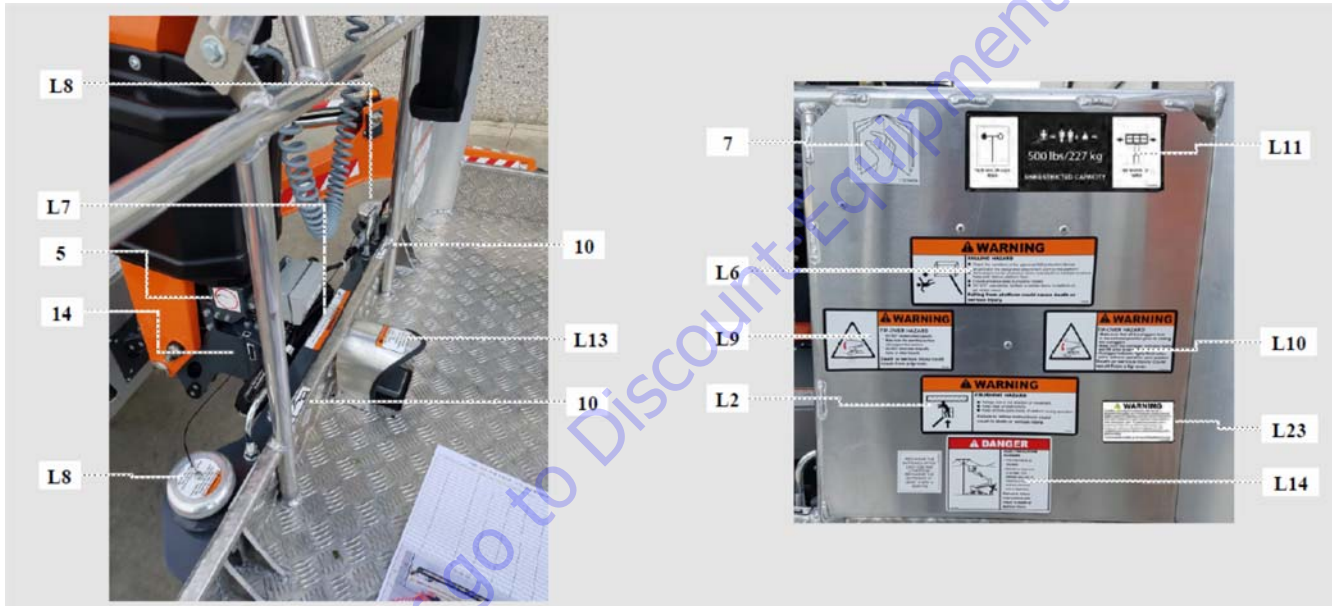

OL00720

Figure 4-17. X1000AJ - Decal Installation - Sheet 7

SECTION 4 - MACHINE OPERATION



Figure 4-18. X1000AJ - Decal Installation - Sheet 8

SECTION 4 - MACHINE OPERATION



Figure 4-19. X1000AJ - Decal Installation - Sheet 9

SECTION 4 - MACHINE OPERATION

Table 4-2. X1000AJ - Decal Installation - Standard

ITEM #	PART NUMBER	DESCRIPTION
1	06555500	OUTRIGGER NUMBER 1
2	06555600	OUTRIGGER NUMBER 2
3	06555700	OUTRIGGER NUMBER 3
4	06555800	OUTRIGGER NUMBER 4
5	1001125483	DO NOT WASH
6	06040500	YELLOW ARROW BLACK BACKGROUND
7	1701640	READ THE MANUAL
8	1703814	ANCHORING POINT
9	07071200	LIFTING POINT
10	1704277	SAFETY POINT ATTACH
11	06164700	HYDRAULIC OIL FILTER
12	07056700	PROHIBITION OF LIFTING
13	07350300	LIFTING PLATFORM
14	06706500	BASKET ALIGNMENT (2 PIECES)
15	1702155	BATTERY DISCONNECT UNDER
16		
17	06165000	HYDRAULIC OIL LEVEL
18	06136900	GREASE POINTS
19	08042100	REACTION TO THE SOIL STABILIZERS
20	07240300_B	DISTANCE 1m ON TELE / RADIO CONTROLS
21		

SECTION 4 - MACHINE OPERATION

Table 4-2. X1000AJ - Decal Installation - Standard

ITEM #	PART NUMBER	DESCRIPTION
22		
23	1704125	ATTACQ ARIA E ACQUA
24	08056100	RIGHT FRONT STABILIZER POSITION CONTROL
25	08056200	RIGHT REAR STABILIZERS POSITION CONTROL
26	08061400	LEFT REAR STABILIZER POSITION CONTROL
27	08061300	LEFT FRONT STABILIZER POSITION CONTROL
28	08042600	RED POS
29	08042700	POSM BLACK
30	08061600	AIR AND WATER ATTACH
C1	07060500	JLG DECAL
C2	08014500	X1000AJ DECAL
C3	08042000	JLG LIFT DECAL
C4	07690100	JLG DECAL
C5	07691500	WWW.JLG.COM DECAL
C6	06039900	RED/WHITIE STRIPES
C7	06039700	RED/WHITE STRIPES
C8	07268300	ATTENTION LIFTING FORKS
C9	07268400	ATTENTION LIFTING FORKS
D1	07056300	DANGER 230 VOLT
D1	07056400_B	DANGER 120 VOLT

SECTION 4 - MACHINE OPERATION

Table 4-2. X1000AJ - Decal Installation - Standard

ITEM #	PART NUMBER	DESCRIPTION
D2	06214200	REFRIGERANT LIQUID BACKGROUND
D3	06060000	ENGINE OIL LEVEL
D4	1701505	DIESEL FUEL
D5	06056300	DANGER STICK HAZARD
D6	17527700014	BIODEGRADABLE OIL
D7	1001228370	CANADIAN REGULATIONS
D7	1001223453	CANADIAN REGULATIONS
L1	07056100	CRUSH DANGER
L2	1706387	PERICOLO SCHIACCIAMENTO
L3	1706099	PERICOLO SCHIACCIAMENTO
L4	1702868_B	PERICOLO SCHIACCIAMENTO
L5	07056200	CRUSH ATTACK LOWER LIM
L6	1706386	DANGER HAZARD
L7	07051100_B	FALL DANGER - RESTORE THE CAPS
L8	07051000	UNLOCK ONLY IN THE CASES EXPECTED
L9	1706133_C	DANGER
L10	07058700	STABILIZER POSITION
L11	081081GB	MAX LOAD IN PLATFORM
L12	1702901	EMERGENCY DESTRUCTION
L13	3252347_B	ATTENTION PEDAL
L14	1706128_E	DANGER ELECTRIC SHOCK

SECTION 4 - MACHINE OPERATION

Table 4-2. X1000AJ - Decal Installation - Standard

ITEM #	PART NUMBER	DESCRIPTION
L15	1703813	DANGER BATTERY EXPLOSION
L16	1704972_C	DANGER EXPLOSION
L17	080422GB	EMERGENCY DESCENT THERMAL ENGINE AND LITHIUM
L18	1706385_C	SCROLLING OF BARRIER CLOSING
L19	1705514	CSA COMPLIANCE
L20	1706135_B	USE PLATFORM
L21	080423GB	DISTRIBUTOR BUTTONS UPPER AERIAL PARTS
L22	080424GB	DISTRIBUTOR BUTTONS UPPER AERIAL PARTS
L23	08069800	PROP 65

4.13 MACHINE DECALS (X33JP)

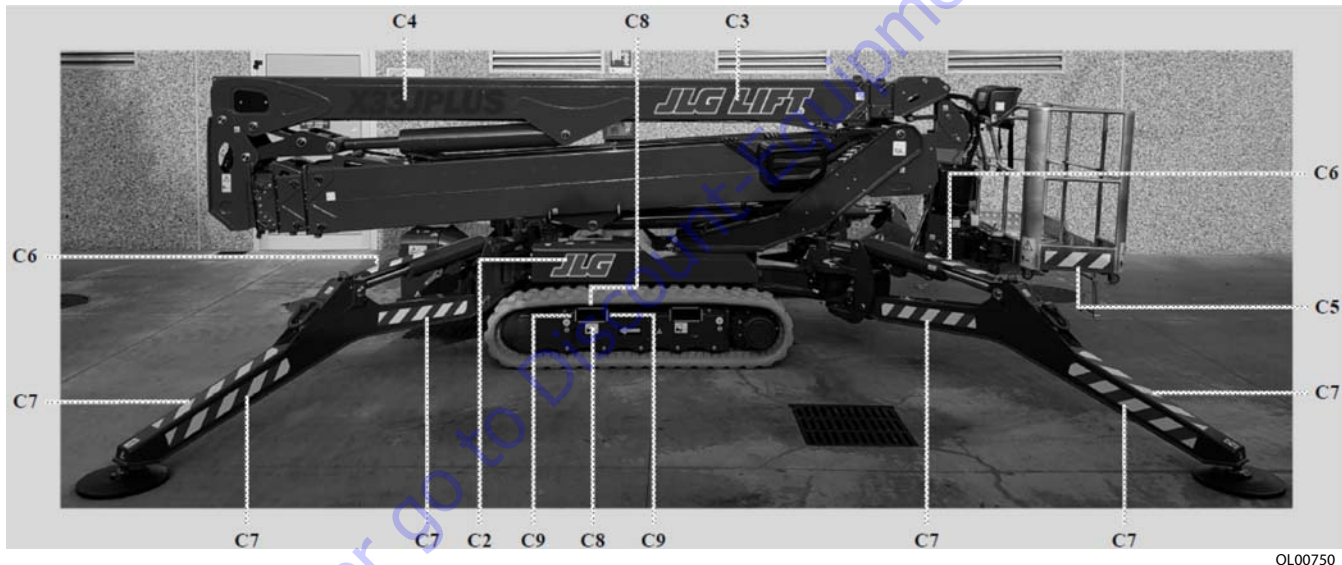

Figure 4-20. X33JP - Decal Installation - Sheet 1

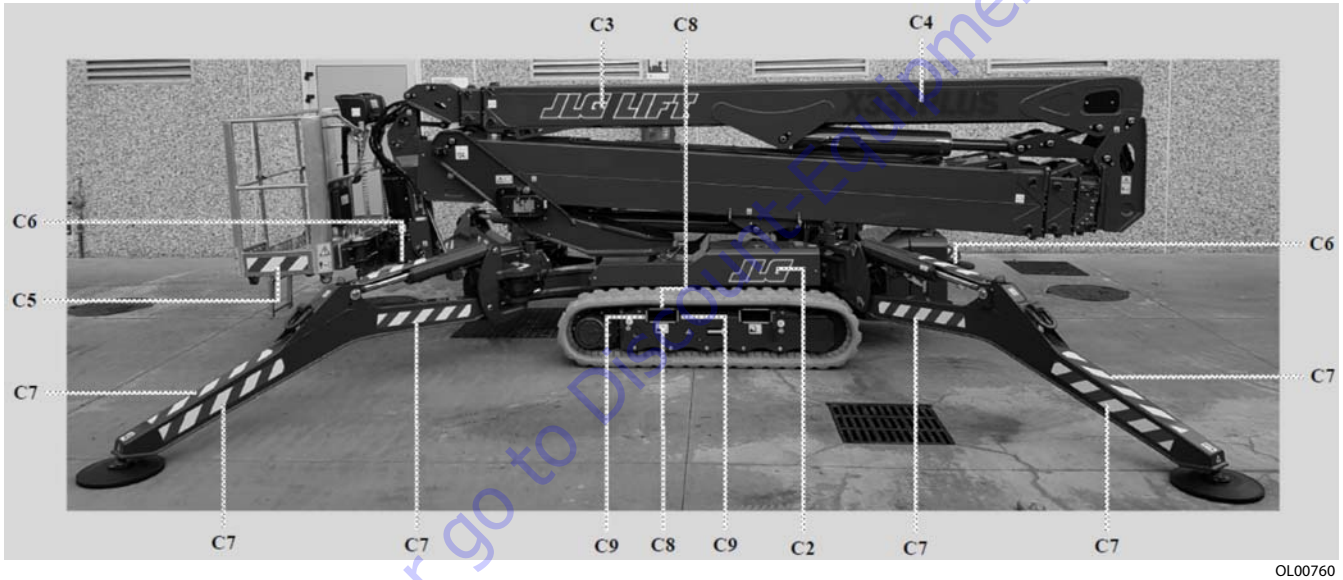
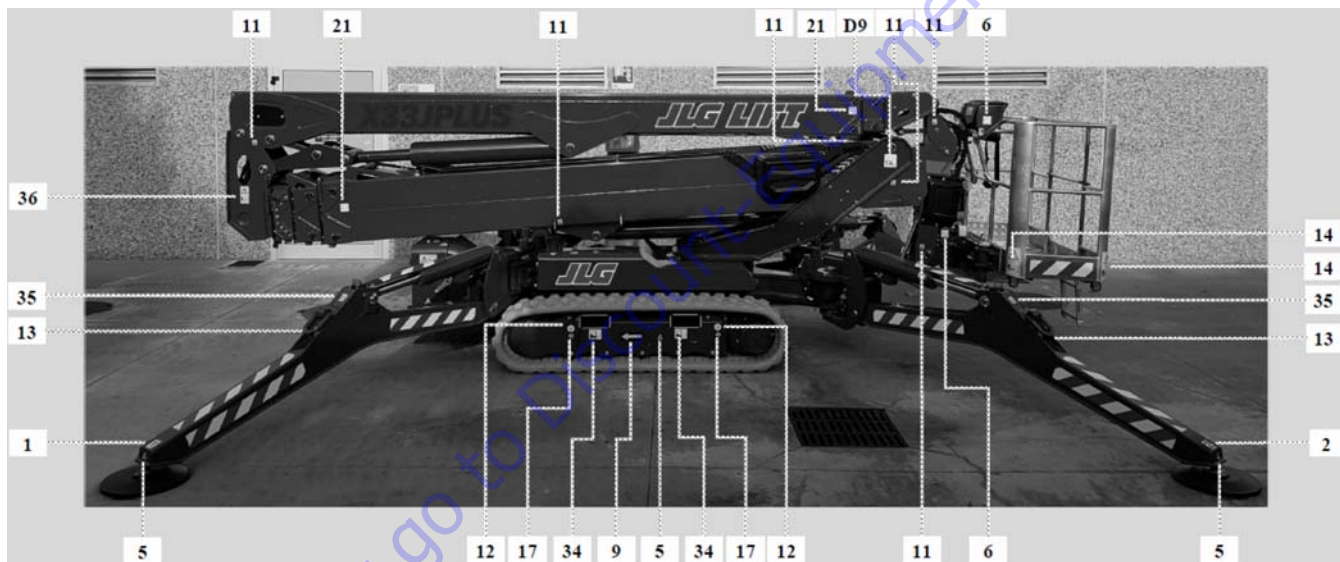

Figure 4-21. X33JP - Decal Installation - Sheet 2

SECTION 4 - MACHINE OPERATION



OL00770

Figure 4-22. X33JP - Decal Installation - Sheet 3

SECTION 4 - MACHINE OPERATION

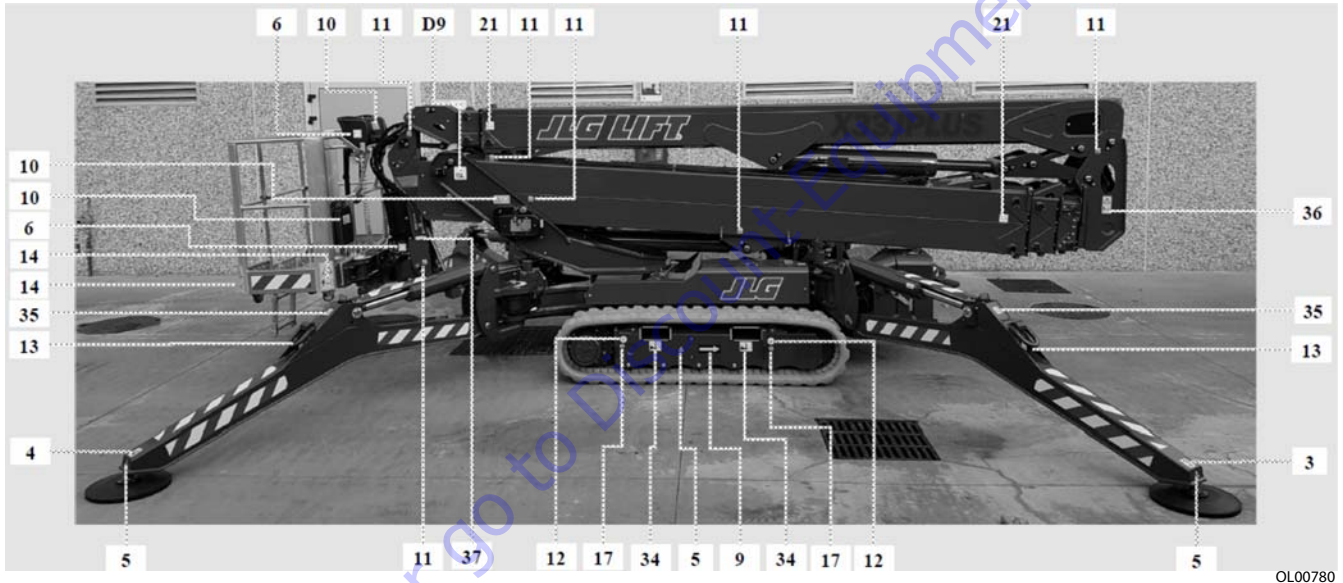

Figure 4-23. X33JP - Decal Installation - Sheet 4

SECTION 4 - MACHINE OPERATION

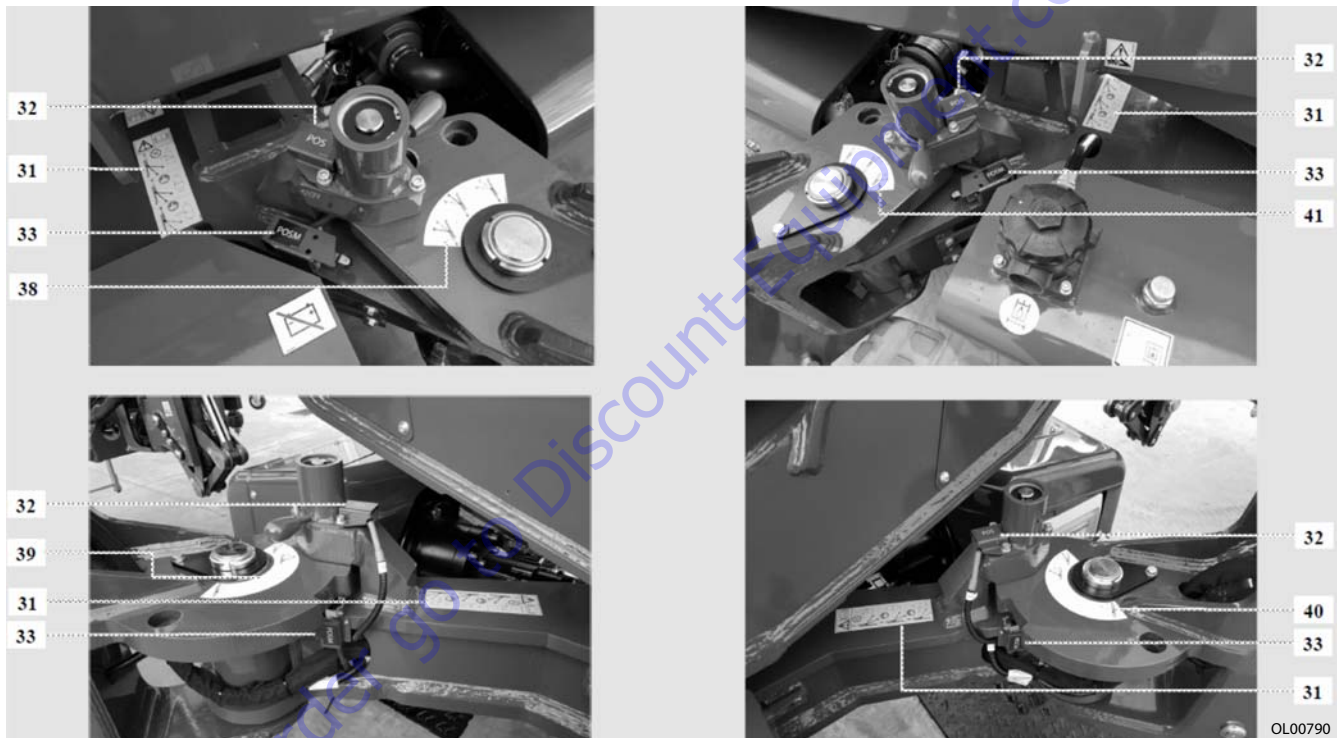

Figure 4-24. X33JP - Decal Installation - Sheet 5

SECTION 4 - MACHINE OPERATION



Figure 4-25. X33JP - Decal Installation - Sheet 6

SECTION 4 - MACHINE OPERATION

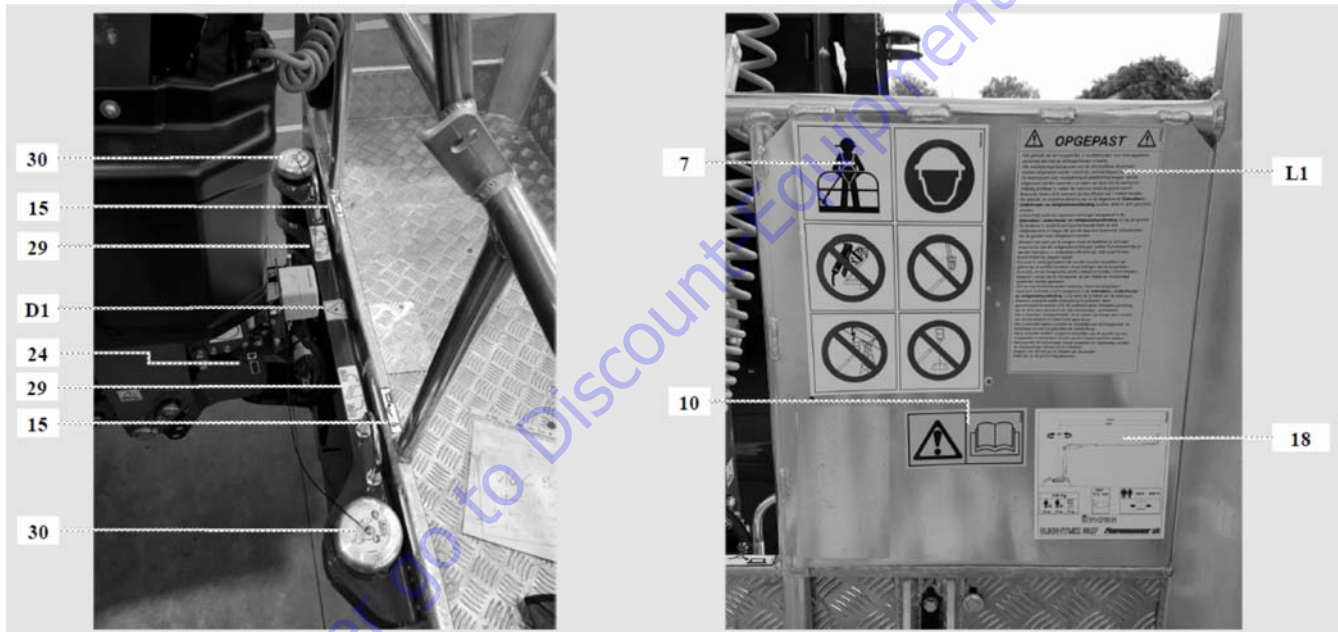

OL00810

Figure 4-26. X33JP - Decal Installation - Sheet 7

SECTION 4 - MACHINE OPERATION

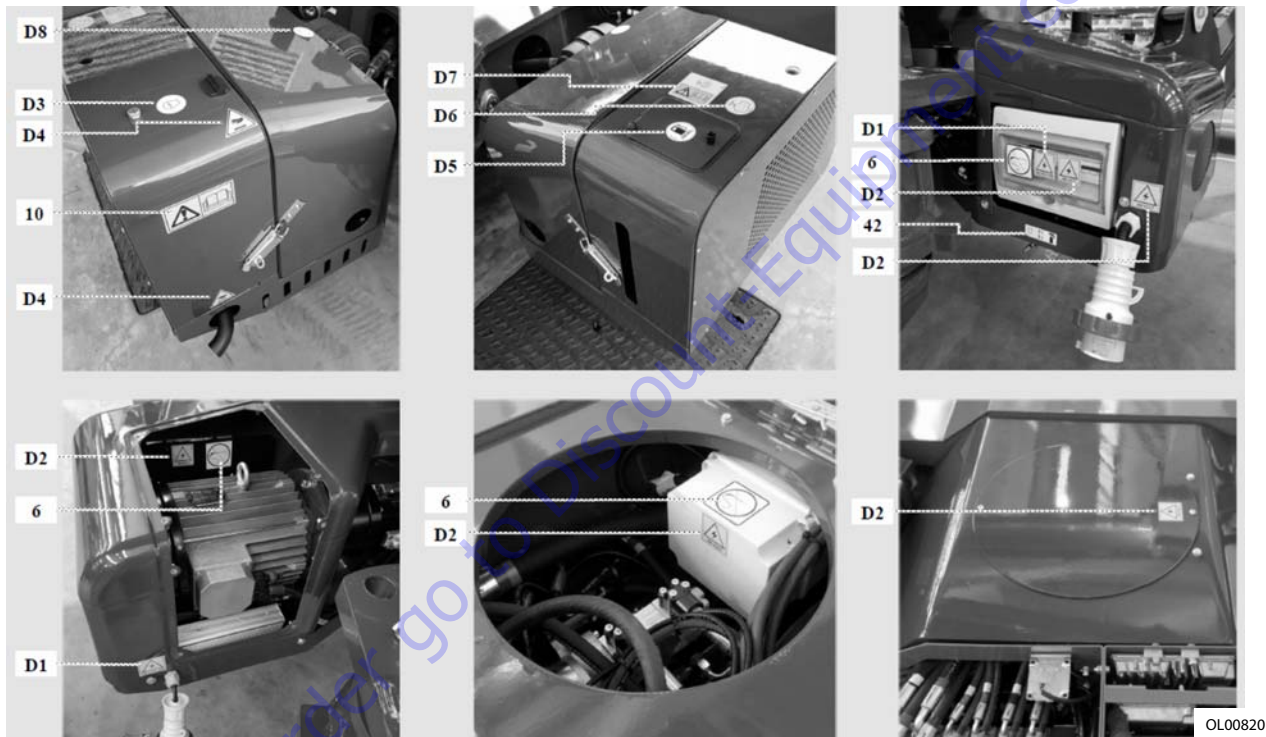

Figure 4-27. X33JP - Decal Installation - Sheet 8

SECTION 4 - MACHINE OPERATION



OL00830

Figure 4-28. X33JP - Decal Installation - Sheet 9

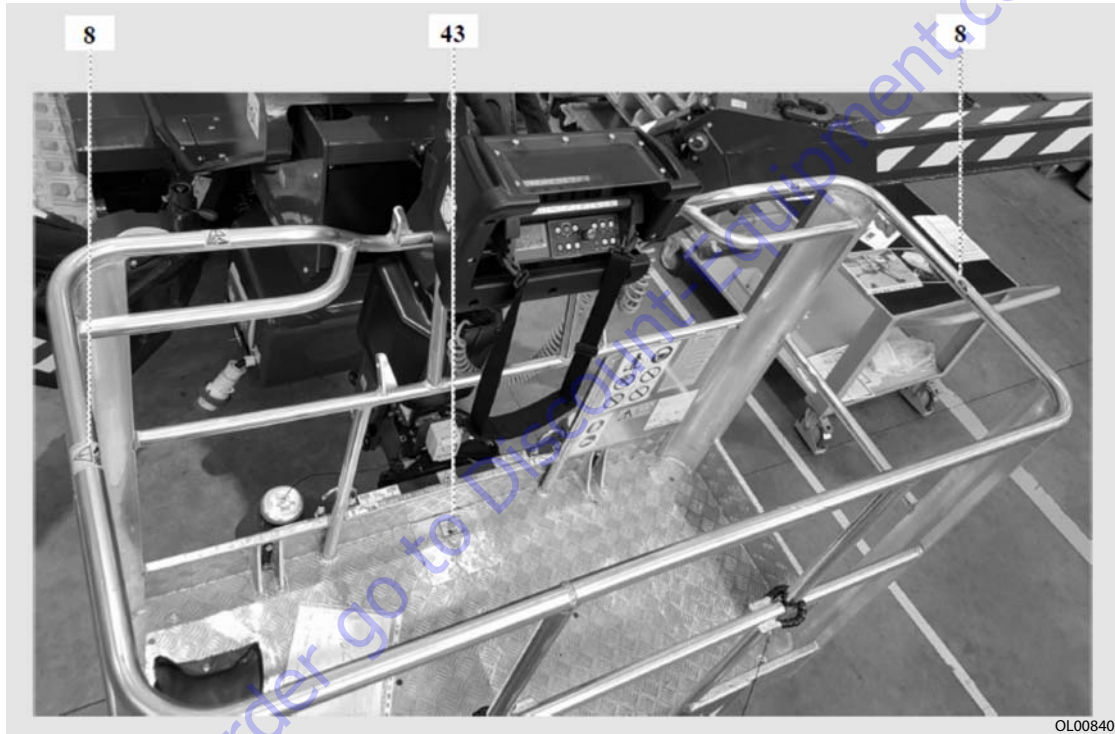

Figure 4-29. X33JP - Decal Installation - Sheet 10

SECTION 4 - MACHINE OPERATION

Table 4-3. X33JP - Decal Installation - Standard

ITEM #	PART NUMBER	DESCRIPTION
1	06555500	OUTRIGGER NUMBER 1
2	06555600	OUTRIGGER NUMBER 2
3	06555700	OUTRIGGER NUMBER 3
4	06555800	OUTRIGGER NUMBER 4
5	06041200	CRUSHING FOOT HAZARD
6	1001125483	DO NOT WASH
7	06924300	IMBRAGATURA - DIVIETI SERIE METAL
8	1706493_B	SLOWING LOCKING CLOSING
9	06040500	YELLOW ARROW BLACK BACKGROUND
10	06040900	READ THE MANUAL
11	06041300_B	CAUTION DANGER CUTS
12	1703814	ANCHORING POINT
13	07071200	LIFTING POINT
14	06040300	DANGER KEEP DISTANCE
15	1704277	SAFTEY BELT ATTACH
16	06136900	GREASE POINT
17	06311200	PROHIBITION OF LIFTING

SECTION 4 - MACHINE OPERATION

Table 4-3. X33JP - Decal Installation - Standard

ITEM #	PART NUMBER	DESCRIPTION
18	08043400	TWO PERSON RATING X33JPLUS
19	08042800	DISTRIBUTOR BUTTONS UPPER AERIAL PARTS
20	08042900	DISTRIBUTOR BUTTONS UPPER AERIAL PARTS
21	06704400_B	SHOULDER PADS ADJUSTMENT
22	07240300_B	DISTANCE 1 METER ON TELE / RADIO CONTROLS
23	07056800	EMERGENCY DESCENT INSIDE
24	06706500	PLATFORM ALIGNMENT (2 PIECES)
25	1702155	BATTERY
26	1701504	HYDRAULIC OIL
27	06164700	HYDRAULIC OIL FILTER
28	06165000	HYDRAULIC OIL LEVEL
29	06448100_B	RESTORE THE STOPS GUIDE
30	06448200_B	UNLOCK ONLY IN THE CASES EXPECTED
31	08042500	MICRO STABILIZERS CONTROL
32	08042600	POS RED
33	08042700	POSM BLACK
34	07350300	LIFTING PLATFROM
35	08043000	REACTION TO THE SOIL STABILIZERS
36	07058800	DANGER KEEP DISTANCE

SECTION 4 - MACHINE OPERATION

Table 4-3. X33JP - Decal Installation - Standard

ITEM #	PART NUMBER	DESCRIPTION
37	1704125	AIR AND WATER ATTACH
38	08056100	RIGHT FRONT STABILIZER POSITION CONTROL
39	08056200	RIGHT REAR STABILIZERS POSITION CONTROL
40	08061400	LEFT REAR STABILIZER POSITION CONTROL
41	08061300	LEFT FRONT STABILIZER POSITION CONTROL
42	08061600	AIR AND WATER ATTACH
43	1705828	INSTRUCTIONS PEDAL
C2	07060500	JLG DECAL
C3	08042000	JLG LIFT DECAL
C4	08038500	X33JPLUS DECAL
C5	06086700	RED/WHITE STRIPES DECAL
C6	06039900	RED/WHITE STRIPES DECAL
C7	06039700	RED/WHITE STRIPES DECAL
C8	07268400	ATTENTION LIFTING FORKS
C9	07268300	LIFTING FORKS
C10	07678200	HINOWA DECAL
D1	07056300	DANGER 220 VOLT 16A

SECTION 4 - MACHINE OPERATION

Table 4-3. X33JP - Decal Installation - Standard

ITEM #	PART NUMBER	DESCRIPTION
D1	07056400_B	DANGER 230VOLT 16A
D2	08061500	DANGER 400 VOLT
D3	06214200	REFRIGERANT LIQUID
D4	06056300	BURN HAZARD
D5	06043900	DIESEL FUEL
D6	06060000	ENGINE OIL LEVEL
D7	06227200_B	CHECK ENGINE OIL LEVEL
D8	06164600	AIR FILTER
D9	07034200_B	NOISE 104 Db
L1	06555300_C	USE TRACKED AIR PLATFORM - ITALIAN
L2	080432IT	DESCENT OF EMERG LL3317 THERMAL ENGINE AND LITHIUM -ITALIAN
L1	06562600_C	USE TRACKED AIR PLATFORM - ENGLISH
L2	080432GB	DESCENT OF EMERG LL3317 THERMAL ENGINE AND LITHIUM -ENGLISH
L1	06562600_C	USE TRACKED AIR PLATFORM - FRENCH
L2	080432FR	DESCENT OF EMERG LL3317 THERMAL ENGINE AND LITHIUM - FRENCH

SECTION 4 - MACHINE OPERATION

Table 4-3. X33JP - Decal Installation - Standard

ITEM #	PART NUMBER	DESCRIPTION
L1	06562600_C	USE TRACKED AIR PLATFORM - GERMAN
L2	080432DE	DESCENT OF EMERG LL3317 THERMAL ENGINE AND LITHIUM - GERMAN
L1	06562600_C	USE TRACKED AIR PLATFORM - SPANISH
L2	080432ES	DESCENT OF EMERG LL3317 THERMAL ENGINE AND LITHIUM - SPANISH
L1	06562600_C	USE TRACKED AIR PLATFORM - DUTCH
L2	080432NL	DESCENT OF EMERG LL3317 THERMAL ENGINE AND LITHIUM - DUTCH
L1	06562600_C	USE TRACKED AIR PLATFORM - SWEDISH
L2	080432SW	DESCENT OF EMERG LL3317 THERMAL ENGINE AND LITHIUM - SWEDISH
L1	06562600_C	USE TRACKED AIR PLATFORM - PORTUGUESE
L2	080432PT	DESCENT OF EMERG LL3317 THERMAL ENGINE AND LITHIUM - PORTUGUESE
L1	06562600_C	USE TRACKED AIR PLATFORM - DANISH
L2	080432DA	DESCENT OF EMERG LL3317 THERMAL ENGINE AND LITHIUM - DANISH
L1	06562600_C	USE TRACKED AIR PLATFORM - NORWEGIAN

SECTION 4 - MACHINE OPERATION

Table 4-3. X33JP - Decal Installation - Standard

ITEM #	PART NUMBER	DESCRIPTION
L2	080432NO	DESCENT OF EMERGLL3317 THERMAL ENGINE AND LITHIUM - NORWEGIAN
L1	06562600	USE TRACKED AIR PLATFORM - RUSSIAN
L2	080432RU	DESCENT OF EMERGLL3317 THERMAL ENGINE AND LITHIUM - RUSSIAN
L1	06562600_B	USE TRACKED AIR PLATFORM - POLISH
L2	080432PL	DESCENT OF EMERGLL3317 THERMAL ENGINE AND LITHIUM - POLISH
L1	06562600	USE TRACKED AIR PLATFORM - SLOVENIAN
L2	080432SL	DESCENT OF EMERGLL3317 THERMAL ENGINE AND LITHIUM - SLOVENIAN
L1	06562600_B	USE TRACKED AIR PLATFORM - FINNISH
L2	080432FI	DESCENT OF EMERGLL3317 THERMAL ENGINE AND LITHIUM - FINNISH
L1	06562600	USE TRACKED AIR PLATFORM - CZECH
L2	080432CE	DESCENT OF EMERGLL3317 THERMAL ENGINE AND LITHIUM - CZECH
L1	06562600	USE TRACKED AIR PLATFORM - JAPANESE
L2	080432JA	DESCENT OF EMERGLL3317 THERMAL ENGINE AND LITHIUM - JAPANESE

TO PURCHASE THIS PRODUCT PLEASE CONTACT US



**Equipment Financing and
Extended Warranties Available**



**Discount-Equipment.com is your online resource for
commercial and industrial quality parts and equipment sales.**

561-964-4949

visit us on line @ www.discount-equipment.com

Select an option below to find your Equipment

Search by Manufacturer

Search by Product Type

Request a Quote

We sell worldwide for the brands: Genie, Terex, JLG, MultiQuip, Mikasa, Essick, Whiteman, Mayco, Toro Stone, Diamond Products, Generac Magnum, Airman, Haulotte, Barreto, Power Blanket, Nifty Lift, Atlas Copco, Chicago Pneumatic, Allmand, Miller Curber, Skyjack, Lull, Skytrak, Tsurumi, Husquvarna Target, Stow, Wacker, Sakai, Mi-T-M, Sullair, Basic, Dynapac, MBW, Weber, Bartell, Bennar Newman, Haulotte, Ditch Runner, Menegotti, Morrison, Contec, Buddy, Crown, Edco, Wyco, Bomag, Laymor, EZ Trench, Bil-Jax, F.S. Curtis, Gehl Pavers, Heli, Honda, ICS/PowerGrit, IHI, Partner, Imer, Clipper, MMD, Koshin, Rice, CH&E, General Equipment, Amida, Coleman, NAC, Gradall, Square Shooter, Kent, Stanley, Tamco, Toku, Hatz, Kohler, Robin, Wisconsin, Northrock, Oztec, Toker TK, Rol-Air, APT, Wylie, Ingersoll Rand / Doosan, Innovatech, Con X, Ammann, Mecalac, Makinex, Smith Surface Prep, Small Line, Wanco, Yanmar

SECTION 5. EMERGENCY PROCEDURES

5.1 GENERAL

This section explains the steps to be taken in case of an emergency situation while operating.

5.2 INCIDENT NOTIFICATION

JLG Industries, Inc. must be notified immediately of any incident involving a JLG product. Even if no injury or property damage is evident, the factory should be contacted by telephone and provided with all necessary details.

- USA: 877-JLG-SAFE (554-7233)
- EUROPE: (32) 0 89 84 82 20
- AUSTRALIA: (61) 2 65 811111
- E-mail: ProductSafety@JLG.com

Failure to notify the manufacturer of an incident involving a JLG Industries product within 48 hours of such an occurrence may void any warranty consideration on that particular machine.

NOTICE

FOLLOWING ANY ACCIDENT, THOROUGHLY INSPECT MACHINE AND TEST ALL FUNCTIONS FIRST FROM GROUND CONTROLS, THEN FROM PLATFORM CONTROLS. DO NOT LIFT ABOVE 10 FT (3 M) UNTIL YOU ARE SURE ALL DAMAGE HAS BEEN REPAIRED, IF REQUIRED, AND ALL CONTROLS ARE OPERATING CORRECTLY.

SECTION 5 - EMERGENCY PROCEDURES

5.3 EMERGENCY OPERATION

Power Main Cut-Off Switch Location

A battery cut-off switch (1) - (RED handle) is located on the inside of the battery/electrical box tray, just behind the outrigger mount. When switched off - handle turn all the way counter-clockwise - all electrical power to the lithium system is shut down. The 12v system will remain active to supply power to the boards.

POWER ON

Clockwise
(As Shown)

POWER OFF

Counter-
Clockwise

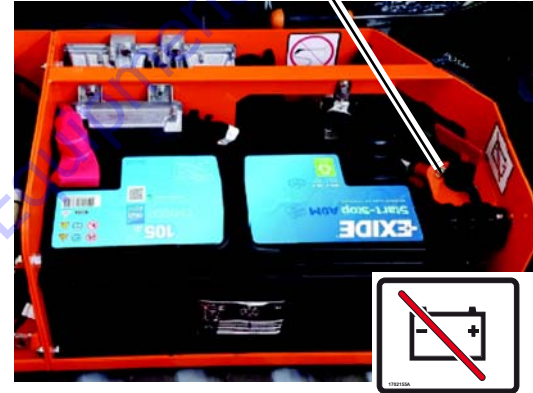

OL00220

BATTERY DISCONNECT SWITCH - DIESEL/AC-ELECTRIC

SECTION 5 - EMERGENCY PROCEDURES

Operator Unable to Control Machine

IF PLATFORM OPERATOR IS PINNED, TRAPPED OR UNABLE TO OPERATE OR CONTROL MACHINE:

1. Other personnel should operate the machine from ground controls only as required.
2. Other qualified personnel on the platform may use the platform controls. DO NOT CONTINUE OPERATION IF CONTROLS DO NOT FUNCTION PROPERLY.
3. Cranes, forklift trucks or other equipment can be used to remove platform occupants and stabilize machine motion.

Platform or Boom Caught Overhead

If the platform or boom becomes jammed or snagged in over-head structures or equipment, do the following:

1. Shut off the machine.
2. Rescue all people in the platform before freeing the machine. Personnel must be out of the platform before operating any controls on the machine.
3. Use cranes, forklifts, or other equipment to stabilize motion of the machine to prevent a tip over as required.
4. From the ground controls, use the Auxiliary Power System (if equipped) to carefully free the platform or boom from the object.
5. Once clear, restart the machine and return the platform to a safe position.
6. Inspect the machine for damage. If the machine is damaged or does not operate properly, turn off the machine immediately. Report the problem to the proper maintenance personnel. Do not operate the machine until it is declared safe for operation.

SECTION 5 - EMERGENCY PROCEDURES

Emergency Descent

The purpose of the Emergency Descent function (ED) is to bring the operator down to an accessible zone in case the main power source (diesel engine or electric motor) is not working. The purpose of this system is not to close the machine or operate boom functions. It can be activated from the platform control box or ground control station.

In order to activate ED, the same safety conditions valid for normal operation boom movements must be verified by the system. The "machine stabilized icon" must be present on the display.

In order to activate ED, it is necessary to keep the emergency descent button (4) pressed in while performing the appropriate function.



While using ED, if the main power comes back on, ED will continue to draw power from the 12V battery.

Once the triangle button is pressed and held, the desired function can be selected. Once the function is selected, the DC electric pump is activated. The DC electric pump is deactivated when the function selection (joystick) is released.

In order to use the 12V battery to perform an emergency descent, it must contain 11V to start the procedure. During the procedure, if the battery drops to 9V, the emergency descent will stop. You will have to charge the battery before the emergency procedure can continue. Stopping the emergency procedure at 9V ensures that the battery will have

enough power to keep the machine's various circuit boards supplied with the correct voltage.

NOTE: *When using the 12V battery to perform an emergency descent, operation of the swing and main boom retract function are limited to 10 seconds. You must activate the function again to continue emergency descent by releasing the function and re-engaging.*

Some functions will not operate since this is a gravity lowering system. The MAIN DOWN symbol will appear on the display if one of those functions are selected. Also, if the function is not allowed, when trying to perform a function, the pump will run for 5 seconds and shut off.

Functions possible during emergency descent are:

- Tower Boom retract
- Main Boom lowering
- Main Boom retract, only possible if the angle between main boom and ground is over -15° , limited to 10 second intervals
- Swing, limited to 10 second intervals
- Jib open and close

⚠ CAUTION

ENSURE BOOM IS NOT POSITIONED OVER THE OUTRIGGERS OR OVERHEAD OF PERSONNEL BEFORE LOWERING.

SECTION 5 - EMERGENCY PROCEDURES

Using Platform Control Box from Platform

(See Figure 5-1.)

1. Check emergency stop button (**10**) is in the ON position by turning it clockwise.
2. Press platform foot switch and hold to floor on platform.
3. Press and hold down the emergency lowering button (**4**) with hazard symbol on platform control box. The LCD display (**23**) will show the hazard triangle symbol in position 8 on the LCD display. 
4. Select a boom function to operate by moving it's controller in the direction for lowering and swing. (*items 15, 16, 17, 19 and 20*)
5. When finished, release emergency lowering button (**4**), and foot switch.
6. Position (*press*) the emergency stop button (**10**) to the OFF position.

NOTE: *The same functions can be operated with the ground control station to lower the platform.*

SECTION 5 - EMERGENCY PROCEDURES

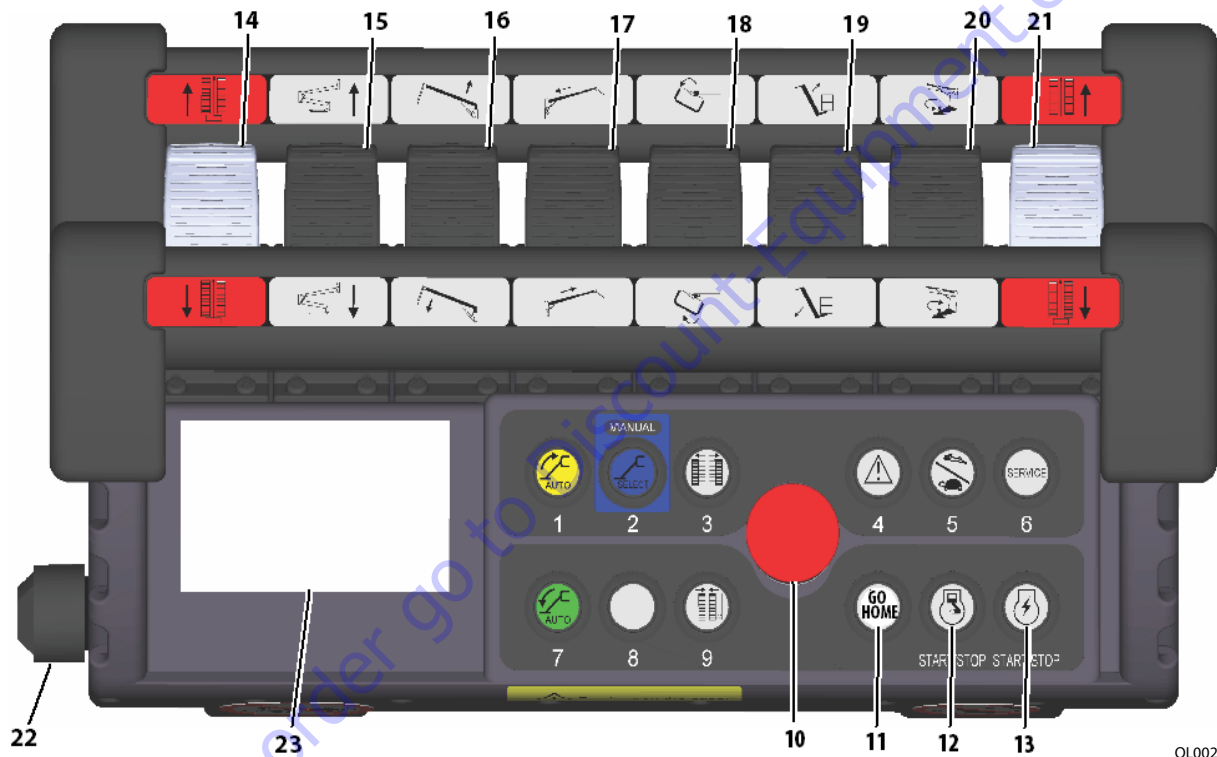

OL00290

Figure 5-1. Platform/Remote Control Station

SECTION 5 - EMERGENCY PROCEDURES

5.4 BYPASS KEY

⚠ WARNING

THIS FEATURE MUST ONLY BE USED AS DESCRIBED BELOW. THE MACHINE COULD TIP OVER IF THESE DIRECTIONS ARE NOT FOLLOWED.

The machine has a key for bypassing the platform safety systems. The key used to activate the bypass switch. It is fastened to the inside cover of the ground control station.

The bypass system is used to operate (and will only operate) a machine with a qualifying fault. The bypass icon is displayed and the alarm will sound. This system must only be used by qualified personnel.



1. Remove key and insert it into the bypass key switch (1). Turn switch (right/left) and hold to activate bypass button (2). The bypass icon will be displayed.
2. Press the bypass button (2) to activate bypass mode and operate the appropriate functions to bring the machine to safety while keeping bypass key turned.
3. After operation, return bypass key to its neutral position and return key to its fastener.



After using the bypass system, a qualified JLG mechanic must be contacted to determine the reason for needing to use this feature. Return the key to the where you found it and secure it in that location.

The safety device circuit board records every time the safety device bypass key is activated along with the movements made during these operations.

NOTE: *In case of machine with restricted area of operation, the bypass of the safety devices does not allow the boom assembly to go out of the safe working area.*

⚠ WARNING

SAFETY DEVICE BYPASS ALLOWS OPERATION OF MACHINE WITH AN OVERLOAD IN THE PLATFORM. THE OVERLOAD ALARM WILL SOUND AND THE OVERLOAD ICON WILL BE ON THE PLATFORM/REMOTE CONTROL BOX DISPLAY. REMOVE OVERLOAD FROM THE PLATFORM BEFORE OPERATION.

SECTION 5 - EMERGENCY PROCEDURES

Using Emergency Descent In Case Of An Outrigger Losing Contact With The Ground

One or more of the outriggers may lose contact with the ground which will result in the platform control box functions being inoperable except for emergency lowering.

To restore platform control box functions, lower and retract the booms and then reposition the machine and properly set the outriggers.

Use the emergency descent from the platform if possible by using the following sequence, fully retract main boom, fully lower jib and fully lower main boom.

If this is not possible, have a properly trained person on the ground bypass the platform safety devices and allow the operator in the platform to lower and retract the booms or allow emergency operations to bring the platform back to the ground.

1. Remove key and insert it into the bypass key switch (1). Turn switch (right/left) and hold to activate bypass button (2). The bypass icon will be displayed.
2. Press the bypass button (2) to activate bypass mode and operate the appropriate functions to bring the machine to safety while keeping bypass key turned.



3. Operate the machine from the platform control ONLY carrying out operations that allow the tower boom lowering, main boom retract and jib lowering. The main boom must be fully retracted prior to operating swing and main boom lowering functions.
4. After operation, return bypass key to its neutral position and return key to its fastener.

⚠ WARNING

NEVER PERFORM OPERATIONS DIFFERENT TO THOSE LISTED OR THAT CAN IN SOME WAY REDUCE THE STABILITY OF THE MACHINE. THE ORDER OF THE BOOM MOVEMENTS MUST BE DONE IN A WAY TO PREVENT ANY OPERATION THAT REDUCES THE STABILITY OF THE MACHINE.

5. Once booms and jib are fully lowered and aligned, release the key and secure the key to the emergency ground control box.

If machine is set up in the reduced stabilization area, bypassing the safety devices does not allow the boom to go out of the working area related to that outrigger configuration.

SECTION 5 - EMERGENCY PROCEDURES

Machine Realignment Emergency Procedure

THIS OPERATION MUST ONLY BE PERFORMED WITH THE BOOMS AND JIB FULLY LOWERED AND RETRACTED TO THE WORKING POSITION.

During transport, the turntable may swing and become out of alignment with the base. If this occurs, one of the two EMERGENCY PROCEDURES given below can be used:

Machine Realignment:

1. Open the ground control station.
2. Remove key and insert it into the bypass key switch (1). Turn switch (right/left) and hold to activate bypass button (2). The bypass icon will be displayed.
3. Press the bypass button (2) to activate bypass mode and operate the appropriate swing function to bring the machine into alignment while keeping bypass key turned.



4. Once machine is aligned, return bypass key to its neutral position and return key to its fastener.

NOTE: *In case of machine with restricted work area, the bypass of the safety devices does not allow the boom assembly to go out of the working area related to that outrigger configuration.*

SECTION 5 - EMERGENCY PROCEDURES

Movement Of Tracks With Machine Not Aligned:

OPERATION ONLY ALLOWED TO GO TO A CONDITION SUITABLE TO CARRY OUT THE PROCEDURE INDICATED IN "MACHINE RE-ALIGNMENT" ABOVE. ALL OTHER USE IS PROHIBITED.

1. Open the ground control station.
2. Remove key and insert it into the bypass key switch (1). Turn switch (right/left) and hold to activate bypass button (2). The bypass icon will be displayed.
3. Press the bypass button (2) to activate bypass mode and operate the appropriate drive/steer functions while extreme caution while keeping bypass key turned.



4. Move machine to a proper location to perform "Machine Realignment" procedure to realign the machine.
5. At the end of operation, return bypass key to its neutral position and return key to its fastener.

The control circuit board records every activation of the safety device bypass key.

TO PURCHASE THIS PRODUCT PLEASE CONTACT US



**Equipment Financing and
Extended Warranties Available**



**Discount-Equipment.com is your online resource for
commercial and industrial quality parts and equipment sales.**

561-964-4949

visit us on line @ www.discount-equipment.com

Select an option below to find your Equipment

Search by Manufacturer

Search by Product Type

Request a Quote

We sell worldwide for the brands: Genie, Terex, JLG, MultiQuip, Mikasa, Essick, Whiteman, Mayco, Toro Stone, Diamond Products, Generac Magnum, Airman, Haulotte, Barreto, Power Blanket, Nifty Lift, Atlas Copco, Chicago Pneumatic, Allmand, Miller Curber, Skyjack, Lull, Skytrak, Tsurumi, Husquvarna Target, Stow, Wacker, Sakai, Mi-T-M, Sullair, Basic, Dynapac, MBW, Weber, Bartell, Bennar Newman, Haulotte, Ditch Runner, Menegotti, Morrison, Contec, Buddy, Crown, Edco, Wyco, Bomag, Laymor, EZ Trench, Bil-Jax, F.S. Curtis, Gehl Pavers, Heli, Honda, ICS/PowerGrit, IHI, Partner, Imer, Clipper, MMD, Koshin, Rice, CH&E, General Equipment, Amida, Coleman, NAC, Gradall, Square Shooter, Kent, Stanley, Tamco, Toku, Hatz, Kohler, Robin, Wisconsin, Northrock, Oztec, Toker TK, Rol-Air, APT, Wylie, Ingersoll Rand / Doosan, Innovatech, Con X, Ammann, Mecalac, Makinex, Smith Surface Prep, Small Line, Wanco, Yanmar

SECTION 6. GENERAL SPECIFICATIONS AND OPERATOR MAINTENANCE

6.1 INTRODUCTION

This section of the manual provides additional necessary information to the operator for proper operation and maintenance of this machine.

The maintenance portion of this section is intended as information to assist the machine operator to perform daily maintenance tasks only, and does not replace the more thorough Preventive Maintenance and Inspection Schedule included in the Service and Maintenance Manual.

NOTICE

AVOID PRESSURE-WASHING ELECTRICAL/ELECTRONIC COMPONENTS. IF PRESSURE-WASHING THE MACHINE IS NEEDED, ENSURE MACHINE IS SHUT DOWN BEFORE PRESSURE-WASHING. SHOULD PRESSURE WASHING BE UTILIZED TO WASH AREAS CONTAINING ELECTRICAL/ELECTRONIC COMPONENTS, JLG INDUSTRIES, INC. RECOMMENDS A MAXIMUM PRESSURE OF 750 PSI (52 BAR) AT A MINIMUM DISTANCE OF 12 IN (30.5 CM) AWAY FROM THESE COMPONENTS. IF ELECTRICAL/ELECTRONIC COMPONENTS ARE SPRAYED, SPRAYING MUST NOT BE DIRECT AND ONLY FOR BRIEF TIME PERIODS TO AVOID HEAVY SATURATION.

SECTION 6 - GENERAL SPECIFICATIONS AND OPERATOR MAINTENANCE

6.2 OPERATING SPECIFICATIONS

Table 6-1. Operating Specifications

Model	X1000AJ/X33JP
Maximum work load (capacity)	500 lbs (230 kg)
Max. Vertical Platform Height	100 ft (30,5 m)
Max. Vertical Working Height	108 ft (33 m)
Max. Horizontal Platform Reach	52.5 ft (16 m)

Dimensional Data

Table 6-2. Dimensional Data

Model	X1000AJ/X33JP
Overall Width	without Platform: 3.92 ft (1,19 m) with Platform: 5.25 ft (1,6 m)
Outriggers Deployed Full Width	15.1 ft x 20.7 ft (4.6 m x 6.3 m)
Stowed Height	6.5 ft (1.99m)
Stowed Length	21.3 ft (6.5 m)
Approach angle	Front: 18° Rear: 16°

Chassis

Table 6-3. Chassis Data

Model	X1000AJ/X33JP
Maximum Travel Grade w/ boom in stowed position (gradeability)	16°
Maximum Travel Side Slope w/ boom in stowed position	16° (29%)
Turning radius	360°
Maximum ground pressure per outrigger	58 psi (4 daN/cm ²)
Maximum outrigger pad load	11,240 lb (5000 daN)
Outrigger pad diameter	14.7 in (400 mm)
Max drive speed (with std. 2nd speed)	Diesel Engine: 1.1 mph (1,8 km/h) (Lithium) Electric Engine: 0.8 mph (1,3 km/h)
Max hydraulic system pressure	3,046 psi (210 bar)
Maximum wind speed	28 mph (12,5m/s)
Maximum manual force	90 lb (400 N)
Electrical system voltage	12V
Lithium-Ion system voltage	76V
Gross machine weight (platform empty)	Diesel: 16,865 lb (7650 kg) Lithium: 16,975 lb (7700 kg)

SECTION 6 - GENERAL SPECIFICATIONS AND OPERATOR MAINTENANCE

Capacities

Table 6-4. Capacities

Model	X1000AJ/X33JP
Hydraulic Tank	21.1 gal (80 L)
Fuel Tank	Diesel: 6.6 gal (25 L)
Engine Oil	Diesel: 0.98 gal (3.71 L)

Electric Motor Data

Table 6-6. Electric Motor Specifications

Model	X1000AJ/X33JP
Rated Input Voltage	380V
Rated Frequency	50Hz
Rated Power	11 Kw

Engine Data

Table 6-5. Kubota D902 Specifications

Model	X1000AJ/X33JP
Type	Liquid cooled
Number of cylinders	3
Displacement	55 cu. in. (898 cm ³)
Output	21.6 hp (16.1 kW)
High engine speed	3200 RPM
Battery	12V - 105Ah - 950A
Alternator	40A - 3200RPM

SECTION 6 - GENERAL SPECIFICATIONS AND OPERATOR MAINTENANCE

Lithium-Ion Battery Pack Specifications

Table 6-7. Lithium Ion Specifications

Model	X1000AJ/X33JP
Battery Pack	
No. of cells in the battery pack:	26 cells
Rated voltage of each cell:	3.2 volt
Max. cell voltage:	3.65 volt
Min. cell voltage:	2.5 volt
Features of complete pack:	76 volt - 100 ampere/h
*Charge cycles:	2000 cycles
Cathode:	Lithium Ion Phosphate (LiFePO4)
Anode:	Graphite
Memory effect:	NO
Battery Charger	
Type:	120 V (+/- 30V) - 50/60 Hz
Necessary time to recharge:	4 hrs to 80% of recharge
Electric System	76 volt for the Lithium battery pack - 12 volt lead battery
Electric Motor	76 volt - three phase - 2000 watt
* The charge cycles have to be considered based on the fact that there is not memory effect in the lithium batteries, i.e. 2000 charges at 100% or 4000 charges at 50%, etc.	

Major Component Weights

Table 6-8. Major Component Weights

Model	X1000AJ/X33JP
Engine (Dry Weight)	Kubota D902 Diesel: 158 lb. (72 kg)
Boom Sections Combined	4,916 lb. (2,230 kg)
Lift Cylinders	
	Level Cylinder: 16.5 lb. (7.5 kg)
	Jib Cylinder: 26.5 lb. (12 kg)
	3rd boom level cylinder: 16.5 lb. (7.5 kg)
	Lift cylinder: 198.4 lb. (90 kg)
	Upper lift cylinder: 154.3 lb. (70 kg)
	Swing Actuator: 44 lb. (20 kg)
	Telescope cylinder: 209.4 lb. (95 kg)
Platform	1 - occupants: 77.2 lb. (35 kg) 2 - occupants: 110.2 lb (50 kg)
Chassis	Diesel: 4,718 lb (2,140 kg)

6.3 SERVICE/MAINTENANCE

Cleaning the Machine

WARNING

WHEN WASHING THE MACHINE, THE MAIN POWER SWITCH MUST BE DISENGAGED, THE KEY REMOVED AND THE EMERGENCY STOP BUTTON PRESSED.

- Washing the outside of the machine;
 - Never use flammable liquids. Adopt the above safety measures to prevent sparks due to short-circuits.
 - If washing the track with a cleaning solution, carefully cover all the vital parts and above all the electrical components. Follow the instructions provided by the manufacturer of the cleaning solution.
 - Clean the machine using only water-soluble detergents.
 - The more often the machine is cleaned, the more it will need to be re-greased (*see lubrication chart*).
 - Do not wet the electric motors and the other electrical components directly.
 - Do not aim the spray directly onto decals and rating plates.

- Cleaning the electrical system;

WARNING

NEVER CLEAN THE INVERTER OR THE ELECTRIC MOTOR WITH WATER, AS THIS MAY CAUSE DAMAGE TO THE ELECTRICAL SYSTEM.

NOTICE

ONLY USE DRY DETERGENTS, IN ACCORDANCE WITH THE MANUFACTURERS' INSTRUCTIONS. NEVER REMOVE COVERS, GUARDS AND THE LIKE.

Clean the electrical system using a dry, non-metallic brush and low pressure air.

- After cleaning
 - Dry the machine carefully before starting it again (for example using compressed air).

WARNING

IF, DESPITE ALL THE PRECAUTIONS, MOISTURE HAS PENETRATED INTO THE ELECTRIC MOTOR OR OTHER PARTS OF THE ELECTRIC SYSTEM, THESE MUST BE DRIED USING COMPRESSED AIR TO AVOID THE RISK OF SHORT CIRCUITS.

Lubrication

(See Figure 6-1.)

Hydraulic Oil

SECTION 6 - GENERAL SPECIFICATIONS AND OPERATOR MAINTENANCE

Table 6-9. Hydraulic Oil Specifications

Hydraulic System Operating Temperature Range	Viscosity Grade
14deg F (-10 deg C) and 104deg F (+40deg C)	ISO VG46
14deg F (-10 deg C) or above 104deg F (+40deg C)	ISO 68

NOTE: When adding or replacing hydraulic oil only use JLG approved hydraulic oil. Do not mix oils unless directed by JLG.

Recommended Gearbox Oils

600 XP 150
EP 150
Blasia 150
Spartan EP150

Engine Oil

SAE 10W30

Greasing and Lubrication

Recommended lubricants

Contact Grease EP (blue in color) is used to grease the turntable and cylinder pins on the chassis

GR MU EP1 Grease is used to grease the expansion guide of the chassis, the track tension valve, and basket support pins

White EP NLGI 2 Grease is used on the boom extensions

Either MU EP1 or Esso Beacon EP2 is used to grease the coupler and belt tensioner

Greasing Locations (See Figure 6-1.)

NOTE: Use a brush to spread grease onto telescopic boom wear pad areas.

SECTION 6 - GENERAL SPECIFICATIONS AND OPERATOR MAINTENANCE

Hydraulic Oil Specifications

Fluid Description	Proprieties		Base				Classifications		
	Viscosity at 40°C (cst, Typical)	Viscosity Index	Mineral Oils	Vegetable Oils	Syntetic	Syntetic Polyol Esters	Readily Biodegradable*	Virtually Non-toxic**	Fire Resistant***
Pakelo Hydraulic EP Extra ISO 68	68	180	X						
Pakelo Hydraulic EP Extra ISO 46	46	160	X						
GeolubeECO Hydraulic ISO 46 (P/N 17527700)	47.3	144				X	X		
Pakelo Hydraulic EP Extra ISO 32	32	160	X						
Pakelo Hydraulic EP Extra ISO 22	22	180	X						
SHELL TELLUS S3V 68	68	180	X						
SHELL TELLUS S3V 46	46	160	X						
MobilEAL EnviroSynH46 (P/N2300029)	46	145				X	X		
SHELL TELLUS S3V 32	32	160	X						
SHELL TELLUS S3V 22	22	180	X						

Figure 6-1. Hydraulic Oil Specifications

* Readily biodegradable classification indicates one of the following: CO2 Conversion > 60% per EPA 560/6-82-003 / CO2 Conversion > 80% per CEC-L-33-A-93.

** Virtually Non-toxic classification indicates an LC50 > 5000 per OECD 203.

*** Fire Resistant classification indicates Factory Mutual Research Corp. (FMRC) Approval.

SECTION 6 - GENERAL SPECIFICATIONS AND OPERATOR MAINTENANCE

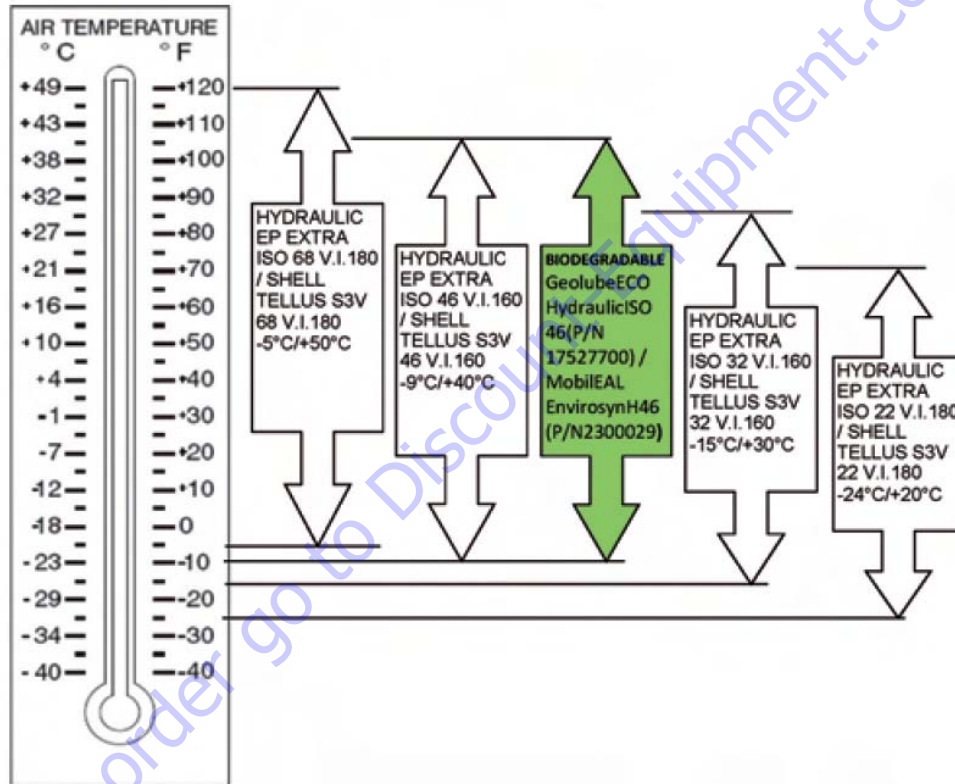

Figure 6-2. Hydraulic Oil Operating Temperatures

SECTION 6 - GENERAL SPECIFICATIONS AND OPERATOR MAINTENANCE

Table 6-10. Component Maintenance Intervals - X1000AJ/X33JP - with Diesel Engine

Component	Operation	Pre-Start	As Needed	Hours						
				10	50	100	250	500	1000	2000
Dry Air Filter(Diesel Engine)	Check/Clean	•								
	Replace							•		
Engine Oil (Diesel Engine)	Check Level	•								
	Replace				•*	•				
Engine Oil Filter (Diesel Engine)	Check/Clean				•					
	Replace						•			
Fuel Filter (Diesel Engine)	Clean	•								
	Replace							•		
Cooling System (Diesel Engine)	Check Level	•								
	Liquid Add and Replacement							•		
Water Separator (Diesel Engine)	Clean and Drain Water	•			•*		•			
Hydraulic Oil	Check Level	•								
	Replace								•	
Hydraulic Oil Filter	Replace Cartridge				•*		•			
Articulated Joint Points	Grease				•*	•				
Battery	Check		•							
Reduction Gear Oil	Check Level					•				
	Replace					•*			•	
Machine	General Periodic Check								•	•*

SECTION 6 - GENERAL SPECIFICATIONS AND OPERATOR MAINTENANCE

Table 6-10. Component Maintenance Intervals - X1000AJ/X33JP - with Diesel Engine

Component	Operation	Pre-Start	As Needed	Hours						
				10	50	100	250	500	1000	2000
Extension Arm Internal Sliding Ring (if equipped)	Check Wear						•			
	Replace								•	
Turntable Bolt Tightening	Check						•*	•		
Platform Mount Pin Nuts	Check torque 148 ft. lb. (200 Nm)								•****	
Extension Ropes and pulleys (if equipped)	Check Wear								•**	•*
	Replace									•***



- * 1st time interval then per chart thereafter
- ** At least every 3 months or 1000 hrs. of operation
- *** At least every 5 years or 2000 hrs of operation. Check every year. If torque is not correct, replace the nuts with new nuts of same specification.
Install dry without using grease or oil to specified torque.
- **** At least once a year. Replace nuts if not properly torqued.

SECTION 6 - GENERAL SPECIFICATIONS AND OPERATOR MAINTENANCE

Table 6-11. Component Maintenance Intervals - X1000AJ/X33JP - with Lithium-Ion Battery Pack

Component	Operation	Pre-Start	As Needed	Hours						
				10	50	100	250	500	1000	2000
Hydraulic Oil	Check Level	•								
	Replace								•	
Hydraulic Oil Filter	Replace Cartridge				•*		•			
Articulated Joint Points	Grease				•*	•				
Battery (Auxiliary)	Check		•							
Reduction Gear Oil	Check Level					•				
	Replace				•*				•	
Machine	General Periodic Check								•	•*
Extension Arm Internal Sliding Ring (if equipped)	Check Wear						•			
	Replace								•	
Turntable Bolt Tightening	Check						•*	•		
Platform Mount Pin Nuts	Check torque 148 ft. lb. (200 Nm)								•****	
Extension Ropes and pulleys (if equipped)	Check Wear								•**	•*
	Replace									•***

* 1st time interval then per chart thereafter

** At least every 3 months or 1000 hrs. of operation

*** At least every 5 years or 2000 hrs of operation. Check every year. If torque is not correct, replace the nuts with new nuts of same specification.

Install dry without using grease or oil to specified torque.

**** At least once a year. Replace nuts if not properly torqued.



SECTION 6 - GENERAL SPECIFICATIONS AND OPERATOR MAINTENANCE

Engine Air Filter

Kubota
D902
Diesel

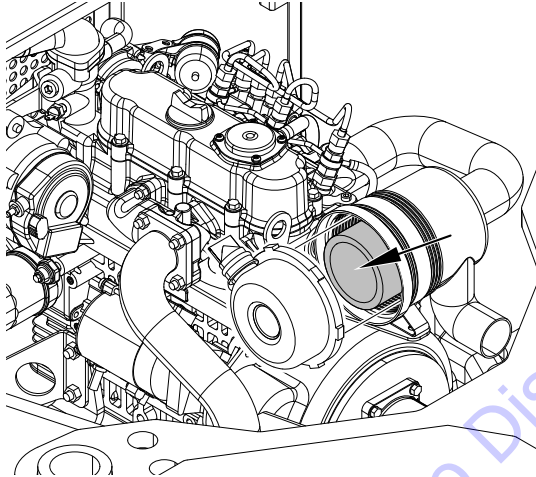

Lube Point(s) - Replaceable Paper Element, or Foam Filter Element

Interval - Check daily. Replace paper element after 500 hrs of operation, sooner if operating in a dusty environment.

The foam element can be washed out in warm soapy water, then rinse and let dry, Dip in clean engine oil and squeeze out the excess oil. If too much oil is left in the foam the engine will smoke when started.

Engine Oil

Kubota
D902
Diesel

DIPSTICK

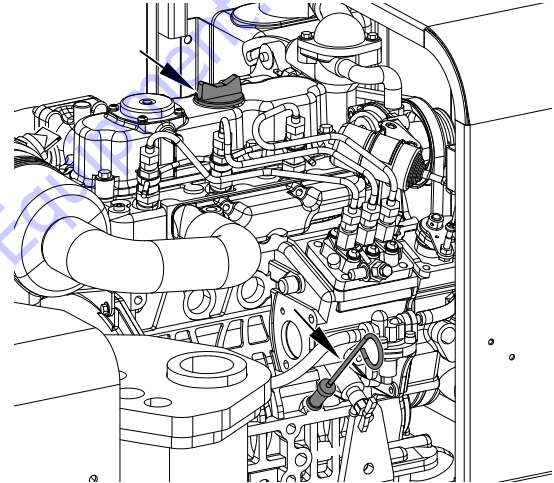

Lube Point(s) - Fill Cap on Valve Cover or Dip Stick Tube

Oil Capacity - Diesel 0.98 gal (3.71L) - API - CC grade or better

Interval - Check fill level on dipstick daily.

Change oil/filter per maintenance interval chart -
(See Table 6-10)

SECTION 6 - GENERAL SPECIFICATIONS AND OPERATOR MAINTENANCE

Engine Oil Filter (if equipped)

Kubota
D902
Diesel

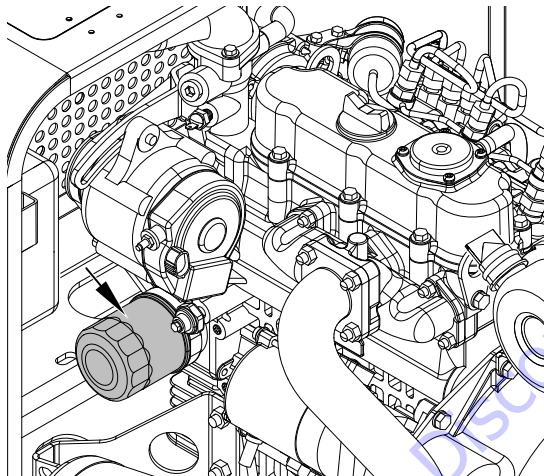

Lube Point(s) - Filter Cartridge/replaceable
Interval - Clean every 100 hours. Replace 500 hours.

Engine Fuel Filter/Sediment Bowl (if equipped)

Kubota
D902
Diesel



Interval - Clean every 100 hours

Engine Cooling System and Fluid (if equipped)

Kubota
D902
Diesel

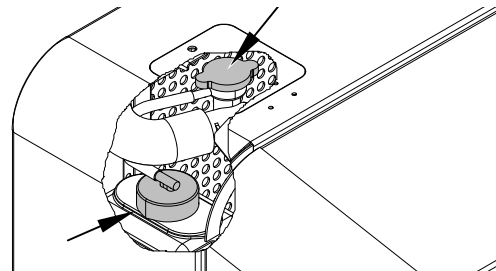

Interval - Check daily. Replace fluid every 500 hours

NOTE: Coolant utilized is to be compliant with SAE J 1034

SECTION 6 - GENERAL SPECIFICATIONS AND OPERATOR MAINTENANCE

Hydraulic Oil

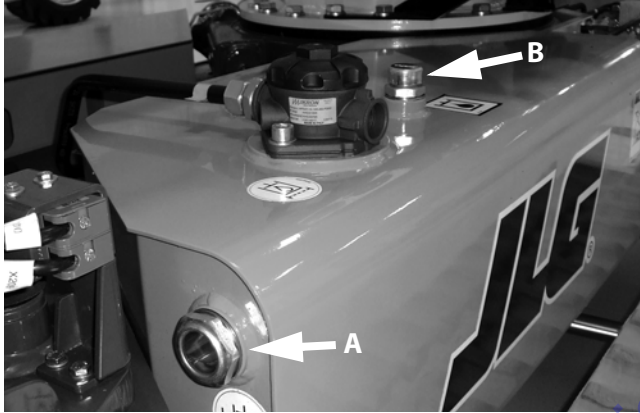

Lube Point(s) - Fill Cap

Capacity - 21.1 gallons (80 liters)

Interval - Check level daily. Change every two years or 1000 hours of operation

NOTE: Hydraulic oil levels are to be checked with the machine in transport position while on a firm, level and uniform surface. Oil level must be half-way in the level indicator (Indicator-A). To add hydraulic oil use (cap-B).

Hydraulic Oil Filter Cartridge



Lube Point(s) - Filter Cap (Indicator A)

Interval - Replace after first 50 hours of use. Replace thereafter every 250 hours and every time the hydraulic oil is replaced.

SECTION 6 - GENERAL SPECIFICATIONS AND OPERATOR MAINTENANCE

Rubber Track Maintenance/Replacement

Check track tension

Stop the machine on a firm, level, and uniform surface. Raise the machine off the surface using the outriggers. Measure distance A from the bottom of the roller to the inside of the rubber belt. The rubber track tension is to be between 0.4 in (10 mm) and 0.6 in (15 mm).

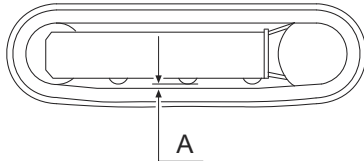

NOTE: If the track is out of tolerance immediately discontinue use of the machine

⚠ WARNING

THE GREASE CONTAINED WITHIN THE HYDRAULIC TRACK IS PRESSURIZED. NEVER LOOSEN GREASING VALVE 1 MORE THAN ONE (1) TURN. NEVER LOOSEN GREASE VALVE 2.

1. Ensure all debris has been removed between the wheel teeth and track links.
2. Remove the screws from the adjustment access lid 3.

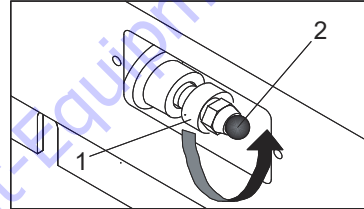

⚠ DANGER

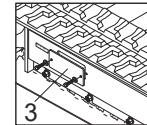

3. Loosening of the track.
4. Slowly unscrew valve 1 in the counterclockwise direction. Do not exceed one (1) screw rotation.
5. If the grease does not begin to drain, slowly rotate the track.
6. Once correct track tension has been achieved, turn grease valve 1 clockwise to tighten valve.
7. Clean area of all trace grease.

SECTION 6 - GENERAL SPECIFICATIONS AND OPERATOR MAINTENANCE

Tightening of the track

- Connect a grease gun to grease valve 2 and add grease until belt tension is within the specified values.

NOTE: If the track does not return to the specified values by following the above procedure immediately discontinue use and contact service personnel.

Checking the rubber tracks

- If broken steel ropes are noted discontinue use until damaged components are replaced

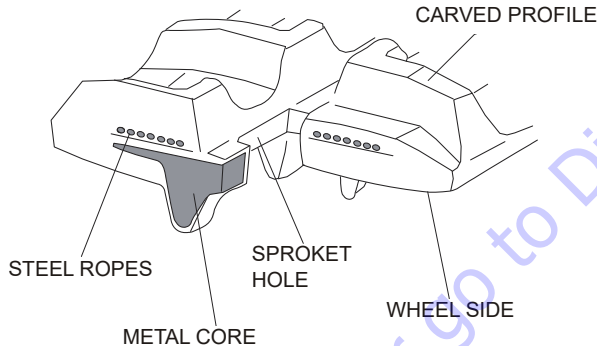

- If broken metal cores are noted discontinue use until damaged components are replaced

- If metal cores are separating discontinue use of the machine until the damaged components are replaced.

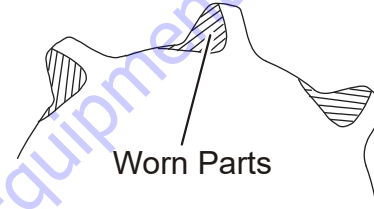

- If abrasive or fatigue cracks are noted it is recommended the machine be removed from service until the components are replaced.



Track Torque

It is extremely important to apply and maintain proper track mounting torque.

⚠ WARNING

TRACK NUTS MUST BE INSTALLED AND MAINTAINED AT THE PROPER TORQUE TO PREVENT LOOSENING OF THE TRACK, BROKEN STUDS, AND POSSIBLE DANGEROUS SEPARATION OF THE TRACK FROM THE TEETH.

SECTION 6 - GENERAL SPECIFICATIONS AND OPERATOR MAINTENANCE

Replacing Rubber Tracks

1. Elevate the machine on firm, level and uniform surface utilizing the outriggers.
2. Remove the screws and remove cover 3 as shown in figure.

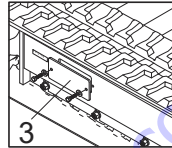
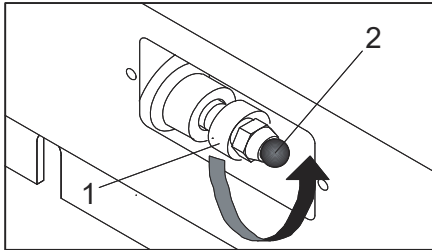

3. To loosen the track, slowly unscrew valve 1 in a counter-clockwise direction. Do NOT exceed one (1) rotation.
4. Allow grease to drain. If grease does not drain, slowly rotate the track.
5. Insert three steel pipes 4 between the rollers of the track. Turn the driving wheel backwards 5 to engage the track tensioning wheel. Apply an outward force 6 to lift the track from the track tensioning wheel.

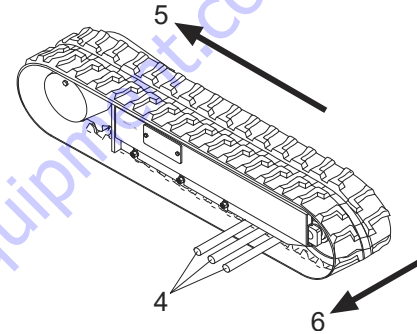

Installation of Rubber Track

1. Ensure all hydraulic cylinder grease have been removed
2. Align the track links with the wheel teeth. Position the other end of the track on the track tensioning wheel
3. Slowly rotate the drive wheel in reverse while, using one steel pipe, pushing the track plate inside the frame.
4. Verify the track links have engaged the wheel teeth in the track tensioning wheel
5. Adjust track tension (see Loosening/Tightening track section).

SECTION 6 - GENERAL SPECIFICATIONS AND OPERATOR MAINTENANCE

Wire Cable Inspection

A qualified technician shall conduct the following:

1. Remove all covers from the third boom section and two boom extensions and inspect the wire ropes and pulleys for any damage.
2. Wire cables when pulled on manually shall not move more than an eighth (1/8) inch.
3. Wire rope torque is 10Nm

Inspection

NOTE: The pictures in this section are just samples to show the replacement criteria of the rope.

1. Inspect ropes for broken wires, particularly valley wire breaks and breaks at end terminations.

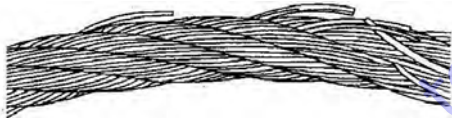

NOTE: Flexing a wire rope can often expose broken wires hidden in valleys between strands.

2. Inspect ropes for corrosion.
3. Inspect ropes for kinks or abuse.

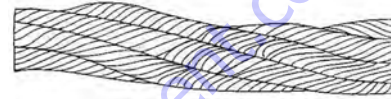

NOTE: A kink is caused by pulling down a loop in a slack line during improper handling, installation, or operation.

4. Inspect sheaves for condition of bearings/pins.
5. Inspect sheaves for condition of flanges.
6. Inspect sheaves with a groove wearout gauge for excessive wear.

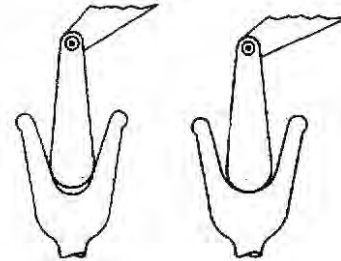

NOTE: Observe the groove so that it may be clearly seen whether the contour of the gauge matches the contour of the bottom of the groove.

7. Ropes passing inspection should be lubricated with wire rope lubricant before reassembly.

SECTION 6 - GENERAL SPECIFICATIONS AND OPERATOR MAINTENANCE

Wire Cable Adjustment

To check for correct wire cable tension position machine on a firm, level, and uniform surface.

1. Remove the cover on the third boom section
2. Loosen the register counter-nuts allowing for access to the wire cable adjustment nuts
3. Position both boom extensions until approximately 12-15 inches of the inner booms are showing
4. Tighten nuts on the retract cables to a torque of 10Nm (7.4ftlbs)

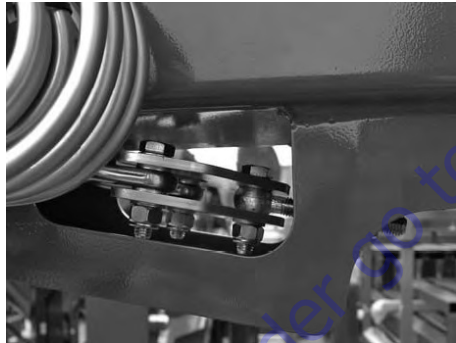

5. Fully extend both boom extensions. Retract the boom extension sections between 12-15 inches.

6. Torque the bolts on the extend cables until the threads extend $2\text{-}1/2 \pm 0.11$ inches ($65\text{mm} \pm 3\text{mm}$) from the boom section. Do not twist cable while tightening.

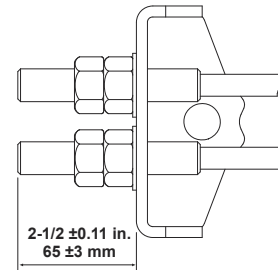
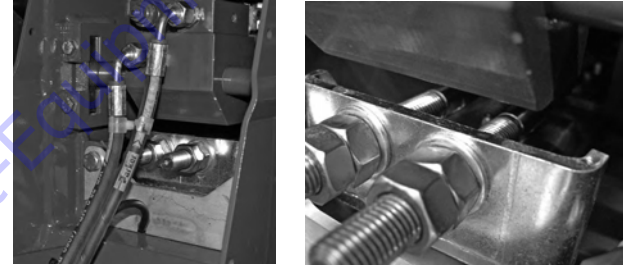

7. Cycle the boom extensions five (5) times and verify the wire cables are at a torque of 10Nm (7.4ft-lbs)
8. Verify during the cycle testing that no rubbing occurs from the wire rope cables

SECTION 6 - GENERAL SPECIFICATIONS AND OPERATOR MAINTENANCE

9. Upon verification tighten the counter-nuts and reattach any removed covers

Wear Pad Inspection

Check for distance between wear pads and boom sections. Distance is to be no more than 1/32nd inch.

Turntable Attach Bolts

Ensure the bolts of the coupling elements (turntable) are torqued to 183 ft-lb. (248 Nm)

Battery Maintenance and Charging - Diesel/AC-Electric

NOTE: *The battery is a maintenance free battery. Do NOT attempt to open a maintenance-free sealed battery.*

External Battery Charger Use

WARNING

WHEN AN EXTERNAL BATTERY CHARGER IS TO BE USED, CHARGING HARNESS MUST BE PLUGGED INTO A GROUNDED RECEPTACLE. IF RECEPTACLE IS NOT GROUNDED AND A MALFUNCTION SHOULD OCCUR, THE MACHINE COULD CAUSE SERIOUS ELECTRICAL SHOCK.

1. Open battery cover.
2. Disconnect the terminal clamps from the battery poles.
3. Connect the cables of the charger to the battery poles. and turn on the battery charger

NOTE: *Re-charge voltage should never exceed 14.7 volts and the load intensity shall be 0.2% of the value indicated below and on the lid of the battery.*

4. When charging is completed turn off the battery charger before disconnecting the cables from the battery poles
5. Return the terminal clamps to the battery poles and lubricate with the appropriate product
6. Close battery cover.

NOTICE

IT IS GOOD PRACTICE TO AVOID PRESSURE-WASHING ELECTRICAL/ELECTRONIC COMPONENTS. IN THE EVENT PRESSURE-WASHING THE MACHINE IS NEEDED, ENSURE THE MACHINE IS SHUT DOWN BEFORE PRESSURE-WASHING. SHOULD PRESSURE WASHING BE UTILIZED TO WASH AREAS CONTAINING ELECTRICAL/ELECTRONIC COMPONENTS, JLG INDUSTRIES, INC. RECOMMENDS A MAXIMUM PRESSURE OF 750 PSI (52 BAR) AT A MINIMUM DISTANCE OF 12 INCHES (30.5 CM) AWAY FROM THESE COMPONENTS. IF ELECTRICAL/ELECTRONIC COMPONENTS ARE SPRAYED, SPRAYING MUST NOT BE DIRECT AND BE FOR BRIEF TIME PERIODS TO AVOID HEAVY SATURATION.

6.4 ELECTRIC MOTOR MAINTENANCE

Periodically check the condition of the following electric motor components.

Electric Motor

The electric motor is located inside of the rear hydraulic valve distributor support cover.

- POWER SUPPLY TERMINALS

Check tightness of the nuts on the power supply terminals and make sure the insulation is intact.

- FAN

Keep air intakes clean and make sure the fan can rotate freely.

- BEARINGS

Check the condition of the bearings, in the event of noise contact JLG for replacement, the life of the bearings is reduced significantly in heavy duty operating conditions.

NOTE: *This motor is "brushless" therefore no brushes need to be checked or replaced.*

6.5 PLATFORM CONTROL SERVICE MENU

Service Button

(See Figure 3-3. on page 3-10)

A SERVICE button (*item 6*) is present on the remote control which allows to view the status of the machine parameters and is an aid in the safety checks of the machine.

By pressing the SERVICE button a numerical menu is displayed on the LCD display (*item 15*), each of these menu items can be accessed by pressing the corresponding platform/remote control buttons (*numbered 1 thru 9*) below the buttons.

1 - INPUT

2 - LANGUAGE

3 - ERRORS

4 - RAMPS

5 - CURRENT

6 - W. HOURS

7 - SETUP

8 - JOYSTICK

9 - EXIT

MENUS 4; 5; CANNOT BE ACCESSED

SECTION 6 - GENERAL SPECIFICATIONS AND OPERATOR MAINTENANCE

Menu Input

The signals that arrive at the board from the various sensors mounted on the machine and from the platform/remote control commands are displayed. The status of the input and the following selection to scroll the menu appears for each screen:

- 1 - PREV - access the previous input
- 2 - NEXT - access the successive input
- 9 - ESC - escape from the INPUT menu

LIGHTLIFT SELF-PROPELLED AERIAL PLATFORM - X100AJ	
ST1 GNDA	Both ON indicate the stabilizer 1 rests on the ground.
ST1 GNDB	
ST2 GNDA	Both ON indicate the stabilizer 2 rests on the ground.
ST2 GNDB	
ST3 GNDA	Both ON indicate the stabilizer 3 rests on the ground.
ST3 GNDB	
ST4 GNDA	Both ON indicate the stabilizer 4 rests on the ground.
ST4 GNDB	
ST1 OPEN A	Both ON indicate the stabilizer 1 is completely open, TOTAL AREA.
ST1 OPEN B	
ST2 OPEN A	Both ON indicate the stabilizer 2 is completely open, TOTAL AREA
ST2 OPEN B	

ST3 OPEN A	Both ON indicate the stabilizer 3 is completely open, TOTAL AREA
ST3 OPEN B	
ST4 OPEN A	Both ON indicate the stabilizer 4 is completely open, TOTAL AREA
ST4 OPEN B	
BYPASAE A	Both ON indicate aerial part safety devices have been disconnected by the specially provided key.
BYPASAE B	
BYPASCB A	Both ON indicate undercarriage part safety devices have been disconnected by the specially provided key.
BYPASCB B	
EM. GRND A	Both ON indicate that emergency stop button isn't pressed (from ground).
EM. GRND B	
FOTO A	Both ON indicate that the photocells are aligned.
FOTO B	
EM R.C. GND	Both ON indicate that the remote control button isn't pressed (from ground).
ST12 CLOSED	ON status indicates the stabilizers 1-2 are completely up and pressurized.
ST34 CLOSED	ON status indicates the stabilizers 3-4 are completely up and pressurized.
TEMP ALRM A	Both ON indicate the external temperature probe is activated (only Russian version).
TEMP ALRM B	
GENERATOR	ON or OFF depending on whether, the engine is ON or OFF.
EMERG. COMM	ON position indicates the emergency buttons are activated.

SECTION 6 - GENERAL SPECIFICATIONS AND OPERATOR MAINTENANCE

MICROROPES	ON position indicates both cables are working.
START M. TE	ON position indicates the engine start button (from ground) is pressed.
MOTOR TEMP.	OFF position with the engine running indicates the alarm is activated.
MOTOR PRESS.	ON position with the engine running indicates the alarm is activated.
START M. EL	ON position indicates the remote control from ground is activated by the provided key.
MICROJIB A	Both ON indicates the JIB arm is completely closed.
MICROJIB B	
PEDALE	ON position indicates the pedal within the basket is pressed. (only pedal version)
EM BASK. A	Both ON indicates the emergency STOP (of the remote control) within the basket isn't pressed
EM BASK. B	
POSM 1 A	Both ON indicates the stabilizer 1 is in stabilization position.
POSM 1 B	
POSM 2 A	Both ON indicates the stabilizer 2 is in stabilization position.
POSM 2 B	
POSM 3 A	Both ON indicates the stabilizer 3 is in stabilization position.
POSM 3 B	

POSM 4A	Both ON indicates the stabilizer 4 is in stabilization position.
POSM 4B	
R.C. PLATFORM	ON position indicates the remote control is in its mount. (in the platform).
INCLIN. X	Indicates the inclination of X axis in tenths of a degree.
INCLIN. Y	Indicates the inclination of Y axis in tenths of a degree.
LOAD	Indicates the weight in the platform in pounds.
POS. 1E2	Indicates 1° and 2° arm cylinder stroke in tenths of a millimeter.
POS. 3	Indicates 3° arm cylinder stroke in tenths of a millimeter.
ROTATION A	Indicates the angular position of the aerial part in degrees (180° - aligned photocells).
MOTOR RPM	Indicates the engine speed.
CURRENT A	Indicates the power to proportional valve.
CURRENT B	Indicates the power to proportional valve.
CURRENT C	Indicates the power to proportional valve.
TEMPERAT.	Indicates the temperature measured by the electrical probe.
SUPPLY (V)	Indicate the voltage (In volts).

SECTION 6 - GENERAL SPECIFICATIONS AND OPERATOR MAINTENANCE

Errors Menu

Indicates the agreement (OK) or not (FAULT) status of the sensors that have a double control.

The sensors are listed on different screens use:

- 1 - PREV - access the previous input
- 2 - NEXT - access the successive input
- 9 - ESC - escape from the INPUT menu

If the OK symbol appears at the side of the sensor it means that the two elements of the same sensor sent identical information.

If the FAULT symbol appears at the side of the sensor it means that the two elements of the same sensor sent inconsistent information.

The last page of the error menu describes the error code relating to the battery charger system, inverter or battery pack. (See "Lithium-Ion Machine Fault Codes" on page 6-26.)

Errors are indicated by the "spanner" icon in position 7 on the remote control display (See "Platform/Remote Control Station Functions" on page 3-9).



If there are operating problems with the machine and the "spanner" icon is shown on the display, do not operate machine until repaired by a JLG factory trained technician.

Working Hours Menu

Indicates the number of machine working hours.

Set-up Menu

The items in this menu cannot normally be accessed.

Joystick Menu

Displays the signal that each individual Joystick sends to the main board.

6.6 LITHIUM-ION MACHINE - MAINTAINANCE

Battery Pack System Components and Maintenance



WHEN RECHARGING THE BATTERY PACK AND DURING ANY OTHER MAINTENANCE OPERATION ON THE BATTERY PACK, IT IS NECESSARY TO USE AT LEAST THE PERSONAL PROTECTIVE EQUIPMENT (PPE) LISTED BELOW.

- Eye protection devices
Protective glasses, for protection against sprays of hazardous materials.

- Hand protection devices
Hand protection gloves, for protection and insulation during work on live parts.
- Foot protection devices
Shoes with antistatic coating able to insulate the worker during work on the electrical parts of the system.

SECTION 6 - GENERAL SPECIFICATIONS AND OPERATOR MAINTENANCE

Lithium-Ion Machine Fault Codes

(See "Errors Menu" on page 6-24 info for display information)

Table 6-12. Inverter Fault Codes

CODE	DESCRIPTION
1	Wrong Config Cause - EEPROM memory not configured. Solution - Contact Hinowa after sales service.
8	Watch Dog Cause - Inverter cannot start or stop electric motor. Solution - Check connections and continuity of electric motor. If OK, replace inverter.
13	Eeprom KO Cause - EEPROM hardware or software problem. Solution - Replace inverter.
16	Aux output KO Cause - Problem with electromechanical brake. Solution - This is generally a temporary problem due to certain working conditions. If problem persists, replace inverter.
17	Logic failure #3 Cause - Activated in the event of high inverter current peaks. Solution - This is generally a temporary problem due to certain working conditions. If problem persists, replace inverter.
18	Logic Failure #2 Cause - Internal fault in the inverter. Solution - Replace inverter.

Table 6-12. Inverter Fault Codes

CODE	DESCRIPTION
19	Logic failure #1 Cause - Sudden voltage surge or voltage drop. Solution - This is a temporary problem due to certain working conditions. If problem persists, replace inverter.
30	VMN low Cause - Inverter power supply voltage is lower than battery voltage, or alternatively incorrect connection to positive battery pole. Solution - Check connection to positive battery pole. If problem persists, replace inverter.
31	VMN High Cause - One motor phase not connected correctly or faulty. Solution - Check motor phases. If problem persists, replace inverter.
37	Contact closed Cause - Relay remains closed when power to coil is disconnected. Solution - Check relay.
38	Contact Open Cause - Inverter supplies power to relay coil but contact doesn't close. Solution - Check relay and power supply to coil.
49	I=0 Ever Cause - Feedback current from motor sensor not constantly at 0. Solution - Check connection to motor.

SECTION 6 - GENERAL SPECIFICATIONS AND OPERATOR MAINTENANCE

Table 6-12. Inverter Fault Codes

CODE	DESCRIPTION
53	STBY I high Cause – Internal fault detected in the inverter. Solution – This is generally a temporary problem due to certain working conditions. If problem persists, replace inverter.
60	Capacitor Charge Cause – Internal fault in the inverter. Solution – Check connections and motor phases.
61	High temperature Cause – High temperature inside the inverter. Solution – Improve cooling to inverter. If fault persists, contact JLG after-sales service.
65	Motor temperature Cause – High motor temperature. Solution – Temporarily stop machine to allow motor to cool down.
67	Can Bus KO Cause – Inverter doesn't receive any information from Can Bus line. Solution – Check connections using multifunction tester.
70	Encoder Error Cause – Problem detected with encoder (=motor speed sensor). Solution – Check speed sensor connection. Anomaly may also have been caused by fault with bearing.

Table 6-12. Inverter Fault Codes

CODE	DESCRIPTION
73	Thermis sensor KO Cause – Signal from temperature sensor greater than 4.95 Volts or less than 0.1 Volt. Solution – This is generally a temporary problem due to certain working conditions. If problem persists, replace inverter.
74	Driver shorted Cause – Relay power supply fault. Solution – Check relay power supply. This is generally a temporary problem due to certain working conditions. If problem persists, replace inverter.
75	Driver shorted Cause – Relay power supply fault. Solution – Check relay power supply. This is generally a temporary problem due to certain working conditions. If problem persists, replace inverter.
76	Coil shorted Cause – Problem detected with relay coil. Solution – Make sure relay coil is intact.
78	VACC not OK Cause – Solution – This is generally a temporary problem due to certain working conditions. If problem persists, replace inverter.

SECTION 6 - GENERAL SPECIFICATIONS AND OPERATOR MAINTENANCE

Table 6-12. Inverter Fault Codes

CODE	DESCRIPTION
79	Incorrect start Cause – Incorrect starting procedure. Solution – Check electrical connections. This is generally a temporary problem due to certain working conditions. If problem persists, replace inverter.
86	Pedal wire KO Cause – Solution – This is generally a temporary problem due to certain working conditions. If problem persists, replace inverter.
93	Wrong set batt Cause – With power connected, battery test detected incorrect batteries fitted. Solution – Replace batteries with the original ones supplied directly by JLG.
94	Current sensor KO Cause – Set up procedure for maximum current in progress. Solution – Contact JLG after-sales service.
99	Check up needed Cause – Solution – Contact Hinowa after.sales service.

SECTION 6 - GENERAL SPECIFICATIONS AND OPERATOR MAINTENANCE

BMS Fault Codes - (Battery Management System)

(See "Errors Menu" on page 6-24 info for display information)

NOTE: The CODE column indicates the CAN CODE in the message sent by the battery charger. The normal mains voltage tolerance is the rated value $\pm 15\%$.

CODE – TYPE OF ERROR

A99E01 – Configuration error

A99E02 – Incorrect voltage

A99E03 – Incorrect temperature

A99E04 – Excess discharge current

A99E05 – Excess charge current

A99E06 – Pre.charge error

A99E07 – No 12 V power supply

A99E08 – No 12 V power supply

A99E09 – High battery compartment temperature

A99E10 – High electronic board temperature

A99E11 – Incorrect self.protection device temperature

A99E12 – Fault on all temperature sensors

A99E13 – Temperature sensor fault

A99E14 – Earth connection fault

A99E01 – Incorrect system configuration

A99E02 – Incorrect voltage

A99E03 – Incorrect temperature

A99E04 – Excess discharge current

A99E05 – Excess charge current

A99E06 – Pre.charge error

A99E07 – No 12 V power supply

A99E08 – No 12 V power supply

A99E09 – High battery compartment temperature

A99E15 – Boot loader error

A99E16 – Secondary protection

A99E17 – Control device error

A99E18 – Power board error

A99E19 – I2C module not ready

A99E20 – I2C TX error

A99E21 – I2C RX error

A99E22 – I2C RX error 2

A99E23 – AD error

A99E99 – General error

SECTION 6 - GENERAL SPECIFICATIONS AND OPERATOR MAINTENANCE

Battery Charger Fault Codes

(See "Errors Menu" on page 6-24 info for display information)

Table 6-13. Battery Charger Fault Codes

CODE	DESCRIPTION	STATUS	ACTION
8	Internal logic fault.	Battery charger stops working.	Contact service dept. or change product.
13	Communication problem with external memory.	Battery charger stops working.	Contact service dept. or change product.
18	Extended shutdown or power failure.	Battery charger stops supplying power. Operation resumes as soon as alarm conditions are no longer present or after restarting.	If problem is a power failure, check battery charger mains power supply.
19	Internal logic fault.	Battery charger stops working.	Contact service dept. or change product.
240	Digital input is open and managed as hardware start-stop.	Battery charger stops charging until digital input closes.	Close digital input.
241	Problem in CANBUS communication with other systems in the network.	The way this is managed may change based on different firmware releases.	Check correct operation of CANBUS system.
242	Error when reading internal memory on micro controller.	Battery charger stops working.	Contact service dept. or change product.
244	Mains voltage lower than maximum operating range tolerance.	Battery charger won't start charging until mains voltage returns within normal operating range.	Make sure mains voltage is within correct operating parameters.
245	Abnormal current draw in primary section.	Battery charger stops supplying power. Operation resumes as soon as alarm conditions are no longer present.	If problem persists, contact service dept. or change product.

SECTION 6 - GENERAL SPECIFICATIONS AND OPERATOR MAINTENANCE

Table 6-13. Battery Charger Fault Codes

CODE	DESCRIPTION	STATUS	ACTION
246	Stage 1 ended by timeout without reaching control voltage.	Battery charger stops working.	Make sure battery capacity is compatible or check that battery is compliant with battery charger. If battery is correct and problem persists, contact service dept.
248	Temperature inside battery charger too high.	If internal temperature exceeds 80°C, battery charger reduces power to 80%, while it stops operating altogether if internal temperature exceeds 90°C. Battery charger starts at full power again when internal temperature falls below 70°C.	
249	Battery temperature too high.	If temperature exceeds 55°C or is less than -20°C, battery charger stops working. When battery temperature falls below 45°C or exceeds -10°C battery charger resumes normal operation.	
251	Power failure detected.	Battery charger stops supplying power. Operation resumes as soon as alarm conditions are no longer present.	If problem persists, check battery charger mains power supply.
252	Short-circuit in battery charger output.	Battery charger stops working.	Turn off battery charger and resolve short circuit at output. If problem persists, contact service dept. or change product.
253	Mains voltage higher than maximum operating range tolerance.	Battery charger won't start charging until mains voltage returns within normal operating range.	Make sure mains voltage is within correct operating parameters.

6.7 LITHIUM-ION BATTERY PACK - HANDLING IN DANGEROUS CONDITIONS

Battery cells must be handled correctly in order to ensure proper and safe use. However, if mistakes are made in handling the cells, causing explosion or venting, the user has to be equipped so as to be able to face this emergency.

The purpose of this section is to train the user on safe handling of cells that have been subjected to extreme conditions.

These Conditions Are As Follows:

1. Hot cells
2. Cells that have released substances or vented
3. Exploded cells
4. Fire enveloping the lithium batteries

Procedure For Handling Hot Cells

As soon as it has been established the temperature of a cell has risen considerably, the first action is evacuation of personnel from the affected area. The area has to be isolated and nobody can enter if not strictly necessary.

If possible, before leaving the area, the person who first identified the problem has to check if there is an external short-circuit and resolve it as soon as possible. After the short-circuit has been resolved, the cell will start to cool down. However, the area has to remain isolated until the cell reaches ambient temperature and is removed from the area. The temperature of the cell has to be checked periodically using a remote sensor such as an infrared sensor. If the cell remains hot the following actions must be assessed.

Minimum Equipment Required:

- Infrared temperature probe
- Safety glasses
- Hard hat with impact resistant face visor
- Non-conductive pliers
- Hand, arm and body protection

SECTION 6 - GENERAL SPECIFICATIONS AND OPERATOR MAINTENANCE

Start Procedure;

1. Evacuate the area as soon as abnormal cell temperature has been established.
2. Periodically check temperature of the cell using a remote sensor for the first two hours or until one of the following cases occur:
 - The cell starts to cool down
 - The cell vents
 - The cell explodes
3. If the cell starts cooling, check the temperature every hour until ambient temperature has been reached.
4. If a temperature sensor is not available, do not handle the cell for a minimum of 24 hours.
5. Remove cell from the work area when ambient temperature has been reached and return to normal operations.
6. Dispose of the cell in accordance with existing legislation (in the country in question) on hazardous materials.

Procedures in cases of venting or explosion are examined in the following paragraphs.

Procedure For Handling Vented Cells

In normal conditions a cell does not show leaks or venting, however a cell may vent or release substances if the critical temperature is reached or if the protective glass metal seal breaks due to severe mechanical conditions.

The severity of the leak consequent to venting ranges from slight leak around the seal to a violent leak of substances through the vent. In some cases, if the cell is not plugged, it may behave as a projectile.

Electrolyte inside the cell may cause very serious irritation to the respiratory tract, eyes and skin. In addition, venting may cause emission of highly corrosive vapors in the work environment. In this case, all protective equipment suited to limit exposure to toxic fumes must be available.

Minimum Equipment Required;

- Class D fire extinguisher
- Eye protection or face shield
- Respirator with filter for hydrochloric acid and sulphur dioxide
- Neoprene gloves
- Acid resistant lab coats
- Baking soda, calcium oxide or acid absorbent in kit form
- Vermiculite
- Plastic bags

SECTION 6 - GENERAL SPECIFICATIONS AND OPERATOR MAINTENANCE

Start Procedure;

In the event of electrolyte release from the cells, proceed as follows:

1. Evacuate the people exposed to fumes from the area.
2. Air the environment until the complete removal of the cell and until the characteristic pungent odor has disappeared.
3. If the cell is too hot, allow it to cool to ambient temperature before handling it (see "Procedure For Handling Hot Cells" on page 6-32).
4. Wear safety equipment: coat, gloves, mask and filters, and move the cell to a well-ventilated area.
5. Place every cell in a sealable plastic bag and remove the excess air, then seal the bag.
6. Place a cup of vermiculite in a second bag, place first bag in the second and seal it.
7. Place everything in a third bag with some baking soda and seal the bag.
8. Absorb and collect the leaked electrolyte with absorbent material or baking soda.
9. Place the absorbent material in a bag and seal it.
10. Clean area with plenty of water.
11. Dispose of hazardous material in accordance with the local legislation in force.

First Aid In The Event Of Contact With The Electrolyte

EYES

Immediately wash the eyes in abundant running water for at least 15 minutes, keeping the eyelids open and flushing the eye and back of the eyelid. Immediately seek medical help.

SKIN

Wash in cold water under a shower, remove contaminated garments. Continue washing for at least 15 minutes. Seek medical help where necessary.

RESPIRATORY TRACT

Move person(s) outdoors into the open air. If person(s) has difficulty breathing, have oxygen administered by trained personnel. If breathing stops, apply mouth-to-mouth resuscitation and immediately seek emergency medical help.

SECTION 6 - GENERAL SPECIFICATIONS AND OPERATOR MAINTENANCE

Procedure For Exploded Cells

Explosion of lithium batteries is not likely, it is a rare event that only occurs when an abnormal condition causes the temperature to rise and reach a critical point. However, in the event of lithium battery explosion the environment will quickly be filled with dense white smoke which will cause serious irritation to the respiratory tract, eyes and skin. Precautions must be taken to limit exposure to these fumes.

Minimum Equipment Required;

- Class D fire extinguisher
- Class ABC extinguisher for any secondary fires
- Eye protection or face shield
- Respirator with filter for hydrochloric acid and sulphur dioxide
- Neoprene gloves
- Acid resistant lab coats
- Baking soda, calcium oxide or acid absorbent in kit form
- Vermiculite
- Plastic bags

Start Procedure;

In the event of cell explosion, proceed as follows:

1. Evacuate personnel from the areas contaminated by smoke.
2. Ventilate the rooms until the cell has been removed from the area and until the characteristic pungent odor has disappeared.
3. Even if this is quite unlikely, there may be fires as a consequence of the explosion. The ways these emergencies are faced are described in the following paragraph.
4. The exploded cell may be hot. Allow it to cool down to ambient temperature before handling it (see Procedure for handling hot cells).
5. Wear safety equipment: coat, gloves, mask and filters.
6. In case of explosion the area around the cell will be covered by a black carbonaceous material which contains metallic parts of the cell. Cover the carbonaceous residues with a 50/50 mixture of baking soda and vermiculite or other absorbent material. Avoid contact between the metallic residues and charged cells, as this condition may cause a short.circuit.
7. Place contaminated material in a sealable plastic bag and remove excess air.
8. Seal the bag.

SECTION 6 - GENERAL SPECIFICATIONS AND OPERATOR MAINTENANCE

9. Place a cup of vermiculite in a second bag, place the first bag in the second and seal it.
10. Clean area with plenty of water and keep cleaning with water and soap.
11. Dispose of hazardous material in accordance with the local legislation in force.

First Aid In The Event Of Contact With The Electrolyte;

EYES

Immediately wash eyes in abundant running water for at least 15 minutes, keeping the eyelids open and flushing the eye and back of the eyelid. Immediately seek medical help.

SKIN

Wash in cold water under a shower, remove contaminated garments. Continue washing for at least 15 minutes. Seek medical help where necessary.

RESPIRATORY TRACT

Move casualty outdoors into the open air. If person(s) has difficulty breathing, have oxygen administered by trained personnel. If breathing stops, apply mouth-to-mouth resuscitation and immediately seek emergency medical help.

Lithium Battery Fire

All metals may burn in certain conditions, which depend on certain factors such as: physical state, presence of oxidizing atmospheres and severity of the source of ignition. Alkali metals such as lithium may burn in normal atmospheres. In addition, lithium reacts explosively with water to form hydrogen and the presence of small quantities of water may set fire to the material and the hydrogen gas that is released. Once metal fires start they are very hard to extinguish with ordinary equipment. This is partly due to the strong heat produced by the burning metal, whose temperature may reach 1832°F (1000°C). In addition, lithium may react with certain materials commonly used in fire extinguishers, like water and CO₂. Special extinguishers are required, designed for controlling and extinguishing lithium fires.

In particular, graphite-based extinguishers (Lith-x) are used. Usually these extinguishers work by forming a crust or a layer of material on the surface of the burning metal. Lith-x, which is a common graphite-based agent, may be used with an extinguisher or spread over the fire. In the event of lithium fire, the room may fill with a dense white smoke, mostly formed by lithium oxide and other metal oxides. This condition may cause serious damage to the respiratory tract, skin and eyes. All precautions needed to limit exposure to these fumes must be adopted. It should be noted that this procedure is applicable only to fires on individual cells. Larger fires have to be managed only by professionally trained personnel.

SECTION 6 - GENERAL SPECIFICATIONS AND OPERATOR MAINTENANCE

Finally, it should be noted that in the presence of combustible materials other than lithium it is advisable to use different types of extinguishers in conjunction to better ensure the extinguishing action of each on the appropriate material, however do not use water or CO2 extinguishers directly on lithium fires.

Minimum Equipment Required;

- Class D fire extinguisher
- Class ABC extinguisher for any secondary fires
- Breathing apparatus
- Fireproof clothing
- Fireproof gloves
- Mask or protective glasses
- Non-conductive pliers
- Dustpan, mineral oil

Start Procedure;

1. In the event of fire on one cell, a team of experienced fire-fighting personnel has to be contacted. The personnel must be properly trained to fight lithium battery fires.
2. Evacuate personnel from all areas and sound the fire alarm.
3. The fire-fighting personnel go to the area where the fire is located and gather all the information regarding the situation and the person who gave the alarm.

4. Quarantine the area. Air the rooms until the burning material has been removed from the area and the characteristic pungent odor has disappeared.
5. Two members of the team enter the area with appropriate safety equipment.

NOTE: *Lithium melts at 356°F (180°C). It becomes highly reactive and when it catches fire it may eject molten lithium particles. For this reason the surrounding cells may overheat and cause a violent explosion. The fire-fighting personnel must pay attention to any dangerous materials located near the fire.*

6. Completely cover fire with extinguishing material. Never leave fire unattended as it may develop again.
7. If necessary, extinguish secondary fires with suitable extinguishers.
8. After all material has burned and cooled down, carefully mix residual material to prevent resumption of the fire.
9. Put the material in a metal drum, cover the surface with plenty of extinguishing material.
10. Residual material may contain un-reacted lithium, therefore limit exposure to rain by covering, for example, with mineral oil.
11. Wear safety equipment: coat, gloves, mask and filters.

SECTION 6 - GENERAL SPECIFICATIONS AND OPERATOR MAINTENANCE

12. The area around the cell will be covered by a black carbonaceous deposit which contains metallic parts of the cell. Cover the carbonaceous residue with a 50/50 mixture of baking soda and vermiculite or other absorbent material. Avoid contact between the metallic residue and charged cells as this condition may cause a short.circuit.
13. Place the contaminated material in a sealable plastic bag and remove the excess air.
14. Seal the bag.
15. Place a cup of vermiculite in a second bag, place the first bag in the second and seal it.
16. Clean the area with plenty of water and keep cleaning with water and soap.
17. Dispose of hazardous material in accordance with the local legislation in force.

First Aid In The Event Of Contact With The Electrolyte;

EYES

Immediately wash the eyes in abundant running water for at least 15 minutes, keeping the eyelids open and flushing the eye and back of the eyelid. Immediately seek medical help.

SKIN

Wash in cold water under a shower, remove contaminated garments. Continue washing for at least 15 minutes. Seek medical help where necessary.

RESPIRATORY TRACT

Move person(s) outdoors into the open air. If person(s) has difficulty breathing, have oxygen administered by trained personnel. If breathing stops apply mouth-to-mouth resuscitation and immediately seek emergency medical help.

TO PURCHASE THIS PRODUCT PLEASE CONTACT US



**Equipment Financing and
Extended Warranties Available**



**Discount-Equipment.com is your online resource for
commercial and industrial quality parts and equipment sales.**

561-964-4949

visit us on line @ www.discount-equipment.com

Select an option below to find your Equipment

Search by Manufacturer

Search by Product Type

Request a Quote

We sell worldwide for the brands: Genie, Terex, JLG, MultiQuip, Mikasa, Essick, Whiteman, Mayco, Toro Stone, Diamond Products, Generac Magnum, Airman, Haulotte, Barreto, Power Blanket, Nifty Lift, Atlas Copco, Chicago Pneumatic, Allmand, Miller Curber, Skyjack, Lull, Skytrak, Tsurumi, Husquvarna Target, Stow, Wacker, Sakai, Mi-T-M, Sullair, Basic, Dynapac, MBW, Weber, Bartell, Bennar Newman, Haulotte, Ditch Runner, Menegotti, Morrison, Contec, Buddy, Crown, Edco, Wyco, Bomag, Laymor, EZ Trench, Bil-Jax, F.S. Curtis, Gehl Pavers, Heli, Honda, ICS/PowerGrit, IHI, Partner, Imer, Clipper, MMD, Koshin, Rice, CH&E, General Equipment, Amida, Coleman, NAC, Gradall, Square Shooter, Kent, Stanley, Tamco, Toku, Hatz, Kohler, Robin, Wisconsin, Northrock, Oztec, Toker TK, Rol-Air, APT, Wylie, Ingersoll Rand / Doosan, Innovatech, Con X, Ammann, Mecalac, Makinex, Smith Surface Prep, Small Line, Wanco, Yanmar



3121783

JLG[®]

An Oshkosh Corporation Company

**Discount
Equipment**

www.Discount-Equipment.com

To order 914 Discount-Equipment.com