



An Oshkosh Corporation Company



www.Discount-Equipment.com

---

# Electrical Schematic Manual

## Models **X33JP - X1000AJ**

**31217109 Rev A**

April 5, 2019

Go to Discount-Equipment.com to order your parts

**ANSI**

**CE**



---

An Oshkosh Corporation Company

# PARTS FINDER

**Search Website  
by Part Number**



**Search Manual  
Library For Parts  
Manual & Lookup Part  
Numbers – Purchase  
or Request Quote**

**Search Manuals**

Enter your information to help us find the right manual for your machine.

\* Brand:

\* Model:

\* Serial:

\* Part Number:

SEARCH

**Can't Find Part or  
Manual? Request Help  
by Manufacturer,  
Model & Description**

**Parts Order Form**

Please fill in the following information to help us find the right part for your machine.

MANUFACTURER:

MODEL:

DESCRIPTION:

SEARCH

Discount-Equipment.com is your online resource for quality parts & equipment.

Florida: **561-964-4949** Outside Florida TOLL FREE: **877-690-3101**

**Need parts?**

Click on this link: <http://www.discount-equipment.com/category/5443-parts/> and choose one of the options to help get the right parts and equipment you are looking for. Please have the machine model and serial number available in order to help us get you the correct parts. If you don't find the part on the website or on one of the online manuals, please fill out the request form and one of our experienced staff members will get back to you with a quote for the right part that your machine needs.

We sell worldwide for the brands: Genie, Terex, JLG, MultiQuip, Mikasa, Essick, Whiteman, Mayco, Toro Stone, Diamond Products, Generac Magnum, Airman, Haulotte, Barreto, Power Blanket, Nifty Lift, Atlas Copco, Chicago Pneumatic, Allmand, Miller Curber, Skyjack, Lull, Skytrak, Tsurumi, Husquvarna Target, , Stow, Wacker, Sakai, Mi-T- M, Sullair, Basic, Dynapac, MBW, Weber, Bartell, Bennar Newman, Haulotte, Ditch Runner, Menegotti, Morrison, Contec, Buddy, Crown, Edco, Wyco, Bomag, Laymor, Barreto, EZ Trench, Bil-Jax, F.S. Curtis, Gehl Pavers, Heli, Honda, ICS/PowerGrit, IHI, Partner, Imer, Clipper, MMD, Koshin, Rice, CH&E, General Equipment, ,AMida, Coleman, NAC, Gradall, Square Shooter, Kent, Stanley, Tamco, Toku, Hatz, Kohler, Robin, Wisconsin, Northrock, Oztec, Toker TK, Rol-Air, Small Line, Wanco, Yanmar

## ELECTRIC DIAGRAM

DESCRIPTION	REFERENCE
• How to read the electric wiring diagrams	
• Outrigger switches (Part 1)	1
• Outrigger switches (Part 2)	2
• Outrigger switches (Part 3)	3
• Modem – Telematics – CanBus Line 0 – CanBus Line 2	4
• CanBus Line 1 (Part 1): Tower boom cylinder - Tower boom extension cylinder	5
• CanBus Line 1 (Part 2): Main boom cylinder – Main boom extension cylinder	6
• CanBus Line 1 (Part 3): Basket devices	7
• CanBus Line 3 – CanBus Line 4 – Chassis level sensor	8
• Ground dashboard and plugs	9
• Safety Exclusion	10
• Ground control box	11
• Load Cell sensor – Rotation sensor – Remote control stop switch - Pedal	12
• Widening Cylinder sensors – Emergency electro pump – Horn – Warning Buzzer – Flashing Light – Sky Guard lamp	13
• Boards feed	14
• Sky Guard system	15
• Tower boom closed switch – Tower boom ropes switches	16
• Right and left ropes proximity sensors on tower boom	17
• Main boom ropes switches	18
• Electro valves: tracks, undercarriage widening	19
• Electro valves: outriggers	20
• Electro valves: tower boom, tower extension, main boom , main extension, rotation	21
• Electro valves: jib, basket levelling, basket rotation	22
• Electro valves: 2° speed – deviators – Tank Line – Pump sum and sensor	23
• Kubota Engine	24A,24B,24C
• 120/220 Volt line	25
• Electric motor 380 Volt	26A,26B
• Components location	27
• ECM 1 input and output list	A1
• ECM 3 & 4 input and output list	A2
• Components abbreviation meaning	A3
• Connectors layout	A4
• Lithium system	

## SCHEMA ELETTRICO

DESCRIZIONE	RIFERIMENTO
• Come leggere gli schemi elettrici	
• Interruttori stabilizzatori (Parte 1)	1
• Interruttori stabilizzatori (Parte 2)	2
• Interruttori stabilizzatori (Parte 3)	3
• Modem – Telematics – Linea 0 CanBus – Linea 2 CanBus	4
• Linea 1 CanBus (Parte 1): Cilindro tower boom – Cilindro sfilo tower boom	5
• Linea 1 CanBus (Parte 2): Cilindro main boom - Cilindro sfilo main boom	6
• Linea CanBus 1 (Parte 3): Dispositivi al cesto	7
• Linea CanBus 3- Linea CanBus 4 – Sensore livellamento a terra	8
• Pannello di controllo a terra	9
• Esclusione sicurezze	10
• Scatola di comando a terra	11
• Sensore cella di carico – Sensore di rotazione – Stop sul telecomando -Pedale	12
• Sensori allargamento carro – Elettro pompa di emergenza – Clacson – Segnalatore acustico – Luce lampeggiante – Lampada Sky Guard	13
• Alimentazione schede	14
• Sistema Sky Guard	15
• Interruttore tower boom chiuso – Interruttore funi tower boom	16
• Sensori proximity per fune destra e sinistra del tower boom	17
• Interruttori funi main boom	18
• Electrovalvole: traini, allargamento carro	19
• Electrovalvole: stabilizzatori	20
• Electrovalvole: tower boom, sfilo tower, main boom , sfilo main, rotazione	21
• Electrovalvole: jib, livellamento cesto, rotazione cesto	22
• Electrovalvole: 2° velocità, deviatori, – Linea di scarico – Somma pompe e sensore	23
• Motore Kubota	24A,24B,24C
• Linea 120/220 Volt	25
• Motore elettrico 380 Volt	26A,26B
• Locazione componenti	27
• Lista input e output ECM 1	A1
• Lista input e output ECM 3 & 4	A2
• Significato abbreviazione componenti	A3
• Layout connettori	A4
• Sistema Litio	

# INSTALACIÓN ELÉCTRICA

DESCRIPCIÓN	REFERENCIA
• Como leer la instalación eléctrica	
• Interruptores estabilizadores (Parte 1)	1
• Interruptores estabilizadores (Parte 2)	2
• Interruptores estabilizadores (Parte 3)	3
• Modem – Telematics – Línea 0 CanBus – Línea 2 CanBus	4
• Línea 1 CanBus (Parte 1): Cilindro tower boom – Cilindro telescópico tower boom	5
• Línea 1 CanBus (Parte 2): Cilindro main boom – Cilindro telescópico main boom	6
• Línea CanBus 1 (Parte 3): Dispositivos en la cesta	7
• Línea CanBus 3 – Línea CanBus 4 – Sensor de nivel en tierra	8
• Panel de control en tierra	9
• Exclusion seguridades	10
• Caja de control en tierra	11
• Sensor célula de carga – Sensor rotación – Stop en el mando – Pedal	12
• Sensores posición orugas – Electro bomba de emergencia - Clacson – Zumbador – Parpadeo - Luz Sky Guard	13
• Alimentación placas electrónicas	14
• Sistema Sky Guard	15
• Interruptor tower boom cerrado – Interruptor cuerdas tower boom	16
• Sensores proximity para las cuerdas en el tower boom	17
• Interruptores cuerdas main boom	18
• Electroválvulas: orugas, extensión del carro	19
• Electroválvulas: estabilizadores	20
• Electroválvulas: tower, telescópico tower, main, telescópico main, rotación	21
• Electroválvulas: jib, nivelación cesta, rotación cesta	22
• Electroválvulas: 2º velocidad, conmutadores, – Línea de drenaje – Suma bombas y sensor	23
• Motor Kubota	24A,24B,24C
• Línea 120/220 Volt	25
• Motor eléctrico 380 Volt	26A,26B
• Colocación componentes	27
• Liste input y output ECM 1	A1
• Liste input y output ECM 3 & 4	A2
• Significado abreviatura componentes	A3
• Layout conectores	A4
• Sistema Litio	

## PLAN ÉLECTRIQUE

DESCRIPTION	RÉFÉRENCE
• Comment lire les plans électriques	
• Interrupteurs stabilisateurs (Partie 1)	1
• Interrupteurs stabilisateurs (Partie 2)	2
• Interrupteurs stabilisateurs (Partie 3)	3
• Modem – Telematics – Lingne 0 CanBus – Lingne 2 CanBus	4
• Ligne 1 CanBus (Partie 1): Vérin tower boom – Vérin bras d'extension tower	5
• Ligne 1 CanBus (Partie 2): Vérin main boom – Vérin bras d'extension main	6
• Lingne CanBus 1 (Partie 3) : Appareils dans le panier	7
• Ligne CanBus 3 – Ligne CanBus 4 – Capteur de niveau au sol	8
• Panneau de control au sol	9
• Exclusion sécurités	10
• Boîte de commande en terre	11
• Capteur de poids – Capteur de roulement – Stop dans le telècommande – Pédale	12
• Capteurs position chenilles – Elettro pompe d'urgence – Clacson – Alarme acoustique – Clignotant – Lumière Sky Guard	13
• Alimentation cartes	14
• Système Sky Guard	15
• Interrupteur tower boom fermé – Interrupteur de cordes tower boom	16
• Capteur proximity pour les cordes dans le tower boom	17
• Interrupteurs cordes dans le main boom	18
• Electrovanne: chenilles, élargissement chenilles	19
• Electrovanne: stabilisateurs	20
• Electrovanne: tower, bras d'extension tower, main, bras d'extension main, rotación	21
• Electrovanne: jib, nivellement panier, rotation panier	22
• Electrovanne: 2° vites, déviateurs, – Ligne de drainage – somme pompes et capteur	23
• Moteur Kubota	24A,24B,24C
• Ligne 120/220 Volt	25
• Moteur électrique 380 Volt	26A,26B
• Disposition composants	27
• Liste input et output ECM 1	A1
• Liste input et output ECM 3 & 4	A2
• Signifie abréviations des composants	A3
• Layout connecteurs	A4
• Système lithium	

- HOW TO READ THE WIRING DIAGRAMS
- COME LEGGERE GLI SCHEMI ELETTRICI
- CÓMO LEER LOS ESQUEMAS ELÉCTRICOS
- COMMENT LI RE LES PLANS ÉLECTRIQUES

- Letter X always identify connectors
- La lettera X identifica sempre connettori
- La letra X identifica siempre conectores
- La lettre X indique toujours connecteurs

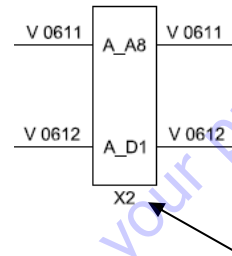

- Every wire is identified by the color and, if present, a number
- Ogni cavo è identificato dal colore e, se presente, da un numero
- Todos los cables son identificados da el color y, si presente, da un numero
- Chaque câble est identifié par le couleur et, si présente, par le nombre

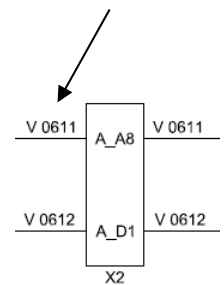

#### COLOUR CODES

A = AZURE  
 B = BLACK  
 BL = BLUE  
 BR = BROWN  
 G = GREEN  
 GR = GREY  
 OR = ORANGE  
 P = PINK  
 R = RED  
 V = PURPLE  
 W = WHITE  
 Y = YELLOW  
 SCH = SHIELDING

#### TABELLA COLORI

A = AZZURRO  
 B = NERO  
 BL = BLU  
 BR = MARRONE  
 G = VERDE  
 GR = GRIGIO  
 OR = ARANCIO  
 P = ROSA  
 R = ROSSO  
 V = VIOLA  
 W = BIANCO  
 Y = GIALLO  
 SCH = SCHERMATURA

#### TABLA COLORES

A = AZUL  
 B = NEGRO  
 BL = AZUL  
 BR = MARRÓN  
 G = VERDE  
 GR = GRIS  
 OR = NARANJA  
 P = ROSA  
 R = ROJO  
 V = VIOLETA  
 W = BLANCO  
 Y = AMARILLO  
 SCH = CRIBADO

#### TABLEAU COULEURES

A = BLEU CLAIR  
 B = NOIR  
 BL = BLEU  
 BR = MARRON  
 G = VERT  
 GR = GRIS  
 OR = ORANGE  
 P = ROSE  
 R = ROUGE  
 V = VIOLET  
 W = BLANC  
 Y = JAUNE  
 SCH = BLINDAGE

- Figures in the connectors, shows the pin numbers
- Le cifre all'interno dei connettori, indicano il numero del pin
- Las cifras dentro de los conectores, indican el numero del los contactos
- Les chiffres dans les connecteurs, indiquent le nombre des goupilles

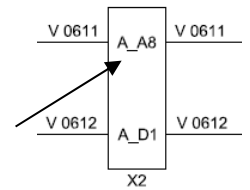

- Circles show welds with two or more wires. Each weld has an identification number
- I cerchi mostrano saldature con due o più cavi. Ogni saldatura ha un numero identificativo
- Los circulo muestra soldaduras con dos o más cables. Cada soldadura tiene un numero de identificación
- Les cercles indiquent les soudures avec deux ou plusieurs câbles. Chaque soudure a un numéro d'identification

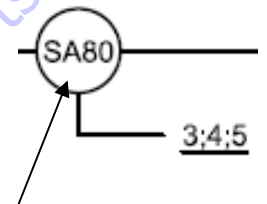

- Underlined letters show the page where the component is present too
- Le lettere sottolineate indicano le altre pagine dove il componente è presente
- Las letras subrayadas indican las otras páginas en donde el componente está presente
- Les lettres soulignées indiquent les autres pages où le composant est présent

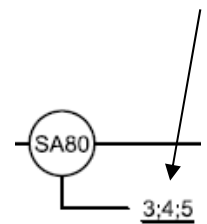

Go to Discount-Equipment.com to order your parts



# 1 - OUTRIGGER SWITCHES (PART 1)

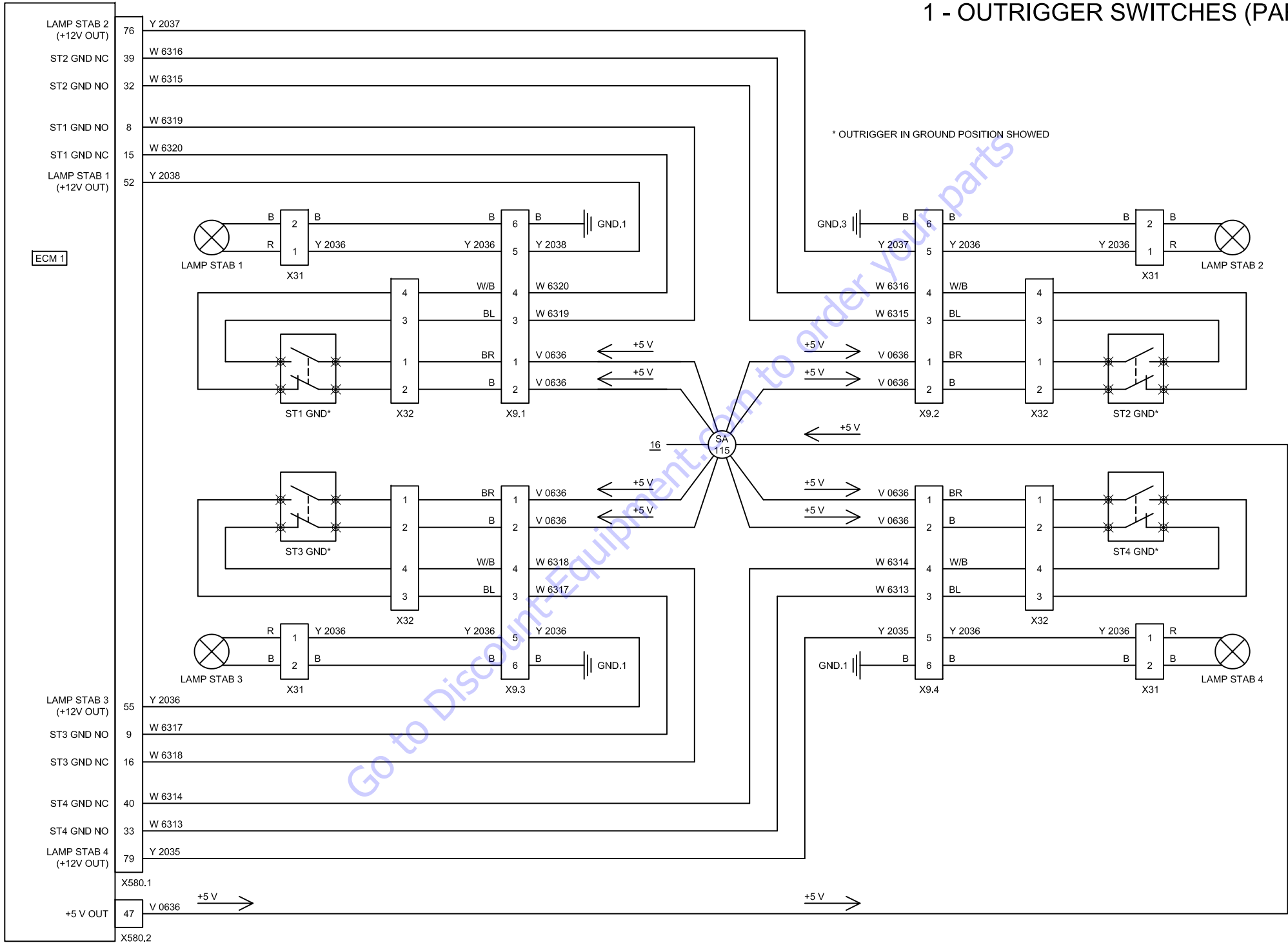

## 2 - OUTRIGGER SWITCHES (PART 2)

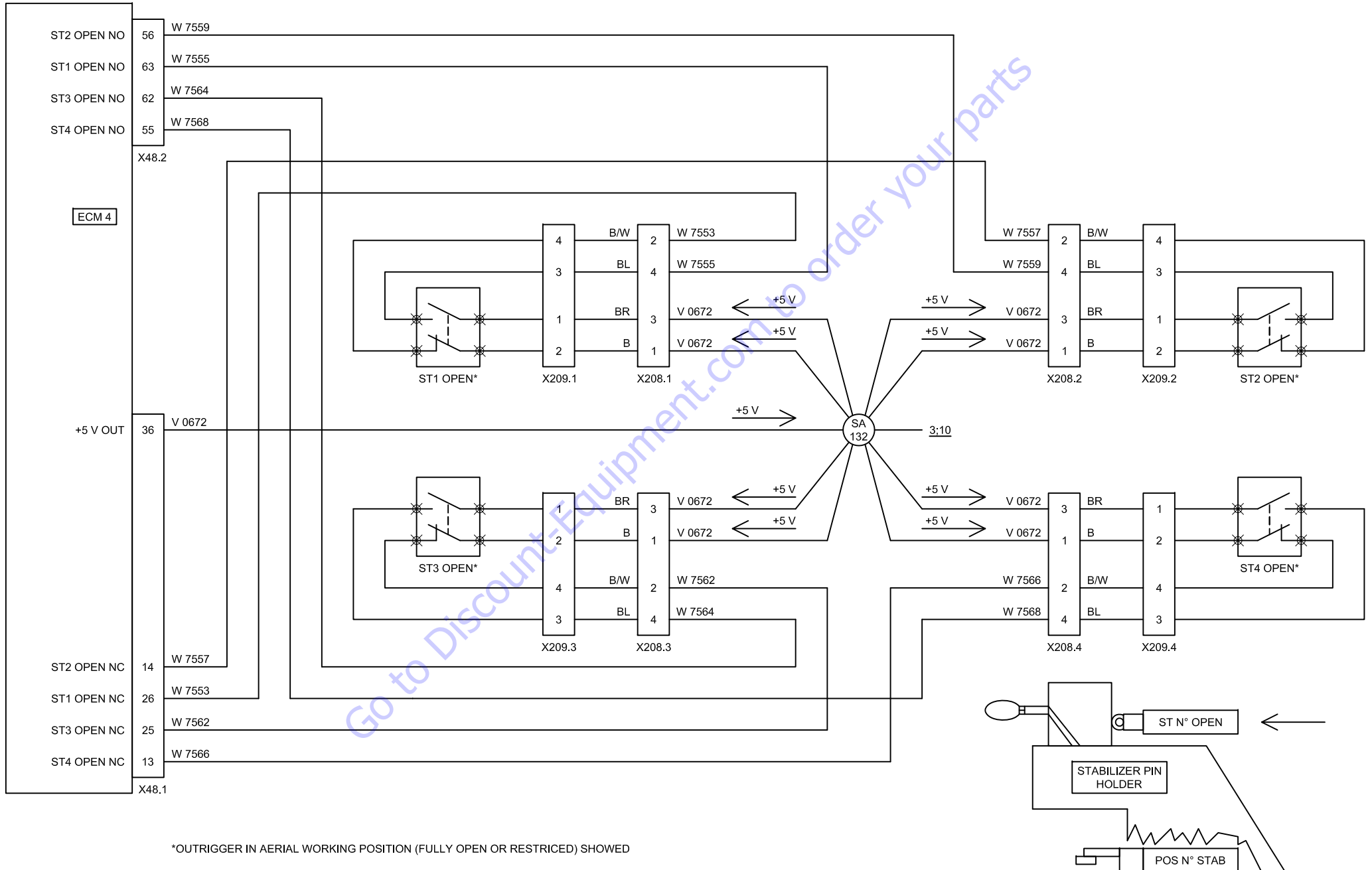

### 3 - OUTRIGGER SWITCHES (PART 3)

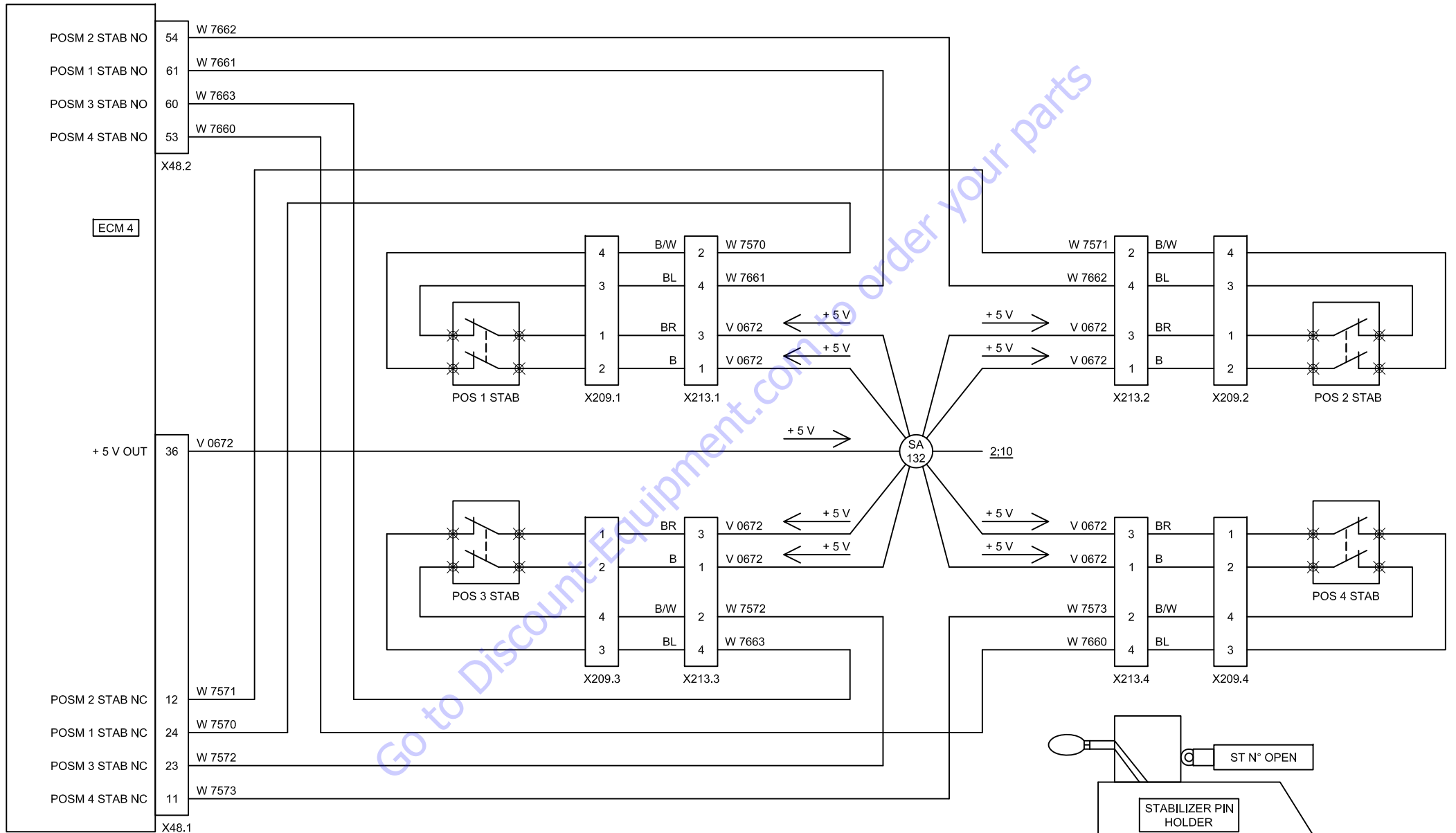

\* OUTRIGGER IN FULLY OPEN POSITION SHOWN

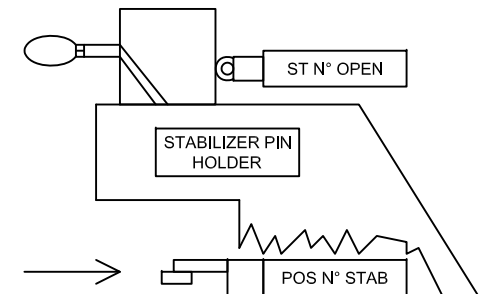

# 4 - MODEM - TELEMATICS - CAN BUS LINE 0 - CAN BUS LINE 2

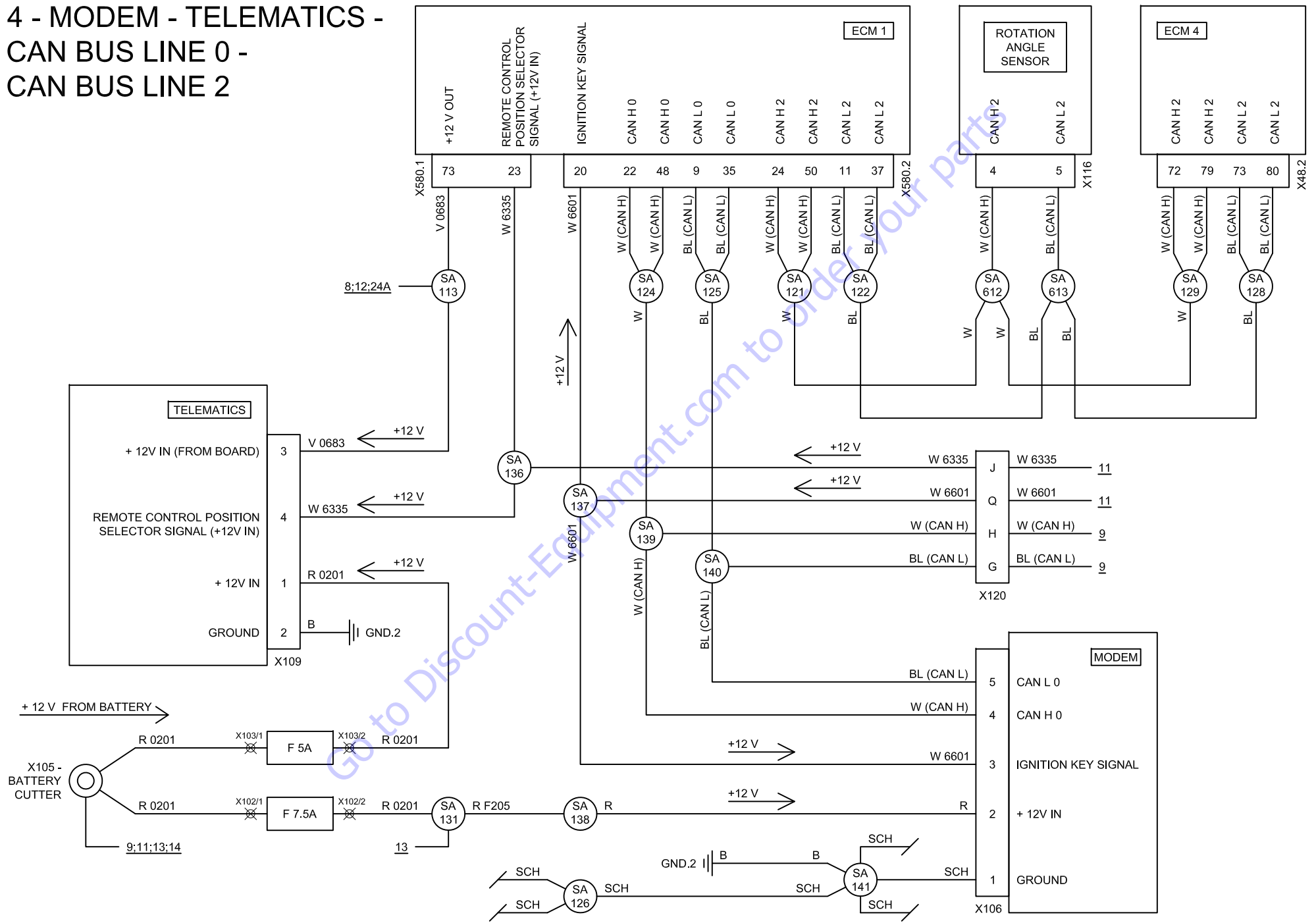

# 5 - CANBUS LINE 1 (PART 1): TOWER BOOM CYLINDER - TOWER BOOM EXTENSION CYLINDER

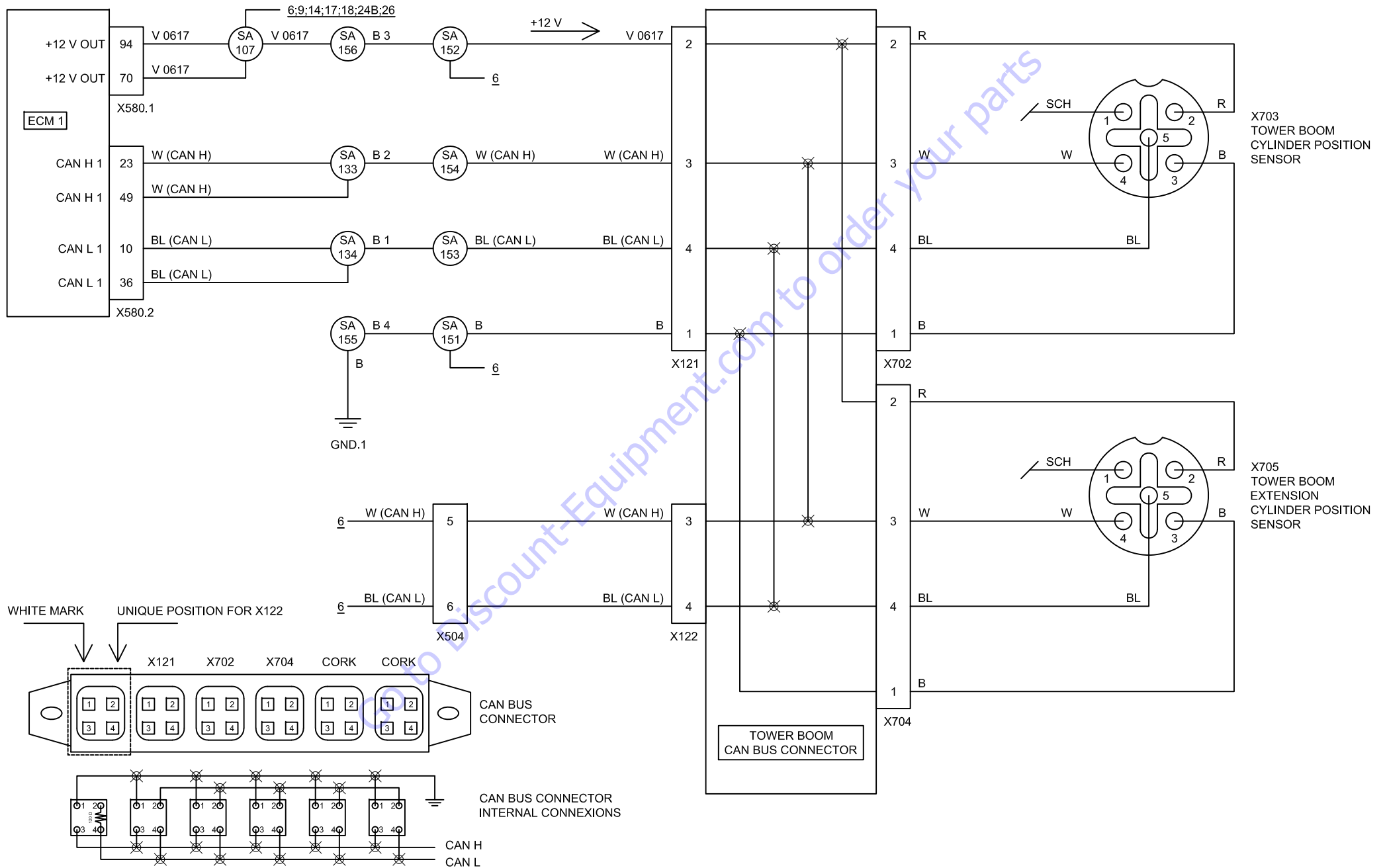

# 6 - CANBUS LINE 1 (PART 2): MAIN BOOM CYLINDER - MAIN BOOM EXTENSION CYLINDER

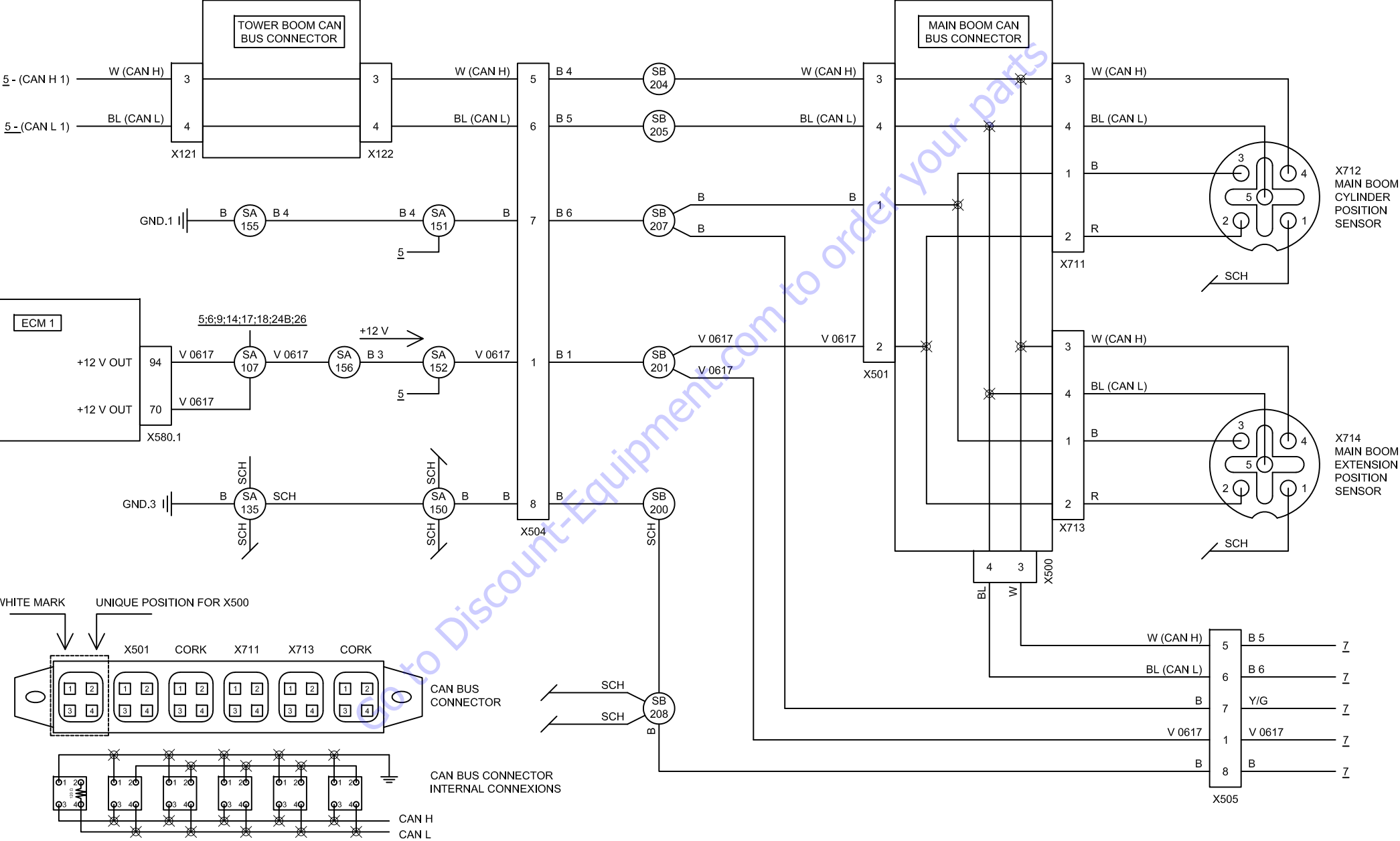

# 7 - CANBUS LINE 1 (PART 3): BASKET DEVICES

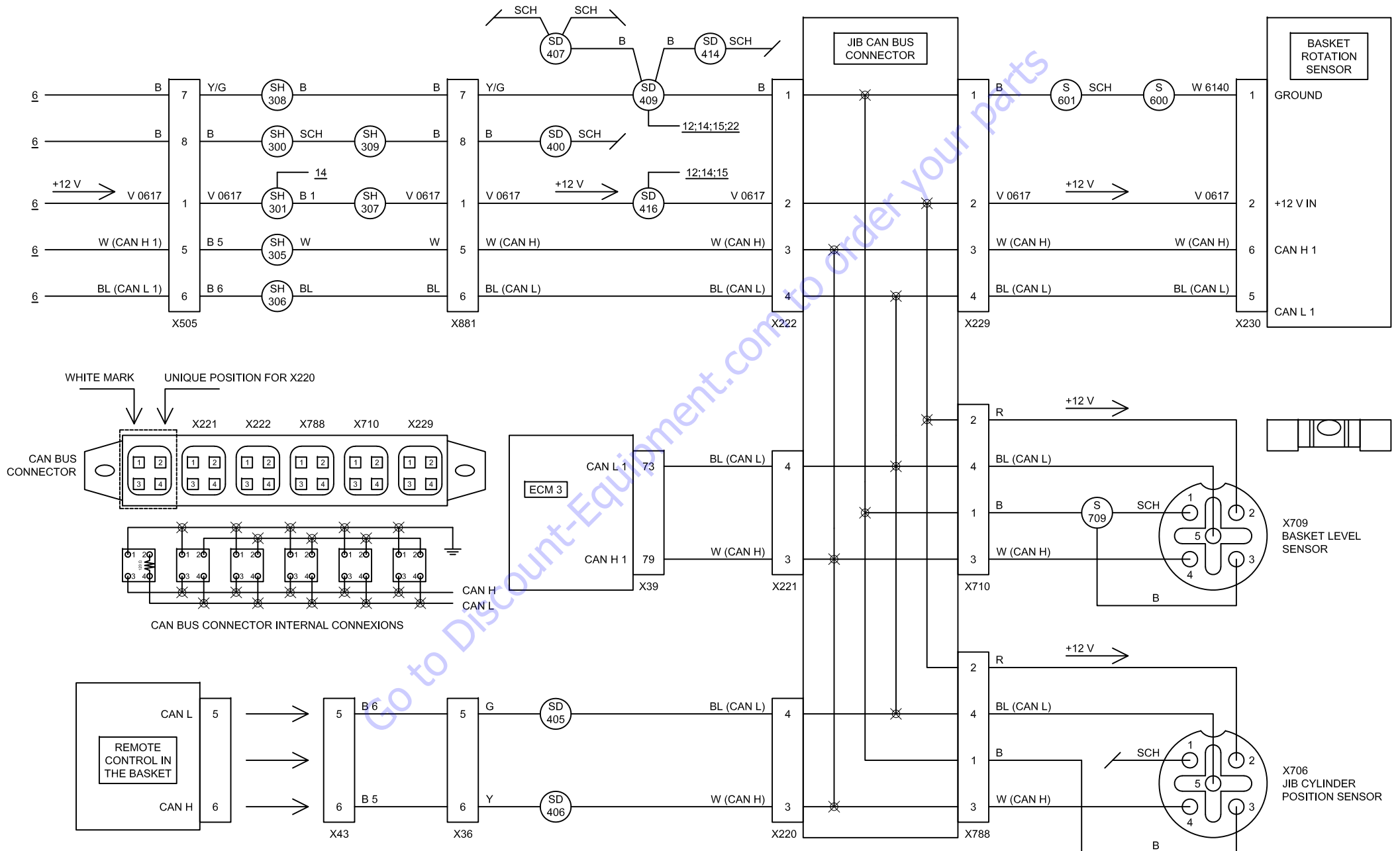

# 8 - CANBUS LINE 3 - CAN BUS LINE 4 - CHASSIS LEVEL SENSOR

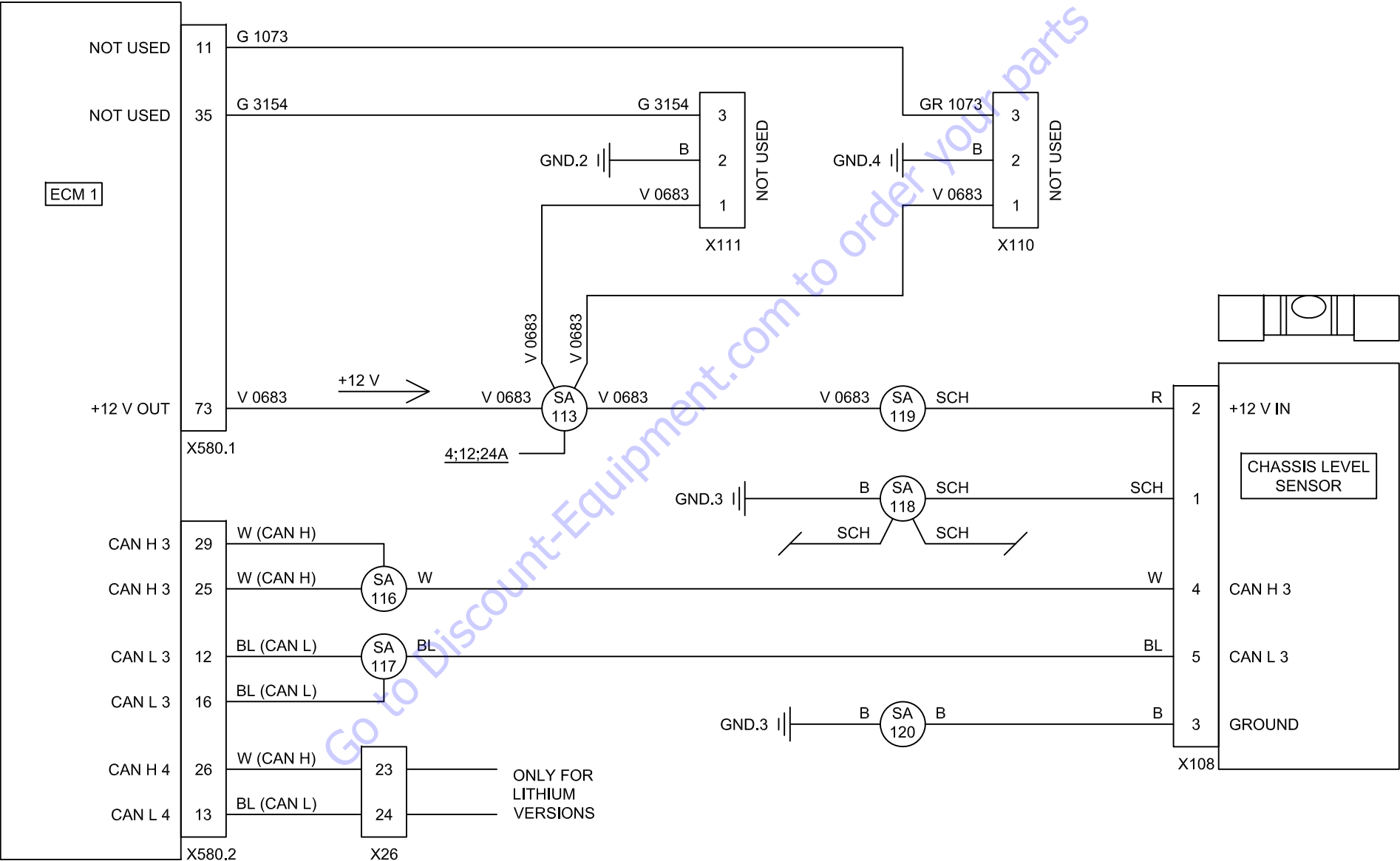



# 9 - GROUND DASHBOARD AND PLUGS

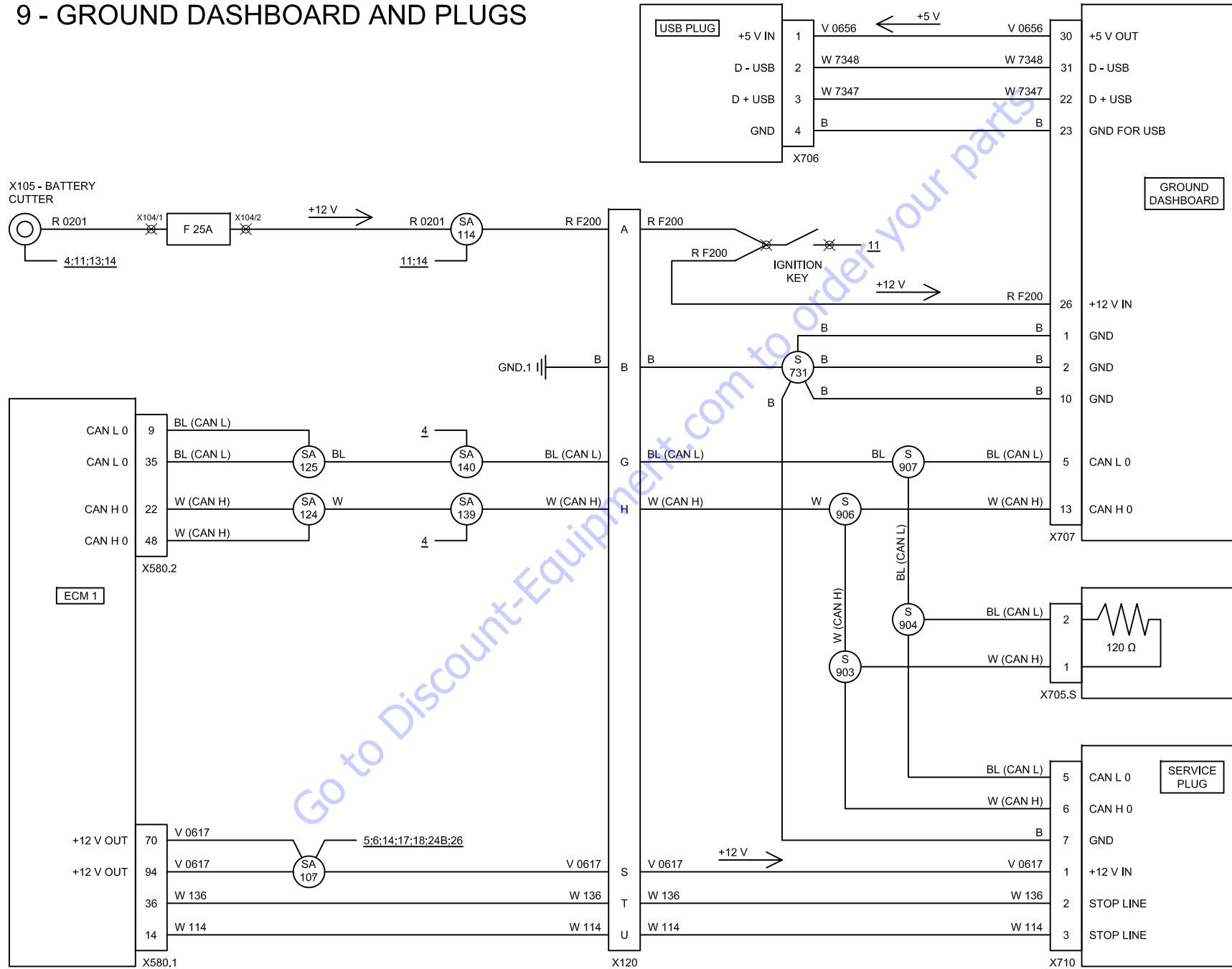

# 10 - SAFETY EXCLUSION

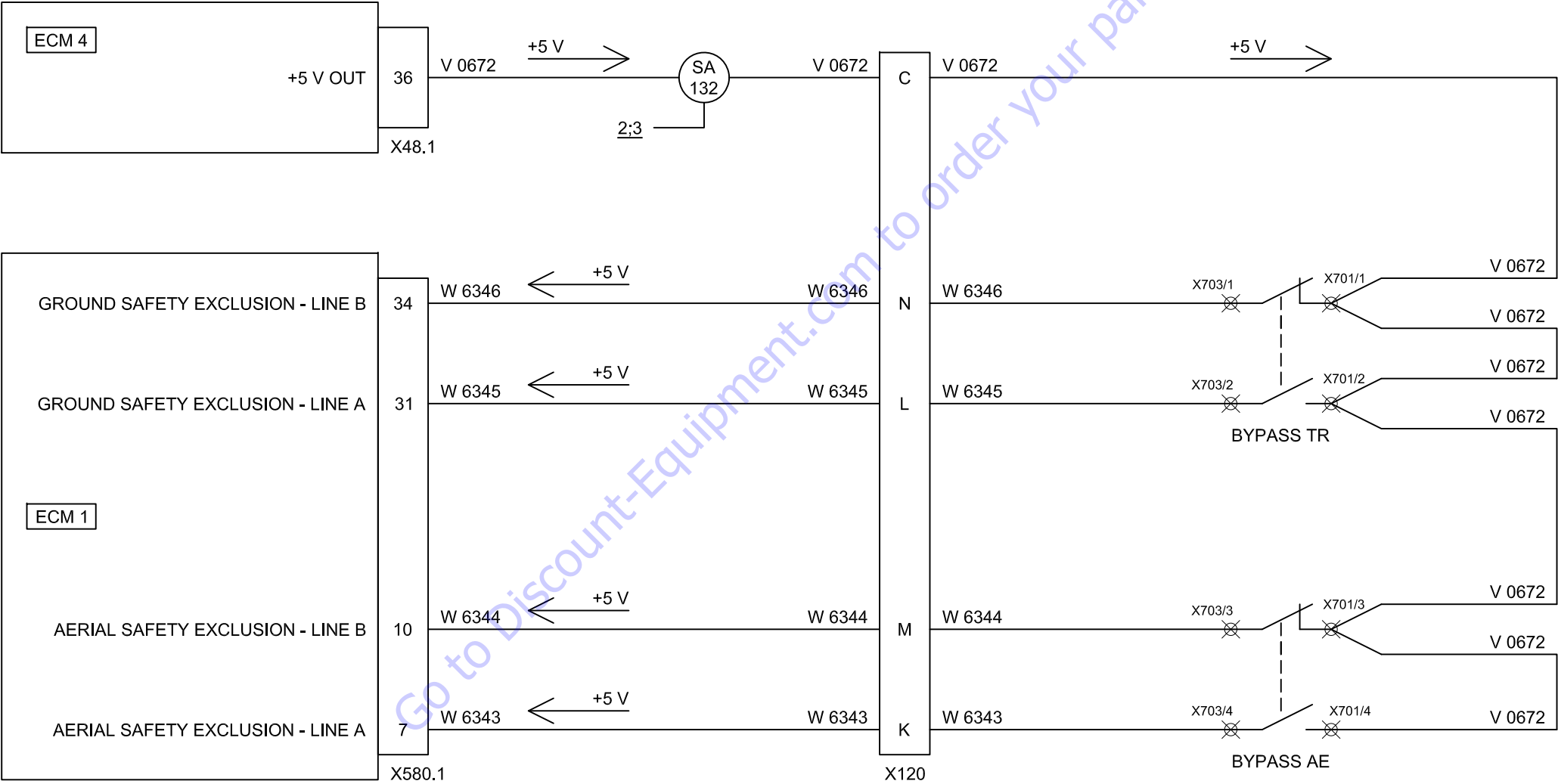

# 11 - GROUND CONTROL BOX

X105 - BATTERY CUTTER

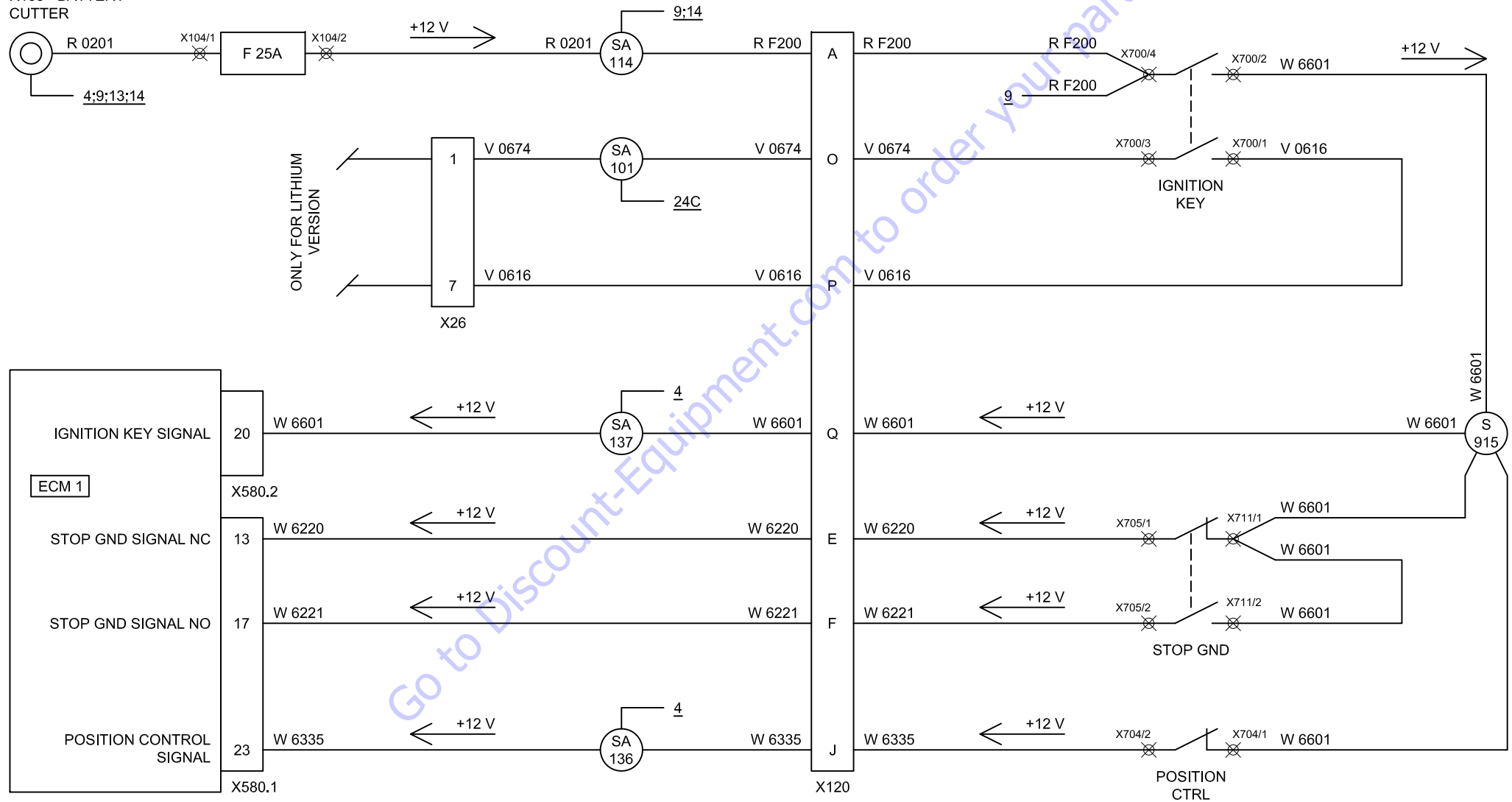

# 12 - LOAD CELL SENSOR - ROTATION SENSOR - REMOTE CONTROL STOP SWITCH - PEDAL

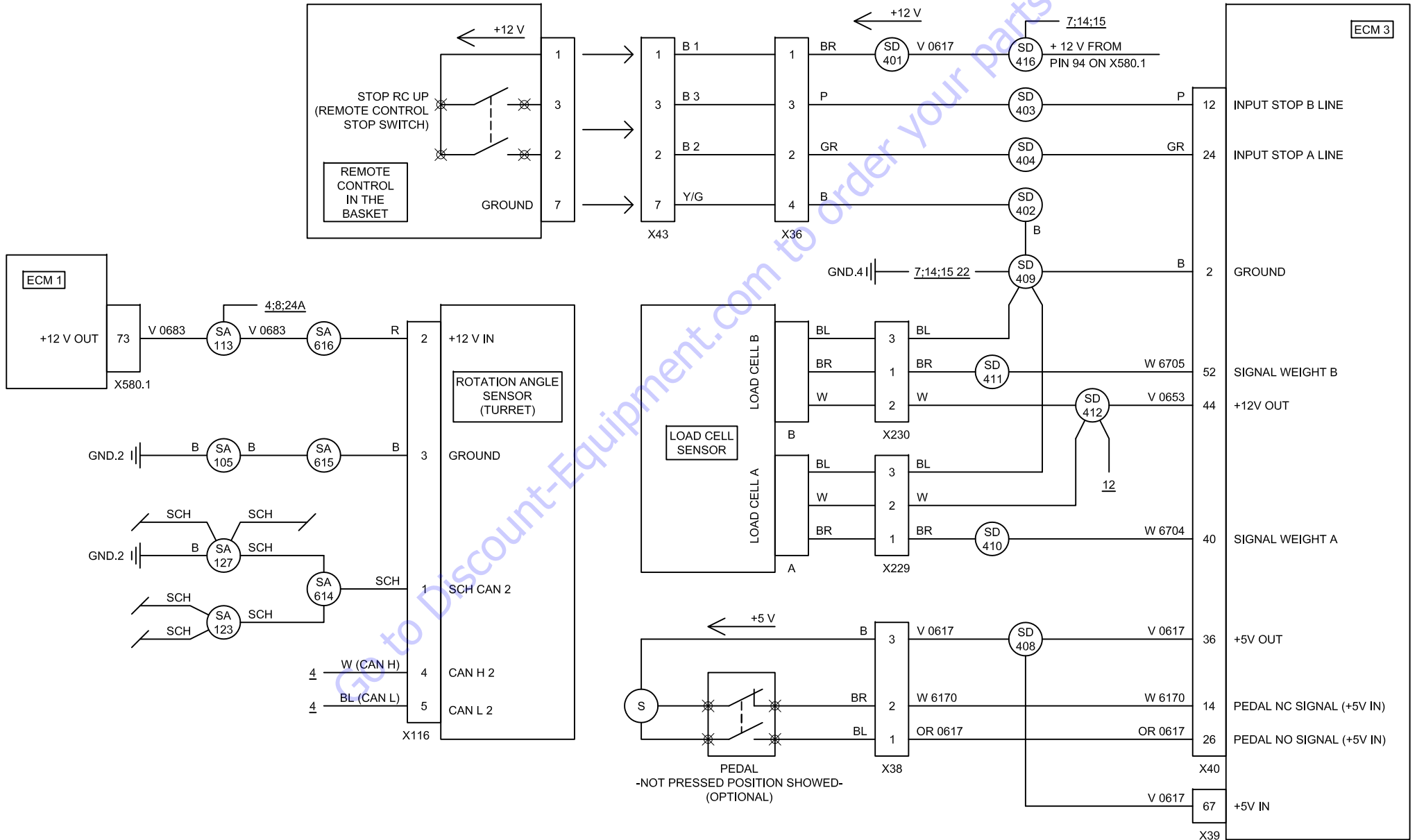

# 13 - WIDENING CYLINDER SENSORS - EMERGENCY ELECTRO PUMP - HORN - WARNING BUZZER - FLASHING LIGHT - SKY GUARD LAMP

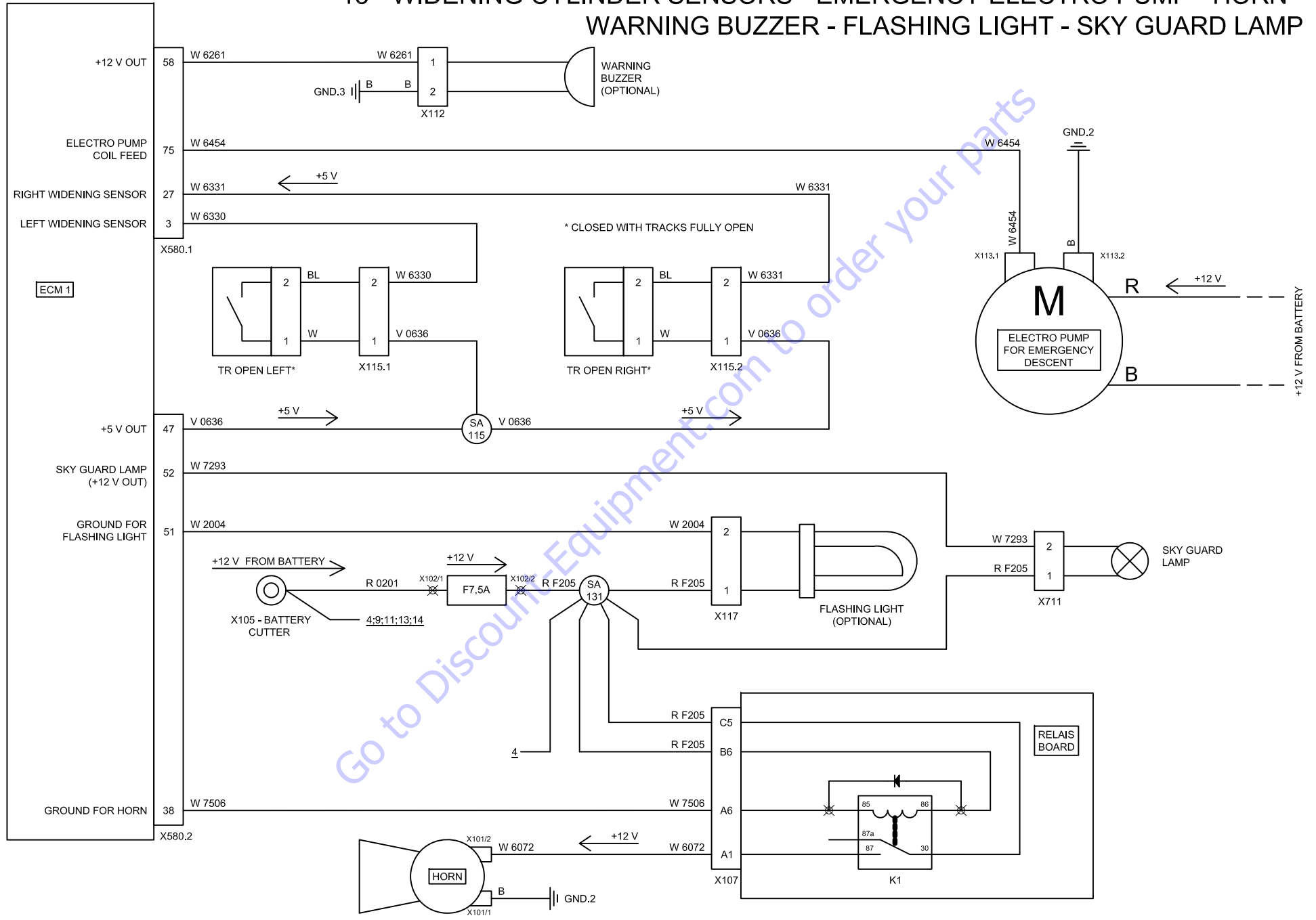

# 14 - BOARDS FEED

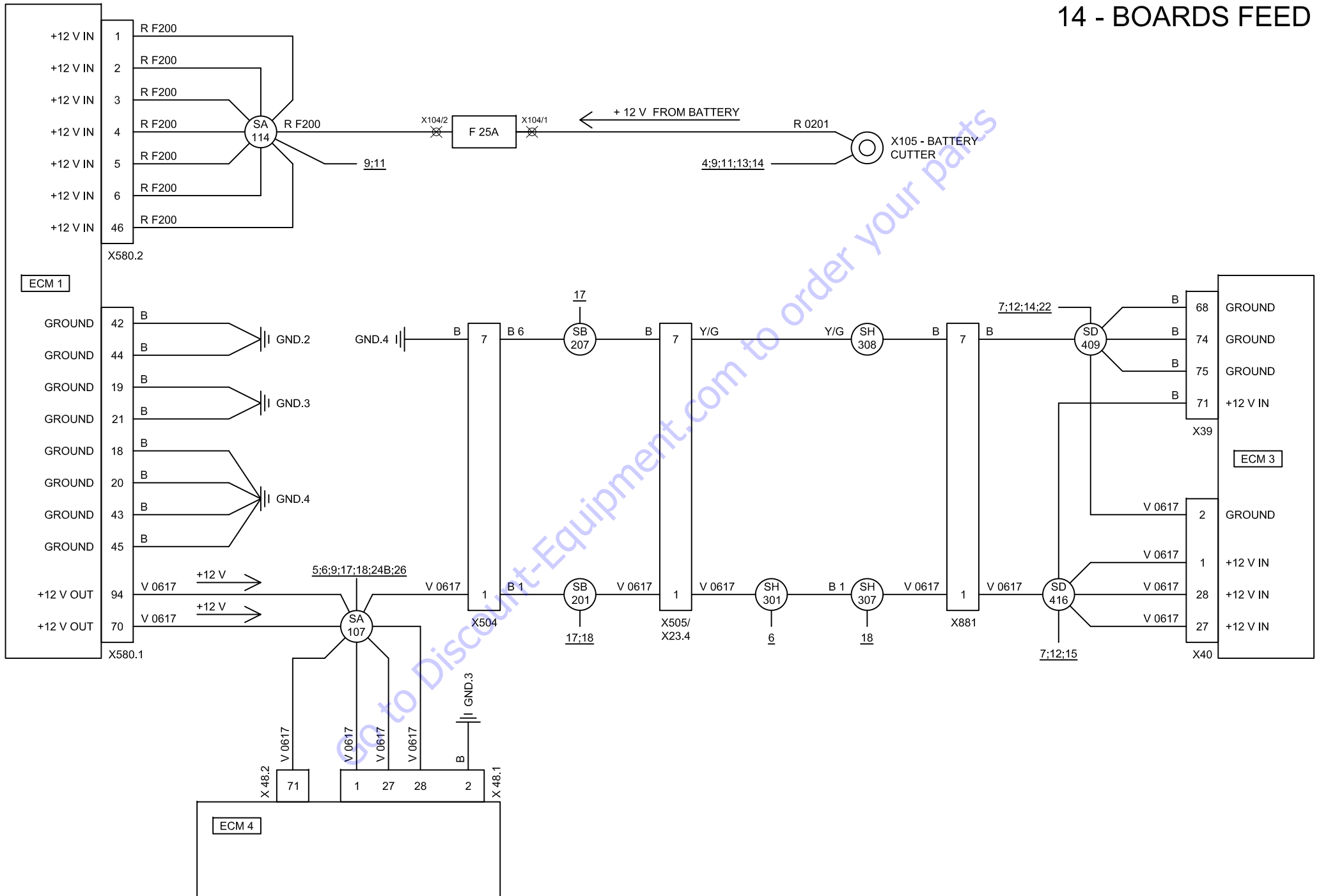

# 15 - SKY GUARD SYSTEM

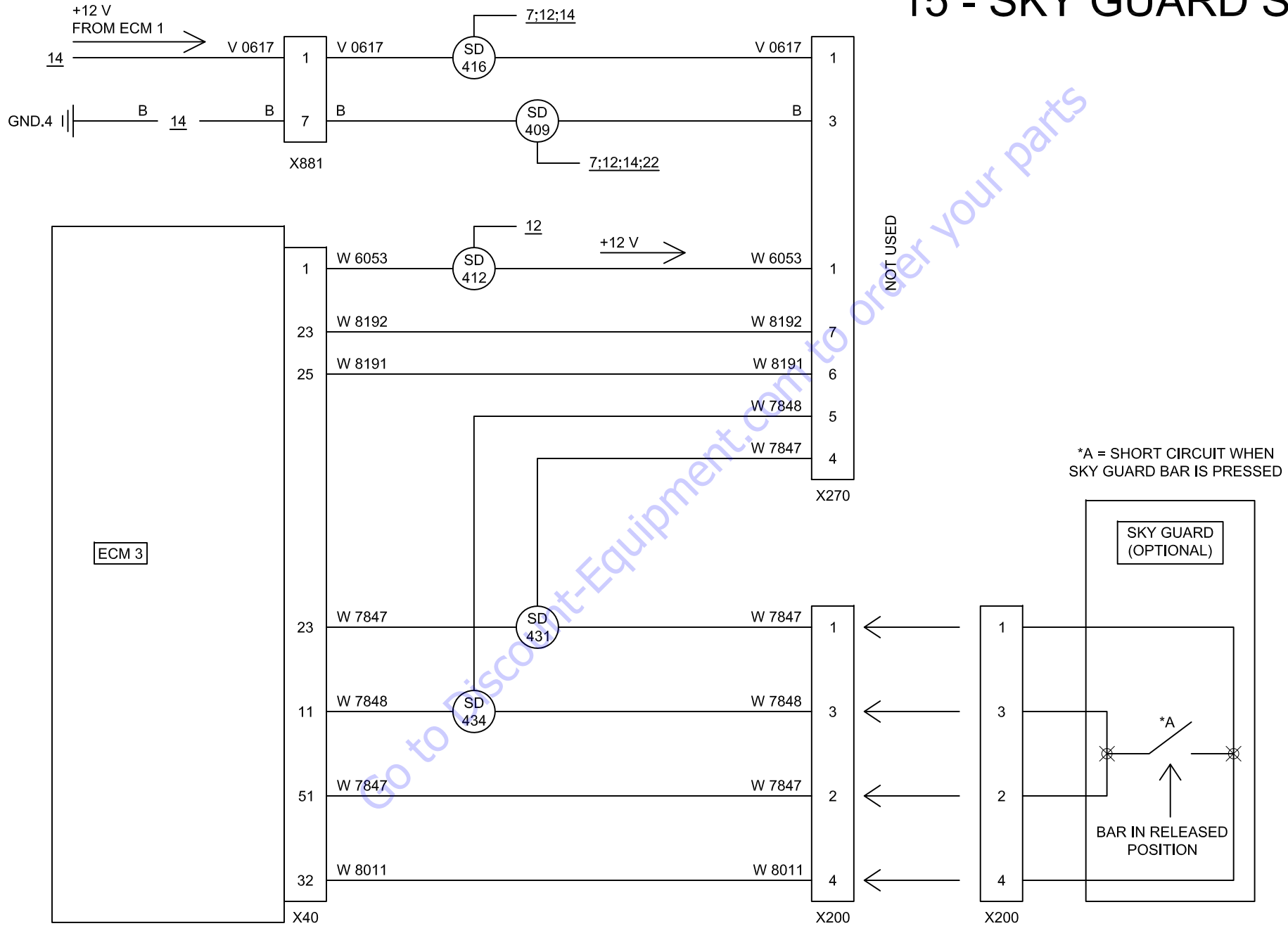

# 16 - TOWER BOOM CLOSED SWITCH - TOWER BOOM ROPES SWITCH

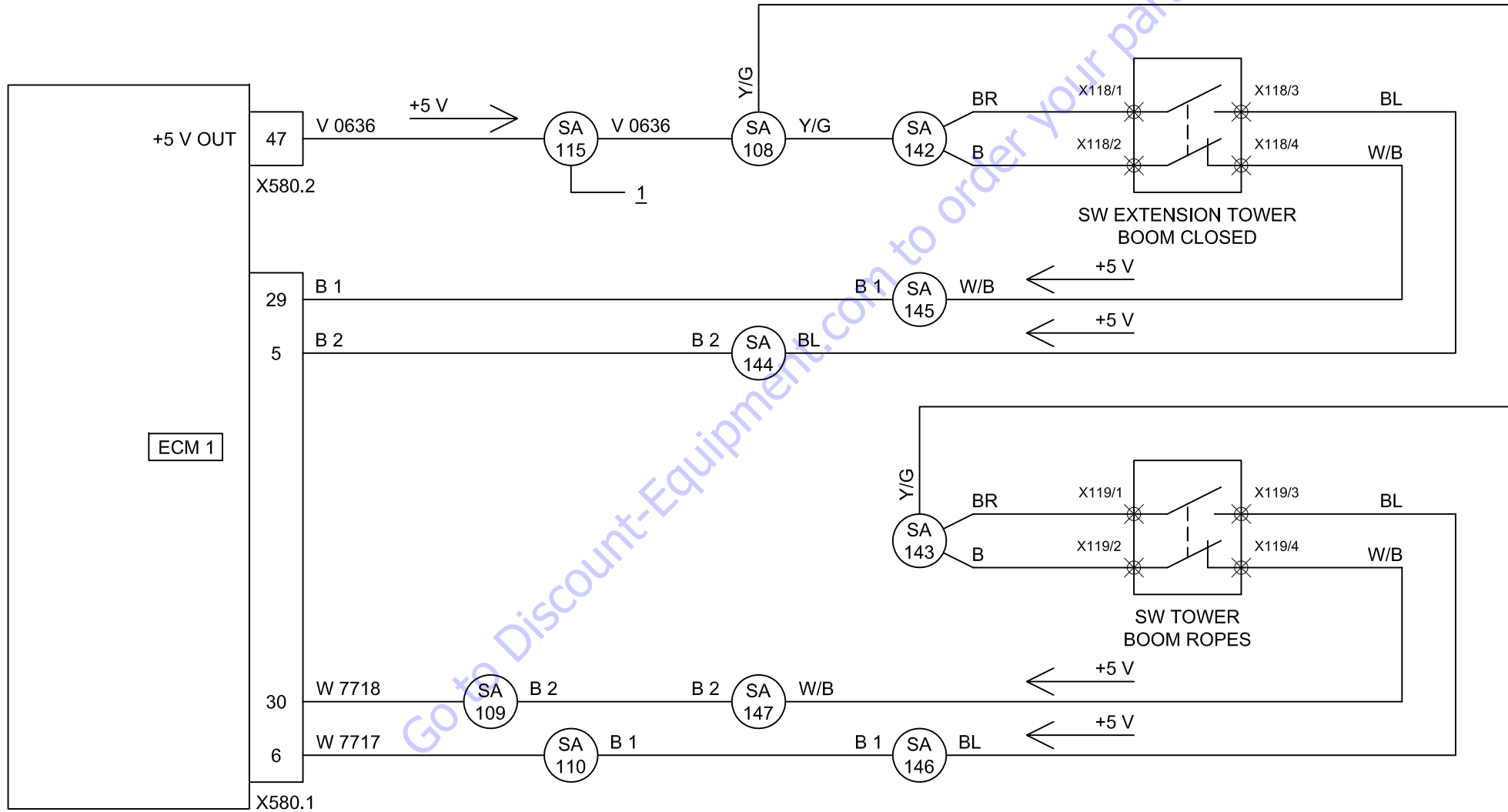



# 17 - RIGHT & LEFT ROPES PROXIMITY SENSOR ON TOWER BOOM

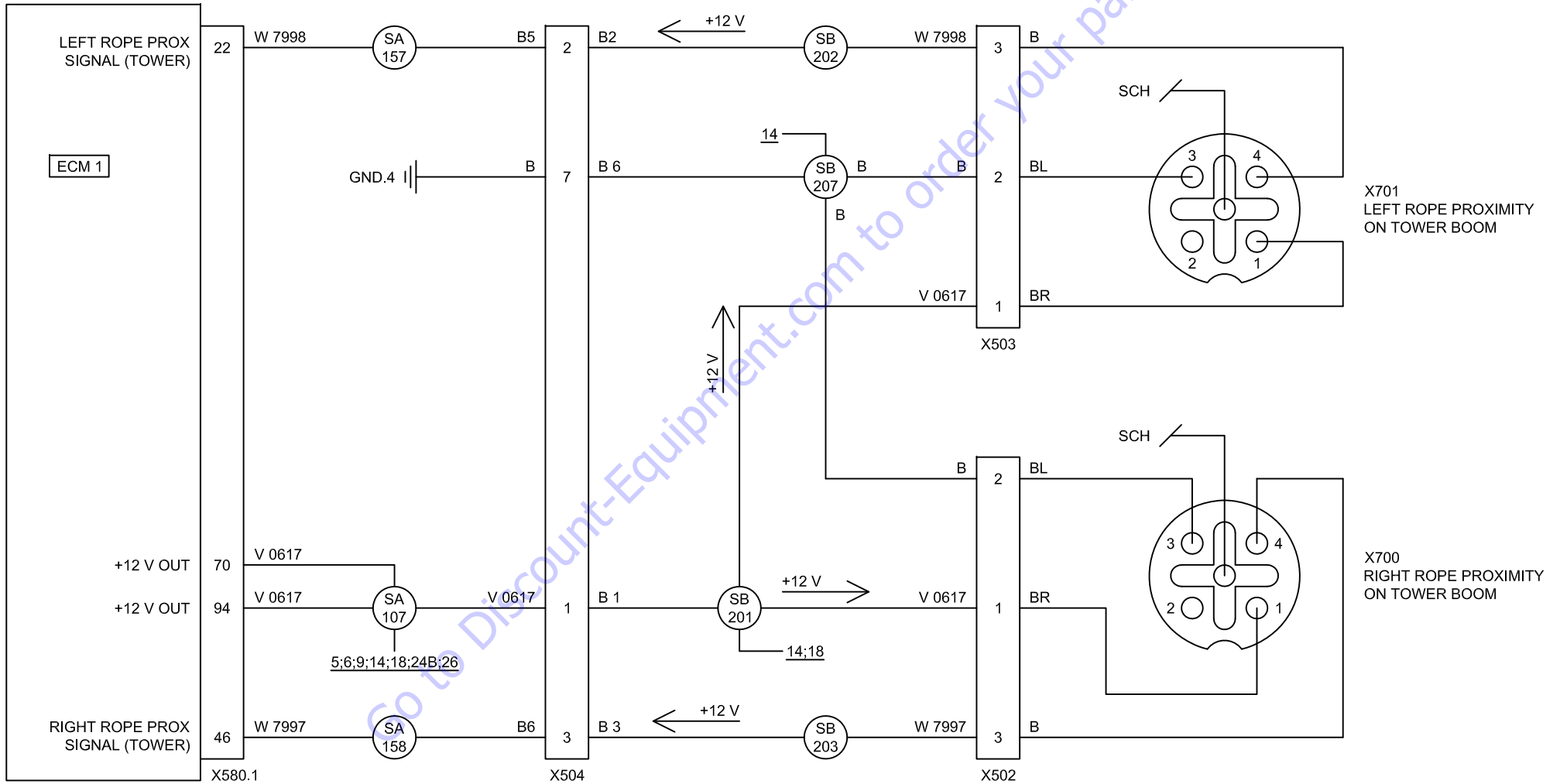

# 18 - MAIN BOOM ROPES SWITCHES

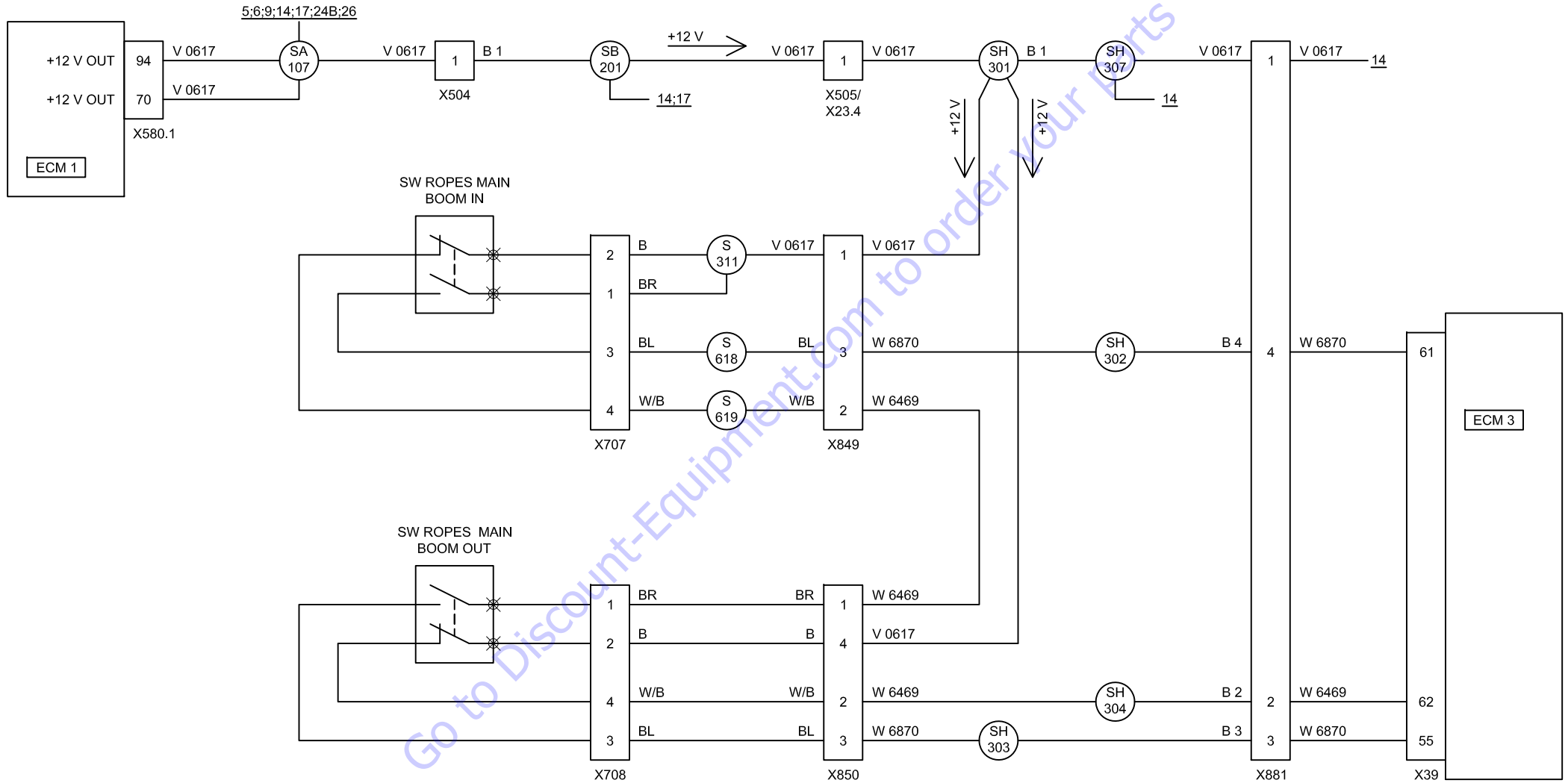

# 19 - ELECTRO VALVES: TRACKS, UNDERCARRIAGE WIDENING

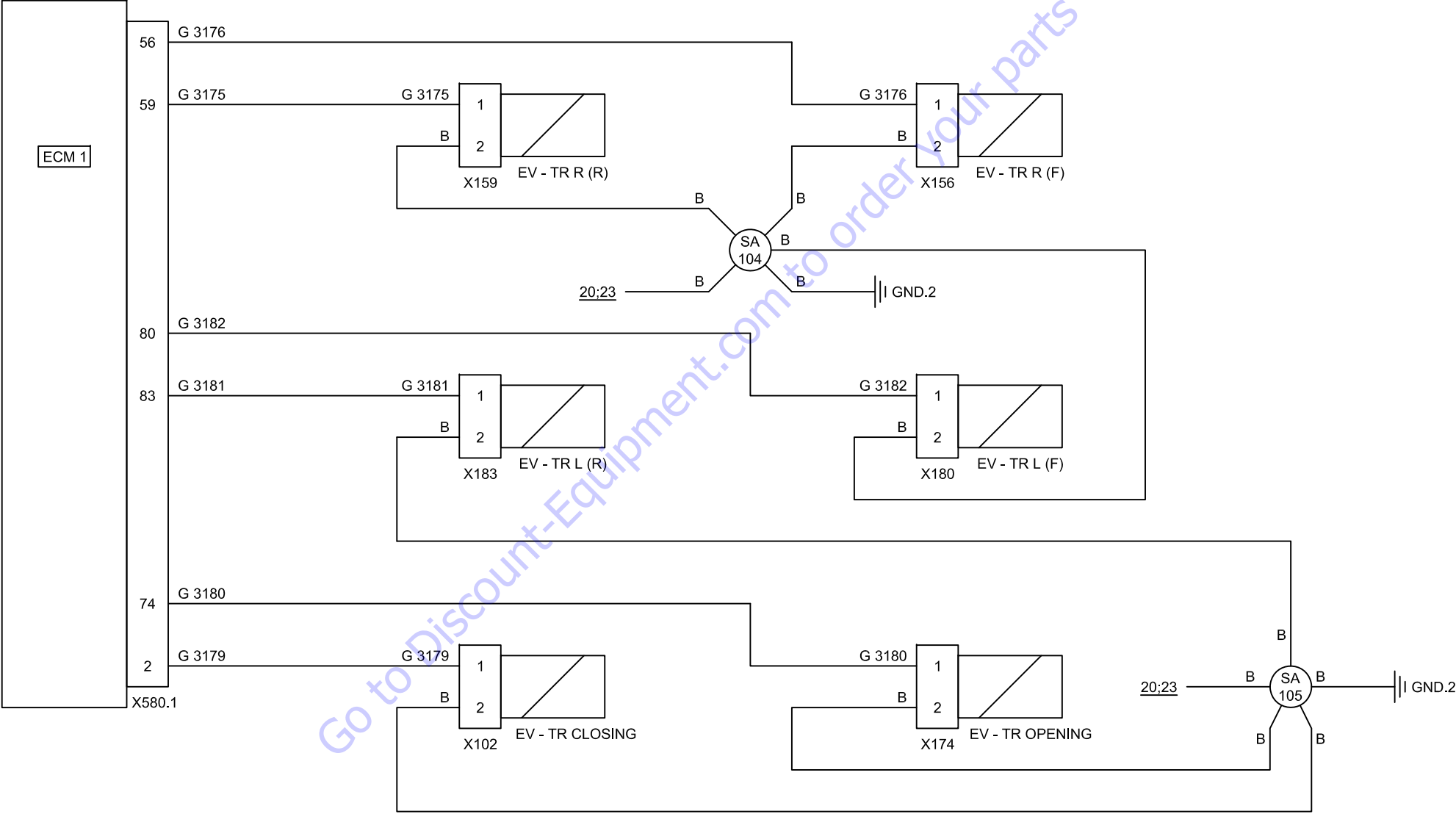

NOTE: X156, X159, X180 AND X183 ARE PROPORTIONAL VALVES.

# 20 - ELECTRO VALVES: OUTRIGGERS

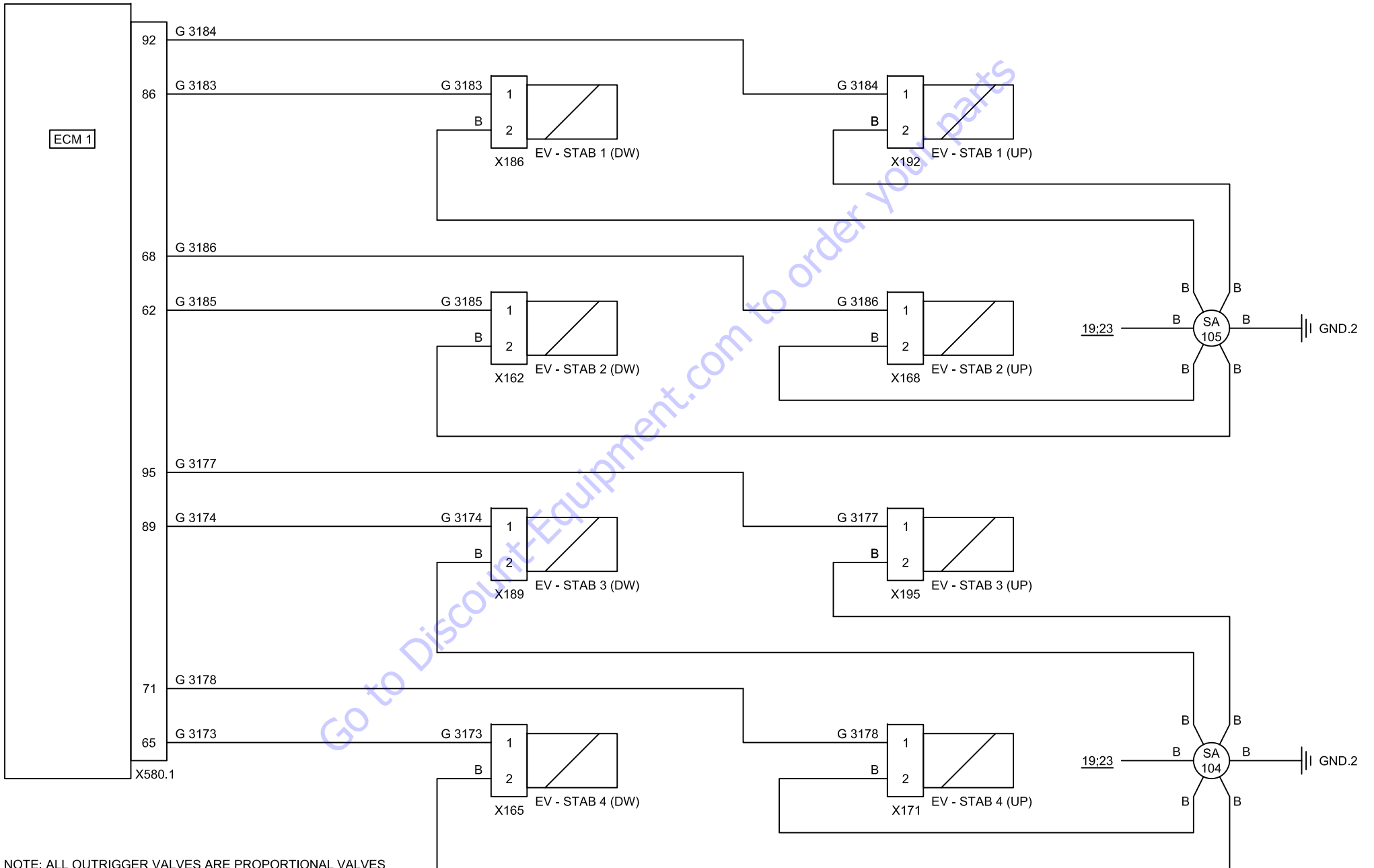

# 21 - ELECTRO VALVES: TOWER BOOM , TOWER EXTENSION, MAIN BOOM , MAIN EXTENSION, ROTATION

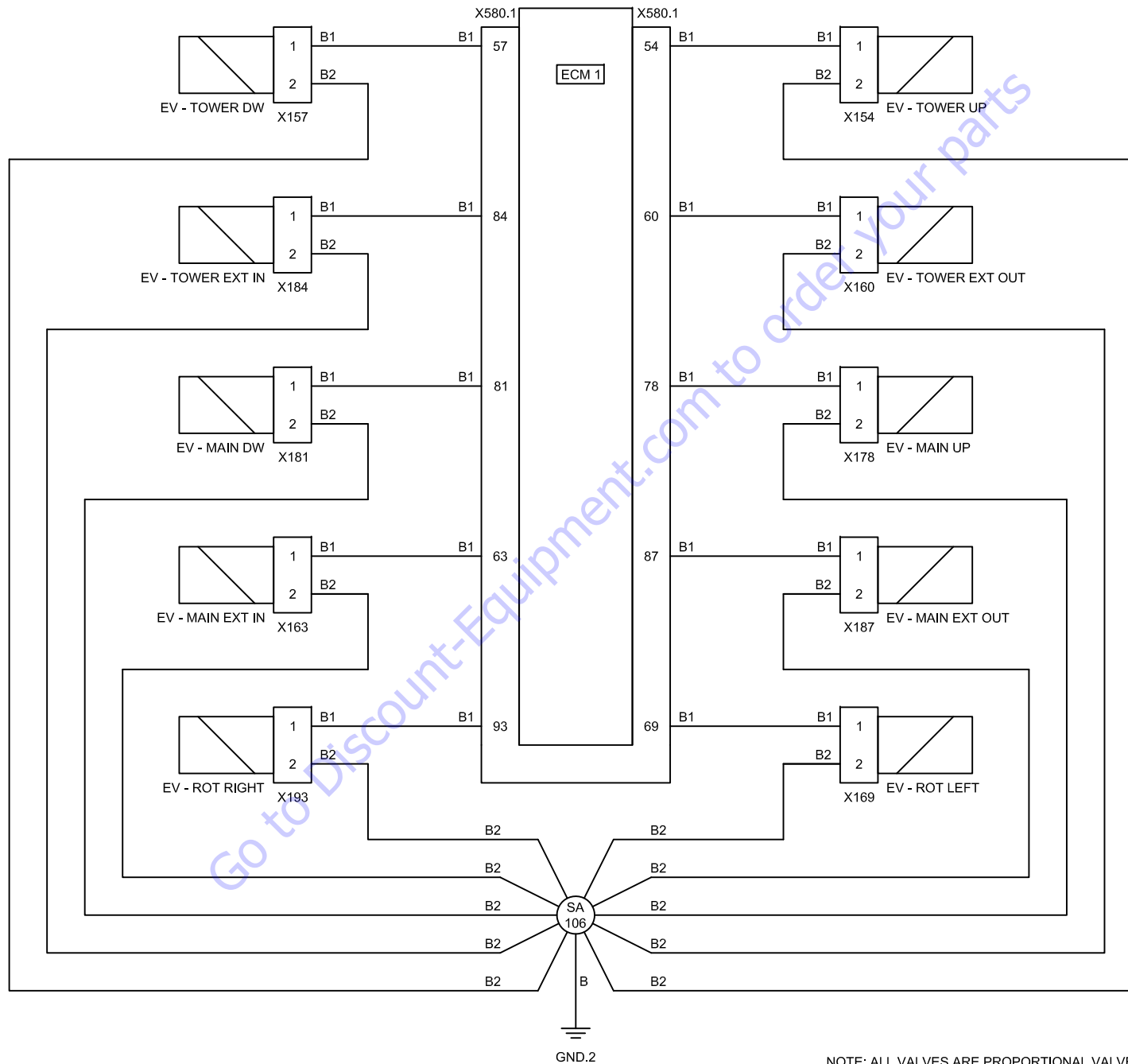

## 22 - ELECTRO VALVES: JIB, BASKET LEVELLING, BASKET ROTATION

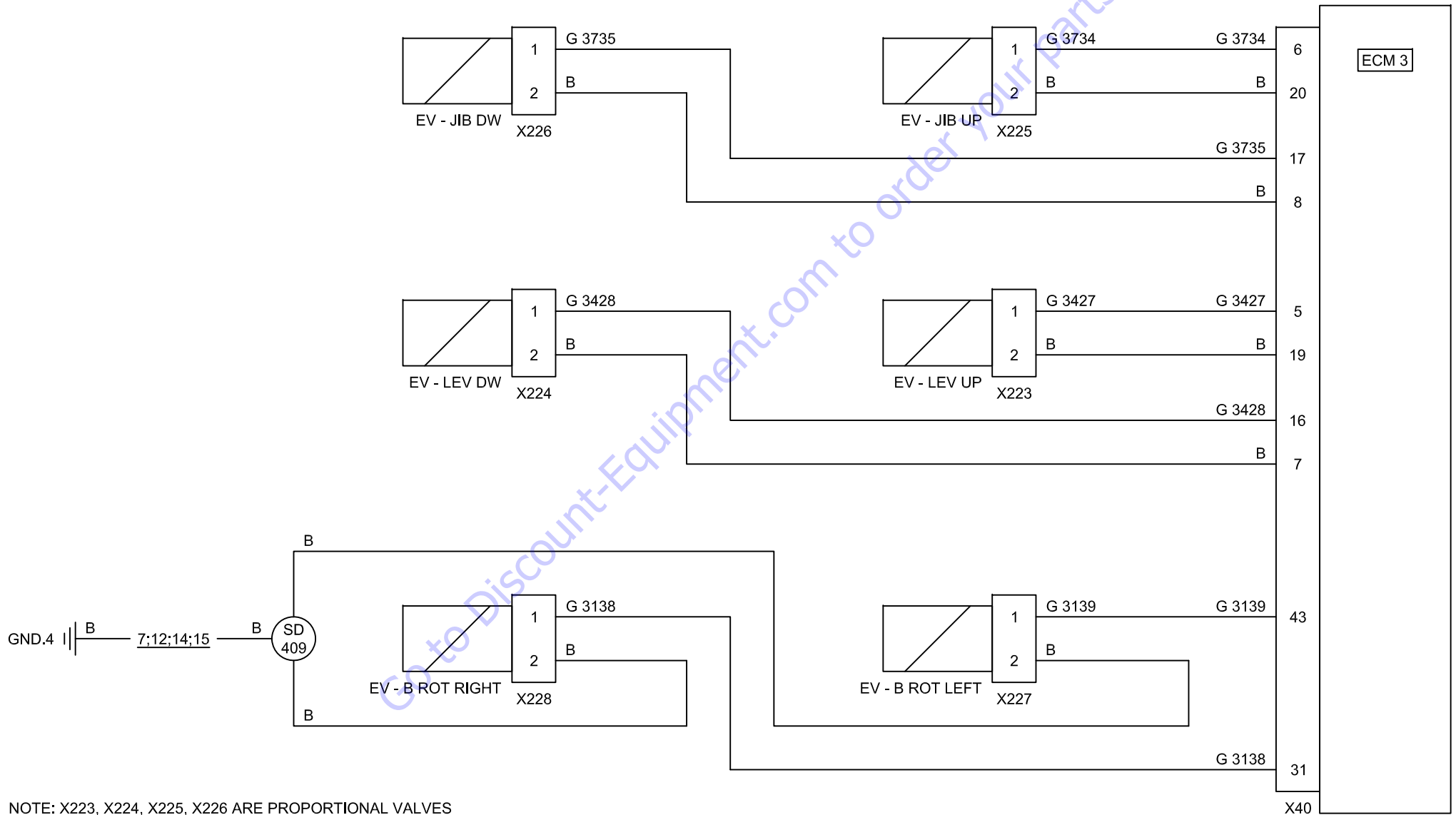

# 23 - ELECTRO VALVES: 2° SPEED - DIVERTERS - TANK LINE - PUMP SUM AND SENSOR

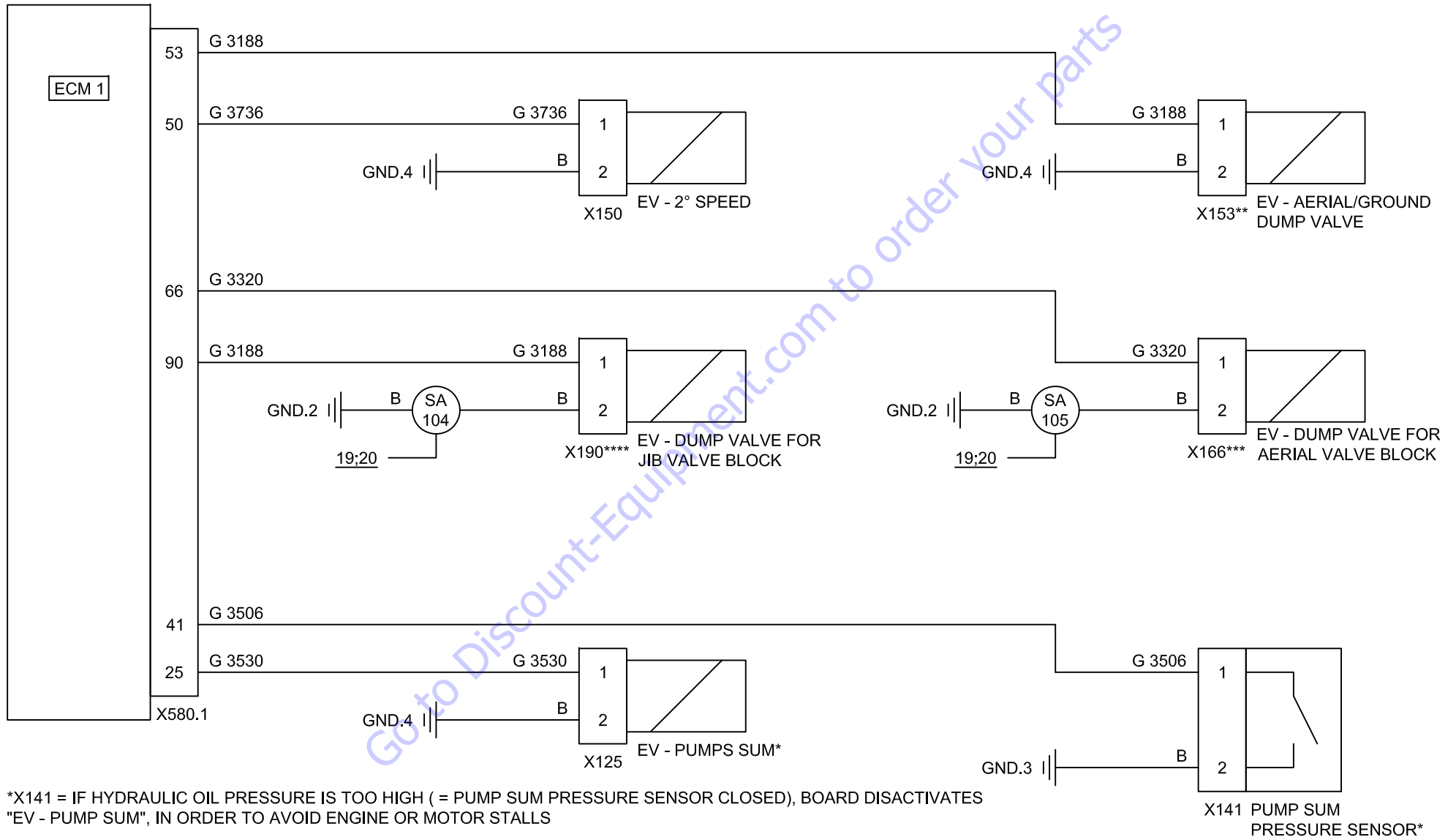

\*X141 = IF HYDRAULIC OIL PRESSURE IS TOO HIGH (= PUMP SUM PRESSURE SENSOR CLOSED), BOARD DISACTIVATES "EV - PUMP SUM", IN ORDER TO AVOID ENGINE OR MOTOR STALLS

\*\*X153 = DIVERTER FOR AERIAL/GROUND MOVEMENTS

\*\*\*X166 = SAFETY DIVERTER FOR AERIAL VALVE BLOCK

\*\*\*\*X190 = SAFETY DIVERTER FOR JIB VALVE BLOCK

# 24A - KUBOTA ENGINE

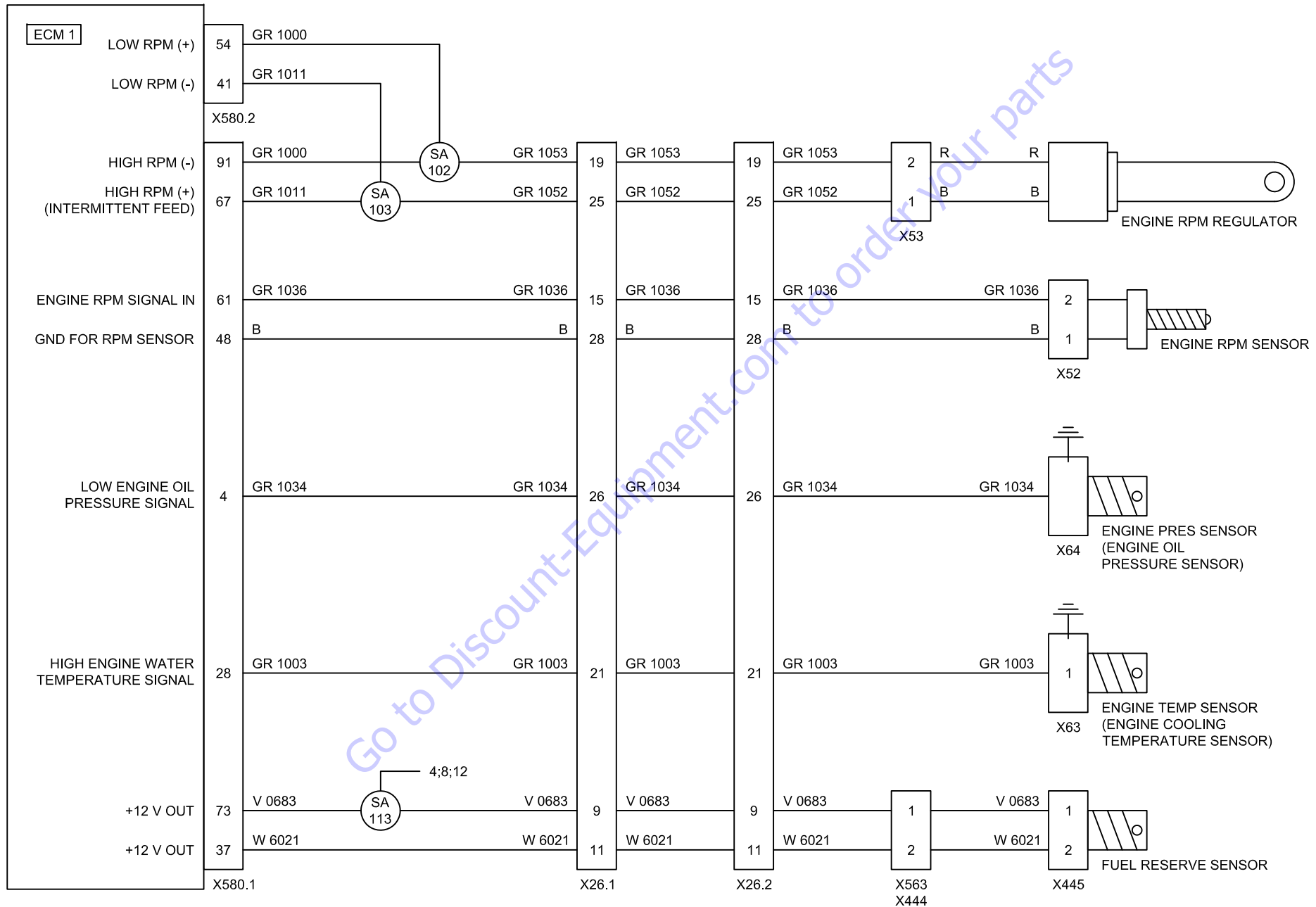



24B - KUBOTA ENGINE

\* PUMP IS ACTIVATED A WHILE BEFORE TO START ON THE ENGINE

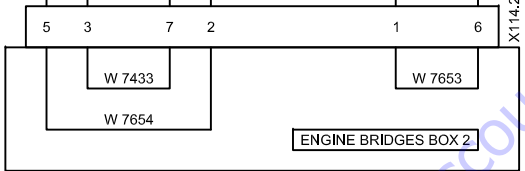
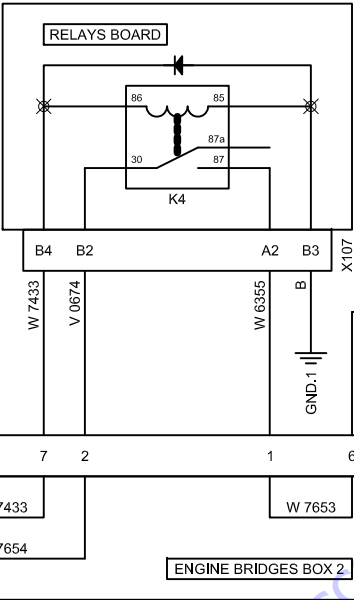
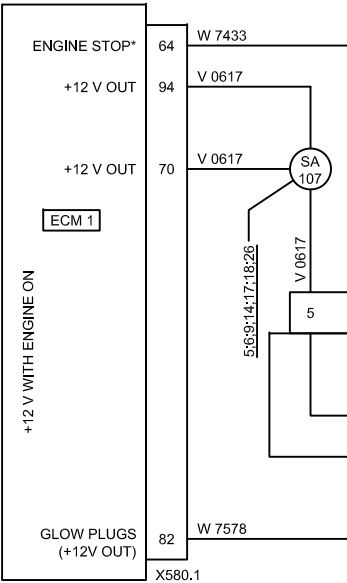
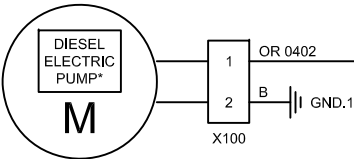

ONLY FOR LITHIUM VERSIONS

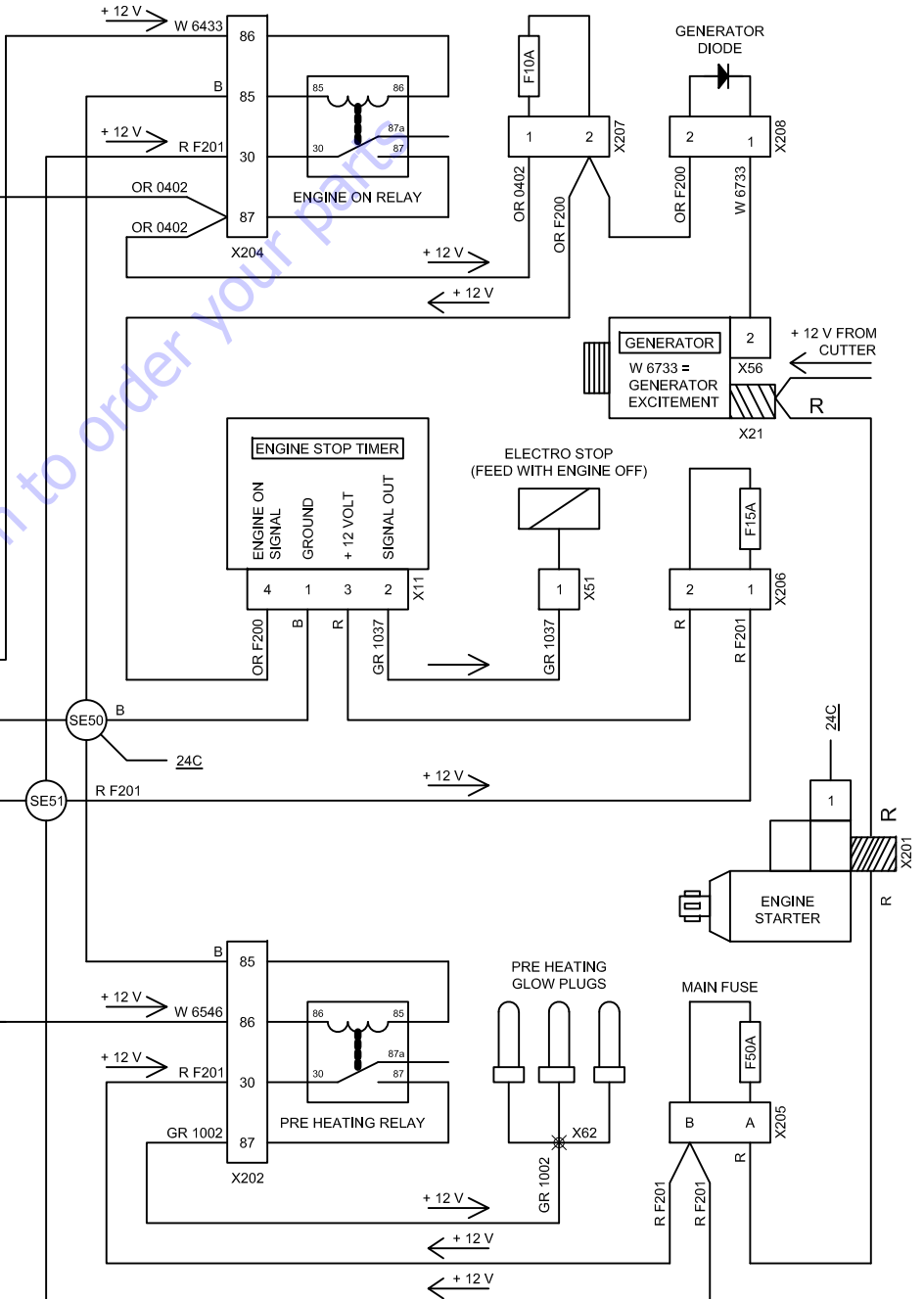
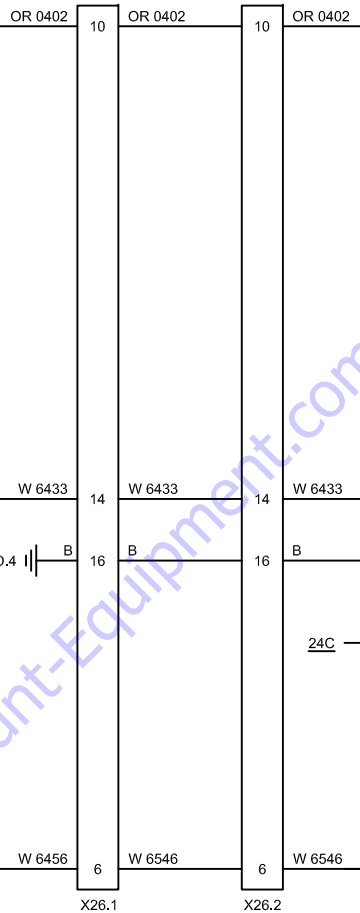

# 24C - KUBOTA ENGINE

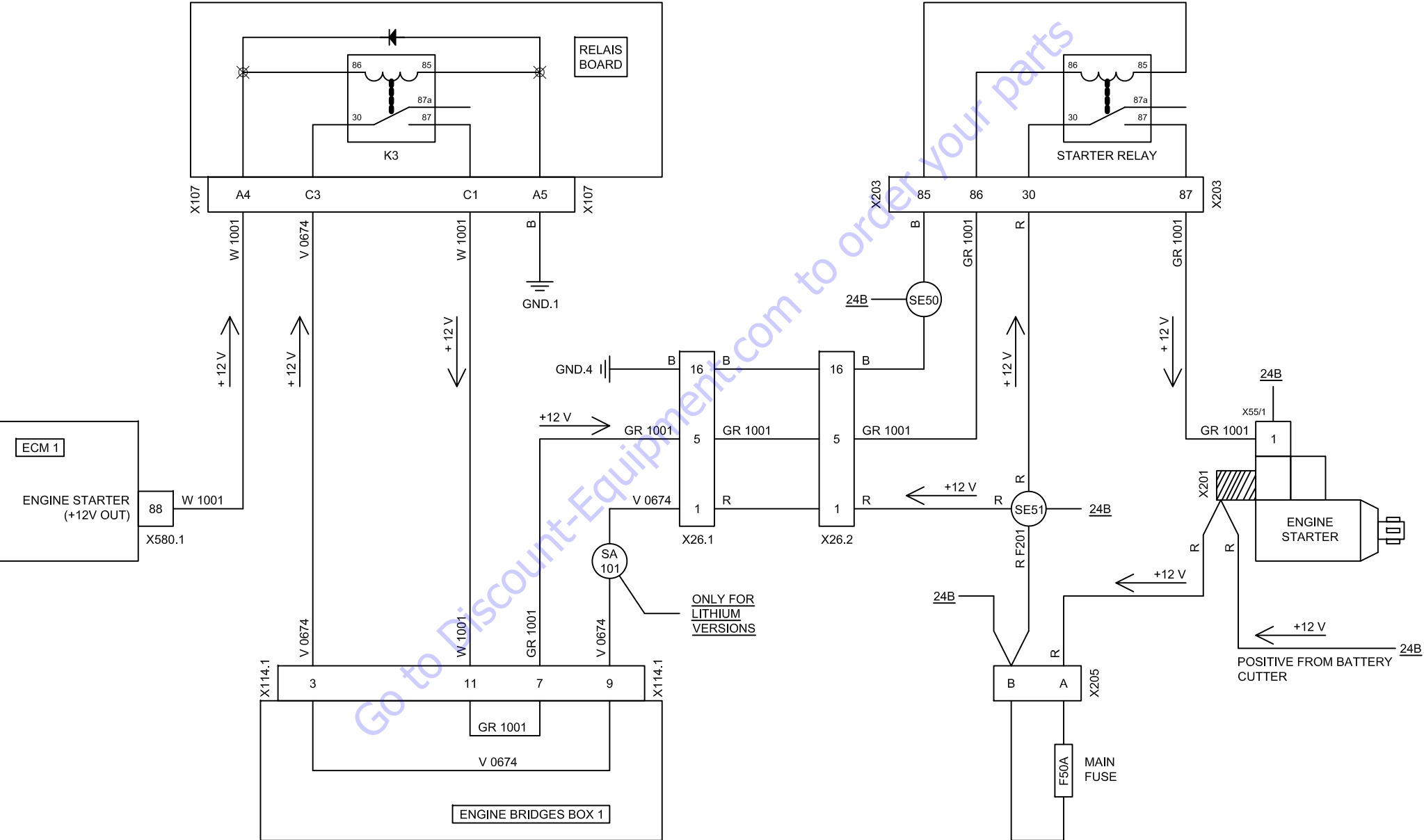

# 25 - 120 / 220 VOLT LINE

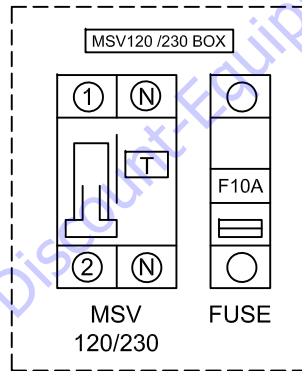
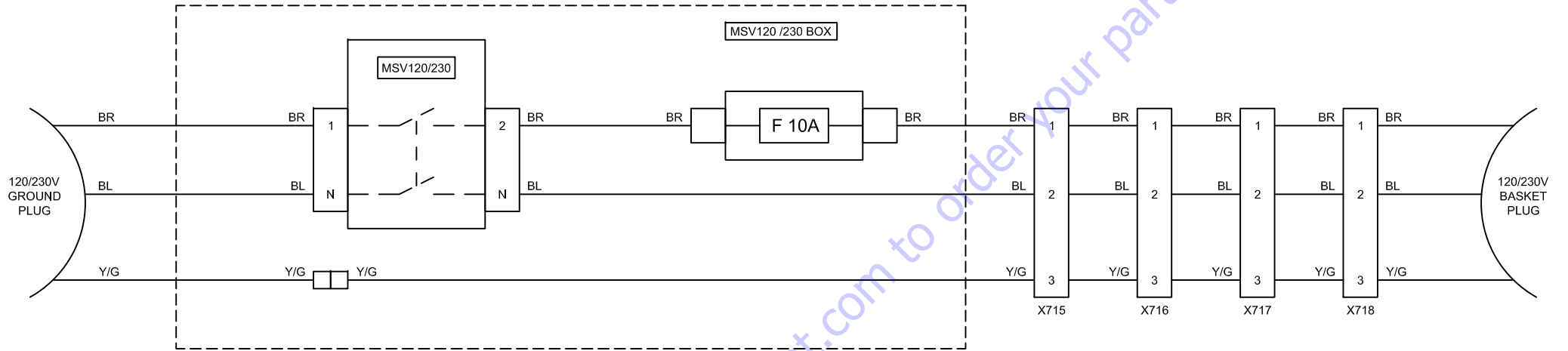

Go to Discount Equipment.com to order your parts

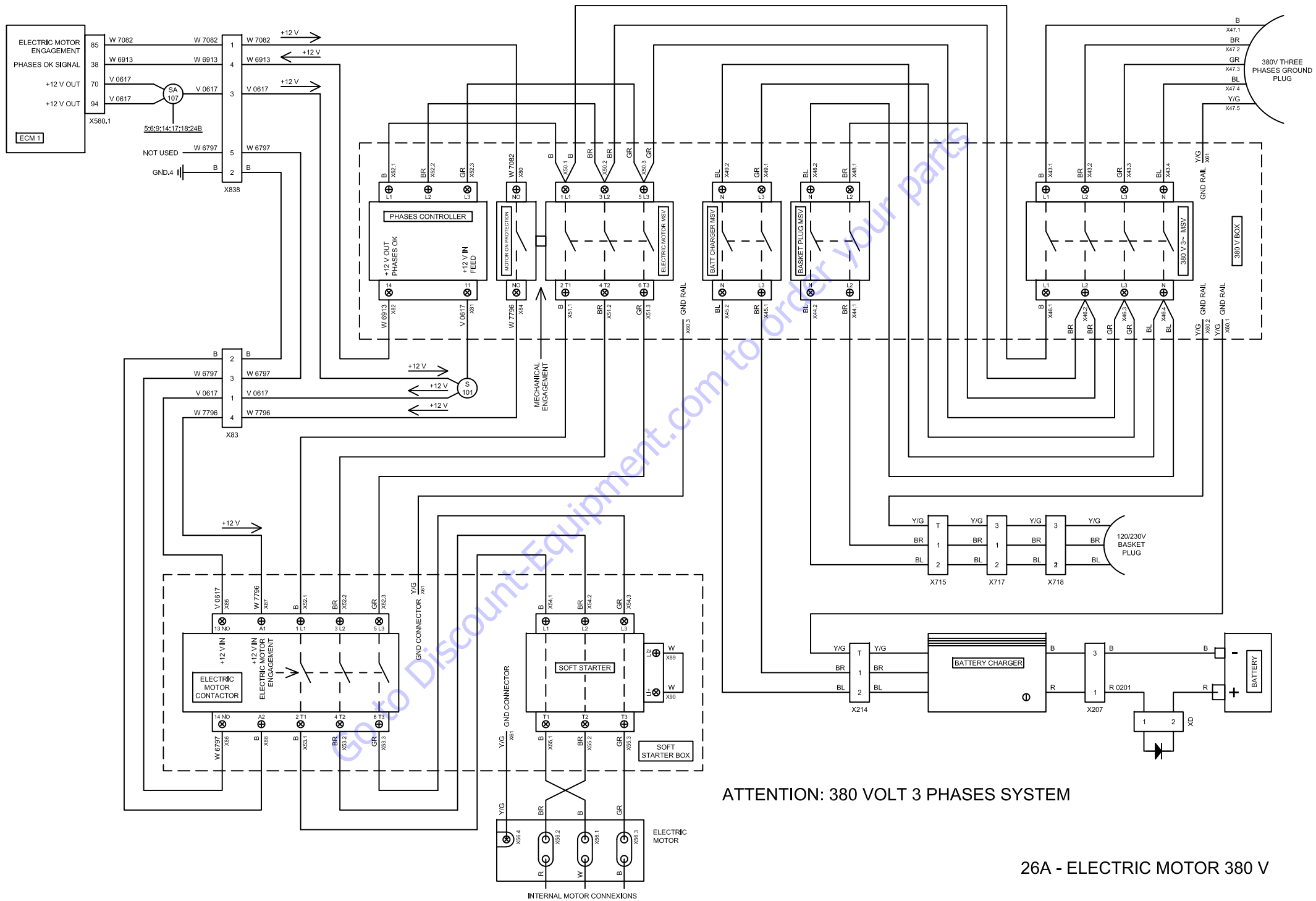

ATTENTION: 380 VOLT 3 PHASES SYSTEM

26A - ELECTRIC MOTOR 380 V

# 26B - ELECTRIC MOTOR 380 VOLT

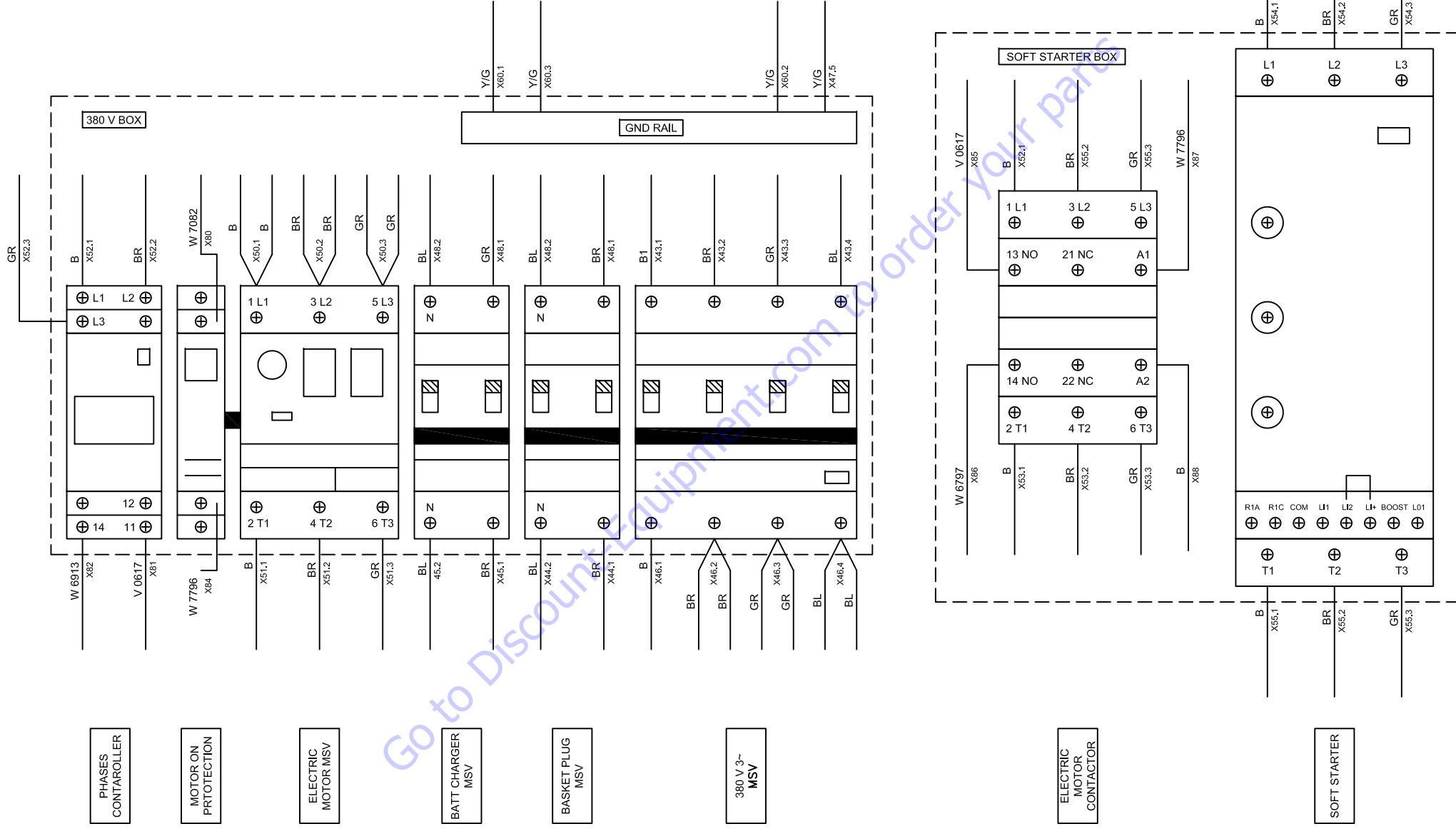

Go to DiscountEquipment.com to order your parts

- 27 - COMPONENTS LOCATION
- 27 - LOCAZIONE COMPONENTI
- 27 - COLOCACION COMPONENTES
- 27 - DISPOSITION COMPOSANTS

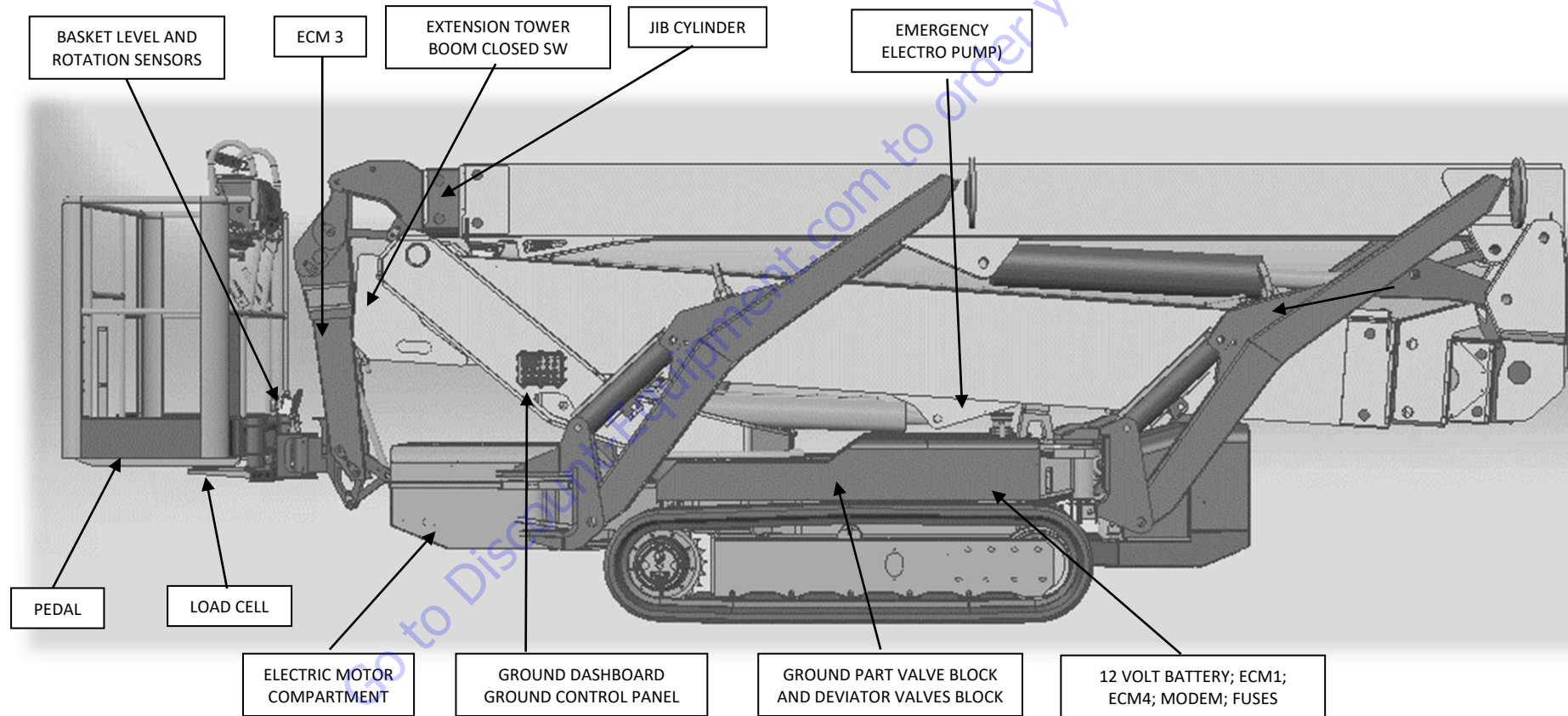

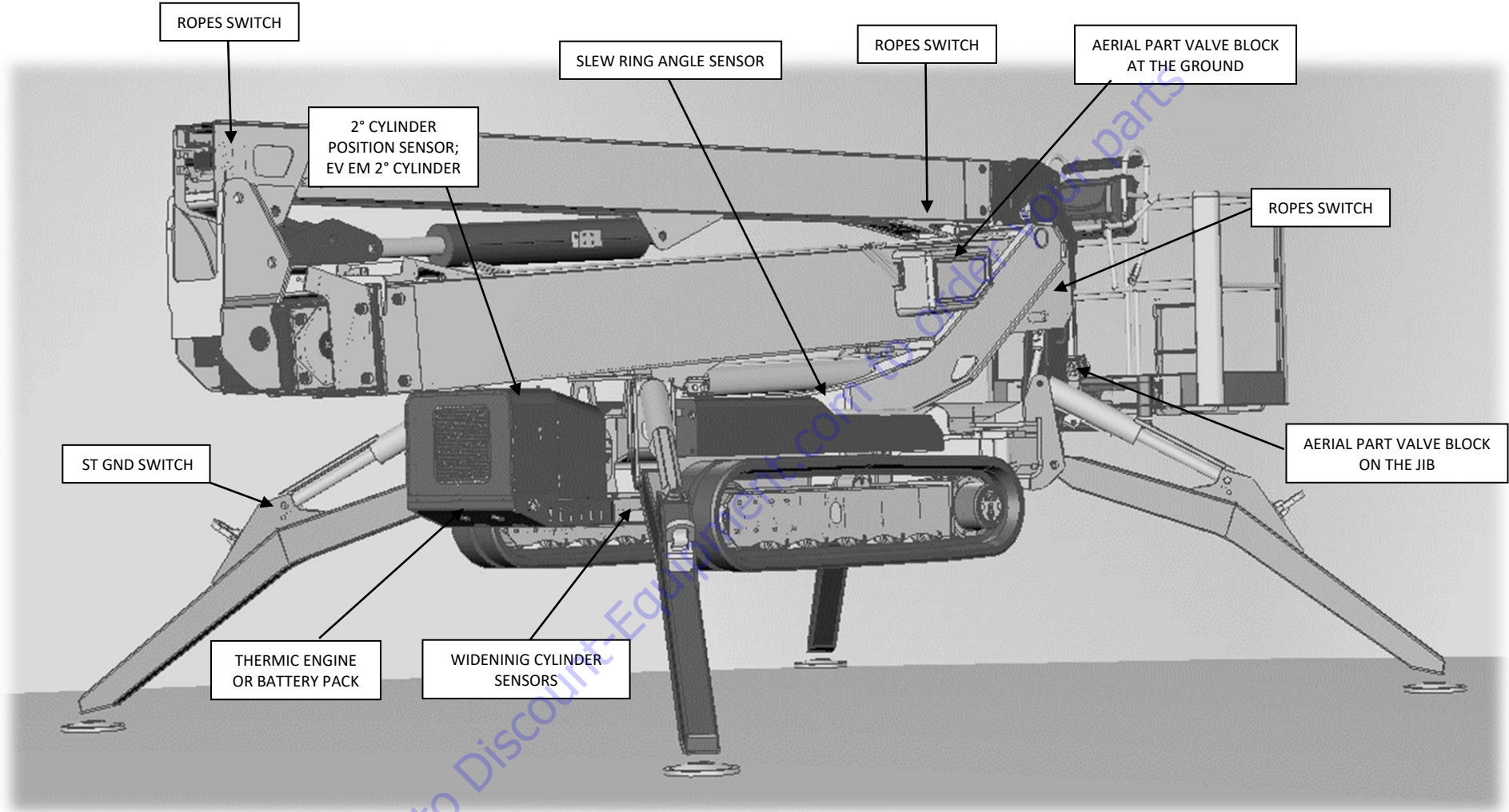

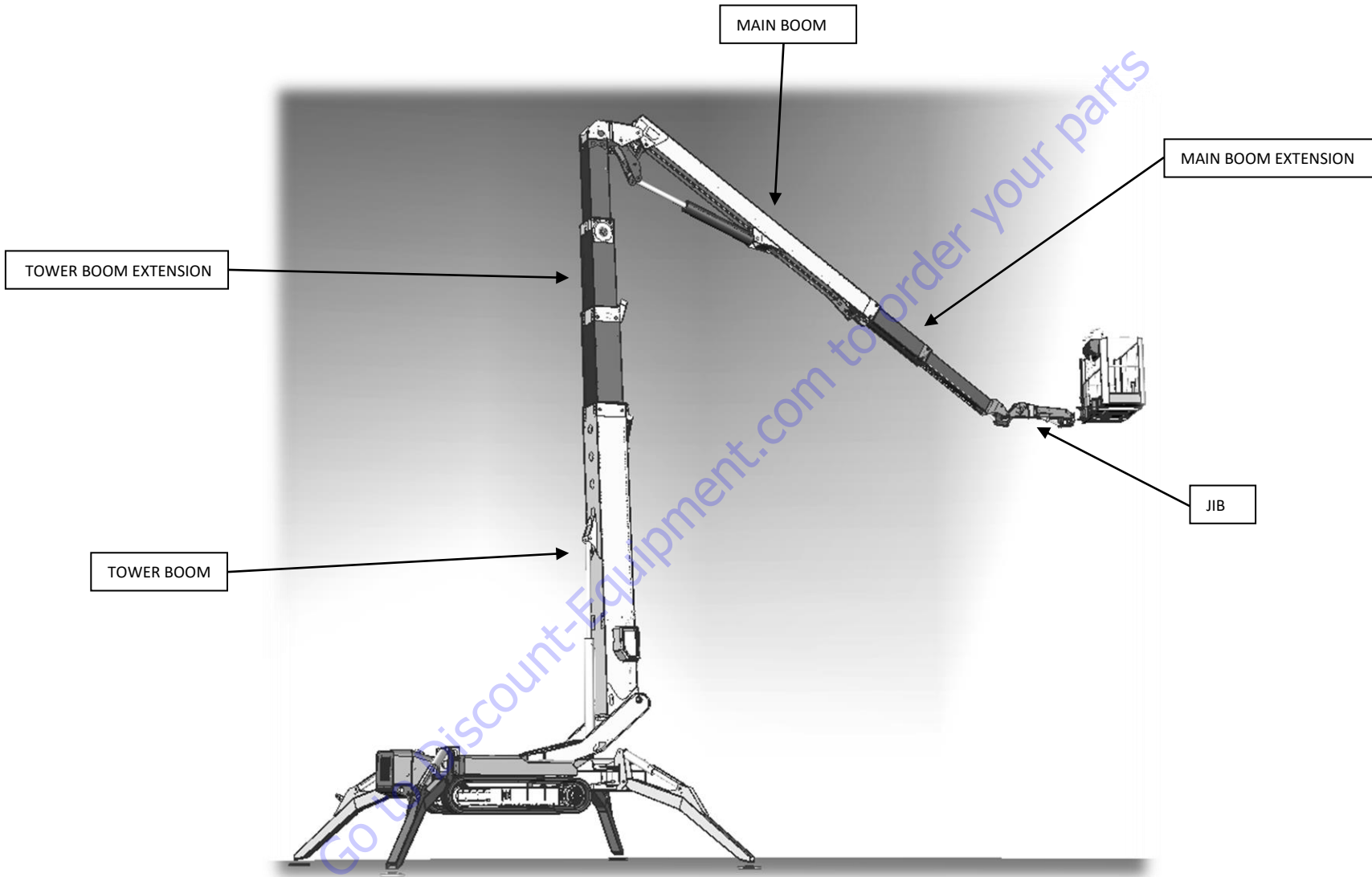



CONNECTORS – CONNETTORI – CONECTORES - CONNECTEURS

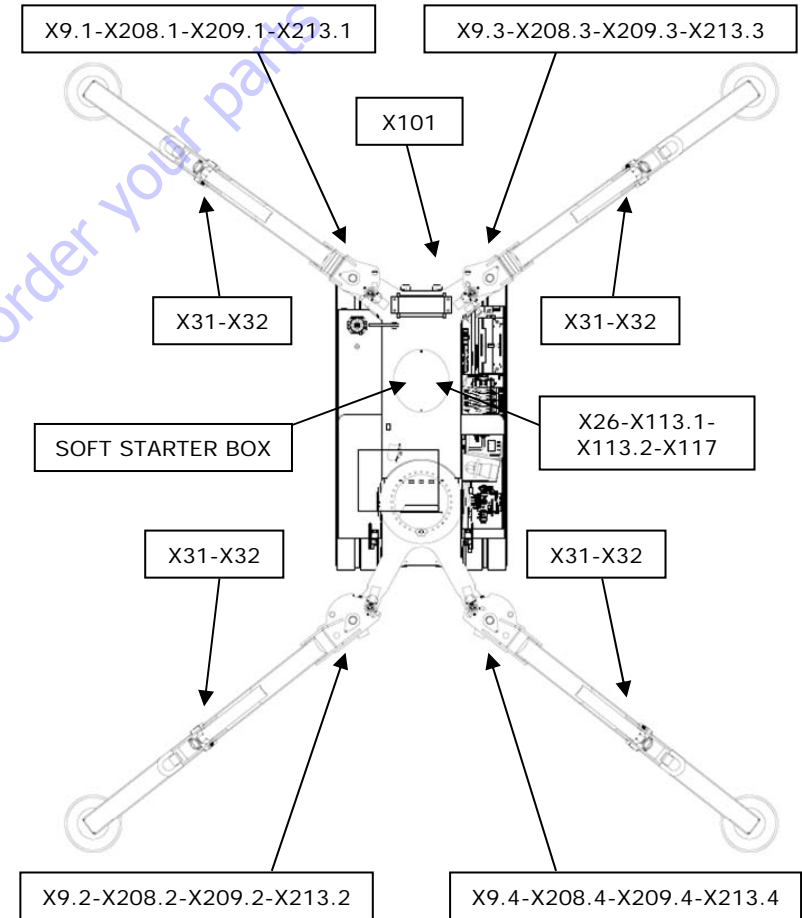
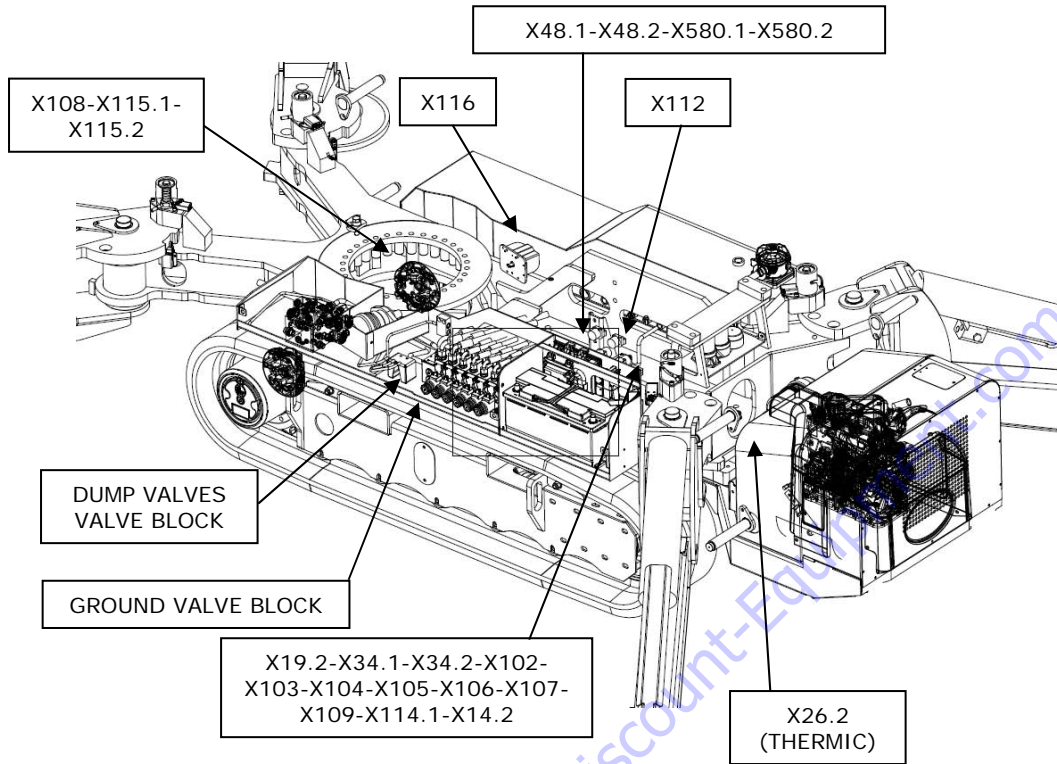

Go to Discount-Ed.com to order your parts

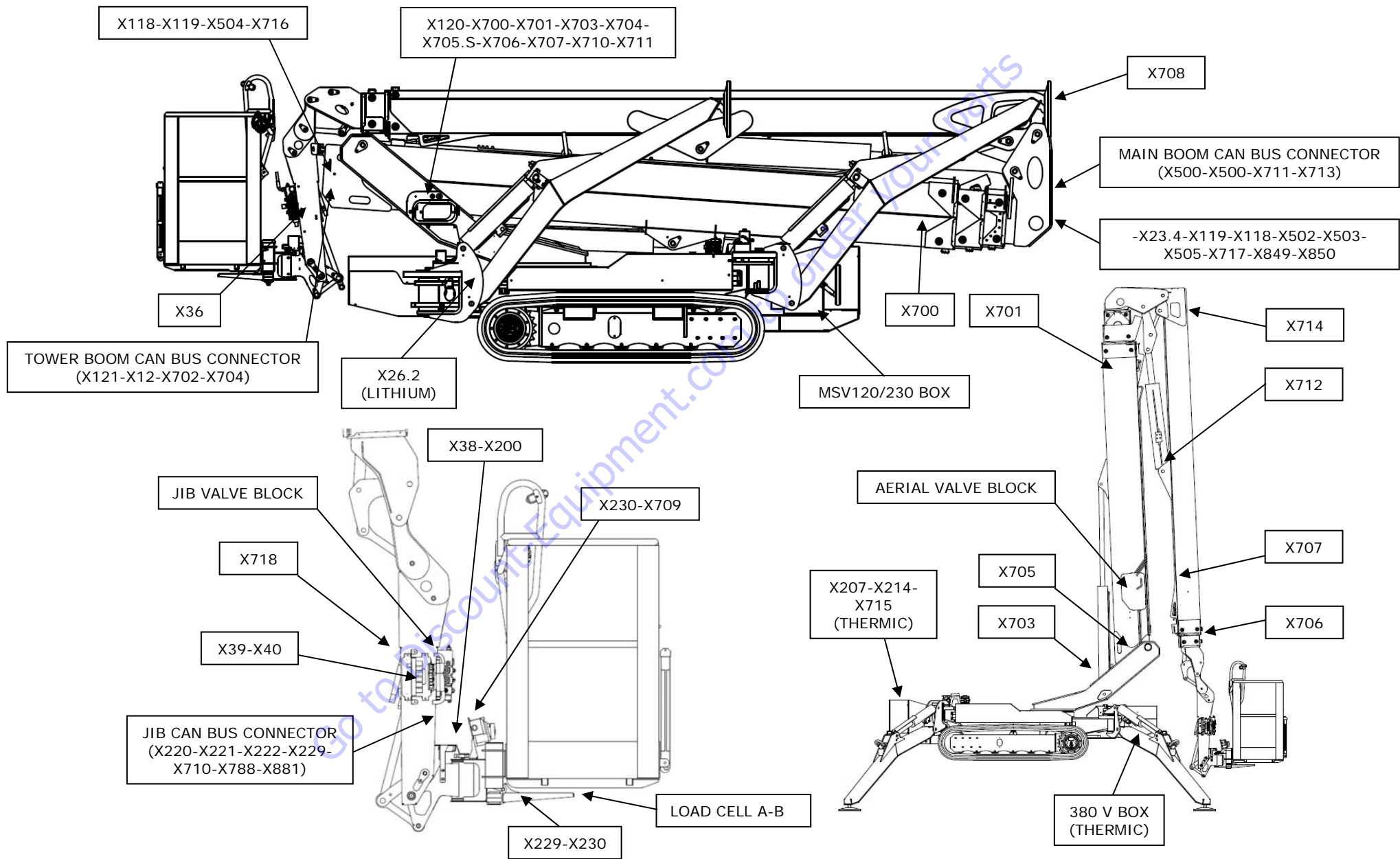

# ENGINE CONNECTORS

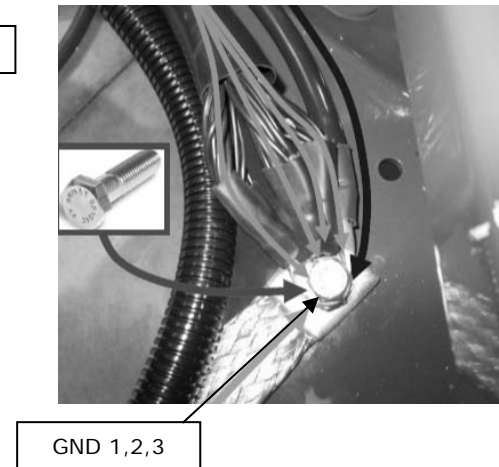
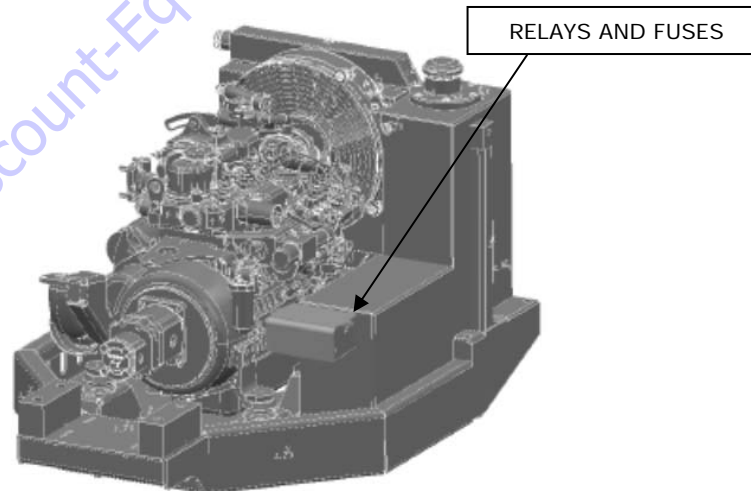
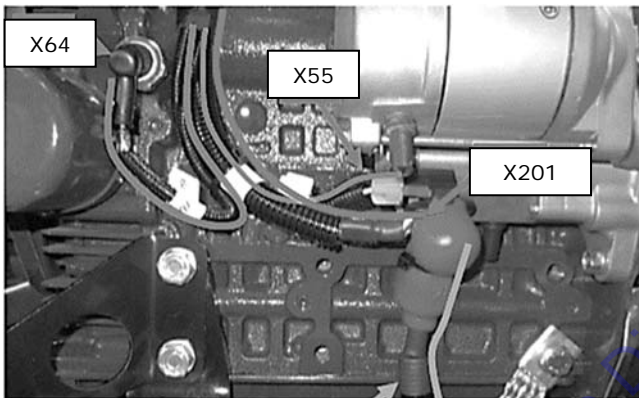
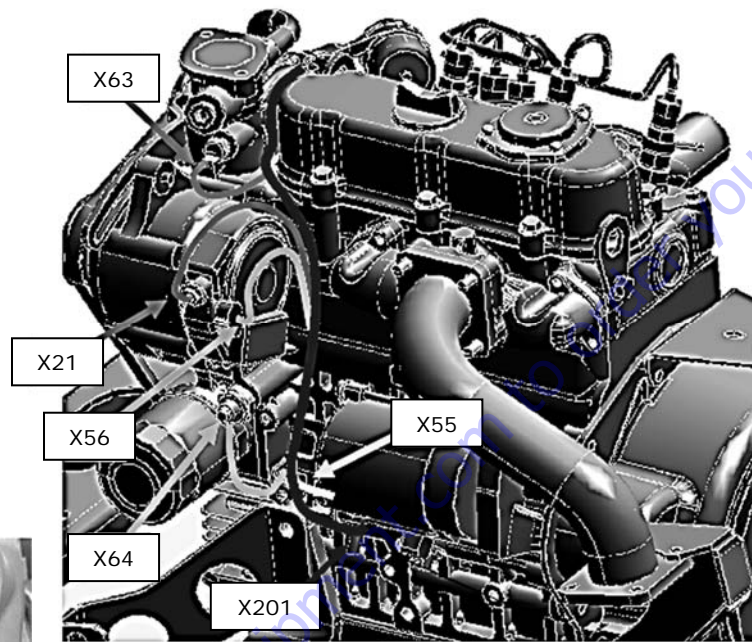
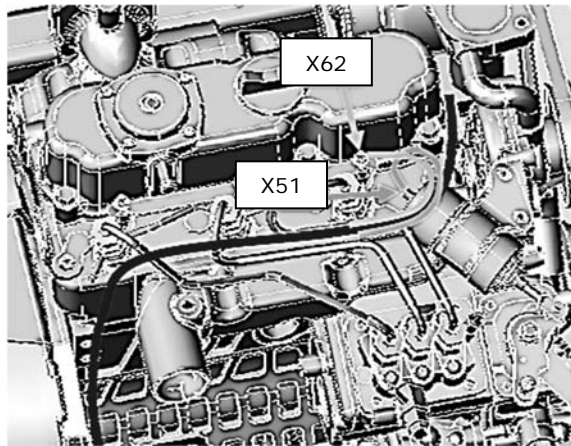

# ELECTRIC MOTORS, FUSES AND 380 V PLUG

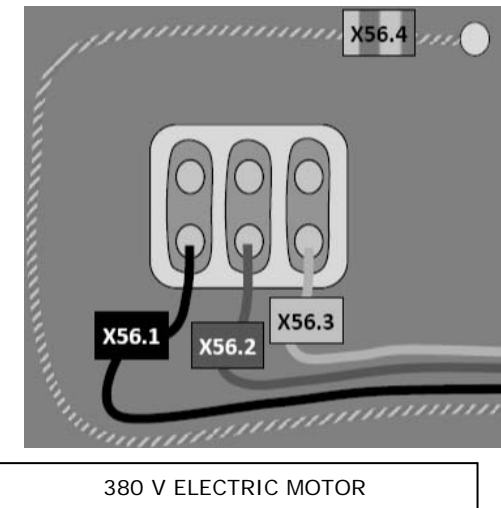
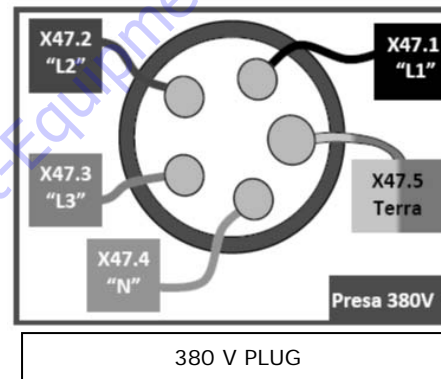
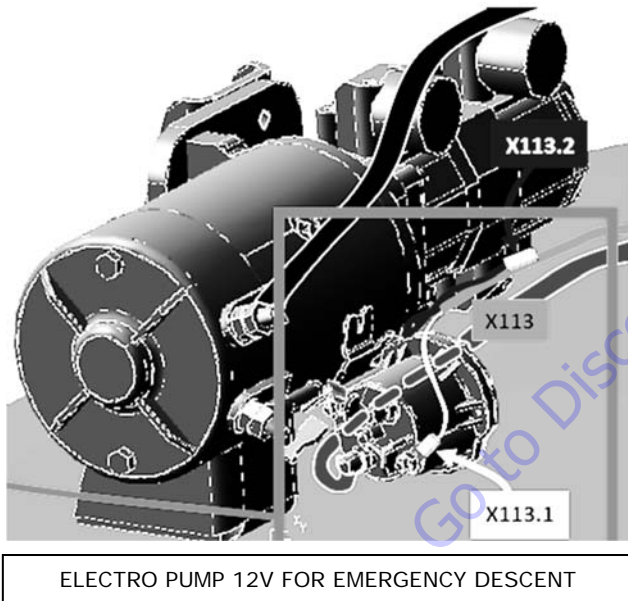
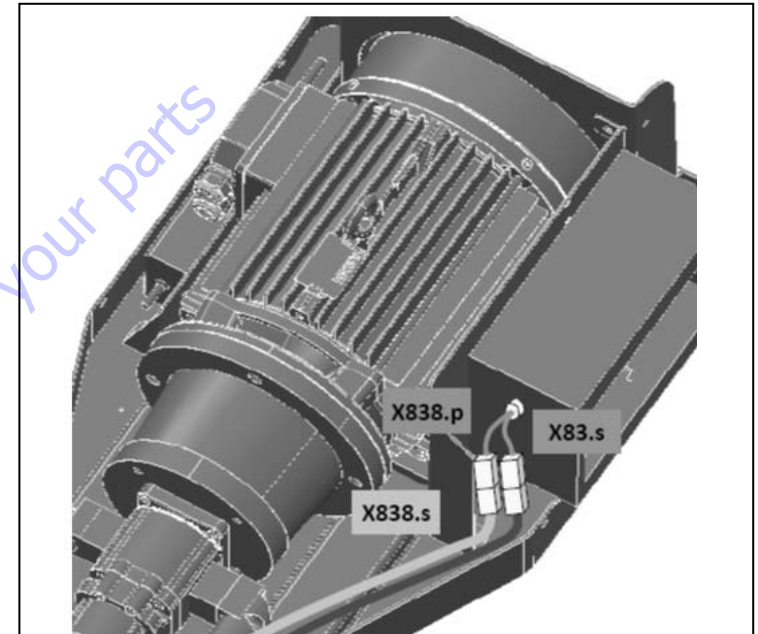
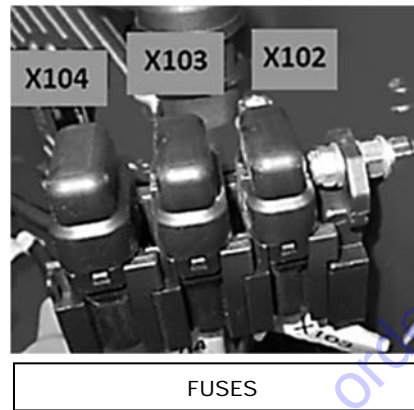
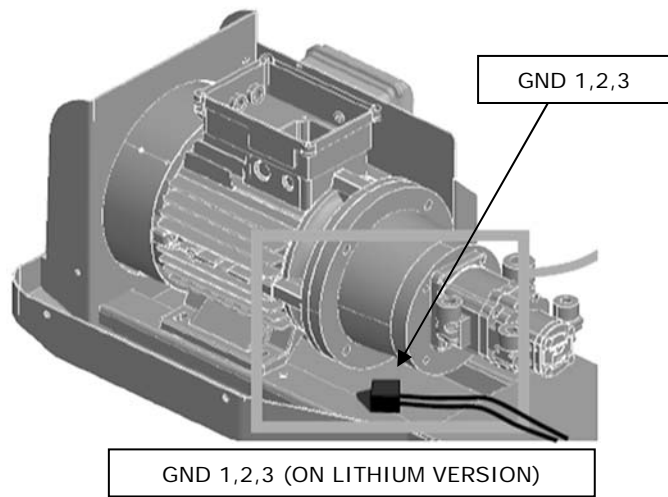

# VALVE BLOCKS CONNECTORS

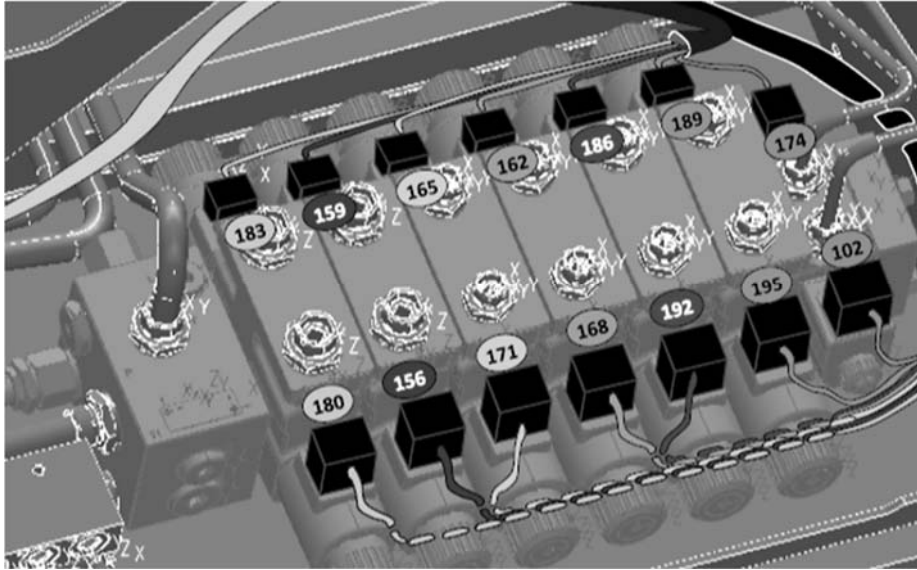

GROUND VALVE BLOCK

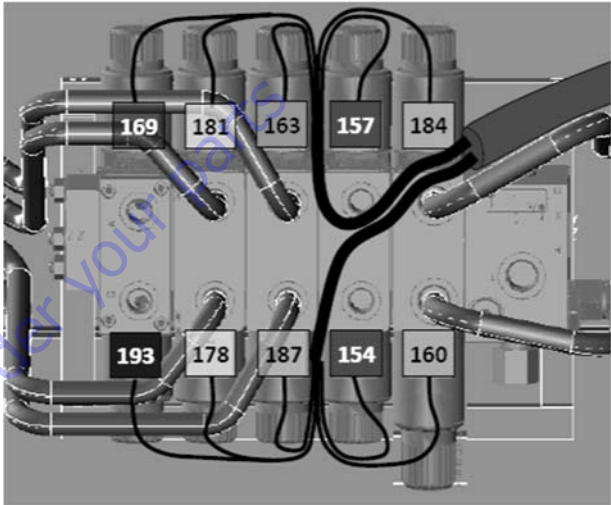

AERIAL VALVE BLOCK

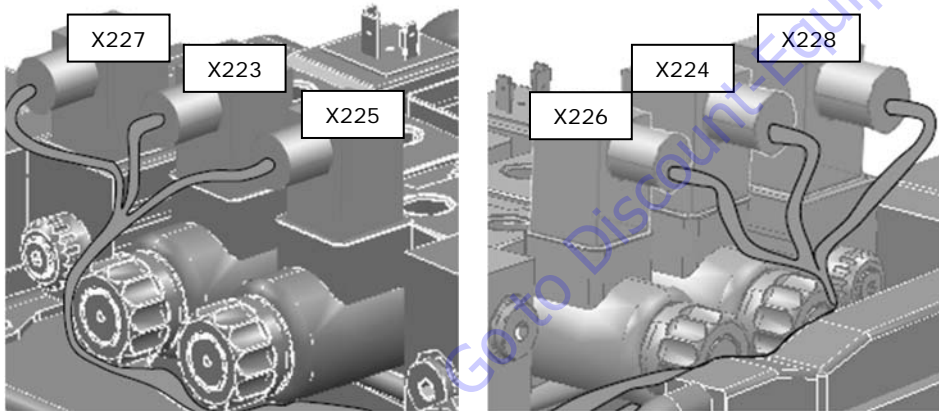

JIB VALVE BLOCK

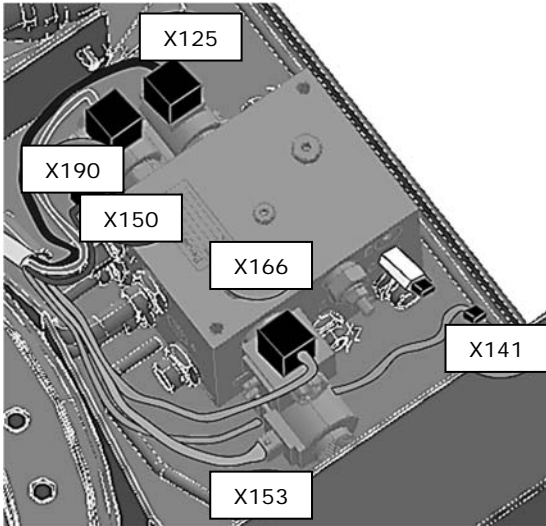

DUMP VALVES VALVE BLOCK

# BOOM ROPES SENSOR AND BASKET SENSORS

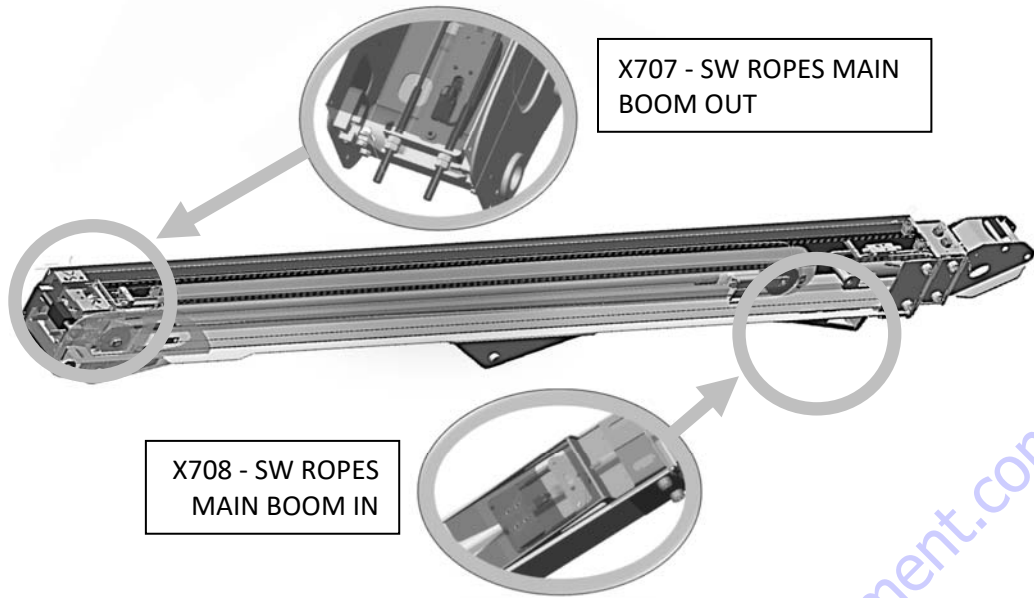

X707 - SW ROPES MAIN BOOM OUT

X708 - SW ROPES MAIN BOOM IN

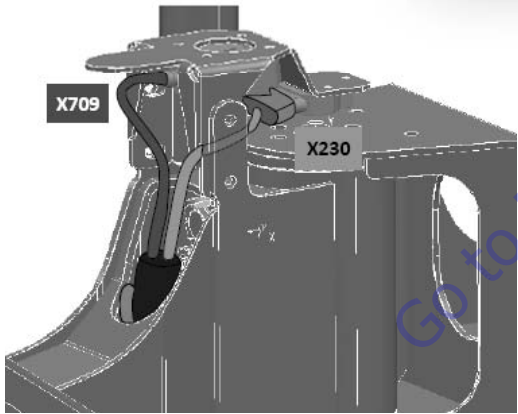

X709

X230

BASKET LEVEL SENSOR  
BASKET ROTATION SENSOR

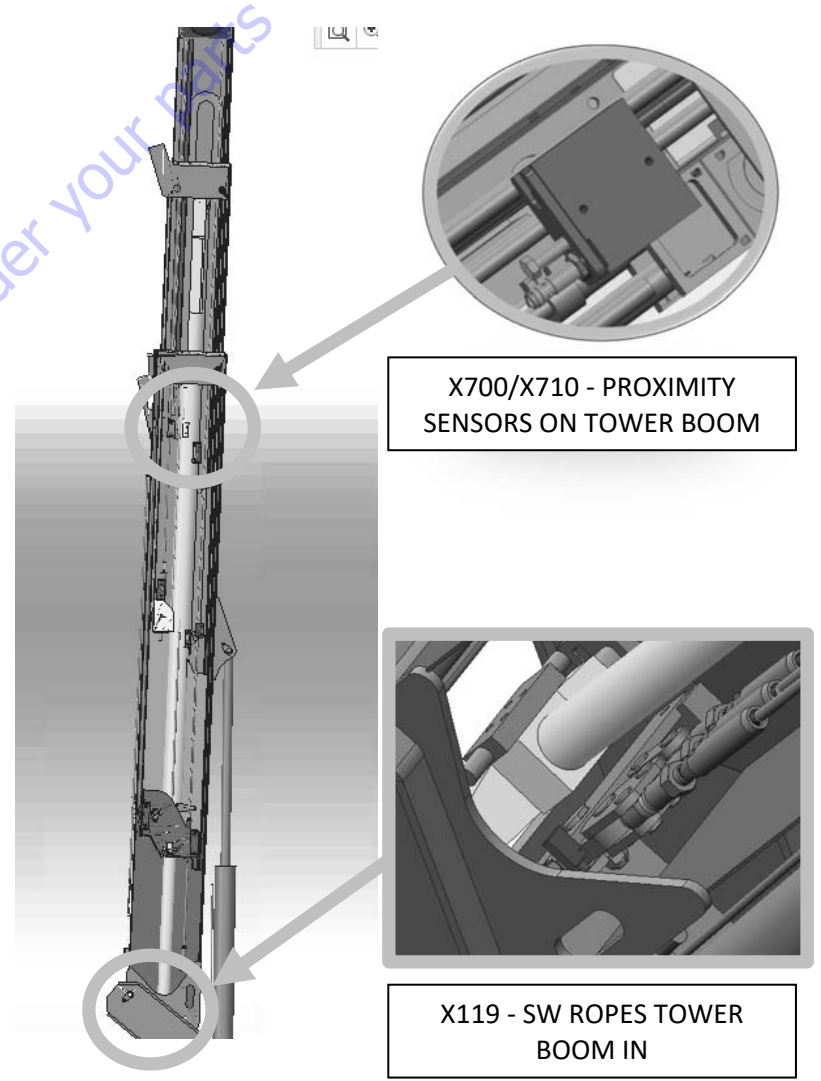

X700/X710 - PROXIMITY SENSORS ON TOWER BOOM

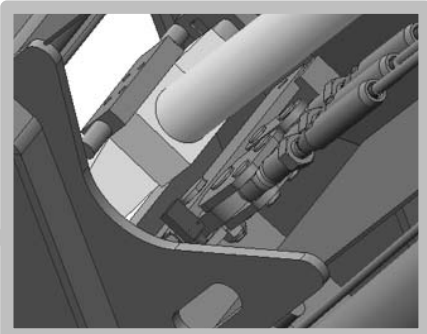

X119 - SW ROPES TOWER BOOM IN

Go to [Discount-Equipment.com](http://Discount-Equipment.com) to order your parts

# A1 - ECM 1 INPUT AND OUTPUT LIST

FREE	49	1	FREE
SECOND SPEED ELECTRO VALVE	50	2	WIDENING CLOSING ELECTRO VALVE
FREE	51	3	LEFT TRACK OPEN (+5V IN)
LAMP STABILIZER 1 (+12V OUT)	52	4	ENGINE OIL PRESSURE SENSOR (TO GND)
AERIAL/GROUND DUMP ELECTRO VALVE	53	5	SW EXTENSION TOWER BOOM CLOSED NO (+5V IN)
TOWER BOOM UP ELECTRO VALVE	54	6	SW TOWER BOOM ROPES NO (+5V IN)
LAMP STABILIZER 3 (+12V OUT)	55	7	AERIAL SAFETY EXCLUSION LINE A (+5V IN)
RIGHT TRACK FORWARD ELECTRO VALVE	56	8	FRONT LEFT OUTRIGGER SWITCH NO (+5V IN)
TOWER BOOM DW ELECTRO VALVE	57	9	FRONT RIGHT OUTRIGGER SWITCH NO (+5V IN)
WARNING BUZZER (+12V OUT)	58	10	AERIAL SAFETY EXCLUSION LINE B (+5V IN)
RIGHT TRACK BACKWARD ELECTRO VALVE	59	11	NOT USED
TOWER EXTENSION OUT ELECTRO VALVE	60	12	FREE
ENGINE RPM SENSOR	61	13	STOP GND SIGNAL (+12V IN)
STABILIZER 2 DW ELECTRO VALVE	62	14	STOP LINE FOR SERVICE PLUG
MAIN BOOM EXTENSION IN ELECTRO VALVE	63	15	FRONT LEFT OUTRIGGER SWITCH NC (+5V IN)
ENGINE STOP (+12V OUT)	64	16	FRONT RIGHT OUTRIGGER SWITCH NC (+5V IN)
STABILIZER 4 DW ELECTRO VALVE	65	17	STOP GND SIGNAL (+12V IN)
DUMP ELECTRO VALVE FOR AERIAL VALVE BLOCK	66	18	GND
HIGH RPM (+)	67	19	GND
STABILIZER 2 UP ELECTRO VALVE	68	20	GND
LEFT ROTATION ELECTRO VALVE	69	21	GND
REMOTE STOP, SENSORS AND ECM4 FEED (+12V OUT)	70	22	LEFT TOWER BOOM ROPE PROXIMITY (12V IN)
STABILIZER 4 UP ELECTRO VALVE	71	23	RC SELECTOR POSTION SWITCH (+12V IN)
FREE	72	24	FREE
SENSORS FEED (+12V OUT)	73	25	PUMP SUM ELECTRO VALVE
WIDENING OUT ELECTRO VALVE	74	26	FREE
ELECTRO PUMP COIL FEED (+12V OUT)	75	27	RIGHT TRACK OPEN (+5V IN)
LAMP STABILIZER 2 (+12V OUT)	76	28	ENGINE WATER TEMPERATURE SENSOR (TO GND)
FREE	77	29	SW EXTENSION TOWER BOOM CLOSED NC (+5V IN)
MAIN BOOM UP ELECTRO VALVE	78	30	SW TOWER BOOM ROPES NC (+5V IN)
LAMP STABILIZER 4 (+12V OUT)	79	31	GROUND SAFETY EXCLUSION LINE A (+5V IN)
LEFT TRACK FORWARD ELECTRO VALVE	80	32	REAR LEFT OUTRIGGER SWITCH NO (+5V IN)
MAIN BOOM DW DW ELECTRO VALVE	81	33	REAR RIGHT OUTRIGGER SWITCH NO (+5V IN)
GLOW PLUG FEED (+12V OUT)	82	34	GROUND SAFETY EXCLUSION LINE B (+5V IN)
LEFT TRACK BACKWARD ELECTRO VALVE	83	35	NOT USED
TOWER EXTENSION IN ELECTRO VALVE	84	36	STOP LINE FOR SERVICE PLUG
3 PHASES 380 V OK SIGNAL (+12V IN)	85	37	FUEL RESERVE SENSOR (+12V IN)
STABILIZER 1 DW ELECTRO VALVE	86	38	ELECTRIC MOTOR ENGAGEMENT (+12V OUT)
MAIN BOOM EXTENSION OUT ELECTRO VALVE	87	39	REAR LEFT OUTRIGGER SWITCH NC (+5V IN)
ENGINE STARTER (+12V OUT)	88	40	REAR RIGHT OUTRIGGER SWITCH NC (+5V IN)
STABILIZER 3 DW ELECTRO VALVE	89	41	PUMP SUM PRESSURE SENSOR
DUMP ELECTRO VALVE FOR JIB VALVE BLOCK	90	42	GND
HIGH RPM (-)	91	43	GND
STABILIZER 1 UP ELECTRO VALVE	92	44	GND
RIGHT ROTATION ELECTRO VALVE	93	45	GND
REMOTE STOP, SENSORS AND ECM4 FEED (+12V OUT)	94	46	RIGHT TOWER BOOM ROPE PROXIMITY (12V IN)
STABILIZER 3 UP ELECTRO VALVE	95	47	FREE
FREE	96	48	GND FOR ENGINE RPM SENSOR

X580.1

Go to [www.goldparts.com](http://www.goldparts.com) to order your parts

FEED (+12V IN)	4	1	FEED (+12V IN)
FEED (+12V IN)	5	2	FEED (+12V IN)
FEED (+12V IN)	6	3	FEED (+12V IN)
FREE	33	7	FREE
FREE	34	8	FREE
CAN L 0	35	9	CAN L 0
CAN L 1	36	10	CAN L 1
CAN L 2	37	11	CAN L 2
GND FOR HORN	38	12	CAN L 3
FREE	39	13	CAN L 4
FREE	40	14	FREE
LOW RPM (-)	41	15	FREE
FREE	42	16	CAN L 3
FREE	43	17	FREE
FREE	44	18	FREE
FREE	45	19	FREE
FEED (+12V IN)	46	20	IGNITION KEY SIGNAL (+12V IN)
SENSORS FEED (+5V OUT)	47	21	MACHINE STABILIZED LAMP (+12V OUT)
CAN H 0	48	22	CAN H 0
CAN H 1	49	23	CAN H 1
CAN H 2	50	24	CAN H 2
GND FOR FLASHING LIGHT	51	25	CAN H 3
FREE	52	26	CAN H 4
FREE	53	27	FREE
LOW RPM (+)	54	28	FREE
FREE	55	29	CAN H 3
FREE	56	30	FREE
FREE	57	31	FREE
FREE	58	32	FREE

X580.2

# A2 - ECM 3 & 4 INPUT AND OUTPUT LIST

ECM3

FEED (+12V IN)	27	1	FEED (+12V IN)
FEED (+12V IN)	28	2	GND
FREE	29	3	FREE
FREE	30	4	FREE
BASKET ROT RIGHT ELECTRO VALVE (FEED)	31	5	BASKET LEV UP ELECTRO VALVE (FEED)
SKY GUARD	32	6	JIB UP ELECTRO VALVE (FEED)
FREE	33	7	BASKET LEV DW ELECTRO VALVE (GND)
FREE	34	8	JIB UP ELECTRO VALVE (GND)
FREE	35	9	FREE
SENSORS FEED (+5V OUT)	36	10	FREE
FREE	37	11	SKY GUARD
FREE	38	12	RC UP STOP B LINE (+12V IN)
FREE	39	13	FREE
SIGNAL FROM LOAD CELL B	40	14	PEDAL NC SIGNAL (+5V IN)
FREE	41	15	FREE
FREE	42	16	BASKET LEV DW ELECTRO VALVE (FEED)
BASKET ROT LEFT ELECTRO VALVE (FEED)	43	17	JIB DW ELECTRO VALVE (FEED)
LOAD CELL FEED (+12V OUT)	44	18	FREE
FREE	45	19	BASKET LEV UP ELECTRO VALVE (GND)
FREE	46	20	JIB UP ELECTRO VALVE (GND)
FREE	47	21	FREE
FREE	48	22	FREE
FREE	49	23	SKY GUARD
FREE	50	24	RC UP STOP A LINE (+12V IN)
SKY GUARD	51	25	FREE
SIGNAL FROM LOAD CELL A	52	26	PEDAL NO SIGNAL (+5V IN)

X40

+5V IN	67	53	FREE
GND	68	54	FREE
FEED (+12V IN)	69	55	SW ROPES MAIN BOOM OUT (+12V IN)
FREE	70	56	FREE
FEED (+12V IN)	71	57	FREE
FREE	72	58	FREE
CAN L 1	73	59	FREE
GND	74	60	FREE
GND	75	61	SW NO ROPES MAIN BOOM IN (+12V IN)
FREE	76	62	SW NC ROPES MAIN BOOM OUT (+12V IN)
FREE	77	63	FREE
FREE	78	64	FREE
CAN H 1	79	65	FREE
FREE	80	66	FREE

X39

FEED (+12V IN)	27	1	FEED (+12V IN)
FEED (+12V IN)	28	2	FEED GND
FREE	29	3	FREE
FREE	30	4	FREE
FREE	31	5	FREE
FREE	32	6	FREE
FREE	33	7	FREE
FREE	34	8	FREE
FREE	35	9	FREE
SENSORS FEED (+5V OUT)	36	10	FREE
FREE	37	11	POS 4 NC (+5V IN)
FREE	38	12	POS 2 NC (+5V IN)
FREE	39	13	ST4 OPEN NC (+5V IN)
FREE	40	14	ST2 OPEN NC (+5V IN)
FREE	41	15	FREE
FREE	42	16	FREE
FREE	43	17	FREE
FREE	44	18	FREE
FREE	45	19	FREE
FREE	46	20	FREE
FREE	47	21	FREE
FREE	48	22	FREE
FREE	49	23	POS 3 NC (+5V IN)
FREE	50	24	POS 1 NC (+5V IN)
FREE	51	25	ST3 OPEN NC (+5V IN)
FREE	52	26	ST1 OPEN NC (+5V IN)

X48.1

FREE	67	53	POS 4 NO (+5V IN)
FREE	68	54	POS 2 NO (+5V IN)
FREE	69	55	ST4 OPEN NO (+5V IN)
FREE	70	56	ST2 OPEN NO (+5V IN)
FEED (+12V IN)	71	57	FREE
CAN H 2	72	58	FREE
CAN L 2	73	59	FREE
FREE	74	60	POS 3 NO (+5V IN)
FREE	75	61	POS 1 NO (+5V IN)
FREE	76	62	ST3 OPEN NO (+5V IN)
FREE	77	63	ST1 OPEN NO (+5V IN)
FREE	78	64	FREE
CAN H 2	79	65	FREE
CAN L 2	80	66	FREE

X48.2

ECM4



A3 - COMPONENTS ABBREVIATION MEANING

A3 - SIGNIFICATO ABBREVIAZIONI COMPONENTI

A3 - SIGNIFICADO ABREVIATURA COMPONENTES

A3 - SIGNIFICACION ABREVIACION COMPOSANT

ABBREVIATION	DESCRIPTION	DESCRIZIONE	DESCRIPCION	DESCRIPTION
120/230V GROUND PLUG	120/230 VOLT PLUG AT THE GROUND	PRESA 120/230 VOLT A TERRA	ENCHUFE 120/230 VOLT EN TIERRA	PRISE 120/230 VOLT AU SOL
120/230V BASKET PLUG	120/230 VOLT PLUG IN THE BASKET	PRESA 120/230 VOLT NEL CESTO	ENCHUFE 120/230 VOLT EN LA CESTA	PRISE 120/230 VOLT DANS LE PANIER
380 V 3 - MSV	380 VOLT THREE PHASES PROTECTOR	MAGNETOTERMICO 380 VOLT TRIFASE	INTERRUPTOR DE PROTECCION 380 V TRIFASICO	PROTECTION LIGNE 380 V TROIS PHASES
380 V THREE PHASES GROUND PLUG	380 V THREE PHASES GROUND PLUG	PRESA 380 VOLT A TERRA	ENCHUFE 380 VOLT EN TIERRA	PRISE 380 VOLT AU SOL
380 V BOX	380 V THREE PHASES BOX	SCATOLA 380 VOLT	CAJA 380 VOLT	BOÎTE 380 VOLT
BASKET LEVEL SENSOR	BASKET LEVEL SENSOR	SENSORE LIVELLAMENTO CESTO	SENSOR DE NIVEL DE LA CESTA	CAPTEUR DE NIVEAU DANS LE PANIER
BASKET PLUG MSV	BASKET PLUG PROTECTOR	MAGNETOTERMICO PER PRESA NEL CESTO	INTERRUPTOR DE PROTECCION PARA EL ENCHUFE EN LA CESTA	PROTECTION LIGNE POUR LE PANIER
BASKET ROTATION SENSOR	ROTATION ANGLE SENSOR ON THE BASKET	SENSORE ANGOLO DI ROTAZIONE CESTO	SENSOR ANGULO DE ROTACION CESTA	CAPTEUR ANGLE DE ROTATION PANIER
BATTERY	BATTERY	BATTERIA	BATERIA	BATTERIE
BATTERY CHARGER	BATTERY CHARGER	BATTERIA	BATERIA	BATTERIE
BATT CHARGER MSV	BATTERY CHARGER PROTECTOR	MAGNETOTERMICO PER CARICA BATTERIA	INTERRUPTOR DE PROTECCION PARA EL CARGA BATERIA	PROTECTION LIGNE POUR LE CHARGEUR DE BETTERIE
BYPASS AE	AERIAL PART SAFETY BYPASS KEY SWITCH	INTERRUTTORE A CHIAVE ESCLUSIONE SICUREZZE PARTE AEREA	INTERRUPTOR DE LLAVE EXCLUSION SEGURIDADES PARTE AEREA	INTERRUPTEUR EXCLUSION SÉCURITÉES PARTIE AÉRIENNE
BYPASS TR	GROUND PART SAFETY BYPASS KEY SWITCH	INTERRUTTORE A CHIAVE ESCLUSIONE SICUREZZE PARTE CARRO	INTERRUPTOR DE LLAVE EXCLUSION SEGURIDADES PARTE DE TIERRA	INTERRUPTEUR EXCLUSION SÉCURITÉES PARTIE TERRE
CHASSIS LEVEL SENSOR	LEVEL SENSOR ON THE CHASSIS	SENSORE DI LIVELLO A TERRA	SENSOR DE NIVEL DE EN TIERRA	CAPTEUR DE NIVEAU AU SOL
CONNECTOR	CONNECTOR	CONNETTORE	CONECTOR	CONNECTEUR
DIESEL ELECTRIC PUMP	DIESEL ELECTIC PUMP	POMPA ELETTRICA MOTORE DIESEL	BOMBA ELECTRICA MOTOR DIESEL	POMPE ELECTRICQUE MOTEUR DIESEL
ECM 1	MASTER BOARD	SCHEDA MASTER	TARJETA MASTER	FICHE ÉLECTRONIQUE DE CONTRÔLE
ECM 3	BOARD ON THE BASKET	SCHEDA CELLA DI CARICO	TARJETA CELA DE CARGA	FICHE CELLULE DE CHARGEMENT
ECM 4	STABILIZATION AREA CONTROL BOARD	SCHEDA AREA RIDOTTA	TARJETA AREA REDUCIDA	FICHE SURFACE REDUIT
ELECTRIC MOTOR	ELECTRIC MOTOR	MOTORE ELETTRICO	MOTOR ELECTRICO	MOTEUR ÉLECTRIQUE
ELECTRIC MOTOR MSV	ELECTRIC MOTOR PROTECTOR	MAGNETOTERMICO PER IL MOTORE ELETTRICO	INTERRUPTOR DE PROTECCION PARA EL MOTOR ELETTRICO	PROTECTION LIGNE POUR LE MOTEUR ELECTRIQUE
ELECTRIC MOTOR CONTACTOR	ELECTRIC MOTOR CONTACTOR	MOTORE ELETTRICO	MOTOR ELECTRICO	MOTEUR ÉLECTRIQUE
ELECTRO PUMP FOR EMERGENCY DESCENT	ELECTRO PUMP FOR EMERGENCY DESCENT	ELETTO POMPA PER DISCESA DI EMERGENZA	ELECTRO BOMBA PARA BAJADA DE EMERGENCIA	ELECTRO POMPE POUR DESCENTE D'URGENCE
ELECTRO STOP	ELECTRO STOP FOR ENGINE	ELETTO STOP MOTORE TERMICO	ELECTRO STOP MOTOR TERMICO	ELECTRO STOP MOTEUR THERMIQUE
ENGINE BRIDGES BOX	ENGINE ELECTRIC BRIDGES BOX	SCATOLA PONTI ELETTRICI MOTORE	CAJA PUENTES ELECTRICOS MOTOR	BOITE PONTES ELECTRIQUE MOTEUR
ENGINE ON RELAY	ENGINE ON RELAY	RELE' AVVIAMENTO MOTORE TERMICO	RELAY DE ARRANQUE MOTOR TERMICO	RELAIS DE DÉMARRAGE MOTEUR THERMIQUE
ENGINE PRES SENSOR	ENGINE OIL PRESSURE SENSOR	SENSORE PRESSIONE OLIO MOTORE	SENSOR PRESION ACEITE MOTOR	CAPTEUR PRESSION HUILE MOTEUR
ENGINE RPM REGULATOR	ENGINE REVOLUTION REGULATOR	REGOLATORE GIRI MOTORE	REGOLADOR REVOLUCIONAS MOTOR	RÉGULATEUR TOURS DU MOTEUR
ENGINE RPM SENSOR	ENGINE REVOLUTION SENSOR	SCATOLA PONTI ELETTRICI MOTORE	CAJA PUENTES ELECTRICOS MOTOR	BOITE PONTES ELECTRIQUE MOTEUR
ENGINE STARTER	ENGINE STARTER	MOTORINO DI AVVIAMENTO	MOTOR DE ARRANQUE	STARTER MOTEUR
ENGINE STOP TIMER	ENGINE STOP TIMER	TIMER SPEGNIMENTO MOTORE	TIMER STOP MOTOR	TIMER STOP MOTEUR
ENGINE TEMP SENSOR	ENGINE COOLING TEMPERATURE SENSOR	SENSORE TEMPERATURA ACQUA MOTORE	SENSOR TEMPERATURA AGUA MOTOR	CAPTEUR TEMPERATURE EAU MOTEUR
EV - 2° SPEED	TRACKS 2° SPEED ELECTRO VALVE	ELETTROVALVOLA 2° VELOCITA'	ELECTROVALVULA 2° VELOCIDAD	ÉLECTROVANNE 2EME VITESSE
EV - B ROT LEFT	BASKET ROTATION ON-OFF ELECTRO VALVE (LEFT)	ELETTROVALVOLA ON-OFF ROTAZIONE CESTO (SINISTRA)	ELECTROVALVULA ON-OFF ROTACION DE LA CESTA (IZQUIERDA)	ÉLECTROVANNE ON-OFF ROTATION PANIER (GAUCHE)
EV - B ROT RIGHT	BASKET ROTATION ON-OFF ELECTRO VALVE (RIGHT)	ELETTROVALVOLA ON-OFF ROTAZIONE CESTO (DESTRA)	ELECTROVALVULA ON-OFF ROTACION DE LA CESTA (DERECHA)	ÉLECTROVANNE ON-OFF ROTATION PANIER (DROIT)
EV - AERIAL/GROUND DUMP VALVE	DIVERTER FOR AERIAL/GROUND MOVEMENTS	ELETTROVALVOLA DEVIATRICE	ELECTROVALVULA CONMUTADORA PARTE AEREA	ÉLECTROVANNE DEVIATRICE
EV- DUMP VALVE FOR AERIAL VALVE BLOCK	SAFETY DIVERTER FOR AERIAL VALVE BLOCK	ELETTROVALVOLA DI SICUREZZA PER DISTRIBUTORE PARTE AEREA	ELECTROVALVULA CONMUTADORA PARA DISTRIBUIDOR PARTE AREA	ÉLECTROVANNE DEVIATRICE DE SECURITE
EV - DUMP VALVE FOR JIB VALVE BLOCK	SAFETY DIVERTER FOR JIB VALVE BLOCK	ELETTROVALVOLA DEVIATRICE DI SICUREZZA PER DISTRIBUTORE SUL JIB	ELECTROVALVULA DE SEGURIDAD PARA DISTRIBUIDOR EN EL JIB	ÉLECTROVANNE DE SECURITE
EV - JIB DW	JIB ON-OFF ELECTRO VALVE (DOWN)	ELETTROVALVOLA ON-OFF JIB (CHIUSURA)	ELECTROVALVULA ON-OFF JIB (CLAUSURA)	ÉLECTROVANNE ON-OFF JIB (FERMETURE)
EV - JIB UP	JIB ON-OFF ELECTRO VALVE (UP)	ELETTROVALVOLA ON-OFF JIB (APERTURA)	ELECTROVALVULA ON-OFF JIB (APERTURA)	ÉLECTROVANNE ON-OFF JIB (OUVERTURE)
EV - LEV DW	BASKET LEVELLING ON-OFF ELECTRO VALVE (DOWN)	ELETTROVALVOLA ON-OFF LIVELLAMENTO CESTO (CHIUSURA)	ELECTROVALVULA ON-OFF NIVELACION DE LA CESTA (CLAUSURA)	ÉLECTROVANNE ON-OFF NIVELAGE PANIER (FERMETURE)
EV - LEV UP	BASKET LEVELLING ON-OFF ELECTRO VALVE (UP)	ELETTROVALVOLA ON-OFF LIVELLAMENTO CESTO (APERTURA)	ELECTROVALVULA ON-OFF NIVELACION DE LA CESTA (APERTURA)	ÉLECTROVANNE ON-OFF NIVELAGE PANIER (OUVERTURE)
EV - MAIN DW	MAIN BOOM ON-OFF ELECTRO VALVE (DOWN)	ELETTROVALVOLA ON-OFF MAIN BOOM (CHIUSURA)	ELECTROVALVULA ON-OFF MAIN BOOM (CLAUSURA)	ÉLECTROVANNE ON-OFF MAIN BOOM (FERMETURE)
EV - MAIN UP	MAIN BOOM ON-OFF ELECTRO VALVE (UP)	ELETTROVALVOLA ON-OFF MAIN BOOM (APERTURA)	ELECTROVALVULA ON-OFF MAIN BOOM (APERTURA)	ÉLECTROVANNE ON-OFF MAIN BOOM (OUVERTURE)
EV - MAIN EXT IN	MAIN BOOM EXTENSION ON-OFF ELECTRO VALVE (IN)	ELETTROVALVOLA ON-OFF SFILO MAIN BOOM (CHIUSURA)	ELECTROVALVULA ON-OFF TELESCOPICO MAIN BOOM (CLAUSURA)	ÉLECTROVANNE ON-OFF BRAS D'EXTRACTION MAIN BOOM (FERMETURE)
EV - MAIN EXT OUT	MAIN BOOM EXTENSION ON-OFF ELECTRO VALVE (OUT)	ELETTROVALVOLA ON-OFF SFILO MAIN BOOM (APERTURA)	ELECTROVALVULA ON-OFF TELESCOPICO MAIN BOOM (APERTURA)	ÉLECTROVANNE ON-OFF BRAS D'EXTRACTION MAIN BOOM (OUVERTURE)
EV - PUMPS SUM	PUMPS SUM ELECTRO VALVE	ELETTO VALVOLA SOMMATORIA POMPE	ELECTRO VALVULA SOMA BOMBAS	ELECTO VANNE SOMME POMPES
EV - ROT LEFT	TURRET ON-OFF ELECTRO VALVE (LEFT)	ELETTROVALVOLA ON-OFF ROTAZIONE (SINISTRA)	ELECTROVALVULA ON-OFF ROTACION (IZQUIERDA)	ÉLECTROVANNE ON-OFF ROTATION (GAUCHE)
EV - ROT RIGHT	TURRET ON-OFF ELECTRO VALVE (RIGHT)	ELETTROVALVOLA ON-OFF ROTAZIONE (DESTRA)	ELECTROVALVULA ON-OFF ROTACION (DERECHA)	ÉLECTROVANNE ON-OFF ROTATION (DROIT)
EV - STAB 1 (DW)	LEFT FRONT OUTRIGGER ON-OFF ELECTRO VALVE (DOWN)	ELETTROVALVOLA ON-OFF STABILIZZATORE ANTERIORE SINISTRO (APERTURA)	ELECTROVALVULA ON-OFF ESTABILIZADOR DELANTERO IZQUIERDO (APERTURA)	ÉLECTROVANNE ON-OFF STABILISATEUR ANTERIEUR GAUCHE (OUVERTURE)
EV - STAB 1 (UP)	LEFT FRONT OUTRIGGER ON-OFF ELECTRO VALVE (UP)	ELETTROVALVOLA ON-OFF STABILIZZATORE ANTERIORE SINISTRO (CHIUSURA)	ELECTROVALVULA ON-OFF ESTABILIZADOR DELANTERO IZQUIERDO (CLAUSURA)	ÉLECTROVANNE ON-OFF STABILISATEUR ANTERIEUR GAUCHE (FERMETURE)
EV - STAB 2 (DW)	LEFT REAR OUTRIGGER ON-OFF ELECTRO VALVE (DW)	ELETTROVALVOLA ON-OFF STABILIZZATORE POSTERIORE SINISTRO (APERTURA)	ELECTROVALVULA ON-OFF ESTABILIZADOR TRASERO IZQUIERDO (APERTURA)	ÉLECTROVANNE ON-OFF STABILISATEUR POSTÉRIEUR GAUCHE (OUVERTURE)
EV - STAB 2 (UP)	LEFT REAR OUTRIGGER ON-OFF ELECTRO VALVE (UP)	ELETTROVALVOLA ON-OFF STABILIZZATORE POSTERIORE SINISTRO (CHIUSURA)	ELECTROVALVULA ON-OFF ESTABILIZADOR TRASERO IZQUIERDO (CLAUSURA)	ÉLECTROVANNE ON-OFF STABILISATEUR ANTERIEUR DROIT (OUVERTURE)
EV - STAB 3 (DW)	RIGHT FRONT OUTRIGGER ON-OFF ELECTRO VALVE (DOWN)	ELETTROVALVOLA ON-OFF STABILIZZATORE ANTERIORE DESTRO (APERTURA)	ELECTROVALVULA ON-OFF ESTABILIZADOR DELANTERO DERECHO (APERTURA)	ÉLECTROVANNE ON-OFF STABILISATEUR ANTERIEUR DROITE (OUVERTURE)

ABBREVIATION	DESCRIPTION	DESCRIZIONE	DESCRIPCION	DESCRIPTION
EV - STAB 3 (UP)	RIGHT FRONT OUTRIGGER ON-OFF ELECTRO VALVE (UP)	ELETTROVALVOLA ON-OFF STABILIZZATORE ANTERIORE DESTRO (CHIUSURA)	ELECTROVALVULA ON-OFF ESTABILIZADOR DELANTERO DERECHO (CLAUSURA)	ÉLECTROVANNE ON-OFF STABILISATEUR ANTERIEUR DROIT (FERMETURE)
EV - STAB 4 (DW)	RIGHT REAR OUTRIGGER ON-OFF ELECTRO VALVE (DW)	ELETTROVALVOLA ON-OFF STABILIZZATORE POSTERIORE DESTRO (APERTURA)	ELECTROVALVULA ON-OFF ESTABILIZADOR TRASERO DERECHO (APERTURA)	ÉLECTROVANNE ON-OFF STABILISATEUR POSTÉRIEUR DROITE (OUVERTURE)
EV - STAB 4 (UP)	RIGHT REAR OUTRIGGER ON-OFF ELECTRO VALVE (UP)	ELETTROVALVOLA ON-OFF STABILIZZATORE POSTERIORE DESTRO (CHIUSURA)	ELECTROVALVULA ON-OFF ESTABILIZADOR TRASERO DERECHO (CLAUSURA)	ÉLECTROVANNE ON-OFF STABILISATEUR POSTÉRIEUR DROITE (FERMETURE)
EV - TOWER DW	TOWER BOOM ON-OFF ELECTRO VALVE (DOWN)	ELETTROVALVOLA ON-OFF TOWER BOOM (CHIUSURA)	ELECTROVALVULA ON-OFF TOWER BOOM (CLAUSURA)	ÉLECTROVANNE ON-OFF TOWER BOOM (FERMETURE)
EV - TOWER UP	TOWER BOOM ON-OFF ELECTRO VALVE (UP)	ELETTROVALVOLA ON-OFF TOWER BOOM (APERTURA)	ELECTROVALVULA ON-OFF TOWER BOOM (APERTURA)	ÉLECTROVANNE ON-OFF TOWER BOOM (OUVERTURE)
EV - TOWER EXT IN	TOWER BOOM EXTENSION ON-OFF ELECTRO VALVE (IN)	ELETTROVALVOLA ON-OFF SFILO TOWER BOOM (CHIUSURA)	ELECTROVALVULA ON-OFF TELESCOPICO TOWER BOOM (CLAUSURA)	ÉLECTROVANNE ON-OFF BRAS D'EXTRACTION TOWER BOOM (FERMETURE)
EV - TOWER EXT OUT	TOWER BOOM EXTENSION ON-OFF ELECTRO VALVE (OUT)	ELETTROVALVOLA ON-OFF SFILO TOWER BOOM (APERTURA)	ELECTROVALVULA ON-OFF TELESCOPICO TOWER BOOM (APERTURA)	ÉLECTROVANNE ON-OFF BRAS D'EXTRACTION TOWER BOOM (OUVERTURE)
EV - TR CLOSING	UNDERCARRIAGE WIDENING ON-OFF ELECTRO VALVE (CLOSING)	ELETTROVALVOLA ON-OFF ALLARGAMENTO CARRO (CHIUSURA)	ELECTROVALVULA ON-OFF EXTENSION DEL CARRO (CLAUSURA)	ÉLECTROVANNE ON-OFF ÉLARGISSEMENT CHENILLARD (FERMETURE)
EV - TR L ( R)	LEFT TRACK ON-OFF ELECTRO VALVE (REAR)	ELETTROVALVOLA ON-OFF CINGOLO SINISTRO (INDIETRO)	ELECTROVALVULA ON-OFF ORUGA IZQUIERDA (ATRAS)	ÉLECTROVANNE ON-OFF CHENILLE GAUCHE (EN ARRIÈRE)
EV - TR L (F)	LEFT TRACK ON-OFF ELECTRO VALVE (FRONT)	ELETTROVALVOLA ON-OFF CINGOLO SINISTRO (AVANTI)	ELECTROVALVULA ON-OFF ORUGA IZQUIERDA (ADELANTE)	ÉLECTROVANNE ON-OFF CHENILLE GAUCHE (EN AVANT)
EV - TR OPENING	UNDERCARRIAGE WIDENING ON-OFF ELECTRO VALVE (OPENING)	UNDERCARRIAGE WIDENING ON-OFF ELECTRO VALVE (OPENING)	ELETTROVALVOLA ON-OFF ALLARGAMENTO CARRO (APERTURA)	ELECTROVALVULA ON-OFF EXTENSION DEL CARRO (APERTURA)
EV - TR R (R)	RIGHT TRACK ON-OFF ELECTRO VALVE (REAR)	ELETTROVALVOLA ON-OFF CINGOLO DESTRO (INDIETRO)	ELECTROVALVULA ON-OFF ORUGA DERECHA (ATRAS)	ÉLECTROVANNE ON-OFF CHENILLE DROITE (EN ARRIÈRE)
EV - TR R (F)	RIGHT TRACK ON-OFF ELECTRO VALVE (FRONT)	ELETTROVALVOLA ON-OFF CINGOLO DESTRO (AVANTI)	ELECTROVALVULA ON-OFF ORUGA DERECHA (ADELANTE)	ELETTROVALVOLA ON-OFF CINGOLO DESTRO (AVANTI)
FLASHING LIGHT (OPTIONAL)	FLASHING LIGHT (OPTIONAL)	LAMPEGGIANTE (OPTIONAL)	PARPADEO (OPCIONAL)	CLIGNOTANT (EN OPTION)
FUEL LEVEL SENSOR	FUEL LEVEL SENSOR	SENSORE LIVELLO CARBURANTE	SENSOR NIVEL COMBUSTIBLE	CAPTEUR NIVEAU DE CARBURANT
F N°	FUSE NUMBER	NUMERO DEL FUSIBILE	NÚMERO DEL FUSIBLE	FICHE' MICRO RELAY
GENERATOR	ENGINE GENERATOR	GENERATORE MOTORE TERMICO	GENERATOR MOTOR	GENERATEUR MOTEUR
GENERATOR DIODE	GENERATOR DIODE	DIODI GENERATORE	DIODOS GENERATOR	DIODES MOTEUR
GND RAIL	GROUND RAIL	PIASTRA MASSE	PLACA MASSE	PLAQUE DE MASSE
GROUND DASHBOARD	GROUND DASHBOARD	PANNELLO DI CONTROLLO A TERRA	PANEL DE CONTROL EN TIERRA	PANNEAU DE CONTROLE AU SOL
HORN	HORN	CLACSON	CLACSON	CLACSON
IGNITION KEY	IGNITION KEY SWITCH	INTERRUTTORE A CHIAVE MOTORE	INTERRUOTOR DE LLAVE MOTOR	INTERRUPTEUR A CLEF MOTEUR
JIB CAN BUS CONNECTOR	JIB CAN BUS CONNECTOR	CONNETTORE CAN BUS SUL JIB	CONNECTOR CAN BUS EN EL JIB	CONNECTEUR CAN BUS AU BRAS JIB
JIB CYLINDER POSITION SENSOR	JIB CYLINDER POSITION SENSOR	SENSORE DI POSIZIONE BRACCIO JIB	SENSOR POSICION BRAZO JIB	CAPTEUR DE POSITION BRAS JIB
LAMP STAB 1	FRONT LEFT OUTIGGER LAMP	LAMPADA STABILIZZATORE ANTERIORE SINISTRO	LUZ ESTABILIZADOR DELANTERO IZQUIERDO	LUMIÈRE STABILISATEUR N° 1
LAMP STAB 2	REAR LEFT OURIGGER LAMP	LAMPADA STABILIZZATORE POSTERIORE SINISTRO	LUZ ESTABILIZADOR TRASERO IZQUIERDO	LUMIÈRE STABILISATEUR N° 2
LAMP STAB 3	FRONT RIGHT OUTRIGGER LAMP	LAMPADA STABILIZZATORE ANTERIORE DESTRO	LUZ ESTABILIZADOR DELANTERO DERECHO	LUMIÈRE STABILISATEUR N° 3
LAMP STAB 4	REAR RIGHT OUTRIGGER LAMP	LAMPADA STABILIZZATORE POSTERIORE DESTRO	LUZ ESTABILIZADOR TRASERO DERECHO	LUMIÈRE STABILISATEUR N° 4
LEFT ROPE PROXIMITY ON TOWER BOOM	LEFT ROPE PROXIMITY SENSOR ON TOWER BOOM	SENSORE PROXIMITY FUNE SINISTRA NEL TOWER BOOM	SENSOR PROXIMITY CUERDA IZQUIERDA EN EL TOWER BOOM	CAPTEUR PROXIMITY CABLE GAUCHE DANS LE TOWER BOOM
LOAD CELL SENSOR	LOAD CELL SENSOR	SENSORE CELLULA DI CARICO	SENSOR CELULA DE CARGA	CAPTEUR CELLULE DE CHARGEMENT
MAIN BOOM CAN BUS CONNECTOR	MAIN BOOM CAN BUS CONNECTOR	CONNETTORE CAN BUS SUL MAIN BOOM	CONNECTOR CAN BUS EN EL MAIN BOOM	CONNECTEUR CAN BUS AU MAIN BOOM
MAIN BOOM CYLINDER POSITION SENSOR	MAIN BOOM CYLINDER POSITION SENSOR	SENSORE DI POSIZIONE CILINDRO MAIN BOOM	SENSOR POSICION CYLINDRO MAIN BOOM	CAPTEUR DE POSITION BOUTEILLE MAIN BOOM
MAIN BOOM EXTENSION POSITION SENSOR	MAIN BOOM EXTENSION CYLINDER POSITION SENSOR	SENSORE DI POSIZIONE CILINDRO SFILO MAIN BOOM	SENSOR POSICION CYLINDRO TELESCOPICO MAIN BOOM	CAPTEUR DE POSITION BOUTEILLE BRAS D'EXTRACTION MAIN BOOM
MAIN FUSE	MAIN FUSE	FUSIBILE PRINCIPALE	FUSIBLE PRINCIPAL	FUSIBIL PRINCIPAL
MAIN SWITCH	BATTERY CUTTER	STACCA BATTERIE	SACA BATERIA	COUPE BATTERIE
MODEM	MODEM	MODEM	MODEM	MODEM
MOTOR ON PROTECTION	MOTOR ON SIGNAL PROTECTION	SEGNALE DI PROTEZIONE MOTORE ON	SIGNAL DE PROTECCION MOTOR ON	SIGNAL DE PROTECTION DU MOTEUR ON
MSV120/230	120/230 VOLT PROTECTION SWITCH	MAGNETOTERMICO 120/230 VOLT	INTERRUPTOR DE PROTECCION 120/230 V	PROTECTION LIGNE 120/230 VOLT
MSV120/230V BOX	THERMIC SWITCH BOX	SCATOLA INTERRUTTORE TERMICO	CAJA INTERRUPTOR TERMICO	BOÎTE INTERRUPTEUR THERMIQUE
PEDAL (optional)	PEDAL	PEDALE	PEDAL	PEDALE
PHASES CONTROLLER	3 PHASES 380 V CONTROLLER	STRUMENTO VERIFICA DIREZIONE FASI	VERIFICACION DE DIRECCION FASES	INSTRUMENT DE VERIFICATION DE DIRECTION DE PHASES
POSITION CTRL	POSITION CONTROL SELECTOR	SELETORE POSIZIONE DI COMANDO	SELECTOR POSICION DE CONTROL	SELECTEUR DE POSITION DE CONTROLE
POS 1 STAB	FRONT LEFT OUTRIGGER MIDDLE POSITION SWITCH	INTERRUTTORE POSIZIONE RIDOTTA STABILIZZATORE ANTERIORE SINISTRO	INTERRUPTOR POSICION REDUCIDA ESTABILIZADOR DELANTERO IZQUIERDO	INTERRUPTEUR POSITION REDUITE STABILISATEUR ANTERIEUR GAUCHE
POS 2 STAB	REAR LEFT OUTRIGGER MIDDLE POSITION SWITCH	INTERRUTTORE POSIZIONE RIDOTTA STABILIZZATORE POSTERIORE SINISTRO	INTERRUPTOR POSICION REDUCIDA ESTABILIZADOR TRASERO IZQUIERDO	INTERRUPTEUR POSITION REDUITE STABILISATEUR POSTÉRIEUR GAUCHE
POS 3 STAB	FRONT RIGHT OUTRIGGER MIDDLE POSITION SWITCH	INTERRUTTORE POSIZIONE RIDOTTA STABILIZZATORE ANTERIORE DESTRO	INTERRUPTOR POSICION REDUCIDA ESTABILIZADOR DELANTERO DERECHO	INTERRUPTEUR POSITION REDUITE STABILISATEUR ANTERIEUR DROIT
POS 4 STAB	REAR RIGHT OUTRIGGER MIDDLE POSITION SWITCH	INTERRUTTORE POSIZIONE RIDOTTA STABILIZZATORE POSTERIORE DESTRO	INTERRUPTOR POSICION REDUCIDA ESTABILIZADOR TRASERO DERECHO	INTERRUPTEUR POSITION REDUITE STABILISATEUR POSTÉRIEUR DROIT
PRE HEATING GLOW PLUGS	PRE HEATING GLOW PLUGS	CANDELETTE PRE-RISCALDO	BUJIAS PRE CALEFACION	PETITES BOUGIES DE PRECHAUFFAGE
PRE HEATING RELAY	PRE HEATING RELAY	RELE' PRE-RISCALDO	RELE PRE CALEFACION	RELÉ PRECHAUFFAGE
PUMP SUM PRESSURE SENSOR	PRESSURE SENSORLIMIT FOR PUMP SUM	SENSORE DI PRESSIONE LIMITE PER SOMMA POMPA	SENSOR DE PRESSION LIMITE PARA SOMA BOMBAS	CAPTEUR DE PRESSION LIMITE POUR SOMME POMPES
RELAYS BOARD	RELAYS BOARD	SCHEDA RELE'	PLACA RELE	CARTE RELAIS
REMOTE CONTROL	REMOTE CONTROL	TELECOMANDO	TELEMANDO	TÉLÉCOMMANDE
REMOTE CONTROL IN THE BASKET	REMOTE CONTROL IN THE BASKET	TELECOMANDO NEL CESTO	MANDO EN LA CESTA	TÉLÉCOMMANDE DANS LE PANIER
RIGHT ROPE PROXIMITY ON TOWER BOOM	RIGHT ROPE PROXIMITY SENSOR ON TOWER BOOM	SENSORE PROXIMITY FUNE DESTRA NEL TOWER BOOM	SENSOR PROXIMITY CUERDA DERECHA EN EL TOWER BOOM	CAPTEUR PROXIMITY CABLE DROIT DANS LE TOWER BOOM
ROTATION ANGLE SENSOR	ROTATION ANGLE SENSOR ON THE TURRET	SENSORE ANGOLO DI ROTAZIONE DELLA TORRETTA	SENSOR ANGULO DE ROTACION PARTE AEREA	CAPTEUR ANGLE DE ROTATION PARTIE ARIENNE
SERVICE PLUG	PLUG FOR SERVICE	PRESA PER SERVICE	ENCHUFE PARA SERVICE	PRISE DE SERVICE
SKY GUARD (OPTIONAL)	SKY GUARD	SKY GUARD	SKY GUARD	SKY GUARD

ABBREVIATION	DESCRIPTION	DESCRIZIONE	DESCRIPCION	DESCRIPTION
SKY GUARD LAMP	SKY GUARD LAMP	LAMPADA SKY GUARD	SKY GUARD LUZ	LUMIÈRE SKY GUARD
SOFT STARTER	SOFT STARTER FOR 380V ELECTRIC MOTOR	SOFT STARTER PER MOTORE ELETTRICO 380V	SOFT STARTER PARA MOTOR ELECTRICO 380V	SOFT STARTER POUR MOTEUR ELECTRIQUE 380V
SOFT STARTER BOX	SOFT STARTER BOX	SCATOLA SOFT STARTER	CAJA SOFT STARTER	BOITE SOFT STARTER
STARTER RELAY	ENGINE START RELAY	RELE' AVVIAMENTO MOTORE	RELE' ARRANQUE MOTOR	RELAJ DEMARREUR MOTEUR
STOP GND	GROUND STOP SWITCH	INTERRUTTORE STOP A TERRA	INTERRUPTOR DE STOP EN TIERRA	INTERRUPTEUR D'ARRÊT AU SOL
ST1 GND	FRONT LEFT OUTIGGER SWITCH (GROUND)	INTERRUTTORE STABILIZZATORE ANTERIORE SINISTRO	INTERRUPTOR ESTABILIZADOR DELANTERO IZQUIERDO	INTERRUPTEUR STABILISATEUR ANTERIEUR GAUCHE
ST1 OPEN	FRONT LEFT OUTRIGGER FULLY OPEN POSITION SWITCH	INTERRUTTORE POSIZIONE APERTA STABILIZZATORE ANTERIORE SINISTRO	INTERRUPTOR POSICION ABIERTA ESTABILIZADOR DELANTERO IZQUIERDO	INTERRUPTEUR POSITION OUVERT STABILISATEUR ANTERIEUR GAUCHE
ST2 GND	REAR LEFT OUTRIGGER SWITCH (GROUND)	INTERRUTTORE STABILIZZATORE POSTERIORE SINISTRO	INTERRUPTOR ESTABILIZADOR TRASERO IZQUIERDO	INTERRUPTEUR STABILISATEUR POSTERIEUR GAUCHE
ST2 OPEN	REAR LEFT OUTRIGGER FULLY OPEN POSITION SWITCH	INTERRUTTORE POSIZIONE APERTA STABILIZZATORE POSTERIORE SINISTRO	INTERRUPTOR POSICION ABIERTA ESTABILIZADOR TRASERO IZQUIERDO	INTERRUPTEUR POSITION OUVERT STABILISATEUR POSTERIEUR GAUCHE
ST3 GND	FRONT RIGHT OUTRIGGER SWITCH (GROUND)	INTERRUTTORE STABILIZZATORE ANTERIORE DESTRO	INTERRUPTOR ESTABILIZADOR DELANTERO DERECHO	INTERRUPTEUR STABILISATEUR ANTERIEUR DROIT
ST3 OPEN	FRONT RIGHT OUTRIGGER FULLY OPEN POSITION SWITCH	INTERRUTTORE POSIZIONE APERTA STABILIZZATORE ANTERIORE DESTRO	INTERRUPTOR POSICION ABIERTA ESTABILIZADOR DELANTERO DERECHO	INTERRUPTEUR POSITION OUVERT STABILISATEUR ANTERIEUR DROIT
ST4 GND	REAR RIGHT OUTRIGGER SWITCH (GROUND)	INTERRUTTORE STABILIZZATORE POSTERIORE DESTRO	INTERRUPTOR ESTABILIZADOR TRASERO DERECHO	INTERRUPTEUR STABILISATEUR POSTERIEUR DROIT
ST4 OPEN	REAR RIGHT OUTRIGGER FULLY OPEN POSITION SWITCH	INTERRUTTORE POSIZIONE APERTA STABILIZZATORE POSTERIORE DESTRO	INTERRUPTOR POSICION ABIERTA ESTABILIZADOR TRASERO DERECHO	INTERRUPTEUR POSITION OUVERT STABILISATEUR POSTERIEUR DROIT
SW EXTENSION TOWER BOOM CLOSED	TOWER BOOM EXTENSION CLOSED POSITION SWITCH	INTERRUTTORE SFILLO TOWER BOOM CHIUSO	INTERRUPTOR TELESCOPICO TOWER BOOM CIERRADO	INTERRUPTEUR BRAS D'EXTRACTION TOWER BOOM FERMEE
SW ROPES MAIN BOOM IN	SENSOR FOR MAIN BOOM IN ROPES	SENSORE FUNI CHIUSURA MAIN BOOM	SENSOR CUERDAS CLAUSURA MAIN BOOM	CAPTEUR CABLES FERMETURE MAIN BOOM
SW ROPES MAIN BOOM OUT	ROPES MAIN BOOM OUT POSITION SWITCH	SENSORE FUNI APERTURA MAIN BOOM	SENSOR CUERDAS APERTURA MAIN BOOM	CAPTEUR CABLES OUVERTURE MAIN BOOM
SW TOWER BOOM BOOM ROPES	TOWER BOOM ROPES SWITCH SENSOR	SENSORE FUNI TOWER	SENSOR CUERDAS TOWER	CAPTEUR CABLES TOWER
TELEMATICS	TELEMATICS DEVICE	SISTEMA TELEMATICS	SISTEMA TELEMATIC	SYSTEME TELEMATIC
TOWER BOOM CAN BUS CONNECTOR	TOWER BOOM CAN BUS CONNECTOR	CONNETTORE CAN BUS SUL TOWER BOOM	CONNECTOR CAN BUS EN EL TOWER BOOM	CONNECTEUR CAN BUS AU TOWER BOOM
TOWER BOOM CYLINDER POSITION SENSOR	TOWER BOOM CYLINDER POSITION SENSOR	SENSORE DI POSIZIONE CILINDRO TOWER BOOM	SENSOR POSICION CILINDRO TOWER BOOM	CAPTEUR DE POSITION BOUTEILLE TOWER BOOM
TOWER BOOM EXTENSION CYLINDER	TOWER BOOM EXTENSION CYLINDER POSITION SENSOR	SENSORE DI POSIZIONE CILINDRO SFILLO MAIN BOOM	SENSOR POSICION CILINDRO TELESCOPICO MAIN BOOM	CAPTEUR DE POSITION BOUTEILLE BRAS D'EXTRACTION MAIN BOOM
TR OPEN LEFT	LEFT TRACK OPEN SENSOR	SENSORE POSIZIONE CILINDRO SINISTRO CARRO	SENSOR POSICION CILINDRO IZQUIERDO ORUGAS	CAPTEUR POSITION GAUCHE CHENILLES
TR OPEN RIGHT	RIGHT TRACK OPEN SENSOR	SENSORE POSIZIONE CILINDRO DESTRO CARRO	SENSOR POSICION CILINDRO DERECHO ORUGAS	CAPTEUR POSITION ADROIT CHENILLES
USB PLUG	USB PLUG	PRESA USB	ENCHUFE ISB	PRISE USB
WARNING BUZZER (OPTIONAL)	WARNING BUZZER	AVVISATORE ACUSTICO	ZUMBADOR	ALARME ACOUSTIQUE
SW R-POS STAB 4	REAR RIGHT REDUCED POSITION OUTRIGGER SWITCH	INTERRUTTORE POSIZIONE RIDOTTA STABILIZZATORE POSTERIORE DESTRO	INTERRUPTOR POSICION REDUCIDA ESTABILIZADOR TRASERO DERECHO	INTERRUPTEUR POSITION REDUITE STABILISATEUR POSTERIEUR DROIT
SW STAB 1	FRONT LEFT OUTIGGER SWITCH	INTERRUTTORE STABILIZZATORE ANTERIORE SINISTRO	INTERRUPTOR ESTABILIZADOR DELANTERO IZQUIERDO	INTERRUPTEUR STABILISATEUR ANTERIEUR GAUCHE
SW STAB 2	REAR LEFT OUTRIGGER SWITCH	INTERRUTTORE STABILIZZATORE POSTERIORE SINISTRO	INTERRUPTOR ESTABILIZADOR TRASERO IZQUIERDO	INTERRUPTEUR STABILISATEUR POSTERIEUR GAUCHE
SW STAB 3	FRONT RIGHT OUTRIGGER SWITCH	INTERRUTTORE STABILIZZATORE ANTERIORE DESTRO	INTERRUPTOR ESTABILIZADOR DELANTERO DERECHO	INTERRUPTEUR STABILISATEUR ANTERIEUR DROIT
SW STAB 4	REAR RIGHT OUTRIGGER SWITCH	INTERRUTTORE STABILIZZATORE POSTERIORE DESTRO	INTERRUPTOR ESTABILIZADOR TRASERO DERECHO	INTERRUPTEUR STABILISATEUR POSTERIEUR DROIT
TEMPERATURE SENSOR (OPTIONAL)	ENGINE TEMPERATURE SENSOR	SENSORE DI TEMPERATURA MOTORE	SENSOR DE TEMPERATURA MOTOR	CAPTEUR TEMPERATURE MOTEUR
THERMIC ENGINE	THERMIC ENGINE	MOTORE TERMICO	MOTOR TERMICO	MOTEUR
THERMIC START	THERMIC ENGINE START PUSH BUTTON	PULSANTE AVVIAMENTO MOTORE TERMICO	BOTON DE ARRANQUE MOTOR TERMICO	INTERRUPTEUR DE DEMARRAGE MOTEUR ELECTRIQUE
WARNING BUZZER (OPTIONAL)	WARNING BUZZER	AVVISATORE ACUSTICO	ZUMBADOR	ALARME ACOUSTIQUE
WATER TEMPERATURE SENSOR	WATER COOLING TEMPERATURE SENSOR	SENSORE TEMPERATURA ACQUA MOTORE	SENSOR TEMPERATURA AGUA MOTOR	CAPTEUR TEMPERATURE EAU MOTEUR
WIDENING CYLINDER SENSOR	WIDENING CYLINDER POSITION SENSOR	SENSORE POSIZIONE CILINDRO CARRO	SENSOR POSICION CILINDRO ORUGAS	CAPTEUR POSITION CHENILLES

Go to Discount

# A4 – CONNECTORS LAYOUT

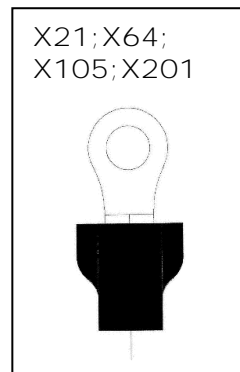
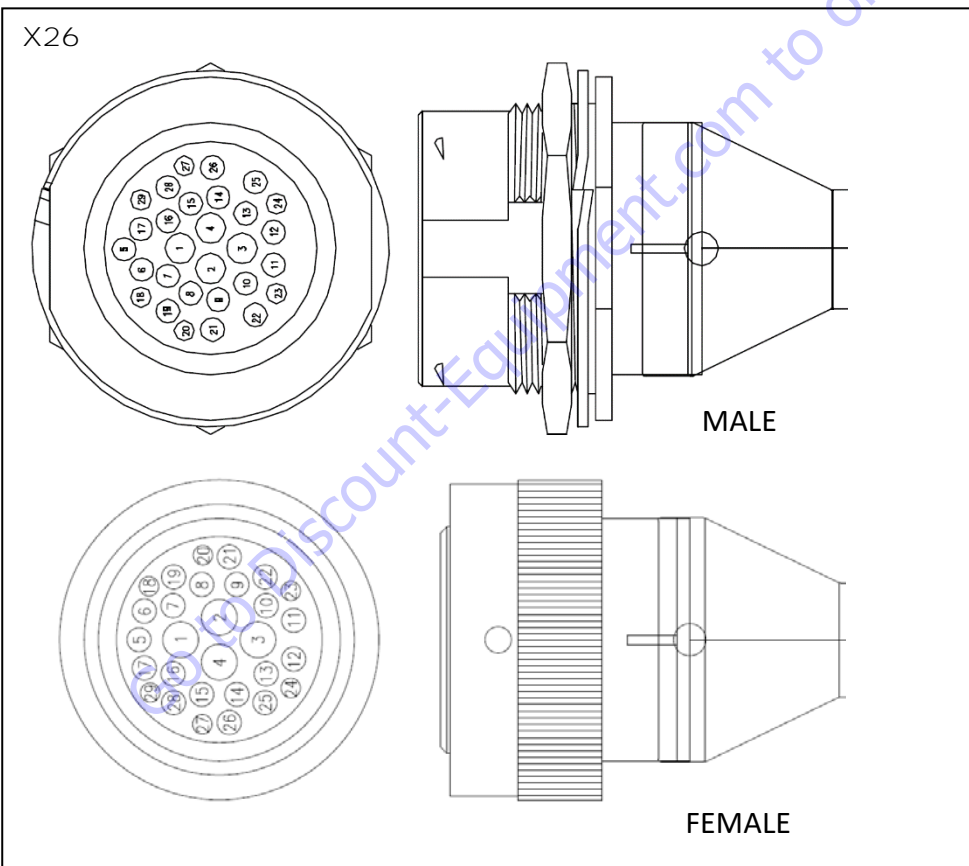
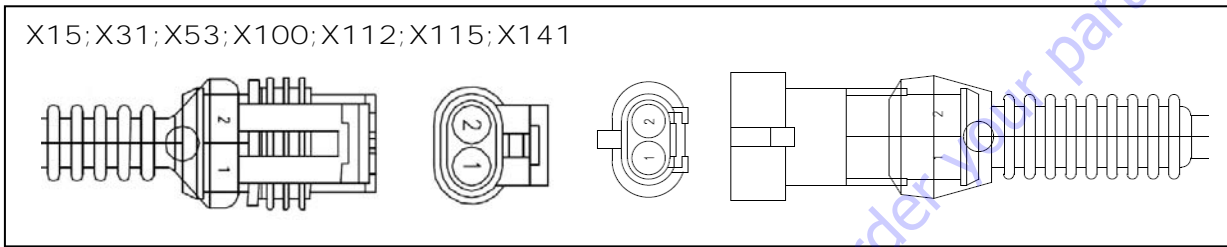
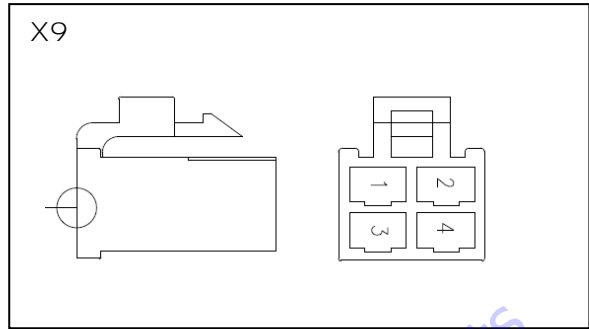
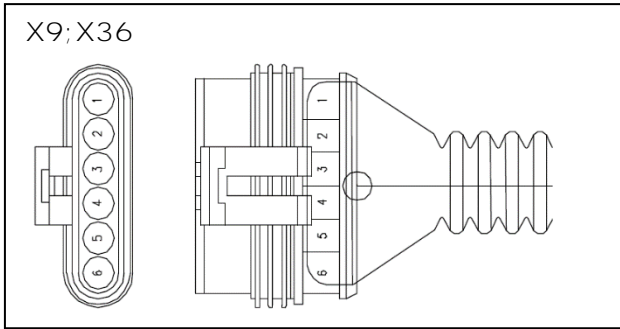

X32;X208;X209;X213;X707;X708;X850

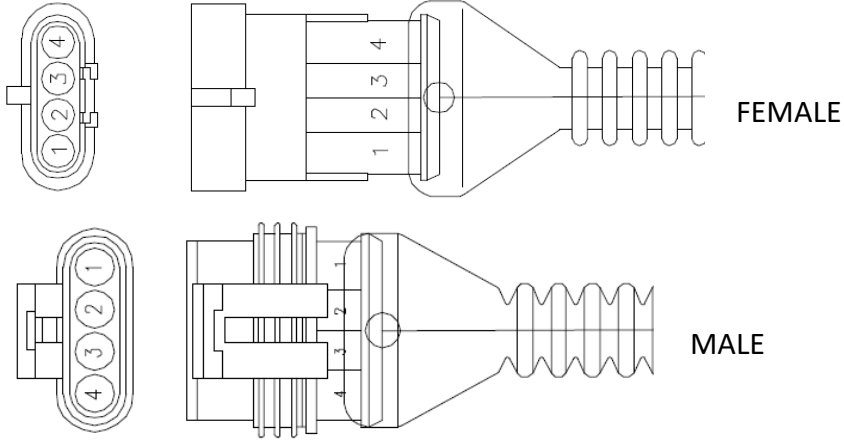

X38;X110;X111;  
X849

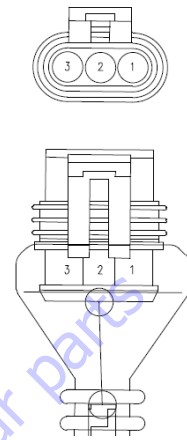

X39;X48.2

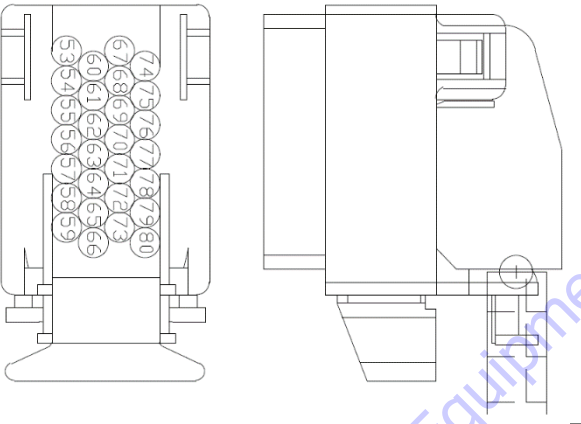

X40;X48.1

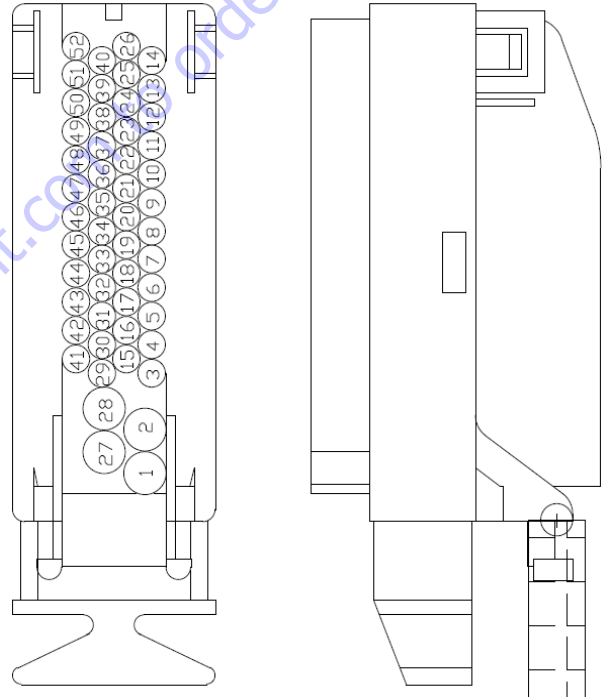

X51;X63;X113

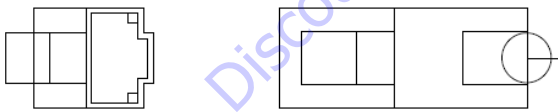

X56

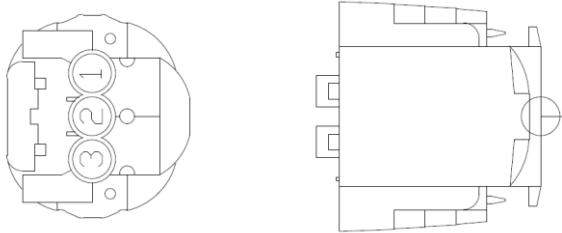

X101

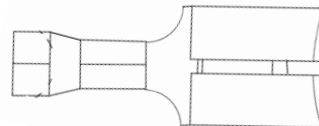

X106; X108; X116; X229; X230;  
X502; X503; X703; X705; X706;  
X709; X712; X714

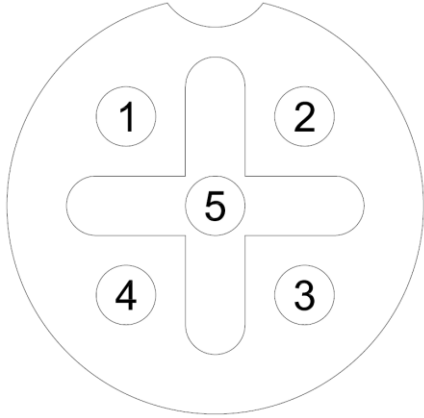

X107

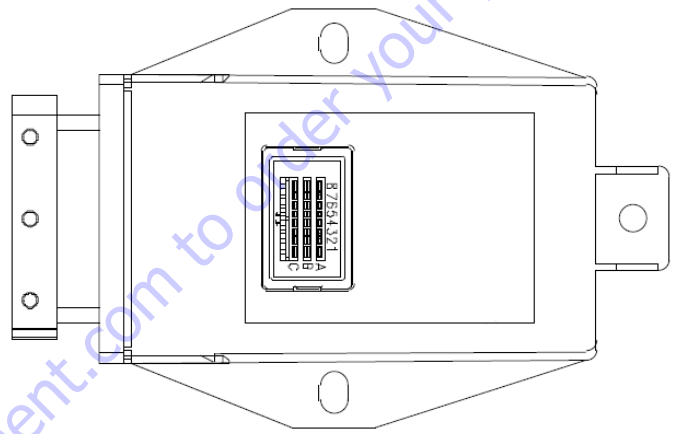
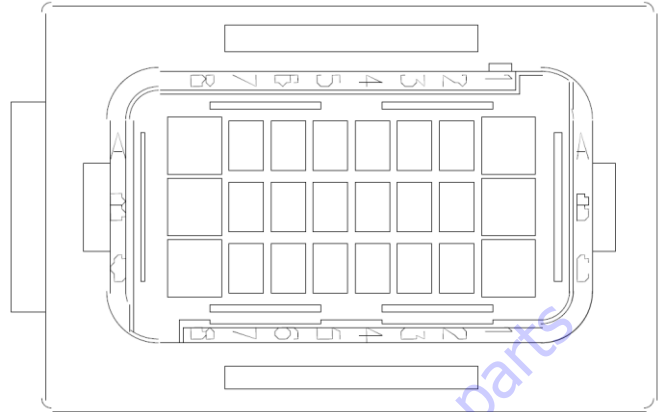

X109; X200

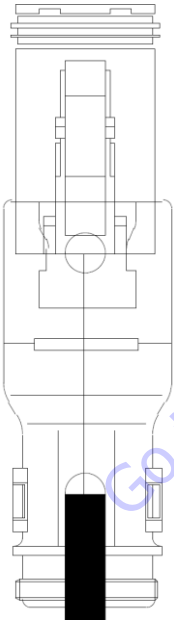

X114

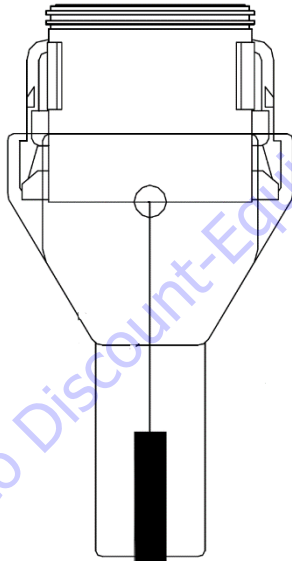
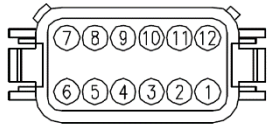

X117

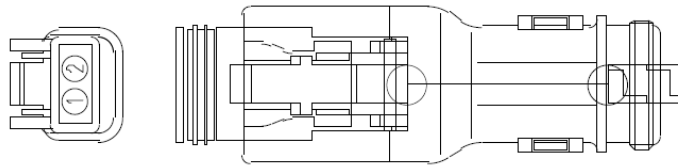

X121; X122; 220; X221; X222; X229; X230;  
X500; X501; X702; X704; X710; X711; X713;  
X788; X837

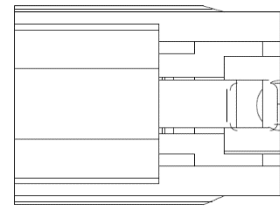
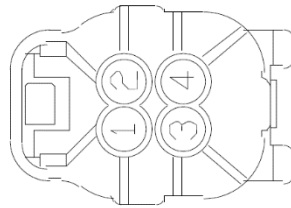

X120

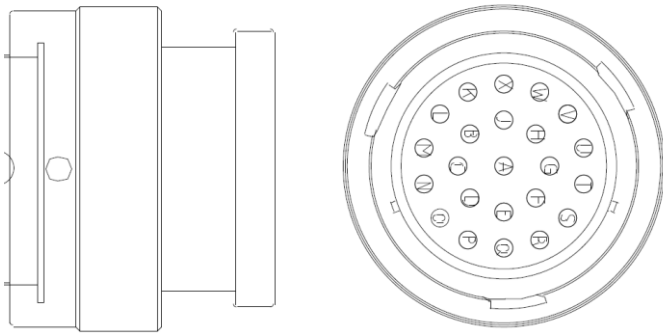

X504;X505;X850;X881

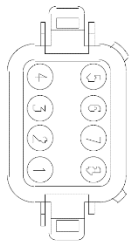
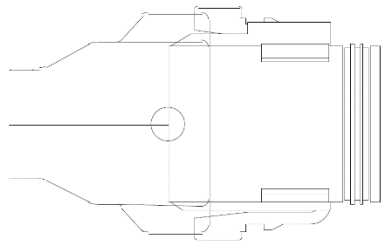

MALE

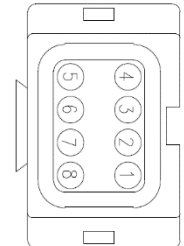
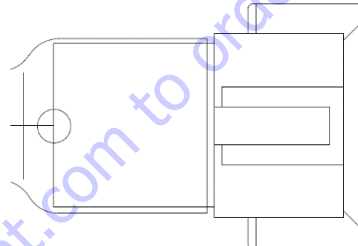

FEMALE

RELAY



RELAY MINI

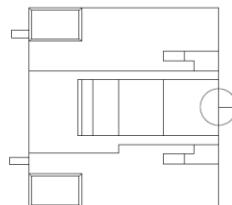
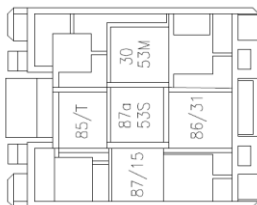
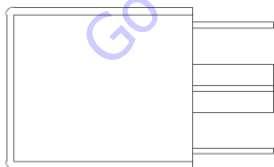

FUSE & DIODE

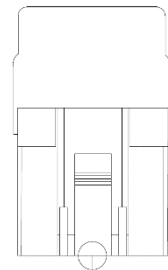
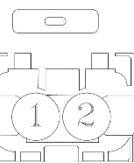

ELECTRO VALVE

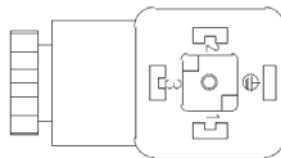
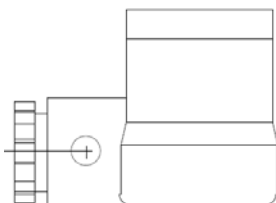

X580.1

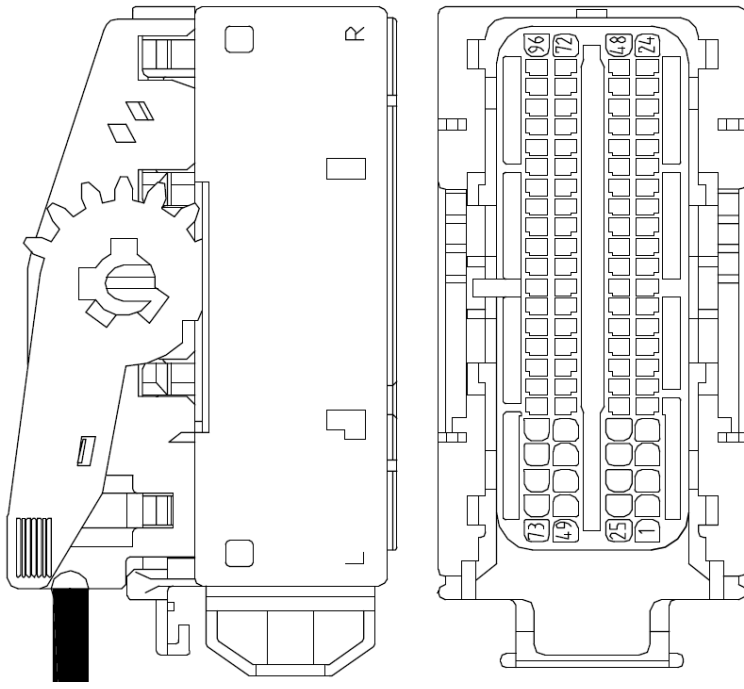

X838

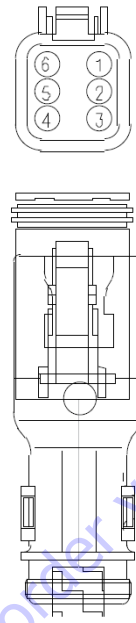

X580.2

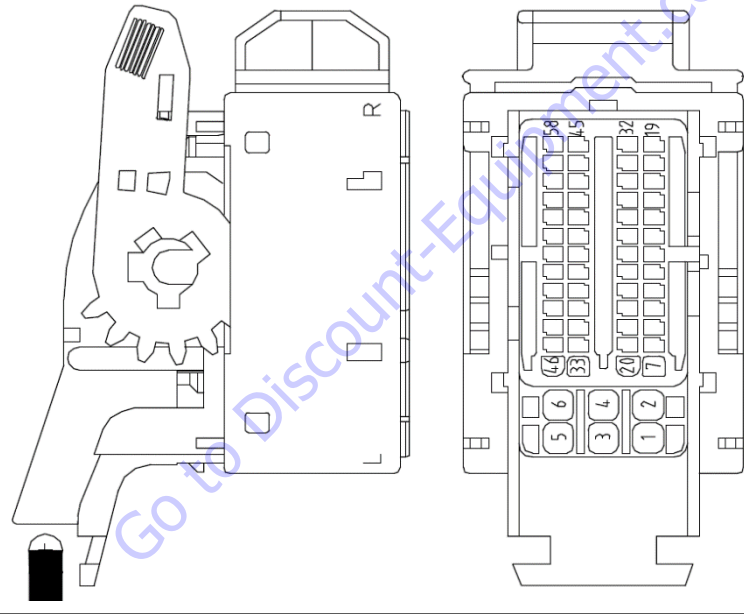

Go to [Discount-Equipment.com](http://Discount-Equipment.com) to order your parts



LITHIUM BATTERY SYSTEM 76 VOLT - 150A  
3RD GENERATION

A - Rev.0

DESCRIPTION - DESCRIZIONE - DESCRIPCION - DESCRIPTION

PAGE	DESCRIPTION	DESCRIZIONE	DESCRIPCION
	COMPONENTS LEGEND	LEGENDA COMPONENTI	LEYENDA COMPONENTES
A	IGNITION KEY	ACCENSIONE	IGNICION
B	DC-DC	DC-DC	DC-DC
C	BATTERY CHARGER	CARICABATTERIE	CARGADOR DE BATERIAS
D	INVERTER	INVERTER	INVERTER
E1	BMS	BMS	BMS
E2	BMS	BMS	BMS
E3	BMS	BMS	BMS
F	CAN BUS NETWORK	LINEA CAN BUS	LINEA CAN BUS
G	COMPONENTS LOCATION	LOCAZIONE COMPONENTI	COLOCACION COMPONENTES
H	LAYOUT BMS	LAYOUT BMS	LAYOUT BMS
I1-12	BMS CONNECTORS	CONNETTORI BMS	CONNECTORES BMS
L	COMPONENTS LAYOUT	LAYOUT COMPONENTI	LAYOUT COMPONENTES

PAGE	DESCRIPTION
	LEGENDE COMPOSANT
A	ALLUMAGE
B	DC-DC
C	CHARGEUR DE BATTERIE
D	INVERTER
E1	BMS
E2	BMS
E3	BMS
F	LINE CAN BUS
G	DISPOSITION COMPOSANT
H	LAYOUT BMS
I1-12	CONNECTEURS BMS
L	LAYOUT COMPOSANT

COMPONENTS LEGEND - 76V 150A  
 LEGENDA COMPONENTI - 76V 150A  
 LEYENDA COMPONENTES - 76V 150A  
 LEGENDE COMPOSANTS - 76V 150A

NAME	DESCRIPTION	DESCRIZIONE	DESCRIPCION
BATTERY 12 VOLT	BATTERY 12 VOLT	BATTERIA 12 VOLT	BATERIA 12 VOLT
BC	BATTERY CHARGER	CARICABATTERIE	CARGADOR DE BATERIAS
BMS	BATTERY MANAGEMENT SYSTEM	BATTERY MANAGEMENT SYSTEM	BATTERY MANAGEMENT SYSTEM
CELL	LITHIUM CELL	CELLA LITIO	CELULA DE LITIO
CELLS TRIO	LITHIUM CELLS TRIO	TRIS DI CELLE LITIO	TRIS DE CELULAS DE LITIO
CONNECTOR	CONNECTOR	CONNETTORE	CONNECTOR
HEATER	CELLS HEATERS	RISCALDATORE CELLE	CALENTADOR PARA CELULAS
INTERNAL CONTACTOR	CONTACTOR IN THE CELLS BOX	CONTATTORE NEL PACCO BATTERIE	CONTACTOR EN EL PAQUETE BATERIAS
DC-DC	38-76V/12V FEEDER	ALIMENTATORE 38-76V/12V	ALIMENTADOR 38-76V/12V
ECM 1	ELECTRONIC CONTROL MODULE 1-2	SCHEDA ELETTRONICA DI CONTROLLO 1-2	TARJETA DE CONTROL 2
F N°	FUSE	FUSIBILE	FUSIBLE
FAN	BATTERY BOX FANS	VENTOLE VANO BATTERIE	PANTALLAS PAQUETE BATERIAS
INV	INVERTER	INVERTER	INVERTER
IGNITION KEY	IGNITION KEY SWITCH	INTERRUTTORE A CHIAVE MOTORE	INTERRUTTORE A LLAVE MOTOR
LEM SENSOR	LEM SENSOR	SENSORE LEM	SENSOR LEM
MOTOR	ELECTRIC MOTOR	MOTORE ELETTRICO	MOTOR ELECTRICO
MR	MAIN RELE'	RELE' PRINCIPALE	RELE' PRINCIPAL
PACK STOP	BATTERY PACK STOP SWITCH	INTERRUTTORE STOP DEL PACCO BATTERIA	INTERRUPTOR DE PARADA EN EL PAQUETE
R N°	RELAY	RELE'	RELE'

NAME	DESCRIPTION
BATTERY 12 VOLT	BATTERIE 12 VOLT
BC	CHARGEUR DE BATTERIE
BMS	BATTERY MANAGEMENT SYSTEM
CELL	CELULE DE LITHIUM
CELLS TRIO	TRIS DE CELULES DE LITHIUM
CONNECTOR	CONNECTEUR
INTERNAL CONTACTOR	CONTACTEUR INTERIEUR PAQUET BATERIE
HEATER	CHAUFFE CELLULES
DC-DC	CHARGEUR 38-76V/12V
ECM 1	FICHE ÉLECTRONIQUE DE CONTRÔLE 1-2
F N°	FUSE
FAN	HELICES PAQUET BATERIE
INV	INVERTER
IGNITION KEY	INTERRUPTEUR A CLEF MOTEUR
LEM SENSOR	CAPTEUR LEM
MOTOR	MOTEUR ELECTRIQUE
MR	RELAIS PRINCIPAL
PACK STOP	INTERRUPTEUR DU STOP DANS LE PAQUET
R N°	RELAIS DU CHARGEUR DE BATTERIE

Note to read the wiring diagrams  
 - Most of the wires have an identification number, indicated in the wiring diagrams  
 - Close to the identification number, every wire shows the two terminal points of connexion

# A - IGNITION KEY

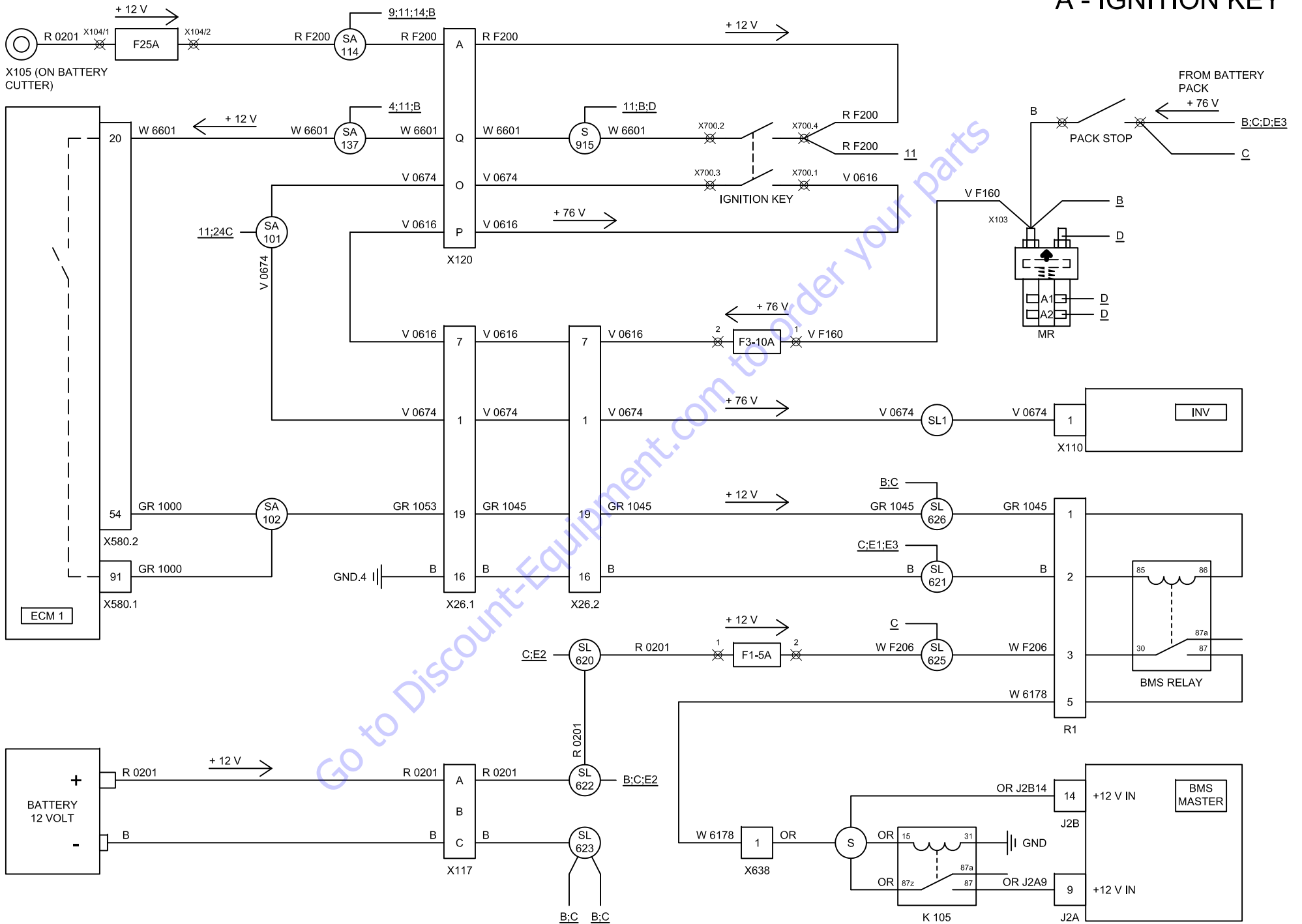

# B - DC-DC

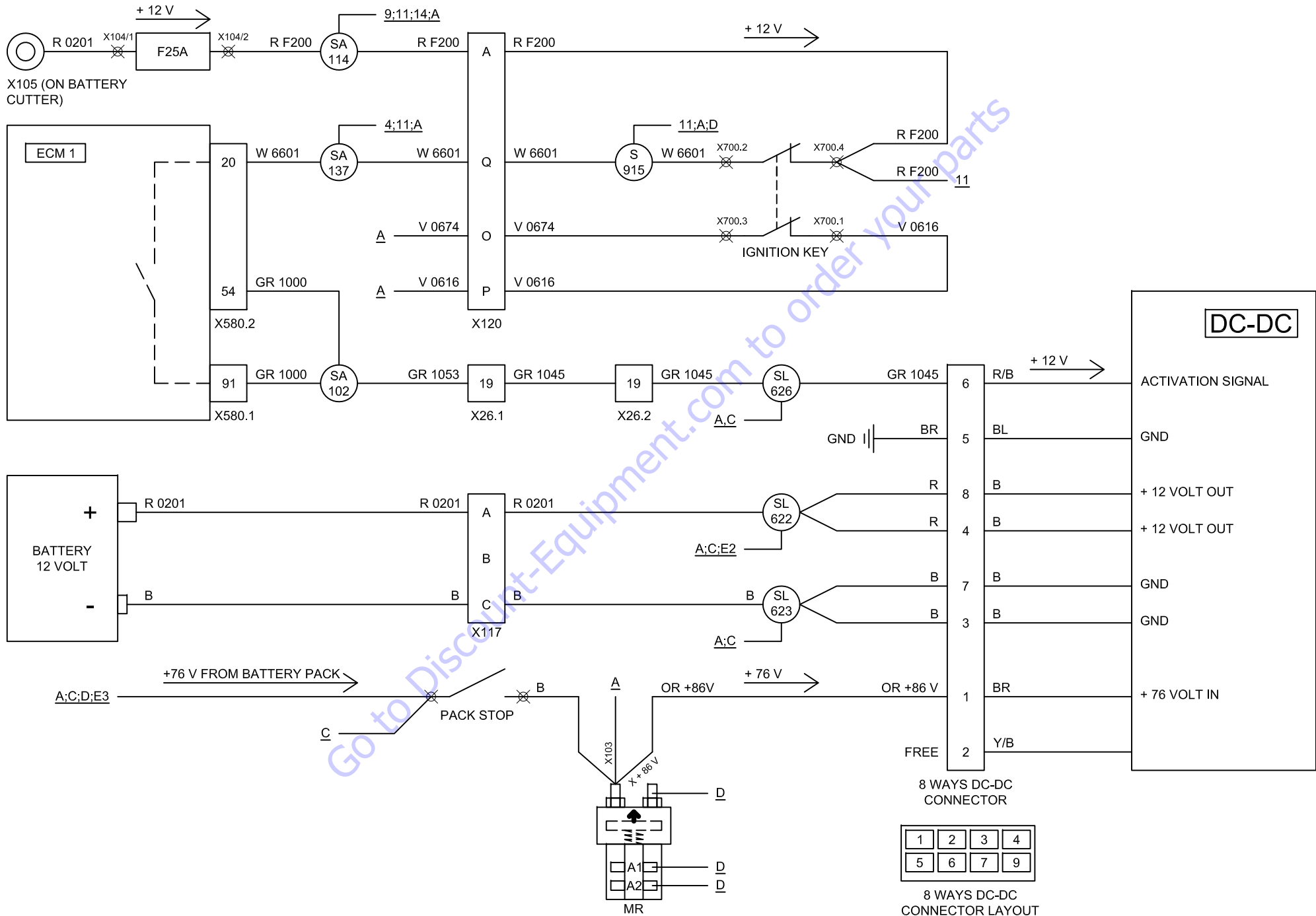

# C - BATTERY CHARGER

\* 110V-220V GROUND PLUG CAN BE THE SAME ONE USED TO FEED THE BASKET PLUG, OR A DIFFERENT ONE, IT DEPENDS ON THE MACHINE VERSION

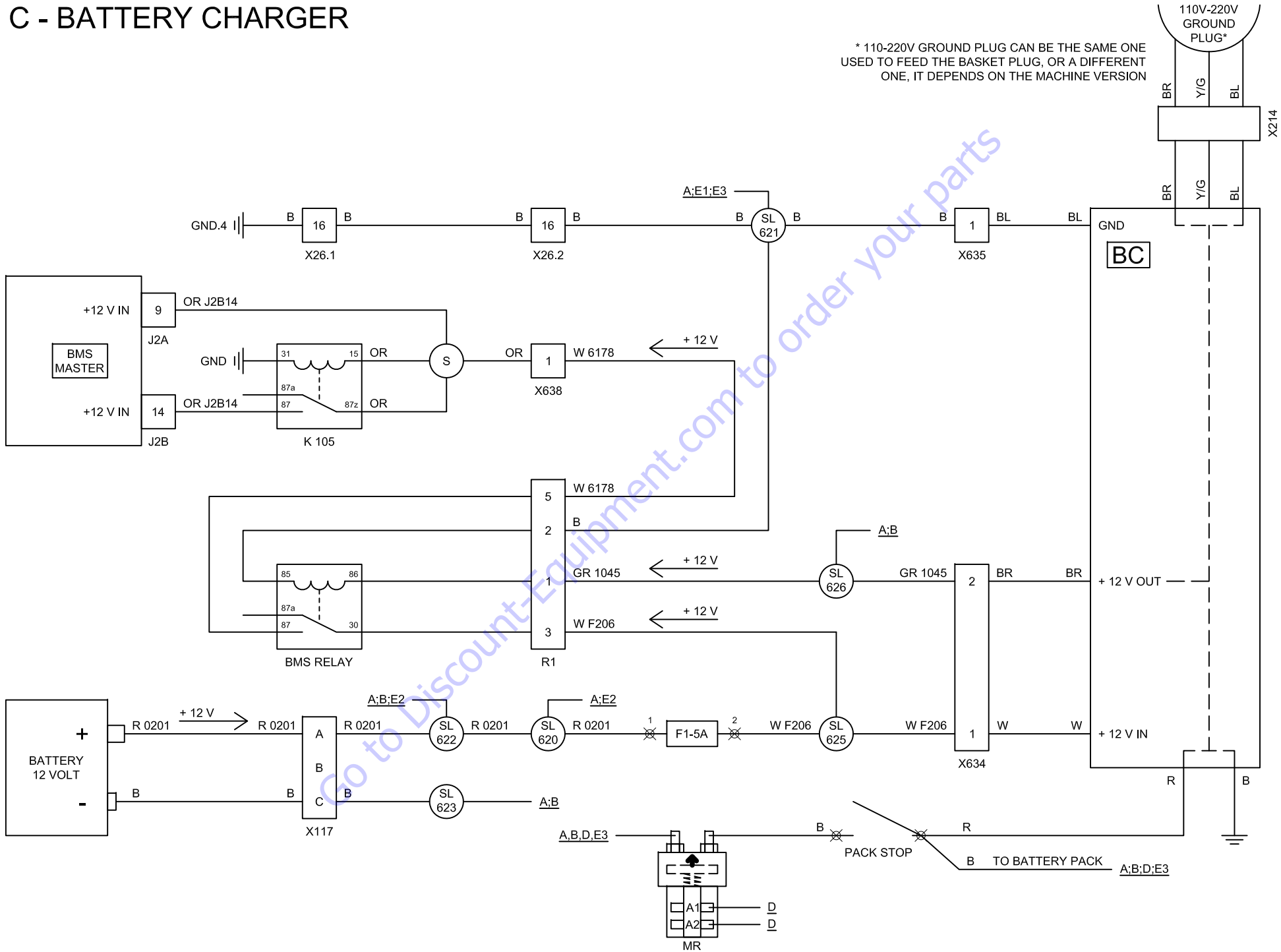

# D - INVERTER

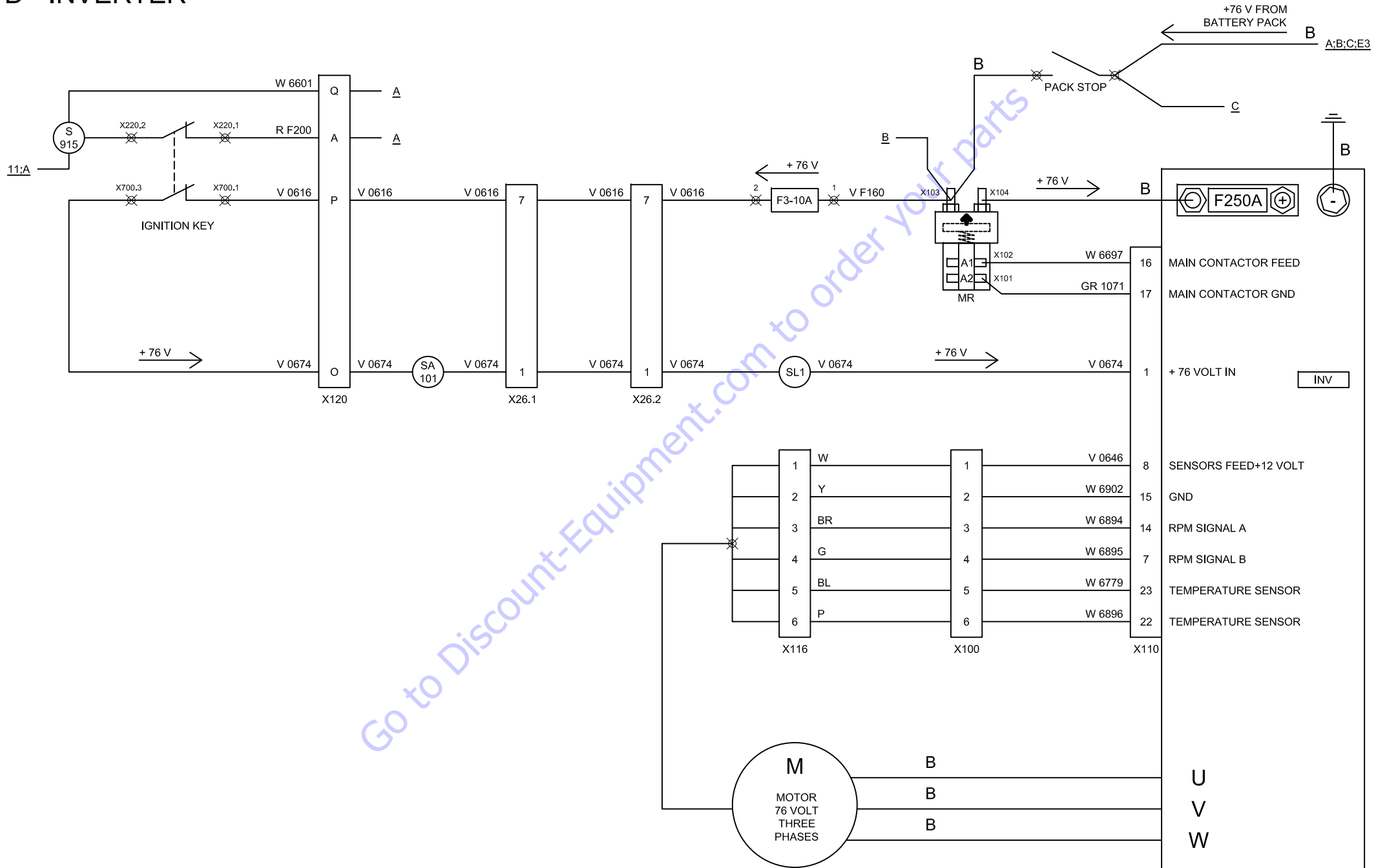

Go to Discount-Equipment.com to order your parts

# E1 - BMS

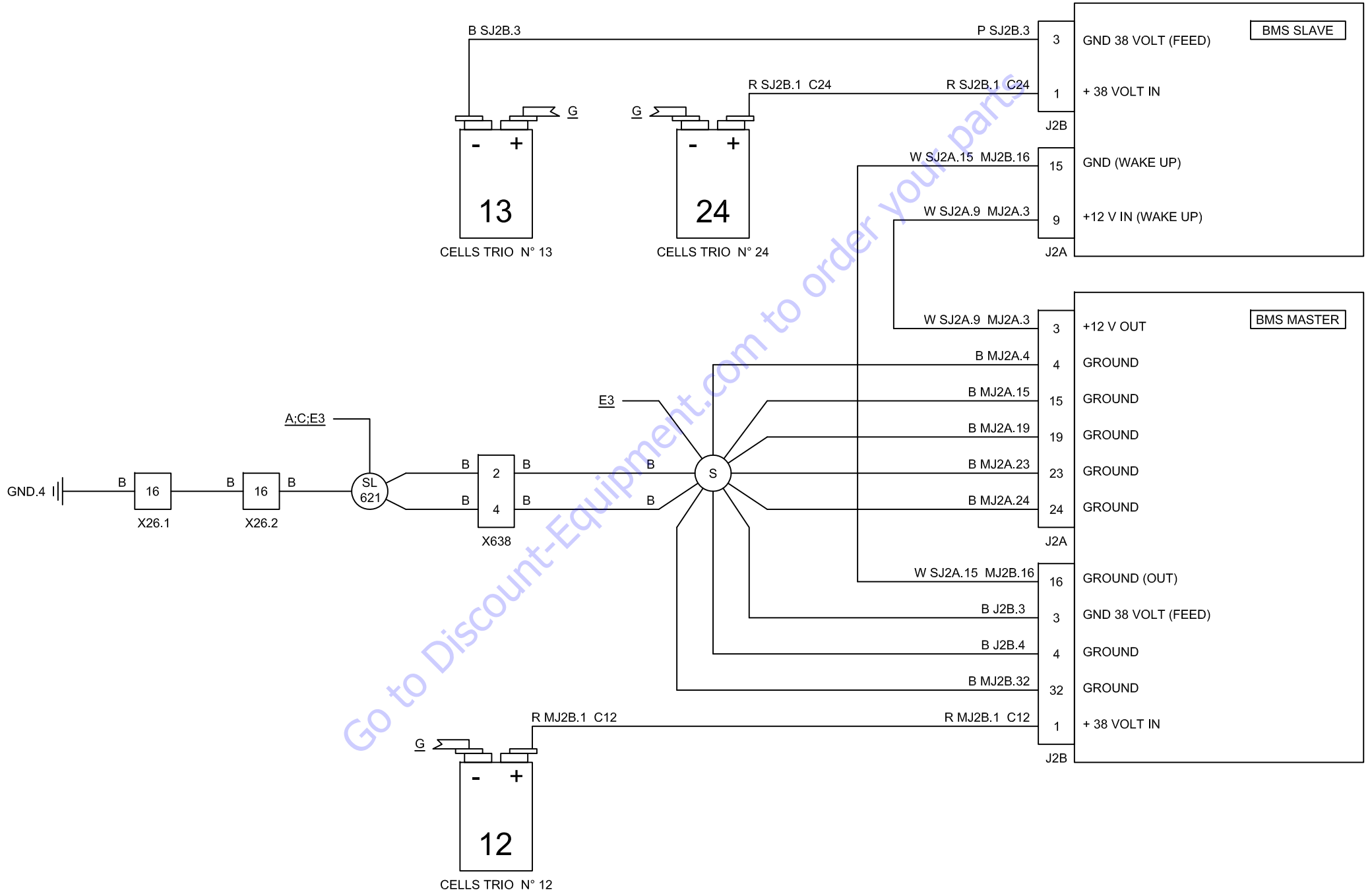

# E2 - BMS

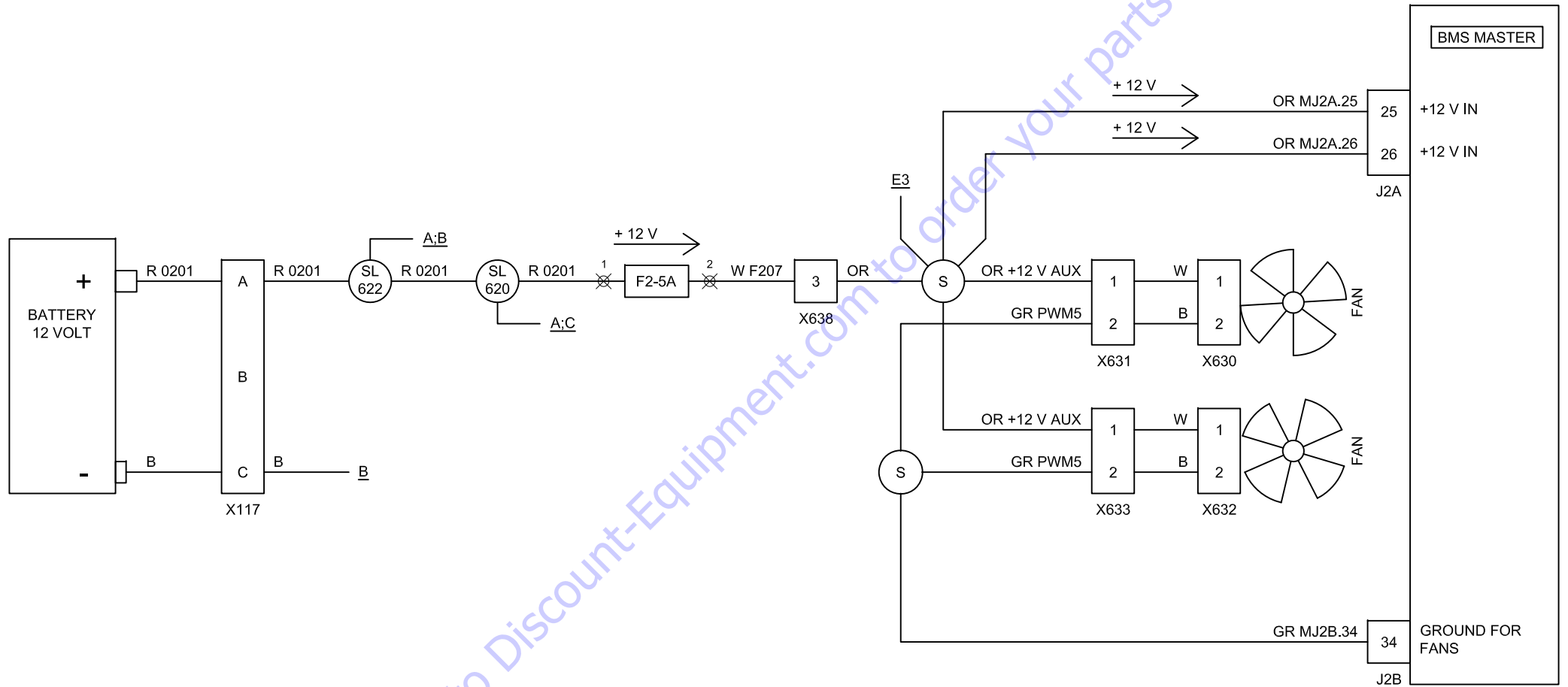



# E3 - BMS

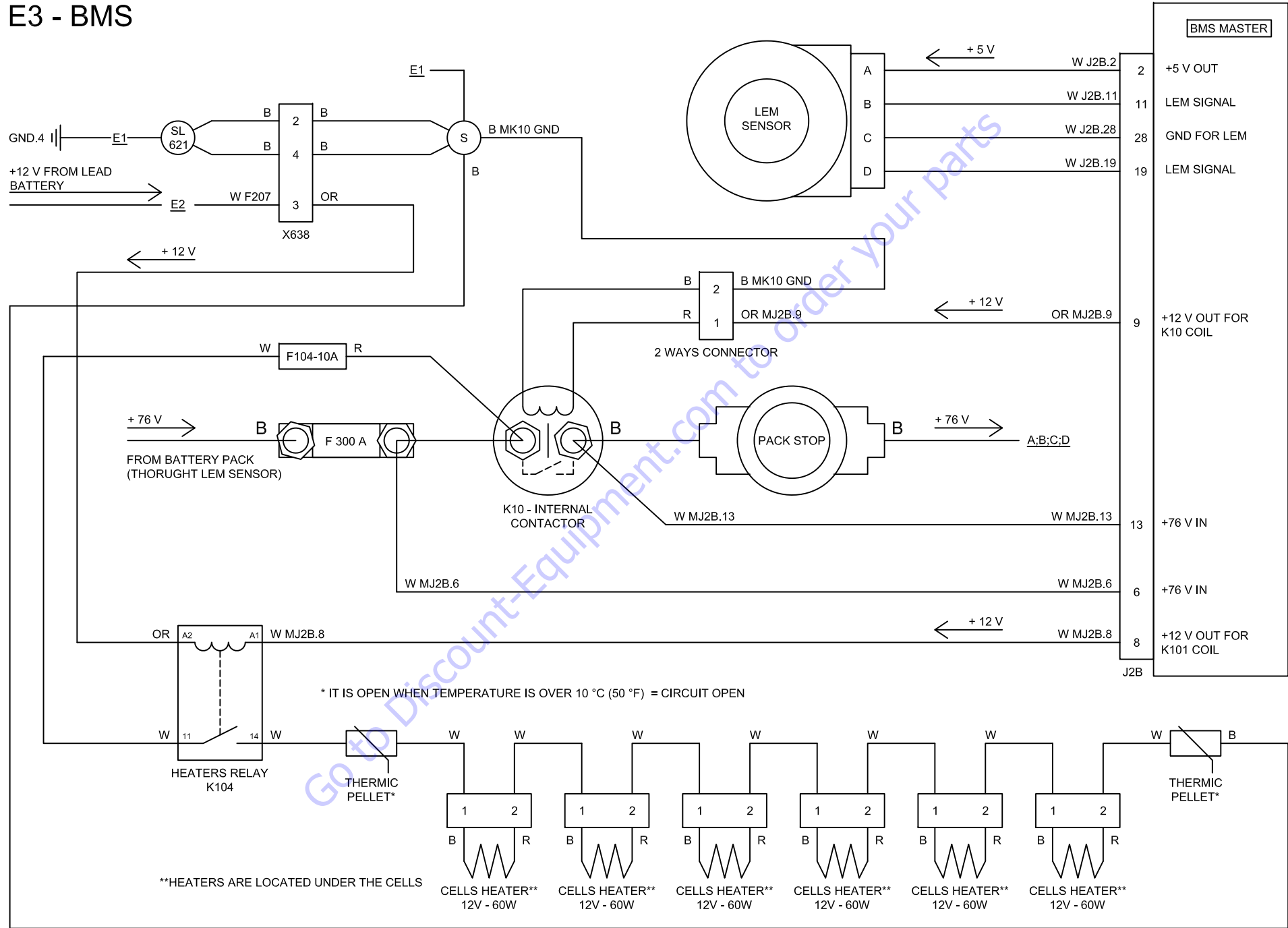

# F - CAN BUS LINE

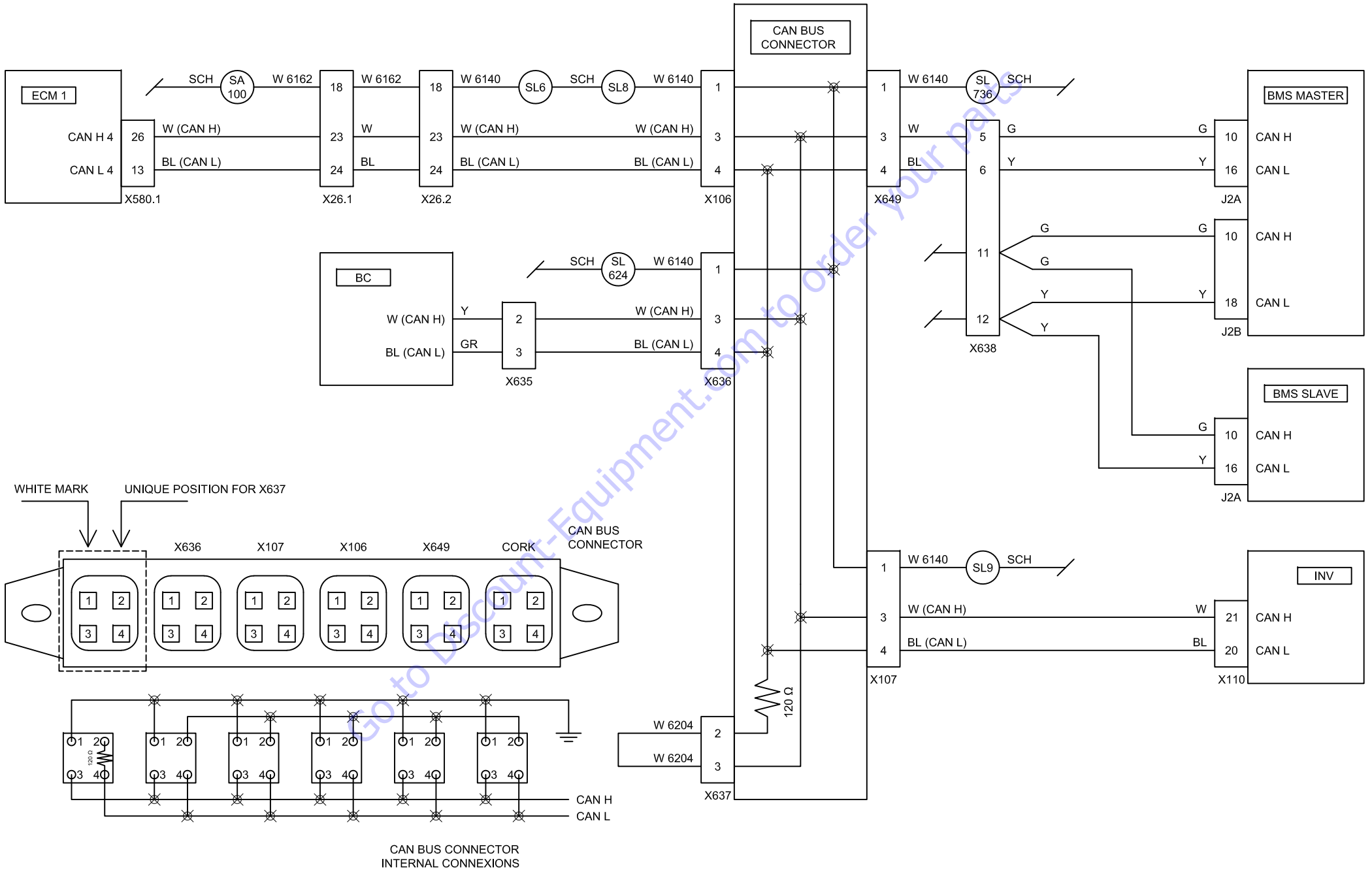

# G - COMPONENTS LOCATION

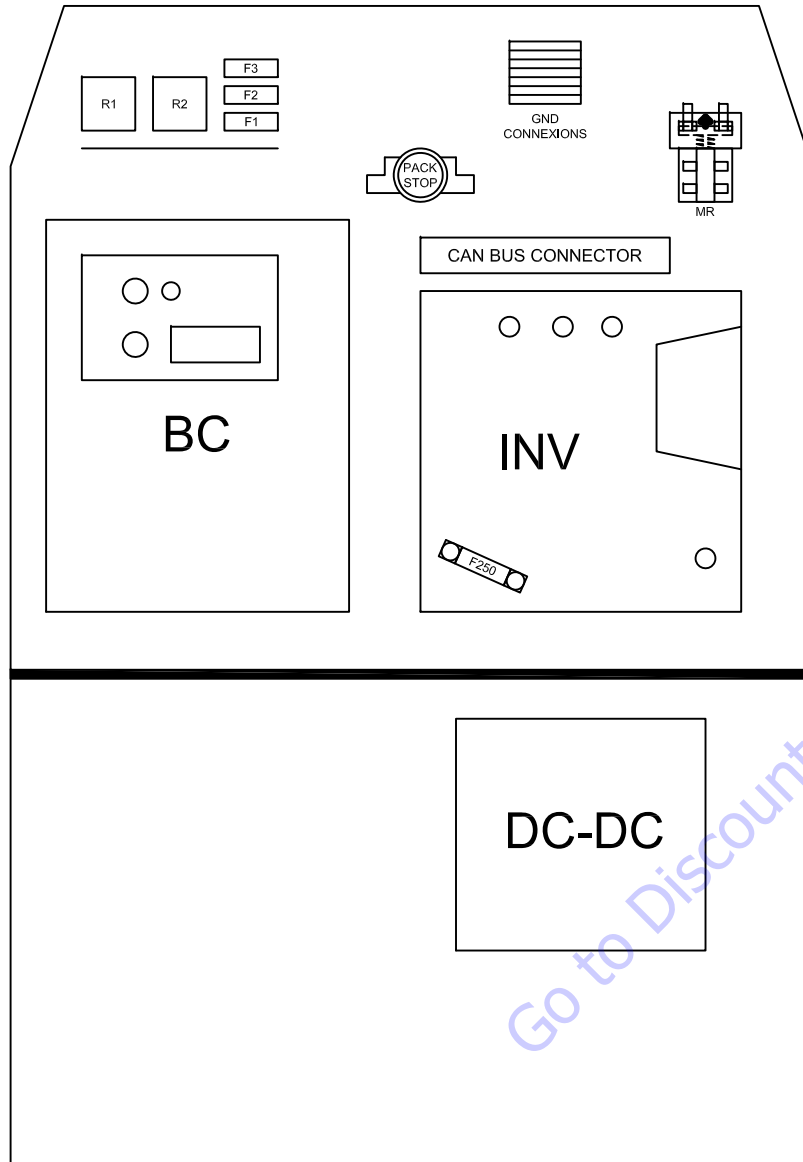

EXTERNAL COMPONENTS

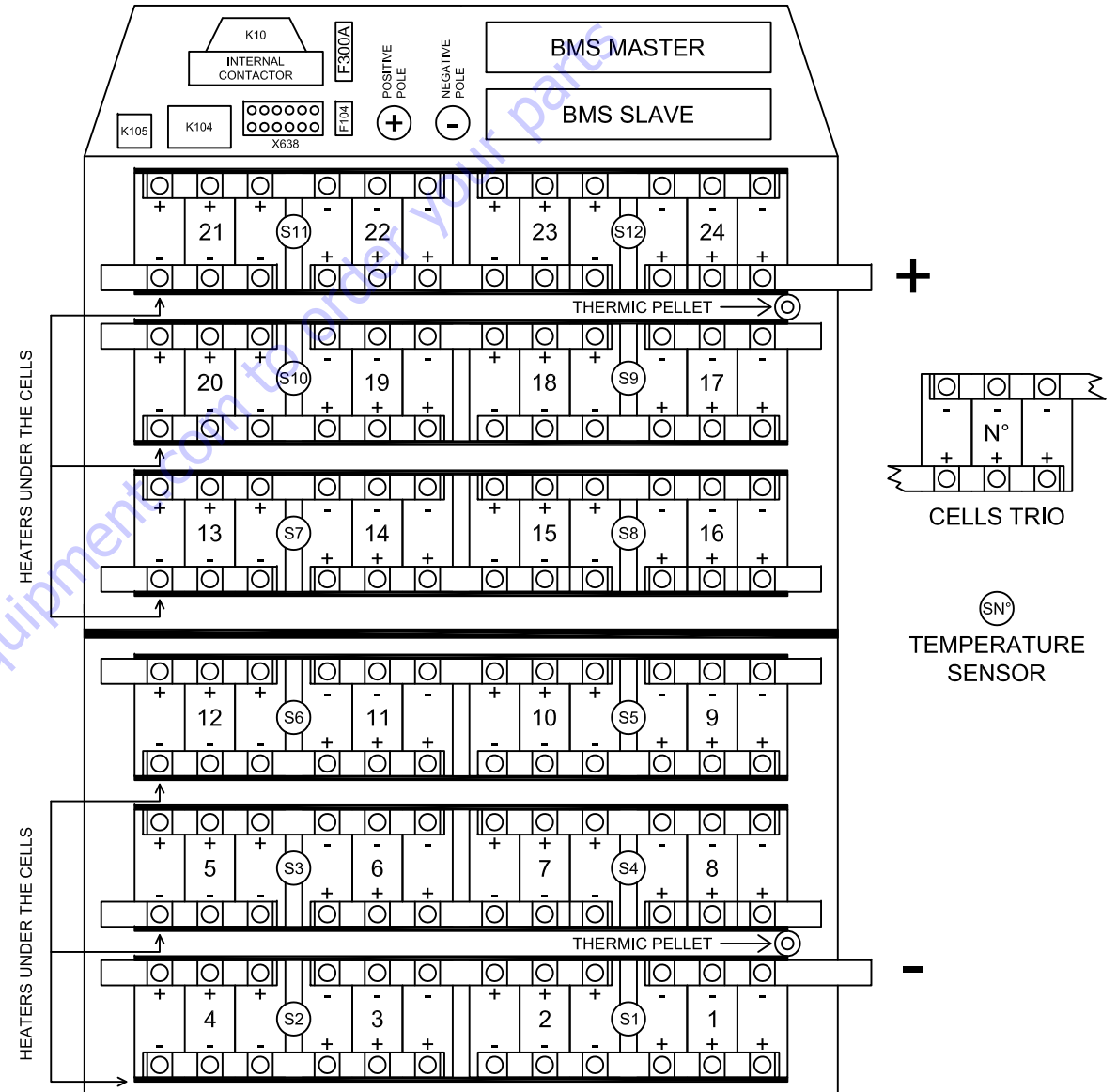

INTERNAL COMPONENTS

# H - LAYOUT BMS

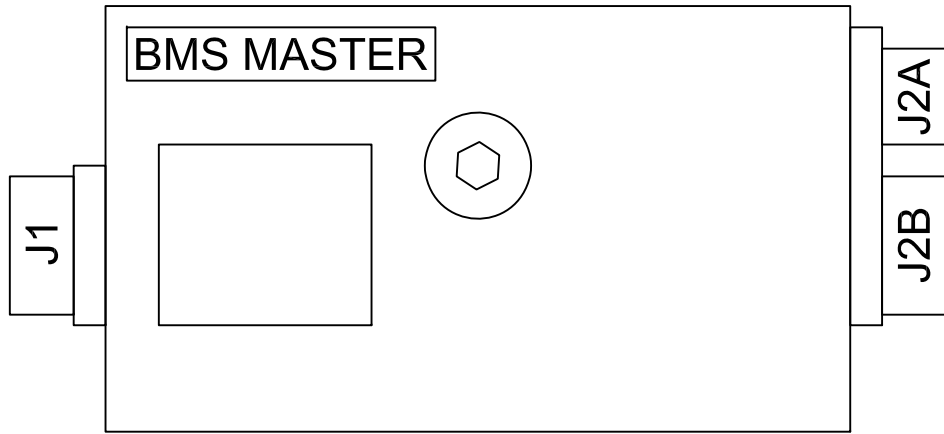

BMS VIEW FROM ABOVE SHOWN

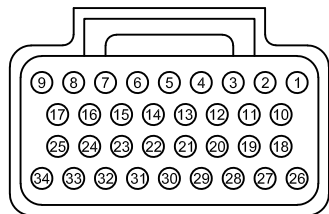
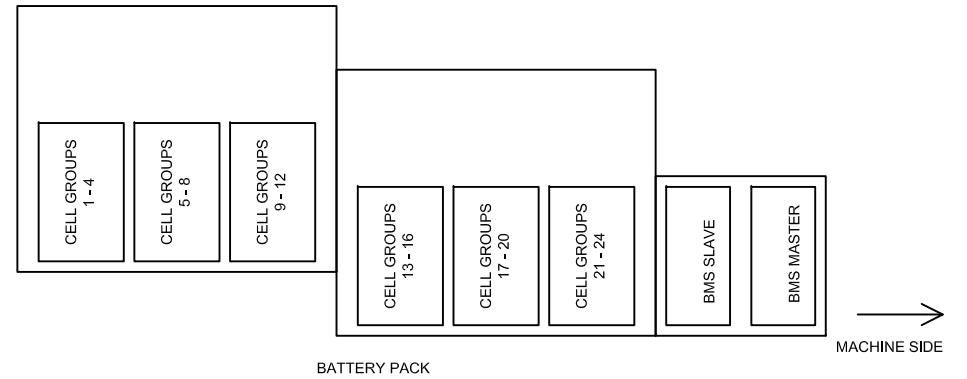
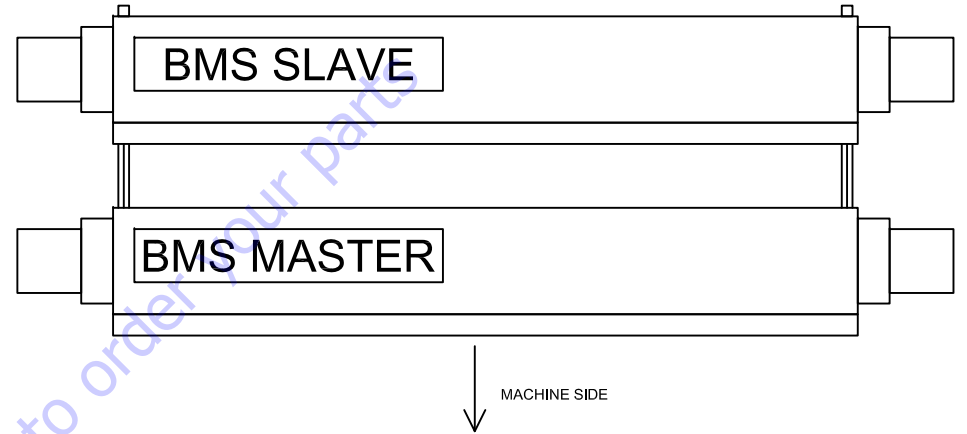
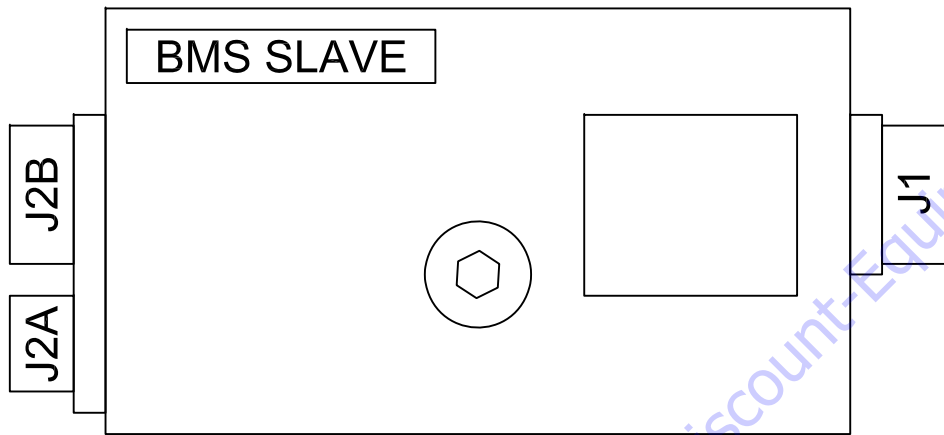

J1 CONNECTOR

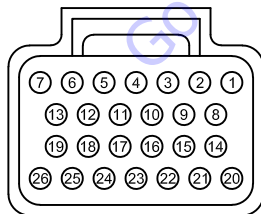

J2A CONNECTOR

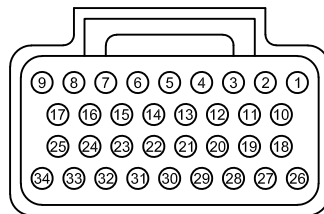

J2B CONNECTOR

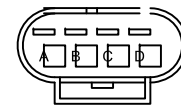

LEM CONNECTOR  
(ON LEM SENSOR)

NOTE: FRONT VIEW CONNECTORS SHOWN

# I1 - BMS MASTER CONNECTORS

J1: Voltage Cells Tris - Temperature Sensors

Pin	Wire (Color and Initial)	Abbreviation on page G	Description
1	W J1.1 C9 POS	C9	Volt cells tris N°9
2	/		/
3	W J1.3 C8 POS	C8	Volt cells tris N°8
4	W J1.4 C7 POS	C7	Volt cells tris N°7
5	/		/
6	B J1.6 C1 NEG	C1 NEG	38 Volt Minus (On Cell N°1)
7	W J1.7 C1 POS	C1	Volt cells tris N°1
8	W J1.8 C2 POS	C2	Volt cells tris N°2
9	/		/
10	/		/
11	/		/
12	Y J1.12 NTC6	S6	Feed Temperature sensor N°6
13	Y J1.13 NTC5	S5	Feed Temperature sensor N°5
14	Y J1.14 NTC4	S4	Feed Temperature sensor N°4
15	Y J1.15 NTC3	S3	Feed Temperature sensor N°3
16	Y J1.16 NTC2	S2	Feed Temperature sensor N°2
17	Y J1.17 NTC1	S1	Feed Temperature sensor N°1
18	/		/
19	/		/
20	Y J1.20 NTC6 GND	S6	Minus Temperature sensor N° 6
21	Y J1.21 NTC5 GND	S5	Minus Temperature sensor N° 5
22	Y J1.22 NTC4 GND	S4	Minus Temperature sensor N° 4
23	Y J1.23 NTC3 GND	S3	Minus Temperature sensor N° 3
24	Y J1.24 NTC2 GND	S2	Minus Temperature sensor N° 2
25	Y J1.25 NTC1 GND	S1	Minus Temperature sensor N° 1
26	W J1.26 C10 POS	C10	Volt cells tris N°10
27	/		/
28	W J1.28 C11 POS	C11	Volt cells tris N°11
29	R J1.29 C12 POS	C12	Volt cells tris N°12
30	W J1.30 C6 POS	C6	Volt cells tris N°6
31	W J1.31 C5 POS	C5	Volt cells tris N°5
32	/		/
33	W J1.33 C4 POS	C4	Volt cells tris N°4
34	W J1.34 C3 POS	C3	Volt cells tris N°3

J2A: Can Line - Feed

Pin	Wire (Color and Initial)	Description
1	/	/
2	/	/
3	W SJ2A.9 MJ2A.3	+12 V OUT
4	B J2A4.4	38 Volt Battery Pack Minus
5	/	/
6	/	/
7	/	/
8	/	/
9	OR MJ2A.9	12 Volt Positive IN
10	G	Can H
11	/	/
12	/	/
13	/	/
14	/	/
15	B MJ2A.15	38 Volt Battery Pack Minus
16	Y	Can L
17	/	/
18	/	/
19	B MJ2A.19 GND	38 Volt Battery Pack Minus
20	/	/
21	/	/
22	/	/
23	B MJ2A.23 GND	38 Volt Battery Pack Minus
24	B MJ2A.24 GND	38 Volt Battery Pack Minus
25	OR MJ2A.25	12 Volt Positive IN
26	OR MJ2A.26	12 Volt Positive IN

J2B: Feed - Lem sensor - Fans - Heaters - Internal Contactor

Pin	Wire (Color and Initial)	Description
1	R MJ2B.1 C12	38 Volt Positive IN
2	W J2B.2	+N155 Volt Out - Lem Sensor
3	B J2B.3	38 Volt Battery Pack Minus
4	B J2B.4	38 Volt Battery Pack Minus
5	/	/
6	W MJ2B.6	76 Volt Positive In
7		38 Volt Battery Pack Minus
8	W MJ2B.8	Heaters activation
9	OR MJ2B.9	Internal contactor feed
10	G MJ2B.10 S J2A.10	Can H
	G	Can H
11	W MJ2B.11	Lem Sensor Signal
12	/	/
13	W MJ2B.13	76 Volt Positive IN
14	OR MJ2B.14	12 Volt Positive IN
15	/	/
16	W MJ2B.16 S J2A.15	GND (OUT)
17	/	/
18	Y MJ2B.18 S J2A.16	Can L
	Y	Can L
19	W MJ2B.19	Lem Sensor Signal
20	/	/
21	/	/
22	/	/
23	/	/
24	/	/
25	/	/
26	/	/
27	/	/
28	W MJ2B.28	Lem Sensor Minus
29	/	/
30	/	/
31	/	/
32	B MJ2B.32 GND	38 Volt Battery Pack Minus
33	/	/
34	GR MJ2B.34	Fans activation (Minus)

## 12 - BMS SLAVE CONNECTORS

J1: Voltage Cells Tris - Temperature Sensors

Pin	Wire (Color and Initial)	Abbreviation on page G	Description
1	W J1.1 C21 POS	C21	Volt cells tris N°21
2	/	/	/
3	W J1.3 C20 POS	C20	Volt cells tris N°20
4	W J1.4 C19 POS	C19	Volt cells tris N°19
5	/	/	/
6	B J1.6 C12 NEG	C13 NEG	Minus On Cell N°13
7	W J1.7 C13 POS	C13	Volt cells tris N°13
8	W J1.8 C14 POS	C14	Volt cells tris N°14
9	/	/	/
10	/	/	/
11	/	/	/
12	Y J1.12 NTC11	S11	Feed Temperature sensor N° 11
13	Y J1.13 NTC12	S12	Feed Temperature sensor N° 12
14	Y J1.14 NTC9	S9	Feed Temperature sensor N°9
15	Y J1.15 NTC10	S10	Feed Temperature sensor N° 10
16	Y J1.16 NTC7	S7	Feed Temperature sensor N°7
17	Y J1.17 NTC8	S8	Feed Temperature sensor N°8
18	/	/	/
19	/	/	/
20	Y J1.20 NTC11 GND	S11	Minus Temperature sensor N° 11
21	Y J1.21 NTC12 GND	S12	Minus Temperature sensor N° 12
22	Y J1.22 NTC9 GND	S9	Minus Temperature sensor N° 9
23	Y J1.23 NTC10 GND	S10	Minus Temperature sensor N° 10
24	Y J1.24 NTC7 GND	S7	Minus Temperature sensor N° 7
25	Y J1.25 NTC8 GND	S8	Minus Temperature sensor N° 8
26	W J1.26 C22 POS	C22	Volt cells tris N°22
27	/	/	/
28	W J1.28 C23 POS	C23	Volt cells tris N°23
29	R J1.29 C24 POS	C24	Volt cells tris N°24
30	W J1.30 C18 POS	C18	Volt cells tris N°18
31	W J1.31 C17 POS	C17	Volt cells tris N°17
32	/	/	/
33	W J1.33 C16 POS	C16	Volt cells tris N° 16
34	W J1.34 C15 POS	C15	Volt cells tris N° 15

J2A: Can Line - Feed

Pin	Wire (Color and Initial)	Description
1	/	/
2	/	/
3	/	/
4	/	/
5	/	/
6	/	/
7	/	/
8	/	/
9	W MJ2A.3 S J2A.9	12 Volt Positive IN
10	G MJ2B.10 S J2A.10	Can H
11	/	/
12	/	/
13	/	/
14	/	/
15	W SJ2A.15 M J2B.16	38 Volt Battery Pack Minus
16	Y MJ2B.18 S J2A.16	Can L
17	/	/
18	/	/
19	/	/
20	/	/
21	/	/
22	/	/
23	/	/
24	/	/
25	/	/
26	/	/

J2B: Feed

Pin	Wire (Color and Initial)	Description
1	R SJ2B.1 C24	38 Volt Positive IN
2	/	/
3	P SJ2B.3	38 Volt Battery Pack Minus
4	/	/
5	/	/
6	/	/
7	/	/
8	/	/
9	/	/
10	/	/
11	/	/
12	/	/
13	/	/
14	/	/
15	/	/
16	/	/
17	/	/
18	/	/
19	/	/
20	/	/
21	/	/
22	/	/
23	/	/
24	/	/
25	/	/
26	/	/
27	/	/
28	/	/
29	/	/
30	/	/
31	/	/
32	/	/
33	/	/
34	/	/

Go to Discount-Equipment.com to order your parts

# L - COMPONENTS LAYOUT

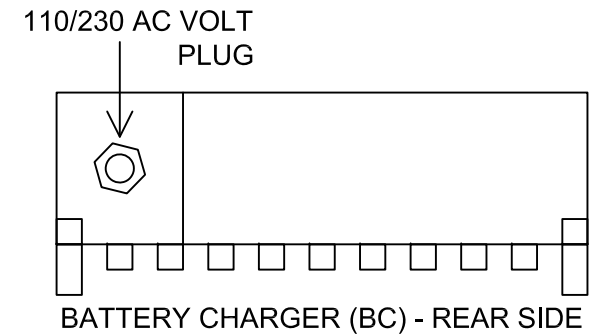
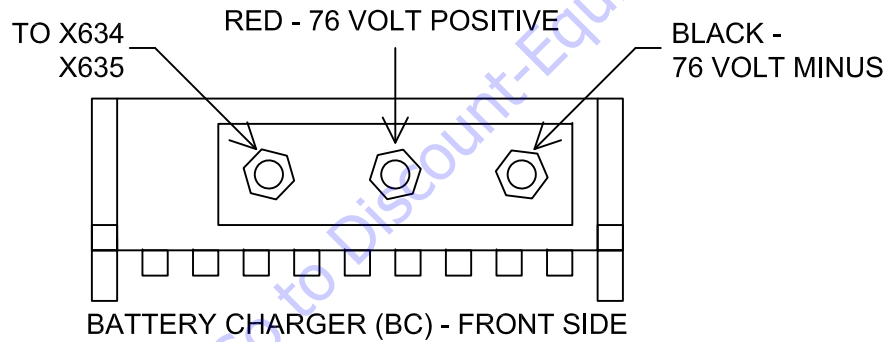
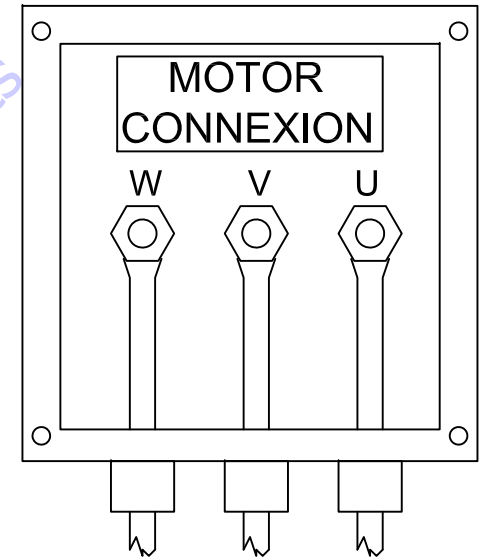
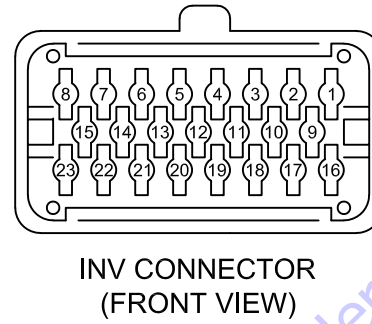
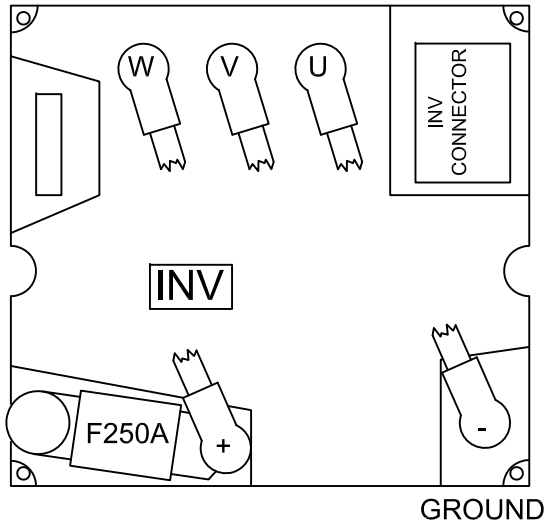
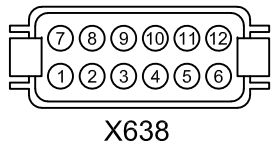
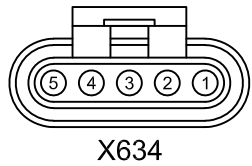
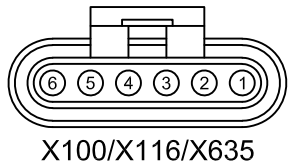
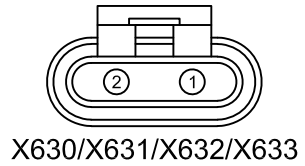
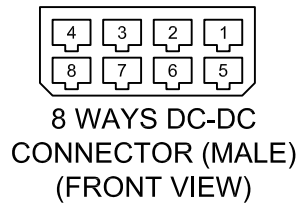
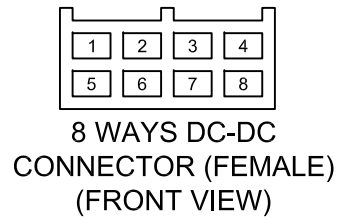

## REVISIONS LIST

### *WDPE3317000A01*

- Multilanguage index added
- Minor modifications at pages 6; 23; 27

### *WDPE3317000A02*

- Changed names at pages 1; 2; 3
- Improved explanations at pages 2; 3

### *WDPE3317000A03*

- Page 12: corrected Load cell sensor connexions, other minor modifications
- Added notes at pages 19; 20; 21; 22; 23
- Page 25: Removed battery charger
- Improved Can Bus Connector description at pages 5; 6; 7; F
- Page 7: Connector X837 renamed as X788

### *WDPE3317000A04*

- Changed name at pages 2; 3
- Improved battery cutter connexion descriptions at pages 4; 9; 11; 13; 14; 24B; 24C; A; B
- Corrected pin X580.1/19 with 580.1/91 at page B
- Lithium GND connexion pint added at page G
- Connectors location added at paragraph 27

Go to [Discount-Equipment.com](http://Discount-Equipment.com) to order your parts



# PARTS FINDER

Search Website  
by Part Number



Search Manual  
Library For Parts  
Manual & Lookup Part  
Numbers – Purchase  
or Request Quote

Can't Find Part or  
Manual? Request Help  
by Manufacturer,  
Model & Description

Discount-Equipment.com is your online resource for quality parts & equipment.

Florida: **561-964-4949** Outside Florida TOLL FREE: **877-690-3101**

Need parts?

Click on this link: <http://www.discount-equipment.com/category/5443-parts/> and choose one of the options to help get the right parts and equipment you are looking for. Please have the machine model and serial number available in order to help us get you the correct parts. If you don't find the part on the website or on once of the online manuals, please fill out the request form and one of our experienced staff members will get back to you with a quote for the right part that your machine needs.

We sell worldwide for the brands: Genie, Terex, JLG, MultiQuip, Mikasa, Essick, Whiteman, Mayco, Toro Stone, Diamond Products, Generac Magnum, Airman, Haulotte, Barreto, Power Blanket, Nifty Lift, Atlas Copco, Chicago Pneumatic, Allmand, Miller Curber, Skyjack, Lull, Skytrak, Tsurumi, Husquvarna Target, , Stow, Wacker, Sakai, Mi-T- M, Sullair, Basic, Dynapac, MBW, Weber, Bartell, Bennar Newman, Haulotte, Ditch Runner, Menegotti, Morrison, Contec, Buddy, Crown, Edco, Wyco, Bomag, Laymor, Barreto, EZ Trench, Bil-Jax, F.S. Curtis, Gehl Pavers, Heli, Honda, ICS/PowerGrit, IHI, Partner, Imer, Clipper, MMD, Koshin, Rice, CH&E, General Equipment, ,AMida, Coleman, NAC, Gradall, Square Shooter, Kent, Stanley, Tamco, Toku, Hatz, Kohler, Robin, Wisconsin, Northrock, Oztec, Toker TK, Rol-Air, Small Line, Wanco, Yanmar



31217109



An Oshkosh Corporation Company



[www.Discount-Equipment.com](http://www.Discount-Equipment.com)

Go to [Discount-Equipment.com](http://Discount-Equipment.com) to order your parts