



An Oshkosh Corporation Company



www.Discount-Equipment.com

---

# ***Electrical Schematic Manual***

***Model***

***X26JP - X770AJ***

***P/N - 3121764***

***November 1, 2016***

***For Machines Prior To  
S/N-C170000944***

***ANSI***

***CE***



---

An Oshkosh Corporation Company



## ELECTRIC DIAGRAM

DESCRIPTION	REFERENCE
• How to read the electric wiring diagrams	
• Photocells – Safety exclusion – Stabilizer pressure sensors	A
• Reduced area stabilizer switches	B
• Total stabilization area position switches	C
• Outrigger stabilization switches	D
• Can Bus Line	E
• Aerial safety line	F
• Boards and devices feed – Ropes, jib and pedal switches	G
• Ground position control box	H
• Emergency descend electro valves – Widening cylinder sensors - Optionals	I
• EV tracks, undercarriage widening, 2° speed, ground proportionals	J
• EV outriggers, electric diverter	K
• EV 1° cylinder, 2° cylinder, extension, rotation	L
• EV basket levelling, basket rotation, pumps sum, jib, aerial proportional	M
• Diesel RPM regulator system	N
• Kubota diesel engine: starter, sparks, stop, sensors	O
• 120/220 Volt line	P
• Components location	T
• Components abbreviation meaning	U
• Connectors layout	V
• Lithium version (83 Volt)	W1, W2...

## SCHEMA ELETTRICO

DESCRIZIONE	RIFERIMENTO
• Come leggere gli schemi elettrici	
• Fotocellule – Esclusione sicurezze – Pressostati stabilizzatori	A
• Interruttori stabilizzatori area ridotta	B
• Interruttori stabilizzatori area totale	C
• Interruttori stabilizzatori	D
• Linea Can Bus	E
• Linea sicurezze parte aerea	F
• Alimentazione schede e sensori – Interruttori funi, jib e pedale	G
• Scatola di comando a terra	H
• Elettrovalvole discesa di emergenza – Sensori allargamento carro – Optional	I
• EV traini, allargamento carro, 2° velocità, proporzionali parte a terra	J
• EV stabilizzatori, deviatrice	K
• EV 1° cilindro, 2° cilindro, sfilo, rotazione	L
• EV livellamento cesto, rotazione cesto, jib, somma pompe, proporzionale parte aerea	M
• Sistema regolazione giri motore	N
• Motore Kubota: starter, candele, stop, sensori	O
• Linea 120/220 Volt	P
• Locazione componenti	T
• Significato abbreviazione componenti	U
• Layout connettori	V
• Versione litio (83 Volt)	W1, W2...

## INSTALACIÓN ELÉCTRICA

DESCRIPCIÓN	RIFERENCIA
• Como leer la instalación eléctrica	
• Fotocélulas – Exclusión seguridades - Sensores de presión estabilizadores	A
• Interruptores estabilizadores área reducida	B
• Interruptores estabilizadores área total	C
• Interruptores estabilizadores	D
• Línea Can Bus	E
• Línea aérea seguridades	F
• Alimentación placas y sensores – Interruptores cuerdas, jib y pedal	G
• Caja de comando en tierra	H
• Electroválvulas bajada de emergencia – Sensores posición orugas - Opcionales	I
• EV orugas, extensión del carro, 2º velocidad, proporcionales parte de tierra	J
• EV estabilizadores, conmutador eléctrico	K
• EV 1º cilindro, 2º cilindro, telescópico, rotación	L
• EV nivelación cesta, rotación cesta, jib, suma bombas, proporcional área	M
• Sistema regulación RPM motor de Diesel	N
• Motor de Diesel: starter, bujías, stop, sensores	O
• Línea 120/230 Volt	P
• Colocación componentes	T
• Significado abreviatura componentes	U
• Layout conectores	V
• Version litio (83 Volt)	W1, W2...

## PLAN ÉLECTRIQUE

DESCRIPTION	RÉFÉRENCE
• Comment lire les plans électriques	
• Cellules photoélectriques - Exclusion sécurités - Capteurs de pression stabilisateurs	A
• Interrupteurs stabilisateurs surface réduit	B
• Interrupteurs stabilisateurs surface total	C
• Interrupteurs stabilisateurs	D
• Ligne Can Bus	E
• Ligne de sécurité arienne	F
• Alimentation cartes et capteurs - Capteurs câbles, jib et pédale	G
• Boité de commande a la terre	H
• Electrovanes descente d'urgence - Capteurs position chenilles - Option	I
• EV chenilles, élargissement chenilles, 2° vîtes, proportionnelle partie au sol	J
• EV stabilisateurs, électrovanne déviatrice	K
• EV 1° cylindre, 2° cylindre, bras télescopique, rotation	L
• EV nivellement panier, rotation panier, jib, somme pompes, proportionnelle	M
• Système du contrôle RPM moteur diesel	N
• Moteur Kubota: demarrage, préchauffage, stop, capteurs	O
• Ligne 120/230 Volt	P
• Disposition composants	T
• Signifie abréviations des composants	U
• Layout connecteurs	V
• Version lithium (83 Volt)	W1, W2...

- **HOW TO READ THE WIRING DIAGRAMS**
- **COME LEGGERE GLI SCHEMI ELETTRICI**
- **CÓMO LEER LOS ESQUEMAS ELÉCTRICOS**
- **COMMENT LIRE LES PLANS ÉLECTRIQUES**

- Big letter identify the page number
- La lettera grande identifica il numero di pagina
- La letra grande identifica el numero de pagina
- La lettre grand indique le numéro du page



**A**

- Letter X always identify connectors
- La lettera X identifica sempre connettori
- La letra X identifica siempre conectores
- La lettre X indique toujours connecteurs

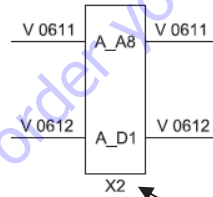

- Every wire is identified by the color and, if present, a number
- Ogni cavo è identificato dal colore e, se presente, da un numero
- Todos los cables son identificados da el color y, si presente, da un numero
- Chaque câble est identifié par le couleur et, si présente, par le nombre

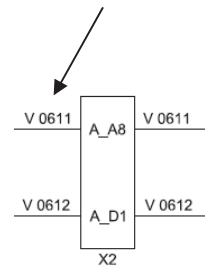

COLOUR CODES
A = AZURE
B = BLACK
BL = BLUE
BR = BROWN
G = GREEN
GR = GREY
OR = ORANGE
P = PINK
R = RED
V = PURPLE
W = WHITE
Y = YELLOW
SCH = SHIELDING

TABELLA COLORI
A = AZZURRO
B = NERO
BL = BLU
BR = MARRONE
G = VERDE
GR = GRIGIO
OR = ARANCIO
P = ROSA
R = ROSSO
V = VIOLA
W = BIANCO
Y = GIALLO
SCH = SCHERMATURA

TABLA COLORES
A = AZUL
B = NEGRO
BL = AZUL
BR = MARRÓN
G = VERDE
GR = GRIS
OR = NARANJA
P = ROSA
R = ROJO
V = VIOLETA
W = BLANCO
Y = AMARILLO
SCH = CRIBADO

TABLEAU COULEURS
A = BLEU CLAIR
B = NOIR
BL = BLEU
BR = MARRON
G = VERT
GR = GRIS
OR = ORANGE
P = ROSE
R = ROUGE
V = VIOLET
W = BLANC
Y = JAUNE
SCH = BLINDAGE

- Figures in the connectors, show the pin numbers
- Le cifre all'interno dei connettori, indicano il numero del pin
- Las cifras dentro de los conectores, indican el numero del los contactos
- Les chiffres dans les connecteurs, indiquent le nombre des goupilles

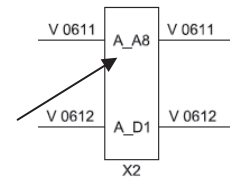

- Circles show welds with two or more wires. Each weld has an identification number
- I cerchi mostrano saldature con due o più cavi. Ogni saldatura ha un numero identificativo
- Los circulo muestra soldaduras con dos o más cables. Cada soldadura tiene un numero de identificación
- Les cercles indiquent les soudures avec deux ou plusieurs câbles. Chaque soudure a un numéro d'identification

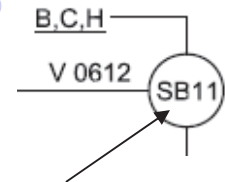

- Underlined letters show the page where the component is present too
- Le lettere sottolineate indicano le altre pagine dove il componente è presente
- Las letras subrayadas indican las otras páginas en donde el componente está presente
- Les lettres soulignées indiquent les autres pages où le composant est présent

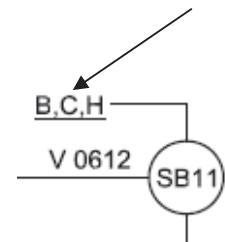

Go to Discount-Equipment.com to order your parts





# B - REDUCED AREA STABILIZER SWITCHES

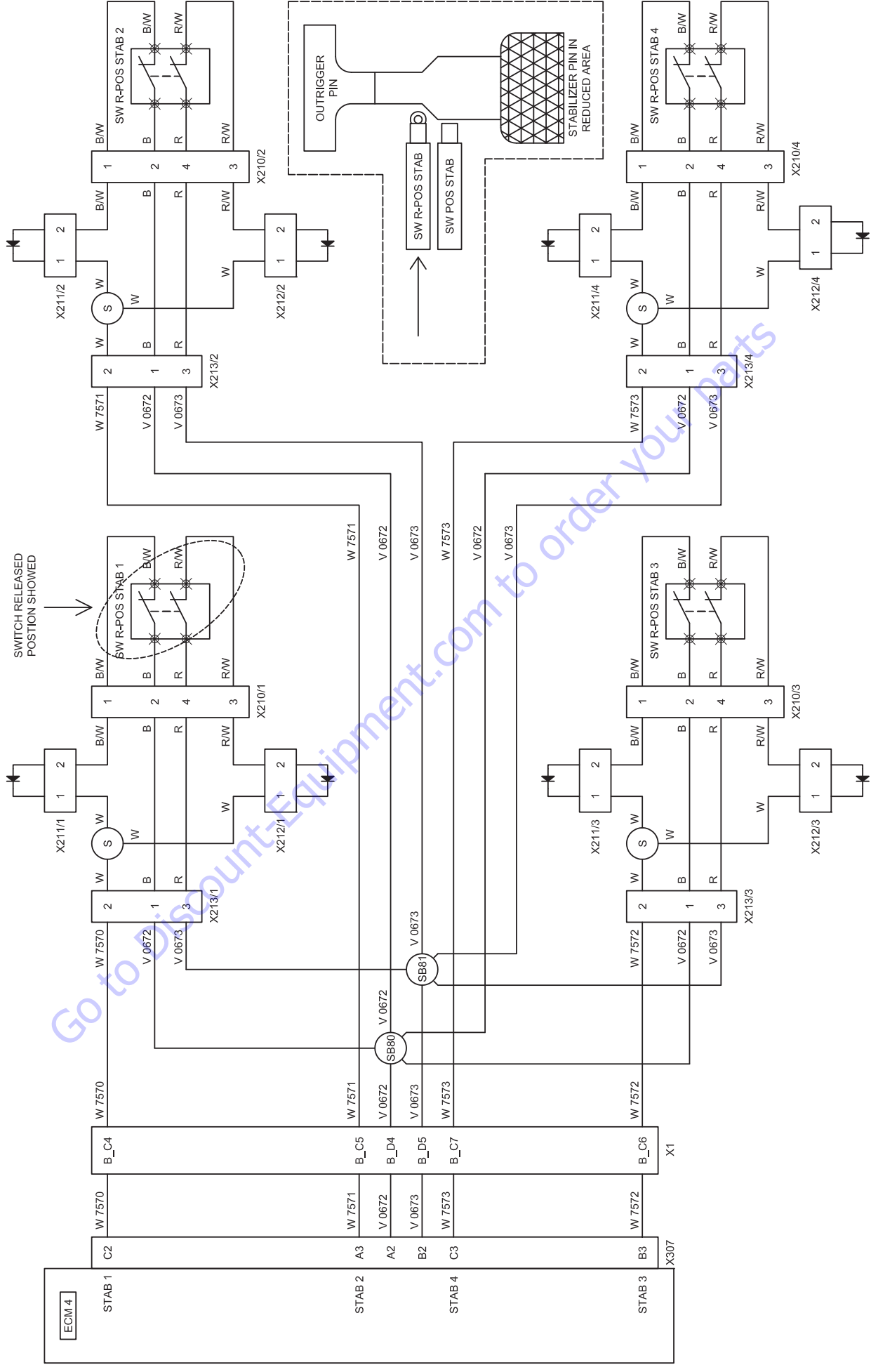

# C - TOTAL STABILIZATION AREA POSITION SWITCHES

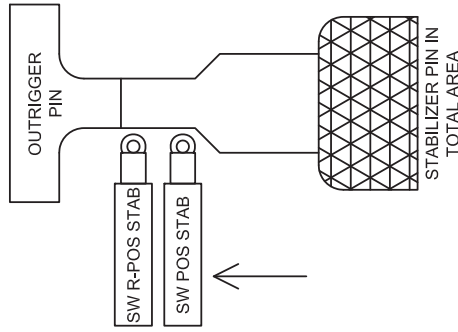
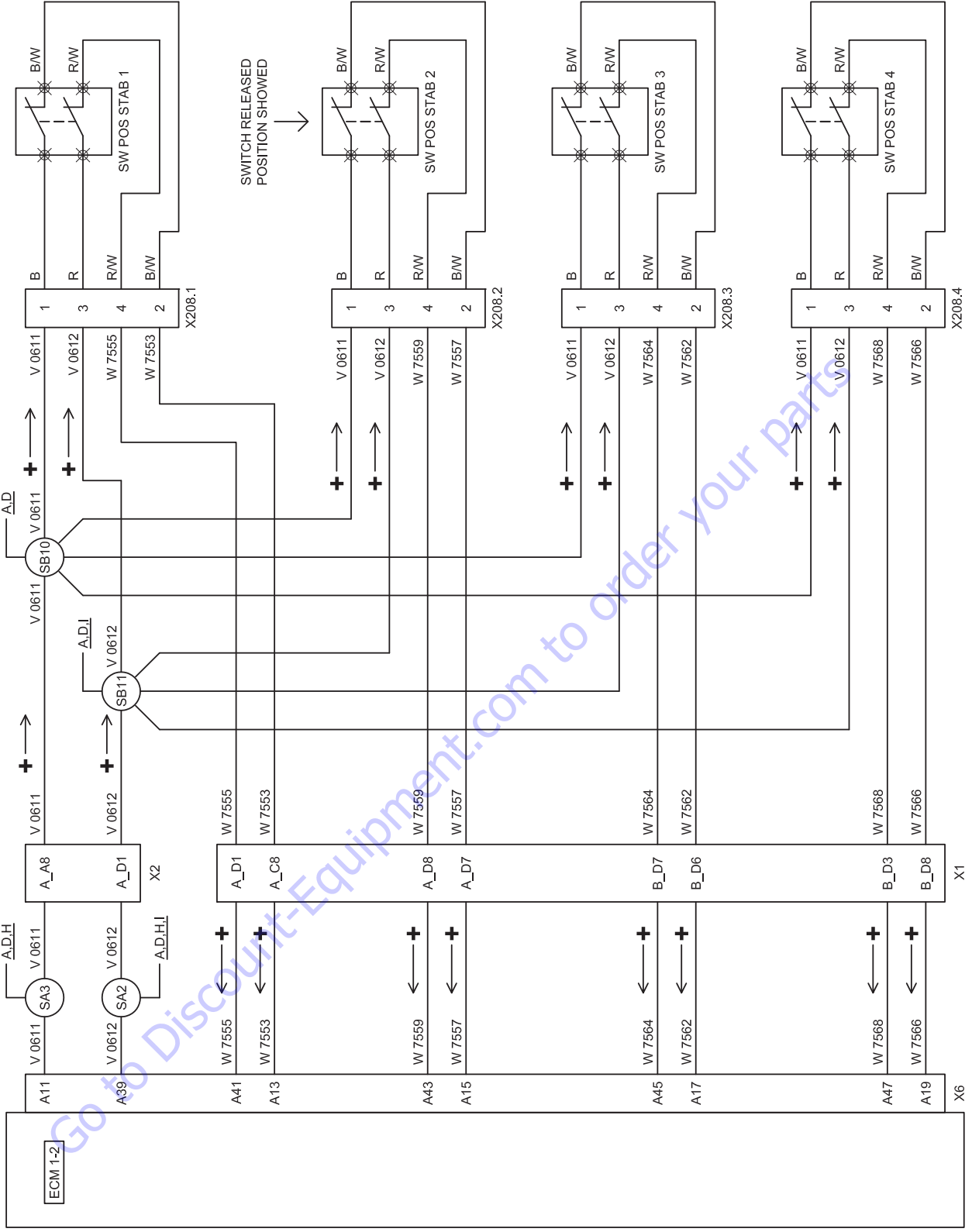

# D - OUTRIGGER STABILIZATION SWITCHES

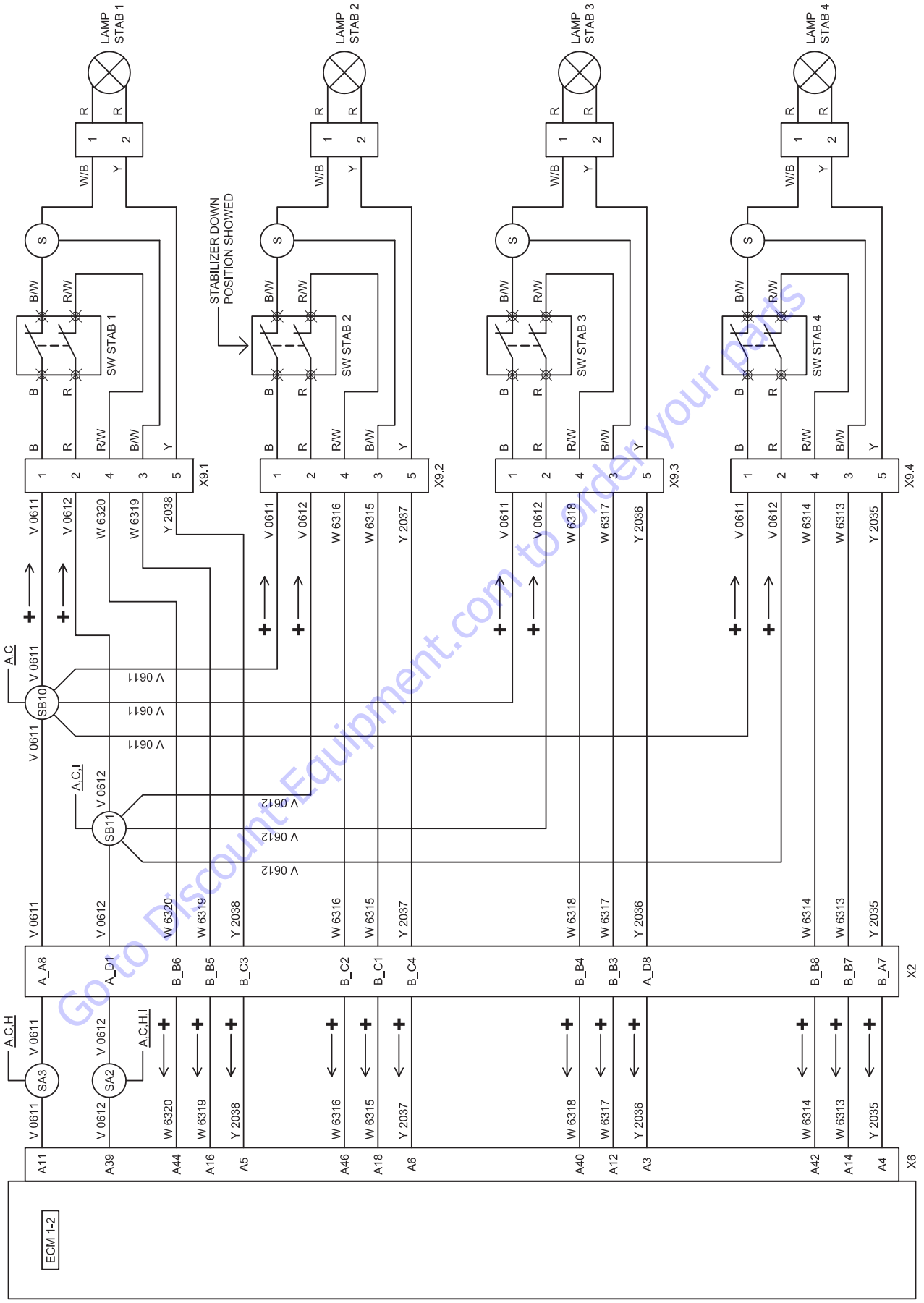

# E - CAN BUS LINE

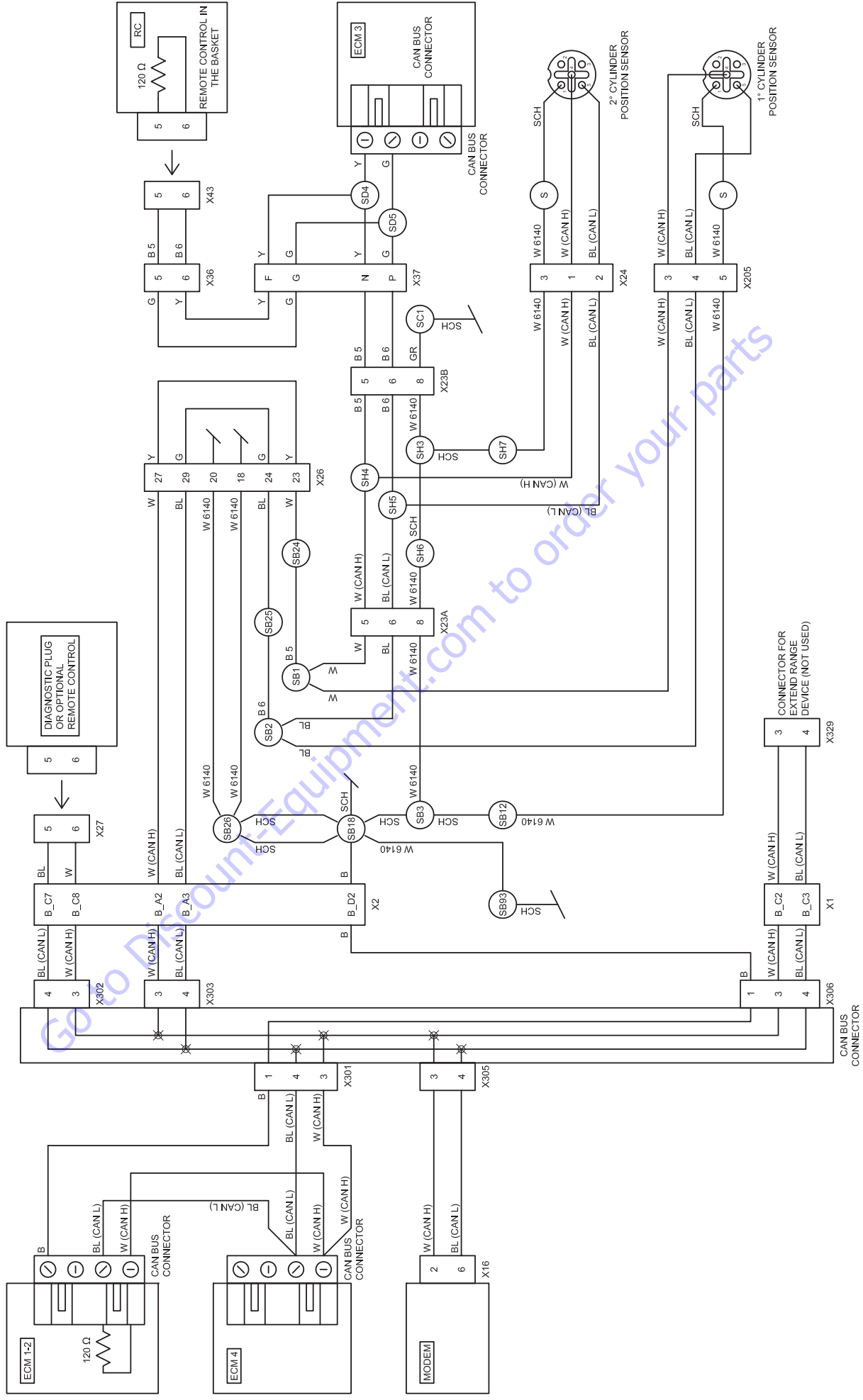

# F - AERIAL SAFETY LINE

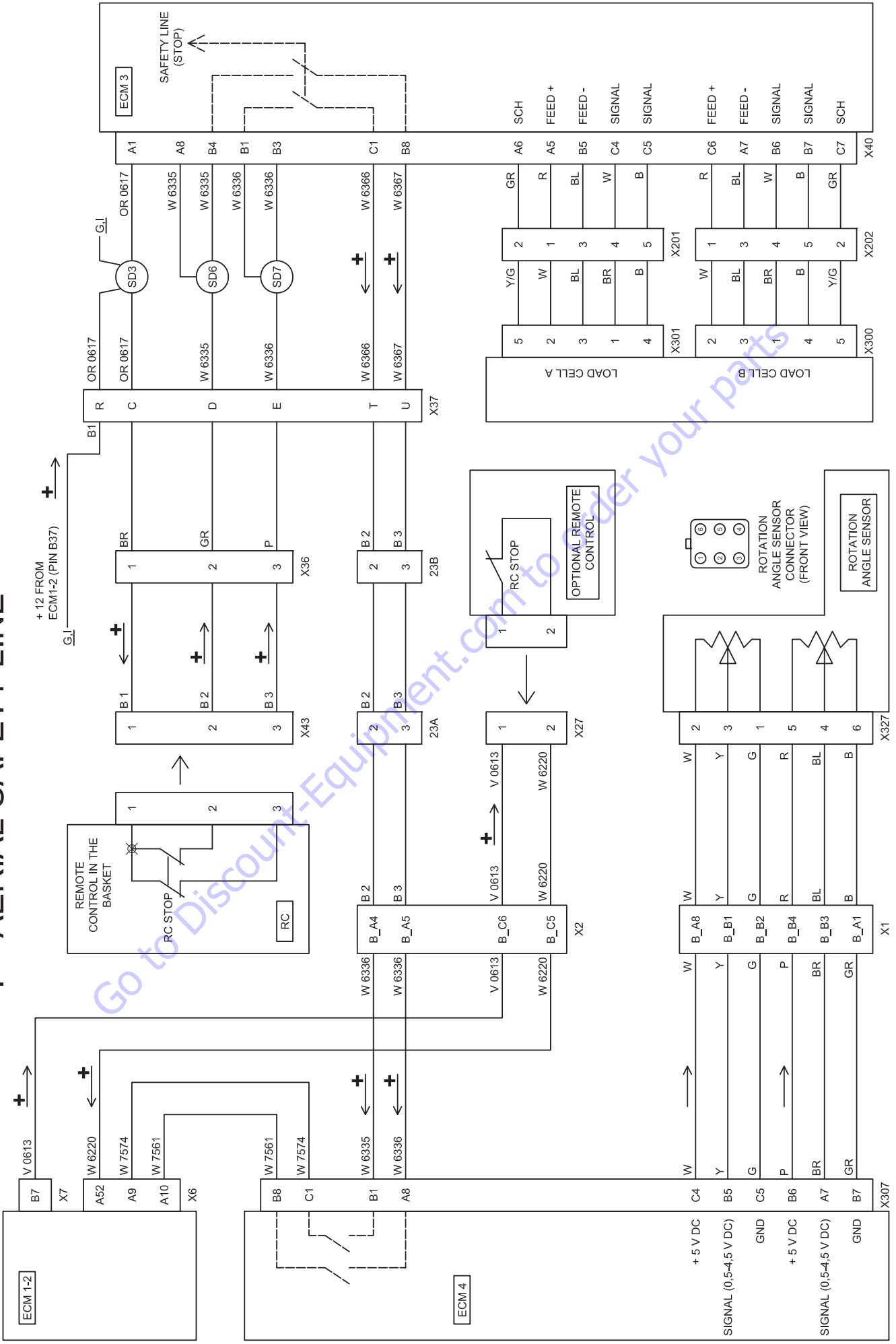

# G - BOARDS AND DEVICES FEED - ROPES, JIB AND PEDAL SWITCHES

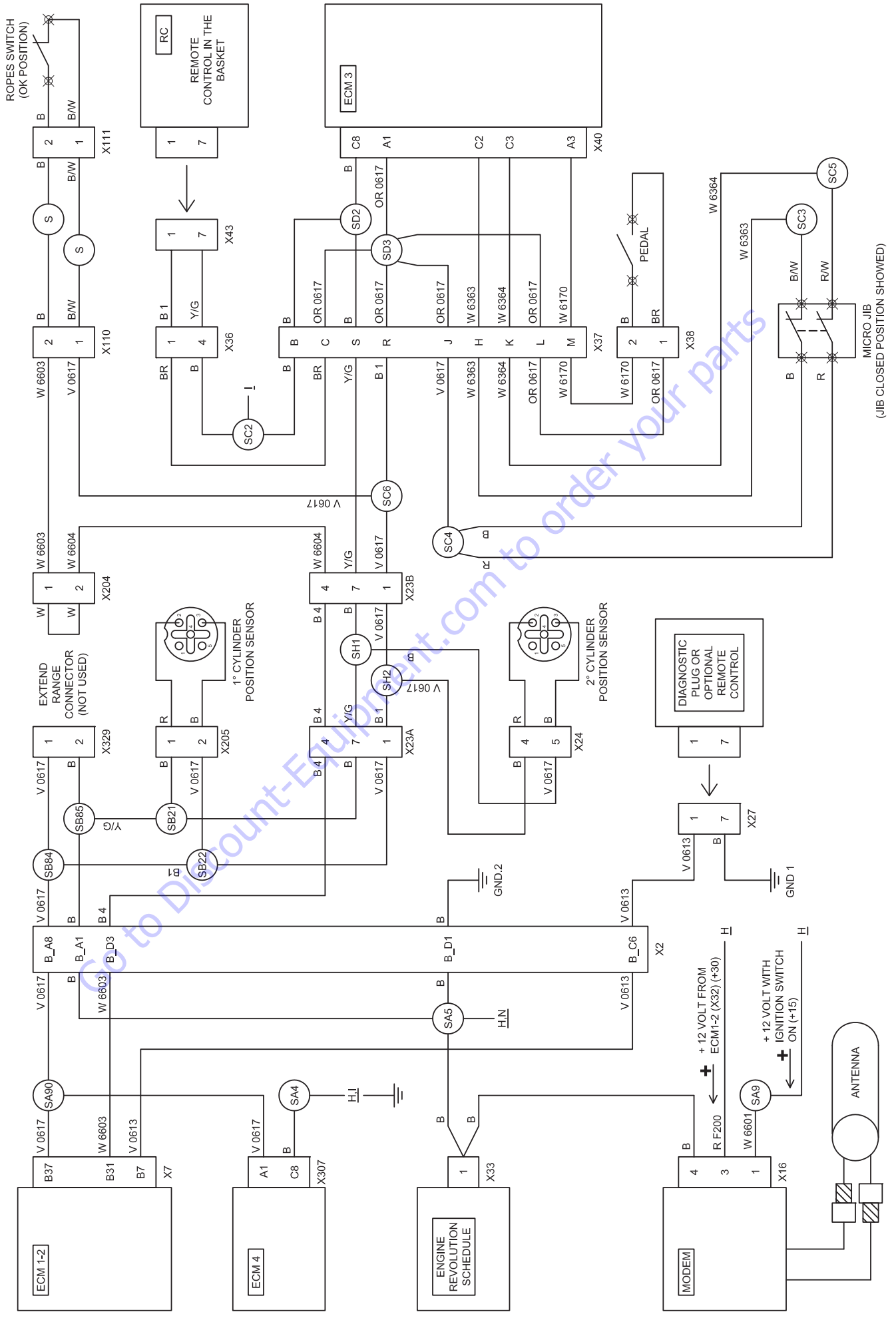

# H - GROUND POSITION CONTROL BOX

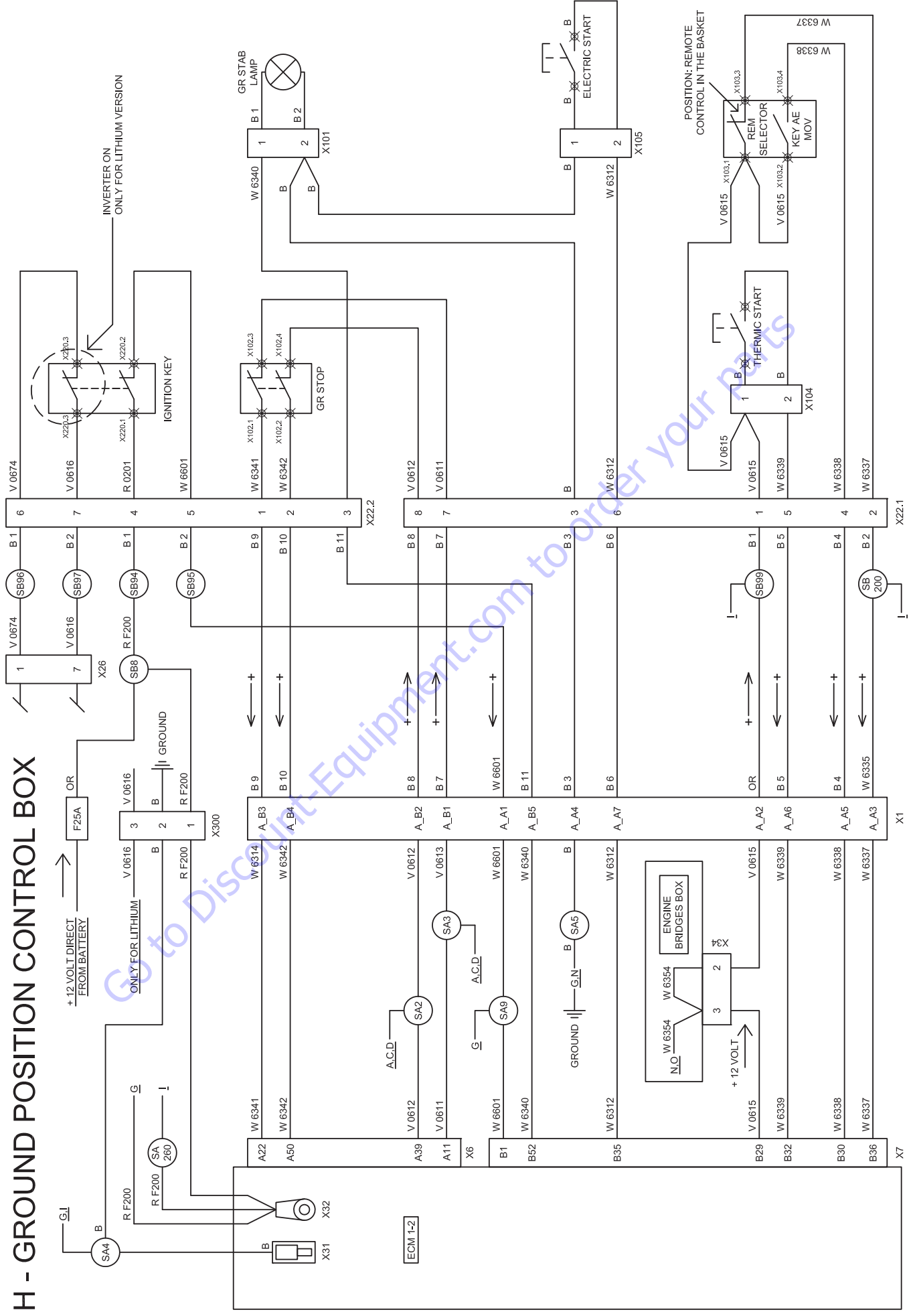





# J - EV TRACKS, UNDERCARRIAGE WIDENING, 2° SPEED, GROUND PROPORTIONALS

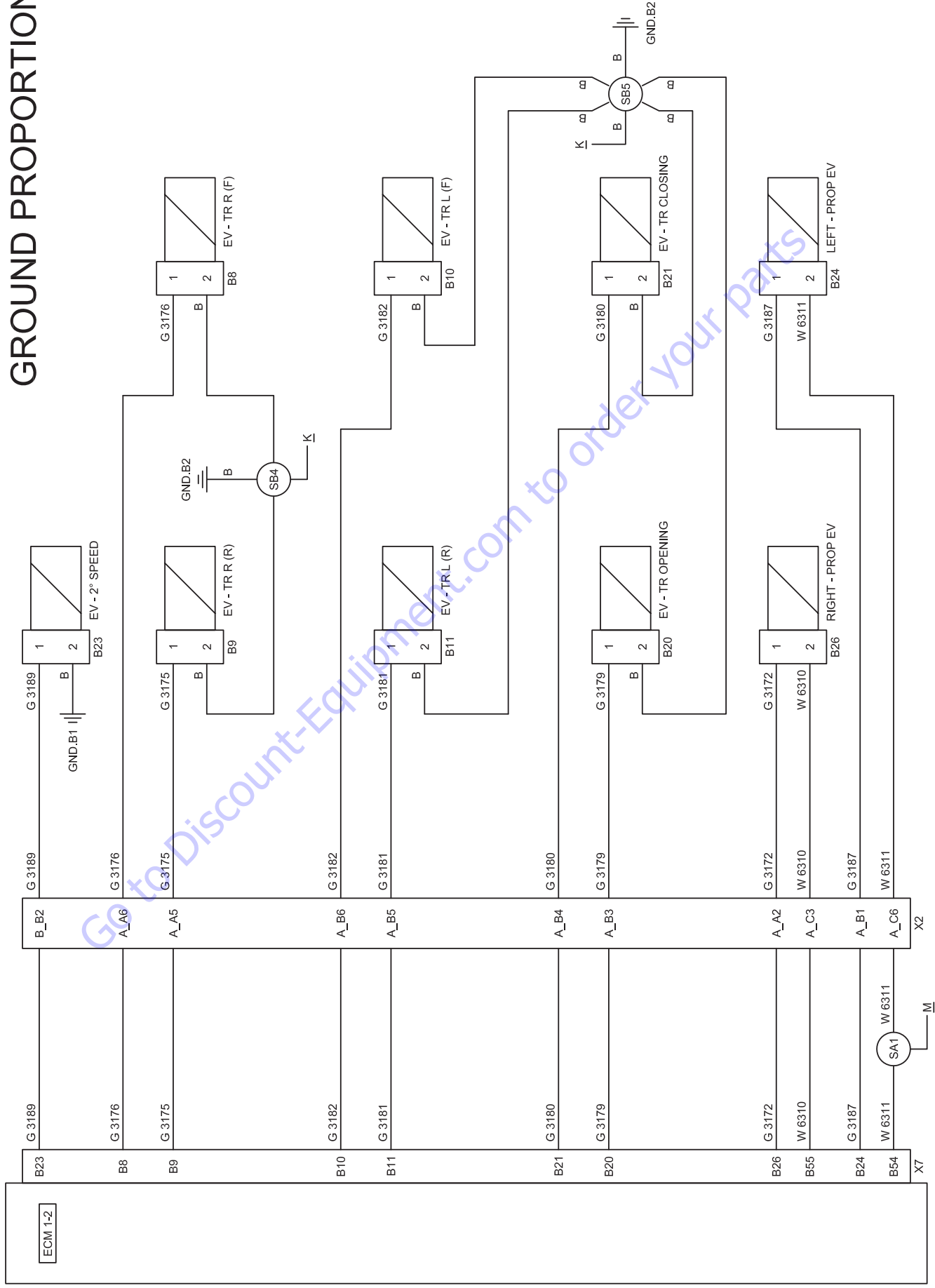

# K - EV OUTTRIGGERS, ELECTRIC DIVERTER

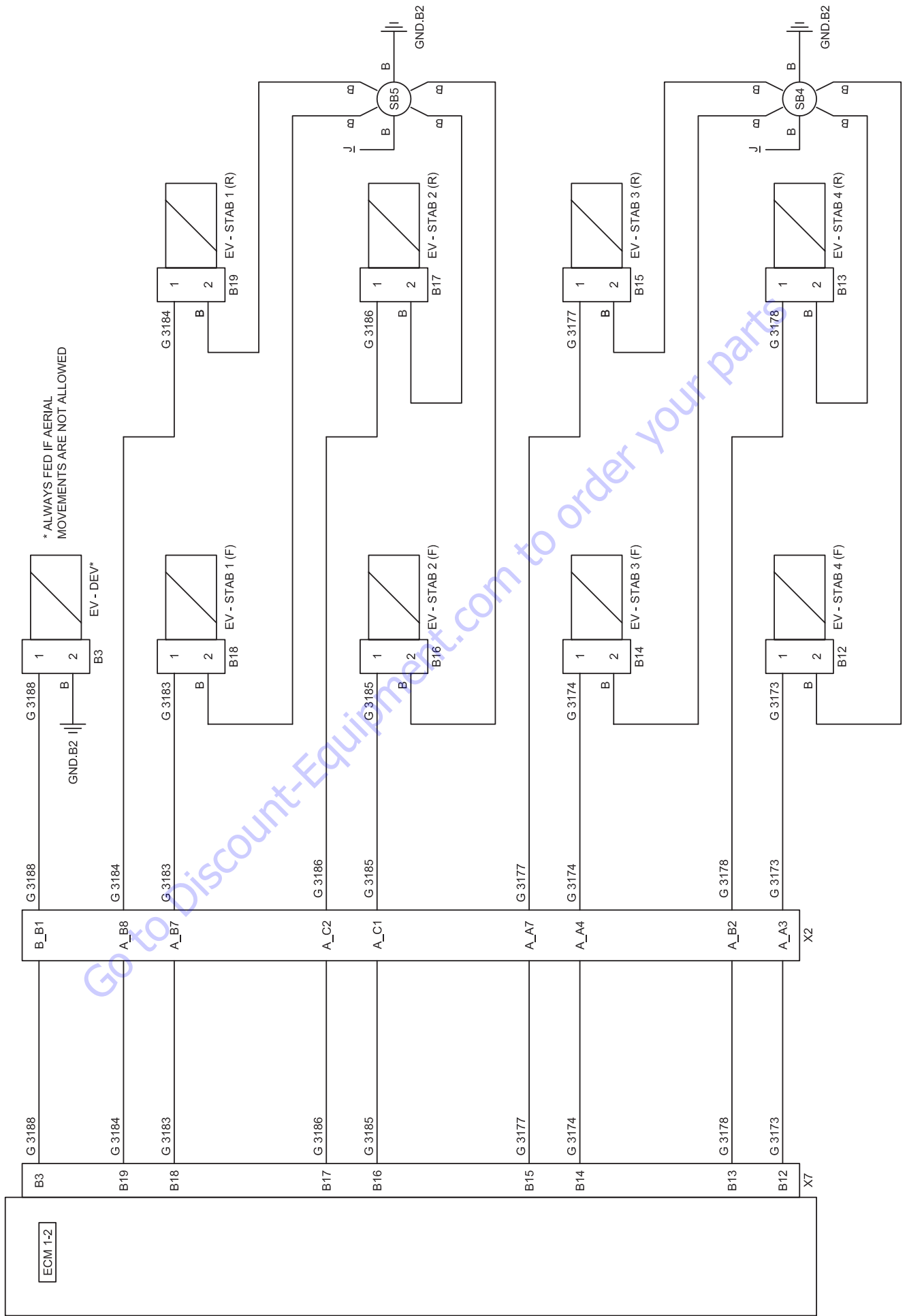

# L - EV 1° CYLINDER, 2° CYLINDER, EXTENSION, ROTATION

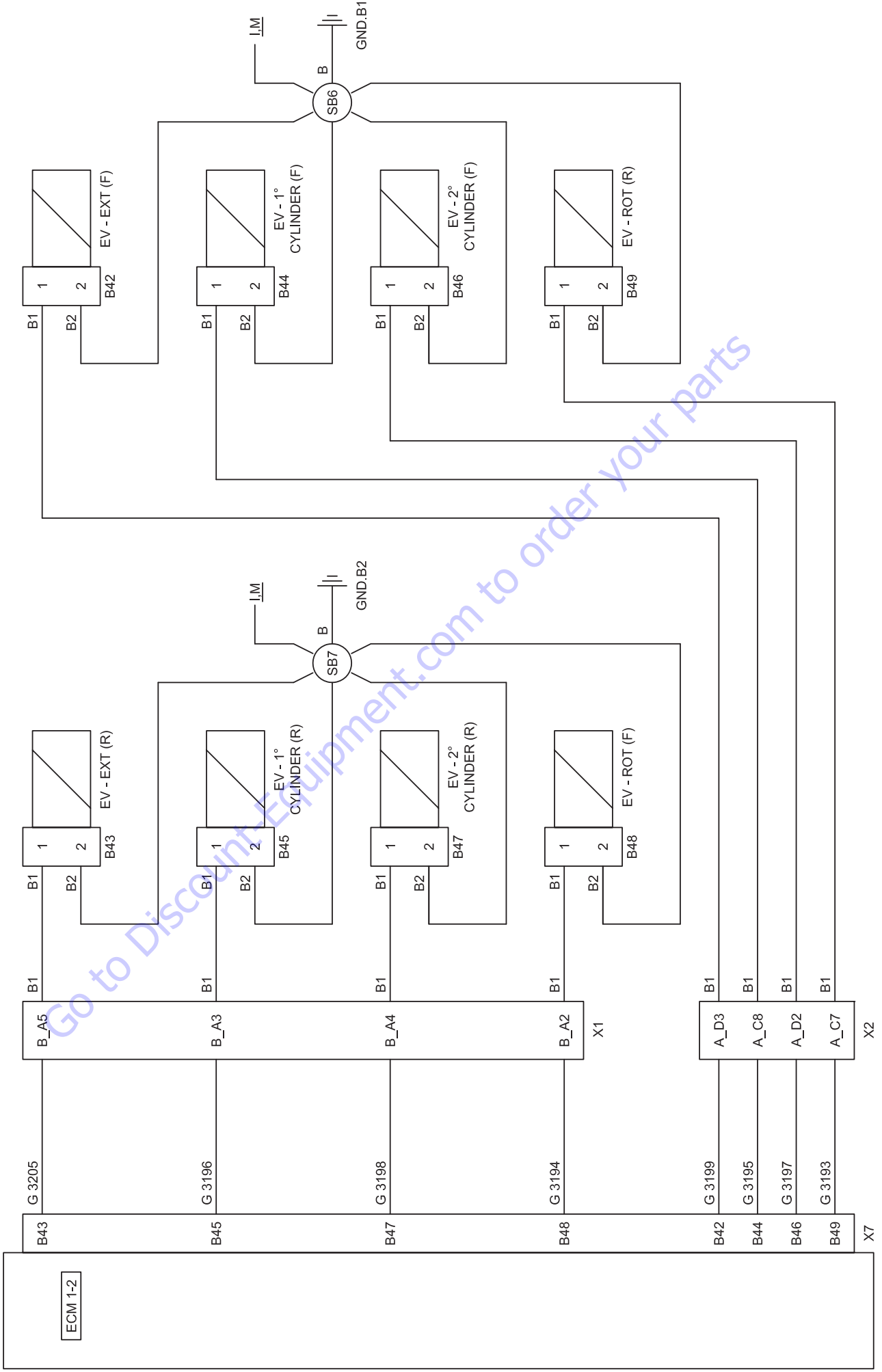







# P - 120 / 220 VOLT LINE

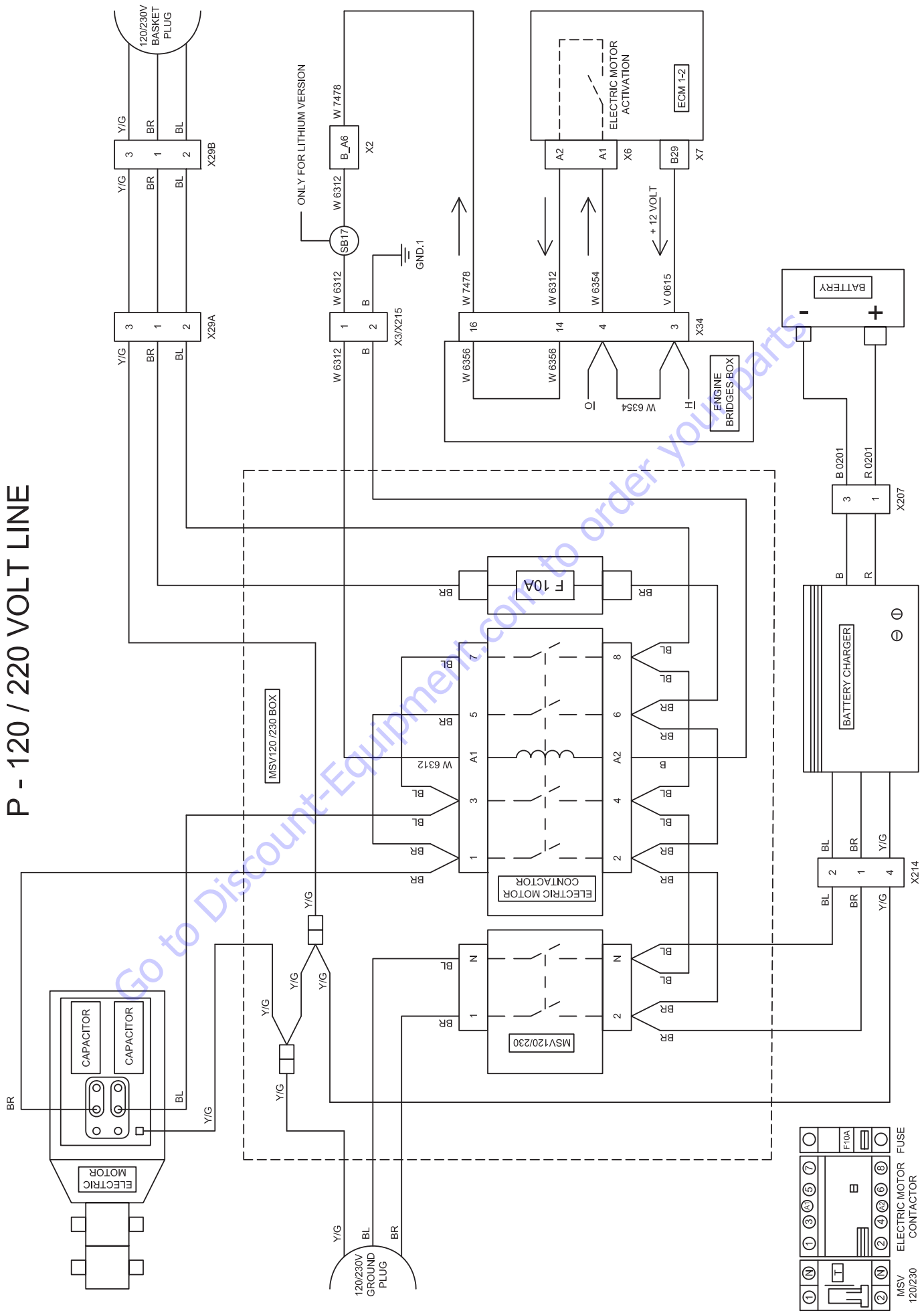

Go to Discount-Equipment.com to order your parts

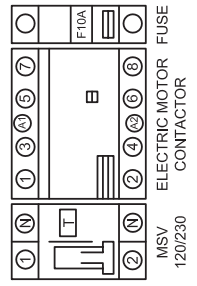



- T - COMPONENTS LOCATION
- T - LOCAZIONE COMPONENTI
- T - COLOCACION COMPONENTES
- T - DISPOSITION COMPOSANTS

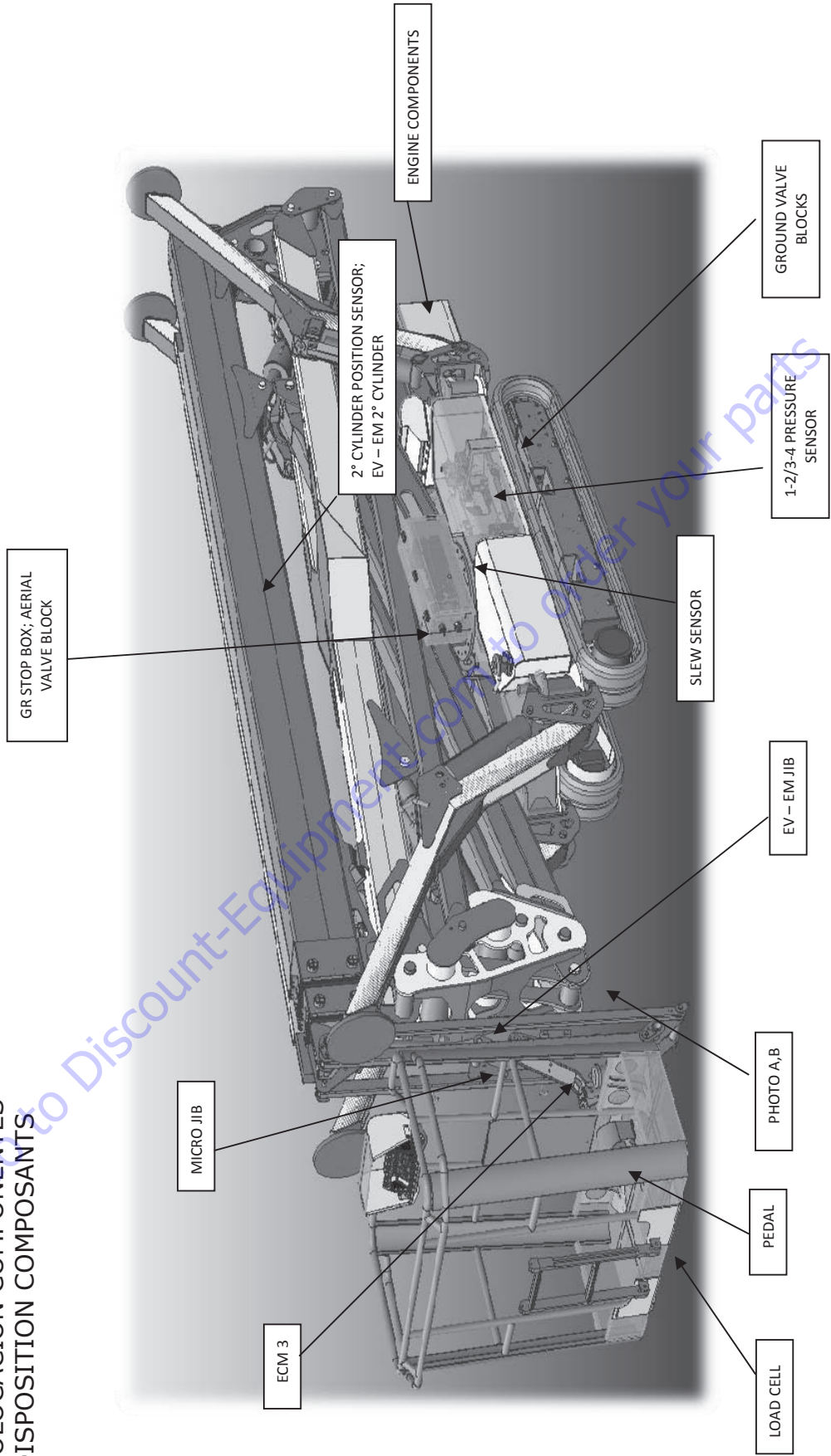

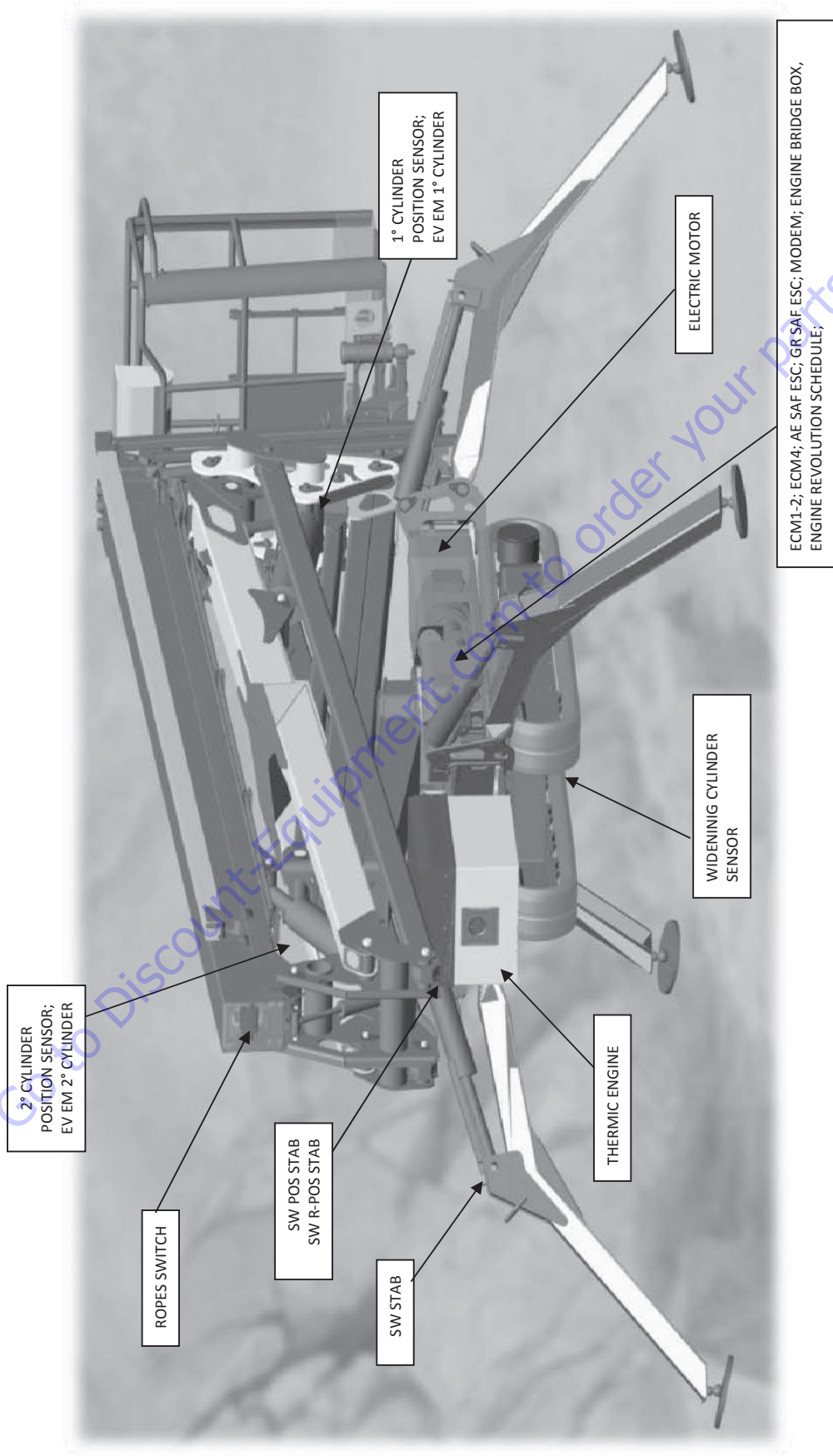

2° CYLINDER  
POSITION SENSOR;  
EV EM 2° CYLINDER

ROPES SWITCH

SW POS STAB  
SW R-POS STAB

SW STAB

1° CYLINDER  
POSITION SENSOR;  
EV EM 1° CYLINDER

THERMIC ENGINE

ELECTRIC MOTOR

WIDENING CYLINDER  
SENSOR

ECM1-2; ECM4; AE SAF ESC; GR SAF ESC; MODEM; ENGINE BRIDGE BOX,  
ENGINE REVOLUTION SCHEDULE;

**U - COMPONENTS ABBREVIATION MEANING**  
**U - SIGNIFICATO ABBREVIAZIONI COMPONENTI**  
**U - SIGNIFICADO ABBREVIATURA COMPONENTES**  
**U - SIGNIFICACION ABBREVIATION COMPONENTS**

NAME	DESCRIPTION	DESCRIZIONE	DESCRIPCIÓN	DESCRIPTION
1° ARM SWITCH	1° ARM POSITION SWITCH	INTERRUTTORE POSIZIONE 1° BRACCIO	INTERRUPTOR POSICION 1° BRAZO	INTERRUPTEUR POSITION 1° BRAS
1° CYLINDER POSITION SENSOR	1° AND 2° ARMS POSITION SENSOR	SENSORE DI POSIZIONE 1° E 2° BRACCIO	SENSOR POSICION 1° E 2° BRAZO	CAPTEUR DE POSITION 1ER ET 2EME BRAS
120/230V BOARD	120/230 VOLT BOARD (BATTERY CHARGE, ELECTRIC ENGINE CONTROLLER)	SCHEDA 120/230 VOLT (CARICA BATTERIE, CONTROLLO MOTORE ELETTRICO)	TARJETA 120/230 VOLT (REGULADOR DE TENSION, CONTROL MOTOR ELECTRICO)	FICHE 120/230 VOLT (CHARGE BATTERIES, CONTRÔLE MOTEUR ÉLECTRIQUE)
120/230V BOX	120/230 VOLT BOX	SCATOLA 120/230 VOLT	CAJA 120/230 VOLT	BOÎTE 120/230 VOLT
120/230V GROUND PLUG	120/230 VOLT PLUG AT THE GROUND	PRESA 120/230 VOLT A TERRA	ENCHUFE 120/230 VOLT EN TIERRA	PRISE 120/230 VOLT AU SOL
2° CYLINDER POSITION SENSOR	3° ARMS POSITION SENSOR	SENSORE DI POSIZIONE 3° BRACCIO	SENSOR POSICION 3° BRAZO	CAPTEUR DE POSITION 3EME BRAS
3-4 PRESSURE SENSOR	PRESSURE SENSOR STABILIZERS 3 AND 4	PRESSOSTATO STABILIZZATORI 3 E 4	SENSOR DE PRESION STABILIZADORES 3 Y 4	CAPTEUR PRESSION STABILISATEURS 3 ET 4
+ 15 FEED RELAY	RELAY +15 LINE	RELE' LINEA +15	RELE LINEA +15	RELAJ LIGNE +15
AE - PROP EV	AERIAL PART PROPORTIONAL ELECTRO VALVE	ELETTROVALVOLA PROPORZIONALE PARTE AEREA	ELECTROVALVULA PROPORCIONAL PARTE AEREA	ÉLECTROVANNE PROPORTIONNELLE PARTIE AÉRIENNE
AE SAF ESC	AERIAL SAFETY BYPASS KEY SWITCH	INTERRUTTORE A CHIAVE ESCLUSIONE SICUREZZE PARTE AEREA	INTERRUPTOR DE LLAVE EXCLUSION SEGURIDADES PARTE AEREA	INTERRUPTEUR EXCLUSION SÉCURITÉES PARTIE AÉRIENNE
BATTERY	BATTERY	BATTERIA	BATERIA	BATTERIE
BATTERY CHARGER	BATTERY CHARGER	CAICA BATTERIA	CARGADOR DE BATERIA	CHARGEUR DE BATTERIE
CAN BUS CONNECTOR	GREEN CAN BUS CONNECTOR	CONNETTORE VERDE LINEA CAN BUS	CONNECTOR VERDE CAN BUS	CAN BUS CONNECTEUR
CAPACITOR	CAPACITOR	CONDENSATORE	CANDENSADOR	CONDENSATEUR
CLACSON (OPTIONAL)	CLACSON	CLACSON	CLACSON	CLACSON
CONNECTOR	CONNECTOR	CONNETTORE	CONNECTOR	CONNECTEUR
DIAGNOSTIC PLUG	DIAGNOSTIC CONNECTOR (RAHMINO)	CONNETTORE DI DIAGNOSI (RAHMINO)	CONNECTOR PARA DIAGNOSTICO (RAHMINO)	CONNECTEUR DE DIAGNOSTIC (RAHMINO)
DIESEL ELECTRIC PUMP	DIESEL ELECTRIC PUMP	POMPA ELETTRICA MOTORE DIESEL	BOMBA ELECTRICA MOTOR DIESEL	POMPE ELECTRIQUE MOTEUR DIESEL
ECM 1-2	MASTER BOARD	SCHEDA MASTER	TARJETA MASTER	FICHE ÉLECTRONIQUE DE CONTRÔLE
ECM1-2 BOX	ELECTRONIC CONTROL MODULE 1-2 BOX	SCATOLA SCHEDA ELETTRONICA CONTROLLO 1 E 2	CAJA TARJETA DE CONTROL 1 Y 2	ECM1-2 BOX

NAME	DESCRIPTION	DESCRIZIONE	DESCRIPCIÓN	DESCRIPTION
ECM3	LOAD CELL BOARD	SCHEDA CELLA DI CARICO	TARJETA CELA DE CARGA	FICHE CELLULE DE CHARGEMENT
ECM 4	REDUCED AREA CONTROL BOARD	SCHEDA AREA RIDOTTA	TARJETA AREA REDUCIDA	FICHE SURFACE REDUIT
ELECTRIC MOTOR	ELECTRIC MOTOR	MOTORE ELETRICO	MOTOR ELECTRICO	MOTEUR ÉLECTRIQUE
ELECTRIC CONTACTOR	ELECTRIC MOTOR CONTACTOR	CONTATTORE MOTORE ELETRICO	RELE' MOTR ELECTRICO	RELAJ MOTEUR ELECTRIQUE
ELECTRIC START	ELECTRIC MOTOR START PUSH BUTTON	PULSANTE AVVIAMENTO MOTORE ELETRICO	BOTON DE ARRANQUE MOTOR ELECTRICO	INTERRUPTEUR DE DÉMARRAGE MOTEUR THERMIQUE
ELECTRO STOP	ELECTRO STOP	ELETTRO STOP	ELECTRO STOP	ÉLECTROSTOP
ELECTRONIC TRANSFORMER	ELECTRONIC TRANSFORMER	TRASFORMATORE ELETRONICO	TRANSFORMADOR ELECTRONICO	TRANSFORMATEUR ÉLECTRONIQUE
ENGINE BRIDGES BOX	ENGINE ELECTRIC BRIDGES BOX	SCATOLA PONTI ELETRICI MOTORE	CAJA PUENTES ELECTRICOS MOTOR	BOITE PONTES ELECTRIQUE MOTEUR
ENGINE BRIDGES CONNECTOR	ENGINE ELECTRIC BRIDGES CONNECTOR	CONNETTORE PONTI ELETRICI MOTORE	CONNECTOR PUENTES ELECTRICOS MOTOR	CONNECTEUR PONTES ELECTRIQUE MOTEUR
ENGINE GENERATOR	ENGINE GENERATOR	GENERATORE	GENERATOR	GÉNÉRATEUR
ENGINE GROUND	ENGINE GROUND	MASSA MOTORE	MASA MOTOR	MASSE MOTEUR
ENGINE REVOLUTION REGULATOR	ENGINE REVOLUTION REGULATOR	REGOLATORE GIRI MOTORE	REGOLADOR REVOLUCIONAS MOTOR	RÉGULATEUR TOURS DU MOTEUR
ENGINE REVOLUTION SCHEDULE	ENGINE REVOLUTION CONTROL SCHEDULE	SCHEDA DI CONTROLLO GIRI MOTORE	PLACA DE CONTROL REVOLUCIONES MOTOR	RÉGULATEUR DU TENSION MOTEUR
ENGINE REVOLUTION SENSOR	ENGINE REVOLUTION SENSOR	SENSORE DI GIRI MOTORE	SENSOR REVOLUCIONES MOTOR	FICHE DU TOURS DE MOTEUR
ENGINE STARTER RELAY	ENGINE STARTER RELAY	RELE' AVVIAMENTO MOTORE	RELE' ARRANQUE MOTOR	RELAJ DÉMARRER MOTEUR
ENGINE STARTER	ENGINE STARTER	MOTORINO DI AVVIAMENTO	MOTOR DE ARRANQUE	STARTER MOTEUR
ENGINE STOP TIMER	ENGINE STOP TIMER	TIMER SPEGNIMENTO MOTORE	TIMER STOP MOTOR	TIMER STOP MOTEUR
ENGINE VOLTAGE REGULATOR	ENGINE VOLTAGE REGULATOR	REGOLATORE DI TENSIONE MOTORE	REGOLADOR DE TENSION DEL MOTOR	CAPTEUR DES TOURS DU MOTEUR
ES HATZ	HATZ ELECTRONIC SCHEDULE	SCHEDA ELETRONICA HATZ	PLACA ELÉCTRONICA HATZ	FICHE ELECTRONIQUE HATZ
EV - 1° CYLINDER ( R )	1° CYLINDER ON-OFF ELECTRO VALVE (CLOSING)	ELETTROVALVOLA ON-OFF 1° CILINDRO (CHIUSURA)	ELECTROVALVULA ON-OFF 1° CILINDRO (CLAUSURA)	ELECTROVANNE ON-OFF 1° CYLINDRE (FERMETURE)
EV - 1° CYLINDER ( F )	1° CYLINDER ON-OFF ELECTRO VALVE (OPENING)	ELETTROVALVOLA ON-OFF 1° CILINDRO (APERTURA)	ELECTROVALVULA ON-OFF 1° CILINDRO (APERTURA)	ELECTROVANNE ON-OFF 1° CYLINDRE (OUVERTURE)
EV - 2° CYLINDER ( R )	2° CYLINDER ON-OFF ELECTRO VALVE (CLOSING)	ELETTROVALVOLA ON-OFF 2° CILINDRO (CHIUSURA)	ELECTROVALVULA ON-OFF 2° CILINDRO (CLAUSURA)	ELECTROVANNE ON-OFF 2° CYLINDRE (FERMETURE)
EV - 2° CYLINDER ( F )	2° CYLINDER ON-OFF ELECTRO VALVE (OPENING)	ELETTROVALVOLA ON-OFF 2° CILINDRO (APERTURA)	ELECTROVALVULA ON-OFF 2° CILINDRO (APERTURA)	ELECTROVANNE ON-OFF 2° CYLINDRE (OUVERTURE)

NAME	DESCRIPTION	DESCRIZIONE	DESCRIPCION	DESCRIPTION
EV - 2° SPEED	TRACKS 2° SPEED ELECTRO VALVE	ELETTROVALVOLE 2° VELOCITA'	ELECTROVALVULA 2° VELOCIDAD	ÉLECTROVANNE 2EME VITESSE
EV - B LEV ( R ) NO LL14.72	BASKET LEVELLING ON-OFF ELECTRO VALVE (CLOSING)	ELETTROVALVOLE ON-OFF LIVELLAMENTO CESTO (CHIUSURA)	ELECTROVALVULA ON-OFF NIVELACION DE LA CESTA (CLAUSURA)	ÉLECTROVANNE ON-OFF NIVELAGE PANIER (FERMETURE)
EV - B LEV ( F )	BASKET LEVELLING ON-OFF ELECTRO VALVE (OPENING)	ELETTROVALVOLE ON-OFF LIVELLAMENTO CESTO (APERTURA)	ELECTROVALVULA ON-OFF NIVELACION DE LA CESTA (APERTURA)	ÉLECTROVANNE ON-OFF NIVELAGE PANIER (OUVERTURE)
EV - B ROT ( R )	BASKET ROTATION ON-OFF ELECTRO VALVE (CLOCKWISE)	ELETTROVALVOLE ON-OFF ROTAZIONE CESTO (ORARIO)	ELECTROVALVULA ON-OFF ROTACION DE LA CESTA (HORARIO)	ÉLECTROVANNE ON-OFF ROTATION PANIER (HORAIRE)
EV - B ROT ( F ) NO LL14.72	BASKET ROTATION ON-OFF ELECTRO VALVE (ANTI CLOCKWISE)	ELETTROVALVOLE ON-OFF ROTAZIONE CESTO (ANTI ORARIO)	ELECTROVALVULA ON-OFF ROTACION DE LA CESTA (ANTI HORARIO)	ÉLECTROVANNE ON-OFF ROTATION PANIER (ANTI-HORAIRE)
EV - DEV	ELECTRIC DIVERTER	ELETTROVALVOLE DEVIATRICE	ELECTROVALVULA PROPORCIONAL PARTE AEREA	ÉLECTROVANNE DEVIATRICE
EV - EM 1° CYLINDER	1° CYLINDER EMERGENCY DESCEND ELECTRO VALVE	ELETTROVALVOLE DISCESA DI EMERGENZA 1° CILINDRO	ELECTROVALVULA BAJADA DE EMERGENCIA 1° CILINDRO	ÉLECTROVANNE DESCENTE D'URGENCE 1ER CYLINDRE
EV - EM 2° CYLINDER	2° CYLINDER EMERGENCY DESCEND ELECTRO VALVE	ELETTROVALVOLE DISCESA DI EMERGENZA 2° CILINDRO	ELECTROVALVULA BAJADA DE EMERGENCIA 2° CILINDRO	ÉLECTROVANNE DESCENTE D'URGENCE 2EME CYLINDRE
EV - EM JIB	JIB EMERGENCY DESCEND ELECTRO VALVE	ELETTROVALVOLE DISCESA DI EMERGENZA JIB	ELECTROVALVULA BAJADA DE EMERGENCIA JIB	ÉLECTROVANNE DESCENTE D'URGENCE JIB
EV - EXT ( R )	EXTENSION ON-OFF ELECTRO VALVE (CLOSING)	ELETTROVALVOLE ON-OFF SFILLO (CHIUSURA)	ELECTROVALVULA ON-OFF TELESCOPICO (CLAUSURA)	ÉLECTROVANNE ON-OFF BRAS D'EXTRACTION (FERMETURE)
EV - EXT ( F )	EXTENSION ON-OFF ELECTRO VALVE (OPENING)	ELETTROVALVOLE ON-OFF SFILLO (APERTURA)	ELECTROVALVULA ON-OFF TELESCOPICO (APERTURA)	ÉLECTROVANNE ON-OFF BRAS D'EXTRACTION (OUVERTURE)
EV - JIB ( R )	JIB ON-OFF ELECTRO VALVE (CLOSING)	ELETTROVALVOLE ON-OFF JIB (CHIUSURA)	ELECTROVALVULA ON-OFF JIB (CLAUSURA)	ÉLECTROVANNE ON-OFF JIB (FERMETURE)
EV - JIB ( F )	JIB ON-OFF ELECTRO VALVE (OPENING)	ELETTROVALVOLE ON-OFF JIB (APERTURA)	ELECTROVALVULA ON-OFF JIB (APERTURA)	ÉLECTROVANNE ON-OFF JIB (OUVERTURE)
EV - ROT ( R )	ROTATION ON-OFF ELECTRO VALVE (CLOCKWISE)	ELETTROVALVOLE ON-OFF ROTAZIONE (ORARIO)	ELECTROVALVULA ON-OFF ROTACION (HORARIO)	ÉLECTROVANNE ON-OFF ROTATION (HORAIRE)
EV - ROT ( F )	ROTATION ON-OFF ELECTRO VALVE (ANTI CLOCKWISE)	ELETTROVALVOLE ON-OFF ROTAZIONE (ANTI ORARIO)	ELECTROVALVULA ON-OFF ROTACION (ANTI HORARIO)	ÉLECTROVANNE ON-OFF ROTATION (ANTI-HORAIRE)
EV - STAB 1 ( R )	LEFT FRONT OUTRIGGER ON-OFF ELECTRO VALVE (CLOSING)	ELETTROVALVOLE ON-OFF STABILIZZATORE ANTERIORE SINISTRO (CHIUSURA)	ELECTROVALVULA ON-OFF ESTABILIZADOR DELANTERO IZQUIERDO (CLAUSURA)	ÉLECTROVANNE ON-OFF STABILISATEUR ANTERIEUR GAUCHE (FERMETURE)
EV - STAB 1 ( F )	LEFT FRONT OUTRIGGER ON-OFF ELECTRO VALVE (OPENING)	ELETTROVALVOLE ON-OFF STABILIZZATORE ANTERIORE SINISTRO (APERTURA)	ELECTROVALVULA ON-OFF ESTABILIZADOR DELANTERO IZQUIERDO (APERTURA)	ÉLECTROVANNE ON-OFF STABILISATEUR ANTERIEUR GAUCHE (OUVERTURE)
EV - STAB 2 ( R )	LEFT REAR OUTRIGGER ON-OFF ELECTRO VALVE (CLOSING)	ELETTROVALVOLE ON-OFF STABILIZZATORE POSTERIORE SINISTRO (CHIUSURA)	ELECTROVALVULA ON-OFF ESTABILIZADOR TRASERO IZQUIERDO (CLAUSURA)	ÉLECTROVANNE ON-OFF STABILISATEUR ANTERIEUR DROIT (OUVERTURE)
EV - STAB 2 ( F )	LEFT REAR OUTRIGGER ON-OFF ELECTRO VALVE (OPENING)	ELETTROVALVOLE ON-OFF STABILIZZATORE POSTERIORE SINISTRO (APERTURA)	ELECTROVALVULA ON-OFF ESTABILIZADOR TRASERO IZQUIERDO (APERTURA)	ÉLECTROVANNE ON-OFF STABILISATEUR POSTERIEUR GAUCHE (OUVERTURE)
EV - STAB 3 ( R )	RIGHT FRONT OUTRIGGER ON-OFF ELECTRO VALVE (CLOSING)	ELETTROVALVOLE ON-OFF STABILIZZATORE ANTERIORE DESTRO (CHIUSURA)	ELECTROVALVULA ON-OFF ESTABILIZADOR DELANTERO DERECHO (CLAUSURA)	ÉLECTROVANNE ON-OFF STABILISATEUR ANTERIEUR DROIT (FERMETURE)
EV - STAB 3 ( F )	RIGHT FRONT OUTRIGGER ON-OFF ELECTRO VALVE (OPENING)	ELETTROVALVOLE ON-OFF STABILIZZATORE ANTERIORE DESTRO (APERTURA)	ELECTROVALVULA ON-OFF ESTABILIZADOR DELANTERO DERECHO (APERTURA)	ÉLECTROVANNE ON-OFF STABILISATEUR ANTERIEUR DROITE (OUVERTURE)
EV - STAB 4 ( R )	RIGHT REAR OUTRIGGER ON-OFF ELECTRO VALVE (CLOSING)	ELETTROVALVOLE ON-OFF STABILIZZATORE POSTERIORE DESTRO (CHIUSURA)	ELECTROVALVULA ON-OFF ESTABILIZADOR TRASERO DERECHO (CLAUSURA)	ÉLECTROVANNE ON-OFF STABILISATEUR POSTERIEUR DROITE (FERMETURE)
EV - STAB 4 ( F )	RIGHT REAR OUTRIGGER ON-OFF ELECTRO VALVE (OPENING)	ELETTROVALVOLE ON-OFF STABILIZZATORE POSTERIORE DESTRO (APERTURA)	ELECTROVALVULA ON-OFF ESTABILIZADOR TRASERO DERECHO (APERTURA)	ÉLECTROVANNE ON-OFF STABILISATEUR POSTERIEUR DROITE (OUVERTURE)

NAME	DESCRIPTION	DESCRIZIONE	DESCRIPCIÓN	DESCRIPTION
EV - TR CLOSING	UNDERCARRIAGE WIDENING ELECTRO VALVE (CLOSING)	ELETTROVALVOLA ON-OFF ALLARGAMENTO CARRO (CHIUSURA)	ELETTROVALVOLA ON-OFF EXTENSION DEL CARRO (CLAUSURA)	ÉLECTROVANNE ON-OFF ÉLARGISSEMENT CHENILLARD (FERMETURE)
EV - TR L ( R )	LEFT TRACK ON-OFF ELECTRO VALVE (REAR)	ELETTROVALVOLA ON-OFF CINGOLO SINISTRO (INDIETRO)	ELETTROVALVOLA ON-OFF ORUGA IZQUIERDA (ATRAS)	ÉLECTROVANNE ON-OFF CHENILLE GAUCHE (EN ARRIÈRE)
EV - TR L ( F )	LEFT TRACK ON-OFF ELECTRO VALVE (FRONT)	ELETTROVALVOLA ON-OFF CINGOLO SINISTRO (AVANTI)	ELETTROVALVOLA ON-OFF ORUGA IZQUIERDA (ADELANTE)	ÉLECTROVANNE ON-OFF CHENILLE GAUCHE (EN AVANT)
EV - TR OPENING	UNDERCARRIAGE WIDENING ELECTRO VALVE (OPENING)	ELETTROVALVOLA ON-OFF ALLARGAMENTO CARRO (APERTURA)	ELETTROVALVOLA ON-OFF EXTENSION DEL CARRO (APERTURA)	ÉLECTROVANNE ON-OFF ÉLARGISSEMENT CHENILLARD (OUVERTURE)
EV - TR R ( R )	RIGHT TRACK ON-OFF ELECTRO VALVE (REAR)	ELETTROVALVOLA ON-OFF CINGOLO DESTRO (INDIETRO)	ELETTROVALVOLA ON-OFF ORUGA DERECHA (ATRAS)	ÉLECTROVANNE ON-OFF CHENILLE DROITE (EN ARRIÈRE)
EV - TR R ( F )	RIGHT TRACK ON-OFF ELECTRO VALVE (FRONT)	ELETTROVALVOLA ON-OFF CINGOLO DESTRO (AVANTI)	ELETTROVALVOLA ON-OFF ORUGA DERECHA (ADELANTE)	ÉLECTROVALVOLA ON-OFF CHENILLE DROITE (AVANTI)
F 25 A	25 A FUSE (FLY)	FUSIBILE 25 A (VOLANTE)	FUSIBILE 25 A (VOLANTE)	FUSIBILE 25 A (VOLANT)
F N°	FUSE NUMBER	NUMERO DEL FUSIBILE	NUMERO DEL FUSIBILE	FICHE' MICRO RELAY
GENERATOR	ENGINE GENERATOR	GENERATORE MOTORE TERMICO	GENERATORE MOTOR	GENERATEUR MOTEUR
GENERATOR DIODES	GENERATOR DIODES	DIODI GENERATRE	DIODOS GENERATOR	DIODES MOTEUR
GR SAF ESC	GROUND SAFETY BYPASS KEY SWITCH	INTERRUTTORE A CHIAVE ESCLUSIONE SICUREZZE PARTE CARRO	INTERRUPTOR DE LLAVE EXCLUSION SEGURIDADES PARTE DE TIERRA	INTERRUPTEUR EXCLUSION SÉCURITÉS PARTIE TERRE
GR STAB LAMP	MACHINE STABILIZED GROUND LAMP	LAMPADA MACCHINA STABILIZZATA A TERRA	LUZ MAQUINA ESTABILIZADA EN TIERRA	LUMIÈRE MACHINE STABILISÉE À TERRE
GR STOP	GROUND STOP BUTTON	INTERRUTTORE DI STOP (GROUND)	INTERRUPTOR DE STOP (EN TIERRA)	INTERRUPTEUR D'ARRÊT (À TERRE)
GR STOP BOX	GROUND STOP BUTTON BOX	SCATOLA INTERRUTTORE DI STOP (A TERRA)	CAJA INTERRUPTOR DE STOP (EN TIERRA)	BOÎTE INTERRUPTEUR D'ARRÊT (À TERRE)
IGNITION KEY	IGNITION SWITCH	INTERRUTTORE A CHIAVE MOTORE	INTERRUPTOR DE LLAVE MOTOR	INTERRUPTEUR A CLEF MOTEUR
KEY AE MOV	CONTROL POSITION SELECTOR KEY	SELETORE CONTROLLO POSIZIONE	SELECTOR CONTROL POSICION	SELECTEUR CONTROLE POSITION
LAMP STAB 1	FRONT LEFT OUTIGGER LAMP	LAMPADA STABILIZZATORE ANTERIORE SINISTRO	LUZ ESTABILIZADOR DELANTERO IZQUIERDO	LUMIÈRE STABILISATEUR N° 1
LAMP STAB 2	REAR LEFT OURIGGER LAMP	LAMPADA STABILIZZATORE POSTERIORE SINISTRO	LUZ ESTABILIZADOR TRASERO IZQUIERDO	LUMIÈRE STABILISATEUR N° 2
LAMP STAB 3	FRONT RIGHT OUTRIGGER LAMP	LAMPADA STABILIZZATORE ANTERIORE DESTRO	LUZ ESTABILIZADOR DELANTERO DERECHO	LUMIÈRE STABILISATEUR N° 3
LAMP STAB 4	REAR RIGHT OUTRIGGER LAMP	LAMPADA STABILIZZATORE POSTERIORE DESTRO	LUZ ESTABILIZADOR TRASERO DERECHO	LUMIÈRE STABILISATEUR N° 4
LEFT - PROP EV	LEFT SIDE PROPORTIONAL ELECTRO VALVE	ELETTROVALVOLA PROPORZIONALE PARTE A TERRA SINISTRA	ELETTROVALVOLA PROPORCIONAL PARTE DE TIERRA IZQUIERDA	ÉLECTROVANNE PROPORTIONNELLE PARTIE À TERRE GAUCHE
LOAD CELL	LOAD CELL SENSOR	SENSORE CELLUIA DI CARICO	SENSOR CELULA DE CARGA	CAPTEUR CELLULE DE CHARGEMENT
MAIN SWITCH	BATTERY CUTTER	STACCA BATTERIE	SACA BATERIA	COUPE BATTERIE



NAME	DESCRIPTION	DESCRIZIONE	DESCRIPCION	DESCRIPTION
MICRO JIB	MICRO SWITCH JIB	SENSORE DI POSIZIONE JIB	SENSOR POSICION JIB	CAPTEUR DE POSITION JIB
MICRO SCHEDULE RELAY	MICRO REALY SCHEDULE	SCHEDA MICRO RELE'	TARJETA MICRO RELE'	FICHE' MICRO RELAY
MODEM	MODEM	MODEM	MODEM	MODEM
MOTOR ON	MOTOR ON SWITCH	INTERRUTTORE MOTORE ELETRICO	INTERRUPTOR MOTOR ELECTRICO	INTERRUTTUR MOTEUR ELECTRIQUE
MSV120/230	120/230 VOLT PROTECTION SWITCH	MAGNETOTERMICO 120/230 VOLT	INTERRUPTOR DE PROTECCION 120/230 V	PROTECTION LIGNE 120/230 VOLT
MSV120/230V BOX	THERMIC SWITCH BOX	SCATOLA INTERRUTTORE TERMICO	CAJA INTERRUPTOR TERMICO	BOÎTE INTERRUPTEUR THERMIQUE
OIL PRESSURE SENSOR	OIL PRESSURE SENSOR	SENSORE PRESSIONE OLIO MOTORE	SENSOR PRESSION ACEITE MOTOR	CAPTEUR PRESSION HUILE MOTEUR
OPTIONAL RC	OPTIONAL REMOTE CONTROL (EMERGENCY GROUND POSITION)	TELECOMANDO OPTIONAL (POSIZIONE DI EMERGENZA A TERRA)	TELEMANDO OPTIONAL (POSICION DE EMERGENCIA EN TIERRA)	TÉLÉCOMMANDE COMME ACCESSOIRE EN OPTION (POSTATION D'URGENCE À TERRE)
P1-2	PRESSURE SENSORE STABILIZERS 1 AND 2	PRESSOSTATO STABILIZZATORI 1 E 2	SENSOR DE PRESION STABILIZADORES 1 Y 2	CAPTEUR PRESSION STABILISATEURS 1 ET 2
P3-4	PRESSURE SENSORE STABILIZERS 3 AND 4	PRESSOSTATO STABILIZZATORI 3 E 4	SENSOR DE PRESION STABILIZADORES 3 Y 4	CAPTEUR PRESSION STABILISATEURS 3 ET 4
PEDAL (optional)	PEDAL	PEDALE	PEDAL	PEDALE
PHOTO A	PHOTOCELL A	FOTOCELLULA A	FOTOCELULA A	CELLULE PHOTOÉLECTRIQUE A
PHOTO B	PHOTOCELL B	FOTOCELLULA B	FOTOCELUL B	CELLULE PHOTOÉLECTRIQUE B
PLUG DW	120/230 V SOCKET (DOWN)	CONNETTORE 120/220 VOLT (SOTTO)	ENCHUFE 120/220 VOLT (BAJO)	CONNECTEUR 120/220 VOLT (BAS)
PLUG UP	120/230 VOLT BOARD CONNECTOR PLUG (UP)	CONNETTORE SCHEDA 120/230 VOLT (SOPRA)	ENCHUFE PLACA 120/230 VOLT (ARRIBA)	CONNECTEUR FICHE 120/230 VOLT (HAUT)
PRE HEATING RELE'	PRE HEATING RELE'	RELE' PRE RISCALDO	RELE PRE CALEFACION	RELÉ PRECHAUFFAGE
PRE HEATING SPARKS	PRE HEATING SPARKS	CANDELLETTE PRERISCALDAMENTO	BUJIAS PRE CALEFACION	PETITES BOUGIES DE PRECHAUFFAGE
PUMPS SUM	PUMPS SUM ELECTRO VALVE	ELETTRO VALVOLA SOMMATORIA POMPE	ELECTRO VALVULA SOMA BOMBAS	ELECTO VANNE SOMME POMPES
RC	REMOTE CONTROL	TELECOMANDO	TELEMANDO	TÉLÉCOMMANDE
RC STOP	ENGINE STOP SWITCH IN THE REMOTE CONTROL	INTERRUTTORE DI STOP NEL TELECOMANDO	INTERRUPTOR DE STOP EN EL TELEMANDO	INTERRUPTEUR D'ARRÊT DANS LA TELECOMMANDE
REMOTE CONTROL	REMOTE CONTROL	TELECOMANDO	TELEMANDO	TÉLÉCOMMANDE
REM SELECTOR	REMOTE CONTROL SELECTOR - UP OR DOWN (OPTIONAL)	SELETORE TELECOMANDO - SOPRA O SOTTO (OPTIONAL)	SELECTOR DEL MANDO - ARRIBA O ABAJO (OPTIONAL)	SÉLECTEUR TÉLÉCOMMANDE - DESSU OU DESSOUS (COMME OPTION)
RIGHT - PROP EV	RIGHT SIDE PROPORTIONAL ELECTRO VALVE	ELETTROVALVOLA PROPORZIONALE PARTE A TERRA DESTRA	ELECTROVALVULA PROPORCIONAL PARTE DE TIERRA DERECHA	ÉLECTROVANNE PROPORTIONNELLE PARTIE À TERRE DROITE
ROPES SWITCH	ROPES SWITCH	INTERRUTTORE DI SICUREZZA FUNI	INTERRUPTOR SEGURIDAD CUERDAS	INTERRUPTEUR DE SÉCURITÉ DES CÂBLES

V—CONNECTORS LAYOUT  
 V—LAYOUT CONNETTORI  
 V—LAYOUT CONECTORES  
 V—LAYOUT CONNECTEURS

**X1 (LL26.14)**

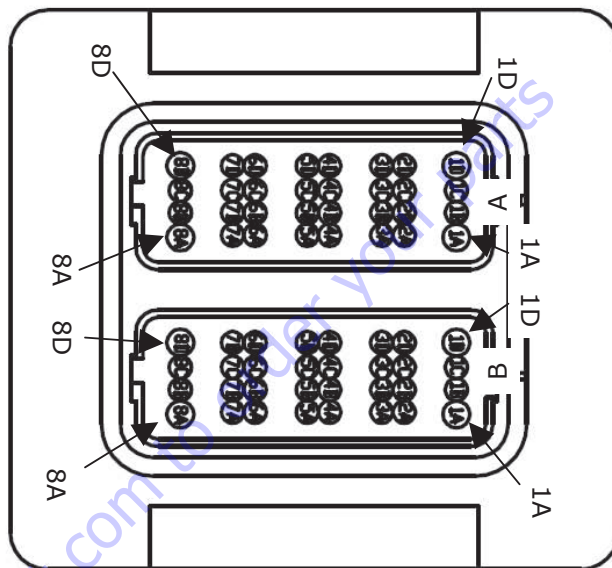
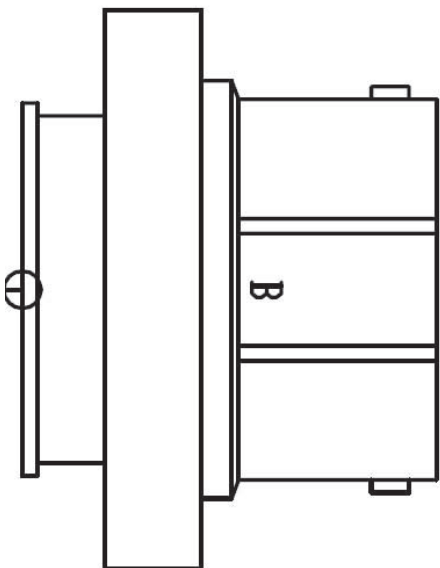

ECM 1-2 SIDE

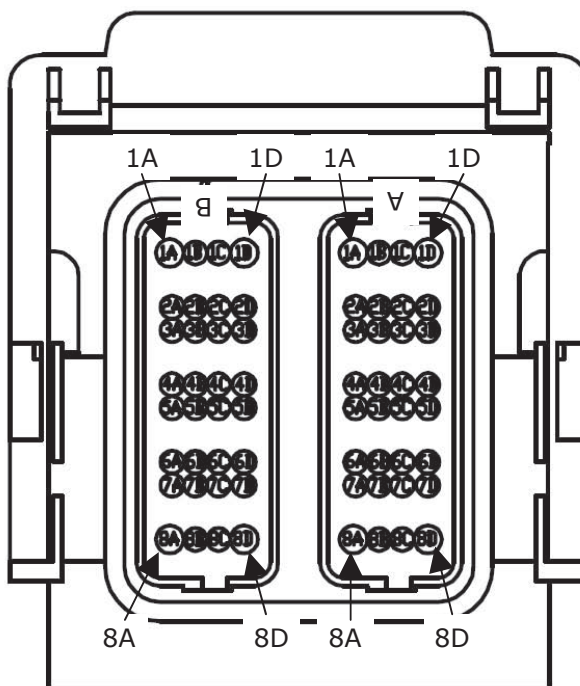
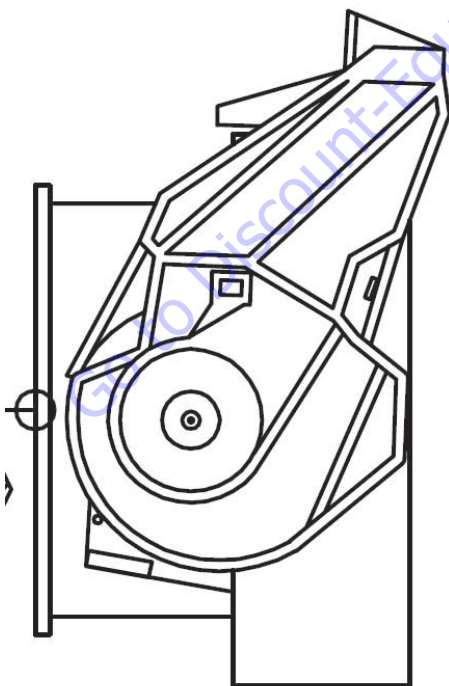

CHASSIS SIDE



**X1 (LL17.75—LL20.10)**

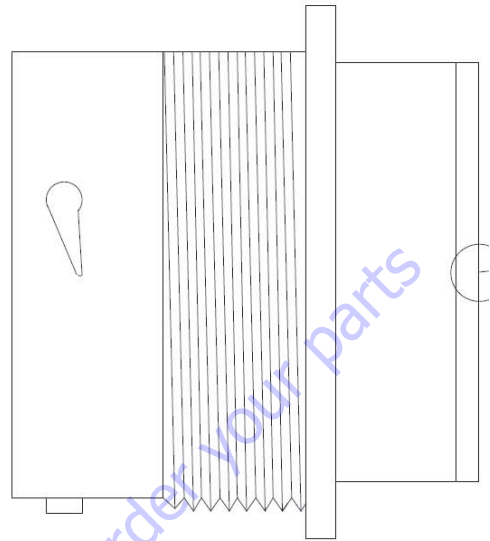
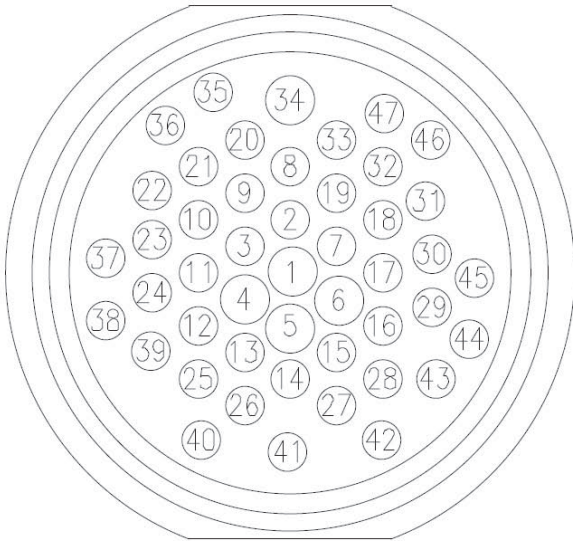

ECM 1-2 SIDE

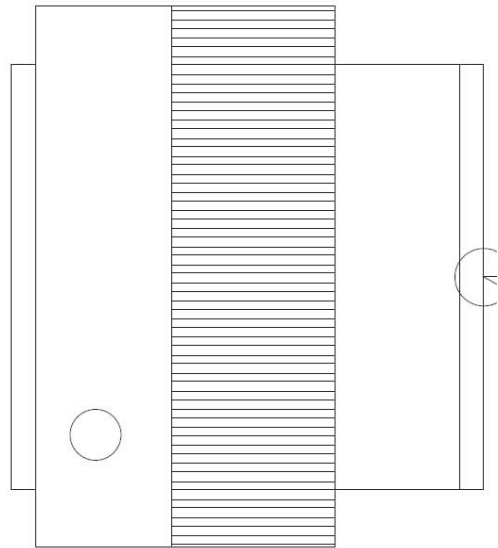
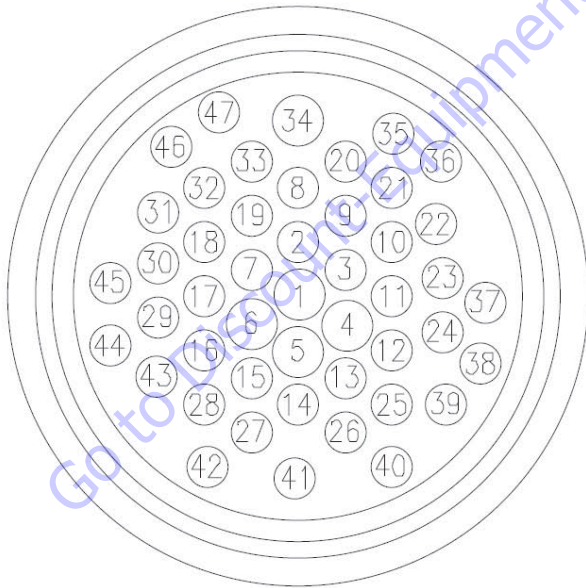

CHASSIS SIDE

X2

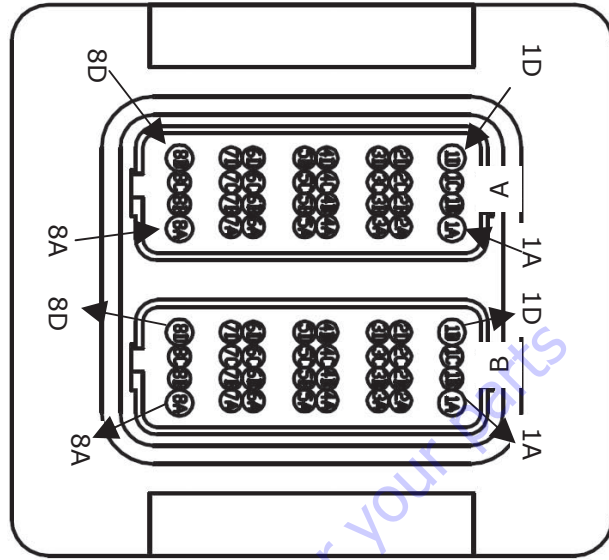
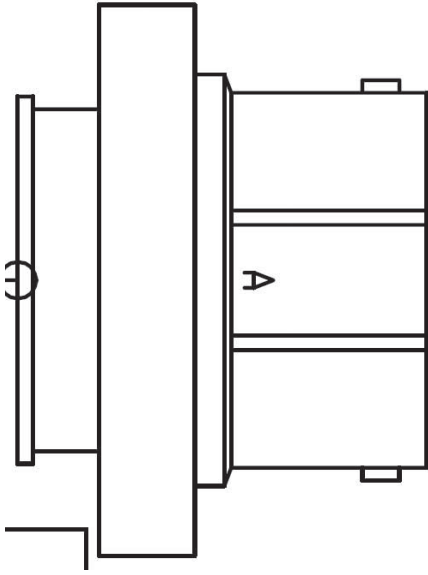

ECM 1-2 SIDE

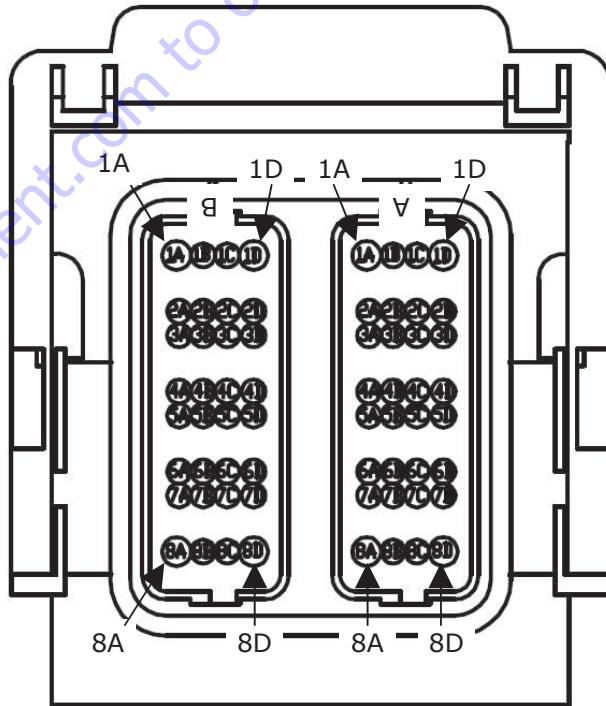
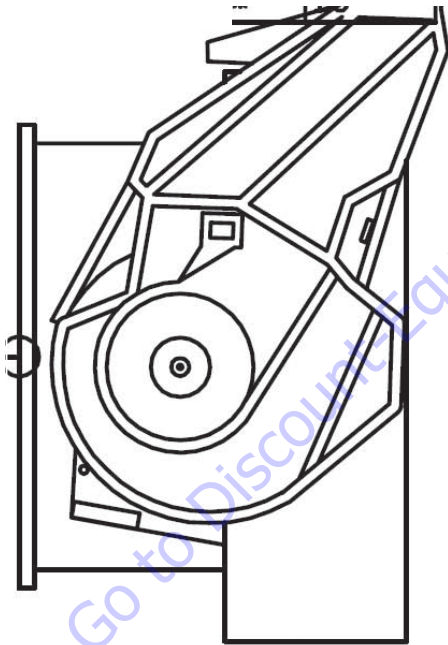

CHASSIS SIDE

X3

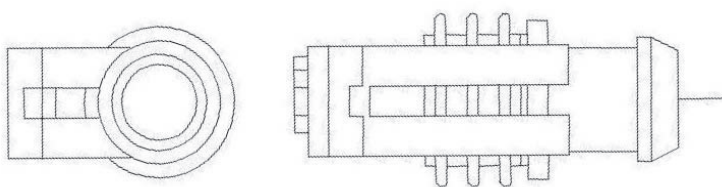

**X4;5;12;15;38;40;52;53;65;66;105;110;111;204;215;450;  
B5;B6;B61**

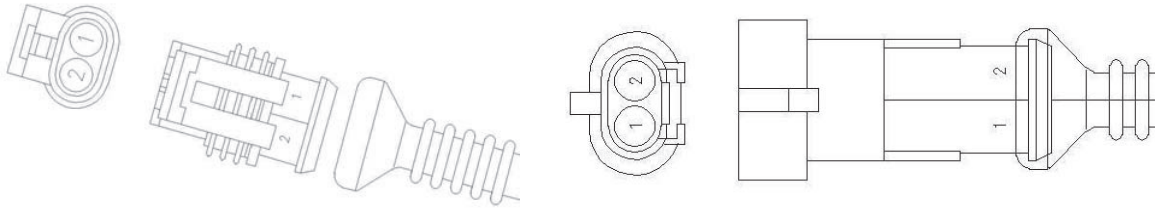

**X6**

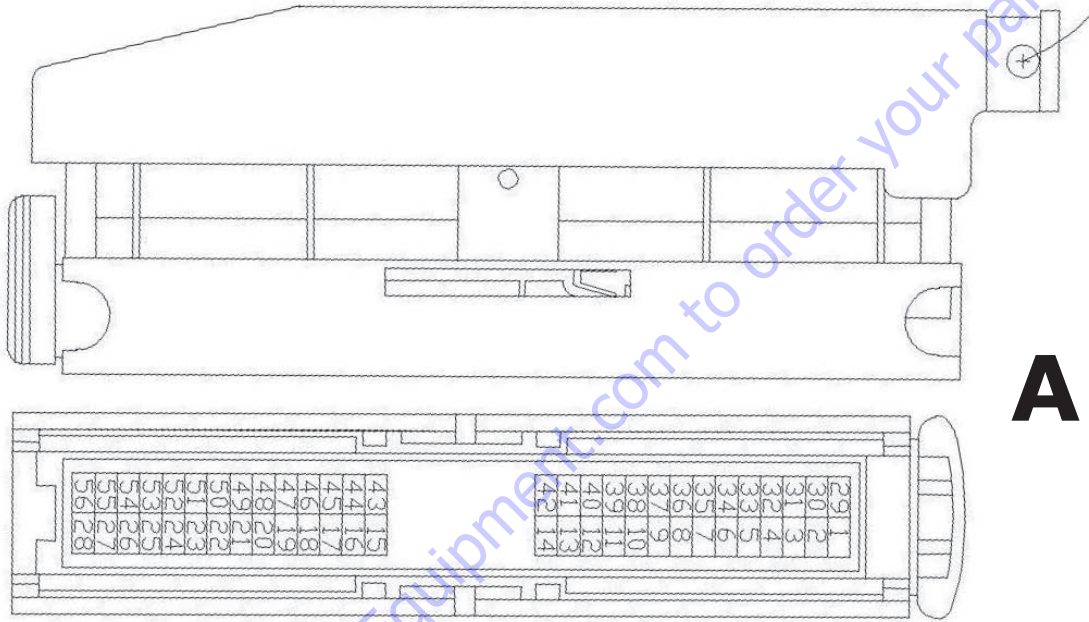

**A**

**X7**

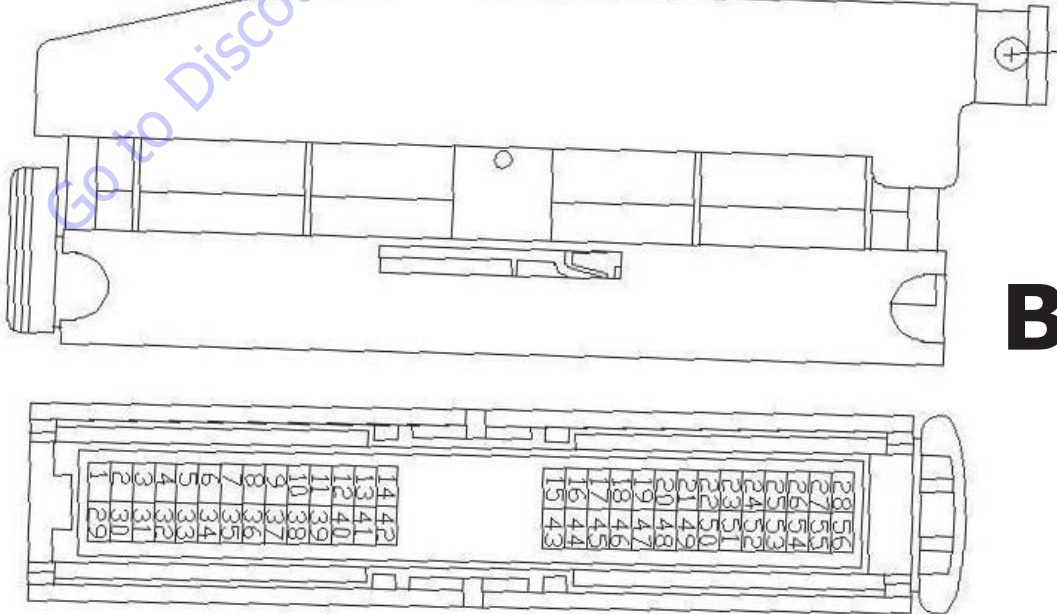

**X9;67**

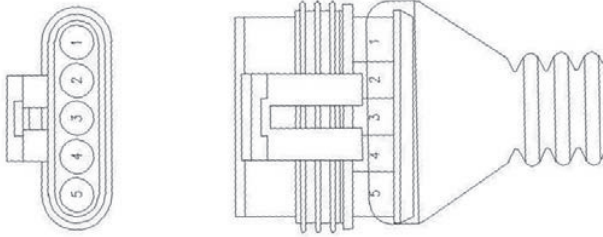

**X11**



**X18—FLY FUSES**

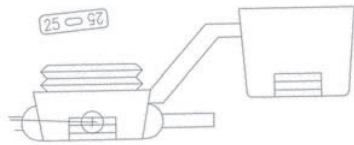

**X19;32;50;56,201**

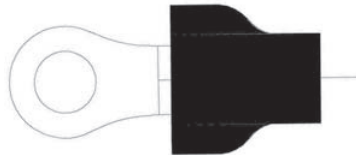

**X14;102;103;  
220,250**

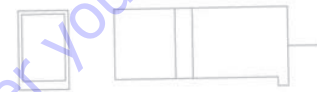

**X22,23**

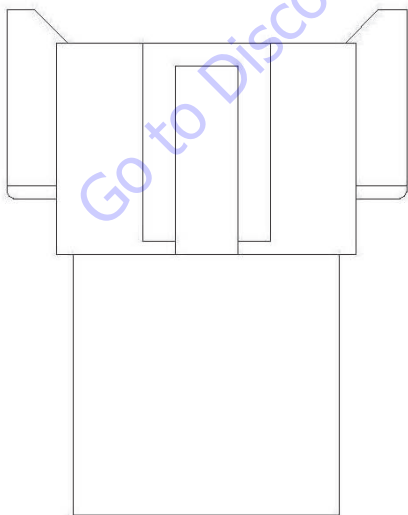
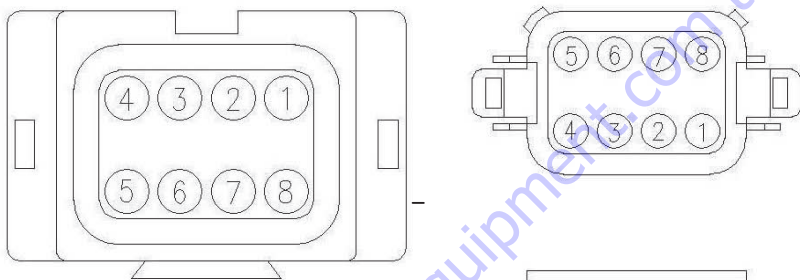

**MALE**

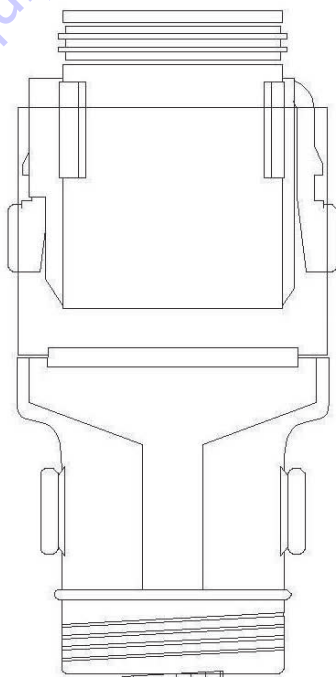

**FEMALE**

**X17;51;55**

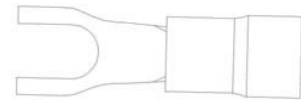

**X16**

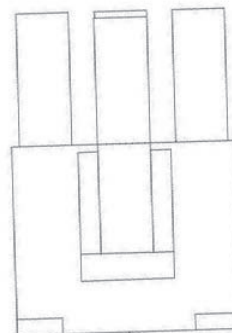
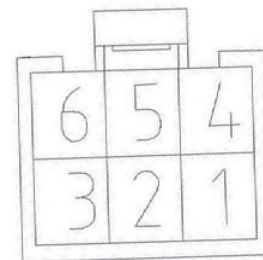



**X24;205;**

**327**

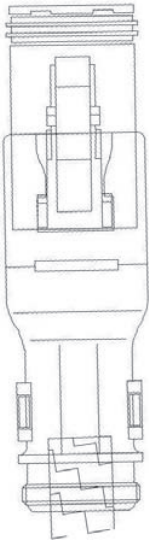

**X26**

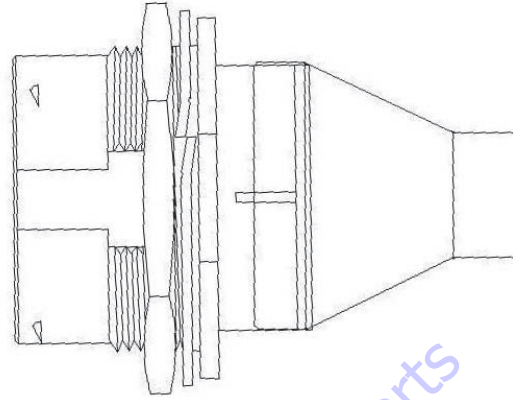
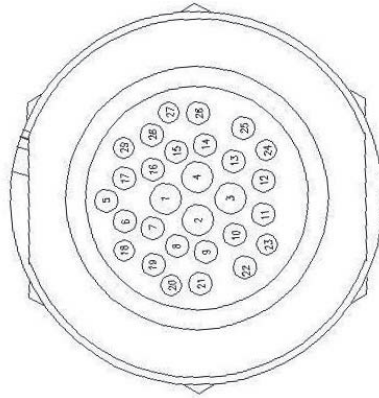

**MALE**

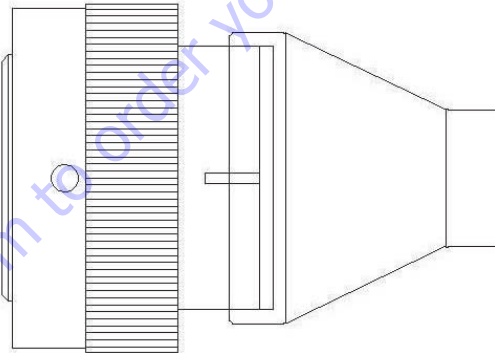
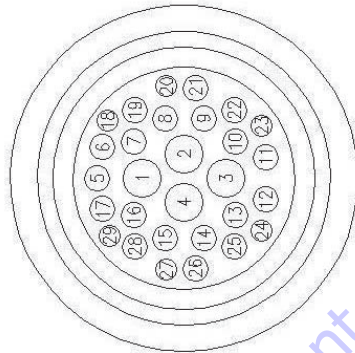

**FEMALE**

**X31**

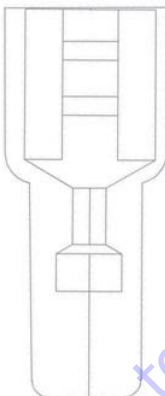

**X33**

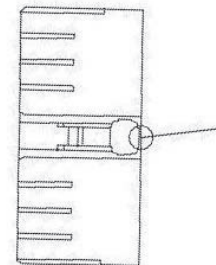
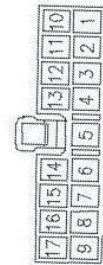
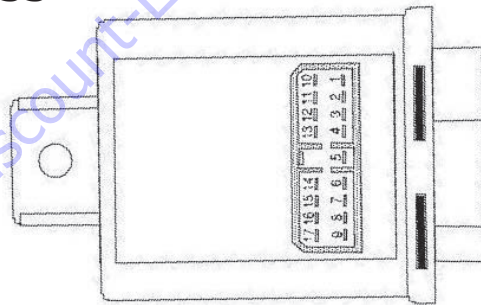

**X34**

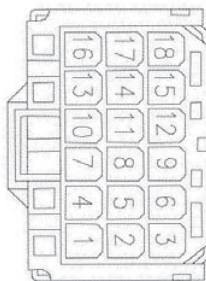
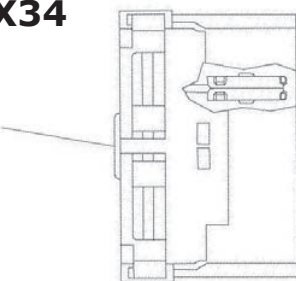

**MALE**

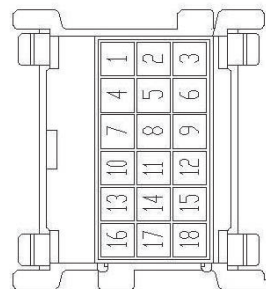

**FEMALE**

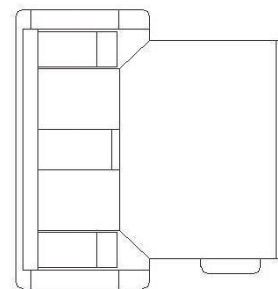

**X27;43**

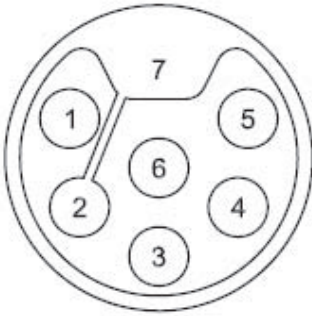

**X36;100;150**

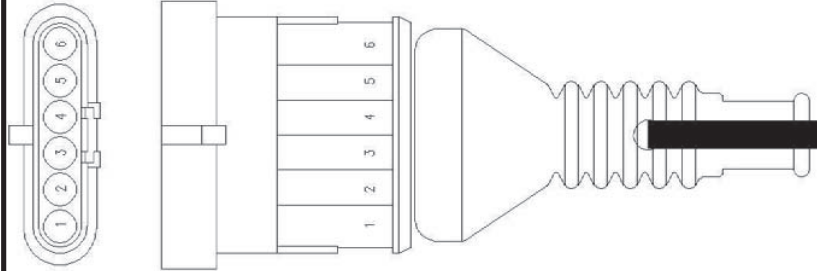

**X37**

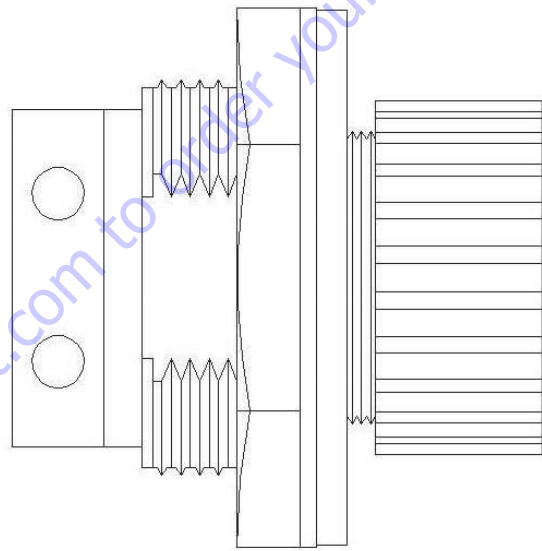
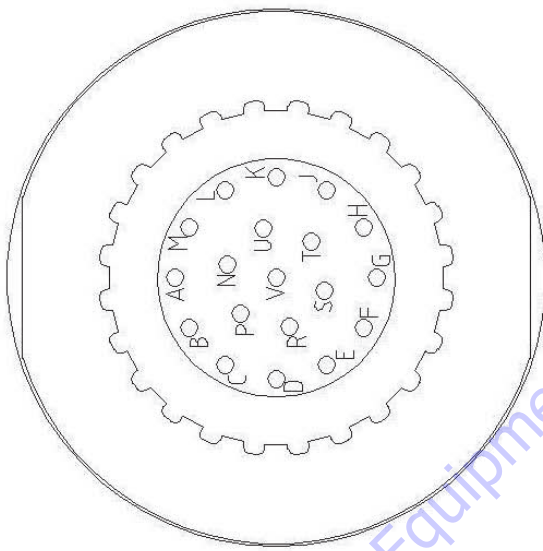

MALE

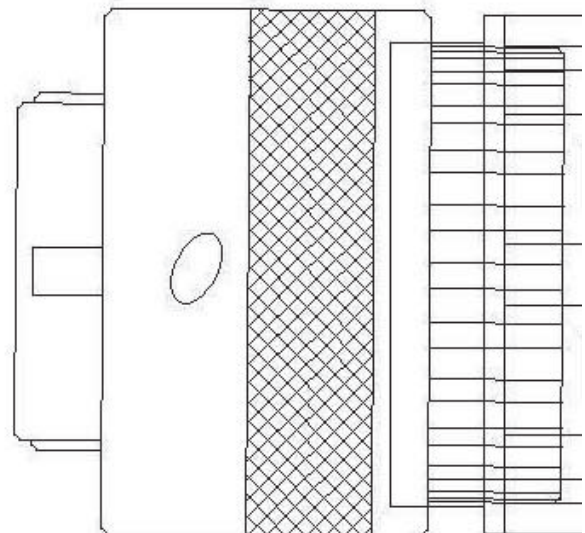
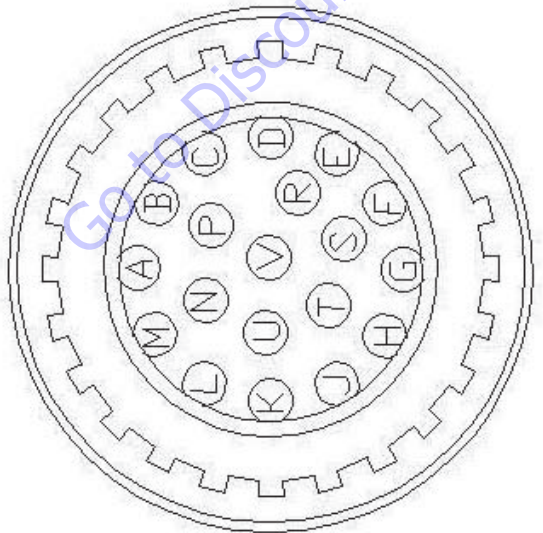

FEMALE

**X40;307**

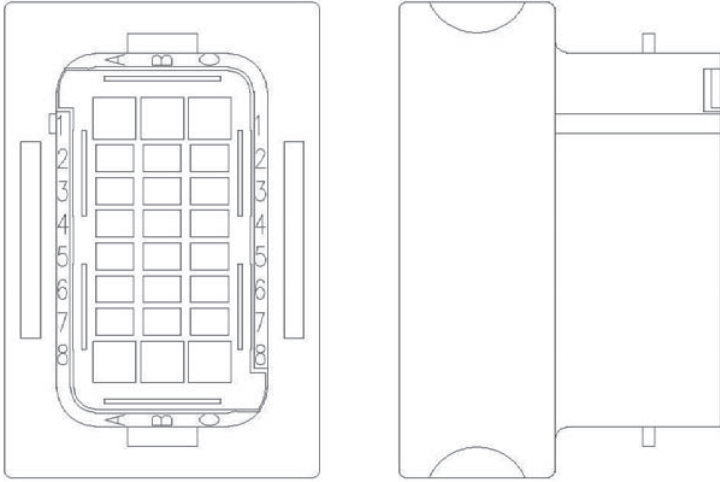

**X56**

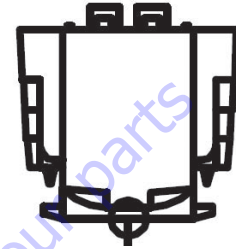
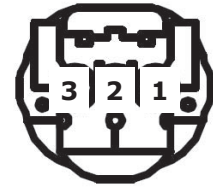

**X41 (Honda Engine)**

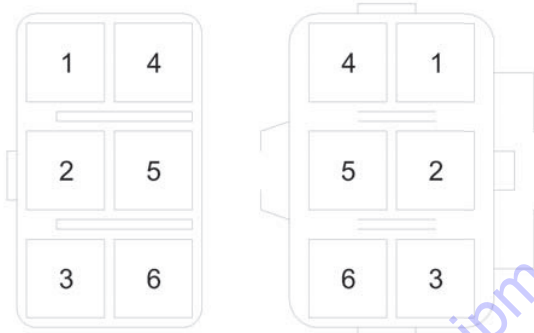

MALE

FEMALE

FRONT VIEW

**X42;43 (Honda Engine)**

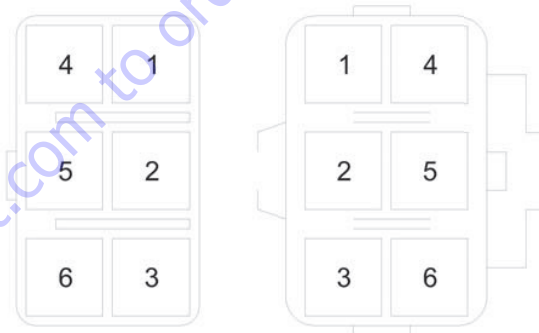

MALE

FEMALE

FRONT VIEW

**X57.1**

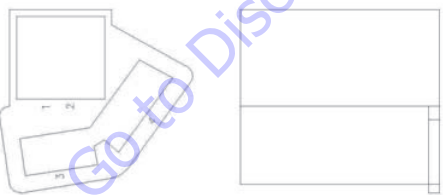

**X57.2**

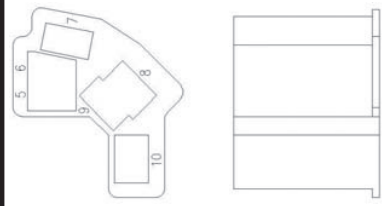

**X58;  
59**

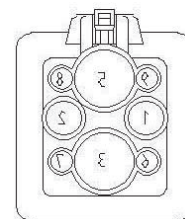
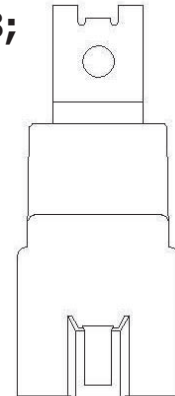

**X60**

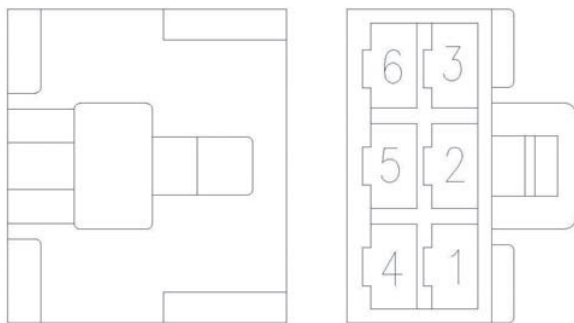

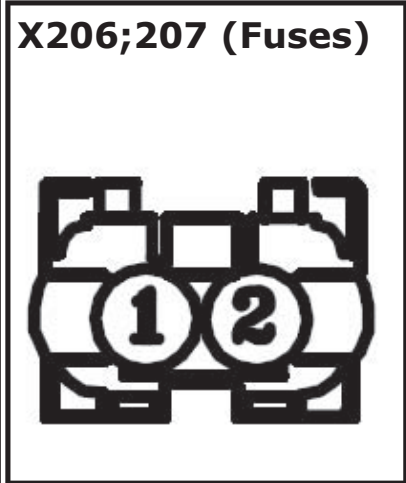
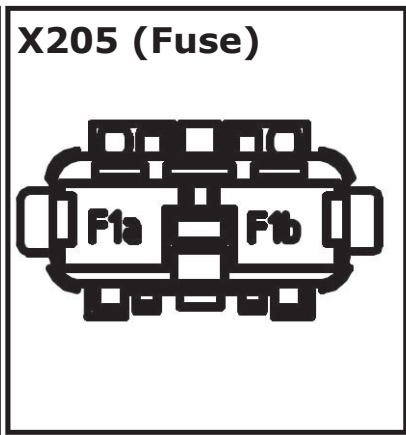
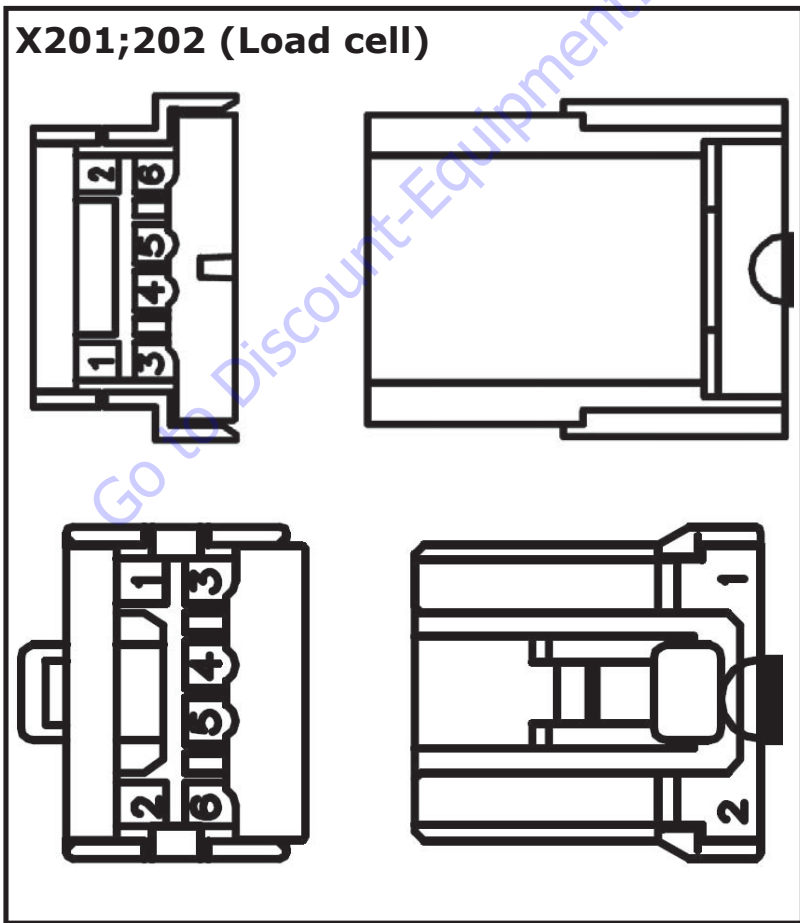
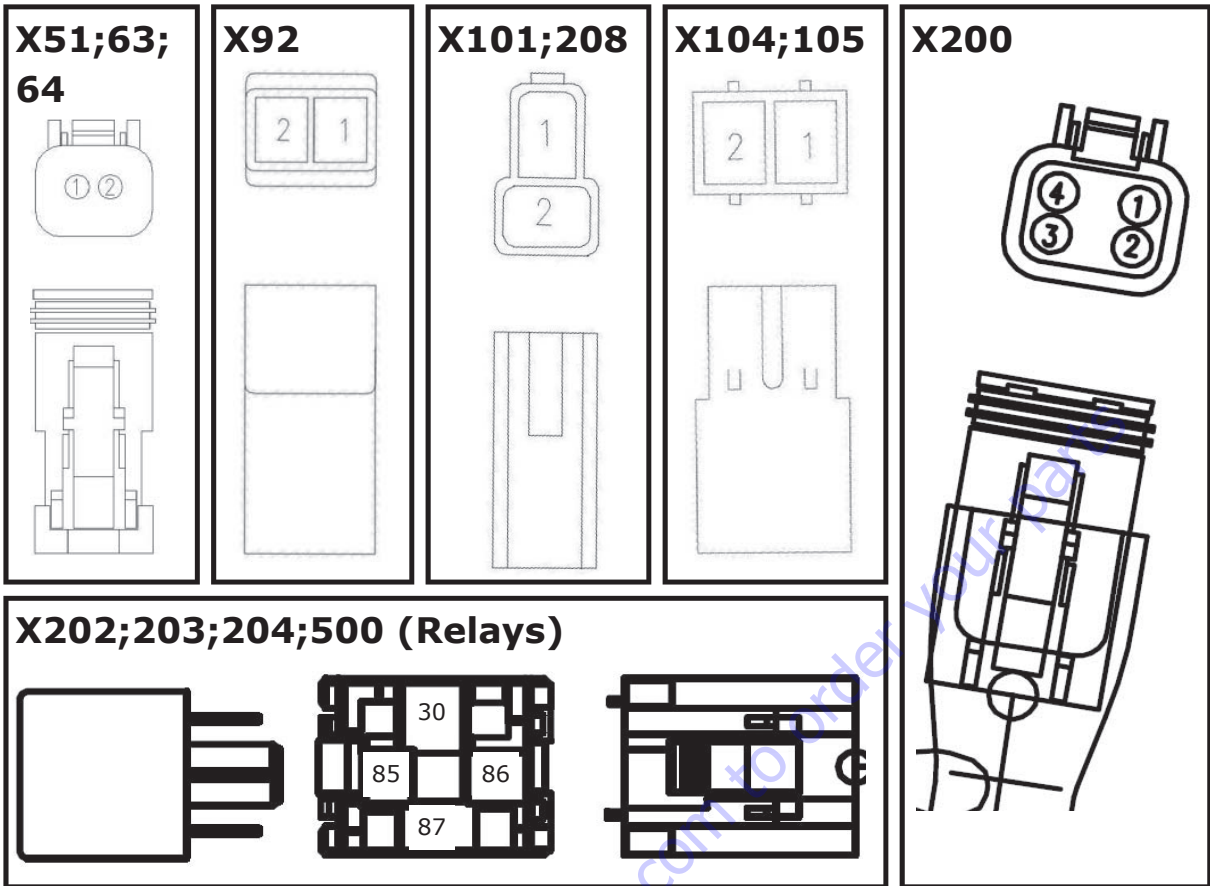



**X207;214 (Battery Charger)**

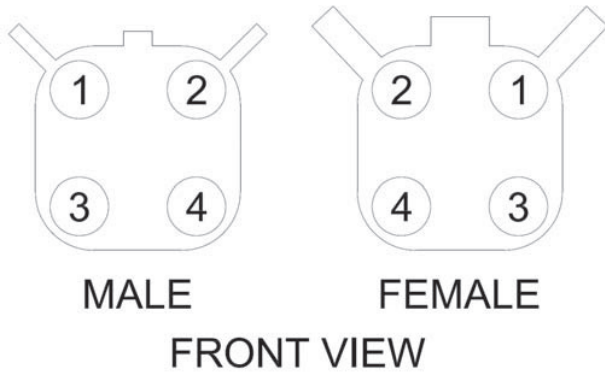

**X211, 212**

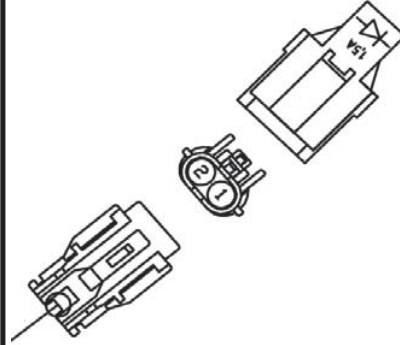

**X208**

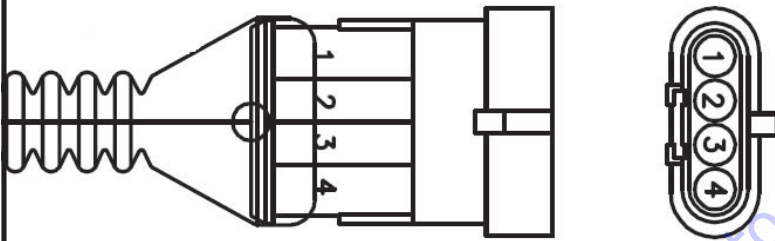

**X213**

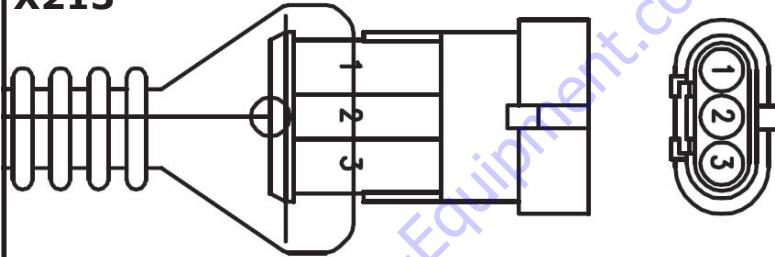

**X300**

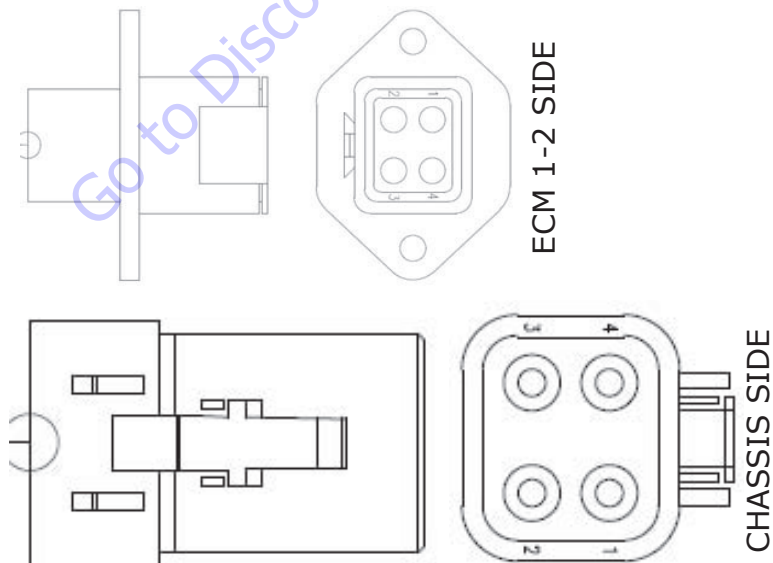

**X301;302;303;  
305**

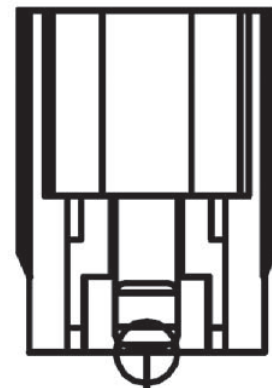

**X329**

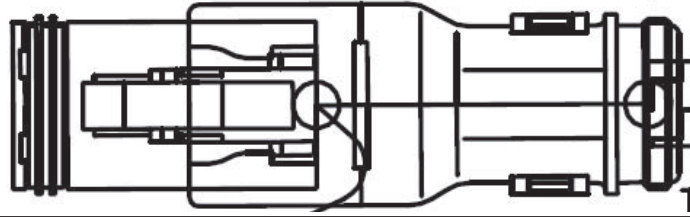
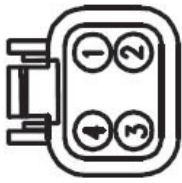

**X310**

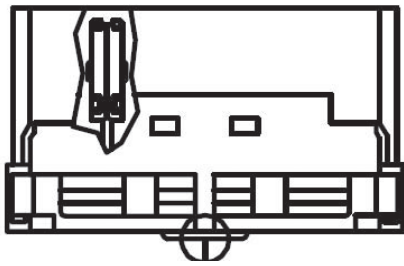
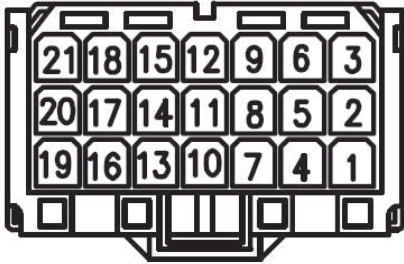

**EV EMERGENCY**

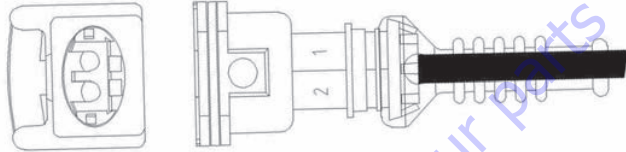

**EV COILS**

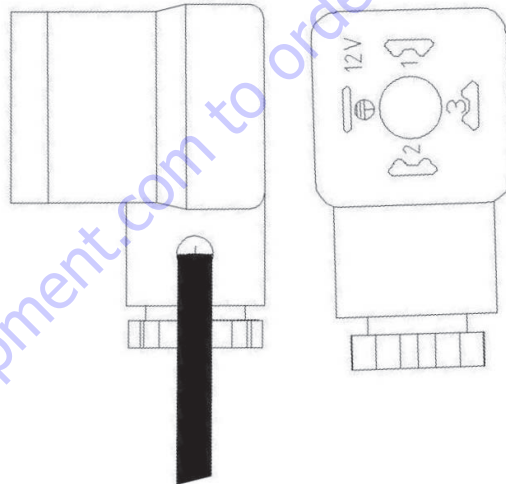

**X350;X352**

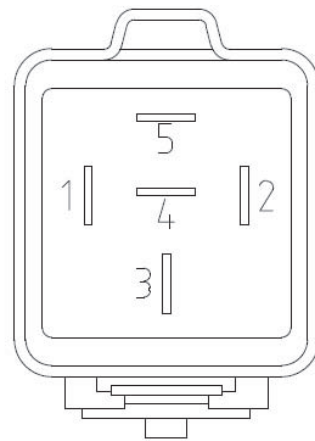
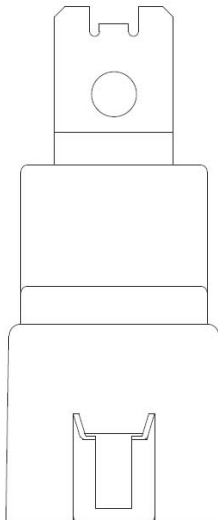
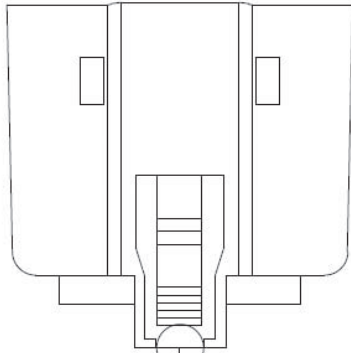
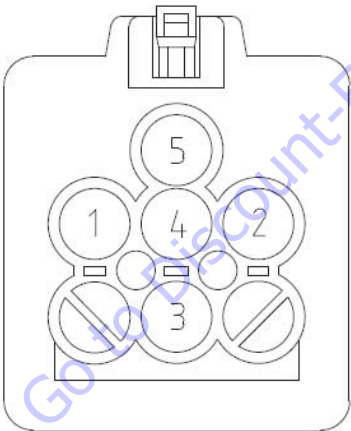

LITHIUM BATTERY SYSTEM 83 VOLT

DESCRIPTION - DESCRIZIONE - DESCRIPCION - DESCRIPTION

PAGE	DESCRIPTION	DESCRIZIONE	DESCRIPCION
W	COMPONENTS LEGEND	LEGENDA COMPONENTI	LEYENDA COMPONENTES
W1	STARTING	ACCENSIONE	IGNICION
W2	DC-DC (83V/12V FEEDER)	DC-DC (ALIMENTATORE 83V/12V)	DC-DC (ALIMENTADOR 83V/12V)
W3	BATTERY CHARGER	CARICABATTERIE	CARGADOR DE BATERIAS
W4	INVERTER	INVERTER	INVERTER
W5	BMS AND FANS	BMS E VENTOLE	BMS Y PANTALLAS
W6	CAN BUS NETWORK	LINEA CAN BUS	LINEA CAN BUS
W7	LAYOUT COMPONENTS	LAYOUT COMPONENTI	LAYOUT COMPONENTES
W8	COMPONENTS LOCATION	LOCAZIONE COMPONENTI	COLOCACION COMPONENTES
W9	LAYOUT BMS	LAYOUT BMS	LAYOUT BMS
W10	BMS CONNECTORS	CONNETTORI BMS	CONNECTORES BMS

PAGE	DESCRIPTION
W	LEGENDE COMPOSANT
W1	ALLUMAGE
W2	DC-DC (CHARGEUR 83V/12V)
W3	CHARGEUR DE BATTERIE
W4	INVERTER
W5	BMS ET HELICES
W6	LINE CAN BUS
W7	LAYOUT COMPOSANT
W8	DISPOSITION COMPOSANT
W9	LAYOUT BMS
W10	CONNECTEURS BMS

- W - COMPONENTS LEGEND
- W - LEGENDA COMPONENTI
- W - LEYENDA COMPONENTES
- W - LEGENDE COMPOSANT

NAME	DESCRIPTION	DESCRIZIONE	DESCRIPCIÓN
AUXILIARY CAN CONNECTOR	CAN CONNECTOR FOR DIAGNOSTIC	CONNETTORE CAN PER DIAGNOSI	CONNECTOR CAN PARA DIAGNOSTICO
AUXILIARY CAN PLUG	PLUG CAN FOR DIAGNOSTIC	PRESA CAN PER DIAGNOSI	ENCHUFE CAN PARA DIAGNOSTICO
BATTERY 12 VOLT	BATTERY 12 VOLT	BATTERIA 12 VOLT	BATERIA 12 VOLT
BC	BATTERY CHARGER	CARICABATTERIE	CARGADOR DE BATERIAS
BMS	BATTERY MANAGEMENT SYSTEM	BATTERY MANAGEMENT SYSTEM	BATTERY MANAGEMENT SYSTEM
CAN BRIDGE BOX	CAN BUS LINE BRIDGE BOX	SCATOLA PONTE LINEA CAN BUS	CAJA PUENTE LINEA CAN BUS
CONNECTOR	CONNECTOR	CONNETTORE	CONNECTOR
INTERNAL CONTACTOR	CONTACTOR IN THE CELLS BOX	CONTACTORE NEL PACCO BATTERIE	CONTACTOR EN EL PAQUETE BATERIAS
DC-DC	48-72- 83V/12V FEEDER	ALIMENTATORE 48-72-83V/12V	ALIMENTADOR 48-72-83V/12V
ECM1-2	ELECTRONIC CONTROL MODULE 1-2	SCHEDA ELETTRONICA DI CONTROLLO 1-2	TARJETA DE CONTROL 2
F N°	FUSE	FUSIBILE	FUSIBLE
FRONT FAN	BATTERY BOX FRONT FANS	VENTOLE FRONTALE VANO BATTERIE	PANTALLA DELANTERA PAQUETE BATERIAS
INV	INVERTER	INVERTER	INVERTER
IS	IGNITION KEY SWITCH	INTERRUTTORE A CHIAVE MOTORE	INTERRUTTORE A LLAVE MOTOR
LEM SENSOR	LEM SENSOR	SENSORE LEM	SENSOR LEM
MOTOR	ELECTRIC MOTOR	MOTORE ELETTRICO	MOTOR ELECTRICO
MR	MAIN RELE*	RELE PRINCIPALE	RELE* PRINCIPAL
R N°	RELAY	RELE*	RELE*
REAR FAN	BATTERY BOX REAR FAN	VENTOLA POSTERIORE VANO BATTERIE	PANTALLA TRASERA PAQUETE BATERIAS

NAME	DESCRIPTION
AUXILIARY CAN CONNECTOR	CONNECTEUR CAN AUXILIAIRES
AUXILIARY CAN PLUG	FICHE CAN AUXILIAIRES
BATTERY 12 VOLT	BATTERIE 12 VOLT
BC	CHARGEUR DE BATTERIE
BMS	BATTERY MANAGEMENT SYSTEM
CAN BRIDGE BOX	BOINTE PONT LIGNE CAN BUS
CONNECTOR	CONNECTEUR
INTERNAL CONTACTOR	CONTACTEUR INTERIEUR PAQUET BATERIE
DC-DC	CHARGEUR 48-72-83V/12V
ECM1-2	FICHE ÉLECTRONIQUE DE CONTRÔLE 1-2
F N°	FUSE
FRONT FAN	HELICES PAQUET BATERIE ANTERIEUR
INV	INVERTER
IS	INTERRUPTEUR A CLEF MOTEUR
LEM SENSOR	CAPTEUR LEM
MOTOR	MOTEUR ELECTRIQUE
MR	RELAIS PRINCIPAL
R N°	RELAIS DU CHARGEUR DE BATTERIE
REAR FAN	HELICES PAQUET BATERIE POSTERIEUR

# W

**Note to read the wiring diagrams**

- All the wires are white, except where different indicated
- Most of the wires have an identifying number, indicated in the wiring diagrams
- Close to the identifying number, every wire shows the two terminal points of connexion

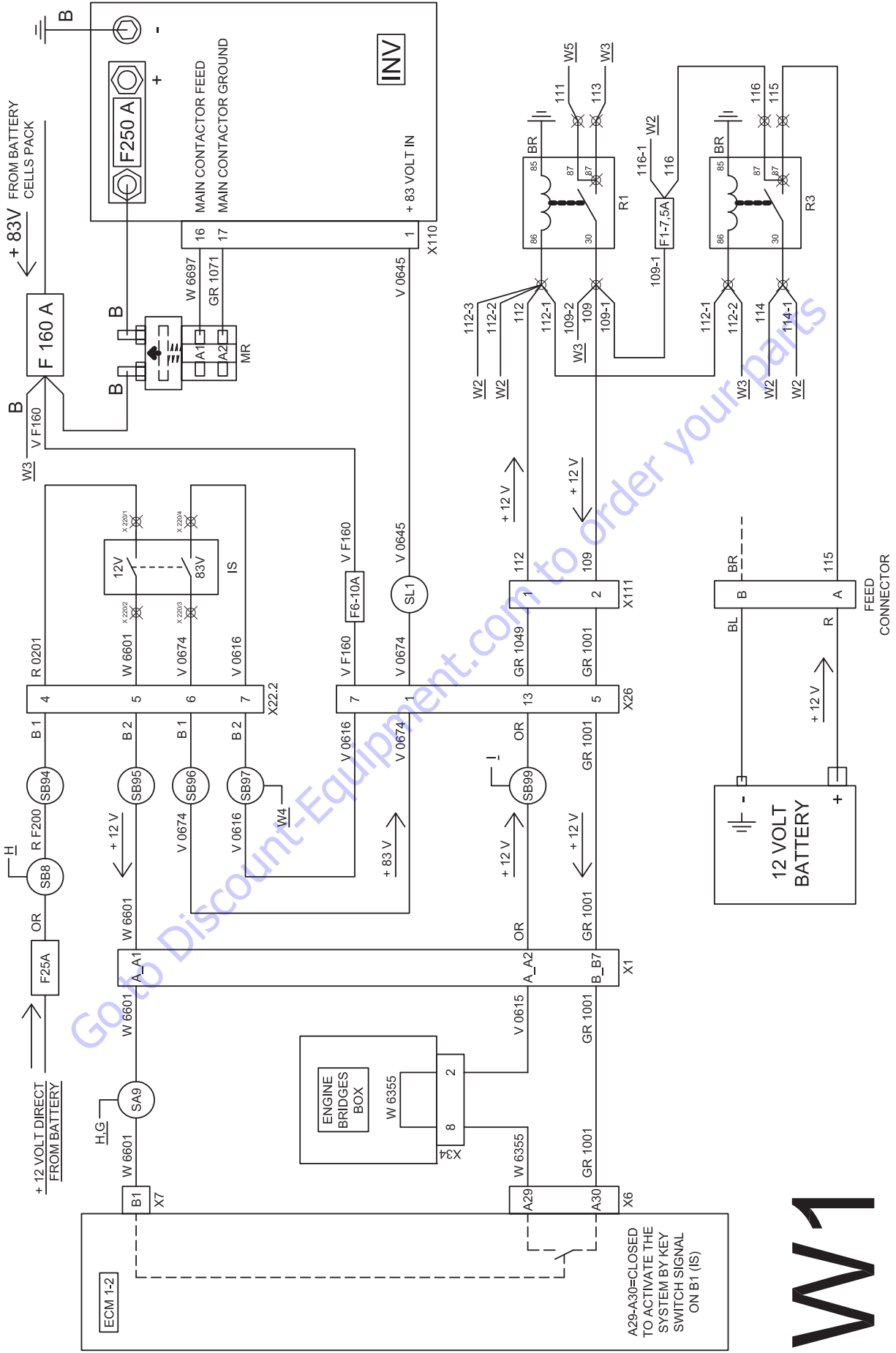

NOTE: R2 IS NOT USED

# W1

Go to Discount-Equipment.com to order your parts

A29-A30=CLOSED TO ACTIVATE THE SYSTEM BY KEY SWITCH SIGNAL ON B1 (IS)

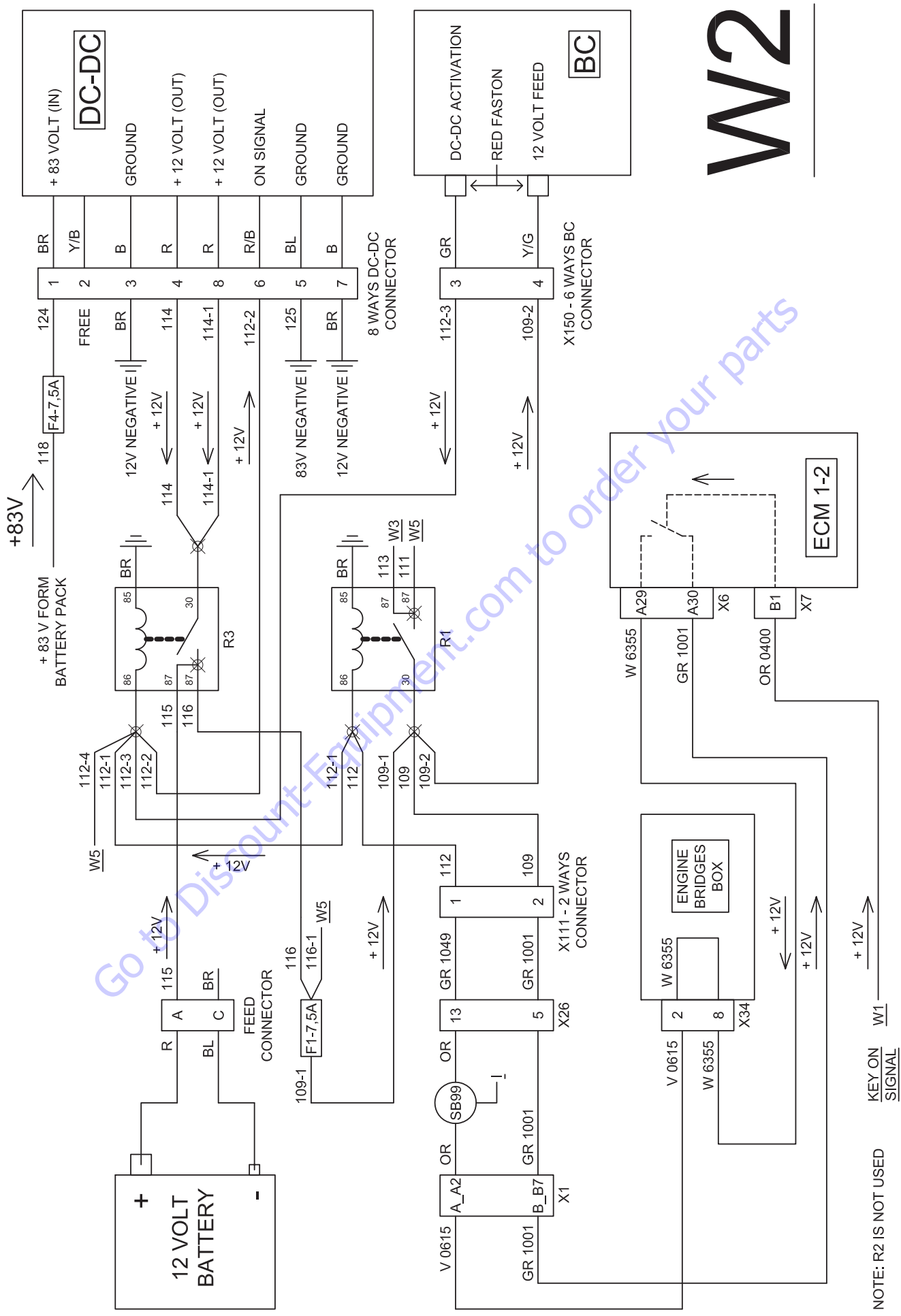

# W2

NOTE: R2 IS NOT USED

KEY ON SIGNAL W1

Go to Discount-Equipment.com to order your parts



# W4

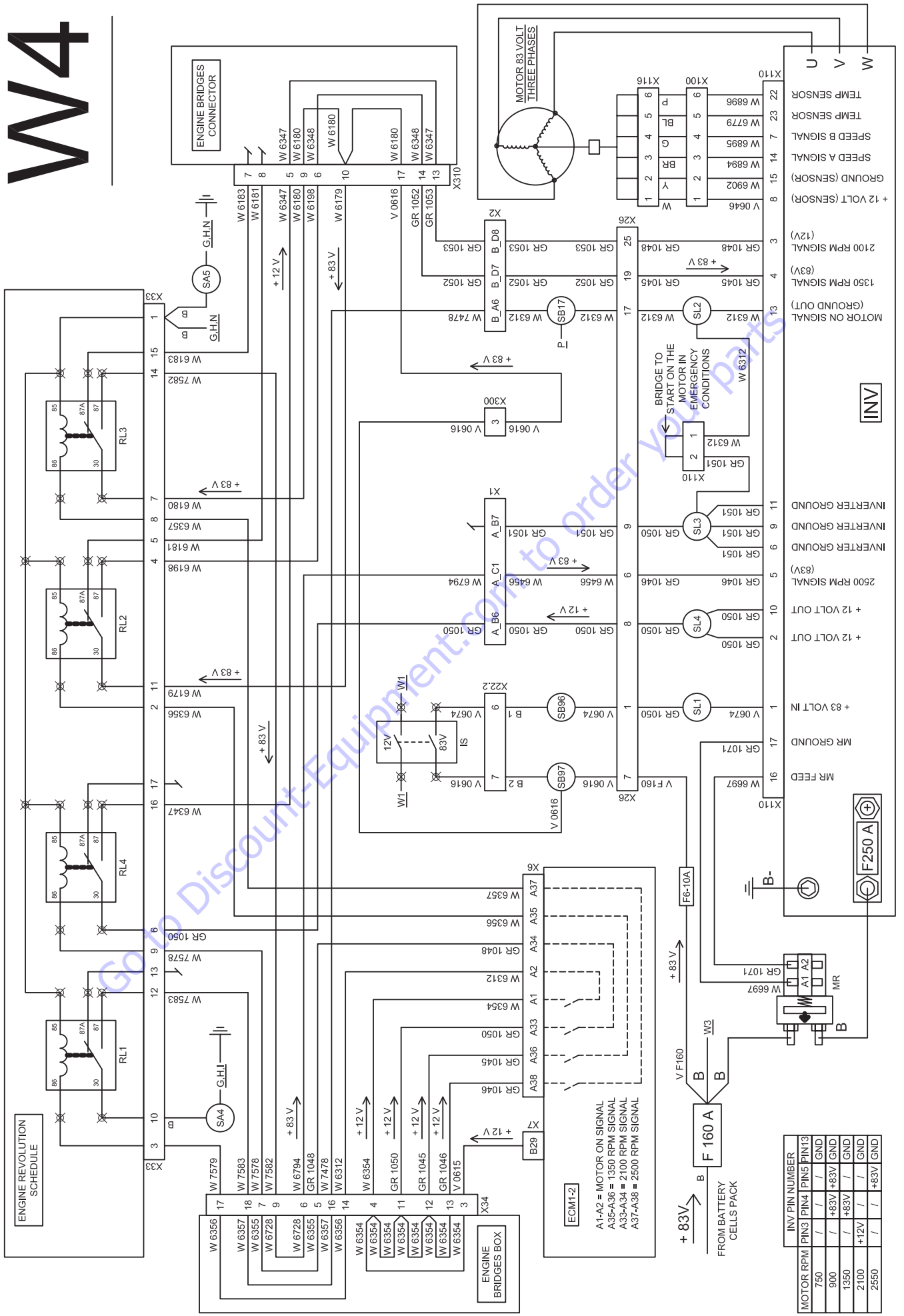



# W5

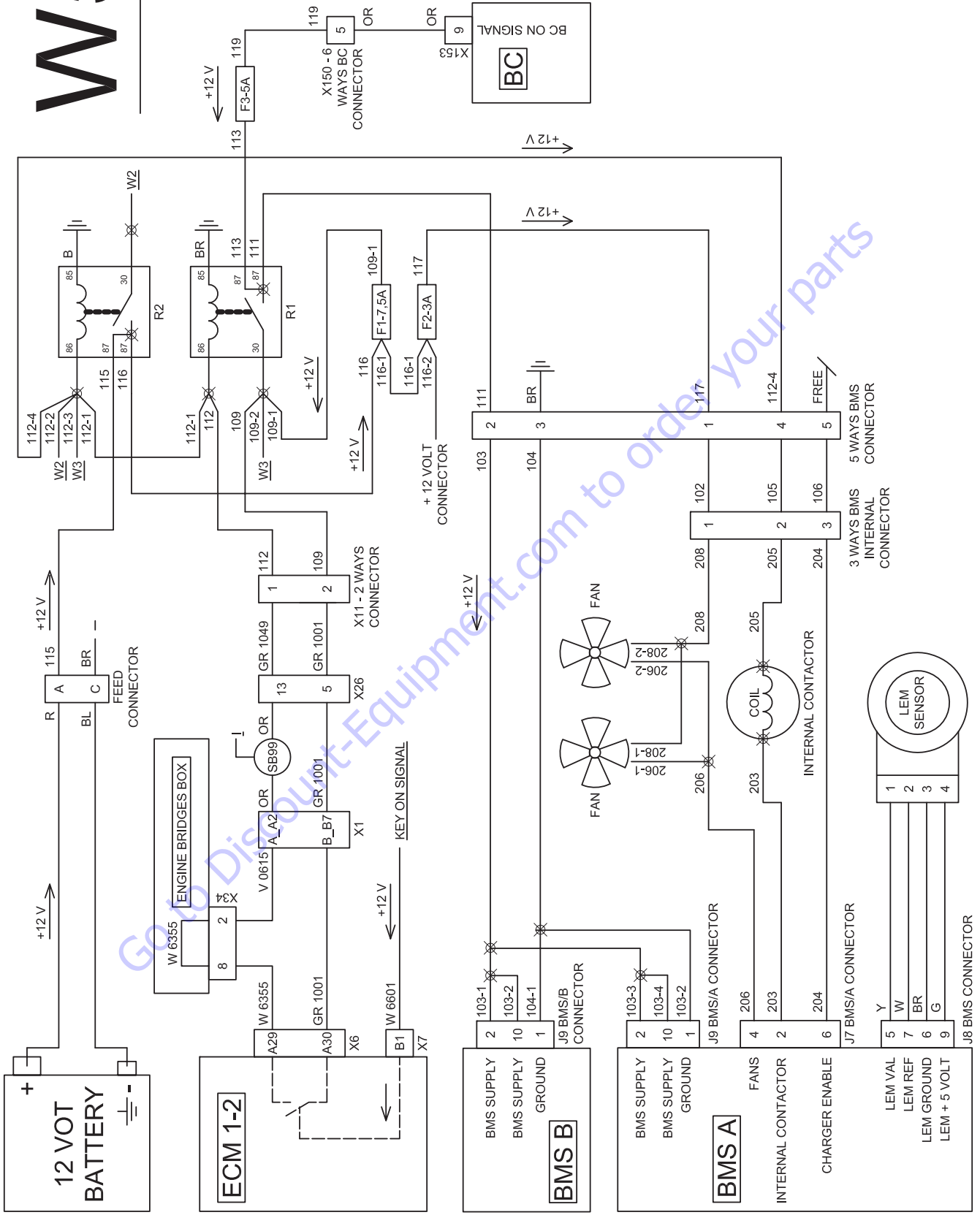

Go to [Discount-Equipment.com](http://Discount-Equipment.com) to order your parts

# W6

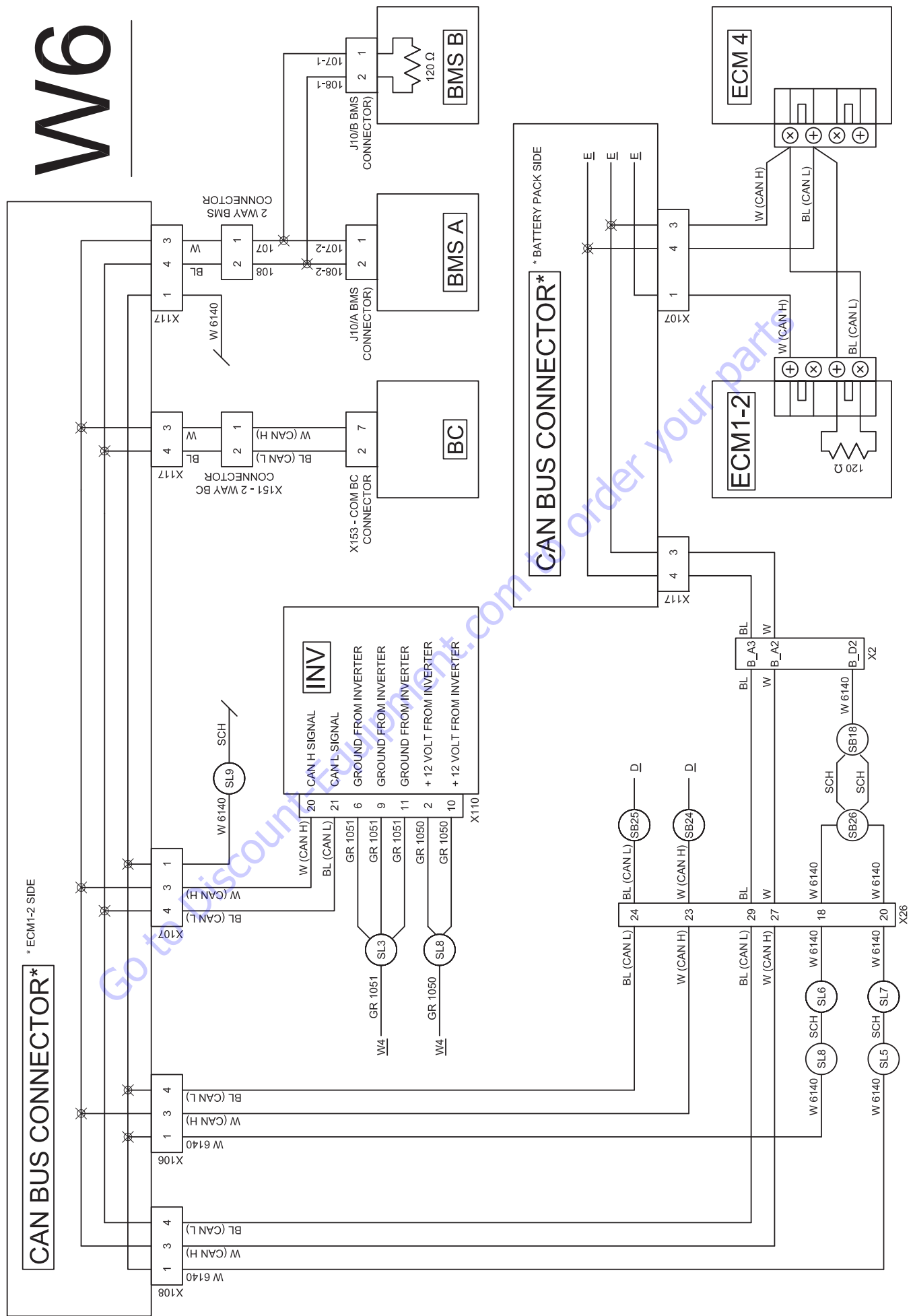

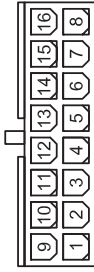
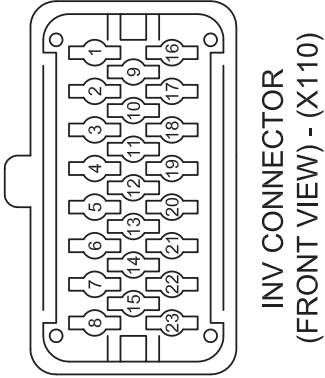
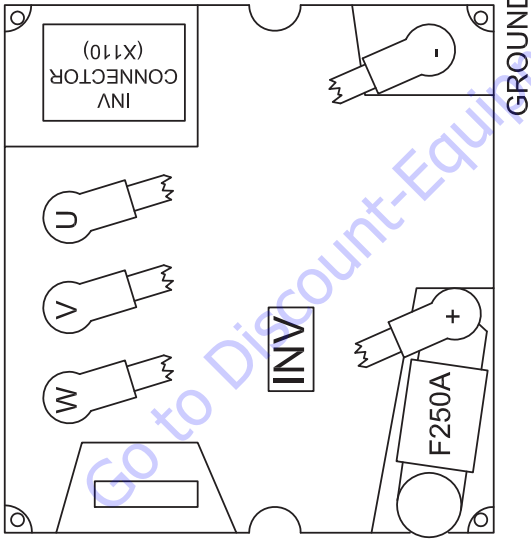
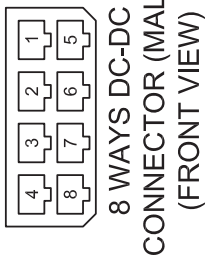
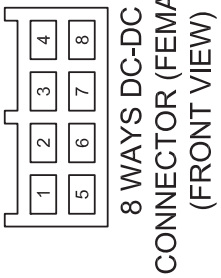

CAN BRIDGE CONNECTOR (FRONT VIEW) - (X154)

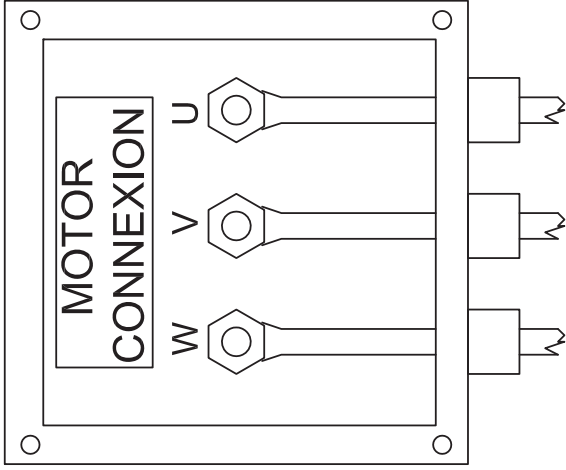

# W7

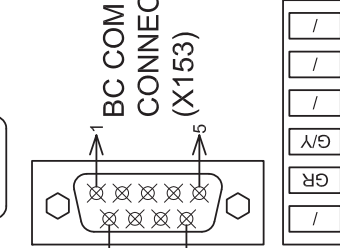
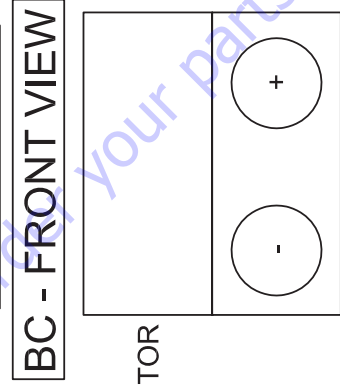
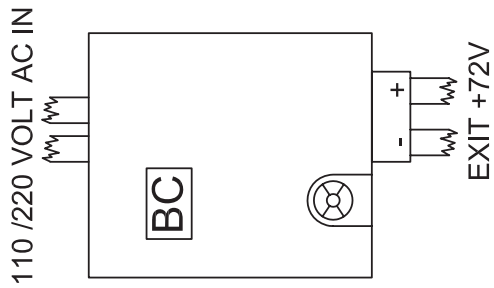
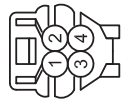

RED FASTON

EXIT +72V

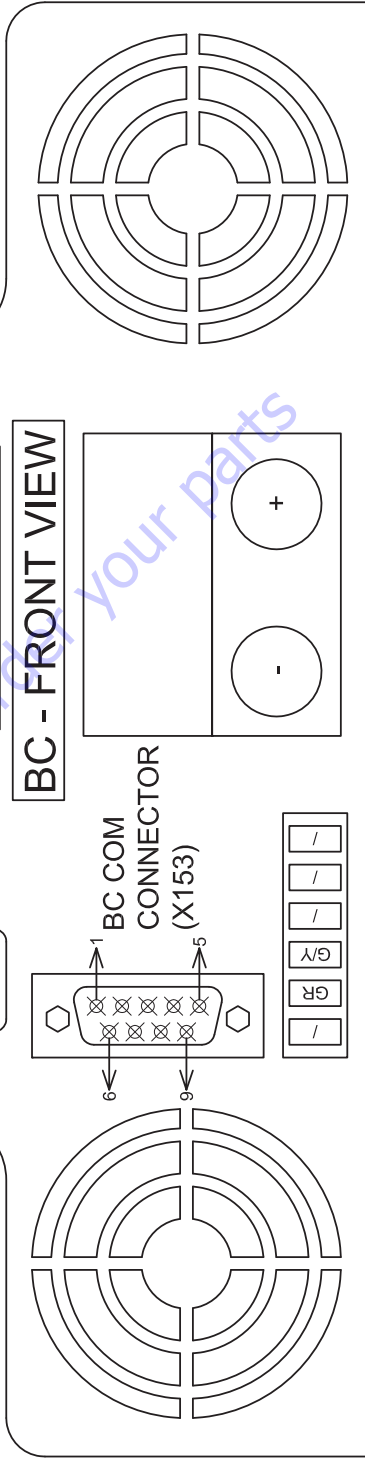

# INTERNAL COMPONENTS

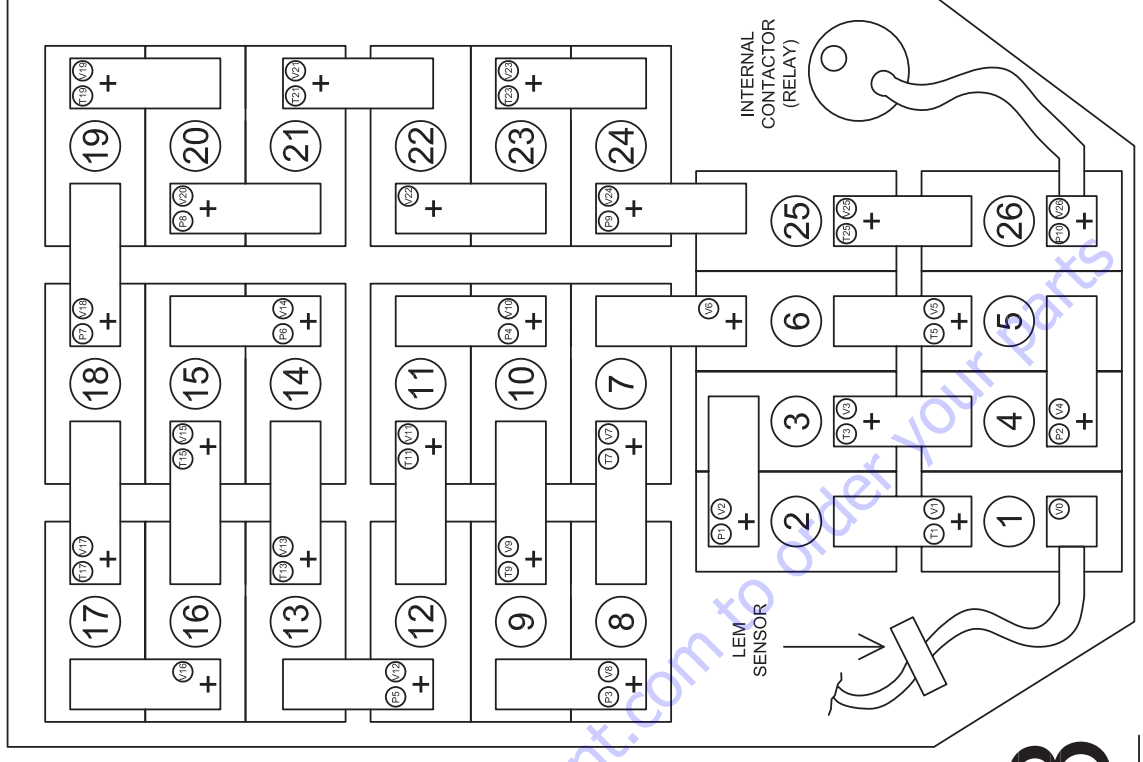

- (N) TEMPERATURE SENSOR
  - (N) TEMPERATURE SWITCH
  - (N) VOLT SENSOR
- CELLS CONNECTION
- CELL ELEMENT

# W8

# EXTERNAL COMPONENTS

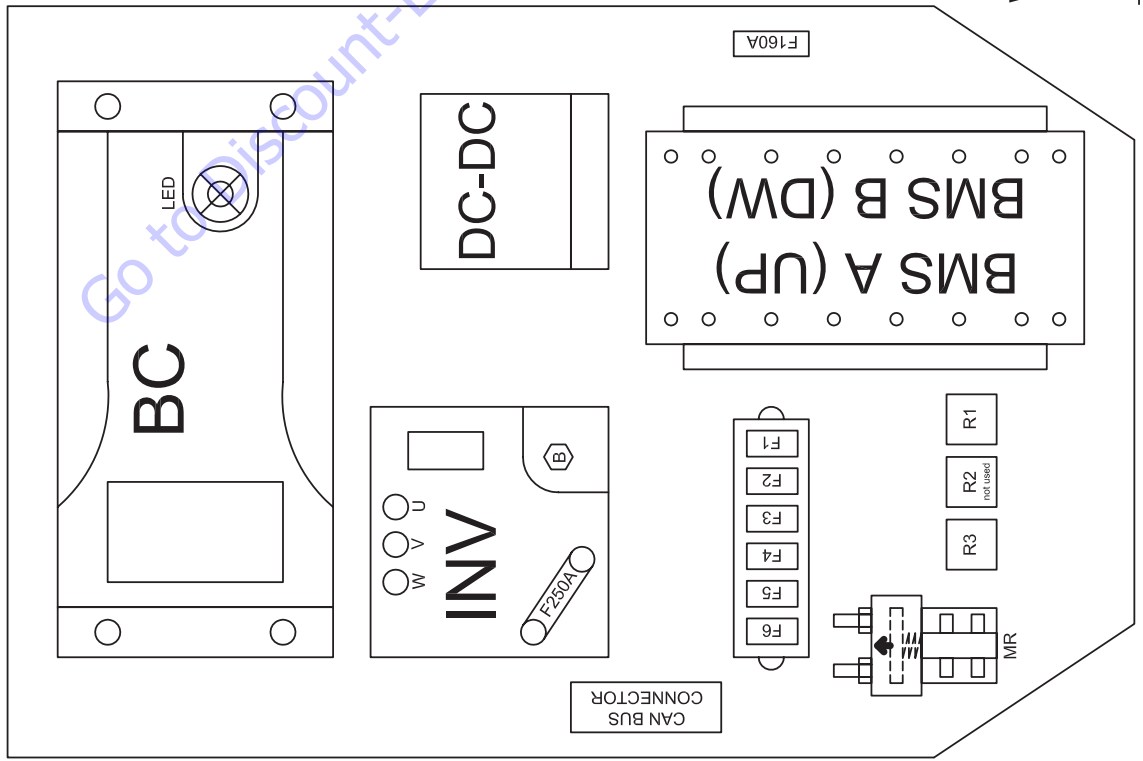

LED MEANING WITH THE NETWORK PLUG CONNECTED:  
 RED = 1<sup>st</sup> STEP - BATTERY UNDER FULLY CHARGE  
 YELLOW FLASH = 2<sup>nd</sup> STEP - BATTERY UNDER LIGHT CHARGE  
 GREEN = 3<sup>rd</sup> STEP - BALANCING AND MAINTENANCE  
 GREEN/RED FLASH = ERROR - THE BATTERY PACKAGE IS DISCONNECTED

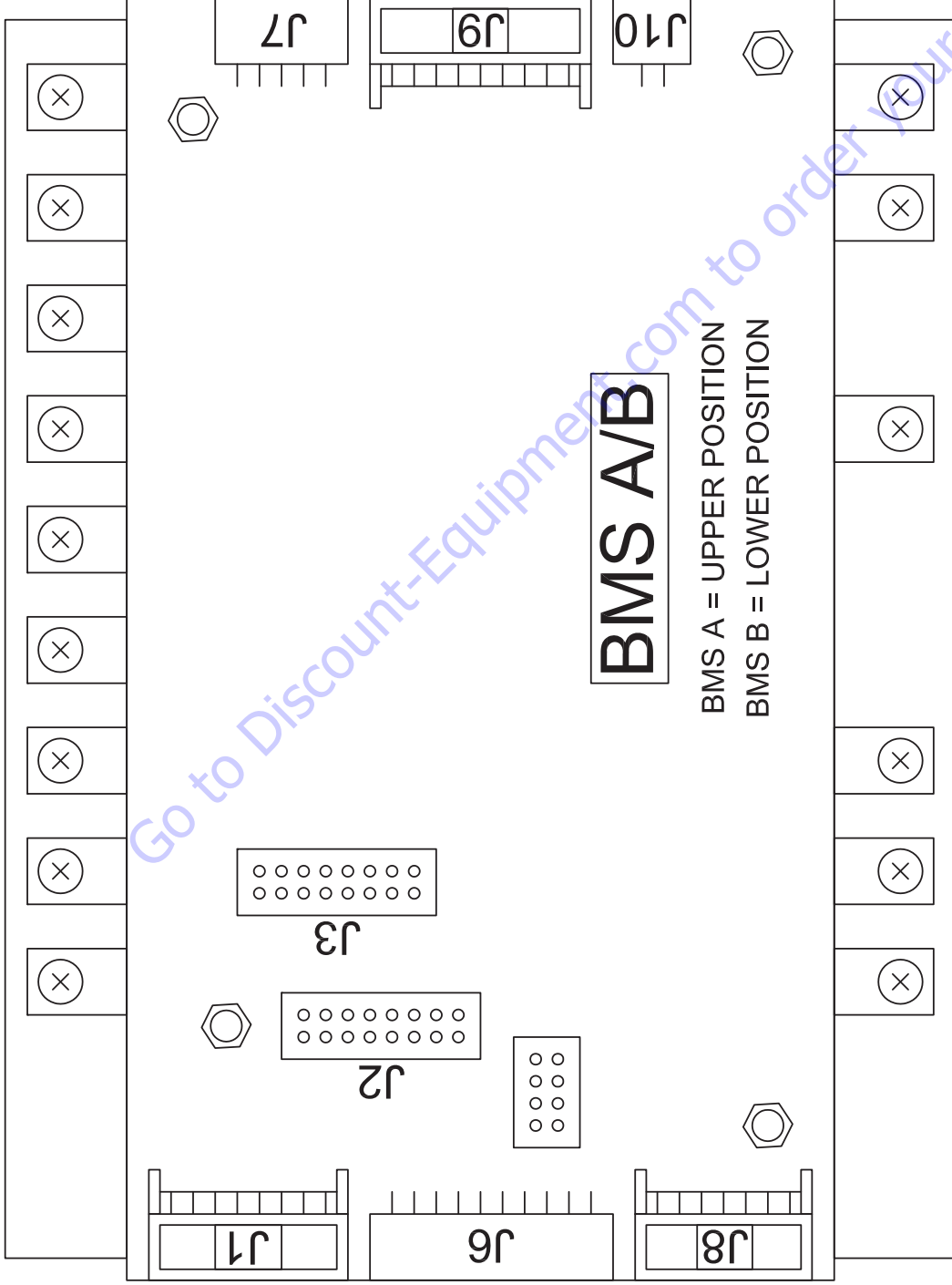

2	4	6	8	10	12	14	16
1	3	5	7	9	11	13	15

J1 A/B - J2 A/B - J3 A/B  
CONNECTOR (WHITE)

2	4	6	8	10	12	14
1	3	5	7	9	11	13

J8 A/B CONNECTOR  
(WHITE)

2	4	6	8	10	12	14	16	18
1	3	5	7	9	11	13	15	17

J9 A/B CONNECTOR  
(WHITE)

# W9

11	12	13	14	15	16	17	18	19	20
1	2	3	4	5	6	7	8	9	10

J6 A/B CONNECTOR  
(BLACK)

5	6	7	8
1	2	3	4

J7 A/B CONNECTOR  
(BLACK)

3	4
1	2

J10 A/B CONNECTOR  
(BLACK)

NOTE: FRONT VIEW  
CONNECTORS SHOWN

**Connector J1/A - Temperature Input**

PIN	COLOR	DESCRIPTION
1	191	NTC Cell 1 - (T1)
2	192	NTC Cell 1 + (T1)
3	/	/
4	/	/
5	193	NTC Cell 3 - (T3)
6	194	NTC Cell 3 + (T3)
7	/	/
8	/	/
9	195	NTC Cell 5 - (T5)
10	196	NTC Cell 5 + (T5)
11	197	NTC HS 1 -
12	198	NTC HS 1 +
13	199	NTC Prot CH 1 - (P1)
14	200	NTC Prot CH 1 + (P1)
15	201	NTC Prot CH 2 - (P2)
16	202	NTC Prot CH 2 + (P2)

**Connector J2/A - Temperature Input**

PIN	COLOR	DESCRIPTION
1	179	NTC Cell 7 - (T7)
2	180	NTC Cell 7 + (T7)
3	/	/
4	/	/
5	181	NTC Cell 9 - (T9)
6	182	NTC Cell 9 + (T9)
7	183	NTC HS 2 -
8	184	NTC HS 2 +
9	/	/
10	/	/
11	185	NTC Cell 11 - (T11)
12	186	NTC Cell 11 + (T11)
13	187	NTC Prot CH 3 - (P3)
14	188	NTC Prot CH 3 + (P3)
15	189	NTC Prot CH 4 - (P4)
16	190	NTC Prot CH 4 + (P4)

**Connector J3/A - Temperature Input**

PIN	COLOR	DESCRIPTION
1		
2	210	NTC Cell 13 - (T13)
3	211	NTC Cell 13 + (T13)
4		
5		
6		
7		
8		
9		
10		
11	212	NTC Cell 15 - (T15)
12	213	NTC Cell 15 + (T15)
13	214	NTC Prot CH 5 - (P5)
14	214-1	NTC Prot CH 5 + (P5)
15	215	NTC Prot CH 6 - (P6)
16	216	NTC Prot CH 6 + (P6)

**Connector J6/A - Voltage Input**

PIN	COLOR	DESCRIPTION
1	161	GND (V0)
2	162	Volt Cell 1
3	163	Volt Cell 2
4	164	Volt Cell 3
5	165	Volt Cell 4
6	166	Volt Cell 5
7	167	Volt Cell 6
8	168	Volt Cell 7
9	169	Volt Cell 8
10	170	Volt Cell 9
11	171	Volt Cell 10
12	172	Volt Cell 10
13	173	Volt Cell 11
14	174	Volt Cell 12
15	175	Volt Cell 13
16	176	Volt Cell 14
17	/	/
18	177	Volt Cell 14
19	178	Volt Cell 15

Note: NTC Cell N° are temperature sensors. They are located in the cell number indicated, and they

measure the temperature continuously

NTC Prot CH N° are temperature switches (ON/OFF) for protection reasons. They are located in the

cell number indicated, and they close the line only when the temperature exceeds 70 °C

NTC HS N° are temperature sensors in the cooler

() Bracket show the position on page Z8 (internal Components)

**Connector J7/A**

**Internal Contactor and fans**

PIN	COLOR	DESCRIPTION
1	/	/
2	203	Internal Contactor
3	/	/
4	206	Fans
5	/	/
6	204	Charger Enable
7	/	/
8	/	/

**Connector J8/A - Current Sensor**

PIN	COLOR	DESCRIPTION
1	/	/
2	/	/
3	/	/
4	/	/
5	Y	Lem Val
6	BR	Lem GND
7	W	Lem Ref
8	R/B	/
9	G	Lem + 5 Volt
10	/	/
11	/	/
12	/	/
13	/	/
14	/	/

**Connector J9/A - Supply**

PIN	COLOR	DESCRIPTION
1	104-2	External GND
2	103-3	BMS Supply
3	/	/
4	/	/
5	/	/
6	/	/
7	/	/
8	/	/
9	/	/
10	103-4	BMS Supply
11	/	/
12	/	/
13	/	/
14	/	/
15	/	/
16	/	/
17	/	/
18	/	/

**Connector J10/A - Can Bus**

PIN	COLOR	DESCRIPTION
1	107-2	CAN H
2	108-2	CAN L
3	/	/
4	/	/

Note: Cell 10 has double signal

**W10A**

**Connector J1/B - Temperature Input**

PIN	COLOR	DESCRIPTION
1	/	/
2	/	/
3	136	NTC Cell 17 - (T17)
4	137	NTC Cell 17 + (T17)
5	/	/
6	/	/
7	138	NTC Cell 19 - (T19)
8	139	NTC Cell 19 + (T19)
9	140	NTC HS 3 -
10	141	NTC HS 3 +
11	142	NTC Cell 21 - (T21)
12	143	NTC Cell 21 + (T21)
13	144	NTC Prot CH 7 - (P7)
14	145	NTC Prot CH 7 + (P7)
15	146	NTC Prot CH 8 - (P8)
16	147	NTC Prot CH 8 + (P8)

**Connector J2/B - Temperature Input**

PIN	COLOR	DESCRIPTION
1	/	/
2	/	/
3	126	NTC Cell 23 - (T23)
4	127	NTC Cell 23 + (T23)
5	128	NTC HS 4 -
6	129	NTC HS 4 +
7	130	NTC Cell 25 - (T25)
8	131	NTC Cell 25 + (T25)
9	/	/
10	/	/
11	/	/
12	/	/
13	132	NTC Prot CH 9 - (P9)
14	133	NTC Prot CH 9 + (P9)
15	134	NTC Prot CH 10 - (P10)
16	135	NTC Prot CH 10 + (P10)

**Connector J3/B - Temperature Input**

PIN	COLOR	DESCRIPTION
1	/	/
2	/	/
3	/	/
4	/	/
5	/	/
6	/	/
7	/	/
8	/	/
9	/	/
10	/	/
11	/	/
12	/	/
13	/	/
14	/	/
15	/	/
16	/	/
17	/	/
18	/	/
19	/	/
20	/	/

**Connector J6/B - Voltage Input**

PIN	COLOR	DESCRIPTION
1	148	Volt Cell 15
2	149	Volt Cell 16
3	150	Volt Cell 17
4	151	Volt Cell 18
5	152	Volt Cell 19
6	153	Volt Cell 20
7	154	Volt Cell 21
8	155	Volt Cell 22
9	156	Volt Cell 23
10	157	Volt Cell 24
11	158	Volt Cell 25
12	159	Volt Cell 25
13	160	Volt Cell 26
14	/	/
15	/	/
16	/	/
17	/	/
18	/	/
19	/	/
20	/	/

Note: NTC Cell N° are temperature sensors. They are located in the cell number indicated, and they

measure the temperature continuously

NTC Prot CH N° are temperature switches (ON/OFF) for protection reasons. They are located in the

cell number indicated, and they close the line only when the temperature exceeds 70 °C

NTC HS N° are temperature sensors in the cooler

( ) Bracket show the position on page Z8 (internal Components)

**Connector J7/B**

Internal Contactor and fans

PIN	COLOR	DESCRIPTION
1	/	/
2	/	/
3	/	/
4	/	/
5	/	/
6	/	/
7	/	/
8	/	/
9	/	/
10	/	/
11	/	/
12	/	/
13	/	/
14	/	/
15	/	/
16	/	/
17	/	/
18	/	/

**Connector J8B - Current Sensor**

PIN	COLOR	DESCRIPTION
1	/	/
2	/	/
3	/	/
4	/	/
5	/	/
6	/	/
7	/	/
8	/	/
9	/	/
10	/	/
11	/	/
12	/	/
13	/	/
14	/	/
15	/	/
16	/	/
17	/	/
18	/	/

**Connector J9/B - Supply**

PIN	COLOR	DESCRIPTION
1	104-1	External GND
2	103-1	BMS Supply
3	/	/
4	/	/
5	/	/
6	/	/
7	/	/
8	/	/
9	/	/
10	103-2	BMS Supply
11	/	/
12	/	/
13	/	/
14	/	/
15	/	/
16	/	/
17	/	/
18	/	/

**Connector J10/B - Can Bus**

PIN	COLOR	DESCRIPTION
1	107-1	CAN H
2	108-1	CAN L
3	/	/
4	/	/

**W10B**

**CALIFORNIAN PROPOSITION 65  
BATTERY WARNING**

Battery posts, terminals and related accessories contain lead and lead compounds, chemicals known to the State of California to cause cancer and reproductive harm.

Batteries also contain other harmful chemicals known to the State of California.

**WASH HANDS  
AFTER HANDLING!**

 **WARNING:** 

The engine exhaust from this product contains chemicals known to the State of California to cause cancer, birth defects, or other reproductive harm.

1702961

Go to Discount-Equipment.com to order your parts



# PARTS FINDER

**Search Website  
by Part Number**



**Search Manual  
Library For Parts  
Manual & Lookup Part  
Numbers – Purchase  
or Request Quote**

**Search Manuals**

Enter your information to search for manuals and parts.

\* Brand:

\* Model:

\* Serial:

\* Part Number:

SEARCH

**Can't Find Part or  
Manual? Request Help  
by Manufacturer,  
Model & Description**

**Parts Order Form**

Please fill in the following information:

Manufacturer:

Model:

Description:

Quantity:

Part Number:

Part Name:

Part Description:

Part Location:

Part Condition:

Part Status:

Part Price:

Part Weight:

Part Dimensions:

Part Material:

Part Color:

Part Finish:

Part Notes:

Part Attachments:

Part Images:

Part Videos:

Part Documents:

Part Links:

Part Other:

Part Comments:

Part Status:

Part Price:

Part Weight:

Part Dimensions:

Part Material:

Part Color:

Part Finish:

Part Notes:

Part Attachments:

Part Images:

Part Videos:

Part Documents:

Part Links:

Part Other:

Part Comments:

Discount-Equipment.com is your online resource for quality parts & equipment.

Florida: **561-964-4949** Outside Florida TOLL FREE: **877-690-3101**

**Need parts?**

Click on this link: <http://www.discount-equipment.com/category/5443-parts/> and choose one of the options to help get the right parts and equipment you are looking for. Please have the machine model and serial number available in order to help us get you the correct parts. If you don't find the part on the website or on once of the online manuals, please fill out the request form and one of our experienced staff members will get back to you with a quote for the right part that your machine needs.

We sell worldwide for the brands: Genie, Terex, JLG, MultiQuip, Mikasa, Essick, Whiteman, Mayco, Toro Stone, Diamond Products, Generac Magnum, Airman, Haulotte, Barreto, Power Blanket, Nifty Lift, Atlas Copco, Chicago Pneumatic, Allmand, Miller Curber, Skyjack, Lull, Skytrak, Tsurumi, Husquvarna Target, , Stow, Wacker, Sakai, Mi-T- M, Sullair, Basic, Dynapac, MBW, Weber, Bartell, Bennar Newman, Haulotte, Ditch Runner, Menegotti, Morrison, Contec, Buddy, Crown, Edco, Wyco, Bomag, Laymor, Barreto, EZ Trench, Bil-Jax, F.S. Curtis, Gehl Pavers, Heli, Honda, ICS/PowerGrit, IHI, Partner, Imer, Clipper, MMD, Koshin, Rice, CH&E, General Equipment, ,AMida, Coleman, NAC, Gradall, Square Shooter, Kent, Stanley, Tamco, Toku, Hatz, Kohler, Robin, Wisconsin, Northrock, Oztec, Toker TK, Rol-Air, Small Line, Wanco, Yanmar



3121764



An Oshkosh Corporation Company



[www.Discount-Equipment.com](http://www.Discount-Equipment.com)

Go to [Discount-Equipment.com](http://Discount-Equipment.com) to order your parts