



An Oshkosh Corporation Company



www.Discount-Equipment.com

Service and Maintenance Manual

Model 1500SJ

3121262

May 24, 2019 - Rev N

ANSI

CE



AS/NZS

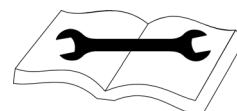

Go to Discount-Equipment.com to order your parts

PARTS FINDER

**Search Website
by Part Number**



**Search Manual
Library For Parts
Manual & Lookup Part
Numbers – Purchase
or Request Quote**

**Can't Find Part or
Manual? Request Help
by Manufacturer,
Model & Description**

Discount-Equipment.com is your online resource for quality parts & equipment.

Florida: **561-964-4949** Outside Florida TOLL FREE: **877-690-3101**

Need parts?

Click on this link: <http://www.discount-equipment.com/category/5443-parts/> and choose one of the options to help get the right parts and equipment you are looking for. Please have the machine model and serial number available in order to help us get you the correct parts. If you don't find the part on the website or on once of the online manuals, please fill out the request form and one of our experienced staff members will get back to you with a quote for the right part that your machine needs.

We sell worldwide for the brands: Genie, Terex, JLG, MultiQuip, Mikasa, Essick, Whiteman, Mayco, Toro Stone, Diamond Products, Generac Magnum, Airman, Haulotte, Barreto, Power Blanket, Nifty Lift, Atlas Copco, Chicago Pneumatic, Allmand, Miller Curber, Skyjack, Lull, Skytrak, Tsurumi, Husquvarna Target, , Stow, Wacker, Sakai, Mi-T- M, Sullair, Basic, Dynapac, MBW, Weber, Bartell, Bennar Newman, Haulotte, Ditch Runner, Menegotti, Morrison, Contec, Buddy, Crown, Edco, Wyco, Bomag, Laymor, Barreto, EZ Trench, Bil-Jax, F.S. Curtis, Gehl Pavers, Heli, Honda, ICS/PowerGrit, IHI, Partner, Imer, Clipper, MMD, Koshin, Rice, CH&E, General Equipment, ,AMida, Coleman, NAC, Gradall, Square Shooter, Kent, Stanley, Tamco, Toku, Hatz, Kohler, Robin, Wisconsin, Northrock, Oztec, Toker TK, Rol-Air, Small Line, Wanco, Yanmar

SECTION A. INTRODUCTION - MAINTENANCE SAFETY PRECAUTIONS

A GENERAL

This section contains the general safety precautions which must be observed during maintenance of the aerial platform. It is of utmost importance that maintenance personnel pay strict attention to these warnings and precautions to avoid possible injury to themselves or others, or damage to the equipment. A maintenance program must be followed to ensure that the machine is safe to operate.

⚠ WARNING

MODIFICATION OR ALTERATION OF AN AERIAL WORK PLATFORM SHALL BE MADE ONLY WITH WRITTEN PERMISSION FROM THE MANUFACTURER.

The specific precautions to be observed during maintenance are inserted at the appropriate point in the manual. These precautions are, for the most part, those that apply when servicing hydraulic and larger machine component parts.

Your safety, and that of others, is the first consideration when engaging in the maintenance of equipment. Always be conscious of weight. Never attempt to move heavy parts without the aid of a mechanical device. Do not allow heavy objects to rest in an unstable position. When raising a portion of the equipment, ensure that adequate support is provided.

⚠ WARNING

SINCE THE MACHINE MANUFACTURER HAS NO DIRECT CONTROL OVER THE FIELD INSPECTION AND MAINTENANCE, SAFETY IN THIS AREA RESPONSIBILITY OF THE OWNER/OPERATOR.

B HYDRAULIC SYSTEM SAFETY

It should be noted that the machines hydraulic systems operate at extremely high potentially dangerous pressures. Every effort should be made to relieve any system pressure prior to disconnecting or removing any portion of the system.

Do not use your hand to check for leaks. Use a piece of cardboard or paper to search for leaks. Wear gloves to help protect hands from spraying fluid.



C MAINTENANCE

⚠ WARNING

FAILURE TO COMPLY WITH SAFETY PRECAUTIONS LISTED IN THIS SECTION COULD RESULT IN MACHINE DAMAGE, PERSONNEL INJURY OR DEATH AND IS A SAFETY VIOLATION.

- ENSURE REPLACEMENT PARTS OR COMPONENTS ARE IDENTICAL OR EQUIVALENT TO ORIGINAL PARTS OR COMPONENTS.
- NO SMOKING IS MANDATORY. NEVER REFUEL DURING ELECTRICAL STORMS. ENSURE THAT FUEL CAP IS CLOSED AND SECURE AT ALL OTHER TIMES.
- REMOVE ALL RINGS, WATCHES AND JEWELRY WHEN PERFORMING ANY MAINTENANCE.
- DO NOT WEAR LONG HAIR UNRESTRAINED, OR LOOSE-FITTING CLOTHING AND NECKTIES WHICH ARE APT TO BECOME CAUGHT ON OR ENTANGLED IN EQUIPMENT.
- OBSERVE AND OBEY ALL WARNINGS AND CAUTIONS ON MACHINE AND IN SERVICE MANUAL.
- KEEP OIL, GREASE, WATER, ETC. WIPED FROM STANDING SURFACES AND HAND HOLDS.
- USE CAUTION WHEN CHECKING A HOT, PRESSURIZED COOLANT SYSTEM.
- NEVER WORK UNDER AN ELEVATED BOOM UNTIL BOOM HAS BEEN SAFELY RESTRAINED FROM ANY MOVEMENT BY BLOCKING OR OVERHEAD SLING, OR BOOM SAFETY PROP HAS BEEN ENGAGED.
- BEFORE MAKING ADJUSTMENTS, LUBRICATING OR PERFORMING ANY OTHER MAINTENANCE, SHUT OFF ALL POWER CONTROLS.
- BATTERY SHOULD ALWAYS BE DISCONNECTED DURING REPLACEMENT OF ELECTRICAL COMPONENTS.
- KEEP ALL SUPPORT EQUIPMENT AND ATTACHMENTS STOWED IN THEIR PROPER PLACE.
- USE ONLY APPROVED, NONFLAMMABLE CLEANING SOLVENTS.

REVISION LOG

Original Issue	A - September 12, 2011
Revised	B - November 9, 2011
Revised	C - March 26, 2012
Revised	D - May 16, 2012
Revised	E - January 10, 2013
Revised	F - February 20, 2013
Revised	G - May 22, 2013
Revised	H - September 30, 2015
Revised	I - March 7, 2016
Revised	J - November 8, 2016
Revised	K - May 23, 2017
Revised	L - May 30, 2018
Revised	M - June 29, 2018 - Revised Covers
Revised	N - May 24, 2019

Go to Discount-Equipment.com to order your parts

SECTION NO.	TITLE	PAGE NO.
SECTION A - INTRODUCTION - MAINTENANCE SAFETY PRECAUTIONS		
A	General	A-1
B	Hydraulic System Safety	A-1
C	Maintenance	A-1
SECTION 1 - SPECIFICATIONS		
1.1	Operating Specifications	1-1
1.2	Dimensional Data	1-1
1.3	Capacities	1-2
1.4	Tires	1-2
1.5	Engine Data	1-2
	Deutz	1-2
1.6	Hydraulic Oil	1-3
1.7	Major Component Weights	1-4
1.8	Operator Maintenance	1-6
SECTION 2 - GENERAL		
2.1	Machine Preparation, Inspection, and Maintenance	2-1
	General	2-1
	Preparation, Inspection, and Maintenance	2-1
	Pre-Start Inspection	2-1
	Pre-Delivery Inspection and Frequent Inspection	2-1
	Annual Machine Inspection	2-1
	Preventive Maintenance	2-1
2.2	Service and Guidelines	2-2
	General	2-2
	Safety and Workmanship	2-2
	Cleanliness	2-2
	Components Removal and Installation	2-2
	Component Disassembly and Reassembly	2-3
	Pressure-Fit Parts	2-3
	Bearings	2-3
	Gaskets	2-3
	Bolt Usage and Torque Application	2-3
	Hydraulic Lines and Electrical Wiring	2-3
	Hydraulic System	2-3
	Lubrication	2-3
	Battery	2-3
	Lubrication and Servicing	2-3
2.3	Lubrication and Information	2-4
	Hydraulic System	2-4
	Hydraulic Oil	2-4
	Changing Hydraulic Oil	2-4
	Lubrication Specifications	2-4
2.4	Cylinder Drift	2-5
	Theory	2-5
	Cylinder Leakage Test	2-5
	Cylinder Thermal Drift	2-5
2.5	Pins and Composite Bearing Repair Guidelines	2-6
2.6	Welding on JLG Equipment	2-6
	Do the Following When Welding on JLG Equipment	2-6
	Do NOT Do the Following When Welding on JLG Equipment	2-6

TABLE OF CONTENTS

SECTION NO.	TITLE	PAGE NO.
SECTION 3 - CHASSIS & TURNTABLE		
3.1	Tires and Wheels	3-1
	Tire Inflation.....	3-1
	Tire Damage	3-1
	Wheel and Tire Replacement.....	3-1
	Wheel Installation	3-1
3.2	Axle Extension System.....	3-2
3.3	Axle Limit Switch Adjustment Procedure	3-2
3.4	Drive System	3-3
3.5	Steering Control System.....	3-3
3.6	Drive/Steering Speed Control.....	3-4
3.7	Traction Control System	3-4
3.8	Drive Orientation System	3-4
	Swing Envelope Service Mode	3-4
3.9	Oscillating Axle System	3-16
3.10	Oscillating Axle Bleeding Procedure and Lockout Test	3-16
	Lockout Cylinder Bleeding	3-16
	Oscillating Axle Lockout Test.....	3-17
3.11	Wheel Drive Assembly.....	3-18
	Removal	3-18
	Installation.....	3-18
3.12	Drive Motor	3-19
	Removal	3-19
	Installation	3-19
3.13	Drive Hub	3-21
	Product Identification	3-21
	Hydraulic Motor Installation	3-21
	Installation of the Wheel Drive on the Machine.....	3-21
	Start Up and Running In.....	3-21
	General Information	3-22
	Connecting the Brake.....	3-22
	Filling-up the Gearbox with Lubricating Oil.....	3-22
	Gearbox Disengagement	3-24
	Maintenance Information	3-26
	Changing the Lubricating oil.....	3-26
	Troubleshooting	3-27
	Disassembly Information	3-27
	Disassembly Procedure	3-27
	Inspection of Parts.....	3-35
	Assembly	3-36
	Final Test and Reinstallation	3-46
3.14	Drive Hub - Reggiana Riduttori	3-51
	Symbol Nomenclature.....	3-51
	Tools.....	3-51
	Disassembly.....	3-56
	Assembly	3-60

SECTION NO.	TITLE	PAGE NO.
3.15	Swing Drive.....	3-67
	Roll and Leak Testing.....	3-67
	Tightening and Torquing Bolts.....	3-67
	Motor Control Valve Disassembly.....	3-68
	Motor and Brake Disassembly.....	3-69
	Main Disassembly.....	3-70
	Hub-Shaft Disassembly.....	3-71
	Carrier Disassembly.....	3-72
	Hub-Shaft Sub-Assembly.....	3-73
	Carrier Sub-Assembly.....	3-73
	Main Assembly.....	3-74
	Motor and Brake Assembly.....	3-75
	Motor Control Valve Assembly.....	3-75
3.16	Swing Brake.....	3-78
	Pre-Installation Checks.....	3-78
	Installation.....	3-79
	Maintenance.....	3-79
	Disassembly.....	3-79
	Examination.....	3-79
	Assembly.....	3-80
3.17	Swing Motor.....	3-82
	Disassembly and inspection.....	3-82
	Assembly.....	3-89
	One Piece Stator Construction.....	3-96
3.18	Procedure For Setting Gear Backlash.....	3-97
3.19	Swing Drive Lubrication.....	3-98
3.20	Swing Bearing.....	3-100
	Turntable Bearing Mounting Bolt Condition Check.....	3-100
	Wear Tolerance.....	3-103
	Turntable/Swing Bearing Removal.....	3-104
	Turntable/Swing Bearing Installation.....	3-116
	Swing Bearing Torque Values.....	3-123
3.21	Swing Speed Proportioning.....	3-124
3.22	Chassis Tilt Indicator System.....	3-124
3.23	Generator.....	3-125
	Every 250 hours.....	3-125
	Every 500 hours.....	3-125
	Overload Protection.....	3-126
	Inspecting Brushes, Replacing Brushes, and Cleaning Slip Rings.....	3-126
3.24	Auxiliary Power System.....	3-128
3.25	Engine (Deutz 2011).....	3-129
	Glow Plugs.....	3-129
	Checking Oil Level.....	3-129
	Changing Engine Oil.....	3-130
	Changing the Oil Filter.....	3-130
	Replacing the Fuel Filter.....	3-131
	Cleaning the Fuel Strainer.....	3-132
3.26	Deutz Engine - Td2.914.....	3-132
	Glow Plugs.....	3-132
	Check Oil Level.....	3-132
	Replacing Engine Oil.....	3-133
	Replacing the Oil Filter.....	3-133
	Replacing the Primary Fuel Filters.....	3-134
	Replacing the Fuel Pre-Filter.....	3-134
	Water in Fuel Sensing System (Optional).....	3-135
	Draining Water.....	3-135
	Auxiliary Fuel Filter.....	3-136

TABLE OF CONTENTS

SECTION NO.	TITLE	PAGE NO.
3.27	Deutz 2.9 L4 (Guo lii) Engine	3-138
3.28	Deutz Td2011 Engine.....	3-140
3.29	Deutz 2.9L4 Engine	3-142
3.30	Deutz EMR 2	3-144
3.31	Bio Fuel in Deutz Engines	3-157
	General	3-157
	Bio Fuel	3-157
	Biological Contamination In Fuels.....	3-158
3.32	Deutz Engine Fault Codes	3-159
3.33	Counterweight	3-206
SECTION 4 - BOOM & PLATFORM		
4.1	Boom Systems	4-1
	Broken Cable Indicator System.....	4-1
	Platform Control Enable System.....	4-1
	Transport Position Sensing System.....	4-1
	Beyond Transport - Drive Speed Cutback System	4-1
	Drive/Steer – Boom Function Interlock System (CE ONLY).....	4-4
	Jib Stow System	4-4
	Envelope Tracking System	4-4
	Moment Control System	4-4
	Boom Control System (BCS) Functional Check (Push to Test) System	4-5
4.2	Boom/Jib System Functionality	4-5
	Main Lift/Jib Velocity Control	4-5
	Jib Leveling During Automatic/Manual Envelope Control.....	4-5
	Jib Lift Functionality	4-7
	Jib Telescope Functionality	4-7
	Jib Swing Functionality	4-7
	Jib Swing Stow Sequence (Jib Pin Unlock)	4-7
	Jib Swing Deploy Sequence (Jib Pin Lock)	4-9
	Jib Lock Pin Lamp Operation	4-9
	Swing/Axle Extend Retract Restrictions.....	4-10
	Dual Capacity	4-10
	Jib Control During Over/Under Moment.....	4-10
	Boom Recovery Mode	4-10
4.3	Platform	4-12
	Platform/Support Removal	4-12
	Platform/Support Installation	4-13
4.4	Rotator.....	4-14
	Removal	4-14
	Installation	4-14
4.5	Boom Removal and Installation	4-15
	Removal	4-15
	Installation	4-17
4.6	Boom Disassembly/Assembly & Cable Replacement	4-20
	Disassembly.....	4-20
	Assembly	4-38
4.7	Load Sensing Pin Removal and Installation	4-53
4.8	Jib	4-55
	Removal	4-55
	Installation	4-57
4.9	Boom Lubrication Application	4-62
4.10	Platform Leveling Cylinder.....	4-62
	Removal	4-62
	Installation	4-63

SECTION NO.	TITLE	PAGE NO.
4.11	Jib Telescope Cylinder.....	4-64
	Removal.....	4-64
	Installation.....	4-66
4.12	Jib Lift Cylinder.....	4-67
	Removal.....	4-67
	Installation.....	4-68
4.13	Jib Straight Shimming Procedure.....	4-69
4.14	Boom Cleanliness Guidelines.....	4-71
4.15	Hose Routing.....	4-71
4.16	Powertrack Maintenance.....	4-75
	One Piece Bracket Maintenance.....	4-75
	Two Piece Bracket Maintenance.....	4-77
	Snap Rings and Screws.....	4-78
4.17	Wire Rope.....	4-80
	Inspection.....	4-80
	Three Month Inspection.....	4-80
	Additional Inspection Required If:.....	4-80
	12 Year or 7000 Hour Replacement.....	4-80
	Additional Replacement Criteria.....	4-81
4.18	Wire Rope Tensioning Adjustment.....	4-81
	Boom Section Re-Positioning.....	4-81
	Wire Rope Tensioning Procedure.....	4-83
4.19	Broken Boom Cable Proximity Switch.....	4-90
	Adjusting the Proximity Switch.....	4-90
4.20	Electronic Platform Leveling.....	4-90
	Description.....	4-90
	Normal Operation.....	4-91
4.21	Rotary Actuator.....	4-92
	Theory of Operation.....	4-92
	Tools Required.....	4-93
	Disassembly.....	4-94
	Inspection.....	4-99
	Assembly.....	4-100
	Greasing Thrust Washers.....	4-104
	Installing Counterbalance Valve.....	4-104
	Testing the Actuator.....	4-104
	Installation and Bleeding.....	4-106
	Troubleshooting.....	4-107
4.22	Jib Rotator Torquing Procedure.....	4-108
4.23	Skyguard®.....	4-110
	Operation.....	4-110
	Function Test.....	4-110
	SkyGuard Only.....	4-110
	Diagnostics & Troubleshooting.....	4-111
4.24	Bolt-on External Fall Arrest.....	4-112
	Inspection Before Use.....	4-112
	Installation.....	4-112

SECTION NO.	TITLE	PAGE NO.
SECTION 5	- BASIC HYDRAULIC INFORMATION & HYDRAULIC SCHEMATICS	
5.1	Lubricating O-Rings in the Hydraulic System	5-1
	Cup and Brush	5-1
	Dip Method	5-2
	Spray Method	5-2
	Brush-on Method.....	5-2
5.2	Hydraulic Connection Assembly and Torque Specification	5-3
	Tapered Thread Types	5-3
	Straight Thread Types, Tube and Hose Connections	5-3
	Straight Thread Types, Port Connections	5-4
	Flange Connection Types	5-4
	Tightening Methods.....	5-4
	Assembly And Torque Specifications	5-5
	Assembly Instructions for American Standard Pipe Thread Tapered (NPTF) Connections.....	5-6
	Assembly Instructions for British Standard Pipe Thread Tapered (BSPT) Connections.....	5-7
	Assembly Instructions for 37° (JIC) Flare Fittings	5-8
	Assembly Instructions for 45° SAE Flare Fittings.....	5-12
	Assembly Instructions for O-Ring Face Seal (ORFS) Fittings.....	5-14
	Assembly Instructions for DIN 24° Flare Bite Type Fittings (MBTL and MBTS)	5-16
	Assembly Instructions for Bulkhead (BH) Fittings	5-18
	Assembly Instructions for O-Ring Boss (ORB) Fittings	5-22
	Assembly Instructions for Adjustable Port End Metric (MFF) Fittings.....	5-30
	Assembly Instructions for Metric ISO 6149 (MPP) Port Assembly Stud Ends	5-38
	Assembly instructions for Adjustable Port End (BSPP) Fittings	5-42
	Assembly Instructions for Flange Connections: (FL61 and FL62)	5-50
	Double Wrench Method	5-53
	FFWR and TFFT Methods.....	5-54
	Adjustable Stud End Assembly.....	5-54
	O-ring Installation (Replacement)	5-55
5.3	Hydraulic Cylinders.....	5-56
	Axle Extension Cylinder.....	5-56
	Axle Lockout Cylinder	5-62
	Jib Level Cylinder (SN 0300209000 through 0300239990).....	5-69
	Jib Level Cylinder (SN 0300239991 to Present).....	5-75
	Platform Level Cylinder (SN 0300209000 through 0300239674)	5-81
	Platform Level Cylinder (SN 0300239675 to Present)	5-87
	Boom Lift Cylinder (SN 0300209000 through 0300239990).....	5-93
	Boom Lift Cylinder (SN 0300239991 to Present).....	5-99
	Jib Lift Cylinder.....	5-104
	Jib Lock Cylinder	5-111
	Steer Cylinder	5-116
	Jib Telescope Cylinder	5-121
	Main Boom Telescope Cylinder (SN 0300209000 through 0300244704).....	5-127
	Main Boom Telescope Cylinder (SN 0300244705 to Present)	5-133
5.4	Cylinder Length Sensor.....	5-138
	Removal	5-138
	Installation	5-140
5.5	Oil Sampling	5-151
	Procedure.....	5-151
5.6	Pressure Setting Procedure	5-152
	Set Up of the Function Pump	5-152
	Adjustments made at the Main Valve Bank	5-153
	Adjustments Made at the Frame Valve Bank.....	5-153
	Adjustments Made at the Platform Valve Bank.....	5-158
	Adjustments Made at the Jib Valve.....	5-159

SECTION NO.	TITLE	PAGE NO.
5.7	Drive Pumps (Rexroth)	5-165
	Troubleshooting Procedure	5-165
	Charge Pressure Relief Valve Adjustment	5-168
	Mechanical Centering of Pump	5-169
	Hydraulic Centering of Control Modules	5-169
	High Pressure Relief Valve Adjustments	5-170
	Removal and inspection of charge pump	5-170
	Routine Maintenance	5-171
	Removal and Installation of Shaft Seal	5-173
5.8	Function Pump (Rexroth).....	5-174
	Spare Parts.....	5-174
	Sealing the Drive Shaft	5-175
	Disassembly and Assembly of the Complete Unit.....	5-176
	Assembly	5-179
	Adjustments	5-180
	Tightening Torques	5-180
	Pump Control Disassembly For Cleaning	5-182
5.9	Drive Pumps (Sauer).....	5-184
	Port Locations and Gauge Installation.....	5-184
	Initial Startup Procedures.....	5-187
	Troubleshooting	5-187
	Adjustments	5-191
	Removing The Pump.....	5-195
	Inspection	5-195
	Replacement.....	5-195
	Electric Control Module	5-196
	Shaft, Seal, and Bearing.....	5-197
	Charge Pump	5-198
	Charge Check / HPRV.....	5-200
	Charge Pressure Relief Valve.....	5-201
	Control Cutoff Valve.....	5-202
5.10	Function Pump (Sauer)	5-205
	Disassembly	5-205
	Inspection	5-207
	Assembly	5-210
5.11	Gear pump (Sauer)	5-214
	Disassembly	5-214
	Assembly	5-217
	Trouble Shooting	5-224
5.12	Drive & Function Pump Start Up Procedures	5-225
	Start-Up Procedure.....	5-225

TABLE OF CONTENTS

SECTION NO.	TITLE	PAGE NO.
SECTION 6 - JLG CONTROL SYSTEM		
6.1	JLG Control System Analyzer Kit Instructions	6-1
	Introduction	6-1
	To Connect the JLG Control System Analyzer	6-2
	Using the Analyzer	6-2
	Changing the Access Level of the Hand Held Analyzer	6-3
	Adjusting Parameters Using the Hand Held Analyzer	6-4
	Machine Setup	6-5
	Level Vehicle Description	6-5
6.2	Machine Personality Settings and Function Speeds	6-16
6.3	Machine Orientation When Setting Function Speeds	6-21
	Test Notes	6-21
6.4	CANbus Communications	6-22
6.5	Calibration Instructions	6-24
6.6	Control System Boom Sensors	6-49
	Sensor #1 -Moment Pin	6-49
	Sensor #2 - Main Boom Angle Sensors	6-49
	Sensor #3 - Main Boom Length Sensor	6-51
	Sensor #4 - Main Boom Cylinder Angle Sensor	6-51
	Sensor #5 - Main Boom Transport Length Switch	6-51
	Sensor #6 - Jib Level Angle Sensor	6-52
	Sensor #7 - Jib Lock Pin Switch with both normally open and normally closed outputs	6-52
	Sensor #8 - Jib Stow Angle Sensor	6-52
	Sensor #9 - Jib Lift Angle Sensor	6-52
	Sensor #10 - Dual Capacity / Jib Transport Length Switches	6-53
	Sensor #11 - Platform Level Cylinder Angle Sensor	6-53
	Sensor #12 - Platform Level Angle Gravity Sensors	6-53
	Sensor #13 - Turntable Swing Angle	6-53
6.7	Jib Control Module	6-54
6.8	CAN Gateway	6-54
6.9	System Test	6-55
	Test from the Platform	6-55
	Test from the Ground Station	6-58
6.10	Calibrating Steer	6-73
6.11	Calibrating Drive	6-76
6.12	LSS System	6-79
	Diagnostic Menu	6-80
	Calibration Procedure	6-81
	Testing & Evaluation	6-86
	Troubleshooting	6-87
6.13	Resetting The MSSO System	6-88
6.14	Electronic Platform Leveling	6-90
	Platform Leveling Fault Warning	6-90
	Fault Response	6-90
6.15	Calibrating Platform Level	6-91
	STEP 1: SETTING THE PLATFORM VALVE MINIMUMS	6-91
	STEP 2: BLEEDING THE PLATFORM VALVES	6-92
	STEP 3: CALIBRATING THE PLATFORM LEVEL UP AND DOWN VALVE CRACKPOINTS	6-93
6.16	Calibrating Lift Crack Point	6-95
6.17	Calibrating Telescope Crack point	6-97
6.18	Calibrating Tilt Sensor	6-101
6.19	Jib Sensor Calibrations	6-103
	Calibrating the Jib Level Up and Down Valve Crackpoints	6-112
6.20	Calibrating the Boom Sensors	6-114
	Boom Control System Check Procedure	6-130

SECTION NO.	TITLE	PAGE NO.
SECTION 7 - BASIC ELECTRICAL INFORMATION & ELECTRICAL SCHEMATICS		
7.1	General	7-1
7.2	Multimeter Basics	7-1
	Grounding	7-1
	Backprobing	7-1
	Min/Max	7-1
	Polarity	7-1
	Scale	7-1
	Voltage Measurement	7-1
	Resistance Measurement	7-2
	Continuity Measurement	7-2
	Current Measurement	7-3
7.3	Applying Silicone Dielectric Compound to Electrical Connections	7-3
	Installation of Dielectric Grease	7-4
	Deutsch HD, DT, DTM, DRC Series	7-4
	AMP Seal	7-4
	AMP Mate-N-Lok	7-5
	DIN Connectors	7-5
	Exclusions	7-5
7.4	AMP Connector	7-8
	Assembly	7-8
	Disassembly	7-10
	Wedge Lock	7-10
	Service - Voltage Reading	7-10
7.5	Deutsch Connectors	7-12
	DT/DTP Series Assembly	7-12
	DT/DTP Series Disassembly	7-12
	HD30/HDP20 Series Assembly	7-13
	HD30/HDP20 Series Disassembly	7-13
7.6	Telematics Gateway	7-14
	Telematics-Ready (TCU) Plug	7-14
	1500SJ ELECTRICAL SCHEMATIC	7-91

FIGURE NO.	TITLE	PAGE NO.
1-1.	Maintenance and Lubrication Diagram	1-5
1-2.	Deutz Engine Dipstick	1-9
1-3.	Torque Chart - Sheet 1 of 5 - (SAE Fasteners)	1-12
1-4.	Torque Chart - Sheet 2 of 5 - (SAE Fasteners)	1-13
1-5.	Torque Chart - Sheet 3 of 5 - (SAE Fasteners)	1-14
1-6.	Torque Chart - Sheet 4 of 5 - (METRIC Fasteners)	1-15
1-7.	Torque Chart - Sheet 5 of 5 - (METRIC Fasteners)	1-16
2-1.	Engine Operating Temperature Specifications - Deutz	2-10
2-2.	Hydraulic Oil Operating Temperature Specifications	2-11
3-1.	Axle Limit Switch Adjustment	3-2
3-2.	Conventional Two Wheel Steer Mode	3-3
3-3.	Crab Steer Mode	3-3
3-4.	Coordinated Steer Mode	3-3
3-5.	Chassis Component Location - Sheet 1 of 2	3-6
3-6.	Chassis Component Location - Sheet 2 of 2	3-7
3-7.	Turntable Component Location - Sheet 1 of 2	3-8
3-8.	Turntable Component Location - Sheet 2 of 2	3-9
3-9.	Oscillating Axle - Sheet 1 of 2	3-10
3-10.	Oscillating Axle - Sheet 2 of 2	3-11
3-11.	Fixed Axle - Sheet 1 of 2	3-12
3-12.	Fixed Axle - Sheet 2 of 2	3-13
3-13.	Axle Loctite Application	3-14
3-14.	Steering Installation	3-15
3-15.	Wheel Drive Removal and Installation	3-18
3-16.	Drive Motor Removal and Installation	3-19
3-17.	Drive Motor Assembly	3-20
3-18.	Drive Hub Identification Plate	3-21
3-19.	Hub Assembly	3-23
3-20.	Gearbox engaged	3-25
3-21.	Gearbox Disengaged	3-26
3-22.	Drive Hub	3-29
3-23.	Drive Hub Special Tools - Sheet 1 of 4	3-47
3-24.	Drive Hub Special Tools - Sheet 2 of 4	3-48
3-25.	Drive Hub Special Tools - Sheet 3 of 4	3-49
3-26.	Drive Hub Special Tools - Sheet 4 of 4	3-50
3-27.	Bearing Track Spacer Mounting C016117	3-51
3-28.	Oil Seal Spacer Mounting C125049	3-51
3-29.	Bearing Spacer Mounting CO16117	3-52
3-30.	Assembly Diagram 1	3-52
3-31.	Wrench For Ring Nut	3-53
3-32.	Anti-rotation Flange	3-53
3-33.	Anti-rotation Block	3-53
3-34.	Anti-rotation Pin	3-53
3-35.	Assembly Diagram 2	3-54
3-36.	Tools For Assembling Bearing 3rd Stage Planetary Gear Assembly Diagram	3-55
3-37.	Reggiana Riduttori Hub - Sheet 1 of 2	3-57
3-38.	Reggiana Riduttori Hub - Sheet 2 of 2	3-58
3-39.	Swing System (SN 030020900 through 0300254531)	3-65
3-40.	Swing System (SN 0300254532 to Present)	3-66
3-41.	Swing Drive - Motor Control Valve Disassembly (SN 030020900 through 0300254531)	3-68
3-42.	Swing Drive - Motor and Brake Disassembly (SN 030020900 through 0300254531)	3-69
3-43.	Swing Drive - Main Disassembly(SN 030020900 through 0300254531)	3-70
3-44.	Swing Drive - Hub Shaft Disassembly(SN 030020900 through 0300254531)	3-71
3-45.	Swing Drive - Carrier Disassembly (SN 030020900 through 0300254531)	3-72
3-46.	Swing Drive (SN 0300254532 to Present)- Sheet 1 of 2	3-76
3-47.	Swing Drive (SN 0300254532 to Present)- Sheet 2 of 2	3-77
3-48.	Swing Brake	3-78

FIGURE NO.	TITLE	PAGE NO.
3-49.	Swing Brake 8 Spring Orientation	3-80
3-50.	Swing Brake 12 Spring Orientation	3-80
3-51.	Swing Brake Assembly	3-81
3-52.	Swing Drive Motor	3-83
3-53.	Swing Drive Ports (SN 0300209000 through 0300254531)	3-98
3-54.	Swing Drive Lubrication (SN 0300209000 through 0300254531)	3-98
3-55.	Swing Drive Ports (SN 0300254532 to Present)	3-99
3-56.	Swing Bearing Tolerance Boom Placement - Sheet 1 of 2	3-101
3-57.	Swing Bearing Tolerance Boom Placement - Sheet 2 of 2	3-102
3-58.	Swing Bolt Feeler Gauge Check	3-103
3-59.	Swing Bearing Removal - Sheet 1 of 4	3-105
3-60.	Swing Bearing Removal - Sheet 2 of 4	3-106
3-61.	Swing Bearing Removal - Sheet 3 of 4	3-107
3-62.	Swing Bearing Removal - Sheet 4 of 4	3-108
3-63.	Swing Bearing Torque Sequence	3-124
3-64.	Inspecting Generator Brushes, Replacing Brushes, and Cleaning Slip Rings	3-127
3-65.	Auxiliary Pump Installation	3-128
3-66.	Deutz Engine Dipstick	3-129
3-67.	Engine Oil Viscosity	3-130
3-68.	Deutz Engine Dipstick	3-132
3-69.	Engine Oil Viscosity	3-133
3-70.	Location of the oil filter	3-133
3-71.	Location of the Primary Fuel Filter	3-134
3-72.	Location of Fuel Pre-Filter	3-134
3-73.	Components of Fuel Pre-Filter	3-135
3-74.	Components of Auxiliary Fuel Filter	3-136
3-75.	Detuz 2.9 L4 (GUO III) Engine Installation - Sheet 1 of 2	3-138
3-76.	Detuz 2.9 L4 (GUO III) Engine Installation - Sheet 2 of 2	3-139
3-77.	Detuz TD2011 L040 Engine Installation	3-140
3-78.	Detuz TCD2.9L4 Engine Installation - Sheet 1 of 2	3-142
3-79.	Detuz TCD2.9L4 Engine Installation - Sheet 2 of 2	3-143
3-80.	EMR 2 Engine Side Equipment	3-145
3-81.	Deutz EMR 2 Troubleshooting Flow Chart	3-146
3-82.	Deutz EMR 2 Vehicle Side Connection Diagram	3-147
3-83.	Deutz EMR 2 Engine Side Connection Diagram - Sheet 1 of 2	3-148
3-84.	Deutz EMR 2 Engine Side Connection Diagram - Sheet 2 of 2	3-149
3-85.	EMR 2 Engine Plug Pin Identification	3-150
3-86.	EMR 2 Vehicle Plug Pin Identification	3-151
3-87.	EMR2 Fault Codes - Sheet 1 of 5	3-152
3-88.	EMR2 Fault Codes - Sheet 2 of 5	3-153
3-89.	EMR2 Fault Codes - Sheet 3 of 5	3-154
3-90.	EMR2 Fault Codes - Sheet 4 of 5	3-155
3-91.	EMR2 Fault Codes - Sheet 5 of 5	3-156
3-92.	Counterweight Bolt Torque	3-206
4-1.	Boom Component Location - Sheet 1 of 2	4-2
4-2.	Boom Component Location - Sheet 2 of 2	4-3
4-3.	Location of Components	4-12
4-4.	Rotator Removal/Installation	4-14
4-5.	Boom Assembly - Sheet 1 of 7	4-22
4-6.	Boom Assembly - Sheet 2 of 7	4-23
4-7.	Boom Assembly - Sheet 3 of 7	4-24
4-8.	Boom Assembly - Sheet 4 of 7	4-25
4-9.	Boom Assembly - Sheet 5 of 7	4-26
4-10.	Boom Assembly - Sheet 6 of 7	4-27
4-11.	Boom Assembly - Sheet 7 of 7	4-28
4-12.	Boom Assembly Torque Values	4-40
4-13.	Locations for Threadlocker Application - Sheet 1 of 4	4-41

FIGURE NO.	TITLE	PAGE NO.
4-14.	Locations for Threadlocker Application - Sheet 2 of 4	4-42
4-15.	Locations for Threadlocker Application - Sheet 3 of 4	4-43
4-16.	Locations for Threadlocker Application - Sheet 4 of 4	4-44
4-17.	Load Pin Removal Tool, JLG PN 4846765	4-54
4-18.	Jib Assembly - Sheet 1 of 3	4-59
4-19.	Jib Assembly - Sheet 2 of 3	4-60
4-20.	Jib Assembly - Sheet 3 of 3	4-61
4-21.	Jib Straight Shimming	4-70
4-22.	Powertrack Hosing - Sheet 1 of 3	4-72
4-23.	Powertrack Hosing - Sheet 2 of 3	4-73
4-24.	Powertrack Hosing - Sheet 3 of 3	4-74
4-25.	Wire Rope Wire Breaks	4-80
4-26.	Wire Rope Kink	4-80
4-27.	Sheave Groove Wear	4-80
4-28.	Torque Sequence for Fly Extend Rope	4-84
4-29.	Wire Rope Tensioning	4-86
4-30.	Outer Mid Boom Extend/Retract Cables	4-87
4-31.	Fly Boom Extend/Retract Cables	4-88
4-32.	Wire Rope Adjustment Tools (Optional)	4-89
4-33.	Broken Boom Cable Proximity Switch Location	4-90
4-34.	Actuator Theory of Operation	4-92
4-35.	Rotary Actuator - Assembly Drawing	4-95
4-36.	Rotary Actuator - Exploded View	4-96
4-37.	Rotator Counterbalance Valve	4-105
4-38.	Jib Rotator Torque	4-108
4-39.	Platform Support Torque Values	4-109
4-40.	Bolt-On External Fall Arrest Cable Tension	4-112
4-41.	Bolt-On External Fall Arrest System	4-114
5-1.	NPTF Thread	5-3
5-2.	BSPT Thread	5-3
5-3.	JIC Thread	5-3
5-4.	SAE Thread	5-3
5-5.	ORFS Thread	5-3
5-6.	MTBL-MBTS Thread	5-3
5-7.	Bulkhead Thread	5-3
5-8.	ORB-MPP Thread	5-4
5-9.	MFF-BSPP Thread	5-4
5-10.	ORB-MPP Thread	5-4
5-11.	Torque Wrench Angle	5-5
5-12.	Double Wrench Method	5-53
5-13.	FFWR Method	5-54
5-14.	Adjustable Stud End Assembly	5-55
5-15.	Cylinder Barrel Support	5-56
5-16.	Cap Screw Removal	5-56
5-17.	Cylinder Rod Support	5-56
5-18.	Axle Extension Cylinder	5-57
5-19.	Tapered Bushing Removal	5-58
5-20.	Composite Bearing Installation	5-59
5-21.	Rod Seal Installation	5-59
5-22.	Cylinder Head Seal Installation	5-59
5-23.	Wiper Seal Installation	5-60
5-24.	Installation of Head Seal Kit	5-60
5-25.	Tapered Bushing Installation	5-60
5-26.	Seating the Tapered Bearing	5-60
5-27.	Piston Seal Kit Installation	5-61
5-28.	Rod Assembly Installation	5-61
5-29.	Cylinder Barrel Support	5-62

FIGURE NO.	TITLE	PAGE NO.
5-30.	Cap Screw Removal	5-62
5-31.	Cylinder Rod Support	5-62
5-32.	Axle Lockout Cylinder (SN 0300209000 through 0300239674)	5-63
5-33.	Axle Lockout Cylinder (SN 0300239675 to Present)	5-64
5-34.	Tapered Bushing Removal	5-65
5-35.	Composite Bearing Installation	5-66
5-36.	Rod Seal Installation	5-66
5-37.	Cylinder Head Seal Installation	5-66
5-38.	Wiper Seal Installation	5-67
5-39.	Installation of Head Seal Kit	5-67
5-40.	Tapered Bushing Installation	5-67
5-41.	Seating the Tapered Bearing	5-67
5-42.	Hydrolock Piston Seal Installation	5-68
5-43.	Piston Seal Installation	5-68
5-44.	Rod Assembly Installation	5-68
5-45.	Cylinder Barrel Support	5-69
5-46.	Cap Screw Removal	5-69
5-47.	Cylinder Rod Support	5-69
5-48.	Jib Level Cylinder	5-70
5-49.	Tapered Bushing Removal	5-71
5-50.	Composite Bearing Installation	5-72
5-51.	Rod Seal Installation	5-72
5-52.	Cylinder Head Seal Installation	5-72
5-53.	Wiper Seal Installation	5-73
5-54.	Installation of Head Seal Kit	5-73
5-55.	Tapered Bushing Installation	5-73
5-56.	Seating the Tapered Bearing	5-73
5-57.	Hydrolock Piston Seal Installation	5-74
5-58.	Piston Seal Installation	5-74
5-59.	Rod Assembly Installation	5-74
5-60.	Cylinder Barrel Support	5-75
5-61.	Cylinder Head Removal	5-75
5-62.	Cylinder Rod Support	5-75
5-63.	Jib Level Cylinder	5-76
5-64.	Piston Removal	5-77
5-65.	Piston Seal Disassembly	5-77
5-66.	Cylinder Head Disassembly	5-77
5-67.	Bushing Installation	5-78
5-68.	Wiper Seal Installation	5-79
5-69.	Cylinder Head Assembly	5-79
5-70.	Piston Seal Installation	5-80
5-71.	Cylinder Head Tightening	5-80
5-72.	Cylinder Barrel Support	5-81
5-73.	Cylinder Rod Support	5-81
5-74.	Platform Level Cylinder	5-82
5-75.	Tapered Bushing Removal	5-83
5-76.	Composite Bearing Installation	5-84
5-77.	Rod Seal Installation	5-84
5-78.	Cylinder Head Seal Installation	5-84
5-79.	Wiper Seal Installation	5-85
5-80.	Installation of Head Seal Kit	5-85
5-81.	Tapered Bushing Installation	5-85
5-82.	Seating the Tapered Bearing	5-85
5-83.	Hydrolock Piston Seal Installation	5-86
5-84.	Piston Seal Installation	5-86
5-85.	Cylinder Barrel Support	5-87
5-86.	Cylinder Head Installation	5-87

FIGURE NO.	TITLE	PAGE NO.
5-87.	Cylinder Rod Support	5-87
5-88.	Platform Level Cylinder Assembly	5-88
5-89.	Tapered Bushing Removal	5-89
5-90.	Piston Disassembly	5-89
5-91.	Cylinder Head Disassembly	5-89
5-92.	Composite Bushing Installation	5-90
5-93.	Cylinder Head Seal Kit Installation	5-91
5-94.	Piston Seal Kit Installation	5-91
5-95.	Tapered Bushing Installation	5-91
5-96.	Seating the Tapered Bearing	5-92
5-97.	Cylinder Head Tightening	5-92
5-98.	Cylinder Barrel Support	5-93
5-99.	Cap Screw Removal	5-93
5-100.	Cylinder Rod Support	5-93
5-101.	Boom Lift Cylinder	5-94
5-102.	Tapered Bushing Removal	5-95
5-103.	Composite Bearing Installation	5-96
5-104.	Rod Seal Installation	5-96
5-105.	Cylinder Head Seal Installation	5-96
5-106.	Wiper Seal Installation	5-97
5-107.	Installation of Head Seal Kit	5-97
5-108.	Tapered Bushing Installation	5-97
5-109.	Seating the Tapered Bearing	5-97
5-110.	Hydrolock Piston Seal Installation	5-98
5-111.	Piston Seal Installation	5-98
5-112.	Rod Assembly Installation	5-98
5-113.	Cylinder Barrel Support	5-99
5-114.	Cap Screw Removal	5-99
5-115.	Cylinder Rod Support	5-99
5-116.	Boom Lift Cylinder	5-100
5-117.	Piston Disassembly	5-101
5-118.	Cylinder Head Disassembly	5-101
5-119.	Bushing Installation	5-102
5-120.	Cylinder Head Assembly	5-102
5-121.	Piston Assembly	5-103
5-122.	Cylinder Barrel Support	5-104
5-123.	Cap Screw Removal	5-104
5-124.	Cylinder Rod Support	5-104
5-125.	Jib Lift Cylinder (SN 0300209000 through 0300239990)	5-105
5-126.	Jib Lift Cylinder (SN 0300239991 to Present)	5-106
5-127.	Tapered Bushing Removal	5-107
5-128.	Composite Bearing Installation	5-108
5-129.	Rod Seal Installation	5-108
5-130.	Cylinder Head Seal Installation	5-108
5-131.	Wiper Seal Installation	5-109
5-132.	Installation of Head Seal Kit	5-109
5-133.	Tapered Bushing Installation	5-109
5-134.	Seating the Tapered Bearing	5-109
5-135.	Hydrolock Piston Seal Installation	5-110
5-136.	Piston Seal Installation	5-110
5-137.	Rod Assembly Installation	5-110
5-138.	Cylinder Barrel support	5-111
5-139.	Cylinder Head Removal	5-111
5-140.	Cylinder Rod Support	5-111
5-141.	Jib Lock Cylinder	5-113
5-142.	Rod Seal Installation	5-114
5-143.	Cylinder Head Seal Installation	5-114

FIGURE NO.	TITLE	PAGE NO.
5-144.	Piston Seal Installation	5-114
5-145.	Cylinder Head Installation	5-115
5-146.	Cylinder Barrel Support	5-116
5-147.	Cylinder Cap Removal	5-116
5-148.	Cylinder Rod Support	5-116
5-149.	Steer Cylinder (SN 0300209000 through 0300238017)	5-117
5-150.	Steer Cylinder (SN 0300238018 to Present)	5-118
5-151.	Composite Bearing Installation	5-119
5-152.	Rod Seal Installation	5-119
5-153.	Cylinder Head Seal Installation	5-120
5-154.	Piston Seal Installation	5-120
5-155.	Jib Telescope Cylinder (SN 0300209000 through 0300213726)	5-122
5-156.	Jib Telescope Cylinder (SN 0300213727 through 0300244704)	5-123
5-157.	Jib Telescope Cylinder (SN 0300244705 to Present)	5-124
5-158.	Jib Telescope Cylinder Head Gland Detail	5-126
5-159.	Jib Telescope Piston Detail	5-126
5-160.	Cylinder Barrel Support	5-127
5-161.	Cap Screw Removal	5-127
5-162.	Cylinder Rod Support	5-127
5-163.	Boom Telescope Cylinder	5-128
5-164.	Tapered Bushing Removal	5-129
5-165.	Composite Bearing Installation	5-130
5-166.	Rod Seal Installation	5-130
5-167.	Cylinder Head Seal Installation	5-130
5-168.	Wiper Seal Installation	5-131
5-169.	Installation of Head Seal Kit	5-131
5-170.	Tapered Bushing Installation	5-131
5-171.	Seating the Tapered Bearing	5-131
5-172.	Piston Seal Installation	5-132
5-173.	Rod Assembly Installation	5-132
5-174.	Cylinder Barrel Support	5-133
5-175.	Cap Screw Removal	5-133
5-176.	Cylinder Rod Support	5-133
5-177.	Boom Telescope Cylinder	5-134
5-178.	Piston Disassembly	5-135
5-179.	Cylinder Head Disassembly	5-135
5-180.	Bushing Installation	5-136
5-181.	Cylinder Head Assembly	5-136
5-182.	Piston Assembly	5-137
5-183.	Cylinder Length Sensor	5-138
5-184.	Platform Valve Identification	5-141
5-185.	Platform Valve Torque and Resistance Specifications	5-142
5-186.	Platform Valve Fitting Torque Specifications	5-143
5-187.	Jib Control Valve Identification - Sheet 1 of 2	5-144
5-188.	Jib Control Valve Identification - Sheet 2 of 2	5-145
5-189.	Jib Control Valve Torque and Resistance Specifications - Sheet 1 of 2	5-146
5-190.	Jib Control Valve Torque and Resistance Specifications - Sheet 2 of 2	5-147
5-191.	Jib Control Valve Fitting Torque Specifications	5-148
5-192.	Main Valve Identification	5-149
5-193.	Main Valve Cartridge Torque Values	5-150
5-194.	Oil Sampling Port	5-151
5-195.	Steer Pressure Adjustments	5-155
5-196.	Function Pump - Sectional View	5-174
5-197.	Function Pump, Pressure and Flow Control - Sheet 1	5-181
5-198.	Function Pump, Pressure and Flow Control - Sheet 2	5-181
5-199.	Function Pump, Pressure and Flow Control - Sheet 3	5-182
5-200.	Piston Pump Cross Sectional View	5-184

FIGURE NO.	TITLE	PAGE NO.
5-201.	Port locations - Sheet 1 of 2	5-185
5-202.	Port locations - Sheet 2 of 2	5-186
5-203.	Charge Pressure Adjustment	5-191
5-204.	Control Neutral Adjustment	5-192
5-205.	Servo and System Pressure Gauge Port Locations	5-194
5-206.	Control Module And Solenoid Removal/installation	5-196
5-207.	Shaft Assembly	5-197
5-208.	Charge Pump	5-199
5-209.	Charge Check / HPRV	5-200
5-210.	Charge Check / HPRV	5-201
5-211.	Charge Pressure Relief Valve	5-202
5-212.	Control Cutoff Valve	5-203
5-213.	Fastener and Plug Locations	5-204
5-214.	Hydraulic Schematic - Sheet 1 of 10	5-228
5-215.	Hydraulic Schematic - Sheet 2 of 10	5-229
5-216.	Hydraulic Schematic - Sheet 3 of 10	5-230
5-217.	Hydraulic Schematic - Sheet 4 of 10	5-231
5-218.	Hydraulic Schematic - Sheet 5 of 10	5-232
5-219.	Hydraulic Schematic - Sheet 6 of 10	5-233
5-220.	Hydraulic Schematic - Sheet 7 of 10	5-234
5-221.	Hydraulic Schematic - Sheet 8 of 10	5-235
5-222.	Hydraulic Schematic - Sheet 9 of 10	5-236
5-223.	Hydraulic Schematic - Sheet 10 of 10	5-237
6-1.	Hand Held Analyzer	6-1
6-2.	Control System Block Diagram	6-23
6-3.	Analyzer Flow Chart - Sheet 1 of 5 (Software Version P7.29)	6-25
6-4.	Analyzer Flow Chart - Sheet 2 of 5 (Software Version P7.29)	6-26
6-5.	Analyzer Flow Chart - Sheet 3 of 5 (Software Version P7.29)	6-27
6-6.	Analyzer Flow Chart - Sheet 4 of 5 (Software Version P7.29)	6-28
6-7.	Analyzer Flow Chart - Sheet 5 of 5 (Software Version P7.29)	6-29
6-8.	Control Module Location	6-30
6-9.	Ground Control Module	6-32
6-10.	Platform Control Module	6-36
6-11.	Chasis Control Module	6-40
6-12.	BLAM Control Module (SN 030020900 through 0300248621)	6-42
6-13.	BLAM Control Module (SN 0300248622 to Present)	6-44
6-14.	Jib Control Module	6-46
6-15.	Analyzer Connecting Points	6-48
6-16.	Control System Boom Sensors	6-50
6-17.	System Test Flow Chart - Platform Tests	6-57
6-18.	System Test Flow Chart - Ground Station Tests	6-59
6-19.	Boom Sensor Calibration Position 1	6-114
6-20.	Boom Sensor Calibration Position 2	6-119
6-21.	Boom Sensor Calibration Position 3	6-120
6-22.	Boom Sensor Calibration Position 4	6-121
6-23.	Boom Sensor Calibration Position 5	6-122
6-24.	Boom Sensor Calibration Position 6	6-123
6-25.	Boom Sensor Calibration Position 7	6-123
6-26.	Boom Sensor Calibration Position 8	6-124
6-27.	Boom Sensor Calibration Position 9	6-125
6-28.	Boom Sensor Calibration Position 10	6-126
6-29.	Fault Code Light Location	6-131
7-1.	Voltage Measurement (DC)	7-1
7-2.	Resistance Measurement	7-2
7-3.	Continuity Measurement	7-2
7-4.	Current Measurement (DC)	7-3
7-5.	Application to plug/male connector housing	7-4

FIGURE NO.	TITLE	PAGE NO.
7-6.	Use of Seal Plugs	7-5
7-7.	Brad-Harrison M12	7-6
7-8.	Phoenix Contact M12	7-6
7-9.	Connector Assembly Figure 1	7-8
7-10.	AMP Connector	7-8
7-11.	Connector Assembly Figure 2	7-9
7-12.	Connector Assembly Figure 3	7-9
7-13.	Connector Assembly Figure 4	7-9
7-14.	Connector Disassembly	7-10
7-15.	Connector Installation.....	7-11
7-16.	DT/DTP Contact Installation	7-12
7-17.	DT/DTP Contact Removal.....	7-12
7-18.	HD/HDP Contact Installation	7-13
7-19.	HD/HDP Locking Contacts Into Position.....	7-13
7-20.	HD/HDP Contact Removal.....	7-13
7-21.	HD/HDP Unlocking Contacts	7-13
7-22.	Telematics Gateway Harness - Sheet 1 of 3	7-15
7-23.	Telematics Gateway Harness - Sheet 2 of 3	7-16
7-24.	Telematics Gateway Harness - Sheet 3 of 3	7-17
7-25.	Jib Electrical Components	7-18
7-26.	Chassis Electrical Components - Sheet 1 of 2	7-20
7-27.	Chassis Electrical Components - Sheet 2 of 2	7-21
7-28.	Turntable Electrical Components - Sheet 1 of 2	7-22
7-29.	Turntable Electrical Components - Sheet 2 of 2	7-23
7-30.	Console Box Harness (Without Skyguard) - Sheet 1 of 2	7-24
7-31.	Console Box Harness - Sheet 2 of 2	7-25
7-32.	Console Box Harness-With Skugurad (SN 0300220152 through 0300234293).....	7-26
7-33.	Console Box Harness - With Skyguard (SN 0300234294 to Present).....	7-30
7-34.	Platform Valve Harness - Sheet 2 of 2	7-35
7-35.	Jib Valve Harness - Sheet 1 of 3	7-36
7-36.	Jib Valve Harness - Sheet 2 of 3	7-38
7-37.	Jib Valve Harness - Sheet 3 of 3	7-39
7-38.	Boom Length and Angle Harness - Sheet 1 of 2	7-40
7-39.	Boom Length and Angle Harness - Sheet 2 of 2	7-41
7-40.	Main Terminal Box Harness - Sheet 1 of 4	7-43
7-41.	Main Terminal Box Harness - Sheet 2 of 4	7-44
7-42.	Turntable Harness - Sheet 1 of 3	7-47
7-43.	Turntable Harness - Sheet 2 of 3	7-48
7-44.	Pump Harness	7-50
7-45.	Chassis Harness - Sheet 1 of 2.....	7-51
7-46.	Chassis Harness - Sheet 2 of 2.....	7-52
7-47.	BLAM Harness	7-54
7-48.	Beacon Light Harness- Sheet 1 of 2	7-57
7-49.	Beacon Harness- Sheet 2 of 2	7-58
7-50.	Platform Harness.....	7-62

LIST OF FIGURES

FIGURE NO.	TITLE	PAGE NO.
7-51.	Engine Harness - Sheet 1 of 6	7-65
7-52.	Engine Harness - Sheet 2 of 6	7-66
7-53.	Engine Harness - Sheet 3 of 6	7-70
7-54.	Engine Harness - Sheet 4 of 6	7-74
7-55.	Engine Harness - Sheet 4 of 6	7-78
7-56.	Engine Harness - Sheet 5 of 6	7-82
7-57.	Engine Harness - Sheet 6 of 6	7-84
7-58.	Ground Control Box Wiring Diagram - Sheet 1 of 2	7-88
7-59.	Ground Control Box Wiring Diagram - Sheet 2 of 2	7-89
7-60.	Electrical Schematic - Sheet 2 of 18	7-92
7-61.	Electrical Schematic - Sheet 3 of 18	7-93
7-62.	Electrical Schematic - Sheet 4 of 18	7-94
7-63.	Electrical Schematic - Sheet 5 of 18	7-95
7-64.	Electrical Schematic - Sheet 6 of 18	7-96
7-65.	Electrical Schematic - Sheet 7 of 18	7-97
7-66.	Electrical Schematic - Sheet 8 of 18	7-98
7-67.	Electrical Schematic - Sheet 9 of 18	7-99
7-68.	Electrical Schematic - Sheet 10 of 18	7-100
7-69.	Electrical Schematic - Sheet 11 of 18	7-101
7-70.	Electrical Schematic - Sheet 12 of 18	7-102
7-71.	Electrical Schematic - Sheet 13 of 18	7-104
7-72.	Electrical Schematic - Sheet 14 of 18	7-105
7-73.	Electrical Schematic - Sheet 15 of 18	7-106
7-74.	Electrical Schematic - Sheet 16 of 18	7-107
7-75.	Electrical Schematic - Sheet 17 of 18	7-108
7-76.	Electrical Schematic - Sheet 18 of 18	7-109

Go to Discount-Equipment.com to order your parts

TABLE NO.	TITLE	PAGE NO.
1-1	Operating Specifications	1-1
1-2	Dimensional Data	1-1
1-3	Capacities	1-2
1-4	Tire Specifications	1-2
1-5	Deutz TD2011L4 Specifications	1-2
1-6	Deutz TCD2.9L4 Specifications	1-2
1-7	Deutz TD2.9L4 Specifications	1-3
1-8	Hydraulic Oil	1-3
1-9	Mobilfluid 424 Specs	1-3
1-10	Mobil DTE 10 Excel 32 Specs	1-3
1-11	UCon Hydrolube HP-5046	1-3
1-12	Mobil EAL H 46 Specs	1-4
1-13	Mobil EAL 46 Specs	1-4
1-14	Exxon Unisvis HVI 26 Specs	1-4
1-15	Component Weights	1-4
1-16	Lubrication Specifications	1-6
2-1	Inspection and Maintenance	2-2
2-2	Cylinder Drift	2-5
2-3	Inspection and Preventive Maintenance Schedule	2-7
3-1	Wheel Torque Chart	3-1
3-2	Steering Assembly Notes	3-15
3-3	Brake Technical Data	3-22
3-4	Suggested Lubricants According SAE 80W/90 and SAE 85W/140 API GL5 Grade	3-24
3-5	Drive Hub Maintenance Schedule	3-26
3-6	Troubleshooting	3-27
3-7	Engine Fault Codes TCD2.9L4	3-159
4-1	Troubleshooting	4-107
4-2	SkyGuard Function Table	4-111
5-1	NPTF Pipe Thread	5-6
5-2	BSPT Pipe Thread	5-7
5-3	37° Flare (JIC)Thread - Steel	5-9
5-4	37° Flare (JIC)Thread - Aluminum/Brass	5-10
5-5	45° Flare (SAE) - Steel	5-13
5-6	45° Flare (SAE) - Aluminum/Brass	5-13
5-7	O-ring Face Seal (ORFS) - Steel	5-14
5-8	O-ring Face Seal (ORFS) - Aluminum/Brass	5-15
5-9	DIN 24° Cone (MBTL & MBTS)	5-17
5-10	Bulkhead Fittings (BH) - INCH	5-19
5-11	Bulkhead Fittings (BH) - METRIC	5-20
5-12	O-ring Boss (ORB) - Table 1 of 6	5-23
5-13	O-ring Boss (ORB) - Table 2 of 6	5-24
5-14	O-ring Boss (ORB) - Table 3 of 6	5-25
5-15	O-ring Boss (ORB) - Table 4 of 6	5-26
5-16	O-ring Boss (ORB) - Table 5 of 6	5-27
5-17	O-ring Boss (ORB) - Table 6 of 6	5-28
5-18	Metric Flat Face Port (MFF) - L Series - Table 1 of 3	5-31
5-19	Metric Flat Face Port (MFF) - L Series - Table 2 of 3	5-32
5-20	Metric Flat Face Port (MFF) - L Series - Table 3 of 3	5-33
5-21	Metric Flat Face Port (MFF) - S Series - Table 1 of 3	5-34
5-22	Metric Flat Face Port (MFF) - S Series - Table 2 of 3	5-35
5-23	Metric Flat Face Port (MFF) - L Series - Table 3 of 3	5-36
5-24	Metric Pipe Parallel O-Ring Boss (MPP)	5-39
5-25	British Standard Parallel Pipe Port (BSPP) - L Series - Table 1 of 3	5-43
5-26	British Standard Parallel Pipe Port (BSPP) - L Series - Table 2 of 3	5-44
5-27	British Standard Parallel Pipe Port (BSPP) - L Series - Table 3 of 3	5-45
5-28	British Standard Parallel Pipe Port (BSPP) - S Series - Table 1 of 3	5-46
5-29	British Standard Parallel Pipe Port (BSPP) - S Series - Table 2 of 3	5-47

TABLE NO.	TITLE	PAGE NO.
5-30	British Standard Parallel Pipe Port (BSPP) - S Series - Table 3 of 3	5-48
5-31	Flange Code (FL61 & FL62) -Inch Fasteners	5-51
5-32	Flange Code (FL61 & FL62) - Metric Fasteners	5-52
5-33	Platform Valve Specifications	5-142
5-34	Fitting Torque Specifications	5-143
5-35	Jib Control Valve Specifications	5-147
5-36	Fitting Torque	5-148
5-37	Cartridge Torque Values	5-150
5-38	Torque Specs for Relief Valves into Port Block	5-170
5-39	Tightening Torques	5-180
5-40	Port information	5-184
5-41	Electrical troubleshooting	5-188
5-42	Neutral difficult or impossible to find	5-188
5-43	System operating hot	5-188
5-44	System will not operate	5-189
5-45	System noise or vibration	5-189
5-46	Sluggish system response	5-190
5-47	Displacement Limiter Adjustment Data	5-192
5-48	Fastener Size and Torque Chart	5-203
5-49	Plug Size and Torque Chart	5-203
5-50	Troubleshooting	5-224
6-1	Analyzer Abbreviations	6-6
6-2	Machine Configuration Programming Information (Software Version P7.29)	6-8
6-3	Machine Configuration Programming Settings (Software Version P7.29)	6-14
6-4	Machine Personality Settings and Function Speeds	6-16
6-5	Calibration Instructions	6-24
6-6	System Test Messages	6-60
6-7	Machine Diagnostics Parameters	6-63
6-8	Diagnostic Menu Descriptions	6-80
6-9	Accessory Weights	6-82
6-10	SkyGlazier Capacity Reductions	6-84
6-11	Pipe Rack Capacity Reductions	6-84
6-12	LSS Troubleshooting Chart	6-87
6-13	Diagnostic Trouble Code Chart	6-132

PARTS FINDER

**Search Website
by Part Number**



**Search Manual
Library For Parts
Manual & Lookup Part
Numbers – Purchase
or Request Quote**

Search Manuals

Enter your information to help us locate the right manual for your parts.

* Brand:

* Model:

* Serial:

* Part Number:

SEARCH

**Can't Find Part or
Manual? Request Help
by Manufacturer,
Model & Description**

Parts Order Form

Please fill in the following information:

Manufacturer:

Model:

Description:

Quantity:

Part Number:

Part Name:

Part Description:

Part Location:

Part Condition:

Part Status:

Part Price:

Part Weight:

Part Dimensions:

Part Material:

Part Color:

Part Finish:

Part Coating:

Part Treatment:

Part Protection:

Part Packaging:

Part Labeling:

Part Marking:

Part Identification:

Part Tracking:

Part Inventory:

Part Control:

Part Management:

Part Optimization:

Part Innovation:

Part Sustainability:

Part Resilience:

Part Adaptability:

Part Scalability:

Part Flexibility:

Part Versatility:

Part Reliability:

Part Durability:

Part Longevity:

Part Performance:

Part Efficiency:

Part Effectiveness:

Part Productivity:

Part Profitability:

Part ROI:

Part Value:

Part Contribution:

Part Impact:

Part Influence:

Part Reach:

Part Penetration:

Part Adoption:

Part Usage:

Part Engagement:

Part Satisfaction:

Part Loyalty:

Part Retention:

Part Churn:

Part Acquisition:

Part Conversion:

Part Funnel:

Part Attribution:

Part Analytics:

Part Reporting:

Part Dashboard:

Part Alerts:

Part Notifications:

Part Updates:

Part Newsletters:

Part Social Media:

Part Content Marketing:

Part SEO:

Part SEM:

Part SMM:

Part Email Marketing:

Part CRM:

Part ERP:

Part HR:

Part Finance:

Part Operations:

Part Logistics:

Part Supply Chain:

Part Procurement:

Part Sales:

Part Marketing:

Part Customer Service:

Part Support:

Part Training:

Part Development:

Part Innovation:

Part Research:

Part Strategy:

Part Planning:

Part Execution:

Part Monitoring:

Part Evaluation:

Part Improvement:

Part Optimization:

Part Innovation:

Part Sustainability:

Part Resilience:

Part Adaptability:

Part Scalability:

Part Flexibility:

Part Versatility:

Part Reliability:

Part Durability:

Part Longevity:

Part Performance:

Part Efficiency:

Part Effectiveness:

Part Productivity:

Part Profitability:

Part ROI:

Part Value:

Part Contribution:

Part Impact:

Part Influence:

Part Reach:

Part Penetration:

Part Adoption:

Part Usage:

Part Engagement:

Part Satisfaction:

Part Loyalty:

Part Retention:

Part Churn:

Part Acquisition:

Part Conversion:

Part Funnel:

Part Attribution:

Part Analytics:

Part Reporting:

Part Dashboard:

Part Alerts:

Part Notifications:

Part Updates:

Part Newsletters:

Part Social Media:

Part Content Marketing:

Part SEO:

Part SEM:

Part SMM:

Part Email Marketing:

Part CRM:

Part ERP:

Part HR:

Part Finance:

Part Operations:

Part Logistics:

Part Supply Chain:

Part Procurement:

Part Sales:

Part Marketing:

Part Customer Service:

Part Support:

Part Training:

Part Development:

Part Innovation:

Part Research:

Part Strategy:

Part Planning:

Part Execution:

Part Monitoring:

Part Evaluation:

Part Improvement:

Part Optimization:

Discount-Equipment.com is your online resource for quality parts & equipment.

Florida: **561-964-4949** Outside Florida TOLL FREE: **877-690-3101**

Need parts?

Click on this link: <http://www.discount-equipment.com/category/5443-parts/> and choose one of the options to help get the right parts and equipment you are looking for. Please have the machine model and serial number available in order to help us get you the correct parts. If you don't find the part on the website or on once of the online manuals, please fill out the request form and one of our experienced staff members will get back to you with a quote for the right part that your machine needs.

We sell worldwide for the brands: Genie, Terex, JLG, MultiQuip, Mikasa, Essick, Whiteman, Mayco, Toro Stone, Diamond Products, Generac Magnum, Airman, Haulotte, Barreto, Power Blanket, Nifty Lift, Atlas Copco, Chicago Pneumatic, Allmand, Miller Curber, Skyjack, Lull, Skytrak, Tsurumi, Husquvarna Target, , Stow, Wacker, Sakai, Mi-T- M, Sullair, Basic, Dynapac, MBW, Weber, Bartell, Bennar Newman, Haulotte, Ditch Runner, Menegotti, Morrison, Contec, Buddy, Crown, Edco, Wyco, Bomag, Laymor, Barreto, EZ Trench, Bil-Jax, F.S. Curtis, Gehl Pavers, Heli, Honda, ICS/PowerGrit, IHI, Partner, Imer, Clipper, MMD, Koshin, Rice, CH&E, General Equipment, ,AMida, Coleman, NAC, Gradall, Square Shooter, Kent, Stanley, Tamco, Toku, Hatz, Kohler, Robin, Wisconsin, Northrock, Oztec, Toker TK, Rol-Air, Small Line, Wanco, Yanmar

SECTION 1. SPECIFICATIONS

1.1 OPERATING SPECIFICATIONS

Table 1-1. Operating Specifications

Capacity - ANSI Unrestricted Restricted	500 lbs (227 kg) 1000 lbs (454 kg)
Capacity - CE & Australia Unrestricted Restricted	500 lbs (230 kg) 1000 lbs (450 kg)
Maximum Travel Grade, stowed Position (Gradeability)	40%
Maximum Travel Grade, stowed Position (Side Slope)	5°
Maximum Drive Speed	3.0 mph (4.8 kph)
Gross Machine Weight - Approximate	48000 lbs. (21772 kg)
Ground Bearing Pressure - Maximum	113 psi (7.94 kg/cm ²)
Maximum Wind Speed	28 mph (12.5 m/s)
Maximum Manual Force	90 lbs (400 N)
Maximum System Voltage	12 volts
Maximum Main Relief Hyd. Pressure	4600 psi (317 Bar)

1.2 DIMENSIONAL DATA

Table 1-2. Dimensional Data

Turning Radius (Axles Retracted) Outside Inside	22 ft. 6 in. (6.8 m) 14 ft. 5 in. (4.4 m)
Turning Radius (Axles Extended) Inside Outside	8 ft. (2.4 m) 19 ft. 4 in. (5.9 m)
Machine Height (stowed)	9 ft. 11 in. (3.04 m)
Machine Length (stowed)	61 ft. 8-5/8 in. (18.81 m)
Platform Height Unrestricted Capacity Restricted Capacity	150 ft. 1 in. (45.75 m) 130 ft. 2 in. (39.67 m)
Horizontal Reach from centerline of rotation Unrestricted Capacity Restricted Capacity	80 ft. (24.38 m) 64 ft. 11 in. (19.79 m)
Horizontal Reach over end Unrestricted Capacity Restricted Capacity	72 ft. 4 in. (24.38 m) 57 ft. 3 in. (17.45 m)
Horizontal Reach over side Unrestricted Capacity Restricted Capacity	73 ft. 9 in. (22.48 m) 58 ft. 9 in. (17.91 m)
Overall Width Axles Retracted Axles Extended	8 ft. 2 in. (2.49 m) 12 ft. 6 in. (3.8 m)
Wheelbase	12 ft. 6 in. (3.81 m)
Tailswing	5 ft. 5-7/8 in. (1.6 m)
Ground Clearance (Axle)	12 in. (30.4 cm)
Ground Clearance (Chassis)	25.5 in. (64.7 cm)

1.3 CAPACITIES

Table 1-3. Capacities

Hydraulic Oil Tank	55 gal. (208 L)
Fuel Tank - Standard	31 gal. (117 L)
Fuel Tank - Optional	52.8 gal. (200 L)
Drive Hub Bonfiglioli	2.1 quarts (2 liters) ± 10%
Reggiana Riduttori	0.5 quarts (0.5 liters) ± 10%

1.4 TIRES

Table 1-4. Tire Specifications

Size	445/50D710
Load Range	J
Ply Rating	18
Foam Fill	Polyurethane HD (55 Durometer) Foam
Diameter	46.45 in. (117.9 cm)
Width	18 in. (45.7 cm)
Rim Size	15x28
Tire & Wheel Weight	867 lbs. (393 kg)
Max Tire Load	28600 lbs. (12973 kg)
Size	445/65-24
Type	Solid or Solid Non-Marking
Diameter	45.3 in. (115.1 cm)
Width	17.3 in. (43.9 cm)
Rim Size	12.00-24
Tire & Wheel Weight - Solid	960 lbs. (435.4 kg)
Tire & Wheel Weight - Solid Non-Marking	990 lbs. (449 kg)
Max Tire Load	28600 lbs. (12973 kg)

1.5 ENGINE DATA

Deutz

Table 1-5. Deutz TD2011L4 Specifications

Type	Diesel
Number of Cylinders	4
Bore	3.7 in. (94 mm)
Stroke	4.4 in. (112 mm)
Total Displacement	190 cu. in. (3108 cm ³)
Compression Ratio	17.5:1
Firing Order	1-3-4-2
Output	75hp (56 kW)
Oil Capacity	
Cooling System w/Filter	5 Quarts (4.5L)
Total Capacity	11 Quarts (10.5L)
Average Fuel Consumption	16 Quarts (15L)
Idle Engine RPM	1.2 gph (4.1 lph)
Mid Engine RPM	1200
High Engine RPM	1800
	2475

Table 1-6. Deutz TCD2.9L4 Specifications

Type	Diesel
Number of Cylinders	4
Bore	3.6 in. (92 mm)
Stroke	4.3 in. (110 mm)
Total Displacement	178 cu. in. (2925 cm ³)
Firing Order	1-3-4-2
Output	74.2hp (55.4 kW)
Oil Capacity	2.4 Gallon (8.9L)
Coolant Capacity (System)	0.79 Gallon (3 L)
Average Fuel Consumption	1.2 gph (4.1 lph)
Min. Low Engine RPM	900
Mid Engine RPM	1800
Max. High Engine RPM	2500
High RPM set	2500 ± 50 rpm
Low RPM set	1200 ± 50 rpm

Table 1-7. Deutz TD2.9L4 Specifications

Type	Diesel
Number of Cylinders	4
Bore	3.6 in. (92 mm)
Stroke	4.3 in. (110 mm)
Total Displacement	177 cu. in. (2900 cm ³)
Output	74.2hp (55.4 kW)
Oil Capacity	2.11 Gallon (8.0 L)
Coolant Capacity (System)	0.92 Gallon (3.5 L)
Average Fuel Consumption	TBD
Min. Low Engine RPM	900
Mid Engine RPM	1800
Max. High Engine RPM	2600
High RPM set	2500 ± 50 rpm
Low RPM set	1200 ± 50 rpm

1.6 HYDRAULIC OIL

Table 1-8. Hydraulic Oil

Hydraulic System Operating Temperature Range	S.A.E. Viscosity Grade
+0° to +180° F (-18° to +83° C)	10W
+0° to +210° F (-18° to +99° C)	10W-20, 10W30
+50° to +210° F (+10° to +99° C)	20W-20

NOTE: Hydraulic oils require anti-wear qualities at least API Service Classification GL-3, and sufficient chemical stability for mobile hydraulic system service.

NOTE: Aside from JLG recommendations, it is not advisable to mix oils of different brands or types, as they may not contain the same required additives or be of comparable viscosities.

Table 1-9. Mobilfluid 424 Specs

SAE Grade	10W-30
Gravity, API	29.0
Density, Lb/Gal. 60° F	7.35
Pour Point, Max	-46° F (-43° C)
Flash Point, Min.	442° F (228° C)
Viscosity	
Brookfield, cP at -18° C	2700
at 40° C	55 cSt
at 100° C	9.3 cSt
Viscosity Index	152

Table 1-10. Mobil DTE 10 Excel 32 Specs

ISO Viscosity Grade	#32
Gravity API	
Pour Point, Max	-65° F (-54° C)
Flash Point, Min.	482° F (250° C)
Viscosity	
at 40° C	32.7 cSt
at 100° C	6.63 cSt
at 100° F	32.7 cSt
at 210° F	6.63 cSt
cp at -30° F	
Viscosity Index	164
Density (kg/l) @ 15° C	0.8468
Density (lb/in ³) @ 60° F	0.0305

Table 1-11. UCon Hydrolube HP-5046

Type	Synthetic Biodegradable
Specific Gravity	1.082
Pour Point, Max	-58° F (-50° C)
pH	9.1
Viscosity	
at 0° C (32° F)	340 cSt (1600 SUS)
at 40° C (104° F)	46 cSt (215 SUS)
at 65° C (150° F)	22 cSt (106 SUS)
Viscosity Index	170

Table 1-12. Mobil EAL H 46 Specs

Type	Synthetic Biodegradable
ISO Viscosity Grade	46
Density at 15° C	0.874
Pour Point	-49° F (-45° C)
Flash Point	500° F (260° C)
Operating Temp.	-20 to 200° F (-29 to 93° C)
Weight	7.64 lb/gal (0.9 kg/L)
Viscosity	
at 40° C	48.8 cSt
at 100° C	7.8 cSt
Viscosity Index	145

Table 1-13. Mobil EAL 46 Specs

Type	Synthetic Biodegradable
ISO Viscosity Grade	46
Density at 15° C	0.93
Pour Point	-27° F (-33° C)
Flash Point	568° F (298° C)
Operating Temp.	-20 to 200° F (-29 to 93° C)
Weight	7.64 lb/gal (0.9 kg/L)
Viscosity	
at 40° C	43.3 cSt
at 100° C	7.7 cSt
Viscosity Index	149

Table 1-14. Exxon Univis HVI 26 Specs

Specific Gravity	32.1
Pour Point	-76° F (-60° C)
Flash Point	217° F (103° C)
Viscosity	
at 40° C	25.8 cSt
at 100° C	9.3 cSt
Viscosity Index	376
NOTE: Mobil/Exxon recommends that this oil be checked on a yearly basis for viscosity.	

1.7 MAJOR COMPONENT WEIGHTS

WARNING

DO NOT REPLACE ITEMS CRITICAL TO STABILITY WITH ITEMS OF DIFFERENT WEIGHT OR SPECIFICATION (FOR EXAMPLE: BATTERIES, FILLED TIRES, PLATFORM) DO NOT MODIFY UNIT IN ANY WAY TO AFFECT STABILITY.

Table 1-15. Component Weights

Components	LBS.	KG.
Counterweight	9500	4309
Tire and Wheel	867	393
Drive Hub & Motor	275.5	123
Swing Drive	290	132
Engine Assembly	1275	579
Complete Boom (including jib)	12513	5676
Platform 36 x 96	245	111
Platform 36 x 72	195	89
Axle Extension Cylinder	92	42
Axle Lockout Cylinder	74	33.75
Jib Level Cylinder	146.8	66.6
Platform Level	76	34
Boom Lift Cylinder	787	357
Jib Lift Cylinder	186	84
Jib Lock Cylinder	22.3	10.1
Steer Cylinder	49	22
Jib Telescope Cylinder	130.5	59
Boom Telescope Cylinder	1432	650

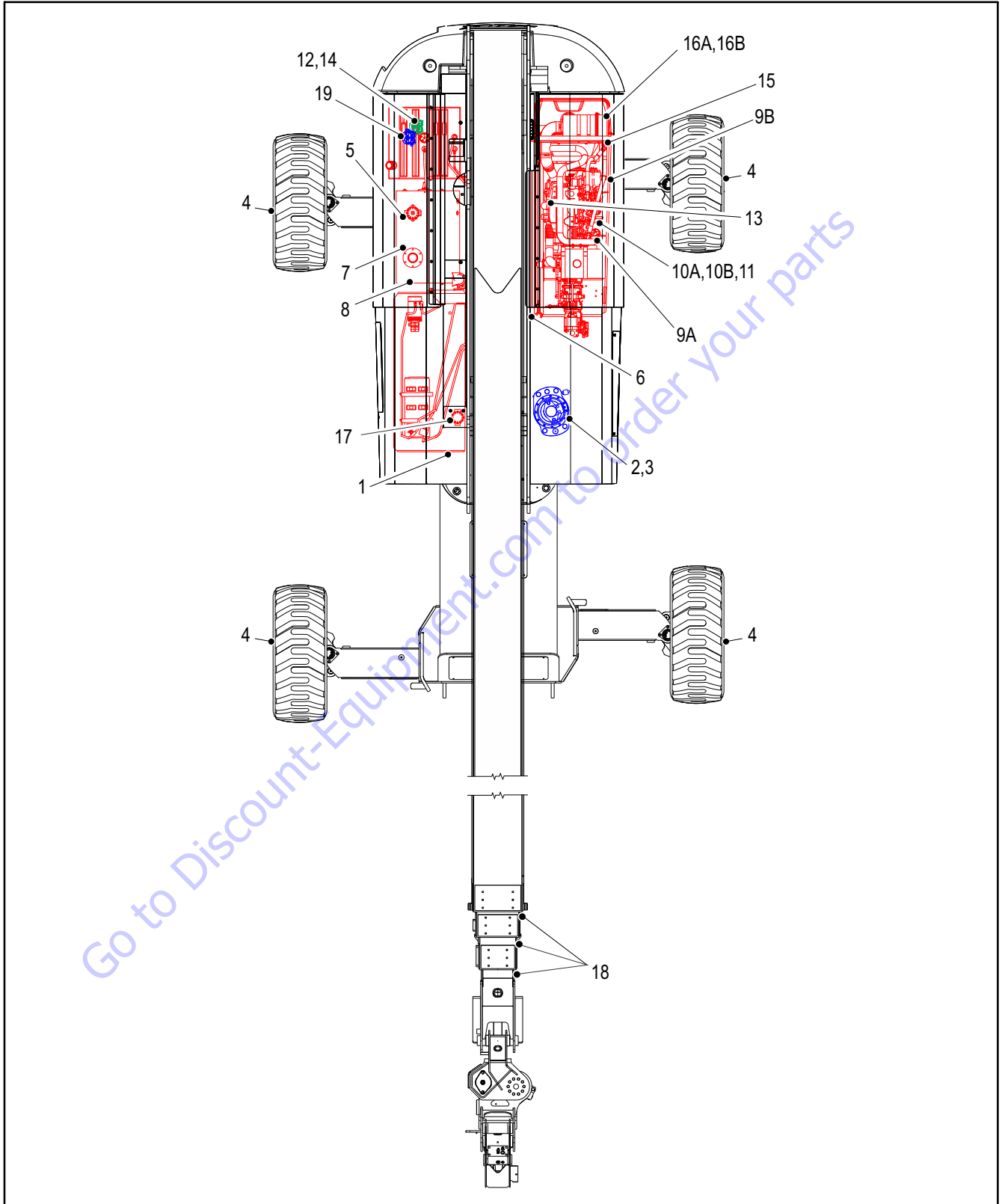

Figure 1-1. Maintenance and Lubrication Diagram

1.8 OPERATOR MAINTENANCE

NOTE: The following numbers correspond to those in Figure 1-1., Maintenance and Lubrication Diagram.

Table 1-16. Lubrication Specifications.

KEY	SPECIFICATIONS
MPG	Multipurpose Grease having a minimum dripping point of 350°F (177°C). Excellent water resistance and adhesive qualities, and being of extreme pressure type. (Timken OK 40 pounds minimum.)
EPGL	Extreme Pressure Gear Lube (oil) meeting API service classification GL-5 or MIL-Spec MIL-L-2105
HO	Hydraulic Oil. API service classification GL-3, e.g. Mobilfluid 424
EO	Engine (crankcase) Oil. Gas - API SF, SH, SG class, MIL-L-2104. Diesel - API CC/CD class, MIL-L-2104B/MIL-L-2104C
Super Lube®	Synthetic-Based Oil, Non-Flammable. Withstands temperatures within -45° to 450°F (-43° to 232°C). JLG PN 3020042.

NOTICE

LUBRICATION INTERVALS ARE BASED ON MACHINE OPERATION UNDER NORMAL CONDITIONS. FOR MACHINES USED IN MULTI-SHIFT OPERATIONS AND/OR EXPOSED TO HOSTILE ENVIRONMENTS OR CONDITIONS, LUBRICATION FREQUENCIES MUST BE INCREASED ACCORDINGLY.

1. Swing Bearing - Remote Lube

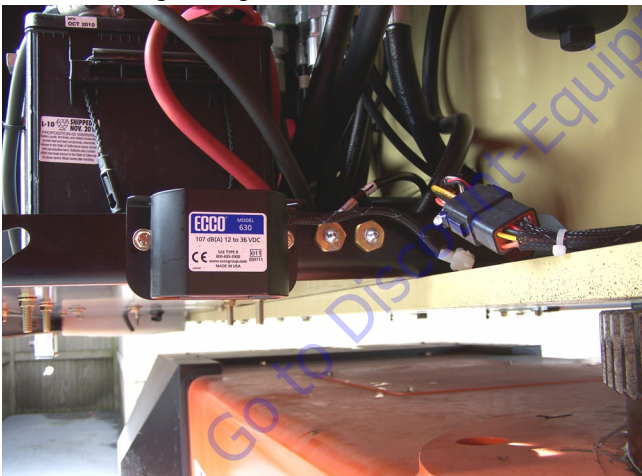

Lube Point(s) - 2 Grease Fitting
 Capacity - A/R
 Lube - MPG
 Interval - Every 3 months or 150 hours of operation.

2. Swing Gearbox

- a. Swing Gearbox (SN 030020900 through 0300254531)

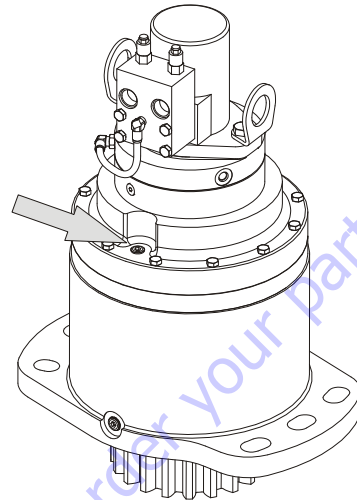

- b. Swing Gearbox (SN 0300254532 to Present)

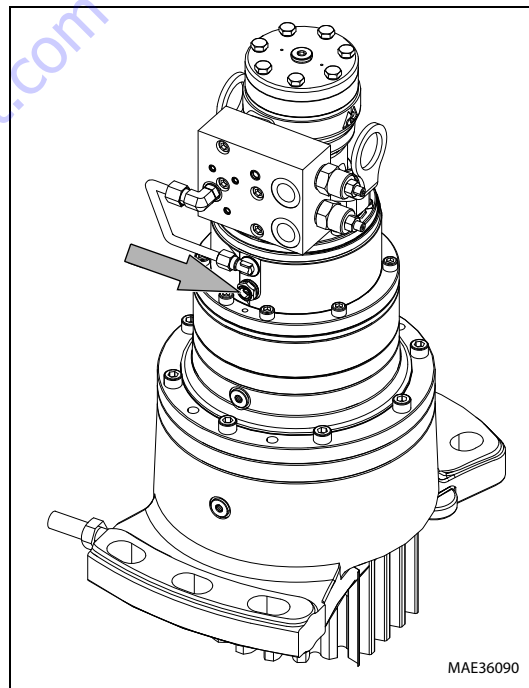

Lube Point(s) - Fill Plug
 Capacity - 79 ounces (2.3 L)
 Lube - GL-5
 Interval - Check level every 150 hrs/Change every 1200 hours of operation. Fill to cover ring gear.

3. Swing Brake

a. Swing Brake (SN 030020900 through 0300254531)

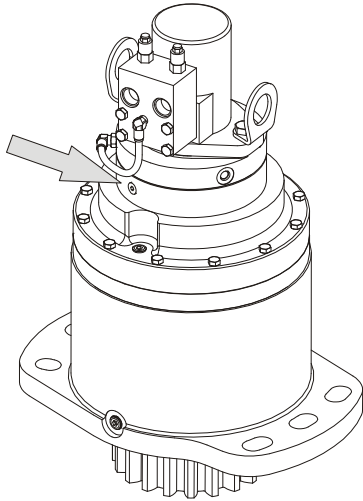

b. Swing Brake (SN 0300254532 to Present)

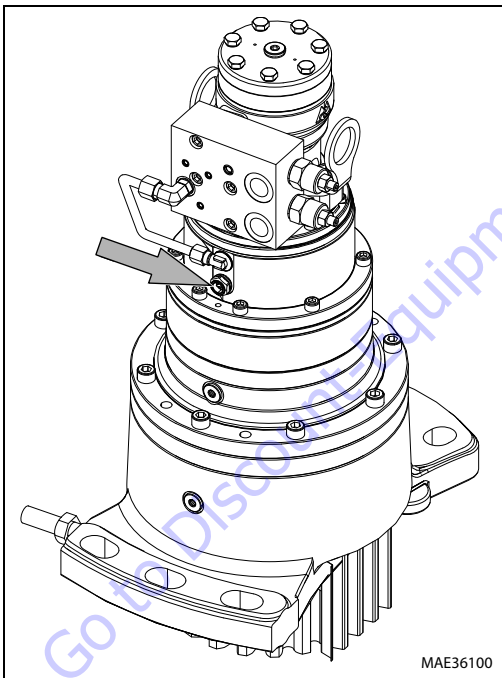

Lube Point(s) - Fill Plug
 Capacity - 2.7 ounces (80 ml)
 Lube - DTE24
 Interval - Check level every 150 hrs/Change every 1200 hours of operation.

4. A. Wheel Drive Hub - Bonfiglioli

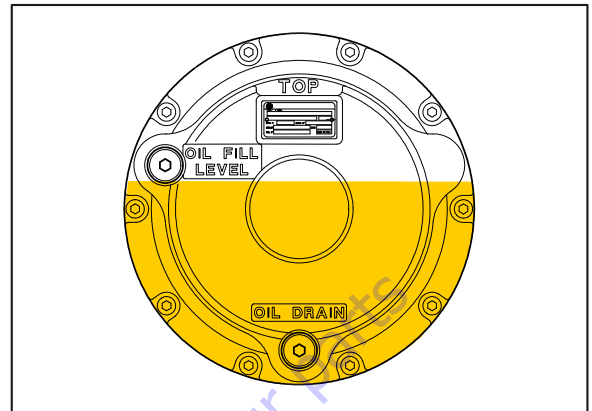

Lube Point(s) - Level/Fill Plug
 Capacity - 2.1 quarts (2 liters) ± 10%
 Lube - EPGL
 Interval - Change after first 150 hours then every 1200 hours of operation
 Comments - Place Fill port at 12 o'clock position and Check port at 8 o'clock position. Pour lubricant into fill port until it just starts to flow out of check port.

B: Wheel Drive Hub - Reggiana Riduttori



Lube Point(s) - Level/Fill Plug
 Capacity - 0.5 quarts (0.5 liters) ± 10%
 Lube - EPGL
 Interval - Change after first 150 hours then every 1200 hours of operation
 Comments - Place Fill port at 12 o'clock position and Check port at 3 o'clock position. Pour lubricant into fill port until it just starts to flow out of check port.

SECTION 1 - SPECIFICATIONS

5. Hydraulic Return Filter



Lube Point(s) - Replaceable Element
Interval - Change after first 50 hours and every 300 hours thereafter or as indicated by condition indicator.

6. Hydraulic Charge Filter



Lube Point(s) - Replaceable Element
Interval - Change after first 50 hours and every 300 hours thereafter or as indicated by condition indicator.

7. Hydraulic Oil

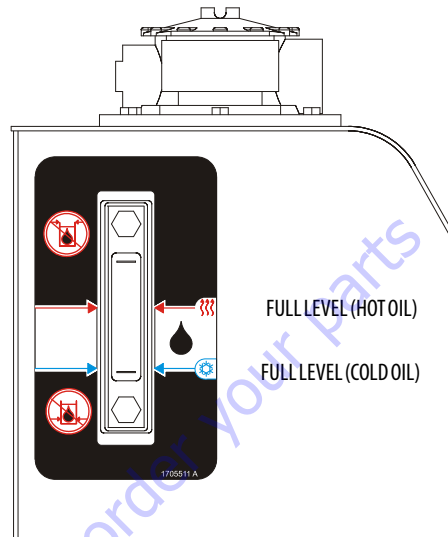

Lube Point(s) - Fill Cap
Capacity - Standard 31 gallons (117 liters)
Optional 52.8 gallons (200 liters)
Lube - HO
Interval - Check level daily. Change every 2 years or 1200 hours of operation.

8. Suction Strainers (In Tank)

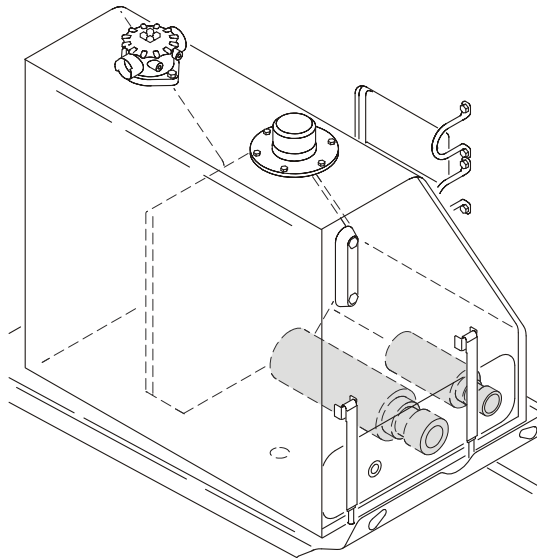

Lube Point(s) - 2
Interval - Every 2 years or 1200 hours of operation.
Remove and clean at time of hydraulic oil change.

9. A. Oil Change w/Filter - Deutz 2011



Lube Point(s) - Fill Cap/Spin-on Element

Capacity -

5 Quarts (4.5 L) Cooling System

11 Quarts (10.5 L) w/Filter

16 Quarts (15 L) Total Capacity

Lube - EO

Interval - Check level daily; change every 500 hours or six months, whichever comes first. Adjust final oil level by mark on dipstick. Refer to Figure 1-2, Deutz Engine Dipstick.

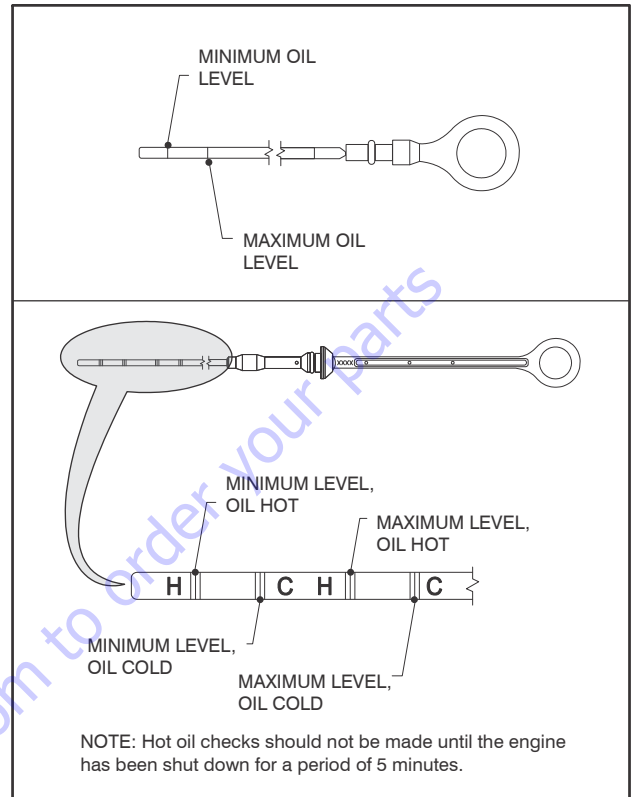

Figure 1-2. Deutz Engine Dipstick

B. Oil Change w/Filter - Deutz TCD2.9



Lube Point(s) - Fill Cap/Spin-on Element

Capacity - 2.4 Gallon (8.9 L)

Lube - EO

Interval - Check level daily; change every 500 hours or six months, whichever comes first. Adjust final oil level by mark on dipstick.



10. A. Fuel Filter - Deutz 2011

Lube Point(s) - Replaceable Element

Interval - Every year or 600 hours of operation.

SECTION 1 - SPECIFICATIONS

B. Fuel Filter - Deutz TCD2.9



Lube Point(s) - Replaceable Element
Interval - Every year or 600 hours of operation.

11. Fuel Strainer - Deutz 2011

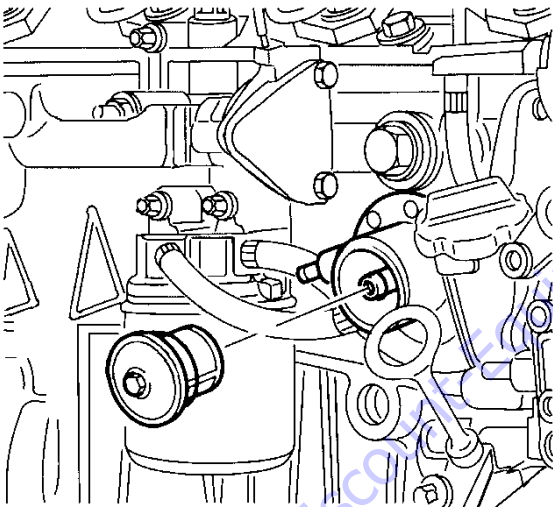

Lube Point(s) - Replaceable Element
Interval - Every year or 600 hours of operation.

12. Fuel Pre-Filter TCD2.9



Lube Point(s) - Replaceable Element
Interval - Drain water daily; Change every year or 600 hours of operation.

13. Radiator Coolant TCD2.9

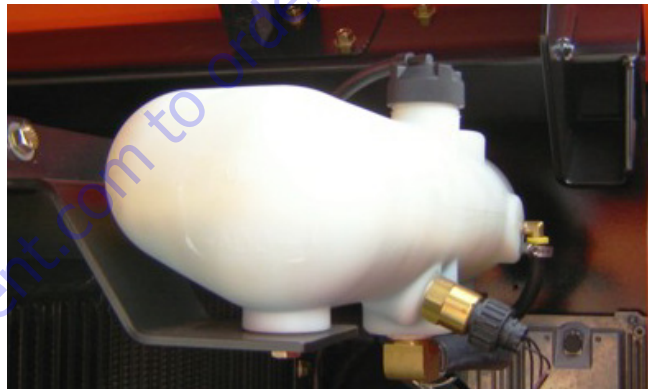

Lube Point(s) - Fill Cap
Capacity - 3.2Gallon (12.1 L)
Lube - Anti-Freeze
Interval - Check level daily; change every 1000 hours or 2 years, whichever comes first.

14. A. Air Filter - DEUTZ 2011

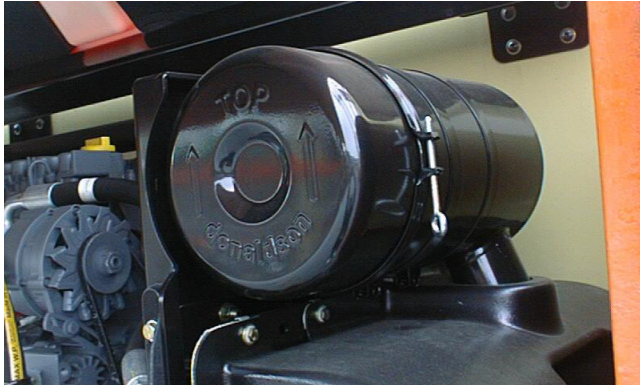

Lube Point(s) - Replaceable Element
 Interval - Every 6 months or 300 hours of operation or as indicated by the condition indicator.

B. Air Filter - Deutz TCD2.9

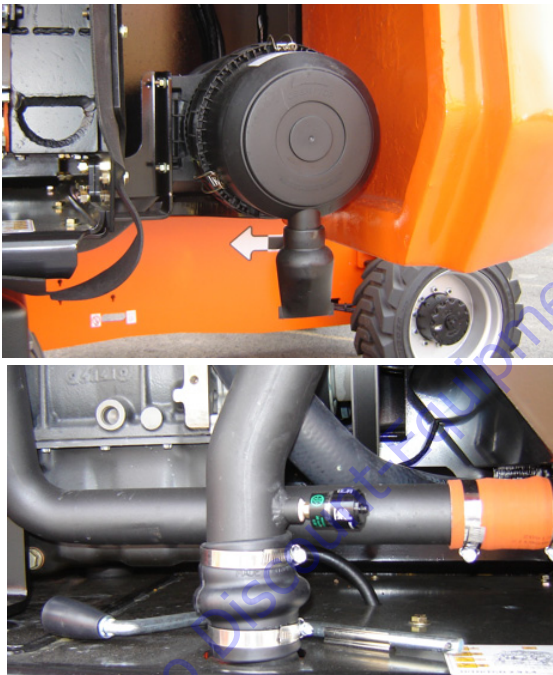

Lube Point(s) - Replaceable Element
 Interval - Every 6 months or 300 hours of operation or as indicated by the condition indicator
 Comments - Check Dust Valve daily.

15. Platform Filter



Lube Point(s) - Replaceable Element
 Interval - Change after first 50 hours and then every year or 600 hours of operation thereafter.

16. Boom

Lube Point(s) - Apply to wear pad contact paths
 Lube - Super Lube®
 Interval - As needed. Refer to the Section 4 - Boom for detailed procedures.

17. Optional Fuel Filter/Water Separator

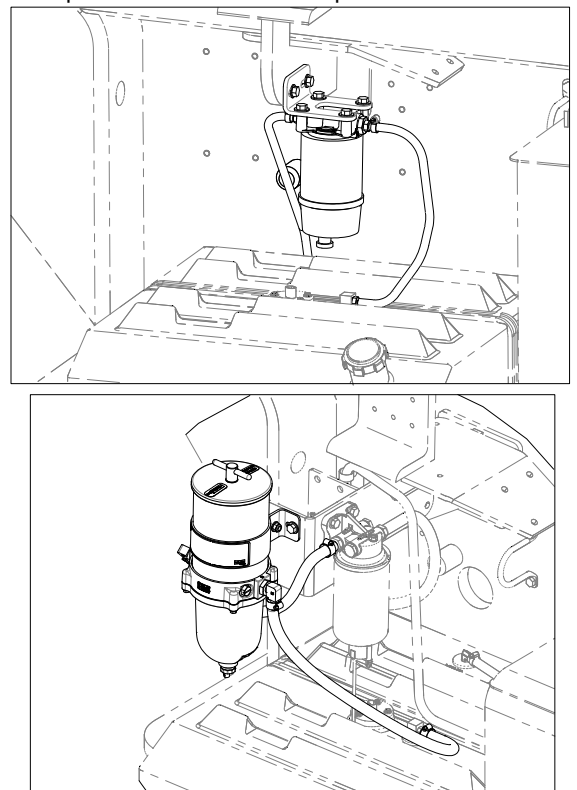

Lube Point(s) - Replaceable Element
 Interval - Drain water daily; Change every year or 600 hours of operation.

Values for Zinc Yellow Chromate Fasteners (Ref 4150707)																	
SAE GRADE 5 BOLTS & GRADE 2 NUTS						SAE GRADE 8 (HEX HD) BOLTS & GRADE 8 NUTS*											
Size	TPI	Bolt Dia	Tensile Stress Area	Clamp Load	Torque (Dry)		Torque Lubricated		Torque (Loclote® 262™ or Vibra-TITE™ 131)		Clamp Load	Torque (Dry or Loclote® 263 K=0.20)		Torque (Loclote® 242™ or 271™ OR Vibra-TITE™ 111 or TITE™ 131) K=0.15			
					IN-LB	[N.m]	IN-LB	[N.m]	IN-LB	[N.m]		IN-LB	[N.m]	IN-LB	[N.m]	IN-LB	[N.m]
4	48	0.1120	0.00604	380	8	0.9	6	0.7									
4	48	0.1120	0.00631	420	9	1.0	7	0.8									
6	32	0.1380	0.00909	580	16	1.8	12	1.4									
6	40	0.1380	0.01015	610	18	2.0	13	1.5									
8	32	0.1640	0.01400	900	30	3.4	22	2.5									
8	36	0.1640	0.01474	940	31	3.5	23	2.6			1320	43	5				
10	24	0.1900	0.01750	1120	43	4.8	32	3.5			1580	60	7				
10	32	0.1900	0.02000	1285	49	5.5	36	4			1800	68	8				
1/4	20	0.2500	0.0318	2020	96	10.8	75	9	105	12	2860	143	16	129	15		
1/4	28	0.2500	0.0364	2320	120	13.5	86	10	135	15	3280	164	19	148	17		
					FT-LB	[N.m]	FT-LB	[N.m]	FT-LB	[N.m]	LB	FT-LB	[N.m]	FT-LB	[N.m]	FT-LB	[N.m]
5/16	18	0.3125	0.0524	3340	17	23	13	18	19	26	4720	25	35	20	25	20	25
5/16	24	0.3125	0.0580	3700	19	26	14	19	21	29	5220	25	35	20	25	20	25
3/8	16	0.3750	0.0775	4940	30	41	23	31	35	48	7000	45	60	40	55	35	50
3/8	24	0.3750	0.0878	5600	35	47	25	34	40	54	7900	50	70	45	60	35	50
7/16	14	0.4375	0.1063	6800	50	68	35	47	55	75	9500	70	95	60	90	50	70
7/16	20	0.4375	0.1187	7560	55	75	40	54	60	82	10700	80	110	70	95	60	80
1/2	13	0.5000	0.1419	9050	75	102	55	75	85	116	12750	105	145	95	130	80	110
1/2	20	0.5000	0.1599	10700	90	122	65	88	100	136	14400	120	165	110	150	90	120
9/16	12	0.5625	0.1820	11600	110	149	80	108	120	163	16400	155	210	140	190	115	155
9/16	18	0.5625	0.2030	12950	120	163	90	122	135	184	18250	170	230	155	210	130	175
5/8	11	0.6250	0.2260	14400	150	203	110	149	165	224	20350	210	285	190	260	160	220
5/8	18	0.6250	0.2560	16300	170	230	130	176	190	258	23000	240	325	210	290	180	245
3/4	10	0.7500	0.3340	21300	260	353	200	285	388	440	30100	375	510	340	460	280	380
3/4	16	0.7500	0.3730	23800	300	407	220	298	407	498	33600	420	570	380	515	315	430
7/8	9	0.8750	0.4620	29400	430	583	320	434	475	648	41600	605	825	545	740	455	620
7/8	14	0.8750	0.5090	32400	470	637	350	475	520	707	45800	670	910	600	815	500	680
1	8	1.0000	0.6060	38600	640	868	480	651	675	918	51500	860	1170	770	1045	645	875
1	12	1.0000	0.6630	42200	700	949	530	719	735	1000	55800	995	1355	895	1215	745	1015
1 1/8	7	1.1250	0.7630	42300	800	1085	600	813	840	1142	59700	1290	1755	1160	1580	965	1310
1 1/8	12	1.1250	0.8560	47500	880	1193	660	895	925	1258	64700	1445	1965	1300	1770	1085	1475
1 1/4	7	1.2500	0.9690	53800	1120	1518	840	1139	1175	1598	72000	1815	2470	1635	2225	1365	1855
1 1/4	12	1.2500	1.0730	59600	1240	1681	920	1247	1300	1768	79600	2015	2740	1810	2460	1510	2055
1.38	6	1.3750	1.1550	64100	1460	1979	1100	1491	1525	2074	104000	2385	3245	2145	2915	1785	2430
1 1/2	12	1.3750	1.3150	73000	1680	2278	1260	1708	1750	2380	118500	2705	3680	2435	3310	2030	2760
1 1/2	6	1.5000	1.4050	78000	1940	2630	1460	1979	2025	2754	126500	3165	4305	2843	3870	2370	3225
1 1/2	12	1.5000	1.5800	87700	2200	2983	1640	2224	2300	3128	142200	3555	4835	3200	4350	2665	3625

NO. 5000059 REV. K

NOTES: 1. THESE TORQUE VALUES DO NOT APPLY TO CADMIUM PLATED FASTENERS
 2. ALL TORQUE VALUES ARE STATIC TORQUE MEASURED PER STANDARD AUDIT METHODS TOLERANCE = ±10%
 3. * ASSEMBLY USES HARDENED WASHER

REFERENCE JLG THREAD LOCKING COMPOUND		
JLG P/N	Loctite® P/N	Description
0100011	242™	Medium Strength (Blue)
0100019	271™	High Strength (Red)
0100071	262™	Medium - High Strength (Red)

Values for Magni Coating Fasteners (Ref 4150701)														
Size	TPI	Bolt Dia	Tensile Stress Area	Clamp Load	SAE GRADE 5 BOLTS & GRADE 2 NUTS				SAE GRADE 8 (HEX HD) BOLTS & GRADE 8 NUTS*					
					Torque (Dry) K=0.17	Torque (Locitite® 242™ or 271™ OR Vibra-TITE™ 111 or 140) K=0.16	Torque (Locitite® 262™ or TITE™ 131) K=0.15	Clamp Load	Torque (Dry or Locitite® 263) K=0.17	Torque (Locitite® 242™ or 271™ OR Vibra-TITE™ 111 or 140) K=0.16	Torque (Locitite® 262™ or TITE™ 131) K=0.15	Torque (Locitite® 262™ or TITE™ 131) K=0.15		
		In	Sq In	LB	IN-LB	FT-LB	IN-LB	FT-LB	IN-LB	FT-LB	IN-LB	FT-LB	IN-LB	FT-LB
4	40	0.1120	0.00604	380	7	0.8								
4.8	48	0.1120	0.00661	420	8	0.9								
6	32	0.1380	0.00909	580	14	1.5								
8	40	0.1380	0.01015	610	14	1.6								
8	32	0.1640	0.01400	900	25	2.8								
36	36	0.1640	0.01474	940	26	2.9								
10	24	0.1900	0.01750	1120	36	4.1								
32	32	0.1900	0.02000	1285	42	4.7								
1/4	20	0.2500	0.0318	2020	86	9.7	80	9	114	13				
28	28	0.2500	0.0364	2320	99	11.1	95	11	131	15				
		In	Sq In	LB	FT-LB	IN-LB	FT-LB	IN-LB	FT-LB	IN-LB	FT-LB	IN-LB	FT-LB	IN-LB
5/16	18	0.3125	0.0524	3340	15	20	14	19	20	25	20	25	20	25
24	24	0.3125	0.0580	3700	15	21	15	21	20	25	20	25	20	25
3/8	16	0.3750	0.0775	4940	25	35	25	34	25	35	30	40	35	50
24	24	0.3750	0.0878	5600	30	40	28	38	25	34	25	40	35	50
7/16	14	0.4375	0.1063	6800	40	55	40	54	35	48	40	55	50	70
20	20	0.4375	0.1187	7550	45	60	44	60	40	54	40	60	60	80
1/2	13	0.5000	0.1419	9050	65	90	60	82	55	75	60	85	115	120
20	20	0.5000	0.1599	10700	75	100	71	97	65	88	100	135	130	120
9/16	12	0.5625	0.1820	11600	90	120	87	118	80	109	130	175	170	155
18	18	0.5625	0.2030	12950	105	145	97	132	90	122	145	195	185	175
5/8	11	0.6250	0.2260	14400	130	175	120	163	115	156	180	245	230	220
18	18	0.6250	0.2560	16300	145	195	136	185	125	170	205	280	260	245
3/4	10	0.7500	0.3340	21300	225	305	213	290	200	272	30100	320	300	280
16	16	0.7500	0.3730	23800	255	345	238	324	225	306	33600	355	335	315
7/8	9	0.8750	0.4620	29400	365	495	343	466	320	435	41600	515	485	455
14	14	0.8750	0.5090	32400	400	545	378	514	355	483	45800	570	535	500
1	8	1.0000	0.6060	38600	545	740	515	700	480	653	51500	730	685	645
12	12	1.0000	0.6830	42200	600	815	563	765	530	721	59700	845	795	745
1 1/8	7	1.1250	0.7630	42300	675	920	635	863	595	809	68700	1095	1030	965
1 1/4	7	1.2500	0.8560	47500	955	1300	897	1219	670	911	77000	1225	1155	1085
1 1/4	12	1.2500	1.0730	59600	1055	1435	993	1351	930	1265	96600	1710	1610	1510
1 3/8	6	1.3750	1.1550	64100	1250	1700	1175	1598	1100	1496	104000	2025	1905	1785
1 1/2	6	1.5000	1.4050	78000	1660	2260	1560	2122	1465	1992	126500	2690	2530	2370
1 1/2	12	1.5000	1.5800	87700	1865	2535	1754	2385	1645	2237	142200	3020	2845	2665

NO. 500059 REV. K

NOTES: 1. THESE TORQUE VALUES DO NOT APPLY TO CADMIUM PLATED FASTENERS
 2. ALL TORQUE VALUES ARE STATIC TORQUE MEASURED PER STANDARD AUDIT METHODS TOLERANCE = ±10%
 3. * ASSEMBLY USES HARDENED WASHER

Figure 1-4. Torque Chart - Sheet 2 of 5 - (SAE Fasteners)

		SOCKET HEAD CAP SCREWS															
		Magni Coating (Ref 4150701)*					Zinc Yellow Chromate Fasteners (Ref 4150707)*										
Size	TPI	Bolt Dia	Tensile Stress Area	Clamp Load See Note 4	Torque (Dry) K = .17		Torque (Loctite® 242™ or 271™ OR Vibra-TITE™ 111 or 140 OR Precoat 85®) K=0.16		Torque (Loctite® 262™ or 131) K=0.15		Clamp Load See Note 4	Torque (Dry) K = .20		Torque (Loctite® 242™ or 271™ OR Vibra-TITE™ 111 or 140 OR Precoat 85®) K=0.18		Torque (Loctite® 262™ or 131) K=0.15	
					IN-LB	[N.m]	IN-LB	[N.m]	IN-LB	[N.m]		IN-LB	[N.m]	IN-LB	[N.m]	IN-LB	[N.m]
		In	Sq In	LB	IN-LB	[N.m]	FT-LB	[N.m]	FT-LB	[N.m]	LB	IN-LB	[N.m]	FT-LB	[N.m]	IN-LB	[N.m]
4	40	0.1120	0.00604														
	48	0.1120	0.00661														
6	32	0.1380	0.00909														
	40	0.1380	0.01015														
8	32	0.1640	0.01400														
	36	0.1640	0.01474														
10	24	0.1900	0.01750														
	32	0.1900	0.02000														
1/4	20	0.2500	0.0318	2860	122	14	114	13			2860	143	16	129	15		
	28	0.2500	0.0364	3280	139	16	131	15			3280	164	19	148	17		
		In	Sq In	LB	IN-LB	[N.m]	FT-LB	[N.m]	FT-LB	[N.m]	LB	IN-LB	[N.m]	FT-LB	[N.m]	IN-LB	[N.m]
5/16	18	0.3125	0.0524	4720	20	25	20	25	20	25	4720	25	35	20	25	20	25
	24	0.3125	0.0580	5220	25	35	20	25	20	25	5220	25	35	25	35	20	25
3/8	16	0.3750	0.0775	7000	35	50	35	50	35	50	7000	45	60	40	55	35	50
	24	0.3750	0.0878	7900	40	55	40	55	35	50	7900	50	70	45	60	35	50
7/16	14	0.4375	0.1063	9550	60	80	55	75	50	70	9550	70	95	65	90	50	70
	20	0.4375	0.1187	10700	65	90	60	80	60	80	10700	80	110	70	95	60	80
1/2	13	0.5000	0.1419	12750	90	120	85	115	80	110	12750	105	145	95	130	80	110
	20	0.5000	0.1599	14400	100	135	95	130	90	120	14400	120	165	110	150	90	120
9/16	12	0.5625	0.1820	16400	130	175	125	170	115	155	16400	155	210	140	190	115	155
	18	0.5625	0.2030	18250	145	195	135	185	130	175	18250	170	230	155	210	130	175
5/8	11	0.6250	0.2260	20350	180	245	170	230	160	220	20350	210	285	190	260	160	220
	18	0.6250	0.2560	23000	205	280	190	260	180	245	23000	240	325	215	290	180	245
3/4	10	0.7500	0.3340	30100	320	435	300	380	280	380	30100	375	510	340	460	280	380
	16	0.7500	0.3730	33600	355	485	335	455	315	430	33600	420	570	380	515	315	430
7/8	9	0.8750	0.4620	41600	515	700	485	660	455	620	41600	605	825	545	740	455	620
	14	0.8750	0.5090	45800	570	775	535	730	500	680	45800	670	910	600	815	500	680
1	8	1.0000	0.6060	51500	730	995	685	930	645	875	51500	860	1170	775	1055	645	875
	12	1.0000	0.6630	59700	845	1150	795	1060	745	1015	59700	995	1365	895	1215	745	1015
1 1/8	7	1.1250	0.7630	68700	1095	1490	1030	1400	965	1310	68700	1290	1765	1160	1580	965	1310
	12	1.1250	0.8560	77000	1225	1685	1155	1570	1085	1475	77000	1445	1985	1300	1770	1085	1475
1 1/4	7	1.2500	0.9690	87200	1545	2100	1455	1980	1365	1855	87200	1815	2470	1635	2225	1365	1855
	12	1.2500	1.0730	96600	1710	2325	1610	2190	1510	2055	96600	2015	2740	1810	2460	1510	2055
1 3/8	6	1.3750	1.1550	104000	2025	2755	1905	2590	1785	2430	104000	2385	3245	2145	2915	1785	2430
	12	1.3750	1.3150	118100	2300	3130	2165	2945	2030	2760	118100	2705	3680	2435	3310	2030	2760
1 1/2	6	1.5000	1.4050	126500	2690	3660	2530	3440	2370	3225	126500	3165	4305	2845	3870	2370	3225
	12	1.5000	1.5800	142200	3020	4105	2845	3870	2865	3625	142200	3555	4835	3200	4350	2865	3625

NO. 500059 REV. K

NOTES: 1. THESE TORQUE VALUES DO NOT APPLY TO CADMIUM PLATED FASTENERS
 2. ALL TORQUE VALUES ARE STATIC TORQUE MEASURED PER STANDARD AUDIT METHODS TOLERANCE = ±10%
 *3. ASSEMBLY USES HARDENED WASHER OR FASTENER IS PLACED AGAINST PLATED STEEL OR RAW ALUMINUM
 4. CLAMP LOAD LISTED FOR SHCS IS SAME AS GRADE 8 OR CLASS 10.9 AND DOES NOT REPRESENT FULL STRENGTH CAPABILITY OF SHCS. IF HIGHER LOAD IS REQUIRED, ADDITIONAL TESTING IS REQUIRED.

Figure 1-5. Torque Chart - Sheet 3 of 5 - (SAE Fasteners)

Values for Zinc Yellow Chromate Fasteners (Ref 4150707)											
CLASS 10.9 METRIC (HEX HEAD) BOLTS CLASS 10 METRIC NUTS CLASS 12.9 SOCKET HEAD CAP SCREWS M3 - M5*											
CLASS 8.8 METRIC (HEX/SOCKET HEAD) BOLTS CLASS 8 METRIC NUTS					CLASS 10.9 METRIC (HEX HEAD) BOLTS CLASS 10 METRIC NUTS CLASS 12.9 SOCKET HEAD CAP SCREWS M3 - M5*						
Size	PITCH	Tensile Stress Area	Clamp Load	Torque (Dry or Loctite® 263™)	Torque (Lub)	Torque (Loctite® 242™ or 271™ OR Vibra-TITE™ 131)	Torque (Loctite® 242™ or 271™ OR Vibra-TITE™ 111 or 140)	Clamp Load	Torque (Dry or Loctite® 263™) K=0.20	Torque (Lub OR Loctite® 242™ or 271™ OR Vibra-TITE™ 111 or 140) K=0.18	Torque (Loctite® 262™ OR Vibra-TITE™ 131) K=0.15
		Sq mm	KN	[N.m]	[N.m]	[N.m]	[N.m]	KN	[N.m]	[N.m]	[N.m]
3	0.5	5.03	2.19	1.3	1.0	1.2	1.4	3.13			
3.5	0.6	6.78	2.95	2.1	1.6	1.9	2.3	4.22			
4	0.7	8.78	3.82	3.1	2.3	2.8	3.4	5.47			
5	0.8	14.20	6.18	6.2	4.6	5.6	6.8	8.85			
6	1	20.10	8.74	11	7.9	9.4	12	12.5			
7	1	28.90	12.6	18	13	16	19	18.0	25	23	19
8	1.25	36.60	15.9	26	19	23	28	22.8	37	33	27
10	1.5	58.00	25.2	50	38	45	55	36.1	70	65	55
12	1.75	84.30	36.7	88	66	79	97	52.5	125	115	95
14	2	115	50.0	140	105	126	154	71.6	200	180	150
16	2	157	68.3	219	164	197	241	97.8	315	280	235
18	2.5	192	83.5	301	226	271	331	119.5	430	385	325
20	2.5	245	106.5	426	320	383	469	152.5	610	550	460
22	2.5	303	132.0	581	436	523	639	189.0	830	750	625
24	3	353	153.5	737	553	663	811	222.0	1065	960	800
27	3	459	199.5	1080	810	970	1130	286.0	1545	1390	1160
30	3.5	561	244.0	1460	1100	1320	1530	349.5	2095	1885	1575
33	3.5	694	302.0	1990	1490	1790	2090	432.5	2855	2570	2140
36	4	817	355.5	2560	1920	2300	2690	509.0	3665	3300	2750
42	4.5	1120	487.0	4090	3070	3680	4290	698.0	5865	5275	4395

NO. 5000059 REV. K

: 1. THESE TORQUE VALUES DO NOT APPLY TO CADMIUM PLATED FASTENERS
 2. ALL TORQUE VALUES ARE STATIC TORQUE MEASURED PER STANDARD AUDIT METHODS TOLERANCE = ±10%
 *3. ASSEMBLY USES HARDENED WASHER OR FASTENER IS PLACED AGAINST PLATED STEEL OR RAW ALUMINUM
 4. CLAMP LOAD LISTED FOR SHCS IS SAME AS GRADE 8 OR CLASS 10.9 AND DOES NOT REPRESENT FULL STRENGTH CAPABILITY OF SHCS. IF HIGHER LOAD IS REQUIRED, ADDITIONAL TESTING IS REQ

Figure 1-6. Torque Chart - Sheet 4 of 5 - (METRIC Fasteners)

Values for Magni Coated Fasteners (Ref 4150701)										
CLASS 8.8 METRIC (HEX/SOCKET HEAD) BOLTS CLASS 8 METRIC NUTS					CLASS 10.9 METRIC (HEX HEAD) BOLTS CLASS 10 METRIC NUTS CLASS 12.9 SOCKET HEAD CAP SCREWS M6 AND ABOVE*					
Size	PITCH	Tensile Stress Area	Clamp Load	Torque (Dry or Loctite® 263™) K=0.17	Torque (Loctite® 262™ OR Vibra-TITE™, 131) K=0.16	Torque (Loctite® 242™ or 271™ OR Vibra-TITE™, 111 or 140) K=0.15	Clamp Load	Torque (Dry or Loctite® 263™) K = 0.17	Torque (Lub OR Loctite® 242™ or 271™ OR Vibra-TITE™ 111 or 140) K= 0.16	Torque (Loctite® 262™ OR Vibra-TITE™ 131) K=0.15
		Sq mm	KN	[N.m]	[N.m]	[N.m]	KN	[N.m]	[N.m]	[N.m]
3	0.5	5.03	2.19	1.1	1.1	1.0	3.13			
3.5	0.6	6.78	2.95	1.8	1.7	1.5	4.22			
4	0.7	8.78	3.82	2.6	2.4	2.3	5.47			
5	0.8	14.20	6.18	5.3	4.9	4.6	8.85			
6	1	20.10	8.74	9	8.4	7.9	12.5	13	12	11
7	1	28.90	12.6	15	14	13	18.0	21	20	19
8	1.25	36.60	15.9	22	20	19	22.8	31	29	27
10	1.5	58.00	25.2	43	40	38	36.1	61	58	55
12	1.75	84.30	36.7	75	70	66	52.5	105	100	95
14	2	115	50.0	119	110	105	71.6	170	160	150
16	2	157	68.3	186	175	165	97.8	265	250	235
18	2.5	192	83.5	256	240	225	119.5	365	345	325
20	2.5	245	106.5	362	340	320	152.5	520	490	460
22	2.5	303	132.0	494	465	435	189.0	705	665	625
24	3	353	153.5	627	590	555	222.0	905	850	800
27	3	459	199.5	916	860	810	286.0	1315	1235	1160
30	3.5	561	244.0	1245	1170	1100	349.5	1780	1680	1575
33	3.5	694	302.0	1694	1595	1495	432.5	2425	2285	2140
36	4	817	355.5	2176	2050	1920	509.0	3115	2930	2750
42	4.5	1120	487.0	3477	3275	3070	698.0	4985	4690	4395

NO. 5000059 REV. K

NOTES: 1. THESE TORQUE VALUES DO NOT APPLY TO CADMIUM PLATED FASTENERS

2. ALL TORQUE VALUES ARE STATIC TORQUE MEASURED PER STANDARD AUDIT METHODS TOLERANCE = ±10%

*3. ASSEMBLY USES HARDENED WASHER OR FASTENER IS PLACED AGAINST PLATED STEEL OR RAW ALUMINUM

4. CLAMP LOAD LISTED FOR SHCS IS SAME AS GRADE 8 OR CLASS 10.9 AND DOES NOT REPRESENT FULL STRENGTH CAPABILITY OF SHCS. IF HIGHER LOAD IS REQUIRED, ADDITIONAL TESTING IS REQUIRED.

Figure 1-7. Torque Chart - Sheet 5 of 5 - (METRIC Fasteners)

PARTS FINDER

**Search Website
by Part Number**



**Search Manual
Library For Parts
Manual & Lookup Part
Numbers – Purchase
or Request Quote**

Search Manuals

Enter the information below to search our manual library for parts manuals.

* Brand:

* Model:

* Serial:

* Part Number:

* Quantity:

**Can't Find Part or
Manual? Request Help
by Manufacturer,
Model & Description**

Parts Order Form

Please fill in the information below to request help finding a part or manual.

* Brand:

* Model:

* Serial:

* Part Number:

* Quantity:

Discount-Equipment.com is your online resource for quality parts & equipment.

Florida: **561-964-4949** Outside Florida TOLL FREE: **877-690-3101**

Need parts?

Click on this link: <http://www.discount-equipment.com/category/5443-parts/> and choose one of the options to help get the right parts and equipment you are looking for. Please have the machine model and serial number available in order to help us get you the correct parts. If you don't find the part on the website or on one of the online manuals, please fill out the request form and one of our experienced staff members will get back to you with a quote for the right part that your machine needs.

We sell worldwide for the brands: Genie, Terex, JLG, MultiQuip, Mikasa, Essick, Whiteman, Mayco, Toro Stone, Diamond Products, Generac Magnum, Airman, Haulotte, Barreto, Power Blanket, Nifty Lift, Atlas Copco, Chicago Pneumatic, Allmand, Miller Curber, Skyjack, Lull, Skytrak, Tsurumi, Husquvarna Target, , Stow, Wacker, Sakai, Mi-T- M, Sullair, Basic, Dynapac, MBW, Weber, Bartell, Bennar Newman, Haulotte, Ditch Runner, Menegotti, Morrison, Contec, Buddy, Crown, Edco, Wyco, Bomag, Laymor, Barreto, EZ Trench, Bil-Jax, F.S. Curtis, Gehl Pavers, Heli, Honda, ICS/PowerGrit, IHI, Partner, Imer, Clipper, MMD, Koshin, Rice, CH&E, General Equipment, ,AMida, Coleman, NAC, Gradall, Square Shooter, Kent, Stanley, Tamco, Toku, Hatz, Kohler, Robin, Wisconsin, Northrock, Oztec, Toker TK, Rol-Air, Small Line, Wanco, Yanmar

SECTION 2. GENERAL

2.1 MACHINE PREPARATION, INSPECTION, AND MAINTENANCE

General

This section provides the necessary information needed by those personnel that are responsible to place the machine in operation readiness and maintain its safe operating condition. For maximum service life and safe operation, ensure that all the necessary inspections and maintenance have been completed before placing the machine into service. With proper care, maintenance, and inspections performed per JLG's recommendations, and with any and all discrepancies corrected, this product will be fit for continued use.

Preparation, Inspection, and Maintenance

It is important to establish and conform to a comprehensive inspection and preventive maintenance program. The following table outlines the periodic machine inspections and maintenance recommended by JLG Industries, Inc. Consult your national, regional, or local regulations for further requirements for aerial work platforms. The frequency of inspections and maintenance must be increased as environment, severity and frequency of usage requires.

Pre-Start Inspection

It is the User's or Operator's primary responsibility to perform a Pre-Start Inspection of the machine prior to use daily or at each change of operator. Reference the Operator's and Safety Manual for completion procedures for the Pre-Start Inspection. The Operator and Safety Manual must be read in its entirety and understood prior to performing the Pre-Start Inspection.

Pre-Delivery Inspection and Frequent Inspection

The Pre-Delivery Inspection and Frequent Inspection shall be performed by a qualified JLG equipment mechanic. JLG Industries, Inc. recognizes a qualified JLG equipment mechanic as a person who, by possession of a recognized degree, certificate, extensive knowledge, training, or experience, has successfully demonstrated the ability and proficiency to service, repair, and maintain the subject JLG product model.

The Pre-Delivery Inspection and Frequent Inspection procedures are performed in the same manner, but at different times. The Pre-Delivery Inspection shall be performed prior to each sale, lease, or rental delivery. The Frequent Inspection shall be accomplished for each machine in service for 3 months or 150 hours (whichever comes first); out of service for a period of more than 3 months; or when purchased used. The frequency of this inspection must be increased as environment, severity and frequency of usage requires.

Reference the JLG Pre-Delivery and Frequent Inspection Form and the Inspection and Preventive Maintenance Schedule for items requiring inspection during the performance of these inspections. Reference the appropriate areas of this manual for servicing and maintenance procedures.

Annual Machine Inspection

The Annual Machine Inspection must be performed on an annual basis, no later than thirteen (13) months from the date of the prior Annual Machine Inspection. JLG Industries recommends this task be performed by a Factory-Trained Service Technician. JLG Industries, Inc. recognizes a Factory-Trained Service Technician as a person who has successfully completed the JLG Service Training School for the subject JLG product model. Reference the machine Service and Maintenance Manual and appropriate JLG inspection form for performance of this inspection.

Reference the JLG Annual Machine Inspection Form and the Inspection and Preventive Maintenance Schedule for items requiring inspection during the performance of this inspection. Reference the appropriate areas of this manual for servicing and maintenance procedures.

For the purpose of receiving safety-related bulletins, it is important that JLG Industries, Inc. has updated ownership information for each machine. When performing each Annual Machine Inspection, notify JLG Industries, Inc. of the current machine ownership.

Preventive Maintenance

In conjunction with the specified inspections, maintenance shall be performed by a qualified JLG equipment mechanic. JLG Industries, Inc. recognizes a qualified JLG equipment mechanic as a person who, by possession of a recognized degree, certificate, extensive knowledge, training, or experience, has successfully demonstrated the ability and proficiency to service, repair, and maintain the subject JLG product model.

Reference the Preventive Maintenance Schedule and the appropriate areas of this manual for servicing and maintenance procedures. The frequency of service and maintenance must be increased as environment, severity and frequency of usage requires.

Table 2-1. Inspection and Maintenance

Type	Frequency	Primary Responsibility	Service Qualification	Reference
Pre-Start Inspection	Prior to use each day; or At each Operator change.	User or Operator	User or Operator	Operation and Safety Manual
Pre-Delivery Inspection	Prior to each sale, lease, or rental delivery.	Owner, Dealer, or User	Qualified JLG Mechanic	Service and Maintenance Manual and applicable JLG inspection form.
Frequent Inspection	In service for 3 months or 150 hours, whichever comes first; or Out of service for a period of more than 3 months; or purchased used.	Owner, Dealer, or User	Qualified JLG Mechanic	Service and Maintenance Manual and applicable JLG inspection form.
Annual Machine Inspection	Annually, no later than 13 months from the date of the prior inspection.	Owner, Dealer, or User	Factory-Trained Service Technician (Recommended)	Service and Maintenance Manual and applicable JLG inspection form.
Preventive Maintenance	At intervals as specified in the Service and Maintenance Manual.	Owner, Dealer, or User	Qualified JLG Mechanic	Service and Maintenance Manual

NOTE: Inspections forms are available from JLG. Use the Service and Maintenance Manual to perform inspections.

2.2 SERVICE AND GUIDELINES

General

The following information is provided to assist you in the use and application of servicing and maintenance procedures contained in this book.

Safety and Workmanship

Your safety, and that of others, is the first consideration when engaging in the maintenance of equipment. Always be conscious of weight. Never attempt to move heavy parts without the aid of a mechanical device. Do not allow heavy objects to rest in an unstable position. When raising a portion of the equipment, ensure that adequate support is provided.

Cleanliness

1. The most important single item in preserving the long service life of a machine is to keep dirt and foreign materials out of the vital components. Precautions have been taken to safeguard against this. Shields, covers, seals, and filters are provided to keep air, fuel, and oil supplies clean; however, these items must be maintained on a scheduled basis in order to function properly.

2. At any time when air, fuel, or oil lines are disconnected, clear adjacent areas as well as the openings and fittings themselves. As soon as a line or component is disconnected, cap or cover all openings to prevent entry of foreign matter.
3. Clean and inspect all parts during servicing or maintenance, and assure that all passages and openings are unobstructed. Cover all parts to keep them clean. Be sure all parts are clean before they are installed. New parts should remain in their containers until they are ready to be used.

Components Removal and Installation

1. Use adjustable lifting devices, whenever possible, if mechanical assistance is required. All slings (chains, cables, etc.) should be parallel to each other and as near perpendicular as possible to top of part being lifted.
2. Should it be necessary to remove a component on an angle, keep in mind that the capacity of an eyebolt or similar bracket lessens, as the angle between the supporting structure and the component becomes less than 90 degrees.
3. If a part resists removal, check to see whether all nuts, bolts, cables, brackets, wiring, etc., have been removed and that no adjacent parts are interfering.

Component Disassembly and Reassembly

When disassembling or reassembling a component, complete the procedural steps in sequence. Do not partially disassemble or assemble one part, then start on another. Always recheck your work to assure that nothing has been overlooked. Do not make any adjustments, other than those recommended, without obtaining proper approval.

Pressure-Fit Parts

When assembling pressure-fit parts, use a molybdenum disulfide base compound or equivalent to lubricate the mating surface.

Bearings

1. When a bearing is removed, cover it to keep out dirt and abrasives. Clean bearings in nonflammable cleaning solvent and allow to drip dry. Compressed air can be used but do not spin the bearing.
2. Discard bearings if the races and balls (or rollers) are pitted, scored, or burned.
3. If bearing is found to be serviceable, apply a light coat of oil and wrap it in clean (waxed) paper. Do not unwrap reusable or new bearings until they are ready to install.
4. Lubricate new or used serviceable bearings before installation. When pressing a bearing into a retainer or bore, apply pressure to the outer race. If the bearing is to be installed on a shaft, apply pressure to the inner race.

Gaskets

Check that holes in gaskets align with openings in the mating parts. If it becomes necessary to hand-fabricate a gasket, use gasket material or stock of equivalent material and thickness. Be sure to cut holes in the right location, as blank gaskets can cause serious system damage.

Bolt Usage and Torque Application

NOTICE

SELF LOCKING FASTENERS, SUCH AS NYLON INSERT AND THREAD DEFORMING LOCKNUTS, ARE NOT INTENDED TO BE REINSTALLED AFTER REMOVAL.

1. Always use new replacement hardware when installing locking fasteners. Use bolts of proper length. A bolt which is too long will bottom before the head is tight against its related part. If a bolt is too short, there will not be enough thread area to engage and hold the part properly. When replacing bolts, use only those having the same specifications of the original, or one which is equivalent.
2. Unless specific torque requirements are given within the text, standard torque values should be used on heat-treated bolts, studs, and steel nuts, in accordance with recommended shop practices. (See Torque Chart Section 1.)

Hydraulic Lines and Electrical Wiring

Clearly mark or tag hydraulic lines and electrical wiring, as well as their receptacles, when disconnecting or removing them from the unit. This will assure that they are correctly reinstalled.

Hydraulic System

1. Keep the system clean. If evidence of metal or rubber particles are found in the hydraulic system, drain and flush the entire system.
2. Disassemble and reassemble parts on clean work surface. Clean all metal parts with non-flammable cleaning solvent. Lubricate components, as required, to aid assembly.

Lubrication

Service applicable components with the amount, type, and grade of lubricant recommended in this manual, at the specified intervals. When recommended lubricants are not available, consult your local supplier for an equivalent that meets or exceeds the specifications listed.

Battery

Clean battery using a non-metallic brush and a solution of baking soda and water. Rinse with clean water. After cleaning, thoroughly dry battery and coat terminals with an anti corrosion compound.

Lubrication and Servicing

Components and assemblies requiring lubrication and servicing are shown in the Lubrication Chart in Section 1.

2.3 LUBRICATION AND INFORMATION

Hydraulic System

1. The primary enemy of a hydraulic system is contamination. Contaminants enter the system by various means, e.g., using inadequate hydraulic oil, allowing moisture, grease, filings, sealing components, sand, etc., to enter when performing maintenance, or by permitting the pump to cavitate due to insufficient system warm-up or leaks in the pump supply (suction) lines.
2. The design and manufacturing tolerances of the component working parts are very close, therefore, even the smallest amount of dirt or foreign matter entering a system can cause wear or damage to the components and generally results in faulty operation. Every precaution must be taken to keep hydraulic oil clean, including reserve oil in storage. Hydraulic system filters should be checked, cleaned, and/or replaced as necessary, at the specified intervals required in the Lubrication Chart in Section 1. Always examine filters for evidence of metal particles.
3. Cloudy oils indicate a high moisture content which permits organic growth, resulting in oxidation or corrosion. If this condition occurs, the system must be drained, flushed, and refilled with clean oil.
4. It is not advisable to mix oils of different brands or types, as they may not contain the same required additives or be of comparable viscosities. Good grade mineral oils, with viscosities suited to the ambient temperatures in which the machine is operating, are recommended for use.

NOTE: *Metal particles may appear in the oil or filters of new machines due to the wear-in of meshing components.*

Hydraulic Oil

1. Refer to Section 1 for recommendations for viscosity ranges.
2. JLG recommends Mobilfluid 424 hydraulic oil, which has an SAE viscosity of 10W-30 and a viscosity index of 152.

NOTE: *Start-up of hydraulic system with oil temperatures below -15 degrees F (-26 degrees C) is not recommended. If it is necessary to start the system in a sub-zero environment, it will be necessary to heat the oil with a low density, 100VAC heater to a minimum temperature of -15 degrees F (-26 degrees C).*

3. The only exception to the above is to drain and fill the system with Mobil DTE 13 oil or its equivalent. This will allow start up at temperatures down to -20 degrees F (-29 degrees C). However, use of this oil will give poor performance at temperatures above 120 degrees F (49 degrees C). Systems using DTE 13 oil should not be operated at temperatures above 200 degrees F (94 degrees C) under any condition.

Changing Hydraulic Oil

1. Filter elements must be changed after the first 50 hours of operation and every 300 hours (unless specified otherwise) thereafter. If it is necessary to change the oil, use only those oils meeting or exceeding the specifications appearing in this manual. If unable to obtain the same type of oil supplied with the machine, consult local supplier for assistance in selecting the proper equivalent. Avoid mixing petroleum and synthetic base oils.
2. Use every precaution to keep the hydraulic oil clean. If the oil must be poured from the original container into another, be sure to clean all possible contaminants from the service container. Always clean the mesh element of the filter and replace the cartridge any time the system oil is changed.
3. While the unit is shut down, a good preventive maintenance measure is to make a thorough inspection of all hydraulic components, lines, fittings, etc., as well as a functional check of each system, before placing the machine back in service.

Lubrication Specifications

Specified lubricants, as recommended by the component manufacturers, are always the best choice, however, multi-purpose greases usually have the qualities which meet a variety of single purpose grease requirements. Should any question arise, regarding the use of greases in maintenance stock, consult your local supplier for evaluation. Refer to Section 1 for an explanation of the lubricant key designations appearing in the Lubrication Chart.

2.4 CYLINDER DRIFT

Theory

When a hydraulic cylinder is supporting a load, cylinder drift may occur as a result of any of the circumstances below:

- Normal leakage of load holding valves or malfunction of load holding valves. See Cylinder Leakage Test and Table 2-2, Cylinder Drift below for evaluation.
- Damaged or worn piston seals.
- Normal thermal expansion or contraction of the hydraulic oil within cylinders (See Cylinder Thermal Drift below).

The first two circumstances may result in cylinder movement due to oil leaking out of the cylinder externally or by leaking back to tank or due to oil leaking internally from one cylinder chamber to the other.

Thermal expansion or contraction of oil in hydraulic cylinders is a normal occurrence and does not result in oil leaking out of the cylinder or leaking internally from one cylinder chamber to the other. Thermal expansion or contraction is the tendency for materials to change size in response to a change in temperature.

Cylinder Leakage Test

Cylinder oil must be at stabilized ambient temperature before beginning this test.

Measure drift at cylinder rod with a calibrated dial indicator.

In an area free of obstructions, cylinder must have load applied and appropriately positioned to detect drift.

Cylinder leakage is acceptable if it passes this test.

Table 2-2. Cylinder Drift

Cylinder Bore Diameter		Max. Acceptable Drift in 10 Minutes	
inches	mm	inches	mm
3	76.2	0.026	0.66
3.5	89	0.019	0.48
4	101.6	0.015	0.38
5	127	0.009	0.22
6	152.4	0.006	0.15
7	177.8	0.005	0.13
8	203.2	0.004	0.10
9	228.6	0.003	0.08

NOTE: This information is based on 6 drops per minute cylinder leakage.

Cylinder Thermal Drift

The oil in all hydraulic cylinders will expand or contract due to thermal effects over time and may result in changes to the boom and/or platform position while the machine is stationary. These effects occur as the cylinder oil changes temperature, usually from a higher oil temperature as it cools and approaches the ambient air temperature. Results of these effects are related to several factors including cylinder length and change in temperature over the time the cylinder remains stationary.

2.5 PINS AND COMPOSITE BEARING REPAIR GUIDELINES

Filament wound bearings.

1. Pinned joints should be disassembled and inspected if the following occurs:
 - a. Excessive sloppiness in joints.
 - b. Noise originating from the joint during operation.
2. Filament wound bearings should be replaced if any of the following is observed:
 - a. Frayed or separated fibers on the liner surface.
 - b. Cracked or damaged liner backing.
 - c. Bearings that have moved or spun in their housing.
 - d. Debris embedded in liner surface.
3. Pins should be replaced if any of the following is observed (pin should be properly cleaned prior to inspection):
 - a. Detectable wear in the bearing area.
 - b. Flaking, peeling, scoring, or scratches on the pin surface.
 - c. Rusting of the pin in the bearing area.
4. Re-assembly of pinned joints using filament wound bearings.
 - a. Housing should be blown out to remove all dirt and debris bearings and bearing housings must be free of all contamination.
 - b. Bearing / pins should be cleaned with a solvent to remove all grease and oil filament wound bearing are a dry joint and should not be lubricated unless otherwise instructed (i.e. sheave pins).
 - c. Pins should be inspected to ensure it is free of burrs, nicks, and scratches which would damage the bearing during installation and operation.

2.6 WELDING ON JLG EQUIPMENT

NOTE: This instruction applies to repairs, or modifications to the machine and to welding performed from the machine on an external structure, or component,

Do the Following When Welding on JLG Equipment

- Disconnect the battery.
- Disconnect the moment pin connection (where fitted)
- Ground only to structure being welded.

Do NOT Do the Following When Welding on JLG Equipment

- Ground on frame and weld on any other area than the chassis.
- Ground on turntable and weld on any other area than the turntable.
- Ground on the platform/support and weld on any other area than the platform/support.
- Ground on a specific boom section and weld on any other area than that specific boom section.
- Allow pins, wear pads, wire ropes, bearings, gearing, seals, valves, electrical wiring, or hoses to be between the grounding position and the welded area.

NOTICE

FAILURE TO COMPLY WITH THE ABOVE REQUIREMENTS MAY RESULT IN COMPONENT DAMAGE (I.E. ELECTRONIC MODULES, SWING BEARING, COLLECTOR RING, BOOM WIRE ROPES ETC.)

Table 2-3. Inspection and Preventive Maintenance Schedule

AREA	INTERVAL	
	Pre-Delivery ¹ or Frequent ² Inspection	Annual ³ (Yearly) Inspection
Boom Assembly		
Boom Weldments	1,2,4	1,2,4
Hose/Cable Carrier Installations	1,2,9,12	1,2,9,12
Pivot Pins and Pin Retainers	1,2	1,2
Sheaves, Sheave Pins	1,2	1,2
Bearings	1,2	1,2
Wear Pads	1,2	1,2
Covers or Shields	1,2	1,2
Extend/Retract Chain or Cable Systems	1,2,3	1,2,3
Boom Assembly		14
Platform Assembly		
Platform		1,2
Railing	1	1,2
Gate	1	1,5
Floor	1	1,2
Rotator	15	15
Lanyard Anchorage Point	1,2,10	1,2,10
Turntable Assembly		
Swing Bearing	1,2,14	1,2,3,13,14
Oil Coupling		
Swing Drive System	11	11
Turntable Lock	1,2,5	1,2,5
Hood, Hood Props, Hood Latches	5	1,2,5
Chassis Assembly		
Tires	16,17,18	16,17,18
Wheel Nuts/Bolts	15	15
Wheel Bearings		14,24
Oscillating Axle/Lockout Cylinder Systems		5,8
Extendable Axle Systems	5,8	5,8
Steer Components		
Spindle Thrust Bearing/Washers		1,2
Drive Hubs	11	11

Table 2-3. Inspection and Preventive Maintenance Schedule

AREA	INTERVAL	
	Pre-Delivery ¹ or Frequent ² Inspection	Annual ³ (Yearly) Inspection
Functions/Controls		
Platform Controls	6	6
Ground Controls	6	6
Function Control Locks, Guards, or Detents	5	5
Footswitch	5	5
Emergency Stop Switches (Ground & Platform)	5	5
Function Limit or Cutout Switch Systems	5	5
Drive Brakes	5	5
Swing Brakes	5	5
Auxiliary Power	5	5
Power System		
Engine Idle, Throttle, and RPM	3	3
Engine Fluids (Oil, Coolant, Fuel)	11	11
Air/Fuel Filter	7	7
Exhaust System	9	9
Batteries		19
Battery Fluid	11	11
Battery Charger		5
Fuel Reservoir, Cap, and Breather	1,5	1,5
Hydraulic/Electric System		
Hydraulic Pumps	1,2,9	1,2,9
Hydraulic Cylinders	1,2,9	1,2,9
Cylinder Attachment Pins and Pin Retainers	1,2	1,2
Hydraulic Hoses, Lines, and Fittings	1,2,9,12	1,2,9,12
Hydraulic Reservoir, Cap, and Breather	1,5	1,5
Hydraulic Filter	7	7
Hydraulic Fluid	7,11	7,11
Electrical Connections	20	20
Instruments, Gauges, Switches, Lights, Horn		5,23
General		
Operation and Safety Manuals in Storage Box	21	21
ANSI and AEM Manuals/Handbooks Installed (ANSI Markets Only)		21
Capacity Decals Installed, Secure, Legible	21	21
All Decals/Placards Installed, Secure, Legible	21	21

Table 2-3. Inspection and Preventive Maintenance Schedule

AREA	INTERVAL	
	Pre-Delivery ¹ or Frequent ² Inspection	Annual ³ (Yearly) Inspection
Annual Machine Inspection Due	21	21
No Unauthorized Modifications or Additions	21	21
All Relevant Safety Publications Incorporated	21	21
General Structural Condition and Welds	2,4	2,4
All Fasteners, Pins, Shields, and Covers	1,2	1,2
Grease and Lubricate to Specifications	22	22
Function Test of All Systems	21	21,22
Paint and Appearance	7	7
Stamp Inspection Date on Frame		22
Notify JLG of Machine Ownership		22
Footnotes:		
¹ Prior to each sale, lease, or delivery		
² In service for 3 months or 150 Hours; or Out of service for 3 months or more; or Purchased used		
³ Annually, no later than 13 months from the date of the prior inspection		
Performance Codes:		
1 - Check for proper and secure installation		
2 - Visual inspection for damage, cracks, distortion or excessive wear		
3 - Check for proper adjustment		
4 - Check for cracked or broken welds		
5 - Operates Properly		
6 - Returns to neutral or "off" position when released		
7 - Clean and free of debris		
8 - Interlocks function properly		
9 - Check for signs of leakage		
10 - Decals installed and legible		
11 - Check for proper fluid level		
12 - Check for chafing and proper routing		
13 - Check for proper tolerances		
14 - Properly lubricated		
15 - Torqued to proper specification		
16 - No gouges, excessive wear, or cords showing		
17 - Properly inflated and seated around rim		
18 - Proper and authorized components		
19 - Fully charged		
20 - No loose connections, corrosion, or abrasions		
21 - Verify		
22 - Perform		
23 - Sealed Properly		
24 - Drain, Clean, Refill		

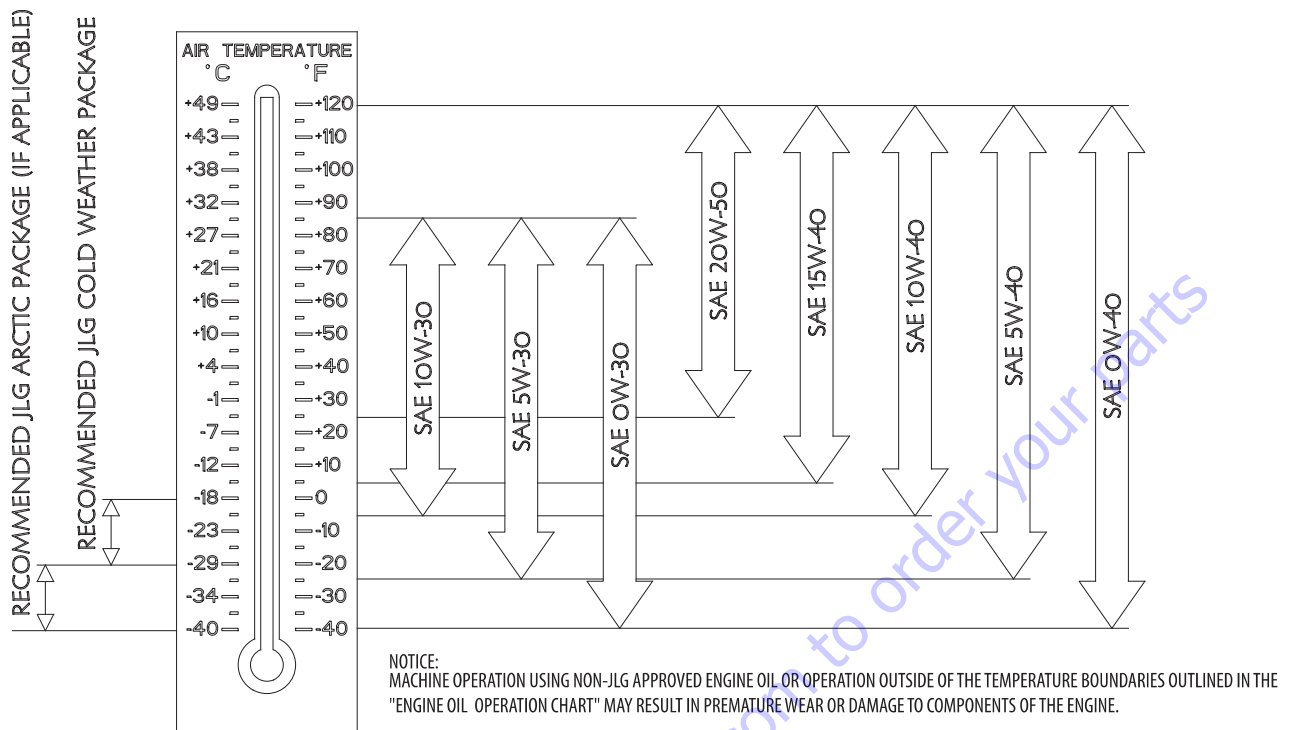
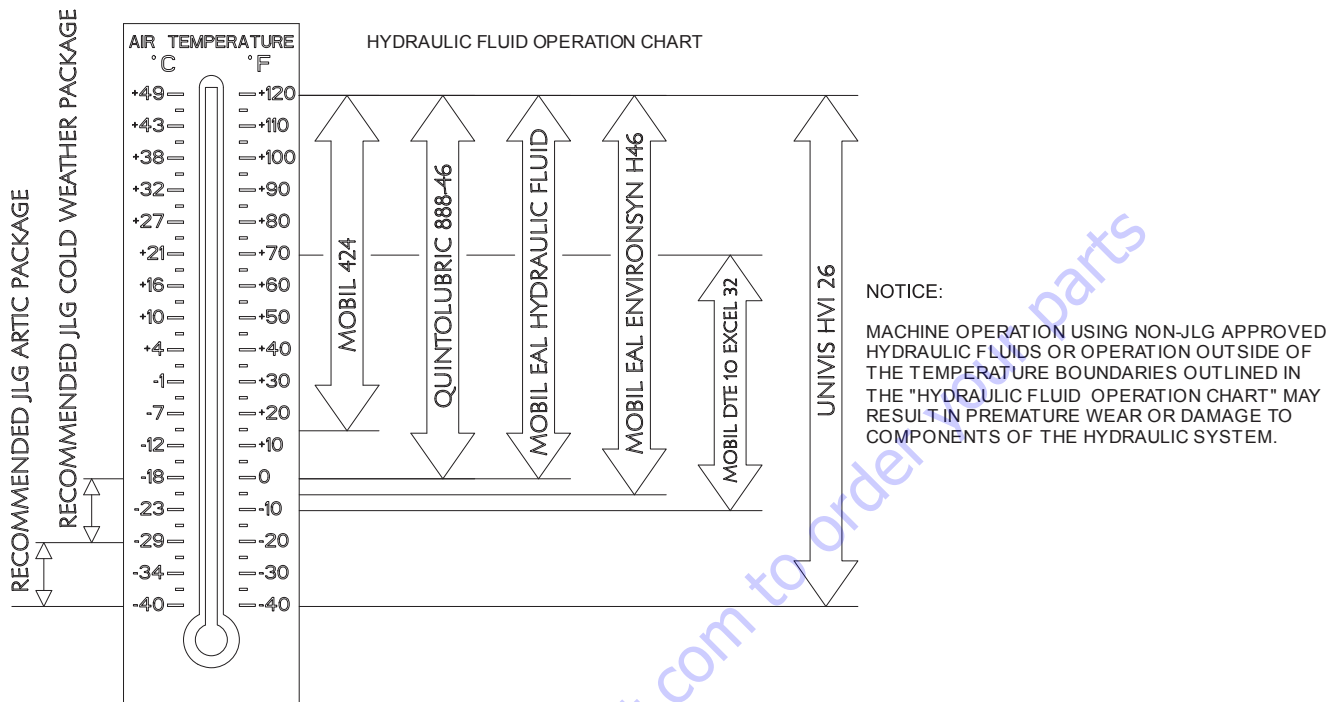

Figure 2-1. Engine Operating Temperature Specifications - Deutz



Fluid	Properties		Base				Classifications			
	Description	Viscosity at 40° C (cSt, Typical)	Viscosity Index	Mineral Oils	Vegetable Oils	Synthetic	Synthetic Polyol Esters	Readily Biodegradable*	Virtually Non-toxic**	Fire Resistant***
Mobilfluid 424		55	145	X						
Mobil DTE 10 Excel 32		32	164	X					X	
Univis HVI 26		26	376	X						
Mobil EAL Hydraulic Oil		47	176		X			X	X	
Mobil EAL EnviroSyn H46		49	145			X		X	X	
Quintolubric 888-46		50	185				X	X	X	X

* Readily biodegradable classification indicates one of the following:

CO2 Conversion > 60% per EPA 560/6-82-003

CO2 Conversion > 80% per CEC-L-33-A-93

** Virtually Non-toxic classification indicates an LC50 > 5000 ppm per OECD 203

*** Fire Resistant classification indicates Factory Mutual Research Corp. (FMRC) Approval

41507408

Figure 2-2. Hydraulic Oil Operating Temperature Specifications

PARTS FINDER

**Search Website
by Part Number**



**Search Manual
Library For Parts
Manual & Lookup Part
Numbers – Purchase
or Request Quote**

Search Manuals

Enter your information to help us locate the right manual for your machine.

* Brand:

* Model:

* Serial:

* Part Number:

SEARCH

**Can't Find Part or
Manual? Request Help
by Manufacturer,
Model & Description**

Parts Order Form

Please fill in the following information to help us locate the part you need.

Manufacturer:	<input type="text"/>
Model:	<input type="text"/>
Description:	<input type="text"/>
Part Number:	<input type="text"/>
Quantity:	<input type="text"/>
Notes:	<input type="text"/>

Discount-Equipment.com is your online resource for quality parts & equipment.

Florida: **561-964-4949** Outside Florida TOLL FREE: **877-690-3101**

Need parts?

Click on this link: <http://www.discount-equipment.com/category/5443-parts/> and choose one of the options to help get the right parts and equipment you are looking for. Please have the machine model and serial number available in order to help us get you the correct parts. If you don't find the part on the website or on one of the online manuals, please fill out the request form and one of our experienced staff members will get back to you with a quote for the right part that your machine needs.

We sell worldwide for the brands: Genie, Terex, JLG, MultiQuip, Mikasa, Essick, Whiteman, Mayco, Toro Stone, Diamond Products, Generac Magnum, Airman, Haulotte, Barreto, Power Blanket, Nifty Lift, Atlas Copco, Chicago Pneumatic, Allmand, Miller Curber, Skyjack, Lull, Skytrak, Tsurumi, Husquvarna Target, , Stow, Wacker, Sakai, Mi-T- M, Sullair, Basic, Dynapac, MBW, Weber, Bartell, Bennar Newman, Haulotte, Ditch Runner, Menegotti, Morrison, Contec, Buddy, Crown, Edco, Wyco, Bomag, Laymor, Barreto, EZ Trench, Bil-Jax, F.S. Curtis, Gehl Pavers, Heli, Honda, ICS/PowerGrit, IHI, Partner, Imer, Clipper, MMD, Koshin, Rice, CH&E, General Equipment, ,AMida, Coleman, NAC, Gradall, Square Shooter, Kent, Stanley, Tamco, Toku, Hatz, Kohler, Robin, Wisconsin, Northrock, Oztec, Toker TK, Rol-Air, Small Line, Wanco, Yanmar

SECTION 3. CHASSIS & TURNTABLE

3.1 TIRES AND WHEELS

Tire Inflation

The air pressure for pneumatic tires must be equal to the air pressure that is stenciled on the side of the JLG product or rim decal for safe and proper operational characteristics.

Tire Damage

For pneumatic tires, JLG Industries, Inc. recommends that when any cut, rip, or tear is discovered that exposes sidewall or tread area cords in the tire, measures must be taken to remove the JLG product from service immediately. Arrangements must be made for replacement of the tire or tire assembly.

For polyurethane foam filled tires, JLG Industries, Inc. recommends that when any of the following are discovered, measures must be taken to remove the JLG product from service immediately and arrangements must be made for replacement of the tire or tire assembly.

- a smooth, even cut through the cord plies which exceeds 3 inches (7.5 cm) in total length
- any tears or rips (ragged edges) in the cord plies which exceeds 1 inch (2.5 cm) in any direction
- any punctures which exceed 1 inch in diameter
- any damage to the bead area cords of the tire

If a tire is damaged but is within the above noted criteria, the tire must be inspected on a daily basis to insure the damage hasn't propagated beyond the allowable criteria.

Wheel and Tire Replacement

The rims installed on each product model have been designed for stability requirements which consist of track width, tire pressure, and load capacity. Size changes such as rim width, center piece location, larger or smaller diameter, etc., without written factory recommendations, may result in an unsafe condition regarding stability.

Wheel Installation

It is extremely important to apply and maintain proper wheel mounting torque.

⚠ WARNING

WHEEL NUTS MUST BE INSTALLED AND MAINTAINED AT THE PROPER TORQUE TO PREVENT LOOSE WHEELS, BROKEN STUDS, AND POSSIBLE DANGEROUS SEPARATION OF WHEEL FROM THE AXLE. BE SURE TO USE ONLY THE NUTS MATCHED TO THE CONE ANGLE OF THE WHEEL.

Tighten the lug nuts to the proper torque to prevent wheels from coming loose. Use a torque wrench to tighten the fasteners. If you do not have a torque wrench, tighten the fasteners with a lug wrench, then immediately have a service garage or dealer tighten the lug nuts to the proper torque. Over-tightening will result in breaking the studs or permanently deforming the mounting stud holes in the wheels.

The proper procedure for attaching wheels is as follows:

1. Start all nuts by hand to prevent cross threading. DO NOT use a lubricant on threads or nuts.
2. Tighten nuts in the following sequence:

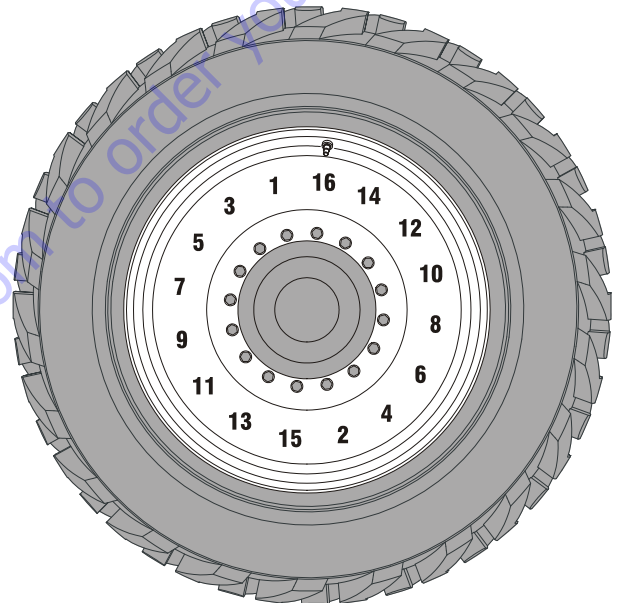

3. The tightening of the nuts should be done in stages. Following the recommended sequence, tighten nuts per wheel torque chart.

Table 3-1. Wheel Torque Chart

TORQUE SEQUENCE		
1st Stage	2nd Stage	3rd Stage
45 ft. lbs. (60 Nm)	100 ft. lbs. (140 Nm)	180 ft. lbs. (252 Nm)

4. Wheel nuts should be torqued before first road use and after each wheel removal. Check and torque every 3 months or 150 hours of operation.

3.2 AXLE EXTENSION SYSTEM

NOTE: The boom must be oriented between the rear wheels to extend or retract the axles.

The Axle Extension System allows each of the four axles to be extended and retracted together while maintaining full steering control as the machine is driven. The system allows the axles to extend or retract only while the boom is in the transport position and in order to minimize wheel scrubbing during axle movement, a minimum drive speed must be attained before axle extension/retraction will be permitted. The system uses four limit switches (one at each axle) to sense when the axles are fully extended. If any of the switches are not made, the control system considers the axles retracted. To extend/retract the axles, the user engages the axle extend/retract switch on the platform console and the drive control at the same time. The axle set indicator will be off when the axles are not fully extended and the axle extend/retract switch is not engaged. It will flash while the axles are extending or retracting and will be on constantly when the axles are fully extended. With the axles not fully extended, the boom is restricted to operation within the transport position. If a signal from any axle extend sensing switch is lost when the boom is beyond the transport position, the axle set indicator will flash and drive/steer functions will be disabled until the boom is brought back into the transport position. The steering angle

will be automatically limited to +/- 25 degrees anytime the axles are not fully extended. If the wheel angle is more than +/- 25 degrees when the axle retract command is engaged, the control system will automatically reduce the wheel angle to 25 degrees during axle retraction.

NOTE: For more detailed information concerning system adjustment and operation, refer to Section 6 - JLG Control System.

3.3 AXLE LIMIT SWITCH ADJUSTMENT PROCEDURE

1. Fully extend the axles.
2. Initially position the limit switch arm straight.
3. Select the mounting plate bolt pattern to position the switch roller within 0.125 inches (3.1 mm) from the edge of the axle cutout. It may be necessary to reposition the switch arm $\pm 10^\circ$ to accomplish this.
4. Ensure the arm will clear the axle (without bottoming out to 70° stroke of the switch) in the retracted position.
5. Check for proper operation. Axle set light is to deactivate when the axle is retracted 0.625 inches (16 mm) maximum from fully extended.

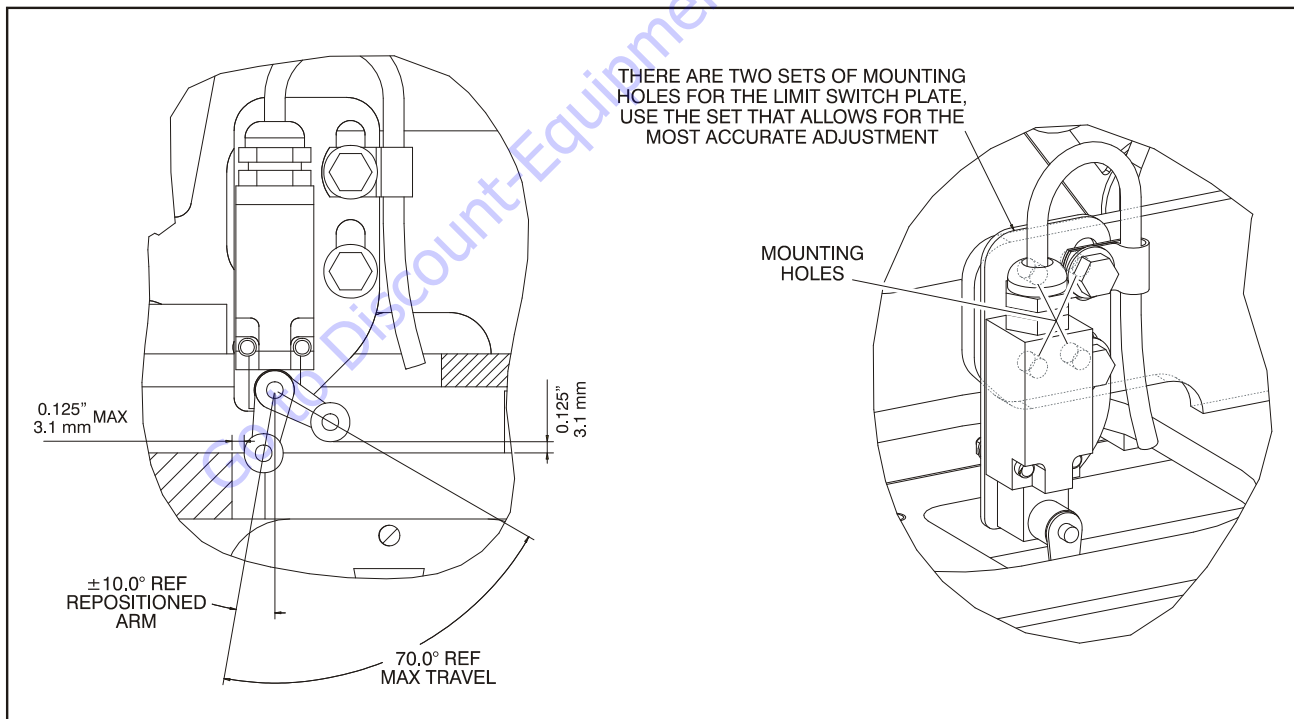

Figure 3-1. Axle Limit Switch Adjustment

3.4 DRIVE SYSTEM

The drive system utilizes 2 traction pumps so each side is powered individually. This produces maximum tractive effort to wheels by minimizing flow divider losses. The maximum drive speed is modulated with the steered angle of the wheels to eliminate the whiplash effect of driving at full speed and maximum steering lock.

3.5 STEERING CONTROL SYSTEM

Each wheel is individually steered by means of a closed circuit control system utilizing a steer sensor on each wheel, 4 steer cylinders, and proportional valves.

The control system senses the wheel position in relation to the steering command (direction and steering mode) and automatically synchronizes the movement of all 4 wheels to the desired position.

There are three different modes of steering selectable by the position of the steer select switch on the platform control panel: conventional two wheel steering, crab and coordinated.

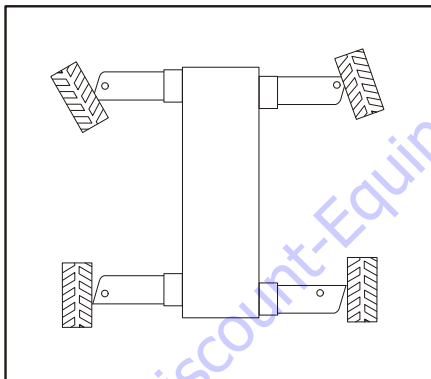

Figure 3-2. Conventional Two Wheel Steer Mode

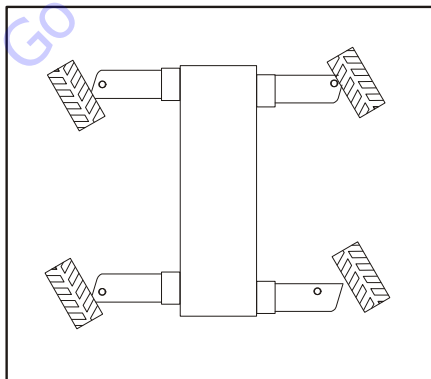

Figure 3-3. Crab Steer Mode

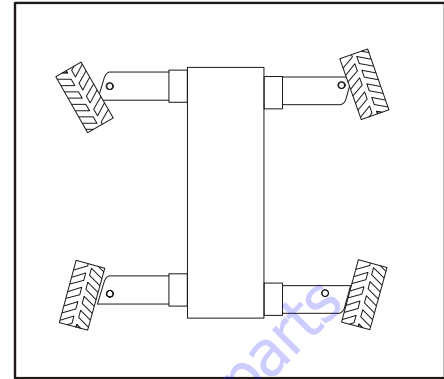

Figure 3-4. Coordinated Steer Mode

Each wheel has its own steer cylinder, wheel angle sensor, and proportional valve, allowing the control system to position each wheel to the ideal angle for all steering modes and all steering commands. Changes in steering modes while the footswitch is depressed causes the wheels to automatically adjust to the appropriate angle for the selected steering mode based on the position of the inside front wheel. If the steer select switch is changed without the footswitch depressed or the EMS is off, the wheels will not move until the footswitch is depressed and a steering or drive command has been initiated. The steering angles are limited to ± 25 degrees anytime the axles are not fully extended. If a wheel cannot achieve its commanded angle within a specified time, it is considered jammed. When a wheel is considered jammed during steering, a fault is reported and the remaining wheels will continue to their commanded position. The fault is cleared when the footswitch is cycled. If a wheel is jammed making it significantly out of position, with regard to the other wheels, the drive motors are restricted to their maximum displacement (slow speed). Wheel angle sensor failures will result in an approximated steering control logic that will allow the operator to move the machine until it can be repaired. The wheel at the failed sensor will be driven based on the information available from the other sensors. This wheel will not track perfectly and will become farther out of position over time. When the wheel becomes prohibitively out of position, the wheels can be re-synchronized by fully steering against the mechanical stops.

NOTE: For more detailed information concerning system adjustment and operation, refer to Section 6 - JLG Control System.

3.6 DRIVE/STEERING SPEED CONTROL

The Drive/Steering Speed Control system uses the steering sensors from the steering control system to increase operator control and comfort by reducing the effect of turning the chassis on the resulting lateral platform speed. The system proportionally varies the drive speed based on the predicted turning radius of the chassis for conventional two wheel steer modes. The tighter the turn the slower the allowable drive speed. As crab steer does not steer on a radius, low speed drive is maintained regardless of steer angle.

NOTE: For more detailed information concerning system adjustment and operation, refer to Section 6 - JLG Control System.

3.7 TRACTION CONTROL SYSTEM

The traction control system uses the steering sensors from the steering control system to optimize the performance of the drive system. This is especially important due to the disparity of wheel speeds generated between the inside and outside wheels of the extended axle chassis with large steering angle capability. The steering sensors are used to predict the rolling path and therefore the required wheel speed of each wheel as the steering angles change and steering modes change. The control system can then command the ideal flow from each of the two drive pumps, one for the right side of the machine and one for the left side. Two flow dividers, one for the right side front to back and one for the left side front to back absorb the variation in wheel speed front to back.

NOTE: For more detailed information concerning system adjustment and operation, refer to Section 6 - JLG Control System.

3.8 DRIVE ORIENTATION SYSTEM

The Drive Orientation System (DOS) is intended to indicate to the operator conditions that could make the direction of movement of the chassis different than the direction of movement of the drive/steer control handle. The system indicates to the operator the need to match the black and white directional arrows on the platform control panel to the arrows on the chassis. The system uses a proximity switch mounted on the hydraulic swivel, an indicator light and an override switch on the platform display panel. The proximity switch trips when the turntable is swung +/- 45 degrees off center of the normal driving position. This occurs roughly when the boom is swung past a rear tire. When the turntable is in the normal drive position with the boom between the rear tires, no indications or interlocks are made. When the machine is actively driving when the turntable is swung past the switch point, the system is ignored until drive/steer is released. When drive is initiated with the boom swung past the switch point, the DOS indicator will flash and the drive/steer functions will be disabled. The operator must engage the DOS override switch to enable Drive/steer (high drive will remain disabled). When the DOS is

enabled, the DOS indicator will be illuminated continuously and a 3-second enable timer will be started and will continue for 3 seconds after the end the last drive/steer command. If the timer expires, the DOS override switch must be re-engaged to enable drive/steer.

Swing Envelope Service Mode

NOTE: If the axles are in the retracted position, boom swing is restricted to between the rear wheels (40 degrees).

The Swing Envelope Service Mode is used if the boom is swung past the rear tires with the axles retracted, there is a disagreement fault between the DOS proximity switch and the turntable angle sensors, or there is a failed turntable angle sensor. (Drive and swing are disabled during these events.) This allows swing and drive functions to enable turntable swing in the correct direction to return the boom between the rear wheels in the event the boom is beyond the swing envelope when the axles are retracted.

Swing Envelope override is accessible in Access Level 1. Using

the Left  and Right  arrow keys until the screen shown below is reached.

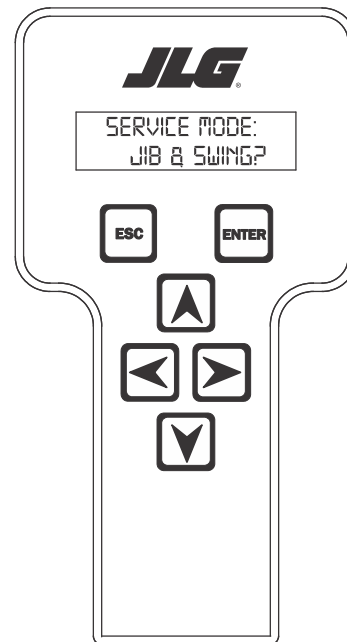

Press ENTER , the screen should read:

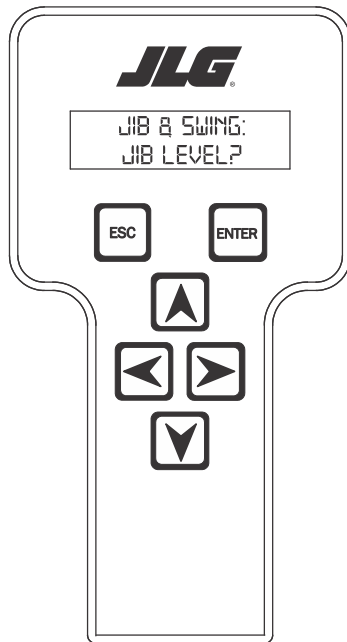

Use the Left  or Right  arrow key until you see:

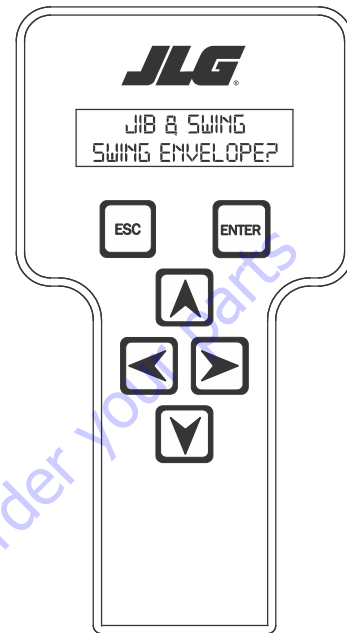

To enable the override mode 58237 must be entered as the code. When the code is entered, the screen will show:

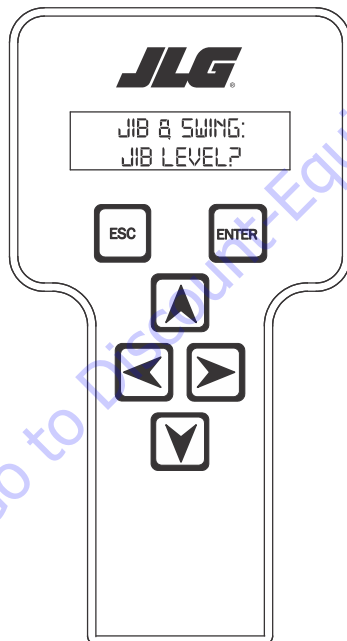

Press ENTER , the screen should read:

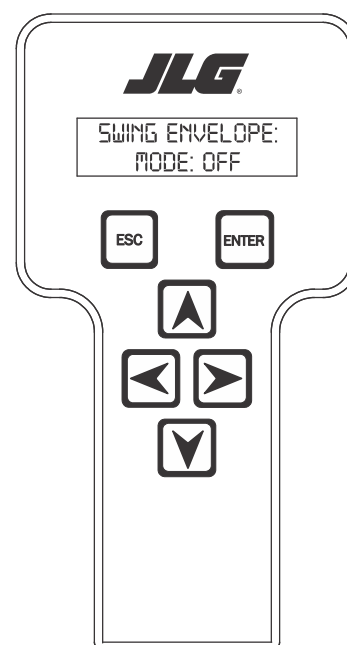

Swing and drive functions can now be used to swing the turntable in the correct direction to return the boom between the rear wheels in the event the boom is beyond the swing envelope when the axles are retracted.

NOTE: For more detailed information concerning system adjustment and operation, refer to Section 6 - JLG Control System.

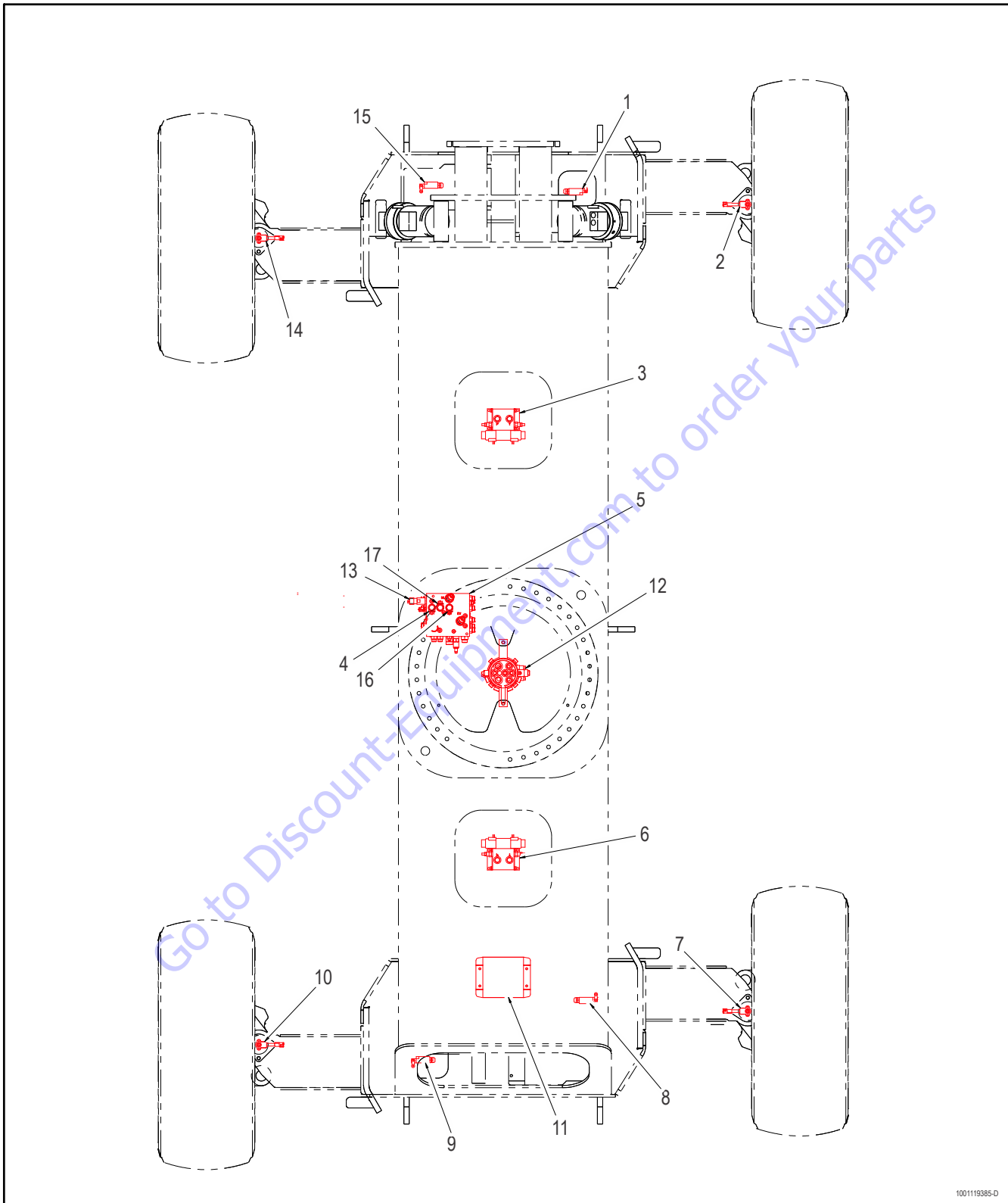
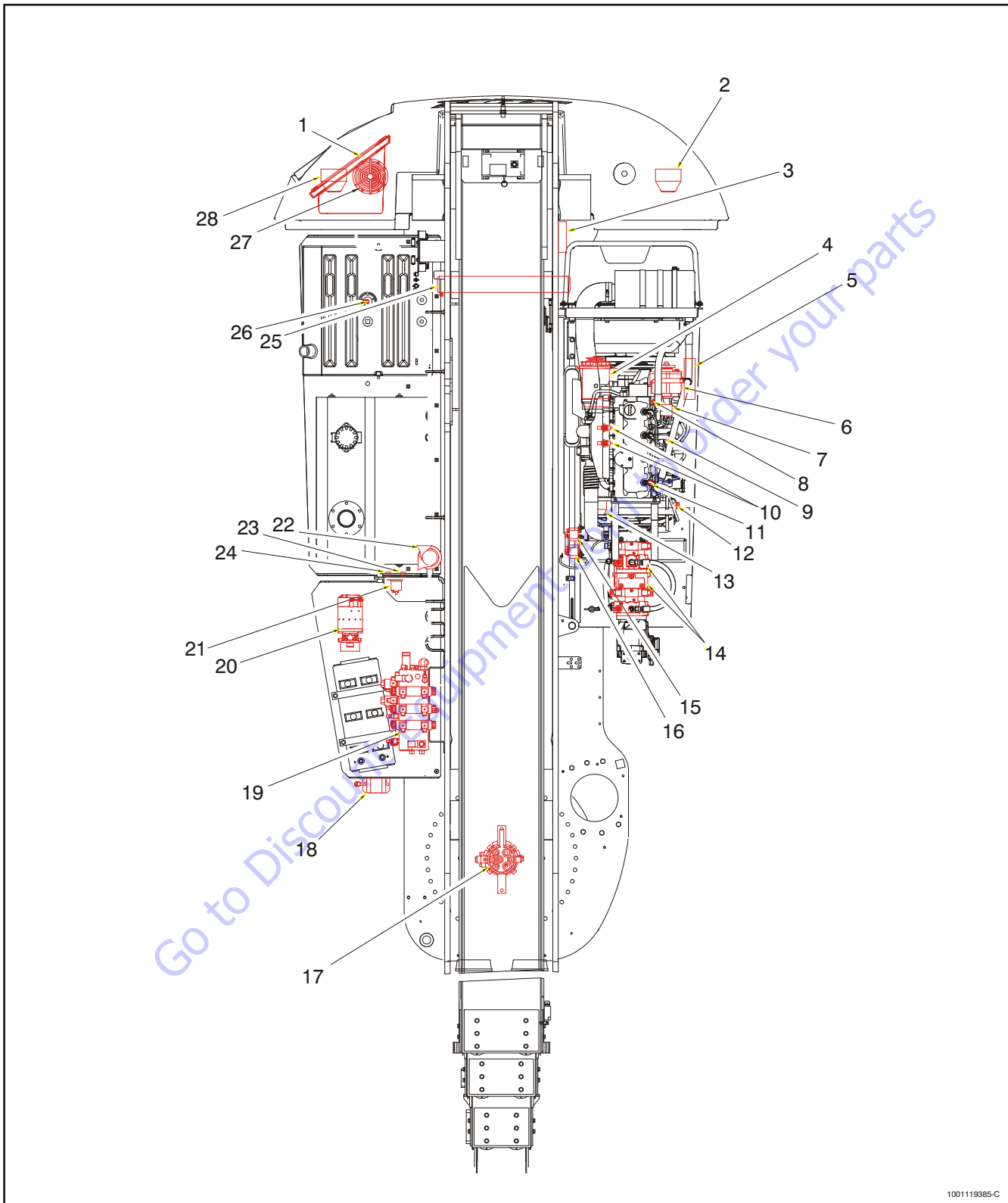

Figure 3-5. Chassis Component Location - Sheet 1 of 2

1. Axle Limit Switch (Right Front)
2. Steer Angle Sensor (Right Front)
3. Steer Valve (Front)
4. Axle Lockout Valve
5. Traction Valve
6. Steer Valve (Rear)
7. Steer Angle Sensor (Right Rear)
8. Axle Limit Switch (Right Rear)
9. Axle Limit Switch (Left Rear)
10. Steer Angle Sensor (Left Rear)
11. Chassis Module
12. Swivel/Collector Ring
13. Axle Lockout Pressure Switch
14. Steer Angle Sensor (Left Front)
15. Axle Limit Switch (Left Front)
16. Brake Valve
17. Two Speed Valve

Figure 3-6. Chassis Component Location - Sheet 2 of 2



100119385-C

Figure 3-7. Turntable Component Location - Sheet 1 of 2

1. Ground Control Box
2. Headlight
3. Deutz EMR2 Module & Diagnostic Connector
4. 110V / 220V Generator
5. 110V / 220V Generator Control Box
6. Alternator
7. Throttle Actuator
8. Oil Temperature Switch
9. Oil Pressure Switch
10. Intake Heaters
11. In-Head Glow Plugs
12. Engine Speed Sensor
13. Starter
14. Drive Pumps
15. Starter Relay
16. Glow Plug Relay
17. Swivel
18. Alarm
19. Main Control Valve
20. Auxiliary Power Pump
21. Auxiliary Power Relay
22. Horn
23. Head & Tail Light Relay
24. Ignition Relay
25. Lift Cylinder Pivot Pin
26. Fuel Level Sensor
27. Strobe
28. Headlight

Figure 3-8. Turntable Component Location - Sheet 2 of 2

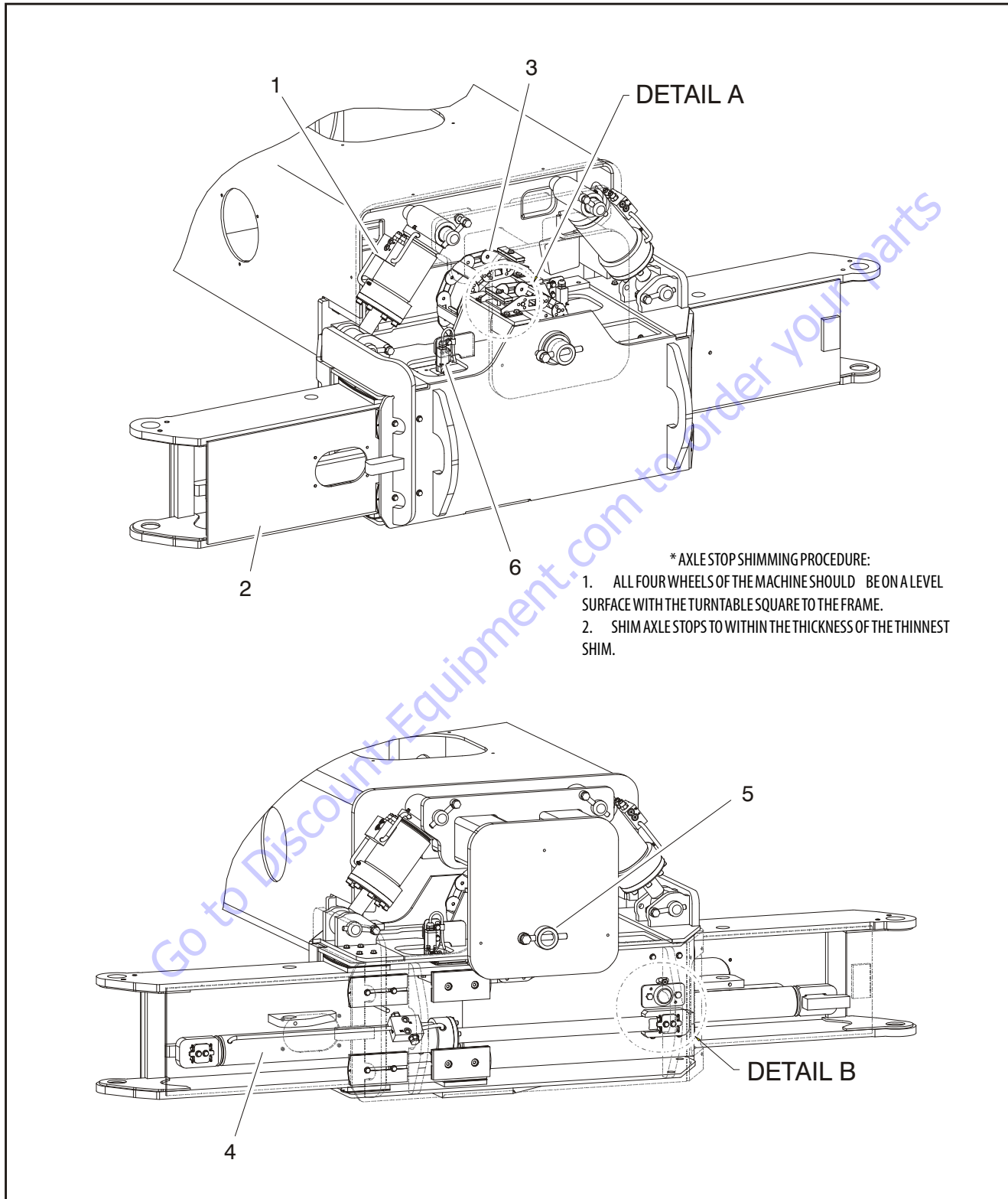

* AXLE STOP SHIMMING PROCEDURE:

1. ALL FOUR WHEELS OF THE MACHINE SHOULD BE ON A LEVEL SURFACE WITH THE TURNTABLE SQUARE TO THE FRAME.
2. SHIM AXLE STOPS TO WITHIN THE THICKNESS OF THE THINNEST SHIM.

Figure 3-9. Oscillating Axle - Sheet 1 of 2

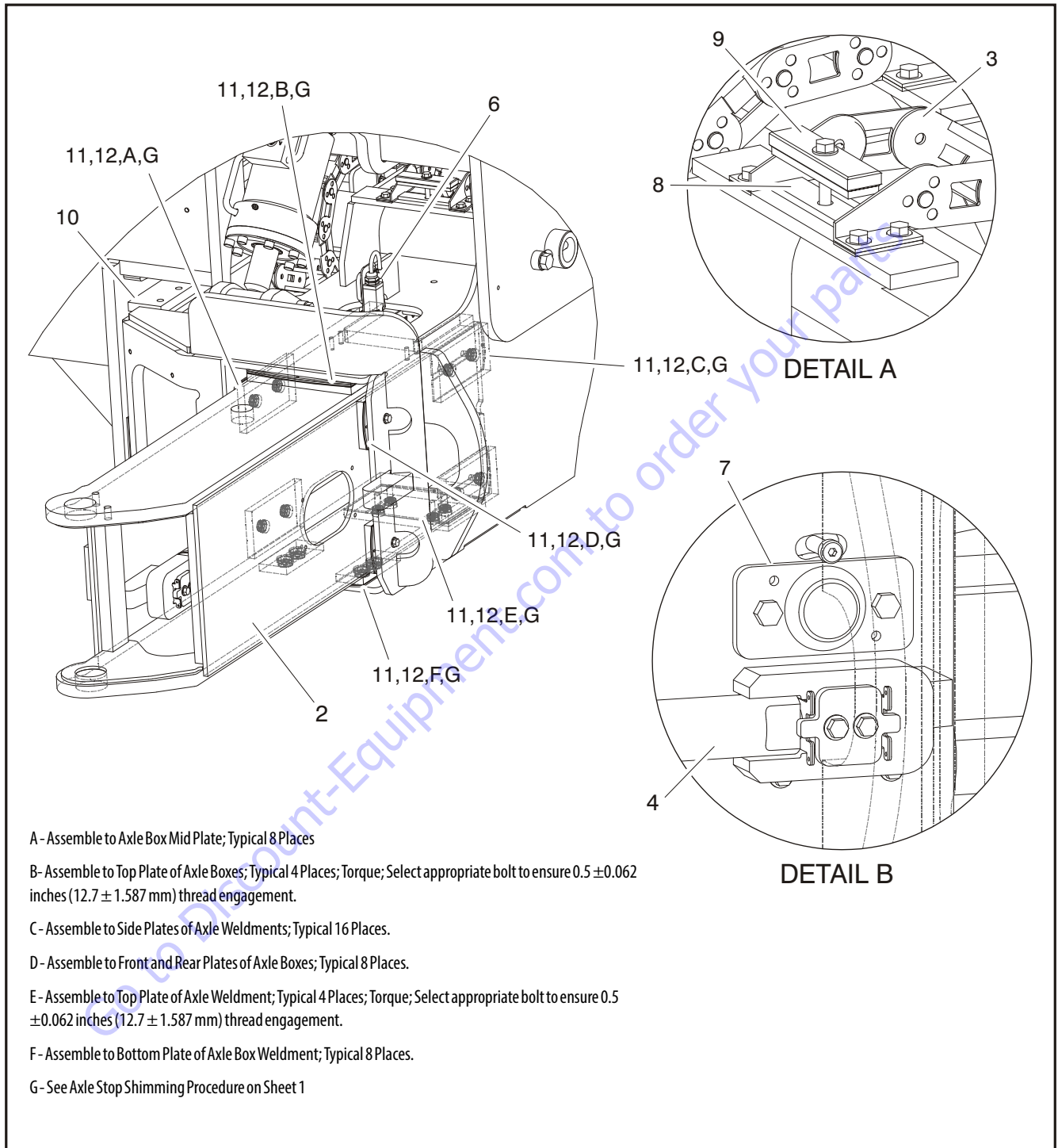

- | | | |
|------------------------------|----------------------|----------------|
| 1. Axle Oscillation Cylinder | 5. Axle Pivot Pin | 9. Hose Clamp |
| 2. Axle | 6. Axle Limit Switch | 10. Stop Block |
| 3. Axle Powertrack | 7. Axle Stop Pin | 11. Wear Pad |
| 4. Extension Cylinder | 8. Rubber Pad | 12. Shim |

Figure 3-10. Oscillating Axle - Sheet 2 of 2

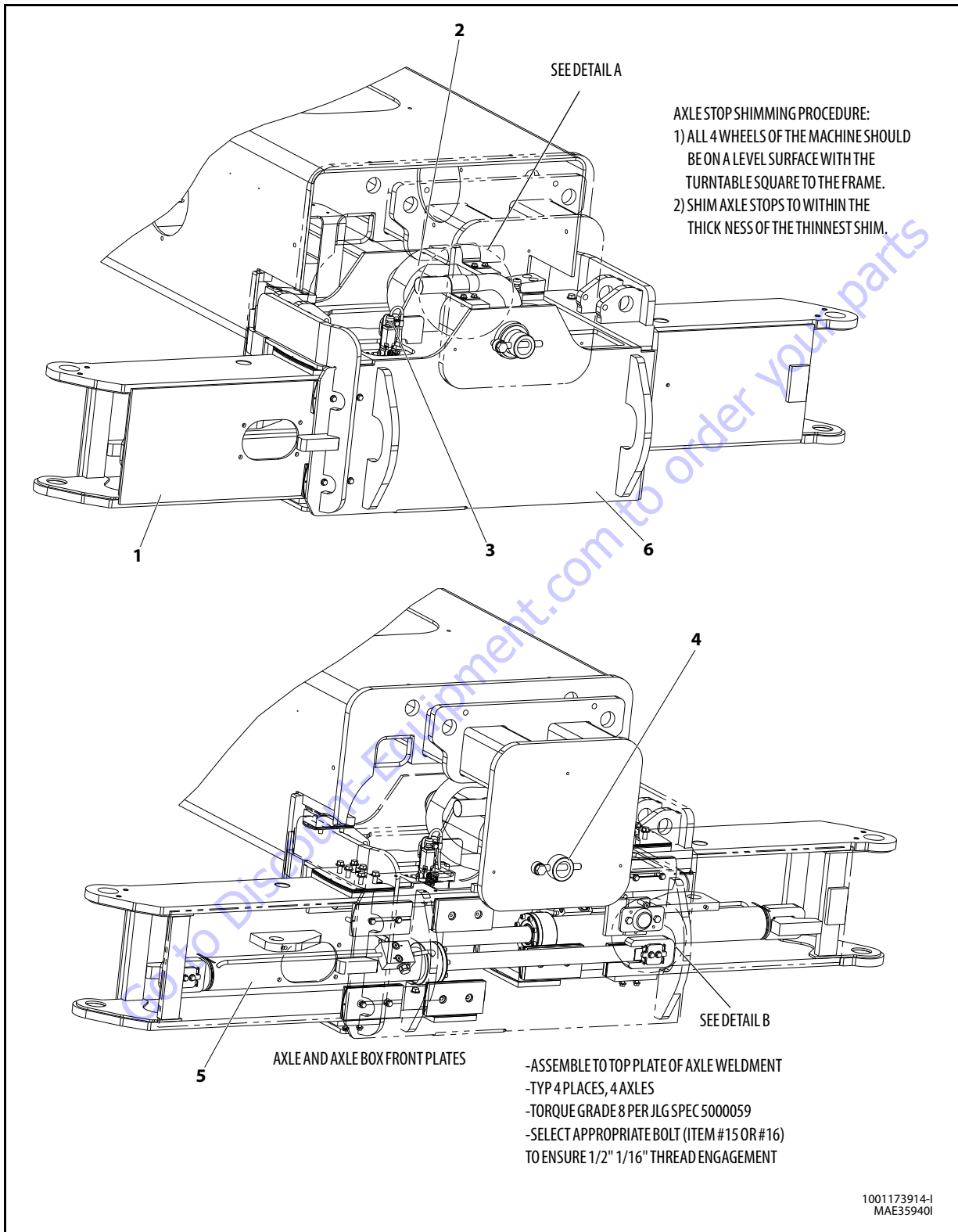
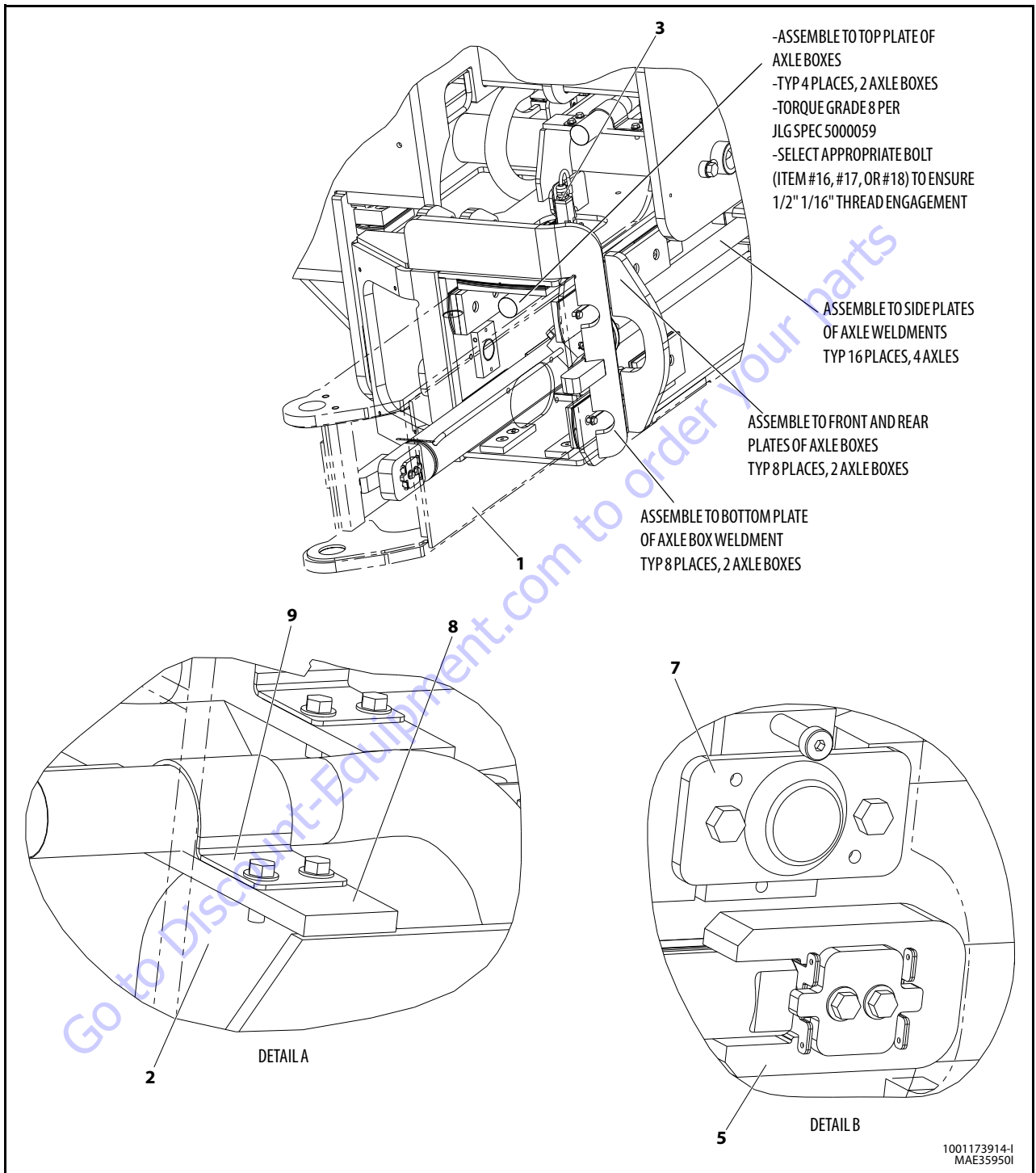

Figure 3-11. Fixed Axle - Sheet 1 of 2



- | | |
|----------------------|------------------------|
| 1. Axle | 5. Extension Cylinder |
| 2. Axle Power Track | 6. Axle Pivot Weldment |
| 3. Axle Limit Switch | 7. Axle Stop Pin |
| 4. Axle Pivot Pin | 8. Rubber Pad |

Figure 3-12. Fixed Axle - Sheet 2 of 2

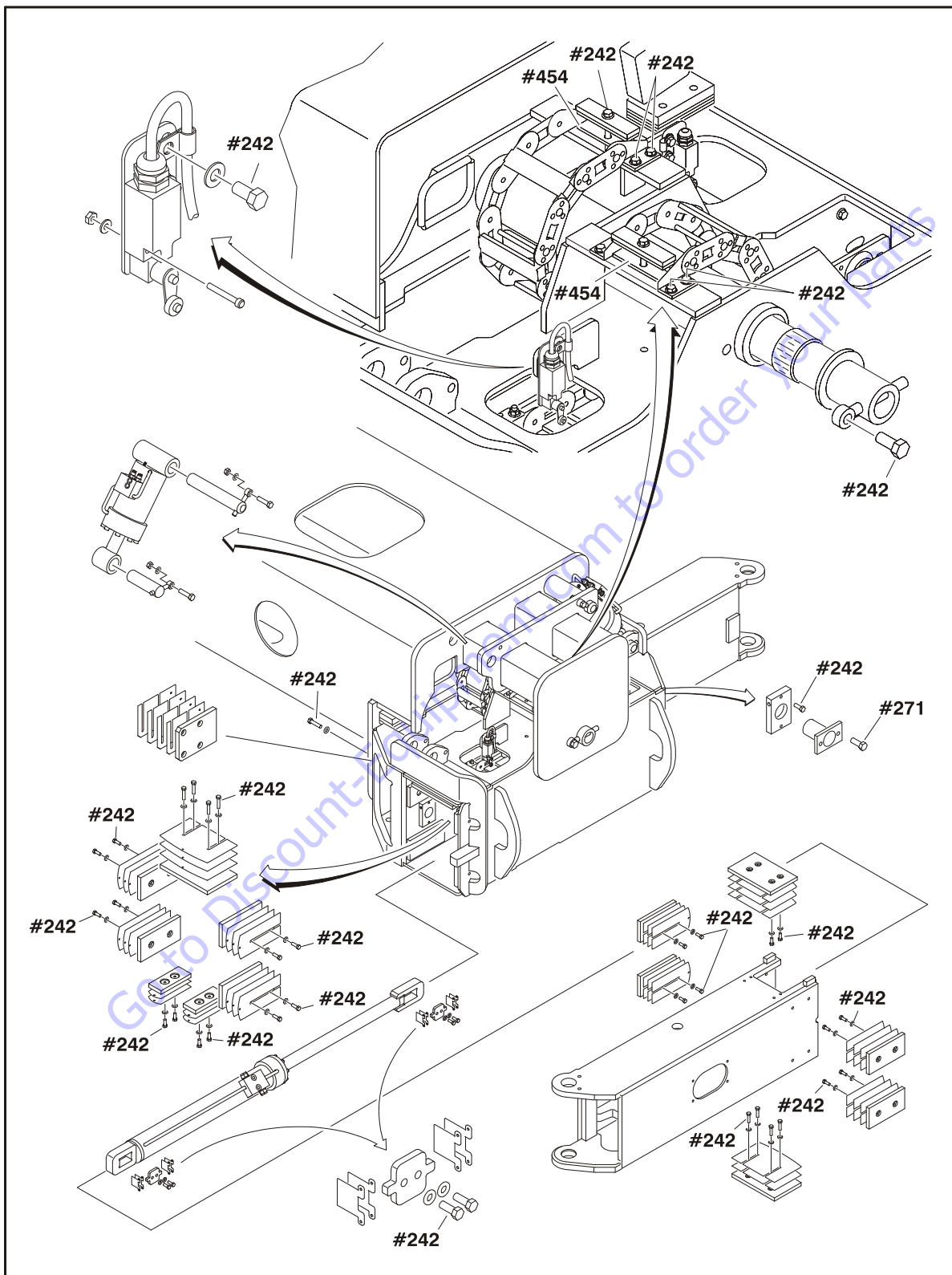
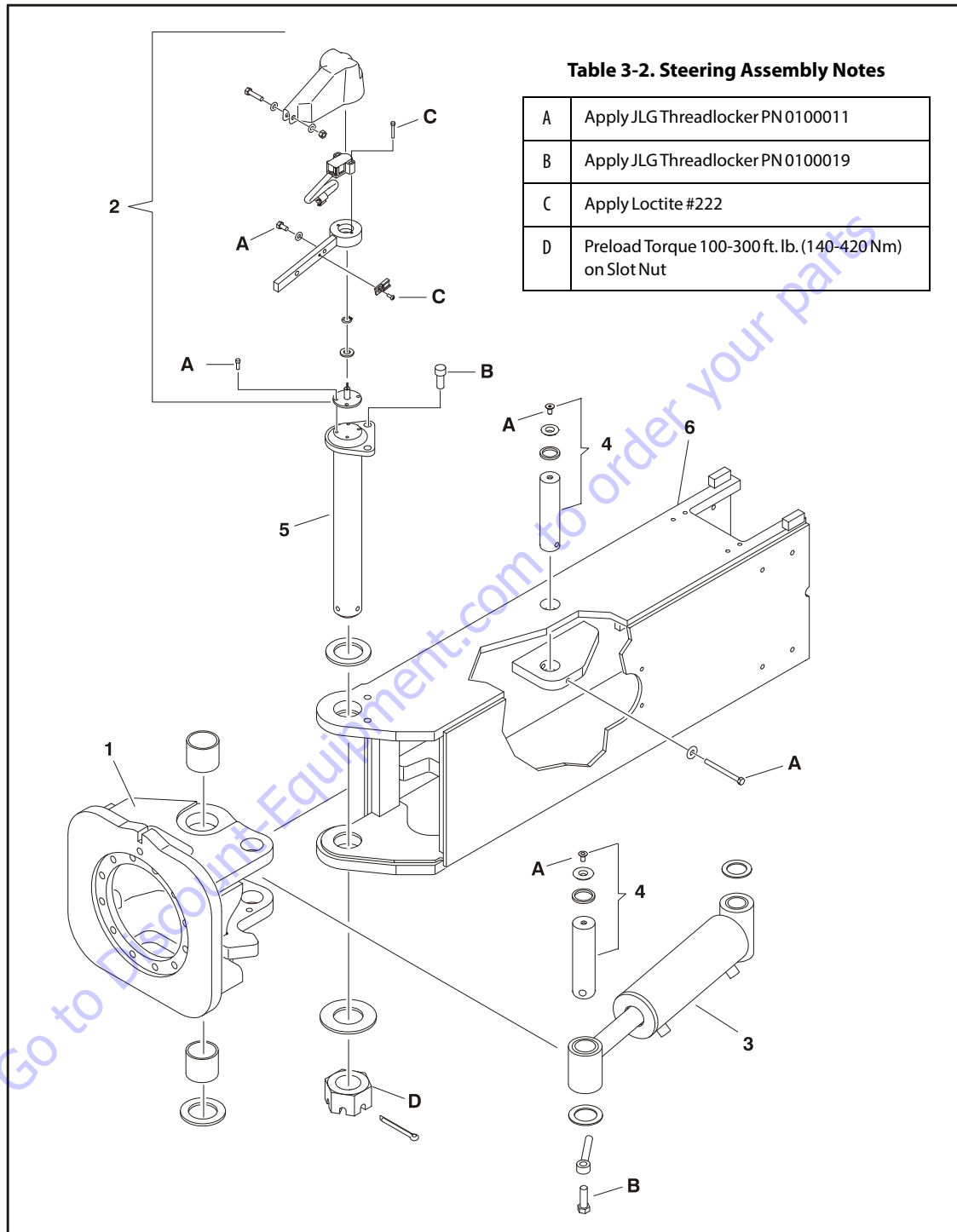

Figure 3-13. Axle Loctite Application



- 1. Spindle
- 2. Angle Sensor Assembly
- 3. Steer Cylinder
- 4. Steer Cylinder Pivot Pin
- 5. King Pin
- 6. Axle

Figure 3-14. Steering Installation

3.9 OSCILLATING AXLE SYSTEM

The oscillating front axle is attached to the frame by a pivot pin, which allows all four wheels to remain on the ground when traveling on rough terrain. The oscillating axle also incorporates two lockout cylinders connected between the frame and the axle. The lockout cylinders permit axle oscillation when the boom is in the transport position and drive is commanded. The lockout cylinders will lock and hold the axle when drive is not commanded or when the boom is outside the transport position. The cylinders unlock when pilot pressure is applied to the holding valves mounted on the cylinders and lock when pilot pressure is removed. Pilot pressure is available from brake pressure and is controlled by a solenoid operated NC lockout valve mounted in the frame. To ensure the lockout valve is functioning correctly, a NO pressure switch is mounted between the lockout valve and the holding valves. The system is "healthy" when pressure trips the pressure switch when the lockout valve is commanded to be open and conversely is healthy when the lack of pressure resets the pressure switch when the lockout valve is commanded to be closed. Failures in the oscillating axle system will cause the control system to disallow main lift up and main and jib telescope out when the boom is within the transport position and will disallow drive/steer, main lift up and main and jib telescope out when the boom is beyond the transport position.

NOTE: For more detailed information concerning system adjustment and operation, refer to Section 6 - JLG Control System.

3.10 OSCILLATING AXLE BLEEDING PROCEDURE AND LOCKOUT TEST

Lockout Cylinder Bleeding

To start the test, the axle must be fully oscillated in one direction. Start with oscillating the axle so that the left lock-out cylinder is fully retracted (left front tire up), and the right lock-out cylinder is fully extended (right front tire down).

NOTICE

ENSURE PLATFORM IS FULLY LOWERED AND BOOM IS CENTERED OVER REAR AXLE PRIOR TO BEGINNING BLEEDING PROCEDURE. MAKING SURE MACHINE IS ON A LEVEL SURFACE AND REAR WHEELS ARE BLOCKED, BRAKE WIRE IS DISCONNECTED.

1. Making sure machine is on a level surface and rear wheels are blocked, machine is in transport mode.
2. Disengage the drive hubs.
3. Use suitable container to catch any residual hydraulic fluid, place container under the lockout cylinder.
4. With the left lock-out cylinder retracted, open the bleeder on top of the cylinder, then have an operator from the platform (on high engine) feather drive. Activate drive fully.
5. Close the bleeder when there is a steady stream of oil and not air.
6. With the axle in the same position, go to the right lock-out cylinder and open the bleeder at the rod end. Activate drive in the same manner and close when all air has been purged.
7. Close the bleeder when there is a steady stream of oil and not air.
8. Oscillate the axle the other direction, left lock-out cylinder extended (tire down), right lock-out cylinder retracted (tire up). Use the same procedure for the bleeder in the rod end of the left lock-out cylinder, Then the piston end of the right lock-out cylinder then close.
9. Repeat this process one more time to ensure that all air has been purged from the system.
10. Perform oscillating axle lockout test.
11. If necessary, repeat steps 1 thru 9.

NOTE: Bleeding of the oscillating axles is an infrequent operation performed after hydraulic line failure and or lock-out cylinder repair.

Oscillating Axle Lockout Test

The front axles will oscillate when the boom is in the transport position (i.e. when the boom is less than 6° above horizontal and not extended beyond 12" [30.4 cm] and drive is selected.

NOTICE

LOCKOUT SYSTEM TEST MUST BE PERFORMED QUARTERLY, ANY TIME A SYSTEM COMPONENT IS REPLACED, OR WHEN IMPROPER SYSTEM OPERATION IS SUSPECTED.

NOTE: *Ensure boom is fully retracted, lowered, and centered between drive wheels prior to beginning lockout cylinder test. The axles must also be fully extended.*

1. Place a 6 .in (15.2 cm) high block with ascension ramp in front of left front wheel.
2. From platform control station, activate machine hydraulic system.
3. Place FUNCTION SPEED CONTROL and DRIVE SPEED/TORQUE SELECT control switches to their respective LOW positions.
4. Place DRIVE control lever to FORWARD position and carefully drive machine up ascension ramp until left front wheel is on top of block.
5. Telescope the boom out of the transport position.
6. Drive machine off of block and ramp back onto the level surface.
7. Have an assistant check to see that left front wheel remains locked in position off of ground.
8. Retract the boom back in to the transport position. Activate drive and the lockout cylinders should release.
9. Place the 6 .in (15.2 cm) high block with ascension ramp in front of right front wheel.
10. Place DRIVE control lever to FORWARD and carefully drive machine up ascension ramp until right front wheel is on top of block.
11. Telescope the boom out of the transport position.
12. Drive machine off of block and ramp back onto the level surface.
13. Have an assistant check to see that right front wheel remains locked in position off of ground.
14. Retract the boom back in to the transport position. Activate drive and the lockout cylinders should release.
15. If lockout cylinders do not function properly, have qualified personnel correct the malfunction prior to any further operation.

3.11 WHEEL DRIVE ASSEMBLY

Removal

NOTE: The drive motor can be removed through the axle flange as part of the wheel drive assembly or they can be removed separately through the bottom of the frame while leaving the torque hub bolted to the axle.

1. Use a jack to lift the frame enough so the tire and wheel assembly is off the ground. Place blocking strong enough to support the weight of the machine under the frame and remove the jack.

NOTE: The solid tire & wheel assembly weighs approximately 960 lbs. (435 kg). The foam-filled tire & wheel assembly weighs approximately 867 lbs. (393 kg).

2. Remove hardware securing wheel and remove wheel assembly.
3. Place a wheel assembly on Clean area.

Installation

1. Place blocking strong enough to support the weight of the machine under the frame and remove the jack.
2. Using adequate support, install wheel into wheel assembly and secure with bolts and washers.

NOTE: Torque the bolts to 180 ft. lbs. (244 Nm).

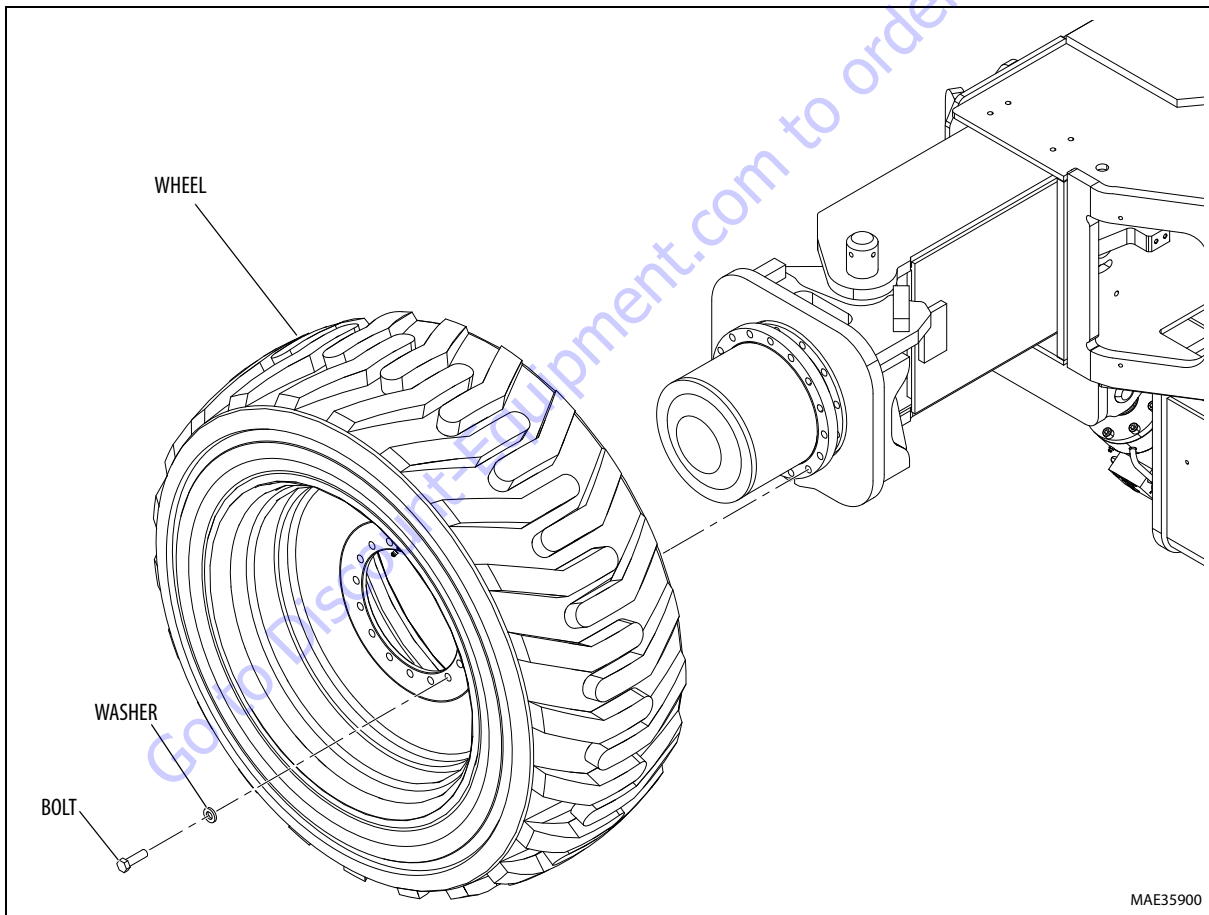

Figure 3-15. Wheel Drive Removal and Installation

3.12 DRIVE MOTOR

Removal

1. Place machine on the firm level surface.
2. Disconnect the battery power and all electrical connections from the drive motor.

NOTE: The drive motor weighs approximately 34 lbs. (15.4 kg).

3. Remove hardware attached drive motor to the drive hub.
4. Remove the drive motor from machine and place in a clean work area.

Installation

1. Make sure that the pump shaft is properly aligned.

NOTE: The drive motor weighs approximately 34 lbs. (15.4 kg).

2. Install the drive motor to the drive hub and secure using bolts and washers.

CAUTION

INCORRECT SHAFT ALIGNMENT MAY RESULT IN DAMAGE TO DRIVE SHAFT, BEARINGS, OR SEAL WHICH CAN CAUSE EXTERNAL OIL LEAKAGE.

3. Reconnect all electrical connections to the drive motor.
4. Start the machine and check the motor for proper functioning.

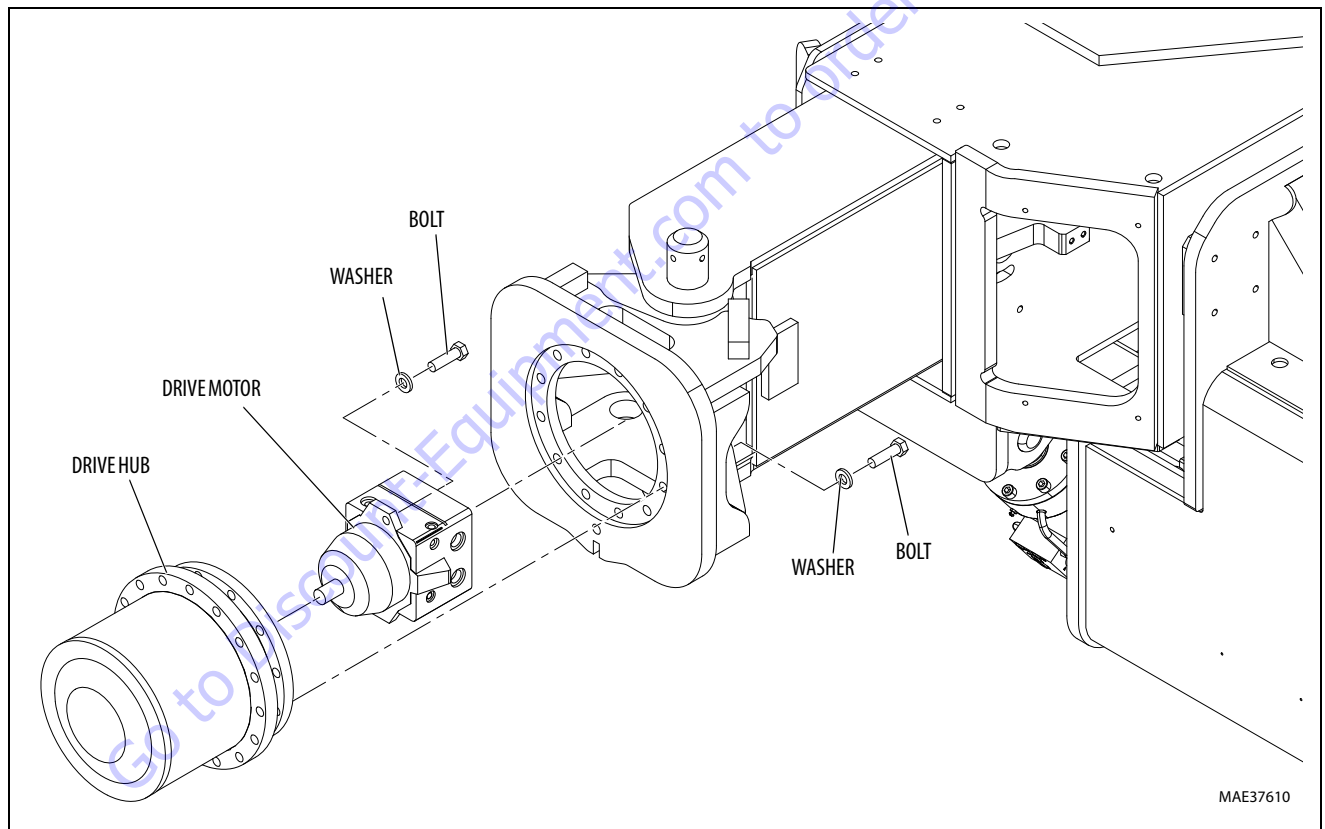
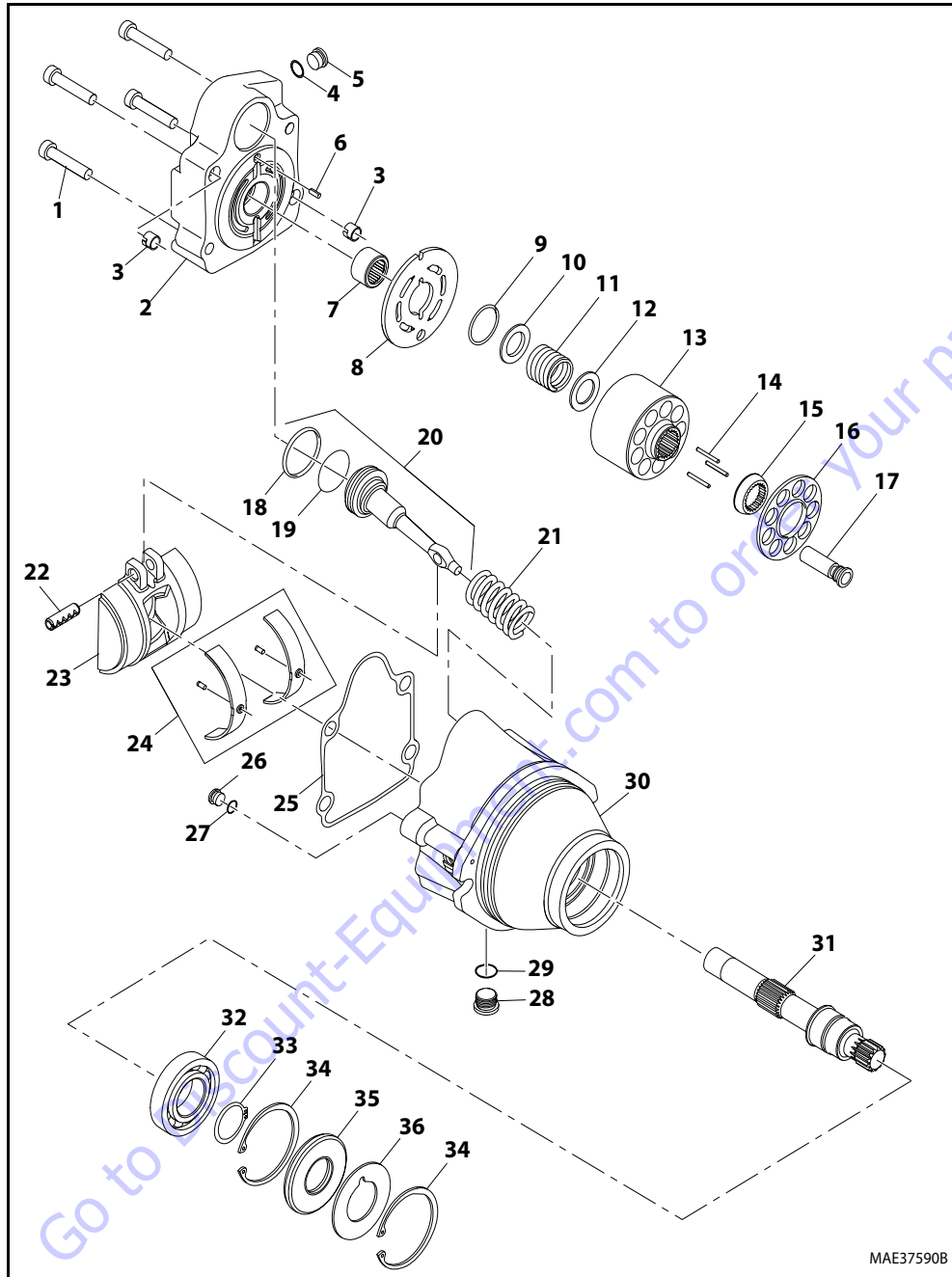

Figure 3-16. Drive Motor Removal and Installation



MAE37590B

- | | | | | |
|-------------------|---------------------|--------------------|-------------|--------------|
| 1. Bolt | 9. Snapring | 17. CylinderPiston | 25. Gasket | 33. Snapring |
| 2. End cap motor | 10. Spring Retainer | 18. Piston Ring | 26. Plug | 34. Snapring |
| 3. Locating pin | 11. Spring | 19. O-ring | 27. O-ring | 35. Seal |
| 4. O-ring | 12. Washer | 20. Piston | 28. Plug | 36. Washer |
| 5. Plug | 13. Cylinder block | 21. Spring | 29. O-ring | |
| 6. Dower pin | 14. Slipper Pin | 22. Pin | 30. Housing | |
| 7. Needle Bearing | 15. Guide | 23. Swash Plate | 31. Shaft | |
| 8. Valve Plate | 16. Slip Retainer | 24. Kit Bearing | 32. Bearing | |

Figure 3-17. Drive Motor Assembly

3.13 DRIVE HUB

NOTE: Machines may be built with either Bonfiglioli or Reggiana Riduttori wheel drive hubs. See Section 3.14, Drive Hub - Reggiana Riduttori. Do not use different hubs on the same machine.

Product Identification

The identification data of the hub is shown on a name plates on the hub. Figure 3-18., Drive Hub Identification Plate shows how the information is displayed.

The informations stamped on the name plates must always be readable. Use the identification data (at least serial number) for spare part enquiries, information and service, etc.

Hydraulic Motor Installation

The mating areas and the pilot diameter of the gearbox where the motor is to be mounted must be clean and without burrs.

Before assembling the hydraulic motor, verify by a depth slide gauge the correct assembly of the unit checking the axial distance as shown in the scheme below as shown in the scheme below.

1. Fit the O-ring seal, supplied with the gearbox, in its seat in the hydraulic motor, and assemble it to the gearbox being careful not to damage the seal already fitted.
2. Torque the bolts to 63.5 ft.lbs. (86 Nm) torque.

Installation of the Wheel Drive on the Machine

1. Clean the mating surfaces from oils or paint and fit the wheel drive on the machine frame.
2. Attach the gearbox to the machine frame with the mounting bolts and torque to 178 ft.lbs. (241 Nm).

Start Up and Running In

If new hubs are being installed, it is advised to follow the measures given below:

1. Bleed air from every part of the hydraulic and add oil in the tank if necessary.

NOTICE

THE PRESENCE OF RESIDUAL AIR IN THE HYDRAULIC CIRCUIT WILL BE RECOGNIZED BY THE PRESENCE OF FOAM IN THE TANK AND WILL LEAD TO A JERKING OF THE MOTOR AS WELL AS EXCESSIVE NOISE COMING FROM THE MOTOR AND THE VALVES.

2. Start the gearmotor at a low speed and gradually increase it after having verified that it is functioning correctly without any noises or vibrations.

NOTICE

DO NOT REACH MAXIMUM PRESSURE UNLESS THE ENTIRE SYSTEM HAS BEEN FILTERED TO ELIMINATE ANY PARTICLES OF DIRT THAT MAY BE PRESENT.

NOTE: During the running-in stage follow the steps given below.

3. Check the correct revolution and direction of rotation.
4. Make sure that the functioning is regular and without any excessive noises and vibrations.
5. Make sure that the oil temperature does not exceed values listed previously.

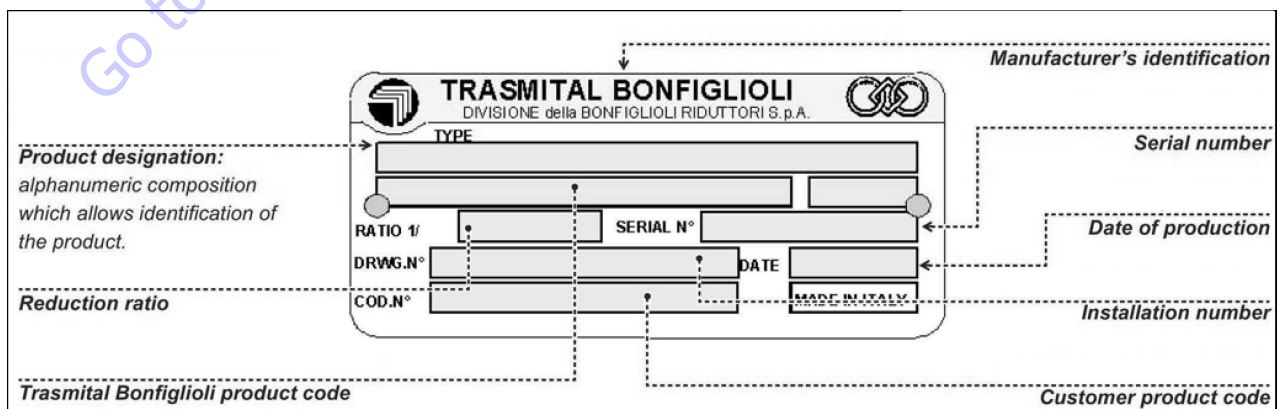

Figure 3-18. Drive Hub Identification Plate

After having finished running-in the gearbox, follow the steps given below.

6. Check that there are no oil leaks. If leaks are present, fix them before proceeding.
7. Check the level of oil in the gearmotor.
8. It possible that the presence of air in the system during the first start up could cause the application of the brake to be slowed down. It is advised to repeat the application and release functions of the brake to purge air from the brake.
9. Check that there are no other problems in general.

General Information

The gearbox is designed and built for wheel drive.

The unit includes planetary gearbox, 3 stages, rotating housing type.

The illustrations show the parts and the main functions of the gearbox.

A strict and consistent compliance with the specifications of this technical manual ensure the minimum operating costs and a longer unit life.

Photographic documentation and drawings are supplied for educational purposes, so as to safely and properly carry out maintenance operations.

Minor deviations from pictures of this manual may appear on the actual gearbox. However, these discrepancies are not relevant to the main parameters, or maintenance functions.

Connecting the Brake

The gearbox is fitted with a negative multi disk safety brake with hydraulic control release (parking brake). For information regarding the characteristics of the brake refer to the installation drawing.

Table 3-3. Brake Technical Data

Brake Release Pressure	232 psi (16 bar)
Maximum Operating Pressure Brake	725 psi (50 bar)
Braking Torque	195 ft.lbs. (265 Nm) ± 10%

Filling-up the Gearbox with Lubricating Oil

The motor and the gearbox have separate lubrication. The gearbox is lubricated by oil splashing. The recommended type of oil is SAE 80W/90 or SAE 85W/140 with EP features complying with MIL-L-2105 C & API GL5. Refer to Table 3-4, Suggested Lubricants According SAE 80W/90 and SAE 85W/140 API GL5 Grade.

NOTE: *During operation the oil temperature must not exceed 185-194° F (85-90° C) intermittent.*

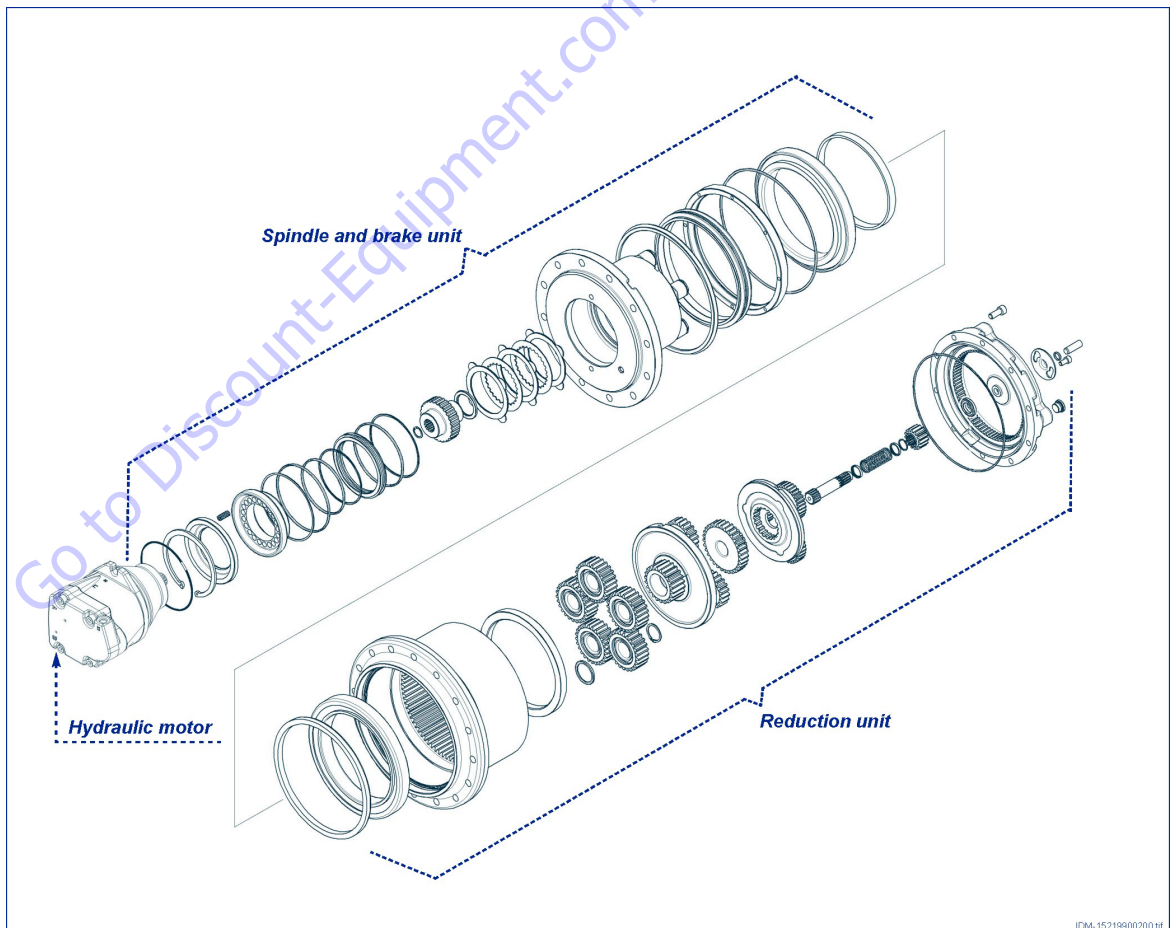
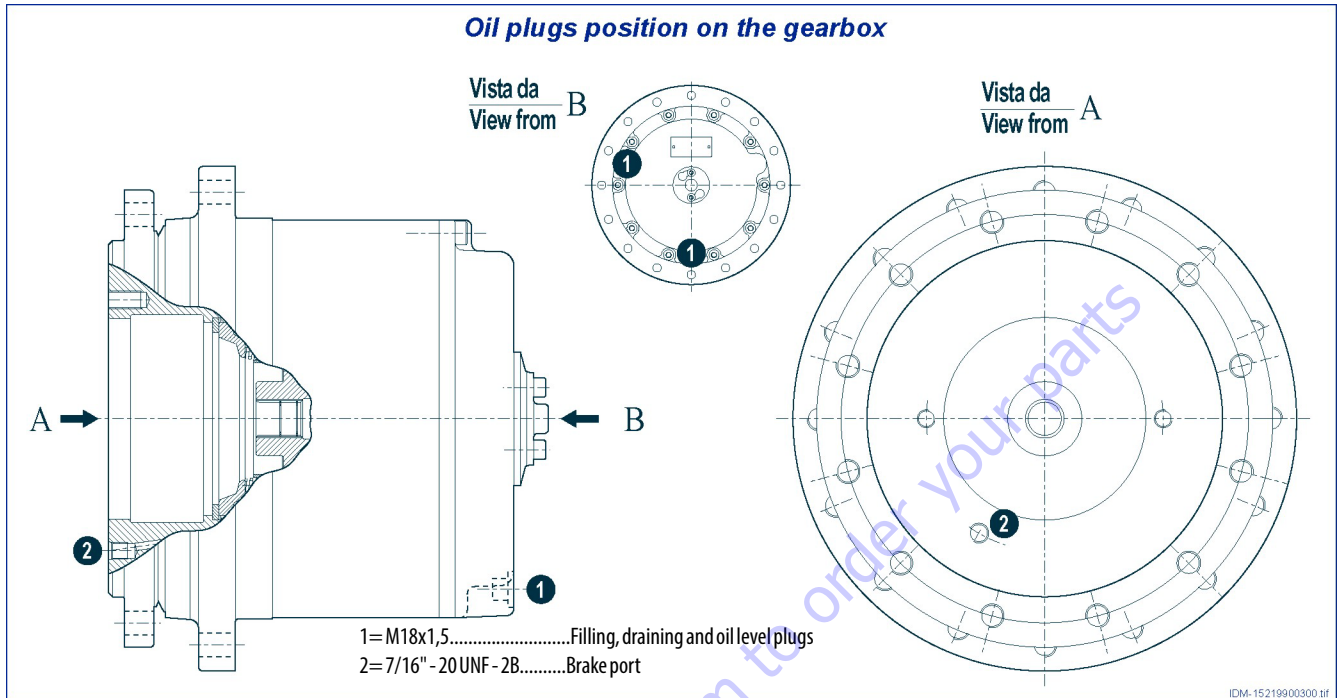

Figure 3-19. Hub Assembly

Table 3-4. Suggested Lubricants According SAE 80W/90 and SAE 85W/140 API GL5 Grade

Ambient temperature Oil viscosity		-20°C / +30°C SAE 80W/90	+10°C / +45°C SAE 85W/140
Manufacturer		Oil Brand	
	SHELL	SPIRAXHD	SPIRAXHD
	AGIP	ROTRAMP	ROTRAMP
	ARAL	GETRIEBEOL HYP	GETRIEBEOL HYP
	BP-MACH	HYPOGEAREP	HYPOGEAREP
	CASTROL	HYPOY	HYPOY
	CHEVRON	UNIVERSAL GEAR LUBRICANT	UNIVERSAL GEAR LUBRICANT
	ELF	TRANSELF B	TRANSELF B
	ESSO	GEAR OIL GX PONTONICMP	GEAR OIL GX PONTONICMP
	I.P.	PONTIAXHD	PONTIAXHD
	MOBIL	MOBILUBE HD	MOBILUBE HD
	TOTAL	TRASSISSION TM	TRASSISSION TM

NOTE: Do not mix together oils of different brands or characteristics.

NOTE: The gearbox is supplied without oil; before putting the gearbox into operation, it is necessary to fill it with oil.

This procedure is undertaken following the indications given below.

1. Check that the gearbox axis is horizontal. Rotate the gearbox housing until the drain plug (A) is on the bottom on the vertical axis of the end cover.
2. Unscrew the fill and level oil plug (B).
3. Fill from the hole until the lubricant flows out.

4. Tighten the fill and level oil plug (B) and let the gearbox run. After a few minutes, stop and check the oil level.

5. If necessary, refill with lubricant oil. Approximate oil capacity = 2 liters ±10%

Gearbox Disengagement

The gearbox is supplied with mechanical disengagement.



THE DISENGAGEMENT OPTION MUST BE CONNECTED OR DISCONNECTED ONLY WHEN THE GEARBOX IS STOPPED ON FLAT GROUND.

NOTICE

THE MAX WHEEL SPEED WITH DISENGAGED GEARBOX MUST NOT EXCEED 25 REV/MIN.

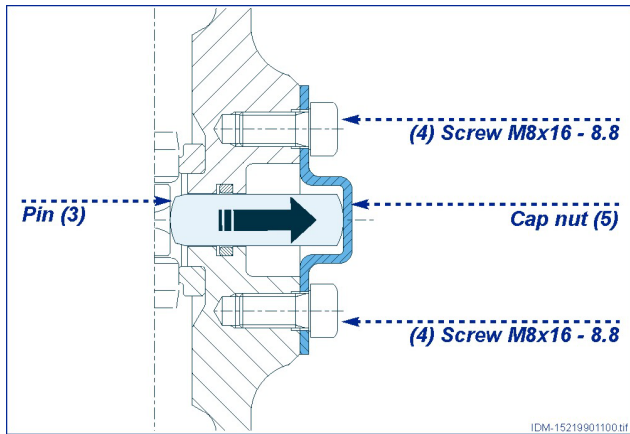
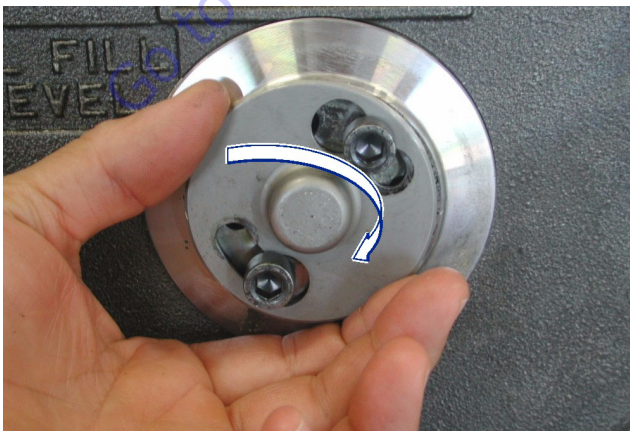

Figure 3-20. Gearbox engaged

1. Unscrew the 2 socket head screws M8x16 (4), grade 8.8, of the end cover (7) with a male hex head wrench.



2. Rotate the cap nut (5).



3. Take out the cap nut (5).



4. Turn the cap nut (5) upside down. As result the pin (3) will be pushed inside in order to permit disengagement of the gearbox.



5. Rotate the cap nut (5).



SECTION 3 - CHASSIS & TURNTABLE

6. Tighten the 2 socket head screws M8x16 (4) with a male hex head torque wrench at 18.4 ft.lbs. (25 Nm) torque.

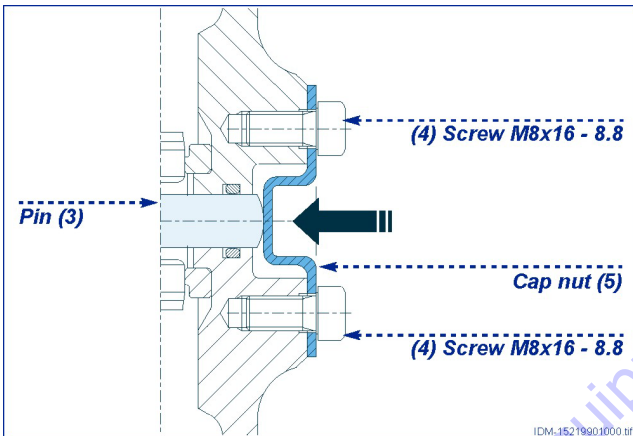

Figure 3-21. Gearbox Disengaged

7. Repeat the above steps to engage the gearbox again.

Operation:

- a. Engaged gearbox
At this condition the motion is transmitted from the hydraulic motor to the gearbox.
- b. Disengaged gearbox

NOTICE

AT THIS CONDITION THE HYDRAULIC MOTOR AND THE BRAKE ARE DISCONNECTED TO THE GEARBOX: THE WHEEL IS IDLE.

Maintenance Information

PERIODIC MAINTENANCE

The gearbox only requires the scheduled maintenance procedures set out by the manufacturer (see Table 3-5).

Good maintenance will ensure an ongoing functioning in time as well as maximum reliability.

Should irregularities in function arise, it will be necessary to consult the troubleshooting checklist to find the most adequate solution.

If unsuccessful, it may be necessary to partially or completely disassemble the gearbox.

Table 3-5. Drive Hub Maintenance Schedule

Inspection	Frequency	Action
Tightening bolts	After the first 50 operating hours of the gearbox	Bolt tightening torque check
Oil level	Every 150 operating hours of the gearbox	Refill oil if necessary
1 st oil change	At 150 operating hours of the gearbox	Oil replacement
Next oil change	Every 1200 operating hours	Oil replacement

Changing the Lubricating oil

1. Check that the gearbox axis is horizontal. Rotate the gearbox housing until the drain plug is on the bottom of the vertical axis of the end cover.

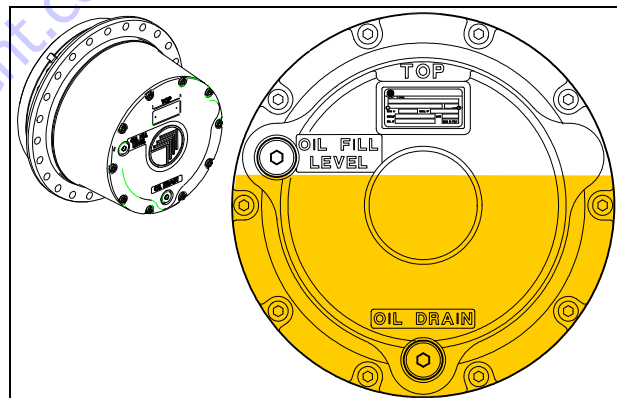

2. Unscrew the both plugs (Fill and Drain) and let the oil flow in a large enough container; in order to facilitate draining the oil must still be warm.
3. Wait a few minutes until all the oil is drained and then proceed to screw on the plugs.
4. Proceed with the oil fill-up. Refer to Filling-up the Gearbox with Lubricating Oil.

NOTE: Never mix mineral oils with synthetic oils and vice versa.

NOTICE

DO NOT DISPOSE OF THE OIL IN THE NATURAL ENVIRONMENT. BE CAREFUL TO ELIMINATE IT IN COMPLIANCE WITH THE RELATIVE RULES AND REGULATIONS THAT GOVERN LOCALLY.

Troubleshooting

The following table is provided to help locate problems in the gearbox.

Table 3-6. Troubleshooting

Symptom	Causes	Remedies
External oil leakage:		
From the lifetime seal	a) Lifetime seal damaged	a) Replace lifetime seal
From the end cover	a) O-ring seal damaged	a) Replace O-ring seals
From the plugs	a) Plug seal damaged	a) Replace plug seal
	b) Plugs or screws loose	b) Tighten the plugs/screws
Too much noise:		
Hydraulic noise (during the slowing down of the motor speed)	a) Hydraulic circuit malfunctioning	a) Verify hydraulic circuit
Inside the gearmotor (reductions)	a) Internal damage	a) Check the gearbox
Other:		
Overheating	a) Insufficient oil level	a) Check the oil level and refill if necessary
	b) Hydraulic oil too warm	b) Check the hydraulic circuit
	c) Brake not fully released	c) Check brake release pressure
Parking brake malfunctioning		
Insufficient braking torque	a) Brake discs worn	a) Replace brake disc pack
	b) Damaged parts	b) Check brake components
Wheel Locked	a) Parking brake locked	a) Check the complete brake release
	b) Mechanical components damaged	b) Replace damaged parts

Disassembly Information

It is also important that this procedure is undertaken in a workshop that is equipped with the proper tools. As well as normal workshop tools it will be necessary to use special tools that can be made (see special tools attachment) or may be requested from the manufacturer.

Special Tools:

Puller.....Code/: 6689960240

Tool for lifetime seal assembly.....Code/: 6689960300

Puller for brake disassembly.....Code/: 6689960310

Torque multiplier.....Code/: ATZ.09.016.0

To be able to produce these special tools refer to Figure 3-23, thru Figure 3-26.

It is important to strictly adhere to all the procedures for disassembling and reassembling the gearbox. Proceed with these instructions using all the necessary safety measures, for example:

1. Plug all the Hydraulic ports on the gearbox to avoid the introduction of any foreign particles in the circuit and the gearbox.

2. Making sure that the coupling surfaces are not damaged.
3. Handle with care so as to be sure that there are no risks for personnel safety and to guarantee the reliability of the gearbox.
4. Making available a work area that is in line with work and health safety in the workplace guidelines.

Disassembly Procedure

NOTE: Below are all the steps to follow during Disassembly and Assembly. Numbers in brackets in the text correspond to the references in the exploded view.

Initial inspection can be made without disassembling the hub from the machine. Before wheel drive disassembling, make sure that the oil is drained from the hub.

Unscrew and remove the nos. 2 screws M12, grade 8,8, and remove the hydraulic motor and its O-ring seal (48).

SECTION 3 - CHASSIS & TURNTABLE

1. Install the special tool (6689960310) on the flanged hub (31) and turn the screw until it compresses the springs (45).



2. Remove the circlip (47) and remove the special tool.

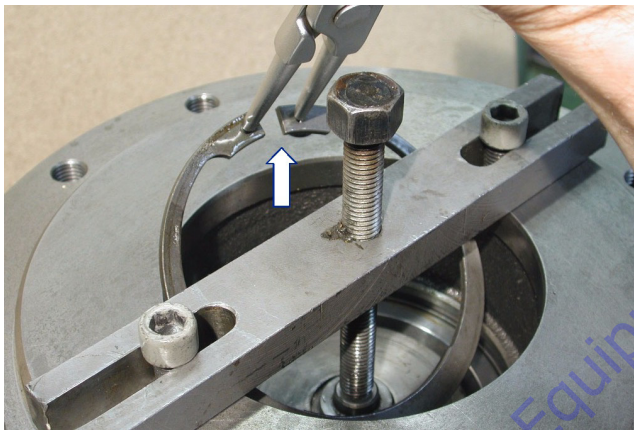

3. Remove the spring retainer disc (46).



4. Mark the position of the springs (45) as a reference for the reassembly.

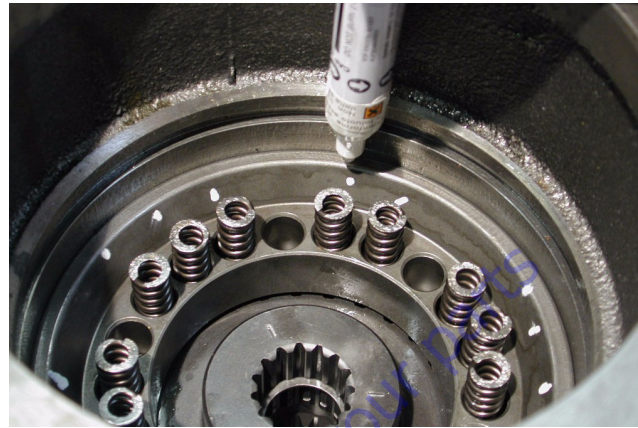

5. Remove the springs (45) from their seats in the brake piston (44).

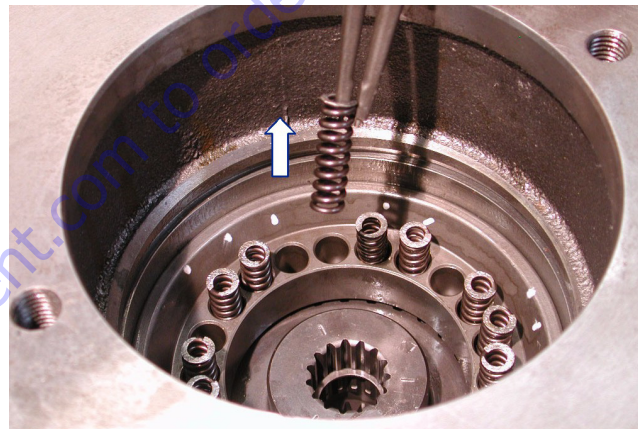

6. By using pliers remove the circlip (36) from its seat in the brake shaft (35).

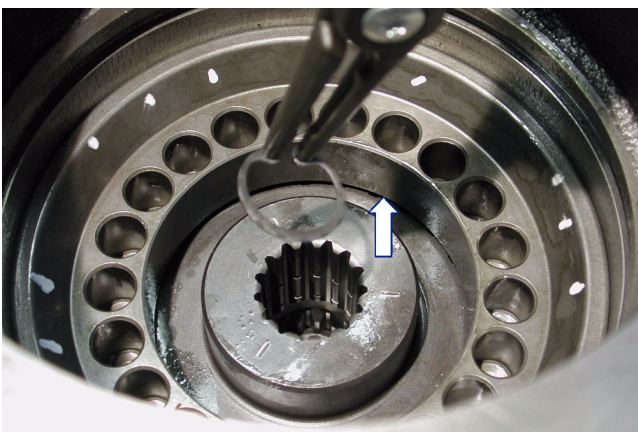

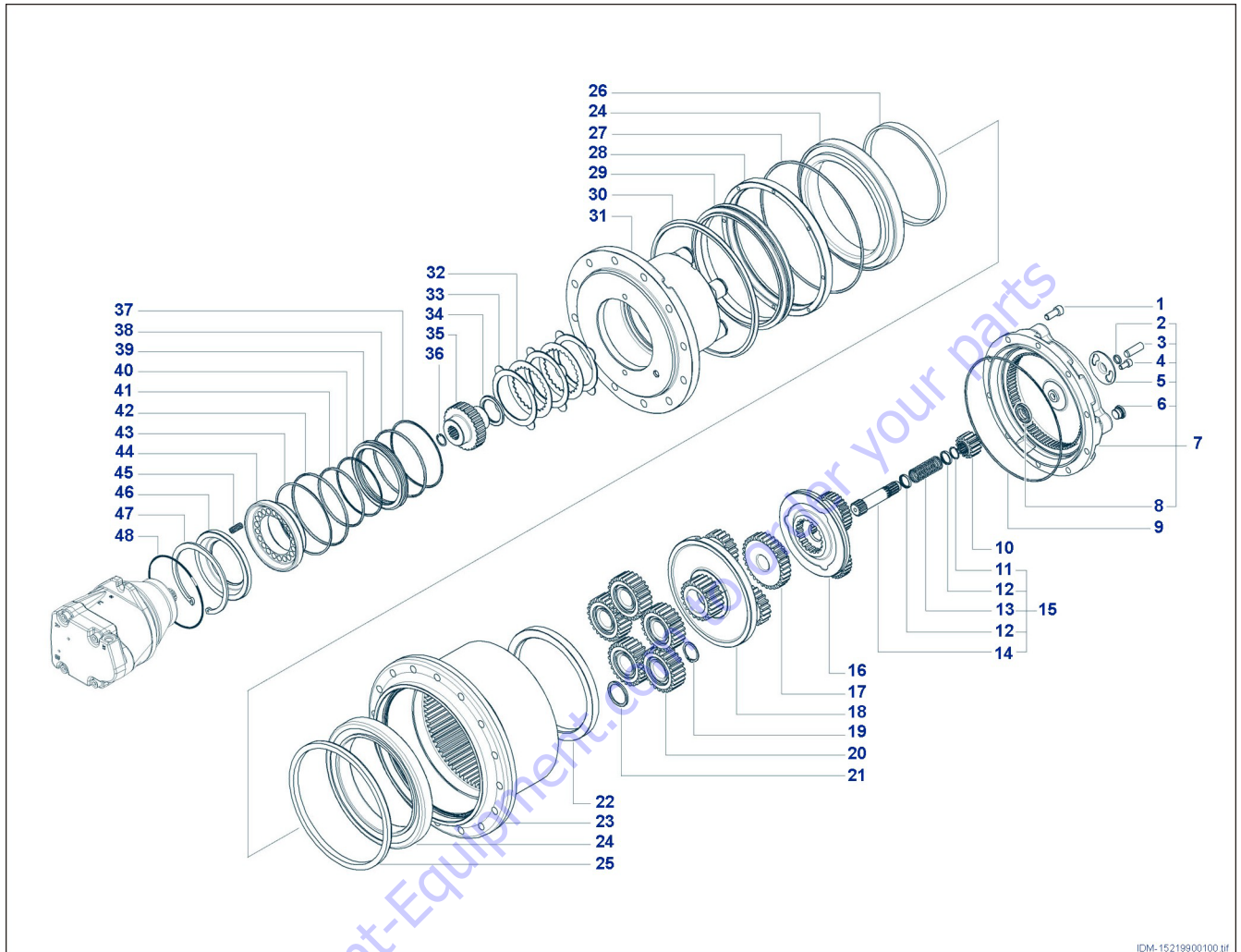

IDM-15219900100.tif

- | | | | | |
|------------------------|----------------------------|---------------------|---------------------------|-------------------|
| 1. Screw | 11. Elastic Ring | 21. Spacer | 31. Flanged Hub | 41. O-ring |
| 2. O-ring | 12. Washers | 22. Ring Nut | 32. Disc (Internal Teeth) | 42. O-ring |
| 3. Pin | 13. Spring | 23. Gearbox Housing | 33. Disc (External Teeth) | 43. Backup Ring |
| 4. Screw | 14. Splined Shaft | 24. Bearing | 34. Spacer | 44. Brake Piston |
| 5. Cap Nut | 15. Disengagement Shaft | 25. Spacer | 35. Brake Shaft | 45. Springs |
| 6. Oil Plug | 16. 1st Reduction Assembly | 26. Spacer | 36. Circlip | 46. Retainer Disc |
| 7. End Cover | 17. 2nd Stage Sun Gear | 27. O-ring | 37. Backup Ring | 47. Circlip |
| 8. Pad | 18. 2nd Reduction Assembly | 28. Spacer | 38. O-ring | 48. O-ring |
| 9. O-ring | 19. Circlip | 29. Half Seal | 39. Spacer | |
| 10. 1st Stage Sun Gear | 20. 3rd Reduction Assembly | 30. Seal Ring | 40. Backup Ring | |

Figure 3-22. Drive Hub

SECTION 3 - CHASSIS & TURNTABLE

7. By using a puller remove, at the same time, the brake piston (44), the spacer (39) and the brake shaft (35).

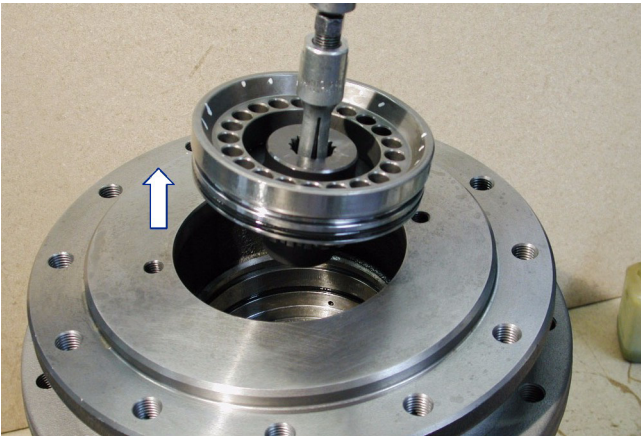

8. Remove the spacer (39) from the brake piston (44).



9. Remove the internal O-Ring seal (41) and the backup ring (40) from their seat in the spacer (39).



10. Remove the external O-Ring seal (38) and the backup ring (37) from their seat in the spacer (39).



11. Remove the O-ring seal (42) and the backup ring (43) from their seats in the flanged hub (31).



12. Remove brake discs pack (32-33).

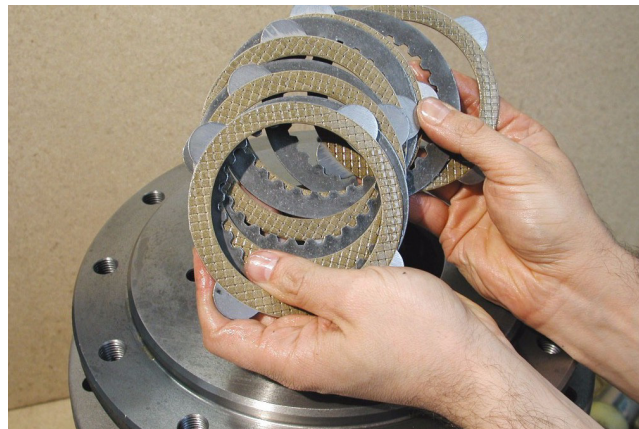

13. Remove the disengagement shaft kit (15).

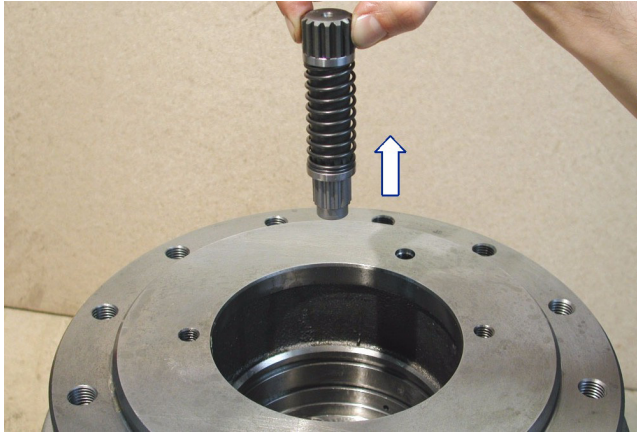

14. Place the disengagement shaft kit (15) inside the special tool (6689960240).



15. Tighten the 2 screws M5x16, grade 8.8, of the cover by a torque wrench to 18.4 ft.lbs. (25 Nm).



16. By using pliers remove the elastic ring (11) from the splined shaft (14).



17. Remove the special tool and remove the spring (13) and the washers (12).



18. Turn the gearbox upside down and unscrew the 2 screws M8x16 (4), grade 8.8, of the end cover (7).



SECTION 3 - CHASSIS & TURNTABLE

19. Remove the cap nut (5).



20. Remove the pin (3).

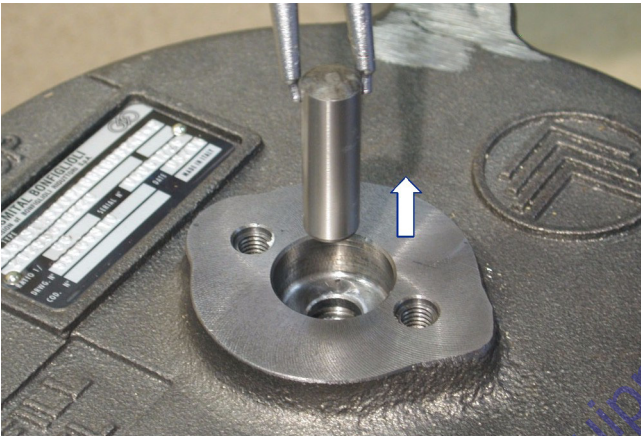

21. Remove the O-ring seal (2) from its seat in the end cover (7).



22. Unscrew the draining-filling-level oil plugs (6) by a male hex head wrench.



23. Unscrew the 10 screws M10X25 (1), grade 12,9, from the end cover (7).



24. Remove the end cover (7).



25. Remove the O-ring seal (9) from its seat in the end cover (7).

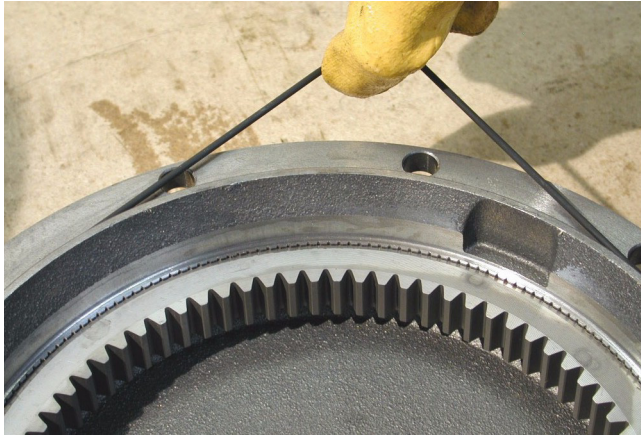

26. Remove the 1st stage sun gear (10).

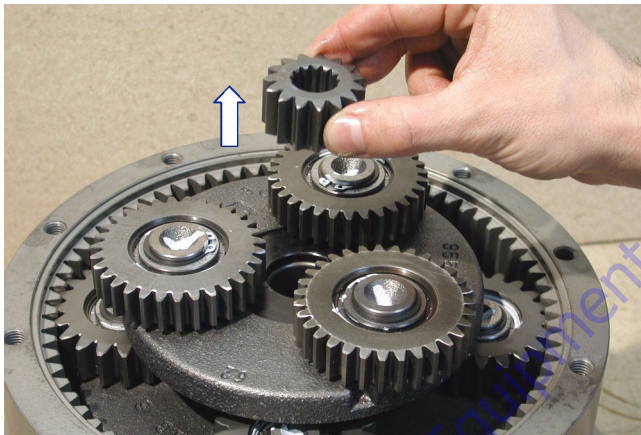

27. Remove the 1st reduction assembly (16).



28. Remove the 2nd stage sun gear (17).

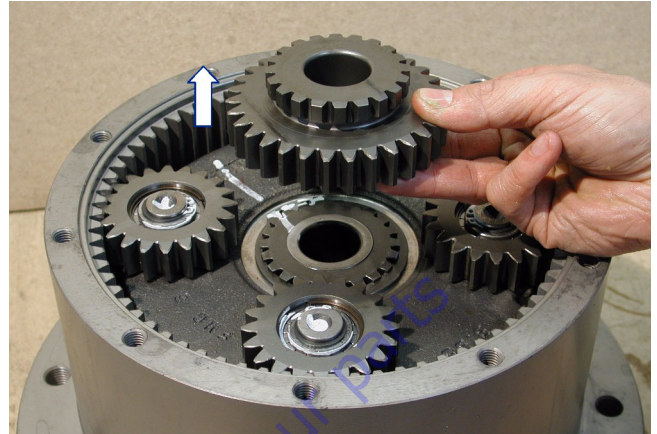

29. Remove the 2nd reduction assembly (18).

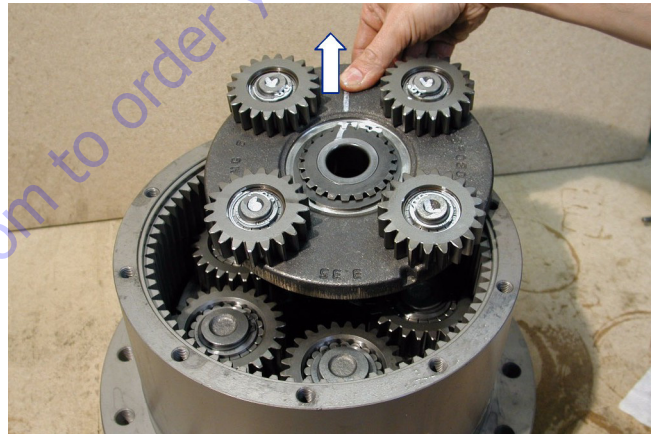

30. By using pliers remove the circlips (19) from their seats in the flanged hub's pins (31).

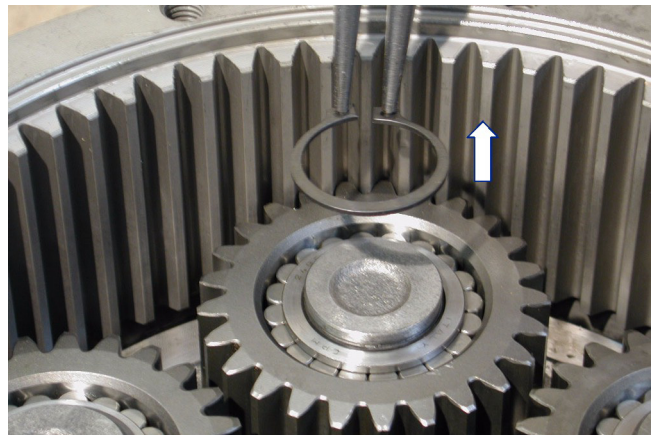

SECTION 3 - CHASSIS & TURNTABLE

31. By using a puller remove the planet assemblies of the 3rd reduction (20).

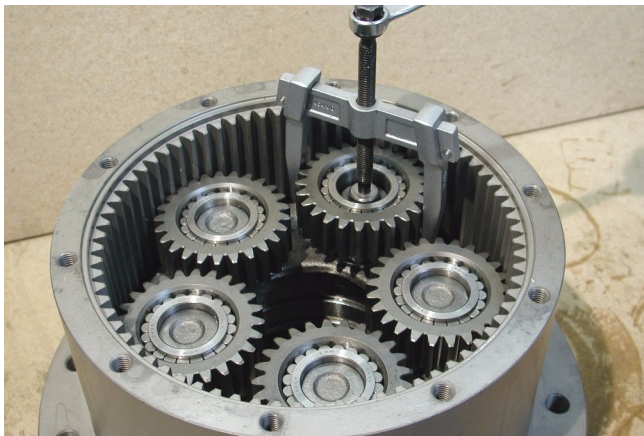

32. Remove the spacer (21) from their seats in the pins of the flanged hub (31).

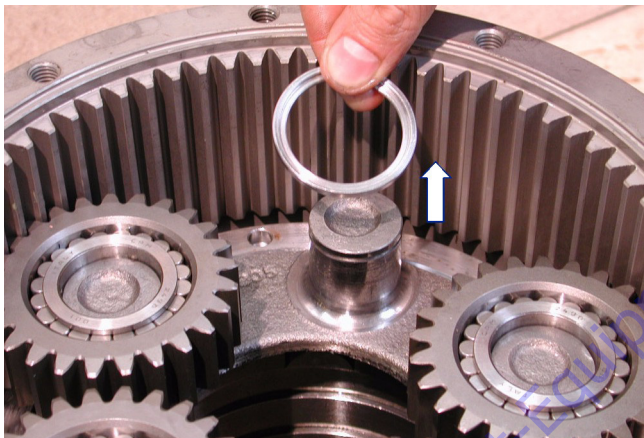

NOTE: In order to proceed with the gearbox disassembly, it is now necessary to remove it from the machine and bring it to a properly equipped workshop.

33. By using a drill remove the caulking on the ring nut (22).



34. By using a tackle place the torque multiplier (ATZ.09.016.0) on the ring nut (22).



35. By using the torque multiplier (ATZ.09.016.0) loosen the ring nut (22).



36. Take out the ring nut (22).

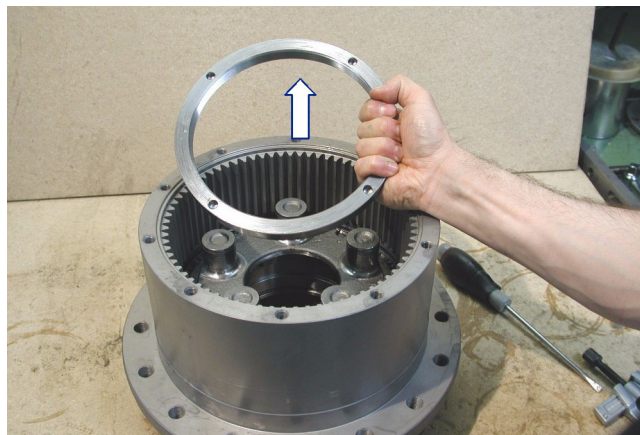

37. By using a puller and a metal stopper, remove the flanged hub (31) from the gearbox housing (23).

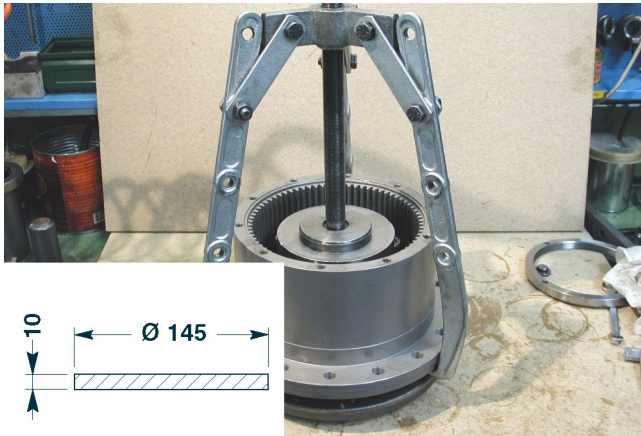

38. By using a tackle remove the gearbox housing (23) from the flanged hub (31).



39. Remove the seal ring (30) from its seat in the flanged hub (31).



NOTE: In case of oil leaks, it may be necessary to check and eventually replace the lifetime seal (29), which means both the metal rings parts and the O-ring seals.

40. By using a screwdriver, remove the 1st half-seal (29) from the flanged hub (31).



41. By using a screwdriver, remove the 2nd half-seal (29) from the gearbox housing (23).



NOTE: The gearbox disassembly ends with the above operation. All items are now available for the necessary inspections.

Inspection of Parts

The pieces that are subject to general wear and tear are the following:

- Gears.
- Bearings.
- All the seals

Replace the used or irregular parts using the following steps:

1. Remove dirt, and in particular properly clean the seals, bearings and locking rings seating.
2. Lubricate the parts before connecting them.
3. In the case of damaged gears, for example a planetary, do not proceed to replace the individual gear but the entire reduction assembly.

SECTION 3 - CHASSIS & TURNTABLE

4. When reassembling a part always replace all the seals involved. Add some grease on the seats and on the new seals to make reassembly easier.
5. Replace all the damaged parts with original spare parts.

Assembly

Apply grease TECNOLUBE SEAL GS730 on the gearbox housing (23).



1. Follow the steps below to prepare the lifetime seal for assembly:
 - a. Carefully clean the seats (A and B) using, if necessary, metallic brushes or solvent (surfaces in contact with or (C) must be perfectly clean and dry).

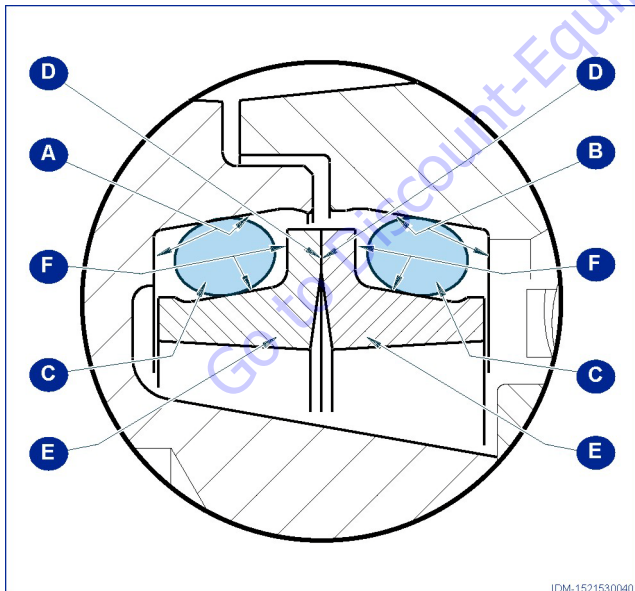

- b. Make sure that sealing surfaces (D) of metal rings (E) are free from scratches, dings or foreign substances; metallic ring surfaces must be perfectly clean and dry. We suggest to dip the metallic rings in volatile solvent or industrial degreasing alcohol.

- c. Carefully clean the lapped surface (D) of metal rings (E) and remove dust or fingerprints. Then lubricate them with a thin oil film, taking care not to oil the other components.

2. Assemble the half seal (29) on the tool (6689960300).



3. Assemble the 1st half seal (29) on the gearbox housing (23).



4. Using the same tool (6689960300), assemble the 2nd half seal (29) on the flanged hub (31).



- Carefully clean the metallic faces of the lifetime seal (29) and lube the surfaces with oil.

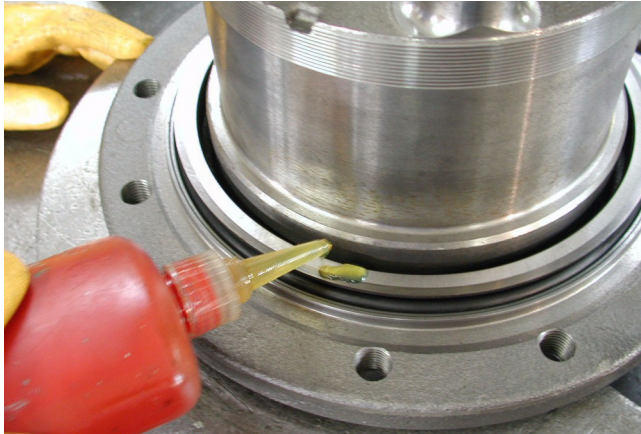

- Insert the seal ring (30) in its seat in the flanged hub (31).

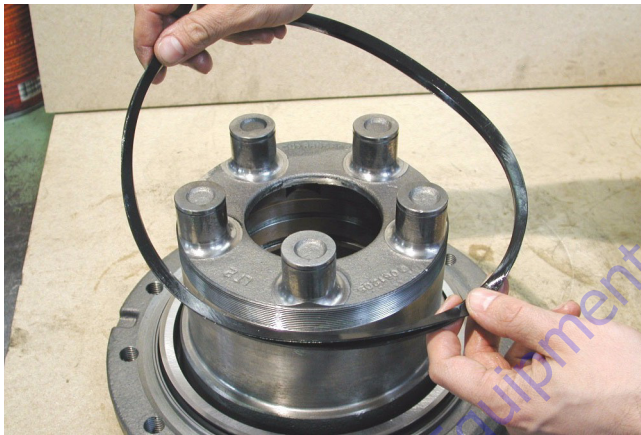

- Apply grease TECNOLUBE SEAL GS730 on the seal ring (30).



NOTICE

AVOID GETTING GREASE IN CONTACT WITH THE LIFETIME SEAL (29)

- By using a hoist, place the gearbox housing (23) on the flanged hub (31).



- By using a press and a metallic stopper, push the gearbox housing (23) against the shoulder on the flanged hub (31) until assembling of the unit is complete.

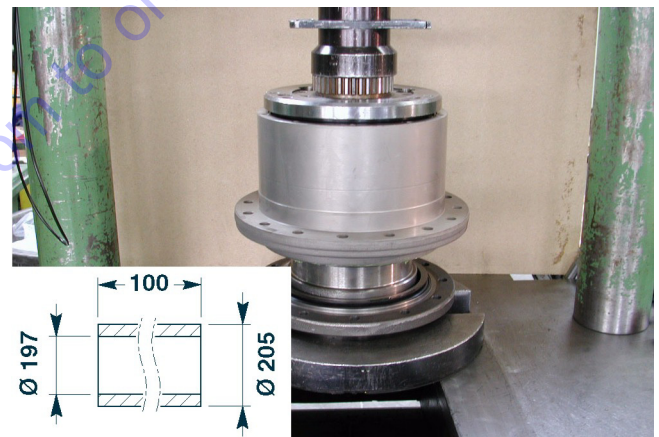

NOTICE

SCREW THE NUT (22) ON PARTIALLY IN ORDER TO PREVENT THE FLANGED HUB (31) FROM COMING OUT OF THE GEARBOX HOUSING (23) DURING THE FOLLOWING STEPS.

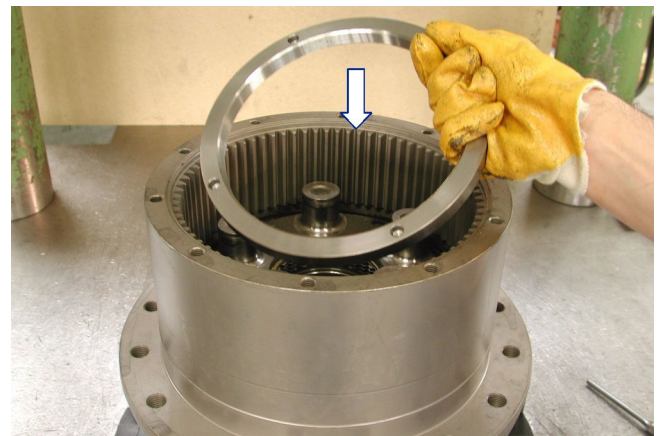

SECTION 3 - CHASSIS & TURNTABLE

10. By using a hoist place the torque multiplier (ATZ.09.016.0) on the ring nut (22).



NOTE: Stake $\varnothing 4+5$ mm (depth 1+1,5 mm).

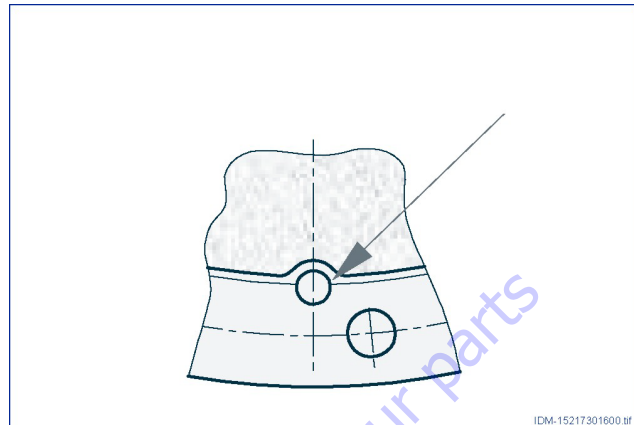

11. By using the multiplier (ATZ.09.016.0), tighten the ring nut (22), using a torque wrench with an input multiplier torque of 71 ± 3 ft.lbs. ($96,5 \pm 4, 5$ Nm) corresponding to an output multiplier torque of 3688 ± 184 ft.lbs. (5000 ± 250 Nm).

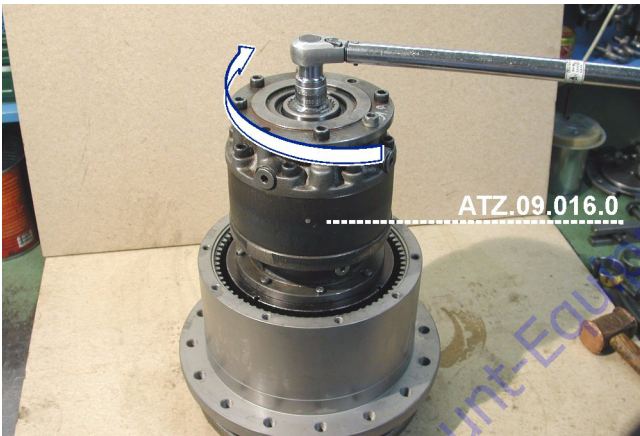

13. Assemble correctly the spacers (21) on the pins of the flanged hub (31).

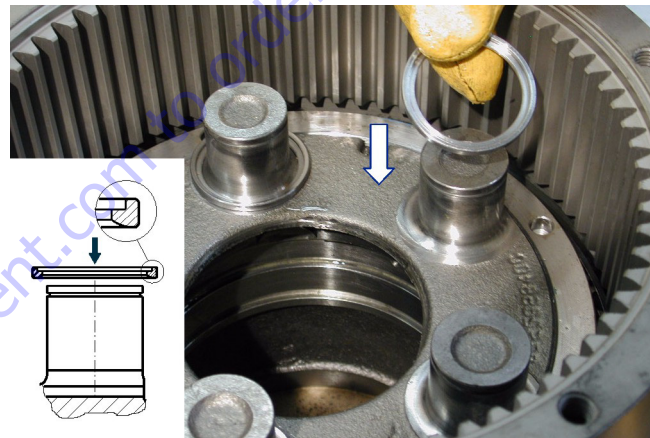

14. Place the 5 planet assemblies of the 3rd reduction (20) in the flanged hub's pin (31).

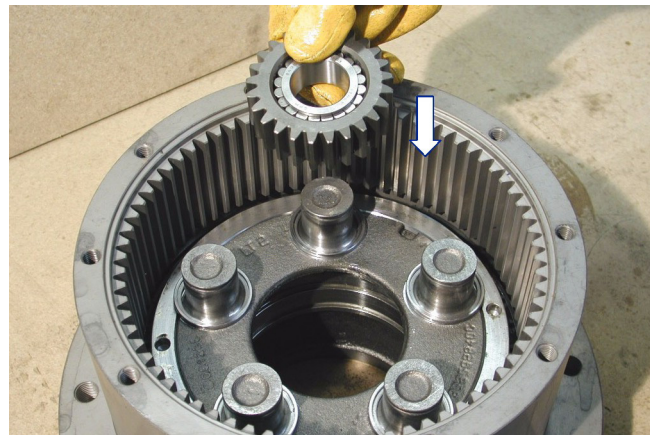

15. By using a rubber hammer and a metal stopper push the planet assemblies of the 3rd reduction (20) against the shoulder until assembly is complete.

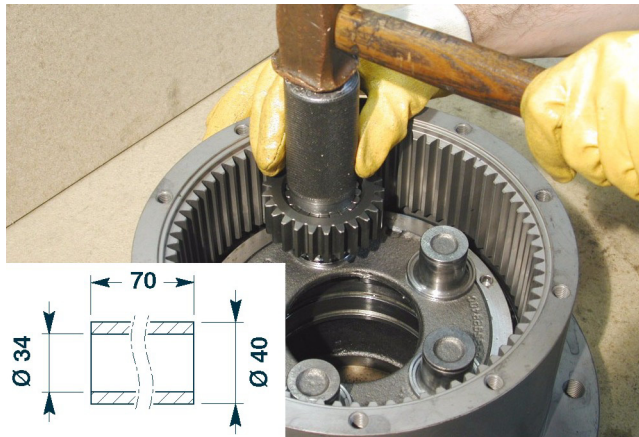

16. By using pliers, assemble the circlips (19) in the flanged hub pin seats (31).

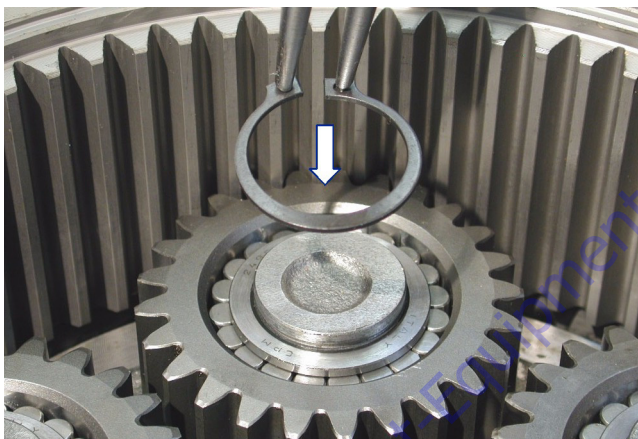

17. Assemble the 2nd reduction assembly (18).

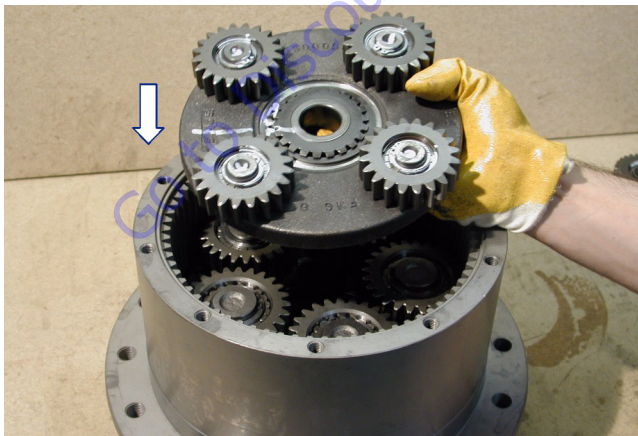

18. Insert the 2nd stage sun gear (17).



19. Assemble the 1st reduction assembly (16).



20. Insert the 1st stage sun gear (10).



SECTION 3 - CHASSIS & TURNTABLE

21. Assemble the O-ring seal (9) into its seat in the end cover (7).



22. Place the end cover (7) on the gearbox housing (23).



23. Tighten the 10 socket head screws M10x25 (1), grade 12,9, by a torque wrench at 62.7 ft.lbs. torque (85 Nm).



24. Insert the plugs (6) into the oil draining-filling holes of the end cover (7). Torque the plugs to 52 ± 7 ft.lbs. (70 ± 10 Nm).



25. Assemble the O-ring seal (2) into its seat in the end cover (7).

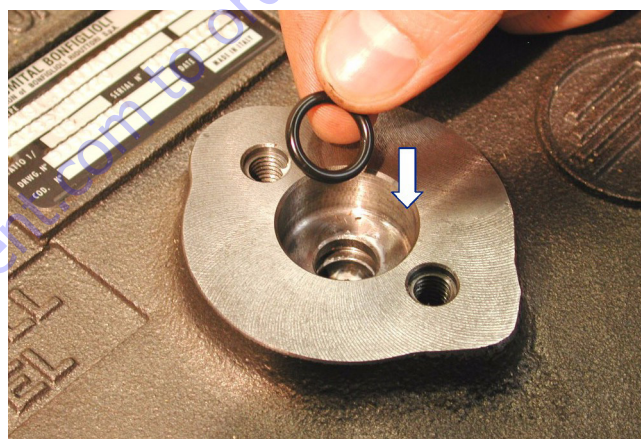

26. Protect the seat and the pin (3) with grease type MOLYKOTE G6000. Wait 15 minutes for it to completely dry. Insert the pin (3) in its seat in the end cover (7).

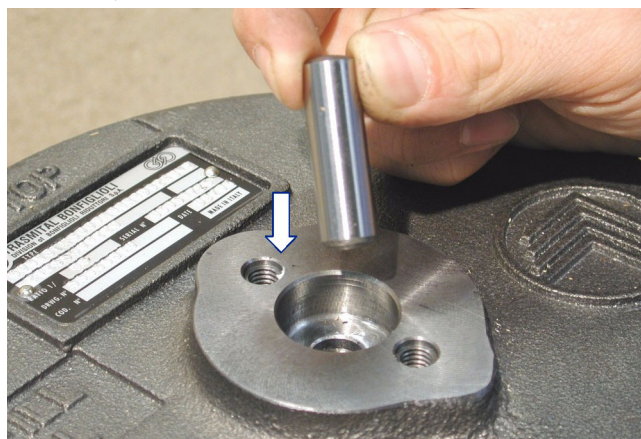

27. Assemble the cap nut (5).



28. Torque the 2 screws M8x16 (4) grade 8.8, to 18.4 ft.lbs. (25 Nm).



29. Insert the 1st washer (12) in the splined shaft (14).



30. Insert the spring (13) in the splined shaft (14).



31. Insert the splined shaft (14) in the equipment (6689960240).



32. Insert the 2nd washer (12) correctly in the splined shaft (14).



SECTION 3 - CHASSIS & TURNTABLE

33. Torque the 2 screws M5x16, grade 8.8, of the cover to 18.4 ft.lbs. (25 Nm).

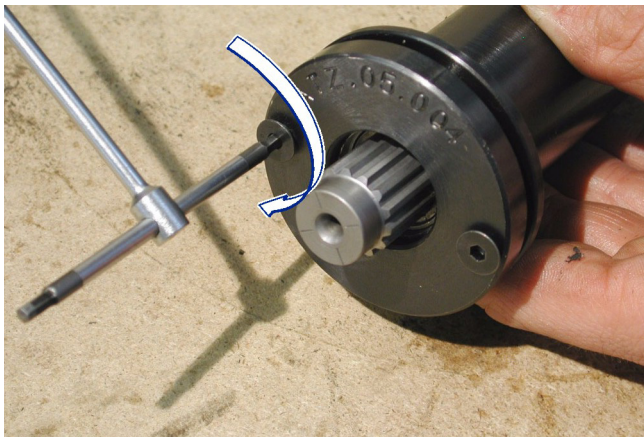

34. By using pliers, assemble the elastic ring (11) into its seat in the splined shaft (14).

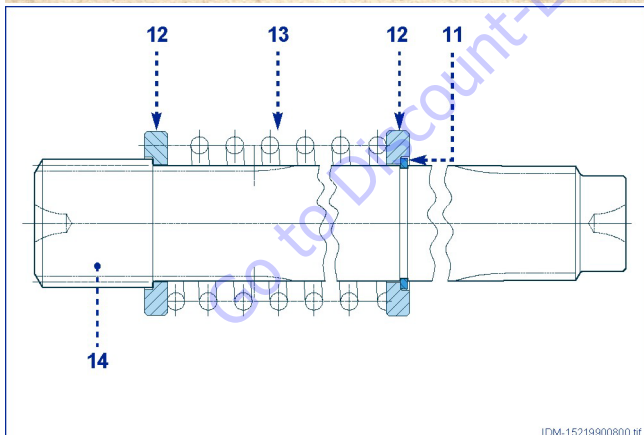

35. Insert the disengagement shaft kit (15) in the flanged hub (31).

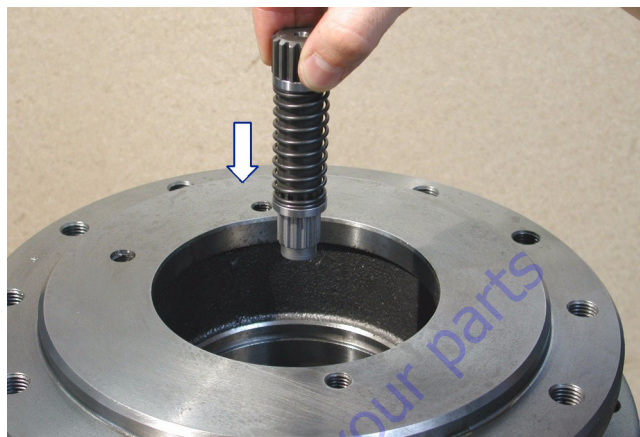

36. By using pliers assemble the circlip (36) into its seat in the brake shaft (35).



37. Turn the gearbox upside down and assemble the brake shaft (35) inside the flanged hub (31).



38. Assemble the brake discs package according to the following order: first, insert one sintered bronze disc with external teeth (33).

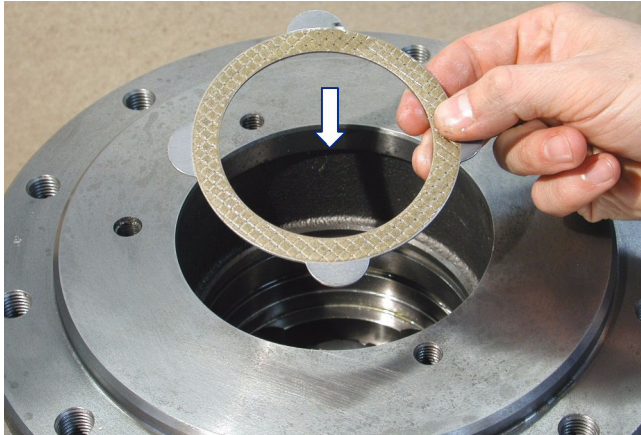

39. Then insert an internally toothed steel disc (32). Repeat the operation until all 5 sintered bronze discs and 4 steel discs have been assembled.

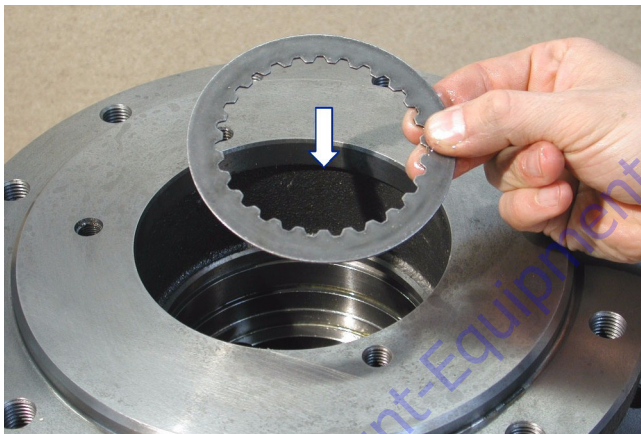

40. Fit the internal O-ring seal (41) and the backup ring (40) into their seats in the spacer (39).



41. Fit the external O-ring seal (38) and the backup ring (37) into their seats in the spacer (39).



42. Insert the spacer (39) inside the flanged hub (31), paying attention not to damage the seals already fitted.



43. By using a rubber hammer and a metal stopper push the spacer (39) against the flanged hub (31), paying attention not to damage the seals already fitted.

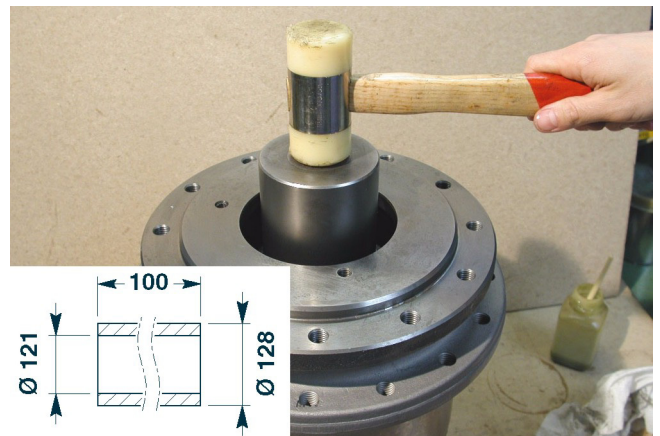

SECTION 3 - CHASSIS & TURNTABLE

44. Lube the seal seats into the flanged hub (31) and assemble the O-ring seal (42) and the backup ring (43).

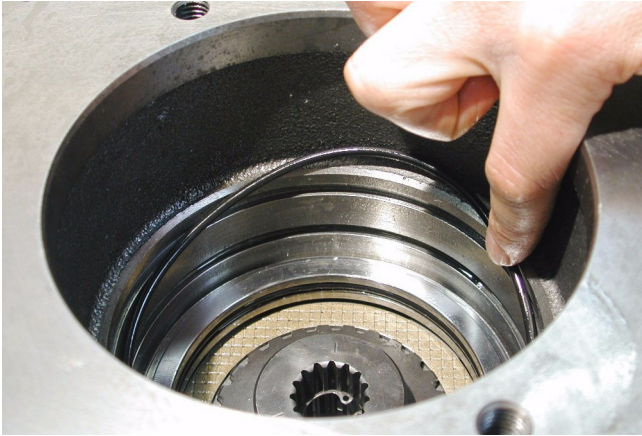

NOTE: The O-ring seals (A) and backup rings (B) must be fitted in the seats according the mutual position as shown in the scheme.

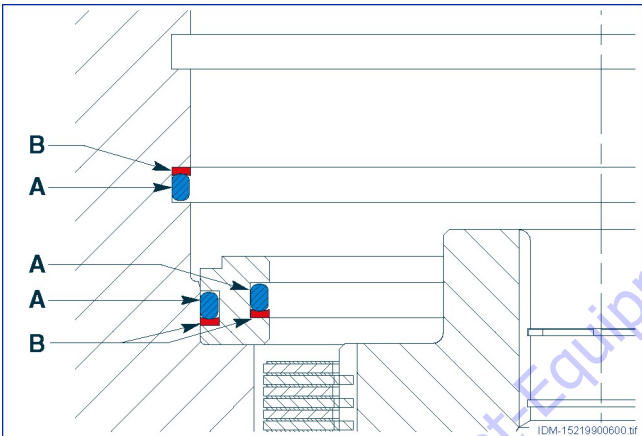

45. Insert the brake piston (44) inside the flanged hub (31), paying attention not to damage the seals already fitted.

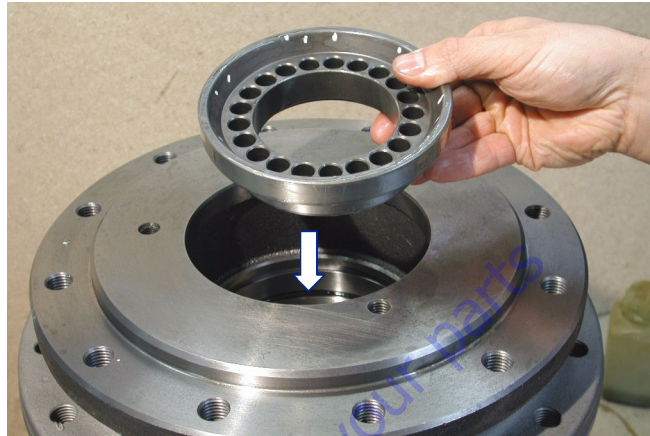

46. By using a rubber hammer and a metal stopper push the brake piston (44) against the flanged hub (31), paying attention not to damage the seals already fitted.

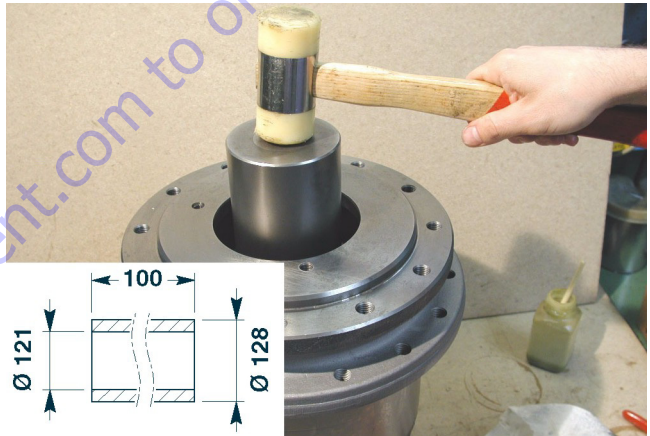

47. Insert the springs (45) into the holes in the brake piston (44) marked previously.

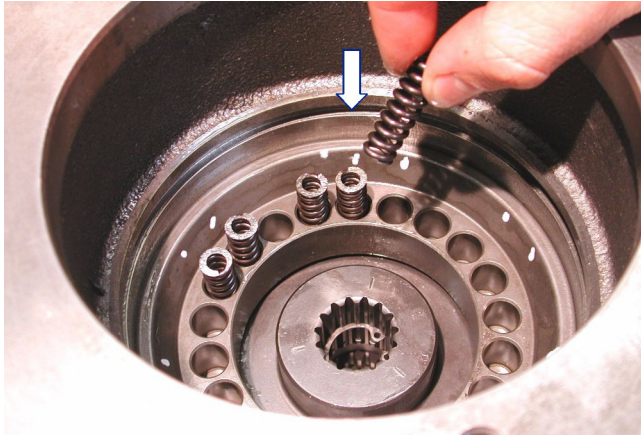

48. Insert the spring retainer disc (46).



49. Install the special tool (6689960310) on the flanged hub (31) and turn the screw until it compresses the springs (45).

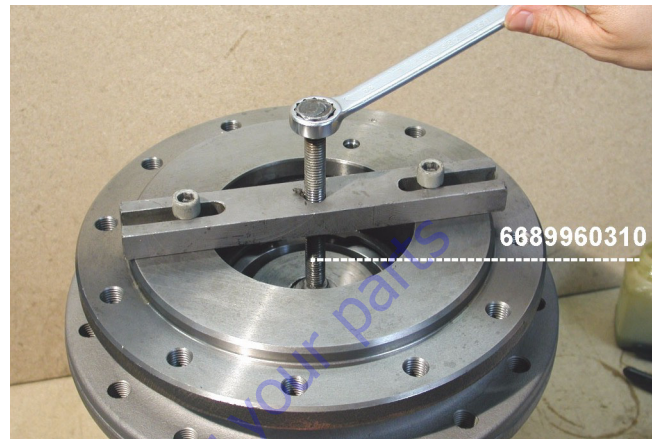

50. Assemble the circlip (47) in its seat and remove the special tool.

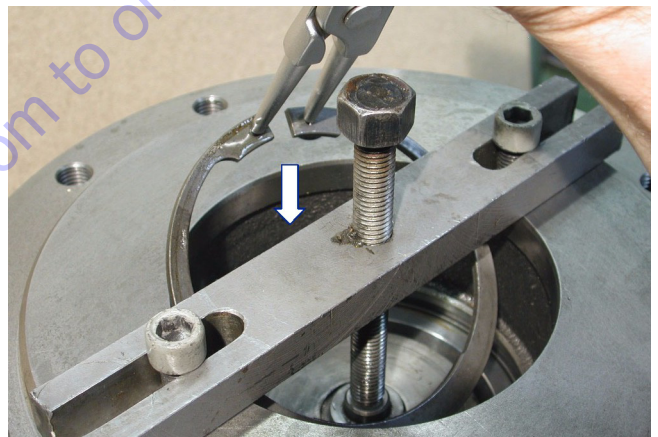

NOTE: Before assembling the hydraulic motor, verify by a depth slide gauge the correct assembly of the unit checking the axial distance as shown below.

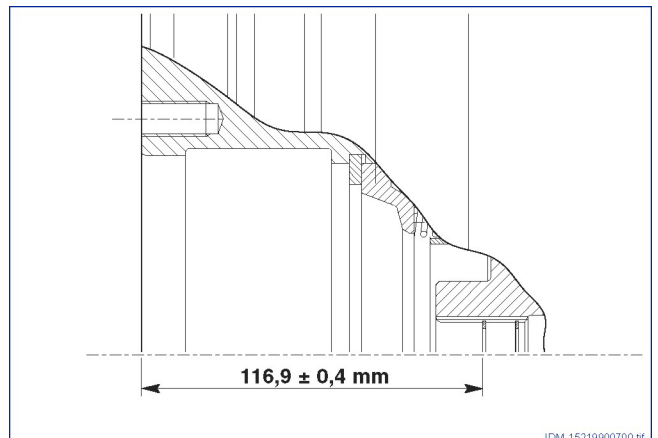

Final Test and Reinstallation

Check the product by remounting it to the machine.

Check the function of the drive hub following all the checks shown in Startup and Running In.

If work on the brake was undertaken, it is important to check that there are no oil leaks. Follow the procedure below:

1. Connect the pressure pilot line with the manometer (with a base scale of 100 bars) to the brake release port.

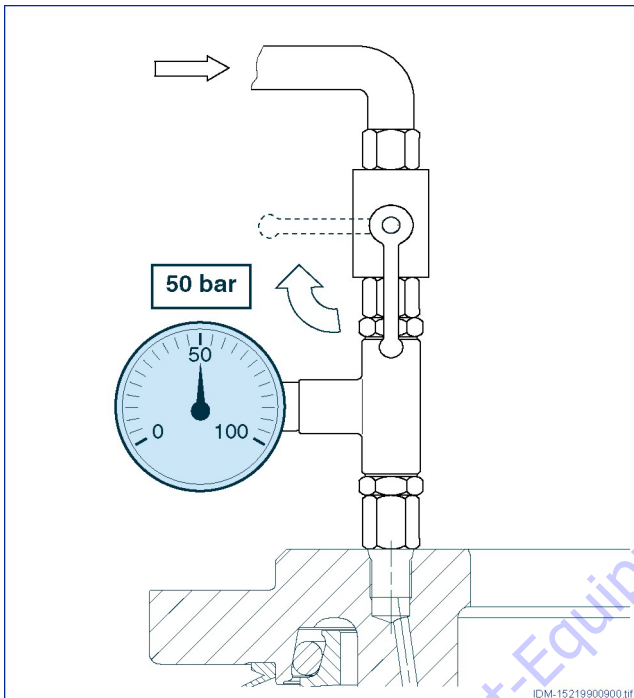

2. Open the flow valve and release the brake with the pilot pressure of 50 bar.
3. Close the flow valve and keep the brake released 3 minutes or longer.
4. Using the manometer, check that the pressure remains constant.

NOTE: If the pressure drops it may mean that the brake seals are not tight and consequently they must be replaced or it may mean that the reassembling was not completed properly.

5. After having reassembled the gearbox, install the hydraulic motor.
6. Fill the gearmotor with the lubricant oil.

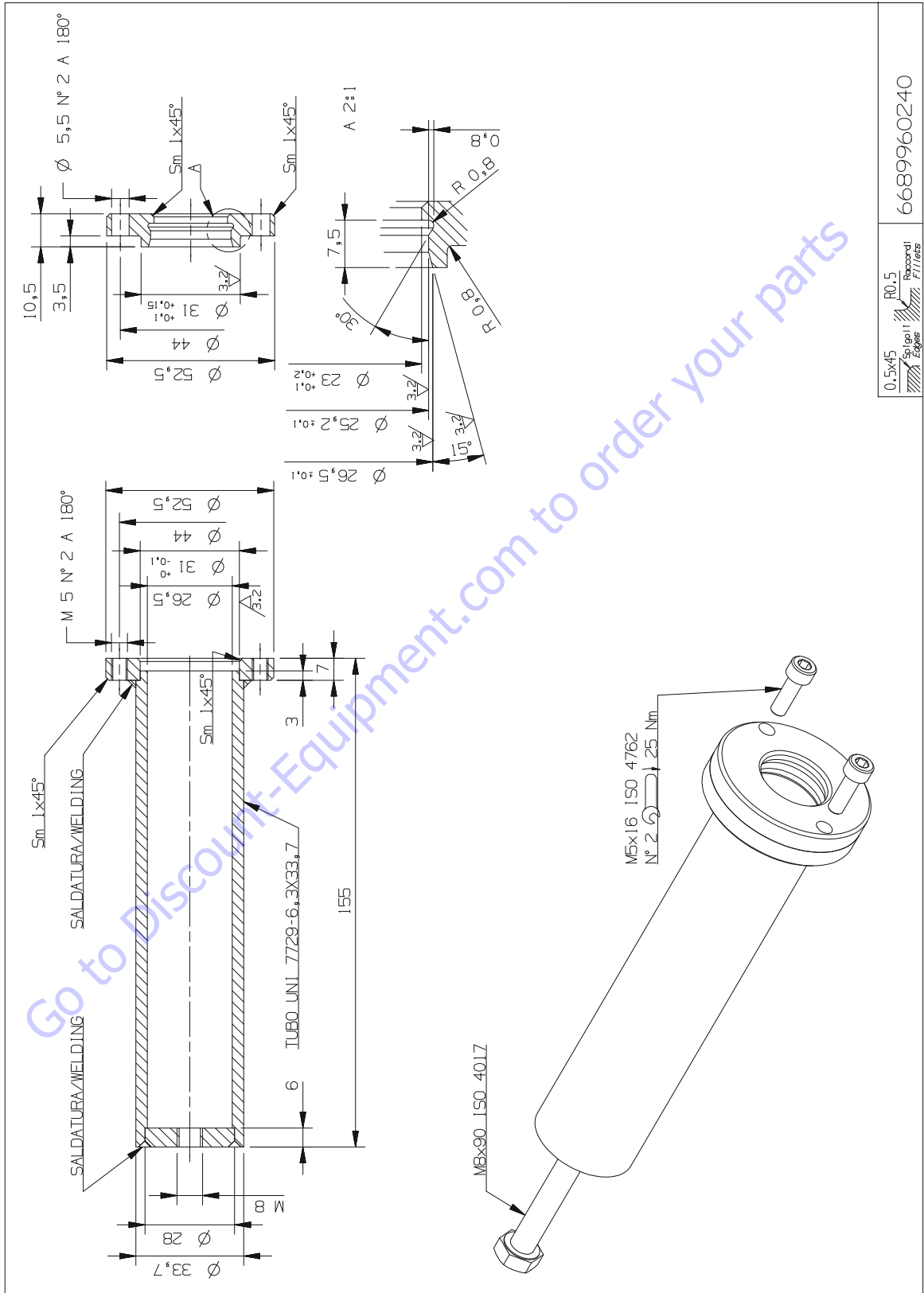

6689960240

Figure 3-23. Drive Hub Special Tools - Sheet 1 of 4

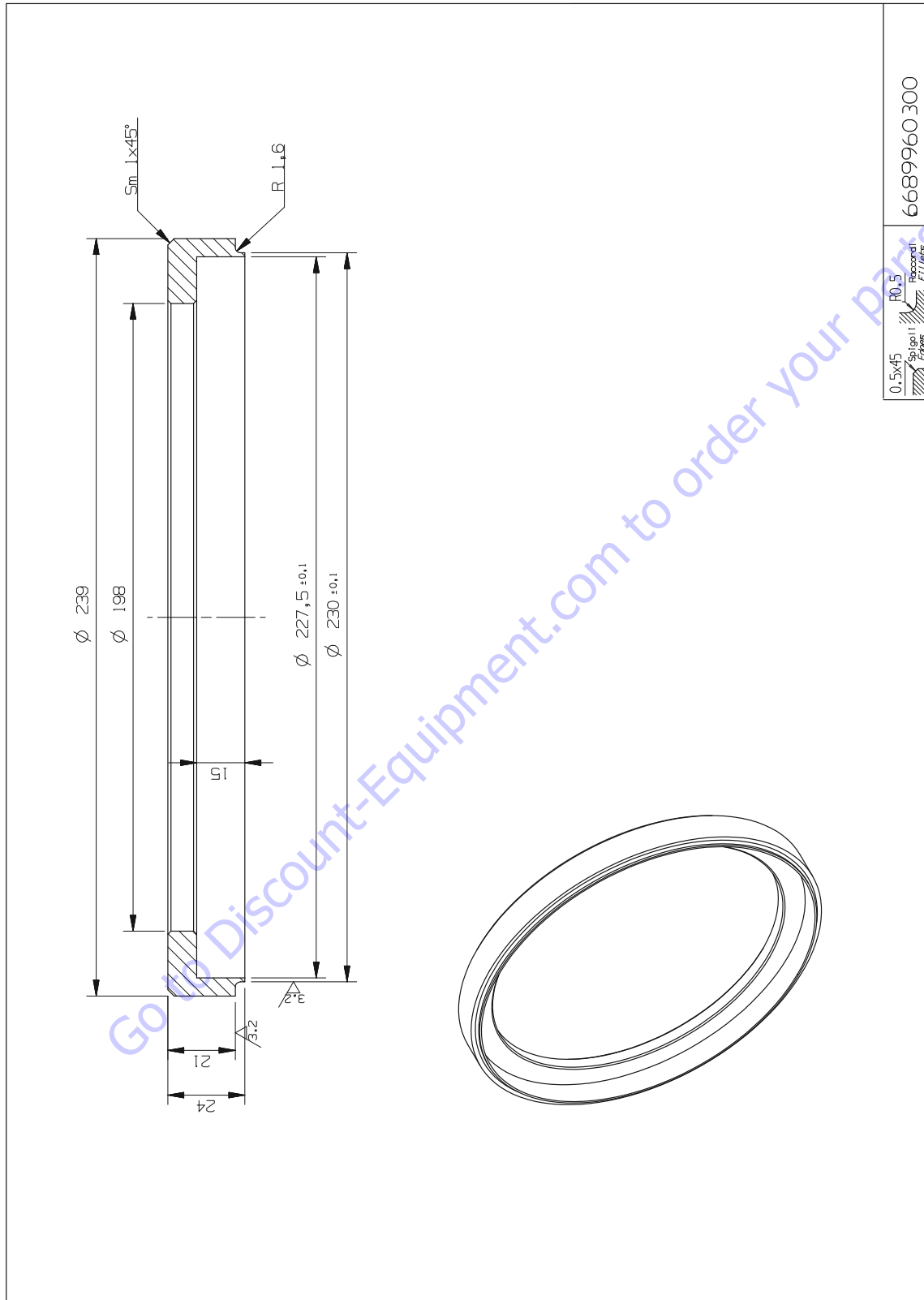

0.5x45	R0.5	6689960 300
Spigot	Recessed	
Edges	Fillers	

Figure 3-24. Drive Hub Special Tools - Sheet 2 of 4

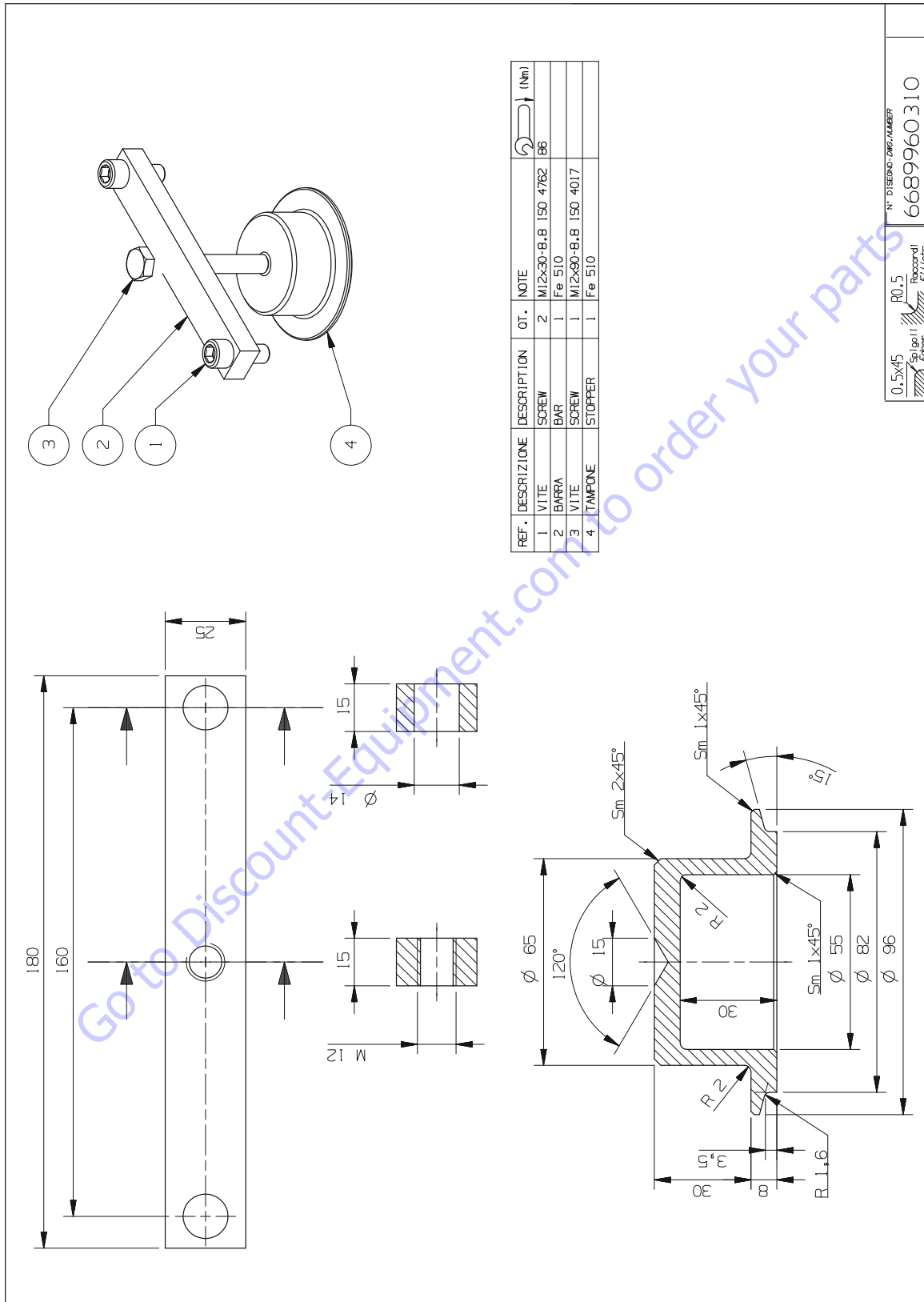

Figure 3-25. Drive Hub Special Tools - Sheet 3 of 4

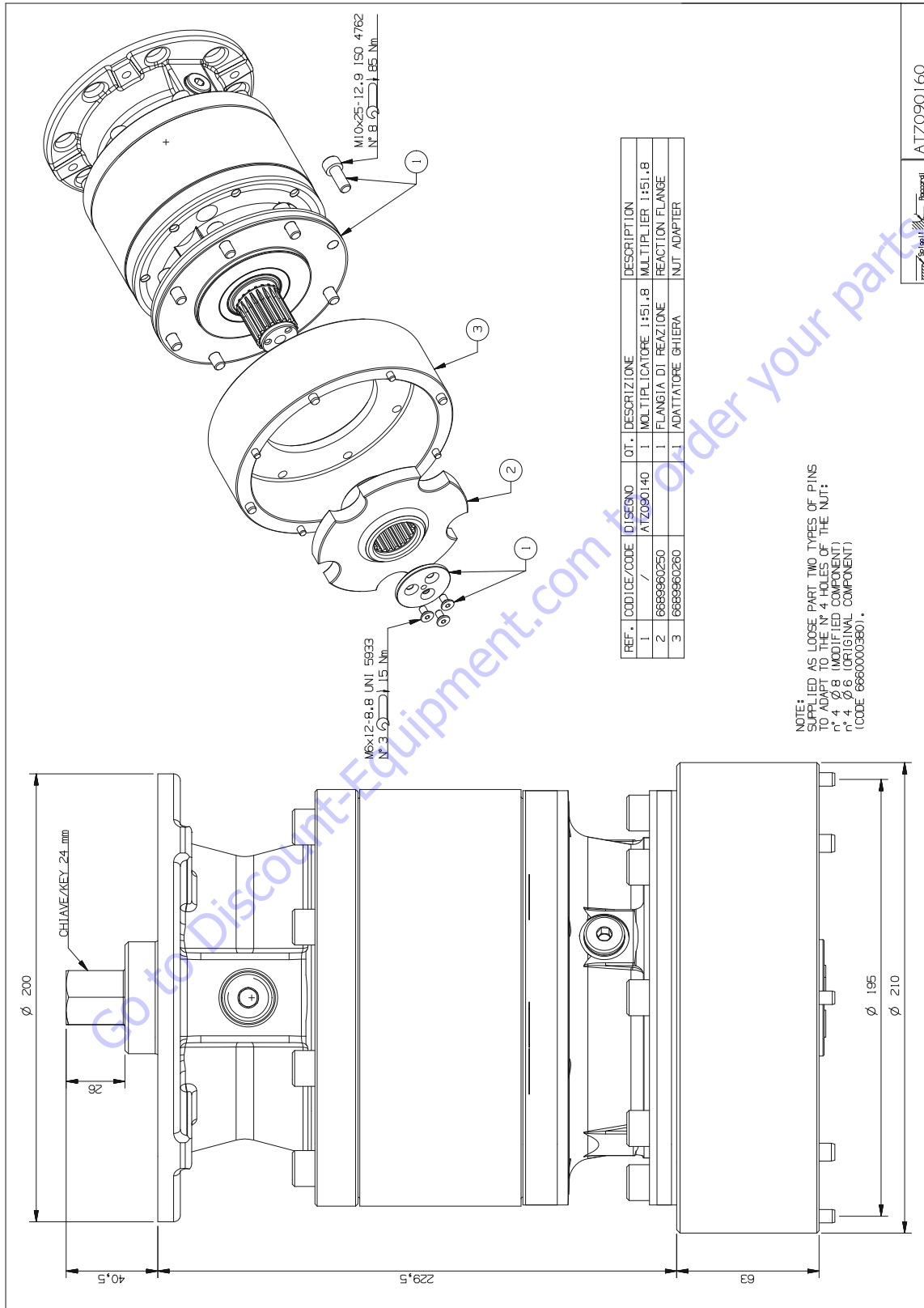

Figure 3-26. Drive Hub Special Tools - Sheet 4 of 4

3.14 DRIVE HUB - REGGIANA RIDUTTORI

NOTE: After SN 0300134389 machines may be built with either Bonfiglioli or Reggiana Riduttori wheel drive hubs. See Section 3.13, Drive Hub. Do not use different hubs on the same machine.

Symbol Nomenclature



= ADHESIVE

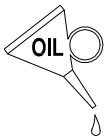

= LUBRICANT



= GREASE

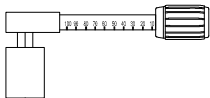

= TORQUE WRENCH



= DISPOSAL

Tools

Tools required for assembling and disassembling the wheel gear RRTD1701TB

1. Hammer;
2. Clamps for inner retention rings;
3. Clamps for outer retention rings;
4. Electric or pneumatic screwdriver;
5. Special spacer mounting;
6. Torque wrench;
7. Hydraulic press;
8. Wrench for M6, M8, M10 socket head screws and 1/4" G plug.

9. Socket wrench for M6 hexagonal screw.

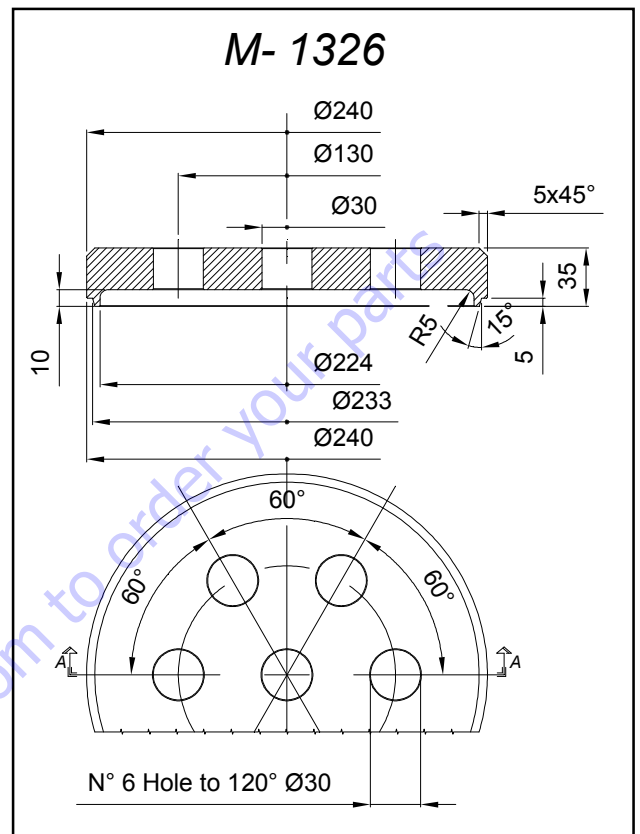

Figure 3-27. Bearing Track Spacer Mounting C016117

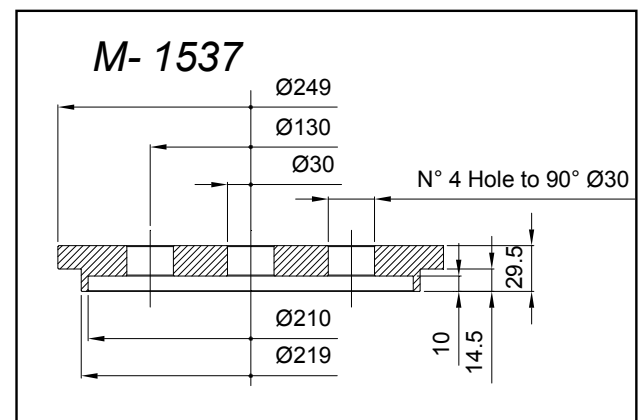

Figure 3-28. Oil Seal Spacer Mounting C125049

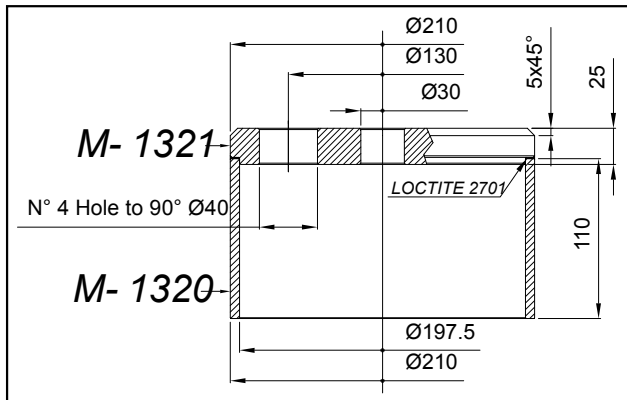

Figure 3-29. Bearing Spacer Mounting CO16117

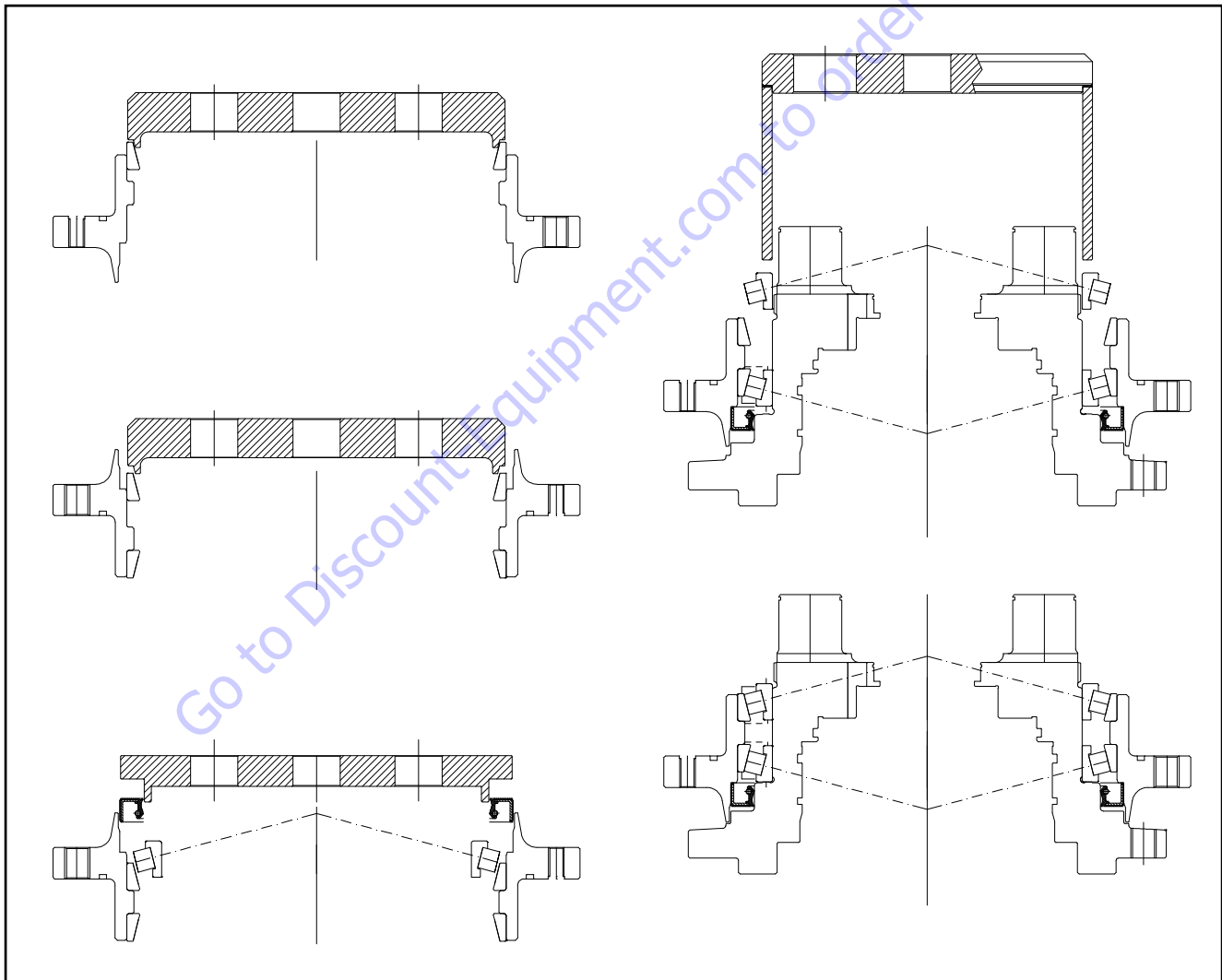

Figure 3-30. Assembly Diagram 1

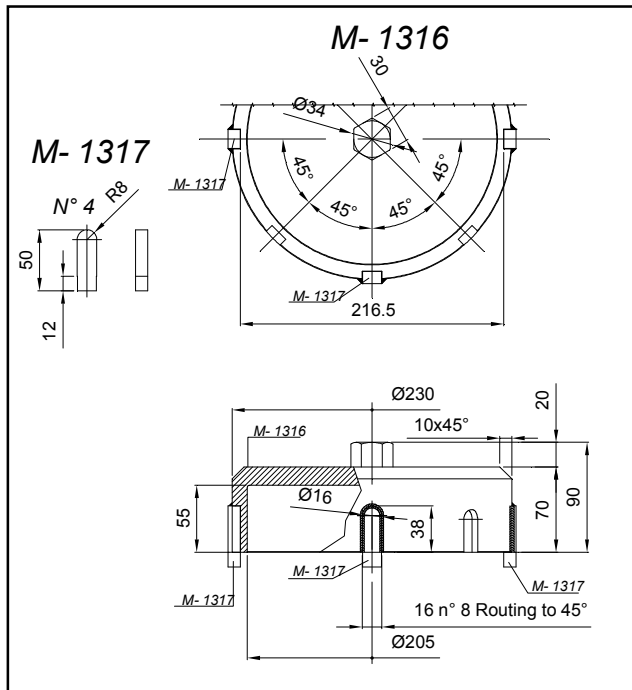

Figure 3-31. Wrench For Ring Nut

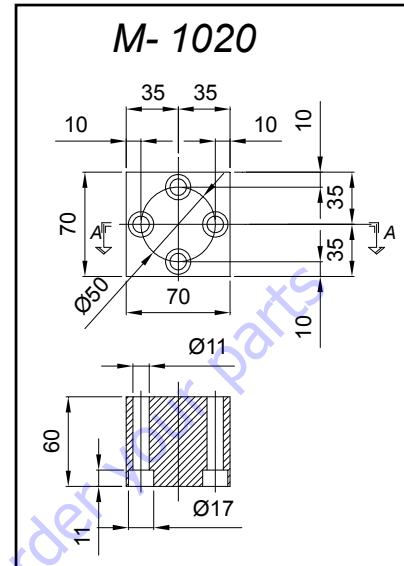

Figure 3-33. Anti-rotation Block

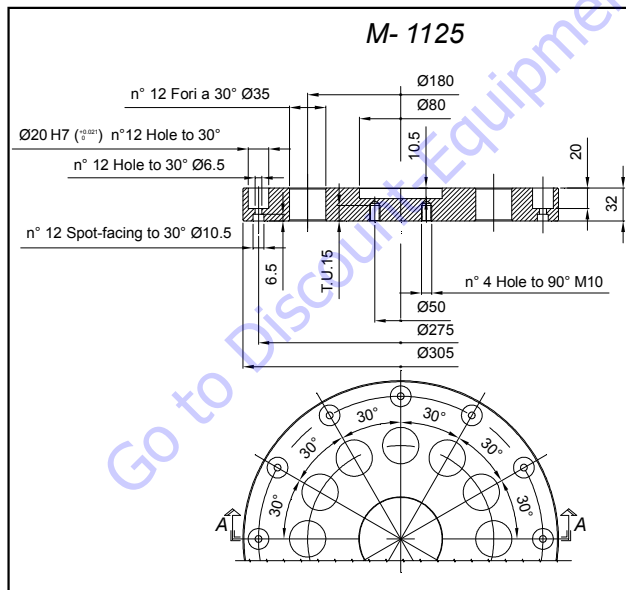

Figure 3-32. Anti-rotation Flange

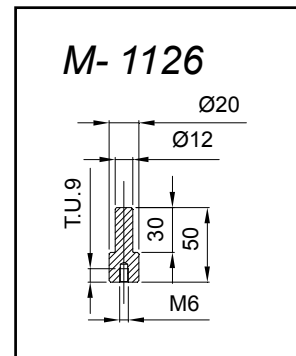

Figure 3-34. Anti-rotation Pin

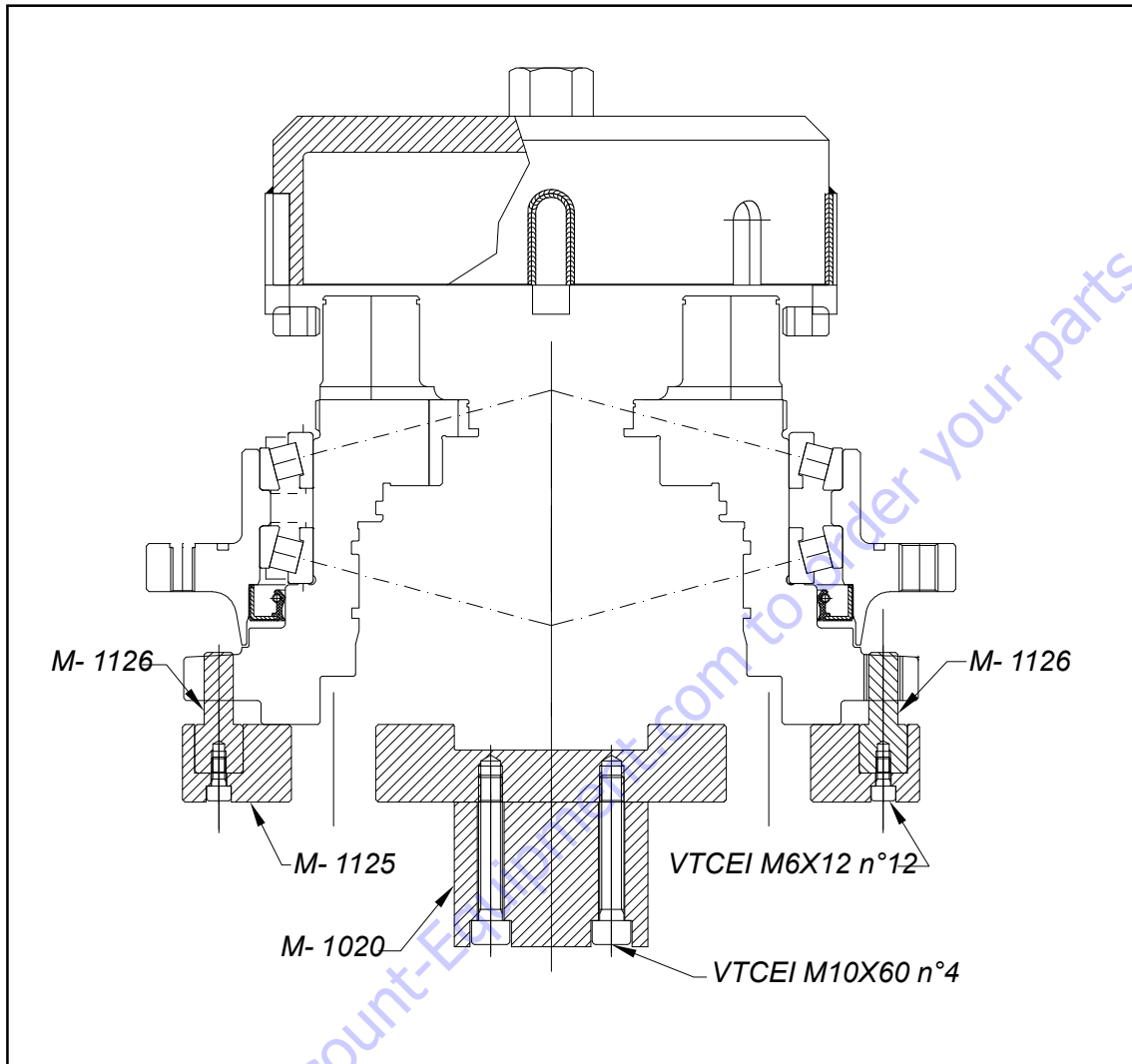

Figure 3-35. Assembly Diagram 2

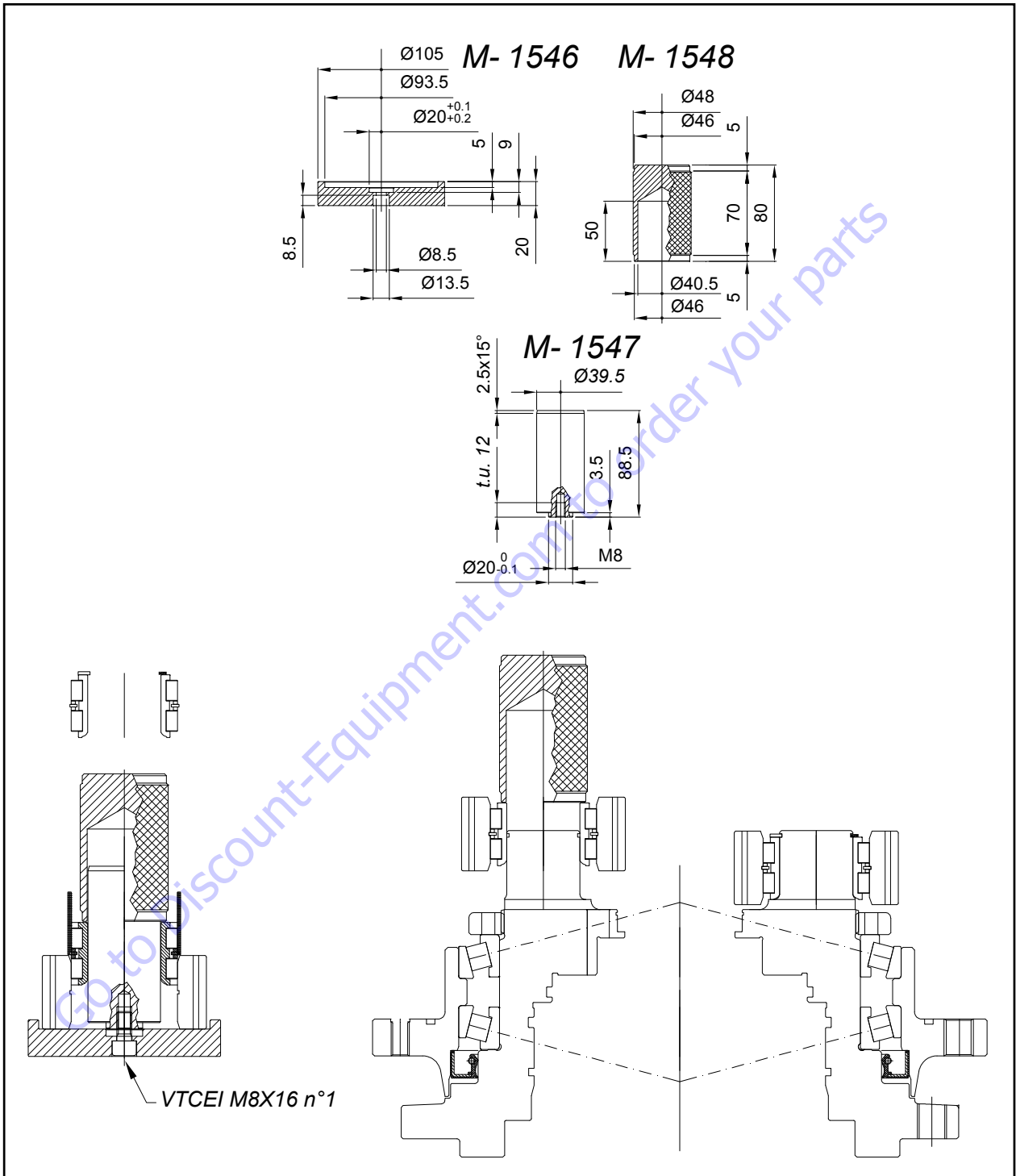
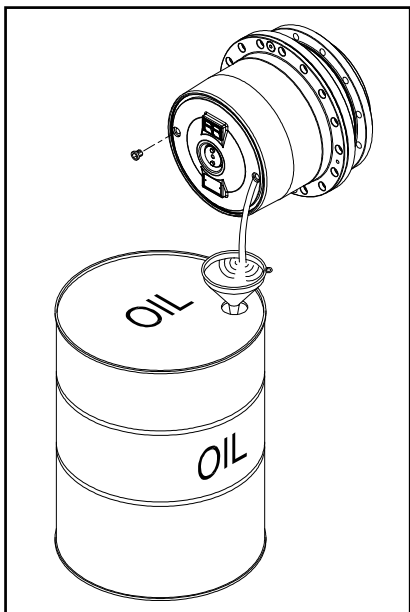

Figure 3-36. Tools For Assembling Bearing 3rd Stage Planetary Gear Assembly Diagram

Disassembly

1. Remove the plugs and pour the lubricant in a container.



2. Release the screws to disassemble the motor flange taking care not to damage the O-Ring.

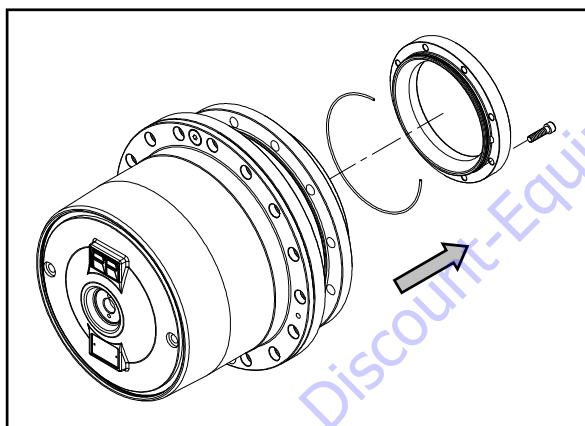

3. Release the screws from the release cover and pull the pin out.

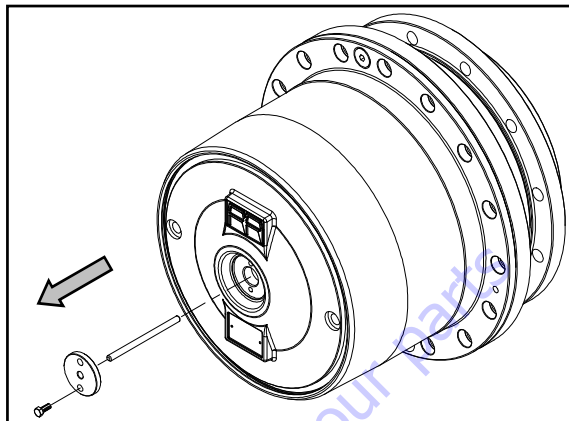

4. Remove the BR250 ring and pull the cover out avoiding to damage the O-Ring.

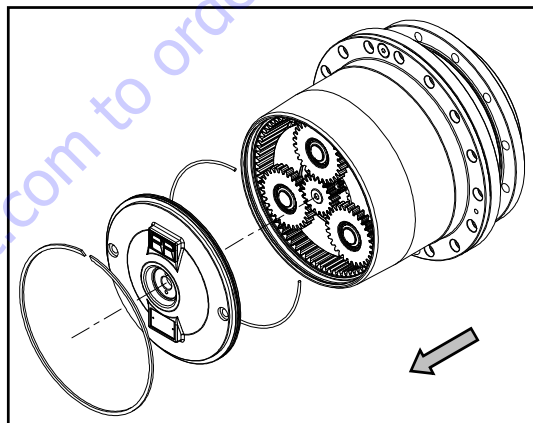

5. Pull the reduction gears out.

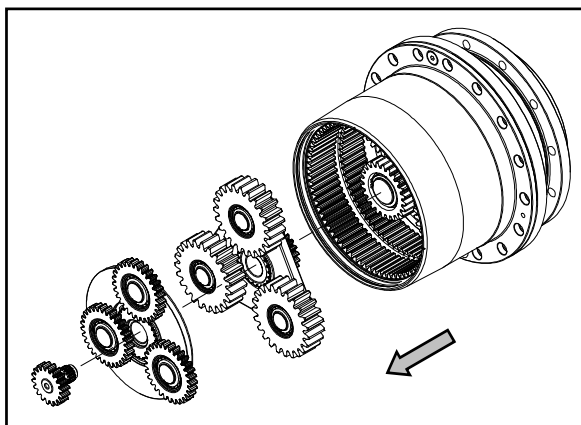

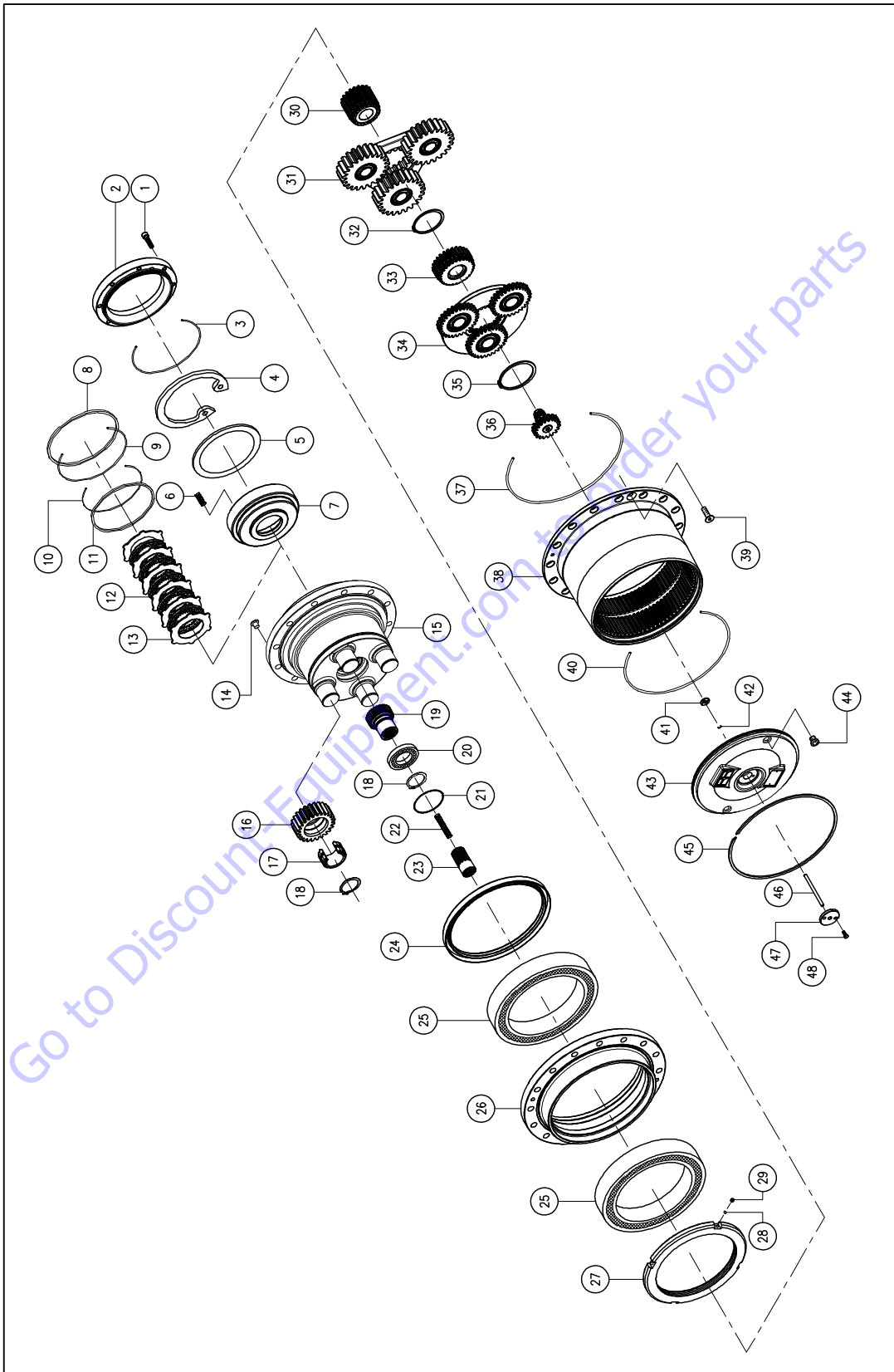
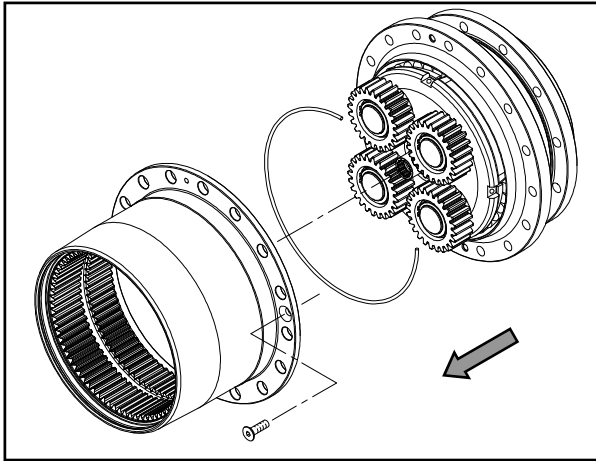

Figure 3-37. Reggiana Reduttori Hub - Sheet 1 of 2

- | | | | |
|-------------------------|--------------------------|----------------------------|--------------------------|
| 1. Screw | 13. Iron Brake Disc | 25. Tapered Roller Bearing | 37. O-ring |
| 2. Motor Support | 14. Plastic Plug | 26. Bearing Support | 38. Crown Gear |
| 3. O-ring | 15. Spindle | 27. Ring Nut | 39. Crown Gear Screw |
| 4. Inner Retention Ring | 16. Planet Wheel | 28. Sphere | 40. O-ring |
| 5. Brake Spring Spacer | 17. Bearing | 29. Screw | 41. Support Tablet |
| 6. Brake Spring | 18. Outer Retention Ring | 30. Pinion | 42. O-ring |
| 7. Brake Piston | 19. Input Shaft | 31. Reduction Gears | 43. Cover |
| 8. Parbak | 20. Input Shaft Bearing | 32. Outer Retention Ring | 44. Steel Plug |
| 9. O-ring | 21. Ring | 33. Pinion | 45. Cover Retaining Ring |
| 10. O-ring | 22. Disengagement Spring | 34. Reduction Gears | 46. Disengagement Stud |
| 11. Parbak | 23. Disengagement Shaft | 35. Outer Retention Ring | 47. Disengagement Cap |
| 12. Sintered Brake Disc | 24. Spindle Oil Seal | 36. Pinion | 48. Disengagement Screw |

Figure 3-38. Reggiana Riduttori Hub - Sheet 2 of 2

- 6.** Loosen the M10x25 flathead socket screws and remove the planetary ring without damaging the O-Ring.



- 9.** Loosen the M6x6 socket headless screws and also remove the 3/16" balls.

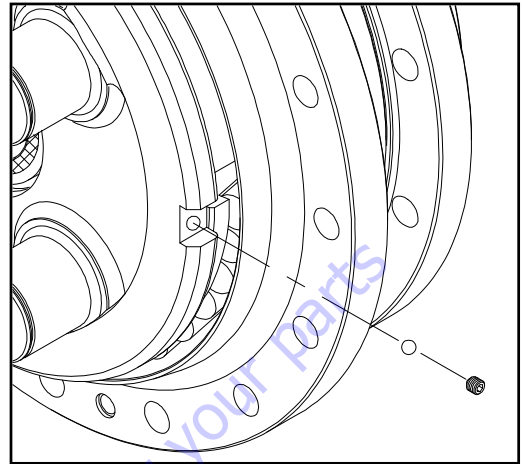

- 7.** Remove the release joint together with the spring.

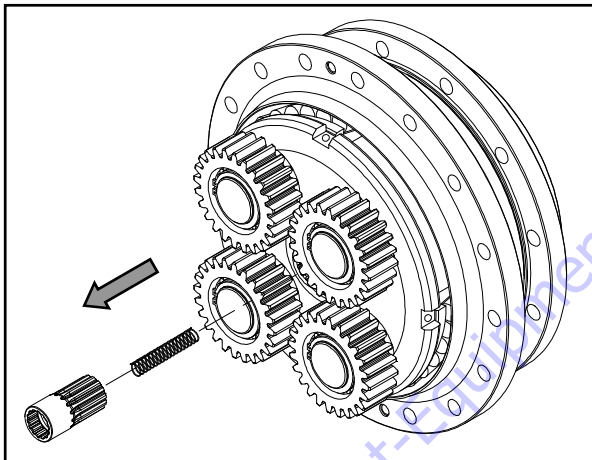

- 10.** Loosen the ring nut using the special wrench.

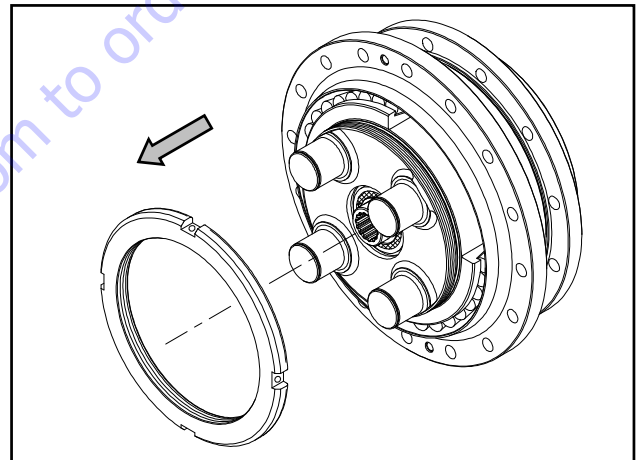

- 8.** Disassemble the Ø40 outer snap rings and using an extractor remove the planetary gears from the spindle pins.

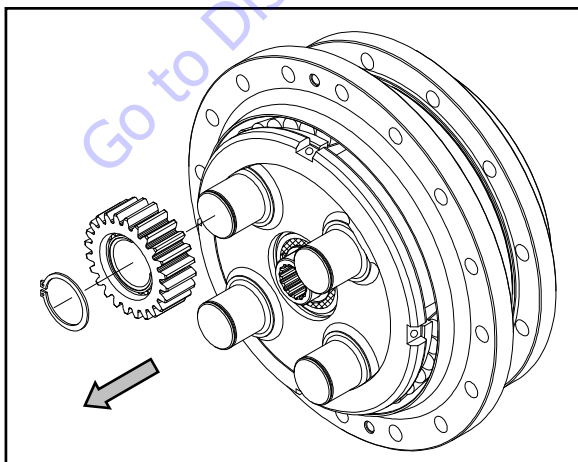

- 11.** Remove the hub support together with the roller bearing inner track.

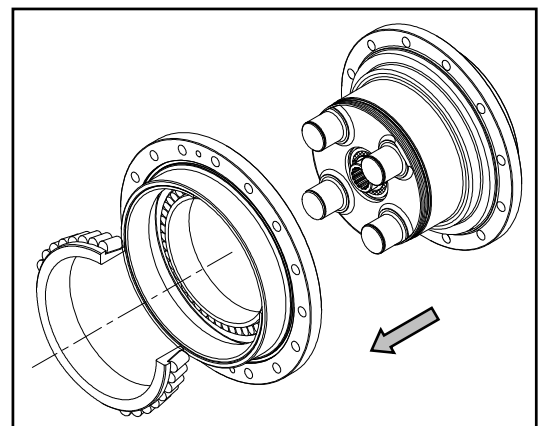

12. Disassemble the $\text{\O}160$ inner snap ring and pull the spring holder spacer out. Remove the springs and using a compressed air jet in the brake control hole pull the piston out of the spindle.

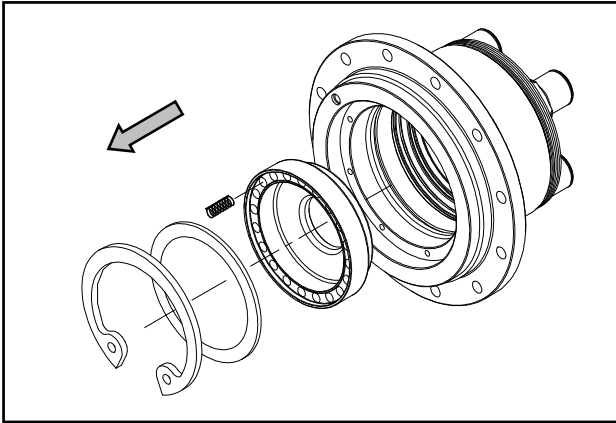

13. Remove the brake discs and seals.

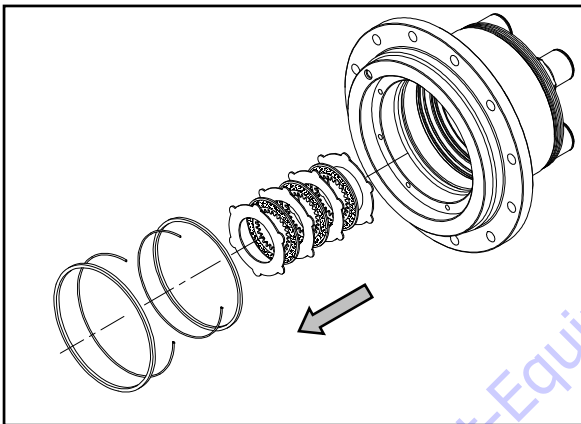

14. Fit the ball bearing into the input shaft and lock it with a $\text{\O}40$ outer snap ring. Then mount the motor shaft in the spindle and lock with a BR68 ring. Lubricate the bearing.

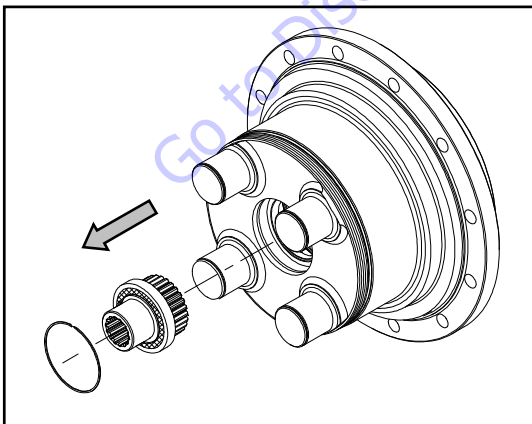

Assembly

1. Make sure all the component parts of the wheel gear are devoid of burrs, machining residues and that they are correctly washed.
2. Fit the ball bearing in the input shaft and lock with a $\text{\O}40$ outer snap ring.

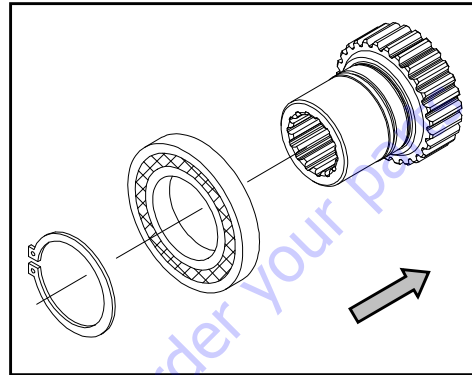

3. Mount the motor shaft in the spindle and lock with BR68 ring. Lubricate the bearing.

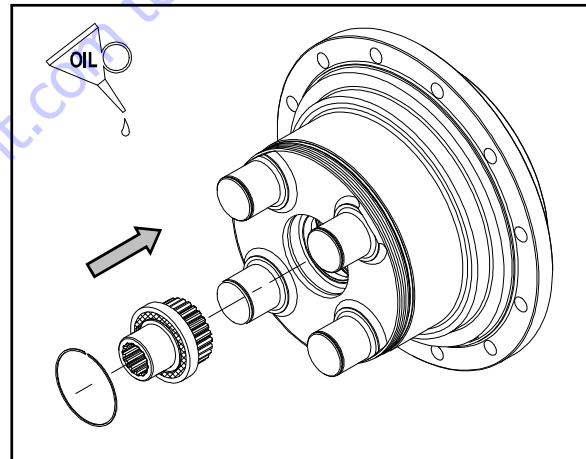

4. Fit the brake sealing rings O-Ring and PARBAK (lubricated with grease) in the respective spindle seats. Place the brake discs making sure to centre them on the spindle and on the input shaft.

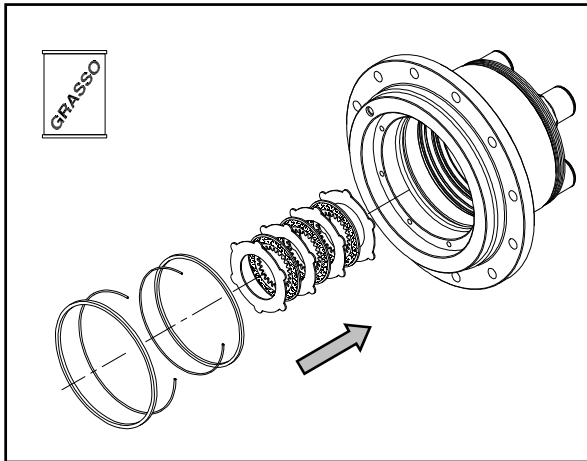

5. Insert the brake piston and place the springs into the piston holes. Close the brake fitting the spring holder plate, then lock with the Ø160 inner snap ring. Check the brake leakage, if any, as well as the static torque and minimum opening pressure.

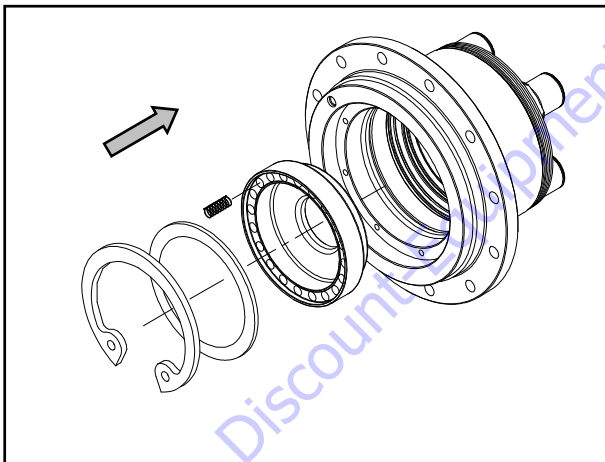

6. Prepare the hub support, mounting on it the two roller bearing outer tracks. Place the first roller bearing inner track.

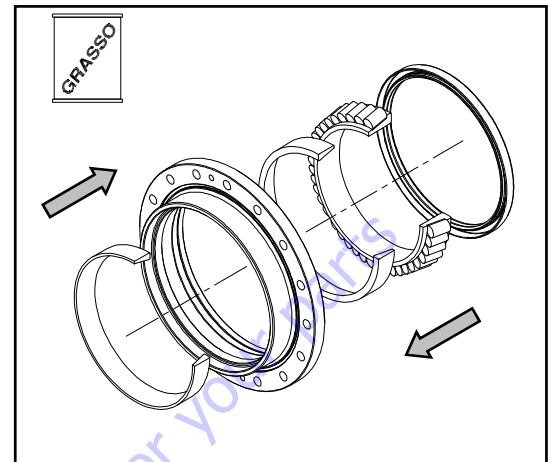

7. Fit the oil seal lubricated with grease onto the support with the special spacer mounting (see figure A).

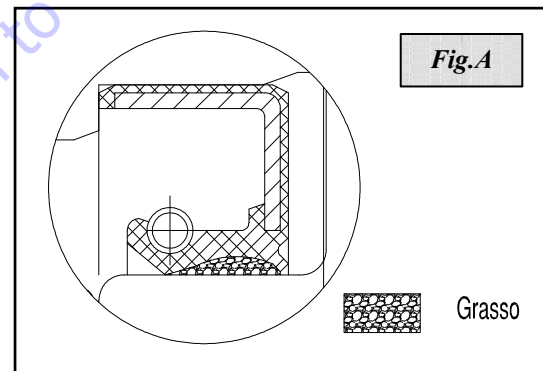

8. Place the hub support already assembled on the spindle making sure that the first roller bearing inner track goes correctly against it; then fit the second roller bearing inner track by means of the spacer mounting. Tighten the ring nut.

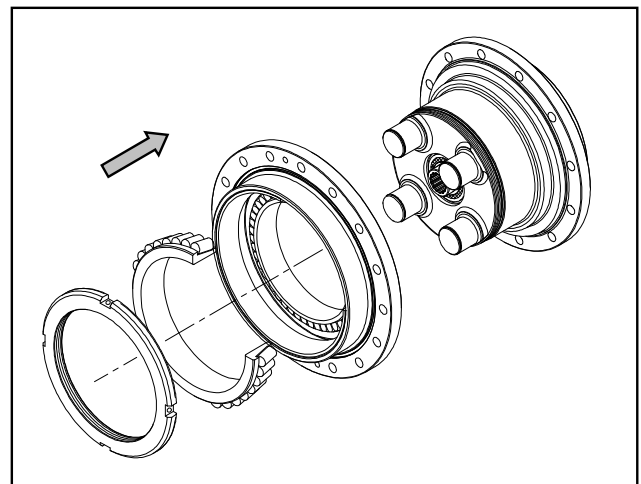

SECTION 3 - CHASSIS & TURNTABLE

9. Now check the unit roll torque and proceed in the following order:
10. By keeping the spindle locked, apply a setting preload by tightening the ring nut at 40daNm, turn completely the hub support twice using the special wrench to recover any bearing cage misalignments. Release and tighten the ring nut at the final torque of 30daNm (alternate tightening and some setting turns). Check the roll torque with seal which must be within $1 \div 1,5$ daNm.

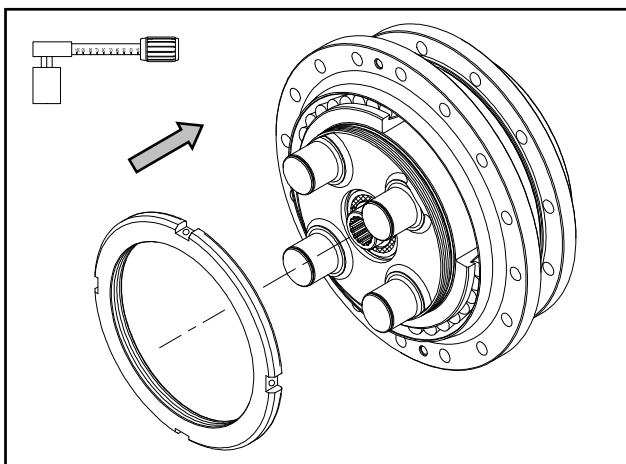

NOTE: Place the ring nut with its convex part facing the roller bearing as shown below.

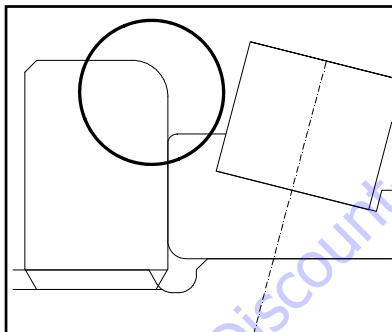

11. Using the special tool and hammer make four dents on the spindle thread by the M6 holes of the ring nut.

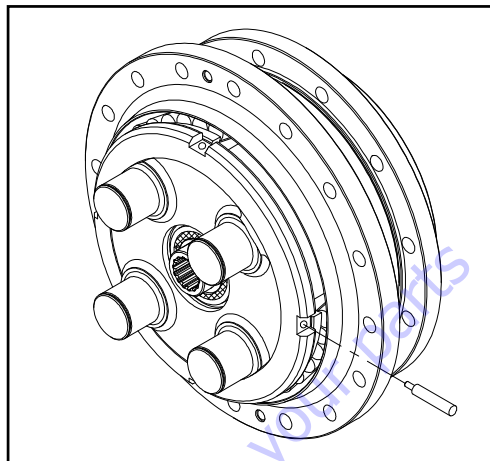

12. Fit the 4 3/16" balls and tighten with LOCTITE 243 the 4 M6x6 socket headless screws at the torque of 1daNm.

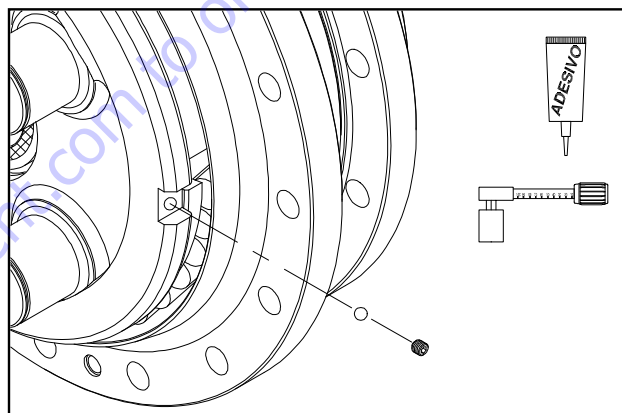

13. Fit the bearings onto the 3rd stage planetary gears and using a spacer mounting mount everything on the spindle pins. Lock with a \dot{y} 40 outer snap ring. Lubricate the bearings.

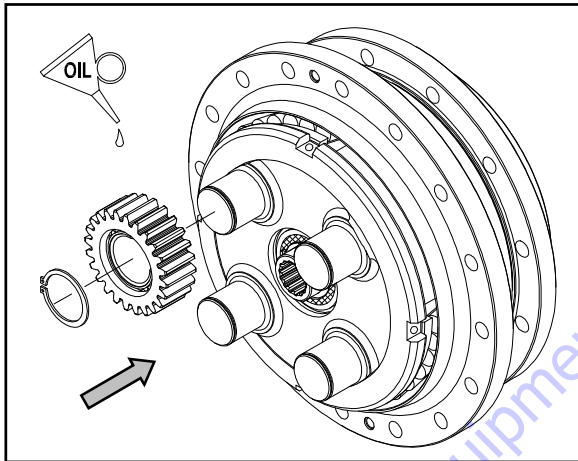
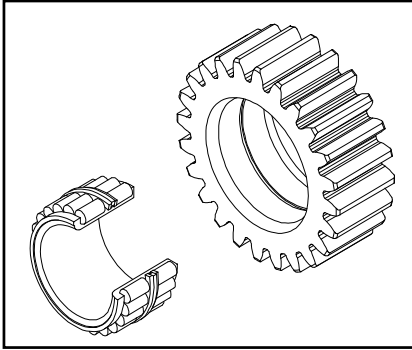

14. Using a marking pen, make a mark between the snap ring and the bearing. Fit the greased spring and the release joint. Use grease to fit the O-Ring 2-275 in the hub support seat.

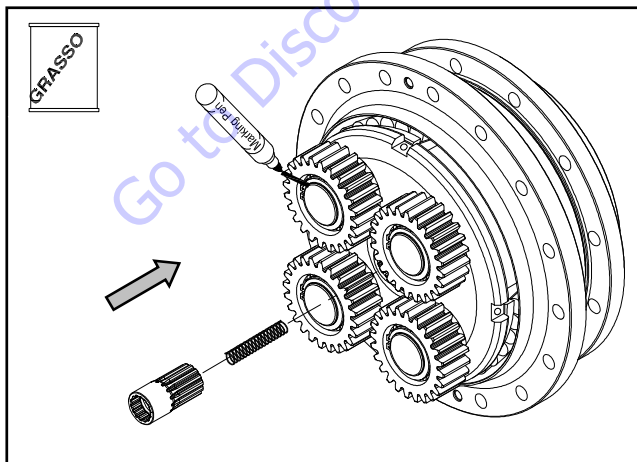

15. Place the hub onto the support making the two holes coincide for tightening the M10x25 flathead socket screws at the torque of 5daNm.

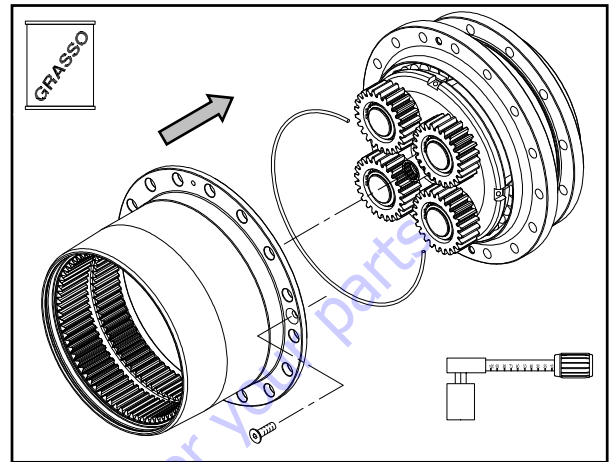

16. Fit the reduction gears and the pinion in the unit.

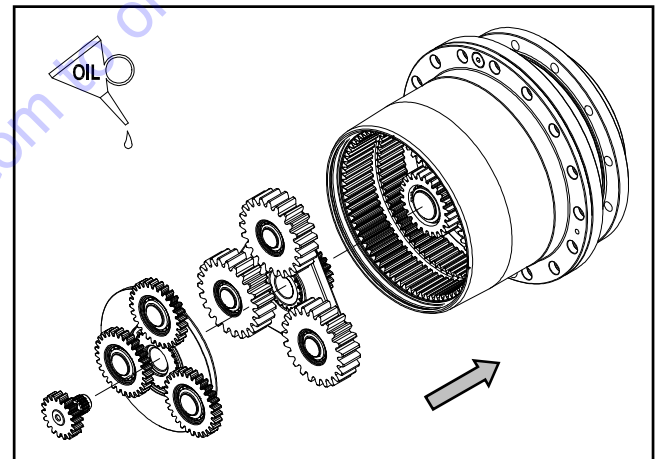

SECTION 3 - CHASSIS & TURNTABLE

17. Prepare the closing cover fitting the O-ring 5-582 suitably greased and lock it with the shimming ring. Lubricate the bearings.

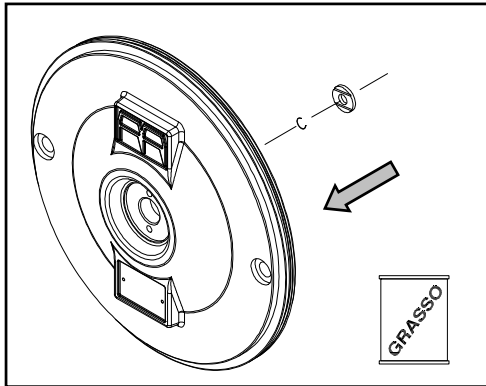

18. Fit the O-Ring 2-177 suitably greased, mount the cover locking it with the BR250 ring.

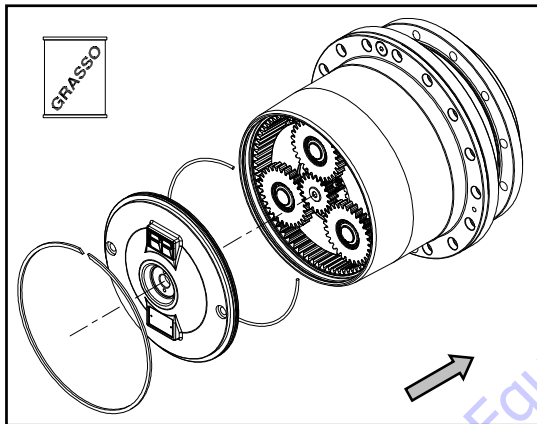

19. Fit the O-Ring 2-163 suitably greased, onto the motor coupling flange S-D LC/KC. Mount the flange on the spindle with 6 M8x25 socket cap screws at the torque of 2.4daNm with LOCTITE 243. Insert the pin and carry out the rotation test according to PGQ-22 standard.

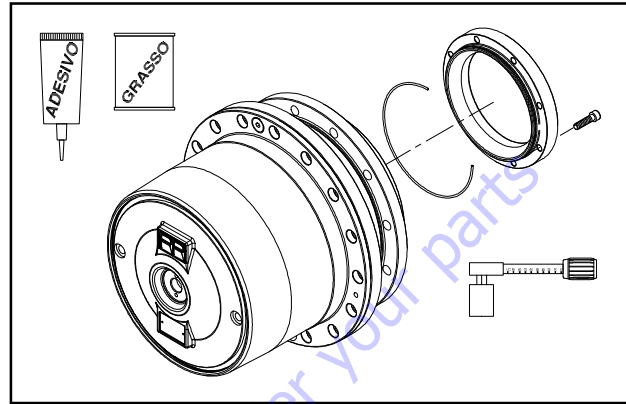

20. Mount the release cover fastening it with 2 M6x20 hexagonal screws at the torque of 1daNm. Mount the 1/4" GAS plugs on the cover at the torque of 1daNm.

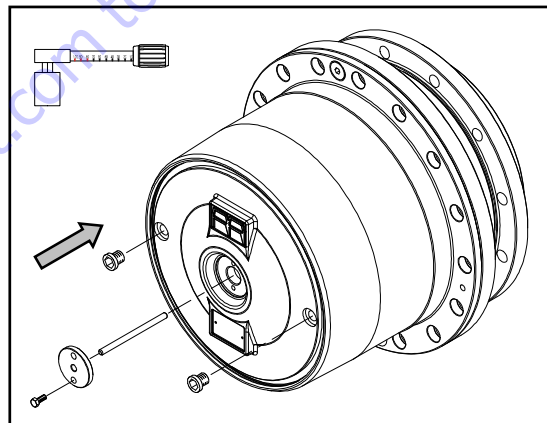

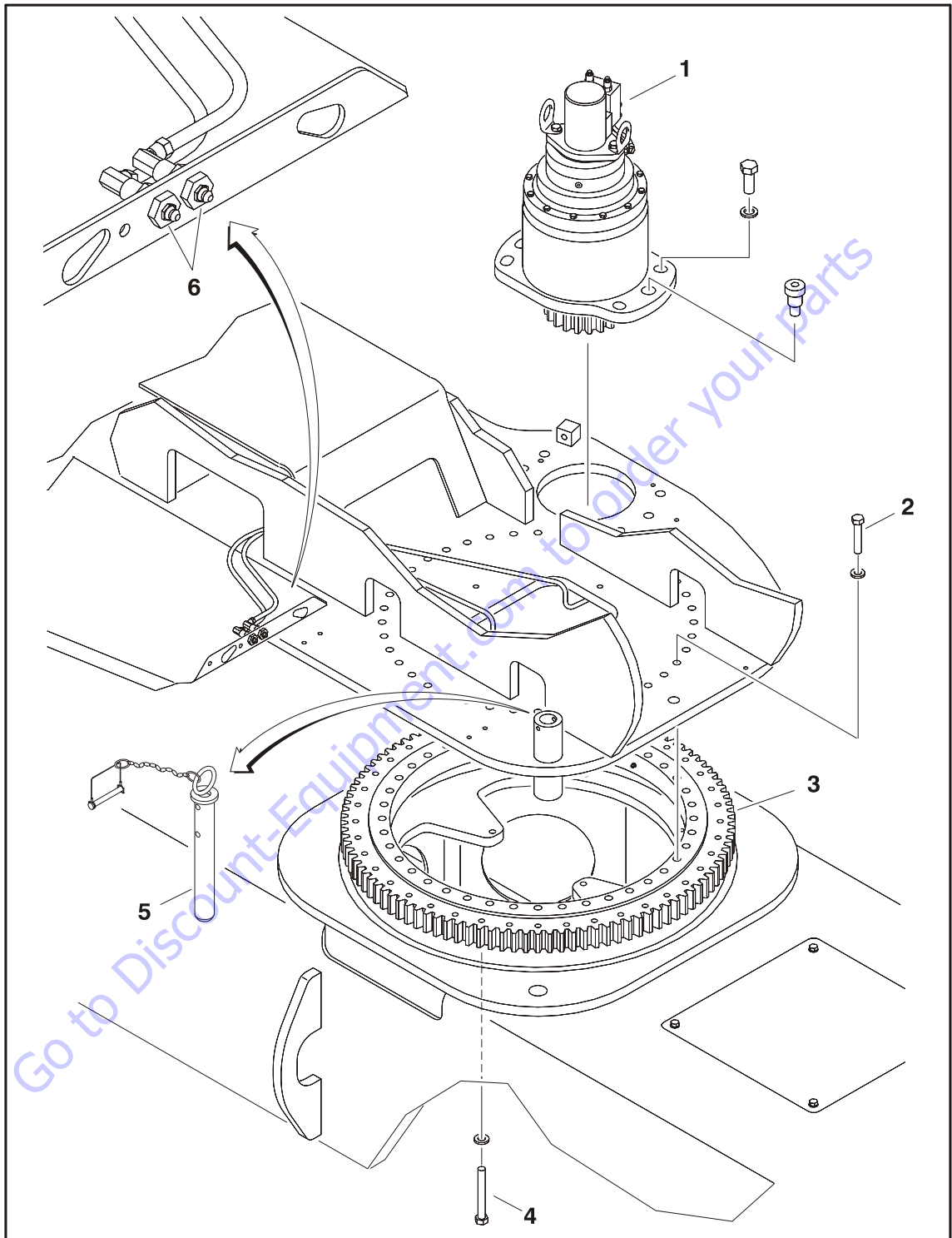

- | | |
|----------------------------|--|
| 1. Swing Drive | 4. Outer Race Bearing Bolt |
| 2. Inner Race Bearing Bolt | 5. Turntable Lock Pin |
| 3. Swing Bearing | 6. Remote Bearing Lubrication Fittings |

Figure 3-39. Swing System (SN 030020900 through 0300254531)

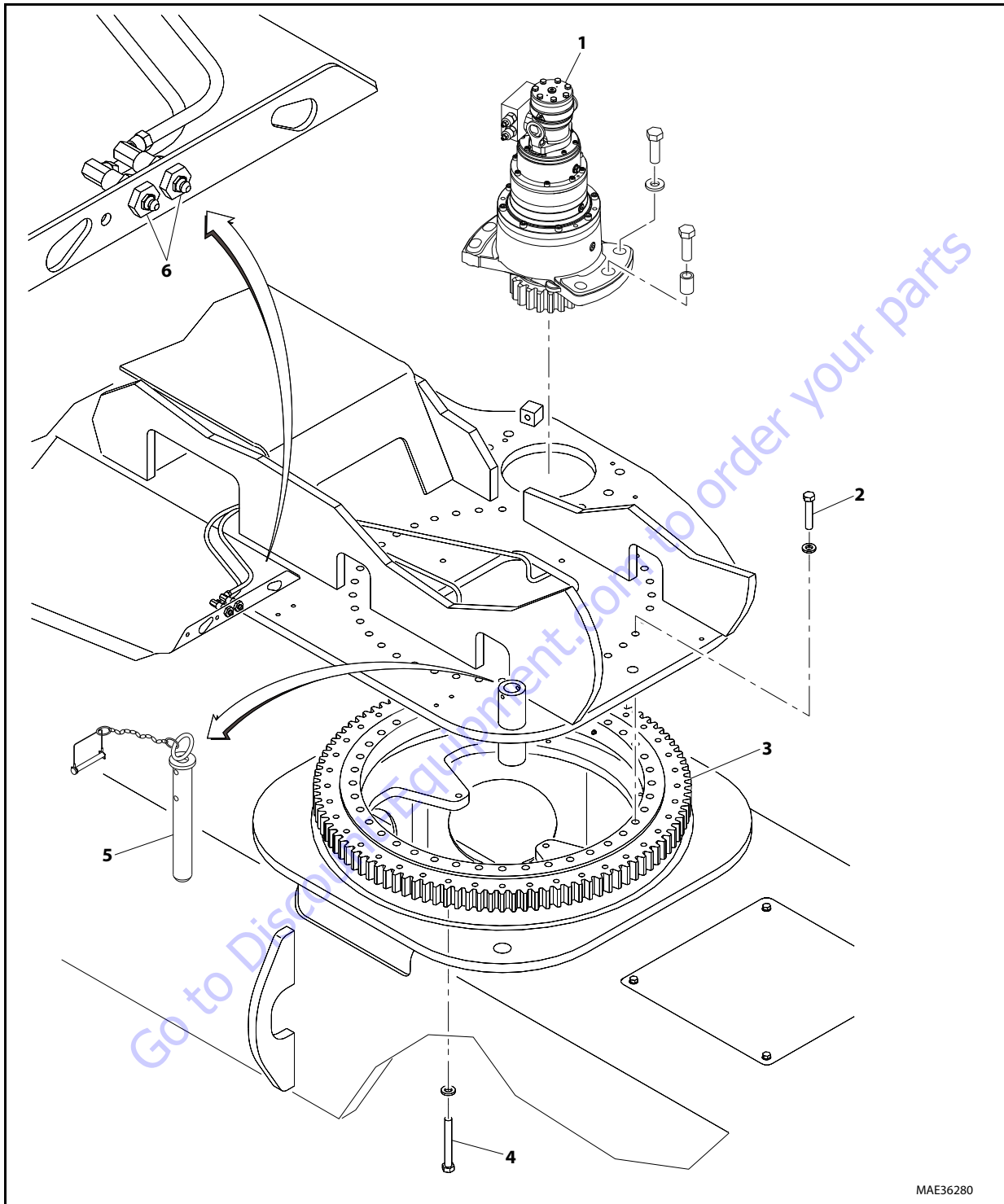

- | | |
|----------------------------|--|
| 1. Swing Drive | 4. Outer Race Bearing Bolt |
| 2. Inner Race Bearing Bolt | 5. Turntable Lock Pin |
| 3. Swing Bearing | 6. Remote Bearing Lubrication Fittings |

Figure 3-40. Swing System (SN 0300254532 to Present)

3.15 SWING DRIVE

Roll and Leak Testing

Torque-Hub units should always be roll and leak tested before disassembly and after assembly to make sure that the unit's gears, bearings and seals are working properly. The following information briefly outlines what to look for when performing these tests.

NOTE: *The brake must be released before performing the roll test. This can be accomplished by either pressure testing using the Brake Leak Test procedure below or by tightening the 12 bolts into the piston through the end plate (See Brake Disassembly Procedure)*

NOTE: *Bolts must be removed while performing brake release test*

Roll Test

The purpose of the roll test is to determine if the unit's gears are rotating freely and properly. You should be able to rotate the gears in your unit by applying constant force to the roll checker. If you feel more drag in the gears only at certain points, then the gears are not rolling freely and should be examined for improper installation or defects. Some gear packages roll with more difficulty than others. Do not be concerned if the gears in your unit seem to roll hard as long as they roll with consistency.

LEAK TEST (MAIN UNIT)

The purpose of a leak test is to make sure the unit is air tight. You can tell if your unit has a leak if the pressure gauge reading on your air checker starts to fall after the unit has been pressurized and allowed to equalize. Leaks will most likely occur at the pipe plugs, the main seal or wherever o-rings or gaskets are located. The exact location of a leak can usually be detected by brushing a soap and water solution around the main seal and where the o-rings or gaskets meet on the exterior of the unit, then checking for air bubbles. If a leak is detected in a seal, o-ring or gasket, the part must be replaced, and the unit rechecked. Leak test at 10 psi (0.7 bar) for 20 minutes.

Tightening and Torquing Bolts

If an air impact wrench is used to tighten bolts, extreme care should be taken to ensure that the bolts are not tightened beyond their specified torque.

The following steps describe how to tighten and torque bolts or socket head cap screws in a bolt circle.

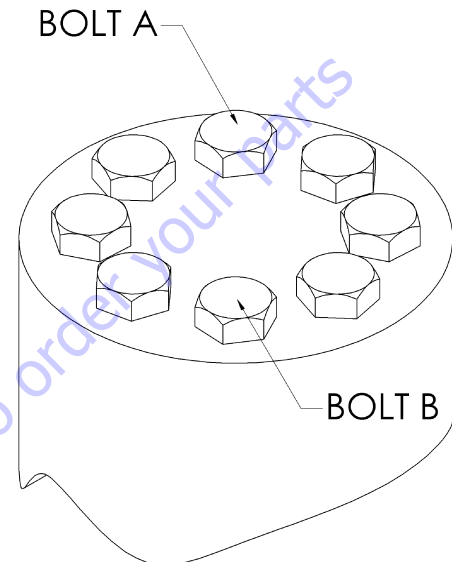

1. Tighten (but do not torque) bolt "A" until snug.
2. Go to the opposite side of the bolt circle and tighten bolt "B" until equally snug.
3. Crisscross around the bolt circle and tighten remaining bolts.
4. Now use a torque wrench to apply the specified torque to bolt "A".
5. Using the same sequence, crisscross around the bolt circle and apply an equal torque to the remaining bolts.

Motor Control Valve Disassembly

1. Place unit on bench with the motor end up.
2. Remove O-ring Plug (1J) and drain the oil from the gear-box.
3. Remove Hydraulic Tubing Assembly (35) by loosening fittings on both ends of tube with a wrench.
4. Using a wrench, loosen jam nuts on Elbow Fittings (36) and remove fittings from Brake (26) and Motor Control Valve (32).
5. Remove O-ring Plugs (21) from Motor Control Valve (32).
6. Remove Motor Control Valve (32) from Motor (10) by removing the four Bolts (34) and washers (33).

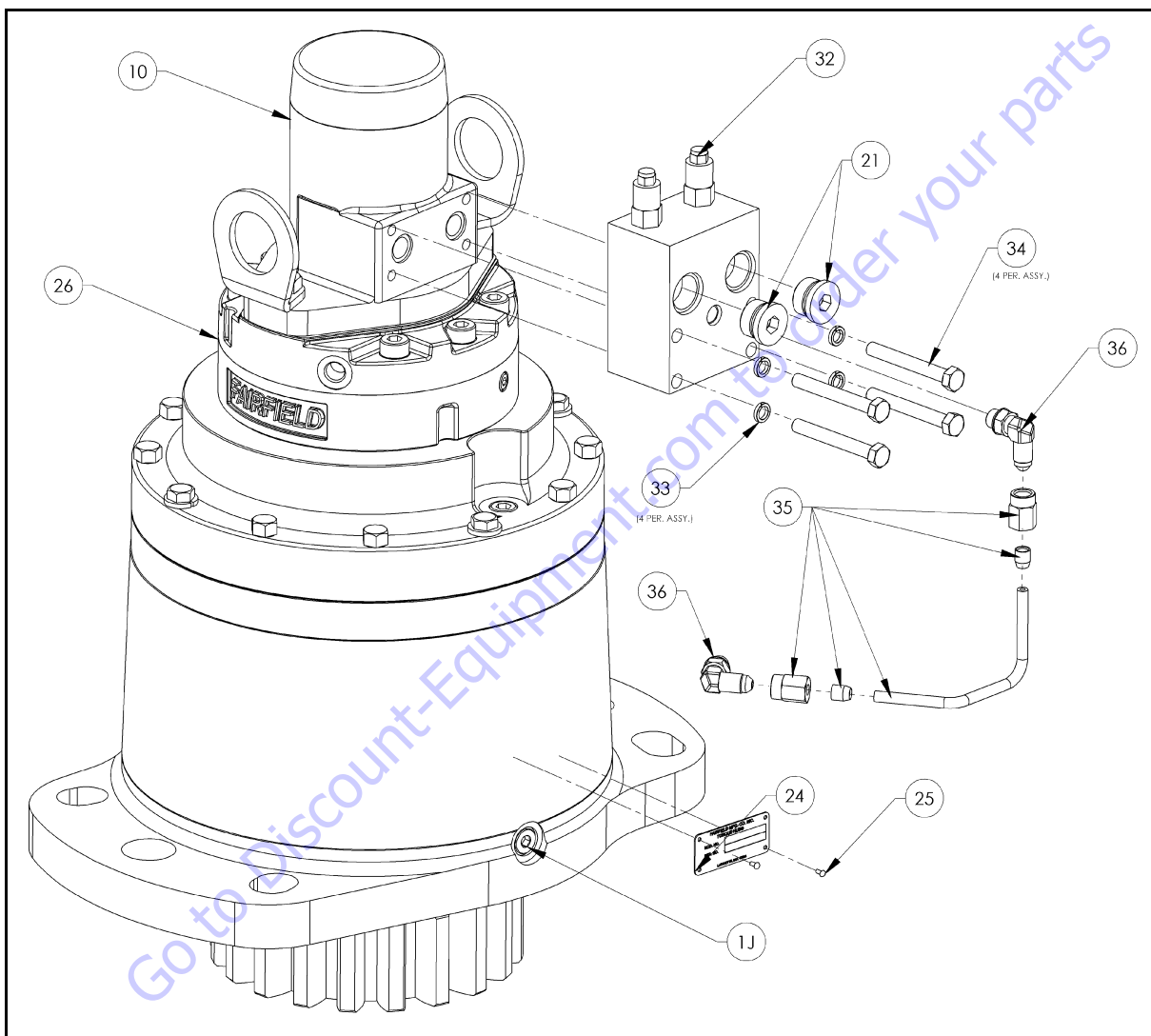

- | | |
|---------------------|-------------------------|
| 1J. O-Ring Plug | 32. Motor Control Valve |
| 10. Hydraulic Motor | 33. Lockwasher |
| 21. Plug | 34. Hex Bolt |
| 24. ID Plate | 35. Hydraulic Tubing |
| 25. Drive Screw | 36. Elbow |
| 26. Hydraulic Brake | |

**Figure 3-41. Swing Drive - Motor Control Valve Disassembly
(SN 030020900 through 0300254531)**

Motor and Brake Disassembly

1. With unit resting on bench with Motor (10) end up, loosen Hex Bolts (29) and remove Lift Lugs (28) from the Motor (10).
2. Pull Motor (10) straight up and remove Motor (10) from Brake (26).
3. Remove Gasket (31) from between Brake (26) and Motor (10).
4. Remove Brake (26) from Main Torque-Hub Assembly and dump oil out of Brake (26).
5. Remove O-ring (27) from between Motor (10) and Brake (26).

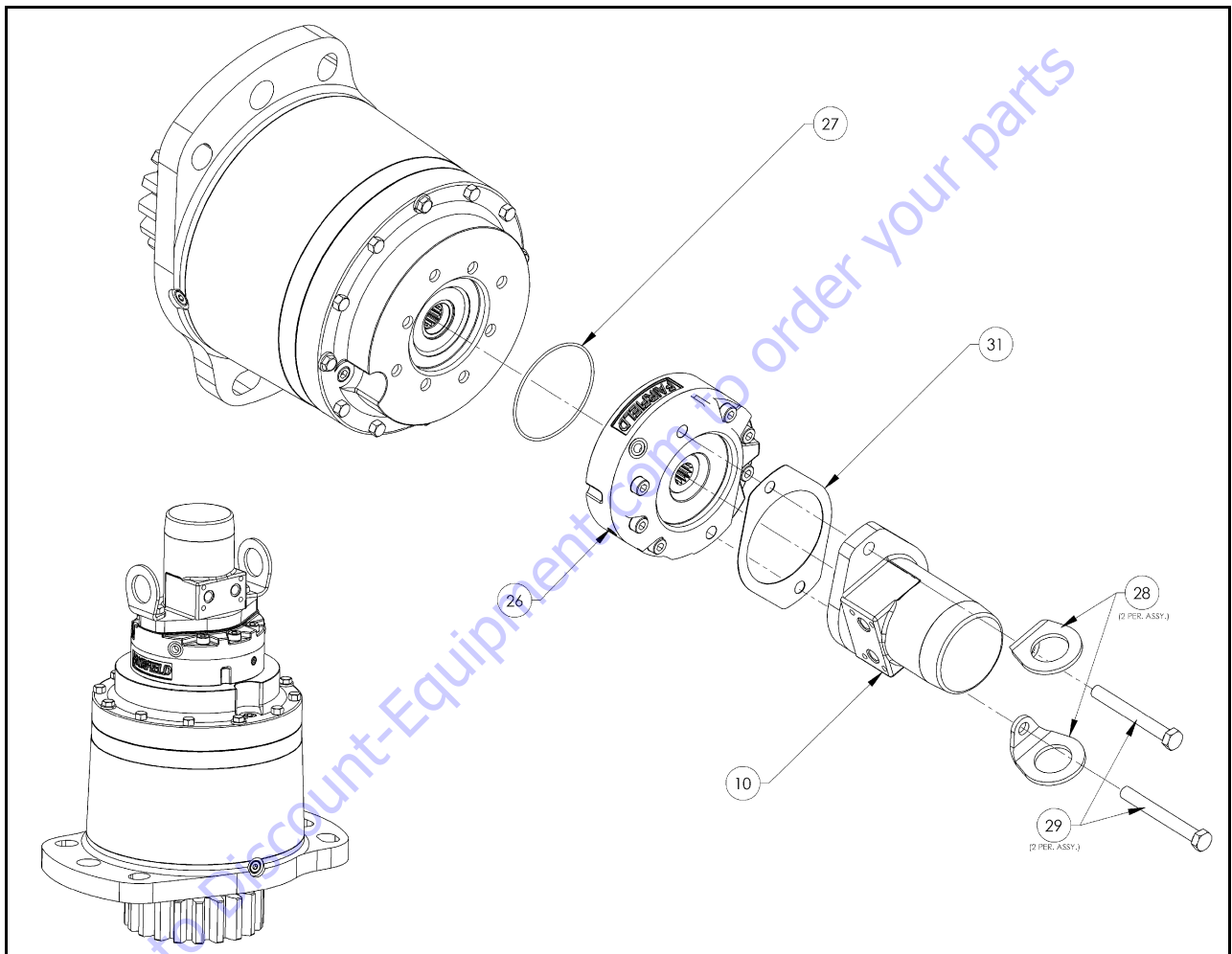

- | | |
|---------------------|--------------|
| 10. Hydraulic Motor | 28. Lift Lug |
| 26. Hydraulic Brake | 29. Bolt |
| 27. O-Ring | 31. Gasket |

**Figure 3-42. Swing Drive - Motor and Brake Disassembly
(SN 030020900 through 0300254531)**

Main Disassembly

1. With the unit resting on the Output Shaft (Pinion) (1A), remove the eight Bolts (17), four Shoulder Bolts (18) and four Lock Washers (19) from the Input Cover (6).
2. Thread either 1/2-13 UNC eye bolts or motor mounting Bolts (29) into threaded holes in Input Cover (6) and pull Input Cover (6) off on the main assembly.
3. Remove O-ring (5) from between Input Cover (6) and Ring Gear (4).
4. Remove Thrust Washer (8) from end of Sun Gear (13).
5. Remove Sun Gear (13).
6. Remove Thrust Washers (16) and Thrust Bearing (15) from between Input Cover (6) and Carrier (3A) Subassembly.
7. Remove Ring Gear (4) from Housing (1G).
8. Remove O-ring (5) from between Ring Gear (4) and Housing (1G).
9. Remove Carrier (3A) Subassembly.
10. Remove Thrust Washers (16) and Thrust Bearing (15) from between Carrier (3A) Subassembly and Internal Gear (2).
11. Remove Internal Gear (2).

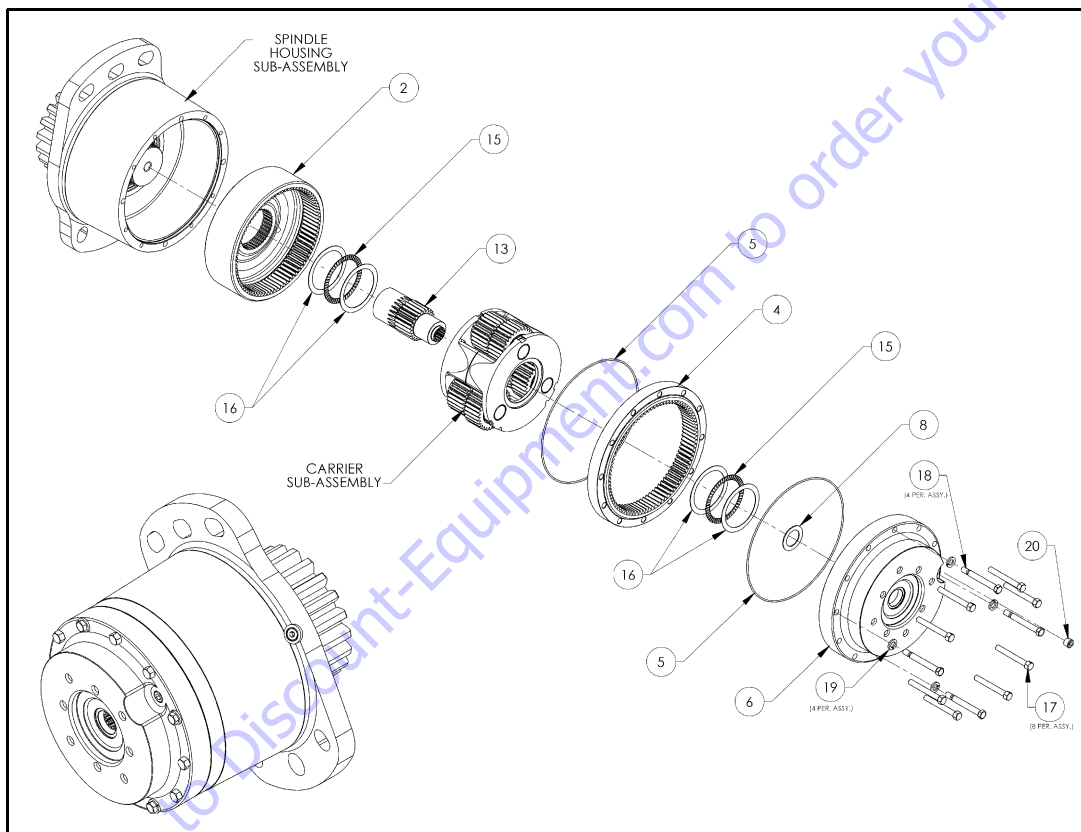

- | | |
|------------------|--------------------|
| 2. Internal Gear | 15. Thrust Bearing |
| 4. Ring Gear | 16. Thrust Washer |
| 5. O-Ring | 17. Hex Bolt |
| 6. Input Cover | 18. Shoulder Bolt |
| 8. Hex Bolt | 19. Lockwasher |
| 13. Sun Gear | 20. Pipe Plug |

**Figure 3-43. Swing Drive - Main Disassembly
(SN 030020900 through 0300254531)**

Hub-Shaft Disassembly

1. Using retaining ring pliers, remove Retaining Ring (1I) from groove in Output Shaft (1A) and discard.

⚠ WARNING

EYE PROTECTION SHOULD BE WORN DURING THIS PROCEDURE.

2. Remove Thrust Washer (1H).
3. While supporting the Housing (1G) on the Output Shaft (1A) end, press the Output Shaft (1A) out of the Housing (1G).

NOTE: The Lip Seal (1B) may or may not be pressed out of the Housing (1G) by the Bearing Cone (1D) during this step.

4. Remove the Bearing Cone (1F) from the Housing (1G).
5. Invert the Housing (1G) and remove the Lip Seal (1B) if not already removed when Output Shaft (1A) was pressed out of Housing (1G).
6. Remove the Bearing Cone (1D).
7. Bearing Cups (1C & 1E) will remain in Housing (1G).

NOTE: If bearing replacement is necessary, the Bearing Cups (1C & 1E) can be removed with a slide hammer puller or driven out with a punch.

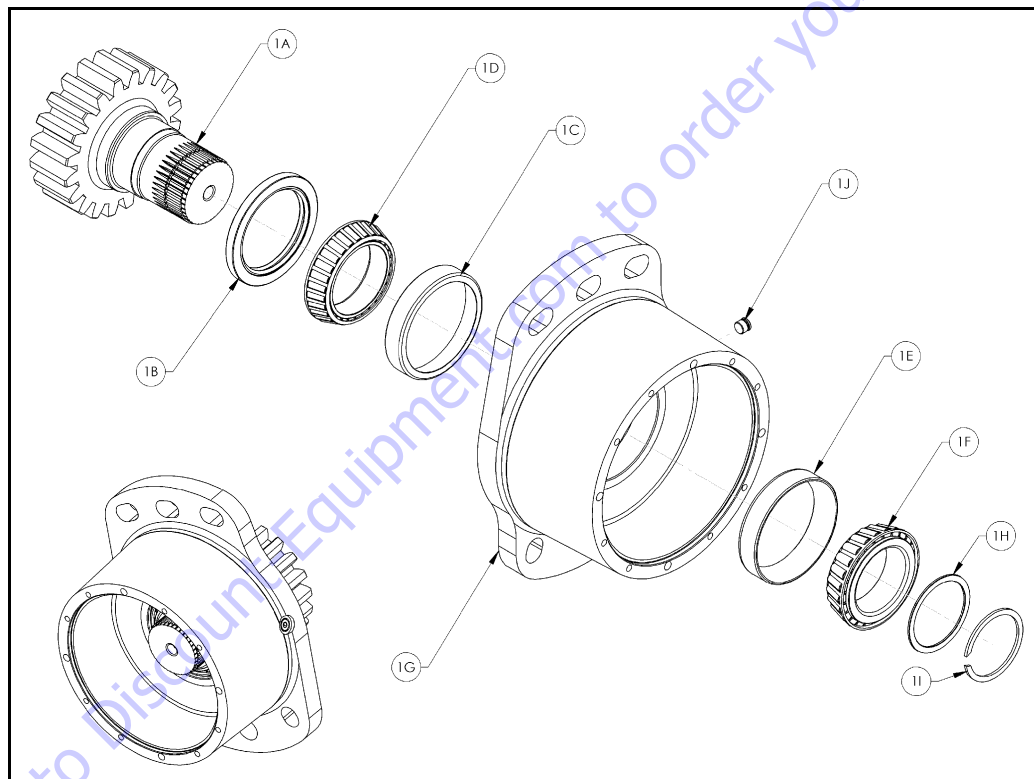

- | | |
|--------------------------|--------------------------|
| 1A. Output Shaft | 1F. Tapered Bearing Cone |
| 1B. Lip Seal | 1G. Housing |
| 1C. Tapered Bearing Cup | 1H. Thrust Washer |
| 1D. Tapered Bearing Cone | 1I. Retaining Ring |
| 1E. Tapered Bearing Cup | 1J. O-Ring Plug |

**Figure 3-44. Swing Drive - Hub Shaft Disassembly
(SN 030020900 through 0300254531)**

Carrier Disassembly

1. Using a 3/16" (5 mm) punch drive the Roll Pin (3G) which holds the Planet Shaft (3E) in the Carrier (3A) down into the Planet Shaft (3E) until it bottoms.

NOTE: Make sure that the Roll Pin has bottomed. Otherwise, damage to the carrier could occur when the Planet Shaft is removed.

2. Remove the Planet Shaft (3E) from the Carrier (3A). Use a small punch to remove the Roll Pin (3G) from the Planet Shaft (3E).

3. Slide the Planet Gear (3F), two Ball-Indented Thrust Washers (3H) and the two Thrust Washers (3B) out of the Carrier (3A).
4. Remove both rows of Needle Bearings (3C) and the Spacer (3D) from the bore of the Planet Gear (3F).
5. Repeat Steps 1 thru 4 for the remaining two Cluster Gears(3F).

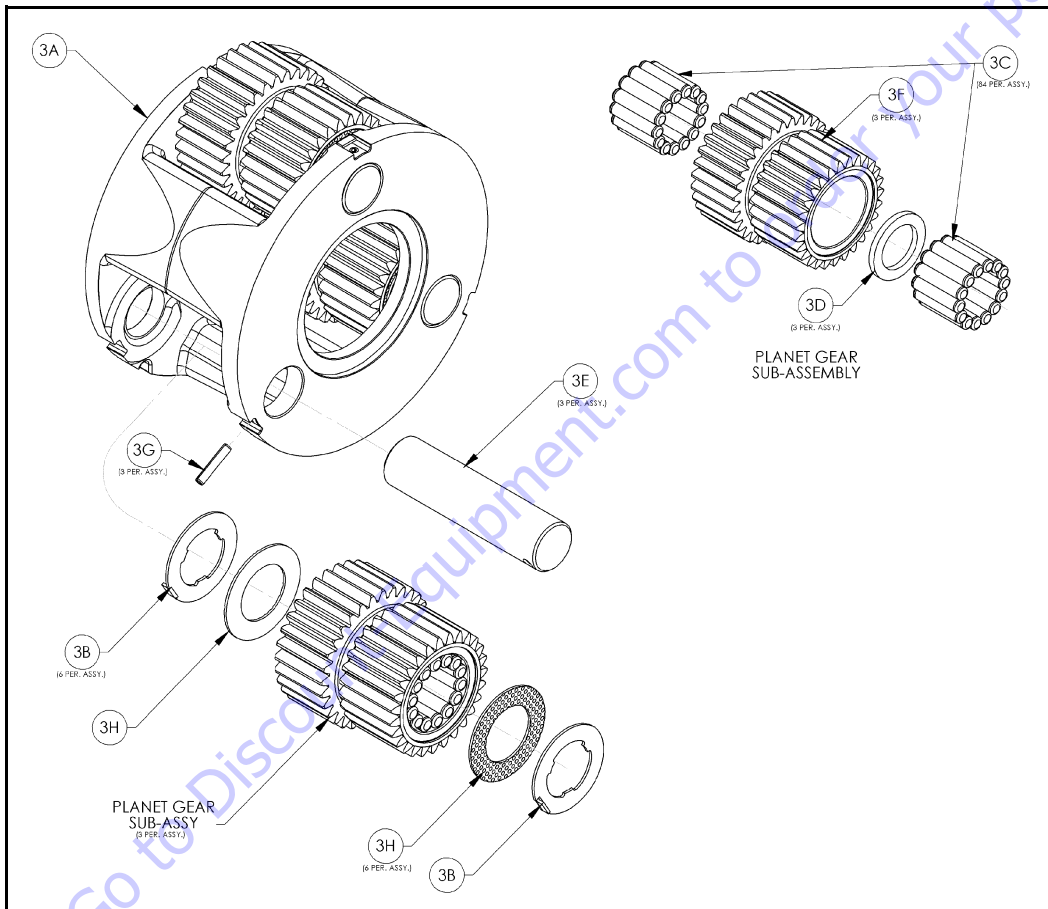

- | | |
|--------------------------|--------------------------|
| 3A. Carrier | 3E. Planet Shaft |
| 3B. Tanged Thrust Washer | 3F. Cluster Gear |
| 3C. Needle Bearing | 3G. Roll Pin |
| 3D. Thrust Washer | 3H. Ball Indented Washer |

**Figure 3-45. Swing Drive - Carrier Disassembly
(SN 030020900 through 0300254531)**

Hub-Shaft Sub-Assembly

NOTE: Refer to Figure 3-44., Swing Drive - Hub Shaft Disassembly (SN 030020900 through 0300254531).

1. Press Bearing Cone (1D) onto Shaft (1A).
2. Press Bearing Cup (1C) into Housing (1G), take care to insure cup starts square with bore of Hub (1G).
3. Place Bearing Cone (1D) in Bearing Cup (1C) in Housing (1G).
4. Press or tap Seal (1B) into the counterbore of Housing (1G) to the point where it becomes flush with the Housing (1G) face. Care should be taken to insure Seal (1B) is being correctly installed (smooth face up).
5. Invert Hub (1G) and press Bearing Cup (1E) into counterbore of Housing (1G).
6. Carefully lower Housing (1G) onto the Output Shaft (1A).
7. Start the Bearing Cone (1F) onto the Output Shaft (1A).
8. Press or tap the Bearing Cone (1F) onto the Output Shaft (1A) until it is seated in the Bearing Cup (1E).
9. Install Bearing Spacer (1H) onto Output Shaft (1A) and against Bearing Cone (1F).
10. Install Retaining Ring (1I) into the groove in the Output Shaft (1A). This Retaining Ring (1I) should never be reused in a repair or rebuild.

⚠ WARNING

EYE PROTECTION SHOULD BE WORN DURING THIS PROCEDURE.

11. Tap the Retaining Ring (1I) with a soft metal punch to ensure that the Retaining Ring (1I) is completely seated in the groove of the Output Shaft (1A).

⚠ WARNING

EYE PROTECTION SHOULD BE WORN DURING THIS PROCEDURE.

12. Install O-ring Plug (1J) and torque 23 to 24 ft-lbs. (32 - 33.5 Nm).

Carrier Sub-Assembly

NOTE: Refer to Figure 3-45., Swing Drive - Carrier Disassembly (SN 030020900 through 0300254531).

1. Apply a liberal coat of grease to the bore of Cluster Gear (3F). This will enable the Needle Rollers (3C) to be held in place during assembly.
2. Install the first row of 14 Needle Rollers (3C) into the bore of Cluster Gear (3F).
3. Insert Spacer (3D) into bore of Cluster Gear (3F) on top of the Needle Rollers (3C).
4. Place second row of Needle Rollers (3C) into bore of Cluster Gear (3F) against Spacer (3D) and remove Planet Shaft (3E).
5. Place Carrier (3A) into tool fixture so that one of the roll pin holes is straight up.
6. Start Planet Shaft (3E) through the hole in Carrier (3A). Using ample grease to hold it in position, slide one Thrust Washer (3B) over the Planet Shaft (3E) with the tang resting in the cast slot of the Carrier (3A). Place Ball-Indented Thrust Washer (3H) on the Planet Shaft (3E) with the indents against the first washer.
7. With large end of Cluster Gear (3F) facing the roll pin hole in the carrier, place the cluster gear into position in Carrier (3A) and push Planet Shaft (3E) through the Cluster Gear (3F) without going all the way through.
8. Slide the second Thrust Washer (3E) between the Cluster Gear (3F) and the Carrier (3A) with the tang of the washer located in the cast slot of the Carrier (3A). Slide ball-indented Thrust Washer (3H) onto the end of the Planet Shaft with the indents against the second thrust Washer. Finish sliding the Planet Shaft (3E) through the Thrust Washers (3H) & (3B) and into the Carrier (3A).
9. Position the non-chamfered side on the Planet Shaft (3E) roll pin hole so that it is in line with the hole in the Carrier (3A) using a 1/8" (3 mm) diameter punch.
10. After using a 3/16" (5 mm) punch to align the two roll pin holes. Drive the Roll Pin (3G) through Carrier (3A) and into the Planet Shaft (3E) until the Roll Pin (3G) is flush with the bottom of the cast tang slot in the Carrier (3A). Use a 1/4" (6 mm) pin punch to make sure the Roll Pin (3G) is flush in the slot.
11. Repeat Steps 1 thru 10 for the remaining two Cluster Gears(3F).

Main Assembly

NOTE: Refer to Figure 3-43., Swing Drive - Main Disassembly (SN 030020900 through 0300254531).

1. With the Hub Shaft Sub-Assembly resting on the Shaft (1A) install Internal Gear (2). The spline of the Internal Gear (2) bore will mesh with the spline of the Output Shaft (1A).
2. Inspect the location of the Internal Gear (2) on the Output Shaft (1A). The portion of the Output Shaft (1A), which does not have full spline, should protrude through the Internal Gear (2) bore.
3. Install two Thrust Washers (15) and one Thrust Bearing (16) on the portion of Output Shaft (1A) which protrudes through Internal Gear (2).
4. Center the Input Gear (13) on the end of the Output Shaft (1A) opposite the gear with the large diameter down.
5. Place O-ring (5) into Hub counter-bore. Use grease to hold O-ring in place.

⚠ WARNING

BEWARE OF SHARP EDGES OF THE COUNTER BORE WHILE SEATING THIS O-RING.

6. Also at this time locate and mark the four counter reamed holes in the face of the Hub (1G). This is for identification later in the assembly.
7. Place Carrier (3A) Subassembly on bench with the large end of Cluster Gears (3F) up with one at the 12 o'clock position. Find the punch marked tooth on each gear at the large end and locate at 12 o'clock (straight up) from each planet pin. Marked tooth will be located just under the Carrier on upper two gears. Check the timing through the slots in the carrier.
8. With large shoulder side of Ring Gear (4) facing down, place Ring Gear (4) over (into mesh with) large end of gears. Be sure that punch marks remain in correct location during Ring Gear (4) installation. The side of the Ring Gear (4) with an "X" or punch mark stamped on it should be up.

9. While holding Ring Gear (4) and Cluster Gears (3F) in mesh, place small end of Cluster Gears (3F) into mesh with the Internal Gear (2) and Input Gear (13). On the Ring Gear (4) locate the hole marked "X", or punch marked, over one of the marked counter-bored holes (Step 5) in Hub (1G). Check timing through the slots in the carrier. Rotate carrier in assembly to check for freedom of rotation.

NOTE: If gears do not mesh easily or Carrier Assembly does not rotate freely, then remove the Carrier and Ring Gear and check the Cluster Gear timing

10. Install Thrust Washer (15) Thrust Bearing (16) set into the counter-bore in the face of the carrier. Use grease to hold in place.
11. Place O-ring (5) into Cover (6) counter-bore. Use grease to hold O-Ring in place.

⚠ WARNING

CAUTION: BEWARE OF SHARP EDGES OF THE COUNTER-BORE WHILE SEATING THIS O-RING.

12. Using sufficient grease to hold in place, install Thrust Washer (8) into the counter-bore of the interface of the Cover (6).
13. The Cover (6) is now installed, taking care to correctly align Pipe Plug hole (20) with those in the Hub (1J). Check timing sheet.
14. Locate the 4 counter-bored holes in Hub (1G) [marked in Step 5] and install 4 Shoulder Bolts (18) with Lockwashers (19). Start the shoulder bolts by hand.
15. Install Grade 8 Bolts (17) with Lockwashers (19) into remaining holes.
16. Torque Shoulder Bolts (18) 43 to 47 ft.-lbs. (60 to 65 Nm) and Grade 8 Bolts (17) to 43 to 47 ft.-lbs. (60 to 65 Nm). Roll and leak test the assembly.
17. With gearbox standing on the pinion end fill gearbox with GEAROIL 80W90, to bottom of plug hole in cover at Pipe Plug (20).
18. Install Pipe Plug (20) into Cover (6) using thread sealant.

Motor and Brake Assembly

NOTE: Refer to Figure 3-42., Swing Drive - Motor and Brake Disassembly (SN 030020900 through 0300254531).

1. Place O-ring (27) onto end of Brake (26) and locate brake into pilot of cover.
2. Place Gasket (31) onto the brake face and line up the holes.
3. Place Motor (10) into Brake pilot against the Gasket (31).
4. Assemble Lift Lugs (28) onto Hex Bolts (29). Assemble Hex Bolts (29) with Lift Lugs through the Motor (10) and Brake (26) against the motor flange. Torque to 35 ft-lbs.
5. Fill Brake (26) with 2.7 oz. (80cc) of BRAKOILVG32 (DTE24).

Motor Control Valve Assembly

NOTE: Refer to Figure 3-41., Swing Drive - Motor Control Valve Disassembly (SN 030020900 through 0300254531).

1. Lay assembly down with motor ports facing up. Remove the two plastic plugs in the motor ports, being careful not to lose the O-ring in each port. Assemble the Motor control Valve (32) onto the Motor (10) with Bolt (34) and Lock Washers (33). Torque Bolts (33) 23 to 27 ft-lbs. (32 to 38 Nm).

NOTE: Be sure to align the holes in the control valve with the motor ports.

2. Install Elbow Fittings (36) into Brake (26) and torque 13 to 15 ft-lbs. (18 to 21 Nm).
3. Install Elbow Fittings (36) into Motor Control Valve (32) and torque to 13 to 15 ft-lbs. (18 to 21 Nm).
4. Assemble Tube (35) into Elbow Fittings (36) and torque 13 to 15 ft-lbs. (18 to 21 Nm).
5. Install O-ring Plugs (21) into Motor Control Valve (32) and torque 30 to 31 ft-lbs. (42 to 43 Nm).
6. Pressure test brake, tube and control valve connections by applying 3000 psi (207 bar) pressure to the brake bleed port and holding for 1 minute. Check for leaks at the control-valve-motor interface and the tube connections. Release pressure.
7. Place I.D. Plate (24) onto Housing (1G) with two Drive Screws (25). I.D. Plate (24) is to be inline with O-ring Plug (1J) as shown on assembly print.

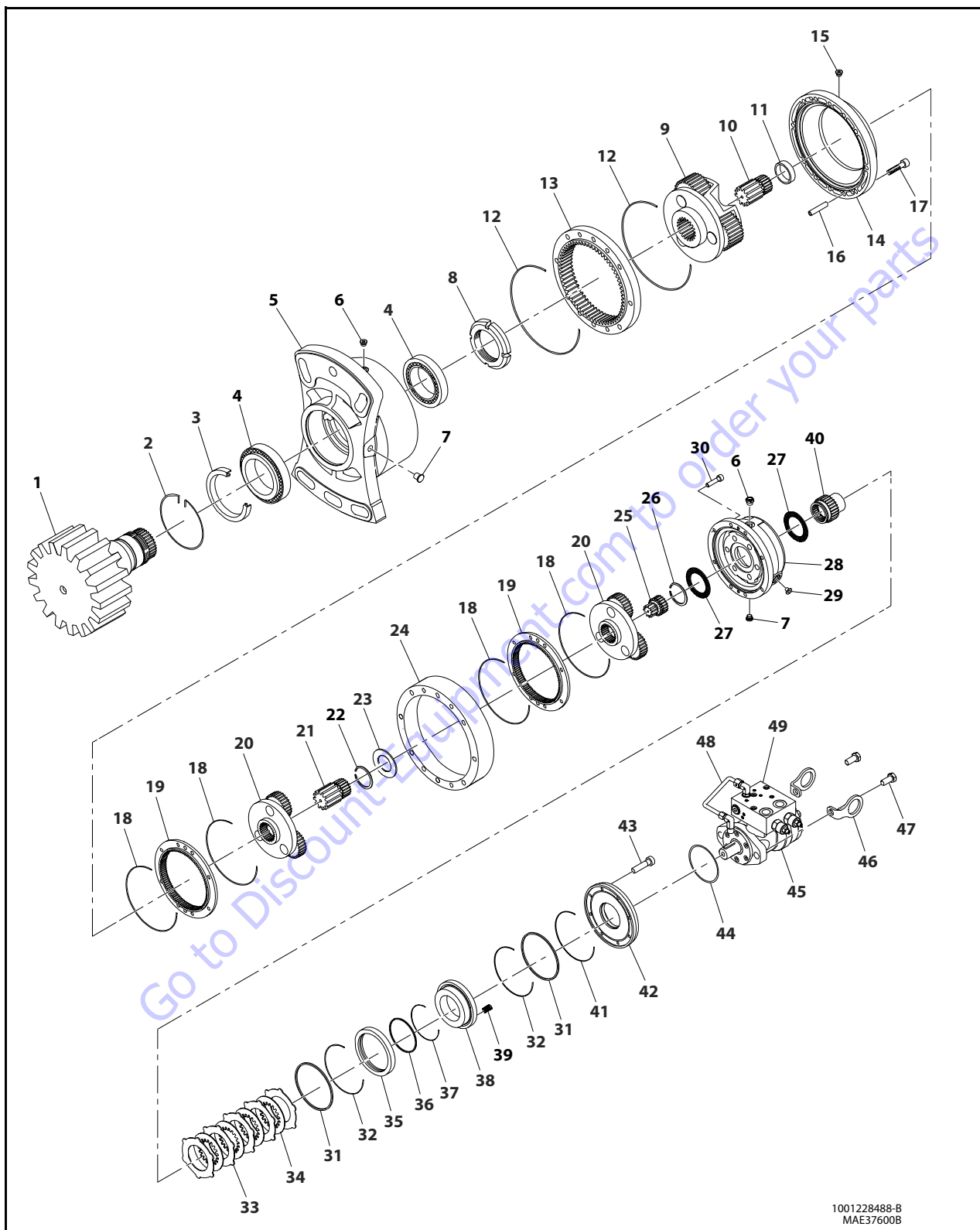

Figure 3-46. Swing Drive (SN 0300254532 to Present)- Sheet 1 of 2

1. Shaft	11. Spacer	21. Pinion	31. Seal	41. O-ring
2. Ring	12. O-Ring	22. Ring	32. O-Ring	42. Cover
3. Oil Seal	13. Planetary Gear	23. Spacer	33. Steel Disc	43. Screw
4. Bearing	14. Spacer	24. Spacer	34. Disc	44. O-ring
5. Support	15. O-Ring Plug	25. Pinion	35. Disc	45. Motor
6. O-ring Plug	16. Spring	26. Ring	36. Seal	46. Lung Lifting
7. O-ring Plug	17. Capscrew	27. Washer	37. O-ring	47. Capscrew
8. Nut Ring	18. O-ring	28. Brake Housing	38. Piston Brake	48. Brake valve adapter
9. Reduction Gear	19. Planetary Ring	29. Plug	39. Spring Brake	49. Valve
10. Pinion	20. Reduction Gear	30. Capscrew	40. Shaft Input	

Figure 3-47. Swing Drive (SN 0300254532 to Present)- Sheet 2 of 2

3.16 SWING BRAKE

Pre-Installation Checks

MECHANICAL

Checks prior to assembly, the mounting features and other parts of the brake are undamaged. Make sure that the shaft to which the brake is mounted are clean and free from burrs and swellings.

HYDRAULIC/MECHANICAL

To check brake release, connect an appropriate hydraulic pressure supply set to the required level up to a maximum of 3000 psi (200bar) and check that brake shaft (1) is free to rotate.

Remove hydraulic supply from brake, checking to ensure that the friction plates (3 & 6) have engaged thus preventing rotation of brake shaft (1)

NOTICE

RELEASE PRESSURE DURING BENCH TESTING SHOULD BE LIMITED TO 2000 PSI (138 BAR) UNLESS BRAKE IS FULLY INSTALLED USING 2-OFF 1/2" UNC MOUNTING BOLTS IN THE THROUGH (MOUNTING) HOLES.

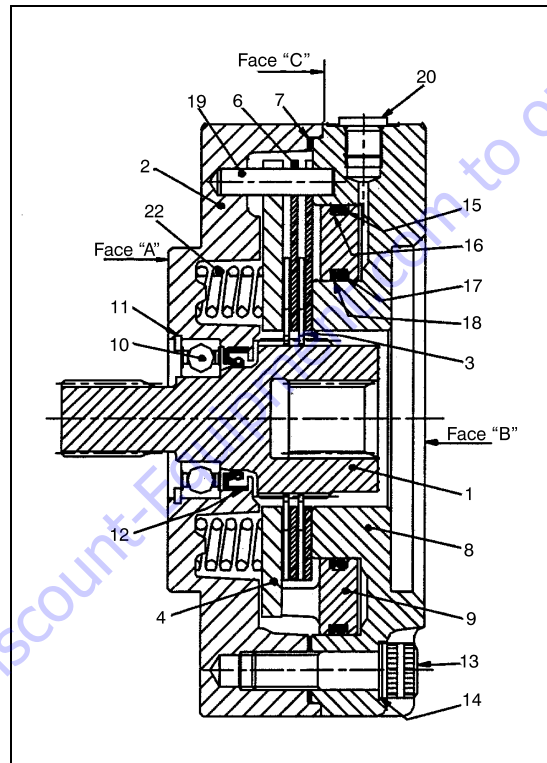

- | | | |
|-------------------------|------------------------------|---------------------------|
| 1. Brake Shaft | 9. Piston | 17. O-Ring |
| 2. Housing | 10. Deep Groove Ball Bearing | 18. Backing Ring |
| 3. Inner Friction Plate | 11. Internal Retaining Ring | 19. Dowel Pin |
| 4. Pressure Plate | 12. Rotary Shaft Seal | 20. Hexagon Plug |
| 5. Gasket | 13. Socket Head Cap Screw | 21. Plastic Plug |
| 6. Outer Plate | 14. Shakeproof Washer | 21A. Socket Pressure Plug |
| 7. Gasket | 15. O-Ring | 22. Spring (Natural) |
| 8. Cylinder | 16. Backing Ring | 23. Spring (Blue) |

Figure 3-48. Swing Brake

Installation

Position 1-off gasket (5) over male pilot on brake housing (4). Locate brake shaft (1) and secure brake in position using 2-off 1/2" UNC mounting bolts in the through mounting (fixing) holes provided.

Connect hydraulic pressure supply to brake pressure inlet port. Ensure that the hydraulic pressure is set to the required level up to a maximum of 3000 psi (200 bar) and check that the brake disengages and re-engages correctly.

Maintenance

The brake is required to be kept in good working order and must be included in the planned maintenance program for the equipment to which the brake is installed.

This must include torque testing together with inspection and replacement of the working parts such as friction plates (3 & 6) and, springs (22 & 23). The frequency of inspection depends on the duty demanded of the brake.

Disassembly

To remove brake from its installed position, reverse procedure previously described in the installation instructions. Place the complete brake assembly on a clean, dry work bench.

Remove external gasket (5) as necessary.

NOTE: Refer to Diagrams for the following.

1. Supporting brake face "A", remove the six socket head cap screws and washers (items 13 & 14) in equal increments to ensure the spring pressure within the brake is reduced gradually and evenly. Alternatively, if press is available, the cylinder housing (8) can be restrained on face "B" while removing the six socket head cap screws and washers (13 & 14). The brake assembly can now be fully dismantled and parts examined.
2. Remove cylinder housing (8) and piston (9) subassembly and dismantle if required, removing O-ring seals (15 & 17) and backing rings (16 & 18) as necessary.
3. Remove gasket (7) from housing (2).
4. Remove friction plates (3 & 6) and pressure plate (4).
5. Remove 2-off dowel pins (19).

6. Remove springs (8). Take note of quantity and orientation of springs.
7. Should it be necessary to replace ball bearing (10) or shaft seal (12), reverse remainder of brake sub-assembly, supporting on face "c" of housing (2).
8. Remove internal retaining ring (11).
9. Using arbor press or similar to break Loctite seal, remove brake shaft (1) from housing (2) and lay aside.
10. Reverse housing (2) and press out ball bearing (10). Shaft seal (12) can also be removed if necessary.

Examination

All components can now be examined and inspected, paying particular attention to the following.

1. Inspect friction plates (3 & 6) and friction surface on pressure plate (4) for wear or damage.
2. Examine friction plates (3) and brake shaft (1) for wear or damage to splines.
3. Examine input and output splines of brake shaft (1) for wear or damage.
4. Examine compression springs (22 & 23) for damage or fatigue.
5. Check ball bearing (10) for axial float or wear.
6. Examine O-ring seals (15 & 17) and backing rings (16 & 18) for damage.
7. Obtain replacement parts as required.

Assembly

Clean all parts thoroughly.
Reverse procedure previously outlined in Dismantling instructions taking particular care with.

- a. Assembly of shaft seal (12).
 - b. Assembly of bearing (10).
 - c. Quantity and orientation of springs (8).
 - d. Assembly sequence of friction plates (3 & 6).
1. Lightly lubricate rotary shaft seal (12) and assemble to housing (2) taking care not to damage seal lip.
 2. Apply ring of Loctite 641 or equivalent adhesive to full circumference of housing (2) bearing recess adjacent to shoulder.
Apply complete coverage of Loctite 641 to outside diameter of bearing (10) and assemble fully in housing (2), retaining with internal retaining ring (11). Remove excess adhesive with clean cloth.
Press shaft (1) through bearing (10), ensuring bearing inner ring is adequately supported.
 3. Assemble correct quantity of springs (8) in orientation required. Refer to (See Figure 3-54.) and (See Figure 3-55.).

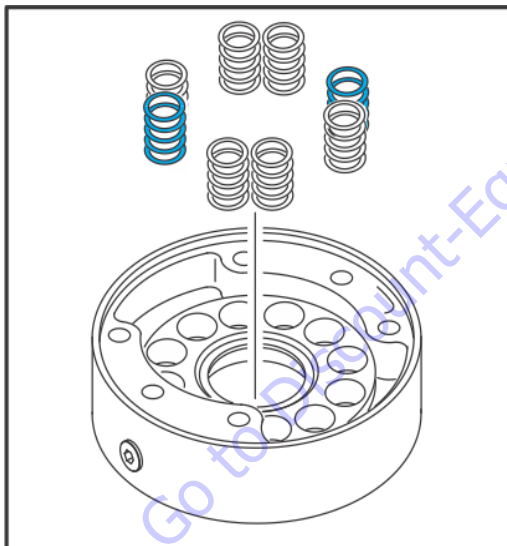

Figure 3-49. Swing Brake 8 Spring Orientation

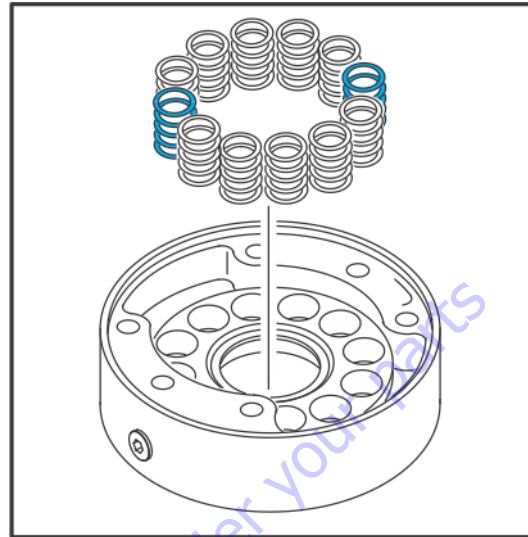
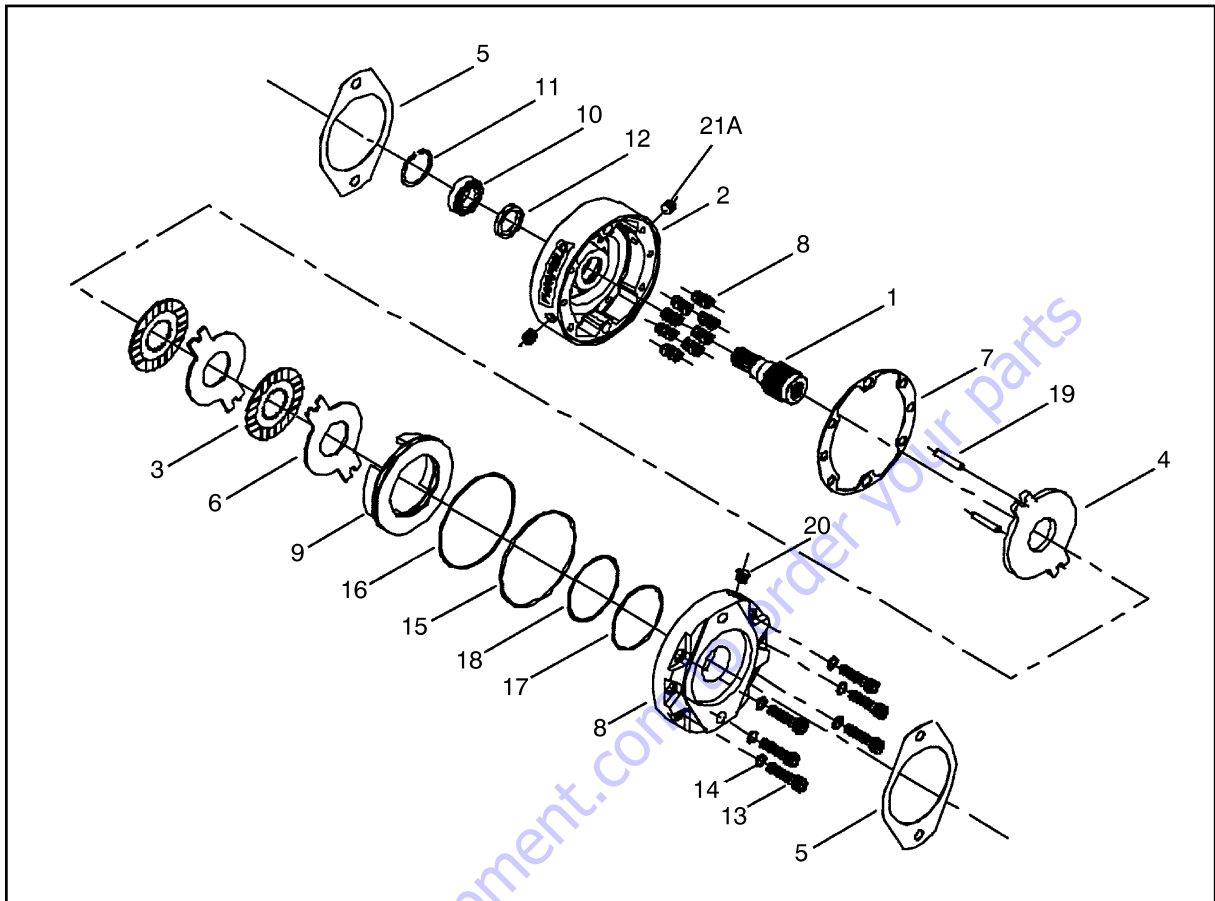

Figure 3-50. Swing Brake 12 Spring Orientation

4. Lubricate O-ring seals (15 & 17) with Molykote 55M (or equivalent) silicone grease and assemble together with backing rings (16 & 18) to piston (9). To ensure correct brake operation, it is important that the backing rings are assembled opposite to the pressurized side of piston (9).
5. Correctly orientate piston (9) aligning spaces with the two dowel pin holes and, assemble into cylinder housing (2) taking care not to damage seals and carefully lay aside.
6. Loctite 2-off pins (19) in housing (2) followed by pressure plate (4) and friction plates i.e. an inner (3) followed by an outer (6) in correct sequence.
7. Position gasket (7) in correct orientation.
8. Align two holes in cylinder with dowel pins (19) and assemble piston & cylinder sub-assembly to remainder of brake securing with 6-off socket head cap screws and washers (13 & 14). Torque to 55ft-lbs. (75 Nm).

NOTE: The use of a suitable press (hydraulic or arbor) Pressing down on cylinder end face "B" will ease assembly of the socket head cap screws (13).



- | | | |
|-------------------------|------------------------------|---------------------------|
| 1. Brake Shaft | 8. Cylinder | 15. O-Ring |
| 2. Housing | 9. Piston | 16. Backing Ring |
| 3. Inner Friction Plate | 10. Deep Groove Ball Bearing | 17. O-Ring |
| 4. Pressure Plate | 11. Internal Retaining Ring | 18. Backing Ring |
| 5. Gasket | 12. Rotary Shaft Seal | 19. Dowel Pin |
| 6. Outer Plate | 13. Socket Head Cap Screw | 20. Hexagon Plug |
| 7. Gasket | 14. Shakeproof Washer | 21. Plastic Plug |
| | | 21A. Socket Pressure Plug |

Figure 3-51. Swing Brake Assembly

3.17 SWING MOTOR

Disassembly and inspection

1. Place the Torqlink™ in a soft jawed vice, with coupling shaft (12) pointed down and the vise jaws clamping firmly on the sides of the housing (18) mounting flange or port bosses. Remove manifold port O-rings (18A) if applicable.

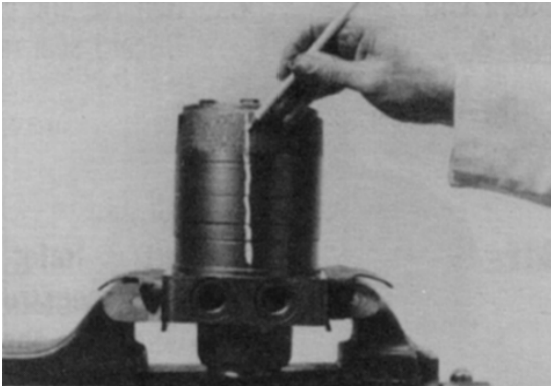

⚠ WARNING

IF THE TORQLINK™ IS NOT FIRMLY HELD IN THE VISE, IT COULD BE DISLODGED DURING THE SERVICE PROCEDURES, CAUSING INJURY.

2. Scribe an alignment mark down and across the Torqlink™ components from end cover (2) to housing (18) to facilitate reassembly orientation where required. Loosen two shuttle or relief valve plugs (21) for disassembly later if included in end cover. 3/16 or 3/8 inch Allen wrench or 1 inch hex socket required.

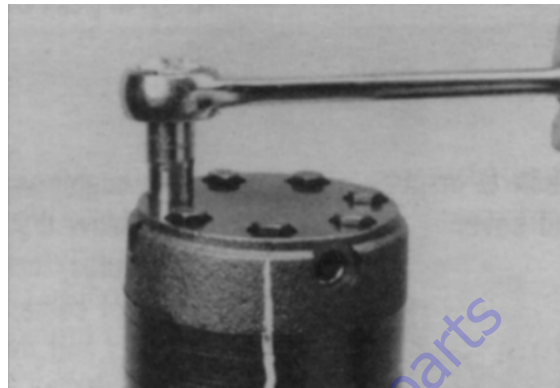

3. Remove the five, six, or seven special ring head bolts (1) using an appropriate 1/2 or 9/16 inch size socket. Inspect bolts for damaged threads, or sealing rings, under the bolt head. Replace damaged bolts.



4. Remove end cover assembly (2) and seal ring (4). Discard seal ring.



NOTE: Refer to the appropriate "alternate cover construction" on the exploded view to determine the end cover construction being serviced.

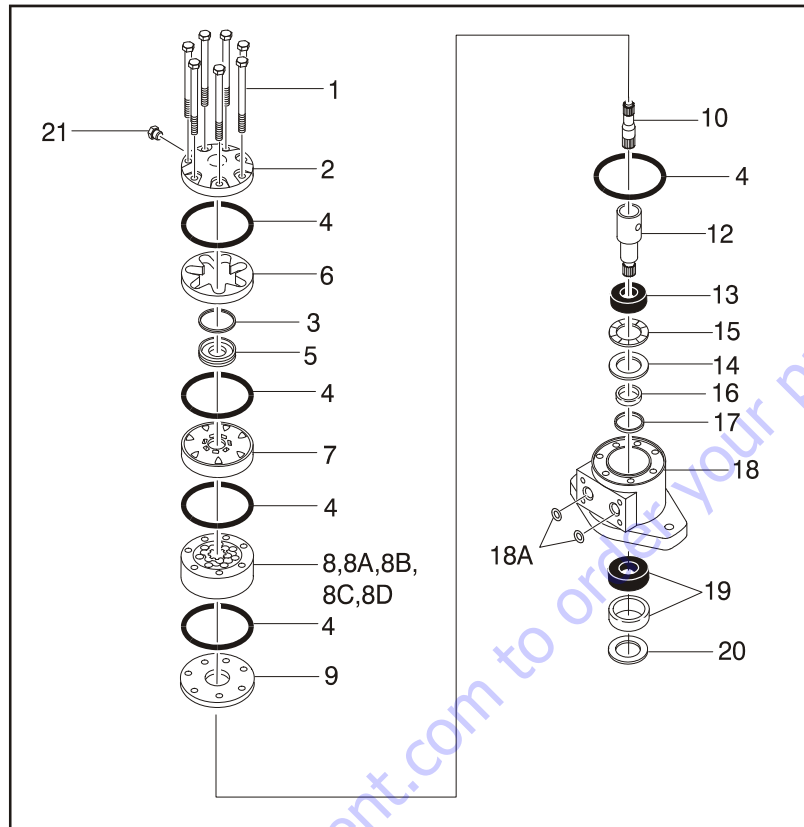

- | | | |
|-------------------------|----------------------------|----------------------------|
| 1. Special Bolts | 8B. Stator or Stator Vane | 15. Thrust Bearing |
| 2. End Cover | 8C. Vane | 16. Seal |
| 3. Seal Ring-Commutator | 8D. Stator Half | 17. Back-up Washer |
| 4. Seal Ring | 9. Wear Plate | 18. Housing |
| 5. Commutator Ring | 10. Drive Link | 18A. O-Ring |
| 6. Commutator Ring | 11. Not Used | 19. Bearing/Bushing, Outer |
| 7. Manifold | 12. Coupling Shaft | 20. Dirt & Water Seal |
| 8. Rotor Set | 13. Bearing/Bushing, Inner | 21. Plug |
| 8A. Rotor | 14. Thrust Washer | |

Figure 3-52. Swing Drive Motor

- If the end cover (2) is equipped with shuttle valve components, remove the two previously loosened plugs (21).

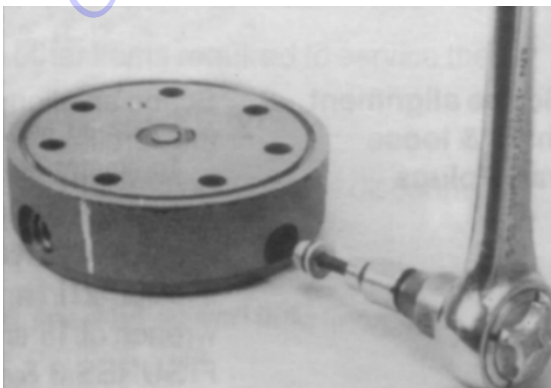

NOTICE

BE READY TO CATCH THE SHUTTLE VALVE OR RELIEF VALVE COMPONENTS THAT WILL FALL OUT OF THE END COVER VALVE CAVITY WHEN THE PLUGS ARE REMOVED.

NOTE: The insert and if included the orifice plug in the end cover (2) must not be removed as they are serviced as an integral part of the end cover.

SECTION 3 - CHASSIS & TURNTABLE

6. Thoroughly wash end cover (2) in proper solvent and blow dry. Be sure the end cover valve apertures, including the internal orifice plug, are free of contamination. Inspect end cover for cracks and the bolt head recesses for good bolt head sealing surfaces. Replace end cover as necessary.

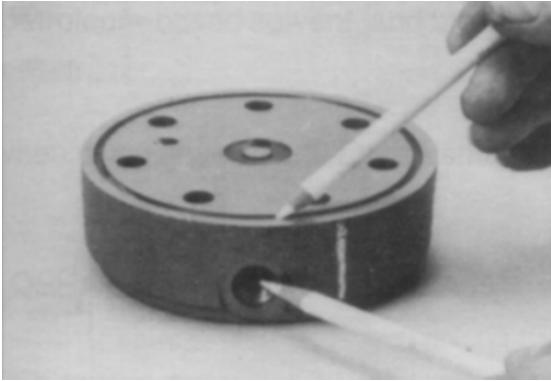

NOTE: A polished pattern (not scratches) on the cover from rotation of the commutator (5) is normal. Discoloration would indicate excess fluid temperature, thermal shock, or excess speed and require system investigation for cause and close inspection of end cover, commutator, manifold, and rotor set.

7. Remove commutator ring (6). Inspect commutator ring for cracks, or burrs.



8. Remove commutator (5) and seal ring (3) Remove seal ring from commutator, using an air hose to blow air into ring groove until seal ring is lifted out and discard seal ring. Inspect commutator for cracks or burrs, wear, scoring, spalling or brinelling. If any of these conditions exist, replace commutator and commutator ring as a matched set.



9. Remove manifold (7) and inspect for cracks surface scoring, brinelling or spalling. Replace manifold if any of these conditions exist. A polished pattern on the ground surface from commutator or rotor rotation is normal. Remove and discard the seal rings (4) that are on both sides of the manifold.



NOTE: The manifold is constructed of plates bonded together to form an integral component not subject to further disassembly for service. Compare configuration of both sides of them as if old to ensure that same surface is reassembled against the rotor set.

10. Remove rotor set (8) and warplane (9), together to retain the rotor set in its assembled form, maintaining the same rotor vane (8C) to stator (8B) contact surfaces. The drive link (10) may come away from the coupling shaft (12) with the rotor set, and wearplate. You may have to shift the rotor set on the warplane to work the drive link out of the rotor (8A) and warplane. Inspect the rotor set in its assembled form for nicks, scoring, or spalling on any surface and for broken or worn splines. If the rotor set component requires replacement, the complete rotor set must be replaced as it is a matched set. Inspect the warplane for cracks, brinelling, or scoring. Discard seal ring (4) that is between the rotor set and wearplate.



NOTE: The rotor set (8) components may become disassembled during service procedures. Marking the surface of the rotor and stator that is facing UP, with etching ink or grease pencil before removal from Torqlink™ will ensure correct reassembly of rotor into stator and rotor set into Torqlink™. Marking all rotor components and mating spline components for exact repositioning at assembly will ensure maximum wear life and performance of rotor set and Torqlink™.



NOTE: Series TG Torqlinks™ may have a rotor set with two stator halves (8B) with a seal ring (4) between them and two sets of seven vanes (8C). Discard seal ring only if stator halves become disassembled during the service procedures.

NOTE: A polished pattern on the wear plate from rotor rotation is normal.

11. Place rotor set (8) and wear plate (9) on a flat surface and center rotor (8A) in stator (8B) such that two rotor lobes (180 degrees apart) and a roller vane (8C) centerline are on the same stator centerline. Check the rotor lobe to roller vane clearance with a feeler gage at this common centerline. If there is more than 0.005 inches (0.13 mm) of clearance, replace rotor set.

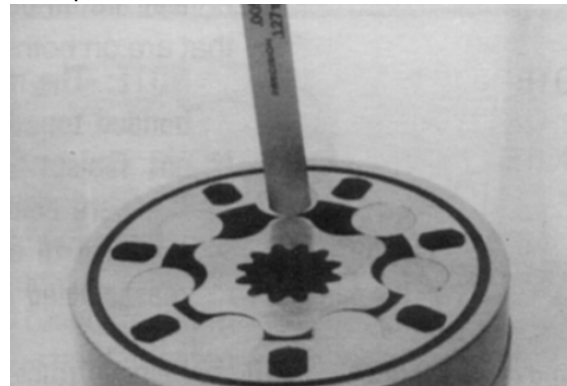

NOTE: If rotor set (8) has two stator halves (8B & 8D) and two sets of seven vanes (8C & 8E) as shown in the alternate construction TG rotor set assembly view, check the rotor lobe to roller vane clearance at both ends of rotor.

12. Remove drive link (10) from coupling shaft (12) if it was not removed with rotor set and wear plate. Inspect drive link for cracks and worn or damaged splines. No perceptible lash (play) should be noted between mating spline parts. Remove and discard seal ring (4) from housing (18).



13. Remove thrust bearing (11) from top of coupling shaft (12). Inspect for wear, brinelling, corrosion and a full complement of retained rollers.



14. Check exposed portion of coupling shaft (12) to be sure you have removed all signs of rust and corrosion which might prevent its withdrawal through the seal and bearing. Crocus cloth or fine emery paper may be used.

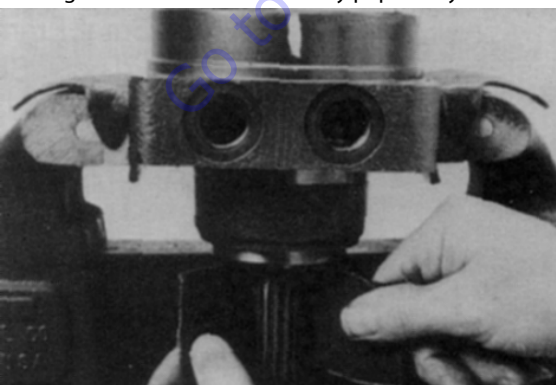

15. Remove coupling shaft (12), by pushing on the output end of shaft. Inspect coupling shaft bearing and seal surfaces for spalling, nicks, grooves, severe wear or corrosion and discoloration. Inspect for damaged or worn internal and external splines or keyway. Replace coupling shaft if any of these conditions exist.

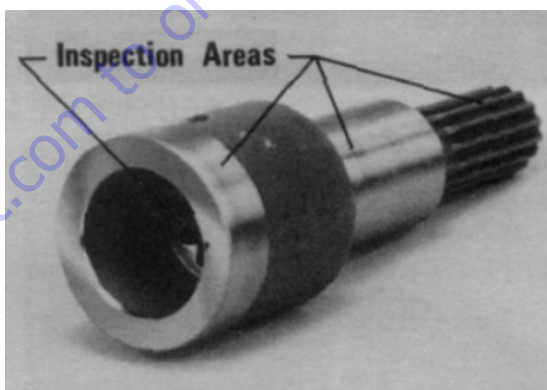
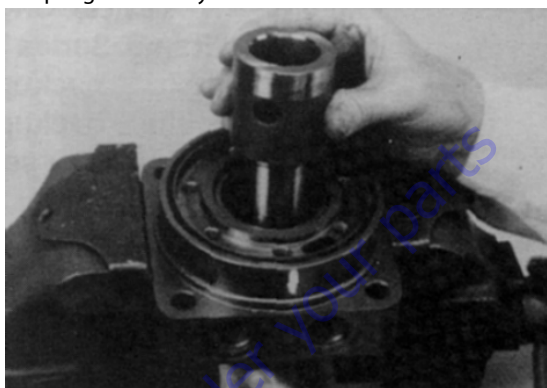

NOTE: Minor shaft wear in seal area is permissible. If wear exceeds 0.020 inches (0.51 mm) diametrically, replace coupling shaft.

NOTE: A slight "polish" is permissible in the shaft bearing areas. Anything more would require coupling shaft replacement.

16. Remove and discard seal ring (4) from housing (18).

- 17.** Remove thrust bearing (15) and thrust washer (14) Inspect for wear, brinelling, corrosion and a full complement of retained rollers.



- 18.** Remove seal (16) and back up washer (17) from Small Frame, housing (18). Discard both.



- 19.** Remove housing (18) from vise, invert it and remove and discard seal (20). A blind hole bearing or seal puller is required.

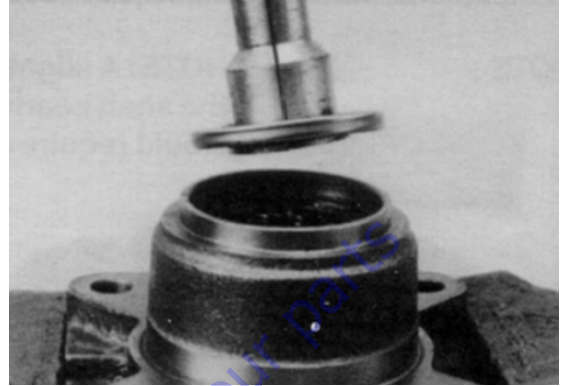

- 20.** Inspect housing (18) assembly for cracks, the machined surfaces for nicks, burrs, brinelling or corrosion. Remove burrs that can be removed without changing dimensional characteristics. Inspect tapped holes for thread damage. If the housing is defective in these areas, discard the housing assembly.

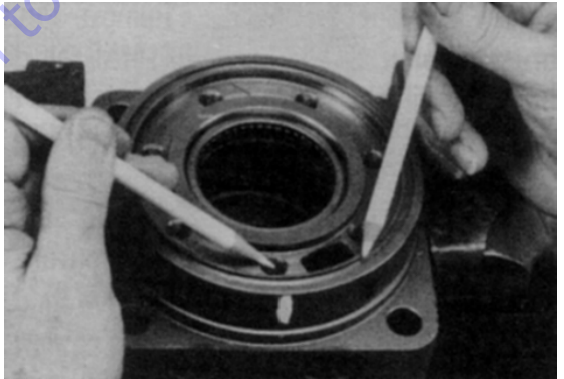

21. If the housing (18) assembly has passed inspection to this point, inspect the housing bearings/bushings (19) and (13) and if they are captured in the housing cavity the two thrust washers (14) and thrust bearing (15). The bearing rollers must be firmly retained in the bearing cages, but must rotate and orbit freely. All rollers and thrust washers must be free of brinelling and corrosion. The bearing (19) or (13) to coupling shaft diameter clearance must not exceed 0.010 inch (0.025 mm). A bearing, bushing, or thrust washer that does not pass inspection must be replaced. If the housing has passed this inspection the disassembly of the Torqlink™ is completed.

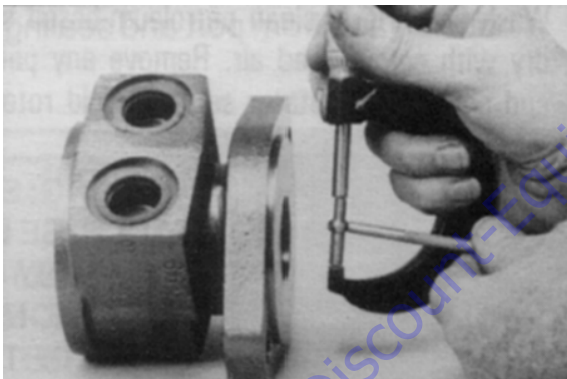
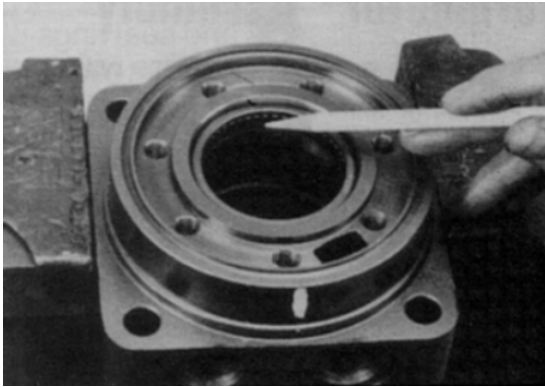

NOTE: The depth or location of bearing/bushing (13) in relation to the housing wear plate surface and the depth or location of bearing/bushing (19) in relation to the beginning of bearing/bushing counter bore should be measured and noted before removing the bearings/ bushings. This will facilitate the correct reassembly of new bearings/bushings.

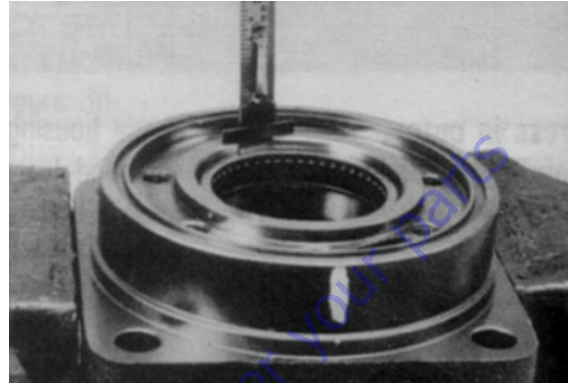

22. If the bearings, bushing or thrust washers must be replaced use a suitable size bearing puller to remove bearing/bushings (19) and (13) from housing (18) without damaging the housing. Remove thrust washers (14) and thrust bearing (15) if they were previously retained in the housing by bearing (13).

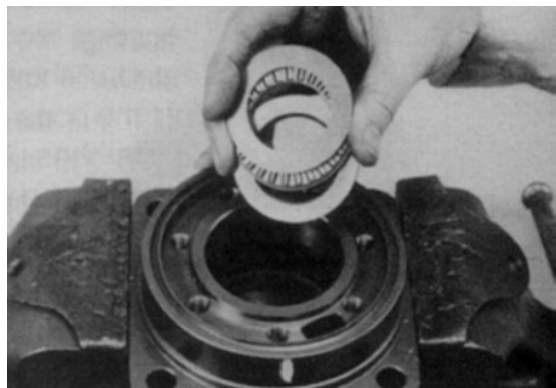
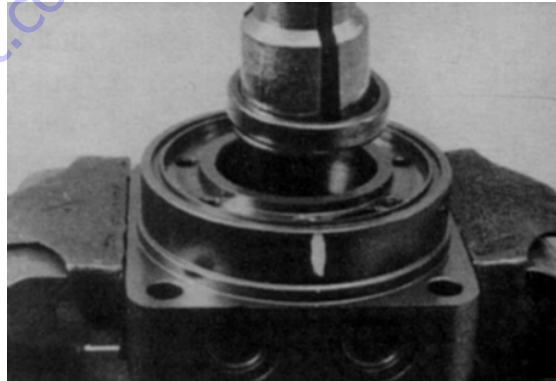

Assembly

Replace all seals and seal rings with new ones each time you reassemble the Torqlink™ unit. Lubricate all seals and seal rings with SAE 10W40 oil or clean grease before assembly.

NOTE: Individual seals and seal rings as well as a complete seal kit are available. The parts should be available through most OEM parts distributors or Parker approved Torqlink™ distributors. (Contact your local dealer for availability).

NOTE: Unless otherwise indicated, do not oil or grease parts before assembly.

Wash all parts in clean petroleum-based solvents before assembly. Blow them dry with compressed air. Remove any paint chips from mating surfaces of the end cover, commutator set, manifold rotor set, wear plate and housing and from port and sealing areas.

⚠ DANGER

SINCE THEY ARE FLAMMABLE, BE EXTREMELY CAREFUL WHEN USING ANY SOLVENT. EVEN A SMALL EXPLOSION OR FIRE COULD CAUSE INJURY OR DEATH.

⚠ WARNING

WEAR EYE PROTECTION AND BE SURE TO COMPLY WITH OSHA OR OTHER MAXIMUM AIR PRESSURE REQUIREMENTS.

1. If the housing (18) bearing components were removed for replacement, thoroughly coat and pack a new outer bearing/bushing (19) with clean corrosion resistant grease recommended in the material section. Press the new bearing/bushing into the counterbore at the mounting flange end of the housing, using the appropriate sized bearing mandrel, which will control the bearing/ bushing depth.

Torqlink™ housings require the use of bearing mandrel to press bearing/ bushing (19) into the housing to a required depth of 0.151/0.161 inches (3.84/4.09 mm) from the end of the bearing counterbore.



NOTE: Bearing mandrel must be pressed against the lettered end of bearing shell. Take care that the housing bore is square with the press base and the bearing/bushing is not cocked when pressing a bearing/bushing into the housing.

NOTICE

IF THE BEARING MANDREL SPECIFIED IN THE "TOOLS AND MATERIALS REQUIRED FOR SERVICING" SECTION IS NOT AVAILABLE AND ALTERNATE METHODS ARE USED TO PRESS IN BEARING/BUSHING (13) AND (19) THE BEARING/BUSHING DEPTHS SPECIFIED MUST BE ACHIEVED TO INSURE ADEQUATE BEARING SUPPORT AND CORRECT RELATIONSHIP TO ADJACENT COMPONENTS WHEN ASSEMBLED.

NOTICE

BECAUSE THE BEARING/BUSHINGS (13) AND (19) HAVE A PRESS FIT INTO THE HOUSING THEY MUST BE DISCARDED WHEN REMOVED. THEY MUST NOT BE REUSED.

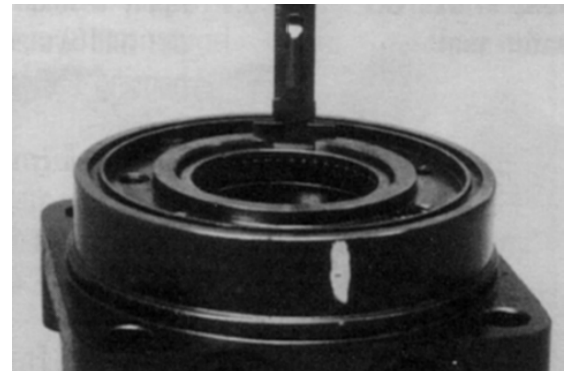

2. The Torqlink™ inner housing bearing/bushing (13) can now be pressed into its counterbore in housing (18) flush to 0.03 inch (.76 mm) below the housing wear plate contact face. Use the opposite end of the bearing mandrel that was used to press in the outer bearing/bushing (19).

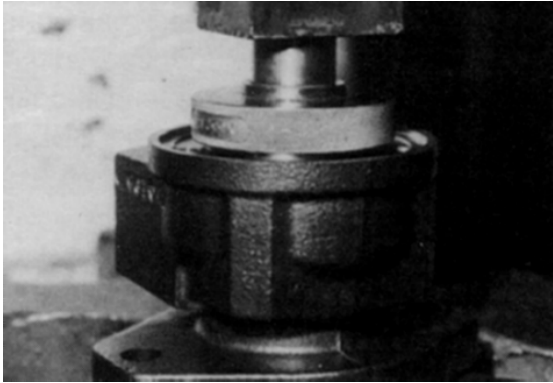

3. Press a new dirt and water seal (20) into the housing (18) outer bearing counterbore.

The Torqlink™ dirt and water seal (20) must be pressed in until its flange is flush against the housing.

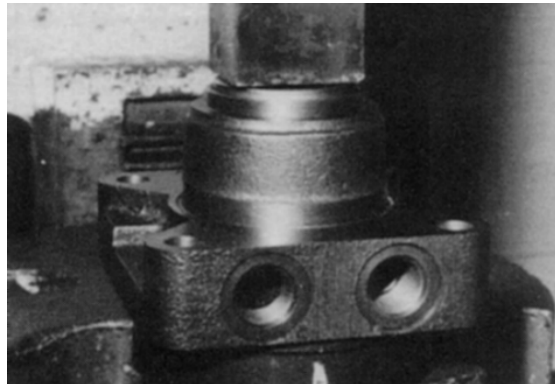
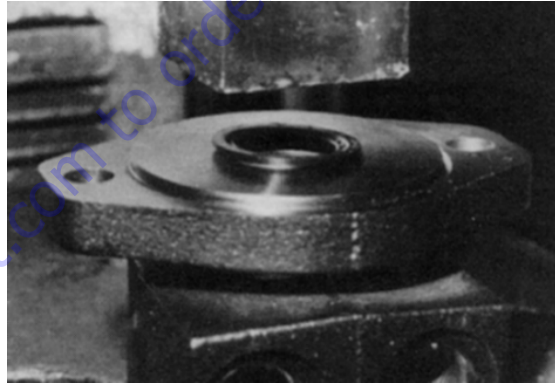

- Place housing (18) assembly into a soft jawed vise with the coupling shaft bore down, clamping against the mounting flange.

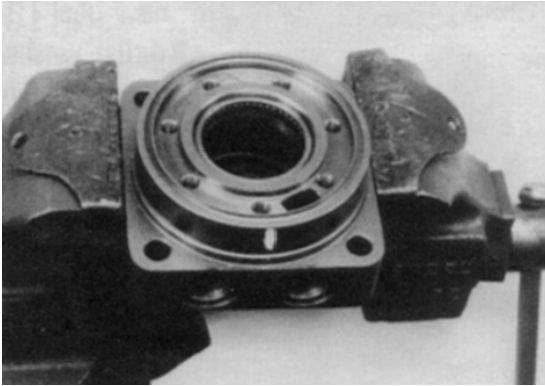

- On the Torqlinks™ assemble a new backup washer (17) and new seal (16) with the seal lip facing toward the inside of Torqlink™, into their respective counterbores in housing (18) if they were not assembled in procedure 2.

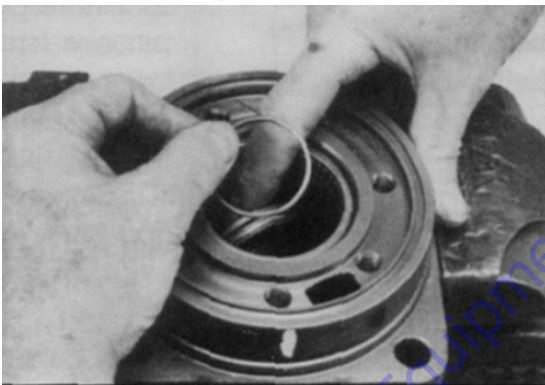

NOTICE

ORIGINAL DESIGN LARGE FRAME, TF & TG TORQLINKS™ THAT DO NOT HAVE BACKUP WASHER (25) WHEN DISASSEMBLED MUST BE ASSEMBLED WITH A NEW BACKUP WASHER (17), NEW BACKUP WASHER (25), AND NEW SEAL (16).

- Assemble thrust washer (14) then thrust bearing (15) that was removed from the Torqlink™.

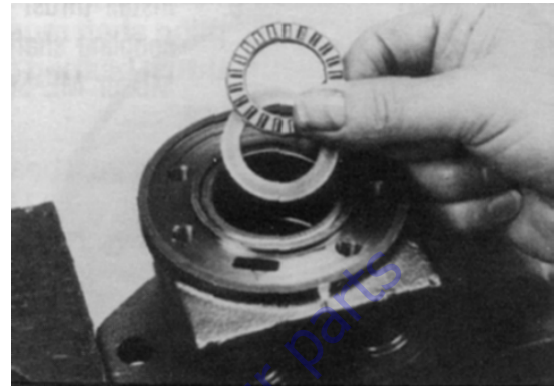

NOTE: Torqlinks™ require one thrust washer (14) with thrust bearing (15). The coupling shaft will be seated directly against the thrust

- Apply masking tape around splines or keyway on shaft (12) to prevent damage to seal.



- Be sure that a generous amount of clean corrosion resistant grease has been applied to the lower (outer) housing bearing/bushing (19). Install the coupling shaft (12) into housing (18), seating it against the thrust bearing (15) in the housings.



NOTICE

THE OUTER BEARING (19) IS NOT LUBRICATED BY THE SYSTEM'S HYDRAULIC FLUID. BE SURE IT IS THOROUGHLY PACKED WITH THE RECOMMENDED GREASE, PARKER GEAR GREASE SPECIFICATION #045236, E/M LUBRICANT #K-70M.

NOTE: Mobil Mobilith SHC[®] 460

NOTE: A 102Tube (PN 406010) is included in each seal kit.

NOTE: The coupling shaft (12) will be flush or just below the housing wear plate surface on Torqlinks™ when properly seated. The coupling shaft must rotate smoothly on the thrust bearing package.

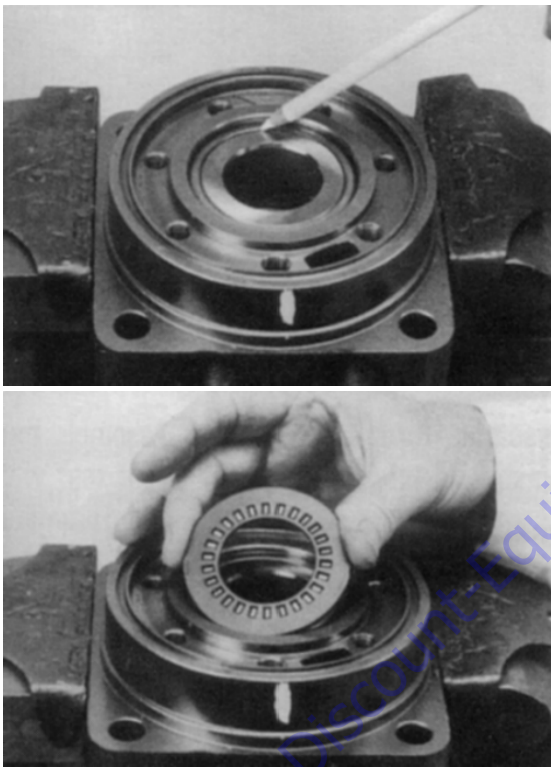

9. Apply a small amount of clean grease to a **new** seal ring (4) and insert it into the housing (18) seal ring groove.

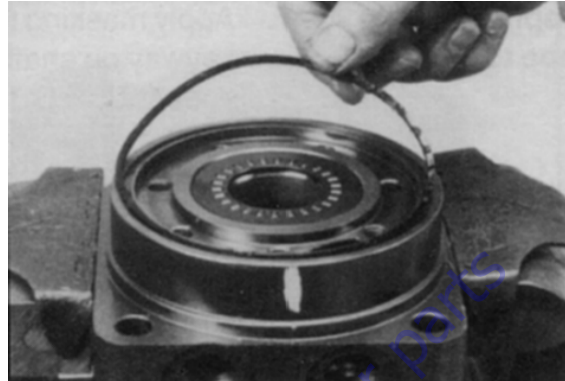

NOTE: One or two alignment studs screwed finger tight into housing (18) bolt holes, approximately 180 degrees apart, will facilitate the assembly and alignment of components as required in the following procedures. The studs can be made by cutting off the heads of either 3/8-24 UNF 2A or 5/16-24 UNF 2A bolts as required that are over 0.5 inch (12.7 mm) longer than the bolts (1) used in the Torqlink™.

10. Install drive link (10) the long splined end down into the coupling shaft (12) and engage the drive link splines into mesh with the coupling shaft splines.

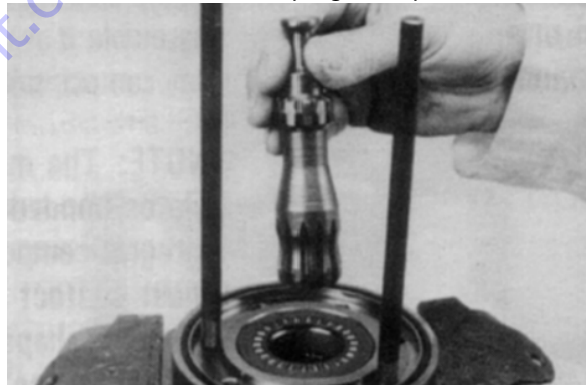

NOTE: Use any alignment marks put on the coupling shaft and drive link before disassembly to assemble the drive link splines in their original position in the mating coupling shaft splines.

11. Assemble wear plate (9) over the drive link (10) and alignment studs onto the housing (18).

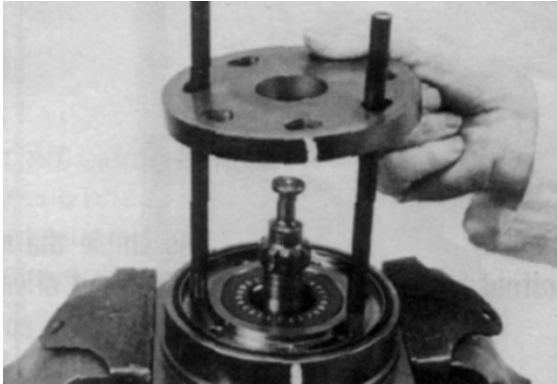

12. Apply a small amount of clean grease to a new seal ring (4) and assemble it into the seal ring groove on the wear plate side of the rotor set stator (8B).

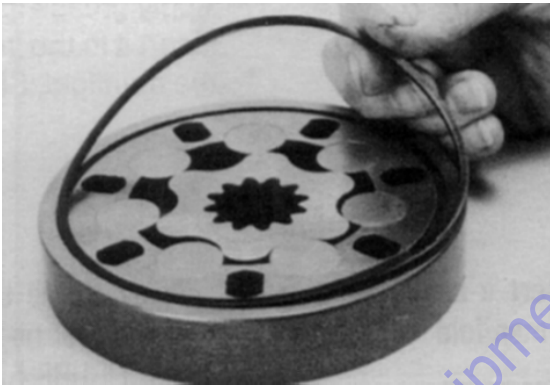

13. Install the assembled rotor set (8) onto wear plate (9) with rotor (8A) counterbore and seal ring side down and the splines into mesh with the drive link splines.

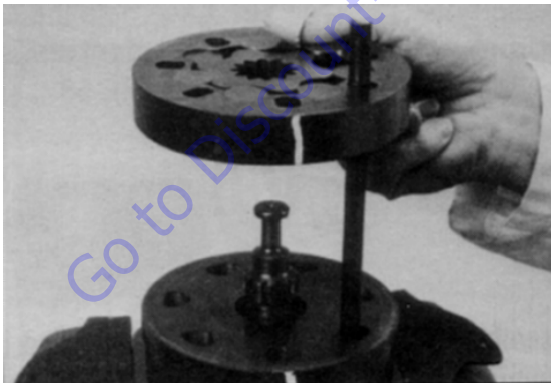

NOTE: It may be necessary to turn one alignment stud out of the housing (18) temporarily to assemble rotor set (8) or manifold (7) over the drive link.

NOTE: If necessary, go to the appropriate, "Rotor Set Component Assembly Procedure."

NOTE: The rotor set rotor counterbore side must be down against wear plate for drive link clearance and to maintain the original rotor-drive link spline contact. A rotor set without a counterbore and that was not etched before disassembly can be reinstalled using the drive link spline pattern on the rotor splines if apparent, to determine which side was down. The rotor set seal ring groove faces toward the wear plate (9).

14. Apply clean grease to a new seal ring (4) and assemble it into the seal ring groove in the rotor set contact side of manifold (7).

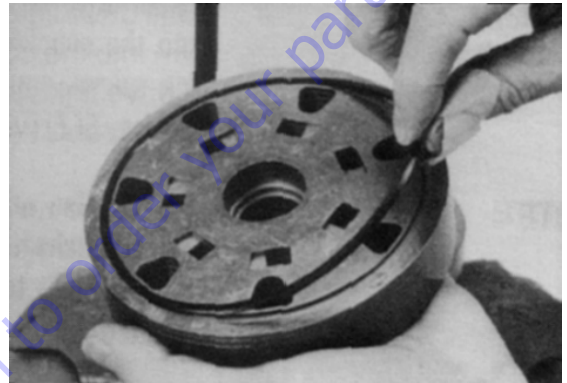

NOTE: The manifold (7) is made up of several plates bonded together permanently to form an integral component. The manifold surface that must contact the rotor set has it's series of irregular shaped cavities on the largest circumference or circle around the inside diameter. The polished impression left on the manifold by the rotor set is another indication of which surface must contact the rotor set.

15. Assemble the manifold (7) over the alignment studs and drive link (10) and onto the rotor set. Be sure the correct manifold surface is against the rotor set.

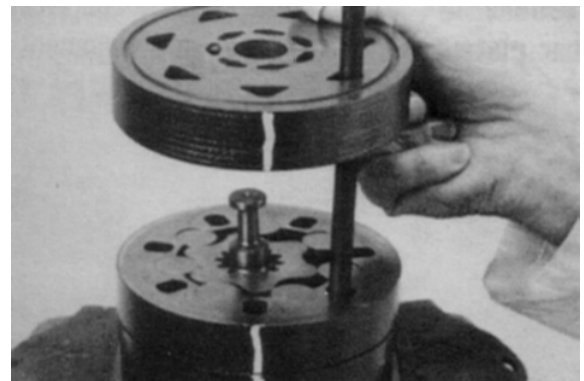

SECTION 3 - CHASSIS & TURNTABLE

16. Apply grease to a new seal ring (4) and insert it in the seal ring groove exposed on the manifold.

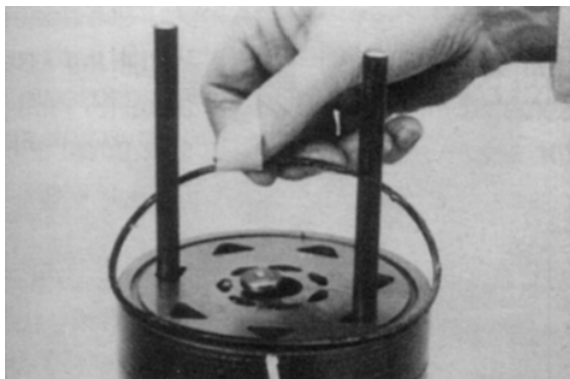

17. Assemble the commutator ring (6) over alignment studs onto the manifold.

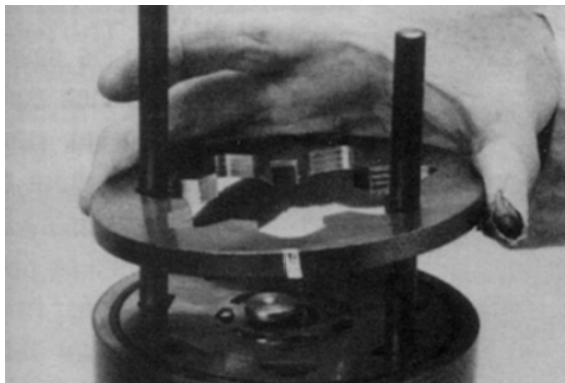

18. Assemble a new seal ring (3) flat side up, into commutator (5) and assemble commutator over the end of drive link (10) onto manifold (7) with seal ring side up.

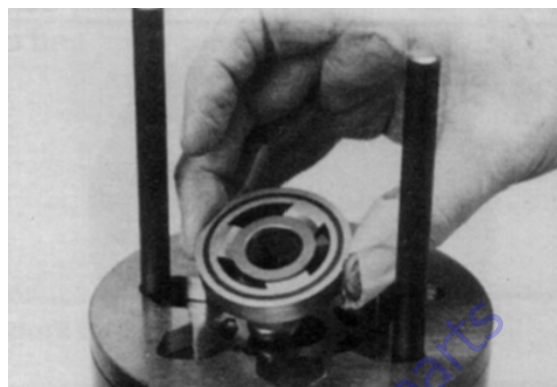
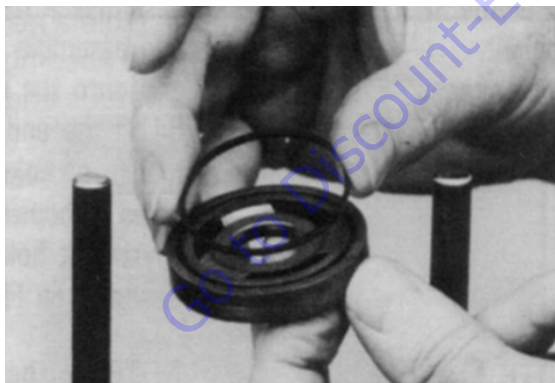

19. If shuttle valve components items #21, were removed from the end cover (2) turn a plug (21), loosely into one end of the valve cavity in the end cover. A 3/16 inch Allen wrench is required.

20. Assemble a new seal ring (4) into end cover (2) and assemble end cover over the alignment studs and onto the commutator set. If the end cover has only 5 bolt holes be sure the cover holes are aligned with the 5 threaded holes in housing (18). The correct 5 bolt end cover bolt hole relationship to housing port bosses.

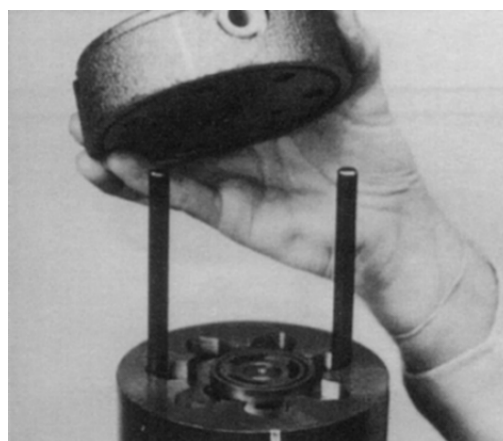
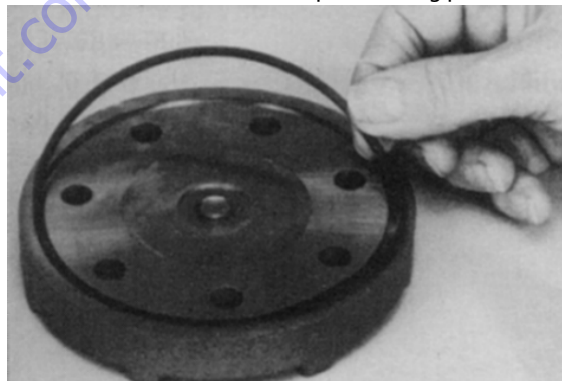

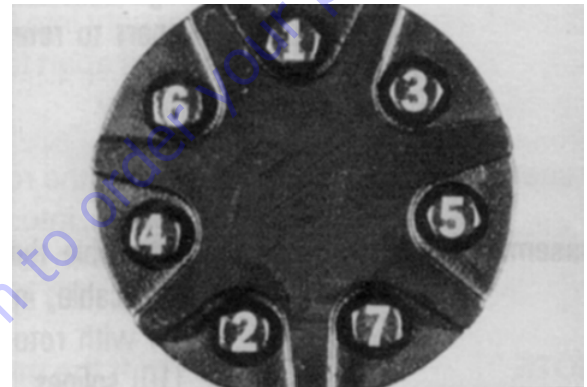
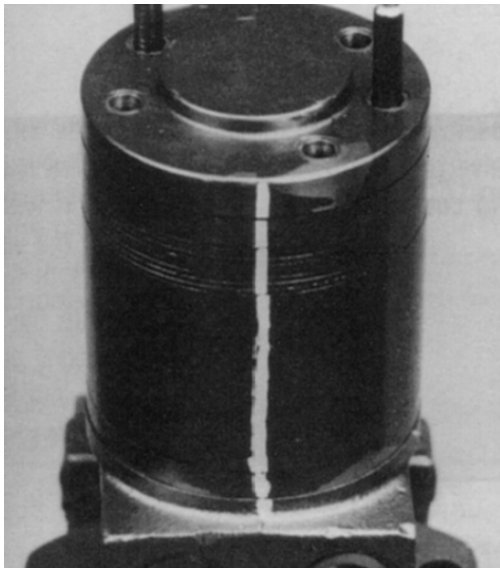

NOTE: If the end cover has a valve (24) or has five bolt holes, use the line you previously scribed on the cover to radially align the end cover into its original position.

21. Assemble the 5 or 7 special bolts (1) and screw in finger tight. Remove and replace the two alignment studs with bolts after the other bolts are in place. Alternately and progressively tighten the bolts to pull the end cover and other components into place with a final torque of 22-26 ft. lbs. 45-55 ft. lbs.(61-75 N m) for the seven 3/8-24 threaded bolts.

NOTE: The special bolts required for use with the relief or shuttle valve (24) end cover assembly (2) are longer than the bolts required with standard and cover assembly. Refer to the individual service parts lists or parts list charts for correct service part number if replacement is required.



22. Torque the two shuttle valve plug assemblies (21) in end cover assembly to 9-12 ft. lbs. (12-16 Nm) if cover is so equipped.

Torque the two relief valve plug assemblies (21) in end cover assembly to 45-55 ft. lbs. (61-75 Nm) if cover is so equipped.

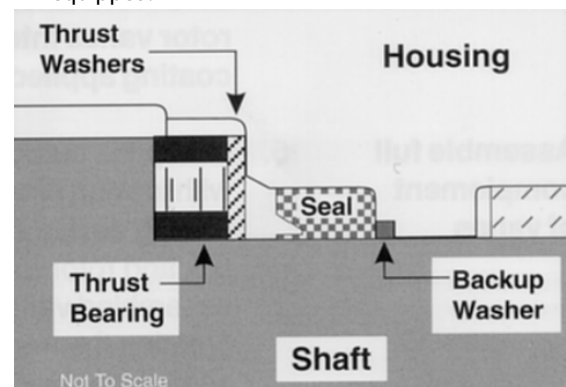

One Piece Stator Construction

A disassembled rotor (8A) stator (8B) and vanes (8C) that cannot be readily assembled by hand can be assembled by the following procedures.

1. Place stator (8B) onto wear plate (9) with seal ring (4) side down, after following Torqlink™ assembly procedures 1 through 13. Be sure the seal ring is in place.

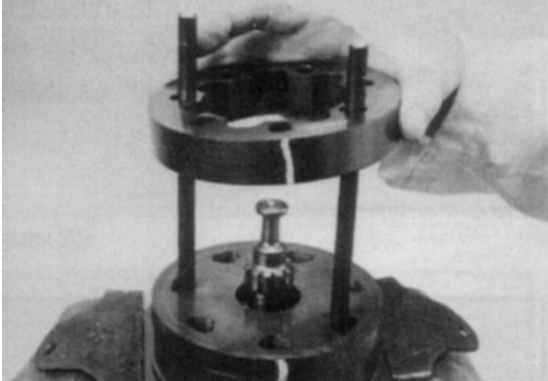

2. If assembly alignment studs are not being utilized, align stator bolt holes with wear plate and housing bolt holes and turn two bolts (1) finger tight into bolt holes approximately 180 degrees apart to retain stator and wear plate stationary.
3. Assemble the rotor (8A), counterbore down if applicable, into stator (8B), and onto wear plate (9) with rotor splines into mesh with drive link (10) splines.

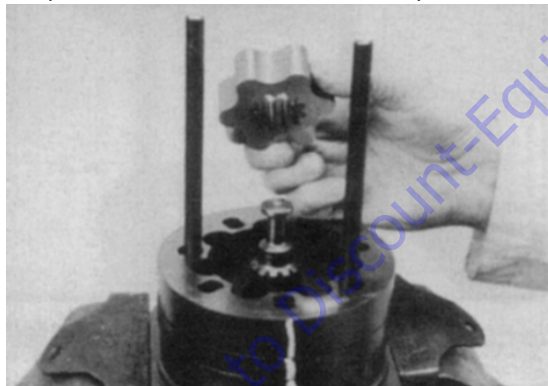

NOTE: If the manifold side of the rotor was etched during Torqlink disassembly, this side should be up. If the rotor is not etched and does not have a counterbore, use the drive link spline contact pattern apparent on the rotor splines to determine the rotor side that must be against the wear plate.

4. Assemble six vanes (8C), or as many vanes that will readily assemble into the stator vane pockets.



NOTICE

EXCESSIVE FORCE USED TO PUSH THE ROTOR VANES INTO PLACE COULD SHEAR OFF THE COATING APPLIED TO THE STATOR VANE POCKETS.

5. Grasp the output end of coupling shaft (12) with locking pliers or other appropriate turning device and rotate coupling shaft, drive link and rotor to seat the rotor and the assembled vanes (8C) into stator (8B), creating the necessary clearance to assemble the seventh or full complement of seven vanes. Assemble the seven vanes using minimum force.

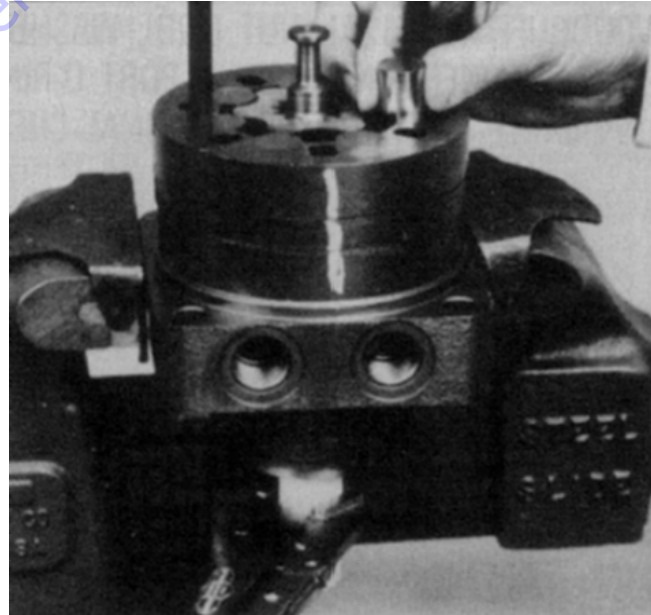

6. Remove the two assembled bolts (1) if used to retain stator and wear plate.

3.18 PROCEDURE FOR SETTING GEAR BACKLASH

1. Set backlash to 0.010 to 0.015" using the following procedure.
2. Place shim (JLG PN 4071041) between pinion and bearing on the bearing high spot. The bearing high spot should be stamped with an "X" on the surface below the teeth and marked with yellow paint in the tooth space.

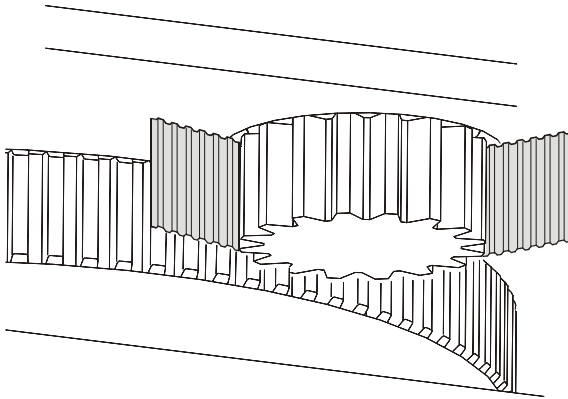

3. Torque the shoulder screw (shown below) to 660 ft-lbs (896 Nm) with JLG Threadlocker PN 0100019.

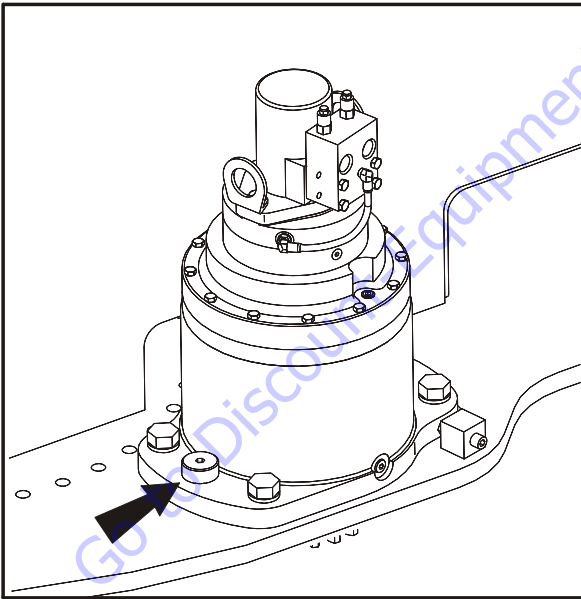

4. Remove the turntable lock pin.

5. Pre-torque the capscrews (shown below) to 90 ft-lbs (122 Nm) with JLG Threadlocker PN 0100019.

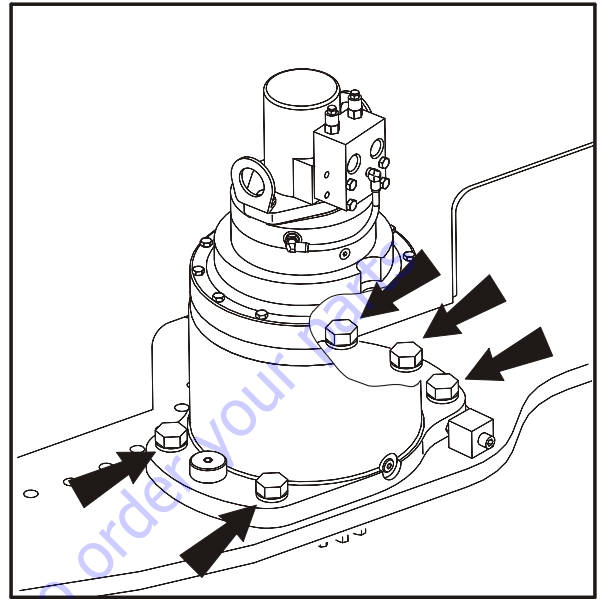

6. Tighten the setscrew (shown below) until the pinion is completely snug against the shim and bearing and then back off the setscrew.

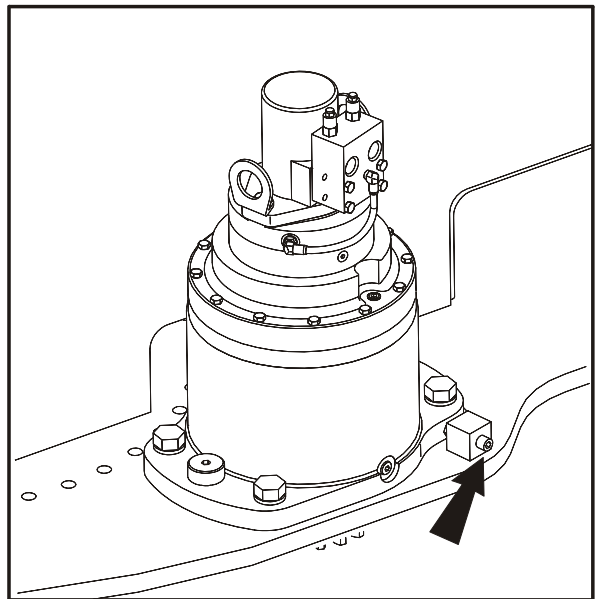

7. Torque the setscrew to 50 ft-lbs (68 Nm).

8. Tighten the jam nut (shown below) with JLG Thread-locker PN 0100019.

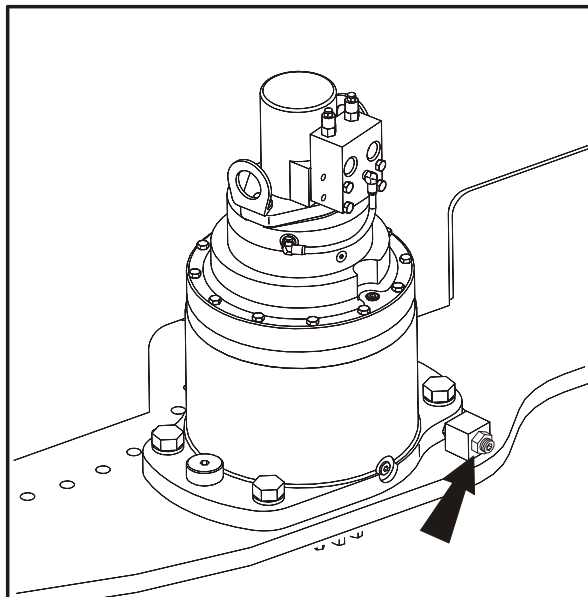

9. Torque the capscrews shown in step 5 to 660 ft-lbs (896 Nm).
10. Remove shim and discard.

The Swing Gearbox is to be filled with 79 ounces (2.3 L) of API Service Classification GL-5 Extreme Pressure Gear Lube. Fill to cover the ring gear.

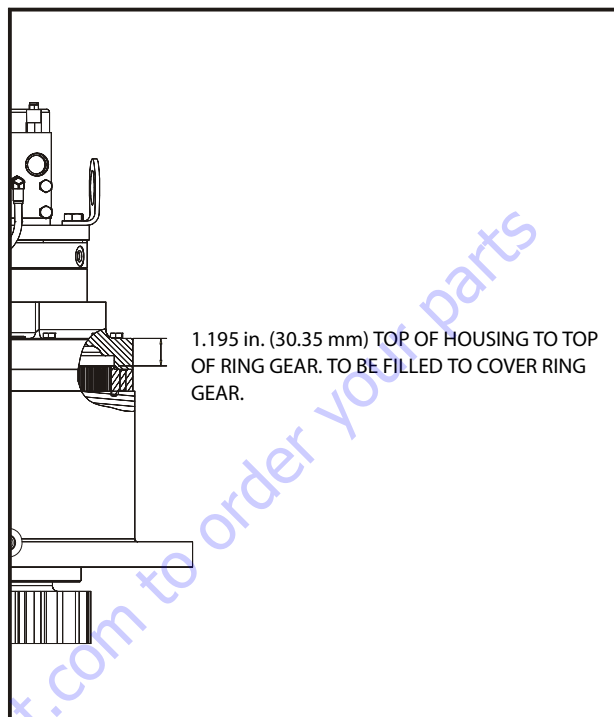
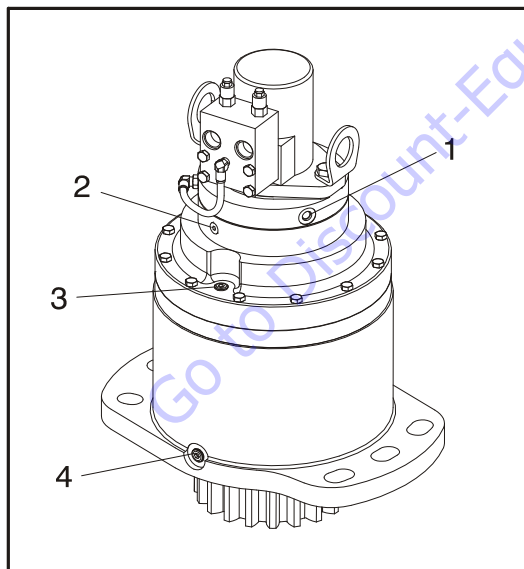

Figure 3-54. Swing Drive Lubrication (SN 0300209000 through 0300254531)

3.19 SWING DRIVE LUBRICATION



- 1 Brake Bleed Port
- 2 Brake Fill Port
- 3 Gearbox Fill Port
- 4 Gearbox Drain Port

Figure 3-53. Swing Drive Ports (SN 0300209000 through 0300254531)

The Swing Brake is to be filled half full, 2.7 ounces (80 ml), with DTE24 oil.

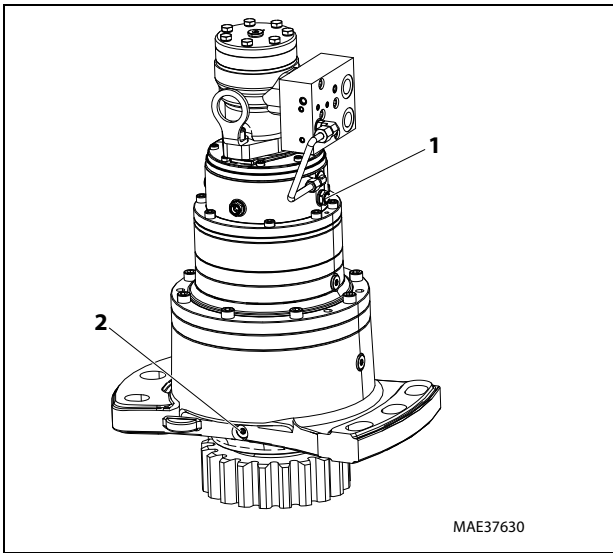

- 1 Swing Gearbox/Brake Fill Port
- 2 Swing Gearbox/Brake Drain Port

Figure 3-55. Swing Drive Ports (SN 0300254532 to Present)

The brake on swing drive uses same oil cavity as gearbox. Remove the swing gearbox/brake fill plug and fill the unit with 105 ounces (3.1 L) of ISO VG 150 oil, until oil reaches halfway of the plug opening. Close the swing gearbox/brake fill port (1) immediately. Drain oil through the swing gearbox/brake drain port (2).

3.20 SWING BEARING

Turntable Bearing Mounting Bolt Condition Check

NOTICE

THE SWING BEARING IS ONE OF THE MOST CRITICAL POINTS ON AN AERIAL LIFT. IT IS HERE THAT THE STRESSES OF LIFTING ARE CONCENTRATED, AT THE CENTER OF ROTATION. BECAUSE OF THIS, PROPER MAINTENANCE OF THE SWING BEARING BOLTS IS A MUST FOR SAFE OPERATION.

NOTE: This check is designed to replace the existing bearing bolt torque checks on JLG Lifts in service. This check must be performed after the first 50 hours of machine operation and every 600 hours of machine operation thereafter. If during this check any bolts are found to be missing or loose, replace missing or loose bolts with new bolts and torque to the value specified in the torque chart, after applying JLG Threadlocker PN 0100019, to the bolt threads. After replacing and retorquing bolt or bolts recheck all existing bolts for looseness.

1. Check the frame to bearing attach bolts as follows:
 - a. Fully elevate the main boom. (See Figure 3-56.).
 - b. At the position indicated on Figure 3-56., try to insert a 0.0015" feeler gauge between the bolt and hardened washer at the arrow indicated position.
 - c. Ensure that the 0.0015" feeler gauge will not penetrate under the bolt head to the bolt shank.
 - d. Swing the turntable 90 degrees, and check some selected bolts at the new position.
 - e. Continue rotating the turntable at 90 degree intervals until a sampling of bolts have been checked in all quadrants.
2. Check the turntable to bearing attach bolts as follows:
 - a. Elevate the fully retracted main boom to full elevation.
 - b. At the position indicated on Figure 3-58, try to insert the 0.0015" feeler gauge between the bolt head and hardened washer at the arrow indicated position.
 - c. Lower the boom to horizontal and fully extend the boom.
 - d. At the position indicated on Figure 3-57., try and insert the 0.0015" feeler gauge between the bolt head and hardened washer at the arrow indicated position.

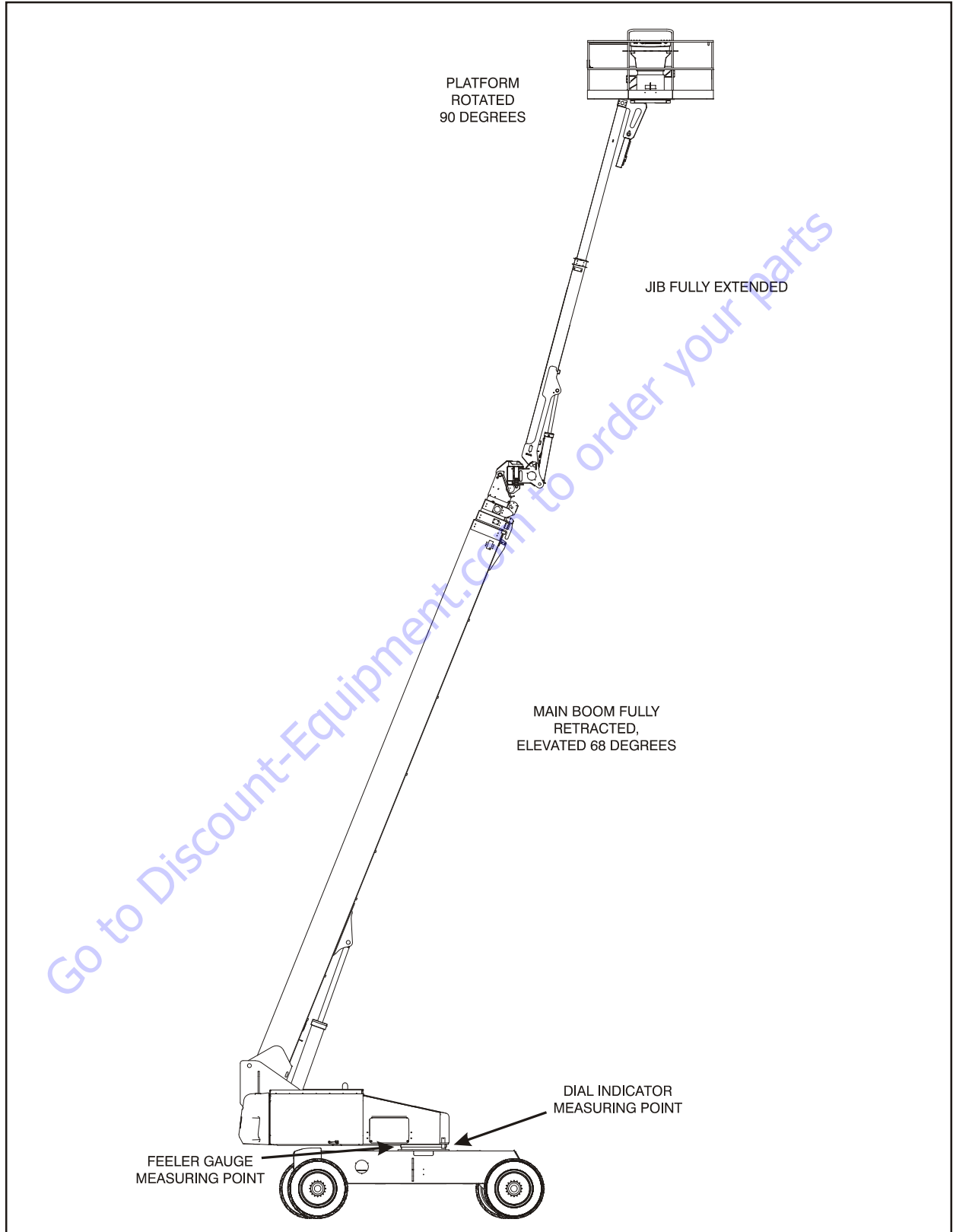

Figure 3-56. Swing Bearing Tolerance Boom Placement - Sheet 1 of 2

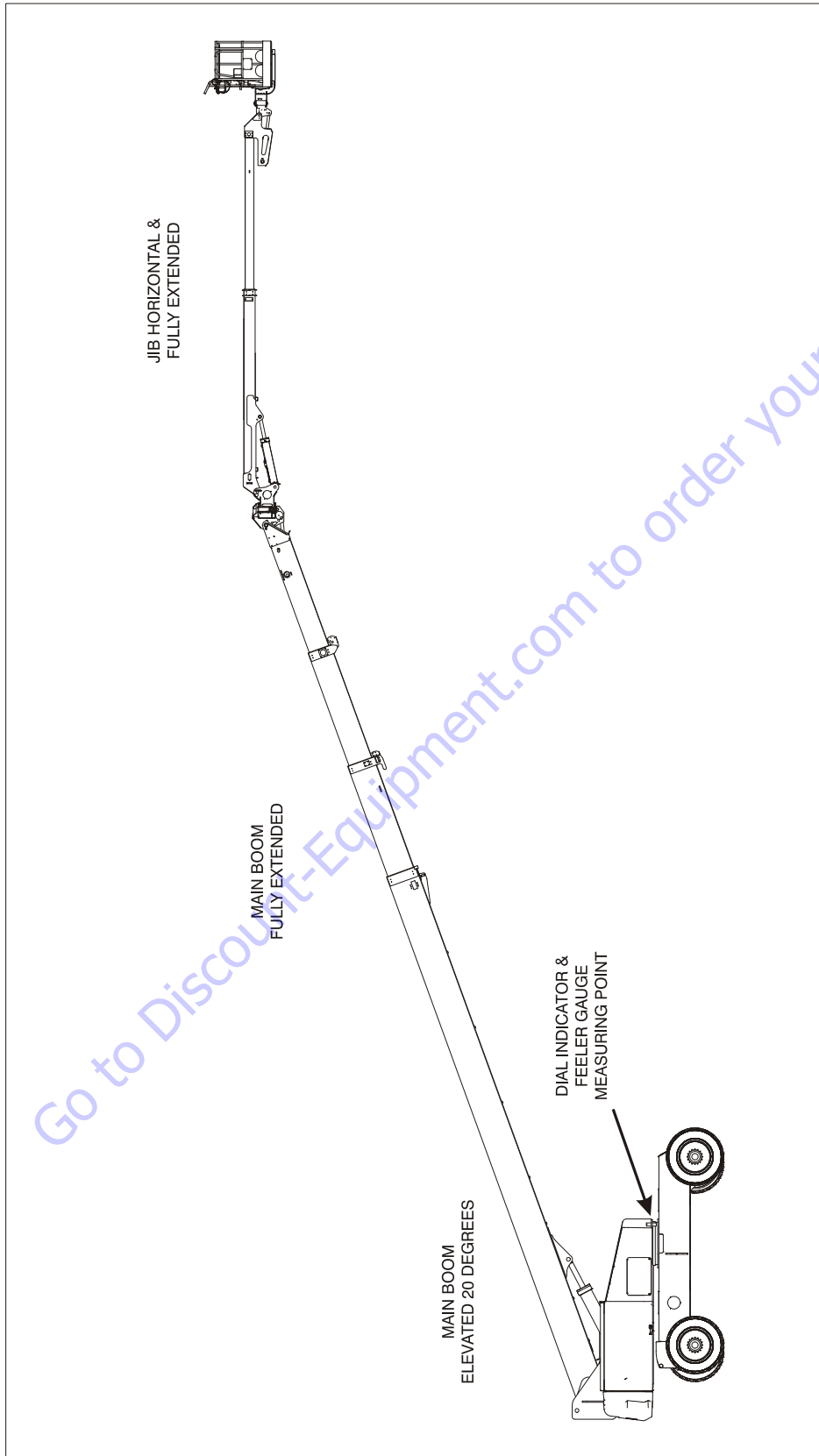

Figure 3-57. Swing Bearing Tolerance Boom Placement - Sheet 2 of 2

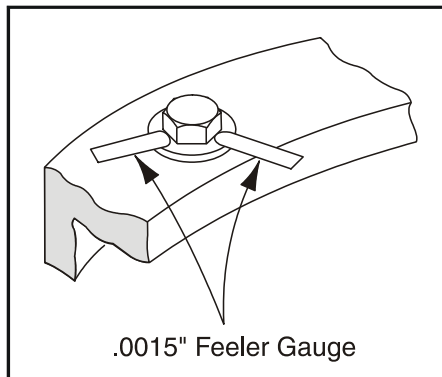
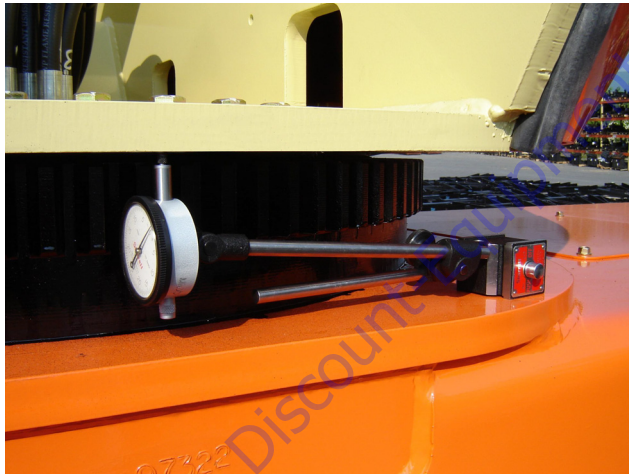

Figure 3-58. Swing Bolt Feeler Gauge Check

3. If the measurement is greater than 0.094 in. (2.387 mm), the swing bearing should be replaced.
4. If the measurement is less than 0.094 in. (2.387 mm), and any of the following conditions exist, the bearing should be removed, disassembled, and inspected for the following:
 - a. Metal particles in the grease.
 - b. Increased drive power required.
 - c. Noise.
 - d. Rough rotation.
5. If bearing inspection shows no defects, reassemble and return to service.

Wear Tolerance

1. From the underside of the machine, at rear center, with the main boom fully elevated and fully retracted, as shown in Figure 3-56., Swing Bearing Tolerance Boom Placement - Sheet 1 of 2, set up a magnetic base dial indicator as shown below and set the indicator to 0 (zero).



2. Next, position the main boom fully extended and horizontal as shown in Figure 3-57., Swing Bearing Tolerance Boom Placement - Sheet 2 of 2. Read the measurement recorded on the dial indicator gauge.

Turntable/Swing Bearing Removal

The following procedure was accomplished using two overhead cranes with the jib assembly and the boom removed prior to un-decking the turntable. For un-decking information concerning lifting the entire upperstructure as a unit, or removing the boom and jib assembly together refer to Section 4 - Boom & Platform.

1. Lower the platform to the ground or onto blocking to support the weight of the jib.
2. Tag and disconnect the electrical harnesses that run to the jib. If necessary, loosen the guide block to allow the harnesses and hoses to move more freely.



3. Remove the jib valve protection plate.

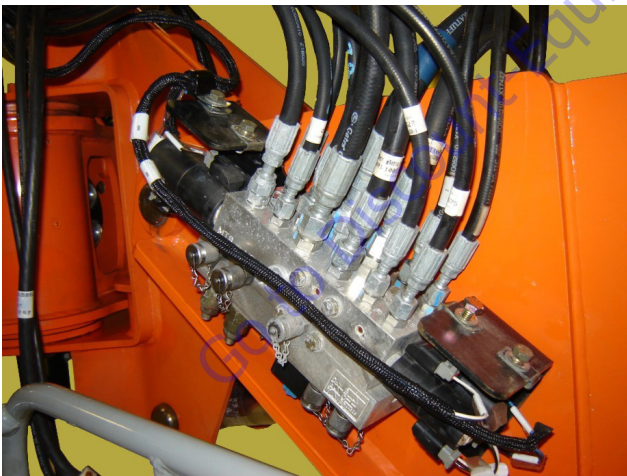

4. Have a container or absorption material ready to catch residual hydraulic fluid. Tag and disconnect the hydraulic hoses that run from the boom to the jib control valve.

It may be necessary to disconnect additional lines to gain access to certain fittings. Cap or plug all openings.



5. Remove the valve from the boom.



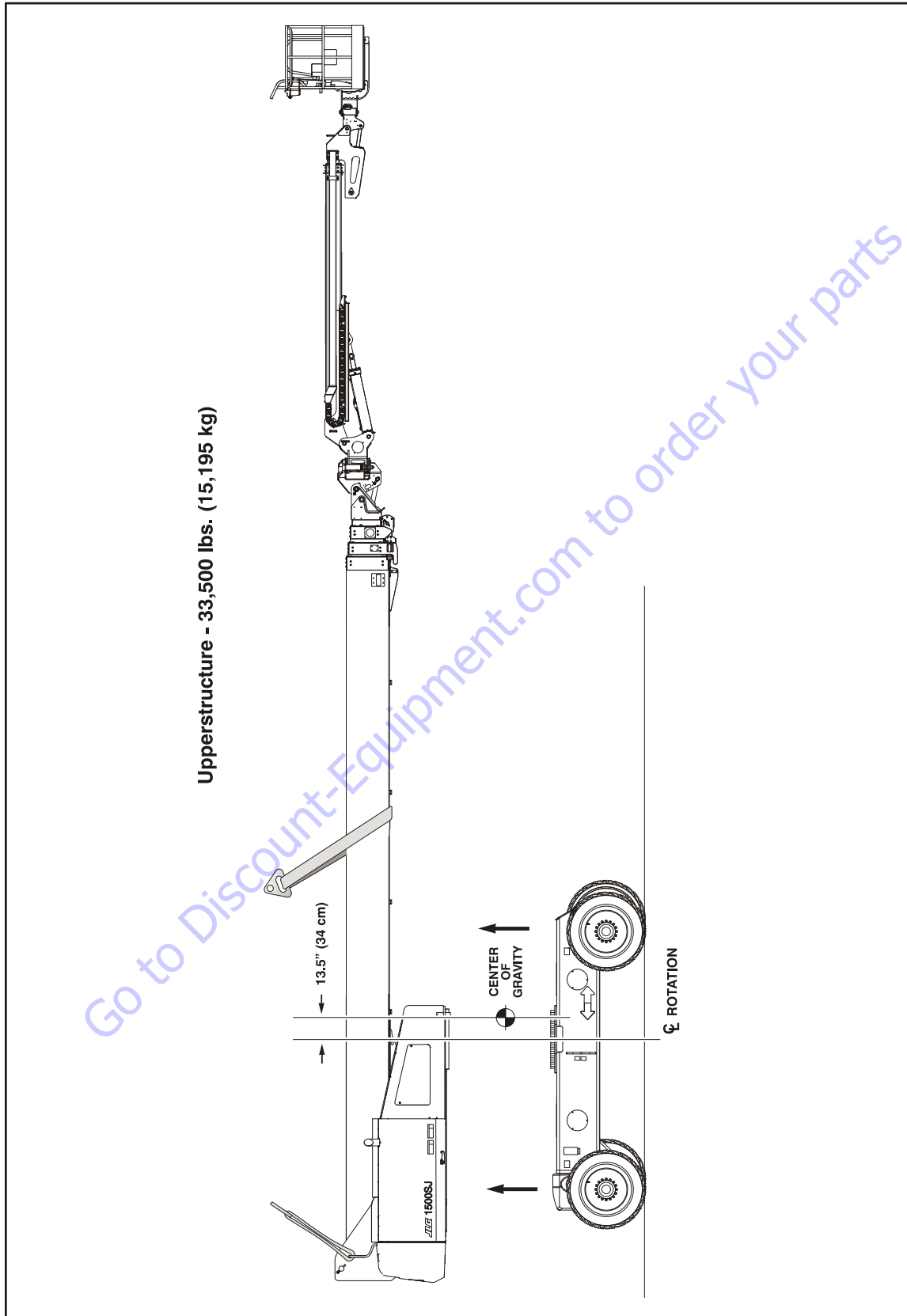

Figure 3-59. Swing Bearing Removal - Sheet 1 of 4

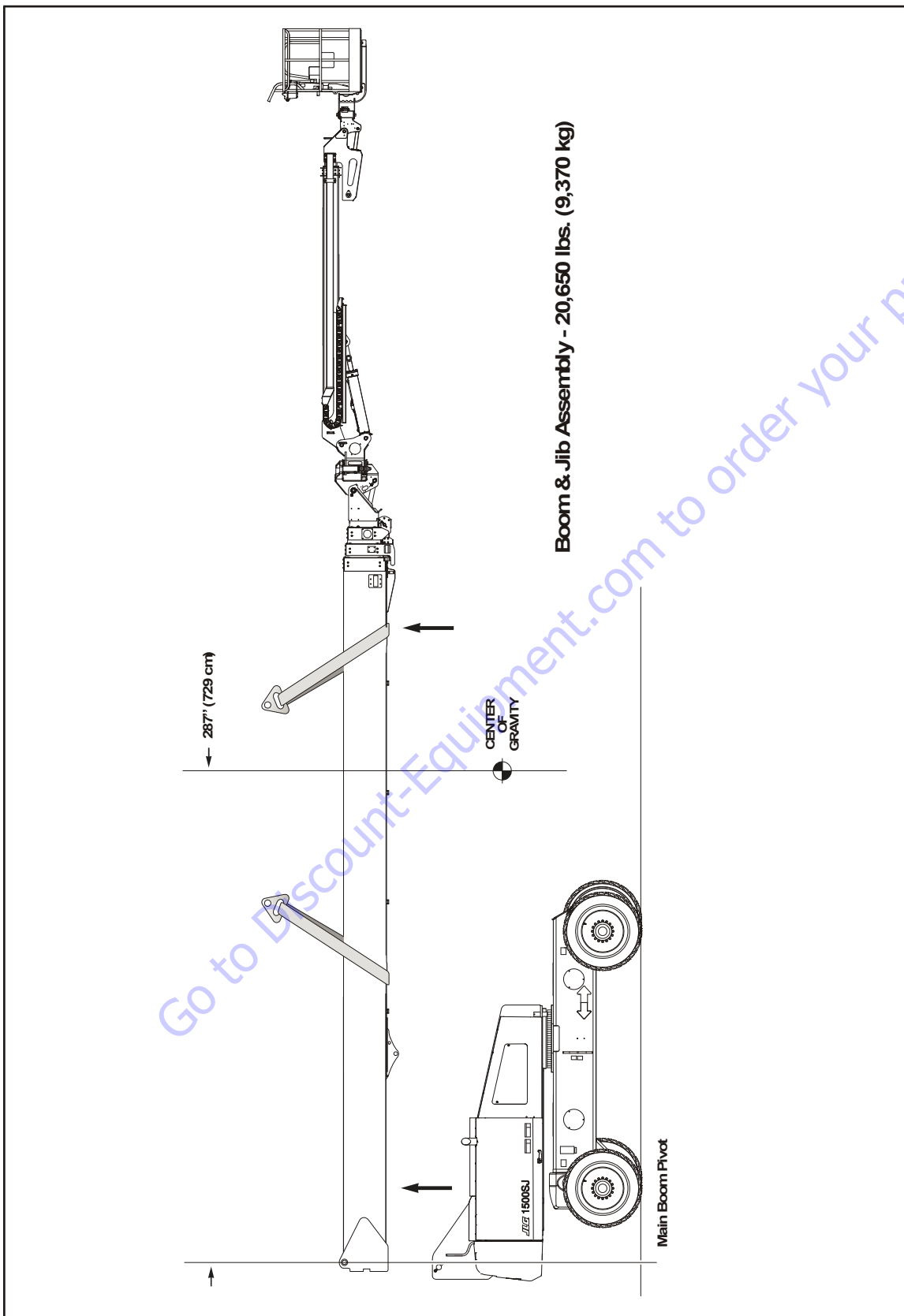

Figure 3-60. Swing Bearing Removal - Sheet 2 of 4

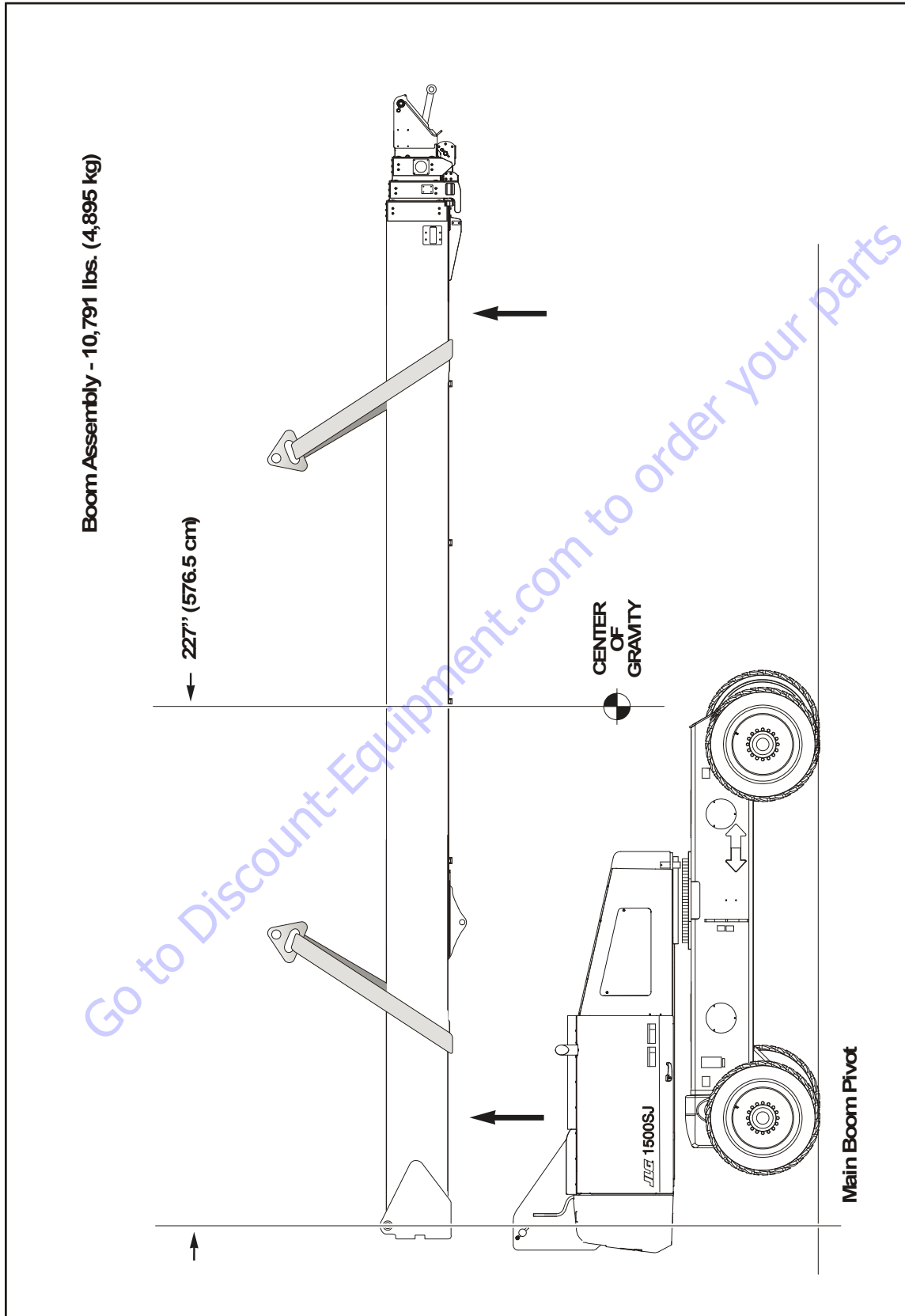

Figure 3-61. Swing Bearing Removal - Sheet 3 of 4

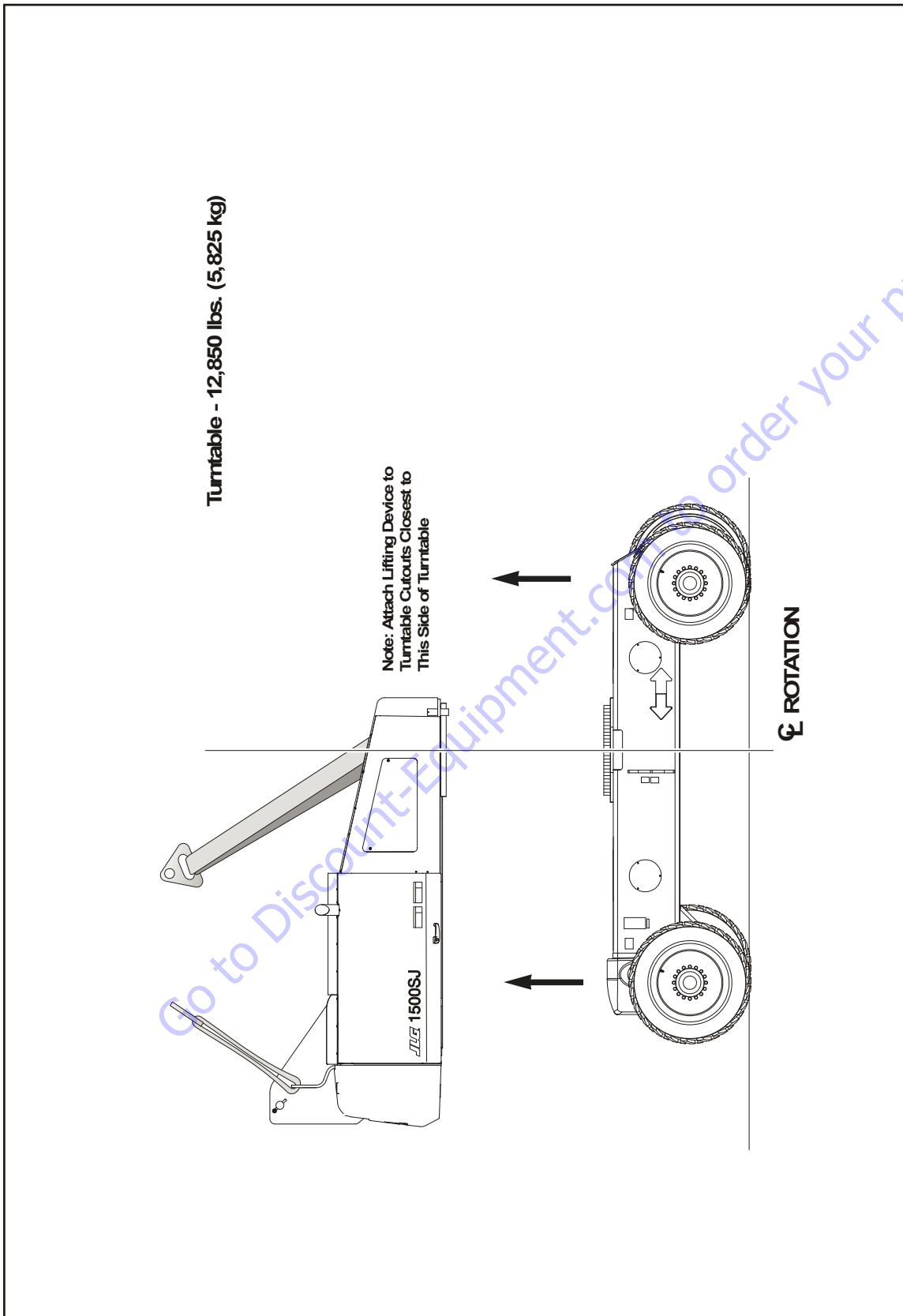
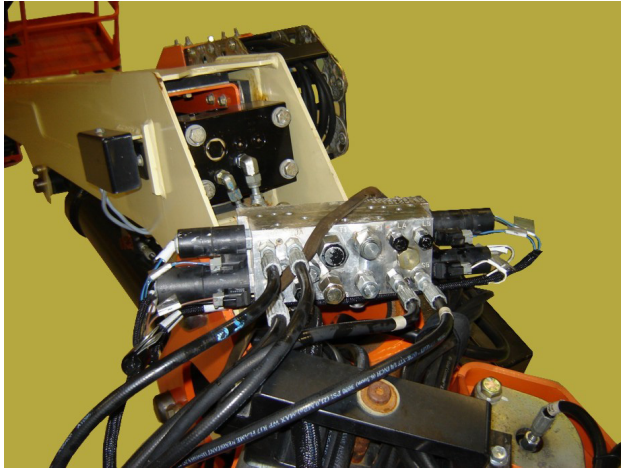

Figure 3-62. Swing Bearing Removal - Sheet 4 of 4

6. Lay the jib control valve aside on the jib. Secure it in place so it does not fall.



7. Disconnect the jib protractor sensor linkage from the boom.



8. Remove the bolt and keeper pin securing the jib level cylinder pivot pin and remove the pin. Place blocking or a soft material under the cylinder rod to protect the rod surface from being scratched.

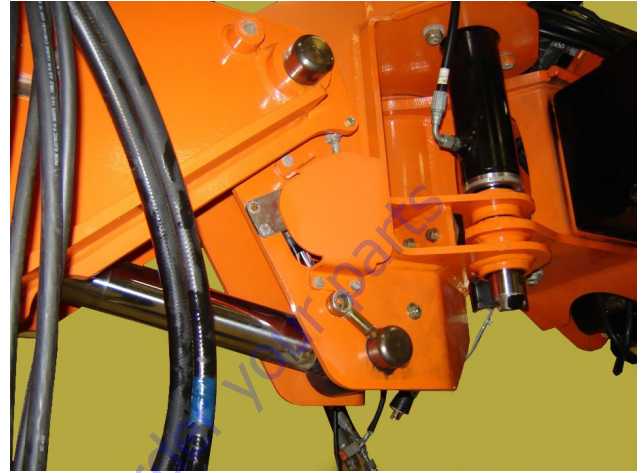

NOTE: The jib and platform assembly weighs approximately 2100 lbs. (953 kg.).

SECTION 3 - CHASSIS & TURNTABLE

9. Attach an adequate supporting device to the jib to support its weight. Remove the bolt and keeper pin securing the jib pivot pin and remove the pin.

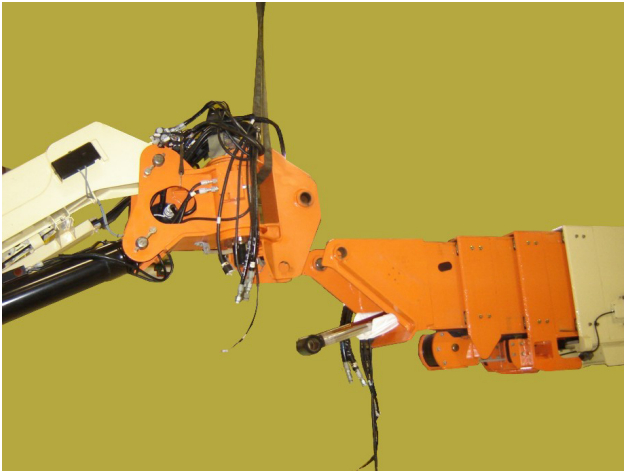

10. Remove the jib and platform assembly from the boom.



11. At the rear of the turntable, tag and disconnect all wiring harnesses that run from the powertrack to the ground control station. The connector inside the ground control box will have to be removed from the wires to allow the harness to be pulled out of the control box. It will simplify installation if a diagram of the wiring running into the connector is made at this time.



12. Have a container or absorption material ready to catch residual hydraulic fluid. Disconnect the pressure line going into the platform filter, taking care to slowly bleed off hydraulic pressure. Cap or plug all openings..



13. Have a container or absorption material ready to catch residual hydraulic fluid. Disconnect the telescope hoses from the bottom of the hydraulic control valve. Cap or plug all openings. Pull the hoses out so they can be lifted away from the machine with the boom.

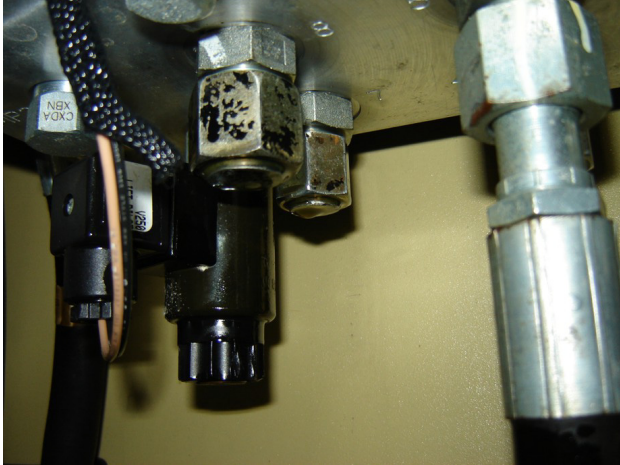

14. Have a container or absorption material ready to catch residual hydraulic fluid. Disconnect the pressure hose from the end of the main control valve. Cap or plug all openings.



15. Remove the cover from the rear of the boom and disconnect the wiring harnesses and hoses running from the turntable to the boom.



16. Disassemble the end of the turntable-to-boom powertrack from the turntable. Use a lifting device to pull the powertrack up so the hydraulic hoses and wiring harnesses can be pulled out from the turntable.



SECTION 3 - CHASSIS & TURNTABLE

- Using the Main Lift Crackpoint option under the Calibrations menu on the JLG Analyzer, lift the boom enough to access the boom lift cylinder rod pivot pin. Refer to Section 6 - JLG Control System for additional analyzer instructions.



NOTE: The boom assembly weighs approximately 10,800 lbs. (4,900 kg.).

- Using an adequate lifting device, support the weight of the boom.



- Attach a lifting device to support the weight of the boom lift cylinder.



NOTE: To assist in determining when the lift cylinder is properly supported, use the JLG Analyzer and select *Diagnostics > Moment > Actual Moment* and get a reading as close to zero (0) as possible.

- Remove the bolt and keeper pin securing the boom lift cylinder rod pivot pin and drive out the pivot pin.



- Lower the lift cylinder until it rests on the turntable.

- Attach an adequate lifting device to support the pivot end of the boom.

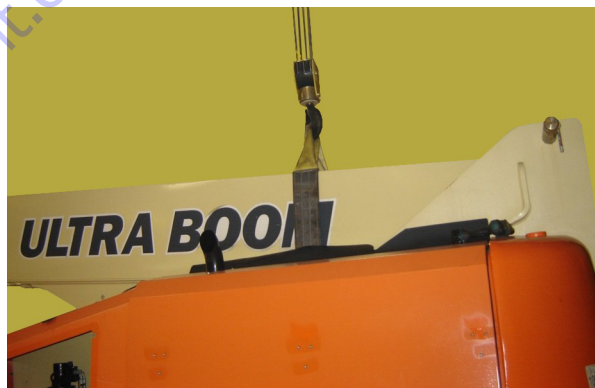

- Remove the bolt and keeper pin securing the boom pivot pin and remove the pivot pin. Remove the boom from the machine and place it on adequate supports.

24. Disconnect the negative battery terminal from the battery.



25. Place a container under the machine to catch escaping hydraulic fluid.



NOTE: The hood assembly weighs approximately 72 lbs. (33 kg).

26. Attach an adequate lifting device to the rear hood assembly.



27. Remove the attaching hardware securing the side of the hood.



28. Remove the attaching hardware securing the top of the hood.



29. Remove the front hood from the machine.

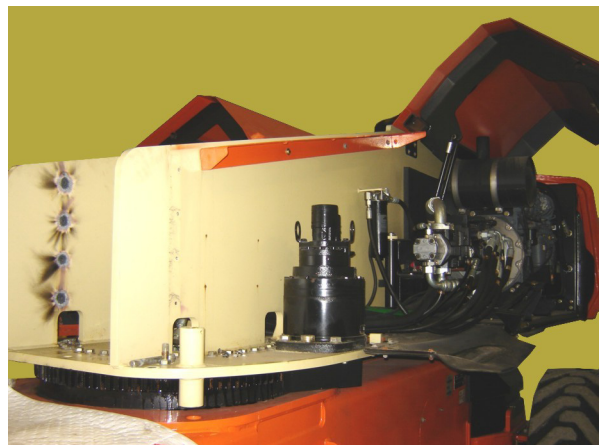

30. Repeat steps 4, 5, and 6 for the front hood on the other side of the machine.

SECTION 3 - CHASSIS & TURNTABLE

31. Tag and disconnect the hoses from the top of the swivel. Cap or plug all openings. Use a tie strap to secure the hoses together.



32. Tie off the bundle of hydraulic hoses to the center support to prevent any damage to the hoses during the remainder of the procedure.



33. Remove the hardware securing the swing brake to the swing drive and lay the swing brake and motor to the side.

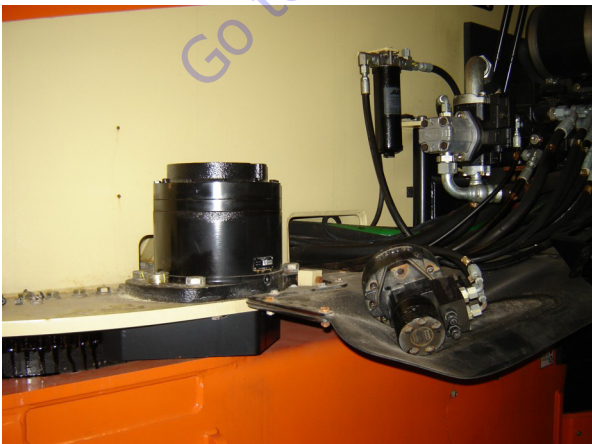

NOTE: The complete swing drive assembly weighs approximately 290 lbs. (132 kg).

34. Remove the hardware securing the swing drive to the turntable and remove the swing drive.

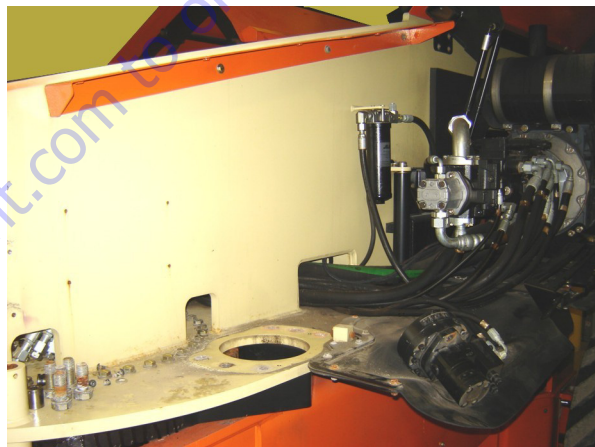
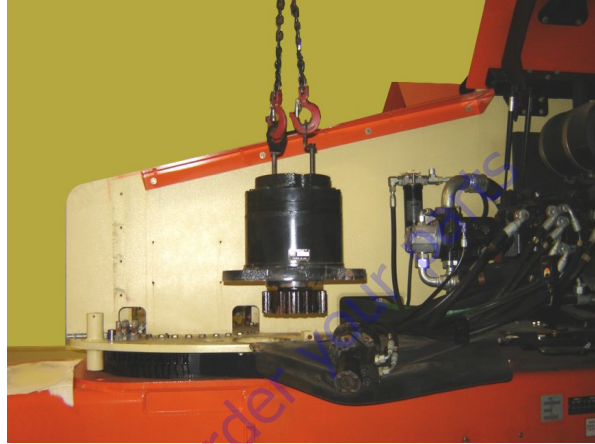

NOTE: Remove the shoulder/pivot bolt last.

NOTE: The turntable assembly weighs approximately 20,650 lbs. (9370 kg).

35. Using the lifting lugs and the center support, attach a lifting device to the front and rear of the turntable to support its weight.

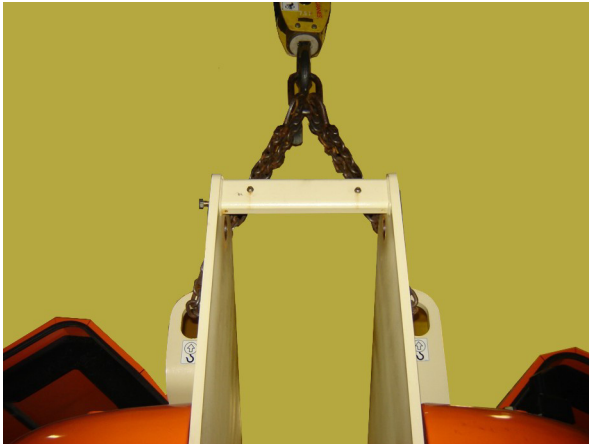

36. Remove the swing bearing inner race bolts. Remove the bolts on the inside of the turntable first, leaving 3-4 bolts on both sides of the outside of the turntable to be removed last.



NOTE: The turntable assembly weighs approximately 20,650 lbs. (9370 kg).

37. Lift the turntable assembly off of the swing bearing and place it on adequate supports.



38. Remove the remote grease lines from the bearing.

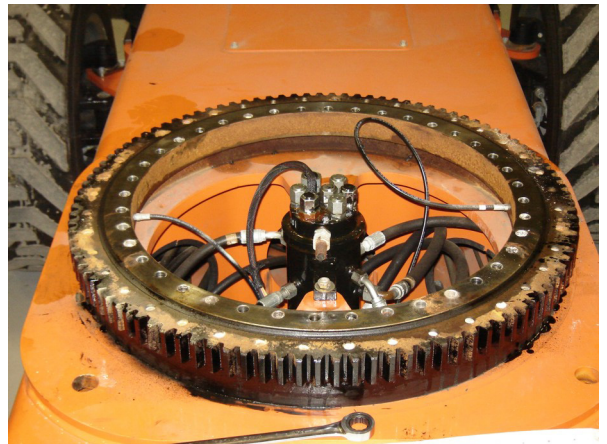

39. Remove the outer race bearing bolts from the underside of the frame.

40. Install lifting eyes into the swing bearing for removal.



NOTE: The swing bearing weighs approximately 300 lbs. (136 kg).

41. Attach an adequate lifting device to the swing bearing and remove it from the frame.

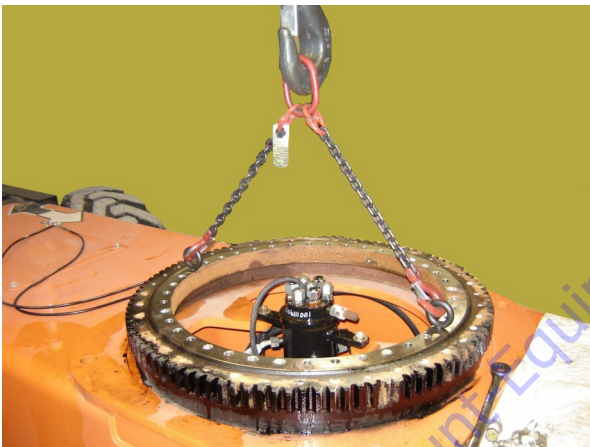

Turntable/Swing Bearing Installation

1. Remove the attaching hardware securing the swivel and lay it off to the side.

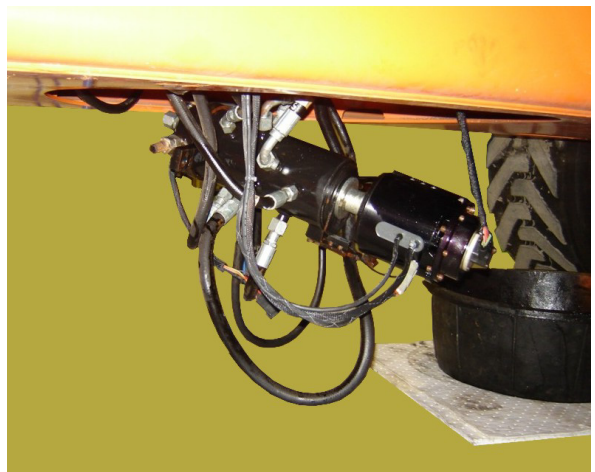
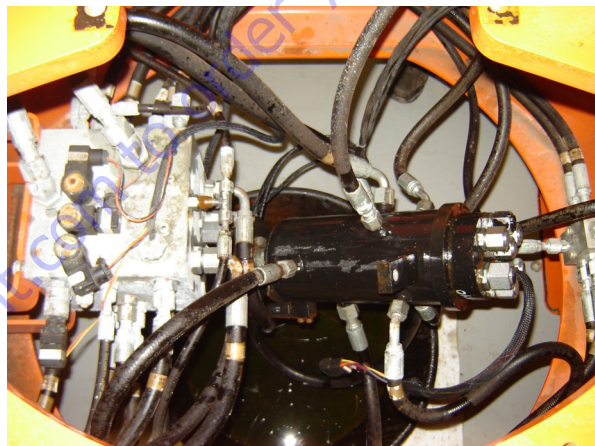

2. Thoroughly clean the bearing mounting surface and mounting holes.

3. Locate the high spot on the swing bearing. This will be marked by blue paint and two X's on the bearing teeth.

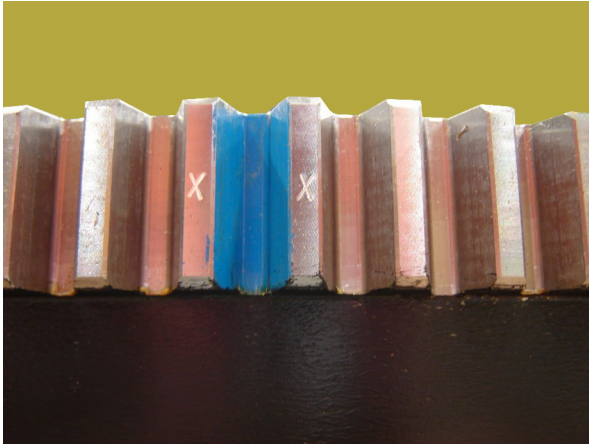

4. Place the new bearing onto the frame orienting the high spot as close as possible to where the swing drive gear will be.



5. Once the bearing is positioned on the frame, start the outer race bolts by hand until they are all installed.
6. Tighten all the outer race bearing bolts until snug and then torque them according to the torquing procedures in this section.

7. Install grease fittings into the bearing and also install two pins to facilitate turning the bearing by hand and for alignment of the turntable.



8. Using the pins, turn the bearing slowly by hand while an assistant applies grease to the fitting. Apply grease until the bearing is adequately greased around the entire circumference of the bearing.
9. Place the swivel back into position and secure in place with the mounting hardware.
10. Line up the two grease holes in the bearing perpendicular to the chassis and install the remote grease lines.

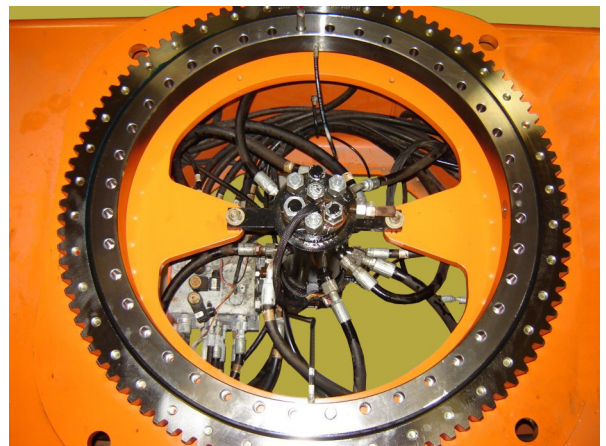

11. Clean the bearing mounting surface on the bottom of the turntable. If necessary, run a tap through the swing drive mounting holes to clean the threads.

SECTION 3 - CHASSIS & TURNTABLE

12. Lift the turntable into place on the bearing using the previously installed guide pins for alignment.



13. Install all of the inner race bearing bolts hand tight. Remove the guide pins to install the last two bolts. After all of the bolts are installed, tighten them until snug. Disconnect the front lifting device at the front of the turntable (leaving the rear lifting device in place) to gain full access to all bolts and torque the bolts according to the torquing procedures in this section.

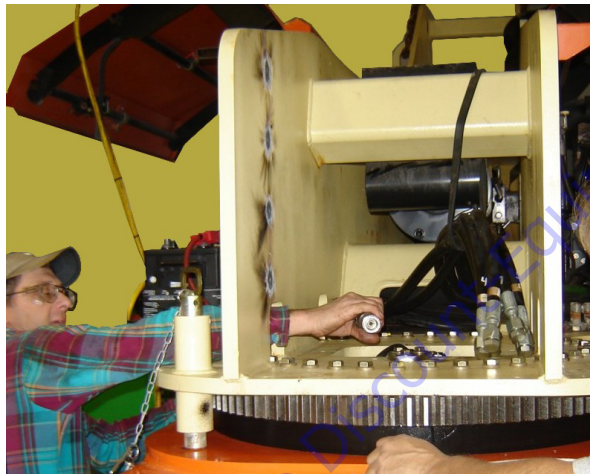

14. After all swing bearing bolts are torqued, the rear lifting device can be disconnected.

15. Connect the hoses to the top of the swivel as tagged during removal. Secure the hoses together with a tie strap as shown.



16. Using an adequate lifting device, set the swing drive in place on the turntable. Make sure the swing bearing high spot is still aligned with the swing drive gear. If necessary, swing the turntable slightly to align the mark with the gear.



- 17.** Position the swing drive mounting bolts and backlash adjusting shim, JLG PN 4071041. Set backlash following the procedures in this section.

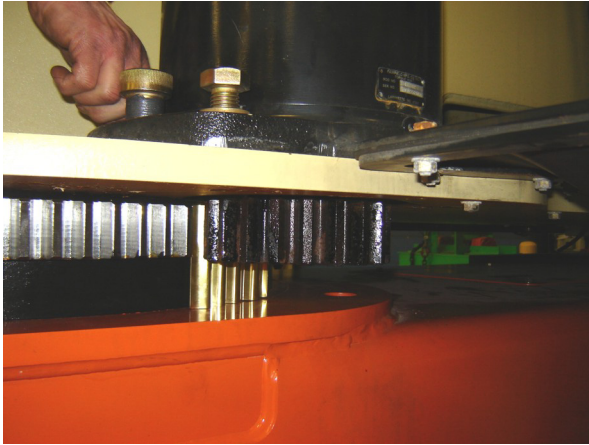

- 18.** Attach the swing bearing remote lubrication lines to the turntable.

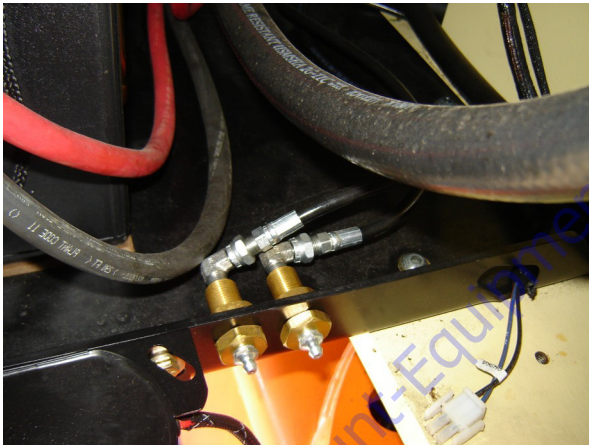

- 19.** Lift the boom from its supports.

