

(en) **Operator's Manual**  
**Maxi-Air™ Towable Compressor**  
**MA185 (185 CFM)**

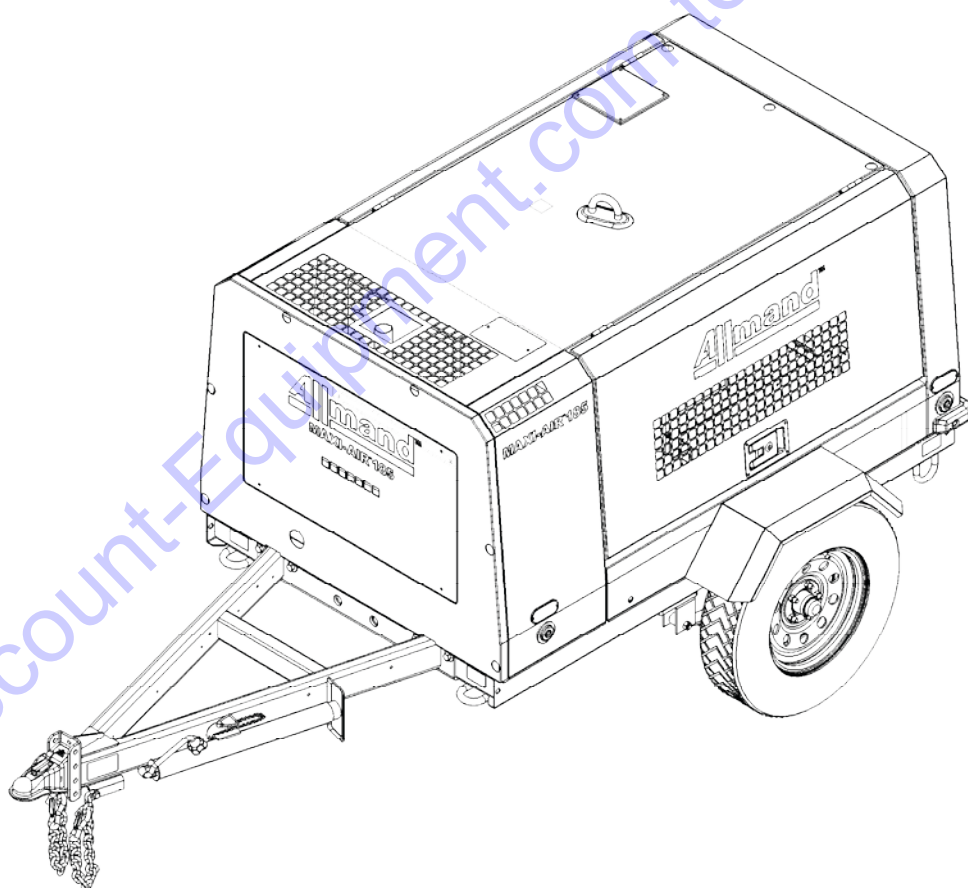

**Discount  
Equipment**

[www.discount-equipment.com](http://www.discount-equipment.com)

# PARTS FINDER

**Search Website  
by Part Number**



**Search Manual  
Library For Parts  
Manual & Lookup Part  
Numbers – Purchase  
or Request Quote**

**Search Manuals**

Enter your information to help us find the right parts manual for your machine.

\* Brand:

\* Model:

\* Serial:

\* Part Number:

SEARCH

**Can't Find Part or  
Manual? Request Help  
by Manufacturer,  
Model & Description**

**Parts Order Form**

Please fill in the following information to help us find the right part for your machine.

Manufacturer:	<input type="text"/>
Model:	<input type="text"/>
Description:	<input type="text"/>
Part Number:	<input type="text"/>
Quantity:	<input type="text"/>
Notes:	<input type="text"/>

Submit

Discount-Equipment.com is your online resource for quality parts & equipment.

Florida: **561-964-4949** Outside Florida TOLL FREE: **877-690-3101**

**Need parts?**

Click on this link: <http://www.discount-equipment.com/category/5443-parts/> and choose one of the options to help get the right parts and equipment you are looking for. Please have the machine model and serial number available in order to help us get you the correct parts. If you don't find the part on the website or on one of the online manuals, please fill out the request form and one of our experienced staff members will get back to you with a quote for the right part that your machine needs.

We sell worldwide for the brands: Genie, Terex, JLG, MultiQuip, Mikasa, Essick, Whiteman, Mayco, Toro Stone, Diamond Products, Generac Magnum, Airman, Haulotte, Barreto, Power Blanket, Nifty Lift, Atlas Copco, Chicago Pneumatic, Allmand, Miller Curber, Skyjack, Lull, Skytrak, Tsurumi, Husquvarna Target, Stow, Wacker, Sakai, Mi-T-M, Sullair, Basic, Dynapac, MBW, Weber, Bartell, Bennar Newman, Haulotte, Ditch Runner, Menegotti, Morrison, Contec, Buddy, Crown, Edco, Wyco, Bomag, Laymor, EZ Trench, Bil-Jax, F.S. Curtis, Gehl Pavers, Heli, Honda, ICS/PowerGrit, IHI, Partner, Imer, Clipper, MMD, Koshin, Rice, CH&E, General Equipment, Amida, Coleman, NAC, Gradall, Square Shooter, Kent, Stanley, Tamco, Toku, Hatz, Kohler, Robin, Wisconsin, Northrock, Oztec, Toker TK, Rol-Air, APT, Wylie, Ingersoll Rand / Doosan, Innovatech, Con X, Ammann, Mecalac, Makinex, Smith Surface Prep, Small Line, Wanco, Yanmar

**Thank you** for purchasing this quality-built Allmand towable compressor. We are pleased that you've placed your confidence in the Allmand brand. When operated and maintained according to the instructions in this manual, your Allmand compressor will provide many years of dependable service.

**This manual contains** safety information to make you aware of the hazards and risks associated with towable compressors and how to avoid them. Because Allmand does not necessarily know all the applications this towable compressor could be used for, it is important that you read and understand these instructions thoroughly before attempting to start or operate this equipment. **Save these original instructions for future reference.**

Knowing the model number of your Allmand Air Compressor will make it easy to order maintenance or repair parts either online or from your local dealer. The model number is generally a number stamped into metal or on a sticker directly on your product.

**Towable Compressor**

Model Number \_\_\_\_\_

Revision \_\_\_\_\_

Serial Number \_\_\_\_\_

**Date Purchased** \_\_\_\_\_

**Engine**

Model Number \_\_\_\_\_

Type Number \_\_\_\_\_

Code Number \_\_\_\_\_

Go to Discount-Equipment.com to order your parts

## Table of Contents

Operator Safety . . . . .	4
Features and Controls . . . . .	9
Transporting and Set-Up . . . . .	12
Operation . . . . .	13
Maintenance . . . . .	23
Storage . . . . .	31
Troubleshooting . . . . .	32
Specifications . . . . .	36
Wiring Diagram . . . . .	39
Piping Diagram . . . . .	40
Operation Log . . . . .	42
Noise Emission . . . . .	44
Addendum A - Tire Safety Information . . .	48
Addendum B - Unit Options . . . . .	59

Go to [Discount-Equipment.com](http://Discount-Equipment.com) to order your parts

# Operator Safety

## Equipment Description



Read this manual carefully and become familiar with your towable compressor. Know its applications, its limitations, and any hazards involved.

Every effort has been made to ensure that information in this manual is accurate and current. Figures and drawings in this manual may differ slightly from your model. However, we reserve the right to change, alter, or otherwise improve the product and this document at any time without prior notice.

## Safety and Control Symbols

The safety alert symbol indicates a potential personal injury hazard. A safety symbol may be used to represent the type of hazard. **DANGER** indicates a hazard which, if not avoided, will result in death or serious injury. **WARNING** indicates a hazard which, if not avoided, *could* result in death or serious injury. **CAUTION** indicates a hazard which, if not avoided, *could* result in minor or moderate injury. **NOTICE** indicates information considered important, but not hazard-related.



Operator's Manual



Alert



Organic Waste



Toxic Fumes



Explosion



Clothing



Prohibited



Fire



Hot Surface



Hand Injury



Battery



Protective Gear



Amputation Hazard



Explosive Pressure



Safety Fittings



Rotating Parts



Propelling Parts



Lighting Apparatus



**WARNING**



Read and follow safety directions:

- Be sure safety decals are present and legible. Replace if damaged or missing.
- Do not modify machine without prior approval. Machine safety may be compromised, functions may be altered, or machine life may be shortened.
- Never use machine for purpose of compression of gases other than air, or as a vacuum pump. Death or serious injury could result.



**DANGER!**



Compressed air is not to be used for human respiration.

- Compressed air from this machine contains poisonous materials. Never use compressed air for human respiration. Breathing compressed air could result in death or serious injury.
- This machine is not designed to provide air for working inside wells or tunnels. Doing so could result in death or serious injury.



**WARNING**



**VENTILATION!**

- Exhaust gas from the engine is poisonous, and could cause death when inhaled.
- Avoid using the machine in an insufficiently ventilated building or tunnel.



**WARNING**



- Keep flames away from battery.

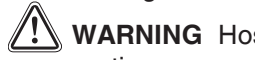

- Battery may generate hydrogen gas, which is explosive.
- Battery electrolyte is dilute sulfuric acid. Mishandling could result in severe burns.
- When handling battery, be sure to wear appropriate safety protection such as safety goggles and gloves.
- Dispose of battery according to local, state and/or federal regulations.



**WARNING**



Hose attachment and removal precautions:



- Piping or hose connected to compressor service valve must meet or exceed rated discharge pressure. Failure to observe and comply could result in death or serious injury.
- Connect piping or hose to machine service valve securely before operation. Failure to do so could result in death or serious injury.
- Removing piping or hose prior to closing service valve or discharging pressure could result in death or serious injury. Stop machine, close service valve, and discharge remaining pressure before removing piping or hose.
- Use proper tools when connecting or disconnecting piping or hose.

 **WARNING**  When operating machine, do not wear:



- Loose clothes
- Clothes with unbuttoned sleeves
- Hanging tie or scarf
- Accessories such as dangling jewelry
- Such items could be caught in rotating parts of machine, and could result in death or serious injury.



 **WARNING** Do not operate machine when tired or under influence of drugs or alcohol. Careless operation could result in death or serious injury.

 **WARNING**  Wear appropriate personal protective equipment (PPE), such as a helmet, safety glasses, earplugs, safety shoes, gloves, and a dust mask.

 **WARNING**  Have first-aid boxes and fire extinguishers near machine in case of emergency such as injury and fires. It is also advisable to have a list of phone numbers of doctors, ambulance and fire department available in case of emergency.

 **WARNING** To prevent injury, tools, cables, hoods, covers and other unnecessary items should be cleaned and removed from machine before operation.



 **WARNING**  Do not open oil filler cap of separator receiver tank during or immediately after operation. Explosive pressure could cause death or serious injury.



 **WARNING**  Do not open fluid drain valves or plugs during operation. this includes:

- Separator receiver tank drain valve
- Coolant drain valve and plug
- Engine oil drain valve
- Oil cooler drain valve
- Fuel tank drain valve and plug

 **WARNING**  Never direct compressed air at people, pets or foods:

- Never blow compressed air directly at people. Dirt, dust, oil or foreign objects in compressed air could cause serious injury to eyes and skin.
- Do not blow compressed air on food.

 **WARNING**  Contact with rotating parts or belts could cause death or serious injury. Keep hands from rotating parts and belts while machine is in operation.

 **WARNING**  Do not open radiator cap during or immediately after operation. Explosive pressure of hot liquid could cause severe burns, resulting in death or serious injury.

 **WARNING**   Operation with compressed air supply port opened is prohibited:

- Do not operate machine with service valves and/or relief valve open, unless piping and/or hose is connected. Uncontrolled pressurized air could cause death or serious injury.
- If machine must be temporarily operated with port open, be sure to mount a silencer to reduce noise, and wear personal protective equipment such as earplugs to protect hearing.

 **WARNING**  Do not touch hot parts.



- Never work nearby hot portions of the machine while it is running.
- Parts such as engine, exhaust manifold, exhaust pipe, muffler, radiator, oil cooler, air-end, pipe, separator receiver tank, and discharging pipe are especially hot. Never touch these parts, as it could result in serious burns.
- Compressor oil, coolant water, and engine oil are also very hot and dangerous to touch. Do not check or add while machine is running.



 **WARNING**   Fire prevention.

- Fuel and oils are extremely flammable. Do not bring lit cigarettes or matches near machine when checking or adding fuel and oils.
- Adding fuel and oils should be done outdoors or in a well-ventilated location.
- Refuel after stopping engine, and never leave fuel near machine. Do not spill. If spilled, wipe up completely.
- Do not fill fuel oil up to cap level. Fuel oil will overflow due to volume expansion caused by rise of ambient temperature. Fuel can also spill during machine movement or transporting.
- Parts such as muffler and exhaust pipe can be extremely hot. Remove twigs, dried leaves, dried grass, waste paper, etc. from around muffler and exhaust pipe.
- Keep a fire extinguisher available by machine in case of fire.

 **WARNING** Hang a “Now Checking and under Maintenance” tag:

- Remove starter key from starter switch before starting inspection, and hang up a “Now Checking and under Maintenance” tag where it can be easily seen. Inspector must keep key during checking and maintenance.
- Remove black negative (-) cable from battery.
- Neglecting above procedure could result in death or serious injury.

 **WARNING**  When refilling separator receiver tank with compressor oil, stop engine, and make sure pressure gauge indicates 0 MPa, then gradually loosen oil filler cap. Residual pressure in separator receiver tank could cause extremely hot compressed air and oil to jet out, resulting in death or serious injury.

 **WARNING**  Be careful of high-pressurized blowout.

- After stopping engine, make sure pressure gauge indicates 0 MPa. Even when the gauge shows 0 MPa, open service valve to make sure there is no residual pressure in air piping.
- Residual air under pressure could result in serious injury.

 **WARNING**  **Draining separator receiver tank.**



- After stopping engine, confirm pressure gauge indicates 0 MPa and there is no residual pressure, then gradually open drain valve to drain compressor oil.
- Residual pressure in separator receiver tank could cause extremely hot compressed air and oil to jet out, resulting in death or serious injury.

 **WARNING**  **Adjusting belt tension:**

- Attempting to adjust belt tension with machine running could result in death or serious injury.
- Stop engine, remove starter key, and remove black negative (-) cable from battery before adjusting belt tension.



 **WARNING**  **Hands off cooling fan:**

- Contact with cooling fan while machine is running could result in death or serious injury.
- Stop engine and remove starter key whenever maintenance is to be performed near cooling fan.

 **WARNING**  Wear safety glasses when cleaning dust accumulated in such devices as air-filter by blowing compressed air.

 **WARNING**  **Lighting apparatus:**



- If work site is dark, use lighting to illuminate work area. Working without illumination could result in death or serious injury.
- Work lighting should be fitted with safety guard to protect against breakage.
- Do not allow work light to contact fuel or oils, as they could ignite, causing death or serious injury.

 **WARNING**  Opening coolant water drain valve cap:

- Stop engine and let coolant water sufficiently cool down before draining.
- If drain valve is opened before coolant water is cooled enough, hot water could jet out, resulting in death or serious injury.

 **CAUTION**  **Refilling or draining engine oil:**

- Engine oil is extremely hot during and just after operation.
- Stop engine and wait 10 to 20 minutes before checking, adding or draining engine oil.

 **CAUTION**  Be sure to perform periodic check of compressor oil and oil separator. Neglecting checks could cause overheating oil, resulting in a fire.

 **CAUTION**  Treatment of organic wastes.

- Waste liquid from machine contains harmful material. Do not discharge onto ground or into rivers, lakes or sea. Such material will contaminate the environment.
- Be sure to use an approved container to hold waste liquid from machine.
- Be sure to follow local, state or federal regulations when disposing of oil, fuel, coolant (antifreeze), filter, battery or other harmful materials.

**NOTICE** Parts of this machine contain sensitive electronic components. If welding work is required, disconnect any electronic equipment on the machine to prevent damage due to excessive current.

 **WARNING**

Breathing diesel engine exhaust exposes you to chemicals known to the State of California to cause cancer and birth defects or other reproductive harm.

- Always start and operate the engine in a well-ventilated area.
- If in an enclosed area, vent the exhaust to the outside.
- Do not modify or tamper with the exhaust system.
- Do not idle the engine except as necessary.

For more information go to [www.P65warnings.ca.gov/diesel](http://www.P65warnings.ca.gov/diesel).

 **WARNING**

- Battery posts, terminals, and related accessories contain lead and lead compounds, chemicals known to the State of California to cause cancer, birth defects, or other reproductive harm. Wash hands after handling.

## Safety Decals and Locations

The following safety decals are attached to the machine. Keep them clean at all times. If they are damaged or missing, contact your authorized dealer for replacements. Part numbers are indicated on the lower right corner of the label. Adhere a new one to the original location.

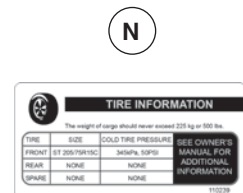
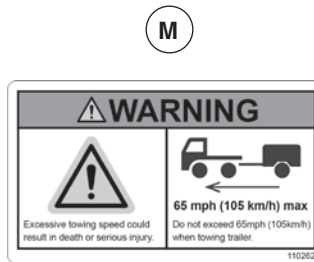
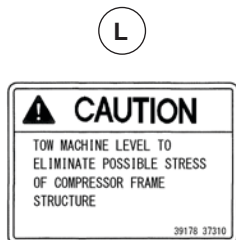
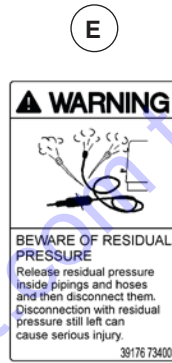
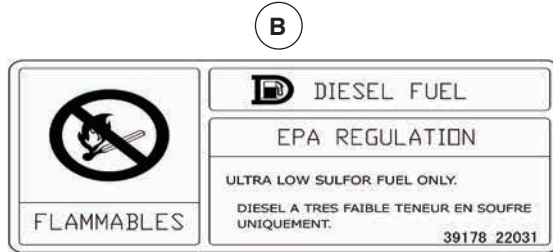



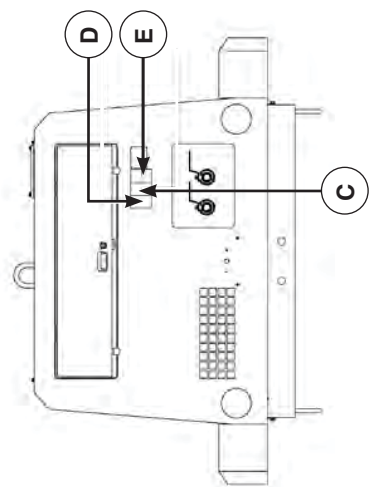
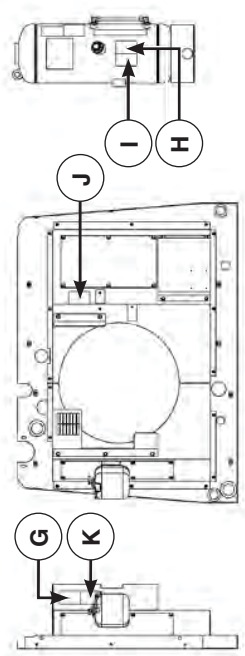
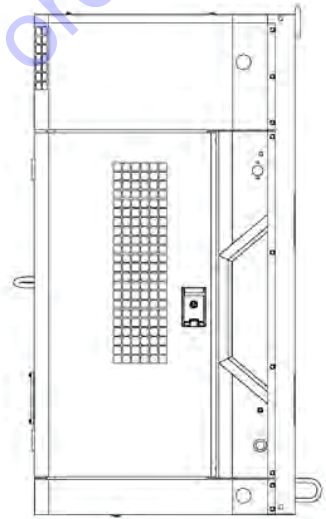
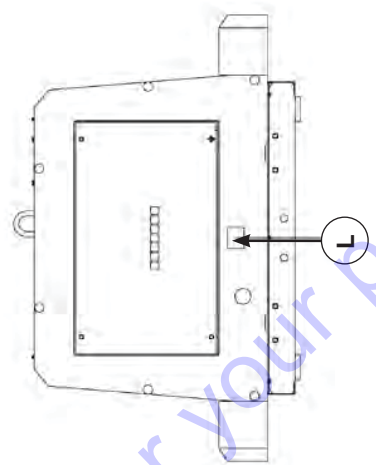
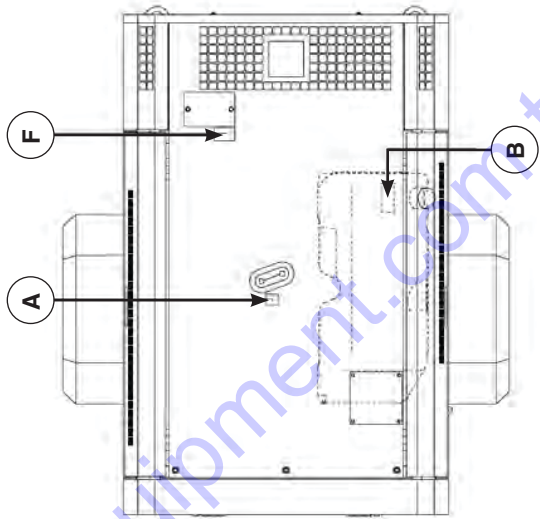
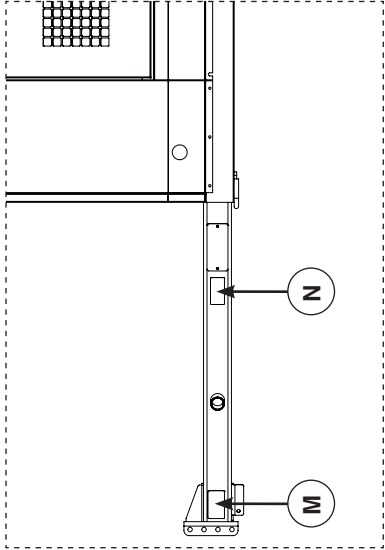

## Features and Controls



**Read this Operator's Manual and safety rules before operating your towable compressor.**

Compare the illustrations with your towable compressor, to familiarize yourself with the locations of various controls and adjustments. Save this manual for future reference.

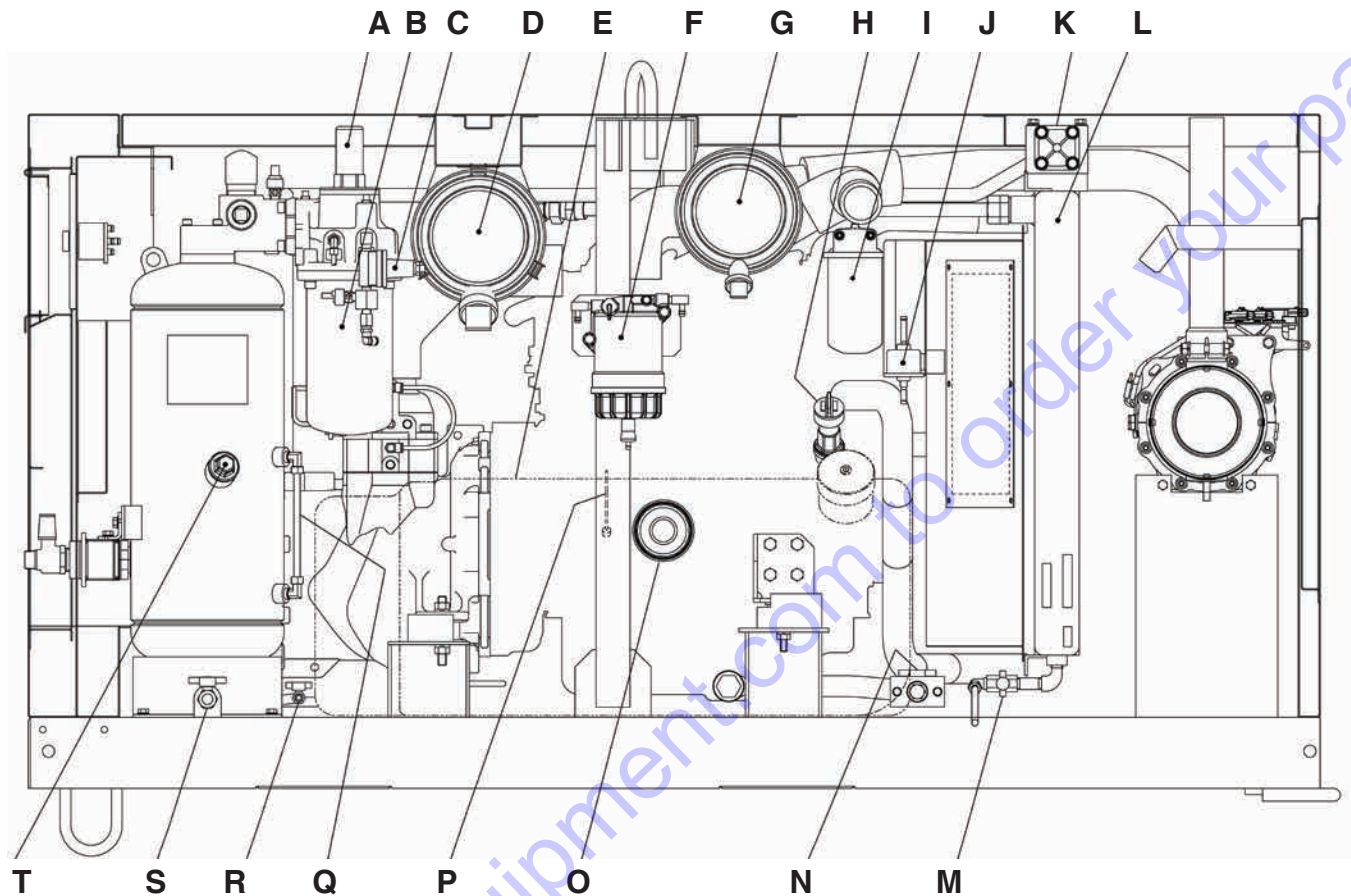

- A - Pressure Control Valve** — Keeps receiver tank pressure higher than 56 PSI (4 BAR) in tank.
- B - Oil Separator** — Separates oil mist mixed in compressed air.
- C - Pressure Regulator** — Regulates intake air volume.
- D - Compressor Air Filter** — Filters compressor air.
- E - Fuel Tank** — Stores diesel fuel oil.
- F - Fuel -pre-filter** — Filters impurities in fuel oil and separates water from fuel.
- G - Engine Air Filter** — Filters engine air.
- H - Engine Oil Filler Port** — Location for adding engine oil to engine.
- I - Fuel Filter** — Filters impurities from fuel.
- J - Air bleeding electromagnetic pump** — Filters impurities from fuel.

- K - Bypass Valve** — Maintains compressor oil temperature
- L - Oil Cooler** — Cools compressor oil circulating in system
- M - Oil Cooler Drain Valve** — Drains compressor oil from oil cooler and oil lines
- N - Engine Oil Drain Valve** — Drains engine oil.
- O - Engine Oil Filter** — Filters engine oil.
- P - Engine Oil Level Gauge** — Indicates engine oil level.
- Q - Compressor Oil Level Gauge** — Indicates compressor oil level.
- R - Fuel Tank Drain Valve** — Drains condensate accumulated in fuel tank.
- S - Separator Receiver Tank Drain Valve** — Drains condensate from separator-receiver tank.
- T - Compressor Oil Filler Port** — Location for adding compressor oil.

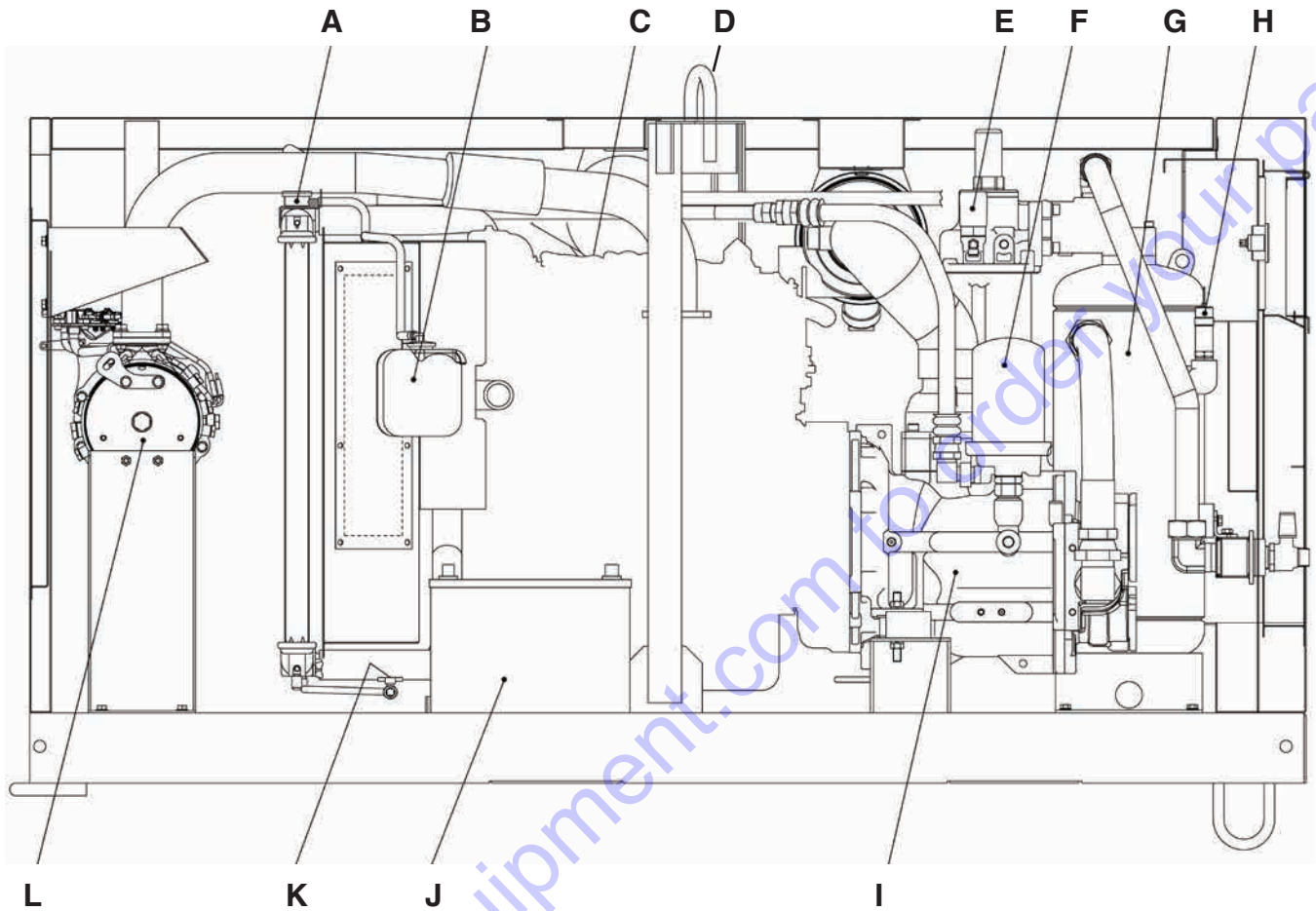

- A - Radiator** — Cools engine.
- B - Reserve Tank** — Collects engine coolant overflow.
- C - Engine** — Powers compressor.
- D - Lifting Bail** — For lifting unit.
- E - Solenoid Valve** — Reduces load at start-up.
- F - Compressor Oil Filter** — Filters impurities from compressor oil.

- G - Separator receiver tank** — Filters impurities in fuel oil and separates water from fuel.
- H - Safety Valve** — Releases compressed air to atmosphere when rated pressure is exceeded.
- I - Compressor air-end** — Compresses air.
- J - Battery** — Supplies power to start engine.
- K - Radiator Drain Valve** — Drains engine coolant.
- L - DPF (Diesel Particulate Filter)** — Removes harmful components contained in exhaust gas.

## Instrument Panel

Each display of the operation panel is illustrated as follows.  
Read and fully understand the explanations and be sure to operate safely.

**A - Monitor Change / Error Code Switch** — When this switch is pushed while lamp is blinking, it displays error code. When starter switch is turned to STOP, display screen resets. See **Troubleshooting** for details of the blinking state warning and the illumination state (trouble) of failure codes.

**B - Auto Idle Switch** — The switch is used for minimizing fuel consumption at no-load operation. It functions when the lamp goes on.

**C - Digital Monitor** — When power is supplied, revolution speed (lamp lighting) is indicated.

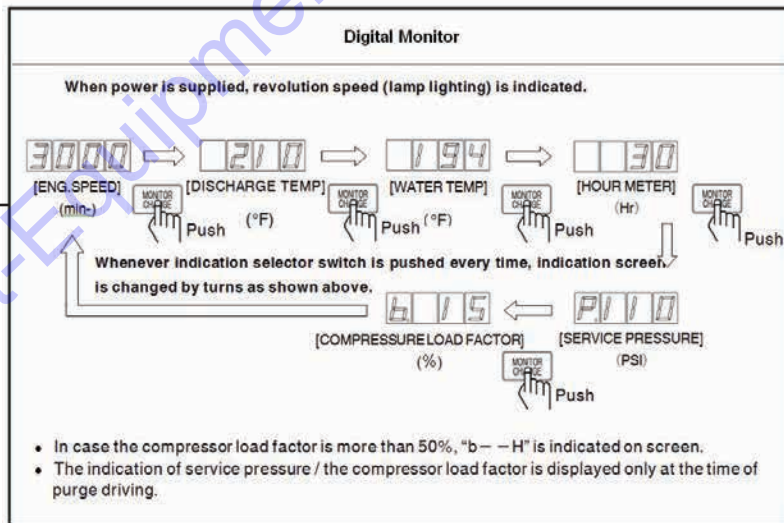
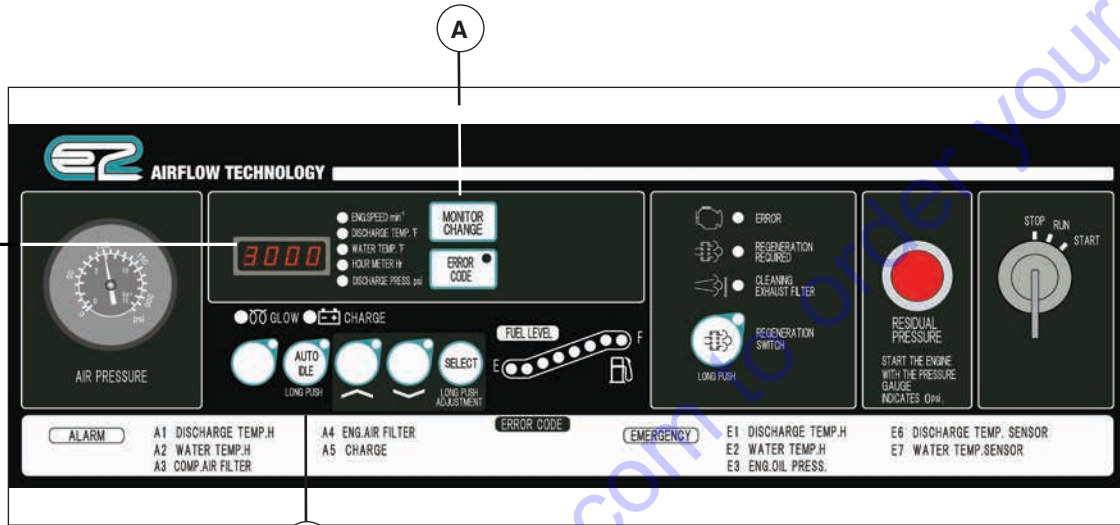

## Transporting and Set-Up



**Read entire Operator's Manual before you attempt to setup, transport, or operate your new towable compressor.**

Your towable compressor is ready for use after it has been properly setup with the recommended oil and fuel. If you have any problems with the setup of your towable compressor, contact your authorized dealer

### Setup Compressor



**WARNING**

- Exhaust gas from the engine is poisonous, and could cause death when inhaled.
- Avoid using the machine in an insufficiently ventilated building or tunnel.
- Do not position the exhaust gas outlet in the direction of a person or house.

The machine should be operated in the following conditions:

- Ambient temperature 5°F to 104°F.
- Humidity less than 80%.
- At altitudes lower than 4,291 ft. above sea level.
- Set up the machine in a place with good ventilation, lower temperature, and with surroundings as dry as possible.
- If more than two machines are placed parallel in operation, keep enough distance so that exhaust air from one machine does not affect the other.
- Set up the unit in an area where fresh air is always available.
- Keep enough space around the unit for inspection and maintenance access.



**WARNING** The machine must be parked horizontally on a level surface. If the machine must be parked on a slope, place it across the grade to prevent rolling. Do not park on a slope exceeding 15°. Be sure to place wheel chocks (A) against the front and back of each wheel.

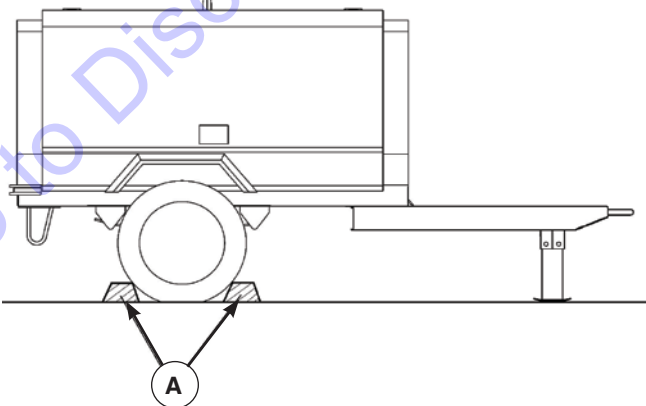

## Transporting



**WARNING** When loading and unloading the unit, be sure to use the lifting bail (B) located at the top center of the unit.

- Never get under the unit when lifted.
- Never lift the unit while in operation.
- If the unit is transferred by truck, fasten it by ropes at the front eye and rear stand. Also be sure to place a set of chocks against the front and rear of each wheel.

### Lifting the Compressor

Before lifting the unit, make sure to check the lifting bail for any cracks, loose bolts, etc.

1. Connect the hook (C) of the crane or shackle with the lifting bail (B) eye fitted at the top center of the unit. Ensure there is no person standing around the unit. Then perform hoisting operation.
2. Select a truck or crane with capacity sufficient for the weight and size of the unit. See *Specifications*.

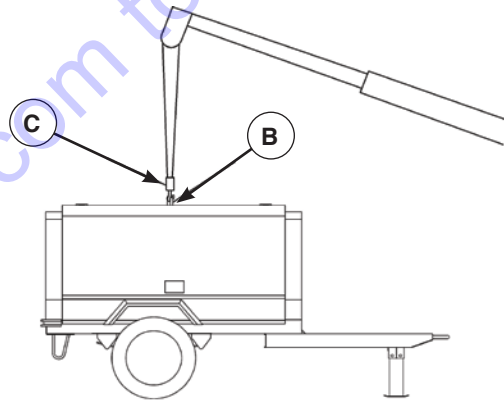

### Towing the Compressor



**WARNING** Before towing the machine, make sure to check and confirm the following points. Failure to follow the instructions below, could result in serious injury or death.

- Proper tire air pressure.
- Tire lug nuts are not loose.
- Tires are not worn or damaged. See Addendum A - Tire Safety Information.
- Ensure that the end of the drawbar is securely connected to the coupler of the towing vehicle.
- Ensure there is no damage to the towing vehicle and the drawbar of the machine.
- Be sure to keep hands and fingers away from any part of the coupling device when coupling or uncoupling a drawing device to a draw bar.
- Be sure the height of the hitch is adjusted so that the trailer is level while connected to the tow vehicle.
- Make sure to drive the towing vehicle safely.

## Operation

If you have any problems operating your towable compressor, please contact your authorized dealer.

### **WARNING** **POISONOUS GAS HAZARD.**

Engine exhaust contains carbon monoxide, a poisonous gas that could kill you in minutes. You CANNOT smell it, see it, or taste it. Even if you do not smell exhaust fumes, you could still be exposed to carbon monoxide gas.

- Operate this product ONLY outside far away from windows, doors and vents to reduce the risk of carbon monoxide gas from accumulating and potentially being drawn towards occupied spaces.
- Install battery-operated carbon monoxide alarms or plug-in carbon monoxide alarms with battery back-up according to the manufacturer's instructions. Smoke alarms cannot detect carbon monoxide gas.
- Avoid using the machine in insufficiently ventilated buildings, garages or tunnels, even if using fans for ventilation. Carbon monoxide can quickly build up in these spaces and can linger for hours, even after this product has shut off.
- ALWAYS place this product downwind and point the engine exhaust away from occupied spaces.

If you start to feel sick, dizzy, or weak while using this product, get to fresh air RIGHT AWAY. See a doctor. You may have carbon monoxide poisoning.

## Oil Recommendations

### Engine Oil

We recommend the use of CJ-4 class engine oil or superior class for best performance. Using poor quality engine oil may shorten the life of the engine. Outdoor temperatures determine the proper oil viscosity for the engine.

Use the chart to select the best viscosity for the outdoor temperature range expected.

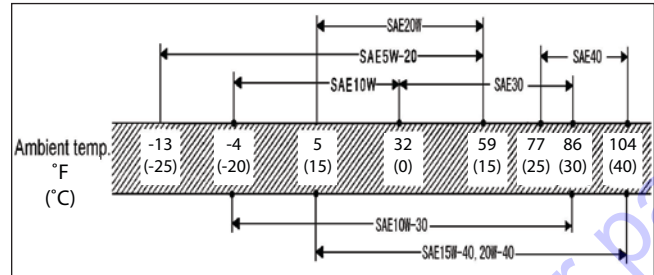

*Note:* When two or more different brands of oil are mixed, its performance can be deteriorated. When it is expected to be used for a long period at light load (less than 20% load), it's better to replace the oil with suitable oil.

### Compressor Oil

Be sure to use the recommended compressor oil listed in the table below.

Maker and Brand of Recommended Oil	
Maker	Brand
HULS	ANDEROL 3032
MOBIL	RARUS SHC 1024
TEXACO	SYN-STAR DE32

- Even continuous oil replenishment cannot improve its deteriorated condition. Be sure to change the oil completely at every scheduled interval.
- Do not mix it with other brand oil, or it will cause poor performance and shorten the life of the compressor oil.
- Running the unit with old and deteriorated compressor oil will cause damage to bearings, or serious accident like ignition in a separator receiver tank. Be sure to change the oil completely at every scheduled interval.

## USE OUTDOORS - AVOID CARBON MONOXIDE POISONING

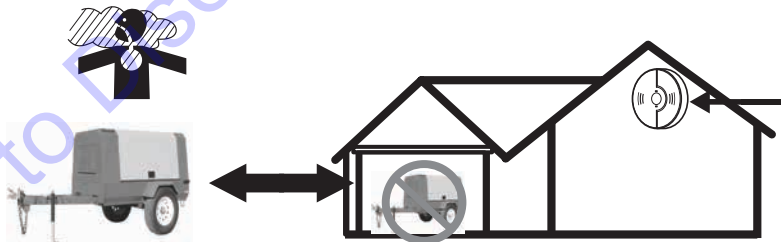



point away from home

### CARBON MONOXIDE ALARM(S)

Install carbon monoxide alarms inside your home. Without working carbon monoxide alarms, you will not realize you are getting sick and dying from carbon monoxide poisoning.

## Checking / Adding Engine Oil

**WARNING**   Be sure to check the unit before operation. If any issue is found, be sure to repair it before restarting the unit. Be sure to make daily checks before operation. Operating the unit without prior inspection could result in death or serious injury, or unit damage.

**NOTICE** Unit should be on level before checking oil level. When you check oil level after initial operation, wait 10 to 20 minutes after stopping engine before checking the oil level.

1. Place compressor on a flat, level surface.
2. Clean area around oil fill, remove oil level gauge (A), and wipe it with a clean cloth.
3. Re-insert the oil level gauge fully and pull it out again. The oil level should be between LOW and HIGH (B).

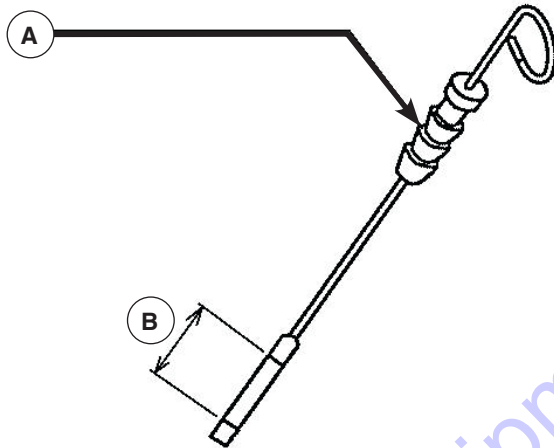

4. If the oil level is below LOW, add engine oil to the oil filler port (C).
- While checking oil level, check also for contamination. If the oil is found dirty, contaminated or should it be changed according to the periodic inspection list, change the oil. See **Maintenance**.

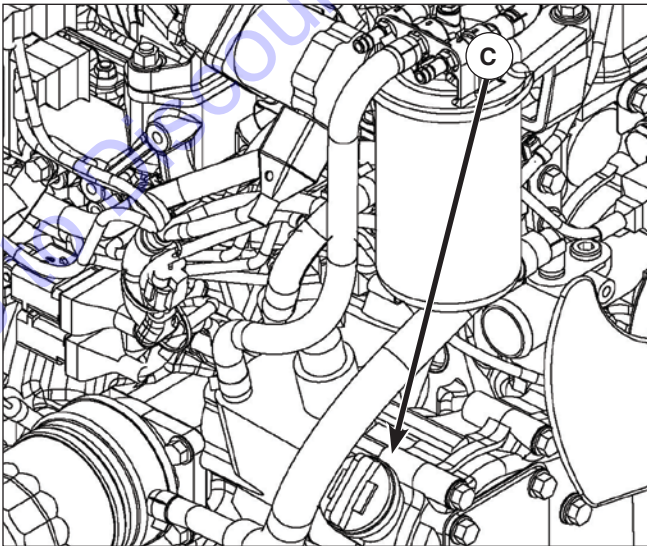

- Excessive engine oil supply could cause engine output degradation. Therefore, never fill more than the HIGH level.

## Checking / Adding Compressor Oil

**WARNING**   **Refilling of compressor oil.**

- When refilling the separator receiver tank with compressor oil, stop the engine, and make sure that the pressure gauge indicates 0psi (0bar) and there is no residual pressure in it, and then gradually loosen the oil filler cap for refilling oil.
  - Should any residual pressure be left in the separator receiver tank, hot compressed air and hot compressor oil jetting out could cause burning or serious injury to persons nearby.
1. Place compressor on a flat, level surface.
  2. After checking and confirming that the residual pressure in separator receiver tank is 0 psi (0 bar), replenish the tank with compressor to between the upper limit and lower limit of oil level gauge when the machine is on. See **Maintenance**.

**NOTICE** Oil level drops when starting operation. Supply of excessive oil can cause deterioration of oil separation performance. Never supply oil at a higher level than the upper level of oil level gauge.

## Checking Coolant Level

**WARNING**   **Taking off the radiator cap.**

- Be sure to stop the machine and allow time to cool. Then loosen the radiator cap one notch. After the coolant water is sufficiently cooled and the inner pressure is released, take the cap off. If this procedure is neglected, the inner pressure can blow off the cap. Steam jetting out of the radiator could result in serious burns.

**NOTICE** Continuing operation at low coolant levels could result in damage to the radiator.

1. Check the coolant level (D) in the reserve tank. If it is lower than the limit, open the cap and replenish the coolant. Level must be kept above LOW mark.
2. If there is a little or no coolant in the reserve tank, remove the radiator cap and check the coolant level. Supply coolant to the radiator and also the reserve tank, if necessary. See **Maintenance**.

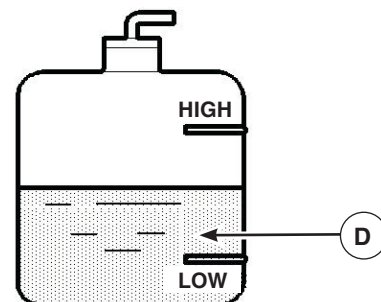

## Checking / Adding Fuel

### Fuel must meet these requirements:

- Do not use such diesel fuel having higher sulfur content above 0.0015%(15 ppm).
- Use ultra-low sulfur diesel fuel only for diesel engine.
- Use such diesel fuel which conforms to either standard EN590 or ASTM D975.
- Do not use kerosene. And never use fuel mixed with kerosene.
- Carbon residue content in fuel must be a low.
- Follow the designated regulations to dispose of fuel.

**NOTICE** Fuel for **DIESEL** engines must have the following specific characteristics:

- It must be free from even minute dust particles in it. (Do not use such diesel fuel which has been long stored in a oil drum.)
- It must have optimum viscosity.
- It must have high cetane number.
- It must have high fluidity even at low temperature.
- Carbon residue content in fuel must be a low.
- It must not contain zinc and NA (sodium).

**NOTICE** Before starting operation, make sure to check the level of residual fuel so that fuel shortage during operation can be avoided. Drain condensate accumulated at the bottom of the fuel tank whenever necessary.

 **WARNING**  Fire Prevention.

- Do not allow lit cigarettes or matches near fuel.
- Fuel is extremely flammable and dangerous. Handle with extreme care.
- Refuel only after stopping engine, and never leave open fuel can near machine. Do not spill. If fuel is spilled, wipe up completely.
- Refilling fuel tank should be done outdoors or in a well-ventilated location.
- Do not fill fuel oil up to the cap level. When fuel tank is filled to cap level, fuel oil will overflow due to volume expansion caused by rise of ambient temperature. Fuel may also spill due to machine movement or transporting.

## Draining the Fuel Tank

1. Open the drain valve (**B**) fitted under the fuel tank (**A**). Drain the condensate from the tank.
2. When completely drained, firmly close the drain valve.
3. Drain the condensate in container and dispose of condensate according to the designated regulations.

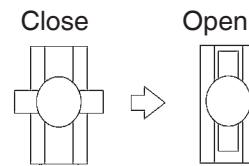
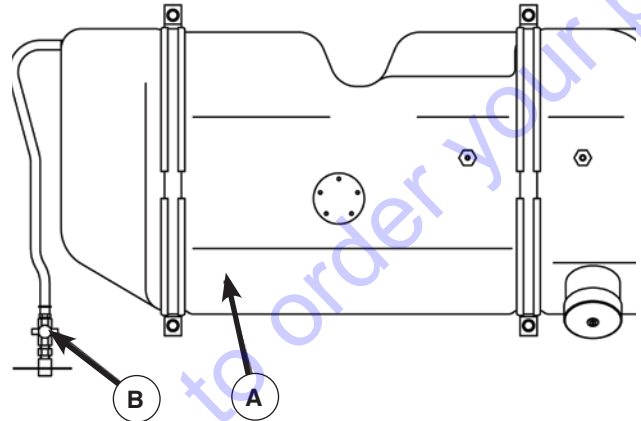



### Checking and Draining Pre-Filter for Condensate

1. When red float (A) under element (B) in Pre- filter is raised up to upper level, drain water.
2. Turn fuel selector valve (C) to OFF position.
3. Loosen the drain valve (D) and drain out condensed water inside.

*NOTE:* Make sure to tighten the drain valve securely, after draining the condensate.

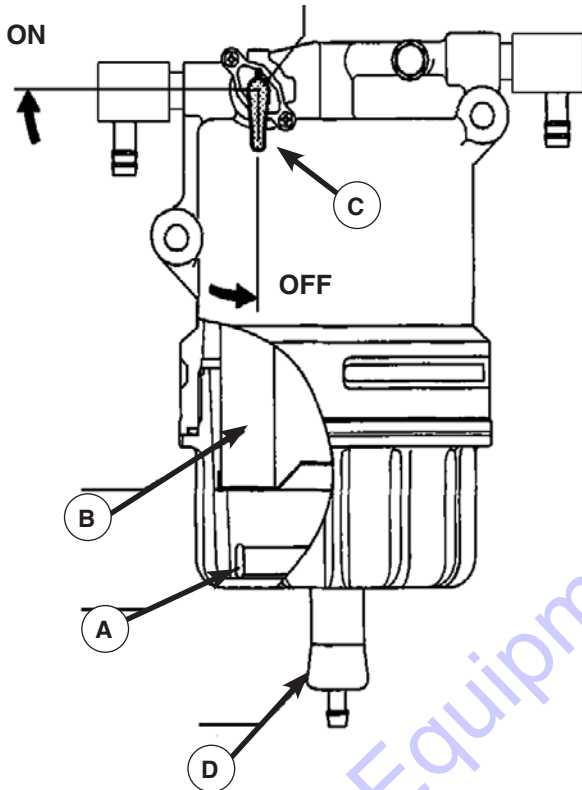

4. Drain the condensate in container and dispose of condensate according to the local, state and/or federal regulations.



### Checklist Before Starting Engine

Review the unit's assembly to ensure you have performed all of the following.

1. Be sure to read **Operator Safety** and **Operation** before operating the compressor.
2. Make sure compressor is in place and secure.
3. Check that oil has been added to proper level.
4. Check wiring of each part for any loose connections, damage to insulating sheathed portion, disconnection, and short circuit.
5. Check piping of each part for any loose connections, tears, and leaks.
6. Check each hose for tear and leaks.
7. Clean debris from interior of unit. Periodically check the inside of the unit for debris. Any flammables such as chips of wood, dead leaves, and waste paper, especially near the muffler and exhaust pipe, should be removed.

**WARNING**   **Operation with compressed air supply port opened is prohibited.**

- Do not operate machine with service valves and relief valve open unless air hoses and/or pipes are connected. Unregulated, high-pressurized air could result in serious injury.
- When the machine has to be unavoidably temporarily operated with its port open, be sure to mount a silencer to reduce noise and wear personal protective equipment (PPE) such as earplugs to prevent hearing damage.

**WARNING**  

- Keep the door closed and locked while running the unit.
- When the door has to be opened, be careful not to touch portions that are rotating or very hot. Careless contact could result in serious injury.
- Pull the handle forward to open the door.
- Be sure to close the door tightly so that it latches securely.

## Starting the Compressor

**NOTICE** Be sure to let unit warm up after starting for smooth operation of the engine and the compressor. Do not operate the engine at full load immediately after it starts up. This will shorten the equipment life.

- During machine warm-up, inspect the equipment for any loose parts, fluid leakage, and other issues.
- Make sure that monitor lamps are off.

To start compressor:

1. Make sure discharge air pressure gauge indicates 0 psi.
2. Fully close service valve.
3. Turn starter switch (A) to RUN position. The glow lamp (B) will turn on.

4. When the glow lamp goes out, turn the starter switch to START position.
  - Perform starter switch operation within 15 seconds.
  - Make sure to wait longer than 2 minutes before starting next operation. Failure to wait the designated time could cause the starter motor to overheat, and could damage it.
  - If residual pressure is present in the separator receiver tank, the residual pressure lamp (C) will illuminate, and the starter will not rotate. Make sure the residual pressure remains 0 psi (0 bar).
  - According to engine cooling water temperature, the times in the table below are required.

Engine Coolant Temperature	Required Preheating Time	Required Time for Starting Unloader Operation
Higher than 50°F	1 second	30 seconds
Lower than 50°F	20 seconds	Shorter time either 120 seconds or the time when engine coolant temperature becomes higher than 50°F.

5. Once engine starts, leave it running to warm up for 5 minutes. The discharge air pressure gauge (D) ranges from 44 to 102 psi (3 to 7 bar).
6. After warm-up is complete, open the service valve at the outlet of compressed air, and start service job.

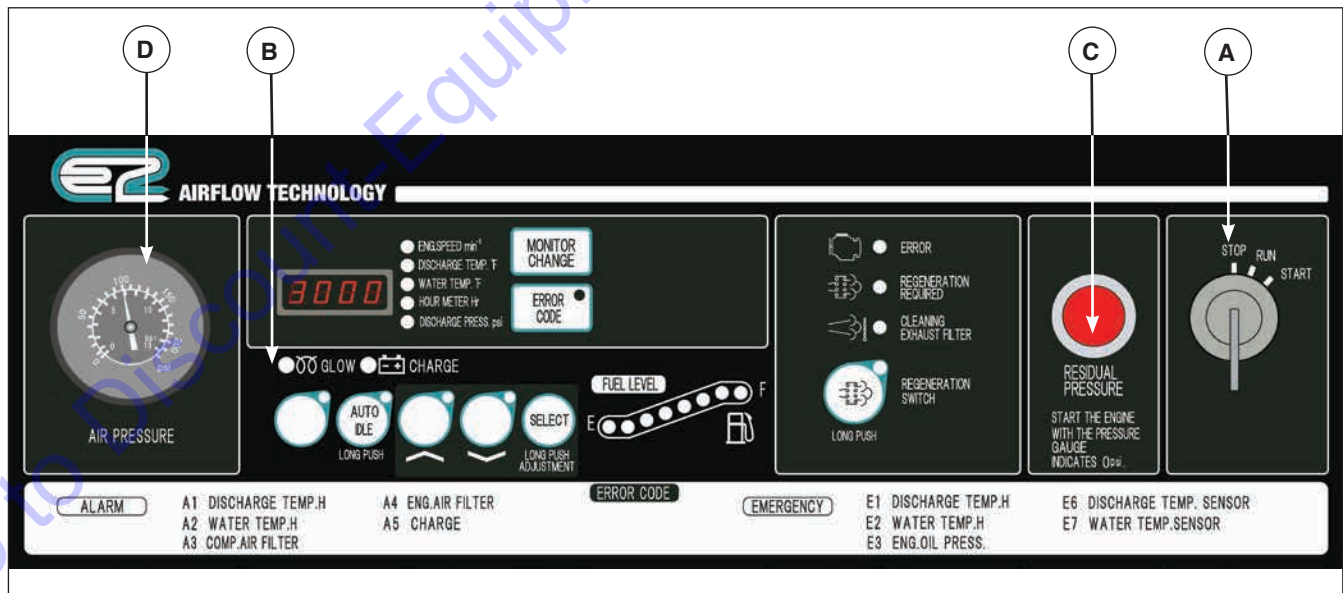

### Engine Fails to Start

1. If the engine fails to start after performing starting procedure, steps 1 - 4, do not keep the starter running.
2. Set the starter switch to STOP, wait approximately 2 minutes, then repeat the startup procedure.
3. If the repeated startup procedure does not allow the engine to run, check for the following causes:
  - No fuel
  - Clogged fuel filter
  - Discharge of battery or low cranking speed
  - Ambient temperature is too low

### Starting the Compressor at Low Temperature

**NOTICE** When operating compressor under cold weather conditions below 23°F (-5°C):

- Use SAE10W-30 (CJ-4) for the engine oil.
- When the unit is used in a cold region and possible freezing is expected, it is recommended to use LLC (Antifreeze) for the coolant.
- Adjust mixing ratio of LLC (Antifreeze) with water according to the temperature.
- Use LLC (Antifreeze) within the range of its mixing ratio between 35 and 60%.
- If LLC (Antifreeze) in the water exceeds more than 60%, it may decrease its antifreezing effect. (Upon delivery from the works, LLC density is 55%).
- Use LLC (anti-freeze) which conforms to one of such standards: SAE JB13, SAE J1034 and ASTM D3306.
- Battery should always be fully charged.
- Follow the designated regulations to dispose of LLC (Antifreeze).

When it is difficult to start engine in cold weather, complete the following steps:

1. Fully close the service valves.
2. Start engine by following steps 1 - 6 in **Starting the Compressor**.



### CAUTION



When operating the unit in a low temperature, change engine oil, compressor oil, LLC, and diesel fuel according to the ambient temperature.

### Gauge Indication While Operating Compressor

**NOTICE** Minimum discharge air pressure is 58 psi (4 bar) during operation. Continuing equipment operation at a lower pressure than the above pressure may cause overheating, since it affects the separation of lubricating oil inside the oil separator and reduces the oil flow to the compressor air-end, resulting in temperature rise.

- Make sure to check that gauges or each component of the compressor are properly working, or if there is any air-leak, oil-leak, water-leak or fuel-leak etc.
- During normal operation, each indication of instruments is shown in the table below. Refer to the table for daily checks.

		Discharge Pressure Gauge
In Operation	Full Load	* 58 to 100 psi (4 to 6.9 bar)
	No Load (Unload)	* 116 to 131 psi (8 to 9 bar)
	At purge control (AUTO IDLE)	* 36 to 58 psi (2.5 to 4bar)
* Values may vary slightly depending on the operating conditions and other factors.		

Protection device	Indicator lamp					
	GLOW	CHARGE	DPF REGENERATION REQUIRED	DURING DPF REGENERATION	ENGINE ERROR	AUTO IDLE
Monitor						AUTO IDLE
Starting Starter switch set to "RUN" position	● OFF ※1	 ON	● OFF	● OFF	● OFF ※2	● OFF
In operation	● OFF					

※1 This lamp will be OFF in 0 to 20 seconds, (varying upon ambient temperature.)

※2 This lamp will be OFF in about 2 seconds.

## Capacity Control Device

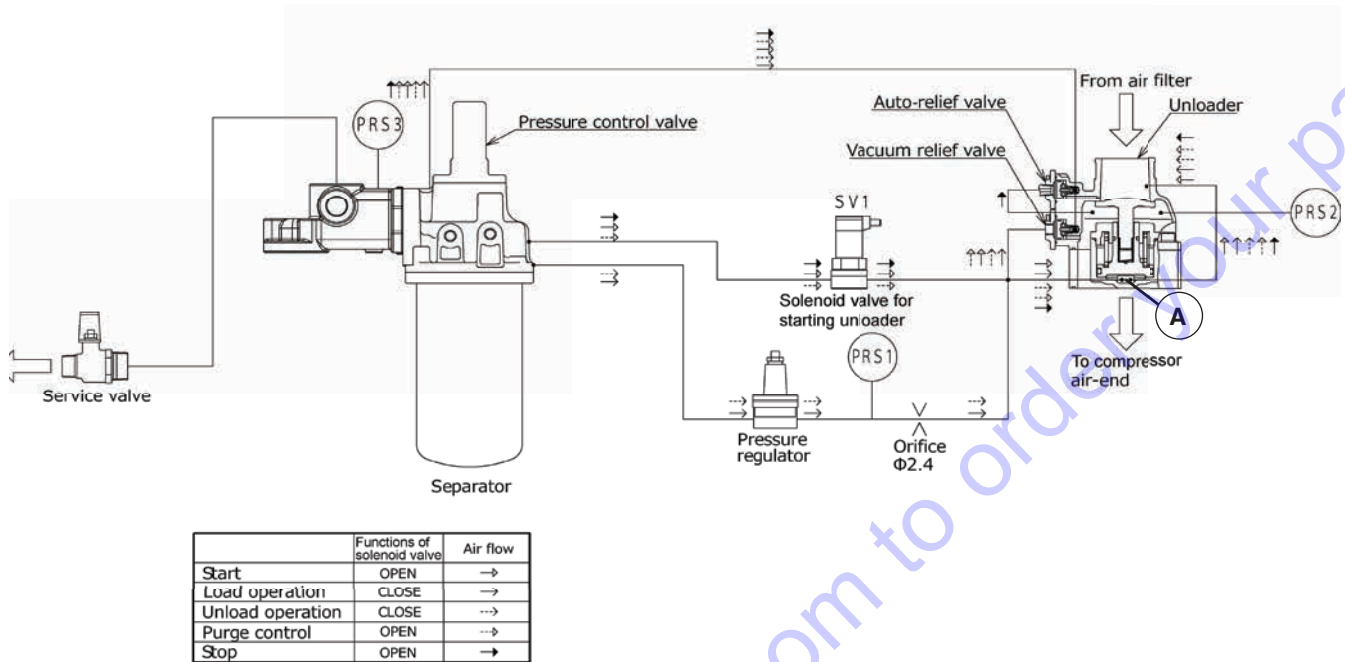

Step	Response
Start	Compressed air flows into unloader chamber (A) because solenoid valve for purge control SV1 is opened at start-up. The pressure in chamber (A) rises soon to close unloader valve (A) fully and accordingly it can reduce the load at start-up.
Load Operation	After starting, SV1 is closed after automatic unloaded operation, and the air volume which is sent to chamber (A) increases and decreases according to the rise and drop of the discharge air pressure and consequently the opening width of the unloader valve is changed. Further, engine revolution (RPM) is changed by the pressure which PRS1 detects, and it steplessly controls the air volume in the range from 0 to 100%.
Suction Port Closing Unload Operation	When compressed air pressure exceeds the rated pressure with reduction of air consumption, PRS1 detects the pressure and it reduces engine speed (rpm) in proportion to the pressure rise, and it closes unloader valve at the same time. When compressor air-end becomes vacuum during unload operation, vacuum noise is caused. To prevent this noise, it opens vacuum relief valve by detection of secondary pressure of pressure regulator. Thus high vacuum condition of compressor air-end is prevented.
Purge Control Unload Operation	When the certain set time (it can be changed.) has passed at lower pressure than the set negative pressure, detecting the negative pressure inside the compressor air end with a pressure sensor PRS2, solenoid valve SV1 opens and it closes unloader valve. At the same time, it functions to relieve the compressed air from separator receiver tank to the atmosphere and thus it lowers the pressure. Thus the compressor power is saved. When air consumption increases, and the pressure used for load drops below the set pressure, pressure sensor PRS3 detects it and it disengages the purge control (SV1 closes) to start full load operation.
Stop	When stopping operation, it opens Auto relief valve to relieve the compressed air in separator receiver tank to atmosphere, detecting the pressure inside compressor air-end.

### AUTO IDLE control (Purge Control)

This model is equipped with auto idle control operation mode. This operation mode is recommended when minimal continuous air consumption is required, and when minimum power consumption under unloaded operation is required.

To select auto idle control:

1. During operation, push and hold the auto idle switch (A) until the auto idle indicator lamp (B) goes on, then release switch.
2. Fully close service valve.
3. To stop this operation mode, push auto idle switch until the lamp (B) goes out.

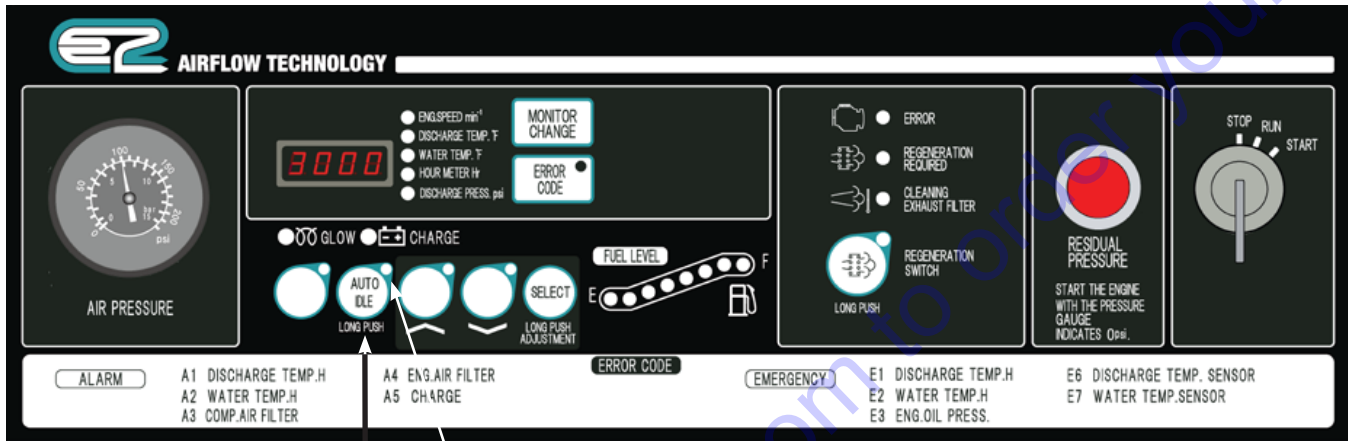

Function of AUTO IDLE Control (Purge Control)	Conditions of Auto Idle Lamp
First engine speed drops to the minimum speed by pressure regulator, owing to reduction of air consumption. Later the air consumption is reduced further, the unloader valve gradually closes and intake negative pressure increases. In this stage, the pressure sensor detects the intake negative pressure. Then when the intake negative pressure becomes higher than the set pressure, the "AUTO IDLE" lamp flickers at short intervals.	Lamp flickers at short intervals.
When this condition continues for a certain time, the solenoid valve functions to start purge mode operation. Consequently, the pressure inside separator receiver tank drops and reduces the power of compressor air end. In this stage, the lamp "AUTO IDLE" flickers at longer intervals.	Lamp flickers at longer intervals.
Next, when the pressure for load down to the purge releasing pressure owing to the increase of air consumption, the solenoid valve operation gets "OFF" and it is transferred to normal operation. In this stage, the lamp "AUTO IDLE" goes on.	Lamp goes on.

## Stopping the Compressor

1. Close the service valve completely and operate the machine about 5 minutes, until it cools down.
  2. Turn the starter switch to STOP position to stop the engine.
  3. Remove the key from the compressor every time you stop the engine. Keep the key and be careful not to lose it.
- Unless all service valves are fully closed upon stopping operation, the compressed air will be sent in reverse direction in the hoses (pipes) connected to air tools and relieved to atmosphere continuously through the auto-relief valve. When re-starting operation next time, compressed air will be jetted out through service valves.

## Air Bleeding in Fuel Line

Should the machine stop due to fuel shortage, perform air bleeding according to the following

- Replenish fuel.
- When starter switch is turned to RUN position, electromagnetic pump starts to automatically bleed air in fuel line.
- Air bleeding is completed about 1 minute.

## DPF (Diesel Particulate Filter) Regeneration (Purge)



**WARNING**

- During DPF regeneration operation, exhaust gas of high temperature is discharged. Check and confirm that there are no persons or flammables near by. Exhaust gases could cause severe burns, and could result in a fire.
- During regeneration operation in closed spaces, carefully monitor carbon monoxide levels to avoid carbon monoxide poisoning.

When regeneration control is begun and finished, noise of engine air intake throttle and EGR opening width adjustment is sometimes caused. This is normal.

The smell of the exhaust gas caused during regeneration operation is different from that of diesel fuel exhaust.

## Passive Regeneration

Soot collected in the DPF is burnt automatically because of high temperature during normal operation under heavy load application.

## Active (Automatic) Regeneration

- Operation under light load application or no load requires active regeneration, because engine exhaust temperature is not high enough to burn soot collected in the DPF.
- During active regeneration mode operation, it is possible to continue servicing job.

### Active Regeneration Mode

1. Cleaning exhaust filter lamp (A) turns ON.
2. The regeneration process will last for about 30 minutes.
3. The lamp will turn OFF when regeneration is complete.

*Note:* Time required for regeneration depends on load factor and ambient temperature.

### NOTICE

- Do not stop engine during active regeneration operation, except for unavoidable conditions.

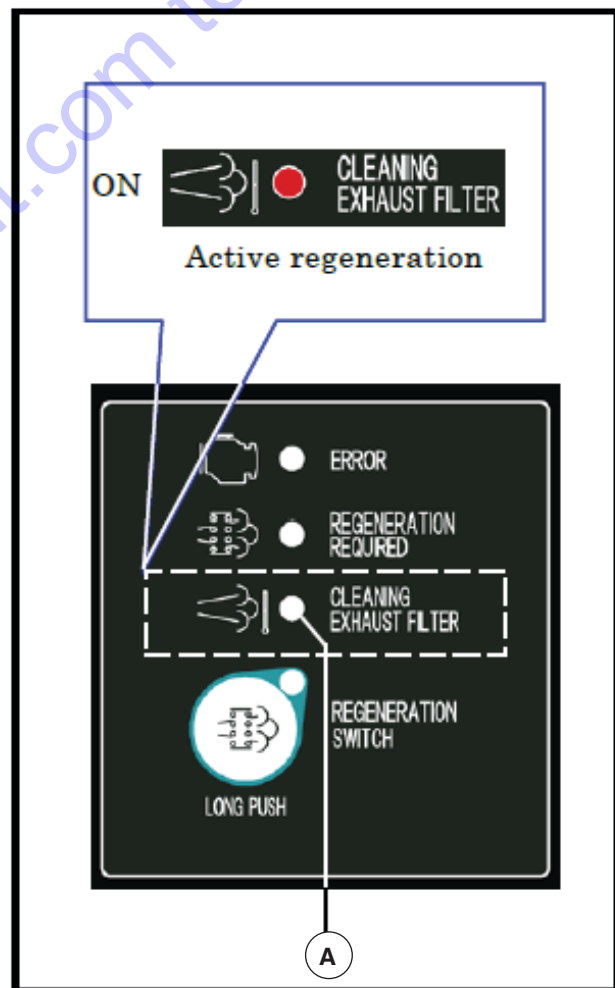

## Manual (Forced) Regeneration

During no-load or almost no-load operation, or when ambient temperature is very low, incomplete soot combustion occurs. If operated continuously in these same conditions, manual, or forced, regeneration may be required. In this case:

1. REGENERATION REQUIRED lamp (A) and ERROR lamp (E) go on. At the same time, REGENERATION SWITCH lamp (C) flashes. Engine speed automatically changes to 1,350 min<sup>-1</sup>.
2. Press and hold REGENERATION SWITCH (B) longer than 3 seconds.
3. REGENERATION REQUIRED lamp turns off and CLEANING EXHAUST FILTER lamp (D) turns ON. Then REGENERATION SWITCH lamp (C) stays on instead of flashing. At this time, manual regeneration operation starts.
4. Engine speed gradually increases up to approximately 2,220 min<sup>-1</sup>.

5. Manual regeneration operation is performed in about 30 minutes.

*Note:* Time of regeneration varies upon the ambient temperature.

6. When manual regeneration is completed, all lamps turn off, and both normal engine speed and normal operation resume.
- If continuing operation for approximately ten hours without conducting manual regeneration once REGENERATION REQUIRED lamp (A) is lit, machine will go into low idling operation only. At this point, it will be impossible to conduct manual regeneration, and it will be necessary to clean the DPF. If this occurs, contact your authorized dealer.

**WARNING**  When DPF regeneration lamp goes on, take immediate specified action to conduct manual regeneration. If it is continuously operated without manual regeneration, excessive soot will accumulate and it could damage DPF due to abnormal burning, and it could cause a fire.

**NOTICE** Do not stop engine during manual (forced) regeneration operation, except for unavoidable conditions.

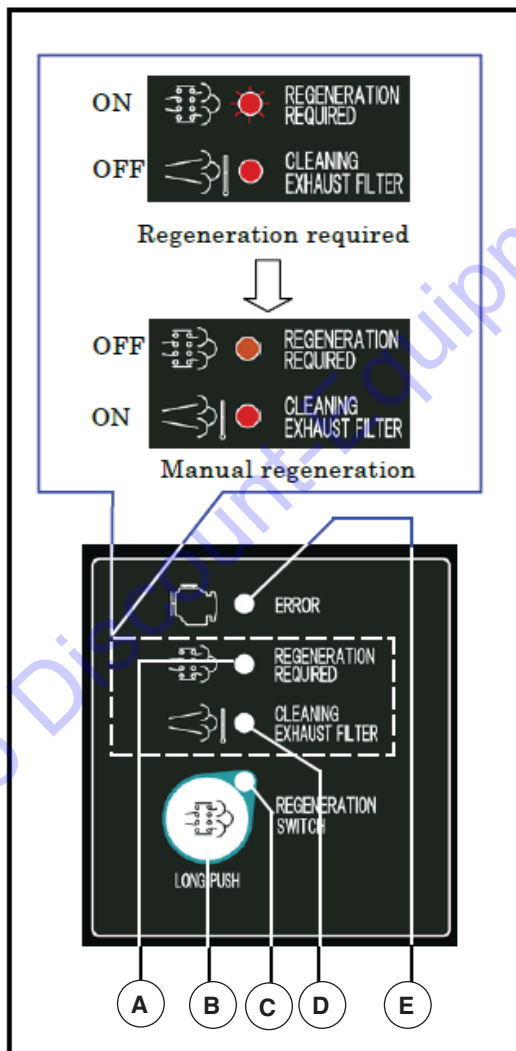

## Maintenance

Regular maintenance of the compressor and engine will improve the performance and extend the life of the compressor. See any qualified dealer for service.

### Compressor Maintenance Schedule

Follow the hourly or calendar intervals, whichever occurs first. More frequent service is required when operating in adverse conditions noted below.

<b>Daily</b>
<ul style="list-style-type: none"> <li>• Check compressor oil level</li> <li>• Drain separator receiver tank</li> <li>• Check looseness in pipe connecting part, and wear and tear of pipe.</li> <li>• Check oil, water, fuel and air leak</li> <li>• Check functions of all instruments and devices</li> </ul>
<b>Every 250 Hours</b>
<ul style="list-style-type: none"> <li>• Clean and change air filter element</li> </ul>
<b>First Time and Every 350 Hours</b>
<ul style="list-style-type: none"> <li>• Change compressor oil</li> <li>• Change compressor oil filter</li> </ul>
<b>Every 500 Hours</b>
<ul style="list-style-type: none"> <li>• Change compressor oil</li> <li>• Clean strainer in the scavenging orifice</li> <li>• Clean and change air filter element</li> </ul>
<b>Every 1,000 Hours</b>
<ul style="list-style-type: none"> <li>• Change compressor oil filter</li> <li>• Clean outside of the oil cooler</li> </ul>
<b>Every 2,000 Hours</b>
<ul style="list-style-type: none"> <li>• Change oil separator<sup>1</sup></li> <li>• Change nylon tubes<sup>1,2</sup></li> </ul>
<b>Every 3,000 Hours</b>
<ul style="list-style-type: none"> <li>• Change unloader o-ring<sup>1,2</sup></li> <li>• Change pressure regulator<sup>1</sup></li> <li>• Check rubber hose<sup>1,2</sup></li> <li>• Check consumable parts of the auto-relief valve<sup>1,2</sup></li> <li>• Check consumable parts of the vacuum relief valve<sup>1,2</sup></li> <li>• Performance check of pressure control valve<sup>1</sup></li> <li>• Check and change o-ring and pressure control valve piston<sup>1</sup></li> <li>• Inspect solenoid valve<sup>1,4</sup></li> </ul>
<b>Every 8,000 Hours</b>
<ul style="list-style-type: none"> <li>• Change oil seal and bearing<sup>1</sup></li> </ul>

<sup>1</sup>Contact an authorized dealer. Item requires expert knowledge.

<sup>2</sup>Should be replaced every 2 years even if they are not in disorder within their periodical maintenance interval because their materials will change or become degraded as time passes.

<sup>3</sup>Should be replaced every 3 years because their materials will change or become degraded as time passes.

<sup>4</sup>If it is found good, it is possible to continue to use it.

## Engine Maintenance Schedule

Refer to engine operation manual for inspection and maintenance of engine.

### Undercarriage Maintenance Schedule

<b>Every 300 Hours or 3 Months</b>
<ul style="list-style-type: none"> <li>• Supply grease to trailer hub bearing</li> <li>• Check drawbar hardware for proper tightness</li> </ul>
<b>Every 1,000 Hours</b>
<ul style="list-style-type: none"> <li>• Check undercarriage bracket hardware for proper tightness</li> <li>• Check wheel lug nuts for proper tightness</li> </ul>



## Replacement Parts

Note: Part numbers may change without notice.

Contact your authorized dealer.

Part Name		Part Number	Qty
Engine Oil Filter		41290 01200 (Yanmar 129150-35153)	1
Compressor Oil Filter		37438 08900	1
Air Filter Element	Compressor Air End	32143 11800	1
	Engine	32143 11800	1
Fuel Filter		43543 02100 (Yanmar 129A00-55800)	1
Fuel Pre-Filter Element	Element	Yanmar 129A00-55730	1
	O-Ring (Element Side)	Yanmar 129A00-55740	1
	Drain Plug (With O-Ring)	Yanmar 129242-53740	1
Oil Separator Element		34224 03000	1
O-Ring		03502 15145	1
Pressure Regulator		36400 19000	1
Auto Relief Valve and Vacuum Relief Valve	O-Ring 1	21221 02100	2
	O-Ring 2	03402 25021	2
	O-Ring 3	03402 25008	2
Unloader Valve	O-Ring 1	03402 10125	2
	O-Ring 2	03402 10070	1
	O-Ring 3	21221 04800	1
	O-Ring 4	21221 04900	1
Pressure Control Valve	O-Ring 1	03402 15075	1
	O-Ring 2	03402 25032	1
	Spring 3	22144 07700	1
	Piston 4	35303 03300	1
Solenoid Valve	For Starting Unloader / Purge	46811 30000	1
Belt		Yanmar 129612-42350	1

## Maintenance Items

### Change Engine Oil



Engine oil is very hot and highly pressurized during or just after operation. Hot oil could blow out of the tank and can cause serious injury.

#### NOTICE

Never supply more engine oil than specified level. Excessive engine oil could cause engine damage.

1. After stopping engine, wait 10 to 20 minutes until engine oil cools off.
2. Remove drain plug (A), open drain valve (B), and discharge engine oil drain. Dispose of used oil according to local, state and/or federal regulations.
3. When oil is completely drained, close drain valve and replace drain plug.
4. Remove engine oil filler cap (C), and fill engine with oil. See **Checking / Adding Engine Oil** in **Operation**. (Oil capacity: approx. 0.9 gal.(3.4L))
5. Check oil level: Remove dipstick (D), wipe clean, replace, then remove. Oil level should read between marks on lower end of dipstick (E). Add as needed.

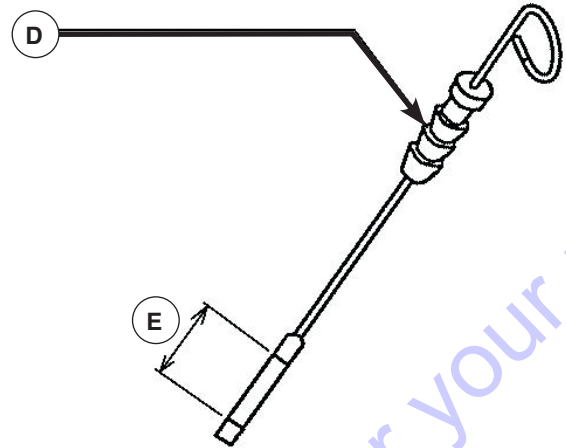
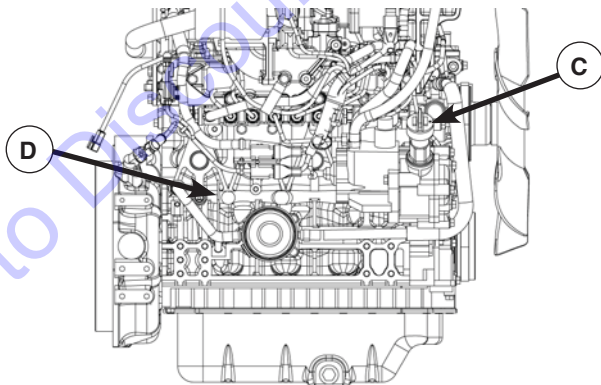
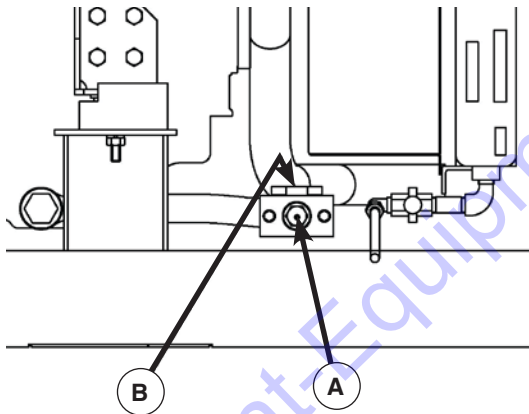

### Change Engine Oil Filter

(For part number, see Replacement Parts)

1. Remove old oil filter (F) using a filter wrench.
2. Apply a light coating of oil on oil filter seal (G).
3. Install new oil filter until seal contacts oil pump, then tighten 1 additional turn by hand.
4. After installing oil filter, check for leaks. Tighten as necessary.

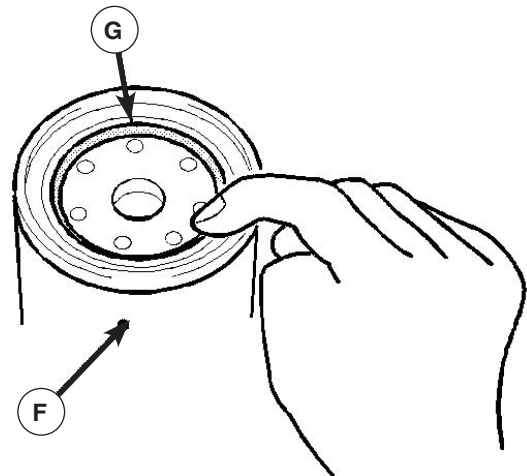

### Battery Maintenance



- Keep flames away from battery.
- Battery may generate hydrogen gas and may explode.
- Charging should be done at a well-ventilated place.
- Do not spark near the battery nor light a match, nor bring lit cigarette and match close to the battery.
- Do not check the battery by short-circuiting the positive and negative terminals.

- Do not operate machine or charge battery with low electrolyte level. Doing so may damage battery, or may cause explosion.
- Add distilled water so that electrolyte level reads between “UPPER” and “LOWER” level.
- Do not charge frozen battery. Otherwise it may explode. If battery is frozen, warm it up until the battery temperature becomes 16°C to 30°C.
- Battery electrolyte is dilute sulfuric acid.
- Mishandling battery could cause severe burns.
- Wear protective gloves and safety glasses when handling battery.
- If battery electrolyte contacts clothes or skin, wash immediately with large amount of water.
- If battery electrolyte gets into eyes, flush with plenty of water and seek immediate medical attention.
- Dispose of battery according to local, state and/or federal regulations.

### Check Battery Electrolyte

Standard battery:

1. Check battery electrolyte level. If low, add distilled water.
2. Measure specific gravity of battery electrolyte. If below 1.24, recharge battery. See **Charge Battery**.

Maintenance-free battery:

1. Check indicator on top surface of battery.
2. If indicator shows that charge is needed, recharge battery.

### Charge Battery

1. Disconnect cables between battery and unit, black negative (-) cable first, and charge battery (A) with a 12-volt battery charger (B). Do not charge two batteries at the same time.
2. Be sure not to connect (+) and (-) terminals backwards.
3. Read operation manual of battery charger before use.

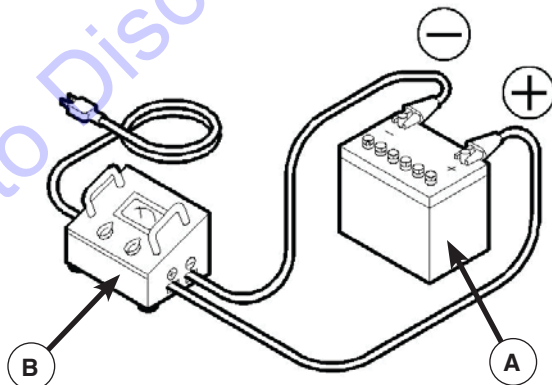

### Booster Cables

To use booster cables:

1. Connect one end of red positive (+) cable (C) to positive (+) terminal of machine battery (D).
2. Connect other end of red positive (+) cable to positive (+) terminal of external battery (E).
3. Connect one end of black negative (-) cable (F) to negative (-) terminal of external battery.
4. Connect other end of black negative (-) cable to engine block of machine (G, not shown).

### NOTICE

Be careful not to connect positive (+) and negative (-) terminals backwards.

5. Start engine.
6. Disconnect booster cables by following above procedure in reverse order.

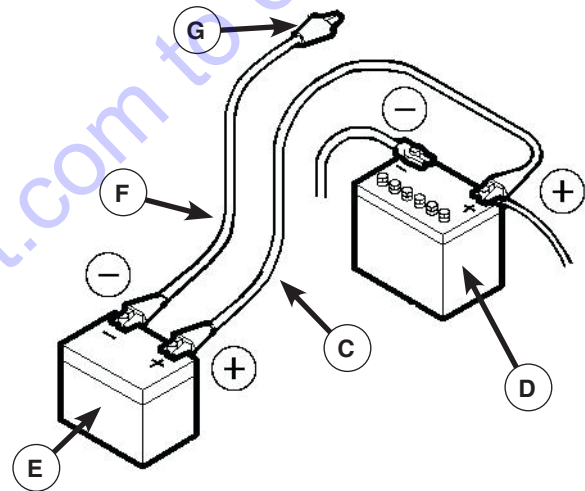

### Clean Air Filter Element

1. Loosen latch (B), and remove cap (A). Clean interior of cap. Be sure O-ring (D) is properly seated in cap.
2. Remove and clean filter element (C). If damaged or heavily soiled, replace. (For part numbers, see **Replacement Parts**.)
3. Clean interior of case (E).
4. Install filter element into case, then install cap, securing with latch.

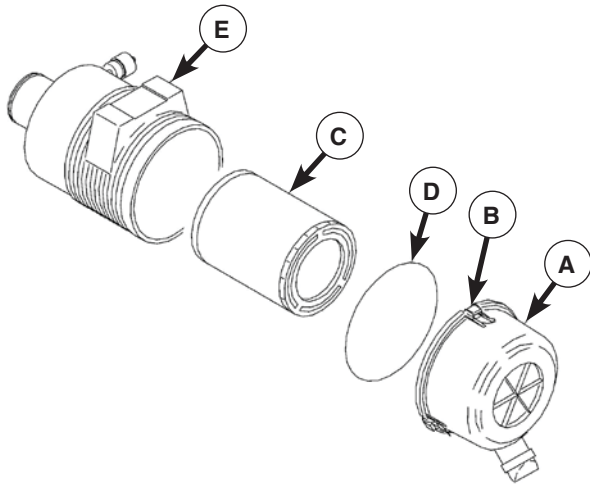

## Change Compressor Oil



### WARNING

- When you refill the separator receiver tank with compressor oil, stop the engine, and make sure that the pressure gauge indicates 0psi (0bar) and there is no residual pressure in it, and then gradually loosen the oil filler cap for refilling oil.
  - Note residual pressure in the receiver tank could force both extremely hot compressed air and oil to jet out and you may be scalded or seriously injured.
  - Even continuous oil replenishment cannot improve its deteriorated condition. Be sure to change the oil completely at every scheduled interval.
  - Do not mix it with other brand oil, or it will cause poor performance and shorten the life of the compressor oil. (But fresh compressor oil could accept a mixture of small amount of different brands.)
  - Running the unit with old and deteriorated compressor oil will cause damage to bearings, or serious accident like ignition in a separator receiver tank. Be sure to change the oil completely at every scheduled interval.
  - Follow the designated regulations to dispose of compressor oil.
1. After residual pressure is completely relieved from separator receiver tank, remove oil filler cap (F) and open drain valve (G) to drain oil. Then open drain valve of oil cooler to drain oil accumulated in bottom of oil cooler.

*NOTE: Warm oil drains more quickly.*

2. After compressor oil is completely drained, close drain valve.
3. Refill with fresh compressor oil to upper limit of level gauge, then replace oil filler cap. (Oil Capacity: Approx 3.96 gal (15L).) Check o-ring (H) of oil filler cap for damage or wear. Replace if necessary.

4. Start engine and allow to run for a minute or two, then replenish oil to fill any shortage. Repeat this procedure for 1 to 2 times to check if oil level has reached appropriate level. Be careful not to overfill the oil.

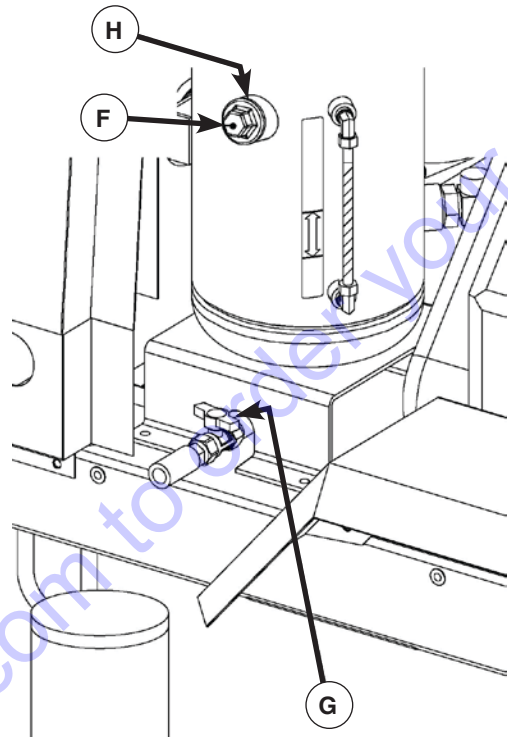

## Change Compressor Oil Filter

For filter part number, see **Replacement Parts**.

1. Remove old filter (A) using a filter wrench.
2. Apply a light coating of oil on filter seal (B).
3. Install new filter until seal contacts pump, then tighten 1 additional turn by hand.
4. After installing filter, check for leaks. Tighten as necessary.

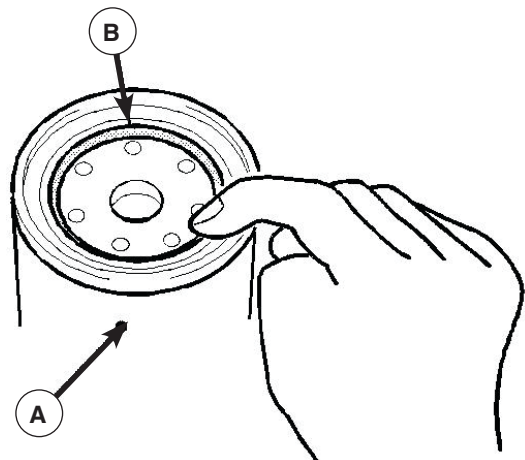

## Clean Oil Separator Strainer

1. Remove pipe (C) using a spanner.
2. Remove bushing (D).
3. Remove strainer (E).
4. Wash strainer in diesel oil and carefully blow out debris with compressed air. (Be sure to wear safety goggles.)
5. Install strainer by reversing steps 1 through 3.

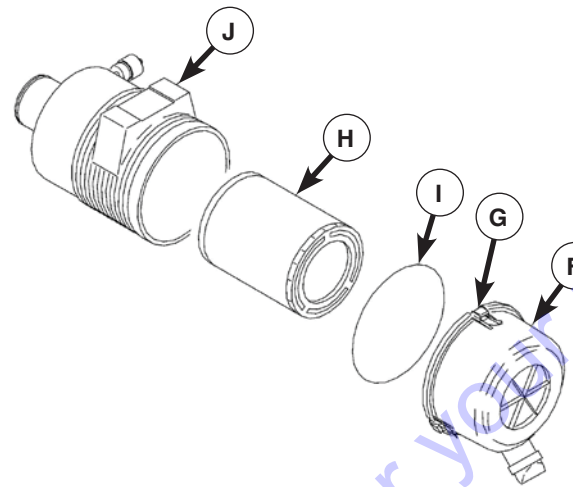
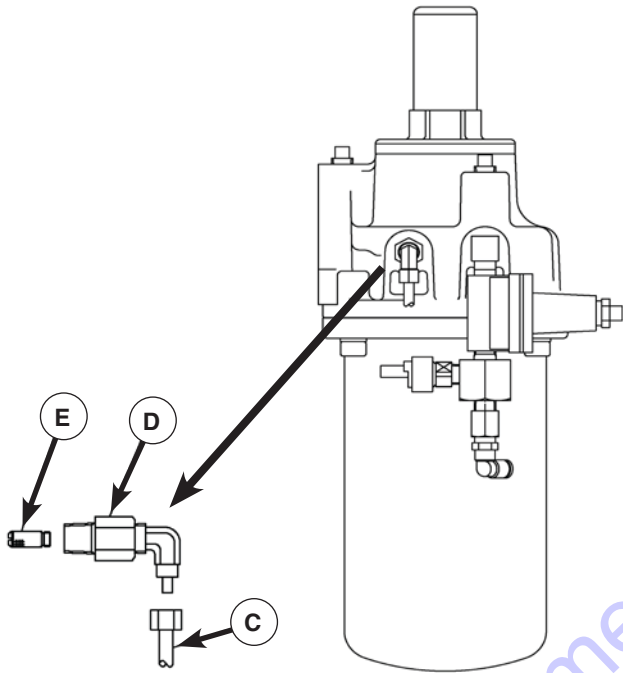

## Clean / Change Fuel Pre-Filter Element

For filter element part number, see **Replacement Parts**.

Turn fuel selector valve (A) to OFF position.

Loosen drain valve (B) and drain out condensed water.

Turn cup (C) counterclockwise to remove. Wipe out split fuel.

Remove float (D) inside cup.

Wash element (E) and inside of cup with new fuel.

Check element and o-ring, and replace if worn, broken or damaged.

If air is found in fuel pipe, turn starter switch to RUN position and loosen air bleeding bolt (F) to bleed air. Tighten after bleeding.

Drain condensate, and dispose according to local, state and/or federal regulations.

## Change Air Filter Element

For filter element part number, see **Replacement Parts**.

1. Loosen latch (G), and remove cap (F). Clean interior of cap. Be sure O-ring (I) is properly seated in cap.
2. Dispose of old filter element (H), replacing with new.
3. Clean interior of case (J).
4. Install filter element into case, then install cap, securing with latch.

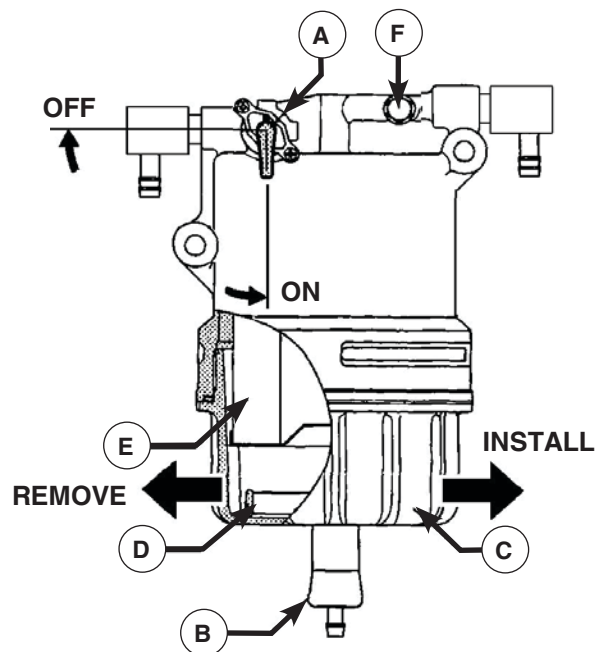

## Change Fuel Filter

For filter part number, see *Replacement Parts*.

1. Remove old filter (**G**) using a filter wrench.
2. Apply a light coating of oil on filter seal (**H**).
3. Install new filter until seal contacts pump, then tighten 1 additional turn by hand.
4. After installing filter, check for leaks. Tighten as necessary.

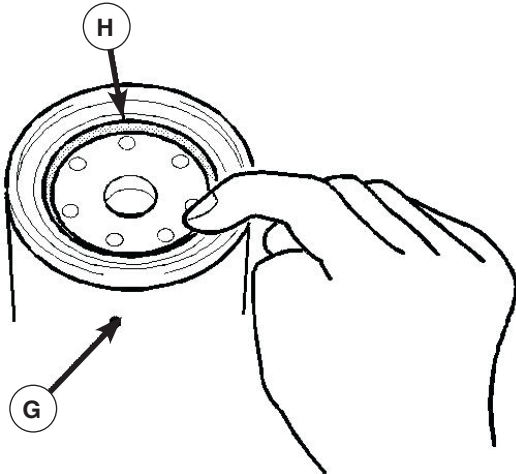

## Clean Outside Of Radiator / Oil Cooler

Gently clean fin tubes (**I**) of radiator / oil cooler of dirt and debris.

### NOTICE

Do not use high pressure cleaning equipment, as it may damage fin tubes.

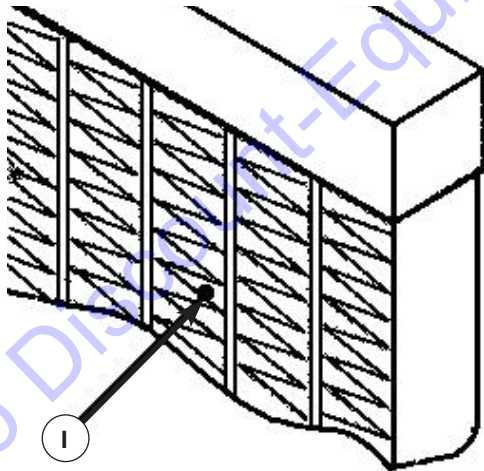

## Clean Inside Of Radiator

Contact your authorized dealer.

## Grease Trailer Hub Bearing

Contact your authorized dealer.

## Change Coolant



- Be sure to stop the machine and allow time to cool. Then loosen the radiator cap one notch. After the coolant water is sufficiently cooled and the inner pressure is released, take the cap off. If this procedure is neglected, the inner pressure can blow off the cap. Steam jetting out of the radiator could result in causing scalding. Follow this procedure under all circumstances.
  - LLC (Antifreeze) is a toxic material. If swallowed, seek immediate medical attention. Do not induce vomiting. If in eyes, wash eyes with clean running water and seek immediate medical attention. When storing, store in an approved container, clearly labeled 'LLC (Antifreeze) inside', away from children.
  - Keep away from fire and flame.
1. To drain coolant, remove radiator cap (**A**). Remove operation side radiator drain plug (**B**) and open drain valve (**C**, engine side) for drainage.
  2. After draining, close drain valve and replace drain plug, then supply coolant through filler port (**A**). (Coolant capacity: approx. 1.93 gal (7.3L).)
  3. After filling with coolant, run machine in unloaded condition for approximately 2 to 3 minutes. Stop machine and check coolant level. Add as needed.

4. Dispose of used coolant according to local, state and/or federal regulations.

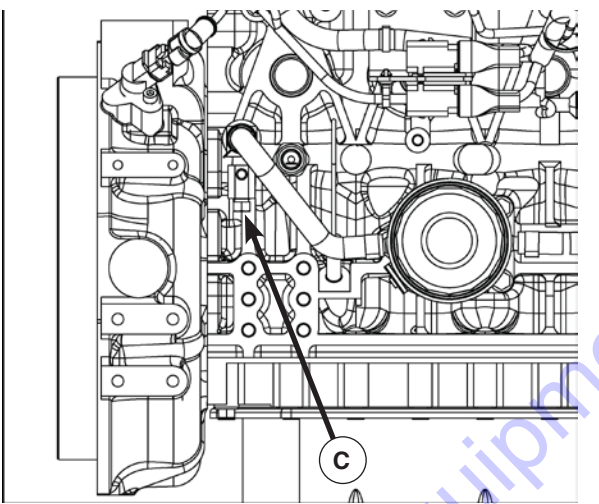
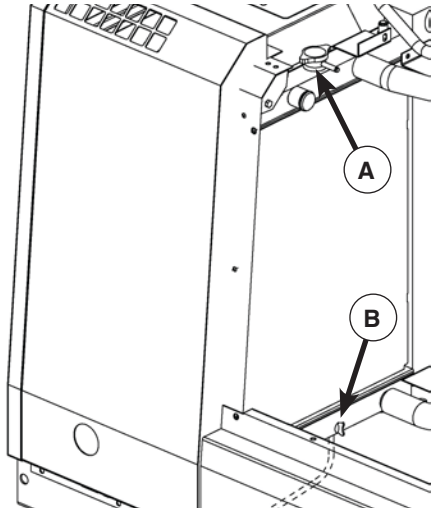

**Change Oil Separator**

Contact your authorized dealer.

**Change Nylon Tubes**

Contact your authorized dealer.

**Change Fuel Hose**

Contact your authorized dealer.

**Change Pressure Regulator**

Contact your authorized dealer.

**Change Unloader O-Rings**

For part numbers, see *Replacement Parts*.

When reassembling, apply sufficient grease to O-ring Slot/O-ring and sliding surface.

Use CALTEX MULTIFAK EP1 grease or equivalent. Grease of poor quality will deteriorate the material.

Supply grease to O-ring (A, B, C, D) after replacement.

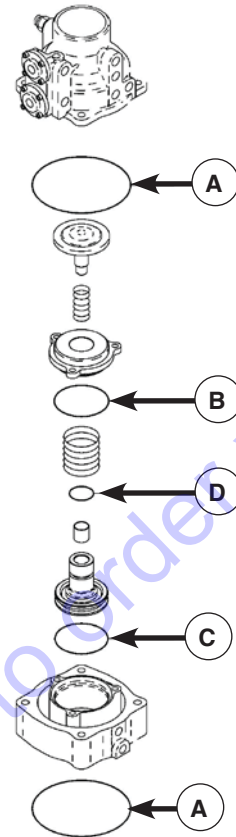

**Check Rubber Hose**

Contact your authorized dealer.

**Change Radiator Hoses**

Contact your authorized dealer.

**Check / Replace Auto-Relief Valve / Vacuum Relief Valve Parts**

For part numbers, see *Replacement Parts*.

When reassembling, apply sufficient grease to O-ring Slot/O-ring and sliding surface.

Use CALTEX MULTIFAK EP1 grease or equivalent. Grease of poor quality will deteriorate the material.

After disassembling and cleaning auto-relief valve, check O-rings (E, F, G). Replace if worn or damaged.

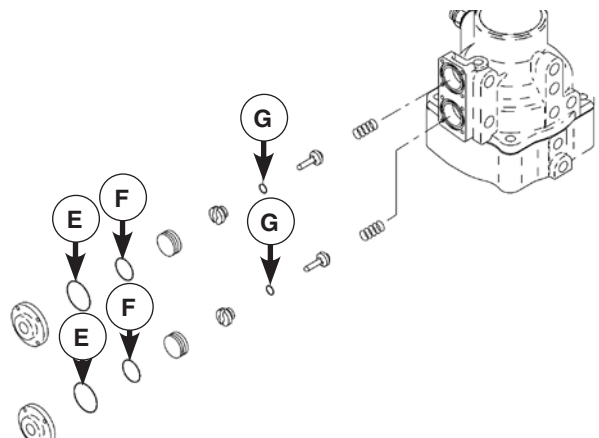

### Check Pressure Control Valve

Close stop valve and fully open service valve while machine is running. Make sure discharge pressure gauge shows between 49 and 68 psi (3.4 and 4.7 bar). If pressure is lower than 49 psi (3.4 bar) or higher than 68 psi (4.7 bar), contact your authorized dealer.

### Check Pressure Control Valve O-Rings / Piston

Contact your authorized dealer.

### Check Drawbar Hardware for Proper Tightness

Check tightness of drawbar hardware (H). Tighten to 140 lb-ft (190 Nm).

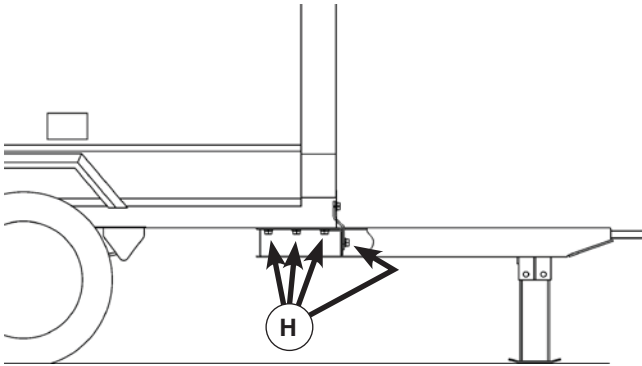

### Check Undercarriage Bracket Hardware for Correct Tightness

Check tightness of undercarriage bracket hardware (A). Tighten to 100 lb-ft (136 Nm).

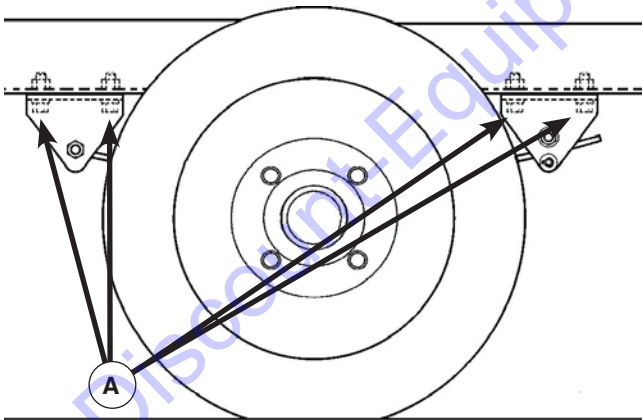

### Check Wheel Lug Nuts / Tire Pressure

Check tightness of wheel lug nuts (B). Tighten to 80 lb-ft (108 Nm).

Also check tire pressure. Adjust to 50 psi (345 kPa).

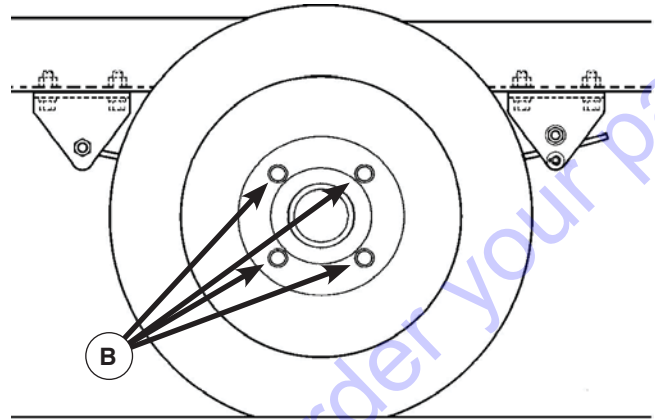

### Storage

#### Preparation for Long-term Storage

If the machine is left unused or not operated longer than six months:

- Store in a clean, dry place. Avoid leaving machine outside.
- Remove battery from machine, if possible, and store in a dry place.
- Charge battery (at least once every month).
- Drain engine oil from machine.
- Drain coolant and fuel from machine.\*
- Seal engine, air-intake port and other openings with vinyl sheet, packing tape, etc., to protect from moisture and dust.
- Perform any necessary repairs or maintenance items.

#### Disposal of Products



In case of disposal of this unit, at first drain and dispose of all fluids according to local, state and/or federal regulations.

For further information, please contact your authorized dealer.



# Troubleshooting

## Indicator Lamps and Warning / Emergency Displays

Indicator Lamp			
Item	Indication	Remedy	Monitor
Glow	Glow plug preheating	-----	
Charge	Alternator not charging	Check Wiring Check alternator	

Warning Display			
Item	Failure Code	Indication	Remedy
Discharge Temp H	A1	Lamp flickers when air temperature at outlet of air-end reaches 239°F (115°C).	See Troubleshooting Chart
Water Temp H	A2	Lamp flickers when coolant temperature reaches 221°F (105°C).	
Comp. Air Filter	A3	Lamp comes on when air filter gets clogged and suction resistance increases above 6.2 kPa	Clean or replace
Eng. Air Filter	A4		
Charge	A5	Alternator not charging	See Troubleshooting Chart

Emergency Display			
Item	Failure Code	Indication	Remedy
Discharge Temp H	E1	Lamp displays when air temperature at outlet of air-end reaches 248°F (120°C).	See Troubleshooting Chart
Water Temp H	E2	Lamp displays when coolant temperature reaches 230°F (110°C).	
Eng. Oil Pressure	E3	Lamp goes on when engine oil pressure drops below 7.3 psi (0.5 bar)	
Discharge Air Temp Sensor Disconnection	E6	Air temperature sensor at outlet of compressor air end disconnected	
Coolant Temp Sensor Disconnection	E7	Coolant temperature sensor disconnected	

## Troubleshooting Chart

Problem	Cause	Correction
Low starter revolution speed	1. Battery low or dead	1. Check battery; charge or replace as needed
Starter rotates but engine does not start	1. Fuel filter clogging 2. Fuel pre-filter clogging 3. No diesel fuel 4. Air mixing in fuel pipings 5. Failure of engine stop solenoid	1. Clean / replace 2. Clean / replace 3. Add diesel fuel 4. Bleed air 5. Contact authorized dealer
Discharge air pressure does not reach 100 psi (6.9 bar)	1. Pressure regulator needs adjustment 2. Pressure regulator trouble.	1. Adjust 2. Contact authorized dealer
Engine does not reach maximum speed	1. Failure of engine controller 2. Unloader orifice clogging 3. Engine trouble 4. Fuel filter clogged 5. Water accumulated in fuel pre-filter 6. Air filter element clogged	1. Contact authorized dealer 2. Clean 3. Contact authorized dealer 4. Clean / replace 5. Drain 6. Clean / replace
Revolution drops before discharge air pressure reaches 100 psi (6.9 bar)	1. Pressure regulator needs adjustment 2. Pressure regulator issue 3. Unloader orifice clogged	1. Adjust 2. Contact authorized dealer 3. Check / clean
Engine does not reach minimum revolution at unload	1. Failure of engine controller 2. Failure of accelerator controller	1. Contact authorized dealer 2. Contact authorized dealer
Safety valve relieves at unload	1. Pressure regulator needs adjustment 2. Unloader valve / seat damage 3. Faulty safety valve 4. Faulty engine speed sensor	1. Adjust 2. Contact authorized dealer 3. Contact authorized dealer 4. Contact authorized dealer
Oil mixes in air (poor oil separation)	1. Scavenging orifice strainer clogged 2. Excessive oil in separator receiver tank 3. Low discharge pressure 4. Oil separator deteriorated	1. Clean 2. Drain 3. Check unloader 4. Contact authorized dealer
Insufficient free air delivery	1. Air filter element clogged 2. Unloader valve cannot fully open 3. Engine does not reach rather speed	1. Clean / replace 2. Contact authorized dealer 3. Contact authorized dealer

Problem	Cause	Correction
Low engine oil pressure, engine stops	<ol style="list-style-type: none"> <li>1. Engine oil level low</li> <li>2. Engine oil filter clogged</li> <li>3. Faulty oil pressure switch</li> <li>4. Loose or broken wire</li> </ol>	<ol style="list-style-type: none"> <li>1. Add engine oil</li> <li>2. Replace</li> <li>3. Contact authorized dealer</li> <li>4. Connect; contact authorized dealer</li> </ol>
Coolant temperature high, engine stops	<ol style="list-style-type: none"> <li>1. Radiator clogged</li> <li>2. Faulty thermostat</li> <li>3. Faulty coolant temp switch</li> <li>4. Belt slipping</li> <li>5. Low coolant level</li> <li>6. Loose or broken wire</li> <li>7. Coolant temp sensor disconnected</li> </ol>	<ol style="list-style-type: none"> <li>1. Change coolant</li> <li>2. Contact authorized dealer</li> <li>3. Contact authorized dealer</li> <li>4. Contact authorized dealer</li> <li>5. Add coolant</li> <li>6. Connect; contact authorized dealer</li> <li>7. Contact authorized dealer</li> </ol>
Discharge temperature high, engine stops	<ol style="list-style-type: none"> <li>1. Oil cooler clogged</li> <li>2. Oil filter clogged</li> <li>3. Faulty discharge air temp switch</li> <li>4. Belt slipping</li> <li>5. Compressor oil level low</li> <li>6. Loose or broken wire</li> <li>7. Discharge air temp sensor disconnected</li> </ol>	<ol style="list-style-type: none"> <li>1. Change coolant</li> <li>2. Replace</li> <li>3. Contact authorized dealer</li> <li>4. Contact authorized dealer</li> <li>5. Add compressor oil</li> <li>6. Connect; contact authorized dealer</li> <li>7. Contact authorized dealer</li> </ol>
Engine monitor alarm lamp lit	<ol style="list-style-type: none"> <li>1. Engine trouble</li> </ol>	<ol style="list-style-type: none"> <li>1. Contact authorized dealer</li> </ol>
Contact your authorized dealers for all other issues.		

## Data Adjustment

No.	Item	Indication	Unit	Primary Set Value	Set Value Range
1	Purge releasing pressure		PSI	86	70 ~ 100
2	Waiting time for transfer to purge mode operation		Second	10	7 ~ 60
3	Load factor for transfer to purge mode operation		%	15	5 ~ 30
4	High-speed side correction (Full load rotational speed)		min <sup>-1</sup>	100	0 ~ 200
5	Low-speed side correction (Unload rotational speed)		min <sup>-1</sup>	100	0 ~ 200

## Data Adjustment Procedure

When SELECT switch is pressed longer than 5 seconds, first P (Purge releasing pressure) is displayed. Each time SELECT switch is pressed, each indication will be selected. Then each time it is pressed one time, T (Waiting time for transfer to purge mode operation) is switched to b (Load factor for transfer to purge mode operation) to H (Full load rotational speed) to L (Unload rotational speed), according to the set orders.

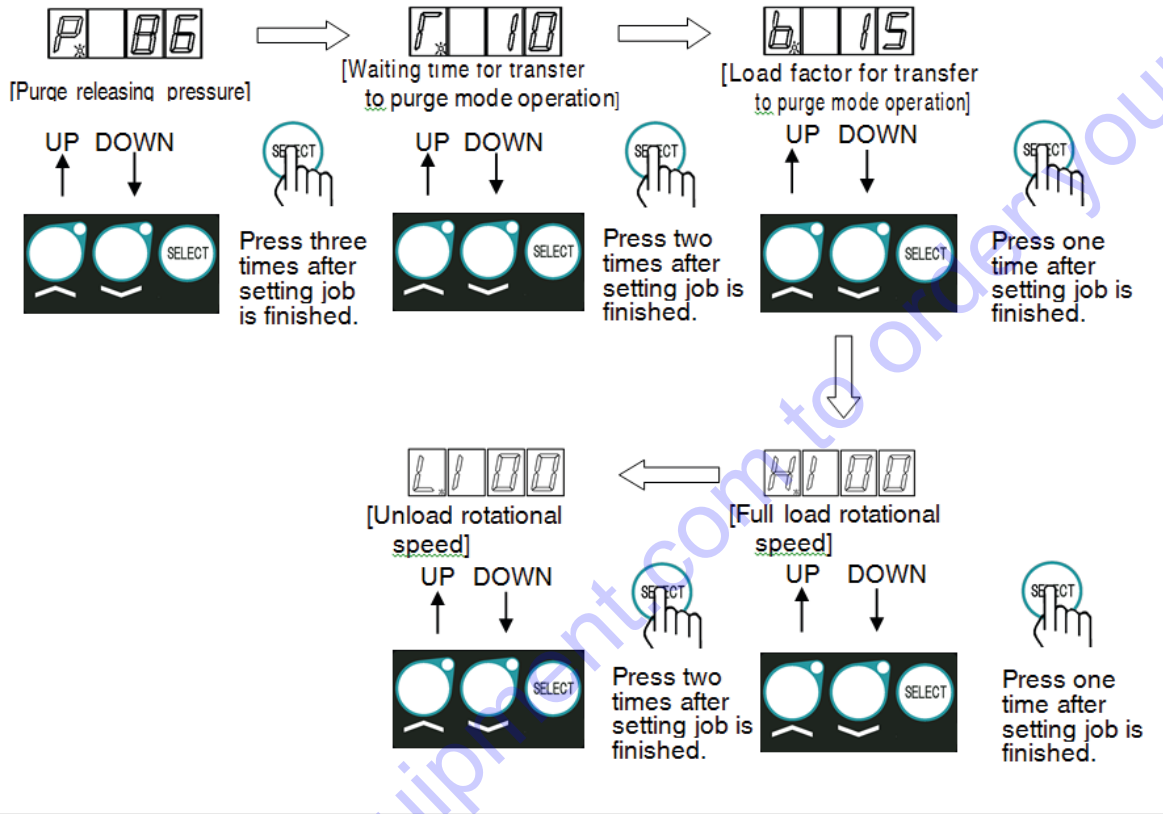

## Specifications

Model		MA185	
Compressor	Type		Single-stage oil cooled, screw type compressor
	Free Air Delivery	cfm (m <sup>3</sup> /min)	185 (5.2)
	Working Pressure	psi (bar)	100 (6.9)
	Lubricating System		Forced lubrication by compressed pressure
	Driving System		Direct driving with gear coupling
	Receiver Tank Capacity	cu in (m <sup>3</sup> )	1,221 (0.021)
	Lubricating Oil Capacity	gal (L)	3.96 (15)
Engine	Model		Yanmar 4TNV88C-DHKS
	Type		Water-cooled 4-cycle direct injection
	No Cylinders, Bore Stroke	in (mm)	4 - 3.46 x 3.54 in (4 - 88 mm x 90 mm)
	Total Displacement	cu in (L)	133.6 (2.189)
	Rated Output (Gross)	kW / min <sup>-1</sup>	35.5 / 3,000
	Rated Output (Net)		34.0 / 3,000
	Lubricating Oil Capacity	gal (L)	0.9 (3.1)
	Coolant Capacity (including Radiator)	gal (L)	1.80 (6.8)
	Battery		95D31 (12V)
	Fuel Tank Capacity	gal (L)	24 (90)
General Specifications	Overall Length	in (mm)	134 (3,404)
	Overall Length (Bonnet Only)	in (mm)	75.2 (1,910)
	Overall Width	in (mm)	66.3 (1,685)
	Overall Height	in (mm)	61 (1,550)
	Net Dry Mass	lb (kg)	2050 (930)
	Operating Mass	lb (kg)	2,450 (1,111)

Go to Discount-Equipment.com to order your parts

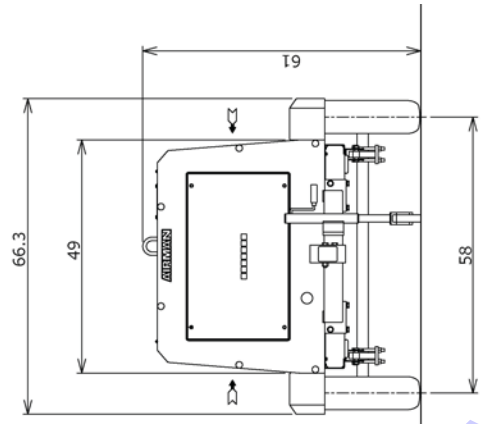
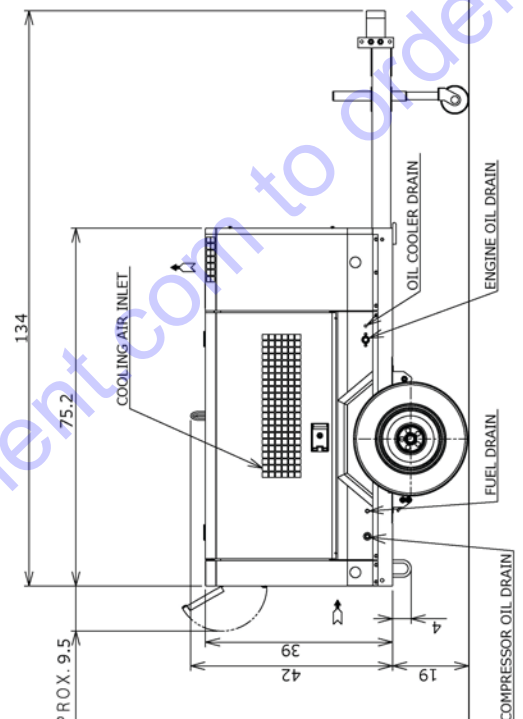
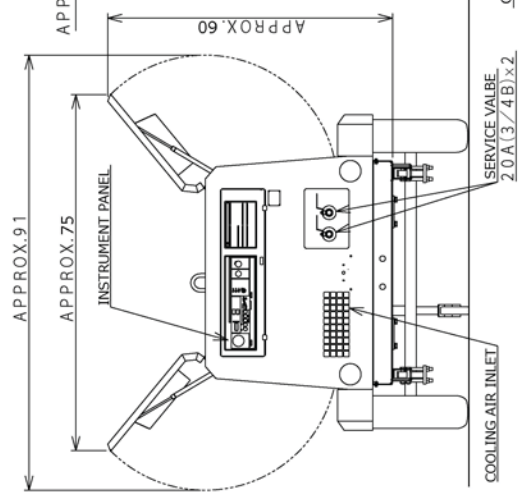
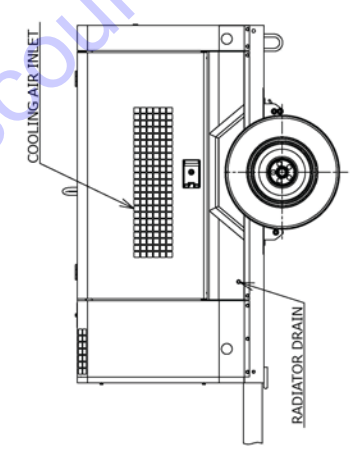
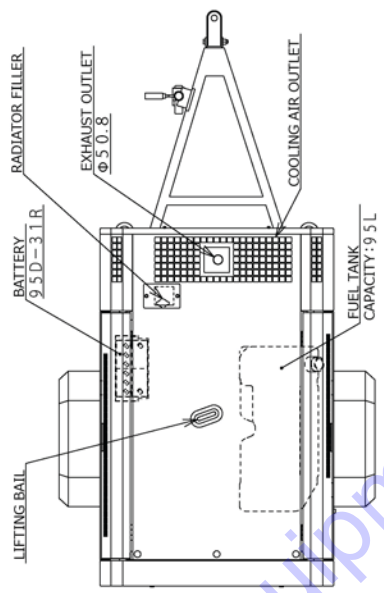

Go to Discount-Equipment.com to order your parts

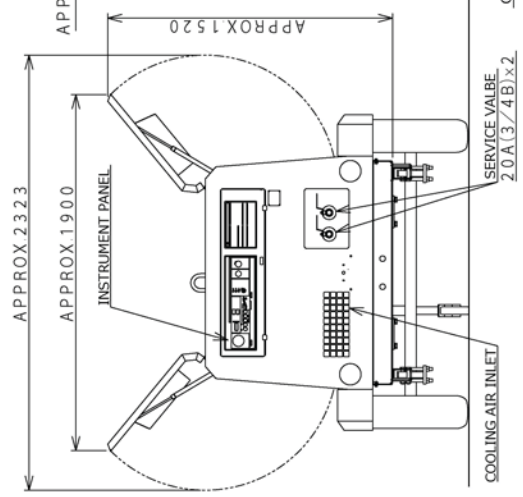
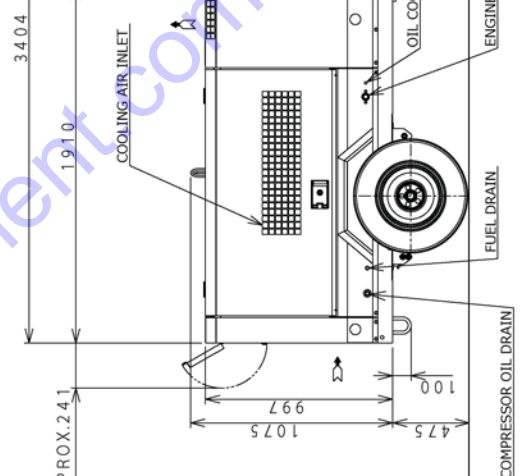
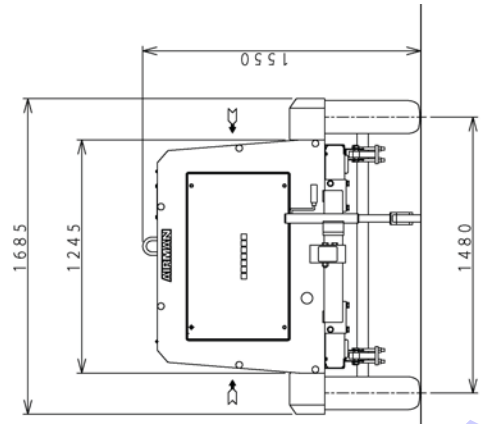
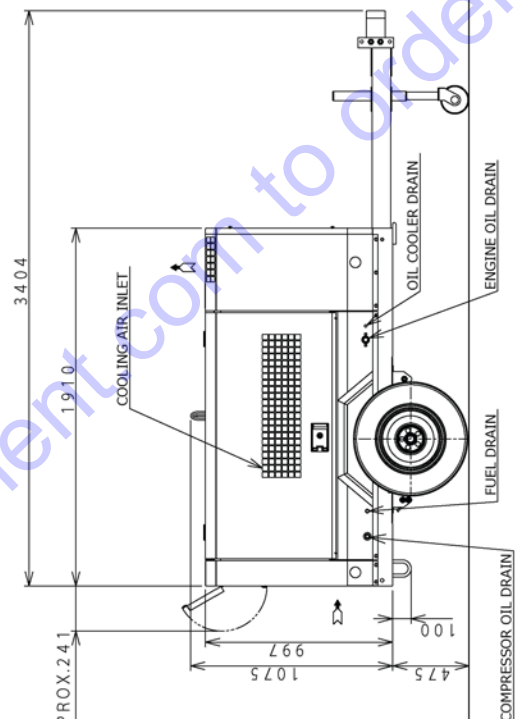
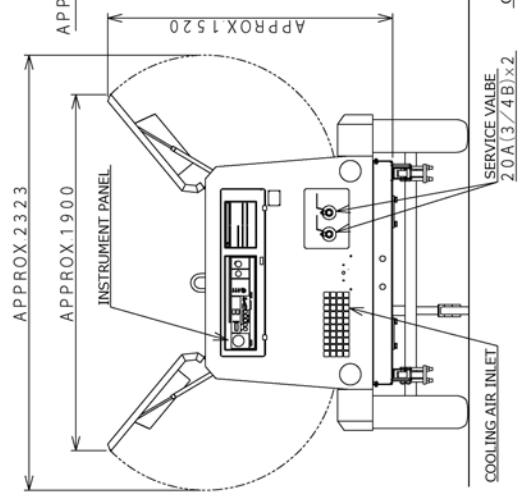
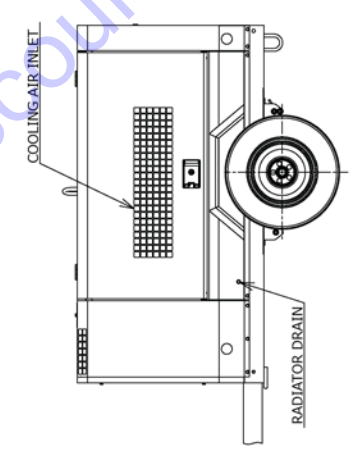
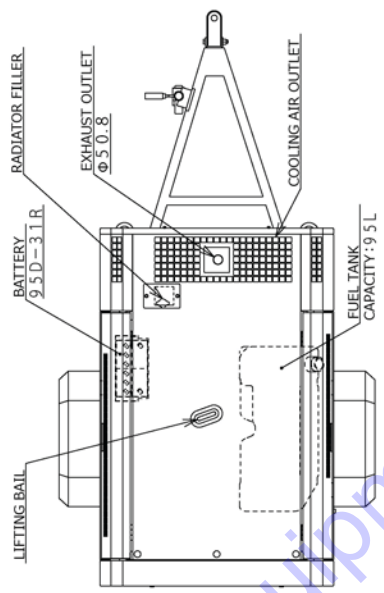

# Wiring Diagram

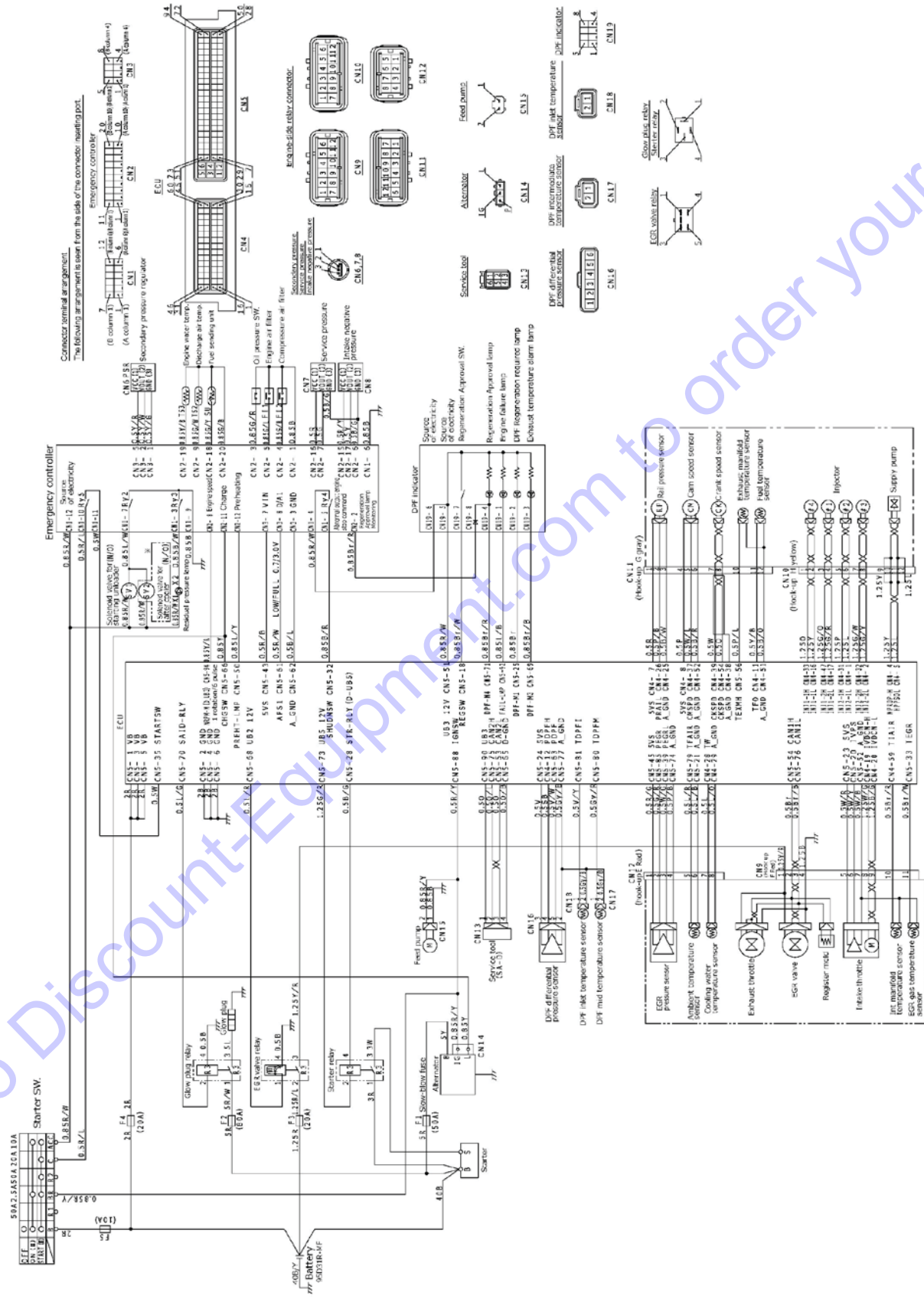



# Piping Diagram

## Air Piping - Compressor Oil Piping

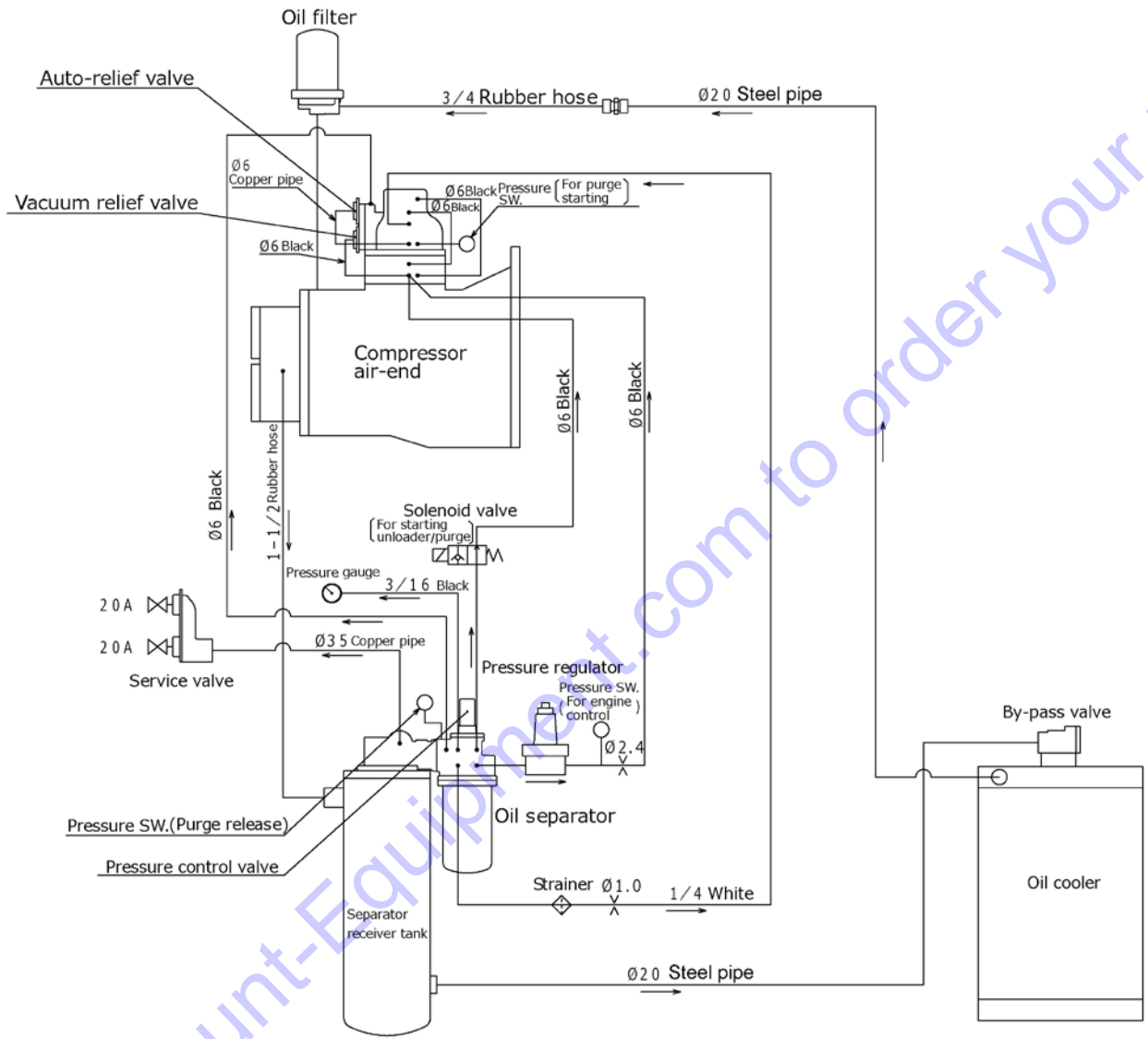

## Air Piping - Compressor Oil Piping

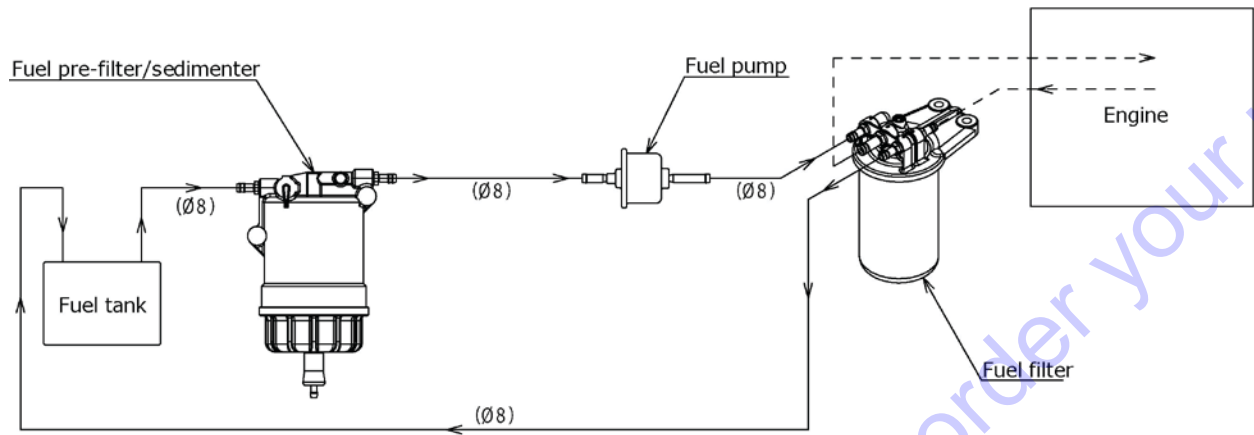

Go to [Discount-Equipment.com](http://Discount-Equipment.com) to order your parts

## OPERATION LOG

OPERATION DATE	OPERATION TIME		TOTAL OPERATION HOURS (h)	DISCHARGE AIR PRESS.(PSI)	AMBIENT TEMP.(° F)	DISCHARGE AIR TEMP. (° F)	COOLANT TEMP.(° F)	RATED RPM (rpm.min <sup>-1</sup> )	ENG.OIL REPLACEMENT HOUR (h)	COMP.OIL SUPPLY(gal.)	REMARKS (INSPECTION/PART CHANGE HISTORY ETC.)
	START TIME	STOP TIME									
. . .	:	:									
. . .	:	:									
. . .	:	:									
. . .	:	:									
. . .	:	:									
. . .	:	:									
. . .	:	:									
. . .	:	:									
. . .	:	:									
. . .	:	:									
. . .	:	:									
. . .	:	:									
. . .	:	:									
. . .	:	:									
. . .	:	:									
. . .	:	:									
. . .	:	:									
. . .	:	:									
. . .	:	:									
. . .	:	:									
. . .	:	:									

Go to DiscountEquipment.com to order your parts

# OPERATION LOG

OPERATION DATE	OPERATION TIME		TOTAL OPERATION HOURS (h)	DISCHARGE AIR PRESS.(MPa)	AMBIENT TEMP.(°C)	DISCHARGE AIR TEMP. (°C)	COOLANT TEMP.(°C)	RATED RPM (rpm.min <sup>-1</sup> )	ENG.OIL REPLACEMENT HOUR (h)	COMP.OIL SUPPLY(L)	REMARKS (INSPECTION/PART CHANGE HISTORY ETC.)
	START TIME	STOP TIME									
.	.	:	:								
.	.	:	:								
.	.	:	:								
.	.	:	:								
.	.	:	:								
.	.	:	:								
.	.	:	:								
.	.	:	:								
.	.	:	:								
.	.	:	:								
.	.	:	:								
.	.	:	:								
.	.	:	:								
.	.	:	:								
.	.	:	:								
.	.	:	:								
.	.	:	:								
.	.	:	:								
.	.	:	:								
.	.	:	:								
.	.	:	:								
.	.	:	:								
.	.	:	:								
.	.	:	:								
.	.	:	:								
.	.	:	:								
.	.	:	:								
.	.	:	:								
.	.	:	:								
.	.	:	:								
.	.	:	:								

Go to DiscountEquipment.com to order your parts

# Noise Emission

This section pertains only to machines distributed within the United States.

## WARNING

### Tampering with Noise Control System Prohibited

Federal law prohibits the following acts or the causing thereof:

1. The removal or rendering inoperative by any persons, other than for purposes of maintenance, repair, or replacement, of any device or element of design incorporated into any new compressor for the purpose of noise control prior to its sale or delivery to the ultimate purchaser or while it is in use; or
2. the use of the compressor after such device or element of design has been removed or rendered inoperative by any person.

Among those acts included in the prohibition against tampering are these:

3. Removal or rendering inoperative any of the following:
  - a.the engine exhaust system or parts thereof
  - b.the air intake system or parts thereof
  - c.enclosure or parts thereof
4. Removal of any of the following:
  - a.fan shroud
  - b.vibration mounts
  - c.sound absorption material
5. Operation of the compressor with any of the enclosure doors open.

### Compressor Noise Emission Control Information

- A. The removal or rendering inoperative, other than for the purpose of maintenance, repair, or replacement of any noise control device or element of design incorporated into this compressor in compliance with noise control act;
- B. The use of this compressor after such device or element of design has been removed or rendered inoperative.

**NOTE: The above information applies only to units that are built in compliance with the U.S. Environmental Protection Agency.**

The Manufacturer reserves the right to make changes or add improvements without notice and without incurring any obligation to make such changes or add such improvements to products sold previously.

The Purchaser is urged to include the above provisions in any agreement for any resale of this compressor.

# Noise Emission Control Maintenance Log

<b>COMPRESSOR MODEL</b> _____
<b>SERIAL NO.</b> _____
<b>USER UNIT NO.</b> _____

<b>UNIT IDENTIFICATION</b>	<b>DEALER OR DISTRIBUTOR FROM WHOM PURCHASED:</b>
Engine Make & Model: _____	_____
Serial No.: _____	_____
Purchaser or Owner: _____	_____
Address: _____	Date Purchased: _____

The Noise Control Act of 1972 (86 Stat. 1234) prohibits tampering with the noise control system of any compressor manufactured and sold under the above regulations, specifically the following acts or the causing thereof:

(1) the removal or rendering inoperative by any persons, other than for purposes of maintenance, repair, or replacement, of any device or element of design incorporated into new compressor for the purpose of noise control prior to its sale or delivery to the ultimate purchaser or while it is in use; or (2) the use of the compressor after such device or element of design has been removed or rendered inoperative by any person.

## Noise Emission Warranty

The manufacturer warrants to the ultimate purchaser and each subsequent purchaser that this air compressor was designed, built and equipped to conform at the time of sale to the first retail purchaser, with all applicable U.S. EPA Noise Control Regulations.

This warranty is not limited to any particular part, component, or system of the air compressor. Defects in the design, assembly or in any part, component, or system of the compressor which, at the time of sale to the first retail purchaser, caused noise emissions to exceed Federal Standards are covered by this warranty for the life of the air compressor.

## Introduction

The unit for which this Maintenance Log is provided conforms to U.S. E.P.A. Regulations for Noise Emissions, applicable to Portable Air Compressors.

The purpose of this book is to provide (1) the Maintenance Performance Schedule for all required noise emission controls and (2) space so that the purchaser or owner can record what maintenance was done, by whom, where and when. The Maintenance Schedule and detailed instructions on the maintenance items are given on following page.

### Maintenance Schedule

Item	Area	Period
A.	Compressed Air Leaks	As Detected
B.	Safety and Control Systems	As Detected
C.	Acoustic Materials	Daily
D.	Fasteners	100 hours
E.	Enclosure Panels	100 hours
F.	Air Intake & Engine Exhaust	100 hours
G.	Cooling Systems	250 hours
H.	Isolation Mounts	250 hours
I.	Engine Operation	See Operator's Manual
J.	Fuels & Lubricants	See Operator's Manual

#### A. Compressed Air Leaks

Correct all compressed air leaks during the first shutdown period after discovery. If severe enough to cause serious noise problems and efficiency loss, shut down immediately and correct the leak(s).

#### B. Safety and Control Systems

Repair or replace all safety and control systems or circuits as malfunction occurs. No compressor should be operated with either system bypassed, disabled, or nonfunctional.

#### C. Acoustic Materials

In daily inspections, observe these materials. Maintain all acoustic material as nearly as possible in its original condition. Repair or replace all sections that have: 1) sustained damage, 2) have partially separated from panels to which they were attached, 3) are missing, or have otherwise deteriorated due to severe operating or storage conditions.

#### D. Fasteners

All fasteners such as hinges, nuts, bolts, clamps, screws, rivets, and latches should be inspected for looseness after each 100 hours of operation. They should be retightened, repaired, or if missing, replaced immediately to prevent subsequent damage and noise emission increase.

#### E. Enclosure Panels

Enclosure panels should also be inspected at 100 hour operational intervals. All panels that are warped, punctured, torn, or otherwise

deformed, such that their noise containment function is reduced, should be repaired or replaced before the next operation interval. Doors, access panels, and hatch closures especially, should be checked and adjusted at this time to insure continuous seating between gasket or acoustic material and the mating frame.

#### F. Air Intake and Engine Exhaust

Engine and compressor air intake and engine exhaust systems should be inspected after each 100 hours of operation for loose, damaged, or deteriorated components. Repairs or replacements should be made before the next period of use.

#### G. Cooling Systems

All components of the cooling system for engine water and compressor oil should be inspected every 250 hours of use. Any discrepancies found should be corrected before placing the unit back in operation. Unrestricted airflow over the radiator and oil cooler must be maintained at all times during operation.

#### H. Isolation Mounts

Engine/airend isolation mounts should be inspected after each 250 hours of operation. Those mounts with cracks or splits in the molded rubber, or with bent or broken bolts due to operation or storage in severe environments, all should be replaced with equivalent parts.

#### I. Engine Operation

Inspect and maintain engine condition and operation as recommended in the manuals supplied by the engine manufacturer.

#### J. Fuels and Lubricants

Use only the types and grades of fuels and lubricants recommended in the Equipment and Engine Manufacturer's Operator and Maintenance Manuals.

**Maintenance Record For Noise Emission Control**

Item No.	Description Of Work	Hourmeter Reading	Maint / Inspect Date	Location City / State	Work Done By (Name)

Go to Discount-Equipment.com to order your parts



# Addendum A - Tire Safety Information

This portion of the User's Manual contains tire safety information as required by 49 CFR 575.6.

Section 1.1 contains "Steps for Determining Correct Load Limit - Trailer".

Section 1.2 contains "Steps for Determining Correct Load Limit – Tow Vehicle".

Section 1.3 contains a Glossary of Tire Terminology, including "cold inflation pressure", "maximum inflation pressure", "recommended inflation pressure", and other non-technical terms.

Section 1.4 contains information from the NHTSA brochure entitled "Tire Safety – Everything Rides On It". This brochure, as well as the preceding subsections, describes the following items;

- Tire labeling, including a description and explanation of each marking on the tires, and information about the DOT Tire Identification Number (TIN).
- Recommended tire inflation pressure, including a description and explanation of:
  - A. Cold inflation pressure.
  - B. Vehicle Placard and location on the vehicle.
  - C. Adverse safety consequences of under inflation (including tire failure).
  - D. Measuring and adjusting air pressure for proper inflation.
- Tire Care, including maintenance and safety practices.
- Vehicle load limits, including a description and explanation of the following items:
  - A. Locating and understanding the load limit information, total load capacity, and cargo capacity.
  - B. Calculating total and cargo capacities with varying seating configurations including quantitative examples showing / illustrating how the vehicles cargo and luggage capacity decreases as combined number and size of occupants' increases. This item is also discussed in Section 3.
  - C. Determining compatibility of tire and vehicle load capabilities.
  - D. Adverse safety consequences of overloading on handling and stopping on tires.

## **1.1. STEPS FOR DETERMINING CORRECT LOAD LIMIT – TRAILER**

Determining the load limits of a trailer includes more than understanding the load limits of the tires alone. On all trailers there is a Federal certification/VIN label that is located on the forward half of the left (road) side of the unit. This certification/VIN label will indicate the trailer's Gross Vehicle Weight Rating (GVWR). This is the most weight the fully loaded trailer can weigh. It will also provide the Gross Axle Weight Rating (GAWR). This is the most a particular axle can weigh. If there are multiple axles, the GAWR of each axle will be provided.

If your trailer has a GVWR of 10,000 pounds or less, there is a vehicle placard located in the same location as the certification label described above. This placard provides tire and loading information. In addition, this placard will show a statement regarding maximum cargo capacity. Cargo can be added to the trailer, up to the maximum weight specified on the placard. The combined weight of the cargo is provided as a single number. In any case, remember: the total weight of a fully loaded trailer can not exceed the stated GVWR.

For trailers with living quarters installed, the weight of water and propane also need to be considered. The weight of fully filled propane containers is considered part of the weight of the trailer before it is loaded with cargo, and is not considered part of the disposable cargo load. Water however, is a disposable cargo weight and is treated as such. If there is a fresh water storage tank of 100 gallons, this tank when filled would weigh about 800 pounds. If more cargo is being transported, water can be off-loaded to keep the total amount of cargo added to the vehicle within the limits of the GVWR so as not to overload the vehicle. Understanding this flexibility will allow you, the owner, to make choices that fit your travel needs.

When loading your cargo, be sure it is distributed evenly to prevent overloading front to back and side to side. Heavy items should be placed low and as close to the axle positions as reasonable. Too many items on one side may overload a tire. The best way to know the actual weight of the vehicle is to weigh it at a public scale. Talk to your dealer to discuss the weighing methods needed to capture the various weights related to the trailer. This would include the weight empty or unloaded, weights per axle, wheel, hitch or king-pin, and total weight.

Excessive loads and/or underinflation cause tire overloading and, as a result, abnormal tire flexing occurs. This situation can generate an excessive amount of heat within the tire. Excessive heat may lead to tire failure. It is the air pressure that enables a tire to support the load, so proper inflation is critical. The proper air pressure may be found on the certification/VIN label and/or on the Tire Placard. This value should never exceed the maximum cold inflation pressure stamped on the tire.

### 1.1.1. TRAILERS 10,000 POUNDS GVWR OR LESS

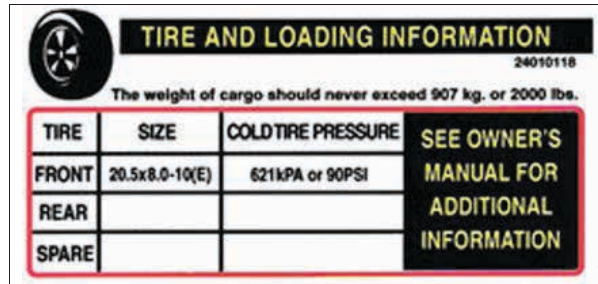

Tire and Loading Information Placard – Figure 1-1

1. Locate the statement, “The weight of cargo should never exceed XXX kg or XXX lbs.,” on your vehicle’s placard. See figure 1-1.
2. This figure equals the available amount of cargo and luggage load capacity.
3. Determine the combined weight of luggage and cargo being loaded on the vehicle. That weight may not safely exceed the available cargo and luggage load capacity.

The trailer’s placard refers to the Tire Information Placard attached adjacent to or near the trailer’s VIN (Certification) label at the left front of the trailer.

### 1.1.2. TRAILERS OVER 10,000 POUNDS GVWR (NOTE: THESE TRAILERS ARE NOT REQUIRED TO HAVE A TIRE INFORMATION PLACARD ON THE VEHICLE)

1. Determine the empty weight of your trailer by weighing the trailer using a public scale or other means. This step does not have to be repeated.
2. Locate the GVWR (Gross Vehicle Weight Rating) of the trailer on your trailer’s VIN (Certification) label.
3. Subtract the empty weight of your trailer from the GVWR stated on the VIN label. That weight is the maximum available cargo capacity of the trailer and may not be safely exceeded.

## 1.2. STEPS FOR DETERMINING CORRECT LOAD LIMIT – TOW VEHICLE

1. Locate the statement, “The combined weight of occupants and cargo should never exceed XXX lbs.,” on your vehicle’s placard.
2. Determine the combined weight of the driver and passengers who will be riding in your vehicle.
3. Subtract the combined weight of the driver and passengers from XXX kilograms or XXX pounds.
4. The resulting figure equals the available amount of cargo and luggage capacity. For example, if the “XXX” amount equals 1400 lbs. and there will be five 150 lb. passengers in your vehicle, the amount of available cargo and luggage capacity is 650 lbs. (1400-750 (5 x 150) = 650 lbs.).
5. Determine the combined weight of luggage and cargo being loaded on the vehicle. That weight may not safely exceed the available cargo and luggage capacity calculated in Step # 4.
6. If your vehicle will be towing a trailer, load from your trailer will be transferred to your vehicle. Consult the tow vehicle’s manual to determine how this weight transfer reduces the available cargo and luggage capacity of your vehicle.

## 1.3. GLOSSARY OF TIRE TERMINOLOGY

### Accessory weight

The combined weight (in excess of those standard items which may be replaced) of automatic transmission, power steering, power brakes, power windows, power seats, radio and heater, to the extent that these items are available as factory-installed equipment (whether installed or not).

**Bead**

The part of the tire that is made of steel wires, wrapped or reinforced by ply cords and that is shaped to fit the rim.

**Bead separation**

This is the breakdown of the bond between components in the bead.

**Bias ply tire**

A pneumatic tire in which the ply cords that extend to the beads are laid at alternate angles substantially less than 90 degrees to the centerline of the tread.

**Carcass**

The tire structure, except tread and sidewall rubber which, when inflated, bears the load.

**Chunking**

The breaking away of pieces of the tread or sidewall.

**Cold inflation pressure**

The pressure in the tire before you drive.

**Cord**

The strands forming the plies in the tire.

**Cord separation**

The parting of cords from adjacent rubber compounds.

**Cracking**

Any parting within the tread, sidewall, or inner liner of the tire extending to cord material.

**CT**

A pneumatic tire with an inverted flange tire and rim system in which the rim is designed with rim flanges pointed radially inward and the tire is designed to fit on the underside of the rim in a manner that encloses the rim flanges inside the air cavity of the tire.

**Curb weight**

The weight of a motor vehicle with standard equipment including the maximum capacity of fuel, oil, and coolant, and, if so equipped, air conditioning and additional weight optional engine.

**Extra load tire**

A tire designed to operate at higher loads and at higher inflation pressures than the corresponding standard tire.

**Groove**

The space between two adjacent tread ribs.

**Gross Axle Weight Rating**

The maximum weight that any axle can support, as published on the Certification / VIN label on the front left side of the trailer. Actual weight determined by weighing each axle on a public scale, with the trailer attached to the towing vehicle.

**Gross Vehicle Weight Rating**

The maximum weight of the fully loaded trailer, as published on the Certification / VIN label. Actual weight determined by weighing trailer on a public scale, without being attached to the towing vehicle.

**Hitch Weight**

The downward force exerted on the hitch ball by the trailer coupler.

**Innerliner**

The layer(s) forming the inside surface of a tubeless tire that contains the inflating medium within the tire.

**Innerliner separation**

The parting of the innerliner from cord material in the carcass.

**Intended outboard sidewall**

The sidewall that contains a white-wall, bears white lettering or bears manufacturer, brand, and/or model name molding that is higher or deeper than the same molding on the other sidewall of the tire or the outward facing sidewall of an asymmetrical tire that has a particular side that must always face outward when mounted on a vehicle.

**Light truck (LT) tire**

A tire designated by its manufacturer as primarily intended for use on lightweight trucks or multipurpose passenger vehicles.

**Load rating**

The maximum load that a tire is rated to carry for a given inflation pressure.

**Maximum load rating**

The load rating for a tire at the maximum permissible inflation pressure for that tire.

**Maximum permissible inflation pressure**

The maximum cold inflation pressure to which a tire may be inflated.

**Maximum loaded vehicle weight**

The sum of curb weight, accessory weight, vehicle capacity weight, and production options weight.

**Measuring rim**

The rim on which a tire is fitted for physical dimension requirements.

**Pin Weight**

The downward force applied to the 5<sup>th</sup> wheel or gooseneck ball, by the trailer kingpin or gooseneck coupler.

**Non-pneumatic rim**

A mechanical device which, when a non-pneumatic tire assembly incorporates a wheel, supports the tire, and attaches, either integrally or separably, to the wheel center member and upon which the tire is attached.

**Non-pneumatic spare tire assembly**

A non-pneumatic tire assembly intended for temporary use in place of one of the pneumatic tires and rims that are fitted to a passenger car in compliance with the requirements of this standard.

**Non-pneumatic tire**

A mechanical device which transmits, either directly or through a wheel or wheel center member, the vertical load and tractive forces from the roadway to the vehicle, generates the tractive forces that provide the directional control of the vehicle and does not rely on the containment of any gas or fluid for providing those functions.

**Non-pneumatic tire assembly**

A non-pneumatic tire, alone or in combination with a wheel or wheel center member, which can be mounted on a vehicle.

**Normal occupant weight**

This means 68 kilograms (150 lbs.) times the number of occupants specified in the second column of Table I of 49 CFR 571.110.

**Occupant distribution**

The distribution of occupants in a vehicle as specified in the third column of Table I of 49 CFR 571.110.

**Open splice**

Any parting at any junction of tread, sidewall, or innerliner that extends to cord material.

**Outer diameter**

The overall diameter of an inflated new tire.

**Overall width**

The linear distance between the exteriors of the sidewalls of an inflated tire, including elevations due to labeling, decorations, or protective bands or ribs.

**Ply**

A layer of rubber-coated parallel cords.

**Ply separation**

A parting of rubber compound between adjacent plies.

**Pneumatic tire**

A mechanical device made of rubber, chemicals, fabric and steel or other materials, that, when mounted on an automotive wheel, provides the traction and contains the gas or fluid that sustains the load.

**Production options weight**

The combined weight of those installed regular production options weighing over 2.3 kilograms (5 lbs.) in excess of those standard items which they replace, not previously considered in curb weight or accessory weight, including heavy duty brakes, ride levelers, roof rack, heavy duty battery, and special trim.

**Radial ply tire**

A pneumatic tire in which the ply cords that extend to the beads are laid at substantially 90 degrees to the centerline of the tread.

**Recommended inflation pressure**

This is the inflation pressure provided by the vehicle manufacturer on the Tire Information label and on the Certification / VIN tag.

**Reinforced tire**

A tire designed to operate at higher loads and at higher inflation pressures than the corresponding standard tire.

**Rim**

A metal support for a tire or a tire and tube assembly upon which the tire beads are seated.

**Rim diameter**

This means the nominal diameter of the bead seat.

**Rim size designation**

This means the rim diameter and width.

**Rim type designation**

This means the industry of manufacturer's designation for a rim by style or code.

**Rim width**

This means the nominal distance between rim flanges.

**Section width**

The linear distance between the exteriors of the sidewalls of an inflated tire, excluding elevations due to labeling, decoration, or protective bands.

**Sidewall**

That portion of a tire between the tread and bead.

**Sidewall separation**

The parting of the rubber compound from the cord material in the sidewall.

**Special Trailer (ST) tire**

The "ST" is an indication the tire is for trailer use only.

**Test rim**

The rim on which a tire is fitted for testing, and may be any rim listed as appropriate for use with that tire.

**Tread**

That portion of a tire that comes into contact with the road.

**Tread rib**

A tread section running circumferentially around a tire.

**Tread separation**

Pulling away of the tread from the tire carcass.

**Treadwear indicators (TWI)**

The projections within the principal grooves designed to give a visual indication of the degrees of wear of the tread.

**Vehicle capacity weight**

The rated cargo and luggage load plus 68 kilograms (150 lbs.) times the vehicle's designated seating capacity.

**Vehicle maximum load on the tire**

The load on an individual tire that is determined by distributing to each axle its share of the maximum loaded vehicle weight and dividing by two.

**Vehicle normal load on the tire**

The load on an individual tire that is determined by distributing to each axle its share of the curb weight, accessory weight, and normal occupant weight (distributed in accordance with Table I of CRF 49 571.110) and dividing by 2.

**Weather side**

The surface area of the rim not covered by the inflated tire.

**Wheel center member**

In the case of a non-pneumatic tire assembly incorporating a wheel, a mechanical device which attaches, either integrally or separably, to the non-pneumatic rim and provides the connection between the non-pneumatic rim and the vehicle; or, in the case of a non-pneumatic tire assembly not incorporating a wheel, a mechanical device which attaches, either integrally or separably, to the non-pneumatic tire and provides the connection between tire and the vehicle.

**Wheel-holding fixture**

The fixture used to hold the wheel and tire assembly securely during testing.

**1.4. TIRE SAFETY - EVERYTHING RIDES ON IT**

The National Traffic Safety Administration (NHTSA) has published a brochure (DOT HS 809 361) that discusses all aspects of Tire Safety, as required by CFR 575.6. This brochure is reproduced in part below. It can be obtained and downloaded from NHTSA, free of charge, from the following web site:

[http://www.nhtsa.dot.gov/cars/rules/TireSafety/ridesonit/tires\\_index.html](http://www.nhtsa.dot.gov/cars/rules/TireSafety/ridesonit/tires_index.html)

Studies of tire safety show that maintaining proper tire pressure, observing tire and vehicle load limits (not carrying more weight in your vehicle than your tires or vehicle can safely handle), avoiding road hazards, and inspecting tires for cuts, slashes, and other irregularities are the most important things you can do to avoid tire failure, such as tread separation or blowout and flat tires. These actions, along with other care and maintenance activities, can also:

- Improve vehicle handling
- Help protect you and others from avoidable breakdowns and accidents
- Improve fuel economy
- Increase the life of your tires.

This booklet presents a comprehensive overview of tire safety, including information on the following topics:

- Basic tire maintenance
- Uniform Tire Quality Grading System
- Fundamental characteristics of tires

- Tire safety tips.

Use this information to make tire safety a regular part of your vehicle maintenance routine. Recognize that the time you spend is minimal compared with the inconvenience and safety consequences of a flat tire or other tire failure.

## **1.5. SAFETY FIRST—BASIC TIRE MAINTENANCE**

Properly maintained tires improve the steering, stopping, traction, and load-carrying capability of your vehicle. Underinflated tires and overloaded vehicles are a major cause of tire failure. Therefore, as mentioned above, to avoid flat tires and other types of tire failure, you should maintain proper tire pressure, observe tire and vehicle load limits, avoid road hazards, and regularly inspect your tires.

### **1.5.1. FINDING YOUR VEHICLE'S RECOMMENDED TIRE PRESSURE AND LOAD LIMITS**

Tire information placards and vehicle certification labels contain information on tires and load limits. These labels indicate the vehicle manufacturer's information including:

- Recommended tire size
- Recommended tire inflation pressure
- Vehicle capacity weight (VCW—the maximum occupant and cargo weight a vehicle is designed to carry)
- Front and rear gross axle weight ratings (GAWR—the maximum weight the axle systems are designed to carry).

Both placards and certification labels are permanently attached to the trailer near the left front.

### **1.5.2. UNDERSTANDING TIRE PRESSURE AND LOAD LIMITS**

Tire inflation pressure is the level of air in the tire that provides it with load-carrying capacity and affects the overall performance of the vehicle. The tire inflation pressure is a number that indicates the amount of air pressure—measured in pounds per square inch (psi)—a tire requires to be properly inflated. (You will also find this number on the vehicle information placard expressed in kilopascals (kpa), which is the metric measure used internationally.)

Manufacturers of passenger vehicles and light trucks determine this number based on the vehicle's design load limit, that is, the greatest amount of weight a vehicle can safely carry and the vehicle's tire size. The proper tire pressure for your vehicle is referred to as the "recommended cold inflation pressure." (As you will read below, it is difficult to obtain the recommended tire pressure if your tires are not cold.)

Because tires are designed to be used on more than one type of vehicle, tire manufacturers list the "maximum permissible inflation pressure" on the tire sidewall. This number is the greatest amount of air pressure that should ever be put in the tire under normal driving conditions.

### **1.5.3. CHECKING TIRE PRESSURE**

It is important to check your vehicle's tire pressure at least once a month for the following reasons:

- Most tires may naturally lose air over time.
- Tires can lose air suddenly if you drive over a pothole or other object or if you strike the curb when parking.
- With radial tires, it is usually not possible to determine underinflation by visual inspection.

For convenience, purchase a tire pressure gauge to keep in your vehicle. Gauges can be purchased at tire dealerships, auto supply stores, and other retail outlets.

The recommended tire inflation pressure that vehicle manufacturers provide reflects the proper psi when a tire is cold. The term cold does not relate to the outside temperature. Rather, a cold tire is one that has not been driven on for at least three hours. When you drive, your tires get warmer, causing the air pressure within them to increase. Therefore, to get an accurate tire pressure reading, you must measure tire pressure when the tires are cold or compensate for the extra pressure in warm tires.

#### **1.5.4. STEPS FOR MAINTAINING PROPER TIRE PRESSURE**

- Step 1: Locate the recommended tire pressure on the vehicle's tire information placard, certification label, or in the owner's manual.
- Step 2: Record the tire pressure of all tires.
- Step 3: If the tire pressure is too high in any of the tires, slowly release air by gently pressing on the tire valve stem with the edge of your tire gauge until you get to the correct pressure.
- Step 4: If the tire pressure is too low, note the difference between the measured tire pressure and the correct tire pressure. These "missing" pounds of pressure are what you will need to add.
- Step 5: At a service station, add the missing pounds of air pressure to each tire that is underinflated.
- Step 6: Check all the tires to make sure they have the same air pressure (except in cases in which the front and rear tires are supposed to have different amounts of pressure).

If you have been driving your vehicle and think that a tire is underinflated, fill it to the recommended cold inflation pressure indicated on your vehicle's tire information placard or certification label. While your tire may still be slightly underinflated due to the extra pounds of pressure in the warm tire, it is safer to drive with air pressure that is slightly lower than the vehicle manufacturer's recommended cold inflation pressure than to drive with a significantly underinflated tire. Since this is a temporary fix, don't forget to recheck and adjust the tire's pressure when you can obtain a cold reading.

#### **1.5.5. TIRE SIZE**

To maintain tire safety, purchase new tires that are the same size as the vehicle's original tires or another size recommended by the manufacturer. Look at the tire information placard, the owner's manual, or the sidewall of the tire you are replacing to find this information. If you have any doubt about the correct size to choose, consult with the tire dealer.

#### **1.5.6. TIRE TREAD**

The tire tread provides the gripping action and traction that prevent your vehicle from slipping or sliding, especially when the road is wet or icy. In general, tires are not safe and should be replaced when the tread is worn down to 1/16 of an inch. Tires have built-in treadwear indicators that let you know when it is time to replace your tires. These indicators are raised sections spaced intermittently in the bottom of the tread grooves. When they appear "even" with the outside of the tread, it is time to replace your tires. Another method for checking tread depth is to place a penny in the tread with Lincoln's head upside down and facing you. If you can see the top of Lincoln's head, you are ready for new tires.

#### **1.5.7. TIRE BALANCE AND WHEEL ALIGNMENT**

To avoid vibration or shaking of the vehicle when a tire rotates, the tire must be properly balanced. This balance is achieved by positioning weights on the wheel to counterbalance heavy spots on the wheel-and-tire assembly. A wheel alignment adjusts the angles of the wheels so that they are positioned correctly relative to the vehicle's frame. This adjustment maximizes the life of your tires. These adjustments require special equipment and should be performed by a qualified technician.

#### **1.5.8. TIRE REPAIR**

The proper repair of a punctured tire requires a plug for the hole and a patch for the area inside the tire that surrounds the puncture hole. Punctures through the tread can be repaired if they are not too large, but punctures to the sidewall should not be repaired. Tires must be removed from the rim to be properly inspected before being plugged and patched.

#### **1.5.9. TIRE FUNDAMENTALS**

Federal law requires tire manufacturers to place standardized information on the sidewall of all tires. This information identifies and describes the fundamental characteristics of the tire and also provides a tire identification number for safety standard certification and in case of a recall.



### 1.5.9.1. Information on Passenger Vehicle Tires

Please refer to the diagram below.



#### **P**

The "P" indicates the tire is for passenger vehicles.

#### **Next number**

This three-digit number gives the width in millimeters of the tire from sidewall edge to sidewall edge. In general, the larger the number, the wider the tire.

#### **Next number**

This two-digit number, known as the aspect ratio, gives the tire's ratio of height to width. Numbers of 70 or lower indicate a short sidewall for improved steering response and better overall handling on dry pavement.

#### **R**

The "R" stands for radial. Radial ply construction of tires has been the industry standard for the past 20 years.

#### **Next number**

This two-digit number is the wheel or rim diameter in inches. If you change your wheel size, you will have to purchase new tires to match the new wheel diameter.

#### **Next number**

This two- or three-digit number is the tire's load index. It is a measurement of how much weight each tire can support. You may find this information in your owner's manual. If not, contact a local tire dealer. Note: You may not find this information on all tires because it is not required by law.

#### **M+S**

The "M+S" or "M/S" indicates that the tire has some mud and snow capability. Most radial tires have these markings; hence, they have some mud and snow capability.

#### **Speed Rating**

The speed rating denotes the speed at which a tire is designed to be driven for extended periods of time. The ratings range from 99 miles per hour (mph) to 186 mph. These ratings are listed below. Note: You may not find this information on all tires because it is not required by law.

## Tire Safety Information

Letter Rating	Speed Rating
Q	99 mph
R	106 mph
S	112 mph
T	118 mph
U	124 mph
H	130 mph
V	149 mph
W	168* mph
Y	186* mph

\* For tires with a maximum speed capability over 149 mph, tire manufacturers sometimes use the letters ZR. For those with a maximum speed capability over 186 mph, tire manufacturers always use the letters ZR.

### U.S. DOT Tire Identification Number

This begins with the letters "DOT" and indicates that the tire meets all federal standards. The next two numbers or letters are the plant code where it was manufactured, and the last four numbers represent the week and year the tire was built. For example, the numbers 3197 means the 31st week of 1997. The other numbers are marketing codes used at the manufacturer's discretion. This information is used to contact consumers if a tire defect requires a recall.

### Tire Ply Composition and Materials Used

The number of plies indicates the number of layers of rubber-coated fabric in the tire. In general, the greater the number of plies, the more weight a tire can support. Tire manufacturers also must indicate the materials in the tire, which include steel, nylon, polyester, and others.

### Maximum Load Rating

This number indicates the maximum load in kilograms and pounds that can be carried by the tire.

### Maximum Permissible Inflation Pressure

This number is the greatest amount of air pressure that should ever be put in the tire under normal driving conditions.

### 1.5.9.2. UTQGS Information

#### Treadwear Number

This number indicates the tire's wear rate. The higher the treadwear number is, the longer it should take for the tread to wear down. For example, a tire graded 400 should last twice as long as a tire graded 200.

#### Traction Letter

This letter indicates a tire's ability to stop on wet pavement. A higher graded tire should allow you to stop your car on wet roads in a shorter distance than a tire with a lower grade. Traction is graded from highest to lowest as "AA", "A", "B", and "C".

#### Temperature Letter

This letter indicates a tire's resistance to heat. The temperature grade is for a tire that is inflated properly and not overloaded. Excessive speed, underinflation or excessive loading, either separately or in combination, can cause heat build-up and possible tire failure. From highest to lowest, a tire's resistance to heat is graded as "A", "B", or "C".

### 1.5.9.3. Additional Information on Light Truck Tires

Please refer to the following diagram.

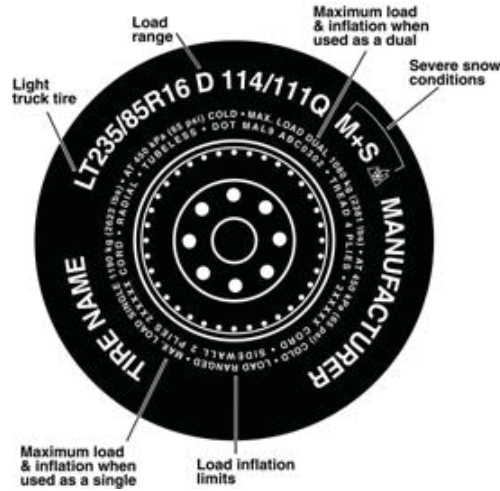

Tires for light trucks have other markings besides those found on the sidewalls of passenger tires.

#### **LT**

The "LT" indicates the tire is for light trucks or trailers.

#### **ST**

An "ST" is an indication the tire is for trailer use only.

#### **Max. Load Dual kg (lbs) at kPa (psi) Cold**

This information indicates the maximum load and tire pressure when the tire is used as a dual, that is, when four tires are put on each rear axle (a total of six or more tires on the vehicle).

#### **Max. Load Single kg (lbs) at kPa (psi) Cold**

This information indicates the maximum load and tire pressure when the tire is used as a single.

#### **Load Range**

This information identifies the tire's load-carrying capabilities and its inflation limits.

### 1.6. TIRE SAFETY TIPS

#### **Preventing Tire Damage**

- Slow down if you have to go over a pothole or other object in the road.
- Do not run over curbs or other foreign objects in the roadway, and try not to strike the curb when parking.

#### **Tire Safety Checklist**

- Check tire pressure regularly (at least once a month), including the spare.
- Inspect tires for uneven wear patterns on the tread, cracks, foreign objects, or other signs of wear or trauma.
- Remove bits of glass and foreign objects wedged in the tread.
- Make sure your tire valves have valve caps.
- Check tire pressure before going on a long trip.
- Do not overload your vehicle. Check the Tire Information and Loading Placard or User's Manual for the maximum recommended load for the vehicle.

# Addendum B - Unit Options

## Block Heater

The optional block heater keeps the engine block heated while the unit is stored or not in use.

The block heater should be used whenever the unit is stored or not in use in temperatures below 32° F (0° C).

1. Plug the cord of the block heater into the female end of a heavy-duty power cord (not supplied).
2. Plug the male end of the power cord into a standard 120V outlet.
3. Unplug the block heater before putting the unit into operation.

## Battery Charger

The optional battery charger keeps the battery charged while the unit is stored or not in use.

1. Plug the cord of the battery charger into the female end of a heavy-duty power cord (not supplied).
2. Plug the male end of the power cord into a standard 120V outlet.
3. The red light (A) on the battery charger module indicates the battery is charging. The green light (B) indicates full charge. (The battery charger can stay plugged in after the battery reaches full charge without damaging the battery.)
4. Unplug the battery charger before putting the unit into operation.

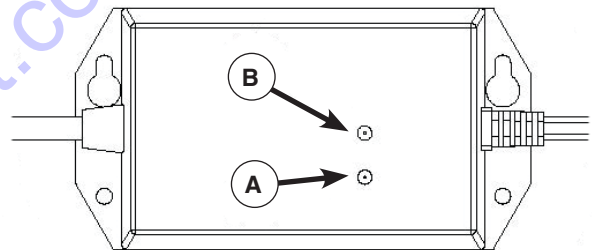

## Battery Disconnect

The optional battery disconnect allows convenient, tool-free disconnection of the battery while the unit is in storage or not in use, or to prevent unauthorized unit operation.

To disconnect the battery:

1. Turn the switch (C) to the Disconnect position (D).
2. A padlock (not supplied) can be used for added security.

To connect the battery:

1. Remove the padlock (if used).
2. Turn the switch to the Connect position (E).

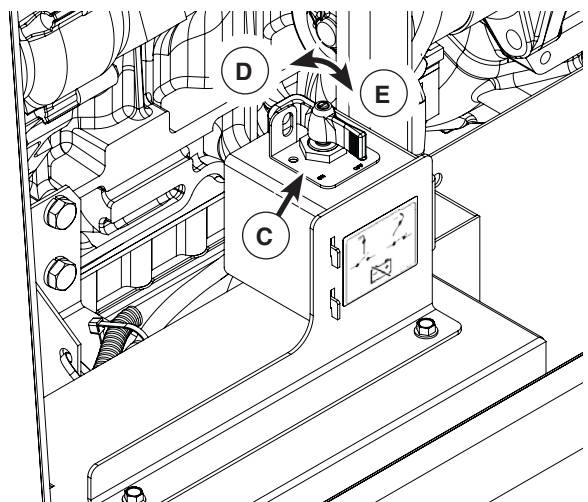

## Hose Reel

The optional hose reel allows convenient dispensing, retrieval and storage of air hose.

To operate:

1. Start the unit and allow unit operation to stabilize. See **Operation**.
2. Pull the reel locking pin (**A**).
3. Remove the hose end from the storage adapter (**B**).
4. Unreel the desired length of air hose (**C**) by using the reel crank (**D**), or by simply pulling hose manually from the reel.
5. Open the ball valve (**E**) as shown to supply air to the air hose.



### WARNING

Firmly hold the end of the air hose when opening the ball valve. High pressure air entering a loose air hose could result in death or serious injury.

6. When operation is complete, close the ball valve (**E**), fully retract the air hose (**C**) with the reel crank (**D**), return the hose end to the storage adapter (**B**), and lock the reel with the locking pin (**A**).

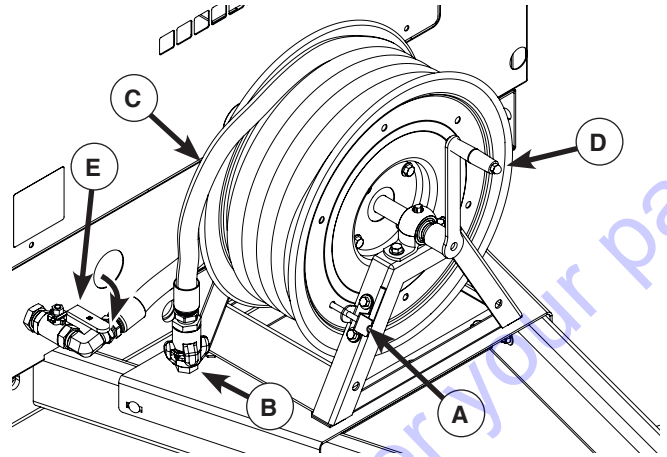

Go to Discount-Equipment.com to order your parts

# PARTS FINDER

**Search Website  
by Part Number**



**Search Manual  
Library For Parts  
Manual & Lookup Part  
Numbers – Purchase  
or Request Quote**

**Search Manuals**

Enter your information to help us find the right parts manual for your machine.

\* Brand:

\* Model:

\* Serial:

\* Part Number:

SEARCH

**Can't Find Part or  
Manual? Request Help  
by Manufacturer,  
Model & Description**

**Parts Order Form**

Please fill in the following information to help us find the right part for your machine.

Manufacturer:	<input type="text"/>
Model:	<input type="text"/>
Description:	<input type="text"/>
Part Number:	<input type="text"/>
Quantity:	<input type="text"/>
Notes:	<input type="text"/>

Discount-Equipment.com is your online resource for quality parts & equipment.

Florida: **561-964-4949** Outside Florida TOLL FREE: **877-690-3101**

**Need parts?**

Click on this link: <http://www.discount-equipment.com/category/5443-parts/> and choose one of the options to help get the right parts and equipment you are looking for. Please have the machine model and serial number available in order to help us get you the correct parts. If you don't find the part on the website or on one of the online manuals, please fill out the request form and one of our experienced staff members will get back to you with a quote for the right part that your machine needs.

We sell worldwide for the brands: Genie, Terex, JLG, MultiQuip, Mikasa, Essick, Whiteman, Mayco, Toro Stone, Diamond Products, Generac Magnum, Airman, Haulotte, Barreto, Power Blanket, Nifty Lift, Atlas Copco, Chicago Pneumatic, Allmand, Miller Curber, Skyjack, Lull, Skytrak, Tsurumi, Husquvarna Target, Stow, Wacker, Sakai, Mi-T-M, Sullair, Basic, Dynapac, MBW, Weber, Bartell, Bennar Newman, Haulotte, Ditch Runner, Menegotti, Morrison, Contec, Buddy, Crown, Edco, Wyco, Bomag, Laymor, EZ Trench, Bil-Jax, F.S. Curtis, Gehl Pavers, Heli, Honda, ICS/PowerGrit, IHI, Partner, Imer, Clipper, MMD, Koshin, Rice, CH&E, General Equipment, Amida, Coleman, NAC, Gradall, Square Shooter, Kent, Stanley, Tamco, Toku, Hatz, Kohler, Robin, Wisconsin, Northrock, Oztec, Toker TK, Rol-Air, APT, Wylie, Ingersoll Rand / Doosan, Innovatech, Con X, Ammann, Mecalac, Makinex, Smith Surface Prep, Small Line, Wanco, Yanmar