

# AIRMAN

---

# SG

---

## INSTRUCTION MANUAL

### ENGINE GENERATOR

## **SDG400S-8E1**

[ENVIRONMENTAL CONTAINMENT  
BASE TANK TYPE]



[www.discount-equipment.com](http://www.discount-equipment.com)

Please be sure to read this manual  
before using this machine.

**HOKUETSU INDUSTRIES CO., LTD.**

# PARTS FINDER

**Search Website  
by Part Number**



**Search Manual  
Library For Parts  
Manual & Lookup Part  
Numbers – Purchase  
or Request Quote**

**Can't Find Part or  
Manual? Request Help  
by Manufacturer,  
Model & Description**

Discount-Equipment.com is your online resource for quality parts & equipment.

Florida: **561-964-4949** Outside Florida TOLL FREE: **877-690-3101**

**Need parts?**

Click on this link: <http://www.discount-equipment.com/category/5443-parts/> and choose one of the options to help get the right parts and equipment you are looking for. Please have the machine model and serial number available in order to help us get you the correct parts. If you don't find the part on the website or on one of the online manuals, please fill out the request form and one of our experienced staff members will get back to you with a quote for the right part that your machine needs.

We sell worldwide for the brands: Genie, Terex, JLG, MultiQuip, Mikasa, Essick, Whiteman, Mayco, Toro Stone, Diamond Products, Generac Magnum, Airman, Haulotte, Barreto, Power Blanket, Nifty Lift, Atlas Copco, Chicago Pneumatic, Allmand, Miller Curber, Skyjack, Lull, Skytrak, Tsurumi, Husquvarna Target, Stow, Wacker, Sakai, Mi-T-M, Sullair, Basic, Dynapac, MBW, Weber, Bartell, Bennar Newman, Haulotte, Ditch Runner, Menegotti, Morrison, Contec, Buddy, Crown, Edco, Wyco, Bomag, Laymor, EZ Trench, Bil-Jax, F.S. Curtis, Gehl Pavers, Heli, Honda, ICS/PowerGrit, IHI, Partner, Imer, Clipper, MMD, Koshin, Rice, CH&E, General Equipment, Amida, Coleman, NAC, Gradall, Square Shooter, Kent, Stanley, Tamco, Toku, Hatz, Kohler, Robin, Wisconsin, Northrock, Oztec, Toker TK, Rol-Air, APT, Wylie, Ingersoll Rand / Doosan, Innovatech, Con X, Ammann, Mecalac, Makinex, Smith Surface Prep, Small Line, Wanco, Yanmar

# Preface

---

Thank you for choosing “AIRMAN”

- ◆ Keep this manual at hand and refer to it as necessary.
- ◆ If this manual is missing or damaged, order a new copy from our office or your nearest dealer.  
Make sure that the manual is included with the machine when it is handed over to another user.
- ◆ The contents of this manual may differ from the machine as a result of design changes. If anything is unclear or you want advisement, contact our office or your nearest dealer.
- ◆ Refer to the Engine Operation Manual for engine handling, maintenance, and safety information.

Go to [Discount-Equipment.com](http://Discount-Equipment.com) to order your parts

# Table of Contents

---



<b>1. Major Components</b>	<b>1-1</b>
1.1 Internal Components	1- 1
<b>2. Transportation and Installation</b>	<b>2-1</b>
2.1 Transporting Machine	2- 1
2.2 Conditions of Installation	2- 2
2.3 Grounding	2- 5
2.4 Selecting Cable	2- 8
2.5 Fuel Pipe Selector Valve	2- 9
<b>3. Operation</b>	<b>3-1</b>
3.1 Control Panel	3- 1
3.2 Connecting Loads	3- 3
3.3 Engine oil · Coolant · Fuel · DEF	3- 7
3.4 Before Starting the Unit	3-10
3.5 Operating Procedure	3-16
3.6 Emergency Stop	3-23
3.7 SCR Cleaning	3-24
3.8 SCR Inducement	3-25
3.9 How to activate Escape Mode	3-26
<b>4. Failure and Troubleshooting</b>	<b>4-1</b>
4.1 Protection device	4- 1
4.2 Troubleshooting	4- 3
<b>5. Periodic Inspection</b>	<b>5-1</b>
5.1 Important Items at Periodic Inspection and Maintenance	5- 1
5.2 Maintenance Schedule	5- 2
5.3 Periodic Replacement Parts	5- 3
5.4 Maintenance Items	5- 4
<b>6. Storage and Disposal</b>	<b>6-1</b>
6.1 Preparation for Long-term Storage	6- 1
6.2 Disposal of Product	6- 1
<b>7. Specifications</b>	<b>7-1</b>
7.1 Specifications	7- 1
7.2 Outline drawing	7- 2
7.3 Generator Wiring Diagram	7- 4
7.4 Engine Wiring Diagram	7- 5
7.5 Piping Diagram	7- 7

# Safety

This section explains safety precautions for operation, inspection, maintenance, installation, movement and transportation. Read these safety requirements carefully and fully understand the contents before starting the machine.

For better understanding of the precautions in this manual and on this machine, safety precautions are classified into “DANGER”, “WARNING” and “CAUTION” messages with a warning symbol  marked, according to the degree of hazard.

When one of these messages is found, please take preventive measures for safety and carry out “SAFE OPERATION AND PROPER MAINTENANCE OF THE MACHINE”.

 <b>DANGER</b>	DANGER indicates an imminently hazardous situation which, if not avoided, will result in death or serious injury.
 <b>WARNING</b>	WARNING indicates a potentially hazardous situation which, if not avoided, could result in death or serious injury.
 <b>CAUTION</b>	CAUTION indicates a potentially hazardous situation which, if not avoided, may result in minor or moderate injury. It may also be used to alert against unsafe practices.
<b>IMPORTANT</b>	IMPORTANT indicates important caution messages for the performance or durability of the machine, which has no concern to injury or accident of or to a human body.

This manual does not describe all safety items. We, therefore, advise you to pay special attention to all items (even though they may not be described in the manual) for your safety.

## PROPOSITION 65 WARNING

 <b>WARNING</b>
<p>Breathing engine exhaust exposes you to chemicals known to the State of California to cause cancer and birth defects or other reproductive harm.</p> <ul style="list-style-type: none"><li>● Always start and operate the engine in a well-ventilated area.</li><li>● If in an enclosed area, vent the exhaust system.</li><li>● Do not modify or tamper with the exhaust system.</li><li>● Do not idle the engine except as necessary</li></ul> <p>For more information, go to <a href="http://www.P65warnings.ca.gov/diesel">www.P65warnings.ca.gov/diesel</a></p>

# Safety

- ◆ If you have any questions about the machine, please contact our office or your nearest dealer.  
Be sure to have your machine's serial number to assist in providing the correct information for you.  
A plate stamped with the model and serial number is attached to side of the machine.

ENGINE GENERATOR	
MODEL	<input type="text"/>
SER. NO.	<input type="text"/>
GEN. OUTPUT	<input type="text"/> kVA
VOLTAGE	<input type="text"/> V
FREQUENCY	<input type="text"/> Hz
POWER FACTOR	80% PHASE 3
RULE	JEM 1398
NET DRY MASS	<input type="text"/> kg
OPERATING MASS	<input type="text"/> kg
HOKUETSU INDUSTRIES CO., LTD. MADE IN JAPAN	

A040491

※ Each illustrated figure (Fig.) has a number (for instance, A040491) at the right bottom. This number is not a part number, but it is used only for our reference number.

# Safety

## [Safety Warning Labels]

Following labels are attached to the machine.

Keep them clean at all times. If they are damaged or missing, immediately place an order with your nearest dealer for replacement. Part numbers are indicated on the lower right corner of the label.

Adhere a new one to the original location.

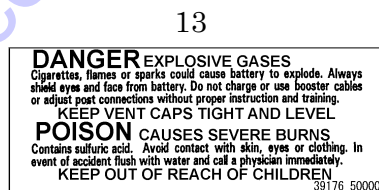
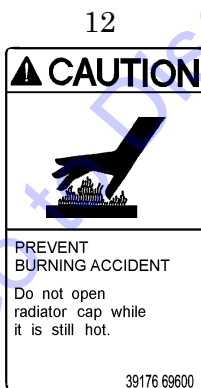
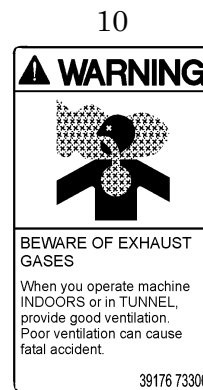
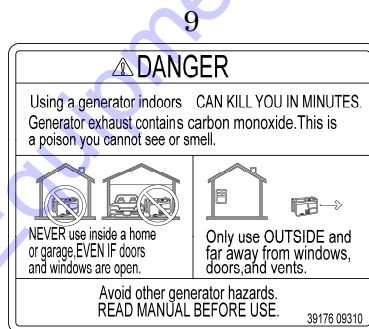
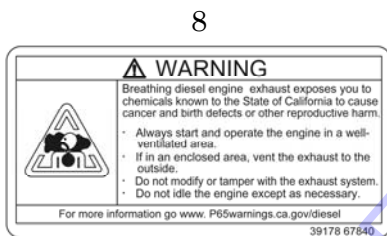
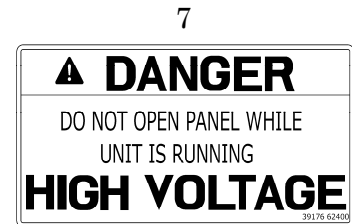
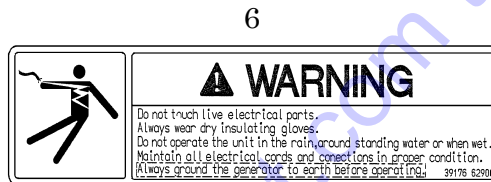
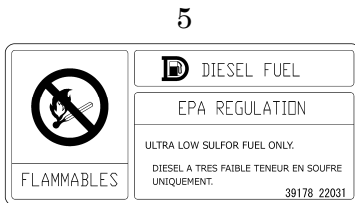
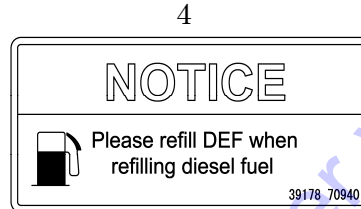
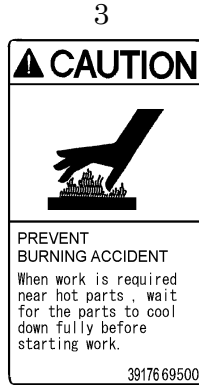

# Safety

- The locations of the safety warning labels are as follows.

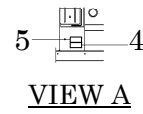
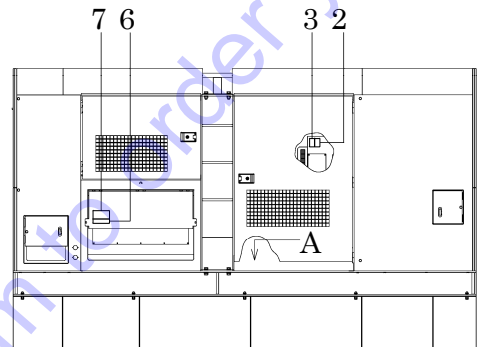
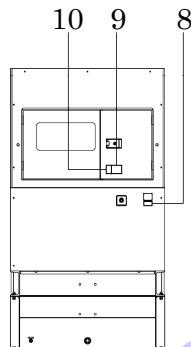
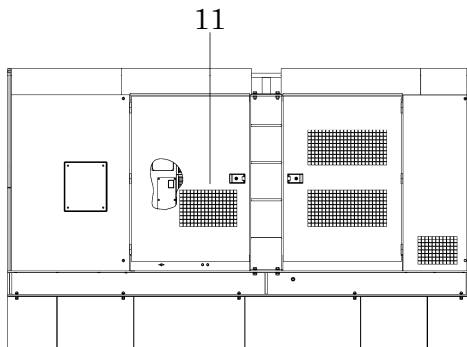
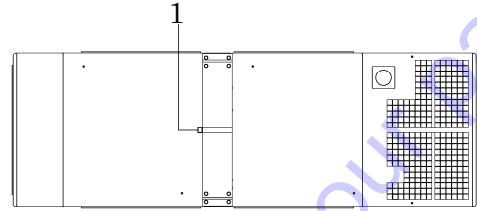
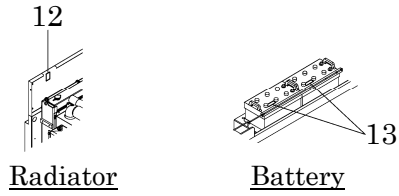

A190013



# Safety

## DANGER

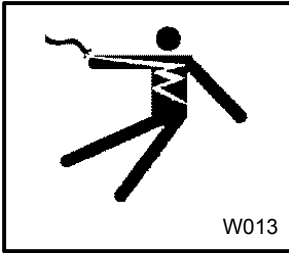

- Never touch the control panel during operation. Be aware that a voltage of several hundred volts is applied to the control panel.
- Be sure to stop the engine and turn control power switch OFF whenever the control panel has to be checked or operated. Disconnect the negative battery terminal during checking and maintenance.

## WARNING

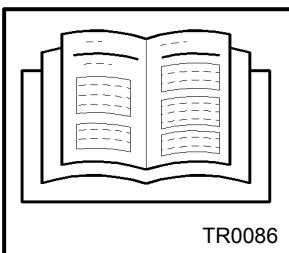

- Read each instruction plate which is displayed in the manual or on the machine carefully, understand its content and follow the indications thereof. Do not modify the machine without prior approval.
- The safety may be compromised, functions may be deteriorated, or machine life may be shortened.
- Never use the machine for the other purposes than power supply. Otherwise, serious accidents may occur.

## WARNING

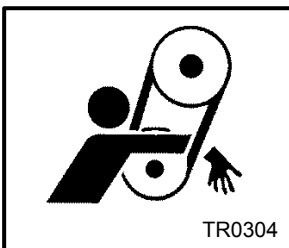

- Keep hands off from the rotating machinery or belts while running. It could cause serious injuries to hands.

## WARNING

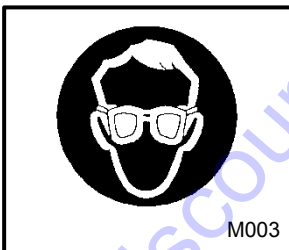

- When cleaning dust accumulated in devices such as filters, etc., with compressed air, wear safety glasses, etc. to protect your eyes

# Safety

## CAUTION

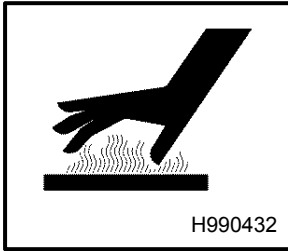

- Be sure to stop the engine and let the coolant water sufficiently cool down before draining it.
- If the drain valve is opened before the coolant water is cool enough, hot water could jet out, causing burns or scalding.

## CAUTION

- When washing the machine, cover the control panel, generator and its electric parts to prevent them from being exposed to splashing water and avoid possible decrease in electrical insulation or other troubles to the machine.
- Dust, sand and dirt accumulated inside control panel could cause malfunction or difficulties with the instruments. Clean them using compressed air.

## CAUTION

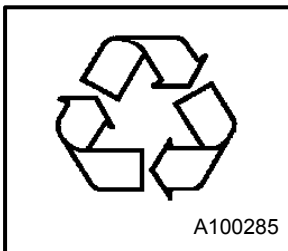

- Waste liquid from the machine contains harmful material. Do not discharge it onto the ground or into the river, lake or sea. Such material will pollute the environment.
- Be sure to use a container to hold waste liquid from the machine.
- Be sure to follow the designated regulations when disposing of oil, fuel, coolant (antifreeze), filter, battery or other harmful materials.

## CAUTION

- The engine of this machine contains many electrical and electronic parts. Before welding, be sure to disconnect all electronic control equipment.  
Failure to do so could result in equipment malfunction due to excessive current.

# 1. Major Components

## 1.1 Internal Components

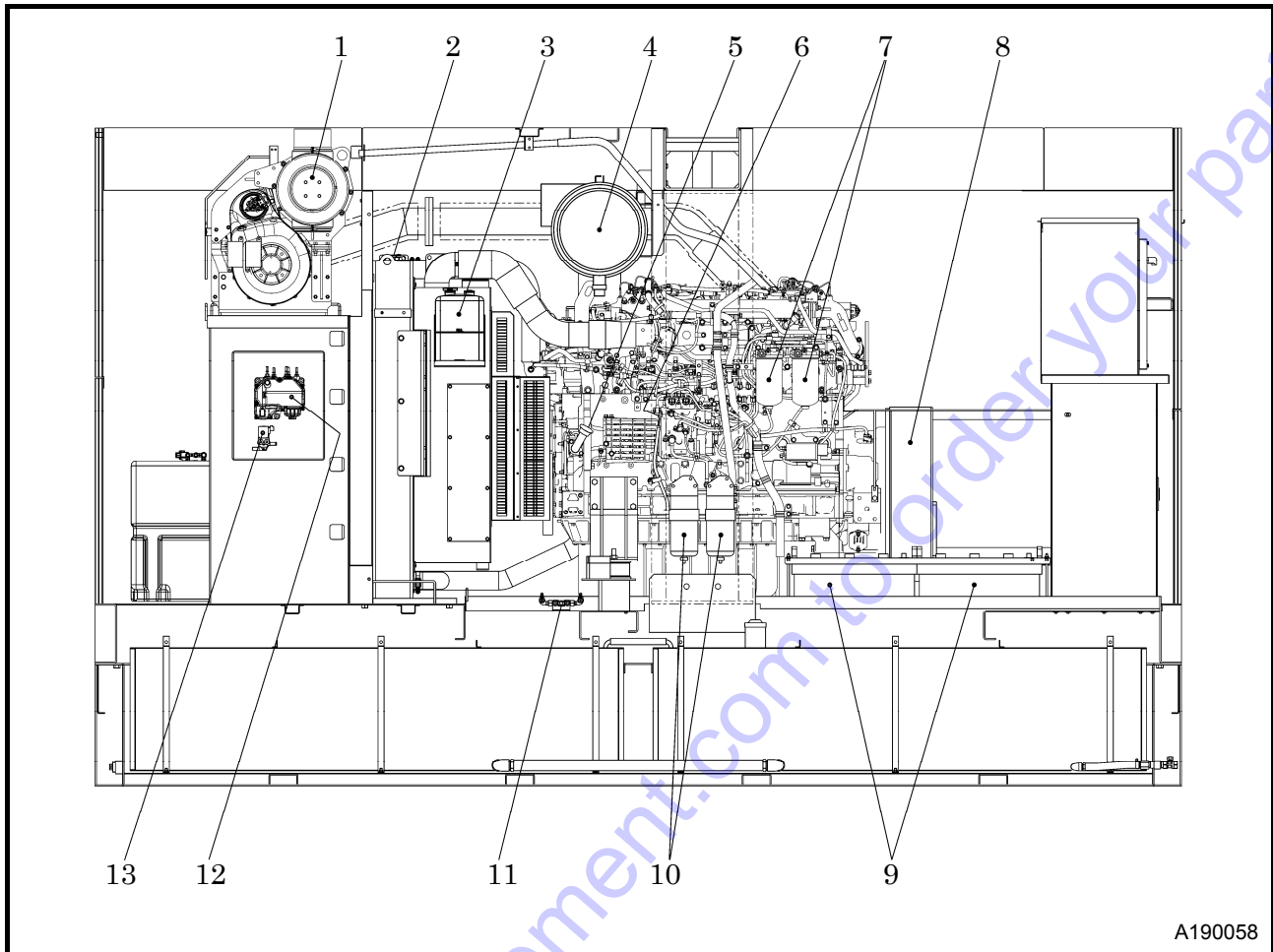

No.	Description	Function
1	SCR(Selective Catalytic Reduction)	Selective reduction-type catalyst that uses DEF as a reducing agent.
2	Radiator	Cooling the coolant for engine in the system.
3	Reserve Tank	Checking coolant level and supplying it.
4	Air Filter	Filtering dust from intake air.
5	Engine Oil Filler Port	Supplying and replenishing engine oil to engine.
6	Engine Oil Level Gauge	Checking the engine oil level and contamination
7	Fuel Filter	Filtering foreign matter and dust mixed in fuel.
8	Alternator	Generating AC power to be supplied.
9	Battery	Electrically starting engine.
10	Fuel Pre-Filter	Removing dust and water mixed in fuel.
11	Fuel Pipe Selector Valve	Switching to supply fuel from outer tank.
12	Supply Module	Pump unit for supplying DEF.
13	CCV(Coolant Control Valve)	Valve for coolant to warm up DEF piping at cold temperature.

# 1. Major Components

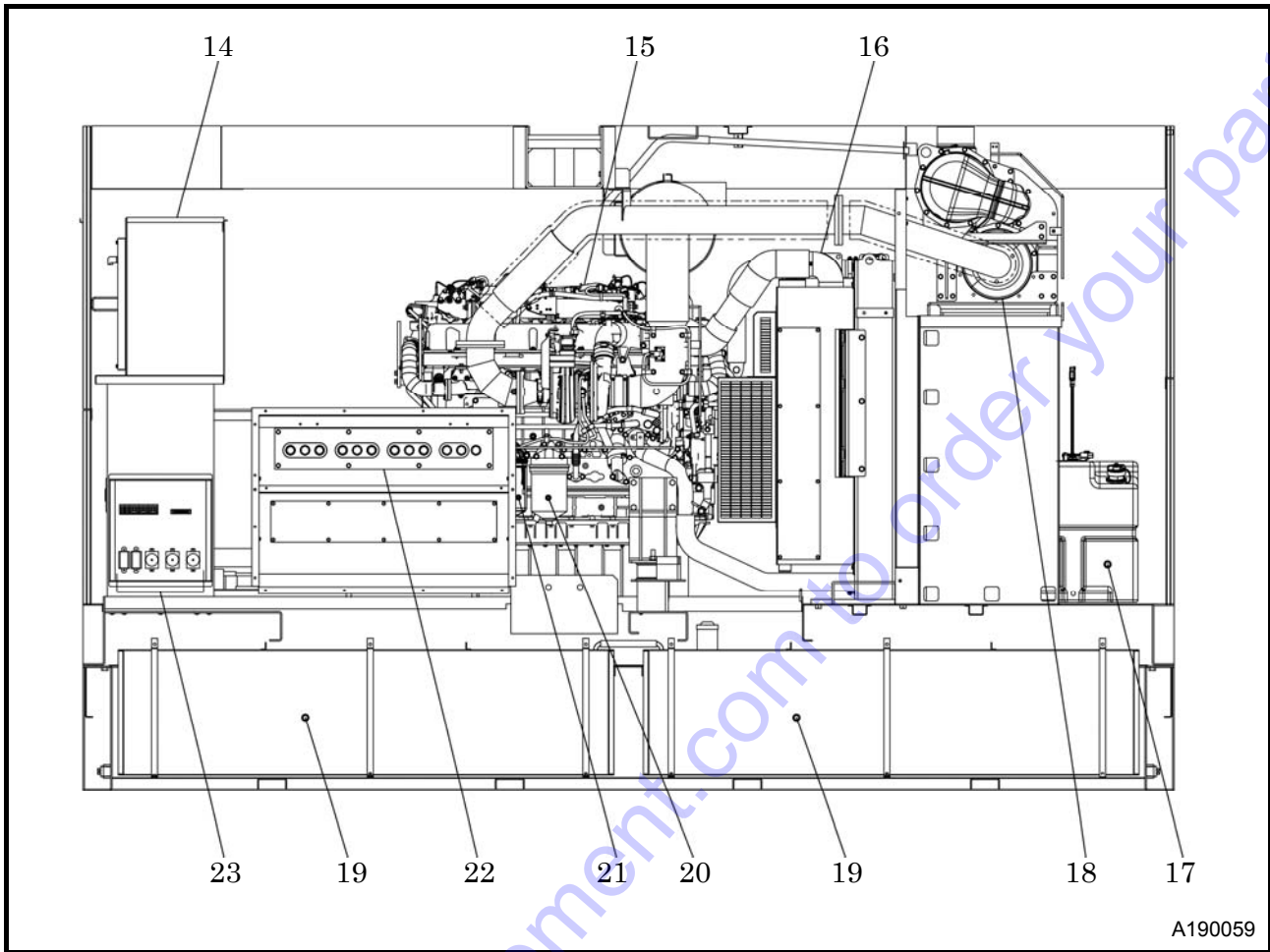

No.	Description	Function
14	Control Panel	Controlling device; various meters and controls.
15	Engine	Driving the generator.
16	Intercooler	Cooling the air compressed by engine supercharger.
17	DEF Tank	Container for DEF
18	DOC(Diesel Oxidation Catalyst)	Catalyst for oxidizing exhaust gas.
19	Fuel Tank	Storing fuel.
20	Engine Oil Filter (By-pass)	Filtering engine oil in the system.
21	Engine Oil Filter (Main)	
22	Output Terminal	Outlet port for AC power.
23	Receptacles	Receptacles for AC power.

## 2. Transportation and Installation

### 2.1 Transporting Machine

When loading and unloading machine, be sure to use the lifting bail provided on the center of the machine top.

#### 2.1.1 Lifting

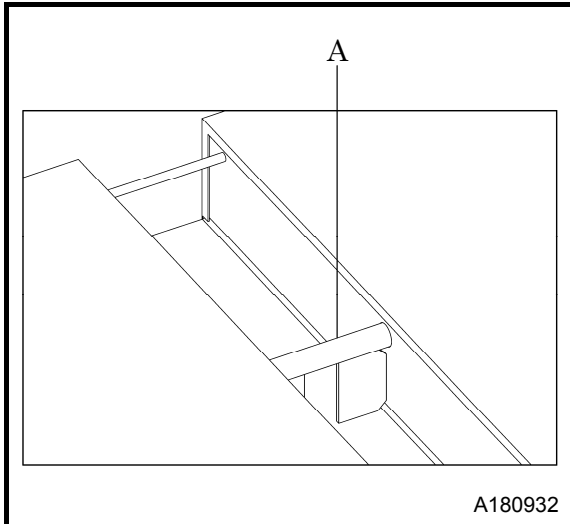

<Procedure>

1. Before lifting the unit up, make sure to check the lifting bail [A] for any cracks or loosened bolts.
  2. Connect the hook of the crane or shackle with lifting bail fitted at the top center of the unit, and make sure that there is no person standing around the unit. Then perform hoisting operation.
- Select an appropriate crane or truck by referring to the mass and dimensions mentioned in “Specifications”.
  - Only a qualified crane operator is allowed to operate a crane.



**WARNING**

#### ***Transportation***

- Never go underneath the unit when suspended because it is very dangerous.
- Do not lift the unit while it is running. Otherwise, a fatal or serious accident may occur.

# 2. Transportation and Installation

## 2.2 Conditions of Installation



The machine has to be installed on a dry, firm, and level area.

- The machine should be operated in the following conditions:
  - Ambient temp: -5°F to 104°F (-15°C to 40°C)
  - Humidity: Less than 85%
  - Altitude: Lower than 1,000m above sea level.
- ※ Using the machine outside the above conditions may cause serious failure.
- If more than two units are placed parallel in operation, keep enough distance so that exhaust air from the one does not affect the other one.
- Keep enough space around the unit for inspection and maintenance access.

### WARNING

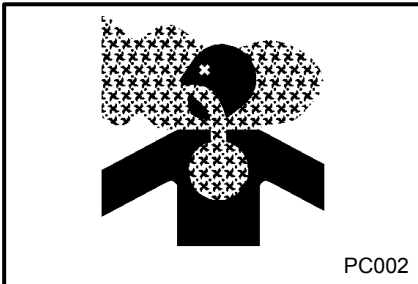

- Exhaust gas from the engine is poisonous, and it could cause casualties if inhaled. Avoid using the machine in an insufficiently ventilated building or a tunnel.
- Do not position the exhaust gas outlet in the direction of a person or a house.

### WARNING

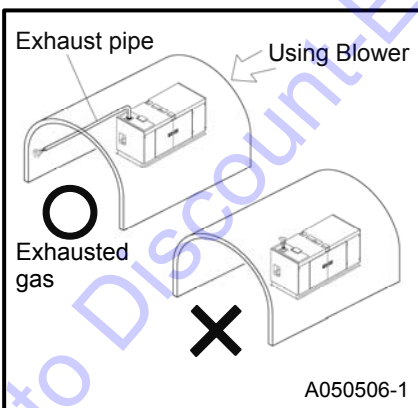

- In case that the unit is installed inside any tunnel, make sure to provide fresh air and ventilate it.
- In this case, make sure to extend the exhaust fume pipe outdoors, and also make sure to prevent any leak from any connection pipes.

## 2. Transportation and Installation

### WARNING

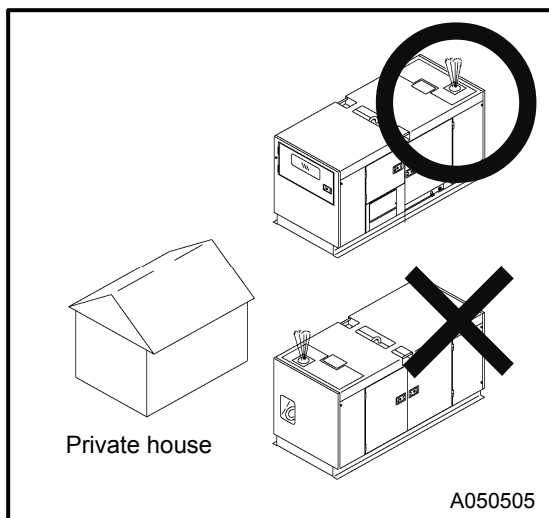

- Never locate the unit with the exhaust muffer facing any private house.
- As the exhaust gas from the engine is poisonous, never direct it to any other persons passing by.

### WARNING

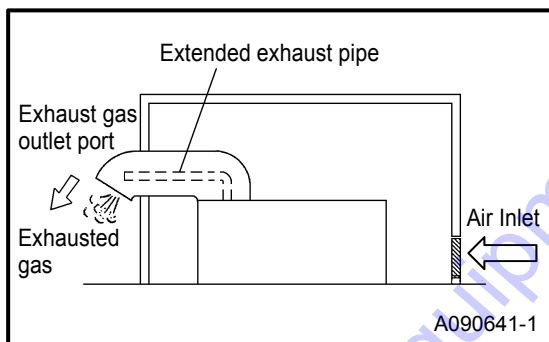

### ***In case that the machine is installed indoors***

- In case that the unit is installed indoors for operation, suction air port and exhaust fume outlet port should be provided for better air ventilation.
- Make sure to secure enough space in front of air suction port and to secure it after exhaust fume outlet port so that the engine will not get overheated.
- An exhaust pipe or the like should be provided at the exhaust outlet port so as to send exhaust fumes outdoors.
- The cooling air outlet port of radiator should have access to the outdoors through a duct or the like for air ventilation.

## 2. Transportation and Installation

### CAUTION

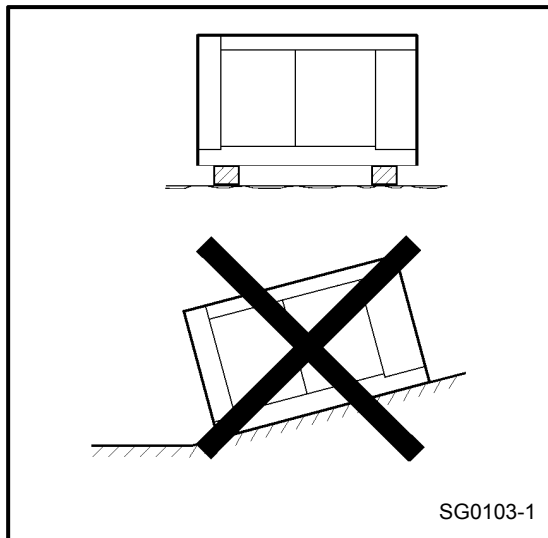

- The unit should be installed within 5 ° degree inclination.
- If installation site is not flat, put square bar under the unit so as to install it horizontally.
- Avoid installing the unit in a damp place or a place where water collects. Such an installation could cause electric shock.
- When installing the unit at the sea shore, make sure that it is not exposed directly to sea water because there is a risk of the change to the insulation resistance of the generator assembly or control panel inside. To request a model with measures against salt damage, please consult the nearest sales office.
- When installing the unit at a sandy place, make sure that exhaust from the generator or radiator does not blow the sand up in the air or into the machine.

### CAUTION

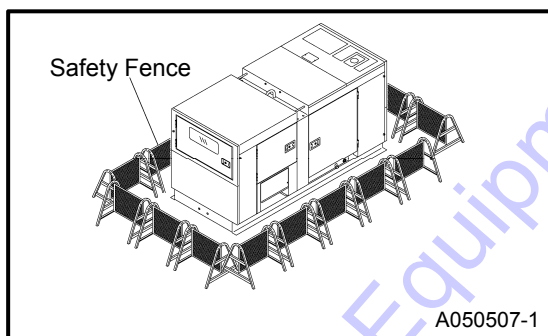

- In order to prevent from any persons other than those engaged in the job site from using or interacting with the machine, please prepare for safety fences around the unit.



## 2. Transportation and Installation

### 2.3 Grounding

#### 2.3.1 Ground Terminal

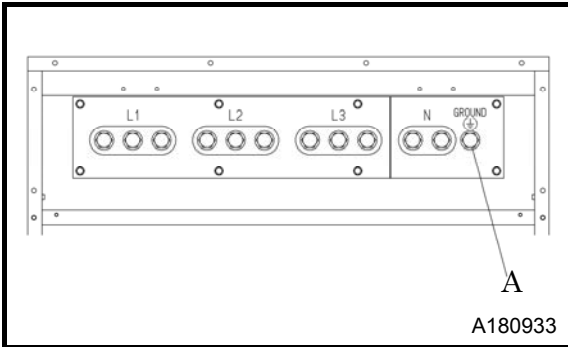

- The ground terminal [A] on the AC output terminal board is connected to the earth ground of this unit and to the earth terminal of each outlet.

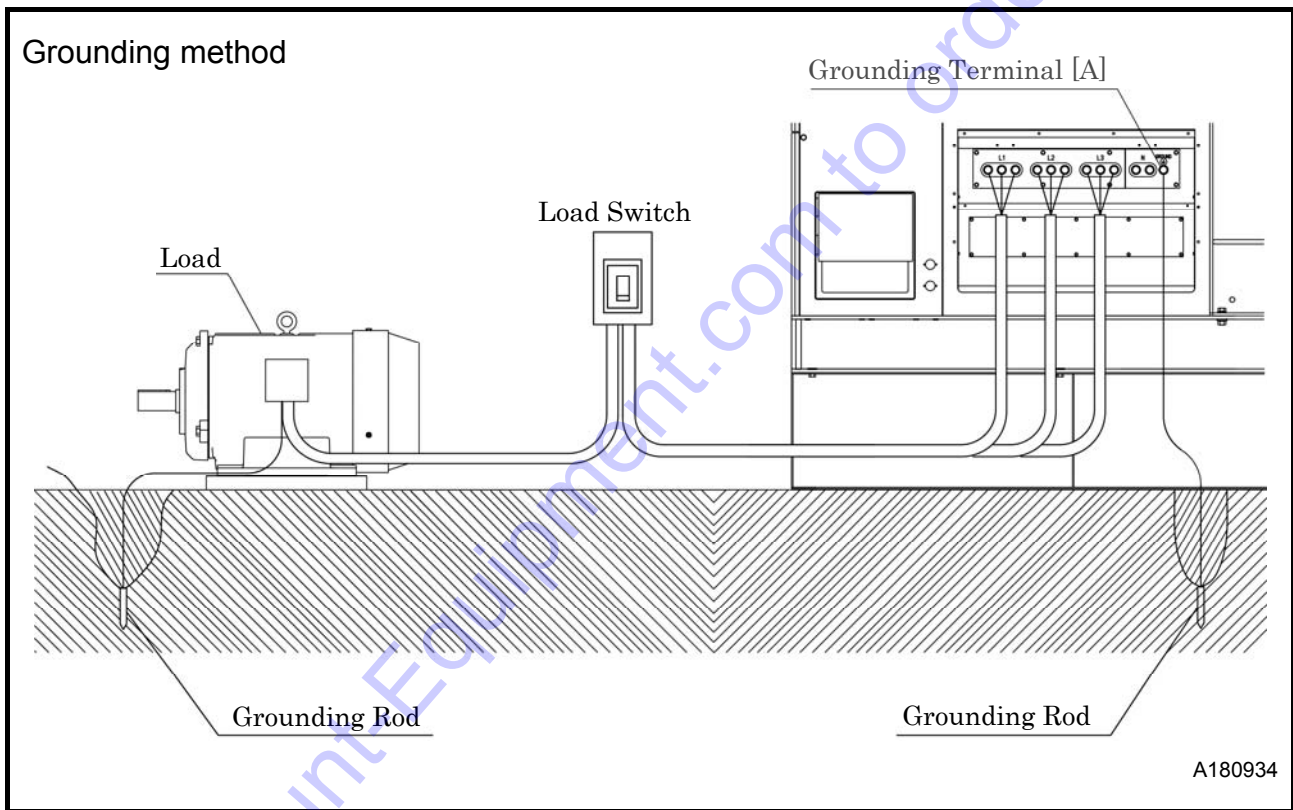

#### 2.3.2 Grounding System

AIRMAN's generators have a system ground that connects generator frame components to the ground terminals in the AC output receptacles. The AC neutral wire (N) is connected to the system ground.

## 2. Transportation and Installation

### 2.3.3 GFCI Receptacles

- All of the 20 ampere 120 volt receptacles on the generator are protected by a GFCI (Ground-fault circuit interrupter) for protection against the hazards of ground fault currents. An example of ground-fault current is the current which would flow through a person who is using an appliance with faulty insulation and, at the same time, is in contact with an electrical ground such as a plumbing fixture, wet floor, or earth.
- The ground-fault circuit interrupter will not protect against short circuits or overloads. The circuit breaker in the control panel which supplies power to the circuit provides that protection.
- The ground-fault circuit interrupter can be identified by the TEST and RESET buttons. The receptacles on the GFCI can be tested with the TEST and RESET buttons.

TEST BUTTON: To test, depress the "TEST" button. (Power is turned off)

RESET BUTTON: To restore power, depress the "RESET" button.

- Perform this test monthly or every 250 hours operation, whichever comes first, in order to ensure proper operation of the GFCI receptacle. If the generator is stored outdoors, unprotected from the weather, test the GFCI receptacle before each use. Record your test on the GFCI test card provided on the control panel.

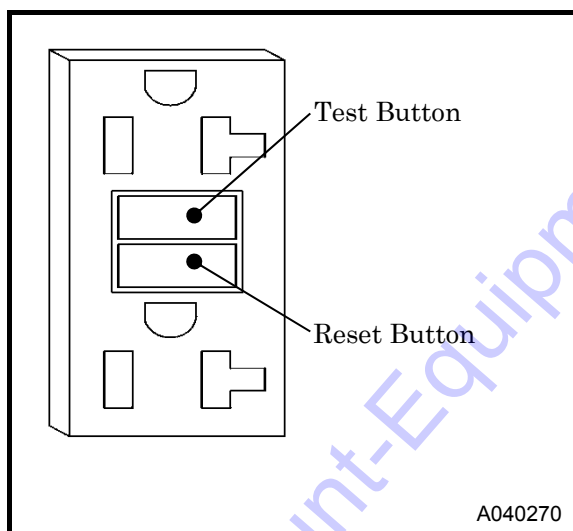

#### CAUTION

- Using the generator in rain, snow or near water can lead to death from electric shock. Keep the generator dry.

## 2. Transportation and Installation

---

### 2.3.4 Connections to a Building's Electrical System

Connections for standby power to a building's electrical system must be made by a qualified electrician. The connection must isolate the generator power from utility power and must comply with all applicable laws and electrical codes.

 **CAUTION**

- Improper connections to a building's electrical system can allow electrical current from the generator to backfeed into the utility lines. Such backfeed may electrocute utility company workers or others who are in contact with the lines during a power outage. Consult the utility company or a qualified electrician.
- Improper connections to a building's electrical system can allow electrical current from the utility company to backfeed into the generator. When utility power is restored, the generator may explode, burn, or cause a fire in the building's electrical system.

## 2. Transportation and Installation

### 2.4 Selecting Cable

- Select a cable with sufficient diameter by considering the permissible current on the cable and the distance from the generator to the load.
- If the current flowing to the load exceeds the permissible current of the cable, resultant overheating may burn the cable. Similarly, if the cable is too small in thickness to the length, the input voltage to the load will fall to cause the load input power to drop, as a result, the performance of the machine cannot be displayed.

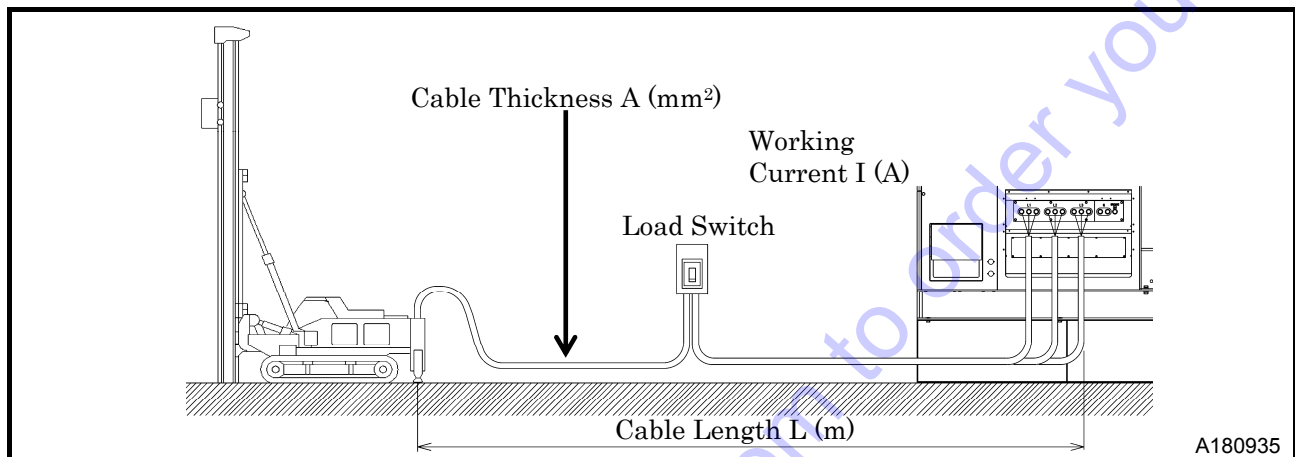

- Simplified formula to seek voltage drop or cross-sectional area of the cable from cable length and working current. Select such a cable length and thickness so that the voltage drop will remain within 5%.

Output System	Voltage Drop	Cross-sectional area of Cable	e: Voltage drop(V) e': Voltage drop between outside line or one line of each phase and neutral line.
3 Phase, 3 Wire	$e = \frac{30.8 \times L \times I}{1000 \times A}$	$A = \frac{30.8 \times L \times I}{1000 \times e}$	A: Cable thickness (mm <sup>2</sup> ) L: Cable length (m) I: Working current (A)
3 Phase, 4 Wire	$e' = \frac{17.8 \times L \times I}{1000 \times A}$	$A = \frac{17.8 \times L \times I}{1000 \times e'}$	

- The following tables show the relations between the cable length and the cable thickness (nominal cross-sectional area) suited to the working current.

(Based on the condition that working voltage is 200 V, with voltage drop of 10V.)

#### Single-Conductor Cable

(Unit: mm<sup>2</sup>)

Length \ Current	165ft (50m)	246ft (75m)	328ft (100m)	410ft (125m)	492ft (150m)	656ft (200m)
400A	125	125	150	200	200	250
600A	200	200	200	250	150×2	200×2
1,000A	125×2	125×2	150×2	200×2	250×2	200×3

#### Three-Conductor Cable

(Unit: mm<sup>2</sup>)

Length \ Current	165ft (50m)	246ft (75m)	328ft (100m)	410ft (125m)	492ft (150m)	656ft (200m)
400A	60×2	60×2	60×2	80×2	100×2	125×2
600A	100×2	100×2	100×2	125×2	150×2	200×2
1,000A	150×3	150×3	150×3	150×3	200×3	200×3

# 2. Transportation and Installation

## 2.5 Fuel Pipe Selector Valve

### 2.5.1 Overview

This valve is designed to feed fuel directly from an external fuel tank or from the installed fuel tank as described below.

### 2.5.2 Operation method

<Procedure>

1. Machine is delivered from factory with fuel line piping and selector valves built in as shown in the following Fig.1. When operating a machine, using installed fuel tank, run the machine with the fuel line piping and the handles of selector valves factory-arranged.
2. When using a separate storage tank, remove the plug fitted at the connections to the separator tank and make piping as shown in Fig.2. And then turn the handles of the selector valve as shown in Fig.2.
3. When removing the piping connection, make sure to return the handles to the original positions shown in Fig.1 and install the plugs.

### 2.5.3 Installation of Separate Storage Fuel tank and piping method

<Procedure>

1. Use oil resistant hoses with an inside diameter of 8mm to 10mm.
2. Install the fuel tank so that the fuel level of the tank is between 0 and 2.5m high from the machine installation level.
3. In order to avoid suction of water and sediment together, install the suction pipe so that the inlet port of suction pipe may be kept between 15mm and 20mm higher than the bottom line of the tank. Also install the outlet port of the return pipe inside the tank. (See Fig.2·A)
4. When refilling fuel in the tank, take great care to not allow water and sediment in.

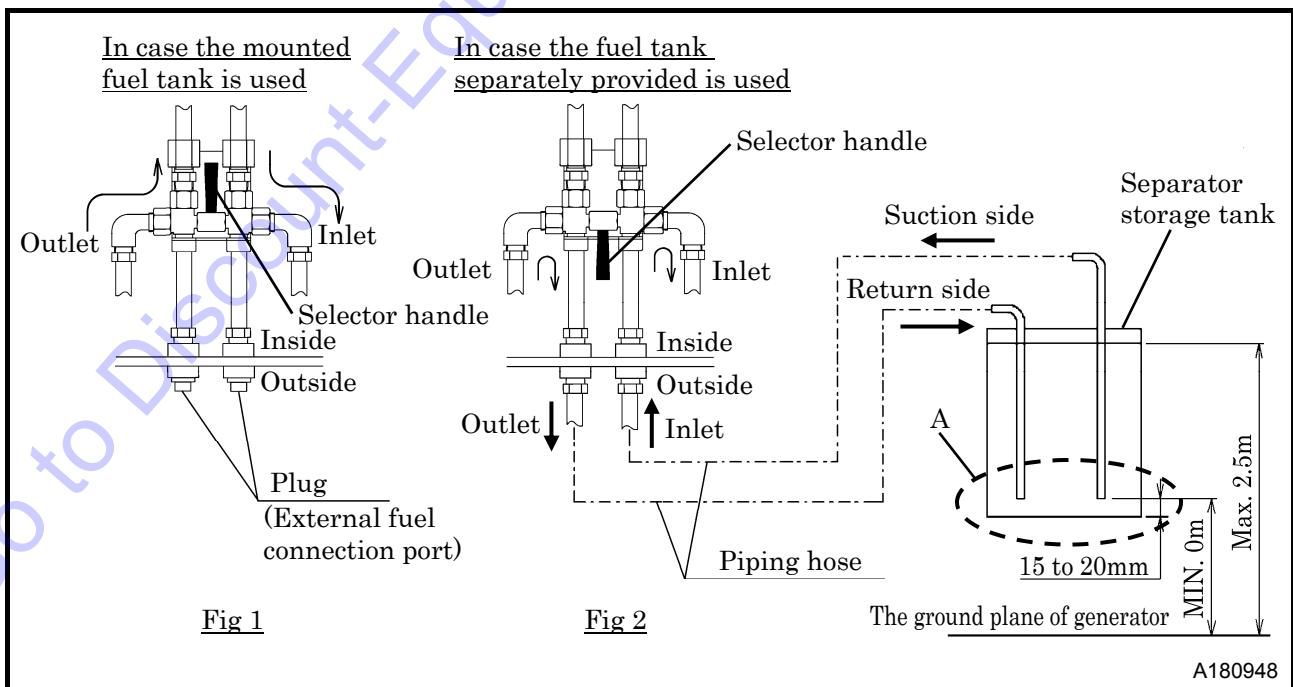

## 2. Transportation and Installation

---

 CAUTION

- Always keep watching the fuel feeding conditions while feeding fuel from the external fuel storage tank.
- When using an external fuel tank, take care to ensure that the DEF tank is also refilled as needed.
- Make sure to change the handles of the selector valves to the predetermined positions. If you make a mistake in turning the handles, it can burst the fuel pipe and cause overflowing. It could lead to a serious accident.
- Do not use excessive force to the selector valve handle. It could cause damage or fuel leakage.
- When using the external fuel tank, the Fuel Level displayed on the monitor will not provide an accurate measurement.

# 3. Operation

## 3.1 Control Panel

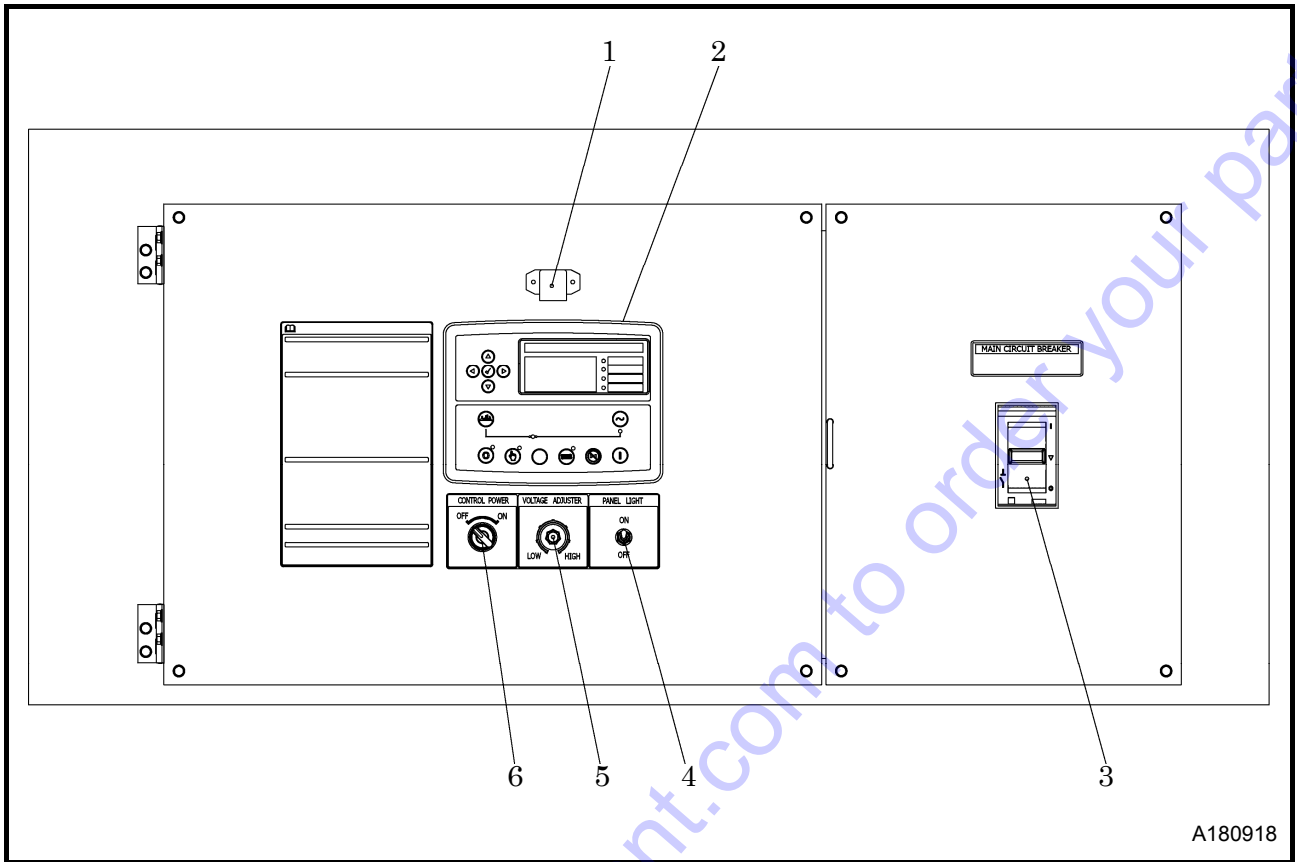

A180918

- 1. Panel Light
- 2. Control Panel
- 3. Circuit Breaker

- 4. Panel Light Switch
- 5. Voltage Adjuster
- 6. Control Power Switch

# 3. Operation

## Control Panel

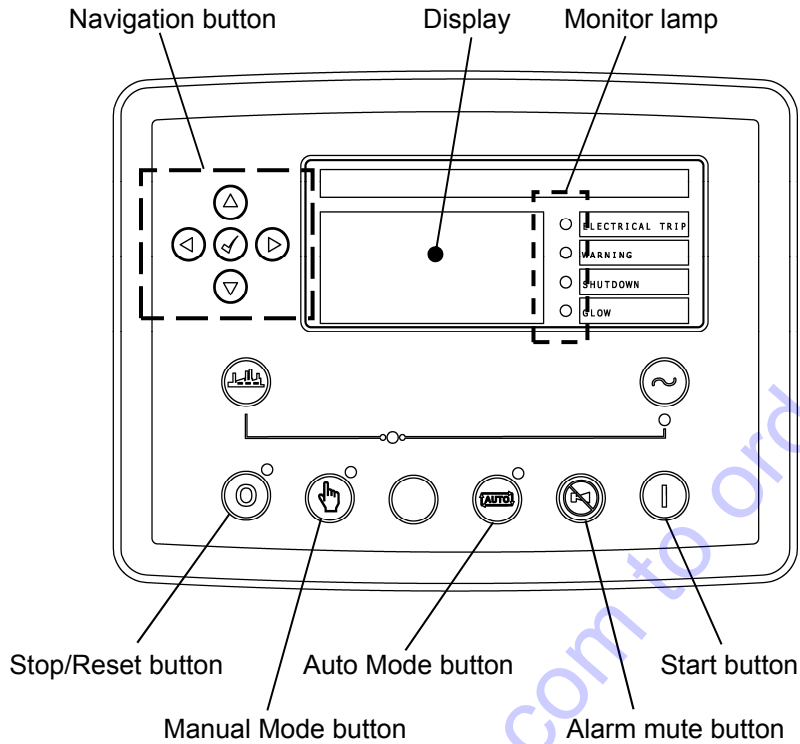

A180097E

[How to switch monitor]

1. Items shown below can be selected by pressing ◀ or ▶ button.

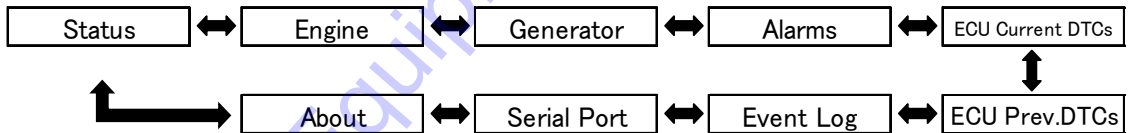

2. Parameters within an item can be viewed by pressing ▲ and ▼ button.

3. Monitor will return to main screen if no commands are entered for 3 minutes.

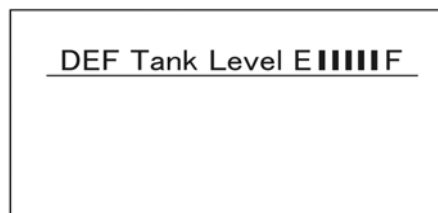

Main Screen



# 3. Operation

## 3.2 Connecting Loads

Select a cable with sufficient diameter by considering the load capacity and the distance from the generator to the load. Use terminals for connection and securely fasten them. **(See 2.4)**

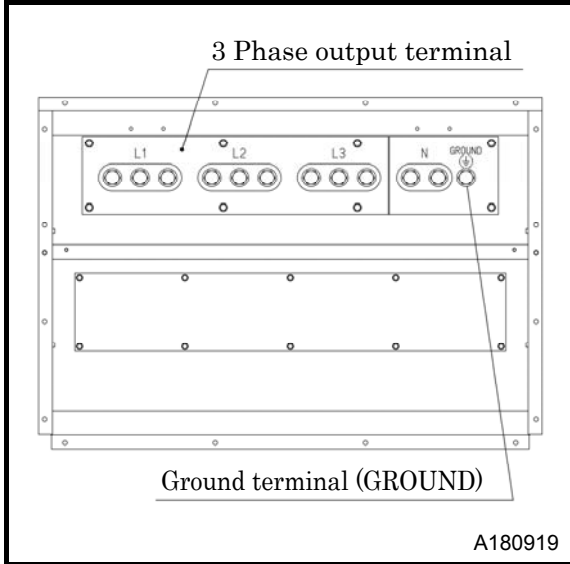

- After checking phase number and voltage of the load, make sure to connect them correctly.

---Terminal Size---

3 Phase output (L1,L2,L3,N)	M16
Ground terminal (GROUND)	M16

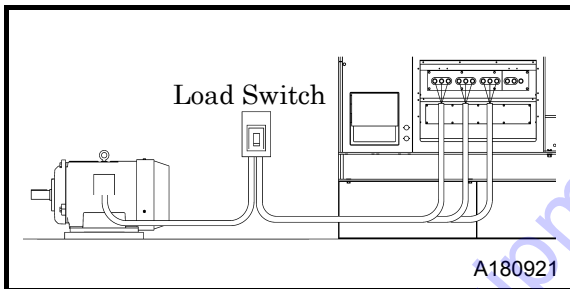

- Install a load switch between the output terminal and the load to switch on/off the load. Do not switch the load on/off directly by the circuit-breaker of the generator. It could cause damage to the circuit-breaker.
- Connect the connecting cable to the load so that the output terminals should not touch each other.

**⚠ WARNING**



W013

- When removing or connecting a connecting cable for changing load, be sure to switch OFF the circuit breaker, and then carry out a work. The operator must keep the key during operation.
- For a connecting cable to load, do not use a cable with damaged sheath nor an inappropriate insulation cable to the voltage. Secure connections between each cable terminal and input/output terminal. Otherwise, it may be slackened during operation and may cause a fire or an electric shock accident.

# 3. Operation

## 3.2.1 How To Switch Voltages

- Open the operation panel and connect the terminal bars as shown in the diagrams below to achieve desired voltage.
- For the 480/277V configuration, stack 2 bars for each connection.

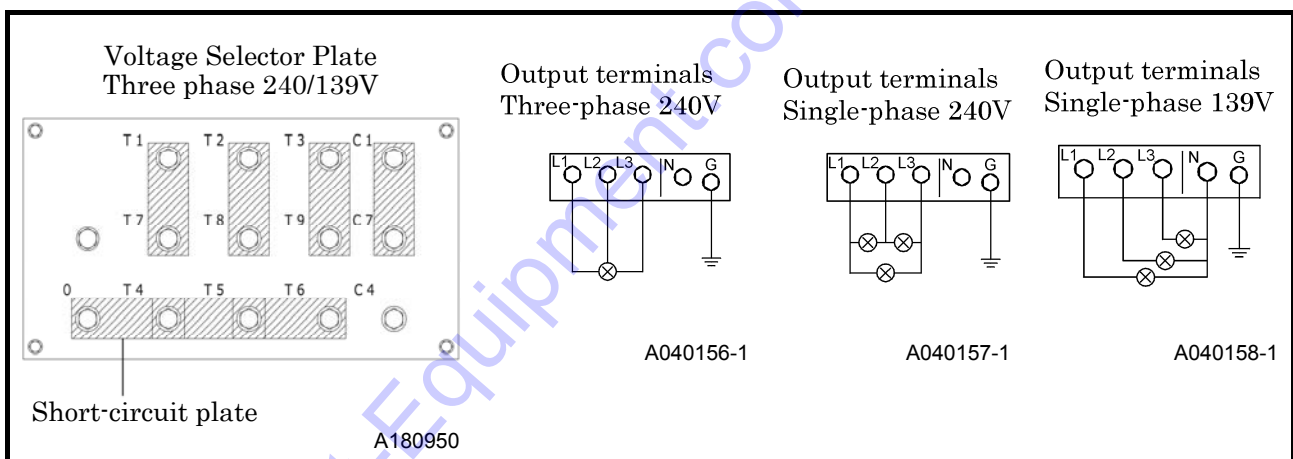
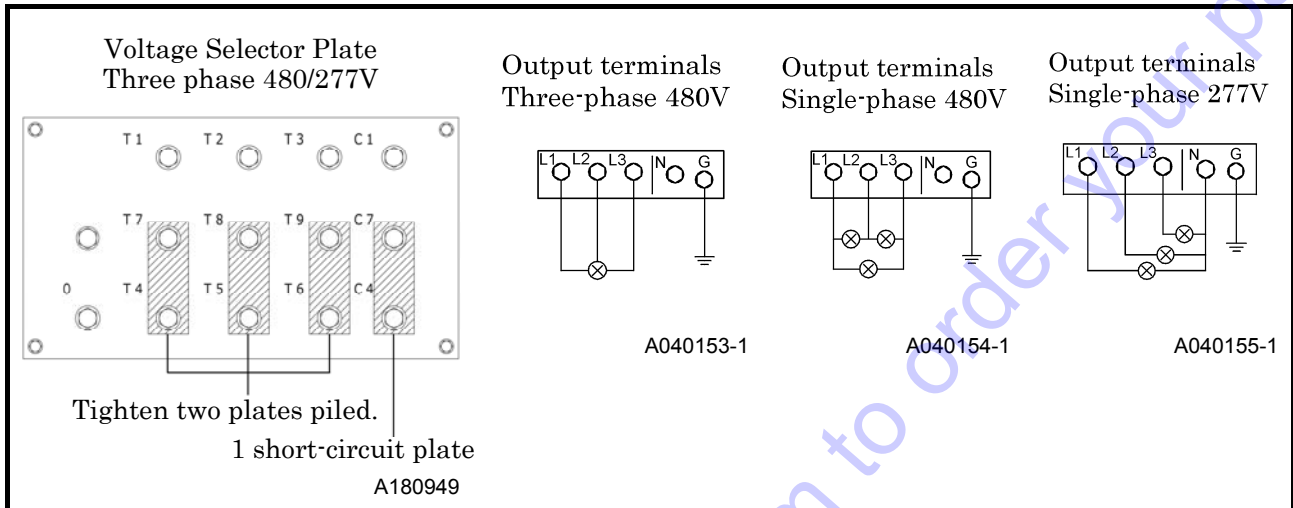

**⚠ WARNING**

- It is possible to select 3-phase 4 wire 240 volt or 3 phase 4 wire 480 volt.
- But before starting operation, make sure to confirm the voltage set for the machine without fail. If any load is connected to the machine with the wrong voltage set, it can cause damage or burning accident to the load.
- When switching the voltages, make sure to stop the machine.



# 3. Operation

## 3.2.3 The Maximum Combined Simultaneous Power Consumption

Refer to the table below for maximum load capacity of the GFCI receptacles at different voltages. (GFCI amperage values are per receptacle.)

[Allowable load capacity of GFCI at three phase]

Three Phase (240/480V)	GFCI Receptacle
kVA	A
400	0
396	5
392	10
388	15
383	20

 **CAUTION**

- When the main terminal, three-phase (240/480V) is used together with the GFCI outlet (single-phase 120V), the above allowable load capacity of the GFCI outlet must not be exceeded.

# 3. Operation

## 3.3 Engine Oil • Coolant • Fuel • DEF

### 3.3.1 Engine Oil

Use engine oil recommended below. Be sure to use CJ-4 class or higher engine oil or superior class.  
(Using engine oil with poor quality may shorten the life of the engine).

Classification	API service classification CJ-4 class or higher
Viscosity	SAE10W-40 (as ex-factory)

#### IMPORTANT

- Viscosity of engine oil greatly affects starting, performance, and oil consumption of the engine, as well as wear of the moving parts. Choose appropriate oil based upon the table below according to the outside air temperature.

**Ambient temperature range and oil viscosity (SAE)**

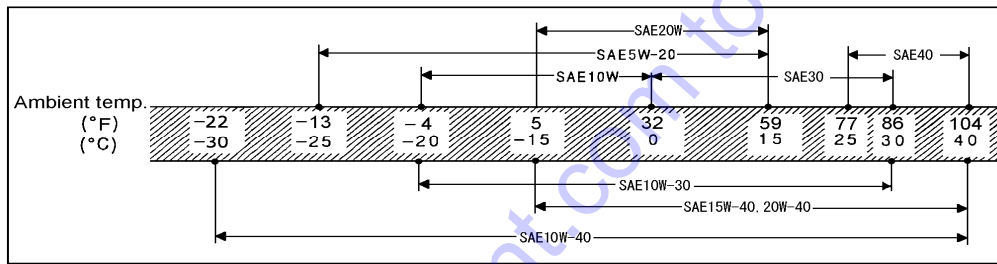

A180818E

- Do not mix oils. If two or more different brands of oil are mixed, its performance can be deteriorated.
- When the machine is operating under a light low (20% or less) for a prolonged period of time, check the viscosity of the engine oil and other fluids, and replace oil early using about half of the regular replacement time as a guide.
- Unit is delivered ex. factory, filled with engine oil recommended by engine manufacturer
- Dispose of oil in accordance with local laws and regulations.

# 3. Operation

## 3.3.2 Coolant

Coolant freezing could cause cracks of cylinder and radiator. Be sure to always use mixture of LLC (antifreeze) and soft water (like tap water) of good quality.

### IMPORTANT

- When water with dirt, sand, or dust, or hard water such as well water (ground water) is used, deposits can form inside the radiator or on the cylinder head and resulting in engine overheat from poor coolant flow.
- Adjust mixing ratio of coolant according to the temperature. (55% volume coolant is filled when the unit is shipped from factory.) Use coolant within the range of its mixing ratio between 60%. (If LLC (antifreeze) exceeds more than 60%, it may decrease its antifreezing effect.)

Mixing ratio of LLC (antifreeze) (reference)

Outside temperature (°F)	5	-4	-13	-22	-31	-40	-49
Outside temperature (°C)	-15	-20	-25	-30	-35	-40	-45
Mixing ratio (%)	30	35	40	45	50	55	60

- Dispose of LLC (Antifreeze) in accordance with local laws and regulations.

## 3.3.3 Fuel

### IMPORTANT

- Never use fuel with sulfur content greater than 0.0015% (15 ppm).
- Use only ultra-low sulfur fuel.
- Use such diesel fuel which conforms to either standard EN590 or ASTM D975.
- Dispose of fuel in accordance with local laws and regulations.

### CAUTION

- Diesel fuel is required to meet the following conditions.
  - Free from even minute dust particles
  - High optimum viscosity
  - High cetane number (more than 45)
  - High fluidity even at low temperature
  - Low carbon residue content

# 3. Operation

---

## 3.3.4 DEF

DEF (AdBlue or equivalent) is a transparent, colorless, and non-hazardous. In some circumstances, DEF will put off odor, but this is normal and not indicative of any problems.

### IMPORTANT

- Only use DEF which conforms to API standards.
- Store DEF in a sealed container away from direct sunlight to prevent water evaporation.
- The use period of DEF changes depending on the temperature. Refer to the engine instruction manual for more information.
- If a substantial quantity of DEF is not within specification, contact the DEF supplier for assistance with disposal.

### CAUTION

- DEF is harmless to the human body even if touched, However, it may cause inflammation in rare circumstances depending on its constitution. In such cases, take the following actions.
  - Avoid prolonged contact with skin. In case of accidental contact, wash skin immediately with soap and water.
  - Do not ingest DEF. In the event DEF is ingested, contact a physician immediately.
  - Avoid contact with eyes. In case of contact, immediately flush eyes with large amounts of water for a minimum of 15 minutes.
- Reference the Materials Safety Data Sheet (MSDS) for additional information.

# 3. Operation

## 3.4 Before Starting the Unit

Be sure to check the unit before operation. When any abnormality is found, be sure to repair it before starting. Be sure to make daily check before operation. If the unit is operated without prior check and without noticing its abnormality, such operation could cause seizure of components or may even cause fire.

### 3.4.1 Check Engine Oil Level

The unit should be level before the checking oil level. When you check oil level after you have started operation, wait more than 10 minutes after stopping the engine before checking the oil level.

<Procedures>

1. Pull out the engine oil level gauge and wipe it with a clean cloth.
2. Re-insert the engine oil level gauge fully and pull it out again. If the gauge shows the oil level between LOW and FULL limits, it is normal.
3. When the oil level is below its LOW, add engine oil from engine oil filler port [A].
  - If the oil is found to be dirty or contaminated, change the oil. (See 5.4.1)
  - To prevent engine output reduction when oil level is too high, do not put more oil in than FULL.

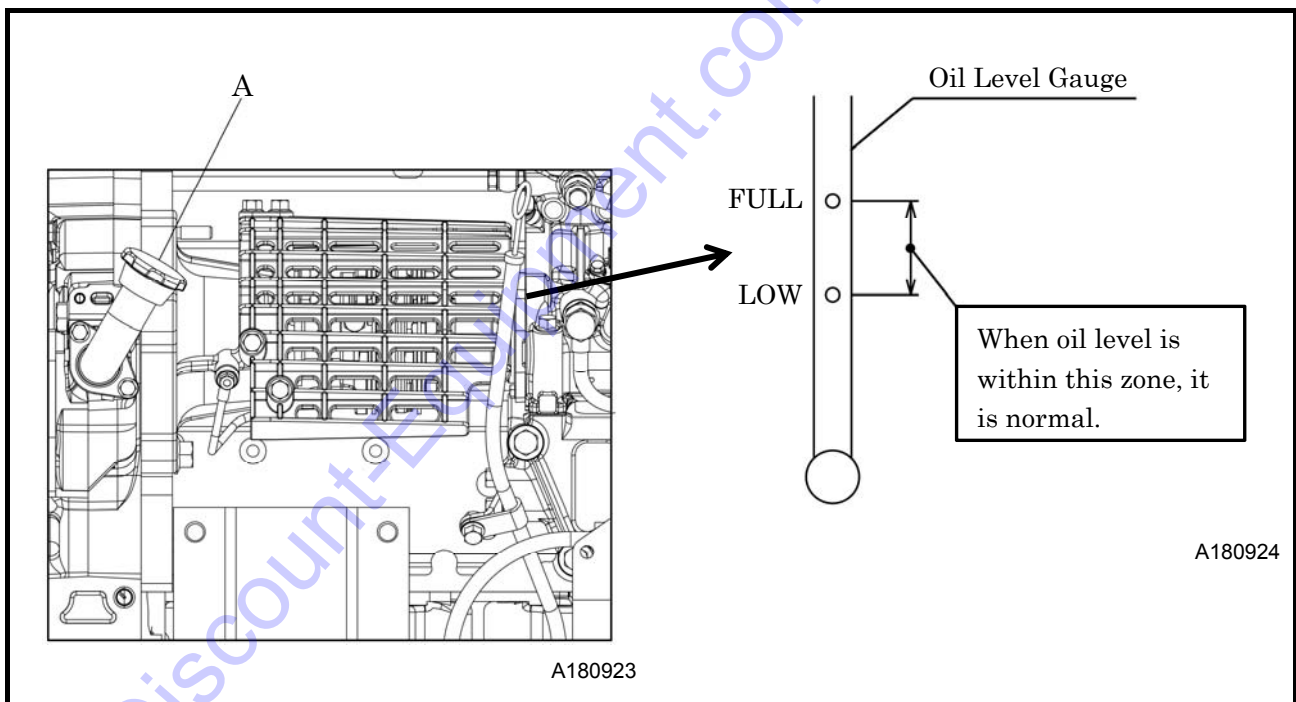



## 3. Operation

### 3.4.2 Check Coolant Level

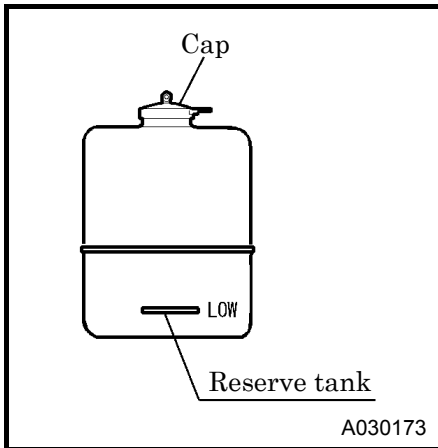

- Check the coolant level in the surge tank. If it is lower than the limit, open the cap and refill the coolant. (Level must be kept above LOW.)
- If the coolant in the surge tank is exceedingly low or empty, remove the radiator cap and check the amount of coolant in the radiator. Refill coolant within the radiator and surge tank. (See 5.4.22)

#### CAUTION

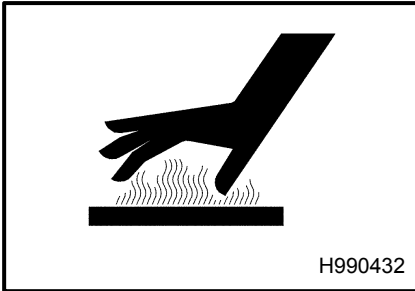

- When removing the radiator cap, lightly turn it and release the internal pressure without completely opening it once the first stage lock is released. After confirming that the internal pressure has been released, turn it off while pushing in until the second stage lock is released. If this procedure is neglected, its inner pressure can blow off the radiator cap, and steam jetting out of the radiator could cause scalding.

#### IMPORTANT

- Do not operate the machine without sufficient coolant. Insufficient coolant can cause air bubbles to form and damage the radiator.

# 3. Operation

## 3.4.3 Check Fuel

Before starting operation, make sure to check the level of residual fuel so that fuel shortage during operation can be avoided. If necessary, drain condensate accumulated at the bottom of the fuel tank.

- Refilling fuel tank should be done in an outdoor well-ventilated place.
- **Do not fill fuel up to the filler level.**

**When fuel tank is filled up to the filler level, the expansion volume of the tank is too small and could lead to problems with fuel flow and containment. Furthermore, fuel may spill from the fuel tank due to vibration caused during movement or transportation of the unit.**

※ When using an external fuel tank, note that the Fuel Level indication on the monitor will not reflect the actual fuel level.

**CAUTION**



D004

- Do not, under any circumstance, bring lit cigarettes and/or matches to the fuel.
- The fuel is extremely flammable and dangerous. Be careful of fire because the fuel is very likely to catch fire.
- Refuel only after stopping the engine, and never leave open fuel can near the machine. Do not spill. It could cause a fire. When it is spilt, wipe it up completely.
- Never use alcohol-base cleaning fluid. If it sticks to such parts made of plastic, it causes degradation of liquid surface visibility, and, in the worst case, can lead to cracking and result in fuel leaks.

## 3.4.4 Check Fuel Pre-Filter Drain

If the red float [B] inside the fuel pre-filter is above line [A], drain water from the fuel pre-filter.

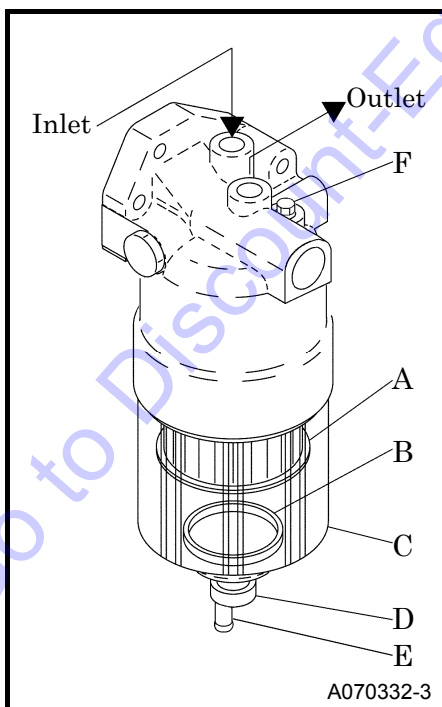

<Procedure>

1. Connect a hose to drain outlet [E] when drain.
  2. Prepare a container. Loosen drain plug [D] and air bleeding plug [F] to drain.
  3. After draining finished, be sure to tighten [D] and [F].
- Do not remove pre-filter case [C] as fuel is overflow if it is removed. If it is necessary to remove it, plug inlet hose with a clip etc.
  - Drain the condensate into a container, and then dispose of condensate according to the designated regulations.

# 3. Operation

## 3.4.5 Check DEF Level

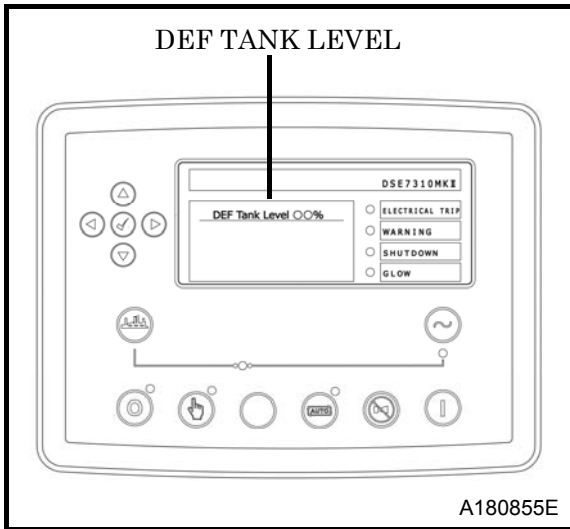

- If DEF tank level is below 10%, warning lamps will illuminate and symbols will be displayed as shown below.
- If DEF tank level is at 0% and the engine is operated with no DEF, the engine will shut down.
- Do not forget to refill DEF when using external fuel supply.

※ **When refilling diesel fuel, refill DEF as well.**

DEF Tank level display

State Description	DEF Level	Over 10%	Below 10%	Below 5%	0% (Shutdown)
Monitor Screen Display	Icon (DEF Level)	-	(On)	(Slow Blinking)	(Rapid Blinking)
	Icon (Inducement)	-	(On)	(Slow Blinking)	(Rapid Blinking)
	Pop-up	-	REFILL DEF	REFILL DEF	REFILL DEF NO POWER
Monitor Lamp	Warning	-	ON	ON	ON

## 3.4.6 Check Interior

Periodically check the inside of the generator for dust and flammables

### CAUTION

- Please wear personal protective equipment, such as a helmet, safety glasses, earplugs, safety shoes, gloves, and a mask as appropriate to the work environment.
- Periodically check the inside of the generator for dust and flammables. When any flammables such as chips of wood, dead leaves (dry leaves) and waste paper are left near heated exhaust muffler and heated exhaust pipe, all of them should be removed.
- Keep a fire extinguisher available by the machine in case of unexpected fire.
- It is advisable to have a list of phone numbers of doctors, ambulance and the fire department available in case of emergency.

# 3. Operation

## 3.4.7 Clean Instruments In Control Panel

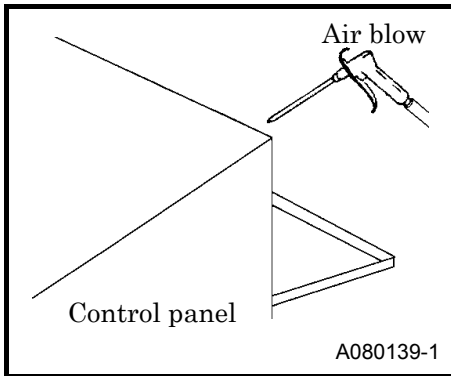

- Before starting operation, open control panel and check each breaker, terminal plate and each controller for any dust, sand and dirt accumulated.
- If the machine is operated with dust, sand, or dirt in the instrumentation, it could cause malfunction or damage. When necessary, clean the inside of the panel with compressed air. Wear protective eyewear when cleaning.

## 3.4.8 Check Belt Tension

Adjust the alternator [A] belt by the following procedure:

Unfasten the mounting bolts and nuts of the alternator to adjust the alternator belt.

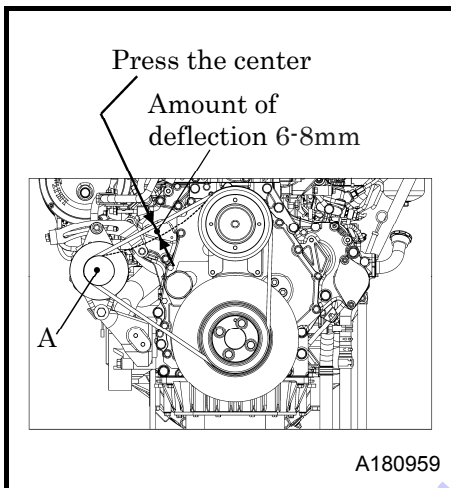

<Procedure>

1. Visually check there are no cracks or wear or other damage to the belt.
  2. Belt tension is adjusted by loosening the alternator mounting bolts and nuts. While pressing the center of the belt slightly, adjust belt tension by loosening fitting bolt so the amount of deflection is between 6 and 8 mm (98 N).
  3. If there is any oil or coolant on the belt, wipe it off completely during service.
- Refer to engine instruction manual for more details for belt adjustment.

**WARNING**

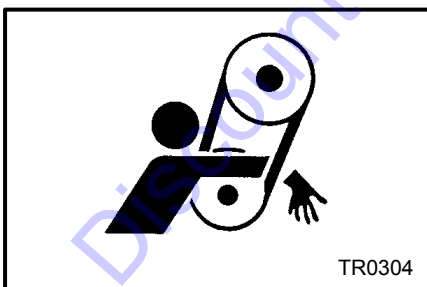

- Be sure to stop the engine whenever the tension of the belt is to be adjusted.
- Remove the negative (-) side cable from the battery.
- If the machine is running, it might catch the operator's hand into the belts, and this could cause a serious injury.
- Be sure to stop the engine whenever inspections and maintenance near the cooling fan.
- If the machine is running, it might catch the operator's hand into the fan, and this could cause a serious injury.

**IMPORTANT**

- Over-tensioning of the belt leads to shaft breakage and reduced bearing life. If it is too loose, belt slippage may lead to premature breakage of the belt or damage to the machine due to overheating.

# 3. Operation

## 3.4.9 Check Thermo Label of Alternator

Thermo-label on the stator irreversibly changes its color from white to brown by reaching or exceeding 212°F (100°C), that signalize overload during operation. Do not overload the generator.

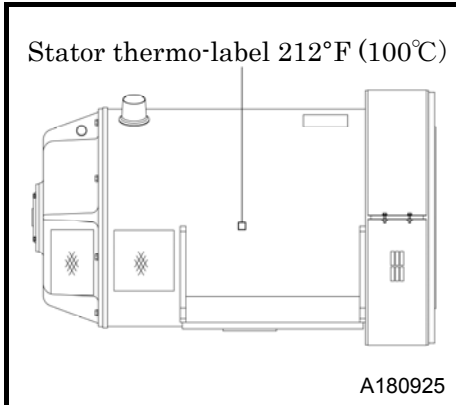

- Remove the trash and dust from the generator inside by compressed air blowing.
- Replace thermo-label, if it have changed the color once.
- When replacing, contact your nearest dealer.

## 3.4.10 Check Oil Fence Drain

Oil fence drain port is located on the operation side and the front side (2 places).

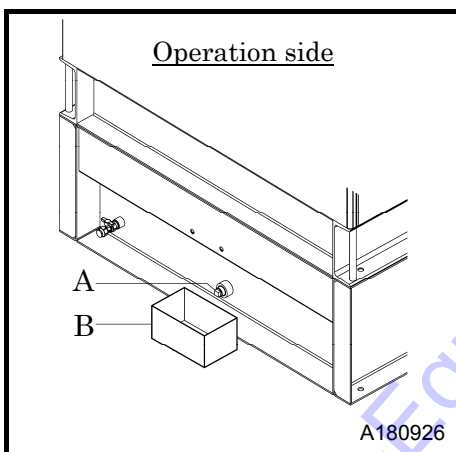

- Remove drain plug [A] from the oil fence drain to drain the condensate.
- Check that all condensate is drained, and then re-install the drain plug.
- Drain the condensate into a container [B], and then dispose of condensate according to the designated regulations.

## 3.4.11 Check Doors

Pull the handle forward to open the door. Be sure to close the door tightly so that its latch is firmly caught.

**WARNING**

PK0028

- Keep the door closed and locked while running the machine.
- When opening the door unavoidably, be careful not to touch the moving s and hot parts. Scalding or serious injury could result.

# 3. Operation

## 3.5 Operating Procedure

Make sure that all enclosure doors are closed before starting.

### 3.5.1 Operating Procedure

To start, please follow the procedure below.

#### Manual Start Procedure

<Procedure>

1. Set the circuit breaker [A] on the instrument panel to [OFF] position.
2. Set the selector switch [B] to [ON] position.
3. Push the manual mode button [C].
4. Push the start button [D] to run the engine.

(Preheating is started automatically in cold weather. After the glow lamp [E] is off, the engine starts.)

5. Once engine has started, let it warm up approximately 5 minutes at no-load condition.

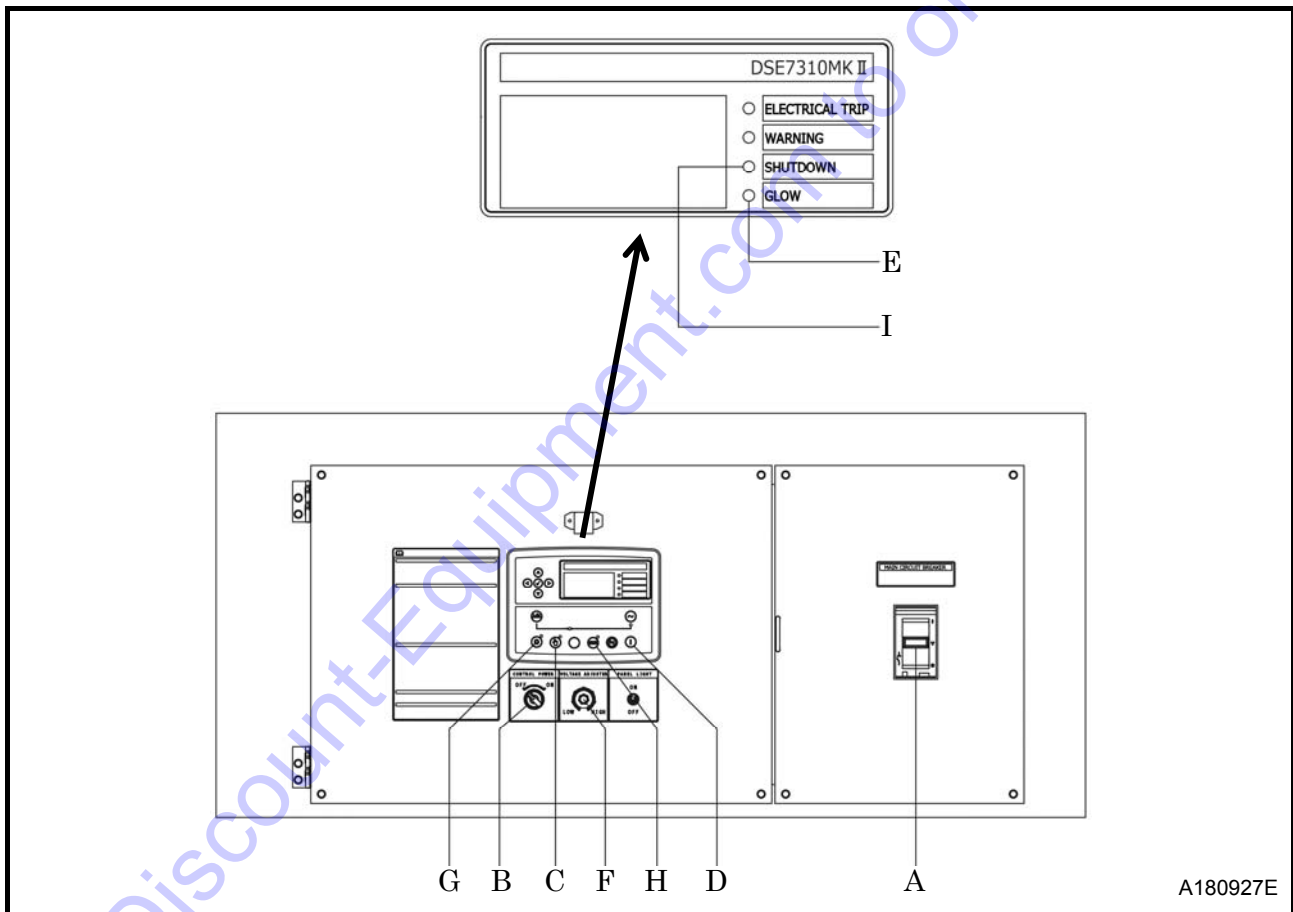

#### WARNING



- Keep the output terminal cover shut and locked whenever the machine is running. Note that a voltage of several hundred volts is applied to the output terminal and control board. When opening the output terminal cover is unavoidable, be careful not to touch the output terminal. Electric shock or serious injury could result.

# 3. Operation

## Check frequency and voltage

<Procedure>

1. After warming up, display **Generator** monitor and press ▲▼ to show [Generator Frequency].  
Check that the frequency of the generator is at 60Hz after warm up. (See 3-2)

Generator Frequency	
60.0 Hz	

Monitor Screen

2. Press ▲▼ to show [Generator Voltage] and adjust to rated voltage with a voltage adjuster [F].

Generator Voltage	
L1-L2	480V
L2-L3	480V
L3-L1	480V

Display



Voltage Adjuster

## Operation with Load

<Procedure>

1. Set the circuit breaker [A] to [ON] and supply power to the load.
  - During operation, check and confirm whether the generator functions properly. (See. 3.5.2)
  - ※ Before starting to supply power to the load, make sure that the voltage is in accordance with the load.

### IMPORTANT

- After the engine starts up, warm it up unloaded for approx. 5 minutes.
- Warming up after starting up is necessary for smooth operation of the engine.  
Do not operate the engine at full load immediately after it starts up.  
This will shorten the equipment life.
- During the warm-up operation, examine the different parts of the equipment for any looseness, leakage of water, oil, fuel, and other irregularities.
- Also, make sure that the alarm lamps are off.
- Be sure to operate the generator at the rated frequency, irrespective of the load capacity.  
If the machine is operated with a frequency lower than the rated frequency, it could cause the generator main machine or to be burned.

<Shutdown Procedure>

1. Stop the load.
  2. Set the circuit-breaker [A] to [OFF] position.
  3. After about 5 minutes cooling down operation, push the stop button [G] to stop the engine.
  4. Set the power control switch [B] to [OFF] position.
- ※ The engine controller is on for a few minutes after engine is stopped. Do not remove the battery cables, etc., during this period.

# 3. Operation

## Auto Start

1. Cable connection method of remote control switch.

- The remote control terminal [J] is provided inside the output terminal. Perform cable connection as shown below for remote control operation of the machine. For this cable connection job, make sure to remove the battery cathode cable terminal.

<Procedure>

1. Perform manual start to adjust voltage, stop the engine.
2. Push the auto mode button [H].
3. Set the circuit breaker [A] to [ON] position.
4. Setting remote control terminals [A1-A2] to [ON] starts the engine.  
(In cold conditions, pre-heating starts automatically. After glow lamp [E] is switched off, the engine starts.)
5. Setting remote control terminals [A1-A2] to OFF stops the engine.

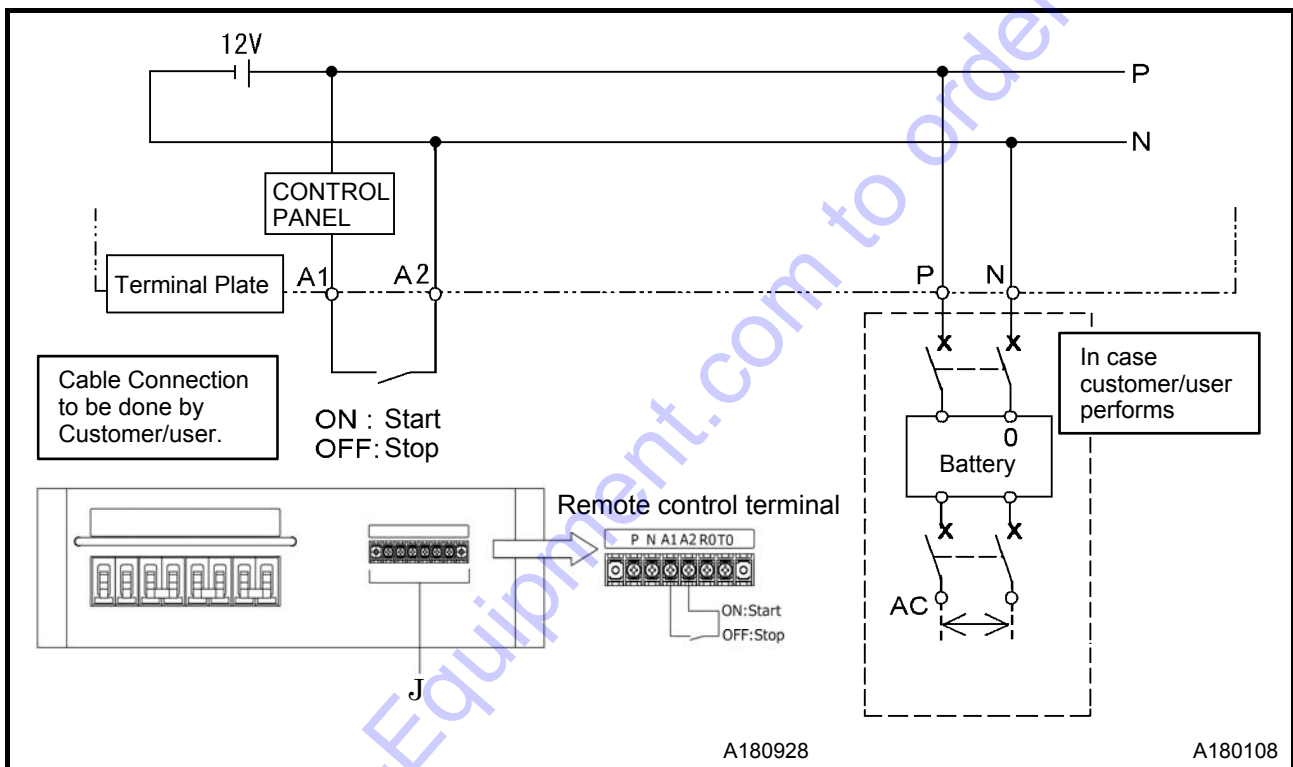

### CAUTION



### Inspection and maintenance prohibited during automatic operation

- Never put your hands close to the interior of the machine, because the generator can begin operation without warning even while the machine is set to the stop position.
- Before starting inspection and maintenance job, make sure to hang the tag "Under inspection and maintenance".
- Remove the battery cathode cable terminal.

### IMPORTANT

#### Install the battery charger

- While the unit is in stand-by conditions during automatic operation, battery discharge occurs. Make sure to charge battery, operating the battery charger.



# 3. Operation

## 2. Function

- When the start signal activates in stand-by mode, it starts the unit. (This includes preheating.)  
When the stop signal activates, the unit will continue to operate for 10 seconds to cool down, then the unit stops and is placed again in stand-by mode.

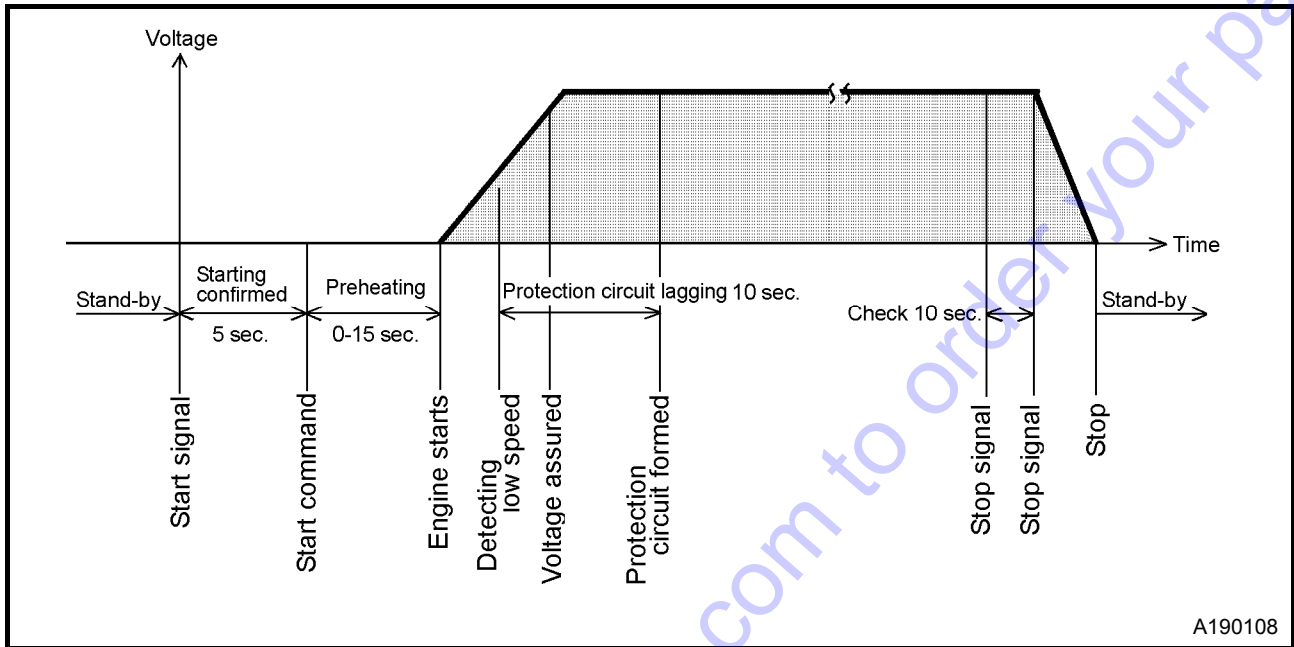

## 3. Starting Action

- If the engine will not start after cranking for 10 seconds, stop it for 8 seconds before trying again. If the engine will not start even after cranking is repeated three times, the SHUTDOWN lamp [I] will illuminate due to Fail to Start error.
- If the engine will not start and the SHUTDOWN lamp is illuminated, troubleshoot the cause of engine failure before proceeding.

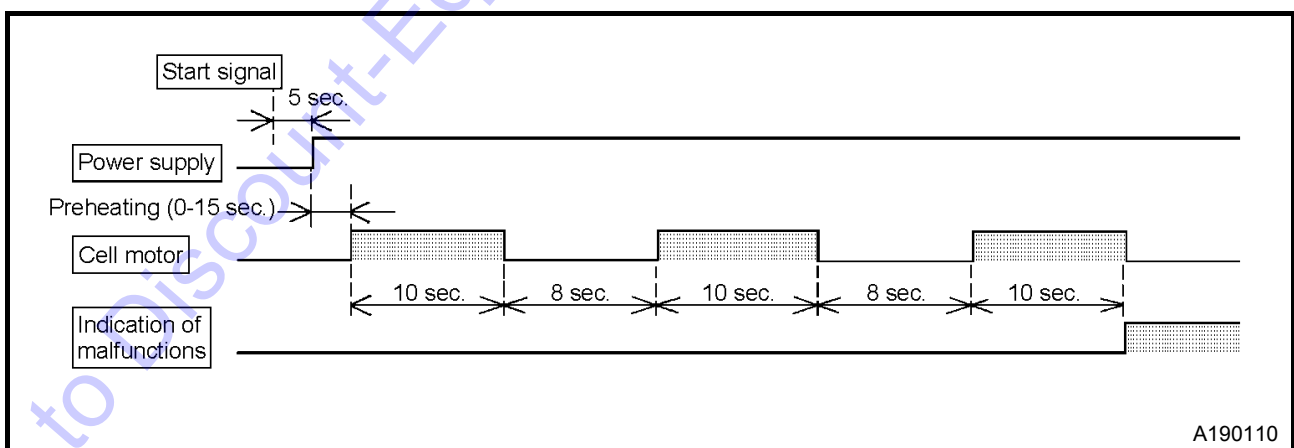

**IMPORTANT** Perform periodical inspection and maintenance of the generator

- To check performance, run the unit for 5 to 10 minutes once in a week.

# 3. Operation

## 3.5.2 Meters and indicator lights during operation

During normal operation, each indication of instruments is shown in the table below. Refer to the table for daily checks.

Note: The values marked \* vary with location of the voltage selector switch.

		Voltage (V)	Frequency (Hz)	Ammeter (A)	Monitor Lamp			
					ELECTRICAL TRIP	WARNING	SHUTDOWN	GLOW
Before Start	CONTROL POWER switch (ON)	0	0	0	● OFF	● OFF	● OFF	● OFF
		* 240 480	60	Less than rated current	● OFF			

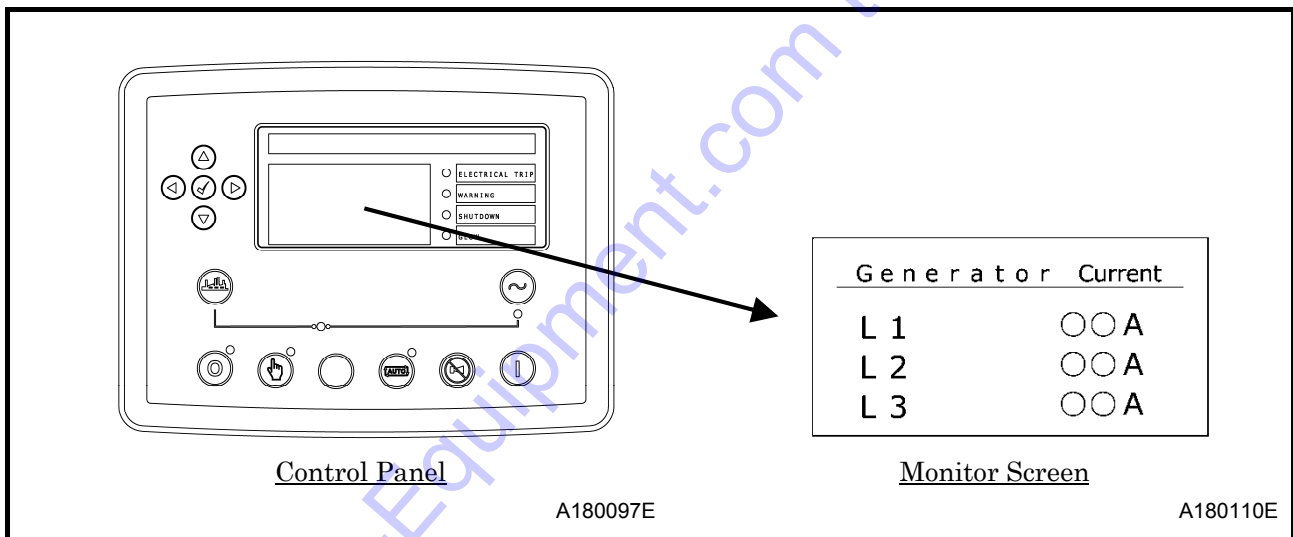

- Be sure to frequently check meters and indicators for proper operation, or any machine water, oil, fuel leaks, etc.
- The above table gives standard values. They may vary slightly depending on operating conditions and other factors.
- In single-phase load operation, check the current of L1, L2, and L3 phase with displaying **Generator** page. Each current should be balanced if unbalanced. Change load connections so the current of L1, L2, and L3 is equally balanced. Make sure that the current of each phase does not exceed the rated one.

※ Keeping a record of machine operation and service checks in the Operation Log will help with discovering any underlying issues or problems with the machine before they become severe.

## 3. Operation

### CAUTION



- Do not under any circumstance, open the portions below during operation.
- Coolant drain valve
- Engine oil drain valve

### CAUTION

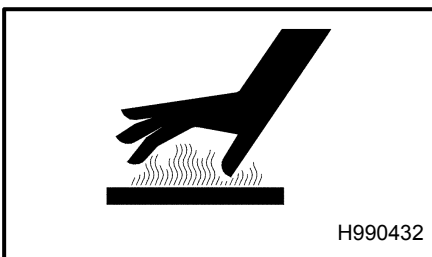

- Never work nearby hot portions of the machine while it is running.
- Do not touch hot portions of the machine while inspecting the machine when running.
- Parts such as the engine, exhaust manifold, exhaust pipe, muffler, radiator and intercooler are especially hot. Never touch those parts, because it could cause scalding.
- Coolant water and engine oil are also very hot and dangerous to touch. Avoid checking or refilling them while the machine is running.

### CAUTION

- When the breaker functions often during operation, reduce the load.
- When using 1-phase load, check the current of each phase and try to keep the load of each phase constantly average.
- If you continue to operate the generator while ignoring or neglecting these cautions, it could cause overheating and result in fire. Furthermore, should operation continue at a lower level than the standard rated frequency, it could burn the generator and any motors of the attached load.

### 3.5.3 Panel light

- The panel is equipped with an LED light. Turn the panel light switch [ON] to use.
- When illumination is not necessary, turn the light [OFF]. If the machine is always operated with the lamp switched [ON], the lamp life can be reduced.

### 3.5.4 Operating procedures when engine fails to start up on first attempt

If the engine repeatedly fails to start, the following causes are suspected. Check the following:

- No fuel
- Clogging of the fuel filter
- Discharge of battery (Low cranking speed)

# 3. Operation

## 3.5.5 Fuel line air bleeding device

If the machine runs out of fuel, bleed the air, according to the following procedures.

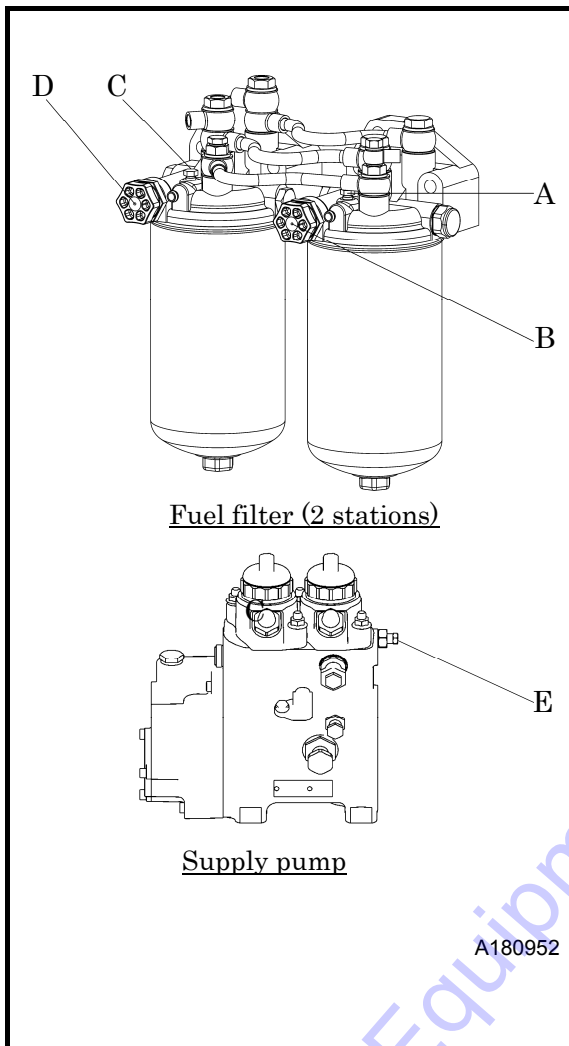

### <Procedure>

1. Loosen air bleeding plug [A] of fuel filter.
2. Loosen it till the head of priming pump [B] comes out.
3. Operating priming pump [B] repeatedly, confirm that fuel comes out from air bleeding plug [A].
4. After confirming that air is completely bled, retighten the air bleeding plug [A] and wait about one minute after operating more than 10 times till priming pump [B] gets filled with fuel.
5. Operate 2. - 4. procedures more than 3 times till air will not come out.
6. Perform the above operations for the left-side filter, using the air bleeding plug [C] and priming pump [D], until filled with fuel.
7. Loosen air bleeding plug [E] of supply pump and operate priming pump [B] till air bubble will not come out.
8. Retighten air bleeding plug [E] of supply pump.
9. Operate it till the priming pump [B] will not move lightly.
10. Retighten priming pumps [B] and [D] with both pressed in and return them as they were.
11. Start engine after the above procedures have been completely finished. If engine would not start, repeat the procedures from 9..

# 3. Operation

## 3.6 Emergency Stop

### 3.6.1 Emergency stopping procedures

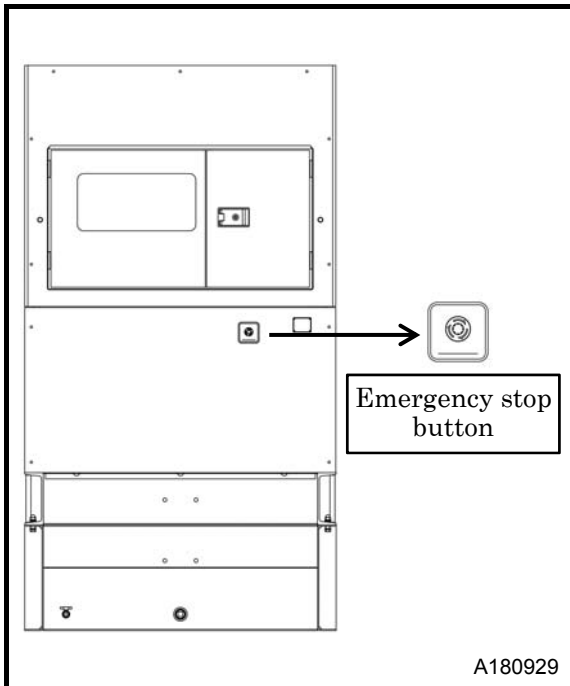

- If it is necessary to stop the generator for emergency, press the Emergency Stop button located under the control panel.  
When shutting down with the emergency stop button, the machine will stop immediately.

### 3.6.2 Cancellation of emergency stop button

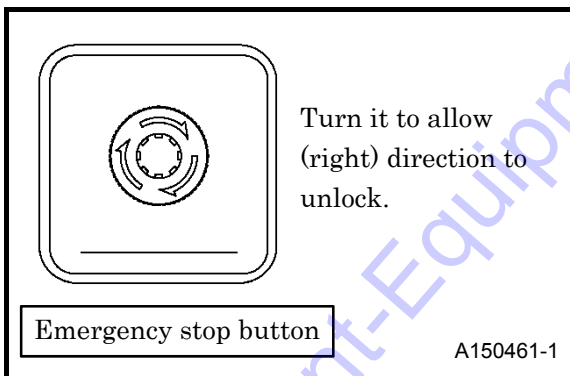

- After emergency stopping, be sure to carry out an investigation of the problem which caused you to use the emergency stop and take appropriate countermeasures. Release emergency stop button only after resolving the problem that required an emergency stop. To reset the button, turn the button head in the direction of the arrow.  
※ If it is not reset, the machine cannot restart.

# 3. Operation

## 3.7 SCR Cleaning

- SCR (Selective Catalytic Reduction) is a cleaning device to reduce nitrogen oxide (NO<sub>x</sub>) in exhaust gas by converting it into harmless water (H<sub>2</sub>O) and nitrogen (N<sub>2</sub>).
- In order to maintain the function of the system, cleaning (purge) is performed automatically for each fixed operating time. It usually takes about 10 minutes to complete.
- Auto cleaning may not be completed at low load operation.
- If auto cleaning is failed, forced cleaning will start.
- SCR cleaning symbol  is displayed during auto or forced cleaning.

### CAUTION

- During SCR system cleaning, there may be white smoke or ammonia smell generated temporary. This is normal.
- Do not operate the unit in area where ventilation is insufficient.
- Make sure to install ventilation/exhaust system to provide proper ventilation when running indoors. If you feel sick, stop the engine immediately and ventilate the area.
- Exhaust gas from tailpipe have a different smell from normal diesel engine due to exhaust gas cleaning system.
- Applying heavy load during cleaning may cause reduction of responsiveness.
- Low load operation during forced cleaning may produce abnormal sound. This is normal.

### WARNING













- Pay attention during auto or manual exhaust filter cleaning, since SCR system and exhaust gases reach temperatures hot enough to burn people or cause fire.

# 3. Operation

## 3.8 SCR Inducement

- The warnings below will be indicated before the situation become critical when sensing problems such as no DEF supply, use of poor quality DEF, DEF injection issues, or disconnection of sensors etc.
- If no action is performed, the engine will shutdown 3.5 hours later.
- If the engine stops in this condition, contact your nearest dealer as special service tool is required to restore operation.
- In case of emergency, it is possible to operate the unit for 30 minutes by performing escape mode. (See 3-9)

[Monitor Display during SCR Inducement]

	State	-	Detect	3.0 Hr From Detect	3.5 Hr From Detect
	Warning Level	Normal	Level 1 Warning	Level 2 Early Inducement	Level 3 Final Inducement (Shutdown)
	ENG.OUTPUT	100%	100%	100%	-
Indicator	SCR system malfunction	-	 (On)	 (Slow Blinking)	 (Quick Blinking)
	ECU Alarm	-	 	 	 
	Warning lamp	-	EXH. SYS	EXH. SYS	EXH. SYS
Monitor Lamp	Shutdown lamp	-	 ON	 ON	 ON

 **CAUTION**

- If the SCR system malfunction symbol is displayed during normal operation, stop the engine immediately and contact your nearest dealer.

# 3. Operation

## 3.9 How to activate Escape Mode

- When the engine is stopped due to final Inducement, the unit can only be run for 30 minutes by performing Escape mode.

<Procedure>

1. Press and hold the tick ✓ button on the control panel to access the Running Editor.
2. Press the right arrow ► button until “Editor – Engine” is displayed.
3. Press the down arrow ▼ button until “Escape Mode” is shown.

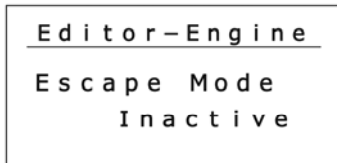

4. Press the tick ✓ button to edit (Inactive begins to flash), press the up arrow ▲ to change to “Active”, press the tick to ✓ confirm. (Active ceases to flash)
5. Press and hold the tick ✓ button to return to main screen.
6. Start engine with normal procedure.

- Remaining operation time can be seen by pressing ► for engine and ▼ for SCR Action timer.

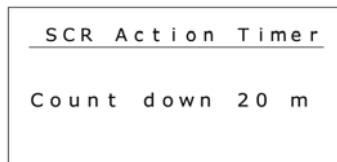

- Engine will stop when count down timer reaches 0. Contact your nearest dealer as special service tools are required to restore operation.
- If the error code is resolved and warning is below level 1 while Escape Mode activated, Escape Mode will automatically exit and normal operation will resume.



# 4. Failure and Troubleshooting

## 4.1 Protection device

To prevent issues during operation, this machine is equipped with various protection devices.

### 4.1.1 List of protective devices, warning lamps, and monitor alarms

This machine is equipped with protective devices, and indicates the type of issue with lamps and messages on the monitor display as shown in the table below.

Shown below are the typical items. When the Warning lamp is activated or any other monitor alarm is displayed due to other engine trouble, contact your nearest dealer.

Item	Control Panel					Function
	Monitor Lamp			Screen		
	Electrical Trip	Warning	Shutdown	Alarms	ECU Current DTCs	
Low Engine Oil Pressure	☀️ ON	-	☀️ ON	ECU Red	ENG Oil Press. Low	Warning: lower than 7PSI (48kPa)
High Coolant Temp	☀️ ON	-	☀️ ON	ECU Red	Water Temp High	Shutdown: above 212°F (100°C)
Over speed	☀️ ON	-	☀️ ON	ECU Red	Engine Speed High	Shutdown: above 2070rpm
Clogging Air Filter	-	☀️ ON	-	Air Filter	-	When it is clogged or necessary to clean.
Oil Fence	-	☀️ ON	-	Containment Level	-	When condensate (fuel, engine oil and coolant) is accumulated more than 26gal (100 liters)
Low Fuel Level*	-	☀️ ON	-	Low Fuel	-	Warning: less than 5% of capacity
Over Current/ Short Circuit	☀️ ON	-	☀️ ON	Over Current	-	When it occurs
High Voltage	☀️ ON	-	☀️ ON	Over Voltage	-	Shutdown: above 108%
Other Engine Trouble	**	**	**	-	**	**

\*Not functional when using an auxiliary/external fuel tank.

\*\*Please contact your nearest dealer.

When ECU Red or ECU Amber is displayed, press button once to change screen to ECU current DTCs and check screen.

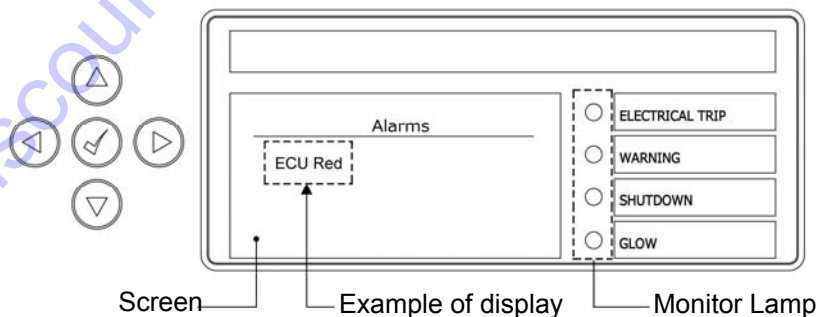

A180100E

#### CAUTION

- If the protective device operates and the engine stops or the circuit breaker trips, refer to the cause of the failure and the countermeasure item, eliminate the cause and restart operation.

# 4. Failure and Troubleshooting

## 4.1.2 Circuit Breaker

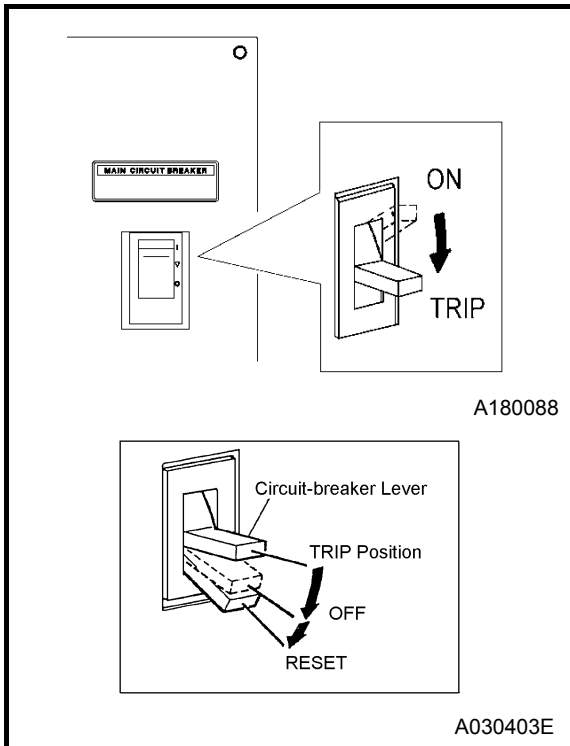

- In case of an overload or short-circuited wire connection, the circuit-breaker trips.
- When the breaker is tripped, stop the machine immediately and reset the circuit breaker after resolving the cause of the trouble.

<How to reset>

- In order to reset the lever of circuit breaker, press the lever downward firmly until the lever “clicks” into place.

## 4.1.3 Circuit protector (CP) for AVR protection

AVR is equipped with a circuit-protector (CP) for protection against over current. It will activate under the following conditions:

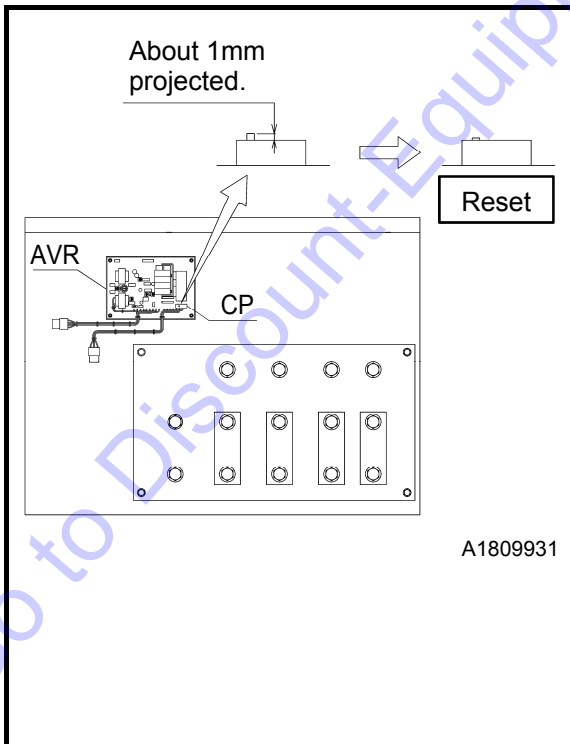

- The machine is overloaded while engine speed is still low.
- The output voltage of machine is increased higher than the specified voltage.

<Symptom>

- When the CP operates, following symptoms will occur.
  1. The voltage will not reach rated voltage.
  2. The voltage is usable, but voltage fluctuation is wide and voltage restoration is slow when loaded.

<How to reset>

- Reset it by pressing CP (AVR) button provided at the side of the breaker plate in the control panel.

Note: Do not hold the button with such sharply pointed things as a screwdriver, ball point pens etc.

# 4. Failure and Troubleshooting

## 4.2 Troubleshooting

Should any trouble occur during operation, do not leave it. Investigate the cause and take appropriate measures. Read the manual carefully and fully understand what to do in case of trouble.

- The better you understand the construction and function of the machine, the faster you can find a problem and solution.
- This chapter describes the state, cause and countermeasures of important troubles in detail:

Symptom	Cause	Counter measures
Starter does not rotate. Low starter revolution speed even when starting.	(1) Battery malfunction (2) Charging malfunction (3) Alternator malfunction (4) Starter malfunction	Check Battery→Charge/Change  Change Change
Starter rotates normally but engine does not start up.	(1) No diesel fuel oil (2) Air mixing in fuel piping (3) Fuel filter clogging (4) Nozzle clogging (5) Malfunction of controller	Replenish fuel Bleed air Disassemble/Clean and Change Disassemble and clean Check fuse Check connector Check controller
※ “Engine Oil Pressure Low” is displayed on the monitor screen.	(1) Engine oil shortage (2) Engine oil filter clogging (3) Loosened or disconnected wiring, or connector (4) Oil pressure switch malfunction	Replenish fuel Change Check/tightening  Change
※ “Water Temperature High” is displayed the monitor screen.	(1) Shortage of coolant (2) Slip of belt (3) Radiator clogging (4) Faulty thermostat (5) Looseness, disconnection of wiring or connectors (6) Faulty coolant temperature switch	Replenish Adjust tension Clean Change Check/tightening  Change
※ “Air Filter” is displayed on the monitor screen.	(1) Air filter clogging	Clean
※ “Containment Level” is displayed on the monitor screen.	(1) Condensate accumulated in the oil fence. (2) Oil fence level sensor is not functioning.	Drain Check/Change

※ Refer to section 4.1.1 for monitor lamp and display.

## 4. Failure and Troubleshooting

Symptom	Cause	Counter measures
Circuit breaker trips.	(1) Overloaded (2) Short-circuit occurred at the load side.	Reduce the load Get rid of cause of short-circuiting.
Even when operated at a rated speed, no voltage or too low voltage generated.	(1) Poor tightening of terminals (2) Broken or short-circuited circuit to exciter field winding (3) Faulty exciter (4) Function circuit protector (CP) for AVR protection (5) Faulty AVR (6) Broken or short-circuited winding of generator main machine (7) Faulty silicon rectifier (mounted on generator main machine rotor) (8) Faulty voltmeter	Check/tightening Repair Repair Reset Change Repair Change Change
Too high voltage generated when set at the rated frequency (50Hz/60Hz), Voltage will not drop even when the voltage regulator controlling knob is turned.	(1) Loosened or disconnected wiring, or connector to AVR (2) Broken wire or poor contact of AVR variable resistor (3) Faulty AVR	Check/tightening Repair or change Change
Unstable voltage generation	(1) Poor tightening of each terminal (2) Function circuit protector (CP) for AVR protection (3) Faulty AVR	Check/tightening Reset Change

- Contact your nearest dealer if you find it difficult to repair by yourselves.
- Please see engine operation manual for more details of engine trouble.

# 5. Periodic Inspection

## 5.1 Important Items at Periodic Inspection and Maintenance

The following table shows the inspection and maintenance intervals under normal operation conditions. When used or operated under hard environmental conditions, it is impossible to warrant the machine even if the above conditions are performed according to the intervals listed in the above table.

- Be sure to use appropriate tools for inspection and maintenance work. Inappropriate tools could cause unexpected injury.
- Please wear personal protective equipment such as a helmet, safety glasses, earplugs, safety shoes, gloves, and a mask as appropriate to the work environment
- Do not touch hot portions of the machine while inspecting the machine when running. Parts such as the engine, exhaust manifold, exhaust pipe, exhaust muffler, radiator, inter cooler, generator, and pipe are especially hot, so never touch those parts, because it could cause scalding.

### **WARNING**

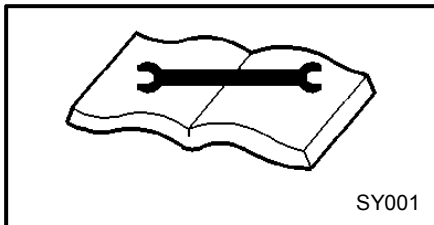

### **Hang a "Under Maintenance" tag**

- Before starting inspection, set the machine's circuit breaker to OFF, and then attach the "Under Inspection" label to an easy-to-see location.
- Remove the negative (–) side cable from the battery. If the above procedure is neglected, and another person starts operating the machine during check or maintenance, it could cause serious injury.

### **IMPORTANT**

### **Instructions and unspecified work prohibited**

- Be sure to use recommended fuel, DEF, oil, grease, or antifreeze.
- Do not disassemble or adjust engine, compressor or part(s) for which inspection or maintenance is not referred to in this manual.
- Use genuine parts for replacement.
- Any breakdown, caused by using unapproved parts or by wrong handling, will be out of the scope of "WARRANTY".
- Do not pour water or steam on electrical components.
- Place a container or a pan underneath the oil port to receiver waste liquid so that such liquid cannot be spilled out on the floor or inside the machine.
- Be sure that no waste liquid is disposed of on the ground. Such waste on the ground, river or lake will cause serious environmental contamination. Be sure to follow the local regulations. If harmful material such as oil, antifreeze solution or filters are disposed of incorrectly, the responsible person should be punished by the authority.
- Observe local regulations when disposing of such toxic materials as oil, fuel, coolant (Antifreeze), filters, and battery etc.

# 5. Periodic Inspection

## 5.2 Maintenance Schedule

Such items marked ○ shall be carried out by customers. For the following items or clauses marked ●, contact your nearest dealer because they require expert technical knowledge on them.

The following table shows the intervals of inspection and maintenance under normal operation conditions. Inspection and maintenance should be done at either of the hour or the period mentioned in the remarks column, whichever comes earlier.

(This table is a guide only, it is not a guaranteed time. Please change maintenance interval according to usage load environmental condition.)

Maintenance	Daily	Every 250 hours	Every 500 hours	Every 1,000 hours	Ref.	Remarks
Generator	Clean instruments in control panel	○			3-14	Clean as required.
	Check thermo-label of alternator	○			3-15	
	Check control panel	○			3-20	
	Check GFCI receptacles		○		5-8	Every 1 month
	Check insulation resistance		○		5-9	Every 2 months
	Check thermo label on the generator		○		5-10	Every 2 months
Engine related	Check engine oil level	○			3-10	
	Check coolant level	○			3-11	
	Check fuel	○			3-12	
	Check fuel pre-filter drain	○			3-12	
	Check DEF level	○			3-13	
	Check belt tension	○			3-14	In the case of NG, it exchanges.
	Change engine oil			○	5-4	
	Change engine oil filter element (Main / By-pass)			○	5-5	
	Check battery electrolyte		○		5-5	
	Check and clean air filter elements		○		5-7	
	Check accumulations in exhaust system		○		5-8	
	Drain fuel tank		○		5-10	
	Check specific gravity of battery electrolyte.			○	5-5	
	Change fuel filter element			○	5-11	
	Change fuel pre-filter element			○	5-11	
	Clean outside of radiator and intercooler			○	5-11	Clean as required.
	Check and cleaning of the supply pump strainer			○	5-12	
	Check exhaust flexible pipe			○	5-13	Every 4 months
	Change air filter element				○ 5-14	
	Change coolant (LLC)				○ (Every 2 years) 5-16	
Clean fuel tank				●		

# 5. Periodic Inspection

Maintenance		Daily	Every 250 hours	Every 500 hours	Every 1,000 hours	Ref.	Remarks
Others	Check interior	○				3-13	
	Check oil fence drain	○				3-15	
	Check terminal and wirings			○		5-13	Every 4 months
	Check engine/generator mount				○	5-14	Every 1 year
	Check each rubber hose				○	5-15	Every 1 year
	Clean the oil fence and check for rust				●	5-15	Every 1 year

The above intervals of inspection and maintenance are respectively based on the operation time of 125 hours of used per month and of 1,500 hours of use per year.

Maintenance		Every 1,000 hours	Every 3,000 hours	Every 4,500 hours	Ref.	Remarks
Engine body	Check engine valve clearance	●				
	Change DEF dosing unit filter		○		5-15	
	Clean DEF tank	●				Clean as required.

## 5.3 Periodic Replacement Parts

Part number changes upon modification. For replacement of parts, make sure whether the part number is correct or applicable.

Description		Part Number	Q'ty
Air Filter Element	Outer Element [C]	32143 16000	1
	Inner Element [D]	32143 15901	1
Engine Oil Filter Element (Main)		ISUZU 113240-2330	1
Engine Oil Filter Element (By-pass)		ISUZU 113240-2410	1
Fuel Pre-filter Element		43543 00900 ISUZU 898074-2881	2
Fuel Filter Element		43543 02800 ISUZU 898312-9180	2
Strainer [A] for Engine Supply Pump		ISUZU 115619-5090	1
Strainer [B] for Engine Supply Pump		ISUZU 115619-5070	2
Belt		ISUZU 113671-5030	1
DEF Dosing unit filter		ISUZU 898169-4030	1



# 5. Periodic Inspection

## 5.4 Maintenance Items

### 5.4.1 Change Engine Oil (Change the engine oil filter at the same time)

#### Every 500 Hours

When checking, replenishing, and draining the engine oil, be sure to wait more than 10 minutes after engine stops to allow it to cool down. When draining oil, prepare a small length of hose (300mm), hose joint (R3/4), and a container for drained oil.

<Procedure>

1. Remove the engine oil filler port cap [A] and then open the drain valve [B] fixed inside to drain oil.
  2. After draining completed, close the drain valve [B] and supply engine oil. **[Oil supply: about 60L]**
  3. After finishing the oil supply, tighten the engine oil filler port cap [A] firmly.
  4. Make sure to check engine oil level with the engine oil level gauge before start the unit.
  5. After finishing the oil supply, tighten the engine oil filler port cap [A] firmly.
- Drain the condensate into a container [C], and then dispose of condensate according to the designated regulations.

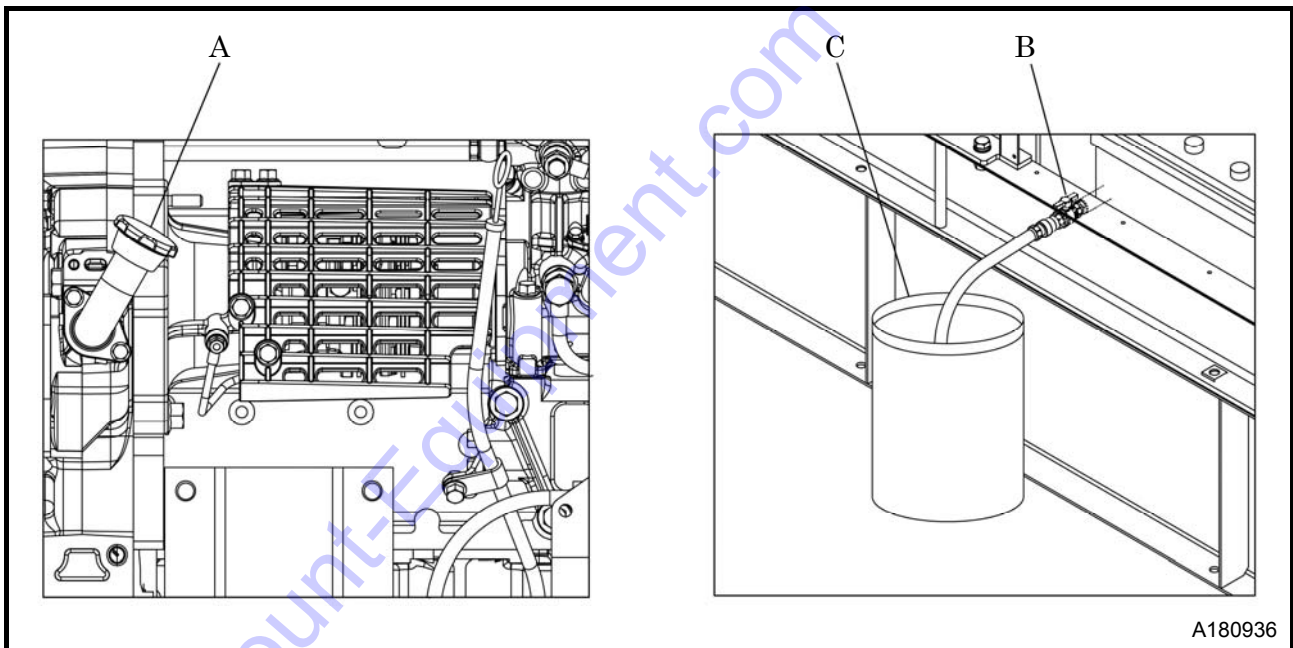

**CAUTION**

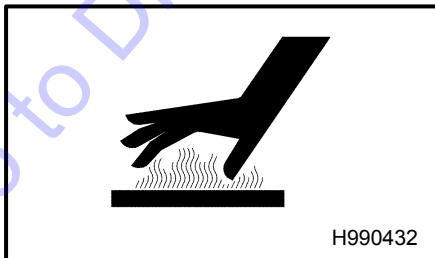

#### **Caution in filling or draining engine oil**

- Engine oil is very hot and highly pressurized during or just after the operation. Hot oil could blow out and can cause injury
- Never supply more engine oil than the proper level. Too much oil could cause white smoke out of the exhaust, and it can cause damage and accident to engine.



# 5. Periodic Inspection

## 5.4.2 Change Engine Oil Filter Element (Main / By-pass)

**Every 500 Hours**

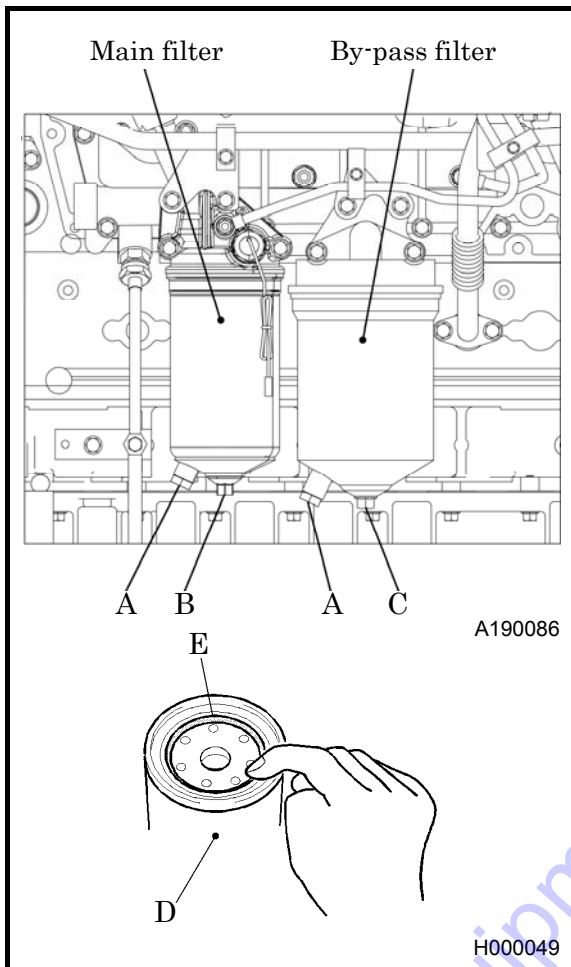

<Procedure>

1. Loosen the drain plugs [A] on the main filter and by-pass filter and drain.
2. Loosen the center bolt [B] and [C] of each filter.
3. Wash inside the each filter case with diesel oil.
4. After applying a thin layer of oil to the filter element's [D] packing [E], insert the center bolt into the case and screw element on. Once the packing [E] comes into contact with the sheet surface, tighten and secure center bolt
5. After installing an oil filter element, check for fuel leakage during operation.

(For part number, See 5.3)

- Tightening torque

Center bolt [B]	$50 \pm 5 \text{ N} \cdot \text{m}$
Center bolt [C]	$100 \pm 5 \text{ N} \cdot \text{m}$

- Dispose of condensate according to the designated regulations.
- Refer to the engine instruction manual for more details.

## 5.4.3 Check Battery

**Battery electrolyte : every 250 hours**

**Specific gravity of battery electrolyte : every 500 hours**

If there to be a problem in starting an engine due to a flat battery, carry out the checks by following the procedures below:

- **Ordinary type battery:**

Measure specific gravity of battery electrolyte, and if it shows below 1.24, recharge the battery immediately. (See 5.4.4)

- **Enclosed type battery:**

Check the indicator on top surface of the battery.

If the indicator shows that charge is needed, recharge the battery immediately.





If specific gravity of battery electrolyte does not rise despite replenishing distilled water or charging battery, replace battery with a new one quickly.

# 5. Periodic Inspection

## 5.4.4 Maintenance of Battery

Battery may generate hydrogen gas and may explode. Therefore, recharging should be done at a well-ventilated place.

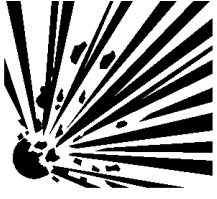
- Do not check the battery by short-circuiting the positive and negative terminals with a metallic piece.
- Never operate the machine nor charge the batteries with low battery liquid. Continuing operation at this lower level will cause deterioration of some parts, reduction of battery life, and also it may cause explosions. Add distilled water so that the liquid level is between the “UPPER LEVEL” and “LOWER LEVEL” if the level is too low.
- Wear protective gloves and safety glasses when handling a battery.
  - If battery electrolytes contact your clothes or skin, wash it away with a large amount of water immediately.
  - If the battery electrolytes get into your eyes, flush them immediately with plenty of water and see a doctor at once. Severe damage to eyes and vision may result.

 <b>WARNING</b>	<b>Handling Battery</b>
 D004	<ul style="list-style-type: none"><li>● Keep flames away from battery.</li><li>● Do not spark near the battery nor light a match, nor bring lit cigarette and match close to the battery.</li><li>● Do not charge a frozen battery as it may explode. If the battery is frozen, warm it up until the battery temperature becomes 61°F to 86°F (16°C to 30°C).</li><li>● Battery electrolyte is diluted sulfuric acid. In case of mishandling, it could cause skin burning.</li><li>● Dispose of battery, observing local regulations.</li></ul>
 W010	
 TR0093	

### [Charge battery]

- Use the battery charger after you confirm whether it is in good operating condition and ready for use.
- Disconnect the cable between battery and the machine, and charge the battery with a 12V battery charger. Do not charge two batteries at the same time.
- Be sure not to connect (+) and (-) terminals backwards.

# 5. Periodic Inspection

[How to use booster cable]

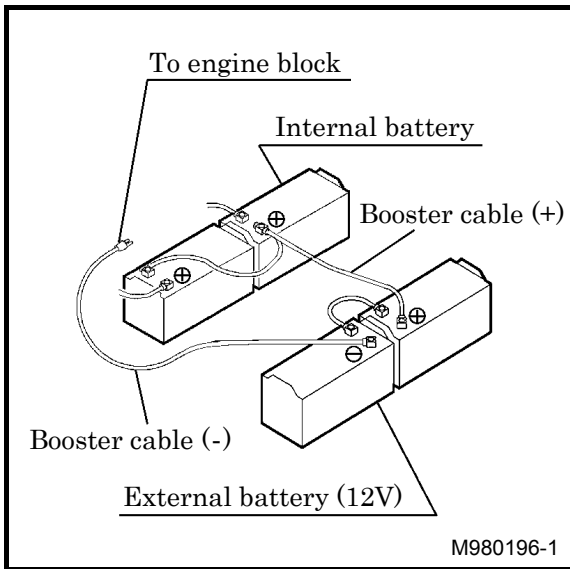

<Procedure>

1. Stop the engine.
2. Connect one end of the (+) booster cable to the (+) terminal of the machine battery.
3. Connect the other end of the (+) booster cable to the (+) terminal of the external battery.
4. Connect one end of the (-) booster cable to the (-) terminal of the external battery.
5. Connect the other end of the (-) booster cable to the engine block of the machine.
6. Start up the engine.
7. Disconnect the booster cable by following the procedure back in the reverse order.

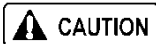

**CAUTION** *Do not reverse the cable connection*

- When a booster cable has to be used or when cables are connected again after a battery is replaced, be careful not to connect (+) and (-) terminals backwards. A backwards connection will cause sparking and damage to each component.

## 5.4.5 Check and Clean Air Filter Elements

**Every 250 Hours**

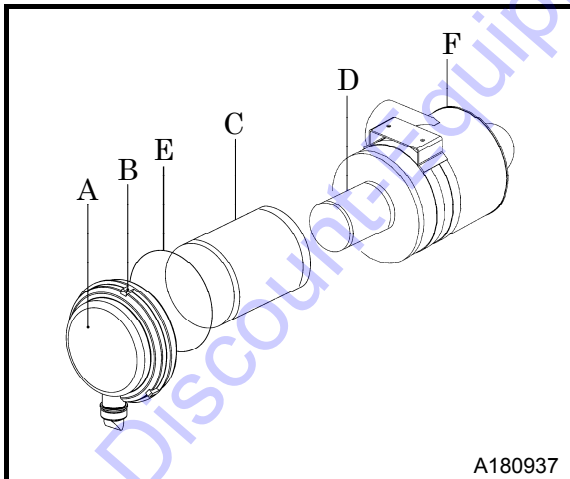

Clean the air filter displayed on the monitor screen.

<Procedure>

1. After removing the cap [A] by loosening its cap fixing latch [B], clean its interior properly.
  2. Remove the outer element [C], and clean it. Do not remove the inner element [D] to prevent dust from entering.
  3. When cap is installed after it is cleaned, push O-ring [E] surely in case [F] so that it will not be extruded and confirm that the hook of cap fixing latch is surely installed. Then tighten it.
- If the element is found heavily dusty, replace it with a new one. **(For part number, See 5.3)**

**IMPORTANT**

- When an element that is clogged or has holes or cracks is used, dust or foreign material will get in the engine. This causes accelerated wear in moving parts within the engine. Be sure to perform daily checks and appropriate cleaning so that the life of the engine will not be shortened.

# 5. Periodic Inspection

## 5.4.6 Check Accumulations in Exhaust System

### Every 250 Hours

When a diesel engine driven generator is continuously operated with less than 30% load or no load for a long time, carbon will be stuck inside the exhaust pipes, exhaust muffler, and engine body. Unburned fuel may also come out from connected portions of exhaust pipe and outlet port of the exhaust muffler. If it is continuously operated under the conditions, the fuel which comes out could ignite and cause a fire.

Further, wet-stacking and carbon accumulation could cause power drop in the engine as well as overheating, resulting a serious damage to the engine. If this occurs, eliminate the carbon accumulation by burning it under full load operation (to increase exhaust heat) until the exhaust gas becomes almost clear.

(For load current, refer to the following table as a standard value.)

Frequency	Hz	60	
Rated voltage	V	240	480
Load current	A	770	385

### CAUTION

- In case of load operation, increase load factor step by step with checking the conditions of exhaust. Do not place flammables surroundings because it could sometimes cause sparks from exhaust pipe.

## 5.4.7 Check GFCI Receptacles

### Every 1 month or 250 Hours

Periodically, check the GFCI operation for safety.

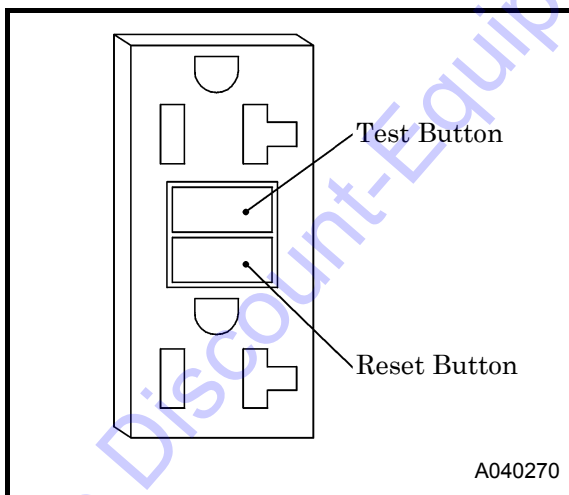

#### <Procedure>

1. Unplug all appliances from the generator.
2. Start the engine.
3. Turn [ON] the breaker on the instrument panel of this machine.
4. Press the test button.
5. Press the reset button.
  - The reset button should extend with a click.
  - If the reset button does not extend, contact your nearest dealer.
6. When the reset button extends during operation.
  - Unplug all appliances from the GFCI protected receptacle.
  - Press the reset button:

If the GFCI cannot be reset: The GFCI is faulty. Contact your nearest dealer.

If the GFCI resets properly: Check the appliance or the power cord.

### DANGER

- If the generator is stored outdoors, unprotected from the weather, test the GFCI receptacle before each use.
- In case the GFCI has tripped due to the hazard of ground fault currents, investigate the cause and correct it.

# 5. Periodic Inspection

## 5.4.8 Check Insulation Resistance

**Every 2 months or 250 Hours**

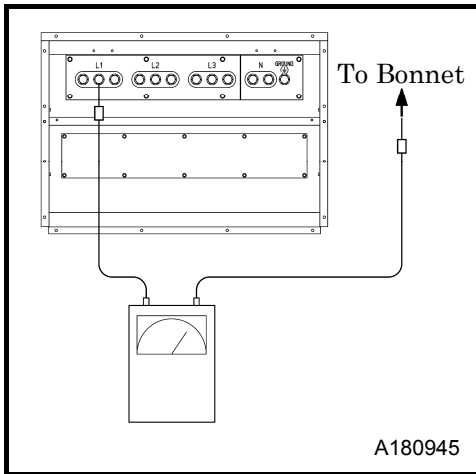

<Procedure>

1. Remove the load side cable from the output terminal board.
2. Loose and remove the bolt (M8) securing the ground cable between [N] and [GROUND] on the output terminal board.
3. Remove the connector [A] inside the generator control panel.
4. Remove connector [B] at the rear side of the control panel.
5. Switch ON circuit breaker [C], measure each insulation resistance between the terminals L1, L2, L3 terminal and bonnet.
6. If insulation resistance value measured is found more than  $1\text{M}\Omega$ , it is good.
7. After checking the insulation resistance, reinstall the ground cable between [N] and [GROUND], AVR connector [A], and connector [B] at the rear side of the control panel.

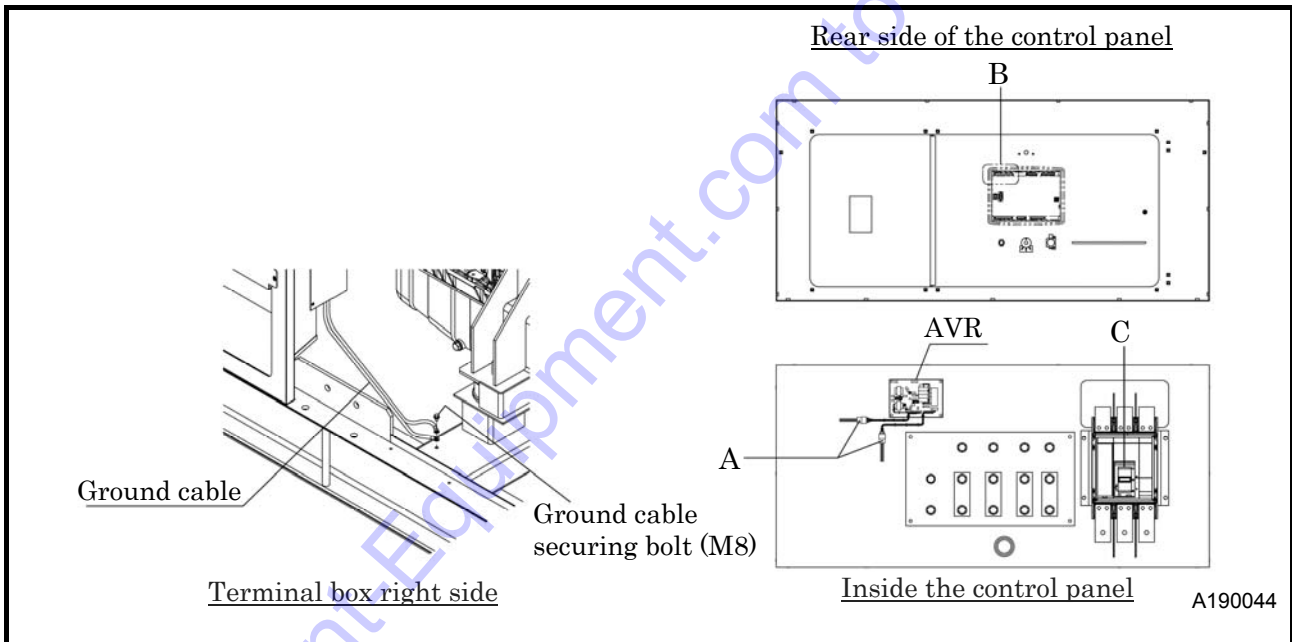

### IMPORTANT

- Insulation resistance should be regularly checked or measured with a 500V insulation resistance meter. If it is reduced to lower than  $1\text{M}\Omega$ , it could cause an electrical leakage or a fire.
- For recovery or improvement of insulation resistance, wipe and clean dust and dirt around output terminals, circuit breaker, generator body outlet port and receptacle and dry them. If it insulation resistance does not recover after cleaning, contact your nearest dealer.

### **⚠ DANGER**

- After making sure that the insulation resistance of the generator is higher than  $1\text{M}\Omega$ , be sure to re-connect the cable between the terminal [N] and terminal [GROUND] just as it was originally connected. If it is left disconnected, the grounding becomes imperfect so that it could cause electric shock.

# 5. Periodic Inspection

## 5.4.9 Check Thermo Label on the Generator

**Every 2 months or 250 Hours**

Thermo-label on the rotor bearing irreversibly changes its color from white to blue by reaching or exceeding 176°F (80°C). Be sure to check the bearing for abnormal noise and vibration if it has changed color.

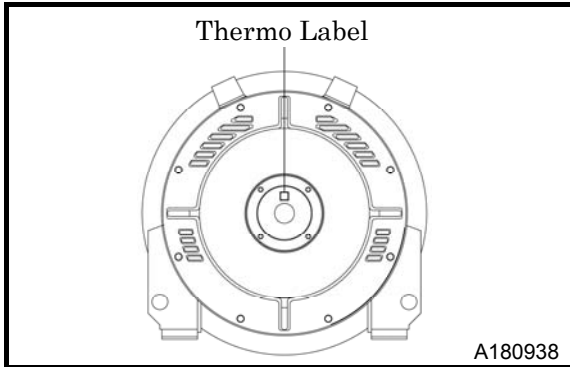

- Replace thermo-label if it has changed color.
- When replacing, contact your nearest dealer.

## 5.4.10 Drain Fuel Tank

**Every 250 Hours**

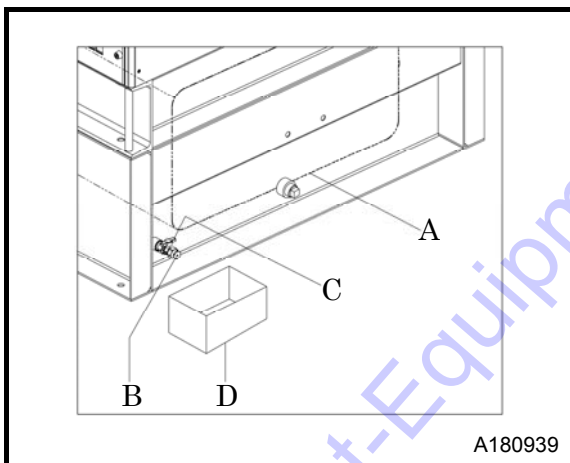

- To drain fuel tank, remove drain plug [B], and open drain valve [C] to drain the condensate accumulated in fuel tank [A].
- After making sure that all condensate is completely drained out, close drain valve [C] firmly and install drain plug [B].
- Drain the condensate into a container [D] and dispose of condensate according to applicable regulations.

## 5.4.11 Change Fuel Filter Element

**Every 500 Hours**

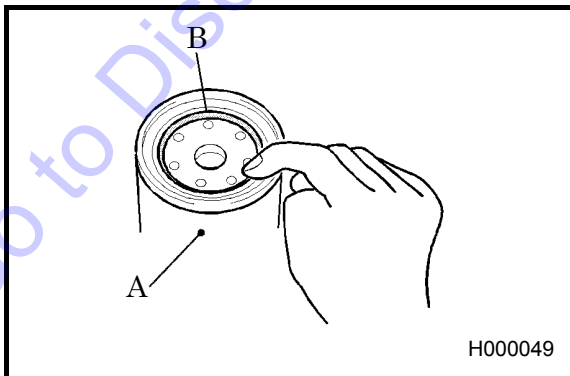

<Procedure>

1. Take out the filter case [A] using a filter wrench.
2. After thinly applying fuel on the new gasket [B], screw it in. **(For part number, See 5.3)**
3. After the gasket touches the sealing face, tighten another 2/3 turn with a filter wrench.
4. Bleed air from fuel. **(See 3.5.5)**
5. After installing the fuel filter, check it for any leak during operation.

# 5. Periodic Inspection

## 5.4.12 Change Fuel Pre-filter Element

Every 500 Hours

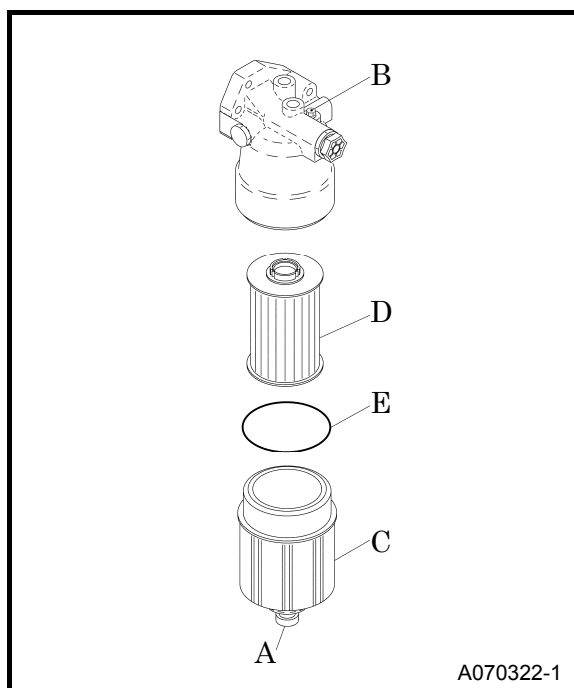

<Procedure>

1. Loosen the drain plug [A] and air bleeder plug [B] to discharge the fuel inside the filter. After draining completed, tighten the plugs [A] and [B] securely.
  2. Use the special filter wrench to remove the filter case [C].
  3. Replace the O-ring [E] with new one and place new element [D] in the case. Thinly apply the fuel on the O-ring, and screw in the element.  
**(For part number, See 5.3)**
  4. After the O-ring contact seal surface, tighten the case with the filter wrench.
  5. Remove the air from fuel. **(See 3.5.5)**
- Refer to the engine instruction manual for more details.

## 5.4.13 Clean Outside of Radiator and Intercooler

Every 500 Hours

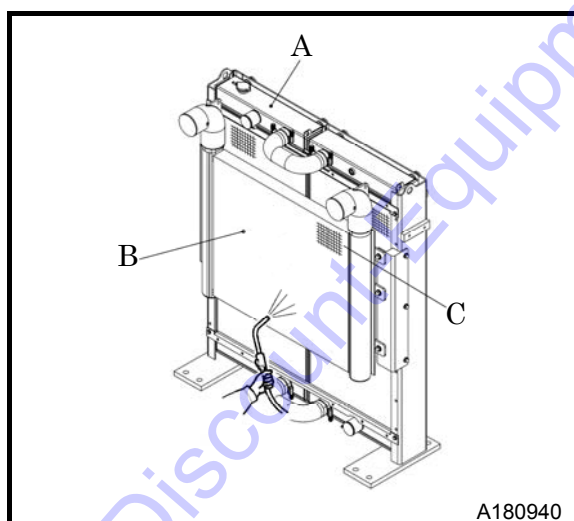

- If the fin tubes [C] of radiator [A] and intercooler [B] are clogged by dust or other foreign materials, the heat exchange efficiency drops and this will raise coolant temperature. These tubes and fins should be cleaned depending on the state of dirt inside the tubes even before maintenance schedule.
- Do not use high pressure washer for cleaning as it may damage fin tubes.
- When the unit is used or installed near seaside, clean the radiator using fresh water at least than once a month.



# 5. Periodic Inspection

## 5.4.14 Check and Cleaning of the Supply pump strainer

**Every 500 Hours**

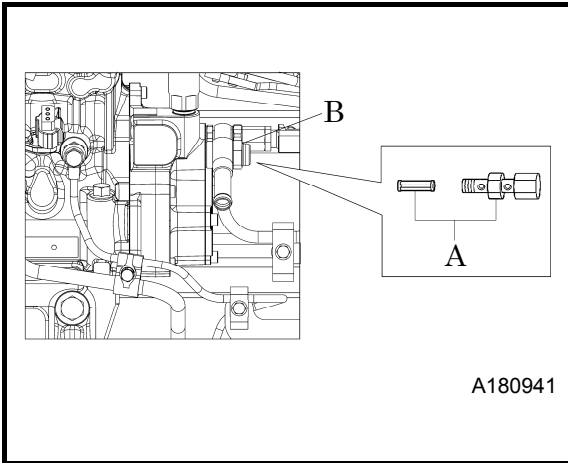

- Loosen the supply pump strainer [A] (joint bolt built-in type) and remove it. After washing it with diesel oil, blow dust and dirt off with high pressure air. Replace the gasket [B] as well.  
**(For part number, See 5.3)**
- In case the conditions of lowered engine power and engine stop will not be improved even after the supply pump strainer (joint bolt built-in type) has been cleaned, it should be replaced.  
**(For part number, See 5.3)**

### **CAUTION**

- Do not pull out the strainer inside as it cannot be disassembled. (For more information, please refer to the engine instruction manual)

## 5.4.15 Check Terminal and Wirings

**Every 4 months or 500 Hours**

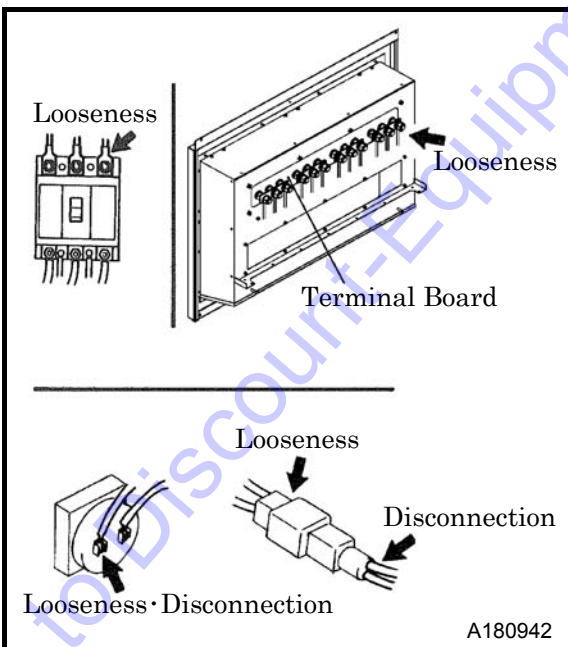

Check for any looseness on the cables, any damage on insulated covers, and disconnection, disconnected cables, or short-circuits etc.

[Checking points of electrical circuits on the generator side]

- Terminal connection of 3-phase output terminal plate.
- Main circuit of circuit breaker.
- Terminal connection on control box.
- Each terminal connection of each instrument.

[Checking points of electrical circuits on the engine side]

- Portion of connectors to the engine.
- Check for looseness of terminal connections.
- Rubbing and wear of the wire.



# 5. Periodic Inspection

## 5.4.16 Check Exhaust Flexible Pipe

**Every 4 months or 500 Hours**

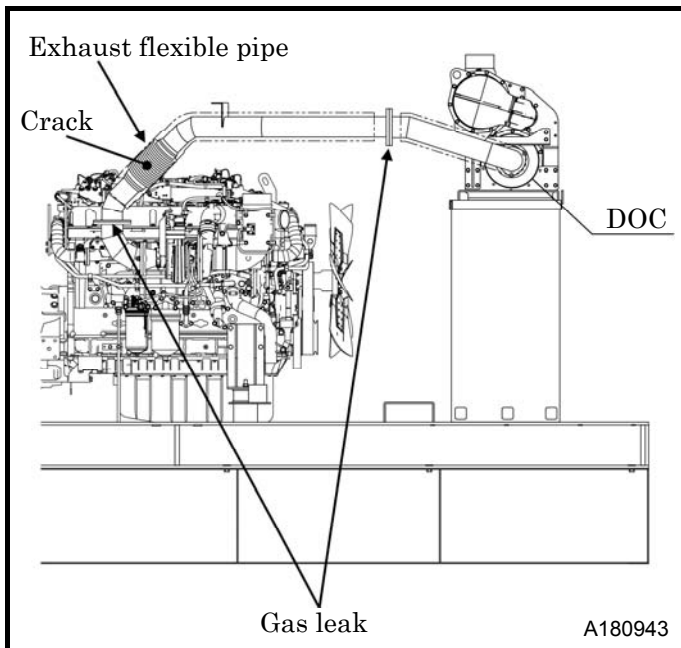

- Check the flexible pipe between the DOC and engine exhaust outlet for cracks and exhaust gas leakage.
- If any leak is found, take care to avoid getting burned by exhaust gas.

## 5.4.17 Change Air Filter Elements

**Every 1,000 Hours**

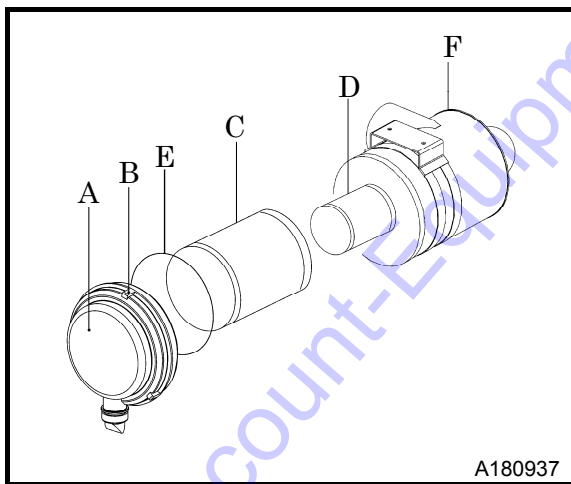

<Procedure>

1. After removing the cap [A] by loosening its cap fixing latch [B], clean its interior properly.
2. Replace elements [C] and [D] with new ones.  
**(For part number, See 5.3)**
3. When cap [A] is installed after it is replaced, push O-ring [E] surely in case [F] so that it will not be extruded and confirm that the hook of cap fixing latch [B] is surely installed. Then tighten it.

### IMPORTANT

- Air filter is an important part which is crucial to machine's performance and life.  
Be sure to use genuine parts.
- Be careful not to let dusts enter inside when removing inner element [D].

# 5. Periodic Inspection

## 5.4.18 Check Engine/Generator Mount

**Every year or 1,000 Hours**

The vibration isolation rubbers [A] are used for the support of generator and engine. Check the rubber for any damage or deterioration due to oil sticking.

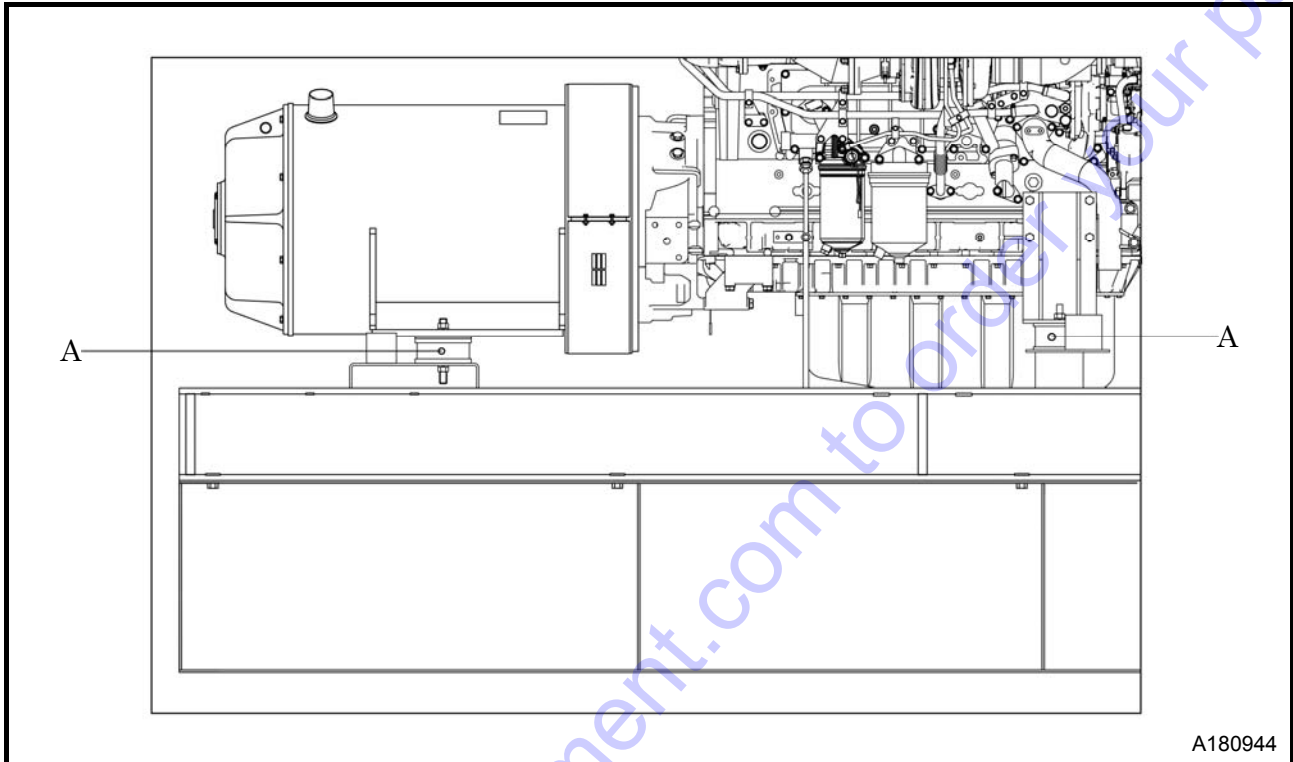

## 5.4.19 Clean the oil fence and check for rust

**Every year or 1,000 Hours**

Expert knowledge is required to clean the inside of the oil fence and to check it for rust. Contact your nearest dealer.

## 5.4.20 Check Each Rubber Hose

**Every year or 1,000 Hours**

Check all the rubber hoses for hardening, cracks, and fissures.

- If any hardening, cracks, or fissures are found on a hose (air filter, intercooler, radiator, fuel and drain), replace it with a new one.
- Check each hose clamp and if any loose hoses are found, retighten them.
- Even before the maintenance interval comes, replace hoses if hardening, cracks, or fissures are found. When replacing, contact your nearest dealer.

# 5. Periodic Inspection

## 5.4.21 Change DEF Dosing Unit Filter

Every 3,000 Hours

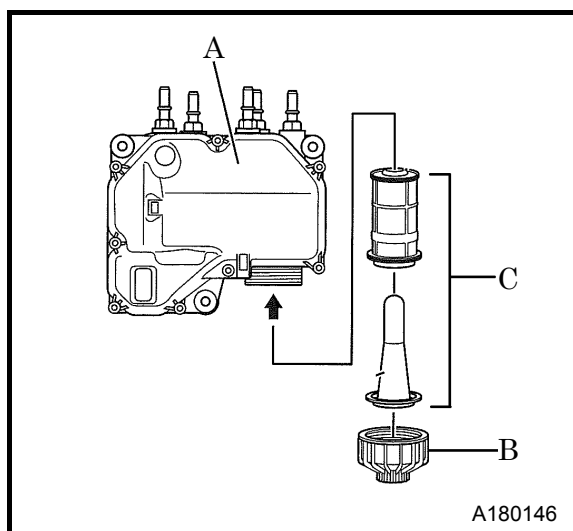

<Procedure>

1. Set a container under supply module [A], loosen cover [B], and pull it out together with DEF Dosing Unit Filter [C].
2. Assemble a new DEF Dosing Unit Filter [C].  
**(For part number, See 5.3)**
3. Lastly, secure cover [B].

### IMPORTANT

- Reuse of the DEF Dosing Unit Filter may cause trouble. Be sure to replace it with a new one.
- Always replace the DEF Dosing Unit Filter as a set.

# 5. Periodic Inspection

## 5.4.22 Change Coolant

**Every 2 years**

When removing the radiator cap, be sure to stop the machine and wait until the coolant cools down.

<Procedure>

1. To drain coolant, remove the radiator cap [A], then loosen the drain valve [B].
  2. Remove pipe cap [D] from the air bleed valve [C] and then loosen the plug [E].
  3. Be sure to also open the drain plug [F] on the engine cylinder block for drainage.
  4. Drain coolant of reserve tank.
  5. When the coolant is completely drained out, close each drain valve [B] and drain plug [E] and [F], and supply new coolant from the filler port of radiator [G].
  6. After changing the coolant, run the engine under unload operation for 2 to 3 minutes, then stop it. Check the coolant level again and replenish it if necessary.
- For the details of replacement, refer to engine operation manual.

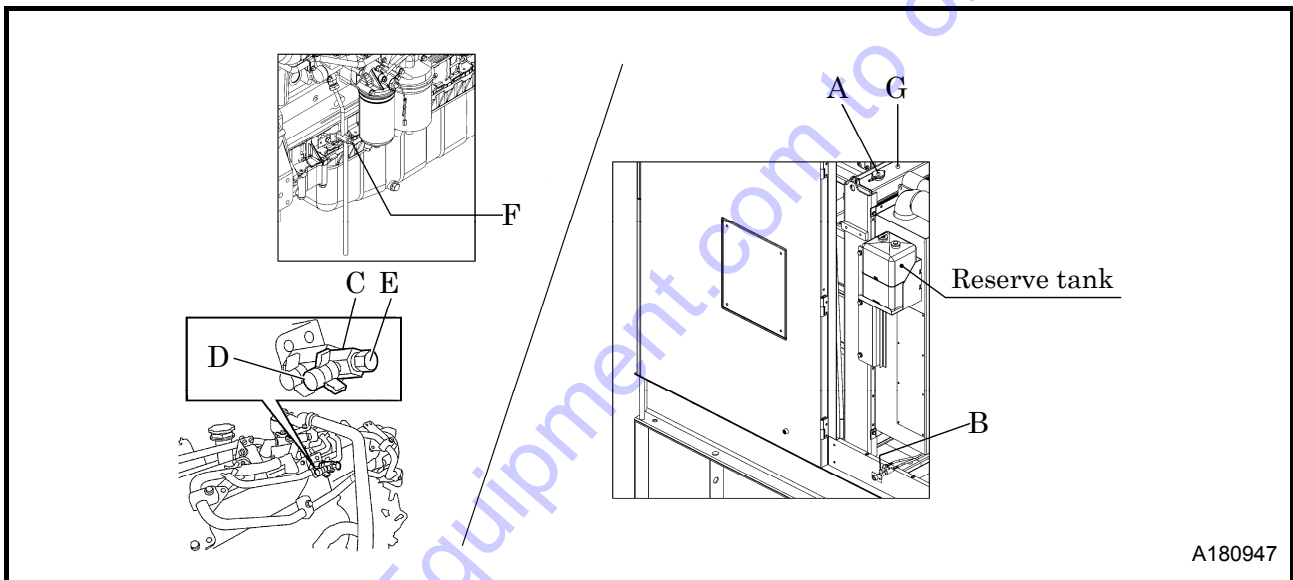

**CAUTION**

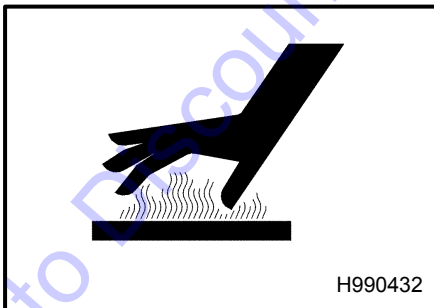

### **Caution in changing coolant**

- Be sure to stop the machine and loosen the radiator cap slowly, after the coolant water is sufficiently cooled and the inner pressure is released, then take the cap off. If the following procedures are neglected, the radiator cap could be blown by the internal pressure or hot moisture air be blown out to cause burning. Therefore, make sure to carry out them without fail.
- LLC (Antifreeze) is a toxic material.
- When a person has drunk LLC (Antifreeze) by accident, make him vomit and make him see a doctor immediately.
- When a person gets LLC (Antifreeze) in his eyes, wash the eyes with clean running water and make him see a doctor immediately.
- When LLC (Antifreeze) is stored, put it in a container with an indication saying "LLC (Antifreeze) inside" and seal it up, then Keep it in a place away from children.
- Beware of flames.

# 6. Storage and Disposal

---

## 6.1 Preparation for Long-term Storage

When the machine is left unused or not operated longer than half a year (6 months), store it in a dry place free of dust after the following treatments have been done to it.

- Put the machine in an enclosure if it is stored outside. Avoid leaving the machine outside with a sheet cover directly on the paint for a long period of time, or this will cause rust to the machine.
- Perform the following treatments at least once every three months.

<Procedure>

1. Discharge existing lubricant from the engine oil pan. Pour new lubricant in the engine to clean the internals of the engine. After running it for a while, drain it again.
2. Spread lubricant on each moving part.
3. Completely charge the battery and disconnect grounding wires. Remove the battery from the machine, if possible, and store it in a dry place. (Charge the battery at least once every month.)
4. Discharge coolant and fuel from the machine.
5. Seal air-intake port of engine and other openings like the muffler with a vinyl sheet, packing tape, etc., to prevent moisture and dust from getting in the machine.
6. Measure the insulation resistance of the generator, and make sure that it is more than 1M Ohms. **(See 5.4.8)**
7. Be sure to repair any trouble and maintain the machine so that it will be ready for the next operation.

## 6.2 Disposal of Product

- When disposing of this machine, first drain the cooling water and oils. If you require any additional instruction or advice, contact your nearest dealer.

# 7. Specifications

## 7.1 Specifications

Model		SDG400S-8E1		
Generator	Exciting system	Brushless		
	Armature Connection	Star with Neutral		
	Phase number	3 Phase – 4 wire		
	Power Factor	%	80	
	Frequency	Hz	60	
	Rated Output	kVA (kW)	400 (320)	
	Voltage	V	240	480
	Amps	A	962	481
Engine	Model	ISUZU BQ-6WG1XAGD-02		
	Type	4 Cycle, water cooled, direct injection, Turbocharged, EGR		
	Aftertreatment	DOC+SCR		
	No. of Cylinders	6		
	Displacement	cu.in.(liters)	957 (15.681)	
	Output	HP (kW)	458.4 (341.8)	
	Engine Speed	rpm	1,800	
	Lubricating Oil Capacity	gal. (liters)	15.9 (60)	
	Coolant Capacity (including radiator)	gal. (liters)	19.8 (75)	
	Battery	225H52×2 (24V)		
	Fuel Tank Capacity	gal. (liters)	483 (1,830)	
	DEF Tank Capacity	gal. (liters)	25 (94.6)	
Dimensions	Length	in. (mm)	177.2 (4,500)	
	Width	in. (mm)	59 (1,500)	
	Height	in. (mm)	107.5 (2,730)	
	Dry Weight	lbs. (kg)	13,206 (5,990)	
	Operating Weight	lbs. (kg)	17,042 (7,730)	
Others	Oil Fence Capacity	gal. (liters)	246 (930)	

# 7. Specifications

## 7.2 Outline drawing

[Unit : in.]

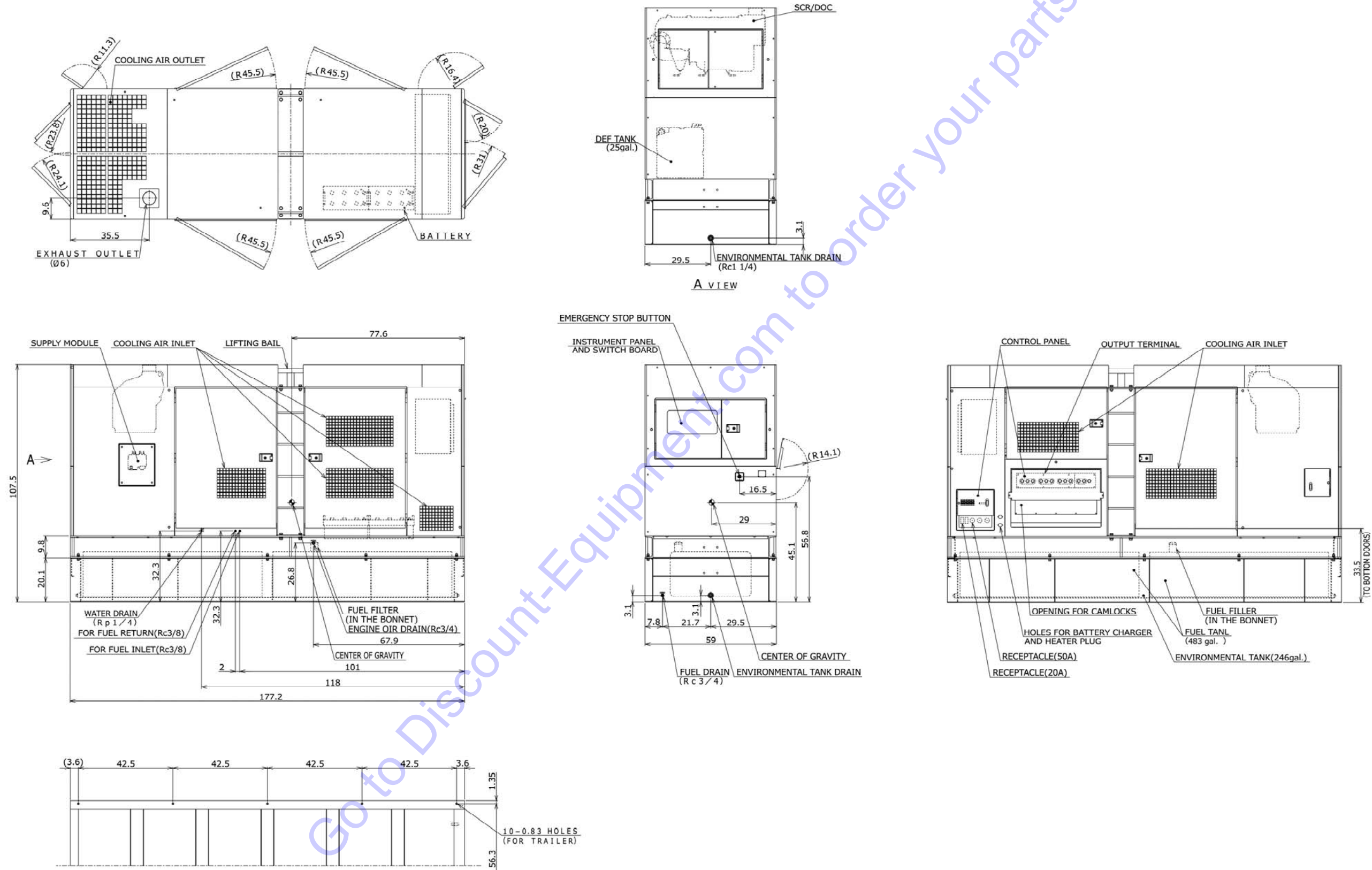



# 7. Specifications

[Unit : mm]

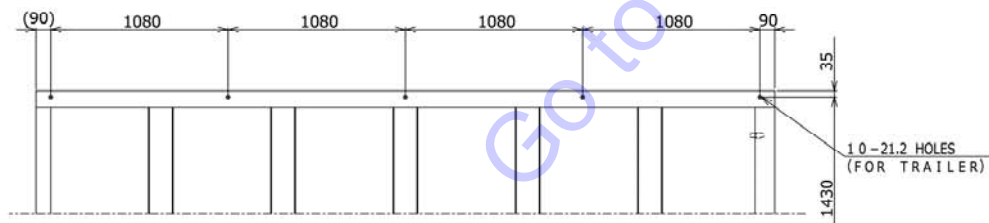
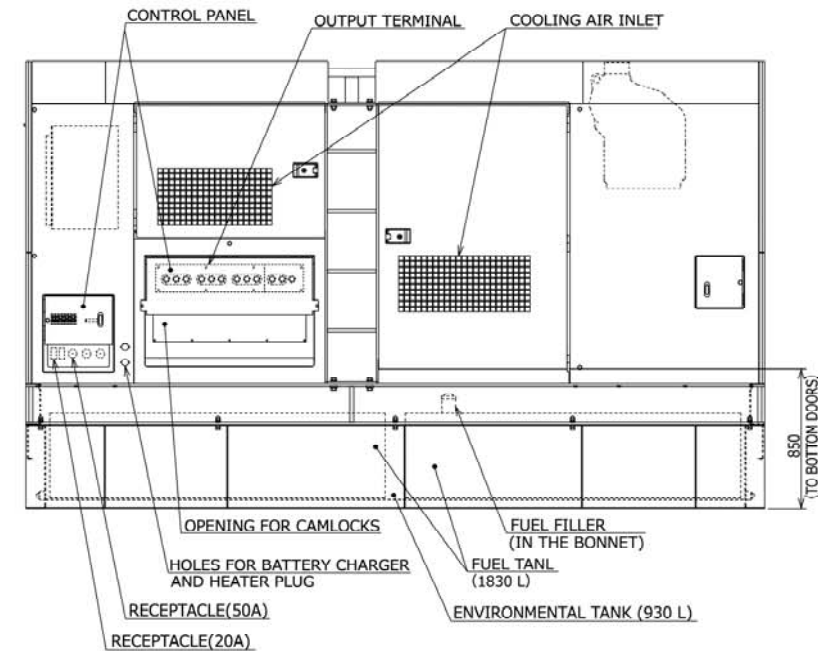
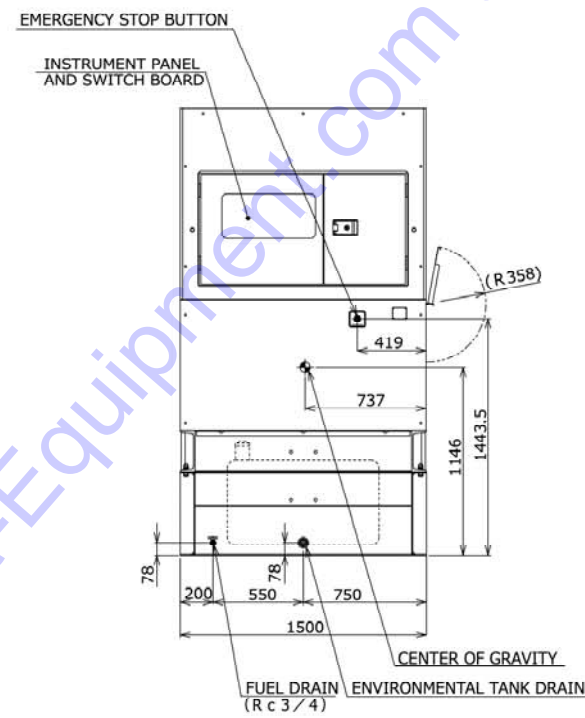
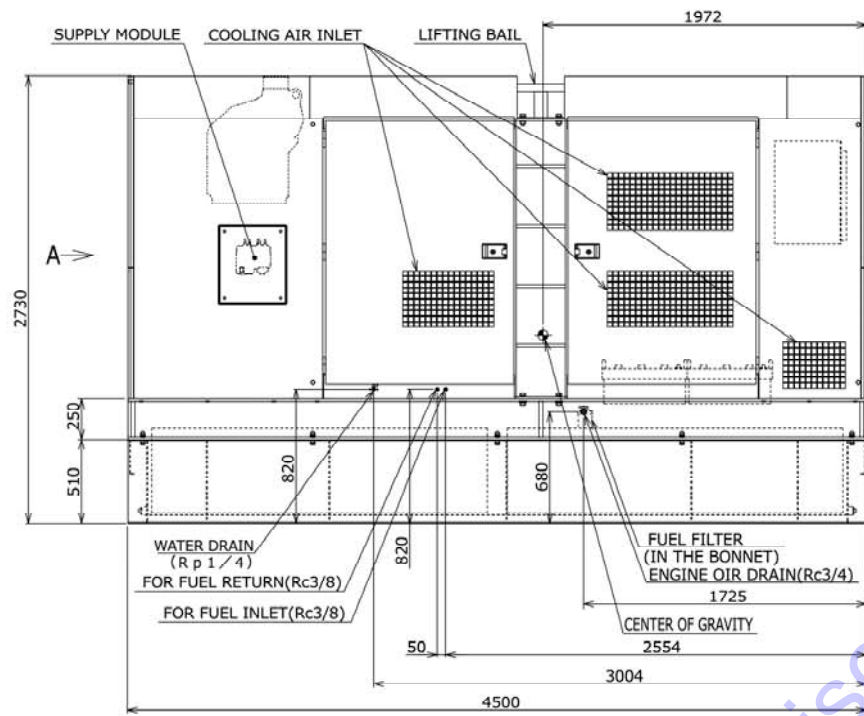
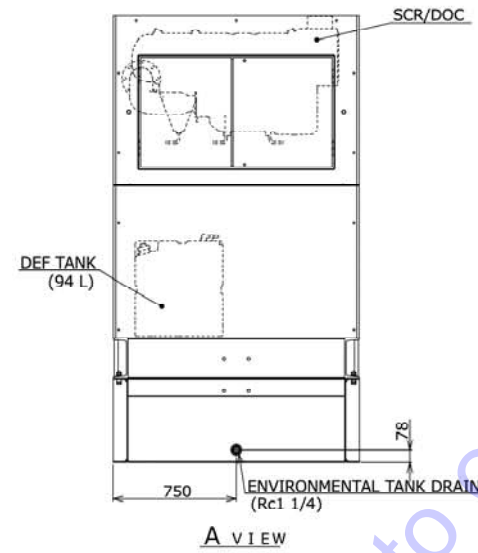
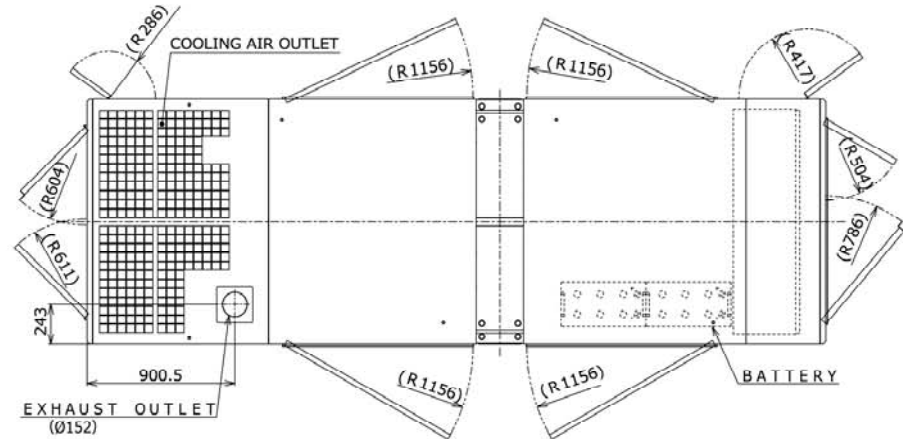



# 7. Specifications

## 7.3 Generator Wiring Diagram

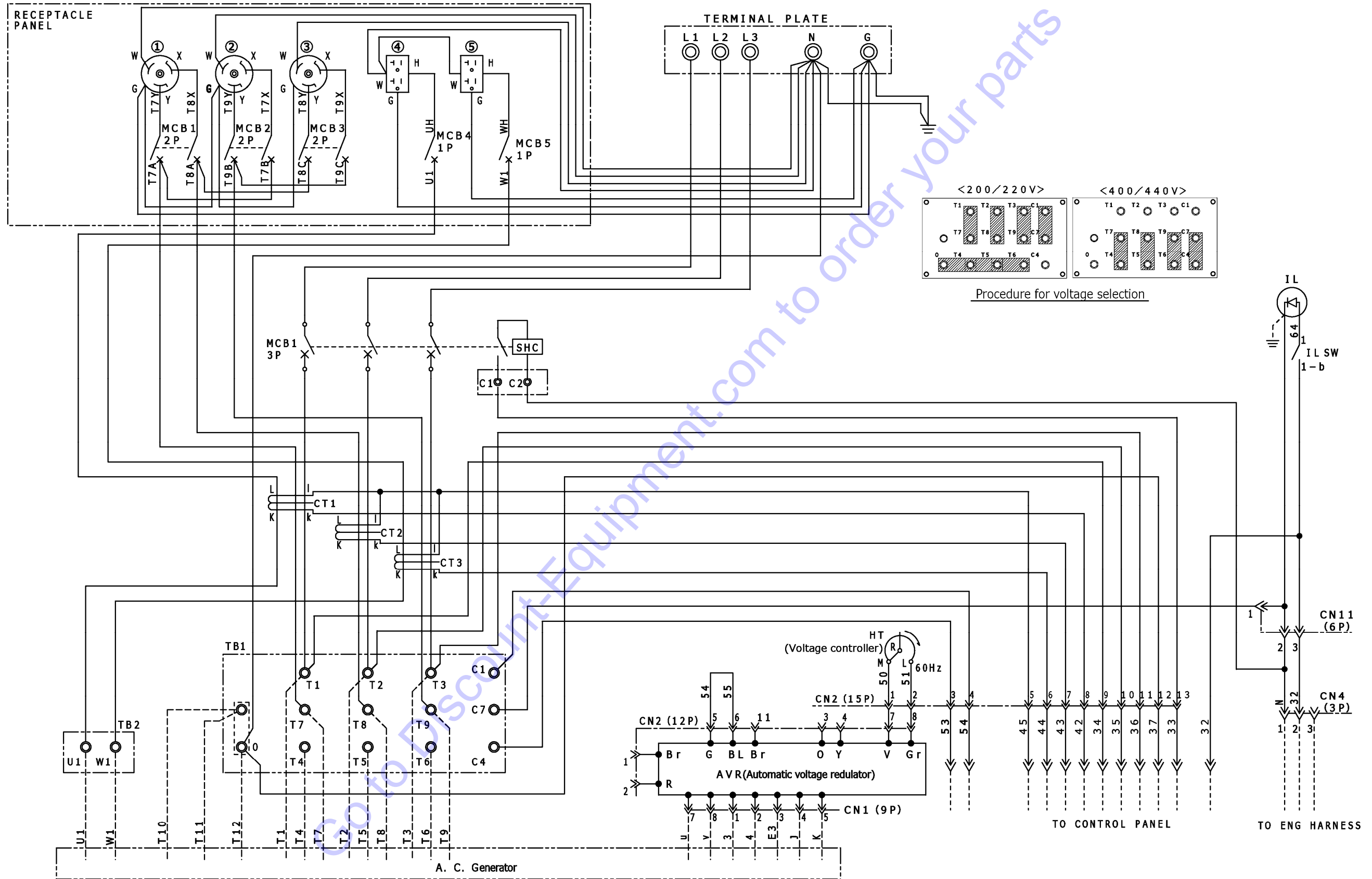

# 7. Specifications

## 7.4 Engine Wiring Diagram

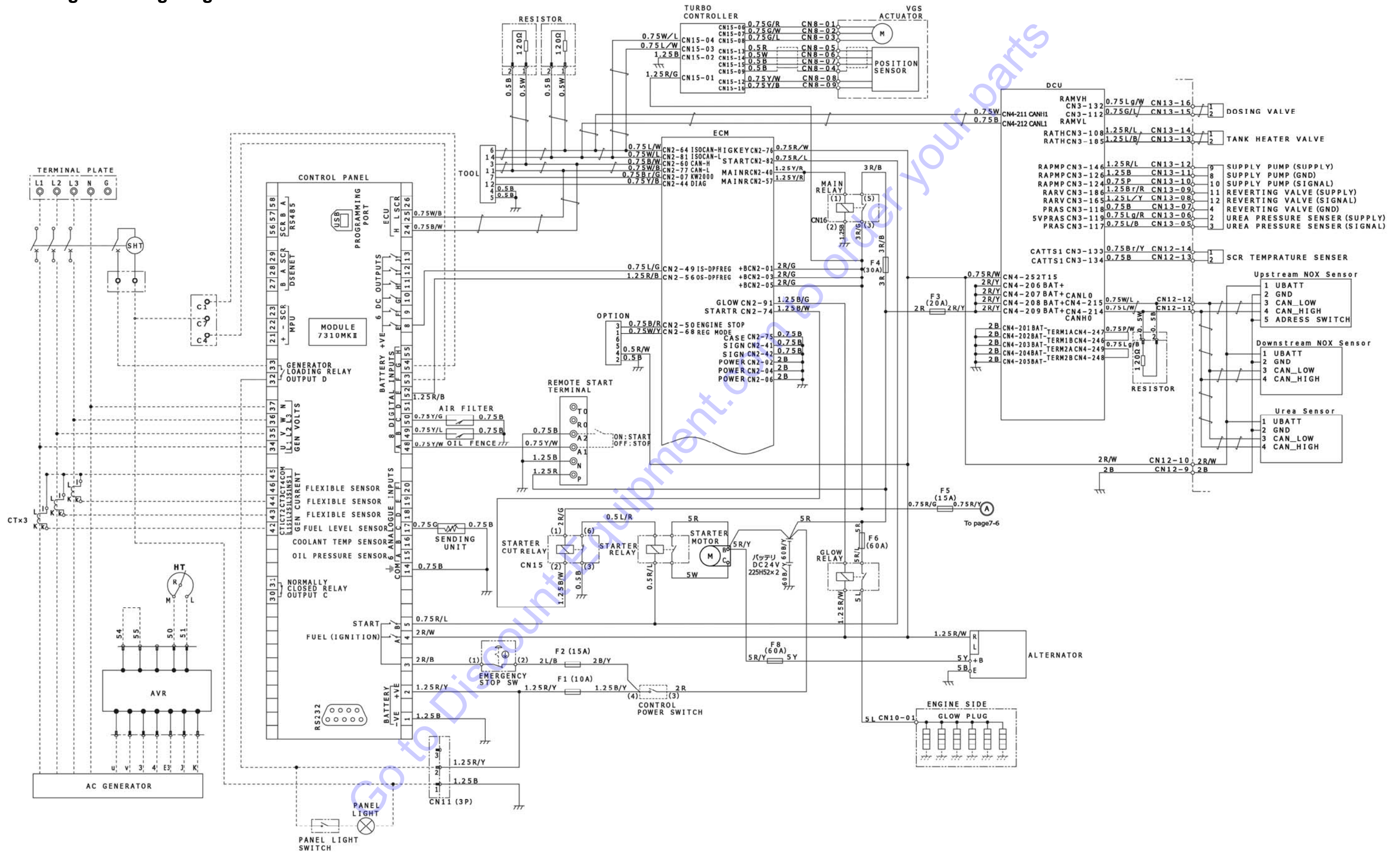



# 7. Specifications

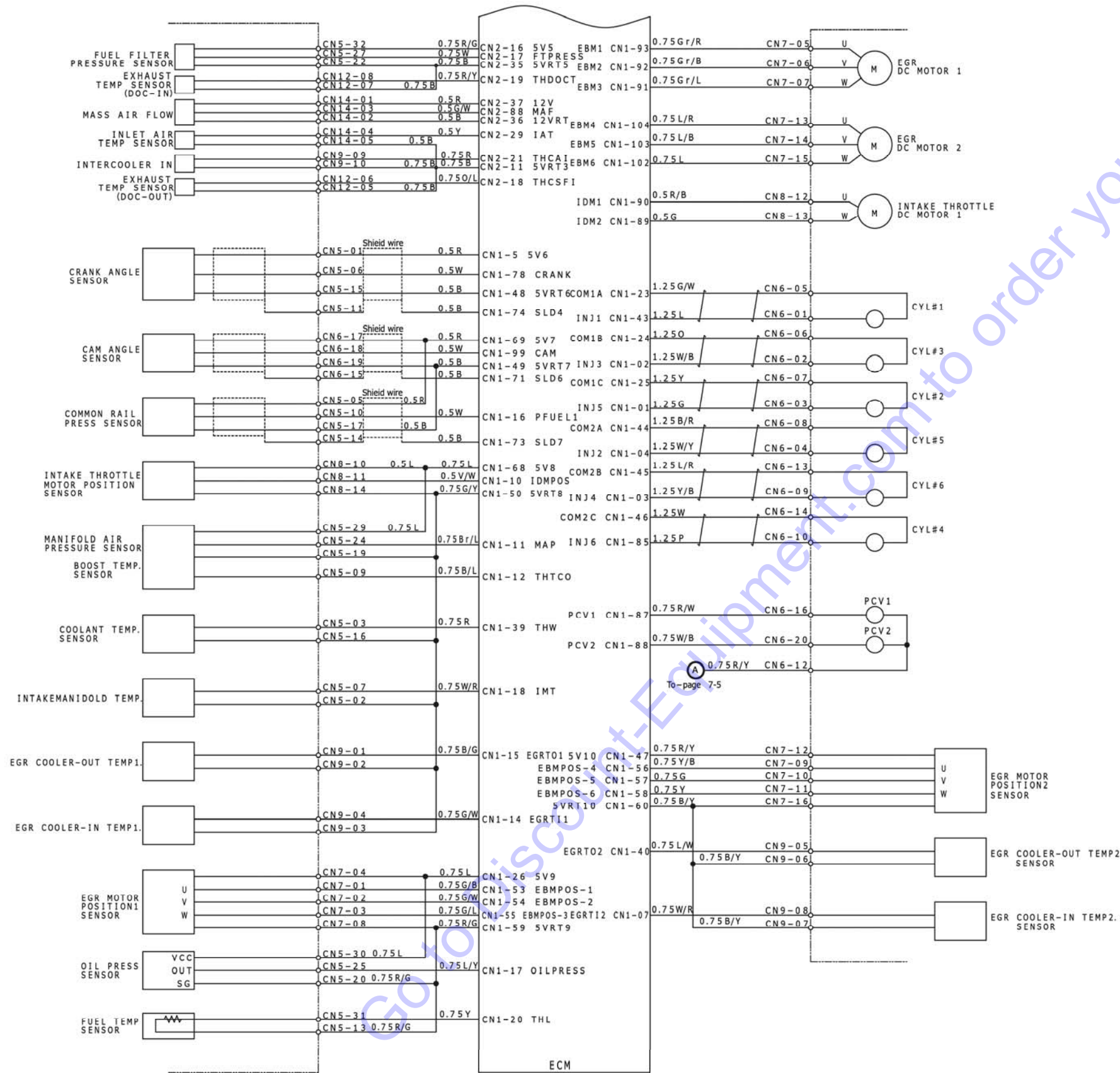

## Connector terminal arrangement

The following arrangement is seen from the side of the connector inserting port.

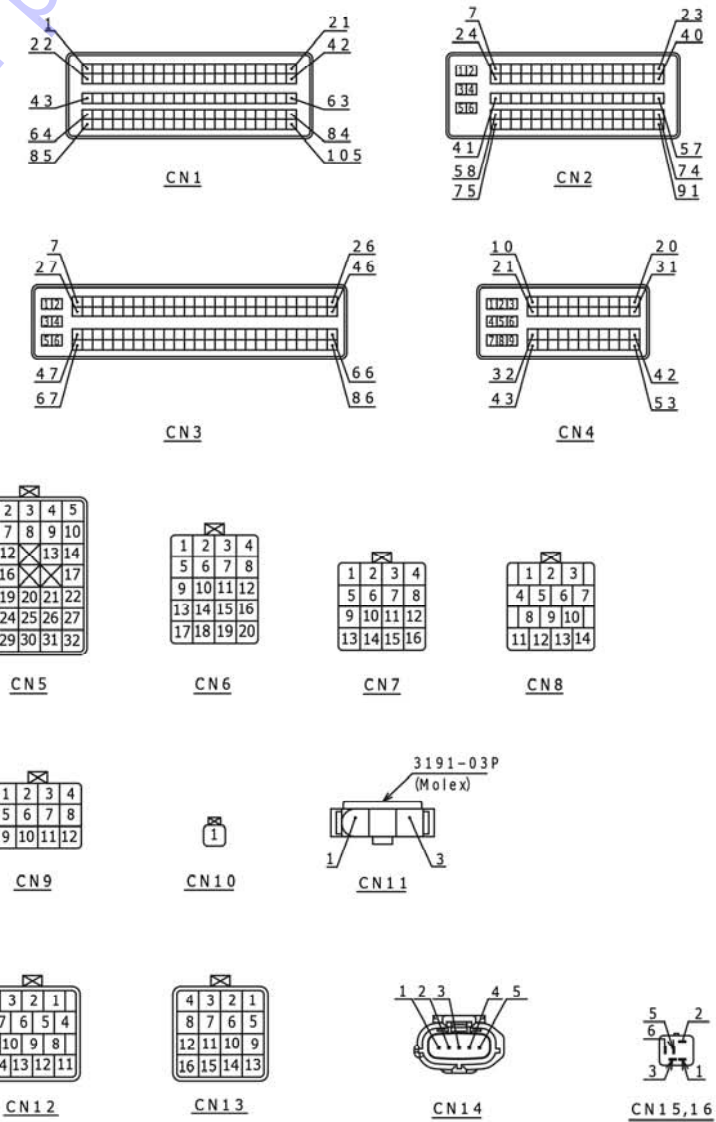

# 7. Specifications

## 7.5 Piping Diagram

[Fuel piping]

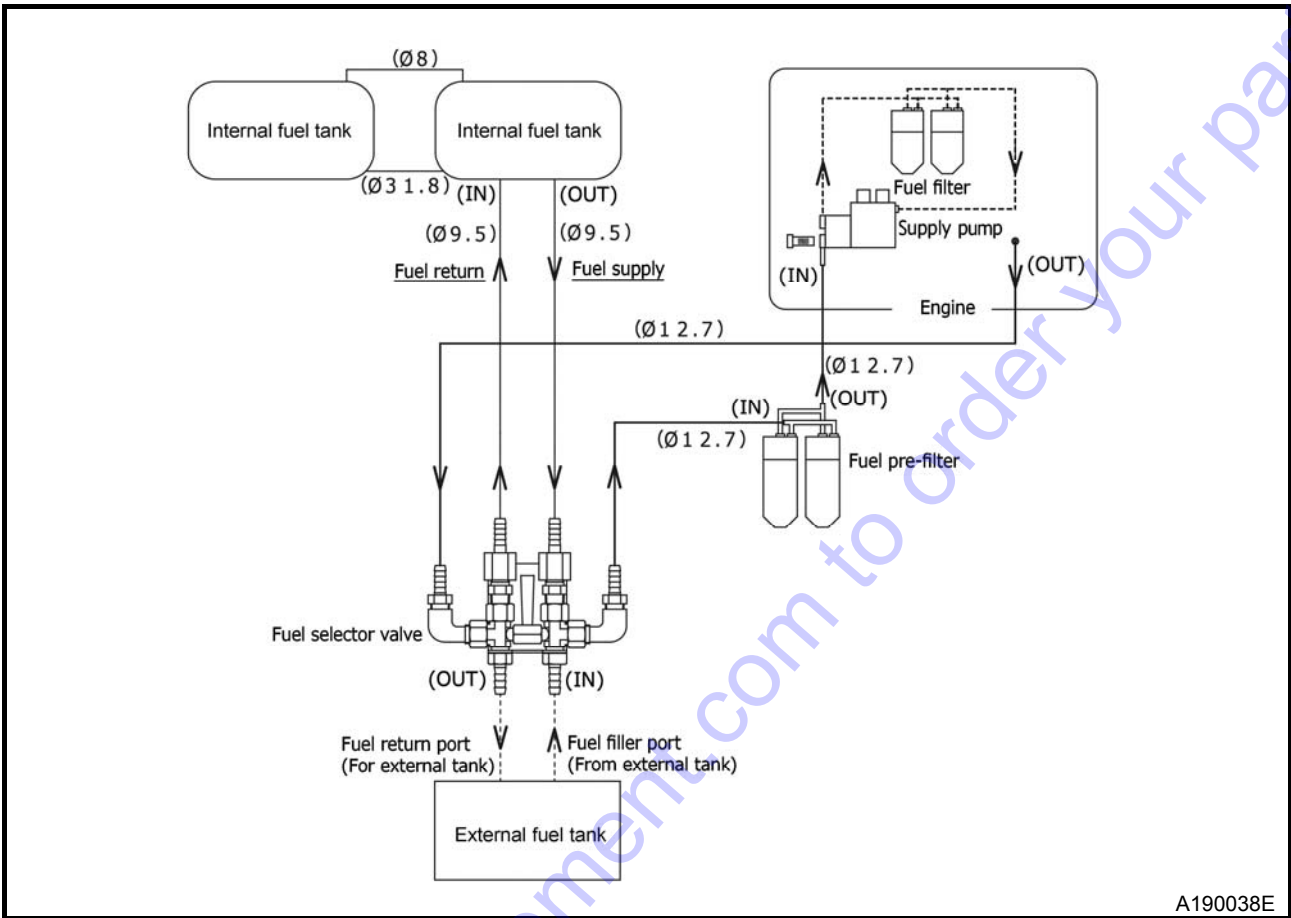

[DEF piping]

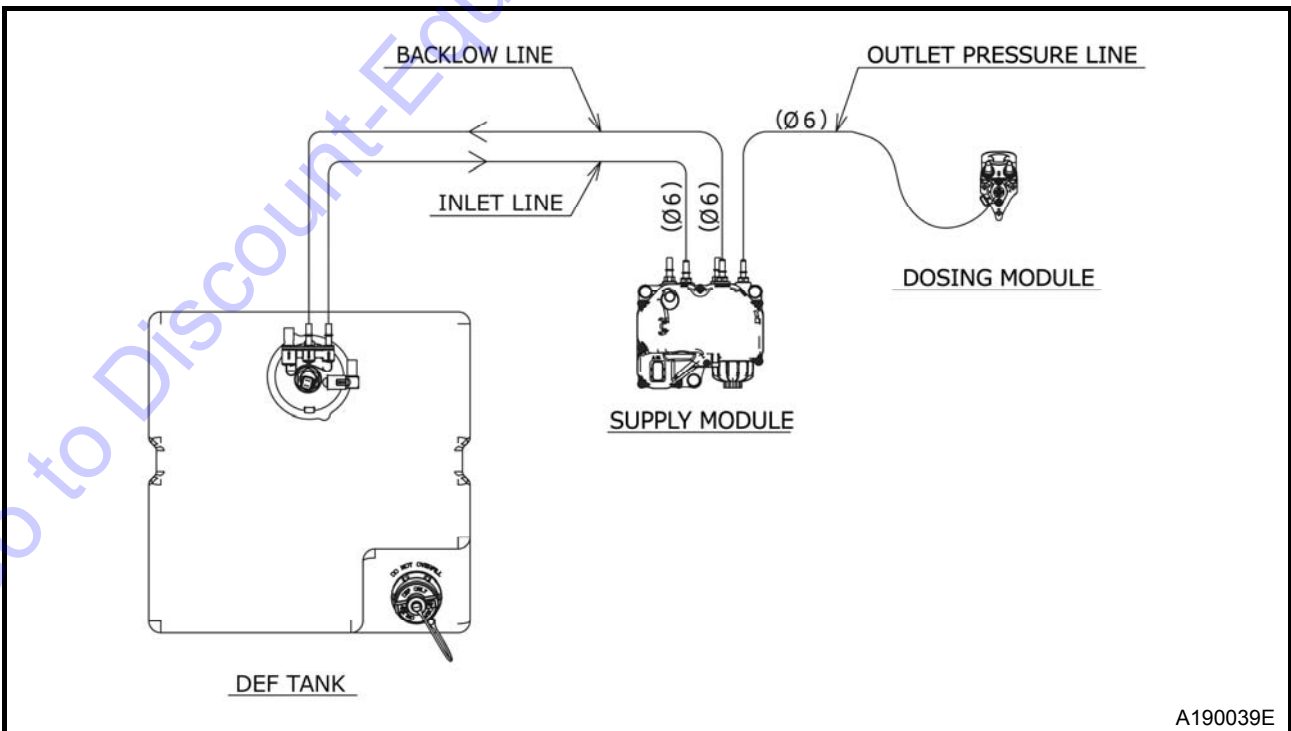

# 7. Specifications

[Coolant piping]

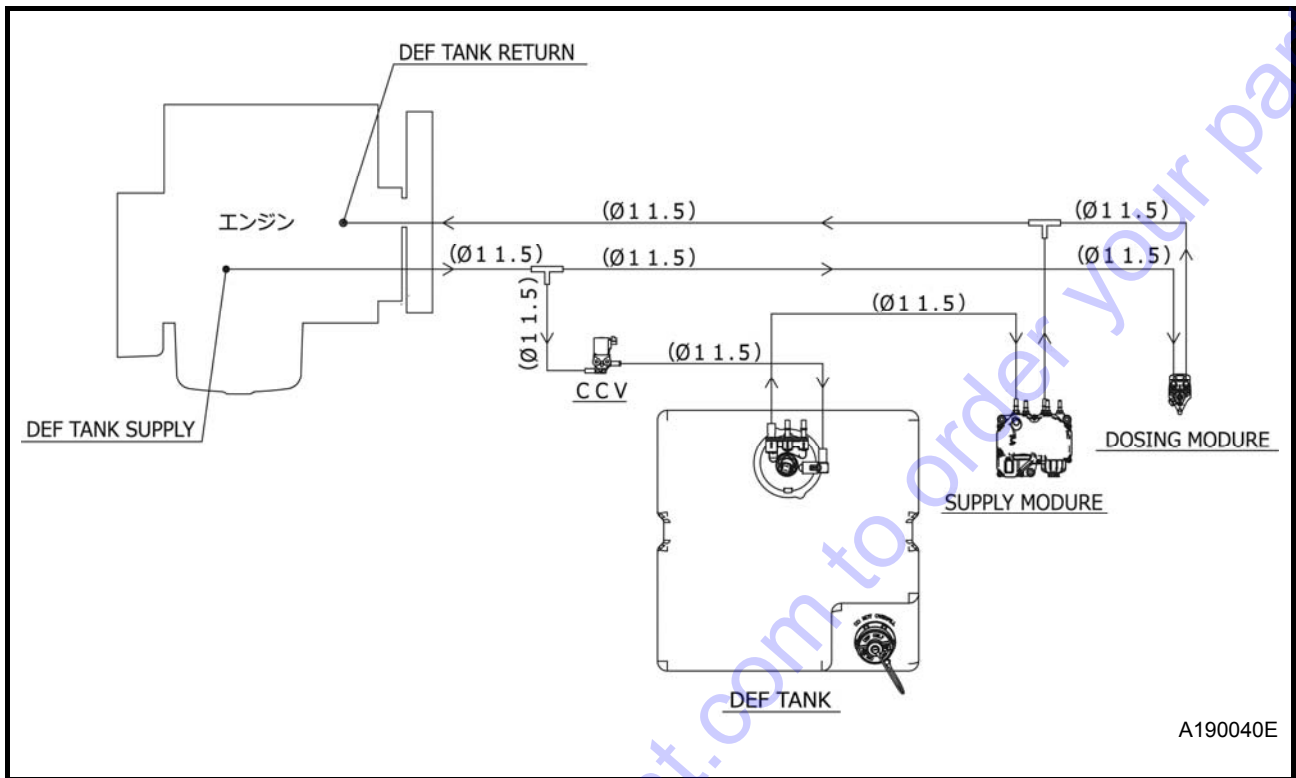



# PARTS FINDER

**Search Website  
by Part Number**



**Search Manual  
Library For Parts  
Manual & Lookup Part  
Numbers – Purchase  
or Request Quote**

**Can't Find Part or  
Manual? Request Help  
by Manufacturer,  
Model & Description**

Discount-Equipment.com is your online resource for quality parts & equipment.

Florida: **561-964-4949** Outside Florida TOLL FREE: **877-690-3101**

**Need parts?**

Click on this link: <http://www.discount-equipment.com/category/5443-parts/> and choose one of the options to help get the right parts and equipment you are looking for. Please have the machine model and serial number available in order to help us get you the correct parts. If you don't find the part on the website or on one of the online manuals, please fill out the request form and one of our experienced staff members will get back to you with a quote for the right part that your machine needs.

We sell worldwide for the brands: Genie, Terex, JLG, MultiQuip, Mikasa, Essick, Whiteman, Mayco, Toro Stone, Diamond Products, Generac Magnum, Airman, Haulotte, Barreto, Power Blanket, Nifty Lift, Atlas Copco, Chicago Pneumatic, Allmand, Miller Curber, Skyjack, Lull, Skytrak, Tsurumi, Husquvarna Target, Stow, Wacker, Sakai, Mi-T-M, Sullair, Basic, Dynapac, MBW, Weber, Bartell, Bennar Newman, Haulotte, Ditch Runner, Menegotti, Morrison, Contec, Buddy, Crown, Edco, Wyco, Bomag, Laymor, EZ Trench, Bil-Jax, F.S. Curtis, Gehl Pavers, Heli, Honda, ICS/PowerGrit, IHI, Partner, Imer, Clipper, MMD, Koshin, Rice, CH&E, General Equipment, Amida, Coleman, NAC, Gradall, Square Shooter, Kent, Stanley, Tamco, Toku, Hatz, Kohler, Robin, Wisconsin, Northrock, Oztec, Toker TK, Rol-Air, APT, Wylie, Ingersoll Rand / Doosan, Innovatech, Con X, Ammann, Mecalac, Makinex, Smith Surface Prep, Small Line, Wanco, Yanmar



[www.discount-equipment.com](http://www.discount-equipment.com)

HOKUETSU INDUSTRIES CO., LTD.

Copyright (C) 2019 HOKUETSU INDUSTRIES CO., LTD. All Rights Reserved.

39600 05640

Printed OCT. 2019

Go to [Discount-Equipment.com](http://Discount-Equipment.com) to order your parts