

# OPERATION AND PARTS MANUAL



***WHITEMAN* SERIES**  
**MODEL HTN-31VTCSL5**  
**MODEL HTO-31VTCSL5**  
**RIDE-ON POWER TROWEL**  
**(B & S VANGUARD GASOLINE ENGINE)**

Revision #5 (05/04/07)



THIS MANUAL MUST ACCOMPANY THE EQUIPMENT AT ALL TIMES.

P/N 12899

# PARTS FINDER

**Search Website  
by Part Number**



**Search Manual  
Library For Parts  
Manual & Lookup Part  
Numbers – Purchase  
or Request Quote**

**Search Manuals**

Enter your information to help us find the right parts manual for your machine.

\* Brand:

\* Model:

\* Serial:

\* Part Number:

SEARCH

**Can't Find Part or  
Manual? Request Help  
by Manufacturer,  
Model & Description**

**Parts Order Form**

Please fill in the following information to help us find the right part for your machine.

Manufacturer:	<input type="text"/>
Model:	<input type="text"/>
Description:	<input type="text"/>
Part Number:	<input type="text"/>
Quantity:	<input type="text"/>
Notes:	<input type="text"/>

Submit

Discount-Equipment.com is your online resource for quality parts & equipment.

Florida: **561-964-4949** Outside Florida TOLL FREE: **877-690-3101**

**Need parts?**

Click on this link: <http://www.discount-equipment.com/category/5443-parts/> and choose one of the options to help get the right parts and equipment you are looking for. Please have the machine model and serial number available in order to help us get you the correct parts. If you don't find the part on the website or on one of the online manuals, please fill out the request form and one of our experienced staff members will get back to you with a quote for the right part that your machine needs.

We sell worldwide for the brands: Genie, Terex, JLG, MultiQuip, Mikasa, Essick, Whiteman, Mayco, Toro Stone, Diamond Products, Generac Magnum, Airman, Haulotte, Barreto, Power Blanket, Nifty Lift, Atlas Copco, Chicago Pneumatic, Allmand, Miller Curber, Skyjack, Lull, Skytrak, Tsurumi, Husquvarna Target, Stow, Wacker, Sakai, Mi-T-M, Sullair, Basic, Dynapac, MBW, Weber, Bartell, Bennar Newman, Haulotte, Ditch Runner, Menegotti, Morrison, Contec, Buddy, Crown, Edco, Wyco, Bomag, Laymor, EZ Trench, Bil-Jax, F.S. Curtis, Gehl Pavers, Heli, Honda, ICS/PowerGrit, IHI, Partner, Imer, Clipper, MMD, Koshin, Rice, CH&E, General Equipment, Amida, Coleman, NAC, Gradall, Square Shooter, Kent, Stanley, Tamco, Toku, Hatz, Kohler, Robin, Wisconsin, Northrock, Oztec, Toker TK, Rol-Air, APT, Wylie, Ingersoll Rand / Doosan, Innovatech, Con X, Ammann, Mecalac, Makinex, Smith Surface Prep, Small Line, Wanco, Yanmar



## WARNING



### **CALIFORNIA — Proposition 65 Warning**

Engine exhaust and some of its constituents, and some dust created by power sanding, sawing, grinding, drilling and other construction activities contains chemicals known to the State of California to cause cancer, birth defects and other reproductive harm. Some examples of these chemicals are:

- Lead from lead-based paints.
- Crystalline silica from bricks.
- Cement and other masonry products.
- Arsenic and chromium from chemically treated lumber.

Your risk from these exposures varies, depending on how often you do this type of work. To reduce your exposure to these chemicals: **ALWAYS** work in a well ventilated area, and work with approved safety equipment, such as dust masks that are specially designed to filter out microscopic particles.

## **WARNING**



### **SILICOSIS WARNING**

Grinding/cutting/drilling of masonry, concrete, metal and other materials with silica in their composition may give off dust or mists containing crystalline silica. Silica is a basic component of sand, quartz, brick clay, granite and numerous other minerals and rocks. Repeated and/or substantial inhalation of airborne crystalline silica can cause serious or fatal respiratory diseases, including silicosis. In addition, California and some other authorities have listed respirable crystalline silica as a substance known to cause cancer. When cutting such materials, always follow the respiratory precautions mentioned above.

## **WARNING**

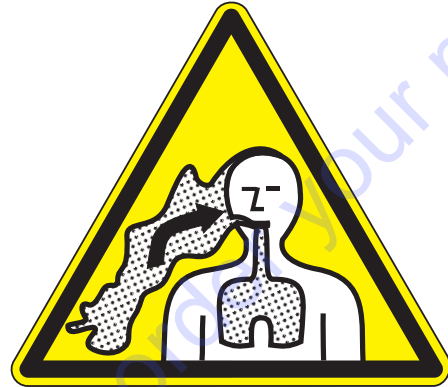

### **RESPIRATORY HAZARDS**

Grinding/cutting/drilling of masonry, concrete, metal and other materials can generate dust, mists and fumes containing chemicals known to cause serious or fatal injury or illness, such as respiratory disease, cancer, birth defects or other reproductive harm. If you are unfamiliar with the risks associated with the particular process and/or material being cut or the composition of the tool being used, review the material safety data sheet and/or consult your employer, the material manufacturer/supplier, governmental agencies such as OSHA and NIOSH and other sources on hazardous materials. California and some other authorities, for instance, have published lists of substances known to cause cancer, reproductive toxicity, or other harmful effects.

Control dust, mist and fumes at the source where possible. In this regard use good work practices and follow the recommendations of the manufacturers or suppliers, OSHA/NIOSH, and occupational and trade associations. Water should be used for dust suppression when wet cutting is feasible. When the hazards from inhalation of dust, mists and fumes cannot be eliminated, the operator and any bystanders should always wear a respirator approved by NIOSH/MSHA for the materials being used.

# HTN/HTO-31V — TABLE OF CONTENTS

## MQ WHITEMAN — HTN/HTO-31V RIDE-ON POWER TROWEL (VANGUARD ENGINE)

California Proposition 65 Warning .....	2
Silicosis/Respiratory Warnings .....	3
Table Of Contents .....	4
Training Checklist .....	5
Daily Pre-Operation Checklist .....	6
Safety Message Alert Symbols .....	7-8
Rules For Safe Operation .....	9-12
Dimensions/Specifications (Trowel) .....	13
Specifications (Engine) .....	14
General Information .....	15
Controls and Indicators .....	16-17
Engine Components .....	18
Setup .....	19
Inspection .....	20
Operation .....	21-22
Maintenance (Engine) .....	23-25
Maintenance (Trowel) .....	25-33
Troubleshooting (Trowel) .....	34-35
Troubleshooting (Engine) .....	36-37
Explanation Of Codes In Remarks Colum .....	38
Suggested Spare Parts .....	39

## COMPONENT DRAWINGS

Nameplate and Decals Assembly .....	40-41
Pivot Assembly .....	42-43
Steering Handles Assembly .....	44-45
Steering Assist Control Assembly .....	46-47
Twin Pitch Assy. (Left/Right) .....	48-49
Twin Pitch and Mitre Box Assy. (Left/Right) .....	50-51
Engine Mounting Bracket Assembly .....	52-53
Muffler Assy. S/N CC020199 and Below .....	54-55
Muffler Assy. S/N CC020200 and Above .....	56-57
Fuel Tank Assembly .....	58-59
Clutch Assembly .....	60-61
Radiator Guard/Overflow Bracket Assy. ....	62-63
V-Belt Guard Assembly .....	64-65
Engine Service Parts .....	66-67
Gearbox Assembly (Left-Side) .....	68-71
Gearbox Assembly (Right-Side) .....	72-75
Drive Assembly .....	76-77
5-Blade Spider Assembly (Left-Side) .....	78-79
5-Blade Spider Assembly (Right-Side) .....	80-81
Seat and Frame Assembly .....	82-83
Frame and Components Assembly .....	84-85
Foot Pedals Assembly .....	86-87
Throttle Assembly .....	88-89
Battery Assembly .....	90-91
Spray Assembly .....	92-93
Control Panel Assembly .....	94-95
E-Z Mover and Lift Handle Assembly .....	96-97
Terms and Conditions Of Sale .....	98

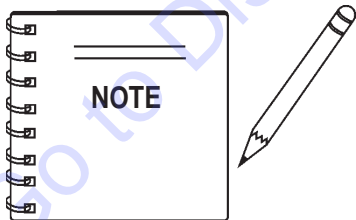

**Specifications and part numbers are subject to change without notice.**

# HTN/HTO-31V — TRAINING CHECKLIST

## TRAINING CHECKLIST

This checklist will lists some of the minimum requirements for machine maintenance and operation. Please feel free to detach it and make copies. Use this checklist whenever a new operator is to be trained or it can be used as a review for more experienced operator's.

TRAINING CHECKLIST			
NO.	DESCRIPTION	OK?	DATE
1	Read Operator's Manual completely.		
2	Machine layout, location of components, checking of engine oil, and hydraulic oil levels.		
3	Fuel system, refueling procedure		
4	Operation of spray and lights.		
5	Operation of controls (machine not running).		
6	Safety controls, seat kill switch operation.		
7	Emergency stop procedures.		
8	Startup of machine.		
9	Maintaining a hover.		
10	Maneuvering		
11	Pitching		
12	Matching blade pitch. Twin Pitch™.		
13	Concrete finishing techniques.		
14	Shutdown of machine.		
15	Lifting of machine (lift loops).		
16	Machine transport and storage.		

Operator \_\_\_\_\_ Trainee \_\_\_\_\_

COMMENTS:

# HTN/HTO-31V — DAILY PRE-OPERATION CHECKLIST

## DAILY PRE-OPERATION CHECKLIST

DAILY PRE-OPERATION CHECKLIST		✓	✓	✓	✓	✓	✓
1	Engine Oil Level.						
2	Gearbox Fluid Level.						
3	Radiator Coolant Level.						
4	Condition of Blades.						
5	Blade Pitch Operation.						
6	Safety-Stop Switch Operation.						
7	Steering Control Operation.						
8	Condition of Belts.						

COMMENTS:

Go to Discount-Equipment.com to order your parts

# HTN/HTO-31V — SAFETY MESSAGE ALERT SYMBOLS

## FOR YOUR SAFETY AND THE SAFETY OF OTHERS!

Safety precautions should be followed at all times when operating this equipment. Failure to read, understand and comply with the Safety Messages and Operating Instructions could result in injury to yourself and others.

This Operation Manual has been developed to provide instructions for the safe and efficient operation of the Ride-On Trowel. For engine maintenance information, please refer to the engine manufacturer's instructions for data relative to its safe operation.



**Before using this Ride-On Trowel, ensure that the operating individual has read, understands, and complies with all instructions in this manual.**

## SAFETY MESSAGE ALERT SYMBOLS

The three (3) Safety Messages shown below will inform you about potential hazards that could injure you or others. The Safety Messages specifically address the level of exposure to the operator, and are preceded by one of three words: **DANGER**, **WARNING**, or **CAUTION**.

### **DANGER**

You **WILL** be **KILLED** or **SERIOUSLY INJURED** if you **DO NOT** follow directions.

### **WARNING**

You **CAN** be **KILLED** or **SERIOUSLY INJURED** if you **DO NOT** follow directions.

### **CAUTION**

You **CAN** be **INJURED** if you **DO NOT** follow directions.

Potential hazards associated with trowel operation will be referenced with Hazard Symbols which appear throughout this manual, and will be referenced in conjunction with Safety Message Alert Symbols.

## HAZARD SYMBOLS

### **WARNING - Lethal Exhaust Gases**

Engine exhaust gases contain poisonous carbon monoxide. This gas is colorless and odorless, and can cause death if inhaled. **NEVER** operate this equipment in a confined area or enclosed structure that does not provide ample free flow air.



### **DANGER - Explosive Fuel**

**Diesel Fuel** is extremely flammable, and its vapors can cause an explosion if ignited. **DO NOT** start the engine near spilled fuel or combustible fluids.



**DO NOT** fill the fuel tank while the engine is running or hot. **DO NOT** overfill tank, since spilled fuel could ignite if it comes into contact with hot engine parts or sparks from the ignition system. Store fuel in approved containers, in well-ventilated areas and away from sparks and flames.

### **WARNING - Burn Hazards**

Engine components can generate extreme heat. To prevent burns, **DO NOT** touch these areas while the engine is running or immediately after operations. Never operate the engine with heat shields or heat guards removed.



### **CAUTION - Rotating Parts**

**NEVER** operate equipment with covers, or guards removed. Keep fingers, hands, hair and clothing away from all moving parts to prevent injury.





## HTN/HTO-31V — SAFETY MESSAGE ALERT SYMBOLS

### CAUTION - Accidental Starting

**ALWAYS** place the engine **ON/OFF** switch in the **OFF** position, when equipment is not in use.



### CAUTION - Respiratory Hazard

**ALWAYS** wear approved *respiratory* protection when required.



### CAUTION - Rotating Blades

**ALWAYS** keep hands and loose clothing from rotating blades.



### CAUTION - Sight and Hearing Hazards

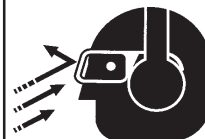

**ALWAYS** wear approved eye and hearing protection.

### WARNING - Over Speed

**NEVER** tamper with the factory settings of the engine governor or settings. Personal injury and damage to the engine or equipment can result if operating in speed ranges above maximum allowable



### CAUTION - Equipment Damage Messages

Other important messages are provided throughout this manual. Your equipment, other property, or the surrounding environment could be damaged if you do not follow instructions.

# HTN/HTO-31V — RULES FOR SAFE OPERATION

## **WARNING - Read this Manual**

Failure to follow instructions in this manual may lead to serious injury or even death! This equipment is to be operated by trained and qualified personnel only! This equipment is for industrial use only.

The following safety guidelines should always be used when operating the Ride-On Trowel.

### SAFETY

■ **DO NOT** operate or service this equipment before you read, understand, and comply with all safety messages in this manual. The manual must be kept available and accessible to the operator.



■ This equipment should not be operated by persons under the minimum statutory age limit.

■ **NEVER** operate this equipment without proper protective clothing, shatterproof glasses, steel-toed boots and other protective devices required for the job.



■ **NEVER** operate this equipment when not feeling well due to fatigue, illness or taking medicine.



■ **NEVER** operate the saw under the influence of drugs or alcohol.



■ **NEVER** use accessories or attachments which are not recommended by the manufacturer for this equipment. Damage to the equipment and/or injury to user may result.

■ Manufacturer does not assume responsibility for any accident due to equipment modifications. Unauthorized equipment modification will void all warranties. Any modification which could lead to a change in the original characteristics of the machine should be made only by the manufacturer who shall confirm that the machine is in conformity with appropriate safety regulations.

■ Replace nameplate, operation and safety decals when they become difficult to read.

■ **ALWAYS** check for loosened hardware such as nuts and bolts before starting.

■ **NEVER** touch the hot exhaust manifold, muffler or cylinder. Allow these parts to cool before servicing the equipment. Contact with **hot** components can cause serious burns.



## **DANGER - Lethal Exhaust Gases**

**NEVER** operate the equipment in any enclosed or narrow area where free flow of the air is restricted. If the air flow is restricted, it will cause serious damage to the engine and may cause injury to people. Remember the engine gives off **DEADLY** carbon monoxide gas. When operating equipment in confined spaces such as tunnels, buildings or similar areas, ensure proper air flow to move engine exhaust away from the operator.



■ **ALWAYS** refuel in a well-ventilated area, away from sparks and open flames.

■ Topping-off to filler port is dangerous, as it tends to spill fuel.

■ **NEVER** use fuel as a cleaning agent.

■ **ALWAYS** use extreme caution when working with **flammable** liquids. When refueling, **STOP** the engine. Allow the engine to cool before adding fuel or performing service and maintenance functions.

■ **NEVER** operate the equipment in an explosive atmosphere where fumes are present, or near combustible materials. An explosion or fire could result in severe **bodily harm or even death**.



■ **NEVER** smoke around or near the machine. Fire or explosion could result from **fuel vapors**, or if fuel is spilled on a **hot** engine.



■ **NEVER** run engine without air filter. Severe engine damage may occur. Service air filter frequently to prevent carburetor malfunction.

■ **NEVER** place your **feet** or **hands** inside the guard rings while starting or operating this equipment.

# HTN/HTO-31V — RULES FOR SAFE OPERATION

## WARNING - Clear Operating Area

**ALWAYS** make sure that the operating area is clear before starting the engine.

- **AVOID** wearing jewelry or loose fitting clothing that may snag on the controls or moving parts as this can cause a serious injury.
- **ALWAYS** keep clear of *rotating* or *moving parts* while operating the equipment. Shut down the engine before performing service or maintenance functions. Contact with moving parts can cause serious injury.
- **NEVER** leave the machine *unattended* while the engine is running.
- **ALWAYS** be sure the operator is familiar with proper safety precautions and operations techniques before using equipment.
- **ALWAYS** keep the work area well organized.
- **ALWAYS** clear the work area of any debris, tools, etc. that would constitute a hazard while the equipment is in operation.
- No one other than the operator is to be in the working area when the equipment is in operation.
- **NEVER** store the trowel with fuel in the tank for any extended period of time. Always clean up spilled fuel immediately.
- **NEVER** allow passengers or riders on the trowel during operation.
- **ALWAYS** observe all applicable compulsory regulations relevant to environmental protection, especially, fuel storage, the handling of hazardous substances, and the wearing of protective clothing and equipment. Instruct the user as necessary, or as the user, request this information and training.
- **ALWAYS** disconnect spark plug wires and battery cables before attempting any service or maintenance on the ride-on trowel
- Reference engine manual for specific information on tuning up your engine, checking and gapping the spark plugs, etc.
- **ALWAYS** store equipment properly when it is not being used. Equipment should be stored in a clean, dry location out of the reach of children.

## Additional Safety Information

A handy safety manual for operating and maintenance personnel of concrete power trowels produced by the Association of Equipment Manufacturers (AEM) can be obtained for a fee by ordering through their website at [www.aem.org](http://www.aem.org).

Order FORM PT-160.



## Lifting the Ride-On Trowel

### CAUTION - Heavy Lifting

This ride-on trowel is very **heavy** and awkward to move around. Use proper heavy lifting procedures and **DO NOT** attempt to lift the ride-on trowel by the guard rings.

This Ride-On Power Trowel is designed to be moved and handled several ways.

The easiest way to lift the trowel is to utilize the lift loops that are welded to the frame. These lift loops are located to the left and right sides of the operator's seat.

A strap or chain can be attached to these lift loops, allowing a forklift or crane to lift the trowel up onto and off of a slab of concrete. The strap or chain should have a minimum 2,000 pounds (1000 kg) lifting capacity and the lifting gear must be capable of lifting at least this amount.

### DANGER - Lifting Trowel

**NEVER** stand under or allow anyone else to stand under the trowel while it is being lifted.



## Transporting

- **ALWAYS** shutdown engine before transporting.
- Tighten fuel tank cap securely and close fuel cock to prevent fuel from spilling.
- Drain fuel when transporting equipment for long distances or over bad roads.
- When placing the equipment on a truck-bed for transport, **always** tie-down the equipment.
- If the equipment is being transported via a trailer, make sure the trailer complies with all local and state safety transportation laws. Refer to the following "**Towing Safety Precautions**" for basic towing techniques.

# HTN/HTO-31V — RULES FOR SAFE OPERATION

## Towing Safety Precautions

### CAUTION - Transporting

Conform to **Safety Towing Regulations** before transporting trowel on public roads.

To reduce the possibility of an accident while transporting the equipment on public roads, always make sure the trailer that supports the equipment and the towing vehicle are in good operating condition and that both units are mechanically sound.

The following list of suggestions should be used when towing your trowel:

- Make sure the hitch and coupling of the towing vehicle are rated equal to or greater than the trailer "gross vehicle weight rating" (GVWR) of 6,000 lbs.
- **ALWAYS** inspect the hitch and coupling for wear. **NEVER** tow a trailer with defective hitches, couplings, chains, etc.
- Check the tire air pressure on both towing vehicle and trailer. **Trailer tires should be inflated to 50 psi cold.** Also check the tire tread wear on both vehicles.
- **ALWAYS** make sure the trailer is equipped with "Safety Chains".
- **ALWAYS** attach trailer's safety chains to towing vehicle properly.
- **ALWAYS** make sure the vehicle and trailer directional, backup, brake, and trailer lights are connected and working.
- **DO NOT** exceed the recommended highway speed when towing. Unless posted otherwise, do not exceed 45 MPH highway, and 10 MPH off-road.
- Use chock-blocks at each wheel when parked to prevent trailer from rolling.
- Use the trailer's swivel jack to adjust the trailer height to a level position while parked.
- Avoid sudden stops and starts. This can cause the trailer to skid or jack-knife. Smooth, gradual starts and stops will improve towing.
- Avoid sharp turns.
- Trailer should be adjusted to a level position at all times when towing.
- Raise and lock trailer wheel stand in the "UP" position when transporting.
- Safety towing regulations require to connect and test electric brake operation and to secure portable power cables in cable tray with tie wraps.

## Battery

The battery contains acids that can cause injury to the eyes and skin. To avoid eye irritation, **always** wear safety glasses or face shielding. Use well-insulated gloves when picking up the battery. Use the following guidelines when handling the battery.

- **DO NOT** drop the battery. Any impact to the battery may cause it to explode.
- **DO NOT** expose the battery to open flames, sparks, lit cigarettes etc. The battery contains combustible gases and liquids. If these gases and liquids come in contact with a flame or spark an explosion can occur.
- **ALWAYS** keep the battery charged. If the battery is not charged, a buildup of combustible gas will occur.
- **ALWAYS** keep battery cables in good working condition. Repair or replace all worn cables.
- **ALWAYS** disconnect the **negative battery terminal** before performing service on the equipment.
- Inadequate battery connections may cause poor starting of the trowel, and create other malfunctions.
- **ALWAYS** recharge the battery in a vented air environment to avoid risk of a dangerous concentration of combustible gases.
- **DO NOT** charge battery if frozen. Battery can explode. When frozen, warm battery to at least 61°F (16°C).
- If the battery liquid (dilute sulfuric acid) comes in contact with **clothing or skin**, rinse skin or clothing immediately with plenty of water.
- If the battery liquid (dilute sulfuric acid) comes in contact with your **eyes**, rinse eyes immediately with plenty of water, then contact the nearest doctor or hospital and seek medical attention.



# HTN/HTO-31V — RULES FOR SAFE OPERATION

## Maintenance Safety

- **ALWAYS** shut down the engine and disconnect battery before performing service or maintenance functions. Contact with moving parts can cause serious injury.
- Securely support any equipment components that must be raised.
- **NEVER** lubricate components or attempt service on a running equipment.
- **ALWAYS** allow the equipment a proper amount of time to cool before servicing.
- Keep the trowel in proper running condition.
- Make sure that there is no buildup of concrete, grease, oil or debris on the machine.
- Repair damage to the trowel immediately and always replace broken parts.
- Dispose of hazardous waste properly. Examples of potentially hazardous waste are used motor oil, fuel and fuel filters.
- **DO NOT** use plastic food containers to dispose of hazardous waste.
- **DO NOT** pour waste oil or fuel directly onto the ground, down a drain or into any water source.
- **NEVER** store equipment with fuel in the tank for any extended period of time. Always clean up spilled fuel immediately.

## Emergencies

- **ALWAYS** know the location of the nearest **fire extinguisher**.



- **ALWAYS** know the location of the nearest **first aid kit**.



- Know the phone numbers of the nearest **ambulance, doctor and fire department**. Ensure that a phone or radio is readily available at the jobsite. If this is not possible, know the location of the nearest phone. This information will be invaluable in the event of an emergency.



# HTN/HTO-31V — DIMENSIONS/SPECIFICATIONS (TROWEL)

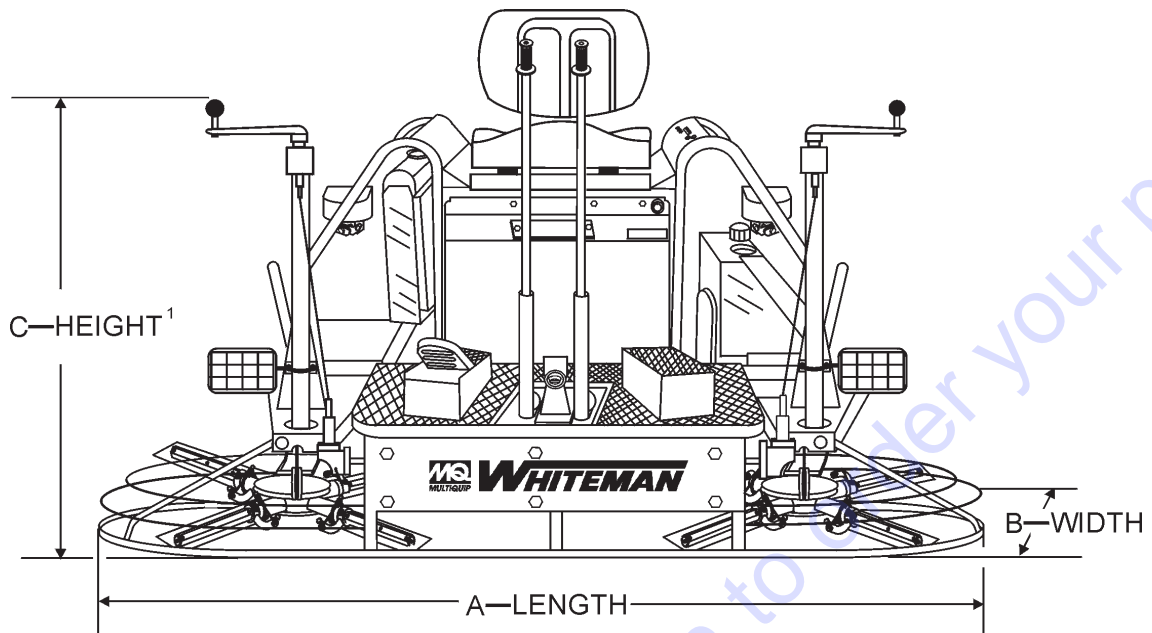

Figure 1. HTN/HTO Dimension Specifications

Table 1. HTN/HTO Series Specifications

SPECIFICATION PARAMETER	HTN-31V(VANGUARD)	HTO-31V (VANGUARD)
A—Length – in. (cm)	97.00 (246.4)	92.5 (234.9)
B—Width – in. (cm)	50.0 (127)	50.0 (127)
C—Height – in. (cm) <sup>1</sup>	46.0 (117)	46.0 (117)
Weight – lbs. (kgs.) Operating	1,000 (453)	1,042 (477)
Weight – lbs. (kgs.) Shipping	1,200 (544)	1,224 (555)
Sound Pressure – dBA <sup>2</sup>	95	95
Vibration – ft/s <sup>2</sup> (m/ s <sup>2</sup> ) <sup>3</sup>	<8.0 (2.5)	<8.0 (2.5)
Blade Tip Speed – FPM (m/s)	1216 (6.2)	1216 (6.2)
Engine – H.P.	31	31
Fuel Tank – gallons (liters)	5 (19)	5 (19)
Rotor – RPM	60 to 145	60 to 145
Path Width – in. (cm)	91 (231)	88 (224)
Hydraulic Oil <sup>4</sup>	Whiteman P/N 10139 Or ISO 680	Whiteman P/N 10139 Or ISO 680

**NOTE:**

1. This value does not include seat height. To obtain total height (seat ) add 4 inches (10.2 cm.).
2. Sound pressure is "A" weighted . Measured at the operators ear position while the ride-on trowel is operating at full throttle on concrete in a manner most often experienced in "**normal**" circumstances. Sound pressure may vary depending upon the condition of the concrete. Hearing protection is always recommended.
3. The vibration level indicated is the maximum RMS (Root Mean Square) value obtained at the handle grip while operating the ride-on trowel on curing concrete in a manner most often experienced in "**normal**" circumstances. Values were obtained from all three axes of motion. The values shown represent the maximum RMS value from these measurements.

## HTN/HTO-31V — SPECIFICATIONS (ENGINE)

**Table 2. HTN/HTO-31V Engine Specifications**

<b>Model</b>	Briggs & Stratton Vanguard 950G
<b>Type</b>	Gasoline Engine
<b>Cylinders</b>	3
<b>Power</b>	31 HP (23.1 kW) @3600 rpm
<b>Maximum Torque</b>	51.7 ft lbs. (70.1 Nm) @ 2200 rpm
<b>Displacement</b>	58.1 cu.in. (952 cc)
<b>Bore</b>	2.9 in. (72 mm)
<b>Stroke</b>	3.1 in. (78 mm)
<b>Engine Oil Capacity</b>	3.2 qt. (3 liters)
<b>Dry Weight</b>	159 lbs. (72.3 Kg)
<b>Dimensions (L x W x H)</b>	15.6 in. x 17.1 in. x 19.7 in. (431.3 mm x 443.2 mm x 501.4 mm)

## HTN/HTO Ride-On Trowel Familiarization

The HTN/HTO series Ride-On Power Trowels are designed for the floating and finishing of concrete slabs. These ride-on trowels are available in non-overlapping (HTN), and overlapping (HTO) configurations.

Take a walk around the HTN/HTO Ride-On Power Trowel. Take note of all the major components like the engine, blades, air cleaner, fuel system, fuel shut-off valve, ignition switch etc. Check that there is always oil in the engine, and gear oil in the gear box assembly.

Read all the safety instructions carefully. Safety instructions will be found throughout this manual and on the machine. Keep all safety information in good, readable condition. Operators should be well trained on the operation and maintenance of the HTN/HTO Ride-On Power Trowels.

Look at the operator control levers. Grab the control levers and move them around a bit. Look to see how moving the control levers causes the gearboxes and frame to move.

Notice the foot pedal which controls the engine speed. Also take a look at the main driveline of the trowel. Take note and reference how the belts look, this is the way the belts should look when adjusted properly.

Before using your HTN/HTO Ride-On Power Trowel, test it on a flat watered down section of finished concrete. This trial test run will increase your confidence in using the trowel and at the same time it will familiarize you with the trowel's controls and indicators. In addition you will understand how the trowel will handle under actual conditions.

## Engine

The HTN/HTO Ride-On Power Trowel is equipped with a liquid cooled 31 HP Vanguard gasoline engine. Refer to the engine owner's manual for specific instructions regarding engine operation. This manual is included with the ride-on trowel at the time of shipping from Whiteman. Please contact your nearest Multiquip Dealer for a replacement should the original manual disappear.

## Blades

The blades of the ride-on power trowel finish the concrete as they are swirled around the surface. Blades are classified as combination (10 or 8 inches wide), finish (6 inches wide). The HTN/HTO ride-on power trowels are equipped with five blades per rotor equally spaced in a radial pattern and attached to a vertical rotating shaft by means of a **spider assembly**.

## Gearboxes

The HTN/HTO Ride on Power Trowel consist of two separate gearbox assemblies that are enclosed in rugged cast aluminum gear cases. The main gear is a high quality bronze and steel composite. The worm gear is composed of hardened steel.

Cooling fins and fans are integrated into the gearbox to provide maximum cooling for the gearbox oil. The gearbox casing holds 50% more oil capacity than competitors, which allows more lubrication to be provided to critical points.

## Steering Assist

Dual control levers located in front of the operator's seat are provided for steering the HTN/HTO Ride on Power Trowel. The control levers are linked to two spring loaded cylinders.

Push the left control lever forward and pull the right control lever backward and the trowel will rotate clockwise on approximately a center axis. Pull the left control lever backward and push the right control lever forward and the trowel will rotate counterclockwise.

## Constant Velocity Joints (CV-Joints)

Constant velocity joints insure the efficient transfer of power to the drive shaft and maintains the timing of the gearboxes without any chance of slippage.

## Training

For proper training, please use the "**TRAINING CHECKLIST**" located in the front of this manual. This checklist will provide an outline for an experienced operator to provide training to a new operator.



## HTN/HTO-31V — CONTROLS AND INDICATORS

Figures 2 and 3 show the location of the controls, indicators and general maintenance parts. Each control may perform more than one function. The functions of each control or indicator is described below and on the next page.

1. **Seat** – Place for operator to sit. Engine will not start unless operator is seated. Seat is adjustable, fore and aft for operator comfort.
2. **Steering Control Lever (right side)** -Allows the unit to move in either a forward, reverse left or right direction.
3. **Retardant Spray Control Button** –When pressed allows retardant spray to flow through the spray nozzle located at the front of the machine.
4. **Twin Pitch Control** – Adjusts the blade pitch for right side of the trowel. Turn the crank as marked on its top surface to increase or decrease blade pitch.
5. **Twin Pitch Control** – Adjusts the blade pitch for left side of the trowel. Turn the crank as marked on its top surface to increase or decrease blade pitch.
6. **Steering Control Lever (left side)** -Allows the unit to move in either a forward, reverse left or right direction.
7. **Light Switch** – When activated, turns on four halogen lights. Lights offer better visibility when working indoors.
8. **Ignition Switch** – With key inserted turn clockwise to start engine.
9. **Oil Indicator Light** - Lights red when oil pressure is low.
10. **Water Indicator Light** - Lights red when water temperature is high.
11. **Charge Indicator** - Lights red when electrical system is not charging properly.
12. **Hour Meter** - Indicates number of hours machine has been in use or hours engine was run.
13. **Choke Control Lever.** - In cold weather pull this lever forward about half way to start engine. After engine warms push knob all the way in.
14. **Fuel Gauge/Filler Cap** - Indicates the amount of fuel in the fuel tank. Remove this cap to add fuel.
15. **Fuel Tank** - Holds 5 gallons of unleaded gasoline.
16. **Spare Belt Carrier** - Contains 2 spare belts. Belts are used on the drive pulley.
17. **Left Foot Riser** – Operator foot rest pedal.
18. **Spray Nozzle** – Spray nozzle for retardant.
19. **Right Foot Pedal** – Controls blade speed. Slow blade speed is accomplished by slightly depressing the foot pedal. Maximum blade speed is accomplished by fully depressing the foot pedal.
20. **EZ-Mover Boss** – Front -side insertion point for EZ Mover. Used when the transporting of the trowel is required.

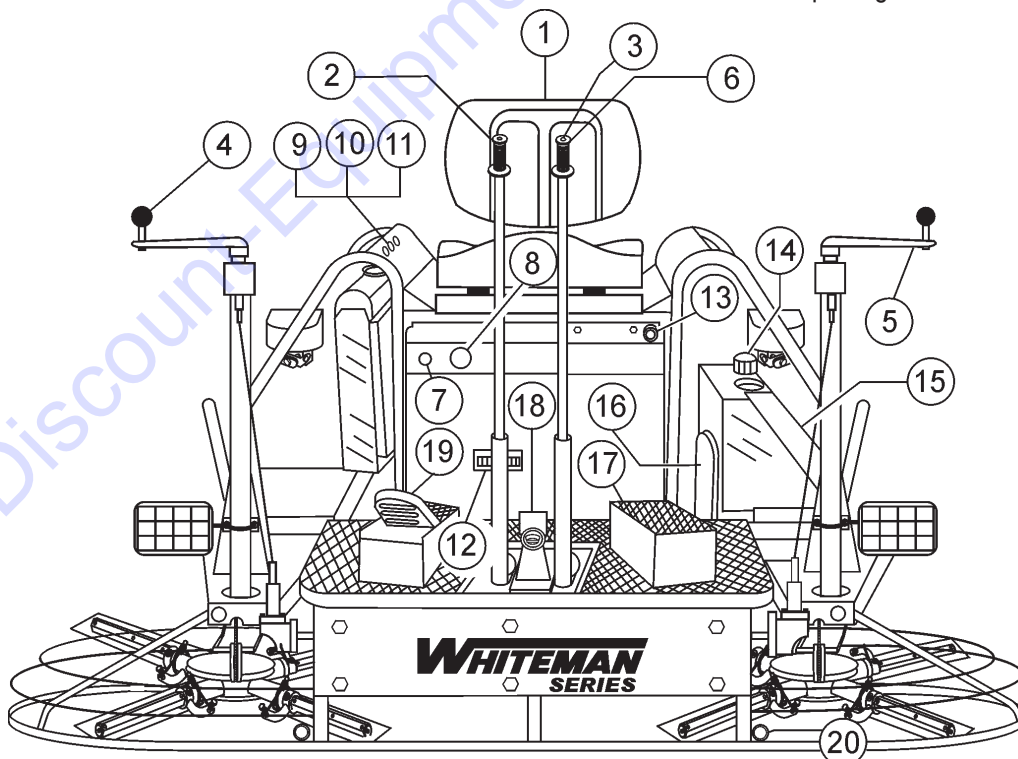

Figure 2. HTN/HTO Controls and Indicators (Front)

## HTN/HTO-31V — CONTROLS AND INDICATORS

21. **Radiator/Filler Cap** – Holds coolant or water necessary to keep engine at a safe operating temperature. Remove this cap to add water or antifreeze.
22. **Lift Loops** – Located on both the left and right sides of the main frame. Used when the trowel must be lifted onto a concrete slab.
23. **Lights** – Four 12 volt halogen lights are provided with this unit.
24. **Right-Side Spider** – Consists (basic) of trowel arms, blades, wear plate, and thrust collar etc.
25. **Left-Side Spider** – Consists (basic) of trowel arms, blades, wear plate, and thrust collar etc.
26. **Safety Kill Switch** – Shuts down engine when operator is **not** sitting in seat.
27. **Engine Oil Filler Cap** - Remove this cap to add engine oil.
28. **Overflow Bottle** - Supplies coolant to the radiator when radiator coolant level is low. Fill to indicated level as shown on bottle.
29. **Engine Air Filter** – Prevents dirt and other debris from entering the fuel system. Lift locking latch on air filter canister to gain access to filter element.
30. **Engine Dip Stick** – Indicates engine oil level. Add oil as required.
31. **Oil Filter** – Provides oil filtering for the engine.
32. **Battery** – Provides +12V DC power to the electrical system
33. **Retardant Spray Motor** – Used in conjunction with the left spray control button.
34. **Retardant Spray Tank** – Holds 5 gallons of retardant.
35. **Belt Guard** – Encloses V-belts used in conjunction with clutch.
36. **EZ-Mover Boss** – Back-side insertion point for EZ Mover. Used when the transporting of the trowel is required.

The following section is intended as a basic guide to the ride-on trowel operation, and is not to be considered a complete guide to concrete finishing. It is strongly suggested that all operators (experienced and novice) read "**Slabs on Grade**" published by the American Concrete Institute, Detroit Michigan.

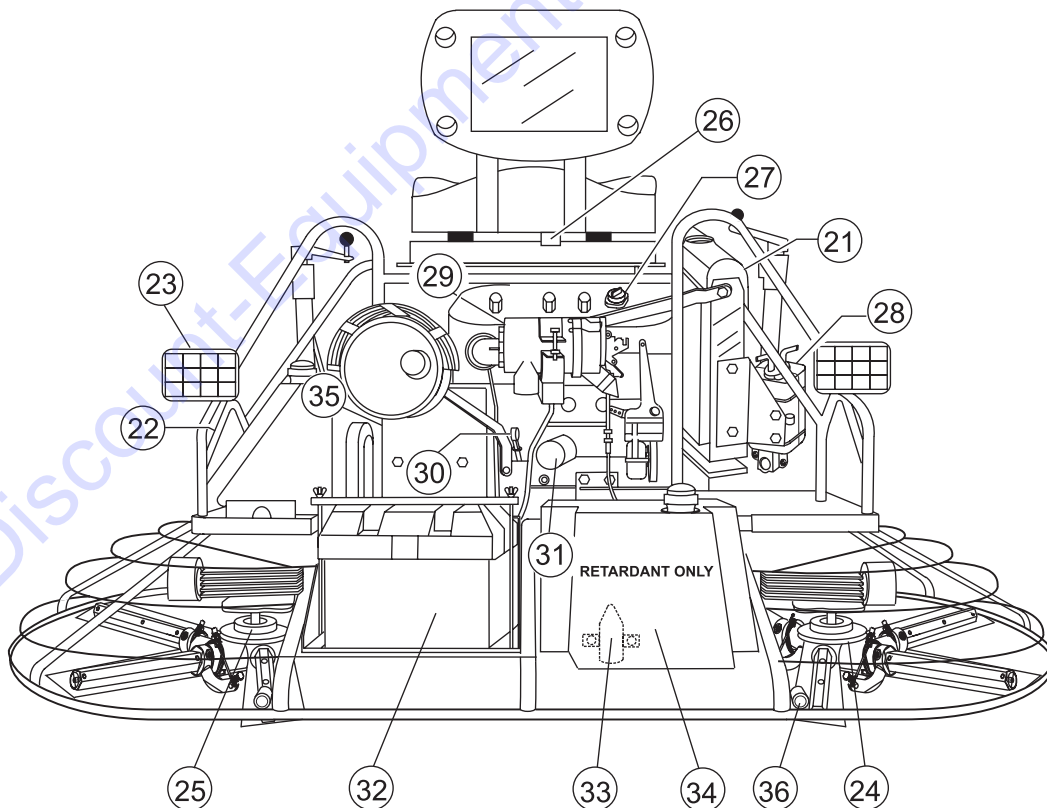
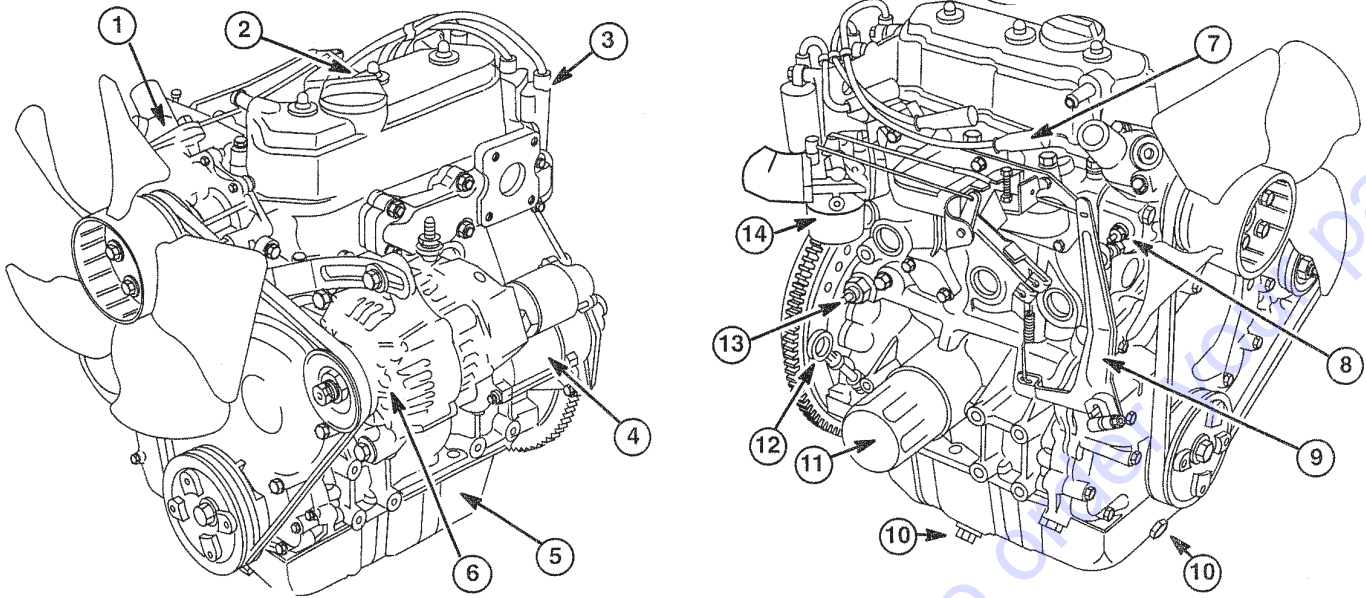

Figure 3. HTN/HTO Controls and Indicators (Rear)



**Figure 4. Engine Components**

The following refer to the basic engine components for reference (Figure 4). Refer to the manufacturer's engine manual for instructions and details of operation and servicing. The engine shown above is a **Briggs & Stratton Vanguard** gasoline engine. Operation for other types of engines may vary somewhat.

1. **Thermostat**— Regulates the temperature of the engine coolant.
2. **Oil Filler Cap** – Remove to add engine oil.
3. **Ignition Coil** – Regulates coolant temperature.
4. **Electric Starter** – Starts engine when ignition key is rotated to the "ON" position.
5. **Oil Pan** – Holds a maximum of 3.2 quarts (3.0 liters) of motor oil.
6. **Alternator** - Provides current to the electrical system and charges the battery.
7. **Spark Plug** – Provides spark to the ignition system. Set spark plug gap to 0.028 ~ 0.031 inch (0.6~0.7 mm). Clean spark plug once a week.
8. **Coolant Temperature Sending Unit** - Device that measures coolant temperature.
9. **Governor Lever** – This lever restricts engine speed (high idle or low idle) through a speed control device linked to the accelerator system.
10. **Oil Drain** – Used to drain crankcase oil. Always dispose of used oil and oil filters in an environmentally safe manner. **DO NOT** allow used oil to drain onto the ground or into a water runoff drain.
11. **Oil Filter** – Prevents dirt and other debris from entering the engine oil.
12. **Oil Dip Stick** – Remove to check amount and condition of oil in crankcase.
13. **Oil Pressure Sending Unit** – Device that measures engine oil pressure.
14. **Carburetor** – Low-emission carburetor equipped with an idle mixture valve with a limiter which allows adjustment.

**! WARNING - Hot Engine**

Engine components can generate extreme heat. To prevent burns, **DO NOT** touch these areas while the engine is running or immediately after operating. **NEVER** operate the engine with the muffler removed.



# HTN/HTO-31V — SETUP

## Trowel Setup Instructions

The purpose of this section is to assist the user in the setting up of a **NEW** trowel. If your trowel is already assembled (seats, handles, knobs and battery, then this section can be skipped.

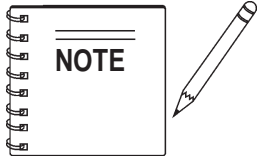

The new ride-on trowel cannot be put into service until the setup installation instructions are completed. These pre-setup instructions only need to be performed at the time of unpacking a **NEW** trowel.

Before packaging and shipping this Whiteman Ride-On Power Trowel was run and tested at the factory. If there are problems, please let us know.

## Control Handle Assembly

The steering control handles are not attached to the trowel's two lower handles at the time of shipment. To attach the steering control handles to the two lower handle assemblies perform the following:

1. Remove the bolts from the plastic bag tied to the control towers.
2. Remove all protective wrapping and straps from the control handles.
3. Slip the top (loose) piece into the base of the corresponding handle, making sure to line up the holes.
4. Install the bolt through the lined up holes and tighten the acorn nut onto the threaded end.
5. Pay close attention to any wires that may be inside the control handles. **DO NOT** pinch or cut any wires during installation.
6. Inside the plastic bag of parts are two knobs for the pitch control tower cranks. Install these two knobs onto the tower crank levers.

## Seat Assembly

The seat is not installed on the trowel for shipping purposes. To attach the seat perform the following:

1. Remove the seat from the protective wrapping.
2. Remove the bolts on the bottom of the seat, and place seat on the seat mounting plate, then insert the bolts through the holes or slots on the seat mounting plate and tighten. Attach wires to seat.

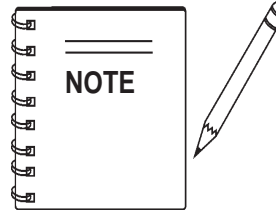

There are two types of seats, depending on what type of trowel you have. J and B series trowels have slots on the seat mounting plate that allow **fore** and **aft** adjustment of the seat. H-series trowels have a seat that is mounted on tracks, similar to an automobile seat. This seat can be adjusted fore and aft via the control lever under the front of the seat.

## Battery Setup

This trowel was shipped with a wet charged battery. This battery may need to be charged for a brief period of time as per the manufacturer instructions.

**! WARNING - Battery Safety**

Use all safety precautions specified by the battery manufacturer when working with the battery.

Flammable, explosive gas. (produces hydrogen gas while charging or during operation). Keep area around battery well ventilated and keep from any fire source.



Battery electrolyte contains corrosive, toxic chemical. (dilute sulfuric acid). Avoid contact with eyes and skin.

Shock or Fire due to electric short-circuit. Disconnect battery cables before inspecting electrical system and never "spark" battery terminals to test for charge.



To install the battery on the trowel, make sure that the battery is well seated in the battery box and the terminals are properly connected. Close the plastic battery box cover and secure the battery box.

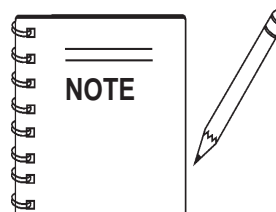

**ALWAYS** be sure the battery cables are properly connected to the battery terminal. The **RED** cable is connected to the positive terminal of the battery, and the **BLACK** cable is connected to the negative terminal of the battery.

1. Check and clean battery terminals for corrosion.
2. Check and keep battery electrolyte between upper and lower limits indicated on the battery. Never operate or recharge without sufficient fluid in the battery.
3. Never attempt to charge a battery that is frozen. The battery can explode unless first allowed to thaw.
4. Disconnect the negative terminal (-) of the battery during storage. If unit will be stored where ambient temperature will drop to -15° C or less, remove and store battery in a warm, dry place.

This section is intended to assist the operator with the initial start-up of the HTN/HTO series Ride-On Power trowel. It is extremely important that this section be read carefully before attempting to use the trowel in the field.

**DO NOT** use your ride-on power trowel until this section is thoroughly understood.

**! WARNING - Damage and Injury**

Failure to understand the operation of the HTN/HTO-31V Ride-On Power Trowel could result in severe damage to the trowel or personal injury.

See Figures 2 and 3 for the location of any control or indicator referenced in this manual.

### Engine Oil Level

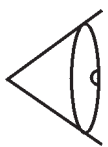

1. Pull the engine oil dipstick from its holder.
2. Determine if engine oil is low (Figure 5), add correct amount of engine oil to bring oil level to a normal safe level.

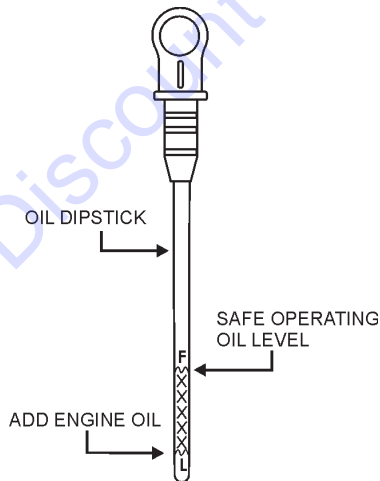
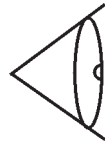

Figure 5. Engine Oil Dipstick

### Gearbox Oil Level



1. Check the gearbox oil level in both gearboxes by removing the plug located on the side of the gearbox. See Figure 6.

**! CAUTION - Gearbox Plugs**

Use caution when removing plugs on the gearbox, there are two of them. Removal of the bottom most plug (Drain Plug) will drain the oil in the gearbox.

2. The level of oil in the gearbox should just reach the bottom of the fill plug hole. The fill hole plug is located approximately half way up the side of the gearbox. If needed, refill with specially formulated Whiteman gearbox lubricant P/N 10139 or ISO 680 oil.

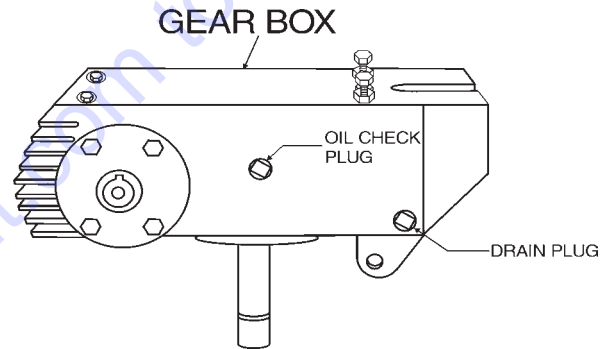

Figure 6. Gearbox Oil Plugs

### Fuel

To determine if the engine fuel is low, remove the cap from the fuel tank and visually inspect the fuel level. If fuel level is low, fill with unleaded gasoline. Handle fuel safely. Motor fuels are highly flammable and can be dangerous if mishandled. **DO NOT** smoke while refueling. Do not attempt to refuel the ride-on trowel if the engine is hot or running.

## Important Information Before You Start

1. This **ride-on trowel** is equipped with a safety "**safety stop switch**". This switch is located beneath the seat assembly. Remember the engine will not start unless an operator is sitting in the operator's seat. The weight of an operator depresses an electrical switch which will allow the engine to start.



### CAUTION - Kill Switch

**NEVER** disable or disconnect the "safety stop switch". It is provided for the **operator's safety** and injury or death may result if it is disabled, disconnected or improperly maintained.

2. The safety stop switch should be used to stop the engine after every use. Doing this will verify the switch is working properly thus providing safety for the operator. Remember to turn the key to the "**OFF**" position after stopping the machine. Not doing so will drain the battery.
3. The right foot pedal (Figure 7) controls blade and engine speed. The position of the foot pedal determines the blade speed. Slow blade speed is obtained by slightly depressing the pedal. Maximum blade speed is obtained by fully depressing the pedal.

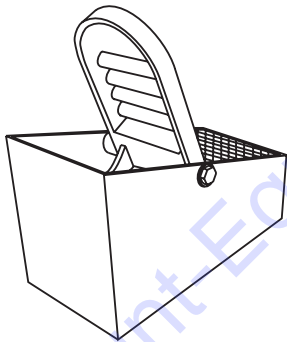
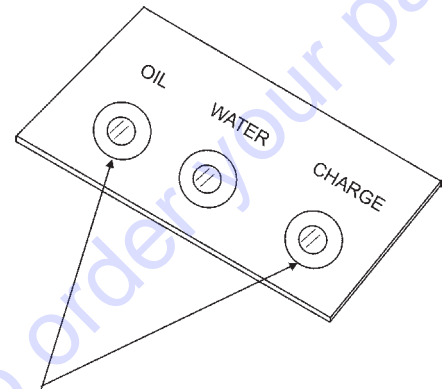

**Figure 7. Blade Speed Control Foot Pedal**

## Starting the Engine

1. With one foot on the ground and the other foot placed on the trowel's platform, grab the frame near the seat and lift yourself onto the trowel. Sit in the operator's seat and ensure the control handles, foot pedal and control panel items can be comfortably accessed.

2. Keep your foot **OFF** the gas pedal. If the engine is cold, adjust the choke but in all circumstances, start the engine at idle (without touching gas pedal).
3. Insert the **ignition key** into the ignition switch .
4. Turn the ignition key clockwise to the (start) position. The **oil** and **charge** indicator lights (Figure 8) should be on.



OIL AND CHARGE INDICATOR LIGHTS COME ON WHEN IGNITION SWITCH IS IN THE ON POSITION.

**Figure 8. Oil and Charge Indicator Lights**

5. Turn ignition key fully clockwise and listen for engine to start. Once engine has started release ignition key.
6. If the engine fails to start in this manner, consult the engine owner's manual supplied with the trowel.
7. Test the safety kill switch by standing up briefly. The switch under the seat should cause the engine to stop. If the kill switch fails to shut down the engine. Turn off the engine with the key switch and fix the safety kill switch. See Troubleshooting Chart for possible problems.
8. Repeat this section a few times to get fully acquainted with the engine starting procedure.
9. Let the engine idle for 3-5 minutes. If choke is applied, push the choke to the open position as soon as the engine will run smoothly.

## Steering

Two control levers located in front of the operator's seat provide directional control for the trowel. Table 3 illustrates the various directional positions of the joysticks and their effect on the ride-on trowel.

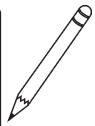
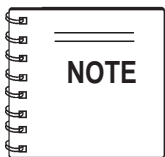

All directional references with respect to the steering control levers are from the **operator's** seat position.

1. Push both the left and right control levers forward. See Figure 9.

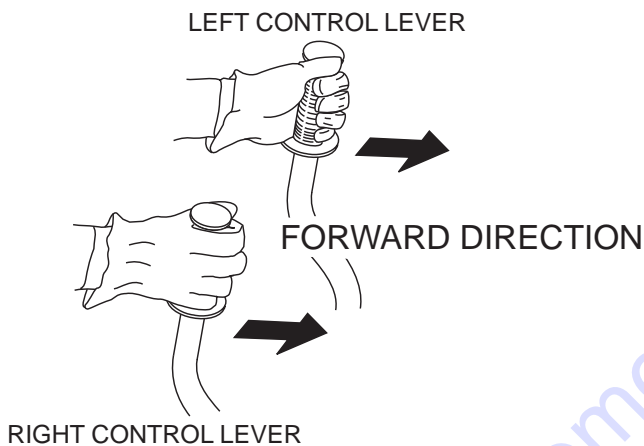

**Figure 9. Left and Right Control Levers**

2. With your right foot quickly depress the right foot pedal halfway. Notice that the ride-on power trowel begins to move in a forward direction. Return both joystick controls to their neutral position to stop forward movement, then remove your right foot from the right foot pedal.
3. Practice holding the machine in one place as you increase blade speed. When about 75% of maximum blade speed has been reached, the blade will be moving at proper finishing speed. The machine may be difficult to keep in one place. Trying to keep the ride-on trowel stationary is a good practice for operation.
4. Practice maneuvering the ride-on trowel using the information listed in Table 3. Try to practice controlled motions as if you were finishing a slab of concrete. Practice edging and covering a large area.

6. Try adjusting the pitch of the blades. This can be done with the ride-on trowel stopped or while the trowel is moving, whatever feels comfortable. Test the operation of optional equipment like retardant spray and lights if equipped.
7. Push both the left and right joysticks backward and repeat steps 3 through 6 while substituting the word reverse for forward.

**Table 3. Control Lever Directional Positioning**

CONTROL LEVER & DIRECTION	RESULT
Move <b>LEFT</b> Control Lever <b>FORWARD</b> ↑	Causes only the left side of the ride-on trowel to move forward. 
Move <b>LEFT</b> Control Lever <b>BACKWARD</b> ↓	Causes only the left side of the ride-on trowel to move backward. 
Move <b>RIGHT</b> Control Lever <b>FORWARD</b> ↑	Causes only the right side of the ride-on trowel to move forward. 
Move <b>RIGHT</b> Control Lever <b>BACKWARD</b> ↓	Causes only the right side of the ride-on trowel to move backward. 
Move <b>BOTH</b> Control Levers <b>FORWARD</b> ↑      ↑	Causes the ride-on trowel to move forward in a straight line. ↑      ↑
Move <b>BOTH</b> Control Lever <b>BACKWARD</b> ↓      ↓	Causes the ride-on trowel to move backward in a straight line. ↓      ↓
Move <b>BOTH</b> Control Levers to the <b>RIGHT</b> →      →	Causes the ride-on trowel to move to the right. →      →
Move <b>BOTH</b> Control Levers to the <b>LEFT</b> ←      ←	Causes the ride-on trowel to move to the left. ←      ←



### CAUTION - Obstructions

Trowel arms can be damaged by rough handling or by striking exposed plumbing or forms while in operation. **ALWAYS** look-out for objects which might cause damage to the trowel arms.

## MAINTENANCE

When performing any maintenance on the trowel or engine, follow all safety messages and rules for safe operation stated at the beginning of this manual.

At the front of the book there is a “Daily Pre-Operation Checklist”. Make copies of this checklist and use it on a daily basis.

### Daily Maintenance

Thoroughly remove dirt and oil from the engine and control area. Clean or replace the air filter element as necessary. Check and retighten all fasteners as necessary.

Perform the engine maintenance procedures as indicated on the preceding pages.

**! WARNING - Accidental Starting**

Accidental starts can cause severe injury or death.

**OFF**

**ALWAYS** place the ON/OFF switch in the OFF position.

Disconnect and ground spark plug leads and disconnect negative battery cable from battery before servicing.

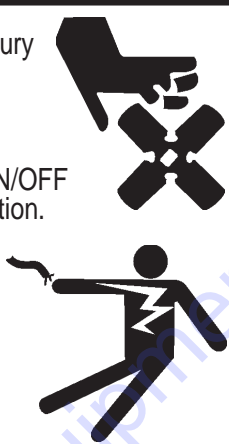

### Maintenance Schedule

1. Check and retighten all fasteners as necessary.

#### Daily (8-10 Hours)

1. Check the fluid levels in the engine and gearboxes, fill as necessary. Check air filter. See section on air filter servicing.

#### Weekly (30-40 Hours)

1. Relube arms, thrust collar and steering links.
2. Replace blades if necessary.
3. Check and clean or replace the engine air filter as necessary. (See following section on air Filter Maintenance.)
4. Replace engine oil and filter as necessary. (See following section on Oil and Filter.)

### Air Filter (As Required)

Thoroughly remove dirt and oil from the engine and control area. Clean or replace the air cleaner elements as necessary. Check and retighten all fasteners as necessary.

1. Release the two latch clamps (Figure 10) from the air cleaner cover, and remove the cover.

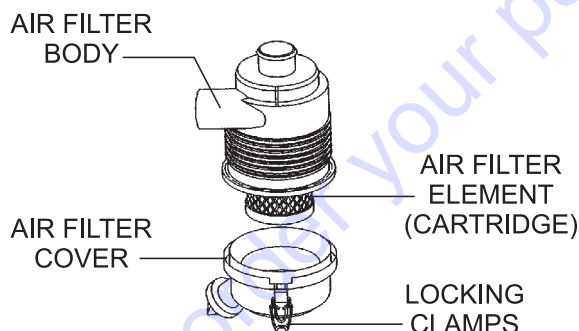

**Figure 10. Air Cleaner Components**

2. Remove the air filter cartridge from the cover.
3. Inspect the air filter element, replace if necessary.
4. To clean the air filter element (cartridge), blow compressed air (not to exceed 30 psi (207 kPa, 2.1 kgf/cm<sup>2</sup>) through the filter element from the air cleaner case side.
5. **NEVER!** try to brush off dirt; brushing will force dirt into the fibers. If the air filter element (cartridge) is excessively dirty, replace element.
6. Wipe dirt from the inside of the air cleaner body and cover, using a moist cloth. Be careful not to let any dirt or debris enter the air chamber that leads to the carburetor.
7. Reinstall the air filter element (cartridge) back into the air cleaner cover. Securely latch the two locking clamps on the air cleaner cover

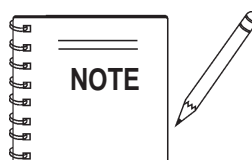

If trowel is used in severe windy or dusty areas, service air filter more frequently to prevent damage to the engine.



# HTN/HTO-31V— MAINTENANCE (ENGINE)

## Changing Engine Oil (200 Hours)

1. Change the engine oil after the first 50 hours of use, then change every 6 months or 200 hours. Drain oil while engine is warm.
2. Remove the oil filler cap (Figure 11), and fill engine crankcase with recommended type oil as listed in Table 4. Fill to the upper limit (F) of dipstick.
3. Reinstall oil filler cap, start engine and run at idle for 5 minutes. Stop engine. Recheck oil level. Add oil if necessary. **DO NOT** over-fill.

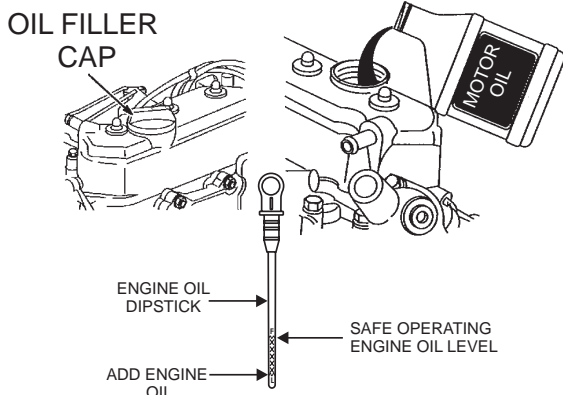

Figure 11. Adding Engine Oil

Starting Temperature Range Anticipated Before Next Oil Change	Recommended Viscosity Grades
-30 to 10 °F (-34 to -12 °C)	5W-30
10 to 50 °F (-12 to 10 °C)	10W-30, 10W-40, 10W-50
50 to 110 °F (10 to 43 °C)	30

\* A synthetic 5W-30 oil may be used.

1. Change the engine oil filter (Figure 12) after the first 50 hours of use, then change every 6 months or 200 hours.
2. Be sure to coat the **rubber gasket** of the new oil filter with clean engine oil.

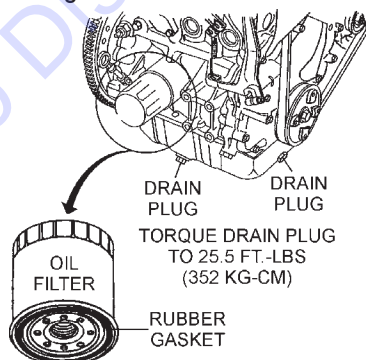

Figure 12. Engine Oil Filter

## Oil And Fuel Lines

- Check the oil and fuel lines and connections regularly for leaks or damage. Repair or replace as necessary.
- Replace the oil and fuel lines every two years to maintain the line's performance and flexibility.

## Fuel Filter (600 Hours)

### CAUTION - Fuel Filter Replacement

Drain fuel tank or close fuel shut-off valve before replacing fuel filter.

1. Replace the engine fuel filter (Figure 13) every 600 hours.
2. To prevent the spillage of fuel which could cause a fire or an explosion. Always make sure fuel hose clamps are secured tightly and that fuel flows in the correct direction as indicated by arrow.

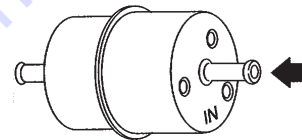

Figure 13. Fuel Filter

## Coolant (Antifreeze/Summer Coolant/Water)

1. Briggs and Stratton recommends antifreeze/summer coolant for use in their engines, which can be purchased in concentrate (and mixed with 50% demineralized water) or pre-diluted.
2. Check coolant level daily (Figure 14) and change yearly.

### CAUTION - Check Coolant

#### CHECK DAILY

1. Maintain water/coolant level at **top** of radiator coils.
2. Maintain reserve tank water/coolant level between H and L mark. Use a mixture of 50/50 Anti-Freeze/Water.
3. Add coolant when reserve tank is low (L). Fill to the H mark with Anti-Freeze/Water.

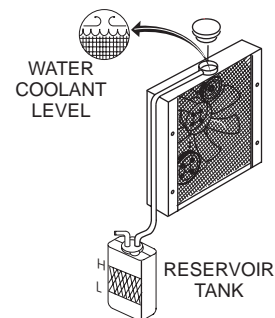

Figure 14. Check Coolant Level

# HTN/HTO-31V — MAINTENANCE (ENGINE/TROWEL)

## Radiator/Cooling System

1. Check and clean radiator fins.
2. Check cooling water.
3. Check radiator hoses for fatigue or cracking.
4. Check radiator cap sea.

Refer to your engine manual for additional information.

### **! WARNING - BURN HAZARDS**

If adding coolant/antifreeze mix to the radiator, **DO NOT** remove the radiator cap until the unit has completely cooled. The possibility of **hot!** coolant exists which can cause severe burns.



Day-to-day addition of coolant is done from the reservoir tank. When adding coolant to the radiator, **DO NOT** remove the radiator cap until the unit has completely cooled. Make sure the coolant level in the reservoir tank is always between the "H" and the "L" markings.

## Engine Fan Belt (Yearly)

1. Check the condition of the fan belt periodically, if worn or damage replace immediately.
2. For long lasting V-belt life, check fan belt (Figure 15) for correct tension. There should be between 3/8-1/2-inch (10~12 mm) deflection at the center point of the V-belt between the fan and the alternator.
3. Torque alternator bolt A to 14 ft-lbs (195 kg-cm) and torque alternator bolt B to 45 ft-lbs (622 kg-cm).

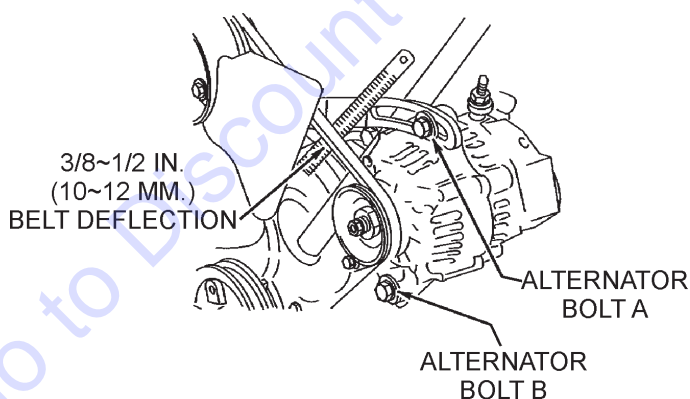

Figure 15. V-Belt Deflection

## Spark Plug (Yearly)

1. Remove and clean the spark plug (Figure 16), then adjust the spark gap to 0.028 ~0.031 inch (0.6~0.7 mm).

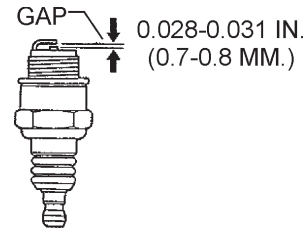

Figure 16. Spark Plug Gap

## Checking Drive V-Belts

In order to inspect the the drive V-belts for signs of wear or, belt adjustment the V-belt guard cover (Figure 17) must be removed.

### **! CAUTION - Rotating Parts/V-Belt Safety**

**NEVER** perform service on the trowel or insert hands or tools into the belt area while the engine is running.

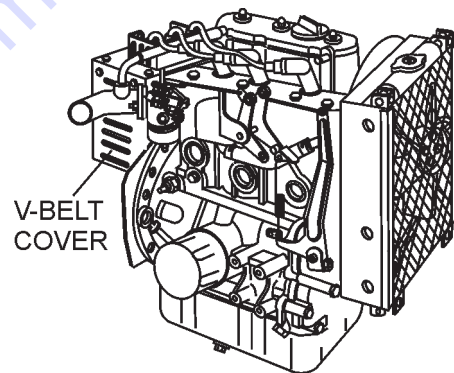

Figure 17. V-belt Cover Removal

The first indication of belt wear is reduced blade speed despite the engine running at full speed. Visually inspect the belts for signs of damage or excessive wear.

Always replace the belt guard after inspecting, adjusting or replacing the belts.

## Drive Belt Tension Adjustment Procedure

Belt tension is adjusted by sliding the entire engine fore and aft on the trowel, The motor mount plate is slotted to allow this motion.

To adjust the belt tension, loosen the four engine mounting bolts, slide the engine forward to tighten the belts or slide the engine towards the rear of the machine to loosen the belts. Make sure to tighten the engine mounting bolts after setting the belt tension.

## Belt Changing Procedure

The belts need to be changed as soon as they show signs of wear. Remember that all belts should be changed at the same time. Do not reuse a belt under any circumstances. Indications of excessive belt wear are fraying, squealing when in use, belts that emit smoke or a burning rubber smell when in use.

Under normal operating conditions, a set of belts may last approximately six months. If your trowel is not reaching this kind of life span for belts, there are some things to check when you replace a set of belts.

Check to ensure that the belts are tensioned correctly. Next, check to make sure that the lower drive pulley (Figure 18) is aligned properly.

Your machine is equipped with a spare belt carrier (Figure 18). It is located opposite the clutch, mounted on the fuel tank. Make sure that there are belts in the carrier before the trowel is placed on a slab to finish concrete.

To install new belts from the spare belt carrier, first cut off the old belts. Next, remove the spare belt carrier by unscrewing the two bolts that attach it to the fuel tank.

The next step is to loosen the four engine mounting bolts and slide the engine toward the rear of the trowel. Slide the first belt over the clutch and place it on the upper drive pulley, then pull it down and place it on the lower drive pulley. Repeat this procedure for the second belt.

Realign the engine as described in the **Belt Tension Adjustment Procedure**, and replace the belts in the spare belt carrier.

## Replacing Spare Belts

After the spare set of belts has been installed on the clutch pulley, it will be necessary to replace the spare set of belts that were in the spare belt carrier.

To replace a spare set of belts, be prepared to disassemble the **driveline**.

The driveline is located directly under the spare belt carrier. There are three bolts that need to be removed that will disconnect the CV-joint from the gearbox coupler. Reference Figure 18.

Once the CV-joint has been separated from the gearbox coupler, push the CV-joint inward so that a gap exist between the coupler and the CV-joint. Slide the replacement belts between this gap, and place them onto the spare belt carrier. Secure the spare belt carrier to the fuel tank.

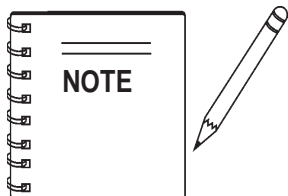

Make sure that there are belts in the belt carrier before the trowel is placed on a slab to finish concrete.

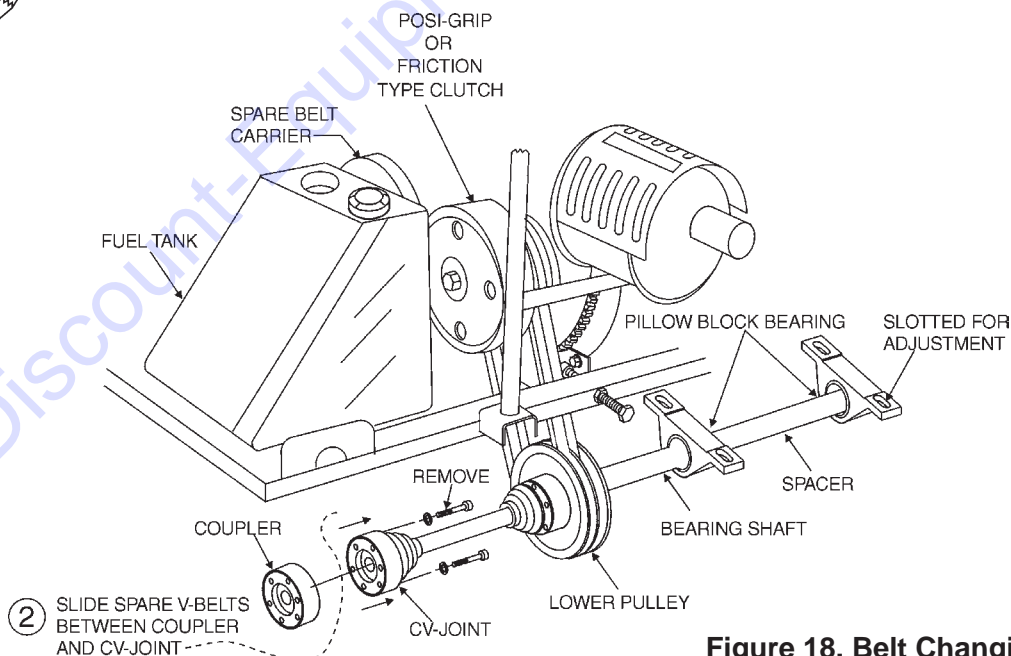

① TO REPLACE SPARE V-BELTS, REMOVE RETAINING SCREWS SECURING CV-JOINT TO COUPLER THEN PUSH CV-JOINT TOWARDS LOWER PULLEY.

Figure 18. Belt Changing Diagram

# HTN/HTO-31V — MAINTENANCE (TROWEL)

## WARNING - BURN HAZARDS

**ALWAYS** allow the engine to cool before servicing. **NEVER** attempt any maintenance work on a **hot!** engine.



## Trowel Maintenance Schedules

### Weekly (50-60 Hours)

1. Relube arms, thrust collar and clutch.
2. Replace blades if necessary.

### Monthly (200-300 Hours)

1. Remove, clean, reinstall and relube the arms and thrust collar. Adjust the blade arms.
2. Replace gearbox lubricant after the first 100 hours of operation. Replace every 500-600 hours thereafter.
3. Check drive belt for excessive wear. (Refer to following section on Drive Belt maintenance.)
4. Remove, clean, reinstall clutch.

### Yearly (2000-2500 Hours)

1. Check and replace if necessary the arm bushings, and thrust collar bushings, shaft seals and belts.
2. Check pitch control cables for wear.
3. Replace gearbox lubricant.

## Trowel Arm Adjustment Procedure

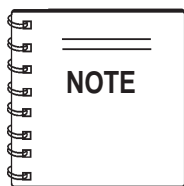

The following procedure should be followed to adjust trowel arms when it becomes apparent that the trowel is finishing poorly or in need of routine maintenance.

A **level**, clean area to test the trowel prior to and after is essential. Any uneven **spots** in the floor or debris under the trowel blades will give an incorrect perception of adjustment. Ideally, a 5-foot by 5 foot three-quarter inch thick **flat** steel plate should be used for testing.

To determine which blades need adjustment, place the trowel in the test area (three-quarter inch thick plate) and look for the following conditions:

- Pitch the blades as flat as possible and look at the **adjustment bolts**. They should all barely make contact with the **lower wear plate** on the spider. If you can see that one of them is not making contact, some adjustment will be necessary.
- Is the machine wearing out blades unevenly (i.e. one blade is completely worn out while the others look new)?

Figure 19 below illustrates a "**worn spider bushings or bent trowel arms**". Check to see that adjustment bolt is barely touching (0.10" max. clearance) lower wear plate. All alignment bolts should be spaced the same distance from the lower wear plate.

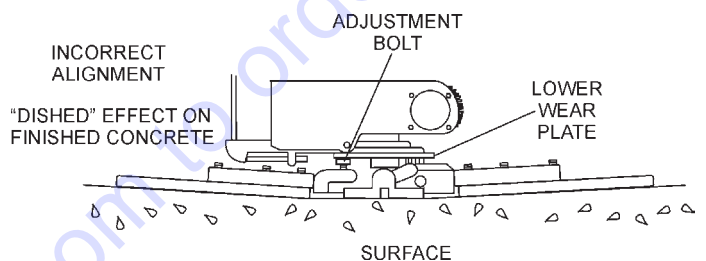

Figure 19. Worn Spider Plate

Figure 20 below illustrates the "**correct alignment**" for a spider plate (as shipped from the factory).

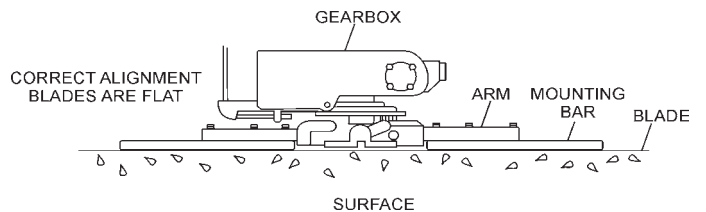

Figure 20. Correct Spider Plate Alignment

Start engine, and bring trowel blades up to full speed and look for the following conditions:

- Does the trowel have a perceived rolling or bouncing motion when in use?
- Look at the trowel while it is running, does the guard ring "rock up and down" relative to the ground?

## Spider Removal (Disassembly)

1. Once it is determined that an adjustment is required, remove the spider assembly from the gearbox shaft as follows:
  - a. Locate cone point square head set screw (Figure 21) and attached jam nut found on the side of the spider assembly.

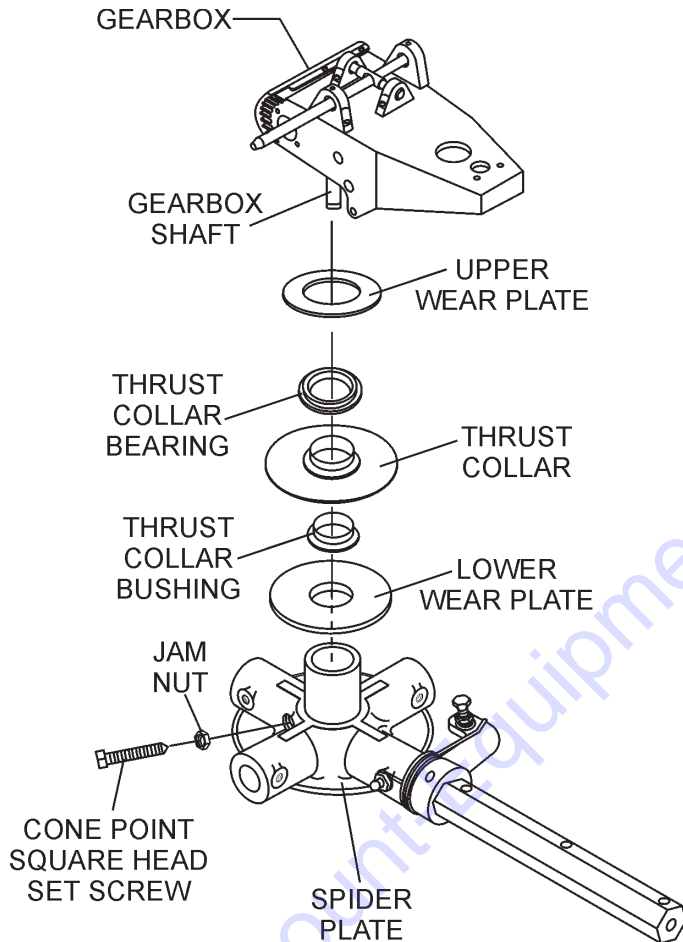

Figure 21. Spider/Gearbox Removal

- b. Loosen the jam nut and cone point square head set screw, and carefully lift the **upper trowel assembly** off of the spider assembly. A slight tap with a rubber mallet may be necessary to dislodge the spider from the main shaft of the gearbox.
    - c. If the trowel is equipped with an outer stabilizer ring (Figure 21), remove the four bolts at the end of each spider arm.

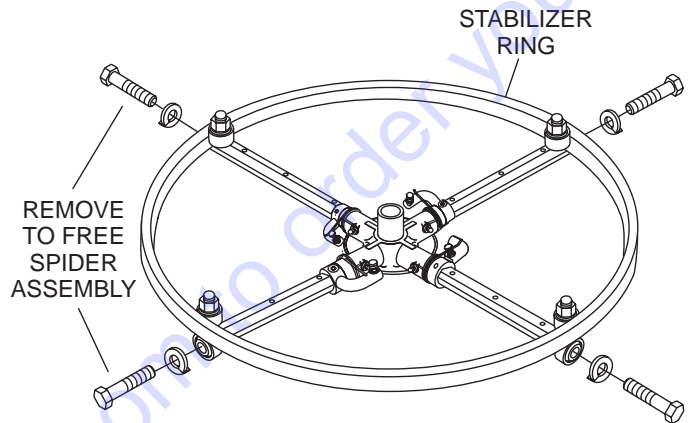

Figure 22. Stabilizer Ring

- d. Examine stabilizer ring for out of round or bends. If ring is damaged, replace ring. If ring is found to be correct with no damage, set aside.

## Trowel Arm Removal

1. Each trowel arm is held in place at the spider plate by a hex head bolt (zerk grease fitting) and a roll pin. Remove both the hex head bolt and the roll pin (Figure 23) from the spider plate.
2. Remove the trowel arm from the spider plate.

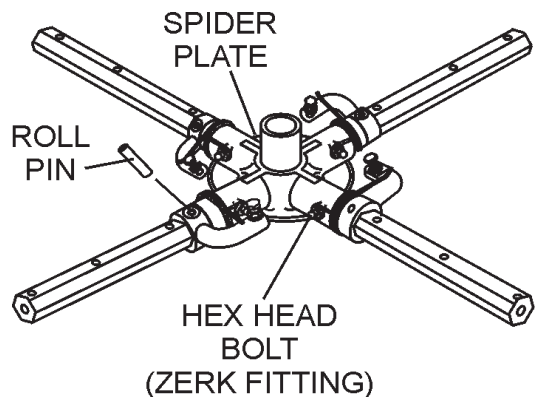

Figure 23. Removing Roll Pin and Zerk Grease Fitting

- Should the trowel arm inserts (bronze bushing) come out with the trowel arm, remove the bushing from the trowel arm and set aside in a safe place. If the bushing is retained inside the spider plate, carefully remove the bushing.
- Examine the bronze trowel arm bushing insert (Figure 24), clean if necessary. Replace bushing if out-of-round or worn.

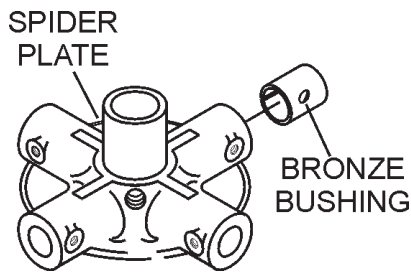

Figure 24. Bronze Bushings

### Trowel Blade Removal

- Remove the trowel blades from the trowel arm by removing the three hex head bolts (Figure 25) from the trowel arm. Set blades aside.

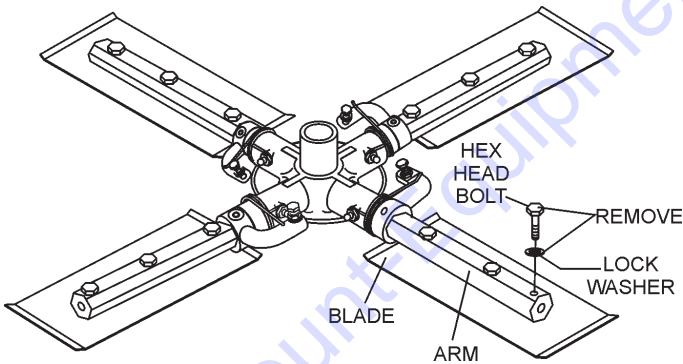

Figure 25. Trowel Blades

- Wire brush** any build-up of concrete from all six sides of the trowel arm. Repeat this for the remaining three arms.

### Checking Trowel Arm Straightness

Trowel arms can be damaged by rough handling, (such as dropping the trowel on the pad), or by striking exposed plumbing, forms, or rebar while in operation. A bent trowel arm will not allow the trowel to operate in a smooth fluid rotation. If bent trowel arms are suspect, check for flatness as follows, refer to Figures 26 and 27.

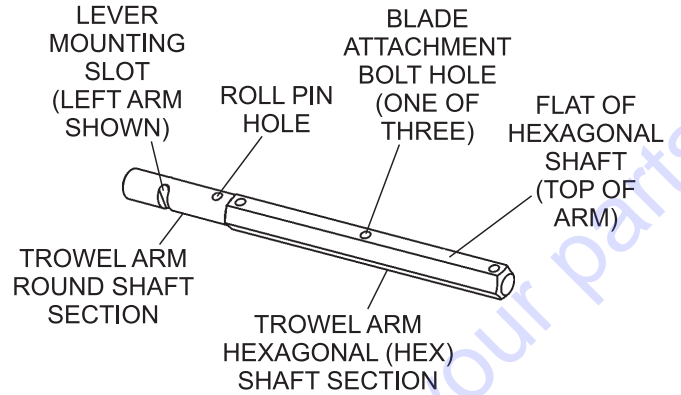

Figure 26. Typical Trowel Arm

### Trowel Arm Flatness Test

- Using a piece of 3/4 inch thick steel plate or any surface which is **true** and **flat**, check all **six sides** of each trowel arm for flatness.
- Check each of the six sides of the trowel arm (hex section). A feeler gauge of .004" (0.10 mm) should not pass between the flat of the trowel arm and the test surface along its length on the test surface (Figure 46, A).

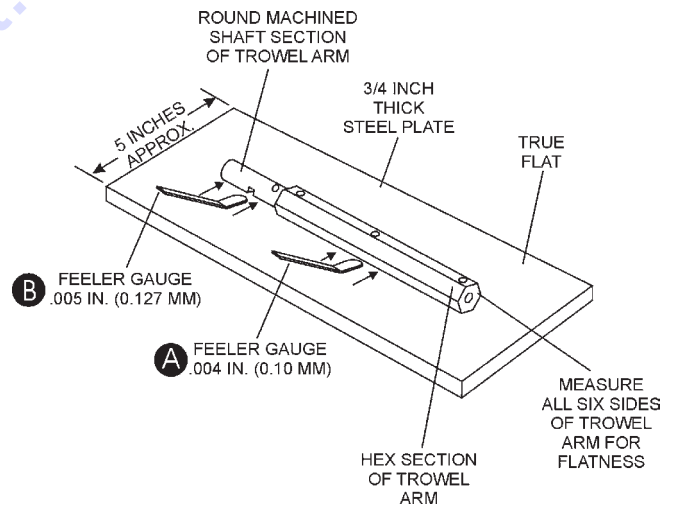

Figure 27. Trowel Arm Flatness Test

- Next, check the clearance between the round shaft and the test surface as one of the flat hex sections of the arm rests on the test surface. Rotate the arm to each of the flat hex sections and check the clearance of the round shaft. Use a feeler gauge of .005" (0.127 mm). Each section should have the **same clearance** between the round of the trowel arm shaft and the test surface (Figure 27, B).

# HTN/HTO-31V — MAINTENANCE (TROWEL)

## Trowel Arm Adjustment

Shown in Figure 28 is the adjustment fixture with a trowel arm inserted. As each trowel arm is locked into the fixture, the arm bolt is adjusted to where it contacts a stop on the fixture. This will consistently adjust all of the trowel arms, keeping the finisher as flat and evenly pitched as possible.

1. Locate the trowel arm adjustment tool P/N 9177.
2. Ensure the fixture arm is in the proper position (up or down) for your trowel arm rotation as shown in Figure 29.

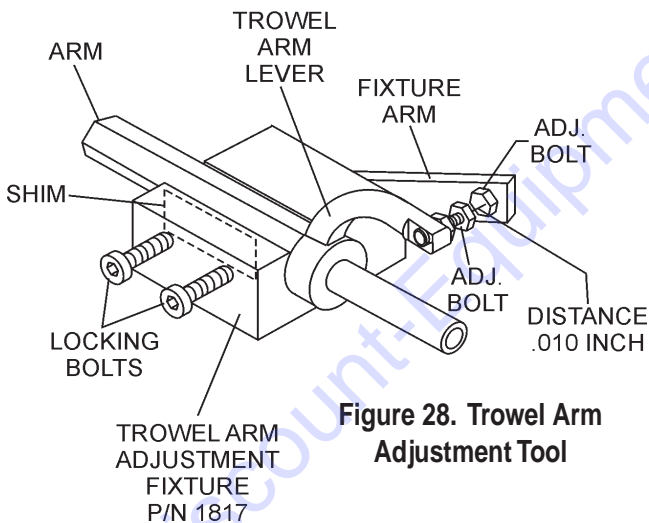
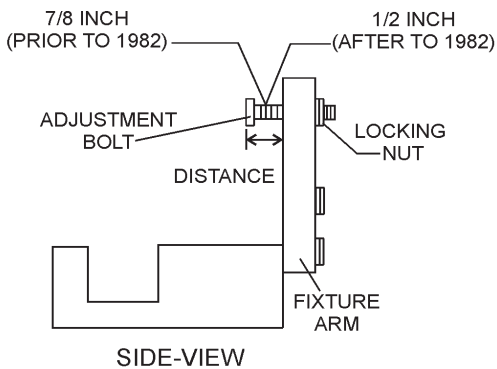

**NOTE** HTN/HTO trowels manufactured prior to June of 1982 require that the distance from the end of the adjusting bolt and the fixture arm must be 7/8" (Figure 28). Conversely, trowels manufactured after June of 1982 require that the distance from the end of the adjusting bolt and the fixture arm must be 1/2".

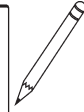
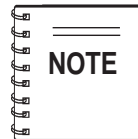

Arms with CLOCK-WISE blade rotation use the fixture arm in the UP position (A in Figure 39). Arms with COUNTER CLOCK-WISE blade rotation use the fixture with the fixture arm in the DOWN position. (B in Figure 29)

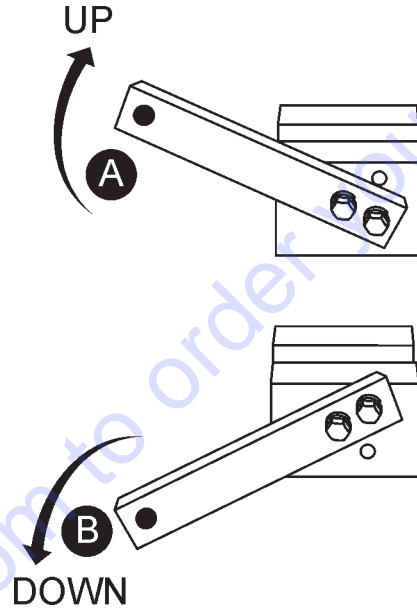

Figure 29. Trowel Arm Adjustment Setup

3. Un-screw the locking bolts on the adjustment tool, and place the trowel arm into the adjustment fixture channel as shown in Figure 28. A *thin shim* may be required to cover the blade holes on the trowel arm. Make sure to align the trowel adjustment bolt with the fixture adjustment bolt.
4. Adjust the bolt "distance" shown in Figure 28 to match one of the arms. The other arms will be adjusted to match this distance.
5. Using an allen wrench, tighten the locking bolts on the adjustment tool and securely lock the trowel arm in place.
6. Loosen the locking nut on the trowel arm lever, then turn the trowel arm adjusting bolt until it barely touches (.010") the adjusting bolt on the fixture.
7. After the correct adjustment has been made, tighten lock nut on trowel arm lever to lock in place.
8. Loosen locking bolts on adjustment fixture, and remove trowel arm from fixture.
9. Repeat steps 2-8 for the remaining trowel arms.

## Re-Assembly

1. Clean and examine the upper/lower wear plates and thrust collar. Examine the entire spider assembly. Wire brush any concrete or rust build-up. If any of the spider components are found to be damaged or out of round, replace them.
2. Make sure that the bronze trowel arm bushing is not damage or out of round. Clean the bushing if necessary. If the bronze bushing is damage or worn, replace it.
3. Reinstall bronze bushing onto trowel arm.
4. Repeat steps 2 -3 for each trowel arm.
5. Make sure that the spring tensioner is in the correct position to exert tension on the trowel arm.
6. Insert all trowel arms with levers into spider plate (with bronze bushing already installed) using care to align grease hole on bronze bushing with grease hole fitting on spider plate.
7. Lock trowel arms in place by tightening the hex head zerk grease fitting and jam nut.
8. Re-install the blades back onto the trowel arms
8. Install stabilizer ring onto spider assembly.
9. Reinstall **lower wear plate**, **thrust collar** and **upper wear ring** in the **reverse order** that they were disassembled onto the spider shaft. Make sure that there is little or no lateral movement between the thrust collar and the spider shaft.
10. Lubricate all grease points (zerk fittings) with premium "Lithum 12" based grease, conforming to NLG1 Grade #2 consistency.

## Blade Pitch Overview

Sometimes it may be necessary to match blade pitch between the two sets of blades. There are some signs that this may be necessary. For example, the differences in pitch could cause a noticeable difference in finish quality between the two sets of blades. Or, the difference in blade pitch could make the machine difficult to control. This is due to the surface area in contact with the concrete (the blade set with the greater contact area tends to stick to the concrete more).

The maintenance adjustment of blade pitch is an adjustment that is made by a bolt (Figure 30) on the arm of the trowel blade finger.

This bolt is the contact point of the trowel arm to the lower wear plate on the thrust collar. The goal of adjustment is to promote consistent blade pitch and finishing quality.

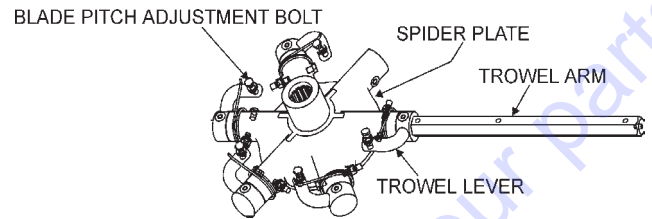

**Figure 30. Blade Pitch Adjustment Bolt**

There are some things to look for when checking to see if adjustment is necessary. Is the machine wearing out blades unevenly (i.e. one blade is completely worn out while the others look new)? Does the machine have a perceptible rolling or bouncing motion when in use? Look at the machine while it is running, do the guard rings "rock up and down" relative to the ground? Do the pitch control towers rock back and forth? These are some of the indications that the blade pitch may need to be adjusted using the adjustment bolts on the trowel blade finger.

The easiest and most consistent way to make this adjustment is to use the Trowel Arm Adjustment Fixture (P.N. 9177). See Figure 30. This fixture will allow consistent adjustment of the trowel arm fingers. It comes with all the hardware necessary to properly accomplish this maintenance and instructions on how to properly utilize this tool. Adjusting the trowel arm fingers without a fixture requires a special talent.

If a trowel arm adjustment fixture is not available and immediate adjustment is necessary; we suggest the following procedure. If you can see or feel which blade is pulling harder, adjust the bolt that corresponds to that blade.

Another way to determine which blades need adjustment is to place the machine on a flat surface and pitch the blades as flat as possible. Now, look at the adjustment bolts. They should all barely make contact with the lower wear plate on the spider. If you can see that one of them is not making contact; some adjustment will be necessary.

It will be possible to adjust the "high" bolts down to the level of the one that is not touching, or adjust the "low" bolt up to the level of the higher ones. If possible, adjust the low bolt up to the level of the rest of the bolts. This is the fastest way, but may not always work. Verify that after adjustment, the blades pitch correctly.



Often times, if the blades are incorrectly adjusted, they will not be able to pitch flat. This occurs when the adjusting bolts have been raised too high. Conversely, sometimes the adjusting bolts are too low and the blades cannot be pitched high enough for finishing operations.

## Matching Blade Pitch for Both Sets of Blades

The HTN/HTO trowels are equipped with **Twin Pitch™** controls and may need to have blade pitch between the two sets of blades "**synchronized**". If the blades need to be synchronized this is easily accomplished by performing the following. Refer to Figure 31.

1. Lift the pitch adjustment handle on either side. Once lifted, that side is now disconnected from the **Twin Pitch™** system.
2. Adjust to match the opposite side.
3. When adjusted, lower the handle to **Twin Pitch™** operating position

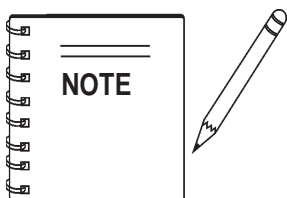

On a **Twin Pitch™** trowel, the operator must lift up on one of the pitch control handles, disengaging the linkage between the towers. Once this is done, a pitch control crank can be turned to adjust the difference. Make sure to lock the linkage back in place when finished with the adjustments.

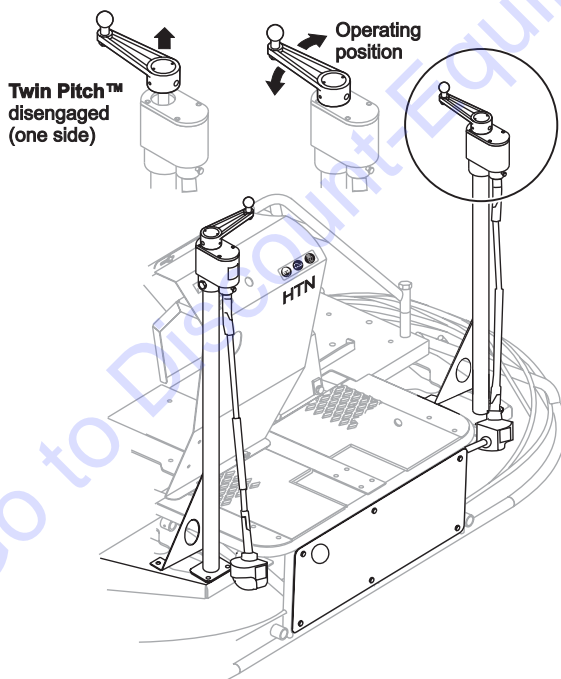

Figure 31. Pitch Towers

## Changing a Blade

It is recommended that all blades on the trowel be changed at the **same time**. If only one or some of the blades are changed at one time, the machine will not finish concrete consistently and the machine may wobble or bounce.

1. Place the machine on a flat, level surface. Adjust the blade pitch control to make the blades as flat as possible. Note the blade orientation on the trowel arm. This is important for ride-on trowels as the two sets of blades counter-rotate. Lift the machine up, placing blocks under the main guard ring to support it.
2. Remove the bolts and lock washers on the trowel arm, (Figure 32) and then remove the blade.
3. Scrape all concrete and debris from the trowel arm. This is important to properly seat the new blade.
4. Install the new blade, maintaining the proper orientation for direction of rotation.
5. Affix the bolts and lock washers.
6. Repeat steps 2-5 for all remaining blades.

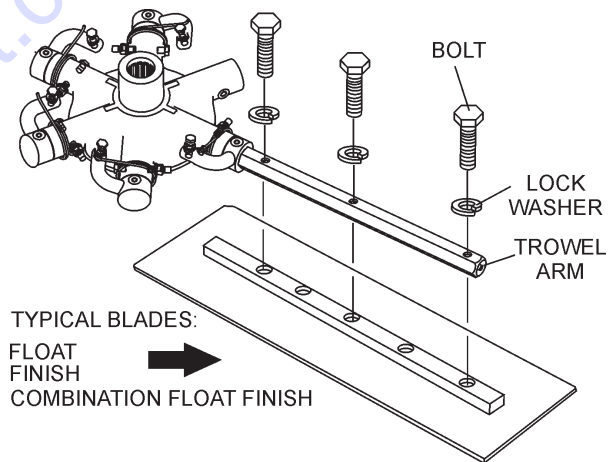
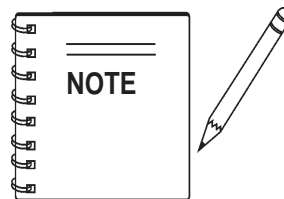

Figure 32. Changing Blades



**NEVER** allow concrete to harden on the trowel or blades. Immediately after each use wash any concrete off the trowel or blades with water, be careful not to spray the water. An old paint brush or broom may help loosen any concrete that has started to harden.

## Installing Pans Onto Finisher Blades

These round discs sometimes referred to as "pans" attach to the spiders arms and allow early floating on wet concrete and easy movement from wet to dry areas. They are also very effective in embedding large aggregates and surface hardeners.



## CAUTION - Installing Float/Finishing Pans

**ALWAYS** install pans either on the work area or on an area that is next to and level with the work area. **DO NOT** lift the trowel when the pans are attached.

Refer to Figure 33 when installing pans onto finisher blades.

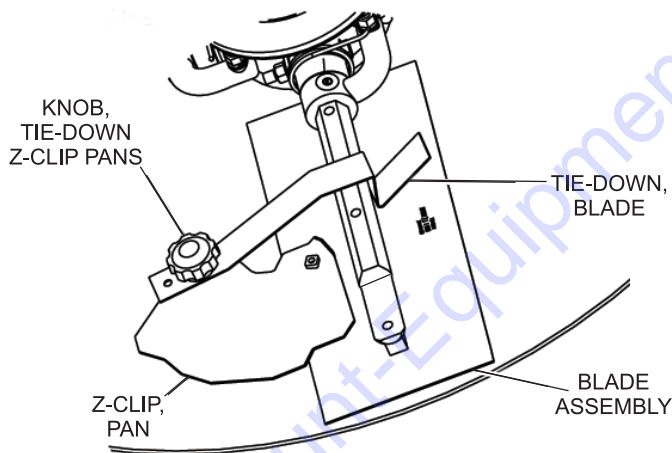

**Figure 33. Z-Clip Finisher Pan Installation**

1. Lift trowel just enough to slide pan under blades. Lower finisher onto pan with blades (Item #1) adjacent to Z-Clips (Item #4).
2. Rotate blades into position under Z-Clips. Ensure that the blades are rotated in the direction of travel when the machine is in operation or use the engine to rotate the blades into position.

3. Attach the blade tie-downs (Item #3) to the far side of the Z-Clip brackets (Item #4) with tie-down knobs (Item #2) as shown in Figure 33.
4. Check to make certain that the blade edges are secured under the Z-Clips and the tie-downs are secured completely over the edges of the blade bar before the machine is put back into operation.

## Long Term Storage

For storage of the trowel for over 30 days, the following is required:

- Run the engine until the fuel in the carburetor is completely consumed.
- Remove the battery.
- Completely drain fuel from fuel tank, fuel line and carburetor.
- Completely drain used oil from the engine crankcase and fill with fresh clean oil, then follow the procedures described in the engine manual for engine storage.
- Remove spark plug and add 1 oz. (30 ml) of motor oil into cylinder. Crank engine 3 to 4 times so that oil reaches all internal parts.
- Clean exterior with a cloth soaked in clean oil.
- Clean dirt and debris from engine body and muffler areas.
- Store unit covered with plastic sheet in moisture and dust-free location out of direct sunlight.

## Decommissioning Trowel/Components

Decommissioning is a controlled process used to safely retire a piece of equipment that is no longer serviceable. If the equipment poses an unacceptable and unreparable safety risk due to wear or damage or is no longer cost effective to maintain, (beyond life-cycle reliability) and is to be decommissioned, (demolition and dismantlement), the following procedure must take place:

1. Drain all fluids completely. These may include oil, gasoline, hydraulic oil and antifreeze. Dispose of properly in accordance with local and governmental regulations. Never pour on ground or dump down drains or sewers.
2. Remove battery and bring to appropriate facility for lead reclamation. Use safety precautions when handling batteries that contain sulfuric acid, reference "Rules for Safe Operation", battery section.
3. The remainder can be brought to a salvage yard or metal reclamation facility for further dismantling.

# HTN/HTO-31V — TROWEL TROUBLESHOOTING

**TABLE 5. TROWEL TROUBLESHOOTING**

SYMPTOM	POSSIBLE PROBLEM	SOLUTION
Engine running rough or not at all.	Kill switch malfunction?	Make sure that the kill switch is functioning when the operator is seated; replace switch if necessary.
	Fuel?	Look at the fuel system. Make sure there is fuel being supplied to the engine. Check to ensure that the fuel filter is not clogged.
	Ignition?	Check to ensure that the ignition switch has power and is functioning correctly.
Safety kill switch not functioning.	Other problems?	Consult engine manufacturer's manual.
	Loose wire connections?	Check wiring. Replace as necessary.
	Bad contacts?	Replace switch.
If trowel "bounces, rolls concrete, or makes uneven swirls in concrete".	Blades?	Make certain blades are in good condition, not excessively worn. Finish blades should measure no less than 2" (50mm) from the blade bar to the trailing edge, combo blades should measure no less than 3.5" (89mm). Trailing edge of blade should be straight and parallel to the blade bar.
	Spider?	Check that all blades are set at the same pitch angle as measured at the spider. A field adjustment tool is available for height adjustment of the trowel arms (see Optional Equipment).
	Bent trowel arms?	Check the spider assembly for bent trowel arms. If one of the arms is even slightly bent, replace it immediately.
	Trowel arm bushings?	Check the trowel arm bushings for tightness. This can be done by moving the trowel arms up and down. If there is more than 1/8" (3.2 mm) of travel at the tip of the arm, the bushings should be replaced. All bushings should be replaced at the same time.
	Thrust collar?	Check the flatness of the thrust collar by rotating it on the spider. If it varies by more than 0.02" (0.5 mm) replace the thrust collar.
	Thrust collar bushing?	Check the thrust collar by rocking it on the spider. If it can tilt more than 3/32" (2.4 mm) [as measured at the thrust collar O.D.], replace the bushing in the thrust collar.
	Thrust bearing worn?	Check the thrust bearing to see that it is spinning free. Note: Thrust cap, replace if necessary.
	Blade pitch?	Check blades for consistent pitch. Adjust per Maintenance section instructions if necessary.
Machine has a perceptible rolling motion while running.	Main shaft?	The main output shaft of the gearbox assembly should be checked for straightness. The main shaft must run straight and cannot be more than 0.003" (0.08 mm) out of round at the spider attachment point.
	Yoke?	Check to make sure that both fingers of the yoke press evenly on the wear cap. Replace yoke as necessary.
	Blades?	Check to ensure that each blade is adjusted to have the same pitch as all other blades.

# HTN/HTO-31V — TROWEL TROUBLESHOOTING

**TABLE 5. TROWEL TROUBLESHOOTING (CONTINUED)**

SYMPTOM	POSSIBLE PROBLEM	SOLUTION
Lights not working.	Wiring?	Check all electrical connections, including the master on/off switch and check to see if wiring is in good condition with no shorts. Replace as necessary.
	Lights?	Check to see if light bulbs are still good. Replace if broken.
Retardant spray not working.	Retardant?	Check the tank to make sure retardant is present. Fill tank as necessary.
	Wiring?	Check all electrical connections, including master on/off switch connections. Replace components and wiring as necessary.
	Bad switch?	Check the continuity of master on/off switch. Replace if broken.
	Bad spray pump?	If pump has a voltage present when the switch is turned on, but does not operate and electrical connections to the pump are good, replace the pump.
Steering effort is too high or unresponsive.	Steering linkages out of adjustment?	Adjust the connecting linkage found at the base of the handle.
	Worn components?	Replace all parts that are bent.
	Gearbox pivots?	Check to ensure free movement of gearboxes.
Operating position is uncomfortable.	Seat adjust for operator?	Adjust seat with lever located on the front of the seat.
Control handles are too close together or too far apart.	Steering linkages out of adjustment?	See section on steering adjustment.
	Bent control handles?	Replace all parts that are bent
Clutch slipping or sluggish response when responding to engine speed.	Belt tension?	Adjust the belt tension?
	Worn belts?	Replace.
	Dirty Clutch?	Disassemble and clean the clutch.
	Worn out Clutch?	Replace shoes on friction clutch. Posi-Grip, replace entire clutch.
	Worn Bearings in gearbox?	Rotate gearbox input shaft by hand. If shaft rotates with difficulty, check the input and output shaft bearings. Replace if necessary.
	Worn or broken gears in gearbox?	Check in particular to verify that the gearbox output shaft rotates when the input shaft is rotated. Replace both the worm gear and worm as a set.
	Worn drive shaft bearings	Inspect driveline bearings, replace if necessary.
Linkage on Twin Pitch not working.	Crank handles?	Make sure that both crank handles are pushed down as far as possible. Doing this ensures that the linkage is engaged.
	Broken part?	Replace all broken parts immediately.
Belts wearing out too fast.	Drive pulley alignment?	Check to see if lower drive pulley is correctly aligned with the clutch.
	Tension?	Check to ensure that belts are properly tensioned.

# HTN/HTO-31V8-TC — ENGINE TROUBLESHOOTING

**TABLE 6. ENGINE TROUBLESHOOTING**

SYMPTOM	POSSIBLE PROBLEM	SOLUTION
<b>Engine Cranks But Will Not Start</b>	Fuel tank is empty.	Fill fuel tank.
	Shut-off valve is closed.	Open fuel shut-off valve.
	Fuel line has suction leak or is restricted. Fuel filter, or fuel tank cap vent is obstructed.	Check fuel line condition and fuel line clamps. Ensure that fuel line is not kinked. Check fuel filter for restriction and replace if necessary. Check fuel cap vent and clean or replace as necessary.
	Fuel supply is contaminated.	Drain and clean fuel tank, clean tank and refill with fuel.
	If carbureted, carburetor is underchoked or overchoked.	Apply recommended amount of choke for cold and warm weather.
	Spark plug is fouled, improperly gapped, or damaged. Spark plug leads disconnected.	Check spark plug for fouling, check gap, and inspect for damage. Clean or replace spark plug as necessary. Reattach spark plug leads if disconnected.
	Safety stop switch malfunction.	Ensure that the Safety Stop Switch is functioning when the operator is seated; replace switch if necessary.
<b>Engine Starts But Will Not Continue Running</b>	Fuel tank is empty.	Fill fuel tank.
	Shut-off valve is closed.	Open fuel shut-off valve.
	Fuel line has suction leak or is restricted. Fuel filter is obstructed, or fuel tank cap vent is blocked.	Check fuel line condition and fuel line clamps. Ensure that fuel line is not kinked. Check fuel filter for restriction and replace if necessary. Check fuel cap vent and clean or replace as necessary.
	If engine is carbureted, carburetor is underchoked or over choked.	Apply recommended amount of choke for cold and warm weather.
	Faulty ignition switch or starter.	Replace defective switch or starter.
	Engine is seized.	Repair or replace engine.

# HTN/HTO-31V8-TC — ENGINE TROUBLESHOOTING

**TABLE 6. ENGINE TROUBLESHOOTING (CONTINUED)**

SYMPTOM	POSSIBLE PROBLEM	SOLUTION
<b>Engine Lacks Power</b>	Air filter is obstructed.	Replace air filter.
	Altitude causes 3% loss of horsepower per 1000 feet of altitude.	If available, install high altitude jets in carburetor.
	Choke is partially closed.	Open choke.
	Faulty spark plugs or spark plug leads. Spark plug lead disconnected.	Replace spark plugs or spark plug leads if faulty. Reattach spark plug lead if disconnected.
	Fuel is contaminated.	Drain and clean fuel tank. Refill with clean fuel.
	There is a lack of lubrication.	Check engine oil.
	Engine is overheated	Allow engine to cool. Find and repair cause of overheating.
	Exhaust is restricted.	Remove or repair restriction.
	Ignition timing incorrect.	Set engine ignition timing to manufacturer's specification.
<b>Engine Overheats</b>	Ignition timing incorrect.	Set engine ignition timing to manufacturer's specification.
	Fuel mixture is too lean.	Look for intake system leak. Repair any leaks found.
	Exhaust is restricted.	Remove or repair restriction.
	Fan shroud or fan is broken or missing.	Replace fan shroud.
	Coolant level is low.	Fill radiator when cool. Add coolant to fill line on reservoir.
	Low or Hi crankcase oil level	Check engine oil. Fill if low, drain if overfilled.
<b>Engine Will Not Crank</b>	Battery is discharged or defective.	Charge and test battery. Replace if defective.
	Loose or faulty wires or connections.	Inspect wiring, repair any bad connections or wires.
	Faulty ignition switch or starter.	Replace defective switch or starter.
	Engine is seized.	Repair or replace engine.

# HTN/HTO-31V — EXPLANATION OF CODE IN REMARKS COLUMN

The following section explains the different symbols and remarks used in the Parts section of this manual. Use the help numbers found on the back page of the manual if there are any questions.

The contents and part numbers listed in the parts section are subject to change **without notice**. Multiquip does not guarantee the availability of the parts listed.

Sample Parts List:

NO.	PART NO.	PART NAME	QTY.	REMARKS
1	12345	BOLT .....	1 ....	INCLUDES ITEMS W/*
2*		WASHER, 1/4 IN. ....		NOT SOLD SEPARATELY
2*	12347	WASHER, 3/8 IN. ....	1 ....	MQ-45T ONLY
3	12348	HOSE .....	A/R ..	MAKE LOCALLY
4	12349	BEARING .....	1 ....	S/N 2345B AND ABOVE

## NO. Column

**Unique Symbols** - All items with same unique symbol (\*, #, +, %, or >) in the number column belong to the same assembly or kit, which is indicated by a note in the "Remarks" column.

**Duplicate Item Numbers** - Duplicate numbers indicate multiple part numbers are in effect for the same general item, such as different size saw blade guards in use or a part that has been updated on newer versions of the same machine.

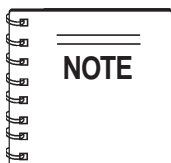

When ordering a part that has more than one item number listed, check the remarks column for help in determining the proper part to order.

## PART NO. Column

**Numbers Used** - Part numbers can be indicated by a number, a blank entry, or TBD.

TBD (To Be Determined) is generally used to show a part that has not been assigned a formal part number at time of publication.

A blank entry generally indicates that the item is not sold separately or is not sold by Multiquip. Other entries will be clarified in the "Remarks" Column.

## QTY. Column

**Numbers Used** - Item quantity can be indicated by a number, a blank entry, or A/R.

A/R (As Required) is generally used for hoses or other parts that are sold in bulk and cut to length.

A blank entry generally indicates that the item is not sold separately. Other entries will be clarified in the "Remarks" Column.

## REMARKS Column

Some of the most common notes found in the "Remarks" Column are listed below. Other additional notes needed to describe the item can also be shown.

**Assembly/Kit** - All items on the parts list with the same unique symbol will be included when this item is purchased.

Indicated by:

"INCLUDES ITEMS W/(unique symbol)"

**Serial Number Break** - Used to list an effective serial number range where a particular part is used.

Indicated by:

"S/N XXXXX AND BELOW"

"S/N XXXX AND ABOVE"

"S/N XXXX TO S/N XXX"

**Specific Model Number Use** - Indicates that the part is used only with the specific model number or model number variant listed. It can also be used to show a part is NOT used on a specific model or model number variant.

Indicated by:

"XXXXX ONLY"

"NOT USED ON XXXX"

**"Make/Obtain Locally"** - Indicates that the part can be purchased at any hardware shop or made out of available items. Examples include battery cables, shims, and certain washers and nuts.

**"Not Sold Separately"** - Indicates that an item cannot be purchased as a separate item and is either part of an assembly/kit that can be purchased, or is not available for sale through Multiquip.

# HTN/HTO-31V — SUGGESTED SPARE PARTS

## 31 VANGUARD ENGINE

### 1 to 3 Units

Qty.	P/N	Description
1	11792	ACCESSORY SOLENOID
5	2829	ARMS
4	10937	BELT (B-37)
2	11693	BOLT BATTERY
2	8381	BOOT, TOGGLE SWITCH
2	11692	BRACKET BATTERY
1	11771	BRACKET ENGINE THROTTLE CABLE
11	12771	BRONZE GEAR (L.S. FOR 1-1/4 SHAFT)
1	12772	BRONZE GEAR (R.S. FOR 1-1/4 SHAFT)
5	11039	BUSHING
2	12460	CABLE, PITCH
20	1162A	CAP GREASE FITTING
2	2108	CAP SPRAY TANK
1	2580	CHOKE CABLE
1	2673	CIRCUIT BREAKER 30 AMP, 12V
1	10434	CLAMP
1	10463	CLAMP
2	820263	ELEMENT, AIR CLEANER
2	821075	FAN BELT
2	29509	FUEL CAP STEEL TANK
2	11418	FUEL CAP/GUAGE PLASTIC TANK
1	820026	FUEL FILTER
2	2618	GASKET KIT
1	9032	GEAR WORM
4	189	HANDLE GRIP
4	2267	HANDLE GRIP (RIGHT SIDE)
1	12849	HEADER PIPE
2	825557	HOSE
2	825133	HOSE
2	29640	HOUR METER (NEW STYLE)
2	2655	HOUR METER (OLD STYLE)
20	1876	JAM NUT
1	2323	KEY 1/4 X 1/4 13/16
4	11078	KEYS, IGNITION (SWITCH)
2	12833	KIT, BEARING (1-1/4 SHAFT)
2	2737	KNOB ASSY.
1	10922	LEFT-SIDE FAN
1	1617	LEVER ASSY. TROWEL ADJUSTMENT
2	9005	LEVER TROWEL ARM (L.S.)
2	1986	LEVER TROWEL ARM (R.S.)
1	12764	MAIN SHAFT, 1-1/4 DIAMETER
1	10208	MUFFLER W/CLAMP
20	1456	NUT (3/8 -16)
2	491056	OIL FILTER
1	9028	PIN YOKE
1	10921	RIGHT-SIDE FAN

Qty.	P/N	Description
2	21870	SAFETY KILL SWITCH
20	0164B	SCREW
20	4514	SCREW (HHC 1/4-20 X 5/8)
20	16602	SCREW (HHC 3/8 -16 X 3/8)
20	12097	SCREW (SQH 3/8-16 X 1 3/4 CONE)
20	1322	SCREW ASSY., ARM RETAINING
1	21861	SEAT
1	12586	SHAFT GEARBOX INPUT W/FAN
3	496018S	SPARK PLUG
2	12787	SPIDER, 1-1/4 DIA. MAINSHAFT
2	12548	SPRAY PUMP
2	9111	SPRING (L.S.)
2	2143	SPRING (R.S.)
1	11430	SWITCH
2	10958	SWITCH, IGNITION
1	19301	TERMINAL STRIP (10-POLE)
2	2124	THROTTLE CABLE
2	20938	THRUST COLLAR KIT
2	4682	TOGGLE SWITCH
20	0166A	WASHER
20	1875	WASHER
20	0181B	WASHER 1/4 IN
10	10031	WASHER 1/4 IN.
6	2509	WING NUT
1	1139	WOODRUFF KEY
1	9027	YOKE

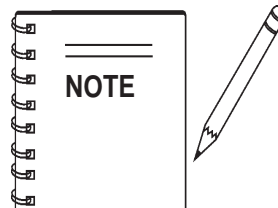

Part numbers on this Suggested Spare Parts List may supercede/replace the P/N shown in the text pages of this book.



# HTN/HTO-31V — NAMEPLATE AND DECALS ASSY.

## NAMEPLATE AND DECALS ASSY.

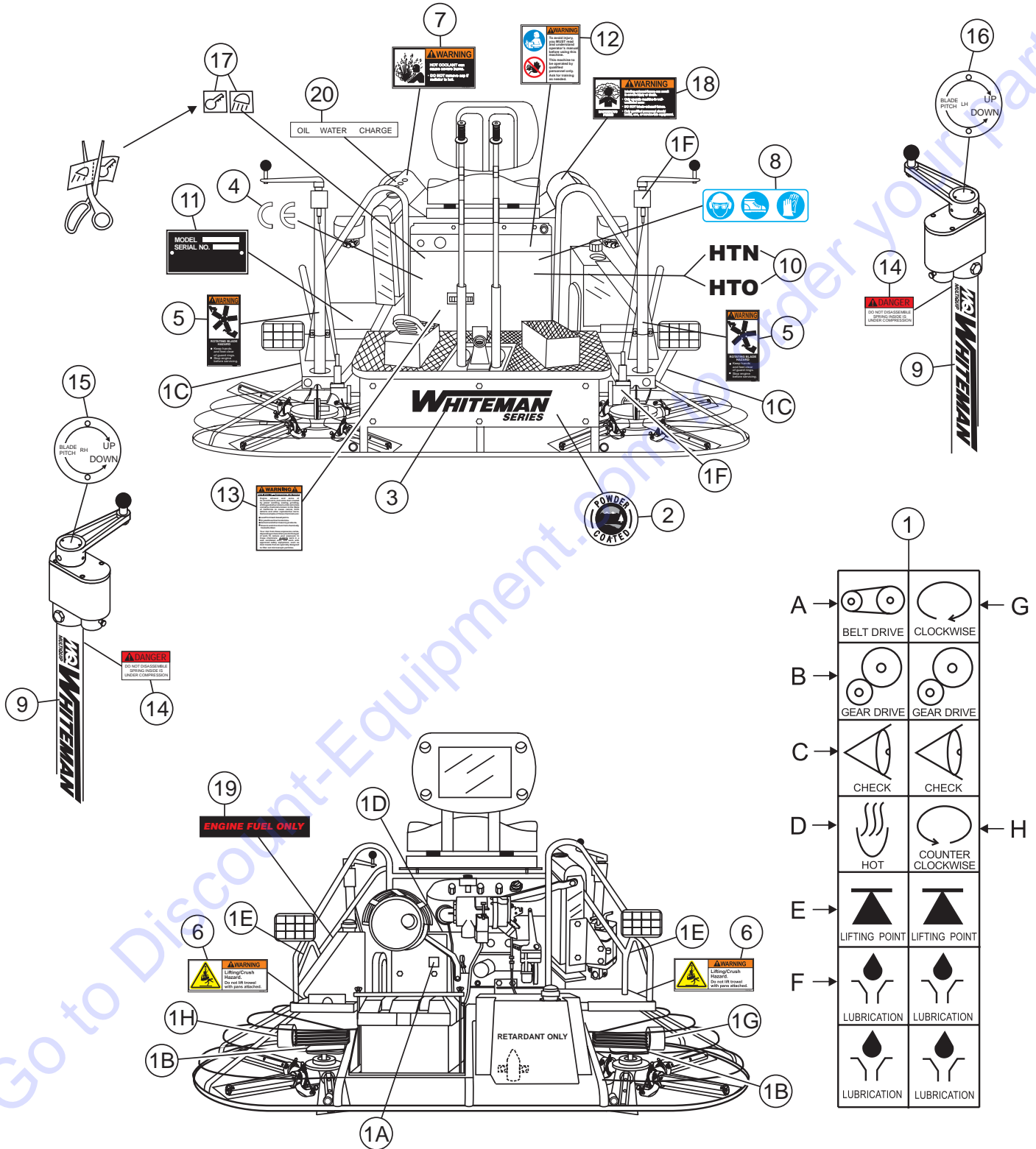

# HTN/HTO-31V — NAMEPLATE AND DECALS ASSY.

## NAMEPLATE AND DECALS ASSY.

<u>NO.</u>	<u>PART NO.</u>	<u>PART NAME</u>	<u>QTY.</u>	<u>REMARKS</u>
1	11246	DECAL SET, INTERNATIONAL STDS .....	1	INCLUDES ITEMS W/#
1A#		DECAL, BELT DRIVE	1	
1B#		DECAL, GEAR DRIVE	2	
1C#		DECAL, CHECK OIL	2	
1D#		DECAL, HOT SURFACE	1	
1E#		DECAL, LIFT POINT	2	
1F#		DECAL, LUBRICATION	4	
1G#		DECAL, CLOCKWISE ROTATION	1	
1H#		DECAL, COUNTER-CLOCKWISE ROTATION	1	
2	13118	DECAL, POWDER COATED	1	
3	21589	DECAL, WHITEMAN SERIES 4.76 X 21.82	1	
4	11092	DECAL, "CE"	1	
5	35168	DECAL, ROTATING BLADE HAZARD, 2.0 x 4.3	2	
6	21455	DECAL, LIFTING/CRUSH HAZARD	2	
7	36091	DECAL, HOT COOLANT 3.5 X 1.75 WRSDPU	1	
8	36099	DECAL, PROTECTIVE CLOTHING	1	
9	1499	DECAL, WHITEMAN	2	
10	21796	DECAL, HTN, 1.73" x 5.09"	1	
10	21797	DECAL, HTO SERIES	1	
11	21600	DECAL, SERIAL PLATE-RIDER, 3.13 x 2.25	1	
12	35137	DECAL, READ MANUAL, ASK FR TRAINING 2.75"	1	
13	20525	DECAL, WARNING "PROP 65", 3.25 x 4.25	1	
14	2634	DECAL, SPRING SAFETY	2	
15	2300	DECAL, AL. PITCH, RH	1	
16	2332	DECAL, AL PITCH, LH	1	
17	2814	DECAL, CONTR PNL	1	
18	36090	DECAL, VENTILATION	1	
19	22088	DECAL, "ENGINE FUEL ONLY" 1.50" x 8.00"	1	
20	12571	DECAL, INSTRUMENT LITES (31V)	1	

# HTN/HTO-31V — PIVOT ASSY.

PIVOT ASSY.

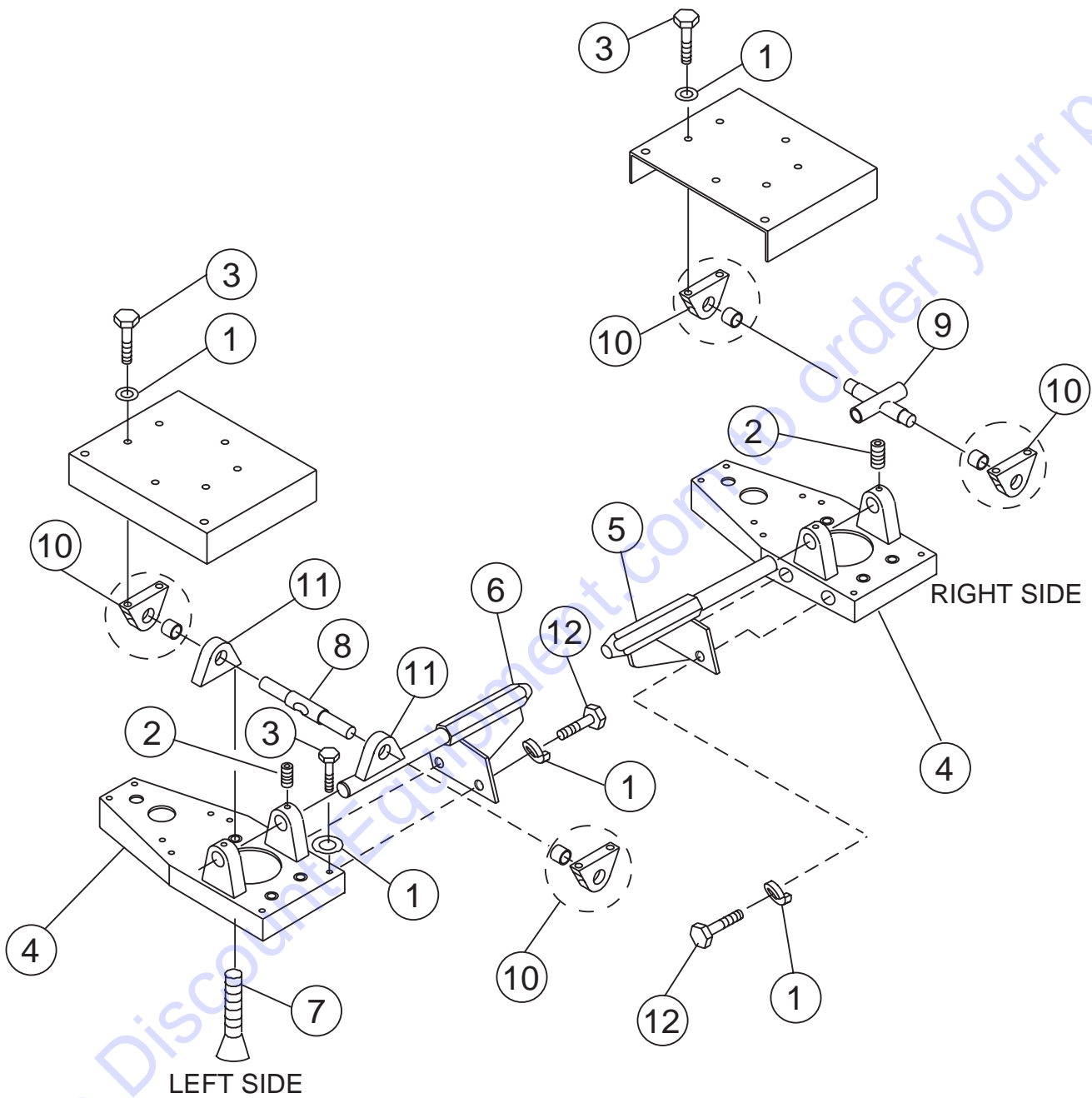

## PIVOT ASSY.

<u>NO</u>	<u>PART NO</u>	<u>PART NAME</u>	<u>QTY.</u>	<u>REMARKS</u>
1	0166 A	WASHER, LOCK, 3/8 MED.	20	
2	10138	SCREW, SHS 1/4-20 X 1/2, N.P.	4	
3	1023	SCREW, HHC 3/8-16 X 1 1/4	16	
4	11248	PLATE, GEARBOX ADAPTOR	2	
5	12412	ARM, PIVOT RIGHT HTN	1	
5	12414	ARM, PIVOT RIGHT HTO	1	
6	12413	ARM, PIVOT LEFT HTN	1	
6	12415	ARM, PIVOT LEFT HTO HTO	1	
7	1394	SCREW, FHSC 3/8-16 X 1	4	
8	2145	PIVOT JOINT, SINGLE ROCKER	1	
9	2146	PIVOT, DOUBLE ROCKER	1	
10	2304	ROCKER BLOCK	4	
11	2312	ROCKER BLOCK	2	
12	4196	SCREW, HHC 3/8-16 X 3/4	4	

Go to Discount-Equipment.com to order your parts

# HTN/HTO-31V — STEERING HANDLES ASSY.

STEERING HANDLES ASSY.

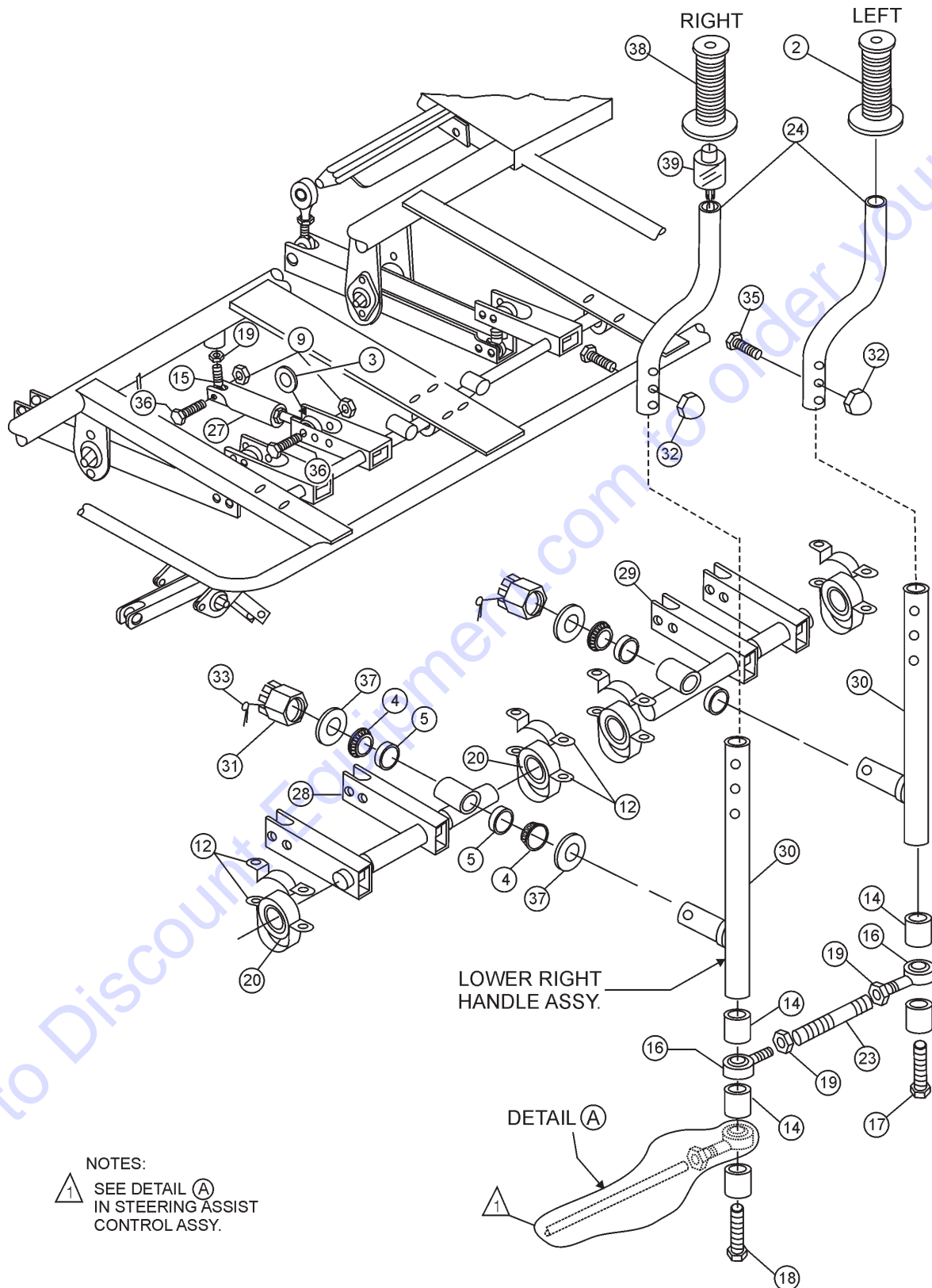

## HTN/HTO-31V — STEERING HANDLES ASSY.

### CONTROL STEERING (ASSIST)

<u>NO</u>	<u>PART NO</u>	<u>PART NAME</u>	<u>QTY.</u>	<u>REMARKS</u>
2	0189	GRIP, HANDLE	1	
3	0447	WASHER, FLAT, 1/2 SAE	2	
4	0735	BEARING, CONE, TIMKEN #A6075	4	
5	0735 A	BEARING, CUP, TIMKEN #A6157	4	
9	10176	NUT, NYLOC 1/2-13	4	
12	11138	BEARING, P-BLOCK HOUSING 47MPB	4	
14	11141	SPACER, ROD END	5	
15	11142	ROD END, 1/2-20 MALE RH	2	
16	11143	ROD END, 1/2-20 FEMALE RH	2	
17	11144	SCREW, SHC 1/2-20 X 2 PLTD	1	
18	11145	SCREW, SHC 1/2-20 X 3 PLTD	1	
19	11146	NUT, HEX JAM 1/2-20	4	
20	11149	BEARING, SB-204-12	4	
23	11173	THREADPIECE, 1/2-20 X 2 PLTD	1	
24	11177	HANDLE TUBE, UPPER	2	
27	12200	ASSIST ASM, STEERING SPRING	2	
28	12374	STEERING CONTROL W/A RS ASSIST	1	
29	12375	STEERING CONTROL W/A LS ASSIST	1	
30	12425	HANDLE , LOWER W/A	2	
31	12426	NUT, SLOTTED 3/4-16 PLATED	2	
32	2197	NUT, ACORN 1/4-20	2	
33	2219	PIN, COTTER 1/8 X 1 1/2	2	
35	5277	SCREW, HHC 1/4-20 X 1 1/2	2	
36	EM963105	SCREW, HHC 1/2-13 X 2	4	
37	8151	WASHER, FLAT, 3/4 SAE	4	
38	2267	GRIP HANDLE, RIGHT	1	
39	11430	SWITCH, PUSHBUTTON	1	

# HTN/HTO-31V — STEERING ASSIST CONTROL ASSY.

STEERING ASSIST CONTROL ASSY.

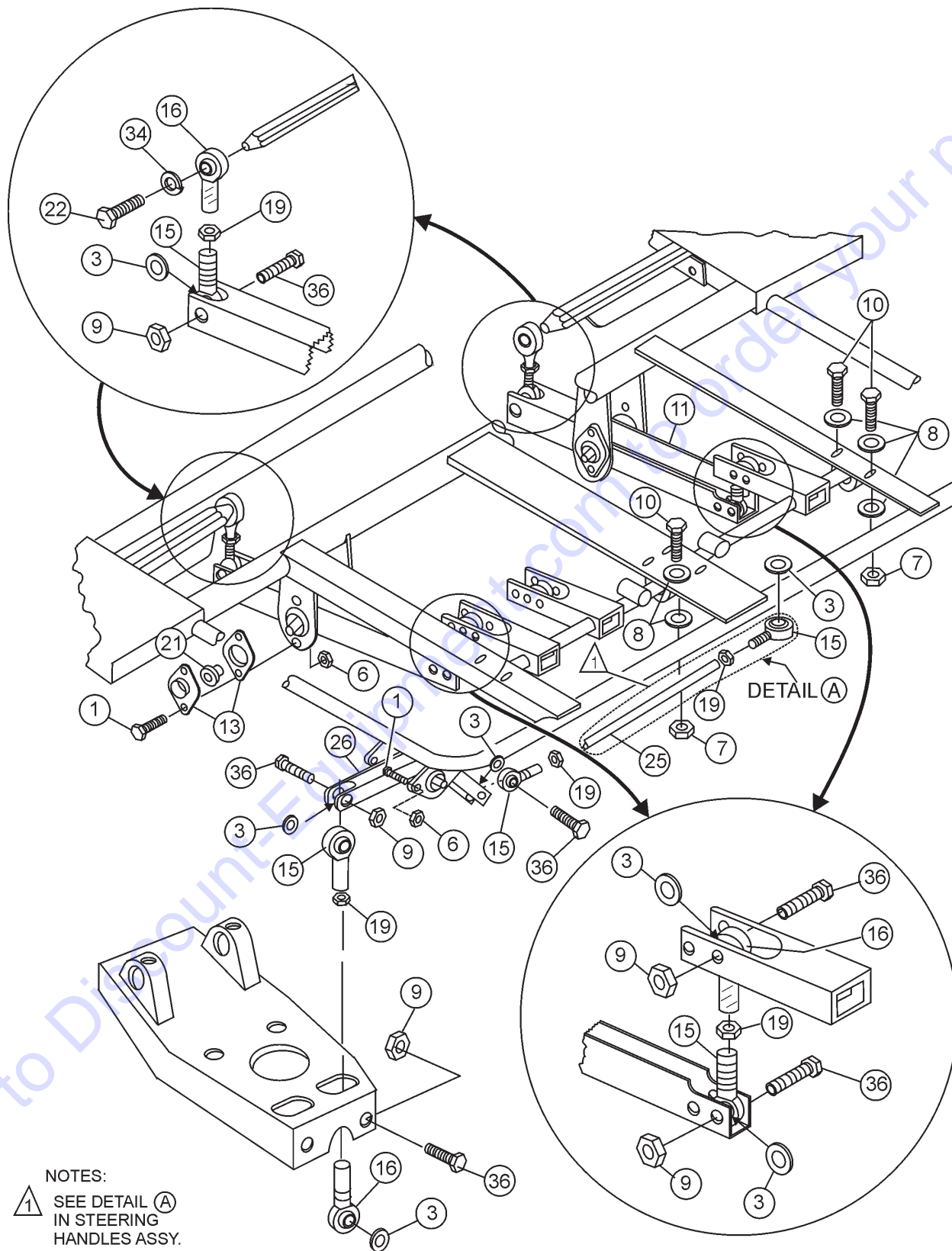

NOTES:  
1 SEE DETAIL (A)  
IN STEERING  
HANDLES ASSY.

# HTN/HTO-31V — STEERING ASSIST CONTROL ASSY.

## STEERING ASSIST CONTROL ASSY.

<u>NO</u>	<u>PART NO</u>	<u>PART NAME</u>	<u>QTY.</u>	<u>REMARKS</u>
1	0131 A	SCREW, HHC 1/4-20 X 3/4	12	
3	0447	WASHER, FLAT, 1/2 SAE	12	
6	10024	NUT, NYLOC 1/4-20	12	
7	10133	NUT, NYLOC 3/8-16	8	
8	10136	WASHER, FLAT, 3/8 SAE	16	
9	10176	NUT, NYLOC 1/2-13	9	
10	1023	SCREW, HHC 3/8-16 X 1 1/4	8	
11	11127	LEVER, STEERING CONTROL W/A	2	
13	11139	BEARING, FLANGE HOUSING 40M-2	6	
15	11142	ROD END, 1/2-20 MALE RH	7	
16	11143	ROD END, 1/2-20 FEMALE RH	5	
19	11146	NUT, HEX JAM 1/2-20	7	
21	11150	BEARING, SB-201-8	6	
22	8136	SCREW, HHC 1/2-20 X 1.1/2" .....	2	REPLACES 11170
25	11205	<b>HTN</b> - ROD, L/R MOTION	1	
25	11172	<b>HTO</b> - L/R MOTION	1	
26	12193	LEVER, L/R CONTROL W/A	1	
34	5054 A	WASHER, LOCK, 1/2 MED.	2	
36	6159 A	SCREW, HHC 1/2-13 X 2	9	

Go to Discount-Equipment.com to order your parts



# HTN/HTO-31V — TWIN PITCH ASSY. (LEFT/RIGHT)

## TWIN PITCH ASSY. (LEFT/RIGHT)

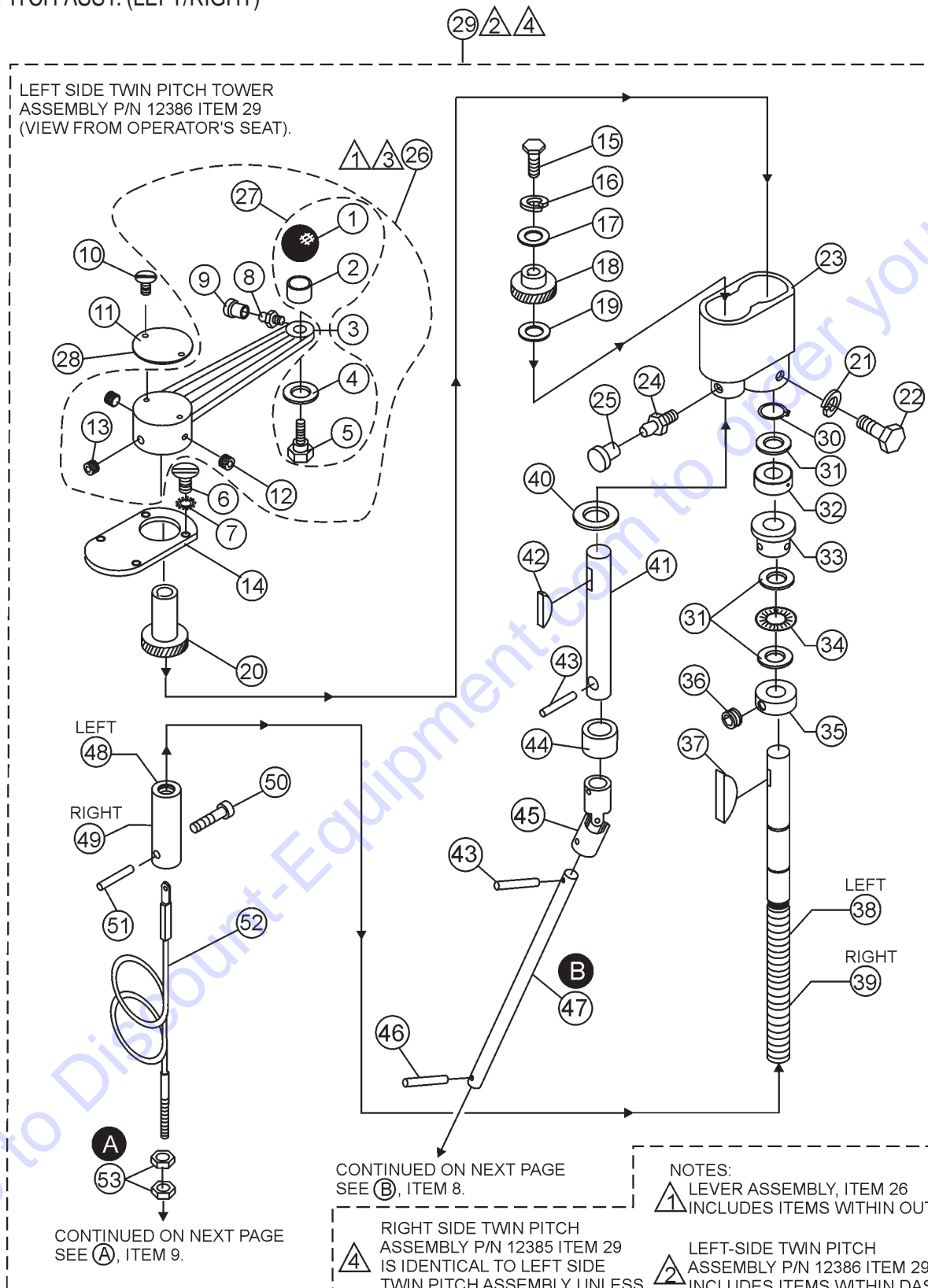

# HTN/HTO-31V — TWIN PITCH ASSY. (LEFT/RIGHT)

## TWIN PITCH ASSY. (LEFT/RIGHT)

<u>NO</u>	<u>PART NO</u>	<u>PART NAME</u>	<u>QTY.</u>	<u>REMARKS</u>
1#	4403	KNOB, SHIFT	1	
2#	3231	SPACER	1	
3#	1615	CRANK LEVER	1	
4#	1733	HARDENED WASHER	1	
5#	1616	SHOULDER BOLT	1	
6+	2620	SCREW, BHC 10 – 24 X 5/8	4	
7	10114	WASHER, EXT. SHKP, #8	4	
8#	2621	FITTING GREASE	1	
9#	1162 A	CAP, GREASE ZERK/2	1	
10	4014	SCREW, 2–3/16 P-K TYPE U-DRIVE	2	
11	2300	DECAL, AL PITCH, RH .....	1	RIGHT-SIDE ONLY
12#	1528	SCREW, SHSS 1/4–20 X 5/16"	2	
13#	0185	SCREW, SHSS 3/8–16 X 3/8"	1	
14+	2649	COVER, PITCH CONT HOUSING	1	
15+	1579	SCREW, HHC 1/4–20 X 1/2	1	
16+	0181 B	WASHER, LOCK, 1/4 MED	4	
17+	0948	WASHER, FLAT, 1/4 SAE	1	
18+	1530	GEAR, SLAVE, TPC	1	
19+	1733	WASHER, 1/32 X 1/2 HARDENED	8	
20+	1529	GEAR, MASTER, TPC	1	
21+	0161 C	WASHER, LOCK 5/16 MED	1	
22+	0655	SCREW, HHC 5/16 –18 X 3/4	1	
23+	10546	HOUSING, PITCH CONTROL, 1–3/4	1	
24+	2621	ZERK, GREASE STR 1/4–28	1	
25+	1162 A	CAP, GREASE ZERK	1	
26	1617	LEVER ASSY, TROWEL ADJUSTMENT .....	1	INCLUDES ITEMS W/#
27	2737	KNOB, KIT .....	1	INCLUDES ITEMS W/\$
28	2332	DECAL, AL PITCH, LH .....	1	LEFT SIDE ONLY
29	12386	TOWER ASSEMBLY, LEFT TPC .....	1	INCLUDES ITEMS W/+
29	12385	TOWER ASSEMBLY, RIGHT TPC .....	1	INCLUDES ITEMS W/%
30+	10512	RING, SNAP, TRUARC 5160 – 75	1	
31+	2170	BEARING, RACE, TORR #TRA 1220	3	
32+	1604	BEARING, BALL THRUST	1	
33+	1612	BEARING, ALUM – PITCH CONTR	1	
34+	2169	BEARING, THRUST, TORR #NTA 1220	1	
35+	2367	SET COLLAR .....	1	INCLUDES ITEM W/■
36+	0685	SCREW, SHS 5/16 - 18 X 5/16	1	
37+	0126	KEY, WOODRUFF #9	1	
38+	10511	SHAFT, PITCH CONTROL, LH TPC .....	1	LEFT SIDE ONLY
39%	10510	SHAFT, PITCH CONTROL, RH TPC .....	1	RIGHT SIDE ONLY
40+	1733	WASHER, 1/32 X 1/2 HARDENED	4	
41+	2007	SHAFT	1	
42+	1578	KEY, WOODRUFF, #3	1	
43+	11654	PIN, ROLL 1/8 X 1 PLATED	1	
44+	2311	SPACER, 3/4 X 1/2 X 0.8L	1	
45+	11583	U-JOINT, PITCH CONTROL	1	
46+	1586	PIN, ROLL 1/8 X 3/4	1	
47+	12365	SHAFT, PITCH CONTROL	1	
48+	10722	SLIDE BLOCK, LH PITCH CONTROL .....	1	LEFT SIDE ONLY
49 %	10721	SLIDE BLOCK, RH PITCH CONTROL .....	1	RIGHT SIDE ONLY
50+	10382	BOLT, SHOULDER 3/8 X 3/8 LONG	1	
51+	10723	PIN, SPIROL 3/16 X 1 3/8 HD	1	
52+	12460	CABLE, PITCH ASSEMBLY	1	
53+	1116	NUT, BRASS JAM 5/16 –18	2	

**NOTE:** INDICATED QUANTITIES ARE FOR ONE PITCH TOWER. IF ORDERING FOR TWO PITCH TOWERS DOUBLE QUANTITY.

# PARTS FINDER

**Search Website  
by Part Number**



**Search Manual  
Library For Parts  
Manual & Lookup Part  
Numbers – Purchase  
or Request Quote**

**Search Manuals**

Enter your information to help us find the right parts manual for your machine.

\* Brand:

\* Model:

\* Serial:

\* Part Number:

SEARCH

**Can't Find Part or  
Manual? Request Help  
by Manufacturer,  
Model & Description**

**Parts Order Form**

Please fill in the following information to help us find the right part for your machine.

Manufacturer:	<input type="text"/>
Model:	<input type="text"/>
Description:	<input type="text"/>
Part Number:	<input type="text"/>
Quantity:	<input type="text"/>
Notes:	<input type="text"/>

Discount-Equipment.com is your online resource for quality parts & equipment.

Florida: **561-964-4949** Outside Florida TOLL FREE: **877-690-3101**

**Need parts?**

Click on this link: <http://www.discount-equipment.com/category/5443-parts/> and choose one of the options to help get the right parts and equipment you are looking for. Please have the machine model and serial number available in order to help us get you the correct parts. If you don't find the part on the website or on one of the online manuals, please fill out the request form and one of our experienced staff members will get back to you with a quote for the right part that your machine needs.

We sell worldwide for the brands: Genie, Terex, JLG, MultiQuip, Mikasa, Essick, Whiteman, Mayco, Toro Stone, Diamond Products, Generac Magnum, Airman, Haulotte, Barreto, Power Blanket, Nifty Lift, Atlas Copco, Chicago Pneumatic, Allmand, Miller Curber, Skyjack, Lull, Skytrak, Tsurumi, Husquvarna Target, Stow, Wacker, Sakai, Mi-T-M, Sullair, Basic, Dynapac, MBW, Weber, Bartell, Bennar Newman, Haulotte, Ditch Runner, Menegotti, Morrison, Contec, Buddy, Crown, Edco, Wyco, Bomag, Laymor, EZ Trench, Bil-Jax, F.S. Curtis, Gehl Pavers, Heli, Honda, ICS/PowerGrit, IHI, Partner, Imer, Clipper, MMD, Koshin, Rice, CH&E, General Equipment, Amida, Coleman, NAC, Gradall, Square Shooter, Kent, Stanley, Tamco, Toku, Hatz, Kohler, Robin, Wisconsin, Northrock, Oztec, Toker TK, Rol-Air, APT, Wylie, Ingersoll Rand / Doosan, Innovatech, Con X, Ammann, Mecalac, Makinex, Smith Surface Prep, Small Line, Wanco, Yanmar

# HTN/HTO-31V — TWIN PITCH AND MITER BOX ASSY. (LEFT/RIGHT)

## TWIN PITCH MITER BOX ASSY. (LEFT/RIGHT)

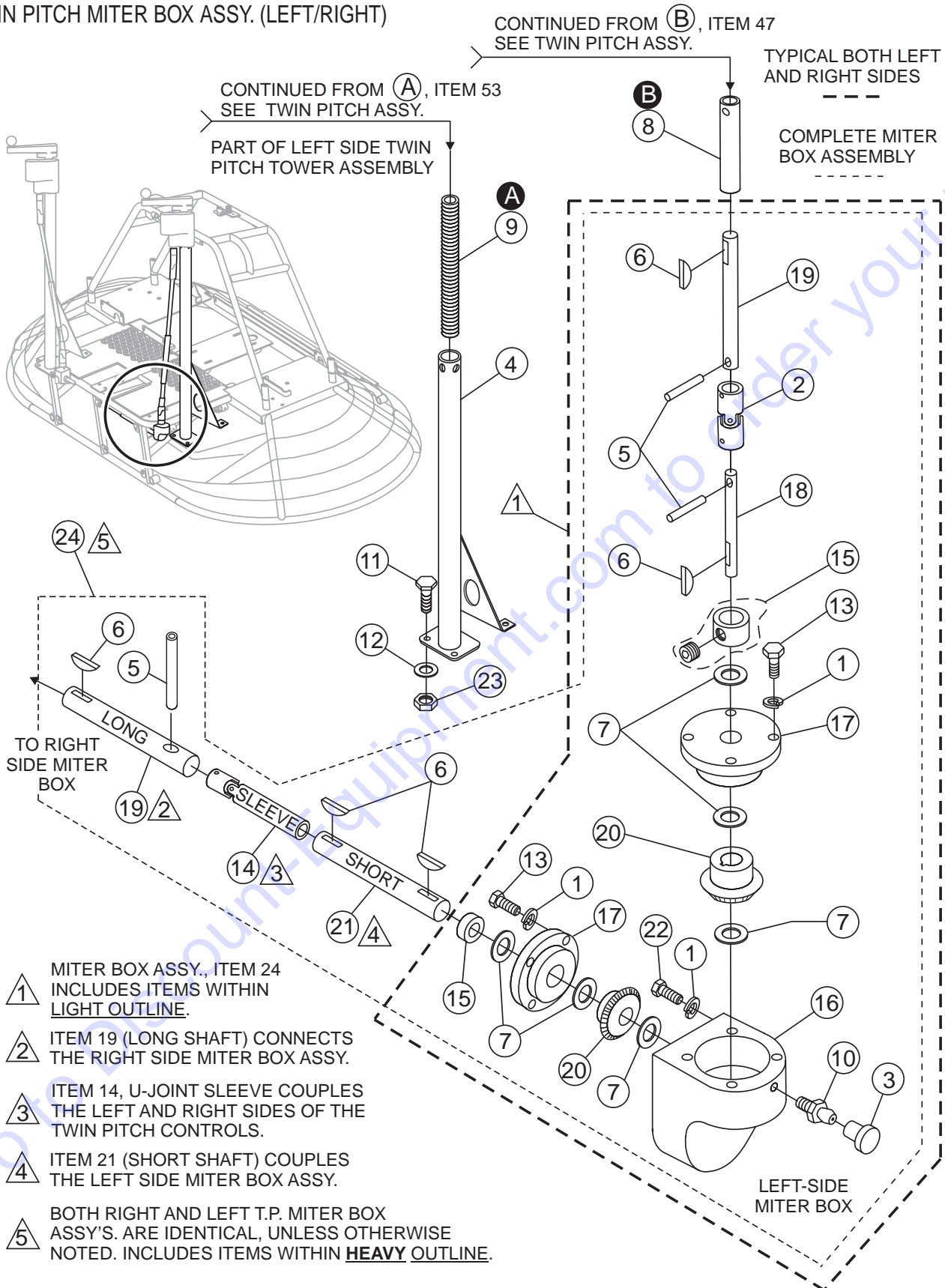

# HTN/HTO-31V — TWIN PITCH AND MITER BOX ASSY. (LEFT/RIGHT)

## TWIN PITCH MITER BOX ASSY. (LEFT/RIGHT)

<u>NO</u>	<u>PART NO</u>	<u>PART NAME</u>	<u>QTY.</u>	<u>REMARKS</u>
1*	0181 B	WASHER, LOCK, 1/4 MED	10	
2*	11583	U-JOINT, PITCH CONTROL	1	
3*	1162 A	CAP, GREASE ZERK	1	
4	10548	TUBE, PITCH CONTROL	1	
5*	11654	PIN, ROLL 1/8 X 1"	3	
6*	1578	KEY, WOODRUFF, #3	6	
7*	1733	WASHER, 1/32 X 1/2 HARDENED	6	
8	2012	SLEEVE, ADJ – LONG, RIDER	1	
9	2156	SPRING, COIL	1	
10*	2621	ZERK, GREASE STR 1/4 – 28	1	
11	0202	SCREW, HHC 5/16 –18 X 1	4	
12	0300 B	WASHER, FLAT, 5/16 SAE	4	
13*	0730	SCREW, HHC 1/4 –20 X 1	8	
14*	11653	SLEEVE, W/U-JOINT	1	
15*	1577	SET COLLAR, 1/2	1	
16*	1987	MITER BOX, PITCH CONTROL	1	
17*	1988	MITER BOX, BEARING CAP RIDERS	1	
18*	2021	SHAFT, MITER VERTICAL	1	
19*	2022	SHAFT, MITER	2	
20*	2062	GEAR, MITER	1	
21*	2845	SHAFT, MITER BOX HORIZ, (HTN)	1	
21*	2049	SHAFT, MITER BOX HORIZ, (HTO)	1	
22*	4514	SCREW, HHC 1/4 –20 X 5/8	4	
23	5283	NUT, NYLOC 5/16 –18	4	
24	11655	MITER BOX ASSEMBLY, (HTN) .....	1	INCLUDES ITEMS W/*
24	12456	MITER BOX ASSEMBLY, (HTO) .....	1	INCLUDES ITEMS W/*

**NOTE:**

Indicated quantities are for one pitch tower. If ordering for two pitch towers, double the quantity unless otherwise noted.

Go to Discount-Equipment.com to order your parts

# HTN/HTO 31V — ENGINE MOUNTING BRACKETS ASSY.

## ENGINE MOUNTING BRACKETS ASSY.

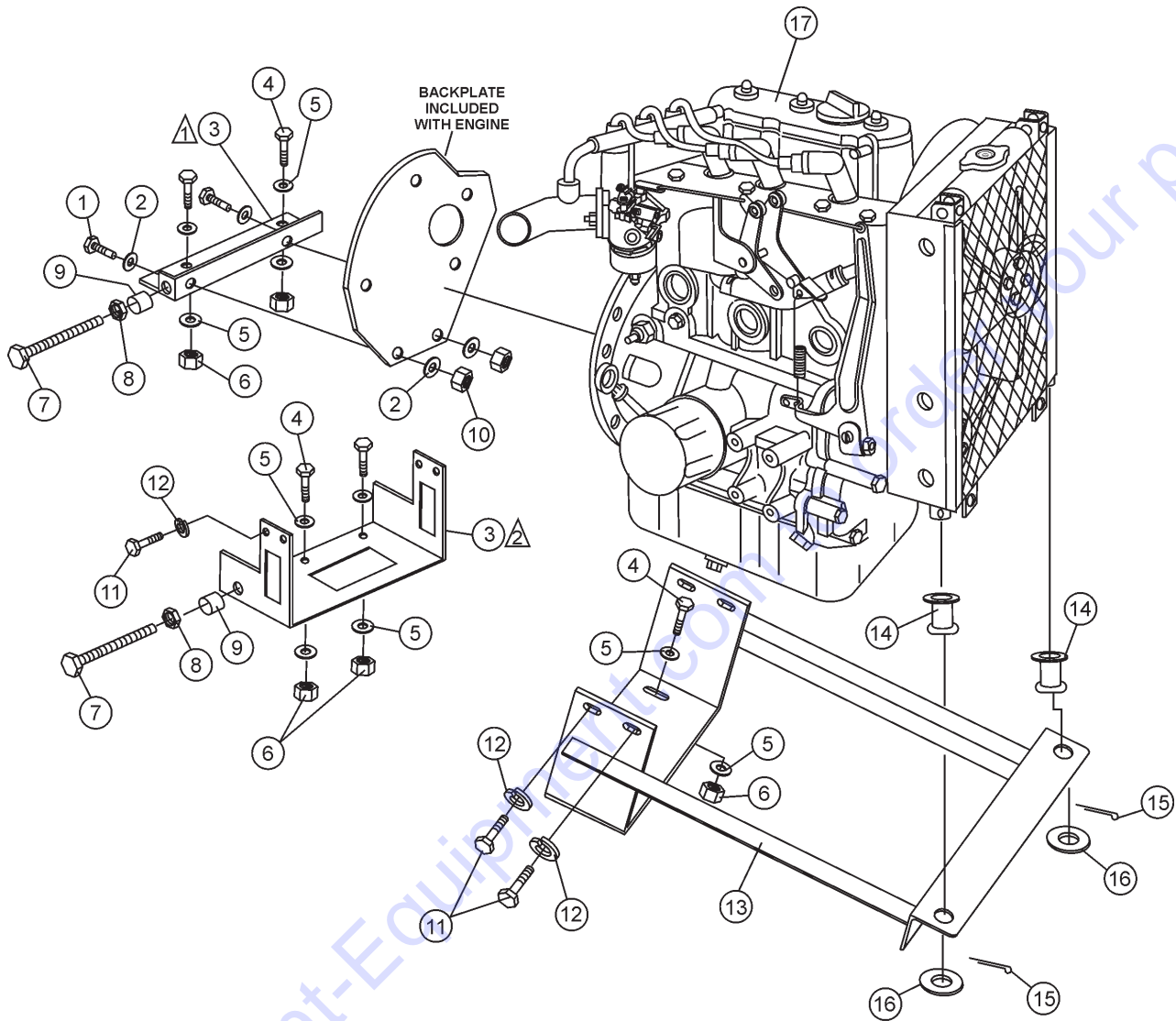

### NOTES:

▲ MOUNT REAR LEFT P/N 12458  
S/N CC0202199 AND BELOW

▲ BRACKET ENGINE MOUNT P/N 21628  
S/N CC0202200 AND ABOVE

## HTN/HTO 31V — ENGINE MOUNTING BRACKETS ASSY.

### ENGINE MOUNTING BRACKETS ASSY.

<u>NO</u>	<u>PART NO</u>	<u>PART NAME</u>	<u>QTY.</u>	<u>REMARKS</u>
1	0202	SCREW, HHC 5/16-18 X 1	2	
2	0300 B	WASHER, FLAT, 5/16 SAE	4	
3	21628	BRACKET, ENGINE MOUNT LEFT .....	1	S/N CC0202200 AND ABOVE
4	1023	SCREW, HHC 3/8-16 X 1 1/4	4	
5	10136	WASHER, FLAT, 3/8 SAE	8	
6	10133	NUT, NYLOC 3/8-16	4	
7	11155	SCREW, HHC, FT, 5/16-24 X 4"	1	
8	6014 C	NUT, HEX FINISH 5/16-24	1	
9	11153	CAP, ENGINE ADJUST BOLT	1	
10	5283	NUT, NYLOC 5/16-18	2	
11	2866	SCREW, HHC M8 1.25 X 20 MM GR 8.8	8	
12	0161 C	WASHER, LOCK, 5/16 MED.	8	
13	11753	MOUNT, ENGINE FRONT W/A (RIGHT)	1	
14	19468	GROMMET, MINOR PN Z-4004	2	
15	0183	PIN, COTTER 1/8D X 1-1/4	2	
16	0447	WASHER, FLAT SAE1/2	2	
17	11292	ENGINE, BRIGGS 31 HP,DM950G	1	

Go to Discount-Equipment.com to order your parts

# HTN/HTO 31V — MUFFLER ASSY. S/NCC020199 AND BELOW

MUFFLER ASSEMBLY S/NCC0202199 AND BELOW

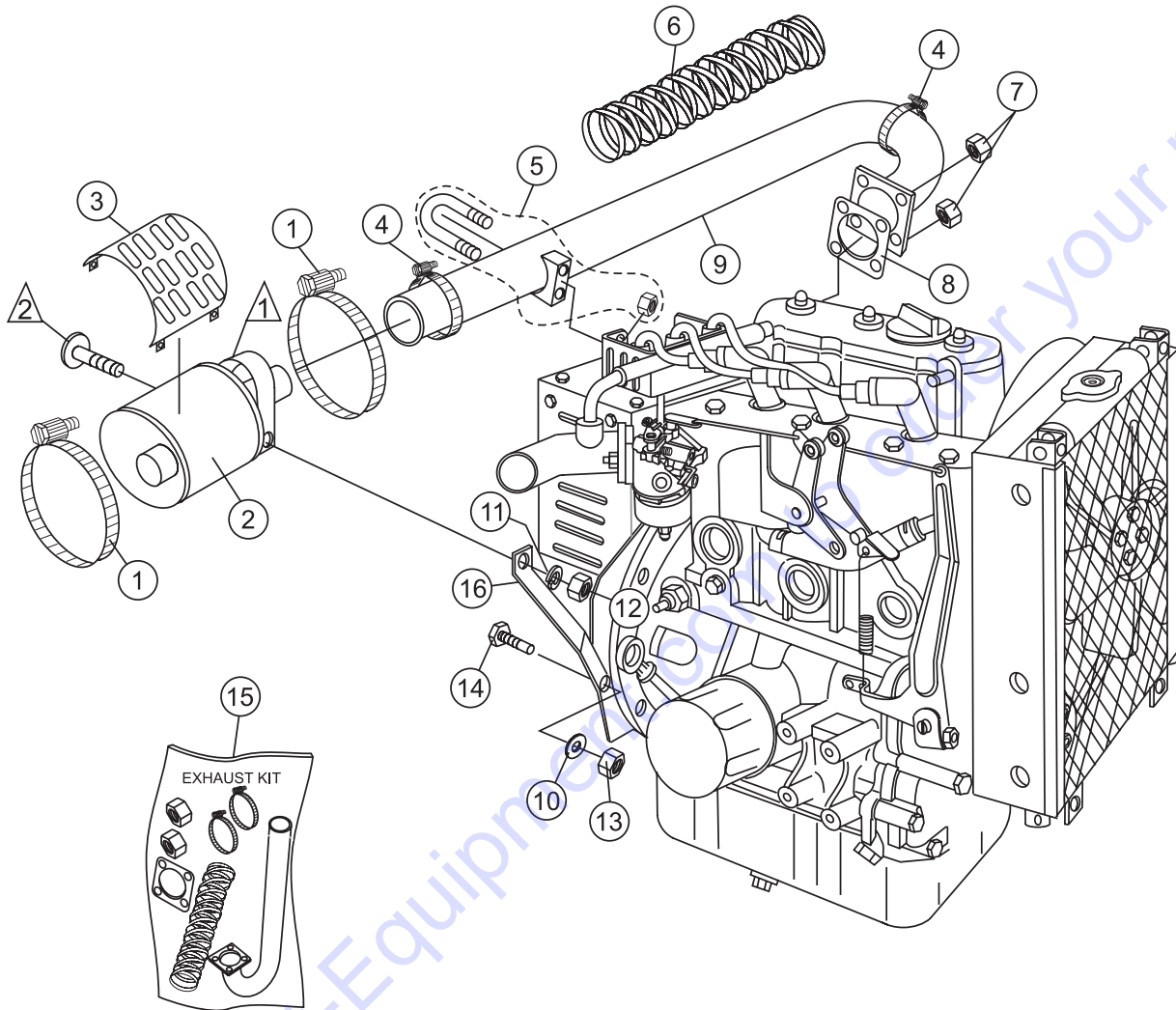

## NOTES:

- ▲ 1 CLAMP IS PART OF MUFFLER.
- ▲ 2 INCLUDED WITH MUFFLER CLAMP



## HTN/HTO 31V — MUFFLER ASSY. S/NCC020199 AND BELOW

### MUFFLER ASSEMBLY S/NCC0202199 AND BELOW

<u>NO</u>	<u>PART NO</u>	<u>PART NAME</u>	<u>QTY.</u>	<u>REMARKS</u>
1	10463	CLAMP, 7" HOSE, SIZE 104	2	
2	10208	MUFFLER W/ CLAMP	1	
3	12194	HEAT SHIELD W/A, MUFFLER	1	
4%	10434	CLAMP, 2" HOSE	2	
5	10855	CLAMP, 1-1/2 MUFFLER	1	
6%	60025	TAPE, 1/8 X 2 FIBERGLASS HI TEMP .....	13 FT. ....	SOLD BY THE FOOT. 13 FT. REQD.
7%	12848	EXHAUST FLANGE NUT	4	
8%	12847	EXHAUST GASKET	1	
9%	12781	EXHAUST W/A	1	
10	0300 B	WASHER, FLAT, 5/16 SAE	1	
11	0161 C	WASHER, LOCK, 5/16 MED.	1	
12	1456	NUT, HEX FINISH 3/8-16	1	
13	5283	NUT, NYLOC 5/16-18	1	
14	0202	SCREW, HHC 5/16-18 X 1	1	
15	12849	EXHAUST KIT .....	1 .....	INCLUDES ITEMS W/%
16	12226	BRACKET MUFFLER SUPPORT	1	

Go to Discount-Equipment.com to order your parts

# HTN/HTO 31V — MUFFLER ASSY. S/NCC020200 AND ABOVE

MUFFLER ASSEMBLY S/NCC0202200 AND ABOVE

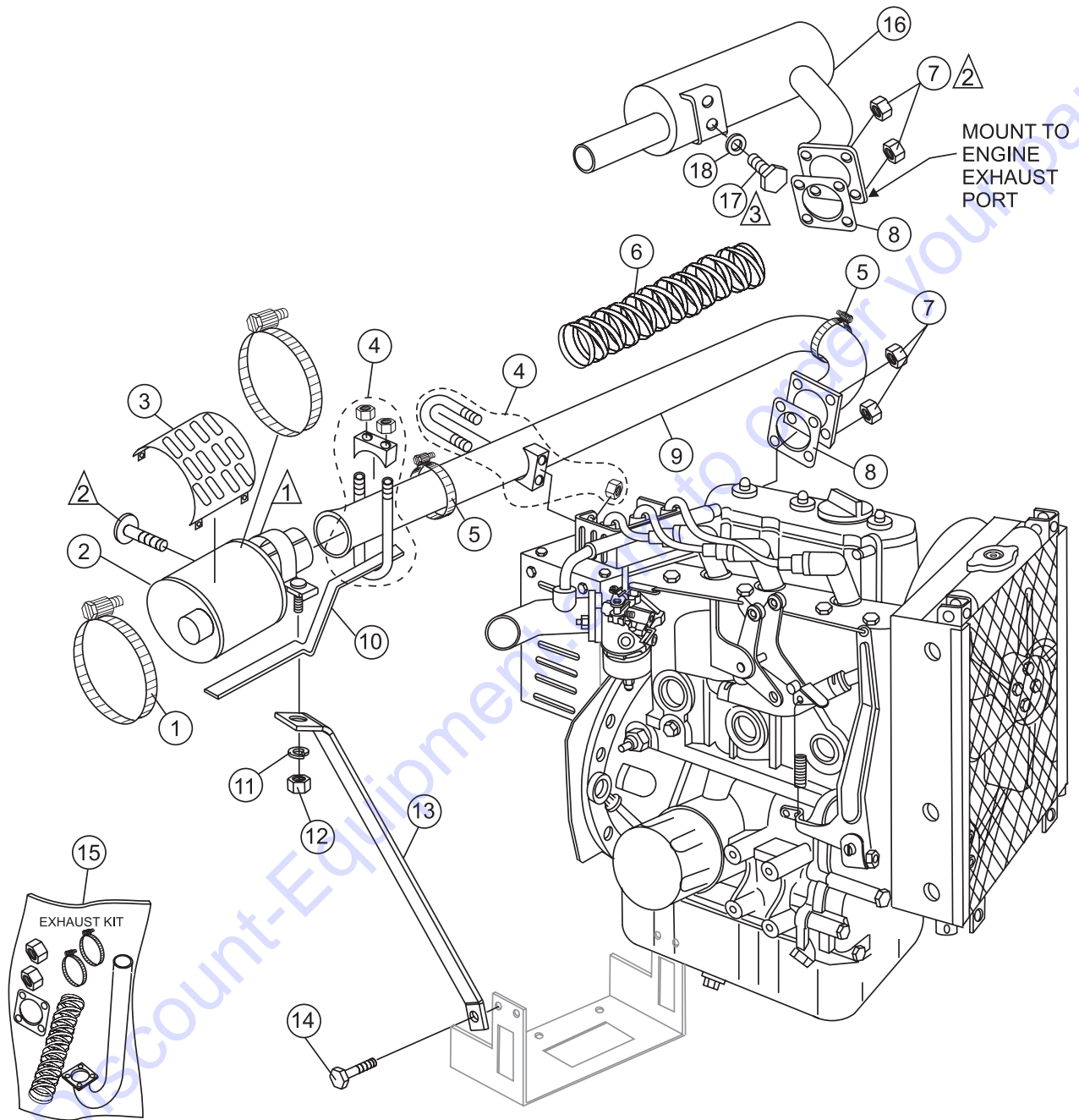

## NOTES:

- ① CLAMP AND BOLT ARE PART OF MUFFLER.
- ② TORQUE TO 15 LB-FT.
- ③ TORQUE TO 15 LB-FT. APPLY BLUE LOCTITE 246 P/N 60097.

## HTN/HTO 31V — MUFFLER ASSY. S/NCC020200 AND ABOVE

### MUFFLER ASSEMBLY S/NCC0202200 AND ABOVE

<u>NO</u>	<u>PART NO</u>	<u>PART NAME</u>	<u>QTY.</u>	<u>REMARKS</u>
1	10463	CLAMP, 7" HOSE, SIZE 104 .....	2 .....	MARCH 27, 2007 AND BELOW
2	10208	MUFFLER W/ CLAMP .....	1 .....	MARCH 27, 2007 AND BELOW
3	12194	HEAT SHIELD W/A, MUFFLER .....	1 .....	MARCH 27, 2007 AND BELOW
4	10855	CLAMP, 1-1/2 MUFFLER .....	1 .....	MARCH 27, 2007 AND BELOW
5%	10434	CLAMP, 2" HOSE .....	2 .....	MARCH 27, 2007 AND BELOW
6%	60025	TAPE, 1/8 X 2 FIBERGLASS HI TEMP .....	13 FT. ....	SOLD BY THE FOOT. 13 FT. REQ. MARCH 27, 2007 AND BELOW
7%	12848	EXHAUST FLANGE NUT	4	
8%	12847	EXHAUST GASKET	1	
9%	12781	EXHAUST W/A .....	1 .....	MARCH 27, 2007 AND BELOW
10	12917	BRACKET, MUFFLER SUPPORT .....	1 .....	MARCH 27, 2007 AND BELOW
11	0161 C	WASHER, LOCK, 5/16 MED. ....	1 .....	MARCH 27, 2007 AND BELOW
12	1456	NUT, HEX FINISH 3/8-16 .....	1 .....	MARCH 27, 2007 AND BELOW
13	21629	BRACKET, MUFFLER SUPPORT .....	1 .....	MARCH 27, 2007 AND BELOW
14	1605	SCREW, HHC M8-1.25 X 25mm .....	1 .....	MARCH 27, 2007 AND BELOW
15	12849	EXHAUST KIT .....	1 .....	INCLUDES ITEMS W/% MARCH 27, 2007 AND BELOW
16	20908	MUFFLER .....	1 .....	MARCH 28, 2007 AND ABOVE
17	0655	SCREW, HHC 5/16-18 X 3/4	2	
18	0300 B	WASHER, FLAT 5/16 SAE	2	

Go to Discount-Equipment.com to get your parts

# HTN/HTO 31V — FUEL TANK ASSY.

## FUEL TANK ASSY.

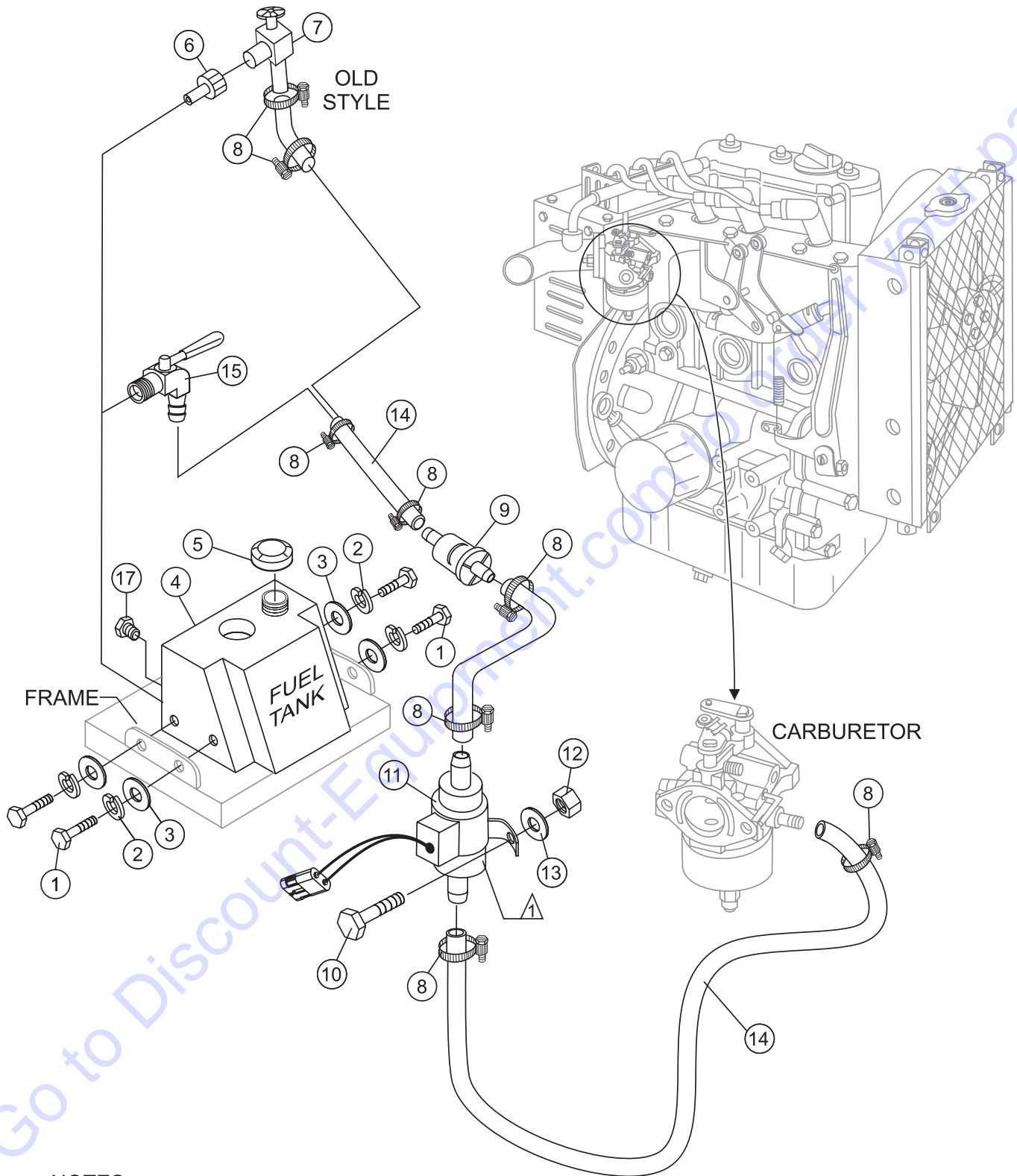

### NOTES:

▲ SECURE TO BATTERY BOX.

# HTN/HTO 31V — FUEL TANK ASSY.

## FUEL TANK ASSY.

<u>NO</u>	<u>PART NO</u>	<u>PART NAME</u>	<u>QTY.</u>	<u>REMARKS</u>
1	4514	SCREW, HHC 1/4-20 X 5/8	4	
2	0181 B	WASHER, LOCK, 1/4 MED.	6	
3	0948	WASHER, FLAT, 1/4 SAE	8	
4	12404	TANK, HTO/N 5 GAL., PLASTIC .....	1	MARCH 14, 2007 AND BELOW
4	12404	TANK, FUEL, STEEL .....	1	MARCH 15, 2007 AND ABOVE
5	11418	FUEL CAP/GAUGE (10.5"), PLASTIC TANK ....	1	MARCH 14, 2007 AND BELOW
5	29509	FUEL CAP/GAUGE, STEEL TANK .....	1	MARCH 15, 2007 AND ABOVE
6	19633	BUSHING, RUBBER FUEL DAPCO10672 .....	1	MARCH 14, 2007 AND BELOW
7	19661	VALVE, FUEL DRAIN DAPCO 11478 .....	1	MARCH 14, 2007 AND BELOW
8	19473	CLAMP, WORM HOSE, #4 (1/4-5/8) .....	6	DECEMBER 27, 2006 AND BELOW
8	22067	CLAMP, STEPLESS EAR 1/4" .....	6	DECEMBER 28, 2006 AND ABOVE
9	11984	IN-LINE FUEL FILTER 5/16	1	
10	0131 A	SCREW, HHC 1/4-20 X 3/4	2	
11	825232	FUEL PUMP	1	
12	10024	NUT, NYLOC 1/4-20	2	
13	0948	WASHER, FLAT, 1/4 SAE	8	
14	60013	HOSE, .25 ID RUBBER FUEL LINE .....	3 FT	SOLD BY THE FOOT. 3 FT. REQD.
15	20795	VALVE SHUTOFF 4MBARB X6SBARB .....	1	JULY 17, 2001~ MAR., 14, 2007
16	22081	VALVE SHUTOFF 1/4 NPT, 1/4 HOSE .....	1	MARCH, 15, 2007 AND ABOVE
17	16185	FITTING, PLUG 1/4" SQ. HD. ....	1	MARCH, 15, 2007 AND ABOVE

Go to Discount-Equipment.com to order parts

# HTN/HTO 31V — CLUTCH ASSY.

CLUTCH ASSY.

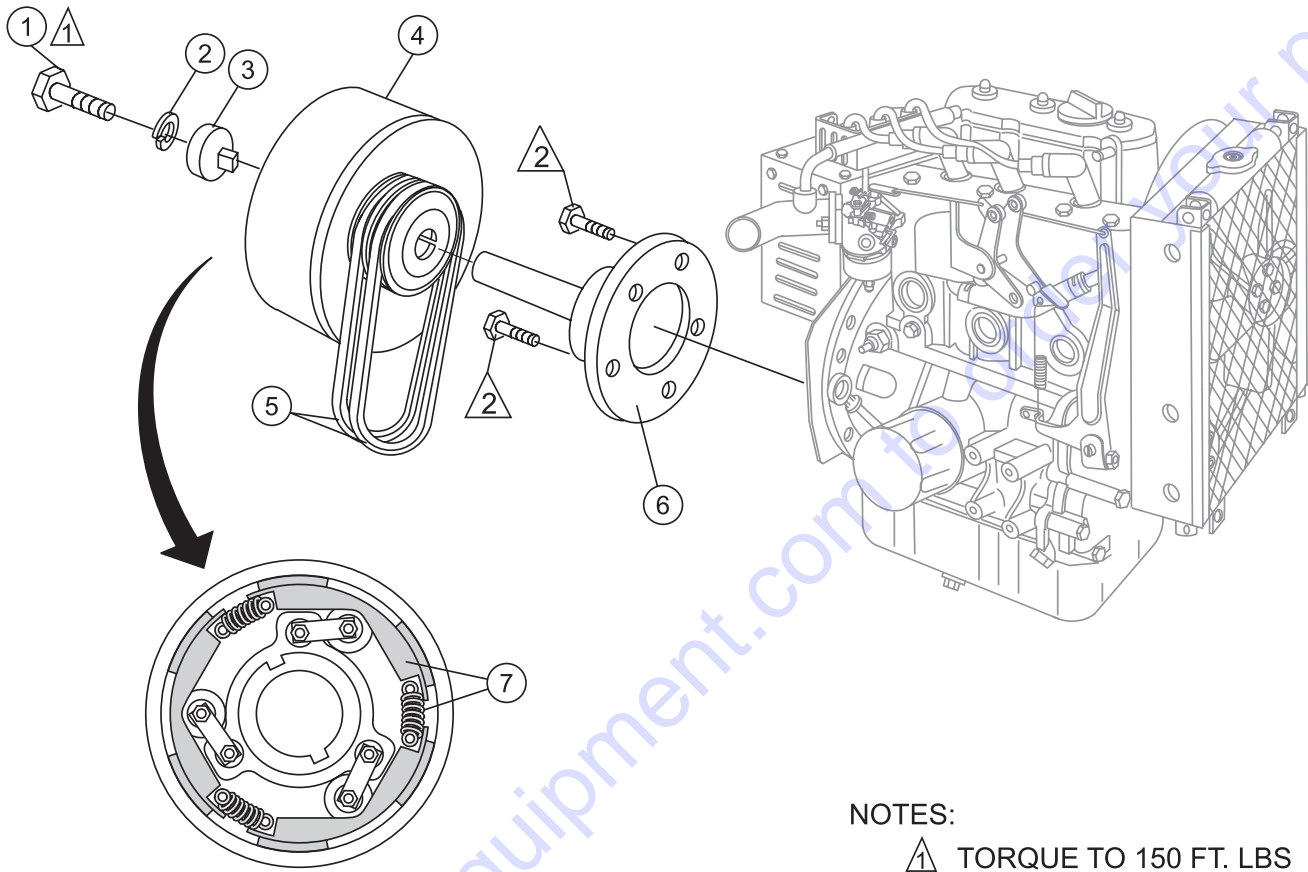

## NOTES:

⚠ TORQUE TO 150 FT. LBS

⚠ TORQUE TO 15 FT. LBS.  
BOLT IS INCLUDED WITH  
ENGINE.

## HTN/HTO 31V — CLUTCH ASSY.

### CLUTCH ASSY.

<u>NO</u>	<u>PART NO</u>	<u>PART NAME</u>	<u>QTY.</u>	<u>REMARKS</u>
1	12417	SCREW, HHC 5/8-18 X 2	1	
2	4703	WASHER, LOCK, 5/8 MED.	1	
3	12188	RETAINER, 1-7/16 BLM CLUTCH	1	
4	11994	CLUTCH, F74H-3080 X 1-7/16"	1	
5	10937	BELT, B37 GATES HP 11	2	
6	11758	ADAPTOR, CLUTCH, 31HP.VANGUARD	1	
7	12463	SHOES/SPRINGS KIT	1	

Go to Discount-Equipment.com to order your parts

# HTN/HTO 31V — RADIATOR GUARD/OVERFLOW BRACKET ASSY.

RADIATOR GUARD/OVERFLOW BRACKET ASSY.

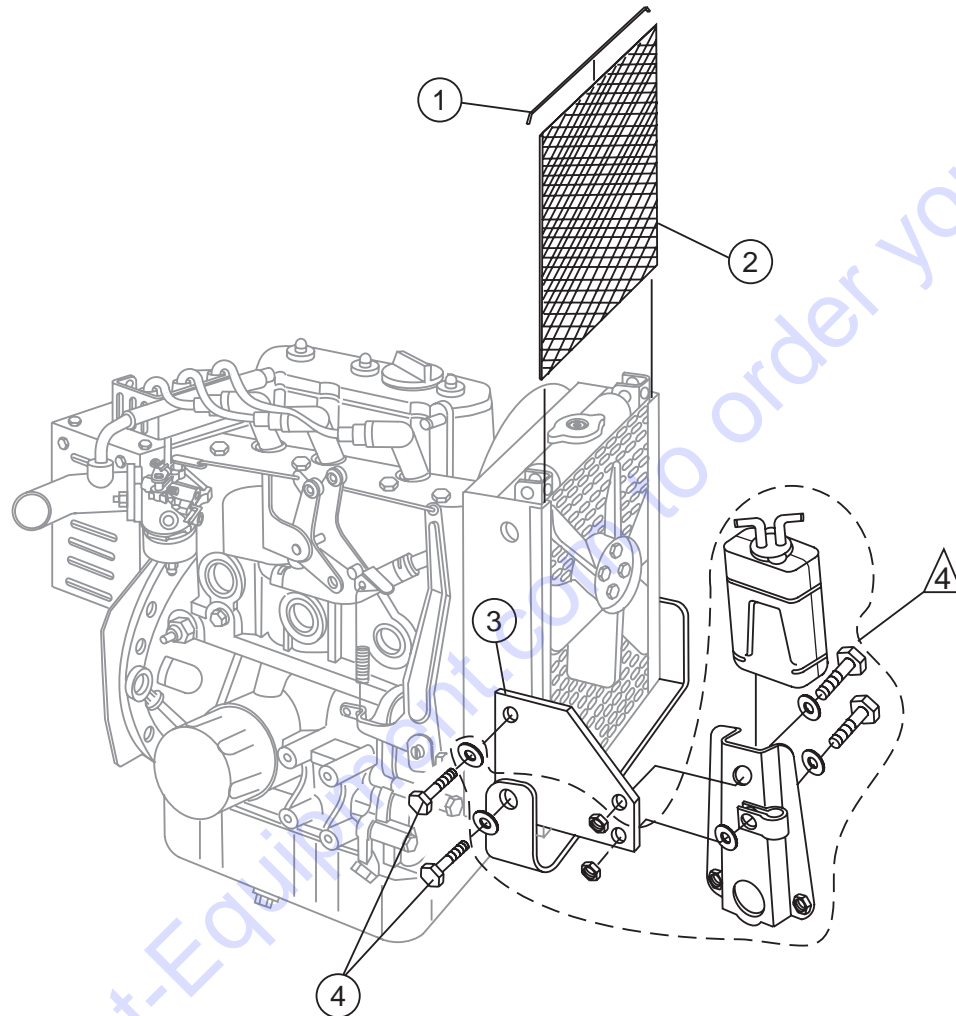

## NOTES:

- △ 4 ITEMS WITHIN DASHED LINE  
ARE INCLUDED WITH ENGINE.  
REFER TO ENGINE PARTS MANUAL.



## HTN/HTO 31V — RADIATOR GUARD/OVERFLOW BRACKET ASSY.

RADIATOR GUARD/OVERFLOW BRACKET ASSY.

<u>NO</u>	<u>PART NO</u>	<u>PART NAME</u>	<u>QTY.</u>	<u>REMARKS</u>
1	60049	TRIM EDGE, 1/32 (62B3-1/32)	1.5 FT	
2	12450	GUARD, RADIATOR (31 VAN)	1	
3	11900	MOUNT, RADIATOR OVERFLOW	1	
4	12464	SCREW, HHC M6-1.0 X 16mm	3	

Go to Discount-Equipment.com to order your parts

# HTN/HTO 31V — V-BELT GUARD ASSY.

V-BELT GUARD ASSY.

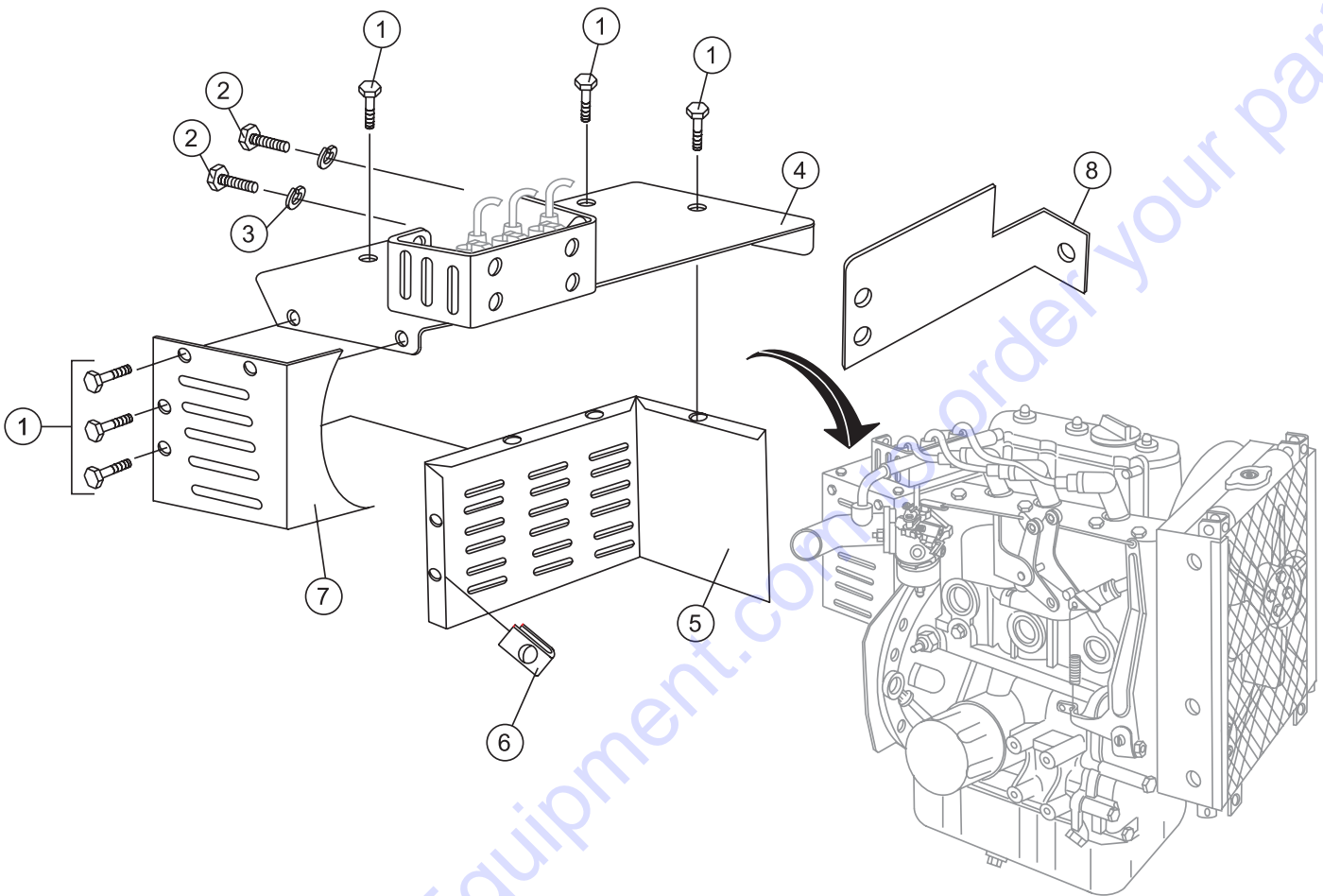

## HTN/HTO 31V — V-BELT GUARD ASSY.

### V-BELT GUARD ASSY.

<u>NO</u>	<u>PART NO</u>	<u>PART NAME</u>	<u>QTY.</u>	<u>REMARKS</u>
1	11819	SCREW, HHC 1/4-20 X 3/4 W/WASH	7	
2	1605	SCREW, HHC M8-1.25 X 25mm	4	
3	0161 C	WASHER, LOCK, 5/16 MED.	4	
4	12542	BELT GUARD/MUFFLER SPPT W/A .....	1	MARCH 27, 2007 AND BELOW
4	21036	BELT GUARD/MUFFLER SPPT W/A .....	1	MARCH 28, 2007 AND ABOVE
5	12545	PLATE, BELT GUARD SIDE .....	1	MARCH 27, 2007 AND BELOW
5	21190	PLATE, BELT GUARD SIDE .....	1	MARCH 28, 2007 AND ABOVE
6	11534	NUT, "U" TYPE, 1/4-20	7	
7	12544	PLATE, BELT GUARD REAR .....	1	MARCH 16, 2004 AND BELOW
7	21633	PANEL, BELT GUARD REAR .....	1	MARCH 17, 2004 TO MARCH 27, 2007
7	21197	PANEL, BELT GUARD REAR .....	1	MARCH 28, 2007 AND ABOVE
8	20178	MUFFLER HEAT SHIELD .....	1	MARCH 28, 2007 AND ABOVE

Go to Discount-Equipment.com to order your parts

# HTN/HTO 31V — ENGINE SERVICE PARTS

## ENGINE SERVICE PARTS

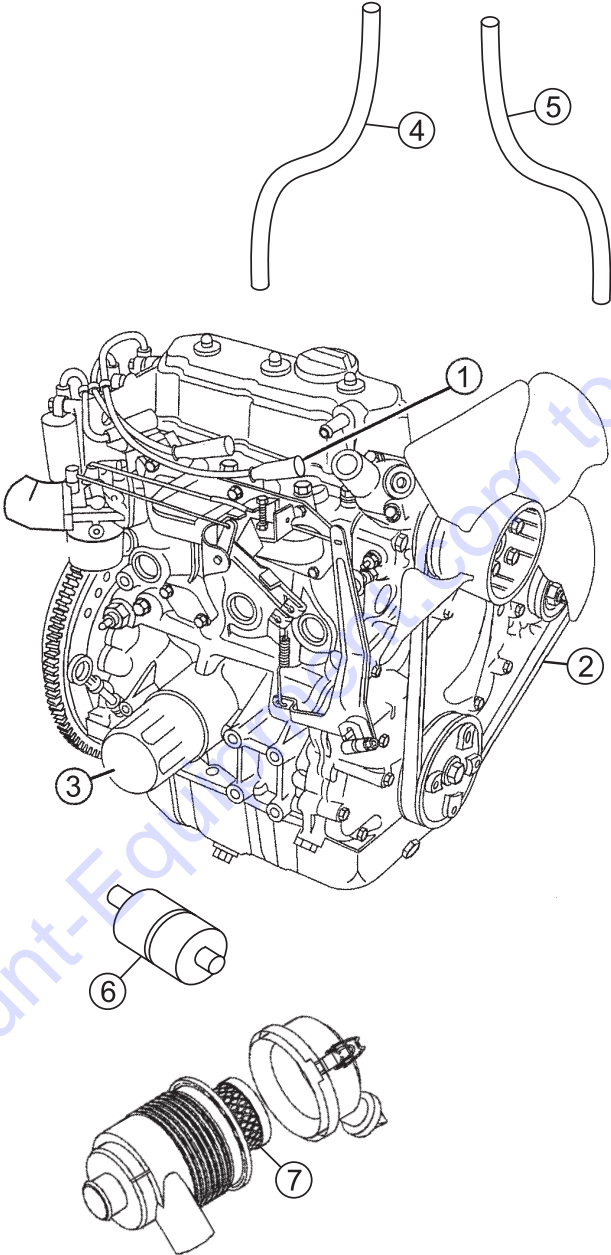

## HTN/HTO 31V — ENGINE SERVICE PARTS

### ENGINE SERVICE PARTS

<u>NO</u>	<u>PART NO</u>	<u>PART NAME</u>	<u>QTY.</u>	<u>REMARKS</u>
1	496018S	SPARK PLUG	1	
2	821075	FAN BELT	1	
3	491056	OIL FILTER	1	
4	825557	HOSE	1	
5	825133	HOSE	1	
6	820026	FUEL FILTER	1	
7	820263	ELEMENT, AIR CLEANER	1	

Go to Discount-Equipment.com to order your parts

# HTN/HTO-31V — GEARBOX ASSY. (LEFT-SIDE)

## GEARBOX ASSY (LEFT-SIDE)

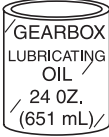
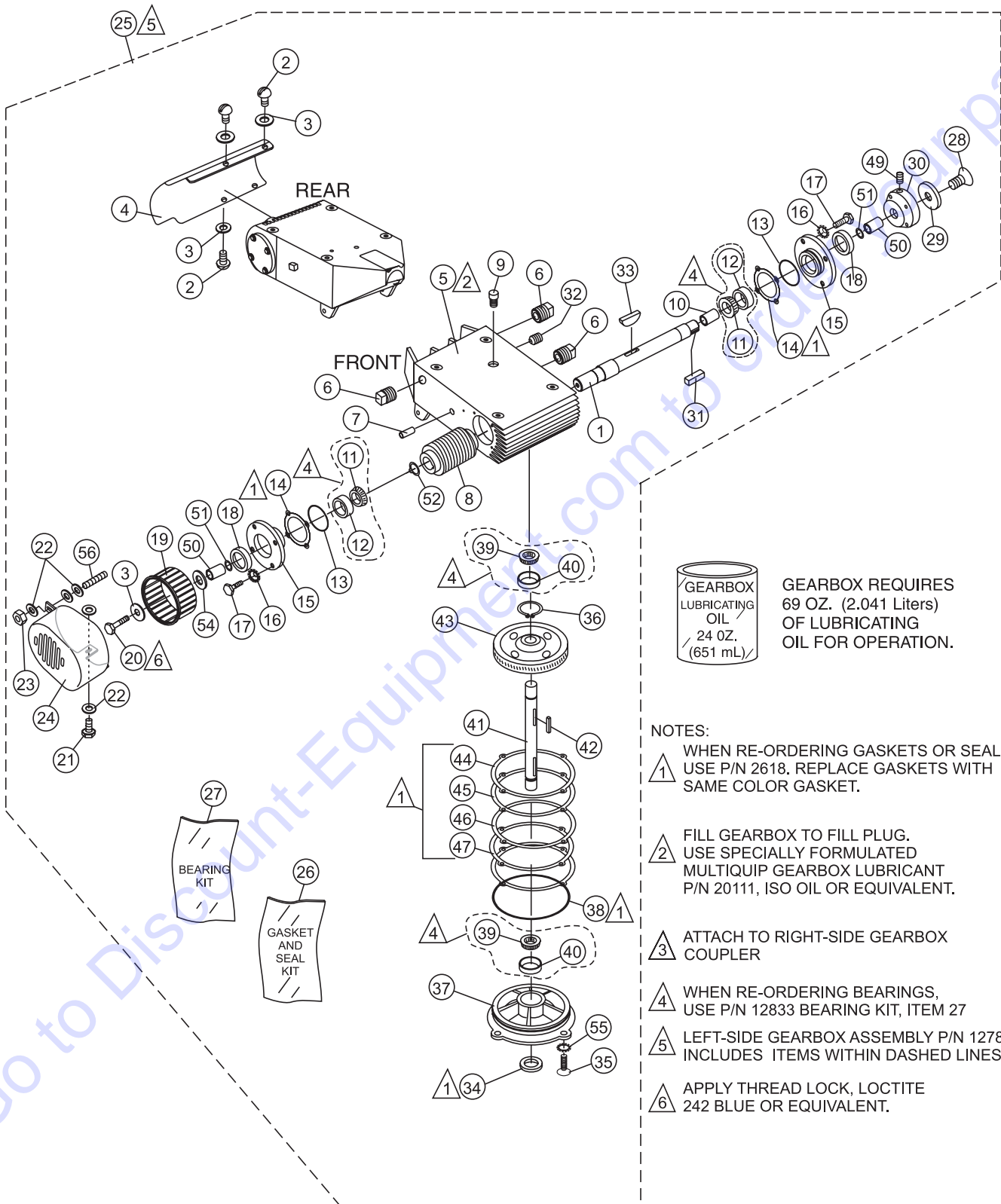

GEARBOX REQUIRES  
69 OZ. (2.041 Liters)  
OF LUBRICATING  
OIL FOR OPERATION.

**NOTES:**

- 1 WHEN RE-ORDERING GASKETS OR SEALS USE P/N 2618. REPLACE GASKETS WITH SAME COLOR GASKET.
- 2 FILL GEARBOX TO FILL PLUG. USE SPECIALLY FORMULATED MULTIQUIP GEARBOX LUBRICANT P/N 20111, ISO OIL OR EQUIVALENT.
- 3 ATTACH TO RIGHT-SIDE GEARBOX COUPLER
- 4 WHEN RE-ORDERING BEARINGS, USE P/N 12833 BEARING KIT, ITEM 27
- 5 LEFT-SIDE GEARBOX ASSEMBLY P/N 12789 INCLUDES ITEMS WITHIN DASHED LINES.
- 6 APPLY THREAD LOCK, LOCTITE 242 BLUE OR EQUIVALENT.

# HTN/HTO-31 V— GEARBOX ASSY. (LEFT-SIDE)

## GEARBOX ASSY (LEFT-SIDE)

<u>NO.</u>	<u>PART NO.</u>	<u>PART NAME</u>	<u>QTY.</u>	<u>REMARKS</u>
1%	12586	SHAFT, GEARBOX INPUT W/FAN .....	1 .....	OCT. 07, 1999 AND BELOW
1%	12906	SHAFT, GEARBOX INPUT W/FAN .....	1 .....	OCT. 08, 1999 AND ABOVE
2%	5031 A	SCREW, RHM 1/4-20 X1/2	4	
3%	0948	WASHER, FLAT, 1/4 SAE	1	OCT. 07, 1999 AND BELOW
3%	0948	WASHER, FLAT, 1/4 SAE	5	OCT. 08, 1999 AND ABOVE
4%	12982	SHROUD, GB FIN COVER, LEFT	1	
5%	12765	GEAR BOX HD RIDER 1-1/4 SHAFT .....	1 .....	HOUSING ONLY
6%	0121 A	FITTING, PLUG 3/8MP SQUARE HEAD	3	
7%	10989	STUD, N10 - 32 X 3/4	1	
8%	1993	LEFT HAND WORM .....	1 .....	OCT. 07, 1999 AND BELOW
8%	12907	LEFT HAND WORM .....	1 .....	OCT. 08, 1999 AND ABOVE
9%	1132	VENT, AIR	1	
10%	12583	SPACER, 1.380D X 1.015 X 1.168L	1	
11*%	9045	BEARING, CONE TIMKEN #1986	2	
12*%	0232 A	BEARING, CUP, TIMKEN #1932	2	
13+%	2309	O-RING, 2 -13/16" VINTON	2	
14+%		GASKET, RED .....	1 .....	SOLD AS KIT ONLY
15%	2307	FLANGE, COUNTERSHAFT	2	
16%	0133 W	WASHER, FLAT 9/16 COPPER .....	8 .....	OCT. 17, 2000 AND BELOW
16%	10031	WASHER, EXT SHKP 1/4 .....	8 .....	OCT. 18, 2000 AND ABOVE
17%	0730	SCREW, HHC 1/4-20 X 1 .....	8 .....	OCT. 17, 2000 AND BELOW
17%	2295	SCREW, HHC 1/4-20 X 7/8 .....	8 .....	OCT. 18, 2000 AND ABOVE
18%	9044	SEAL, OIL, NATIONAL #471413 .....	2 .....	OCT. 07, 1999 AND BELOW
18%	12909	SEAL, OIL, NATIONAL #471689V .....	2 .....	OCT. 08, 1999 AND ABOVE
19%	10922	FAN, LEFT (CCW)	1	
20%	0424	SCREW, HHC 1/4-X0 X 1-1/4 .....	1 .....	DEC. 26, 2001 AND BELOW
20%	0730	SCREW, HHC 1/4-20 X 1 .....	1 .....	DEC. 27, 2001 AND ABOVE
21%	19477	SCREW, HHC, WASHER 10-32 X 1/2	1	
22%	2203	WASHER, FLAT #10 SAE	4	
23%	10019	NUT, NYLOC 10-32	1	
24%	10893	LEFT-SIDE FAN COVER	1	
25	12789	GEAR BOX ASSY., COMPLETE LEFT-SIDE .....	1 .....	INCLUDES ITEMS W/%

# HTN/HTO-31V — GEARBOX ASSY. (LEFT-SIDE)

## GEARBOX ASSY (LEFT-SIDE)

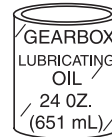
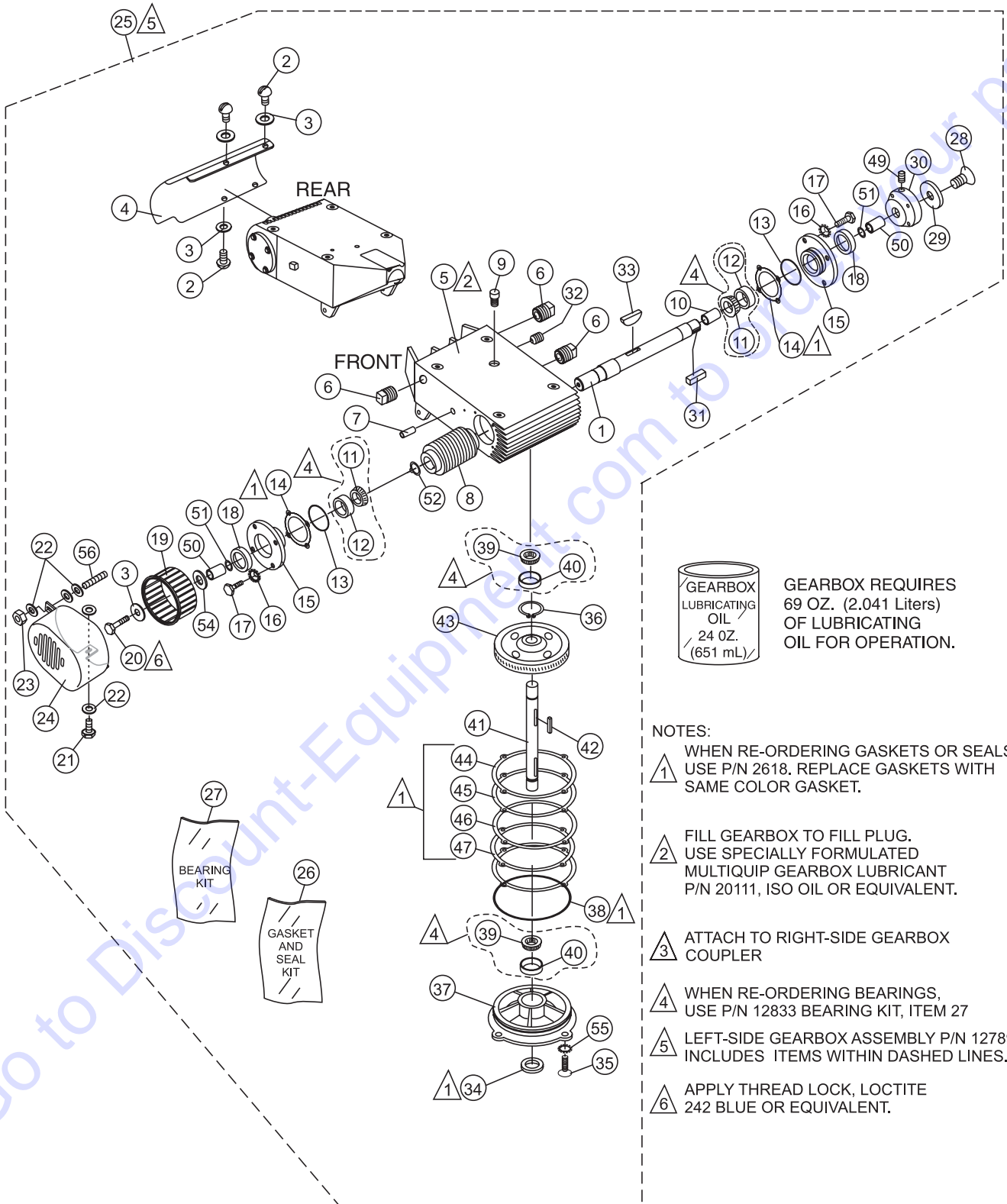

GEARBOX REQUIRES  
69 OZ. (2.041 Liters)  
OF LUBRICATING  
OIL FOR OPERATION.

### NOTES:

1 WHEN RE-ORDERING GASKETS OR SEALS  
USE P/N 2618. REPLACE GASKETS WITH  
SAME COLOR GASKET.

2 FILL GEARBOX TO FILL PLUG.  
USE SPECIALLY FORMULATED  
MULTIQUIP GEARBOX LUBRICANT  
P/N 20111, ISO OIL OR EQUIVALENT.

3 ATTACH TO RIGHT-SIDE GEARBOX  
COUPLER

4 WHEN RE-ORDERING BEARINGS,  
USE P/N 12833 BEARING KIT, ITEM 27

5 LEFT-SIDE GEARBOX ASSEMBLY P/N 12789  
INCLUDES ITEMS WITHIN DASHED LINES.

6 APPLY THREAD LOCK, LOCTITE  
242 BLUE OR EQUIVALENT.



# HTN/HTO-31 V— GEARBOX ASSY. (LEFT-SIDE)

## GEARBOX ASSY (LEFT-SIDE)

<u>NO.</u>	<u>PART NO.</u>	<u>PART NAME</u>	<u>QTY.</u>	<u>REMARKS</u>
26	2618	GASKET KIT .....	1 .....	INCLUDES ITEMS W/+
27%	12833	BEARING KIT .....	1 .....	INCLUDES ITEMS W/*
28%	1313	SCREW, FHSC 3/8 - 24 X 3/4 PLAIN	1	
29%	9120	RETAINER, DRIVEN PULLEY	1	
30%	2048	COUPLER - 7/8" ID	1	
31%	2323	KEY, 1/4 X1/4 X13/16	1	
32%	10450	SCREW, SHS 10-32 X1/4	1	
33%	1139	KEY, WOODRUFF #21 HARDENED	1	
34+%	12769	SEAL, 1-1/4 DIA NAT # 471766V	1	
34+%	9041	SEAL, OIL LIP DUAL VITON TCM BRAND	1	
35%	1146	SCREW, FHSC 5/16-18 .....	4 .....	JUNE 17, 2002 AND BELOW
35%	20875	SCREW, FHS 5/16 -18 X 3/4 .....	4 .....	JUNE 18, 2002 AND ABOVE
36%	12770	RING, SNAP TRUARC #5100 - 125	1	
37%	12766	COVER, HD GEARBOX 1-1/4 SHAFT	1	
38+%	9038	O-RING, A - 264 VITON	1	
39*%	12768	BEARING, CONE TIMKEN #15126	2	
40*%	12767	BEARING, CUP, TIMKEN #15245	2	
41%	12764	SHAFT, MAIN HD RIDER 1-1/4 SHAFT	1	
42%	9180	KEY, 5/16 X 2 -1/4 HRDND	1	
43%	12771	GEAR, WORM LH. HT 1-1/4	1	
44+%		GASKET, RED .....	1 .....	SOLD AS KIT ONLY
45+%		GASKET, GREEN .....	1 .....	SOLD AS KIT ONLY
46+%		GASKET, BLUE .....	1 .....	SOLD AS KIT ONLY
47+%		GASKET, BROWN .....	1 .....	SOLD AS KIT ONLY
48+%		GASKET, YELLOW .....	1 .....	SOLD AS KIT ONLY
49%	10138	SCREW, SHS 1/4-20 X 1/2, N.P.	1	
50%	9043	SPACER, 1-1/4 X 1 X 1.375L .....	2 .....	UP TO OCT. 07, 1999
51%	2116	O-RING, SIZE -022, BUNA-N .....	2 .....	UP TO OCT. 07, 1999
52%	12582	RING, SNAP TRUARC 5160-98 .....	1 .....	UP TO OCT. 07, 1999
54%	10930	WASHER, FENDER 1/4 X 1-1/4 .....	1 .....	UP TO OCT. 07, 1999
55%	10235	WASHER, C/S EXT. SHKP, 5/16 .....	4 .....	UP TO JUNE 17, 2002
56%	10989	STUD, 10-32 X 3/4	1	

Go to Discount.com to order your parts

# HTN/HTO-31V — GEARBOX ASSY. (RIGHT-SIDE)

## GEARBOX ASSY (RIGHT-SIDE)

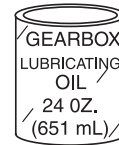
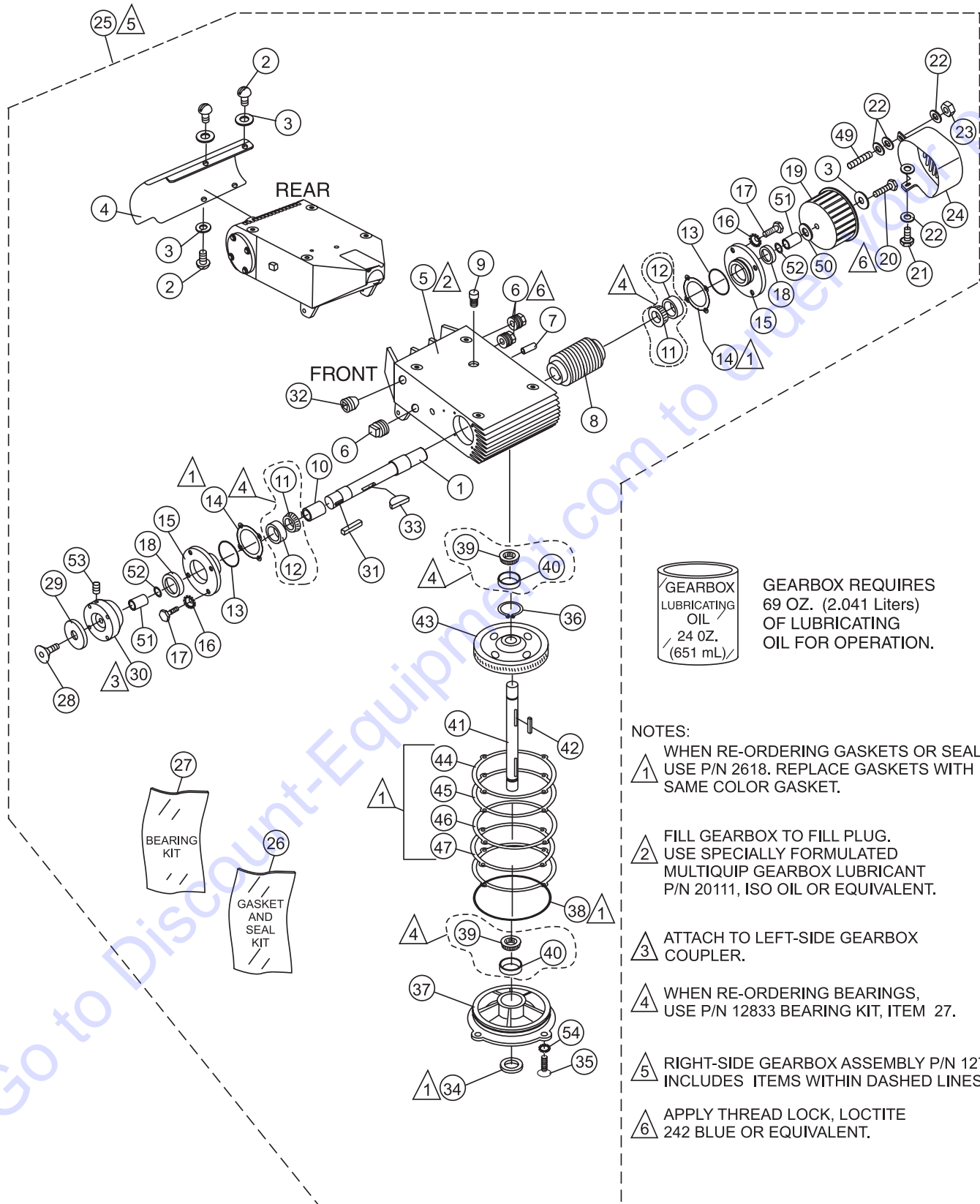

GEARBOX REQUIRES  
69 OZ. (2.041 Liters)  
OF LUBRICATING  
OIL FOR OPERATION.

### NOTES:

- 1 WHEN RE-ORDERING GASKETS OR SEALS USE P/N 2618. REPLACE GASKETS WITH SAME COLOR GASKET.
- 2 FILL GEARBOX TO FILL PLUG. USE SPECIALLY FORMULATED MULTIQUIP GEARBOX LUBRICANT P/N 20111, ISO OIL OR EQUIVALENT.
- 3 ATTACH TO LEFT-SIDE GEARBOX COUPLER.
- 4 WHEN RE-ORDERING BEARINGS, USE P/N 12833 BEARING KIT, ITEM 27.
- 5 RIGHT-SIDE GEARBOX ASSEMBLY P/N 12788 INCLUDES ITEMS WITHIN DASHED LINES.
- 6 APPLY THREAD LOCK, LOCTITE 242 BLUE OR EQUIVALENT.

## HTN/HTO-31V — GEARBOX ASSY. (RIGHT-SIDE)

### GEARBOX ASSY (RIGHT-SIDE)

<u>NO.</u>	<u>PART NO.</u>	<u>PART NAME</u>	<u>QTY.</u>	<u>REMARKS</u>
1%	12586	SHAFT, GEARBOX INPUT W/ FAN .....	1 .....	OCT. 07, 1999 AND BELOW
1%	12906	SHAFT, GEARBOX INPUT W/FAN .....	1 .....	OCT. 08, 1999 AND ABOVE
2%	5031 A	SCREW, RHM 1/4-20 X1/2 .....	4 .....	OCT. 08, 1999 AND ABOVE
3%	0948	WASHER, FLAT, 1/4 SAE .....	1 .....	OCT. 07, 1999 AND BELOW
3%	0948	WASHER, FLAT, 1/4 SAE .....	5 .....	OCT. 08, 1999 AND ABOVE
4%	12981	SHROUD, GB FIN COVER, RIGHT .....	1 .....	DEC. 12, 1999 AND ABOVE
5%	12765	GEAR BOX HD RIDER 1-1/4 SHAFT .....	1 .....	HOUSING ONLY
6%	0121 A	FITTING, PLUG 3/8MP SQUARE HEAD	3	
7%	10989	STUD, N10 - 32 X 3/4	1	
8%	9032	RIGHT HAND WORM .....	1 .....	OCT. 07, 1999 AND BELOW
8%	12908	RIGHT HAND WORM .....	1 .....	OCT. 08, 1999 AND ABOVE
9%	1132	VENT, AIR	1	
10%	12583	SPACER, X 11D X 1.168L	1	
11*%	9045	BEARING, CONE TIMKEN #1986	2	
12*%	0232 A	BEARING, CUP, TIMKEN #1932	2	
13+%	2309	O-RING, 2 -13/16" VINTON	2	
14+%		GASKET, RED .....	1 .....	SOLD AS KIT ONLY
15%	2307	FLANGE, COUNTERSHAFT	2	
16%	0133 W	WASHER, FLAT 9/16 COPPER .....	8 .....	OCT. 17, 2000 AND BELOW
16%	10031	WASHER, EXT SHKP 1/4 .....	8 .....	OCT. 18, 2000 AND ABOVE
17%	0730	SCREW, HHC 1/4-20 X 1 .....	8 .....	OCT. 17, 2000 AND BELOW
17%	2295	SCREW, HHC 1/4-20 X 7/8 .....	8 .....	OCT. 18, 2000 AND ABOVE
18%	9044	SEAL, OIL, NATIONAL #471413 .....	2 .....	OCT. 07, 1999 AND BELOW
18%	12909	SEAL, OIL, NATIONAL #471689V .....	2 .....	OCT. 08, 1999 AND ABOVE
19%	10921	FAN, RIGHT (CW)	1	
20%	0424	SCREW, HHC 1/4-20 X 1-1/4 .....	1 .....	DEC. 26, 2001 AND BELOW
20%	0730	SCREW, HHC 1/4-20 X 1 .....	1 .....	DEC. 27, 2001 AND ABOVE
21%	19477	SCREW, HHC, WASHER 10-32 X 1/2	1	
22%	2203	WASHER, FLAT #10 SAE	4	
23%	10019	NUT, NYLOC 10-32	1	
24%	10894	RIGHT-SIDE FAN COVER	1	
25	12788	GEAR BOX ASSY., COMPLETE RIGHT-SIDE .....	1 .....	INCLUDES ITEMS W/%

# HTN/HTO-31V — GEARBOX ASSY. (RIGHT-SIDE)

## GEARBOX ASSY (RIGHT-SIDE)

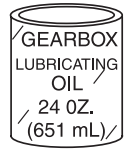
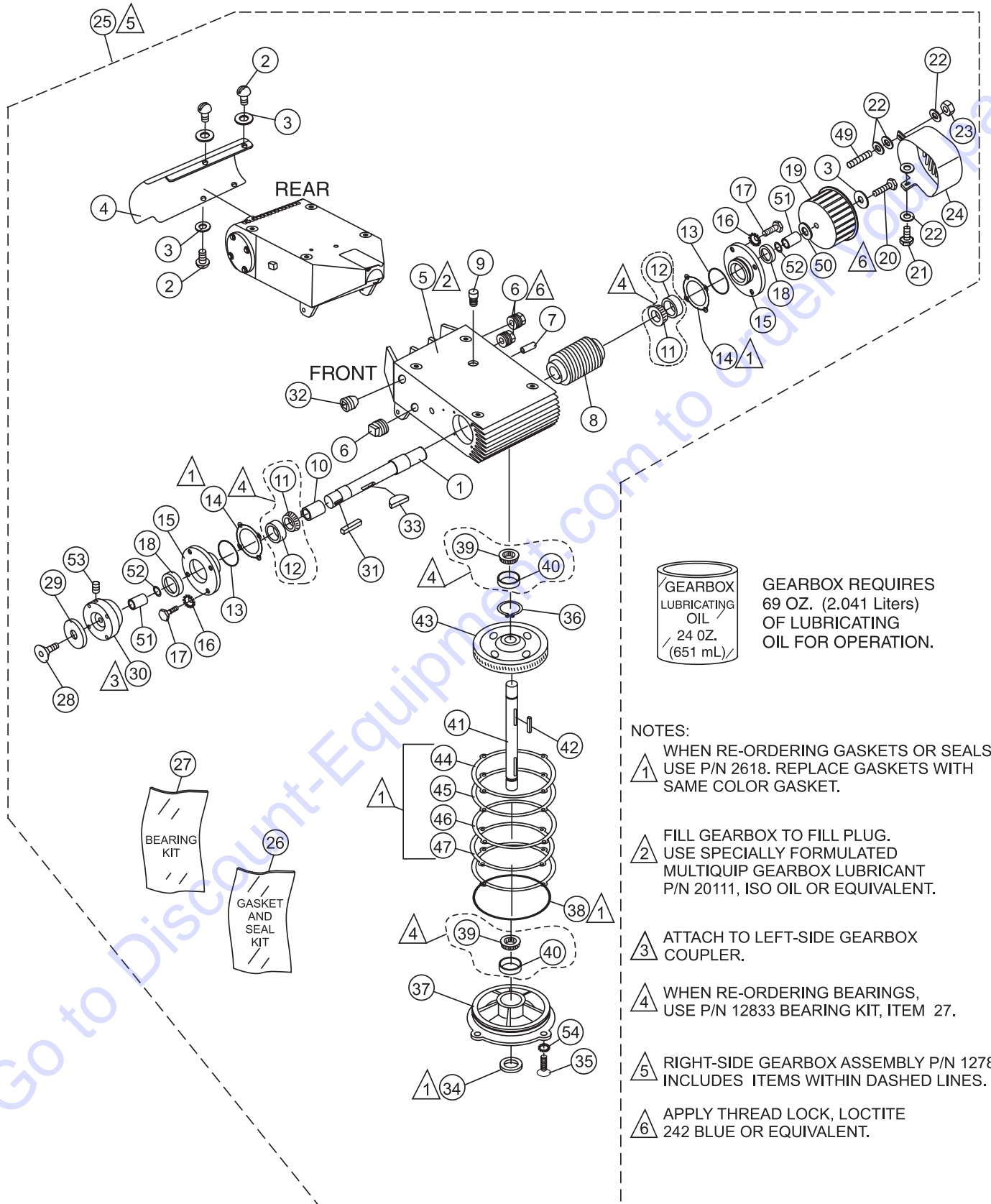

GEARBOX REQUIRES  
69 OZ. (2.041 Liters)  
OF LUBRICATING  
OIL FOR OPERATION.

**NOTES:**

- 1 WHEN RE-ORDERING GASKETS OR SEALS USE P/N 2618. REPLACE GASKETS WITH SAME COLOR GASKET.
- 2 FILL GEARBOX TO FILL PLUG. USE SPECIALLY FORMULATED MULTIQUIP GEARBOX LUBRICANT P/N 20111, ISO OIL OR EQUIVALENT.
- 3 ATTACH TO LEFT-SIDE GEARBOX COUPLER.
- 4 WHEN RE-ORDERING BEARINGS, USE P/N 12833 BEARING KIT, ITEM 27.
- 5 RIGHT-SIDE GEARBOX ASSEMBLY P/N 12788 INCLUDES ITEMS WITHIN DASHED LINES.
- 6 APPLY THREAD LOCK, LOCTITE 242 BLUE OR EQUIVALENT.

# HTN/HTO-31V — GEARBOX ASSY. (RIGHT-SIDE)

## GEARBOX ASSY (RIGHT-SIDE)

<u>NO.</u>	<u>PART NO.</u>	<u>PART NAME</u>	<u>QTY.</u>	<u>REMARKS</u>
26	2618	GASKET KIT .....	1	INCLUDES ITEMS W/+
27%	12833	BEARING KIT .....	1	INCLUDES ITEMS W/*
28%	1313	SCREW, FHSC 3/8 - 24 X 3/4 PLAIN	1	
29%	9120	RETAINER, DRIVEN PULLEY	1	
30%	2048	COUPLER - 7/8" ID	1	
31%	2323	KEY, 1/4 X 1/4 X 13/16	1	
32%	10450	SCREW, SHS 10-32 X 1/4	1	
33%	1139	KEY, WOODRUFF #21 HARDENED	1	
34+%	12769	SEAL, 1-1/4 DIA NAT # 471766V	1	
35%	1146	SCREW, FHSC 5/16-18X1, NYLOC, NP .....	4	JUNE 17, 2002 AND BELOW
35%	20875	SCREW, FHS 5/16 - 18 X 3/4 .....	4	JUNE 18, 2002 AND ABOVE
36%	12770	RING, SNAP TRUARC #5100 - 125	1	
37%	9036	PLATE, COVER	1	
37%	12766	COVER, HD GEARBOX 1-1/4 SHAFT	1	
38+%	9038	O-RING, A - 264 VITON	1	
39*%	12768	BEARING, CONE TIMKEN #15126	2	
40*%	12767	BEARING, CUP, TIMKEN #15245	2	
41%	12764	SHAFT, MAIN HD RIDER 1-1/4 SHAFT	1	
42%	9180	KEY, 5/16 X 2 - 1/4 HRDND	1	
43%	12772	GEAR, WORM RH. HT 1-1/4	1	
44+%		GASKET, RED .....	1	SOLD AS KIT ONLY
45+%		GASKET, GREEN .....	1	SOLD AS KIT ONLY
46+%		GASKET, BLUE .....	1	SOLD AS KIT ONLY
47+%		GASKET, BROWN .....	1	SOLD AS KIT ONLY
48+%		GASKET, YELLOW .....	1	SOLD AS KIT ONLY
49%	10989	STUD, 10-32 X 3/4	1	
50	10930	WASHER, FENDER, 1/4 X 1-1/4 .....	1	UP TO OCT. 07, 1999
51	9043	SPACER, 1-1/4 X 1 X 1/375L .....	2	UP TO OCT. 07, 1999
52	2116	RING, O, SIZE -22, BUNA-N .....	2	UP TO OCT. 07, 1999
53	10138	SCREW, SHS 1/4-20 X 1/2, N.P.	1	
54	10235	WASHER, C/S EXT. SHKP, 5/16 .....	4	UP TO JUNE 17, 200299

Go to DiscountElement.com to order your parts

# HTN/HTO-31V — DRIVE ASSY.

DRIVE ASSY.

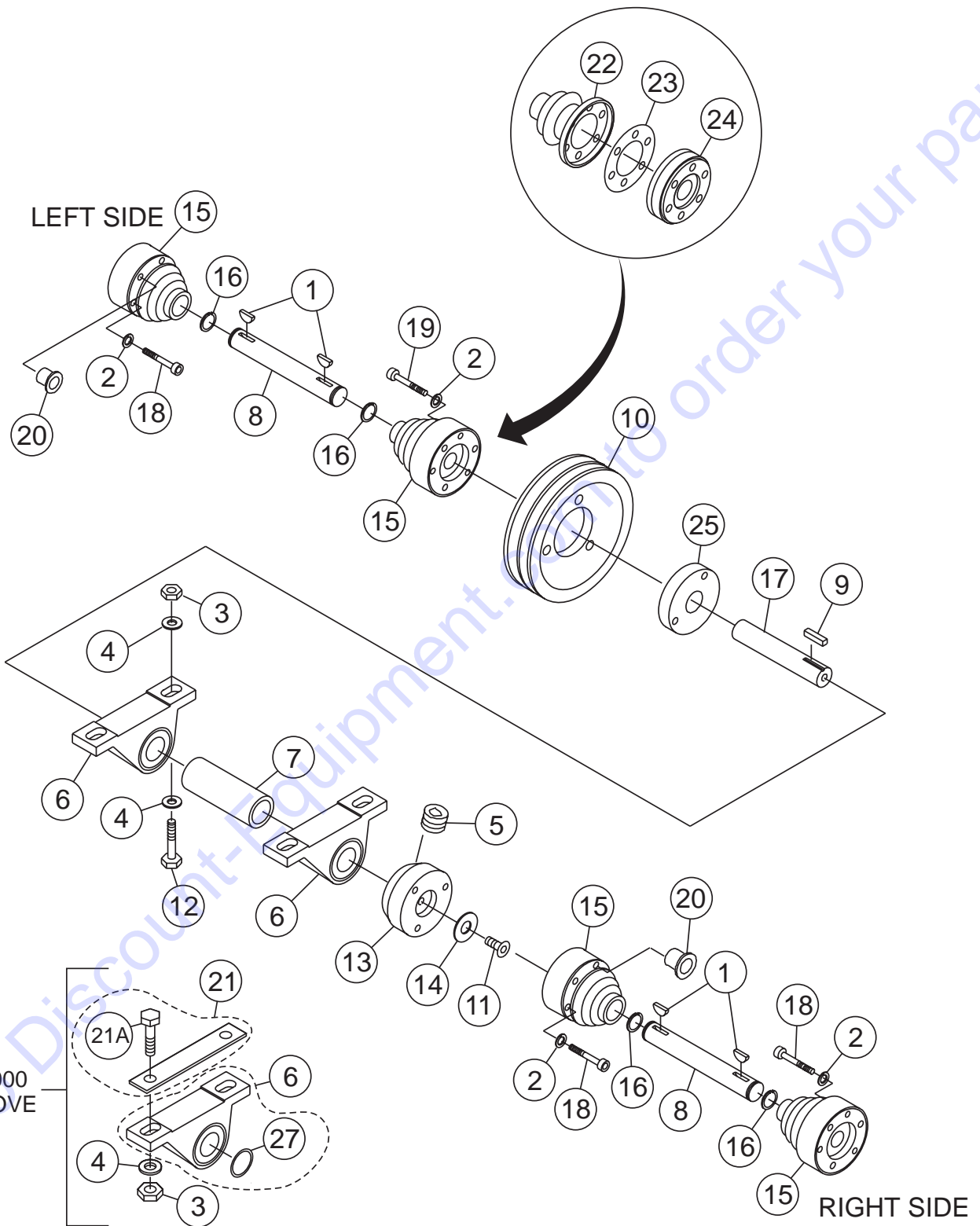

04/11/2000  
AND ABOVE

NOTE: PROVIDES 145 RPM BLADE SPEED

# HTN/HTO-31V — DRIVE ASSY.

DRIVE ASSY.

<u>NO</u>	<u>PART NO</u>	<u>PART NAME</u>	<u>QTY.</u>	<u>REMARKS</u>
1	0126	KEY, WOODRUFF #9	4	
2	0161 C	WASHER, LOCK, 5/16 MED	12	
3	10133	NUT, NYLOC 3/8-16	4	
4	10136	WASHER, FLAT 3/8 SAE .....	8	APRIL 10, 2001 AND BELOW
4	10136	WASHER, FLAT 3/8 SAE .....	4	APRIL 11, 2001 AND ABOVE
5	10138	SCREW, SHS 1/4-20 X 1/2, N.P.	1	
6	10337	BEARING, P-BLOCK, FAF YAK-1 .....	2	INCLUDES ITEMS W/@
7	10514	SPACER, BEARING SHAFT	1	
8	10748	<b>HTN</b> , SHAFT, CV JOINT	1	
8	2122	<b>HTO</b> , SHAFT, CV JOINT	1	
9	10909	KEY, 3/16" SQ X 11/16	1	
10	11171	PULLEY, "B" 6-1/2 OD (145 RPM)	1	
11	1146	SCREW, FHSC 5/16-18X1, NYLOC, NP	1	
12	1284	SCREW, HHC 3/8-16 X 1-1/2 .....	4	APRIL 10, 2001 AND BELOW
13	2029	COUPLER - 1" ID- RIDER	1	
14	2037	WASHER, RETAINING	1	
15	2052	JOINT, CV (W/BOOT)	4	
16	2090	RING, SNAP, TRUARC #5100106	4	
17	2129	SHAFT, BEARING ASM	1	
18	2186	SCREW, SHC 5/16-18 X 2-1/4 PLTD	9	
19	2187	SCREW, SHC 5/16-18 X 2-1/2 PLTD	3	
20	2218	CAP PLUG, 1/8"-RIDER .....	12	APRIL 10, 2001 AND BELOW
21	20186	PLATE, BEARING MOUNT W/A .....	2	APRIL 11, 2001 AND ABOVE
		..... INCLUDES ITEM W/#		
21A#	20187	SCREW, HHC 3/8-16 X 1-1/2 SS .....	4	APRIL 11, 2001 AND ABOVE
22	2259	BOOT, CV JOINT	4	
23	11108	GASKET, CV JOINT BOOT	4	
24	392052	JOINT, CV	4	
25	10904	COUPLER, BEARING SHAFT	1	
27@	11773	SHIM, TRUNNION, .031" THICK .....	2	APRIL 06, 2001 AND ABOVE

Go to DiscountParts.com to order your parts

# HTN/HTO-31V — 5-BLADE SPIDER ASSY. (LEFT-SIDE)

LEFT SIDE SPIDER ASSEMBLY (5-BLADE).  
VIEW FROM OPERATORS SEAT.

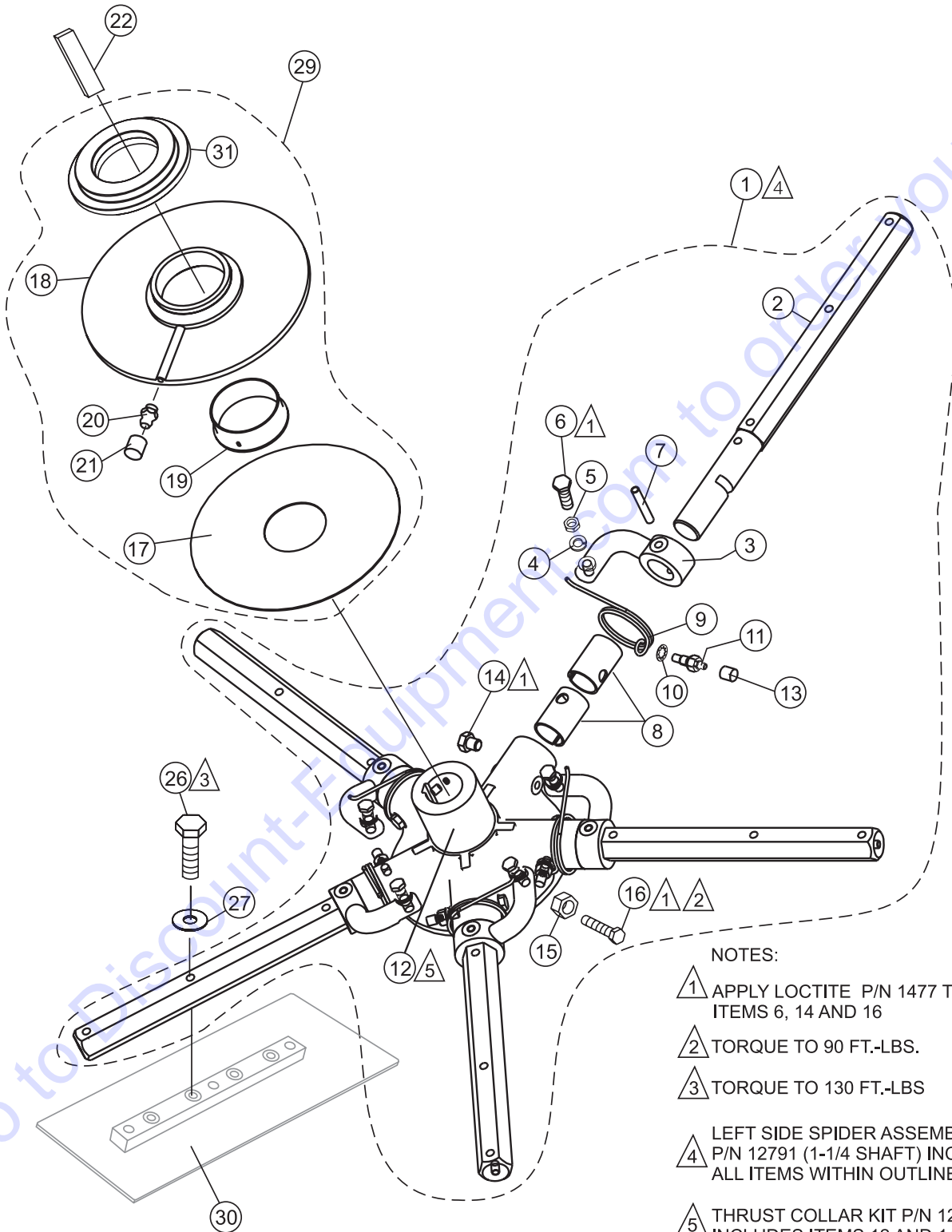

NOTES:

- ① APPLY LOCTITE P/N 1477 TO ITEMS 6, 14 AND 16
- ② TORQUE TO 90 FT.-LBS.
- ③ TORQUE TO 130 FT.-LBS
- ④ LEFT SIDE SPIDER ASSEMBLY P/N 12791 (1-1/4 SHAFT) INCLUDES ALL ITEMS WITHIN OUTLINE.
- ⑤ THRUST COLLAR KIT P/N 12787 INCLUDES ITEMS 12 AND 14.



## HTN/HTO-31V — 5-BLADE SPIDER ASSY. (LEFT-SIDE)

### 5-BLADE SPIDER ASSY. (LEFT)

<u>NO</u>	<u>PART NO</u>	<u>PART NAME</u>	<u>QTY.</u>	<u>REMARKS</u>
1	12791	SPIDER ASM, LEFT SIDE (1-1/4) .....	1	INCLUDES ITEMS W/%
2%	2829	ARM, TROWEL EXTENDED	5	
3%	9005	LEVER, TROWEL ARM LEFT SIDE	5	
4%	0166 A	WASHER, LOCK, 3/8 MED	5	
5%	1876	NUT, HEX JAM 3/8	5	
6%	0164 B	SCREW, HHC	5	
7%	9006	PIN, ROLL 5/16 X 2	5	
8%	11039	BUSHING, ARM 2 PIECE	10	
9%	9111	SPRING, LEFT TROWEL	5	
10%	1875	WASHER, INT SHKP 3/8	5	
11%	1322	SCREW ASSY, ARM RETAINING	5	
12%	12787	SPIDER KIT, 5 BLADE (1-1/4) .....	1	INCLUDES ITEM W/ >
13%	1162 A	CAP, GREASE ZERK / 2	5	
14% >	11602	SCREW, HHC 3/8-16 X 3/8	5	
15	1456	NUT, HEX FINISH 3/8 -16	2	
16	12097	SCREW, SQHS 3/8-16 X 1-3/4 CONE 8	2	
17*	11419	PLATE, WEAR	1	
18*	11431	THRUST COLLAR .....	1	INCLUDES ITEM W/+
19+*	11464	BUSHING, THRUST COLLAR	1	
20*	2621	FITTING, GREASE	1	
21*	1162 A	CAP, GREASE ZERK	1	
22	12101	KEY, 5/16 X 2-5/8 HRDND	1	
26	0105	SCREW, HHCS 5/16-18 X 11/2"	15	
27	0161C	Lock Washer 5/16"	15	
29	20938	THRUST COLLAR KIT .....	1	INCLUDES ITEMS W/*
30		BLADE ASSEMBLY .....	5	CONTACT UNIT SALES
31	12779	BEARING	1	

Go to Discount-Equipment.com to order your parts

# HTN/HTO-31V — 5-BLADE SPIDER ASSY. (RIGHT-SIDE)

RIGHT SIDE SPIDER ASSEMBLY (5-BLADE).  
VIEW FROM OPERATORS SEAT.

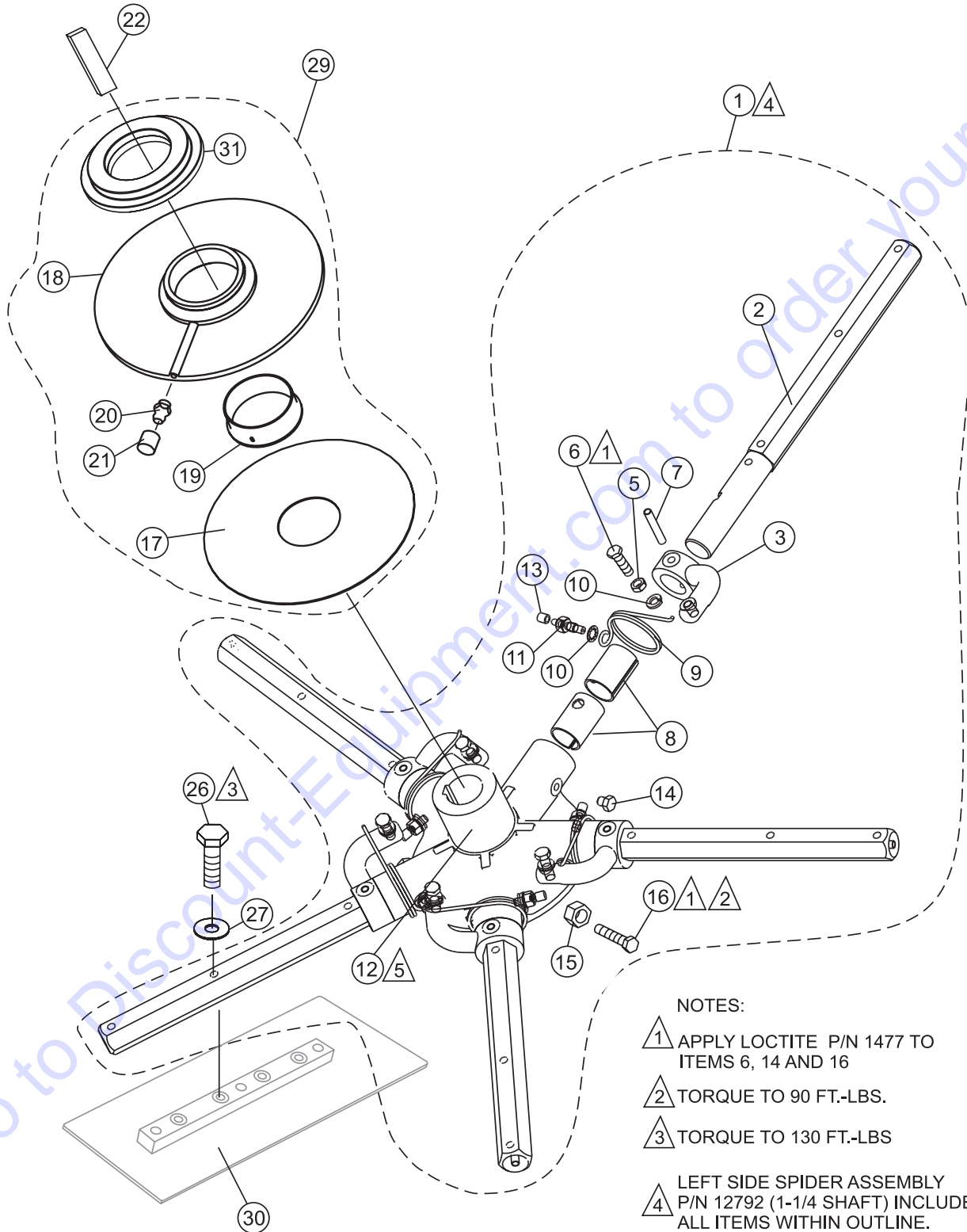

NOTES:

▲1 APPLY LOCTITE P/N 1477 TO ITEMS 6, 14 AND 16

▲2 TORQUE TO 90 FT.-LBS.

▲3 TORQUE TO 130 FT.-LBS

▲4 LEFT SIDE SPIDER ASSEMBLY P/N 12792 (1-1/4 SHAFT) INCLUDES ALL ITEMS WITHIN OUTLINE.

▲5 THRUST COLLAR KIT P/N 12787 INCLUDES ITEMS 12 AND 14.

## HTN/HTO-31V — 5-BLADE SPIDER ASSY. (RIGHT-SIDE)

### 5-BLADE SPIDER ASSY. (LEFT)

<u>NO</u>	<u>PART NO</u>	<u>PART NAME</u>	<u>QTY.</u>	<u>REMARKS</u>
1	12792	SPIDER ASM, LEFT SIDE (1-1/4) .....	1	INCLUDES ITEMS W/%
2%	2829	ARM, TROWEL EXTENDED	5	
3%	1986	LEVER, TROWEL ARM LEFT SIDE	5	
4%	0166 A	WASHER, LOCK, 3/8 MED	5	
5%	1876	NUT, HEX JAM 3/8	5	
6%	0164 B	SCREW, HHC	5	
7%	9006	PIN, ROLL 5/16 X 2	5	
8%	11039	BUSHING, ARM 2 PIECE	10	
9%	2143	SPRING, LEFT TROWEL	5	
10%	1875	WASHER, INT SHKP 3/8	5	
11%	1322	SCREW ASSY, ARM RETAINING	5	
12%	12787	SPIDER KIT, 5 BLADE (1-1/4) .....	1	INCLUDES ITEM W/ >
13%	1162 A	CAP, GREASE ZERK / 2	5	
14% >	11602	SCREW, HHC 3/8-16 X 3/8	5	
15	1456	NUT, HEX FINISH 3/8 -16	2	
16	12097	SCREW, SQHS 3/8-16 X 1-3/4 CONE 8	2	
17*	11419	PLATE, WEAR	1	
18*	11431	THRUST COLLAR .....	1	INCLUDES ITEM W/+
19+*	11464	BUSHING, THRUST COLLAR	1	
20*	2621	FITTING, GREASE	1	
21*	1162 A	CAP, GREASE ZERK	1	
22	12101	KEY, 5/16 X 2-5/8 HRDND	1	
26	0105	SCREW, HHCS 5/16-18 X 11/2"	15	
27	0161C	LOCK WASHER 5/16"	15	
29	20938	THRUST COLLAR KIT .....	1	INCLUDES ITEMS W/*
30		BLADE ASSEMBLY .....	5	CONTACT UNIT SALES
31	12779	BEARING	1	

# HTN/HTO-31V — SEAT AND FRAME ASSY.

SEAT AND FRAME ASSY.

(VIEW FROM OPERATOR'S SEAT)

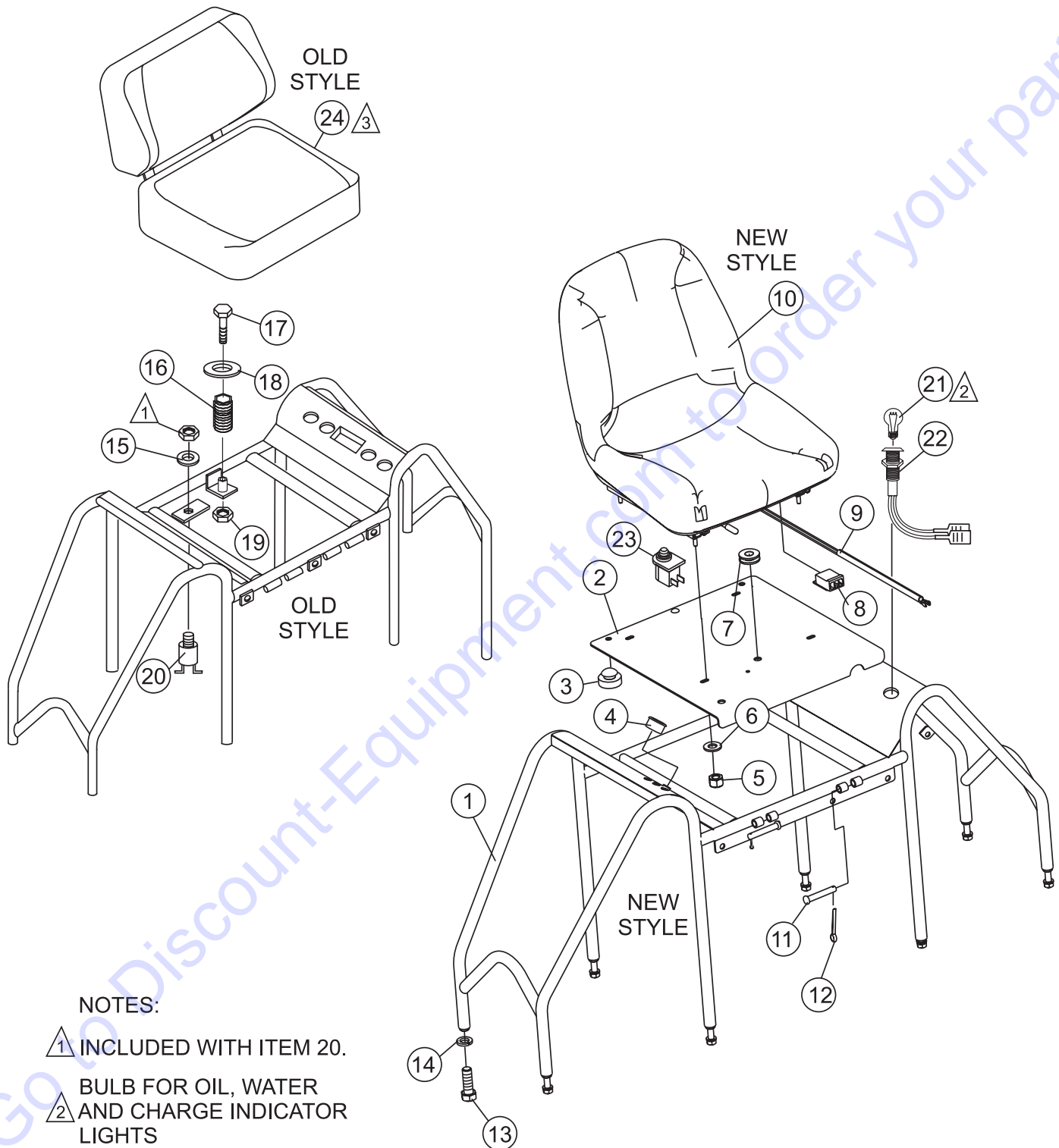

**NOTES:**

① INCLUDED WITH ITEM 20.

② BULB FOR OIL, WATER AND CHARGE INDICATOR LIGHTS

③ WHEN OLD STYLE SEAT, PARTS ORDER STOCK HAS BEEN DEPLETED (ITEM 24). NEW STYLE SEAT MUST BE ORDERED (ITEM 10).

# HTN/HTO-31V — SEAT AND FRAME ASSY.

## SEAT AND FRAME ASSY.

<u>NO</u>	<u>PART NO</u>	<u>PART NAME</u>	<u>QTY.</u>	<u>REMARKS</u>
1	12109	FRAME, HTN SEAT W/A VAN	1	
1	11829	FRAME, HTO SEAT W/A VAN	1	
2	11660	PLATE, SEAT W/A HTN/HTO	1	
3	21597	BUMPER, STEM .....	3	MAR. 27, 2006 AND ABOVE
4	21507	PLUG, PANEL 11/16 DIA.	1	
5	5283	NUT, NYLOC 5/16-18	4	
6	0300 B	WASHER, FLAT, 5/16 SAE	4	
7	19468	GROMMET, MINOR Z-4004 .....	2	MAR. 27, 2006 AND ABOVE
8	21936	CONNECTOR, BODY 2-PIN .....	1	MAR. 27, 2006 AND ABOVE
9	21938	WIRE ASSY., KILL SWITCH 37" .....	1	MAR. 27, 2006 AND ABOVE
10	21861	SEAT, ADJUSTABLE W/O ARMS .....	1	MAR. 27, 2006 AND ABOVE, SEE NOTE
11	8081	PIN, CLEVIS 1/2X2 3/4	2	
12	0183	PIN, COTTER 1/8X1 1/4	2	
13	5218	SCREW, HHC 1/2-13X1 1/2	8	
14	5054A	WASHER, LOCK, 1/2 MED.	8	
15	4684	WASHER, FLAT, 5/8 PLD .....	1	MAR. 26, 2006 AND BELOW
16	11593	SPRING, SEAT .....	1	MAR. 26, 2006 AND BELOW
17	8156	SCREW, HHC 3/8-16X2 1/2 .....	1	MAR. 26, 2006 AND BELOW
18	4001	WASHER, FLAT, 3/8 USS PLD .....	1	MAR. 26, 2006 AND BELOW
19	10133	NUT, NYLOC 3/8-16 .....	1	MAR. 26, 2006 AND BELOW
20	12005	SWITCH, KILL .....	1	MAR. 26, 2006 AND BELOW
21	12307	BULB, INDICATOR LIGHT	3	
22	12305	PLUG INDICATOR LIGHT	3	
23	21870	SEAT KILL SWITCH .....	1	MAR. 26, 2006 AND ABOVE
24	20989	SEAT, ADJUSTABLE .....	1	MAR. 26, 2006 AND BELOW, SEE NOTE

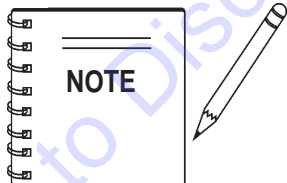

WHEN OLD STYLE SEAT, PARTS ORDER STOCK HAS BEEN DEPLETED (ITEM 24). NEW STYLE SEAT MUST BE ORDERED (ITEM 10).

# HTN/HTO-31V — FRAME AND COMPONENTS ASSY.

## FRAME AND COMPONENTS

VIEW FROM OPERATOR'S SEAT

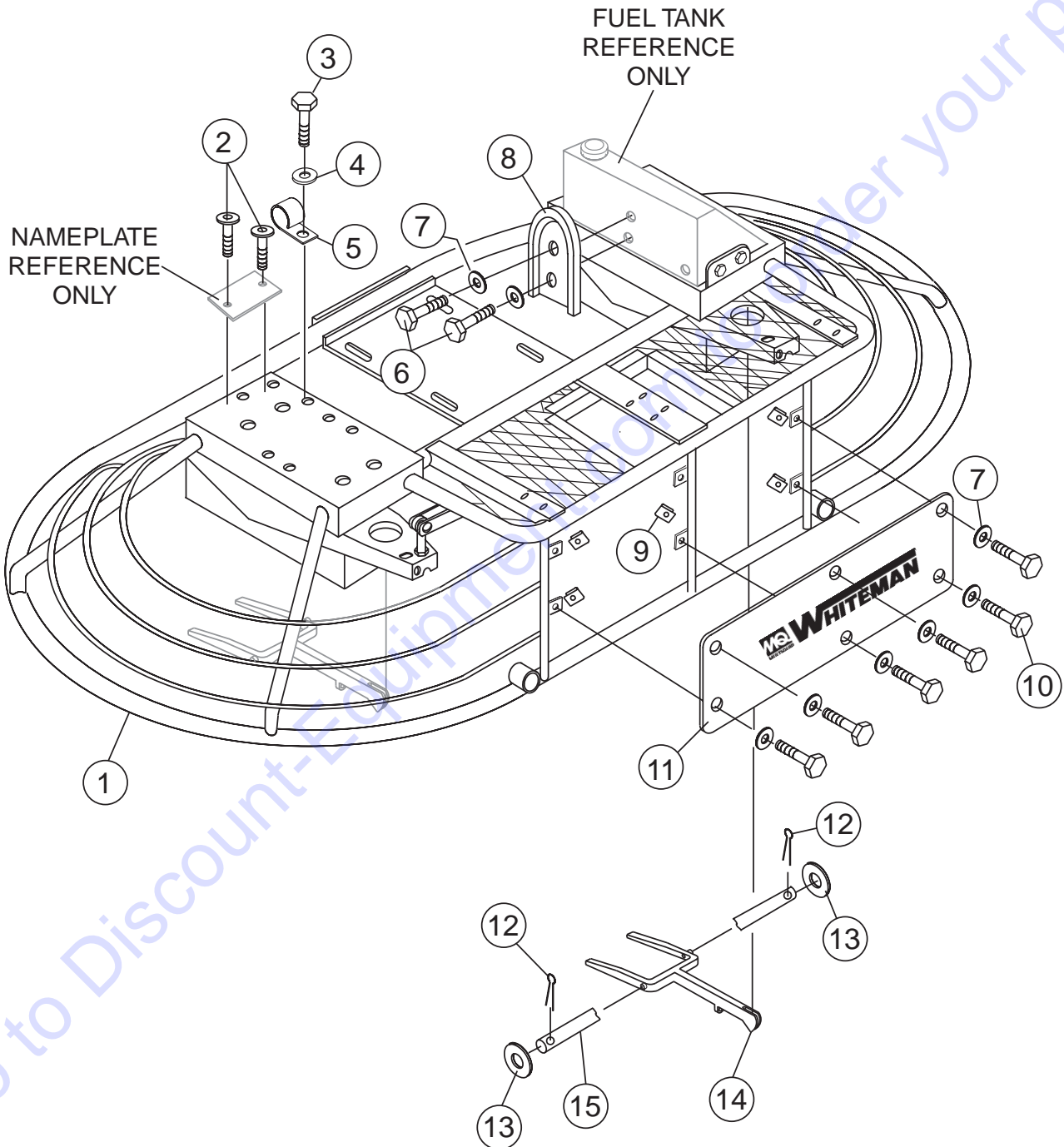

# HTN/HTO-31V — FRAME AND COMPONENTS ASSY.

## FRAME AND COMPONENTS

<u>NO</u>	<u>PART NO</u>	<u>PART NAME</u>	<u>QTY.</u>	<u>REMARKS</u>
1	12345	FRAME HTN-V	1	
1	12453	FRAME HTO-V	1	
2	4014	SCREW, 2-3/16 P-K TYPE U DRIVE	2	
3	5065B	SCREW, RHM 10-32X1/2	1	
4	2203	WASHER, FLAT, #10	1	
5	8126	CLAMP, HOSE SUPPORT 1/2" SMALL	1	
6	4514	SCREW, HHC 1/4-20X5/8	2	
7	0948	WASHER, FLAT, 1/4 SAE	9	
8	2429	HOLDER, SPARE BELT	1	
9	11534	NUT "U" TYPE, 1/4-20	6	
10	4514	SCREW, HHC 1/4-20X5/8	6	
11	11223	PANEL, FRONT (HTN) .....	1	UP TO ~DEC 17, 2001
11	20947	PANEL, FRONT (HTN) .....	1	DEC 18, 2001 AND ABOVE
11	11241	PANEL, FRONT (HTO) .....	1	UP TO ~DEC 17, 2001
11	20945	PANEL, FRONT (HTO) .....	1	DEC 18, 2001 AND ABOVE
12	0683	PIN COTTER 3/32X3/4	4	
13	10136	WASHER, FLAT, 3/8 SAE	4	
14	12100	YOKE, HTO/HTN-V	2	
15	9028	PIN, YOKE	2	

Go to Discount-Equipment.com to order your parts

# HTN/HTO-31V — FOOT PEDALS ASSY.

## FOOT PEDALS ASSY.

VIEW FROM OPERATOR'S SEAT

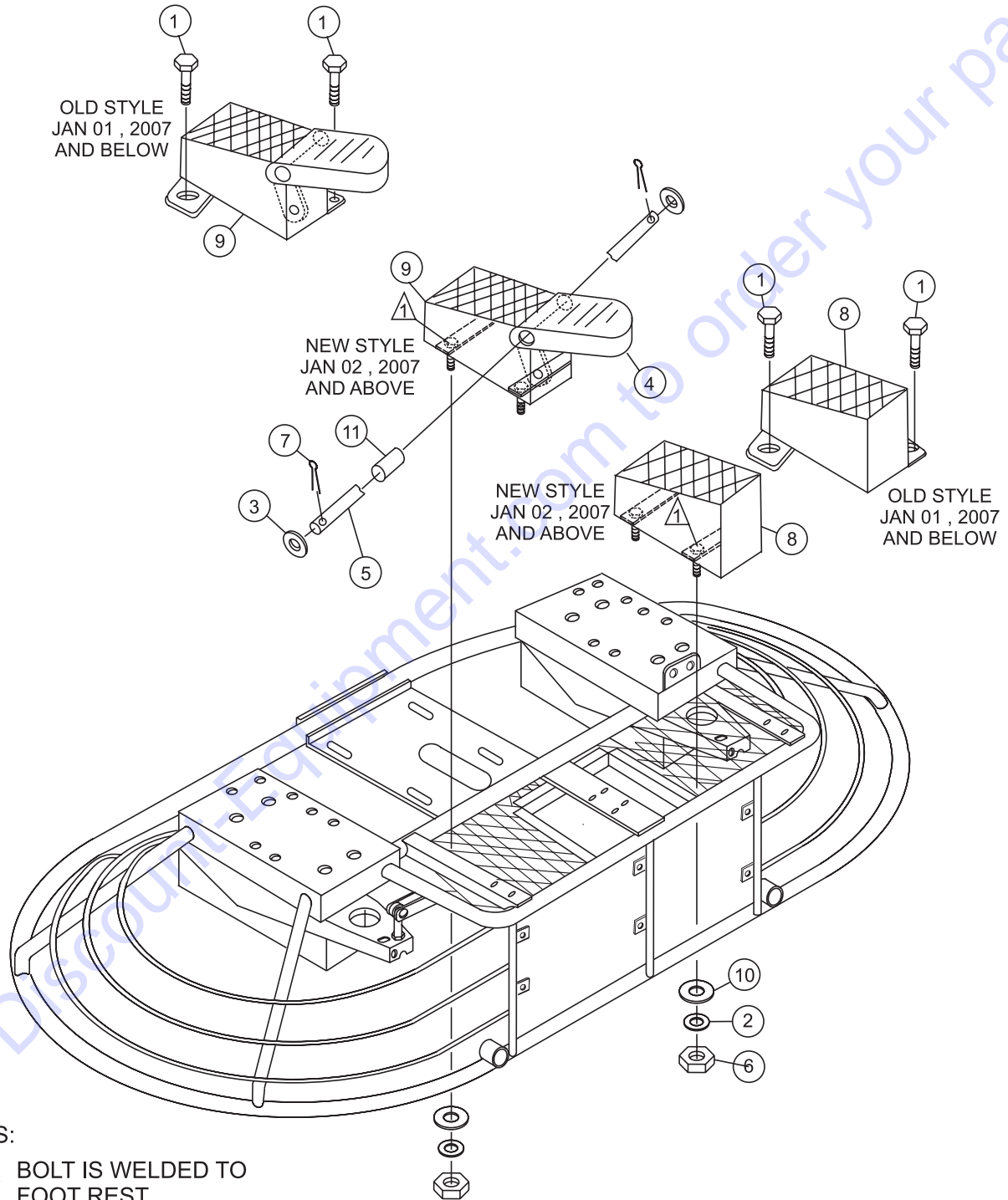



# HTN/HTO-31V — FOOT PEDALS ASSY.

FOOT PEDALS ASSY.

<u>NO</u>	<u>PART NO</u>	<u>PART NAME</u>	<u>QTY.</u>	<u>REMARKS</u>
1	0202	SCREW, HHC 5/16-18X1 .....	4	UP TO ~JAN 01, 2007
2	0300B	WASHER, FLAT, 5/16 SAE	4	
3	10136	WASHER, FLAT, 3/8 SAE	2	
4	2086	PEDAL, ACCELERATOR	1	
5	2772	PIN, ACC MOUNT	1	
6	5283	NUT, NYLOC 5/16-18	4	
7	6014B	PIN, COTTER 3/32X1	2	
8	12635	LEFT SIDE FOOT REST (TALL) .....	1	UP TO ~JAN 01, 2007
8	22035	FOOT RISER W/A RIDER LEFT SIDE .....	1	JAN 02, 2007 AND ABOVE
9	12637	RIGHT SIDE FOOT REST (TALL) .....	1	UP TO ~JAN 01, 2007
9	22037	FOOT RISER W/A, RIDER ACCELERATOR SIDE .....	1	JAN 02, 2007 AND ABOVE
10	3233	WASHER, FENDER, 1.5" OD X3/8" ID	4	
11	3083	SPACER	1	

Go to Discount-Equipment.com to order your parts

# HTN/HTO-31V — THROTTLE ASSY.

## THROTTLE FOOT PEDAL ASSY.

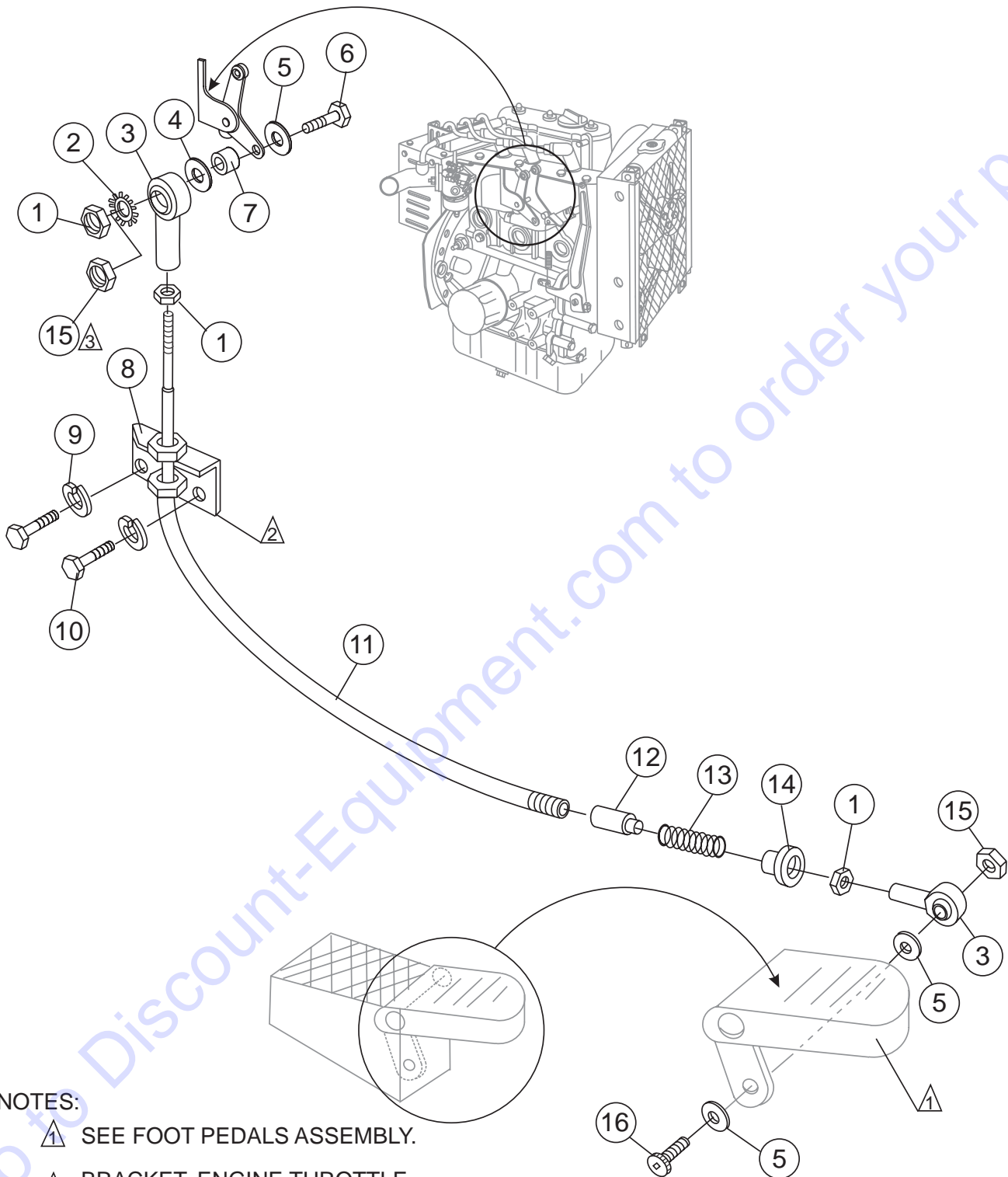

### NOTES:

- ▲ SEE FOOT PEDALS ASSEMBLY.
- ▲ BRACKET, ENGINE THROTTLE CABLE. MOUNT TO ENGINE.
- ▲ REMOVE ITEM 1 P/N 937 AND REPLACE WITH ITEM 15, P/N 10019 ON UNITS MADE AFTER MAY 16, 2000

# HTN/HTO-31V — THROTTLE ASSY.

## THROTTLE FOOT PEDAL ASSY.

<u>NO</u>	<u>PART NO</u>	<u>PART NAME</u>	<u>QTY.</u>	<u>REMARKS</u>
1	0937	NUT, HEX 10-32 .....	3 .....	UP TO MAY 15, 2000
1	0937	NUT, HEX 10-32 .....	2 .....	MAY16, 2000 AND ABOVE
2	10237	WASHER, EXT. SHKP, 5/16 .....	1 .....	UP TO MAY,15 2000
3	2153	ROD END, 10-32 FEMALE RH	2	
4	0300 B	WASHER, FLAT, 5/16 SAE .....	1 .....	UP TO MAY 15, 2000
4	2203	WASHER, FLAT, #10 .....	1 .....	MAY16, 2000 AND ABOVE
5	2203	WASHER, FLAT, #10	4	
6	8133	SCREW, RHM 10-32 X 3/4 .....	1 .....	UP TO MAY 15, 2000
6	3513	SCREW, HHF 10-32 X 1 .....	1 .....	MAY16, 2000 AND ABOVE
7	11710	SPACER, ENGINE THROTTLE	1	
8	11771	BRACKET, ENGINE THROTTLE CABLE	1	
9	0161 C	WASHER, LOCK, 5/16 MED.	2	
10	0730	SCREW, HHC 1/4-20 X 1	2	
11	2124	CABLE, THROTTLE (RT)	1	
12	2754	ADAPTOR, THROTTLE RET. SPRING LONG .....	1 .....	JAN 01, 2007 AND BELOW
12	22042	SPACER, THROTTLE SPRING 1.0 X.5 X3.0 .....	1 .....	JAN 02, 2007 AND ABOVE
13	2753	SPRING, THROTTLE RETURN, LOWER	1	
14	2755	ADAPTOR, THROTTLE RET. SPRING SHORT	1	
15	10019	NUT, NYLOC 10-32 .....	1 .....	UP TO MAY 15, 2000
15	10019	NUT, NYLOC 10-32 .....	2 .....	MAY16, 2000 AND ABOVE
16	10018	SCREW, SHC 10-32X1 NO PLATE	1	

Go to Discount-Equipment.com to order your parts

# HTN/HTO-31V — BATTERY ASSY.

## BATTERY ASSY.

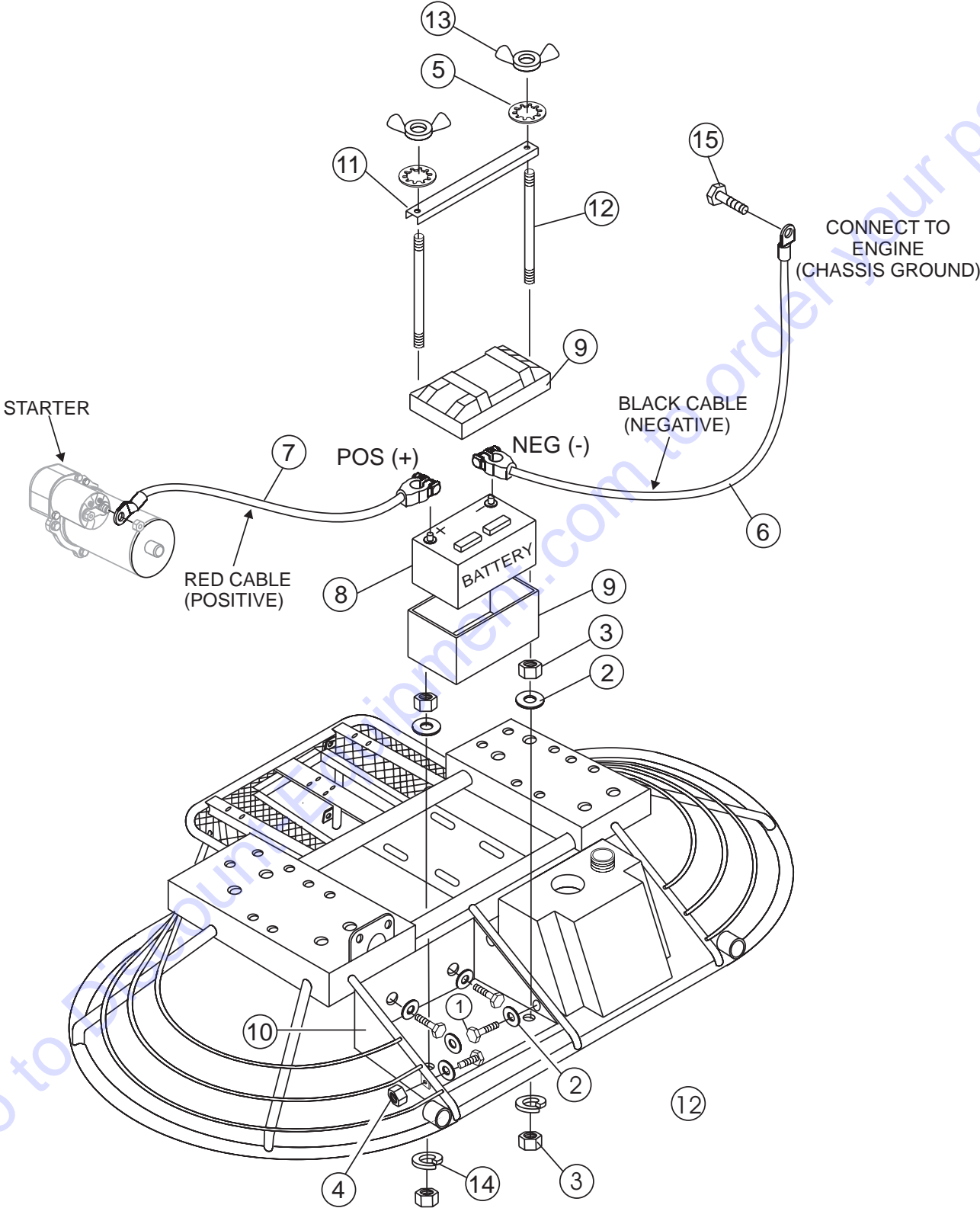

## HTN/HTO-31V — BATTERY ASSY.

### BATTERY ASSY.

<u>NO</u>	<u>PART NO</u>	<u>PART NAME</u>	<u>QTY.</u>	<u>REMARKS</u>
1	0730	SCREW, HHC 1/4-20X1	4	
2	0948	WASHER, FLAT, 1/4SAE	8	
3	0949	NUT, HEX FINISH 1/4-20	4	
4	10024	NUT, NYLOC 1/4-20	4	
5	10031	WASHER, EXT SHKP, 1/4	2	
6	10313	CABLE, NEG BATTERY BLACK 20"	1	
7	19303	CABLE, POS BATTERY RED 48"	1	
8	10315	BATTERY, 12V WET GROUP 22	1	
9	10318	BATTERY BOX, GROUP 24, W/LID	1	
10	11362	BATTERY FRAME BOX	1	
11	11692	BRACKET, BATTERY BOX HOLD DOWN	1	
12	11693	BOLT, BATTERY BRKT	2	
13	2509	NUT, WING 1/4-20 PLATED	2	
14	181B	WASHER, LOCK 1/4 MED	2	
15	2866	SCREW, HHC M8 1.25 X 20 MM GR 8.8	1	

Go to Discount-Equipment.com to order your parts

# HTN/HTO-31V — SPRAY ASSY.

SPRAY ASSY.

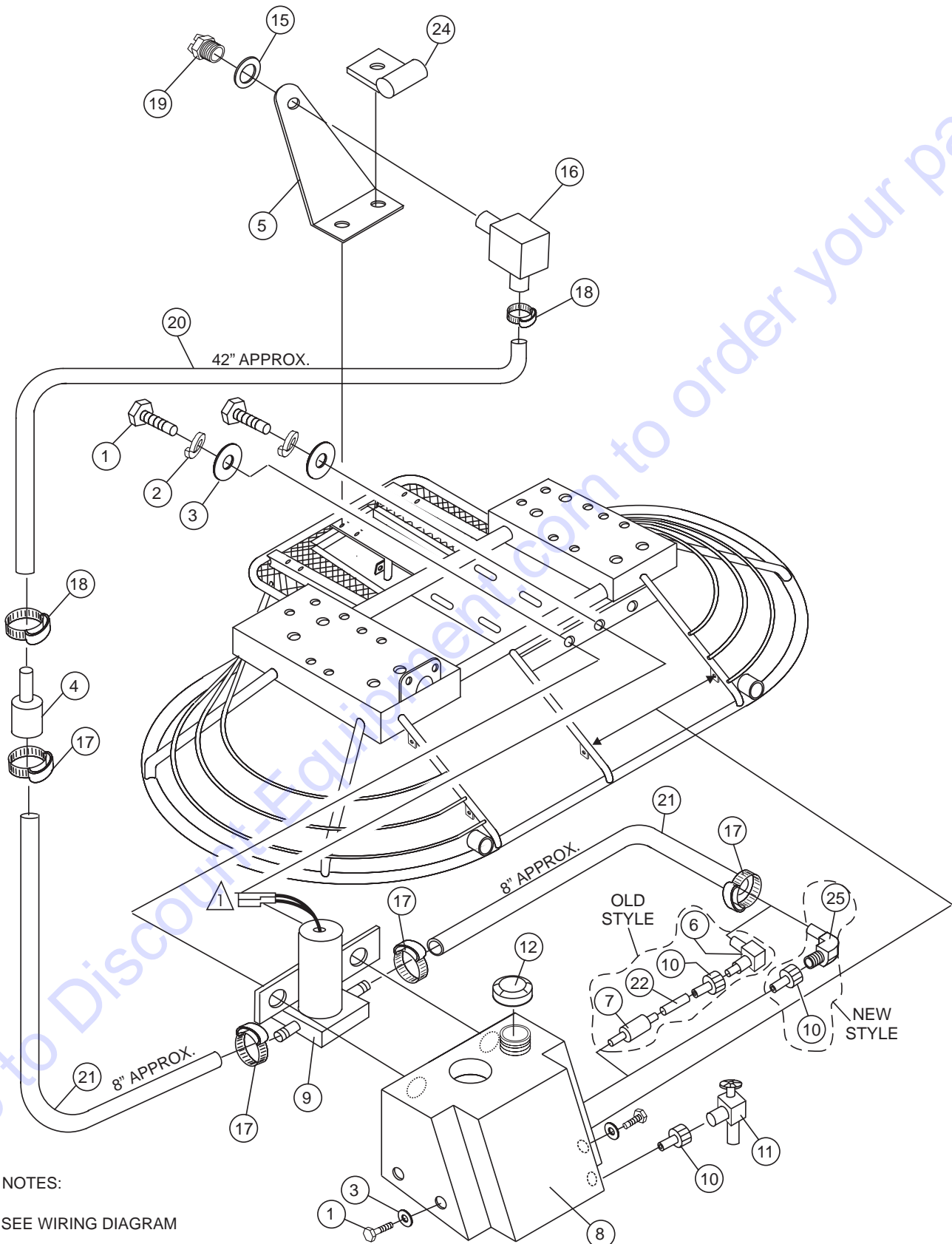

SPRAY ASSY.

<u>NO</u>	<u>PART NO</u>	<u>PART NAME</u>	<u>QTY.</u>	<u>REMARKS</u>
1	0131A	SCREW, HHC 1/4-20X3/4	4	
2	0181B	WASHER, LOCK, 1/4 MED.	4	
3	0948	WASHER, FLAT, 1/4 SAE	4	
4	10022	FITTING, PLASTIC 6BARB-4BARB	1	
5	11222	MOUNT, SPRAY NOZZLE	1	
6	12008	FITTING, 90° 6BARB-4BARB .....	1	UP TO APRIL 08, 2005
7	12009	SCREEN, FILTER DAPCO 11604 .....	1	UP TO APRIL 08, 2005
8	12036	TANK, RETARDANT 5 GALLON	1	
9	10043	PUMP, SPRAY, SHURFLO 100-000-21	1	
10	19633	BUSHING, RUBBER DAPCO 10672	2	
11	19661	VALVE, DRAIN DAPCO 11478	1	
12	2108	CAP, SPRAY TANK	1	
15	2898	WASHER, BONDED NEOPRENE 1"X1/2"	1	
16	2912	FITTING, 90 4BARB-1/4FP	1	
17	2918	CLAMP, HOSE, .475-.536 I.D.	4	
18	2930	CLAMP, HOSE, .360-.410 I.D.	2	
19	392292	NOZZLE, SPRAY	1	
20	60001	HOSE, .25 ID X.375 OD TYGON .....	3.5 FT.	APPROX. LENGTH
21	60002	HOSE, .375 ID X.5 OD TYGON .....	1.5 FT.	APPROX. LENGTH
22	60058	HOSE, 1/4X3/8 PVC YELLOW (1-1/4 INCH LONG) .....	1	UP TO APRIL 08, 2005
24	8128	CLAMP, HOSE SUPPORT, 5/16"	1	
25	29677	FITTING, 90° BARB X 4BARB TRUTANK SCREEN .....	1	APRIL 09, 2005 AND ABOVE

Go to Discount-Equipment.com to order your parts

# HTN/HTO-31V — CONTROL PANEL ASSY.

## FRONT PANEL ASSY.

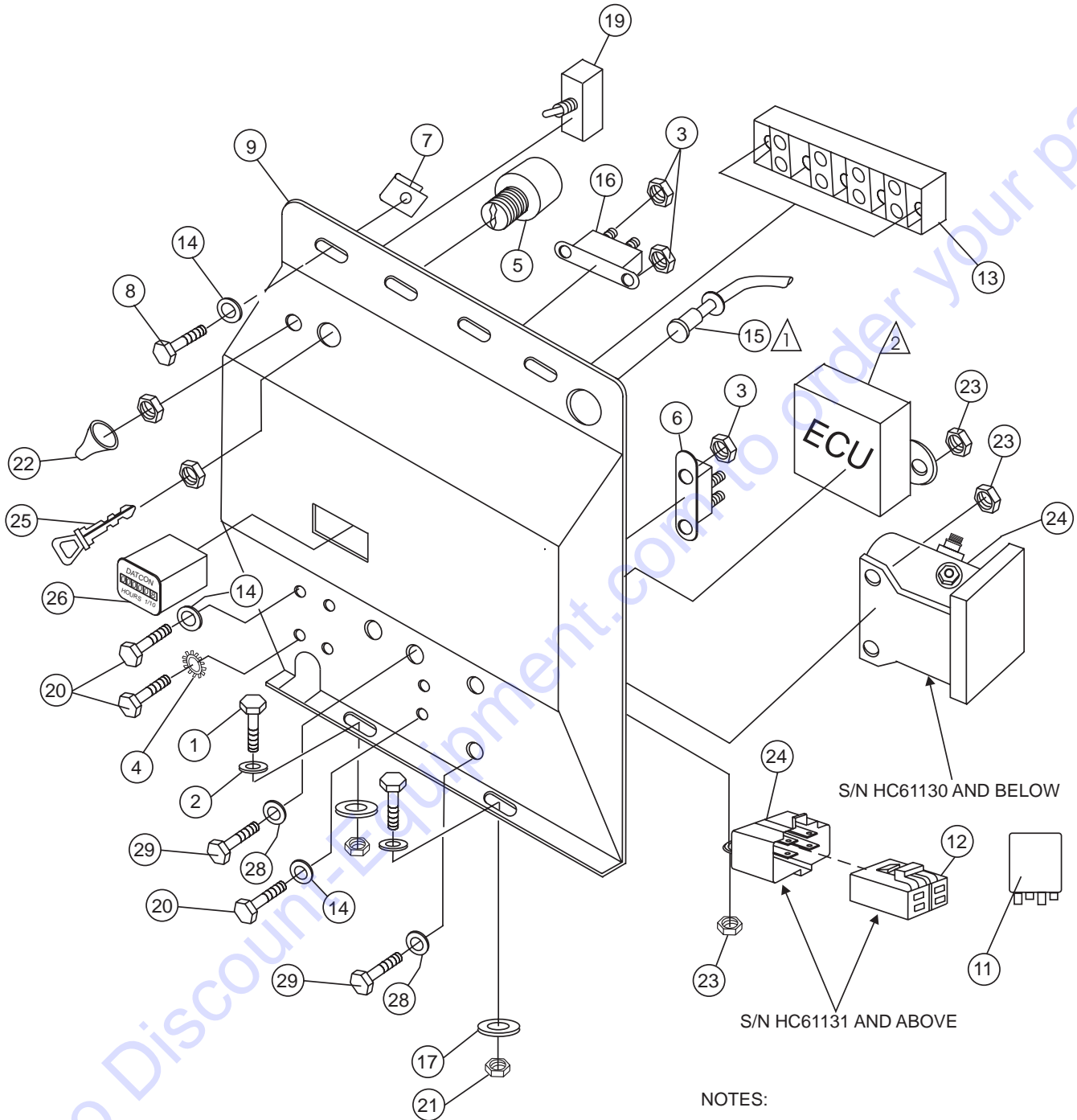

**NOTES:**

△ 1 CHOKE CABLE ASSY. CONNECT TO CARBURETOR LINKAGE

△ 2 ELECTRONIC CONTROL UNIT (ECU) IS INCLUDED WITH ENGINE. SEE VANGUARD ENGINE OWNER'S MANUAL.



# HTN/HTO-31V — CONTROL PANEL ASSY.

## FRONT PANEL ASSY.

<u>NO</u>	<u>PART NO</u>	<u>PART NAME</u>	<u>QTY.</u>	<u>REMARKS</u>
1	0202	SCREW, HHC 5/16-18 X 1	2	
2	0300B	WASHER, FLAT, 5/16 SAE	2	
3	10019	NUT, NYLOC 10-32	8	
4	10114	WASHER, EXT. SHKP, #8	2	
5	10958	SWITCH, IGNITION VAN W/KEYS	1	
6	11098	CIRCUIT BREAKER, 40A, 12V	1	
7	11534	NUT, "U" TYPE, -20	4	
8	11819	SCREW, HHC -20 X 3/4 W/WASH	4	
9	21319	PANEL, HTO/N VANGUARD CONTROL .....	1	REPLACES P/N 11861
11	12017	RELAY, KILL	1	
12	12018	CONNECTOR, RELAY .....	1	S/N HC61131 AND ABOVE
13	19301	TERMINAL STRIP	.5	
14	2203	WASHER, FLAT, #10	4	
15	2580	CABLE, CHOKE	1	
16	2673	CIRCUIT BREAKER, 30A, 12V	1	
17	3233	WASHER, FENDER, 1.5od X 3/8id	2	
19	4682	SWITCH, TOGGLE	1	
20	5065 B	SCREW, RHM 10-32 X 1/2	4	
21	5283	NUT, NYLOC 5/16-18	2	
22	8381	BOOT, TOGGLE SWITCH	1	
23	10024	NUT, NYLOC 1/4 20	4	
24	11792	ACCESSORY SOLENOID .....	1	S/N HC61130 AND BELOW
24	11912	ACCESSORY RELAY .....	1	S/N HC61131 AND ABOVE
25	11078	KEY, IGNITION SWITCH	1	
26	11694	HOUR METER, DATCON .....	1	OLD STYLE
26	29640	HOUR METER, FLUSH MOUNT .....	1	NEW STLE
28	0948	FLAT WASHER 1/4"	4	
29	12287	SCREW, THP 1/4-20 X 3/4-SS	4	

Go to Discount-Equipment.com to order your parts



## HTN/HTO-31V — E-Z MOVER AND LIFT HANDLE ASSY.

### E-Z MOVER (EMR2) AND LIFT HANDLE

<u>NO</u>	<u>PART NO</u>	<u>PART NAME</u>	<u>QTY.</u>	<u>REMARKS</u>
1	0189	HAND GRIP	2	
2	2336	UPPER HANDLE	1	
3	1869	SNAP PIN	1	
4	7170	CLIP	4	
5	11684	DOLLY AXLE	4	
6	10440	WHEEL & TIRE	4	
7	0655	SCREW, HHCS 5/16-18 x 3/4"	2	
8	0300B	FLAT WASHER 5/16"	2	
9	2364	WHEEL	2	
10	10445	FRAME	1	
11	4684	FLAT WASHER 5/8"	2	
12	0183	COTTER PIN	4	
13	10446	FLAT WASHER 3/4"	8	
14	8151	FLAT WASHER 3/4" SAE	8	
15	0161C	LOCK WASHER 5/16"	2	

EMR-2 E-Z MOVER ASSY — PURCHASE THROUGH DISCOUNT-EQUIPMENT

Go to Discount-Equipment.com to order your parts

# PARTS FINDER

**Search Website  
by Part Number**



**Search Manual  
Library For Parts  
Manual & Lookup Part  
Numbers – Purchase  
or Request Quote**

**Search Manuals**

Enter your information to help us find the right parts manual for your machine.

\* Brand:

\* Model:

\* Serial:

\* Part Number:

SEARCH

**Can't Find Part or  
Manual? Request Help  
by Manufacturer,  
Model & Description**

**Parts Order Form**

Please fill in the following information to help us find the right part for your machine.

Manufacturer:	<input type="text"/>
Model:	<input type="text"/>
Description:	<input type="text"/>
Part Number:	<input type="text"/>
Quantity:	<input type="text"/>
Notes:	<input type="text"/>

Submit

Discount-Equipment.com is your online resource for quality parts & equipment.

Florida: **561-964-4949** Outside Florida TOLL FREE: **877-690-3101**

**Need parts?**

Click on this link: <http://www.discount-equipment.com/category/5443-parts/> and choose one of the options to help get the right parts and equipment you are looking for. Please have the machine model and serial number available in order to help us get you the correct parts. If you don't find the part on the website or on one of the online manuals, please fill out the request form and one of our experienced staff members will get back to you with a quote for the right part that your machine needs.

We sell worldwide for the brands: Genie, Terex, JLG, MultiQuip, Mikasa, Essick, Whiteman, Mayco, Toro Stone, Diamond Products, Generac Magnum, Airman, Haulotte, Barreto, Power Blanket, Nifty Lift, Atlas Copco, Chicago Pneumatic, Allmand, Miller Curber, Skyjack, Lull, Skytrak, Tsurumi, Husquvarna Target, Stow, Wacker, Sakai, Mi-T-M, Sullair, Basic, Dynapac, MBW, Weber, Bartell, Bennar Newman, Haulotte, Ditch Runner, Menegotti, Morrison, Contec, Buddy, Crown, Edco, Wyco, Bomag, Laymor, EZ Trench, Bil-Jax, F.S. Curtis, Gehl Pavers, Heli, Honda, ICS/PowerGrit, IHI, Partner, Imer, Clipper, MMD, Koshin, Rice, CH&E, General Equipment, Amida, Coleman, NAC, Gradall, Square Shooter, Kent, Stanley, Tamco, Toku, Hatz, Kohler, Robin, Wisconsin, Northrock, Oztec, Toker TK, Rol-Air, APT, Wylie, Ingersoll Rand / Doosan, Innovatech, Con X, Ammann, Mecalac, Makinex, Smith Surface Prep, Small Line, Wanco, Yanmar