



An Oshkosh Corporation Company



[www.Discount-Equipment.com](http://www.Discount-Equipment.com)

---

# **Operation and Safety Manual**

*Original Instructions - Keep this manual with the machine at all times.*

**Boom Lift Models**

**800S**

**860SJ**

**Prior to S/N 0300182742**

**ANSI CE** 

**3121138**

March 24, 2014

---

**TO PURCHASE THIS PRODUCT PLEASE CONTACT US**



**Equipment Financing and  
Extended Warranties Available**



**Discount-Equipment.com is your online resource for  
commercial and industrial quality parts and equipment sales.**

**561-964-4949**

**visit us on line @ [www.discount-equipment.com](http://www.discount-equipment.com)**

Select an option below to find your Equipment

**Search by Manufacturer**

**Search by Product Type**

**Request a Quote**

We sell worldwide for the brands: Genie, Terex, JLG, MultiQuip, Mikasa, Essick, Whiteman, Mayco, Toro Stone, Diamond Products, Generac Magnum, Airman, Haulotte, Barreto, Power Blanket, Nifty Lift, Atlas Copco, Chicago Pneumatic, Allmand, Miller Curber, Skyjack, Lull, Skytrak, Tsurumi, Husquvarna Target, Stow, Wacker, Sakai, Mi-T-M, Sullair, Basic, Dynapac, MBW, Weber, Bartell, Bennar Newman, Haulotte, Ditch Runner, Menegotti, Morrison, Contec, Buddy, Crown, Edco, Wyco, Bomag, Laymor, EZ Trench, Bil-Jax, F.S. Curtis, Gehl Pavers, Heli, Honda, ICS/PowerGrit, IHI, Partner, Imer, Clipper, MMD, Koshin, Rice, CH&E, General Equipment, Amida, Coleman, NAC, Gradall, Square Shooter, Kent, Stanley, Tamco, Toku, Hatz, Kohler, Robin, Wisconsin, Northrock, Oztec, Toker TK, Rol-Air, APT, Wylie, Ingersoll Rand / Doosan, Innovatech, Con X, Ammann, Mecalac, Makinex, Smith Surface Prep, Small Line, Wanco, Yanmar

## **FOREWORD**

This manual is a very important tool! Keep it with the machine at all times.

The purpose of this manual is to provide owners, users, operators, lessors, and lessees with the precautions and operating procedures essential for the safe and proper machine operation for its intended purpose.

Due to continuous product improvements, JLG Industries, Inc. reserves the right to make specification changes without prior notification. Contact JLG Industries, Inc. for updated information.

## SAFETY ALERT SYMBOLS AND SAFETY SIGNAL WORDS



This is the Safety Alert Symbol. It is used to alert you to the potential personal injury hazards. Obey all safety messages that follow this symbol to avoid possible injury or death

### **DANGER**

INDICATES AN IMMINENTLY HAZARDOUS SITUATION. IF NOT AVOIDED, WILL RESULT IN SERIOUS INJURY OR DEATH. THIS DECAL WILL HAVE A RED BACKGROUND.

### **WARNING**

INDICATES A POTENTIALLY HAZARDOUS SITUATION. IF NOT AVOIDED, COULD RESULT IN SERIOUS INJURY OR DEATH. THIS DECAL WILL HAVE AN ORANGE BACKGROUND.

### **CAUTION**

INDICATES A POTENTIALLY HAZARDOUS SITUATION. IF NOT AVOIDED, MAY RESULT IN MINOR OR MODERATE INJURY. IT MAY ALSO ALERT AGAINST UNSAFE PRACTICES. THIS DECAL WILL HAVE A YELLOW BACKGROUND.

### **NOTICE**

INDICATES INFORMATION OR A COMPANY POLICY THAT RELATES DIRECTLY OR INDIRECTLY TO THE SAFETY OF PERSONNEL OR PROTECTION OF PROPERTY.

**⚠ WARNING**

**THIS PRODUCT MUST COMPLY WITH ALL SAFETY RELATED BULLETINS. CONTACT JLG INDUSTRIES, INC. OR THE LOCAL AUTHORIZED JLG REPRESENTATIVE FOR INFORMATION REGARDING SAFETY-RELATED BULLETINS WHICH MAY HAVE BEEN ISSUED FOR THIS PRODUCT.**

**NOTICE**

**JLG INDUSTRIES, INC. SENDS SAFETY RELATED BULLETINS TO THE OWNER OF RECORD OF THIS MACHINE. CONTACT JLG INDUSTRIES, INC. TO ENSURE THAT THE CURRENT OWNER RECORDS ARE UPDATED AND ACCURATE.**

**NOTICE**

**JLG INDUSTRIES, INC. MUST BE NOTIFIED IMMEDIATELY IN ALL INSTANCES WHERE JLG PRODUCTS HAVE BEEN INVOLVED IN AN ACCIDENT INVOLVING BODILY INJURY OR DEATH OF PERSONNEL OR WHEN SUBSTANTIAL DAMAGE HAS OCCURRED TO PERSONAL PROPERTY OR THE JLG PRODUCT.**

**For:**

- Accident Reporting
- Product Safety Publications
- Current Owner Updates
- Questions Regarding Product Safety
- Standards and Regulations Compliance Information
- Questions Regarding Special Product Applications
- Questions Regarding Product Modifications

**Contact:**

Product Safety and Reliability Department  
JLG Industries, Inc.  
13224 Fountainhead Plaza  
Hagerstown, MD 21742  
USA

or Your Local JLG Office  
(See addresses on inside of manual cover)

**In USA:**

Toll Free: 877-JLG-SAFE (877-554-7233)

**Outside USA:**

Phone: 240-420-2661  
Fax: 301-745-3713  
E-mail: ProductSafety@JLG.com

## REVISION LOG

Original Issue	- October 9, 2001
Revised	- October 31, 2001
Revised	- December 4, 2001
Revised	- March 1, 2002
Revised	- January 1, 2003
Revised	- April 24, 2003
Revised	- May 4, 2005
Revised	- March 3, 2006
Revised	- July 7, 2006
Revised	- August 13, 2008
Revised	- November 25, 2009
Revised	- February 9, 2010
Revised	- October 31, 2011
Revised	- July 17, 2012
Revised	- March 24, 2014

<b>SECTION - PARAGRAPH, SUBJECT</b>	<b>PAGE</b>	<b>SECTION - PARAGRAPH, SUBJECT</b>	<b>PAGE</b>
<b>SECTION - 1 - SAFETY PRECAUTIONS</b>			
1.1 GENERAL	1-1	2.3 HORIZONTAL AND CAPACITY LIMIT SWITCHES	2-10
1.2 PRE-OPERATION	1-1	2.4 OSCILLATING AXLE LOCKOUT TEST (IF EQUIPPED)	2-14
Operator Training and Knowledge	1-1		
Workplace Inspection	1-2		
Machine Inspection	1-2		
1.3 OPERATION	1-3	<b>SECTION - 3 - MACHINE CONTROLS AND INDICATORS</b>	
General	1-3	3.1 GENERAL	3-1
Trip and Fall Hazards	1-3	3.2 CONTROLS AND INDICATORS	3-1
Electrocution Hazards	1-4	Ground Control Station	3-1
Tipping Hazards	1-6	Ground Control Indicator Panel	3-6
Crushing and Collision Hazards	1-7	Platform Station	3-9
1.4 TOWING, LIFTING, AND HAULING	1-8	Platform Control Indicator Panel	3-15
1.5 ADDITIONAL HAZARDS / SAFETY	1-9		
		<b>SECTION - 4 - MACHINE OPERATION</b>	
<b>SECTION - 2 - USER RESPONSIBILITIES, MACHINE PREPARATION, AND INSPECTION</b>		4.1 DESCRIPTION	4-1
2.1 PERSONNEL TRAINING	2-1	4.2 OPERATING CHARACTERISTICS AND LIMITATIONS	4-1
Operator Training	2-1	Capacities	4-1
Training Supervision	2-1	Stability	4-1
Operator Responsibility	2-1	4.3 ENGINE OPERATION	4-2
2.2 PREPARATION, INSPECTION, AND MAINTENANCE	2-2	Starting Procedure	4-2
Pre-Start Inspection	2-4	Shutdown Procedure	4-3
Function Check	2-5	4.4 TRAVELING (DRIVING)	4-5
		Traveling Forward and Reverse	4-6

## TABLE OF CONTENTS

SECTION - PARAGRAPH, SUBJECT	PAGE	SECTION - PARAGRAPH, SUBJECT	PAGE
4.5 STEERING . . . . .	4-6	(IF EQUIPPED) . . . . .	5-2
4.6 PLATFORM . . . . .	4-8	To Retract and Lower Boom. . . . .	5-3
Platform Level Adjustment. . . . .	4-8	To Lower Boom with Fully Retracted Telescope . . . . .	5-3
Platform Rotation . . . . .	4-8		
4.7 BOOM . . . . .	4-8	<b>SECTION - 6 - GENERAL SPECIFICATIONS &amp; OPERATOR MAINTENANCE</b>	
Swinging the Boom . . . . .	4-9	6.1 INTRODUCTION . . . . .	6-1
Raising and Lowering the Boom . . . . .	4-9	6.2 OPERATING SPECIFICATIONS . . . . .	6-1
4.8 FUNCTION SPEED CONTROL . . . . .	4-9	Specifications and Performance Data . . . . .	6-3
4.9 OSCILLATING AXLE LOCKOUT TEST (IF EQUIPPED) . . . . .	4-9	Capacities . . . . .	6-4
4.10 EMERGENCY TOWING . . . . .	4-10	Engine Data . . . . .	6-5
4.11 TOW BAR (IF EQUIPPED) . . . . .	4-11	Battery . . . . .	6-7
4.12 SHUT DOWN AND PARK . . . . .	4-13	Tires . . . . .	6-7
4.13 LIFTING AND TIE DOWN. . . . .	4-13	Major Component Weights. . . . .	6-8
Lifting . . . . .	4-13	Hydraulic Oil . . . . .	6-8
Tie Down . . . . .	4-14	6.3 SERIAL NUMBER LOCATION . . . . .	6-11
		6.4 OPERATOR MAINTENANCE . . . . .	6-21
<b>SECTION - 5 - EMERGENCY PROCEDURES</b>		6.5 TIRES & WHEELS . . . . .	6-30
5.1 GENERAL . . . . .	5-1	Tire Inflation . . . . .	6-30
5.2 INCIDENT NOTIFICATION. . . . .	5-1	Tire Damage . . . . .	6-30
5.3 EMERGENCY OPERATION. . . . .	5-1	Tire Replacement . . . . .	6-31
Operator Unable to Control Machine . . . . .	5-1	Wheel Replacement . . . . .	6-31
Platform or Boom Caught Overhead. . . . .	5-2	Wheel Installation . . . . .	6-32
5.4 EMERGENCY TOWING PROCEDURES . . . . .	5-2	6.6 DRAINING OIL BUILD UP FROM THE PROPANE	
5.5 MANUAL DESCENT INSTRUCTIONS			



<b>SECTION - PARAGRAPH, SUBJECT</b>	<b>PAGE</b>
REGULATOR (PRIOR TO S/N 0300134626) . . .	6-33
6.7 PROPANE FUEL FILTER REPLACEMENT . . . . .	6-35
Removal . . . . .	6-35
Installation . . . . .	6-35
6.8 PROPANE FUEL SYSTEM PRESSURE RELIEF . .6-37	
6.9 SUPPLEMENTAL INFORMATION . . . . .	6-37

**SECTION - 7 - INSPECTION AND REPAIR LOG**

**LIST OF FIGURES**

2-1. Basic Nomenclature - Sheet 1 of 2 . . . . .	2-6
2-2. Basic Nomenclature - Sheet 2 of 2 . . . . .	2-7
2-2. Daily Walk-Around Inspection - Sheet 1 of 2 . . . . .	2-8
2-3. Daily Walk-Around Inspection - Sheet 2 of 2 . . . . .	2-9
2-4. Horizontal and Capacity Limit Switches - Sheet 1 of 2 . . . . .	2-10
2-5. Horizontal and Capacity Limit Switches - Sheet 2 of 2 . . . . .	2-11
2-6. Limiting and Cut-Out Switches - Sheet 1 of 2 . . . . .	2-12
2-7. Limiting and Cut-Out Switches - Sheet 2 of 2 . . . . .	2-13
3-1. Ground Control Station - 800S . . . . .	3-3
3-1. Ground Control Station - 860SJ . . . . .	3-4
3-2. Ground Control Indicator Panel - Sheet 1 of 2 . . . . .	3-7
3-3. Ground Control Indicator Panel - Sheet 2 of 2 . . . . .	3-8
3-4. Platform Control Console . . . . .	3-11

<b>SECTION - PARAGRAPH, SUBJECT</b>	<b>PAGE</b>
3-5. Platform Control Console - w/Drive Orientation . .	3-12
3-6. Platform Light Panel . . . . .	3-18
3-7. Platform Light Panel - w/Drive Orientation . . . . .	3-19
4-1. Position of Least Backward Stability . . . . .	4-3
4-2. Position of Least Forward Stability . . . . .	4-4
4-3. Grade and Side Slopes . . . . .	4-7
4-4. Drive Disconnect Hub . . . . .	4-10
4-5. Typical 800S/860SJ Transport . . . . .	4-15
4-6. Lifting and Tie Down Chart . . . . .	4-16
4-7. Decal Location - Rear Entry Platform - Sheet 1 of 2 . . . . .	4-17
4-8. Decal Location - Rear Entry Platform - Sheet 2 of 2 . . . . .	4-18
4-9. Decal Location - Side Entry Platform - Sheet 1 of 5 . . . . .	4-31
4-10. Decal Location - Side Entry Platform - Sheet 2 of 5 . . . . .	4-32
4-11. Decal Location - Side Entry Platform - Sheet 3 of 5 . . . . .	4-33
4-12. Decal Location - Side Entry Platform - Sheet 4 of 5 . . . . .	4-34
4-13. Decal Location - Side Entry Platform - Sheet 5 of 5 . . . . .	4-35
6-1. Serial Number Locations . . . . .	6-11
6-2. Engine Operating Temperature Specifications - Deutz - Sheet 1 of 2 . . . . .	6-12

## TABLE OF CONTENTS

SECTION - PARAGRAPH, SUBJECT	PAGE
6-3. Engine Operating Temperature Specifications - Deutz - Sheet 2 of 2 . . . . .	6-13
6-4. Engine Operating Temperature Specifications - Ford - Sheet 1 of 2 . . . . .	6-14
6-5. Engine Operating Temperature Specifications - Ford - Sheet 2 of 2 . . . . .	6-15
6-6. Engine Operating Temperature Specifications - Caterpillar - Sheet 1 of 2 . . . . .	6-16
6-7. Engine Operating Temperature Specifications - Caterpillar - Sheet 2 of 2 . . . . .	6-17
6-8. Engine Operating Temperature Specifications - GM - Sheet 1 of 2 . . . . .	6-18
6-9. Engine Operating Temperature Specifications - GM - Sheet 2 of 2 . . . . .	6-19
6-10. Operator Maintenance and Lubrication Diagram	6-20
6-11. Filter Lock Assembly . . . . .	6-36

SECTION - PARAGRAPH, SUBJECT	PAGE
<b>LIST OF TABLES</b>	
1-1 Minimum Approach Distances (M.A.D.) . . . . .	1-5
1-2 Beaufort Scale (For Reference Only) . . . . .	1-10
2-1 Inspection and Maintenance Table . . . . .	2-3
4-1 Decal Location Legend - Rear Entry Platform . . . . .	4-19
4-2 Decal Location Legend - Rear Entry Platform . . . . .	4-23
4-3 Decal Location Legend - Rear Entry Platform . . . . .	4-27
4-4 Decal Location Legend, 800S - Side Entry Platform - Prior to S/N 0300143294 . . . . .	4-36
4-5 Decal Location Legend, 800S - Side Entry Platform - S/N 0300143294 & B30000153 to S/N 0300182742 . . . . .	4-40
4-6 Decal Location Legend, 860SJ - Side Entry Platform - Prior to S/N 0300143294 . . . . .	4-44
4-7 Decal Location Legend, 860SJ - Side Entry Platform - S/N 0300143294 & B300000153 to S/N 0300182742 . . . . .	4-48
6-1 Operating Specifications - Prior to S/N 0300143294 . . . . .	6-1
6-2 Operating Specifications - S/N 0300143294 & B300000153 to S/N 0300182742 . . . . .	6-2
6-3 Specifications and Performance Data . . . . .	6-3
6-4 Capacities . . . . .	6-4
6-5 Ford LRG-425 Specifications . . . . .	6-5
6-6 Deutz F4M2011 Specifications . . . . .	6-5

<b>SECTION - PARAGRAPH, SUBJECT</b>	<b>PAGE</b>	<b>SECTION - PARAGRAPH, SUBJECT</b>	<b>PAGE</b>
6-7 Deutz D2011L04 Specifications . . . . .	6-6		
6-8 Caterpillar 3044C/ Caterpillar 3.4 . . . . .	6-6		
6-9 GM 3.0L . . . . .	6-7		
6-10 Battery Specifications . . . . .	6-7		
6-11 Tire Specifications . . . . .	6-7		
6-12 Component Weights . . . . .	6-8		
6-13 Hydraulic Oil . . . . .	6-8		
6-14 Mobilfluid 424 Specs . . . . .	6-9		
6-15 Mobil DTE 13M Specs . . . . .	6-9		
6-16 Mobil EAL 224H Specs . . . . .	6-10		
6-17 UCon Hydrolube HP-5046 . . . . .	6-10		
6-18 Exxon Unavis HVI 26 Specs . . . . .	6-11		
6-19 Lubrication Specifications . . . . .	6-21		
6-20 Wheel Torque Chart . . . . .	6-33		
7-1 Inspection and Repair Log . . . . .	7-1		

**TABLE OF CONTENTS**

---

**SECTION - PARAGRAPH, SUBJECT**

**PAGE**

**SECTION - PARAGRAPH, SUBJECT**

**PAGE**

**This page left blank intentionally.**

## SECTION 1. SAFETY PRECAUTIONS

### 1.1 GENERAL

This section outlines the necessary precautions for proper and safe machine operation and maintenance. For proper machine use, it is mandatory that a daily routine is established based on the content of this manual. A maintenance program, using the information provided in this manual and the Service and Maintenance Manual, must also be established by a qualified person and followed to ensure the machine is safe to operate.

The owner/user/operator/lessor/lessee of the machine should not operate the machine until this manual has been read, training is accomplished, and operation of the machine has been completed under the supervision of an experienced and qualified operator.

If there are any questions with regard to safety, training, inspection, maintenance, application, and operation, please contact JLG Industries, Inc. (“JLG”).

#### **⚠ WARNING**

**FAILURE TO COMPLY WITH THE SAFETY PRECAUTIONS LISTED IN THIS MANUAL COULD RESULT IN MACHINE DAMAGE, PROPERTY DAMAGE, PERSONAL INJURY OR DEATH.**

### 1.2 PRE-OPERATION

#### Operator Training and Knowledge

- Read and understand this manual before operating the machine.

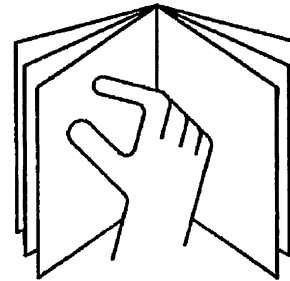

- Do not operate this machine until complete training is performed by authorized persons.
- Only authorized and qualified personnel can operate the machine.

## SECTION 1 - SAFETY PRECAUTIONS

---

- Read, understand, and obey all DANGERS, WARNINGS, CAUTIONS, and operating instructions on the machine and in this manual.
- Use the machine in a manner which is within the scope of its intended application set by JLG.
- All operating personnel must be familiar with the emergency controls and emergency operation of the machine as specified in this manual.
- Read, understand, and obey all applicable employer, local, and governmental regulations as they pertain to operation of the machine.

### Workplace Inspection

- The operator is to take safety measures to avoid all hazards in the work area prior to machine operation.
- Do not operate or raise the platform while on trucks, trailers, railway cars, floating vessels, scaffolds or other equipment unless approved in writing by JLG.
- Do not operate the machine in hazardous environments unless approved for that purpose by JLG.
- Be sure that the ground conditions are able to support the maximum load shown on the decals located on the machine.

### Machine Inspection

- Before machine operation, perform inspections and functional checks. Refer to Section 2 of this manual for detailed instructions.
- Do not operate this machine until it has been serviced and maintained according to requirements specified in the Service and Maintenance Manual.
- Be sure the footswitch and all other safety devices are operating properly. Modification of these devices is a safety violation.

### WARNING

**MODIFICATION OR ALTERATION OF AN AERIAL WORK PLATFORM SHALL BE MADE ONLY WITH WRITTEN PERMISSION FROM THE MANUFACTURER**

- Do not operate any machine on which safety or instruction placards or decals are missing or illegible.
- Avoid any buildup of debris on the platform floor. Keep mud, oil, grease, and other slippery substances from footwear and platform floor.

### 1.3 OPERATION

#### General

- Do not use the machine for any purpose other than positioning personnel, their tools, and equipment.
- Never operate a machine that is not working properly. If a malfunction occurs, shut down the machine.
- Never slam a control switch or lever through neutral to an opposite direction. Always return switch to neutral and stop before moving the switch to the next function. Operate controls with slow and even pressure.
- Do not allow personnel to tamper with or operate the machine from the ground with personnel in the platform, except in an emergency.
- Do not carry materials directly on platform railing. Contact JLG for approved material handling accessories.
- When two or more persons are in the platform, the operator shall be responsible for all machine operations.
- Always ensure that power tools are properly stowed and never left hanging by their cord from the platform work area.

- Supplies or tools which extend outside the platform are prohibited unless approved by JLG.
- When driving, always position boom over rear axle in line with the direction of travel. Remember, if boom is over the front axle, steer and drive functions will be reversed.
- Do not assist a stuck or disabled machine by pushing, pulling, or by using boom functions. Only pull the unit from the tie-down lugs on the chassis.
- Do not place boom or platform against any structure to steady the platform or to support the structure.
- Stow boom and shut off all power before leaving machine.

#### Trip and Fall Hazards

During operation, occupants in the platform must wear a full body harness with a lanyard attached to an authorized lanyard anchorage point. Attach only one (1) lanyard per lanyard anchorage point.

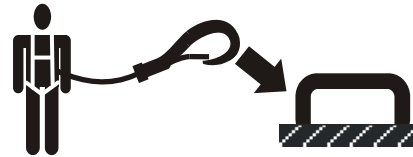

## SECTION 1 - SAFETY PRECAUTIONS

- Before operating the machine, make sure all gates are closed and fastened in their proper position.

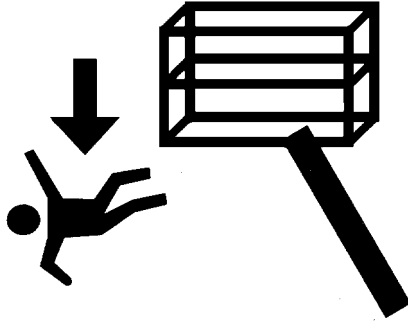

- Keep both feet firmly positioned on the platform floor at all times. Never use ladders, boxes, steps, planks, or similar items on platform to provide additional reach.
- Never use the boom assembly to enter or leave the platform.

- Use extreme caution when entering or leaving platform. Be sure that the boom is fully lowered. It may be necessary to telescope out to position the platform closer to the ground for entry/exit. Face the machine, maintain “three point contact” with the machine, using two hands and one foot or two feet and one hand during entry and exit.

### Electrocution Hazards

- This machine is not insulated and does not provide protection from contact or proximity to electrical current.

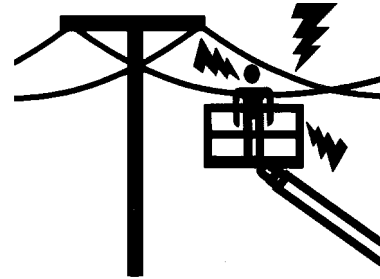



## SECTION 1 - SAFETY PRECAUTIONS

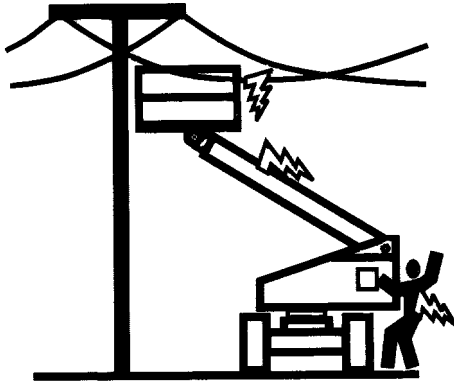

- Maintain distance from electrical lines, apparatus, or any energized (exposed or insulated) parts according to the Minimum Approach Distance (MAD) as shown in Table 1-1.
- Allow for machine movement and electrical line swaying.

Table 1-1. Minimum Approach Distances (M.A.D.)

Voltage Range (Phase to Phase)	MINIMUM APPROACH DISTANCE in Feet (Meters)
0 to 50 KV	10 (3)
Over 50KV to 200 KV	15 (5)
Over 200 KV to 350 KV	20 (6)
Over 350 KV to 500 KV	25 (8)
Over 500 KV to 750 KV	35 (11)
Over 750 KV to 1000 KV	45 (14)

**NOTE:** This requirement shall apply except where employer, local or governmental regulations are more stringent.

- Maintain a clearance of at least 10 ft. (3m) between any part of the machine and its occupants, their tools, and their equipment from any electrical line or apparatus carrying up to 50,000 volts. One foot additional clearance is required for every additional 30,000 volts or less.

## SECTION 1 - SAFETY PRECAUTIONS

- The minimum approach distance may be reduced if insulating barriers are installed to prevent contact, and the barriers are rated for the voltage of the line being guarded. These barriers shall not be part of (or attached to) the machine. The minimum approach distance shall be reduced to a distance within the designed working dimensions of the insulating barrier. This determination shall be made by a qualified person in accordance with the employer, local, or governmental requirements for work practices near energized equipment

### **⚠ DANGER**

**DO NOT MANEUVER MACHINE OR PERSONNEL INSIDE PROHIBITED ZONE (MAD). ASSUME ALL ELECTRICAL PARTS AND WIRING ARE ENERGIZED UNLESS KNOWN OTHERWISE.**

### **Tipping Hazards**

- The user must be familiar with the surface before driving. Do not exceed the allowable sideslope and grade while driving.

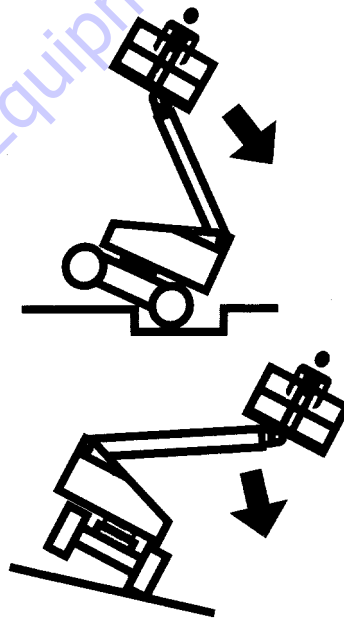

- Do not elevate platform or drive with platform elevated while on a sloping, uneven, or soft surface.
- Before driving on floors, bridges, trucks, and other surfaces, check allowable capacity of the surfaces.
- Never exceed the maximum platform capacity. Distribute loads evenly on platform floor.
- Do not raise the platform or drive from an elevated position unless the machine is on firm, level and smooth surfaces.
- Keep the chassis of the machine at least 2 ft. (0.6m) from holes, bumps, drop-offs, obstructions, debris, concealed holes, and other potential hazards on the floor/surface.
- Do not push or pull any object with the boom.
- Never attempt to use the machine as a crane. Do not tie-off machine to any adjacent structure.
- Do not operate the machine when wind conditions exceed 28 mph (12.5 m/s). Refer to Table 1-2, Beaufort Scale (For Reference Only).
- Do not increase the surface area of the platform or the load. Increase of the area exposed to the wind will decrease stability.
- Do not increase the platform size with unauthorized deck extensions or attachments.

- If boom assembly or platform is in a position that one or more wheels are off the ground, all persons must be removed before attempting to stabilize the machine. Use cranes, forklift trucks, or other appropriate equipment to stabilize machine.

### Crushing and Collision Hazards

- Approved head gear must be worn by all operating and ground personnel.
- Check work area for clearances overhead, on sides, and bottom of platform when lifting or lowering platform, and driving.

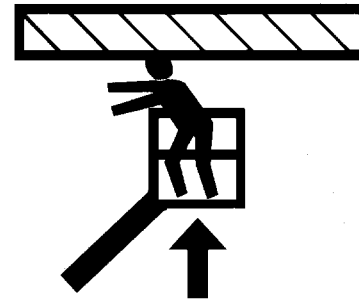

- During operation, keep all body parts inside platform railing.

## SECTION 1 - SAFETY PRECAUTIONS

---

- Use the boom functions, not the drive function, to position the platform close to obstacles.
- Always post a lookout when driving in areas where vision is obstructed.
- Keep non-operating personnel at least 6 ft. (1.8m) away from machine during all driving and swing operations.
- Limit travel speed according to conditions of ground surface, congestion, visibility, slope, location of personnel, and other factors which may cause collision or injury to personnel.
- Be aware of stopping distances in all drive speeds. When driving in high speed, switch to low speed before stopping. Travel grades in low speed only.
- Do not use high speed drive in restricted or close quarters or when driving in reverse.
- Exercise extreme caution at all times to prevent obstacles from striking or interfering with operating controls and persons in the platform.
- Be sure that operators of other overhead and floor level machines are aware of the aerial work platform's presence. Disconnect power to overhead cranes.
- Warn personnel not to work, stand, or walk under a raised boom or platform. Position barricades on floor if necessary.

### 1.4 TOWING, LIFTING, AND HAULING

- Never allow personnel in platform while towing, lifting, or hauling.
- This machine should not be towed, except in the event of emergency, malfunction, power failure, or loading/unloading. Refer to the Emergency Procedures section of this manual for emergency towing procedures.
- Ensure boom is in the stowed position and the turntable locked prior to towing, lifting or hauling. The platform must be completely empty of tools.
- When lifting machine, lift only at designated areas of the machine. Lift the unit with equipment of adequate capacity.
- Refer to the Machine Operation section of this manual for lifting information.

## **1.5 ADDITIONAL HAZARDS / SAFETY**

- Do not use machine as a ground for welding.
- When performing welding or metal cutting operations, precautions must be taken to protect the chassis from direct exposure to weld and metal cutting spatter.
- Do not refuel the machine with the engine running.
- Battery fluid is highly corrosive. Avoid contact with skin and clothing at all times.
- Charge batteries only in a well ventilated area.

## SECTION 1 - SAFETY PRECAUTIONS

### NOTICE

DO NOT OPERATE THE MACHINE WHEN WIND CONDITIONS EXCEED 28 MPH (12.5 M/S).

Table 1-2. Beaufort Scale (For Reference Only)

Beaufort Number	Wind Speed		Description	Land Conditions
	mph	m/s		
0	0	0-0.2	Calm	Calm. Smoke rises vertically
1	1-3	0.3-1.5	Light air	Wind motion visible in smoke
2	4-7	1.6-3.3	Light breeze	Wind felt on exposed skin. Leaves rustle
3	8-12	3.4-5.4	Gentle breeze	Leaves and smaller twigs in constant motion
4	13-18	5.5-7.9	Moderate breeze	Dust and loose paper raised. Small branches begin to move.
5	19-24	8.0-10.7	Fresh breeze	Smaller trees sway.
6	25-31	10.8-13.8	Strong breeze	Large branches in motion. Whistling heard in overhead wires. Umbrella use becomes difficult.
7	32-38	13.9-17.1	Near Gale/Moderate Gale	Whole trees in motion. Effort needed to walk against the wind.
8	39-46	17.2-20.7	Fresh Gale	Twigs broken from trees. Cars veer on road.
9	47-54	20.8-24.4	Strong Gale	Light structure damage.

## **SECTION 2. USER RESPONSIBILITIES, MACHINE PREPARATION, AND INSPECTION**

### **2.1 PERSONNEL TRAINING**

The aerial platform is a personnel handling device; so it is necessary that it be operated and maintained only by trained personnel.

Persons under the influence of drugs or alcohol or who are subject to seizures, dizziness or loss of physical control must not operate this machine.

#### **Operator Training**

Operator training must cover:

1. Use and limitations of the controls in the platform and at the ground, emergency controls and safety systems.
2. Control labels, instructions, and warnings on the machine.
3. Rules of the employer and government regulations.
4. Use of approved fall protection device.
5. Enough knowledge of the mechanical operation of the machine to recognize a malfunction or potential malfunction.
6. The safest means to operate the machine where overhead obstructions, other moving equipment, and obstacles, depressions, holes, dropoffs.
7. Means to avoid the hazards of unprotected electrical conductors.
8. Specific job requirements or machine application.

#### **Training Supervision**

Training must be done under the supervision of a qualified person in an open area free of obstructions until the trainee has developed the ability to safely control and operate the machine.

#### **Operator Responsibility**

The operator must be instructed that he/she has the responsibility and authority to shut down the machine in case of a malfunction or other unsafe condition of either the machine or the job site.

## **2.2 PREPARATION, INSPECTION, AND MAINTENANCE**

The following table covers the periodic machine inspections and maintenance required by JLG Industries, Inc. Consult local regulations for further requirements for aerial work platforms. The frequency of inspections and maintenance must be increased as necessary when the machine is used in a harsh or hostile environment, if the machine is used with increased frequency, or if the machine is used in a severe manner.

### **NOTICE**

**JLG INDUSTRIES, INC. RECOGNIZES A FACTORY-TRAINED SERVICE TECHNICIAN AS A PERSON WHO HAS SUCCESSFULLY COMPLETED THE JLG SERVICE TRAINING SCHOOL FOR THE SPECIFIC JLG PRODUCT MODEL.**



## SECTION 2 - USER RESPONSIBILITIES, MACHINE PREPARATION, AND INSPECTION

**Table 2-1. Inspection and Maintenance Table**

Type	Frequency	Primary Responsibility	Service Qualification	Reference
Pre-Start Inspection	Before using each day; or whenever there's an Operator change.	User or Operator	User or Operator	Operator and Safety Manual
Pre-Delivery Inspection (See Note)	Before each sale, lease, or rental delivery.	Owner, Dealer, or User	Qualified JLG Mechanic	Service and Maintenance Manual and applicable JLG inspection form
Frequent Inspection (See Note)	In service for 3 months or 150 hours, whichever comes first; or Out of service for a period of more than 3 months; or Purchased used.	Owner, Dealer, or User	Qualified JLG Mechanic	Service and Maintenance Manual and applicable JLG inspection form
Annual Machine Inspection (See Note)	Annually, no later than 13 months from the date of prior inspection.	Owner, Dealer, or User	Factory Trained Service Technician (Recommended)	Service and Maintenance Manual and applicable JLG inspection form
Preventative Maintenance	At intervals as specified in the Service and Maintenance Manual.	Owner, Dealer, or User	Qualified JLG Mechanic	Service and Maintenance Manual
<b>NOTE:</b> Inspection forms are available from JLG. Use the Service and Maintenance Manual to perform inspections.				

### Pre-Start Inspection

The Pre-Start Inspection should include each of the following:

1. **Cleanliness** – Check all surfaces for leakage (oil, fuel, or battery fluid) or foreign objects. Report any leakage to the proper maintenance personnel.
2. **Structure** - Inspect the machine structure for dents, damage, weld or parent metal cracks or other discrepancies.

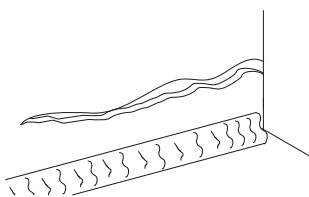

Parent Metal Crack

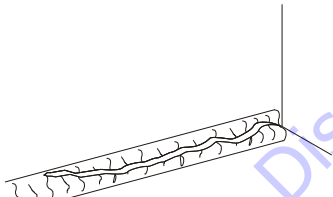

Weld Crack

3. **Decals and Placards** – Check all for cleanliness and legibility. Make sure none of the decals and placards are missing. Make sure all illegible decals and placards are cleaned or replaced.
4. **Operators and Safety Manuals** – Make sure a copy of the Operator and Safety Manual, EMI Safety Manual (Domestic only), and ANSI Manual of Responsibilities

(Domestic only) is enclosed in the weather resistant storage container.

5. **“Walk-Around” Inspection** – Refer to Figure 2-2. and Figure 2-3.
6. **Battery** – Charge as required.
7. **Fuel** (Combustion Engine Powered Machines) – Add the proper fuel as necessary.
8. **Engine Oil Supply** - Ensure the engine oil level is at the Full mark on the dipstick and the filler cap is secure.
9. **Hydraulic Oil** – Check the hydraulic oil level. Ensure hydraulic oil is added as required.
10. **Function Check** – Once the “Walk-Around” Inspection is complete, perform a functional check of all systems in an area free of overhead and ground level obstructions. Refer to Section 4 for more specific instructions.

### **⚠ WARNING**

**IF THE MACHINE DOES NOT OPERATE PROPERLY, TURN OFF THE MACHINE IMMEDIATELY! REPORT THE PROBLEM TO THE PROPER MAINTENANCE PERSONNEL. DO NOT OPERATE THE MACHINE UNTIL IT IS DECLARED SAFE FOR OPERATION.**

### Function Check

Perform the Function Check as follows:

1. From the ground control panel with no load in the platform:
  - a. Check that all guards protecting the switches or locks are in place;
  - b. Operate all functions and check all limiting and cut-out switches;
  - c. Check auxiliary power (or manual descent);
  - d. Ensure that all machine functions are disabled when the Emergency Stop Button is activated.
2. From the platform control console:
  - a. Ensure that the control console is firmly secured in the proper location;
  - b. Check that all guards protecting the switches or locks are in place;
  - c. Operate all functions and check all limiting and cut-out switches;
  - d. Ensure that all machine functions are disabled when the Emergency Stop Button is pushed in.
3. With the platform in the transport (stowed) position:
  - a. Drive the machine on a grade, not to exceed the rated gradeability, and stop to ensure the brakes hold;
  - b. Check the tilt sensor alarm to ensure proper operation.

## SECTION 2 - USER RESPONSIBILITIES, MACHINE PREPARATION, AND INSPECTION

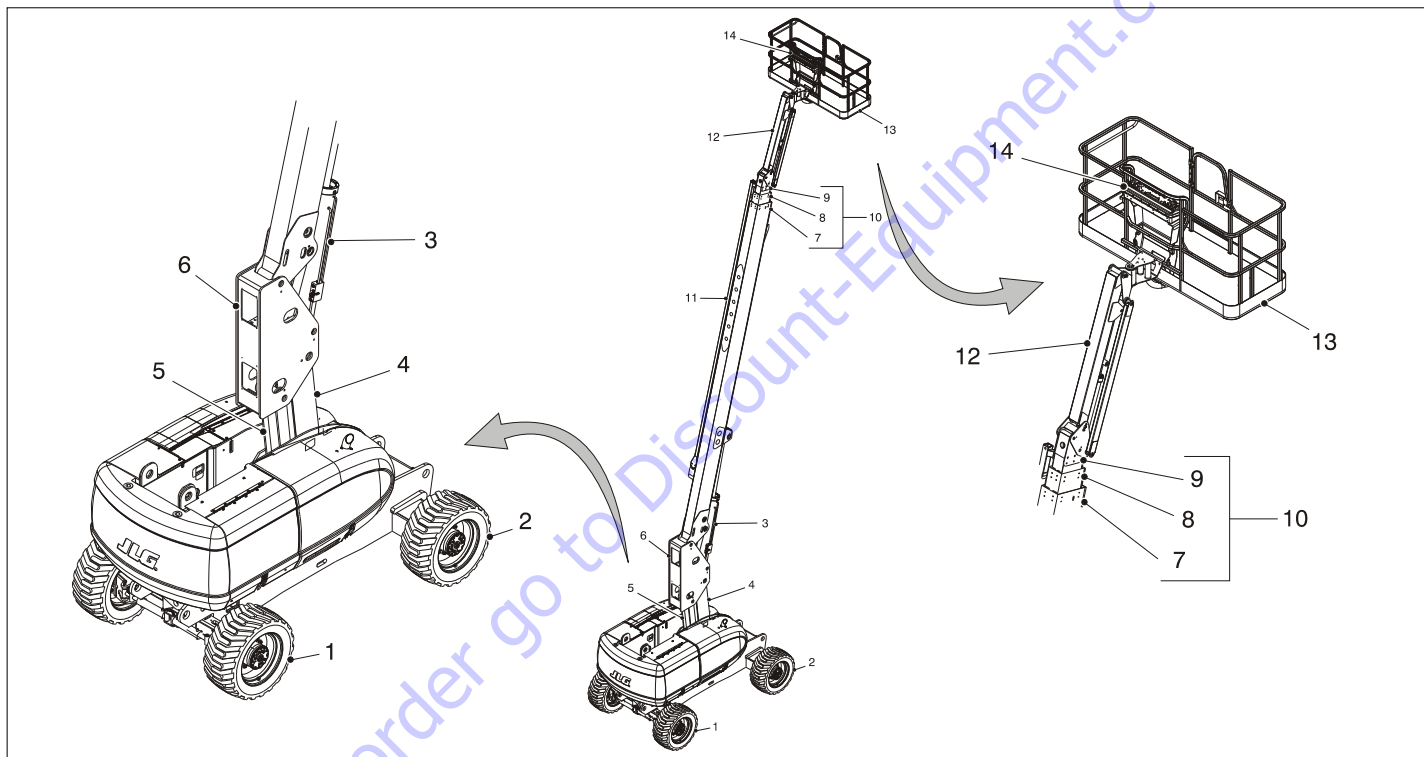

Figure 2-1. Basic Nomenclature - Sheet 1 of 2

1. Steer Wheels
2. Drive Wheels
3. Lift Cylinder
4. Tower
5. Level Link
6. Upright
7. Base Boom Section
8. Mid Boom Section
9. Fly Boom Section
10. Boom Assembly
11. Power Track
12. Jib (If Equipped)
13. Platform
14. Platform Console

**Figure 2-2. Basic Nomenclature - Sheet 2 of 2**

## SECTION 2 - USER RESPONSIBILITIES, MACHINE PREPARATION, AND INSPECTION

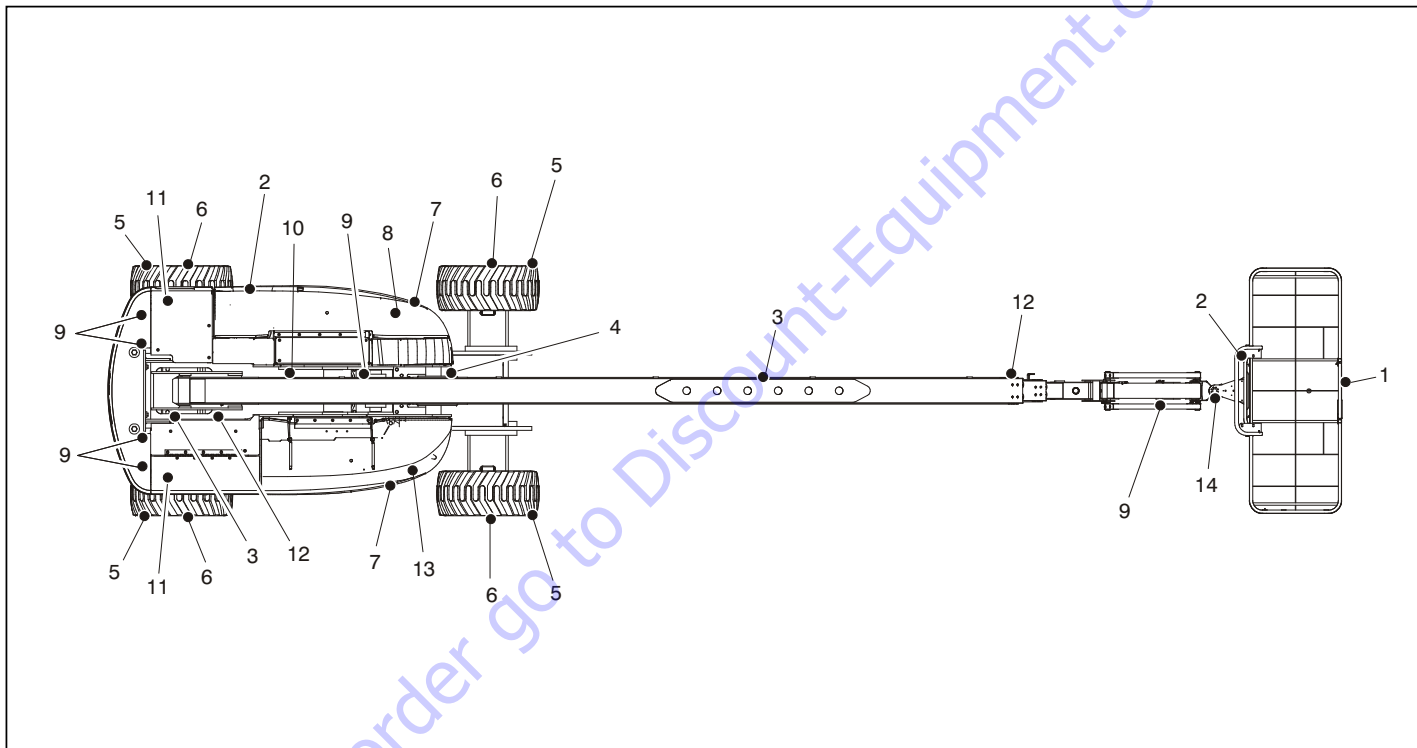

Figure 2-2. Daily Walk-Around Inspection - Sheet 1 of 2

## SECTION 2 - USER RESPONSIBILITIES, MACHINE PREPARATION, AND INSPECTION

### General

Begin the "Walk-Around Inspection" at Item 1, as noted on the diagram. Continue to the right (counterclockwise viewed from top) checking each item in sequence for the conditions listed in the following checklist.

#### **WARNING**

**TO AVOID POSSIBLE INJURY, BE SURE MACHINE POWER IS OFF.**

**DO NOT OPERATE MACHINE UNTIL ALL MALFUNCTIONS HAVE BEEN CORRECTED.**

***INSPECTION NOTE:** On all components, make sure there are no loose or missing parts, that they are securely fastened, and no visible damage, leaks or excessive wear exists in addition to any other criteria mentioned.*

- 1. Platform Assembly and Gate** - Footswitch works properly, not modified, disabled or blocked. Latch, stop, and hinges in working condition.
- 2. Platform & Ground Control Consoles** - Switches and levers return to neutral, decals/placards secure and legible, control markings legible.
- 3. Boom Sections/Uprights/Turntable** - See Inspection Note.
- 4. Swing Drive** - No evidence of damage.
- 5. Wheel/Tire Assemblies** - No loose or missing lug nuts, proper inflation (pneumatic). Inspect for worn tread, cuts, tears or other discrepancies. Inspect wheels for damage and corrosion.
- 6. Drive Motor, Brake, and Hub** - No evidence of leakage.
- 7. Hood Assemblies** - See Inspection Note.
- 8. Auxiliary Hydraulic Pump** - See Inspection Note.
- 9. All Hydraulic Cylinders** - No visible damage; pivot pins and hydraulic hoses undamaged, not leaking.
- 10. Turntable Bearing** - Evidence of proper lubrication. No evidence of loose bolts or looseness between bearing and machine.
- 11. Tie Rod Ends and Steering Spindles** - See Inspection Note.
- 12. Horizontal and Capacity Limit Switches** - Switches operate properly.
- 13. Main Hydraulic Pump** - See Inspection Note.
- 14. Platform Rotator** - See Inspection Note.

**Figure 2-3. Daily Walk-Around Inspection - Sheet 2 of 2**

## 2.3 HORIZONTAL AND CAPACITY LIMIT SWITCHES

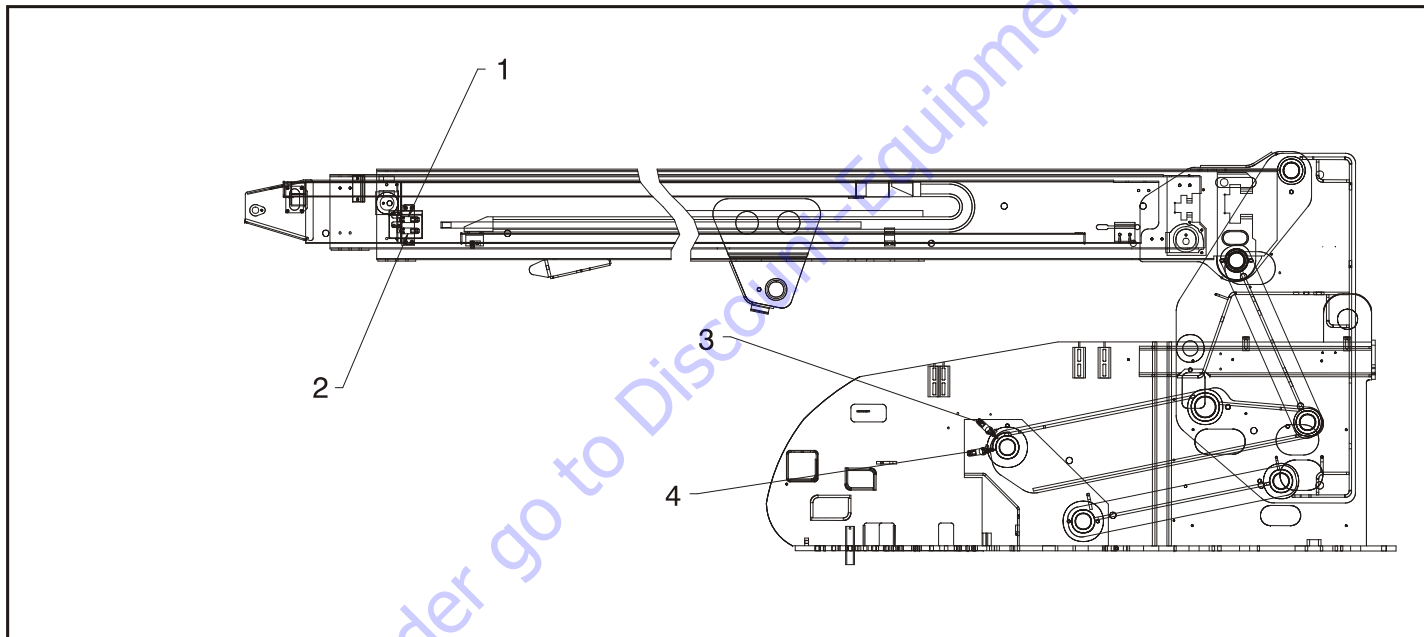

Figure 2-4. Horizontal and Capacity Limit Switches - Sheet 1 of 2



## SECTION 2 - USER RESPONSIBILITIES, MACHINE PREPARATION, AND INSPECTION

Item	Description	Operation Characteristic
1	<b>Boom Capacity Length Switch</b>	Activates platform capacity light to indicate the platform capacity at a designated boom length.
2	<b>Boom Extension Switch</b>	Reduces drive speed when boom reaches a designated length.
3	<b>Boom Capacity Angle Switch</b>	Activates platform capacity light to indicate the platform capacity at a designated boom height.
4	<b>Boom Elevation Switch</b>	Reduces drive speed when boom is raised above horizontal.

Figure 2-5. Horizontal and Capacity Limit Switches - Sheet 2 of 2

## SECTION 2 - USER RESPONSIBILITIES, MACHINE PREPARATION, AND INSPECTION

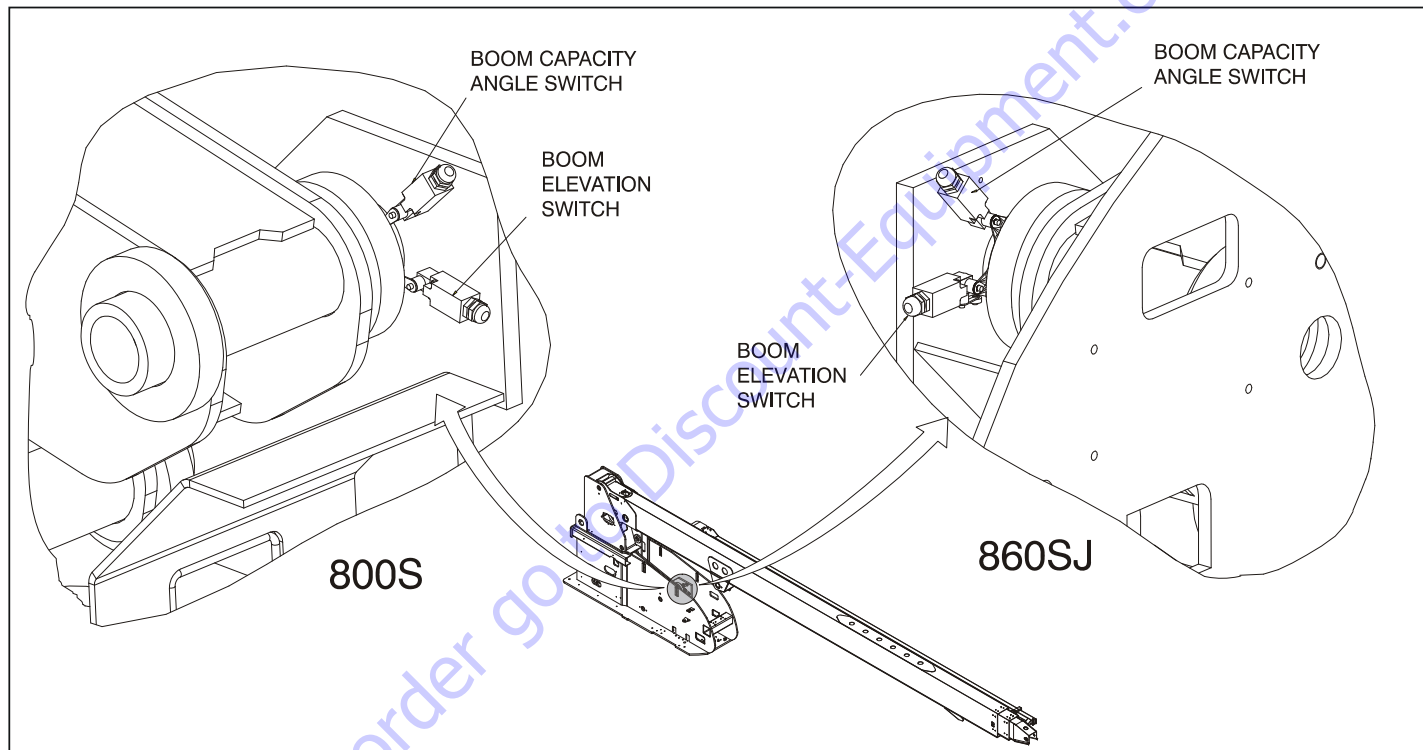
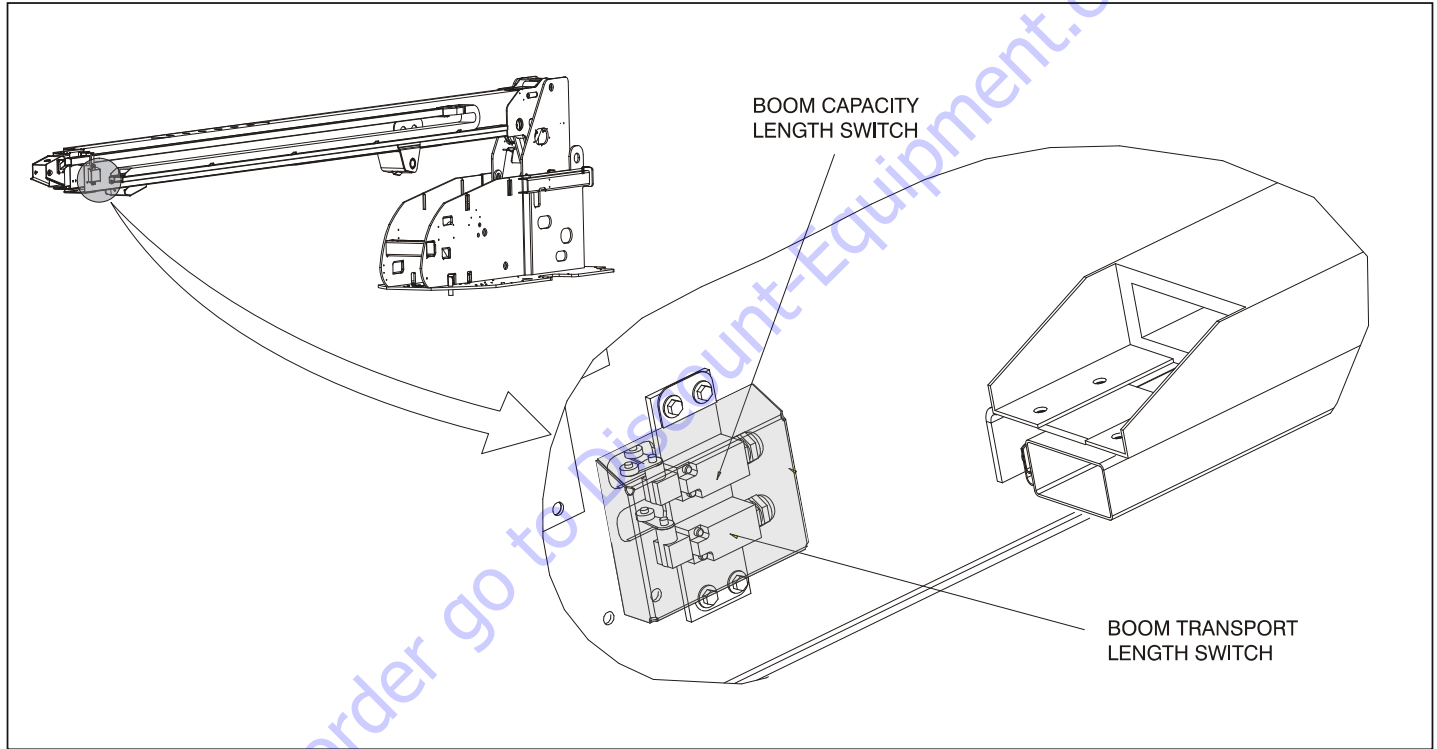

Figure 2-6. Limiting and Cut-Out Switches - Sheet 1 of 2



**Figure 2-7. Limiting and Cut-Out Switches - Sheet 2 of 2**

## **2.4 OSCILLATING AXLE LOCKOUT TEST (IF EQUIPPED)**

### **NOTICE**

**LOCKOUT SYSTEM TEST MUST BE PERFORMED QUARTERLY, ANY TIME A SYSTEM COMPONENT IS REPLACED, OR WHEN IMPROPER SYSTEM OPERATION IS SUSPECTED.**

**NOTE:** *Ensure boom is fully retracted, lowered, and centered between drive wheels prior to beginning lockout cylinder test.*

1. Place a 6 inches (15.2 cm) high block with ascension ramp in front of left front wheel.
2. From platform control station, start engine
3. Place the Drive control lever to the forward position and carefully drive machine up ascension ramp until left front wheel is on top of block.
4. Carefully activate Swing control lever and position boom over right side of machine.
5. With boom over right side of machine, place Drive control lever to Reverse and drive machine off of block and ramp.
6. Have an assistant check to see that left front or right rear wheel remains elevated in position off of ground.
7. Carefully activate Swing control lever and return boom to stowed position (centered between drive wheels). When boom reaches center, stowed position, lockout cylinders should release and allow wheel to rest on ground, it may be necessary to activate Drive to release cylinders.

## **SECTION 2 - USER RESPONSIBILITIES, MACHINE PREPARATION, AND INSPECTION**

---

- 8.** Place the 6 inches (15.2 cm) high block with ascension ramp in front of right front wheel.
- 9.** Place Drive control lever to Forward and carefully drive machine up ascension ramp until right front wheel is on top of block.
- 10.** With boom over left side of machine, place Drive control lever to Reverse and drive machine off of block and ramp.
- 11.** Have an assistant check to see that right front or left rear wheel remains elevated in position off of ground.
- 12.** Carefully activate Swing control lever and return boom to stowed position (centered between drive wheels). When boom reaches center, stowed position, lockout cylinders should release and allow wheel to rest on ground, it may be necessary activate Drive to release cylinders.
- 13.** If lockout cylinders do not function properly, have qualified personnel correct the malfunction prior to any further operation.

**TO PURCHASE THIS PRODUCT PLEASE CONTACT US**



**Equipment Financing and  
Extended Warranties Available**



**Discount-Equipment.com is your online resource for  
commercial and industrial quality parts and equipment sales.**

**561-964-4949**

**visit us on line @ [www.discount-equipment.com](http://www.discount-equipment.com)**

Select an option below to find your Equipment

**Search by Manufacturer**

**Search by Product Type**

**Request a Quote**

We sell worldwide for the brands: Genie, Terex, JLG, MultiQuip, Mikasa, Essick, Whiteman, Mayco, Toro Stone, Diamond Products, Generac Magnum, Airman, Haulotte, Barreto, Power Blanket, Nifty Lift, Atlas Copco, Chicago Pneumatic, Allmand, Miller Curber, Skyjack, Lull, Skytrak, Tsurumi, Husquvarna Target, Stow, Wacker, Sakai, Mi-T-M, Sullair, Basic, Dynapac, MBW, Weber, Bartell, Bennar Newman, Haulotte, Ditch Runner, Menegotti, Morrison, Contec, Buddy, Crown, Edco, Wyco, Bomag, Laymor, EZ Trench, Bil-Jax, F.S. Curtis, Gehl Pavers, Heli, Honda, ICS/PowerGrit, IHI, Partner, Imer, Clipper, MMD, Koshin, Rice, CH&E, General Equipment, Amida, Coleman, NAC, Gradall, Square Shooter, Kent, Stanley, Tamco, Toku, Hatz, Kohler, Robin, Wisconsin, Northrock, Oztec, Toker TK, Rol-Air, APT, Wylie, Ingersoll Rand / Doosan, Innovatech, Con X, Ammann, Mecalac, Makinex, Smith Surface Prep, Small Line, Wanco, Yanmar

## SECTION 3. MACHINE CONTROLS AND INDICATORS

### 3.1 GENERAL

#### **NOTICE**

**THE MANUFACTURER HAS NO DIRECT CONTROL OVER MACHINE APPLICATION AND OPERATION. THE USER AND OPERATOR ARE RESPONSIBLE FOR CONFORMING WITH GOOD SAFETY PRACTICES.**

This section provides the necessary information needed to understand control functions.

### 3.2 CONTROLS AND INDICATORS

**NOTE:** *This machines is equipped with control panels that use symbols to indicate control functions. Refer to decal located on the control box guard in front of the control box or by the ground controls for these symbols and the corresponding functions.*

### Ground Control Station

(See Figure 3-1., Ground Control Station - 800S and Figure 3-1., Ground Control Station - 860SJ)

**NOTE:** *When Power/Emergency Stop switch is in the “ON” position and engine is not running, an alarm will sound, indicating Ignition is “ON”.*

#### **CAUTION**

**WHEN THE MACHINE IS SHUT DOWN THE MASTER/EMERGENCY STOP SWITCH MUST BE POSITIONED TO THE “OFF” POSITION TO PREVENT DRAINING THE BATTERY.**

**NOTE:** *If equipped, the Function Enable switch must be held down in order to operate Telescope, Swing, Lift, Jib Lift, Platform Level Override, and Platform Rotate functions.*



## SECTION 3 - MACHINE CONTROLS AND INDICATORS

---

### 1. Indicator Panel.

The LED Indicator Panel contains indicator lights that signal problem conditions or functions operating during machine operation.

### WARNING

**TO AVOID SERIOUS INJURY, DO NOT OPERATE MACHINE IF ANY CONTROL LEVERS OR TOGGLE SWITCHES CONTROLLING PLATFORM MOVEMENT DO NOT RETURN TO THE OFF POSITION WHEN RELEASED.**

### 2. Telescope Control.

Provides extension and retraction of the boom, when positioned to IN or OUT.

### 3. Swing Control.

Provides 360 degrees continuous turntable rotation.

### 4. Lift Control.

Provides raising and lowering of the main boom.

### 5. Platform/Ground Select Switch

A three position, key operated switch supplies power to the platform control console when positioned to PLATFORM. With the switch key held in the GROUND position, power is shut off to platform and only ground controls are operable.

**NOTE:** *With PLATFORM/GROUND SELECT switch in the center position, power is shut off to controls at both operating stations.*

### 6. Hourmeter.

Registers the amount of time the machine has been in use, with engine running. By connecting into the oil pressure circuit of the engine, only engine run hours are recorded. The hourmeter registers up to 9,999.9 hours and cannot be reset.

### 7. Power/Emergency Stop Switch.

A two-position red mushroom shaped switch furnishes power to PLATFORM/GROUND SELECT switch when pulled out (on). When pushed in (off), power is shut off to the PLATFORM/GROUND SELECT switch.



## SECTION 3 - MACHINE CONTROLS AND INDICATORS

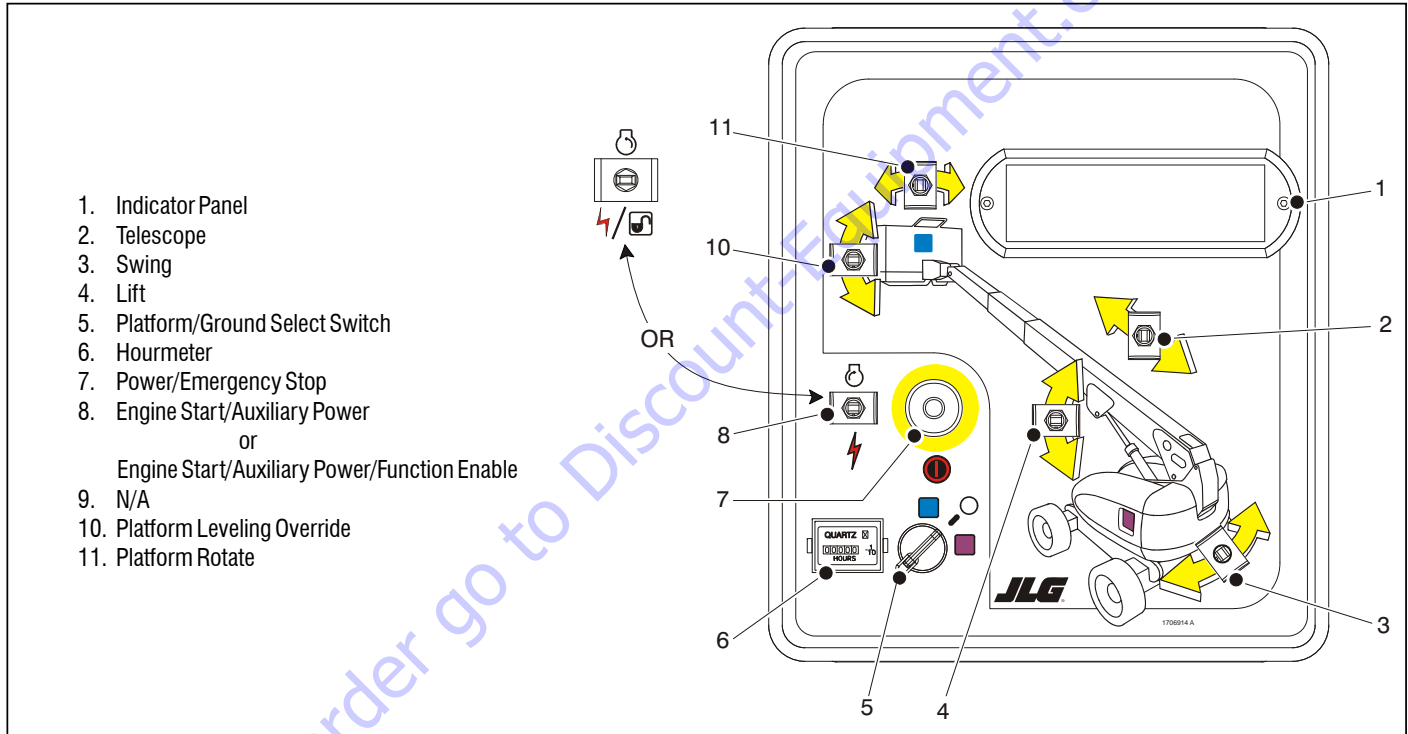

Figure 3-1. Ground Control Station - 800S

## SECTION 3 - MACHINE CONTROLS AND INDICATORS

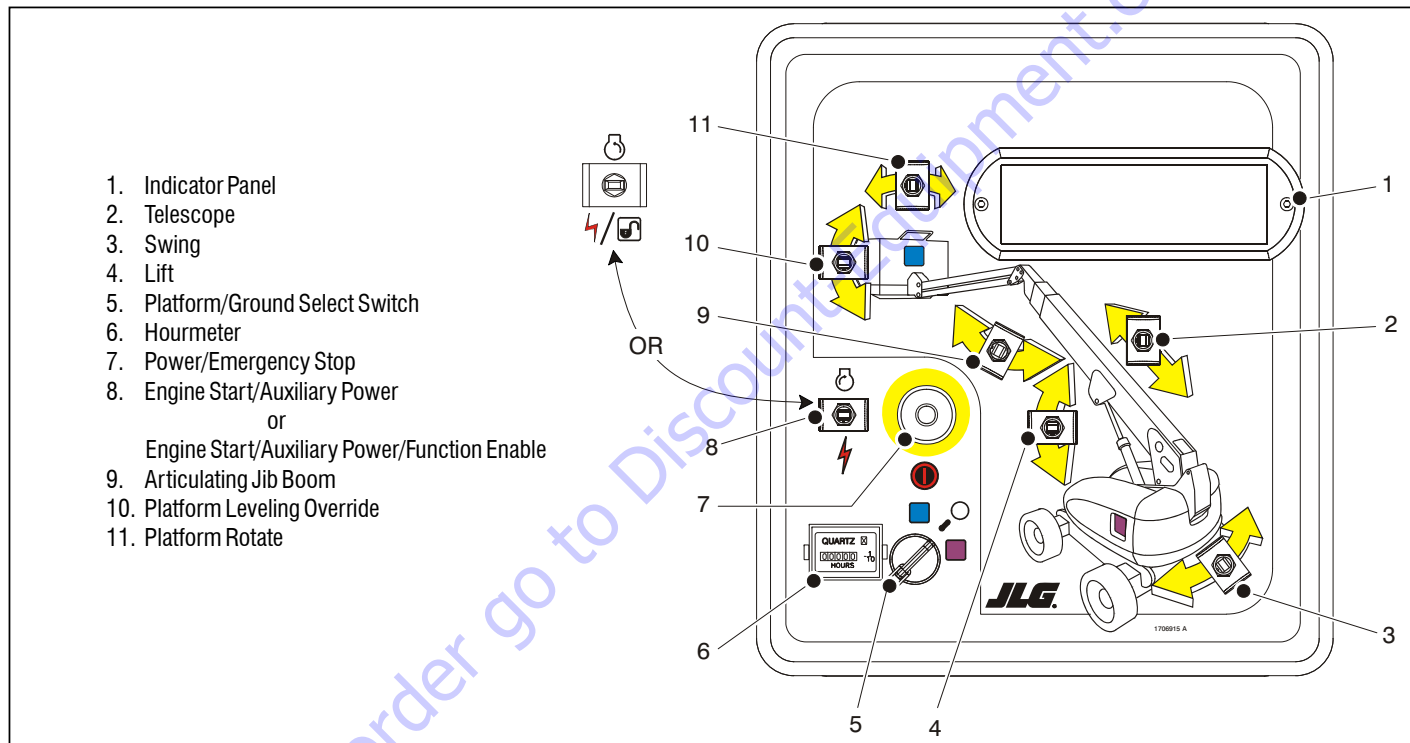

Figure 3-1. Ground Control Station - 860SJ

## SECTION 3 - MACHINE CONTROLS AND INDICATORS

### 8. Engine Start/Auxiliary Power Switch

or

Engine Start/ Auxiliary Power Switch /Function Enable.

To start the engine, the switch must be held "UP" until the engine starts.



To use auxiliary power, the switch must be held "DOWN" for duration of auxiliary pump use. Aux power can only be used if the engine is not running.



If equipped, the enable switch must be held "DOWN" to enable all boom controls when the engine is running.



**NOTE:** Auxiliary power only works if there is no engine oil pressure, and is disabled if engine is running.

**NOTE:** Functions will operate at a slower than normal rate because of the lesser flow of hydraulic fluid delivered.

### **⚠ CAUTION**

**WHEN USING AUXILIARY POWER, DO NOT OPERATE MORE THAN ONE FUNCTION AT A TIME. (SIMULTANEOUS OPERATION CAN OVERLOAD THE AUXILIARY PUMP.)**

### 9. Articulating Jib Boom. (If Equipped)

This switch provides raising and lowering of the jib.

### 10. Platform Leveling Override.

A three position switch allows the operator to compensate for any difference in the automatic self leveling system.

### **⚠ WARNING**

**ONLY USE THE PLATFORM LEVELING OVERRIDE FUNCTION FOR SLIGHT LEVELING OF THE PLATFORM. INCORRECT USE COULD CAUSE THE LOAD/OCCUPANTS TO SHIFT OR FALL. FAILURE TO DO SO COULD RESULT IN DEATH OR SERIOUS INJURY.**

### 11. Platform Leveling Override

A three position switch allows the operator to adjust the automatic self leveling system. This switch is used to adjust platform level in situations such as ascending/descending a grade.

### Ground Control Indicator Panel

(See Figure 3-2. and Figure 3-3.)

#### 1. Battery Charging Indicator

Indicates a problem in the battery or charging circuit, and service is required.

#### 2. Low Engine Oil Pressure Indicator.

Indicates that engine oil pressure is below normal and service is required.

#### 3. High Engine Coolant Temperature Indicator (Ford)

Indicates that engine coolant temperature is abnormally high and service is required.

#### 4. Engine Oil Temperature Indicator (Deutz).

Indicates the temperature of the engine oil, which also serves as engine coolant, is abnormally high and service is required.

#### 5. Malfunction Indicator

Indicates that the JLG Control System has detected a malfunction and a Diagnostic Trouble Code has been set. Refer to the Service Manual for instructions concerning the trouble codes and trouble code retrieval.

The malfunction indicator light will illuminate for 2-3 seconds when the key is positioned to the on position to act as a self test.

#### 6. Low Fuel Level Indicator

Indicates that the fuel level is 1/8 full or less. When the light first turns on, there are approximately four usable gallons of fuel remaining.

#### 7. Glow Plug Indicator

Indicates the glow plugs are operating. After turning on ignition, wait until light goes out before cranking engine.

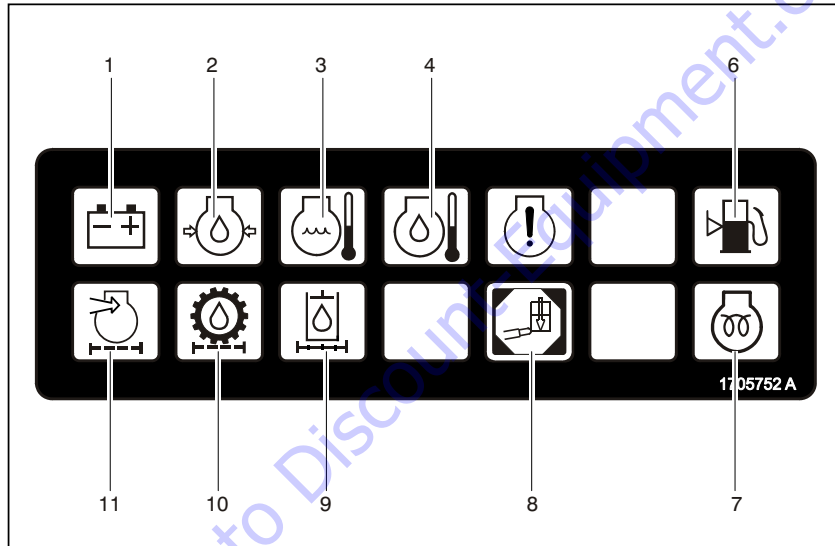

Prior to S/N 0300099882

- |                              |                      |                        |
|------------------------------|----------------------|------------------------|
| 1. Battery Charging          | 5. Not Used          | 6. Low Fuel            |
| 2. Low Engine Oil Pressure   | 6. Low Fuel          | 10. Charge Pump Filter |
| 3. High Engine Coolant Temp. | 7. Glow Plug         | 11. Engine Air Filter  |
| 4. High Engine Oil Temp.     | 8. Platform Overload |                        |

**Figure 3-2. Ground Control Indicator Panel - Sheet 1 of 2**

## SECTION 3 - MACHINE CONTROLS AND INDICATORS

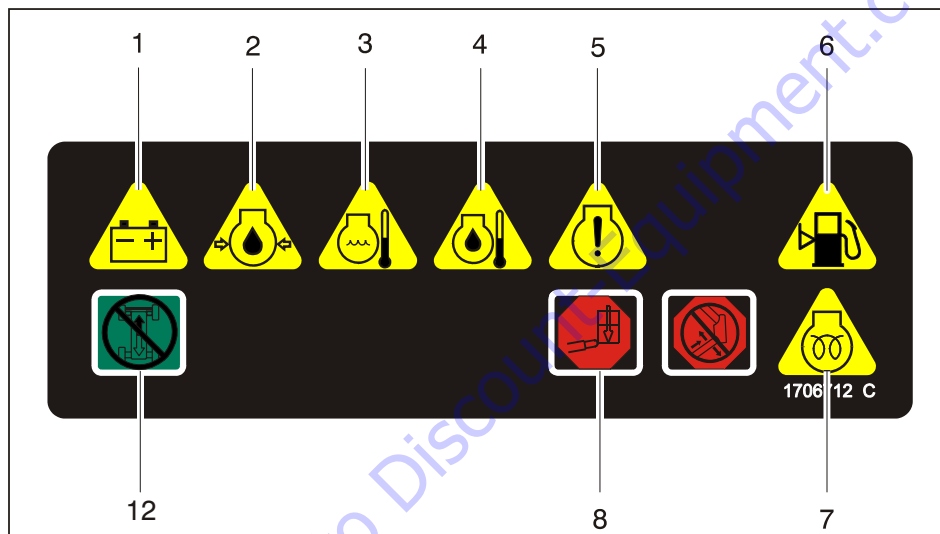

S/N 0300099882 to S/N 0300182742

- |                        |                          |                             |
|------------------------|--------------------------|-----------------------------|
| 1. Battery Charging    | 5. Malfunction Indicator | 9. Not Used                 |
| 2. Engine Oil Pressure | 6. Low Fuel              | 10. Not Used                |
| 3. Engine Water Temp.  | 7. Glow Plug             | 11. Not Used                |
| 4. Engine Oil Temp.    | 8. Platform Overload     | 12. Drive and Steer Disable |

**Figure 3-3. Ground Control Indicator Panel - Sheet 2 of 2**

### 8. Platform Overload Indicator (If Equipped)

Indicates the platform has been overloaded.

### 9. Hydraulic Oil Filter Indicator (Prior to S/N 85332)

Indicates the return oil filter is too restrictive and in the bypass mode and needs to be replaced.

### 10. Charge Pump Oil Filter Indicator (Prior to S/N 85332)

Indicates that charge pump filter is too restrictive and needs to be replaced.

### 11. Engine Air Filter Indicator (Prior to S/N 85332)

Indicates that the air filter is too restrictive and needs to be replaced.

### 12. Drive and Steer Disable Indicator (If equipped)

Indicates the Drive and Steer Disable function has been activated.

## Platform Station

(See Figure 3-4., Platform Control Console)

### 1. Power/Emergency Stop

A two-position red mushroom shaped switch furnishes power to PLATFORM Controls when pulled out (on). When pushed in (off), power is shut off to the platform functions.

Within about 2 seconds of pulling the switch out, the machine will perform a diagnostic check of the various electrical circuits, and if everything is OK, the platform alarm will beep once. During this time the lights on the indicator panel will also blink once as a bulb check.

### 2. Horn

If pressed, this switch supplies power to the horn.

## SECTION 3 - MACHINE CONTROLS AND INDICATORS

---

**NOTE:** MAIN LIFT, SWING, and DRIVE control levers are spring-loaded and will automatically return to neutral (OFF) position when released.

### **WARNING**

**TO AVOID SERIOUS INJURY, DO NOT OPERATE MACHINE IF ANY CONTROL LEVERS OR TOGGLE SWITCHES CONTROLLING PLATFORM MOVEMENT DO NOT RETURN TO THE OFF OR NEUTRAL POSITION WHEN RELEASED.**

#### 3. Main Lift/Swing Controller

An infinitely proportional dual axis joystick is provided for main lift and swing. Push forward to lift up, pull backward to lift down. Move right to swing right, move left to swing left.

**NOTE:** To operate the Main Lift/Swing Joystick, pull up on the locking ring below the handle.

#### 4. Main Telescope Control

This control allows extension and retraction of the main boom.

#### 5. Drive/Steer

The DRIVE joystick provides for driving either forward or backward. The controller is 'ramped' to allow variable drive speed.

Steering is controlled by a thumb operated switch on top of the joystick.

**NOTE:** To operate the Drive Joystick, pull up on the locking ring below the handle.

**NOTE:** When boom is positioned above horizontal and any of the following switches, DRIVE SPEED/TORQUE SELECT or FUNCTION SPEED, are positioned to HIGH, high function speeds are automatically cut out and the machine continues to operate at a lower speed.

### **CAUTION**

**DO NOT OPERATE MACHINE IF DRIVE SPEED /TORQUE SELECT OR FUNCTION SPEED SWITCHES OPERATE WHEN BOOM IS ABOVE HORIZONTAL.**



## SECTION 3 - MACHINE CONTROLS AND INDICATORS

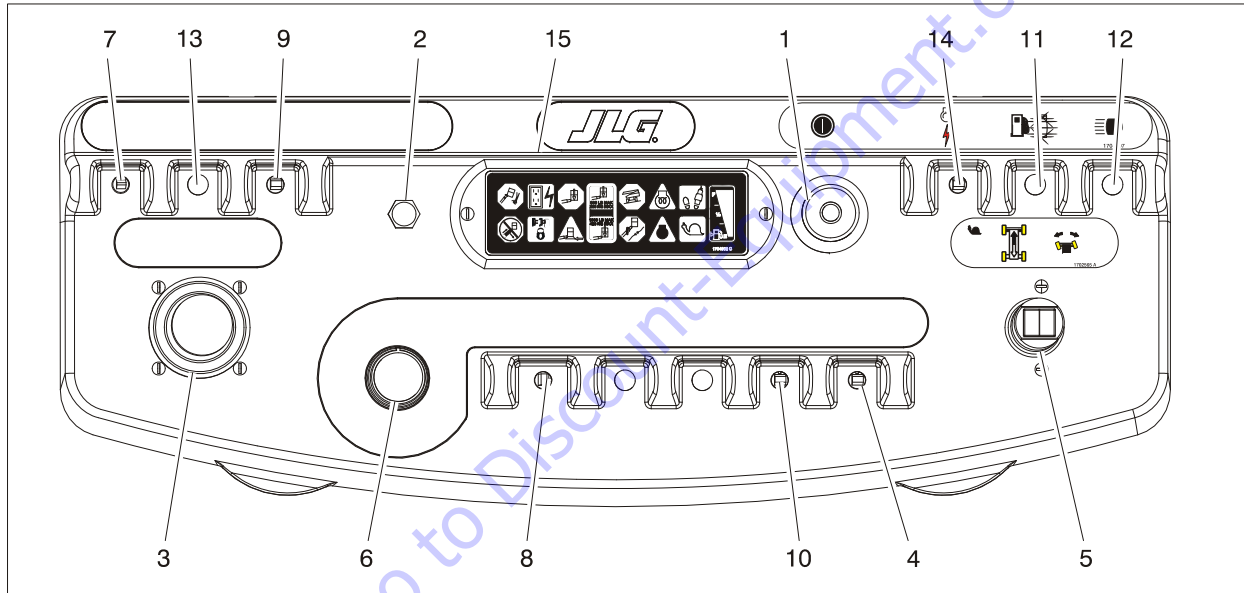

- |                         |                               |                              |                             |
|-------------------------|-------------------------------|------------------------------|-----------------------------|
| 1. Power/Emergency Stop | 5. Drive/Steer                | 9. Platform Level Override   | 13. Steer Select            |
| 2. Horn                 | 6. Function Speed Control     | 10. Articulating Jib (860SJ) | 14. Engine Start/ Aux Power |
| 3. Main Lift/ Swing     | 7. Drive Speed/ Torque Select | 11. Fuel Select              | 15. Light Panel             |
| 4. Telescope            | 8. Platform Rotate            | 12. Lights                   |                             |

**Figure 3-4. Platform Control Console**

## SECTION 3 - MACHINE CONTROLS AND INDICATORS

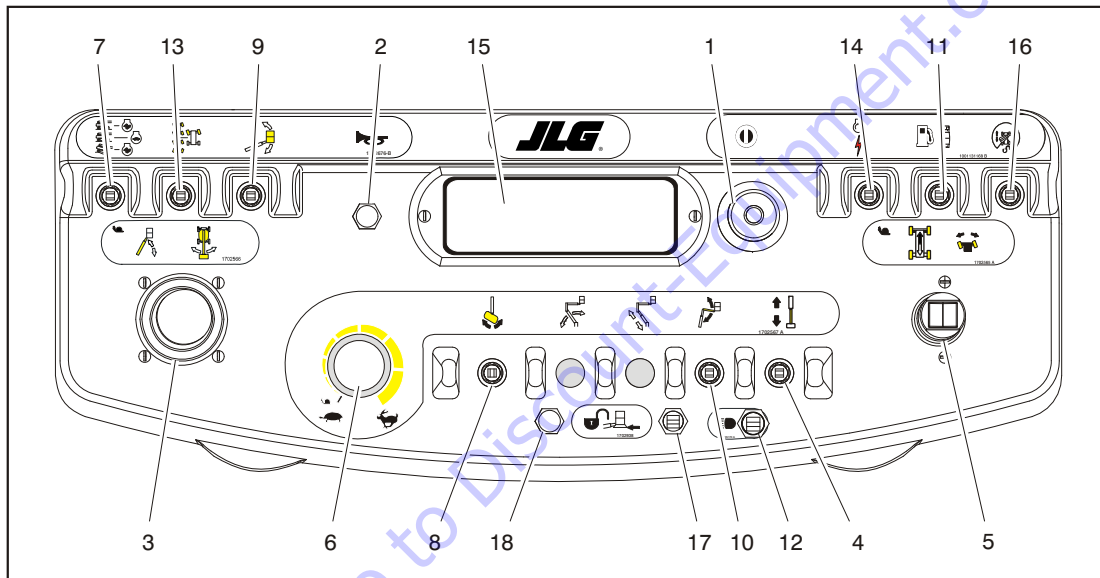

- |                         |                              |                            |                                |
|-------------------------|------------------------------|----------------------------|--------------------------------|
| 1. Power/Emergency Stop | 6. Function Speed Control    | 11. Fuel Select            | 16. Drive Orientation Override |
| 2. Horn                 | 7. Drive Speed/Torque Select | 12. Lights                 | 17. Soft Touch Override        |
| 3. Main Lift/Swing      | 8. Platform Rotate           | 13. Steer Select           | 18. Soft Touch Indicator       |
| 4. Telescope            | 9. Platform Level Override   | 14. Engine Start/Aux Power |                                |
| 5. Drive/Steer          | 10. Articulating Jib (860SJ) | 15. Light Panel            |                                |

**Figure 3-5. Platform Control Console - w/Drive Orientation**

### 6. Function Speed Control

Controls the speed of Boom and Swing Functions. Rotate CCW for slower speed and CW for faster speed. To adjust to creep, turn knob fully CCW until it clicks.

### 7. Drive Speed/Torque Select

The forward position gives maximum drive speed by shifting the drive motors to minimum the displacement and giving high engine when drive controller is moved. The back position gives maximum torque for rough terrain and climbing grades by shifting the wheel motors to maximum displacement and giving high engine speed when drive controller is moved. The center position allows the machine to be driven as quietly as possible by leaving the engine at mid speed and the drive motors in maximum displacement.

### 8. Platform Rotate

This switch allows the operator to rotate the basket to the left or right.

### WARNING

**ONLY USE THE PLATFORM LEVELING OVERRIDE FUNCTION FOR SLIGHT LEVELING OF THE PLATFORM. INCORRECT USE COULD CAUSE THE LOAD/OCCUPANTS TO SHIFT OR FALL. FAILURE TO DO SO COULD RESULT IN DEATH OR SERIOUS INJURY.**

### 9. Platform Leveling Override

A three position switch allows the operator to adjust the automatic self leveling system. This switch is used to adjust platform level in situations such as ascending/descending a grade.

### 10. Articulating Jib Boom (860SJ)

Push forward to lift up, pull back to lift down. Variable lift speed is using the Function Speed Control.

### 11. Fuel Select (Dual Fuel Engine Only) (If Equipped)

Gasoline or liquid propane fuel may be selected by moving the switch to the appropriate position. It is unnecessary to purge the fuel system before switching fuels, so there is no waiting period when switching fuels while the engine is running.

## SECTION 3 - MACHINE CONTROLS AND INDICATORS

---

### 12. Lights. (If Equipped)

This switch operates control console panel lights and head lights if the machine is so equipped. The ignition switch does not have to be on to operate the lights, so care must be taken to avoid draining the battery if left unattended. The master switch and / or the ignition switch at the ground control will turn off power to all lights.

### 13. Steer Select. (If Equipped)

When equipped with four wheel steering, the action of the steering system is operator selectable. The center switch position gives conventional front wheel steering with the rear wheels unaffected. This is for normal driving at maximum speeds. The forward position is for “crab” steering. When in this mode both front and rear axles steer in the same direction, which allows the chassis to move sideways as it goes forward. This can be used for positioning the machine in aisle ways or against buildings. The back switch position is for “coordinated” steering. In this mode the front and rear axles steer in the opposite directions to produce the tightest turning circle for maneuvering in confined areas.

To re-synchronize the front and rear axles, position the rear drive wheels to the forward drive position by select-

ing either crab or compound steer, then select front steer (center switch position) to operate the normal steering function.

### 14. Start/Auxiliary Power.

When pushed forward, the switch energizes the starter motor to start the engine.

When pushed back, it energizes the electrically operated hydraulic pump, when actuated. (Switch must be held ON for duration of auxiliary pump use.)

The auxiliary pump functions to provide sufficient oil flow to operate the basic machine functions should the main pump or engine fail. The auxiliary pump will operate tower boom lift, tower telescope, main boom lift, main telescope and swing.

### 15. Indicator Panel.

The LED Indicator Panel contains indicator lights that signal problem conditions or functions operating during machine operation.

### 16. Drive Orientation Override

When the boom is swung over the rear tires or further in either direction, the Drive Orientation indicator will illuminate when the drive function is selected. Push and release the switch, and within 3 seconds move the Drive/Steer control to activate drive or steer. Before driving, locate the black/white orientation arrows on both the chassis and the platform controls and match the control direction arrow to the intended chassis direction.

### 17. Soft Touch Override Switch (If equipped)

This switch enables the functions that were cut out by the Soft Touch system to operate again at creep speed, allowing the operator to move the platform away from the obstacle that caused the shutdown situation.

### 18. Soft Touch Indicator (If Equipped)

Indicates the Soft Touch bumper is against an object. All controls are cut out until the override button is pushed, at which time controls are active in the Creep Mode.

## Platform Control Indicator Panel

(See Figure 3-7., Platform Light Panel - w/Drive Orientation)

**NOTE:** The platform control indicator panel uses different shaped symbols to alert the operator to different types of operational situations that could arise. The meaning of those symbols are explained below.



Indicates a potentially hazardous situation, which if not corrected, could result in serious injury or death. This indicator will be red.



Indicates an abnormal operating condition, which if not corrected, may result in machine interruption or damage. This indicator will be yellow.



Indicates important information regarding the operating condition, i.e. procedures essential for safe operation. This indicator will be green with the exception of the capacity indicator which will be green or yellow depending upon platform position.

## SECTION 3 - MACHINE CONTROLS AND INDICATORS

---

### 1. Level System Fault Indicator

Indicates a fault in the electronic leveling system. The fault indicator will flash and an alarm sound. All functions will default to creep if the boom is extended more than 20 inches (51 cm) or elevated above horizontal.

#### **⚠ WARNING**

**IF THE LEVEL SYSTEM FAULT INDICATOR IS ILLUMINATED, SHUT DOWN THE MACHINE, RECYCLE THE EMERGENCY STOP, AND RESTART THE MACHINE. IF THE FAULT PERSISTS, RETURN THE PLATFORM TO THE STOWED POSITION, USING MANUAL LEVELING AS REQUIRED, AND HAVE LEVELING SYSTEM REPAIRED.**

### 2. AC Generator (Green)

Indicates the generator is in operation.

### 3. Overload Indicator. (If equipped)

Indicates the platform has been overloaded.

### 4. Capacity Indicator

Indicates the maximum platform capacity for the current position of the platform. Restricted capacities are permitted at restricted platform positions (shorter boom lengths and higher boom angles).

**NOTE:** Refer to the capacity decals on the machine for restricted and unrestricted platform capacities.

### 5. Tilt Alarm Warning Light and Alarm

This orange illuminator indicates that the chassis is on a slope. An alarm will also sound when the chassis is on a slope and the boom is above horizontal. If lit when boom is raised or extended, retract and lower to below horizontal then reposition machine so that it is level before continuing operation. If the boom is above horizontal and the machine is on a slope, the tilt alarm warning light will illuminate and an alarm will sound and CREEP is automatically activated.

#### **⚠ WARNING**

**IF TILT WARNING LIGHT IS ILLUMINATED WHEN BOOM IS RAISED OR EXTENDED, RETRACT AND LOWER TO BELOW HORIZONTAL THEN REPOSITION MACHINE SO THAT IT IS LEVEL BEFORE EXTENDING BOOM OR RAISING BOOM ABOVE HORIZONTAL.**

## SECTION 3 - MACHINE CONTROLS AND INDICATORS

### 6. Glow Plug Indicator

Indicates the glow plugs are operating. After turning on ignition, wait until light goes out before cranking engine.

### 7. Footswitch/Enable Indicator

To operate any function, the footswitch must be depressed and the function selected within seven seconds. The enable indicator shows that the controls are enabled. If a function is not selected within seven seconds, or if a seven second lapse between ending one function and beginning the next function, the enable light will go out and the footswitch must be released and depressed again to enable the controls.

Releasing the footswitch removes power from all controls and applies the drive brakes.

#### **WARNING**

**TO AVOID SERIOUS INJURY, DO NOT REMOVE, MODIFY OR DISABLE THE FOOTSWITCH BY BLOCKING OR ANY OTHER MEANS.**

#### **WARNING**

**FOOTSWITCH MUST BE ADJUSTED IF FUNCTIONS ACTIVATE WHEN SWITCH ONLY OPERATES WITHIN LAST 1/4" OF TRAVEL, TOP OR BOTTOM.**

## SECTION 3 - MACHINE CONTROLS AND INDICATORS

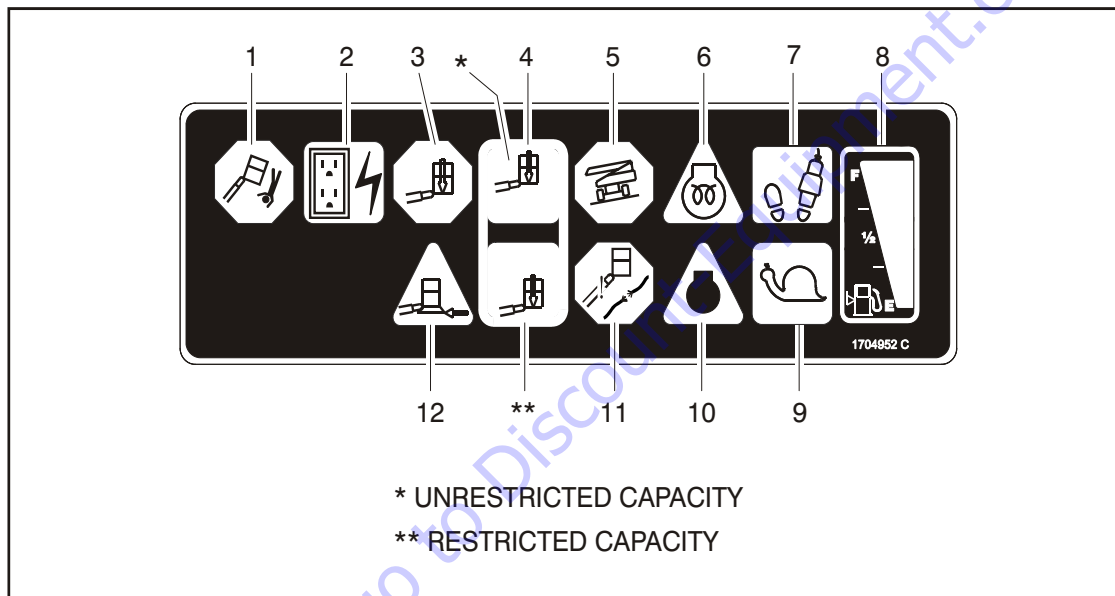

- |                 |                       |                                  |
|-----------------|-----------------------|----------------------------------|
| 1. Level System | 5. Tilt Alarm Warning | 9. Creep Speed Indicator         |
| 2. AC Generator | 6. Glow Plug          | 10. Engine Malfunction Indicator |
| 3. Overload     | 7. Enable             | 11. Cable Service Indicator      |
| 4. Capacity     | 8. Fuel Level         | 12. Soft Touch Indicator         |

**Figure 3-6. Platform Light Panel**



## SECTION 3 - MACHINE CONTROLS AND INDICATORS

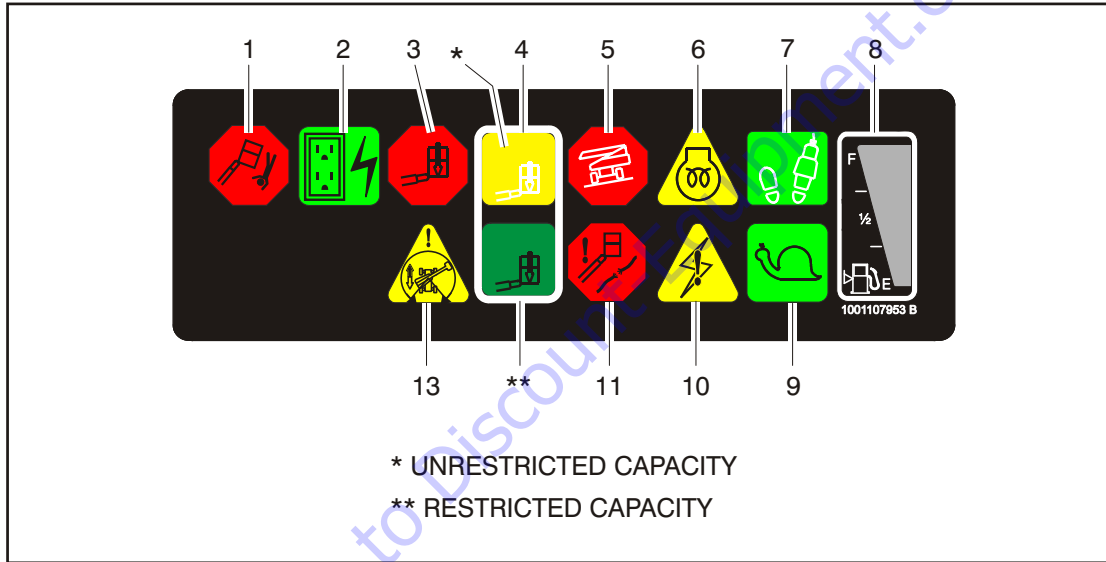

- |                       |                |                        |
|-----------------------|----------------|------------------------|
| 1. Level System       | 6. Glow Plug   | 10. Engine Malfunction |
| 2. AC Generator       | 7. Enable      | 11. Cable Service      |
| 3. Overload           | 8. Fuel Level  | 12. Not Used           |
| 4. Capacity           | 9. Creep Speed | 13. Drive Orientation  |
| 5. Tilt Alarm Warning |                |                        |

**Figure 3-7. Platform Light Panel - w/Drive Orientation**

## SECTION 3 - MACHINE CONTROLS AND INDICATORS

---

### 8. Fuel Level Indicator

Indicates the level of fuel in the fuel tank.

### 9. Creep Speed Indicator

When the Function Speed Control is turned to the creep position, the indicator acts as a reminder that all functions are set to the slowest speed.

### 10. Malfunction Indicator

Indicates that the JLG Control System has detected a malfunction and a Diagnostic Trouble Code has been set in the system memory. Refer to the Service Manual for instructions concerning the trouble codes and trouble code retrieval.

The malfunction indicator light will illuminate for 2-3 seconds when the key is positioned to the on position to act as a self test.

### 11. Cable Service Indicator (If Equipped)

When illuminated, the light indicates the boom cables are loose or broken and must be repaired or adjusted immediately.



**IF THE CABLE SERVICE INDICATOR IS ILLUMINATED, RETURN THE PLATFORM TO THE STOWED POSITION, SHUT DOWN THE MACHINE, AND HAVE THE BOOM CABLES INSPECTED.**

### 12. Soft Touch Indicator (If Equipped)

Indicates the Soft Touch bumper is against an object. All controls are cut out until the override button is pushed, at which time controls are active in the Creep mode.

### 13. Drive Orientation Indicator

When the boom is swung beyond the rear drive tires or further in either direction, the Drive Orientation indicator will illuminate when the drive function is selected. This is a signal for the operator to activate the Drive Orientation Override Switch and verify the drive control direction is correct.

**TO PURCHASE THIS PRODUCT PLEASE CONTACT US**



**Equipment Financing and  
Extended Warranties Available**



**Discount-Equipment.com is your online resource for  
commercial and industrial quality parts and equipment sales.**

**561-964-4949**

**visit us on line @ [www.discount-equipment.com](http://www.discount-equipment.com)**

Select an option below to find your Equipment

**Search by Manufacturer**

**Search by Product Type**

**Request a Quote**

We sell worldwide for the brands: Genie, Terex, JLG, MultiQuip, Mikasa, Essick, Whiteman, Mayco, Toro Stone, Diamond Products, Generac Magnum, Airman, Haulotte, Barreto, Power Blanket, Nifty Lift, Atlas Copco, Chicago Pneumatic, Allmand, Miller Curber, Skyjack, Lull, Skytrak, Tsurumi, Husquvarna Target, Stow, Wacker, Sakai, Mi-T-M, Sullair, Basic, Dynapac, MBW, Weber, Bartell, Bennar Newman, Haulotte, Ditch Runner, Menegotti, Morrison, Contec, Buddy, Crown, Edco, Wyco, Bomag, Laymor, EZ Trench, Bil-Jax, F.S. Curtis, Gehl Pavers, Heli, Honda, ICS/PowerGrit, IHI, Partner, Imer, Clipper, MMD, Koshin, Rice, CH&E, General Equipment, Amida, Coleman, NAC, Gradall, Square Shooter, Kent, Stanley, Tamco, Toku, Hatz, Kohler, Robin, Wisconsin, Northrock, Oztec, Toker TK, Rol-Air, APT, Wylie, Ingersoll Rand / Doosan, Innovatech, Con X, Ammann, Mecalac, Makinex, Smith Surface Prep, Small Line, Wanco, Yanmar

## SECTION 4. MACHINE OPERATION

### 4.1 DESCRIPTION

This machine is a self-propelled hydraulic lift equipped with a work platform on the end of an elevating and rotating boom.

The primary operator control station is in the platform. From this control station, the operator can drive and steer the machine in both forward and reverse directions. The operator can raise or lower the upper or lower boom or swing the boom to the left or right. Standard boom swing is 360 degree continuous left and right of the stowed position. The machine has a Ground Control Station which will override the Platform Control Station. Ground Controls operate Boom Lift and Swing, and are to be used in an emergency to lower the platform to the ground should the operator in the platform be unable to do so. The Ground Control is also to be used in Pre-Start Inspection.

### 4.2 OPERATING CHARACTERISTICS AND LIMITATIONS

#### Capacities

The boom can be raised above horizontal with or without any load in platform, if:

1. Machine is positioned on a smooth, firm and level surface.
2. Load is within manufacturer's rated capacity.
3. All machine systems are functioning properly.
4. Proper tire pressure.
5. Machine is as originally equipped from JLG.

#### Stability

Machine stability is based on two (2) conditions which are called FORWARD and BACKWARD stability. The machine's position of least FORWARD stability is shown in (See Figure 4-2.), and its position of least BACKWARD stability is shown in (See Figure 4-1.)

### **⚠ WARNING**

TO AVOID FORWARD OR BACKWARD TIPPING, DO NOT OVERLOAD MACHINE OR OPERATE THE MACHINE ON AN OUT-OF-LEVEL SURFACE.

## 4.3 ENGINE OPERATION

*NOTE: Initial starting should always be performed from the Ground Control station.*

### Starting Procedure

### **⚠ CAUTION**

IF ENGINE FAILS TO START PROMPTLY, DO NOT CRANK FOR AN EXTENDED TIME. SHOULD ENGINE FAIL TO START AGAIN, ALLOW STARTER TO “COOL OFF” FOR 2-3 MINUTES. IF ENGINE FAILS AFTER SEVERAL ATTEMPTS, REFER TO ENGINE MAINTENANCE MANUAL.

*NOTE: Diesel engines only: After turning on ignition, operator must wait until glow plug indicator light goes out before cranking engine.*

1. Turn key of SELECT switch to GROUND. Position POWER/EMERGENCY STOP switch to ON, then push the ENGINE START switch until engine starts.

### **⚠ CAUTION**

ALLOW ENGINE TO WARM-UP FOR A FEW MINUTES AT LOW SPEED BEFORE APPLYING ANY LOAD.

2. After engine has had sufficient time to warm up, shut engine off.
3. Turn SELECT switch to PLATFORM.
4. From Platform, pull POWER/EMERGENCY STOP switch out, then push the ENGINE START switch until engine starts.

*NOTE: Footswitch must be in released (up) position before starter will operate. If starter operates with footswitch in the depressed position, DO NOT OPERATE MACHINE.*

### Shutdown Procedure

**⚠ CAUTION**

IF AN ENGINE MALFUNCTION CAUSES AN UNSCHEDULED SHUTDOWN, DETERMINE THE CAUSE AND CORRECT IT BEFORE RESTARTING THE ENGINE.

- 1. Remove all load and allow engine to operate at low speed for 3-5 minutes; this allows further reduction of internal engine temperature.
- 2. Push POWER/EMERGENCY STOP switch in.
- 3. Turn MASTER switch to Off.

Refer to Engine Manufacturer's manual for detailed information.

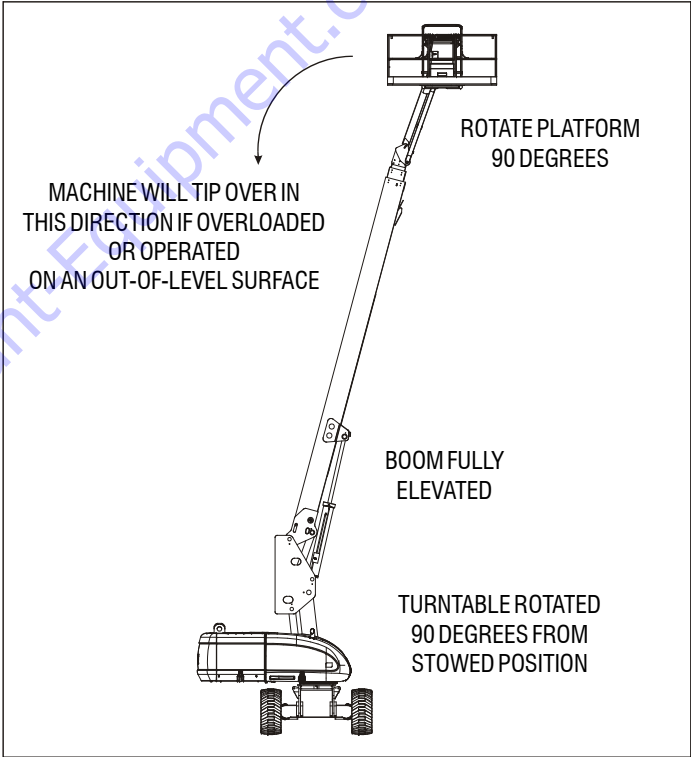

Figure 4-1. Position of Least Backward Stability

## SECTION 4 - MACHINE OPERATION

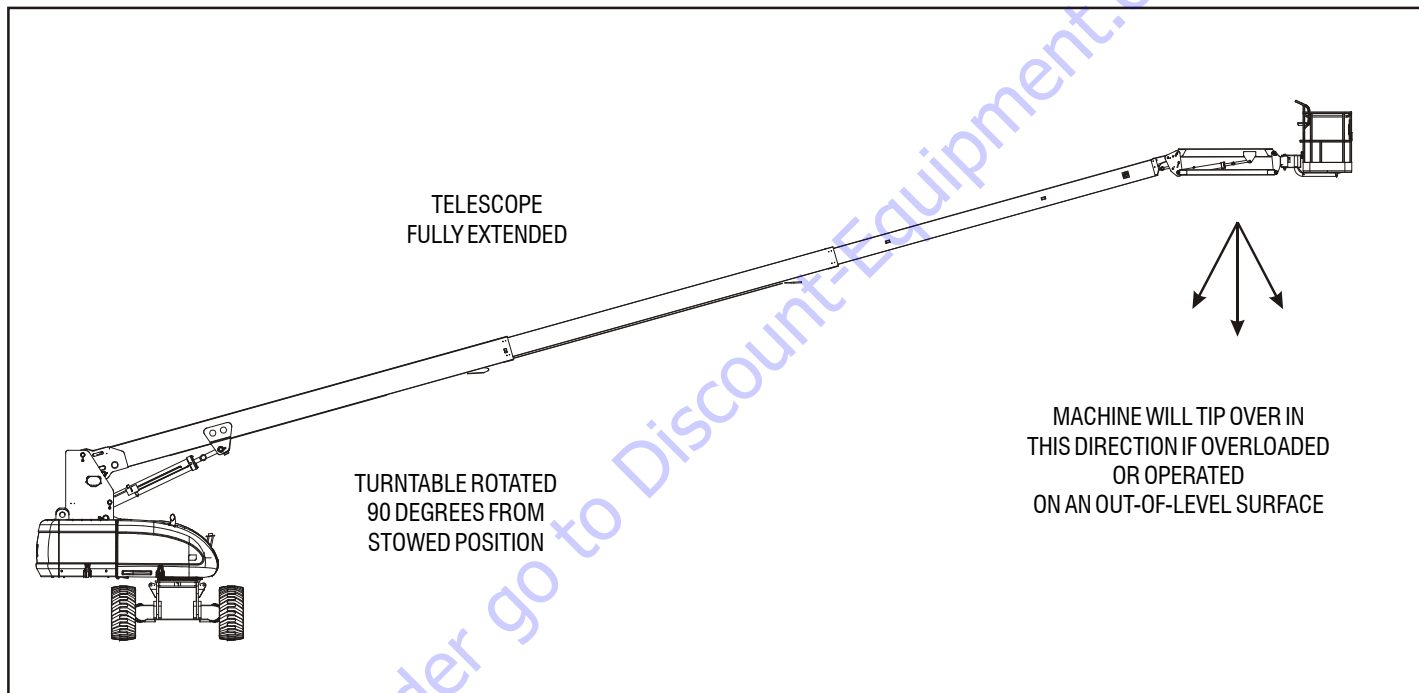

Figure 4-2. Position of Least Forward Stability

### 4.4 TRAVELING (DRIVING)

**NOTE:** When the upper boom is raised approximately 11 degrees above horizontal, the high drive function will automatically be in low drive.



**DO NOT DRIVE WITH BOOM ABOVE HORIZONTAL EXCEPT ON A SMOOTH, FIRM AND LEVEL SURFACE.**

**TO AVOID LOSS OF TRAVEL CONTROL OR “TIP OVER” , DO NOT DRIVE MACHINE ON GRADES EXCEEDING THOSE SPECIFIED ON THE SERIAL NUMBER PLATE.**

**DO NOT DRIVE ON SIDESLOPES WHICH EXCEED 5 DEGREES.**

**USE EXTREME CAUTION WHEN DRIVING IN REVERSE AND AT ALL TIMES WHEN THE PLATFORM IS ELEVATED.**

**BEFORE DRIVING, LOCATE THE BLACK/WHITE ORIENTATION ARROWS ON BOTH THE CHASSIS AND THE PLATFORM CONTROLS. MOVE THE**

**DRIVE CONTROLS IN A DIRECTION MATCHING THE DIRECTIONAL ARROWS.**

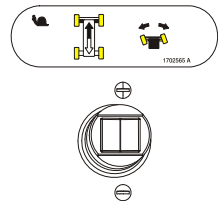
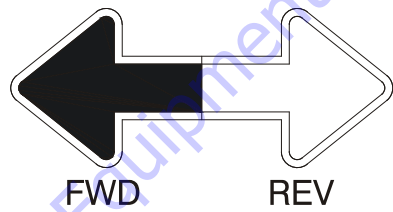



### Traveling Forward and Reverse

1. At Platform Controls, pull out Emergency Stop switch, start engine, and activate footswitch.
2. Position Drive controller to FORWARD or REVERSE as desired.

This machine is equipped with a Drive Orientation Indicator. The yellow light on the platform control console indicates that the boom is swung beyond the rear drive tires and the machine may Drive/Steer in the opposite direction from the movement of the controls. If the indicator is illuminated, operate the Drive function in the following manner:

1. Match the black and white direction arrows on both platform control panel and the chassis to determine the direction the machine will travel.
2. Push and release the Drive Orientation Override switch. Within 3 seconds, slowly move the Drive control toward the arrow matching the intended direction of machine travel. The indicator light will flash during the 3 second interval until the drive function is selected.

### 4.5 STEERING

Position thumb switch on Drive/Steer controller to RIGHT for steering right, or to LEFT for steering left.

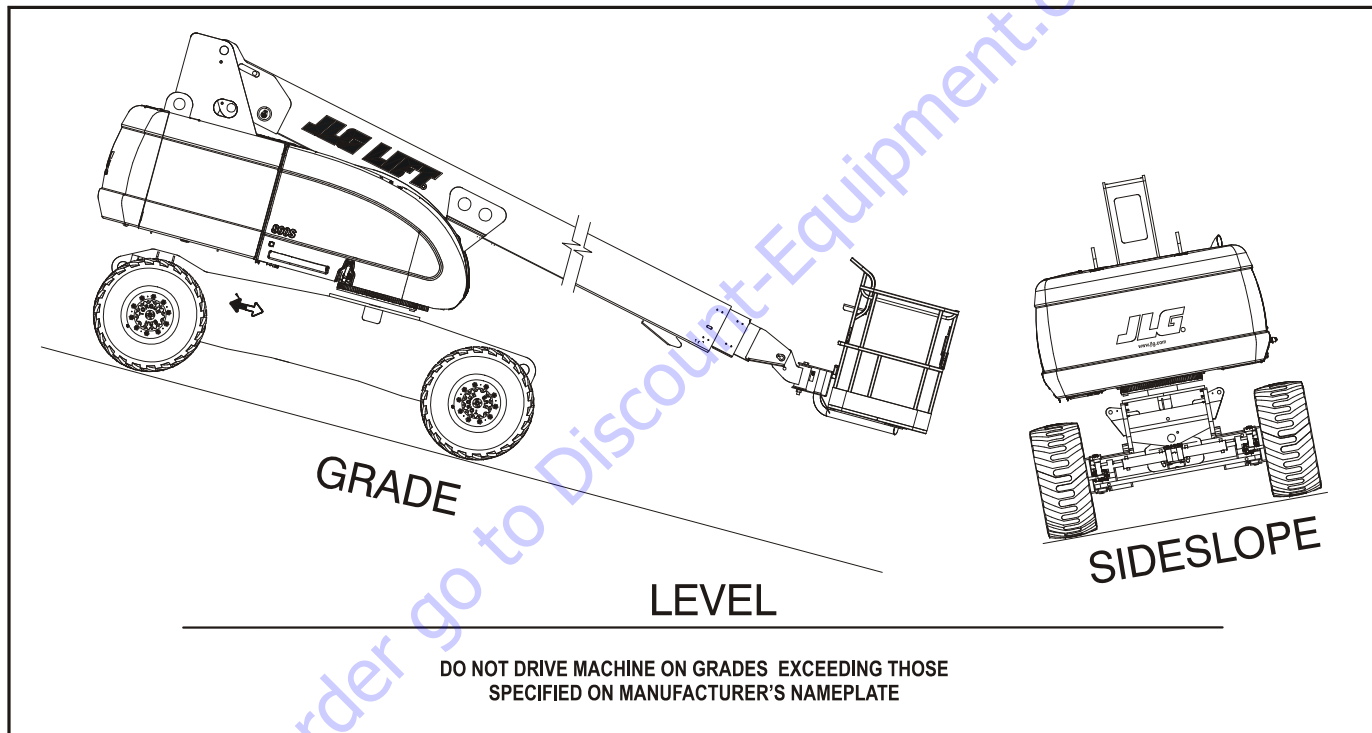

Figure 4-3. Grade and Side Slopes

### 4.6 PLATFORM

#### Platform Level Adjustment

During normal operation of the machine, the platform will automatically maintain it's position. To manually Level Up or Down - Position the Platform/Level control switch Up or Down and hold until the desired platform position is obtained.

#### **⚠ WARNING**

ONLY USE THE PLATFORM LEVELING OVERRIDE FUNCTION FOR SLIGHT LEVELING OF THE PLATFORM. INCORRECT USE COULD CAUSE THE LOAD/OCCUPANT TO SHIFT OR FALL. FAILURE TO DO SO COULD RESULT IN DEATH OR SERIOUS INJURY.

#### Platform Rotation

To rotate the platform to the left or right, use the Platform Rotate control switch to select the direction and hold until desired position is reached.

### 4.7 BOOM

#### **⚠ WARNING**

DO NOT SWING OR RAISE BOOM ABOVE HORIZONTAL WHEN MACHINE IS OUT OF LEVEL.

DO NOT DEPEND ON TILT ALARM AS A LEVEL INDICATOR FOR THE CHASSIS.

TO AVOID TIP OVER, LOWER PLATFORM TO GROUND LEVEL. THEN DRIVE MACHINE TO A LEVEL SURFACE BEFORE RAISING BOOM.

TO AVOID SERIOUS INJURY, DO NOT OPERATE MACHINE IF ANY CONTROL LEVER OR TOGGLE SWITCH CONTROLLING PLATFORM MOVEMENT DOES NOT RETURN TO THE 'OFF' OR NEUTRAL POSITION WHEN RELEASED.

IF THE PLATFORM DOES NOT STOP WHEN A CONTROL SWITCH OR LEVER IS RELEASED, REMOVE FOOT FROM FOOTSWITCH OR USE EMERGENCY STOP SWITCH TO STOP THE MACHINE.

## Swinging the Boom

To swing boom, use SWING control to select RIGHT or LEFT direction.

### **NOTICE**

WHEN SWINGING THE BOOM MAKE SURE THERE IS AMPLE ROOM FOR THE BOOM TO CLEAR SURROUNDING WALLS, PARTITIONS AND EQUIPMENT.

## Raising and Lowering the Boom

To raise or lower the Boom, use Boom Lift control to select UP or DOWN movement.

## 4.8 FUNCTION SPEED CONTROL

This control affects the speed of all boom functions and Platform Rotate. When in the CCW maximum position, Drive is placed in creep speed.

## 4.9 OSCILLATING AXLE LOCKOUT TEST (IF EQUIPPED)

### **NOTICE**

LOCKOUT SYSTEM TEST MUST BE PERFORMED QUARTERLY, ANY TIME A SYSTEM COMPONENT IS REPLACED, OR WHEN IMPROPER SYSTEM OPERATION IS SUSPECTED.

Refer to Section 2.4, Oscillating Axle Lockout Test (If Equipped) for procedure.

## 4.10 EMERGENCY TOWING

### **⚠ WARNING**

RUNAWAY VEHICLE/MACHINE HAZARD. MACHINE HAS NO TOWING BRAKES. TOWING VEHICLE MUST BE ABLE TO CONTROL MACHINE AT ALL TIMES. ON-HIGHWAY TOWING NOT PERMITTED. FAILURE TO FOLLOW INSTRUCTIONS COULD CAUSE SERIOUS INJURY OR DEATH.

MAXIMUM TOWING SPEED 5 M.P.H. (8 K.M.H.)

MAXIMUM TOWING GRADE 25%.

### **⚠ CAUTION**

DO NOT TOW MACHINE WITH ENGINE OPERATING OR DRIVE HUBS ENGAGED.

1. Retract, lower and position boom in travel position; lock turntable.
2. Disconnect drive hubs by inverting disconnect cap.

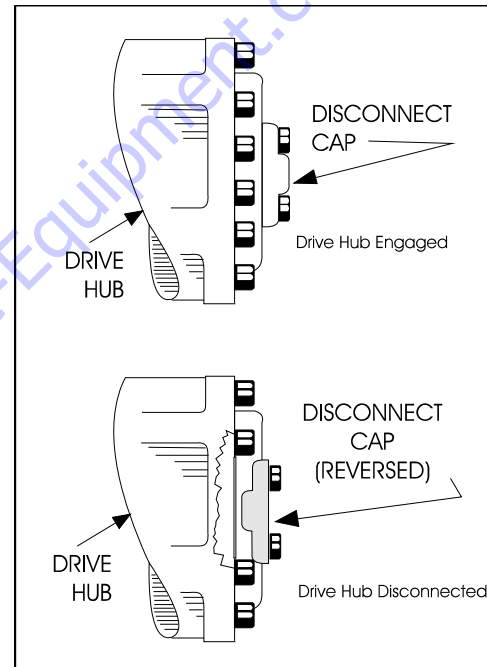

Figure 4-4. Drive Disconnect Hub

3. Reconnect the drive hubs by inverting the disconnect cap when towing is complete.

## 4.11 TOW BAR (IF EQUIPPED)

### **⚠ WARNING**

**RUNAWAY VEHICLE/MACHINE HAZARD. MACHINE HAS NO TOWING BRAKES. TOWING VEHICLE MUST BE ABLE TO CONTROL MACHINE AT ALL TIMES. ON-HIGHWAY TOWING NOT PERMITTED. FAILURE TO FOLLOW INSTRUCTIONS COULD CAUSE SERIOUS INJURY OR DEATH.**

**MAXIMUM TOWING SPEED 5 M.P.H. (8 K.M.H.)**

**MAXIMUM TOWING GRADE 25%.**

Prior to towing the machine, complete the following:

### **⚠ CAUTION**

**DO NOT TOW MACHINE WITH ENGINE OPERATING OR DRIVE HUBS ENGAGED.**

1. Retract, lower and position boom in travel position; lock turntable.
2. Lower towbar and connect to towing vehicle

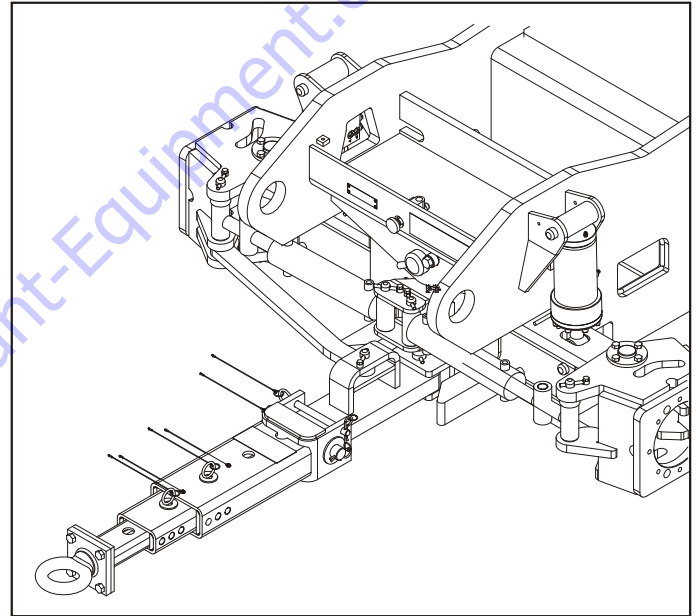

3. Disconnect drive hubs by inverting disconnect cap. Refer to Figure 4-4., Drive Disconnect Hub.

## SECTION 4 - MACHINE OPERATION

4. Position steer/tow selector valve for towing; pull valve knob OUT for towing. The machine is now in the towing mode.

### After towing the machine, complete the following:

1. Actuate steer/tow selector valve for steering; push valve knob IN to the actuated position.
2. Reconnect drive hubs by inverting disconnect cap.
3. Disconnect towbar from towing vehicle and place it in the stowed position as shown below. The machine is now in the driving mode.

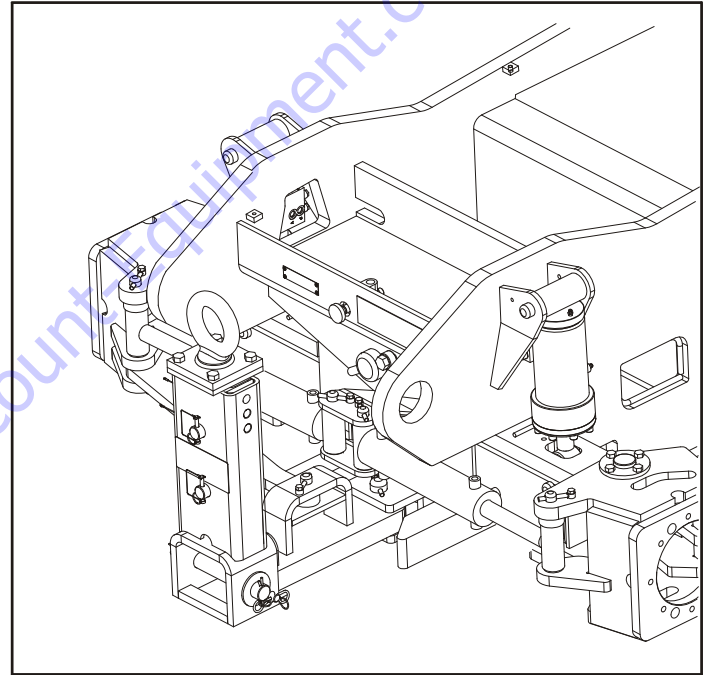

## **4.12 SHUT DOWN AND PARK**

To shut down and park the machine, the procedures are as follows:

1. Drive machine to a reasonably well protected area.
2. Ensure boom is lowered over rear drive axle.
3. Push in the Emergency Stop at Platform Controls.
4. Push in the Emergency Stop at Ground Controls. Position Platform/Ground Select switch to center OFF.
5. If necessary, cover Platform Controls to protect instruction placards, warning decals and operating controls from hostile environment.

## **4.13 LIFTING AND TIE DOWN**

### **Lifting**

1. Call JLG Industries or weigh the individual unit to find out the Gross Vehicle Weight.
2. Place the boom in the stowed position with the turntable locked.
3. Remove all loose items from the machine.
4. Properly adjust the rigging to prevent damage to the machine and so the machine remains level.



### Tie Down

#### **NOTICE**

**WHEN TRANSPORTING THE MACHINE, THE BOOM MUST BE FULLY LOWERED INTO THE BOOM REST.**

1. Remove all loose items from the machine.
2. When transporting an 800S/860SJ a step-deck or single-drop trailer is required. To avoid damage to the platform and to obtain proper weight distribution, load the machine onto the trailer as follows;
  - a. Position the boom over the front wheels.

#### **⚠ WARNING**

**DO NOT SWING THE BOOM WHILE THE MACHINE IS POSITIONED ON A TRAILER. TIPOVER MAY RESULT**

- b. Place the boom in the stowed position with the turntable locked.

#### **NOTICE**

**DRIVE AND STEER CONTROLLERS WILL BE REVERSED WHEN THE BOOM IS POSITIONED OVER THE FRONT WHEELS.**

- c. Drive it onto the trailer with the boom and platform positioned towards the truck. Refer to Figure 4-5., Typical 800S/860SJ Transport.
  3. Secure the chassis and the platform using straps or chains of adequate strength.

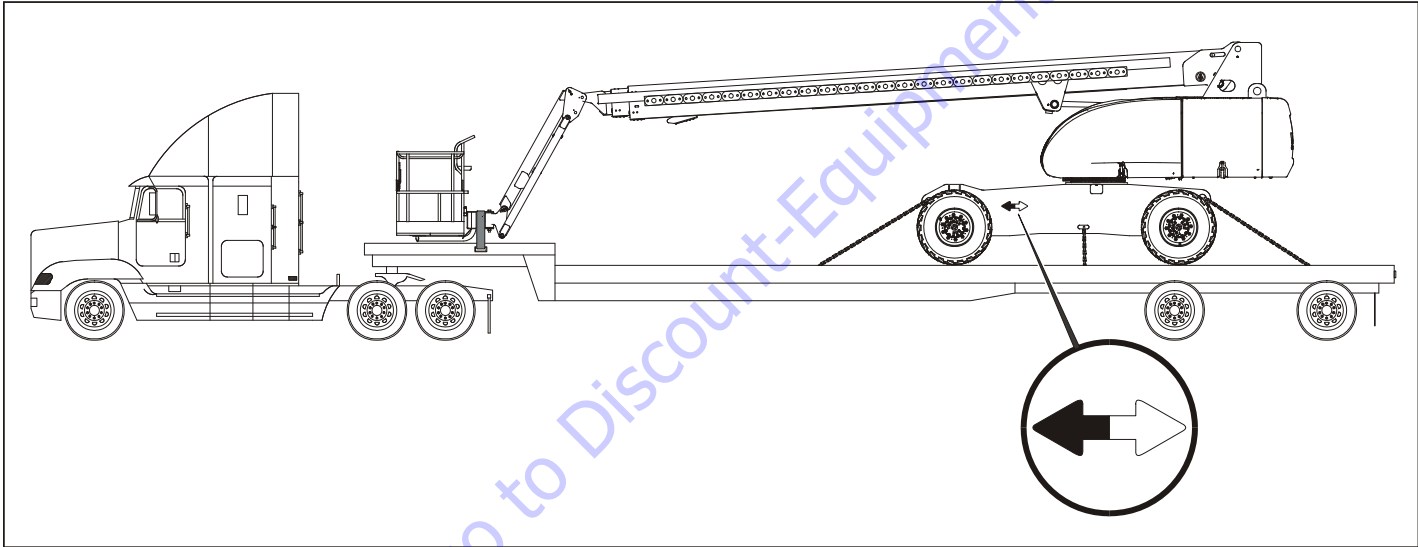

Figure 4-5. Typical 800S/860SJ Transport

## SECTION 4 - MACHINE OPERATION

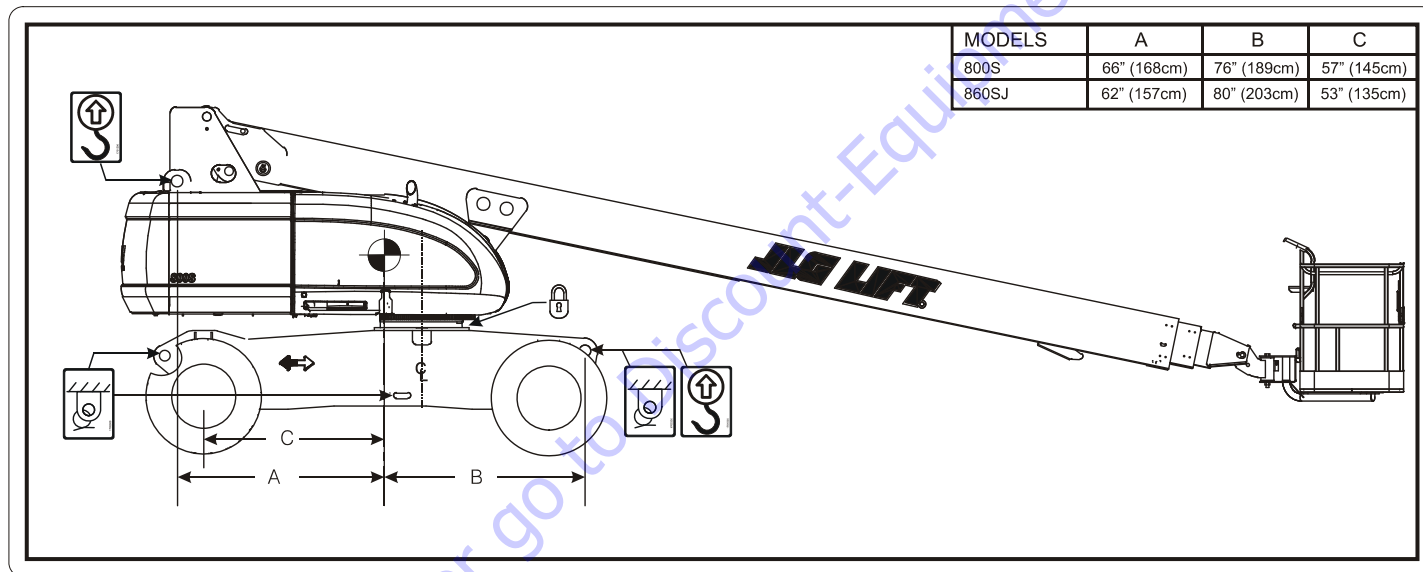

Figure 4-6. Lifting and Tie Down Chart

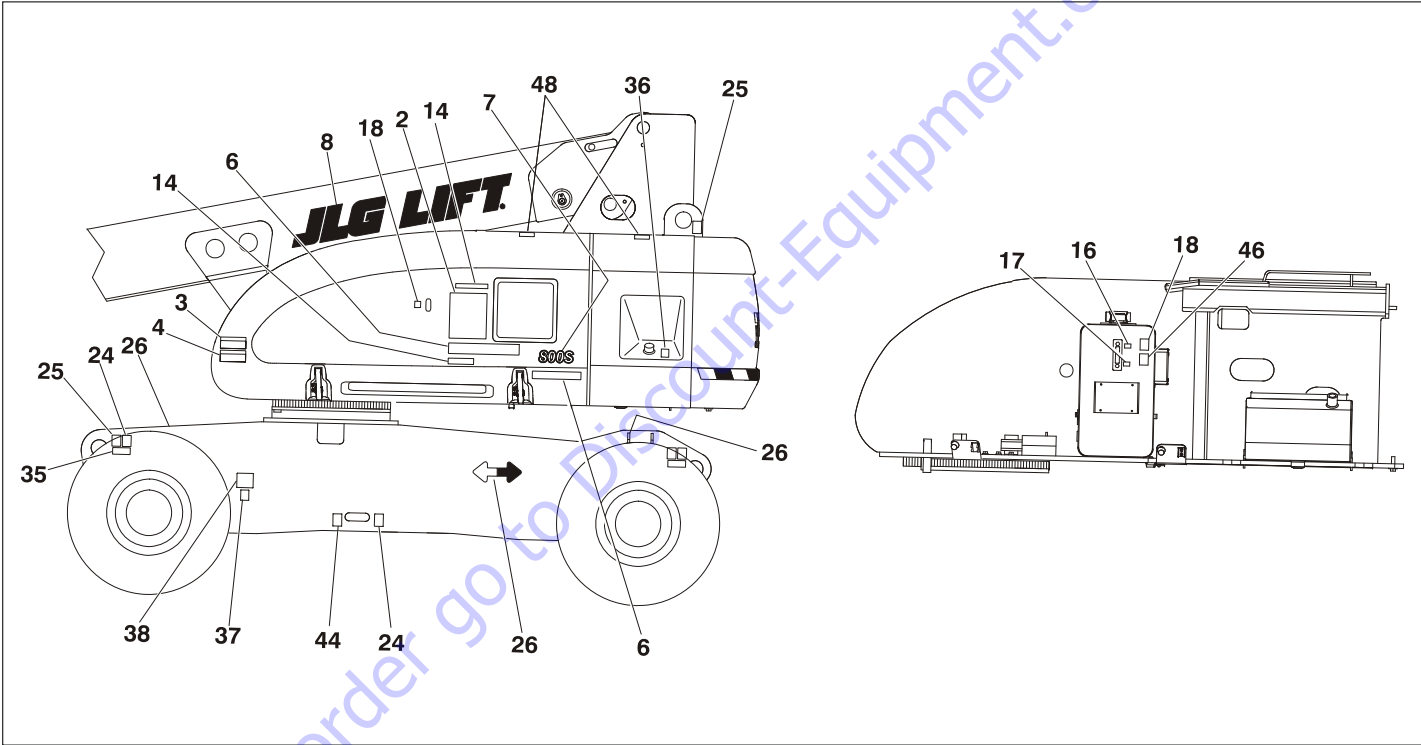
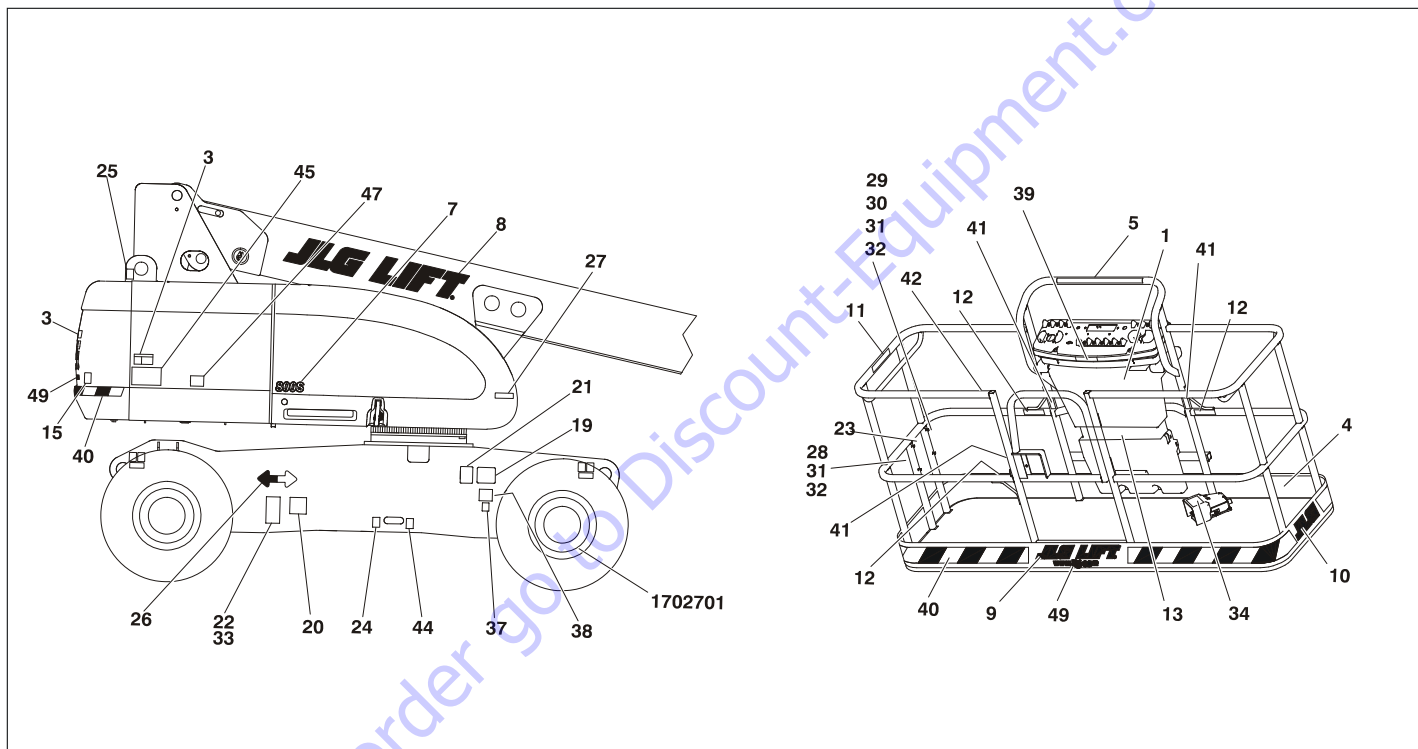

Figure 4-7. Decal Location - Rear Entry Platform - Sheet 1 of 2

## SECTION 4 - MACHINE OPERATION



**Table 4-1. Decal Location Legend - Rear Entry Platform**

<b>Item #</b>	<b>ANSI 0270907-2 860SJ</b>	<b>Australian 0270909-2 0270910-2</b>	<b>China/ English 0270931-1 0270932-1</b>	<b>Dutch 0270915-2 0270916-2</b>	<b>Finnish 0271830-2 0271831-1</b>	<b>French 0270919-2 0270920-2</b>	<b>French/ English 0270929-1 0270930-1</b>	<b>German 0270913-2 0270914-2</b>	<b>Italian 0270917-2 0270918-2</b>
1	1703797	1703992	1703925	1704809	1705053	1704811	1703924	1704767	1704810
2	1703798	1704819	1703931	1704821	1705055	1704823	1703930	1704820	1704822
3	1703805	--	1703937	--	--	--	1703936	--	--
4	1703804	1701518	1703949	1701518	1701518	1701518	1703948	1701518	1701518
5	1705015	--	--	--	--	--	1705015	--	--
6	1703808	--	--	--	--	--	1703808	--	--
7	1704906 (800S) 1704907 (860SJ)	1704906 (800S) 1704907 (860SJ)	1704906 (800S) 1704907 (860SJ)	1704906 (800S) 1704907 (860SJ)	1704906 (800S) 1704907 (860SJ)	1704906 (800S) 1704907 (860SJ)	1704906 (800S) 1704907 (860SJ)	1704906 (800S) 1704907 (860SJ)	1704906 (800S) 1704907 (860SJ)
8	--	--	--	--	--	--	--	--	--
9	--	--	--	--	--	--	--	--	--
10	--	--	--	--	--	--	--	--	--
11	1702868	--	--	--	--	--	1704000	--	--
12	1704277	1704277	1704277	1704277	1704277	1704277	1704277	1704277	1704277

## SECTION 4 - MACHINE OPERATION

Table 4-1. Decal Location Legend - Rear Entry Platform

Item #	ANSI 0270907-2 860SJ	Australian 0270909-2 0270910-2	China/ English 0270931-1 0270932-1	Dutch 0270915-2 0270916-2	Finnish 0271830-2 0271831-1	French 0270919-2 0270920-2	French/ English 0270929-1 0270930-1	German 0270913-2 0270914-2	Italian 0270917-2 0270918-2
13	1705088	1705088 (800S) 1704995 (860SJ)	1704101	--	--	--	1704099	--	--
14	1705089	1705089 (800S) 1704996 (860SJ)	1704109	--	--	--	1704107	--	--
15	3251813	--	--	1705084	1705084	1705084	3251813	1705084	1705084
16	1701502	1701502	1701502	1701502	1701502	1701502	1701502	1701502	1701502
17	1701503	1701503	1701503	1701503	1701503	1701503	1701503	1701503	1701503
18	1701504	1701504	1701504	1701504	1701504	1701504	1701504	1701504	1701504
19	1702153	--	--	--	--	--	1704006	--	--
20	1702631	1702631	1702631	1702631	1702631	1702631	1702631	1702631	1702631
21	1700584	1700584	1700584	1700584	1700584	1700584	1700584	1700584	1700584
22	--	--	--	--	--	--	--	--	--
23	1701509	1701509	1701509	1701509	1701509	1701509	1701509	1701509	1701509
24	1702300	1702300	1702300	1702300	1702300	1702300	1702300	1702300	1702300

**SECTION 4 - MACHINE OPERATION**

**Table 4-1. Decal Location Legend - Rear Entry Platform**

Item #	ANSI 0270907-2 860SJ	Australian 0270909-2 0270910-2	China/ English 0270931-1 0270932-1	Dutch 0270915-2 0270916-2	Finnish 0271830-2 0271831-1	French 0270919-2 0270920-2	French/ English 0270929-1 0270930-1	German 0270913-2 0270914-2	Italian 0270917-2 0270918-2
25	1701500	1701500	1701500	1701500	1701500	1701500	1701500	1701500	1701500
26	1701501	1701501	1701501	1701501	1701501	1701501	1701501	1701501	1701501
27	--	--	--	--	--	--	--	--	--
28	--	--	--	--	--	--	--	--	--
29	--	--	--	--	--	--	--	--	--
30	--	--	--	--	--	--	--	--	--
31	--	--	--	--	--	--	--	--	--
32	--	--	--	--	--	--	--	--	--
33	--	--	--	--	--	--	--	--	--
34	--	--	1703982	1703518	1701600	1693292	1703984	1693294	1701600
35	1703475 (800S) 1703482 (860SJ)	1703475 (800S) 1703482 (860SJ)	1703475 (800S) 1703482 (860SJ)	1703475 (800S) 1703482 (860SJ)	1703475 (800S) 1703482 (860SJ)	1703475 (800S) 1703482 (860SJ)	1703475 (800S) 1703482 (860SJ)	1703475 (800S) 1703482 (860SJ)	1703475 (800S) 1703482 (860SJ)
36	--	--	--	--	--	--	--	--	--
37	--	--	--	--	--	--	--	--	--
38	--	--	--	--	--	--	--	--	--
39	--	--	--	--	--	--	3252221	--	--



## SECTION 4 - MACHINE OPERATION

Table 4-1. Decal Location Legend - Rear Entry Platform

Item #	ANSI 0270907-2	Australian 0270909-2	China/ English 0270931-1	Dutch 0270915-2	Finnish 0271830-2	French 0270919-2	French/ English 0270929-1	German 0270913-2	Italian 0270917-2
	0270908-2	0270910-2	0270932-1	0270916-2	0271831-1	0270920-2	0270930-1	0270914-2	0270918-2
40	--	--	--	--	--	--	--	--	--
41	--	--	--	--	--	--	--	--	--
42	--	--	--	--	--	--	--	--	--
43	--	--	--	--	--	--	--	--	--
44	1701499	1701499	1701499	1701499	1701499	1701499	1701499	1701499	1701499
45	3252781	3252781	3252781	3252781	3252781	3252781	3252781	3252781	3252781
46	1704412	1704412	1704412	1704412	1704412	1704412	1704412	1704412	1704412
47	1704540	1704540	1704540	1704540	1704540	1704540	1704540	1704540	1704540
48	1701691	1701691	1701691	1701691	1701691	1701691	1701691	1701691	1701691
49	--	--	--	--	--	--	--	--	--
50	--	--	--	--	--	--	--	--	--
51	--	--	--	--	--	--	--	--	--
52	--	--	--	--	--	--	--	--	--

**Table 4-2. Decal Location Legend - Rear Entry Platform**

<b>Item #</b>	<b>ANSI 0270907-2 860SJ</b>	<b>Australian 0270909-2 0270910-2</b>	<b>China/ English 0270931-1 0270932-1</b>	<b>Dutch 0270915-2 0270916-2</b>	<b>Finnish 0271830-2 0271831-1</b>	<b>French 0270919-2 0270920-2</b>	<b>French/ English 0270929-1 0270930-1</b>	<b>German 0270913-2 0270914-2</b>	<b>Italian 0270917-2 0270918-2</b>
1	1703797	1703992	1703925	1704809	1705053	1704811	1703924	1704767	1704810
2	1703798	1704819	1703931	1704821	1705055	1704823	1703930	1704820	1704822
3	1703805	--	1703937	--	--	--	1703936	--	--
4	1703804	1701518	1703949	1701518	1701518	1701518	1703948	1701518	1701518
5	1705015	--	--	--	--	--	1705015	--	--
6	1703808	--	--	--	--	--	1703808	--	--
7	1704906 (800S) 1704907 (860SJ)	1704906 (800S) 1704907 (860SJ)	1704906 (800S) 1704907 (860SJ)	1704906 (800S) 1704907 (860SJ)	1704906 (800S) 1704907 (860SJ)	1704906 (800S) 1704907 (860SJ)	1704906 (800S) 1704907 (860SJ)	1704906 (800S) 1704907 (860SJ)	1704906 (800S) 1704907 (860SJ)
8	--	--	--	--	--	--	--	--	--
9	--	--	--	--	--	--	--	--	--
10	--	--	--	--	--	--	--	--	--
11	1702868	--	--	--	--	--	1704000	--	--
12	1704277	1704277	1704277	1704277	1704277	1704277	1704277	1704277	1704277

## SECTION 4 - MACHINE OPERATION

Table 4-2. Decal Location Legend - Rear Entry Platform

Item #	ANSI 0270907-2 860SJ	Australian 0270909-2 0270910-2	China/ English 0270931-1 0270932-1	Dutch 0270915-2 0270916-2	Finnish 0271830-2 0271831-1	French 0270919-2 0270920-2	French/ English 0270929-1 0270930-1	German 0270913-2 0270914-2	Italian 0270917-2 0270918-2
13	1705088	1705088 (800S) 1704995 (860SJ)	1704101	--	--	--	1704099	--	--
14	1705089	1705089 (800S) 1704996 (860SJ)	1704109	--	--	--	1704107	--	--
15	3251813	--	--	1705084	1705084	1705084	3251813	1705084	1705084
16	1701502	1701502	1701502	1701502	1701502	1701502	1701502	1701502	1701502
17	1701503	1701503	1701503	1701503	1701503	1701503	1701503	1701503	1701503
18	1701504	1701504	1701504	1701504	1701504	1701504	1701504	1701504	1701504
19	1702153	--	--	--	--	--	1704006	--	--
20	1702631	1702631	1702631	1702631	1702631	1702631	1702631	1702631	1702631
21	1700584	1700584	1700584	1700584	1700584	1700584	1700584	1700584	1700584
22	--	--	--	--	--	--	--	--	--
23	1701509	1701509	1701509	1701509	1701509	1701509	1701509	1701509	1701509
24	1702300	1702300	1702300	1702300	1702300	1702300	1702300	1702300	1702300

**SECTION 4 - MACHINE OPERATION**

**Table 4-2. Decal Location Legend - Rear Entry Platform**

Item #	ANSI 0270907-2 860SJ	Australian 0270909-2 0270910-2	China/ English 0270931-1 0270932-1	Dutch 0270915-2 0270916-2	Finnish 0271830-2 0271831-1	French 0270919-2 0270920-2	French/ English 0270929-1 0270930-1	German 0270913-2 0270914-2	Italian 0270917-2 0270918-2
25	1701500	1701500	1701500	1701500	1701500	1701500	1701500	1701500	1701500
26	1701501	1701501	1701501	1701501	1701501	1701501	1701501	1701501	1701501
27	--	--	--	--	--	--	--	--	--
28	--	--	--	--	--	--	--	--	--
29	--	--	--	--	--	--	--	--	--
30	--	--	--	--	--	--	--	--	--
31	--	--	--	--	--	--	--	--	--
32	--	--	--	--	--	--	--	--	--
33	--	--	--	--	--	--	--	--	--
34	--	--	1703982	1703518	1701600	1693292	1703984	1693294	1701600
35	1703475 (800S) 1703482 (860SJ)	1703475 (800S) 1703482 (860SJ)	1703475 (800S) 1703482 (860SJ)	1703475 (800S) 1703482 (860SJ)	1703475 (800S) 1703482 (860SJ)	1703475 (800S) 1703482 (860SJ)	1703475 (800S) 1703482 (860SJ)	1703475 (800S) 1703482 (860SJ)	1703475 (800S) 1703482 (860SJ)
36	--	--	--	--	--	--	--	--	--
37	--	--	--	--	--	--	--	--	--
38	--	--	--	--	--	--	--	--	--
39	--	--	--	--	--	--	3252221	--	--

## SECTION 4 - MACHINE OPERATION

Table 4-2. Decal Location Legend - Rear Entry Platform

Item #	ANSI 0270907-2	Australian 0270909-2	China/ English 0270931-1	Dutch 0270915-2	Finnish 0271830-2	French 0270919-2	French/ English 0270929-1	German 0270913-2	Italian 0270917-2
	0270908-2	0270910-2	0270932-1	0270916-2	0271831-1	0270920-2	0270930-1	0270914-2	0270918-2
40	--	--	--	--	--	--	--	--	--
41	--	--	--	--	--	--	--	--	--
42	--	--	--	--	--	--	--	--	--
43	--	--	--	--	--	--	--	--	--
44	1701499	1701499	1701499	1701499	1701499	1701499	1701499	1701499	1701499
45	3252781	3252781	3252781	3252781	3252781	3252781	3252781	3252781	3252781
46	1704412	1704412	1704412	1704412	1704412	1704412	1704412	1704412	1704412
47	1704540	1704540	1704540	1704540	1704540	1704540	1704540	1704540	1704540
48	1701691	1701691	1701691	1701691	1701691	1701691	1701691	1701691	1701691
49	--	--	--	--	--	--	--	--	--
50	--	--	--	--	--	--	--	--	--
51	--	--	--	--	--	--	--	--	--
52	--	--	--	--	--	--	--	--	--

## SECTION 4 - MACHINE OPERATION

**Table 4-3. Decal Location Legend - Rear Entry Platform**

Item #	Japan	Korean	Portuguese	Portuguese/ Spanish	Spanish	Spanish/ English	Swedish	UK
800S	0270923-1	0270925-1	0271392-2	0270933-1	0270921-2	0270927-1	0271832-2	0270911-2
860SJ	0270924-1	0270926-1	0271393-2	0270934-1	0270922-2	0270928-1	0271833-2	0270912-2
1	1703926	1703927	1704985	1703928	1704812	1703923	1705054	1704808
2	1703932	1703933	1704986	1703934	1704824	1703929	1705056	1704819
3	1703938	1703939	--	1703940	--	1703935	--	--
4	1703950	1703951	1701518	1703952	1701518	1703947	1701518	1701518
5	--	--	--	--	--	1705015	--	--
6	--	--	--	--	--	1703808	--	--
7	1704906 (800S) 1704907 (860SJ)	1704906 (800S) 1704907 (860SJ)	1704906( 800S) 1704907( 860SJ)	1704906(8 00S) 1704907(8 60SJ)	1704906 (800S) 1704907 (860SJ)	1704906 (800S) 1704907 (860SJ)	1704906 (800S) 1704907 (860SJ)	1704906 (800S) 1704907 (860SJ)
8	--	--	--	--	--	--	--	--
9	--	--	--	--	--	--	--	--
10	--	--	--	--	--	--	--	--
11	--	--	--	1704002	--	1704001	--	--
12	1704277	1704277	--	1704277	1704277	1704277	1704277	1704277
13	1704102	1704103	--	1704100	--	1704098	--	--
14	1704110	1704111	--	1704108	--	1704106	--	--
15	--	--	1705084	3251813	1705084	3251813	1705084	1705084

## SECTION 4 - MACHINE OPERATION

Table 4-3. Decal Location Legend - Rear Entry Platform

Item #	Japan 0270923-1 860SJ 0270924-1	Korean 0270925-1 0270926-1	Portuguese 0271392-2 0271393-2	Portuguese/ Spanish 0270933-1 0270934-1	Spanish 0270921-2 0270922-2	Spanish/ English 0270927-1 0270928-1	Swedish 0271832-2 0271833-2	UK 0270911-2 0270912-2
16	1701502	1701502	1701502	1701502	1701502	1701502	1701502	1701502
17	1701503	1701503	1701503	1701503	1701503	1701503	1701503	1701503
18	1701504	1701504	1701504	1701504	1701504	1701504	1701504	1701504
19	--	--	--	1704008	--	1704007	--	--
20	1702631	1702631	1702631	1702631	1702631	1702631	1702631	1702631
21	1700584	1700584	1700584	1700584	1700584	1700584	1700584	1700584
22	--	--	--	--	--	--	--	--
23	1701509	1701509	1701509	1701509	1701509	1701509	1701509	1701509
24	1702300	1702300	1702300	1702300	1702300	1702300	1702300	1702300
25	1701500	1701500	1701500	1701500	1701500	1701500	1701500	1701500
26	1701501	1701501	1701501	1701501	1701501	1701501	1701501	1701501
27	--	--	--	--	--	--	--	--
28	--	--	--	--	--	--	--	--
29	--	--	--	--	--	--	--	--
30	--	--	--	--	--	--	--	--
31	--	--	--	--	--	--	--	--
32	--	--	--	--	--	--	--	--

**SECTION 4 - MACHINE OPERATION**

**Table 4-3. Decal Location Legend - Rear Entry Platform**

<b>Item #</b>	<b>Japan</b>	<b>Korean</b>	<b>Portuguese</b>	<b>Portuguese/ Spanish</b>	<b>Spanish</b>	<b>Spanish/ English</b>	<b>Swedish</b>	<b>UK</b>
<b>800S</b>	<b>0270923-1</b>	<b>0270925-1</b>	<b>0271392-2</b>	<b>0270933-1</b>	<b>0270921-2</b>	<b>0270927-1</b>	<b>0271832-2</b>	<b>0270911-2</b>
<b>860SJ</b>	<b>0270924-1</b>	<b>0270926-1</b>	<b>0271393-2</b>	<b>0270934-1</b>	<b>0270922-2</b>	<b>0270928-1</b>	<b>0271833-2</b>	<b>0270912-2</b>
33	--	--	--	--	--	--	--	--
34	1703980	1703981	1701600	1703985	1701791	1703983	1701600	--
35	1703475 (800S) 1703482 (860SJ)	1703475 (800S) 1703482 (860SJ)	1703475( 800S) 1703482 (860SJ)	1703475(8 00S) 1703482 (860SJ)	1703475 (800S) 1703482 (860SJ)	1703475 (800S) 1703482 (860SJ)	1703475 (800S) 1703482 (860SJ)	1703475 (800S) 1703482 (860SJ)
36	--	--	--	--	--	--	--	--
37	--	--	--	--	--	--	--	--
38	--	--	--	--	--	--	--	--
39	--	--	--	--	--	--	--	--
40	--	--	--	--	--	--	--	--
41	--	--	--	--	--	--	--	--
42	--	--	--	--	--	--	--	--
43	--	--	--	--	--	--	--	--
44	1701499	1701499	1701499	1701499	1701499	1701499	1701499	1701499
45	3252781	3252781	3252781	3252781	3252781	3252781	3252781	3252781
46	1704412	1704412	1704412	1704412	1704412	1704412	1704412	1704412
47	1704540	1704540	1704540	1704540	1704540	1704540	1704540	1704540



## SECTION 4 - MACHINE OPERATION

Table 4-3. Decal Location Legend - Rear Entry Platform

Item #	Japan	Korean	Portuguese	Portuguese/ Spanish	Spanish	Spanish/ English	Swedish	UK
800S	0270923-1	0270925-1	0271392-2	0270933-1	0270921-2	0270927-1	0271832-2	0270911-2
860SJ	0270924-1	0270926-1	0271393-2	0270934-1	0270922-2	0270928-1	0271833-2	0270912-2
48	1701691	1701691	1701691	1701691	1701691	1701691	1701691	1701691
49	--	--	--	--	--	--	--	--
50	--	--	--	--	--	--	--	--
51	--	--	--	--	--	--	--	--
52	--	--	--	--	--	--	--	--

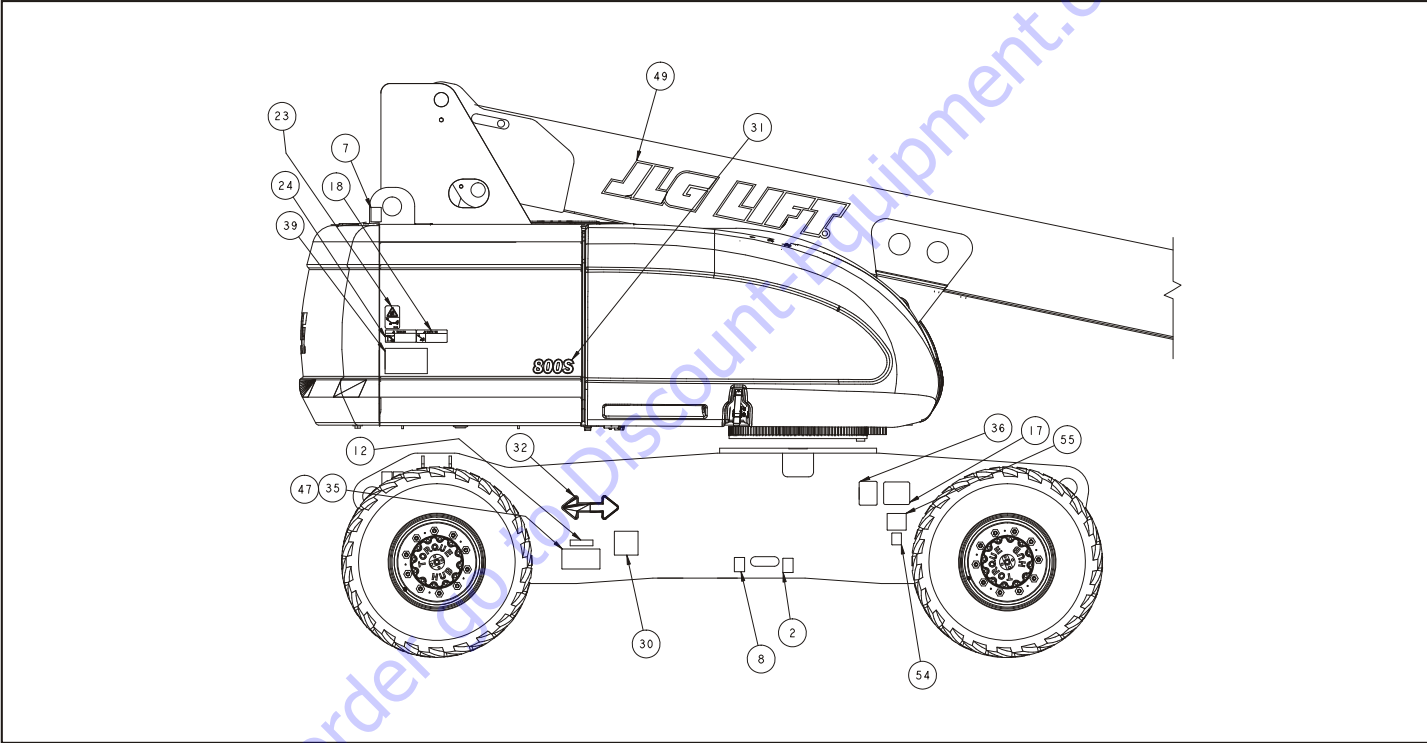

Figure 4-9. Decal Location - Side Entry Platform - Sheet 1 of 5

## SECTION 4 - MACHINE OPERATION

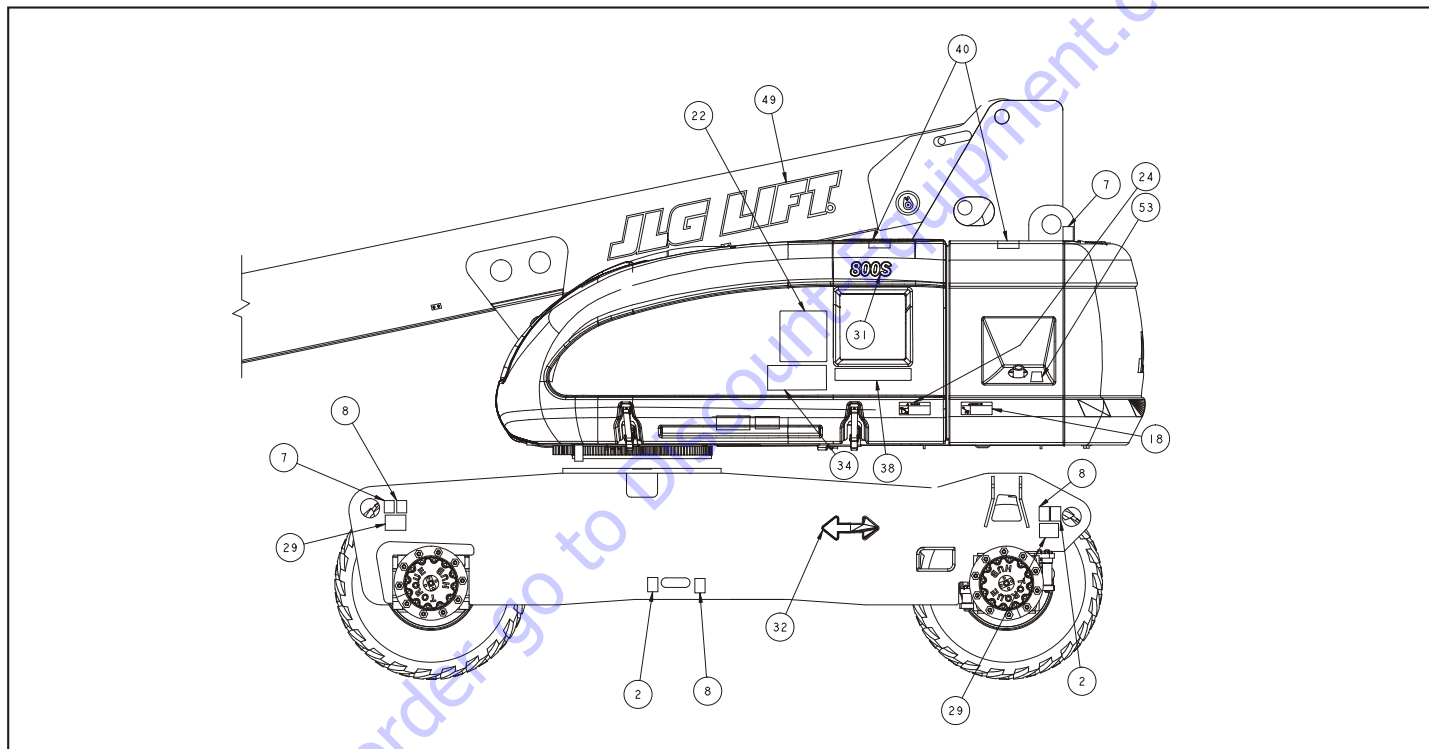

Figure 4-10. Decal Location - Side Entry Platform - Sheet 2 of 5

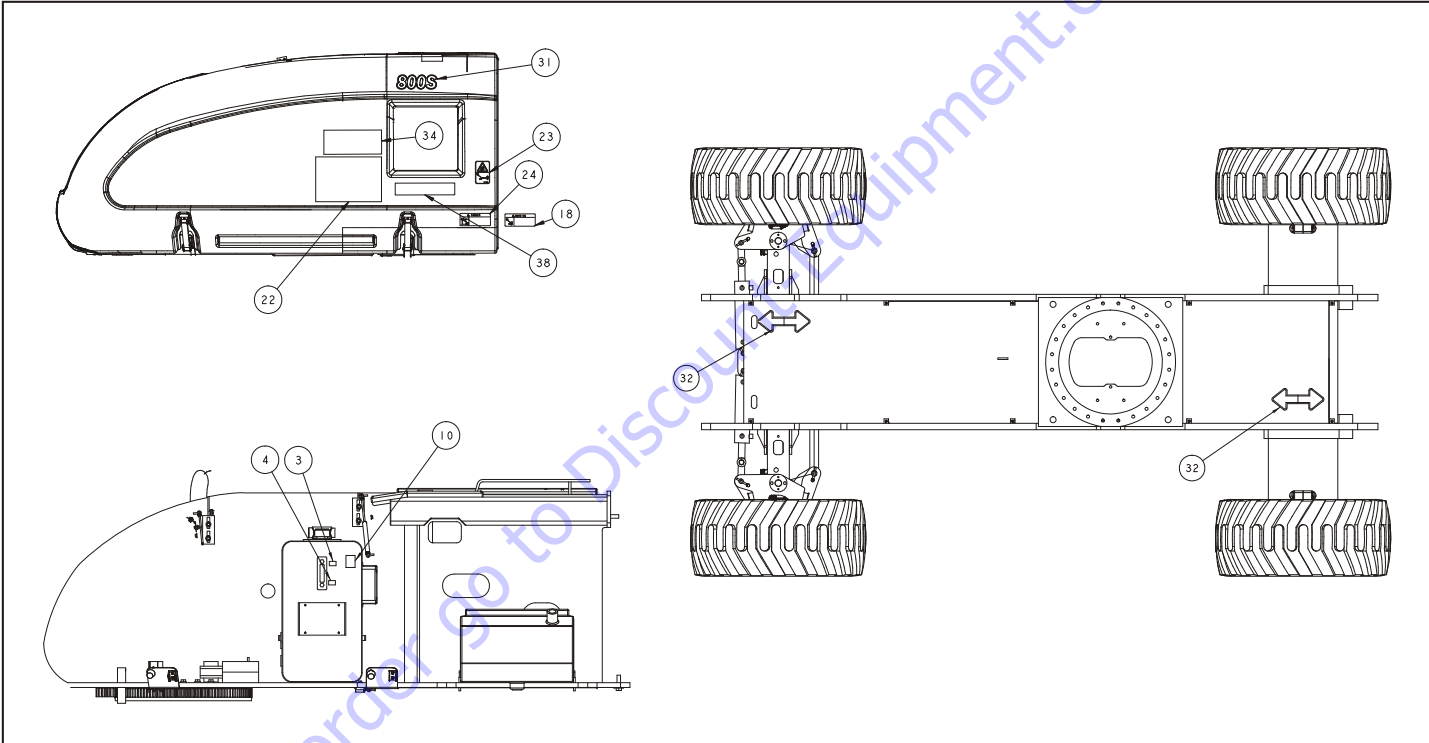

Figure 4-11. Decal Location - Side Entry Platform - Sheet 3 of 5

## SECTION 4 - MACHINE OPERATION

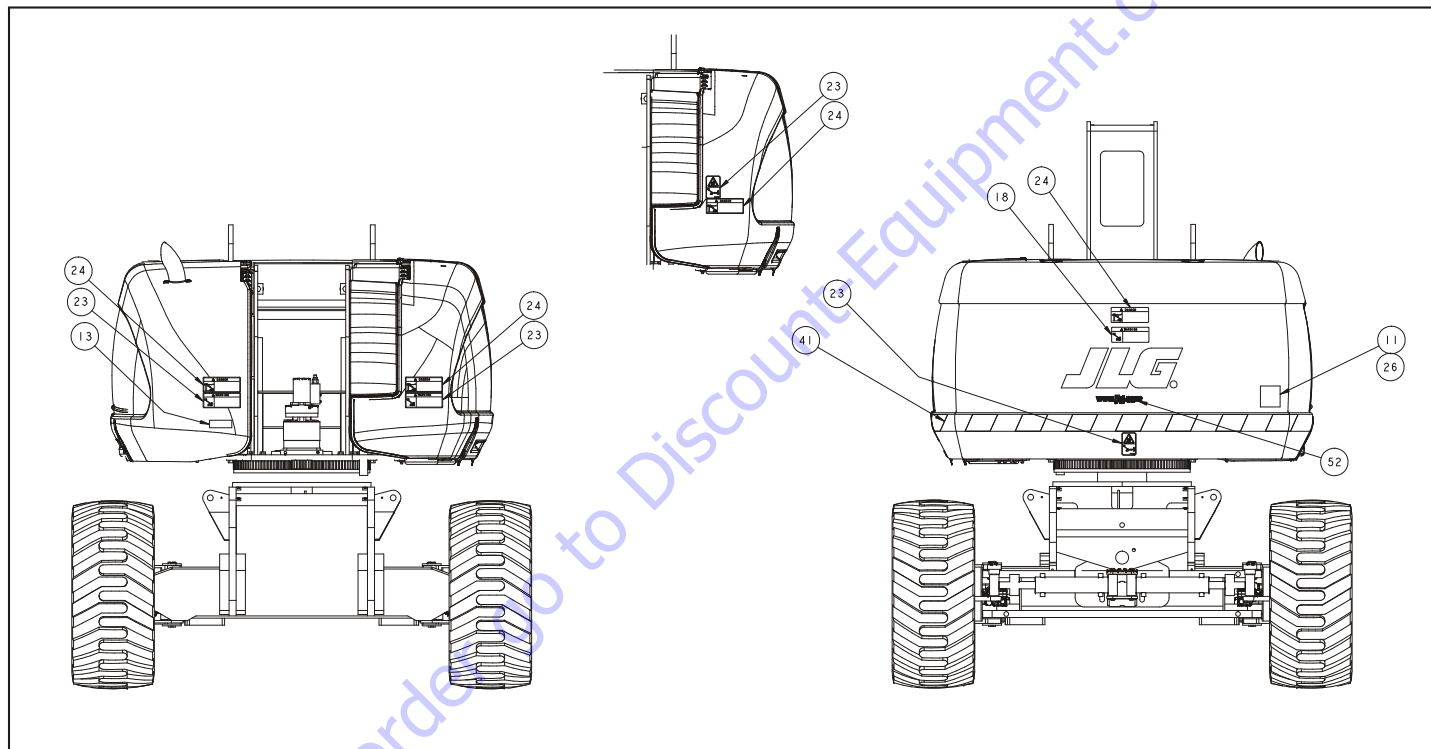

Figure 4-12. Decal Location - Side Entry Platform - Sheet 4 of 5

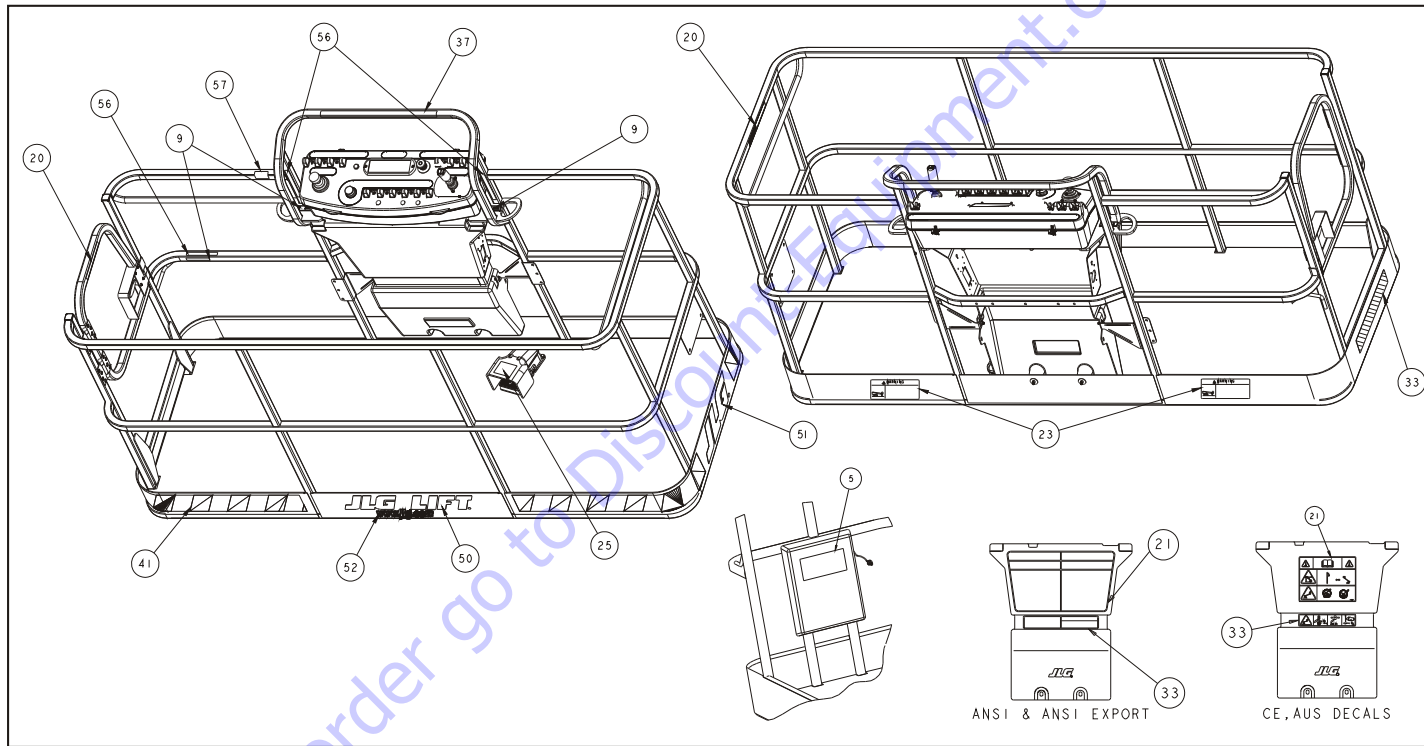

Figure 4-13. Decal Location - Side Entry Platform - Sheet 5 of 5

## SECTION 4 - MACHINE OPERATION

Table 4-4. Decal Location Legend, 800S - Side Entry Platform - Prior to S/N 0300143294

Item #	ANSI 0274499-8	Korean 0274501-6	Chinese 0274503-6	Spanish 0274513-6	Portuguese 0274505-7	French 0274507-6	CE/Aus 0274509-3	Japanese 0274511-6
1	--	--	--	--	--	--	--	--
2	1701499	1701499	1701499	1701499	1701499	1701499	1701499	1701499
3	--	--	--	--	--	--	--	--
4	--	--	--	--	--	--	--	--
5	1701509	1701509	1701509	1701509	1701509	1701509	1701509	1701509
6	--	--	--	--	--	--	--	--
7	1703811	1703811	1703811	1703811	1703811	1703811	1703811	1703811
8	1703814	1703814	1703814	1703814	1703814	1703814	1703814	1703814
9	1704277	1704277	1704277	1704277	1704277	1704277	1704277	1704277
10	1704412	1704412	1704412	1704412	1704412	1704412	1704412	1704412
11	--	--	--	--	--	--	1705084	--
12	--	--	--	--	--	--	--	--
13	--	--	--	--	--	--	--	--
14	--	--	--	--	--	--	--	--
15	--	--	--	--	--	--	--	--
16	--	--	--	--	--	--	--	--
17	--	--	1702153	1704007	1705901	1704006	--	--
18	1703953	1703945	1703943	1703941	1705903	1703942	--	1703944

**SECTION 4 - MACHINE OPERATION**

**Table 4-4. Decal Location Legend, 800S - Side Entry Platform - Prior to S/N 0300143294**

<b>Item #</b>	<b>ANSI 0274499-8</b>	<b>Korean 0274501-6</b>	<b>Chinese 0274503-6</b>	<b>Spanish 0274513-6</b>	<b>Portuguese 0274505-7</b>	<b>French 0274507-6</b>	<b>CE/Aus 0274509-3</b>	<b>Japanese 0274511-6</b>
19	--	--	--	--	--	--	--	--
20	1702868	1705969	1702868	1704001	1705967	1704000	--	--
21	1703797	1703927	1703925	1703923	1705895	1703924	1705921	1703926
22	1705336	1705345	1705348	1705917	1705896	1705347	1705822	1705344
23	1703804	1703951	1703949	1703947	1705898	1703948	1701518	1703950
24	1703805	1703939	1703937	1703935	1705897	1703936	1705961	1703938
25	3252347	1703981	1703982	1703983	1705902	1703984	1705828	1703980
26	3251813	--	3251813	3251813	3251813	3251813	--	3251813
27	--	--	--	--	--	--	--	--
28	--	--	--	--	--	--	--	--
29	1703475	1703475	1703475	1703475	1703475	1703475	1703475	1703475
30	1702631	1702631	1702631	1702631	1702631	1702631	1702631	1702631
31	1704906	1704906	1704906	1704906	1704906	1704906	1704906	1704906
32	1701501	1701501	1701501	1701501	1701501	1701501	1701501	1701501
33	1705088	1704103	1704101	1704098	1706380	1704099	1705978	1704102
34	1707016	1707043	1707045	1707048	1707051	1707046	1705978	1707053
35	1706948	1706948	1706948	1706948	1706948	1706948	--	1706948
36	1700584	1700584	1700584	1700584	1700584	1700584	1700584	1700584



## SECTION 4 - MACHINE OPERATION

Table 4-4. Decal Location Legend, 800S - Side Entry Platform - Prior to S/N 0300143294

Item #	ANSI 0274499-8	Korean 0274501-6	Chinese 0274503-6	Spanish 0274513-6	Portuguese 0274505-7	French 0274507-6	CE/Aus 0274509-3	Japanese 0274511-6
37	1001108496	1001108496	1001108496	1001108496	1001108496	1001108496	--	1001108496
38	1706941	1706941	1706941	1706941	1706941	1706941	--	1706941
39	3252781	3252781	3252781	3252781	3252781	3252781	3252781	3252781
40	1701691	1701691	1701691	1701691	1701691	1701691	1701691	1701691
41	--	--	--	--	--	--	--	--
42	--	--	--	--	--	--	--	--
43	--	--	--	--	--	--	--	--
44	--	--	--	--	--	--	--	--
45	--	--	--	--	--	--	--	--
46	--	--	--	--	--	--	--	--
47	--	--	--	--	--	--	--	--
48	--	--	--	--	--	--	--	--
49	--	--	--	--	--	--	--	--
50	--	--	--	--	--	--	--	--
51	--	--	--	--	--	--	--	--
52	--	--	--	--	--	--	--	--
53	--	--	--	--	--	--	--	--
54	--	--	--	--	--	--	--	--

## SECTION 4 - MACHINE OPERATION

Table 4-4. Decal Location Legend, 800S - Side Entry Platform - Prior to S/N 0300143294

Item #	ANSI 0274499-8	Korean 0274501-6	Chinese 0274503-6	Spanish 0274513-6	Portuguese 0274505-7	French 0274507-6	CE/Aus 0274509-3	Japanese 0274511-6
55	--	--	--	--	--	--	--	--
56	--	--	--	--	--	--	--	--
57	--	--	--	--	--	--	--	--
58	--	--	--	--	--	--	--	--
59	1705351	1705427	1705430	1705910	1705905	1705429	--	1705426

## SECTION 4 - MACHINE OPERATION

Table 4-5. Decal Location Legend, 800S - Side Entry Platform - S/N 0300143294 & B30000153 to S/N 0300182742

Item #	ANSI 0274499-9	Korean 0274501-7	Chinese 0274503-7	Spanish 0274513-7	Portuguese 0274505-8	French 0274507-7	CE/Aus 0274509-3	Japanese 0274511-7
1	--	--	--	--	--	--	--	--
2	1701499	1701499	1701499	1701499	1701499	1701499	1701499	1701499
3	--	--	--	--	--	--	--	--
4	--	--	--	--	--	--	--	--
5	1701509	1701509	1701509	1701509	1701509	1701509	1701509	1701509
6	--	--	--	--	--	--	--	--
7	1703811	1703811	1703811	1703811	1703811	1703811	1703811	1703811
8	1703814	1703814	1703814	1703814	1703814	1703814	1703814	1703814
9	1704277	1704277	1704277	1704277	1704277	1704277	1704277	1704277
10	1704412	1704412	1704412	1704412	1704412	1704412	1704412	1704412
11	--	--	--	--	--	--	1705084	--
12	--	--	--	--	--	--	--	--
13	--	--	--	--	--	--	--	--
14	--	--	--	--	--	--	--	--
15	--	--	--	--	--	--	--	--
16	--	--	--	--	--	--	--	--
17	--	--	1702153	1704007	1705901	1704006	--	--
18	1703953	1703945	1703943	1703941	1705903	1703942	--	1703944

## SECTION 4 - MACHINE OPERATION

**Table 4-5. Decal Location Legend, 800S - Side Entry Platform - S/N 0300143294 & B30000153 to S/N 0300182742**

Item #	ANSI 0274499-9	Korean 0274501-7	Chinese 0274503-7	Spanish 0274513-7	Portuguese 0274505-8	French 0274507-7	CE/Aus 0274509-3	Japanese 0274511-7
19	--	--	--	--	--	--	--	--
20	1702868	1705969	1702868	1704001	1705967	1704000	--	--
21	1703797	1703927	1703925	1703923	1705895	1703924	1705921	1703926
22	1705336	1705345	1705348	1705917	1705896	1705347	1705822	1705344
23	1703804	1703951	1703949	1703947	1705898	1703948	1701518	1703950
24	1703805	1703939	1703937	1703935	1705897	1703936	1705961	1703938
25	3252347	1703981	1703982	1703983	1705902	1703984	1705828	1703980
26	3251813	--	3251813	3251813	3251813	3251813	--	3251813
27	--	--	--	--	--	--	--	--
28	--	--	--	--	--	--	--	--
29	1703475	1703475	1703475	1703475	1703475	1703475	1703475	1703475
30	1702631	1702631	1702631	1702631	1702631	1702631	1702631	1702631
31	1704906	1704906	1704906	1704906	1704906	1704906	1704906	1704906
32	1701501	1701501	1701501	1701501	1701501	1701501	1701501	1701501
33	1001122507	1001122200	1001121809	1001121804	1001121806	1001121802	1705978	1001121807
34	1001122515	1001122201	1001121822	1001121817	1001121819	1001121815	1705978	1001121820
35	1706948	1706948	1706948	1706948	1706948	1706948	--	1706948
36	1700584	1700584	1700584	1700584	1700584	1700584	1700584	1700584

## SECTION 4 - MACHINE OPERATION

Table 4-5. Decal Location Legend, 800S - Side Entry Platform - S/N 0300143294 & B30000153 to S/N 0300182742

Item #	ANSI 0274499-9	Korean 0274501-7	Chinese 0274503-7	Spanish 0274513-7	Portuguese 0274505-8	French 0274507-7	CE/Aus 0274509-3	Japanese 0274511-7
37	1001108496	1001108496	1001108496	1001108496	1001108496	1001108496	--	1001108496
38	1706941	1706941	1706941	1706941	1706941	1706941	--	1706941
39	3252781	3252781	3252781	3252781	3252781	3252781	3252781	3252781
40	1701691	1701691	1701691	1701691	1701691	1701691	1701691	1701691
41	--	--	--	--	--	--	--	--
42	--	--	--	--	--	--	--	--
43	--	--	--	--	--	--	--	--
44	--	--	--	--	--	--	--	--
45	--	--	--	--	--	--	--	--
46	--	--	--	--	--	--	--	--
47	--	--	--	--	--	--	--	--
48	--	--	--	--	--	--	--	--
49	--	--	--	--	--	--	--	--
50	--	--	--	--	--	--	--	--
51	--	--	--	--	--	--	--	--
52	--	--	--	--	--	--	--	--
53	--	--	--	--	--	--	--	--
54	--	--	--	--	--	--	--	--

**SECTION 4 - MACHINE OPERATION**

**Table 4-5. Decal Location Legend, 800S - Side Entry Platform - S/N 0300143294 & B30000153 to S/N 0300182742**

<b>Item #</b>	<b>ANSI 0274499-9</b>	<b>Korean 0274501-7</b>	<b>Chinese 0274503-7</b>	<b>Spanish 0274513-7</b>	<b>Portuguese 0274505-8</b>	<b>French 0274507-7</b>	<b>CE/Aus 0274509-3</b>	<b>Japanese 0274511-7</b>
55	--	--	--	--	--	--	--	--
56	--	--	--	--	--	--	--	--
57	--	--	--	--	--	--	--	--
58	--	--	--	--	--	--	--	--
59	1705351	1705427	1705430	1705910	1705905	1705429	--	1705426

## SECTION 4 - MACHINE OPERATION

Table 4-6. Decal Location Legend, 860SJ - Side Entry Platform - Prior to S/N 0300143294

Item #	ANSI 0274500-8	Korean 0274502-7	Chinese 0274504-7	Spanish 0274514-7	Portuguese 0274506-8	French 0274508-7	CE/Aus 0274510-4	Japanese 0274512-7
1	--	--	--	--	--	--	--	--
2	1701499	1701499	1701499	1701499	1701499	1701499	1701499	1701499
3	--	--	--	--	--	--	--	--
4	--	--	--	--	--	--	--	--
5	1701509	1701509	1701509	1701509	1701509	1701509	1701509	1701509
6	--	--	--	--	--	--	--	--
7	1703811	1703811	1703811	1703811	1703811	1703811	1703811	1703811
8	1703814	1703814	1703814	1703814	1703814	1703814	1703814	1703814
9	1704277	1704277	1704277	1704277	1704277	1704277	1704277	1704277
10	1704412	1704412	1704412	1704412	1704412	1704412	1704412	1704412
11	--	--	--	--	--	--	1705084	--
12	--	--	--	--	--	1705514	--	--
13	--	--	--	--	--	--	--	--
14	--	--	--	--	--	--	--	--
15	--	--	--	--	--	--	--	--
16	--	--	--	--	--	--	--	--
17	1702153	--	--	1704007	1705901	1704006	1704006	--
18	1703953	1703945	1703943	1703941	1705903	1703942	1703942	1703944

**SECTION 4 - MACHINE OPERATION**

**Table 4-6. Decal Location Legend, 860SJ - Side Entry Platform - Prior to S/N 0300143294**

<b>Item #</b>	<b>ANSI 0274500-8</b>	<b>Korean 0274502-7</b>	<b>Chinese 0274504-7</b>	<b>Spanish 0274514-7</b>	<b>Portuguese 0274506-8</b>	<b>French 0274508-7</b>	<b>CE/Aus 0274510-4</b>	<b>Japanese 0274512-7</b>
19	--	--	--	--	--	--	--	--
20	1702868	1705969	1705968	1704001	1705967	1704000	--	--
21	1703797	1703927	1703925	1703923	1705895	1703924	1705921	1703926
22	1705336	1705345	1705348	1705917	1705896	1705347	1705822	1705344
23	1703804	1703951	1703949	1703947	1705898	1703948	1701518	1703950
24	1703805	1703939	1703937	1703935	1705897	1703936	1705961	1703938
25	3252347	1703981	1703982	1703983	1705902	1703984	1705828	1703980
26	3251813	--	3251813	3251813	3251813	3251813	--	3251813
27	--	--	--	--	--	--	--	--
28	--	--	--	--	--	--	--	--
29	1703482	1703482	1703482	1703482	1703482	1703482	1703482	1703472
30	1702631	1702631	1702631	1702631	1702631	1702631	1702631	1702631
31	1704907	1704907	1704907	1704906	1704907	1704907	1704907	1704907
32	1701501	1701501	1701501	1701501	1701501	1701501	1701501	1701501
33	1704995	1001094798	1001094800	1001094802	1001094804	1001094806	1705978	1707059
34	1707015	1001094799	1001094801	1001094803	1001094805	1001094808	1705978	1707054
35	1706948	1706948	1706948	1706948	1706948	1706948	--	1706948
36	1700584	1700584	1700584	1700584	1700584	1700584	1700584	1700584



## SECTION 4 - MACHINE OPERATION

Table 4-6. Decal Location Legend, 860SJ - Side Entry Platform - Prior to S/N 0300143294

Item #	ANSI 0274500-8	Korean 0274502-7	Chinese 0274504-7	Spanish 0274514-7	Portuguese 0274506-8	French 0274508-7	CE/Aus 0274510-4	Japanese 0274512-7
37	1001108496	1001108496	1001108496	1001108496	1001108496	1001108496	--	1001108496
38	1706941	1706941	1706941	1706941	1706941	1706941	--	1706941
39	3252781	3252781	3252781	3252781	3252781	3252781	3252781	3252781
40	1701691	1701691	1701691	1701691	1701691	1701691	1701691	1701691
41	--	--	--	--	--	--	--	--
42	--	--	--	--	--	--	--	--
43	--	--	--	--	--	--	--	--
44	--	--	--	--	--	--	--	--
45	--	--	--	--	--	--	--	--
46	--	--	--	--	--	--	--	--
47	--	--	--	--	--	--	--	--
48	--	--	--	--	--	--	--	--
49	--	--	--	--	--	--	--	--
50	--	--	--	--	--	--	--	--
51	--	--	--	--	--	--	--	--
52	--	--	--	--	--	--	--	--
53	--	--	--	--	--	--	--	--
54	--	--	--	--	--	--	--	--

**SECTION 4 - MACHINE OPERATION**

**Table 4-6. Decal Location Legend, 860SJ - Side Entry Platform - Prior to S/N 0300143294**

Item #	ANSI 0274500-8	Korean 0274502-7	Chinese 0274504-7	Spanish 0274514-7	Portuguese 0274506-8	French 0274508-7	CE/Aus 0274510-4	Japanese 0274512-7
55	--	--	--	--	--	--	--	--
56	--	--	--	--	--	--	--	--
57	--	--	--	--	--	--	--	--
58	--	--	--	--	--	--	--	--
59	1705351	1705427	1705430	1705910	1705905	1705429	--	1705426

## SECTION 4 - MACHINE OPERATION

Table 4-7. Decal Location Legend, 860SJ - Side Entry Platform - S/N 0300143294 & B300000153 to S/N 0300182742

Item #	ANSI 0274500-9	Korean 0274502-8	Chinese 0274504-8	Spanish 0274514-8	Portuguese 0274506-9	French 0274508-8	CE/Aus 0274510-4	Japanese 0274512-8
1	--	--	--	--	--	--	--	--
2	1701499	1701499	1701499	1701499	1701499	1701499	1701499	1701499
3	--	--	--	--	--	--	--	--
4	--	--	--	--	--	--	--	--
5	1701509	1701509	1701509	1701509	1701509	1701509	1701509	1701509
6	--	--	--	--	--	--	--	--
7	1703811	1703811	1703811	1703811	1703811	1703811	1703811	1703811
8	1703814	1703814	1703814	1703814	1703814	1703814	1703814	1703814
9	1704277	1704277	1704277	1704277	1704277	1704277	1704277	1704277
10	1704412	1704412	1704412	1704412	1704412	1704412	1704412	1704412
11	--	--	--	--	--	--	1705084	--
12	--	--	--	--	--	1705514	--	--
13	--	--	--	--	--	--	--	--
14	--	--	--	--	--	--	--	--
15	--	--	--	--	--	--	--	--
16	--	--	--	--	--	--	--	--
17	1702153	--	--	1704007	1705901	1704006	1704006	--
18	1703953	1703945	1703943	1703941	1705903	1703942	1703942	1703944

**SECTION 4 - MACHINE OPERATION**

**Table 4-7. Decal Location Legend, 860SJ - Side Entry Platform - S/N 0300143294 & B300000153 to S/N 0300182742**

Item #	ANSI 0274500-9	Korean 0274502-8	Chinese 0274504-8	Spanish 0274514-8	Portuguese 0274506-9	French 0274508-8	CE/Aus 0274510-4	Japanese 0274512-8
19	--	--	--	--	--	--	--	--
20	1702868	1705969	1705968	1704001	1705967	1704000	--	--
21	1703797	1703927	1703925	1703923	1705895	1703924	1705921	1703926
22	1705336	1705345	1705348	1705917	1705896	1705347	1705822	1705344
23	1703804	1703951	1703949	1703947	1705898	1703948	1701518	1703950
24	1703805	1703939	1703937	1703935	1705897	1703936	1705961	1703938
25	3252347	1703981	1703982	1703983	1705902	1703984	1705828	1703980
26	3251813	--	3251813	3251813	3251813	3251813	--	3251813
27	--	--	--	--	--	--	--	--
28	--	--	--	--	--	--	--	--
29	1703482	1703482	1703482	1703482	1703482	1703482	1703482	1703472
30	1702631	1702631	1702631	1702631	1702631	1702631	1702631	1702631
31	1704907	1704907	1704907	1704906	1704907	1704907	1704907	1704907
32	1701501	1701501	1701501	1701501	1701501	1701501	1701501	1701501
33	1001122508	1001122509	1001122510	1001122511	1001122512	1001122513	1705978	1001122514
34	1001122516	1001122517	1001122518	1001122519	1001122520	1001122521	1705978	1001122522
35	1706948	1706948	1706948	1706948	1706948	1706948	--	1706948
36	1700584	1700584	1700584	1700584	1700584	1700584	1700584	1700584

## SECTION 4 - MACHINE OPERATION

Table 4-7. Decal Location Legend, 860SJ - Side Entry Platform - S/N 0300143294 & B300000153 to S/N 0300182742

Item #	ANSI 0274500-9	Korean 0274502-8	Chinese 0274504-8	Spanish 0274514-8	Portuguese 0274506-9	French 0274508-8	CE/Aus 0274510-4	Japanese 0274512-8
37	1001108496	1001108496	1001108496	1001108496	1001108496	1001108496	--	1001108496
38	1706941	1706941	1706941	1706941	1706941	1706941	--	1706941
39	3252781	3252781	3252781	3252781	3252781	3252781	3252781	3252781
40	1701691	1701691	1701691	1701691	1701691	1701691	1701691	1701691
41	--	--	--	--	--	--	--	--
42	--	--	--	--	--	--	--	--
43	--	--	--	--	--	--	--	--
44	--	--	--	--	--	--	--	--
45	--	--	--	--	--	--	--	--
46	--	--	--	--	--	--	--	--
47	--	--	--	--	--	--	--	--
48	--	--	--	--	--	--	--	--
49	--	--	--	--	--	--	--	--
50	--	--	--	--	--	--	--	--
51	--	--	--	--	--	--	--	--
52	--	--	--	--	--	--	--	--
53	--	--	--	--	--	--	--	--
54	--	--	--	--	--	--	--	--

**SECTION 4 - MACHINE OPERATION**

**Table 4-7. Decal Location Legend, 860SJ - Side Entry Platform - S/N 0300143294 & B300000153 to S/N 0300182742**

<b>Item #</b>	<b>ANSI 0274500-9</b>	<b>Korean 0274502-8</b>	<b>Chinese 0274504-8</b>	<b>Spanish 0274514-8</b>	<b>Portuguese 0274506-9</b>	<b>French 0274508-8</b>	<b>CE/Aus 0274510-4</b>	<b>Japanese 0274512-8</b>
55	--	--	--	--	--	--	--	--
56	--	--	--	--	--	--	--	--
57	--	--	--	--	--	--	--	--
58	--	--	--	--	--	--	--	--
59	1705351	1705427	1705430	1705910	1705905	1705429	--	1705426

## SECTION 5. EMERGENCY PROCEDURES

### 5.1 GENERAL

This section explains the steps to be taken in case of an emergency situation while operating.

### 5.2 INCIDENT NOTIFICATION

JLG Industries, Inc. must be notified immediately of any incident involving a JLG product. Even if no injury or property damage is evident, the factory should be contacted by telephone and provided with all necessary details.

In USA:

JLG Phone: 877-JLG-SAFE (554-7233)  
(8am till 4:45pm EST)

Outside USA:  
240-420-2661

E-mail:

ProductSafety@JLG.com

Failure to notify the manufacturer of an incident involving a JLG Industries product within 48 hours of such an occurrence may void any warranty consideration on that particular machine.

### NOTICE

**FOLLOWING ANY ACCIDENT, THOROUGHLY INSPECT THE MACHINE AND TEST ALL FUNCTIONS FIRST FROM THE GROUND CONTROLS, THEN FROM THE PLATFORM CONTROLS. DO NOT LIFT ABOVE 3 M (10 FT.) UNTIL YOU ARE SURE THAT ALL DAMAGE HAS BEEN REPAIRED, IF REQUIRED, AND THAT ALL CONTROLS ARE OPERATING CORRECTLY.**

### 5.3 EMERGENCY OPERATION

#### Operator Unable to Control Machine

IF THE PLATFORM OPERATOR IS PINNED, TRAPPED OR UNABLE TO OPERATE OR CONTROL MACHINE:

1. Other personnel should operate the machine from ground controls only as required.
2. Other qualified personnel on the platform may use the platform controls. DO NOT CONTINUE OPERATION IF CONTROLS DO NOT FUNCTION PROPERLY.
3. Cranes, forklift trucks or other equipment can be used to remove platform occupants and stabilize motion of the machine.

### Platform or Boom Caught Overhead

If the platform or boom becomes jammed or snagged in overhead structures or equipment, rescue platform occupants prior to freeing the machine.

### 5.4 EMERGENCY TOWING PROCEDURES

Towing this machine is prohibited, unless properly equipped. However, provisions for moving the machine have been incorporated. For specific procedures, refer to Section 4.

### 5.5 MANUAL DESCENT INSTRUCTIONS (IF EQUIPPED)

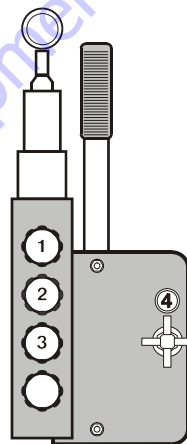

#### **NOTICE**

**PLATFORM WILL NOT REMAIN LEVEL DURING MANUAL DESCENT OPERATION.**



## To Retract and Lower Boom

1. Turn knob #1 and #4 clockwise until tight.
2. Turn knobs #2 and #3 counterclockwise 3 turns.
3. Pump the hand pump until tight.
4. After telescope has fully retracted turn knob #4 counterclockwise until fully open to continue lowering boom.

## To Lower Boom with Fully Retracted Telescope

1. Turn knob #1 and #3 clockwise until tight.
2. Turn knob #2 counterclockwise 3 turns.
3. Turn knob #4 counterclockwise until fully open.
4. Pump the hand pump until tight.

**NOTE:** When the manual descent operation has been completed, knobs #1, #2, and #3 should be open (counterclockwise), knob #4 should be closed (clockwise).

**TO PURCHASE THIS PRODUCT PLEASE CONTACT US**



**Equipment Financing and  
Extended Warranties Available**



**Discount-Equipment.com is your online resource for  
commercial and industrial quality parts and equipment sales.**

**561-964-4949**

**visit us on line @ [www.discount-equipment.com](http://www.discount-equipment.com)**

Select an option below to find your Equipment

**Search by Manufacturer**

**Search by Product Type**

**Request a Quote**

We sell worldwide for the brands: Genie, Terex, JLG, MultiQuip, Mikasa, Essick, Whiteman, Mayco, Toro Stone, Diamond Products, Generac Magnum, Airman, Haulotte, Barreto, Power Blanket, Nifty Lift, Atlas Copco, Chicago Pneumatic, Allmand, Miller Curber, Skyjack, Lull, Skytrak, Tsurumi, Husquvarna Target, Stow, Wacker, Sakai, Mi-T-M, Sullair, Basic, Dynapac, MBW, Weber, Bartell, Bennar Newman, Haulotte, Ditch Runner, Menegotti, Morrison, Contec, Buddy, Crown, Edco, Wyco, Bomag, Laymor, EZ Trench, Bil-Jax, F.S. Curtis, Gehl Pavers, Heli, Honda, ICS/PowerGrit, IHI, Partner, Imer, Clipper, MMD, Koshin, Rice, CH&E, General Equipment, Amida, Coleman, NAC, Gradall, Square Shooter, Kent, Stanley, Tamco, Toku, Hatz, Kohler, Robin, Wisconsin, Northrock, Oztec, Toker TK, Rol-Air, APT, Wylie, Ingersoll Rand / Doosan, Innovatech, Con X, Ammann, Mecalac, Makinex, Smith Surface Prep, Small Line, Wanco, Yanmar

## SECTION 6. GENERAL SPECIFICATIONS & OPERATOR MAINTENANCE

### 6.1 INTRODUCTION

This section of the manual provides additional necessary information to the operator for proper operation and maintenance of this machine.

The maintenance portion of this section is intended as information to assist the machine operator to perform daily maintenance tasks only, and does not replace the more thorough Preventive Maintenance and Inspection Schedule included in the Service and Maintenance Manual.

#### Other Publications Available:

Service and Maintenance Manual .....	3121139
Illustrated Parts Manual (ANSI, CSA Spec) .....	3121140
Illustrated Parts Manual (Global) .....	3121270
Illustrated Parts Manual (CE Spec).....	3121842

### 6.2 OPERATING SPECIFICATIONS

**Table 6-1. Operating Specifications - Prior to S/N 0300143294**

Maximum Work Load (Capacity) Unrestricted: Restricted	500 lb (230 kg) Refer to Capacity Decals on machine for restricted platform capacities
Maximum Capacity - Dual Rating 800S 860SJ	1000 lb. (450 kg) 750 lb. (340 kg)
Maximum Travel Grade (Gradeability)* 2WD 4WD	30% 45%
Maximum Travel Grade (Side Slope)*	5°
Maximum Vertical Platform Height:	800S - 80 ft. (24.3 m) 860SJ - 86 ft. (26.2 m)
Maximum Horizontal Platform Reach 800S 860SJ	71 ft. (21.6 m) 75 ft. (22.9 m)
Turning Radius (outside)	22 ft. 6 in. (6.8 m)
Turning Radius (inside)	12 ft. (3.6 m)

## SECTION 6 - GENERAL SPECIFICATIONS & OPERATOR MAINTENANCE

**Table 6-1. Operating Specifications - Prior to S/N 0300143294**

Maximum Drive Speed:	3.5 mph (1.5 m/s)
Max. Hydraulic System Pressure	4500 psi (310 Bar)
Maximum Wind Speed	28 mph (12.5 m/s)
Maximum Manual Force	400 N
Electrical System Voltage	12 Volts
Gross Machine Weight (Platform Empty)	
800S	34,700 lbs. (15,740 kg)
860SJ	37,900 lbs. (17,191 kg)

\* With boom in stowed position

**Table 6-2. Operating Specifications - S/N 0300143294 & B300000153 to S/N 0300182742**

Maximum Work Load (Capacity) ANSI Unrestricted: Restricted	500 lb (227 kg) Refer to Capacity Decals on machine for restricted platform capacities
Maximum Work Load (Capacity) CE & Australia Unrestricted: Restricted	500 lb (230 kg) Refer to Capacity Decals on machine for restricted platform capacities
Maximum Capacity - Dual Rating ANSI 800S 860SJ	1000 lb. (454 kg) 750 lb. (340 kg)
Maximum Capacity - Dual Rating CE & Australia 800S 860SJ	1000 lb. (450 kg) 750 lb. (340 kg)
Maximum Travel Grade (Gradeability)* 2WD 4WD	30% 45%

## SECTION 6 - GENERAL SPECIFICATIONS & OPERATOR MAINTENANCE

**Table 6-2. Operating Specifications - S/N 0300143294 & B300000153 to S/N 0300182742**

Maximum Travel Grade (Side Slope)*	5°
Maximum Vertical Platform Height:	800S - 80 ft. (24.3 m) 860SJ - 86 ft. (26.2 m)
Maximum Horizontal Platform Reach	800S 71 ft. (21.6 m) 860SJ 75 ft. (22.9 m)
Turning Radius (outside)	22 ft. 6 in. (6.8 m)
Turning Radius (inside)	12 ft. (3.6 m)
Maximum Drive Speed:	3.5 mph (1.5 m/s)
Max. Hydraulic System Pressure	4500 psi (310 Bar)
Maximum Wind Speed	28 mph (12.5 m/s)
Maximum Manual Force	400 N
Electrical System Voltage	12 Volts
Gross Machine Weight (Platform Empty)	800S 34,700 lbs. (15,740 kg) 860SJ 37,900 lbs. (17,191 kg)

\* With boom in stowed position

## Specifications and Performance Data

**Table 6-3. Specifications and Performance Data**

Swing	360°
Tail Swing	4'8" (1.42 m)
Platforms	36" x 72" (0.91m x 1.83m) 36" x 96" (0.91m x 2.44m)
Overall Width	8' 2" (2.5 m)
Stowed Height	800S 9' 10.6" (3.01 m) 860SJ 10' (3.04 m)
Stowed Length	800S 37' 3.25" (11.4 m) 860SJ 40' (12.2 m)
Wheel base	10' (3.04 m)
Ground Clearance	15.625" (0.4 m)
Drive Speed	Stowed 2WD 3.0 mph (5.5 kph) Stowed 4WD 3.5 mph (5.6 kph) Elevated 0.75 mph (1.2 kph)

## SECTION 6 - GENERAL SPECIFICATIONS & OPERATOR MAINTENANCE

**Table 6-3. Specifications and Performance Data**

Ground Bearing Pressure - 800S	
15-625	72 psi (5.0 kgm/cm <sup>2</sup> )
15-625FF	79 psi (5.5 kgm/cm <sup>2</sup> )
41/18LLx22.5	68 psi (4.8 kgm/cm <sup>2</sup> )
Ground Bearing Pressure - 860SJ	
15-625	81 psi (5.7 kgm/cm <sup>2</sup> )
15-625FF	92 psi (6.5 kgm/cm <sup>2</sup> )
41/18LLx22.5	79 psi (5.5 kgm/cm <sup>2</sup> )
Max. Tire Load - 800S	17,350 lbs. (7870 kg)
Max. Tire Load - 860SJ	20,200 lbs. (9163 kg)

## Capacities

**Table 6-4. Capacities**

Fuel Tank	Approx. 31 gallons (117 liters)
Fuel Tank (Optional)	Approx. 52.8 gallons (200 liters)
Hydraulic Tank	Approx. 47.8 gallons (181 liters)
Engine Oil Capacity	
Ford	4.5 Quarts (4.25 L) w/Filter
Deutz	
Cooling System	5 Quarts (4.5 L)
Crankcase	11 Quarts (10.5 L) w/Filter
Total Capacity	16 Quarts (15 L)
Caterpillar	10.6 quarts (10 L)
GM	4.5 Quarts (4.25 L) w/Filter

## SECTION 6 - GENERAL SPECIFICATIONS & OPERATOR MAINTENANCE

### Engine Data

**Table 6-5. Ford LRG-425 Specifications**

Type	Water-cooled
Fuel	Gasoline
Oil Capacity	4.5 Quarts (4.25 L) w/Filter
Idle RPM	1000
Low RPM	1800
High RPM	2800
Alternator	95 Amp, Belt Drive
Fuel Consumption	
Low RPM	3.45 GPH (13.06 lph)
High RPM	4.60 GPH (17.41 lph)
Horsepower	74 @ 3000 RPM, full load
Cooling System	16 Quarts (15.14 L)
Spark Plug	AWSF-52-C
Spark Plug Gap	0.044 in. (1.117 mm)

**Table 6-6. Deutz F4M2011 Specifications**

Type	Liquid Cooled (Oil)
Fuel	Diesel
Oil Capacity	
Cooling System	5 Quarts (4.5 L)
Crankcase	11 Quarts (10.5 L) w/Filter
Total Capacity	16 Quarts (15 L)
Idle RPM	1000
Low RPM	1800
High RPM	2800
Alternator	55 Amp, belt drive
Fuel Consumption	
Low RPM	1.90 GPH (7.19 lph)
High RPM	2.50 GPH (9.46 lph)
Horsepower	66 @ 3000 RPM, full load

## SECTION 6 - GENERAL SPECIFICATIONS & OPERATOR MAINTENANCE

**Table 6-7. Deutz D2011L04 Specifications**

Type	Liquid Cooled (Oil)
Fuel	Diesel
Oil Capacity	5 Quarts (4.5 L)
Cooling System	11 Quarts (10.5 L) w/Filter
Crankcase	16 Quarts (15 L)
Total Capacity	
Idle RPM	1000
Low RPM	1800
High RPM	2600
Alternator	55 Amp, belt drive
Fuel Consumption	
Low RPM	1.90 GPH (7.19 lph)
High RPM	2.50 GPH (9.46 lph)
Battery	1000 Cold Cranking Amps, 210 minutes Reserve Capacity, 12VDC
Horsepower	64 @ 2600 RPM, full load

**Table 6-8. Caterpillar 3044C/ Caterpillar 3.4**

Type	Four Stroke Cycle
Cylinders	4 in-line
Bore	3.70 inch (94 mm)
Stroke	4.72 inch (120 mm)
Aspiration	turbocharged
Compression ratio	19:1
Displacement	203 in <sup>3</sup> (3.33 L)
Firing Order	1-3-4-2
Rotation (viewed from flywheel)	Counterclockwise
Oil Capacity (w/filter)	10.6 quarts (10 L)
Cooling System (Engine Only)	5.8 quarts (5.5 L)
Idle RPM	1000
Low RPM	1800
High RPM - 3044C	2600
High RPM - 3.4	2500
Alternator	60 Amp, belt drive



## SECTION 6 - GENERAL SPECIFICATIONS & OPERATOR MAINTENANCE

**Table 6-9. GM 3.0L**

Fuel	Gasoline or Gasoline/LP Gas
No. of Cylinders	4
BHP	
Gasoline	83 hp @ 3000 rpm
LP	75 hp @ 3000 rpm
Bore	4.0 in. (101.6 mm)
Stroke	3.6 in. (91.44 mm)
Displacement	181 cu.in. (3.0 L, 2966 cc)
Oil Capacity w/filter	4.5 qts. (4.25 L)
Minimum Oil Pressure	
at idle	6 psi (0.4 Bar) @ 1000 rpm
Hot	18 psi (1.2 Bar) @ 2000 rpm
Compression Ratio	9.2:1
Firing Order	1-3-4-2
Max. RPM	2800

### Battery

**Table 6-10. Battery Specifications**

Voltage	12 Volt
Type	31-950
Cold Cranking Amps	950 CCA @ 0° F (-18° C)
Reserve Capacity	205 Minutes @ 80° F (27° C)

### Tires

**Table 6-11. Tire Specifications**

Size	Type	Ply Rating	Load Range	Weight (Tire & Wheel)
15 - 625	Pneumatic 95 psi (6.5 Bar)	16	H	269 lbs. (122 kg)
15 - 625	Foam-Filled	16	H	544 lbs. (247 kg)
18 - 625	Pneumatic 85 psi (6.5 Bar)	16	H	288 lbs. (131 kg)
18 - 625	Foam-Filled	16	H	601 lbs. (273 kg)
41/ 18LL x 22.5	Foam-Filled	16	H	724 lbs. (329 kg)

## Major Component Weights

**Table 6-12. Component Weights**

Component	Pounds	Kilograms
Turntable (bare)	3700	1678
Counterweight (800S)	7000	3175
Counterweight (860SJ)	8750	3969
Upright	1050	476
Tower	685	311
Fly Boom (SJ)	472	214
Fly Boom (S)	490	222
Mid Boom (SJ)	750	340
Mid Boom (S)	740	336
Base Boom (SJ)	1400	635
Base Boom (S)	1410	640
Boom Assembly	3337	1514
Telescope Cylinder (800S)	590	268
Telescope Cylinder (860SJ)	570	259
Slave Cylinder	73	33
Torque Hub (2WD)	218	99
Tire & Wheel (pneu)	269	122
Tire & Wheel (FF)	544	247

## Hydraulic Oil

**Table 6-13. Hydraulic Oil**

Hydraulic System Operating Temperature Range	S.A.E. Viscosity Grade
+0° to +180° F (-18° to +83° C)	10W
+0° to +210° F (-18° to +99° C)	10W-20, 10W30
+50° to +210° F (+10° to +99° C)	20W-20

**NOTE:** Hydraulic oils must have anti-wear qualities at least to API Service Classification GL-3, and sufficient chemical stability for mobile hydraulic system service. JLG Industries recommends Mobilfluid 424 hydraulic oil, which has an SAE viscosity index of 152.

**NOTE:** When temperatures remain consistently below 20 degrees F. (-7 degrees C.), JLG Industries recommends the use of Mobil DTE13.

## SECTION 6 - GENERAL SPECIFICATIONS & OPERATOR MAINTENANCE

Aside from JLG recommendations, it is not advisable to mix oils of different brands or types, as they may not contain the same required additives or be of comparable viscosities. If use of hydraulic oil other than Mobilfluid 424 is desired, contact JLG Industries for proper recommendations.

**Table 6-14. Mobilfluid 424 Specs**

SAE Grade	10W30
Gravity, API	29.0
Density, Lb/Gal. 60°F	7.35
Pour Point, Max	-46°F (-43°C)
Flash Point, Min.	442°F (228°C)
Viscosity	
Brookfield, cP at -18°C	2700
at 40° C	55 cSt
at 100° C	9.3 cSt
Viscosity Index	152

**Table 6-15. Mobil DTE 13M Specs**

ISO Viscosity Grade	#32
Specific Gravity	0.877
Pour Point, Max	-40°F (-40°C)
Flash Point, Min.	330°F (166°C)
Viscosity	
at 40° C	33cSt
at 100° C	6.6 cSt
at 100° F	169 SUS
at 210° F	48 SUS
cp at -20° F	6,200
Viscosity Index	140

## SECTION 6 - GENERAL SPECIFICATIONS & OPERATOR MAINTENANCE

**Table 6-16. Mobil EAL 224H Specs**

Type	Synthetic Biodegradable
ISO Viscosity Grade	32/46
Specific Gravity	.922
Pour Point, Max	-25°F (-32°C)
Flash Point, Min.	428°F (220°C)
Operating Temp.	0 to 180°F (-17 to 162°C)
Weight	7.64 lb. per gal. (0.9 kg per liter)
Viscosity	
at 40° C	37 cSt
at 100° C	8.4 cSt
Viscosity Index	213
<b>NOTE:</b> Must be stored above 32°F (14°C)	

**Table 6-17. UCon Hydrolube HP-5046**

Type	Synthetic Biodegradable
Specific Gravity	1.082
Pour Point, Max	-58°F (-50°C)
pH	9.1
Viscosity	
at 0° C (32° F)	340 cSt (1600SUS)
at 40° C (104° F)	46 cSt (215SUS)
at 65° C (150° F)	22 cSt (106SUS)
Viscosity Index	170

Table 6-18. Exxon Univis HVI 26 Specs

Specific Gravity	32.1
Pour Point	-76°F (-60°C)
Flash Point	217°F (103°C)
Viscosity	
at 40° C	25.8 cSt
at 100° C	9.3 cSt
Viscosity Index	376
<b>NOTE:</b> Mobil/Exxon recommends that this oil be checked on a yearly basis for viscosity.	

### 6.3 SERIAL NUMBER LOCATION

A serial number plate is affixed to the left rear side of the frame. If the serial number plate is damaged or missing, the machine serial number is stamped on the left side of the frame.

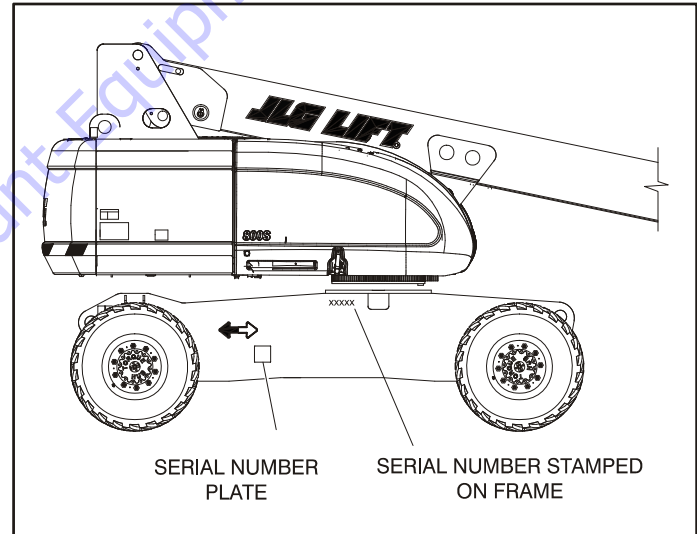

Figure 6-1. Serial Number Locations

# SECTION 6 - GENERAL SPECIFICATIONS & OPERATOR MAINTENANCE

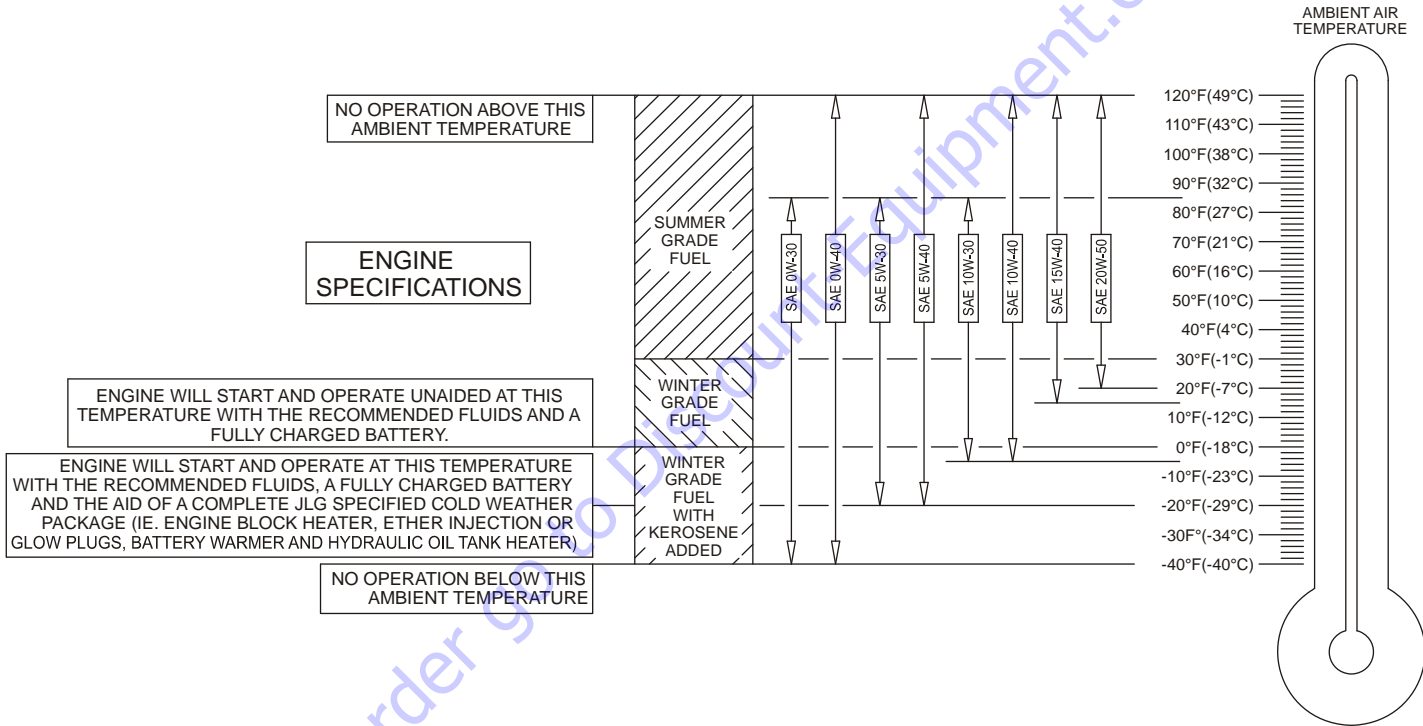

Figure 6-2. Engine Operating Temperature Specifications - Deutz - Sheet 1 of 2

# SECTION 6 - GENERAL SPECIFICATIONS & OPERATOR MAINTENANCE

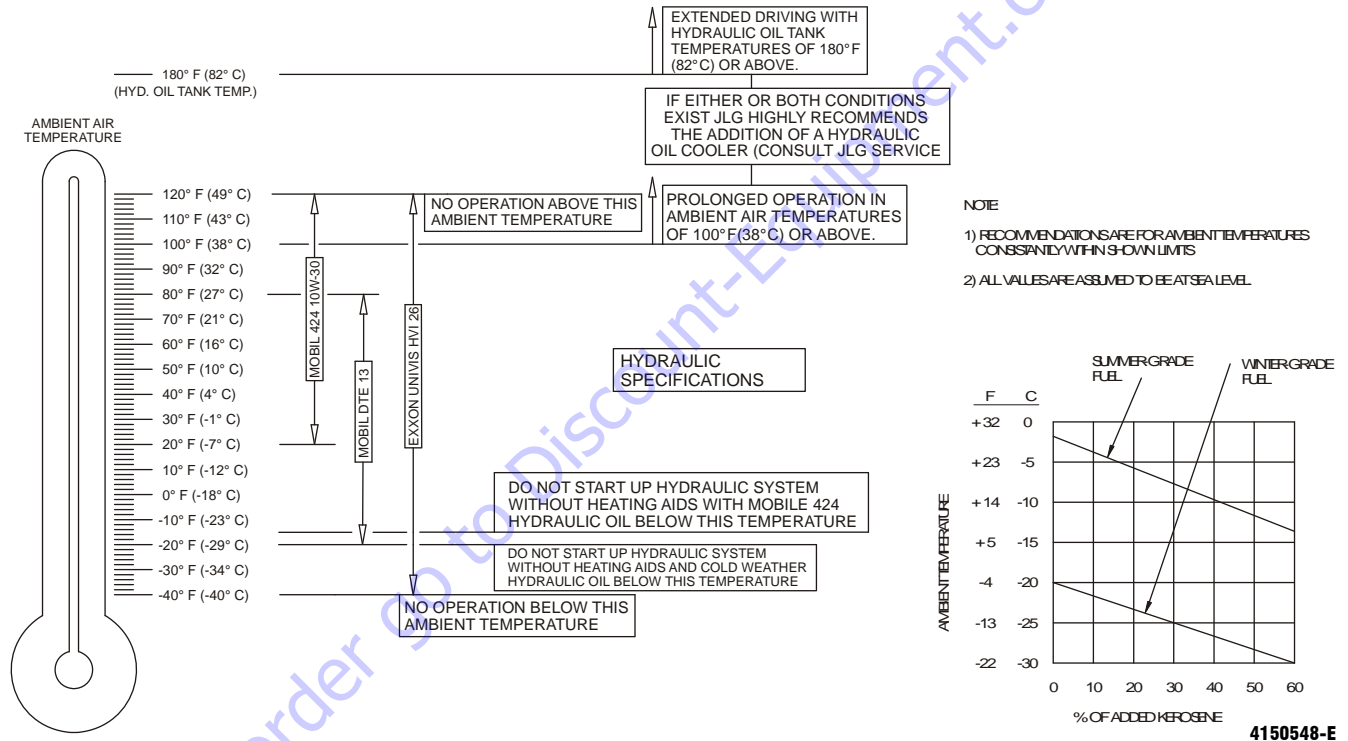

Figure 6-3. Engine Operating Temperature Specifications - Deutz - Sheet 2 of 2

## SECTION 6 - GENERAL SPECIFICATIONS & OPERATOR MAINTENANCE

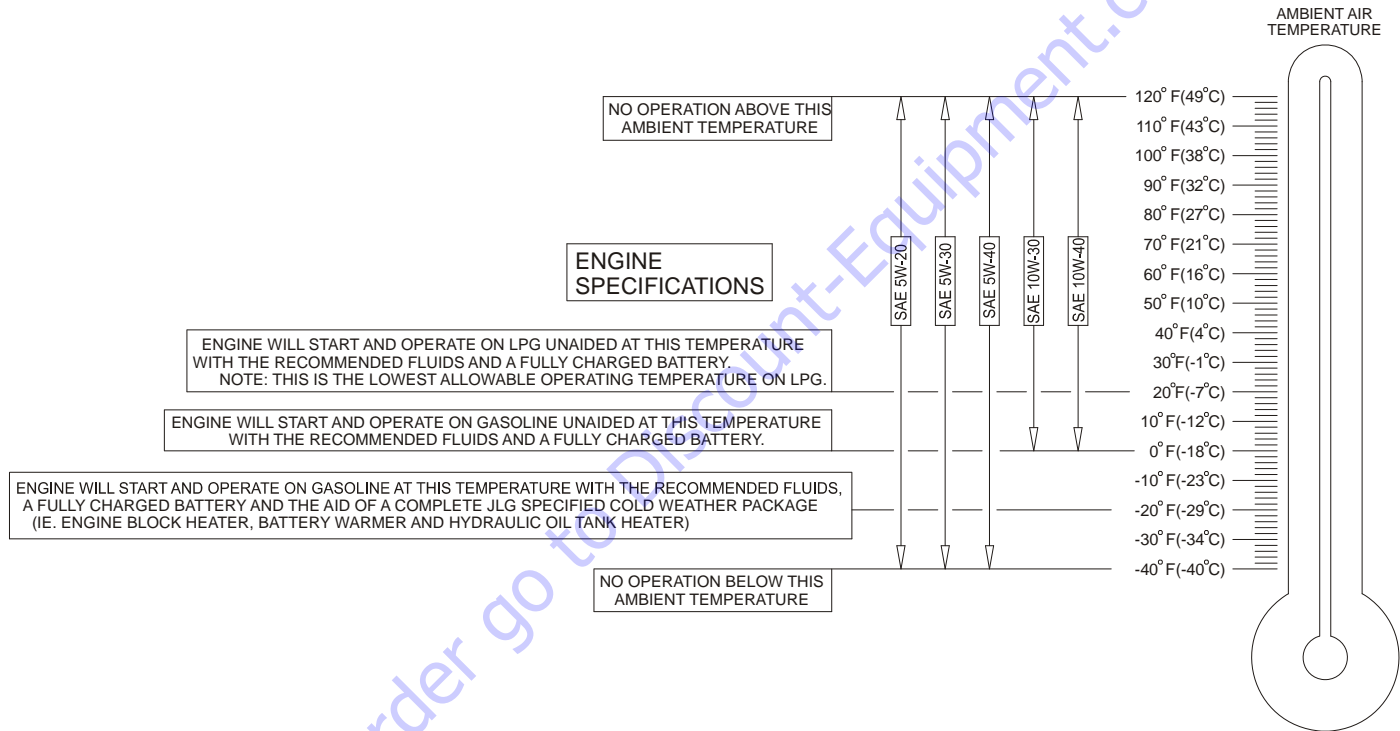
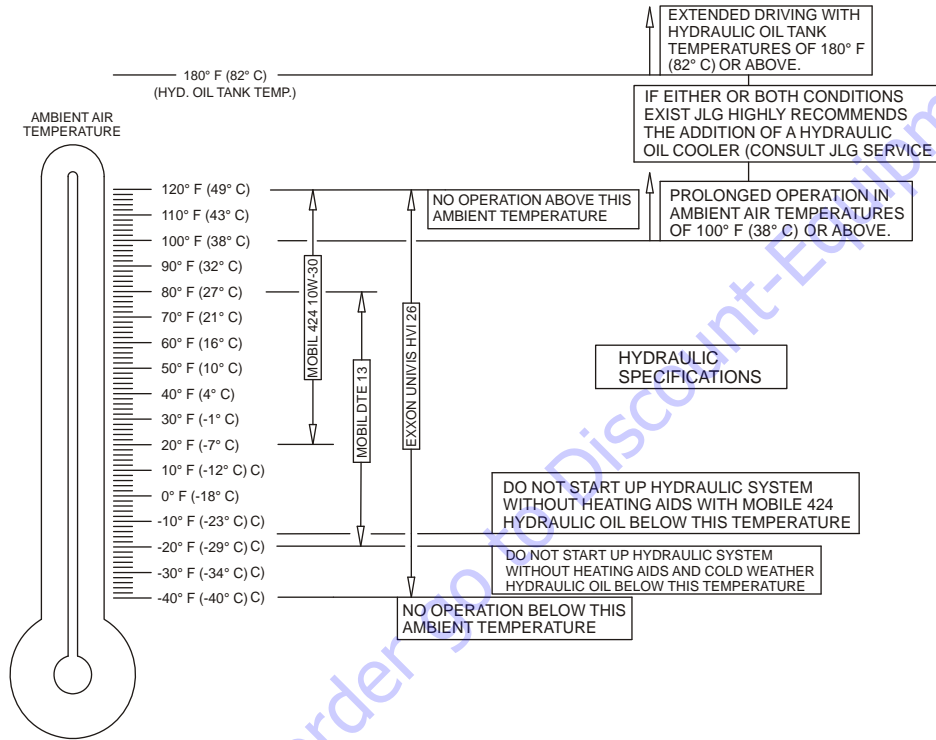

Figure 6-4. Engine Operating Temperature Specifications - Ford - Sheet 1 of 2



# SECTION 6 - GENERAL SPECIFICATIONS & OPERATOR MAINTENANCE



NOTE:

- 1) RECOMMENDATIONS ARE FOR AMBIENT TEMPERATURES CONSISTANTLY WITHIN SHOWN LIMITS
- 2) ALL VALUES ARE ASSUMED TO BE AT SEA LEVEL.

Figure 6-5. Engine Operating Temperature Specifications - Ford - Sheet 2 of 2

4150548-E

# SECTION 6 - GENERAL SPECIFICATIONS & OPERATOR MAINTENANCE

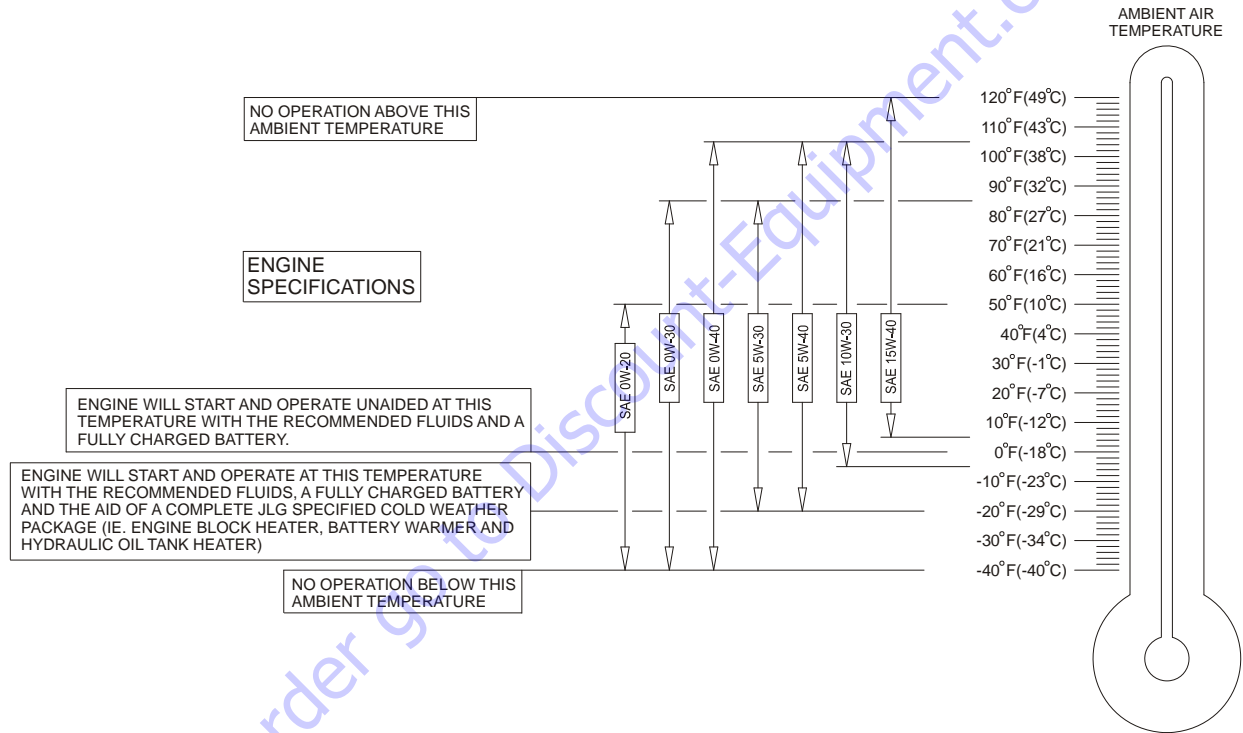
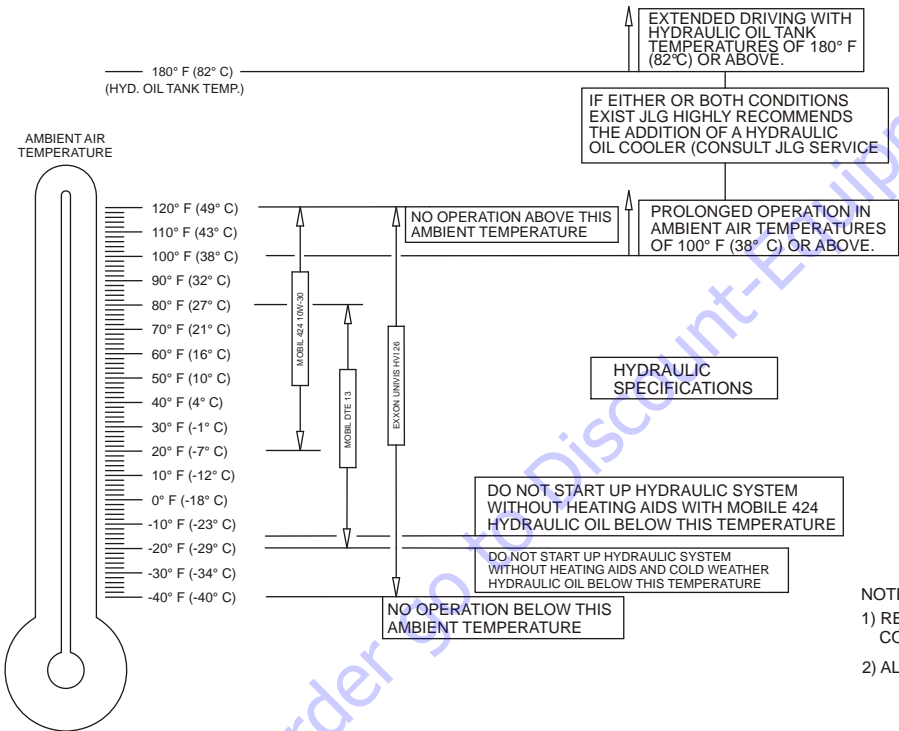

Figure 6-6. Engine Operating Temperature Specifications - Caterpillar - Sheet 1 of 2

# SECTION 6 - GENERAL SPECIFICATIONS & OPERATOR MAINTENANCE



- NOTE:
- 1) RECOMMENDATIONS ARE FOR AMBIENT TEMPERATURES CONSISTENTLY WITHIN SHOWN LIMITS
  - 2) ALL VALUES ARE ASSUMED TO BE AT SEA LEVEL.

Figure 6-7. Engine Operating Temperature Specifications - Caterpillar - Sheet 2 of 2

4150548-E

## SECTION 6 - GENERAL SPECIFICATIONS & OPERATOR MAINTENANCE

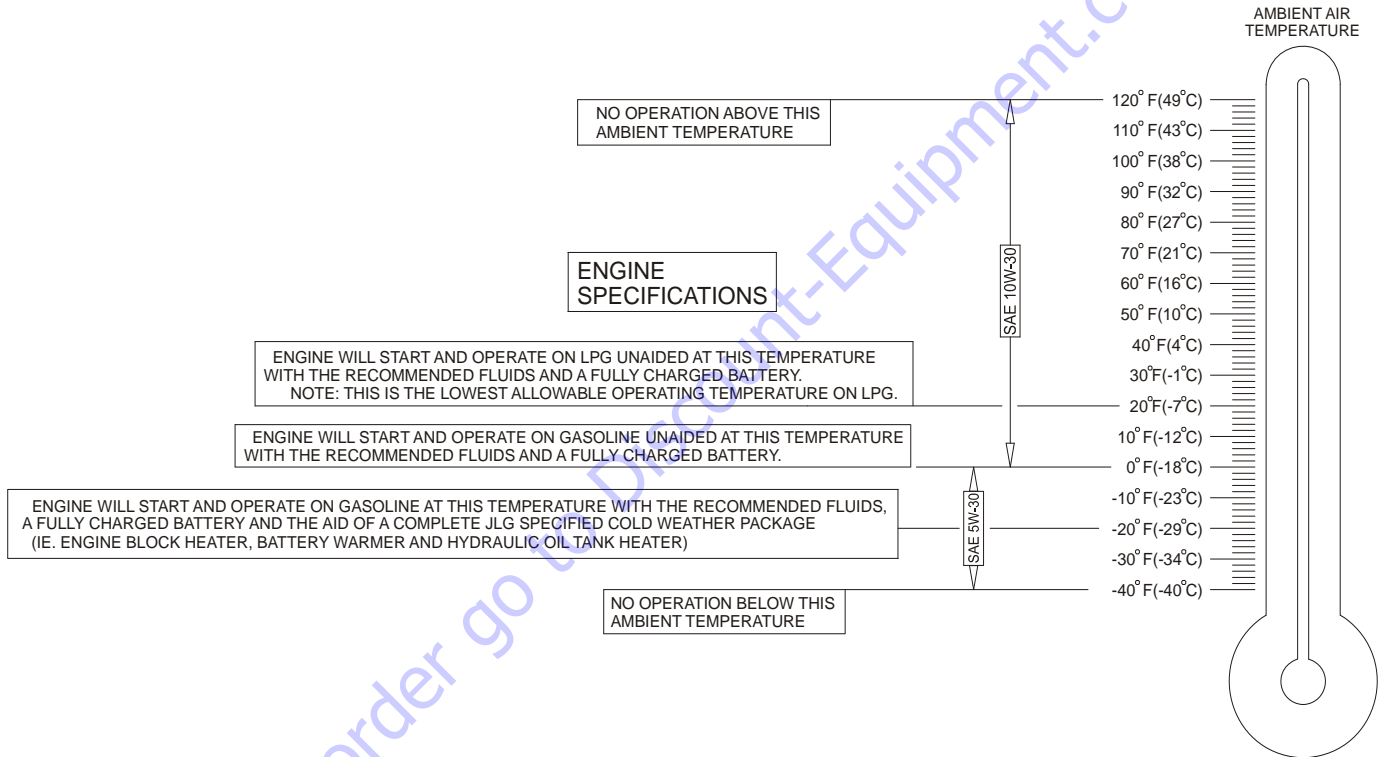
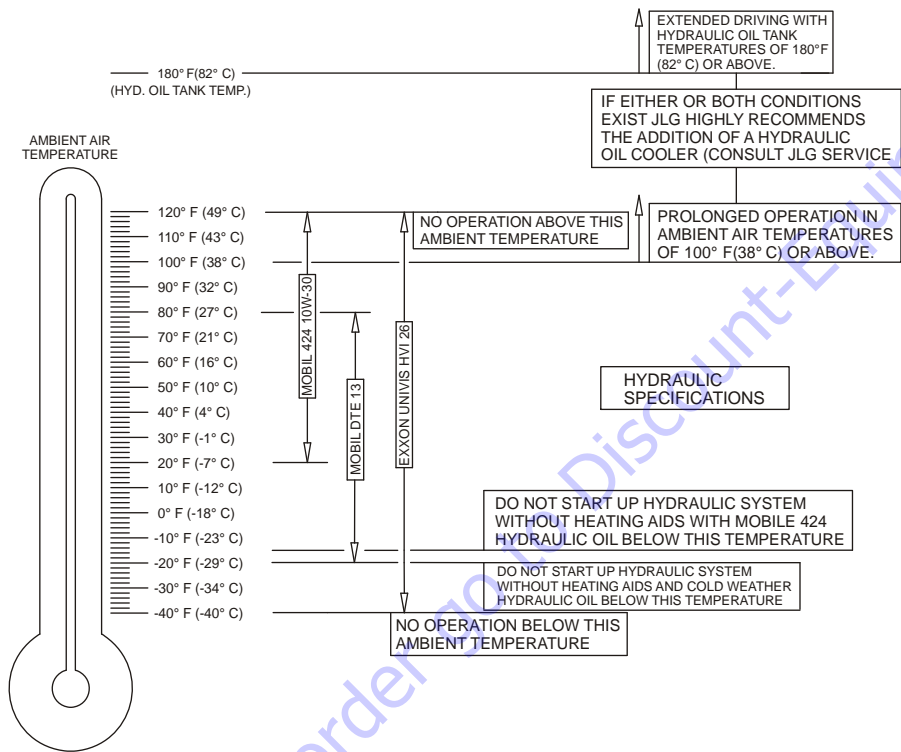

Figure 6-8. Engine Operating Temperature Specifications - GM - Sheet 1 of 2

## SECTION 6 - GENERAL SPECIFICATIONS & OPERATOR MAINTENANCE



NOTE:

- 1) RECOMMENDATIONS ARE FOR AMBIENT TEMPERATURES CONSISTENTLY WITHIN SHOWN LIMITS
- 2) ALL VALUES ARE ASSUMED TO BE AT SEA LEVEL.

**Figure 6-9. Engine Operating Temperature Specifications - GM - Sheet 2 of 2**

4150548-E

## SECTION 6 - GENERAL SPECIFICATIONS & OPERATOR MAINTENANCE

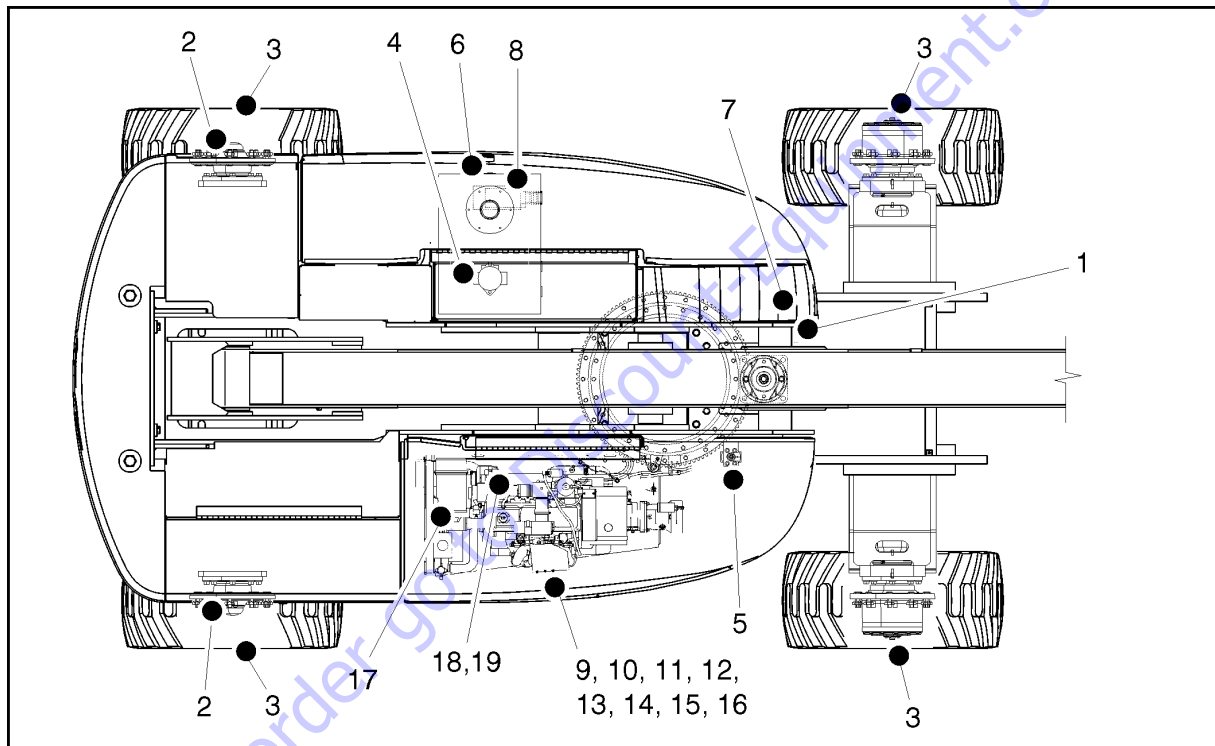

## SECTION 6 - GENERAL SPECIFICATIONS & OPERATOR MAINTENANCE

### 6.4 OPERATOR MAINTENANCE

**NOTE:** The following numbers correspond to those in Figure 6-10., Operator Maintenance and Lubrication Diagram.

**Table 6-19. Lubrication Specifications**

KEY	SPECIFICATIONS
MPG	Multipurpose Grease having a minimum dripping point of 350° F (177° C). Excellent water resistance and adhesive qualities, and being of extreme pressure type. (Timken OK 40 pounds minimum.)
EPGL	Extreme Pressure Gear Lube (oil) meeting API service classification GL-5 or MIL-Spec MIL-L-2105
HO	Hydraulic Oil. API service classification GL-3, e.g. Mobilfluid 424.
EO	Engine (crankcase) Oil. Gas - API SF, SH, SG class, MIL-L-2104. Diesel - API CC/CD class, MIL-L-2104B/MIL-L-2104C.

#### **NOTICE**

**LUBRICATION INTERVALS ARE BASED ON MACHINE OPERATION UNDER NORMAL CONDITIONS. FOR MACHINES USED IN MULTI-SHIFT OPERATIONS AND/OR EXPOSED TO HOSTILE ENVIRONMENTS OR CONDITIONS, LUBRICATION FREQUENCIES MUST BE INCREASED ACCORDINGLY.**

**NOTE:** It is recommended as a good practice to replace all filters at the same time.

#### 1. Swing Bearing - Internal Ball Bearing



Lube Point(s) - 1 Grease Fittings

Capacity - A/R

Lube - MPG

Interval - Every 3 months or 150 hrs of operation

Comments - Remote Access

## SECTION 6 - GENERAL SPECIFICATIONS & OPERATOR MAINTENANCE

### 2. Wheel Bearings

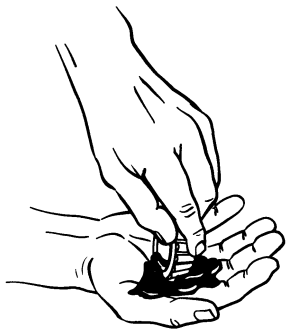

Lube Point(s) - Repack

Capacity - A/R

Lube - MPG

Interval - Every 2 years or 1200 hours of operation

### 3. Wheel Drive Hub

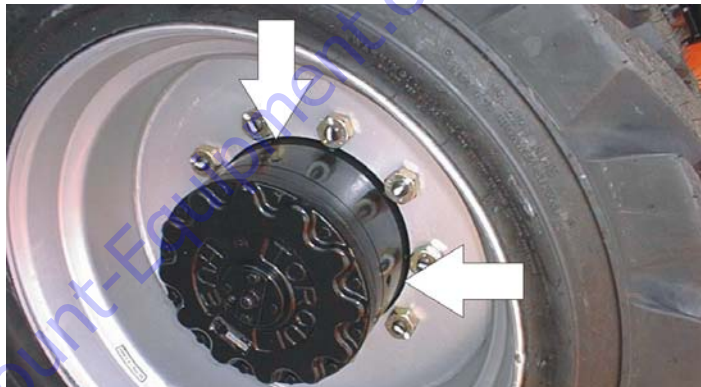

Lube Point(s) - Level/Fill Plug

Capacity - 17 oz. (0.5 L) - 1/2 Full

Lube - EPGL

Interval - Check level every 3 months or 150 hrs of operation; change every 2 years or 1200 hours of operation

Comments - Place Fill port at 12 o'clock position and Check port at 3 o'clock position. Pour lubricant into fill port until it just starts to flow out of check port.



## SECTION 6 - GENERAL SPECIFICATIONS & OPERATOR MAINTENANCE

### 4. Hydraulic Return Filter



Interval - Change after first 50 hrs. and every 6 months or 300 hrs. thereafter or as indicated by Condition Indicator.

### 5. Hydraulic Charge Filter



Interval - Change after first 50 hrs. and every 6 months or 300 hrs. thereafter or as indicated by Condition Indicator (if equipped).

## SECTION 6 - GENERAL SPECIFICATIONS & OPERATOR MAINTENANCE

### 6. Hydraulic Tank



Lube Point(s) - Fill Cap

Capacity - 116 liters Tank 124 liters System

Lube - HO

Interval - Check Level daily; Change every 2 years or 1200 hours of operation.

### 7. Platform Filter

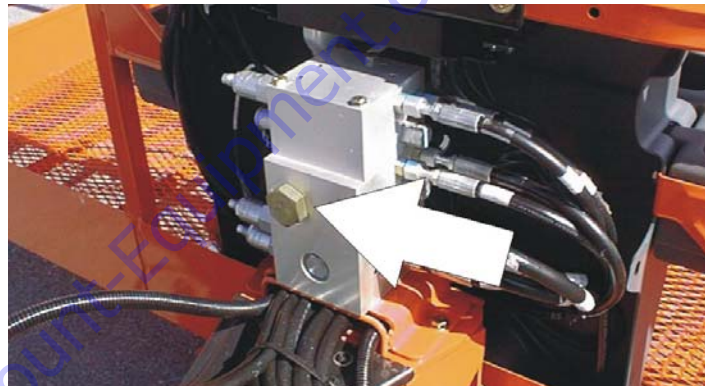

Interval - Change as necessary

## SECTION 6 - GENERAL SPECIFICATIONS & OPERATOR MAINTENANCE

### 8. Suction Strainers

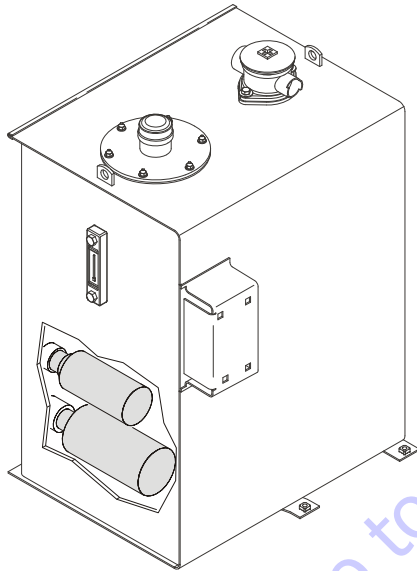

Lube Point(s) - 2

Interval - Every 2 years or 1200 hours of operation, remove and clean at time of hydraulic oil change.

### 9. Oil Change w/Filter - Ford

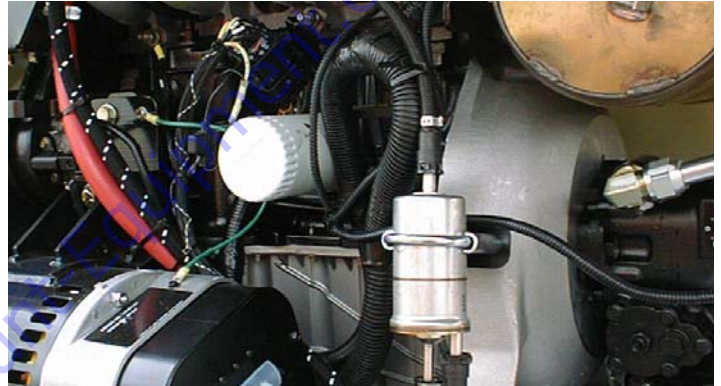

Lube Point(s) - Fill Cap/Spin-on Element

Capacity - 4.5 Quarts

Lube - EO

Interval - 3 Months or 150 hours of operation

Comments - Check level daily/Change in accordance with engine manual.

## SECTION 6 - GENERAL SPECIFICATIONS & OPERATOR MAINTENANCE

---

### 10. Oil Change w/Filter - Deutz

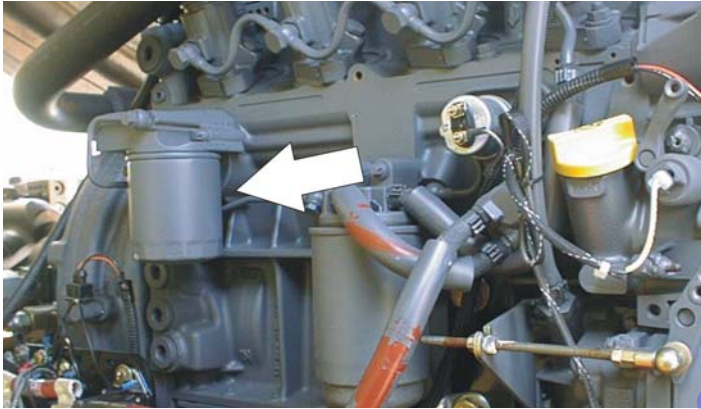

Lube Point(s) - Fill Cap/Spin-on Element  
Capacity - 11 Quarts(10.5 L) Crankcase;  
Lube - EO  
Interval - Every Year or 1200 hours of operation  
Comments - Check level daily/Change in accordance with engine manual.

### 11. Oil Change w/Filter - Caterpillar

Lube Point(s) - Fill Cap/Spin-on Element  
Capacity - 10.6 Quarts  
Lube - EO  
Interval - 3 Months or 150 hours of operation  
Comments - Check level daily/Change in accordance with engine manual.

## SECTION 6 - GENERAL SPECIFICATIONS & OPERATOR MAINTENANCE

### 12. Oil Change w/Filter - GM



Lube Point(s) - Fill Cap/Spin-on Element  
Capacity - 4.5 qt. (4.25 L) w/filter  
Lube - EO  
Interval - 3 Months or 150 hours of operation  
Comments - Check level daily/Change in accordance with engine manual.

### 13. Fuel Filter - Ford

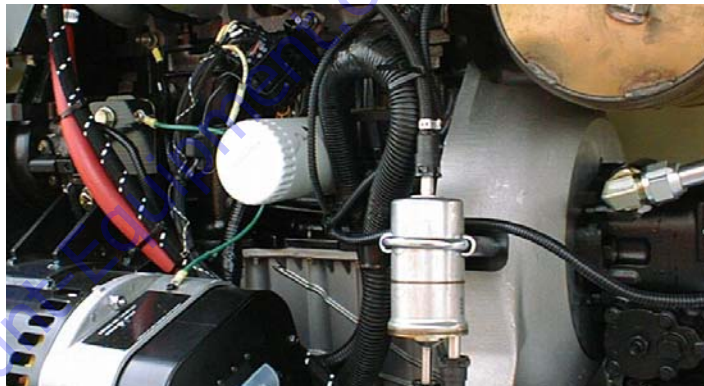

Lube Point(s) - Replaceable Element  
Interval - Every Year or 1200 hours of operation

## SECTION 6 - GENERAL SPECIFICATIONS & OPERATOR MAINTENANCE

### 14. Fuel Filter - Deutz

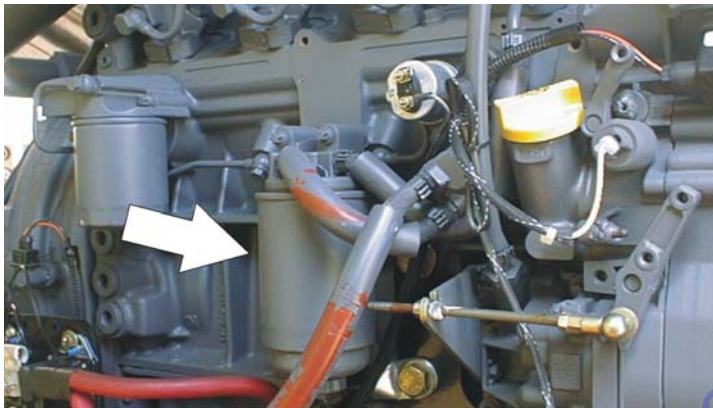

Lube Point(s) - Replaceable Element  
Interval - Every Year or 600 hours of operation

### 15. Fuel Filter - Caterpillar

Lube Point(s) - Replaceable Element  
Interval - Every Year or 600 hours of operation

### 16. Fuel Filter (Gasoline) - GM

Lube Point(s) - Replaceable Element  
Interval - Every 6 months or 300 hours of operation

### 17. Air Filter

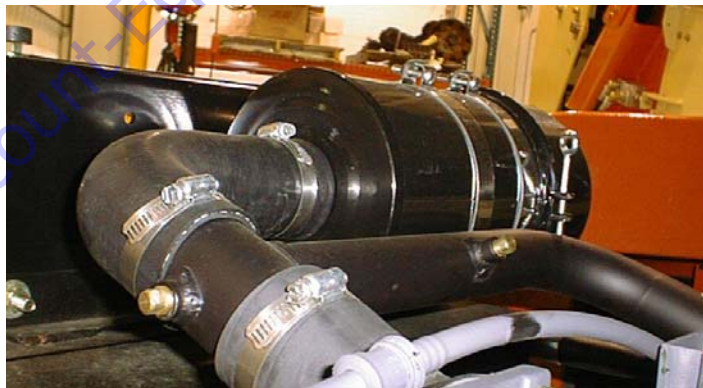

Lube Point(s) - Replaceable Element  
Interval - Every 6 months or 300 hours of operation or as indicated by the condition indicator

## SECTION 6 - GENERAL SPECIFICATIONS & OPERATOR MAINTENANCE

### 18. Electronic Pressure Regulator (LP only)

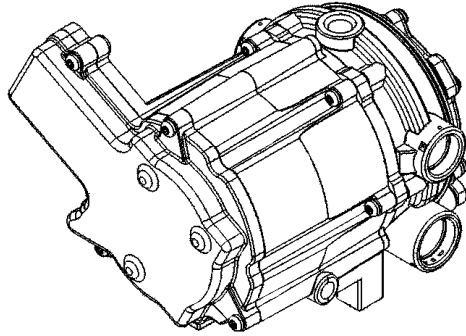

Interval - 3 Months or 150 hours of operation  
Comments - Drain oil build up. Refer to Section 6.6,  
Draining Oil Build Up From The Propane Regulator  
(Prior to S/N 0300134626)

### 19. Fuel Filter (Propane) - GM Engine



Interval - 3 Months or 150 hours of operation  
Comments - Replace filter. Refer to Section 6.7, Propane  
Fuel Filter Replacement

### 6.5 TIRES & WHEELS

#### Tire Inflation

The air pressure for pneumatic tires must be equal to the air pressure that is stenciled on the side of the JLG product or rim decal for safe and proper operational characteristics.

#### Tire Damage

For pneumatic tires, JLG Industries, Inc. recommends that when any cut, rip, or tear is discovered that exposes sidewall or tread area cords in the tire, measures must be taken to remove the JLG product from service immediately. Arrangements must be made for replacement of the tire or tire assembly.

For polyurethane foam filled tires, JLG Industries, Inc. recommends that when any of the following are discovered, measures must be taken to remove the JLG product from service immediately and arrangements must be made for replacement of the tire or tire assembly.

- a smooth, even cut through the cord plies which exceeds 3 inches (7.5 cm) in total length
- any tears or rips (ragged edges) in the cord plies which exceeds 1 inch (2.5 cm) in any direction
- any punctures which exceed 1 inch in diameter
- any damage to the bead area cords of the tire

If a tire is damaged but is within the above noted criteria, the tire must be inspected on a daily basis to insure the damage has not propagated beyond the allowable criteria.



### Tire Replacement

JLG recommends a replacement tire be the same size, ply and brand as originally installed on the machine. Please refer to the JLG Parts Manual for the part number of the approved tires for a particular machine model. If not using a JLG approved replacement tire, we recommend that replacement tires have the following characteristics:

- Equal or greater ply/load rating and size of original
- Tire tread contact width equal or greater than original
- Wheel diameter, width, and offset dimensions equal to the original
- Approved for the application by the tire manufacturer (including inflation pressure and maximum tire load)

Unless specifically approved by JLG Industries Inc. do not replace a foam filled or ballast filled tire assembly with a pneumatic tire. When selecting and installing a replacement tire, ensure that all tires are inflated to the pressure recommended by JLG. Due to size variations between tire brands, both tires on the same axle should be the same.

### Wheel Replacement

The rims installed on each product model have been designed for stability requirements which consist of track width, tire pressure, and load capacity. Size changes such as rim width, center piece location, larger or smaller diameter, etc., without written factory recommendations, may result in an unsafe condition regarding stability.

### Wheel Installation

It is extremely important to apply and maintain proper wheel mounting torque.

#### **⚠ WARNING**

**WHEEL NUTS MUST BE INSTALLED AND MAINTAINED AT THE PROPER TORQUE TO PREVENT LOOSE WHEELS, BROKEN STUDS, AND POSSIBLE DANGEROUS SEPARATION OF WHEEL FROM THE AXLE. BE SURE TO USE ONLY THE NUTS MATCHED TO THE CONE ANGLE OF THE WHEEL.**

Tighten the lug nuts to the proper torque to prevent wheels from coming loose. Use a torque wrench to tighten the fasteners. If you do not have a torque wrench, tighten the fasteners with a lug wrench, then immediately have a service garage or dealer tighten the lug nuts to the proper torque. Over-tightening will result in breaking the studs or permanently deforming the mounting stud holes in the wheels. The proper procedure for attaching wheels is as follows:

1. Start all nuts by hand to prevent cross threading. DO NOT use a lubricant on threads or nuts.

2. Tighten nuts in the following sequence:

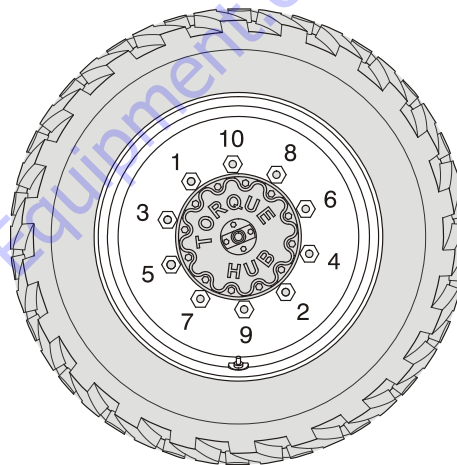

- The tightening of the nuts should be done in stages. Following the recommended sequence, tighten nuts per wheel torque chart.

Table 6-20. Wheel Torque Chart

TORQUE SEQUENCE		
1st Stage	2nd Stage	3rd Stage
70 ft. lbs. (95 Nm)	170 ft. lbs. (225 Nm)	300 ft. lbs. (405 Nm)

- Wheel nuts should be torqued after first 50 hours of operation and after each wheel removal. Check torque every 3 months or 150 hours of operation.

## 6.6 DRAINING OIL BUILD UP FROM THE PROPANE REGULATOR (PRIOR TO S/N 0300134626)

During the course of normal operation oils may build inside the primary and secondary chambers of the propane pressure regulator. These oils may be a result of poor fuel quality, contamination of the fuel supply chain, or regional variation in the make up of the fuel. If the build up of the oil is significant this can effect the operation of the fuel control system. Refer to Section 6.4, Operator Maintenance for maintenance intervals. More frequent draining may be required if the fuel supply has been contaminated.

### NOTICE

**FOR BEST RESULTS WARM THE ENGINE TO OPERATING TEMPERATURE BEFORE DRAINING. THIS WILL ALLOW THE OILS TO FLOW FREELY FROM THE REGULATOR.**

- Move the equipment to a well ventilated area. Ensure there are no external ignition sources.
- Start the engine and bring to operating temperature.
- With the engine running, close the manual tank valve and run the engine out of fuel.

## SECTION 6 - GENERAL SPECIFICATIONS & OPERATOR MAINTENANCE

4. Push in the Emergency Switch once the engine stops.
5. Disconnect the electrical connection to the LPG fuel temperature sensor in the auxiliary fuel port of the EPR.



6. Remove the retainer clip for the LPG fuel temperature sensor and remove the sensor from the regulator body.

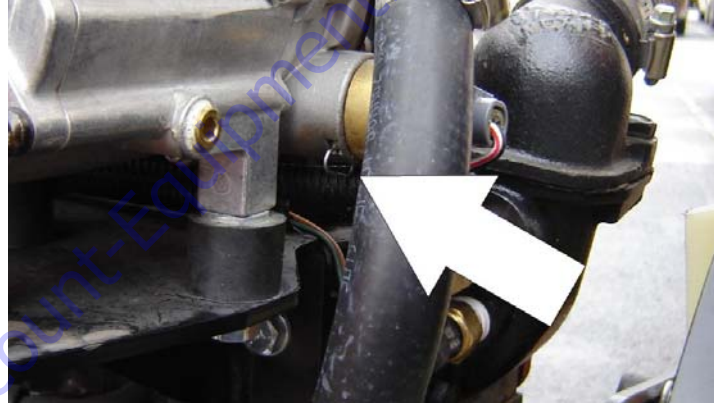

**NOTE:** Have a small container ready to collect oil that will drain freely from the regulator at this point.

7. Once all of the oil has been drained, reinstall the LPG fuel temperature sensor and reconnect the electrical connector.
8. Open the fuel tank manual valve.
9. Start the engine and verify all connections are secure.
10. Dispose of any drained oil per local regulations in a safe and proper fashion.

## 6.7 PROPANE FUEL FILTER REPLACEMENT

### Installation

#### **NOTICE**

**BE SURE TO REINSTALL THE FILTER MAGNET INTO THE HOUSING BEFORE INSTALLING NEW SEAL**

### Removal

1. Relieve the propane fuel system pressure. Refer to Propane Fuel System Pressure Relief.
2. Disconnect the negative battery cable.
3. Slowly loosen the Filter housing and remove it.
4. Pull the filter housing from the Electric lock off assembly.
5. Remove the filter from the housing.
6. Locate Filter magnet and remove it.
7. Remove and discard the housing seal.
8. If equipped, remove and discard the retaining bolt seal.
9. Remove and discard mounting plate to lock off O-ring seal.

1. Install the mounting plate to lock off O-ring seal.
2. If equipped, install the retaining bolt seal.
3. Install the housing seal.
4. Drop the magnet into the bottom of the filter housing.
5. Install the filter into the housing.
6. If equipped, install the retaining bolt into the filter housing.
7. Install the filter up to the bottom of the electric lock off.
8. Tighten the filter bowl retainer to 106 in lbs (12 Nm).
9. Open manual shut-off valve. Start the vehicle and leak check the propane fuel system at each serviced fitting. Refer to Propane Fuel System Leak Test.

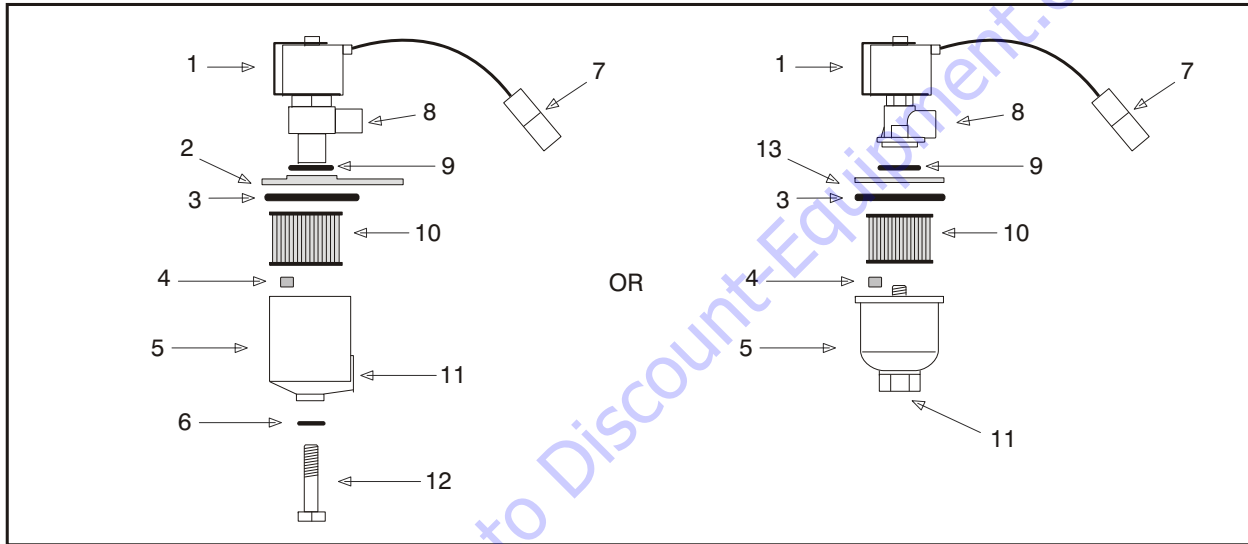

- |                               |                         |                    |
|-------------------------------|-------------------------|--------------------|
| 1. Electric Lock Off Solenoid | 6. Seal                 | 10. Filter         |
| 2. Mounting Plate             | 7. Electrical Connector | 11. Fuel Inlet     |
| 3. Housing Seal               | 8. Fuel Outlet          | 12. Retaining Bolt |
| 4. Filter Magnet              | 9. O-ring               | 13. Ring           |
| 5. Filter Housing             |                         |                    |

**Figure 6-11. Filter Lock Assembly**

## 6.8 PROPANE FUEL SYSTEM PRESSURE RELIEF 6.9 SUPPLEMENTAL INFORMATION

### CAUTION

THE PROPANE FUEL SYSTEM OPERATES AT PRESSURES UP TO 312 PSI (21.5 BAR). TO MINIMIZE THE RISK OF FIRE AND PERSONAL INJURY, RELIEVE THE PROPANE FUEL SYSTEM PRESSURE (WHERE APPLICABLE) BEFORE SERVICING THE PROPANE FUEL SYSTEM COMPONENTS.

To relieve propane fuel system pressure:

1. Close the manual shut-off valve on the propane fuel tank.
2. Start and run the vehicle until the engine stalls.
3. Turn the ignition switch OFF.

### CAUTION

RESIDUAL VAPOR PRESSURE WILL BE PRESENT IN THE FUEL SYSTEM. ENSURE THE WORK AREA IS WELL VENTILATED BEFORE DISCONNECTING ANY FUEL LINE.

The following information is provided in accordance with the requirements of the European Machinery Directive 2006/42/EC and is only applicable to CE machines.

For electric powered machines, the equivalent continuous A-Weighted sound pressure level at the work platform is less than 70dB(A)

For combustion engine powered machines, guaranteed Sound Power Level (LWA) per European Directive 2000/14/EC (Noise Emission in the Environment by Equipment for Use Outdoors) based on test methods in accordance with Annex III, Part B, Method 1 and 0 of the directive, is 104 dB.

The vibration total value to which the hand-arm system is subjected does not exceed 2,5 m/s<sup>2</sup>. The highest root mean square value of weighted acceleration to which the whole body is subjected does not exceed 0,5 m/s<sup>2</sup>.

**SECTION 7. INSPECTION AND REPAIR LOG**

Machine Serial Number \_\_\_\_\_

**Table 7-1. Inspection and Repair Log**

<b>Date</b>	<b>Comments</b>



**SECTION 7 - INSPECTION AND REPAIR LOG**

**Table 7-1. Inspection and Repair Log**

Date	Comments



## **WARNING:**



**The engine exhaust from this product contains chemicals known to the State of California to cause cancer, birth defects, or other reproductive harm.**

1702961

## **PROPOSITION 65 WARNING**

- **Battery posts, terminals and related accessories contain lead and lead compounds, chemicals known to the State of California to cause cancer and reproductive harm.**
- **Batteries also contain other chemicals known to the State of California to cause cancer.**
- **Wash hands after handling.**



An Oshkosh Corporation Company



3121138



[www.Discount-Equipment.com](http://www.Discount-Equipment.com)

---

---

---

---

To order go to [Discount-Equipment.com](http://Discount-Equipment.com)

**TO PURCHASE THIS PRODUCT PLEASE CONTACT US**



**Equipment Financing and  
Extended Warranties Available**



**Discount-Equipment.com is your online resource for  
commercial and industrial quality parts and equipment sales.**

**561-964-4949**

**visit us on line @ [www.discount-equipment.com](http://www.discount-equipment.com)**

Select an option below to find your Equipment

**Search by Manufacturer**

**Search by Product Type**

**Request a Quote**

We sell worldwide for the brands: Genie, Terex, JLG, MultiQuip, Mikasa, Essick, Whiteman, Mayco, Toro Stone, Diamond Products, Generac Magnum, Airman, Haulotte, Barreto, Power Blanket, Nifty Lift, Atlas Copco, Chicago Pneumatic, Allmand, Miller Curber, Skyjack, Lull, Skytrak, Tsurumi, Husquvarna Target, Stow, Wacker, Sakai, Mi-T-M, Sullair, Basic, Dynapac, MBW, Weber, Bartell, Bennar Newman, Haulotte, Ditch Runner, Menegotti, Morrison, Contec, Buddy, Crown, Edco, Wyco, Bomag, Laymor, EZ Trench, Bil-Jax, F.S. Curtis, Gehl Pavers, Heli, Honda, ICS/PowerGrit, IHI, Partner, Imer, Clipper, MMD, Koshin, Rice, CH&E, General Equipment, Amida, Coleman, NAC, Gradall, Square Shooter, Kent, Stanley, Tamco, Toku, Hatz, Kohler, Robin, Wisconsin, Northrock, Oztec, Toker TK, Rol-Air, APT, Wylie, Ingersoll Rand / Doosan, Innovatech, Con X, Ammann, Mecalac, Makinex, Smith Surface Prep, Small Line, Wanco, Yanmar