



An Oshkosh Corporation Company



www.Discount-Equipment.com

Service and Maintenance Manual

Model
600SC
660SJC

S/N 0300174703
to Present

P/N - 3121607

November 8, 2016

ANSI

CE



AS/NZS

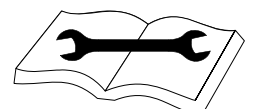

PARTS FINDER

**Search Website
by Part Number**



**Search Manual
Library For Parts
Manual & Lookup Part
Numbers – Purchase
or Request Quote**

Search Manuals

Enter your information to search for manuals and parts.

* Brand:

* Model:

* Serial:

* Part Number:

SEARCH

**Can't Find Part or
Manual? Request Help
by Manufacturer,
Model & Description**

Parts Order Form

Please fill in the following information:

Manufacturer:

Model:

Description:

Quantity:

Part Number:

Part Name:

Part Description:

Part Category:

Part Location:

Part Status:

Part Condition:

Part Material:

Part Color:

Part Weight:

Part Dimensions:

Part Price:

Part Notes:

Submit

Discount-Equipment.com is your online resource for quality parts & equipment.

Florida: **561-964-4949** Outside Florida TOLL FREE: **877-690-3101**

Need parts?

Click on this link: <http://www.discount-equipment.com/category/5443-parts/> and choose one of the options to help get the right parts and equipment you are looking for. Please have the machine model and serial number available in order to help us get you the correct parts. If you don't find the part on the website or on once of the online manuals, please fill out the request form and one of our experienced staff members will get back to you with a quote for the right part that your machine needs.

We sell worldwide for the brands: Genie, Terex, JLG, MultiQuip, Mikasa, Essick, Whiteman, Mayco, Toro Stone, Diamond Products, Generac Magnum, Airman, Haulotte, Barreto, Power Blanket, Nifty Lift, Atlas Copco, Chicago Pneumatic, Allmand, Miller Curber, Skyjack, Lull, Skytrak, Tsurumi, Husquvarna Target, , Stow, Wacker, Sakai, Mi-T- M, Sullair, Basic, Dynapac, MBW, Weber, Bartell, Bennar Newman, Haulotte, Ditch Runner, Menegotti, Morrison, Contec, Buddy, Crown, Edco, Wyco, Bomag, Laymor, Barreto, EZ Trench, Bil-Jax, F.S. Curtis, Gehl Pavers, Heli, Honda, ICS/PowerGrit, IHI, Partner, Imer, Clipper, MMD, Koshin, Rice, CH&E, General Equipment, ,AMida, Coleman, NAC, Gradall, Square Shooter, Kent, Stanley, Tamco, Toku, Hatz, Kohler, Robin, Wisconsin, Northrock, Oztec, Toker TK, Rol-Air, Small Line, Wanco, Yanmar

SECTION A. INTRODUCTION - MAINTENANCE SAFETY PRECAUTIONS

A GENERAL

This section contains the general safety precautions which must be observed during maintenance of the aerial platform. It is of utmost importance that maintenance personnel pay strict attention to these warnings and precautions to avoid possible injury to themselves or others, or damage to the equipment. A maintenance program must be followed to ensure that the machine is safe to operate.

⚠ WARNING

MODIFICATION OR ALTERATION OF AN AERIAL WORK PLATFORM SHALL BE MADE ONLY WITH WRITTEN PERMISSION FROM THE MANUFACTURER.

The specific precautions to be observed during maintenance are inserted at the appropriate point in the manual. These precautions are, for the most part, those that apply when servicing hydraulic and larger machine component parts.

Your safety, and that of others, is the first consideration when engaging in the maintenance of equipment. Always be conscious of weight. Never attempt to move heavy parts without the aid of a mechanical device. Do not allow heavy objects to rest in an unstable position. When raising a portion of the equipment, ensure that adequate support is provided.

⚠ WARNING

SINCE THE MACHINE MANUFACTURER HAS NO DIRECT CONTROL OVER THE FIELD INSPECTION AND MAINTENANCE, SAFETY IN THIS AREA RESPONSIBILITY OF THE OWNER/OPERATOR.

B HYDRAULIC SYSTEM SAFETY

It should be noted that the machines hydraulic systems operate at extremely high potentially dangerous pressures. Every effort should be made to relieve any system pressure prior to disconnecting or removing any portion of the system.

C MAINTENANCE

⚠ WARNING

FAILURE TO COMPLY WITH SAFETY PRECAUTIONS LISTED IN THIS SECTION COULD RESULT IN MACHINE DAMAGE, PERSONNEL INJURY OR DEATH AND IS A SAFETY VIOLATION.

- ENSURE REPLACEMENT PARTS OR COMPONENTS ARE IDENTICAL OR EQUIVALENT TO ORIGINAL PARTS OR COMPONENTS.
- NO SMOKING IS MANDATORY. NEVER REFUEL DURING ELECTRICAL STORMS. ENSURE THAT FUEL CAP IS CLOSED AND SECURE AT ALL OTHER TIMES.
- REMOVE ALL RINGS, WATCHES AND JEWELRY WHEN PERFORMING ANY MAINTENANCE.
- DO NOT WEAR LONG HAIR UNRESTRAINED, OR LOOSE-FITTING CLOTHING AND NECKTIES WHICH ARE APT TO BECOME CAUGHT ON OR ENTANGLED IN EQUIPMENT.
- OBSERVE AND OBEY ALL WARNINGS AND CAUTIONS ON MACHINE AND IN SERVICE MANUAL.
- KEEP OIL, GREASE, WATER, ETC. WIPED FROM STANDING SURFACES AND HAND HOLDS.
- USE CAUTION WHEN CHECKING A HOT, PRESSURIZED COOLANT SYSTEM.
- NEVER WORK UNDER AN ELEVATED BOOM UNTIL BOOM HAS BEEN SAFELY RESTRAINED FROM ANY MOVEMENT BY BLOCKING OR OVERHEAD SLING, OR BOOM SAFETY PROP HAS BEEN ENGAGED.
- BEFORE MAKING ADJUSTMENTS, LUBRICATING OR PERFORMING ANY OTHER MAINTENANCE, SHUT OFF ALL POWER CONTROLS.
- BATTERY SHOULD ALWAYS BE DISCONNECTED DURING REPLACEMENT OF ELECTRICAL COMPONENTS.
- KEEP ALL SUPPORT EQUIPMENT AND ATTACHMENTS STOWED IN THEIR PROPER PLACE.
- USE ONLY APPROVED, NONFLAMMABLE CLEANING SOLVENTS.

REVISION LOG

Original Issue - March 10, 2014
Revision - November 8, 2016

Go to Discount-Equipment.com to order your parts

SECTION NO.	TITLE	PAGE NO.
SECTION H	- INTRODUCTION - MAINTENANCE SAFETY PRECAUTIONS	
A	General	A-1
B	Hydraulic System Safety	A-1
C	Maintenance	A-1
SECTION 1	- SPECIFICATIONS	
1.1	Operating Specifications	1-1
1.2	Dimensional Data	1-1
1.3	Capacities	1-1
1.4	Engine Data	1-1
1.5	Function Speeds	1-2
	Machine Orientation When Doing Speed Tests	1-2
	Test Notes	1-2
1.6	Torque Requirements	1-2
1.7	Hydraulic Oil	1-3
1.8	Major Component Weights	1-4
1.9	Operator Maintenance	1-5
SECTION 2	- GENERAL	
2.1	Machine Preparation, Inspection, and Maintenance	2-1
	General	2-1
	Preparation, Inspection, and Maintenance	2-1
	Pre-Start Inspection	2-1
	Pre-Delivery Inspection and Frequent Inspection	2-1
	Annual Machine Inspection	2-1
	Preventive Maintenance	2-1
2.2	Service and Guidelines	2-2
	General	2-2
	Safety and Workmanship	2-2
	Cleanliness	2-2
	Components Removal and Installation	2-2
	Component Disassembly and Reassembly	2-3
	Pressure-Fit Parts	2-3
	Bearings	2-3
	Gaskets	2-3
	Bolt Usage and Torque Application	2-3
	Hydraulic Lines and Electrical Wiring	2-3
	Hydraulic System	2-3
	Lubrication	2-3
	Battery	2-3
	Lubrication and Servicing	2-3
2.3	Lubrication and Information	2-4
	Hydraulic System	2-4
	Hydraulic Oil	2-4
	Changing Hydraulic Oil	2-4
	Lubrication Specifications	2-4
2.4	Cylinder Drift Test	2-4
	Platform Drift	2-4
	Cylinder Drift	2-4
2.5	Pins and Composite Bearing Repair Guidelines	2-5
2.6	Welding on JLG Equipment	2-5
	Do the Following When Welding on JLG Equipment:	2-5
	Do NOT Do the Following When Welding on JLG Equipment:	2-5

SECTION NO.	TITLE	PAGE NO.
SECTION 3 - CHASSIS & TURNTABLE		
3.1	Chassis Components and Servicing	3-1
	Service Notes.....	3-2
	Track and Chain	3-4
	Replace Track	3-5
	Track tensioning.....	3-6
	Rubber Track Pad Installation	3-6
	Rollers	3-9
	Idler Roller Assembly	3-10
3.2	Drive Motor	3-13
	Disassembly.....	3-16
	Assembly	3-18
	Install Motor Assembly	3-19
	Rotary Coupling	3-20
3.3	Swing Drive	3-24
	Gear Backlash	3-26
	Swing Drive Lubrication	3-26
	Motor Control Valve Disassembly	3-26
	Motor and Brake Disassembly.....	3-27
	Main Disassembly	3-28
	Hub-Shaft Disassembly	3-28
	Carrier Disassembly.....	3-29
	Hub-Shaft Subassembly	3-30
	Carrier Subassembly	3-31
	Main Assembly	3-32
	Motor and Brake Assembly	3-33
	Motor Control Valve Assembly	3-33
3.4	Swing Bearing.....	3-34
	Turntable Bearing Mounting Bolt Condition Check	3-34
	Wear Tolerance.....	3-34
	Swing Bearing Replacement	3-36
	Swing Bearing Torque Values	3-37
	See Figure 3-34. Swing Bearing Torque Sequence.....	3-37
3.5	Generator	3-38
	Every 250 hours	3-38
	Every 500 hours	3-38
	Overload Protection	3-39
	Inspecting Brushes, Replacing Brushes, and Cleaning Slip Rings	3-39
3.6	Deutz D2.9 L4 Engine.....	3-41
	Check Oil Level.....	3-43
	Change Engine Oil.....	3-43
	Change Oil Filter	3-44
	Change Fuel Filters	3-44
3.7	Deutz D2011 Engine.....	3-45
	Checking Oil Level.....	3-49
	Changing Engine Oil.....	3-49
	Changing Oil Filter	3-50
	Replace Fuel Filter	3-50
	Clean Fuel Strainer	3-51
3.8	Spark Arrester Cleaning Instructions	3-51
3.9	Glow Plugs.....	3-51
3.10	Deutz EMR 2	3-52
3.11	Bio Fuel in Deutz Engines	3-64
	General	3-64
	Bio Fuel	3-64
	Biological Contamination In Fuels.....	3-65

SECTION NO.	TITLE	PAGE NO.
SECTION 4 - BOOM & PLATFORM		
4.1	Boom Systems	4-1
	Removal	4-1
4.2	Wear Pads	4-2
4.3	Boom Disassembly/Assembly & Cable Replacement	4-3
	Boom Section Disassembly	4-3
4.4	Wire Rope	4-4
	Inspection	4-4
	Three Month Inspection	4-4
	12 Year or 7000 Hour Replacement	4-4
	Additional Replacement Criteria	4-4
4.5	Wire Rope Tensioning Adjustment	4-5
	Wire Rope Tensioning Procedure	4-5
	Inspection	4-9
	Assembly	4-10
	Installation	4-13
4.6	Articulating Jib Boom	4-14
	Removal	4-14
	Disassembly	4-14
	Inspection	4-14
	Assembly	4-15
4.7	Limit Switches and Cam Valve Adjustment	4-15
4.8	Boom Cleanliness Guidelines	4-15
4.9	Rotary Actuator	4-18
	Theory of Operation	4-18
	Required Tools	4-18
	Disassembly	4-21
	Inspection	4-25
	Assembly	4-26
	Installing Counterbalance Valve	4-30
	Testing Actuator	4-31
	Testing Actuator for Internal Leaks	4-31
	Installation and Bleeding	4-31
	Troubleshooting	4-32
4.10	Foot Switch Adjustment	4-33
4.11	Platform	4-33
	Platform Support Torque Settings	4-33
	Replace Platform Sections	4-33
4.12	Powertrack Maintenance	4-34
	Remove Link	4-34
	Install New Link	4-37
	Replace Fixed End Brackets	4-40
	Replace Moving End Brackets	4-41
SECTION 5 - HYDRAULICS		
5.1	O-Ring Lubrication	5-1
	Cup and Brush	5-1
	Dip	5-2
	Spray	5-2
	Brush-On	5-2
5.2	Cylinders - Theory of Operation	5-3
	Systems With Double Acting Cylinders	5-3
	Systems With Holding Valves	5-3
5.3	Cylinder Checking Procedure	5-3
	Cylinders Without Counterbalance Valves - Master Cylinder and Steer Cylinder	5-3
	Cylinders With Single Counterbalance Valve	5-4
	Cylinders With Dual Counterbalance Valves	5-4

TABLE OF CONTENTS

SECTION NO.	TITLE	PAGE NO.
5.4	Cylinder Removal and Installation	5-5
	Main Boom Telescope Cylinder Removal	5-5
	Main Boom Telescope Cylinder Installation	5-5
	Main Boom Lift Cylinder Removal	5-6
	Main Boom Lift Cylinder Installation	5-6
5.5	Cylinder Repair	5-6
	Disassembly	5-6
	Cylinder Locations	5-7
	Main Lift Cylinder	5-8
	Cleaning and Inspection	5-10
	Assembly	5-11
	Master Cylinder	5-13
	Cleaning and Inspection	5-15
	Assembly	5-16
	Telescope Cylinder	5-18
	Cleaning and Inspection	5-20
	Assembly	5-21
	Platform Level (Slave) Cylinder	5-23
	Cleaning and Inspection	5-25
	Assembly	5-26
	Jib Lift Cylinder (SJC Only)	5-28
	Cleaning and Inspection	5-30
	Assembly	5-31
5.6	Hydraulic Pump (Gear)	5-33
	Disassembly	5-33
	Inspect Parts For Wear	5-35
	General Information	5-36
	Reverse Shaft Rotation of Pump	5-36
	Assembly	5-36
	Placing Pump Back Into Service	5-39
5.7	Variable Pump	5-39
	Ports and Pressure Gauges	5-39
	NFPE Control	5-39
	Remove and Install FNR and NFPE Modules	5-40
	Remove and Install FNR and NFPE Control Orifices	5-40
	Charge Relief Valve	5-40
	Shaft Seal and Shaft Replacement	5-43
	Hydraulic Pump W/Hayes Pump Drive Coupling Lubrication	5-44
	Charge Pump	5-45
5.8	Hydraulic Component Start-Up	5-46
5.9	Pressure Setting Procedures	5-47
	Main Relief	5-47
	Lift Down	5-47
	Swing	5-47
	Platform Level Up	5-47
	Platform Level Down	5-47
	Jib Up	5-47
	Jib Down	5-47
SECTION 6 - JLG CONTROL SYSTEM		
6.1	Introduction	6-1
	Connect JLG Control System Analyzer	6-3
	Using Analyzer	6-3
	Changing Access Level	6-4
	Adjust Parameters	6-5
	Machine Setup	6-6
	Level Vehicle Description	6-6
6.2	Machine Personality Settings	6-14

SECTION NO.	TITLE	PAGE NO.
6.3	Machine Orientation When Setting Function Speeds	6-34
	Test Notes	6-34
6.4	CANbus Communications	6-35
 SECTION 7 - BASIC ELECTRICAL INFORMATION & SCHEMATICS		
7.1	General	7-1
7.2	Multimeter Basics	7-1
	Grounding	7-1
	Backprobing	7-1
	Min/Max	7-1
	Polarity	7-1
	Scale	7-1
	Voltage Measurement	7-1
	Resistance Measurement	7-2
	Continuity Measurement	7-2
	Current Measurement	7-3
7.3	Applying Silicone Dielectric Compound to Electrical Connections	7-3
	Dielectric Grease Application	7-4
	Deutsch HD, DT, DTM, DRC Series	7-4
	AMP Seal	7-4
	AMP Mate-N-Lok	7-5
	DIN Connectors	7-5
	Exclusions	7-5
7.4	AMP Connector	7-6
	Contact Assembly	7-6
	Connector Assembly	7-6
	Disassembly	7-7
	Wedge Lock	7-7
	Service - Voltage Reading	7-7
7.5	Deutsch Connectors	7-8
	DT/DTP Series Assembly	7-8
	DT/DTP Series Disassembly	7-8
	HD30/HDP20 Series Assembly	7-9
	HD30/HDP20 Series Disassembly	7-9

FIGURE NO.	TITLE	PAGE NO.
1-1.	Maintenance and Lubrication	1-5
1-2.	Torque Chart - Sheet 1 of 5 - (SAE Fasteners)	1-8
1-3.	Torque Chart - Sheet 2 of 5 - (SAE Fasteners)	1-9
1-4.	Torque Chart - Sheet 3 of 5 - (SAE Fasteners)	1-10
1-5.	Torque Chart - Sheet 4 of 5 - (METRIC Fasteners)	1-11
1-6.	Torque Chart - Sheet 5 of 5 - (METRIC Fasteners)	1-12
2-1.	Deutz Engine and Hydraulic Operating Temperature Specifications	2-9
3-1.	Chassis Assembly	3-1
3-2.	Chassis Service Notes - 1 of 2	3-2
3-3.	Chassis Service Notes - 2 of 2	3-3
3-4.	Track and Chain	3-4
3-5.	Bottom Track Roller Assembly	3-7
3-6.	Upper Carrier Track Roller Assembly	3-8
3-7.	Idler Assembly	3-10
3-8.	Spring & Shock Assembly	3-11
3-9.	Crawler Drive Motor Control	3-13
3-10.	Crawler Drive Motor Assembly	3-14
3-11.	Crawler Drive - Gearbox	3-15
3-12.	Rotary Coupling Installation	3-20
3-13.	Hose Routing - 1 of 2	3-21
3-14.	Hose Routing - 2 of 2	3-22
3-15.	Swing Drive Assembly	3-24
3-16.	Swing Motor and Brake Assembly	3-25
3-17.	Swing Drive Shim Placement	3-26
3-18.	Swing Drive Pivot and Mounting Bolts	3-26
3-19.	Swing Drive Jam Nut and Mounting Bolt	3-26
3-20.	Swing Drive Lubrication	3-26
3-21.	Main Control Valve Disassembly	3-27
3-22.	Motor and Brake Disassembly	3-27
3-23.	Main Disassembly	3-28
3-24.	Hub-Shaft Disassembly	3-28
3-25.	Carrier Disassembly	3-29
3-26.	Hub-Shaft Subassembly	3-30
3-27.	Carrier Subassembly	3-31
3-28.	Main Assembly	3-32
3-29.	Motor and Brake Assembly	3-33
3-30.	Motor Control Valve Assembly	3-33
3-31.	Swing Bearing Bolt Feeler Gauge Check	3-34
3-32.	Swing Bearing Tolerance Measuring Point	3-34
3-33.	Swing Bearing Tolerance Measurement Location & Boom Placement	3-35
3-34.	Swing Bearing Torque Sequence	3-37
3-35.	Generator Belt Tension	3-38
3-36.	Generator Brushes and Slip Rings	3-38
3-37.	Generator Cleaning	3-38
3-38.	Generator Circuit Breaker Location	3-39
3-39.	Inspecting Generator Brushes, Replacing Brushes, and Cleaning Slip Rings	3-40
3-40.	Deutz D2.9 L4 Engine Installation - Sheet 1 of 2	3-41
3-41.	Deutz D2.9 L4 Engine Installation - Sheet 2 of 2	3-42
3-42.	Deutz 2.9 T4F Dipstick Markings	3-43
3-43.	Engine Oil Viscosity	3-43
3-44.	Deutz D2011 Engine (Battery Engine Side) Installation - 1 of 2	3-45
3-45.	Deutz D2011 Engine (Battery Engine Side) Installation - 2 of 2	3-46
3-46.	Deutz D2011 Engine (Battery Tank Side) Installation - 1 of 2	3-47
3-47.	Deutz D2011 Engine (Battery Tank Side) Installation - 2 of 2	3-48
3-48.	Deutz Dipstick Markings	3-49
3-49.	Engine Oil Viscosity	3-49
3-50.	EMR 2 Engine Side Equipment	3-52
3-51.	Deutz EMR 2 Troubleshooting Flow Chart	3-53
3-52.	Deutz EMR 2 Vehicle Side Connection Diagram	3-54
3-53.	Deutz EMR 2 Engine Side Connection Diagram - Sheet 1 of 2	3-55

FIGURE NO.	TITLE	PAGE NO.
3-54.	Deutz EMR 2 Engine Side Connection Diagram - Sheet 2 of 2	3-56
3-55.	EMR 2 Engine Plug Pin Identification	3-57
3-56.	EMR 2 Vehicle Plug Pin Identification	3-58
3-57.	EMR2 Fault Codes - Sheet 1 of 5	3-59
3-58.	EMR2 Fault Codes - Sheet 2 of 5	3-60
3-59.	EMR2 Fault Codes - Sheet 3 of 5	3-61
3-60.	EMR2 Fault Codes - Sheet 4 of 5	3-62
3-61.	EMR2 Fault Codes - Sheet 5 of 5	3-63
4-1.	Location of Components - Platform Support	4-1
4-2.	Rotator and Leveling Cylinder Locations	4-1
4-3.	Boom Powertrack Components	4-2
4-4.	Location and Thickness of Wear Pads	4-2
4-5.	Clamping Wire Ropes	4-3
4-6.	Proximity Switch Assembly Disassembly	4-3
4-7.	Wire Rope Wire Breaks	4-4
4-8.	Wire Rope Kink	4-4
4-9.	Sheave Groove Wear	4-4
4-10.	Dimensions of Boom Sections	4-5
4-11.	Clamping Wire Ropes	4-5
4-12.	Boom Assembly Cutaway - Sheet 1 of 3	4-6
4-13.	Boom Assembly Cutaway - Sheet 2 of 3	4-7
4-14.	Boom Assembly Cutaway - Sheet 3 of 3	4-8
4-15.	Disassembly of Sheave Assembly	4-8
4-16.	Wire Rope Routing Disassembly	4-9
4-17.	Dimension of Sheaves When New	4-9
4-18.	Routing Installation of Retract Wire Ropes	4-10
4-19.	Boom Powertrack Installation	4-11
4-20.	Proximity Switch Installation	4-12
4-21.	Boom Powertrack Assembly	4-13
4-22.	Articulating Jib Boom Components	4-14
4-23.	Horizontal Limit and Dual Capacity Limit Switches Adjustments	4-16
4-24.	Transport Switch Adjustments - CE Machines Only	4-17
4-25.	Rotary Actuator - Exploded View	4-19
4-26.	Rotary Actuator - Assembly Drawing	4-20
4-27.	Rotator Counterbalance Valve	4-30
4-28.	Actuator Bleed Ports	4-31
4-29.	Foot Switch Adjustment	4-33
4-30.	Platform Support Torque Values	4-33
4-31.	Platform Section Replacement	4-33
5-1.	Boom Positioning and Support, Cylinder Repair	5-3
5-2.	Hydraulic Cylinder Locations	5-7
5-3.	Cylinder Barrel Support	5-8
5-4.	Marking Cylinder for Alignment	5-8
5-5.	Cylinder Rod Support	5-8
5-6.	Main Lift Cylinder Assembly	5-9
5-7.	Tapered Bushing Removal	5-10
5-8.	Composite Bushing Installation	5-10
5-9.	Rod Seal Installation	5-11
5-10.	Poly-Pak Piston Seal Installation	5-11
5-11.	Wiper Seal Installation	5-11
5-12.	Head Seal Kit Installation	5-11
5-13.	Piston Seal Kit Installation	5-12
5-14.	Tapered Bushing Installation	5-12
5-15.	Rod Assembly Installation	5-12
5-16.	Cylinder Barrel Support	5-13
5-17.	Marking Cylinder for Alignment	5-13
5-18.	Cylinder Rod Support	5-13
5-19.	Master Cylinder Assembly	5-14
5-20.	Tapered Bushing Removal	5-15
5-21.	Composite Bushing Installation	5-15

FIGURE NO.	TITLE	PAGE NO.
5-22.	Rod Seal Installation	5-16
5-23.	Poly-Pak Piston Seal Installation.....	5-16
5-24.	Wiper Seal Installation	5-16
5-25.	Head Seal Kit Installation	5-16
5-26.	Piston Seal Kit Installation.....	5-17
5-27.	Tapered Bushing Installation.....	5-17
5-28.	Rod Assembly Installation	5-17
5-29.	Cylinder Barrel Support	5-18
5-30.	Marking Cylinder for Alignment.....	5-18
5-31.	Cylinder Rod Support.....	5-18
5-32.	Telescope Cylinder Assembly	5-19
5-33.	Tapered Bushing Removal	5-20
5-34.	Composite Bushing Installation	5-20
5-35.	Rod Seal Installation	5-21
5-36.	Poly-Pak Piston Seal Installation.....	5-21
5-37.	Wiper Seal Installation	5-21
5-38.	Head Seal Kit Installation	5-21
5-39.	Piston Seal Kit Installation.....	5-22
5-40.	Tapered Bushing Installation.....	5-22
5-41.	Rod Assembly Installation	5-22
5-42.	Cylinder Barrel Support	5-23
5-43.	Marking Cylinder for Alignment.....	5-23
5-44.	Cylinder Rod Support.....	5-23
5-45.	Platform Level (Slave) Cylinder Assembly.....	5-24
5-46.	Tapered Bushing Removal	5-25
5-47.	Composite Bushing Installation	5-25
5-48.	Rod Seal Installation	5-26
5-49.	Poly-Pak Piston Seal Installation.....	5-26
5-50.	Wiper Seal Installation	5-26
5-51.	Head Seal Kit Installation	5-26
5-52.	Piston Seal Kit Installation.....	5-27
5-53.	Tapered Bushing Installation.....	5-27
5-54.	Rod Assembly Installation	5-27
5-55.	Cylinder Barrel Support	5-28
5-56.	Marking Cylinder for Alignment.....	5-28
5-57.	Cylinder Rod Support.....	5-28
5-58.	Jib Lift Cylinder Assembly(660SJC)	5-29
5-59.	Tapered Bushing Removal	5-30
5-60.	Composite Bushing Installation	5-30
5-61.	Rod Seal Installation	5-31
5-62.	Poly-Pak Piston Seal Installation.....	5-31
5-63.	Wiper Seal Installation	5-31
5-64.	Head Seal Kit Installation	5-31
5-65.	Piston Seal Kit Installation.....	5-32
5-66.	Tapered Bushing Installation.....	5-32
5-67.	Rod Assembly Installation	5-32
5-68.	Shim Adjustable Charge Relief Valve Components	5-40
5-69.	Gauge Port Locations.....	5-41
5-70.	Plugs/Fittings Size & Torque	5-42
5-71.	Screw Adjustable Charge Relief Valve Components.....	5-43
5-72.	Shaft Seal Components.....	5-43
5-73.	Installation of Shaft Seal	5-43
5-74.	Shaft Components	5-44
5-75.	Charge Pump Components	5-45
5-76.	Location of Components - Main Control Valve.....	5-48
5-77.	Articulating Jib Valve	5-49
6-1.	Hand-Held Analyzer (WANALYZER Controls and Display Similar)	6-1
6-2.	Controller Block Diagram	6-2
6-3.	Analyzer Platform Connector	6-3
6-4.	Analyzer Ground Control Box Connector	6-3

FIGURE NO.	TITLE	PAGE NO.
6-5.	Analyzer Software Version 6.8 - Sheet 1 of 6	6-8
6-6.	Analyzer Software Version 6.8 - Sheet 2 of 6	6-9
6-7.	Analyzer Software Version 6.8 - Sheet 3 of 6	6-10
6-8.	Analyzer Software Version 6.8 - Sheet 4 of 6	6-11
6-9.	Analyzer Software Version 6.8 - Sheet 5 of 6	6-12
6-10.	Analyzer Software Version 6.8 - Sheet 6 of 6	6-13
6-11.	Control Module Locations	6-45
6-12.	Ground Control Module Pin Connections 1 of 3	6-46
6-13.	Ground Control Module Pin Connections 2 of 3	6-47
6-14.	Ground Control Module Pin Connections 3 of 3	6-48
6-15.	Platform Control Module Pin Connections 1 of 2	6-49
6-16.	Platform Control Module Pin Connections 2 of 2	6-50
7-1.	Voltage Measurement (DC)	7-1
7-2.	Resistance Measurement	7-2
7-3.	Continuity Measurement	7-2
7-4.	Current Measurement (DC)	7-3
7-5.	Applying Dielectric Grease	7-4
7-6.	Deutsch Connector	7-4
7-7.	Dielectric Grease On Female Contacts	7-4
7-8.	Seal Plugs	7-4
7-9.	AMP Mate-N-Lok Connector	7-5
7-10.	DIN Connector	7-5
7-11.	Brad Harrison/Phoenix Connectors	7-5
7-12.	AMP Junior Timer	7-5
7-13.	AMP Connector	7-6
7-14.	AMP Contact Assembly	7-6
7-15.	AMP Connector Assembly	7-6
7-16.	AMP Contact Installation	7-6
7-17.	Close Wedge Lock	7-7
7-18.	Seating Wedge Lock	7-7
7-19.	AMP Connector Disassembly	7-7
7-20.	DT/DTP Contact Installation	7-8
7-21.	DT/DTP Contact Removal	7-8
7-22.	HD/HDP Contact Installation	7-9
7-23.	HD/HDP Locking Contacts Into Position	7-9
7-24.	HD/HDP Contact Removal	7-9
7-25.	HD/HDP Unlocking Contacts	7-9
7-26.	Electrical Components 1 of 2	7-10
7-27.	Electrical Components 2 of 2	7-11
7-28.	Platform and Ground Control Electrical Schematic - 1 of 2	7-12
7-29.	Platform and Ground Control Electrical Schematic - 2 of 2	7-13
7-30.	Generator Wiring Schematic	7-14
7-31.	Deutz EMR2 Wiring Schematic	7-15
7-32.	Deutz Engine Harness Electrical Schematic 1 of 2	7-16
7-33.	Deutz Engine Harness Electrical Schematic 2 of 2	7-17
7-34.	Hydraulic Schematic 1 of 2	7-18
7-35.	Hydraulic Schematic 2 of 2	7-19
7-36.	Crawler Hydraulic Drive Schematic 1 of 2	7-20
7-37.	Crawler Hydraulic Drive Schematic 2 of 2	7-21
7-38.	Hydraulic Port Schematic - 1 of 2	7-22
7-39.	Hydraulic Port Schematic - 2 of 2	7-23
7-40.	Crawler Drive Motor Hydraulic Schematic	7-24

LIST OF TABLES

TABLE NO.	TITLE	PAGE NO.
1-1	Dimensional Data	1-1
1-2	Capacities	1-1
1-3	Deutz TD 2.9 Specifications	1-1
1-4	Function Speeds (In Seconds)	1-2
1-5	Torque Requirements	1-2
1-6	Hydraulic Oil	1-3
1-7	Mobilfluid 424	1-3
1-8	Mobil DTE 13M	1-3
1-9	UCon Hydrolube HP-5046	1-3
1-10	Mobil EAL H 46	1-4
1-11	Exxon Unis HVI 26	1-4
1-12	Major Component Weights	1-4
1-13	Lubrication Specifications	1-5
2-1	Inspection and Maintenance	2-2
2-2	Cylinder Drift	2-4
2-3	Inspection and Preventive Maintenance Schedule	2-6
4-1	Troubleshooting	4-32
5-1	Hydraulic Pump Bolt Torque Chart	5-38
5-2	Recommended Gauge Size	5-39
6-1	Analyzer Abbreviations	6-7
6-2	Personality Ranges/Defaults	6-14
6-3	Help Fault Codes, Displayed Faults, and Descriptions	6-17
6-4	Help Message/Fault Listing	6-26
6-5	Machine Configuration Programming Information	6-30
6-6	Fault Code List	6-36

Go to Discount-Equipment.com to order your parts

PARTS FINDER

**Search Website
by Part Number**



**Search Manual
Library For Parts
Manual & Lookup Part
Numbers – Purchase
or Request Quote**

Search Manuals

Enter your information to search for manuals and parts.

* Brand:

* Model:

* Serial:

* Part Number:

SEARCH

**Can't Find Part or
Manual? Request Help
by Manufacturer,
Model & Description**

Parts Order Form

Please fill in the following information:

Manufacturer:

Model:

Description:

Quantity:

Part Number:

Part Name:

Part Description:

Part Location:

Part Condition:

Part Status:

Part Price:

Part Weight:

Part Dimensions:

Part Material:

Part Color:

Part Finish:

Part Notes:

Submit

Discount-Equipment.com is your online resource for quality parts & equipment.

Florida: **561-964-4949** Outside Florida TOLL FREE: **877-690-3101**

Need parts?

Click on this link: <http://www.discount-equipment.com/category/5443-parts/> and choose one of the options to help get the right parts and equipment you are looking for. Please have the machine model and serial number available in order to help us get you the correct parts. If you don't find the part on the website or on once of the online manuals, please fill out the request form and one of our experienced staff members will get back to you with a quote for the right part that your machine needs.

We sell worldwide for the brands: Genie, Terex, JLG, MultiQuip, Mikasa, Essick, Whiteman, Mayco, Toro Stone, Diamond Products, Generac Magnum, Airman, Haulotte, Barreto, Power Blanket, Nifty Lift, Atlas Copco, Chicago Pneumatic, Allmand, Miller Curber, Skyjack, Lull, Skytrak, Tsurumi, Husquvarna Target, , Stow, Wacker, Sakai, Mi-T- M, Sullair, Basic, Dynapac, MBW, Weber, Bartell, Bennar Newman, Haulotte, Ditch Runner, Menegotti, Morrison, Contec, Buddy, Crown, Edco, Wyco, Bomag, Laymor, Barreto, EZ Trench, Bil-Jax, F.S. Curtis, Gehl Pavers, Heli, Honda, ICS/PowerGrit, IHI, Partner, Imer, Clipper, MMD, Koshin, Rice, CH&E, General Equipment, ,AMida, Coleman, NAC, Gradall, Square Shooter, Kent, Stanley, Tamco, Toku, Hatz, Kohler, Robin, Wisconsin, Northrock, Oztec, Toker TK, Rol-Air, Small Line, Wanco, Yanmar

SECTION 1. SPECIFICATIONS

1.1 OPERATING SPECIFICATIONS

Maximum Work Load (Capacity) - ANSI Unrestricted:	500 lb. (227 kg)
Restricted - 600SC	1000 lb. (454 kg)
Restricted - 660SJC	500 lb. (227 kg)
Maximum Work Load (Capacity) - CE & Australia Unrestricted:	500 lb. (230 kg)
Restricted - 600SC	1000 lb. (450 kg)
Restricted - 660SJC	500 lb. (230 kg)
Maximum Travel Grade (Gradeability)*	55%
Maximum Travel Grade (Side Slope)*	5°
Max. Vertical Platform Height:	
600SC	60 ft. 3 in. (18.36 m)
660SJC	66 ft. 8 in. (20.32 m)
Max. Horizontal Platform Reach:	
600SC	49 ft. 6 in. (15.09 m)
660SJC	56 ft. 9 in. (17.3 m)
Turning Radius	0
Maximum Ground Bearing Pressure	
600SC	5.45 psi (0.383 kg/cm ²)
660SJC	6.5 psi (0.457 kg/cm ²)
Maximum Drive Speed:	1.6 mph (2.6 kph)
Max. Hydraulic System Pressure	4500 psi (310 Bar)
Maximum Wind Speed	28 mph (12.5 m/s)
Maximum Manual Force	101 lb. (450 N)
Electrical System Voltage	12 Volts
Gross Machine Weight (Platform Empty)	
600SC	22,500 lb. (10,205 kg)
660SJC	27,100 lb. (12,292 kg)

* Boom in stowed position.

1.2 DIMENSIONAL DATA

Table 1-1. Dimensional Data

Machine Height (Stowed)	8 ft. 5 in. (2.57 m)
Machine Length (Stowed)	
600SC	27 ft. 11 in. (8.51 m)
660SJ	35 ft. 8 in. (10.88 m)
Machine Width	8 ft 2 in. (2.49 m)
Ground Clearance	15 in. (0.38 m)
Platform Height	
600SC	60 ft. 3 in. (18.36 m)
660SJC	66 ft. 8 in. (20.32 m)
Horizontal Reach	
600SC	49 ft. 6 in. (15.08 m)
660SJC	56 ft. 9 in. (17.30 m)
Tail Swing	3 ft. 7-1/2 in. (1.10 m)

1.3 CAPACITIES

Table 1-2. Capacities

Fuel Tank	39 US. Gal (147.6 L)
Hydraulic Oil Tank	
Total Volume	26 U.S. Gal (98.4 L)
at Full Mark	31.1 U.S. Gal (117.7 L)
Hydraulic System (Including Tank)	40 U.S. Gal (151.4 L)
Engine Crankcase	11 Qt (10.5 L)
Fuel Tank	39 US. Gal (147.6 L)

1.4 ENGINE DATA

Table 1-3. Deutz TD 2.9 Specifications

Fuel	Ultra Low Sulfur Diesel (15 ppm)
Output	67 hp (50 kW)
Torque	173 ft.lbs. (234 Nm) @ 1800rpm
Oil Capacity (Crankcase)	2.4 Gal (8.9 L) w/Filter
Cooling System	3.3 Gal (12.5 L)
Low RPM	1200 ± 50 rpm
High RPM	2600 ± 50 rpm
Alternator	95 Amp
Fuel Consumption	0.65 GPH (2.48 lph)

SECTION 1 - SPECIFICATIONS

1.5 FUNCTION SPEEDS

Table 1-4. Function Speeds (In Seconds)

Function	600SC	660SJC
Lift Up	46-60	46-60
Lift Down	33-43	33-43
Swing Right & Left*	79-101	79-101
Telescope In	22-33	25-33
Telescope Out	50-67	50-67
Platform Rotate Right & Left**	16-25	25-32
Jib Up	N/A	22-34
Jib Down	N/A	16-26
Drive Forward & Reverse	85-90 (1.55 MPH)	85-90 (1.55 MPH)
Drive (Out of Transport) Forward & Reverse	80-85 (.40 MPH)	80-85 (.40 MPH)
*Max 10% Difference Between Left & Right		
**Max 15% Difference Between Left & Right		

Machine Orientation When Doing Speed Tests

Lift: Boom retracted. Telescope retracted. Lift up, record time, Lift down, record time.

Swing: Boom at full elevation. Telescope retracted. Swing turntable off center and stop. Swing opposite direction and start test when centered. This eliminates controller ramp up and ramp down affecting times.

Telescope: Boom at full elevation; Telescope retracted; Telescope out, record time. Telescope In, record time.

Tracking: Test to be done on a graveled level surface. Position machine at a reference point (no steer correction) driving at high speed. Results should be 4 - 6 ft (1.2 - 1.8 m) tracking error at 200 ft (61 m).

Drive: Test to be done on a graveled level surface. Set Drive Select Switch to High Speed. Start approximately 10 ft (7.6 m) from starting point so unit is at maximum speed when starting test. Record results for a 200 ft. (61 m) course. Drive forward, record time. Drive reverse, record time.

Drive (Out of Transport): Test should be done on a graveled level surface. Set Drive Select Switch to High Engine, High Speed. Select Platform Speed Knob out of creep speed. Raise boom above horizontal. Results should be recorded for a 50 ft (15.2 m) course. Drive forward, record time. Drive reverse, record time.

Platform Rotate: Platform level and completely rotated one direction. Rotate opposite direction, record time. Rotate other direction, record time.

Jib: Platform level and centered with boom. Start with Jib down. Jib up, record time. Jib down, record time.

Test Notes

1. Start stop watch with function, not with controller or switch.
2. All speed tests are run from platform. Speeds do not reflect ground control operation.
3. Platform speed knob control must be at full speed (turned clockwise completely).
4. Test with oil temperature above 100° F (38° C). Function speeds vary if hydraulic oil is cold and thick.
5. Some flow control functions may not work with speed knob clicked into creep position.

1.6 TORQUE REQUIREMENTS

Table 1-5. Torque Requirements

Description	Torque Value (Dry)	Interval Hours
Bearing To Chassis	190 ft. lbs. (258 Nm)	50/600*
Bearing To Turntable	190 ft. lbs. (258 Nm)	50/600*
Wire Rope	15 ft. lbs (20 Nm)	150
Wheel Lugs	170 ft. lbs (231 Nm)	150
Engine Mounting Bolts	165 ft. lbs. (231 Nm)	A/R
Engine Manifold Mounting Bolts	30 ft. lbs. (42 Nm)	A/R
*Check swing bearing bolts after first 50 hours of operation and every 600 hours thereafter. (See Swing Bearing in Section 3.)		

1.7 HYDRAULIC OIL

Table 1-6. Hydraulic Oil

Hydraulic System Operating Temperature Range	S.A.E. Viscosity Grade
+0° to +180° F (-18° to +83° C)	10W
+0° to +210° F (-18° to +99° C)	10W-20, 10W30
+50° to +210° F (+10° to +99° C)	20W-20

NOTE: Hydraulic oils require anti-wear qualities at least API Service Classification GL-3, and sufficient chemical stability for mobile hydraulic system service.

NOTE: Aside from JLG recommendations, it is not advisable to mix oils of different brands or types. They may not contain required additives or be of comparable viscosities. If hydraulic oil other than Mobil 424 is desired, contact JLG Industries for proper recommendations.

Table 1-7. Mobilfluid 424

SAE Grade	10W30
Gravity, API	29.0
Density, Lb/Gal. 60°F	7.35
Pour Point, Max	-46°F (-43°C)
Flash Point, Min.	442°F (228°C)
Viscosity	
Brookfield, cP at -18°C	2700
at 40° C	55 cSt
at 100° C	9.3 cSt
Viscosity Index	152

Table 1-8. Mobil DTE 13M

ISO Viscosity Grade	#32
Specific Gravity	0.877
Pour Point, Max	-40°F (-40°C)
Flash Point, Min.	330°F (166°C)
Viscosity	
at 40° C	33cSt
at 100° C	6.6 cSt
at 100° F	169SUS
at 210° F	48 SUS
cp at -20° F	6,200
Viscosity Index	140

Table 1-9. UCon Hydrolube HP-5046

Type	Synthetic Biodegradable
Specific Gravity	1.082
Pour Point, Max	-58°F (-50°C)
pH	9.1
Viscosity	
at 0° C (32° F)	340 cSt (1600SUS)
at 40° C (104° F)	46 cSt (215SUS)
at 65° C (150° F)	22 cSt (106SUS)
Viscosity Index	170

SECTION 1 - SPECIFICATIONS

Table 1-10. Mobil EAL H 46

Type	Synthetic Biodegradable
ISO Viscosity Grade	46
Specific Gravity	.910
Pour Point	-44°F (-42°C)
Flash Point	500°F (260°C)
Operating Temp.	0 to 180°F (-17 to 162°C)
Weight	7.64 lb. per gal. (0.9 kg per liter)
Viscosity	
at 40° C	45 cSt
at 100° C	8.0 cSt
Viscosity Index	153

Table 1-11. Exxon Univis HVI 26

Specific Gravity	32.1
Pour Point	-76°F (-60°C)
Flash Point	217°F (103°C)
Viscosity	
at 40° C	25.8 cSt
at 100° C	9.3 cSt
Viscosity Index	376
NOTE: ExxonMobil recommends checking oil viscosity yearly.	

1.8 MAJOR COMPONENT WEIGHTS

WARNING

DO NOT REPLACE ITEMS CRITICAL TO STABILITY WITH ITEMS OF DIFFERENT WEIGHT OR SPECIFICATION (FOR EXAMPLE: BATTERIES, FILLED TIRES, PLATFORM) DO NOT MODIFY UNIT IN ANY WAY TO AFFECT STABILITY.

Table 1-12. Major Component Weights

	660SJ		600S	
	Lb	Kg	Lb	Kg
Platform Control Console	250	113	250	113
Platform Level Cylinder	60	27	46	21
Main Boom (Includes Lift Cyl., Rotator, and Support)	3783	1716	3527	1600
Turntable Complete (including engine)	9065	4112	7315	3318

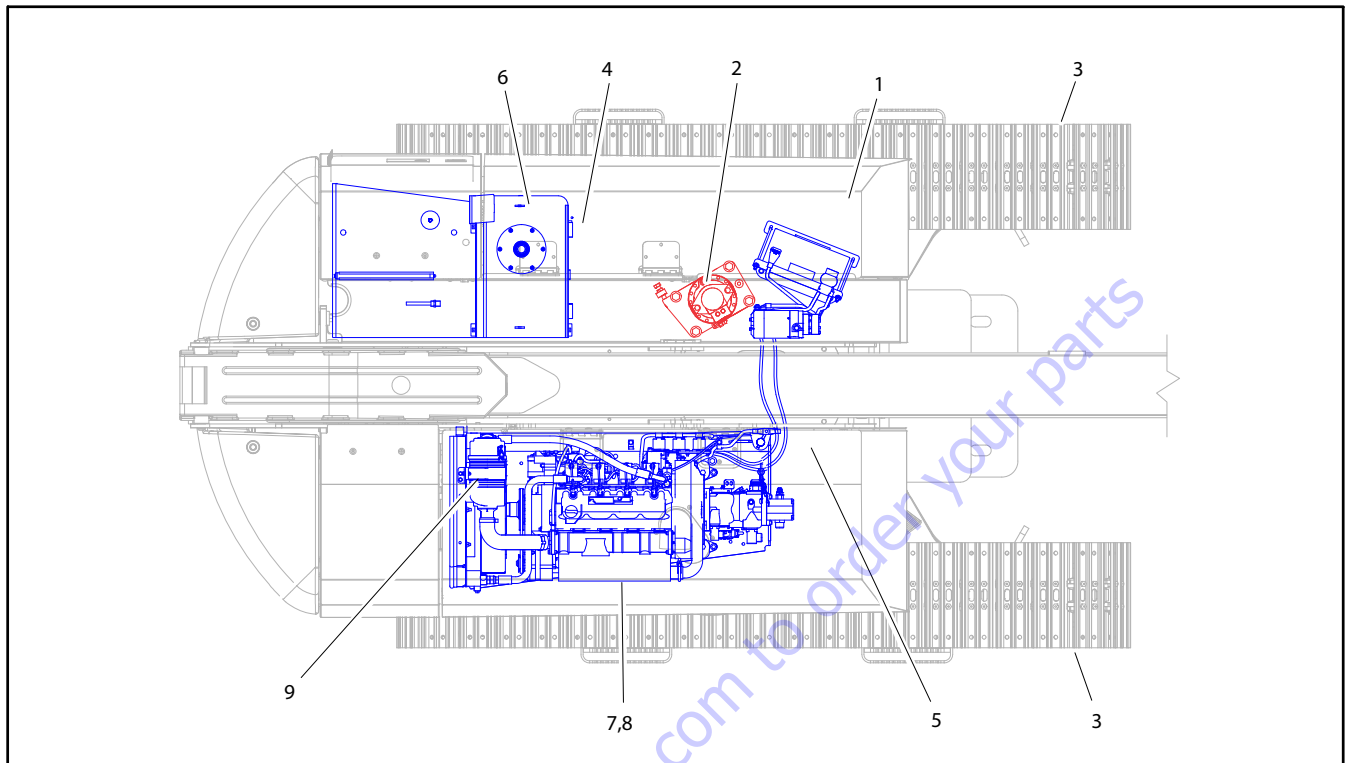

Figure 1-1. Maintenance and Lubrication

1.9 OPERATOR MAINTENANCE

NOTE: The following numbers correspond to those in Figure 1-1., Maintenance and Lubrication.

Table 1-13. Lubrication Specifications.

KEY	SPECIFICATIONS
MPG	Multipurpose Grease having a minimum dripping point of 350° F (177° C). Excellent water resistance and adhesive qualities, and being of extreme pressure type. (Timken OK 40 pounds minimum.)
EPGL	Extreme Pressure Gear Lube (oil) meeting API service classification GL-5 or MIL-Spec MIL-L-2105
HO	Hydraulic Oil. API service classification GL-3, e.g. Mobil-fluid 424
EO	Engine (crankcase) Oil. Gas - API SF, SH, SG class, MIL-L-2104. Diesel - API CC/CD class, MIL-L-2104B/MIL-L-2104C

1. Swing Bearing

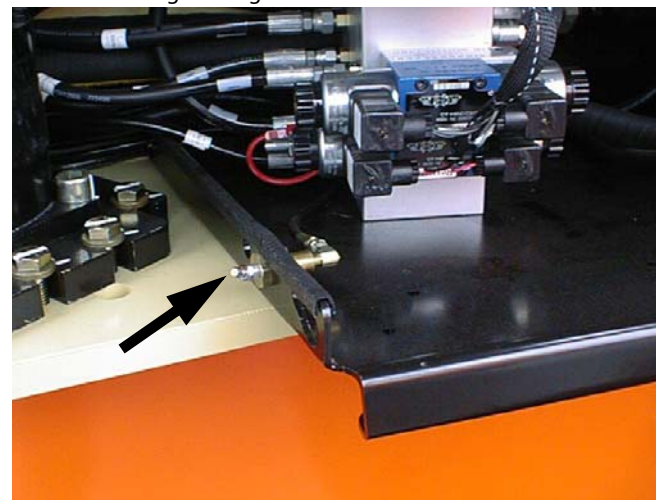

Lube Point(s) - 1 Grease Fittings
 Capacity - A/R
 Lube - MPG
 Interval - Every 3 months or 150 hrs of operation
 Comments - Remote Access. Apply grease and rotate in 90 degree intervals until bearing is completely lubricated.

NOTICE

LUBRICATION INTERVALS ARE BASED ON MACHINE OPERATION UNDER NORMAL CONDITIONS. FOR MACHINES USED IN MULTI-SHIFT OPERATIONS AND/OR EXPOSED TO HOSTILE ENVIRONMENTS OR CONDITIONS, LUBRICATION FREQUENCIES MUST BE INCREASED ACCORDINGLY.

SECTION 1 - SPECIFICATIONS

2. Swing Drive Hub

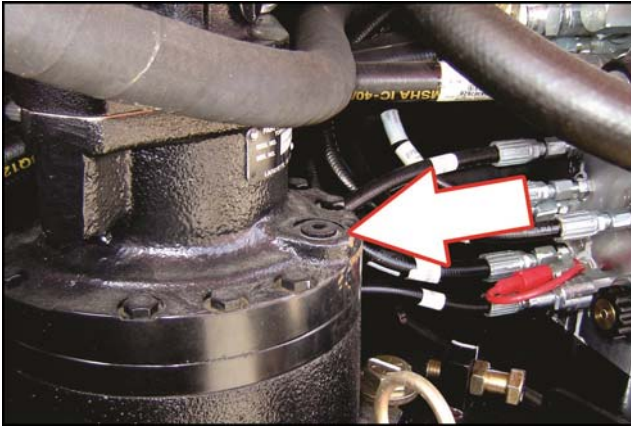

Lube Point(s) - Level/Fill Plug
Capacity - 17 oz. (1/2 Full)
Lube - EPGL
Interval - Check level every 3 months or 150 hrs of operation; change every 2 years or 1200 hours of operation.

3. Final Drive Hub

Lube Point(s) - Level/Fill Plug
Capacity - 2.1 gal.(7.9 L); 1/2 Full
Lube - EPGL
Interval - Check level every 3 months or 150 hrs of operation; change every 2 years or 1200 hours of operation.

4. Hydraulic Return Filter



Interval - Change after first 50 hrs. and every 6 months or 300 hrs. thereafter or as shown by Condition Indicator.

5. Hydraulic Charge Filter



Interval - Change after first 50 hrs. and every 6 months or 300 hrs. thereafter, or as shown by Condition Indicator.

6. Hydraulic Tank Lube Point(s) - Fill Cap

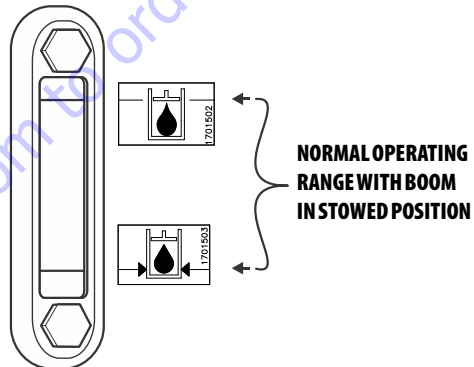

Capacity - 26 gal. Tank; 40 gal. System
Lube - HO
Interval - Check Level daily; Change every 2 years or 1200 hours of operation

7. Oil Change w/Filter - Deutz D2.9

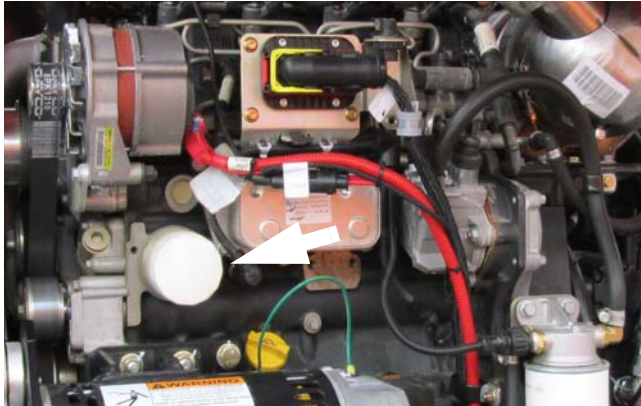

Lube Point(s) - Fill Cap/Spin-on Element
Capacity - 8.45 Qt (8 L) Crankcase and Filter
Interval - Every Year or 600 hours of operation
Comments - Check level daily/Change in accordance with engine manual..

8. Air Filter - Deutz D2.9

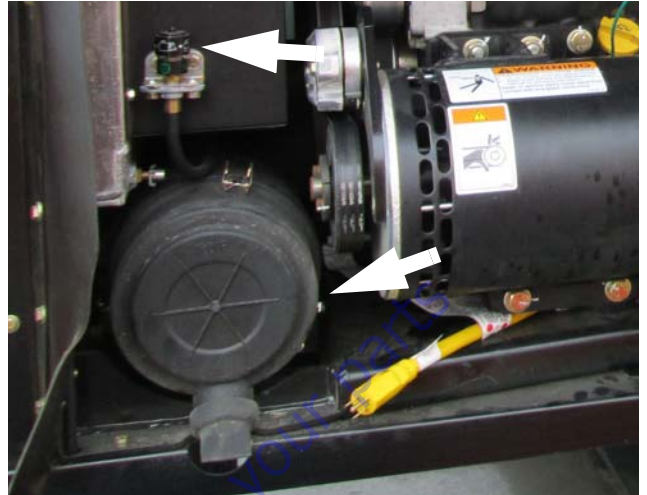

Lube Point(s) - Replaceable Element
Interval - Every 6 months or 300 hours of operation or as shown by condition indicator

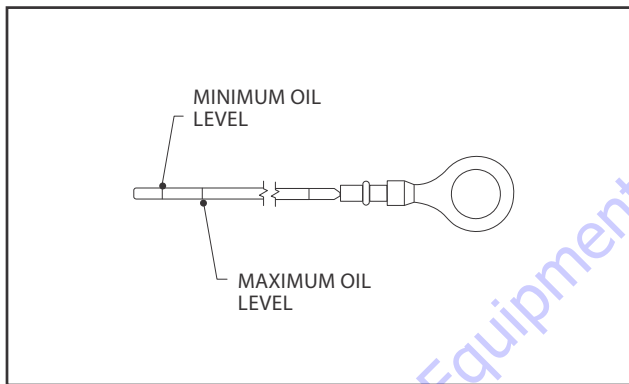

Values for Zinc Yellow Chromate Fasteners (Ref 4150707)															
SAE GRADE 5 BOLTS & GRADE 2 NUTS										SAE GRADE 8 (HEX HD) BOLTS & GRADE 8 NUTS*					
Size	TPI	Bolt Dia	Tensile Stress Area	Clamp Load		Torque (Dry)		Torque Lubricated		Torque (Loctite® 242™ or 271™ OR Vibra-TITE™ 111 or 140)		Torque (Loctite® 262™ or Vibra-TITE™ 131)		Torque (Loctite® 262™ or Vibra-TITE™ 131) K=0.15	
				LB	IN-LB	IN-LB	FT-LB	IN-LB	FT-LB	IN-LB	FT-LB	IN-LB	FT-LB		IN-LB
4	40	0.1120	0.00604	380	8	0.9	6	0.7							
	48	0.1120	0.00661	420	9	1.0	7	0.8							
6	32	0.1380	0.00909	580	16	1.8	12	1.4							
	40	0.1380	0.01015	610	18	2.0	13	1.5							
8	32	0.1640	0.01400	900	30	3.4	22	2.5							
	36	0.1640	0.01474	940	31	3.5	23	2.6							
10	24	0.1900	0.01750	1120	43	4.8	32	3.5							
	32	0.1900	0.02000	1285	49	5.5	36	4							
1/4	20	0.2500	0.0318	2020	96	10.8	75	8	105	12	143	16	129	15	
	28	0.2500	0.0384	2320	120	13.5	86	10	135	15	164	19	148	17	
5/16	18	0.3125	0.0524	3340	17	23	13	18	19	26	16	22	35	20	25
	24	0.3125	0.0580	3700	19	26	14	19	21	29	17	23	35	20	25
3/8	16	0.3750	0.0775	4940	30	41	23	31	35	48	28	38	45	60	55
	24	0.3750	0.0878	5600	35	47	25	34	40	54	32	43	7900	50	35
7/16	14	0.4375	0.1063	6800	50	68	35	47	55	75	45	61	9550	70	95
	20	0.4375	0.1187	7550	55	75	40	54	60	82	50	68	10700	80	110
1/2	13	0.5000	0.1419	9050	75	102	55	75	85	116	68	92	12750	105	130
	20	0.5000	0.1599	10700	90	122	65	88	100	136	80	108	14400	120	150
9/16	12	0.5625	0.1820	11600	110	149	80	108	120	163	98	133	16400	155	190
	18	0.5625	0.2030	12950	120	163	90	122	135	184	109	148	18250	170	230
5/8	11	0.6250	0.2260	14400	150	203	110	149	165	224	135	183	20350	210	285
	18	0.6250	0.2560	16300	170	230	130	176	190	258	153	207	23000	240	325
3/4	10	0.7500	0.3340	21300	260	353	200	285	388	388	240	325	30100	375	510
	16	0.7500	0.3730	23800	300	407	220	298	330	449	288	363	33600	420	570
7/8	9	0.8750	0.4620	29400	430	583	320	434	475	646	386	523	41600	605	825
	14	0.8750	0.5090	32400	470	637	350	475	520	707	425	576	45800	670	910
1	8	1.0000	0.6060	38600	640	868	480	651	675	918	579	785	51500	860	1170
	12	1.0000	0.6630	42200	700	949	530	719	735	1000	633	868	59700	995	1355
1 1/8	7	1.1250	0.7630	42300	800	1085	600	813	840	1142	714	968	66700	1290	1755
	12	1.1250	0.8560	47500	860	1183	660	895	925	1258	802	1087	77000	1445	1965
1 1/4	7	1.2500	0.9690	53800	1120	1518	840	1139	1175	1598	1009	1368	87200	1815	2470
	12	1.2500	1.0730	59600	1240	1681	920	1247	1300	1768	1118	1516	96600	2015	2740
1 3/8	6	1.3750	1.1550	64100	1460	1979	1100	1491	1525	2074	1322	1792	104000	2385	3245
	12	1.3750	1.3150	73000	1680	2278	1260	1708	1750	2380	1508	2042	118100	2705	3680
1 1/2	6	1.5000	1.4050	78000	1940	2630	1460	1979	2025	2754	1755	2379	126500	3165	4305
	12	1.5000	1.5800	87700	2200	2983	1640	2224	2300	3128	1974	2676	142200	3555	4835

NO. 5000059 REV. K

NOTES: 1. THESE TORQUE VALUES DO NOT APPLY TO CADMIUM PLATED FASTENERS
 2. ALL TORQUE VALUES ARE STATIC TORQUE MEASURED PER STANDARD AUDIT METHODS TOLERANCE = ±10%
 3. * ASSEMBLY USES HARDENED WASHER

Figure 1-2. Torque Chart - Sheet 1 of 5 - (SAE Fasteners)

Values for Magni Coating Fasteners (Ref 4150701)																											
SAE GRADE 5 BOLTS & GRADE 2 NUTS						SAE GRADE 8 (HEX HD) BOLTS & GRADE 8 NUTS*																					
Size	TPI	Bolt Dia	Tensile Stress Area	Clamp Load	Torque (Dry) K=0.17	Torque (Locitite® 242™ or 271™ OR Vibra-TITE™ 111 or 140) K=0.16		Torque (Locitite® 262™ or TITE™ 131) K=0.15		Clamp Load	Torque (Dry or Locitite® 263) K=0.17	Torque (Locitite® 242™ or 271™ OR Vibra-TITE™ 111 or 140) K=0.16		Torque (Locitite® 262™ or TITE™ 131) K=0.15													
						IN-LB	FT-LB	IN-LB	FT-LB			IN-LB	FT-LB		IN-LB	FT-LB											
4	40	0.1120	0.00604	380	7	0.8																					
	48	0.1120	0.00661	420	8	0.9																					
6	32	0.1380	0.00909	580	14	1.5																					
	40	0.1380	0.01015	610	14	1.6																					
8	32	0.1640	0.01400	900	25	2.8																					
	36	0.1640	0.01474	940	26	2.9				1320	37	4															
10	24	0.1900	0.01750	1120	36	4.1				1580	51	6															
	32	0.1900	0.02000	1285	42	4.7				1800	58	7															
1/4	20	0.2500	0.0318	2020	86	9.7	80	9		2860	122	14	114	13													
	28	0.2500	0.0364	2320	99	11.1	95	11		3280	139	16	131	15													
		In	Sq In	LB	FT-LB	IN-LB	FT-LB	IN-LB	FT-LB	LB	FT-LB	IN-LB	FT-LB	IN-LB	FT-LB	IN-LB	FT-LB	IN-LB	FT-LB	[N.m]	[N.m]	[N.m]	[N.m]	[N.m]	[N.m]	[N.m]	[N.m]
5/16	18	0.3125	0.0524	3340	15	20	14	19	15	20	4720	20	25	20	25	20	25	20	25	20	25	20	25	20	25	20	25
	24	0.3125	0.0580	3700	15	20	15	21	15	20	5220	25	35	20	25	20	25	20	25	20	25	20	25	20	25	20	25
3/8	16	0.3750	0.0775	4840	25	35	25	34	25	34	7000	35	50	35	50	35	50	35	50	35	50	35	50	35	50	35	50
	24	0.3750	0.0878	5600	30	40	28	38	25	34	7900	40	55	40	55	40	55	40	55	40	55	40	55	40	55	40	55
7/16	14	0.4375	0.1063	6800	40	55	40	54	40	54	9550	60	80	60	80	60	80	60	80	60	80	60	80	60	80	60	80
	20	0.4375	0.1187	7550	45	60	44	60	44	60	10700	65	90	65	90	65	90	65	90	65	90	65	90	65	90	65	90
1/2	13	0.5000	0.1419	9050	65	90	60	82	65	90	12750	90	120	90	120	90	120	90	120	90	120	90	120	90	120	90	120
	20	0.5000	0.1589	10700	75	100	71	97	88	115	14400	100	135	100	135	100	135	100	135	100	135	100	135	100	135	100	135
9/16	12	0.5625	0.1820	11600	90	120	87	118	80	109	16400	130	175	125	175	125	175	125	175	125	175	125	175	125	175	125	175
	18	0.5625	0.2030	12950	105	145	97	132	90	122	18250	145	195	145	195	145	195	145	195	145	195	145	195	145	195	145	195
5/8	11	0.6250	0.2260	14400	130	175	120	163	115	156	20350	180	245	170	245	170	245	170	245	170	245	170	245	170	245	170	245
	18	0.6250	0.2560	16300	145	195	136	185	125	170	23000	205	280	190	280	190	280	190	280	190	280	190	280	190	280	190	280
3/4	10	0.7500	0.3340	21300	225	305	213	290	200	272	30100	320	435	300	435	300	435	300	435	300	435	300	435	300	435	300	435
	16	0.7500	0.3730	23800	255	345	238	324	225	306	33600	355	485	335	485	335	485	335	485	335	485	335	485	335	485	335	485
7/8	9	0.8750	0.4620	29400	365	495	343	466	320	435	41600	515	700	485	700	485	700	485	700	485	700	485	700	485	700	485	
	14	0.8750	0.5090	32400	400	545	378	514	355	483	45800	570	775	535	775	535	775	535	775	535	775	535	775	535	775	535	
1	8	1.0000	0.6060	38600	545	740	515	700	480	653	51500	730	995	685	995	685	995	685	995	685	995	685	995	685	995	685	
	12	1.0000	0.6630	42200	600	815	600	815	563	765	59700	845	1150	845	1150	845	1150	845	1150	845	1150	845	1150	845	1150	845	
1 1/8	7	1.1250	0.7630	42300	675	920	635	863	635	863	68700	1095	1490	1030	1490	1030	1490	1030	1490	1030	1490	1030	1490	1030	1490	1030	
	12	1.1250	0.8560	47500	765	1025	713	969	670	911	77000	1225	1665	1155	1665	1155	1665	1155	1665	1155	1665	1155	1665	1155	1665	1155	
1 1/4	7	1.2500	0.9690	53800	965	1300	897	1219	840	1142	87200	1545	2100	1455	2100	1455	2100	1455	2100	1455	2100	1455	2100	1455	2100	1455	
	12	1.2500	1.0730	59600	1055	1435	993	1351	930	1265	96600	1710	2325	1610	2325	1610	2325	1610	2325	1610	2325	1610	2325	1610	2325	1610	
1 3/8	6	1.3750	1.1550	64100	1250	1700	1175	1598	1100	1496	104000	2025	2755	1905	2755	1905	2755	1905	2755	1905	2755	1905	2755	1905	2755	1905	
	12	1.3750	1.3150	73000	1420	1930	1338	1820	1255	1707	118100	2300	3130	2165	3130	2165	3130	2165	3130	2165	3130	2165	3130	2165	3130	2165	
1 1/2	6	1.5000	1.4050	78000	1660	2260	1560	2122	1465	1992	126500	2690	3660	2530	3660	2530	3660	2530	3660	2530	3660	2530	3660	2530	3660	2530	
	12	1.5000	1.5800	87700	1865	2535	1754	2385	1645	2237	142200	3020	4105	2845	4105	2845	4105	2845	4105	2845	4105	2845	4105	2845	4105	2845	

NO. 5000059 REV. K

NOTES: 1. THESE TORQUE VALUES DO NOT APPLY TO CADMIUM PLATED FASTENERS
 2. ALL TORQUE VALUES ARE STATIC TORQUE MEASURED PER STANDARD AUDIT METHODS TOLERANCE = ±10%
 3. * ASSEMBLY USES HARDENED WASHER

Figure 1-3. Torque Chart - Sheet 2 of 5 - (SAE Fasteners)

SOCKET HEAD CAP SCREWS													
Size	TPI	Bolt Dia	Tensile Stress Area	Clamp Load See Note 4	Magni Coating (Ref 4150701)*				Zinc Yellow Chromate Fasteners (Ref 4150707)*				
					Torque (Dry) K = .17	Torque (Loctite® 242™ or 271™ OR Vibra-TITE™ 111 or 140 OR Precoat 85®) K=0.16	Torque (Loctite® 262™ or Vibra-TITE™ 131) K=0.15	Clamp Load See Note 4	Torque (Dry) K = .20	Torque (Loctite® 242™ or 271™ OR Vibra-TITE™ 111 or 140 OR Precoat 85®) K=0.18	Torque (Loctite® 262™ or Vibra-TITE™ 131) K=0.15		
		In	Sq In	LB	IN-LB [N.m]	FT-LB [N.m]	IN-LB [N.m]	FT-LB [N.m]	LB	IN-LB [N.m]	FT-LB [N.m]	IN-LB [N.m]	FT-LB [N.m]
4	40	0.1120	0.00604										
48	48	0.1120	0.00661										
6	32	0.1380	0.00909										
40	40	0.1380	0.01015										
8	32	0.1640	0.01400										
36	36	0.1640	0.01474										
10	24	0.1900	0.01750										
32	32	0.1900	0.02000										
1/4	20	0.2500	0.0318	2860	122	14	114	13	2860	143	16	129	15
28	28	0.2500	0.0364	3280	139	16	131	15	3280	164	19	148	17
5/16	18	0.3125	0.0524	4720	20	25	20	25	4720	25	35	20	25
24	24	0.3125	0.0580	5220	25	35	20	25	5220	25	35	25	35
3/8	16	0.3750	0.0775	7000	35	50	35	50	7000	45	60	40	55
24	24	0.3750	0.0878	7900	40	55	40	55	7900	50	70	45	60
7/16	14	0.4375	0.1063	9550	60	80	55	70	9550	70	95	65	90
20	20	0.4375	0.1187	10700	65	90	60	80	10700	80	110	70	95
1/2	13	0.5000	0.1419	12750	90	120	85	110	12750	105	145	95	130
9/16	12	0.5625	0.1820	16400	100	135	95	130	16400	120	165	110	150
18	18	0.5625	0.2030	18250	145	195	135	185	18250	170	230	155	210
5/8	11	0.6250	0.2260	20350	180	245	170	230	20350	210	285	190	260
18	18	0.6250	0.2560	23000	205	280	190	260	23000	240	325	215	290
3/4	10	0.7500	0.3340	30100	320	435	300	380	30100	375	510	340	460
16	16	0.7500	0.3730	33600	355	485	335	455	33600	420	570	380	515
7/8	9	0.8750	0.4620	41600	515	700	485	660	41600	605	825	545	740
14	14	0.8750	0.5090	45800	570	775	535	730	45800	670	910	600	815
1	8	1.0000	0.6060	51500	730	995	685	930	51500	860	1170	775	1055
1 1/8	7	1.1250	0.7630	68700	845	1160	795	1080	68700	995	1365	895	1215
1 1/4	7	1.2500	0.8560	77000	1095	1490	1030	1400	77000	1290	1795	1160	1580
1 3/8	6	1.3750	1.1550	104000	2025	2765	1905	2590	104000	2365	3245	2145	2915
1 1/2	6	1.5000	1.4050	128500	2690	3660	2530	3440	128500	3165	4305	2845	3870
12	12	1.5000	1.5800	142200	3020	4105	2845	3870	142200	3555	4835	3200	4350

NO. 5000059 REV. K

NOTES: 1. THESE TORQUE VALUES DO NOT APPLY TO CADMIUM PLATED FASTENERS
 2. ALL TORQUE VALUES ARE STATIC TORQUE MEASURED PER STANDARD AUDIT METHODS TOLERANCE = +10%
 *3. ASSEMBLY USES HARDENED WASHER OR FASTENER IS PLACED AGAINST PLATED STEEL OR RAW ALUMINUM
 4. CLAMP LOAD LISTED FOR SHCS IS SAME AS GRADE 8 OR CLASS 10.9 AND DOES NOT REPRESENT FULL STRENGTH CAPABILITY OF SHCS. IF HIGHER LOAD IS REQUIRED, ADDITIONAL TESTING IS REQUIRED.

Figure 1-4. Torque Chart - Sheet 3 of 5 - (SAE Fasteners)

Values for Zinc Yellow Chromate Fasteners (Ref 4150707)											
CLASS 8.8 METRIC (HEX/SOCKET HEAD) BOLTS CLASS 8 METRIC NUTS					CLASS 10.9 METRIC (HEX HEAD) BOLTS CLASS 10 METRIC NUTS CLASS 12.9 SOCKET HEAD CAP SCREWS M3 - M5*						
Size	PITCH	Tensile Stress Area	Clamp Load	Torque (Dry or Loctite® 263™)	Torque (Lub)	Torque (Loctite® 262™ OR VIBRA-TITE™ 131)	Torque (Loctite® 242™ or 271™ OR VIBRA-TITE™ 111 or 140)	Clamp Load	Torque (Dry or Loctite® 263™) K = 0.20	Torque (Lub OR Loctite® 242™ or 271™ OR VIBRA-TITE™ 111 or 140) K = 0.18	Torque (Loctite® 262™ OR VIBRA-TITE™ 131) K=0.15
		Sq mm	KN	[N.m]	[N.m]	[N.m]	[N.m]	KN	[N.m]	[N.m]	[N.m]
3	0.5	5.03	2.19	1.3	1.0	1.2	1.4	3.13			
3.5	0.6	6.78	2.95	2.1	1.6	1.9	2.3	4.22			
4	0.7	8.78	3.82	3.1	2.3	2.8	3.4	5.47			
5	0.8	14.20	6.18	6.2	4.6	5.6	6.8	8.85			
6	1	20.10	8.74	11	7.9	9.4	12	12.5			
7	1	28.90	12.6	18	13	16	19	18.0	25	23	19
8	1.25	36.60	15.9	26	19	23	28	22.8	37	33	27
10	1.5	58.00	25.2	50	38	45	55	36.1	70	65	55
12	1.75	84.30	36.7	88	66	79	97	52.5	125	115	95
14	2	115	50.0	140	105	126	154	71.6	200	180	150
16	2	157	68.3	219	164	197	241	97.8	315	280	235
18	2.5	192	83.5	301	226	271	331	119.5	430	385	325
20	2.5	245	106.5	426	320	383	469	152.5	610	550	460
22	2.5	303	132.0	581	436	523	639	189.0	830	750	625
24	3	353	153.5	737	553	663	811	222.0	1065	960	800
27	3	459	199.5	1080	810	970	1130	286.0	1545	1390	1160
30	3.5	561	244.0	1460	1100	1320	1530	349.5	2095	1885	1575
33	3.5	694	302.0	1990	1490	1790	2090	432.5	2855	2570	2140
36	4	817	355.5	2560	1920	2300	2690	509.0	3665	3300	2750
42	4.5	1120	487.0	4090	3070	3680	4290	698.0	5865	5275	4395

NOTES: 1. THESE TORQUE VALUES DO NOT APPLY TO CADMIUM PLATED FASTENERS
 2. ALL TORQUE VALUES ARE STATIC TORQUE MEASURED PER STANDARD AUDIT METHODS TOLERANCE = ±10%
 *3. ASSEMBLY USES HARDENED WASHER OR FASTENER IS PLACED AGAINST PLATED STEEL OR RAW ALUMINUM
 4. CLAMP LOAD LISTED FOR SHCS IS SAME AS GRADE 8 OR CLASS 10.9 AND DOES NOT REPRESENT FULL STRENGTH CAPABILITY OF SHCS. IF HIGHER LOAD IS REQUIRED, ADDITIONAL TESTING IS REQUIRED.

NO. 500059 REV. K

Figure 1-5. Torque Chart - Sheet 4 of 5 - (METRIC Fasteners)

Values for Magni Coated Fasteners (Ref 4150701)										
CLASS 8.8 METRIC (HEX/SOCKET HEAD) BOLTS CLASS 8 METRIC NUTS					CLASS 10.9 METRIC (HEX HEAD) BOLTS CLASS 10 METRIC NUTS CLASS 12.9 SOCKET HEAD CAP SCREWS M6 AND ABOVE*					
Size	PITCH	Tensile Stress Area	Clamp Load	Torque (Dry or Loctite® 263™) K=0.17	Torque (Loctite® 262™ OR Vibra-TITE™ 131) K=0.16	Torque (Loctite® 242™ or 271™ OR Vibra-TITE™ 111 or 140) K=0.15	Clamp Load	Torque (Dry or Loctite® 263™) K = 0.17	Torque (Lub OR Loctite® 242™ or 271™ OR Vibra-TITE™ 111 or 140) K= 0.16	Torque (Loctite® 262™ OR Vibra-TITE™ 131) K=0.15
		Sq mm	KN	[N.m]	[N.m]	[N.m]	KN	[N.m]	[N.m]	[N.m]
3	0.5	5.03	2.19	1.1	1.1	1.0	3.13			
3.5	0.6	6.78	2.95	1.8	1.7	1.5	4.22			
4	0.7	8.78	3.82	2.6	2.4	2.3	5.47			
5	0.8	14.20	6.18	5.3	4.9	4.6	8.85			
6	1	20.10	8.74	9	8.4	7.9	12.5	13	12	11
7	1	28.90	12.6	15	14	13	18.0	21	20	19
8	1.25	36.60	15.9	22	20	19	22.8	31	29	27
10	1.5	58.00	25.2	43	40	38	36.1	61	58	55
12	1.75	84.30	36.7	75	70	66	52.5	105	100	95
14	2	115	50.0	119	110	105	71.6	170	160	150
16	2	157	68.3	186	175	165	97.8	265	250	235
18	2.5	192	83.5	256	240	225	119.5	365	345	325
20	2.5	245	106.5	362	340	320	152.5	520	490	460
22	2.5	303	132.0	494	465	435	189.0	705	665	625
24	3	353	153.5	627	590	555	222.0	905	850	800
27	3	459	199.5	916	860	810	286.0	1315	1235	1160
30	3.5	561	244.0	1245	1170	1100	349.5	1780	1680	1575
33	3.5	694	302.0	1694	1595	1495	432.5	2425	2285	2140
36	4	817	355.5	2176	2050	1920	509.0	3115	2930	2750
42	4.5	1120	487.0	3477	3275	3070	698.0	4985	4690	4395

NO. 500059 REV. K

NOTES: 1. THESE TORQUE VALUES DO NOT APPLY TO CADMIUM PLATED FASTENERS
 2. ALL TORQUE VALUES ARE STATIC TORQUE MEASURED PER STANDARD AUDIT METHODS TOLERANCE = ±10%
 *3. ASSEMBLY USES HARDENED WASHER OR FASTENER IS PLACED AGAINST PLATED STEEL OR RAW ALUMINUM
 4. CLAMP LOAD LISTED FOR SHCS IS SAME AS GRADE 8 OR CLASS 10.9 AND DOES NOT REPRESENT FULL STRENGTH CAPABILITY OF SHCS. IF HIGHER LOAD IS REQUIRED, ADDITIONAL TESTING IS REQUIRED.

Figure 1-6. Torque Chart - Sheet 5 of 5 - (METRIC Fasteners)

SECTION 2. GENERAL

2.1 MACHINE PREPARATION, INSPECTION, AND MAINTENANCE

General

This section provides information needed by personnel responsible to place machine in operation readiness and maintain its safe operating condition. For maximum service life and safe operation, ensure all necessary inspections and maintenance have been completed before placing machine in service.

Preparation, Inspection, and Maintenance

It is important to establish and conform to a comprehensive inspection and preventive maintenance program. The following table outlines periodic machine inspections and maintenance recommended by JLG Industries, Inc. Consult your national, regional, or local regulations for further requirements for aerial work platforms. Frequency of inspections and maintenance must be increased as environment, severity and frequency of usage requires.

Pre-Start Inspection

It is the User's or Operator's primary responsibility to perform a Pre-Start Inspection of the machine before use daily or at each change of operator. Reference the Operator's and Safety Manual for Pre-Start Inspection procedures. The Operator and Safety Manual must be read and understood in its entirety before performing the Pre-Start Inspection.

Pre-Delivery Inspection and Frequent Inspection

The Pre-Delivery Inspection and Frequent Inspection shall be performed by a qualified JLG equipment mechanic. JLG Industries, Inc. recognizes a qualified JLG equipment mechanic as a person who, by possession of a recognized degree, certificate, extensive knowledge, training, or experience, has successfully demonstrated the ability and proficiency to service, repair, and maintain the subject JLG product model.

The Pre-Delivery Inspection and Frequent Inspection procedures are performed in the same manner, but at different times. The Pre-Delivery Inspection shall be performed prior to each sale, lease, or rental delivery. The Frequent Inspection shall be accomplished for each machine in service for 3 months or 150 hours (whichever comes first); out of service for a period of more than 3 months; or when purchased used. Frequency of this inspection must be increased as environment, severity and frequency of usage requires.

Reference the JLG Pre-Delivery and Frequent Inspection Form and Inspection and Preventive Maintenance Schedule for items requiring inspection. Reference appropriate areas of this manual for servicing and maintenance procedures.

Annual Machine Inspection

The Annual Machine Inspection must be performed on an annual basis, no later than thirteen (13) months from the date of the prior Annual Machine Inspection. JLG Industries recommends this task be performed by a Factory-Trained Service Technician. JLG Industries, Inc. recognizes a Factory-Trained Service Technician as a person who has successfully completed the JLG Service Training School for the subject JLG product model. Reference the machine Service and Maintenance Manual and appropriate JLG inspection form for performance of this inspection.

Reference the JLG Annual Machine Inspection Form and Inspection and Preventive Maintenance Schedule for items requiring inspection. Reference appropriate areas of this manual for servicing and maintenance procedures.

For the purpose of receiving safety-related bulletins, it is important that JLG Industries, Inc. has updated ownership information for each machine. When performing each Annual Machine Inspection, notify JLG Industries, Inc. of current machine ownership.

Preventive Maintenance

In conjunction with specified inspections, maintenance shall be performed by a qualified JLG equipment mechanic. JLG Industries, Inc. recognizes a qualified JLG equipment mechanic as a person who, by possession of a recognized degree, certificate, extensive knowledge, training, or experience, has successfully demonstrated the ability and proficiency to service, repair, and maintain the subject JLG product model.

Reference the Preventive Maintenance Schedule and appropriate areas of this manual for servicing and maintenance procedures. Frequency of service and maintenance must be increased as environment, severity and frequency of usage requires.

Table 2-1. Inspection and Maintenance

Type	Frequency	Primary Responsibility	Service Qualification	Reference
Pre-Start Inspection	Prior to use each day; or at each Operator change.	User or Operator	User or Operator	Operation and Safety Manual
Pre-Delivery Inspection	Prior to each sale, lease, or rental delivery.	Owner, Dealer, or User	Qualified JLG Mechanic	Service and Maintenance Manual and applicable JLG inspection form.
Frequent Inspection	In service for 3 months or 150 hours, whichever comes first; or out of service for a period of more than 3 months; or purchased used.	Owner, Dealer, or User	Qualified JLG Mechanic	Service and Maintenance Manual and applicable JLG inspection form.
Annual Machine Inspection	Annually, no later than 13 months from date of prior inspection.	Owner, Dealer, or User	Factory-Trained Service Technician (Recommended)	Service and Maintenance Manual and applicable JLG inspection form.
Preventive Maintenance	At intervals as specified in Service and Maintenance Manual.	Owner, Dealer, or User	Qualified JLG Mechanic	Service and Maintenance Manual

2.2 SERVICE AND GUIDELINES

General

Following information is provided to assist you in using servicing and maintenance procedures in this manual.

Safety and Workmanship

Your safety, and that of others, is the first consideration in maintenance of equipment. Always be conscious of weight. Never attempt to move heavy parts without aid of a mechanical device. Do not allow heavy objects to rest in an unstable position. Ensure adequate support is provided when raising a portion of the equipment.

Cleanliness

1. The most important single item in preserving the long service life of a machine is to keep dirt and contamination out of vital components. Shields, covers, seals, and filters are provided to keep air, fuel, and oil supplies clean; however, these items must be maintained on a schedule to function properly.
2. Any time air, fuel, or oil lines are disconnected, clean adjacent areas as well as the openings and fittings themselves. As soon as a line or component is disconnected, cap or cover all openings to prevent contamination.

3. Clean and inspect all parts during servicing or maintenance. Ensure all passages and openings are unobstructed. Cover all parts to keep them clean. Make sure all parts are clean before they are installed. New parts should remain in their containers until ready to be used.

Components Removal and Installation

1. Use adjustable lifting devices, whenever possible, if mechanical assistance is required. All slings (chains, cables, etc.) should be parallel to each other and as near perpendicular as possible to top of part being lifted.
2. Should it be necessary to remove a component on an angle, keep in mind the capacity of an eyebolt or similar bracket lessens, as the angle between the supporting structure and component becomes less than 90 degrees.
3. If a part resists removal, check to see if all nuts, bolts, cables, brackets, wiring, etc., have been removed and no adjacent parts are interfering.

Component Disassembly and Reassembly

Complete procedural steps in sequence when disassembling or reassembling a component. Do not partially disassemble or assemble one part, then start on another. Always recheck your work to ensure nothing is overlooked. Do not make any adjustments, other than those recommended, without obtaining proper approval.

Pressure-Fit Parts

When assembling pressure-fit parts, use a molybdenum disulfide base compound or equivalent to lubricate the mating surface.

Bearings

1. When a bearing is removed, cover it to keep out dirt and abrasives. Clean bearings in nonflammable cleaning solvent and allow to drip dry. Compressed air can be used, but do not spin the bearing.
2. Discard bearings if races and balls (or rollers) are pitted, scored, or burned.
3. If bearing is found to be serviceable, apply a light coat of oil and wrap it in clean (waxed) paper. Do not unwrap reusable or new bearings until ready to install.
4. Lubricate new or used serviceable bearings before installation. Apply pressure to the outer race when pressing a bearing into a retainer or bore. Apply pressure to the inner race if bearing is installed on a shaft.

Gaskets

Check holes in gaskets align with openings in mating parts. If it is necessary to hand-fabricate a gasket, use gasket material or stock of equivalent material and thickness. Be sure to cut holes in the correct location. Blank gaskets can cause serious system damage.

Bolt Usage and Torque Application

NOTICE

SELF LOCKING FASTENERS, SUCH AS NYLON INSERT AND THREAD DEFORMING LOCKNUTS, ARE NOT INTENDED TO BE REINSTALLED AFTER REMOVAL.

1. Always use new replacement hardware when installing locking fasteners. Use bolts of proper length. A bolt which is too long will bottom before the head is tight against its related part. If a bolt is too short, there will not be enough thread area to engage and hold the part properly. When replacing bolts, use only those having the same specifications of the original, or one which is equivalent.

2. Unless specific torque requirements are given within the text, use standard torque values on heat-treated bolts, studs, and steel nuts, in accordance with recommended shop practices. (See Torque Chart in Section 1.)

Hydraulic Lines and Electrical Wiring

Clearly mark or tag hydraulic lines and electrical wiring, and their receptacles, when disconnecting or removing them from the unit. This ensures correct reinstallation.

Hydraulic System

1. Keep the system clean. If evidence of metal or rubber particles are found in the hydraulic system, drain and flush the entire system.
2. Disassemble and reassemble parts on clean work surface. Clean all metal parts with non-flammable cleaning solvent. Lubricate components as needed to aid assembly.

Lubrication

Service applicable components with the amount, type, and grade of lubricant recommended in this manual at the specified intervals. When recommended lubricants are not available, consult your local supplier for an equivalent that meets or exceeds the specifications listed.

Battery

Clean battery using a non-metallic brush and a solution of baking soda and water. Rinse with clean water. After cleaning, thoroughly dry battery and coat terminals with an anti corrosion compound.

Lubrication and Servicing

Components and assemblies requiring lubrication and servicing are shown in the Lubrication Chart in Section 1.

2.3 LUBRICATION AND INFORMATION

Hydraulic System

1. The primary enemy of a hydraulic system is contamination. Contaminants can enter the system by using inadequate hydraulic oil; allowing moisture, grease, filings, sealing components, sand, etc., to enter when performing maintenance; or allowing the pump to cavitate due to insufficient system warm-up or leaks in pump supply (suction) lines.
2. Design and manufacturing tolerances of component working parts are very close. The smallest amount of dirt or other contamination entering a system can cause wear or damage to components and faulty operation. Take every precaution to keep hydraulic oil clean - including reserve oil in storage. Check, clean, and replace hydraulic system filters as at intervals specified in the Lubrication Chart in Section 1. Always examine filters for metal particles.
3. Cloudy oils indicate high moisture content which permits organic growth and causes oxidation or corrosion. If this condition occurs, the system must be drained, flushed, and refilled with clean oil.
4. It is not advisable to mix oils of different brands or types. They may not contain required additives or be of comparable viscosities. Good grade mineral oils, with viscosities suited to ambient temperatures in which the machine is operating, are recommended for use.

NOTE: Metal particles may appear in oil or filters of new machines due to wear-in of meshing components.

Hydraulic Oil

1. Refer to Section 1 for viscosity ranges.

Changing Hydraulic Oil

1. Filter elements must be changed after the first 50 hours of operation and every 300 hours (unless specified otherwise) thereafter. If it is necessary to change the oil, use only those oils meeting or exceeding specifications in this manual. If unable to obtain the same type of oil supplied with the machine, consult local supplier for assistance in selecting the proper equivalent. Avoid mixing petroleum and synthetic base oils.
2. Keep hydraulic oil clean. If oil must be poured from original container into another, clean all possible contaminants from the service container. Always clean filter mesh element and replace cartridge any time system oil is changed.

3. While unit is shut down, a good preventive maintenance measure is to make a thorough inspection of all hydraulic components, lines, fittings, etc., as well as a functional check of each system, before placing machine back in service.

Lubrication Specifications

Specified lubricants, as recommended by component manufacturers, are always the best choice. However, multi-purpose greases usually have qualities which meet a variety of single purpose grease requirements. Should questions arise regarding use of greases in maintenance stock, consult your local supplier for evaluation. Refer to Section 1 for an explanation of lubricant key designations in the Lubrication Chart.

2.4 CYLINDER DRIFT TEST

Measure maximum acceptable cylinder drift using the following methods.

Platform Drift

Measure platform drift to ground. Lower booms (if equipped) slightly elevated, main boom fully extended with rated load in platform and power off. Maximum allowable drift is 2 inches (5 cm) in 10 minutes. If machine does not pass this test, proceed with the following.

Cylinder Drift

Table 2-2. Cylinder Drift

Cylinder Bore Diameter		Max. Acceptable Drift in 10 Minutes*	
inches	mm	inches	mm
3	76.2	0.026	0.66
3.5	89	0.019	0.48
4	101.6	0.015	0.38
5	127	0.009	0.22
6	152.4	0.006	0.15
7	177.8	0.005	0.13
8	203.2	0.0038	0.10
9	228.6	0.0030	0.08

*Based on 6 drops per minute cylinder leakage.

Measure drift at cylinder rod with a calibrated dial indicator. Cylinder oil must be at stabilized ambient temperature.

Cylinder must have normal platform load applied.

Cylinder is acceptable if it passes this test.

2.5 PINS AND COMPOSITE BEARING REPAIR GUIDELINES

Filament wound bearings.

1. Pinned joints should be disassembled and inspected if the following occurs:
 - a. Excessive sloppiness in joints.
 - b. Noise originating from joint during operation.
2. Filament wound bearings should be replaced if any of the following is observed:
 - a. Frayed or separated fibers on the liner surface.
 - b. Cracked or damaged liner backing.
 - c. Bearings that have moved or spun in their housing.
 - d. Debris embedded in liner surface.
3. Pins should be replaced if any of the following is observed (Clean pin before inspection):
 - a. Detectable bearing area wear.
 - b. Flaking, peeling, scoring, or scratches on pin surface.
 - c. Rusting of pin in bearing area.
4. Re-assembly of pinned joints using filament wound bearings:
 - a. Blow out housing using compressed air to remove all dirt and debris. Bearings and bearing housings must be free of all contamination.
 - b. Clean bearings and pins with solvent to remove all grease and oil.

NOTE: *Filament wound bearings are a dry joint and should not be lubricated unless otherwise instructed (i.e. sheave pins).*

- c. Inspect pin to ensure it is free of burrs, nicks, and scratches which can damage bearing during installation and operation.

2.6 WELDING ON JLG EQUIPMENT

NOTE: *This instruction applies to repairs, or modifications to the machine and to welding performed from the machine on an external structure, or component,*

Do the Following When Welding on JLG Equipment:

- Disconnect battery.
- Disconnect moment pin connection (where fitted)
- Ground only to structure being welded.

Do NOT Do the Following When Welding on JLG Equipment:

NOTICE

FAILURE TO COMPLY WITH THESE INSTRUCTIONS MAY RESULT IN COMPONENT DAMAGE (I.E. ELECTRONIC MODULES, SWING BEARING, COLLECTOR RING, BOOM WIRE ROPES ETC.)

- Do NOT ground on frame and weld on any other area than chassis.
- Do NOT ground on turntable and weld on any other area than turntable.
- Do NOT ground on platform/support and weld on any other area than platform/support.
- Do NOT ground on a specific boom section and weld on any other area than that specific boom section.
- Do NOT allow pins, wear pads, wire ropes, bearings, gearing, seals, valves, electrical wiring, or hoses to be between grounding position and welded area.

SECTION 2 - GENERAL

Table 2-3. Inspection and Preventive Maintenance Schedule

AREA	INTERVAL				
	Weekly Preventive Maintenance	Monthly Preventive Maintenance	Pre-Delivery ² or Frequent ³ Inspection	Annual ⁴ (Yearly) Inspection	Every 2 Years
Boom Assembly					
Boom Weldments			1,2,4	1,2,4	
Hose/Cable Carrier Installations			1,2,9,12	1,2,9,12	
Pivot Pins and Pin Retainers			1,2	1,2	
Sheaves, Sheave Pins			1,2	1,2	
Bearings			1,2	1,2	
Wear Pads			1,2	1,2	
Covers or Shields			1,2	1,2	
Extend/Retract Chain or Cable Systems			1,2,3	1,2,3	
Boom Assembly				14	
Platform Assembly					
Platform				1,2	
Railing			1	1,2	
Gate		5	1	1,5	
Floor			1	1,2	
Rotator	9,5		15		
Lanyard Anchorage Point			1,2,10	1,2,10	
Turntable Assembly					
Swing Bearing			1,2,14	1,2,3,13,14	
Oil Coupling	9				
Swing Drive System			11	11	
Turntable Lock			1,2,5	1,2,5	
Hood, Hood Props, Hood Latches			5	1,2,5	
Chassis Assembly					
Tires	16,17		16,17,18	16,17,18	
Wheel Nuts/Bolts	15		15	15	
Wheel Bearings					14,24
Oscillating Axle/Lockout Cylinder Systems				5,8	
Extendable Axle Systems			5,8	5,8	
Steer Components					
Spindle Thrust Bearing/Washers				1,2	
Drive Hubs			11	11	

Table 2-3. Inspection and Preventive Maintenance Schedule

AREA	INTERVAL				
	Weekly Preventive Maintenance	Monthly Preventive Maintenance	Pre-Delivery ² or Frequent ³ Inspection	Annual ⁴ (Yearly) Inspection	Every 2 Years
Functions/Controls					
Platform Controls	5		6	6	
Ground Controls	5		6	6	
Function Control Locks, Guards, or Detents	1,5		5	5	
Footswitch			5	5	
Emergency Stop Switches (Ground & Platform)			5	5	
Function Limit or Cutout Switch Systems			5	5	
Drive Brakes			5		
Swing Brakes			5		
Auxiliary Power			5	5	
Power System					
Engine Idle, Throttle, and RPM			3	3	
Engine Fluids (Oil, Coolant, Fuel)	9,11		11	11	
Air/Fuel Filter	1,7		7	7	
Exhaust System		1,9	9	9	
Batteries	1,9			19	
Battery Fluid	11		11	11	
Battery Charger	5			5	
Fuel Reservoir, Cap, and Breather		2	1,5	1,5	
Hydraulic/Electric System					
Hydraulic Pumps	1,9		1,2,9		
Hydraulic Cylinders	1,9,7	2	1,2,9	1,2,9	
Cylinder Attachment Pins and Pin Retainers	1,9		1,2	1,2	
Hydraulic Hoses, Lines, and Fittings	1,9	12	1,2,9,12	1,2,9,12	
Hydraulic Reservoir, Cap, and Breather	1,9	2	1,5	1,5	24
Hydraulic Filter	1,9		7	7	
Hydraulic Fluid			7,11	7,11	
Electrical Connections	1		20	20	
Instruments, Gauges, Switches, Lights, Horn	1			5,23	
General					
Operation and Safety Manuals in Storage Box			21	21	
ANSI and AEM Manuals/Handbooks Installed (ANSI Markets Only)				21	
Capacity Decals Installed, Secure, Legible			21	21	
All Decals/Placards Installed, Secure, Legible			21	21	

SECTION 2 - GENERAL

Table 2-3. Inspection and Preventive Maintenance Schedule

AREA	INTERVAL				
	Weekly Preventive Maintenance	Monthly Preventive Maintenance	Pre-Delivery ² or Frequent ³ Inspection	Annual ⁴ (Yearly) Inspection	Every 2 Years
Annual Machine Inspection Due			21		
No Unauthorized Modifications or Additions			21	21	
All Relevant Safety Publications Incorporated			21	21	
General Structural Condition and Welds			2,4	2,4	
All Fasteners, Pins, Shields, and Covers			1,2	1,2	
Grease and Lubricate to Specifications			22	22	
Function Test of All Systems			21	21,22	
Paint and Appearance			7	7	
Stamp Inspection Date on Frame				22	
Notify JLG of Machine Ownership				22	

Footnotes:

¹ Prior to use each day; or at each Operator change

² Prior to each sale, lease, or delivery

³ In service for 3 months or 150 Hours; or Out of service for 3 months or more; or Purchased used

⁴ Annually, no later than 13 months from the date of the prior inspection

Performance Codes:

- 1 - Check for proper and secure installation
- 2 - Visual inspection for damage, cracks, distortion or excessive wear
- 3 - Check for proper adjustment
- 4 - Check for cracked or broken welds
- 5 - Operates Properly
- 6 - Returns to neutral or "off" position when released
- 7 - Clean and free of debris
- 8 - Interlocks function properly
- 9 - Check for signs of leakage
- 10 - Decals installed and legible
- 11 - Check for proper fluid level
- 12 - Check for chafing and proper routing
- 13 - Check for proper tolerances
- 14 - Properly lubricated
- 15 - Torqued to proper specification
- 16 - No gouges, excessive wear, or cords showing
- 17 - Properly inflated and seated around rim
- 18 - Proper and authorized components
- 19 - Fully charged
- 20 - No loose connections, corrosion, or abrasions
- 21 - Verify
- 22 - Perform
- 23 - Sealed Properly
- 24 - Drain, Clean, Refill

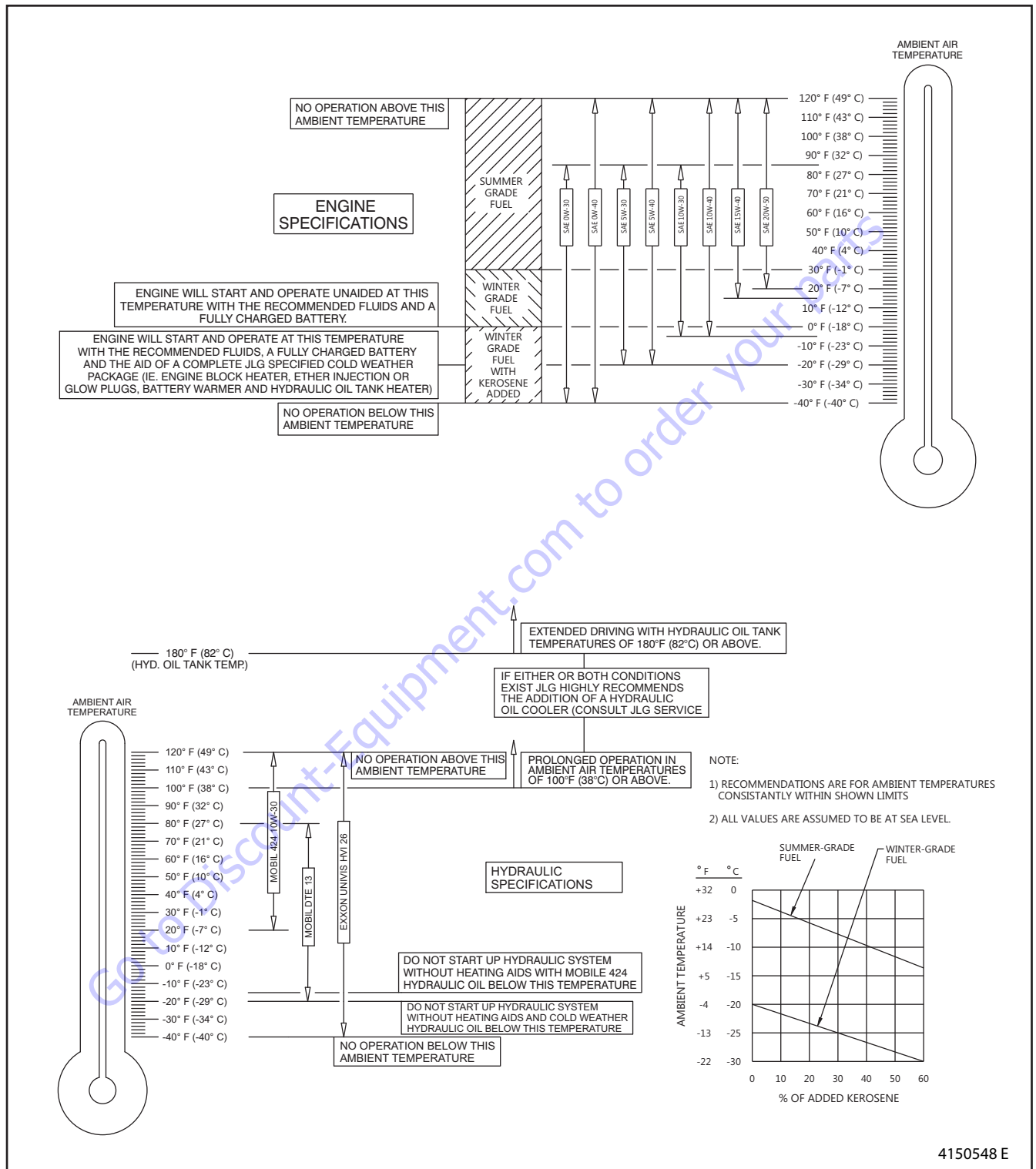

Figure 2-1. Deutz Engine and Hydraulic Operating Temperature Specifications

PARTS FINDER

**Search Website
by Part Number**



**Search Manual
Library For Parts
Manual & Lookup Part
Numbers – Purchase
or Request Quote**

Search Manuals

Enter your information to search for manuals and parts.

* Brand:

* Model:

* Serial:

* Part Number:

SEARCH

**Can't Find Part or
Manual? Request Help
by Manufacturer,
Model & Description**

Parts Order Form

Please fill in the following information:

Manufacturer:

Model:

Description:

Quantity:

Part Number:

Part Name:

Part Description:

Part Location:

Part Condition:

Part Status:

Part Price:

Part Weight:

Part Dimensions:

Part Material:

Part Color:

Part Finish:

Part Notes:

Submit

Discount-Equipment.com is your online resource for quality parts & equipment.

Florida: **561-964-4949** Outside Florida TOLL FREE: **877-690-3101**

Need parts?

Click on this link: <http://www.discount-equipment.com/category/5443-parts/> and choose one of the options to help get the right parts and equipment you are looking for. Please have the machine model and serial number available in order to help us get you the correct parts. If you don't find the part on the website or on once of the online manuals, please fill out the request form and one of our experienced staff members will get back to you with a quote for the right part that your machine needs.

We sell worldwide for the brands: Genie, Terex, JLG, MultiQuip, Mikasa, Essick, Whiteman, Mayco, Toro Stone, Diamond Products, Generac Magnum, Airman, Haulotte, Barreto, Power Blanket, Nifty Lift, Atlas Copco, Chicago Pneumatic, Allmand, Miller Curber, Skyjack, Lull, Skytrak, Tsurumi, Husquvarna Target, , Stow, Wacker, Sakai, Mi-T- M, Sullair, Basic, Dynapac, MBW, Weber, Bartell, Bennar Newman, Haulotte, Ditch Runner, Menegotti, Morrison, Contec, Buddy, Crown, Edco, Wyco, Bomag, Laymor, Barreto, EZ Trench, Bil-Jax, F.S. Curtis, Gehl Pavers, Heli, Honda, ICS/PowerGrit, IHI, Partner, Imer, Clipper, MMD, Koshin, Rice, CH&E, General Equipment, ,AMida, Coleman, NAC, Gradall, Square Shooter, Kent, Stanley, Tamco, Toku, Hatz, Kohler, Robin, Wisconsin, Northrock, Oztec, Toker TK, Rol-Air, Small Line, Wanco, Yanmar

SECTION 3. CHASSIS & TURNTABLE

3.1 CHASSIS COMPONENTS AND SERVICING

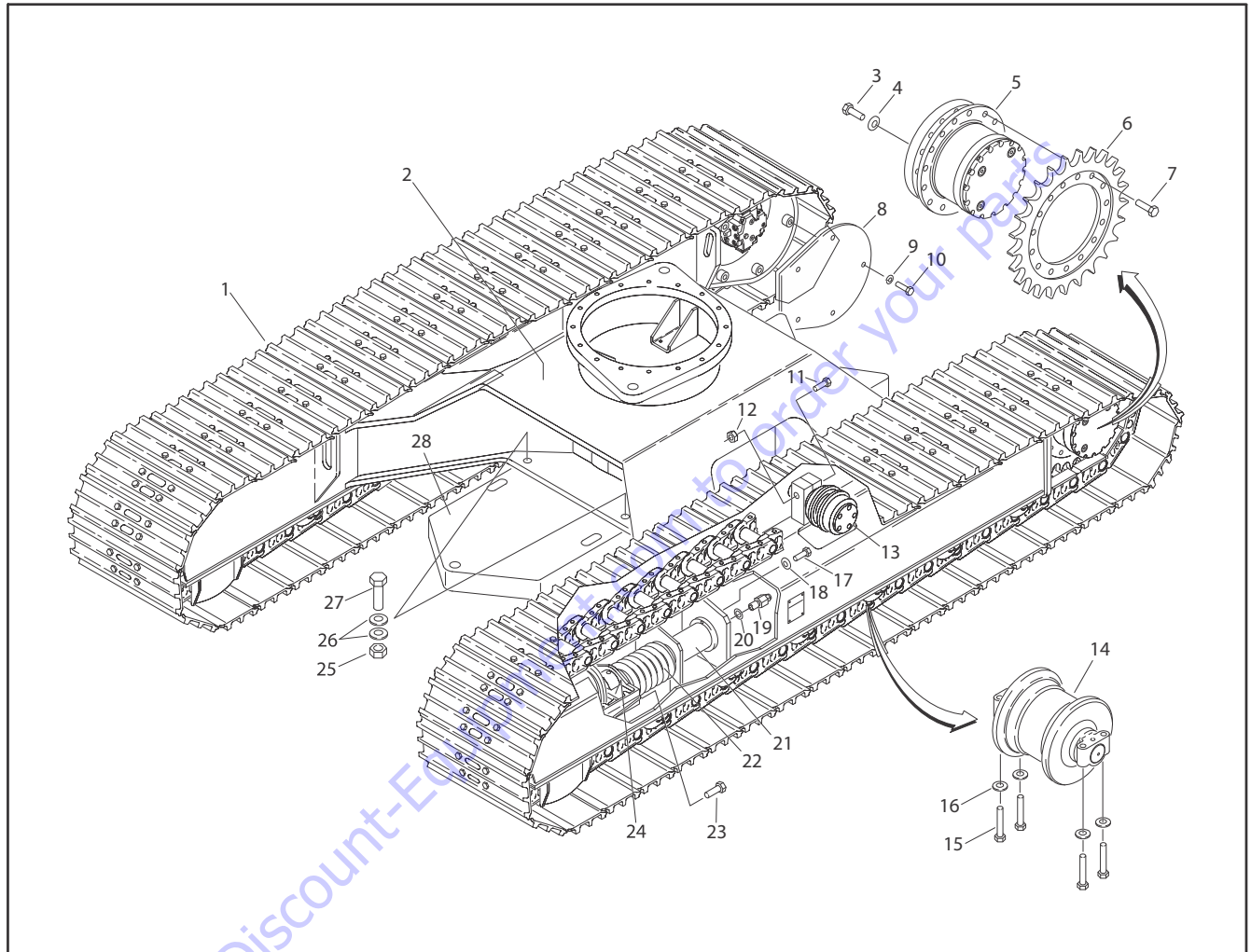

- | | | | | |
|-------------------------|-----------------|--------------------------|---------------------|----------------------------|
| 1. Track Chain Assembly | 7. Flanged Bolt | 13. Carrier Track Roller | 19. Grease Fitting | 25. Nut |
| 2. Undercarriage | 8. Cover Plate | 14. Bottom Track Roller | 20. Seal | 26. Flat Washer |
| 3. Bolt | 9. Lockwasher | 15. Bolt | 21. Shock Assembly | 27. Bolt |
| 4. Flat Washer | 10. Bolt | 16. Flat Washer | 22. Spring Assembly | 28. Counterweight (660SJC) |
| 5. Drive Assembly | 11. Bolt | 17. Bolt | 23. Capscrew | |
| 6. Drive Sprocket | 12. Locknut | 18. Lockwasher | 24. Idler Assembly | |

Figure 3-1. Chassis Assembly

Service Notes

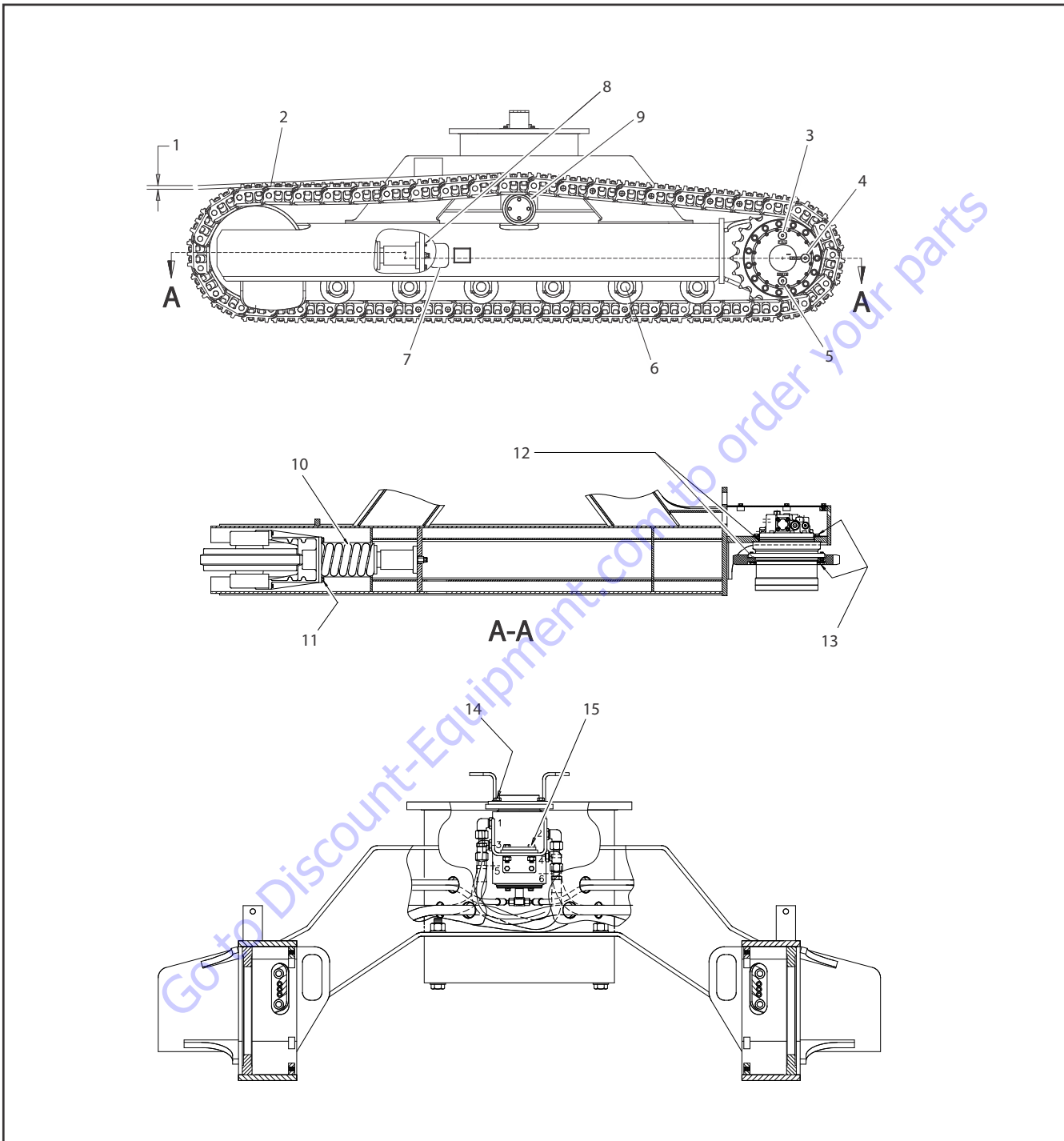
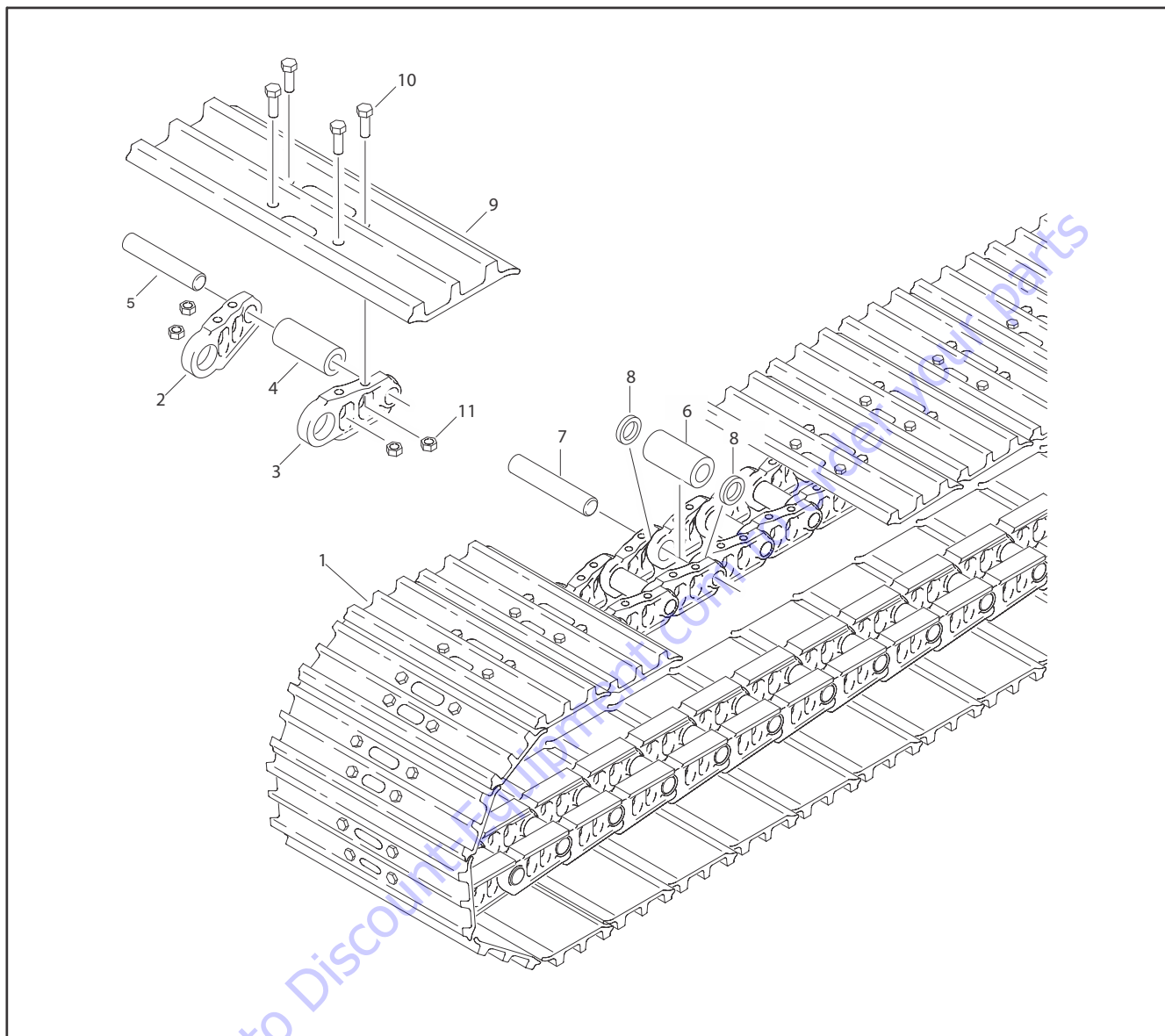

Figure 3-2. Chassis Service Notes - 1 of 2

1	Track tension adjustment to be made between the idler and carrier roller: 0.781 in (19.8 mm)
2	Anti-Seize Compound to be used on master link pin before assembly. Torque Pad bolts over master link to 65 ft-lbs +6,-6 then tighten 1/3 (120°) turn further.
3	Fill Plug
4	Check oil level of left & right crawler drives (0.69 Gal [2.6L] grade 90 Gear Oil)
5	Drain Plug
6	Torque to 200 ft-lb, +15 -0 (280 Nm, +21 -0)
7	Use Gradall 8381-3109 Large Button Head Grease Fitting Adapter to Adjust Tracks
8	Torque to 65 ft-lb, +10 -0 (91 Nm, +15 -0)
9	Torque to 340 ft-lb, +25 -0 (476 Nm, +35 -0)
10	Offset in Idler Spring from centerline of Idler to be oriented down.
11	Torque to 165 ft-lb, +15 -0 (231 Nm, +21 -0)
12	Apply Anti-Seize Compound to both mounting pilots Drive Motors
13	Torque to 230 ft-lb, +15 -0 (322 Nm, +21 -0)
14	Torque to 93 ft-lb, +10 -0 (130 Nm, +14 -0)
15	Torque to 53 ft-lb, +5 -0 (74 Nm, +7 -0)

Figure 3-3. Chassis Service Notes - 2 of 2

Track and Chain



- | | | | |
|-------------------|-------------------|---------------------|----------|
| 1. Track Assembly | 4. Bushing | 7. Splice Hinge Pin | 10. Bolt |
| 2. Left Link | 5. Hinge Pin | 8. Spacer | 11. Nut |
| 3. Right Link | 6. Splice Bushing | 9. Track Cleat | |

Figure 3-4. Track and Chain

TRACK SHOES

1. Visually check for loose or missing bolts at the start of each operating shift.
2. Check bolt torque approximately every 100 hours. Torque track shoe bolts to 65 ft-lb, +6 (91 Nm, +8.4), then tighten 1/3 turn (120°) further.

TRACK PIN

The track pin is pressed in the right and left link of the chain. It is also installed through bushing at each end of the link. Outside diameter (O.D.) of pin wears against inside diameter (I.D.) of bushing with which it is making contact. Once pin reaches allowable wear limit it may be rotated 180 degrees for extended life.

TRACK BUSHING (BEARING)

Track bushings fit in the counterbore of each link. There is one bushing per link set. The O.D. of the bushing contacts drive sprocket teeth during travel and results in bushing wear at sprocket side only. This wear and pin wear is a major factor in looseness and damage to the chain by increasing pitch length.

Replace Track**REMOVE TRACK****WARNING**

UNCONTROLLED TRACK MOVEMENT CAN CAUSE SERIOUS INJURY. KEEP CLEAR OF TRACK WHEN REMOVING PIN.

1. Use wood blocking, a come-along, or other device to prevent track and chain assembly from falling uncontrolled to ground.

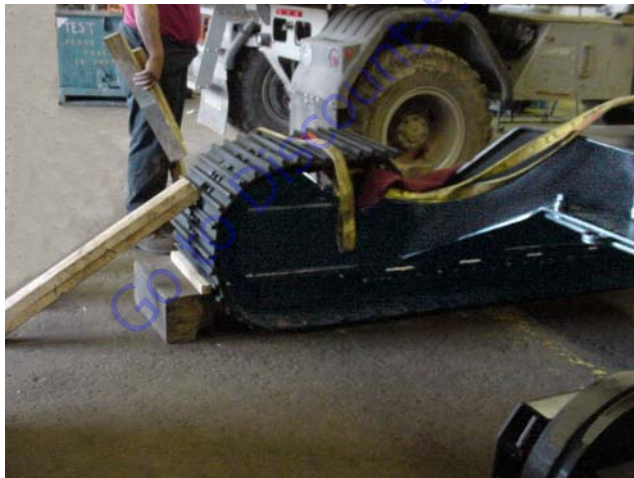

2. Remove four bolts (10), nuts (11), and track cleat (9) from chain assembly. Repeat with adjacent track cleat.

3. Use a portable press to push pin (5) out. Remove bushing (4).

**LINKS, PIN, AND BUSHING WEAR MEASUREMENT**

To establish average wear measurement, choose a length of 4 sections of link assembly on top of the undercarriage in a well tensioned zone.

When wear measurement reaches 100% limit turn pins 180° for extended life. If this operation has been previously performed, worn parts must be replaced.

INSTALL TRACK

NOTE: Chain must be installed with pin end of links facing back of machine at ground level.

1. Align chain and C-clamp spacer in two places on chain. Hammer in chain link aligning pin hole.
2. Insert alignment pin through hole to temporarily hold track together.
3. Position wood blocks to frame rail for tracks to lay onto when connecting track ends to get proper extension for connecting end links.



NOTICE

PINS AND BUSHINGS MUST BE WELL LUBRICATED DURING ASSEMBLY.

4. Apply anti-seize compound to pin. Line up end links. start pin in hole by driving with a hammer.
5. Place portable power pin press over track and pin. place washers in press ends. Carefully press in track pin.



6. Re-assemble four track shoes to assembled links.
7. Torque track shoe bolts to 65 ft-lb, +6 (91 Nm, +8.4), then tighten 1/3 turn (120°) further.

Track tensioning

1. Using special grease fitting tool (P/N 83813109), pump in grease to add tension to track.



2. Check for 0.781 in (19.8 mm) tension between idler & carrier roller with level and gage. Remove special fitting.



Rubber Track Pad Installation

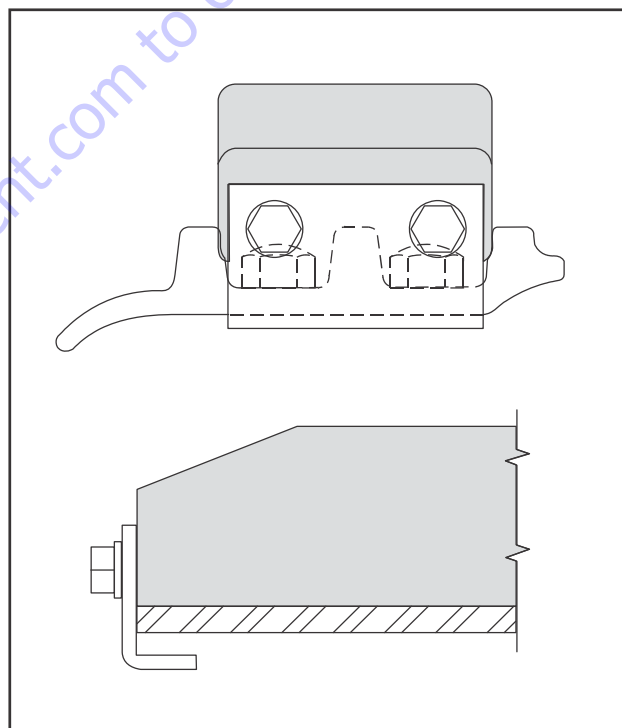

1. Seat rubber track pad over center rib of steel track.
2. Apply JLG Thread Locking Compound PN 0100011 to retaining plate bolts. Install bolts and flat washers to end of rubber pad.
3. Torque bolts to 70 ft-lb (97 Nm).

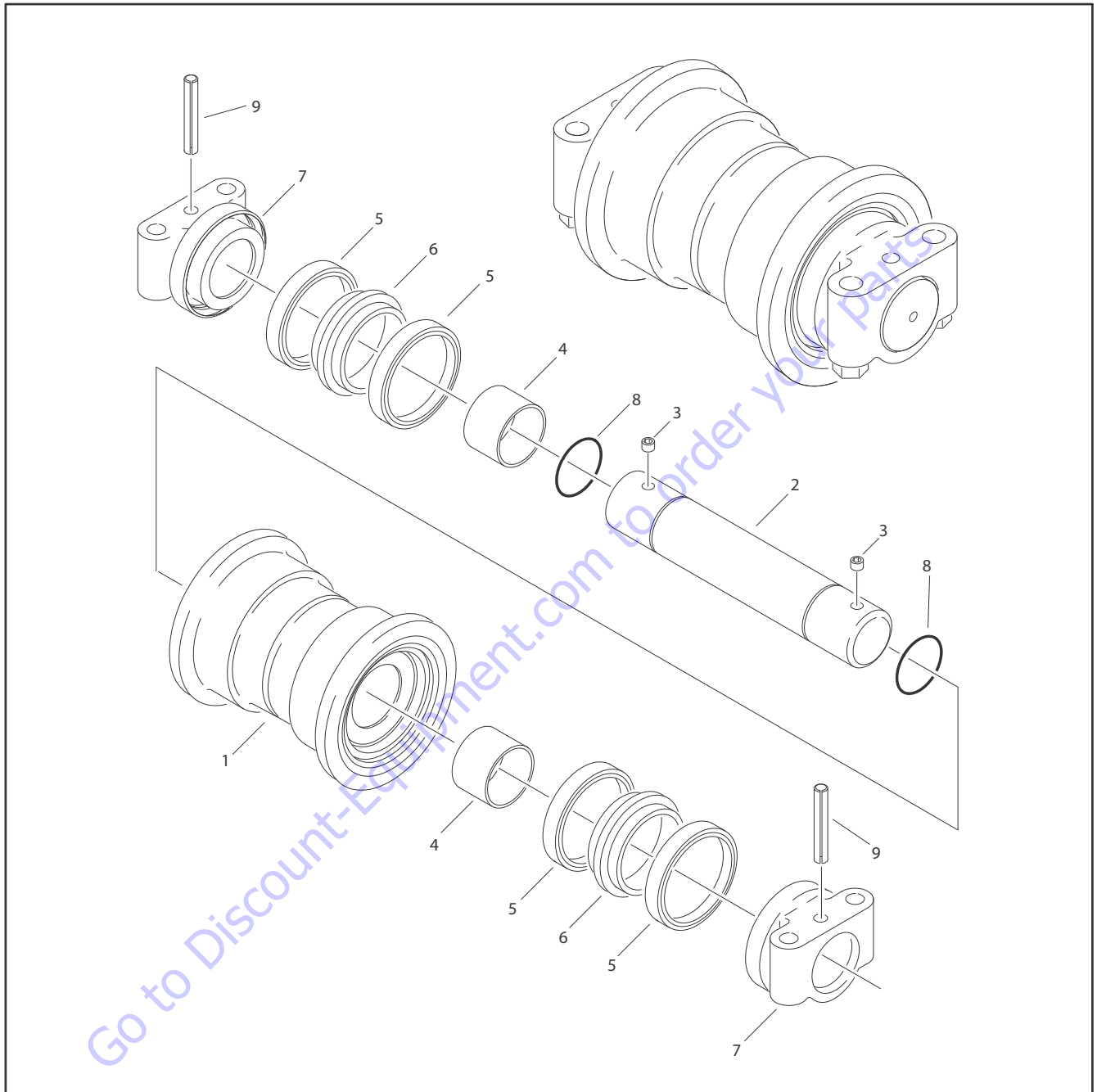

- | | | |
|-----------------|------------|---------------------|
| 1. Guide Roller | 4. Bearing | 7. Mounting Bracket |
| 2. Shaft | 5. Ring | 8. O-ring |
| 3. Plug | 6. Seal | 9. Roll Pin |

Figure 3-5. Bottom Track Roller Assembly

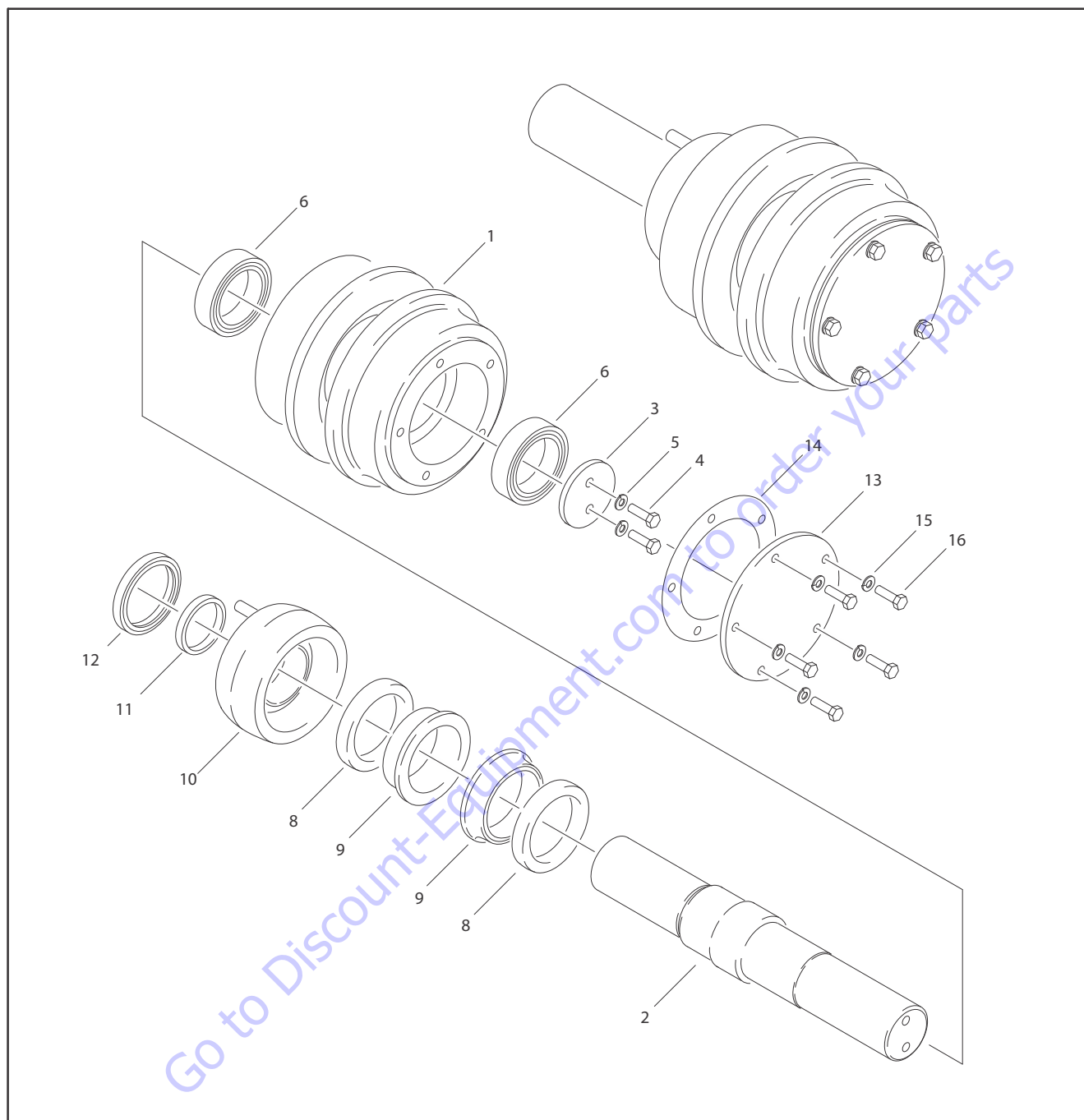

- | | | | |
|-------------------|-------------------|------------------|----------------|
| 1. Guide Roller | 5. Washer | 9. Tension Ring | 13. Cover |
| 2. Shaft | 6. Roller Bearing | 10. Collar | 14. Cover Seal |
| 3. Internal Cover | 7. Not Used | 11. Packing Ring | 15. Lockwasher |
| 4. Bolt | 8. Seal Ring | 12. Seal Ring | 16. Bolt |

Figure 3-6. Upper Carrier Track Roller Assembly

Rollers

Rollers are “lifetime” lubricated and under normal working conditions no further lubrication is required. Idlers should be randomly checked while working to protect against destruction should a seal be damaged.

ROLLER SEALS

NOTICE

USED SEALS WILL MOST LIKELY FAIL SHORTLY AFTER REBUILD. ALWAYS USE NEW SEALS WHEN REASSEMBLING TRACK ROLLER.

NOTE: *Mating surface where seals contact must be dry and clean; free of dirt, nicks, and burrs.*

1. Install O-ring on roller shaft.
2. Install seal group into roller shell seat. Remove plastic band holding rings together.
3. Press collar on roller shaft and lock in place with dowel.
4. Invert roller assembly and perform steps 1 through 4.
5. Fill roller with lube.

TRACK ROLLER DISASSEMBLY

1. Remove lube fill plug and dump lube into a container.
2. Press dowel pin out of collar.
3. Remove seals and shaft.
4. Press out bushings.

TRACK ROLLER ASSEMBLY

1. Install bushings in roller shell.
2. Install collar to roller shaft.
3. Install dowel pin through collar and shaft.
4. Install O-ring in roller shaft.
5. Install seal group in roller shell seal seat.
6. Insert collar and shaft into shell until collar bottoms to the seal group.
7. Invert roller 180°.
8. Complete component assembly as in steps 2 through 6.
9. Fill Roller with lube.

BOTTOM TRACK ROLLER INSTALLATION

1. Blow out roller mounting holes With air gun. Wipe mounting surfaces clean with rag. Threads must be clean of grease and oil.
2. Apply JLG Thread Locking Compound PN 0100011 to four bolts. Align roller on frame and secure with four washers and bolts.
3. Torque bolts to 200 ft-lb +15-0 (280 Nm, +21 -0).
4. Use a low pressure pump with a nozzle that will fit through idler body fill hole. Fill with SAE 30 or SAE 40 oil at capacities for your machine.

Idler Roller Assembly

The idler roller assembly is located at the front of each side frame and acts as a shock absorber for the track system. Compensation is accomplished by a tensioning spring and hydraulic cylinder.

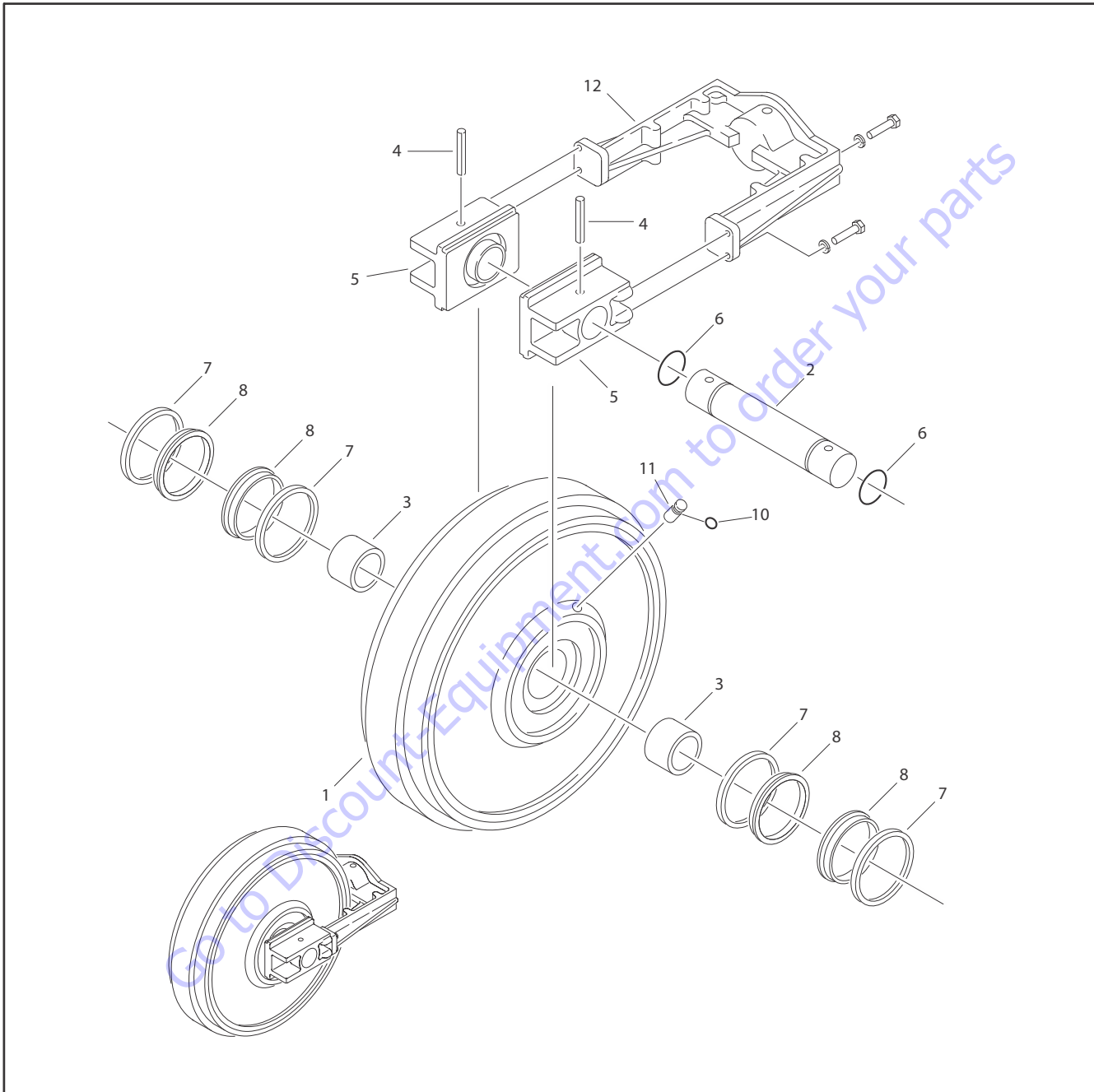

- | | | |
|-------------|---------------------|-------------|
| 1. Idler | 5. Mounting Bracket | 9. Not Used |
| 2. Shaft | 6. Seal | 10. O-ring |
| 3. Bearing | 7. Seal | 11. Plug |
| 4. Roll Pin | 8. Seal Holder | 12. Bracket |

Figure 3-7. Idler Assembly

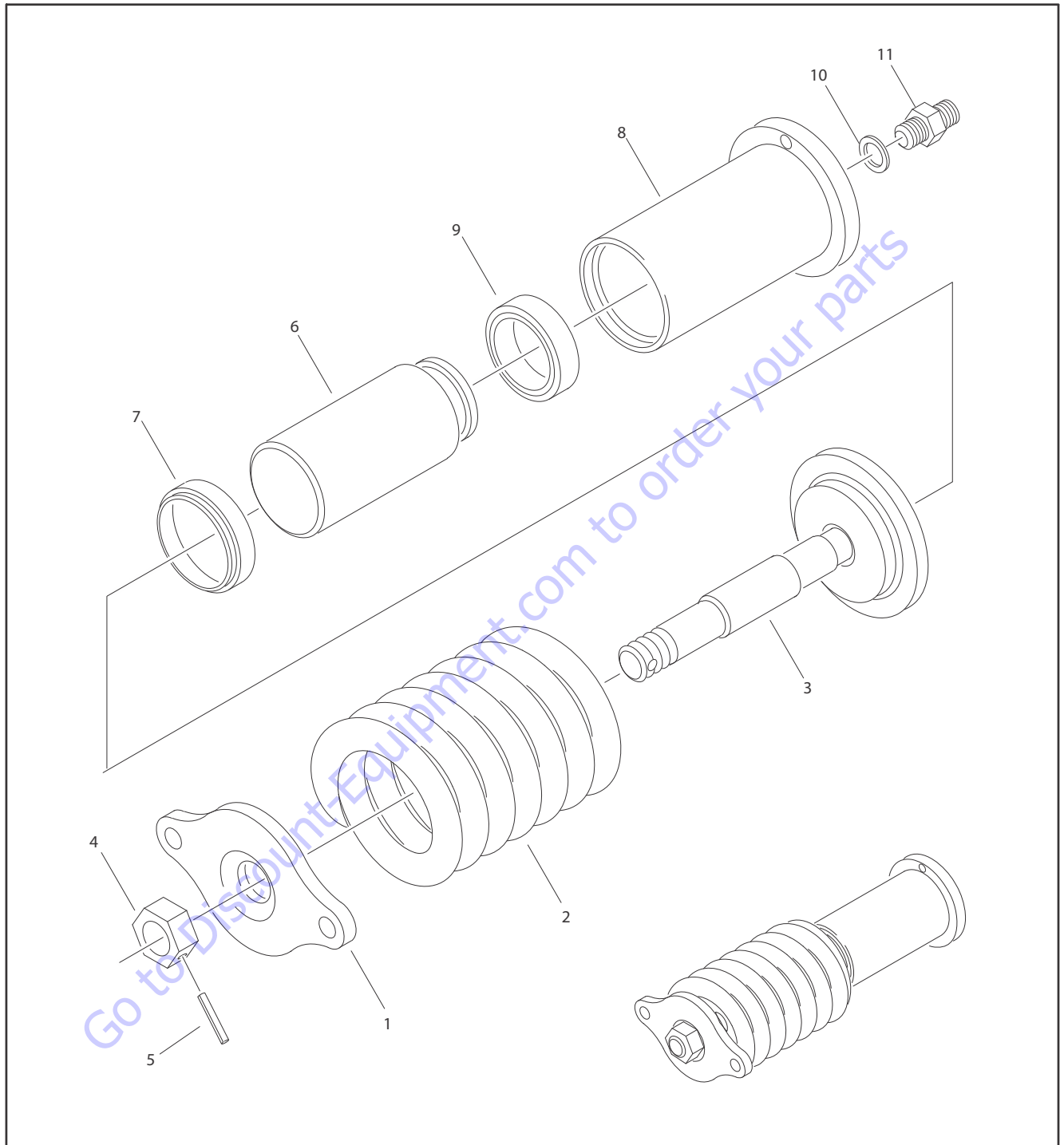

- | | | |
|--------------------|---------------|-------------|
| 1. Mounting Flange | 5. Roll Pin | 9. Seal |
| 2. Spring | 6. Piston/Rod | 10. Seal |
| 3. Base Plate | 7. Wiper | 11. Fitting |
| 4. Locknut | 8. Barrel | |

Figure 3-8. Spring & Shock Assembly

TRACK TENSION AND IDLER ROLLER DISASSEMBLY

1. Relieve all pressure from track tensioning cylinder.
2. Carefully separate track chain and lay it on the ground.
3. Remove recoil device group.
4. Remove track tension group.
5. Remove two (slide brackets) support groups and idler pin from side frame.
6. Remove idler roller from machine.
7. Examine all fasteners and seals for damage. Replace damaged components.

TRACK TENSION AND IDLER ROLLER REASSEMBLY

1. Clean, lubricate, and check all components for damage.
2. Reassemble idler roller with support group and fork and install into side frame.
3. Install track tension group.
4. Torque all fasteners to correct value.
5. Reassemble track chain to side frame and lack master pin and bushing as required.
6. Pressurize tensioning cylinder to achieve the correct track adjustment.
7. Install cover over opening in side frame for valve used for tensioning cylinder adjustment.

IDLER ROLLER DISASSEMBLY

NOTE: Remove recoil components to access idler roller.

1. Remove one of the dowel pins that fasten the bracket to the shaft.
2. Remove remaining components which are now free of shaft.
3. Press out bushing. (Bushing can only be removed by a vertical press with correct tooling.)
4. If necessary, remove remaining dowel pins and bracket.

IDLER ROLLER ASSEMBLY (SEE FIGURE 25)

1. Press bushings into idler shell.
2. Mount a bracket on shaft.
3. Insert seal group into idler shell seal seat.
4. Install O-ring on shaft.
5. Insert complete sub assembly in idler shell to point where it bottoms the seal group.
6. Invert idler and assemble components as in steps 1 through 4.
7. After loose assembly press tightly together using a vertical press.

NOTE: Seal group is assembled same as in bottom rollers.

IDLER ROLLER AND TRACK TENSIONER REMOVAL AND REPLACEMENT TO SIDE FRAME

WARNING

SERIOUS INJURY COULD RESULT IF THE PRESSURE IS NOT RELIEVED FROM TENSIONER AND RECOIL SYSTEM.

1. To remove pressure from cylinder, carefully back off one or two turns on the fill fitting. As soon as lube starts to come out vent hole **STOP backing off fitting.**
2. Once pressure is relieved it is safe to remove roller and tensioner assembly.
3. Assemble fitting and fitting seal in end of each shock assembly. Torque to chart specifications.

INSTALL SHOCK

4. Assemble shock assembly in position. Secure with bolts, washers, and JLG Thread Locking Compound PN 0100011. Torque to 65 ft-lb +10-0 (91 Nm, +15 -0).
5. Using an adequate lifting device, pick up spring assembly upright onto idler assembly. Install using bolts, washers, and JLG Thread Locking Compound PN 0100011. Torque to 165 ft-lb +15-0 (231 Nm, +21 -0).
6. Reference offset in idler spring from centerline of idler (to be oriented down). Using gantry crane and sling, pick up and slide spring/idler assembly into pre-greased slider area. Use nylon sledge hammer lightly to assemble.
7. Push idler assembly against seat. Using special adapter, pump in grease to expand shock assembly just enough to inspect for proper assembly.

3.2 DRIVE MOTOR

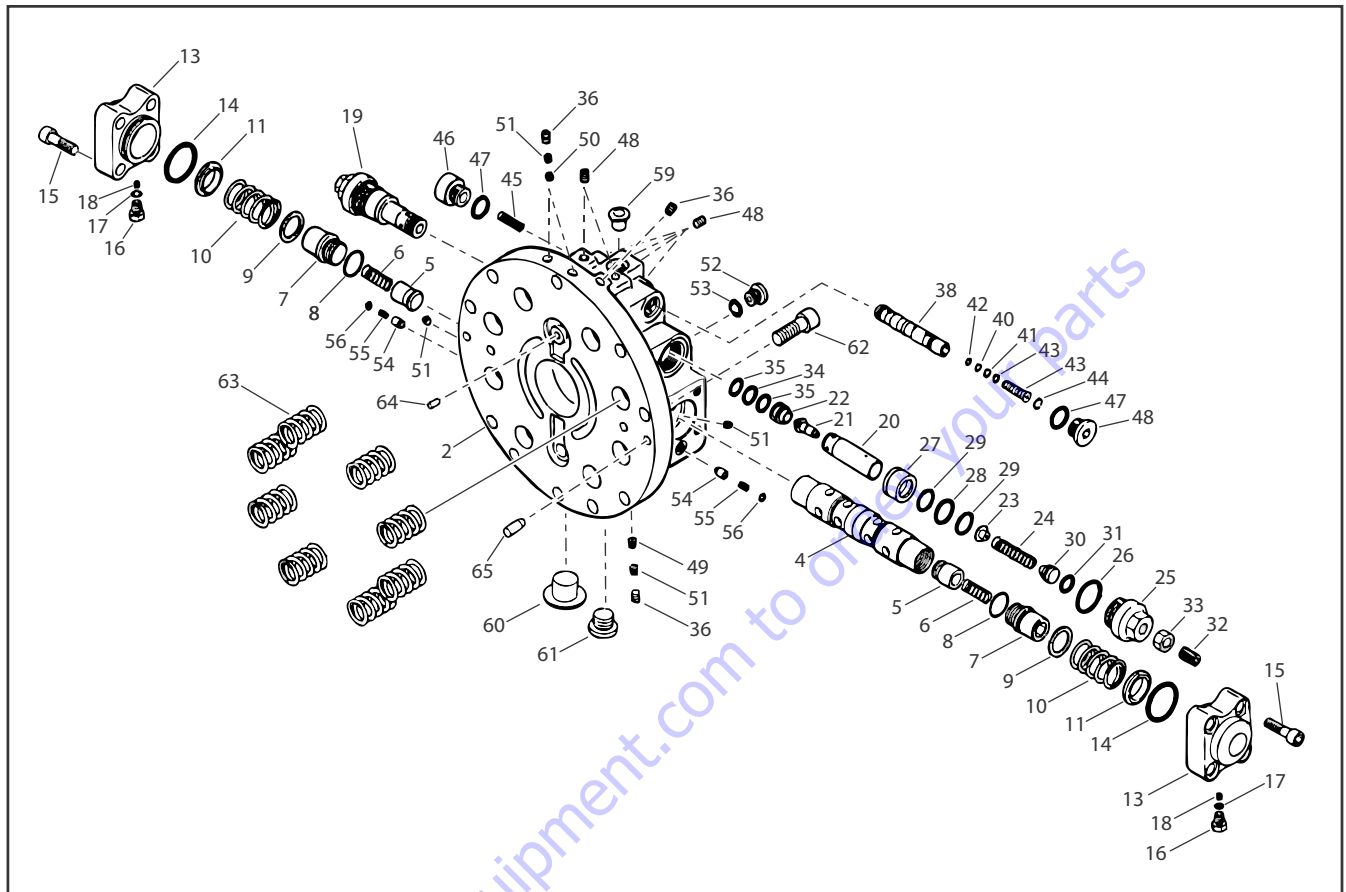

- | | | | | |
|---|---|--------------------------------------|-----------------|-----------------|
| 1. Base Plate Assembly
(Items 2 -56) | 13. Cap | 26. O-Ring | 39. Filter | 53. O-Ring |
| 2. Base Plate | 14. O-Ring | 27. Piston | 40. O-Ring | 54. Check Valve |
| 3. Spool Assembly
(Items 4 -8) | 15. Socket Head Capscrew | 28. O-Ring | 41. O-Ring | 55. Spring |
| 4. Spool | 16. Plug | 29. Backup Ring | 42. Backup Ring | 56. O-Ring |
| 5. Check Valve | 17. O-Ring | 30. Guide Spring | 43. Backup Ring | 57. Not Used |
| 6. Spring | 18. Setscrew | 31. O-Ring | 44. Snap Ring | 58. Not Used |
| 7. Plug | 19. Relief Valve Assembly
(Items 20 -35) | 32. Setscrew | 45. Spring | 59. Plug |
| 8. O-Ring | 20. Relief Housing | 33. Nut | 46. Plug | 60. Plug |
| 9. Spring Seat | 21. Poppet | 34. O-Ring | 47. O-Ring | 61. Plug |
| 10. Spring | 22. Poppet Seal | 35. Backup Ring | 48. Plug | 62. Capscrew |
| 11. Spring Seat | 23. Spring Seat | 36. Plug | 49. Orifice | 63. Spring |
| 12. Cap Assembly
(Items 13 -18) | 24. Spring | 37. Valve Assembly
(Items 38 -44) | 50. Orifice | 64. Pin |
| | 25. Plug | 38. Spool | 51. Orifice | 65. Pin |
| | | | 52. Plug | |

Figure 3-9. Crawler Drive Motor Control

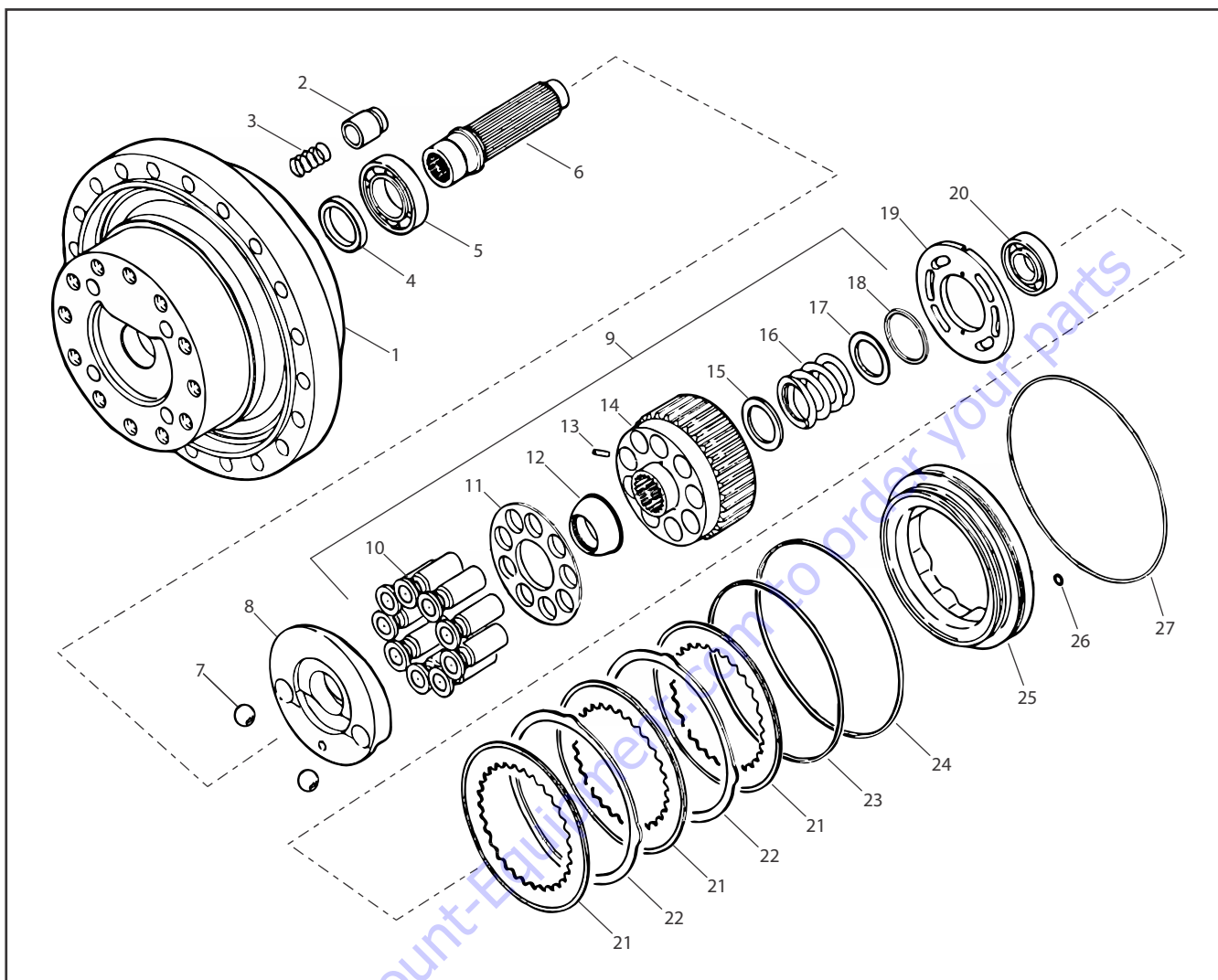

- | | | | | |
|--------------------|----------------------------|---------------------|------------------|--------------------|
| 1. Flange | 6. Shaft | 11. Plate Retainer | 16. Spring | 22. Friction Plate |
| 2. Piston Assembly | 7. Steel Ball | 12. Retainer Holder | 17. Collar | 23. O-Ring |
| 3. Spring | 8. Swash Plate | 13. Pin | 18. Snap Ring | 24. O-Ring |
| 4. Oil Seal | 9. Cylinder Block Assembly | 14. Cylinder Block | 19. Valve Plate | 25. Piston Brake |
| 5. Ball Bearing | 10. Piston Assembly | 15. Spring Seat | 20. Ball Bearing | 26. O-Ring |
| | | | 21. Disc Plate | 27. O-Ring |

Figure 3-10. Crawler Drive Motor Assembly

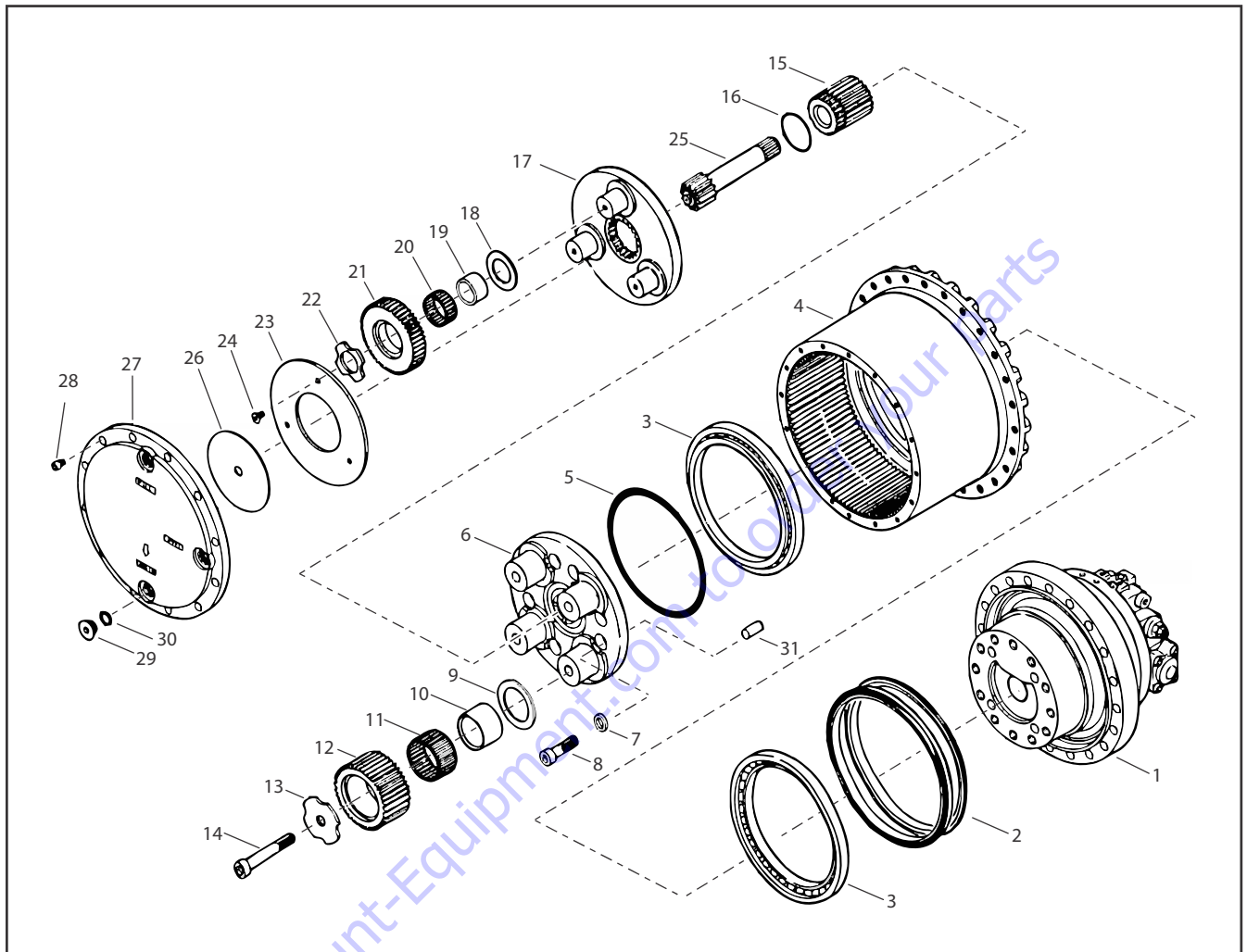

- | | | | | |
|--------------------|--------------------|------------------|--------------------|------------------|
| 1. Piston Motor | 7. Washer | 13. Thrust Plate | 19. Inner Race | 25. Drive Gear |
| 2. Floating Seal | 8. Bolt | 14. Bolt | 20. Needle Bearing | 26. Thrust Plate |
| 3. Angular Bearing | 9. Thrust Plate | 15. Sun Gear | 21. Planetary Gear | 27. Cover |
| 4. Housing | 10. InnerRadius | 16. Snap Ring | 22. Thrust Plate | 28. Bolt |
| 5. Shim | 11. Needle bearing | 17. Holder | 23. Thrust Plate | 29. Plug |
| 6. Holder | 12. Planetary Gear | 18. Thrust Plate | 24. Screw | 30. O-Ring |
| | | | | 31. Pin |

Figure 3-11. Crawler Drive - Gearbox

Disassembly

PREPARATION

1. Drain all oil before removing motor.
2. Clean outside of motor and Cover oil ports to prevent contamination.
3. Warm parts during disassembly to prevent damage.

BASE PLATE

1. Place drive assembly with piston motor side up. Loosen Socket Head Bolts evenly. Remove Flange, Spring Seat, Spring, and Spring Seat.
2. Turn and pull Plunger Assembly out. If difficulty is encountered, tap end of Plunger and insert it. Be sure Plunger slides smoothly and then try again. Do not disassemble Plunger Assembly.
3. Loosen Plug and Remove Relief Valve Assembly.

NOTICE

DO NOT LOOSEN NUT AND SET SCREW. SETTING PRESSURE IS CHANGED BY LOOSENING NUT AND SET SCREW.

4. Remove Poppet Seat from Base Plate.
5. Remove Plugs and Spring. Turn and pull Spool out. If difficulty is encountered, tap end of Spool and insert it. Be sure Spool slides smoothly, then try again.

NOTE: Do not loosen Plugs and Orifices if it is not necessary.

6. Loosen Socket Head Bolts evenly and pull assembly off Case and Base Plate out of Flange. If difficulty is encountered, tap top of Base Plate and insert it, then try again.
7. Position Case and Base Plate Assembly with shaft down. Loosen Socket Head Bolts evenly and remove Base Plate.
8. Remove Valve Plate, Springs, O-Ring and Pin. Do not damage Valve Plate.

BRAKE PISTON

1. Blow compressed air in brake oil passage to remove Brake Piston from Case. Brake Piston may be ejected out.
2. Remove O-Rings from Brake Piston. Remove three Disk Plates and two Friction Plates.

CYLINDER BLOCK

1. Pull out Cylinder Block Assembly by holding Retainer Plate and Cylinder Block. Do not damage Piston Shoe and Cylinder Block.
2. Mark Piston Assembly and Cylinder Block to identify each position. Remove Piston Assembly and Retainer Plate from Cylinder Block.
3. Remove Retainer Holder and Pins.
4. Compress Spring and remove Snap Ring. Remove Collar and Spring from Cylinder Block.
5. Remove Swash Plate.
6. Remove Spring from Flange. Steel Balls may come off with Swash Plate.
7. Remove Shaft, Ball Bearing, and Oil Seal.

GEAR BOX

1. Remove Plugs and drain oil.
2. Remove Socket Head Bolts from Cover. Tap Cover with plastic hammer to break seal and remove Cover.
3. Remove Thrust Plate.
4. Remove Drive Gear and Holder A S/A.
5. Remove Thrust Plate and Sun Gear B.
6. Remove Holder B S/A and Sun Gear C.
7. Loosen Socket Head Bolts evenly and remove Ring Gear. Pins may stick.
8. Loosen Socket Head Bolts and remove Plate. Using a press, remove Holder C S/A with the caution not to have the Pins stick.
9. Remove Shim.
10. Remove Coupling.
11. Press Flange out of Housing.
12. Remove Floating Seal from Housing with a flat-tip screwdriver.
13. Press Angular Bearings out of Housing.
14. Using flat-tip screwdriver and remove another Floating Seal from Flange.
15. Wash parts with cleaning solvent. Apply rust preventative if parts are stored before reassembly.

HYDRAULIC MOTOR PARTS REPLACEMENT CRITERIA

Item	Inspection	Allowable Limit	Parts to be Replaced
Piston Assy (106)	(a) Deep score or roughness on shoe. (b) Deep score or roughness on reciprocating portion. (c) Large clearance between Piston and Cylinder Block. (d) Play on shoe ball portion.	0.8a 1.2a 0.060mm 0.40mm	Cylinder Block Kit (B6)
Cylinder Block (104)	(a) Deep score or roughness on sliding portion. (b) Deep score or roughness inside bore. (c) Large clearance between Piston. (d) Large clearance between Shaft spline.	0.8a 1.6a 0.060mm 38.749(pin dia.3.333)	Cylinder Block Kit (B6)
Valve Plate (105)	(a) Roughness of the sliding portion or deep scoring caused by serious damage, seizure, and partial wear.	0.8a <0.02mm(scoring depth)	Valve Plate (105)
Retainer Plate (107) Retainer Holder (108)	(a) Roughness of the sliding portion or deep scoring caused by serious damage, seizure, and partial wear.	0.8a <0.02mm(scoring depth)	Retainer Plate (107) Retainer Holder (108)
Swash Plate (109)	(a) Roughness of the sliding portion or deep score caused by damage, seizure, and wear. (b) Deep scoring or roughness on Steel Ball portion. (c) Depth of Steel Ball portion.	0.8a <0.02mm(scoring depth) 1.6a 14.5mm	Swash Plate (109) Steel Ball (110)
Shaft (103)	(a) Deep lip mark, roughness, or serious damage on sliding portion for Oil Seal. (b) Excessive wear or breakage on spline (c) Large clearance between Cylinder Block spline hole. (d) Large clearance between Coupling spline hole.	1.6a <0.02mm(scoring depth) 47.380(pin dia.3.000 30.498(pin dia.3.33)	Shaft (103)
Brake Piston (125)	(a) Dimension (b) Roughness or serious damage on sliding portion.	45.7mm (Height) 2.5a	Brake Kit (125)
Disk Plate (127)	(a) Dimension (b) Serious damage or peeling.	3.2 (Thickness)	Brake Kit (127)
Ball Bearing (112), (113)	(a) Serious damage on races and Balls. (b) Discontinuous rotation		Ball Bearing (112), (113)
Piston Assy (111)	(a) Deep score or roughness on shoe. (b) Deep score or roughness on reciprocating portion. (c) Large clearance between Piston and Flange Holder. (d) Play on shoe ball portion.	1.6a 1.2a 0.040mm 1.0mm	Case Kit (B7)
Plunger Assy (102-2)	(a) Serious damage, roughness, or deep scoring. (b) Large clearance between Plunger and bore.	0.8a <0.02mm(scoring depth) 0.060mm	Base Plate Kit (B5)
Base Plate (102)	(a) Serious damage, roughness, or deep scoring on bore.	0.8a <0.02mm(scoring depth)	Base Plate Kit (B5)
Spool (102-9)	(a) Serious damage, roughness, or deep scoring. (b) Large clearance between Spool and bore.	0.8a 0.060mm	Base Plate Kit (B5)
Relief Valve Assy (102-7)	(a) Roughness or serious damage on Free Piston sliding	<0.02mm(scoring depth)	Relief Valve Assy (B4)

Assembly

Handle all parts with care to prevent damage.

Replace all seals when disassembling motor.

Clean all parts. Check for dust, damage, scratches, or other damage before assembly. Replace all Seals and bearings.

GEAR BOX

1. Grease Floating seals. Install one Floating Seal in Flange.
2. Put other Floating Seal on Floating seal already set on Flange. Ensure concentricity of Floating Seals.
3. Press inner race of Angular Bearing in Flange.
4. Press outer races of both Angular Bearings in Housing from both sides.
5. Carefully place Housing on Flange.
6. Press inner race of Angular Bearing remaining in Flange.
7. Press top of inner race of Angular Bearing already installed in Flange with even thrust force of 3000kgf. While pressing, measure gap.
8. Press Pins in Flange so Pins project from Flange 26.5 – 27.5 mm.
9. Grease Shim(s) and place on bottom surface of Holder C S/A (203).
10. Put Holder C S/A on Flange. Pins must be properly inserted in Flange.
11. Apply High Strength Thread Locking Compound (JLG P/N 0100019 to Socket Head Bolts and evenly tighten them into flange.
12. Tap Pins on Housing so Pins project from the top surface of the Flange by 17mm.
13. Install O-Ring in Housing.
14. Put Ring Gear on Housing. Tighten Socket Head Bolts evenly.
15. Ensure Snap Rings and are properly installed in Sun Gear C and Sun Gear B. Put Sun Gear C in Holder C S/A, Holder B S/A on Sun Gear C, and Sun Gear B in Holder B S/A.
16. Grease Thrust Plate and place on bottom surface of Holder A S/A.
17. Put Holder A S/A on Sun Gear B.
18. Put Drive Gear in Sun Gears B and C. Drive Gear must be properly engaged with planetary gears of Holder A S/A.
19. Place Thrust Plate on Drive Gear (204).
20. Degrease contact surface of Ring Gear and Cover. Apply liquid gasket evenly and put Cover on Ring Gear. Tighten Socket Head Bolts.

21. Apply Teflon tape to plugs. Install and tighten Plugs.
22. Position Gear Box with piston motor side up. Degrease thread surface of Socket Head Bolts and thread hole of Flange.
23. Apply Loctite 217 or equivalent on thread surface of Socket Head bolts. Install Plates in Flange. Tighten Socket Head Bolts.
24. Ensure Pin is completely inserted in Coupling. Install coupling on spline shaft Drive Gear.

MOTOR SECTION

1. Apply grease to Oil Seal and press into Flange. Ensure Oil Seal is completely seated.
2. Place two Springs in bores at bottom of Flange. Apply grease on sliding surfaces of two Piston Assemblies and insert in bores.
3. Press Ball Bearing on Shaft. Insert Shaft in Flange. Ensure Shaft rotates smoothly.
4. Apply hydraulic fluid on two Steel Balls and spherical hollows at bottom of Flange. Place Steel Balls in hollows and Swash Plate in Flange.
5. Place Spring Seat, Spring and Collar in Cylinder Block. Compress Spring and install Snap Ring.
6. Apply grease on three Pins. Insert Pins in Cylinder Block. Place Retainer Holder on Cylinder Block.
7. Insert nine Piston Assemblies through flat side of Retainer Plate.
8. Apply hydraulic fluid in bores of Cylinder Block and on spherical surface of Retainer Holder. Insert Piston Assemblies in Cylinder Block.
9. Apply hydraulic fluid on sliding surface of Swash Plate and sliding surfaces of nine Piston Assembly shoes. Insert Cylinder Block Assembly on Shaft.
10. Submerge Valve Plate in hydraulic fluid before assembly. Place Disk Plate, Friction Plate, Disk Plate, Friction Plate, and Disk Plate in Flange (1).
11. Fit O-Rings in grooves of Brake Piston. Apply grease on sliding surface of Brake Piston. Insert in Flange so holes for pins on Brake Piston and Case align.
12. Put Springs on Brake Piston.

BASE PLATE

1. Press Bearing in Base Plate.
2. Insert Pin in Valve Plate.
3. Apply grease to back of Valve Plate. Place Valve Plate on Base Plate with bronze color side up.
4. Apply grease to O-Ring and place it on Case.
5. Place O-Rings on Case without grease. Insert Pins in Base Plate with tapered side up.
6. Place Base Plate on Case. Do not allow any parts under Base Plate to fall out. Tighten Socket Head Bolts.
7. Insert Spool, Spring, and Spring Guide in Base Plate. Ensure O-Rings are installed in Plugs. Tighten Plugs in Base Plate.
8. Install Poppet Seat at top of Relief Valve. Apply grease to Relief Valve O-Rings. Insert Relief Valve Assembly in Base Plate and Tighten.
9. Insert Plunger Assembly in Base Plate. Place Spring Seat, Spring, and another Spring Seat on each side of Plunger Assembly. Ensure O-Ring is put in groove on Cap Assembly. Put both Caps on Base Plate. Tighten Socket Head Bolts.

Install Motor Assembly

1. Clean drive motor. Wash motor mount area inside and out using brush and solvent container. Wipe dry using clean, dry rags.
2. Clean machined mounting surfaces.
3. Get hardware for mounting drive motors and place washers on each bolt. Apply JLG Thread Locking Compound PN 0100011.

4. Lift drive assembly in place with adequate lifting device and nylon straps. Level, check, and fill (if needed) oil. Apply Anti-Seize Compound to motor mount area. Re-align motor in nylon straps as needed & assemble to car-body. Torque to 230 ft-lb +15-0 (322 Nm, +21 -0).



NOTE: Sprockets are not directional.

5. Apply Anti-Seize Compound to sprocket mounting area. Hook to crane using strap and alignment pin. Lift up and place on motor drive. Secure with bolts and JLG Thread Locking Compound PN 0100011. Torque to 230 ft-lb +1.
6. Starting with brake hose for easy access, torque three small hoses on both sides of drive motor according to torque chart specifications.
7. Torque two large hoses on drive motor according to torque chart specifications.
8. Place washers on cover plate retaining bolts and apply JLG Thread Locking Compound PN 0100011 on each bolt. Install cover plates and torque bolts according to chart specifications.

Rotary Coupling

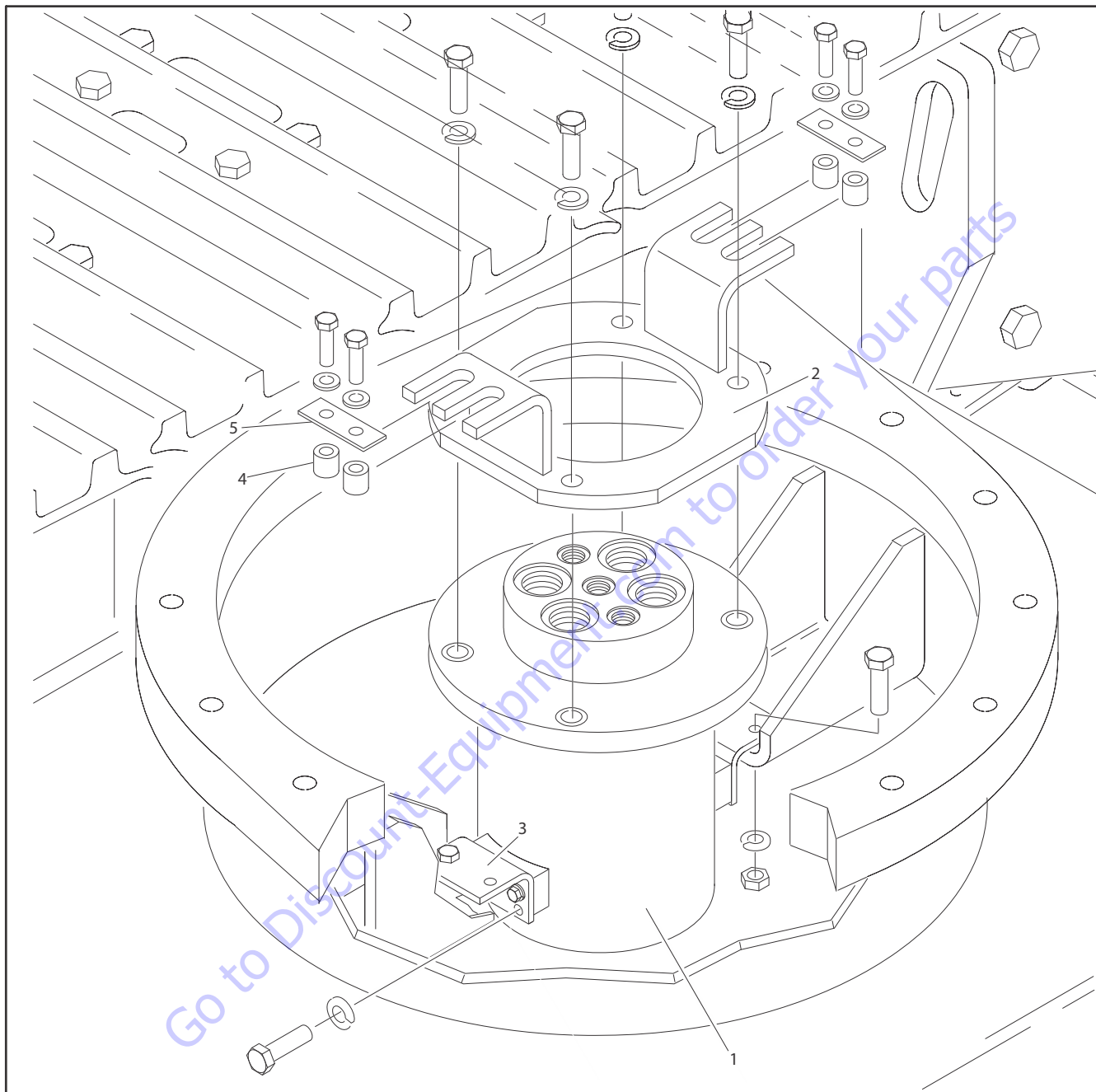

- | | | |
|---------------|------------|-----------|
| 1. Coupling | 3. Support | 5. Keeper |
| 2. Stabilizer | 4. Spacer | |

Figure 3-12. Rotary Coupling Installation

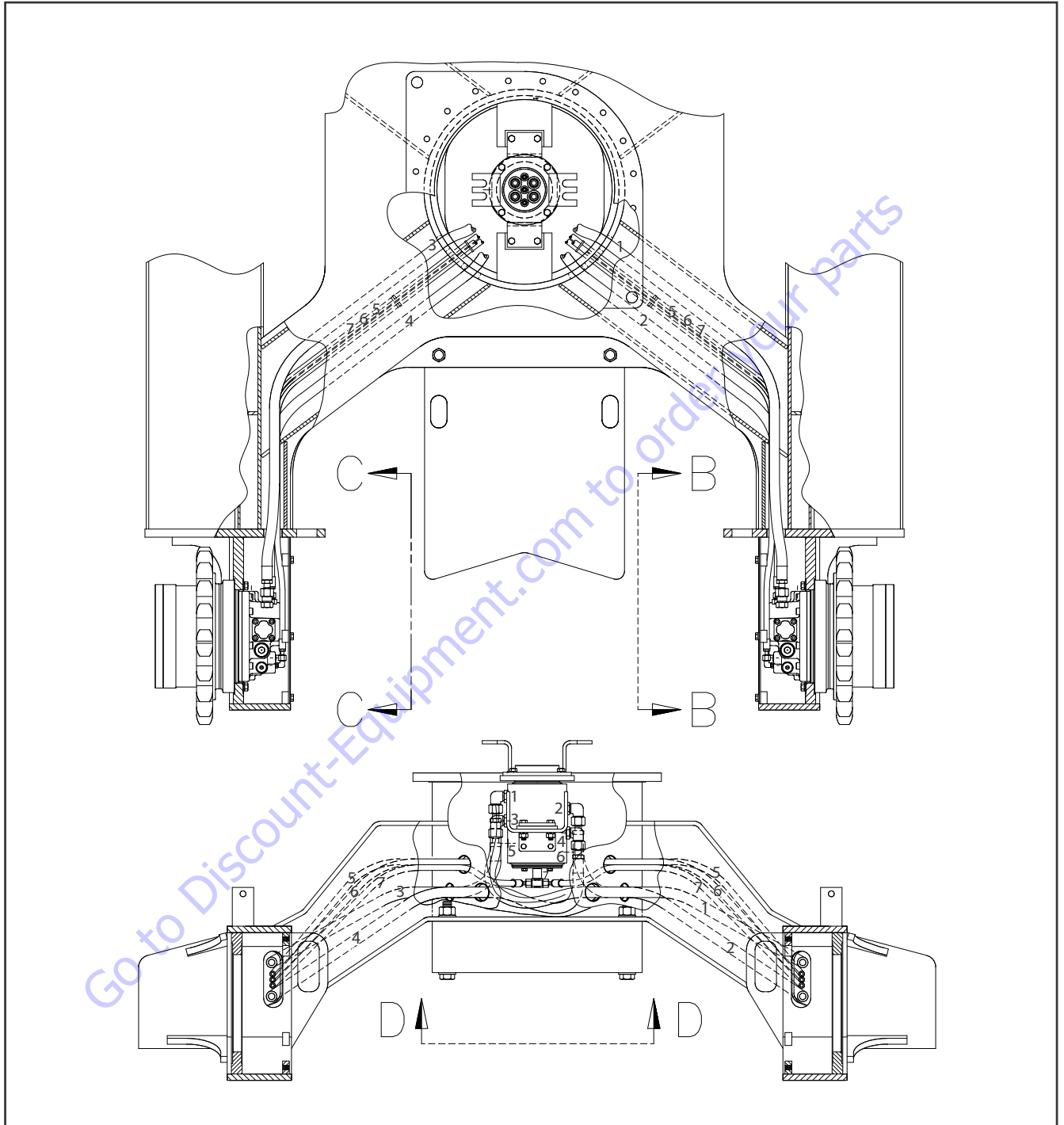

Figure 3-13. Hose Routing - 1 of 2

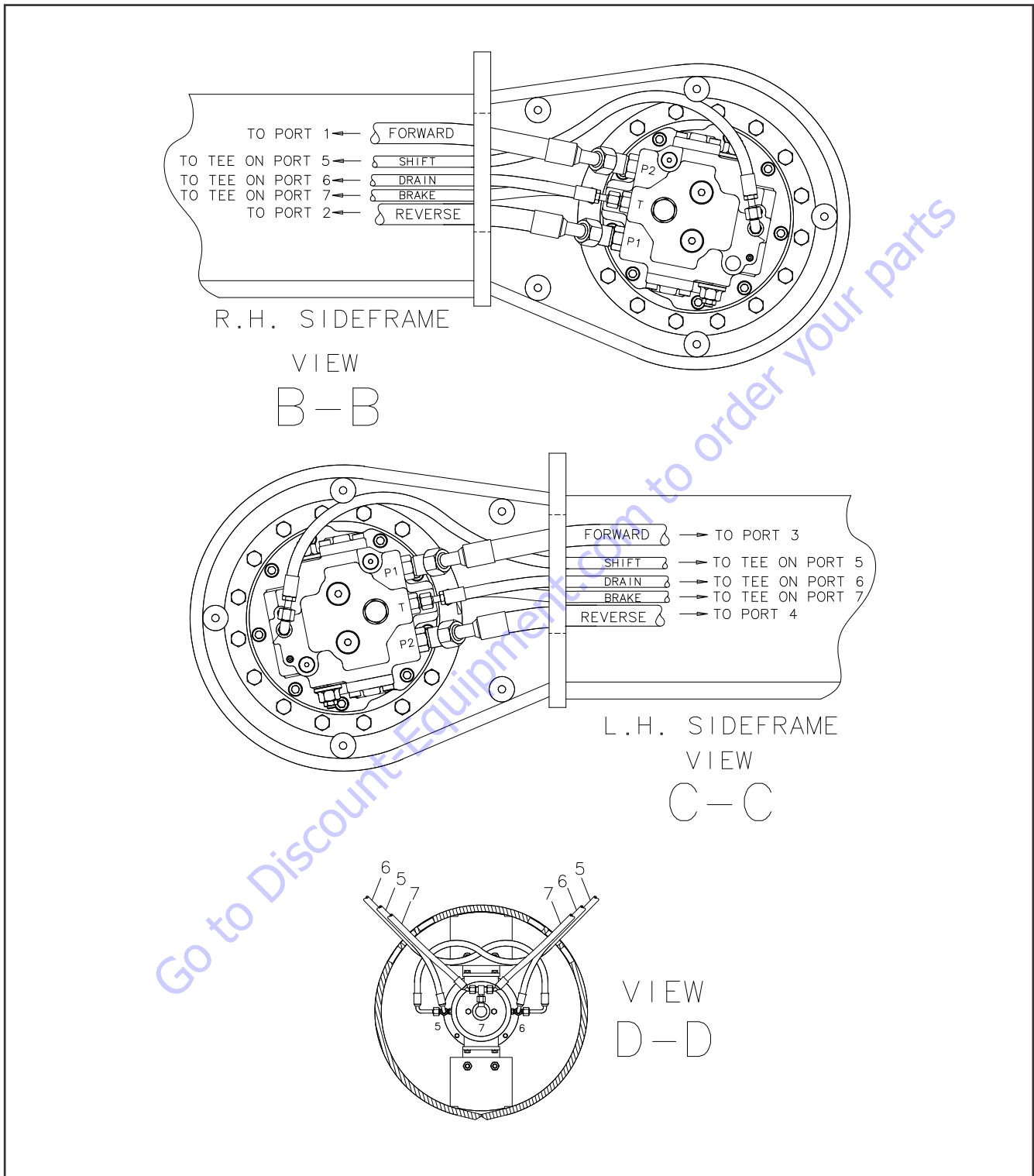
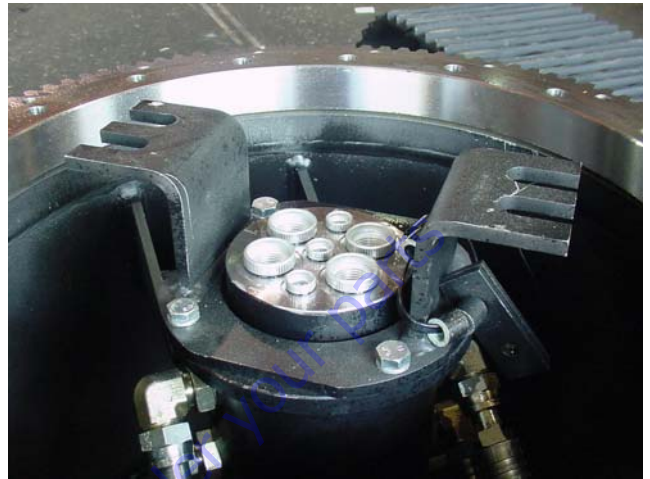

Figure 3-14. Hose Routing - 2 of 2

1. Assemble fittings for hoses to drive motor finger tight until correct positioning is established.
2. Install swivel supports with hardware and JLG Thread Locking Compound PN 0100011. Torque to 53 ft-lb +5-0 (74 Nm, +7 -0).
3. Lift swivel using supports previously installed, and assemble to frame. Use JLG Thread Locking Compound PN 0100011 on bolts. Torque to 68 ft-lb (95 Nm).
4. Route hoses from swivel area through side frame. Make initial connections for hoses from swivel to drive motors.
5. Route brake, shift, and drain hoses through side frame. Lubricate O-rings and hand tighten hoses to right-hand drive motor fittings.

6. Install swivel stabilizer and secure With JLG Thread Locking Compound PN 0100011. Torque to 93 ft-lb +10-0 (130 Nm, +14 -0).



7. Clean split post on each side of frame. Wipe off grease from roller assembly. Apply Anti-Seize Compound. Slide roller assembly into split post hole and secure with nut, bolt, and JLG Thread Locking Compound PN 0100011. Torque to 340 ft-lb +25-0 (476 Nm, +35 -0) on both sides.

3.3 SWING DRIVE

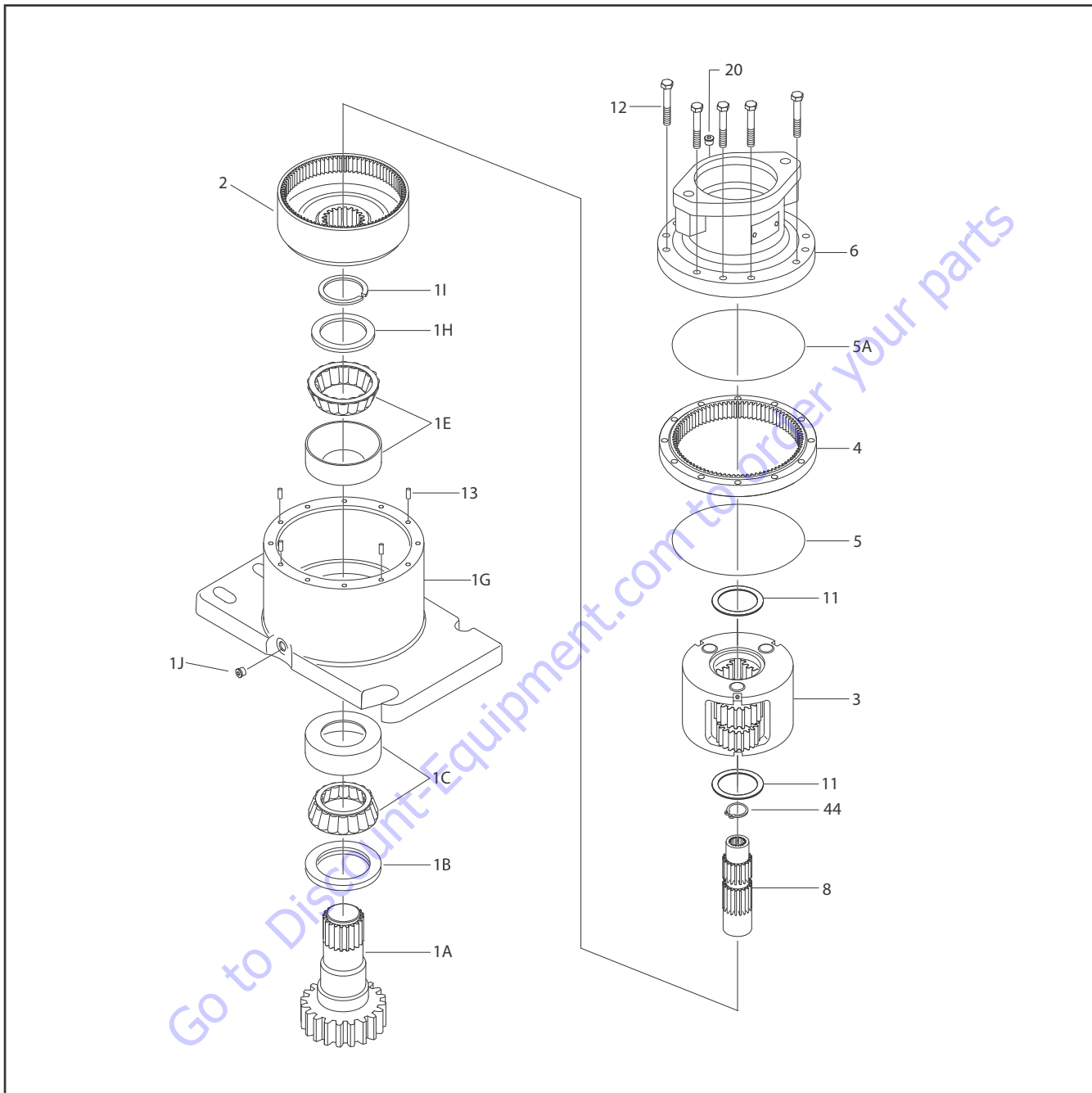

- | | | | | |
|------------------|--------------------|---------------------|-------------------|-----------------------------|
| 1A. Output Shaft | 1G. Housing | 2. Internal Gear | 5A. O-Ring | 12. Bolt |
| 1B. Lip Seal | 1H. Thrust Washer | 3. Carrier Assembly | 6. Brake Housing | 13. Dowel Pin |
| 1C. Bearing | 1I. Retaining Ring | 4. Ring Gear | 8. Sun Gear | 20. Pipe Plug |
| 1E. Bearing | 1J. Pipe Plug | 5. O-Ring | 11. Thrust Washer | 44. Internal Retaining Ring |

Figure 3-15. Swing Drive Assembly

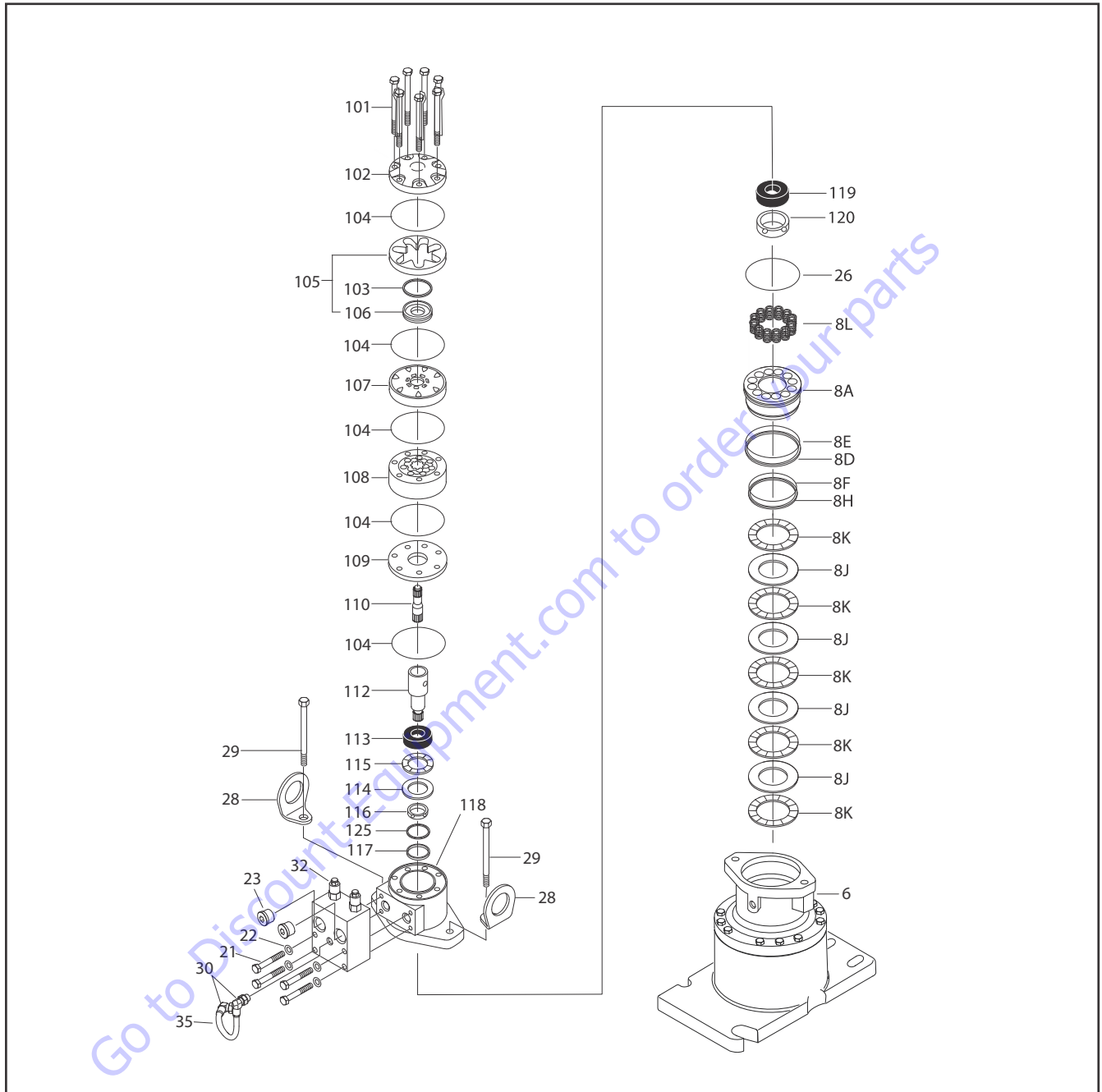

- | | | | | |
|------------------|-----------------|-------------------------------|---------------------|---------------------|
| 6. Brake Housing | 8L. Spring | 35. Tube | 108. Rotor Set | 117. Back-up Washer |
| 8A. Piston | 21. Bolt | 101. Bolt | 109. Wear Plate | 118. Housing |
| 8D. O-Ring | 22. Lockwasher | 102. End Cover | 110. Drive Link | 119. Outer Bearing |
| 8E. Back-Up Ring | 23. Pipe Plug | 103. Commutator Seal | 112. Coupling Shaft | 120. Seal |
| 8F. O-Ring | 26. O-Ring | 104. Ring Seal | 113. Inner Bearing | 125. Back-up Washer |
| 8H. Back-up Ring | 28. Lifting Lug | 105. Commutator and Ring Assy | 114. Thrust Washer | |
| 8J. Rotor Disc | 29. Bolt | 106. Ring | 115. Thrust Bearing | |
| 8K. Stator Disc | 30. Elbow | 107. Manifold | 116. Inner Seal | |

Figure 3-16. Swing Motor and Brake Assembly

Gear Backlash

Set backlash to .010 - .015 in (0.254 to 0.381 mm).

1. Insert shim (JLG P/N 4071009) between pinion and bearing on the bearing high spot. The bearing high spot should be stamped with an "X" on the surface below the teeth and marked with yellow paint in the tooth space.

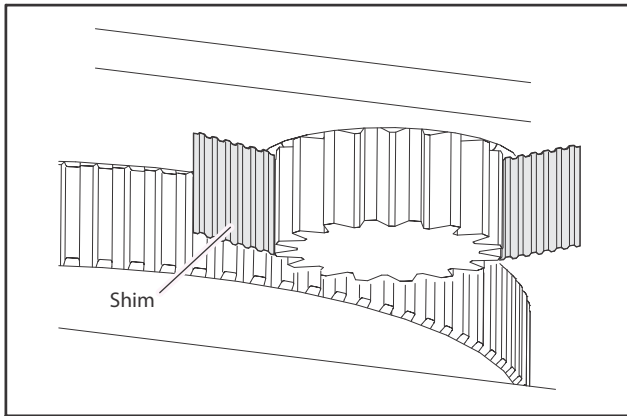

Figure 3-17. Swing Drive Shim Placement

2. Apply JLG Thread Locking Compound P/N 0100019 to pivot bolt. Torque pivot bolt to 205 ft-lb (280 Nm).
3. Remove turntable lock pin.
4. Apply JLG Thread locking compound P/N 0100019 to four mounting bolts. Torque mounting bolts to 30 ft-lb (40 Nm).

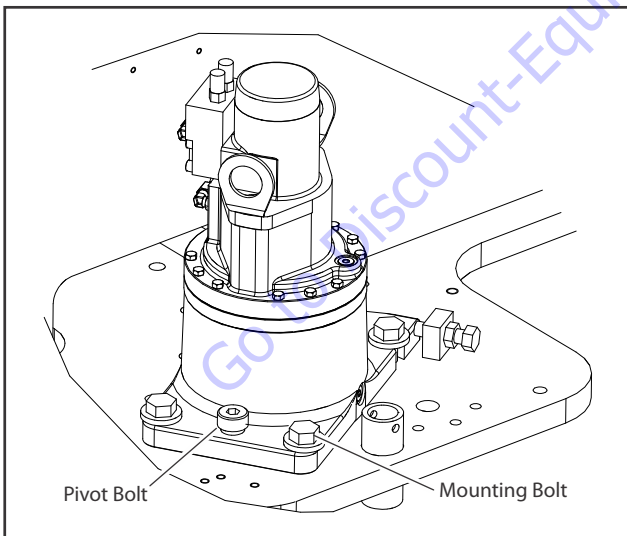

Figure 3-18. Swing Drive Pivot and Mounting Bolts

5. Loosen jam nut.
6. Tighten jack bolt until pinion is snug against shim and bearing, then loosen jack bolt.
7. Apply JLG Thread locking compound P/N 0100019 to jack bolt threads. Torque jack bolt to 50 ft-lb (68 Nm).
8. Tighten jam nut.
9. Torque four mounting bolts to 340 ft-lb (461 Nm).

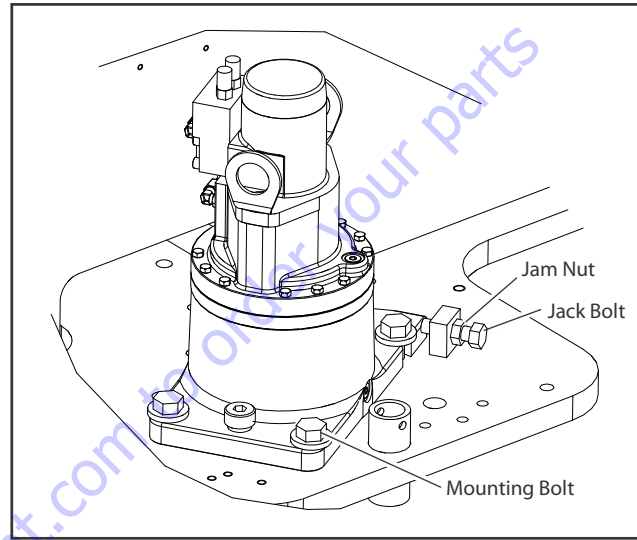

Figure 3-19. Swing Drive Jam Nut and Mounting Bolt

10. Remove and discard swing drive shim.

Swing Drive Lubrication

Fill Swing Drive Gearbox with 43 oz (1.27L) 90w80 gear oil with EP additives. Oil should cover the ring gear. Torque pipe plug 23 - 24 ft-lb (31 - 32.5 Nm).

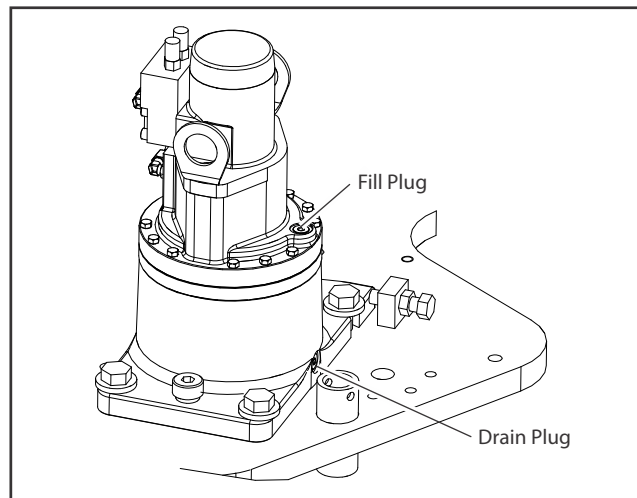

Figure 3-20. Swing Drive Lubrication

Motor Control Valve Disassembly

1. Place unit on bench with motor end up.
2. Remove Drain Plug (1P) and drain oil from gearbox.
3. Remove Hydraulic Tubing Assembly (35).
4. Loosen jam nuts on Elbow Fittings (30). Remove fittings from Brake (6) and Motor Control Valve (32).
5. Remove O-ring Plugs (23) from Motor Control Valve (32).
6. Remove four bolts (21), washers (22), and Motor Control Valve (32) from Motor (31).
7. Reinstall Drain Plug (1P). Torque to 23 - 24 ft-lb (31 - 32.5 Nm).

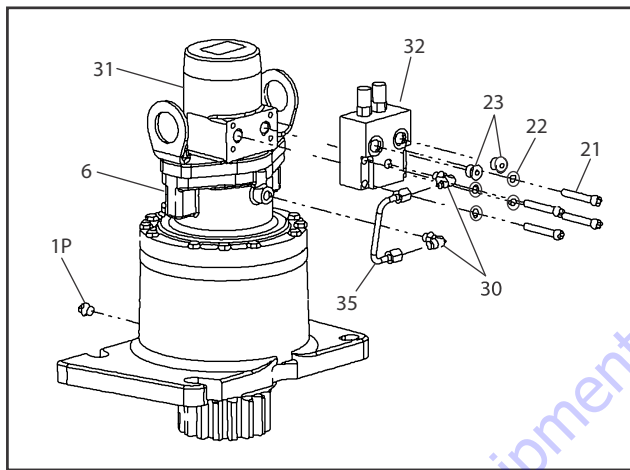

Figure 3-21. Main Control Valve Disassembly

Motor and Brake Disassembly

1. With unit resting on bench with Motor (31) end up, remove Hex Bolts (29) and Lift Lugs (28) from Motor (31).
2. Pull Motor (31) straight up and remove Motor (31) from Brake Housing (6).
3. Remove O-ring (26) between Motor (31) and Brake Housing (6).
4. Remove Springs (8L) from piston.

⚠ CAUTION

PISTON (8A) MAY MOVE QUICKLY. WEAR EYE PROTECTION.

5. Apply less than 50 psi air to brake port to remove Brake Piston (8A).
6. Remove Rotors (8J) and Stators (8K) from Brake Housing (6).

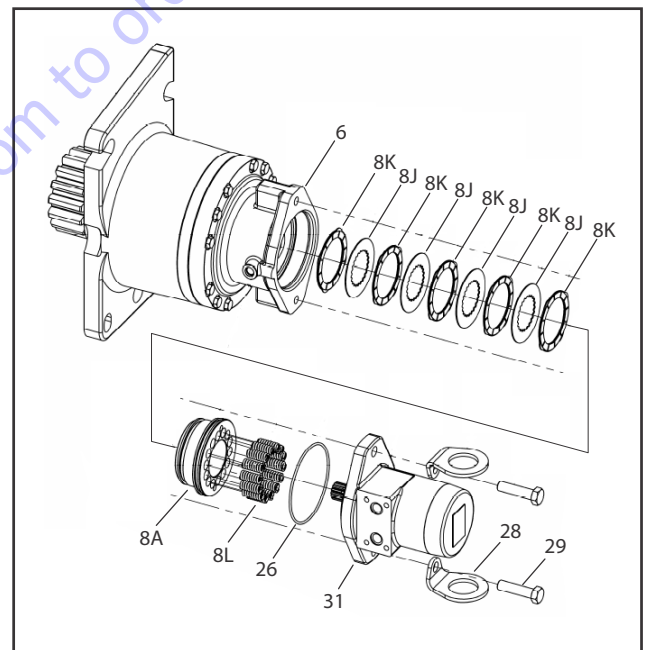

Figure 3-22. Motor and Brake Disassembly

Main Disassembly

1. Remove Sun Gear (8) with Retaining Ring (44) inside.
2. With unit resting on Output Shaft (Pinion) (1A), remove Bolts (12) from Brake Housing (6).
3. Remove Brake Housing (6) from main assembly.
4. Remove O-ring (5A) from Brake Housing (6) and Ring Gear (4).
5. Remove Thrust Washer (11) from Brake Housing (6) and Carrier Subassembly.
6. Remove Ring Gear (4) from Housing (1G).
7. Remove O-ring (5) from Ring Gear (4) and Housing (1G).
8. Remove Carrier Subassembly.
9. Remove Thrust Washer (11) between Carrier Subassembly and Internal Gear (2).
10. Remove Internal Gear (2).

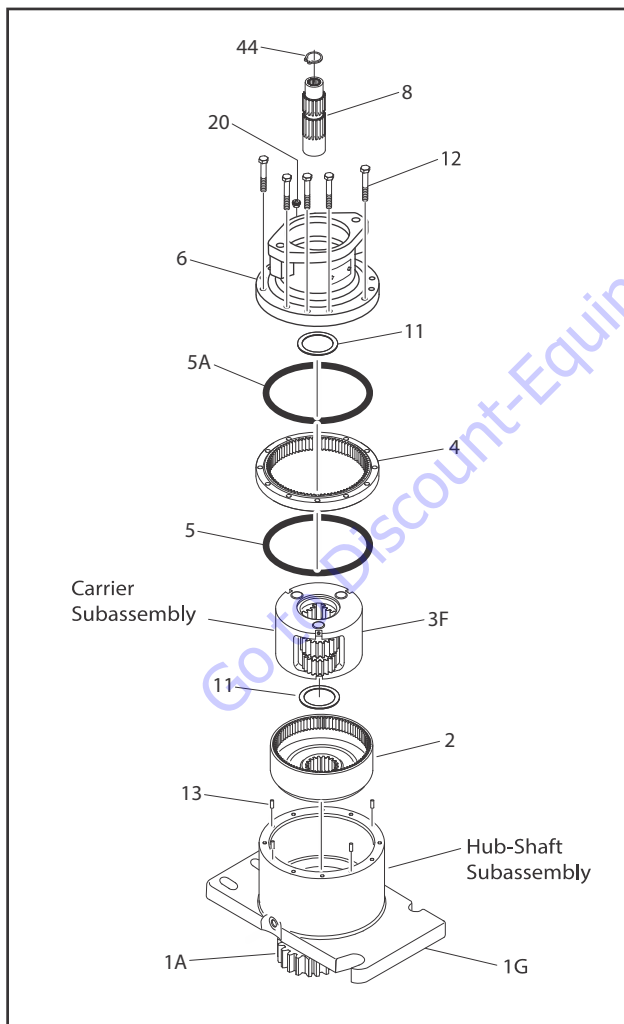

Figure 3-23. Main Disassembly

Hub-Shaft Disassembly

CAUTION

WEAR EYE PROTECTION DURING THIS PROCEDURE.

11. Using retaining ring pliers, remove and discard Retaining Ring (11) from groove in Output Shaft (1A).
12. Remove Thrust Washer (1H).
13. Support Housing (1G) on Output Shaft (1A) end. Press Output Shaft (1A) out of Housing (1G).

NOTE: Lip Seal (1B) will be pressed out of Housing (1G) by Bearing Cone (1D) during this step.

14. Remove Bearing Cone (1E) from Housing (1G).
15. Use a bearing puller to remove Bearing Cone (1D) from Shaft (1A). Bearing Cups (1C & 1F) will remain in Housing (1G).

NOTE: If bearing replacement is necessary, Bearing Cups (1C & 1F) can be removed with a slide hammer puller or driven out with a punch.

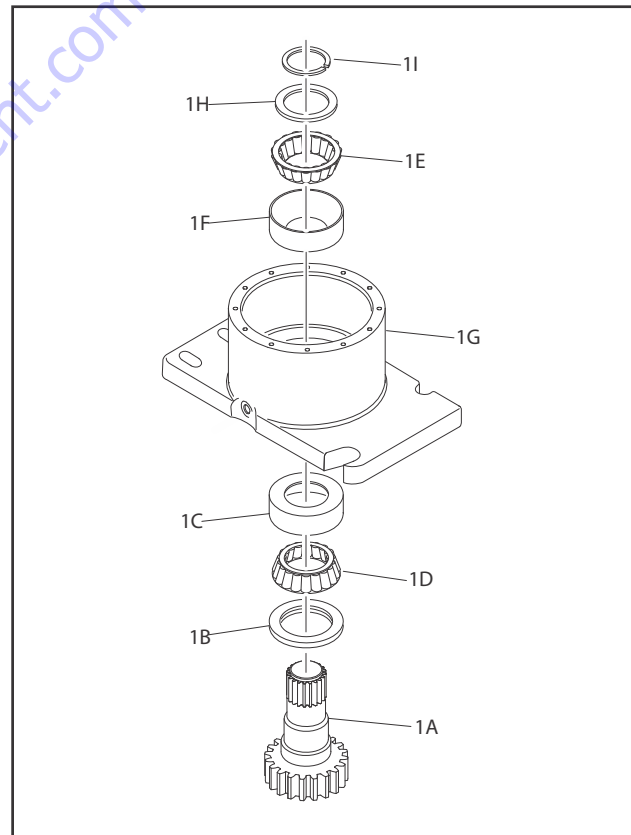

Figure 3-24. Hub-Shaft Disassembly

Carrier Disassembly

1. Using a 3/16" punch drive Roll Pin (3G) holding Planet Shaft (3E) in Carrier (3A) in Planet Shaft (3E) until it bottoms.

NOTICE

MAKE SURE ROLL PIN HAS BOTTOMED OR CARRIER MAY BE DAMAGED WHEN PLANET SHAFT IS REMOVED.

2. Remove Planet Shaft (3E) from Carrier (3A). Use a small punch to remove Roll Pin (3G) from Planet Shaft (3E).
3. Slide Planet Gear (3F) and two Thrust Washers (3B) out of Carrier (3A).
4. Remove both rows of Needle Bearings (3C) and Spacer (3D) from bore of Planet Gear (3F).
5. Repeat Steps 1 thru 4 for remaining Cluster Gears (3F).

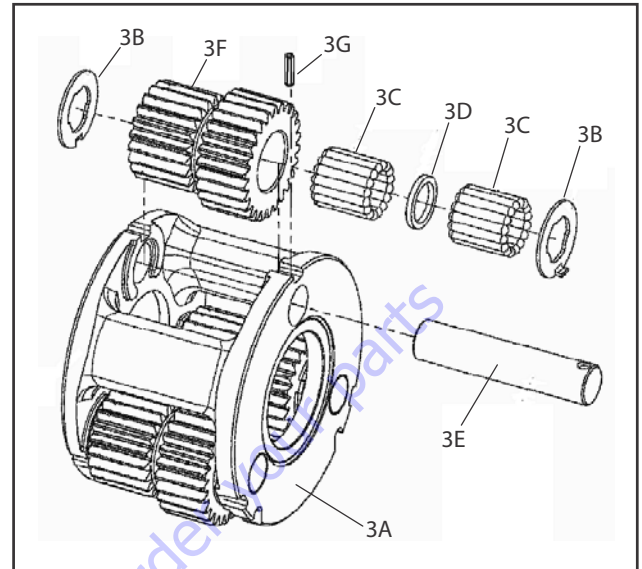

Figure 3-25. Carrier Disassembly

Hub-Shaft Subassembly

1. Press Bearing Cup (1C) in Housing (1G). Make sure cup starts square with bore of Hub (1G).
2. Place Bearing Cone (1D) in Bearing Cup (1C) in Housing (1G).
3. Apply grease to rubber portion of Seal (1B). Press or tap Seal (1B) with smooth face up, in counterbore of Housing (1G) until it is flush with Housing (1G) face bore.
4. Invert Hub (1G) and press Bearing Cup (1E) in counterbore of Housing (1G).
5. Carefully lower Housing (1G) on Output Shaft (1A) until Bearing Cone (1D) contacts Output Shaft (1A).
6. Press on small end of Bearing Cone (1D), being careful not to contact the bearing cage, until Bearing Cone (1D) seats on Output Shaft (1A) shoulder.
7. Start Bearing Cone (1F) on Output Shaft (1A).
8. Press or tap Bearing Cone (1F) on Output Shaft (1A) until it is just seated in Bearing Cup (1E), while rotating the Housing (1G).
9. Install Bearing Spacer (1H) on Output Shaft (1A) against Bearing Cone (1F).

CAUTION

RINGS UNDER TENSION CAN FLY OUT AND CAUSE SERIOUS INJURY. WEAR EYE PROTECTION WHEN INSTALLING RINGS.

NOTICE

NEVER REUSE A RETAINING RING IN REBUILD OR REPAIR.

10. Install new Retaining Ring (1I) in groove of Output Shaft (1A).
11. Tap Retaining Ring (1I) with a soft metal punch to ensure it is completely seated in groove of Output Shaft (1A).

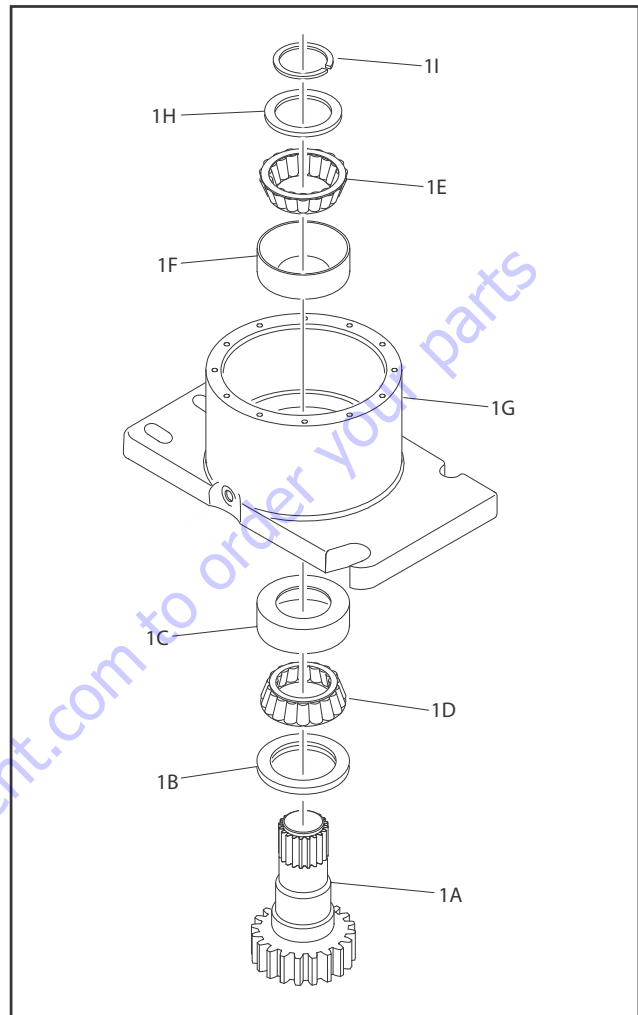

Figure 3-26. Hub-Shaft Subassembly

12. Reinstall Drain Plug if not already installed (1P from Fig. 3-45). Torque to 23 - 24 ft-lb (31 - 32 Nm).

Carrier Subassembly

1. Apply a liberal coat of grease to bore of Cluster Gear (3F). This holds Needle Rollers (3C) in place during assembly.
2. Install first row of Needle Rollers (3C) in bore of Cluster Gear (3F).
3. Insert Spacer (3D) in bore of Cluster Gear (3F) on top of Needle Rollers (3C).
4. Place second row of Needle Rollers (3C) in bore of Cluster Gear (3F) against Spacer(3D).
5. Place Carrier (3A) with one roll pin hole straight up.
6. Start Planet Shaft (3E) through hole in Carrier (3A). Using ample grease to hold it in position, slide one Thrust Washer (3B) over Planet Shaft (3E) with tang resting in cast slot of Carrier (3A).
7. With large end of Cluster Gear (3F) facing roll pin hole in Carrier, place Cluster Gear in position in Carrier (3A). Push Planet Shaft (3E) through Cluster Gear (3F) without going all the way through.
8. Slide second Thrust Washer (3B) between Cluster Gear (3F) and Carrier (3A) with washer tang located in cast slot of Carrier (3A). Finish sliding Planet Shaft (3E) through Thrust Washer (3B) into Carrier (3A).
9. Position non-chamfered side on Planet Shaft (3E) Roll Pin hole in line with hole in Carrier (3A) using a 1/8 inch diameter punch.
10. Use a 3/16" punch to align two roll pin holes. Drive roll pin (3G) through Carrier (3A) and into Planet Shaft (3E) until Roll Pin (3G) is flush with bottom of cast slot in Carrier (3A) outside diameter at Thrust Washer (3B) tang. Use a 1/4" pin punch to make sure roll pin (3G) is flush in slot.
11. Repeat Steps 1 thru 10 for remaining Cluster Gears (3F).

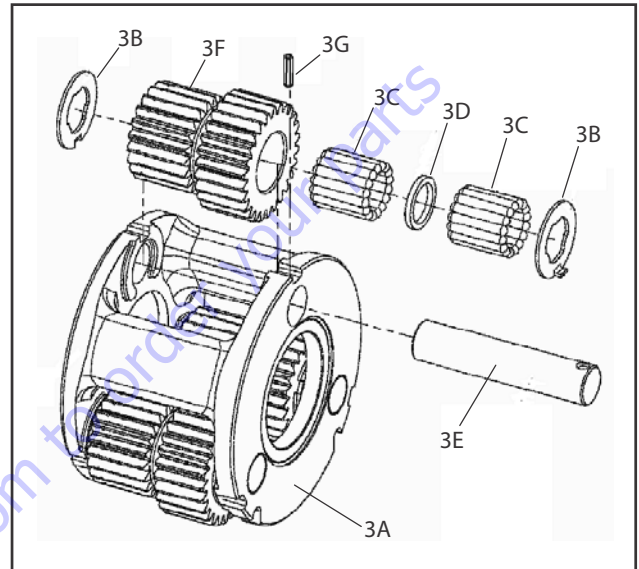

Figure 3-27. Carrier Subassembly

Main Assembly

1. With Hub Shaft Subassembly resting on Shaft (1A) install Internal Gear (2). The spline of Internal Gear (2) bore will mesh with spline of Output Shaft (1A). This will be a tight fit.
2. Inspect location of Internal Gear (2) on Output Shaft (1A). A portion of Output Shaft (1A) should protrude through Internal Gear (2) bore.
3. Install 4 Dowel Pins (13) into counter bore holes in Hub (1G).
4. Install Thrust Washer (11) in counter bore of Carrier Subassembly (Small Cluster-Gear end) Use grease to hold in place.
5. Place O-ring (5) into Hub counter-bore. Use grease to hold O-ring in place.

CAUTION

SHARP EDGES OF COUNTER-BORE CAN CAUSE SERIOUS INJURY. BE CAREFUL WHEN SEATING O-RING.

6. Place Carrier Subassembly on bench with large end of Cluster Gears (3F) facing up with one at 12 o'clock position. Find punch marked tooth on each gear at large end and locate at 12 o'clock (straight up) from each planet pin. Marked tooth will be located just under Carrier on upper two gears. Check timing through slots in carrier. (See Carrier Subassembly)
7. With longer shoulder side of Ring Gear (4) facing down, place Ring Gear (4) over (into mesh with) cluster gears (3F). Be sure cluster gear timing marks (punch marks) remain in correct location during Ring Gear (4) installation. Ring Gear (4) side with an "X" or punch mark stamped on it should be up.
8. While holding Ring Gear (4) and Cluster Gears (3F) in mesh, place small end of Cluster Gears (3F) into mesh with Internal Gear (2). On Ring Gear (4), locate hole marked "X" or punch marked over one of the marked counter-bored holes (Step 5) in Hub (1G). Check timing through slots in carrier. Rotate carrier in assembly to check freedom of rotation.

NOTE: *If gears do not mesh easily or Carrier Assembly does not rotate freely, remove Carrier and Ring Gear. Check Cluster Gear timing.*

9. Install Thrust Washer (11) in counter bore on face of carrier. Use grease to hold in place.
10. Place O-ring (5A) into counter bore of Brake Housing (6). Use grease to hold O-Ring in place.

CAUTION

SHARP EDGES OF COUNTER-BORE CAN CAUSE SERIOUS INJURY. BE CAREFUL WHEN SEATING O-RING.

11. Install Brake Housing (6). Align Pipe Plug hole (20) with those in the Hub (1G).
12. Install Bolts (12) through Brake Housing (6) into Hub (1G). Torque to 23 - 27 ft-lb (31-36 Nm).
13. With gearbox standing on pinion end, fill gearbox with 43 oz of ISO VG150 / VG220 gear oil.
14. Install Retaining Ring (44) in groove of Sun Gear (8).
15. Install Sun Gear (8) into mesh with Planet Gears (3F).
16. Install Pipe Plug (20) in Cover (6). Torque to 23 to 24 ft-lb (31 - 32 Nm).

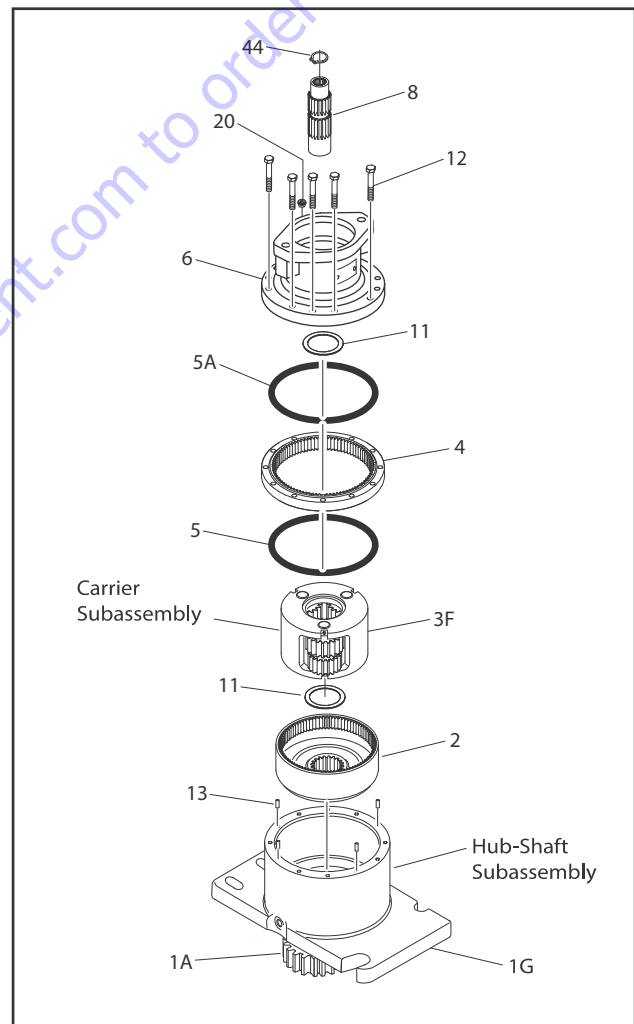

Figure 3-28. Main Assembly

Motor and Brake Assembly

1. Insert Stator (8K) (O.D. lobes) in bore of Brake Housing (6). Alternate Rotors (8J) (I.D. splines) and Stators, ending with a Stator (8K).
2. Grease O-rings (8F) & (8D) and Back-up rings (8H) & (8E). Place them in their respective grooves in Brake Housing (6) and Piston (8A). Make sure Back-up rings are correctly positioned.
3. Apply grease sparingly to Piston O.D. (8A) and bore of Brake Housing (6). Insert Piston (8A) in Brake Housing (6). Do not damage O-rings.
4. Install Springs (8L) in Piston (8A) spring pockets.
5. Test brake and perform roll test. Remove Brake Test Plate.
6. Install O-ring (26) on pilot of Motor (31). Use grease to keep O-ring in place.
7. Place Motor (31) in Brake pilot and line up holes. Check timing sheet.
8. Assemble Lift Lugs (28) on Hex Bolts (29). Assemble Hex Bolts (29) with Lift Lugs (28) through Motor (31) and Brake (6) against Motor flange. Torque to 80-100 ft-lb (108-135 Nm).

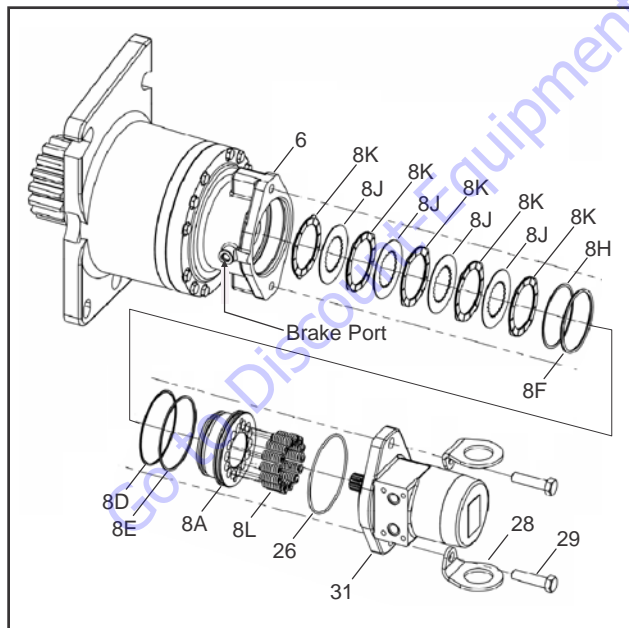

Figure 3-29. Motor and Brake Assembly

Motor Control Valve Assembly

1. Lay assembly down with motor ports facing up. Remove two plastic plugs in the motor ports. Do not lose O-ring in each port. Assemble Motor control Valve (32) on Motor (31) with Bolt (21) and Lock Washers (22). Torque Bolts (21) to 23-27 ft-lb (31-36 Nm).

NOTE: Align holes in control valve with motor ports.

2. Install Elbow Fittings (30) in Brake (6). Do not tighten jam nuts.
3. Install Elbow Fittings (30) in Motor Control Valve (32). Do not tighten jam nuts.
4. Assemble Tube (35) in Elbow Fittings (30). Torque jam nuts to 13-15 ft-lb (17-20 Nm).
5. Install one O-ring Plug (23) in Motor Control Valve (32). Torque to 30-31 ft-lb (40-42 Nm).
6. Pressure test brake, tube, and control valve connections by applying 3000 psi (207 bar) pressure to open port in Motor Control Valve (32) and holding for one minute. Check for leaks at control-valve-motor interface and tube connections. Release pressure and install remaining O-ring Plug (23) in Motor Control Valve (32). Torque to 30-31 ft-lb (40-42 Nm).

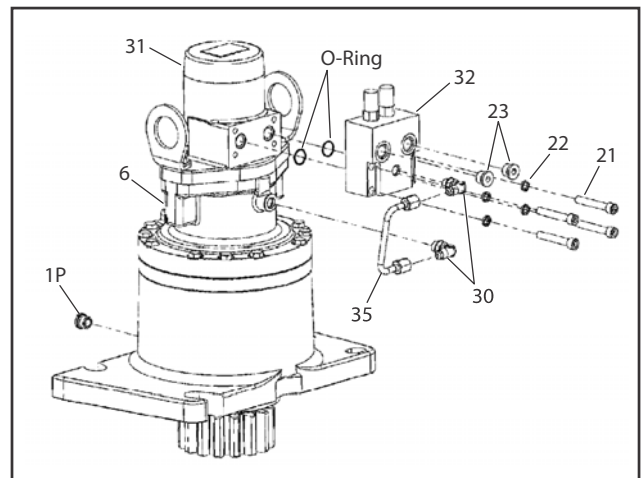

Figure 3-30. Motor Control Valve Assembly

3.4 SWING BEARING

Turntable Bearing Mounting Bolt Condition Check

NOTE: This check is designed to replace existing bearing bolt torque checks on JLG Lifts in service. This check must be performed after first 50 hours of machine operation and every 600 hours of machine operation thereafter. If any bolts are missing or loose, replace missing or loose bolts with new bolts and torque to value specified in torque chart after lubricating bolt threads with JLG Thread Locking Compound PN 0100019. After replacing and retorquing bolt or bolts, recheck all bolts for looseness.

1. Check frame to bearing. Attach bolts as follows:
 - a. Elevate fully retracted boom to 70° (full elevation).
 - b. Try and insert a 0.0015" feeler gauge between bolt head and hardened washer at position shown in Figure 3-31.
 - c. Make sure 0.0015" feeler gauge will not fit under bolt head to bolt shank.
 - d. Swing turntable 90° and check some selected bolts at new position.
 - e. Continue rotating turntable at 90° intervals until a sampling of bolts are checked in all quadrants.
2. Check turntable to bearing. Attach bolts as follows:
 - a. Elevate fully retracted boom to 70° (full elevation).
 - b. try and insert a 0.0015" feeler gauge between bolt head and hardened washer at positions shown in Figure 3-31.
 - c. Lower boom to horizontal and fully extend boom.
 - d. Try and insert the 0.0015" feeler gauge between bolt head and hardened washer at position shown in Figure 3-31.

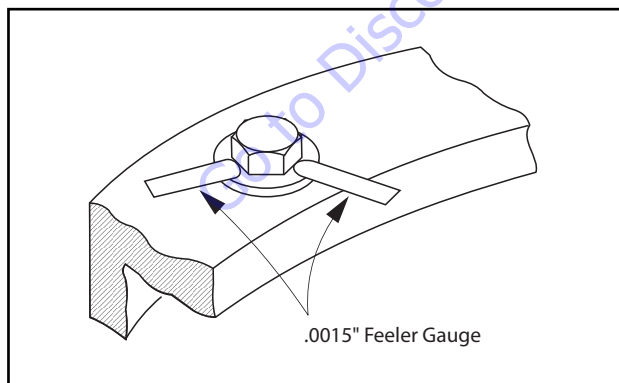

Figure 3-31. Swing Bearing Bolt Feeler Gauge Check

Wear Tolerance

⚠ WARNING

SWING BEARING IS ONE OF THE MOST CRITICAL POINTS ON AN AERIAL LIFT. IT IS HERE STRESSES OF LIFTING ARE CONCENTRATED, AT CENTER OF ROTATION. BECAUSE OF THIS, PROPER MAINTENANCE OF SWING BEARING BOLTS IS A MUST FOR SAFE OPERATION.

1. From underside of machine, at rear center, with boom fully elevated and fully retracted, as shown in Figure 3-33., Swing Bearing Tolerance Measurement Location & Boom Placement A, using a magnetic base dial indicator, measure and record distance between swing bearing and turntable as shown in Figure 3-32., Swing Bearing Tolerance Measuring Point.
2. At the same point, with boom horizontal and fully extended, and tower boom fully elevated as shown in - Swing Bearing Tolerance Boom Placement B, using a magnetic base dial indicator, measure and record distance between swing bearing and turntable as shown in Figure 3-32., Swing Bearing Tolerance Measuring Point.
3. If difference is greater than 0.079 in. (2.00 mm), replace swing bearing.
4. If difference is less than 0.079 in. (2.00 mm) and any of the following conditions exist:
 - a. Metal particles in grease.
 - b. Increased drive power required.
 - c. Noise.
 - d. Rough rotation.
5. Remove, disassemble, and inspect bearing. If bearing inspection shows no defects, reassemble and return to service.

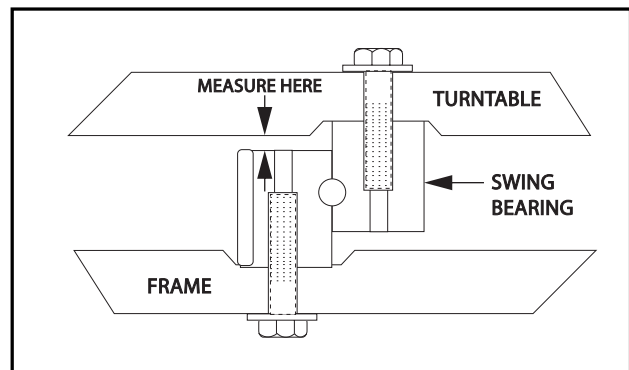

Figure 3-32. Swing Bearing Tolerance Measuring Point

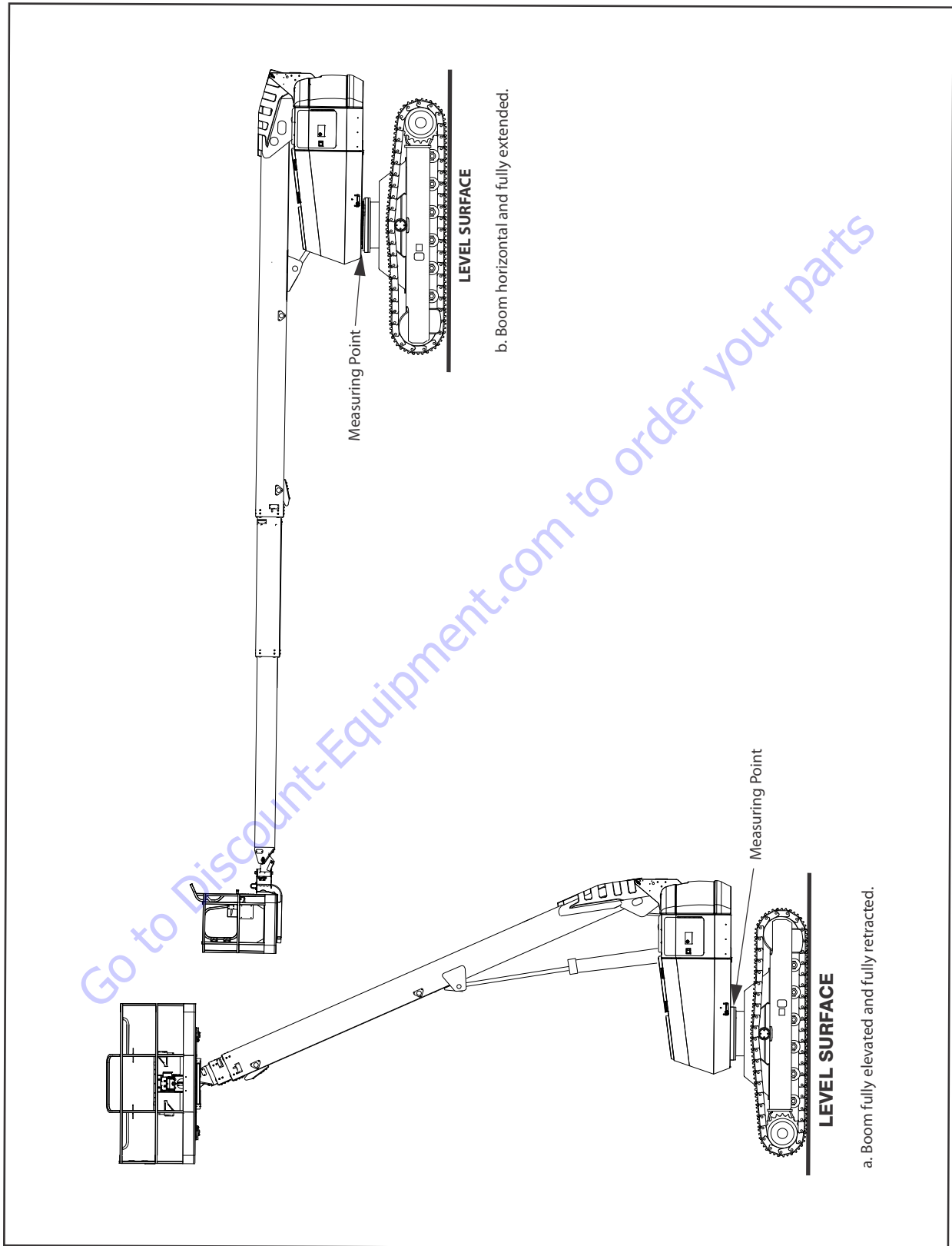

Figure 3-33. Swing Bearing Tolerance Measurement Location & Boom Placement

Swing Bearing Replacement

REMOVAL

1. Operate boom from Ground Control station to provide access to frame opening or rotary coupling.

⚠ WARNING

NEVER WORK BENEATH THE BOOM WITHOUT FIRST ENGAGING BOOM SAFETY PROP OR PROVIDING ADEQUATE OVERHEAD SLING SUPPORT AND/OR BLOCKING.

2. Attach an adequate support sling to boom and draw all slack from sling. Prop or block boom if feasible.
3. From inside turntable, remove mounting hardware attaching rotary coupling retaining yoke brackets to turntable.

NOTICE

HYDRAULIC LINES AND PORTS SHOULD BE CAPPED IMMEDIATELY AFTER DISCONNECTING LINES TO AVOID THE ENTRY OF CONTAMINANTS INTO THE SYSTEM.

4. Tag and disconnect hydraulic lines from fittings on top of rotary coupling. Use a suitable container to retain any residual hydraulic fluid. Immediately cap lines and ports.
5. Attach suitable overhead lifting equipment to base of turntable weldment.
6. Use a suitable tool to scribe a line on swing bearing inner race an underside of turntable. This will aid in aligning bearing upon installation. Remove bolts and washers which attach turntable to bearing inner race. Discard bolts.
7. Use lifting equipment to carefully lift complete turntable assembly from bearing. Ensure no damage occurs to turntable, bearing, or frame-mounted components.
8. Carefully place turntable on a suitably supported trestle.
9. Use a suitable tool to scribe a line on outer swing bearing race and frame. This line will aid in aligning bearing upon installation. Remove bolts and washers which attach outer race of bearing to frame. Discard bolts. Use suitable lifting equipment to remove bearing from frame, then move bearing to a clean, suitably supported work area.

INSTALLATION

1. Using suitable lifting equipment, carefully lower swing bearing in position on frame. Ensure scribed line of outer bearing race aligns with scribed line on frame. If a new swing bearing is used, ensure filler plug fitting is 90° from fore and aft center line of frame.

⚠ CAUTION

JLG INDUSTRIES RECOMMENDS ALL REMOVED BEARING BOLTS BE DISCARDED AND REPLACED WITH NEW BOLTS. SINCE THE SWING BEARING IS THE ONLY STRUCTURAL LINK BETWEEN THE FRAME AND TURNTABLE, IT IS IMPERATIVE SUCH REPLACEMENT HARDWARE MEETS JLG SPECIFICATIONS. USE OF GENUINE JLG HARDWARE IS HIGHLY RECOMMENDED.

⚠ CAUTION

CHECK TORQUE SETTING ACCURACY OF TOOL IF COMPRESSED AIR OR ELECTRICALLY OPERATED IMPACT WRENCH IS USED TO TIGHTEN BEARING ATTACHMENT BOLTS.

2. Refer to Torque Sequence diagram as shown in Figure 3-34., Swing Bearing Torque Sequence. Clean residue off new bearing bolts and apply a light coating of Thread Locking Compound JLG P/N 0100019. Install bolts and washers through frame and outer bearing race. Torque bolts to 190 ft-lb (258 Nm). Remove lifting equipment from bearing.
3. Using suitable lifting equipment, carefully position turntable assembly above machine frame.
4. Carefully lower turntable onto swing bearing. Ensure scribed line of inner bearing race aligns with scribed line on turntable. If a new swing bearing is used, ensure filler plug fitting is 90° fore and aft center line of turntable.
5. Clean residue off new bearing bolts and apply a light coating of Thread Locking Compound JLG P/N 0100019. Install bolts and washers through turntable and bearing inner race.

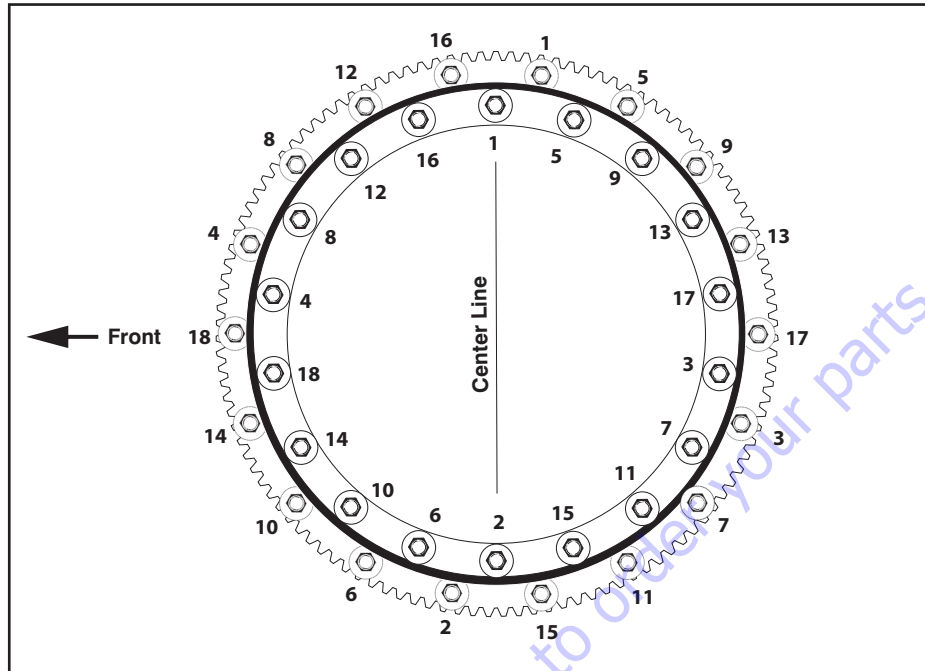

Figure 3-34. Swing Bearing Torque Sequence

6. Following Torque Sequence diagram shown in Figure 3-34., Swing Bearing Torque Sequence, torque bolts to 190 ft-lb (258 Nm).
7. Remove lifting equipment.
8. Install rotary coupling retaining yoke brackets. Apply a light coating of Thread Locking Compound, JLG P/N 0100011 to attaching bolts. Secure yoke to turntable with mounting hardware.
9. Connect hydraulic lines to rotary coupling as tagged prior to removal.
10. At ground control station, use boom lift control to lower boom to stowed position.
11. Using all applicable safety precautions, activate hydraulic system and check swing system for proper and safe operation.

Swing Bearing Torque Values

See Figure 3-34. Swing Bearing Torque Sequence.

1. Outer Race - 190 ft-lb (258 Nm).
2. Inner Race - 190 ft-lb (258 Nm).

WARNING

CHECK OR MISSING OR LOOSE INNER AND OUTER SWING BEARING BOLTS AFTER FIRST 50 HOURS OF OPERATION AND EVERY 600 HOURS THEREAFTER.

3.5 GENERATOR

Every 250 hours

Check drive belt tension every 250 hours of operation,.

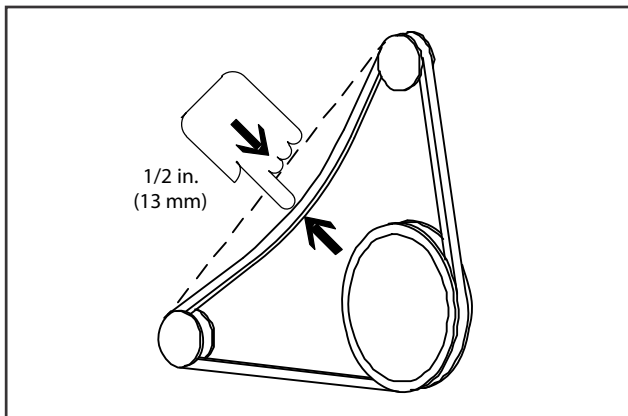

Figure 3-35. Generator Belt Tension

Every 500 hours

Service generator brushes and slip rings every 500 hours of operation. Hostile environments may require more frequent service.

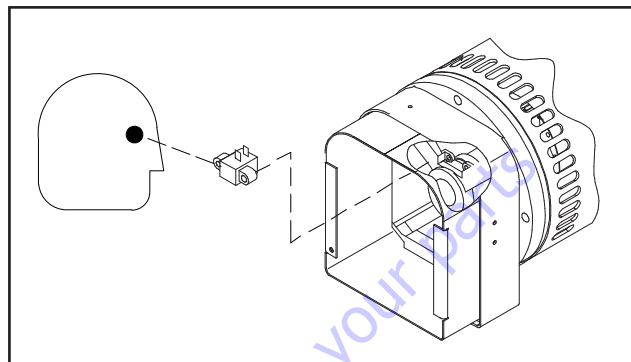

Figure 3-36. Generator Brushes and Slip Rings

Blow out inside of generator every 500 hours of service. If operating in a hostile environment, clean monthly.

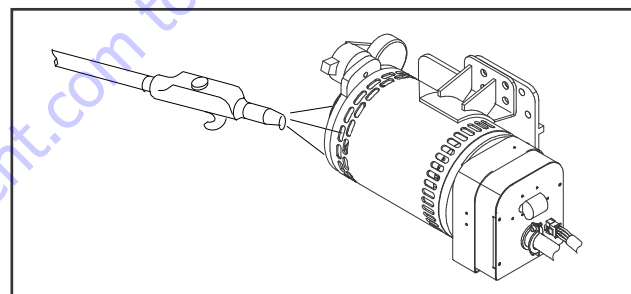

Figure 3-37. Generator Cleaning

Overload Protection

⚠ CAUTION

STOP ENGINE WHENEVER CHECKING OR INSPECTING CIRCUIT BREAKER.

The circuit breaker protects generator windings from overload. Generator output stops if circuit breaker opens.

If circuit breaker continues to open, check for faulty equipment connected to platform receptacles.

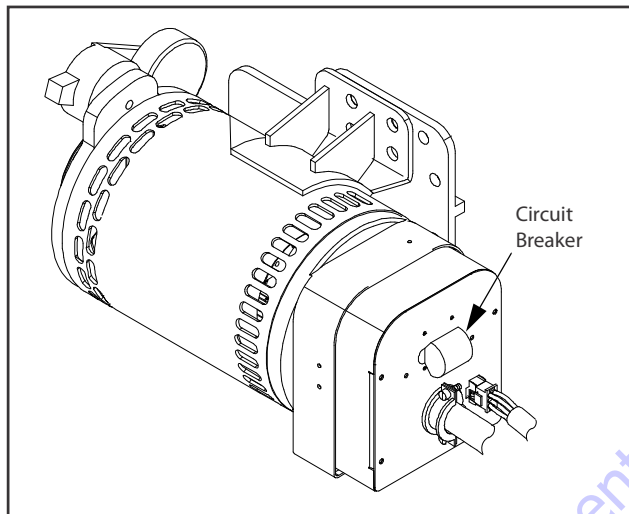

Figure 3-38. Generator Circuit Breaker Location

Inspecting Brushes, Replacing Brushes, and Cleaning Slip Rings

Refer to Figure 3-39, *Inspecting Generator Brushes, Replacing Brushes, and Cleaning Slip Rings.*

INSPECTING BRUSH POSITION

Inspect brush alignment with slip rings. View alignment through air vents in stator barrel. Brushes must ride completely on slip rings.

INSPECTING BRUSHES

1. Remove end panel. Inspect wires.
2. Remove brush holder assembly. Pull brushes from holders.
3. Replace brushes if damaged, or if brush is at or near minimum length.

CLEANING SLIP RINGS

1. Visually inspect the slip rings. Under normal use, the rings turn dark brown.
2. If slip rings are corroded or their surface is uneven, remove belt to turn shaft by hand for cleaning.
3. Clean rings with 220 grit emery paper. Remove as little material as possible. If rings are deeply pitted and do not clean up, consult generator factory service.
4. Reinstall belt, brush holder assembly, and end panel.

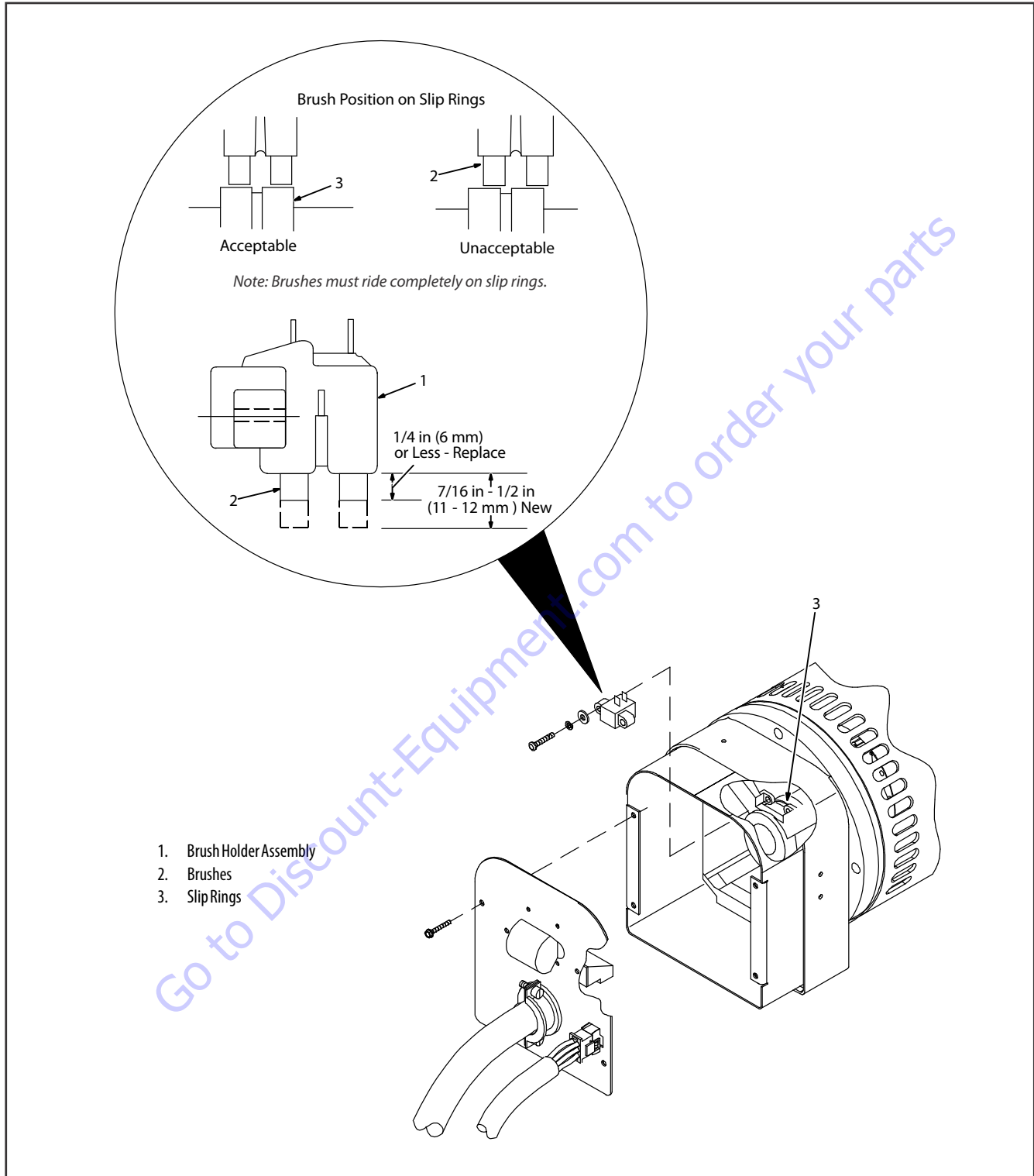
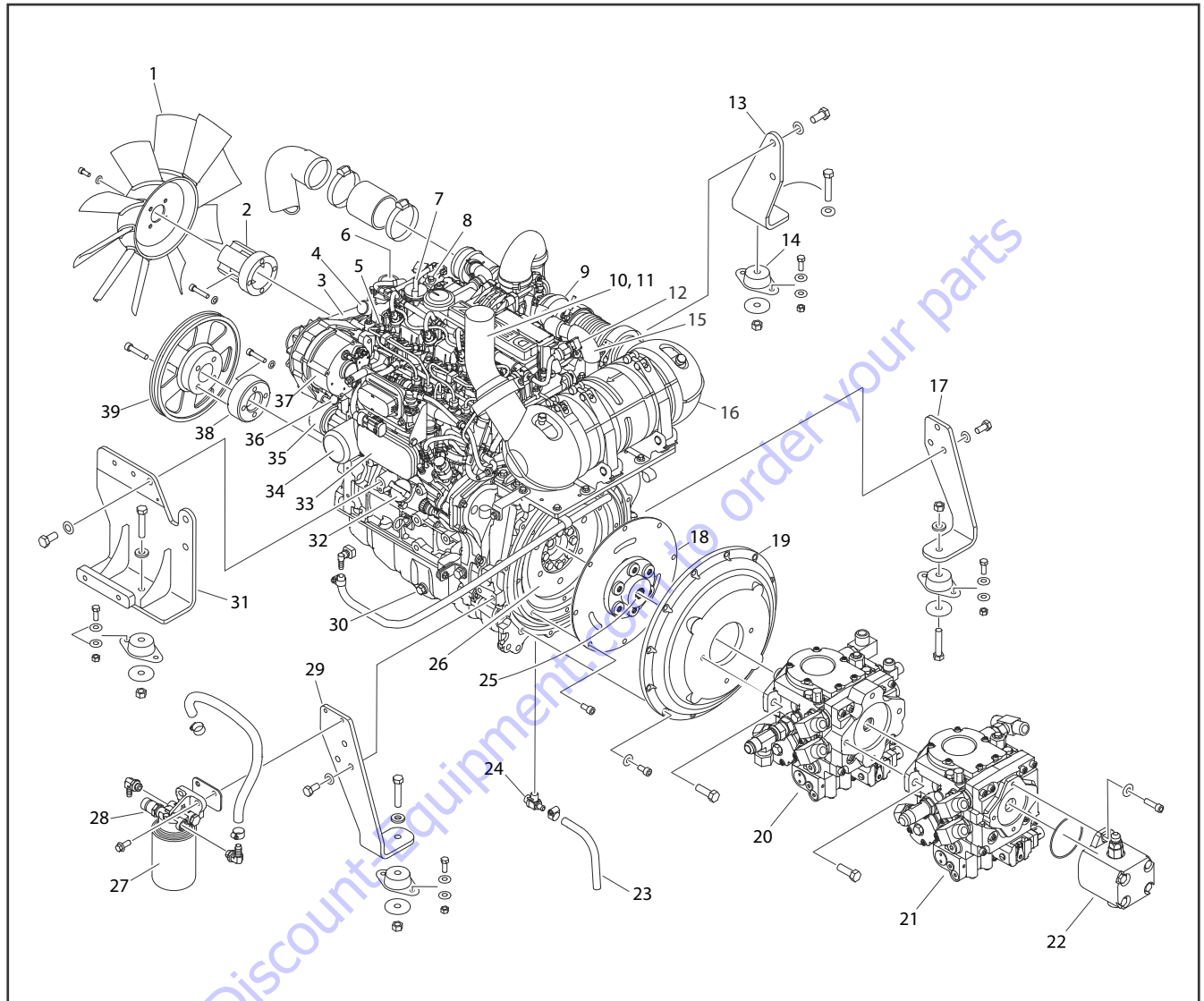

Figure 3-39. Inspecting Generator Brushes, Replacing Brushes, and Cleaning Slip Rings

3.6 DEUTZ D2.9 L4 ENGINE



- | | | | | |
|-----------------------|---------------------------------|----------------------------|----------------------------------|--------------------|
| 1. Fan | 9. Turbocharger | 17. Rear Engine Mount | 25. Pump Coupler | 33. Oil Cooler |
| 2. Adapter | 10. Exhaust Pipe | 18. Coupling | 26. Flywheel | 34. Oil Filter |
| 3. Drive Belt | 11. Spark Arrester | 19. Pump Adapter Plate | 27. Fuel Filter | 35. Belt Tensioner |
| 4. Water Pump | 12. Pressure Sensor | 20. Right Track Drive Pump | 28. Pressure Sensor | 36. Plug |
| 5. Fuel Injector | 13. Front Engine Mount | 21. Left Track Drive Pump | 29. Rear Engine Mount | 37. Alternator |
| 6. Thermostat | 14. Motor Mount | 22. Gear Pump | 30. Oil Pan Drain Plug | 38. Adapter |
| 7. Oil Fill Cap | 15. Shuttle Valve | 23. Oil Drain Hose | 31. Front Engine/Generator Mount | 39. Pulley |
| 8. Temperature Sender | 16. Catalytic Converter/Muffler | 24. Oil Drain Valve | 32. Oil Fill Cap | |

Figure 3-40. Deutz D2.9 L4 Engine Installation - Sheet 1 of 2

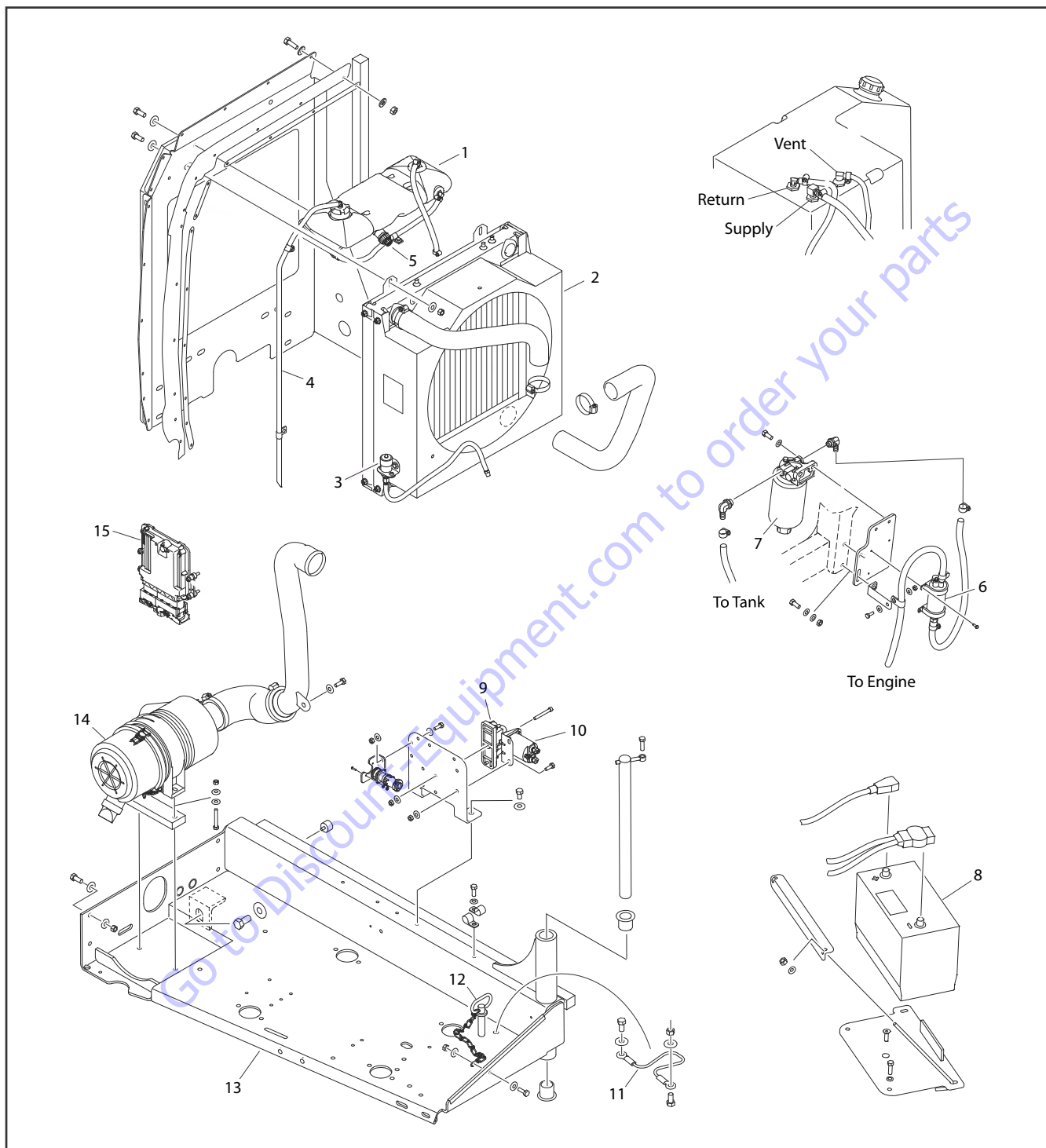

- | | | | | |
|---------------------------------|--------------------------|-----------------------|---------------|-------------------------------|
| 1. Coolant Recovery Tank | 4. Coolant Overflow Hose | 7. Fuel Pre-Filter | 10. Relay | 13. Engine Tray |
| 2. Radiator Assembly | 5. Coolant Level Sensor | 8. Battery | 11. Lanyard | 14. Air Filter Assembly |
| 3. Air Filter Service Indicator | 6. Fuel Pump | 9. Power Module Relay | 12. Hitch Pin | 15. Engine Control Unit (ECU) |

Figure 3-41. Deutz D2.9 L4 Engine Installation - Sheet 2 of 2

NOTE: Refer to engine manufacturer's manual for detailed operating and maintenance instructions.

Check Oil Level

1. Make sure machine and engine are level and switch engine OFF before checking oil level.
2. Remove oil dipstick and wipe with clean cloth.
3. Insert dipstick to the stop and remove again.
4. Check oil level. Top oil level as shown in figure below with an approved grade and type of oil outlined in engine manufacturer's operator's manual.

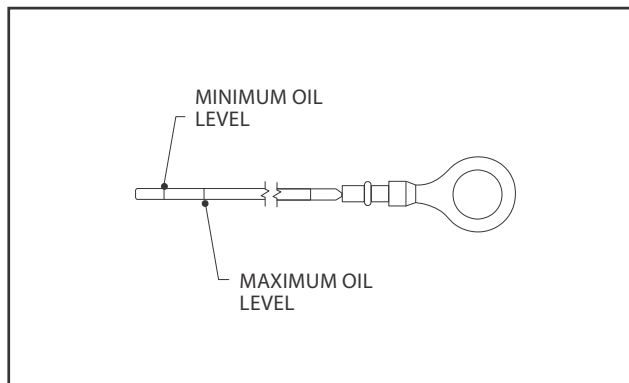

Figure 3-42. Deutz 2.9 T4F Dipstick Markings

5. Replace dipstick until fully seated.

Change Engine Oil

1. Allow engine to warm up. Engine oil should reach approximately 176° F (80° C).
2. Make sure machine and engine are level and switch off engine.
3. Place oil tray under engine.

CAUTION

HOT ENGINE OIL CAN CAUSE BURNS. AVOID CONTACT WITH HOT OIL WHEN DRAINING.

NOTICE

COLLECT USED OIL IN A CONTAINER SUITABLE FOR DISPOSAL OR RECYCLING. DISPOSE OF USED ENGINE OIL IN ACCORDANCE WITH ENVIRONMENTAL REGULATIONS.

4. Open oil drain valve and drain oil.
5. Close oil drain valve.
6. Pour in new engine oil. Refer to Section 1 for capacity and Figure 3-49., Engine Oil Viscosity.

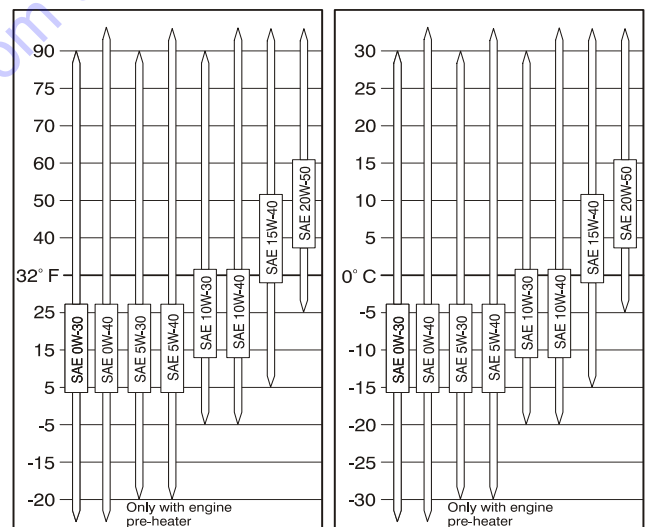
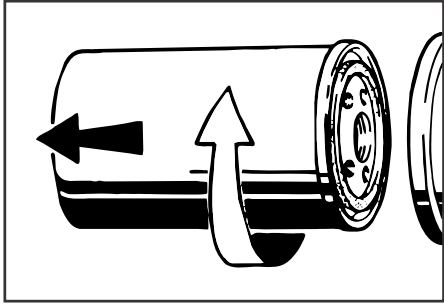

Figure 3-43. Engine Oil Viscosity

Change Oil Filter

1. Wipe area around filter to clean any dirt from area.
2. Using a suitable oil filter removal tool, loosen lube oil filter cartridge and spin off.



3. Catch any escaping oil.
4. Clean any dirt from filter carrier sealing surface.
5. Lightly coat new oil filter rubber gasket with clean oil
6. Screw in new filter by hand until gasket is flush.
7. Hand-tighten filter another half-turn.

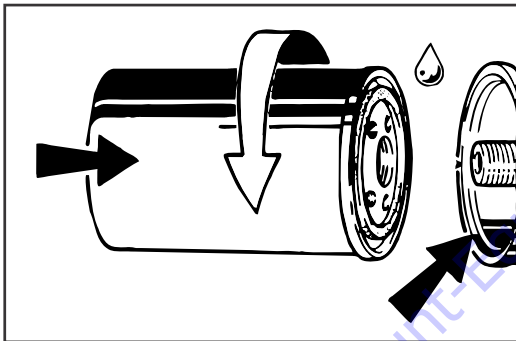

8. Check oil level.
9. Check oil pressure.
10. Check oil filter cartridge for leaks.

Change Fuel Filters

⚠ WARNING

FUEL IS FLAMMABLE AND CAN CAUSE DEATH OR SERIOUS INJURY. MAKE SURE NO OPEN FLAMES OR SPARKS ARE IN THE AREA WHEN WORKING ON FUEL SYSTEM. DO NOT SMOKE WHEN WORKING ON FUEL SYSTEM.

1. Wipe area around filter to clean any dirt from area.
2. Disconnect water sensor connector (Pre-filter Only).
3. Remove fuel filter cartridge. Catch any escaping fuel.

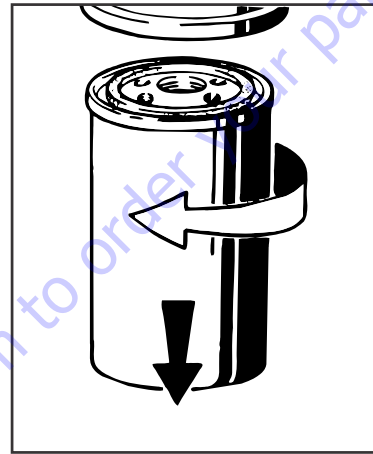

4. Clean dirt from filter carrier sealing surface.
5. Apply light film of oil or diesel fuel to rubber gasket of new filter cartridge.
6. Screw in new filter by hand until gasket is flush. Hand-tighten filter another half-turn.

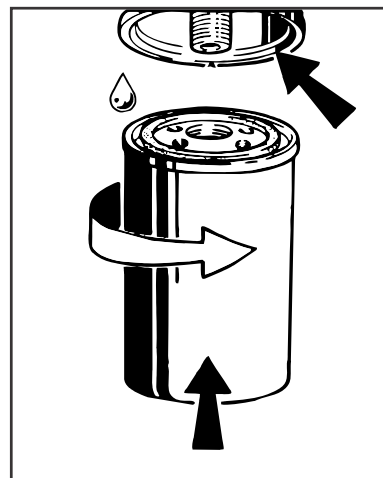

7. Connect water sensor connector (Pre-filter Only).
8. Open fuel shut-off valve.
9. Check for leaks.

3.7 DEUTZ D2011 ENGINE

NOTE: Your machine may have the battery mounted on the engine side or hydraulic tank side of the platform. Refer to the following illustrations to locate components on your specific machine.

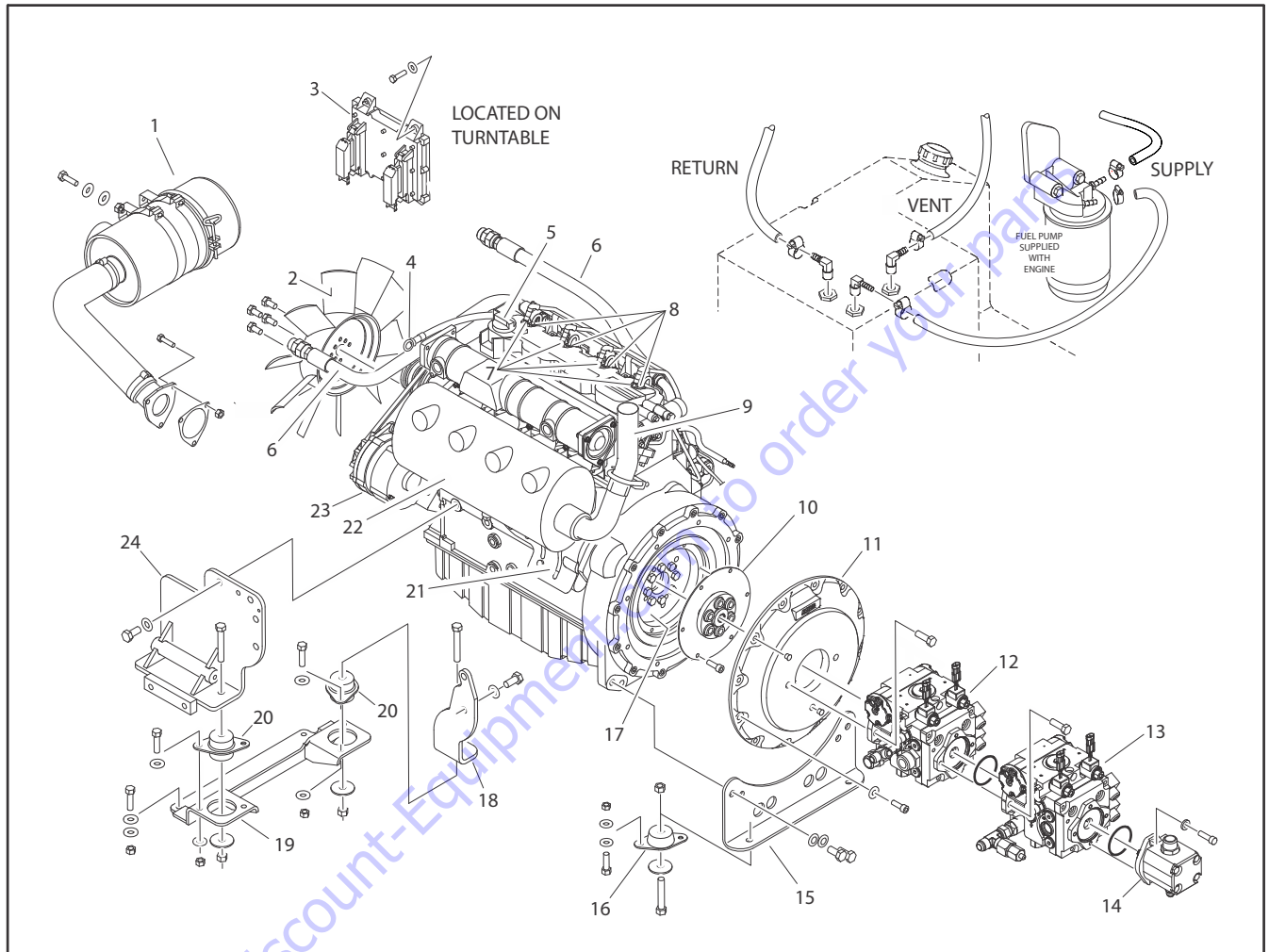

- | | | | |
|--------------------|----------------------------|--------------------------------|---|
| 1. Air Filter | 7. Glow Plug | 13. Left Track Drive Pump | 19. Front Engine Mounting Plate |
| 2. Fan | 8. Injector | 14. Gear Pump | 20. Front Engine Mount |
| 3. ECM | 9. Exhaust Pipe | 15. Rear Engine Mounting Plate | 21. Starter |
| 4. Dipstick | 10. Coupling | 16. Rear Engine Mount | 22. Muffler |
| 5. Oil Filler Cap | 11. Pump Adapter Plate | 17. Engine Mount | 23. Alternator |
| 6. Oil Cooler Hose | 12. Right Track Drive Pump | 18. Right Front Engine Support | 24. Left Front Engine/Generator Support |

Figure 3-44. Deutz D2011 Engine (Battery Engine Side) Installation - 1 of 2

SECTION 3 - CHASSIS & TURNTABLE

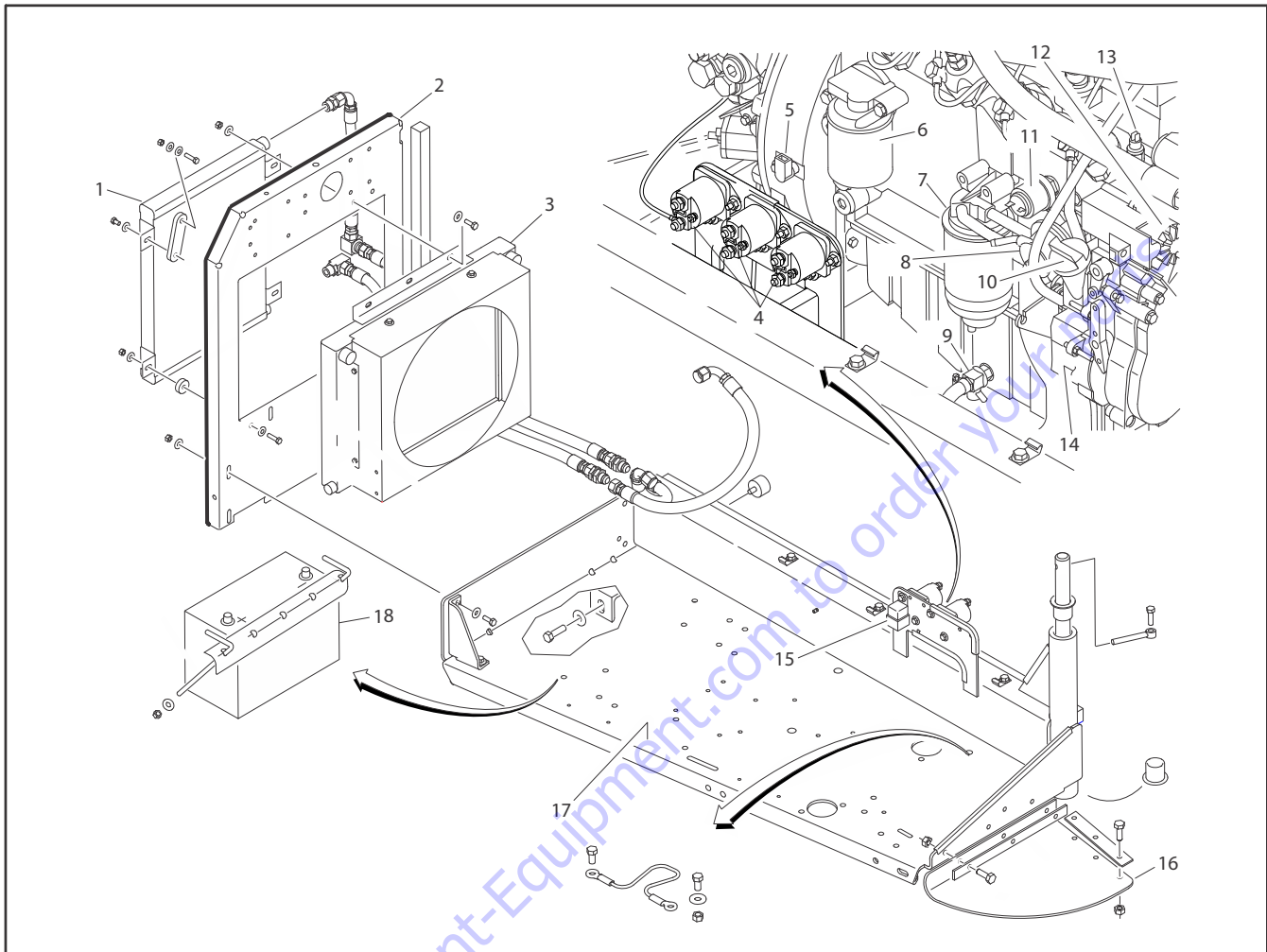

- | | | | | |
|----------------------------|------------------------|------------------------|------------------------|-----------------|
| 1. Oil Cooler | 5. Speed Sensor | 9. Throttle Actuator | 13. Temperature Sensor | 16. Plate |
| 2. Radiator Mounting Plate | 6. Oil Filter | 10. Temperature Sensor | 14. Starter | 17. Engine Tray |
| 3. Radiator | 7. Fuel Filter | 11. Starter | 15. Relay | 18. Battery |
| 4. Relay | 8. Oil Pressure Sensor | 12. Oil Lube Pump | | |

Figure 3-45. Deutz D2011 Engine (Battery Engine Side) Installation - 2 of 2

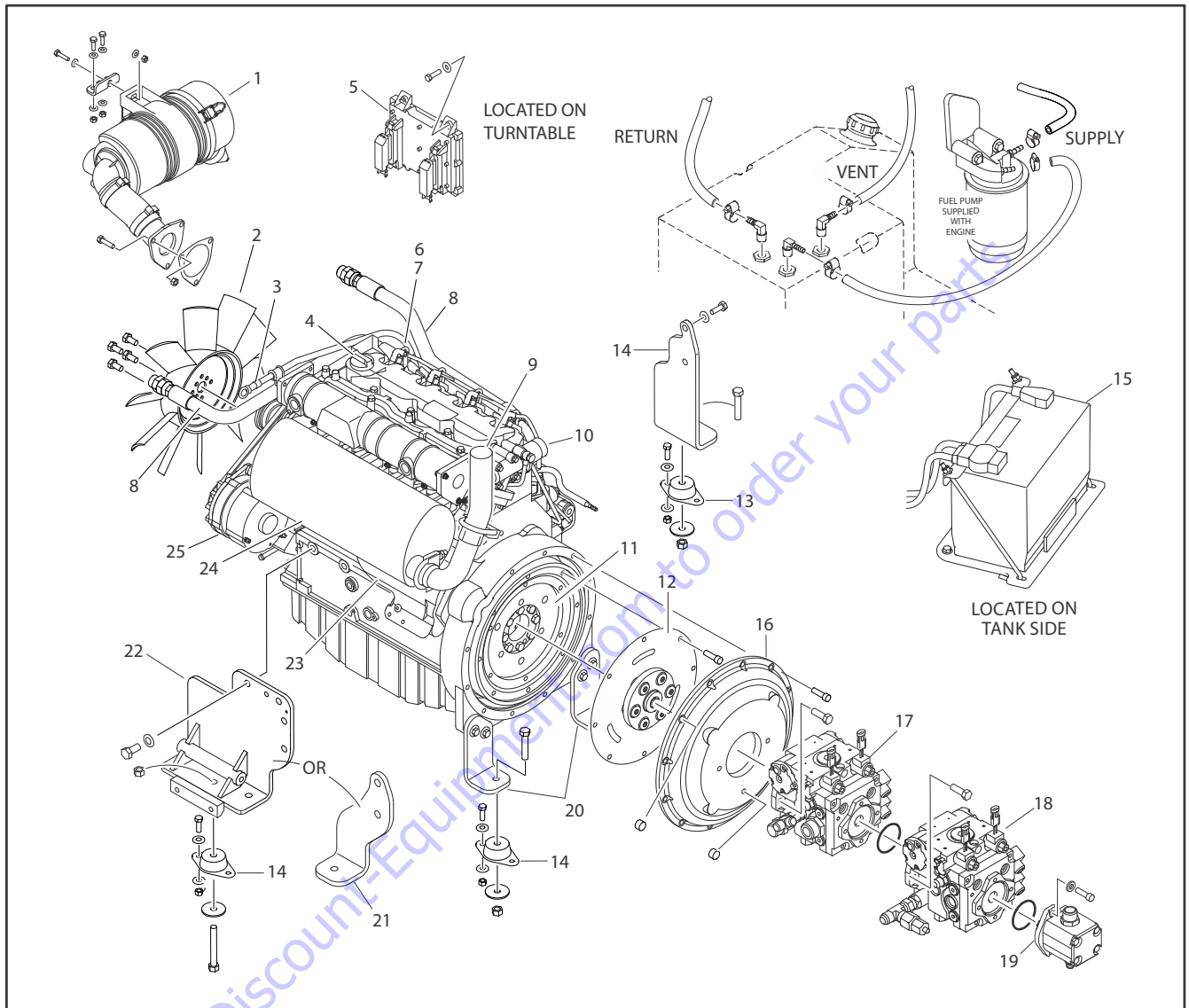

- | | | | |
|-------------------|--------------------|---------------------------------------|---|
| 1. Air Filter | 7. Injector | 13. Engine Mount | 19. Gear Pump |
| 2. Fan | 8. Oil Cooler Hose | 14. Right Front Engine Mounting Plate | 20. Rear Engine Mounting Plates |
| 3. Dipstick | 9. Exhaust Pipe | 15. Battery (Tank Side) | 21. Left Front Engine Mounting Plate |
| 4. Oil Filler Cap | 10. Thermostat | 16. Pump Adapter Plate | 22. Left Front Engine/Generator Support |
| 5. ECM | 11. Flywheel | 17. Right Track Drive Pump | 23. Starter |
| 6. Glow Plug | 12. Coupling | 18. Left Track Drive Pump | 24. Muffler |
| | | | 25. Alternator |

Figure 3-46. Deutz D2011 Engine (Battery Tank Side) Installation - 1 of 2

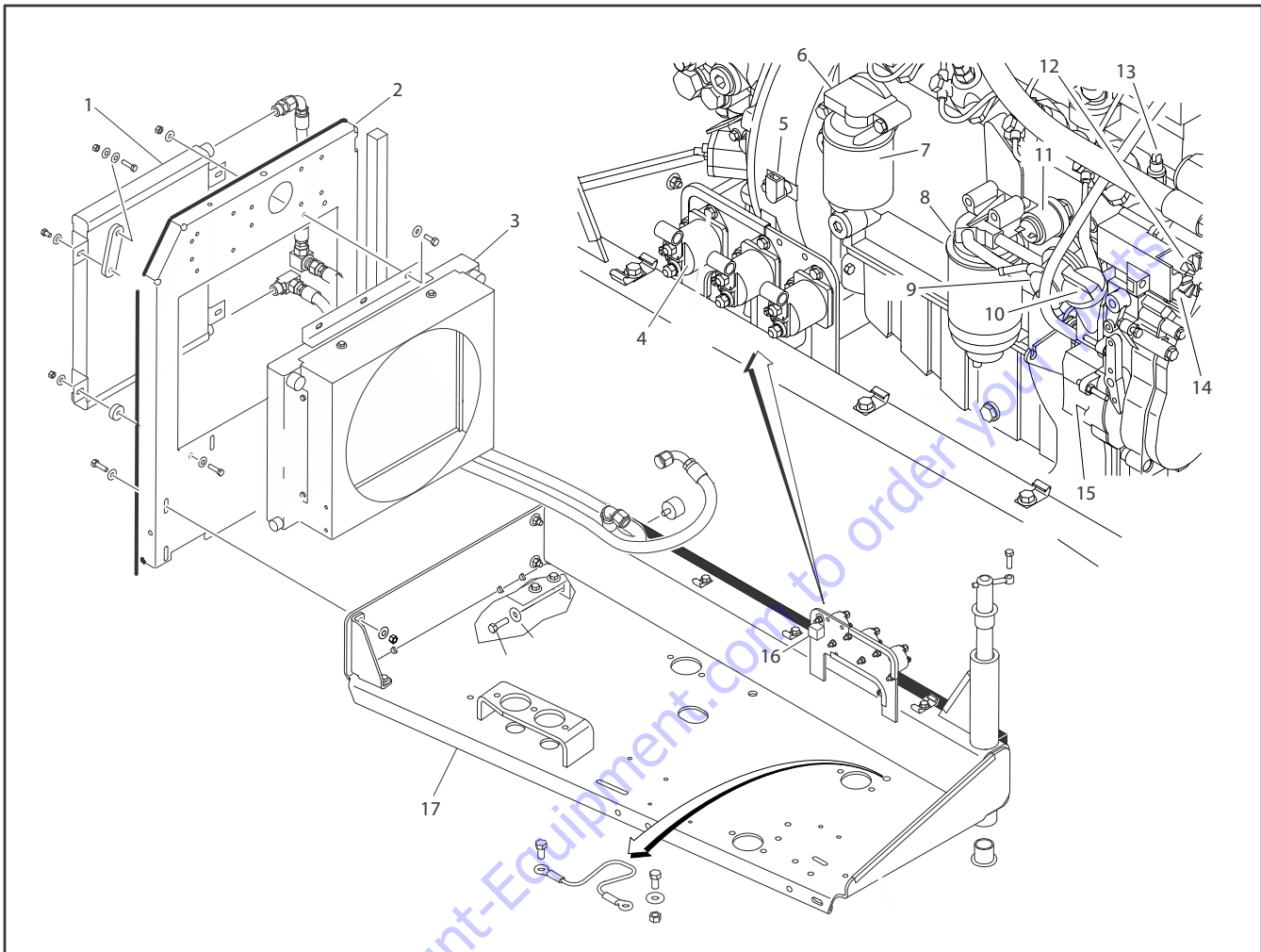

- | | | | |
|----------------------------|-----------------------|-------------------------|------------------------|
| 1. Oil Cooler | 5. Speed Sensor | 9. Fuel Supply Pump | 13. Temperature Sensor |
| 2. Radiator Mounting Plate | 6. Temperature Sensor | 10. Oil Filler Cap | 14. Solenoid |
| 3. Radiator | 7. Oil Filter | 11. Oil Pressure Sensor | 15. Starter |
| 4. Relay | 8. Fuel Filter | 12. Throttle Actuator | 16. Relay |
| | | | 17. Engine Tray |

Figure 3-47. Deutz D2011 Engine (Battery Tank Side) Installation - 2 of 2

NOTE: Refer to engine manufacturer's manual for detailed operating and maintenance instructions.

Checking Oil Level

1. Make sure machine and engine are level and switch engine OFF before checking oil level.
2. Remove oil dipstick and wipe with clean cloth.
3. Insert dipstick to the stop and remove again.
4. Check oil level. Top oil level as shown in figure below with an approved grade and type of oil outlined in engine manufacturer's operator's manual.

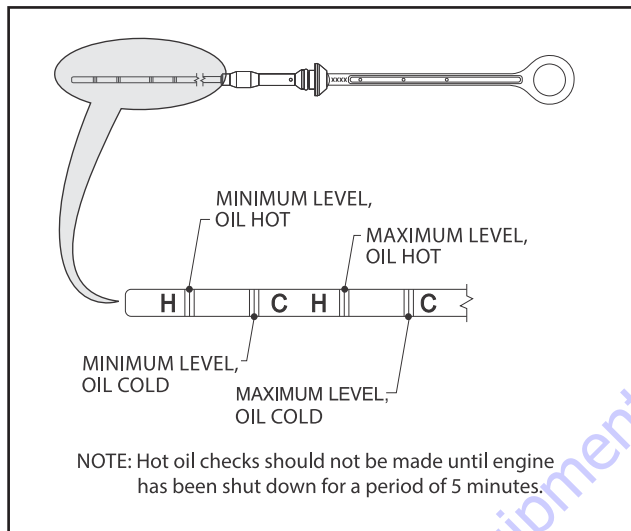

Figure 3-48. Deutz Dipstick Markings

5. Replace dipstick until fully seated.

Changing Engine Oil

1. Allow engine to warm up. Engine oil should reach approximately 176° F (80° C).
2. Make sure machine and engine are level and switch off engine.
3. Place oil tray under engine.

CAUTION

HOT ENGINE OIL CAN CAUSE BURNS. AVOID CONTACT WITH HOT OIL WHEN DRAINING.

NOTICE

COLLECT USED OIL IN A CONTAINER SUITABLE FOR DISPOSAL OR RECYCLING. DISPOSE OF USED ENGINE OIL IN ACCORDANCE WITH ENVIRONMENTAL REGULATIONS.

4. Open oil drain valve and drain oil.
5. Close oil drain valve.
6. Pour in new engine oil. Refer to Section 1 for capacity and Figure 3-49., Engine Oil Viscosity.

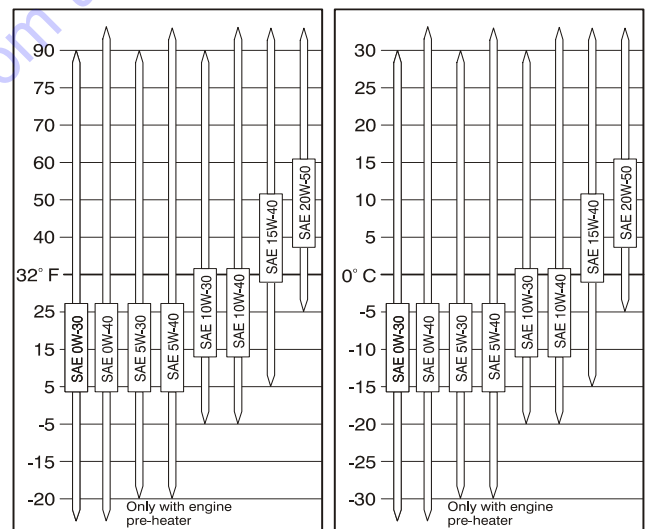
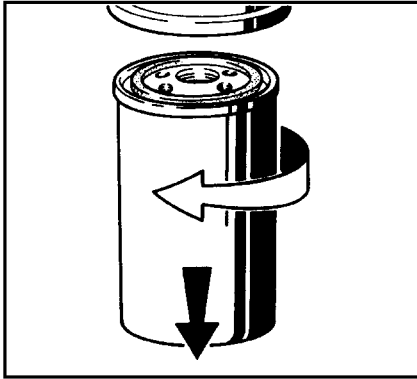

Figure 3-49. Engine Oil Viscosity

Changing Oil Filter

1. Wipe area around filter to clean any dirt from area.
2. Using a suitable oil filter removal tool, loosen lube oil filter cartridge and spin off.



3. Catch any escaping oil.
4. Clean any dirt from filter carrier sealing surface.
5. Lightly coat new oil filter rubber gasket with clean oil.

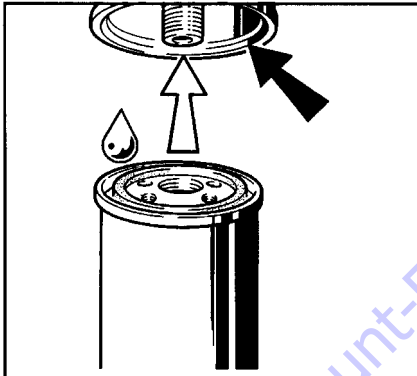

6. Screw in new filter by hand until gasket is flush.

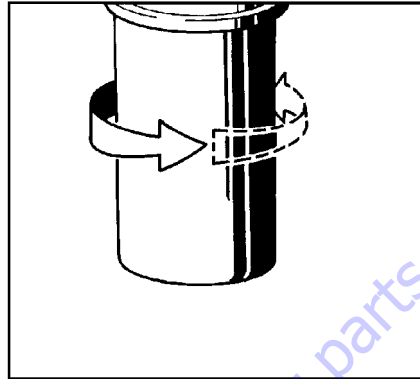

7. Hand-tighten filter another half-turn.
8. Check oil level.
9. Check oil pressure.
10. Check oil filter cartridge for leaks.

Replace Fuel Filter

⚠ WARNING

FUEL IS FLAMMABLE AND CAN CAUSE DEATH OR SERIOUS INJURY. MAKE SURE NO OPEN FLAMES OR SPARKS ARE IN THE AREA WHEN WORKING ON FUEL SYSTEM. DO NOT SMOKE WHEN WORKING ON FUEL SYSTEM.

1. Wipe area around filter to clean any dirt from area.
2. Remove fuel filter cartridge. Catch any escaping fuel.
3. Clean dirt from filter carrier sealing surface.
4. Apply light film of oil or diesel fuel to rubber gasket of new filter cartridge.
5. Screw in new filter by hand until gasket is flush. Hand-tighten filter another half-turn.
6. Open fuel shut-off valve.
7. Check for leaks.

Clean Fuel Strainer

⚠ WARNING

FUEL IS FLAMMABLE AND CAN CAUSE DEATH OR SERIOUS INJURY. MAKE SURE NO OPEN FLAMES OR SPARKS ARE IN THE AREA WHEN WORKING ON FUEL SYSTEM. DO NOT SMOKE WHEN WORKING ON FUEL SYSTEM.

1. Unscrew hexagonal nut (1).

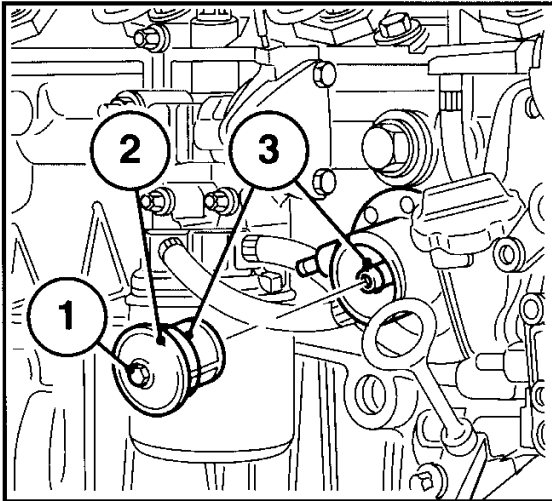

2. Remove fuel strainer cover (2).
3. Clean fuel strainer with diesel fuel and replace as needed.
4. Place seal (3) in position.
5. Install fuel strainer cover (2). Tighten screw (1).
6. Check for leaks.

3.8 SPARK ARRESTER CLEANING INSTRUCTIONS

1. Remove cleanout plug in bottom of spark arrester (muffler).
2. Without causing deformation (or any type of damage to spark arrester) repeatedly tap on arrester near cleanout plug. This may be enough to begin spark trap drainage.
3. An industrial vacuum cleaner can do a complete job at this point.
 - a. Or, IN A SAFE AREA, start engine. Alternate between low idle and high idle for two to three minutes.
 - b. Or, operate engine as required by application for two to three minutes.
4. Install cleanout plug.

3.9 GLOW PLUGS

If glow plug option is enabled in the JLG Control System, glow plug and indicator lamp will be energized when Power/Emergency Stop switch is pulled on if ambient air temperature is less than 50° F (10° C) and engine coolant temperature is less than 140° F (60° C).

This determination occurs one second after the Power/Emergency Stop switch has been pulled on. Lamp and glow plugs remain energized for period of time specified by setting in the JLG Control System. Engine start is disabled during this period.

On Deutz engines, glow plugs continue (post glow) after engine has started three times the machine digit setting.

3.10 DEUTZ EMR 2

The EMR2 consists of sensors, control unit, and actuator. Engine-side controls and the JLG Control System are connected by separate cable harnesses to the EMR control unit.

Sensors attached to the engine provide control unit electronics with all relevant physical parameters. In accordance with information of the current engine conditions and preconditions (throttle position etc.), the EMR2 controls an actuator that operates the control rod of the injection pump and thus doses the fuel quantity in accordance with the performance requirements.

Exact position of the regulating rod is reported back and, if necessary, is corrected, by means of the control rod travel sensor, situated together with the rotation magnets in a housing of the actuator.

The EMR2 is equipped with safety devices and measures in the hardware and software to ensure emergency running (Limp home) functions. In order to switch the engine off, the EMR2 is switched in a de-energized fashion over the ignition switch. A strong spring in the actuator presses the control rod in the de-energized condition into the zero position. As a redundancy measure, an additional solenoid serves for switching off and this, independently of the actuator, also moves the control rod in the de-energized condition into the zero position.

After programming over the ISO9141 interface, the EMR2 possesses a motor-specific data set which is permanently assigned to the engine. Included in this are the various application cases as well as the customer's wishes regarding a particular scope of function.

Each EMR2 module is matched by serial number to the engine. Modules cannot be swapped between engines.

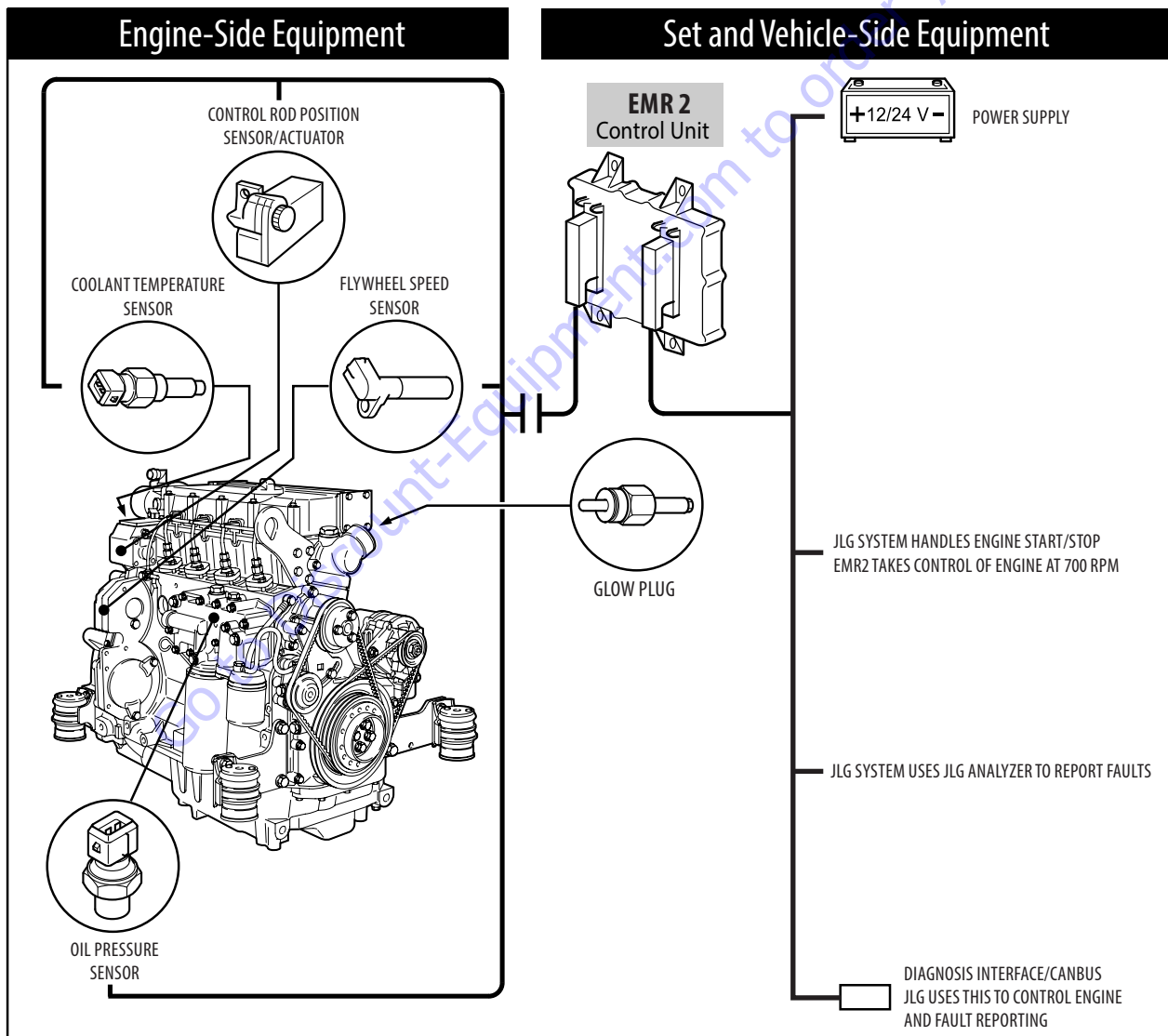

Figure 3-50. EMR 2 Engine Side Equipment

- Notes: (N ...)
- equipment designation according (X22) to H22986, part 1, e.g.
 - bus terminal resistance for CAN interfaces SAE J 1939 to be monitored externally, see page 043 307/10
 - cross-section of conducting lines: 1.5 mm²
 - control unit ECU → actuator: 5,5 m
control unit ECU → battery: 7 m
control unit ECU → battery: 10 m
control unit ECU → battery: 10 m
Steuergerät ECU → Batterie: 7 m
Geräteleiter → Batterie und Anzeigeneinheit: 5 m
 - Max. zulässige Stromstärke: 30 mA
 - Kein BOUTZ-Lieferant
 - AND nicht mit Motormasse verbinden
 - Nach Sicherung
 - Keine zusätzlichen Verbraucher anschliessen
 - Anschlusspunkte nahe an Steuergerät montieren

- Notes: (N ...)
- equipment designation according (X22) to H22986, part 1, e.g.
 - bus terminal resistance for CAN interfaces SAE J 1939 to be monitored externally, see page 043 307/10
 - cross-section of conducting lines: 1.5 mm²
 - control unit ECU → actuator: 5,5 m
control unit ECU → battery: 7 m
control unit ECU → battery: 10 m
control unit ECU → battery: 10 m
Steuergerät ECU → Batterie: 7 m
Geräteleiter → Batterie und Anzeigeneinheit: 5 m
 - Max. zulässige Stromstärke: 30 mA
 - Kein BOUTZ-Lieferant
 - AND nicht mit Motormasse verbinden
 - Nach Sicherung
 - Keine zusätzlichen Verbraucher anschliessen
 - Anschlusspunkte nahe an ECU

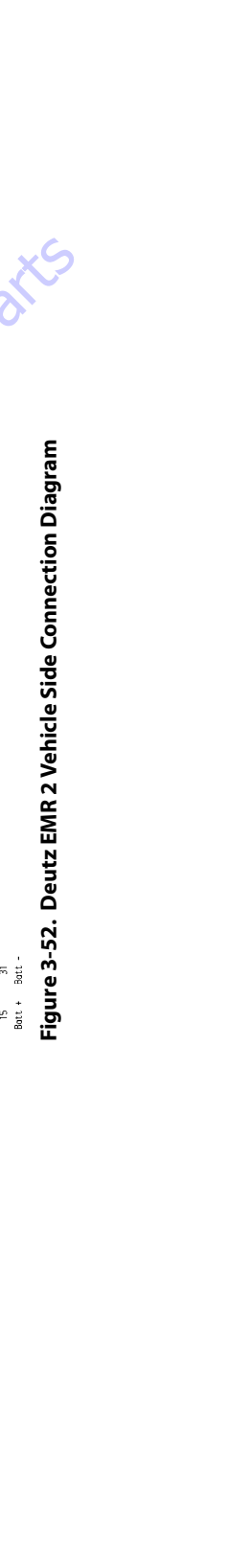
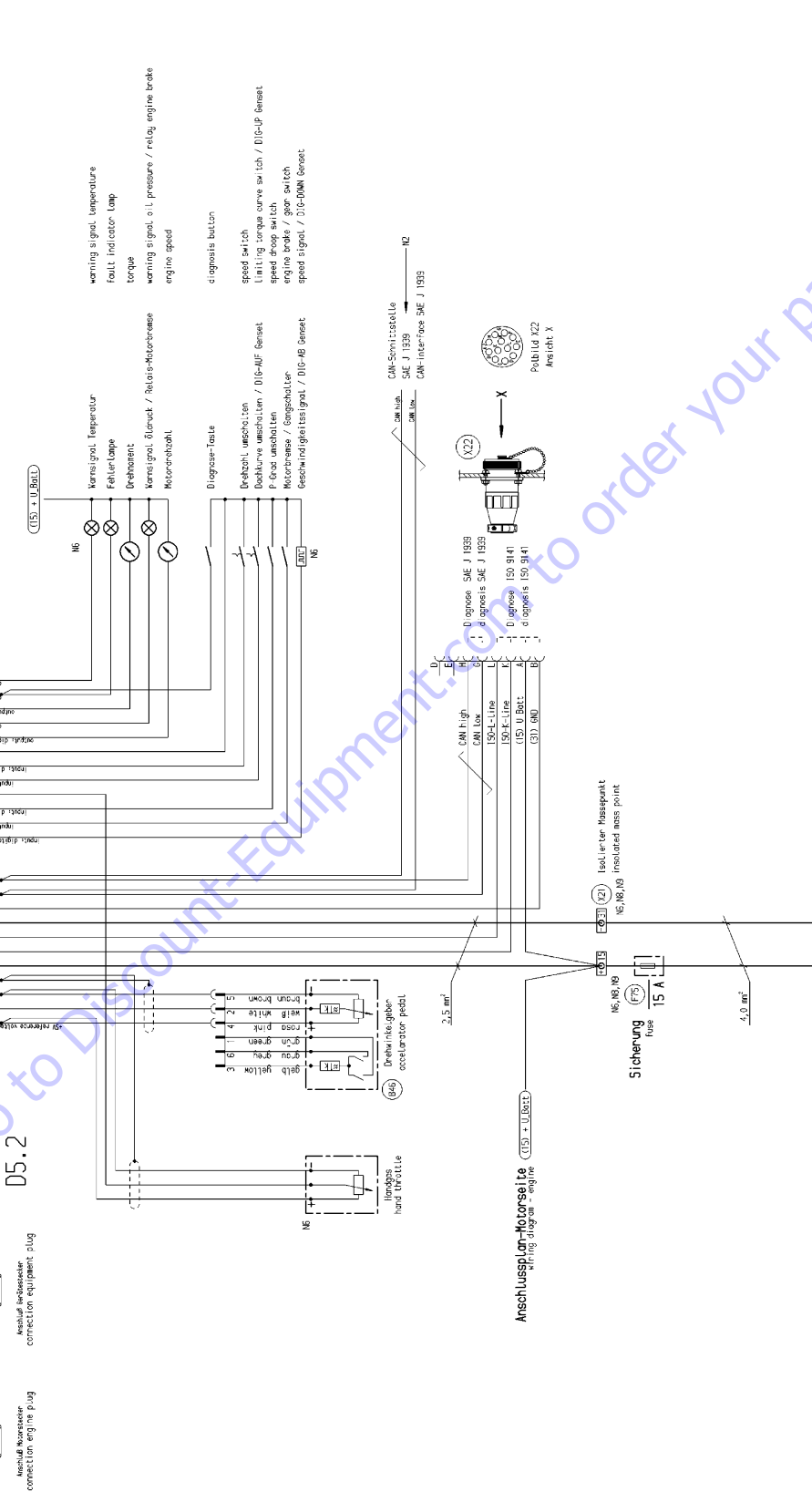
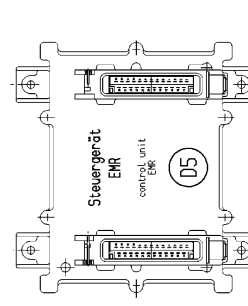
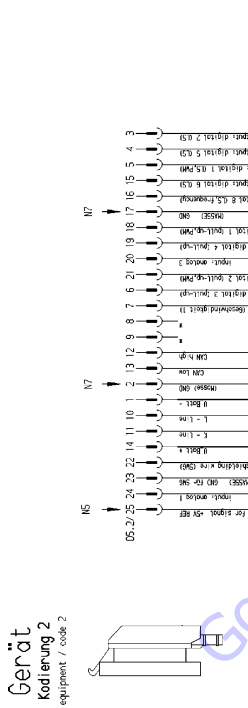

Figure 3-52. Deutz EMR 2 Vehicle Side Connection Diagram

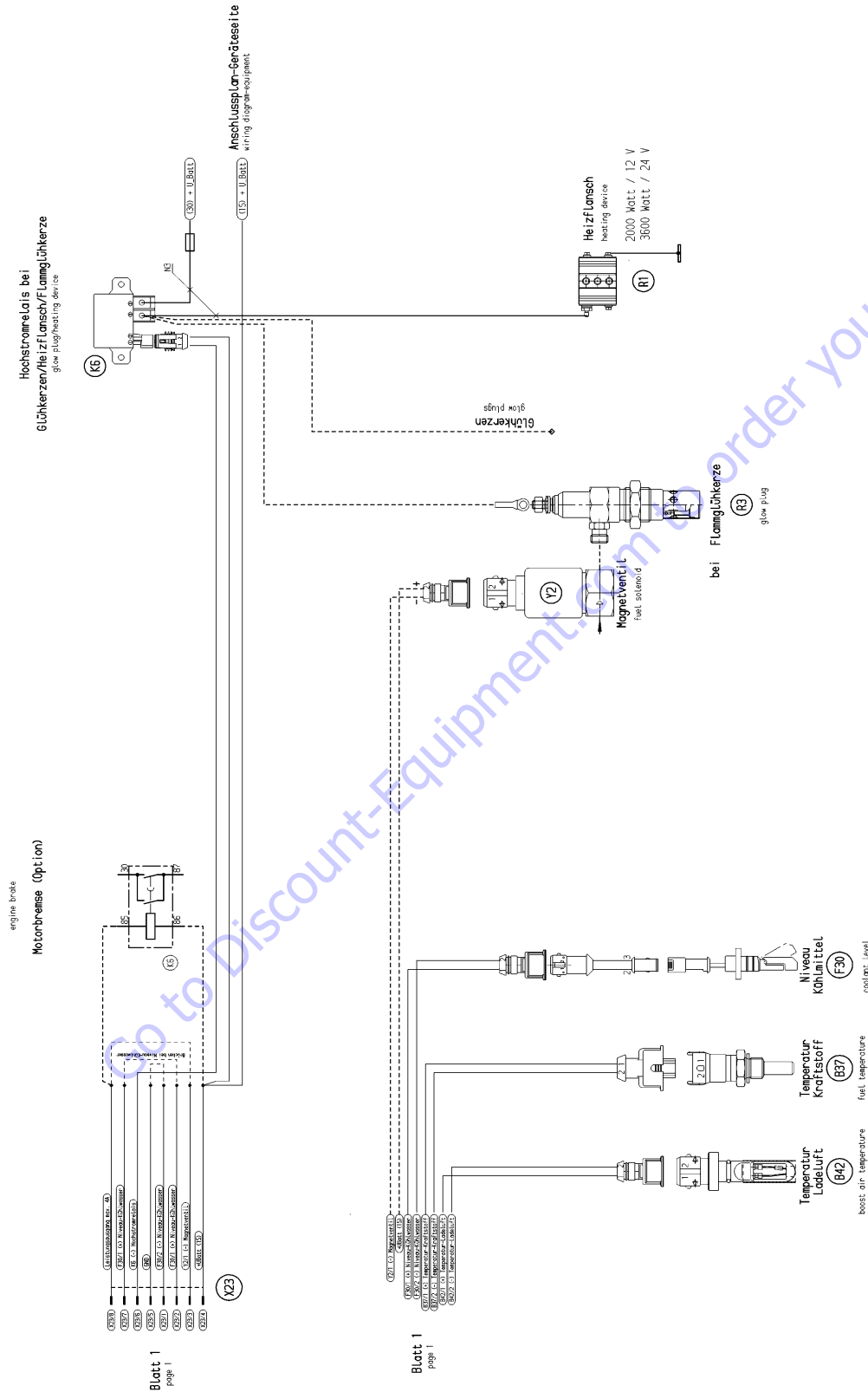
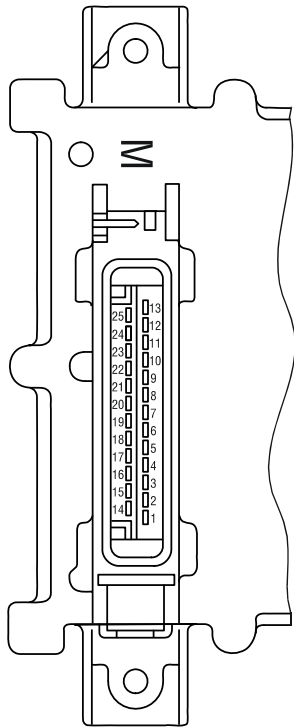

Figure 3-54. Deutz EMR 2 Engine Side Connection Diagram - Sheet 2 of 2



Pin No.	Designation	Description
1	Reserve	Reserve
2	Output: digital 3	Digital output for solenoid ¹⁾
3	Output: digital 4	For heating flange (optional)/ glow plug (optional)
4	Input (optional) Temp 1	Fuel temperature ²⁾
5	Input (optional) Temp 2	Charge air temperature
6	Input (optional) DigIn 5	Coolant level / oil level
7	Output: PWM2/digital 6	
8	GND	Reference potential for analog signal at pin 9
9	Input: analog 7	Analog input for Coolant temperature sensor (NTC)
10	GND	Reference potential for analog signal at pin 11
11	Multi-function input: speed 2/DigIn 2	Digital input second engine speed (crankshaft) (optional) and speed signal (optional)
12	GND	Reference potential for analog signal at pin 13
13	Input: speed 1	Digital input first engine speed (camshaft)
14	STG -	PWM output, signal for actuator coil
15	STG +	PWM output, signal for actuator coil
16	Screen	Screening regulating rod travel sensor (for lines 17, 18, 19)
17	RF -	General connection for reference and measuring coil
18	RF REF	Analog input, reference signal of the reference coil
19	RF MESS	Analog input, measuring signal of the measuring coil
20	GND	Reference potential for signal at pin 21
21	Input: analog 4/digital 9	Analog input 4 (sensor signal oil pressure sensor) or digital input 9
22	+5 V REF	+5 V Reference voltage for signal at pin 21 (max. 15 mA)
23	GND	Reference potential for signal at pin 24
24	Input: analog 2/digital 7	Analog input 2 (sensor signal charge air) or digital input 7
25	+5 V LDA	+5 V Reference potential for signal at pin 24 (max. 15 mA)

1) For continuous power: < 4 A

2) Corresponds to special function "fuel temperature compensation at the EMR (0211 2571)

Figure 3-55. EMR 2 Engine Plug Pin Identification

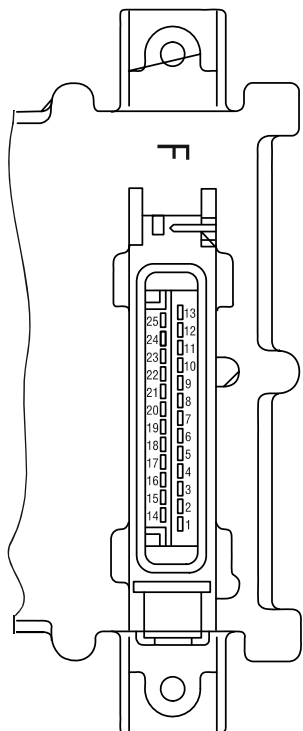

Pin-No.	Designation	Description
1	U Batt -	Negative pole at battery (clamp 31)
2	GND	Reference potential for signal
3	Output: digital 2	PWM or digital output, various functions
4	Input / output: DigInOut	Fault lamp and diagnostic button
5	Output: PWM 1/Dig 1	PWM or digital output, various functions
6	Multi-function input: DigIn 3	Genset applications/gear shift/motor brake
7	Input: digital 10/velocity	Speed signal (tacho input)
8	NC	Not occupied
9	NC	Not occupied
10	L-line	Serial ISO 9141 interface
11	K-line	Serial ISO 9141 interface
12	CAN high	Interface for CAN-Bus
13	CAN low	Interface for CAN-Bus
14	U Batt +	Positive pole for battery (clamp 15)
15	Output: digital 5	Digital output, various functions
16	Output: digital 7/Frequency	Frequency, PWM or digital output, various functions
17	Ground	Reference potential for signal at pins 18, 19 and 21
18	Input: digital 1 / PWM 1	PWM 1 or digital input 1, various functions
19	Multi-function input: DigIn 4	Performance curve switching/genset applications
20	Multi-function input: digital 8 / analog 3	Hand hand throttle/genset applications, Digital (8) or analog input (3)
21	Input: digital 2 / PWM 2	PWM 2 or digital input 2, various functions
22	Screen	Screening (e.g. for lines hand throttle or PWG)
23	GND	Reference potential for signal at pin 24
24	Input: analog 1 / digital 6	Analog input 1 (pedal value sensor, PWG) or digital input 6
25	+5 V REF	+5 V Reference voltage for signal at pin 24

Figure 3-56. EMR 2 Vehicle Plug Pin Identification

Fault group	Fault no. (in SERDIA)	Fault locality/ Fault description	SPN	FMI	Cause	Remarks	Help
Zero error display	-	No faults	524287	31	No active faults present		
Revolutions / speed acquisition	01	Speed sensor 1	190	8	Sensor failure. Distance from gear too far. Additional fault impulses. Cable joint interrupted.	Governor in emergency operation (if sensor 2 available). Emergency switch-off (if sensor 2 not available or failed). Governor in emergency operation (with sensor 1). Emergency switch-off (if sensor 1 not available or failed).	Check distance. Check cable connection. Check sensor and replace if required.
	03	Speed sensor	84	8	Tacho failed. Additional fault impulses. Cable connection interrupted.	Governor in emergency operation.	Check cable connection and Tacho. Replace if required.
	04	Excess speed switch-off	190	0	Speed was/is in excess of limit.e. Check PID setting. Check rods. Check actuator and replace if required. Check cable to actuator (impulse on incorrect speed). Check No. of teeth. For vehicles check for possible thrust mode.	Engine stop.	Check parameter (21). Check speed settings.
Sensors	07	Charge air pressure	102	2			
	08	Oil pressure	100	2			
	09	Coolant temperature	110	2	Fault at corresponding sensor entry (e.g. short circuit or cable break).	With failure of the sensor, the associated monitoring function is de-activated.	Check sensor cable. Check sensor and replace if required. Check fault limits for sensor.
	10	Charge air temperature	105	2			
	11	Fuel temperature	174	2			

NOTE: SID is equal to 512. To get SPN #, add 512 + number. For example, SID 254 would be 512+254 or an SPN of 766.

Figure 3-57. EMR2 Fault Codes - Sheet 1 of 5

SECTION 3 - CHASSIS & TURNTABLE

Fault group	Fault no. (in SERDIA)	Fault locality/ Fault description	SPN	FMI	Cause	Remarks	Help
Functional fault warning	30	Oil pressure warning	100	1	Oil pressure below speed-dependent warning line characteristic	Fault message (disappears when oil pressure is again above recovery limit). After a delay time - fill limitation.	Check engine (oil level, oil pump). Check oil pressure sensor and cable. Check oil pressure warning line characteristic.
	31	Coolant temperature warning	110	0	Coolant temperature has exceeded warning level.	Fault message (disappears when coolant temperature again drops below recovery level). After a delay time - fill limitation.	Check coolant. Check coolant temperature sensor and cable.
	32	Charge air temperature warning	105	0	Charge air temperature has exceeded warning level.	Fault message (disappears when charge air temperature gain drops below recovery level). After a delay time - fill limitation.	Check charge air. Check charge air-temperature sensor and cable.
	34	Coolant level warning	111	1	Switch input "Low coolant level" is active.	Fault message.	Check coolant level. Check coolant level sensor and cable.
	35	Speed warning (with thrust mode operation).	SID 190	14	revolutions was/is above (top) revolution speed limit. "Thrust mode" function is active.		Check parameters. Check speed settings.
	36	Fuel temperature warning	174	0	Fuel-temperature has exceeded warning level.	Fault message (disappears when fuel temperature again drops below recovery level).	Check fuel. Check fuel temperature sensor and cable.

NOTE: SID is equal to 512. To get SPN #, add 512 + number. For example, SID 254 would be 512+254 or an SPN of 766.

Figure 3-58. EMR2 Fault Codes - Sheet 2 of 5

Fault group	Fault no. (in SERDIA)	Fault locality/ Fault description	SPN	FMI	Cause	Remarks	Help
Functional fault, switch-off	42	Charge air temperature switch-off	105	0	Charge air temperature has exceeded switch-off limit.	Emergency stop	Check charge air. Check charge air-temperature sensor and cable. Check switch-off limit.
	44	Coolant level switch-off	111	1	Switch input "Low coolant level" is active.	Emergency stop. Start lock.	Check coolant level. Check coolant level sensor and cable.
Actuator	50	Feedback	SID 24	12	Actuator not connected. Fault in actuator confirmation.	Emergency switch-off. Actuator cannot be operated.	Check actuator, replace if required. Check cable, check fault limits for "Confirmation".
	52	Reference feedback	SID 24	13			Check actuator, replace if required. Check cable, check fault limits for "Rifeness confirmation".
	53	Control travel difference	SID 23	7	Injection pump/actuator jammed or not connected. Difference between nominal/actual control travel is > 10 % of the overall control path.	Fault message (disappears when difference is < 10 %).	Check actuator/actuator rods / injection pump, replace if required. Check actuator cable.
	59	Auto calibration BOSCH-EDC pumps faulty operation	SID 23	13	No automatic actuator equalization possible. Incorrect input of the actuator reference values.	Engine stop / start lock. Governor cannot be taken into use. EDC actuator calibration required.	Check actuator and replaced if required. Check feedback cable. Check fault limits and reference values of the feedback. Program the fault limits for feedback, save the fault limits for feedback, save values. Switch ignition off and on again. Check again, if faulty, inform DEUTZ-Service and carry out automatic equalization again. Set fault limits again.

NOTE: SID is equal to 512. To get SPN #, add 512 + number. For example, SID 254 would be 512+254 or an SPN of 766.

Figure 3-59. EMR2 Fault Codes - Sheet 3 of 5

SECTION 3 - CHASSIS & TURNTABLE

Fault group	Fault no. (in SERDIA)	Fault locality/ Fault description	SPN	FMI	Cause	Remarks	Help
Hardware inputs/outputs	60	Digital output 3 (Switch-off solenoid, pin M 2)	SID 51	2	Fault (short circuit / cable break) at digital output.	Driver level is switched off.	Check cable of digital output (cable break or short circuit).
	62	Digital output 6, pin M 7	SID 60	2		Fault message.	
	63	Excess voltage switch-off solenoid	SID 51	6			
	67	Error Hand Setp1	91	11			
	68	Error CAN Setp1	898	2			
	Communication	70	CAN-Bus controller	SID 231	12	CAN-controller for CAN-bus is faulty. Fault removal despite re-initialising continuously not possible	Application-dependent.
71		CAN interface SAE J 1939	SID 231	9	Overflow in input buffer or a transmission cannot be placed on the bus.		
74		Cable break, short circuit or bus-error	SID 231	14			Check CAN connection, cable connection. Check sensor and replace if required.
Memory	76	Parameter programming (write EEPROM)	SID 253	12	Fault in parameter programming in the governor fixed value memory.	Emergency switch-off, engine cannot be started.	Switch ignition off and on again. Check again, if faulty inform DEUTZ Service
	77	Cyclic program test	SID 240	12	Constant monitoring of program memory shows error (so-called "Flash-test").		
	78	Cyclic RAM test	SID 254	2	Constant monitoring of working memory shows error.		

NOTE: SID is equal to 512. To get SPN #, add 512 + number. For example, SID 254 would be 512+254 or an SPN of 766.

Figure 3-60. EMR2 Fault Codes - Sheet 4 of 5

Fault group	Fault no. (in SERDIA)	Fault locality/ Fault description	SPN	FMI	Cause	Remarks	Help
Control unit hardware	80	Power supply (Actuator)	SID 254	2	Power supply for actuator not in the permissible range.	Fault message (disappears when power again in the normal range).	Switch ignition off and on again. Check again. If faulty inform DEUTZ Service.
	83	Reference voltage 1	SID 254	2	Reference voltage for actuator not in the permissible range.	Fault message (disappears when power again in the normal range). Auxiliary value 5 V	Check voltage supply. Switch ignition off and on again. Check again. If faulty inform DEUTZ Service.
	84	Reference voltage 2	SID 254	2			
	85	Reference voltage 4	SID 254	2			
	86	Internal temperature	171	12	Internal temperature for control unit not in permissible range.	Fault message (disappears when power again in the normal range).	Switch ignition off and on again. Check again. If faulty inform DEUTZ Service.
	87	Atmospheric pressure	108	12	Atmospheric pressure not in permissible range.	Fault message (disappears when power again in normal range). Atmospheric pressure monitoring function de-activated.	
	Program logic	90	Parameter fault (EEPROM retrieval or checksum faulty).	SID 253	2	No data found or checksum of data is faulty (note: fault only occurs during setting of parameter / saving or reset).	Engine cannot be started.
93		Stack overflow	SID 240	2	Internal calculation fault (so-called "Stack overflow" fault).	Emergency switch-off. Engine cannot be started.	Note parameters (3897 and 3898). Switch ignition off and on again. Check again. If faulty inform DEUTZ Service.
94		Internal fault	SID 254	2			

NOTE: SID is equal to 512. To get SPN #, add 512 + number. For example, SID 254 would be 512+254 or an SPN of 766.

Figure 3-61. EMR2 Fault Codes - Sheet 5 of 5

3.11 BIO FUEL IN DEUTZ ENGINES

General

Use of bio fuels is permitted for the compact engines made by DEUTZ.

Distillate fuels with residue oil percentages or mixed fuels may not be used in DEUTZ compact engines.

DEUTZ vehicle engines are designed for diesel fuels in accordance with EN 590 with a cetane number of at least 51. DEUTZ engines for mobile machinery are designed for a cetane number of at least 45. When using fuels of a low cetane number, disturbing white smoke and ignition misfires are to be expected under some circumstances.

A cetane number of at least 40 is permissible for the US market, therefore special engine models have been developed to avoid starting difficulties, extreme white smoke or increased hydrocarbon emissions (EPA specification - US EPA REGULATIONS FOR LARGE NONROAD COMPRESSION-IGNITION ENGINES).

If white smoke is unacceptable when using a very low cetane number, use of ignition improvers is to be recommended as a later remedial measure.

Certification measurements for compliance with legal emission limits are carried out with test fuels prescribed by law. These correspond to diesel fuels in accordance with EN 590 and ASTM D 975. No emission values are guaranteed with other fuels described. It is the obligation of the owner to check permission for use of fuels in accordance with regional regulations.

Bio Fuel

PERMITTED BIO-DIESEL FUELS

Originally only rape seed oil methylester (RME) was sold as a bio-diesel fuel in Europe but fatty acid methylester (FAME) based on other oils have come onto the market increasingly in recent years. However, with the latter there is a risk that the limit values of EN 14214 are not kept in the field. Anyone who uses bio-diesel fuel in DEUTZ engines must therefore choose his supplier very carefully and have him guarantee compliance with the EN 14214 limit values. Since experience has shown that rape seed oil methylester (RME) exceeds the limit values less often than other esters, it is expressly recommended to use only rape seed oil methylester. DEUTZ customers in Germany can additionally ensure the quality by buying bio-diesel fuel with an AGQM certificate (Arbeitsgemeinschaft Qualitäts-Management Biodiesel e.V.).

The use of US bio-diesel based on soy oil methylester is only permissible in mixtures with diesel fuel with a bio-diesel part of a max. 20 weight-%. The US bio-diesel used for the mixture must comply with the ASTM D6751-07a (B100) standard.

APPROVED ENGINES

912, 913, 914, 1011, 2011, 1012, 2012, 1013, 2013, 413 and 513 series are approved for bio-diesel from year of manufacture 1993 under compliance with basic conditions specified below.

BASIC CONDITIONS TO BE OBSERVED

- A power loss of 5-9% in relation to diesel fuel in accordance with EN 590 is possible due to the lower heating value. Blocking of fuel injector is not allowed.
- Lubricating oil quality must correspond to TR 0199-99-3002. Lubricating oil change interval must be halved in relation to operation with diesel fuel in accordance with EN 590.
- Standstills of longer than 4 to 6 weeks must be avoided with bio-diesel. Otherwise, engine must be started and stopped with diesel fuel.
- Bio-diesels can be mixed with normal diesel fuel but basic conditions described in this subsection apply for mixtures. Mixtures with up to 5% (m/m) bio-diesel (B5) which have recently been on sale at European fuel stations are excepted. These fuels must be treated like normal diesel fuels because EN 590 expressly permits adding up to 5% (m/m) bio-diesel in accordance with EN 14214.
- Approximately 30-50 hours after changing from diesel fuel to bio-diesel, the fuel filter should be changed as a preventive measure to avoid a drop in performance due to clogged fuel filters. Deposited fuel ageing products are dissolved by bio-diesel and transported into the fuel filter. They should not be changed immediately, but after 30 to 50 hours because that is the time it takes for most dirt to be dissolved.

PLANT OIL

NOTICE

PURE PLANT OILS (E.G. RAPE SEED OIL, SOY OIL, PALM OIL) ARE NOT CLASSIFIED AS BIO-DIESEL AND EXHIBIT PROBLEMATIC PROPERTIES FOR DIESEL ENGINE OPERATION (STRONG TENDENCY TO COKE, RISK OF PISTON SEIZURE, EXTREMELY HIGH VISCOSITY, AND POOR EVAPORATION BEHAVIOR).

The conversion of DEUTZ engines to rape seed oil fuel operation with conversion kits and modified tanks systems of various manufacturers is not allowed and leads to loss of warranty rights.

Biological Contamination In Fuels

SYMPTOMS

The following symptoms may indicate a fuel tank is contaminated by micro-organisms:

- Internal tank corrosion,
- Filter blockage and associated loss of power due to gel-like deposits on the fuel filter (especially after long standstills)

CAUSE

Micro-organisms (bacteria, yeasts, fungi) can form bio-sludge under unfavorable conditions (favoured particularly by heat and water).

Penetration by water is usually caused by condensation of water in the air. Water does not dissolve in fuel so penetrating water collects at bottom of the tank. Bacteria and fungi grow in the watery phase, at phase boundary to the fuel phase, from which they draw their nutrition. There is an increased risk especially with bio-diesel (FAME).

PREVENTIVE MEASURES

- Keep storage tank clean. Perform regular cleaning of the tank by specialist companies
- Installation of fuel pre-filters with water traps, especially in countries with frequently fluctuating fuel qualities and high percentage of water.

If the fuel system and storage tank have already been attacked by micro-organisms. Biocide must be dosed according to the manufacturer's specifications.

- Avoid direct exposure of the storage tank to sunlight
- Use smaller storage tanks with corresponding low dwell times of the stored fuel

FUEL ADDITIVES

The use of fuel additives is not permitted. The flow improvers mentioned above are an exception. Use of unsuitable additives will result in loss of warranty.

PARTS FINDER

**Search Website
by Part Number**



**Search Manual
Library For Parts
Manual & Lookup Part
Numbers – Purchase
or Request Quote**

Search Manuals

Enter your information to search for manuals and parts.

* Brand:

* Model:

* Serial:

* Part Number:

SEARCH

**Can't Find Part or
Manual? Request Help
by Manufacturer,
Model & Description**

Parts Order Form

Please fill in the following information:

Manufacturer:

Model:

Description:

Quantity:

Part Number:

Part Name:

Part Description:

Part Location:

Part Condition:

Part Status:

Part Material:

Part Color:

Part Weight:

Part Dimensions:

Part Notes:

Submit

Discount-Equipment.com is your online resource for quality parts & equipment.

Florida: **561-964-4949** Outside Florida TOLL FREE: **877-690-3101**

Need parts?

Click on this link: <http://www.discount-equipment.com/category/5443-parts/> and choose one of the options to help get the right parts and equipment you are looking for. Please have the machine model and serial number available in order to help us get you the correct parts. If you don't find the part on the website or on one of the online manuals, please fill out the request form and one of our experienced staff members will get back to you with a quote for the right part that your machine needs.

We sell worldwide for the brands: Genie, Terex, JLG, MultiQuip, Mikasa, Essick, Whiteman, Mayco, Toro Stone, Diamond Products, Generac Magnum, Airman, Haulotte, Barreto, Power Blanket, Nifty Lift, Atlas Copco, Chicago Pneumatic, Allmand, Miller Curber, Skyjack, Lull, Skytrak, Tsurumi, Husquvarna Target, , Stow, Wacker, Sakai, Mi-T- M, Sullair, Basic, Dynapac, MBW, Weber, Bartell, Bennar Newman, Haulotte, Ditch Runner, Menegotti, Morrison, Contec, Buddy, Crown, Edco, Wyco, Bomag, Laymor, Barreto, EZ Trench, Bil-Jax, F.S. Curtis, Gehl Pavers, Heli, Honda, ICS/PowerGrit, IHI, Partner, Imer, Clipper, MMD, Koshin, Rice, CH&E, General Equipment, ,AMida, Coleman, NAC, Gradall, Square Shooter, Kent, Stanley, Tamco, Toku, Hatz, Kohler, Robin, Wisconsin, Northrock, Oztec, Toker TK, Rol-Air, Small Line, Wanco, Yanmar

SECTION 4. BOOM & PLATFORM

4.1 BOOM SYSTEMS

Removal

1. Remove platform/support as follows:
 - a. Disconnect electrical cable from control console.
 - b. Remove eight bolts securing platform to platform support and remove the platform.
 - c. Using an overhead crane or suitable lifting device, strap support platform support.
 - d. Remove six bolts and locknuts securing support to rotator.
 - e. Using a suitable brass drift and hammer, remove rotator shaft, then remove support from rotator.

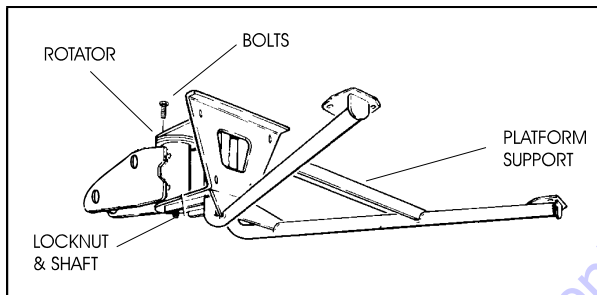

Figure 4-1. Location of Components - Platform Support

2. Remove rotator and slave level cylinder from fly boom as follows:
 - a. Tag and disconnect hydraulic lines to rotator. Use suitable container for residual hydraulic fluid. Cap hydraulic lines and ports.
 - b. Remove hardware from pin #1. Remove pin #1 from fly boom with a suitable brass drift and hammer.
 - c. Support rotator. Remove hardware from pin #2. Remove pin #2 from fly boom with a suitable brass drift and hammer. Remove rotator.
 - d. Telescope fly section out approximately 20 inches (50.8 cm) to access slave leveling cylinder.
 - e. Support slave cylinder. Remove hardware from pin #3. Remove pin #3 from fly boom with a suitable brass drift and hammer.

- f. Tag and disconnect hydraulic lines to slave leveling cylinder. Use a suitable container for residual hydraulic fluid. Cap hydraulic lines and ports. Remove slave cylinder.

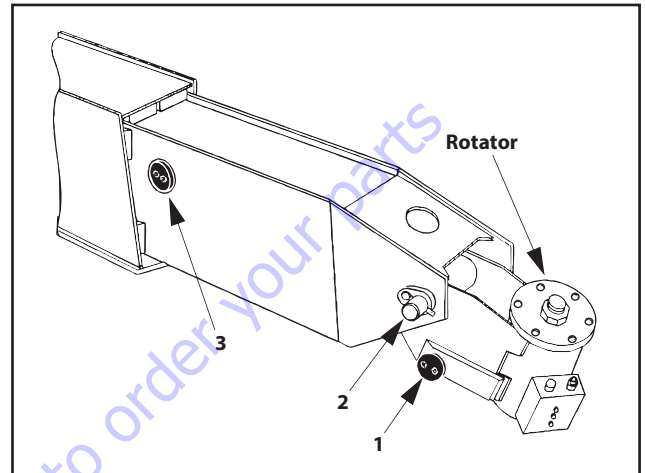

Figure 4-2. Rotator and Leveling Cylinder Locations

3. Remove powertrack from boom as follows:
 - a. Disconnect wiring harness from ground control box.

NOTICE

HYDRAULIC LINES AND PORTS SHOULD BE CAPPED IMMEDIATELY AFTER DISCONNECTING LINES TO AVOID ENTRY OF CONTAMINANTS INTO SYSTEM.

- b. Tag and disconnect hydraulic lines from boom to control valve. Use a suitable container for residual hydraulic fluid. Cap hydraulic lines and ports.
- c. Disconnect dual capacity indicator limit switch from side of boom section.
- d. Remove hydraulic lines and electrical cables from powertrack.
- e. Using a suitable lifting equipment, adequately support powertrack weight along entire length.
- f. Remove bolts #1 securing push tube on fly boom section.
- g. Remove bolts #2 securing push tube on mid boom section.

- h. With powertrack support and using all applicable safety precautions, remove bolts #3 and #4 securing rail to the base boom section. Remove powertrack from boom section.

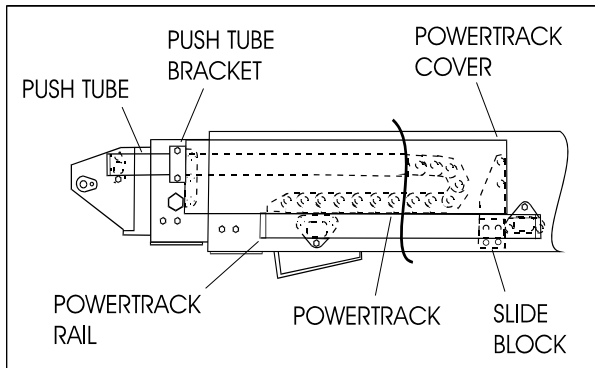

Figure 4-3. Boom Powertrack Components

4. Remove boom assembly from machine as follows:
 - a. Using suitable lifting equipment, adequately support boom assembly weight along entire length.

NOTICE

CAP HYDRAULIC LINES AND PORTS IMMEDIATELY AFTER DISCONNECTING LINES TO PREVENT ENTRY OF CONTAMINANTS INTO SYSTEM.

- b. Tag and disconnect hydraulic lines from telescope cylinder. Use a suitable container for residual hydraulic fluid. Cap hydraulic lines and ports.
- c. Remove hardware securing lift cylinder rod end to base boom section.
- d. Using a suitable brass drift and hammer, remove lift cylinder pin from base boom.
- e. Remove hardware securing master cylinder rod end to base boom section.
- f. Using a suitable brass drift and hammer, remove the master cylinder pin from the base boom.
- g. Remove hardware securing push bar to turntable upright.

NOTICE

WHEN REMOVING PIN FROM PUSHBAR DO NOT DROP PUSHBAR ON WIRE ROPE ADJUSTMENT THREADS. FAILURE TO DO SO WILL DAMAGE THREADS.

- h. Using a suitable brass drift and hammer, remove push bar pin from turntable upright.
- i. Remove hardware securing boom pivot pin to turntable upright.
- j. Using a suitable brass drift and hammer, remove pivot pin from turntable upright.
- k. Using all applicable safety precautions, carefully lift boom assembly clear of turntable and lower to ground or suitably supported work surface.

4.2 WEAR PADS

Wear pads are made of polyethylene. Pads move on polyurethane painted surfaces. No paint is removed and no lubrication is applied.

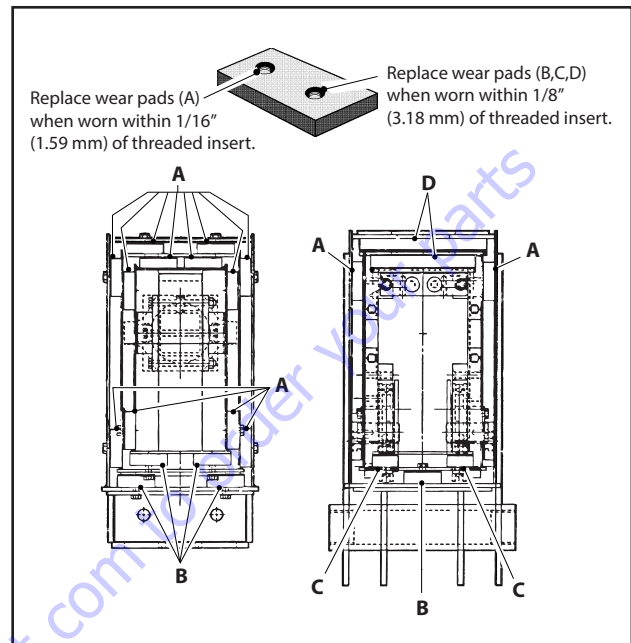

PAD	THICKNESS OF NEW PAD	REPLACE WHEN WORN TO:
A	5/8"	9/16"
B,C,D	3/4"	5/8"

Figure 4-4. Location and Thickness of Wear Pads

1. Shim wear pads to within 1/32 in (.79 mm) tolerance between wear pad and adjacent surface.
2. Replace wear pads when worn within 1/16 in (1.59 mm) and 1/8 in (3.18 mm) - B, C, D of threaded insert. See Location and Thickness Of Wear Pads.
3. Bolt length must be changed when adjusting wear pads and removing or adding shims.
 - a. Longer bolts must be used when adding shims to ensure proper thread engagement in insert.
 - b. Shorter bolts must be used when shims are removed so bolt does not protrude from insert and contact boom surface.

4.3 BOOM DISASSEMBLY/ASSEMBLY & CABLE REPLACEMENT

Boom Section Disassembly

1. Remove hardware securing push bar to aft end of telescope cylinder. Remove pin from cylinder.
2. Remove hardware securing cover plate on bottom front of base boom section.

NOTICE

DO NOT ALLOW WIRE ROPE TO ROTATE. THIS MAY DAMAGE THE WIRE ROPE.

3. Clamp both threaded ends of wire rope to prevent rotation. Note: Do not clamp on threads. Remove jam nuts and nuts which secure wire rope adjustments to bottom front of base boom section.

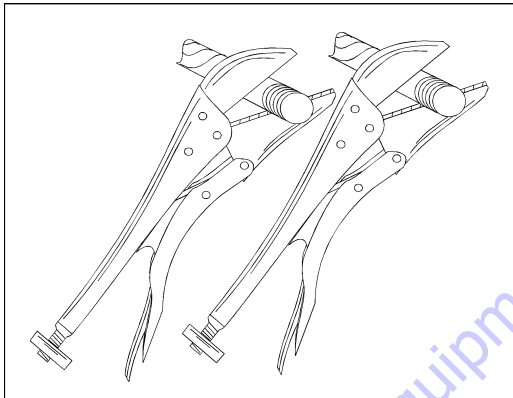

Figure 4-5. Clamping Wire Ropes

NOTE: CE specification machines go to Step 4. All other machines go to Step 5.

4. Remove spring mounting plate, spring, and proximity switch from aft end of base section.

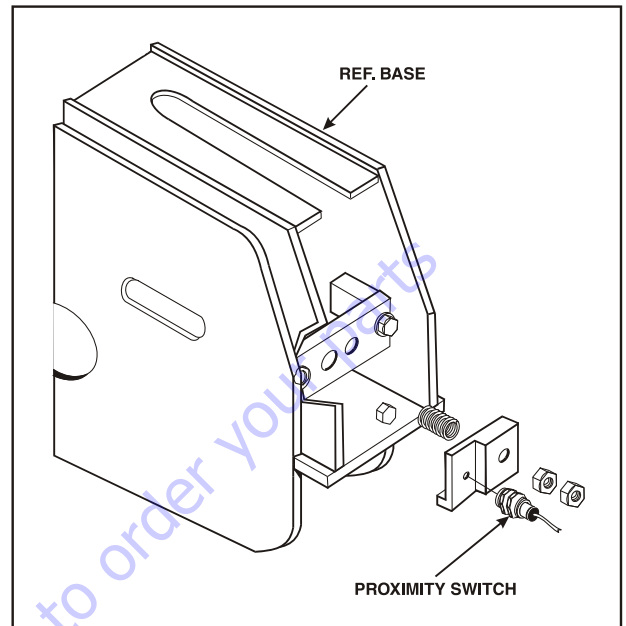

Figure 4-6. Proximity Switch Assembly Disassembly

5. Remove hardware securing wire rope adjustment block to aft end of base boom section and remove block.
6. Remove hardware securing telescope cylinder to aft end of mid boom section.

NOTICE

WHEN REMOVING TELESCOPE CYLINDER FROM BOOM, IT MAY BE NECESSARY TO TURN CYLINDER SLIGHTLY TO CLEAR ASSEMBLIES MOUNTED IN BOOM. MOVE CYLINDER SLOWLY OUT OF POSITION. DAMAGE TO COMPONENTS MAY RESULT FROM FORCIBLE IMPACT WITH ASSEMBLIES.

7. Remove bolts securing wire rope attach bar to top of fly boom section.
8. Pull telescope cylinder and wire ropes partially from aft end of base boom section. Secure cylinder with a suitable sling and lifting device at center of gravity.

4.4 WIRE ROPE

CAUTION

WIRE ROPE CAN HAVE SHARP EDGES AND CAUSE SERIOUS INJURY. NEVER HANDLE WIRE ROPE WITH BARE HANDS.

Each day before using machine:

1. Raise main boom approximately horizontal.
2. Extend and retract the boom sections.
3. Check for delayed movement of fly section which indicates loose wire ropes.

Inspection

NOTE: Pictures in this paragraph are samples to show rope replacement criteria.

1. Inspect ropes for broken wires, particularly valley wire breaks and breaks at end terminations.

NOTE: Flexing a wire rope can often expose broken wires hidden in valleys between strands.

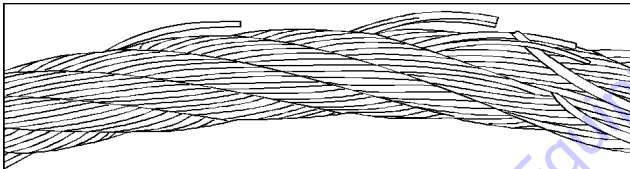

Figure 4-7. Wire Rope Wire Breaks

2. Inspect ropes for corrosion.
3. Inspect ropes for kinks or abuse.

NOTE: A kink is caused by pulling down a loop in a slack line during improper handling, installation, or operation.

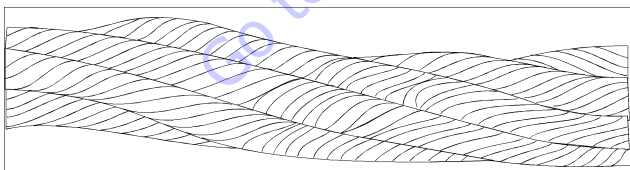

Figure 4-8. Wire Rope Kink

4. Inspect sheaves for condition of bearings/pins. (See Dimension Of Sheaves for proper dimension.) Inspect sheaves for condition of flanges. (See Dimension Of Sheaves for proper dimension.)
5. Inspect sheaves with a groove wearout gauge for excessive wear.

NOTE: Check groove so that it may be clearly seen if gauge contour matches sheave groove contour.

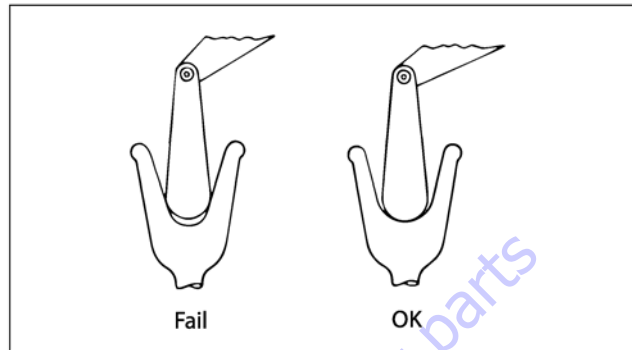

Figure 4-9. Sheave Groove Wear

7. Ropes passing inspection should be lubricated with wire rope lubricant before reassembly.

Three Month Inspection

1. Remove boom covers and visually (with flashlight) inspect the ropes for rust, broken wires, frays, abuse, or any signs of abnormalities.
2. Check wire rope tension by deflecting wire ropes by hand. Properly tensioned ropes should have little or no movement.

12 Year or 7000 Hour Replacement

1. Mandatory wire rope and sheave replacement.

Additional inspection required if:

- a. Machine is exposed to hostile environment or conditions.
- b. Erratic boom operation or unusual noise exists.
- c. Machine is idle for an extended period.
- d. Boom is overloaded or sustained a shock load.
- e. Boom exposed to electrical arc. Wires may be fused internally.

Additional Replacement Criteria

NOTE: Sheaves and wire rope must be replaced as sets.

1. Rusted or corroded wire ropes.
2. Kinked, "bird caged", or crushed ropes.
3. Ropes at end of adjustment range.
4. Sheaves failing wearout gage inspection.
5. Ropes with 6 total broken wires in one rope lay, 3 in one strand in one rope lay, 1 valley break, or 1 break at any end termination.

4.5 WIRE ROPE TENSIONING ADJUSTMENT

Wire Rope Tensioning Procedure

1. Position boom in fully down and retracted position.

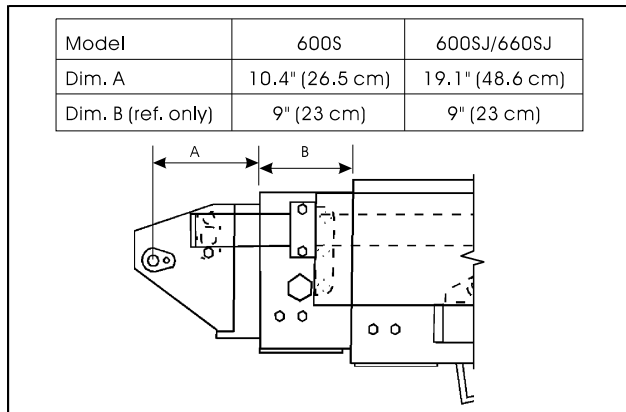

Figure 4-10. Dimensions of Boom Sections

NOTICE

DO NOT CLAMP ON THREADS OR THREADS MAY BE DAMAGED.

DO NOT ALLOW WIRE ROPE TO ROTATE OR WIRE ROPE MAY BE DAMAGED.
CLAMP THREADED ENDS OF WIRE ROPE TO PREVENT ROTATION.

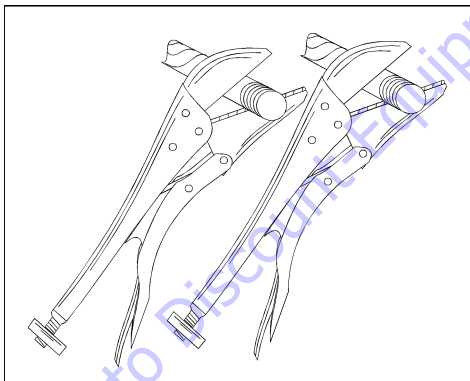

Figure 4-11. Clamping Wire Ropes

2. Install adjusting nuts (or remove nylon collar locknuts if re-adjusting) to both retract and extend wire ropes.
 3. Torque retract adjusting nuts (platform end) to 15 ft-lb (20 Nm) alternating between the two wire ropes and keeping approximately the same amount of thread beyond the adjusting nut.
 4. Repeat torque procedure in step #4 to extend wire ropes (turntable end).
 5. Extend boom 2 - 3 feet using telescope function. Repeat step #4.
 6. Retract boom 1 - 2 feet using telescope function. Do not bottom out telescope cylinder. Repeat step #5.
 7. Extend boom approximately 2 - 3 feet again and check torque on retract wire ropes.
 8. Retract boom without bottoming out telescope cylinder. Check torque on extend wire ropes.
- NOTE:** Step #8 and #9 may need to be repeated to equalize the torque on all 4 wire ropes.
9. After all wire ropes are properly torqued, install nylon collar locknuts. Remove all clamping devices and install all covers and guards. Check boom for proper function.

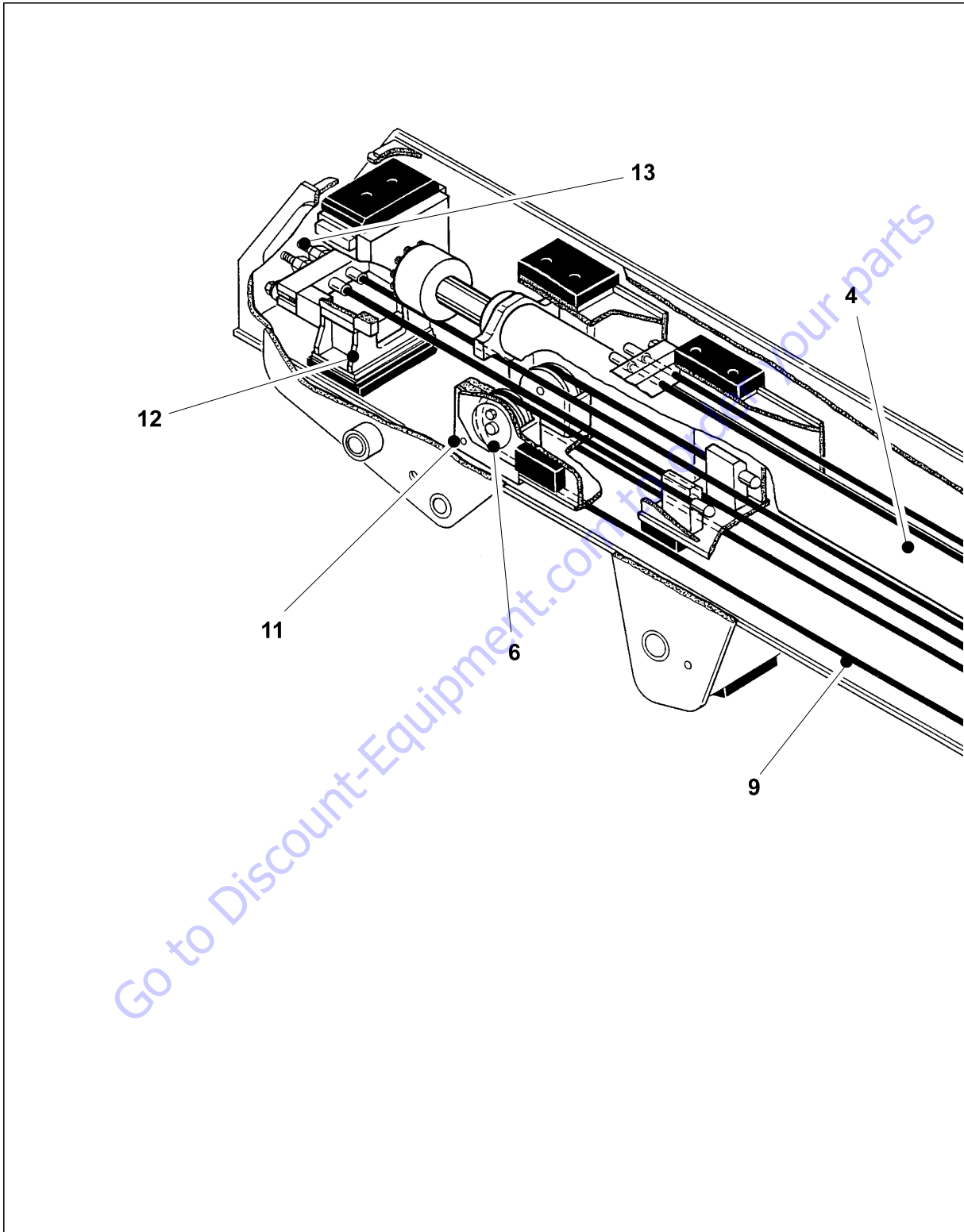

Figure 4-12. Boom Assembly Cutaway - Sheet 1 of 3

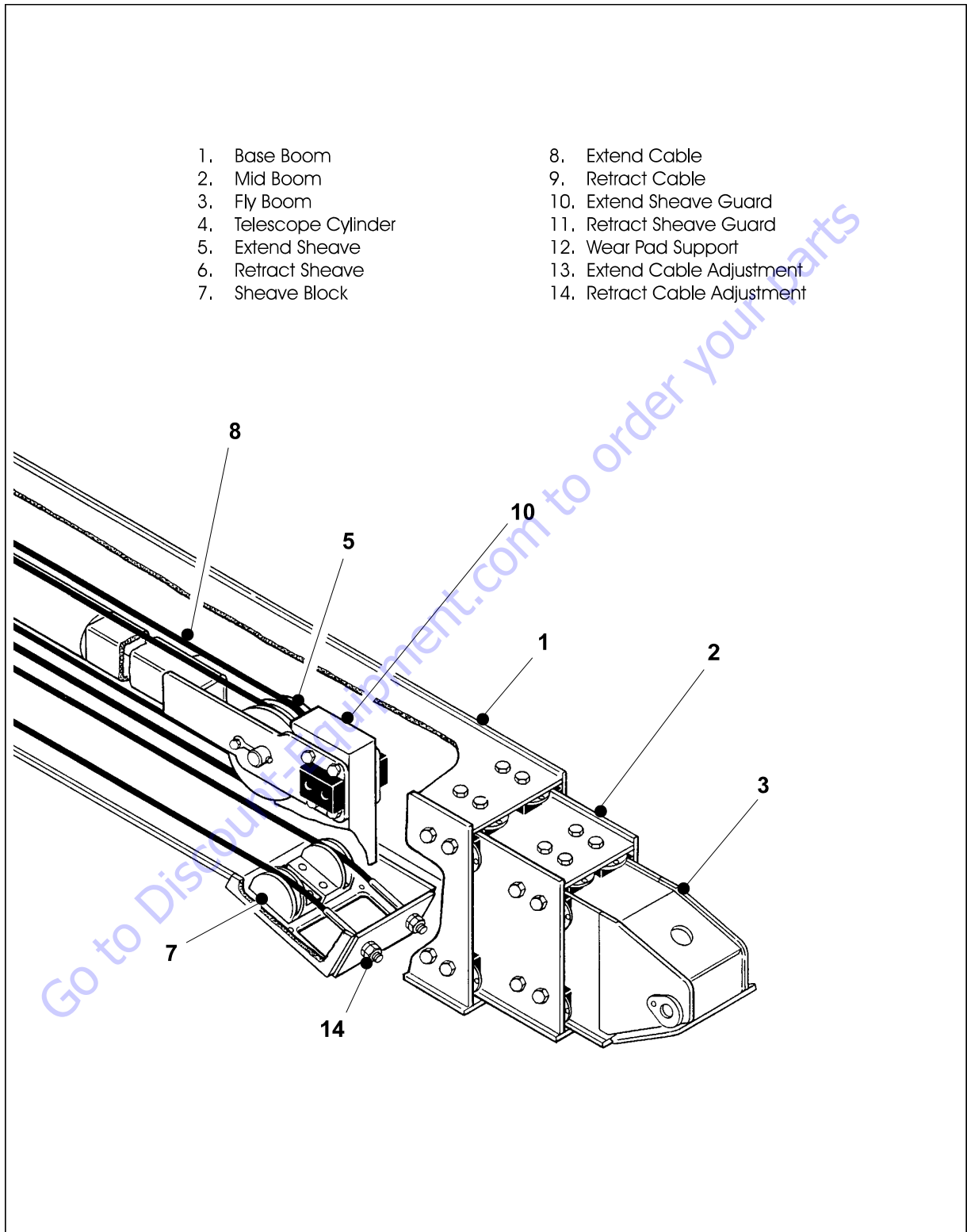

Figure 4-13. Boom Assembly Cutaway - Sheet 2 of 3

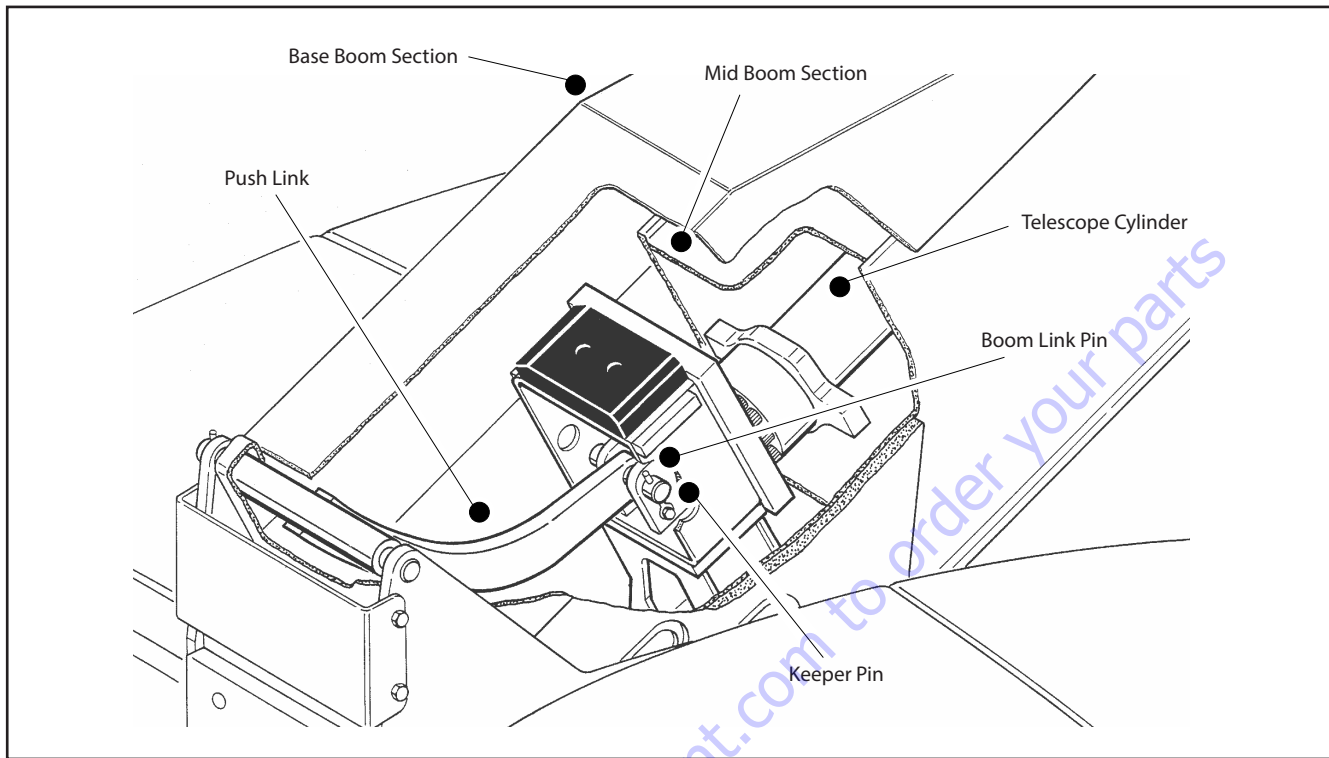
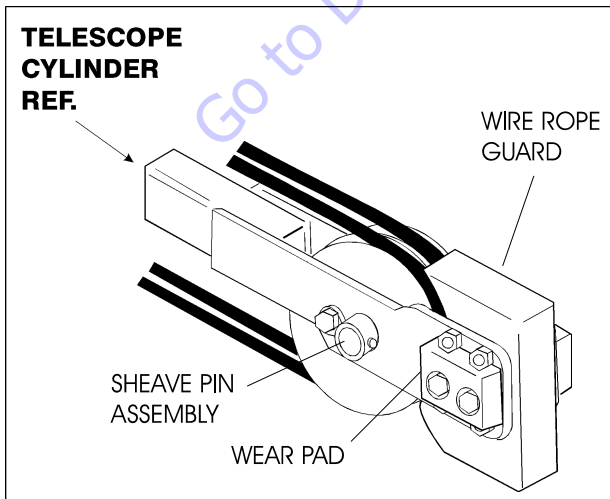

Figure 4-14. Boom Assembly Cutaway - Sheet 3 of 3

10. Carefully remove telescope cylinder and sheave assembly. Place telescope cylinder on a suitable trestle.
 - a. Remove hardware from wear pads. Remove wear pads from cylinder.
 - b. Remove hardware from wire rope guard. Remove guard from cylinder.
 - c. Remove hardware from sheave pin. Remove pin and sheave from cylinder.

Figure 4-15. Disassembly of Sheave Assembly

11. Remove hardware securing wear pads to front of base boom section. Remove wear pads from top, sides, and bottom of base boom section.
12. Using an overhead crane or suitable lifting device, remove mid and fly boom sections from base section. Note: When removing mid and fly boom sections from base boom section, retract wire rope must be dragged along with boom sections.
13. Remove hardware which secures wear pads to aft end of mid boom section. Remove wear pads from top, sides, and bottom of mid boom section.
14. Remove hardware which secures sheave guards and sheave assemblies to mid boom section. Remove sheave assemblies from mid boom section.
15. Remove hardware which secures wear pads to front of mid boom section. Remove wear pads from top, sides, and bottom of the mid boom section.



- Remove fly boom section from mid section using an overhead crane or suitable lifting device.

NOTE: When removing fly boom section from mid boom section, retract wire rope must be dragged along with fly boom section.

- Remove hardware which secures wear pads to aft end of fly boom section. Remove wear pads from top, sides, and bottom of fly boom section.
- When removing wire rope from fly boom section, push cable into fly boom. Route wire rope back through holes in side of fly boom section.

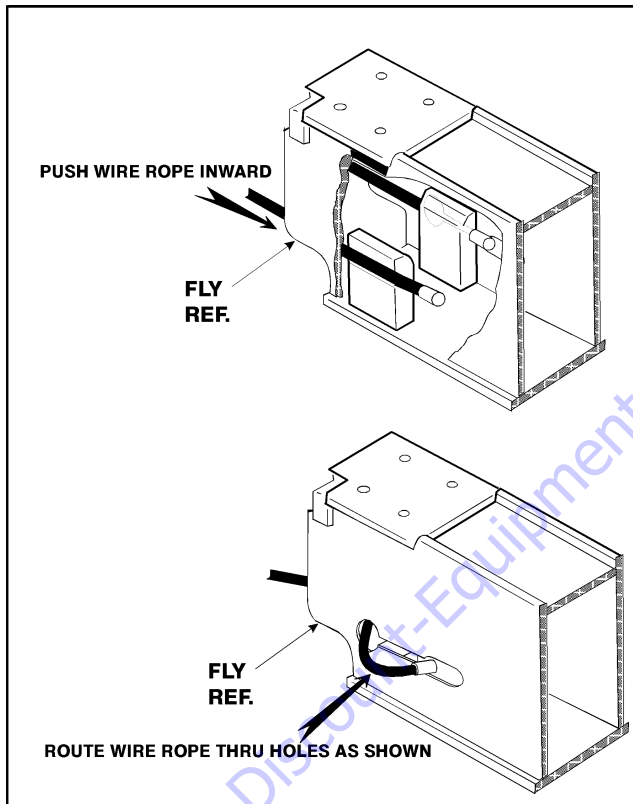

Figure 4-16. Wire Rope Routing Disassembly

Inspection

NOTE: Refer to guidelines established in Section 2 - General when inspecting pins and bearings.

- Inspect all sheaves (extend and retract wire ropes and telescope cylinder) for excessive groove wear, burrs, or other damage. Replace sheaves as necessary.

NOTE: Use a groove gauge to check size, contour, and amount of wear. Replace sheave if worn as shown in the following drawing.

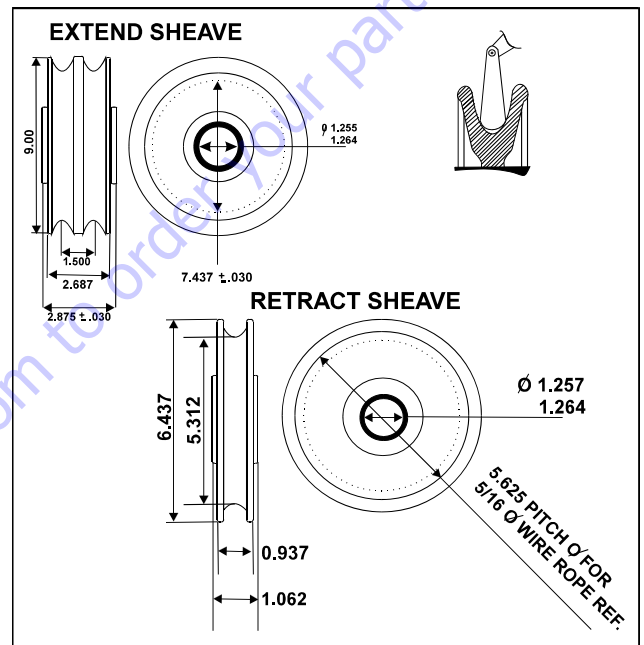

Figure 4-17. Dimension of Sheaves When New

SECTION 4 - BOOM & PLATFORM

2. Inspect extend and retract wire rope sheave bearings for wear, scoring or other damage, and ovality.
3. Inspect extend wire rope and retract wire rope sheave pins for scoring, tapering and ovality. Replace pins as necessary.
4. Inspect telescope cylinder sheave pin for scoring, tapering and ovality. Replace pins as necessary.
5. Inspect boom pivot pin for wear, scoring, tapering and ovality, or other damage. Replace pins as necessary.
6. Inspect telescope cylinder attach point for scoring, tapering and ovality. Replace pins as necessary.
7. Inspect upper lift cylinder attach pin for wear, scoring, tapering and ovality, or other damage. Ensure pin surfaces are protected prior to installation. Replace pins as necessary.
8. Inspect inner diameter of boom pivot bushing for scoring, distortion, wear, or other damage. Replace bearing as necessary.
9. Inspect all wear pads for excessive wear or other damage. Replace pads when worn to within 1/8 inch (3.2 mm) of threaded insert.
10. Inspect extend and retract wire rope attach point components for cracks, stretching, distortion, or other damage. Replace components as necessary.
11. Inspect all threaded components for damage such as stretching, thread deformation, or twisting. Replace as necessary.
12. Inspect structural units of boom assembly for bending, cracking, separation of welds, or other damage. Replace boom sections as necessary.

Assembly

NOTE: Install same number and thickness of shims removed during disassembly when installing fly section wear pads.

1. Measure inside dimensions of base and mid sections to determine number of shims required for proper lift.

2. Measure inside dimensions of mid section to determine number of shims required for proper lift.
3. Install side, top, and bottom wear pads to aft end of fly section. Shim evenly to inside measurements of mid section.
4. Install retract wire ropes in aft end of fly section. Route wire ropes through holes in side of fly boom section and pull into slot.

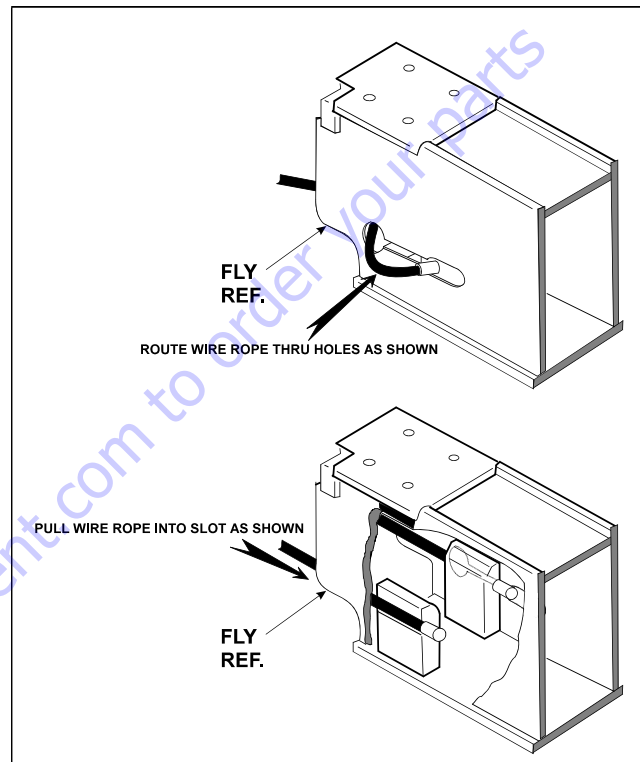

Figure 4-18. Routing Installation of Retract Wire Ropes

5. Install side, top, and bottom wear pads to aft end of mid section. Shim evenly to mid section inside measurements.

NOTICE

WHEN ASSEMBLING BOOM SECTIONS, ENSURE BOOM SLIDING TRAJECTORIES ARE CLEAR OF CHAINS, TOOLS, AND OTHER OBSTRUCTIONS.

6. Shim insides of boom sections for a total of 1/16 inch (0.062) clearance (if action is centered, there will be 1/32 inch clearance on each side).

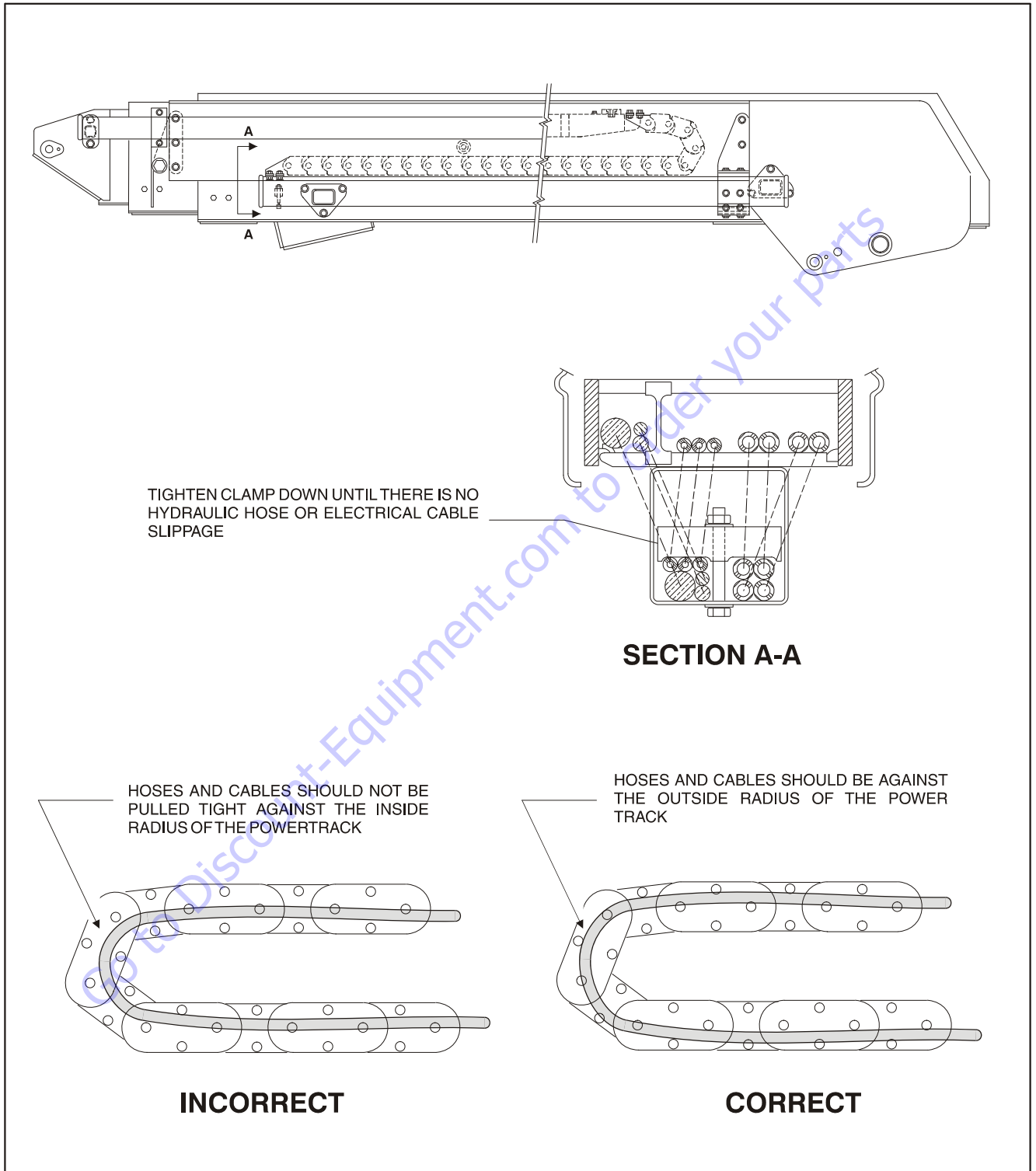

Figure 4-19. Boom Powertrack Installation

SECTION 4 - BOOM & PLATFORM

7. Slide fly boom section into mid boom section. Shim boom, if necessary, for a total of 1/16 inch (0.062) clearance.
 8. Install wear pads in forward position of the mid boom section. Shim boom, if necessary, for a total of 2/10 inch (0.20) clearance.
 9. Properly position retraction wire rope sheaves assemblies at aft end of mid boom section. Ensure all sheave-to-mounting block attachment holes align. Install sheave pins and secure them with mounting hardware. Position retract wire ropes onto sheaves.
 10. Install sheave guards to aft end of mid boom section and secure with mounting hardware.
 11. Slide mid boom section into base boom section. Allow retraction wire ropes to trail between bottom surfaces of boom sections. Shim boom, if necessary, for a total of 1/16 inch (0.062) clearance.
 12. Install wear pads into the forward position of base boom section. Shim boom, if necessary, for a total of 2/10 inch (0.20) clearance.
 13. Install sheave block to bottom of base boom section and adjust block so that retract wire ropes do not come into contact with boom surfaces.
 14. Install wire rope threaded ends thru attachment holes in bottom of base boom section. Loosely install nuts and jam nuts on threaded ends of wire ropes.
 15. Align telescope cylinder barrel-to-sheave attachment point. Install extend sheave pin through telescope cylinder barrel and sheave assembly; secure pin with mounting hardware.
 16. Route extend wire ropes around extend sheave and secure wire ropes to the telescope cylinder.
 17. Install extend wire rope mounting blocks to threaded ends of wire ropes. Loosely install nuts and jam nuts on threaded ends of wire ropes.
- NOTE:** Do not twist or cross wire ropes during installation.
- NOTE:** For non CE specification machines, skip step 18 and proceed to step 19.
18. Install extend wire rope mounting blocks, proximity mounting plate and spring to threaded ends of wire ropes. Loosely install nuts and jam nuts on threaded ends of wire ropes. Refer to Figure 4-20., Proximity Switch Installation.
 19. Secure sling and lifting device at telescope cylinder's approximate center of gravity, and lift cylinder to aft end of boom assembly.

NOTICE

WHEN INSERTING TELESCOPE CYLINDER IN BOOM, IT MAY BE NECESSARY TO TURN CYLINDER SLIGHTLY TO CLEAR ASSEMBLIES MOUNTED IN BOOM. CARE MUST BE TAKEN TO MOVE CYLINDER SLOWLY INTO POSITION. DAMAGE TO COMPONENTS MAY RESULT FROM FORCIBLE IMPACT WITH ASSEMBLIES.

20. Align cylinder with slots at aft end of mid boom section, then secure cylinder with mounting hardware.
21. Align holes in aft end of fly boom section with holes in wire rope mounting block. Secure with mounting hardware.

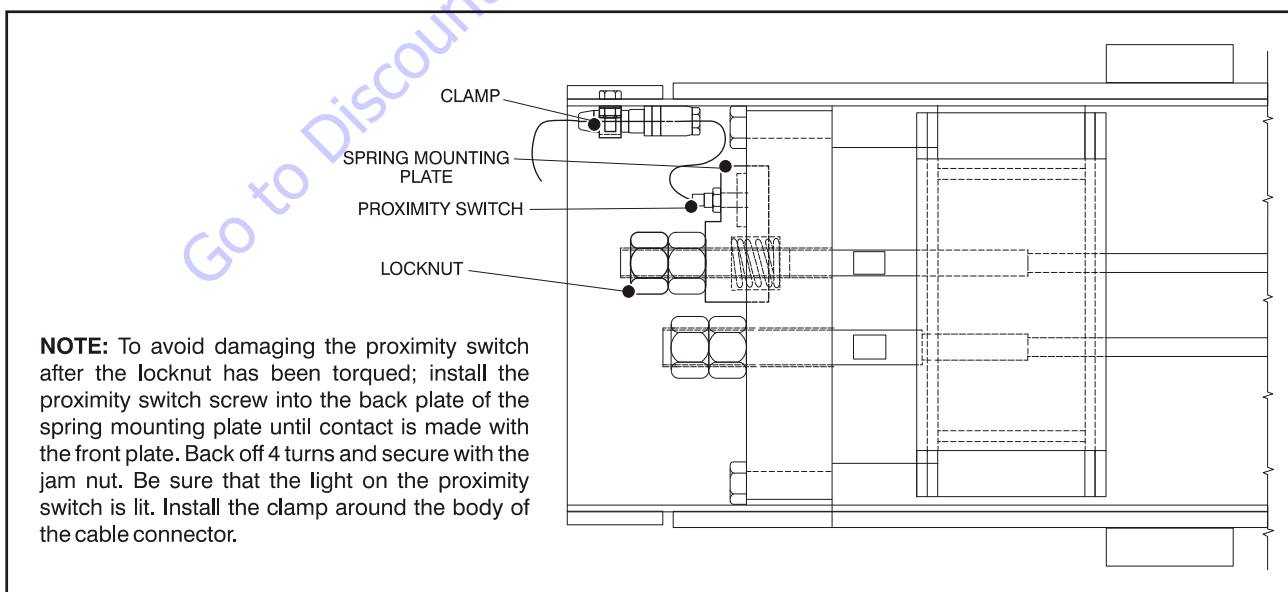

Figure 4-20. Proximity Switch Installation

22. Align holes in aft end of mid boom section with holes in wire rope mounting block. Secure with mounting hardware.

NOTE: Boom wire ropes must be torqued after installation of boom assembly.

23. Align holes in rod end of telescope cylinder with holes in push bar. Install push bar pin and secure with mounting hardware.
23. Install hydraulic lines and electrical cables, and harnessing powertrack components as follows:
 - a. Align holes in powertrack rail with attachment holes in side of base boom section. Secure rail with mounting hardware.
 - b. Install powertrack to rail with mounting hardware.
 - c. Attach push tube bracket to side of mid boom section with mounting hardware.

NOTE: Do not over tighten attach bolt on push tube bracket. It should pivot freely.

- d. Install slide block and wear pads to powertrack rail with mounting hardware.
- e. Install powertrack to push tube with mounting hardware.
- f. Carefully feed hoses and electrical cables through aft end of powertrack rail, powertrack, and push tube.
- g. Ensure all hoses and cables are properly routed through powertrack rail, powertrack, and push tube. Tighten or install all clamping or securing apparatus to hoses or cables, as necessary.
- h. Install powertrack cover and push tube rods with mounting hardware.

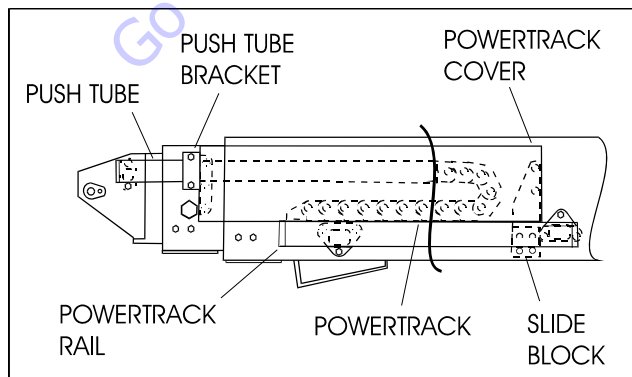

Figure 4-21. Boom Powertrack Assembly

Installation

1. Using a suitable lifting device, position boom assembly on turntable so pivot holes in both boom and turntable are aligned.
2. Install boom pivot pin. Ensure location of hole in pin is aligned with attach point on turntable.
3. If necessary, gently tap pin into position with soft headed mallet. Secure pin mounting hardware.
4. Align push bar pivot hole with pivot holes in turntable. Install push bar pivot pin. Ensure location of hole in pin is aligned with attach point on turntable.
5. If necessary, gently tap pin into position with soft headed mallet. Secure pin mounting hardware.
6. Connect all wiring to ground control box.
7. Connect all hydraulic lines running along side of boom assembly.
8. Using all applicable safety precautions, operate lifting device to position boom lift cylinder so holes in cylinder rod end and boom structure are aligned. Insert lift cylinder pin. Ensure location of hole in pin is aligned with attach point on boom.
9. Align holes in boom structure with hole in master cylinder. Insert master cylinder pin. Ensuring hole in pin is aligned with attach point on boom.
10. Adjust retract and extend cables to proper torque. Refer to paragraph 2-6, boom cable torque procedures.
11. Using all applicable safety precautions, operate machine systems and raise and extend boom fully. Note extension cycle performance.
12. Retract and lower boom. Note retraction cycle performance.

4.6 ARTICULATING JIB BOOM

Removal

1. For platform/support removal see platform/support removal diagram. See Section 4-1., Location of Components - Platform Support.
2. Position articulating jib boom level with ground.
3. Remove mounting hardware from slave leveling cylinder pin #1. Using a suitable brass drift and hammer, remove cylinder pin from articulating jib boom.

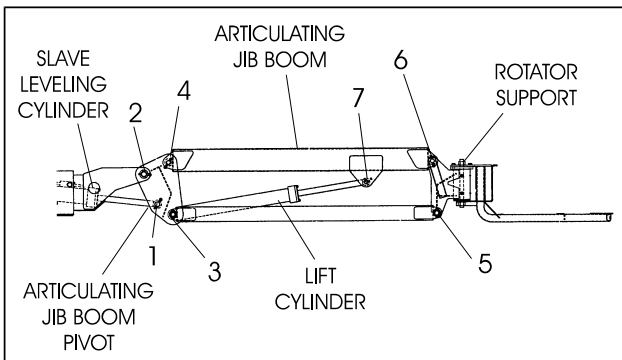

Figure 4-22. Articulating Jib Boom Components

4. Remove mounting hardware from articulating jib boom pivot pin #2. Using a suitable brass drift and hammer, remove pivot pin from boom assembly.

Disassembly

1. Remove mounting hardware from articulating jib boom pivot pins #3 and #4. Using a suitable brass drift and hammer, remove the pins from articulating jib boom pivot weldment.
2. Remove mounting hardware from rotator support pins #5 and #6. Using a suitable brass drift and hammer, remove pins from rotator support.
3. Remove mounting hardware from lift cylinder pin #7. Using a suitable brass drift and hammer, remove the cylinder pin from articulating jib boom.

Inspection

NOTE: Refer to Section 2 - General, when inspecting pins and bearings.

1. Inspect articulating fly boom pivot pin for wear, scoring, tapering and ovality, or other damage. Replace pins as necessary.
2. Inspect articulating fly boom pivot attach points for scoring, tapering and ovality, or other damage. Replace pins as necessary.
3. Inspect inner diameter of articulating fly boom pivot bearings for scoring, distortion, wear, or other damage. Replace bearings as necessary.
4. Inspect lift cylinder attach pin for wear, scoring, tapering and ovality, or other damage. Ensure pin surfaces are protected prior to installation. Replace pins as necessary.
5. Inspect inner diameter of rotator attach point bearings for scoring, distortion, wear, or other damage. Replace bearing as necessary.
6. Inspect all threaded components for damage such as stretching, thread deformation, or twisting. Replace as necessary.
7. Inspect structural units of articulating jib boom assembly for bending, cracking, separation of welds, or other damage. Replace boom sections as necessary.

Assembly

NOTE: For location of components See Section 4-22., Articulating Jib Boom Components.

1. Align lift cylinder with attach holes in articulating jib boom. Using a soft head mallet, install cylinder pin #7 into articulating jib boom and secure with mounting hardware.
2. Align rotator support with attach hole in articulating jib boom. Using a soft head mallet, install rotator support pin #6 into articulating jib boom and secure with mounting hardware.
3. Align bottom tubes with attach holes in rotator support. Using a soft head mallet, install rotator support pin #5 into articulating jib boom and secure with mounting hardware.
4. Align articulating jib boom with attach hole in articulating jib boom pivot weldment. Using a soft head mallet, install rotator support pin #4 into articulating jib boom and secure with mounting hardware.
5. Align bottom tubes with attach holes in articulating jib boom pivot weldment. Using a soft head mallet, install rotator support pin #3 into articulating jib boom pivot weldment. Secure with mounting hardware.
6. Align articulating jib boom pivot weldment with attach holes in fly boom assembly. Using a soft head mallet, install pivot pin #2 into fly boom assembly. Secure with mounting hardware.
7. Align slave leveling cylinder with attach holes in articulating jib boom pivot weldment. Using a soft head mallet, install slave leveling cylinder pin #1 into articulating jib boom pivot weldment. Secure with mounting hardware.

4.7 LIMIT SWITCHES AND CAM VALVE ADJUSTMENT

Adjust switches and cam valve as shown in Figure 4-23., Horizontal Limit and Dual Capacity Limit Switches Adjustments and Figure 4-24., Transport Switch Adjustments - CE Machines Only.

4.8 BOOM CLEANLINESS GUIDELINES

The following are guidelines for internal boom cleanliness for machines used in excessively dirty environments.

1. JLG recommends use of JLG Hostile Environment Package to keep internal portions of a boom cleaner and help prevent dirt and debris from entering the boom. This package reduces the amount of contamination which can enter the boom, but does not eliminate the need for more frequent inspections and maintenance when used in these types of environments.
2. JLG recommends you follow all guidelines for servicing your equipment in accordance with instruction in the JLG Service & Maintenance Manual for your machine. Periodic maintenance and inspection is vital to proper operation of the machine. Frequency of service and maintenance must be increased as environment, severity, and frequency of usage requires.
3. Debris and contamination inside the boom can cause premature failure of components and should be removed. Methods to remove debris should always be done using all applicable safety precautions outlined in the JLG Operation & Safety Manual and the JLG Service & Maintenance Manuals.
4. The first attempt to remove debris from inside the boom must be to utilize pressurized air to blow the debris toward the nearest exiting point from the boom. Make sure that all debris is removed before operating the machine.
5. If pressurized air cannot dislodge debris, then water with mild solvents applied with a pressure washer can be used. Wash debris toward the nearest exiting point from the boom. Make sure all debris is removed, no "puddling" of water has occurred, and boom internal components are dry before operating machine. Make sure you comply with all federal and local laws for disposing of wash water and debris.
6. If pressurized air or washing boom does not dislodge and remove debris, disassemble boom following instructions outlined in the JLG Service & Maintenance Manual to remove debris.

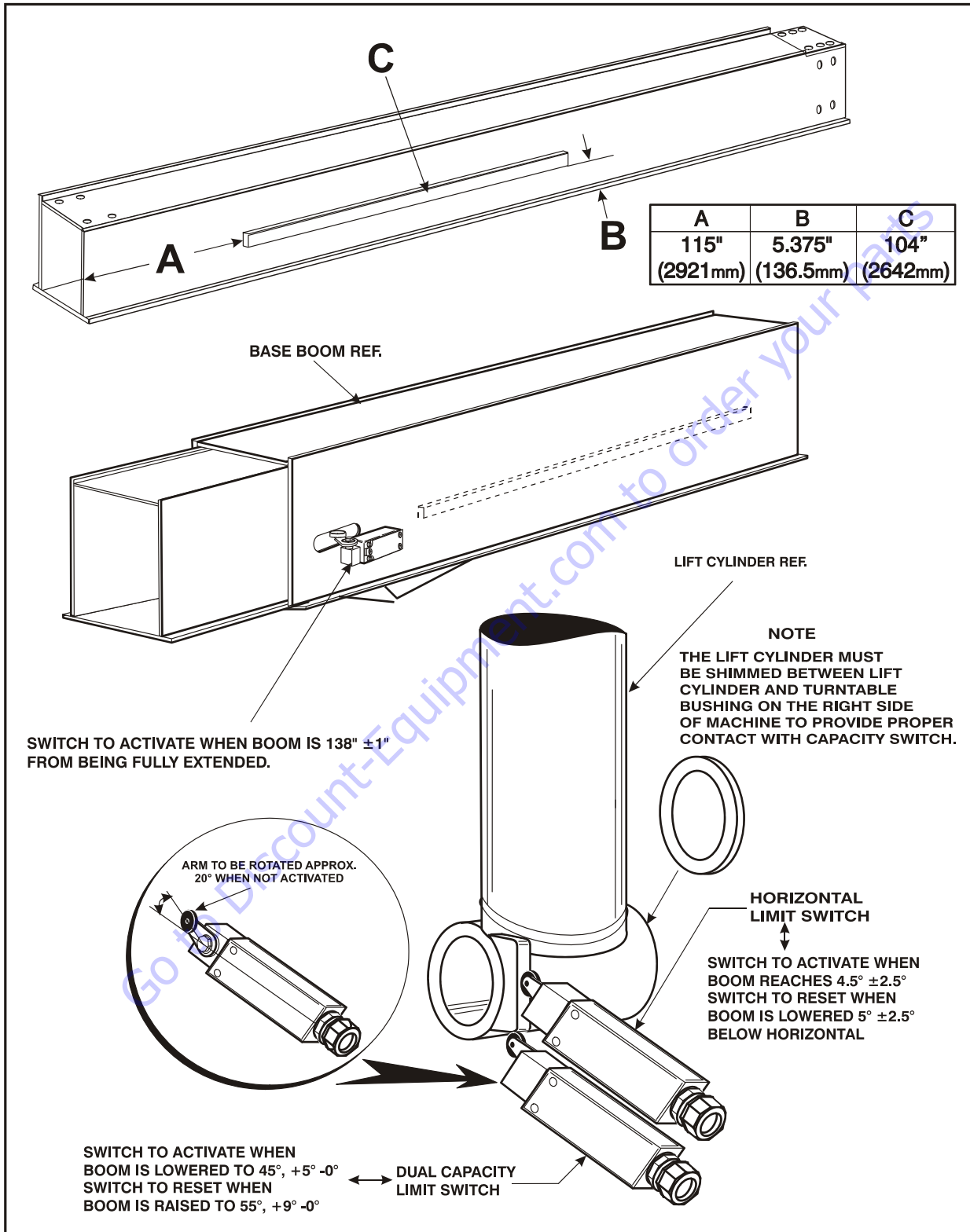

Figure 4-23. Horizontal Limit and Dual Capacity Limit Switches Adjustments

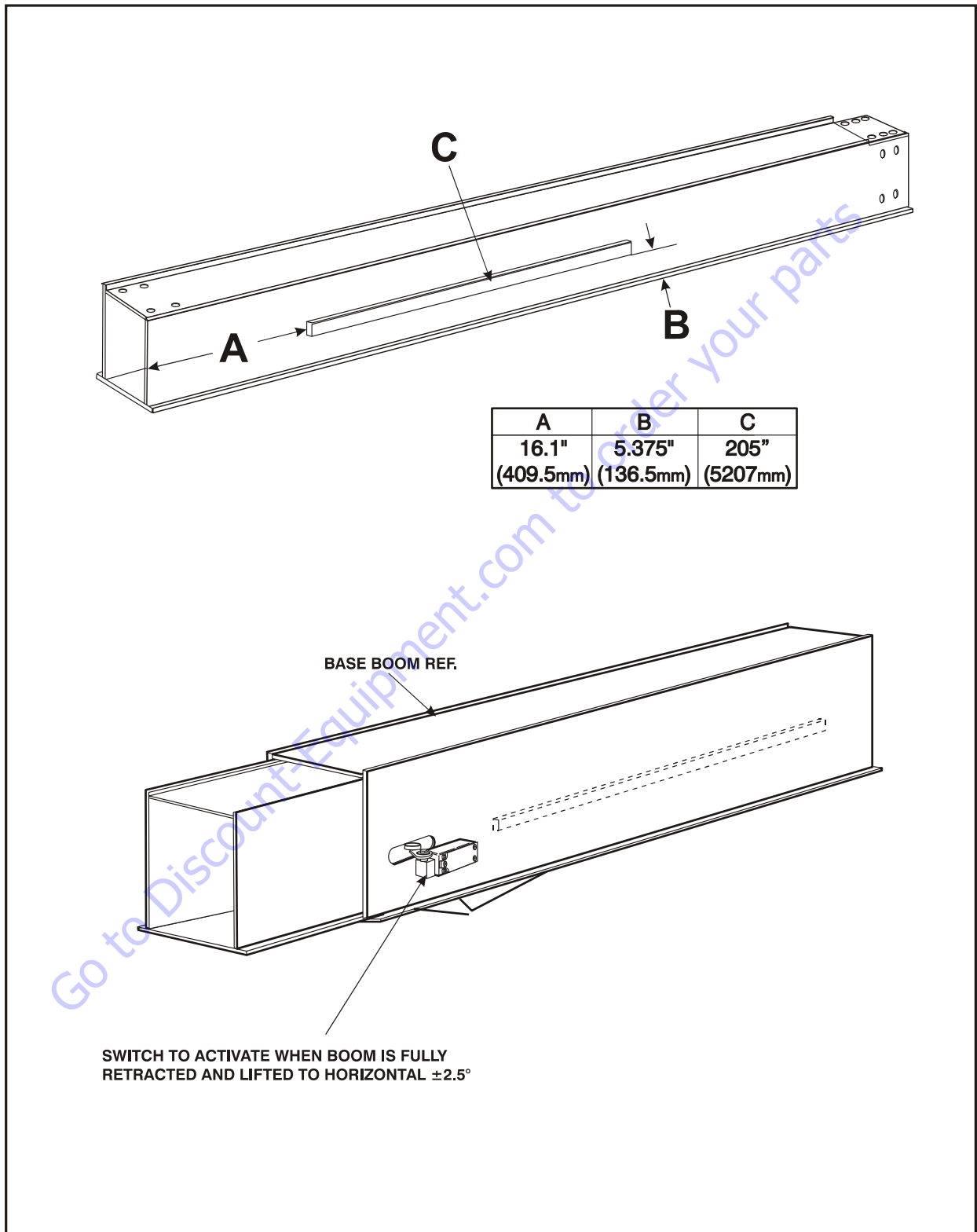

Figure 4-24. Transport Switch Adjustments - CE Machines Only

4.9 ROTARY ACTUATOR

Theory of Operation

The L20 Series rotary actuator is a simple mechanism that uses the sliding spline operating concept to convert linear piston motion into powerful shaft rotation.

Each actuator is composed of a housing with integrated gear teeth (01) and only two moving parts: the central shaft with integrated bearing tube and mounting flange (02), and the annular piston sleeve (03). Helical spline teeth machined on the shaft engage matching splines on the piston inside diameter. The piston outside diameter carries a second set of opposite direction splines which engage with matching splines in the housing.

As hydraulic pressure is applied, piston is displaced axially within the housing - similar to operation of a hydraulic cylinder - while splines cause shaft to rotate. When control valve is closed, oil is trapped inside the actuator, preventing piston movement and locking the shaft in position. The shaft is sup-

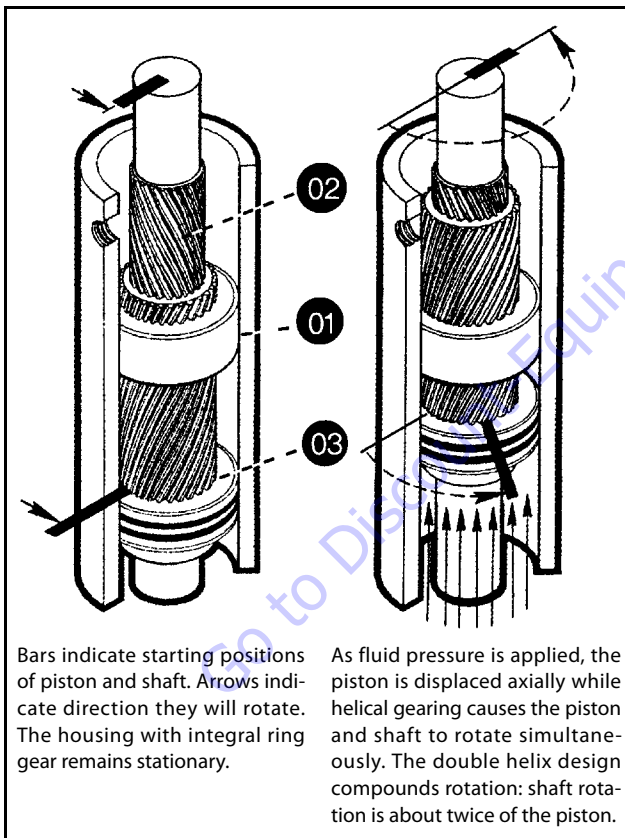

Bars indicate starting positions of piston and shaft. Arrows indicate direction they will rotate. The housing with integral ring gear remains stationary.

As fluid pressure is applied, the piston is displaced axially while helical gearing causes the piston and shaft to rotate simultaneously. The double helix design compounds rotation: shaft rotation is about twice of the piston.

ported radially by the large upper radial bearing and lower radial bearing. Axially, the shaft is separated from the housing by upper and lower thrust washers. End cap is adjusted for axial clearance and locked in position by set screws or pins.

Required Tools



1. Flashlight - Examine timing marks, component failure, and overall condition.
2. Felt Marker - Match mark timing marks and outline troubled areas.
3. Allen wrench - Remove port plugs and set screws.
4. Box knife - removal of seals.
5. Seal tool - assembly and disassembly of seals and wear guides.
6. Pry bar - End cap removal and manual rotation of shaft.
7. Rubber mallet- Removal and installation of shaft and piston sleeve assembly.
8. Nylon drift - Piston sleeve installation.
9. End cap dowel pins - removal and installation of end cap (sold with Helac seal kit).

The seal tool is a customized standard flat head screwdriver. To make this tool, heat flat end with a torch. Secure heated end of screwdriver in a vice and bend to a slight radius. Once radius is achieved, round off all sharp edges using a grinder. There may be some slight modifications for your personal preference.

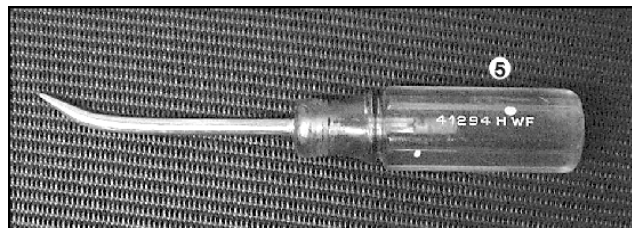

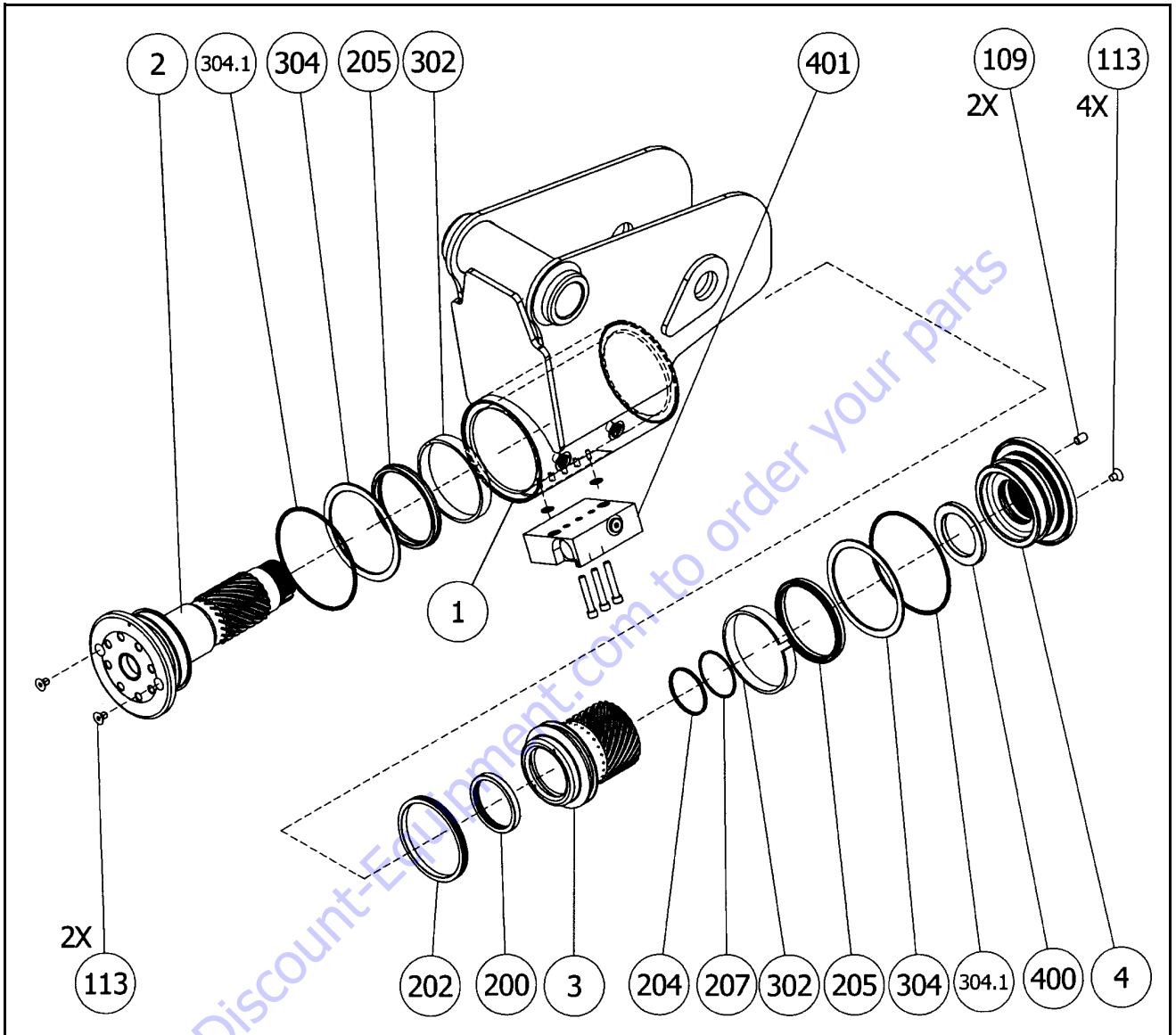

PARTS

- 1. Housing
- 2. Shaft
- 3. Piston Sleeve
- 4. End Cap

HARDWARE

- 103.1. Screw
- 103.2. Washer
- 106.1. Port Plug
- 106.2. Port Plug
- 109. Lock Pin
- 113. Capscrew

SEALS

- 200. T-Seal
- 202. T-Seal
- 204. O-ring
- 205. Cup Seal
- 207. Backup Ring
- 304.1. Wiper Seal

BEARINGS

- 302. Wear Guide
- 304. Thrust Washer

ACCESSORIES

- 400. Stop Tube
- 420.1 Bushing
- 420.2 Bushing
- 421.1 Bushing

Figure 4-25. Rotary Actuator - Exploded View

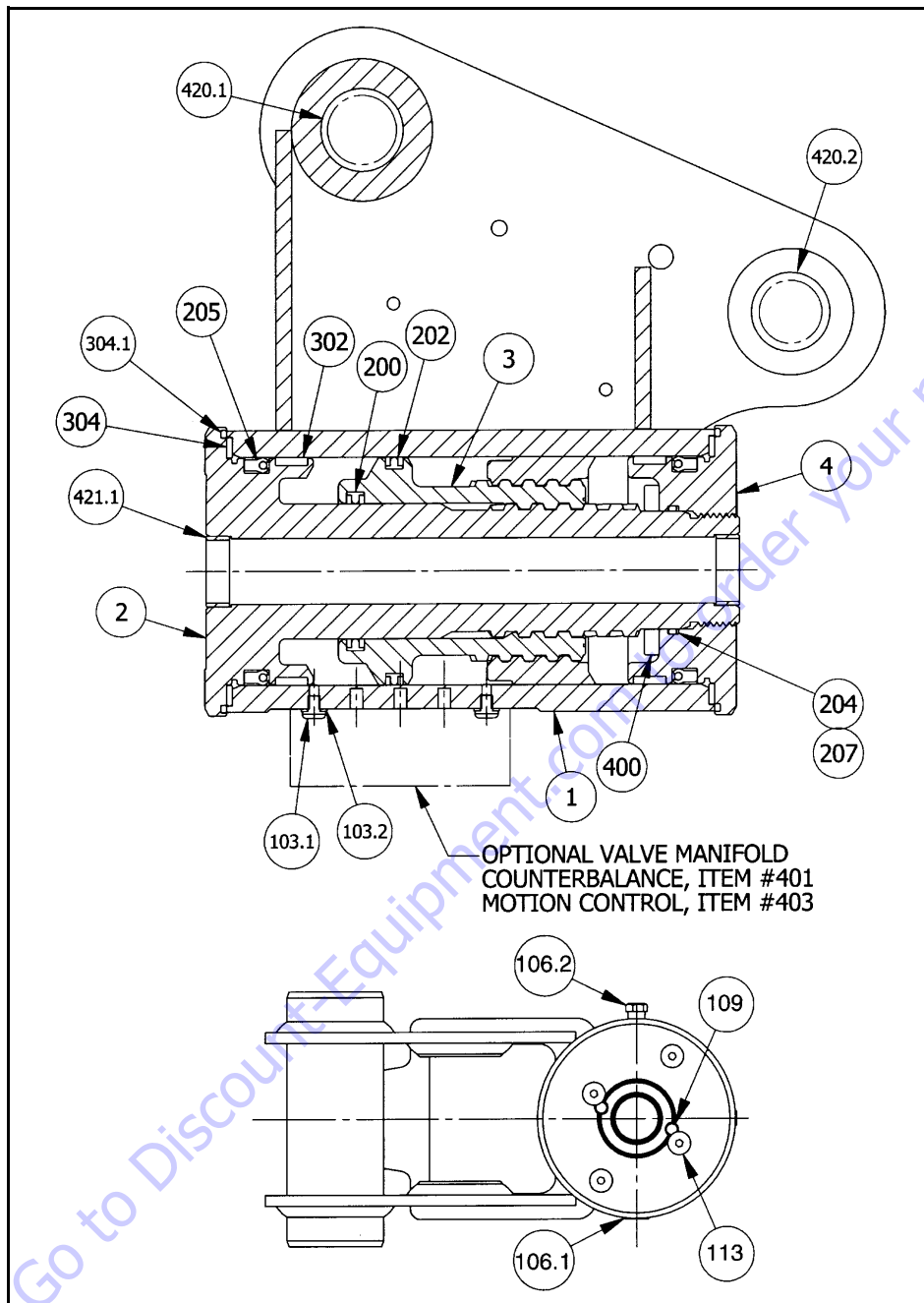

PARTS	HARDWARE	SEALS	BEARINGS	ACCESSORIES
1. Housing	103.1. Screw	200. T-Seal	302. Wear Guide	400. Stop Tube
2. Shaft	103.2. Washer	202. T-Seal	304. Thrust Washer	420.1 Bushing
3. Piston Sleeve	106.1. Port Plug	204. O-ring		420.2 Bushing
4. End Cap	106.2. Port Plug	205. Cup Seal		421.1 Bushing
	109. Lock Pin	207. Backup Ring		
	113. Capscrew	304.1. Wiper Seal		

Figure 4-26. Rotary Actuator - Assembly Drawing

Disassembly

1. Remove capscrews (113) over end cap lock pins (109).

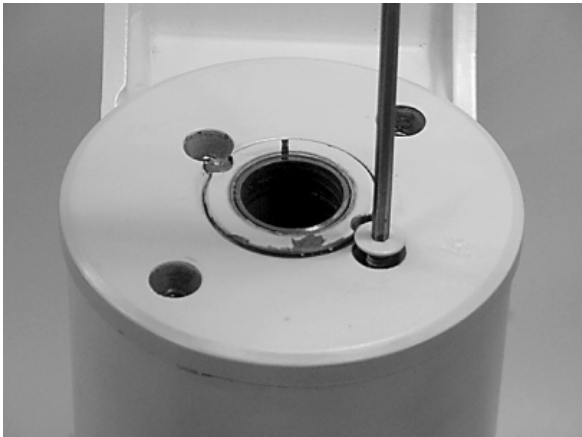

2. Using a 1/8" (3.18mm) drill bit, drill a hole in center of each lock pin approximately 3/16" (4.76mm) deep.



3. Remove lock pins using an "Easy Out" (Size #2 shown. If pin will not come out, use 5/16" drill bit 1/2" (12.7mm) deep to drill out entire pin.



4. Remove end cap (4) using tools provided with Helac seal kit.



5. Using a metal bar or similar tool, unscrew end cap (4) by turning it counter clockwise.



6. Remove end cap (4) and set aside for later inspection.



SECTION 4 - BOOM & PLATFORM

7. Remove stop tube if installed.



8. Actuator has timing marks for proper engagement.

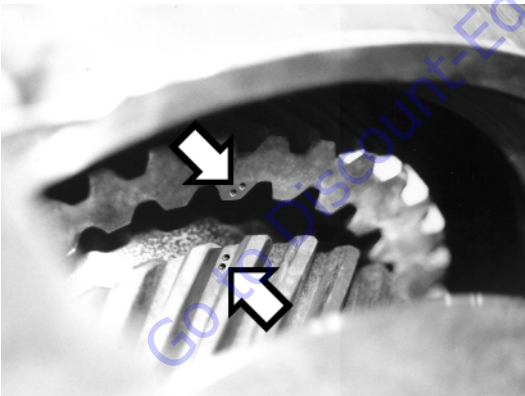
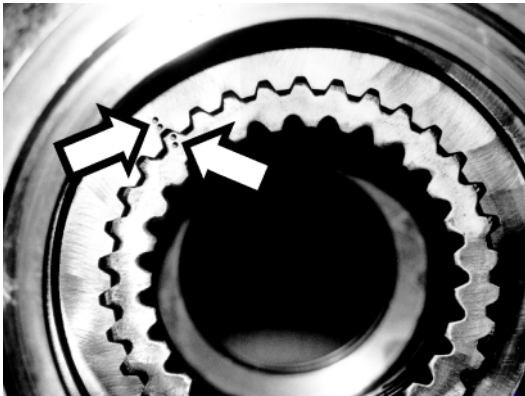

9. Before removing shaft, (2), use a felt marker to clearly indicate timing marks between shaft and piston. This simplifies timing during assembly.



10. Remove shaft (2). It may be necessary to strike threaded end of shaft with a rubber mallet.

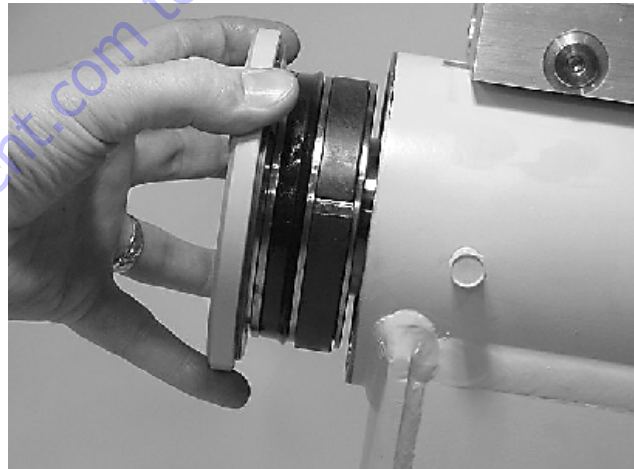

11. Before removing piston (3), mark housing (1) ring gear in relation to piston O.D. gear. There should be timing marks on housing (1) ring gear, piston (3), and shaft (2).



13. At the point when piston gear teeth come out of engagement with housing gear teeth, mark piston and housing with a marker as shown.



12. To remove piston (3), use a rubber mallet and plastic mandrel so piston is not damaged.

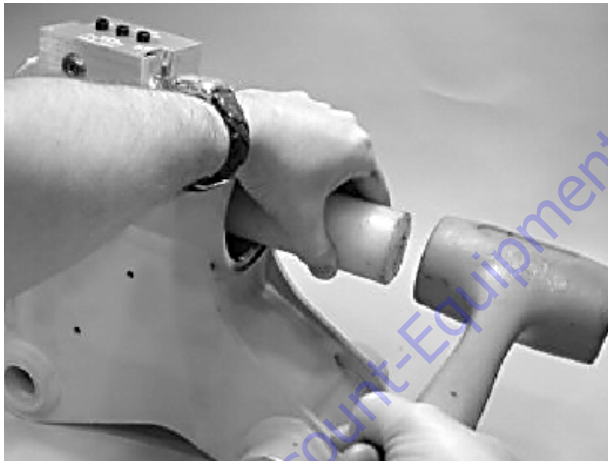

14. Remove O-ring (204) and backup ring (207) from end cap (4) and set aside for inspection.



SECTION 4 - BOOM & PLATFORM

15. Remove wear guides (302) from end cap (4) and shaft (2).

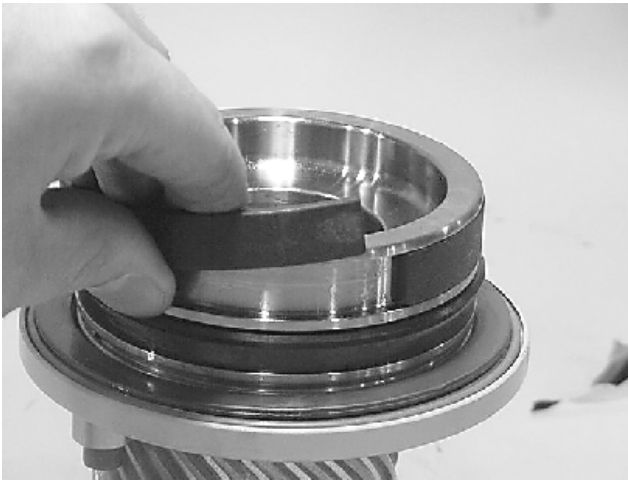

17. Remove thrust washers (304) from end cap (4) and shaft (2).



16. To remove main pressure seals (205), cut them with a sharp razor blade. Do not to damage seal groove.

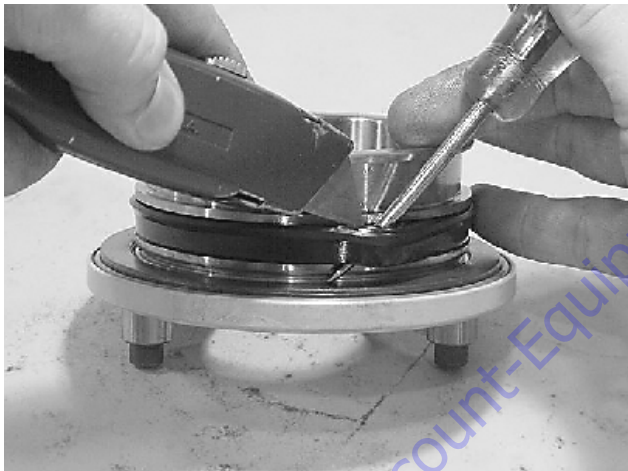

18. Remove wiper seal (304.1) from end cap (4) and shaft (2).



19. Remove piston O.D. seal (202).



20. Remove piston I.D. seal (200).



Inspection

1. Clean all parts in a solvent tank and dry with compressed air before inspecting. Carefully inspect all critical areas for any surface finish abnormalities: Seal grooves, bearing grooves, thrust surfaces, rod surface, housing bore, and gear teeth.



2. Inspect thrust washers (304) for rough or worn edges and surfaces. Measure thickness is within specifications (Not less than 0.092" or 2.34 mm).

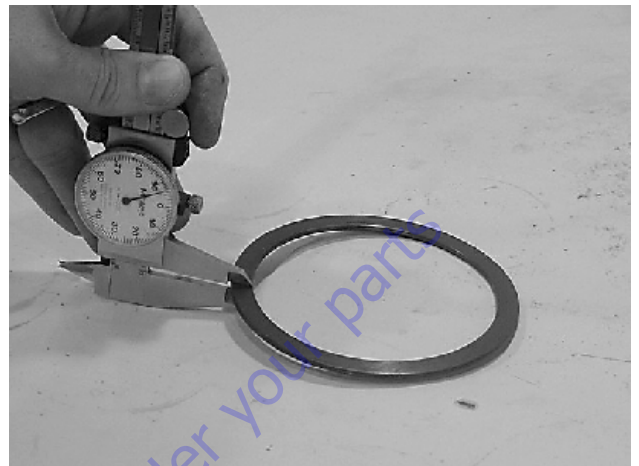

3. Inspect wear guide condition and measure thickness (not less than 0.123" or 3.12 mm).

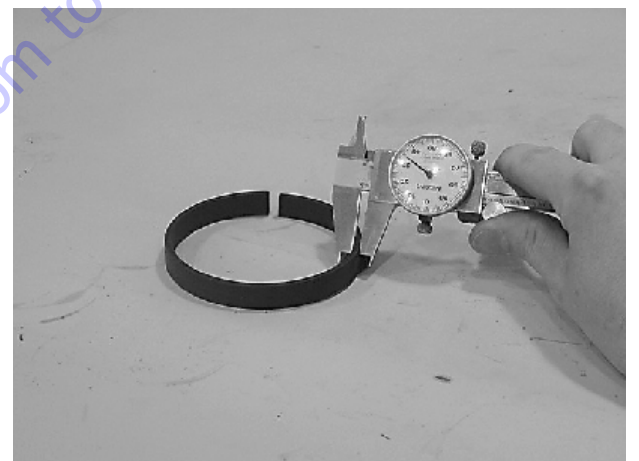

Assembly

1. Gather all components and tools to one location. Use cut away drawing to reference seal orientations.



2. Install thrust washer (304) on shaft (2) and end cap (4).



3. Install wiper seal (304.1/green O-ring) in groove on shaft (2) and end cap (4) - around outside edge of thrust washer (304).



4. Use a seal tool install main pressure seal (205) on shaft (2) and end cap (4). Use seal tool in a circular motion.



5. Install wear guide (302) on end cap (4) and shaft (2).

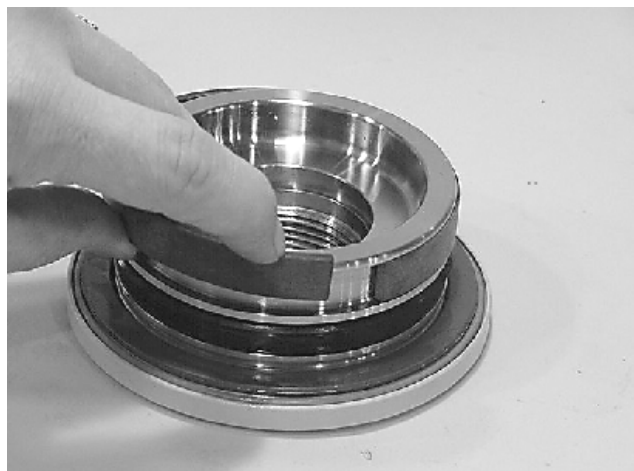

6. Install inner T-seal (200) in piston (3) using a circular motion. Install outer T-seal (202) by stretching it around the groove in a circular motion. Each T-seal has two back-up rings (see drawing for orientation).



7. Beginning with inner seal (200) insert one end of b/u ring in lower groove and feed the rest in using a circular motion. Make sure wedged ends overlap correctly.

Repeat for outer seal (202).



8. Insert piston (3) in housing (1) as shown, until outer piston seal (202) touches inside housing bore.

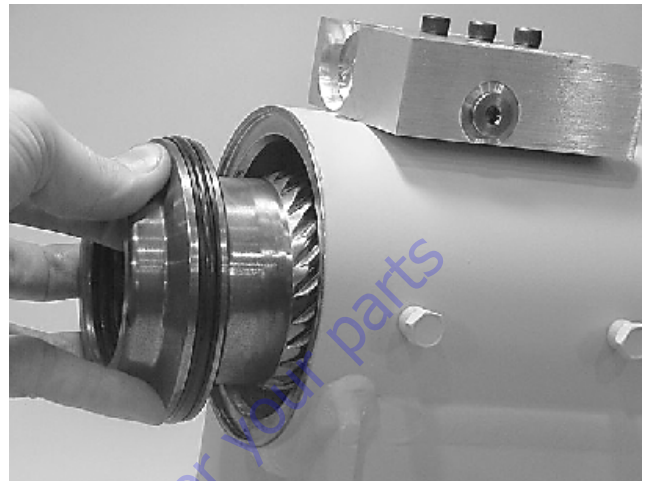

9. Looking from angle shown, rotate piston (3) until marks you put on piston and housing (1) during disassembly line up as shown. Using a rubber mallet, tap piston in housing to point where gear teeth meet.

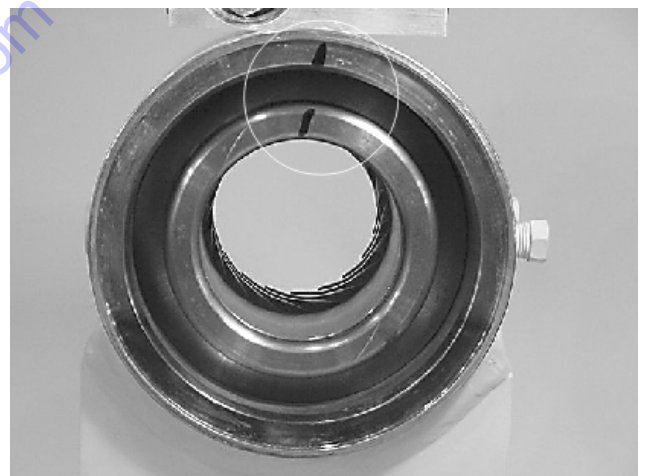

SECTION 4 - BOOM & PLATFORM

10. Looking from opposite end of housing (1) when timing marks line up, tap piston (3) in until gear teeth mesh together. Tap piston in housing until it bottoms out.



11. Install shaft (2) in piston (3). Do not damage seals. Do not engage piston gear teeth.

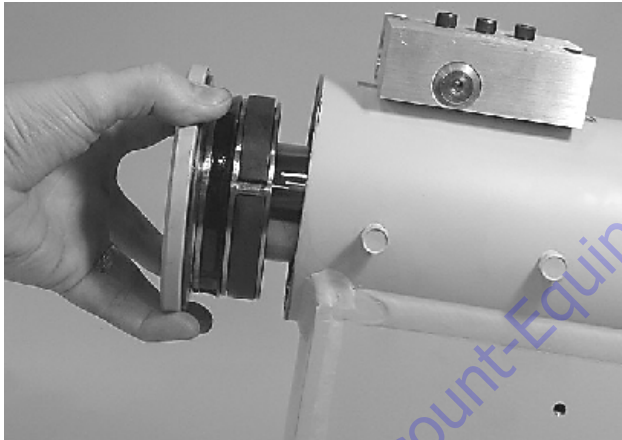

12. Looking from view shown, use existing timing marks to line up gear teeth on shaft (2) with gear teeth on inside of piston (3). Tap flange end of shaft with rubber mallet until gear teeth engage.



13. Install 2 bolts in threaded holes in flange. Using a bar, rotate shaft clockwise until wear guides are seated in housing bore.

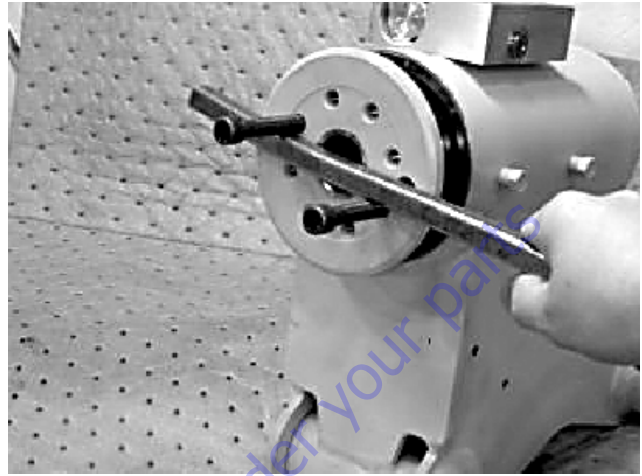

14. Install stop tube on shaft end. Stop tube is an available option to limit actuator rotation.

15. Coat threads on end of shaft with anti-seize grease to prevent galling.

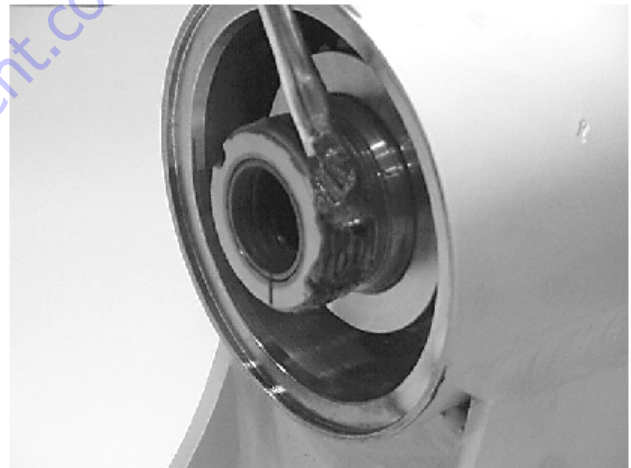

16. Install O-ring (204) and back-up ring (207) in inner seal groove on end cap (4).



17. Thread end cap (4) on shaft (2) end. Ensure wear guide stays in place on end cap as it is threaded in housing (1).

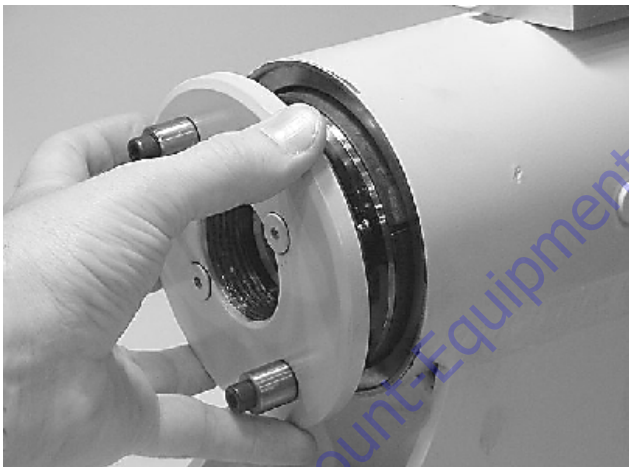

18. Tighten end cap (4). Ensure holes for lock pins line up.



19. Place lock pins (109) provided in Helac seal kit in holes with dimple side up. Using a punch, tap lock pins to bottom of hole.



20. Insert set screws (113) over lock pins. Tighten to 25 in-lb (2.825 Nm).

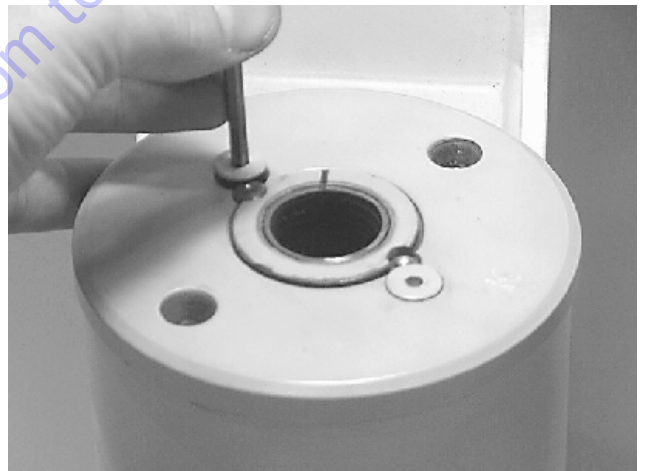

Installing Counterbalance Valve

Refer to Figure 4-27., Rotator Counterbalance Valve.

1. Make sure surface of actuator is clean and free of any contamination and debris, including old Loctite.
2. Make sure new valve has the O-rings in counterbores of valve to seal it to the actuator housing.
3. Bolts that come with valve are Grade 8 bolts. Install new bolts with a new valve. Apply Loctite #242 to shanks of the three bolts at time of installation.
4. Torque 1/4-inch bolts 110-120 in-lb (12.4-13.5 Nm). Do not torque over 125 in-lb (14.1 Nm). Torque 5/16-inch bolts to 140 in-lb (15.8 Nm). Do not torque over 145 in-lb (16.3 Nm).

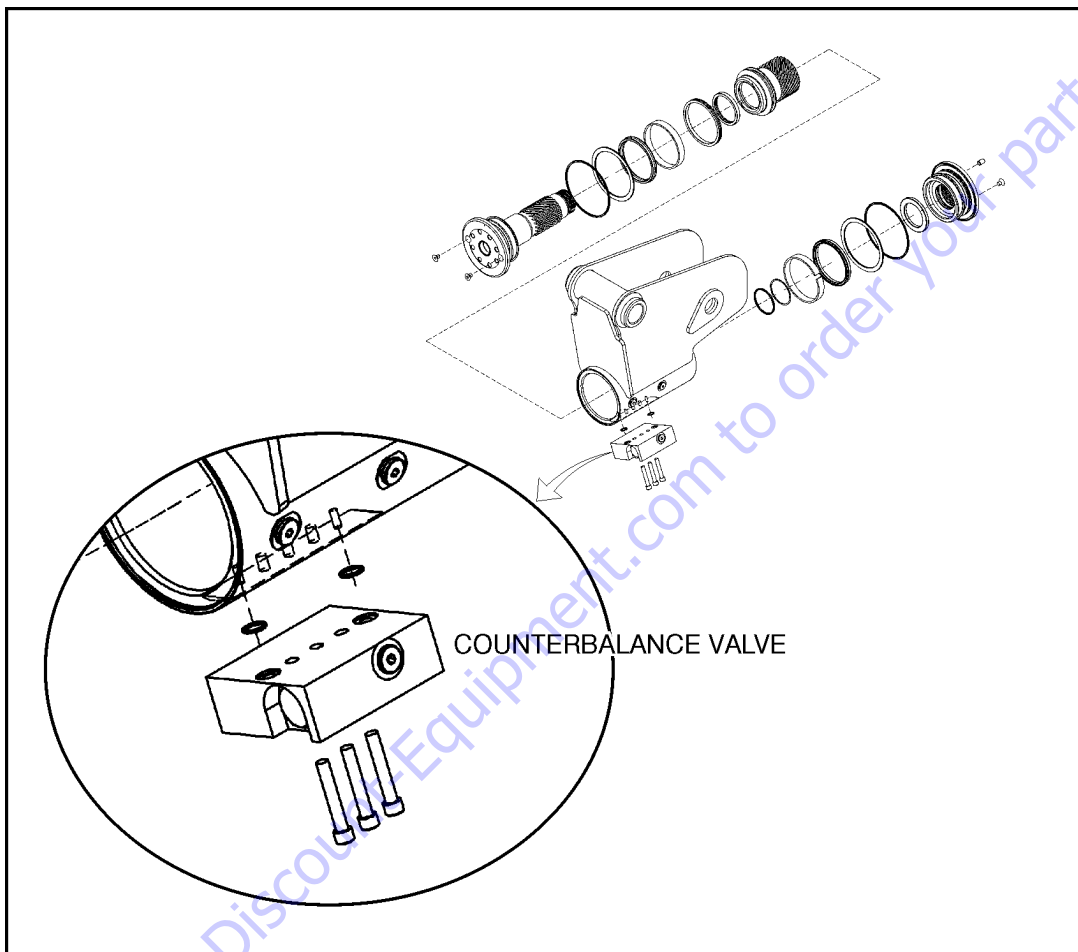

Figure 4-27. Rotator Counterbalance Valve

Testing Actuator

If equipment is available, test actuator on a hydraulic test bench. Breakaway pressure — the pressure at which the shaft begins to rotate — should be approximately 400 psi (28 bar). Cycle actuator at least 25 times at 3000 psi (210 bar) pressure. After 25 rotations, increase pressure to 4500 psi (315 bar). Check for leaks and cracks. Perform test again at end of rotation in the opposite direction.

Testing Actuator for Internal Leaks

If actuator is equipped with a counterbalance valve, plug valve ports, connect hydraulic lines to housing ports. Bleed all air from actuator (see Installation and Bleeding). Rotate shaft to end of rotation at 3000 psi (210 bar) and maintain pressure. Remove hydraulic line from non-pressurized side.

Continuous oil flow from open housing port indicates internal leakage across the piston. Replace line and rotate shaft to end of rotation in opposite direction. Repeat test procedure outlined above for other port. If there is an internal leak, disassemble, inspect, and repair.

Installation and Bleeding

⚠ WARNING

AFTER INSTALLING ACTUATOR, IT IS IMPORTANT THAT ALL SAFETY DEVICES SUCH AS TIE RODS OR SAFETY CABLES ARE PROPERLY REATTACHED.

To purge air from hydraulic lines, connect them together to create a closed loop and pump hydraulic fluid through them. Review hydraulic schematic to determine which hydraulic lines to connect. The linear feet and inside diameter of hydraulic supply lines together with pump capacity determine amount of pumping time required to fully purge the hydraulic system.

Bleeding may be necessary if excessive backlash is exhibited after actuator is connected to hydraulic system. The following steps are recommended when a minimum of two gal (8L) is purged.

1. Connect a 3/16" inside diameter x 5/16" outside diameter x 5 foot clear, vinyl drain tube to each of the two bleed nipples. Secure with hose clamps. Place vinyl tubes in a clean 5-gallon container to collect purged oil.
2. Oil can be returned to reservoir after procedure is completed.

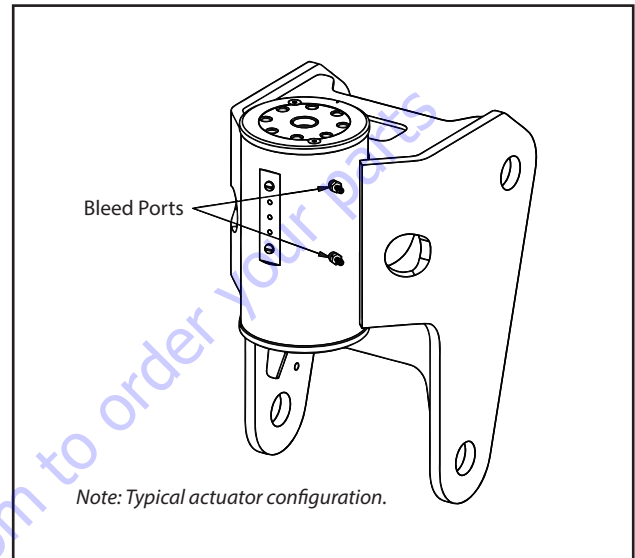

Figure 4-28. Actuator Bleed Ports

3. With an operator in the platform, open both bleed nipples 1/4 turn. Hydraulically rotate platform to end of rotation (clockwise or counterclockwise), and maintain hydraulic pressure. Oil with small air bubbles will be seen flowing through the tubes. Allow 1/2 gallon of fluid to be purged from actuator.
4. Keep fittings open and rotate platform in opposite direction to end position. Maintain hydraulic pressure until an additional 1/4 gallon of fluid is pumped into the container.
5. Repeat steps 2 & 3. After last 1/2 gallon is purged, close both bleed nipples before rotating away from end position.

Troubleshooting

Table 4-1. Troubleshooting

Problem	Cause	Solution
1. Shaft rotates slowly or not at all	<p>a. Insufficient torque output</p> <p>b. Low rate of fluid flow</p> <p>c. Control or counterbalance valve has internal leak</p> <p>d. Piston and/or shaft seal leak</p> <p>e. Corrosion build-up on the thrust surfaces</p> <p>f. Swollen seals and composite bearings caused by incompatible hydraulic fluid</p>	<p>a. Verify correct operating pressure. Do not exceed OEM's pressure specifications. Load may be above maximum capacity of the actuator.</p> <p>b. Inspect ports for obstructions and hydraulic lines for restrictions and leaks.</p> <p>c. Disconnect hydraulic lines and bypass valve. Leave valve ports open and operate actuator through housing ports (do not exceed OEM's operating pressure). Valve must be replaced if a steady flow of fluid is seen coming from valve ports.</p> <p>d. Remove plug and housing's valve ports. Operate actuator through housing ports. Conduct internal leakage test.</p> <p>e. Rebuild actuator. Remove all rust then polish. Replacement parts may be needed.</p> <p>f. Rebuild actuator. Use fluid compatible with all seals and bearings.</p>
2. Operation is erratic or not responsive	a. Air in actuator	a. Purge air from actuator. See bleeding procedures.
3. Shaft will not fully rotate	<p>a. Twisted or chipped gear teeth</p> <p>b. Port fittings are obstructing the piston</p>	<p>a. Check for gear binding. Actuator may not be able to be rebuilt and may need to be replaced. Damage could be a result of overload or shock.</p> <p>b. Check thread length of port fittings. Fittings should during stroke not reach inside housing bore.</p>
4. Selected position cannot be maintained	<p>a. Control or counterbalance valve has internal leak</p> <p>b. Piston and/or shaft seal leak</p> <p>c. Air in actuator</p>	<p>a. Disconnect hydraulic lines and bypass valve. Leave valve ports open and operate actuator through housing ports (do not exceed OEM's operating pressure). Valve must be replaced if a steady flow of fluid is seen coming from valve ports.</p> <p>b. Remove plug and housing's valve ports. Operate actuator through housing ports. Conduct internal leakage test.</p> <p>c. Purge air from actuator. See bleeding procedures</p>

4.10 FOOT SWITCH ADJUSTMENT

Adjust foot switch to operate functions when pedal is at center of travel. Adjust if switch operates within last 1/2 in. (6.35 mm) of top or bottom travel.

⚠ WARNING

ELECTRIC SHOCK OR UNCONTROLLED MACHINE MOVEMENT CAN CAUSE DEATH OR SERIOUS INJURY. DISCONNECT INPUT POWER BEFORE PERFORMING INSTALLATION OR MAINTENANCE.

NOTE: For models with two switches, both switches can be independently adjusted.

1. Remove four socket head cap screws and cover from foot switch assembly.
2. To increase travel before switch is activated, turn Adjustment Screw clockwise.
3. To decrease travel before switch is activated, turn Adjustment Screw counter-clockwise.

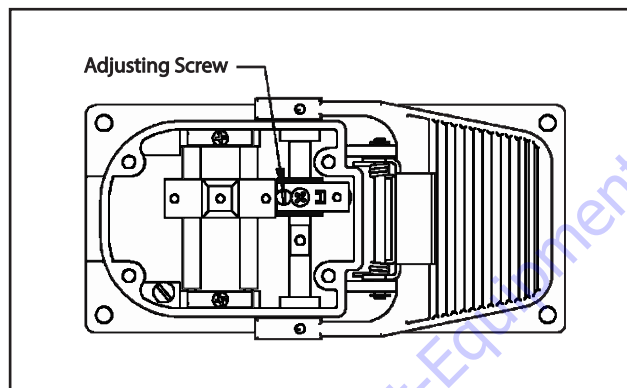

Figure 4-29. Foot Switch Adjustment

4. Install cover and secure with four socket head caps screws. Torque to 18-22 in-lb (2-3 Nm).

4.11 PLATFORM

Platform Support Torque Settings

NOTE: If any rotator bolts are replaced, re-torque all rotator bolts.

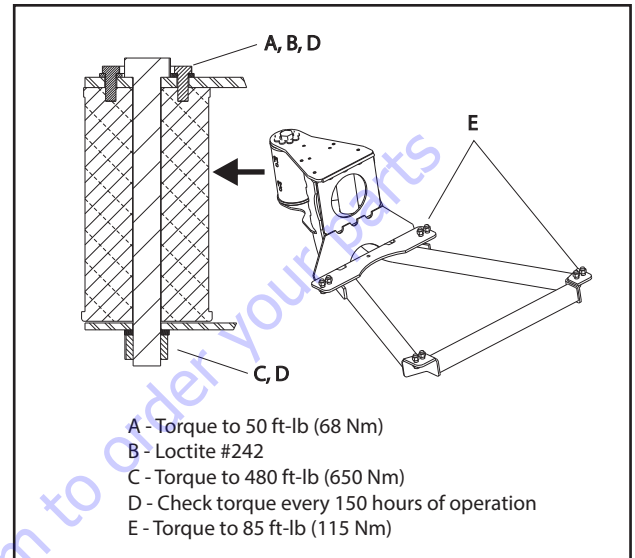

Figure 4-30. Platform Support Torque Values

Replace Platform Sections

The platform is made up of five sections: floor, right side, left side, back (console box mounting.), and gate. Sections are secured with Huck magna grip fastener and collars.

1. Support Huck collar with a suitable support.
2. Using a hammer and chisel, remove collar from fastener.

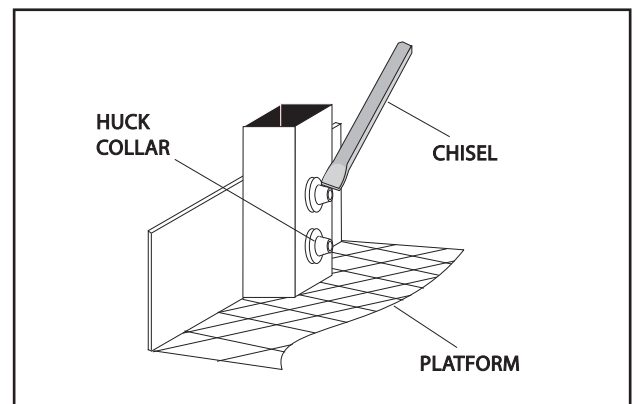

Figure 4-31. Platform Section Replacement

3. Replace Huck fasteners with 1/4 x 20 NC x 2 1/4" grade 5 bolts, flat washers, and locknuts when installing new section of platform.
4. Replace rivets with 1/4 x 20 NC x 2 "grade 5 bolts, flat washers, and locknuts when installing a new gate to platform.

4.12 POWERTRACK MAINTENANCE

Remove Link

NOTE: Hoses shown in powertrack are for example only. Actual hose and cable arrangements are different.



1. Clamp bar and poly roller tightly so they do not spin when removing screw. With a small ¼" ratchet and a T-20 Torx bit, remove 8-32 x 0.500 screw from one side.



2. Repeat step 1 and remove screw from other side of track. Remove bar/poly roller from powertrack.

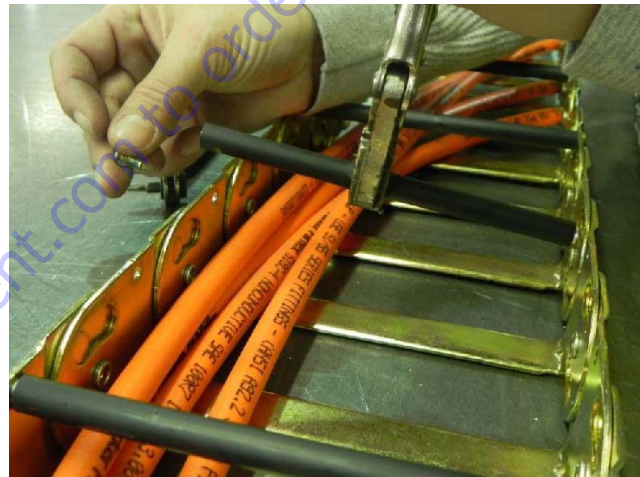
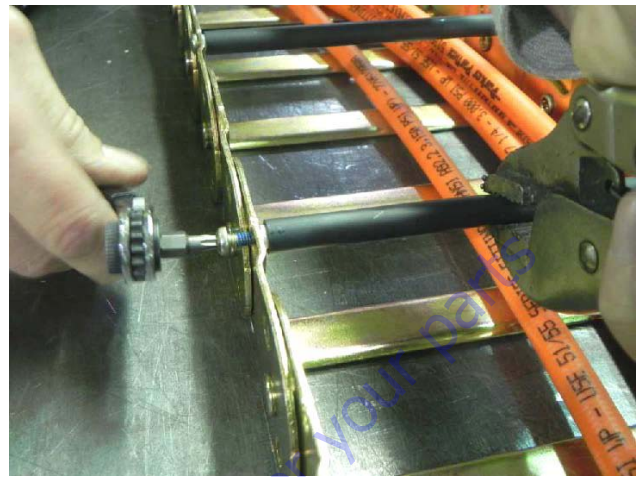

NOTICE

REPOSITION CABLES/HOSES. KEEP COVERED DURING GRINDING TO PREVENT DAMAGE.

3. To remove a link, rivets holding links together must be removed. Use a right-angle pneumatic die grinder with a 1/4" ball double cut bur attachment.



4. insert tool into rolled over end of rivet. Grind out middle of rivet until rolled over part of rivet falls off. Repeat for all rivets to be removed.

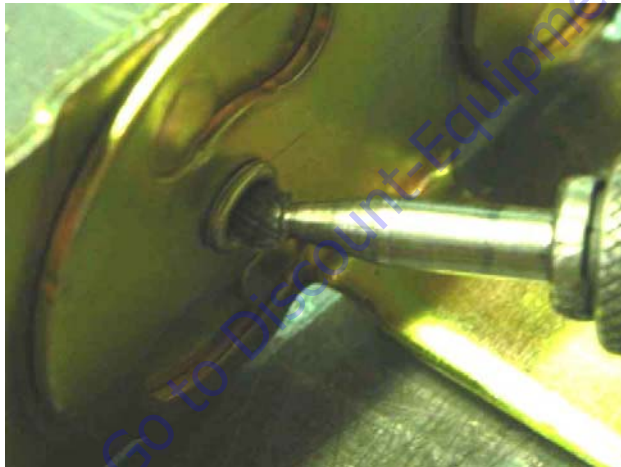

5. After grinding it may be necessary to use a center punch with a hammer to remove rivet.

NOTE: It may be necessary to loosen fixed end brackets from machine to move track section enough to disconnect links.



SECTION 4 - BOOM & PLATFORM

6. Insert flat head screwdriver between links. Twist and pull links apart.

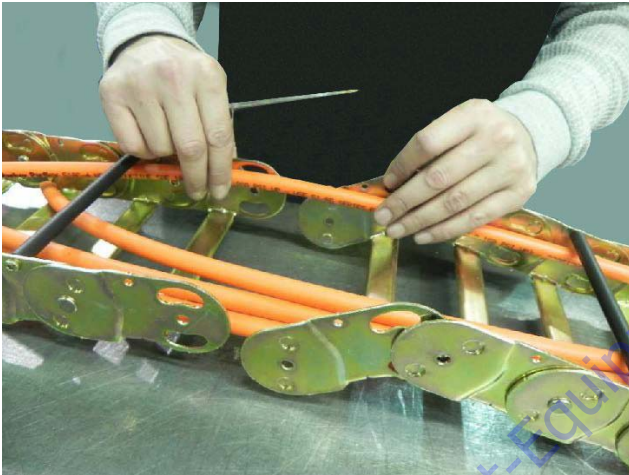
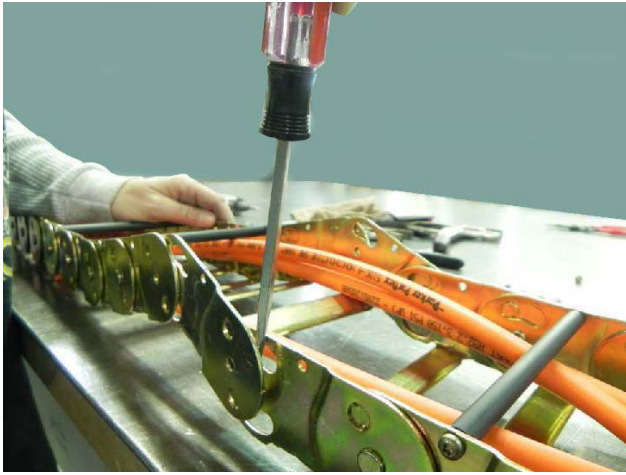

7. Remove link from other section of powertrack using screwdriver.

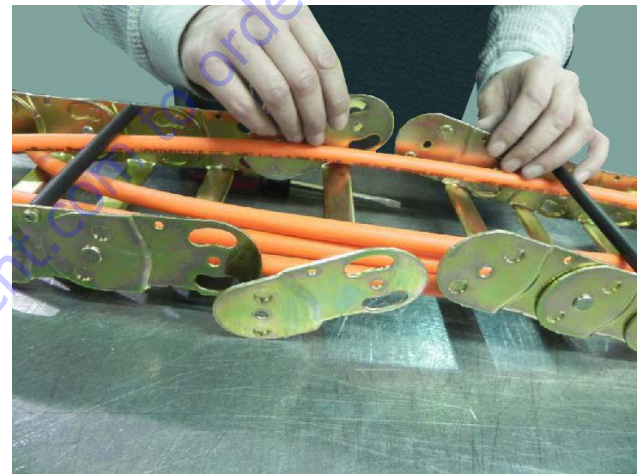

Install New Link

1. Squeeze cut-out end of new link into half-shear (female) end of track section.

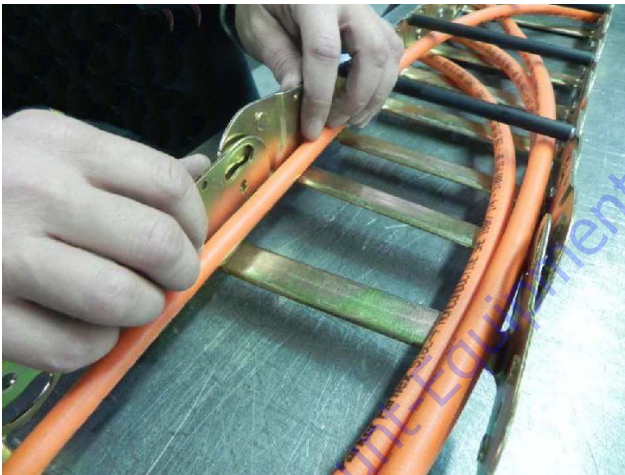

2. Spread half-shear (female) end of new link and slide cut-out end of track section into it. Use screwdriver if necessary.

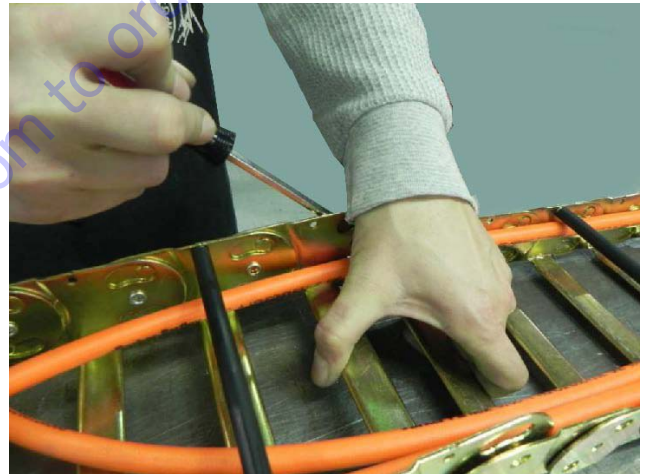
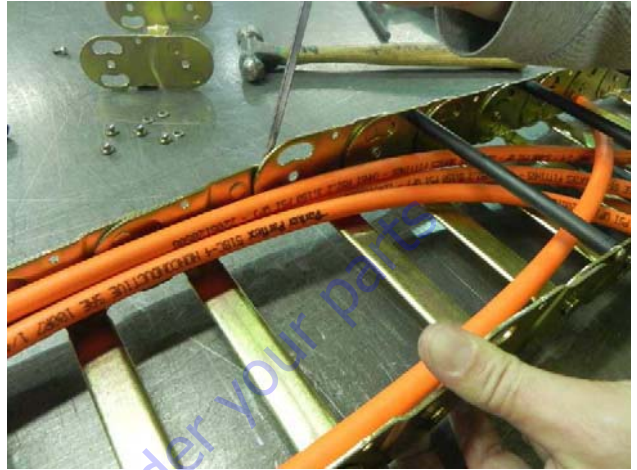

3. Round half-shears will not fit properly in cut-outs after new link is installed .

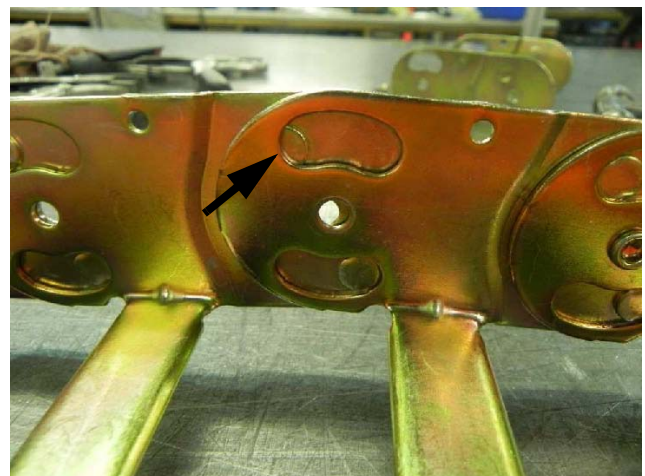

SECTION 4 - BOOM & PLATFORM

4. Pull moving end over track so new connection is positioned in curve of powertrack. Round half-shears will rotate into cut-outs.

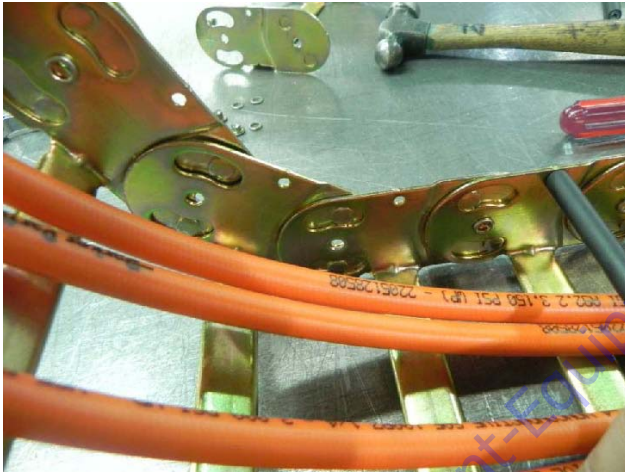
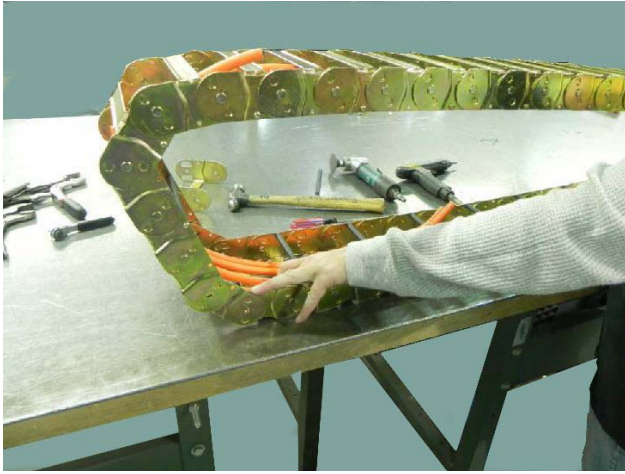

5. Parts shown below connect new link to powertrack.

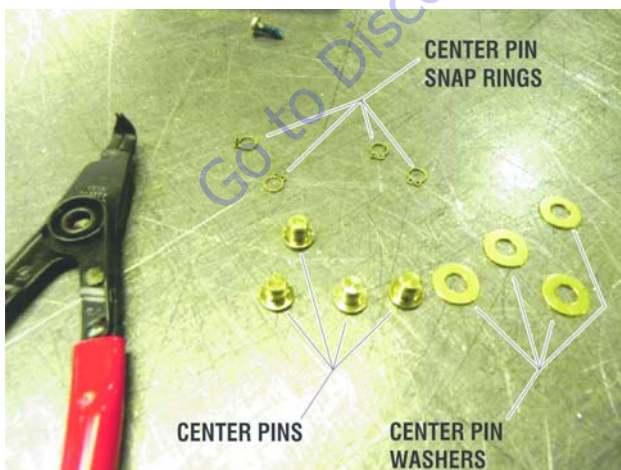

6. Push pin through center hole. Slide washer on pin.



7. Install snap ring in groove on pin. Repeat pin installation steps for all center holes with rivets removed.



NOTE: Make sure snap rings are seated in pin groove and closed properly.



1. Install new 8-32 x 0.500 self-threading Torx head screw in end of new aluminum round bar. Torque to 18-20 in-lb (2-2.25 Nm).



2. Pull up on other end of round bar. Slide new poly roller on bar.

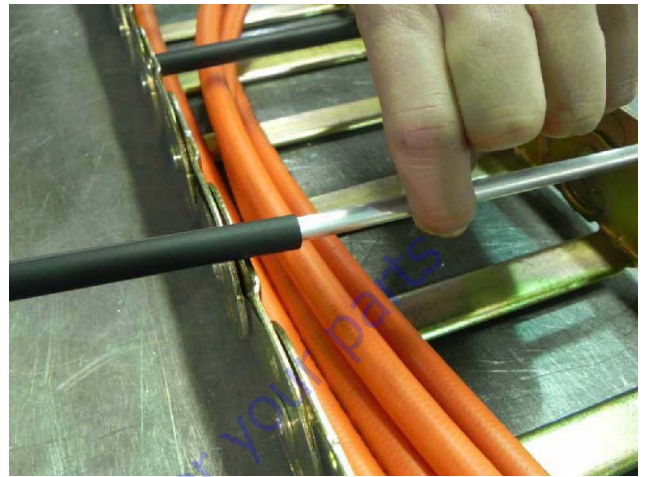

SECTION 4 - BOOM & PLATFORM

3. Install new 8-32 x 0.500 self threading screw on other side. Torque to 18-20 in-lb (2-2.25 Nm).

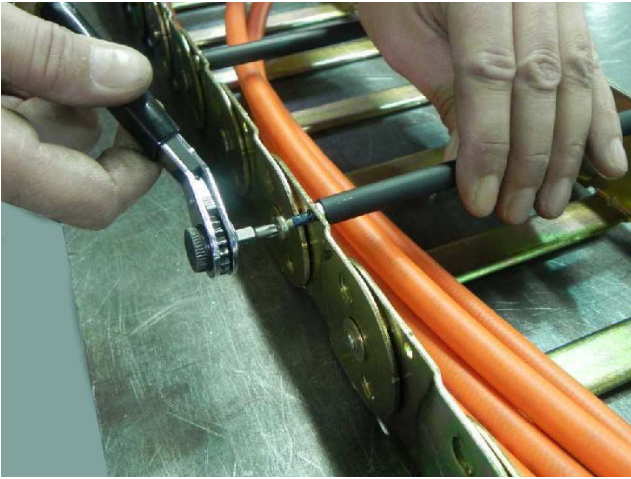

NOTE: When tightening screws make sure screw head is seated against link with no space in between link and underside of screw head.



Replace Fixed End Brackets

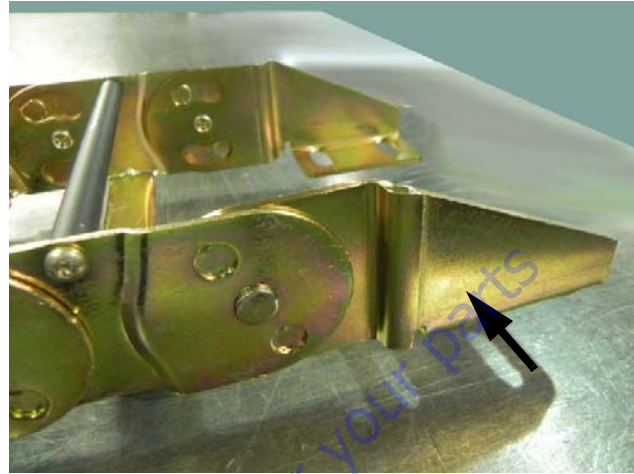

NOTICE

REPOSITION CABLES/HOSES. KEEP COVERED DURING GRINDING TO PREVENT DAMAGE.

1. Remove rivets as shown in link removal instructions..



2. Parts used: Bracket Center Pin and Center Pin Snap Ring.



3. Take new bracket and install bracket center pin and snap ring. Repeat on other bracket if replacing it.



NOTE: Ensure snap rings are seated in pin groove and closed properly.



Replace Moving End Brackets

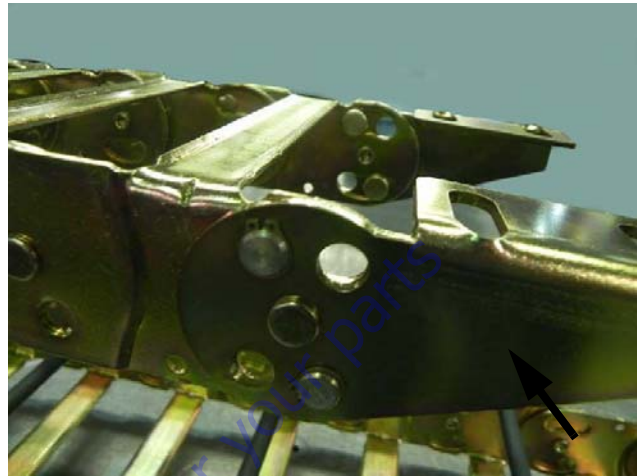

NOTICE

REPOSITION CABLES AND HOSES. KEEP COVERED DURING GRINDING TO PREVENT DAMAGE.

1. Remove existing pins and center rivet. Remove rivet as shown in link removal instructions on page 4-20. Repeat on other bracket if replaced.

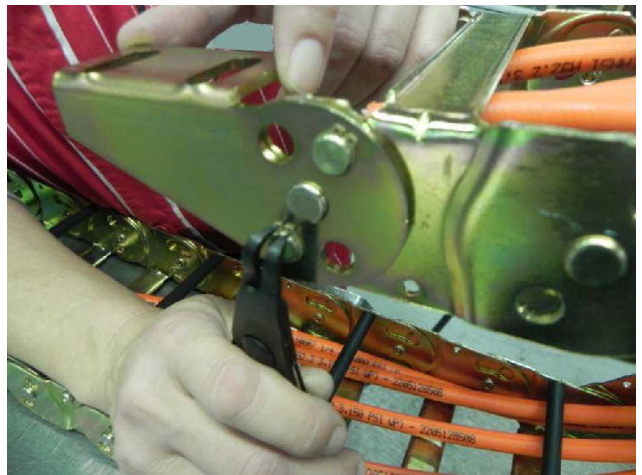

SECTION 4 - BOOM & PLATFORM

2. Install center pin with snap ring in new bracket.

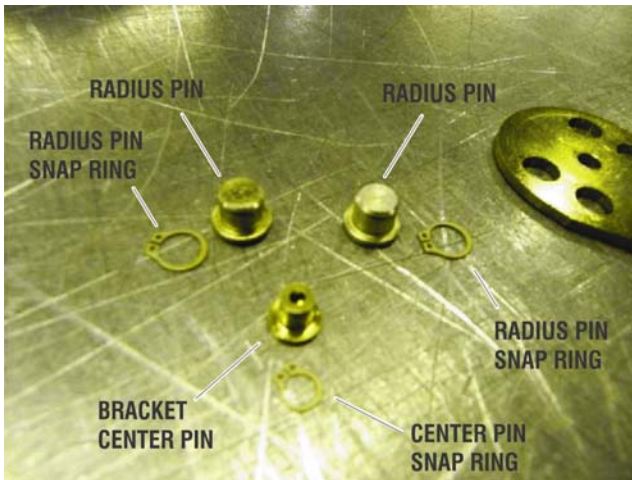

3. Install radius pins and snap rings in original locations. Repeat with other moving end if replaced.

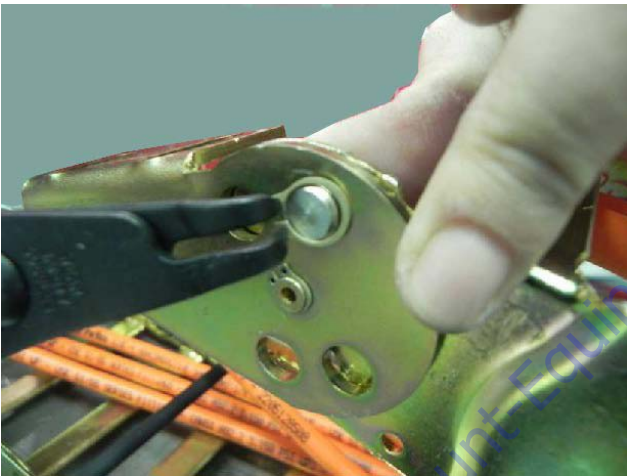

NOTE: Ensure snap rings are seated in pin groove and closed properly.

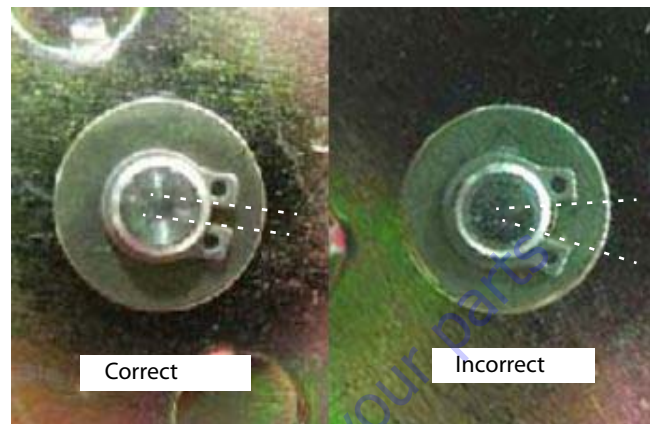

1. Make sure both brackets rotate correctly.



PARTS FINDER

**Search Website
by Part Number**



**Search Manual
Library For Parts
Manual & Lookup Part
Numbers – Purchase
or Request Quote**

A screenshot of the "Search Manuals" form. The form has a title "Search Manuals" and a subtitle "Please provide information to help us locate the manual and/or parts you need." It includes fields for "Brand", "Model", "Serial", "Part Number", "Part Name", and "Quantity". There is a "Search" button at the bottom.

**Can't Find Part or
Manual? Request Help
by Manufacturer,
Model & Description**

A screenshot of the "Parts Order Form". The form has a title "Parts Order Form" and a subtitle "Please fill in as much information as possible." It includes fields for "Manufacturer", "Model", "Description", "Part Number", "Part Name", "Quantity", and "Comments". There is a "Submit" button at the bottom.

Discount-Equipment.com is your online resource for quality parts & equipment.

Florida: **561-964-4949** Outside Florida TOLL FREE: **877-690-3101**

Need parts?

Click on this link: <http://www.discount-equipment.com/category/5443-parts/> and choose one of the options to help get the right parts and equipment you are looking for. Please have the machine model and serial number available in order to help us get you the correct parts. If you don't find the part on the website or on once of the online manuals, please fill out the request form and one of our experienced staff members will get back to you with a quote for the right part that your machine needs.

We sell worldwide for the brands: Genie, Terex, JLG, MultiQuip, Mikasa, Essick, Whiteman, Mayco, Toro Stone, Diamond Products, Generac Magnum, Airman, Haulotte, Barreto, Power Blanket, Nifty Lift, Atlas Copco, Chicago Pneumatic, Allmand, Miller Curber, Skyjack, Lull, Skytrak, Tsurumi, Husquvarna Target, , Stow, Wacker, Sakai, Mi-T- M, Sullair, Basic, Dynapac, MBW, Weber, Bartell, Bennar Newman, Haulotte, Ditch Runner, Menegotti, Morrison, Contec, Buddy, Crown, Edco, Wyco, Bomag, Laymor, Barreto, EZ Trench, Bil-Jax, F.S. Curtis, Gehl Pavers, Heli, Honda, ICS/PowerGrit, IHI, Partner, Imer, Clipper, MMD, Koshin, Rice, CH&E, General Equipment, ,AMida, Coleman, NAC, Gradall, Square Shooter, Kent, Stanley, Tamco, Toku, Hatz, Kohler, Robin, Wisconsin, Northrock, Oztec, Toker TK, Rol-Air, Small Line, Wanco, Yanmar

SECTION 5. HYDRAULICS

5.1 O-RING LUBRICATION

When assembling connectors, all fittings with O-rings must be lubricated with hydraulic oil before assembly. There are four methods of lubricating O-rings:

1. Cup and Brush
2. Dip
3. Spray
4. Brush-On

Cup and Brush

Tools needed:

- Small container for hydraulic oil
- Small paint brush



1. Hold fitting in one hand and dip brush into container with other hand. Remove excess hydraulic oil from brush so an even film of oil is applied to O-ring.



2. Hold fitting over hydraulic oil container and brush an even film of oil around entire O-ring in fitting. Make sure O-ring is completely saturated.



3. Turn fitting over and repeat previous step to O-ring on other side of fitting. Make sure entire O-ring is coated with hydraulic oil.



Dip

NOTE: This method works best with Face Seal O-rings, but will work for all O-ring fitting types.

Tools needed:

- Small leak proof container
 - Sponge cut to fit inside container
 - Small amount of hydraulic oil to saturate sponge.
1. Place sponge inside container and add hydraulic oil to sponge until fully saturated.
 2. Dip fitting into sponge using firm pressure.



3. After lifting fitting, a small droplet should form and drip from bottom of fitting. This indicates an even coating of oil.



NOTE: O-ring boss-type fittings require more pressure to immerse more of fitting into saturated sponge. This also causes more oil to be dispersed from sponge.

Spray

This method requires a pump or trigger spray bottle.

1. Fill spray bottle with hydraulic oil.
2. Hold fitting over suitable catch can.
3. Spray entire O-ring surface with medium coat of oil.



Brush-On

This method requires a sealed bottle brush.

1. Fill bottle with hydraulic oil.
2. Using slight pressure to body of spray bottle, invert bottle so brush end faces down.
3. Brush an even coat of hydraulic oil on entire O-ring.



5.2 CYLINDERS - THEORY OF OPERATION

Systems With Double Acting Cylinders

Systems with double acting cylinders are the Slave Level, Master Level, Lift, Telescope, Articulating Jib Boom Lift, Axle Lockout, and Steer. A double acting cylinder is one that requires oil flow to operate the cylinder rod in both directions. Directing oil (by actuating the corresponding control valve to piston side of cylinder) forces the piston to travel toward the rod end of the barrel, extending the cylinder rod (piston attached to rod). When oil flow is stopped, movement of rod stops. By directing oil to the rod side of the cylinder, the piston is forced in the opposite direction and the cylinder rod retracts.

Systems With Holding Valves

Holding valves are used in the Lift, Telescope, Lockout, Slave Level, and Articulating Jib Boom Lift circuits to prevent retraction of the cylinder rod should a hydraulic line rupture or a leak develop between the cylinder and its control valve.

5.3 CYLINDER CHECKING PROCEDURE

NOTE: Cylinder check must be performed anytime a system component is replaced or when improper system operation is suspected.

Cylinders Without Counterbalance Valves - Master Cylinder and Steer Cylinder

1. Using all applicable safety precautions, activate engine and fully extend cylinder to be checked. Shut down engine.
2. Carefully disconnect hydraulic hoses from retract port of cylinder. There will be some initial weeping of hydraulic fluid which can be caught in a suitable container. After initial discharge, there should be no further drainage from the retract port.
3. Activate engine and extend cylinder.
4. If cylinder retract port leakage is less than 6-8 drops per minute, carefully reconnect hose to port and retract cylinder. If leakage continues at a rate of 6-8 drops per minute or more, repair cylinder.
5. With cylinder fully retracted, shut down engine and carefully disconnect hydraulic hose from cylinder extend port.
6. Activate engine and retract cylinder. Check extend port for leakage.
7. If extend port leakage is less than 6-8 drops per minute, carefully reconnect hose to extend port, then activate cylinder through one complete cycle and check for leaks. If leakage continues at a rate of 6-8 drops per minute or more, repair cylinder.

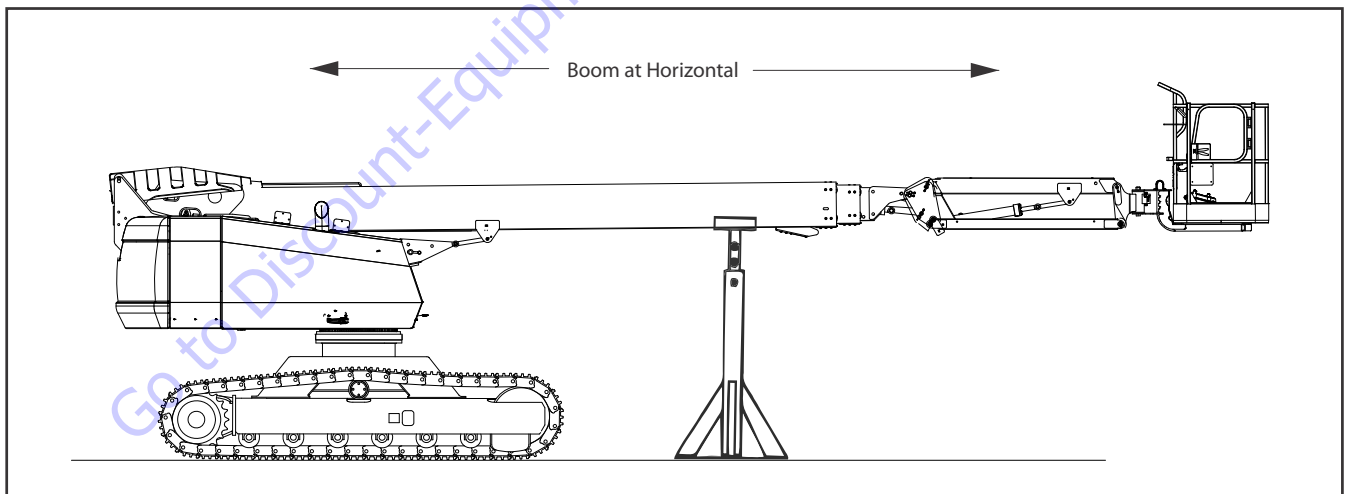

Figure 5-1. Boom Positioning and Support, Cylinder Repair

Cylinders With Single Counterbalance Valve

(Upper Lift Cylinder)

⚠ WARNING

OPERATE ALL FUNCTIONS FROM GROUND CONTROL STATION ONLY.

1. Using all applicable safety precautions, activate hydraulic system.

⚠ WARNING

WHEN WORKING ON MAIN LIFT CYLINDER, RAISE BOOM TO HORIZONTAL AND PLACE A BOOM PROP APPROXIMATELY 1 INCH (2.54 CM) BELOW THE MAIN BOOM. DO NOT WORK ON CYLINDER WITHOUT A SUITABLE PROP IN PLACE.

2. Shut down hydraulic system and allow machine to sit for 10-15 minutes. If machine is equipped with proportional control valves, turn IGNITION SWITCH to ON, move control switch or lever for applicable cylinder in each direction, then turn IGNITION SWITCH to OFF. If machine is equipped with hydraulic control valves, move control lever for applicable cylinder in each direction. This is done to relieve hydraulic line pressure. Carefully remove hydraulic hoses from appropriate cylinder port block.
3. There will be initial weeping of hydraulic fluid, which can be caught in a suitable container. After initial discharge, there should be no further leakage from the ports. If leakage continues at a rate of 6-8 drops per minute or more, counterbalance valve is defective and must be replaced.
4. To check piston seals, carefully remove counterbalance valve from the retract port. After initial discharge, there should be no further leakage from the ports. If leakage occurs at a rate of 6-8 drops per minute or more, piston seals are defective and must be replaced.
5. If no repairs are necessary or when repairs have been made, replace counterbalance valve and connect hydraulic hoses to cylinder port block.
6. If used, remove lifting device from upright or remove prop from below main boom. Activate hydraulic system and run cylinder through one complete cycle to check for leaks.

Cylinders With Dual Counterbalance Valves

(Articulating Jib Boom Lift, and Slave), Slave Level, Lower Lift, Upright level, Main Telescope and Tower Telescope)

⚠ WARNING

OPERATE ALL FUNCTIONS FROM GROUND CONTROL STATION ONLY.

1. Using all applicable safety precautions, activate hydraulic system.

⚠ WARNING

IF WORKING ON TOWER BOOM LIFT CYLINDER, RAISE TOWER BOOM HALF-WAY, FULLY ELEVATE MAIN BOOM WITH TELESCOPE CYLINDER FULLY RETRACTED. ATTACH AN OVERHEAD CRANE TO THE UPRIGHT FOR SUPPORT, LEAVING APPROXIMATELY 1 INCH (2.54 CM) OF SLACK IN CHAIN OR SLING FOR TEST PURPOSES. IF WORKING ON THE UPRIGHT LEVEL, RAISE TOWER BOOM HALF-WAY, THEN RAISE MAIN BOOM TO HORIZONTAL AND POSITION A SUITABLE BOOM PROP APPROXIMATELY 1 INCH (2.54 CM) BELOW MAIN BOOM. IF WORKING ON PLATFORM LEVEL CYLINDER, STROKE PLATFORM LEVEL CYLINDER FORWARD UNTIL PLATFORM SITS AT A 45 DEGREES ANGLE.

2. Shut down hydraulic system and allow machine to sit for 10-15 minutes. If machine is equipped with proportional control valves, turn IGNITION SWITCH to ON, move control switch or lever for applicable cylinder in each direction, then turn IGNITION SWITCH to OFF. If machine is equipped with hydraulic control valves, move control lever for applicable cylinder in each direction. This is done to relieve hydraulic line pressure.
3. Carefully remove hydraulic hoses from appropriate cylinder port block. Catch initial weeping of hydraulic fluid in a suitable container. After initial discharge, there should be no further leakage from the ports. If leakage continues at a rate of 6-8 drops per minute or more, counterbalance valve is defective and must be replaced.
4. To check piston seals, carefully remove counterbalance valve from retract port. After initial discharge, there should be no further leakage from the ports. If leakage occurs at a rate of 6-8 drops per minute or more, piston seals are defective and must be replaced.
5. If no repairs are necessary or when repairs have been made, replace counterbalance valve and carefully connect hydraulic hoses to cylinder port block.
6. Remove lifting device from upright or remove prop from below main boom. Activate hydraulic system and run cylinder through one complete cycle to check for leaks.

5.4 CYLINDER REMOVAL AND INSTALLATION

Main Boom Telescope Cylinder Removal

1. Place machine on a flat and level surface, with main boom in the horizontal position.
2. Shut down engine. Support main boom basket end with a prop. (See Figure 5-1., Boom Positioning and Support, Cylinder Repair).

NOTICE

CAP HYDRAULIC LINES AND PORTS IMMEDIATELY AFTER DISCONNECTING LINES TO PREVENT ENTRY OF CONTAMINANTS INTO THE SYSTEM.

3. Tag and disconnect hydraulic lines to telescope cylinder. Use a suitable container to retain residual hydraulic fluid. Cap hydraulic lines and ports.
4. Remove hardware securing cover plate on bottom of base boom section and remove cover.

NOTICE

DO NOT ALLOW CABLE TO ROTATE. THIS MAY DAMAGE THE CABLE.

5. Clamp both threaded ends of cable to prevent rotation. Note: Do not clamp on threads. Remove jam nuts and loosen adjustment nuts so there is slack in the cables. (See Section 4 - Boom & Platform).
6. Remove hardware securing push bar to turntable and telescope cylinder.
7. Using a suitable brass drift, carefully drive push bar pins from telescope cylinder rod and turntable.
8. Remove hardware securing cable adjustment block to aft end of the base boom section and remove block.
9. Remove hardware securing telescope cylinder to aft end of mid boom section.

NOTICE

WHEN REMOVING TELESCOPE CYLINDER FROM BOOM, IT MAY BE NECESSARY AT SOME POINT TO TURN CYLINDER SLIGHTLY IN ORDER TO CLEAR ASSEMBLIES MOUNTED IN THE BOOM. MOVE CYLINDER SLOWLY INTO POSITION OR DAMAGE TO COMPONENTS MAY RESULT FROM FORCIBLE IMPACT WITH THESE ASSEMBLIES.

10. Remove bolts securing cable attach bar to top of fly boom section.
11. Pull telescope cylinder and cables partially from aft end of base boom section. Secure cylinder with a suitable sling and lifting device at center of gravity.
12. Carefully remove telescope cylinder and sheave assembly. Place telescope cylinder on a suitable trestle.

Main Boom Telescope Cylinder Installation

1. Route extend cables around extend sheave and secure cables to the telescope cylinder.
2. Install extend cables mounting blocks to threaded ends of cables. Loosely install nuts and jam nuts on threaded end of cables.

NOTICE

DO NOT TO TWIST OR CROSS CABLES DURING INSTALLATION.

3. Secure sling and lifting device at telescope cylinder's center of gravity. Lift cylinder to aft end of boom assembly.
4. Install extend cable mounting blocks to threaded ends of cables. Loosely install nuts and jam nuts on threaded ends of cables.

NOTICE

WHEN INSERTING TELESCOPE CYLINDER INTO BOOM, IT MAY BE NECESSARY TO TURN CYLINDER SLIGHTLY TO CLEAR ASSEMBLIES MOUNTED IN THE BOOM. MOVE CYLINDER SLOWLY INTO POSITION OR DAMAGE TO COMPONENTS MAY RESULT FROM FORCIBLE IMPACT WITH THESE ASSEMBLIES.

5. Carefully install telescope cylinder barrel end support into slots in mid boom and secure with blocks and bolts. Use Loctite #242 on bolts.
6. Align holes in aft end of fly boom section with holes in cable mounting block. Secure with mounting hardware.
7. Align holes in aft end of base boom section with holes in cable mounting block. Secure with mounting hardware.
8. Remove cylinder port plugs and hydraulic line caps. Correctly attach lines to cylinder ports.
9. Align holes in rod end of telescope cylinder with holes in push bar. Install push bar pin and secure with mounting hardware.
10. Align holes in push bar with holes in turntable. Install push bar pin and secure with mounting hardware.

NOTE: *Boom cables must be torqued after telescope cylinder installation. (See Section 4.1, Boom Rope Torquing Procedures)*

Main Boom Lift Cylinder Removal

1. Place machine on a flat and level surface. Start engine and place main boom in horizontal position. Shut down engine and prop boom. (See Figure 5-1., Boom Positioning and Support, Cylinder Repair)
2. Remove hardware retaining cylinder rod attach pin to boom. Using a suitable brass drift, drive out cylinder rod pin.
3. Using auxiliary power, retract the lift cylinder rod completely.
4. Disconnect, cap and tag the main boom lift cylinder hydraulic lines and ports.
5. Remove barrel end attach pin retaining hardware. Using a suitable brass drift drive out the barrel end attach pin from the turntable.
6. Remove the cylinder from the turntable and place in a suitable work area.

Main Boom Lift Cylinder Installation

1. Install lift cylinder in place using suitable slings or supports, aligning attach pin mounting holes on the turntable.
2. Using a suitable drift, drive barrel end attach pin through mounting holes in lift cylinder and turntable. Secure in place with pin retaining hardware.
3. Remove cylinder port plugs and hydraulic line caps and correctly attach lines to cylinder ports.
4. Using auxiliary power, extend cylinder rod until attach pin hole aligns with those in the boom. Using a suitable soft mallet, drive cylinder rod attach pin through the boom and lift cylinder. Secure pin in place with attaching hardware.
5. Remove boom prop and overhead crane. Activate hydraulic system.
6. Using all applicable safety precautions, operate boom functions. Check for correct operation and hydraulic leaks. Secure as necessary.
7. Check fluid level of hydraulic tank. Adjust as necessary.

5.5 CYLINDER REPAIR

NOTE: Following are general procedures that apply to all cylinders on this machine. Procedures that apply to a specific cylinder are noted.

Disassembly

NOTICE

CYLINDER DISASSEMBLY SHOULD BE PERFORMED ON A CLEAN WORK SURFACE IN A DIRT FREE WORK AREA TO PREVENT CONTAMINATION.

1. Connect a suitable auxiliary hydraulic power source to cylinder port block fitting.

⚠ WARNING

DO NOT FULLY EXTEND CYLINDER TO END OF STROKE. RETRACT CYLINDER SLIGHTLY TO AVOID TRAPPING PRESSURE.

2. Operate hydraulic power source and extend the cylinder. Shut down and disconnect power source. Adequately support cylinder rod, if applicable.
3. If applicable, remove cartridge-type holding valve and fittings from cylinder port block. Discard O-rings.

Cylinder Locations

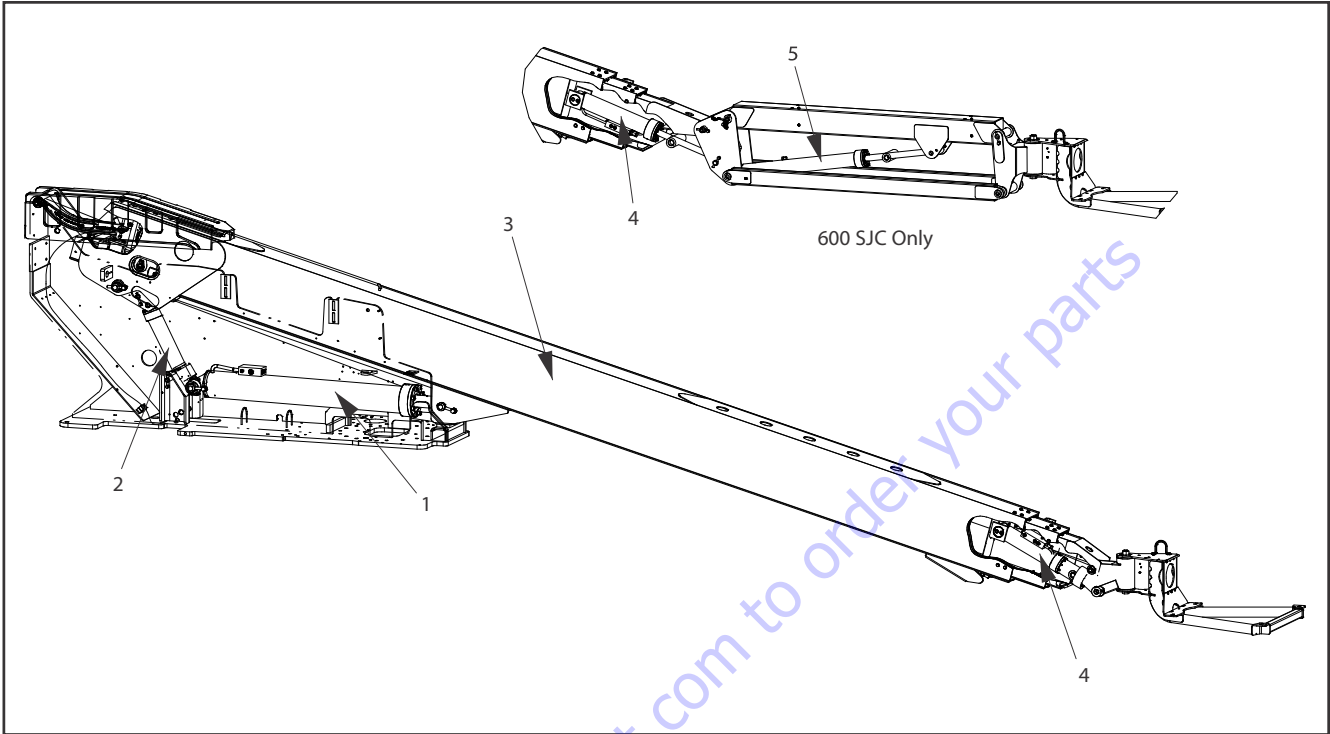

Item	Cylinder
1	Main Lift
2	Master
3	Telescope
4	Platform Level (Slave)
5	Jib Lift

Figure 5-2. Hydraulic Cylinder Locations

Main Lift Cylinder

DISASSEMBLY

NOTE: Refer to Figure 5-6.

NOTICE

CONTAMINATION MAY DAMAGE EQUIPMENT. DISASSEMBLE CYLINDER ON A CLEAN WORK SURFACE IN A DIRT FREE WORK AREA.

1. Connect a suitable auxiliary hydraulic power source to cylinder port block fitting.

WARNING

DO NOT FULLY EXTEND CYLINDER TO THE END OF STROKE. RETRACT CYLINDER SLIGHTLY TO AVOID TRAPPING PRESSURE.

2. Operate hydraulic power source and extend cylinder. Shut down and disconnect power source. Adequately support cylinder rod, if applicable.
3. If applicable, remove cartridge-type counterbalance valve and fittings from cylinder port block. Discard O-rings.
4. Place cylinder barrel in a suitable holding fixture. Tap around outside of cylinder head retainer with a suitable hammer to break thread-locking compound.

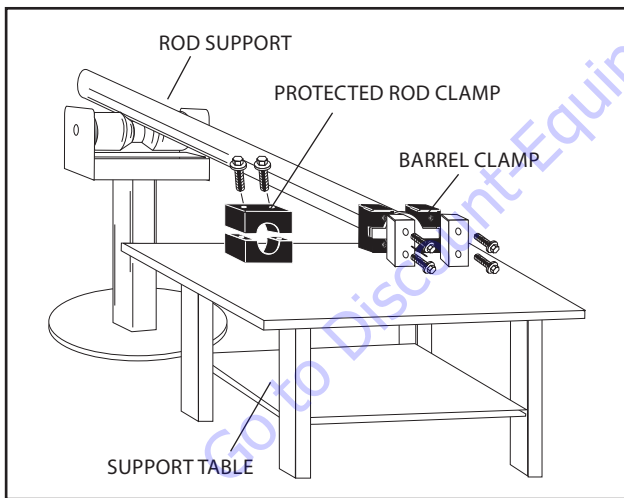

Figure 5-3. Cylinder Barrel Support

5. Mark cylinder head (1) and barrel (2) with center punch marks (3) for later realignment. Remove eight cylinder head cap screws (4).

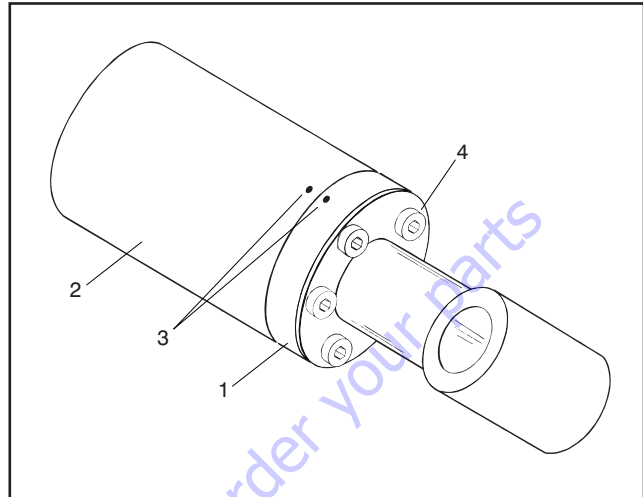

Figure 5-4. Marking Cylinder for Alignment

NOTICE

PULLING ROD OFF-CENTER CAN DAMAGE PISTON AND CYLINDER BARREL SURFACES. USE EXTREME CARE WHEN REMOVING CYLINDER ROD, HEAD, AND PISTON.

6. Clamp barrel securely. Pull rod assembly and cylinder head from barrel.
7. Protect cylinder rod from damage and clamp in a vise or holding fixture as close to piston as possible.

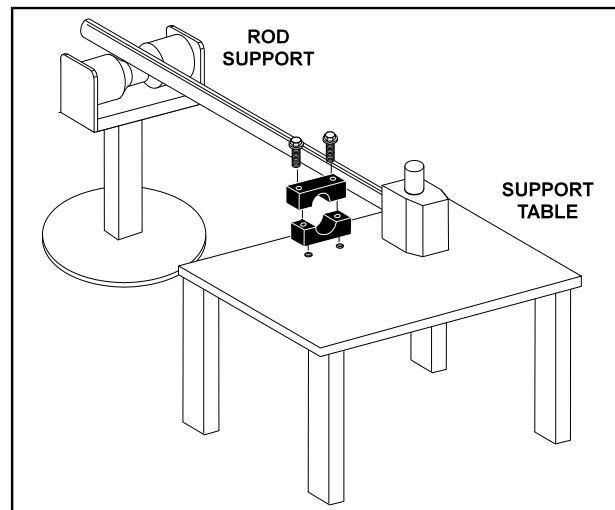
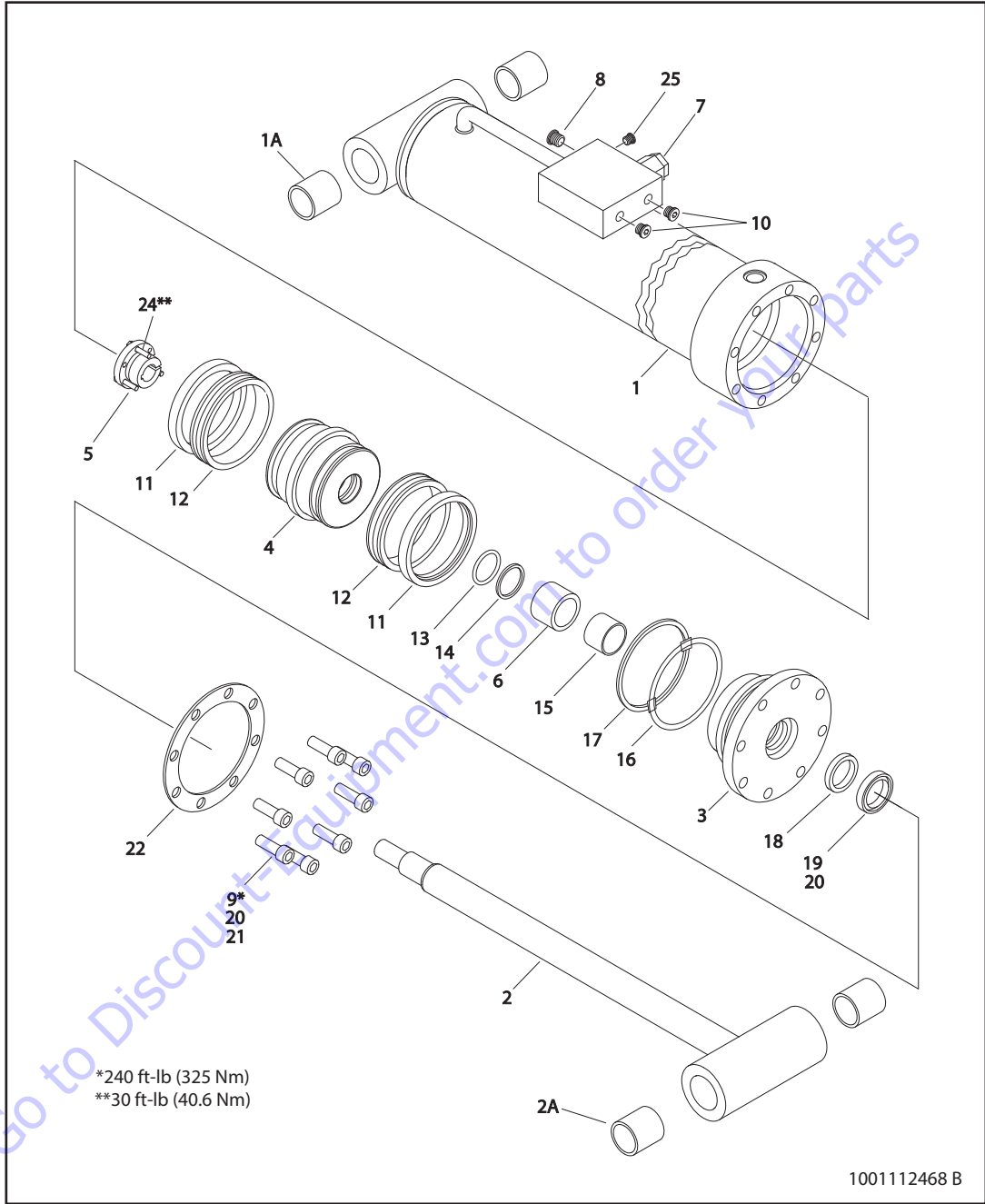

Figure 5-5. Cylinder Rod Support



Go to Discount-Equipment.com to order your parts

*240 ft-lb (325 Nm)
 **30 ft-lb (40.6 Nm)

1001112468 B

- | | | | | |
|-----------------------|--------------------|--------------------|----------------------|-----------------------|
| 1. Barrel | 5. Tapered Bushing | 11. Lock Ring | 17. Back-Up Ring | 23. Not Used |
| 1a. Composite Bushing | 6. Spacer | 12. Hydrolock Seal | 18. Rod Seal | 24. Socket Head Screw |
| 2. Rod | 7. Cartridge Valve | 13. O-Ring | 19. Wiper | 25. O-Ring Plug |
| 2a. Composite Bushing | 8. O-Ring Plug | 14. Back-Up Ring | 20. Locking Compound | |
| 3. Head | 9. 5/16"-11x2 Bolt | 15. Wear Ring | 21. Locking Primer | |
| 4. Piston | 10. O-Ring Plug | 16. O-Ring | 22. Ring Washer | |

Figure 5-6. Main Lift Cylinder Assembly

SECTION 5 - HYDRAULICS

8. Using suitable protection, clamp cylinder rod in a vise or similar holding fixture as close to piston as possible.
9. Loosen and remove nut attaching piston to rod. Remove piston.
10. Loosen and remove cap screw(s), if applicable, attaching tapered bushing to piston.
11. Insert cap screw(s) in threaded holes in outer piece of tapered bushing. Progressively tighten cap screw(s) until bushing is loose on piston.
12. Remove tapered bushing from piston.
13. Screw piston counter-clockwise by hand and remove from cylinder rod.

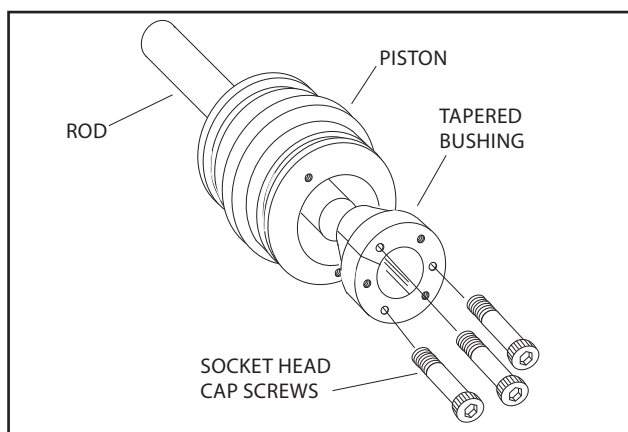

Figure 5-7. Tapered Bushing Removal

14. Remove and discard piston O-rings, seal rings, and backup rings.
15. Remove piston spacer, if applicable, from rod.
16. Remove rod from holding fixture. Remove cylinder head gland and retainer plate, if applicable. Discard O-rings, back-up rings, rod seals, and wiper seals.

Cleaning and Inspection

1. Clean parts thoroughly with approved cleaning solvent.
2. Inspect cylinder rod for scoring, tapering, ovality, or other damage. If necessary, dress rod with Scotch Brite or equivalent. Replace rod if necessary.
3. Inspect threaded portion of rod for excessive damage. Dress threads as necessary.
4. Inspect inner surface of cylinder barrel tube for scoring or other damage. Check inside diameter for tapering or ovality. Replace if necessary.
5. Inspect threaded portion of barrel for damage. Dress threads as necessary.
6. Inspect piston surface for damage, scoring, or distortion. Dress piston surface or replace piston as necessary.

7. Inspect threaded portion of piston for damage. Dress threads as necessary.
8. Inspect seal and O-ring grooves in piston for burrs and sharp edges. Dress surfaces as necessary.
9. Inspect cylinder head inside diameter for scoring or other damage, and for ovality and tapering. Replace as necessary.
10. Inspect threaded portion of head for damage. Dress threads as necessary.
11. Inspect seal and O-ring grooves in head for burrs and sharp edges. Dress applicable surfaces as necessary.
12. Inspect cylinder head outside diameter for scoring, damage, ovality, and tapering. Replace as necessary.
13. If applicable, inspect rod and barrel bearings for signs of correct excessive wear or damage. Replace as necessary.
 - a. Thoroughly clean hole, (steel bushing) of burrs, dirt etc. to facilitate bearing installation.
 - b. Inspect steel bushing for wear or other damage. If steel bushing is worn or damaged, rod/barrel must be replaced.
 - c. Lubricate inside of the steel bushing with WD40 prior to bearing installation.

NOTE: Lubrication is not required with nickel plated pins and bearings. Install pin in composite bushing dry.

- d. Press composite bushing into barrel or rod bushing with correct size arbor.

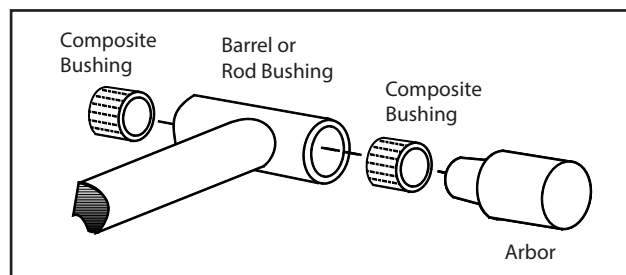

Figure 5-8. Composite Bushing Installation

14. Inspect travel limiting collar or spacer for burrs and sharp edges. If necessary, dress inside diameter surface with Scotch Brite or equivalent.
15. If applicable, inspect port block fittings and holding valve. Replace as necessary.
16. Inspect oil ports for blockage or presence of dirt or other foreign material. Repair as necessary.
17. If applicable, inspect piston rings for cracks or other damage. Replace as necessary.

Assembly

NOTE: Use proper cylinder seal kit for cylinder assembly. See your JLG Parts Manual.

Apply a light film of hydraulic oil to all components before assembly.

1. Use seal tool to install new rod seal into applicable cylinder head gland groove.

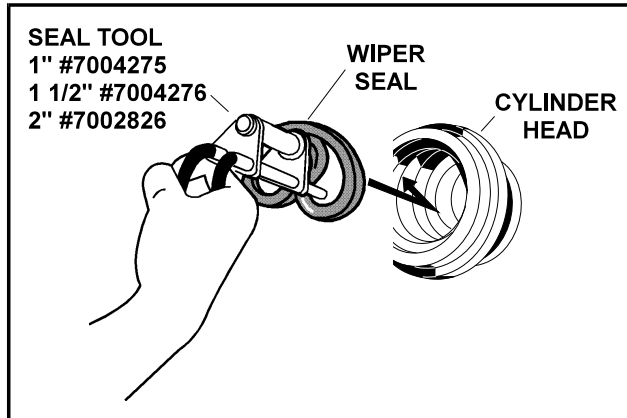

Figure 5-9. Rod Seal Installation

NOTICE

IMPROPER SEAL INSTALLATION CAN CAUSE CYLINDER LEAKS AND IMPROPER CYLINDER OPERATION. ENSURE 'POLY-PAK' PISTON SEALS ARE PROPERLY INSTALLED. REFER TO WIPER SEAL INSTALLATION FOR CORRECT SEAL ORIENTATION.

2. Use a soft mallet to tap new wiper seal into applicable cylinder head gland groove. Install new wear ring in applicable cylinder head gland groove.

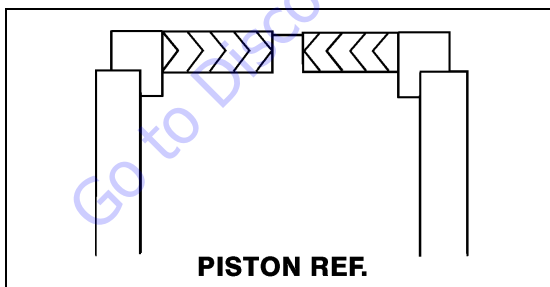

Figure 5-10. Poly-Pak Piston Seal Installation

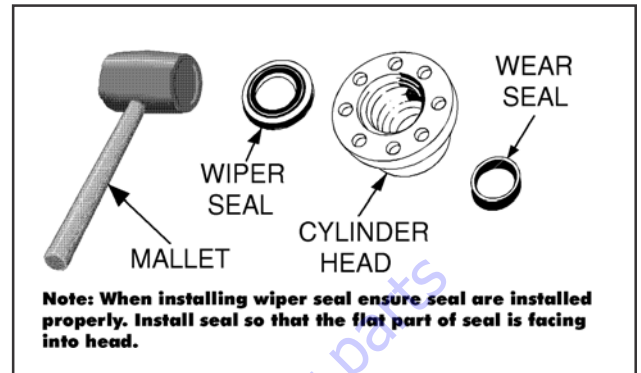

Figure 5-11. Wiper Seal Installation

3. Place new O-ring and back-up seal in applicable outside diameter groove of cylinder head.

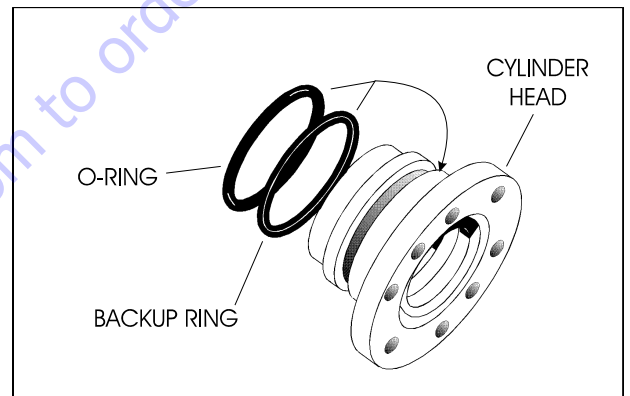

Figure 5-12. Head Seal Kit Installation

4. Install washer ring on rod. Carefully install head gland on rod. Do not damage or dislodge wiper and rod seals. Push head along rod to rod end, as applicable.
5. Carefully slide piston spacer on rod.

NOTE: Upper telescope cylinder piston has an O-ring installed inside spacer.

SECTION 5 - HYDRAULICS

- If applicable, place new O-ring and back-up rings in inner piston diameter groove.

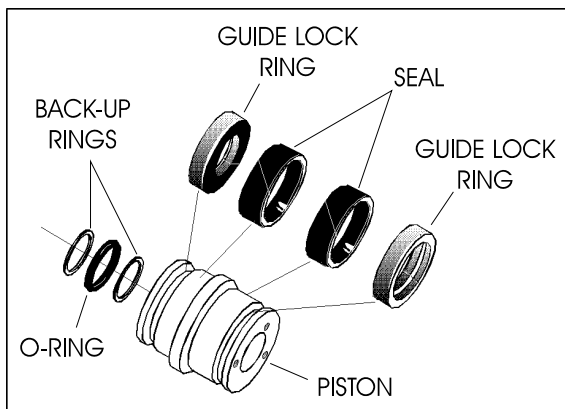

Figure 5-13. Piston Seal Kit Installation

- Using suitable protection, clamp cylinder rod in a vise or similar holding fixture as close to piston as possible.
- Carefully thread piston on cylinder rod hand tight, Ensure O-ring and back-up rings are not damaged or dislodged.

NOTE: Piston and mating end of rod must be free of oil when installing tapered bushing.

- Thread piston onto rod until it aligns with spacer end and install tapered bushing.

NOTE: Apply LOCTITE #242 or equivalent to tapered bushing bolts when rebuilding master, slave, lift, and telescope cylinders.

- Install bolts in tapered bushing using loctite #242

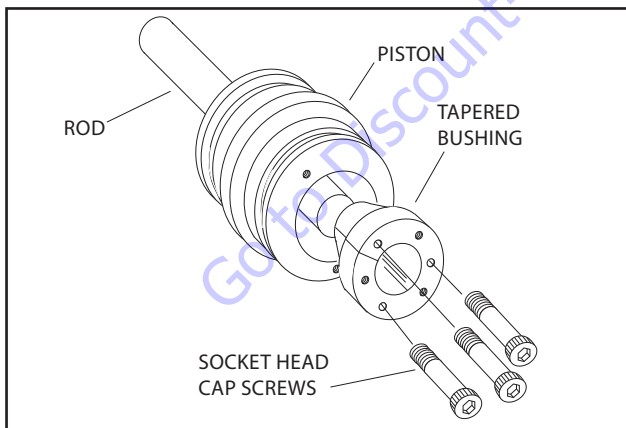

Figure 5-14. Tapered Bushing Installation

- Remove cylinder rod from holding fixture.
- Place new guide locks and seals in applicable outside diameter grooves of cylinder piston. (See Figure 2-28. Piston Seal Kit Installation.)
- Position cylinder barrel in a suitable holding fixture.

NOTICE

INSERTING ROD OFF-CENTER CAN DAMAGE PISTON AND CYLINDER BARREL SURFACES. USE EXTREME CARE WHEN INSTALLING CYLINDER ROD, HEAD, AND PISTON.

- Clamp barrel clamped securely and support rod. Insert piston end into barrel cylinder. Do not damage or dislodge piston loading O-ring and seal ring.
- Continue pushing rod into barrel until cylinder head gland can be inserted into barrel cylinder.
- Secure cylinder head gland using washer ring and socket head bolts.

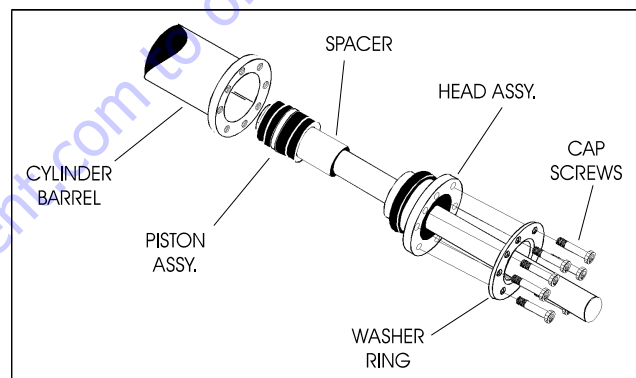

Figure 5-15. Rod Assembly Installation

Master Cylinder

DISASSEMBLY

NOTE: Refer to Figure 5-19. Master Cylinder.

NOTICE

CONTAMINATION MAY DAMAGE EQUIPMENT. DISASSEMBLE CYLINDER ON A CLEAN WORK SURFACE IN A DIRT FREE WORK AREA.

1. Connect a suitable auxiliary hydraulic power source to cylinder port block fitting.

WARNING

DO NOT FULLY EXTEND CYLINDER TO THE END OF STROKE. RETRACT CYLINDER SLIGHTLY TO AVOID TRAPPING PRESSURE.

2. Operate hydraulic power source and extend cylinder. Shut down and disconnect power source. Adequately support cylinder rod, if applicable.
3. If applicable, remove cartridge-type counterbalance valve and fittings from cylinder port block. Discard O-rings.
4. Place cylinder barrel in a suitable holding fixture. Tap around outside of cylinder head retainer with a suitable hammer to break thread-locking compound.

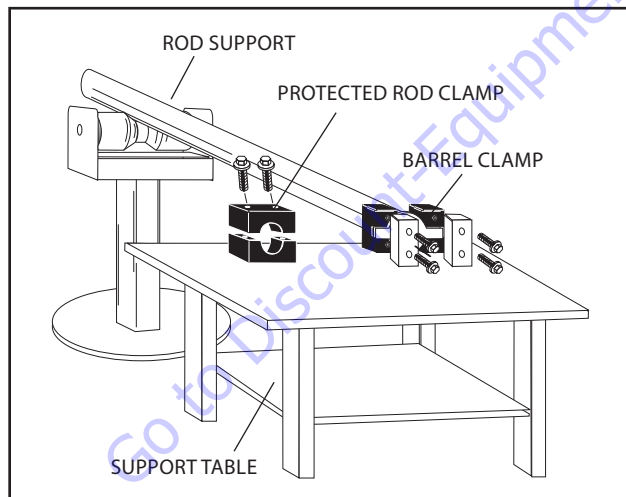

Figure 5-16. Cylinder Barrel Support

5. Mark cylinder head (1) and barrel (2) with center punch marks (3) for later realignment. Remove eight cylinder head cap screws (4).

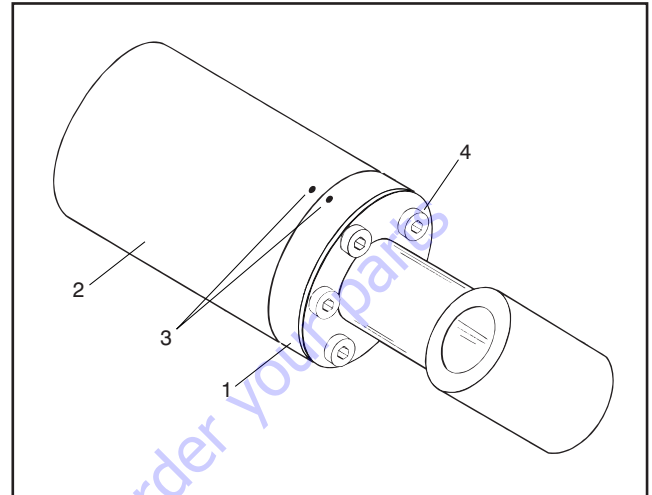

Figure 5-17. Marking Cylinder for Alignment

NOTICE

PULLING ROD OFF-CENTER CAN DAMAGE PISTON AND CYLINDER BARREL SURFACES. USE EXTREME CARE WHEN REMOVING CYLINDER ROD, HEAD, AND PISTON.

6. Clamp barrel securely. Pull rod assembly and cylinder head from barrel.
7. Protect cylinder rod from damage and clamp in a vise or holding fixture as close to piston as possible.

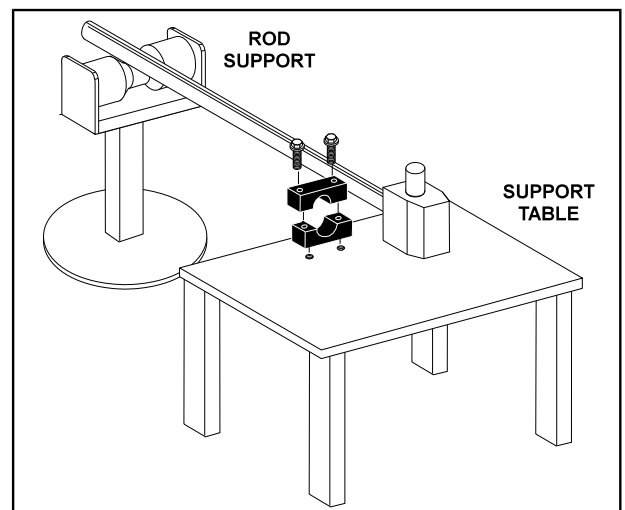
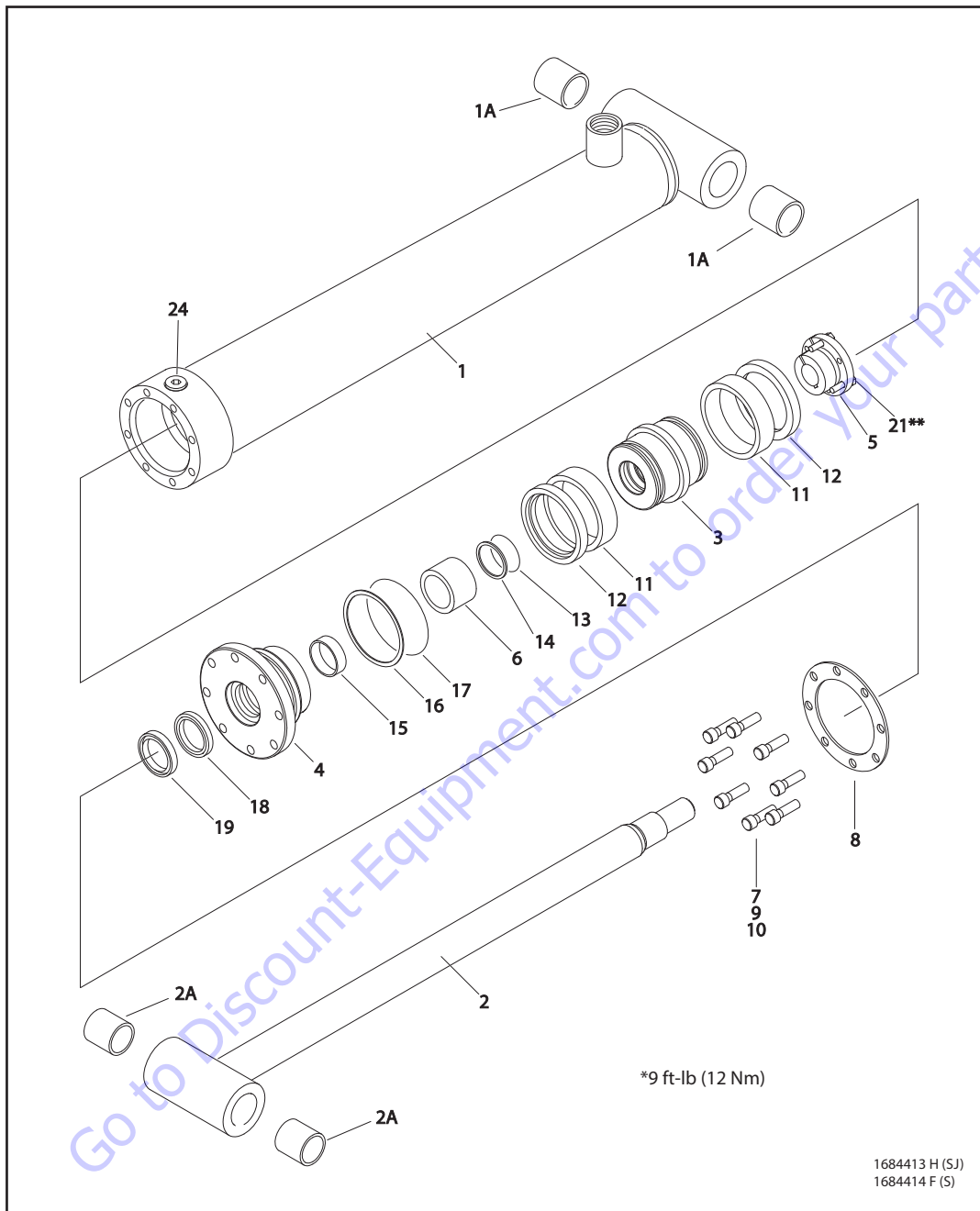

Figure 5-18. Cylinder Rod Support



- | | | | | |
|-----------------------|--------------------|---------------------|------------------|--------------|
| 1. Barrel | 4. Head | 9. Locking Compound | 14. Back-Up Ring | 19. Wiper |
| 1a. Composite Bushing | 5. Tapered Bushing | 10. Locking Primer | 15. Wear Ring | 20. Not Used |
| 2. Rod | 6. Spacer | 11. Seal | 16. O-Ring | 21. Capscrew |
| 2a. Composite Bushing | 7. Capscrew | 12. Lock Ring | 17. Back-Up Ring | |
| 3. Piston | 8. Ring Washer | 13. O-Ring | 18. Rod Seal | |

Figure 5-19. Master Cylinder Assembly

8. Using suitable protection, clamp cylinder rod in a vise or similar holding fixture as close to piston as possible.
9. Loosen and remove nut attaching piston to rod. Remove piston.
10. Loosen and remove cap screw(s), if applicable, attaching tapered bushing to piston.
11. Insert cap screw(s) in threaded holes in outer piece of tapered bushing. Progressively tighten cap screw(s) until bushing is loose on piston.
12. Remove tapered bushing from piston.
13. Screw piston counter-clockwise by hand and remove from cylinder rod.

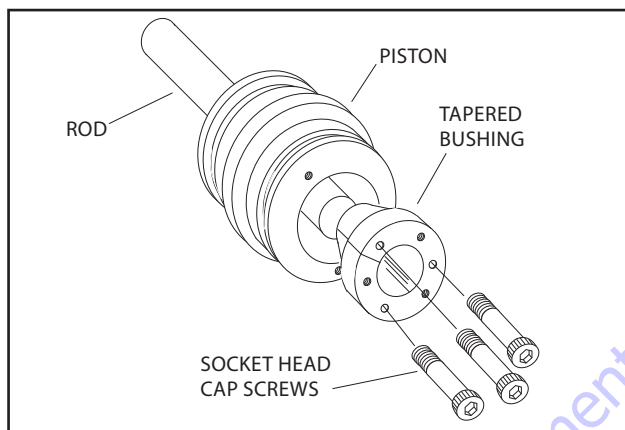

Figure 5-20. Tapered Bushing Removal

14. Remove and discard piston O-rings, seal rings, and backup rings.
15. Remove piston spacer, if applicable, from rod.
16. Remove rod from holding fixture. Remove cylinder head gland and retainer plate, if applicable. Discard O-rings, back-up rings, rod seals, and wiper seals.

Cleaning and Inspection

1. Clean parts thoroughly with approved cleaning solvent.
2. Inspect cylinder rod for scoring, tapering, ovality, or other damage. If necessary, dress rod with Scotch Brite or equivalent. Replace rod if necessary.
3. Inspect threaded portion of rod for excessive damage. Dress threads as necessary.
4. Inspect inner surface of cylinder barrel tube for scoring or other damage. Check inside diameter for tapering or ovality. Replace if necessary.
5. Inspect threaded portion of barrel for damage. Dress threads as necessary.
6. Inspect piston surface for damage, scoring, or distortion. Dress piston surface or replace piston as necessary.

7. Inspect threaded portion of piston for damage. Dress threads as necessary.
8. Inspect seal and O-ring grooves in piston for burrs and sharp edges. Dress surfaces as necessary.
9. Inspect cylinder head inside diameter for scoring or other damage, and for ovality and tapering. Replace as necessary.
10. Inspect threaded portion of head for damage. Dress threads as necessary.
11. Inspect seal and O-ring grooves in head for burrs and sharp edges. Dress applicable surfaces as necessary.
12. Inspect cylinder head outside diameter for scoring, damage, ovality, and tapering. Replace as necessary.
13. If applicable, inspect rod and barrel bearings for signs of correct excessive wear or damage. Replace as necessary.
 - a. Thoroughly clean hole, (steel bushing) of burrs, dirt etc. to facilitate bearing installation.
 - b. Inspect steel bushing for wear or other damage. If steel bushing is worn or damaged, rod/barrel must be replaced.
 - c. Lubricate inside of the steel bushing with WD40 prior to bearing installation.

NOTE: Lubrication is not required with nickel plated pins and bearings. Install pin in composite bushing dry.

- d. Press composite bushing into barrel or rod bushing with correct size arbor.

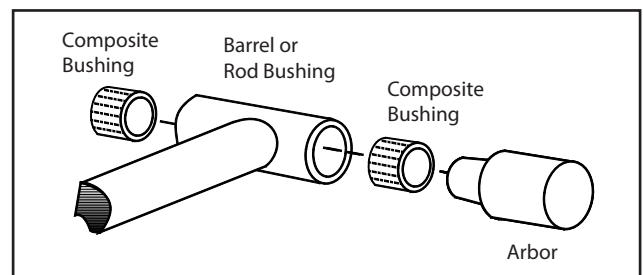

Figure 5-21. Composite Bushing Installation

14. Inspect travel limiting collar or spacer for burrs and sharp edges. If necessary, dress inside diameter surface with Scotch Brite or equivalent.
15. If applicable, inspect port block fittings and holding valve. Replace as necessary.
16. Inspect oil ports for blockage or presence of dirt or other foreign material. Repair as necessary.
17. If applicable, inspect piston rings for cracks or other damage. Replace as necessary.

Assembly

NOTE: Use proper cylinder seal kit for cylinder assembly. See your JLG Parts Manual.

Apply a light film of hydraulic oil to all components before assembly.

1. Use seal tool to install new rod seal into applicable cylinder head gland groove.

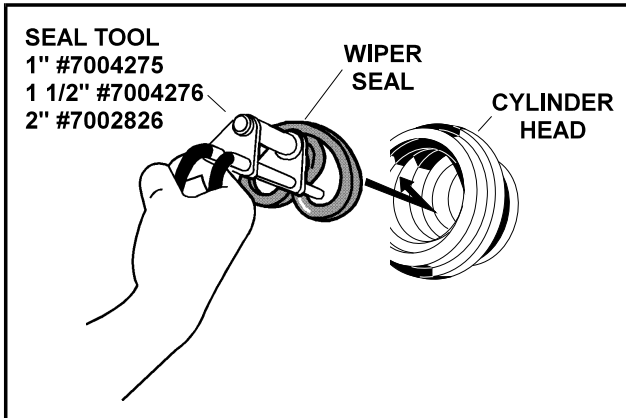

Figure 5-22. Rod Seal Installation

NOTICE

IMPROPER SEAL INSTALLATION CAN CAUSE CYLINDER LEAKS AND IMPROPER CYLINDER OPERATION. ENSURE 'POLY-PAK' PISTON SEALS ARE PROPERLY INSTALLED. REFER TO WIPER SEAL INSTALLATION FOR CORRECT SEAL ORIENTATION.

2. Use a soft mallet to tap new wiper seal into applicable cylinder head gland groove. Install new wear ring in applicable cylinder head gland groove.

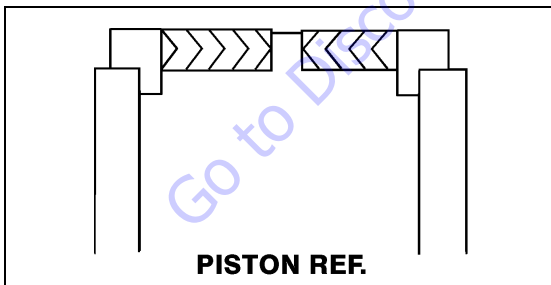

Figure 5-23. Poly-Pak Piston Seal Installation

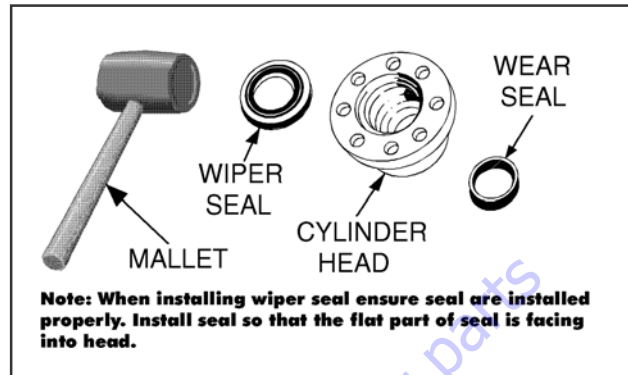

Figure 5-24. Wiper Seal Installation

3. Place new O-ring and back-up seal in applicable outside diameter groove of cylinder head.

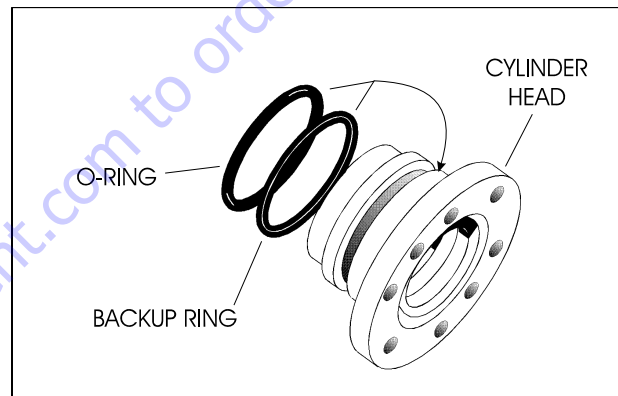

Figure 5-25. Head Seal Kit Installation

4. Install washer ring on rod. Carefully install head gland on rod. Do not damage or dislodge wiper and rod seals. Push head along rod to rod end, as applicable.
5. Carefully slide piston spacer on rod.

NOTE: Upper telescope cylinder piston has an O-ring installed inside spacer.

6. If applicable, place new O-ring and back-up rings in inner piston diameter groove.

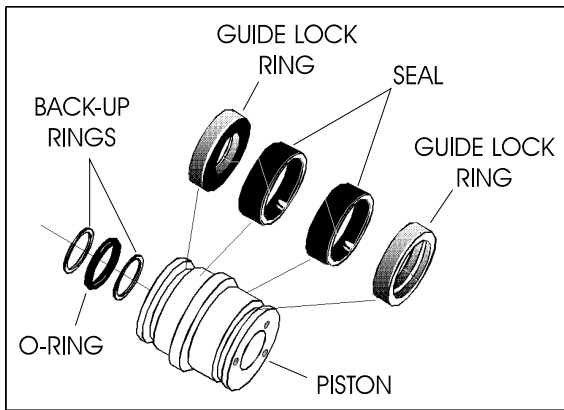

Figure 5-26. Piston Seal Kit Installation

7. Using suitable protection, clamp cylinder rod in a vise or similar holding fixture as close to piston as possible.
8. Carefully thread piston on cylinder rod hand tight, Ensure O-ring and back-up rings are not damaged or dislodged.

NOTE: Piston and mating end of rod must be free of oil when installing tapered bushing.

9. Thread piston onto rod until it aligns with spacer end and install tapered bushing.

NOTE: Apply LOCTITE #242 or equivalent to tapered bushing bolts when rebuilding master, slave, lift, and telescope cylinders.

10. Install bolts in tapered bushing using loctite #242

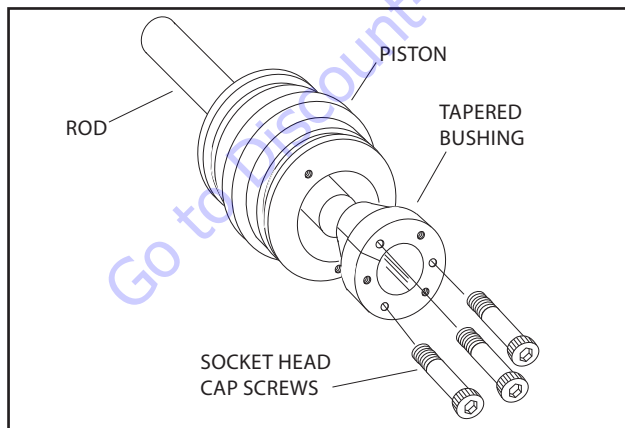

Figure 5-27. Tapered Bushing Installation

11. Remove cylinder rod from holding fixture.
12. Place new guide locks and seals in applicable outside diameter grooves of cylinder piston. (See Figure 2-28. Piston Seal Kit Installation.)
13. Position cylinder barrel in a suitable holding fixture.

NOTICE

INSERTING ROD OFF-CENTER CAN DAMAGE PISTON AND CYLINDER BARREL SURFACES. USE EXTREME CARE WHEN INSTALLING CYLINDER ROD, HEAD, AND PISTON.

14. Clamp barrel clamped securely and support rod. Insert piston end into barrel cylinder. Do not damage or dislodge piston loading O-ring and seal ring.
15. Continue pushing rod into barrel until cylinder head gland can be inserted into barrel cylinder.
16. Secure cylinder head gland using washer ring and socket head bolts.

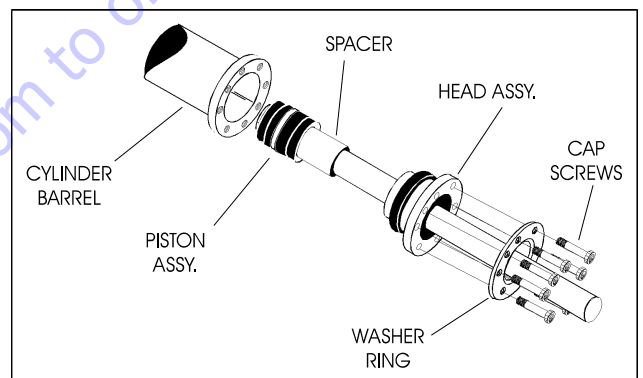

Figure 5-28. Rod Assembly Installation

Telescope Cylinder

DISASSEMBLY

NOTICE

CONTAMINATION MAY DAMAGE EQUIPMENT. DISASSEMBLE CYLINDER ON A CLEAN WORK SURFACE IN A DIRT FREE WORK AREA.

1. Connect a suitable auxiliary hydraulic power source to cylinder port block fitting.

WARNING

DO NOT FULLY EXTEND CYLINDER TO THE END OF STROKE. RETRACT CYLINDER SLIGHTLY TO AVOID TRAPPING PRESSURE.

2. Operate hydraulic power source and extend cylinder. Shut down and disconnect power source. Adequately support cylinder rod, if applicable.
3. If applicable, remove cartridge-type counterbalance valve and fittings from cylinder port block. Discard O-rings.
4. Place cylinder barrel in a suitable holding fixture. Tap around outside of cylinder head retainer with a suitable hammer to break thread-locking compound.

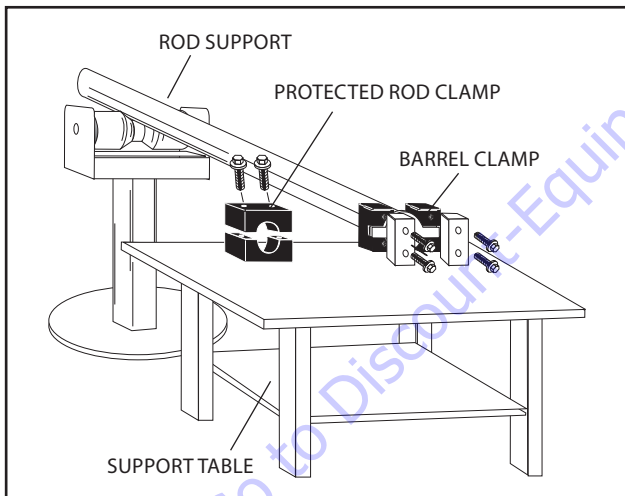

Figure 5-29. Cylinder Barrel Support

5. Mark cylinder head (1) and barrel (2) with center punch marks (3) for later realignment. Remove eight cylinder head cap screws (4).

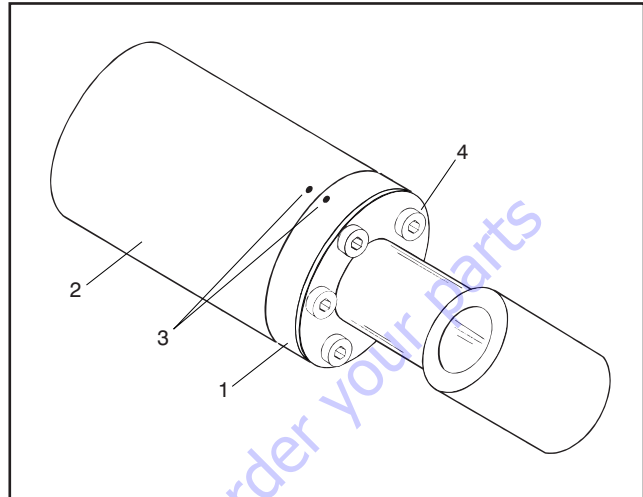

Figure 5-30. Marking Cylinder for Alignment

NOTICE

PULLING ROD OFF-CENTER CAN DAMAGE PISTON AND CYLINDER BARREL SURFACES. USE EXTREME CARE WHEN REMOVING CYLINDER ROD, HEAD, AND PISTON.

6. Clamp barrel securely. Pull rod assembly and cylinder head from barrel.
7. Protect cylinder rod from damage and clamp in a vise or holding fixture as close to piston as possible.

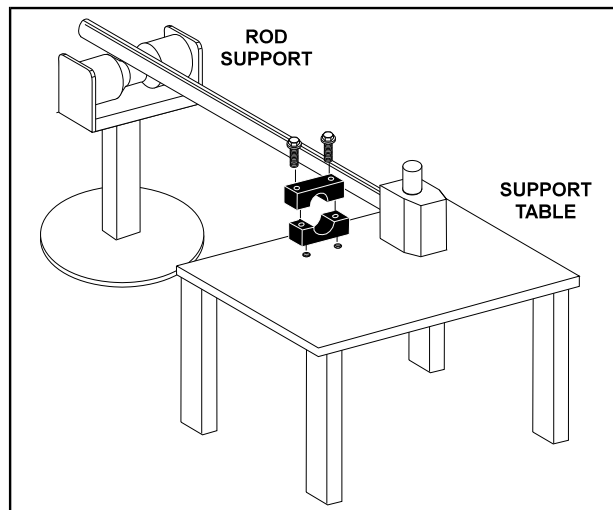
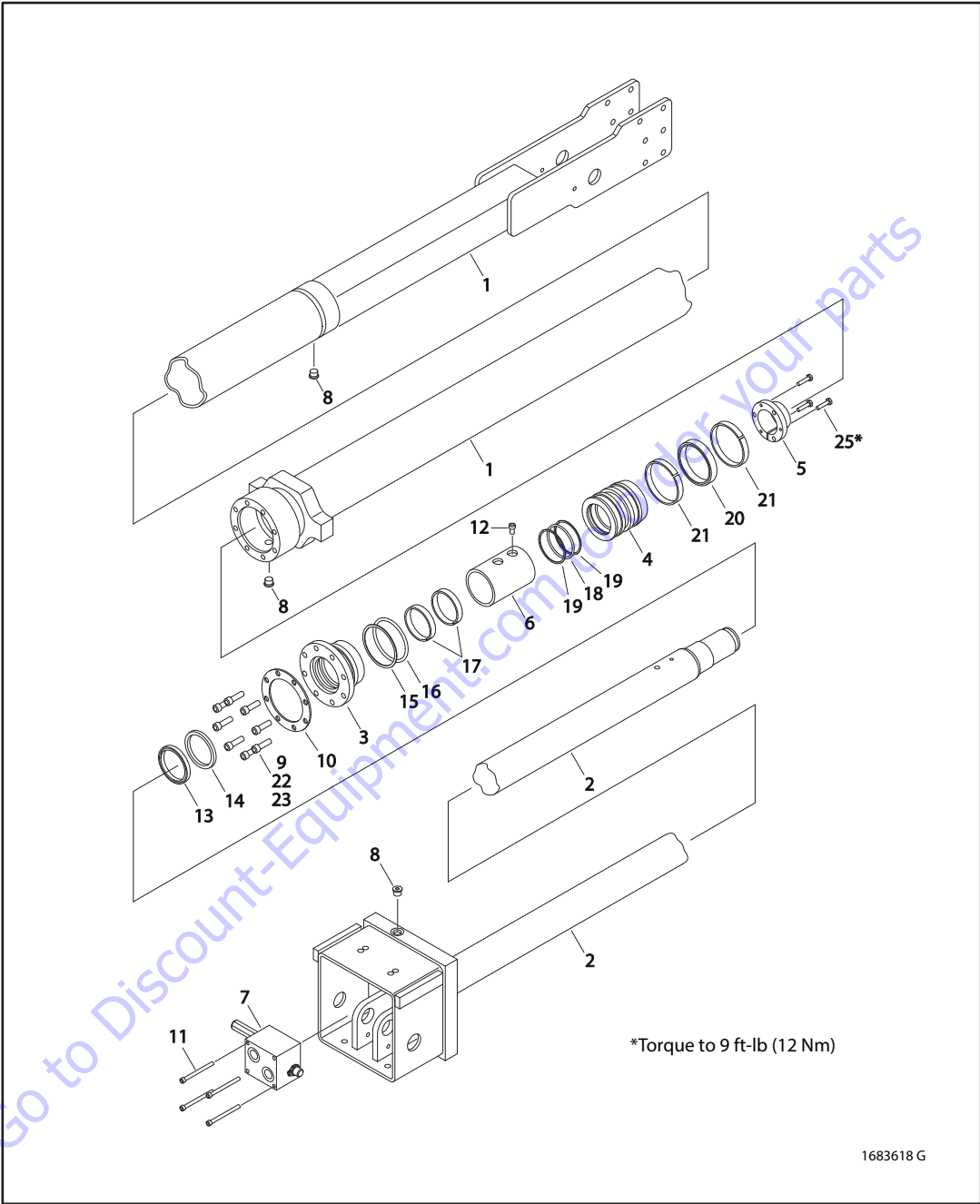

Figure 5-31. Cylinder Rod Support



- | | | | | |
|--------------------|-------------------|--------------|------------------|----------------------|
| 1. Barrel | 6. Spacer | 11. Capscrew | 16. Back-Up Ring | 21. Wear Ring |
| 2. Rod | 7. Valve Assembly | 12. Capscrew | 17. Wear Ring | 22. Locking Compound |
| 3. Head | 8. O-Ring Plug | 13. Wiper | 18. O-Ring | 23. Locking primer |
| 4. Piston | 9. Capscrew | 14. Rod Seal | 19. Back-Up Ring | 24. Not Used |
| 5. Tapered Bushing | 10. Ring Washer | 15. O-Ring | 20. T-Seal | 25. Bolt |

Figure 5-32. Telescope Cylinder Assembly

8. Using suitable protection, clamp cylinder rod in a vise or similar holding fixture as close to piston as possible.
9. Loosen and remove nut attaching piston to rod. Remove piston.
10. Loosen and remove cap screw(s), if applicable, attaching tapered bushing to piston.
11. Insert cap screw(s) in threaded holes in outer piece of tapered bushing. Progressively tighten cap screw(s) until bushing is loose on piston.
12. Remove tapered bushing from piston.
13. Screw piston counter-clockwise by hand and remove from cylinder rod.

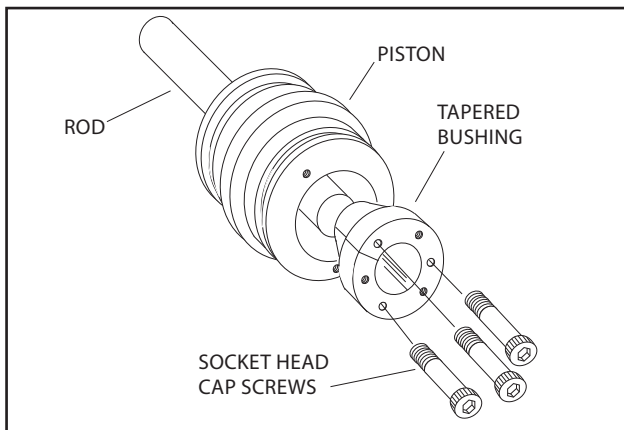

Figure 5-33. Tapered Bushing Removal

14. Remove and discard piston O-rings, seal rings, and backup rings.
15. Remove piston spacer, if applicable, from rod.
16. Remove rod from holding fixture. Remove cylinder head gland and retainer plate, if applicable. Discard O-rings, back-up rings, rod seals, and wiper seals.

Cleaning and Inspection

1. Clean parts thoroughly with approved cleaning solvent.
2. Inspect cylinder rod for scoring, tapering, ovality, or other damage. If necessary, dress rod with Scotch Brite or equivalent. Replace rod if necessary.
3. Inspect threaded portion of rod for excessive damage. Dress threads as necessary.
4. Inspect inner surface of cylinder barrel tube for scoring or other damage. Check inside diameter for tapering or ovality. Replace if necessary.
5. Inspect threaded portion of barrel for damage. Dress threads as necessary.
6. Inspect piston surface for damage, scoring, or distortion. Dress piston surface or replace piston as necessary.

7. Inspect threaded portion of piston for damage. Dress threads as necessary.
8. Inspect seal and O-ring grooves in piston for burrs and sharp edges. Dress surfaces as necessary.
9. Inspect cylinder head inside diameter for scoring or other damage, and for ovality and tapering. Replace as necessary.
10. Inspect threaded portion of head for damage. Dress threads as necessary.
11. Inspect seal and O-ring grooves in head for burrs and sharp edges. Dress applicable surfaces as necessary.
12. Inspect cylinder head outside diameter for scoring, damage, ovality, and tapering. Replace as necessary.
13. If applicable, inspect rod and barrel bearings for signs of correct excessive wear or damage. Replace as necessary.
 - a. Thoroughly clean hole, (steel bushing) of burrs, dirt etc. to facilitate bearing installation.
 - b. Inspect steel bushing for wear or other damage. If steel bushing is worn or damaged, rod/barrel must be replaced.
 - c. Lubricate inside of the steel bushing with WD40 prior to bearing installation.

NOTE: Lubrication is not required with nickel plated pins and bearings. Install pin in composite bushing dry.

- d. Press composite bushing into barrel or rod bushing with correct size arbor.

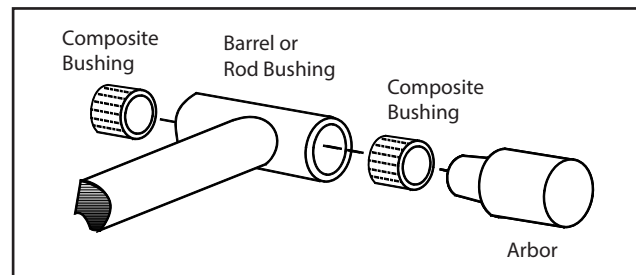

Figure 5-34. Composite Bushing Installation

14. Inspect travel limiting collar or spacer for burrs and sharp edges. If necessary, dress inside diameter surface with Scotch Brite or equivalent.
15. If applicable, inspect port block fittings and holding valve. Replace as necessary.
16. Inspect oil ports for blockage or presence of dirt or other foreign material. Repair as necessary.
17. If applicable, inspect piston rings for cracks or other damage. Replace as necessary.

Assembly

NOTE: Use proper cylinder seal kit for cylinder assembly. See your JLG Parts Manual.

Apply a light film of hydraulic oil to all components before assembly.

1. Use seal tool to install new rod seal into applicable cylinder head gland groove.

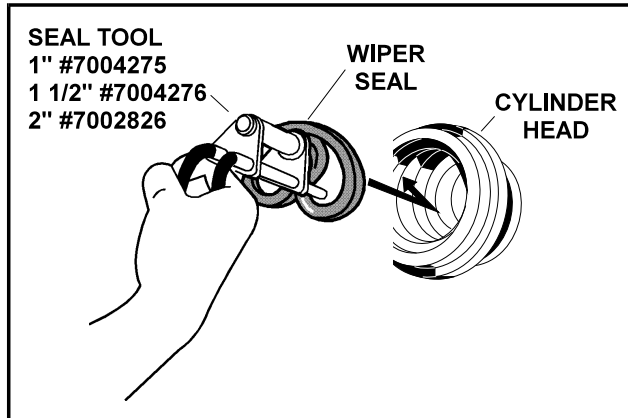

Figure 5-35. Rod Seal Installation

NOTICE

IMPROPER SEAL INSTALLATION CAN CAUSE CYLINDER LEAKS AND IMPROPER CYLINDER OPERATION. ENSURE 'POLY-PAK' PISTON SEALS ARE PROPERLY INSTALLED. REFER TO WIPER SEAL INSTALLATION FOR CORRECT SEAL ORIENTATION.

2. Use a soft mallet to tap new wiper seal into applicable cylinder head gland groove. Install new wear ring in applicable cylinder head gland groove.

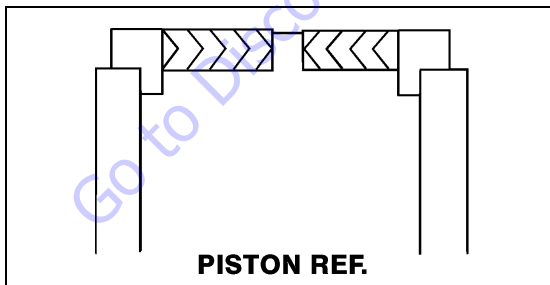

Figure 5-36. Poly-Pak Piston Seal Installation

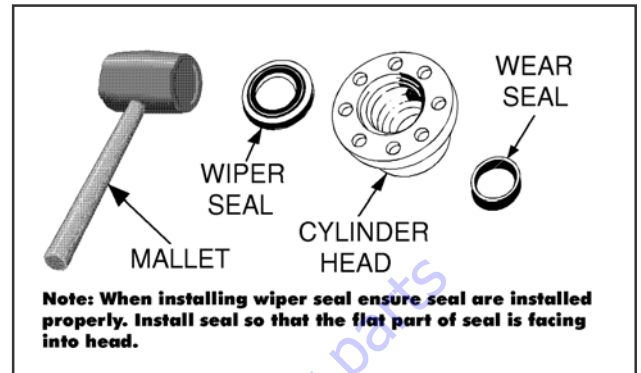

Figure 5-37. Wiper Seal Installation

3. Place new O-ring and back-up seal in applicable outside diameter groove of cylinder head.

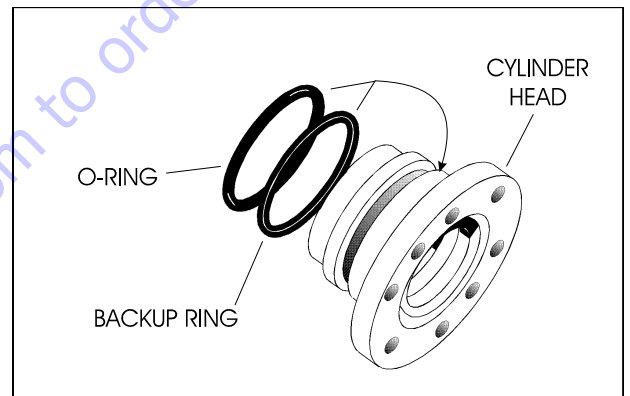

Figure 5-38. Head Seal Kit Installation

4. Install washer ring on rod. Carefully install head gland on rod. Do not damage or dislodge wiper and rod seals. Push head along rod to rod end, as applicable.
5. Carefully slide piston spacer on rod.

NOTE: Upper telescope cylinder piston has an O-ring installed inside spacer.

SECTION 5 - HYDRAULICS

- If applicable, place new O-ring and back-up rings in inner piston diameter groove.

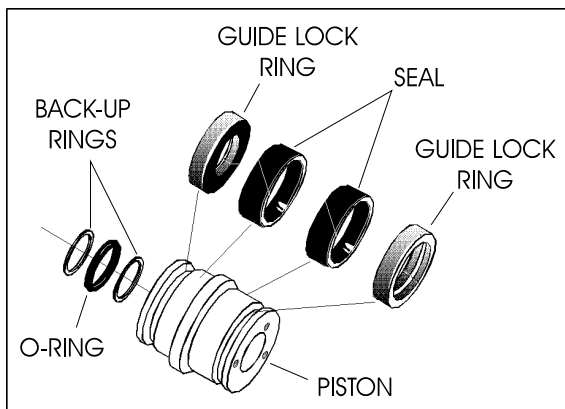

Figure 5-39. Piston Seal Kit Installation

- Using suitable protection, clamp cylinder rod in a vise or similar holding fixture as close to piston as possible.
- Carefully thread piston on cylinder rod hand tight, Ensure O-ring and back-up rings are not damaged or dislodged.

NOTE: Piston and mating end of rod must be free of oil when installing tapered bushing.

- Thread piston onto rod until it aligns with spacer end and install tapered bushing.

NOTE: Apply LOCTITE #242 or equivalent to tapered bushing bolts when rebuilding master, slave, lift, and telescope cylinders.

- Install bolts in tapered bushing using loctite #242

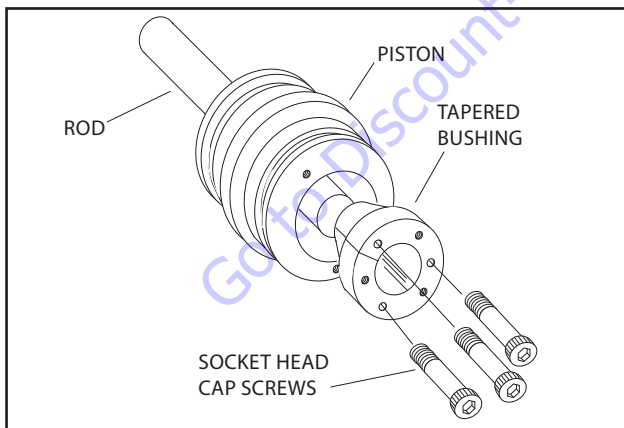

Figure 5-40. Tapered Bushing Installation

- Remove cylinder rod from holding fixture.
- Place new guide locks and seals in applicable outside diameter grooves of cylinder piston. (See Figure 2-28. Piston Seal Kit Installation.)
- Position cylinder barrel in a suitable holding fixture.

NOTICE

INSERTING ROD OFF-CENTER CAN DAMAGE PISTON AND CYLINDER BARREL SURFACES. USE EXTREME CARE WHEN INSTALLING CYLINDER ROD, HEAD, AND PISTON.

- Clamp barrel clamped securely and support rod. Insert piston end into barrel cylinder. Do not damage or dislodge piston loading O-ring and seal ring.
- Continue pushing rod into barrel until cylinder head gland can be inserted into barrel cylinder.
- Secure cylinder head gland using washer ring and socket head bolts.

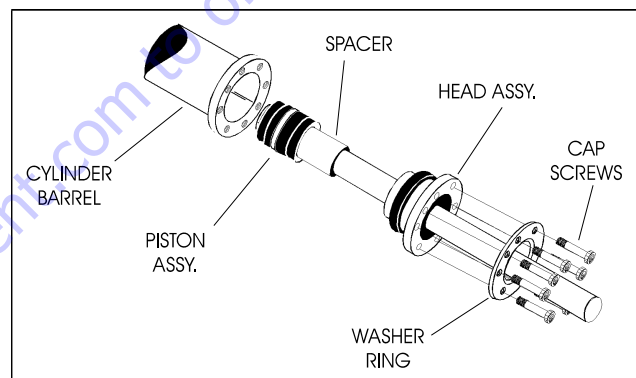

Figure 5-41. Rod Assembly Installation

Platform Level (Slave) Cylinder

DISASSEMBLY

NOTICE

CONTAMINATION MAY DAMAGE EQUIPMENT. DISASSEMBLE CYLINDER ON A CLEAN WORK SURFACE IN A DIRT FREE WORK AREA.

1. Connect a suitable auxiliary hydraulic power source to cylinder port block fitting.

WARNING

DO NOT FULLY EXTEND CYLINDER TO THE END OF STROKE. RETRACT CYLINDER SLIGHTLY TO AVOID TRAPPING PRESSURE.

2. Operate hydraulic power source and extend cylinder. Shut down and disconnect power source. Adequately support cylinder rod, if applicable.
3. If applicable, remove cartridge-type counterbalance valve and fittings from cylinder port block. Discard O-rings.
4. Place cylinder barrel in a suitable holding fixture. Tap around outside of cylinder head retainer with a suitable hammer to break thread-locking compound.

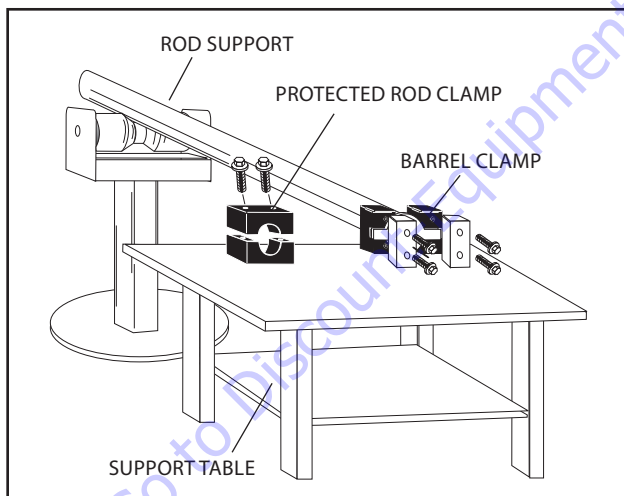

Figure 5-42. Cylinder Barrel Support

5. Mark cylinder head (1) and barrel (2) with center punch marks (3) for later realignment. Remove eight cylinder head cap screws (4).

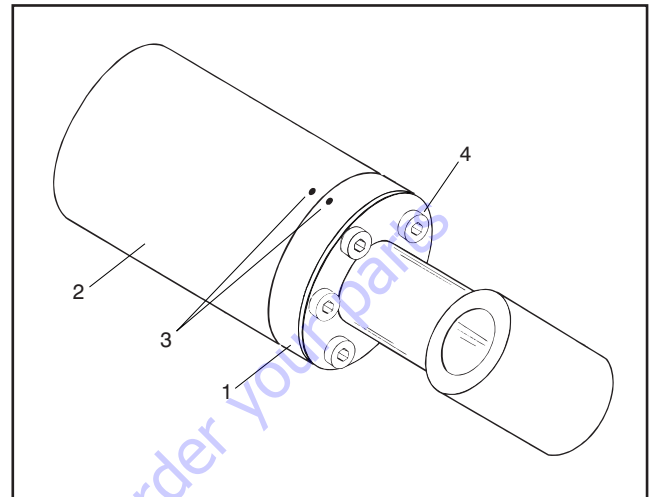

Figure 5-43. Marking Cylinder for Alignment

NOTICE

PULLING ROD OFF-CENTER CAN DAMAGE PISTON AND CYLINDER BARREL SURFACES. USE EXTREME CARE WHEN REMOVING CYLINDER ROD, HEAD, AND PISTON.

6. Clamp barrel securely. Pull rod assembly and cylinder head from barrel.
7. Protect cylinder rod from damage and clamp in a vise or holding fixture as close to piston as possible.

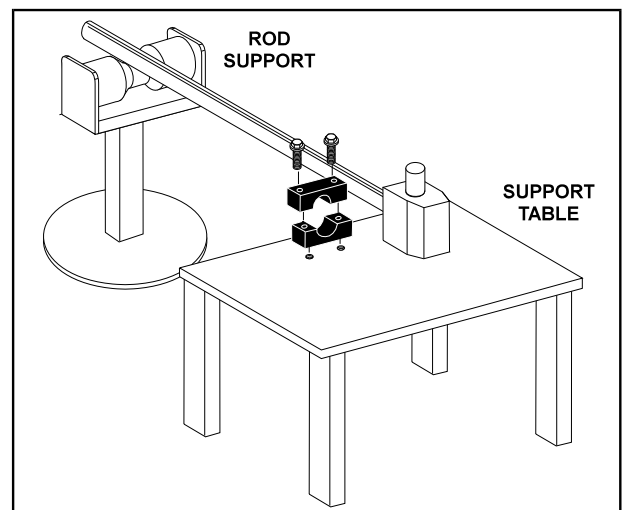

Figure 5-44. Cylinder Rod Support

8. Using suitable protection, clamp cylinder rod in a vise or similar holding fixture as close to piston as possible.
9. Loosen and remove nut attaching piston to rod. Remove piston.
10. Loosen and remove cap screw(s), if applicable, attaching tapered bushing to piston.
11. Insert cap screw(s) in threaded holes in outer piece of tapered bushing. Progressively tighten cap screw(s) until bushing is loose on piston.
12. Remove tapered bushing from piston.
13. Screw piston counter-clockwise by hand and remove from cylinder rod.

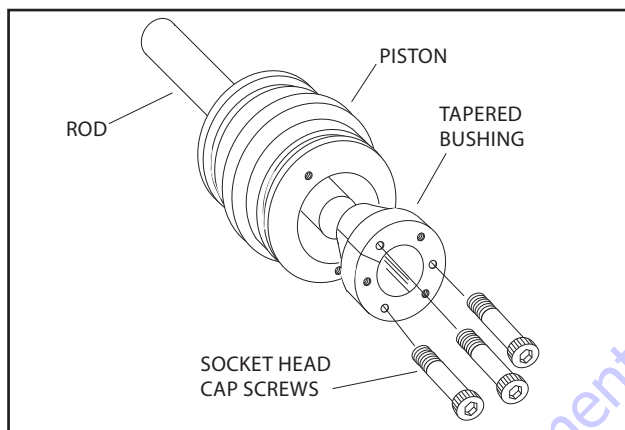

Figure 5-46. Tapered Bushing Removal

14. Remove and discard piston O-rings, seal rings, and backup rings.
15. Remove piston spacer, if applicable, from rod.
16. Remove rod from holding fixture. Remove cylinder head gland and retainer plate, if applicable. Discard O-rings, back-up rings, rod seals, and wiper seals.

Cleaning and Inspection

1. Clean parts thoroughly with approved cleaning solvent.
2. Inspect cylinder rod for scoring, tapering, ovality, or other damage. If necessary, dress rod with Scotch Brite or equivalent. Replace rod if necessary.
3. Inspect threaded portion of rod for excessive damage. Dress threads as necessary.
4. Inspect inner surface of cylinder barrel tube for scoring or other damage. Check inside diameter for tapering or ovality. Replace if necessary.
5. Inspect threaded portion of barrel for damage. Dress threads as necessary.
6. Inspect piston surface for damage, scoring, or distortion. Dress piston surface or replace piston as necessary.

7. Inspect threaded portion of piston for damage. Dress threads as necessary.
8. Inspect seal and O-ring grooves in piston for burrs and sharp edges. Dress surfaces as necessary.
9. Inspect cylinder head inside diameter for scoring or other damage, and for ovality and tapering. Replace as necessary.
10. Inspect threaded portion of head for damage. Dress threads as necessary.
11. Inspect seal and O-ring grooves in head for burrs and sharp edges. Dress applicable surfaces as necessary.
12. Inspect cylinder head outside diameter for scoring, damage, ovality, and tapering. Replace as necessary.
13. If applicable, inspect rod and barrel bearings for signs of correct excessive wear or damage. Replace as necessary.
 - a. Thoroughly clean hole, (steel bushing) of burrs, dirt etc. to facilitate bearing installation.
 - b. Inspect steel bushing for wear or other damage. If steel bushing is worn or damaged, rod/barrel must be replaced.
 - c. Lubricate inside of the steel bushing with WD40 prior to bearing installation.

NOTE: Lubrication is not required with nickel plated pins and bearings. Install pin in composite bushing dry.

- d. Press composite bushing into barrel or rod bushing with correct size arbor.

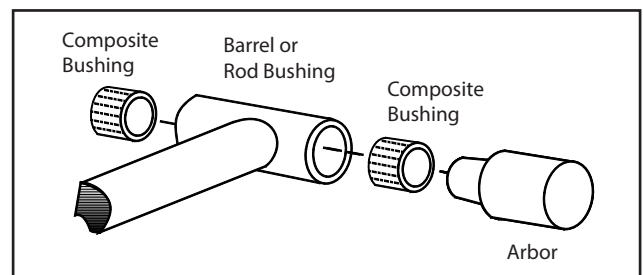

Figure 5-47. Composite Bushing Installation

14. Inspect travel limiting collar or spacer for burrs and sharp edges. If necessary, dress inside diameter surface with Scotch Brite or equivalent.
15. If applicable, inspect port block fittings and holding valve. Replace as necessary.
16. Inspect oil ports for blockage or presence of dirt or other foreign material. Repair as necessary.
17. If applicable, inspect piston rings for cracks or other damage. Replace as necessary.

Assembly

NOTE: Use proper cylinder seal kit for cylinder assembly. See your JLG Parts Manual.

Apply a light film of hydraulic oil to all components before assembly.

1. Use seal tool to install new rod seal into applicable cylinder head gland groove.

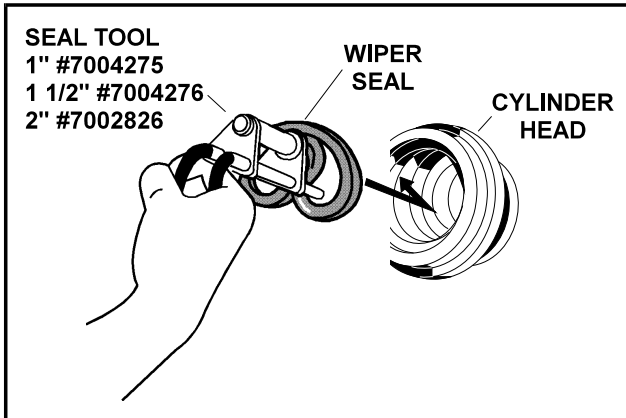

Figure 5-48. Rod Seal Installation

NOTICE

IMPROPER SEAL INSTALLATION CAN CAUSE CYLINDER LEAKS AND IMPROPER CYLINDER OPERATION. ENSURE 'POLY-PAK' PISTON SEALS ARE PROPERLY INSTALLED. REFER TO WIPER SEAL INSTALLATION FOR CORRECT SEAL ORIENTATION.

2. Use a soft mallet to tap new wiper seal into applicable cylinder head gland groove. Install new wear ring in applicable cylinder head gland groove.

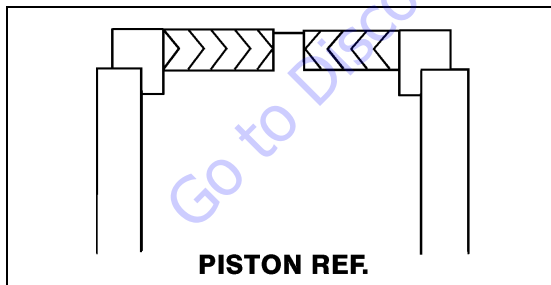

Figure 5-49. Poly-Pak Piston Seal Installation

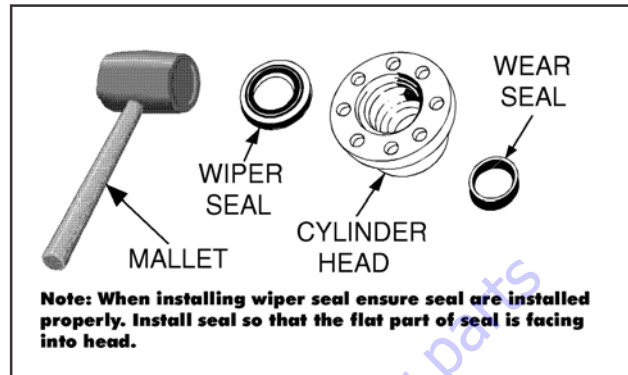

Figure 5-50. Wiper Seal Installation

3. Place new O-ring and back-up seal in applicable outside diameter groove of cylinder head.

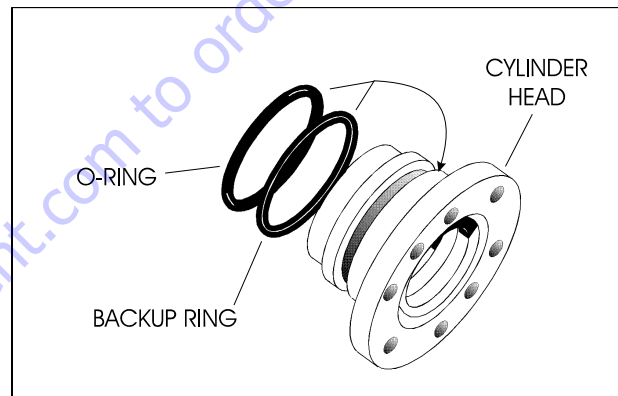

Figure 5-51. Head Seal Kit Installation

4. Install washer ring on rod. Carefully install head gland on rod. Do not damage or dislodge wiper and rod seals. Push head along rod to rod end, as applicable.
5. Carefully slide piston spacer on rod.

NOTE: Upper telescope cylinder piston has an O-ring installed inside spacer.

- If applicable, place new O-ring and back-up rings in inner piston diameter groove.

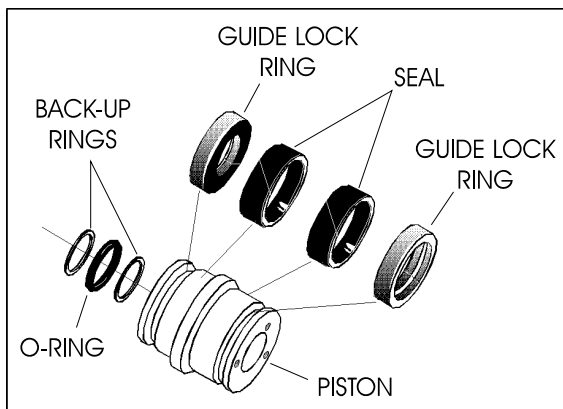

Figure 5-52. Piston Seal Kit Installation

- Using suitable protection, clamp cylinder rod in a vise or similar holding fixture as close to piston as possible.
- Carefully thread piston on cylinder rod hand tight, Ensure O-ring and back-up rings are not damaged or dislodged.

NOTE: Piston and mating end of rod must be free of oil when installing tapered bushing.

- Thread piston onto rod until it aligns with spacer end and install tapered bushing.

NOTE: Apply LOCTITE #242 or equivalent to tapered bushing bolts when rebuilding master, slave, lift, and telescope cylinders.

- Install bolts in tapered bushing using loctite #242

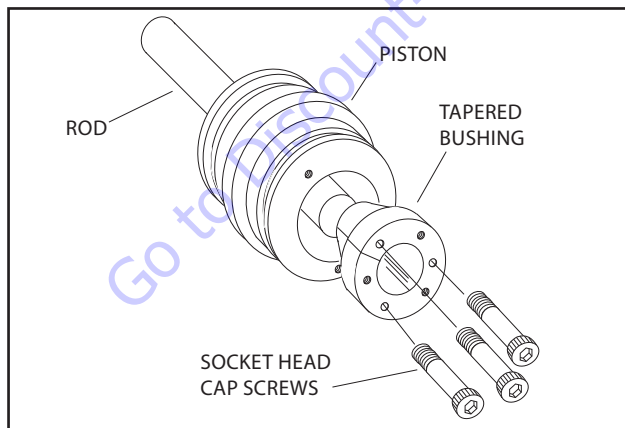

Figure 5-53. Tapered Bushing Installation

- Remove cylinder rod from holding fixture.
- Place new guide locks and seals in applicable outside diameter grooves of cylinder piston. (See Figure 2-28. Piston Seal Kit Installation.)
- Position cylinder barrel in a suitable holding fixture.

NOTICE

INSERTING ROD OFF-CENTER CAN DAMAGE PISTON AND CYLINDER BARREL SURFACES. USE EXTREME CARE WHEN INSTALLING CYLINDER ROD, HEAD, AND PISTON.

- Clamp barrel clamped securely and support rod. Insert piston end into barrel cylinder. Do not damage or dislodge piston loading O-ring and seal ring.
- Continue pushing rod into barrel until cylinder head gland can be inserted into barrel cylinder.
- Secure cylinder head gland using washer ring and socket head bolts.

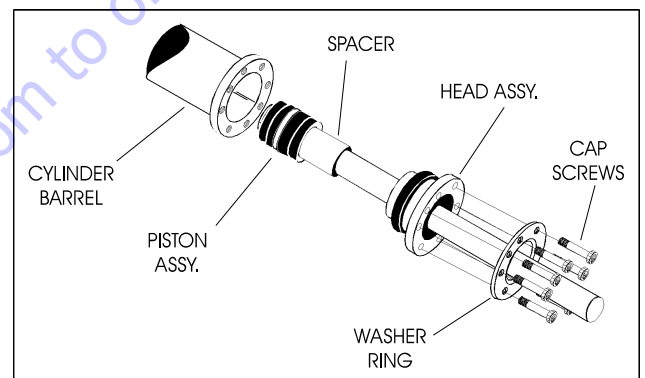

Figure 5-54. Rod Assembly Installation

Jib Lift Cylinder (SJC Only)

DISASSEMBLY

NOTICE

CONTAMINATION MAY DAMAGE EQUIPMENT. DISASSEMBLE CYLINDER ON A CLEAN WORK SURFACE IN A DIRT FREE WORK AREA.

1. Connect a suitable auxiliary hydraulic power source to cylinder port block fitting.

WARNING

DO NOT FULLY EXTEND CYLINDER TO THE END OF STROKE. RETRACT CYLINDER SLIGHTLY TO AVOID TRAPPING PRESSURE.

2. Operate hydraulic power source and extend cylinder. Shut down and disconnect power source. Adequately support cylinder rod, if applicable.
3. If applicable, remove cartridge-type counterbalance valve and fittings from cylinder port block. Discard O-rings.
4. Place cylinder barrel in a suitable holding fixture. Tap around outside of cylinder head retainer with a suitable hammer to break thread-locking compound.

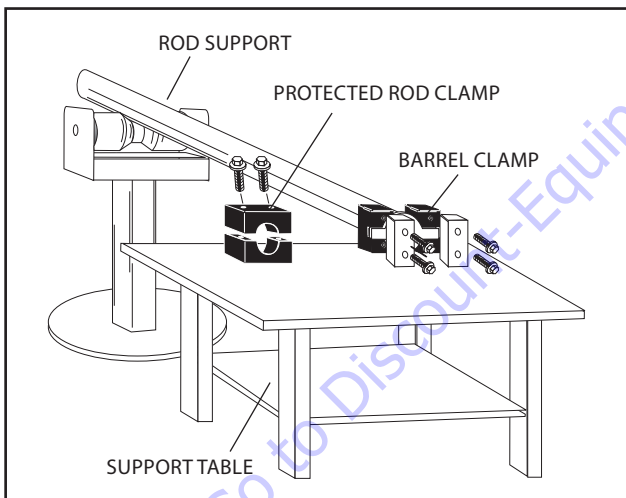

Figure 5-55. Cylinder Barrel Support

5. Mark cylinder head (1) and barrel (2) with center punch marks (3) for later realignment. Remove eight cylinder head cap screws (4).

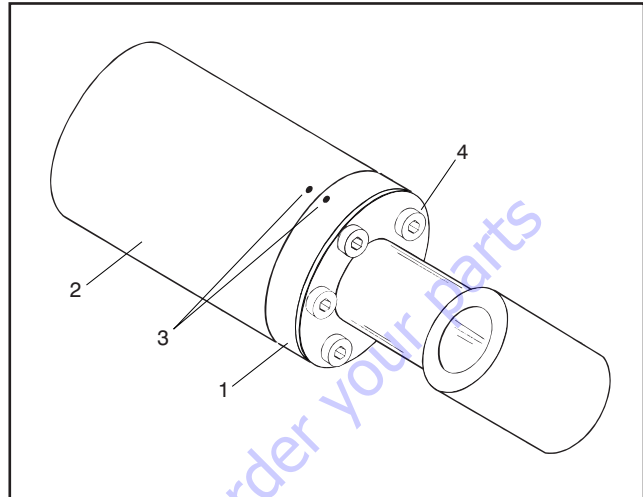

Figure 5-56. Marking Cylinder for Alignment

NOTICE

PULLING ROD OFF-CENTER CAN DAMAGE PISTON AND CYLINDER BARREL SURFACES. USE EXTREME CARE WHEN REMOVING CYLINDER ROD, HEAD, AND PISTON.

6. Clamp barrel securely. Pull rod assembly and cylinder head from barrel.
7. Protect cylinder rod from damage and clamp in a vise or holding fixture as close to piston as possible.

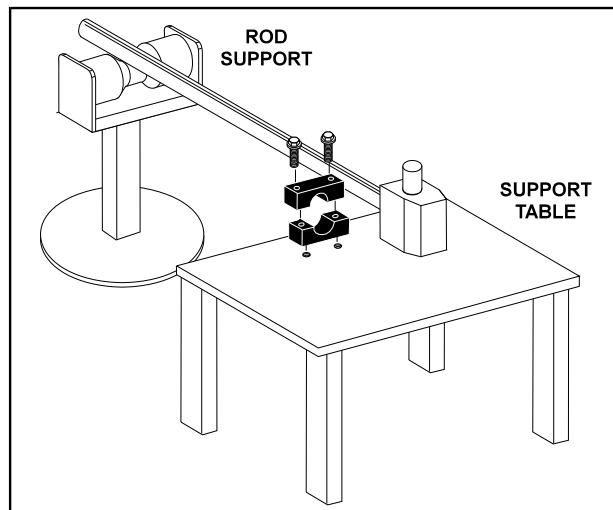
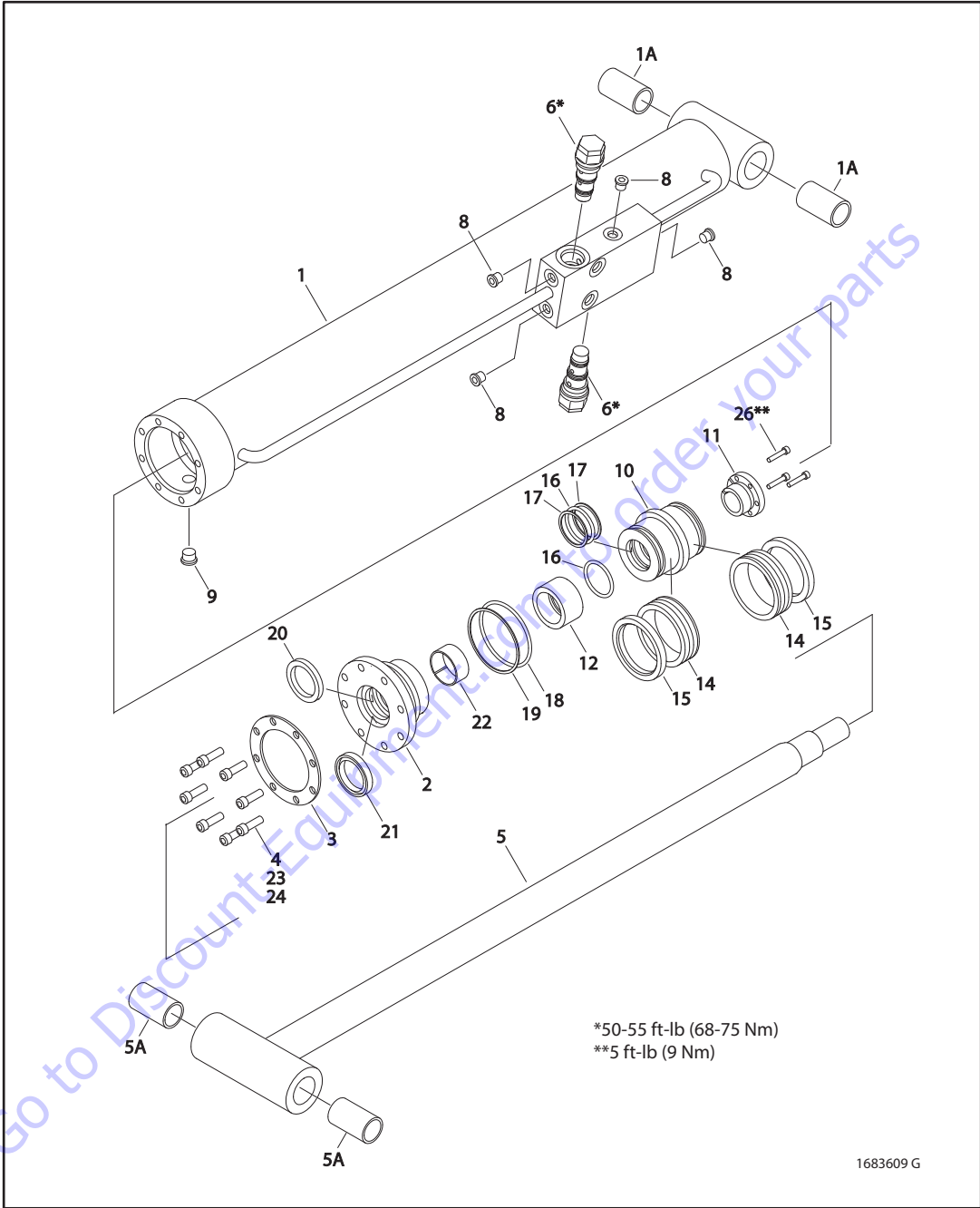

Figure 5-57. Cylinder Rod Support



- | | | | | | |
|----------------|--------------------|---------------------|------------------|----------------------|--------------------|
| 1. Barrel | 5. Rod | 9. O-Ring Plug | 14. Seal | 19. Wiper | 24. Locking Primer |
| 1a. Bushing | 5a. Bushing | 10. Piston | 15. Lock Ring | 20. Wear Ring | 25. Not Used |
| 2. Head | 6. Cartridge Valve | 11. Tapered Bushing | 16. O-Ring | 21. Wiper | 26. Bolt |
| 3. Ring Washer | 7. Not Used | 12. Spacer | 17. Back-Up Ring | 22. Wear Ring | |
| 4. Capscrew | 8. O-Ring Plug | 13. Not Used | 18. Rod Seal | 23. Locking Compound | |

Figure 5-58. Jib Lift Cylinder Assembly(660SJC)

SECTION 5 - HYDRAULICS

8. Using suitable protection, clamp cylinder rod in a vise or similar holding fixture as close to piston as possible.
9. Loosen and remove nut attaching piston to rod. Remove piston.
10. Loosen and remove cap screw(s), if applicable, attaching tapered bushing to piston.
11. Insert cap screw(s) in threaded holes in outer piece of tapered bushing. Progressively tighten cap screw(s) until bushing is loose on piston.
12. Remove tapered bushing from piston.
13. Screw piston counter-clockwise by hand and remove from cylinder rod.

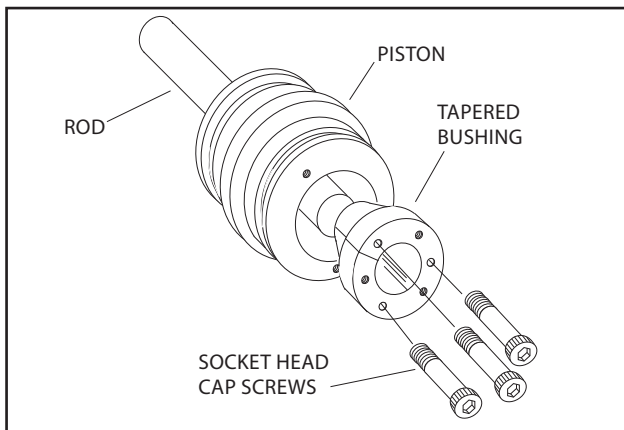

Figure 5-59. Tapered Bushing Removal

14. Remove and discard piston O-rings, seal rings, and backup rings.
15. Remove piston spacer, if applicable, from rod.
16. Remove rod from holding fixture. Remove cylinder head gland and retainer plate, if applicable. Discard O-rings, back-up rings, rod seals, and wiper seals.

Cleaning and Inspection

1. Clean parts thoroughly with approved cleaning solvent.
2. Inspect cylinder rod for scoring, tapering, ovality, or other damage. If necessary, dress rod with Scotch Brite or equivalent. Replace rod if necessary.
3. Inspect threaded portion of rod for excessive damage. Dress threads as necessary.
4. Inspect inner surface of cylinder barrel tube for scoring or other damage. Check inside diameter for tapering or ovality. Replace if necessary.
5. Inspect threaded portion of barrel for damage. Dress threads as necessary.
6. Inspect piston surface for damage, scoring, or distortion. Dress piston surface or replace piston as necessary.

7. Inspect threaded portion of piston for damage. Dress threads as necessary.
8. Inspect seal and O-ring grooves in piston for burrs and sharp edges. Dress surfaces as necessary.
9. Inspect cylinder head inside diameter for scoring or other damage, and for ovality and tapering. Replace as necessary.
10. Inspect threaded portion of head for damage. Dress threads as necessary.
11. Inspect seal and O-ring grooves in head for burrs and sharp edges. Dress applicable surfaces as necessary.
12. Inspect cylinder head outside diameter for scoring, damage, ovality, and tapering. Replace as necessary.
13. If applicable, inspect rod and barrel bearings for signs of correct excessive wear or damage. Replace as necessary.
 - a. Thoroughly clean hole, (steel bushing) of burrs, dirt etc. to facilitate bearing installation.
 - b. Inspect steel bushing for wear or other damage. If steel bushing is worn or damaged, rod/barrel must be replaced.
 - c. Lubricate inside of the steel bushing with WD40 prior to bearing installation.

NOTE: Lubrication is not required with nickel plated pins and bearings. Install pin in composite bushing dry.

- d. Press composite bushing into barrel or rod bushing with correct size arbor.

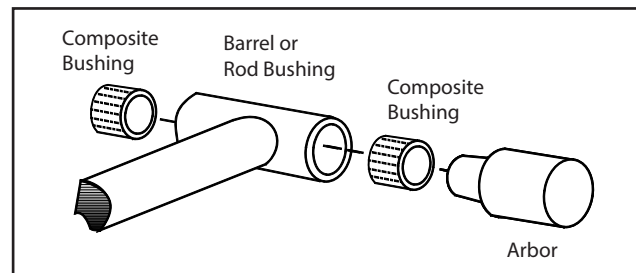

Figure 5-60. Composite Bushing Installation

14. Inspect travel limiting collar or spacer for burrs and sharp edges. If necessary, dress inside diameter surface with Scotch Brite or equivalent.
15. If applicable, inspect port block fittings and holding valve. Replace as necessary.
16. Inspect oil ports for blockage or presence of dirt or other foreign material. Repair as necessary.
17. If applicable, inspect piston rings for cracks or other damage. Replace as necessary.

Assembly

NOTE: Use proper cylinder seal kit for cylinder assembly. See your JLG Parts Manual.

Apply a light film of hydraulic oil to all components before assembly.

1. Use seal tool to install new rod seal into applicable cylinder head gland groove.

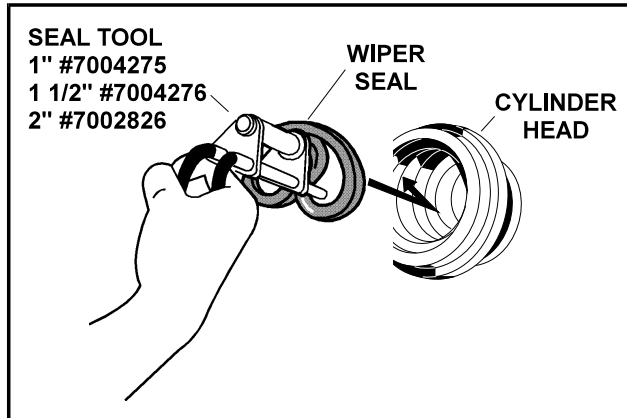

Figure 5-61. Rod Seal Installation

NOTICE

IMPROPER SEAL INSTALLATION CAN CAUSE CYLINDER LEAKS AND IMPROPER CYLINDER OPERATION. ENSURE 'POLY-PAK' PISTON SEALS ARE PROPERLY INSTALLED. REFER TO WIPER SEAL INSTALLATION FOR CORRECT SEAL ORIENTATION.

2. Use a soft mallet to tap new wiper seal into applicable cylinder head gland groove. Install new wear ring in applicable cylinder head gland groove.

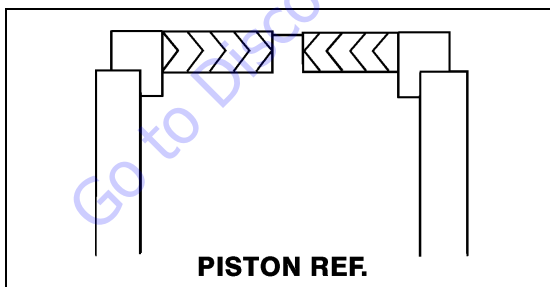

Figure 5-62. Poly-Pak Piston Seal Installation

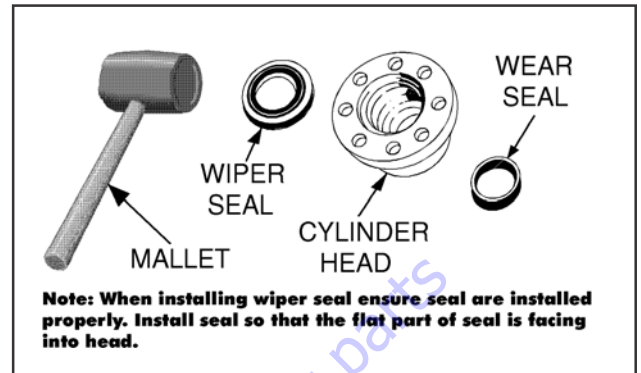

Figure 5-63. Wiper Seal Installation

3. Place new O-ring and back-up seal in applicable outside diameter groove of cylinder head.

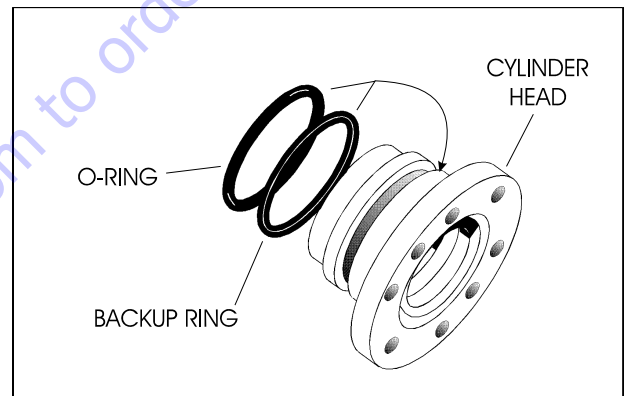

Figure 5-64. Head Seal Kit Installation

4. Install washer ring on rod. Carefully install head gland on rod. Do not damage or dislodge wiper and rod seals. Push head along rod to rod end, as applicable.
5. Carefully slide piston spacer on rod.

NOTE: Upper telescope cylinder piston has an O-ring installed inside spacer.

SECTION 5 - HYDRAULICS

- If applicable, place new O-ring and back-up rings in inner piston diameter groove.

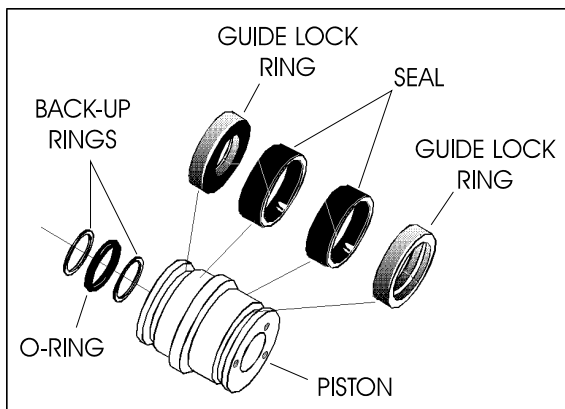

Figure 5-65. Piston Seal Kit Installation

- Using suitable protection, clamp cylinder rod in a vise or similar holding fixture as close to piston as possible.
- Carefully thread piston on cylinder rod hand tight, Ensure O-ring and back-up rings are not damaged or dislodged.

NOTE: Piston and mating end of rod must be free of oil when installing tapered bushing.

- Thread piston onto rod until it aligns with spacer end and install tapered bushing.

NOTE: Apply LOCTITE #242 or equivalent to tapered bushing bolts when rebuilding master, slave, lift, and telescope cylinders.

- Install bolts in tapered bushing using loctite #242

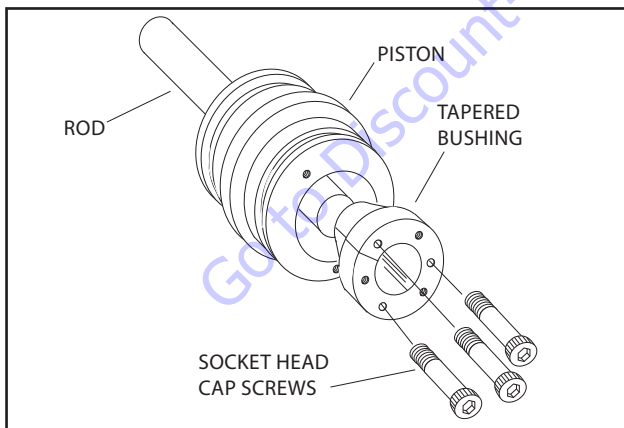

Figure 5-66. Tapered Bushing Installation

- Remove cylinder rod from holding fixture.
- Place new guide locks and seals in applicable outside diameter grooves of cylinder piston. (See Figure 2-28. Piston Seal Kit Installation.)
- Position cylinder barrel in a suitable holding fixture.

NOTICE

INSERTING ROD OFF-CENTER CAN DAMAGE PISTON AND CYLINDER BARREL SURFACES. USE EXTREME CARE WHEN INSTALLING CYLINDER ROD, HEAD, AND PISTON.

- Clamp barrel clamped securely and support rod. Insert piston end into barrel cylinder. Do not damage or dislodge piston loading O-ring and seal ring.
- Continue pushing rod into barrel until cylinder head gland can be inserted into barrel cylinder.
- Secure cylinder head gland using washer ring and socket head bolts.

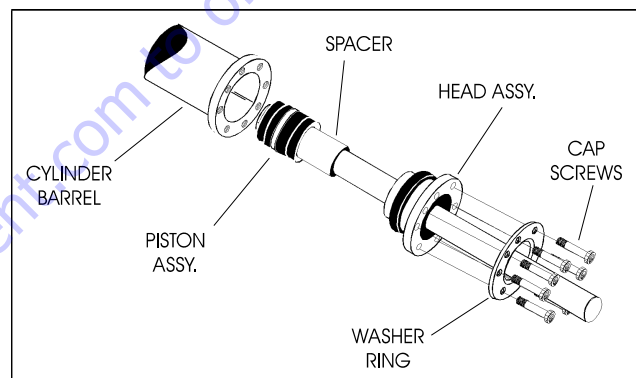

Figure 5-67. Rod Assembly Installation

5.6 HYDRAULIC PUMP (GEAR)

Disassembly

NOTE: The following general instructions also apply to multiple section gear pumps. The only extra parts are the coupling between drive shafts and center distance plate which divides the two pump sections. This repair procedure also applies to "W" series Gear Motors.

1. Always work in a clean work area when repairing hydraulic products. Plug ports and wash exterior of pump with approved cleaning solvent.
2. Remove port plugs and drain oil from pump.

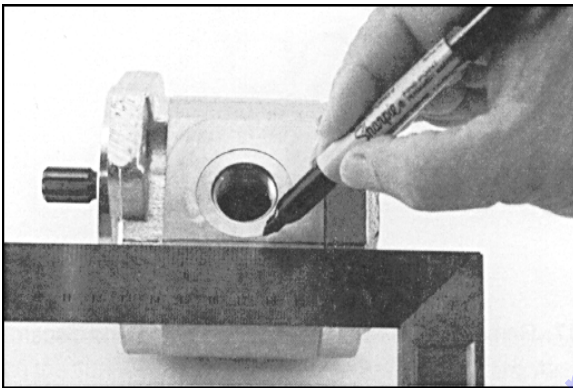

3. Use a permanent marker pen to mark a line across mounting flange, gear housing and end cover. This will assure proper reassembly and rotation of pump.
4. Remove key from drive shaft if applicable.



5. Clamp mounting flange in a protected jaw vise with pump shaft facing down.
6. Loosen four metric hex head bolts.

7. Remove pump from vise and place on clean work bench. Remove four hex head bolts and spacers if applicable.

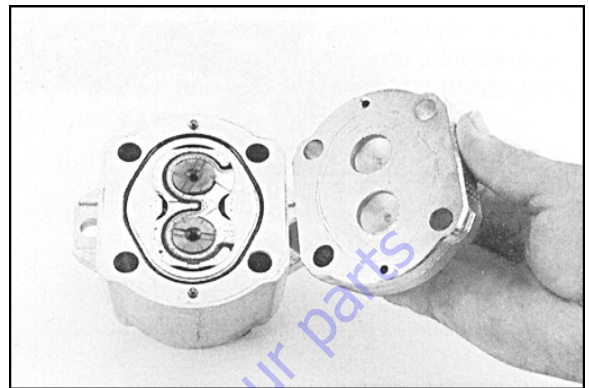

8. Lift and remove end cover.

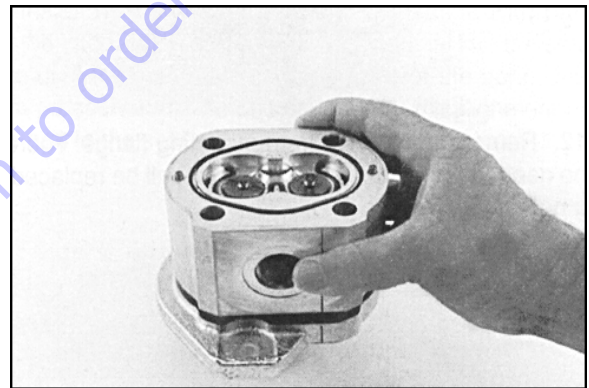

9. Carefully remove gear housing and place on work bench. Make sure rear bearing block remains on drive and idler shafts.

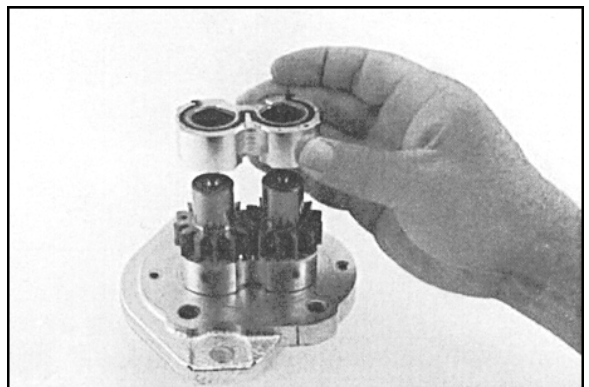

SECTION 5 - HYDRAULICS

10. Remove rear bearing block from drive and idler shafts.

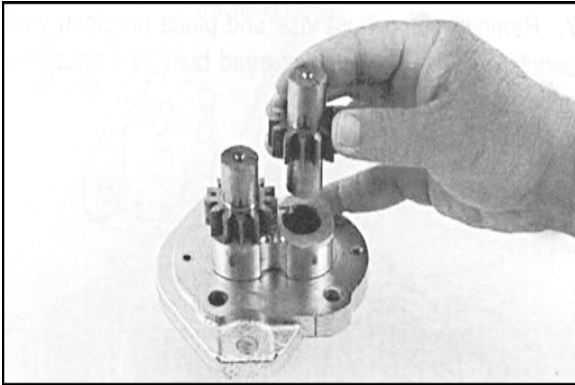

11. Remove idler shaft from bearing block.

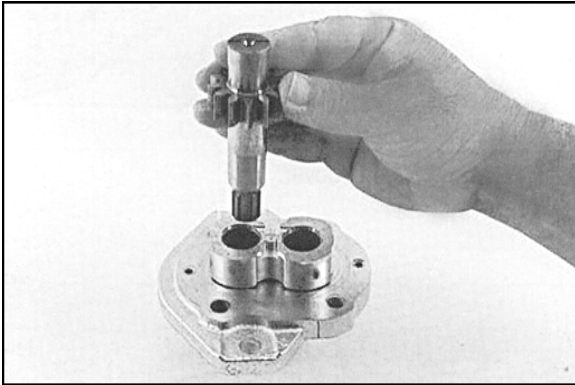

12. Remove drive shaft from mounting flange.

NOTE: Shaft seal will be replaced.

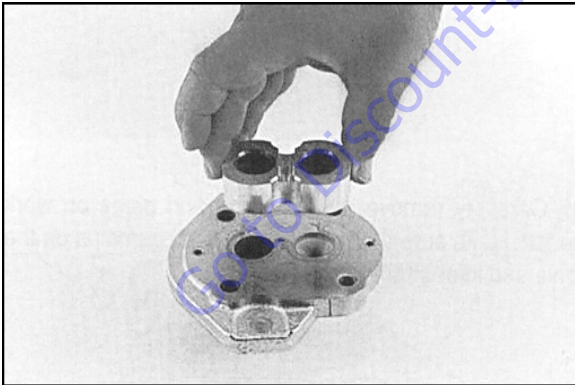

13. Remove front bearing block.

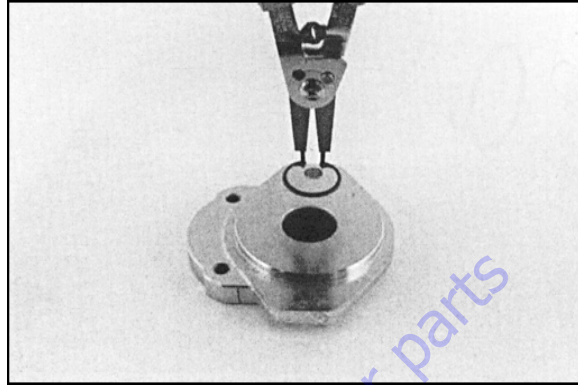

14. Turn mounting flange over, with shaft seal up. Remove retaining ring with snap ring pliers.

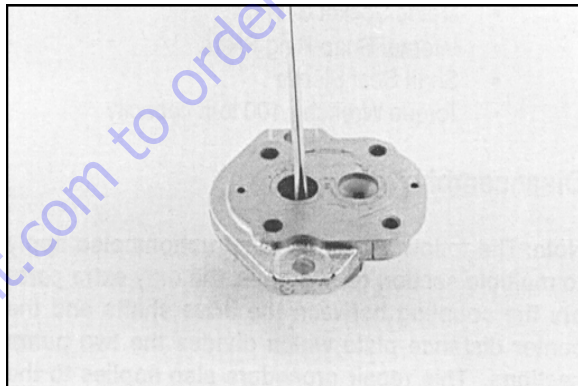

15. Remove oil seal from mounting flange. Do not mar or scratch seal bore.

16. Remove dowel pins from gear housing. Do not lose pins.

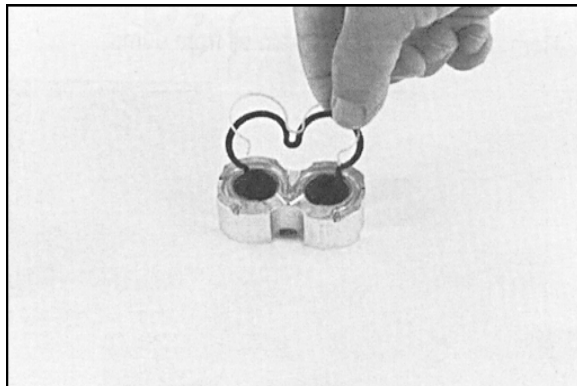

17. Remove and discard seals from both bearing blocks.

Inspect Parts For Wear

1. Clean and dry all parts thoroughly before inspection. It is not necessary to inspect seals. They will be placed as new items.

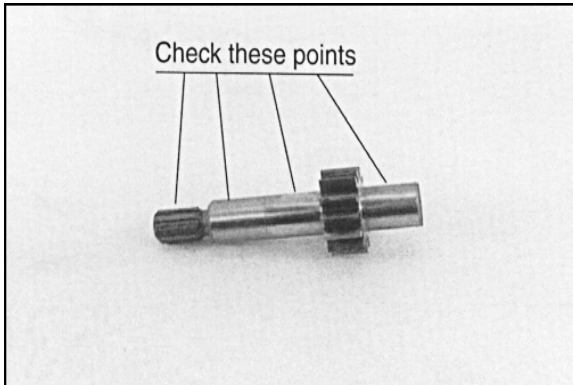

2. Check drive shaft spine for twisted or broken teeth, check keyed drive shaft for broken or chipped keyway. No marks or grooves on shaft in seal area, some discoloration of shaft is allowable.
3. Inspect drive gear shaft and idler gear shafts at bearing points and seal area for rough surfaces and excessive wear.

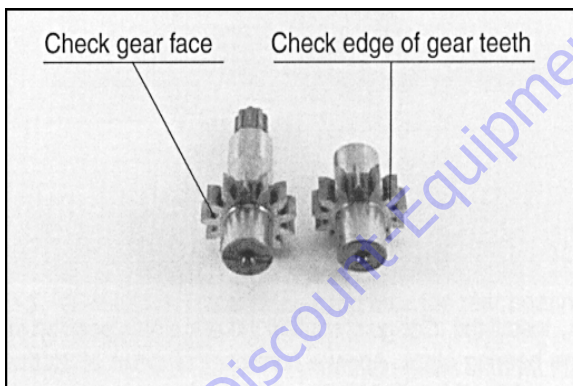

4. Inspect gear face for scoring or excessive wear. If face edge of gear teeth are sharp, they will mill into the bearing blocks. If wear has occurred, parts are unusable.

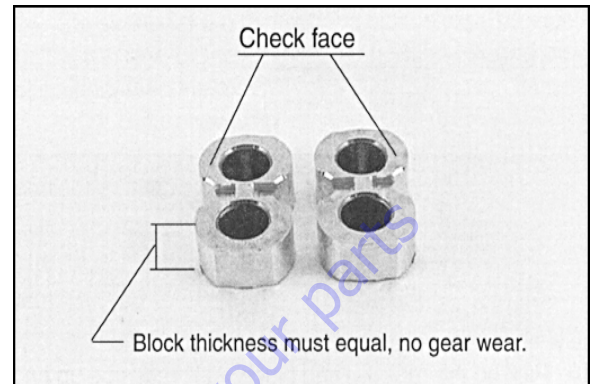

5. Inspect bearing blocks for excessive wear or scoring on surfaces in contact with gears. Inspect bearings for excessive wear or scoring.
6. Inspect area inside gear housing. A clean "wipe" on inside surface of intake side is normal. There should not be excessive wear, deep scratches, or gouges.

General Information

NOTICE

FAILURE TO PROPERLY ASSEMBLE THIS PUMP WILL RESULT WITH LITTLE OR NO FLOW AT RATED PRESSURE. RELATIONSHIP OF MOUNTING FLANGE, BEARING BLOCKS, AND GEAR HOUSING MUST BE CORRECT.

Reverse Shaft Rotation of Pump

NOTE: Pump is not bi-rotational. Use the following procedure if shaft rotation direction is changed.

Reverse shaft rotation of "W" series gear pump by rotating, as a group, two bearing blocks and gear housing 180° in relationship to remaining parts of pump. This places pressure port opposite from original position.

Assembly

NOTE: Install new seals when reassembling pump or motor. Go to page 8 for kit part numbers for W-600, W-900, and W-1500 pumps and motors.

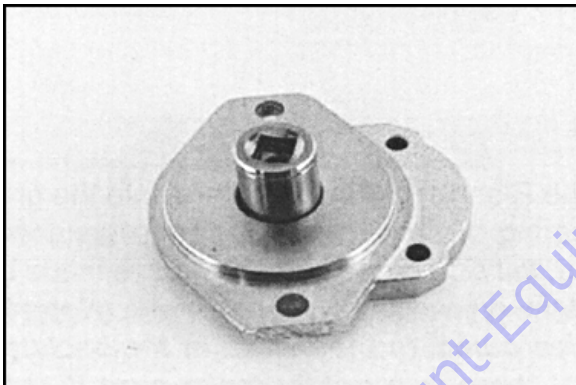

1. Install new shaft seal in mounting flange with part number side facing out. Press seal into seal bore until seal reaches bottom of bore. Use uniform pressure to prevent seal misalignment or damage.

2. Install retaining ring in groove in seal bore of mounting flange.

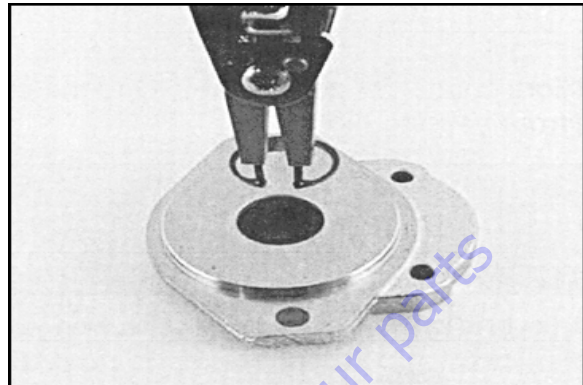

3. Place front and back bearing blocks on a clean surface with E-seal grooves facing up. Apply a light coating of petroleum jelly in the grooves. Coat E-seal and backup with petroleum jelly. This helps keep seals in place during reassembly

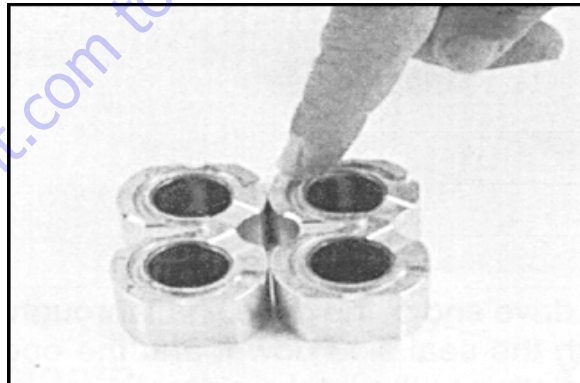

4. Place E-seals, flat side out, into grooves in both bearing blocks. Carefully place backup ring, flat side out, in groove made by E-seal and groove in bearing block. (Note: W900 series pump - In center of backup ring and E-seal there is a notch. Make sure notches line up so backup ring will set flush with E-seal). Backup ring in W1500 pump is symmetrical.

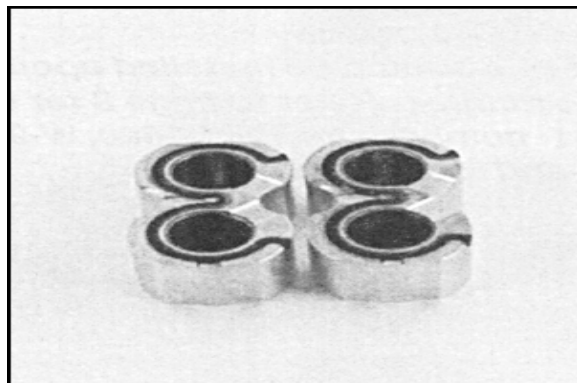

5. Place mounting flange, with shaft seal side down, on a clean flat surface.
6. Apply a light coating of petroleum jelly to exposed face of front bearing block.

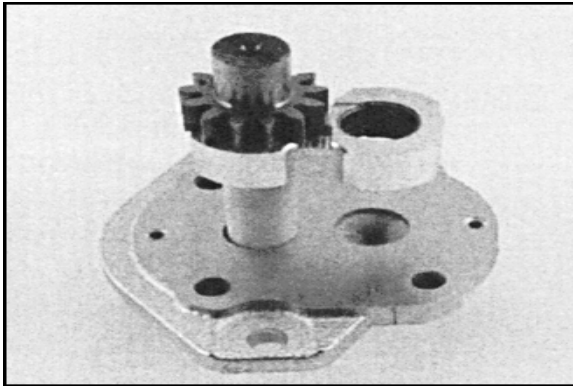

7. Insert drive end of drive shaft through bearing block with seal side down and open side of E-seal pointing to intake side of pump.
8. Install seal sleeve over drive shaft. Carefully slide drive shaft through shaft seal. Remove seal sleeve from shaft.

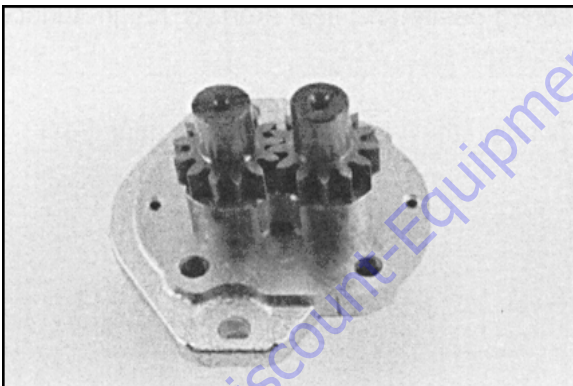

9. Install idler gear shaft in remaining position in bearing block. Apply a light coat of clean oil to face of drive and idler gears.

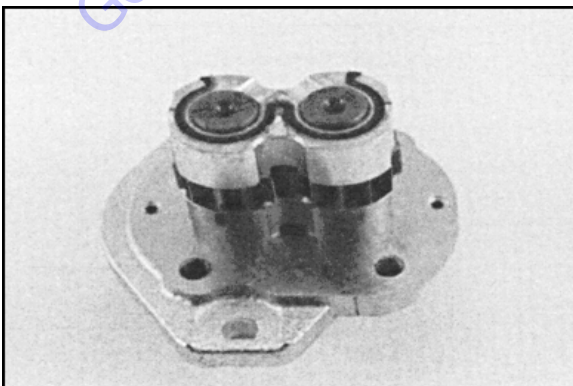

10. Place rear bearing block over drive and idler gear shafts with seal side up and open end of E-seal facing intake side of pump.
11. Install two dowel pins in mounting flange holes or two long dowel pins through gear housing if pump is a multiple section pump.

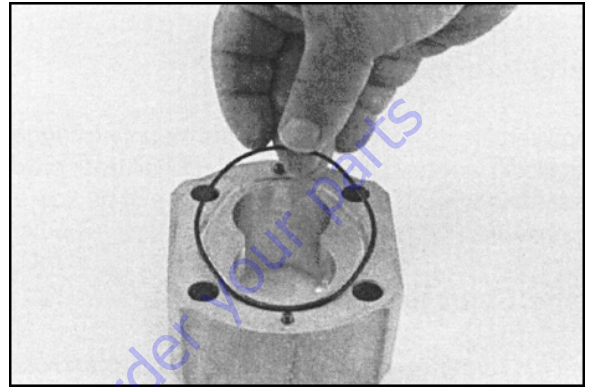

12. Apply a light coating of petroleum jelly in grooves on both sides of gear housing. Coat new O-rings and install in grooves.

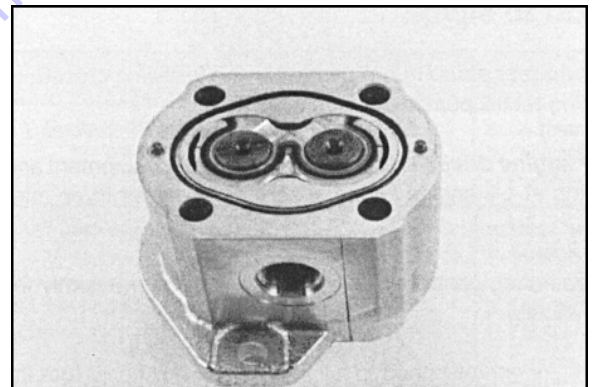

SECTION 5 - HYDRAULICS

13. Gently slide gear housing over rear bearing block assembly. Slide housing down until it engages dowel pins. Press firmly in place with hands, do not force or use any tool. Check intake port in housing is on same side as open end of E-seal, and marked lines on mounting flange and gear housing are aligned.

NOTE: Rear bearing block surface should be slightly below gear housing face. If bearing block is higher than rear face of gear housing, E-seal or O-ring have shifted out of groove. Remove gear housing and check for proper seal installation.

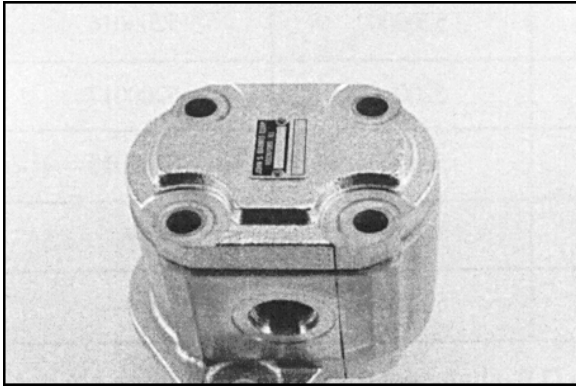

14. Install two remaining dowel pins in rear of gear housing, if applicable. Place end cover over back of pump.



15. Install four spacers (if applicable) and hex head bolts through bolt holes in end cover. Hand tighten.

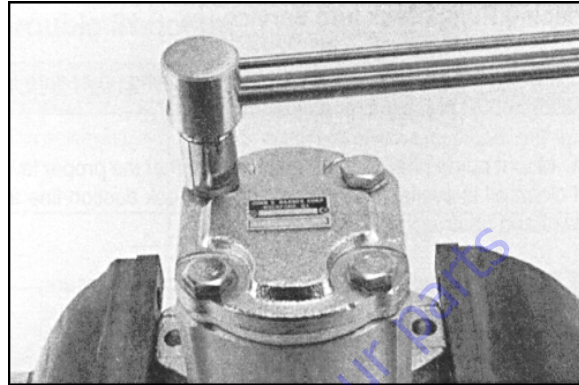

16. Place mounting flange of pump in protected jawed vise and alternately torque bolts to torque chart specifications. All torque figures are for "dry torque" bolts.

Table 5-1. Hydraulic Pump Bolt Torque Chart

Pump Series	Thread Size	Torque Values, Black Oxide End Cover	Torque Values, Zinc Plated End Cover
W-600	M 8 x 1.25	18-21 ft.lb. 24-30 Nm	16-18 ft.lb. 21.7-24.4 Nm
W-900	M 10 x 1.5	50-55 ft.lb. 68-75 Nm	38-43 ft.lb. 51.5-58.3 Nm
W-1500	M 12 x 1.75	80-85 ft.lb. 108-115 Nm	68-73 ft.lb. 92.2-99 Nm

17. Remove pump from vise.
18. Place a small amount of clean oil in pump inlet and rotate drive shaft away from inlet one revolution. If drive shaft binds, disassemble pump and check for assembly problems. Reassemble pump.

Placing Pump Back Into Service

1. *If shop test stand is available, use the following procedure for testing rebuilt pumps:*
 - a. Mount pump on test stand. Make sure proper level of clean oil is available in reservoir. Check suction line for leaks and obstructions.
 - b. Start pump and run for three minutes at zero pressure.
 - c. Intermittently load pump to 500 P.S.I. for three minutes.
 - d. Intermittently load pump to 1000 P.S.I. for three minutes.
 - e. Intermittently load pump to 2000 P.S.I. for three minutes.
 - f. Remove pump from test stand and check for freeness of drive shaft. Check pump for signs of external leakage.
2. *If shop test stand is not available, use the following procedure for testing rebuilt pumps:*
 - a. *For engine driven pumps,* mount pump on equipment and run pump at 1/2 engine speed at zero pressure for three minutes.
 - b. Operate control valve and build pressure intermittently for three minutes.
 - c. Increase engine speed to full throttle and build pressure intermittently for three minutes.
 - d. Stop engine and check pump for external leaks.

5.7 VARIABLE PUMP

Ports and Pressure Gauges

Proper servicing of pumps and motors requires pressure measured and monitored at various hydraulic circuit points. The Series 42 pump has several locations at which to take these measurements. The following outlines show gauge port locations, and gauge and fitting size for each port.

Table 5-2. Recommended Gauge Size

Gauge Port Name	Pressure Measured	Recommended Gauge Size		Fitting
		PSI	Bar	
M1 & M2	System Pressure Ports A & B	10000	600	9/16-18ORF
M3	Charge	1000	60	3/4-16ORF
M4 & M5	Servo	1000	60	9/16-18ORF
L1 & L2	Case	500	35	1-1/16-12ORF
S	Charge Pump Inlet Vacuum	30 in. Hg Vac.	1	1-1/16-12ORF

NFPE Control

The 3-position FNR control, and electric and hydraulic non-feedback proportional (NFPE and NFPH) controls are non-feedback type controls. FNR and NFPE controls consist of pump housing mounted modules. Hydraulic input for NFPH is received through ports on top of pump [9/16-18 SAE O-ring fitting].

Non-feedback controls are factory set. Control modules can be removed to clean ports and change O-rings.

FNR and NFPE orifice plugs are located inside the servo piston covers. NFPH orifice plugs are located in the NFPH ports. Orifice plugs may be cleaned or replaced.

Remove and Install FNR and NFPE Modules

1. Clean pump and module housings.
2. Remove four screws retaining module to pump housing (4 mm Int. Hex). Remove module from housing.
3. Remove O-rings from the control ports. Examine ports for cleanliness.
4. Clean sealing surfaces.
5. Replace locator pin.
6. Install new O-rings.
7. Replace screws. Torque to 3.5 - 4.5 ft-lb (4.7-6.1 Nm).

Remove and Install FNR and NFPE Control Orifices

NOTE: Future models may contain an orifice plate between module and pump housing. This will take the place of the orifice plugs beneath the servo piston cover.

1. Remove servo piston cover.
2. Remove orifice plug (1/8" Int. Hex).
3. Examine orifice and port for cleanliness.
4. Install orifice plug. Torque to 1.5 - 2.5 ft-lb (2.0-3.4 Nm).

Charge Relief Valve

Charge relief valve may be removed for cleaning and installation of new O-rings. Pressure setting may be changed for different charge flows depending on charge pump size and pump speed.

Factory setting is set relative to case pressure at 1800 rpm. Actual charge pressure varies at different speeds.

SHIM ADJUSTABLE STYLE

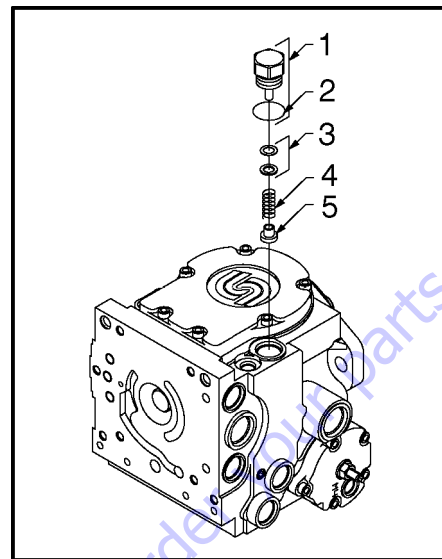

- | | |
|-----------|------------------|
| 1. Plug | 4. Spring T-Seal |
| 2. O-Ring | 5. Poppet |
| 3. Shims | |

Figure 5-68. Shim Adjustable Charge Relief Valve Components

1. Remove shim adjustable charge relief valve plug (1" Hex) from pump housing. Remove O-ring from plug.
2. Remove spring and poppet from housing.
3. Do not alter shims which may be installed between spring and valve plug, or interchange parts with another valve. Inspect poppet and mating seat in housing for damage or foreign material.
4. If desired, change charge relief valve setting. An approximate rule of thumb is 4 bar / 1.25 mm (58 psi / 0.050 in). Effective setting will vary.

To confirm charge relief valve setting, measure charge pressure (port M3) with pump in stroke. Charge pressure should level off when relief setting is reached.

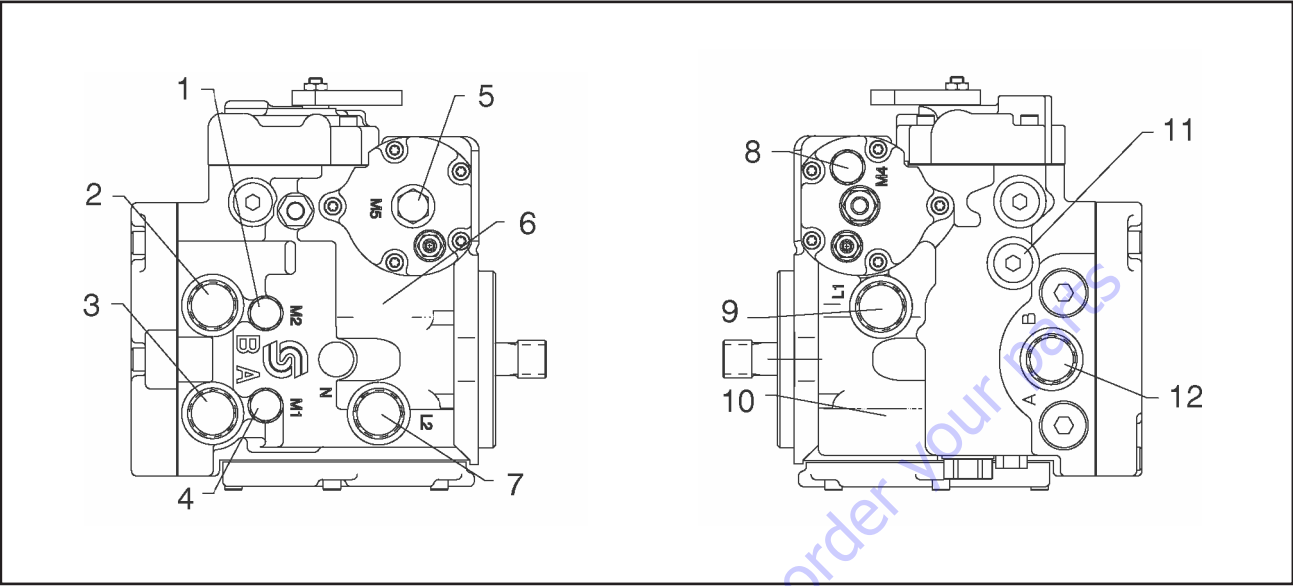

- | | |
|--------------------------------------|---------------------------------------|
| 1. System Pressure Gauge Port M2 | 7. Case Drain Port L2 |
| 2. System Pressure Port B | 8. Servo Pressure Gauge Port L4 |
| 3. System Pressure Port A | 9. Case Drain Port L1 |
| 4. System Pressure Gauge Port M1 | 10. Case Drain Port L1 (non-feedback) |
| 5. Servo Pressure Gauge Port M5 | 11. Charge Pressure Gauge |
| 6. Case Drain Port L2 (non-feedback) | 12. Charge Pump Inlet Port S |

Figure 5-69. Gauge Port Locations

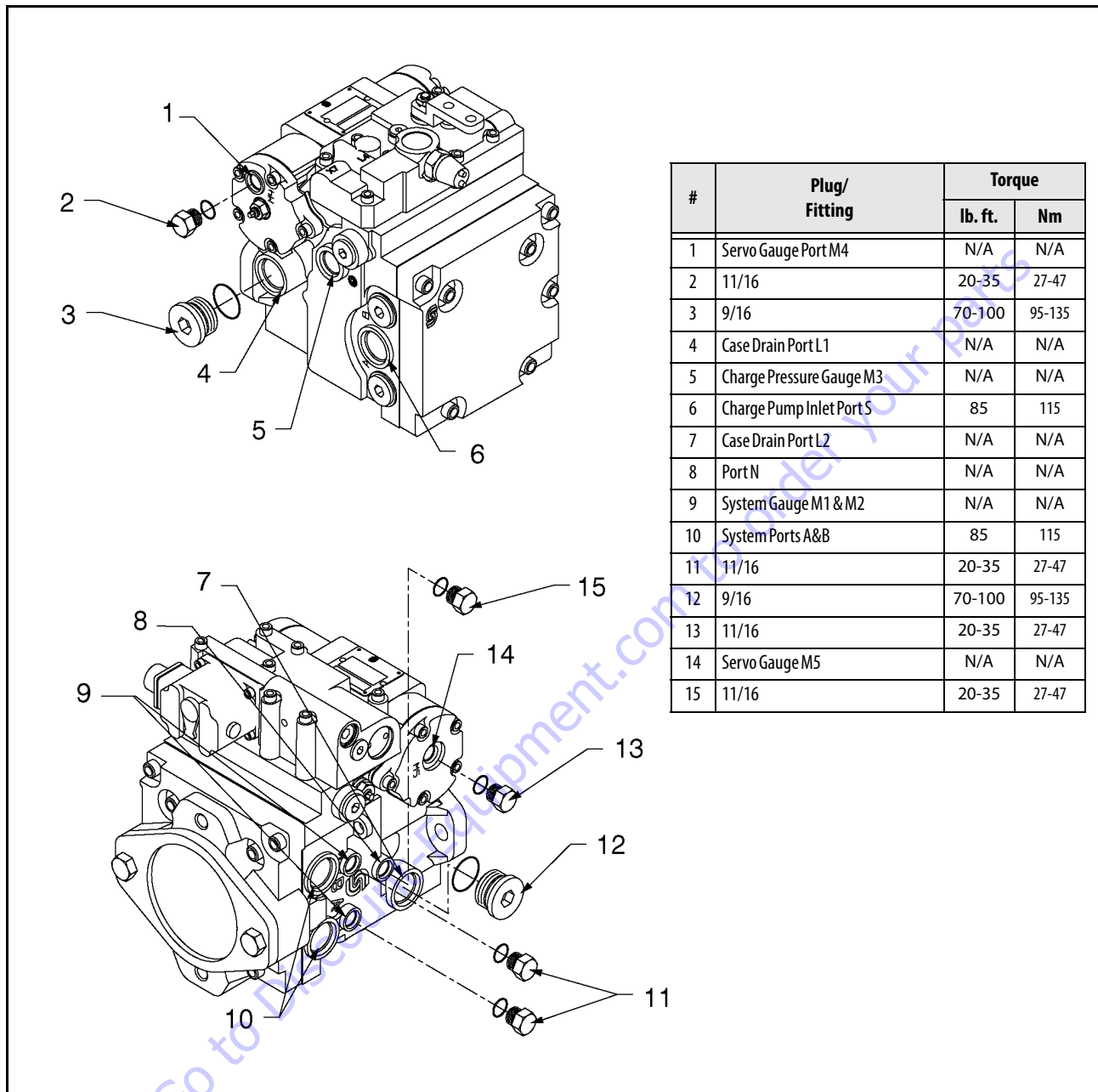
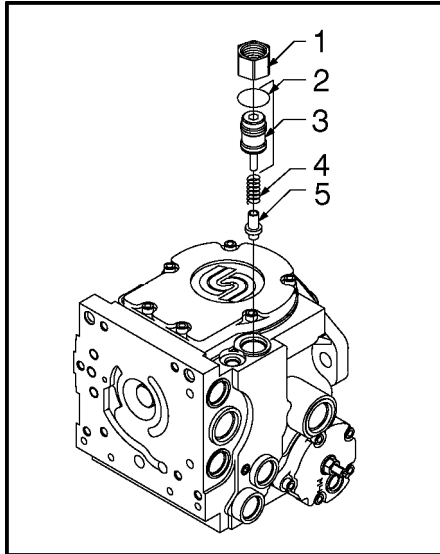

Figure 5-70. Plugs/Fittings Size & Torque

5. Install new O-ring on valve plug. Reinstall poppet, spring, and plug (with shims and O-ring) into pump housing. Torque to 40-100 ft-lb (55-135 Nm).

SCREW ADJUSTABLE STYLE



- | | |
|-------------|------------------|
| 1. Lock Nut | 4. Spring-T-Seal |
| 2. O-Ring | 5. Poppet |
| 3. Plug | |

Figure 5-71. Screw Adjustable Charge Relief Valve Components

1. Mark plug, lock nut, and housing to maintain original adjustment before removing screw adjustable relief valve plug. Loosen lock nut (1-1/16" Hex) and remove plug (8 mm Int. Hex). Remove O-ring from plug.
2. Remove spring and poppet from housing.
3. Inspect poppet and mating seat in housing for damage or foreign material.
4. Install new O-ring on valve plug. Reinstall poppet and spring. Reinstall plug and lock nut. Torque to 34 - 42 ft-lb (47-57 Nm), aligning marks made at disassembly.
5. Check and adjust charge pressure if necessary. For screw adjustable "anti-stall" charge relief valves, an approximate rule of thumb is 2.8 bar/quarter turn (40 psi/quarter turn).
6. Measure charge pressure (port M3) with pump in stroke. Charge pressure should level off when relief setting is reached.

Shaft Seal and Shaft Replacement

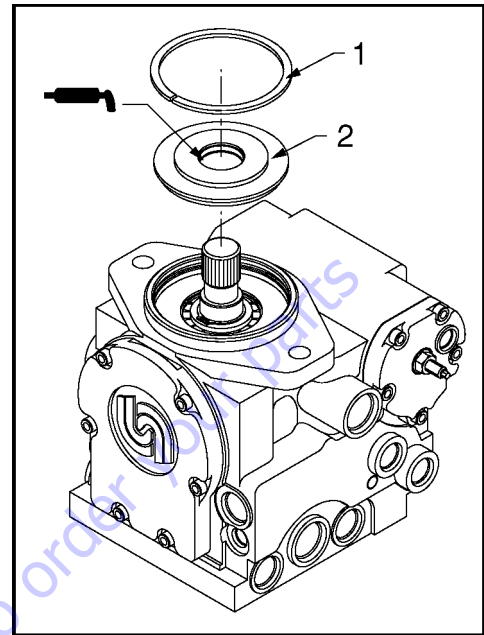

- | | |
|-------------------|--------------------------|
| 1. Retaining Ring | 2. Seal Carrier Assembly |
|-------------------|--------------------------|

Figure 5-72. Shaft Seal Components

A lip type shaft seal is used in Series 42 pumps. Seal and shaft can be replaced without major unit disassembly. Replacement generally requires removing pump from machine.

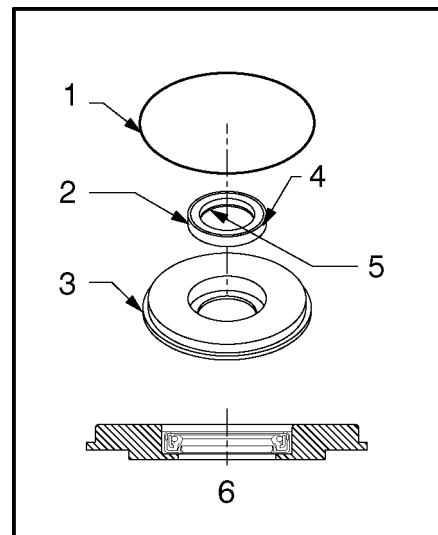

- | | |
|-----------------|--|
| 1. O-Ring | 4. Sealant may be used on outside diameter |
| 2. Seal | 5. Inside Lip (face down) |
| 3. Seal Carrier | 6. Press Seal to Bottom of Seal Carrier |

Figure 5-73. Installation of Shaft Seal

SECTION 5 - HYDRAULICS

1. Position pump with shaft facing up.

NOTE: If unit is positioned horizontally when shaft is removed, cylinder block could move out of place, making shaft installation difficult.

2. Remove retaining ring from housing.
3. Pull out seal carrier assembly.
4. Remove O-ring from seal carrier. To install a new shaft only, go to step 8.
5. Place seal carrier in an arbor press with shaft bearing side down and press out old seal. An appropriately sized pipe spacer or socket wrench can be used as a press tool. Seal is not reusable.
6. Inspect seal carrier and new seal for damage. Inspect sealing area on shaft for rust, wear, or contamination. Polish sealing area on shaft if necessary.
7. Press new seal in shaft bearing side of seal carrier. Seal lip must face outside of pump. Do not damage seal. Outside diameter of seal may be coated with a sealant (e.g. Loctite High Performance Sealant #59231) before installation. This helps prevent leaks caused by damage to seal bore in seal carrier. If shaft is not being replaced go to step 11.
8. Remove shaft and roller bearing assembly from pump or motor.
9. Remove retaining ring from roller bearing assembly with snap ring pliers. Remove roller bearing assembly.
10. Place roller bearing assembly on new shaft and secure with retaining ring.
11. Wrap spline or key end of shaft with thin plastic to prevent damage to seal lip during installation. Lubricate inside diameter of shaft seal with petroleum jelly.
12. Place O-ring on shaft bearing and lubricate with petroleum jelly.
13. Slide seal carrier assembly over shaft and into housing bore. Press against O-ring. Hold inward pressure against shaft to compress cylinder block spring while pressing seal carrier into place.
14. Install retaining ring.

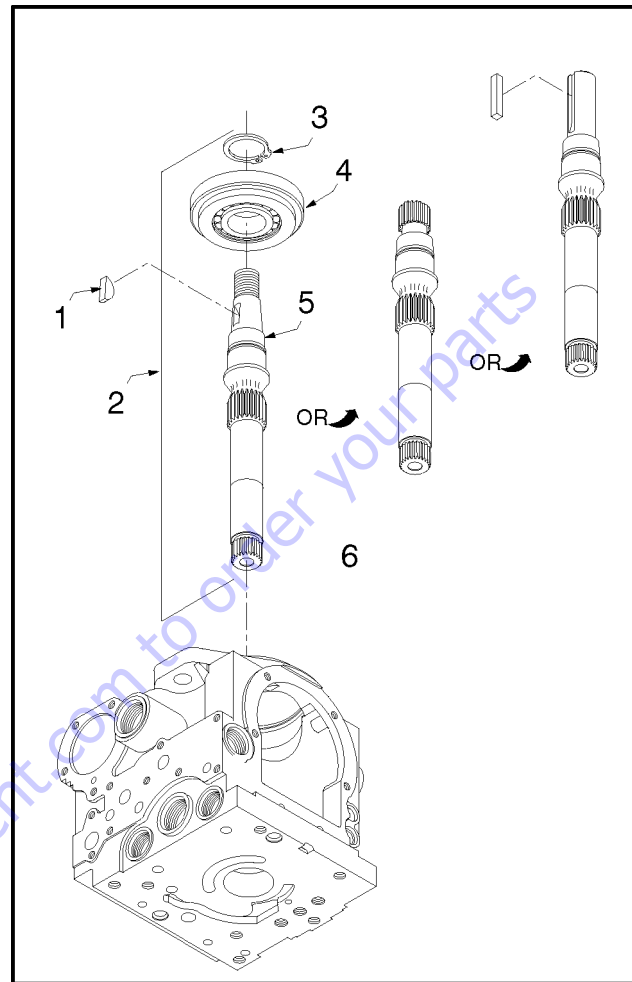

- | | |
|-------------------|-------------------|
| 1. Key | 4. Roller Bearing |
| 2. Shaft Assembly | 5. Shaft |
| 3. Retaining Ring | |

Figure 5-74. Shaft Components

Hydraulic Pump W/Hayes Pump Drive Coupling Lubrication

Coat pump and drive coupling splines with Lithium Soap Base Grease (TEXACO CODE 1912 OR EQUIVALENT) whenever pump or pump drive coupling is removed. Coupling is greased prior to assembly.

Charge Pump

NOTE: Disassemble charge pump to inspect and clean, or change auxiliary shaft drive coupling.

1. Remove auxiliary pump if necessary.
2. Remove screws retaining charge pump cover to pump housing (Torx T). Seven screws are used with "no pad" or SAE "A" auxiliary mounting pad charge pump cover, and six screws are used with SAE "B" auxiliary mounting pad charge pump cover. Remove charge pump cover, gasket, and cover locating pins.
3. Remove gerotor cover assembly from charge pump cover or back of pump housing. Remove gerotor cover O-rings. Two O-rings are used on gerotor cover of all pumps.
4. Remove gerotor assembly from gerotor cover or pump housing.
5. Remove gerotor drive pin and drive coupling. Remove gerotor cover locating pin from pump housing.
6. Inspect each part if they are to be reused. If either gerotor assembly parts needs to be replaced, they must both be replaced. Always replace O-rings and charge pump cover gasket. Inspect journal bearing in gerotor cover for excessive wear.
7. Lubricate gerotor assembly with clean hydraulic oil before assembly.
8. Install gerotor drive pin into hole in drive coupling. Apply grease or petroleum jelly to keep in place.
9. Install drive coupling on pump shaft with smaller outside diameter facing away from shaft.
10. Install gerotor assembly onto coupling.
11. Install gerotor cover locating pin into pump housing. Install gerotor cover assembly over gerotor. Locating pin must engage slot in gerotor cover.

NOTE: Charge pump rotation is determined by location of gerotor recess and pressure balance hole in gerotor cover. Different gerotor covers are used for clockwise and counterclockwise rotation pumps.

12. Install new pressure balance O-rings to gerotor cover and retain with petroleum jelly or grease.
13. Install charge pump cover locating pins and new charge pump cover gasket.
14. Install charge pump cover. Cover must engage gerotor cover and locating pins. Install charge pump cover screws. Torque evenly to 26 - 32 ft-lb (36-43 Nm).
15. Reinstall auxiliary pump if necessary.

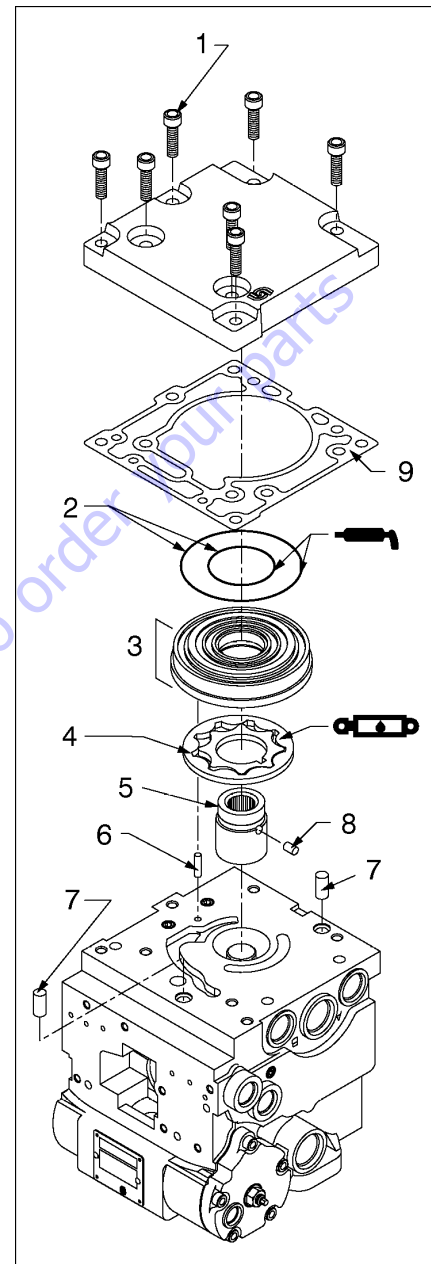

- | | |
|--------------------------|-----------------------------------|
| 1. Cover Retaining Screw | 6. Gerotor Cover Locating Pin |
| 2. O-Ring | 7. Charge Pump Cover Locating Pin |
| 3. Gerotor Cover | 8. Gerotor Drive Pin |
| 4. Gerotor Assembly | 9. Gasket |
| 5. Drive Coupling | |

Figure 5-75. Charge Pump Components

5.8 HYDRAULIC COMPONENT START-UP

The goal at hydrostatic system start up is to preserve the designed life span of the system. Use the following start-up procedure when a new pump or motor is installed or a system is restarted after a pump or motor has been removed and reinstalled.

⚠ WARNING

THE FOLLOWING PROCEDURE MAY REQUIRE MACHINE TO BE DISABLED (WHEELS RAISED OFF THE GROUND, WORK FUNCTIONS DISCONNECTED, ETC.) WHILE PERFORMING PROCEDURE. TO PREVENT INJURY. TAKE NECESSARY SAFETY PRECAUTIONS BEFORE MOVING VEHICLE/MACHINE.

Inspect pumps or motors for damage that may have been incurred during shipping and handling before installation. Make sure all system components (reservoir, hoses, valves, fittings, heat exchanger, etc.) are clean before filling with fluid.

Fill reservoir with recommended hydraulic fluid. This fluid should be passed through a 10 micron (nominal, no bypass) filter before entering reservoir. Using contaminated fluid can damage components and may cause unexpected vehicle/machine movement.

NOTICE

INSPECT ALL PUMPS OR MOTORS FOR DAMAGE AND CONTAMINATION IF ANY PUMP OR MOTOR IS REPLACED DUE TO INTERNAL DAMAGE. FLUSH AND REPLACE ALL HYDRAULIC SYSTEM FLUID OR DAMAGE TO ENTIRE SYSTEM MAY RESULT.

Inlet line from reservoir to pump must be filled prior to start-up. Check inlet line for properly tightened fittings, restrictions, and air leaks.

NOTE: *Reservoir is usually above pump inlet. Pressure head created by higher oil level helps keep inlet pressures within acceptable range and prevent high vacuum levels. However, air may be trapped due to hose routing or low reservoir locations. Bleed air by loosening hose at fitting closest to pump. When oil begins to flow, line is full and air has been purged. Tighten fitting to specified torque. If tank needs to be pressurized to start oil flow, take a vacuum reading at pump inlet during operation to verify pump is not trying to draw an inlet vacuum higher than its capability.*

Fill pump and motor housing with clean hydraulic fluid before start up. Fill housing by pouring filtered oil in upper case drain port.

NOTE: *Use highest possible case drain port. This ensures housing contains as much oil as possible and offers the greatest amount of lubrication to internal components.*

NOTE: *It may be easier to fill housing before installing the case drain line. Component (especially motor) location may prevent case drain port access after installation.*

NOTE: *Oil used to fill component housing must be clean. Store fill container properly to prevent contamination.*

Install 1000 psi (60 bar) pressure gauge in charge pressure gauge port to monitor charge pressure during start-up.

It is recommended external control input signal, (electrical connections for EDC), be disconnected at pump control until after initial start-up. This ensures pump remains in its neutral position.

⚠ WARNING

DO NOT START ENGINE UNLESS PUMP IS IN NEUTRAL POSITION (0° SWASH-PLATE ANGLE). TAKE PRECAUTIONS TO PREVENT MACHINE MOVEMENT IN CASE PUMP IS ACTUATED DURING INITIAL START-UP.

"Jog" or slowly rotate engine until charge pressure starts to rise. Start engine and run at lowest possible RPM until charge pressure is established. Excess air should be bled from system lines as close to motors as possible.

NOTE: *With engine on low idle loosen, do not remove, system lines at motor(s). Continue to run engine at low idle and tighten system lines as soon as oil is observed to leak from them. When oil is observed to "leak" at motor, line is full and air is purged. Tighten system hoses to specified torque.*

Once charge pressure is established, increase speed to normal operating RPM. Charge pressure should be as indicated in the pump model code. If charge pressure is inadequate, shut down and determine cause.

⚠ WARNING

INADEQUATE CHARGE PRESSURE WILL AFFECT OPERATOR'S ABILITY TO CONTROL MACHINE.

Shut down engine and connect external control input signal. Reconnect machine function(s), if disconnected earlier. Start engine, checking pump remains in neutral. With engine at normal operating RPM, slowly check forward and reverse machine operation.

Charge pressure may slightly decrease during forward or reverse operation. Continue to cycle slowly between forward and reverse for at least five minutes.

Shut down engine, remove gauges, and plug ports. Check reservoir level and add filtered fluid if needed.

Machine is ready for operation.

5.9 PRESSURE SETTING PROCEDURES

NOTICE

COLD TEMPERATURES HAVE A SIGNIFICANT IMPACT ON PRESSURE READINGS. JLG INDUSTRIES, INC. RECOMMENDS OPERATING THE MACHINE UNTIL THE HYDRAULIC SYSTEM HAS WARMED TO NORMAL OPERATING TEMPERATURES PRIOR TO CHECKING PRESSURES. JLG ALSO RECOMMENDS USING A CALIBRATED GAUGE. PRESSURE READINGS ARE ACCEPTABLE IF WITHIN +/- 5% OF SPECIFIED PRESSURES.

Main Relief

1. Install pressure gauge at quick disconnect on port MP on main valve.
2. With aid of an assistant, activate telescope in.
3. While monitoring pressure gauge, adjust main relief to 3000 PSI (206.85 Bar). Turn adjuster clockwise to increase pressure or counterclockwise to decrease pressure.

Lift Down

1. Install pressure gauge at quick disconnect in port MP on main valve.
2. With aid of an assistant, activate lift down.
3. While monitoring pressure gauge, adjust lift down relief to 1500 PSI (103 Bar). Turn adjuster clockwise to increase pressure or counterclockwise to decrease pressure.

Swing

NOTE: Left and right swing pressures are set with one adjustment.

1. Install pressure gauge at quick disconnect on port MP on main valve.
2. Lock the turntable using the turntable lock.
3. With the aid of an assistant, activate swing left or right
4. While monitoring pressure gauge, adjust swing relief to 1700 PSI (117 Bar). Turn adjuster clockwise to increase pressure or counterclockwise to decrease pressure.

Platform Level Up

NOTE: Pressure is trapped at port M3 and must be released before installing pressure gauge.

1. Activate level down to end of stroke to release pressure. Install pressure gauge at quick disconnect on port M3 on main valve after releasing pressure.
2. With aid of an assistant, activate level up.
3. While monitoring pressure gauge, adjust level up relief to 2800 PSI (193 Bar). Turn adjuster clockwise to increase pressure or counterclockwise to decrease pressure.

Platform Level Down

NOTE: Pressure is trapped at port M4 and must be released before installing pressure gauge.

1. Activate level up to end of stroke to release pressure. Install pressure gauge at quick disconnect on port M4.
2. With the aid of an assistant, activate level down.
3. While monitoring pressure gauge, adjust the level up relief to 1800 PSI (124 Bar). Turn the adjuster clockwise to increase pressure or counterclockwise to decrease pressure.

Jib Up

1. Install pressure gauge in M port on jib block.
2. With aid of an assistant, activate jib up.
3. While monitoring pressure gauge, adjust jib up relief to 1500 PSI (103 Bar). Turn adjuster clockwise to increase pressure or counterclockwise to decrease pressure.

Jib Down

1. Install pressure gauge on the M port on jib block.
2. With aid of an assistant, activate jib down.
3. While monitoring pressure gauge, adjust jib down relief to 1200 PSI (82 Bar). Turn adjuster clockwise to increase pressure or counterclockwise to decrease pressure.

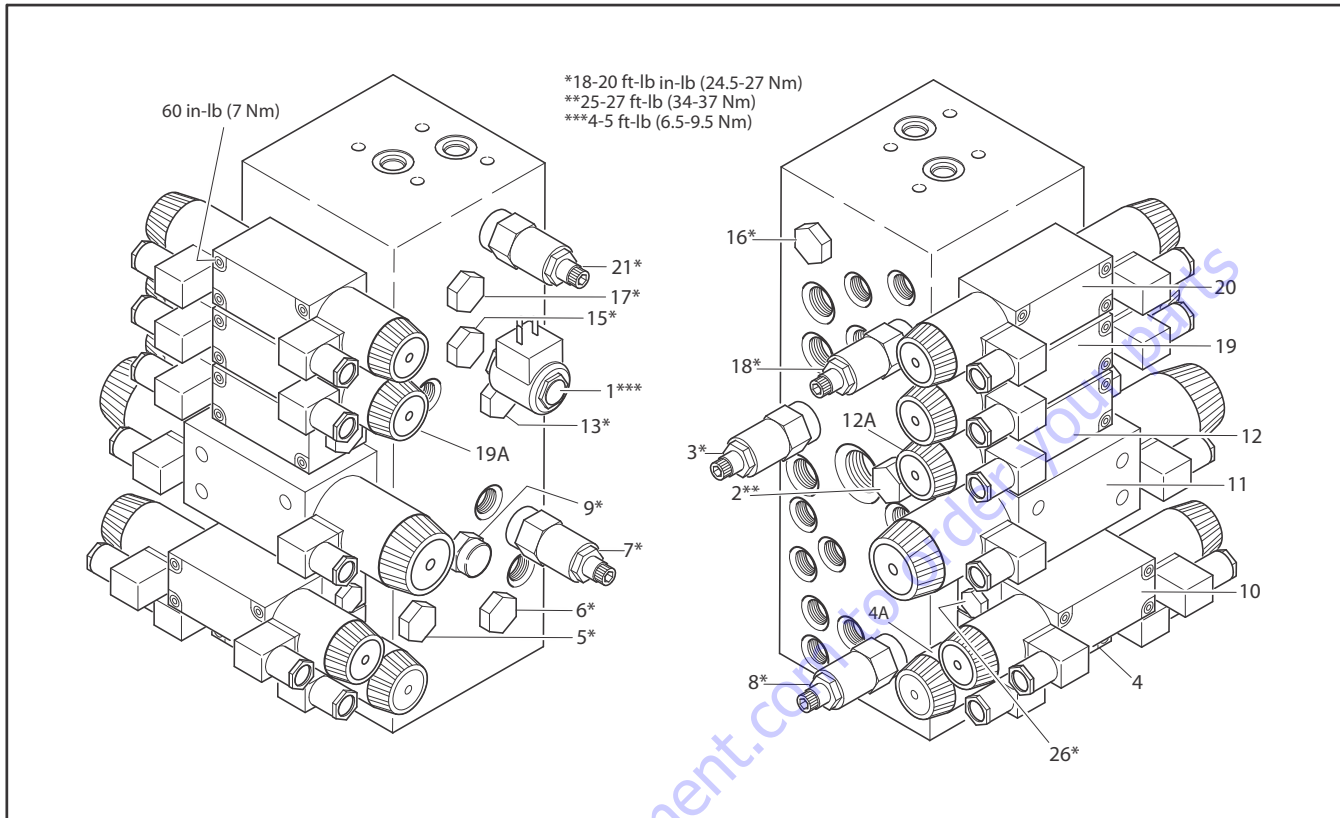

- | | | |
|--|---|--|
| 1. Solenoid Operated 2-Way valve | 10. Platform Rotate Directional Control Valve | 19. Upper Lift Directional Control Valve |
| 2. Pressure Control Load Sense Cartridge | 11. Upper Telescope Directional Control Valve | 20. Swing Directional Control Valve |
| 3. Main Relief Direct Operated Relief Valve | 12. Flow Control Directional Control Valve | 21. Direct Operated Relief Valve |
| 4. Platform Level Directional Control Valve | 13. Load Shuttle Valve | 22. Not Used |
| 5. Platform Level Check Valve | 14. Load Shuttle Valve | 23. Not Used |
| 6. Platform Level Check Valve | 15. Load Shuttle Valve | 24. Not Used |
| 7. Platform Level Relief Valve | 16. Load Shuttle Valve | 25. Not Used |
| 8. Direct Operated Relief Valve | 17. Load Shuttle Valve | 26. Directional Control Valve (Lower Lift) |
| 9. Pressure Compensated Flow Control (Fixed 0.2 GPM) | 18. Direct Operated Relief Valve | |

Figure 5-76. Location of Components - Main Control Valve

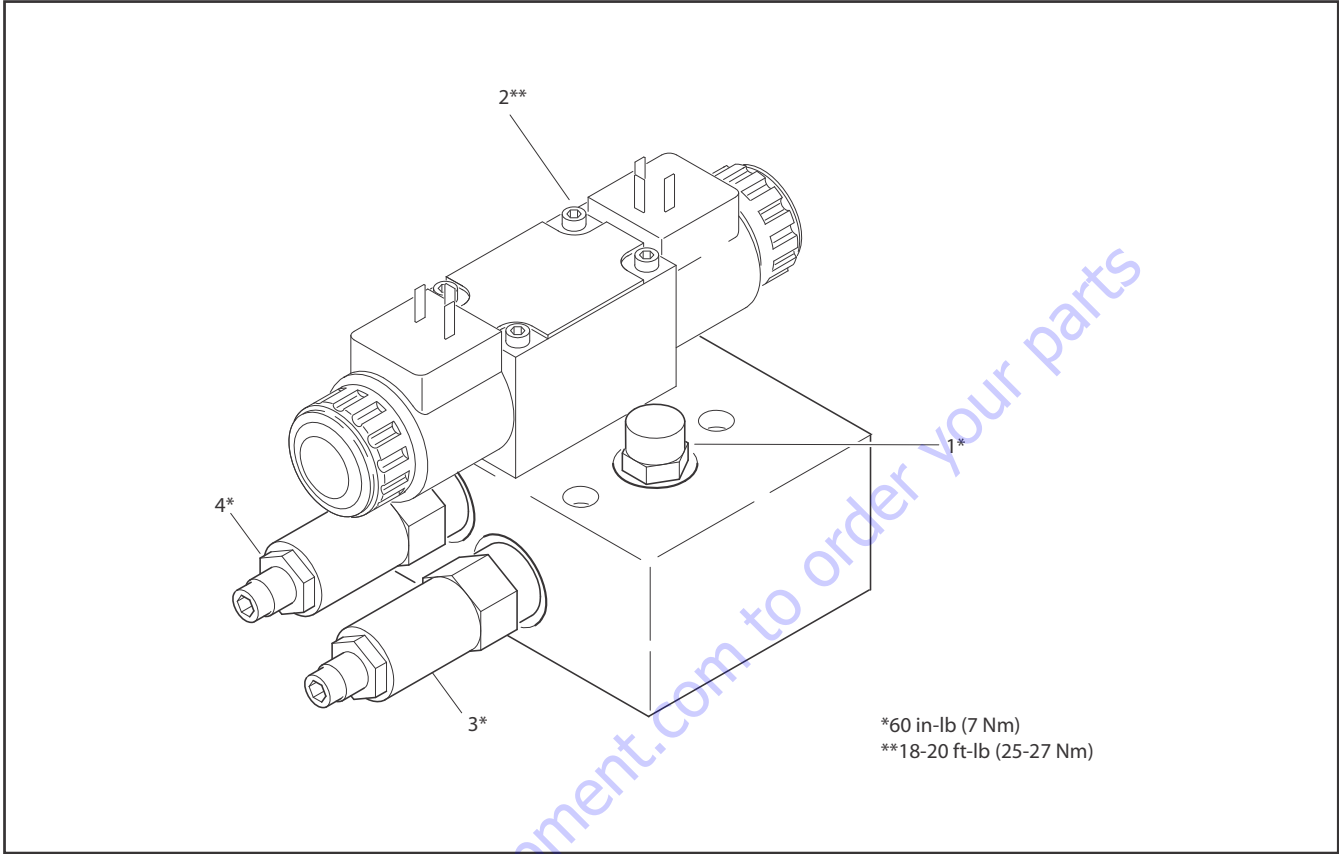

- 1.. Flow Control Cartridge
- 2.1. Directional Control Valve Assembly
- 3. Relief Cartridge
- 4. Relief Cartridge

Figure 5-77. Articulating Jib Valve

SECTION 6. JLG CONTROL SYSTEM

6.1 INTRODUCTION

NOTICE

WHEN INSTALLING A NEW GROUND MODULE CONTROLLER IT IS NECESSARY TO PROGRAM THE CONTROLLER FOR PROPER MACHINE CONFIGURATION, INCLUDING OPTIONS.

NOTICE

AVOID PRESSURE-WASHING ELECTRICAL/ELECTRONIC COMPONENTS. IF PRESSURE-WASHING IS USED TO WASH AREAS CONTAINING ELECTRICAL/ELECTRONIC COMPONENTS, JLG INDUSTRIES, INC. RECOMMENDS A MAXIMUM PRESSURE OF 750 PSI (52 BAR) AT A MINIMUM DISTANCE OF 12 INCHES (30.5 CM) FROM THESE COMPONENTS. IF ELECTRICAL/ELECTRONIC COMPONENTS ARE SPRAYED, SPRAYING MUST NOT BE DIRECT AND FOR BRIEF TIME PERIODS TO AVOID HEAVY SATURATION.

The JLG designed Control System is a 12 volt based motor control unit installed on the boom lift.

The JLG Control System has reduced the need for exposed terminal strips, diodes and trimpots and provides simplicity in viewing and adjusting the various personality settings for smooth control of: acceleration, deceleration, creep, min

speed, and max.-speed for all boom, drive, and steering functions.

Upper lift, swing, and drive are controlled by individual joysticks. Steering is controlled by a rocker switch built in the top of the drive joystick. To activate Drive, Lift, and Swing; pull up the slide lock on the joystick and move the handle in the desired direction.

The control system provides voltage output to the valves and pump, as programmed, for smooth operation and maximum cycle time. Ground control speeds for all boom functions can also be programmed in the control system.

The JLG Control System controller has a built in LED to indicate any faults. The system stores recent faults which may be accessed for troubleshooting. Optional equipment includes a soft touch system, head and tail lights, and ground alarm. These options may be added later but must be programmed into the control system when installed.

The Control System may be accessed with a custom designed, direct connect hand held analyzer or wireless adapter using an app on your Android or iPhone/iPad device. The analyzer or wireless output displays two lines of information at a time, by scrolling through the program.

Each module has a label with JLG part number and a serial number containing a date code.

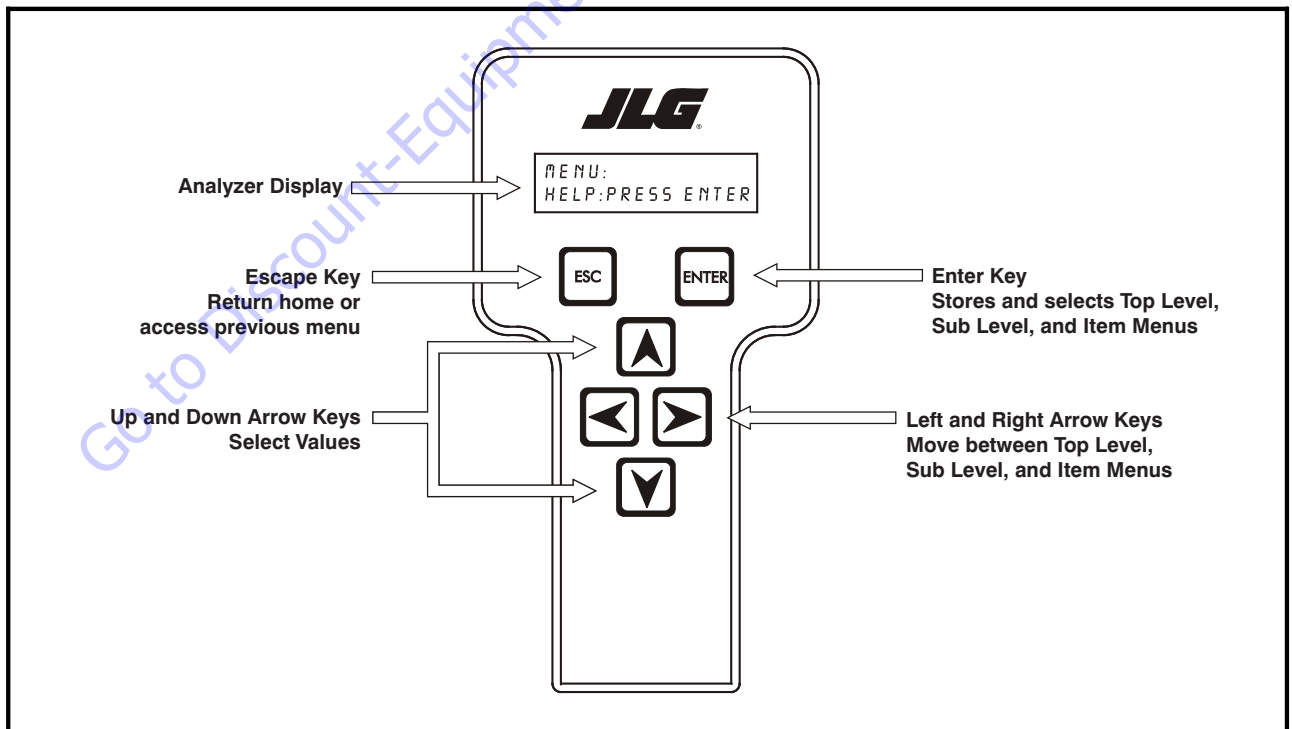

Figure 6-1. Hand-Held Analyzer (WANALYZER Controls and Display Similar)

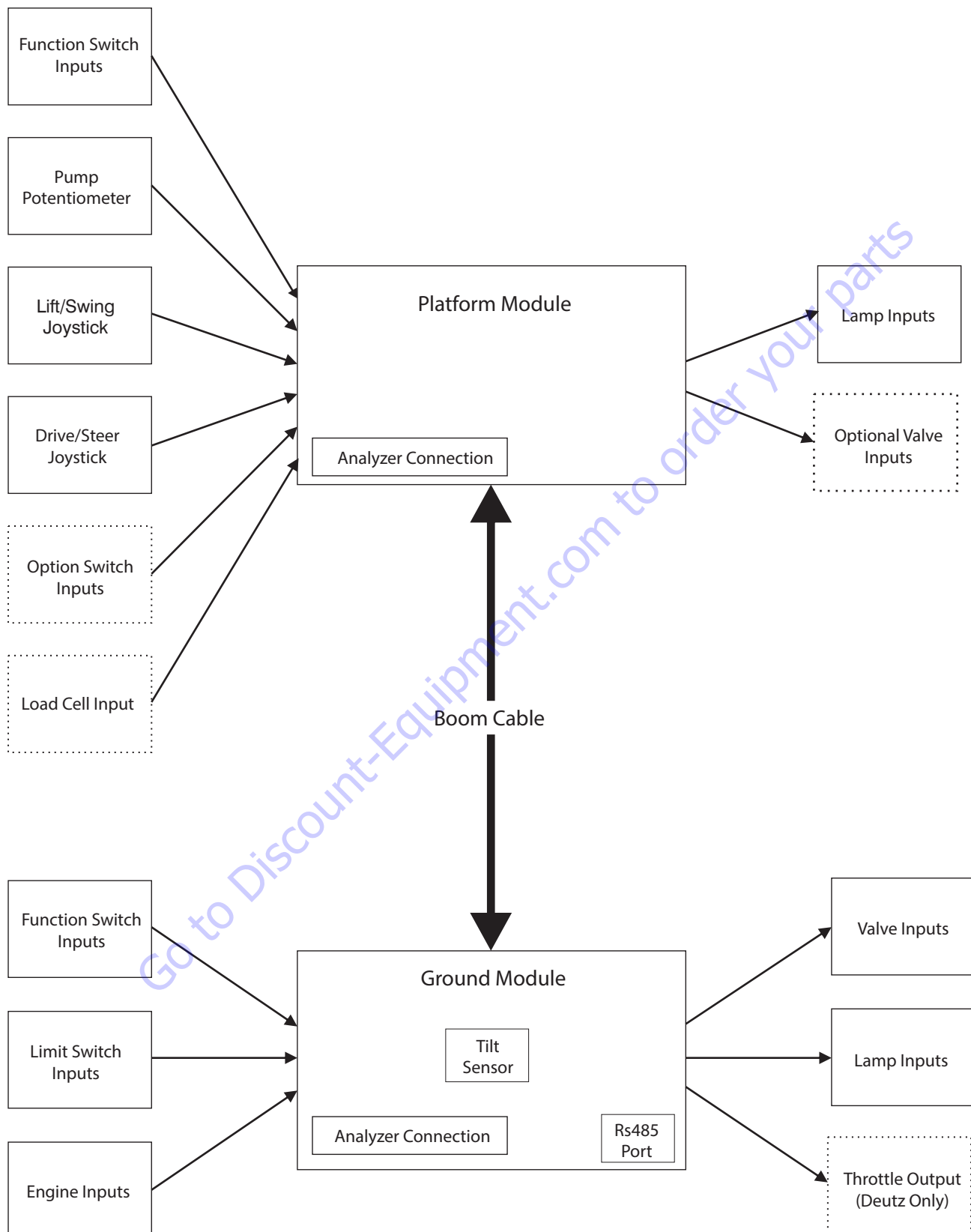

Figure 6-2. Controller Block Diagram

Connect JLG Control System Analyzer

1. Connect four pin end of cable supplied with hand-held or wireless analyzer to controller module on platform box or at controller module inside ground control box. Connect other end of cable to analyzer.

NOTE: Cable has a keyed four pin connector at each end. It cannot be connected backwards.



Figure 6-3. Analyzer Platform Connector

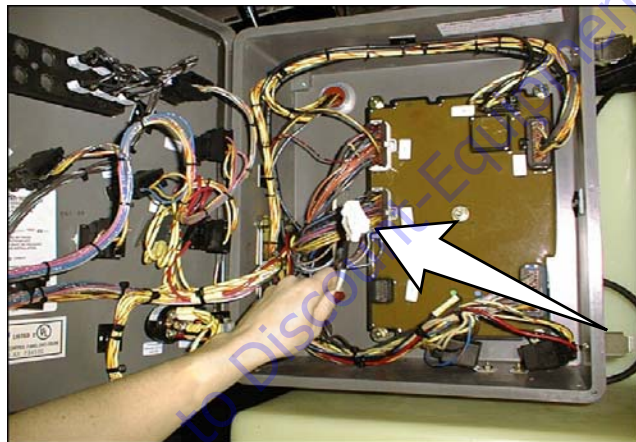

Figure 6-4. Analyzer Ground Control Box Connector

NOTE: Follow instructions provided with Wireless Analyzer (WAN-ALYZER) kit. JLG Analyzer application must be downloaded and installed to your smartphone or tablet device.

Using Analyzer

1. Power up Control System by turning lower key to platform or ground position and pulling both emergency stop buttons out.

Analyzer displays the following with machine power on and analyzer connected properly:

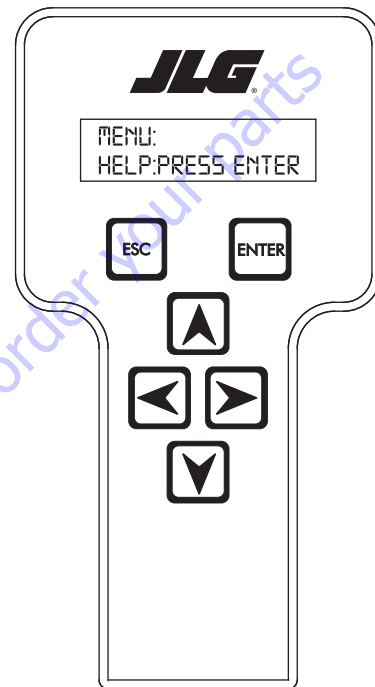

MENU:
HELP:PRESS ENTER

Move between top level menu items using

RIGHT  and **LEFT**  arrow keys. To select a displayed menu item, press **ENTER** . To cancel a selected menu item press **ESC** . Scroll using right and left arrow keys to select a different menu item.

Top level menus:

- HELP**
- DIAGNOSTICS**
- SYSTEM TEST**
- ACCESS LEVEL**
- PERSONALITIES**
- MACHINE SETUP**
- CALIBRATIONS (view only)**

If **ENTER**  is selected at the **HELP: PRESS ENTER** display, and a fault is present, the analyzer display scrolls the fault across the screen. If no fault is detected, the display shows: **HELP: EVERYTHING OK**. If powered up at the ground station, the display shows: **GROUND OK**.

If **ENTER**  is pressed again, display shows the following:

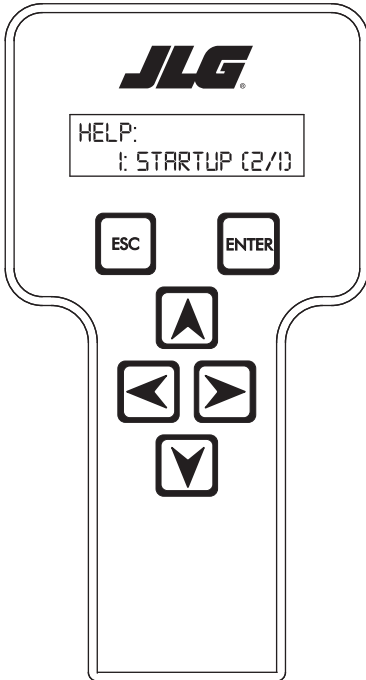

**LOGGED HELP
1: POWER CYCLE (0/0)**

Analyzer displays last system fault if any are present. Use right and left arrow keys to scroll through fault logs and view last 25

faults. Press **ESC**  two times to return to MENU screen. **POWER CYCLE (0/0)** indicates a power up.

When a top level menu is selected, a new set of menu items may be offered: for example:

- DRIVE**
- BOOM**
- SYSTEM**
- DATALOG**
- VERSIONS**

Pressing **ENTER**  with any of the above displayed menus, displays additional sub-menus within the selected menu. In some cases, such as **DRIVE**, the next level is the parameter or information to be changed. Refer to the flow chart for what menus are available within the top level menus. You may only view the personality settings for selected menus while in access level 2. Remember, you may always cancel a selected

menu item by pressing the **ESCAPE**  key.

Changing Access Level

When analyzer is first connected, you will be in access level 2 which enables you to only view most settings which cannot be changed until you enter a password to advance to a lower level. This ensures that a setting cannot be accidentally altered. To change access level, the correct password must be entered. To enter password, scroll to **ACCESS LEVEL** menu. For example:

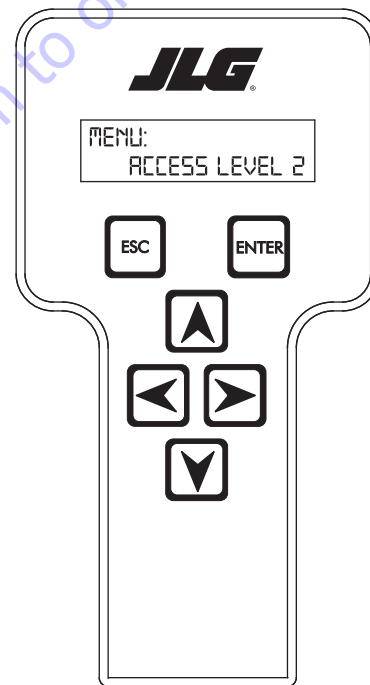

**ACCESS LEVEL:
CODE 00000**

Press **ENTER**  to select the **ACCESS LEVEL** menu.

Using the **UP**  or **DOWN**  arrow keys, enter first digit of the password, 3.

Then using the **RIGHT**  arrow key, position cursor right one space to enter the second digit of the password.

Use the **UP**  or **DOWN**  arrow key to enter the second digit of the password which is 33271.

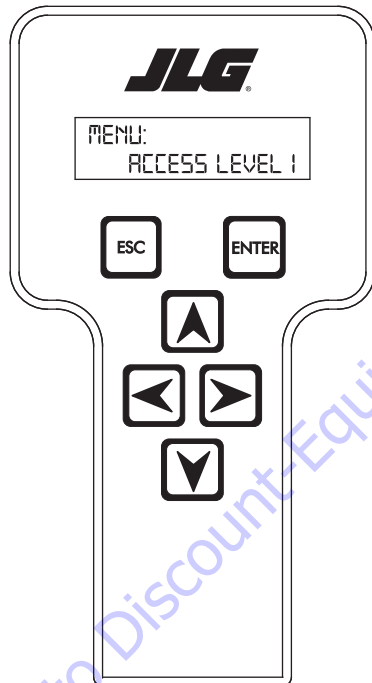

When correct password is displayed, press **ENTER** . The access level displays the following if password was entered correctly:



MENU:
ACCESS LEVEL 1



Repeat above steps if correct access level is not displayed or you can not adjust personality settings.

Adjust Parameters

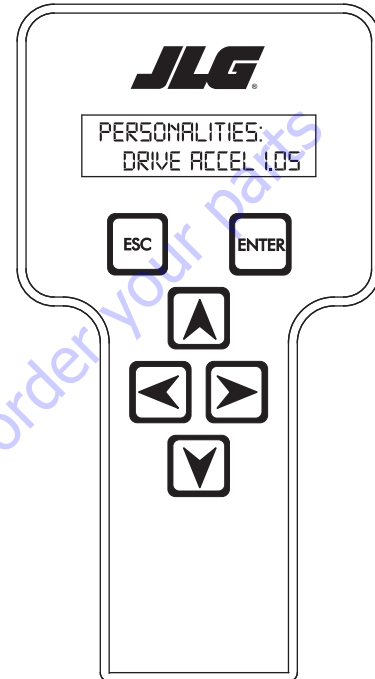

Once you have gained access to level 1, and a personality item is selected, press the **UP**  or **DOWN**  arrow keys to adjust its value, for example:



DRIVE:
ACCEL 1.05

There will be a minimum and maximum for the value to ensure efficient operation. The Value will not increase if the **UP**  arrow is pressed at maximum value or decrease if the **DOWN**  arrow is pressed at minimum value for any personality. If value does not change when pressing up and down arrows, check access level is at access level 1.

Machine Setup

When a machine digit item is selected, press **UP**  or **DOWN**  arrow keys to adjust its value, for example:

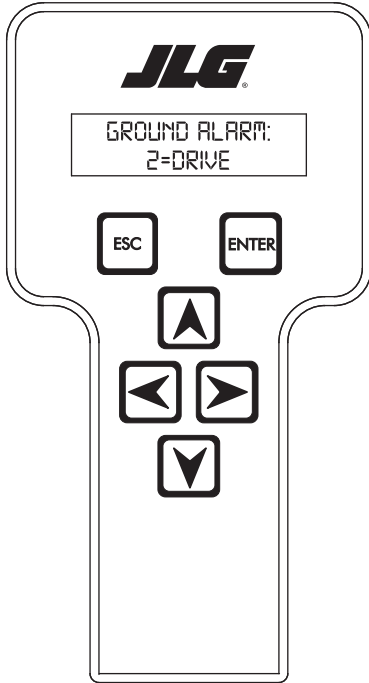

**GROUND ALARM:
2 = DRIVE**

The effect of the machine digit value is displayed along with its value. The above display would be selected if the machine was equipped with a ground alarm and you wanted it to sound when driving. There are certain settings allowed to install optional features or select the machine model.

When selection the machine model to match the size of the machine, the personality settings will all default to the factory recommended setting.

NOTE: Refer to Personality Ranges/Defaults for the recommended factory settings.

NOTE: Password 33271 allows access to level 1 to change machine personality settings.

There is a setting that JLG strongly recommends that you do not change. This setting is so noted below:

ELEVATION CUTBACK

⚠ WARNING

CHANGING ELEVATION CUTBACK SETTING MAY ADVERSELY AFFECT PERFORMANCE OF YOUR MACHINE.

NOTICE

AVOID PRESSURE-WASHING ELECTRICAL/ELECTRONIC COMPONENTS. IF PRESSURE-WASHING IS USED TO WASH AREAS CONTAINING ELECTRICAL/ELECTRONIC COMPONENTS, JLG INDUSTRIES INC. RECOMMENDS A MAXIMUM PRESSURE OF 750 PSI (52 BAR) AT A MINIMUM DISTANCE OF 12 INCHES (30.5CM) FROM THESE COMPONENTS. IF ELECTRICAL/ELECTRONIC COMPONENTS ARE SPRAYED, SPRAYING MUST NOT BE DIRECT AND FOR BRIEF TIME PERIODS TO AVOID HEAVY SATURATION.

Level Vehicle Description

⚠ WARNING

DO NOT LEVEL VEHICLE EXCEPT ON A LEVEL SURFACE.

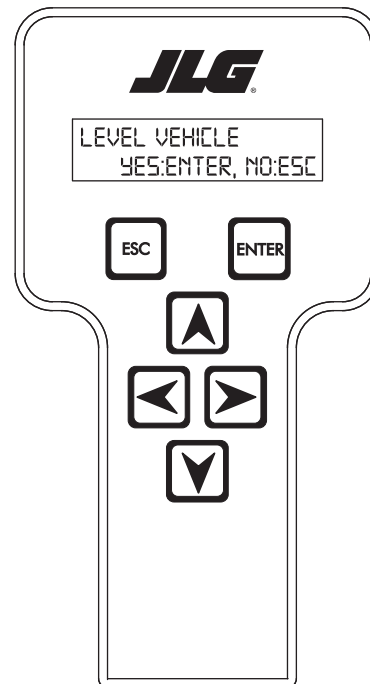

**LEVEL VEHICLE
YES:ENTER, NO:ESC**

Not available at password level 2. **ENTER**  confirms vehicle is current.

Table 6-1. Analyzer Abbreviations

ABBREVIATION	MEANING
ACCEL	ACCELERATE
ACT	ACTIVE
A/D	ANALOG DIGITAL CONVERTER COUNT
AMB.	AMBIENT
ANG	ANGLE
AUX	AUXILIARY
BCS	BOOM CONTROL SYSTEM
BM	BOOM LENGTH ANGLE MODULE
BLAM	BOOM LENGTH ANGLE MODULE
BR	BROKEN
BSK	BASKET
CAL	CALIBRATION
CL	CLOSED
CM	CHASSIS MODULE
CNTL	CONTROL
CNTRL	CONTROL
C/O	CUT OUT
CONT(S)	CONTRACTOR(S)
COOR	COORDINATED
CRKPT	CRACK POINT
CRP	CREEP
CUT	CUTOUT
CYL	CYLINDER
DECEL	DECELERATE
D	DOWN
DN	DOWN
DWN	DOWN
DEG.	DEGREE
DOS	DRIVE ORIENTATION SYSTEM
DRV	DRIVE
E	ERROR
E&T	ELEVATED & TILTED
ELEV	ELEVATION
ENG	ENGINE
EXT	EXTEND
F	FRONT
FL	FLOW
FNT	FRONT
FOR	FORWARD
FWD	FORWARD
FSW	FOOT SWITCH
FUNC	FUNCTION
G	GROUND
GND	GROUND
GRN	GREEN
GM	GROUND MODULE
H	HOURS
HW	HARDWARE
HWFS	HARDWARE FAILSAFE
I	IN or CURRENT
JOY	JOYSTICK
L	LEFT
LB	POUND

Table 6-1. Analyzer Abbreviations

ABBREVIATION	MEANING
LEN	LENGTH
LIM	LIMIT
LT	LEFT
LVL	LEVEL
M	MINUTES
MIN	MINIMUM
MAX	MAXIMUM
M	MAIN
MN	MAIN
NO	NORMALLY OPEN or NO
NC	NORMALLY CLOSED
O	OUT
O/C	OPEN CIRCUIT
OP	OPEN
O/R	OVERRIDE or OUTRIGGER
O//R	OVERRIDE
OSC	OSCILLATING
OVRD	OVERRIDE
P	PLATFORM
P	PRESSURE
PCV	PROPORTIONAL CONTROL VALVE
PLAT	PLATFORM
PLT	PLATFORM
PM	PLATFORM MODULE
POT	POTENTIOMETER
PRES	PRESSURE
PRS	PRESSURE
PT	POINT
R	REAR or RIGHT
REV	REVERSE or REVISION
RET	RETRACT
ROT.	ROTATE
RT	RIGHT
S/C	SHORT CIRCUIT
SEL	SELECTOR
SN	SERIAL NUMBER
SPD	SPEED
STOW	STOWED
STOWD	STOWED
SW	SWITCH or SOFTWARE
TELE	TELESCOPE
TEMP	TEMPERATURE
TORQ.	TORQUE
TRN	TRANSPORT
T/T	TURNTABLE
T	TOWER
TURNTBL	TURNTABLE
TWR	TOWER
U	UPPER or UP
V	VOLT
VER	VERSION
VLV	VALVE
WIT	WITNESS
YEL	YELLOW

SECTION 6 - JLG CONTROL SYSTEM

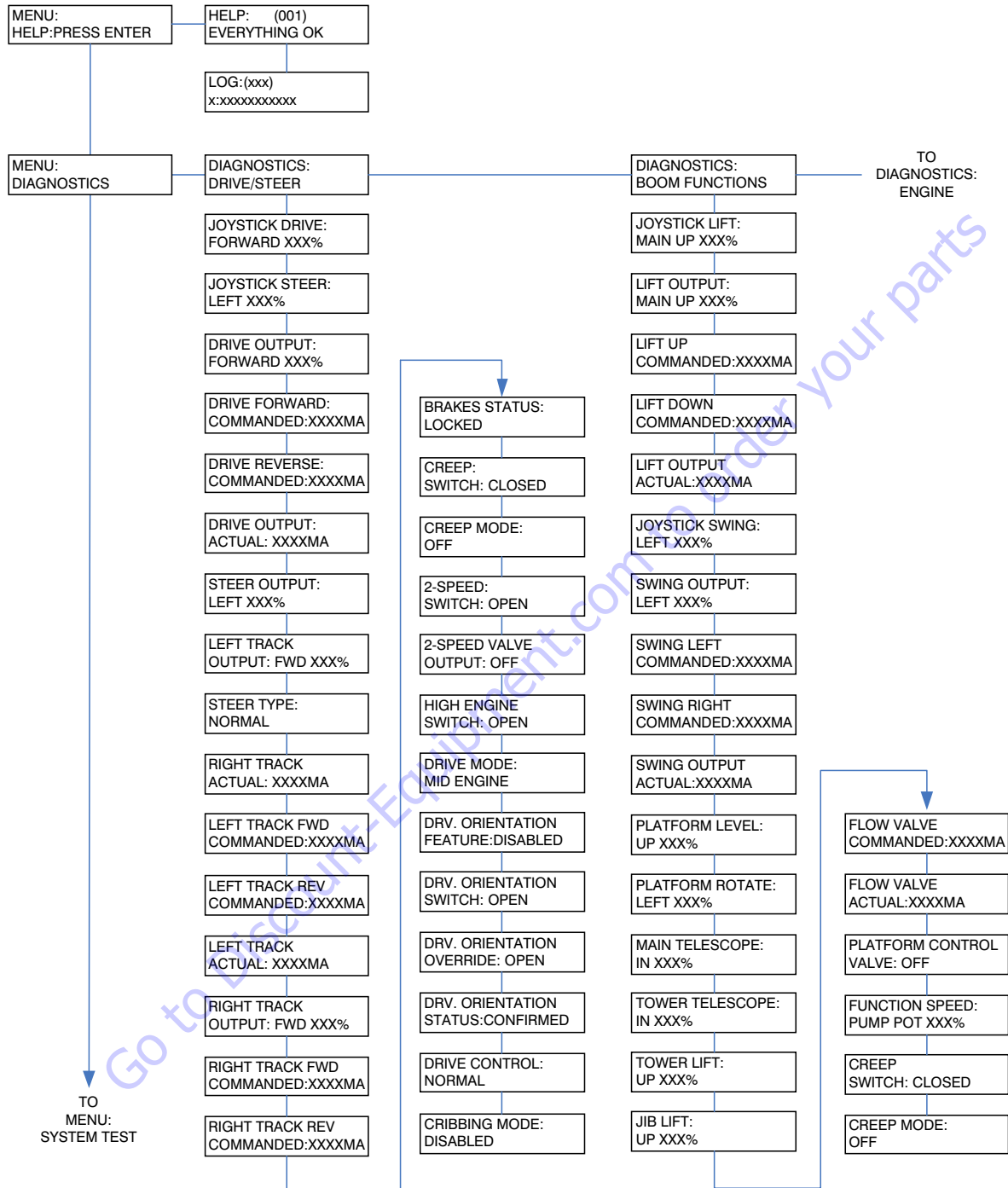

Figure 6-5. Analyzer Software Version 6.8 - Sheet 1 of 6

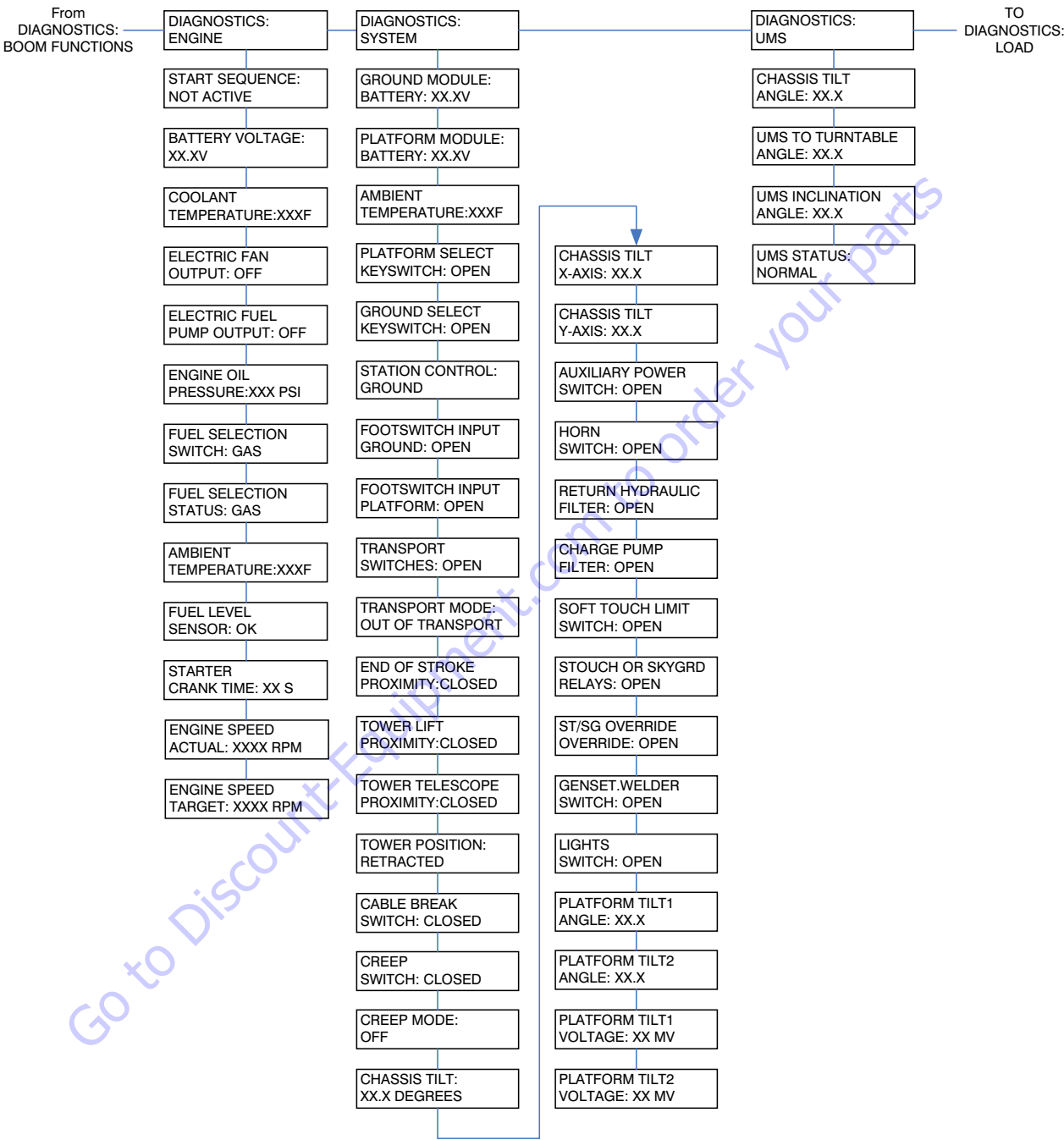

Figure 6-6. Analyzer Software Version 6.8 - Sheet 2 of 6

SECTION 6 - JLG CONTROL SYSTEM

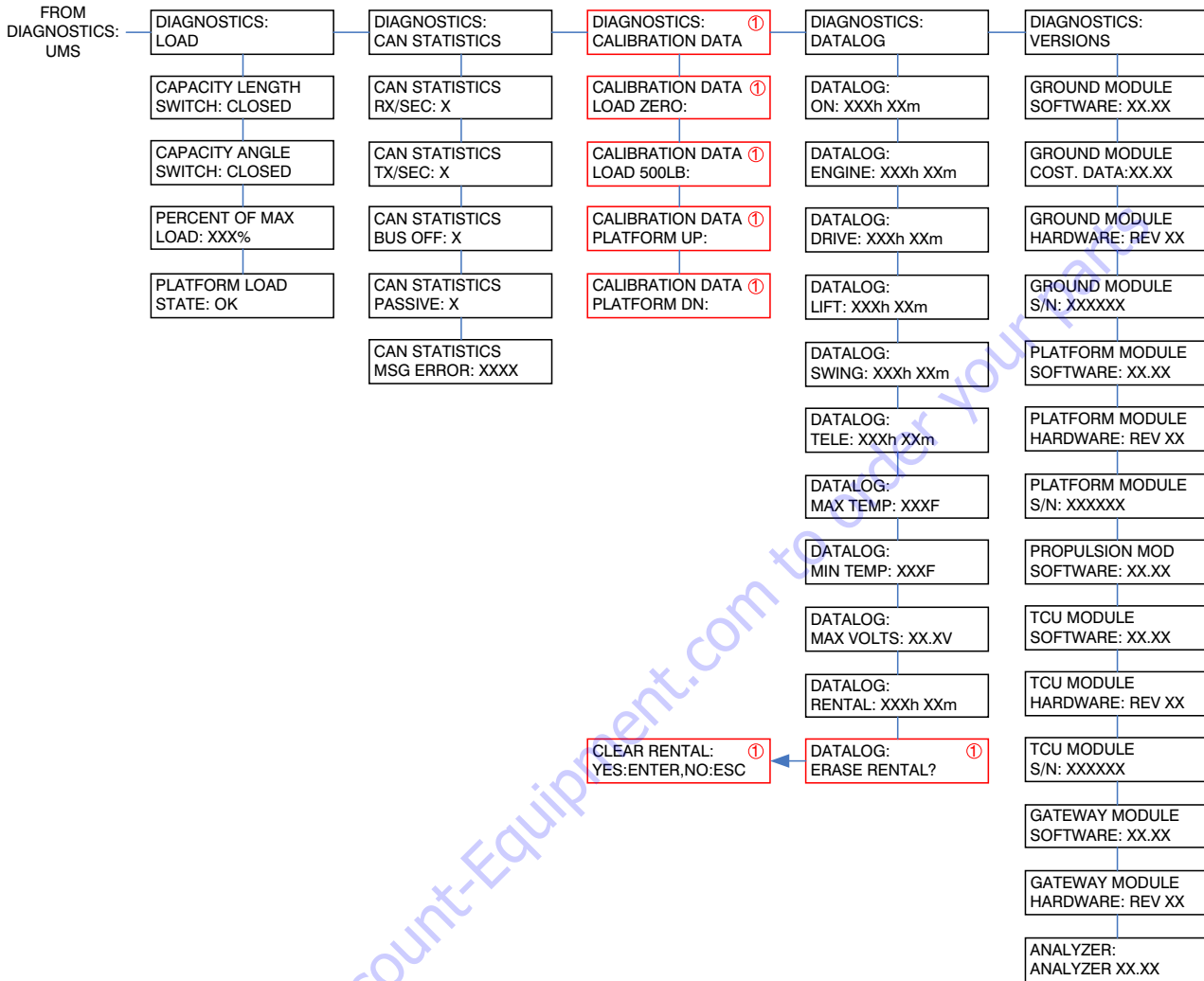

Figure 6-7. Analyzer Software Version 6.8 - Sheet 3 of 6

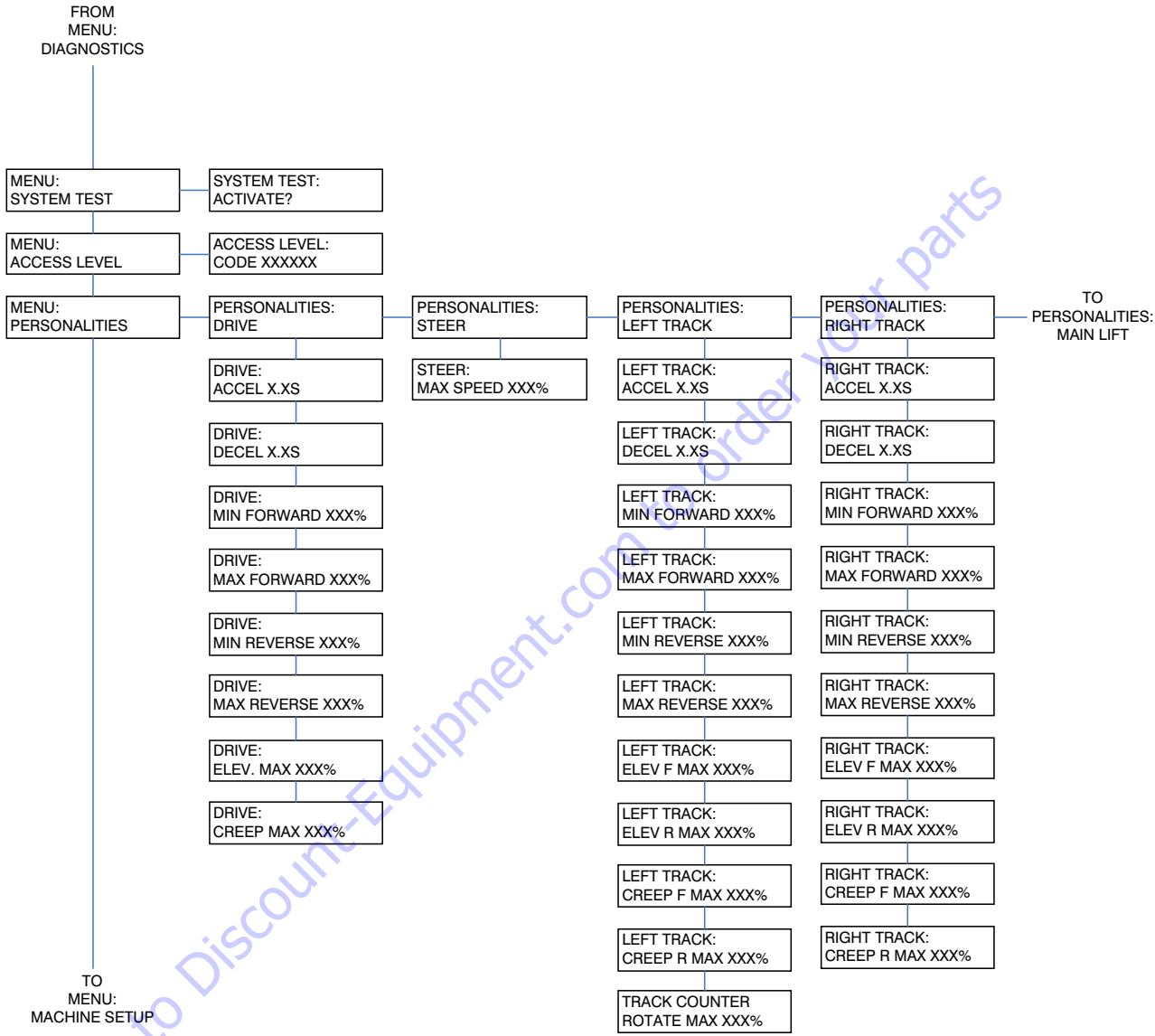

Figure 6-8. Analyzer Software Version 6.8 - Sheet 4 of 6

SECTION 6 - JLG CONTROL SYSTEM

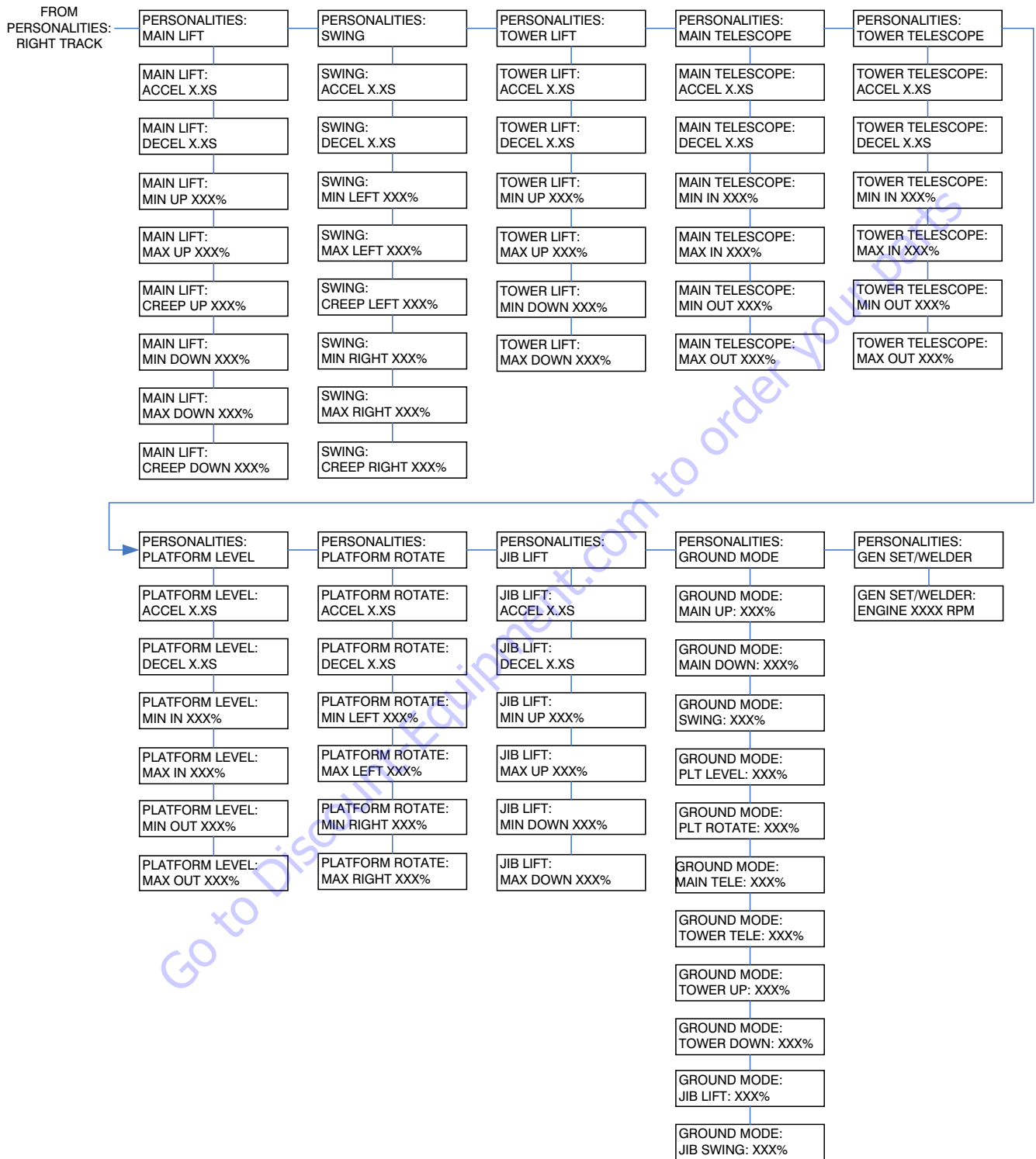

Figure 6-9. Analyzer Software Version 6.8 - Sheet 5 of 6

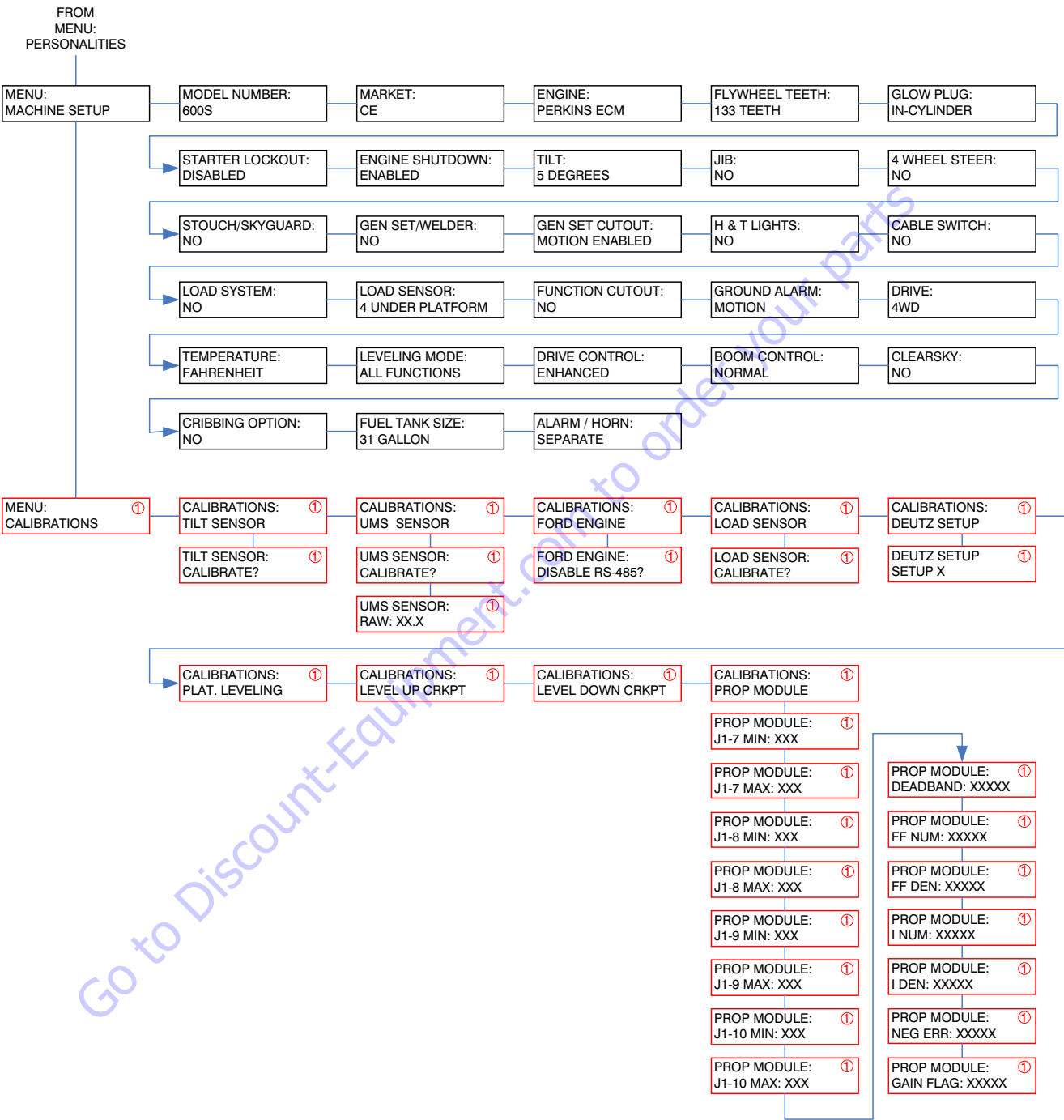

Figure 6-10. Analyzer Software Version 6.8 - Sheet 6 of 6

6.2 MACHINE PERSONALITY SETTINGS

NOTE: Personality settings can be adjusted within the adjustment range for optimum machine performance.

Table 6-2. Personality Ranges/Defaults

FUNCTION	PERSONALITY	RANGE	DEFAULTS - 600S
DRIVE	ACCEleration	0.1sto 5.0s	2.0
	DECEleration	0.1sto 3.0s	2.0
	Forward MINimum speed	0 to 35%	4
	Forward MAXimum speed	0 to 100%	35
	REVerse MINimum speed	0 to 35%	4
	REVerse MAXimum speed	0 to 100%	35
	ELEVATED MAXimum speed	0 to 50%	15
	CREEP MAXimum speed	0 to 50%	25
	Engine RPM	800 to 2900	1800
TOWERLIFT	ACCEleration	0.1 to 5.0	N/A
	DECEleration	0.1 to 3.0	N/A
	MINimum UP speed	0 to 60%	N/A
	MAXimum UP speed	0 to 100%	N/A
	MINimum DOWN speed	0 to 60%	N/A
	MAXimum DOWN speed	0 to 100%	N/A
	Engine RPM	800 to 2900	N/A
UPPER LIFT	ACCEleration	0.1 to 5.0	2.0
	DECEleration	0.1 to 3.0	0.7
	MINimum UP speed	0 to 60%	40
	MAXimum UP speed	0 to 100%	80
	CREEP Maximum UP speed	0 to 65%	55
	MINimum DOWN speed	0 to 60%	40
	MAXimum DOWN speed	0 to 100%	70
	CREEP maximum DOWN speed	0 to 75%	55
	Engine RPM	800 to 2900	1800

Table 6-2. Personality Ranges/Defaults

FUNCTION	PERSONALITY	RANGE	DEFAULTS - 600S
SWING	ACCEleration	0.1 to 5.0s	2.0
	DECEleration	0.1 to 3.0s	1.8
	MINimum LEFT speed	0 to 50%	30
	MAXimum LEFT speed	0 to 100%	65
	CREEP maximum LEFT speed	0 to 65%	45
	MINimum RIGHT speed	0 to 50%	30
	MAXimum RIGHT speed	0 to 100%	65
	CREEP maximum RIGHT speed	0 to 65%	45
	Engine RPM	800 to 2900	1400
TELESCOPE UPPER	ACCEleration	0.1 to 5.0	3.5
	DECEleration	0.1 to 3.0	0.8
	MINimum IN speed	0 to 65%	45
	MAXimum IN speed	0 to 100%	75
	MINimum OUT speed	0 to 65%	45
	MAXimum OUT speed	0 to 100%	70
	Engine RPM	800 to 2900	1800
	TELESCOPE TOWER	ACCEleration	0.1 to 5.0
DECEleration		0.1 to 3.0	N/A
MINimum IN speed		0 to 65%	N/A
MAXimum IN speed		0 to 100%	N/A
MINimum OUT speed		0 to 65%	N/A
MAXimum OUT speed		0 to 100%	N/A
Engine RPM		800 to 2900	N/A
BASKET LEVEL	ACCEleration	0.1 to 5.0	2.5
	DECEleration	0.1 to 3.0	0.5
	MINimum UP speed	0 to 65%	48
	MAXimum UP speed	0 to 100%	52
	MINimum DOWN speed	0 to 65%	45
	MAXimum DOWN speed	0 to 100%	50
	Engine RPM	800 to 2900	1500

SECTION 6 - JLG CONTROL SYSTEM

Table 6-2. Personality Ranges/Defaults

FUNCTION	PERSONALITY	RANGE	DEFAULTS - 600S
BASKET ROTATE	ACCEleration	0.1 to 5.0	1.8
	DECEleration	0.1 to 3.0	0.7
	MINimum LEFT speed	0 to 65%	46
	MAXimum LEFT speed	0 to 100%	50
	MINimum RIGHT speed	0 to 65%	46
	MAXimum RIGHT speed	0 to 100%	50
	Engine RPM	800 to 2900	1500
JIB LIFT	ACCEleration	0.1 to 5.0	5.0
	DECEleration	0.1 to 3.0	1.0
	MINimum UP speed	0 to 65%	46
	MAXimum UP speed	0 to 100%	52
	MINimum DOWN speed	0 to 65%	45
	MAXimum DOWN speed	0 to 100%	52
	Engine RPM	800 to 2900	1800
STEER	MAXimum speed	0 to 100%	100
	Engine RPM	800 to 2900	1800
GROUND MODE	Tower LIFT UP speed	0 to 100%	N/A
	Tower LIFT DOWN speed	0 to 100%	N/A
	Upper LIFT UP	0 to 100%	60
	Upper LIFT DOWN	0 to 100%	60
	SWING speed	0 to 100%	60
	Upper TELEscope speed	0 to 100%	70
	Tower TELEscope speed	0 to 100%	N/A
	BASKET ROTATE speed	0 to 100%	50
	BASKET LEVEL speed	0 to 100%	50
	JIB LIFT speed	0 to 100%	50

NOTE: Personality settings can be adjusted anywhere within the adjustment range for optimum machine performance.

4150365B

Table 6-3. Help Fault Codes, Displayed Faults, and Descriptions

Fault Flash Code	Communicated (Displayed on Analyzer) Fault	Description	Priority
None		No flash code is indicated for the following help messages. They are intended to hint at a possible problem if vehicle is not behaving as expected.	1
	EVERYTHING OK	The "normal" help message in platform mode	
	GROUND MODE OK	The "normal" help message in ground mode	
	FSW OPEN	A drive or boom function has been selected but footswitch is open.	
	RUNNING AT CREEP – CREEP SWITCH OPEN	All function speeds are limited to creep because creep switch is open.	
	RUNNING AT CREEP – TILTED AND ABOVE ELEVATION	All boom function speeds are limited to creep because vehicle is tilted and above elevation.	
	RUNNING AT CUTBACK – ABOVE ELEVATION	Drive speed is limited to "ELEVATED MAX" because vehicle is above elevation.	
	TILT SENSOR OUT OF RANGE	The tilt sensor has indicated a tilt angle greater than 19 degrees for more than 4 seconds. Not reported during 2 second power-up.	
	LOAD SENSOR READING UNDER WEIGHT	The load sensor is reading 20% or more under the calibrated zero point. This fault may occur if platform is resting on the ground. Not reported during 2 second power-up.	
1/1		Flash code 1/1 indicates a "sleep" mode. NOT REQUIRED	
2/1		Flash code 2/1 indicates problems with footswitch.	2
	FSW FAULTY	The two footswitch inputs have read the same state for more than one second.	
	KEYSWITCH FAULTY	Both platform and ground modes are selected simultaneously	
2/2		Flash code 2/2 indicates problems with drive & steer selection. Except where noted, these faults are not reported during 2 second power-up sequence.	3
	DRIVE LOCKED – JOYSTICK MOVED BEFORE FOOTSWITCH	Drive was selected before and during footswitch closure. Can be reported during power-up sequence.	
	FSW INTERLOCK TRIPPED	Footswitch was closed for seven seconds with no function selected. Can be reported during power-up sequence.	
	STEER LOCKED – SELECTED BEFORE FOOTSWITCH	Steer was selected before and during footswitch closure.	
	STEER SWITCHES FAULTY	Both steer switches are active together.	
	DRIVE / STEER WITH NO QPROX	This fault only occurs with inductive joysticks. It occurs if the joystick is moved out of the neutral position with no Qprox sensors active.	
	D/S JOY. QPROX BAD	These faults only occur with inductive joysticks. They indicate that the Q-Prox sensor is reading above 3.18 volts.	
	D/S JOY. OUT OF RANGE LOW	Resistive joysticks: These faults do not occur. Inductive joysticks: The trigger points for these faults are dependent on the centertap voltage reading. These faults will be triggered when the voltage is less than the centertap voltage minus half the center tap voltage minus 0.3 volts. If the centertap is at the high end of the range, these faults will be triggered below 1.05 volts. If the centertap is at the low end of the range, these faults will be triggered below 0.79 volts.	

SECTION 6 - JLG CONTROL SYSTEM

Table 6-3. Help Fault Codes, Displayed Faults, and Descriptions

Fault Flash Code	Communicated (Displayed on Analyzer) Fault	Description	Priority
	D/S JOY. OUT OF RANGE HIGH	Resistive joysticks: These faults do not occur if the Vref voltage is below 8.1 volts. If Vref is above 7.7 volts, Vref is operating out of tolerance or a short to battery has occurred. Inductive joysticks: The trigger points for these faults are dependent on the centertap voltage reading. These faults will be triggered when the voltage is more than the centertap voltage plus half the centertap voltage plus 0.3 volts. If the centertap is at the high end of the range, these faults will be triggered above 4.35 volts. If the centertap is at the low end of the range, these faults will be triggered above 3.8 volts.	
	D/S JOY. CENTER TAP BAD	Resistive joysticks: These faults occur when the center tap voltage is not between 3.08 volts and 3.83 volts. Due to resistor tolerances there is a +/- .1 volt range around these values where the fault may be indicated. Inductive joysticks: These faults occur when the center tap voltage is not between 2.18 volts and 2.70 volts. Due to resistor tolerances there is a +/- .1 volt range around these values where the fault may be indicated.	
	WAITING FOR FSW TO BE OPEN	Footswitch was closed when platform mode was selected. Can be reported during power-up sequence.	
2/3		Flash code 2/3 indicates problems with boom function selection.	3
	LIFT/SWING LOCKED – JOYSTICK MOVED BEFORE FOOTSWITCH	Platform upper lift or swing was selected before and during footswitch closure.	
	PUMP SWITCHES FAULTY – CHECK DIAGNOSTICS/BOOM	A boom function (lower lift, telescope, basket level, basket rotate, jib) has both directions selected together.	
	PUMP SWITCHES LOCKED – SELECTED BEFORE FOOTSWITCH	A platform boom function (lower lift, telescope, basket level, basket rotate, jib) was selected before key switch or footswitch closure.	
	PUMP SWITCHES LOCKED – SELECTED BEFORE AUX POWER	A ground boom function (lower lift, telescope, basket level, basket rotate, jib) was selected before aux power.	
	LIFT / SWING WITH NO QPROX	This fault only occurs with inductive joysticks. It occurs if the joystick is moved out of the neutral position with no Qprox sensors active.	
	I/S JOY. QPROX BAD	These faults only occur with inductive joysticks. They indicate the Q-Prox sensor is reading above 3.18 volts.	
	I/S JOY. OUT OF RANGE LOW	Resistive joysticks: These faults do not occur. Inductive joysticks: The trigger points for these faults are dependent on the centertap voltage reading. These faults will be triggered when voltage is less than centertap voltage minus half the center tap voltage minus 0.3 volts. If centertap is at high end of the range, these faults will be triggered below 1.05 volts. If centertap is at low end of the range, these faults will be triggered below 0.79 volts.	
	I/S JOY. OUT OF RANGE HIGH	Resistive joysticks: These faults do not occur if Vref voltage is below 8.1 volts. If Vref is above 7.7 volts, Vref is operating out of tolerance or a short to battery has occurred. Inductive joysticks: The trigger points for these faults are dependent on the centertap voltage reading. These faults will be triggered when voltage is more than centertap voltage plus half the centertap voltage plus 0.3 volts. If centertap is at high end of the range, these faults will be triggered above 4.35 volts. If centertap is at low end of the range, these faults will be triggered above 3.8 volts.	

Table 6-3. Help Fault Codes, Displayed Faults, and Descriptions

Fault Flash Code	Communicated (Displayed on Analyzer) Fault	Description	Priority
	I/S JOY. CENTER TAP BAD	Resistive joysticks: These faults occur when center tap voltage is not between 3.08 volts and 3.83 volts. Due to resistor tolerances there is a +/- .1 volt range around these values where the fault may be indicated. Inductive joysticks: These faults occur when center tap voltage is not between 2.18 volts and 2.70 volts. Due to resistor tolerances there is a +/- .1 volt range around these values where the fault may be indicated.	
	PUMP SWITCHES LOCKED – SELECTED BEFORE START SWITCH	This fault occurs when a hydraulic function switch is closed before start switch is closed.	
	FOOTSWITCH SELECTED BEFORE START	User attempted to start machine with footswitch engaged.	
2/4		Flash code 2/4 indicates steering digital inputs are faulty. NOT REQUIRED	
2/5		Flash code 2/5 indicates a function is prevented due to a cutout.	4
	BOOM PREVENTED – DRIVE SELECTED	A boom function is selected while a drive function is selected and drive cutout is configured to prevent simultaneous drive & boom operation.	
	DRIVE PREVENTED – ABOVE ELEVATION	Drive is selected while above elevation and drive cutout is configured to prevent drive.	
	DRIVE PREVENTED – BOOM SELECTED	Drive is selected while a boom function is selected and drive cutout is configured to prevent simultaneous drive & boom operation.	
	DRIVE PREVENTED – TILTED & ABOVE ELEVATION	Drive is selected while tilted and above elevation and tilt is configured to cutout drive.	
	MODEL CHANGED – HYDRAULICS SUSPENDED – CYCLE EMS	User changed model number using the analyzer. User must cycle power before hydraulics system will be active again.	11
2/7		Flash code 2/7 indicates accelerator input is faulty. NOT REQUIRED	
2/8		Flash code 2/8 indicates a problem with a hydraulic filter. Not reported during 2 second power-up.	5
	RETURN FILTER BYPASSED	Hydraulic return filter clogged	
	CHARGE PUMP FILTER BYPASSED	Charge pump filter clogged	
3/1		Flash code 3/1 indicates a contactor did not close when energized. NOT REQUIRED	
3/2		Flash code 3/2 indicates a contactor did not open when energized. NOT REQUIRED	
3/3		Flash code 3/3 indicates a driver problem. All driver faults are detected in a similar manner. Open circuit faults are detected when analog feedback reads too high and the output is commanded off. Short to ground is detected when analog feedback reads low and the output is commanded on. Short to battery is detected when analog feedback reads Vbat and the output is commanded off. Not reported during 2 second power-up.	6
	ALTERNATOR/ECM POWER SHORT TO GROUND		
	HOUR METER SHORT TO GROUND		
	HOUR METER SHORT TO BATTERY		
	HORN SHORT TO GROUND		
	HORN OPEN CIRCUIT		

SECTION 6 - JLG CONTROL SYSTEM

Table 6-3. Help Fault Codes, Displayed Faults, and Descriptions

Fault Flash Code	Communicated (Displayed on Analyzer) Fault	Description	Priority
	HORN SHORT TO BATTERY		
	AUX POWER SHORT TO GROUND		
	AUX POWER OPEN CIRCUIT		
	AUX POWER SHORT TO BATTERY		
	GLOW PLUG SHORT TO GROUND		
	GLOW PLUG OPEN CIRCUIT		
	GLOW PLUG SHORT TO BATTERY		
	LP LOCK SHORT TO GROUND		
	LP LOCK OPEN CIRCUIT		
	LP LOCK SHORT TO BATTERY		
	LP START ASSIST SHORT TO GROUND		
	LP START ASSIST OPEN CIRCUIT		
	LP START ASSIST SHORT TO BATTERY		
	MAIN DUMP SHORT TO GROUND		
	MAIN DUMP OPEN CIRCUIT		
	MAIN DUMP SHORT TO BATTERY		
	PARKING BRAKE SHORT TO GROUND		
	PARKING BRAKE OPEN CIRCUIT		
	PARKING BRAKE SHORT TO BATTERY		
	START SOLENOID SHORT TO GROUND		
	START SOLENOID OPEN CIRCUIT		
	START SOLENOID SHORT TO BATTERY		
	STEER DUMP SHORT TO GROUND		
	STEER DUMP OPEN CIRCUIT		
	STEER DUMP SHORT TO BATTERY		
	TWO SPEED SHORT TO GROUND		
	TWO SPEED OPEN CIRCUIT		
	TWO SPEED SHORT TO BATTERY		
	GROUND ALARM SHORT TO GROUND		

Table 6-3. Help Fault Codes, Displayed Faults, and Descriptions

Fault Flash Code	Communicated (Displayed on Analyzer) Fault	Description	Priority
	GROUND ALARM OPEN CIRCUIT		
	GROUND ALARM SHORT TO BATTERY		
	GENERATOR SHORT TO GROUND		
	GENERATOR OPEN CIRCUIT		
	GENERATOR SHORT TO BATTERY		
	WELDER SHORT TO GROUND		
	WELDER OPEN CIRCUIT		
	WELDER SHORT TO BATTERY		
	HEAD TAIL LIGHT SHORT TO GROUND		
	HEAD TAIL LIGHT OPEN CIRCUIT		
	HEAD TAIL LIGHT SHORT TO BATTERY		
	BASKET UP OVERRIDE SHORT TO GROUND	Only occurs on machines with electronic leveling systems.	
	BASKET UP OVERRIDE OPEN CIRCUIT	Only occurs on machines with electronic leveling systems.	
	BASKET UP OVERRIDE SHORT TO BATTERY	Only occurs on machines with electronic leveling systems.	
	BASKET UP SHORT TO GROUND		
	BASKET UP OPEN CIRCUIT		
	BASKET UP SHORT TO BATTERY		
	BASKET DOWN SHORT TO GROUND		
	BASKET DOWN OPEN CIRCUIT		
	BASKET DOWN SHORT TO BATTERY		
	BASKET DOWN OVERRIDE SHORT TO GROUND	Only occurs on machines with electronic leveling systems.	
	BASKET DOWN OVERRIDE OPEN CIRCUIT	Only occurs on machines with electronic leveling systems.	
	BASKET DOWN OVERRIDE SHORT TO BATTERY	Only occurs on machines with electronic leveling systems.	
	BASKET LEFT OPEN CIRCUIT		
	BASKET LEFT SHORT TO BATTERY		
	BASKET LEFT SHORT TO GROUND		
	BASKET RIGHT SHORT TO GROUND		

SECTION 6 - JLG CONTROL SYSTEM

Table 6-3. Help Fault Codes, Displayed Faults, and Descriptions

Fault Flash Code	Communicated (Displayed on Analyzer) Fault	Description	Priority
	BASKET RIGHT OPEN CIRCUIT		
	BASKET RIGHT SHORT TO BATTERY		
	JIB UP SHORT TO GROUND		
	JIB UP OPEN CIRCUIT		
	JIB UP SHORT TO BATTERY		
	JIB DOWN SHORT TO GROUND		
	JIB DOWN OPEN CIRCUIT		
	JIB DOWN SHORT TO BATTERY		
	JIB LEFT SHORT TO GROUND		
	JIB LEFT OPEN CIRCUIT		
	JIB LEFT SHORT TO BATTERY		
	JIB RIGHT SHORT TO GROUND		
	JIB RIGHT OPEN CIRCUIT		
	JIB RIGHT SHORT TO BATTERY		
	TOWER UP SHORT TO GROUND		
	TOWER UP OPEN CIRCUIT		
	TOWER UP SHORT TO BATTERY		
	TOWER DOWN SHORT TO GROUND		
	TOWER DOWN OPEN CIRCUIT		
	TOWER DOWN SHORT TO BATTERY		
	TOWER IN SHORT TO GROUND		
	TOWER IN OPEN CIRCUIT		
	TOWER IN SHORT TO BATTERY		
	TOWER OUT SHORT TO GROUND		
	TOWER OUT OPEN CIRCUIT		
	TOWER OUT SHORT TO BATTERY		
	UPPER IN SHORT TO GROUND		
	UPPER IN OPEN CIRCUIT		
	UPPER IN SHORT TO BATTERY		
	UPPER OUT SHORT TO GROUND		
	UPPER OUT OPEN CIRCUIT		
	UPPER OUT SHORT TO BATTERY		
	LIFT UP DUMP SHORT TO GROUND		
	LIFT UP DUMP OPEN CIRCUIT		

Table 6-3. Help Fault Codes, Displayed Faults, and Descriptions

Fault Flash Code	Communicated (Displayed on Analyzer) Fault	Description	Priority
	LIFT UP DUMP SHORT TO BATTERY		
	LIFT DOWN HOLDING SHORT TO GROUND		
	LIFT DOWN HOLDING OPEN CIRCUIT		
	LIFT DOWN SHORT TO BATTERY		
	HOUR METER OPEN CIRCUIT	This fault cannot be detected during normal operation. It may be reported during self test.	
	FORD ECM POWER OPEN CIRCUIT	This fault cannot be detected during normal operation. It may be reported during self test.	
	FORD ECM POWER SHORT TO BATTERY	This fault cannot be detected during normal operation. It may be reported during self test.	
3/4		Flash code 3/4 indicates a driver problem on a platform valve block valve driver. All driver faults are detected in a similar manner. Open circuit faults are detected when analog feedback reads too high and the output is commanded off. Short to ground is detected when analog feedback reads low and the output is commanded on. Short to battery is detected when analog feedback reads Vbat and the output is commanded off. Not reported during 2 second power-up.	6
	BASKET UP SHORT TO BATTERY		
	BASKET UP SHORT TO GROUND		
	BASKET UP OPEN CIRCUIT		
	BASKET UP SHORT TO BATTERY OR OPEN CIRCUIT	Only occurs on machines with electronic basket leveling	
	BASKET DOWN SHORT TO BATTERY		
	BASKET DOWN SHORT TO GROUND		
	BASKET DOWN OPEN CIRCUIT		
	BASKET DOWN SHORT TO BATTERY OR OPEN CIRCUIT	Only occurs on machines with electronic basket leveling.	
	BASKET LEFT SHORT TO BATTERY		
	BASKER LEFT SHORT TO GROUND		
	BASKET LEFT OPEN CIRCUIT		
	BASKET RIGHT SHORT TO BATTERY		
	BASKET RIGHT SHORT TO GROUND		
	BASKET RIGHT OPEN CIRCUIT		
	JIB UP SHORT TO BATTERY		
	JIB UP SHORT TO GROUND		
	JIB UP OPEN CIRCUIT		

SECTION 6 - JLG CONTROL SYSTEM

Table 6-3. Help Fault Codes, Displayed Faults, and Descriptions

Fault Flash Code	Communicated (Displayed on Analyzer) Fault	Description	Priority
	JIB DOWN SHORT TO BATTERY		
	JIB DOWN SHORT TO GROUND		
	JIB DOWN OPEN CIRCUIT		
	JIB LEFT SHORT TO BATTERY		
	JIB LEFT SHORT TO GROUND		
	JIB LEFT OPEN CIRCUIT		
	JIB RIGHT SHORT TO BATTERY		
	JIB RIGHT SHORT TO GROUND		
	JIB RIGHT OPEN CIRCUIT		
	PLATFORM CONTROL VALVE SHORT TO BATTERY	Only occurs on machines with electronic basket leveling	
	PLATFORM CONTROL VALVE SHORT TO GROUND	Only occurs on machines with electronic basket leveling	
	PLATFORM CONTROL VALVE OPEN CIRCUIT	Only occurs on machines with electronic basket leveling	
3/5		Flash code 3/5 indicates a brake pressure problem. NOT REQUIRED	
4/2		Flash code 4/2 indicates engine is over temperature. NOT REQUIRED	
4/3		Flash code 4/3 indicates problems with the engine. Except where noted, these faults are not reported during 2 second power-up sequence.	9
	HIGH ENGINE TEMP	Occurs when engine temperature is above 117° Celsius for Ford engines, and above 130° Celsius for Deutz engines.	
	AIR FILTER BYPASSED	Air filter clogged	
	NO ALTERNATOR OUTPUT	Engine has been running for 15 seconds or more and battery voltage is still below 12.5 volts.	
	LOW OIL PRESSURE	If a Deutz engine is installed, oil pressure is below 8 PSI and the engine has been running for at least 10 seconds. If a Ford engine is installed, the Ford ECM has reported a low oil pressure fault.	
	OIL PRESSURE SHORT TO BATTERY	If a Deutz engine is installed, this indicates oil pressure sensor is reading above 6.6 volts.	
	OIL PRESSURE SHORT TO GROUND	If a Deutz engine is installed, this indicates oil pressure sensor is reading below 0.1 volts for more than 5 seconds. This fault is not detected during crank.	
	COOLANT TEMPERATURE SHORT TO GROUND	If a Deutz engine is installed, this indicates coolant temperature is reading below 0.1 volts.	
	FORD FAULT CODE ##	All Ford fault codes except 63 are simply passed through from the FORDECM. They only occur if a Ford engine is selected in machine configuration digits. Can be reported during power-up sequence.	
	FORD FAULT CODE UNKNOWN	An unrecognized Ford ECM fault code has been received. Can be reported during power-up sequence.	
	485 COMMUNICATIONS LOST	This fault only occurs with a Ford engine. It occurs when no responses are received from the ECM for 2.5 seconds. Can be reported during power-up sequence.	
	FUEL SENSOR SHORT TO BATTERY	Indicates fuel sensor is reading above 4.3 volts.	

Table 6-3. Help Fault Codes, Displayed Faults, and Descriptions

Fault Flash Code	Communicated (Displayed on Analyzer) Fault	Description	Priority
	FUEL SENSOR SHORT TO GROUND	Indicates fuel sensor is reading below 0.2 volts.	
4/4		Flash code 4/4 indicates problems with the battery supply. Not reported during 2 second power-up.	7
	BATTERY LOW	Battery voltage is below 11V for more than 5 seconds. This fault is not detected during crank. This is a warning – controller does not shut down.	
	BATTERY TOO HIGH – SYSTEM SHUT DOWN	Battery voltage is above 16V. EMS recycle required.	
	BATTERY TOO LOW – SYSTEM SHUT DOWN	Battery voltage is below 9V.	
5/5		Flash code 5/5 indicates problems with vehicle engine RPM or the encoder. Not reported during 2 second power-up.	8
	SPEED SENSOR READING INVALID SPEED	This fault is detected with diesel engines only. The RPM pickup is indicating a speed that greater than 4000 RPM or approximately 8875 Hz.	
	SPEED INPUT LOST	This fault is detected with diesel engines only. It occurs if there is no RPM detected and the oil pressure input is reading above 8 PSI for more than three seconds. This is probably due to wiring problems at the ground module or a faulty speed sensor.	
6/6		Flash code 6/6 indicates problems with the CAN bus.	10
	CAN BUS FAILURE:	Ground module or platform module is not receiving CAN messages. This is probably due to wiring problems between the platform and ground modules.	
7/7		Flash code 7/7 indicates problems with a motor. NOT REQUIRED	
9/9		Flash code 9/9 indicates problems with the controller.	11
	PLATFORM MODULE SOFTWARE UPDATE REQUIRED	Platform module code is too old to support the EIM or BPE load sensor and the machine is configured to use one of these two sensors. The PM code must be updated to a newer version.	
	HIGH RESOLUTION A2D FAILURE – INTERRUPT LOST	The ADS1213 chip in the platform module has stopped asserting its interrupt (DRDY) line for some reason. An EMS cycle is required.	
	HIGH RESOLUTION A2D FAILURE-REINIT LIMIT	The ADS1213 has needed to be reset 3 or more times.	
	PLATFORM MODULE FAILURE: HWFS CODE 1	Platform module V(Low) FET has failed	
	GROUND MODULE FAILURE: HWFS CODE 1	Ground module V(Low) FET has failed	
	GROUND SENSOR REF VOLTAGE OUT OF RANGE	These faults occur when the seven volt reference voltage used for joysticks, sensors, etc. goes out of range. Not reported during 2 second power-up.	
	PLATFORM SENSOR REF VOLTAGE OUT OF RANGE	These faults occur when the seven volt reference voltage used for the joysticks, sensors, etc. goes out of range. Not reported during 2 second power-up.	
	EEPROM FAILURE – CHECK ALL SETTINGS	A critical failure occurred with the EEPROM. Personalities, machine configuration digits, etc. may be reset to default values and should be checked.	
	CHASSIS TILT SENSOR NOT GAIN CALIBRATED	Indicates that chassis tilt sensor calibration information has been lost. Machine will indicate it is tilted at all times. This calibration data is programmed into the unit at the factory.	
	CHASSIS TILT SENSOR GAIN OUT OF RANGE	Indicates chassis tilt sensor calibration is corrupted.	

SECTION 6 - JLG CONTROL SYSTEM

Table 6-4. Help Message/Fault Listing

HELP MESSAGE	FAULT		FAULT REMOVAL
OK	0	0	CLEAR WHEN FAULT IS REMOVED
DRIVING AT CREEP - TILTED	0	0	CLEAR WHEN FAULT IS REMOVED
FSW OPEN	0	0	CLEAR WHEN FAULT IS REMOVED
RUNNING AT CREEP - CREEP SWITCH OPEN	0	0	CLEAR WHEN FAULT IS REMOVED
RUNNING AT CREEP - TILTED AND ABOVE ELEVATION	0	0	CLEAR WHEN FAULT IS REMOVED
RUNNING AT CUTBACK - ABOVE ELEVATION	0	0	CLEAR WHEN FAULT IS REMOVED
TILT SENSOR OUT OF RANGE	0	0	CLEAR WHEN FAULT IS REMOVED
LOAD SENSOR READING UNDER WEIGHT	0	0	CLEAR WHEN FAULT IS REMOVED
FSW FAULTY	2	1	REQUIRES EMS TO BE RECYCLED TO CLEAR FAULT
KEYSWITCH FAULTY	2	1	CLEAR WHEN FAULT IS REMOVED
DRIVE LOCKED - JOYSTICK MOVED BEFORE FOOTSWITCH	2	2	CLEAR WHEN FAULT IS REMOVED
FSW INTERLOCK TRIPPED	2	2	CLEAR WHEN FAULT IS REMOVED
STEER LOCKED - SELECTED BEFORE FOOTSWITCH	2	2	CLEAR WHEN FAULT IS REMOVED
STEER SWITCHES FAULTY	2	2	CLEAR WHEN FAULT IS REMOVED
D/S JOY. QPROX BAD	2	2	CLEAR WHEN FAULT IS REMOVED
L/S JOY. QPROX BAD	2	3	CLEAR WHEN FAULT IS REMOVED
D/S JOY. OUT OF RANGE LOW	2	2	CLEAR WHEN FAULT IS REMOVED
D/S JOY. OUT OF RANGE HIGH	2	2	CLEAR WHEN FAULT IS REMOVED
L/S JOY. OUT OF RANGE LOW	2	3	CLEAR WHEN FAULT IS REMOVED
L/S JOY. OUT OF RANGE HIGH	2	3	CLEAR WHEN FAULT IS REMOVED
D/S JOY. CENTER TAP BAD	2	2	CLEAR WHEN FAULT IS REMOVED
L/S JOY. CENTER TAP BAD	2	3	CLEAR WHEN FAULT IS REMOVED
WAITING FOR FSW TO BE OPEN	2	2	CLEAR WHEN FAULT IS REMOVED
PUMP POT FAULTY	2	3	CLEAR WHEN FAULT IS REMOVED
PUMP SWITCHES FAULTY - CHECK DIAGNOSTICS/BOOM	2	3	CLEAR WHEN FAULT IS REMOVED
PUMP SWITCHES LOCKED - SELECTED BEFORE FOOTSWITCH	2	3	CLEAR WHEN FAULT IS REMOVED
PUMP SWITCHES LOCKED - SELECTED BEFORE START SWITCH	2	3	CLEAR WHEN FAULT IS REMOVED
FOOTSWITCH SELECTED BEFORE START	2	3	CLEAR WHEN FAULT IS REMOVED
BOOM PREVENTED - DRIVE SELECTED	2	5	CLEAR WHEN FAULT IS REMOVED
DRIVE PREVENTED - ABOVE ELEVATION	2	5	CLEAR WHEN FAULT IS REMOVED
DRIVE PREVENTED - TILTED & ABOVE ELEVATION	2	5	CLEAR WHEN FAULT IS REMOVED
DRIVE PREVENTED - BOOM SELECTED	2	5	CLEAR WHEN FAULT IS REMOVED
FORD ECM POWER SHORT TO GROUND	3	3	REQUIRES EMS TO BE RECYCLED TO CLEAR FAULT
HORN SHORT TO GROUND	3	3	REQUIRES EMS TO BE RECYCLED TO CLEAR FAULT
HORN OPEN CIRCUIT	3	3	REQUIRES EMS TO BE RECYCLED TO CLEAR FAULT
HORN SHORT TO BATTERY	3	3	REQUIRES EMS TO BE RECYCLED TO CLEAR FAULT
AUX POWER SHORT TO GROUND	3	3	REQUIRES EMS TO BE RECYCLED TO CLEAR FAULT
AUX POWER OPEN CIRCUIT	3	3	REQUIRES EMS TO BE RECYCLED TO CLEAR FAULT
AUX POWER SHORT TO BATTERY	3	3	REQUIRES EMS TO BE RECYCLED TO CLEAR FAULT
GLOW PLUG SHORT TO GROUND	3	3	REQUIRES EMS TO BE RECYCLED TO CLEAR FAULT
GLOW PLUG OPEN CIRCUIT	3	3	REQUIRES EMS TO BE RECYCLED TO CLEAR FAULT
GLOW PLUG SHORT TO BATTERY	3	3	REQUIRES EMS TO BE RECYCLED TO CLEAR FAULT
LP LOCK SHORT TO GROUND	3	3	REQUIRES EMS TO BE RECYCLED TO CLEAR FAULT
LP LOCK OPEN CIRCUIT	3	3	REQUIRES EMS TO BE RECYCLED TO CLEAR FAULT
LP LOCK SHORT TO BATTERY	3	3	REQUIRES EMS TO BE RECYCLED TO CLEAR FAULT

Table 6-4. Help Message/Fault Listing

HELP MESSAGE	FAULT		FAULT REMOVAL
LP START ASSIST SHORT TO GROUND	3	3	REQUIRES EMS TO BE RECYCLED TO CLEAR FAULT
LP START ASSIST OPEN CIRCUIT	3	3	REQUIRES EMS TO BE RECYCLED TO CLEAR FAULT
LP START ASSIST SHORT TO BATTERY	3	3	REQUIRES EMS TO BE RECYCLED TO CLEAR FAULT
MAIN DUMP SHORT TO GROUND	3	3	REQUIRES EMS TO BE RECYCLED TO CLEAR FAULT
MAIN DUMP OPEN CIRCUIT	3	3	REQUIRES EMS TO BE RECYCLED TO CLEAR FAULT
MAIN DUMP SHORT TO BATTERY	3	3	REQUIRES EMS TO BE RECYCLED TO CLEAR FAULT
PARKING BRAKE SHORT TO GROUND	3	3	REQUIRES EMS TO BE RECYCLED TO CLEAR FAULT
PARKING BRAKE OPEN CIRCUIT	3	3	REQUIRES EMS TO BE RECYCLED TO CLEAR FAULT
PARKING BRAKE SHORT TO BATTERY	3	3	REQUIRES EMS TO BE RECYCLED TO CLEAR FAULT
START SOLENOID SHORT TO GROUND	3	3	REQUIRES EMS TO BE RECYCLED TO CLEAR FAULT
START SOLENOID OPEN CIRCUIT	3	3	REQUIRES EMS TO BE RECYCLED TO CLEAR FAULT
START SOLENOID SHORT TO BATTERY	3	3	REQUIRES EMS TO BE RECYCLED TO CLEAR FAULT
STEER DUMP SHORT TO GROUND	3	3	REQUIRES EMS TO BE RECYCLED TO CLEAR FAULT
STEER DUMP OPEN CIRCUIT	3	3	REQUIRES EMS TO BE RECYCLED TO CLEAR FAULT
STEER DUMP SHORT TO BATTERY	3	3	REQUIRES EMS TO BE RECYCLED TO CLEAR FAULT
TWO SPEED SHORT TO GROUND	3	3	REQUIRES EMS TO BE RECYCLED TO CLEAR FAULT
TWO SPEED OPEN CIRCUIT	3	3	REQUIRES EMS TO BE RECYCLED TO CLEAR FAULT
TWO SPEED SHORT TO BATTERY	3	3	REQUIRES EMS TO BE RECYCLED TO CLEAR FAULT
ALARM SHORT TO GROUND	3	3	REQUIRES EMS TO BE RECYCLED TO CLEAR FAULT
ALARM OPEN CIRCUIT	3	3	REQUIRES EMS TO BE RECYCLED TO CLEAR FAULT
ALARM SHORT TO BATTERY	3	3	REQUIRES EMS TO BE RECYCLED TO CLEAR FAULT
GENERATOR SHORT TO GROUND	3	3	REQUIRES EMS TO BE RECYCLED TO CLEAR FAULT
GENERATOR OPEN CIRCUIT	3	3	REQUIRES EMS TO BE RECYCLED TO CLEAR FAULT
GENERATOR SHORT TO BATTERY	3	3	REQUIRES EMS TO BE RECYCLED TO CLEAR FAULT
HEAD TAIL LIGHT SHORT TO GROUND	3	3	REQUIRES EMS TO BE RECYCLED TO CLEAR FAULT
HEAD TAIL LIGHT OPEN CIRCUIT	3	3	REQUIRES EMS TO BE RECYCLED TO CLEAR FAULT
HEAD TAIL LIGHT SHORT TO BATTERY	3	3	REQUIRES EMS TO BE RECYCLED TO CLEAR FAULT
HOUR METER SHORT TO GROUND	3	3	REQUIRES EMS TO BE RECYCLED TO CLEAR FAULT
HOUR METER SHORT TO BATTERY	3	3	REQUIRES EMS TO BE RECYCLED TO CLEAR FAULT
BASKET UP SHORT TO GROUND	3	3	REQUIRES EMS TO BE RECYCLED TO CLEAR FAULT
BASKET UP OPEN CIRCUIT	3	3	REQUIRES EMS TO BE RECYCLED TO CLEAR FAULT
BASKET UP SHORT TO BATTERY	3	3	REQUIRES EMS TO BE RECYCLED TO CLEAR FAULT
BASKET DOWN SHORT TO GROUND	3	3	REQUIRES EMS TO BE RECYCLED TO CLEAR FAULT
BASKET DOWN OPEN CIRCUIT	3	3	REQUIRES EMS TO BE RECYCLED TO CLEAR FAULT
BASKET DOWN SHORT TO BATTERY	3	3	REQUIRES EMS TO BE RECYCLED TO CLEAR FAULT
BASKET LEFT SHORT TO GROUND	3	3	REQUIRES EMS TO BE RECYCLED TO CLEAR FAULT
BASKET LEFT OPEN CIRCUIT	3	3	REQUIRES EMS TO BE RECYCLED TO CLEAR FAULT
BASKET LEFT SHORT TO BATTERY	3	3	REQUIRES EMS TO BE RECYCLED TO CLEAR FAULT
BASKET RIGHT SHORT TO GROUND	3	3	REQUIRES EMS TO BE RECYCLED TO CLEAR FAULT
BASKET RIGHT OPEN CIRCUIT	3	3	REQUIRES EMS TO BE RECYCLED TO CLEAR FAULT
BASKET RIGHT SHORT TO BATTERY	3	3	REQUIRES EMS TO BE RECYCLED TO CLEAR FAULT
JIB UP SHORT TO GROUND	3	3	REQUIRES EMS TO BE RECYCLED TO CLEAR FAULT
JIB UP OPEN CIRCUIT	3	3	REQUIRES EMS TO BE RECYCLED TO CLEAR FAULT
JIB UP SHORT TO BATTERY	3	3	REQUIRES EMS TO BE RECYCLED TO CLEAR FAULT
JIB DOWN SHORT TO GROUND	3	3	REQUIRES EMS TO BE RECYCLED TO CLEAR FAULT
JIB DOWN OPEN CIRCUIT	3	3	REQUIRES EMS TO BE RECYCLED TO CLEAR FAULT

SECTION 6 - JLG CONTROL SYSTEM

Table 6-4. Help Message/Fault Listing

HELP MESSAGE	FAULT		FAULT REMOVAL
JIB DOWN SHORT TO BATTERY	3	3	REQUIRES EMS TO BE RECYCLED TO CLEAR FAULT
JIB LEFT SHORT TO GROUND	3	3	REQUIRES EMS TO BE RECYCLED TO CLEAR FAULT
JIB LEFT OPEN CIRCUIT	3	3	REQUIRES EMS TO BE RECYCLED TO CLEAR FAULT
JIB LEFT SHORT TO BATTERY	3	3	REQUIRES EMS TO BE RECYCLED TO CLEAR FAULT
JIB RIGHT SHORT TO GROUND	3	3	REQUIRES EMS TO BE RECYCLED TO CLEAR FAULT
JIB RIGHT OPEN CIRCUIT	3	3	REQUIRES EMS TO BE RECYCLED TO CLEAR FAULT
JIB RIGHT SHORT TO BATTERY	3	3	REQUIRES EMS TO BE RECYCLED TO CLEAR FAULT
TOWER UP SHORT TO GROUND	3	3	REQUIRES EMS TO BE RECYCLED TO CLEAR FAULT
TOWER UP OPEN CIRCUIT	3	3	REQUIRES EMS TO BE RECYCLED TO CLEAR FAULT
TOWER UP SHORT TO BATTERY	3	3	REQUIRES EMS TO BE RECYCLED TO CLEAR FAULT
TOWER DOWN SHORT TO GROUND	3	3	REQUIRES EMS TO BE RECYCLED TO CLEAR FAULT
TOWER DOWN OPEN CIRCUIT	3	3	REQUIRES EMS TO BE RECYCLED TO CLEAR FAULT
TOWER DOWN SHORT TO BATTERY	3	3	REQUIRES EMS TO BE RECYCLED TO CLEAR FAULT
TOWER IN SHORT TO GROUND	3	3	REQUIRES EMS TO BE RECYCLED TO CLEAR FAULT
TOWER IN OPEN CIRCUIT	3	3	REQUIRES EMS TO BE RECYCLED TO CLEAR FAULT
TOWER IN SHORT TO BATTERY	3	3	REQUIRES EMS TO BE RECYCLED TO CLEAR FAULT
TOWER OUT SHORT TO GROUND	3	3	REQUIRES EMS TO BE RECYCLED TO CLEAR FAULT
TOWER OUT OPEN CIRCUIT	3	3	REQUIRES EMS TO BE RECYCLED TO CLEAR FAULT
TOWER OUT SHORT TO BATTERY	3	3	REQUIRES EMS TO BE RECYCLED TO CLEAR FAULT
UPPER IN SHORT TO GROUND	3	3	REQUIRES EMS TO BE RECYCLED TO CLEAR FAULT
UPPER IN OPEN CIRCUIT	3	3	REQUIRES EMS TO BE RECYCLED TO CLEAR FAULT
UPPER IN SHORT TO BATTERY	3	3	REQUIRES EMS TO BE RECYCLED TO CLEAR FAULT
UPPER OUT SHORT TO GROUND	3	3	REQUIRES EMS TO BE RECYCLED TO CLEAR FAULT
UPPER OUT OPEN CIRCUIT	3	3	REQUIRES EMS TO BE RECYCLED TO CLEAR FAULT
UPPER OUT SHORT TO BATTERY	3	3	REQUIRES EMS TO BE RECYCLED TO CLEAR FAULT
FUEL SENSOR SHORT TO BATTERY	3	3	CLEAR WHEN FAULT IS REMOVED
FUEL SENSOR SHORT TO GROUND	3	3	CLEAR WHEN FAULT IS REMOVED
OIL PRESSURE SHORT TO BATTERY	4	3	CLEAR WHEN FAULT IS REMOVED
OIL PRESSURE SHORT TO GROUND	4	3	CLEAR WHEN FAULT IS REMOVED
COOLANT TEMPERATURE SHORT TO GROUND	4	3	CLEAR WHEN FAULT IS REMOVED
FORD FAULT CODE 12	4	3	CLEAR WHEN FAULT IS REMOVED
FORD FAULT CODE 13	4	3	CLEAR WHEN FAULT IS REMOVED
FORD FAULT CODE 14	4	3	CLEAR WHEN FAULT IS REMOVED
FORD FAULT CODE 15	4	3	CLEAR WHEN FAULT IS REMOVED
FORD FAULT CODE 21	4	3	CLEAR WHEN FAULT IS REMOVED
FORD FAULT CODE 22	4	3	CLEAR WHEN FAULT IS REMOVED
FORD FAULT CODE 23	4	3	CLEAR WHEN FAULT IS REMOVED
FORD FAULT CODE 24	4	3	CLEAR WHEN FAULT IS REMOVED
FORD FAULT CODE 25	4	3	CLEAR WHEN FAULT IS REMOVED
FORD FAULT CODE 26	4	3	CLEAR WHEN FAULT IS REMOVED
FORD FAULT CODE 31	4	3	CLEAR WHEN FAULT IS REMOVED
FORD FAULT CODE 32	4	3	CLEAR WHEN FAULT IS REMOVED
FORD FAULT CODE 33	4	3	CLEAR WHEN FAULT IS REMOVED
FORD FAULT CODE 34	4	3	CLEAR WHEN FAULT IS REMOVED
FORD FAULT CODE 35	4	3	CLEAR WHEN FAULT IS REMOVED
FORD FAULT CODE 36	4	3	CLEAR WHEN FAULT IS REMOVED

Table 6-4. Help Message/Fault Listing

HELP MESSAGE	FAULT		FAULT REMOVAL
FORD FAULT CODE 41	4	3	CLEAR WHEN FAULT IS REMOVED
FORD FAULT CODE 42	4	3	CLEAR WHEN FAULT IS REMOVED
FORD FAULT CODE 43	4	3	CLEAR WHEN FAULT IS REMOVED
FORD FAULT CODE 44	4	3	CLEAR WHEN FAULT IS REMOVED
FORD FAULT CODE 45	4	3	CLEAR WHEN FAULT IS REMOVED
FORD FAULT CODE 46	4	3	CLEAR WHEN FAULT IS REMOVED
FORD FAULT CODE 51	4	3	CLEAR WHEN FAULT IS REMOVED
FORD FAULT CODE 52	4	3	CLEAR WHEN FAULT IS REMOVED
FORD FAULT CODE 53	4	3	CLEAR WHEN FAULT IS REMOVED
FORD FAULT CODE 54	4	3	CLEAR WHEN FAULT IS REMOVED
FORD FAULT CODE 55	4	3	CLEAR WHEN FAULT IS REMOVED
FORD FAULT CODE 56	4	3	CLEAR WHEN FAULT IS REMOVED
FORD FAULT CODE 57	4	3	CLEAR WHEN FAULT IS REMOVED
FORD FAULT CODE 61	4	3	CLEAR WHEN FAULT IS REMOVED
FORD FAULT CODE 62	4	3	CLEAR WHEN FAULT IS REMOVED
FORD FAULT CODE 63	4	3	CLEAR WHEN FAULT IS REMOVED
FORD FAULT CODE 64	4	3	CLEAR WHEN FAULT IS REMOVED
FORD FAULT CODE UNKNOWN	4	3	CLEAR WHEN FAULT IS REMOVED
RETURN FILTER BYPASSED	2	8	CLEAR WHEN FAULT IS REMOVED
CHARGE PUMP FILTER BYPASSED	2	8	CLEAR WHEN FAULT IS REMOVED
BATTERY LOW	4	4	CLEAR WHEN FAULT IS REMOVED
BATTERY TOO HIGH - SYSTEM SHUT DOWN	4	4	REQUIRES EMS TO BE RECYCLED TO CLEAR FAULT
BATTERY TOO LOW - SYSTEM SHUT DOWN	4	4	CLEAR WHEN FAULT IS REMOVED
SPEED SENSOR READING INVALID SPEED	5	5	CLEAR WHEN FAULT IS REMOVED
SPEED INPUT LOST	5	5	CLEAR WHEN FAULT IS REMOVED
ENGINE TEMP HIGH	4	3	CLEAR WHEN FAULT IS REMOVED
AIR FILTER BYPASSED	4	3	CLEAR WHEN FAULT IS REMOVED
NO ALTERNATOR OUTPUT	4	3	CLEAR WHEN FAULT IS REMOVED
OIL PRESSURE LOW	4	3	CLEAR WHEN FAULT IS REMOVED
485 COMMUNICATIONS LOST	4	3	CLEAR WHEN FAULT IS REMOVED
CAN BUS FAILURE	6	6	CLEAR WHEN FAULT IS REMOVED
LOAD SENSOR NOT CALIBRATED	9	9	CLEAR WHEN FAULT IS REMOVED
TILT SENSOR NOT CALIBRATED	9	9	CLEAR WHEN FAULT IS REMOVED
EEPROM FAILURE - CHECK ALL SETTINGS	9	9	REQUIRES EMS TO BE RECYCLED TO CLEAR FAULT
PLATFORM MODULE FAILURE: HWFS CODE 1	9	9	CLEAR WHEN FAULT IS REMOVED
GROUND MODULE FAILURE: HWFS CODE 1	9	9	CLEAR WHEN FAULT IS REMOVED

SECTION 6 - JLG CONTROL SYSTEM

Table 6-5. Machine Configuration Programming Information

Configuration Digit	Number	Description	Default Number
NOTE: Machine configuration must be completed before any personality settings can be changed. Changing personality settings first and then changing the model number of the machine configuration will cause personality settings to return to default			
MODEL NUMBER: 1	6	600SC	1
MARKET: 2	0 1 2 3 4 5	ANSI USA ANSI EXPORT CSA CE AUSTRALIA JAPAN	0
ENGINE: 3	12 16	DEUTZ ECM: Deutz Engine Control Module (Tier 2 and 3) DEUTZ ECM T4F: Deutz Engine Control Module (Tier 4 Final)	14
GLOW PLUG: 5	0 1 2	NO GLOW PLUGS: No glow plugs installed. AIR INTAKE: Glow plugs installed in the air intake on the manifold. IN-CYLINDER: Glow plugs installed in each cylinder.	2
STARTER LOCKOUT: 6	0 1	DISABLED: Automatic pre-glow time determined by ambient air temperature; engine start can be attempted at any time during pre-glow. ENABLED: Automatic pre-glow time determined by ambient air temperature; engine start is NOT permitted until pre-glow is finished.	0
FUEL CUTOUT: 7	0 1 2	RESTART: Engine allowed to be restarted multiple times when very low fuel level is reached. ONE RESTART: Engine allowed to be restarted once for 2 minutes when very low fuel level is reached. ENGINE STOP: Engine not able to restart when very low fuel level is reached.	0
*This menu item is only visible if non dual fuel engines are selected.			
ENGINE SHUT-DOWN: 8	0 1	DISABLED: No engine shutdown. ENABLED: Shutdown engine when coolant temperature is greater than 110°C or oil pressure is less than 8 PSI.	1

Table 6-5. Machine Configuration Programming Information

Configuration Digit	Number	Description	Default Number
TILT: 9	1	5 DEGREES: Reduces the maximum speed of all boom functions to creep when tilted more than 5 degrees and above elevation; also reduces drive speed to creep.	1
	2	4 DEGREES: Reduces the maximum speed of all boom functions to creep when tilted more than 4 degrees and above elevation; also reduces drive speed to creep.	
	3	3 DEGREES: Reduces the maximum speed of all boom functions to creep when tilted more than 3 degrees and above elevation; also reduces drive speed to creep.	
	4	4 DEGREES + CUT: Reduces the maximum speed of all boom functions to creep when tilted more than 4 degrees and above elevation; also disallows tower lift up, tower telescope out, drive, main telescope out and main lift up.	
	5	3 DEGREES + CUT: Reduces the maximum speed of all boom functions to creep when tilted more than 3 degrees and above elevation; also disallows tower lift up, tower telescope out, drive, main telescope out and main lift up.	
Note: Any of the selections above will light the tilt lamp when a tilted condition occurs and will sound the platform alarm when the machine is also above elevation.			
JIB: 10	0	NO: No Jib installed.	0
	1	YES: Jib installed which has up and down movements only.	
STOUCH/SKY-GUARD: 12	0	NO: No soft touch or SkyGuard system installed.	0
	1	SOFT TOUCH: Soft touch only installed.	
	2	SKYGUARD: SkyGuard only installed.	
	3	BOTH (CUTOFF) - Soft touch and SkyGuard installed.	
GENSET/WELDER: 13	0	NO: No generator installed.	0
	1	BELT DRIVE: Belt driven setup	
GENSET CUTOFF: 14*	0	MOTION ENABLED: Motion enabled when generator is ON.	0
	1	MOTION CUTOFF: Motion cutoff in platform mode only.	
* Only visible if Gen Set / Welder Menu selection is not 0.			
H&T LIGHTS: 15	0	NO: No head and tail lights installed.	0
	1	YES: Head and tail lights installed.	

SECTION 6 - JLG CONTROL SYSTEM

Table 6-5. Machine Configuration Programming Information

Configuration Digit	Number	Description	Default Number
CABLE SWITCH: 16*	0	NO: No broken cable switch installed.	0
	1	YES: Broken cable switch installed.	
* Certain market selections will alter default setting.			
LOAD SYSTEM: 17*	0	NO: No load sensor installed.	0
	1	WARN ONLY: Functions in creep, overload lamp lit, platform alarm beeps (5 sec ON, 2 sec OFF).	
	2	CUTOUT PLATFORM: All functions cutout, overload lamp lit, platform alarm beeps (5 sec ON, 2 sec OFF).	
	3	CUTOUT ALL: All functions cutout, flash overload light (500mS on, 500mS off), platform alarm beeps (5 sec ON, 2 sec OFF).	
	4	SPECIAL 1: Functions in creep, overload lamp lit, disables main telescope out & main lift up, platform alarm beeps (5 sec ON, 2 sec OFF).	
* Only visible under certain market selections. * Certain market selections will limit load system options or alter default setting.			
LOAD SENSOR: 18*	0	1 ON ROTATOR: Use the on-board load sensor for all models except those which use the Leveling Platform Module.	1
	1	4 UNDER PLATFORM: Use the EIM for load sensing.	
* Only visible under certain market selections. * Certain market selections will limit load system options or alter default setting.			
FUNCTION CUT- OUT: 19*	0	NO: No drive cutout.	0
	1	BOOM CUTOUT: Boom function cutout while driving above elevation.	
	2	DRIVE CUTOUT: Drive cutout above elevation.	
	3	DRIVE CUT E&T: Drive cutout above elevation and tilted.	
* Only visible under certain market selections. * Certain market selections will limit load system options or alter default setting.			
GROUND ALARM: 20*	0	NO: No ground alarm installed.	3
	1	DRIVE: Travel alarm sounds when the drive function is active (Option).	
	2	DESCENT: Descent alarm sounds when lift down is active (Option).	
	3	MOTION: Motion alarm sounds when any function is active (Option).	
* Certain market selections will alter default setting.			

Table 6-5. Machine Configuration Programming Information

Configuration Digit	Number	Description	Default Number
DISPLAY UNITS: 22*	0 1	IMPERIAL: DEG F, PSI, LBS METRIC: DEG C, KPA, KGS.	0
* Certain market selections will alter default setting.			
DRIVE CONTROL: 24	0 1 2	NORMAL: Drive coils are energized from the Ground Module. PROPULSION: Drive coils are energized from the Propulsion Module. ENHANCED: Drive coils are energized from the Ground Module and the ground side of the drive coils are brought back to current feedback returns.	2
BOOM CONTROL: 26	0 1	NORMAL: Boom control coils are energized from the Ground Module. ENHANCED: Boom control coils are energized from the Ground Module and the ground side of the drive coils are brought back to current feedback returns.	0
FUNCTION SPEED KNOB: 27	0 1	YES: Machine is equipped with Function Speed Knob. NO: Machine is equipped with Operation Speed Knob.	0
CLEARSKY: 28	0 1	NO: ClearSky (Telematics) system option is disabled. YES: ClearSky (Telematics) system is enabled	0
CRIBBING OPTION: 29	0 1	NO: Cribbing Option is disabled. YES: Cribbing Option is enabled.	0
FUEL TANK SIZE: 30	0 1	31 Gallon tank. 52 Gallon tank.	0
ALARM/HORN: 31	0 1	SEPERATE: Separate alarm and horn. COMBINED: combination alarm/horn.	0
ALERT BEACON 32	0 1	OFF FOR CREEP: Alert beacon will not flash in Creep. 20 FPS FOR CREEP: Alert beacon will flash at 20 FPS while in Creep.	0

4150364G

6.3 MACHINE ORIENTATION WHEN SETTING FUNCTION SPEEDS

LIFT UP: from platform control, lowest elevation up to maximum elevation, boom retracted, jib retracted.

LIFT DOWN: from platform control, maximum elevation down to minimum elevation, boom retracted, jib retracted.

JIB LIFT UP: from platform control, lowest jib elevation up to maximum jib elevation, boom retracted, jib retracted.

JIB LIFT DOWN: from platform control, maximum jib elevation down to minimum jib elevation, boom retracted, jib retracted.

SWING RIGHT(Max): 360°, from platform control, boom approximately 45° elevation, boom retracted, jib retracted.

SWING LEFT(Max): 360°, from platform control, boom approximately 45° elevation, boom retracted, jib retracted.

TELESCOPE OUT: from platform control, boom 20°, 500 lb (226 kg) capacity selected.

TELESCOPE IN: from platform control, boom 20°, 500 lb (226 kg) capacity selected.

JIB TELESCOPE IN: from platform control, boom horizontal, jib horizontal, 500 lb (226 kg) capacity selected.

JIB TELESCOPE OUT: from platform control, boom horizontal, jib horizontal, 500 lb (226 kg) capacity selected.

DRIVE FORWARD (Max): high speed - low torque setting, drive 200 ft (61 m) front wheels to front wheels. Timed after machine has obtained maximum speed.

DRIVE REVERSE (Max): high speed - low torque setting, drive 200 ft (61 m) front wheels to front wheels Timed after machine has obtained maximum speed.

DRIVE FORWARD (Creep Max): high torque - low speed setting, platform speed knob at full creep

DRIVE REVERSE (Creep Max): high torque - low speed setting, platform speed knob at full creep

DRIVE FORWARD (Elevated Max - Boom Beyond Transport): high speed - low torque setting, platform speed knob out of creep, Lift boom above transport, drive forward 50 ft (15 m).

DRIVE REVERSE (Elevated Max - Boom Beyond Transport): high speed - low torque setting, platform speed knob out of creep, Lift boom above transport, drive backward 50 ft (15 m).

Test Notes

1. Personality settings can be adjusted anywhere within the adjustment range for optimum machine performance.
2. Stop watch should start when function is activated - not controller or switch.
3. Unless noted, measure function speeds from platform.
4. Platform speed knob must be at full speed (fully clockwise).
5. Perform tests with oil temperature above 100° F (38° C).

6.4 CANBUS COMMUNICATIONS

CANbus: CAN (Control Area Network) is a two wire differential serial link between the Platform and Ground Modules providing bi-directional communications.

Two-wire: One wire (red) is driven high (5v) and the other low (black) (0v) to send a signal. Both wires "float" (2.5v) when no signal is being sent.

Differential: Any electrical line noise can affect the high or the low wires but never both, so communications is not corrupted.

Serial Link: Messages are being sent bit by bit along the wires; the high bus speed allow all modules to be constantly updated around 20 times per second. Typical traffic is 300 - 500 messages per second.

A complete CANbus circuit is approximately 60 ohms, which can be verified at the "T" fitting inside the ground station. Individual circuits are approximately 120 ohms.

The GROUND MODULE (UGM) is the master system controller. Most functions are dispatched and coordinated from this module. The PLATFORM MODULE handles sub-tasks. All characterized information (values) are stored in the ground module (i.e., Personalities or Calibrations).

Interlocks: Any device that sends an electrical input. (For an example a limit switch, proximity switch, etc;)

Platform Level: The GROUND MODULE stores default values and handles interlocks. The PLATFORM MODULE reads sensors mounted on the platform assembly and controls Level Up / Down valves to maintain setpoint sent from the GROUND MODULE.

Steer: The GROUND MODULE stores crack points, and sends desired drive direction, steering mode, and axle extend/retract commands. The PLATFORM MODULE reports steering switch position to the GROUND MODULE.

Drive: The GROUND MODULE stores crack points and sends commands for each drive pump. (Command is computed from drive joystick input, interlocks, wheel angle, etc).

Lift, Tele, & Swing: The GROUND MODULE stores default values, and handles interlocks and calibration information. Lift, Telescope, and Swing commands depend on interlocks through out the machine. Boom angle, length, and swing are controlled by the GROUND MODULE

Table 6-6. Fault Code List

DTC	Text
001	EVERYTHING OK
0010	RUNNING AT CUTBACK - OUT OF TRANSPORT POSITION
0011	FSW OPEN
0012	RUNNING AT CREEP - CREEP SWITCH OPEN
0013	RUNNING AT CREEP - TILTED AND ABOVE ELEVATION
0014	CHASSIS TILT SENSOR OUT OF RANGE
0030	RUNNING AT CREEP - PLATFORM STOWED
0031	FUEL LEVEL LOW - ENGINE SHUTDOWN
211	POWER CYCLE
212	KEYSWITCH FAULTY
213	FSW FAULTY
224	FUNCTION PROBLEM - STEER LEFT PERMANENTLY SELECTED
225	FUNCTION PROBLEM - STEER RIGHT PERMANENTLY SELECTED
227	STEER SWITCHES FAULTY
2211	FSW INTERLOCK TRIPPED
2212	DRIVE LOCKED - JOYSTICK MOVED BEFORE FOOTSWITCH
2213	STEER LOCKED - SELECTED BEFORE FOOTSWITCH
2216	D/S JOY. OUT OF RANGE HIGH
2217	D/S JOY. CENTER TAP BAD
2219	L/S JOY. OUT OF RANGE HIGH
2220	L/S JOY. CENTER TAP BAD
2221	LIFT/SWING LOCKED - JOYSTICK MOVED BEFORE FOOTSWITCH
2222	WAITING FOR FSW TO BE OPEN
2223	FUNCTION SWITCHES LOCKED - SELECTED BEFORE ENABLE
2224	FOOTSWITCH SELECTED BEFORE START
2247	FUNCTION PROBLEM - PLATFORM ROTATE LEFT PERMANENTLY SELECTED
2248	FUNCTION PROBLEM - PLATFORM ROTATE RIGHT PERMANENTLY SELECTED
2249	FUNCTION PROBLEM - JIB LIFT UP PERMANENTLY SELECTED
2250	FUNCTION PROBLEM - JIB LIFT DOWN PERMANENTLY SELECTED
2251	FUNCTION PROBLEM - TELESCOPE IN PERMANENTLY SELECTED
2252	FUNCTION PROBLEM - TELESCOPE OUT PERMANENTLY SELECTED
2257	FUNCTION PROBLEM - TOWER LIFT UP PERMANENTLY SELECTED
2258	FUNCTION PROBLEM - TOWER LIFT DOWN PERMANENTLY SELECTED
2262	FUNCTION PROBLEM - PLATFORM LEVEL UP PERMANENTLY SELECTED
2263	FUNCTION PROBLEM - PLATFORM LEVEL DOWN PERMANENTLY SELECTED
234	FUNCTION SWITCHES FAULTY - CHECK DIAGNOSTICS/BOOM
235	FUNCTION SWITCHES LOCKED - SELECTED BEFORE AUX POWER
236	FUNCTION SWITCHES LOCKED - SELECTED BEFORE START SWITCH
237	START SWITCH LOCKED - SELECTED BEFORE KEYSWITCH
2310	FUNCTION PROBLEM - GROUND ENABLE PERMANENTLY SELECTED
2370	FUNCTION PROBLEM - JIB LIFT UP PERMANENTLY SELECTED

Table 6-6. Fault Code List

DTC	Text
2371	FUNCTION PROBLEM - JIB LIFT DOWN PERMANENTLY SELECTED
2372	FUNCTION PROBLEM - SWING LEFT PERMANENTLY SELECTED
2373	FUNCTION PROBLEM - SWING RIGHT PERMANENTLY SELECTED
23104	BOOM TRANSPORT SWITCH DISAGREEMENT
23105	FUNCTION PROBLEM - TOWER LIFT UP PERMANENTLY SELECTED
23106	FUNCTION PROBLEM - TOWER LIFT DOWN PERMANENTLY SELECTED
23107	FUNCTION PROBLEM - LIFT UP PERMANENTLY SELECTED
23108	FUNCTION PROBLEM - LIFT DOWN PERMANENTLY SELECTED
23109	FUNCTION PROBLEM - TELESCOPE IN PERMANENTLY SELECTED
23110	FUNCTION PROBLEM - TELESCOPE OUT PERMANENTLY SELECTED
23111	FUNCTION PROBLEM - PLATFORM LEVEL UP PERMANENTLY SELECTED
23112	FUNCTION PROBLEM - PLATFORM LEVEL DOWN PERMANENTLY SELECTED
23113	FUNCTION PROBLEM - PLATFORM ROTATE LEFT PERMANENTLY SELECTED
23114	FUNCTION PROBLEM - PLATFORM ROTATE RIGHT PERMANENTLY SELECTED
259	MODEL CHANGED - HYDRAULICS SUSPENDED - CYCLE EMS
2513	GENERATOR MOTION CUTOFF ACTIVE
2514	BOOM PREVENTED - DRIVE SELECTED
2516	DRIVE PREVENTED - ABOVE ELEVATION
2517	DRIVE PREVENTED - TILTED & ABOVE ELEVATION
2518	DRIVE PREVENTED - BOOM SELECTED
331	BRAKE - SHORT TO BATTERY
332	BRAKE - OPEN CIRCUIT
334	LIFT UP VALVE - OPEN CIRCUIT
335	LIFT DOWN VALVE - SHORT TO BATTERY
336	LIFT DOWN VALVE - OPEN CIRCUIT
3311	GROUND ALARM - SHORT TO BATTERY
3352	LP LOCK - SHORT TO GROUND
3353	LP LOCK - OPEN CIRCUIT
3354	LP LOCK - SHORT TO BATTERY
3355	LP START ASSIST - SHORT TO GROUND
3356	LP START ASSIST - OPEN CIRCUIT
3357	LP START ASSIST - SHORT TO BATTERY
3358	MAIN DUMP VALVE - SHORT TO GROUND
3359	MAIN DUMP VALVE - OPEN CIRCUIT
3360	MAIN DUMP VALVE - SHORT TO BATTERY
3361	BRAKE - SHORT TO GROUND
3362	START SOLENOID - SHORT TO GROUND
3363	START SOLENOID - OPEN CIRCUIT
3364	START SOLENOID - SHORT TO BATTERY
3365	STEER DUMP VALVE - SHORT TO GROUND
3366	STEER DUMP VALVE - OPEN CIRCUIT
3367	STEER DUMP VALVE - SHORT TO BATTERY
3373	GEN SET/WELDER - SHORT TO GROUND

SECTION 6 - JLG CONTROL SYSTEM

Table 6-6. Fault Code List

DTC	Text
3374	GEN SET/WELDER - OPEN CIRCUIT
3375	GEN SET/WELDER - SHORT TO BATTERY
3376	HEAD TAIL LIGHT - SHORT TO GROUND
3377	HEAD TAIL LIGHT - OPEN CIRCUIT
3378	HEAD TAIL LIGHT - SHORT TO BATTERY
3379	HOUR METER - SHORT TO GROUND
3382	PLATFORM LEVEL UP VALVE - SHORT TO GROUND
3383	PLATFORM LEVEL UP VALVE - OPEN CIRCUIT
3384	PLATFORM LEVEL UP VALVE - SHORT TO BATTERY
3388	PLATFORM LEVEL DOWN VALVE - SHORT TO GROUND
3389	PLATFORM LEVEL DOWN VALVE - OPEN CIRCUIT
3390	PLATFORM LEVEL DOWN VALVE - SHORT TO BATTERY
3394	PLATFORM ROTATE LEFT VALVE - SHORT TO GROUND
3395	PLATFORM ROTATE LEFT VALVE - OPEN CIRCUIT
3396	PLATFORM ROTATE LEFT VALVE - SHORT TO BATTERY
3397	PLATFORM ROTATE RIGHT VALVE - SHORT TO GROUND
3398	PLATFORM ROTATE RIGHT VALVE - OPEN CIRCUIT
3399	PLATFORM ROTATE RIGHT VALVE - SHORT TO BATTERY
33100	JIB LIFT UP VALVE - SHORT TO GROUND
33101	JIB LIFT UP VALVE - OPEN CIRCUIT
33102	JIB LIFT UP VALVE - SHORT TO BATTERY
33103	JIB LIFT DOWN VALVE - SHORT TO GROUND
33104	JIB LIFT DOWN VALVE - OPEN CIRCUIT
33105	JIB LIFT DOWN VALVE - SHORT TO BATTERY
33106	TOWER LIFT UP VALVE - SHORT TO GROUND
33107	TOWER LIFT UP VALVE - OPEN CIRCUIT
33109	TOWER LIFT DOWN VALVE - SHORT TO GROUND
33110	TOWER LIFT DOWN VALVE - OPEN CIRCUIT
33118	SWING RIGHT VALVE - SHORT TO GROUND
33119	SWING RIGHT VALVE - OPEN CIRCUIT
33120	TELESCOPE IN VALVE - SHORT TO BATTERY
33122	SWING LEFT VALVE - SHORT TO GROUND
33123	TELESCOPE OUT VALVE - SHORT TO BATTERY
33130	THROTTLE ACTUATOR - SHORT TO GROUND
33131	THROTTLE ACTUATOR - OPEN CIRCUIT
33132	THROTTLE ACTUATOR - SHORT TO BATTERY
33182	LIFT VALVES - SHORT TO BATTERY
33186	TELESCOPE OUT VALVE - OPEN CIRCUIT
33188	TELESCOPE OUT VALVE - SHORT TO GROUND
33189	TELESCOPE IN VALVE - OPEN CIRCUIT
33190	TELESCOPE IN VALVE - SHORT TO GROUND
33279	GLOWPLUG - OPEN CIRCUIT
33280	GLOWPLUG - SHORT TO BATTERY

Table 6-6. Fault Code List

DTC	Text
33281	GLOWPLUG - SHORT TO GROUND
33287	LIFT - CURRENT FEEDBACK READING TOO LOW
33295	SWING LEFT VALVE - OPEN CIRCUIT
33314	FLOW CONTROL VALVE - OPEN CIRCUIT
33315	FLOW CONTROL VALVE - SHORT TO BATTERY
33316	FLOW CONTROL VALVE - SHORT TO GROUND
33317	DRIVE FORWARD VALVE - OPEN CIRCUIT
33318	DRIVE FORWARD VALVE - SHORT TO BATTERY
33319	DRIVE FORWARD VALVE - SHORT TO GROUND
33320	DRIVE REVERSE VALVE - OPEN CIRCUIT
33322	DRIVE REVERSE VALVE - SHORT TO GROUND
33331	DRIVE - CURRENT FEEDBACK READING TOO LOW
33406	LIFT UP VALVE - SHORT TO GROUND
33410	DRIVE - CURRENT FEEDBACK READING LOST
33412	SWING VALVES - SHORT TO BATTERY
33413	TOWER LIFT - CURRENT FEEDBACK READING TOO LOW
33414	SWING - CURRENT FEEDBACK READING TOO LOW
33415	FLOW CONTROL VALVE - CURRENT FEEDBACK READING TOO LOW
33416	TOWER LIFT - CURRENT FEEDBACK READING LOST
33417	LIFT - CURRENT FEEDBACK READING LOST
33418	SWING - CURRENT FEEDBACK READING LOST
33419	FLOW CONTROL VALVE - CURRENT FEEDBACK READING LOST
33420	TRACTION LOCK VALVE - SHORT TO BATTERY
33421	TRACTION LOCK VALVE - OPEN CIRCUIT
33422	TRACTION LOCK VALVE - SHORT TO GROUND
33423	OSCILLATING AXLE VALVES - SHORT TO BATTERY
33424	OSCILLATING AXLE VALVES - SHORT TO GROUND
33425	TOWER LIFT VALVES - SHORT TO BATTERY
342	PLATFORM LEVEL UP VALVE - SHORT TO BATTERY
343	PLATFORM LEVEL UP VALVE - SHORT TO GROUND
345	PLATFORM LEVEL DOWN VALVE - OPEN CIRCUIT
346	PLATFORM LEVEL DOWN VALVE - SHORT TO BATTERY
347	PLATFORM LEVEL DOWN VALVE - SHORT TO GROUND
349	PLATFORM ROTATE LEFT VALVE - OPEN CIRCUIT
3410	PLATFORM ROTATE LEFT VALVE - SHORT TO BATTERY
3411	PLATFORM ROTATE LEFT VALVE - SHORT TO GROUND
3412	PLATFORM ROTATE RIGHT VALVE - OPEN CIRCUIT
3413	PLATFORM ROTATE RIGHT VALVE - SHORT TO BATTERY
3414	PLATFORM ROTATE RIGHT VALVE - SHORT TO GROUND
3415	JIB LIFT UP VALVE - OPEN CIRCUIT
3416	JIB LIFT UP VALVE - SHORT TO BATTERY
3417	JIB LIFT UP VALVE - SHORT TO GROUND
3418	JIB LIFT DOWN VALVE - OPEN CIRCUIT

SECTION 6 - JLG CONTROL SYSTEM

Table 6-6. Fault Code List

DTC	Text
3419	JIB LIFT DOWN VALVE - SHORT TO BATTERY
3420	JIB LIFT DOWN VALVE - SHORT TO GROUND
431	FUEL SENSOR - SHORT TO BATTERY
432	FUEL SENSOR - SHORT TO GROUND
433	OIL PRESSURE - SHORT TO BATTERY
434	OIL PRESSURE - SHORT TO GROUND
435	COOLANT TEMPERATURE - SHORT TO GROUND
437	ENGINE TROUBLE CODE
438	HIGH ENGINE TEMP
4310	NO ALTERNATOR OUTPUT
4311	LOW OIL PRESSURE
4313	THROTTLE ACTUATOR FAILURE
4314	WRONG ENGINE SELECTED - ECM DETECTED
4322	LOSS OF ENGINE SPEED SENSOR
4323	SPEED SENSOR READING INVALID SPEED
4326	FUEL ACTUATOR - SHORT TO GROUND
4327	FUEL ACTUATOR - OPEN CIRCUIT
4328	FUEL ACTUATOR - SHORT TO BATTERY
4329	FUEL ACTUATOR - CURRENT FEEDBACK READING TOO LOW
4330	FUEL ACTUATOR - CURRENT FEEDBACK READING LOST
441	BATTERY VOLTAGE TOO LOW - SYSTEM SHUTDOWN
442	BATTERY VOLTAGE TOO HIGH - SYSTEM SHUTDOWN
443	LSS BATTERY VOLTAGE TOO HIGH
444	LSS BATTERY VOLTAGE TOO LOW
445	BATTERY VOLTAGE LOW
662	CANBUS FAILURE - PLATFORM MODULE
663	CANBUS FAILURE - LOAD SENSING SYSTEM MODULE
666	CANBUS FAILURE - ENGINE CONTROLLER
6613	CANBUS FAILURE - EXCESSIVE CANBUS ERRORS
6622	CANBUS FAILURE - TCU MODULE
6629	CANBUS FAILURE - TELEMATICS CANBUS LOADING TOO HIGH
681	REMOTE CONTRACT MANAGEMENT OVERRIDE - ALL FUNCTIONS IN CREEP
813	CHASSIS TILT SENSOR NOT CALIBRATED
814	CHASSIS TILT SENSOR OUT OF RANGE
815	CHASSIS TILT SENSOR DISAGREEMENT
821	LSS CELL #1 ERROR
822	LSS CELL #2 ERROR
823	LSS CELL #3 ERROR
824	LSS CELL #4 ERROR
825	LSS HAS NOT BEEN CALIBRATED
826	RUNNING AT CREEP - PLATFORM OVERLOADED
827	DRIVE & BOOM PREVENTED - PLATFORM OVERLOADED
828	LIFT UP & TELE OUT PREVENTED - PLATFORM OVERLOADED

Table 6-6. Fault Code List

DTC	Text
8211	LSS READING UNDER WEIGHT
8639	FRONT LEFT STEER VALVE - OPEN CIRCUIT
8640	FRONT LEFT STEER VALVE - SHORT TO BATTERY
8641	FRONT LEFT STEER VALVE - SHORT TO GROUND
8642	FRONT RIGHT STEER VALVE - OPEN CIRCUIT
8643	FRONT RIGHT STEER VALVE - SHORT TO BATTERY
8644	FRONT RIGHT STEER VALVE - SHORT TO GROUND
8669	OSCILLATING AXLE SWITCH DISAGREEMENT
991	LSS WATCHDOG RESET
992	LSS EEPROM ERROR
993	LSS INTERNAL ERROR - PIN EXCITATION
994	LSS INTERNAL ERROR - DRDY MISSING FROM A/D
998	EEPROM FAILURE - CHECK ALL SETTINGS
9910	FUNCTIONS LOCKED OUT - PLATFORM MODULE SOFTWARE VERSION IMPROPER
9911	FUNCTIONS LOCKED OUT - LSS MODULE SOFTWARE VERSION IMPROPER
9915	CHASSIS TILT SENSOR NOT GAIN CALIBRATED
9919	GROUND SENSOR REF VOLTAGE OUT OF RANGE
9920	PLATFORM SENSOR REF VOLTAGE OUT OF RANGE
9921	GROUND MODULE FAILURE - HIGH SIDE DRIVER CUTOFF FAULTY
9922	PLATFORM MODULE FAILURE - HWFS CODE 1
9924	FUNCTIONS LOCKED OUT - MACHINE NOT CONFIGURED
9927	GROUND MODULE CONSTANT DATA UPDATE REQUIRED
9944	CURRENT FEEDBACK GAINS OUT OF RANGE
9945	CURRENT FEEDBACK CALIBRATION CHECKSUM INCORRECT
9949	MACHINE CONFIGURATION OUT OF RANGE - CHECK ALL SETTINGS
9977	LSS CORRUPT EEPROM
9979	FUNCTIONS LOCKED OUT - GROUND MODULE SOFTWARE VERSION IMPROPER
9986	GROUND MODULE VLOW FET FAILURE

SECTION 6 - JLG CONTROL SYSTEM

NOTE: Bold Italic Numbers indicate the default setting. Plain text indicates another available selection. Bold, Italic underlined numbers indicate the default when the option is factory installed.

600SC																													
	MODEL NUMBER		MARKET		ENGINE		GLOW PLUG			STARTER LOCKOUT			FUEL CUTOFF			ENGINE SHUTDOWN			TILT					JIB		GEN SET / WELDER		GEN SET CUTOFF	
	1	2	3	4	5	6	7	8	9	10	11	12	13	14	15	16	17	18	19	20	21	22	23	24	25	26	27		
ANSI USA	6	0	12	0	1	2	0	1	0	1	2	0	1	1	2	3	4	5	0	0	1	0	1						
ANSI EXPORT	6	1	12	0	1	2	0	1	0	1	2	0	1	1	2	3	4	5	0	0	1	0	1						
CSA	6	2	12	0	1	2	0	1	0	1	2	0	1	1	2	3	4	5	0	0	1	0	1						
CE	6	3	12	0	1	2	0	1	0	1	2	0	1	X	X	3	X	5	0	0	1	0	1						
AUSTRALIA	6	4	12	0	1	2	0	1	0	1	2	0	1	X	X	3	X	5	0	0	1	0	1						
JAPAN	6	5	12	0	1	2	0	1	0	1	2	0	1	1	2	3	4	5	0	0	1	0	1						

600SC																						
	HEAD & TAIL LIGHTS		CABLE BREAK SWITCH		LOAD SYSTEM					LOAD SENSOR		FUNCTION CUTOFF			GROUND ALARM			DISPLAY UNITS				
	1	2	3	4	5	6	7	8	9	10	11	12	13	14	15	16	17	18	19	20	21	22
ANSI USA	0	1	0	1	0	X	X	X	X	0	1	0	X	2	X	0	1	2	3	0	1	
ANSI EXPORT	0	1	0	1	0	1	2	3	4	0	1	0	1	2	3	0	1	2	3	0	1	
CSA	0	1	0	1	0	X	X	X	X	0	1	0	1	2	3	0	1	2	3	0	1	
CE	0	1	0	1	0	X	2	3	X	0	1	0	1	X	X	0	1	2	3	0	1	
AUSTRALIA	0	1	0	1	0	X	2	X	X	0	1	0	1	2	3	0	1	2	3	0	1	
JAPAN	0	1	0	1	0	1	2	3	4	0	1	0	1	2	3	0	1	2	3	0	1	

NOTE: Bold Italic Numbers indicate the default setting. Plain text indicates another available selection. Bold, Italic underlined numbers indicate the default when the option is factory installed.

600SC															
	DRIVE CONTROL			BOOM CONTROL			CLEARSKY		FUEL TANK SIZE		ALARM/HORN		ALERT BEACON		
ANSI USA	0	1	<i>2</i>	<i>0</i>	1	1	<i>0</i>	1	1	<i>0</i>	1	1	<i>0</i>	1	1
ANSI EXPORT	0	1	<i>2</i>	<i>0</i>	1	1	<i>0</i>	1	1	<i>0</i>	1	1	<i>0</i>	1	1
CSA	0	1	<i>2</i>	<i>0</i>	1	1	<i>0</i>	1	1	<i>0</i>	1	1	<i>0</i>	1	1
CE	0	1	<i>2</i>	<i>0</i>	1	1	<i>0</i>	1	1	<i>0</i>	1	1	<i>0</i>	1	1
AUSTRALIA	0	1	<i>2</i>	<i>0</i>	1	1	<i>0</i>	1	1	<i>0</i>	1	1	<i>0</i>	1	1
JAPAN	0	1	<i>2</i>	<i>0</i>	1	1	<i>0</i>	1	1	<i>0</i>	1	1	<i>0</i>	1	1

NOTE: Bold Italic Numbers indicate the default setting. Plain text indicates another available selection. Bold, Italic underlined numbers indicate the default when the option is factory installed.

660SJC																													
	MODEL NUMBER	MARKET	ENGINE	GLOW PLUG			STARTER LOCKOUT			FUEL CUTOFF			ENGINE SHUTDOWN					TILT					JIB	GEN SET / WELDER			GEN SET CUTOFF		
ANSI USA	<i>6</i>	<i>0</i>	<i>12</i>	0	1	<i>2</i>	<i>0</i>	1	1	<i>0</i>	1	2	0	<i>1</i>	<i>1</i>	2	3	4	5	<i>1</i>	<i>0</i>	1	1	<i>0</i>	1	1			
ANSI EXPORT	<i>6</i>	<i>1</i>	<i>12</i>	0	1	<i>2</i>	<i>0</i>	1	1	<i>0</i>	1	2	0	<i>1</i>	<i>1</i>	2	3	4	5	<i>1</i>	<i>0</i>	1	1	<i>0</i>	1	1			
CSA	<i>6</i>	<i>2</i>	<i>12</i>	0	1	<i>2</i>	<i>0</i>	1	1	<i>0</i>	1	2	0	<i>1</i>	<i>1</i>	2	3	4	5	<i>1</i>	<i>0</i>	1	1	<i>0</i>	1	1			
CE	<i>6</i>	<i>3</i>	<i>12</i>	0	1	<i>2</i>	<i>0</i>	1	1	<i>0</i>	1	2	0	<i>1</i>	<i>X</i>	<i>X</i>	<i>3</i>	<i>X</i>	5	<i>1</i>	<i>0</i>	1	1	<i>0</i>	1	1			
AUSTRALIA	<i>6</i>	<i>4</i>	<i>12</i>	0	1	<i>2</i>	<i>0</i>	1	1	<i>0</i>	1	2	0	<i>1</i>	<i>X</i>	<i>X</i>	<i>3</i>	<i>X</i>	5	<i>1</i>	<i>0</i>	1	1	<i>0</i>	1	1			
JAPAN	<i>6</i>	<i>5</i>	<i>12</i>	0	1	<i>2</i>	<i>0</i>	1	1	<i>0</i>	1	2	0	<i>1</i>	<i>1</i>	2	3	4	5	<i>1</i>	<i>0</i>	1	1	<i>0</i>	1	1			

SECTION 6 - JLG CONTROL SYSTEM

NOTE: Bold Italic Numbers indicate the default setting. Plain text indicates another available selection. Bold, Italic underlined numbers indicate the default when the option is factory installed.

660SJC																					
	HEAD & TAIL LIGHTS		CABLE BREAK SWITCH		LOAD SYSTEM				LOAD SENSOR		FUNCTION CUTOFF				GROUND ALARM			DISPLAY UNITS			
ANSI USA	0	1	0	1	0	X	X	X	X	0	1	0	X	2	X	0	1	2	3	0	1
ANSI EXPORT	0	1	0	1	0	<u>1</u>	2	3	4	0	1	0	1	2	3	0	1	2	3	0	1
CSA	0	1	0	1	0	X	X	X	X	0	1	0	1	2	3	0	1	2	3	0	1
CE	0	1	0	1	0	X	2	3	X	0	1	0	1	X	X	0	1	2	3	0	1
AUSTRALIA	0	1	0	1	0	X	<u>2</u>	X	X	0	1	0	1	2	3	0	1	2	3	0	1
JAPAN	0	1	0	1	0	1	2	3	4	0	1	0	1	2	3	0	1	2	3	0	1

NOTE: Bold Italic Numbers indicate the default setting. Plain text indicates another available selection. Bold, Italic underlined numbers indicate the default when the option is factory installed.

660SJC															
	DRIVE CONTROL			BOOM CONTROL		CLEARSKY		FUEL TANK SIZE		ALARM/HORN		ALERT BEACON		DRIVE CONTROL	
ANSI USA	0	1	2	0	1	0	1	0	1	0	1	0	1	0	1
ANSI EXPORT	0	1	2	0	1	0	1	0	1	0	1	0	1	0	1
CSA	0	1	2	0	1	0	1	0	1	0	1	0	1	0	1
CE	0	1	2	0	1	0	1	0	1	0	1	0	1	0	1
AUSTRALIA	0	1	2	0	1	0	1	0	1	0	1	0	1	0	1
JAPAN	0	1	2	0	1	0	1	0	1	0	1	0	1	0	1

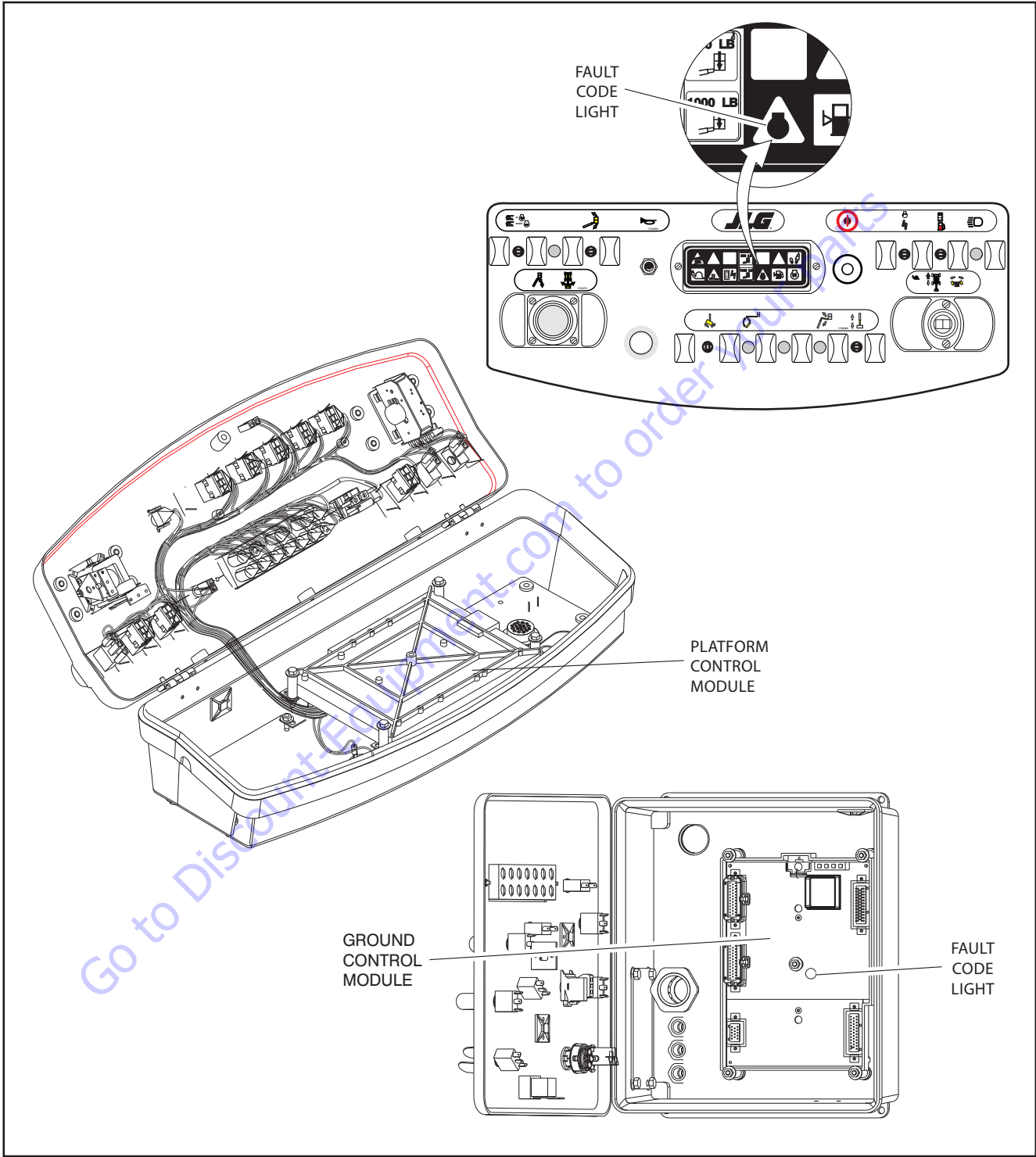

Figure 6-11. Control Module Locations

SECTION 6 - JLG CONTROL SYSTEM

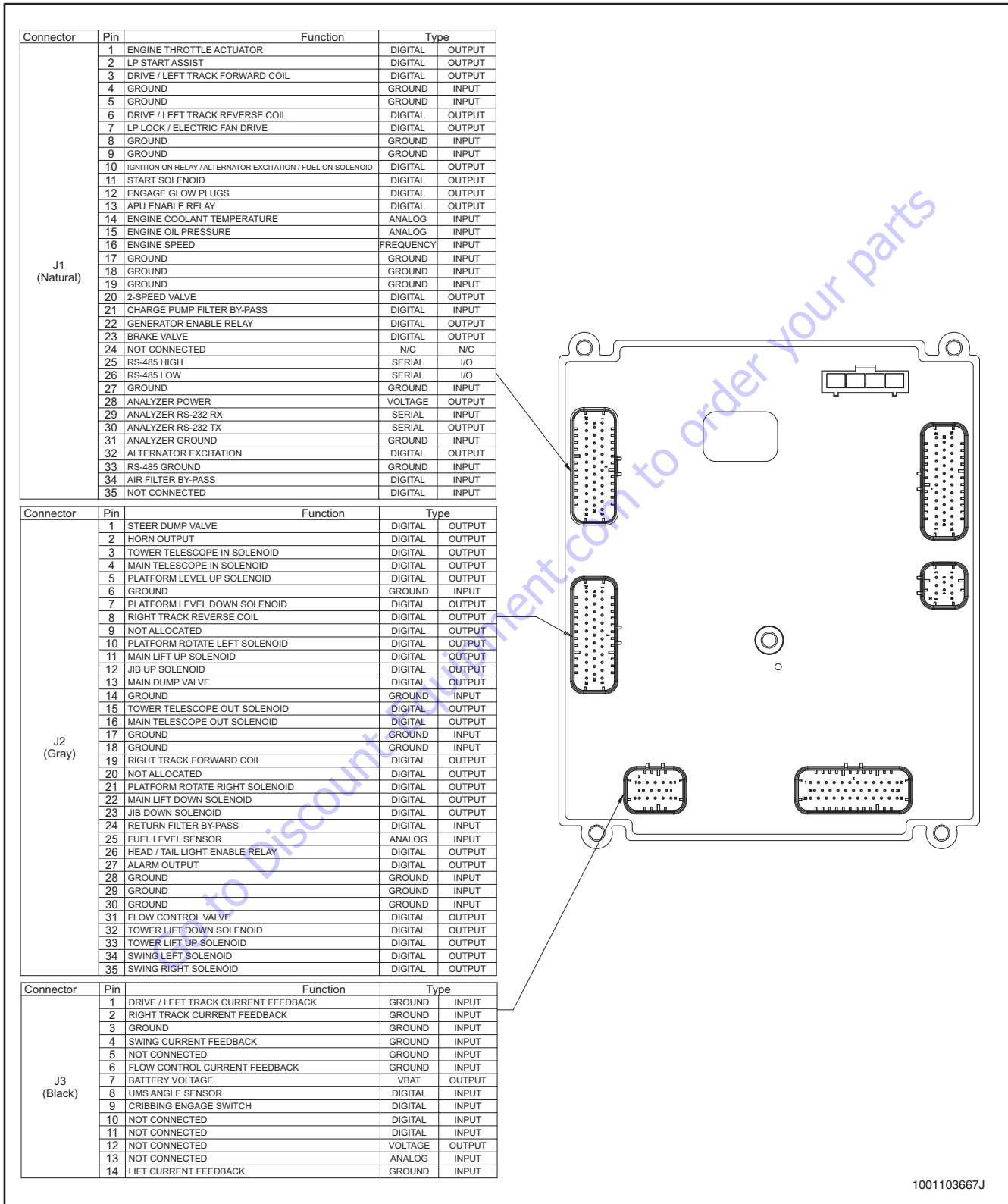

Figure 6-12. Ground Control Module Pin Connections 1 of 3

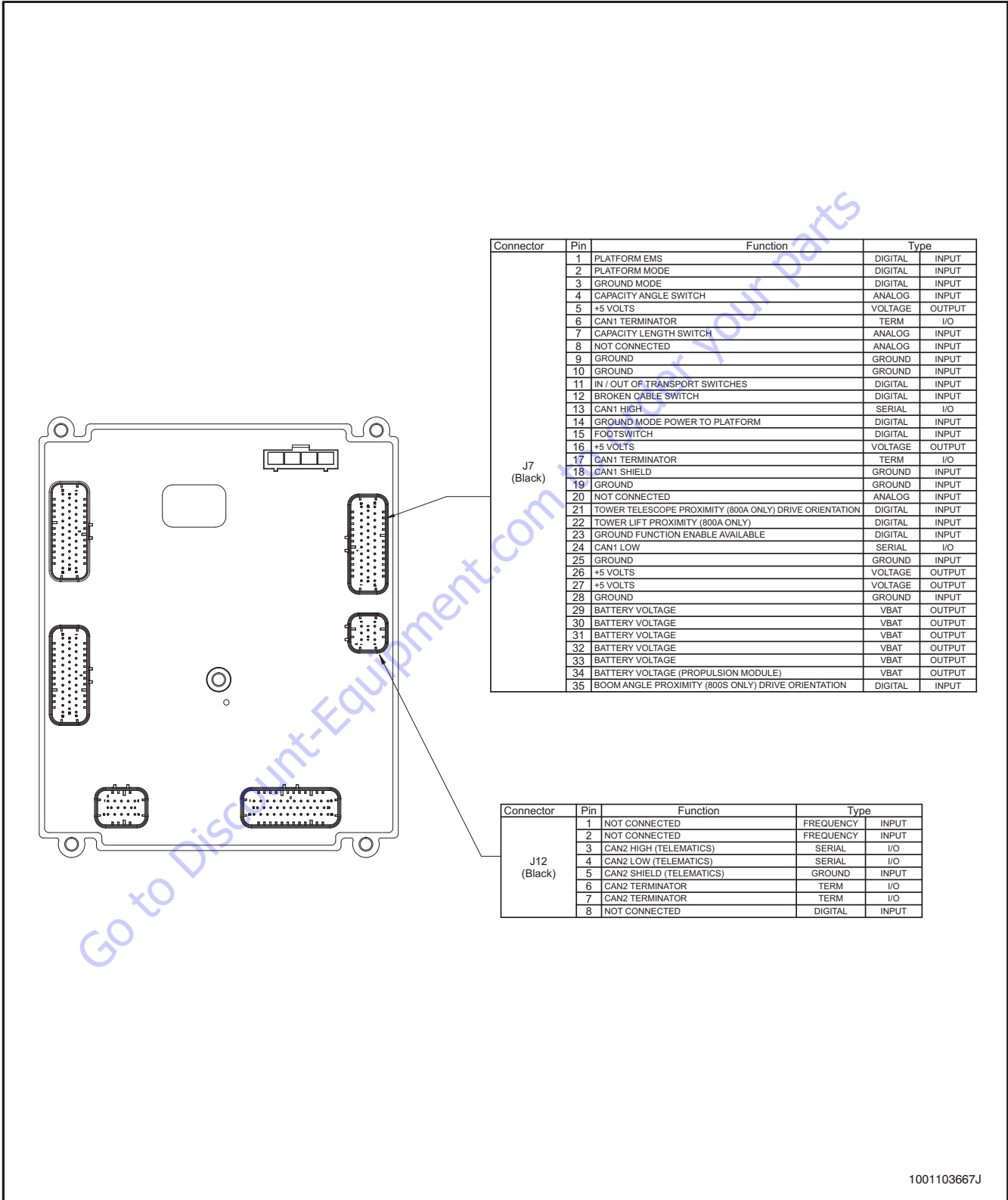

Figure 6-13. Ground Control Module Pin Connections 2 of 3

SECTION 6 - JLG CONTROL SYSTEM

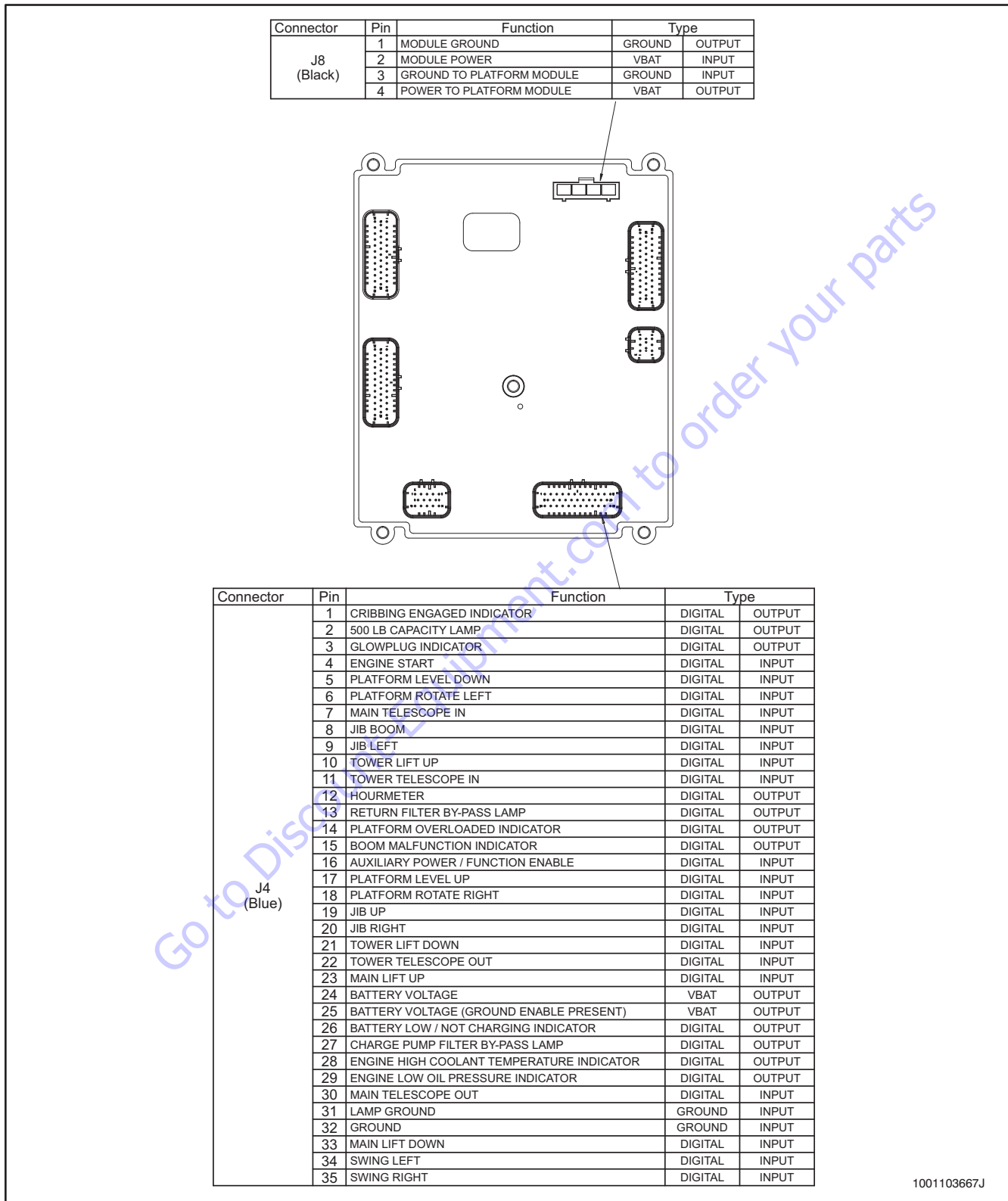
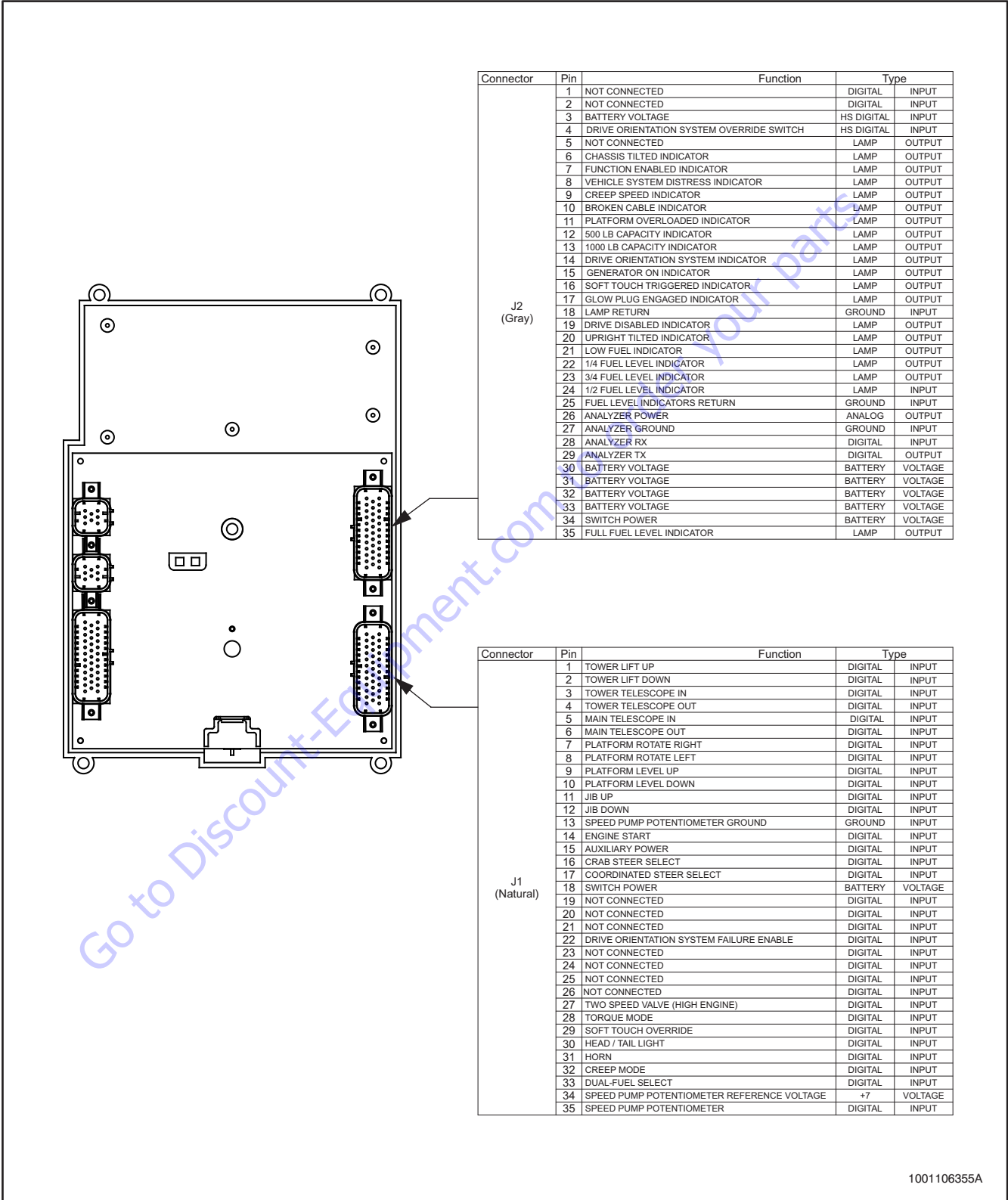

Figure 6-14. Ground Control Module Pin Connections 3 of 3



1001106355A

Figure 6-15. Platform Control Module Pin Connections 1 of 2

SECTION 6 - JLG CONTROL SYSTEM

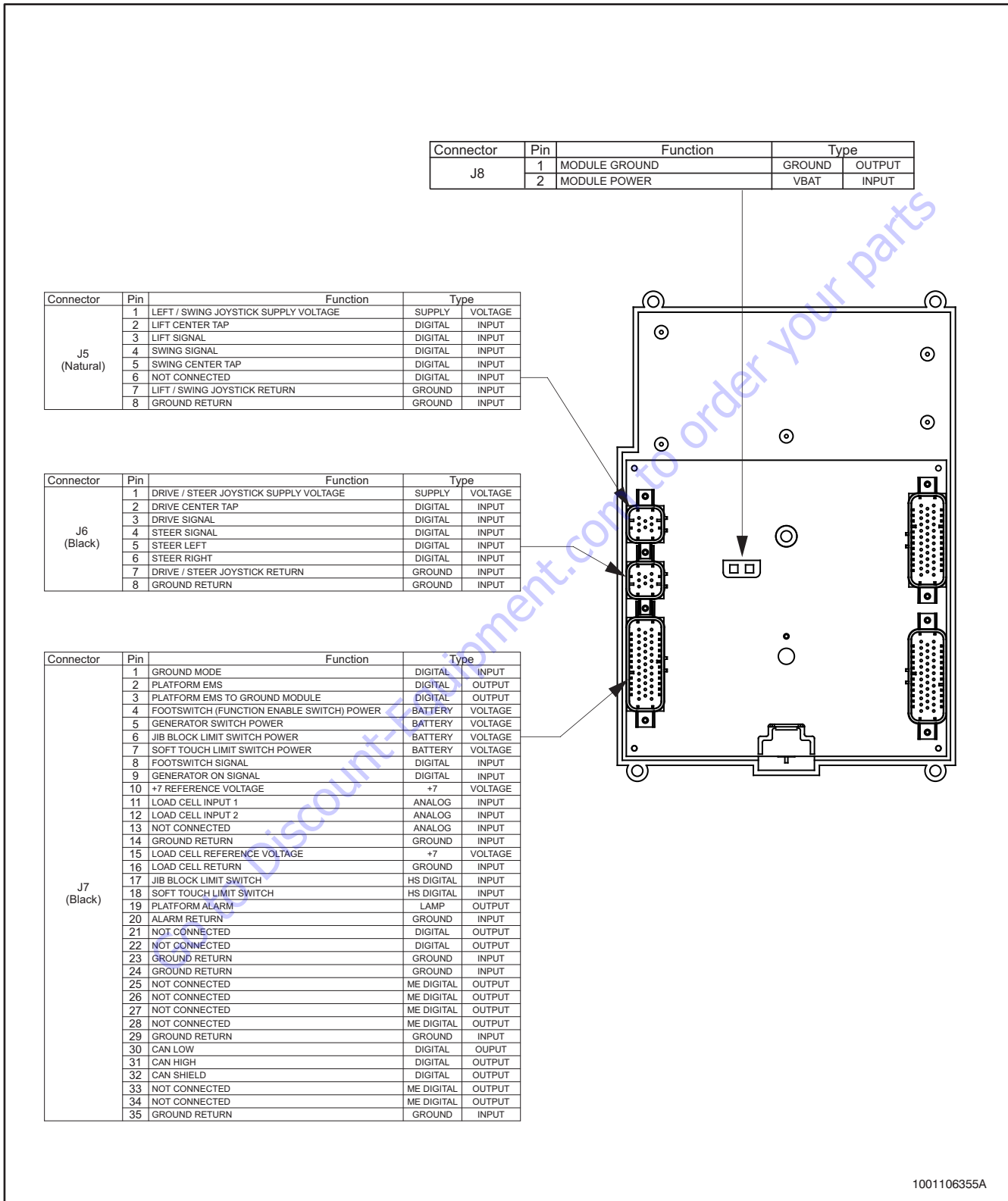

Figure 6-16. Platform Control Module Pin Connections 2 of 2

PARTS FINDER

**Search Website
by Part Number**



**Search Manual
Library For Parts
Manual & Lookup Part
Numbers – Purchase
or Request Quote**

Search Manuals

Enter your information to search for manuals and parts.

* Brand:

* Model:

* Serial:

* Part Number:

SEARCH

**Can't Find Part or
Manual? Request Help
by Manufacturer,
Model & Description**

Parts Order Form

Please fill in the following information:

Manufacturer:

Model:

Description:

Quantity:

Part Number:

Part Name:

Part Description:

Part Location:

Part Condition:

Part Status:

Part Material:

Part Color:

Part Weight:

Part Dimensions:

Part Price:

Part Notes:

Submit

Discount-Equipment.com is your online resource for quality parts & equipment.

Florida: **561-964-4949** Outside Florida TOLL FREE: **877-690-3101**

Need parts?

Click on this link: <http://www.discount-equipment.com/category/5443-parts/> and choose one of the options to help get the right parts and equipment you are looking for. Please have the machine model and serial number available in order to help us get you the correct parts. If you don't find the part on the website or on once of the online manuals, please fill out the request form and one of our experienced staff members will get back to you with a quote for the right part that your machine needs.

We sell worldwide for the brands: Genie, Terex, JLG, MultiQuip, Mikasa, Essick, Whiteman, Mayco, Toro Stone, Diamond Products, Generac Magnum, Airman, Haulotte, Barreto, Power Blanket, Nifty Lift, Atlas Copco, Chicago Pneumatic, Allmand, Miller Curber, Skyjack, Lull, Skytrak, Tsurumi, Husquvarna Target, , Stow, Wacker, Sakai, Mi-T- M, Sullair, Basic, Dynapac, MBW, Weber, Bartell, Bennar Newman, Haulotte, Ditch Runner, Menegotti, Morrison, Contec, Buddy, Crown, Edco, Wyco, Bomag, Laymor, Barreto, EZ Trench, Bil-Jax, F.S. Curtis, Gehl Pavers, Heli, Honda, ICS/PowerGrit, IHI, Partner, Imer, Clipper, MMD, Koshin, Rice, CH&E, General Equipment, ,AMida, Coleman, NAC, Gradall, Square Shooter, Kent, Stanley, Tamco, Toku, Hatz, Kohler, Robin, Wisconsin, Northrock, Oztec, Toker TK, Rol-Air, Small Line, Wanco, Yanmar

SECTION 7. BASIC ELECTRICAL INFORMATION & SCHEMATICS

7.1 GENERAL

This section contains basic electrical information and schematics for locating and correcting most electrical problems. If a problem develops which is not presented in this section or corrected by listed corrective actions, obtain technically qualified guidance before proceeding with any additional maintenance.

NOTE: Some procedures/connectors shown in this section may not apply to all models.

7.2 MULTIMETER BASICS

A wide variety of multimeters or Volt Ohm Meters (VOM) can be used for troubleshooting your equipment. This section shows diagrams of a common, digital VOM configured for several different circuit measurements. Instructions for your VOM may vary. Please consult the meter operator's manual for more information.

Grounding

"Grounding the meter" means to take the black lead (which is connected to the COM (common) or negative port) and touch it to a good path to the negative side of the Voltage source.

Backprobing

To "backprobe" means to take the measurement by accessing a connector's contact on the same side as the wires, the back of the connector. Readings can be done while maintaining circuit continuity this way. If the connector is the sealed type, great care must be taken to avoid damaging the seal around the wire. It is best to use probes or probe tips specifically designed for this technique, especially on sealed connectors. Whenever possible insert probes into the side of the connector such that the test also checks both terminals of the connection. It is possible to inspect a connection within a closed connector by backprobing both sides of a connector terminal and measuring resistance. Do this after giving each wire a gentle pull to ensure the wires are still attached to the contact and contacts are seated in the connector.

Min/Max

"Min/Max" recording feature of some meters can help when taking measurements of intermittent conditions while alone. For example, you can read voltage applied to a solenoid when it is only operational while a switch, far from the solenoid and meter, is held down.

Polarity

Getting a negative Voltage or current reading when expecting a positive reading frequently means the leads are reversed. Check what reading is expected, location of the signal and leads are correctly connected to the device under test. Also check the lead on the "COM" port goes to the ground or negative side of the signal and lead on the other port goes to the positive side of the signal.

Scale

M = Mega = 1,000,000 * (Displayed Number)

k = kilo = 1,000 * (Displayed Number)

m = milli = (Displayed Number) / 1,000

μ = micro = (Displayed Number) / 1,000,000

Example: 1.2 k Ω = 1200 Ω

Example: 50 mA = 0.05 A

Voltage Measurement

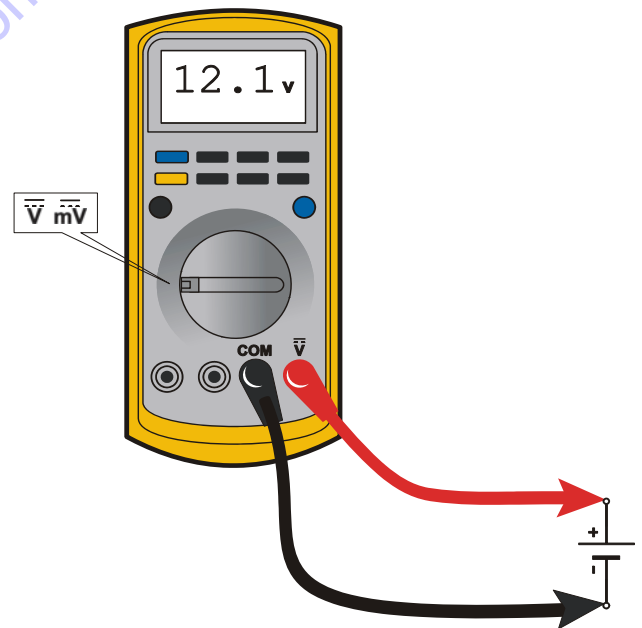

Figure 7-1. Voltage Measurement (DC)

- If meter is not auto ranging, set it to the correct range (See multimeter's operation manual)
- Use firm contact with meter leads

Resistance Measurement

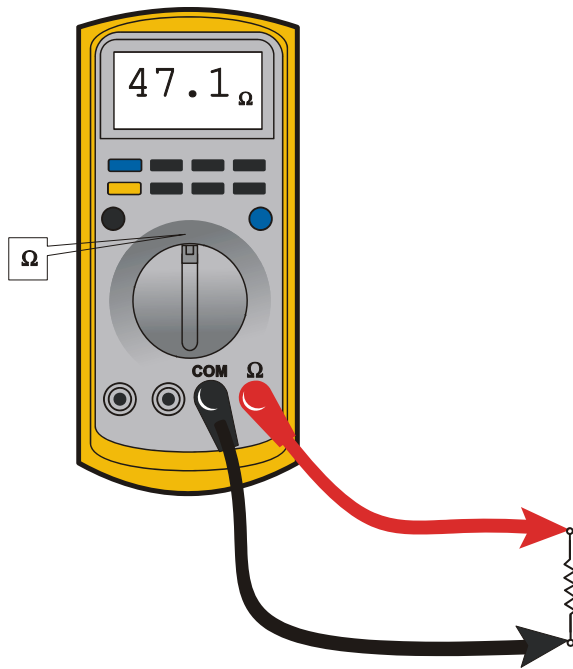

Figure 7-2. Resistance Measurement

- First test meter and leads by touching leads together. Resistance should read a short circuit (very low resistance)
- Circuit power must be turned OFF before testing resistance
- Disconnect component from circuit before testing
- If meter is not auto ranging, set it to the correct range (See multimeter's operation manual)
- Use firm contact with meter leads

Continuity Measurement

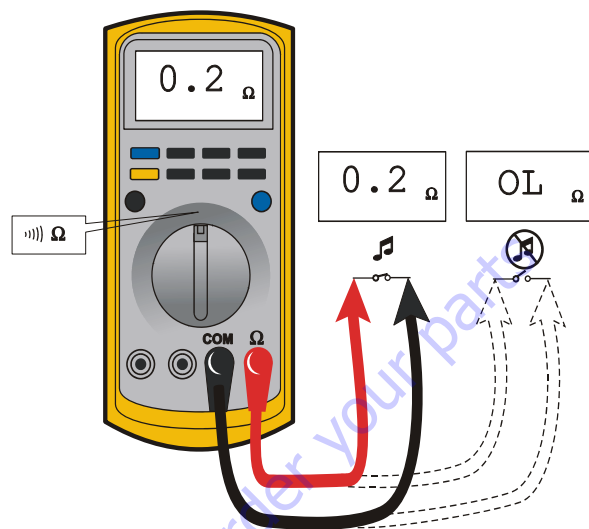

Figure 7-3. Continuity Measurement

- Some meters require a separate button press to enable audible continuity testing
- Circuit power must be turned OFF before testing continuity
- Disconnect component from circuit before testing
- Use firm contact with meter leads
- First test meter and leads by touching leads together. Meter should produce an audible alarm, indicating continuity

Current Measurement

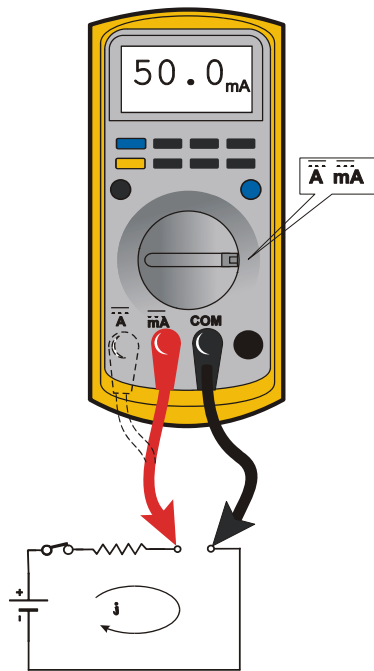

Figure 7-4. Current Measurement (DC)

- Set up meter for expected current range
- Be sure to connect meter leads to correct jacks for selected current range
- If meter is not auto ranging, set it to correct range (See multi meter's operation manual)
- Use firm contact with meter leads

7.3 APPLYING SILICONE DIELECTRIC COMPOUND TO ELECTRICAL CONNECTIONS

NOTE: This section is not applicable for battery terminals.

NOTICE

JLG P/N 0100048 DIELECTRIC GREASE (NOVAGARD G661) IS THE ONLY MATERIAL APPROVED FOR USE AS A DIELECTRIC GREASE.

NOTE: Do NOT apply dielectric grease to the following connections:

- Main Boom Rotary sensor connections (on Celesco Sensor),
- LSS Modules connections,
- Deutz EMR 2 ECM connection.

Silicone Dielectric Compound must be used on all electrical connections except for those mentioned above for the following reasons:

- To prevent oxidation at mechanical joint between male and female pins.
- To prevent electrical malfunction caused by low level conductivity between pins when wet.

Use the following procedure to apply Silicone Dielectric Compound to the electrical connectors. This procedure applies to all plug connections not enclosed in a box. Silicone grease should not be applied to connectors with external seals.

1. To prevent oxidation, silicone grease must be packed completely around male and female pins on the inside of the connector prior to assembly. This is most easily achieved by using a syringe.

NOTE: Over a period of time, oxidation increases electrical resistance at the connection, eventually causing circuit failure.

2. To prevent shorting, silicone grease must be packed around each wire where they enter the outside of the connector housing. Also, silicone grease must be applied at the joint where the male and female connectors come together. Any other joints (around strain reliefs, etc.) where water could enter the connector should also be sealed.

NOTE: This condition is especially common when machines are pressure washed since the washing solution is much more conductive than water.

3. Anderson connectors for battery boxes and battery chargers should have silicone grease applied to contacts only.

NOTE: Curing-type sealants can also be used to prevent shorting and would be less messy, but make future pin removal difficult.

When applied to electrical connections, dielectric grease helps prevent corrosion of electrical contacts and improper conductivity between contacts from moisture intrusion. Open and sealed connectors benefit from application of dielectric grease.

Dielectric grease shall be applied to all electrical connectors at the time of connection (except those noted under Exclusions).

Dielectric Grease Application

Before following these instructions, refer to excluded connector types (See Exclusions below).

1. Use dielectric grease in a tube for larger connection points or apply with a syringe for small connectors.
2. Apply dielectric grease to the female contact (fill it approximately 1/2 full; see example below)
3. Leave a thin layer of dielectric grease on connector face.
4. Assemble connector system immediately to prevent moisture or dust contamination
5. Pierce one of the unused wire seals before assembly if the connector system tends to trap air (i.e. AMP Seal) and then install a seal plug.

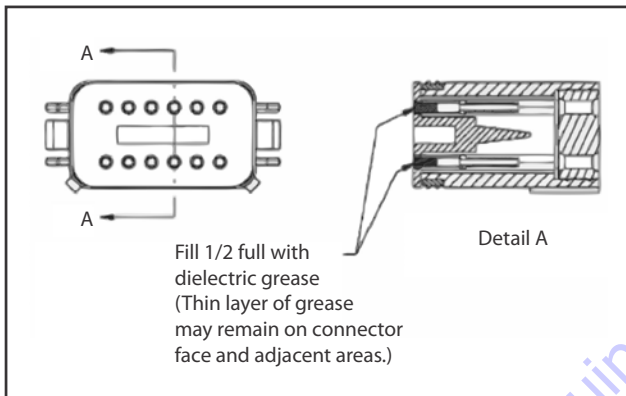

Figure 7-5. Applying Dielectric Grease

Deutsch HD, DT, DTM, DRC Series

The Deutsch connector system is commonly used for harsh environments. Follow installation instructions.



Figure 7-6. Deutsch Connector

AMP Seal

The AMP Seal connector system is used on Control ADE Platform and Ground Modules.

Apply dielectric grease to the female contact. If trapped air prevents connector from latching, pierce one of the unused wire seals.



Figure 7-7. Dielectric Grease On Female Contacts

After assembly, install a seal plug (JLG #4460905) to keep out moisture. Seal plugs may also be installed by the wire harness manufacturer if an unused wire seal was damaged during assembly.

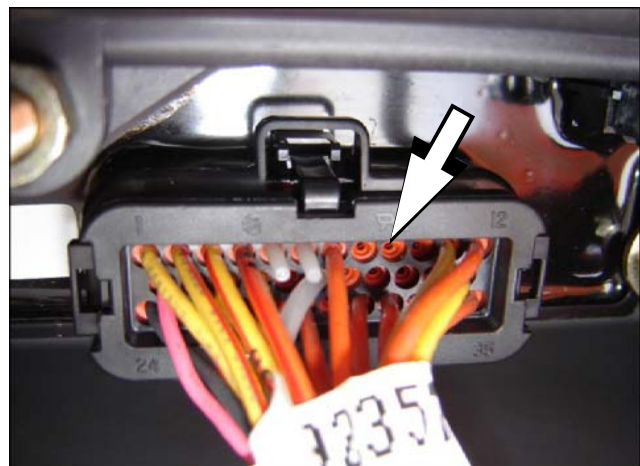

Figure 7-8. Seal Plugs

AMP Mate-N-Lok

Follow manufacturer installation instructions.

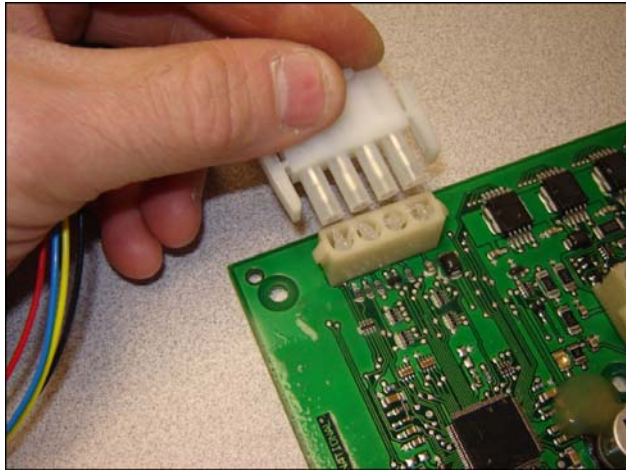

Figure 7-9. AMP Mate-N-Lok Connector

DIN Connectors

This connector is typically used on hydraulic valves. Follow manufacturer installation instructions.



Figure 7-10. DIN Connector

Exclusions

Some connectors do not require or may be permanently damaged by application of dielectric grease. Dielectric grease may not be required in properly sealed enclosures.

NOTICE

DO NOT USE DIELECTRIC GREASE ON BRAD HARRISON/PHOENIX CONTACT M12 OR AMP JUNIOR TIMER CONNECTORS. LOW-FORCE CONTACTS CANNOT DISPLACE DIELECTRIC GREASE AND CREATE ELECTRICAL CONTACT.

BRAD HARRISON/PHOENIX CONTACT M12

This connector uses gold contact material to resist corrosion and an O-ring seal for moisture integrity. Low-force contacts cannot displace dielectric grease to achieve electrical contact. Once contaminated, replacement of female contacts is required. The JLG Load Sensing System and 1250AJP Rotary Angle Sensors are examples of components with the M12 connector system.



Figure 7-11. Brad Harrison/Phoenix Connectors

AMP JUNIOR TIMER

This type of connector uses back-seals to keep out moisture. Low-force contacts cannot displace dielectric grease and create electrical contact. Use solvents (i.e. contact cleaner or mineral spirits) to remove dielectric grease. The Deutz EMR2 engine control module uses this connector.



Figure 7-12. AMP Junior Timer

7.4 AMP CONNECTOR

Plug and header assembly colors are mechanically keyed to mate only with identical colors.

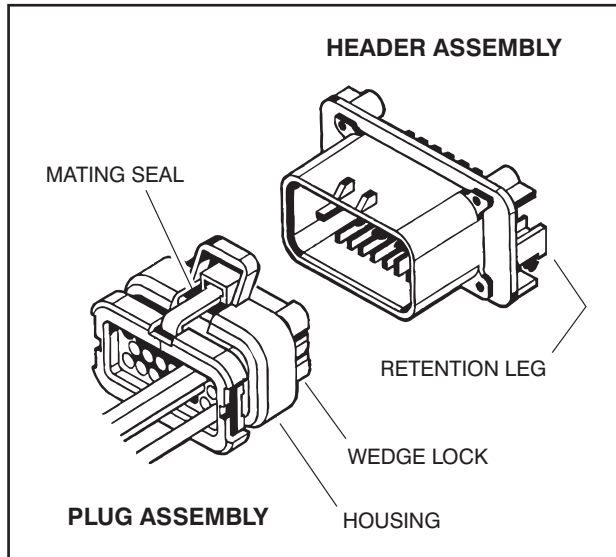

Figure 7-13. AMP Connector

Contact Assembly

1. Strip wire and install in crimp end of connector as shown in Figure 7-14.
2. Crimp connector. Do not damage cutoff tab.

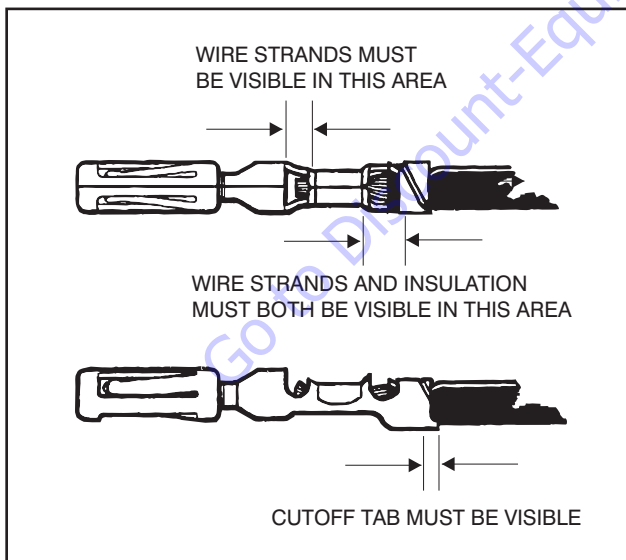

Figure 7-14. AMP Contact Assembly

Connector Assembly

1. Check wedge lock is in the open, or as-shipped, position.

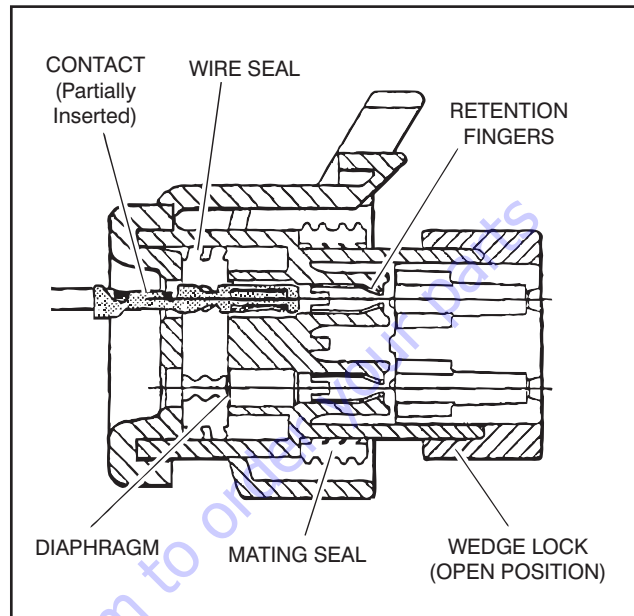

Figure 7-15. AMP Connector Assembly

2. Push contact straight into circuit cavity as far as it will go.
3. Pull on contact wire with a force of 1 - 2 lb to be sure retention fingers are holding contact.

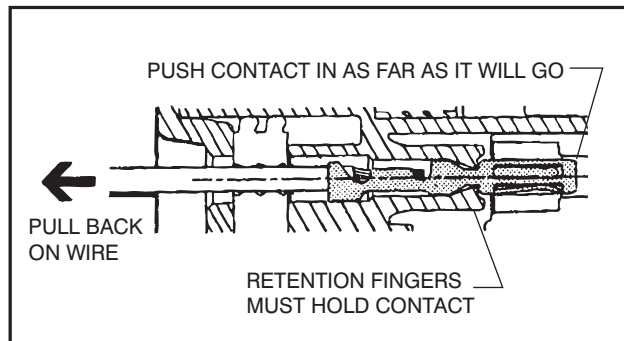

Figure 7-16. AMP Contact Installation

4. After all contacts are inserted, close wedge lock to its locked position. Release locking latches by squeezing them inward.

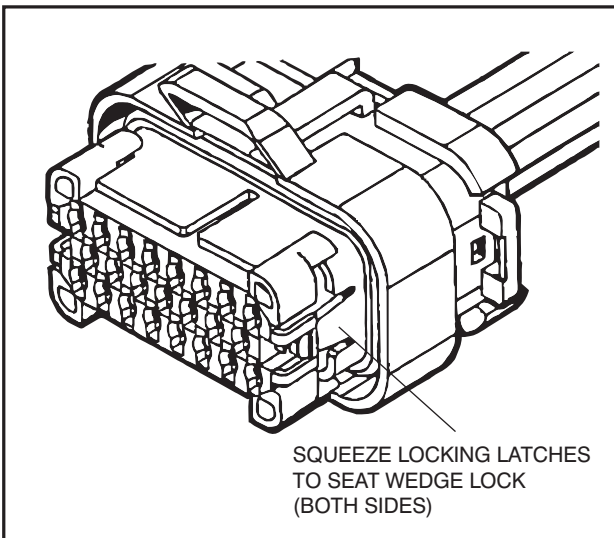

Figure 7-17. Close Wedge Lock

5. Slide wedge lock in housing until flush with housing.

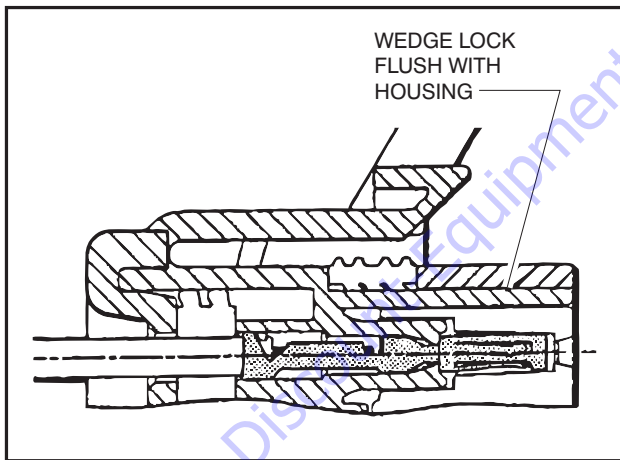

Figure 7-18. Seating Wedge Lock

Disassembly

1. Insert a 4.8 mm (3/16") wide screwdriver blade between mating seal and one of red wedge lock tabs.
2. Pry wedge lock open.
3. While rotating wire back and forth over a half turn (1/4 turn in each direction), gently pull wire until contact is removed.

NOTE: Wedge lock should never be removed from housing for insertion or removal of contacts.

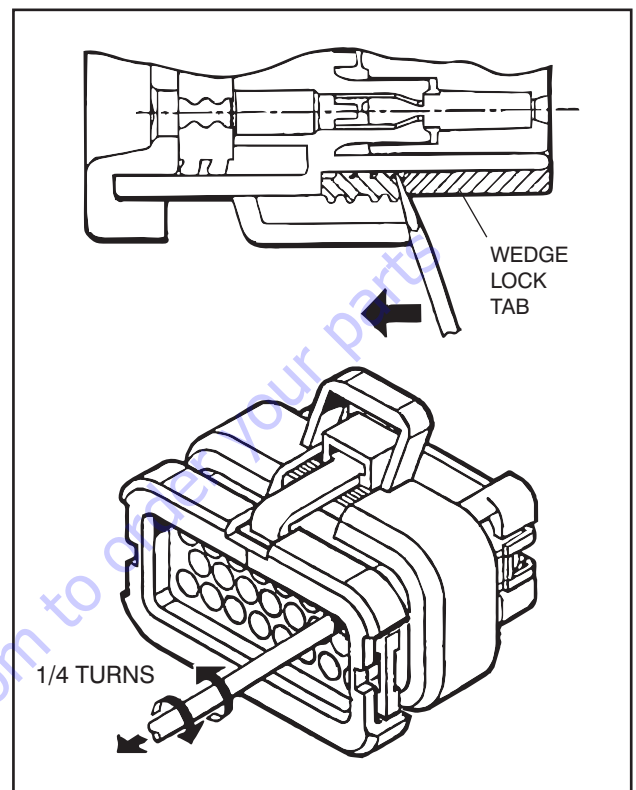

Figure 7-19. AMP Connector Disassembly

Wedge Lock

The wedge lock has slotted openings in the forward, or mating end. These slots accommodate circuit testing in the field by using a flat probe such as a pocket knife. DO NOT use a sharp point such as an ice pick.

Service - Voltage Reading

NOTICE

HOLES IN WIRE INSULATION CAN LET IN MOISTURE AND CAUSE SYSTEM FAILURE. DO NOT PIERCE WIRE INSULATION TO TAKE VOLTAGE READINGS.

It has been common practice in electrical troubleshooting to probe wires by piercing insulation with a sharp point. This practice should be discouraged when dealing with an AMPSEAL plug assembly or any other sealed connector system. Resulting pinholes in the insulation allows moisture to enter by traveling along wire strands and could result in system failure.

7.5 DEUTSCH CONNECTORS

DT/DTP Series Assembly

1. Grasp crimped contact (1) about 25mm behind contact barrel.
2. Hold connector with rear grommet (2) facing you.
3. Push contact straight into connector grommet (3) until a click is felt. A slight tug confirms it is locked in place.
4. Once all contacts are in place, insert wedgelock (4) with arrow pointing toward exterior locking mechanism. The wedgelock will snap into place. Rectangular wedges are not oriented. They may go in either way.

NOTE: Receptacle shown - use same procedure for plug.

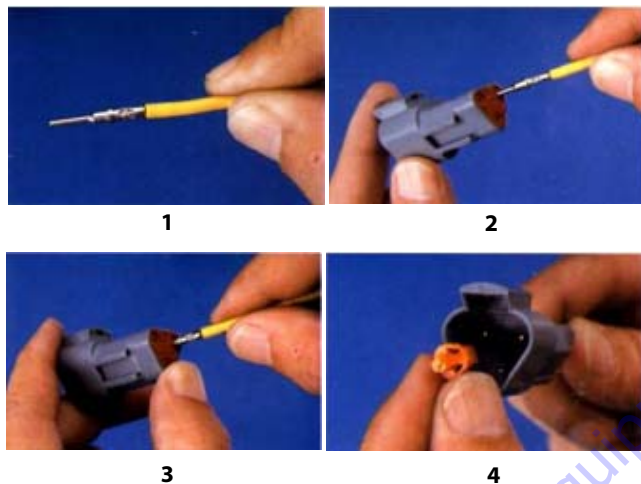

Figure 7-20. DT/DTP Contact Installation

DT/DTP Series Disassembly

1. Remove wedgelock (1) using needle-nose pliers or a hook shaped wire to pull wedge straight out.
2. To remove contacts, gently pull wire backwards at the same time releasing the locking finger (2) by moving it away from contact with a screwdriver.
3. Hold rear seal (3) in place. Removing contact may displace seal.

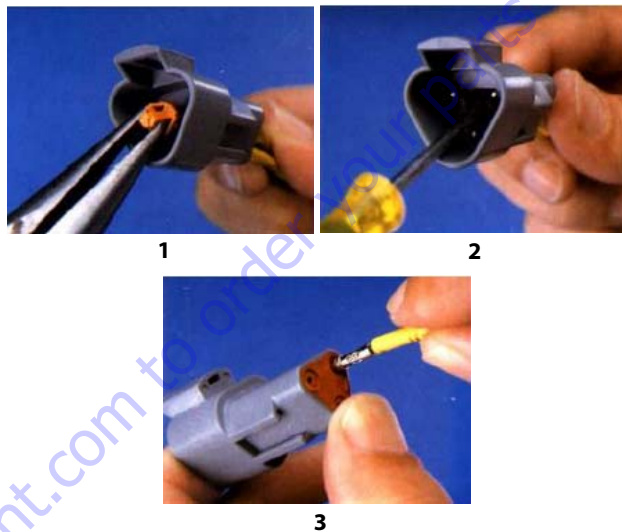

Figure 7-21. DT/DTP Contact Removal

HD30/HDP20 Series Assembly

1. Grasp contact (1) about 25mm behind contact crimp barrel.
2. Hold connector with rear grommet (2) facing you.

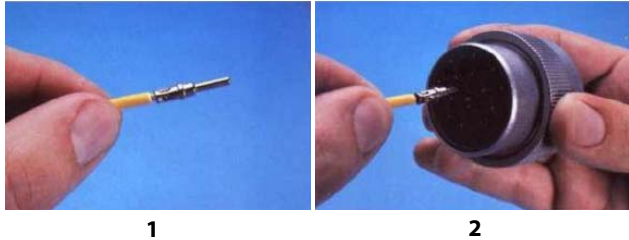

Figure 7-22. HD/HDP Contact Installation

3. Push contact straight into connector grommet until a positive stop is felt. A slight tug will confirm it is locked in place.

LOCKING FINGERS

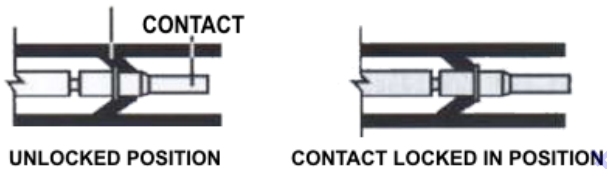

Figure 7-23. HD/HDP Locking Contacts Into Position

NOTE: Insert sealing plugs in unused wire cavities for full environmental sealing.

HD30/HDP20 Series Disassembly

1. With rear insert toward you, snap appropriate size extractor tool (1) over wire of contact to be removed.
2. Push tool in the insert cavity (2) until it engages contact and resistance is felt.

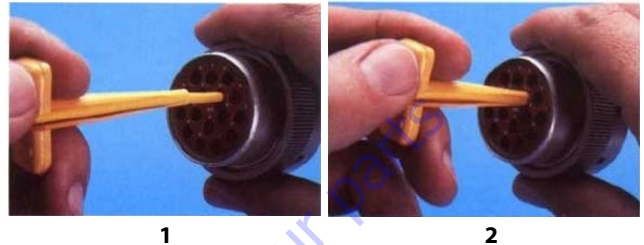

Figure 7-24. HD/HDP Contact Removal

3. Pull contact-wire assembly out of connector

NOTE: Do Not twist or insert tool at an angle.

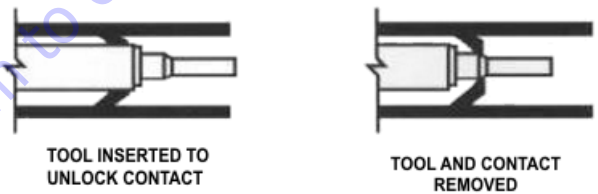

Figure 7-25. HD/HDP Unlocking Contacts

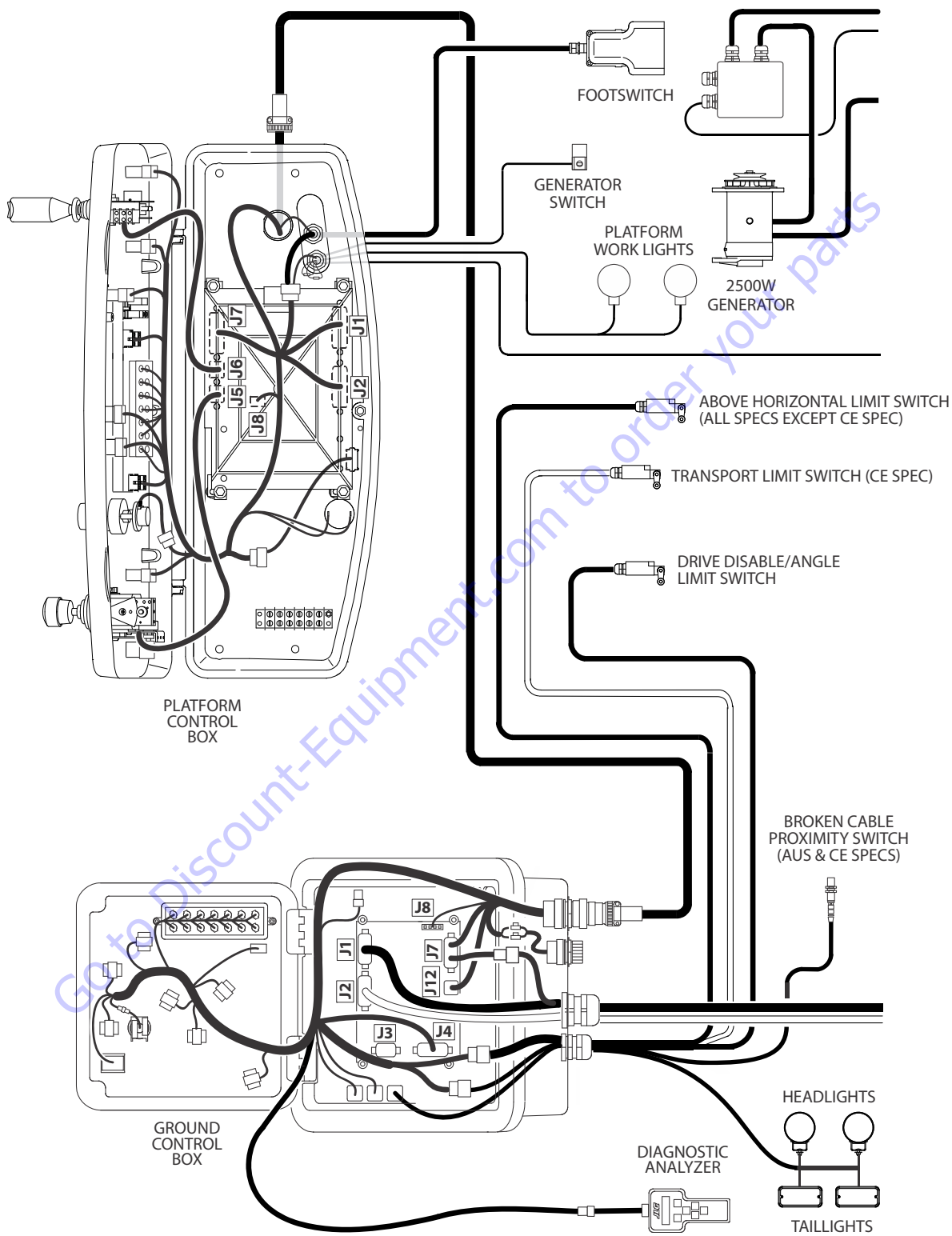

Figure 7-26. Electrical Components 1 of 2

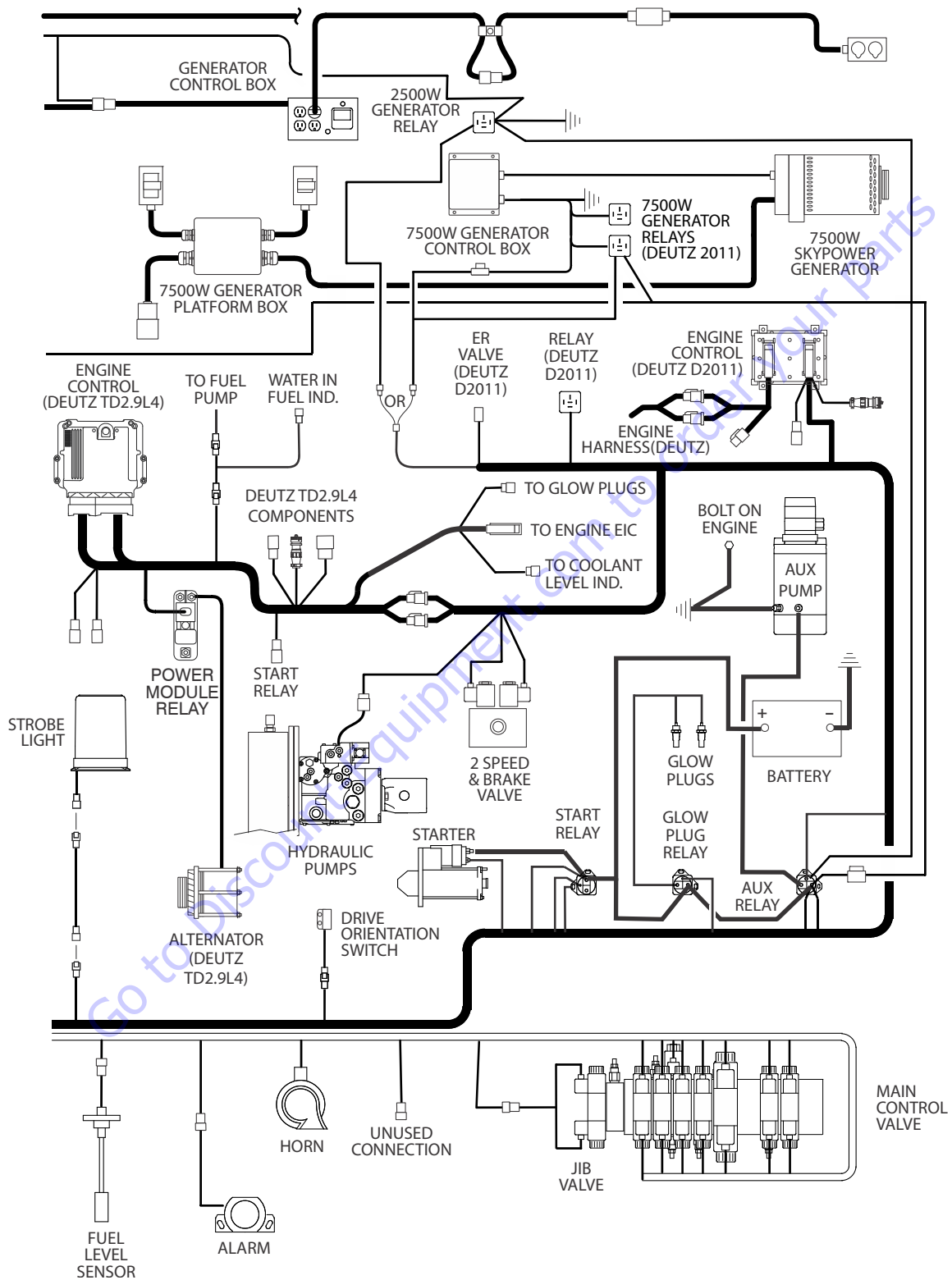

Figure 7-27. Electrical Components 2 of 2

SECTION 7 - BASIC ELECTRICAL INFORMATION & SCHEMATICS

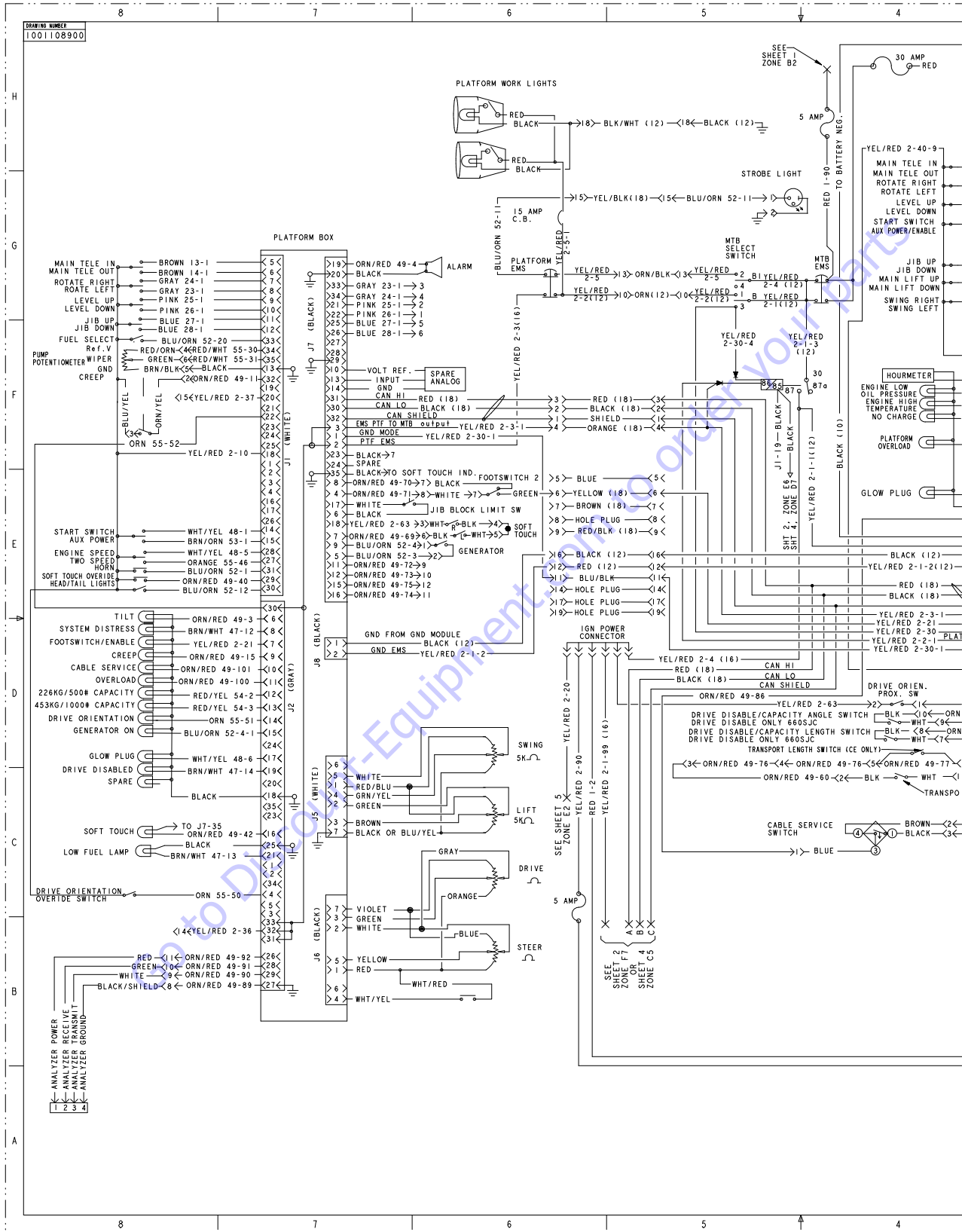
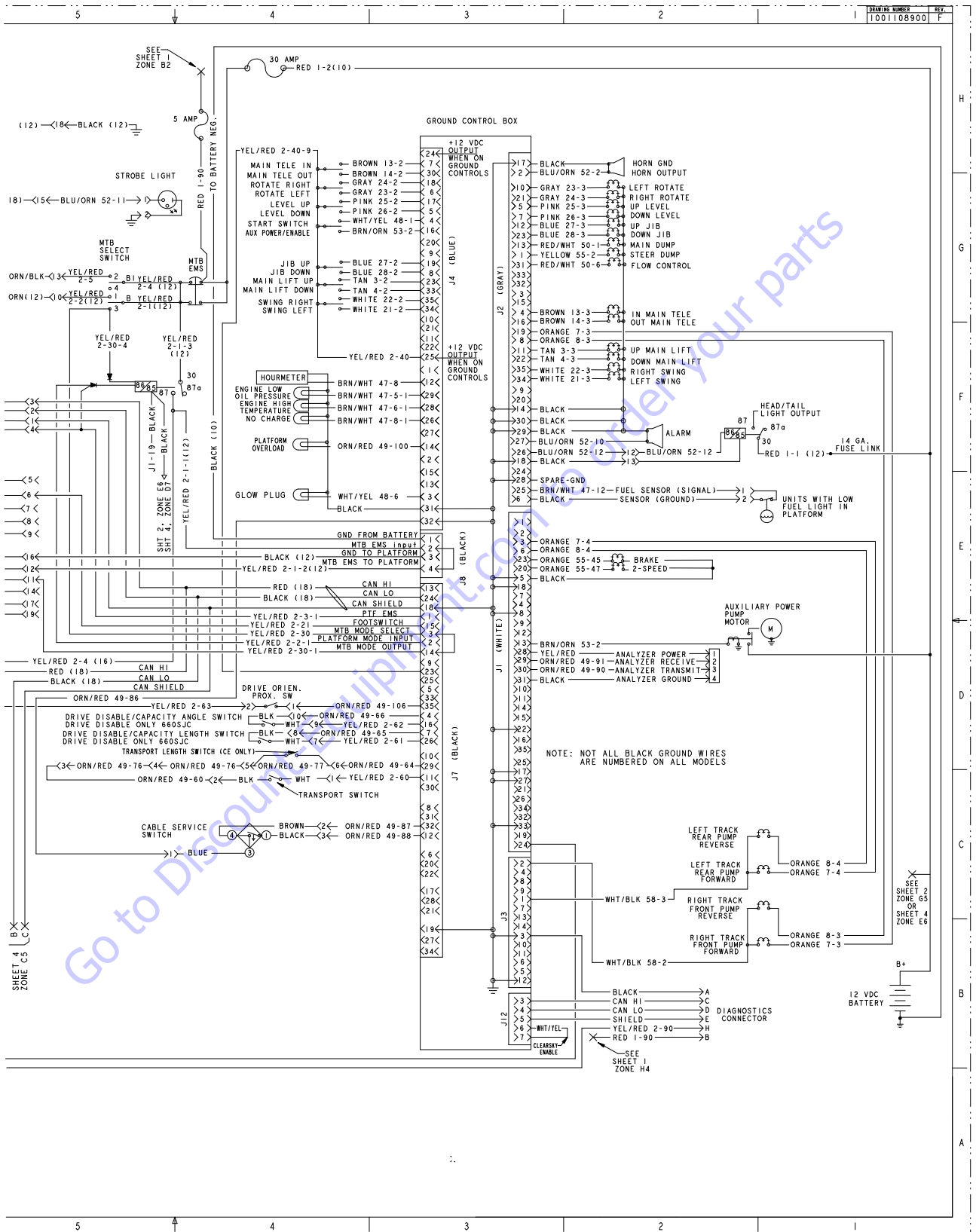

Figure 7-28. Platform and Ground Control Electrical Schematic - 1 of 2

SECTION 7 - BASIC ELECTRICAL INFORMATION & SCHEMATICS



SECTION 7 - BASIC ELECTRICAL INFORMATION & SCHEMATICS

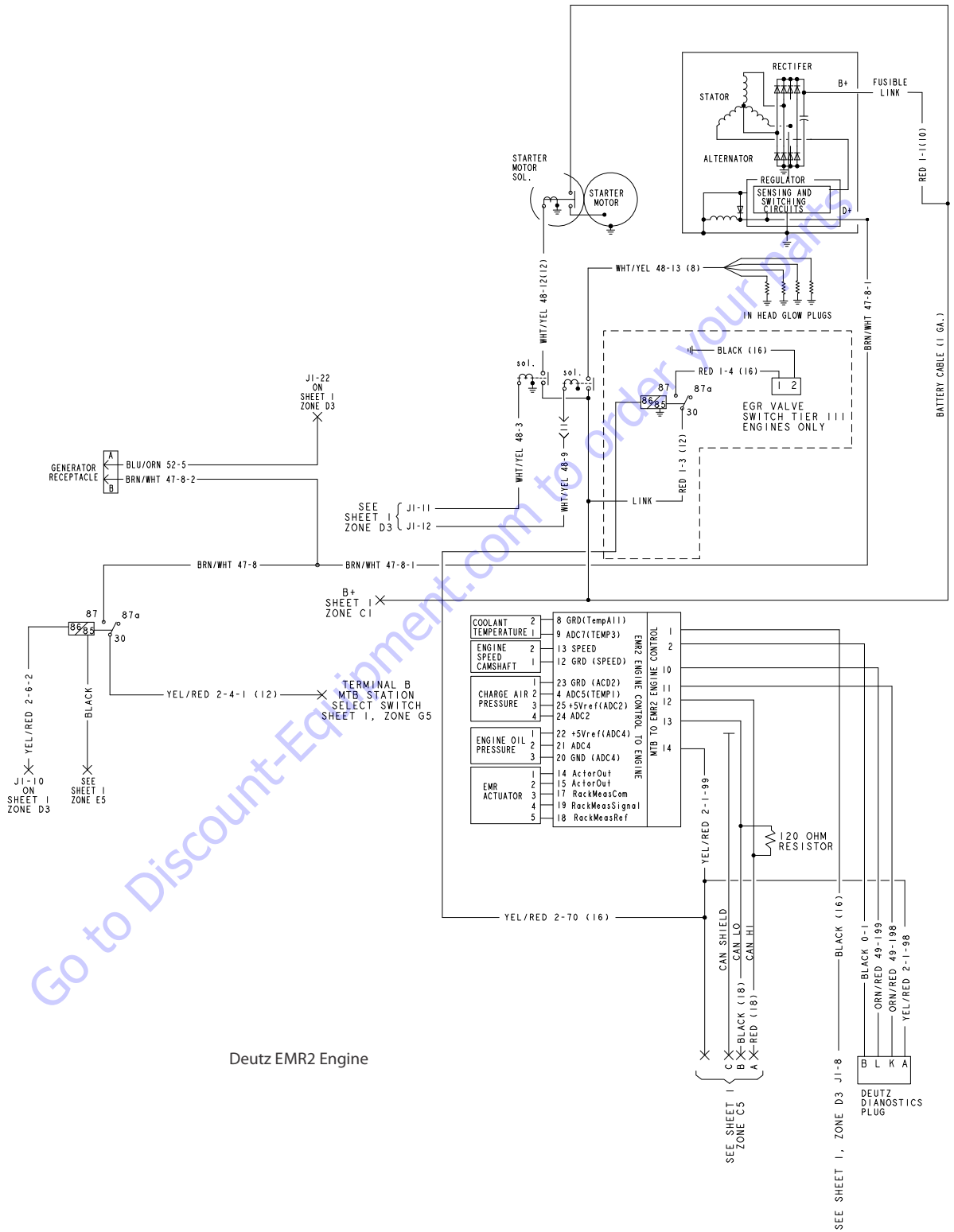
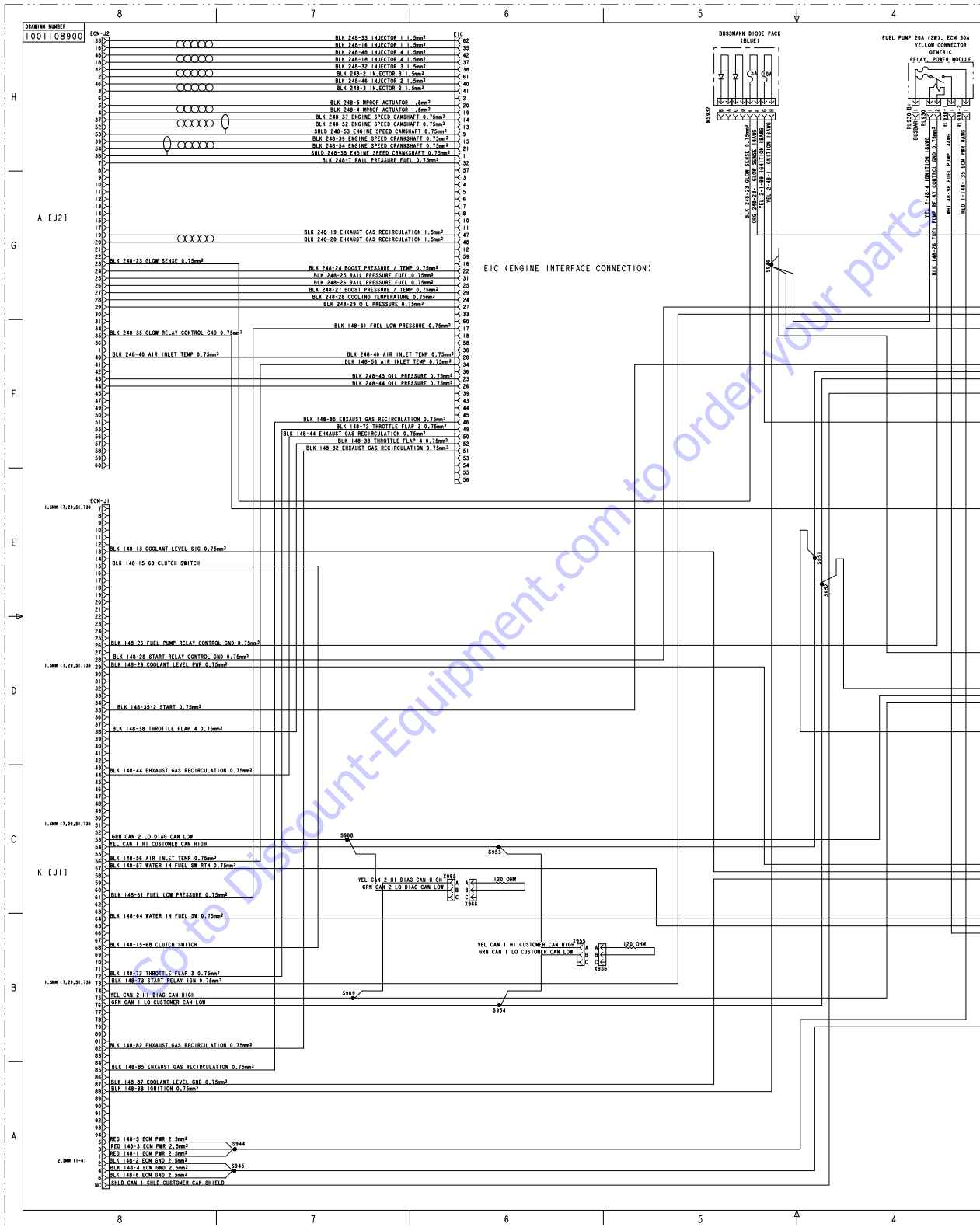

Figure 7-31. Deutz EMR2 Wiring Schematic

SECTION 7 - BASIC ELECTRICAL INFORMATION & SCHEMATICS



SECTION 7 - BASIC ELECTRICAL INFORMATION & SCHEMATICS

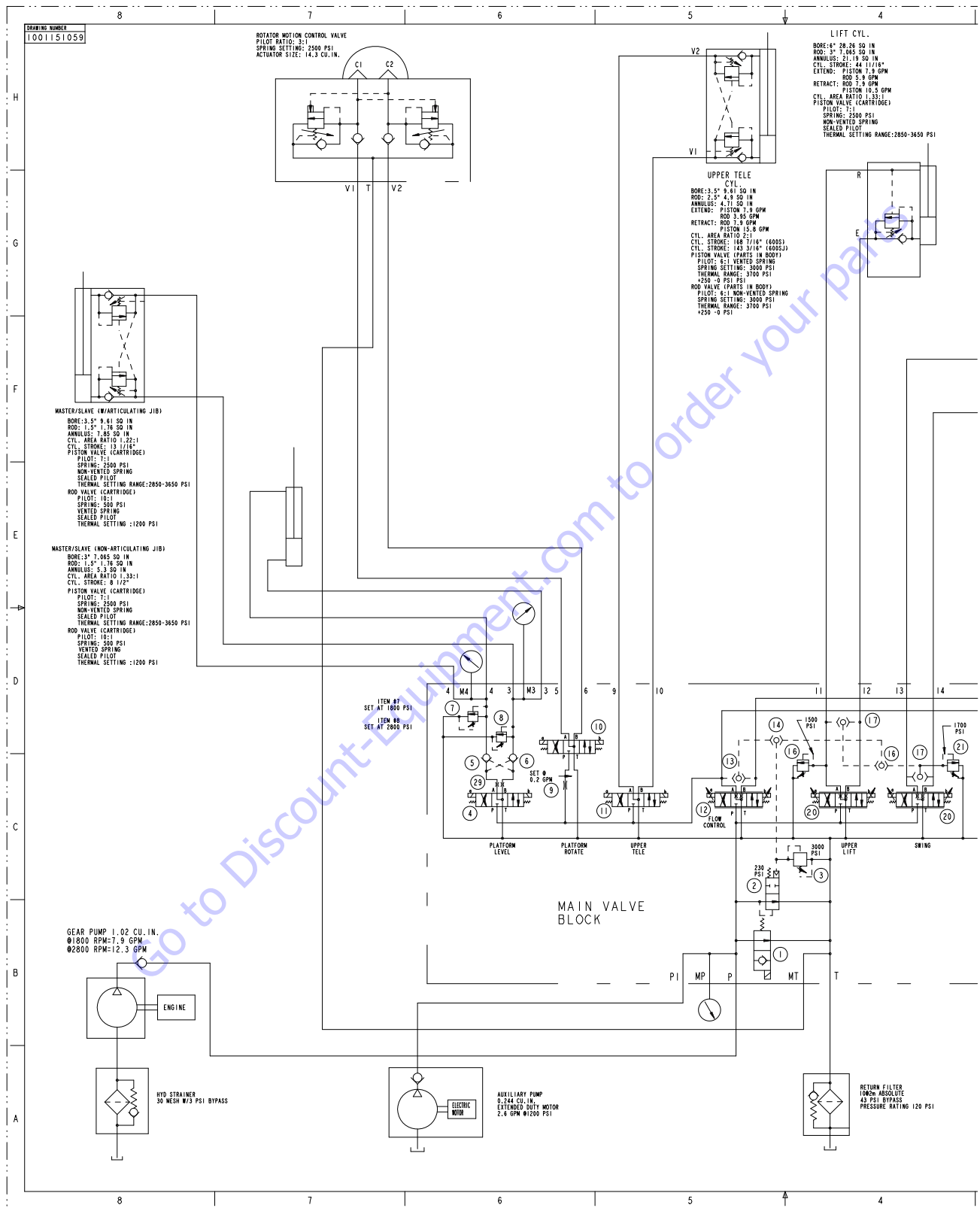

Figure 7-34. Hydraulic Schematic 1 of 2

SECTION 7 - BASIC ELECTRICAL INFORMATION & SCHEMATICS

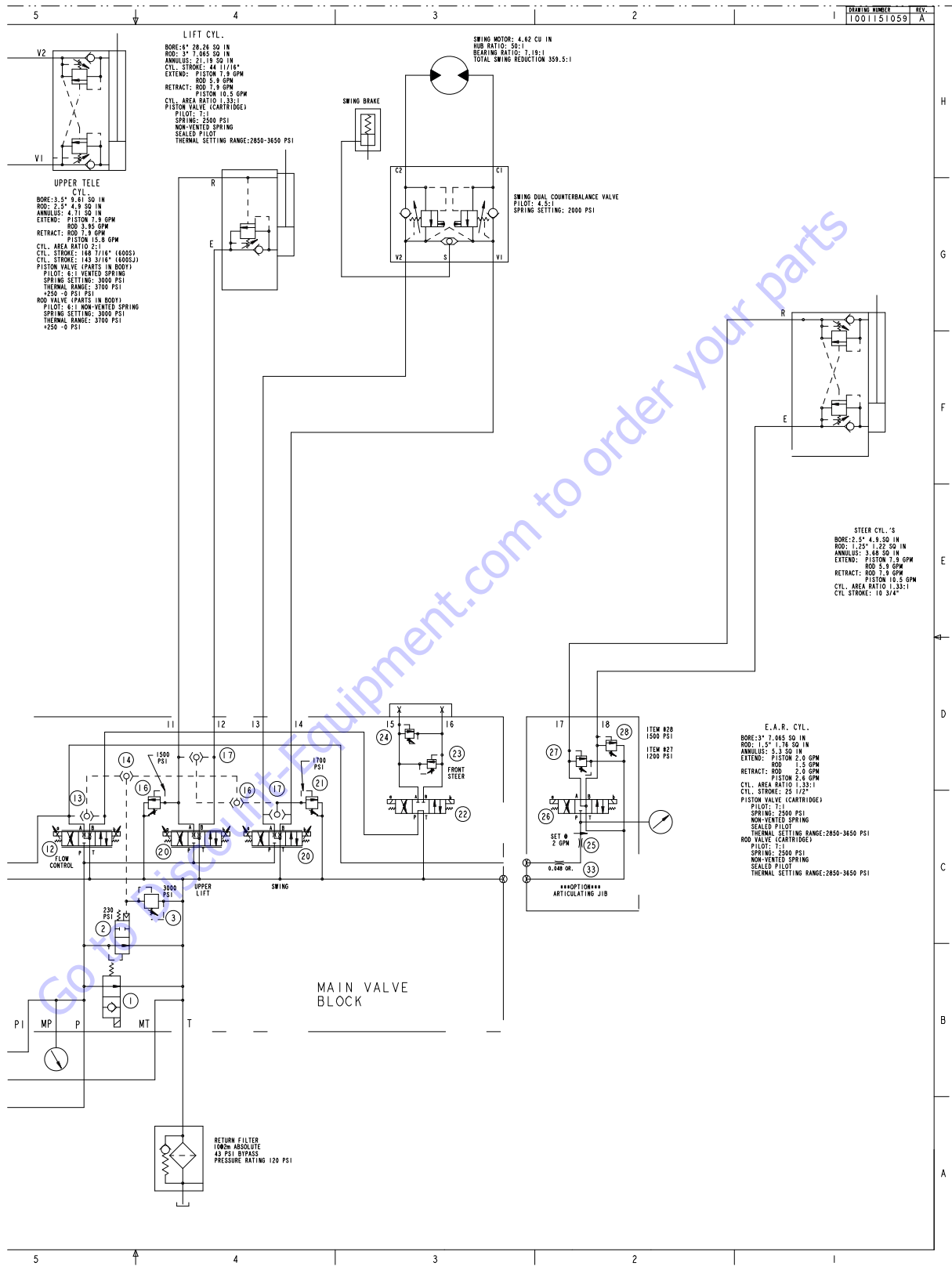

Figure 7-35. Hydraulic Schematic 2 of 2

SECTION 7 - BASIC ELECTRICAL INFORMATION & SCHEMATICS

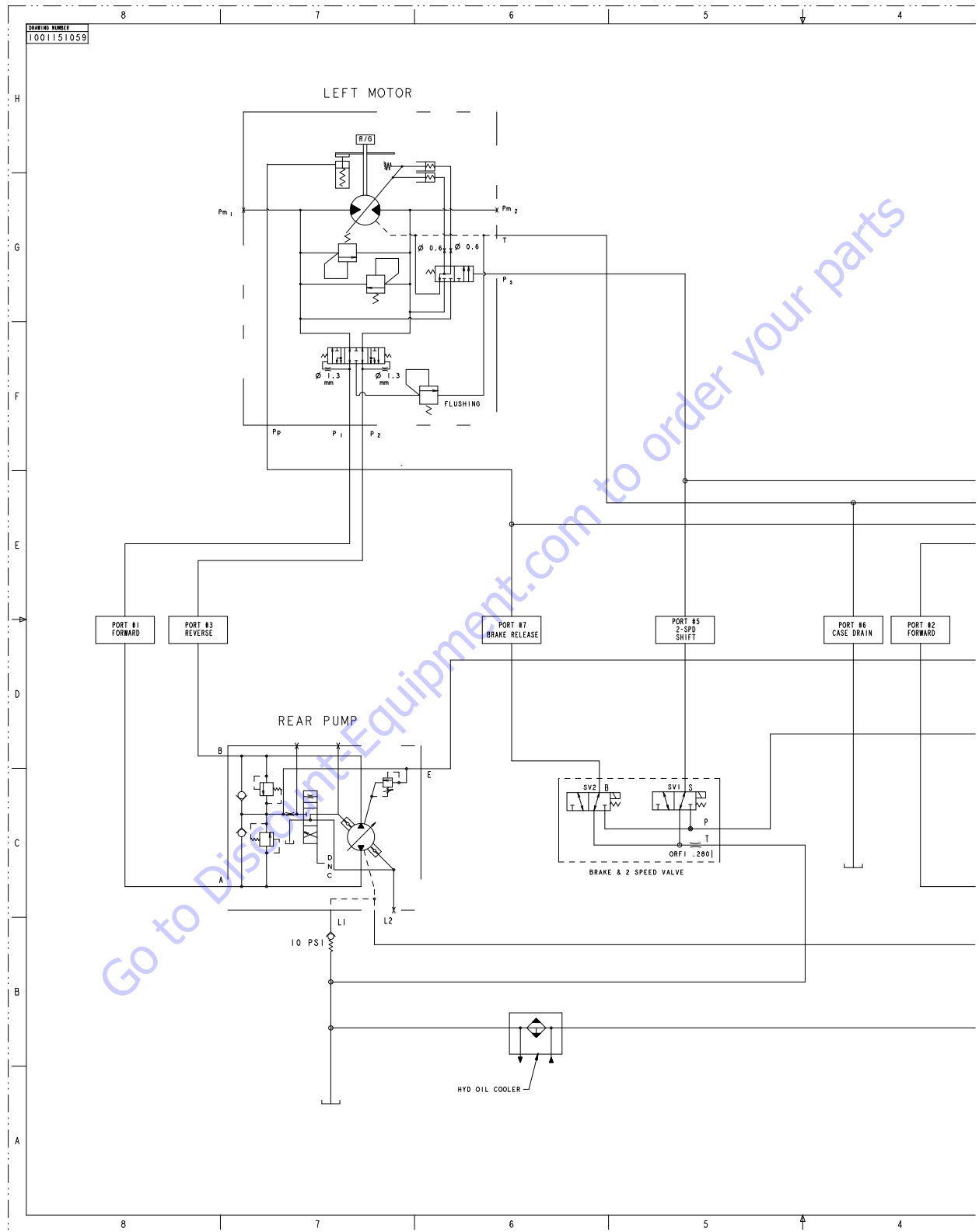

Figure 7-36. Crawler Hydraulic Drive Schematic 1 of 2

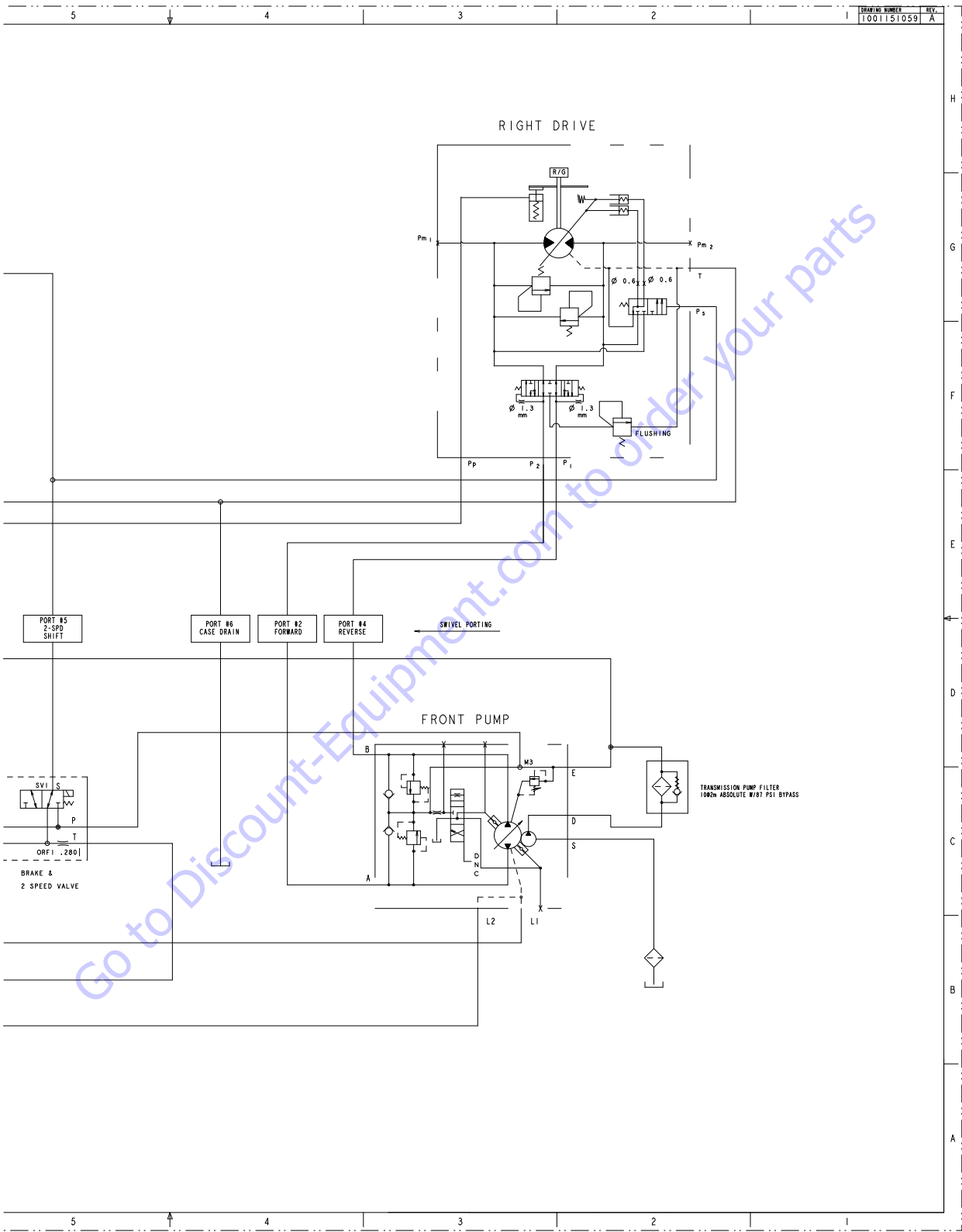

Figure 7-37. Crawler Hydraulic Drive Schematic 2 of 2

SECTION 7 - BASIC ELECTRICAL INFORMATION & SCHEMATICS

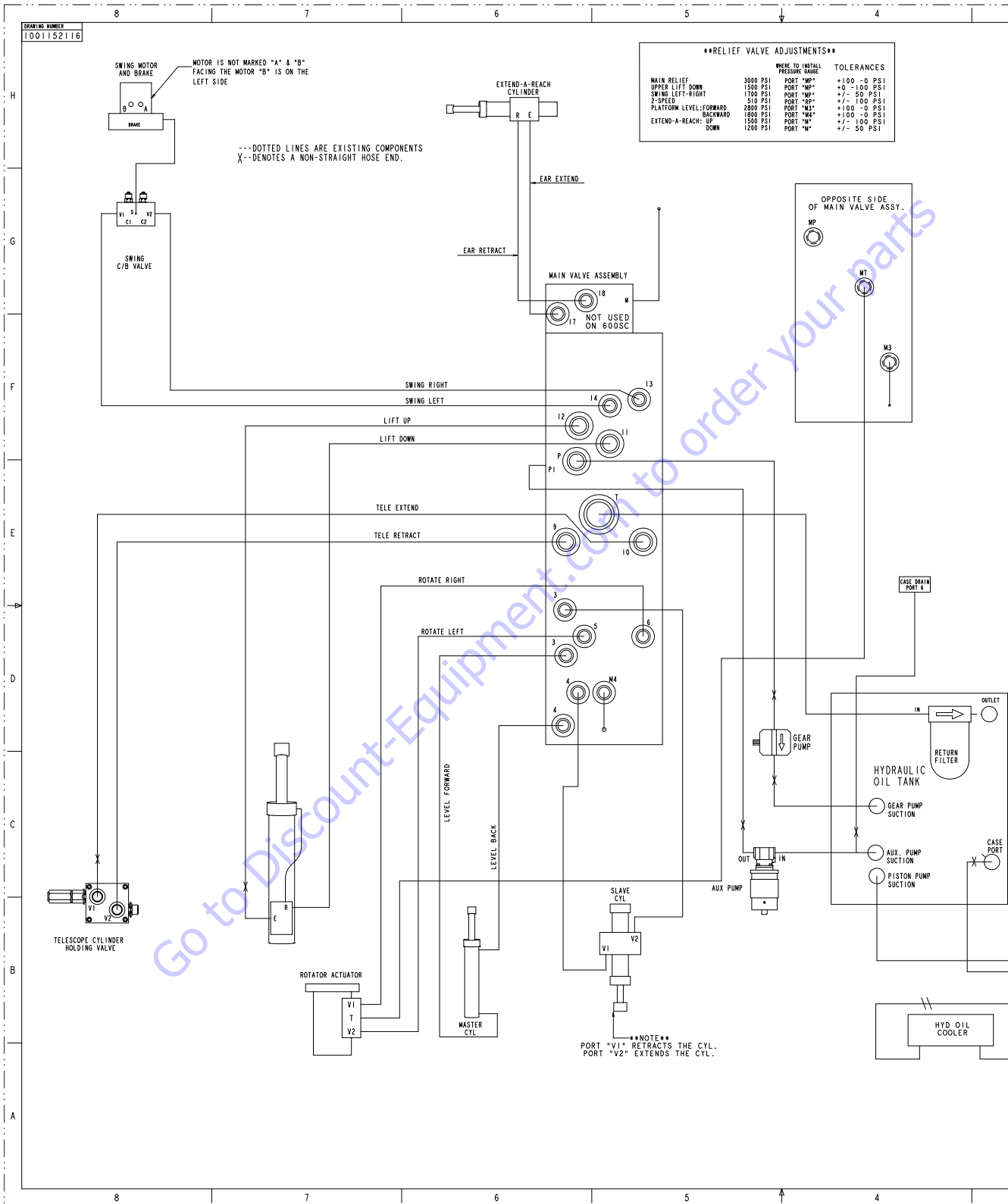

Figure 7-38. Hydraulic Port Schematic - 1 of 2

SECTION 7 - BASIC ELECTRICAL INFORMATION & SCHEMATICS

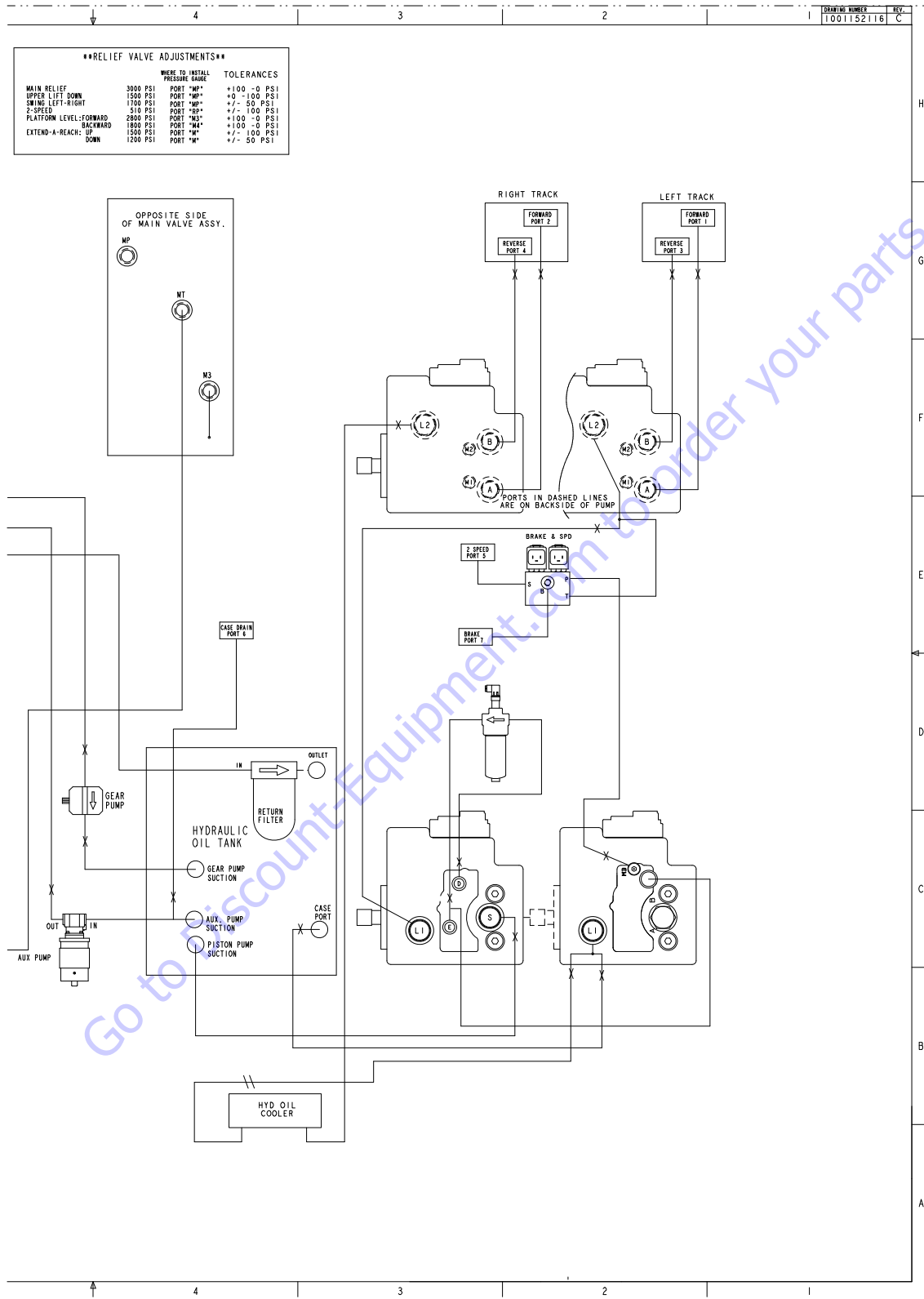

Figure 7-39. Hydraulic Port Schematic - 2 of 2

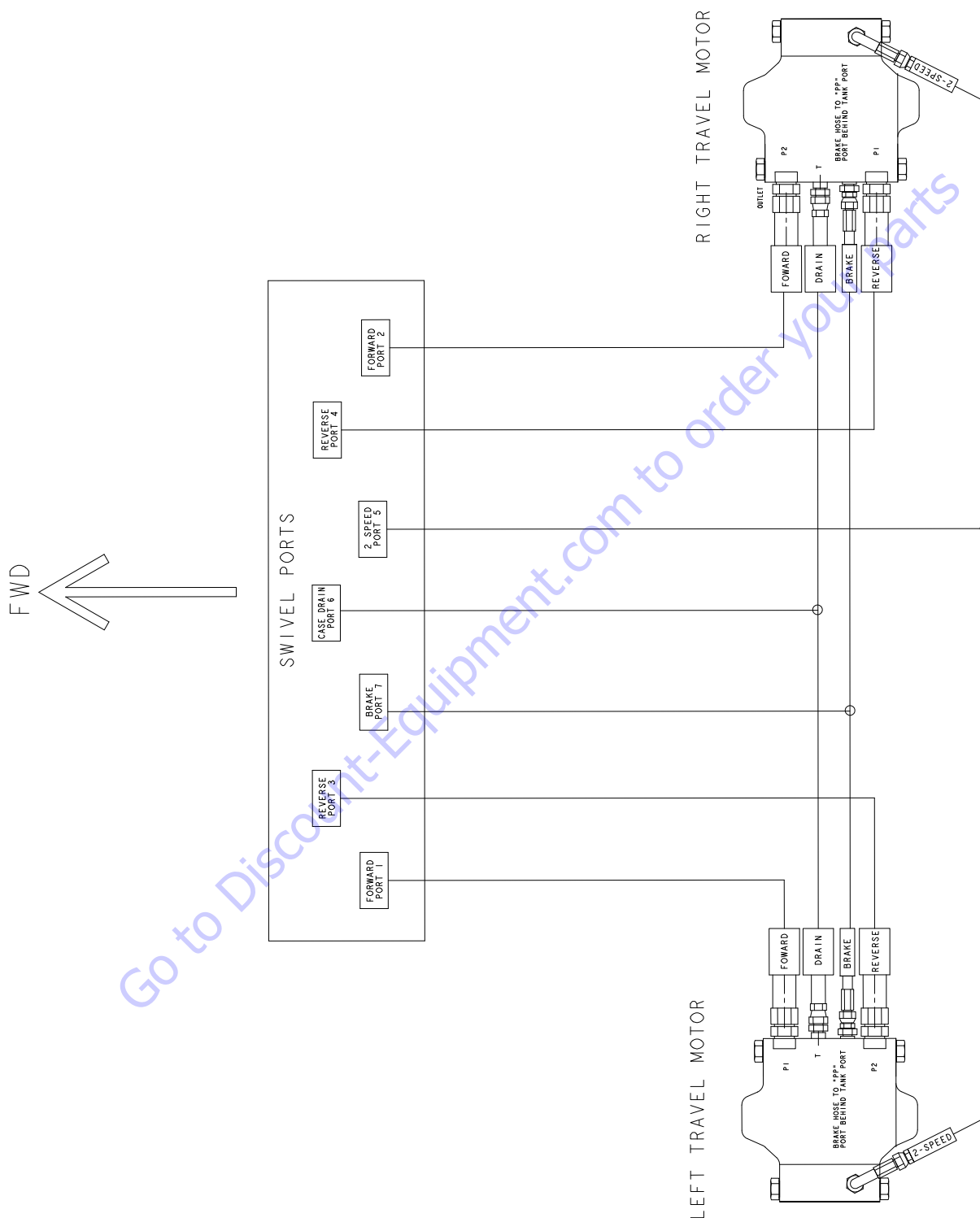

Figure 7-40. Crawler Drive Motor Hydraulic Schematic

PROPOSITION 65 WARNING

- **Battery posts, terminals and related accessories contain lead and lead compounds, chemicals known to the State of California to cause cancer and reproductive harm.**
- **Batteries also contain other chemicals known to the State of California to cause cancer.**
- **Wash hands after handling.**



WARNING:



The engine exhaust from this product contains chemicals known to the State of California to cause cancer, birth defects, or other reproductive harm.

1702961

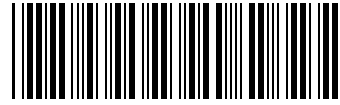

3121607



An Oshkosh Corporation Company



www.Discount-Equipment.com

Go to Discount-Equipment.com to order your parts



PARTS FINDER

**Search Website
by Part Number**



**Search Manual
Library For Parts
Manual & Lookup Part
Numbers – Purchase
or Request Quote**

Search Manuals

Enter your information to search for manuals and parts.

* Brand:

* Model:

* Serial:

* Part Number:

SEARCH

**Can't Find Part or
Manual? Request Help
by Manufacturer,
Model & Description**

Parts Order Form

Please fill in the following information:

Manufacturer:

Model:

Description:

Quantity:

Part Number:

Part Name:

Part Description:

Part Location:

Part Condition:

Part Status:

Part Color:

Part Material:

Part Weight:

Part Dimensions:

Part Price:

Part Notes:

Submit

Discount-Equipment.com is your online resource for quality parts & equipment.

Florida: **561-964-4949** Outside Florida TOLL FREE: **877-690-3101**

Need parts?

Click on this link: <http://www.discount-equipment.com/category/5443-parts/> and choose one of the options to help get the right parts and equipment you are looking for. Please have the machine model and serial number available in order to help us get you the correct parts. If you don't find the part on the website or on once of the online manuals, please fill out the request form and one of our experienced staff members will get back to you with a quote for the right part that your machine needs.

We sell worldwide for the brands: Genie, Terex, JLG, MultiQuip, Mikasa, Essick, Whiteman, Mayco, Toro Stone, Diamond Products, Generac Magnum, Airman, Haulotte, Barreto, Power Blanket, Nifty Lift, Atlas Copco, Chicago Pneumatic, Allmand, Miller Curber, Skyjack, Lull, Skytrak, Tsurumi, Husquvarna Target, , Stow, Wacker, Sakai, Mi-T- M, Sullair, Basic, Dynapac, MBW, Weber, Bartell, Bennar Newman, Haulotte, Ditch Runner, Menegotti, Morrison, Contec, Buddy, Crown, Edco, Wyco, Bomag, Laymor, Barreto, EZ Trench, Bil-Jax, F.S. Curtis, Gehl Pavers, Heli, Honda, ICS/PowerGrit, IHI, Partner, Imer, Clipper, MMD, Koshin, Rice, CH&E, General Equipment, ,AMida, Coleman, NAC, Gradall, Square Shooter, Kent, Stanley, Tamco, Toku, Hatz, Kohler, Robin, Wisconsin, Northrock, Oztec, Toker TK, Rol-Air, Small Line, Wanco, Yanmar