



An Oshkosh Corporation Company



www.Discount-Equipment.com

Operation and Safety Manual

Original Instructions - Keep this manual with the machine at all times.

Boom Lift Models

600SC

660SJC

S/N 74785 to Present



3121156
May 4, 2012

TO PURCHASE THIS PRODUCT PLEASE CONTACT US



**Equipment Financing and
Extended Warranties Available**



**Discount-Equipment.com is your online resource for
commercial and industrial quality parts and equipment sales.**

561-964-4949

visit us on line @ www.discount-equipment.com

Select an option below to find your Equipment

Search by Manufacturer

Search by Product Type

Request a Quote

We sell worldwide for the brands: Genie, Terex, JLG, MultiQuip, Mikasa, Essick, Whiteman, Mayco, Toro Stone, Diamond Products, Generac Magnum, Airman, Haulotte, Barreto, Power Blanket, Nifty Lift, Atlas Copco, Chicago Pneumatic, Allmand, Miller Curber, Skyjack, Lull, Skytrak, Tsurumi, Husquvarna Target, Stow, Wacker, Sakai, Mi-T-M, Sullair, Basic, Dynapac, MBW, Weber, Bartell, Bennar Newman, Haulotte, Ditch Runner, Menegotti, Morrison, Contec, Buddy, Crown, Edco, Wyco, Bomag, Laymor, EZ Trench, Bil-Jax, F.S. Curtis, Gehl Pavers, Heli, Honda, ICS/PowerGrit, IHI, Partner, Imer, Clipper, MMD, Koshin, Rice, CH&E, General Equipment, Amida, Coleman, NAC, Gradall, Square Shooter, Kent, Stanley, Tamco, Toku, Hatz, Kohler, Robin, Wisconsin, Northrock, Oztec, Toker TK, Rol-Air, APT, Wylie, Ingersoll Rand / Doosan, Innovatech, Con X, Ammann, Mecalac, Makinex, Smith Surface Prep, Small Line, Wanco, Yanmar

FOREWORD

This manual is a very important tool! Keep it with the machine at all times.

The purpose of this manual is to provide owners, users, operators, lessors, and lessees with the precautions and operating procedures essential for the safe and proper machine operation for its intended purpose.

Due to continuous product improvements, JLG Industries, Inc. reserves the right to make specification changes without prior notification. Contact JLG Industries, Inc. for updated information.

SAFETY ALERT SYMBOLS AND SAFETY SIGNAL WORDS



This is the Safety Alert Symbol. It is used to alert you to the potential personal injury hazards. Obey all safety messages that follow this symbol to avoid possible injury or death

DANGER

INDICATES AN IMMINENTLY HAZARDOUS SITUATION. IF NOT AVOIDED, WILL RESULT IN SERIOUS INJURY OR DEATH. THIS DECAL WILL HAVE A RED BACKGROUND.

WARNING

INDICATES A POTENTIALLY HAZARDOUS SITUATION. IF NOT AVOIDED, COULD RESULT IN SERIOUS INJURY OR DEATH. THIS DECAL WILL HAVE AN ORANGE BACKGROUND.

CAUTION

INDICATES A POTENTIALLY HAZARDOUS SITUATION. IF NOT AVOIDED, MAY RESULT IN MINOR OR MODERATE INJURY. IT MAY ALSO ALERT AGAINST UNSAFE PRACTICES. THIS DECAL WILL HAVE A YELLOW BACKGROUND.

NOTICE

INDICATES INFORMATION OR A COMPANY POLICY THAT RELATES DIRECTLY OR INDIRECTLY TO THE SAFETY OF PERSONNEL OR PROTECTION OF PROPERTY.

⚠ WARNING

THIS PRODUCT MUST COMPLY WITH ALL SAFETY RELATED BULLETINS. CONTACT JLG INDUSTRIES, INC. OR THE LOCAL AUTHORIZED JLG REPRESENTATIVE FOR INFORMATION REGARDING SAFETY-RELATED BULLETINS WHICH MAY HAVE BEEN ISSUED FOR THIS PRODUCT.

NOTICE

JLG INDUSTRIES, INC. SENDS SAFETY RELATED BULLETINS TO THE OWNER OF RECORD OF THIS MACHINE. CONTACT JLG INDUSTRIES, INC. TO ENSURE THAT THE CURRENT OWNER RECORDS ARE UPDATED AND ACCURATE.

NOTICE

JLG INDUSTRIES, INC. MUST BE NOTIFIED IMMEDIATELY IN ALL INSTANCES WHERE JLG PRODUCTS HAVE BEEN INVOLVED IN AN ACCIDENT INVOLVING BODILY INJURY OR DEATH OF PERSONNEL OR WHEN SUBSTANTIAL DAMAGE HAS OCCURRED TO PERSONAL PROPERTY OR THE JLG PRODUCT.

For:

- Accident Reporting
- Product Safety Publications
- Current Owner Updates
- Questions Regarding Product Safety
- Standards and Regulations Compliance Information
- Questions Regarding Special Product Applications
- Questions Regarding Product Modifications

Contact:

Product Safety and Reliability Department
JLG Industries, Inc.
13224 Fountainhead Plaza
Hagerstown, MD 21742
USA

or Your Local JLG Office
(See addresses on inside of manual cover)

In USA:

Toll Free: 877-JLG-SAFE (877-554-7233)

Outside USA:

Phone: 240-420-2661
Fax: 301-745-3713
E-mail: ProductSafety@JLG.com

REVISION LOG

Original Issue	- October 28, 2003
Revised	- May 4, 2005
Revised	- July 18, 2006
Revised	- September 13, 2006
Revised	- July 30, 2009
Revised	- August 19, 2009
Revised	- December 1, 2009
Revised	- April 3, 2012
Revised	- May 4, 2012

To order go to Discount-Equipment.com

SECTION - PARAGRAPH, SUBJECT	PAGE	SECTION - PARAGRAPH, SUBJECT	PAGE
SECTION - 1 - SAFETY PRECAUTIONS		General	2-12
1.1	GENERAL 1-1	SECTION - 3 - MACHINE CONTROLS AND INDICATORS	
1.2	PRE-OPERATION 1-1	3.1	GENERAL 3-1
	Operator Training and Knowledge 1-1	3.2	CONTROLS AND INDICATORS 3-1
	Workplace Inspection 1-2		Ground Control Station 3-1
	Machine Inspection 1-2		Ground Control Indicator Panel 3-6
1.3	OPERATION 1-3		Platform Control Station 3-9
	General 1-3		Platform Control Indicator Panel 3-16
	Trip and Fall Hazards 1-3	SECTION - 4 - MACHINE OPERATION	
	Electrocution Hazards 1-4	4.1	DESCRIPTION 4-1
	Tipping Hazards 1-6	4.2	ENGINE OPERATION 4-2
	Crushing and Collision Hazards 1-7		Starting Procedure 4-2
1.4	TOWING, LIFTING, AND HAULING 1-8		Shutdown Procedure 4-3
1.5	ADDITIONAL HAZARDS / SAFETY 1-9	4.3	TRAVELING (DRIVING) 4-3
			Traveling Forward or Reverse 4-6
			Stability 4-8
SECTION - 2 - USER RESPONSIBILITIES, MACHINE PREPARATION, AND INSPECTION		4.4	STEERING 4-10
2.1	PERSONNEL TRAINING 2-1	4.5	PARKING AND STOWING 4-10
	Operator Training 2-1	4.6	PLATFORM 4-10
	Training Supervision 2-1		Platform Level Adjustment 4-10
	Operator Responsibility 2-1		Platform Rotation 4-10
2.2	PREPARATION, INSPECTION, AND MAINTENANCE 2-2	4.7	BOOM 4-11
	Pre-Start Inspection 2-4		Swinging the Boom 4-11
	Daily Functional Check 2-5		

TABLE OF CONTENTS

SECTION - PARAGRAPH, SUBJECT	PAGE
Raising and Lowering the Main Boom	4-11
Telescoping the Main Boom	4-12
4.8 SHUT DOWN AND PARK	4-12
4.9 TIE DOWN AND LIFTING.	4-12
Tie Down	4-12
Lifting	4-12
4.10 AUXILIARY POWER.	4-13
4.11 HYDRAULIC TOOL CIRCUIT INSTRUCTIONS (OPTIONAL).	4-16
Tool Circuit.	4-16
4.12 PLACARDS AND DECALS.	4-18

SECTION - 5 - EMERGENCY PROCEDURES

5.1 GENERAL	5-1
5.2 INCIDENT NOTIFICATION.	5-1
5.3 EMERGENCY OPERATION.	5-2
Operator Unable to Control Machine	5-2
Platform or Boom Caught Overhead.	5-2

SECTION - 6 - GENERAL SPECIFICATIONS & OPERATOR MAINTENANCE

6.1 INTRODUCTION	6-1
6.2 OPERATING SPECIFICATIONS	6-1
Capacities	6-3
Engine Data	6-3

SECTION - PARAGRAPH, SUBJECT	PAGE
Hydraulic Oil	6-4
Major Component Weights.	6-7
Serial Number Locations	6-8
6.3 OPERATOR MAINTENANCE	6-14
6.4 SUPPLEMENTAL INFORMATION	6-19

SECTION - 7 - INSPECTION AND REPAIR LOG

SECTION - PARAGRAPH, SUBJECT	PAGE	SECTION - PARAGRAPH, SUBJECT	PAGE
LIST OF FIGURES			
2-1. Drive Function Operating Range Diagrams - Sheet 1 of 3	2-8	4-3. Position of Least Backward Stability	4-8
2-2. Drive Function Operating Range Diagrams - Sheet 2 of 3	2-9	4-4. Position of Least Forward Stability	4-9
2-3. Drive Function Operating Range Diagrams - Sheet 3 of 3	2-10	4-5. Machine Tie Down	4-14
2-4. Daily Walk-Around Inspection Diagram	2-11	4-6. Lifting Chart	4-15
2-5. Daily Walkaround Inspection Points - Sheet 1 of 3	2-12	4-7. Decal Installation - Sheet 1 of 10	4-19
2-6. Daily Walkaround Inspection Points - Sheet 2 of 3	2-13	4-8. Decal Installation - Sheet 2 of 10	4-20
2-7. Daily Walkaround Inspection Points - Sheet 3 of 3	2-14	4-9. Decal Installation - Sheet 3 of 10	4-21
3-1. Ground Control Station - 600SC	3-2	4-10. Decal Installation - Sheet 4 of 10	4-22
3-2. Ground Control Station - 660SJC	3-3	4-11. Decal Installation - Sheet 5 of 10	4-23
3-3. Ground Control Indicator Panel - Sheet 1 of 2	3-7	4-12. Decal Installation - Sheet 6 of 10	4-24
3-4. Ground Control Indicator Panel - Sheet 2 of 2	3-8	4-13. Decal Installation - Sheet 7 of 10	4-25
3-5. Platform Control Console	3-11	4-14. Decal Installation - Sheet 8 of 10	4-26
3-6. Platform Control Console w/Drive Orientation	3-12	4-15. Decal Installation - Sheet 9 of 10	4-27
3-7. Platform Control Indicator Panel	3-17	4-16. Decal Installation - Sheet 10 of 10	4-28
3-8. Platform Control Indicator Panel w/Drive Orientation	3-17	6-1. Serial Number Locations	6-8
4-1. Grades and Sideslopes	4-4	6-2. Engine Operating Temperature Specifications - Deutz - Sheet 1 of 2	6-9
4-2. Machine Motion Hazard	4-5	6-3. Engine Operating Temperature Specifications - Deutz - Sheet 2 of 2	6-10
		6-4. Engine Operating Temperature Specifications - Caterpillar - Sheet 1 of 2	6-11
		6-5. Engine Operating Temperature Specifications - Caterpillar - Sheet 2 of 2	6-12
		6-6. Operator Maintenance and Lubrication Diagram	6-13

TABLE OF CONTENTS

SECTION - PARAGRAPH, SUBJECT	PAGE	SECTION - PARAGRAPH, SUBJECT	PAGE
LIST OF TABLES			
1-1	Minimum Approach Distances (M.A.D.)	7-1	Inspection and Repair Log
1-2	Beaufort Scale (For Reference Only)		7-1
2-1	Inspection and Maintenance Table		
4-1	600SC Decal Legend - Prior to S/N 0300148842 .		
4-2	600SC Decal Legend - S/N 0300148842 to Present.		
4-3	660SJC Decal Legend - Prior to S/N 0300148842		
4-4	660SJC Decal Legend - S/N 0300148842 to Present.		
6-1	Operating Specifications - Prior to S/N 0300148842		
6-2	Operating Specifications - S/N 0300148842 to Present.		
6-3	Capacities		
6-4	Deutz F4M1011F/F4M2011 Specifications		
6-5	Caterpillar 3044C/3.4.		
6-6	Hydraulic Oil		
6-7	Mobilfluid 424 Specs		
6-8	Mobil DTE 13M Specs		
6-9	Exxon Unis HVI 26 Specs		
6-10	Quintolubric 888-46		
6-11	Major Component Weights		
6-12	Lubrication Specifications		

TO PURCHASE THIS PRODUCT PLEASE CONTACT US



**Equipment Financing and
Extended Warranties Available**



**Discount-Equipment.com is your online resource for
commercial and industrial quality parts and equipment sales.**

561-964-4949

visit us on line @ www.discount-equipment.com

Select an option below to find your Equipment

Search by Manufacturer

Search by Product Type

Request a Quote

We sell worldwide for the brands: Genie, Terex, JLG, MultiQuip, Mikasa, Essick, Whiteman, Mayco, Toro Stone, Diamond Products, Generac Magnum, Airman, Haulotte, Barreto, Power Blanket, Nifty Lift, Atlas Copco, Chicago Pneumatic, Allmand, Miller Curber, Skyjack, Lull, Skytrak, Tsurumi, Husquvarna Target, Stow, Wacker, Sakai, Mi-T-M, Sullair, Basic, Dynapac, MBW, Weber, Bartell, Bennar Newman, Haulotte, Ditch Runner, Menegotti, Morrison, Contec, Buddy, Crown, Edco, Wyco, Bomag, Laymor, EZ Trench, Bil-Jax, F.S. Curtis, Gehl Pavers, Heli, Honda, ICS/PowerGrit, IHI, Partner, Imer, Clipper, MMD, Koshin, Rice, CH&E, General Equipment, Amida, Coleman, NAC, Gradall, Square Shooter, Kent, Stanley, Tamco, Toku, Hatz, Kohler, Robin, Wisconsin, Northrock, Oztec, Toker TK, Rol-Air, APT, Wylie, Ingersoll Rand / Doosan, Innovatech, Con X, Ammann, Mecalac, Makinex, Smith Surface Prep, Small Line, Wanco, Yanmar

SECTION 1. SAFETY PRECAUTIONS

1.1 GENERAL

This section outlines the necessary precautions for proper and safe machine operation and maintenance. For proper machine use, it is mandatory that a daily routine is established based on the content of this manual. A maintenance program, using the information provided in this manual and the Service and Maintenance Manual, must also be established by a qualified person and followed to ensure the machine is safe to operate.

The owner/user/operator/lessor/lessee of the machine should not operate the machine until this manual has been read, training is accomplished, and operation of the machine has been completed under the supervision of an experienced and qualified operator.

If there are any questions with regard to safety, training, inspection, maintenance, application, and operation, please contact JLG Industries, Inc. (“JLG”).

⚠ WARNING

FAILURE TO COMPLY WITH THE SAFETY PRECAUTIONS LISTED IN THIS MANUAL COULD RESULT IN MACHINE DAMAGE, PROPERTY DAMAGE, PERSONAL INJURY OR DEATH.

1.2 PRE-OPERATION

Operator Training and Knowledge

- Read and understand this manual before operating the machine.

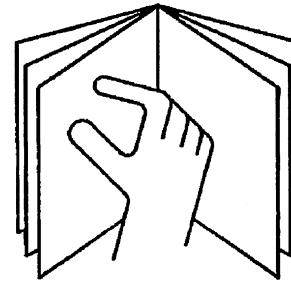

- Do not operate this machine until complete training is performed by authorized persons.
- Only authorized and qualified personnel can operate the machine.

SECTION 1 - SAFETY PRECAUTIONS

- Read, understand, and obey all DANGERS, WARNINGS, CAUTIONS, and operating instructions on the machine and in this manual.
- Use the machine in a manner which is within the scope of its intended application set by JLG.
- All operating personnel must be familiar with the emergency controls and emergency operation of the machine as specified in this manual.
- Read, understand, and obey all applicable employer, local, and governmental regulations as they pertain to operation of the machine.

Workplace Inspection

- The operator is to take safety measures to avoid all hazards in the work area prior to machine operation.
- Do not operate or raise the platform while on trucks, trailers, railway cars, floating vessels, scaffolds or other equipment unless approved in writing by JLG.
- Do not operate the machine in hazardous environments unless approved for that purpose by JLG.
- Be sure that the ground conditions are able to support the maximum load shown on the decals located on the machine.

Machine Inspection

- Before machine operation, perform inspections and functional checks. Refer to Section 2 of this manual for detailed instructions.
- Do not operate this machine until it has been serviced and maintained according to requirements specified in the Service and Maintenance Manual.
- Be sure the footswitch and all other safety devices are operating properly. Modification of these devices is a safety violation.

WARNING

MODIFICATION OR ALTERATION OF AN AERIAL WORK PLATFORM SHALL BE MADE ONLY WITH WRITTEN PERMISSION FROM THE MANUFACTURER

- Do not operate any machine on which safety or instruction placards or decals are missing or illegible.
- Avoid any buildup of debris on the platform floor. Keep mud, oil, grease, and other slippery substances from footwear and platform floor.

1.3 OPERATION

General

- Do not use the machine for any purpose other than positioning personnel, their tools, and equipment.
- Never operate a machine that is not working properly. If a malfunction occurs, shut down the machine.
- Never slam a control switch or lever through neutral to an opposite direction. Always return switch to neutral and stop before moving the switch to the next function. Operate controls with slow and even pressure.
- Hydraulic cylinders should never be left fully extended or fully retracted before shutdown or for long periods of time.
- Do not allow personnel to tamper with or operate the machine from the ground with personnel in the platform, except in an emergency.
- Do not carry materials directly on platform railing. Contact JLG for approved material handling accessories.
- When two or more persons are in the platform, the operator shall be responsible for all machine operations.
- Always ensure that power tools are properly stowed and never left hanging by their cord from the platform work area.

- Supplies or tools which extend outside the platform are prohibited unless approved by JLG.
- When driving, always position boom over rear axle in line with the direction of travel. Remember, if boom is over the front axle, steer and drive functions will be reversed.
- Do not assist a stuck or disabled machine by pushing, pulling, or by using boom functions. Only pull the unit from the tie-down lugs on the chassis.
- Do not place boom or platform against any structure to steady the platform or to support the structure.
- Stow boom and shut off all power before leaving machine.

Trip and Fall Hazards

During operation, occupants in the platform must wear a full body harness with a lanyard attached to an authorized lanyard anchorage point. Attach only one (1) lanyard per lanyard anchorage point.

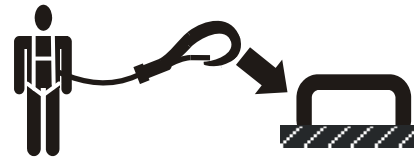

SECTION 1 - SAFETY PRECAUTIONS

- Before operating the machine, make sure all gates are closed and fastened in their proper position.

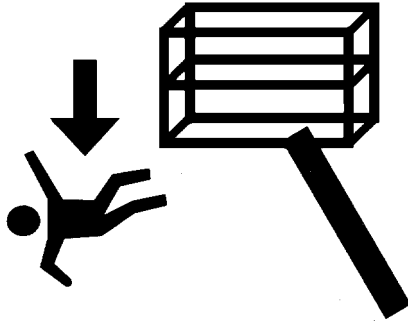

- Keep both feet firmly positioned on the platform floor at all times. Never use ladders, boxes, steps, planks, or similar items on platform to provide additional reach.
- Never use the boom assembly to enter or leave the platform.

- Use extreme caution when entering or leaving platform. Be sure that the boom is fully lowered. It may be necessary to telescope out to position the platform closer to the ground for entry/exit. Face the machine, maintain “three point contact” with the machine, using two hands and one foot or two feet and one hand during entry and exit.

Electrocution Hazards

- This machine is not insulated and does not provide protection from contact or proximity to electrical current.

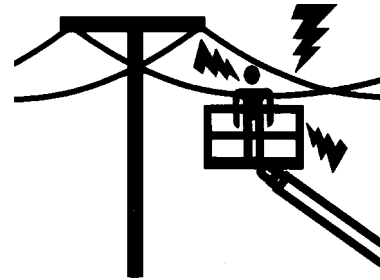

SECTION 1 - SAFETY PRECAUTIONS

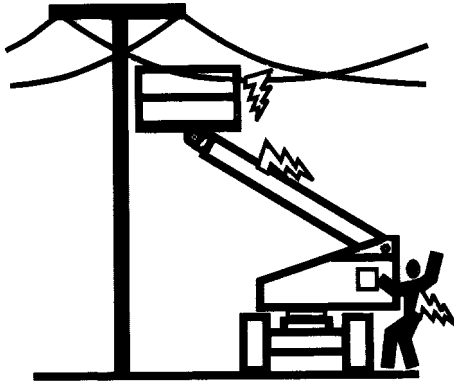

- Maintain distance from electrical lines, apparatus, or any energized (exposed or insulated) parts according to the Minimum Approach Distance (MAD) as shown in Table 1-1.
- Allow for machine movement and electrical line swaying.

Table 1-1. Minimum Approach Distances (M.A.D.)

Voltage Range (Phase to Phase)	MINIMUM APPROACH DISTANCE in Feet (Meters)
0 to 50 KV	10 (3)
Over 50KV to 200 KV	15 (5)
Over 200 KV to 350 KV	20 (6)
Over 350 KV to 500 KV	25 (8)
Over 500 KV to 750 KV	35 (11)
Over 750 KV to 1000 KV	45 (14)

NOTE: *This requirement shall apply except where employer, local or governmental regulations are more stringent.*

- Maintain a clearance of at least 10 ft. (3m) between any part of the machine and its occupants, their tools, and their equipment from any electrical line or apparatus carrying up to 50,000 volts. One foot additional clearance is required for every additional 30,000 volts or less.

SECTION 1 - SAFETY PRECAUTIONS

- The minimum approach distance may be reduced if insulating barriers are installed to prevent contact, and the barriers are rated for the voltage of the line being guarded. These barriers shall not be part of (or attached to) the machine. The minimum approach distance shall be reduced to a distance within the designed working dimensions of the insulating barrier. This determination shall be made by a qualified person in accordance with the employer, local, or governmental requirements for work practices near energized equipment

⚠ DANGER

DO NOT MANEUVER MACHINE OR PERSONNEL INSIDE PROHIBITED ZONE (MAD). ASSUME ALL ELECTRICAL PARTS AND WIRING ARE ENERGIZED UNLESS KNOWN OTHERWISE.

Tipping Hazards

- The user should be familiar with the surface before driving. Do not exceed the allowable sideslope and grade while driving.

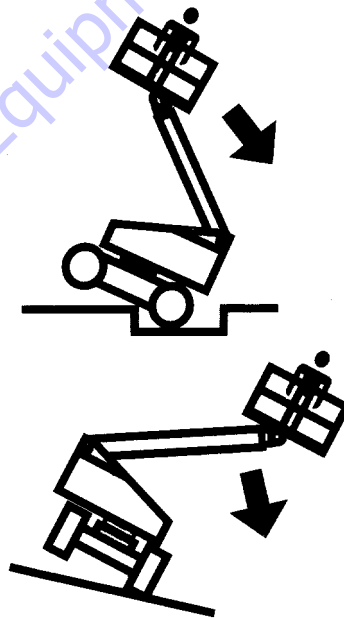

- Do not elevate platform or drive with platform elevated while on a sloping, uneven, or soft surface.
- Before driving on floors, bridges, trucks, and other surfaces, check allowable capacity of the surfaces.
- Never exceed the maximum platform capacity. Distribute loads evenly on platform floor.
- Do not raise the platform or drive from an elevated position unless the machine is on firm, level and smooth surfaces.
- Keep the chassis of the machine at least 2 ft. (0.6m) from holes, bumps, drop-offs, obstructions, debris, concealed holes, and other potential hazards on the floor/surface.
- Do not push or pull any object with the boom.
- Never attempt to use the machine as a crane. Do not tie-off machine to any adjacent structure.
- Do not operate the machine when wind conditions exceed 28 mph (12.5 m/s). Refer to Table 1-2, Beaufort Scale (For Reference Only).
- Do not increase the surface area of the platform or the load. Increase of the area exposed to the wind will decrease stability.
- Do not increase the platform size with unauthorized deck extensions or attachments.

- If boom assembly or platform is in a position that one or more wheels are off the ground, all persons must be removed before attempting to stabilize the machine. Use cranes, forklift trucks, or other appropriate equipment to stabilize machine.

Crushing and Collision Hazards

- Approved head gear must be worn by all operating and ground personnel.
- Check work area for clearances overhead, on sides, and bottom of platform when lifting or lowering platform, and driving.

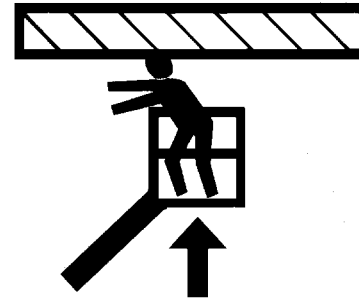

- During operation, keep all body parts inside platform railing.

SECTION 1 - SAFETY PRECAUTIONS

- Use the boom functions, not the drive function, to position the platform close to obstacles.
- Always post a lookout when driving in areas where vision is obstructed.
- Keep non-operating personnel at least 6 ft. (1.8m) away from machine during all driving and swing operations.
- Limit travel speed according to conditions of ground surface, congestion, visibility, slope, location of personnel, and other factors which may cause collision or injury to personnel.
- Be aware of stopping distances in all drive speeds. When driving in high speed, switch to low speed before stopping. Travel grades in low speed only.
- Do not use high speed drive in restricted or close quarters or when driving in reverse.
- Exercise extreme caution at all times to prevent obstacles from striking or interfering with operating controls and persons in the platform.
- Be sure that operators of other overhead and floor level machines are aware of the aerial work platform's presence. Disconnect power to overhead cranes.
- Warn personnel not to work, stand, or walk under a raised boom or platform. Position barricades on floor if necessary.

1.4 TOWING, LIFTING, AND HAULING

- Never allow personnel in platform while towing, lifting, or hauling.
- This machine should not be towed, except in the event of emergency, malfunction, power failure, or loading/unloading. Refer to the Emergency Procedures section of this manual for emergency towing procedures.
- Ensure boom is in the stowed position and the turntable locked prior to towing, lifting or hauling. The platform must be completely empty of tools.
- When lifting machine, lift only at designated areas of the machine. Lift the unit with equipment of adequate capacity.
- Refer to the Machine Operation section of this manual for lifting information.

1.5 ADDITIONAL HAZARDS / SAFETY

- Do not use machine as a ground for welding.
- When performing welding or metal cutting operations, precautions must be taken to protect the chassis from direct exposure to weld and metal cutting spatter.
- Do not refuel the machine with the engine running.
- Battery fluid is highly corrosive. Avoid contact with skin and clothing at all times.
- Charge batteries only in a well ventilated area.

SECTION 1 - SAFETY PRECAUTIONS

NOTICE

DO NOT OPERATE THE MACHINE WHEN WIND CONDITIONS EXCEED 28 MPH (12.5 M/S).

Table 1-2. Beaufort Scale (For Reference Only)

Beaufort Number	Wind Speed		Description	Land Conditions
	mph	m/s		
0	0	0-0.2	Calm	Calm. Smoke rises vertically
1	1-3	0.3-1.5	Light air	Wind motion visible in smoke
2	4-7	1.6-3.3	Light breeze	Wind felt on exposed skin. Leaves rustle
3	8-12	3.4-5.4	Gentle breeze	Leaves and smaller twigs in constant motion
4	13-18	5.5-7.9	Moderate breeze	Dust and loose paper raised. Small branches begin to move.
5	19-24	8.0-10.7	Fresh breeze	Smaller trees sway.
6	25-31	10.8-13.8	Strong breeze	Large branches in motion. Whistling heard in overhead wires. Umbrella use becomes difficult.
7	32-38	13.9-17.1	Near Gale/Moderate Gale	Whole trees in motion. Effort needed to walk against the wind.
8	39-46	17.2-20.7	Fresh Gale	Twigs broken from trees. Cars veer on road.
9	47-54	20.8-24.4	Strong Gale	Light structure damage.

TO PURCHASE THIS PRODUCT PLEASE CONTACT US



**Equipment Financing and
Extended Warranties Available**



**Discount-Equipment.com is your online resource for
commercial and industrial quality parts and equipment sales.**

561-964-4949

visit us on line @ www.discount-equipment.com

Select an option below to find your Equipment

Search by Manufacturer

Search by Product Type

Request a Quote

We sell worldwide for the brands: Genie, Terex, JLG, MultiQuip, Mikasa, Essick, Whiteman, Mayco, Toro Stone, Diamond Products, Generac Magnum, Airman, Haulotte, Barreto, Power Blanket, Nifty Lift, Atlas Copco, Chicago Pneumatic, Allmand, Miller Curber, Skyjack, Lull, Skytrak, Tsurumi, Husquvarna Target, Stow, Wacker, Sakai, Mi-T-M, Sullair, Basic, Dynapac, MBW, Weber, Bartell, Bennar Newman, Haulotte, Ditch Runner, Menegotti, Morrison, Contec, Buddy, Crown, Edco, Wyco, Bomag, Laymor, EZ Trench, Bil-Jax, F.S. Curtis, Gehl Pavers, Heli, Honda, ICS/PowerGrit, IHI, Partner, Imer, Clipper, MMD, Koshin, Rice, CH&E, General Equipment, Amida, Coleman, NAC, Gradall, Square Shooter, Kent, Stanley, Tamco, Toku, Hatz, Kohler, Robin, Wisconsin, Northrock, Oztec, Toker TK, Rol-Air, APT, Wylie, Ingersoll Rand / Doosan, Innovatech, Con X, Ammann, Mecalac, Makinex, Smith Surface Prep, Small Line, Wanco, Yanmar

SECTION 2. USER RESPONSIBILITIES, MACHINE PREPARATION, AND INSPECTION

2.1 PERSONNEL TRAINING

The aerial platform is a personnel handling device; so it is necessary that it be operated and maintained only by trained personnel.

Persons under the influence of drugs or alcohol or who are subject to seizures, dizziness or loss of physical control must not operate this machine.

Operator Training

Operator training must cover:

1. Use and limitations of the controls in the platform and at the ground, emergency controls and safety systems.
2. Control labels, instructions, and warnings on the machine.
3. Rules of the employer and government regulations.
4. Use of approved fall protection device.
5. Enough knowledge of the mechanical operation of the machine to recognize a malfunction or potential malfunction.

6. The safest means to operate the machine where overhead obstructions, other moving equipment, and obstacles, depressions, holes, drop-offs.
7. Means to avoid the hazards of unprotected electrical conductors.
8. Specific job requirements or machine application.

Training Supervision

Training must be done under the supervision of a qualified person in an open area free of obstructions until the trainee has developed the ability to safely control and operate the machine.

Operator Responsibility

The operator must be instructed that he/she has the responsibility and authority to shut down the machine in case of a malfunction or other unsafe condition of either the machine or the job site.

2.2 PREPARATION, INSPECTION, AND MAINTENANCE

The following table covers the periodic machine inspections and maintenance required by JLG Industries, Inc. Consult local regulations for further requirements for aerial work platforms. The frequency of inspections and maintenance must be increased as necessary when the machine is used in a harsh or hostile environment, if the machine is used with increased frequency, or if the machine is used in a severe manner.

NOTICE

JLG INDUSTRIES, INC. RECOGNIZES A FACTORY-TRAINED SERVICE TECHNICIAN AS A PERSON WHO HAS SUCCESSFULLY COMPLETED THE JLG SERVICE TRAINING SCHOOL FOR THE SPECIFIC JLG PRODUCT MODEL.

SECTION 2 - USER RESPONSIBILITIES, MACHINE PREPARATION, AND INSPECTION

Table 2-1. Inspection and Maintenance Table

Type	Frequency	Primary Responsibility	Service Qualification	Reference
Pre-Start Inspection	Before using each day; or whenever there's an Operator change.	User or Operator	User or Operator	Operator and Safety Manual
Pre-Delivery Inspection (See Note)	Before each sale, lease, or rental delivery.	Owner, Dealer, or User	Qualified JLG Mechanic	Service and Maintenance Manual and applicable JLG inspection form
Frequent Inspection (See Note)	In service for 3 months or 150 hours, whichever comes first; or Out of service for a period of more than 3 months; or Purchased used.	Owner, Dealer, or User	Qualified JLG Mechanic	Service and Maintenance Manual and applicable JLG inspection form
Annual Machine Inspection (See Note)	Annually, no later than 13 months from the date of prior inspection.	Owner, Dealer, or User	Factory-Trained Service Technician (Recommended)	Service and Maintenance Manual and applicable JLG inspection form
Preventative Maintenance	At intervals as specified in the Service and Maintenance Manual.	Owner, Dealer, or User	Qualified JLG Mechanic	Service and Maintenance Manual
NOTE: Inspection forms are available from JLG. Use the Service and Maintenance Manual to perform inspections.				

Pre-Start Inspection

The Pre-Start Inspection should include each of the following:

1. **Cleanliness** – Check all surfaces for leakage (oil, fuel, or battery fluid) or foreign objects. Report any leakage to the proper maintenance personnel.
2. **Structure** - Inspect the machine structure for dents, damage, weld or parent metal cracks or other discrepancies.

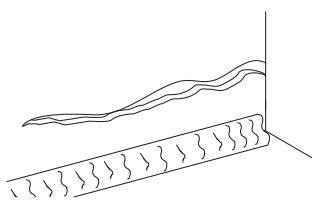

Parent Metal Crack

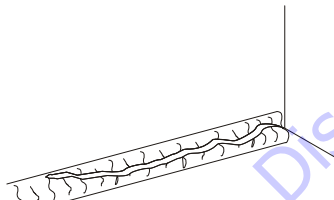

Weld Crack

3. **Decals and Placards** – Check all for cleanliness and legibility. Make sure none of the decals and placards are missing. Make sure all illegible decals and placards are cleaned or replaced.
4. **Operators and Safety Manuals** – Make sure a copy of the Operator and Safety Manual, AEM Safety Manual (Domestic only), and ANSI Manual of Responsibilities

(Domestic only) is enclosed in the weather resistant storage container.

5. **“Walk-Around” Inspection** – Refer to Figure 2-4., Figure 2-6. and Figure 2-7.
6. **Battery** – Charge as required.
7. **Fuel** (Combustion Engine Powered Machines) – Add the proper fuel as necessary.
8. **Engine Oil Supply** - Ensure the engine oil level is at the Full mark on the dipstick and the filler cap is secure.
9. **Hydraulic Oil** – Check the hydraulic oil level. Ensure hydraulic oil is added as required.
10. **Accessories/Attachments** - Reference the Operator and Safety Manual of each attachment or accessory installed upon the machine for specific inspection, operation, and maintenance instructions.
11. **Function Check** – Once the “Walk-Around” Inspection is complete, perform a functional check of all systems in an area free of overhead and ground level obstructions. Refer to Section 4 for more specific operating instructions.

WARNING

IF THE MACHINE DOES NOT OPERATE PROPERLY, TURN OFF THE MACHINE IMMEDIATELY! REPORT THE PROBLEM TO THE PROPER MAINTENANCE PERSONNEL. DO NOT OPERATE THE MACHINE UNTIL IT IS DECLARED SAFE FOR OPERATION.

Daily Functional Check

A functional check of all systems should be performed, once the walk-around inspection is complete, in an area free of overhead and ground level obstructions. First, using the ground controls, check all functions controlled by the ground controls. Next, using the platform controls, check all functions controlled by the platform controls.

WARNING

TO AVOID SERIOUS INJURY, DO NOT OPERATE MACHINE IF ANY CONTROL LEVERS OR TOGGLE SWITCHES CONTROLLING PLATFORM MOVEMENTS DO NOT RETURN TO THE OFF OR NEUTRAL POSITION WHEN RELEASED.

TO AVOID COLLISION AND INJURY IF PLATFORM DOES NOT STOP WHEN A CONTROL SWITCH OR LEVER IS RELEASED, REMOVE FOOT FROM FOOTSWITCH OR USE EMERGENCY STOP TO STOP THE MACHINE.

NOTE: Perform checks from ground controls first, then from platform controls.

1. Operate machine from ground control.

NOTE: For adjustments see Service Manual, Limit Switch Adjustments.

2. Check elevation limit switch as follows:

While driving in high drive, elevate the boom to approximately 10 degrees. Drive should cut back to low speed. The switch should reset when the boom is fully lowered.

3. Check capacity limit switch as follows:

- a. Boom Length Switch.

Raise boom to horizontal. Telescope boom out until 500 lb. light comes on. Make sure the switch resets and the 1000 lb. light comes back on when telescoping in.

- b. Boom Angle Switch.

Telescope boom to full extension.

Lift boom up until 1000 lb. light comes on.

Lift boom down using auxiliary power until 500 lb.

SECTION 2 - USER RESPONSIBILITIES, MACHINE PREPARATION, AND INSPECTION

light comes on. Boom angle must be approximately 45 to 50 degrees

Lift boom up until 1000 lb. light comes on. The switch should reset when the boom angle is about 55 degrees to 64 degrees.

NOTE: *If limit switch settings need to be changed, you will need to recheck that the 500 lb. light comes on at 45 degrees to 50 degrees when lifting down.*

4. Drive Disable Switch (Refer to Figure 2-2., Drive Function Operating Range Diagrams - Sheet 2 of 3).
 - a. Telescope the boom out over 40 ft. (12.2 m).
 - b. Manually tilt the tilt sensor.
 - c. Drive Disable Indicator Light should come on.
 - d. Retract the boom and elevate to at least 55°.
 - e. Manually tilt the tilt sensor.
 - f. The Drive Disable Indicator Light should come on again.
5. Raise main boom, extend and retract telescope. Check for delayed movement of fly section, indicating loose cables.

NOTE: *Turntable lock is on turntable facing platform. To disengage lock, pull snap pin from lock pin, lift lock pin up to*

unlock turntable. Return snap pin to lock pin to hold lock pin in the disengaged position. Reverse procedure to engage turntable lock.

6. Swing turntable to LEFT and RIGHT a minimum of 45 degrees. Check for smooth motion.
7. Check the chassis out of level indicator located on the platform control console by driving, with the machine in level position, up a suitable ramp of at least 5° slope. Check the out of level indicator, with the machine on the ramp. If the light does not illuminate, return the machine to a level surface, shut down the machine, and contact a qualified technician before resuming operation.

ANSI, ANSI Export, CSA, Japan	5°
CE, Australia	3°

8. Check that platform automatic self-leveling system functions properly during raising and lowering of the boom.
9. Check platform level adjustment system for proper operation.
10. Check platform rotator for smooth operation and assure platform will rotate 90 degrees in both directions from centerline of boom.

SECTION 2 - USER RESPONSIBILITIES, MACHINE PREPARATION, AND INSPECTION

11. Drive forward and reverse; check for proper operation.
12. Steer left and right; check for proper operation.
13. Raise and lower Articulating Jib Boom. Check for smooth operation.
14. Footswitch.
- c. With engine power shut down, depress the footswitch. Attempt to start engine. Engine should not attempt to start when footswitch is depressed. If starter engages or engine turns over, shut down machine and contact a certified JLG service technician.

NOTICE

FOOTSWITCH MUST BE ADJUSTED SO THAT FUNCTIONS WILL OPERATE WHEN PEDAL IS APPROXIMATELY AT ITS CENTER OF TRAVEL. IF SWITCH OPERATES WITHIN LAST 1/4" OF TRAVEL, TOP OR BOTTOM, IT SHOULD BE ADJUSTED.

- a. Activate hydraulic system. By depressing footswitch. Operate MAIN TELESCOPE and hold control. Remove foot from footswitch, motion should stop. If it does not, shut down machine and contact a certified JLG service technician.
- b. With footswitch depressed, operate LIFT and hold control. Remove foot from footswitch, motion should stop. If it does not, shut down machine and contact a certified JLG service technician.

15. Auxiliary Power.

Operate each function control switch (e.g. TELE, LIFT and SWING) to assure that they function in both directions using auxiliary power instead of engine power.

16. Ground Controls.

Place GROUND/PLATFORM SELECT switch to GROUND. Start engine. Platform controls should not operate.

SECTION 2 - USER RESPONSIBILITIES, MACHINE PREPARATION, AND INSPECTION

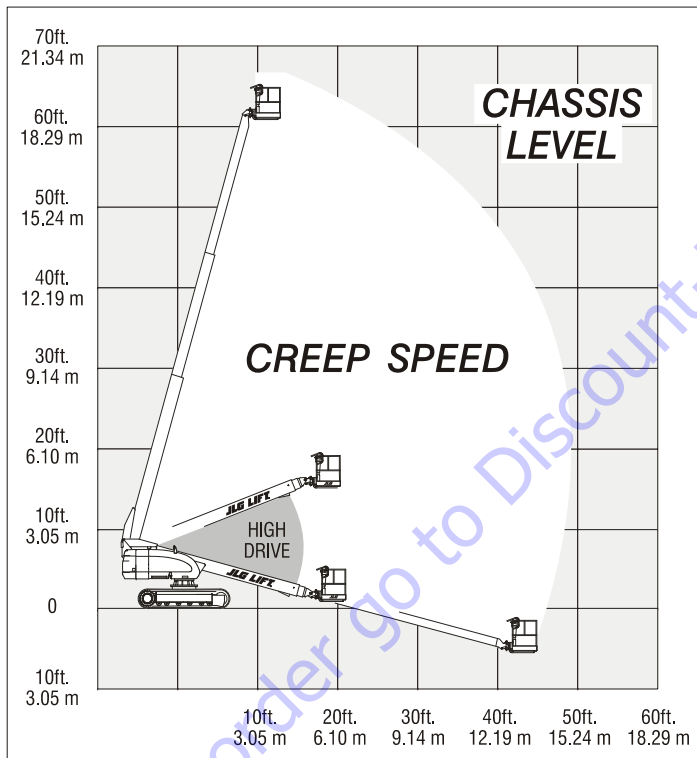

NOTE: In the Transport Mode, High Drive will be disabled above 10° elevation or past 3 feet (1 m) of boom extension.

Figure 2-1. Drive Function Operating Range Diagrams - Sheet 1 of 3

SECTION 2 - USER RESPONSIBILITIES, MACHINE PREPARATION, AND INSPECTION

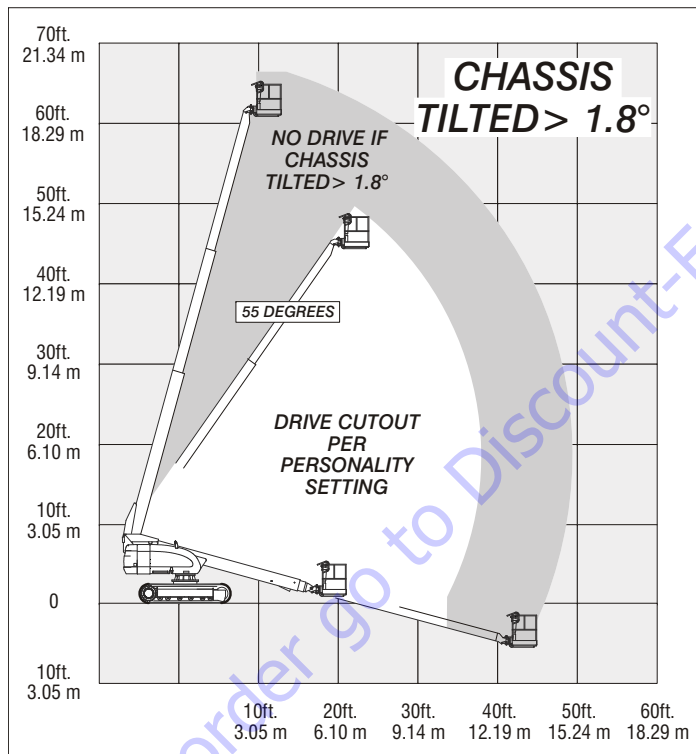
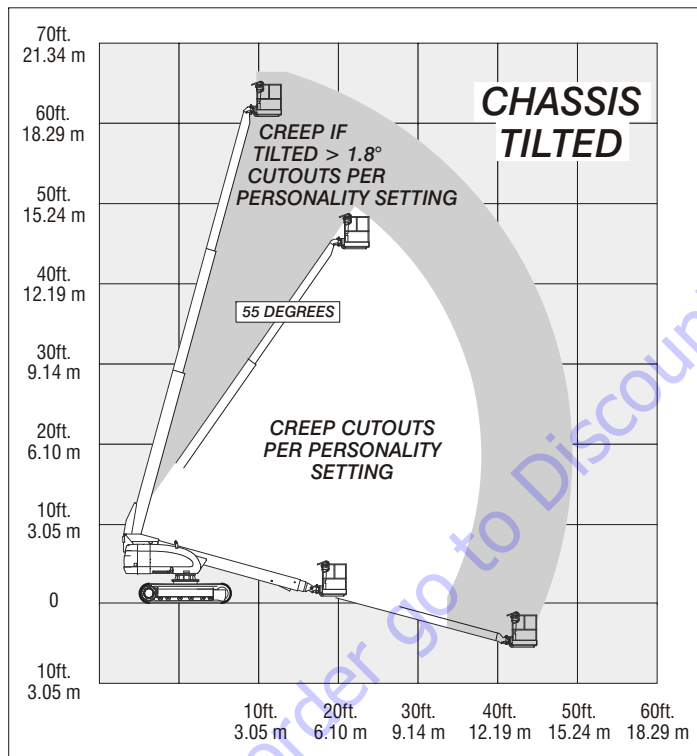

Figure 2-2. Drive Function Operating Range Diagrams - Sheet 2 of 3

NOTE: In the Transport Mode, High Drive will be disabled above 10° elevation or past 3 feet (1 m) of boom extension.

SECTION 2 - USER RESPONSIBILITIES, MACHINE PREPARATION, AND INSPECTION



NOTE: In the Transport Mode, High Drive will be disabled above 10° elevation or past 3 feet (1 m) of boom extension.

Figure 2-3. Drive Function Operating Range Diagrams - Sheet 3 of 3

SECTION 2 - USER RESPONSIBILITIES, MACHINE PREPARATION, AND INSPECTION

General

Begin the "Walk-Around Inspection" at Item 1, as noted on the diagram. Continue to the right (counterclockwise viewed from top) checking each item in sequence for the conditions listed in the following checklist.

WARNING

TO AVOID POSSIBLE INJURY, BE SURE MACHINE POWER IS OFF.

DO NOT OPERATE MACHINE UNTIL ALL MALFUNCTIONS HAVE BEEN CORRECTED.

INSPECTION NOTE: *On all components, make sure there are no loose or missing parts, that they are securely fastened, and no visible damage, leaks or excessive wear exists in addition to any other criteria mentioned.*

1. **Platform Assembly and Gate** - Footswitch works properly, not modified, disabled or blocked. Latch, stop, and hinges in working condition.
2. **Platform Control Console** - Switches and levers return to neutral, decals/placards secure and legible, control markings legible.
3. **Rotator** - See Inspection Note.
4. **Rotator Motion Control Valve** - See Inspection Note.
5. **Articulating Jib Boom** - See Inspection Note.
6. **Dual Capacity Limit Switch, Transport Position Limit Switch** - Switches operate properly.
7. **Power Track** - See Inspection Note.
8. **Turntable Bearing and Pinion** - No evidence of loose bolts or looseness between bearing and structure. See Inspection Note.
9. **Right Track** - Properly secured plates, no loose or missing track bolts, no dislocation of the track pins. Proper tension. See Inspection Note.
10. **Final Drive, Both Sides** - See Inspection Note.
11. **Turntable Lock** - Operable; See Inspection Note.
12. **Auxiliary Power Pump** - See Inspection Note.
13. **Bottom Rollers, Right Side** - See Inspection Note.
14. **Track Carrier Roller, Both Sides** - See Inspection Note.

Figure 2-5. Daily Walkaround Inspection Points - Sheet 1 of 3

SECTION 2 - USER RESPONSIBILITIES, MACHINE PREPARATION, AND INSPECTION

15. **Swing Drive Motor and Brake** - See Inspection Note.
16. **Control Valve (Tank Compartment)** - See Inspection Note.
17. **Hydraulic Oil Return Filter** - Housing secure; See Inspection Note.
18. **Hydraulic Oil Supply** - Recommended oil level sight gauge. (Check level with cold oil, systems shut down, machine in stowed position) Cap in place and secure.
19. **Hydraulic Oil Breather** - Element in place, not clogged, no sign of overflow.
20. **Door and Latches, Right Side** - Hood door and latches in working condition. See Inspection Note.
21. **Ground Controls** - Switches and levers return to neutral, decals/placards secure and legible, control markings legible.
22. **Right Tension Mechanism** - See Inspection Note.
23. **Fuel Supply** - Fuel filler cap secure. Tank - See Inspection Note.
24. **Idler, Right Front** - See Inspection Note.
25. **Dual Capacity Limit Switch** - Switch operates properly.
26. **Left Track** - Properly secured plates, no loose or missing track bolts, no dislocation of the track pins. Proper tension. See Inspection Note.
27. **Idler, Left Front** - See Inspection Note.
28. **Left Tension Mechanism** - See Inspection Note.
29. **Bottom Rollers, Left Side** - See Inspection Note.
30. **Battery** - Proper electrolyte levels; cables tight, no visible damage or corrosion.
31. **Door and Latches, Left Side** - Hood door and latches in working condition, see Inspection Note.
32. **Engine Air Filter** - See Inspection Note.; element clean.
33. **Engine Oil Supply** - Full mark on dipstick; filler cap secure.

Figure 2-6. Daily Walkaround Inspection Points - Sheet 2 of 3

SECTION 2 - USER RESPONSIBILITIES, MACHINE PREPARATION, AND INSPECTION

- 34. **Muffler and Exhaust System** - See Inspection Note.
- 35. **Hydraulic Pump** - See Inspection Note.
- 36. **Engine Tray Pivot** - See Inspection Note.
- 37. **Hydraulic Oil Medium Pressure Filter Housing** - Housing secure; See Inspection Note.
- 38. **Horizontal Cutoff Limit Switch** - (High Engine/High Drive Cut-off Switch) Switch operates properly.
- 39. **Frame** - See Inspection Note.
- 40. **Hydraulic Swivel** - See Inspection Note.
- 41. **Main Boom Sections** - See Inspection Note.

Figure 2-7. Daily Walkaround Inspection Points - Sheet 3 of 3

TO PURCHASE THIS PRODUCT PLEASE CONTACT US



**Equipment Financing and
Extended Warranties Available**



**Discount-Equipment.com is your online resource for
commercial and industrial quality parts and equipment sales.**

561-964-4949

visit us on line @ www.discount-equipment.com

Select an option below to find your Equipment

Search by Manufacturer

Search by Product Type

Request a Quote

We sell worldwide for the brands: Genie, Terex, JLG, MultiQuip, Mikasa, Essick, Whiteman, Mayco, Toro Stone, Diamond Products, Generac Magnum, Airman, Haulotte, Barreto, Power Blanket, Nifty Lift, Atlas Copco, Chicago Pneumatic, Allmand, Miller Curber, Skyjack, Lull, Skytrak, Tsurumi, Husquvarna Target, Stow, Wacker, Sakai, Mi-T-M, Sullair, Basic, Dynapac, MBW, Weber, Bartell, Bennar Newman, Haulotte, Ditch Runner, Menegotti, Morrison, Contec, Buddy, Crown, Edco, Wyco, Bomag, Laymor, EZ Trench, Bil-Jax, F.S. Curtis, Gehl Pavers, Heli, Honda, ICS/PowerGrit, IHI, Partner, Imer, Clipper, MMD, Koshin, Rice, CH&E, General Equipment, Amida, Coleman, NAC, Gradall, Square Shooter, Kent, Stanley, Tamco, Toku, Hatz, Kohler, Robin, Wisconsin, Northrock, Oztec, Toker TK, Rol-Air, APT, Wylie, Ingersoll Rand / Doosan, Innovatech, Con X, Ammann, Mecalac, Makinex, Smith Surface Prep, Small Line, Wanco, Yanmar

SECTION 3. MACHINE CONTROLS AND INDICATORS

3.1 GENERAL

NOTICE

THE MANUFACTURER HAS NO DIRECT CONTROL OVER MACHINE APPLICATION AND OPERATION. THE USER AND OPERATOR ARE RESPONSIBLE FOR CONFORMING WITH GOOD SAFETY PRACTICES.

This section provides the necessary information needed to understand control functions.

3.2 CONTROLS AND INDICATORS

NOTE: This machines is equipped with control panels that use symbols to indicate control functions. Refer to decal located on the control box guard in front of the control box or by the ground controls for these symbols and the corresponding functions.

WARNING

TO AVOID SERIOUS INJURY, DO NOT OPERATE MACHINE IF ANY CONTROL LEVERS OR TOGGLE SWITCHES CONTROLLING PLATFORM MOVEMENT DO NOT RETURN TO THE OFF POSITION WHEN RELEASED.

Ground Control Station

(See Figure 3-1., Ground Control Station - 600SC, and Figure 3-2., Ground Control Station - 660SJC)

NOTE: If equipped, the Function Enable switch must be held down in order to operate Telescope, Swing, Lift, Jib Lift, Platform Level Override, and Platform Rotate functions.



1. Platform Rotate

A three position switch permits rotation of the platform.

SECTION 3 - MACHINE CONTROLS AND INDICATORS

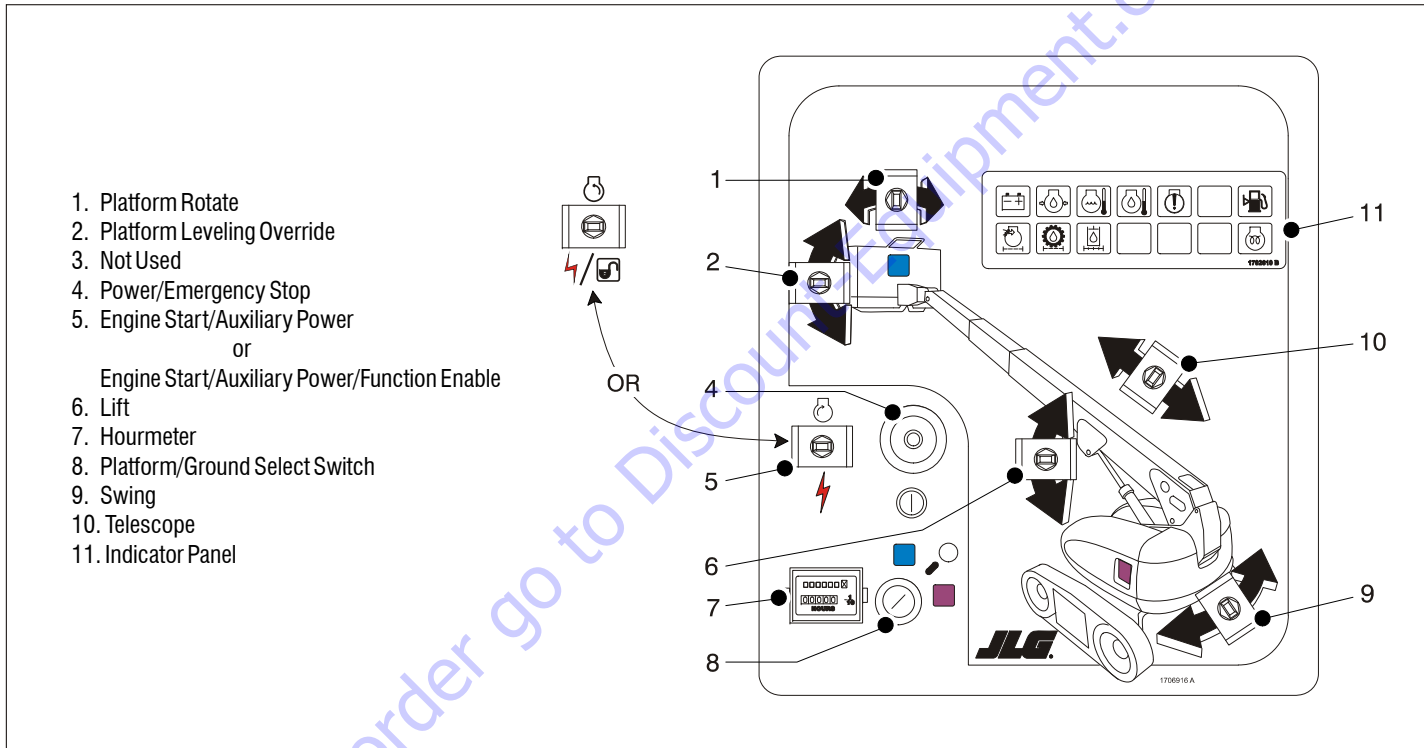

Figure 3-1. Ground Control Station - 600SC

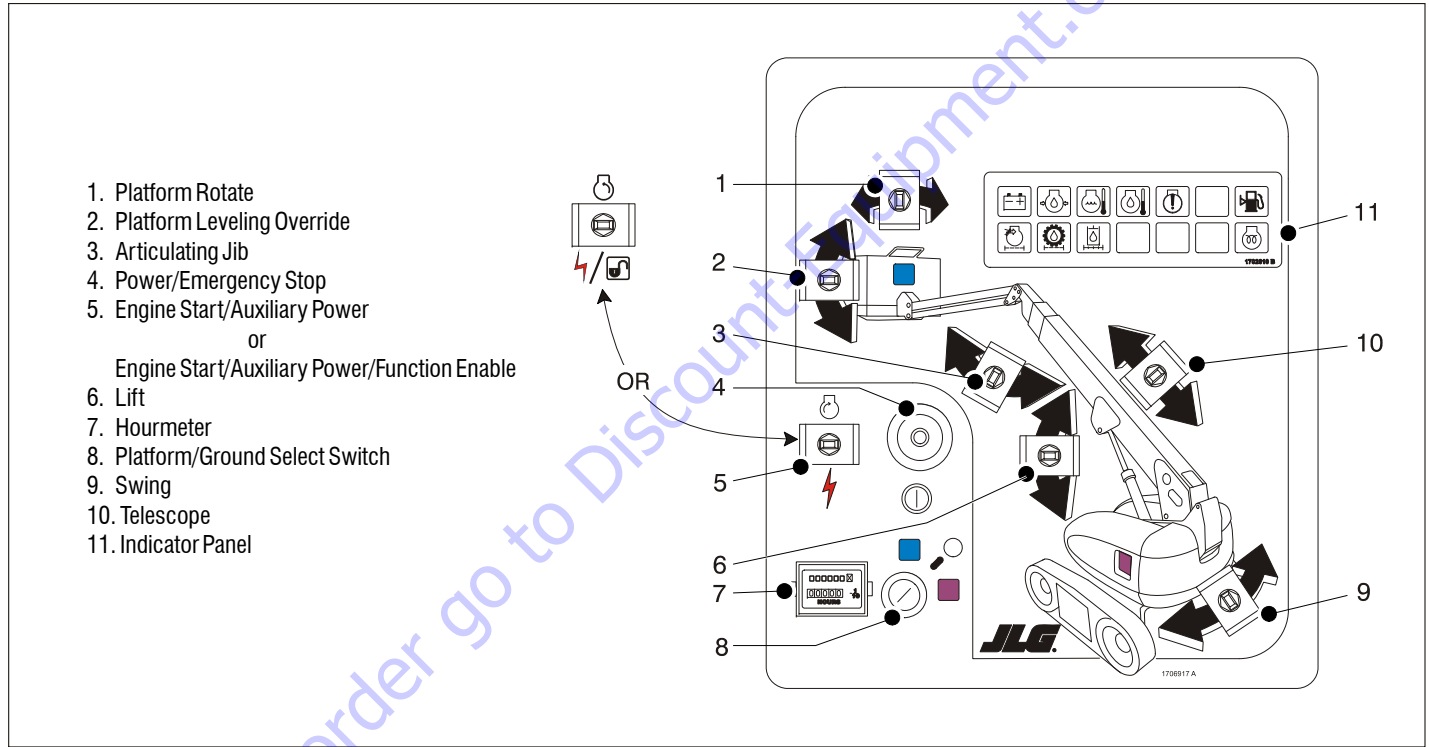

Figure 3-2. Ground Control Station - 660SJC

SECTION 3 - MACHINE CONTROLS AND INDICATORS

WARNING

ONLY USE THE PLATFORM LEVELING OVERRIDE FUNCTION FOR SLIGHT LEVELING OF THE PLATFORM. INCORRECT USE COULD CAUSE THE LOAD/OCCUPANT TO SHIFT OR FALL. FAILURE TO DO SO COULD RESULT IN DEATH OR SERIOUS INJURY.

2. Platform Leveling Override

A three position switch allows the operator to adjust the automatic self leveling system. This switch is used to adjust platform level in situations such as ascending/descending a grade.

3. Articulating Jib

This switch provides raising and lowering of the jib.

NOTE: *When Power/Emergency Stop switch is in the “ON” position and engine is not running, an alarm will sound, indicating Ignition is “ON”.*

CAUTION

WHEN THE MACHINE IS SHUT DOWN THE MASTER/EMERGENCY STOP SWITCH MUST BE POSITIONED TO THE “OFF” POSITION TO PREVENT DRAINING THE BATTERY.

4. Power/Emergency Stop Switch

A two-position red mushroom shaped switch furnishes power to PLATFORM/GROUND SELECT switch when pulled out (on). When pushed in (off), power is shut off to the PLATFORM/GROUND SELECT switch.

CAUTION

WHEN USING AUXILIARY POWER, DO NOT OPERATE MORE THAN ONE FUNCTION AT A TIME. (SIMULTANEOUS OPERATION CAN OVERLOAD THE AUXILIARY PUMP.)

5. Engine Start/Auxiliary Power Switch
or

Engine Start/ Auxiliary Power Switch /Function Enable.

To start the engine, the switch must be held "UP" until the engine starts.



To use auxiliary power, the switch must be held "DOWN" for duration of auxiliary pump use. Aux power can only be used if the engine is not running.



If equipped, the enable switch must be held "DOWN" to enable all boom controls when the engine is running.



6. Lift Control

Provides raising and lowering of the main boom.

7. Hourmeter

Registers the amount of time the machine has been in use with engine running.

NOTE: With PLATFORM/GROUND SELECT switch in the center position, power is shut off to controls at both operating stations.

8. Platform/Ground Select Switch

A three position, key operated switch supplies power to the platform control console when positioned to PLATFORM. With the switch key held in the GROUND position, power is shut off to platform and only ground controls are operable.

9. Swing Control

Provides 360 degrees continuous turntable rotation.

10. Telescope Control.

Provides extension and retraction of the boom when positioned to IN or OUT.

Ground Control Indicator Panel

(See Figure 3-3., Ground Control Indicator Panel - Sheet 1 of 2)

1. Battery Charging Indicator

Indicates a problem in the battery or charging circuit, and service is required.

2. Low Engine Oil Pressure Indicator

Indicates that engine oil pressure is below normal and service is required.

3. High Coolant Temperature Indicator (If equipped)

Indicates that engine coolant temperature is abnormally high and service is required.

4. Engine Oil Temperature Indicator (Deutz)

Indicates the temperature of the engine oil, which also serves as engine coolant, is abnormally high and service is required.

5. System Distress Indicator

The light indicates that the JLG Control System has detected a malfunction and a Diagnostic Trouble Code

has been set in the system memory. Refer to the Service Manual for instructions concerning the trouble codes and trouble code retrieval.

The malfunction indicator light will illuminate for 2-3 seconds when the key is positioned to the on position to act as a self test.

6. Low Fuel Indicator

Indicates the fuel tank is 1/8 full or less. When the light first turns on, there are approximately four usable gallons of fuel remaining.

7. Glow Plug Indicator

Indicates the glow plugs are operating. After turning on ignition, wait until light goes out before cranking engine.

8. Platform Overload Indicator (If equipped)

Indicates the platform has been overloaded.

9. Drive Disabled Indicator

When illuminated, the drive function has been disabled. (Refer to Drive Function Operating Range Diagrams in Section 2).

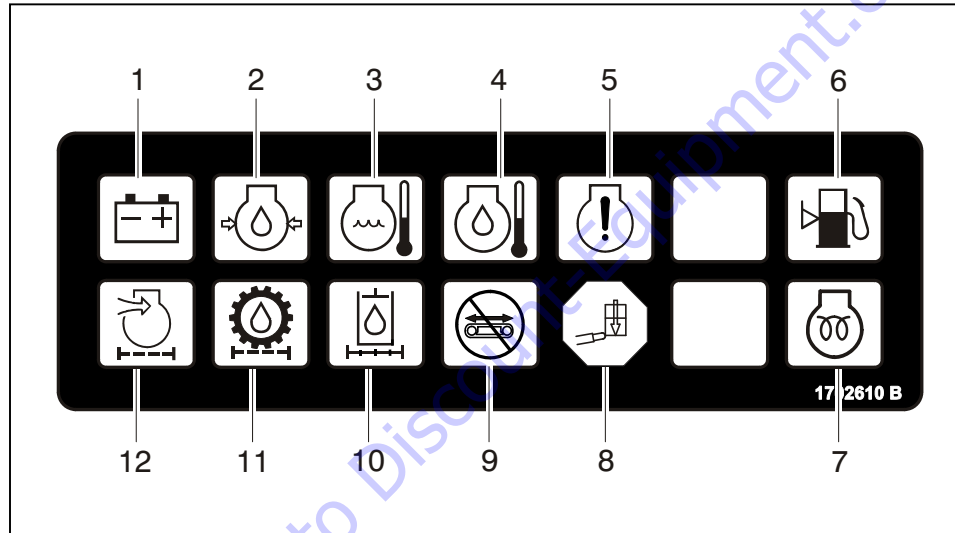

Prior to S/N 0300128000

- | | | |
|------------------------------|----------------------|----------------------------------|
| 1. Battery Charging | 5. System Distress | 9. Drive Disabled |
| 2. Low Engine Oil Pressure | 6. Low Fuel | 10. Hydraulic Oil Filter |
| 3. High Engine Coolant Temp. | 7. Glow Plug | 11. Transmission Pump Oil Filter |
| 4. High Engine Oil Temp. | 8. Platform Overload | 12. Engine Air Filter |

Figure 3-3. Ground Control Indicator Panel - Sheet 1 of 2

SECTION 3 - MACHINE CONTROLS AND INDICATORS

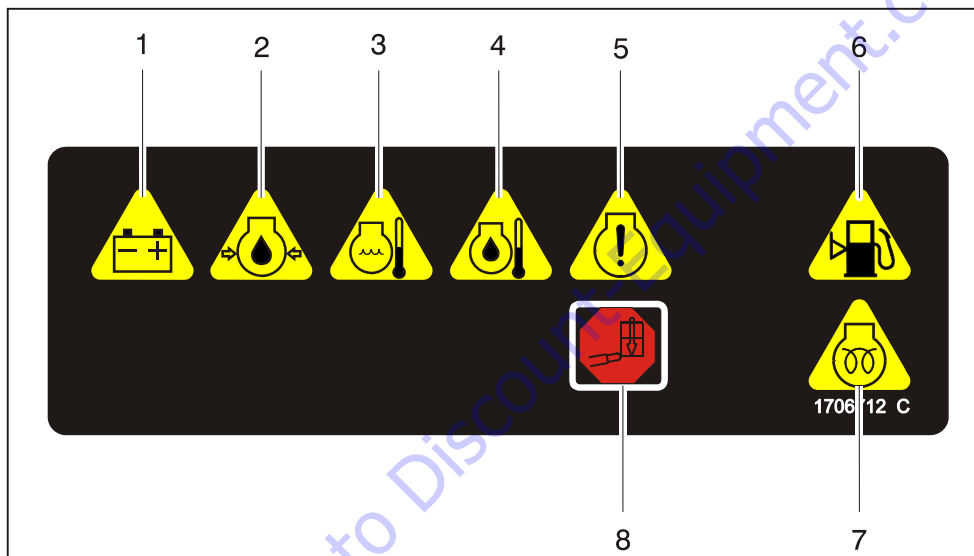

S/N 0300128000 to Present

- | | |
|------------------------|--------------------------|
| 1. Battery Charging | 5. Malfunction Indicator |
| 2. Engine Oil Pressure | 6. Low Fuel |
| 3. Engine Water Temp. | 7. Glow Plug |
| 4. Engine Oil Temp. | 8. Platform Overload |

Figure 3-4. Ground Control Indicator Panel - Sheet 2 of 2

10. Hydraulic Oil Filter Indicator

When illuminated indicates that the return oil filter is too restrictive and needs to be replaced.

11. Transmission Pump Oil Filter Indicator

When illuminated indicates that charge pump filter is too restrictive and needs to be replaced. This indicator has an integral temperature sensor (70 degrees F.) so that false signals are not generated when the hydraulic oil is below normal operating temperature.

12. Engine Air Filter Indicator

When illuminated indicates that the air filter is too restrictive and needs to be replaced.

Platform Control Station

(See Figure 3-6., Platform Control Console w/Drive Orientation)

WARNING

TO AVOID SERIOUS INJURY, DO NOT OPERATE MACHINE IF ANY CONTROL LEVERS OR TOGGLE SWITCHES CONTROLLING PLATFORM MOVEMENT DO NOT RETURN TO THE OFF OR NEUTRAL POSITION WHEN RELEASED.

1. Power/Emergency Stop

A two-position red mushroom shaped switch furnishes power to PLATFORM Controls when pulled out (on). When pushed in (off), power is shut off to the platform functions.

Within about 2 seconds of pulling the switch out, the machine will perform a diagnostic check of the various electrical circuits, and if everything is OK, the platform alarm will beep once. During this time the lights on the indicator panel will also blink once as a bulb check.

SECTION 3 - MACHINE CONTROLS AND INDICATORS

2. Start/Auxiliary Power

When pushed forward, the switch energizes the starter motor to start the engine.

When pushed back, it energizes the electrically operated hydraulic pump, when actuated. (Switch must be held ON for duration of auxiliary pump use.)

The auxiliary pump functions to provide sufficient oil flow to operate the basic machine functions should the main pump or engine fail. The auxiliary pump will operate platform rotate, jib lift, jib swing, platform level override, main boom lift, main telescope and swing.

3. Lights (If Equipped)

This switch operates accessory light packages if the machine is so equipped.

4. Drive/Steer Enable

Located on the top of the Drive Steer Joystick, the button must be pushed in for the Drive/Steer control to function. If at any time the Enable Switch is pushed in and no function is operated for a period of 3 seconds, the switch will "time-out" and the switch must be cycled again to renew normal functions.

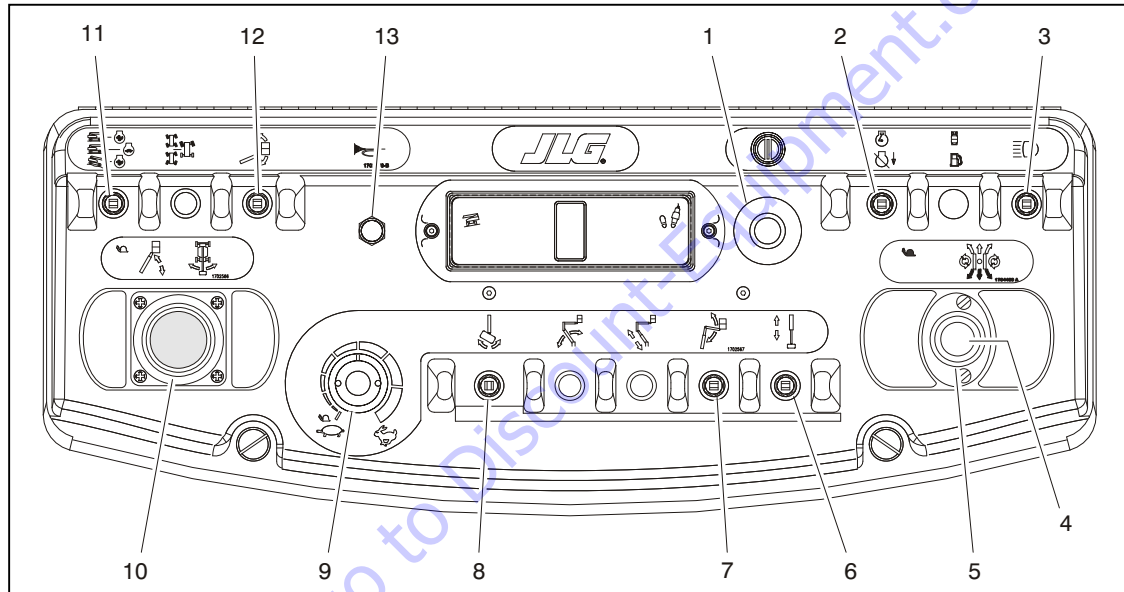

- | | | | |
|-------------------------|---------------------|---------------------------|---------------------------------|
| 1. Power/Emergency Stop | 5. Drive Steer | 8. Platform Rotate | 11. Drive Speed / Torque Select |
| 2. Start/ Aux Power | 6. Telescope | 9. Function Speed Control | 12. Platform Level Override |
| 3. Light | 7. Articulating Jib | 10. Main Lift/ Swing | 13. Horn |
| 4. Drive/Steer Enable | | | |

Figure 3-5. Platform Control Console

SECTION 3 - MACHINE CONTROLS AND INDICATORS

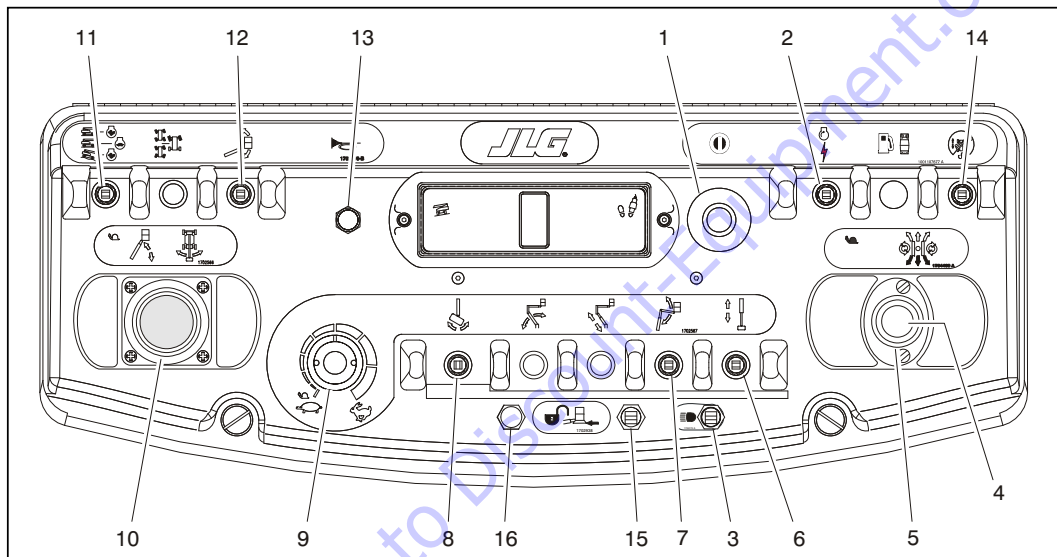

- | | | | |
|-------------------------|---------------------|---------------------------------|--------------------------------|
| 1. Power/Emergency Stop | 5. Drive Steer | 9. Function Speed Control | 13. Horn |
| 2. Start/ Aux Power | 6. Telescope | 10. Main Lift/ Swing | 14. Drive Orientation Override |
| 3. Lights | 7. Articulating Jib | 11. Drive Speed / Torque Select | 15. Soft Touch Override |
| 4. Drive/Steer Enable | 8. Platform Rotate | 12. Platform Level Override | 16. Soft Touch Indicator |

Figure 3-6. Platform Control Console w/Drive Orientation

SECTION 3 - MACHINE CONTROLS AND INDICATORS

5. Drive/Steer

Proportional dual axis joystick is provided to control drive and steer. Push forward to drive straight forward. The joystick is proportional, with the drive speed increasing as the joystick is moved further from its neutral position. Moving the joystick forward and to the side steers the machine in the direction of the side displacement of the joystick. With the joystick positioned all the way to the side and slightly forward, the machine will turn in place with one track stopped and the other one turning the machine around the center of the stopped track.

Moving the joystick to the side (no dislocation in the forward or aft direction) will turn the machine by counter-rotation around the center of the machine by powering the tracks in opposite directions.

Pulling the joystick back and to the sides controls speed and direction of drive in reverse.

NOTE: Both drive and steer functions work in the opposite direction when the boom is positioned over front of the chassis (over idler wheels).

NOTE: When boom is positioned above horizontal and any of the following switches, DRIVE SPEED/TORQUE SELECT or FUNCTION SPEED, are positioned to HIGH, high function speeds are automatically cut out and the machine continues to operate at a lower speed.

NOTE: The drive/steer control joystick on machines equipped with JLG Control System software version p6.1 or higher can only command counter-rotate by being moved in the joystick's left - to - right axis, after first achieving the joystick neutral position. For machines equipped with version p5.12 and lower, the drive/steer joystick can be positioned into the counter-rotate command position without first achieving joystick neutral.

CAUTION

DO NOT OPERATE MACHINE IF DRIVE SPEED /TORQUE SELECT OR FUNCTION SPEED SWITCHES OPERATE WHEN BOOM IS ABOVE HORIZONTAL.

SECTION 3 - MACHINE CONTROLS AND INDICATORS

6. Main Telescope

This control allows extension and retraction of the main boom.

7. Articulating Jib

Push forward to lift up, pull back to lift down. Variable lift speed is using the Function Speed Control.

8. Platform Rotate

This switch allows the operator to rotate the basket to the left or right.

9. Function Speed Control

Controls the speed of Boom and Swing Functions. Rotate CCW for slower speed and CW for faster speed. To adjust to creep, turn knob fully CCW until it clicks.

10. Main Lift/Swing Controller

An infinitely proportional dual axis joystick is provided for main lift and swing. Push forward to lift up, pull backward to lift down. Move right to swing right, move left to swing left.

NOTE: *Main lift and swing functions may be selected in combination. The handle features a round gate so that maximum speed is reduced when multiple functions are selected.*

11. Drive Speed/Torque Select

The machine has a three position switch.

The forward position gives maximum drive speed by shifting the drive motors to minimum the displacement and giving high engine when drive controller is moved.

The back position gives maximum torque for rough terrain, climbing grades, and sharp turns. In this position, the motors are shifted to maximum displacement and the engine in high speed when the drive controller is moved.

The center position allows the machine to be driven as quietly as possible by leaving the engine at mid speed and the drive motors in maximum displacement.

⚠ WARNING

ONLY USE THE PLATFORM LEVELING OVERRIDE FUNCTION FOR SLIGHT LEVELING OF THE PLATFORM. INCORRECT USE COULD CAUSE THE LOAD/OCCUPANT TO SHIFT OR FALL. FAILURE TO DO SO COULD RESULT IN DEATH OR SERIOUS INJURY.

12. Platform Leveling Override

A three position switch allows the operator to adjust the automatic self leveling system. This switch is used to adjust platform level in situations such as ascending/descending a grade.

13. Travel Warning Horn

A push-type HORN switch supplies electrical power to an audible warning device when pressed.

14. Drive Orientation Override

When the boom is swung over the rear in either direction, the Drive Orientation indicator will illuminate when the drive function is selected. Push and release the switch, and within 3 seconds move the Drive/Steer control to activate drive or steer. Before driving, locate the black/white orientation arrows on both the chassis and the platform controls and match the control direction arrow to the intended chassis direction.

15. Soft Touch Override Switch (If equipped)

This switch enables the functions that were cut out by the Soft Touch system to operate again at creep speed, allowing the operator to move the platform away from the obstacle that caused the shutdown situation.

16. Soft Touch Indicator (If Equipped)

Indicates the Soft Touch bumper is against an object. All controls are cut out until the override button is pushed, at which time controls are active in the Creep Mode.

Platform Control Indicator Panel

(See Figure 3-8., Platform Control Indicator Panel w/Drive Orientation)

NOTE: The platform control indicator panel uses different shaped symbols to alert the operator to different types of operational situations that could arise. The meaning of those symbols are explained below.



Indicates a potentially hazardous situation, which if not corrected, could result in serious injury or death. This indicator will be red.



Indicates an abnormal operating condition, which if not corrected, may result in machine interruption or damage. This indicator will be yellow.



Indicates important information regarding the operating condition, i.e. procedures essential for safe operation. This indicator will be green with the exception of the capacity indicator which will be green or yellow depending upon platform position.

1. Tilt Alarm Warning Light and Alarm

Indicates that the chassis is on a slope. An alarm will also sound when the chassis is on a slope and the boom is above horizontal. If lit when boom is raised or extended, retract and lower to below horizontal then reposition machine so that it is level before continuing operation. If the boom is above horizontal and the machine is on a slope, the tilt alarm warning light will illuminate and an alarm will sound and CREEP is automatically activated.

⚠ WARNING

IF TILT WARNING LIGHT IS ILLUMINATED WHEN BOOM IS RAISED OR EXTENDED, RETRACT AND LOWER TO BELOW HORIZONTAL THEN REPOSITION MACHINE SO THAT IT IS LEVEL BEFORE EXTENDING BOOM OR RAISING BOOM ABOVE HORIZONTAL.

2. Platform Overload Indicator (If Equipped)

Indicates the platform has been overloaded.

SECTION 3 - MACHINE CONTROLS AND INDICATORS

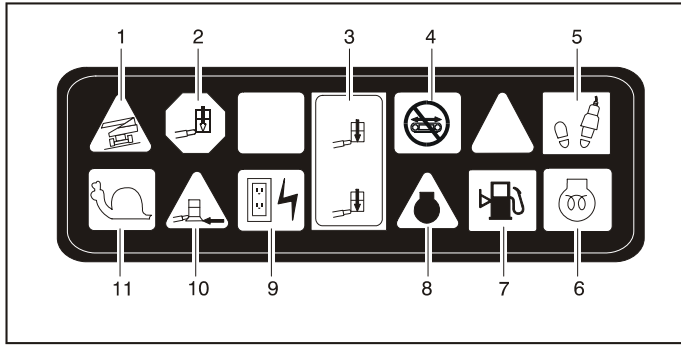

- | | | |
|-----------------------|----------------------|-----------------|
| 1. Tilt Alarm Warning | 5. Footswitch/Enable | 9. AC Generator |
| 2. Platform Overload | 6. Glow Plug | 10. Soft Touch |
| 3. Platform Capacity | 7. Low Fuel | 11. Creep Speed |
| 4. Drive Disabled | 8. System Distress | |

Figure 3-7. Platform Control Indicator Panel

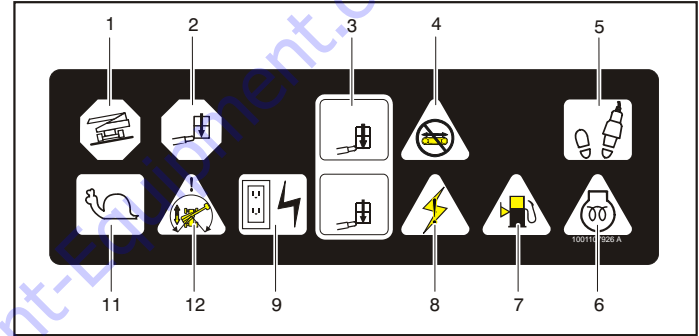

- | | | |
|-----------------------|----------------------|-----------------------|
| 1. Tilt Alarm Warning | 5. Footswitch/Enable | 9. AC Generator |
| 2. Platform Overload | 6. Glow Plug | 10. Not Used |
| 3. Platform Capacity | 7. Low Fuel | 11. Creep Speed |
| 4. Drive Disabled | 8. System Distress | 12. Drive Orientation |

Figure 3-8. Platform Control Indicator Panel w/Drive Orientation

SECTION 3 - MACHINE CONTROLS AND INDICATORS

3. Platform Capacity Indicator (If equipped)

Indicates the maximum platform capacity selected for the platform.

One of the capacity lights should be on at all times. Both lights will flash and an alarm will sound if the platform is out of the operating envelope for the selected capacity.

4. Drive Disabled Indicator

When illuminated, the drive function has been disabled. (Refer to Drive Function Operating Range Diagrams in Section 2).

5. Footswitch/Enable Indicator

To operate any function, the footswitch must be depressed and the function selected within seven seconds. The enable indicator shows that the controls are enabled. If a function is not selected within seven seconds, or if a seven second lapse between ending one function and beginning the next function, the enable light will go out and the footswitch must be released and depressed again to enable the controls.

Releasing the footswitch removes power from all controls and applies the drive brakes.

WARNING

TO AVOID SERIOUS INJURY, DO NOT REMOVE, MODIFY OR DISABLE THE FOOTSWITCH BY BLOCKING OR ANY OTHER MEANS.

WARNING

FOOTSWITCH MUST BE ADJUSTED IF FUNCTIONS ACTIVATE WHEN SWITCH ONLY OPERATES WITHIN LAST 1/4" OF TRAVEL, TOP OR BOTTOM.

6. Glow Plug Indicator

Indicates the glow plugs are operating. After turning on ignition, wait until light goes out before cranking engine.

7. Low Fuel Indicator.

Indicates the fuel tank is 1/8 full or less. When the light first turns on, there are approximately four usable gallons of fuel remaining.

SECTION 3 - MACHINE CONTROLS AND INDICATORS

8. System Distress Indicator

The light indicates that the JLG Control System has detected a malfunction and a Diagnostic Trouble Code has been set in the system memory. Refer to the Service Manual for instructions concerning the trouble codes and trouble code retrieval.

The malfunction indicator light will illuminate for 2-3 seconds when the key is positioned to the on position to act as a self test.

9. AC Generator

Indicates the generator is in operation.

10. Soft Touch Indicator

Indicates the Soft Touch bumper is against an object. All controls are cut out until the override button is pushed, at which time controls are active in the Creep mode.

11. Creep Speed Indicator

When the Function Speed Control is turned to the creep position, the indicator acts as a reminder that all functions are set to the slowest speed. The light flashes if the control system puts the machine into creep speed and will be on continuously if the operator selects creep speed.

12. Drive Orientation Indicator

When the boom is swung beyond the rear in either direction, the Drive Orientation indicator will illuminate when the drive function is selected. This is a signal for the operator to activate the Drive Orientation Override Switch and verify the drive control direction is correct.

TO PURCHASE THIS PRODUCT PLEASE CONTACT US



**Equipment Financing and
Extended Warranties Available**



**Discount-Equipment.com is your online resource for
commercial and industrial quality parts and equipment sales.**

561-964-4949

visit us on line @ www.discount-equipment.com

Select an option below to find your Equipment

Search by Manufacturer

Search by Product Type

Request a Quote

We sell worldwide for the brands: Genie, Terex, JLG, MultiQuip, Mikasa, Essick, Whiteman, Mayco, Toro Stone, Diamond Products, Generac Magnum, Airman, Haulotte, Barreto, Power Blanket, Nifty Lift, Atlas Copco, Chicago Pneumatic, Allmand, Miller Curber, Skyjack, Lull, Skytrak, Tsurumi, Husquvarna Target, Stow, Wacker, Sakai, Mi-T-M, Sullair, Basic, Dynapac, MBW, Weber, Bartell, Bennar Newman, Haulotte, Ditch Runner, Menegotti, Morrison, Contec, Buddy, Crown, Edco, Wyco, Bomag, Laymor, EZ Trench, Bil-Jax, F.S. Curtis, Gehl Pavers, Heli, Honda, ICS/PowerGrit, IHI, Partner, Imer, Clipper, MMD, Koshin, Rice, CH&E, General Equipment, Amida, Coleman, NAC, Gradall, Square Shooter, Kent, Stanley, Tamco, Toku, Hatz, Kohler, Robin, Wisconsin, Northrock, Oztec, Toker TK, Rol-Air, APT, Wylie, Ingersoll Rand / Doosan, Innovatech, Con X, Ammann, Mecalac, Makinex, Smith Surface Prep, Small Line, Wanco, Yanmar

SECTION 4. MACHINE OPERATION

4.1 DESCRIPTION

This machine is a self-propelled hydraulic lift equipped with a work platform on the end of an elevating and rotating boom.

The primary operator control station is in the platform. From this control station, the operator can drive and steer the machine in both forward and reverse directions. The operator can raise or lower the upper or lower boom or swing the boom to the left or right. Standard boom swing is 360 degree continuous left and right of the stowed position. The machine has a Ground Control Station which will override the Platform Control Station. Ground Controls operate Boom Lift and Swing, and are to be used in an emergency to lower the platform to the ground should the operator in the platform be unable to do so.

The JLG Lift is a crawler track type machine with drive power being supplied by a hydraulic motor for each final drive and sprocket. Each final drive is equipped with a spring applied, hydraulically released brake. The swing drive is also equipped with such a brake. These brakes are automatically applied any time the Drive or Swing control levers are returned to the neutral position.

4.2 ENGINE OPERATION

NOTE: Initial starting should always be performed from the Ground Control station.

Starting Procedure

1. Check engine oil. If necessary, add oil in accordance with the Engine Manufacturer's manual.
2. Check fuel level. Add fuel if necessary.
3. Check that air cleaner components are in place and securely fastened.

⚠ CAUTION

IF ENGINE FAILS TO START PROMPTLY, DO NOT CRANK FOR AN EXTENDED PERIOD. SHOULD ENGINE FAIL TO START ONCE AGAIN, ALLOW STARTER TO "COOL OFF" FOR 2-3 MINUTES. IF ENGINE FAILS AFTER SEVERAL ATTEMPTS, REFER TO ENGINE MAINTENANCE MANUAL.

NOTE: Machines with diesel engines. After turning on ignition, operator must wait until glow plug indicator light goes out before cranking engine.

4. Turn key of SELECT switch to GROUND. Position POWER/EMERGENCY STOP switch to ON, then push the ENGINE START switch to the upward position until engine starts.

⚠ CAUTION

ALLOW ENGINE TO WARM-UP FOR A FEW MINUTES AT LOW SPEED BEFORE APPLYING ANY LOAD.

5. After engine has had sufficient time to warm up, shut engine off.
6. Turn key of SELECT switch to PLATFORM.
7. From Platform position POWER/EMERGENCY STOP switch to ON, then push the ENGINE START switch to the forward position until engine starts.

NOTE: Footswitch must be in released (up) position before starter will operate. If starter operates with footswitch in the depressed position, DO NOT OPERATE MACHINE.

Shutdown Procedure

CAUTION

IF AN ENGINE MALFUNCTION NECESSITATES UNSCHEDULED SHUTDOWN, DETERMINE AND CORRECT CAUSE BEFORE RESUMING ANY OPERATION.

1. Remove all load and allow engine to operate at low speed setting for 3-5 minutes; this allows for further reduction of internal engine temperature.
2. Position POWER/EMERGENCY STOP switch to OFF.
3. Turn key of MASTER switch to OFF position.

Refer to Engine Manufacturer's manual for detailed information.

4.3 TRAVELING (DRIVING)

WARNING

DO NOT DRIVE WITH BOOM EXTENDED OR ABOVE HORIZONTAL EXCEPT ON A SMOOTH, FIRM AND LEVEL SURFACE.

TO AVOID LOSS OF TRAVEL CONTROL OR UPSET ON GRADES AND SIDESLOPES, DO NOT DRIVE MACHINE ON GRADES OR SIDESLOPES EXCEEDING THOSE SPECIFIED ON MANUFACTURERS NAMEPLATE

LOCATED ON THE FRAME.

ASSURE THAT TURNTABLE LOCK IS ENGAGED BEFORE BEGINNING ANY EXTENDED TRAVELING. AVOID ANY TERRAIN FEATURES WHICH COULD CAUSE THE MACHINE TO UPSET.

DRIVE SPEED/TORQUE SELECT SWITCH SHOULD BE IN THE BACKWARD POSITION FOR:

- TRAVELING GRADES
- TRAVELING IN DIFFICULT CONDITIONS
- SHARP TURNS (ESPECIALLY WITH ONE TRACK STOPPED)
- COUNTERROTATION

USE EXTREME CAUTION WHEN DRIVING IN REVERSE AND AT ALL TIMES WHEN DRIVING WITH THE PLATFORM ELEVATED AND SPECIALLY WHEN DRIVING WITH ANY PART OF THE MACHINE WITHIN 6 FEET (2M) OF AN OBSTRUCTION. DO NOT USE DRIVE TO MANEUVER PLATFORM CLOSE TO AN OBSTRUCTION. USE ONE OF THE BOOM FUNCTIONS.

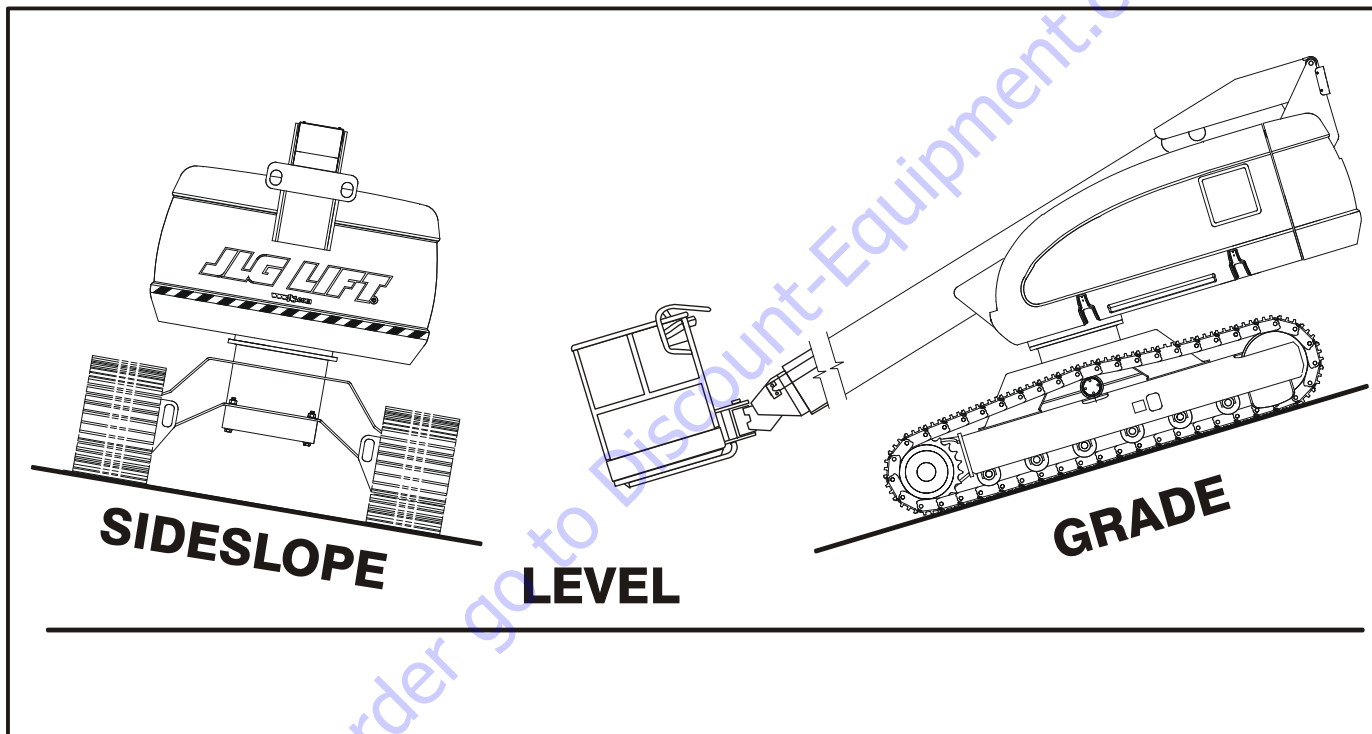

Figure 4-1. Grades and Sideslopes

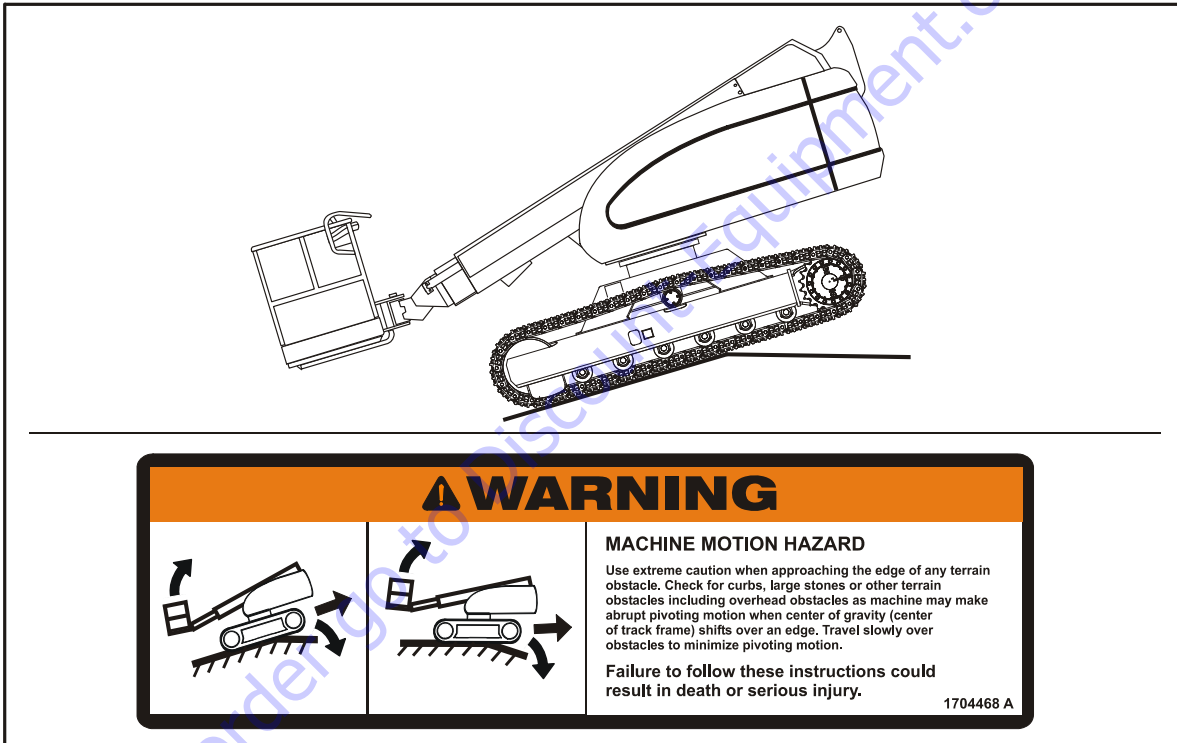

Figure 4-2. Machine Motion Hazard

SECTION 4 - MACHINE OPERATION

⚠ WARNING

USE EXTREME CAUTION WHEN APPROACHING A CREST OF ANY TERRAIN OBSTACLE. CHECK FOR CURBS, LARGE STONES, OR OTHER TERRAIN OBSTACLES INCLUDING OVERHEAD OBSTACLES AS THE MACHINE WILL MAKE UNCONTROLLED PIVOTING MOTIONS WHEN THE CENTER OF GRAVITY (CENTER OF TRACK FRAME) SHIFTS OVER AN EDGE. SLOW DOWN TO MINIMIZE ACCELERATION DURING PIVOTING MOVEMENT.

BEFORE DRIVING, MAKE SURE THE BOOM IS POSITIONED OVER THE REAR OF THE CHASSIS (OVER FINAL DRIVES AND SPROCKETS). IF THE BOOM IS OVER THE FRONT OF THE CHASSIS (OVER THE IDLER WHEELS) STEER AND DRIVE CONTROLS WILL MOVE IN OPPOSITE DIRECTIONS TO MACHINE CONTROLS.

Traveling Forward or Reverse

1. With engine running, depress footswitch and position DRIVE control to FORWARD and hold for the duration of forward travel desired.
2. Depress footswitch and position DRIVE control to REVERSE and hold for duration of reverse travel desired.
3. Depress footswitch, move joystick (DRIVE/STEER CONTROL) to select desired direction of travel (forward or

reverse), move DRIVE/STEER control to RIGHT for smooth turn to right and LEFT for smooth turn to left.

4. To obtain sharp turns, move DRIVE SPEED/TORQUE SELECT switch to the back position, slow down the travel speed and move the DRIVE control lever to RIGHT for a turn to the right and to LEFT for a turn to the left. The sharpest possible turn is achieved when the joystick is in the position to command one track to stop and the other to move slowly.

⚠ CAUTION

TURN IN PLACE ONLY IN AN AREA FREE OF OBSTACLES AND ONLY WITH THE BOOM FULLY RETRACTED. USE SLOW, GENTLE CONTROL MOVEMENTS AND DO NOT OPERATE ANY OTHER FUNCTIONS DURING COUNTER-ROTATION.

5. To obtain counter-rotation (turn in place), stop the machine, move the DRIVE/STEER control lever directly to RIGHT to get clockwise rotation and to LEFT to get counterclockwise rotation.
6. To obtain maximum travel speed, position the DRIVE controller to FAST and activate the following switches:
 - a. Position DRIVE SPEED/TORQUE SELECT switch to FAST. (Forward Position)

7. Prior to stopping the machine, position switches as follows:
 - a. Position DRIVE SPEED/TORQUE SELECT switch to LOW. (Backward Position)
8. For traveling up grades, position switches as follows:
 - a. Position DRIVE SPEED/TORQUE SELECT switch to HIGH. (Backward position)

NOTE: For smoother operation when driving with fully extended boom, place DRIVE control to SLOW before stopping.

This machine is equipped with a Drive Orientation Indicator. The yellow light on the platform control console indicates that the boom is swung beyond the rear and the machine may Drive/Steer in the opposite direction from the movement of the controls. If the indicator is illuminated, operate the Drive function in the following manner:

1. Match the black and white direction arrows on both platform control panel and the chassis to determine the direction the machine will travel.
2. Push and release the Drive Orientation Override switch. Within 3 seconds, slowly move the Drive control toward the arrow matching the intended direction of machine travel. The indicator light will flash during the 3 second interval until the drive function is selected.

Stability

Machine stability is based on two positions which are called FORWARD STABILITY and BACKWARD STABILITY. The machine's position of least forward stability is shown in Figure 4-4., and its position of least backward stability is shown in Figure 4-3.

⚠ WARNING

TO AVOID FORWARD OR BACKWARD UPSET, DO NOT OVERLOAD MACHINE OR OPERATE ON AN OUT-OF-LEVEL SURFACE.

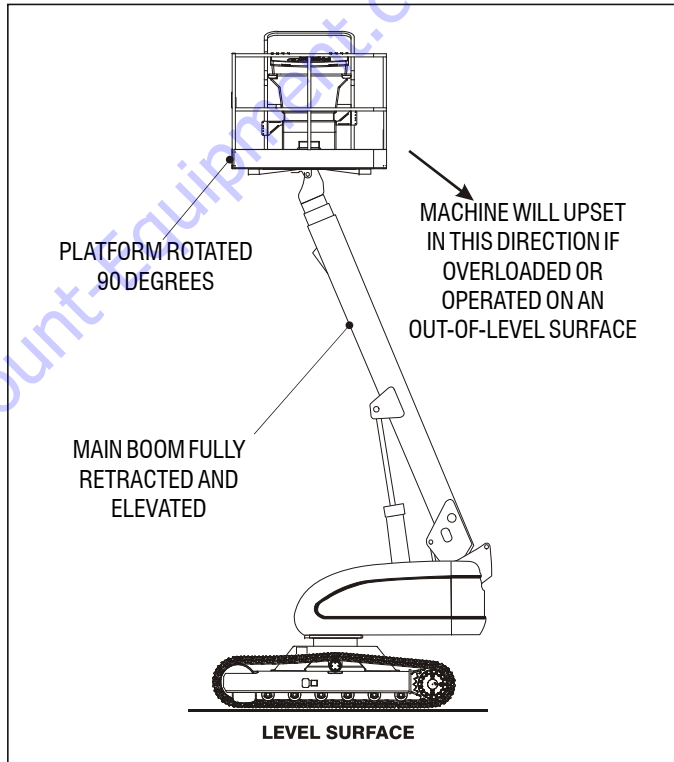

Figure 4-3. Position of Least Backward Stability

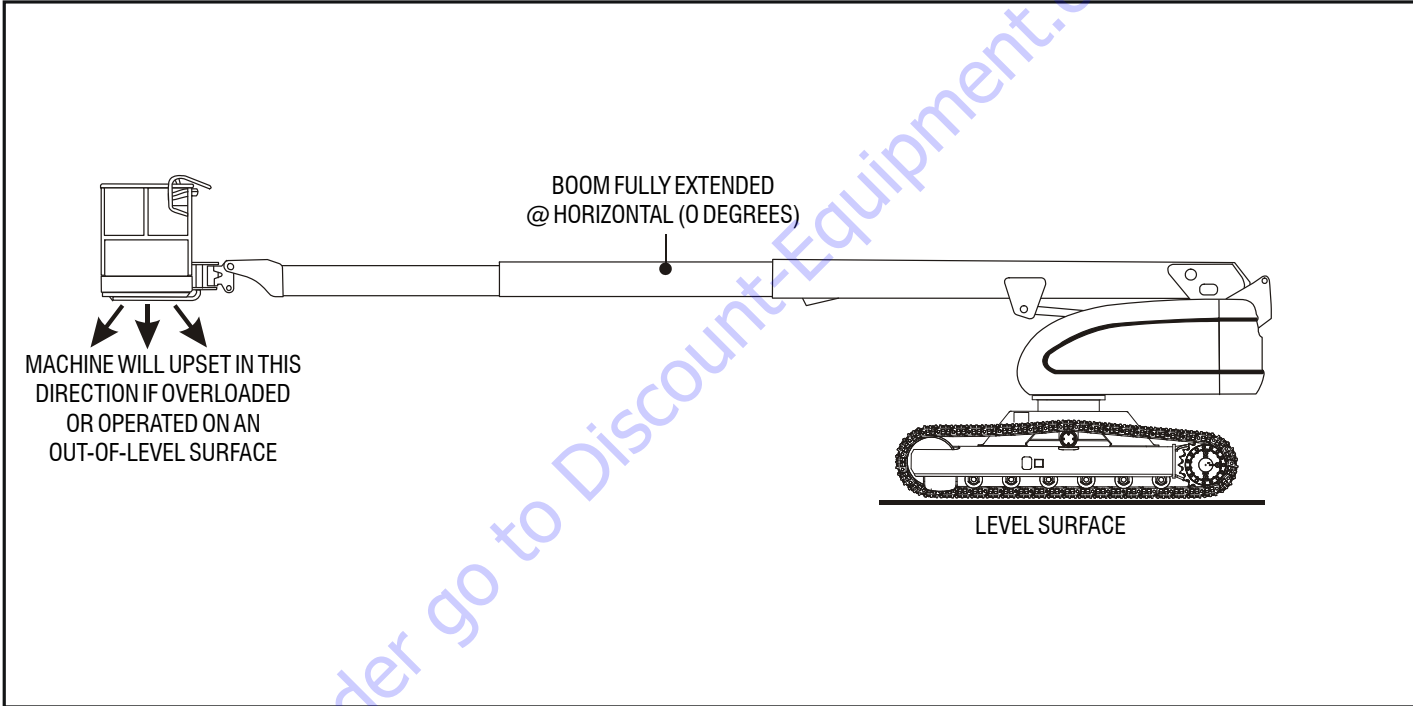

Figure 4-4. Position of Least Forward Stability

4.4 STEERING

Depress footswitch. Move the DRIVE/STEER control lever to RIGHT for a turn to the right and to LEFT for a turn to the left.

⚠ CAUTION

BEFORE OPERATING MACHINE, MAKE SURE BOOM IS POSITIONED OVER REAR OF CHASSIS. IF BOOM IS OVER FRONT OF THE CHASSIS, STEER AND DRIVE CONTROLS WILL MOVE IN OPPOSITE DIRECTION THAN INDICATED ON MACHINE PLACARDS.

4.5 PARKING AND STOWING

Park and stow machine as follows:

1. Park machine in travel position; boom lowered over rear, all access panels and doors closed and secured, ignition off, turntable locked.
2. Check that brakes hold machine in position.
3. Chock tracks front and rear.
4. Turn off SELECT switch and remove key.
5. When parking on frozen ground overnight, drive the machine up on boards to prevent freezing to the ground.

4.6 PLATFORM

Platform Level Adjustment

1. Leveling UP. Depress footswitch. To raise platform, position PLATFORM LEVEL control switch UP and hold until platform is level.
2. Leveling DOWN. Depress footswitch. To lower platform, position PLATFORM LEVEL control switch to DOWN and hold until platform is level.

⚠ WARNING

ONLY USE THE PLATFORM LEVELING OVERRIDE FUNCTION FOR SLIGHT LEVELING OF THE PLATFORM. INCORRECT USE COULD CAUSE THE LOAD/OCCUPANT TO SHIFT OR FALL. FAILURE TO DO SO COULD RESULT IN DEATH OR SERIOUS INJURY.

Platform Rotation

1. Depress footswitch to rotate platform to the left, PLATFORM ROTATE control is positioned to the LEFT and held until desired position is reached.
2. Depress footswitch to rotate platform to the right, PLATFORM ROTATE control is positioned to the RIGHT and held until desired position is reached.

4.7 BOOM

WARNING

A TILT ALARM WARNING LIGHT, LOCATED ON THE CONTROL CONSOLE, LIGHTS WHEN THE CHASSIS IS ON A SEVERE SLOPE (5 DEGREES OR GREATER). DO NOT SWING, EXTEND OR RAISE MAIN BOOM ABOVE HORIZONTAL WHEN LIT.

DO NOT DEPEND ON TILT ALARM AS A LEVEL INDICATOR FOR THE CHASSIS. TILT ALARM INDICATES CHASSIS IS ON A SEVERE SLOPE (5 DEGREES OR GREATER). CHASSIS MUST BE LEVEL BEFORE SWINGING, EXTENDING OR RAISING BOOM ABOVE HORIZONTAL.

TO AVOID UPSET, IF TILT ALARM WARNING LIGHT LIGHTS WHEN MAIN BOOM IS EXTENDED OR RAISED ABOVE HORIZONTAL, RETRACT AND LOWER PLATFORM TO NEAR GROUND LEVEL. THEN REPOSITION MACHINE SO THAT CHASSIS IS LEVEL BEFORE EXTENDING OR RAISING MAIN BOOM.

TRAVELING WITH MAIN BOOM RETRACTED AND BELOW HORIZONTAL IS PERMITTED ON GRADES AND SIDE SLOPES SPECIFIED ON CAUTION PLACARD AT PLATFORM.

TO AVOID SERIOUS INJURY, DO NOT OPERATE MACHINERY IF ANY CONTROL LEVERS OR TOGGLE SWITCHES CONTROLLING PLATFORM MOVEMENT DO NOT RETURN TO THE OFF OR NEUTRAL POSITION WHEN RELEASED.

TO AVOID A COLLISION AND INJURY IF PLATFORM DOES NOT STOP WHEN A CONTROL SWITCH OR LEVER IS RELEASED, REMOVE FOOT FROM FOOTSWITCH OR USE EMERGENCY STOP TO STOP THE MACHINE.

Swinging the Boom

NOTICE

ASSURE THAT TURNABLE LOCK IS DISENGAGED BEFORE STARTING ANY SWING OPERATION.

Depress footswitch. To swing boom, position SWING control switch or controller to RIGHT or LEFT for direction desired.

NOTE: When boom functions are being operated there an interlock prevents the use of DRIVE and STEER functions.

Raising and Lowering the Main Boom

To raise and lower Main Boom, position MAIN LIFT control switch or controller to UP OR DOWN and hold until desired height is reached.

Telescoping the Main Boom

To extend or retract Main Boom, position MAIN TELESCOPE control switch to IN or OUT and hold until platform reaches desired position.

4.8 SHUT DOWN AND PARK

1. Drive machine to a protected area.
2. Assure main boom is fully retracted and lowered over rear (Drive) axle; all access panels and doors closed and secured.
3. Remove all load and allow engine to operate 3-5 minutes at LOW setting to permit reduction of engine internal temperatures.
4. At Ground Controls, turn KEY SELECT switch to (center) OFF. Position POWER/EMERGENCY STOP switch (down) to OFF. Remove key.
5. Cover Platform Control console to protect instruction placards, warning decals and operating controls from hostile environment.

4.9 TIE DOWN AND LIFTING

Tie Down

NOTICE

WHEN TRANSPORTING THE MACHINE, THE BOOM MUST BE FULLY LOWERED INTO THE BOOM REST.

1. Place the boom in the stowed position with the turntable locked.
2. Remove all loose items from the machine.
3. Secure the chassis and the platform using straps or chains of adequate strength and attached to the designated tie down points. (See Figure 4-5., Machine Tie Down.)

Lifting

(See Figure 4-6., Lifting Chart)

1. Weigh the individual unit, refer to the Serial Number plate or call JLG Industries to find out the Gross Vehicle Weight.
2. Place the boom in the stowed position with the turntable locked.

3. Remove all loose items from the machine.
4. Attach lifting device and equipment only to the designated lifting points.
5. Properly adjust the rigging to prevent damage to the machine and so the machine remains level.

4.10 AUXILIARY POWER

A toggle type auxiliary power control switch is located on the platform control station and another is located on the ground control station. Operation of either switch turns on the electrically driven auxiliary hydraulic pump. This should be used in case of failure of the main power plant. The auxiliary pump will operate boom lift, telescope and swing. To activate auxiliary power:

1. Position PLATFORM/GROUND SELECT KEY SWITCH to PLATFORM.
2. Position POWER/EMERGENCY STOP switch to ON.
3. Depress and hold footswitch.
4. Operate appropriate control switch, lever or controller for desired function and hold.
5. Position AUXILIARY POWER switch to ON and hold.
6. Release AUXILIARY POWER switch, selected control switch, lever or controller, and footswitch.

7. Position POWER/EMERGENCY STOP switch to OFF.

To activate auxiliary power from the ground control station:

1. Position PLATFORM/GROUND SELECT KEY SWITCH to GROUND.
2. Position POWER/EMERGENCY STOP switch to ON.
3. Operate appropriate control switch or controller for desired function and hold.
4. Position AUXILIARY POWER switch to ON and hold.
5. Release AUXILIARY POWER switch, and appropriate control switch or controller.
6. Position POWER/EMERGENCY STOP switch to OFF.

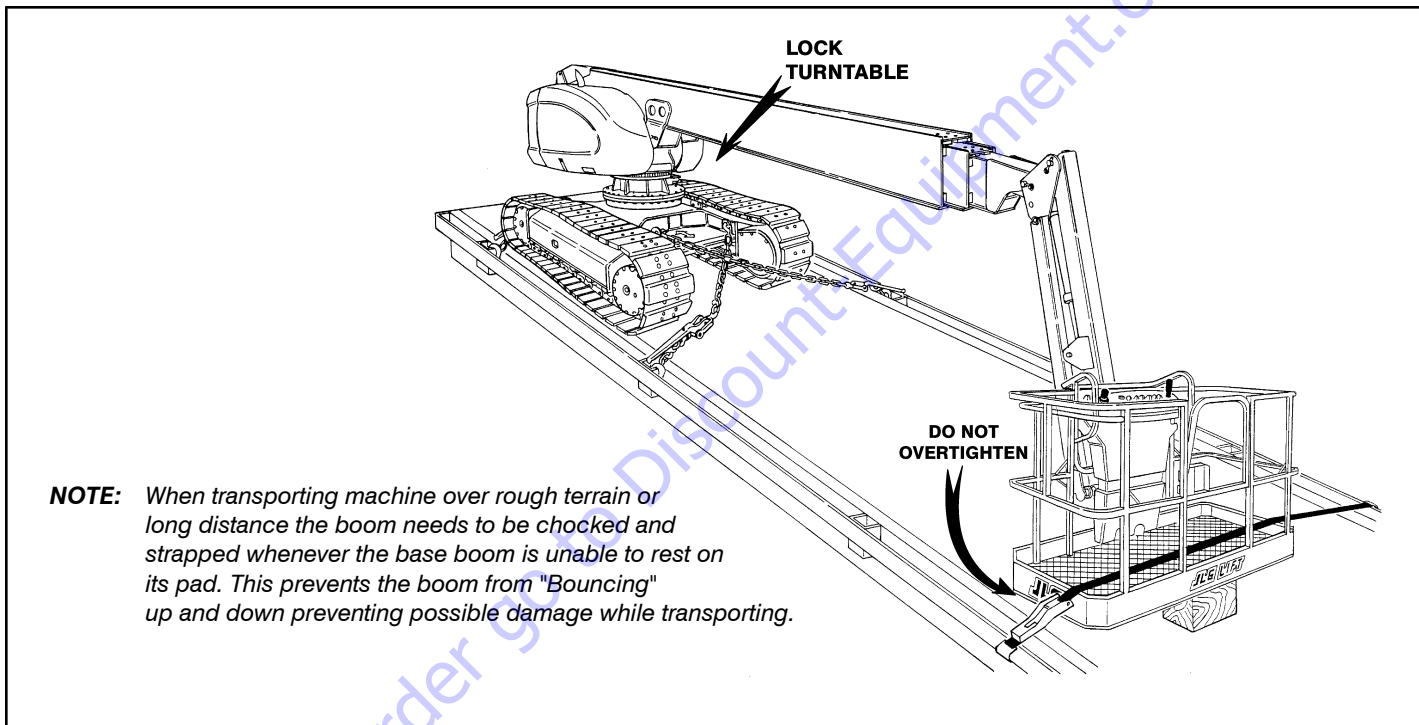

Figure 4-5. Machine Tie Down

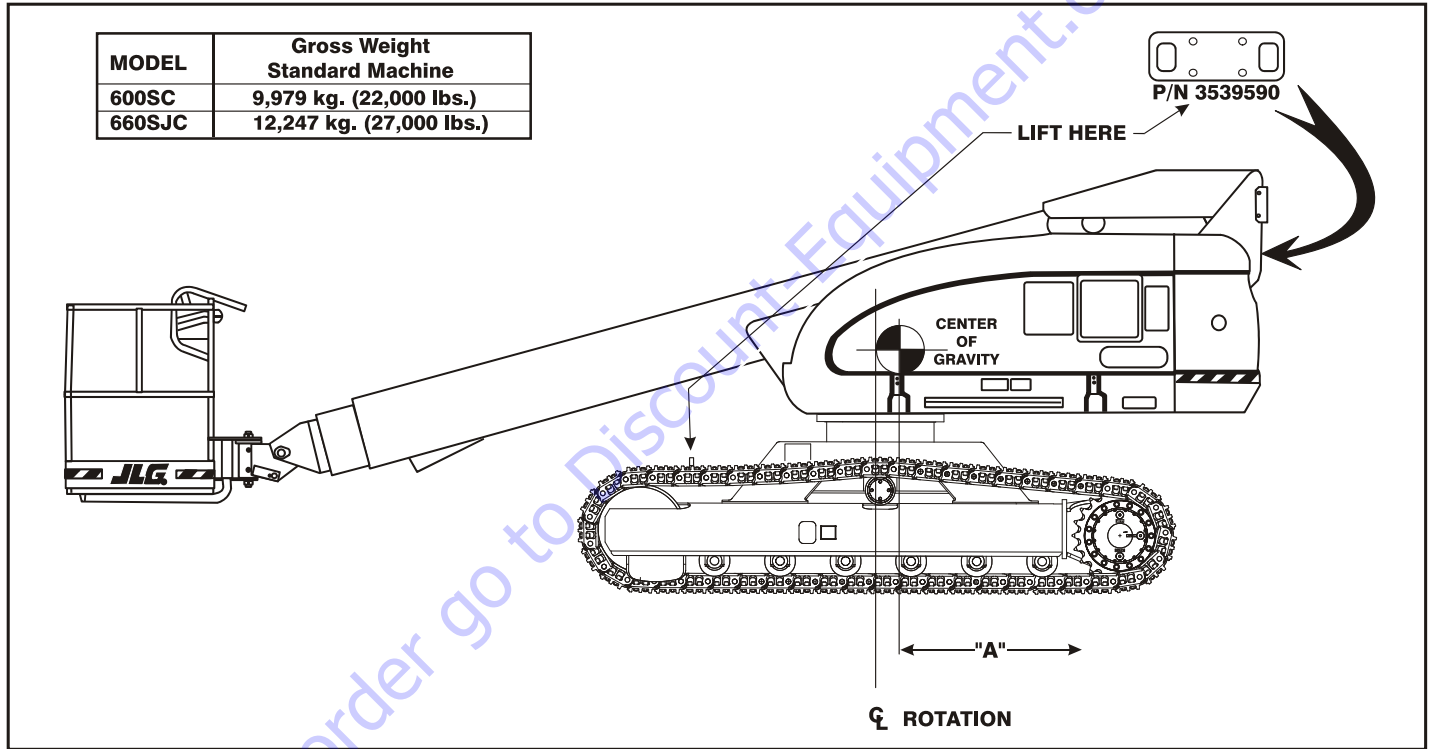

Figure 4-6. Lifting Chart

4.11 HYDRAULIC TOOL CIRCUIT INSTRUCTIONS (OPTIONAL)

Tool Circuit

To Operate: (with engine running and foot switch released).

1. Be sure hydraulic switch is in the "OFF" position. Located on the left side of platform below console box.

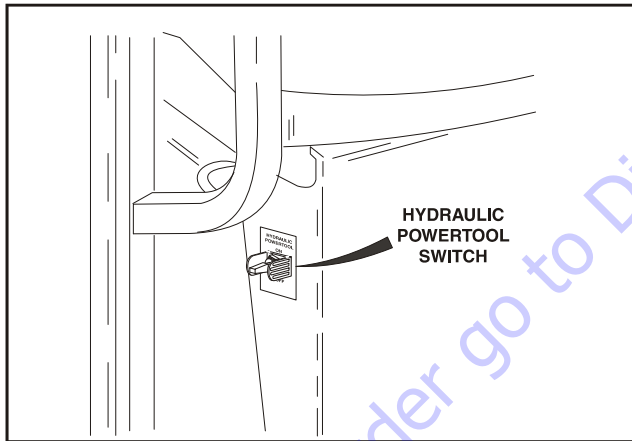

2. Make sure the hydraulic tool about to be operated is at a "safe" setting.

3. Plug tool into quick-disconnect fittings mounted on platform rail. The male quick connect is the pressure feed line.

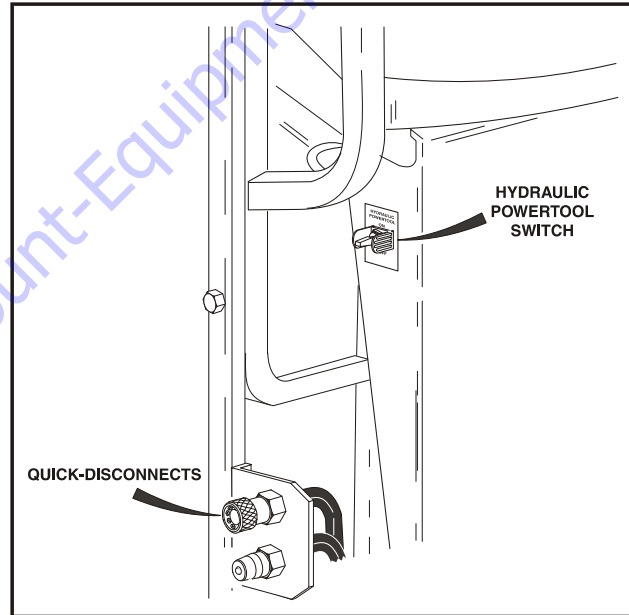

4. Set flow control knob to desired setting.

SECTION 4 - MACHINE OPERATION

NOTE: Each notch in the flow control knob corresponds to approximately 1 GPM (ex. setting 2 = 2 GPM). At setting seven (7) the pump has reached its maximum flow rate therefore any setting past 7 will produce no additional flow.

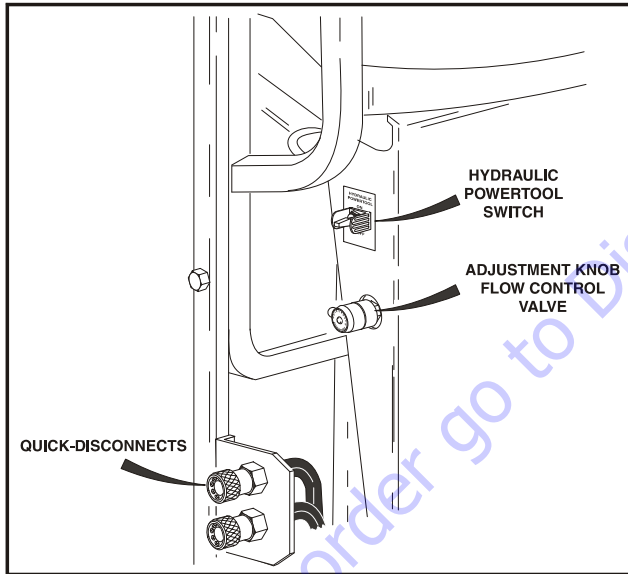

5. Turn hydraulic power tool switch to the "ON" position. Oil will now flow to the tool. It is possible to adjust the flow control knob during operation to achieve desired tool performance.
6. When finished, turn the hydraulic tool switch to the "OFF" position.
7. Disconnect tool from the quick-disconnects.

CAUTION

TURN HYDRAULIC TOOL SWITCH TO THE "OFF" POSITION IN ORDER TO SWITCH TOOLS.

NOTE: The tool circuit will not work with the foot switch depressed. If the foot switch is depressed during tool circuit operation the tool circuit will stop functioning until the foot switch is released.

NOTE: The tool is designed to operate at 2600 psi. If necessary this can be adjusted for a higher or lower pressure.

NOTE: With the foot switch released to operate the tool circuit all drive and boom functions are cut out.

4.12 PLACARDS AND DECALS

Read and understand all placards and decals. Do not operate any machine on which DANGER, WARNING, CAUTION OR INSTRUCTION PLACARDS OR DECALS ARE MISSING OR ILLEGIBLE. Replace placards and decals if damaged, missing or illegible.

Decals are made of Lexan Pressure Sensitive Adhesive with a protective film on the front. Remove the damaged decal and thoroughly clean surface before installing a new decal. Simply peel off, press on to surface.

NOTE: *Placards and Decals can be ordered by using part numbers located by each placard or decal. (See Figure 4-7., Figure 4-13., and Figure 4-15.)*

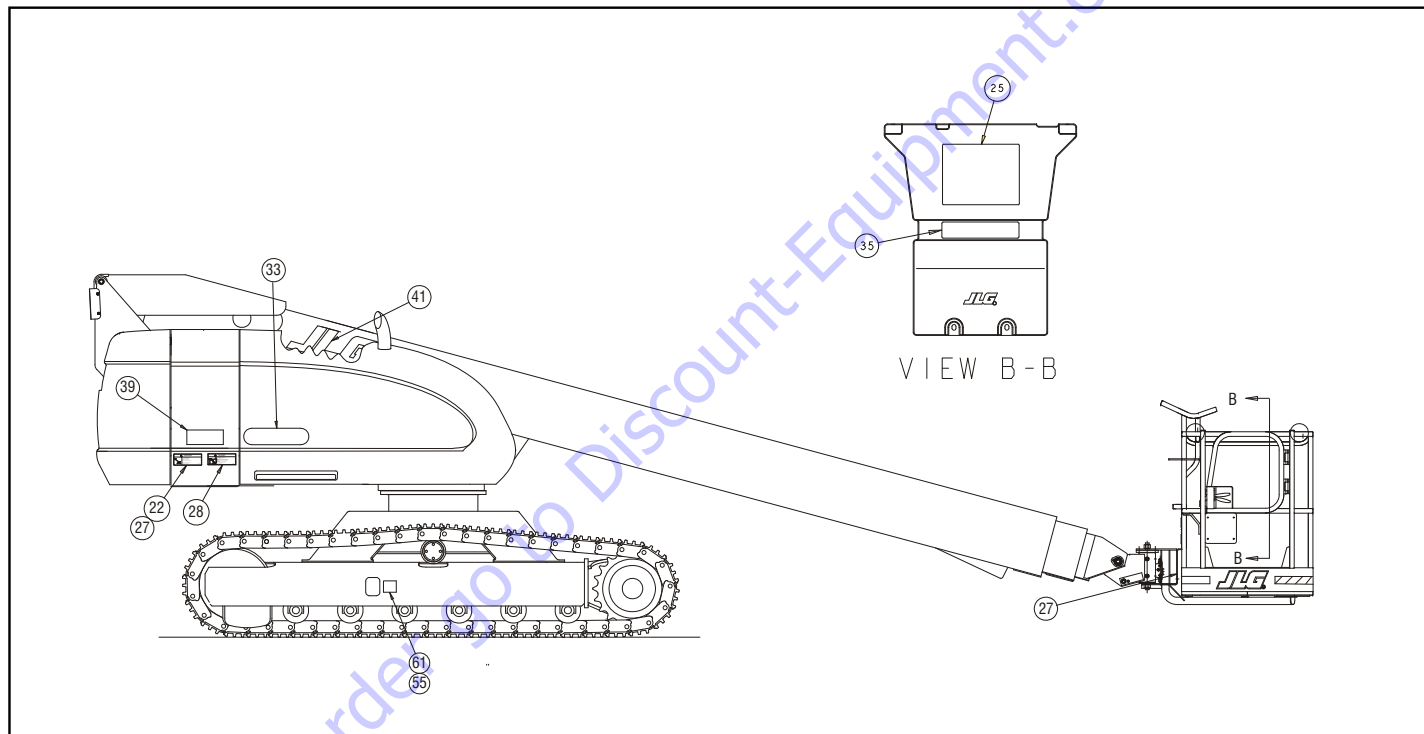

Figure 4-7. Decal Installation - Sheet 1 of 10

SECTION 4 - MACHINE OPERATION

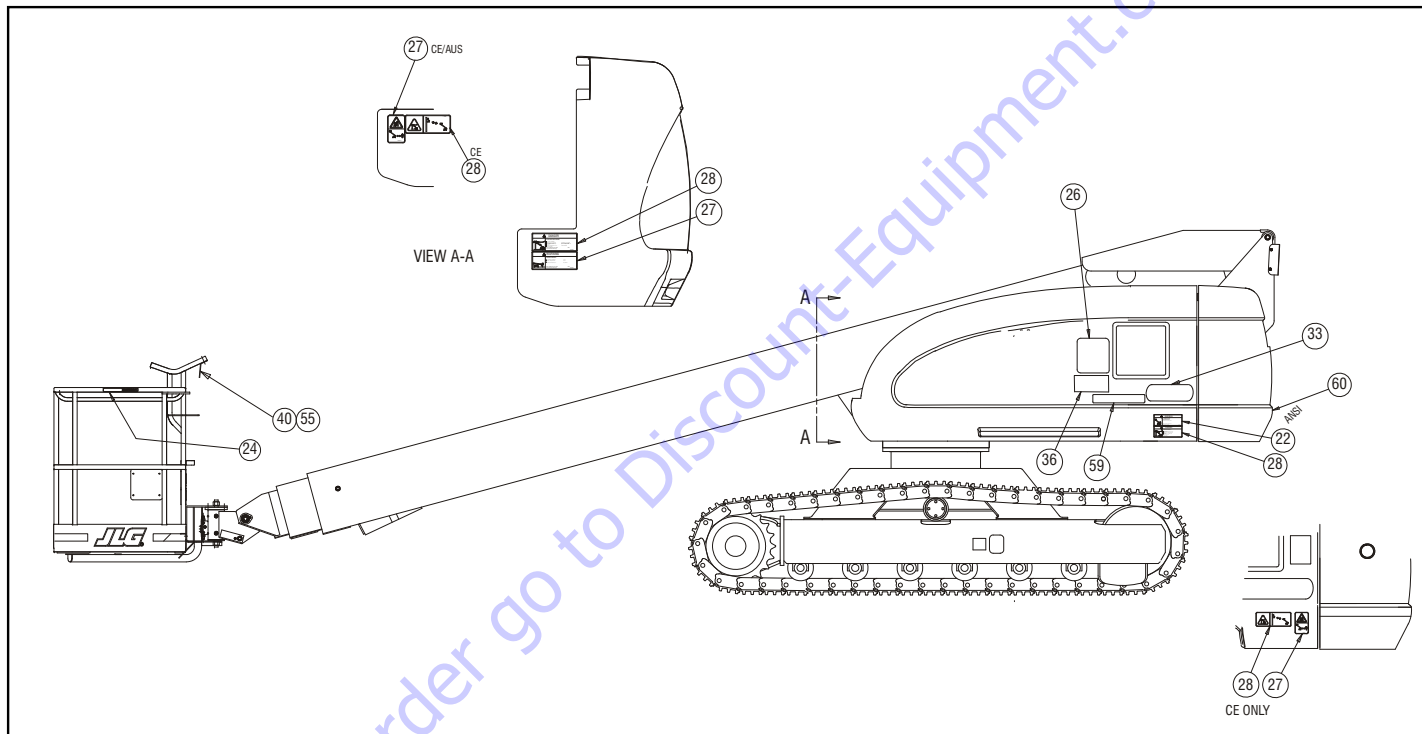

Figure 4-8. Decal Installation - Sheet 2 of 10

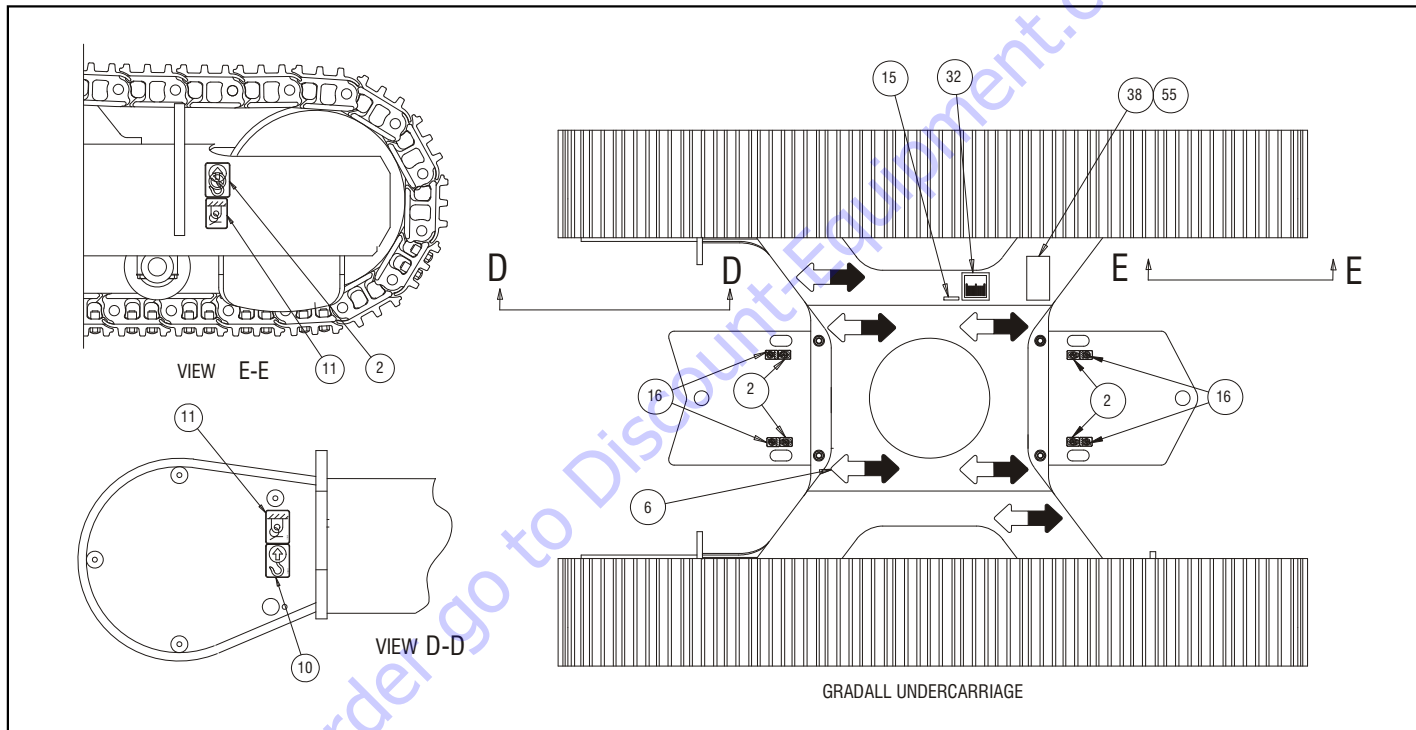

Figure 4-9. Decal Installation - Sheet 3 of 10

SECTION 4 - MACHINE OPERATION

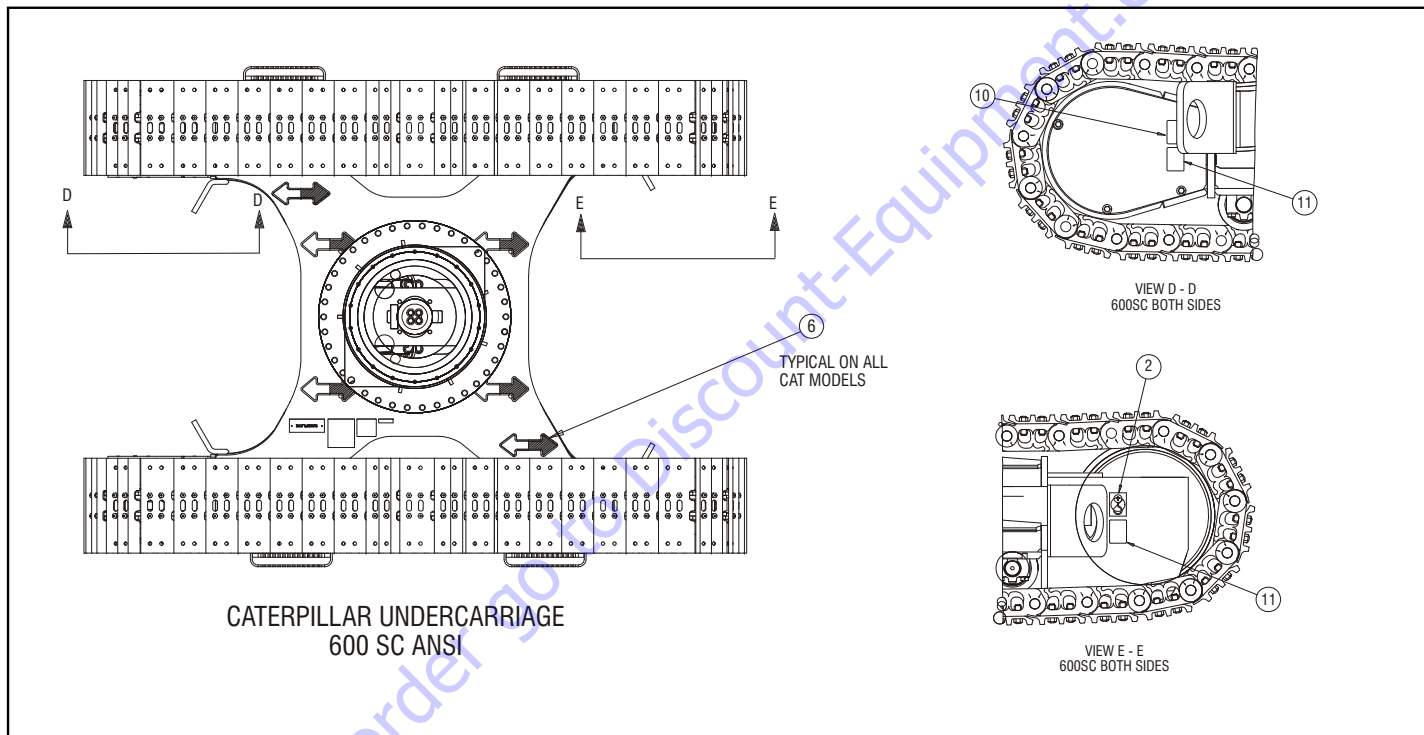

Figure 4-10. Decal Installation - Sheet 4 of 10

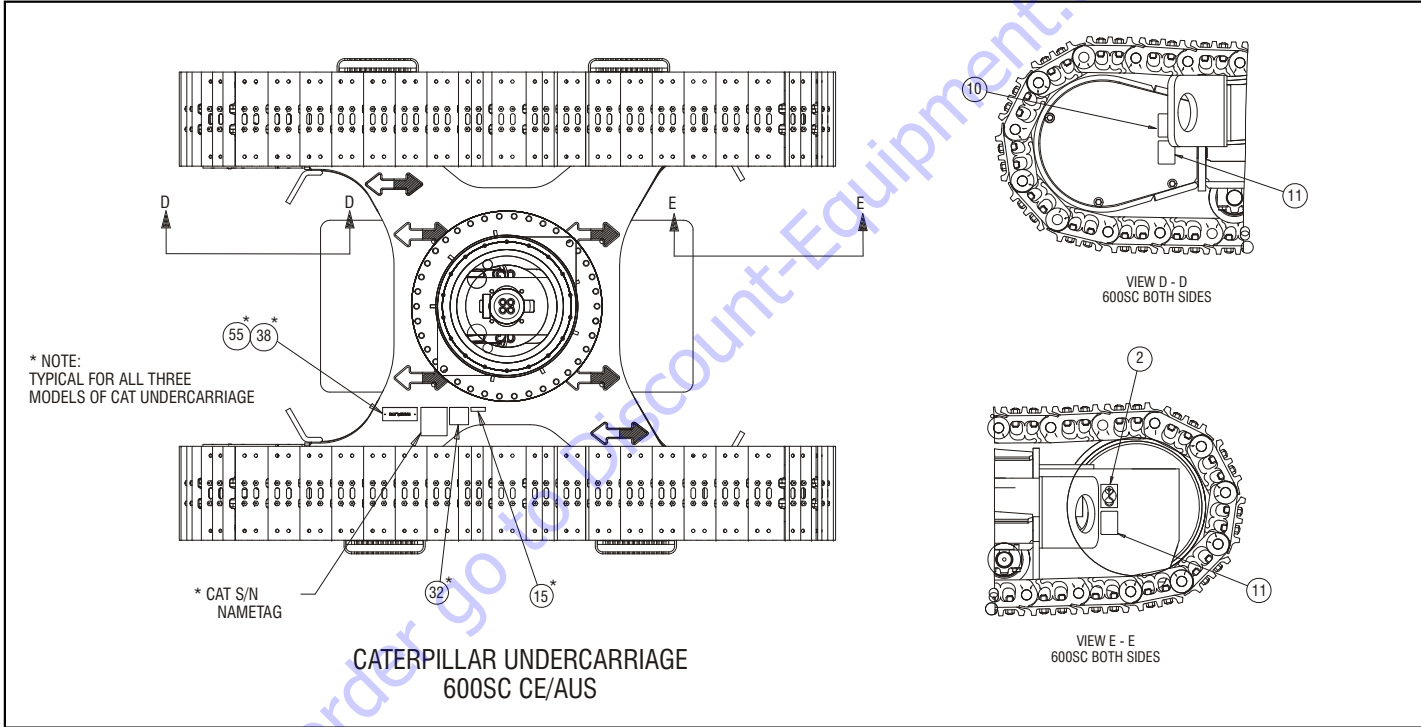

Figure 4-11. Decal Installation - Sheet 5 of 10

SECTION 4 - MACHINE OPERATION

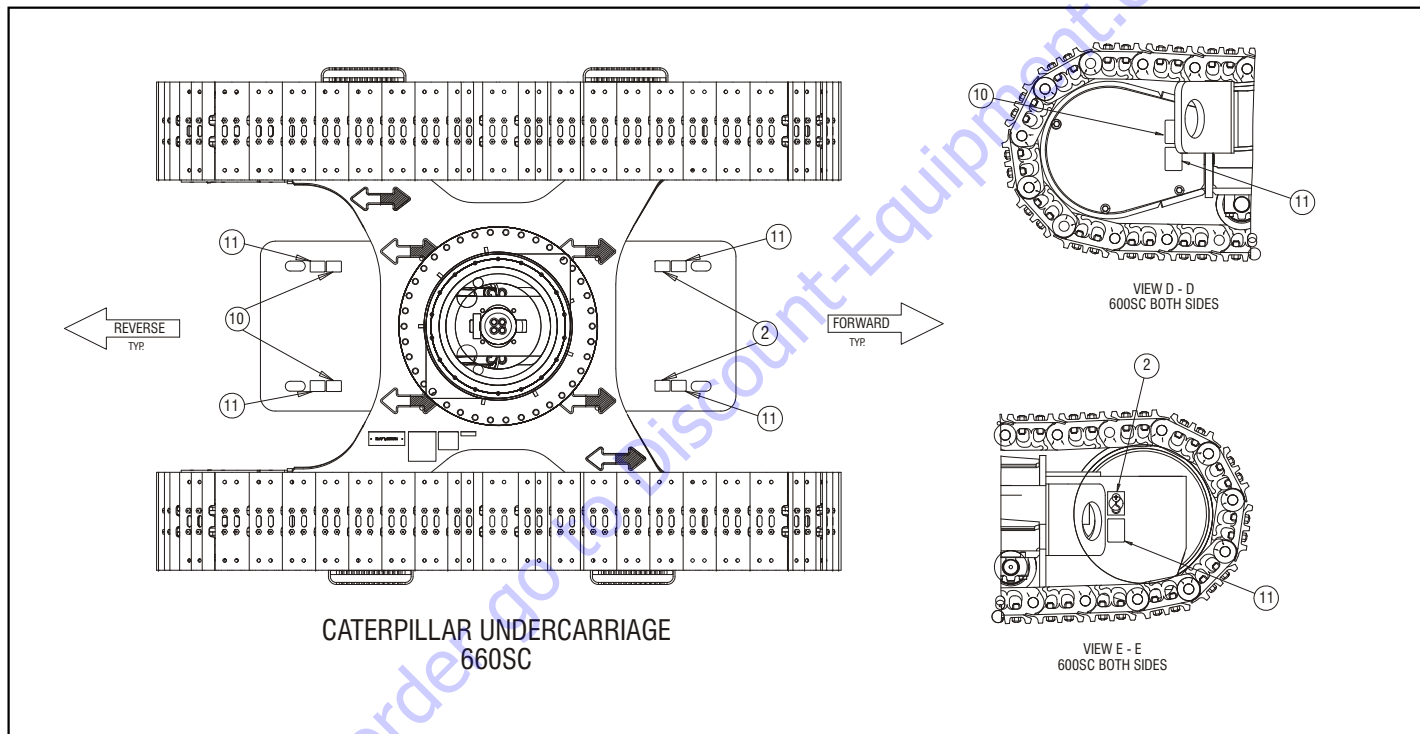

Figure 4-12. Decal Installation - Sheet 6 of 10

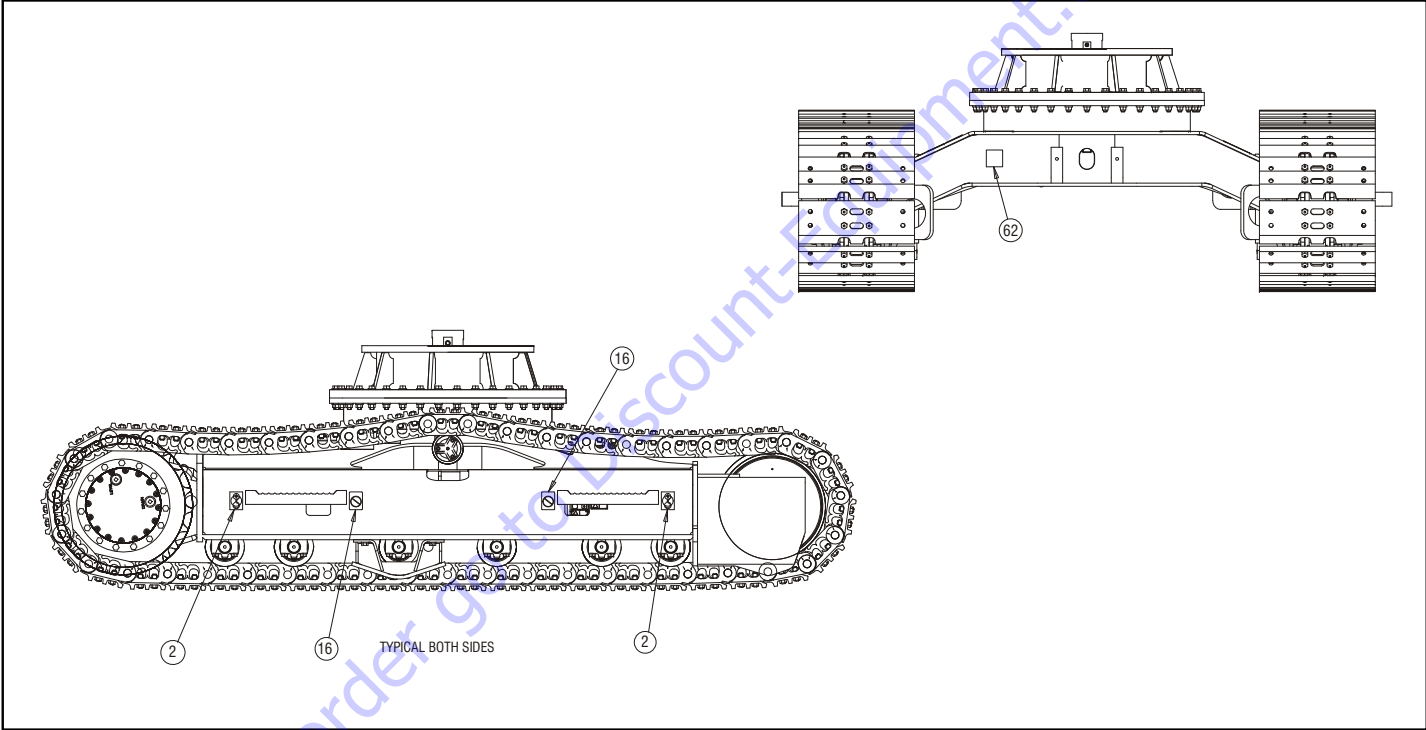

Figure 4-13. Decal Installation - Sheet 7 of 10

SECTION 4 - MACHINE OPERATION

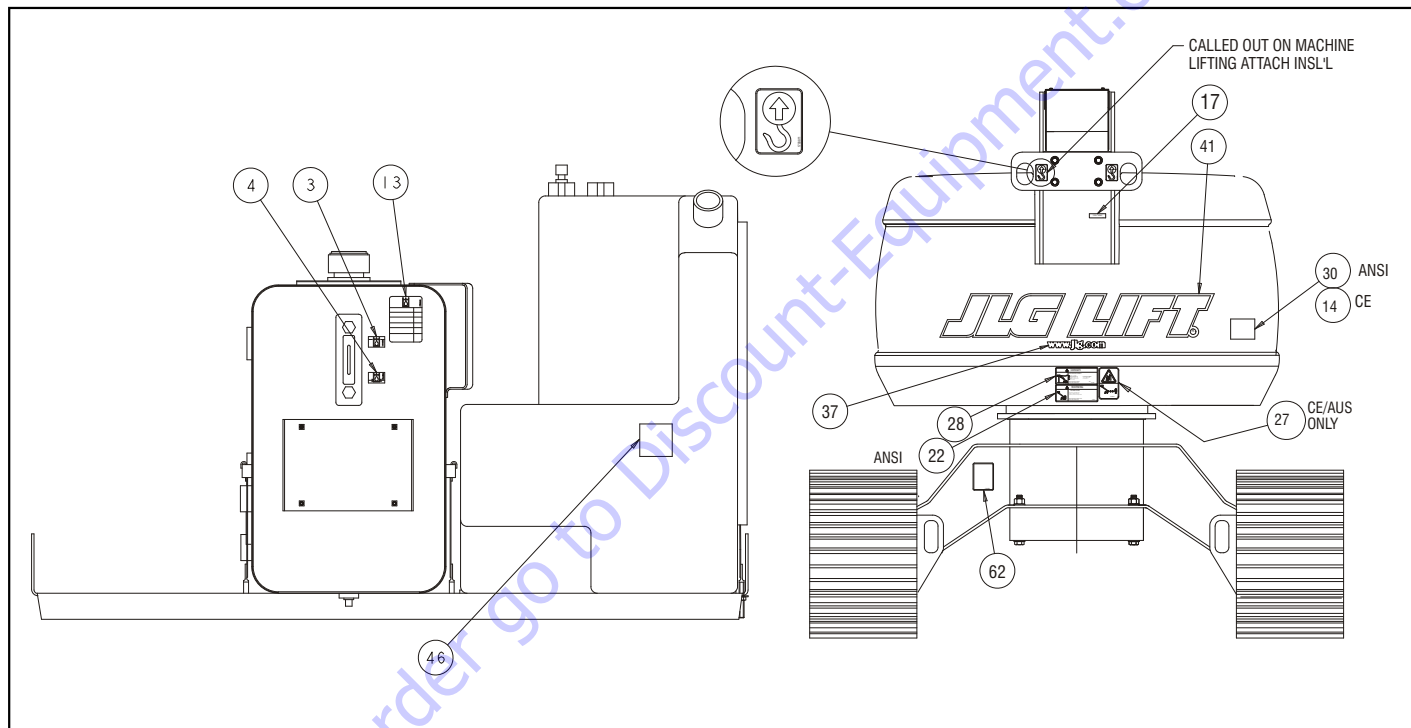

Figure 4-14. Decal Installation - Sheet 8 of 10

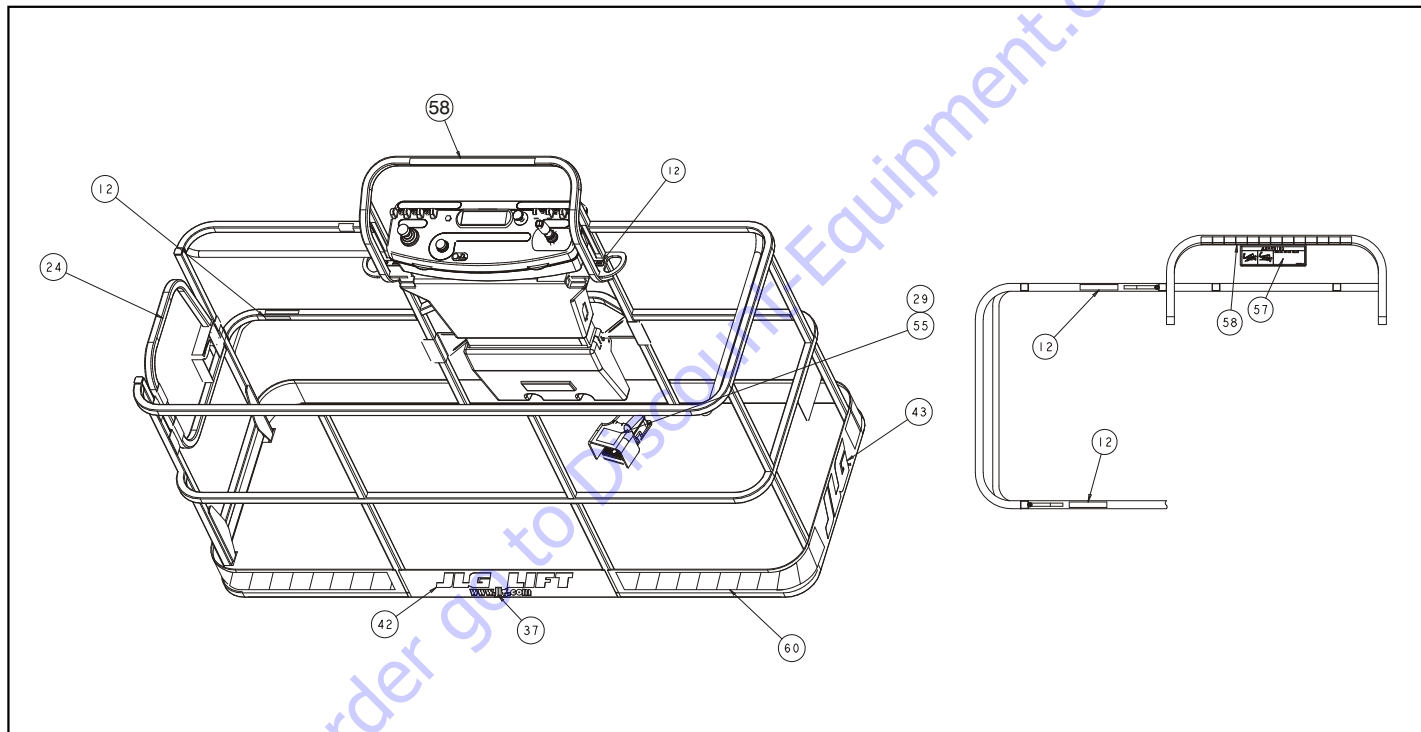

Figure 4-15. Decal Installation - Sheet 9 of 10

SECTION 4 - MACHINE OPERATION

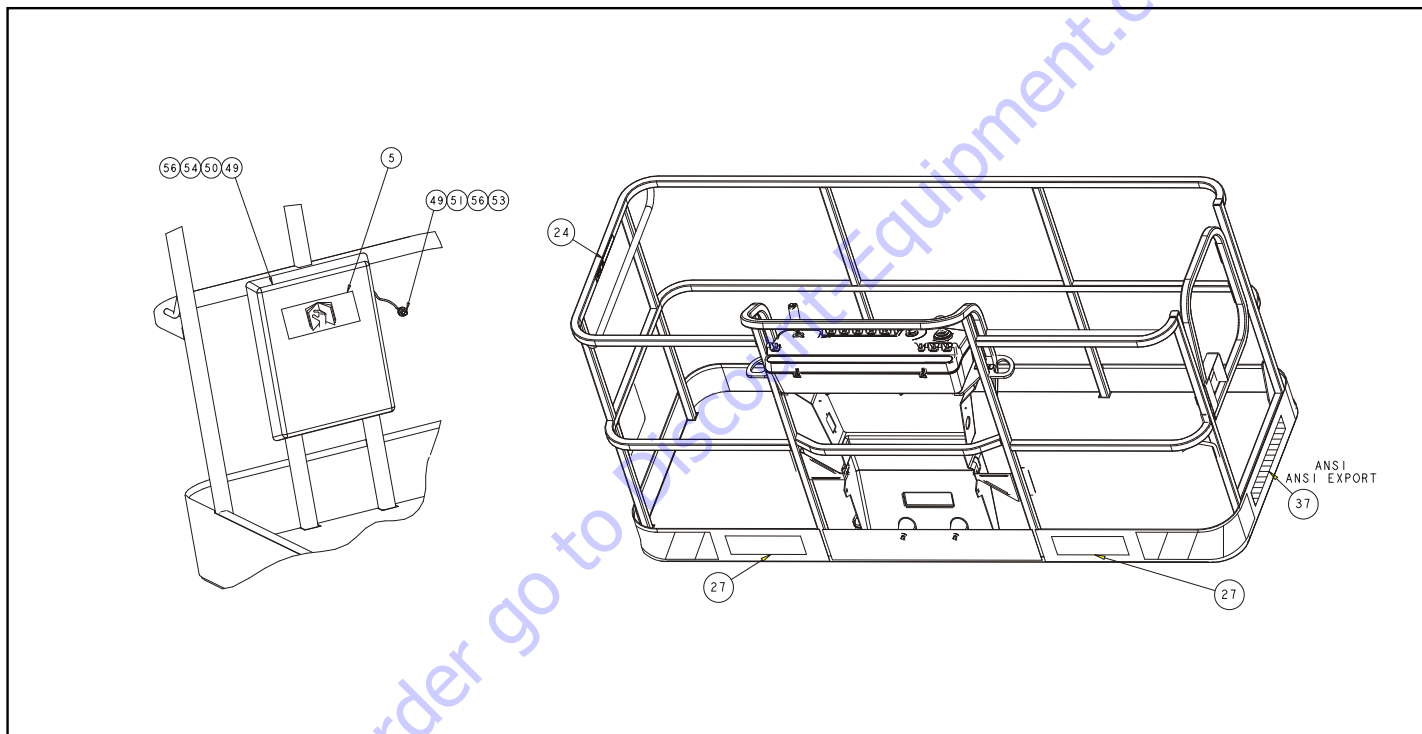

Figure 4-16. Decal Installation - Sheet 10 of 10

SECTION 4 - MACHINE OPERATION

Table 4-1. 600SC Decal Legend - Prior to S/N 0300148842

Item #	ANSI 0273906-6	Canadian French 0273982-7	CE/ Australian 0273985-5	English/ Portuguese 1001093424-4
1	--	--	--	--
2	1701499	1701499	1701499	1701499
3	1701502	1701502	1701502	1701502
4	1701503	1701503	1701503	1701503
5	1701509	1701509	1701509	1701509
6	1701529	1701529	1701529	1701529
7	--	--	--	--
8	--	--	--	--
9	--	--	--	--
10	1703811	1703811	1703811	1703811
11	1703814	1703814	1703814	1703814
12	1704277	1704277	1704277	1704277
13	1704412	1704412	1704412	1704412
14	1705084	1705084	1705084	1705084
15	1705514	1705514	1705514	1705514
16	1704461	1704461	1704461	1704461
17	3251243	3251243	3251243	3251243

Table 4-1. 600SC Decal Legend - Prior to S/N 0300148842

Item #	ANSI 0273906-6	Canadian French 0273982-7	CE/ Australian 0273985-5	English/ Portuguese 1001093424-4
18	--	--	--	--
19	--	--	--	1705904
20	--	--	--	1705906
21	--	--	--	1705901
22	1703953	1703942	--	1705903
23	--	--	--	--
24	1702868	1704000	--	1705967
25	1703797	1703924	1705921	1705895
26	1705336	1705347	1705822	1705896
27	1703804	1703948	1701518	1705898
28	1703805	1703936	1705961	1705897
29	--	1703984	1705828	1705902
30	3251813	3251813	--	3251813
31	--	--	--	--
32	1702631	1702631	1702631	1702631
33	1704434	1703165	1704434	1704434
34	--	--	--	--
35	1704096	1704099	1705978	1706380

SECTION 4 - MACHINE OPERATION

Table 4-1. 600SC Decal Legend - Prior to S/N 0300148842

Item #	ANSI 0273906-6	Canadian French 0273982-7	CE/ Australian 0273985-5	English/ Portuguese 1001093424-4
36	1707014	1707046	1705978	1707051
37	1704885	1704885	1704885	1704885
38	1706948	1706948	--	1706948
39	1705177	1705177	1705177	1705177
40	--	--	--	--
41	--	--	--	--
42	--	--	--	--
43	--	--	--	--
44	--	--	--	--
45	--	--	--	--
46	--	--	--	--
47	--	--	--	--
48	--	--	--	--
49	--	--	--	--
50	--	--	--	--
51	--	--	--	--
52	--	--	--	--
53	--	--	--	--

Table 4-1. 600SC Decal Legend - Prior to S/N 0300148842

Item #	ANSI 0273906-6	Canadian French 0273982-7	CE/ Australian 0273985-5	English/ Portuguese 1001093424-4
54	--	--	--	--
55	--	--	--	--
56	--	--	--	--
57	1704468	1001093684	1704468	1001093439
58	1001108494	1001108494	--	1001108494
59	1706943	1706943	--	1706943
60	--	--	--	--
61	--	--	--	--
62	1700584	1700584	1700584	1700584

SECTION 4 - MACHINE OPERATION

Table 4-2. 600SC Decal Legend - S/N 0300148842 to Present

Item #	ANSI 0273906-9	Canadian French 0273982-9	CE/ Austrian 0273985-6	English/ Portuguese 1001093424-7	Simplified Chinese 1001116970-3	Traditional Chinese 1001116971-3
1	--	--	--	--	--	--
2	1701499	1701499	1701499	1701499	1701499	1701499
3	1701502	1701502	1701502	1701502	1701502	1701502
4	1701503	1701503	1701503	1701503	1701503	1701503
5	1701509	1701509	1701509	1701509	1701509	1701509
6	1701529	1701529	1701529	1701529	1701529	1701529
7	--	--	--	--	--	--
8	--	--	--	--	--	--
9	--	--	--	--	--	--
10	1703811	1703811	1703811	1703811	1703811	1703811
11	1703814	1703814	1703814	1703814	1703814	1703814
12	1704277	1704277	1704277	1704277	1704277	1704277
13	1704412	1704412	1704412	1704412	1704412	1704412
14	1705084	1705084	1705084	1705084	1705084	1705084
15	1705514	1705514	1705514	1705514	1705514	1705514
16	1704461	1704461	1704461	1704461	1704461	1704461
17	3251243	3251243	3251243	3251243	3251243	3251243
18	--	--	--	--	--	--

SECTION 4 - MACHINE OPERATION

Table 4-2. 600SC Decal Legend - S/N 0300148842 to Present

Item #	ANSI 0273906-9	Canadian French 0273982-9	CE/ Australian 0273985-6	English/ Portuguese 1001093424-7	Simplified Chinese 1001116970-3	Traditional Chinese 1001116971-3
19	--	--	--	1705904	1705342	1001117034
20	--	--	--	1705906	1705507	1001117035
21	--	--	--	--	--	--
22	1703953	1703942	--	1705903	1001116845	1703943
23	--	--	--	--	--	--
24	1702868	1704000	--	1705967	1705968	1001116846
25	1703797	1703924	1705921	1705895	1001116847	1703925
26	1705336	1705347	1705822	1705896	1001116848	1001116849
27	1703804	1703948	1701518	1705898	1001116850	1703949
28	1703805	1703936	1705961	1705897	1703937	1001116851
29	--	1703984	1705828	1705902	1001116852	1703982
30	--	--	--	--	--	--
31	--	--	--	--	--	--
32	--	1702631	--	--	--	--
33	1704434	1703165	1704434	1704434	1704434	1704434
34	--	--	--	--	--	--
35	1001121800	1001121802	1705978	1001121806	1001121811	1001121809
36	1001121813	1001121815	1705978	1001121819	1001121824	1001121822

SECTION 4 - MACHINE OPERATION

Table 4-2. 600SC Decal Legend - S/N 0300148842 to Present

Item #	ANSI 0273906-9	Canadian French 0273982-9	CE/ Australian 0273985-6	English/ Portuguese 1001093424-7	Simplified Chinese 1001116970-3	Traditional Chinese 1001116971-3
37	1704885	1704885	1704885	1704885	1704885	1704885
38	1706948	1706948	--	1706948	1706948	1706948
39	1705177	1705177	1705177	1705177	1705177	1705177
40	--	--	--	--	--	--
41	--	--	--	--	--	--
42	--	--	--	--	--	--
43	--	--	--	--	--	--
44	--	--	--	--	--	--
45	--	--	--	--	--	--
46	--	--	--	--	--	--
47	--	--	--	--	--	--
48	--	--	--	--	--	--
49	--	--	--	--	--	--
50	--	--	--	--	--	--
51	--	--	--	--	--	--
52	--	--	--	--	--	--
53	--	--	--	--	--	--
54	--	--	--	--	--	--

SECTION 4 - MACHINE OPERATION

Table 4-2. 600SC Decal Legend - S/N 0300148842 to Present

Item #	ANSI 0273906-9	Canadian French 0273982-9	CE/ Australian 0273985-6	English/ Portuguese 1001093424-7	Simplified Chinese 1001116970-3	Traditional Chinese 1001116971-3
55	--	--	--	--	--	--
56	--	--	--	--	--	--
57	1704468	1001093684	1704468	1001093439	1001116963	1001116964
58	1001108494	1001108494	--	1001108494	1001108494	1001108494
59	1706943	1706943	--	1706943	1706943	1706943
60	--	--	--	--	--	--
61	--	--	--	--	--	--
62	1001131269	1001131269	--	--	--	--

SECTION 4 - MACHINE OPERATION

Table 4-3. 660SJC Decal Legend - Prior to S/N 0300148842

Item #	ANSI 0273908-7	Canadian French 0273984-7	CE/ Australian 0273987-6	English/ Portuguese 1001103292-3
1	--	--	--	--
2	1701499	1701499	1701499	1701499
3	1701502	1701502	1701502	1701502
4	1701503	1701503	1701503	1701503
5	1701509	1701509	1701509	1701509
6	1701529	1701529	1701529	1701529
7	--	--	--	--
8	--	--	--	--
9	--	--	--	--
10	1703811	1703811	1703811	1703811
11	1703814	1703814	1703814	1703814
12	1704277	1704277	1704277	1704277
13	1704412	1704412	1704412	1704412
14	1705084	1705084	1705084	1705084
15	1705514	1705514	1705514	1705514
16	1704461	1704461	1704461	1704461
17	3251243	3251243	3251243	3251243

Table 4-3. 660SJC Decal Legend - Prior to S/N 0300148842

Item #	ANSI 0273908-7	Canadian French 0273984-7	CE/ Australian 0273987-6	English/ Portuguese 1001103292-3
18	--	--	--	--
19	--	--	--	1705904
20	--	--	--	1705906
21	--	--	--	1705901
22	1703953	1703942	--	1705903
23	--	--	--	--
24	1702868	1704000	--	1705967
25	1703797	1703924	1705921	1705895
26	1705336	1705347	1705822	1705896
27	1703804	1703948	1701518	1705898
28	1703805	1703936	1705961	1705897
29	--	1703984	1705828	1705902
30	3251813	3251813	--	3251813
31	--	--	--	--
32	1702631	1702631	1702631	1702631
33	1703165	1703165	1703165	1703165
34	--	--	--	--
35	1701645	1707055	1705978	1701645

SECTION 4 - MACHINE OPERATION

Table 4-3. 660SJC Decal Legend - Prior to S/N 0300148842

Item #	ANSI 0273908-7	Canadian French 0273984-7	CE/ Australian 0273987-6	English/ Portuguese 1001103292-3
36	1707013	1707047	1705978	1707052
37	1704885	1704885	1704885	1704885
38	1706948	1706948	--	1706948
39	1705177	1705177	1705177	1705177
40	--	1001093553	--	--
41	--	--	--	--
42	--	--	--	--
43	--	--	--	--
44	--	--	--	--
45	--	--	--	--
46	--	--	--	--
47	--	--	--	--
48	--	--	--	--
49	--	--	--	--
50	--	--	--	--
51	--	--	--	--
52	--	--	--	--
53	--	--	--	--

Table 4-3. 660SJC Decal Legend - Prior to S/N 0300148842

Item #	ANSI 0273908-7	Canadian French 0273984-7	CE/ Australian 0273987-6	English/ Portuguese 1001103292-3
54	--	--	--	--
55	--	--	--	--
56	--	--	--	--
57	1704468	1001093684	1704468	1001093439
58	1001108494	1001108494	--	1001108494
59	1706943	1706943	--	1706943
60	--	--	--	--
61	--	--	--	--
62	1700584	1700584	1700584	1700584

SECTION 4 - MACHINE OPERATION

Table 4-4. 660SJC Decal Legend - S/N 0300148842 to Present

Item #	ANSI 0273908-10	Canadian French 0273984-9	CE/ Australian 0273987-7	English/ Portuguese 1001103292-6
1	--	--	--	--
2	1701499	1701499	1701499	1701499
3	1701502	1701502	1701502	1701502
4	1701503	1701503	1701503	1701503
5	1701509	1701509	1701509	1701509
6	1701529	1701529	1701529	1701529
7	--	--	--	--
8	--	--	--	--
9	--	--	--	--
10	1703811	1703811	1703811	1703811
11	1703814	1703814	1703814	1703814
12	1704277	1704277	1704277	1704277
13	1704412	1704412	1704412	1704412
14	1705084	1705084	1705084	1705084
15	1705514	1705514	1705514	1705514
16	1704461	1704461	1704461	1704461
17	3251243	3251243	3251243	3251243

Table 4-4. 660SJC Decal Legend - S/N 0300148842 to Present

Item #	ANSI 0273908-10	Canadian French 0273984-9	CE/ Australian 0273987-7	English/ Portuguese 1001103292-6
18	--	--	--	--
19	--	--	--	1705904
20	--	--	--	1705906
21	--	--	--	--
22	1703953	1703942	--	1705903
23	--	--	--	--
24	1702868	1704000	--	1705967
25	1703797	1703924	1705921	1705895
26	1705336	1705347	1705822	1705896
27	1703804	1703948	1701518	1705898
28	1703805	1703936	1705961	1705897
29	3532347	1703984	1705828	1705902
30	--	--	--	3251813
31	--	--	--	--
32	--	1702631	--	--
33	1703165	1703165	1703165	1703165
34	--	--	--	--
35	1001121801	1001121803	1705978	1001121801

SECTION 4 - MACHINE OPERATION

Table 4-4. 660SJC Decal Legend - S/N 0300148842 to Present

Item #	ANSI 0273908-10	Canadian French 0273984-9	CE/ Australian 0273987-7	English/ Portuguese 1001103292-6
36	1001121814	1001121816	1705978	1001121655
37	1704885	1704885	1704885	1704885
38	1706948	1706948	--	1706948
39	1705177	1705177	1705177	1705177
40	--	1001093553	--	1001093553
41	--	--	--	--
42	--	--	--	--
43	--	--	--	--
44	--	--	--	--
45	--	--	--	--
46	--	--	--	--
47	--	--	--	--
48	--	--	--	--
49	--	--	--	--
50	--	--	--	--
51	--	--	--	--
52	--	--	--	--
53	--	--	--	--

Table 4-4. 660SJC Decal Legend - S/N 0300148842 to Present

Item #	ANSI 0273908-10	Canadian French 0273984-9	CE/ Australian 0273987-7	English/ Portuguese 1001103292-6
54	--	--	--	--
55	--	--	--	--
56	--	--	--	--
57	1704468	1001093684	1704468	1001093439
58	1001108494	1001108494	--	1001108494
59	1706943	1706943	--	1706943
60	--	--	--	--
61	--	--	--	--
62	1001131269	1001131269	--	--

TO PURCHASE THIS PRODUCT PLEASE CONTACT US



**Equipment Financing and
Extended Warranties Available**



**Discount-Equipment.com is your online resource for
commercial and industrial quality parts and equipment sales.**

561-964-4949

visit us on line @ www.discount-equipment.com

Select an option below to find your Equipment

Search by Manufacturer

Search by Product Type

Request a Quote

We sell worldwide for the brands: Genie, Terex, JLG, MultiQuip, Mikasa, Essick, Whiteman, Mayco, Toro Stone, Diamond Products, Generac Magnum, Airman, Haulotte, Barreto, Power Blanket, Nifty Lift, Atlas Copco, Chicago Pneumatic, Allmand, Miller Curber, Skyjack, Lull, Skytrak, Tsurumi, Husquvarna Target, Stow, Wacker, Sakai, Mi-T-M, Sullair, Basic, Dynapac, MBW, Weber, Bartell, Bennar Newman, Haulotte, Ditch Runner, Menegotti, Morrison, Contec, Buddy, Crown, Edco, Wyco, Bomag, Laymor, EZ Trench, Bil-Jax, F.S. Curtis, Gehl Pavers, Heli, Honda, ICS/PowerGrit, IHI, Partner, Imer, Clipper, MMD, Koshin, Rice, CH&E, General Equipment, Amida, Coleman, NAC, Gradall, Square Shooter, Kent, Stanley, Tamco, Toku, Hatz, Kohler, Robin, Wisconsin, Northrock, Oztec, Toker TK, Rol-Air, APT, Wylie, Ingersoll Rand / Doosan, Innovatech, Con X, Ammann, Mecalac, Makinex, Smith Surface Prep, Small Line, Wanco, Yanmar

SECTION 5. EMERGENCY PROCEDURES

5.1 GENERAL

This section explains the steps to be taken in case of an emergency situation while operating.

5.2 INCIDENT NOTIFICATION

JLG Industries, Inc. must be notified immediately of any incident involving a JLG product. Even if no injury or property damage is evident, the factory should be contacted by telephone and provided with all necessary details.

In USA:

JLG Phone: 877-JLG-SAFE (554-7233)
(8am till 4:45pm EST)

Outside USA:

240-420-2661

E-mail:

ProductSafety@JLG.com

Failure to notify the manufacturer of an incident involving a JLG Industries product within 48 hours of such an occurrence may void any warranty consideration on that particular machine.

NOTICE

FOLLOWING ANY ACCIDENT, THOROUGHLY INSPECT THE MACHINE AND TEST ALL FUNCTIONS FIRST FROM THE GROUND CONTROLS, THEN FROM THE PLATFORM CONTROLS. DO NOT LIFT ABOVE 3 M (10 FT.) UNTIL YOU ARE SURE THAT ALL DAMAGE HAS BEEN REPAIRED, IF REQUIRED, AND THAT ALL CONTROLS ARE OPERATING CORRECTLY.

5.3 EMERGENCY OPERATION

Operator Unable to Control Machine

IF THE PLATFORM OPERATOR IS PINNED, TRAPPED OR UNABLE TO OPERATE OR CONTROL MACHINE:

1. Other personnel should operate the machine from ground controls only as required.
2. Other qualified personnel on the platform may use the platform controls. **DO NOT CONTINUE OPERATION IF CONTROLS DO NOT FUNCTION PROPERLY.**
3. Cranes, forklift trucks or other equipment can be used to remove platform occupants and stabilize motion of the machine.

Platform or Boom Caught Overhead

If the platform or boom becomes jammed or snagged in overhead structures or equipment, rescue platform occupants prior to freeing the machine.

SECTION 6. GENERAL SPECIFICATIONS & OPERATOR MAINTENANCE

6.1 INTRODUCTION

This section of the manual provides additional necessary information to the operator for proper operation and maintenance of this machine.

The maintenance portion of this section is intended as information to assist the machine operator to perform daily maintenance tasks only, and does not replace the more thorough Preventive Maintenance and Inspection Schedule included in the Service and Maintenance Manual.

Other Publications Available:

Service and Maintenance Manual	3121157
Illustrated Parts Manual (Prior to S/N - 128000 Gradall Chassis).....	3121158
Illustrated Parts Manual (S/N - 128000 to Present) ..	3121251

6.2 OPERATING SPECIFICATIONS

Table 6-1. Operating Specifications - Prior to S/N 0300148842

Maximum Work Load (Capacity) Unrestricted:	500 lb. (230 kg)
Restricted - 600SC	1000 lb. (450 kg)
Restricted - 660SJC	500 lb. (230 kg)
Maximum Travel Grade (Gradeability) *	55%
Maximum Travel Grade (Side Slope) *	5°
Max. Vertical Platform Height:	
600SC	60 ft. 3 in. (18.36 m)
660SJC	66 ft. 8 in. (20.32 m)
Max. Horizontal Platform Reach:	
600SC	49 ft. 6 in. (15.09 m)
660SJC	56 ft. 9 in. (17.3 m)
Turning Radius	0
Maximum Ground Bearing Pressure	
600SC	5.45 psi (0.383 kg/cm ²)
660SJC	6.5 psi (0.457 kg/cm ²)
Maximum Drive Speed:	1.6 mph (2.6 kph)

SECTION 6 - GENERAL SPECIFICATIONS & OPERATOR MAINTENANCE

Table 6-1. Operating Specifications - Prior to S/N 0300148842

Max. Hydraulic System Pressure	4500 psi (310 Bar)
Maximum Wind Speed	28 mph (12.5 m/s)
Maximum Manual Force	101 lb. (450 N)
Electrical System Voltage	12 Volts
Gross Machine Weight (Platform Empty)	
600SC	22,500 lb. (10,205 kg)
660SJC	27,100 lb. (12,292 kg)

* With boom in stowed position.

Table 6-2. Operating Specifications - S/N 0300148842 to Present

Maximum Work Load (Capacity) - ANSI	
Unrestricted:	500 lb. (227 kg)
Restricted - 600SC	1000 lb. (454 kg)
Restricted - 660SJC	500 lb. (227 kg)
Maximum Work Load (Capacity) - CE & Australia	
Unrestricted:	500 lb. (230 kg)
Restricted - 600SC	1000 lb. (450 kg)
Restricted - 660SJC	500 lb. (230 kg)
Maximum Travel Grade (Gradeability)*	55%

Table 6-2. Operating Specifications - S/N 0300148842 to Present

Maximum Travel Grade (Side Slope)*	5°
Max. Vertical Platform Height:	
600SC	60 ft. 3 in. (18.36 m)
660SJC	66 ft. 8 in. (20.32 m)
Max. Horizontal Platform Reach:	
600SC	49 ft. 6 in. (15.09 m)
660SJC	56 ft. 9 in. (17.3 m)
Turning Radius	0
Maximum Ground Bearing Pressure	
600SC	5.45 psi (0.383 kg/cm ²)
660SJC	6.5 psi (0.457 kg/cm ²)
Maximum Drive Speed:	1.6 mph (2.6 kph)
Max. Hydraulic System Pressure	4500 psi (310 Bar)
Maximum Wind Speed	28 mph (12.5 m/s)
Maximum Manual Force	101 lb. (450 N)
Electrical System Voltage	12 Volts
Gross Machine Weight (Platform Empty)	
600SC	22,500 lb. (10,205 kg)
660SJC	27,100 lb. (12,292 kg)

* With boom in stowed position.

Capacities

Table 6-3. Capacities

Fuel Tank	39 US. Gallons (147.6 L)
Hydraulic Oil Tank	31 U.S. Gallons (117.3 L)
Hydraulic System (Including Tank)	37.2 U.S. Gallons (140.8 L)
Engine Crankcase	
Deutz w/Filter	11 quarts (10.5 L)
Caterpillar (w/filter)	10.6 quarts (10 L)

Engine Data

Table 6-4. Deutz F4M1011F/F4M2011 Specifications

Fuel	Diesel
Oil Capacity	
Cooling System	5 Quarts (4.5 L)
Crankcase	11 Quarts (10.5 L) w/Filter
Total Capacity	16 Quarts (15 L)
Idle RPM	1000
Low RPM	1800
High RPM	2800
Alternator	60 Amp, belt drive
Battery	1000 Cold Cranking Amps, 210 Minutes Reserve Capacity, 12 VDC
Fuel Consumption	
Low RPM	1.90 GPH (7.19 lph)
High RPM	2.50 GPH (9.46 lph)
Horsepower	65 @ 3000 RPM, full load

SECTION 6 - GENERAL SPECIFICATIONS & OPERATOR MAINTENANCE

Table 6-5. Caterpillar 3044C/3.4

Type	Four Stroke Cycle
Cylinders	4 in-line
Bore	3.70 inch (94 mm)
Stroke	4.72 inch (120 mm)
Aspiration	turbocharged
Compression ratio	19:1
Displacement	203 in ³ (3.33 L)
Firing Order	1-3-4-2
Rotation (viewed from flywheel)	Counterclockwise
Oil Capacity (w/filter)	10.6 quarts (10 L)
Cooling System (Engine Only)	5.8 quarts (5.5 L)
Idle RPM - 3044C	1000
Idle RPM - 3.4	1200
Low RPM	1800
High RPM	2600
Alternator	60 Amp, belt drive

Hydraulic Oil

Table 6-6. Hydraulic Oil

HYDRAULIC SYSTEM OPERATING TEMPERATURE RANGE	SAE VISCOSITY GRADE
+0° to +180° F (-18° C to +83° C)	10W
+0° F to +210° F (-18° C to +99° C)	10W-20, 10W-30
+50° F to +210° F (+10° C to +210° C)	20W-20

NOTE: Hydraulic oils must have anti-wear qualities at least to API Service Classification GL-3, and sufficient chemical stability for mobile hydraulic system service. JLG Industries recommends Mobilfluid 424 hydraulic oil, which has an SAE viscosity index of 152.

NOTE: When temperatures remain below 20° F (-7 degrees C), JLG Industries recommends the use of Mobil DTE 13M.

Aside from JLG recommendations, it is not advisable to mix oils of different brands or types, as they may not contain the same required additives or be of comparable viscosities. If use of hydraulic oil other than Mobilfluid 424 is desired, contact JLG Industries for proper recommendations.

SECTION 6 - GENERAL SPECIFICATIONS & OPERATOR MAINTENANCE

Table 6-7. Mobilfluid 424 Specs

SAE Grade	10W30
Gravity, API	29.0
Density, Lb/Gal. 60°F	7.35
Pour Point, Max	-46°F (-43°C)
Flash Point, Min.	442°F (228°C)
Viscosity	
Brookfield, cP at -18°C	2700
at 40° C	55 cSt
at 100° C	9.3 cSt
Viscosity Index	152

Table 6-8. Mobil DTE 13M Specs

ISO Viscosity Grade	#32
Specific Gravity	0.877
Pour Point, Max	-40°F (-40°C)
Flash Point, Min.	330°F (166°C)
Viscosity	
at 40° C	33cSt
at 100° C	6.6 cSt
at 100° F	169 SUS
at 210° F	48 SUS
cp at -20° F	6,200
Viscosity Index	140

SECTION 6 - GENERAL SPECIFICATIONS & OPERATOR MAINTENANCE

Table 6-9. Exxon Unavis HVI 26 Specs

Specific Gravity	32.1
Pour Point	-76°F (-60°C)
Flash Point	217°F (103°C)
Viscosity	
at 40° C	25.8 cSt
at 100° C	9.3 cSt
Viscosity Index	376
NOTE: Mobil/Exxon recommends that this oil be checked on a yearly basis for viscosity.	

Table 6-10. Quintolubric 888-46

Density	0.91 @ 15°C (59°F)
Pour Point	< -20°C (< -4°F)
Flash Point	275°C (527°F)
Fire Point	325°C (617°F)
Autoignition Temperature	450°C (842°F)
Viscosity	
at 0° C (32°F)	360 cSt
at 20° C (68°F)	102 cSt
at 40° C (104°F)	46 cSt
at 100° C (212°F)	10 cSt
Viscosity Index	220

Major Component Weights

Table 6-11. Major Component Weights

	660SJ		600S	
	LB.	KG.	LB.	KG.
Platform Control Console	250	113	250	113
Platform Level Cylinder	60	27	46	21
Main Boom (Includes Lift Cyl., Rotator, and Support)	3783	1716	3527	1600
Turntable Complete (including engine)	9065	4112	7315	3318

Serial Number Locations

A serial number plate is affixed to the left rear side of the frame. If the serial number plate is damaged or missing, the

machine serial number is stamped on the left side of the frame.

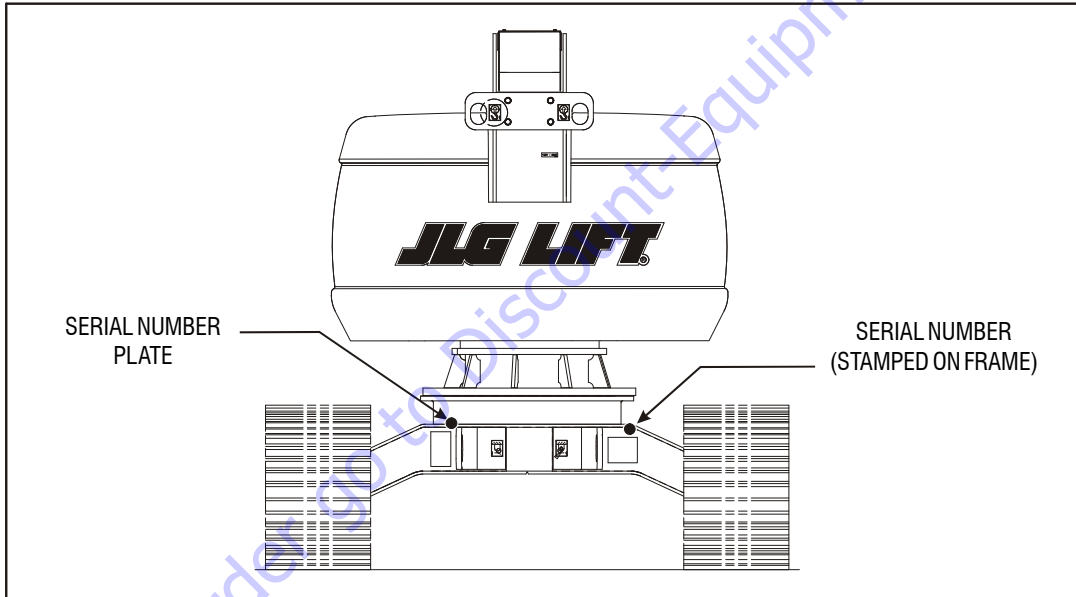

Figure 6-1. Serial Number Locations

SECTION 6 - GENERAL SPECIFICATIONS & OPERATOR MAINTENANCE

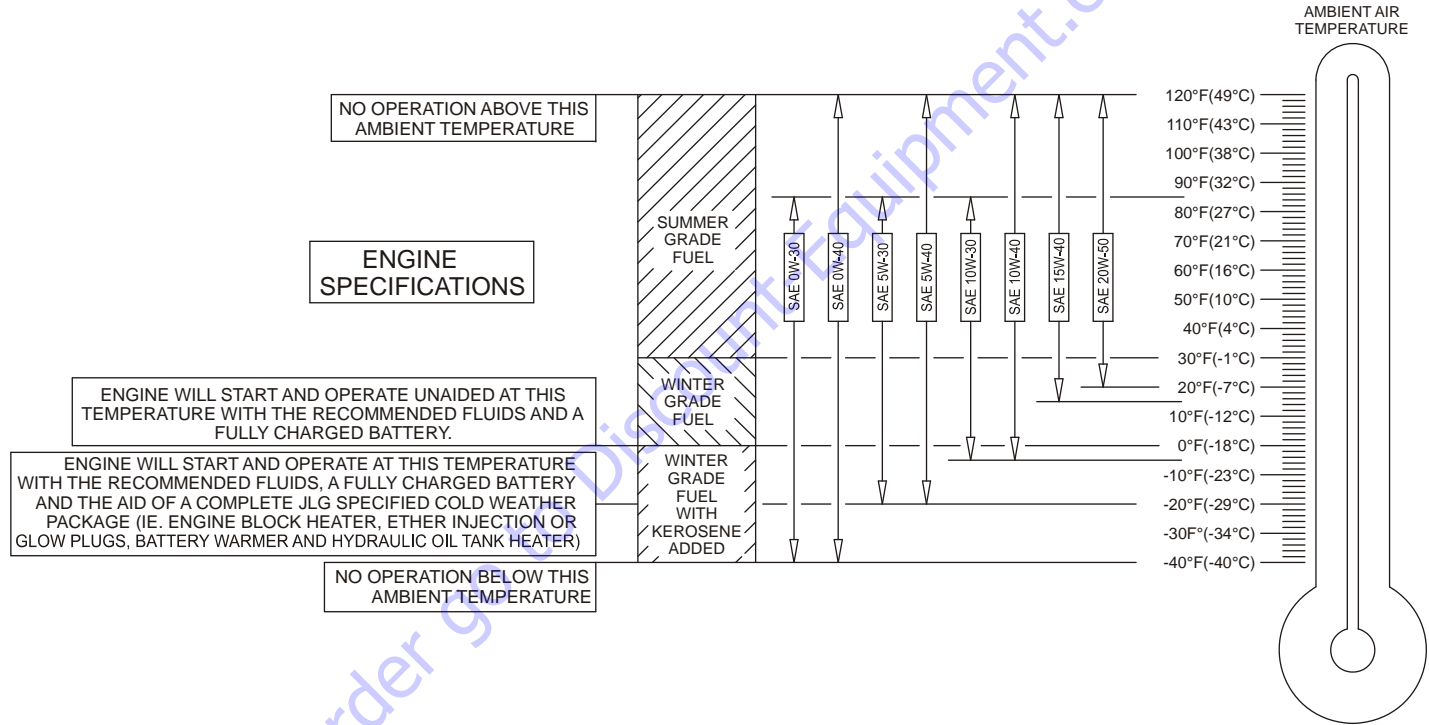

Figure 6-2. Engine Operating Temperature Specifications - Deutz - Sheet 1 of 2

SECTION 6 - GENERAL SPECIFICATIONS & OPERATOR MAINTENANCE

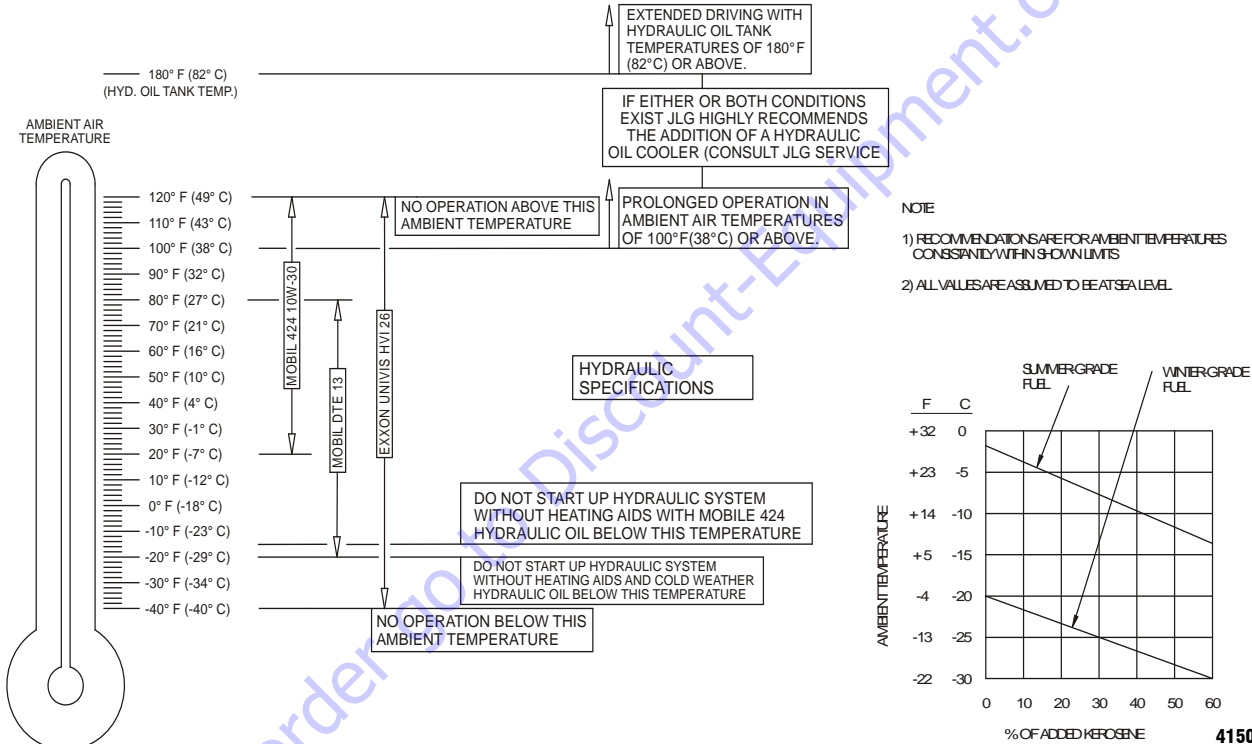

Figure 6-3. Engine Operating Temperature Specifications - Deutz - Sheet 2 of 2

SECTION 6 - GENERAL SPECIFICATIONS & OPERATOR MAINTENANCE

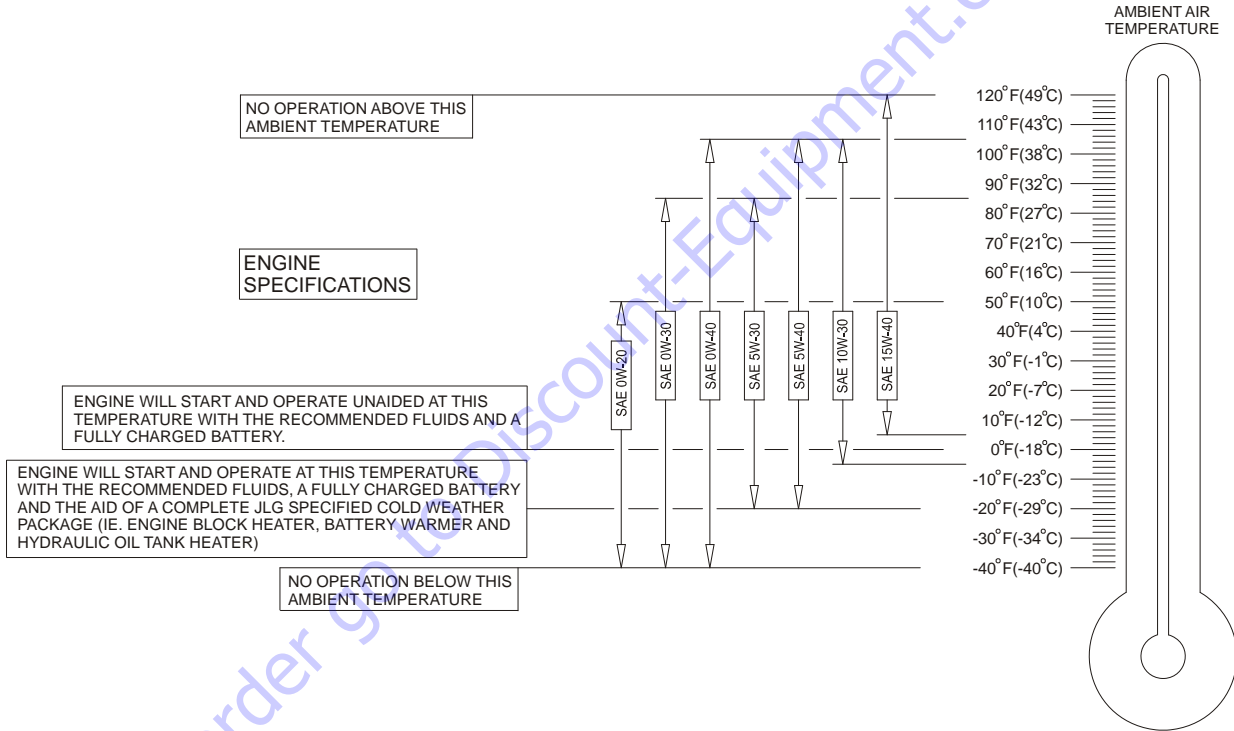
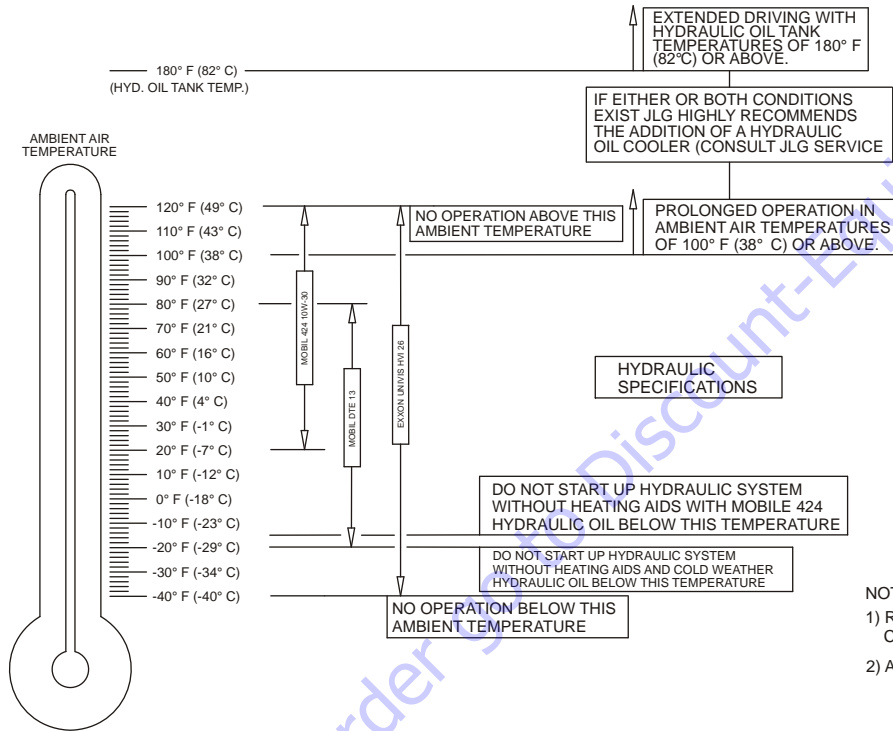

Figure 6-4. Engine Operating Temperature Specifications - Caterpillar - Sheet 1 of 2

SECTION 6 - GENERAL SPECIFICATIONS & OPERATOR MAINTENANCE



NOTE:

- 1) RECOMMENDATIONS ARE FOR AMBIENT TEMPERATURES CONSISTENTLY WITHIN SHOWN LIMITS
- 2) ALL VALUES ARE ASSUMED TO BE AT SEA LEVEL.

Figure 6-5. Engine Operating Temperature Specifications - Caterpillar - Sheet 2 of 2

4150548-E

SECTION 6 - GENERAL SPECIFICATIONS & OPERATOR MAINTENANCE

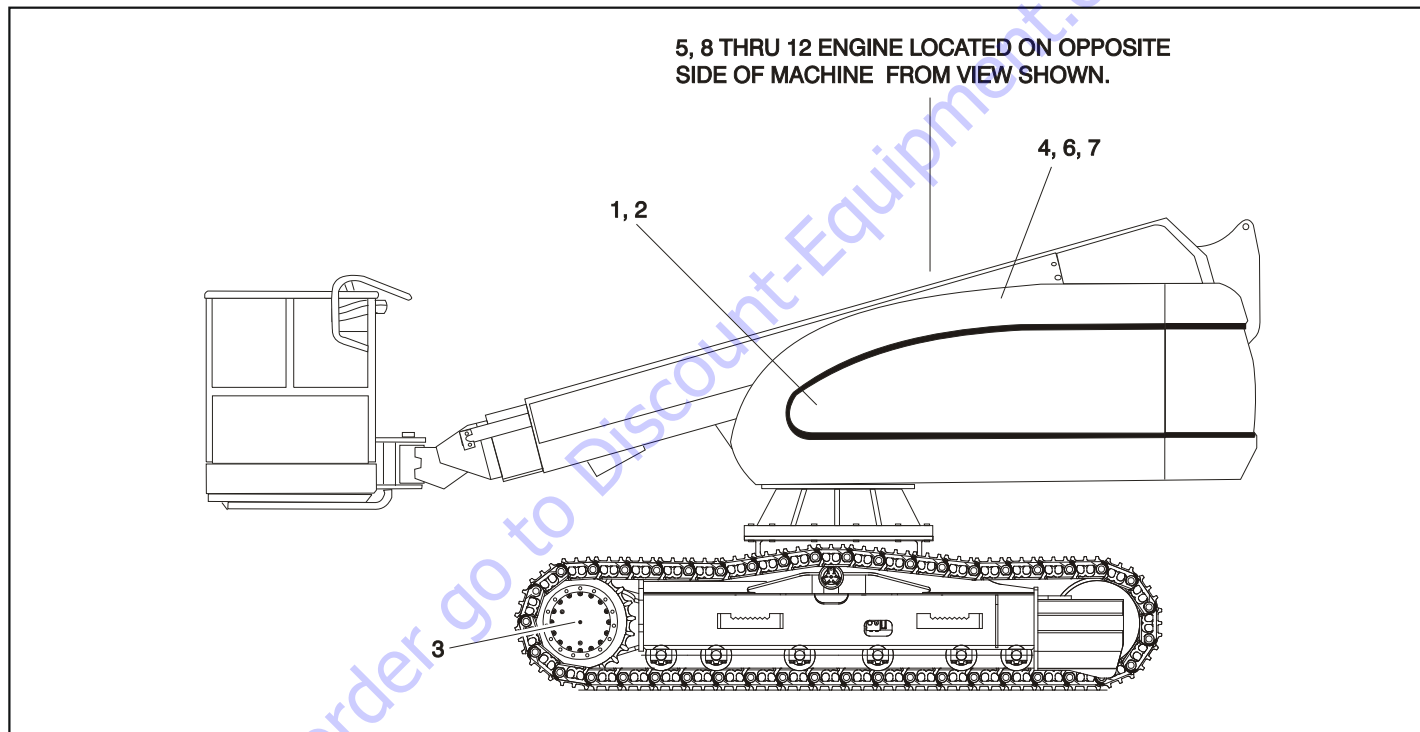

Figure 6-6. Operator Maintenance and Lubrication Diagram

SECTION 6 - GENERAL SPECIFICATIONS & OPERATOR MAINTENANCE

6.3 OPERATOR MAINTENANCE

NOTE: The following numbers correspond to those in Figure 6-6., Operator Maintenance and Lubrication Diagram.

Table 6-12. Lubrication Specifications

KEY	SPECIFICATIONS
MPG	Multipurpose Grease having a minimum dripping point of 350° F (177° C). Excellent water resistance and adhesive qualities, and being of extreme pressure type. (Timken OK 40 pounds minimum.)
EPGL	Extreme Pressure Gear Lube (oil) meeting API service classification GL-5 or MIL-Spec MIL-L-2105
HO	Hydraulic Oil. API service classification GL-3, e.g. Mobilfluid 424.
EO	Engine (crankcase) Oil. Gas - API SF, SH, SG class, MIL-L-2104. Diesel - API CC/CD class, MIL-L-2104B/MIL-L-2104C.

NOTICE

LUBRICATION INTERVALS ARE BASED ON MACHINE OPERATION UNDER NORMAL CONDITIONS. FOR MACHINES USED IN MULTI-SHIFT OPERATIONS AND/OR EXPOSED TO HOSTILE ENVIRONMENTS OR CONDITIONS, LUBRICATION FREQUENCIES MUST BE INCREASED ACCORDINGLY.

1. Swing Bearing

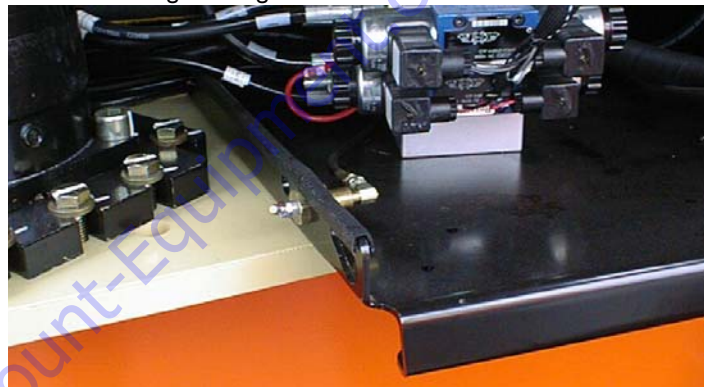

Lube Point(s) - 2 Grease Fittings
Capacity - A/R
Lube - MPG
Interval - Every 3 months or 150 hrs of operation
Comments - Remote Access

SECTION 6 - GENERAL SPECIFICATIONS & OPERATOR MAINTENANCE

2. Swing Drive Hub

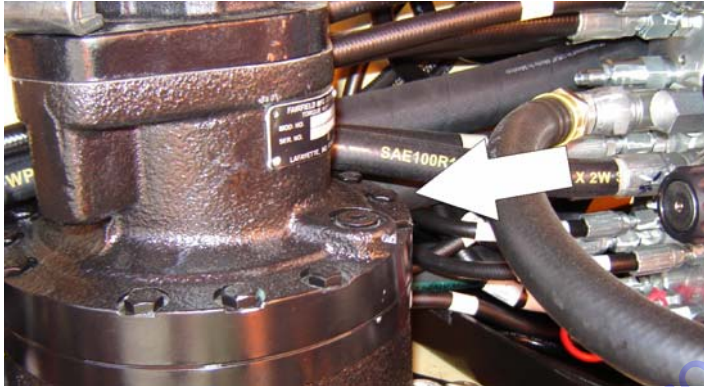

Lube Point(s) - Level/Fill Plug

Capacity - 17 oz. (1/2 Full)

Lube - EPGL

Interval - Check level every 3 months or 150 hrs of operation; change every 2 years or 1200 hours of operation

3. Final Drive Hub

Lube Point(s) - Level/Fill Plug

Capacity - 2.1 gal.(7.9 L); 1/2 Full

Lube - EPGL

Interval - Check level every 3 months or 150 hrs of operation; change every 2 years or 1200 hours of operation

4. Hydraulic Return Filter

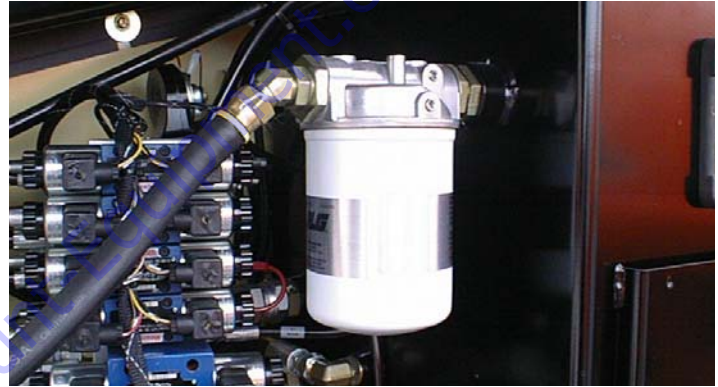

Interval - Change after first 50 hrs. and every 6 months or 300 hrs. thereafter or as indicated by Condition Indicator.

SECTION 6 - GENERAL SPECIFICATIONS & OPERATOR MAINTENANCE

5. Hydraulic Charge Filter



Interval - Change after first 50 hrs. and every 6 months or 300 hrs. thereafter or as indicated by Condition Indicator.

6. Hydraulic Tank

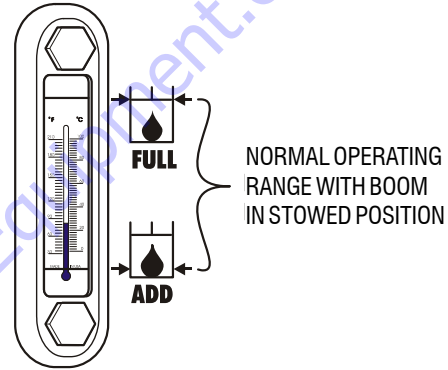

Lube Point(s) - Fill Cap

Capacity - 30.6 gal. Tank; 32.7 gal. System

Lube - HO

Interval - Check Level daily; Change every 2 years or 1200 hours of operation.

SECTION 6 - GENERAL SPECIFICATIONS & OPERATOR MAINTENANCE

7. Suction Strainers (in tank)

REMOVE FILL CAP PLATE FROM
TANK TO GAIN ACCESS TO
STRAINERS

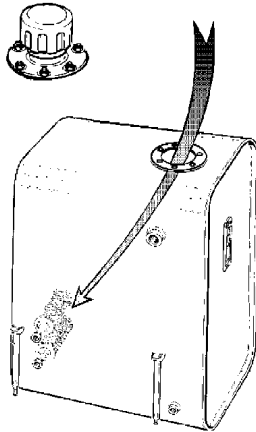

Lube Point(s) - 2

Interval - Every 2 years or 1200 hours of operation, remove and clean at time of hydraulic oil change.

8. Oil Change w/Filter - Deutz

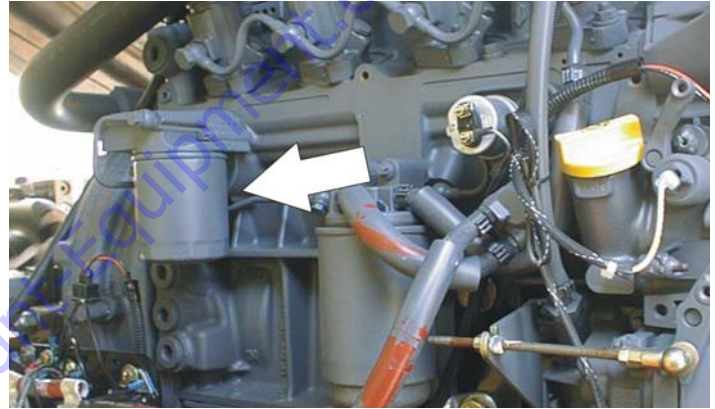

Lube Point(s) - Fill Cap/Spin-on Element

Capacity - 11 Quarts Crankcase; 5 Quarts Cooler

Lube - EO

Interval - Every Year or 1200 hours of operation

Comments - Check level daily/Change in accordance with engine manual.

SECTION 6 - GENERAL SPECIFICATIONS & OPERATOR MAINTENANCE

9. Oil Change w/Filter - Caterpillar



Lube Point(s) - Fill Cap/Spin-on Element
Capacity - 10.6 Quarts
Lube - EO
Interval - 3 Months or 150 hours of operation
Comments - Check level daily/Change in accordance with engine manual.

10. Fuel Filter - Deutz



Lube Point(s) - Replaceable Element
Interval - Every Year or 600 hours of operation

11. Fuel Filter - Caterpillar

Lube Point(s) - Replaceable Element
Interval - Every Year or 600 hours of operation

12. Air Filter

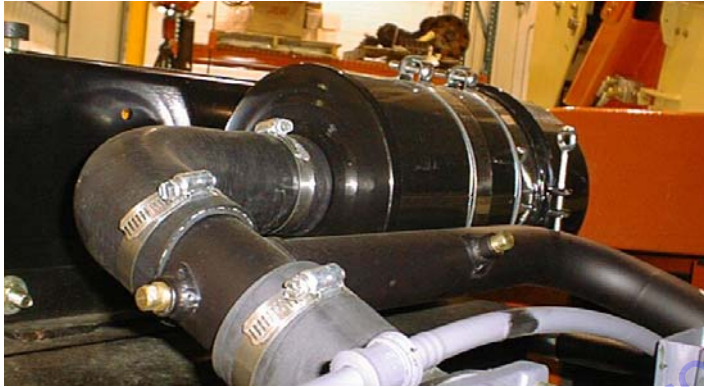

Lube Point(s) - Replaceable Element
Interval - Every 6 months or 300 hours of operation or as indicated by the condition indicator

6.4 SUPPLEMENTAL INFORMATION

The following information is provided in accordance with the requirements of the European Machinery Directive 2006/42/EC and is only applicable to CE machines.

For electric powered machines, the equivalent continuous A-Weighted sound pressure level at the work platform is less than 70dB(A)

For combustion engine powered machines, guaranteed Sound Power Level (LWA) per European Directive 2000/14/EC (Noise Emission in the Environment by Equipment for Use Outdoors) based on test methods in accordance with Annex III, Part B, Method 1 and 0 of the directive, is 104 dB.

The vibration total value to which the hand-arm system is subjected does not exceed $2,5 \text{ m/s}^2$. The highest root mean square value of weighted acceleration to which the whole body is subjected does not exceed $0,5 \text{ m/s}^2$.



WARNING:



The engine exhaust from this product contains chemicals known to the State of California to cause cancer, birth defects, or other reproductive harm.

1702961

PROPOSITION 65 WARNING

- **Battery posts, terminals and related accessories contain lead and lead compounds, chemicals known to the State of California to cause cancer and reproductive harm.**
- **Batteries also contain other chemicals known to the State of California to cause cancer.**
- **Wash hands after handling.**



An Oshkosh Corporation Company



3121156



www.Discount-Equipment.com

To order go to Discount-Equipment.com

TO PURCHASE THIS PRODUCT PLEASE CONTACT US



**Equipment Financing and
Extended Warranties Available**



**Discount-Equipment.com is your online resource for
commercial and industrial quality parts and equipment sales.**

561-964-4949

visit us on line @ www.discount-equipment.com

Select an option below to find your Equipment

Search by Manufacturer

Search by Product Type

Request a Quote

We sell worldwide for the brands: Genie, Terex, JLG, MultiQuip, Mikasa, Essick, Whiteman, Mayco, Toro Stone, Diamond Products, Generac Magnum, Airman, Haulotte, Barreto, Power Blanket, Nifty Lift, Atlas Copco, Chicago Pneumatic, Allmand, Miller Curber, Skyjack, Lull, Skytrak, Tsurumi, Husquvarna Target, Stow, Wacker, Sakai, Mi-T-M, Sullair, Basic, Dynapac, MBW, Weber, Bartell, Bennar Newman, Haulotte, Ditch Runner, Menegotti, Morrison, Contec, Buddy, Crown, Edco, Wyco, Bomag, Laymor, EZ Trench, Bil-Jax, F.S. Curtis, Gehl Pavers, Heli, Honda, ICS/PowerGrit, IHI, Partner, Imer, Clipper, MMD, Koshin, Rice, CH&E, General Equipment, Amida, Coleman, NAC, Gradall, Square Shooter, Kent, Stanley, Tamco, Toku, Hatz, Kohler, Robin, Wisconsin, Northrock, Oztec, Toker TK, Rol-Air, APT, Wylie, Ingersoll Rand / Doosan, Innovatech, Con X, Ammann, Mecalac, Makinex, Smith Surface Prep, Small Line, Wanco, Yanmar