

Connect JLG Control System Analyzer

1. Connect the four pin end of the cable supplied with the analyzer, to the motor controller module located in the platform box or at the power module and connect the remaining end of the cable to the analyzer.

NOTE: The cable has a four pin connector at each end of the cable; the cable cannot be connected backwards.

2. Power up the Control System by turning the lower key to the platform or ground position and pulling both emergency stop buttons on.

Using Analyzer



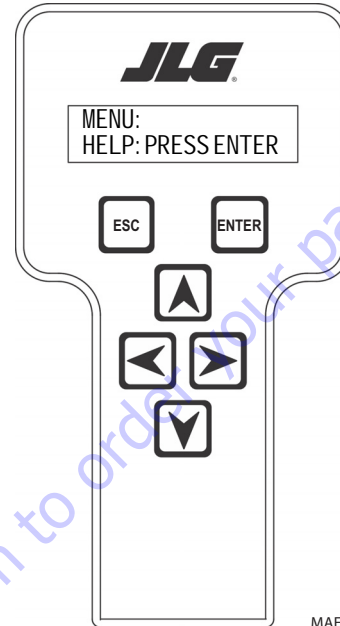

With the machine power on and the analyzer connected properly, the analyzer will display the following:



MAE19060

**MENU:
HELP:PRESS ENTER**

Move between top level menu items using

RIGHT  and **LEFT**  arrow keys. To select a displayed menu item, press **ENTER** . To cancel a selected menu item press **ESC** . Scroll using right and left arrow keys to select a different menu item.

Top level menus are as follows:

- HELP**
- DIAGNOSTICS**
- SYSTEM TEST**
- OPERATOR ACCESS**
- PERSONALITIES**
- MACHINE SETUP**
- CALIBRATIONS**

If you press **ENTER** , at the **HELP: PRESS ENTER** display, and a fault is present, the analyzer display will scroll the fault across the screen. If there was no fault detected, the display will read: **HELP: EVERYTHING OK**. If powered up at the ground station, the display shows: **GROUND OK**.

If **ENTER**  is pressed again, the display moves to the following display:

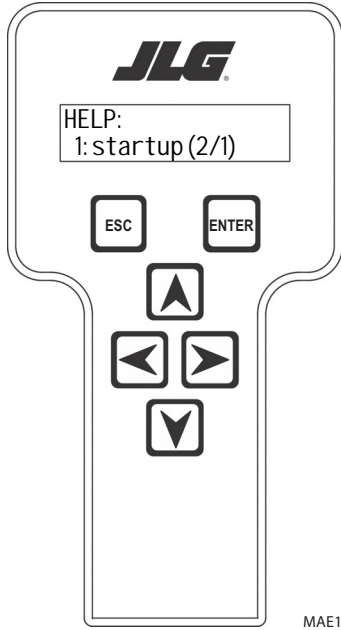

**LOGGED HELP
1: STARTUP (2/1)**

At this point, the analyzer will display the last fault the system has seen, if any are present. You may scroll through the fault logs to view what the last 25 faults were. Use the right and left arrow keys to scroll through the fault logs. To return to the

beginning, press **ESC**  two times. **STARTUP (2/1)** indicates a power up.

When a top level menu is selected, a new set of menu items may be offered: for example:

- DRIVE**
- BOOM**
- ENGINE**
- SYSTEM**
- OPER CONTROLS**
- PLATFORM LOAD**
- CAN STATISTICS**
- CALIBRATION DATA**
- DATALOG**
- VERSIONS**

Pressing **ENTER**  with any of the above displayed menus, displays additional sub-menus within the selected menu. In some cases, such as **DRIVE**, the next level is the parameter or information to be changed. Refer to the flow chart for what menus are available within the top level menus. You may only view the personality settings for selected menus while in access level 2. Remember, you may always cancel a selected

menu item by pressing the **ESCAPE**  key.

Changing Access Level

When analyzer is first connected, you will be in access level 2 which enables you to only view most settings which cannot be changed until you enter a password to advance to a lower level. This ensures that a setting cannot be accidentally altered. To change access level, the correct password must be entered. To enter password, scroll to **ACCESS LEVEL** menu. For example:

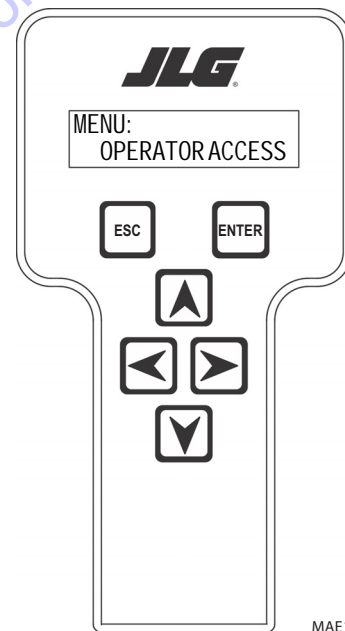

**ACCESS LEVEL:
CODE 00000**

Press **ENTER**  to select the **ACCESS LEVEL** menu.

Using the **UP**  or **DOWN**  arrow keys, enter first digit of the password, 3.

Then using the **RIGHT**  arrow key, position cursor right one space to enter the second digit of the password.

Use the **UP**  or **DOWN**  arrow key to enter the second digit of the password which is 33271.

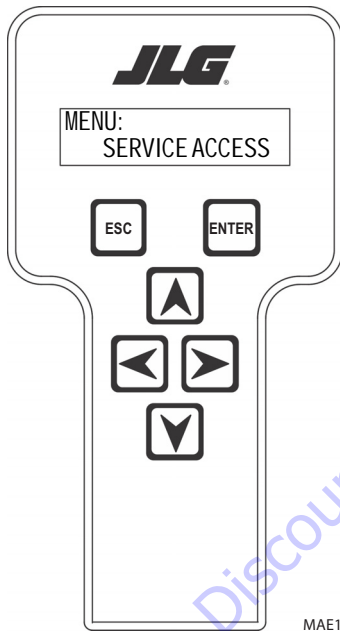

When correct password is displayed, press **ENTER** . The access level displays the following if password was entered correctly:



**MENU:
SERVICE ACCESS**

Repeat above steps if correct access level is not displayed or you can not adjust personality settings.

Adjust Parameters

Once you have gained access to level 1, and a personality item is selected, press the **UP**  or **DOWN**  arrow keys to adjust its value, for example:

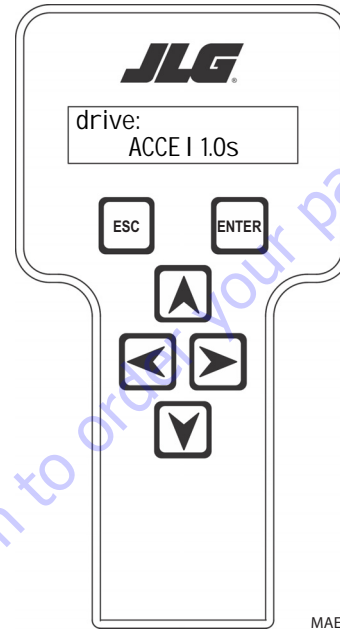



**DRIVE:
ACCEL 1.0S**

There will be a minimum and maximum for the value to ensure efficient operation. The Value will not increase if the **UP**

 arrow is pressed at maximum value or decrease if the

DOWN  arrow is pressed at minimum value for any personality. If value does not change when pressing up and down arrows, check access level is at access level 1.

Machine Setup

When a machine digit item is selected, press **UP**  or **DOWN**  arrow keys to adjust its value, for example:

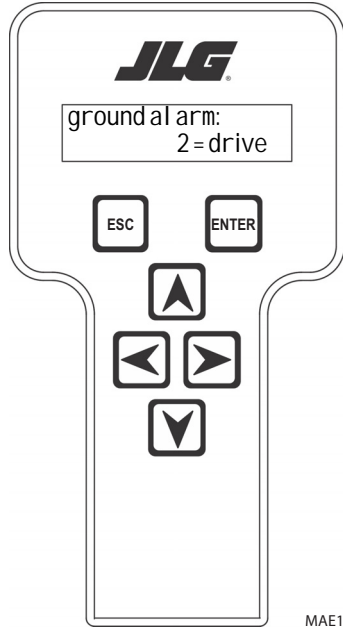

GROUND ALARM: 2 = DRIVE

The effect of the machine digit value is displayed along with its value. The above display would be selected if the machine was equipped with a ground alarm and you wanted it to sound when driving. There are certain settings allowed to install optional features or select the machine model.

When selection the machine model to match the size of the machine, the personality settings will all default to the factory recommended setting.

NOTE: Refer to *Personality Ranges/Defaults* for the recommended factory settings.

NOTE: Password 33271 allows access to level 1 to change machine personality settings.

There is a setting that JLG strongly recommends that you do not change. This setting is so noted below:

ELEVATION CUTBACK

WARNING

CHANGING ELEVATION CUTBACK SETTING MAY ADVERSELY AFFECT PERFORMANCE OF YOUR MACHINE.

NOTICE

AVOID PRESSURE-WASHING ELECTRICAL/ELECTRONIC COMPONENTS. IF PRESSURE-WASHING IS USED TO WASH AREAS CONTAINING ELECTRICAL/ELECTRONIC COMPONENTS, JLG INDUSTRIES INC. RECOMMENDS A MAXIMUM PRESSURE OF 750 PSI (52 BAR) AT A MINIMUM DISTANCE OF 12 INCHES (30.5CM) FROM THESE COMPONENTS. IF ELECTRICAL/ELECTRONIC COMPONENTS ARE SPRAYED, SPRAYING MUST NOT BE DIRECT AND FOR BRIEF TIME PERIODS TO AVOID HEAVY SATURATION.

Level Vehicle Description

WARNING

DO NOT LEVEL VEHICLE EXCEPT ON A LEVEL SURFACE.

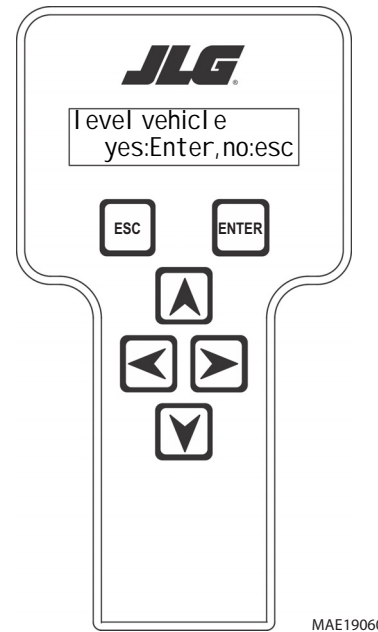

LEVEL VEHICLE YES:ENTER, NO:ESC

Not available at password level 2. **ENTER**  confirms vehicle is currently level, and zeroes the tilt sensor measurements.

SECTION 6 - JLG CONTROL SYSTEM

Table 6-1. Analyzer Abbreviations

ABBREVIATION	MEANING
ACCEL	ACCELERATE
ACT	ACTIVE
A/D	ANALOG DIGITAL CONVERTER COUNT
AMB.	AMBIENT
ANG	ANGLE
AUX	AUXILIARY
BCS	BOOM CONTROL SYSTEM
BM	BOOM LENGTH ANGLE MODULE
BLAM	BOOM LENGTH ANGLE MODULE
BR	BROKEN
BSK	BASKET
CAL	CALIBRATION
CL	CLOSED
CM	CHASSIS MODULE
CNTL	CONTROL
CNTRL	CONTROL
C/O	CUT OUT
CONT(S)	CONTRACTOR(S)
COOR	COORDINATED
CRKPT	CRACK POINT
CRP	CREEP
CUT	CUTOUT
CYL	CYLINDER
DECEL	DECELERATE
D	DOWN
DN	DOWN
DWN	DOWN
DEG.	DEGREE
DOS	DRIVE ORIENTATION SYSTEM
DRV	DRIVE
E	ERROR
E&T	ELEVATED & TILTED
ELEV	ELEVATION
ENG	ENGINE
EXT	EXTEND
F	FRONT
FL	FLOW
FNT	FRONT
FOR	FORWARD
FWD	FORWARD
FSW	FOOT SWITCH
FUNC	FUNCTION
G	GROUND

Table 6-1. Analyzer Abbreviations

ABBREVIATION	MEANING
GND	GROUND
GRN	GREEN
GM	GROUND MODULE
H	HOURS
HW	HARDWARE
HWFS	HARDWARE FAILSAFE
I	IN or CURRENT
JOY	JOYSTICK
L	LEFT
LB	POUND
LEN	LENGTH
LIM	LIMIT
LT	LEFT
LVL	LEVEL
M	MINUTES
MIN	MINIMUM
MAX	MAXIMUM
M	MAIN
MN	MAIN
NO	NORMALLY OPEN or NO
NC	NORMALLY CLOSED
O	OUT
O/C	OPEN CIRCUIT
OP	OPEN
O/R	OVERRIDE or OUTRIGGER
O//R	OVERRIDE
OSC	OSCILLATING
OVRD	OVERRIDE
P	PLATFORM
P	PRESSURE
PCV	PROPORTIONAL CONTROL VALVE
PLAT	PLATFORM
PLT	PLATFORM
PM	PLATFORM MODULE
POT	POTENTIOMETER
PRES	PRESSURE
PRS	PRESSURE
PT	POINT
R	REAR or RIGHT
REV	REVERSE or REVISION
RET	RETRACT
ROT.	ROTATE
RT	RIGHT

Table 6-1. Analyzer Abbreviations

ABBREVIATION	MEANING
S/C	SHORT CIRCUIT
SEL	SELECTOR
SN	SERIAL NUMBER
SPD	SPEED
STOW	STOWED
STOWD	STOWED
SW	SWITCH or SOFTWARE
TELE	TELESCOPE
TEMP	TEMPERATURE
TORQ.	TORQUE
TRN	TRANSPORT
T/T	TURNTABLE
T	TOWER
TURNTBL	TURNTABLE
TWR	TOWER
U	UPPER or UP
V	VOLT
VER	VERSION
VLV	VALVE
WIT	WITNESS
YEL	YELLOW

Go to Discount-Equipment.com to order your parts

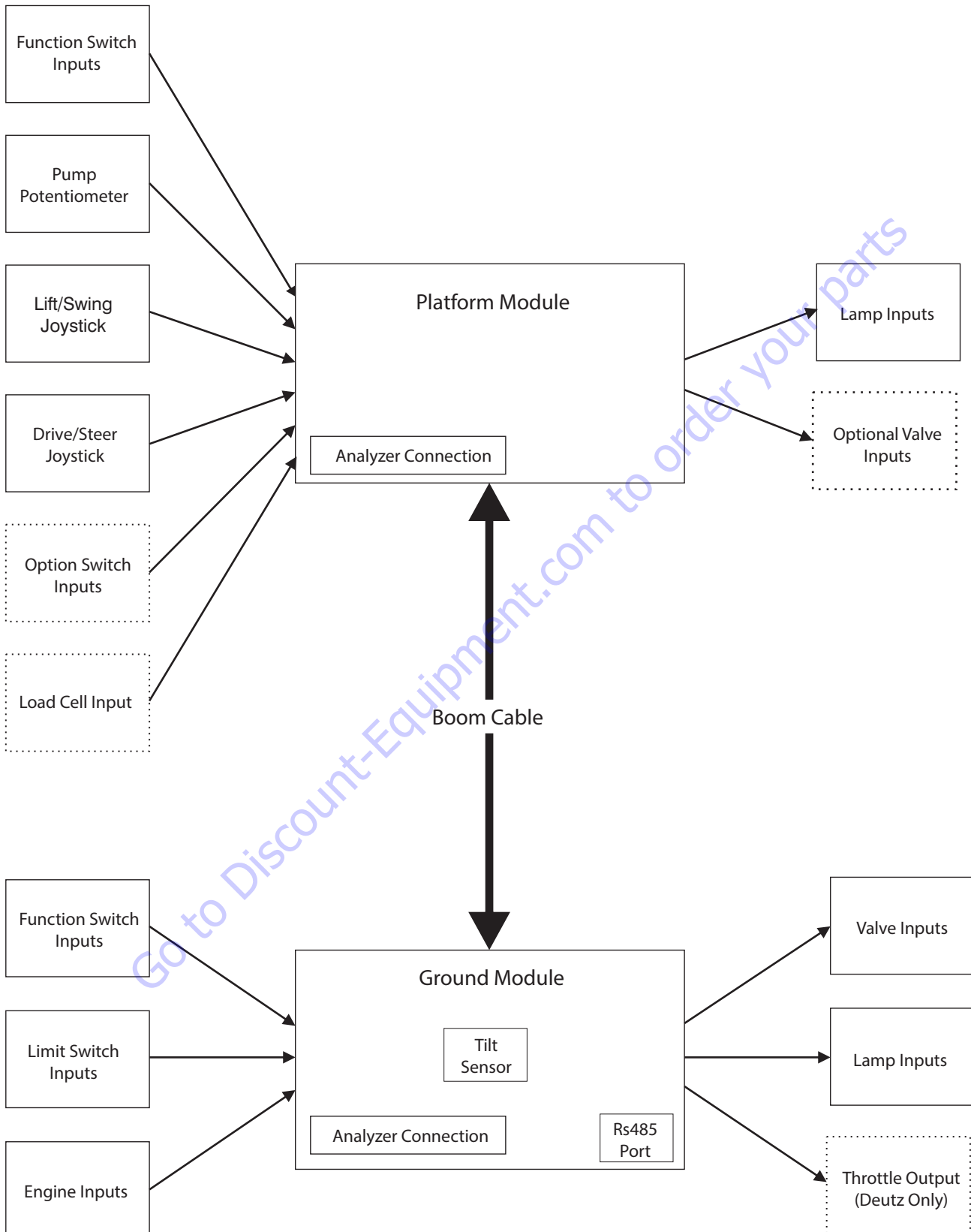
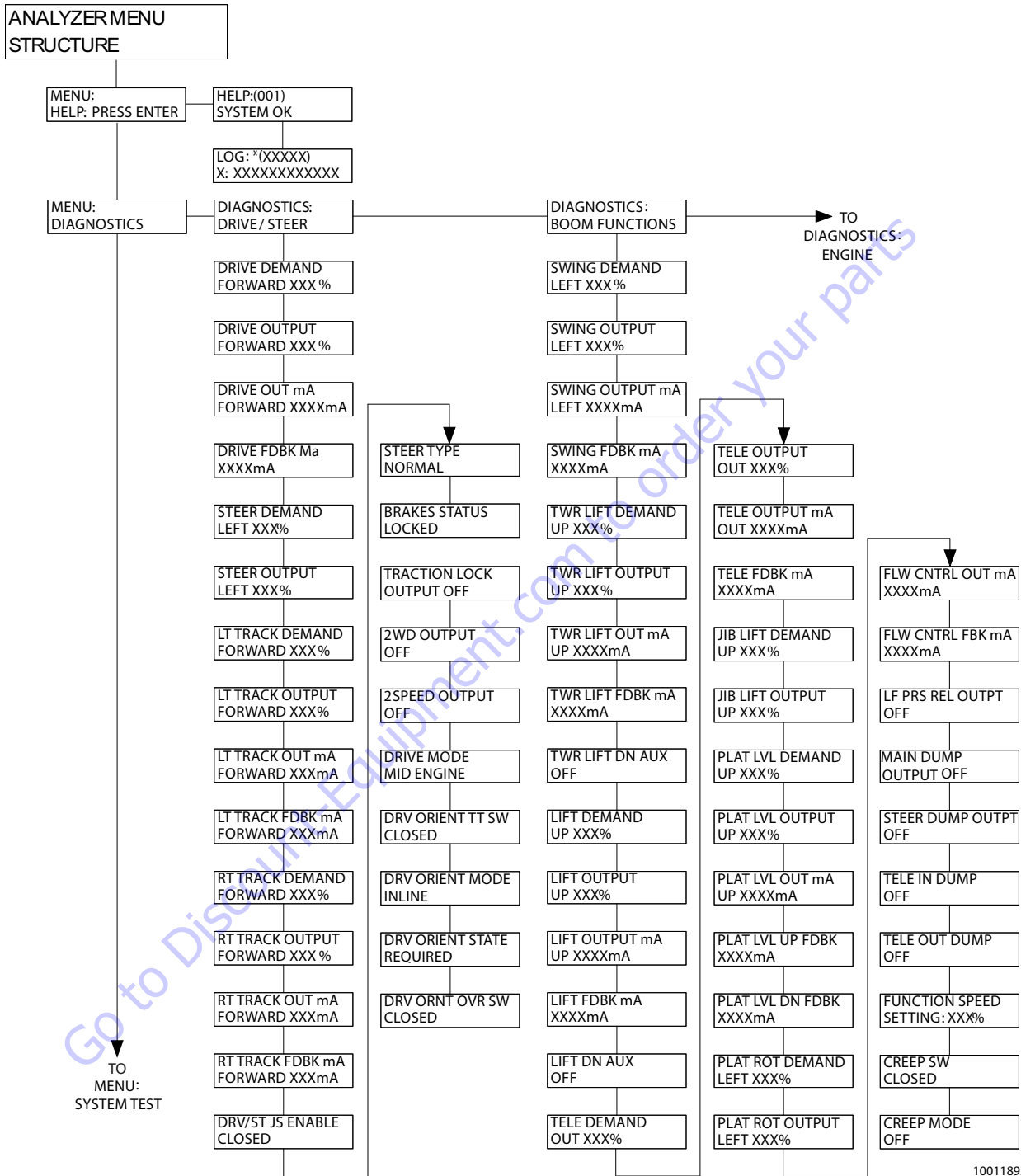

Figure 6-2. ADE Block Diagram



NOTE: The layout shown includes all possible analyzer screens. Please note that some screens may not be available depending upon machine configuration and software versions.

Figure 6-3. Analyzer Software P2.12 - Sheet 1 of 14

SECTION 6 - JLG CONTROL SYSTEM

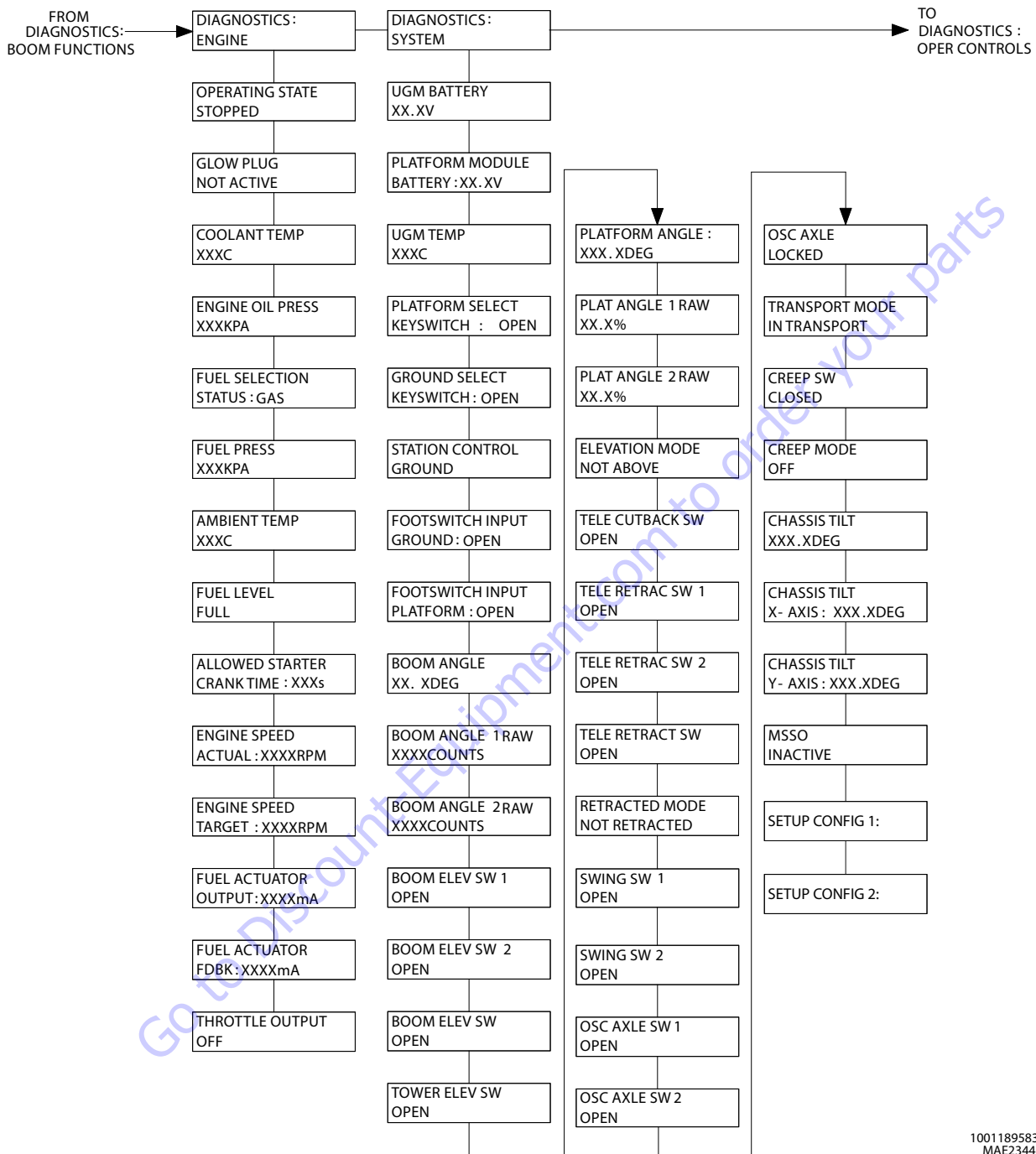

1001189583-G
MAE23440G

NOTE: The layout shown includes all possible analyzer screens. Please note that some screens may not be available depending upon machine configuration and software versions.

Figure 6-4. Analyzer Software P2.12 - Sheet 2 of 14

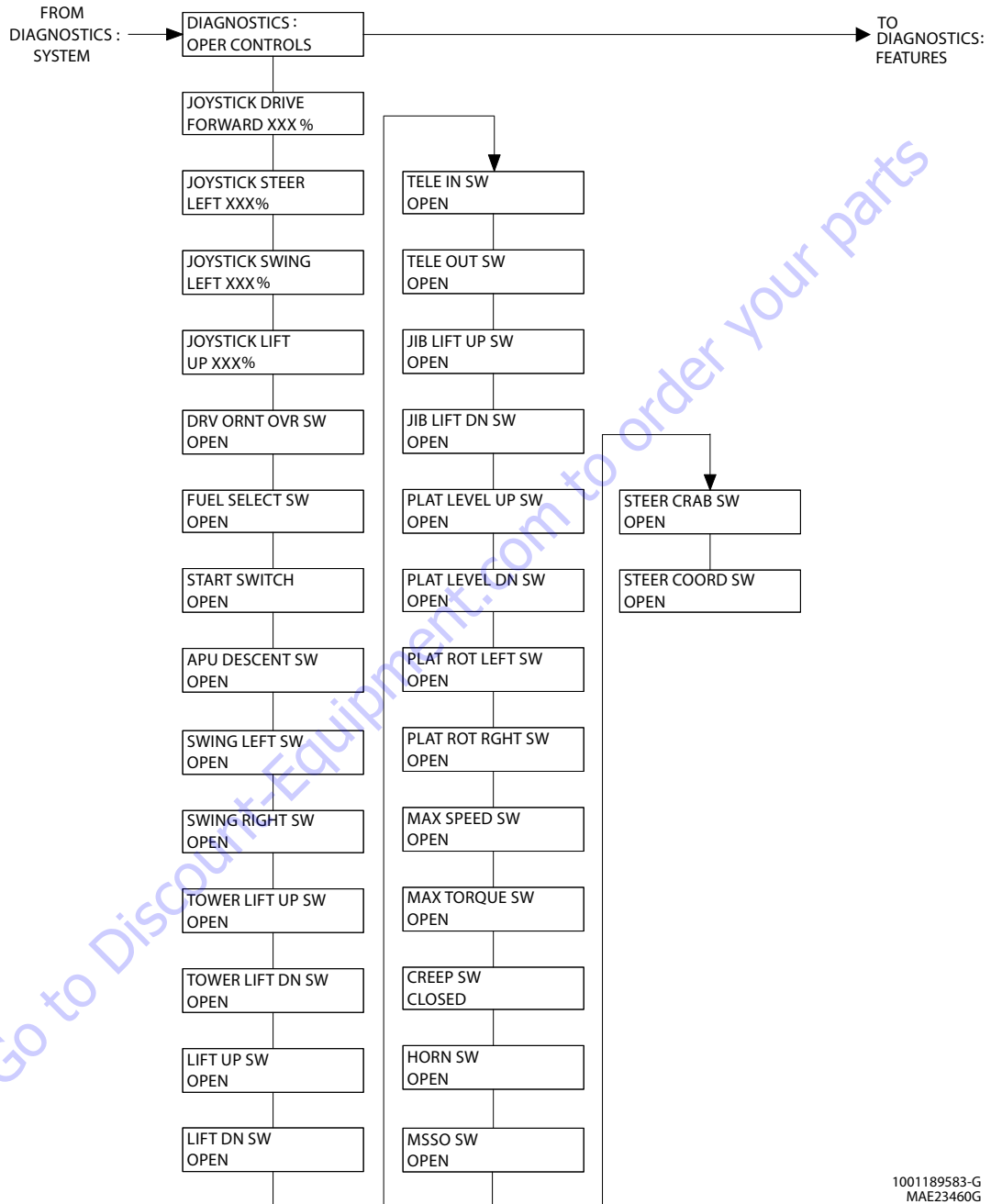

1001189583-G
MAE23460G

NOTE: The layout shown includes all possible analyzer screens. Please note that some screens may not be available depending upon machine configuration and software versions.

Figure 6-5. Analyzer Software P2.12 - Sheet 3 of 14

SECTION 6 - JLG CONTROL SYSTEM

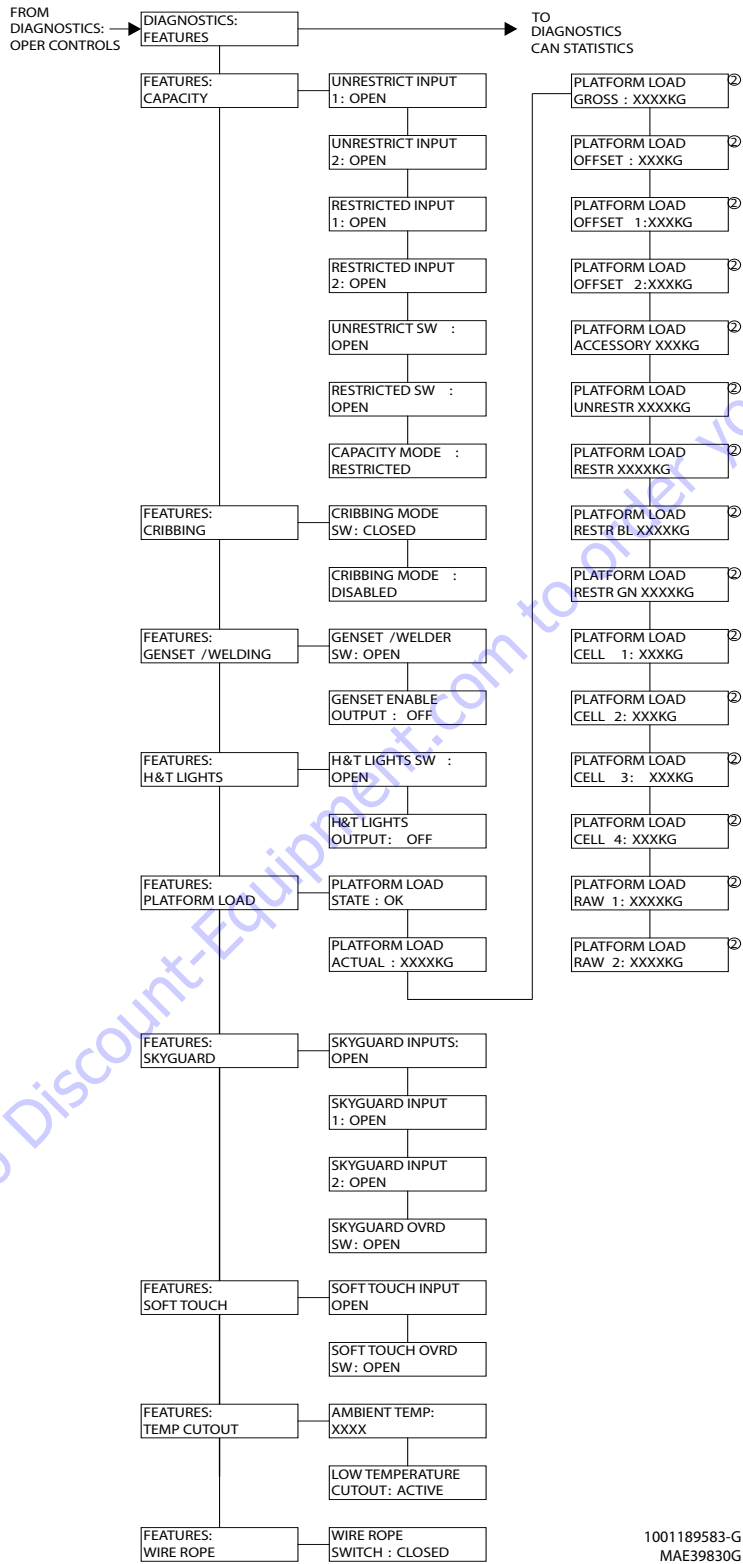

Go to Discount-Equipment.com to order your parts

1001189583-G
MAE39830G

Figure 6-6. Analyzer Software P2.12 - Sheet 4 of 14

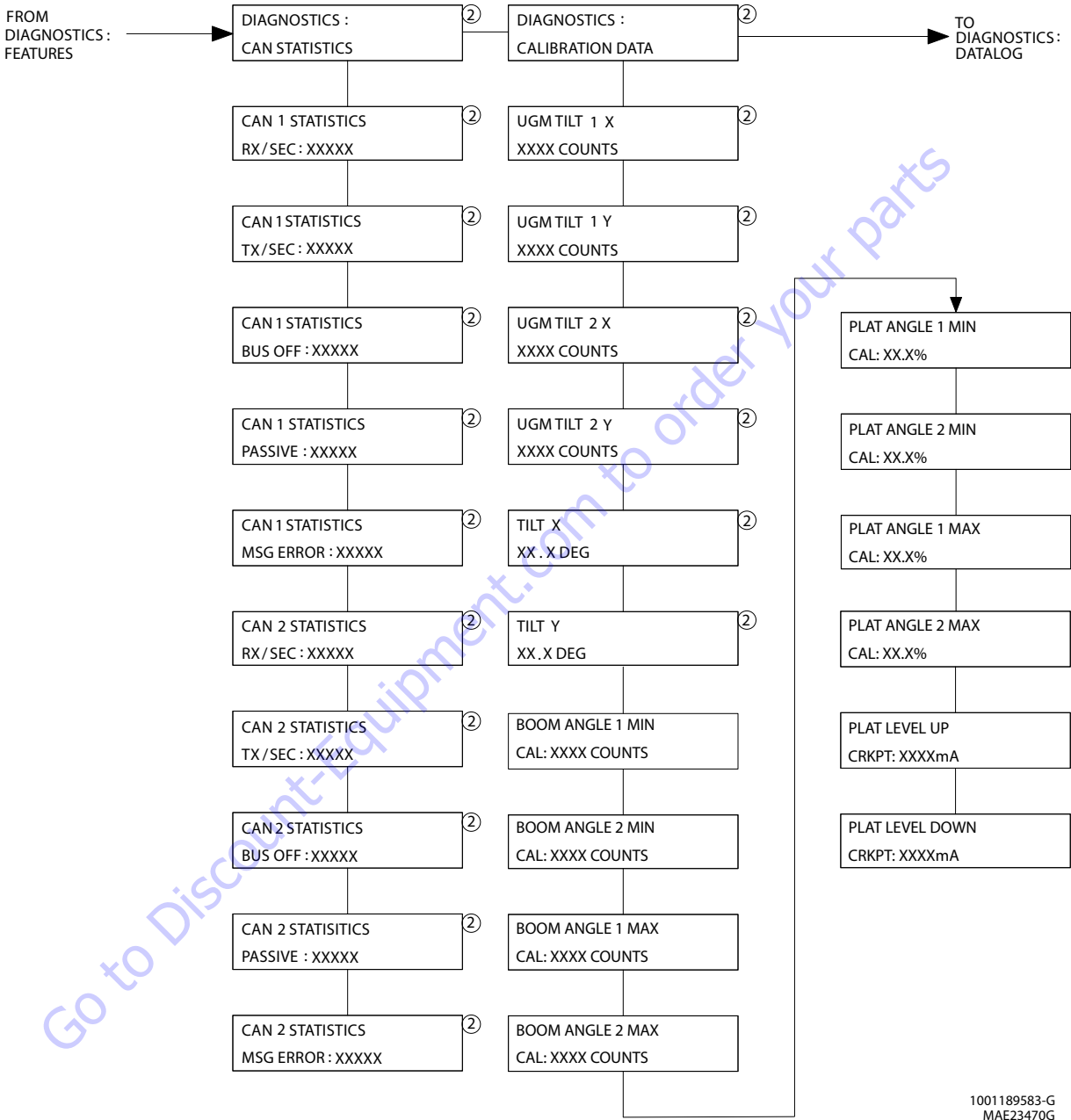

1001189583-G
MAE23470G

NOTE: The layout shown includes all possible analyzer screens. Please note that some screens may not be available depending upon machine configuration and software versions.

Figure 6-7. Analyzer Software P2.12 - Sheet 5 of 14

SECTION 6 - JLG CONTROL SYSTEM

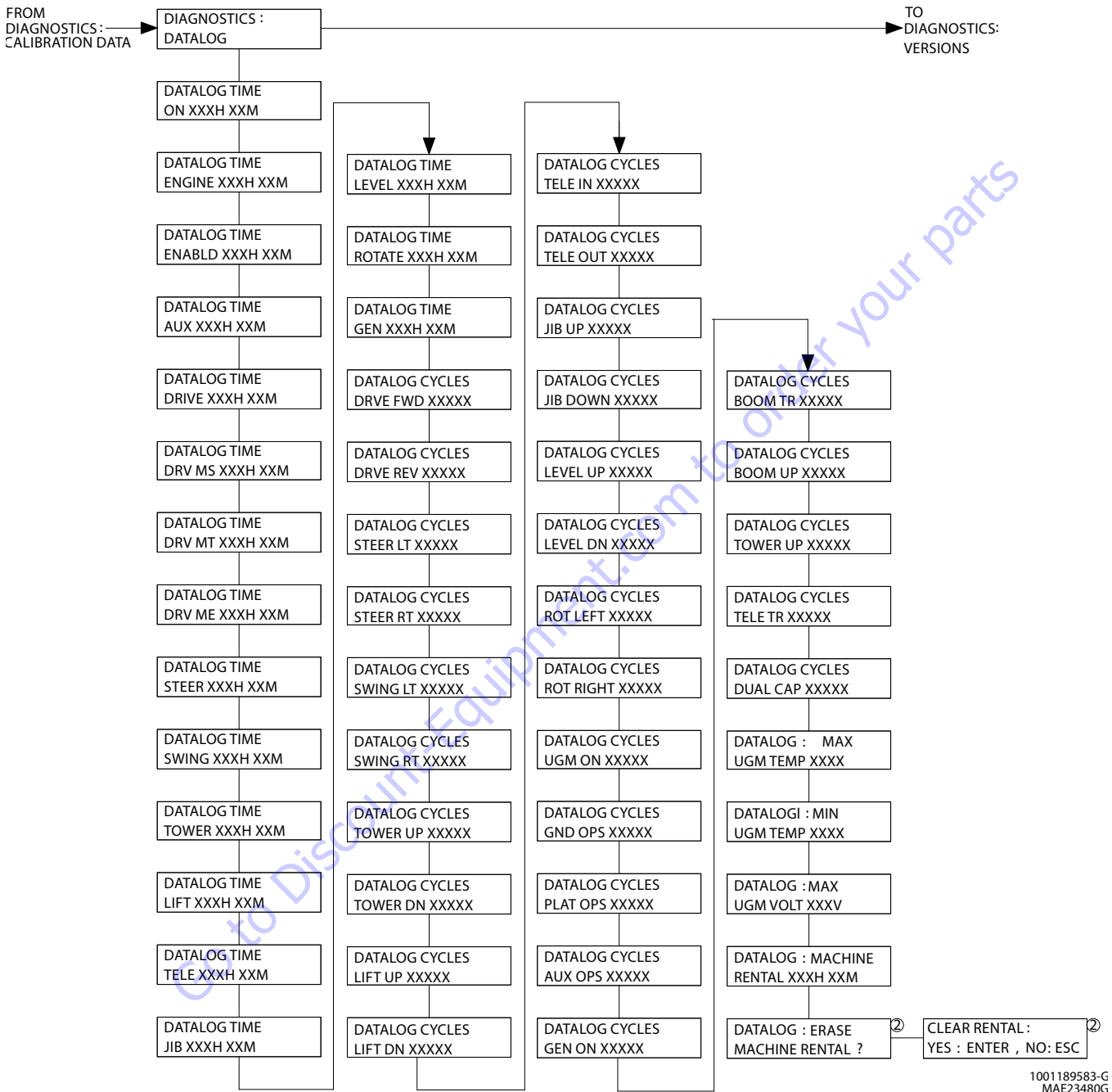

1001189583-G
MAE23480G

NOTE: The layout shown includes all possible analyzer screens. Please note that some screens may not be available depending upon machine configuration and software versions.

Figure 6-8. Analyzer Software P2.12 - Sheet 6 of 14

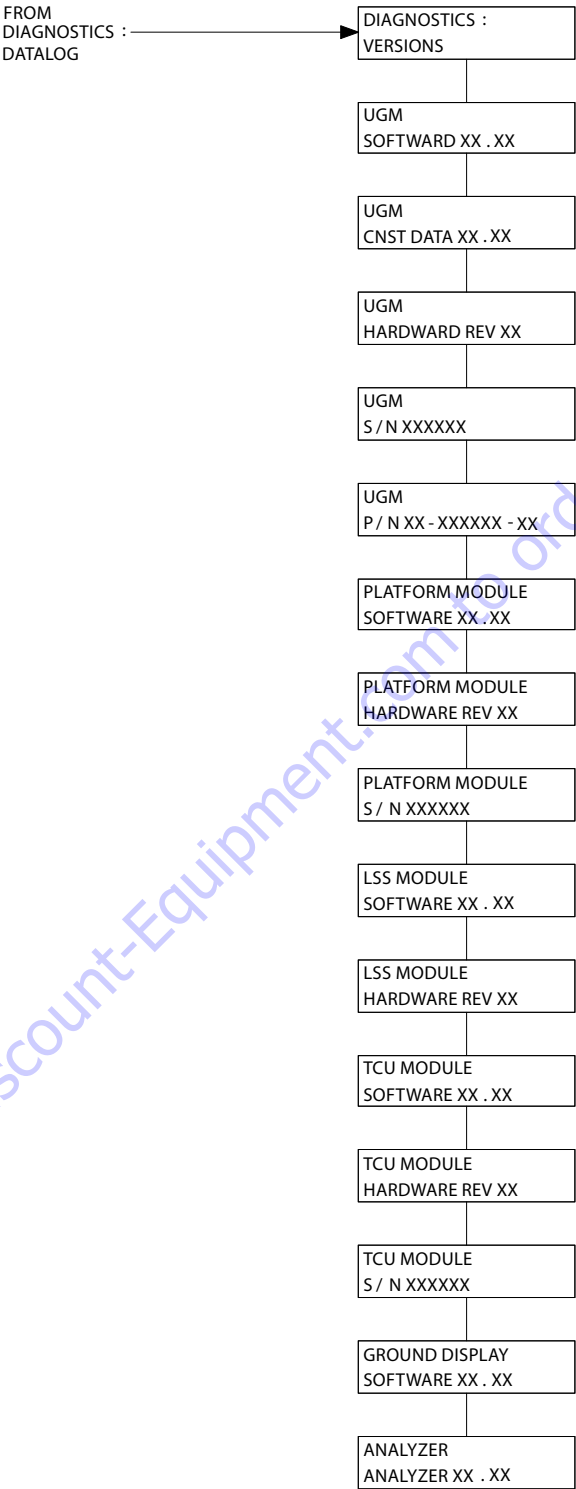

Go to Discount-Equipment.com to order your parts

1001189583-G
MAE23490G

NOTE: The layout shown includes all possible analyzer screens. Please note that some screens may not be available depending upon machine configuration and software versions.

Figure 6-9. Analyzer Software P2.12 - Sheet 7 of 14

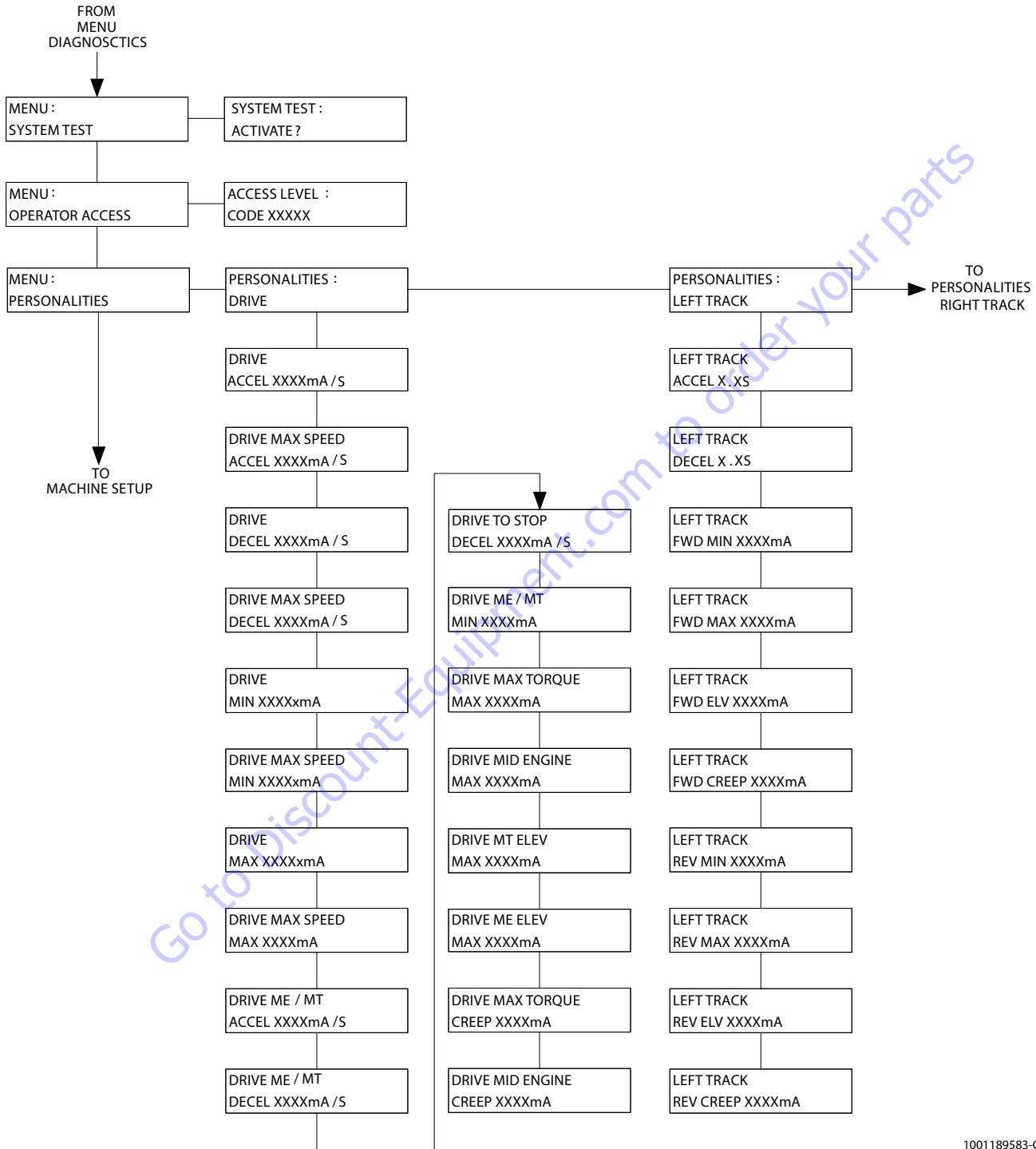

1001189583-G
MAE23500G

NOTE: The layout shown includes all possible analyzer screens. Please note that some screens may not be available depending upon machine configuration and software versions.

Figure 6-10. Analyzer Software P2.12 - Sheet 8 of 14

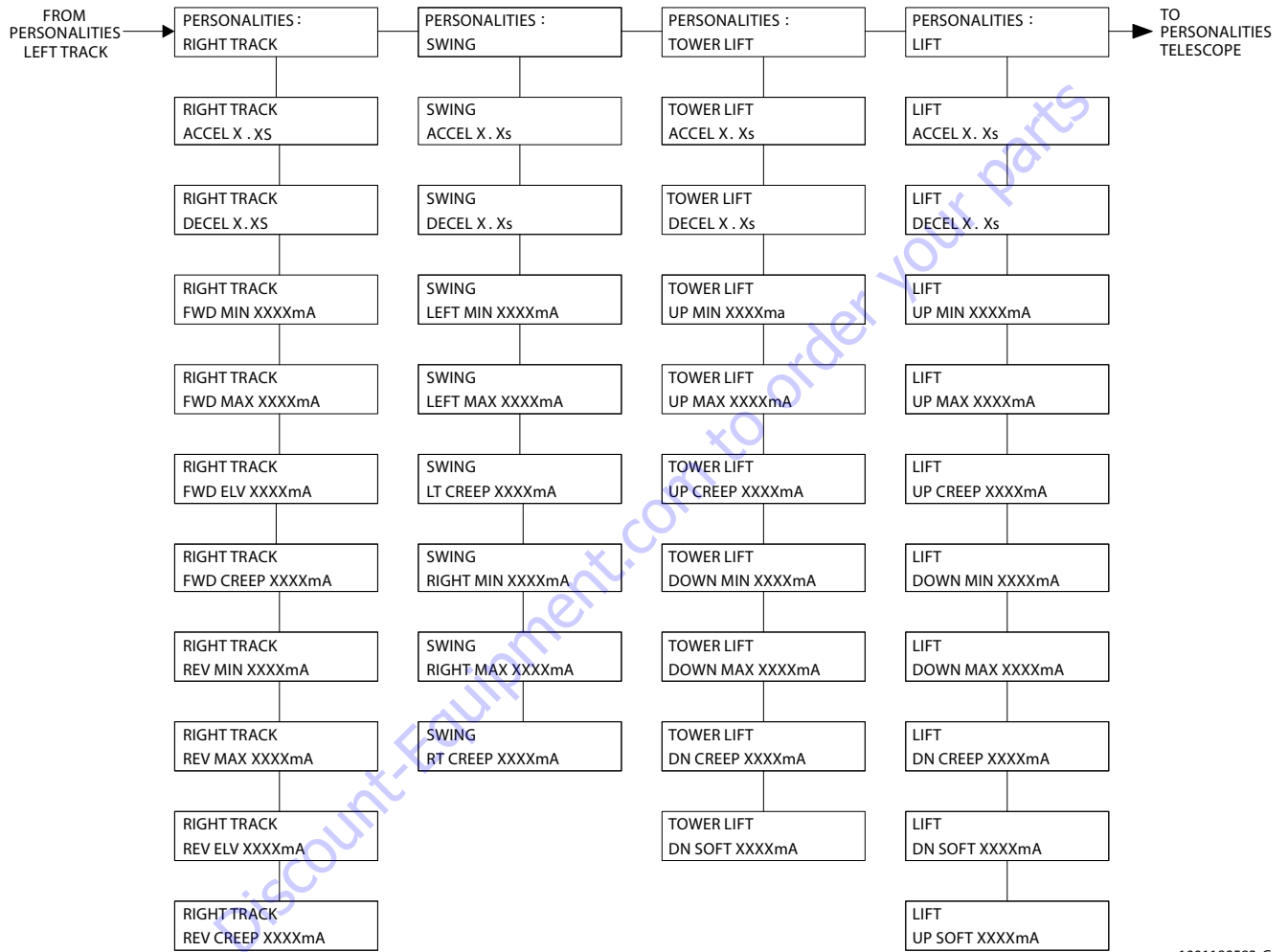

1001189583-G
MAE23520G

NOTE: The layout shown includes all possible analyzer screens. Please note that some screens may not be available depending upon machine configuration and software versions.

Figure 6-11. Analyzer Software P2.12 - Sheet 9 of 14



1001189583-G
MAE23530G

NOTE: The layout shown includes all possible analyzer screens. Please note that some screens may not be available depending upon machine configuration and software versions.

Figure 6-12. Analyzer Software P2.12 - Sheet 10 of 14

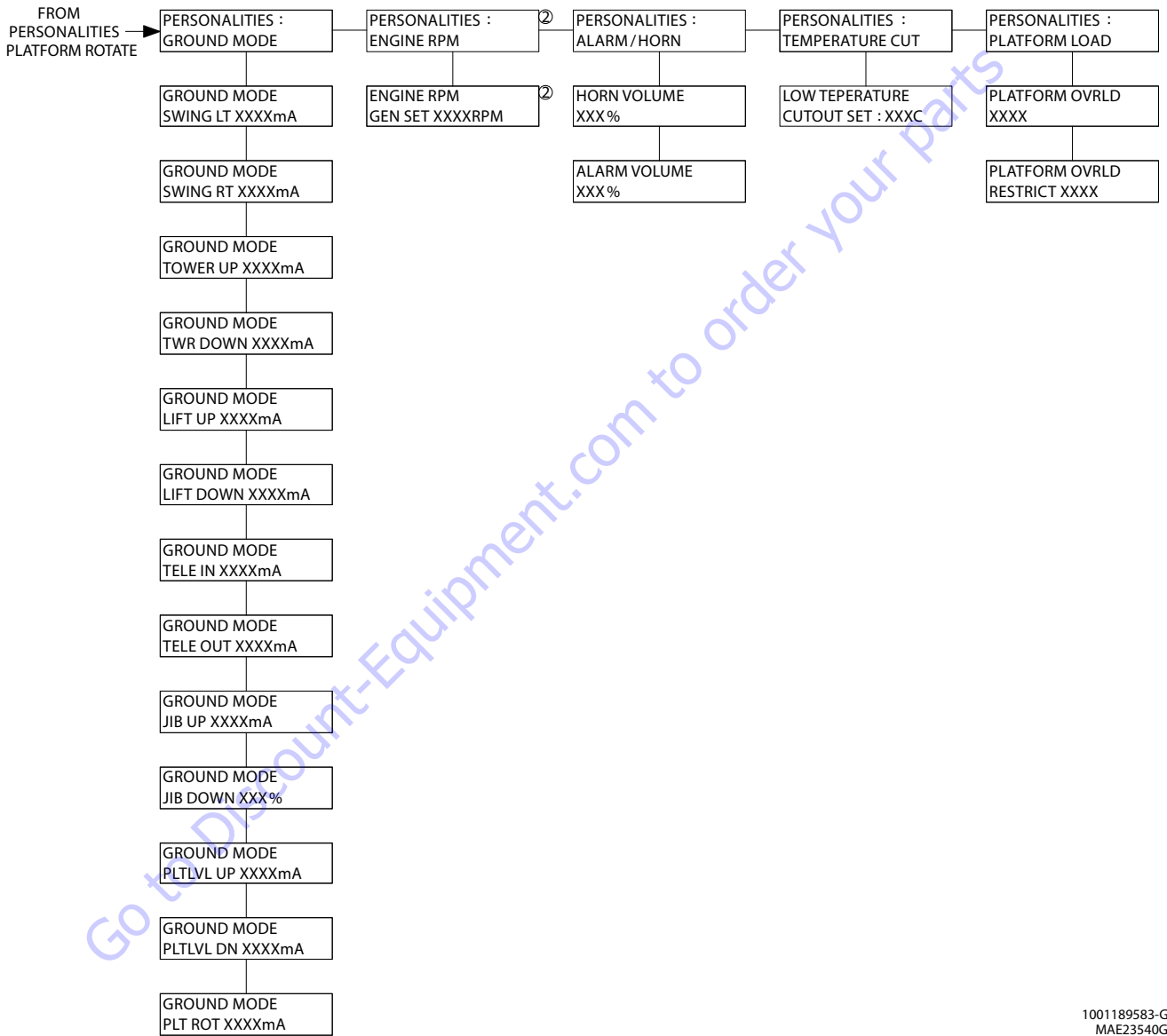

1001189583-G
MAE23540G

NOTE: The layout shown includes all possible analyzer screens. Please note that some screens may not be available depending upon machine configuration and software versions.

Figure 6-13. Analyzer Software P2.12 - Sheet 11 of 14

SECTION 6 - JLG CONTROL SYSTEM

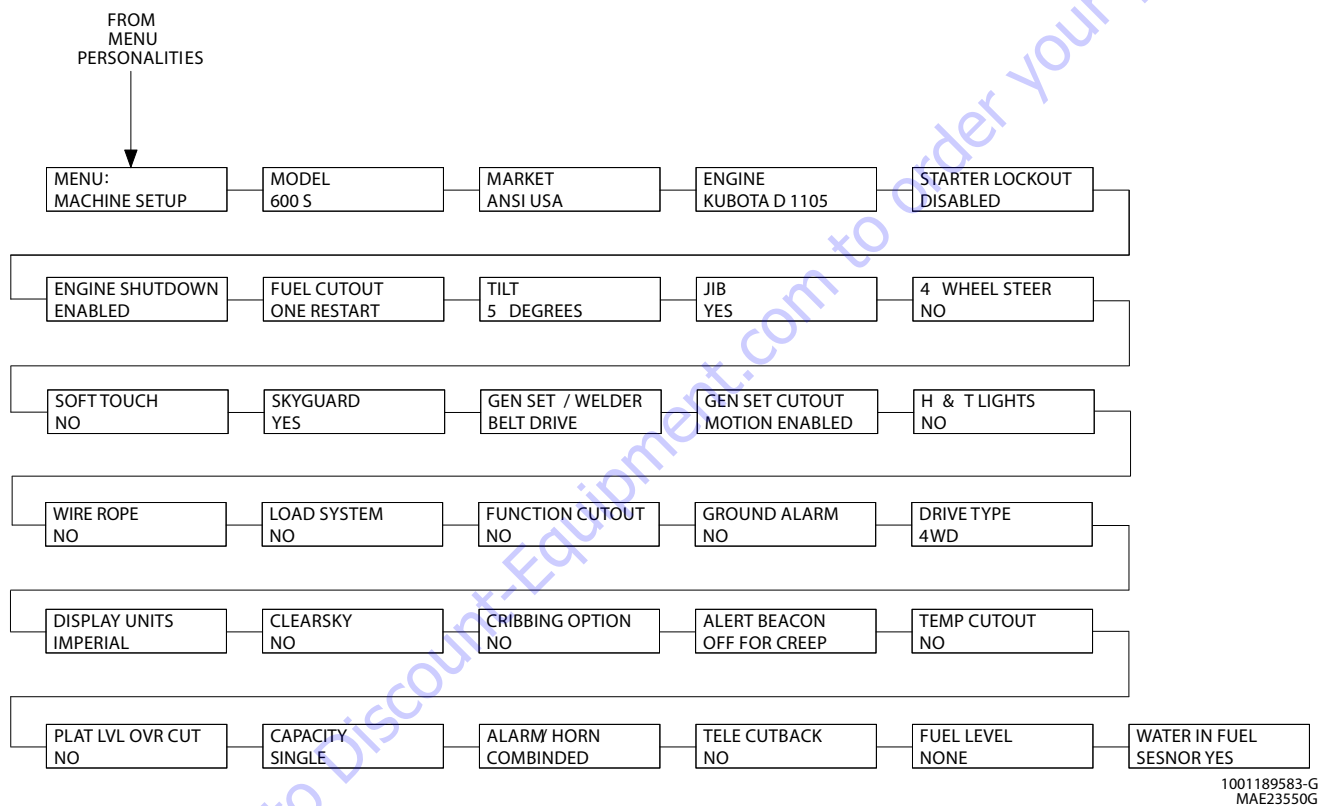

NOTE: The layout shown includes all possible analyzer screens. Please note that some screens may not be available depending upon machine configuration and software versions.

Figure 6-14. Analyzer Software P2.12 - Sheet 12 of 14

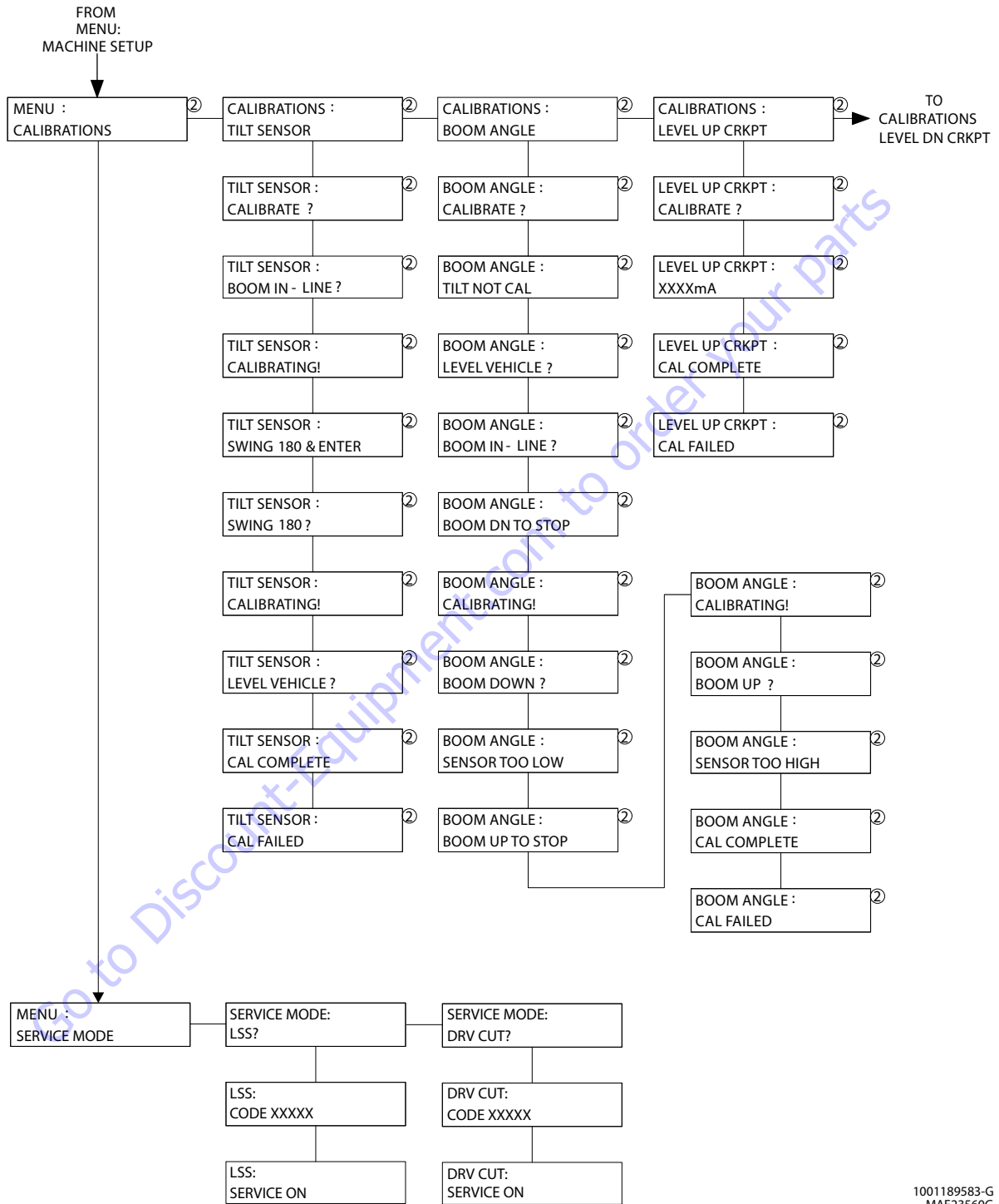

1001189583-G
MAE23560G

NOTE: The layout shown includes all possible analyzer screens. Please note that some screens may not be available depending upon machine configuration and software versions.

Figure 6-15. Analyzer Software P2.12 - Sheet 13 of 14

SECTION 6 - JLG CONTROL SYSTEM

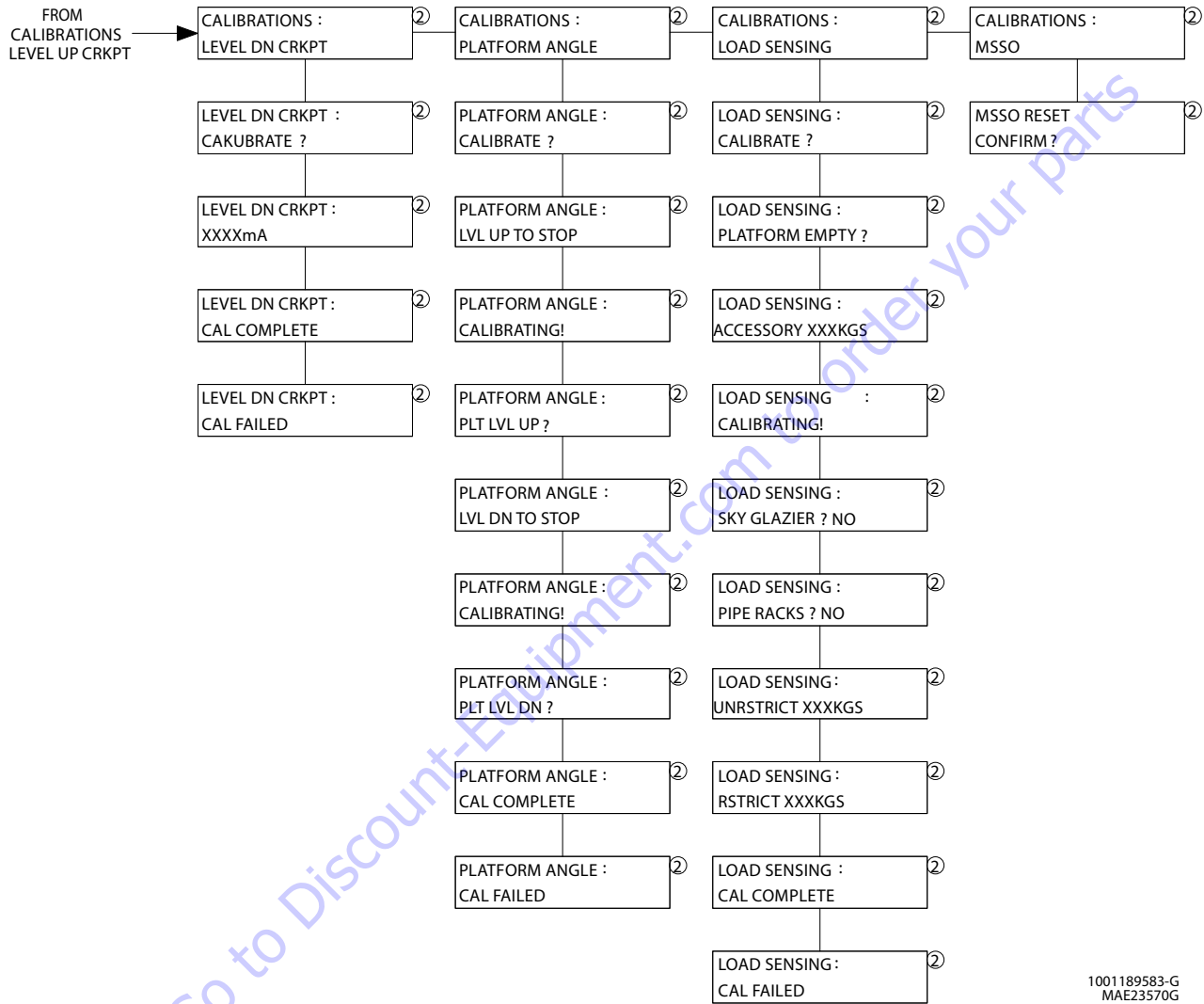

1001189583-G
MAE23570G

NOTE: The layout shown includes all possible analyzer screens. Please note that some screens may not be available depending upon machine configuration and software versions.

Figure 6-16. Analyzer Software P2.12 - Sheet 14 of 14

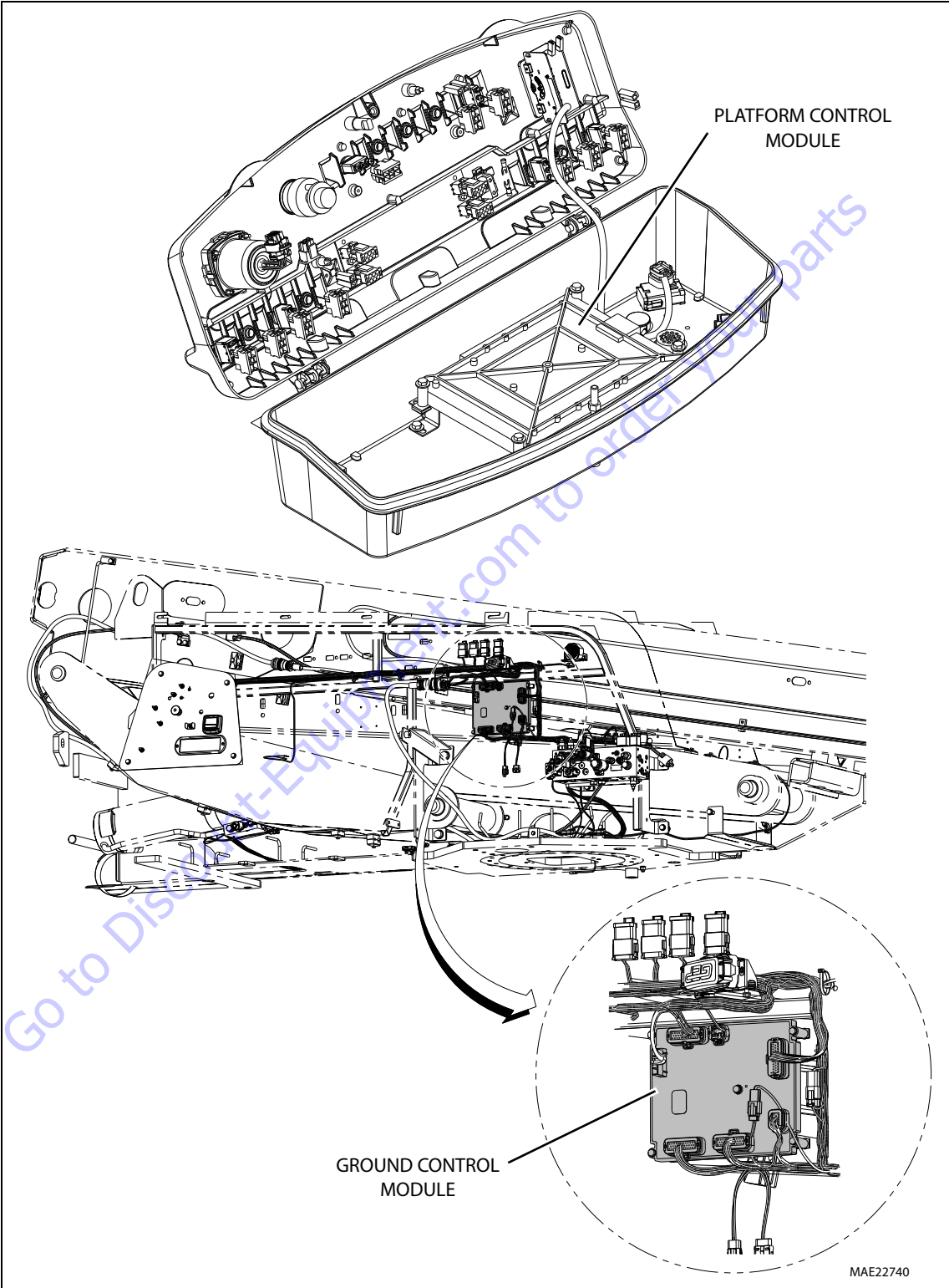
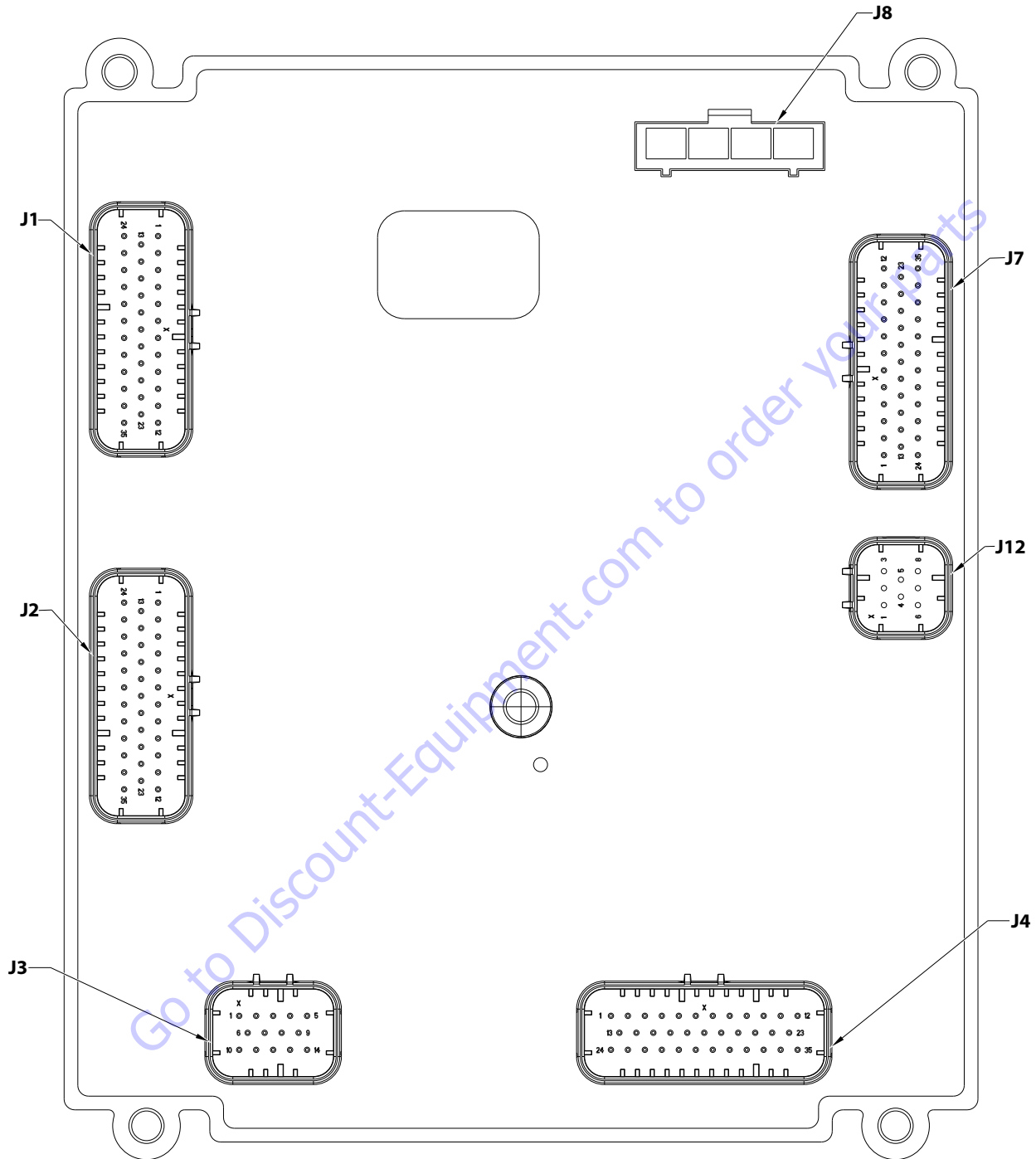

Figure 6-17. Control Module Locations



1001187200-E
MAE21440E

Figure 6-18. Ground Control Module Pin Connections

Connector	Pin	Function	Type	
J1 (Natural)	1	UNUSED (FUEL RACK ACTUATOR)	DIGITAL	OUTPUT
	2	OSCILLATING AXLE VALVE #2	DIGITAL	OUTPUT
	3	DRIVE FORWARD / LEFT TRACK FORWARD VALVE	DIGITAL	OUTPUT
	4	UNUSED	GROUND	INPUT
	5	UNUSED	GROUND	INPUT
	6	DRIVE REVERSE / LEFT TRACK REVERSE VALVE	DIGITAL	OUTPUT
	7	OSCILLATING AXLE VALVE #1	DIGITAL	OUTPUT
	8	UNUSED	GROUND	INPUT
	9	MSSO SWITCH GROUND	GROUND	INPUT
	10	ECU POWER	DIGITAL	OUTPUT
	11	ENGINE START	DIGITAL	OUTPUT
	12	ENGINE GLOW PLUGS	DIGITAL	OUTPUT
	13	APU ENABLE RELAY	DIGITAL	OUTPUT
	14	UNUSED (ENGINE COOLANT TEMPERATURE SENSOR)	ANALOG	INPUT
	15	UNUSED (ENGINE OIL PRESSURE SENSOR)	ANALOG	INPUT
	16	UNUSED (ENGINE SPEED SENSOR)	FREQUENCY	INPUT
	17	UNUSED (ENGINE SPEED SENSOR GROUND)	GROUND	INPUT
	18	UNUSED (ENGINE GROUND)	GROUND	INPUT
	19	UNUSED (ENGINE GROUND)	GROUND	INPUT
	20	2 SPEED VALVE	DIGITAL	OUTPUT
	21	UNUSED (TOWER ELEVATION SWITCH #2)	DIGITAL	INPUT
	22	GENERATOR ENABLE RELAY	DIGITAL	OUTPUT
	23	BRAKE VALVE	DIGITAL	OUTPUT
	24	UNUSED	N/C	N/C
	25	UNUSED (RS-485 HIGH)	SERIAL	I/O
	26	UNUSED (RS-485 LOW)	SERIAL	I/O
	27	BRAKE / 2 SPEED VALVE GROUND	GROUND	INPUT
	28	ANALYZER POWER	VOLTAGE	OUTPUT
	29	ANALYZER RS-232 RX	SERIAL	INPUT
	30	ANALYZER RS-232 TX	SERIAL	OUTPUT
	31	ANALYZER GROUND	GROUND	INPUT
	32	ALTERNATOR EXCITATION	DIGITAL	OUTPUT
	33	UNUSED (RS-485 GROUND)	GROUND	INPUT
	34	TELESCOPE RETRACTED SWITCH #2	DIGITAL	INPUT
	35	CAPACITY LENGTH SWITCH #2	DIGITAL	INPUT

Connector	Pin	Function	Type	
J8 (Black)	1	MODULE GROUND	GROUND	OUTPUT
	2	MODULE POWER	VBAT	INPUT
	3	GROUND TO PLATFORM MODULE	GROUND	INPUT
	4	POWER TO PLATFORM MODULE	VBAT	OUTPUT

Connector	Pin	Function	Type	
J2 (Gray)	1	STEER DUMP VALVE	DIGITAL	OUTPUT
	2	GROUND ALARM	DIGITAL	OUTPUT
	3	PLATFORM DUMP VALVE #1	DIGITAL	OUTPUT
	4	BYPASS DUMP VALVE	DIGITAL	OUTPUT
	5	PLATFORM LEVEL UP VALVE	DIGITAL	OUTPUT
	6	FUEL SENSOR GROUND	GROUND	INPUT
	7	PLATFORM LEVEL DOWN VALVE	DIGITAL	OUTPUT
	8	FRONT STEER RIGHT/RIGHTTRACK REVERSE VALVE	DIGITAL	OUTPUT
	9	MAIN TELESCOPE IN VALVE	DIGITAL	OUTPUT
	10	UNUSED (PLATFORM ROTATE LEFT VALVE)	DIGITAL	OUTPUT
	11	MAIN LIFT UP VALVE	DIGITAL	OUTPUT
	12	UNUSED (JIB LIFT UP VALVE)	DIGITAL	OUTPUT
	13	MAIN DUMP VALVE	DIGITAL	OUTPUT
	14	UNUSED (MAIN TELESCOPE VALVES GROUND)	GROUND	INPUT
	15	UNUSED (TOWER TELESCOPE OUT VALVE)	DIGITAL	OUTPUT
	16	USED (MAIN TELESCOPE OUT VALVE)	DIGITAL	OUTPUT
	17	UNUSED (PLATFORM ROTATE / JIB LIFT VALVE GROUND)	GROUND	INPUT
	18	STEER DUMP VALVE GROUND	GROUND	INPUT
	19	FRONT LEFT STEER VALVE / RIGHT TRACK FORWARD VALVE	DIGITAL	OUTPUT
	20	MAIN TELESCOPEOUT VALVE	DIGITAL	OUTPUT
	21	AUX MAIN LIFT DOWN VALVE	DIGITAL	OUTPUT
	22	MAIN LIFT DOWN VALVE	DIGITAL	OUTPUT
	23	PLATFORM DUMP VALVE #2	DIGITAL	OUTPUT
	24	CONFIGURATION #2	DIGITAL	INPUT
	25	FUEL SENSOR	ANALOG	INPUT
	26	HEAD / TAIL LIGHT ENABLE RELAY	DIGITAL	OUTPUT
	27	GROUND ALARM / HORN	DIGITAL	OUTPUT
	28	STEER VALVES GROUND	GROUND	INPUT
	29	GROUND ALARM / HORN GROUND	GROUND	INPUT
	30	MAIN/TELESCOPE IN/ BYPASS DUMP VALVE GROUND	GROUND	INPUT
	31	TELESCOPE IN DUMP VALVE	DIGITAL	OUTPUT
	32	REAR STEER RIGHT VALVE	DIGITAL	OUTPUT
	33	REAR STEER LEFT VALVE	DIGITAL	OUTPUT
	34	SWING LEFT VALVE	DIGITAL	OUTPUT
	35	SWING RIGHT VALVE	DIGITAL	OUTPUT

SECTION 6 - JLG CONTROL SYSTEM

Connector	Pin	Function	Type	
J12 (RED)	1	UNUSED	FREQUENCY	INPUT
	2	UNUSED	FREQUENCY	INPUT
	3	CAN2 HIGH	SERIAL	I/O
	4	CAN2 LOW	SERIAL	I/O
	5	UNUSED (CAN2 SHIELD)	GROUND	INPUT
	6	CAN2 TERMINATOR	TERM	I/O
	7	CAN2 TERMINATOR	TERM	I/O
	8	MSSO SWITCH	DIGITAL	INPUT

Connector	Pin	Function	Type	
J3 (Black)	1	DRIVE/ LEFT TRACK DRIVE VALVES CURRENT FEEDBACK	GROUND	INPUT
	2	AUX DOWN / RIGHT TRACK VALVES CURRENT FEEDBACK	GROUND	INPUT
	3	WIRE ROPE SERVICE SWITCH GROUND	GROUND	INPUT
	4	SWING VALVES CURRENT FEEDBACK	GROUND	INPUT
	5	AUX DOWN VALVES CURRENT FEEDBACK	GROUND	INPUT
	6	TELESCOPE FLOW CONTROL VALVES CURRENT FEEDBACK	GROUND	INPUT
	7	GROUND ALARM POWER	VBAT	OUTPUT
	8	WIRE ROPE SERVICE SWITCH	DIGITAL	INPUT
	9	CRIBBING ENABLE SWITCH	DIGITAL	INPUT
	10	UNUSED	DIGITAL	INPUT
	11	CONFIGURATION #1	DIGITAL	INPUT
	12	UNUSED	VOLTAGE	OUTPUT
	13	UNUSED	ANALOG	INPUT
	14	MAIN LIFT VALVES CURRENT FEEDBACK	GROUND	INPUT

Connector	Pin	Function	Type	
J4 (Blue)	1	CRIBBING ENGAGED INDICATOR	DIGITAL	OUTPUT
	2	SYSTEM DISTRESS INDICATOR	DIGITAL	OUTPUT
	3	GLOWPLUG INDICATOR	DIGITAL	OUTPUT
	4	ENGINE START SWITCH	DIGITAL	INPUT
	5	PLATFORM LEVEL DOWN SWITCH	DIGITAL	INPUT
	6	PLATFORM ROTATE LEFT SWITCH	DIGITAL	INPUT
	7	MAIN TELESCOPE IN SWITCH	DIGITAL	INPUT
	8	JIB LIFT DOWN SWITCH	DIGITAL	INPUT
	9	UNUSED (JIB LEFT SWITCH)	DIGITAL	INPUT
	10	UNUSED (TOWER LIFT UP SWITCH)	DIGITAL	INPUT
	11	UNUSED (TOWER TELESCOPE IN SWITCH)	DIGITAL	INPUT
	12	UNUSED (HOURMETER)	DIGITAL	OUTPUT
	13	LOW FUEL INDICATOR	DIGITAL	OUTPUT
	14	PLATFORM OVERLOADED INDICATOR	DIGITAL	OUTPUT
	15	UNUSED (UMS INDICATOR)	DIGITAL	OUTPUT
	16	AUXILIARY POWER / FUNCTION ENABLE	DIGITAL	INPUT
	17	PLATFORM LEVEL UP SWITCH	DIGITAL	INPUT
	18	PLATFORM ROTATE RIGHT SWITCH	DIGITAL	INPUT
	19	JIB LIFT UP SWITCH	DIGITAL	INPUT
	20	UNUSED (JIB RIGHT SWITCH)	DIGITAL	INPUT
	21	UNUSED (TOWER LIFT DOWN SWITCH)	DIGITAL	INPUT
	22	UNUSED (TOWER TELESCOPE OUT SWITCH)	DIGITAL	INPUT
	23	MAIN LIFT UP SWITCH	DIGITAL	INPUT
	24	UNUSED	VBAT	OUTPUT
	25	SWITCHES POWER	VBAT	OUTPUT
	26	BATTERY LOW / NOT CHARGING INDICATOR	DIGITAL	OUTPUT
	27	UNUSED	DIGITAL	OUTPUT
	28	UNUSED	DIGITAL	OUTPUT
	29	CHECK ENGINE INDICATOR	DIGITAL	OUTPUT
	30	MAIN TELESCOPE OUT SWITCH	DIGITAL	INPUT
	31	INDICATORS GROUND	GROUND	INPUT
	32	INDICATORS GROUND	GROUND	INPUT
	33	MAIN LIFT DOWN SWITCH	DIGITAL	INPUT
	34	SWING LEFT SWITCH	DIGITAL	INPUT
	35	SWING RIGHT SWITCH	DIGITAL	INPUT

Connector	Pin	Function	Type	
J7 (Black)	1	PLATFORM EMS	DIGITAL	INPUT
	2	PLATFORM MODE	DIGITAL	INPUT
	3	GROUND MODE	DIGITAL	INPUT
	4	BOOM ANGLE SENSOR #1	ANALOG	INPUT
	5	UNUSED (ENGINE SPEED SENSOR)	VOLTAGE	OUTPUT
	6	CAN1 TERMINATOR	TERM	I/O
	7	BOOM ANGLE SENSOR #2	ANALOG	INPUT
	8	UNUSED	ANALOG	INPUT
	9	BOOM ANGLE SENSOR GROUND	GROUND	INPUT
	10	TILT SENSOR GROUND	GROUND	INPUT
	11	UNUSED (TOWER ELEVATION SWITCH #1)	DIGITAL	INPUT
	12	UNUSED (OSCILLATING AXLE SWING SWITCH #1)	DIGITAL	PUT
	13	CAN1 HIGH	SERIAL	I/O
	14	GROUND MODE POWER TO PLATFORM	DIGITAL	INPUT
	15	FOOTSWITCH	DIGITAL	INPUT
	16	BOOM ANGLE SENSOR POWER	VOLTAGE	OUTPUT
	17	CAN1 TERMINATOR	TERM	I/O
	18	UNUSED (CAN1 SHIELD)	GROUND	INPUT
	19	IGNITION RELAY GROUND	GROUND	INPUT
	20	UNUSED (OSCILLATING AXLE SWING SWITCH #2)	ANALOG	INPUT
	21	TELESCOPE RETRACTED SWITCH #1	DIGITAL	INPUT
	22	UNUSED	DIGITAL	INPUT
	23	CAPACITY LENGTH SWITCH #1	DIGITAL	INPUT
	24	CAN1 LOW	SERIAL	I/O
	25	GROUND DISPLAY GROUND	GROUND	INPUT
	26	UNUSED	VOLTAGE	OUTPUT
	27	UNUSED	VOLTAGE	OUTPUT
	28	TELESCOPE RETRACTED SWITCH GROUND	GROUND	INPUT
	29	GROUND DISPLAY POWER	VBAT	OUTPUT
	30	UNUSED	VBAT	OUTPUT
	31	WIRE ROPE SERVICE SWITCH POWER	VBAT	OUTPUT
	32	TRANSPORT SWITCHES POWER	VBAT	OUTPUT
	33	TELESCOPE RETRACTED SWITCH POWER	VBAT	OUTPUT
	34	TILT SENSOR POWER	VBAT	OUTPUT
	35	DOS SWITCH	DIGITAL	INPUT

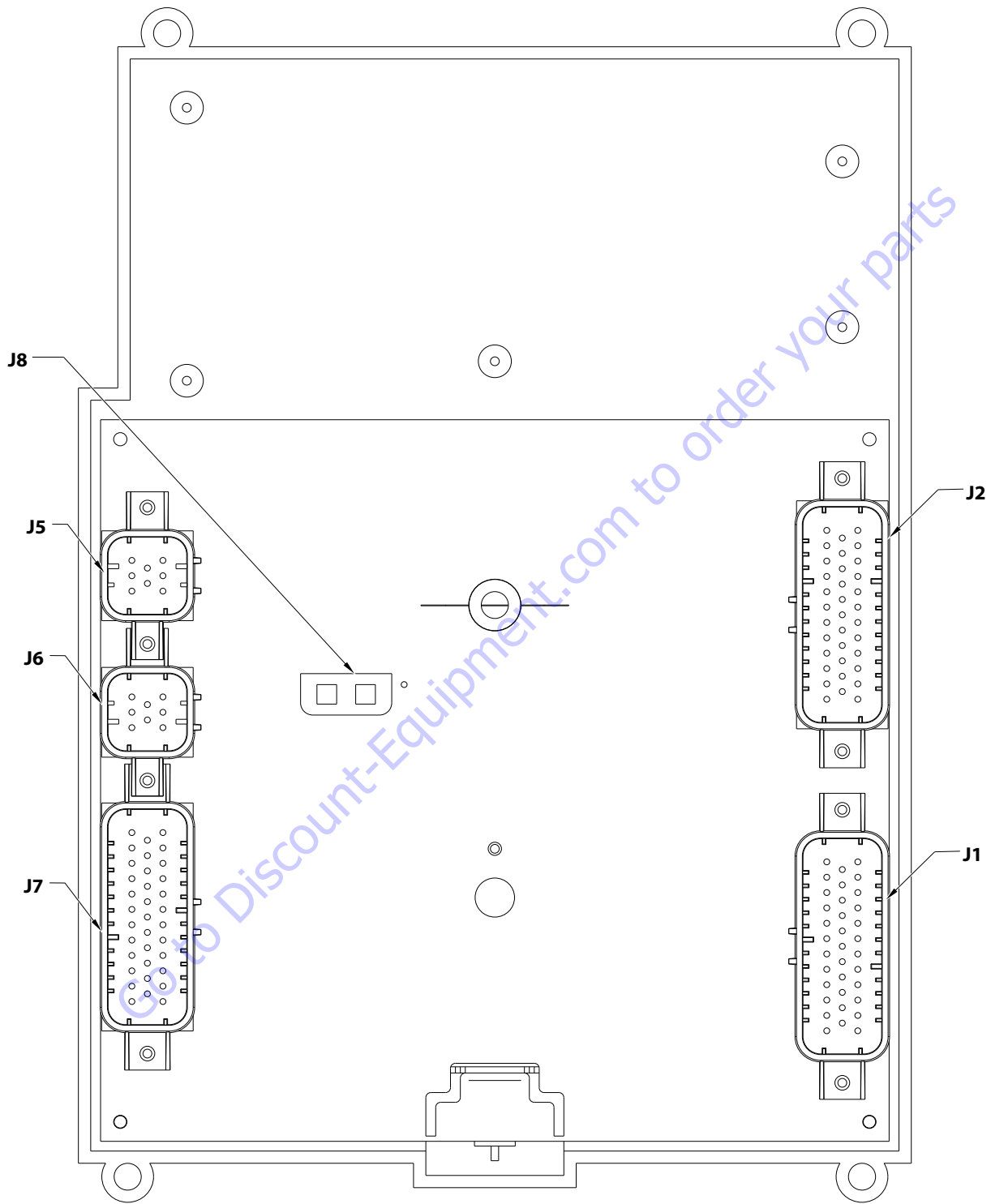

1001185726-E
MAE21470E

Figure 6-19. Platform Control Module Pin Connections

CONNECTOR	PIN	ASSIGNMENT	FUNCTION
J1 (NATURAL)	1	UNUSED(TOWER LIFT UP SWITCH)	HS DIGITAL INPUT
	2	UNUSED(TOWER LIFT DOWN SWITCH)	HS DIGITAL INPUT
	3	UNUSED(TOWER TELESCOPE IN SWITCH)	HS DIGITAL INPUT
	4	UNUSED(TOWER TELESCOPE OUT SWITCH)	HS DIGITAL INPUT
	5	MAIN TELESCOPE IN SWITCH	HS DIGITAL INPUT
	6	MAIN TELESCOPE OUT SWITCH	HS DIGITAL INPUT
	7	PLATFORM ROTATE RIGHT SWITCH	HS DIGITAL INPUT
	8	PLATFORM ROTATE LEFT SWITCH	HS DIGITAL INPUT
	9	PLATFORM LEVEL UP SWITCH	HS DIGITAL INPUT
	10	PLATFORM LEVEL DOWN SWITCH	HS DIGITAL INPUT
	11	JIB LIFT UP SWITCH	HS DIGITAL INPUT
	12	JIB LIFT DOWN SWITCH	HS DIGITAL INPUT
	13	SPEED PUMP POTENTIOMETER GROUND	GROUND
	14	ENGINE START SWITCH	HS DIGITAL INPUT
	15	AUXILIARY POWER SWITCH	HS DIGITAL INPUT
	16	CRAB STEER SELECT SWITCH	HS DIGITAL INPUT
	17	COORDINATED STEER SELECT SWITCH	HS DIGITAL INPUT
	18	SWITCHES POWER	BATTERY VOLTAGE
	19	UNUSED	HS DIGITAL INPUT
	20	SOFT TOUCH SWITCH	HS DIGITAL INPUT
	21	CAPACITY SELECT SWITCH	HS DIGITAL INPUT
	22	UNUSED	HS DIGITAL INPUT
	23	SKYGUARD INPUT #2 SWITCH	HS DIGITAL INPUT
	24	UNUSED	HS DIGITAL INPUT
	25	PLATFORM ANGLE SENSOR #1	HS DIGITAL INPUT
	26	PLATFORM ANGLE SENSOR #2	HS DIGITAL INPUT
	27	MAX ENGINE SPEED SWITCH	HS DIGITAL INPUT
	28	MAX ENGINE TORQUE SWITCH	HS DIGITAL INPUT
	29	SOFT TOUCH / SKYGUARD OVERRIDE SWITCH	HS DIGITAL INPUT
	30	HEAD/TAIL LIGHT SWITCH	HS DIGITAL INPUT
	31	HORN	HS DIGITAL INPUT
	32	CREEP SWITCH	HS DIGITAL INPUT
	33	FUEL SELECT SWITCH	HS DIGITAL INPUT
	34	SPEED PUMP POTENTIOMETER POWER	+7 REFERENCE VOLTAGE
	35	SPEED PUMP POTENTIOMETER	ANALOG INPUT

CONNECTOR	PIN	ASSIGNMENT	FUNCTION
J2 (BLUE)	1	UNUSED (JIB RIGHT SWITCH)	HS DIGITAL INPUT
	2	UNUSED (JIB LEFT SWITCH)	HS DIGITAL INPUT
	3	UNUSED	BATTERY VOLTAGE
	4	DRIVE ORIENTATION SYSTEM OVERRIDE SWITCH	HS DIGITAL INPUT
	5	UNUSED	HS DIGITAL INPUT
	6	CHASSIS TILT INDICATOR	LAMP OUTPUT
	7	FUNCTION ENABLE INDICATOR	LAMP OUTPUT
	8	VEHICLE SYSTEM DISTRESS INDICATOR	LAMP OUTPUT
	9	CREEP SPEED INDICATOR	LAMP OUTPUT
	10	WIRE ROPE SERVICE INDICATOR	LAMP OUTPUT
	11	PLATFORM OVERLOAD INDICATOR	LAMP OUTPUT
	12	UNRESTRICTED CAPACITY INDICATOR	LAMP OUTPUT
	13	RESTRICTED CAPACITY INDICATOR	LAMP OUTPUT
	14	DRIVE ORIENTATION SYSTEM INDICATOR	LAMP OUTPUT
	15	GENERATOR ON INDICATOR	LAMP OUTPUT
	16	SOFT TOUCH/ SKYGUARD INDICATOR	LAMP OUTPUT
	17	GLOW PLUG ENGAGED INDICATOR	LAMP OUTPUT
	18	INDICATOR GROUND	GROUND
	19	LEVEL SYSTEM INDICATOR	LAMP OUTPUT
	20	DRIVE DISABLED INDICATOR	LAMP OUTPUT
	21	LOW FUEL INDICATOR	LAMP OUTPUT
	22	1/4 FUEL LEVEL INDICATOR	LAMP OUTPUT
	23	3/4 FUEL LEVEL INDICATOR	LAMP OUTPUT
	24	1/2 FUEL LEVEL INDICATOR	LAMP OUTPUT
	25	INDICATOR GROUND	GROUND
	26	ANALYZER POWER	ANALYZER POWER
	27	ANALYZER GROUND	ANALYZER GROUND
	28	ANALYZER RX	ANALYZER RX
	29	ANALYZER TX	ANALYZER TX
	30	UNUSED	LAMP OUTPUT
	31	SOFT TOUCH POWER	DIGITAL OUTPUT
	32	LSS POWER	BATTERY VOLTAGE
	33	OPTION POWER	BATTERY VOLTAGE
	34	UNUSED	BATTERY VOLTAGE
	35	FUEL FULL INDICATOR	LAMP OUTPUT

SECTION 6 - JLG CONTROL SYSTEM

CONNECTOR	PIN	ASSIGNMENT	FUNCTION
J5 (NATURAL)	1	MAIN LIFT / SWING JOYSTICK POWER	SUPPLY VOLTAGE
	2	MAIN LIFT CENTER TAP	ANALOG INPUT
	3	MAIN LIFT SIGNAL	ANALOG INPUT
	4	SWING SIGNAL	ANALOG INPUT
	5	SWING CENTER TAP	ANALOG INPUT
	6	UNUSED	ANALOG INPUT
	7	MAIN LIFT / SWING JOYSTICK GROUND	GROUND
	8	UNUSED	GROUND

CONNECTOR	PIN	ASSIGNMENT	FUNCTION
J6 (BLACK)	1	DRIVE / STEER JOYSTICK POWER	SUPPLY VOLTAGE
	2	DRIVE CENTER TAP	ANALOG INPUT
	3	DRIVE SIGNAL	ANALOG INPUT
	4	DRIVE ENABLE	ANALOG INPUT
	5	STEER LEFT / STEER SIGNAL	ANALOG INPUT
	6	STEER RIGHT / STEER CENTER TAP	ANALOG INPUT
	7	DRIVE / STEER JOYSTICK RETURN	GROUND
	8	UNUSED	GROUND

CONNECTOR	PIN	ASSIGNMENT	FUNCTION
J8	1	MODULE GROUND	GROUND
	2	MODULE POWER	BATTERY VOLTAGE

CONNECTOR	PIN	ASSIGNMENT	FUNCTION
J7 (BLACK)	1	GROUND MODE	GROUND MODE
	2	PLATFORM EMS	PLATFORM EMS
	3	PLATFORM EMS TO GROUND MODULE	PLATFORM MODE
	4	FOOTSWITCH (FUNCTION ENABLE SWITCH) POWER	BATTERY VOLTAGE
	5	PLATFORM ROTATE LEFT VALVE	ME DIGITAL OUTPUT
	6	PLATFORM ROTATE RIGHT VALVE	ME DIGITAL OUTPUT
	7	SKYGUARD POWER	BATTERY VOLTAGE
	8	FOOTSWITCH SIGNAL	DIGITAL INPUT
	9	GENERATOR SWITCH	DIGITAL INPUT
	10	UNUSED	+7 REFERENCE VOLTAGE
	11	PLATFORM ANGLE SENSOR POWER	+5V REFERENCE VOLTAGE
	12	UNUSED	+5V REFERENCE VOLTAGE
	13	UNUSED	ANALOG INPUT
	14	PLATFORM ANGLE SENSOR GROUND	GROUND
	15	PLATFORM LEVEL UP VALVE	HS DIGITAL OUTPUT
	16	PLATFORM LEVEL DOWN VALVE	HS DIGITAL OUTPUT
	17	UNUSED	HS DIGITAL INPUT
	18	SKYGUARD INPUT #1 SWITCH	HS DIGITAL INPUT
	19	PLATFORM ALARM	LAMP OUTPUT
	20	PLATFORM ALARM GROUND	GROUND
	21	SKYGUARD GROUND	GROUND
	22	LSS GROUND	GROUND
	23	VALVES GROUND	ANALOG INPUT
	24	UNUSED	DIGITAL OUTPUT
	25	JIB LIFT UP VALVE	ME DIGITAL OUTPUT
	26	JIB LIFT DOWN VALVE	ME DIGITAL OUTPUT
	27	UNUSED (JIG RIGHT VALVE)	ME DIGITAL OUTPUT
	28	UNUSED (JIG LEFT VALVE)	ME DIGITAL OUTPUT
	29	OPTIONS GROUND	GROUND
	30	CAN LOW	CAN LOW
	31	CAN HIGH	CAN HIGH
	32	UNUSED (CAN SHIELD)	CAN SHIELD
	33	UNUSED	GROUND
	34	UNUSED	GROUND
	35	UNUSED	ANALOG INPUT

Table 6-2. Machine Configuration Programming Information - Version P2.12

Configuration Digit	Number	Description	Default Number
NOTE: Machine configuration must be completed before any personality settings can be changed. Changing personality settings first and then changing the model number of the machine configuration will cause personality settings to return to default.			
MODEL NUMBER: 1	0 1	No Model Visible only on a Non-Configured UGM 600S	1
MARKET: 2	1 2 3 4 5 6 7	ANSI USA ANSI EXPORT CSA CE AUSTRALIA JAPAN GB	1
ENGINE: 3	1 2 3	DEUTZ EMR2: (Tier 4i) DEUTZ EMR4: (Tier 4f) FORD DUAL FUEL	1
FLYWHEEL TEETH: 4*	1	98 TEETH: 98 flywheel teeth.	1
* This menu item is not visible			
GLOW PLUG: 5*	1 2	NO GLOW PLUGS: No glow plugs installed. IN-CYLINDER: Glow plugs installed in each cylinder.	2
* This menu item is not visible.			
STARTER LOCKOUT: 6*	1 2	DISABLED: Automatic pre-glow time determined by ambient air temperature; engine start can be attempted at any time during pre-glow. ENABLED: Automatic pre-glow time determined by ambient air temperature; engine start is NOT permitted until pre-glow is finished.	1
* Only visible for Engine Selection = Deutz EMR2 or Deutz EMR4.			
ENGINE SHUTDOWN: 7	1 2	DISABLED: No engine shutdown. ENABLED: Shutdown engine for high coolant temperature fault or low oil pressure fault	2

SECTION 6 - JLG CONTROL SYSTEM

Table 6-2. Machine Configuration Programming Information - Version P2.12

Configuration Digit	Number	Description	Default Number
FUEL CUTOFF: 8*	1 2 3 4	ONE RESTART: One restart with limited run time when near Empty. ENGINE STOP: No starting permitted when near Empty. NONE RESTART: Restarts allowed with limited run time when near Empty	4
* Only visible for Engine Selection = Deutz EMR2 or Deutz EMR4.			
TILT: 9	1 2 3 4 5 6 7 8 9	5 DEGREES: Reduces the maximum speed of all boom functions to creep when tilted more than 5 degrees and above elevation; also reduces drive speed to creep. 4 DEGREES: Reduces the maximum speed of all boom functions to creep when tilted more than 4 degrees and above elevation; also reduces drive speed to creep. 3 DEGREES: Reduces the maximum speed of all boom functions to creep when tilted more than 3 degrees and above elevation; also reduces drive speed to creep. 4 DEGREES + CUT: Reduces the maximum speed of all boom functions to creep when tilted more than 4 degrees and above elevation; also disallows tower lift up, tower telescope out, drive, main telescope out and main lift up. 4 DEG + CUT: Reduces the maximum speed of all boom functions to creep when tilted more than 4 degrees and above elevation; also disallows tower lift up, drive, telescope out and lift up. 3 DEG + CUT: Reduces the maximum speed of all boom functions to creep when tilted more than 3 degrees and above elevation; also disallows tower lift up, drive, telescope out and lift up. 5 DEG + DRV CUT: Reduces the maximum speed of all boom functions to creep when tilted more than 5 degrees and above elevation; also reduces drive speed to creep when drive reversal is allowed, drive is disallowed otherwise. 4 DEG + DRV CUT: Reduces the maximum speed of all boom functions to creep when tilted more than 4 degrees and above elevation; also reduces drive speed to creep when drive reversal is allowed, drive is disallowed otherwise. 3 DEG + DRV CUT: Reduces the maximum speed of all boom functions to creep when tilted more than 3 degrees and above elevation; also reduces drive speed to creep when drive reversal is allowed, drive is disallowed otherwise.	7
* Certain market selections will limit tilt options and alter default setting. Note: Any of the selections above will light the tilt lamp when a tilted condition occurs and will sound the platform alarm when the machine is also above elevation.			
JIB: 10	1 2	NO: No Jib installed. YES: Jib installed which has up and down movements only.	1

Table 6-2. Machine Configuration Programming Information - Version P2.12

Configuration Digit	Number	Description	Default Number
4 WHEEL STEER: 11*	1 2	NO: 4 Wheel Steer not installed. YES: 4 Wheel Steer installed.	1
* Only visible for 600S.			
SOFT TOUCH: 12	1 2	NO: No Soft Touch system installed. YES: Soft Touch system installed.	1
SKYGUARD: 13	1 2	NO: No SkyGuard system installed. SKYGUARD: SkyGuard system only installed.	2
GENSET/WELDER: 14	1 2	NO: No generator installed. BELT DRIVE: Belt driven setup	1
GEN SET CUTOUT: 15*	1 2	MOTION ENABLED: Motion enabled when generator is ON. MOTION CUTOUT: Motion cutout in platform mode only.	1
* Only visible if Gen Set / Welder Menu selection is not 1.			
H & T LIGHTS: 16	1 2	NO: No head and tail lights installed. YES: Head and tail lights installed.	1
LOAD SYSTEM: 17*	1 2 3	NO: No load sensor installed. CUTOUT PLATFORM: All functions cutout, overload lamp lit, platform alarm beeps (5 sec ON, 2 sec OFF). CUTOUT ALL: All functions cutout, flash overload light (500mS on, 500mS off), platform alarm beeps (5 sec ON, 2 sec OFF).	1
* Only visible under certain market selections. * Certain market selections will limit load system options or alter default setting.			

SECTION 6 - JLG CONTROL SYSTEM

Table 6-2. Machine Configuration Programming Information - Version P2.12

Configuration Digit	Number	Description	Default Number
FUNCTION CUTOUT: 18*	1 2 3	NO: No drive cutout. BOOM CUTOUT: Boom function cutout while driving above elevation. DRIVE CUTOUT: Drive cutout above elevation.	1
*Only visible under certain market selections. *Certain market selections will limit function cutout options or alter default setting.			
GROUND ALARM: 19	1 2 3 4	NO: No ground alarm installed. DRIVE: Travel alarm sounds when the drive function is active. DESCENT: Descent alarm sounds when lift down is active. MOTION: Motion alarm sounds when any function is active.	4
DRIVETYPE: 20*	1 2	4 WD: Four wheel drive. 2WD: Two wheel drive.	1
*Only visible for 600S			
DISPLAY UNITS: 21*	1 2	METRIC: Celsius, Kilograms, KiloPascal. IMPERIAL: Fahrenheit, Pounds, Pounds/in²	2
*Certain market selections will alter default setting.			
CLEARSKY: 22	1 2	NO: ClearSky (telematics) options is disabled. YES: ClearSky (telematics) option is enabled.	1
CRIBBING OPTION: 23*	1 2	NO: Cribbing Option is disabled. YES: Cribbing Option is enabled.	1
*Certain market selections will limit cribbing options.			
ALERT BECON: 24	1 2	OFF FOR CREEP IN CREEP 20FPM	1
TEMP CUTOUT: 25*	1 2	NO: No Low Temp Cutout system installed YES: Low Temp Cutout system installed	1
*Certain market selections will temp cutout options.			

Table 6-2. Machine Configuration Programming Information - Version P2.12

Configuration Digit	Number	Description	Default Number
PLAT LVL OVR CUT: 26	1 2	NO: Platform Level functions above elevation YES: Platform Level does not function above elevation	1
DUAL CAPACITY: 27*	1 2	NO: No Dual Capacity system installed. YES: Dual Capacity system installed.	2
* Only visible for 600S.			
ALARM / HORN: 28	1 2	SEPARATE: Ambient alarm installed. COMBINED: Single Horn / Alarm installed.	2
WATER IN FUELSENSOR: 29*	1 2	NO: Water in Fuel Sensor not installed. YES: Water in Fuel Sensor installed.	2
* Only visible under certain market selections. * Only visible for Engine Selection = Deutz EMR4.			

1001198686-D

SECTION 6 - JLG CONTROL SYSTEM

Table 6-3. Machine Configuration Programming Settings - Version P2.12

600S	ANSI USA	ANSI Export	CSA	CE	Australia	Japan	GB
Model Number	1	1	1	1	1	1	1
Market	1	2	3	4	5	6	7
Engine	1	1	1	1	1	1	1
	2	2	2	2	2	2	2
	3	3	3	3	3	3	3
Flywheel Teeth	X	X	X	X	X	X	X
Glow Plug	2	2	2	2	2	2	2
Starter Lockout	1	1	1	1	1	1	1
	2	2	2	2	2	2	2
Engine Shutdown	1	1	1	1	1	1	1
	2	2	2	2	2	2	2
Fuel Cutout	1	1	1	1	1	1	1
	2	2	2	2	2	2	2
	X	X	X	X	X	X	X
	4	4	4	4	4	4	4
Tilt	1	1	1	1	1	1	1
	2	2	2	2	2	2	2
	3	3	3	3	3	3	3
	4	4	4	4	4	4	4
	5	5	5	5	5	5	5
	6	6	6	6	6	6	6
	7	7	7	7	7	7	7
	8	8	8	8	8	8	8
	9	9	9	9	9	9	9
4 Wheel Steer	1	1	1	1	1	1	1
	2	2	2	2	2	2	2
Jib	1	1	1	1	1	1	1
	2	2	2	2	2	2	2
SOFTTOUCH	1	1	1	1	1	1	1
	2	2	2	2	2	2	2
SKYGUARD	1	1	1	1	1	1	1
	2	2	2	2	2	2	2
Gen Set / Welder	1	1	1	1	1	1	1
	2	2	2	2	2	2	2
Gen Set Cutout	1	1	1	1	1	1	1
	2	2	2	2	2	2	2
Head & Tail lights	1	1	1	1	1	1	1
	2	2	2	2	2	2	2

Table 6-3. Machine Configuration Programming Settings - Version P2.12

600S	ANSI USA	ANSI Export	CSA	CE	Australia	Japan	GB
Load System	1	1	1	X	X	1	X
	2	2	2	X	2	2	2
	3	3	3	3	X	3	3
Function Cutout	1	1	1	X	1	1	1
	X	2	2	2	2	2	2
	3	3	3	X	3	3	3
Ground Alarm	1	1	1	1	1	1	1
	2	2	2	2	2	2	2
	3	3	3	3	3	3	3
	4	4	4	4	4	4	4
Drive Type	1	1	1	1	1	1	1
	2	2	2	2	2	2	2
Display Units	1	1	1	1	1	1	1
	2	2	2	2	2	2	2
Clearsky	1	1	1	1	1	1	1
	2	2	2	2	2	2	2
Cribbing Option	1	1	1	X	X	1	1
	2	2	2	X	X	2	2
Alert Beacon	1	1	1	1	1	1	1
	2	2	2	2	2	2	2
Temp Cutout	X	1	X	1	X	X	1
	X	2	X	2	X	X	2
PLAT LVL OVR CUT	1	1	1	1	1	1	1
	2	2	2	2	2	2	2
Dual Capacity	1	1	1	1	1	1	1
	2	2	2	2	2	2	2
ALARM / HORN	1	1	1	1	1	1	1
	2	2	2	2	2	2	2
Water in Fuel Sensor	1	1	1	1	1	1	1
	2	2	2	2	2	2	2

BOLD BLUE text indicates the default setting. Plain text indicates another available selection. **RED ITALIC** text indicates the default when option is factory installed. SHADED CELLS indicate hidden menu or selection.

1001198686-D

Table 6-4. Machine Configuration Programming Settings - Version P2.12

660SJ	ANSI USA	ANSI Export	CSA	CE	Australia	Japan	GB
Model Number	1	1	1	1	1	1	1
Market	1	2	3	4	5	6	7
Engine	1	1	1	1	1	1	1
	2	2	2	2	2	2	2
	3	3	3	3	3	3	3
Flywheel Teeth	X	X	X	X	X	X	X
Glow Plug	2	2	2	2	2	2	2
Starter Lockout	1	1	1	1	1	1	1
	2	2	2	2	2	2	2
Engine Shutdown	1	1	1	1	1	1	1
	2	2	2	2	2	2	2
Fuel Cutout	1	1	1	1	1	1	1
	2	2	2	2	2	2	2
	X	X	X	X	X	X	X
	4	4	4	4	4	4	4
Tilt	1	1	1	1	1	1	1
	2	2	2	2	2	2	2
	3	3	3	3	3	3	3
	4	4	4	4	4	4	4
	5	5	5	5	5	5	5
	6	6	6	6	6	6	6
	7	7	7	7	7	7	7
	8	8	8	8	8	8	8
	9	9	9	9	9	9	9
4 Wheel Steer	1	1	1	1	1	1	1
	2	2	2	2	2	2	2
Jib	1	1	1	1	1	1	1
	2	2	2	2	2	2	2
SOFTTOUCH	1	1	1	1	1	1	1
	2	2	2	2	2	2	2
SKYGUARD	1	1	1	1	1	1	1
	2	2	2	2	2	2	2
Gen Set / Welder	1	1	1	1	1	1	1
	2	2	2	2	2	2	2
Gen Set Cutout	1	1	1	1	1	1	1
	2	2	2	2	2	2	2
Head & Tail lights	1	1	1	1	1	1	1
	2	2	2	2	2	2	2

Table 6-4. Machine Configuration Programming Settings - Version P2.12

660SJ	ANSI USA	ANSI Export	CSA	CE	Australia	Japan	GB
Load System	1	1	1	X	X	1	X
	2	2	2	X	2	2	2
	3	3	3	3	X	3	3
Function Cutout	1	1	1	X	1	1	1
	X	2	2	2	2	2	2
	3	3	3	X	3	3	3
Ground Alarm	1	1	1	1	1	1	1
	2	2	2	2	2	2	2
	3	3	3	3	3	3	3
	4	4	4	4	4	4	4
Drive Type	1	1	1	1	1	1	1
	2	2	2	2	2	2	2
Display Units	1	1	1	1	1	1	1
	2	2	2	2	2	2	2
Clearsky	1	1	1	1	1	1	1
	2	2	2	2	2	2	2
Cribbing Option	1	1	1	X	X	1	1
	2	2	2	X	X	2	2
Alert Beacon	1	1	1	1	1	1	1
	2	2	2	2	2	2	2
Temp Cutout	X	1	X	1	X	X	1
	X	2	X	2	X	X	2
PLAT LVL OVR CUT	1	1	1	1	1	1	1
	2	2	2	2	2	2	2
Dual Capacity	1	1	1	1	1	1	1
	2	2	2	2	2	2	2
ALARM / HORN	1	1	1	1	1	1	1
	2	2	2	2	2	2	2
Water in Fuel Sensor	1	1	1	1	1	1	1
	2	2	2	2	2	2	2

BOLD BLUE text indicates the default setting. Plain text indicates another available selection. **RED ITALIC** text indicates the default when option is factory installed. SHADED CELLS indicate hidden menu or selection.

1001198686 - D

6.2 MACHINE PERSONALITY SETTINGS

NOTE: Personality settings can be adjusted within the adjustment range for optimum machine performance.

Table 6-5. Machine Personality Settings and Function Speed

FUNCTION		ADJUSTMENT RANGES	MODEL DEFAULTS	MODEL TIME RANGE (IN SECONDS)
DRIVE				
MaxSpeed	Accel	25 – 2000 mA/s	500 mA/s	35 to 39
	Decel	25 – 2000 mA/s	925 mA/s	
	MIn	250 – 1000 mA	625 mA	
	Max	250 – 1400 mA	1550 mA	
Drive to Stop	Decel	25 – 2000 mA/s	725 mA/s	
Max Torque Elevated	Max	250 – 1200 mA	950 mA	85 to 97
Mid Engine Elevated	Max	250 – 1200 mA	1050 mA	85 to 97
Max Torque	Creep	250 – 1200 mA	850 mA	
Mid Engine	Creep	250 – 1200 mA	950 mA	
SWING				
	Accel	0.0 to 3.0 s	3.0 s	
	Decel	0.0 to 2.0 s	1.6 s	
LEFT	Min	250 to 1000 mA	430 mA	79 to 99
	Max	250 to 1000 mA	875 mA	
	Creep	250 to 1000 mA	675 mA	
RIGHT	Min	250 to 1000 mA	430 mA	79 to 99
	Max	250 to 1000 mA	900 mA	
	Creep	250 to 1000 mA	675 mA	
LIFT				
	Accel	0.0 to 3.0 s	2.5 s	
	Decel	0.0 to 2.0 s	1.2 s	
UP	Min	250 to 1500 mA	525 mS	55 to 75
	Max	250 to 1500 mA	1400 mS	
	Creep	250 to 1500 mA	1000mS	
DOWN	Min	250 to 1300 mA	700 mS	55 to 75
	Max	250 to 1300 mA	1200mS	
	Creep	250 to 1300 mA	1000 mS	
	Soft Down	250 to 1500 mA	900 mS	
	Soft Down	250 to 1300 mA	850 mS	

Table 6-5. Machine Personality Settings and Function Speed

FUNCTION		ADJUSTMENT RANGES	MODEL DEFAULTS	MODEL TIME RANGE (IN SECONDS)
TELESCOPE				
	Accel	0.0 to 3.0 s	0.7 s	
	Decel	0.0 to 2.0 s	0.5 s	
IN	Min	250 to 1200 mA	420 mA	40 to 50
	Max	250 to 1200 mA	1000 mA	
	Creep	250 to 1200 mA	650 mA	
OUT	Min	250 to 1200 mA	480 mA	42 to 52
	Max	250 to 1200 mA	1050 mA	
	Creep	250 to 1200 mA	710 mA	
JIB LIFT				
	Accel	0.0 to 3.0 s	3.0 s	
	Decel	0.0 to 2.0 s	0.8 s	
UP	Min	10 to 50%	27%	25 to 32
	Max	10 to 50%	41%	
	Creep	10 to 50%	34%	
DOWN	Min	10 to 50%	27%	22 to 28
	Max	10 to 50%	40%	
	Creep	10 to 50%	35%	
	Up Cutback	10 to 50%	33%	
	Down Cutback	10 to 50%	33%	
PLATFORM LEVEL				
	Accel	0.0 to 3.0 s	0.0 s	
	Decel	0.0 to 2.0 s	0.0 s	
UP	Min	250 to 1500 mA	800 mA	
	Max	250 to 1500 mA	1300 mA	
	Creep	250 to 1500 mA	1100 mA	
DOWN	Min	250 to 1500 mA	850 mA	
	Max	250 to 1500 mA	1400 mA	
	Creep	250 to 1500 mA	1250 mA	

Table 6-5. Machine Personality Settings and Function Speed

FUNCTION		ADJUSTMENT RANGES	MODEL DEFAULTS	MODEL TIME RANGE (IN SECONDS)
GROUND MODE				
SWING	Left	250 to 1000 mA	670 mA	
	Right	250 to 1000 mA	895 mA	
Lift	Up	250 to 1500 mA	1395 mA	
	Down	250 to 1300 mA	1195 mA	
Telescope	In	250 to 1200 mA	995 mA	
	Out	250 to 1200 mA	1045 mA	
JIB	Up	10 to 50%	40%	
	Down	10 to 50%	39%	
Platform	Up	250 to 1500 mA	1295 mA	
	Down	250 to 1500 mA	1395 mA	

1001198722-0

Go to Discount-Equipment.com to order your parts

6.3 MACHINE ORIENTATION WHEN SETTING FUNCTION SPEEDS

DRIVE (Below Elevation): Test should be done on a smooth, level surface. The Drive Select Switch should be in the "Max Speed" position. Start approximately 25 ft (7.6m) from starting point so the unit is at a maximum speed when starting the test. Results should be recorded for a 200ft (61m) course. Drive forward, "High Speed", record time.

DRIVE (Above Elevation): Test should be done on a smooth, level surface. The Drive Select Switch should be in the "Max Speed" position, the boom should be > 10° above horizontal to ensure the drive is operating in Max Torque mode. Results should be recorded for a 15.2m (50ft) course. Drive forward, record time. Drive Reverse, record time. Turn Platform Speed Control Knob fully counterclockwise to enter Creep mode; Creep light on Panel must be energized. Verify that machine will Drive Forward and Reverse. Return Knob to fully clockwise.

SWING: Boom at full elevation, Telescope retracted. Swing Right until over rear axle or end stop (if equipped). Swing Left 360° or end stop (if equipped), record time. Swing Right 360° or end stop (if equipped), record time. Turn Platform Speed Control Knob fully counterclockwise to enter Creep mode; Creep light on Panel must be energized. Verify that machine will swing left and right. Return Knob to fully clockwise.

MAIN LIFT: Main Lift in stowed position, Telescope Retracted. Main Lift Up, record time. Main Lift Down, record time. Turn Platform Speed Control Knob fully counterclockwise to enter Creep mode; Creep light on Panel must be energized. Verify that machine will Lift Up and Down. Return Knob to fully clockwise.

TELESCOPE: Main Lift at full elevation, Telescope Retracted. Telescope Out, record time. Telescope In, record time. Turn Platform Speed Control Knob fully counterclockwise to enter Creep mode; Creep light on Panel must be energized. Verify that machine will Telescope In and Out. Return Knob to fully clockwise.

JIB LIFT: Platform level and centered with the boom. Jib Lift Down until stop. Jib Lift Up, record time. Jib Lift Down, record time. Turn Platform Speed Control Knob fully counterclockwise to enter Creep mode; Creep light on Panel must be energized. Verify that machine will Jib Lift Up and Down. Return Knob to fully clockwise.

PLATFORM ROTATE: Platform level, Rotate Platform Right until stop. Platform Left, record time. Platform Right, record time. Turn Platform Speed Control Knob fully counterclockwise to enter Creep mode; Creep light on Panel must be energized. Verify that machine will Platform Rotate Left and Right. Return Knob to fully clockwise.

NOTE: When the platform speed control knob is turned fully counterclockwise. The platform rotate may not work, this is acceptable.

Test Notes

1. Personality settings can be adjusted anywhere within the adjustment range for optimum machine performance.
2. Stop watch should be started with the function movement, not with actuation of the joystick or switch.
3. Drive speeds should be set to the values below regardless of the tire size.
4. All speed tests are run from the platform, these speeds do not reflect the ground control operation.
5. The Platform Speed Control knob must be at full speed (turned clockwise completely) unless noted.
6. Some flow control functions may not work with the Platform Speed Control knob clicked into the creep position.
7. Functional speeds may vary due to cold thick hydraulic oil. Test should be run with the oil temperature above 38° C (100° F).

6.4 CANBUS COMMUNICATIONS

CANbus: CAN (Control Area Network) is a two wire differential serial link between the Platform and Ground Modules providing bi-directional communications.

Two-wire: One wire (red) is driven high (5v) and the other low (black) (0v) to send a signal. Both wires "float" (2.5v) when no signal is being sent.

Differential: Any electrical line noise can affect the high or the low wires but never both, so communications is not corrupted.

Serial Link: Messages are being sent bit by bit along the wires; the high bus speed allow all modules to be constantly updated around 20 times per second. Typical traffic is 300 - 500 messages per second.

A complete CANbus circuit is approximately 60 ohms, which can be verified at the "T" fitting inside the ground station. Individual circuits are approximately 120 ohms.

The GROUND MODULE (UGM) is the master system controller. Most functions are dispatched and coordinated from this module. The PLATFORM MODULE handles sub-tasks. All characterized information (values) are stored in the ground module (i.e., Personalities or Calibrations).

Interlocks: Any device that sends an electrical input. (For an example a limit switch, proximity switch, etc;).

Platform Level: The GROUND MODULE stores default values and handles interlocks. The PLATFORM MODULE reads sensors mounted on the platform assembly and controls Level Up / Down valves to maintain setpoint sent from the GROUND MODULE.

Steer: The GROUND MODULE stores crack points, and sends desired drive direction, steering mode, and axle extend/retract commands. The PLATFORM MODULE reports steering switch position to the GROUND MODULE.

Drive: The GROUND MODULE stores crack points and sends commands for each drive pump. (Command is computed from drive joystick input, interlocks, wheel angle, etc).

Lift, Tele, & Swing: The GROUND MODULE stores default values, and handles interlocks and calibration information. Lift, Telescope, and Swing commands depend on interlocks through out the machine. Boom angle, length, and swing are controlled by the GROUND MODULE

6.5 SYSTEM TEST

The Control System Incorporates a built-in system test to check the system components and functions. To use this function, use the following procedures.

Test from the Platform

1. Position the Platform/Ground select switch to the Platform position.

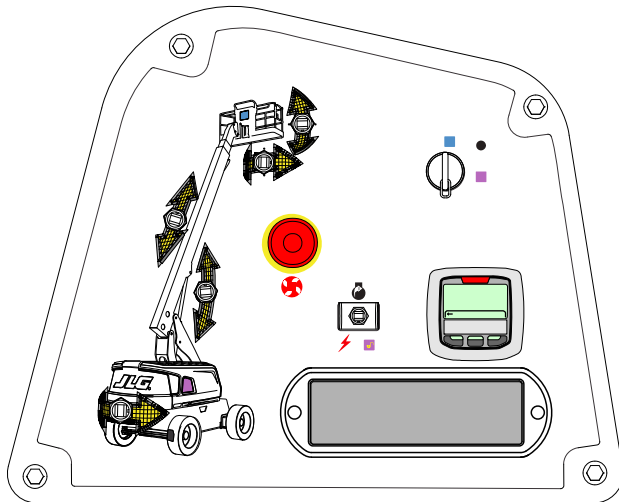

2. Plug the analyzer into the connector at the base of the platform control box.



3. Before proceeding, ensure that the switches on the platform console are in the following positions:
 - a. Drive speed dial is in the slow position. (Turtle Icon)
 - b. Function speed potentiometer out of creep mode switch.
 - c. Generator (if equipped) switched to the off position.
 - d. Head and Tail lights (if equipped) switched to the off position.

4. Pull out the Emergency Stop switch and Start the engine.



5. The analyzer screen should read:

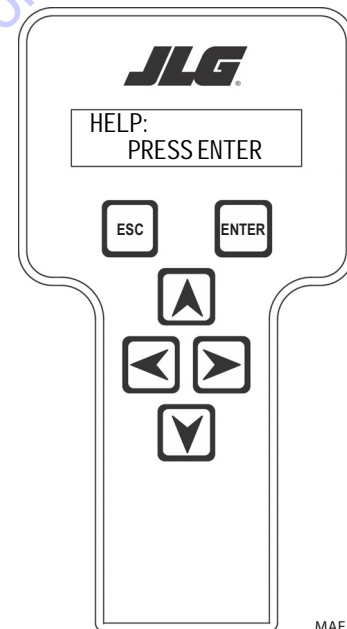

6. Use the arrow button to reach SYSTEM TEST. Hit Enter. The analyzer will prompt you asking if you want to activate the system test; hit Enter again to activate.
7. Follow the flow path in Figure 6-20., System Test Flow Chart - Platform Tests (Sheet 1 of 2) and Figure 6-21., System Test Flow Chart - Platform Tests (Sheet 2 of 2) and go through the component tests. Hit the ESC key during any part of the test to return to the main menu without completing all tests or wait until all tests are complete. During the TEST ALL INPUTS sequence, the analyzer allows control switches to be operated and shows if they are closed (CL) or open (OP).

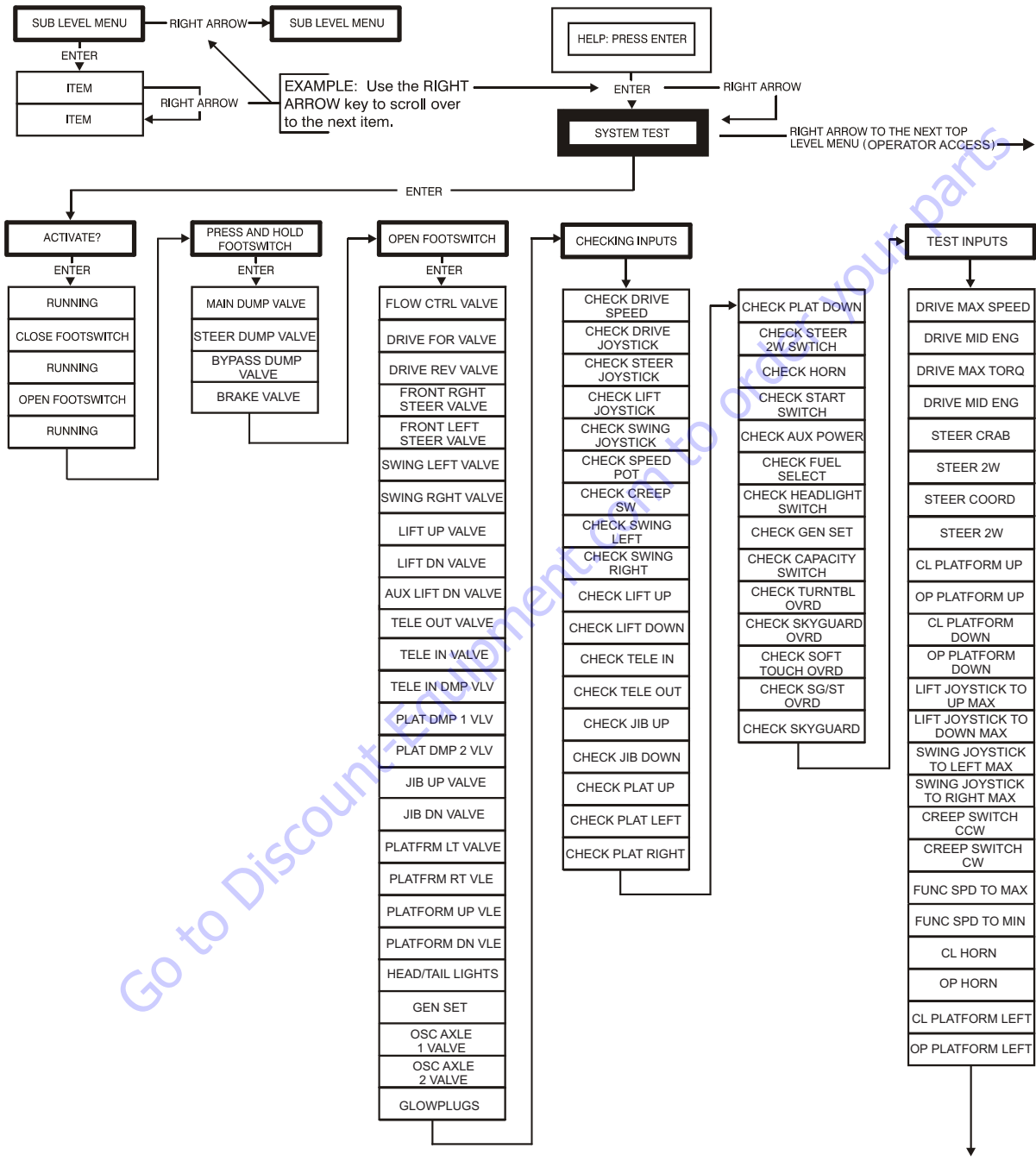

MAE22790

Figure 6-20. System Test Flow Chart - Platform Tests (Sheet 1 of 2)

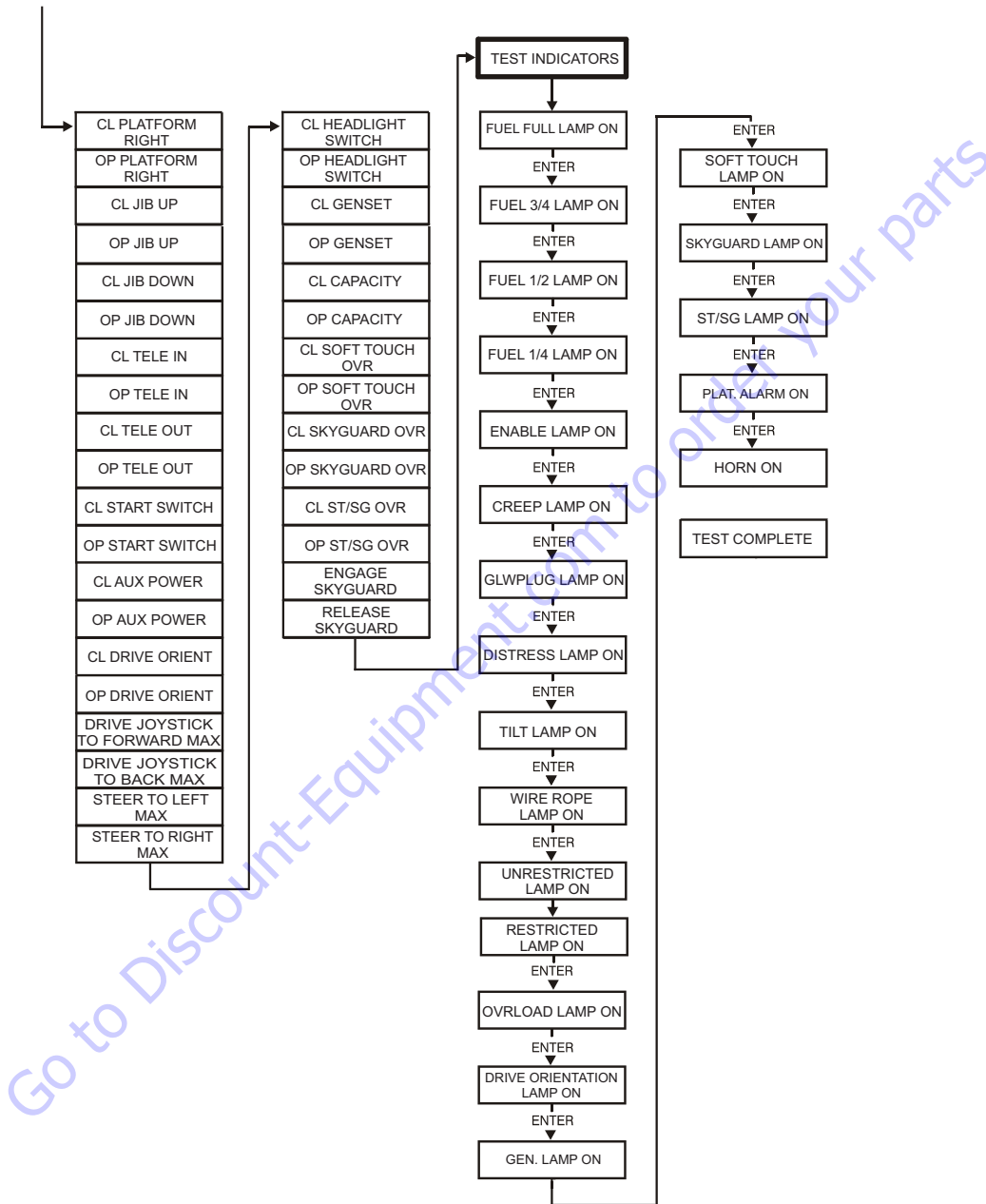

MAE22910

Figure 6-21. System Test Flow Chart - Platform Tests (Sheet 2 of 2)

Test from the Ground Station

1. Position the Platform/Ground select switch to the Platform position.

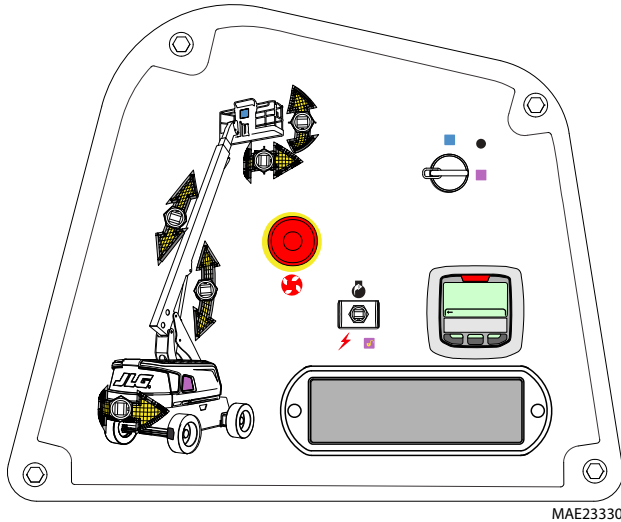

2. Plug the analyzer into the connector inside the Ground control box.

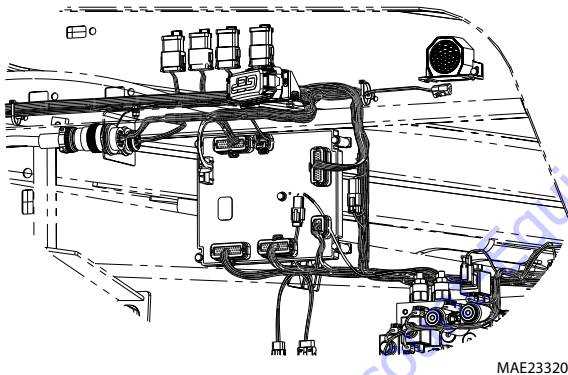

3. Pull out the Emergency Stop switch and Start the engine.

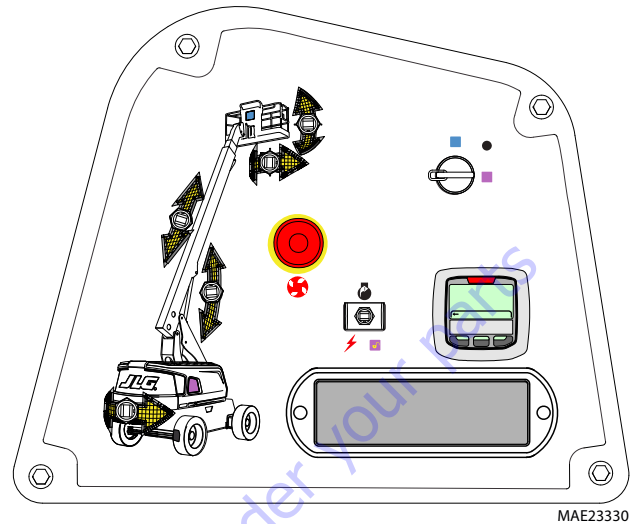

4. The analyzer screen should read:

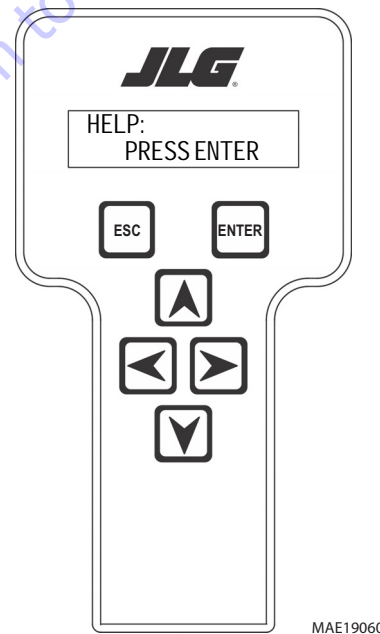

5. Use the arrow button to reach SYSTEM TEST. Hit Enter. The analyzer will prompt you asking if you want to activate the system test; hit Enter again to activate.
6. Follow the flow path in Figure 6-22., System Test Flow Chart - Ground Station Tests and go through the component tests. Hit the ESC key during any part of the test to return to the main menu without completing all tests or wait until all tests are complete. During the TEST ALL INPUTS sequence, the analyzer allows control switches to be operated and shows if they are closed (CL) or open (OP).

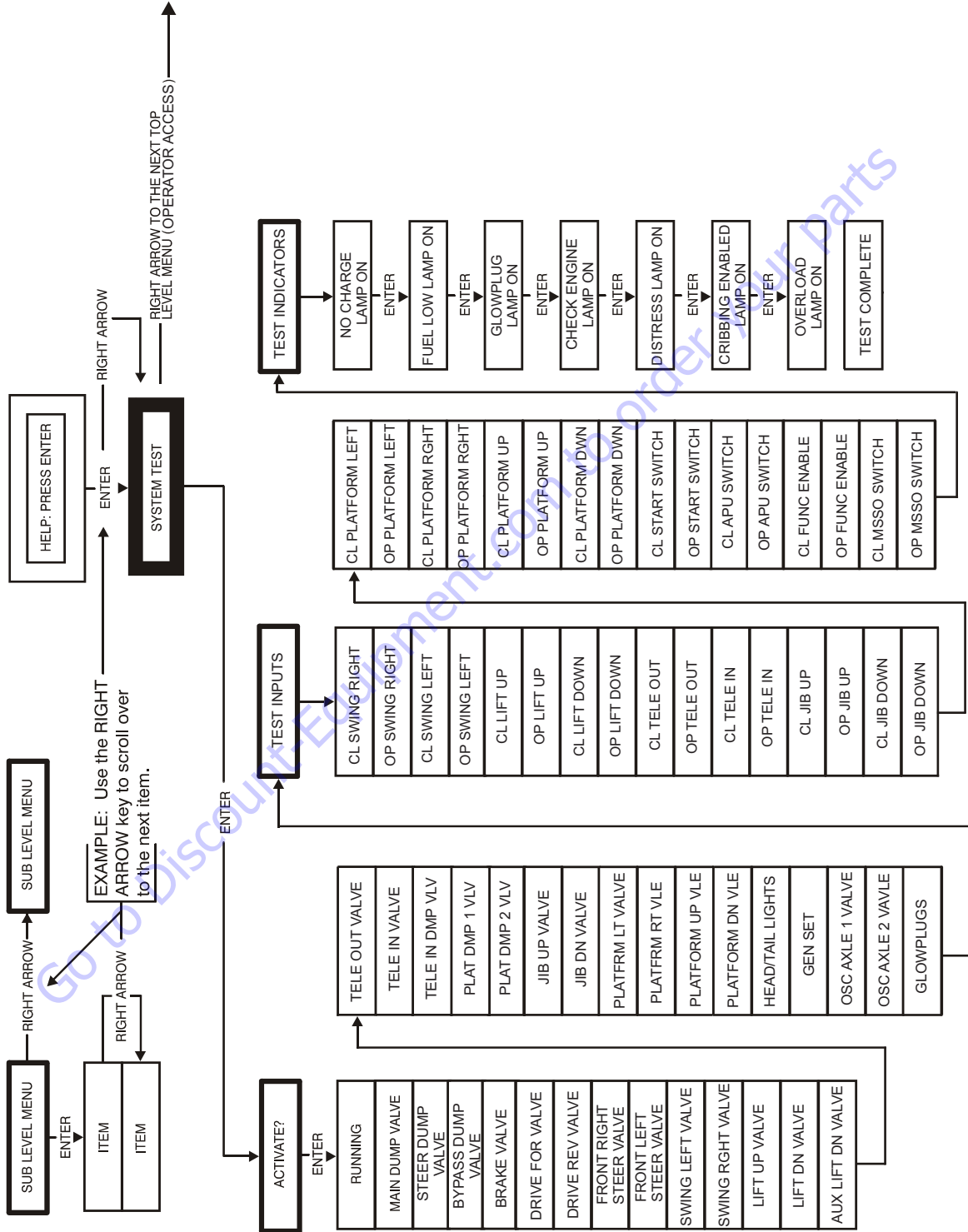

MAE22780

Figure 6-22. System Test Flow Chart - Ground Station Tests

6.6 SYSTEM TEST MESSAGES

Table 6-6. System Test Messages

Message Displayed on Analyzer	Message Displayed on Analyzer	Description
RUNNING		Initial display when system test is run while running certain "critical" checks are made
	CHECK GROUND/ PLATFORM SELECT	The analyzer must be connected to the active control station to run the system test
	BATTERY VOLTAGE TOO LOW	The system test may not run properly with battery voltage below 11V
	BATTERY VOLTAGE TOO HIGH	The system test may not operate properly with the battery voltage above 16V
	CHECK CAN WIRING	The system test will not operate properly unless the CAN bus is functional
	ENGINE RUNNING?	The LOSS OF ENGINE SPEED SENSOR fault 4322 is active or CANBUS FAILURE – ENGINE CONTROLLER fault 666 is active
	HIGH TILT ANGLE	The CHASSIS TILT SENSOR OUT OF RANGE fault 814 is active
	HOT ENGINE	The HIGH ENGINE TEMP fault 438 is active
	OPEN FOOTSWITCH	In platform mode, the footswitch must be open at the start of the test
	CLOSE FOOTSWITCH	In platform mode, the operator must close the footswitch when this message is displayed
	BAD FOOTSWITCH	The two footswitch signals are not changing together, probably because one is open circuit. Check footswitch and wiring
	OPEN FOOTSWITCH	In platform mode, the operator must open the footswitch when this message is displayed
	PLATFORM OVERLOADED	Load Sensing is configured and the ground module considers the platform to be overloaded
TESTING VALVES		Indicates that the valve test is beginning. Each valve is alternately energized and de-energized; checks are made for open- and short- circuit valve coils NOTE: In platform mode, the footswitch must be closed NOTE: Tower lift valves are not tested if TOWER LIFT=NO. Tower telescope valves are not tested if TOWER TELE=NO. Jib valves are not tested if JIB = NO. Extendable axle valves are not tested if EXT AXLES=NO. Four wheel steer valves are not tested if 4WS=NO NOTE: Left/right jib valves are not tested unless JIB = SIDESWING Problems that can be reported include below messages
	CANT TEST VALVES	There is a wiring problem, which prevents the valve test from functioning correctly. Check valve wiring. Check ground alarm & hour meter wiring
	XXXXXXXXS/C	The named valve is drawing too much current so is presumed to be short-circuited. Check valve wiring
	XXXXXXXXO/C	The named valve is drawing too little current so is presumed to be open-circuit. Check valve wiring
CHECKING INPUTS		Indicates that the inputs test is beginning. Every input is checked to ensure that it is in its "normal" position; function switches should be open, cutout switches should be closed, joysticks should be in neutral In platform mode any non-neutral platform switch or joystick is reported; any active cutouts are reported In ground mode any non-neutral ground switches is reported; any active cutouts are reported. NOTE: Switches, which are not in use (due to the settings of machine digits), are not checked. NOTE: The pump pot is checked only for a wire-off condition; it can be at any demand from creep to maximum Problems that can be reported include below messages
	CHECKXXXXXXXX	The named switch is not in its "normal" position. Check switch & wiring
	CHECKXXXXXXXXJOY	The named joystick appears to be faulty. Check joystick

Table 6-6. System Test Messages

Message Displayed on Analyzer	Message Displayed on Analyzer	Description
TESTING LAMPS		Indicates that the lamps test is beginning. Each lamp is energized in turn; a prompt asks for confirmation that the lamp is lit ENTER must be pressed or clicked to continue the test NOTE: Lamps, which are not in use (due to the settings of machine digits), are not checked NOTE: Platform Lamps are only tested in platform mode NOTE: The GM overload lamp and 500# capacity lamp are not tested NOTE: Head and tail lamps are tested in both platform and ground mode if enabled by a machine digit
TESTING ALARMS		Indicates that the alarms test is beginning. Each alarm is energized in turn; a prompt asks for confirmation that the alarm is sounding
		ENTER must be pressed or clicked to continue the test
		NOTE: The platform alarm and the horn are only tested in platform mode
		NOTE: The ground alarm is not tested if GROUND ALARM = NO
TEST ALL INPUTS?		Prompts whether to check every operator input. If ESC is pressed or clicked, the system test ends. If ENTER is pressed or clicked, each operator input is prompted for in turn. In platform mode every platform switch and joystick is tested. In ground mode every ground switch is tested. NOTE: Tower lift switches are not tested if TOWER LIFT=NO. Tower telescope switches are not tested if TOWER TELE=NO. Jib switches are not tested if JIB = NO. Extendable axle switches are not tested if EXT AXLES=NO. Four wheel steer switches are not tested if 4WS=NO. NOTE: Left/right jib switches are not tested unless JIB = SIDESWING. Prompts displayed during the operator input test below messages.
	CLOSE XXXXXXX	The named switch should be closed
	OPEN XXXXXXX	The named switch should be opened
	XXXXXXXX XXXXXXX TO MAX	The named joystick should be pushed to its full extent in the named direction
	XXXXXXXX XXXXXXX TO MIN	The named joystick should be returned to neutral from the named direction
	PUMP POT TO MAX	The pump pot should be turned to maximum
	PUMP POT TO MIN	The pump pot should be turned to minimum
	MULTIPLE CLOSURE	More than one operator input is closed; if only one has been operated, there could be a short between two inputs
TESTS COMPLETE		Indicates that the system test is complete. Any problems reported should have been noted and should now be rectified. Press ESC/CANCEL to return to the RUN SYSTEM TEST Analyzer menu

6.7 MACHINE DIAGNOSTICS PARAMETERS

Table 6-7. Machine Diagnostics Parameters

Diagnosics Submenu (Displayed on Analyzer 1 st Line)	Parameter (Displayed on Analyzer 1 st Line)	Parameter Value (Displayed on Analyzer 2 nd Line)	Description
DRIVE/STEER	DRIVE DEMAND	FORWARD/REVERSE XXX%	Direction and command percentage of Drive as reported by PM
	DRIVE OUTPUT	FORWARD/REVERSE XXX%	Direction and current output percentage
	DRIVE OUT mA	FORWARD/REVERSE XXXmA	Direction and current output command
	DRIVE FDBK mA	XXXmA	Current feedback measurement
	STEER DEMAND	LEFT/RIGHT XXX%	Direction and command percentage of Steer as reported by PM.
	STEER OUPUT	LEFT/RIGHT XXX%	Direction and PWM output percentage
	STEER TYPE	NORMAL/CRAB/COORDINATED	Steer Type Status (MACHINE SETUP → 4 WHEEL STEER = YES)
	BRAKES STATUS	LOCKED/RELEASED	Status of Brake Valve output
	2SPEED OUTPUT	ON/OFF	Status of 2 Speed Valve output (600S)
	DRIVE MODE	MAX SPEED/MAX TORQUE/MID ENGINE	Drive Mode Status
	DRV ORIENT TT SW	OPEN /CLOSED	State of DOS Switch (600S)
	DRV ORIENT MODE	INLINE/SWUNG	DOS state
	DRV ORIENT STATE	CONFIRMED/REQUIRED	InLine and DOS Active = Confirmed
	DRV ORNT OVR SW	CLOSED/OPEN	State of Drive Orientation Override Switch
	CRIBBING MODE SW	CLOSED/OPEN	State of Cribbing Mode Switch; only displayed if MACHINE SETUP → CRIBBING = YES
	CRIBBING MODE	DISABLED/ENABLED	Reflects state of Cribbing Mode Switch; only displayed if MACHINE SETUP → CRIBBING = YES
BOOM FUNCTIONS	SWING DEMAND	LEFT/RIGHT XXX%	Direction and percentage of input command from Swing Joystick or Ground%
	SWING OUTPUT	LEFT/RIGHT XXX%	Direction and current output percentage
	SWING OUTPUT mA	LEFT/RIGHT XXXmA	Direction and current output command
	SWING FDBK mA	XXXmA	Current feedback measurement
	LIFT DEMAND	UP/DOWN XXX%	Direction and percentage of Lift input command
	LIFT OUTPUT	UP/DOWN XXX%	Direction and current output percentage
	LIFT OUTPUT mA	UP/DOWN XXXmA	Direction and current output command
	LIFT FDBK mA	XXXmA	Current feedback measurement
	LIFT DN AUX	ON/OFF	Status of Aux Lift Down (600S)
	TELE DEMAND	IN/OUT XXX%/CREEP	Direction and percentage of input command (or CREEP if selected) from Function Speed Pot or Ground%
	TELE OUTPUT	IN/OUT XXX%	Direction and current output percentage for Flow Control Valve mapped to Tele Personalities
	TELE OUTPUT mA	IN/OUT XXXmA	Direction and current output command (600S)
	TELE FDBK mA	XXXmA	Current feedback measurement (600S)

Table 6-7. Machine Diagnostics Parameters

Diagnosics Submenu (Displayed on Analyzer 1 st Line)	Parameter (Displayed on Analyzer 1 st Line)	Parameter Value (Displayed on Analyzer 2 nd Line)	Description
	JIB LIFT DEMAND	UP/DOWN XXX%/CREEP	Direction and percentage of input command (or CREEP if selected) from Function Speed Pot or Ground%; only displayed if MACHINE SETUP → JIB = YES
	JIB LIFT OUTPUT	UP/DOWN XXX%	For Up, direction and current output percentage for Flow Control mapped to Jib Lift Up Personality range; for Down, direction and PWM output percentage; only displayed if MACHINE SETUP → JIB = YES
	PLAT LVL DEMAND	UP/DOWN XXX%/CREEP	Direction and percentage of input command (or CREEP if selected) from Function Speed Pot or Ground% (600S)
	PLAT LVL OUTPUT	UP/DOWN XXX%	Direction and current output percentage for Flow Control mapped to Platform Level Personality range (600S)
	PLAT LVL OUT mA	UP/DOWN XXXmA	Direction and current output command (600S)
	PLAT LVL UP FDBK	XXXmA	Platform Level Up Current feedback measurement (600S)
	PLAT LVL DN FDBK	XXXmA	Platform Level Down Current feedback measurement (600S)
	PLAT ROT DEMAND	LEFT/RIGHT XXX%/CREEP	Direction and percentage of input command (or CREEP if selected) from Function Speed Pot or Ground% (600S)
	PLAT ROT OUTPUT	LEFT/RIGHT XXX%	Direction and current output percentage for Flow Control mapped to Platform Rotate Personality range; for 600S value = 0% or 100%
	LF PRS REL OUTPT	ON/OFF	Status of Low Flow Pressure Release Valve; Only display if Low Flow Pressure Release is Configured
	MAIN DUMP OUTPUT	ON/OFF	Status of Main Dump Valve
	TELE IN DUMP	ON/OFF	Status of Telescope In Dump Valve (600S)
	FUNCTION SPEED	SETTING: XXX%	Displays the percentage demand from the Function Speed Potentiometer.
	CREEP SW	OPEN/CLOSED	Status of Creep Switch Input
	CREEP MODE	ON/OFF	Displays status of Creep Mode
ENGINE	OPERATING STATE	STOPPED/CRANKING/ STARTING/RUNNING	Displays Engine State
	GLOW PLUG	NOT ACTIVE/ACTIVE	Display diagnostic if glow plugs configured: MACHINE SETUP → GLOW PLUG ≠ NO GLOW PLUGS
	COOLANT TEMP	XXXC/XXXF	Degrees F or C displayed depending on Machine Setup Configuration
	ENGINE OIL PRESS	XXXXPSI/XXXXKPA	If Ford read > 10 PSI display OK, else LOW If Deutz, display transmitted value
	FUEL SELECTION	STATUS GAS/LP	MACHINE SETUP → ENGINE = FORD DUAL FUEL
	FUEL PRESS	XXXXPSI/XXXXKPA	MACHINE SETUP → ENGINE = EMR 4
	AMBIENT TEMP	XXXC/XXXF	
	FUEL LEVEL	FULL; ¾; ½; ¼; LOW; EMPTY; OK; ERROR	MACHINE SETUP → FUEL LEVEL ≠ NONE
	ENGINE SPEED	ACTUAL XXXXRPM	RPM read from speed sensor if engine = over CAN2 for Deutz, Ford Dual Fuel

Table 6-7. Machine Diagnostics Parameters

Diagnosics Submenu (Displayed on Analyzer 1 st Line)	Parameter (Displayed on Analyzer 1 st Line)	Parameter Value (Displayed on Analyzer 2 nd Line)	Description
	ENGINE SPEED	TARGET XXXXRPM	UGM - commanded Target RPM
SYSTEM	UGM BATTERY	XX.XV	UGM measured battery voltage
	PLATFORM MODULE	BATTERY XX.XV	PM measured battery voltage
	UGM TEMP	XXX/XXXF	UGM on-board temperature measurement
	PLATFORM SELECT	KEYSWITCH: OPEN KEYSWITCH: CLOSED	Displays whether Platform Keyswitch position is being selected
	GROUND SELECT	KEYSWITCH: OPEN KEYSWITCH: CLOSED	Displays whether Ground Keyswitch position is being selected
	STATION CONTROL	GROUND/PLATFORM	Displays Active control station per System Mode definition
	FOOTSWITCH INPUT	GROUND: OPEN GROUND: CLOSED	State of Footswitch input at UGM
	FOOTSWITCH INPUT	PLATFORM: OPEN PLATFORM: CLOSED	State of Footswitch input at PM (closed when footswitch not activated)
	PLATFORM ANGLE:	XXX.XDEG	Platform Angle with respect to Chassis (600S)
	PLAT ANGLE 1 RAW	XX.X%	Platform Angle sensor #1 raw PWM% (600S)
	PLAT ANGLE 2 RAW	XX.X%	Platform Angle sensor #2 raw PWM% (600S)
	ELEVATION MODE	ABOVE/NOT ABOVE	Elevation State
	CAPACITY MODE	RESTRICTED/UNRESTRICTED/ERROR	Dual Capacity State; Dual Capacity is configured
	TRANSPORT MODE	IN TRANSPORT/OUT OF TRANSPORT	Transport Position
	CREEP SW	OPEN/CLOSED	Status of Creep Switch Input
	CREEP MODE	ON/OFF	Displays status of Creep Mode
	CHASSIS TILT	XX.XDEG	Combined X/Y Absolute Angle
	CHASSIS TILT	X-AXIS: XX.XDEG	X Angle with respect to sign
	CHASSIS TILT	Y-AXIS: XX.XDEG	Y Angle with respect to sign
	GENSET/WELDER SW	OPEN/CLOSED	Platform Generator Enable switch; only displayed if MACHINE SETUP → GEN SET/WELDER ≠ NO
	GENSET ENABLE	OUTPUT: ON/OFF	UGM Generator Relay Enable output; only displayed if MACHINE SETUP → GEN SET/WELDER ≠ NO
	H&T LIGHTS SW	OPEN/CLOSED	Only displayed if in Platform Mode and MACHINE SETUP → H&T LIGHTS = YES
	H&T LIGHTS OUT	ON/OFF	UGM Nite Brite Relay Enable output; only displayed if in Platform Mode and MACHINE SETUP → H&T LIGHTS = YES
	SOFT TOUCH INPUT	OPEN/CLOSED	State of Soft Touch Platform Input (J1-20); closed when active; only displayed if in Platform Mode and MACHINE SETUP → SOFT TOUCH = YES.
	SKYGUARD INPUTS	OPEN/CLOSED/DISAGREE	SkyGuard Input #1 (PLT J7-18) AND SkyGuard Input #2 (PLT J1-23) state; only displayed if in Platform Mode and MACHINE SETUP → SKYGUARD = YES.

Table 6-7. Machine Diagnostics Parameters

Diagnosics Submenu (Displayed on Analyzer 1 st Line)	Parameter (Displayed on Analyzer 1 st Line)	Parameter Value (Displayed on Analyzer 2 nd Line)	Description
	SKYGUARD INPUT 1	OPEN/CLOSED	State of SkyGuard Platform Input #1 (J7-18); relay NC contacts – closed when active; only displayed if in Platform Mode and MACHINE SETUP → SKYGUARD = YES.
	SKYGUARD INPUT 2	OPEN/CLOSED	State of SkyGuard Platform Input #2 (J1-23); relay NC contacts – closed when active; only displayed if in Platform Mode and MACHINE SETUP → SKYGUARD = YES.
	AMBIENT TEMP	XXXC/XXXF	Ambient Temperature sensor reading; Only displayed if MACHINE SETUP → TEMP CUTOUT = YES
	LOW TEMPERATURE	CUTOUT: ACTIVE/INACTIVE/FAULTY	Status of Low Temperature Cutout; Only displayed if MACHINE SETUP → TEMP CUTOUT = YES
	MSSO	ACTIVE/INACTIVE	Status of MSSO; Only displayed if MACHINE SETUP → MARKET = CE
	WIRE ROPE	SWITCH: OPEN/CLOSED	State of Wire Rope Service Switch input (J3-8); closed when active; MACHINE SETUP → CABLE SWITCH = YES
OPER CONTROLS	JOYSTICK DRIVE	FORWARD/REVERSE XXX%	Drive Joystick drive direction and command percentage as reported from PM; only displayed if in Platform Mode
	JOYSTICK STEER	LEFT/RIGHT XXX%	Drive Joystick steer direction and percentage command as reported from PM; only displayed if in Platform Mode
	JOYSTICK SWING	LEFT/RIGHT XXX%	Lift/Swing Joystick Swing direction and percentage command as reported from PM; only displayed if in Platform Mode
	JOYSTICK LIFT	UP/DOWN XXX%	Lift/Swing Joystick Lift direction and percentage command as reported from PM; only displayed if in Platform Mode
	DRV ORNT OVR SW	CLOSED/OPEN	State of Drive Orientation Override Switch if in Platform Mode
	FUEL SELECT SW	OPEN/CLOSED	Status of Platform Toggle Switch Input if in Platform Mode and MACHINE SETUP → ENGINE = FORD DUAL FUEL
	START SWITCH	OPEN/CLOSED	Status of Ground/Platform Toggle Switch Input
	SWING LEFT SW	OPEN/CLOSED	Status of Ground Toggle Switch Input if in Ground Mode
	SWING RIGHT SW	OPEN/CLOSED	Status of Ground Toggle Switch Input if in Ground Mode
	LIFT UP SW	OPEN/CLOSED	Status of Ground Toggle Switch Input if in Ground Mode
	LIFT DN SW	OPEN/CLOSED	Status of Ground Toggle Switch Input if in Ground Mode
	TELE IN SW	OPEN/CLOSED	Status of Ground/Platform Toggle Switch Input
	TELE OUT SW	OPEN/CLOSED	Status of Ground/Platform Toggle Switch Input

Table 6-7. Machine Diagnostics Parameters

Diagnostics Submenu (Displayed on Analyzer 1 st Line)	Parameter (Displayed on Analyzer 1 st Line)	Parameter Value (Displayed on Analyzer 2 nd Line)	Description
	JIB LIFT UP SW	OPEN/CLOSED	Status of Ground/Platform Toggle Switch Input; only displayed if MACHINE SETUP → JIB = YES
	JIB LIFT DN SW	OPEN/CLOSED	Status of Ground/Platform Toggle Switch Input; only displayed if MACHINE SETUP → JIB = YES
	PLAT LEVEL UP SW	OPEN/CLOSED	Status of Ground/Platform Toggle Switch Input
	PLAT LEVEL DN SW	OPEN/CLOSED	Status of Ground/Platform Toggle Switch Input
	PLAT ROT LEFT SW	OPEN/CLOSED	Status of Ground/Platform Toggle Switch Input
	PLAT ROT RIGHT SW	OPEN/CLOSED	Status of Ground/Platform Toggle Switch Input
	MAX SPEED SW	OPEN/CLOSED	Status of Platform Toggle Switch Input; only displayed if in Platform Mode
	MAX TORQUE SW	OPEN/CLOSED	Status of Platform Toggle Switch Input; only displayed if in Platform Mode
	CREEP SW	OPEN/CLOSED	Status of Creep Switch Input; only displayed if in Platform Mode
	HORN SW	OPEN/CLOSED	Status of Platform Switch Input; only displayed if in Platform Mode
	H&T LIGHT SW	OPEN/CLOSED	Status of Platform Toggle Switch Input; only displayed if in Platform Mode and MACHINE SETUP → H&T LIGHTS = YES
	GENSET/WELDER SW	OPEN/CLOSED	Status of Platform Toggle Switch Input; only displayed if MACHINE SETUP → GEN SET/WELDER ≠ NO
	SG OVERRIDE SW	OPEN/CLOSED	Status of Platform SkyGuard Override Switch Input; only displayed if in Platform Mode MACHINE SETUP → SOFT TOUCH = NO and MACHINE SETUP → SKYGUARD = YES
	ST OVERRIDE SW	OPEN/CLOSED	Status of Platform SkyGuard Override Switch Input; only displayed if in Platform Mode and MACHINE SETUP → SOFT TOUCH = YES and MACHINE SETUP → SKYGUARD = NO
	SG/ST OVRIDE SW	OPEN/CLOSED	Status of Platform SkyGuard Override Switch Input; only displayed if in Platform Mode and MACHINE SETUP → SOFT TOUCH = YES and MACHINE SETUP → SKYGUARD = YES
	MSSO SW	OPEN/CLOSED	Status of Ground MSSO Switch Input; only displayed if MACHINE SETUP → MARKET = CE
	CAPACITY SW	OPEN/CLOSED	Status of Platform Dual Capacity Switch Input; only displayed if Dual Capacity is configured
	STEER CRAB SW	OPEN/CLOSED	Status of the Crab Steer Select Switch Input (MACHINE SETUP → 4 WHEEL STEER = YES)
	STEER COORD SW	OPEN/CLOSED	Status of the Coordinated Steer Select Switch Input (MACHINE SETUP → 4 WHEEL STEER = YES)

Table 6-7. Machine Diagnostics Parameters

Diagnosics Submenu (Displayed on Analyzer 1 st Line)	Parameter (Displayed on Analyzer 1 st Line)	Parameter Value (Displayed on Analyzer 2 nd Line)	Description
PLATFORM LOAD (DIS- PLAY ONLY IF MACHINE SETUP → LOAD SYSTEM ≠ NO)	PLATFORM LOAD	STATE: OK/OVERLOAD	LSS Status
	PLATFORM LOAD	ACTUAL: XXXLBS	Platform Load??? if Platform Load == Unhealthy
	PLATFORM LOAD ²	GROSS: XXXLBS	If 4-Cell LSS; Combined weight of all cells (accounting for sign) If 1-Cell LSS; Platform Gross used to calculate Platform Load ??? if (Platform Gross 1 == Unhealthy and Platform Gross 2 == Unhealthy)
	PLATFORM LOAD ²	OFFSET: XXXLBS	If 4-Cell LSS; Stored Platform Empty weight
	PLATFORM LOAD ²	OFFSET 1: XXXLBS	If 1-Cell LSS; Stored Unloaded Platform Weight of Strain Gauge 1 ??? if DTC 825 is active
	PLATFORM LOAD ²	OFFSET 2: XXXLBS	If 1-Cell LSS; Stored Unloaded Platform Weight of Strain Gauge 2 ??? if DTC 825 is active
	PLATFORM LOAD ²	ACCESSORY XXXLBS	Stored Accessory weight; ??? if DTC 825 is active
	PLATFORM LOAD ²	UNRESTRICT XXXLBS	Stored Unrestricted Rated Load; ??? if DTC 825 is active
	PLATFORM LOAD ²	RSTRIC XXXLBS	If Dual Capacity is Configured; Stored Restricted Rated Load; ??? if DTC 825 is active
	PLATFORM LOAD ²	CELL 1: XXXLBS	If 4-Cell LSS; Gross weight reading of Cell 1
	PLATFORM LOAD ²	CELL 2: XXXLBS	If 4-Cell LSS; Gross weight reading of Cell 2
	PLATFORM LOAD ²	CELL 3: XXXLBS	If 4-Cell LSS; Gross weight reading of Cell 3
	PLATFORM LOAD ²	CELL 4: XXXLBS	If 4-Cell LSS; Gross weight reading of Cell 4
	PLATFORM LOAD ²	RAW 1: XXXLBS	If 1-Cell LSS; Platform Gross 1; ??? if Platform Gross 1 == Unhealthy
	PLATFORM LOAD ²	RAW 2: XXXLBS	If 1-Cell LSS; Platform Gross 2; ??? if Platform Gross 2 == Unhealthy

Table 6-7. Machine Diagnostics Parameters

Diagnostics Submenu (Displayed on Analyzer 1 st Line)	Parameter (Displayed on Analyzer 1 st Line)	Parameter Value (Displayed on Analyzer 2 nd Line)	Description
CAN STATISTICS ²	CAN 1 STATISTICS	RX/SEC: XXX	
	CAN 1 STATISTICS	TX/SEC: XXX	
	CAN 1 STATISTICS	BUS OFF: XXX	
	CAN 1 STATISTICS	PASSIVE: XXX	
	CAN 1 STATISTICS	MSG ERROR: XXXX	
	CAN 2 STATISTICS	RX/SEC: XXX	
	CAN 2 STATISTICS	TX/SEC: XXX	
	CAN 2 STATISTICS	BUS OFF: XXX	
	CAN 2 STATISTICS	PASSIVE: XXX	
	CAN 2 STATISTICS	MSG ERROR: XXXX	

Go to Discount-Equipment.com to order your parts

Table 6-7. Machine Diagnostics Parameters

Diagnostics Submenu (Displayed on Analyzer 1 st Line)	Parameter (Displayed on Analyzer 1 st Line)	Parameter Value (Displayed on Analyzer 2 nd Line)	Description
DEBUG UGM I/O ²	DEBUG DIAG DIGITAL INPUTS	DIG IN J1-21 HIGH/LOW DIG IN J1-34 HIGH/LOW DIG IN J1-35 HIGH/LOW DIG IN J2-24 HIGH/LOW DIG IN J3-8 HIGH/LOW DIG IN J3-9 HIGH/LOW DIG IN J3-10 HIGH/LOW DIG IN J3-11 HIGH/LOW DIG IN J4-4 HIGH/LOW DIG IN J4-5 HIGH/LOW DIG IN J4-6 HIGH/LOW DIG IN J4-7 HIGH/LOW DIG IN J4-8 HIGH/LOW DIG IN J4-9 HIGH/LOW DIG IN J4-10 HIGH/LOW DIG IN J4-11 HIGH/LOW DIG IN J4-16 HIGH/LOW DIG IN J4-17 HIGH/LOW DIG IN J4-18 HIGH/LOW DIG IN J4-19 HIGH/LOW DIG IN J4-20 HIGH/LOW DIG IN J4-21 HIGH/LOW DIG IN J4-22 HIGH/LOW DIG IN J4-23 HIGH/LOW DIG IN J4-30 HIGH/LOW DIG IN J4-33 HIGH/LOW DIG IN J4-34 HIGH/LOW DIG IN J4-35 HIGH/LOW DIG IN J7-2 HIGH/LOW DIG IN J7-3 HIGH/LOW DIG IN J7-12 HIGH/LOW DIG IN J7-15 HIGH/LOW DIG IN J7-21 HIGH/LOW DIG IN J12-8 HIGH/LOW	Left and Right arrow keys scroll through the inputs. 1 st Line = DIG IN JX.XX and 2 nd Line displays measurement value

Table 6-7. Machine Diagnostics Parameters

Diagnostics Submenu (Displayed on Analyzer 1 st Line)	Parameter (Displayed on Analyzer 1 st Line)	Parameter Value (Displayed on Analyzer 2 nd Line)	Description
	DEBUG DIAG DIGITAL OUTPUTS	DIG OUT J1-2 ON/OFF DIG OUT J1-7 ON/OFF DIG OUT J1-11 ON/OFF DIG OUT J1-12 ON/OFF DIG OUT J1-13 ON/OFF DIG OUT J1-23 ON/OFF DIG OUT J1-32 ON/OFF DIG OUT J2-2 ON/OFF DIG OUT J2-3 ON/OFF DIG OUT J2-4 ON/OFF DIG OUT J2-5 ON/OFF DIG OUT J2-7 ON/OFF DIG OUT J2-10 ON/OFF DIG OUT J2-12 ON/OFF DIG OUT J2-13 ON/OFF DIG OUT J2-15 ON/OFF DIG OUT J2-16 ON/OFF DIG OUT J2-21 ON/OFF DIG OUT J2-23 ON/OFF DIG OUT J2-32 ON/OFF DIG OUT J2-33 ON/OFF DIG OUT J4-1 ON/OFF DIG OUT J4-2 ON/OFF DIG OUT J4-3 ON/OFF DIG OUT J4-13 ON/OFF DIG OUT J4-14 ON/OFF DIG OUT J4-15 ON/OFF DIG OUT J4-26 ON/OFF DIG OUT J4-27 ON/OFF DIG OUT J4-28 ON/OFF DIG OUT J4-29 ON/OFF DIG OUT CS1GC ON/OFF ¹ DIG OUT CS2GC ON/OFF ¹ DIG OUT LED ON/OFF DIG OUT TP1 ¹	Left and Right arrow keys scroll through the inputs. 1st Line = DIG OUT JX.XX and 2nd Line displays output value

Table 6-7. Machine Diagnostics Parameters

Diagnostics Submenu (Displayed on Analyzer 1 st Line)	Parameter (Displayed on Analyzer 1 st Line)	Parameter Value (Displayed on Analyzer 2 nd Line)	Description
	DEBUG DIAG PWM OUTPUTS	PWM J1-1 XXX.XX% XXXHZ PWM J1-3 XXX.XX% XXXHZ PWM J1-6 XXX.XX% XXXHZ PWM J1-10 XXX.XX% XXXHZ PWM J1-20 XXX.XX% XXXHZ PWM J1-22 XXX.XX% XXXHZ PWM J2-8 XXX.XX% XXXHZ PWM J2-9 XXX.XX% XXXHZ PWM J2-11 XXX.XX% XXXHZ PWM J2-19 XXX.XX% XXXHZ PWM J2-20 XXX.XX% XXXHZ PWM J2-22 XXX.XX% XXXHZ PWM J2-26 XXX.XX% XXXHZ PWM J2-27 XXX.XX% XXXHZ PWM J2-31 XXX.XX% XXXHZ PWM J2-34 XXX.XX% XXXHZ PWM J2-35 XXX.XX% XXXHZ FET J3-1 XXX.XX% XXXHZ FET J3-2 XXX.XX% XXXHZ FET J3-4 XXX.XX% XXXHZ FET J3-5 XXX.XX% XXXHZ FET J3-6 XXX.XX% XXXHZ	

Table 6-7. Machine Diagnostics Parameters

Diagnostics Submenu (Displayed on Analyzer 1 st Line)	Parameter (Displayed on Analyzer 1 st Line)	Parameter Value (Displayed on Analyzer 2 nd Line)	Description
		FET J3-14 XXX.XX% XXXHZ PWM J4-12 XXX.XX% XXXHZ	
	ANALOG INPUTS	ADC J1-01 FB XXXX1 ADC J1-01 IS XXXX1 ADC J1-02 FB XXXX1 ADC J1-03 FB XXXX1 ADC J1-06 FB XXXX1 ADC J1-07 FB XXXX1 ADC J1-10 FB XXXX1 ADC J1-11 FB XXXX1 ADC J1-12 FB XXXX1 ADC J1-13 FB XXXX1 ADC J1-14 XXXX ADC J1-15 XXXX ADC J1-20 FB XXXX1 ADC J1-22 FB XXXX1 ADC J1-23 FB XXXX1 ADC J2-01 FB XXXX1 ADC J2-02 FB XXXX1 ADC J2-03 FB XXXX1 ADC J2-04 FB XXXX1 ADC J2-05 FB XXXX1 ADC J2-07 FB XXXX1 ADC J2-08 FB XXXX1 ADC J2-09 FB XXXX1 ADC J2-10 FB XXXX1 ADC J2-11 FB XXXX1 ADC J2-12 FB XXXX1 ADC J2-13 FB XXXX1 ADC J2-15 FB XXXX1 ADC J2-16 FB XXXX1 ADC J2-19 FB XXXX1 ADC J2-20 FB XXXX1 ADC J2-22 FB XXXX1 ADC J2-23 FB XXXX1 ADC J2-25 XXXX ADC J2-26 FB XXXX1 ADC J2-27 FB XXXX1 ADC J2-31 FB XXXX1 ADC J2-32 FB XXXX1 ADC J2-33 FB XXXX1	Left and Right arrow keys scroll through the inputs. 1st Line = ADC JX.XX and 2nd Line displays raw A/D counts XXXX of measurement

Table 6-7. Machine Diagnostics Parameters

Diagnosics Submenu (Displayed on Analyzer 1 st Line)	Parameter (Displayed on Analyzer 1 st Line)	Parameter Value (Displayed on Analyzer 2 nd Line)	Description
		ADC J2-34 FB XXXX1 ADC J2-35 FB XXXX1 ADC J3-01 IS XXXX1 ADC J3-02 IS XXXX1 ADC J3-04 IS XXXX1 ADC J3-05 IS XXXX1 ADC J3-06 IS XXXX1 ADC J3-13 XXXX ADC J3-14 IS XXXX1 ADC J4-12 FB XXXX1 ADC J7-2 XXXX ADC J7-04 XXXX ADC J7-07 XXXX ADC J7-08 XXXX ADC J7-20 XXXX ADC J8-02 XXXX ADC AMBIENT XXXX1 ADC VOFCS XXXX1	
	FREQUENCY INPUTS	FREQ IN J1-16 XXXXX HZ FREQ IN J12-1 XXXXX HZ FREQ IN J12-2 XXXXX HZ	Left and Right arrow keys scroll through the inputs. 1st Line = FREQ IN JX.XX and 2nd Line displays frequency of measurement XXXXX Hz
DATALOG	DATALOG TIME	ON XXXXH XXM	*Controller On time
	DATALOG TIME	ENGINE XXXXH XXM	*Engine Running time
	DATALOG TIME	ENABLD XXXXH XXM	*Combined time for Machine Enabled in Platform Mode while ENGINE RUNNING + any function active while in Ground Mode (excludes APU/ Emergency Descent)
	DATALOG TIME	AUX XXXXH XXM	Auxiliary Power/Emergency Descent Active time
	DATALOG TIME	DRIVE XXXXH XXM	Drive Forward + Reverse time
	DATALOG TIME	DRV MS XXXXH XXM	Max Speed Drive Forward + Reverse time
	DATALOG TIME	DRV MT XXXXH XXM	Max Torque Drive Forward + Reverse time
	DATALOG TIME	DRV ME XXXXH XXM	Mid Engine Drive Forward + Reverse time
	DATALOG TIME	DRV CP XXXXH XXM	Creep Drive Forward + Reverse time
	DATALOG TIME	STEER XXXXH XXM	Steer Left + Right time
	DATALOG TIME	SWING XXXXH XXM	Swing Left + Right time
	DATALOG TIME	LIFT XXXXH XXM	Lift Up + Down time
	DATALOG TIME	TELE XXXXH XXM	Tele In + Out time
	DATALOG TIME	JIB XXXXH XXM	Jib Lift Up + Down time (MACHINE SETUP → JIB = YES)
	DATALOG TIME	LEVEL XXXXH XXM	Platform Level Up + Down time
	DATALOG TIME	ROTATE XXXXH XXM	Platform Rotate Left + Right time
DATALOG TIME	GEN XXXXH XXM	*Generator Enable Relay on time	

SECTION 6 - JLG CONTROL SYSTEM

Table 6-7. Machine Diagnostics Parameters

Diagnostics Submenu (Displayed on Analyzer 1 st Line)	Parameter (Displayed on Analyzer 1 st Line)	Parameter Value (Displayed on Analyzer 2 nd Line)	Description
For time logging of functions with 30-second resolution, the first 15 seconds of function run time shall be logged as a ½ minute increment and there after every 30 seconds of run time shall be logged as a ½ minute increment. *The functions annotated with an asterisk in the description are function timers with 60-second resolution, for which the timer in the rule above is doubled.			
	DATALOG CYCLES	DRVE FWD XXXXXXXX	Number of times Drive Forward is commanded
	DATALOG CYCLES	DRVE REV XXXXXXXX	Number of times Drive Reverse is commanded
	DATALOG CYCLES	STEER LT XXXXXXXX	Number of times Steer Left Output is commanded
	DATALOG CYCLES	STEER RT XXXXXXXX	Number of times Steer Right Output is commanded
	DATALOG CYCLES	SWING LT XXXXXXXX	Number of times Swing Left output is commanded
	DATALOG CYCLES	SWING RT XXXXXXXX	Number of times Swing Right output is commanded
	DATALOG CYCLES	LIFT UP XXXXXXXX	Number of times Lift Up output is commanded
	DATALOG CYCLES	LIFT DN XXXXXXXX	Number of times Lift Down output is commanded
	DATALOG CYCLES	TELE IN XXXXXXXX	Number of times Tele In output is commanded
	DATALOG CYCLES	TELE OUT XXXXXXXX	Number of times Tele Out output is commanded
	DATALOG CYCLES	JIB UP XXXXXXXX	Number of times Jib Lift Up is commanded (MACHINE SETUP → JIB = YES)
	DATALOG CYCLES	JIB DOWN XXXXXXXX	Number of times Jib Lift Down is commanded (MACHINE SETUP → JIB = YES)
	DATALOG CYCLES	LEVEL UP XXXXXXXX	Number of times Level Up is commanded
	DATALOG CYCLES	LEVEL DN XXXXXXXX	Number of times Level Down is commanded
	DATALOG CYCLES	ROT LEFT XXXXXXXX	Number of times Rotate Left is commanded
	DATALOG CYCLES	ROT RGHT XXXXXXXX	Number of times Rotate Right is commanded
	DATALOG CYCLES	UGM ON XXXXXXXX	Number of times Power is applied
	DATALOG CYCLES	GND OPS XXXXXXXX	Number of times machine is in Ground Mode and any function is active (excludes APU/Emergency Descent)
	DATALOG CYCLES	PLAT OPS XXXXXXXX	Number of times machine is Enabled from Platform Station (excludes APU/Emergency Descent)
	DATALOG CYCLES	AUX OPS XXXXXXXX	Number of times machine Auxiliary Power/Emergency Descent is Enabled
	DATALOG CYCLES	GEN ON XXXXXXXX	Number of times Generator Enable Relay is turned On; information logged and stored only if machine configured for generator.
	DATALOG CYCLES	BOOM TR XXXXXXXX	Number of times the Boom transitions from Below Elevation to Above Elevation
	DATALOG CYCLES	DUAL CAP XXXXXXXX	Number of times the Boom transitions from Restricted to Unrestricted mode (Dual Capacity is configured)
Cycle counter shall increment up to a limit of 1,000,000, except Steer shall have a limit of 2,000,000 per direction.			
	DATALOG: MAX	UGM TEMP XXXC/ UGM TEMP XXXF	Hottest Temp observed by UGM
	DATALOG: MIN	UGM TEMP XXXC/ UGM TEMP XXXF	Coldest Temp observed by UGM

Table 6-7. Machine Diagnostics Parameters

Diagnosics Submenu (Displayed on Analyzer 1 st Line)	Parameter (Displayed on Analyzer 1 st Line)	Parameter Value (Displayed on Analyzer 2 nd Line)	Description
	DATALOG: MAX	UGM VOLT XX.XV	Maximum input voltage observed by UGM
	DATALOG: MACHINE	RENTAL XXXXH XXM	*Stores Machine hours since last memory clear
	DATALOG: ERASE ²	MACHINE RENTAL?	Erases stored machine rental hours
VERSIONS:	UGM	SOFTWARE PX.X	
	UGM	CNST DATA PX.X	
	UGM	HARDWARE REV X	
	UGM	S/N XXXXXX	
	UGM	P/N XXXXXXXXXX	
	PLATFORM MODULE	SOFTWARE PX.X	
	PLATFORM MODULE	HARDWARE REV X	
	PLATFORM MODULE	S/N XXXXXX	
	LSS MODULE	SOFTWARE PX.X	Displayed on if LSS is configured (4-Cell LSS)
	LSS MODULE	HARDWARE REV X	Display if LSS is configured (4-Cell LSS)
	TCU MODULE	SOFTWARE X.Xx	Displayed on if TCU is configured
	TCU MODULE	HARDWARE REV X	Displayed on if TCU is configured
	TCU MODULE	S/N XXXXXX	Displayed on if TCU is configured
	ANALYZER	ANALYZER vX.X	

6.8 CALIBRATING TILT SENSOR

NOTICE

A NEW TILT MODULE WILL ACT AS IF IT IS TILTED ALL OF THE TIME UNTIL THE FOLLOWING PROCEDURE IS PERFORMED.

WARNING

DO NOT CALIBRATE THE LEVEL SENSOR EXCEPT ON A LEVEL SURFACE.

1. Use the following procedure to calibrate the tilt sensor.
2. Before the tilt sensor can be calibrated, the following conditions must be met:
 - a. Wheels straight.
 - b. Turntable centered.
 - c. Boom fully retracted.
 - d. Boom angle is less than 45°.
 - e. Machine on firm, level ground.
3. Position the Platform/Ground select switch (1) to the Ground position.

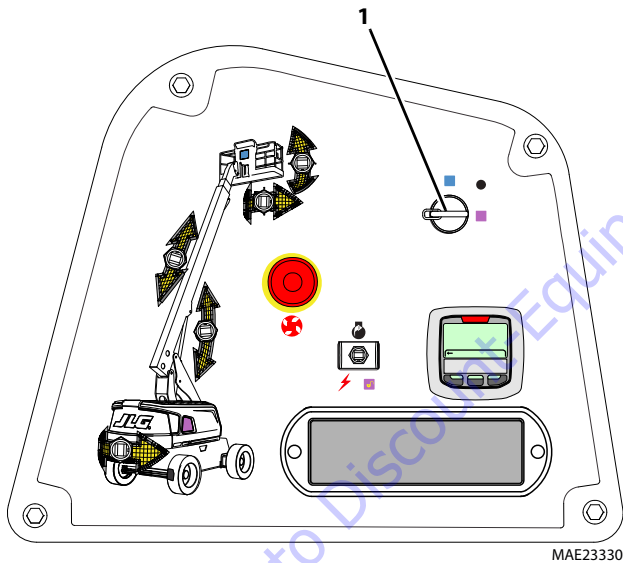

4. Plug the analyzer into the connector (2) inside the Ground control box.

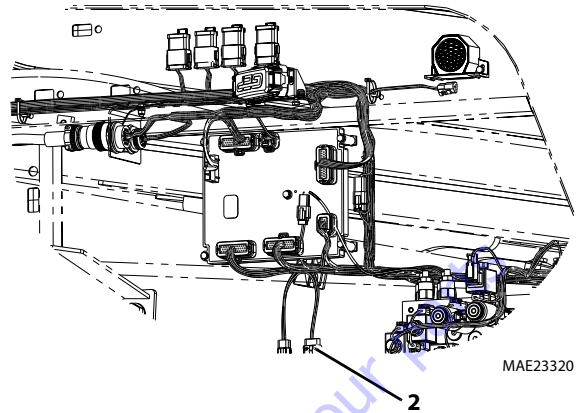

5. Pull out the Emergency Stop switch and Start the engine.

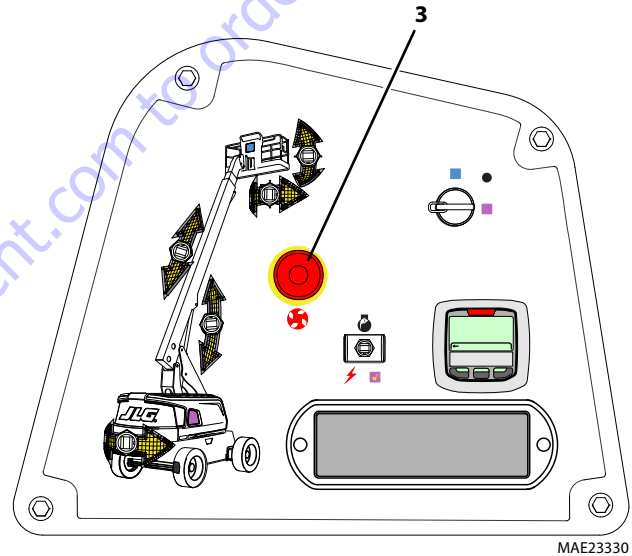

6. The analyzer screen should read:

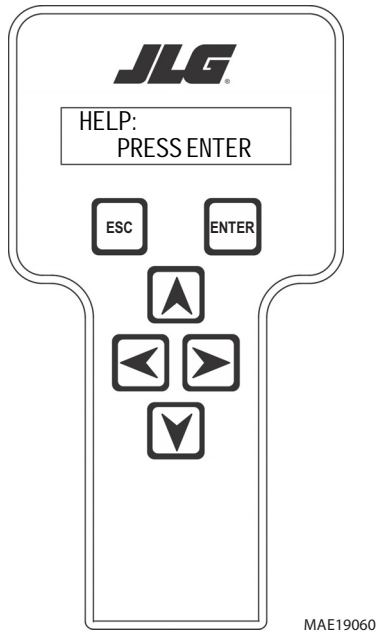

7. Use the arrow button to reach ACCESS LEVEL. Hit Enter.

8. Enter the Access Code, 33271.

9. Use the right Arrow key to reach CALIBRATIONS. Hit Enter.

10. Using the arrow keys, navigate to Calibrations Menu as

shown below and press **ENTER** .

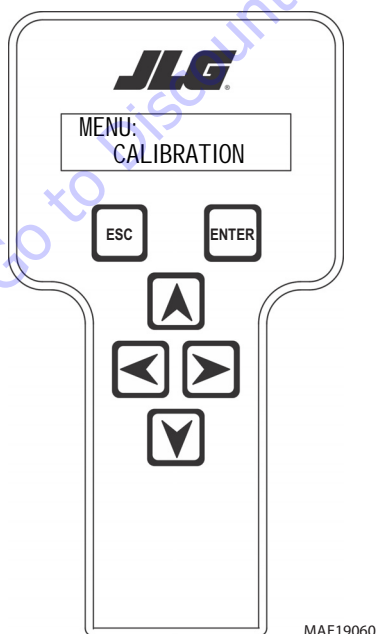

11. Using the arrow keys, navigate to the Tilt Sensor calibration

as shown below and press **ENTER** .

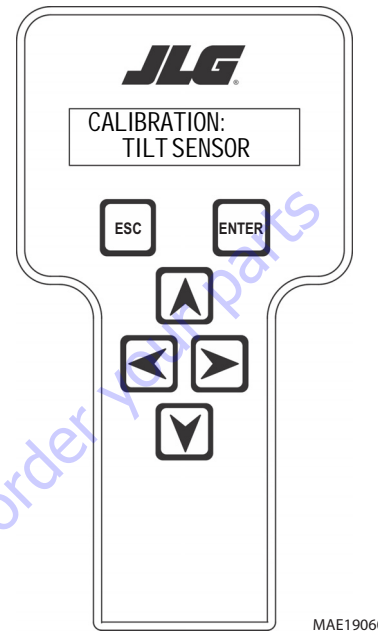

12. Hit Enter. The screen will read.

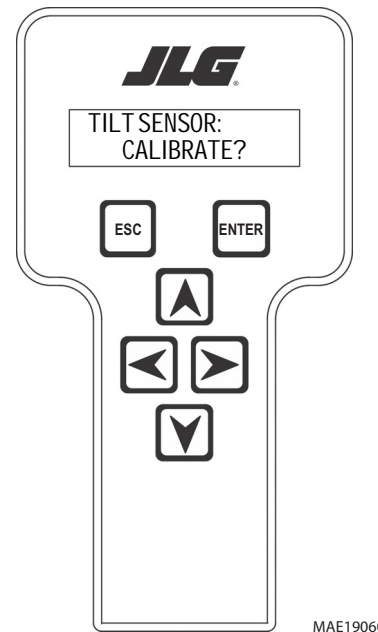

SECTION 6 - JLG CONTROL SYSTEM

13. UGM will confirm the position of the boom, then the screen will read:

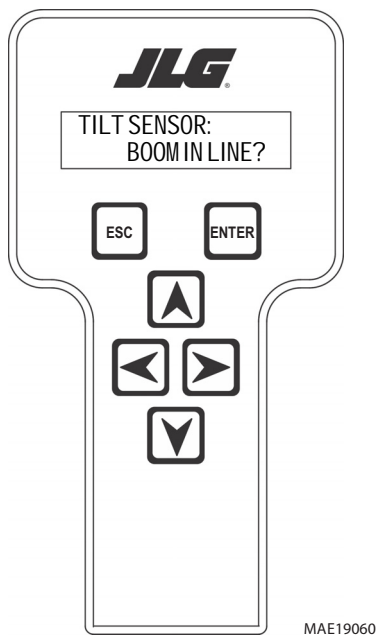

14. When the sensor is calibrated in that position, the screen will read:

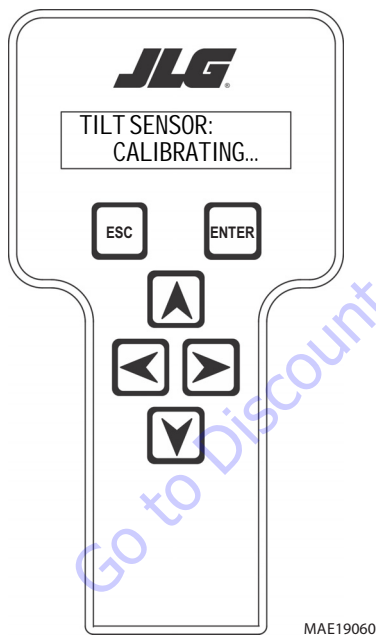
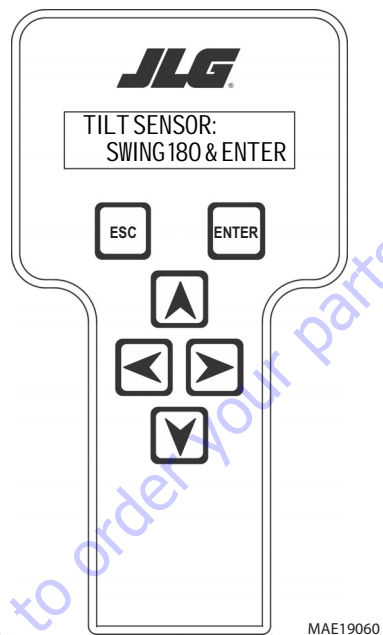

15. Swing the machine 180 degrees, making sure the boom is centered and in the transport position, and

ENTER . The screen will read:

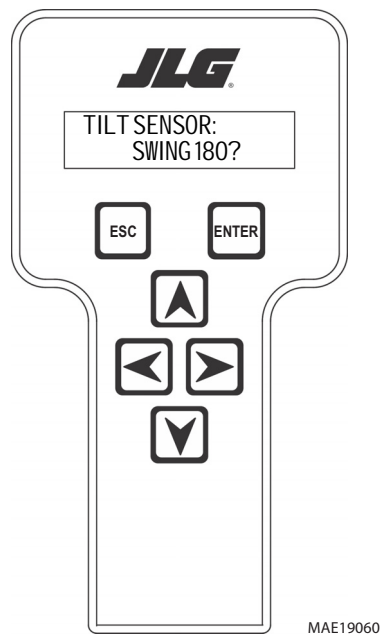

17. When the calibration is complete the screen will read as shown below. Return the machine to the travel position.

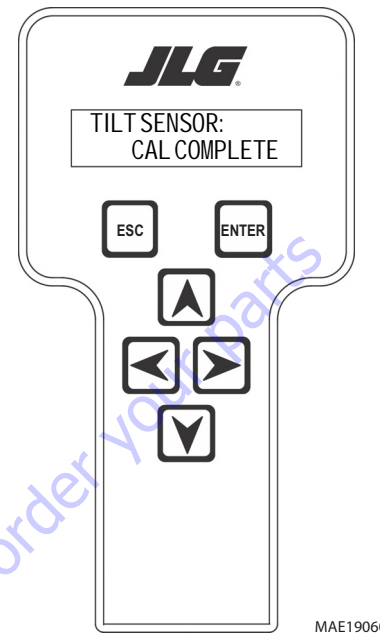
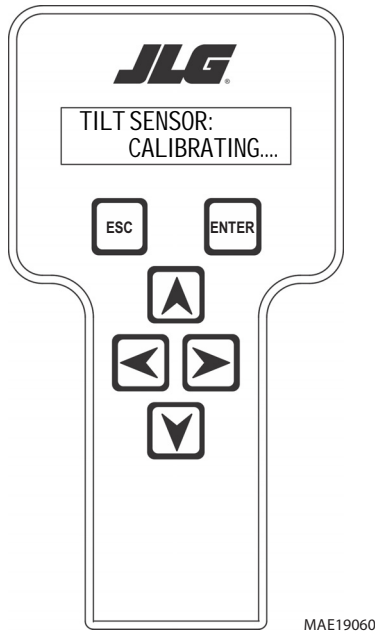

16. Hit Enter. The screen will read.

NOTE: Screen appears only if the machine is on more than a 3 degree slope.

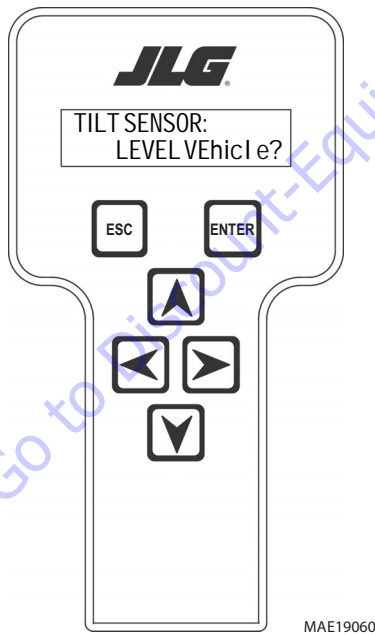

6.9 CALIBRATING BOOM ANGLE

1. Position the Platform/Ground select switch (1) to the Ground position.

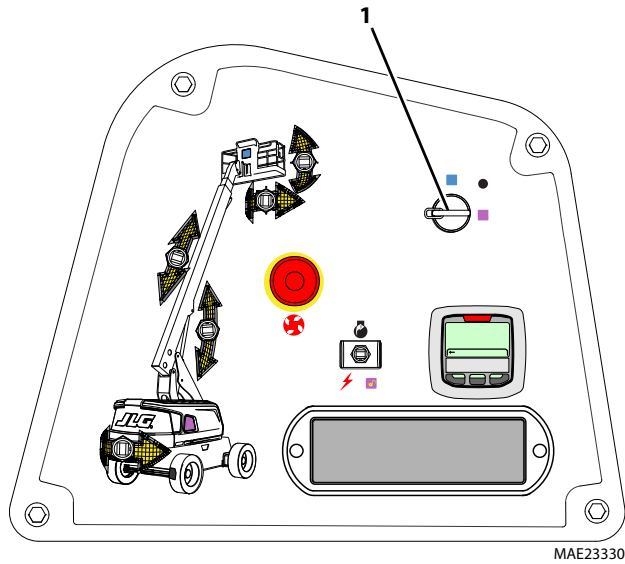

2. Plug the analyzer into the connector (2) inside the Ground control box.

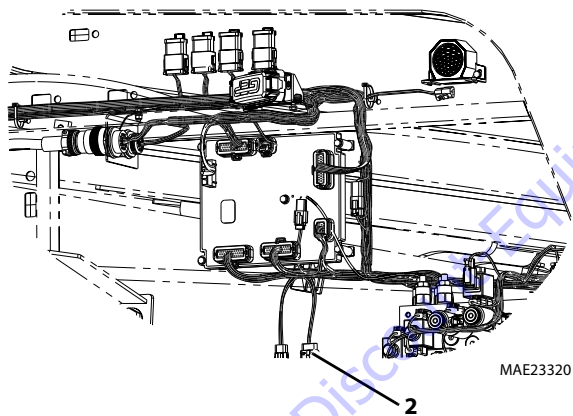

3. Pull out the Emergency Stop switch and Start the engine.

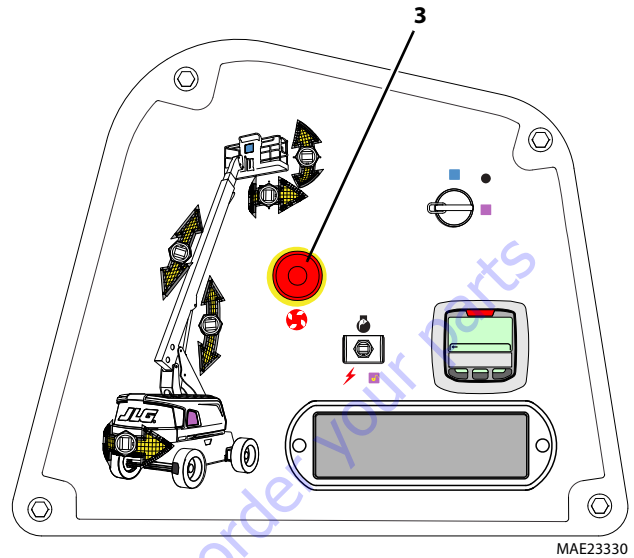

4. The analyzer screen should read:

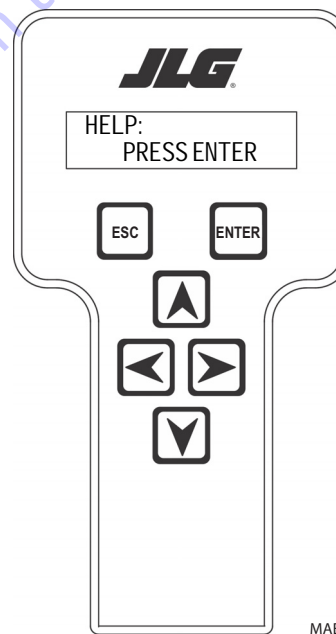

5. Use the arrow button to reach ACCESS LEVEL 2. Hit Enter.
6. Enter the Access Code, 33271.
7. Use the right Arrow key to reach CALIBRATIONS. Hit Enter.

8. Use arrow keys to reach BOOM ANGLE. The Screen will read:

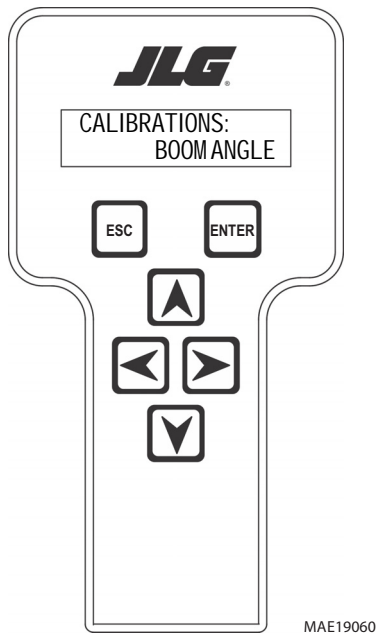

10. UGM will confirm the tilt sensor calibration. The screen will read.

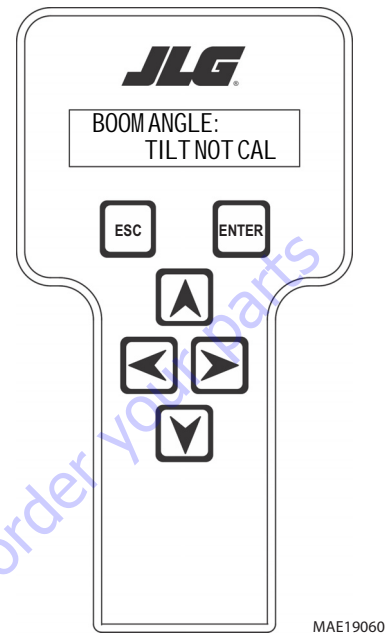

9. Hit Enter. The screen will read.

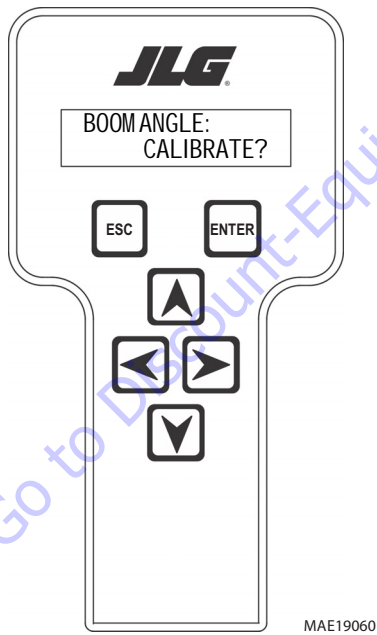

11. Hit Enter. The screen will read.

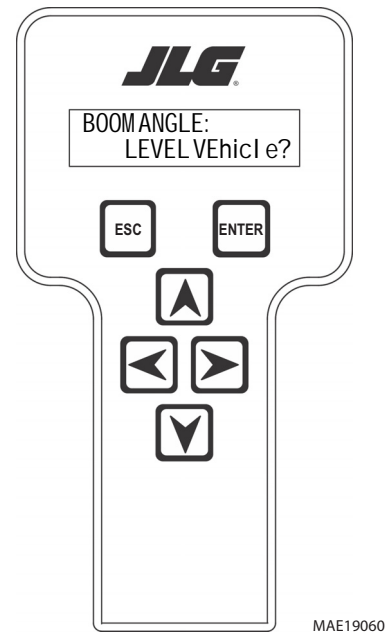

SECTION 6 - JLG CONTROL SYSTEM

12. UGM will confirm the Boom In-Line position. The screen will read:

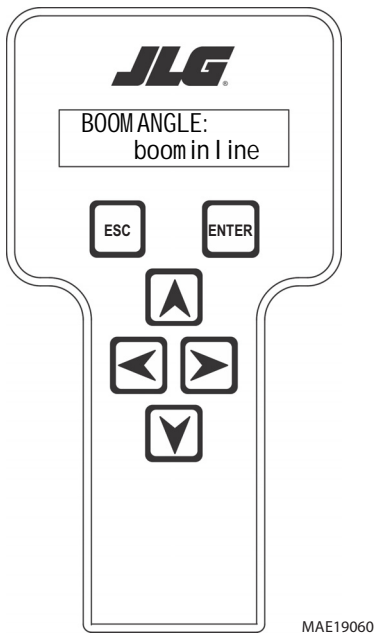

14. When the sensor is calibrated at lower position of the boom. The screen will read:

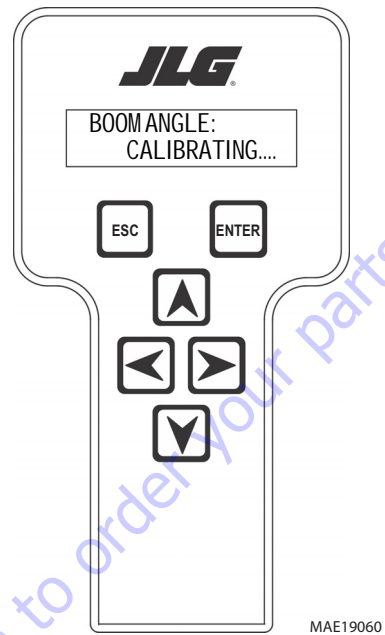

13. Hit Enter. The Screen will read:

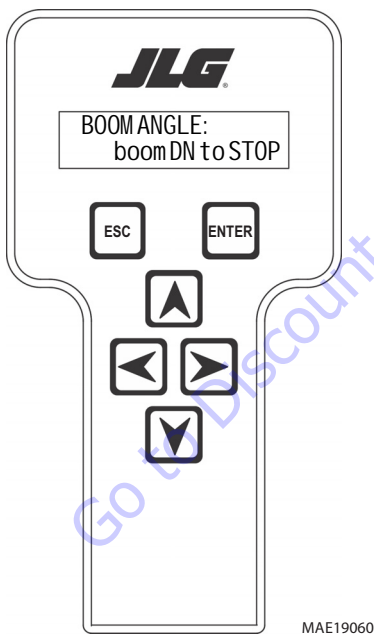

15. Hit Enter. The Screen will read:

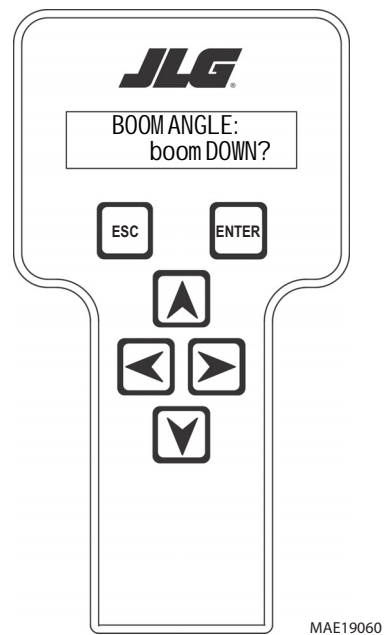

16. Hit Enter. The Screen will read:

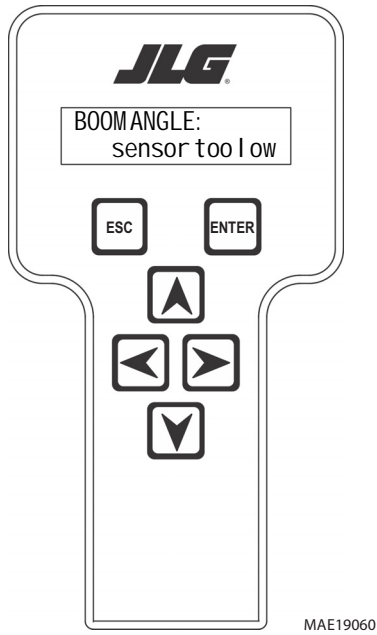

18. When the sensor is calibrated at upper position of the boom. The screen will read:

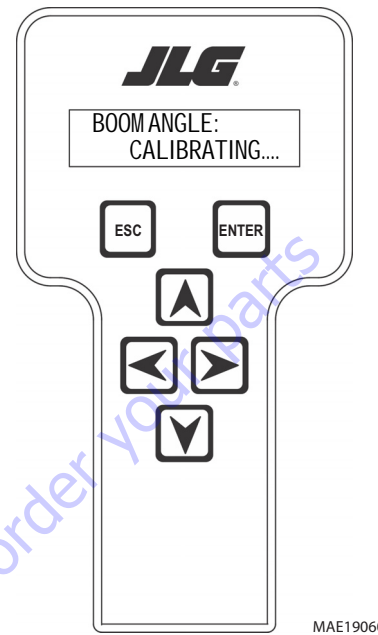

17. UGM will confirm the position of the boom. Press Enter. The screen will read:

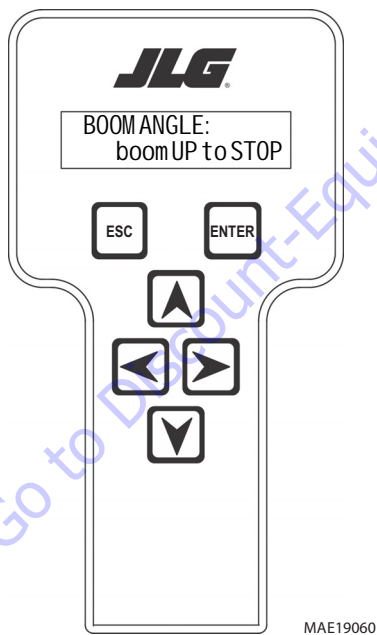

19. UGM will confirm the position of the boom. Press Enter. The screen will read:

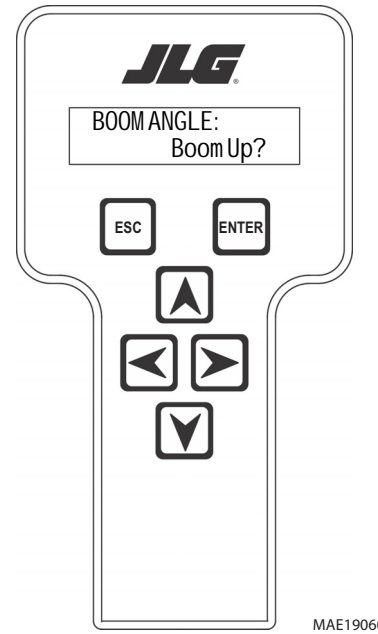

20. Hit Enter. The Screen will read:

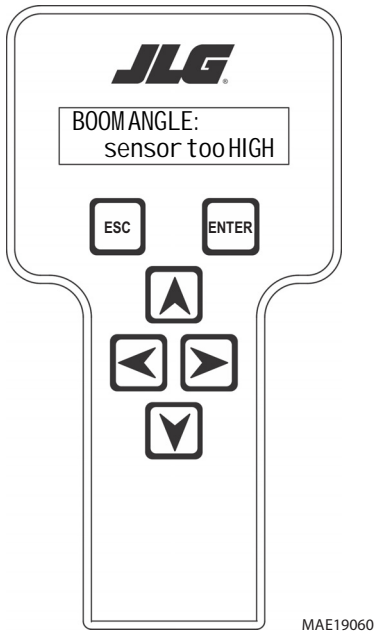

21. After few seconds. The screen will read:

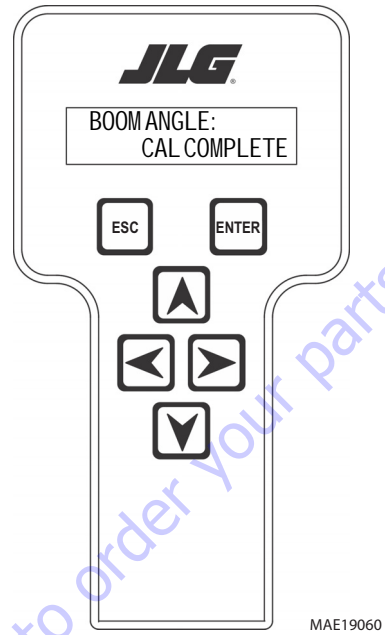

22. Hit ESC twice to go back to CALIBRATIONS.

6.10 CALIBRATING LEVEL UP CRKPT

1. Position the Platform/Ground select switch (1) to the Ground position.

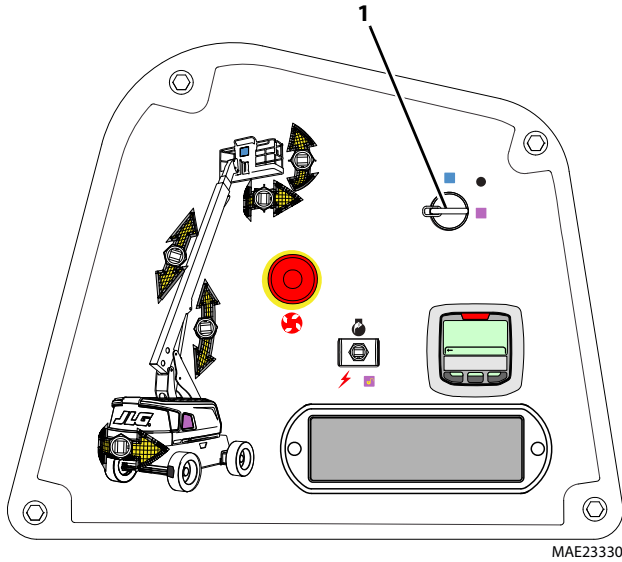

3. Pull out the Emergency Stop switch and Start the engine.

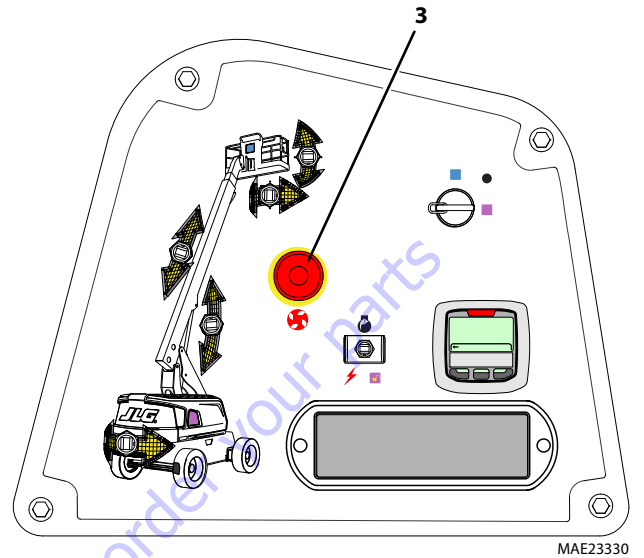

2. Plug the analyzer into the connector (2) inside the Ground control box.

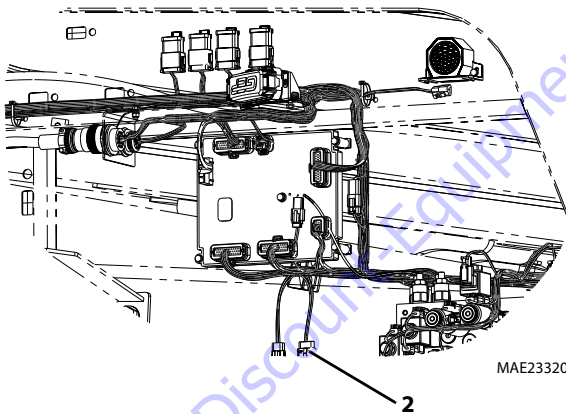

4. The analyzer screen should read:

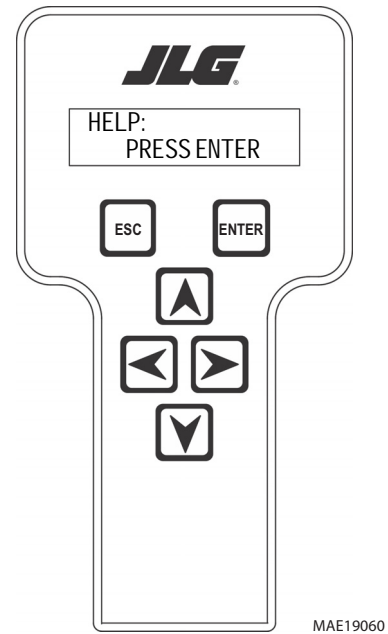

5. Use the arrow button to reach ACCESS LEVEL. Hit Enter.
6. Enter the Access Code, 33271.
7. Use the right Arrow key to reach CALIBRATIONS. Hit Enter.

SECTION 6 - JLG CONTROL SYSTEM

8. Use the arrow keys to reach LEVEL UP CRKPT. The screen will read:

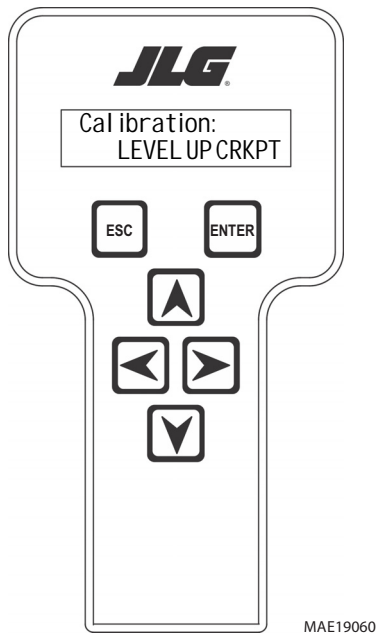

10. UGM shall set the Level Up Crackpoint default value. The screen will read:

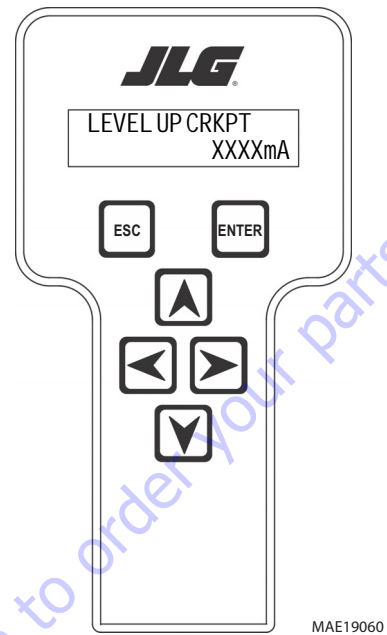

9. Hit Enter. The screen will read:

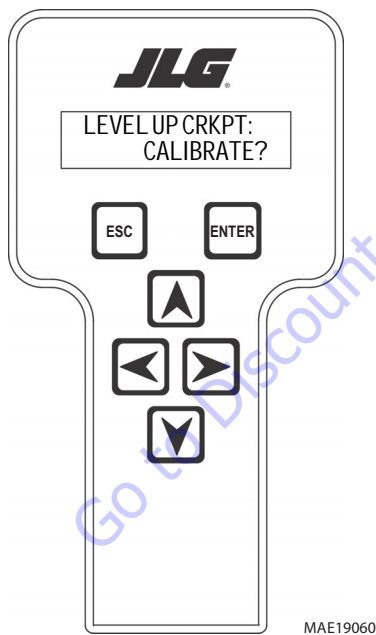

11. Engine RPM will reach to 1400 RPM.

12. Using UP ARROW, increase the value until you see the basket up movement.

NOTE: Maximum Crack Point value is 1200mA. Calibration will fail if the value is increased to more than 1200mA.

13. After few seconds. The screen will read:

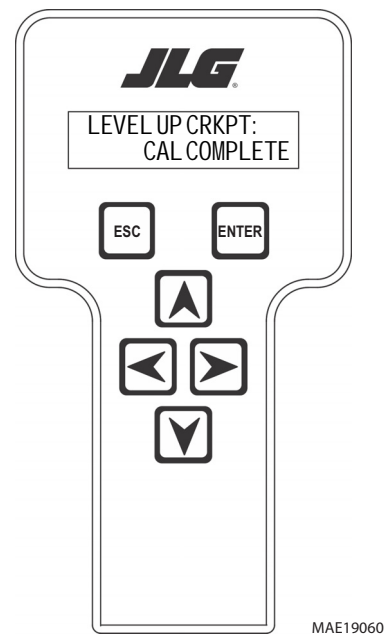

14. Hit ESC twice to go back to CALIBRATIONS.

6.11 CALIBRATING LEVEL DOWN CRACKPOINT

1. Position the Platform/Ground select switch (1) to the Ground position.

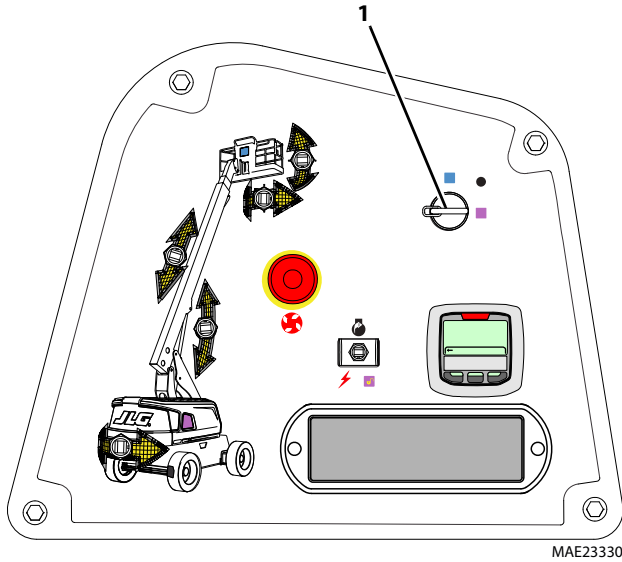

2. Plug the analyzer into the connector (2) inside the Ground control box.

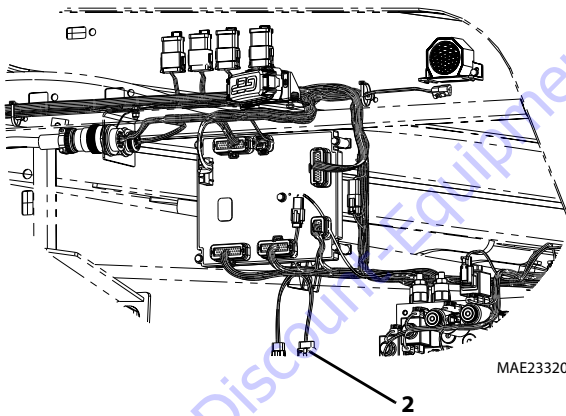

3. Pull out the Emergency Stop switch and Start the engine.

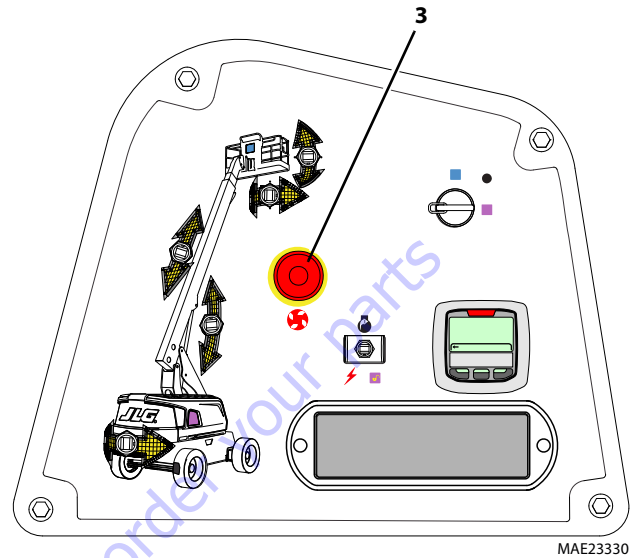

4. The analyzer screen should read:

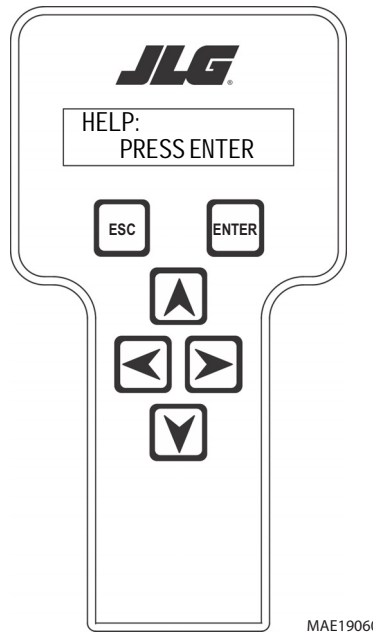

5. Use the arrow button to reach ACCESS LEVEL. Hit Enter.
6. Enter the Access Code, 33271.
7. Use the right Arrow key to reach CALIBRATIONS. Hit Enter.

SECTION 6 - JLG CONTROL SYSTEM

8. Use the arrow keys to reach LEVEL DOWN CRKPT. The screen will read:

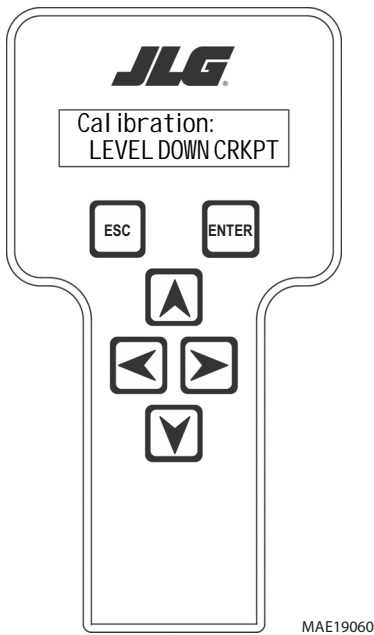

10. UGM shall set the Level Down Crackpoint default value. The screen will read:

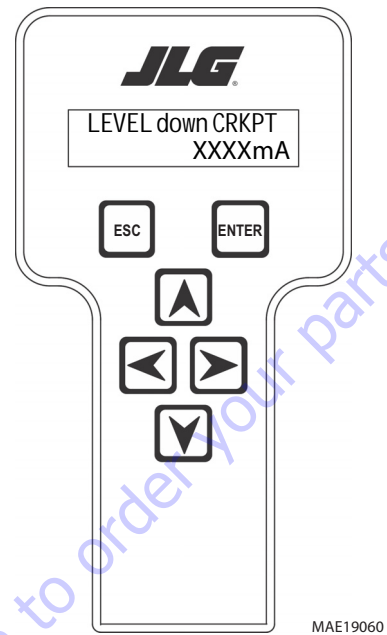

9. Hit Enter. The screen will read:

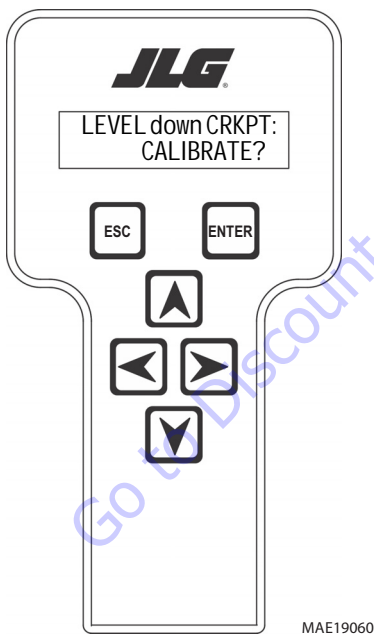

11. Engine RPM will reach to 1400 RPM.

12. Using UP ARROW, increase the value until you see the basket up movement.

NOTE: Maximum Crack Point value is 1200mA. Calibration will fail if the value is increased to more than 1200mA.

13. After few seconds. The screen will read:

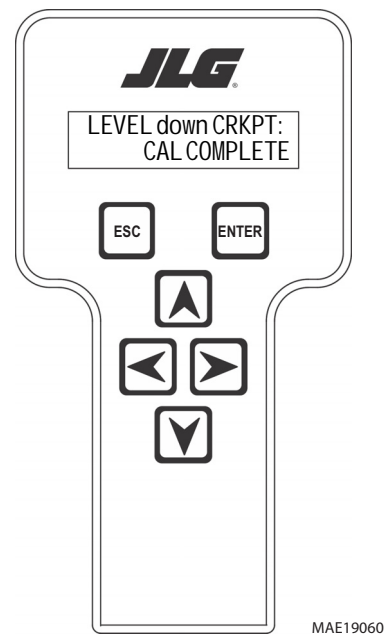

14. Hit ESC twice to go back to CALIBRATIONS.

6.12 CALIBRATING PLATFORM ANGLE SENSOR

1. Position the Platform/Ground select switch (1) to the Ground position.

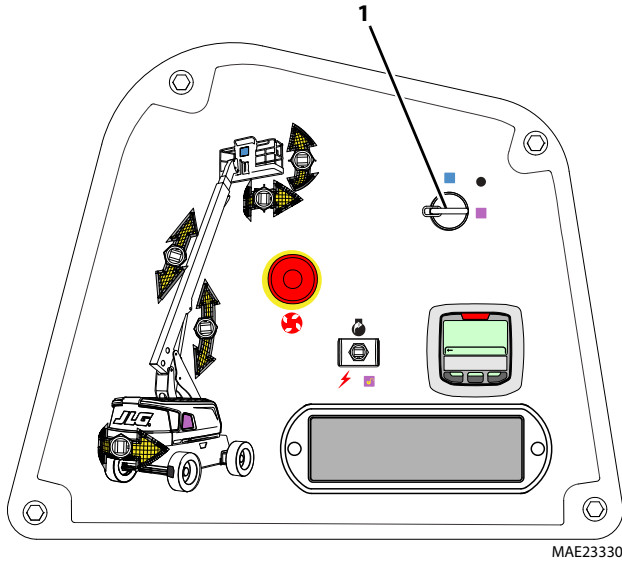

2. Plug the analyzer into the connector (2) inside the Ground control box.

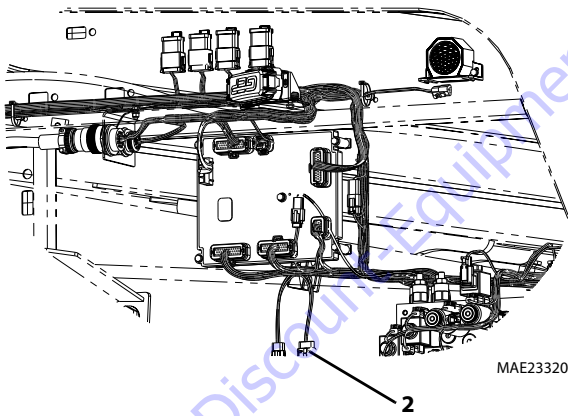

3. Pull out the Emergency Stop switch and Start the engine.

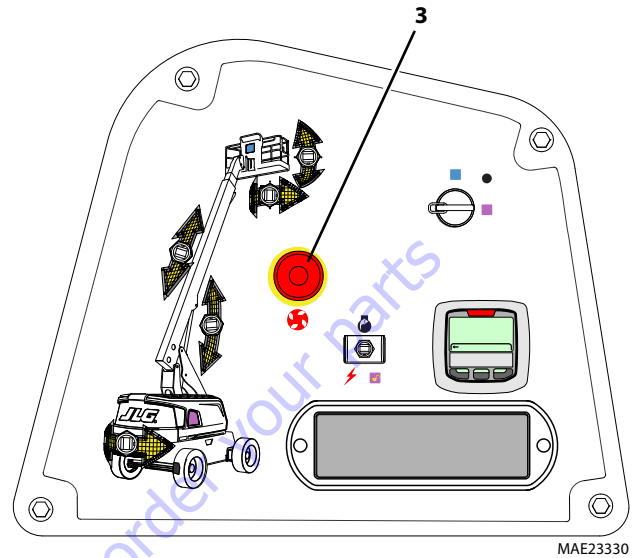

4. The analyzer screen should read:

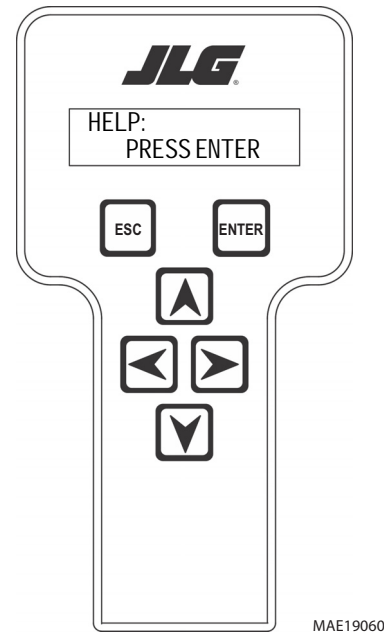

5. Use the arrow button to reach ACCESS LEVEL 2. Hit Enter.
6. Enter the Access Code, 33271.
7. Use the right Arrow key to reach CALIBRATIONS. Hit Enter.

SECTION 6 - JLG CONTROL SYSTEM

8. Use the arrow keys to reach PLATFORM ANGLE. The screen will read:

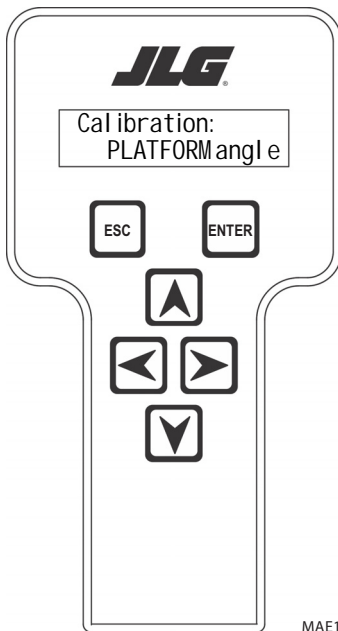

10. Hit Enter. The screen will read:

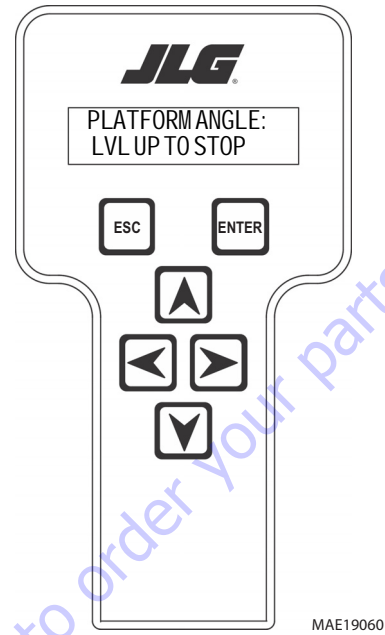

9. Hit Enter. The screen will read:

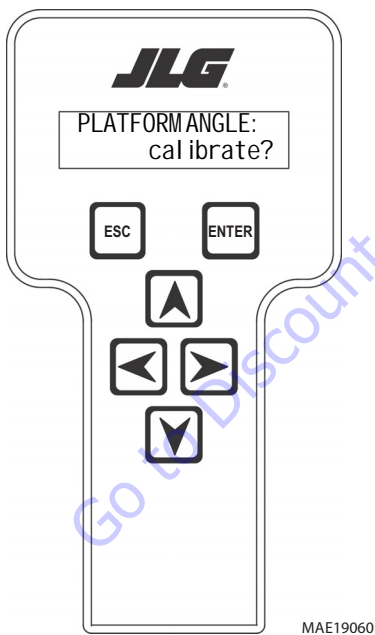

11. Hit Enter. The screen will read:

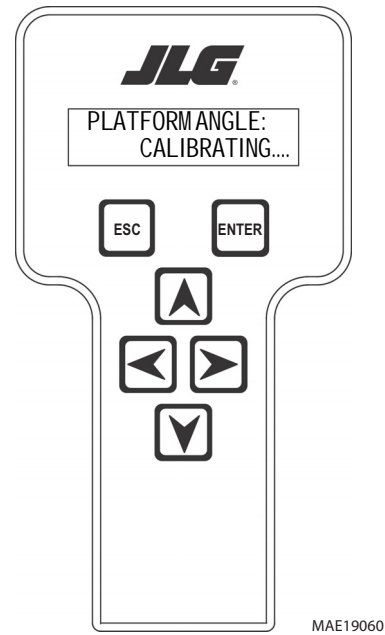

12. UGM will confirm Platform Angle Max sensor readings. The screen will read:

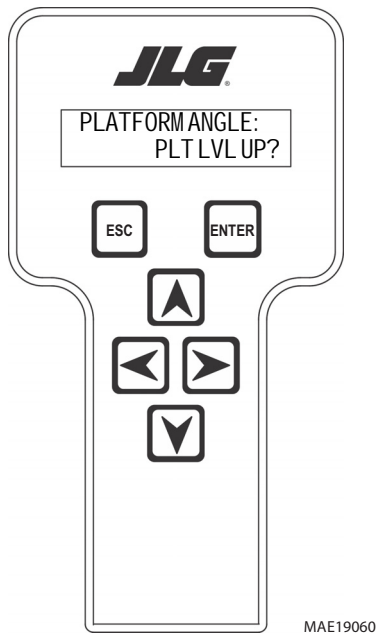

14. After few seconds. The screen will read:

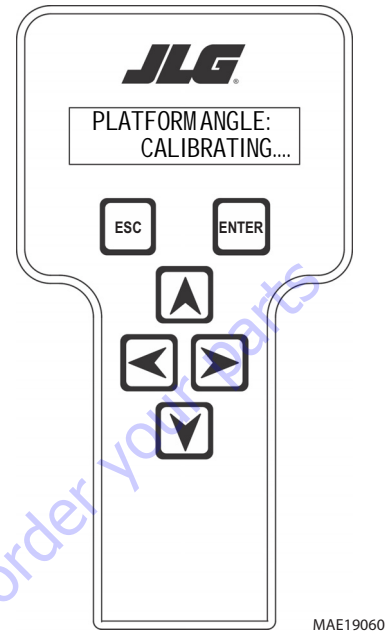

13. Hit Enter. The screen will read:

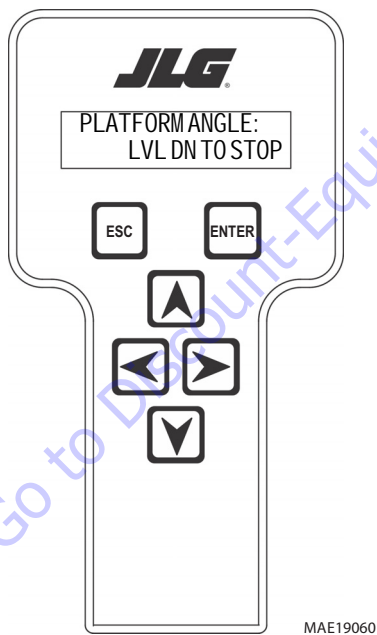

15. UGM will confirm Platform Angle Min sensor readings. The screen will read:

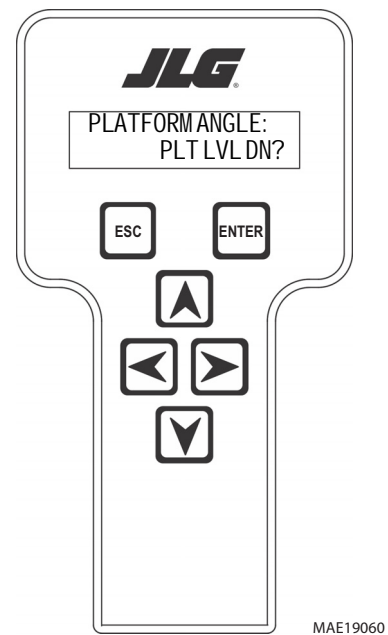

SECTION 6 - JLG CONTROL SYSTEM

16. After few seconds. The screen will read:

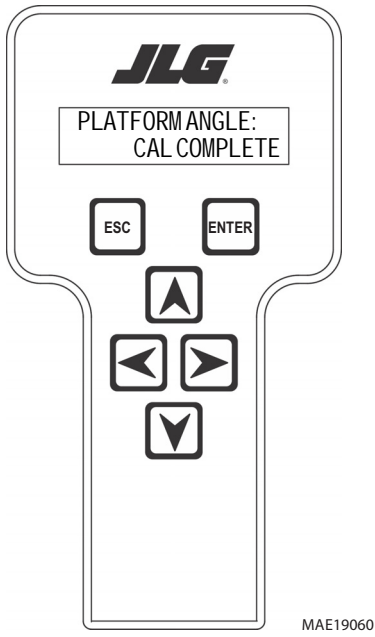

17. Hit ESC twice to go back to CALIBRATIONS.

Go to Discount-Equipment.com to order your parts

6.13 CALIBRATING LOAD SENSING

NOTE: Calibration sub-menu *LOAD SENSING* is visible only if *MACHINE SET-UP* sub-menu *LOAD SYSTEM* is selected to YES.

1. Position the Platform/Ground select switch to the Platform position.

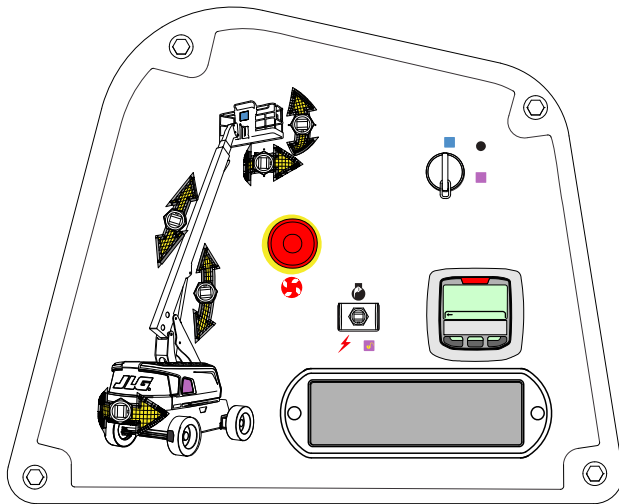

MAE34640

2. Plug the analyzer into the connector at the base of the platform control box.



MAE15680

3. Pull out the Emergency Stop switch and Start the engine.



MAE17820

4. The analyzer screen should read:

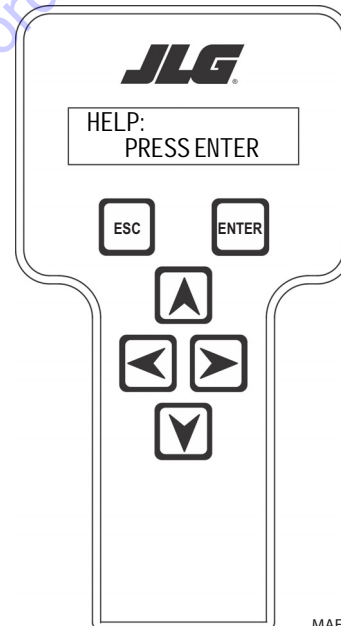

MAE19060

5. Use the arrow button to reach ACCESS LEVEL 2. Hit Enter.
6. Enter the Access Code, 33271.
7. Use the right Arrow key to reach CALIBRATIONS. Hit Enter.

SECTION 6 - JLG CONTROL SYSTEM

8. Use the arrow keys to reach LOAD SENSING. The screen will read:

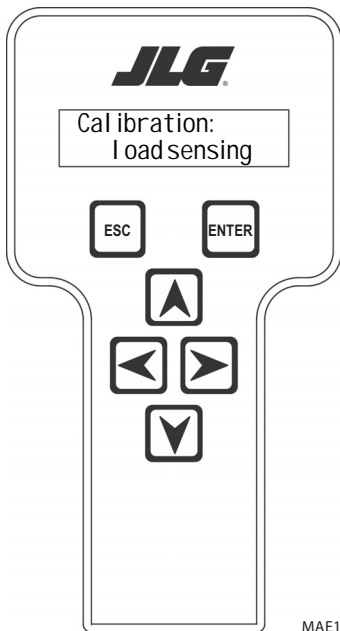

10. Hit Enter. The screen will read:

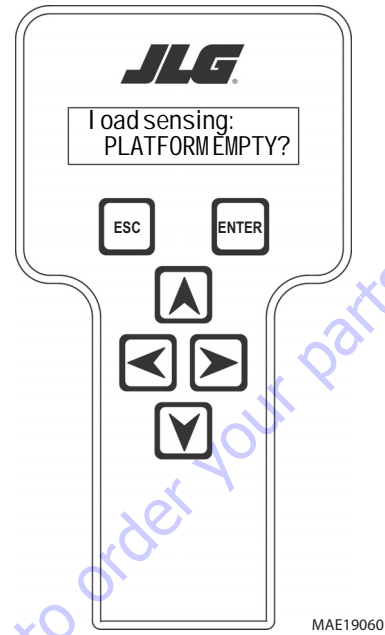

9. Hit Enter. The screen will read:

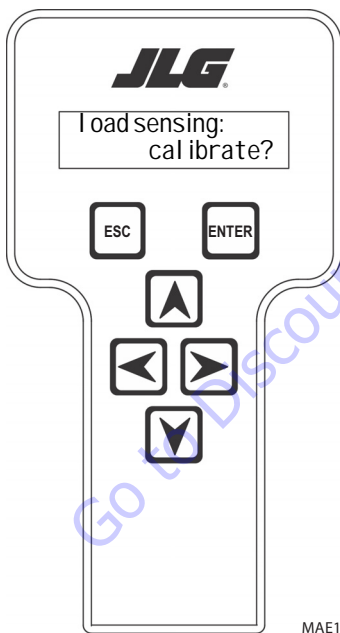

11. UGM will set the Accessory Weight default value. Press Enter. The screen will read:

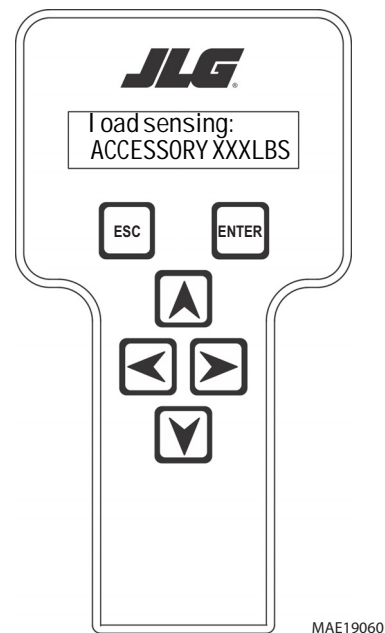

12. Hit Enter. The screen will read:

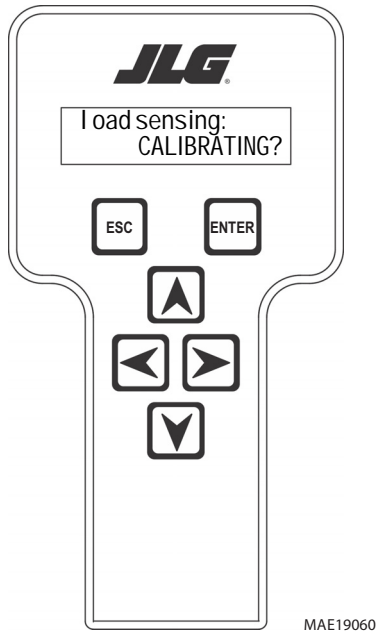

MAE19060

14. UGM will set the Pipe Racks default value. Press Enter. The screen will read:

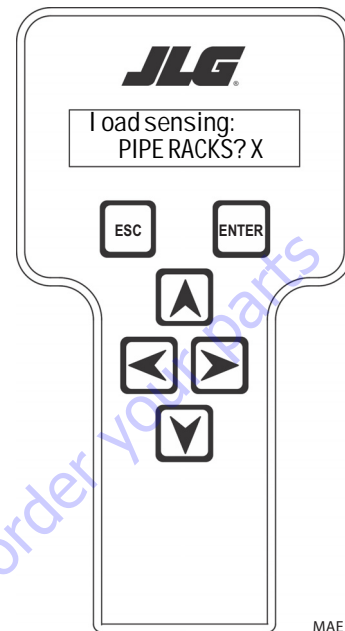

MAE19060

13. UGM will set the Glazier default value. Press Enter. The screen will read:

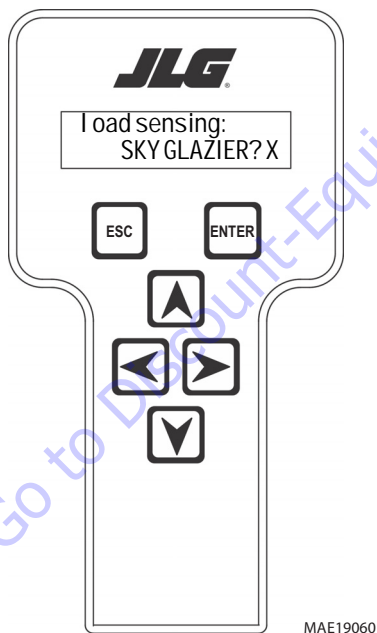

MAE19060

15. UGM will set the Unrestricted Rated Load. Press Enter. The screen will read:

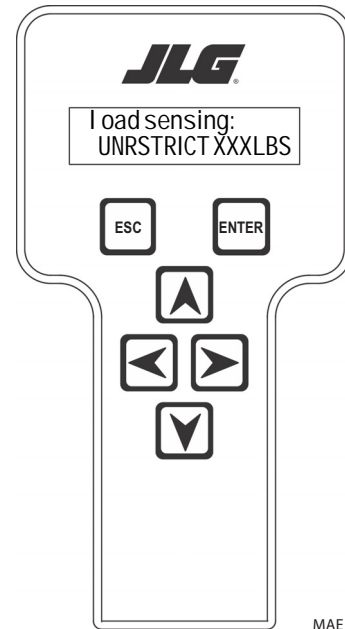

MAE19060

SECTION 6 - JLG CONTROL SYSTEM

16. UGM will set the Restricted Rated Load. Press Enter. The screen will read:

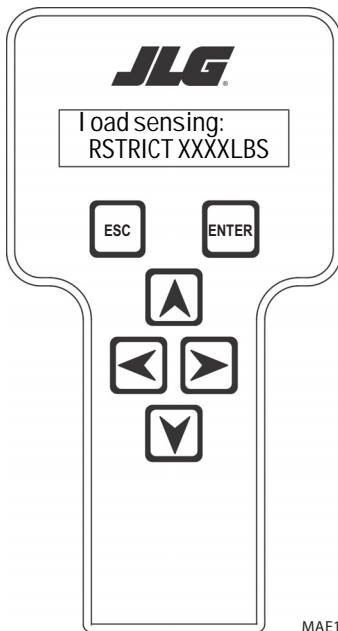

17. After few seconds, the screen will read:

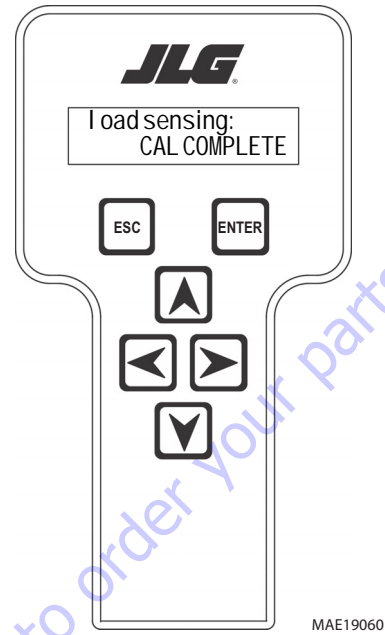

6.14 CALIBRATING MSSO

1. Position the Platform/Ground select switch to the Platform position.

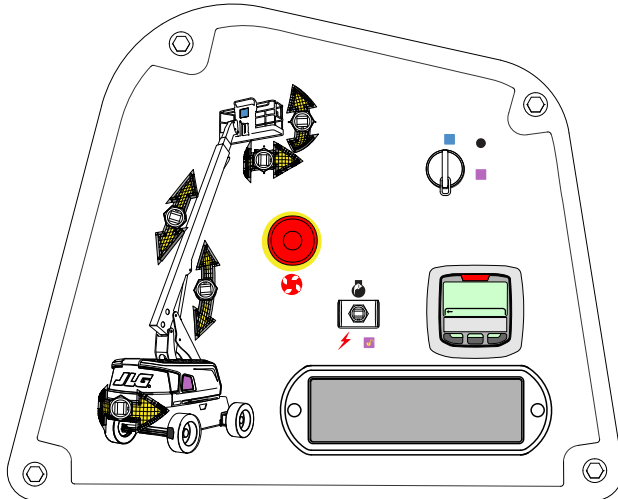

MAE34640

2. Plug the analyzer into the connector at the base of the platform control box.



MAE15680

3. Pull out the Emergency Stop switch and Start the engine.



MAE17820

4. The analyzer screen should read:

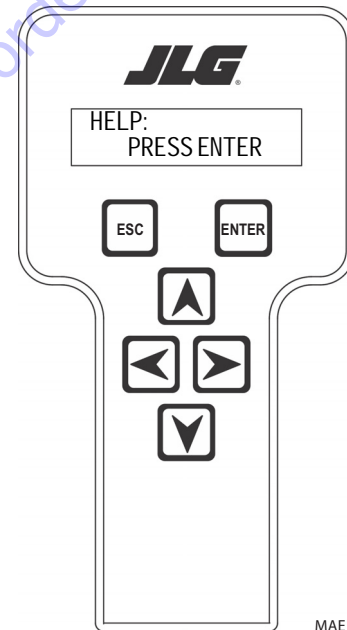

MAE19060

5. Use the arrow button to reach ACCESS LEVEL 2. Hit Enter.
6. Enter the Access Code, 33271.
7. Use the right Arrow key to reach CALIBRATIONS. Hit Enter.

SECTION 6 - JLG CONTROL SYSTEM

8. Use the arrow keys to reach MSSO. The screen will read:

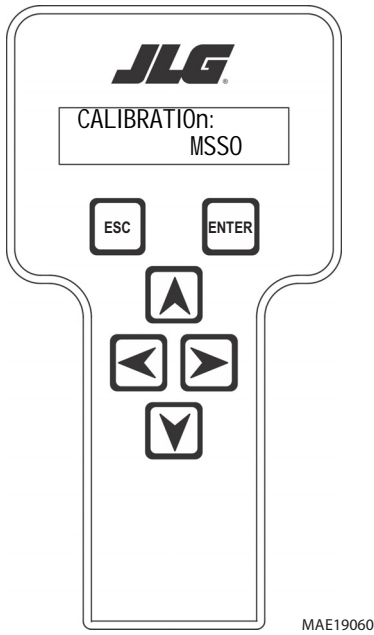

9. Hit Enter. The screen will read:

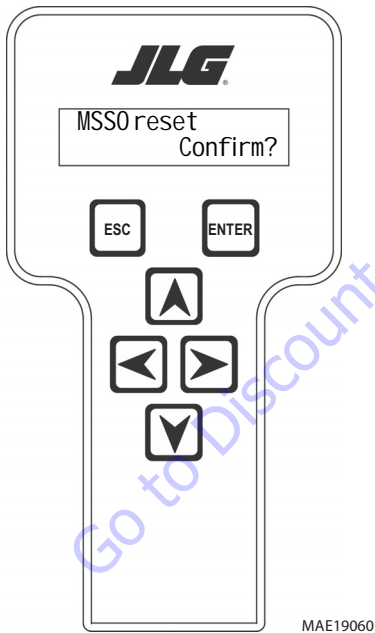

6.15 LSS SYSTEM

The JLG-designed Load Sensing System (LSS) measures platform load via a sensor mounted in the platform support structure. If the actual platform load exceeds the selected Rated Load, the following will occur:

1. The Overload Visual Warning Indicator will flash at the selected control position (platform or ground).
2. The Platform and Ground Alarms will sound 5 seconds On, and 2 seconds Off.
3. All normal movement will be prevented from the platform control position (optional - ground control functions may be prevented).
4. Further movement is permitted by:
 - a. Removing the excess platform load until actual platform load is less than Rated Load.
 - b. Operation of the overriding emergency system (Auxiliary Power Unit).
 - c. By an authorized person at the ground control position (optional - ground control functions may be prevented).



NOTICE

THE LOAD SENSING SYSTEM MUST BE CALIBRATED WHEN ONE OR MORE OF THE FOLLOWING CONDITIONS OCCUR:

- d. LSS Sensor removal or replacement.
- e. Addition or removal of certain platform mounted accessories. (Refer to Calibration).
- f. Platform is removed, replaced, repaired or shows evidence of impact.



NOTICE



THE LOAD SENSING SYSTEM REQUIRES PERIODIC FUNCTION VERIFICATION NOT TO EXCEED 6 MONTHS FROM PREVIOUS VERIFICATION. REFER TO TESTING & EVALUATION.

All calibration procedures are menu driven through the use of a JLG Analyzer.

Diagnostic Menu

The Diagnostic Menu is another troubleshooting tool for the Load Sensing System. Sensor and status information is presented in real-time for the technician. Several sub-menus exist to organize the data.

To access the Diagnostic Menu, use the **LEFT**  and **RIGHT**  Arrow keys to select DIAGNOSTICS from the Top Level Menu. Press the **ENTER**  key to view the menu.

Press the **LEFT**  and **RIGHT**  Arrow keys to view the displays and select the various sub-menus. To access a sub-menu, press the ENTER key. Once in a sub-menu, press the

LEFT  and **RIGHT**  Arrow keys to view the various displays (just like a Top Level menu). To exit a sub-menu, press the **ESC**  key.

Table 6-8, Diagnostic Menu Descriptions details the structure of the Diagnostic Menu, and describes the meaning of each piece of information presented.

Table 6-8. Diagnostic Menu Descriptions

Diagnosics Menu (Displayed on Analyzer 1st Line)	Parameter (Displayed on Analyzer 2nd Line)	Parameter Value (Displayed on Analyzer 2nd Line)	Description
PLATFORM LOAD	STATE:	OK / OVERLOAD	LSS Status.
PLATFORM LOAD	ACTUAL:	XXX.X KG	Calibrated weight of the platform. ??? if Platform Load is Unhealthy**.
PLATFORM LOAD (service*)	GROSS:	XXX.X KG	Gross weight of the platform. ??? if both Cells are Unhealthy**.
PLATFORM LOAD (service*)	OFFSET 1:	XXX.X KG	Stored offset weight of Cell 1. ??? if LSS is not calibrated.
PLATFORM LOAD (service*)	OFFSET 2:	XXX.X KG	Stored offset weight of Cell 1. ??? if LSS is not calibrated.
PLATFORM LOAD (service*)	ACCESSORY	XXX.X KG	Stored accessory weight. ??? if LSS is not calibrated.
PLATFORM LOAD (service*)	UNRESTRICT	XXX.X KG	UGM will set Unrestricted Rated Load as defined by Machine Configuration.
PLATFORM LOAD (service*)	RESTRICT	XXX.X KG	UGM will set Restricted Rated Load as defined by Machine Configuration.
PLATFORM LOAD (service*)	RAW 1:	XXX.X KG	Gross value from Cell 1. ??? if Unhealthy**.
PLATFORM LOAD (service*)	RAW 2:	XXX.X KG	Gross value from Cell 2. ??? if Unhealthy**.
* Indicates only visible in service view mode ** Typically indicates a DTC is active			

Calibration Procedure

1. Remove everything from the platform, except permanently fixed JLG Accessories, to allow the Load Sensing System to record its' weight during calibration. This includes all tools, debris, and customer-installed devices.
2. Plug the JLG Analyzer into the Machine at the Ground Station and enter Service Access Password 33271.
3. The platform should be approximately level for calibration. Level the platform from ground control (if necessary) to within +/- 5°.
4. To access the Calibration Menu, use the LEFT and RIGHT Arrow keys to select CALIBRATION from the Top Level Menu. The screen will read:

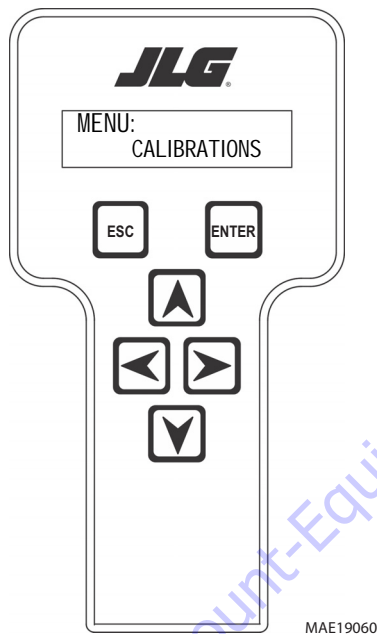

NOTE: The Calibration Menu is not available in OPERATOR ACCESS.

5. Press the ENTER key  to view the menu. Upon entry to the Calibration Menu, the JLG Control System will link to the Analyzer and the screen will read:

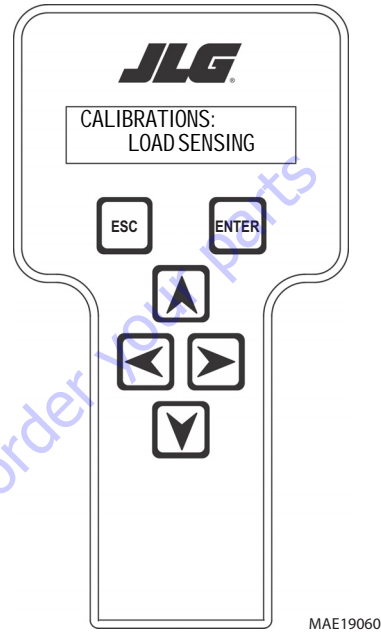

6. Press Enter . The Screen will read:

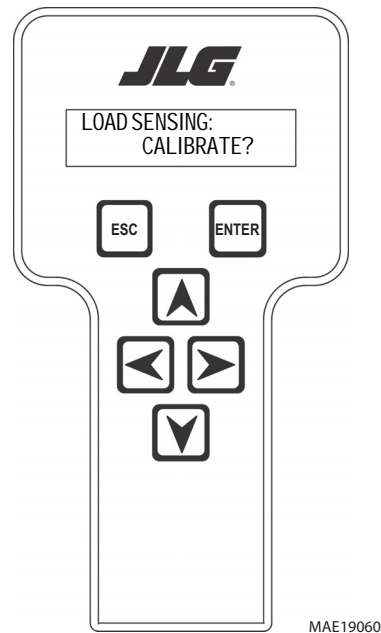

NOTE: Calibration will auto fail if LSS DTC's are active (443, 444, 4479, 4480, 663, 821, 822, 823, 824, 8218, 8222 -> 8238, 991, 992, 993, 994 or 99285).

Pressing the ESC  key after starting calibration and before calibration is complete will display the CAL FAILED message. This will not disturb the prior calibration information.

NOTE: Accessory weight will reset to 0 lbs. each time the machine is re-calibrated and will need to be re-entered.

NOTE: The Accessory weight will be temporarily stored in the Control System until calibration has been completed successfully.

7. Press ENTER . The analyzer screen will read:

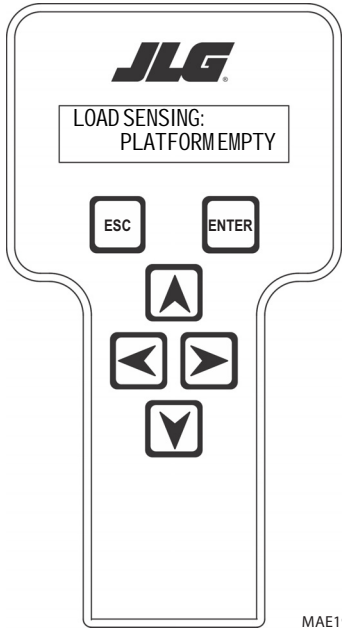

Refer to Table 6-9, Accessory Weights. Use the up and down analyzer keys to enter the accessory weight(s) (in lbs). When all

the accessory weights are entered, press ENTER . The screen will read:

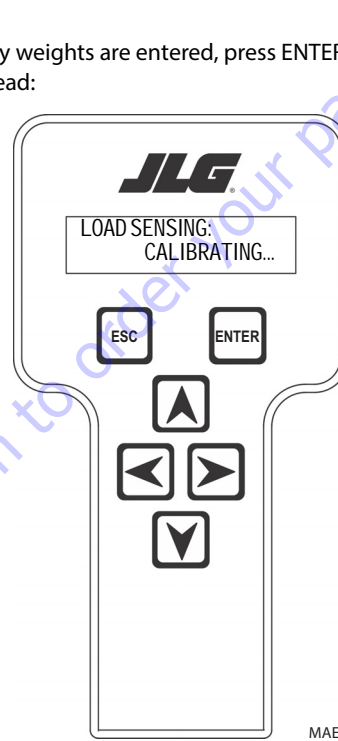

8. If the platform is empty, press ENTER . The screen will read:

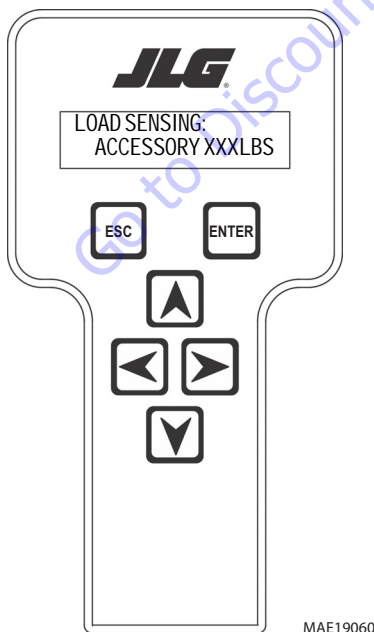

Table 6-9. Accessory Weights

Accessory	Weight
SkyWelder (stick welder)	70 lb. (32 kg)
SkyWelder Prep	Prep only = 15 lb. (7 kg) Full install = 70 lb. (32 kg)
SkyCutter (plasma cutter)	70 lb. (32 kg)
SkyCutter / SkyWelder Combo	140 lb. (64 kg)
Fire Extinguisher	45 lb. (20 kg)
Overhead SoftTouch	80 lb. (36 kg)
Work Surface	20 lb. (9 kg)

NOTE: Not all Accessories are available on every JLG model. Some Accessory combinations are prohibited due to excessive weight and/or load restriction. If any installed JLG Accessories are labeled with weight decals but are not listed in the table above, include their weight when entering the ACC WEIGHT value.

- The control system will calculate the load cell readings and ensure it is greater than 130 lbs. (59 kg), but less than 575 lbs. (261 kg).

If the platform weight is not within the allowed range, the calibration attempt will be unsuccessful and the Analyzer will show the following:

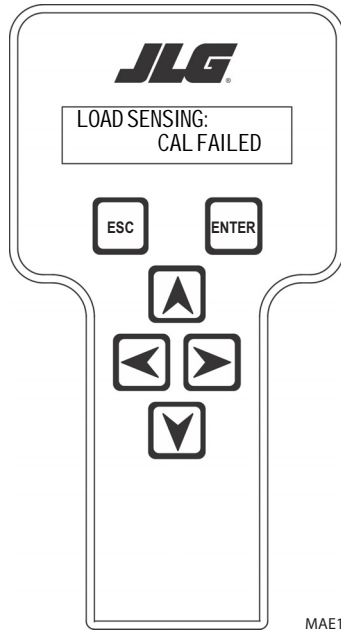

- Use the analyzer keys to select N for no or Y for yes. Press

ENTER . The screen will read:

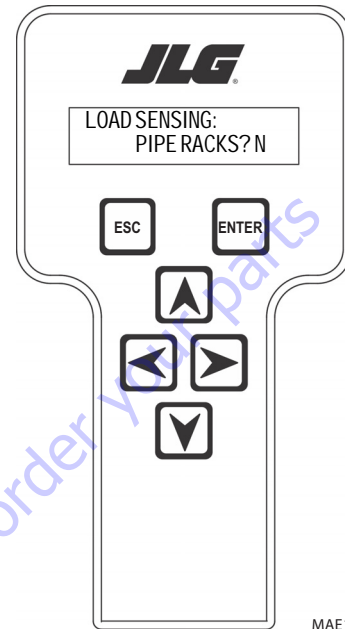

- Press ENTER . The control system will ask for installed accessories. The screen will show the following:

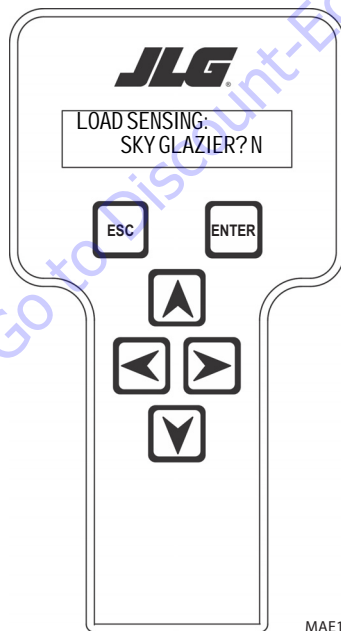

12. Use the analyzer keys to select N for no or Y for yes. Press



ENTER. The control system will default to an estimate of unrestricted capacity, which can be adjusted if necessary. Refer to Table 6-10, SkyGlazier Capacity Reductions and Table 6-11, Pipe Rack Capacity Reductions. The screen will read:

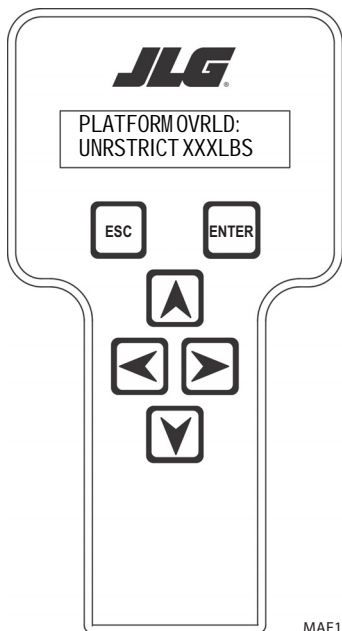

MAE19060

Table 6-10. SkyGlazier Capacity Reductions

Capacity	PLATFORM OVRLD	PLATFORM OVRLD RESTRICT
500 lb. (227 kg)	400 lb. (181 kg)	N/A
550 lb. (250 kg)	400 lb. (181 kg)	N/A
600 lb. (272 kg)	400 lb. (181 kg)	N/A
750 lb. (340 kg)	N/A	590 lb. (268 kg)
1000 lb. (454 kg)	N/A	750 lb. (340 kg)

NOTE: If both SkyGlazier and Pipe Racks are configured, capacity will be the lower of the two values.

Table 6-11. Pipe Rack Capacity Reductions

Capacity	PLATFORM OVRLD	PLATFORM OVRLD RESTRICT
500 lb. (227 kg)	400 lb. (181 kg)	N/A
550 lb. (250 kg)	450 lb. (204 kg)	N/A
600 lb. (272 kg)	500 lb. (227 kg)	N/A
750 lb. (340 kg)	N/A	650 lb. (295 kg)
1000 lb. (454 kg)	N/A	900 lb. (408 kg)

NOTE: If both SkyGlazier and Pipe Racks are configured, capacity will be the lower of the two values.

13. Press ENTER

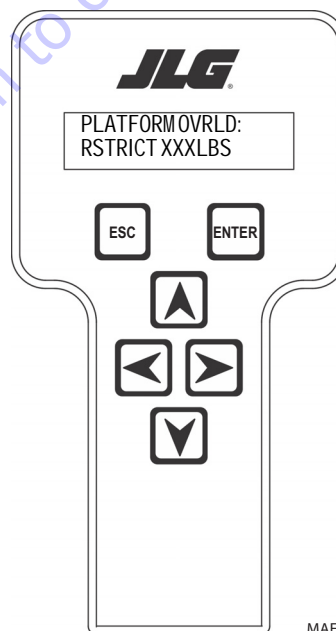

MAE19060

14. Press ENTER . If calibration is successful, the screen will read:

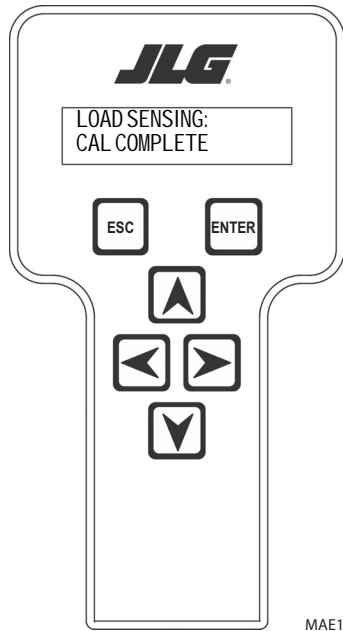

MAE19060

Go to Discount-Equipment.com to order your parts

Testing & Evaluation

Refer to Troubleshooting if the Load Sensing System fails to meet these guidelines.

1. Connect the JLG Analyzer.
2. Level the Platform. The platform should be approximately level for analysis, or the guidelines below will not be applicable. Level the platform from Ground Control (if necessary) to within ± 5 degrees.
3. Observe the Empty Platform Weight. Proceed to the DIAGNOSTICS, PLTLOAD sub-menu and observe the measured platform load. All tools, debris, and customer installed devices shall be removed during evaluation. Ideally, the PLTLOAD should be zero but can vary ± 15 lbs (± 7 kg). Further, the reading should be stable and should not vary by more than ± 2 lbs (± 1 kg) (unless there is heavy influence from wind or vibration).
4. Use the Technician's Weight to Evaluate. The technician should enter the platform and record the PLTLOAD reading while standing in the center of the platform.
5. Confirm Control System Warnings and Interlocks. Using the keyswitch, select Platform Mode and power-up. Start the vehicle's engine and ensure that all controls are functional and the Load Sensing System's Overload Visual and Audible Warnings are not active. Simulate an Overload by unplugging the Shear Beam Load Cell. The Overload Visual Warning should flash, and the Audible Warning (at Platform and Ground) should sound for 5 seconds On, and 2 seconds Off. With the engine running, all control should be prevented. Cycle the Platform EMS to stop the engine and then power-up again. The Overload Visual and Audible Warning should continue. Confirm that controls are responsive when using the Auxiliary Power Unit for emergency movement. Reconnect the Load Cell. The Overload Visual and Audible Warnings should cease and normal control function should return. Switch the vehicle's keyswitch to Ground Mode and repeat the above procedure. The Overload Visual Warning at the Ground Controls should flash, and the Audible Warning (at Platform and Ground) should sound for 5 seconds On, 2 seconds Off. However, the controls should remain functional when using the engine and the Auxiliary Power Unit (if the Control System's MACHINE SETUP, LOAD is set to "2=CUTOUT PLT". If set to "3=CUTOUT ALL", then Ground Controls will be prevented when using the engine as in the platform).
6. Confirm Control System Capacity Indication (optional for vehicles with Dual Capacity Ratings). For vehicles equipped with a Capacity Select switch on the Platform Console Box, it is necessary to examine an additional interface between the Load Sensing System and the Control System. Using the keyswitch, select Platform Mode and power-up. If necessary, put the boom in the transport position (completely stowed) and center the Jib Plus (if equipped). Place the Capacity Select switch in the unrestricted position and ensure that the proper indicator illuminates on the Platform Console Box. Plug the JLG Analyzer into the Analyzer connection and proceed to the DIAGNOSTICS, SYSTEM submenu. Ensure that the CAPACITY displays indicate OFF. Place the Capacity Select switch in the unrestricted position (if so equipped) and ensure that the proper indicator illuminates on the Platform Console Box (but does not flash). For vehicles with unrestricted capacity, ensure that the unrestricted CAPACITY display indicates ON but the restricted CAPACITY indicates OFF. For vehicles with restricted capacity, ensure that the unrestricted CAPACITY display indicates OFF but the restricted CAPACITY indicates ON.
7. Confirm Load Sensing System Performance with Calibrated Weights. Operate the vehicle from Ground Control and place the boom in the transport position (fully stowed) for safety. Plug the JLG Analyzer into the control system connection and proceed to the DIAGNOSTICS, PLTLOAD display. Place 500lbs (230kg) in the platform and ensure that PLTLOAD is with $\pm 5\%$ of the actual weight. For Dual Capacity vehicles, do the same for the alternate capacity (unrestricted or restricted).

LSS Service Mode

To facilitate the servicing and enabling of functions due to component faults, there is a need to override the normal operation of the machine. Service Mode shall become visible only after entering Service Access Level.

Table 6-12. LSS Service Mode

Service Mode Submenu (Displayed on Analyzer 2nd Line)	Parameter (Displayed on Analyzer 1st Line)	Parameter Value (Displayed on Analyzer 2nd Line)	Transition and Software Checks
LSS? (NOT VISIBLE IF MACHINE SETUP? LOAD SYSTEM = NO)	LSS:	CODE: XXXXX	Operator uses Up and Down Arrow keys on Analyzer to input Service Mode Code; On ENTER, UGM to confirm code of 18171. If correct advance to next menu. If incorrect or on ESC, go to SERVICE MODE menu.
	LSS:	SERVICE ON	The UGM shall treat MACHINE SETUP --> LOAD SYSTEM as if it is set to WARN ONLY until: - Power is Cycled - Analyzer is disconnected - ESC is pressed On ESC, go to SERVICE MODE menu.
DRV CUT? (NOT VISIBLE IF MACHINE SETUP --> TILT = X DEGREES)	DRV CUT:	CODE: XXXXX	Operator uses Up and Down Arrow keys on Analyzer to input Service Mode Code; On ENTER, UGM to confirm code of 23732. If correct advance to next menu. If incorrect or on ESC, go to SERVICE MODE menu.
	DRV CUT:	SERVICE ON	UGM shall treat MACHINE SETUP --> TILT as if it is set to X DEGREES (where X is the currently selected tilt degree value) until: - Power is Cycled - Analyzer is disconnected - ESC is pressed On ESC, go to SERVICE MODE menu.

LSS Service Mode Event Log

The Service Mode events listed below shall be stored in the Service Mode event log (DIAGNOSTICS --> DATALOG --> SERVICE LOG) if their corresponding conditions are met.

- SERVICE LSS – Logged when the LSS Service mode transitions from OFF to ON
- SERVICE DRV CUT – Logged when the LSS Service mode transitions from OFF to ON

Troubleshooting

The following tables are furnished to provide possible resolutions for common difficulties. Difficulties are classified as General, Calibration, Measurement Performance, and Host System Functionality.

Table 6-13. LSS Troubleshooting Chart

Difficulty	Possible Resolution
<p>Empty Platform Weight (DIAGNOSTICS, PLATFORM LOAD) is not within ± 15lbs (± 7kg) of zero.</p> <p>or</p> <p>Platform Load readings (DIAGNOSTICS, PLTLOAD) are unstable by more than ± 2lbs (± 1kg) (without the influence of vibration or wind).</p> <p>or</p> <p>There are large variations in Platform Load (DIAGNOSTICS, PLTLOAD) based on the location of the load. Tolerance to variations is 20lbs for an evaluation using the technician's weight, and +5% of Rated Load when using calibrated weights.</p>	<p>The LSS System is unable to properly measure the platform weight.</p> <ol style="list-style-type: none"> The Load Cell is not properly plugged into the LSS Harness. It is possible poor electrical contact is made. Wiring leading to the Load Cell is damaged. Carefully inspect sensor wiring where it passes through cable clamps for signs of damage. Inspect wiring where damage to the channel is apparent. The Load Cell was not assembled properly during installation. Examine the sensor's reading using the JLG Analyzer. Proceed to the DIAGNOSTICS, CELL, LOAD displays and determine if the readings are reasonable. It is often helpful to apply slight downward pressure above the sensor and observe that its output increases (increasing force measurement; decreasing means the sensor is mounted upside-down). The Load Cell is contaminated by debris or moisture. Examine the sensor's reading using the JLG Analyzer. Proceed to the DIAGNOSTICS, CELL, LOAD displays and determine if the readings are reasonable and stable (not changing by more than ± 2lbs (± 1kg) (without the influence of vibration or wind). Lack of measurement stability is a key indication of contamination. Unplug the connector and inspect for dirt or moisture. Look carefully into the female connector on the sensor's cordset for evidence of contamination. Debris should be brushed away with a soft bristle brush (do not introduce any cleaners as they will leave conductive residue). Moisture should be allowed to evaporate or accelerated with a heat-gun (use low heat and be carefully to not melt connector materials). Moisture intrusion into the molded portion of the connector (capillary action into the wire bundle) or the Shear Beam Load Cell itself will require replacement of the sensor. The Load Cell has been mechanically damaged. If the Load Cell is physically deformed or has damage to the cover it should be replaced immediately. It is also possible to have invisible mechanical damage resulting from an extreme overload (> 6000lbs [> 2722kg]).
<p>The Visual and Audible Overload Warnings fail to sound when platform is loaded beyond Rated Load, or when simulated by unplugging the Load Cell. Controls remain functional at Platform and Ground Control positions.</p>	<p>The Control System is failing to regard the overload signal from the LSS System, or the signal is shorted.</p> <ol style="list-style-type: none"> The Load Sensing System must be enabled within the Control System. Plug the JLG Analyzer into the Control System, enter the Access Level 1 password (33271), and examine the MACHINE SETUP, LOAD sub-menu. The selection "2=CUTOUT PLT" should be displayed (platform controls prevented during overload, ground controls remain operational). In country- or customer-specific circumstance, the selection "3=CUTOUT ALL" is used (platform and ground controls prevented during overload).
<p>The Ground Audible Warning fails to sound, but the Platform Audible Warning sounds properly.</p>	<p>The Ground Alarm is missing or improperly installed. Verify that the device is mounted. Verify wiring from the Main Terminal Box and Ground Module.</p>
<p>Controls remain functional at the Ground Control position during an overload, or when simulated by unplugging the Load Cell. The Controls at the Platform Control position are prevented when using the engine, but not when using the Auxiliary Power Unit.</p>	<p>The JLG Control System is configured to prevent platform controls only in the event of overload. Alternately, the Host Control System can be configured to prevent ground and platform controls for country- or customer specific circumstances. Using the JLG Analyzer, enter the Access Level 1 password (33271). Proceed to the MACHINE SETUP, LOAD sub-menu. Set this parameter to "2=CUTOUT PLT" to prevent platform controls in the event of overload. Set this parameter to "3=CUTOUT ALL" to prevent platform and ground controls in the event of overload.</p>

6.16 MACHINE FAULT CODES

Table 6-14. Diagnostic Trouble Codes

DTC	Help Message	Fault Condition/Trigger (For configurable items, fault applies only if configured. All listed conditions to be met unless stated otherwise)	Conditions Required for Movement and/or to Clear Fault
001	EVERYTHING OK	Machine is in Platform Mode; The UGM determines no problems exist	
002	GROUND MODE OK	Machine is in Ground Mode; The UGM determines no problems exist	
0010	RUNNING AT CUTBACK – OUT OF TRANSPORT POSITION	Machine is in the Out of Transport position	Machine is not in the Out of Transport position
0011	FSW OPEN	Machine is in Platform Mode; Any of the following Platform inputs become active after power up, but before Machine Enabled: Drive joystick is not in the neutral position Steer; Lift and/or Swing joystick is not in the neutral position; Telescope; Platform Level; Platform Rotate; Jib Lift (if MACHINE SETUP → JIB = YES)	Controls initialized
0012	RUNNING AT CREEP - CREEP SWITCH OPEN	Machine is in Platform Mode; Platform Creep switch input = HIGH; DTC 0013 is not active	Platform Creep switch input = Low
0013	RUNNING AT CREEP - TILTED AND ABOVE ELEVATION	Machine is in Platform Mode; The Boom is Above Elevation; Machine chassis is considered Tilted	Not all of the trigger conditions are met
0015	LOAD SENSOR READING UNDER WEIGHT	MACHINE SETUP → LOAD SYSTEM ≠ NO; Load System is the 1-Cell LSS; UGM determines that the Platform Load < -50 lbs. for 2 seconds; Do not report if DTC (0030, 825 or 8211) is active or if Platform Load == Unhealthy	UGM determines that the Platform Load >= -50 lbs. for 5 seconds
0031	FUEL LEVEL LOW – ENGINE SHUTDOWN	MACHINE SETUP → FUEL LEVEL ≠ NONE; Engine Shutdown has occurred due to Fuel Level = EMPTY condition.	Power Cycled
0035	APU ACTIVE	Auxiliary Power/Emergency Descent Mode is active	Auxiliary Power/Emergency Descent Mode is not active

SECTION 6 - JLG CONTROL SYSTEM

Table 6-14. Diagnostic Trouble Codes

DTC	Help Message	Fault Condition/Trigger (For configurable items, fault applies only if configured. All listed conditions to be met unless stated otherwise)	Conditions Required for Movement and/or to Clear Fault
0036	FUNCTION PREVENTED - FUNCTION SELECTED BEFORE GROUND ENABLE	Machine is in Ground Mode; (Jumper Configuration Status = 0) and Jumper Configuration Status < 2); Any of the following Ground inputs become active after power up, but before Machine Enabled: Lift; Swing; Telescope; Platform Level; Platform Rotate; Jib Lift (if MACHINE SETUP → JIB = YES)	Controls initialized
0039	SKYGUARD ACTIVE – FUNCTIONS CUTOUT	MACHINE SETUP → SKYGUARD = YES; Machine is in Platform Mode; SkyGuard Enabled	Not all of the trigger conditions are met
212	KEYSWITCH FAULTY	UGM Ground Mode input J7-3 input = High; UGM Platform Mode input J7-2 input = High	(J7-3 input = LOW) or (J7-2 input = LOW)
213	FSW FAULTY	The ground footswitch input and platform footswitch input have been both HIGH or both LOW for greater than or equal to 1 second	Power Cycled
221	FUNCTION PROBLEM - HORN PERMANENTLY SELECTED	Machine is in Platform Mode; The Horn switch input = High at Startup	The Horn switch input = Low
224	FUNCTION PROBLEM - STEER LEFT PERMANENTLY SELECTED	Machine is in Platform Mode; The Steer Left switch input = High at Startup	The Steer Left switch input = Low; Steer Left and Right and full Drive speed permitted after controls are initialized
225	FUNCTION PROBLEM - STEER RIGHT PERMANENTLY SELECTED	Machine is in Platform Mode; The Steer Right switch input = High at Startup	The Steer Right switch input = Low; Steer Left and Right and full Drive speed permitted after controls are initialized
227	STEER SWITCHES FAULTY	The Steer Left switch input = High; The Steer Right switch input = High; (detectable in Platform or Ground mode)	The Steer Left switch input = Low; The Steer Right switch input = Low; Steer and full Drive speed permitted after controls are initialized
2211	FSW INTERLOCK TRIPPED	Machine is in Platform Mode; The Footswitch is active for more than seven seconds with no Drive, Steer, or Boom commands	The footswitch is released
2212	DRIVE LOCKED - JOYSTICK MOVED BEFORE FOOTSWITCH	Machine is in Platform Mode; The UGM detects one of the following conditions: Drive joystick is not in the neutral position at Startup; Drive joystick is not in the neutral position when Footswitch becomes active or while DTC 2213, 2221 or 2223 is active	If triggered by the Drive joystick not being in the neutral position at Startup, then (Drive joystick is returned to its neutral position) and (Drive and Steer permitted after controls initialized) If triggered by the Drive joystick not being in the neutral position when Footswitch becomes active or while DTC 2213, 2221 or 2223, then controls initialized

Table 6-14. Diagnostic Trouble Codes

DTC	Help Message	Fault Condition/Trigger (For configurable items, fault applies only if configured. All listed conditions to be met unless stated otherwise)	Conditions Required for Movement and/or to Clear Fault
2213	STEER LOCKED - SELECTED BEFORE FOOTSWITCH	Machine is in Platform Mode; A Steer input is active when Footswitch becomes active or while DTC 2212, 2221 or 2223 is active	Controls initialized
2216	D/S JOY. OUT OF RANGE HIGH	The PM detects that the Drive or Steer joystick signal voltage > 8.1V and reports the fault to the UGM.	The PM no longer reports the fault
2217	D/S JOY. CENTER TAP BAD	The PM detects that the Drive or Steer center tap voltage is not between 3.31 volts and 3.75 volts and reports the fault to the UGM	The PM detects that the drive/steer center tap voltage is between 3.31 and 3.75 volts and no longer reports the fault to the UGM
2219	L/S JOY. OUT OF RANGE HIGH	The PM detects that the Lift or Swing joystick signal voltage > 8.1V and reports the fault to the UGM.	The PM detects that the Lift and Swing joystick signal voltage is < 8.1V and no longer reports the fault to the UGM
2220	L/S JOY. CENTER TAP BAD	The PM detects that the Lift or Swing center tap voltage is not between 3.31 volts and 3.75 volts and reports the fault to the UGM	The PM detects that the lift/swing center tap voltage is between 3.31 and 3.75 volts and no longer reports the fault to the UGM
2221	LIFT/SWING LOCKED - JOYSTICK MOVED BEFORE FOOTSWITCH	Machine is in Platform Mode; The UGM detects one of the following conditions: Lift and/or Swing joystick is not in the neutral position at Startup; Lift and/or Swing joystick is not in the neutral position when Footswitch becomes active or while DTC 2212, 2213 or 2223 is active	If triggered by the Lift and/or Swing joystick not being in the neutral position at Startup, then (Lift and/or Swing joystick is returned to its neutral position) and (Lift and Swing permitted after controls initialized) If triggered by the Lift and/or Swing joystick is not in the neutral position when Footswitch becomes active or while DTC 2212, 2213 or 2223 is active, then controls initialized
2222	WAITING FOR FSW TO BE OPEN	Machine is in Platform Mode; Footswitch is active at Start Up	Controls initialized
2223	FUNCTION SWITCHES LOCKED - SELECTED BEFORE ENABLE	Machine is in Platform Mode; Any of the following Platform inputs are active when Footswitch becomes active or while DTC 2212, 2213 or 2221 is active: Tower Lift; Telescope; Platform Level; Platform Rotate; Jib Lift (if MACHINE SETUP → JIB = YES)	Controls initialized
2224	FOOTSWITCH SELECTED BEFORE START	Machine is in Platform Mode; The engine is stopped; Startup time has expired; The Footswitch is active before the Platform Engine Start switch input = High	The Platform Engine Start switch input = Low;
2247	FUNCTION PROBLEM - PLATFORM ROTATE LEFT PERMANENTLY SELECTED	Machine is in Platform Mode; The Platform Rotate Left switch input = High at Startup	The Platform Rotate Left switch input = Low; Platform Rotate Left and Right permitted after controls are initialized

SECTION 6 - JLG CONTROL SYSTEM

Table 6-14. Diagnostic Trouble Codes

DTC	Help Message	Fault Condition/Trigger (For configurable items, fault applies only if configured. All listed conditions to be met unless stated otherwise)	Conditions Required for Movement and/or to Clear Fault
2248	FUNCTION PROBLEM - PLATFORM ROTATE RIGHT PERMANENTLY SELECTED	Machine is in Platform Mode; The Platform Rotate Right switch input = High at Startup	The Platform Rotate Right switch input = Low; Platform Rotate Left and Right permitted after controls are initialized
2249	FUNCTION PROBLEM - JIB LIFT UP PERMANENTLY SELECTED	Machine is in Platform Mode; MACHINE SETUP → JIB = YES; The Jib Lift Up switch input = High at Startup	The Jib Lift Up switch input = Low; Jib Lift Up and Down permitted after controls are initialized
2250	FUNCTION PROBLEM - JIB LIFT DOWN PERMANENTLY SELECTED	Machine is in Platform Mode; MACHINE SETUP → JIB = YES; The Jib Lift Down switch input = High at Startup	The Jib Lift Down switch input = Low; Jib Lift Up and Down permitted after controls are initialized
2251	FUNCTION PROBLEM - TELESCOPE IN PERMANENTLY SELECTED	Machine is in Platform Mode; The Telescope In switch input = High at Startup	The Telescope In switch input = Low; Telescope permitted after controls are initialized
2252	FUNCTION PROBLEM - TELESCOPE OUT PERMANENTLY SELECTED	Machine is in Platform Mode; The Telescope Out switch input = High at Startup	The Telescope Out switch input = Low; Telescope permitted after controls are initialized
2262	FUNCTION PROBLEM - PLATFORM LEVEL UP PERMANENTLY SELECTED	Machine is in Platform Mode; The Platform Level Up switch input = High at Startup	The Platform Level Up switch input = Low; Platform Level Up and Down permitted after controls are initialized
2263	FUNCTION PROBLEM - PLATFORM LEVEL DOWN PERMANENTLY SELECTED	Machine is in Platform Mode; The Platform Level Down switch input = High at Startup	The Platform Level Down switch input = Low; Platform Level Up and Down permitted after controls are initialized
2264	FUNCTION PROBLEM - DOS OVERRIDE PERMANENTLY SELECTED	Machine is in Platform Mode; The DOS Override switch input = High at Startup	The DOS Override switch input = Low
2286	FUNCTION PROBLEM - SOFT TOUCH / SKYGUARD OVERRIDE PERMANENTLY SELECTED	[(MACHINE SETUP → SKYGUARD = YES) or (MACHINE SETUP → SOFT TOUCH = YES)]; Machine is in Platform Mode; The Soft Touch / SkyGuard Override switch input = High at Startup	The Soft Touch / SkyGuard Override switch input = Low
2287	PLATFORM ANGLE SENSOR - NOT CALIBRATED	The Platform Angle Sensor has not been calibrated	Platform angle sensor calibrated
2289	PLATFORM ANGLE SENSOR - NOT RESPONDING	The UGM detects the following conditions: The UGM detects < 1 deg change of Platform Angle; Platform Level Up or Platform Level Down output value ≥ Creep output value; Platform Level Up or Platform Level Down has been active longer than 5 seconds; Platform Angle < (Platform Angle Max -1.5 deg); Platform Angle > (Platform Angle Min ± 1.5 deg);	Power Cycled
2290	PLATFORM ANGLE SENSOR DISAGREEMENT	The UGM detects that Platform Angle Sensor #1 and Platform Angle Sensor #2 readings disagree ≥ 2.5 deg for longer than 5 seconds; Do not report if DTC 2287 is active	Power Cycled

Table 6-14. Diagnostic Trouble Codes

DTC	Help Message	Fault Condition/Trigger (For configurable items, fault applies only if configured. All listed conditions to be met unless stated otherwise)	Conditions Required for Movement and/or to Clear Fault
2295	PLATFORM ANGLE SENSOR - OUT OF RANGE HIGH	The UGM detects that Platform Angle Sensor #1 < 5% or Platform Angle Sensor #2 signal voltage > 95%.	Power Cycled
2296	PLATFORM ANGLE SENSOR - OUT OF RANGE LOW	The UGM detects that Platform Angle Sensor #1 > 95% or Platform Angle Sensor #2 signal voltage < 5%.	Power Cycled
2297	PLATFORM ANGLE SENSOR – FREQUENCY OUT OF RANGE	The UGM detects that Platform Angle Sensor #1 or Platform Angle Sensor #2 signal frequency is not within 100Hz +/- 5Hz	Power Cycled
234	FUNCTION SWITCHES FAULTY - CHECK DIAGNOSTICS/BOOM	The UGM detects one of the following conditions (continuous monitoring): The machine is in Ground Mode and both direction inputs of the following boom controls are engaged at the same time: Engine Start/Aux, Telescope, Platform Level, Platform Rotate, Jib Lift, Tower Lift, Lift, or Swing. The machine is in Platform Mode and both direction inputs of the following boom controls are engaged at the same time: Engine Start/Aux, Telescope, Platform Level, Platform Rotate, Jib Lift (MACHINE SETUP → JIB = YES)	None of the boom controls that trigger this fault have both of their direction inputs engaged at the same time
235	FUNCTION SWITCHES LOCKED - SELECTED BEFORE AUX POWER	The UGM detects one of the following conditions: The machine is in Ground Mode and the engine is stopped and the ground APU/Function Enable switch becomes engaged while a Ground control input is already engaged. The machine is in Platform Mode and the engine is stopped and the platform APU/Auxiliary Descent switch becomes engaged while a Platform control input is already engaged.	The applicable APU/Auxiliary Descent switch is disengaged or all applicable control inputs become disengaged or the engine state becomes ENGINE RUNNING
236	FUNCTION SWITCHES LOCKED - SELECTED BEFORE START SWITCH	The UGM detects one of the following conditions: The machine is in Ground Mode and the engine is stopped and any configured boom control is already engaged and the ground start switch changes from not engaged to engaged The machine is in Platform Mode and the engine is stopped and any drive/steer or configured boom control is already engaged and the footswitch is not engaged and the platform start switch changes from not engaged to engaged	The selected station's start switch is no longer engaged
237	START SWITCH LOCKED - SELECTED BEFORE KEYSWITCH	The start switch for the selected station is engaged during the UGM startup sequence	The selected station's start switch is no longer engaged
2310	FUNCTION PROBLEM - GROUND ENABLE PERMANENTLY SELECTED	Machine is in Ground Mode; (Jumper Configuration Status = 0) and Jumper Configuration Status < 2); The Ground Enable switch input = High at Startup	Controls initialized
2343	BOOM ANGLE SENSOR – NOT CALIBRATED	The Boom Angle Sensor has not been calibrated	Boom angle sensor calibrated
2344	BOOM ANGLE SENSOR - OUT OF RANGE HIGH	The UGM detects that Boom Angle Sensor #1 < 0.5V or Boom Angle Sensor #2 signal voltage > 4.5V.	Power Cycled
2345	BOOM ANGLE SENSOR - OUT OF RANGE LOW	The UGM detects that Boom Angle Sensor #1 > 4.5V or Boom Angle Sensor #2 signal voltage < 0.5V.	Power Cycled

SECTION 6 - JLG CONTROL SYSTEM

Table 6-14. Diagnostic Trouble Codes

DTC	Help Message	Fault Condition/Trigger (For configurable items, fault applies only if configured. All listed conditions to be met unless stated otherwise)	Conditions Required for Movement and/or to Clear Fault
2346	BOOM ANGLE SENSOR – NOT RESPONDING	The UGM detects the following conditions: The UGM detects < 1 deg change of Boom Angle; Main Lift Up or Main Lift Down output value \geq Creep output value; Main Lift Up or Main Lift Down has been active longer than 5 seconds; Boom Angle < (Boom Angle Max -1.5 deg); Boom Angle > (Boom Angle Min \pm 1.5 deg);	Power Cycled
2370	FUNCTION PROBLEM - JIB LIFT UP PERMANENTLY SELECTED	Machine is in Ground Mode; MACHINE SETUP \rightarrow JIB = YES; The Jib Lift Up switch input = High at Startup	The Jib Lift Up switch input = Low; Jib Lift Up and Down permitted after controls are initialized
2371	FUNCTION PROBLEM - JIB LIFT DOWN PERMANENTLY SELECTED	Machine is in Ground Mode; MACHINE SETUP \rightarrow JIB = YES; The Jib Lift Down switch input = High at Startup	The Jib Lift Down switch input = Low; Jib Lift Up and Down permitted after controls are initialized
2372	FUNCTION PROBLEM - SWING LEFT PERMANENTLY SELECTED	Machine is in Ground Mode; The Swing Left switch input = High at Startup	The Swing Left switch input = Low; Swing Left and Right permitted after controls are initialized
2373	FUNCTION PROBLEM - SWING RIGHT PERMANENTLY SELECTED	Machine is in Ground Mode; The Swing Right switch input = High at Startup	The Swing Left switch input = Low; Swing Left and Right permitted after controls are initialized
2396	BOOM ANGLE SENSOR DISAGREEMENT	The UGM detects that Boom Angle Sensor #1 and Boom Angle Sensor #2 readings disagree \geq 2.5 deg for longer than 5 seconds; Do not report if DTC 2343 is active	Power Cycled
23107	FUNCTION PROBLEM - LIFT UP PERMANENTLY SELECTED	Machine is in Ground Mode; The Lift Up switch input = High at Startup	The Lift Up switch input = Low; Lift Up and Down permitted after controls are initialized
23108	FUNCTION PROBLEM - LIFT DOWN PERMANENTLY SELECTED	Machine is in Ground Mode; The Lift Down switch input = High at Startup	The Lift Down switch input = Low; Lift Up and Down permitted after controls are initialized
23109	FUNCTION PROBLEM - TELESCOPE IN PERMANENTLY SELECTED	Machine is in Ground Mode; The Telescope In switch input = High at Startup	The Telescope In switch input = Low; Telescope In and Out permitted after controls are initialized
23110	FUNCTION PROBLEM - TELESCOPE OUT PERMANENTLY SELECTED	Machine is in Ground Mode; The Telescope Out switch input = High at Startup	The Telescope Out switch input = Low; Telescope In and Out permitted after controls are initialized
23111	FUNCTION PROBLEM - PLATFORM LEVEL UP PERMANENTLY SELECTED	Machine is in Ground Mode; The Platform Level Up switch input = High at Startup	The Platform Level Up switch input = Low; Platform Level Up and Down permitted after controls are initialized
23112	FUNCTION PROBLEM - PLATFORM LEVEL DOWN PERMANENTLY SELECTED	Machine is in Ground Mode; The Platform Level Down switch input = High at Startup	The Platform Level Down switch input = Low; Platform Level Up and Down permitted after controls are initialized
23113	FUNCTION PROBLEM - PLATFORM ROTATE LEFT PERMANENTLY SELECTED	Machine is in Ground Mode; The Platform Rotate Left switch input = High at Startup	The Platform Rotate Left switch input = Low; Platform Rotate Left and Right permitted after controls are initialized

Table 6-14. Diagnostic Trouble Codes

DTC	Help Message	Fault Condition/Trigger (For configurable items, fault applies only if configured. All listed conditions to be met unless stated otherwise)	Conditions Required for Movement and/or to Clear Fault
23114	FUNCTION PROBLEM - PLATFORM ROTATE RIGHT PERMANENTLY SELECTED	Machine is in Ground Mode; The Platform Rotate Right switch input = High at Startup	The Platform Rotate Right switch input = Low; Platform Rotate Left and Right permitted after controls are initialized
23154	TELESCOPE RETRACT SWITCHES - DISAGREEMENT	The UGM detects the following conditions: Telescope Retracted Switch #1 and Telescope Retracted Switch #2 readings disagree for longer than 5 seconds; Telescope In or Telescope Out output value \geq Creep output value	Power Cycled
23163	FUNCTION PROBLEM – MSSO PERMANENTLY SELECTED	The MSSO switch input = Low at Startup	Power Cycled
23170	BOOM ANGLE SENSOR - SINGLE POINT CALIBRATION PERFORMED	Single point Boom Angle calibration is successfully completed	Fault shall be retentive through Power Cycled; Can be reset if CALIBRATIONS → BOOM ANGLE is successfully completed
23173	CAPACITY LENGTH SWITCHES - DISAGREEMENT	Dual Capacity is configured; The UGM detects the following conditions: Capacity Length Switch #1 and Capacity Length Switch #2 readings disagree for longer than 5 seconds; Telescope In or Telescope Out output value \geq Creep output value	Power Cycled
23239	BOOM ANGLE SENSOR – ANGLE OUT OF RANGE HIGH	The UGM detects a Boom Angle \geq (Boom Angle Max + 1.5 deg); Do not report if Boom Angle == Unhealthy	Fault shall be retentive through Power Cycled; Can be reset by performing a Boom Angle Sensor Calibration
23240	BOOM ANGLE SENSOR - ANGLE OUT OF RANGE LOW	The UGM detects a Boom Angle < (Boom Angle Min - 1.5 deg); Do not report if Boom Angle == Unhealthy	Fault shall be retentive through Power Cycled; Can be reset by performing a Boom Angle Sensor Calibration
241	AMBIENT TEMPERATURE SENSOR – OUT OF RANGE LOW	MACHINE SETUP → TEMP CUTOUT = YES; Ambient Temperature sensor reading \leq -50C; Do not report if DTC 6657 is active	Ambient Temperature sensor reading > -50C; Full Speed permitted after controls are initialized
242	AMBIENT TEMPERATURE SENSOR – OUT OF RANGE HIGH	MACHINE SETUP → TEMP CUTOUT = YES; Ambient Temperature sensor reading \geq 85C; Do not report if DTC 6657 is active	Ambient Temperature sensor reading < 85C; Full Speed permitted after controls are initialized
259	MODEL CHANGED – HYDRAULICS SUSPENDED – CYCLE EMS	The MACHINE SETUP → MODEL NUMBER is changed using the analyzer	Power Cycled
2513	GENERATOR MOTION CUTOUT ACTIVE	MACHINE SETUP → GEN SET = BELT DRIVE; MACHINE SETUP → GEN SET CUTOUT = MOTION CUTOUT; The platform Generator Switch is engaged Footswitch State = Depressed The machine is in Platform mode	Not all of the trigger conditions are met
2514	BOOM PREVENTED – DRIVE SELECTED	MACHINE SETUP → FUNCTION CUTOUT = BOOM CUTOUT; Drive or Steer is already engaged; The boom is Above Elevation The operator is attempting to activate one of the boom functions DTC 2514 supercedes DTC 2518 if drive/steer and boom functions are both active when machine transitions from Below Elevation to Above Elevation.	Not all of the trigger conditions are met

SECTION 6 - JLG CONTROL SYSTEM

Table 6-14. Diagnostic Trouble Codes

DTC	Help Message	Fault Condition/Trigger (For configurable items, fault applies only if configured. All listed conditions to be met unless stated otherwise)	Conditions Required for Movement and/or to Clear Fault
2516	DRIVE PREVENTED – ABOVE ELEVATION	MACHINE SETUP → FUNCTION CUTOUT = DRIVE CUTOUT The boom is Above Elevation The operator is attempting to activate Drive or Steer	Not all of the trigger conditions are met
2517	DRIVE PREVENTED – TILTED & ABOVE ELEVATION	MACHINE SETUP → FUNCTION CUTOUT = DRIVE CUT E&T The boom is Above Elevation The chassis is considered Tilted The operator is attempting to activate Drive or Steer	Not all of the trigger conditions are met
2518	DRIVE PREVENTED – BOOM SELECTED	MACHINE SETUP → FUNCTION CUTOUT = BOOM CUTOUT The boom is Above Elevation Any boom function is already active The operator attempts to activate Drive or Steer	Not all of the trigger conditions are met
2519	DRIVE PREVENTED - TILTED & EXTENDED OR HIGH ANGLE	Chassis Tilt is > 1.8 degrees and either the boom is above 55 degrees main boom angle and/or the boom is telescoped out beyond the drive disable switches. (Dual Cap Prox.)	Boom lifted below 55 degrees and/or the boom retracted to inside the drive disable length switches. (Dual Cap)
2548	SYSTEM TEST MODE ACTIVE	UGM determines that System Test Mode is active	Power Cycle
2549	DRIVE & BOOM PREVENTED - SOFT TOUCH ACTIVE	MACHINE SETUP → SOFT TOUCH = YES; Machine is in Platform Mode; Soft Touch State = Enabled	Not all of the trigger conditions are met
2563	SKYGUARD SWITCH – DISAGREEMENT	MACHINE SETUP → SKYGUARD = YES; Machine is in Platform Mode; [(SkyGuard input #1 Platform Module J7-18) ≠ (SkyGuard input #2 Platform Module J1-23)] > 160ms	[(SkyGuard inputs (Platform Module J7-18 = High) and (Platform Module J1-23 = High)) and (Footswitch State = Not Depressed)]
2568	TEMPERATURE CUTOUT ACTIVE – AMBIENT TEMPERATURE TOO LOW	Low Temperature Cutout = Active	Low Temperature Cutout = Inactive; Full Speed permitted after controls are initialized
2576	PLATFORM LEVEL PREVENTED – ABOVE ELEVATION	Platform Level Override Cutout = Enabled; The Platform Level Up or Down switch input = High; Footswitch is active If 600S: Auto Platform Level = Enabled	Controls initialized
2587	RUNNING AT CREEP – PLATFORM LEVELED UNDER	Platform Leveled Under State = Set	Platform Leveled Under State = Cleared
331	BRAKE – SHORT TO BATTERY	The UGM detects a short to battery at this output	Power Cycled
332	BRAKE – OPEN CIRCUIT	The UGM detects an open circuit at this output	Power Cycled
334	LIFT UP VALVE – OPEN CIRCUIT	The UGM detects an open circuit at this output	The UGM no longer detects open circuit; Full speed Lift Up and Down permitted after controls are initialized
336	LIFT DOWN VALVE – OPEN CIRCUIT	The UGM detects an open circuit at this output	The UGM no longer detects open circuit; Full speed Lift Up and Lift Down permitted after controls are initialized

Table 6-14. Diagnostic Trouble Codes

DTC	Help Message	Fault Condition/Trigger (For configurable items, fault applies only if configured. All listed conditions to be met unless stated otherwise)	Conditions Required for Movement and/or to Clear Fault
3311	GROUND ALARM – SHORT TO BATTERY	MACHINE SETUP → ALARM / HORN = SEPARATE; The UGM detects a short to battery on J2-2	Power Cycled
3358	MAIN DUMP VALVE – SHORT TO GROUND	The UGM detects a short to ground at this output	Power Cycled
3359	MAIN DUMP VALVE – OPEN CIRCUIT	The UGM detects an open circuit at this output	Power Cycled
3360	MAIN DUMP VALVE – SHORT TO BATTERY	The UGM detects a short to battery at this output	Power Cycled
3361	BRAKE – SHORT TO GROUND	The UGM detects a short to ground at this output	Power Cycled
3362	START SOLENOID – SHORT TO GROUND	UGM detects a short to ground at this output	Power Cycled
3363	START SOLENOID – OPEN CIRCUIT	UGM detects an open circuit at this output; if MACHINE SETUP → ENGINE = FORD DUAL FUEL only evaluate until first Start is attempted for each power cycle due to possibility of ECU opening ground solenoid return path to disable Start and causing erroneous diagnostics.	Power Cycled
3364	START SOLENOID – SHORT TO BATTERY	UGM detects a short to battery at this output	Power Cycled
3365	STEER DUMP VALVE – SHORT TO GROUND	The UGM detects a short to ground at this output	Power Cycled
3366	STEER DUMP VALVE – OPEN CIRCUIT	The UGM detects an open circuit at this output	Power Cycled
3367	STEER DUMP VALVE – SHORT TO BATTERY	The UGM detects a short to battery at this output	Power Cycled
3368	TWO SPEED VALVE - SHORT TO GROUND	The UGM detects a short to ground at this output	Power Cycled
3369	TWO SPEED VALVE - OPEN CIRCUIT	The UGM detects an open circuit at this output	Power Cycled
3370	TWO SPEED VALVE - SHORT TO BATTERY	The UGM detects a short to battery at this output	Power Cycled
3371	GROUND ALARM – SHORT TO GROUND	MACHINE SETUP → ALARM / HORN = SEPARATE; The UGM detects a short to ground on J2-2	Power Cycled
3372	GROUND ALARM – OPEN CIRCUIT	MACHINE SETUP → ALARM / HORN = SEPARATE; The UGM detects an open circuit on J2-2	Power Cycled
3373	GEN SET/WELDER – SHORT TO GROUND	MACHINE SETUP → GEN SET = BELT DRIVE and the UGM detects a short to ground at this output	Power Cycled
3374	GEN SET/WELDER – OPEN CIRCUIT	MACHINE SETUP → GEN SET = BELT DRIVE and the UGM detect an open circuit at this output	Power Cycled
3375	GEN SET/WELDER – SHORT TO BATTERY	MACHINE SETUP → GEN SET = BELT DRIVE and the UGM detects a short to battery at this output	Power Cycled
3376	HEAD TAIL LIGHT – SHORT TO GROUND	MACHINE SETUP → H & T LIGHTS = YES and the UGM detects a short to ground at this output	Power Cycled

SECTION 6 - JLG CONTROL SYSTEM

Table 6-14. Diagnostic Trouble Codes

DTC	Help Message	Fault Condition/Trigger (For configurable items, fault applies only if configured. All listed conditions to be met unless stated otherwise)	Conditions Required for Movement and/or to Clear Fault
3377	HEAD TAIL LIGHT – OPEN CIRCUIT	MACHINE SETUP → H & T LIGHTS =YES and the UGM detects an open circuit at this output	Power Cycled
3378	HEAD TAIL LIGHT – SHORT TO BATTERY	MACHINE SETUP → H & T LIGHTS =YES and the UGM detects a short to battery at this output	Power Cycled
3384	PLATFORM LEVEL UP VALVE – SHORT TO BATTERY	The UGM detects a short to battery at this output	Power Cycled
3385	PLATFORM LEVEL UP OVERRIDE VALVE - SHORT TO GROUND	DTC 662 is active; The UGM detects a short to ground at this output	Power Cycled
3386	PLATFORM LEVEL UP OVERRIDE VALVE - OPEN CIRCUIT	DTC 662 is active; The UGM detects an open circuit at this output	Power Cycled
3387	PLATFORM LEVEL UP OVERRIDE VALVE - SHORT TO BATTERY	DTC 662 is active; The UGM detects a short to battery at this output	Power Cycled
3391	PLATFORM DOWN OVERRIDE – SHORT TO GROUND	DTC 662 is active; The UGM detects a short to ground at this output	Power Cycled
3392	PLATFORM DOWN OVERRIDE – OPEN CIRCUIT	DTC 662 is active; The UGM detects an open circuit at this output	Power Cycled
3393	PLATFORM DOWN OVERRIDE – SHORT TO BATTERY	DTC 662 is active; The UGM detects a short to battery at this output	Power Cycled
33118	SWING RIGHT VALVE – SHORT TO GROUND	The UGM detects a short to ground at this output	Power Cycled
33119	SWING RIGHT VALVE – OPEN CIRCUIT	The UGM detects an open circuit at this output	The UGM no longer detects open circuit; Full speed Swing Left and Right permitted after controls are initialized
33122	SWING LEFT VALVE – SHORT TO GROUND	The UGM detects a short to ground at this output	Power Cycled
33182	LIFT VALVES – SHORT TO BATTERY	The UGM detects a short to battery at either the Lift Up or Lift Down valve	Power Cycled
33186	TELESCOPE OUT VALVE – OPEN CIRCUIT	The UGM detects an open circuit at this output	The UGM no longer detects open circuit; Full speed Telescope In and Out permitted after controls are initialized
33187	TELESCOPE VALVES – SHORT TO BATTERY	The UGM detects a short to battery at either the Tele In or Tele Out valve.	Power Cycled
33188	TELESCOPE OUT VALVE – SHORT TO GROUND	The UGM detects a short to ground at this output	Power Cycled
33189	TELESCOPE IN VALVE – OPEN CIRCUIT	The UGM detects an open circuit at this output	The UGM no longer detects open circuit; Telescope Out permitted after controls are initialized; Full speed Telescope In permitted after controls are initialized
33190	TELESCOPE IN VALVE – SHORT TO GROUND	The UGM detects a short to ground at this output	Power Cycled
33208	HORN – SHORT TO BATTERY	The UGM detects a short to battery on J2-27	Power Cycled

Table 6-14. Diagnostic Trouble Codes

DTC	Help Message	Fault Condition/Trigger (For configurable items, fault applies only if configured. All listed conditions to be met unless stated otherwise)	Conditions Required for Movement and/or to Clear Fault
33276	APU PUMP RELAY - OPEN CIRCUIT	The UGM detects an open circuit at this output	Power Cycled
33277	APU PUMP RELAY - SHORT TO BATTERY	The UGM detects a short to battery at this output	Power Cycled
33278	APU PUMP RELAY - SHORT TO GROUND	The UGM detects a short to ground at this output	Power Cycled
33279	GLOWPLUG – OPEN CIRCUIT	MACHINE SETUP → ENGINE ≠ DEUTZ EMR4, FORD DUAL FUEL; MACHINE SETUP → GLOW PLUG ≠ NO; The UGM detects an open circuit at this output	Power Cycled
33280	GLOWPLUG – SHORT TO BATTERY	MACHINE SETUP → ENGINE ≠ DEUTZ EMR4, FORD DUAL FUEL; MACHINE SETUP → GLOW PLUG ≠ NO; The UGM detects a short to battery at this output	Power Cycled
33281	GLOWPLUG – SHORT TO GROUND	MACHINE SETUP → ENGINE ≠ DEUTZ EMR4, FORD DUAL FUEL; MACHINE SETUP → GLOW PLUG ≠ NO; The UGM detects a short to ground at this output	Power Cycled
33287	LIFT – CURRENT FEEDBACK READING TOO LOW	The Engine State = ENGINE RUNNING; The UGM commanded current > 250mA; The difference between the commanded current and the measured feedback current > [the larger of (125mA) or (15% of the commanded function Max)] for longer than 1 second	Power Cycled
33288	TELESCOPE – CURRENT FEEDBACK READING TOO LOW	The Engine State = ENGINE RUNNING; The UGM commanded current > 250mA; The difference between the commanded current and the measured feedback current > [the larger of (125mA) or (15% of the commanded function Max)] for longer than 1 second	Power Cycled
33295	SWING LEFT VALVE – OPEN CIRCUIT	The UGM detects an open circuit at this output	The UGM no longer detects open circuit; Full speed Swing Left and Right permitted after controls are initialized
33317	DRIVE FORWARD VALVE – OPEN CIRCUIT	The UGM detects an open circuit at this output	The UGM no longer detects open circuit; Full speed Drive Forward and Reverse permitted after controls are initialized
33318	DRIVE VALVES – SHORT TO BATTERY	The UGM detects a short to battery at either the Drive Forward or Drive Reverse valve.	Power Cycled
33319	DRIVE FORWARD VALVE – SHORT TO GROUND	The UGM detects a short to ground at this output	Power Cycled
33320	DRIVE REVERSE VALVE – OPEN CIRCUIT	The UGM detects an open circuit at this output	The UGM no longer detects open circuit; Full speed Drive Forward and Reverse permitted after controls are initialized
33322	DRIVE REVERSE VALVE – SHORT TO GROUND	The UGM detects a short to ground at this output	Power Cycled

SECTION 6 - JLG CONTROL SYSTEM

Table 6-14. Diagnostic Trouble Codes

DTC	Help Message	Fault Condition/Trigger (For configurable items, fault applies only if configured. All listed conditions to be met unless stated otherwise)	Conditions Required for Movement and/or to Clear Fault
33331	DRIVE – CURRENT FEEDBACK READING TOO LOW	The Engine State = ENGINE RUNNING; The UGM commanded current > 250mA; The difference between the commanded current and the measured feedback current > [the larger of (125mA) or (15% of the commanded function Max)] for longer than 1 second	Power Cycled
33406	LIFT UP VALVE – SHORT TO GROUND	The UGM detects a short to ground at this output	Power Cycled
33407	LIFT DOWN VALVE – SHORT TO GROUND	The UGM detects a short to ground at this output	Power Cycled
33410	DRIVE – LOSS OF CURRENT FEEDBACK	Measured feedback current < 225mA while PWM output > 40% for a period of 100ms.	Power Cycled
33412	SWING VALVES – SHORT TO BATTERY	The UGM detects a short to battery at either the Swing Right or Swing Left valve	Power Cycled
33414	SWING – CURRENT FEEDBACK READING TOO LOW	The Engine State = ENGINE RUNNING; The UGM commanded current > 250mA; The difference between the commanded current and the measured feedback current > [the larger of (125mA) or (15% of the commanded function Max)] for longer than 1 second	Power Cycled
33417	LIFT – CURRENT FEEDBACK READING LOST	Measured feedback current < 225mA while PWM output > 40% for a period of 100ms.	Power Cycled
33418	SWING – CURRENT FEEDBACK READING LOST	Measured feedback current < 225mA while PWM output > 40% for a period of 100ms.	Power Cycled
33443	TELESCOPE – CURRENT FEEDBACK READING LOST	Measured feedback current < 225mA while PWM output > 40% for a period of 100ms.	Power Cycled
33537	AUXILIARY LIFT DOWN VALVE - SHORT TO GROUND	The UGM detects a short to ground at this output	Power Cycled
33538	AUXILIARY LIFT DOWN VALVE - OPEN CIRCUIT	The UGM detects an open circuit at this output	The UGM no longer detects open circuit
33539	AUXILIARY LIFT DOWN VALVE - SHORT TO BATTERY	The UGM detects a short to battery at this output	Power Cycled
33543	OSCILLATING AXLE #1 VALVE - SHORT TO GROUND	The UGM detects a short to ground at this output	Power Cycled
33544	OSCILLATING AXLE #1 VALVE - OPEN CIRCUIT	The UGM detects an open circuit at this output	Power Cycled
33545	OSCILLATING AXLE #1 VALVE - SHORT TO BATTERY	The UGM detects a short to battery at this output	Power Cycled
33546	OSCILLATING AXLE #2 VALVE - SHORT TO GROUND	The UGM detects a short to ground at this output	Power Cycled
33547	OSCILLATING AXLE #2 VALVE - OPEN CIRCUIT	The UGM detects an open circuit at this output	Power Cycled

Table 6-14. Diagnostic Trouble Codes

DTC	Help Message	Fault Condition/Trigger (For configurable items, fault applies only if configured. All listed conditions to be met unless stated otherwise)	Conditions Required for Movement and/or to Clear Fault
33548	OSCILLATING AXLE #2 VALVE - SHORT TO BATTERY	The UGM detects a short to battery at this output	Power Cycled
33567	AUXILIARY VALVES - SHORT TO BATTERY	The UGM detects a short to battery at either the Aux Lift Down or Aux Tower Lift Down valve	Power Cycled
33568	AUXILIARY - CURRENT FEEDBACK READING LOST	Measured feedback current < 225mA while output is active for a period of 100ms.	Power Cycled
33575	ECM PULL DOWN RESISTOR - OPEN CIRCUIT	MACHINE SETUP → ENGINE = DEUTZ EMR4; Pull down resistor not detected	Power Cycled
33633	PLATFORM DUMP 1 VALVE - SHORT TO BATTERY	The UGM detects a short to battery at this output	Power Cycled
33634	PLATFORM DUMP 1 VALVE - SHORT TO GROUND	The UGM detects a short to ground at this output	Power Cycled
33635	PLATFORM DUMP 1 VALVE - OPEN CIRCUIT	The UGM detects an open circuit at this output	The UGM no longer detects open circuit
33636	PLATFORM DUMP 2 VALVE - SHORT TO BATTERY	The UGM detects a short to battery at this output	Power Cycled
33637	PLATFORM DUMP 2 VALVE - SHORT TO GROUND	The UGM detects a short to ground at this output	Power Cycled
33638	PLATFORM DUMP 2 VALVE - OPEN CIRCUIT	The UGM detects an open circuit at this output	The UGM no longer detects open circuit
33639	TELESCOPE IN DUMP VALVE - SHORT TO BATTERY	The UGM detects a short to battery at this output	Power Cycled
33640	TELESCOPE IN DUMP VALVE - SHORT TO GROUND	The UGM detects a short to ground at this output	Power Cycled
33641	TELESCOPE IN DUMP VALVE - OPEN CIRCUIT	The UGM detects an open circuit at this output	The UGM no longer detects open circuit
33736	BYPASS DUMP VALVE – SHORT TO BATTERY	The UGM detects a short to battery at this output	Power Cycled
33737	BYPASS DUMP VALVE – SHORT TO GROUND	The UGM detects a short to ground at this output	Power Cycled
33738	BYPASS DUMP VALVE – OPEN CIRCUIT	The UGM detects an open circuit at this output	The UGM no longer detects open circuit
343	PLATFORM LEVEL UP VALVE - SHORT TO GROUND	The UGM detects a short to ground at this output	Power Cycled
344	PLATFORM LEVEL UP VALVE - SHORT TO BATTERY OR OPEN CIRCUIT	The UGM detects a short to battery or an open circuit at this output	Power Cycled
347	PLATFORM LEVEL DOWN VALVE - SHORT TO GROUND	The UGM detects a short to ground at this output	Power Cycled

Table 6-14. Diagnostic Trouble Codes

DTC	Help Message	Fault Condition/Trigger (For configurable items, fault applies only if configured. All listed conditions to be met unless stated otherwise)	Conditions Required for Movement and/or to Clear Fault
348	PLATFORM LEVEL DOWN VALVE - SHORT TO BATTERY OR OPEN CIRCUIT	The UGM detects a short to battery or an open circuit at this output	Power Cycled
349	PLATFORM ROTATE LEFT VALVE – OPEN CIRCUIT	The PM detects an open circuit at this output and reports it to the UGM	The PM no longer detects open circuit; Full speed Platform Rotate Right and Left permitted after controls are initialized
3410	PLATFORM ROTATE LEFT VALVE – SHORT TO BATTERY	The PM detects a short to battery at this output and reports it to the UGM	Power Cycled
3411	PLATFORM ROTATE LEFT VALVE – SHORT TO GROUND	The PM detects a short to ground at this output and reports it to the UGM	Power Cycled
3412	PLATFORM ROTATE RIGHT VALVE – OPEN CIRCUIT	The PM detects an open circuit at this output and reports it to the UGM	The PM no longer detects open circuit; Full speed Platform Rotate Right and Left permitted after controls are initialized
3413	PLATFORM ROTATE RIGHT VALVE – SHORT TO BATTERY	The PM detects a short to battery at this output and reports it to the UGM	Power Cycled
3414	PLATFORM ROTATE RIGHT VALVE – SHORT TO GROUND	The PM detects a short to ground at this output and reports it to the UGM	Power Cycled
3415	JIB LIFT UP VALVE – OPEN CIRCUIT	MACHINE SETUP → JIB = YES The PM detects an open circuit at this output and reports it to the UGM	The PM no longer detects open circuit; Full speed Jib Lift Up and Down permitted after controls are initialized
3416	JIB LIFT UP VALVE – SHORT TO BATTERY	MACHINE SETUP → JIB = YES The PM detects a short to battery at this output and reports it to the UGM	Power Cycled
3417	JIB LIFT UP VALVE – SHORT TO GROUND	MACHINE SETUP → JIB = YES The PM detects a short to ground at this output and reports it to the UGM	Power Cycled
3418	JIB LIFT DOWN VALVE – OPEN CIRCUIT	MACHINE SETUP → JIB = YES The PM detects an open circuit at this output and reports it to the UGM	The PM no longer detects open circuit; Jib Lift Up permitted after controls are initialized Full speed Jib Lift Down permitted after controls are initialized
3419	JIB LIFT DOWN VALVE – SHORT TO BATTERY	MACHINE SETUP → JIB = YES The PM detects a short to battery at this output and reports it to the UGM	Power Cycled
3420	JIB LIFT DOWN VALVE – SHORT TO GROUND	MACHINE SETUP → JIB = YES The PM detects a short to ground at this output and reports it to the UGM; detection occurs for PWM output approximately ≤ 15% or for STG condition.	Power Cycled
431	FUEL SENSOR - SHORT TO BATTERY OR OPEN CIRCUIT	MACHINE SETUP → FUEL LEVEL = SENSOR; UGM fuel sensor analog input J2-25 detects a voltage higher than 2.50 volts (A/D > 512)	Power Cycled
432	FUEL SENSOR - SHORT TO GROUND	MACHINE SETUP → FUEL LEVEL = SENSOR; UGM fuel sensor analog input J2-25 detects a voltage less than or equal to 0.3 volts (A/D < 61)	Power Cycled

Table 6-14. Diagnostic Trouble Codes

DTC	Help Message	Fault Condition/Trigger (For configurable items, fault applies only if configured. All listed conditions to be met unless stated otherwise)	Conditions Required for Movement and/or to Clear Fault
437	ENGINE TROUBLE CODE	An engine with a CAN engine controller is configured in MACHINE SETUP The engine controller reports a J1939 fault	Power Cycled
438	HIGH ENGINE TEMP	An engine with a CAN engine controller is <u>not</u> configured in MACHINE SETUP: <ul style="list-style-type: none"> - The Engine State = ENGINE RUNNING > 10 seconds - The coolant temperature is greater than or equal to the configured engines max allowed temperature. - The maximum allowed temperature > 110°C. An engine with a CAN engine controller is configured in MACHINE SETUP: <ul style="list-style-type: none"> - ECM transmits a J1939 DM1 message for an engine coolant high temperature critical fault (SPN:FMI 110:0) on CAN2 or uses the J1939 Transport Protocol every one second to send this information if multiple engine faults exist. 	Power Cycled
4310	NO ALTERNATOR OUTPUT	The Engine State = ENGINE RUNNING > 10 seconds and UGM system voltage < 11.5 volts for 10 seconds	UGM system voltage > 11.7 volts
4311	LOW OIL PRESSURE	An engine with a CAN engine controller is <u>not</u> configured in MACHINE SETUP <ul style="list-style-type: none"> - The Engine State = ENGINE RUNNING > 10 seconds - The engine oil pressure is LOW (debounce 3s). An engine with a CAN engine controller is configured in MACHINE SETUP <ul style="list-style-type: none"> - ECM transmits a J1939 DM1 message for an engine oil low pressure critical fault (SPN:FMI 100:1) on CAN2 or uses the J1939 Transport Protocol every one second to send this information if multiple engine faults exist. 	Power Cycled
4334	ENGINE COOLANT – LOW LEVEL	MACHINE SETUP → ENGINE = DEUTZ EMR4; ECM transmits a J1939 DM1 message for an engine coolant low level fault (SPN:FMI 111:1) on CAN2 or uses the J1939 Transport Protocol every one second to send this information if multiple engine faults exist.	Power Cycled
4375	WATER IN FUEL	MACHINE SETUP → ENGINE = DEUTZ EMR4; ECM transmits a J1939 DM1 message for a water in fuel fault (SPN 97) on CAN2 or uses the J1939 Transport Protocol every one second to send this information if multiple engine faults exist.	Power Cycled
441	BATTERY VOLTAGE TOO LOW – SYSTEM SHUTDOWN	The UGM detects that its supply voltage is less than 9 volts Engine State ≠ ENGINE CRANKING Auxiliary Power/Emergency Descent Mode is not active	Voltage is greater than 9.25 volts
442	BATTERY VOLTAGE TOO HIGH – SYSTEM SHUTDOWN	The UGM detects that its supply voltage > 16.0 volts	Power Cycled
443	LSS BATTERY VOLTAGE TOO HIGH	MACHINE SETUP → LOAD SYSTEM ≠ NO; The UGM determines that the LSS reports supply voltage > 16.0V	Not all of the trigger conditions are met

SECTION 6 - JLG CONTROL SYSTEM

Table 6-14. Diagnostic Trouble Codes

DTC	Help Message	Fault Condition/Trigger (For configurable items, fault applies only if configured. All listed conditions to be met unless stated otherwise)	Conditions Required for Movement and/or to Clear Fault
444	LSS BATTERY VOLTAGE TOO LOW	MACHINE SETUP → LOAD SYSTEM ≠ NO; Engine State ≠ ENGINE CRANKING or ENGINE STARTING; Auxiliary Power/Emergency Descent Mode is not active; If Load System is the 4-Cell LSS; The UGM determines that the LSS reports supply voltage < 9.0V If Load System is the 1-Cell LSS; The UGM determines that the LSS reports supply voltage < 8.0V or the LSS Supply Voltage reports Out of Range Low Error	Not all of the trigger conditions are met
445	BATTERY VOLTAGE LOW	The UGM detects that its supply voltage < 11 volts for 5 seconds. Engine State ≠ ENGINE CRANKING Auxiliary Power/Emergency Descent Mode is not active Glow Plugs are not energized	Voltage is greater than 11.25 volts
4434	ENGINE START FAILED - TOO MANY ATTEMPTS	MACHINE SETUP → ENGINE = FORD DUAL FUEL; Cumulative Crank Time > 24 seconds	Power Cycled
4479	LSS BATTERY VOLTAGE - INITIALIZATION ERROR	MACHINE SETUP → LOAD SYSTEM ≠ NO; Load System is the 1-Cell LSS; LSS Supply Voltage reports Initialization Error	Power Cycled
4480	LSS BATTERY VOLTAGE - NOT CALIBRATED	MACHINE SETUP → LOAD SYSTEM ≠ NO; Load System is the 1-Cell LSS; LSS Supply Voltage reports Not Calibrated Error	Power Cycled
662	CANBUS FAILURE – PLATFORM MODULE	UGM does not receive any CAN messages from the PM in 250ms	CAN messages are received from the PM
663	CANBUS FAILURE – LOAD SENSING SYSTEM MODULE	MACHINE SETUP → LOAD SYSTEM ≠ NO; UGM does not receive any CAN messages from the LSS module in 250ms; If Load System is the 1-Cell LSS; Engine State ≠ (ENGINE CRANKING or ENGINE STARTING) > 2 seconds;	Not all of the trigger conditions are met
666	CANBUS FAILURE – ENGINE CONTROLLER	An engine with a CAN engine controller is configured in MACHINE SETUP No CAN messages are received from the engine controller for more than 250ms	CAN messages are received from the engine controller; UGM shall require re-activation of Footswitch (Platform Mode) or Ground Enable (Ground Mode) to enable functions and resume operation.
6613	CANBUS FAILURE – EXCESSIVE CANBUS ERRORS	More than 22 error frames per second for 4 seconds or more than 500 Bus Off conditions since last power cycle.	Power Cycled
6622	CANBUS FAILURE – TCU MODULE	MACHINE SETUP → CLEARSKY = YES No CAN2 messages are received from the TCU module for more than 30 seconds	Not all of the trigger conditions are met
6635	CANBUS FAILURE – CHASSIS TILT SENSOR	UGM does not receive any CAN messages from the Chassis Tilt Sensor in 250ms	CAN messages are received from the Chassis tilt Sensor and controls are initialized

Table 6-14. Diagnostic Trouble Codes

DTC	Help Message	Fault Condition/Trigger (For configurable items, fault applies only if configured. All listed conditions to be met unless stated otherwise)	Conditions Required for Movement and/or to Clear Fault
6651	CANBUS FAILURE - GROUND DISPLAY	UGM does not receive any CAN messages from the Ground Display in 250ms	CAN messages are received from the Ground Display
6657	CANBUS FAILURE – TEMPERATURE SENSOR	MACHINE SETUP → TEMP CUTOUT = YES; UGM does not receive any CAN messages from the Ambient Temperature sensor in 250ms	CAN messages are received from the Ambient Temperature sensor
681	REMOTE CONTRACT MANAGEMENT OVERRIDE – ALL FUNCTIONS IN CREEP	MACHINE SETUP → CLEARSKY = YES Value set by ClearSky TCU	Cleared by ClearSky TCU
813	CHASSIS TILT SENSOR NOT CALIBRATED	The UGM detects one of the follow conditions: The tilt sensor has not been calibrated; For 600S the Tilt Sensor source Address is 0xC0; For 600S the Tilt Sensor Serial number does not match	Tilt sensor calibrated
814	CHASSIS TILT SENSOR OUT OF RANGE	Fault CHASSIS TILT SENSOR NOT CALIBRATED (813) is not present and Tilt sensor measurement > 19° for 4 seconds (internal tilt sensor based machines) or > 35° (external tilt sensor based machines) Not to be reported during Tilt Sensor calibration.	Not all of the trigger conditions are met.
818	TILT SENSOR STAGNANT	The UGM detects the following conditions: The X axis or Y axis raw readings change by < ±0.05° in 5 second; Drive Forward or Drive Reverse output value is ≥ Creep output value; Do not report if DTC 6635, 813 or 814 are active	Power Cycled
8112	CHASSIS TILT SENSOR - SINGLE POINT CALIBRATION PERFORMED	Single point Chassis Tilt calibration is successfully completed	Fault shall be retentive through Power Cycled; Can be reset if CALIBRATIONS → TILT SENSOR is successfully completed
821	LSS CELL #1 ERROR	MACHINE SETUP → LOAD SYSTEM ≠ NO; Load System is the 4-Cell LSS; The UGM detects that LSS is reporting error with Cell #1	Not all of the trigger conditions are met
822	LSS CELL #2 ERROR	MACHINE SETUP → LOAD SYSTEM ≠ NO; Load System is the 4-Cell LSS; The UGM detects that LSS is reporting error with Cell #2	Not all of the trigger conditions are met
823	LSS CELL #3 ERROR	MACHINE SETUP → LOAD SYSTEM ≠ NO; Load System is the 4-Cell LSS; The UGM detects that LSS is reporting error with Cell #3	Not all of the trigger conditions are met
824	LSS CELL #4 ERROR	MACHINE SETUP → LOAD SYSTEM ≠ NO; Load System is the 4-Cell LSS; The UGM detects that LSS is reporting error with Cell #4.	Not all of the trigger conditions are met

SECTION 6 - JLG CONTROL SYSTEM

Table 6-14. Diagnostic Trouble Codes

DTC	Help Message	Fault Condition/Trigger (For configurable items, fault applies only if configured. All listed conditions to be met unless stated otherwise)	Conditions Required for Movement and/or to Clear Fault
825	LSS HAS NOT BEEN CALIBRATED	MACHINE SETUP → LOAD SYSTEM ≠ NO If Load System is the 4-Cell LSS; The load sensor has not been calibrated, or DTC 992 (LSS EEPROM ERROR) is active, or DTC 9977 (LSS CORRUPT EEPROM) is active If Load System is the 1-Cell LSS; The LSS serial number does not match	Not all of the trigger conditions are met
826	RUNNING AT CREEP – PLATFORM OVERLOADED	Refer to Table 7-1 for trigger conditions and machine response requirements	Not all of the trigger conditions are met
828	LIFT UP & TELE OUT PREVENTED – PLATFORM OVERLOADED	Refer to Table 7-1 for trigger conditions and machine response requirements	Not all of the trigger conditions are met
829	FUNCTIONS CUTOFF – PLATFORM OVERLOADED	Refer to Table 7-1 for trigger conditions and machine response requirements	Not all of the trigger conditions are met
8211	LSS READING UNDER WEIGHT	MACHINE SETUP → LOAD SYSTEM ≠ NO; If Load System is the 4-Cell LSS; The load sensor has been calibrated and Gross Platform Weight < (0.5 * Empty Platform Weight); If Load System is the 1-Cell LSS; UGM determines that the Platform Load < (-1.5 * Unloaded Platform Weight); If Load System is the 1-Cell LSS; Drive Forward / Reverse or Lift Up output value is ≥ Creep output value; Platform Load is < -50 lbs. for the first 5 seconds of command; Do not report if DTC (0030 or 825) is active or if Platform Load == Unhealthy	If Load System is the 4-Cell LSS; Not all of the trigger conditions are met If Load System is the 1-Cell LSS; Power Cycled
8218	LSS SENSOR DISAGREEMENT	MACHINE SETUP → LOAD SYSTEM ≠ NO; Load System is the 1-Cell LSS; The UGM detects that (Platform Load 1 and Platform Load 2 disagree by 50 lbs. for longer than 3 seconds) or (that Platform Gross 1 and Platform Gross 2 disagree by 200 lbs. for longer than 3 seconds); Do not report if (DTC 8222 or 8223) is active or if Platform Load == Unhealthy, Platform Gross 1 == Unhealthy or Platform Gross 2 == Unhealthy	Power Cycled or CALIBRATIONS LOAD SENSING is successfully completed
8222	LSS STRAIN GAUGE 1 - STAGNANT	MACHINE SETUP → LOAD SYSTEM ≠ NO; Engine State ≠ (ENGINE CRANKING or ENGINE STARTING) > 2 seconds; Load System is the 1-Cell LSS; Strain Gauge 1 raw reading does change value for 5 seconds; Do not report if Platform Gross 1 == Unhealthy	Power Cycled

Table 6-14. Diagnostic Trouble Codes

DTC	Help Message	Fault Condition/Trigger (For configurable items, fault applies only if configured. All listed conditions to be met unless stated otherwise)	Conditions Required for Movement and/or to Clear Fault
8223	LSS STRAIN GAUGE 2 - STAGNANT	MACHINE SETUP → LOAD SYSTEM ≠ NO; Engine State ≠ (ENGINE CRANKING or ENGINE STARTING) > 2 seconds; Load System is the 1-Cell LSS; Strain Gauge 2 raw reading does change value for 5 seconds; Do not report if DTC Platform Gross 2= = Unhealthy	Power Cycled
8224	LSS STRAIN GAUGE 1 - OUT OF RANGE LOW	MACHINE SETUP → LOAD SYSTEM ≠ NO; Load System is the 1-Cell LSS; Strain Gauge 1 reports an Out of Range Low error	Power Cycled
8225	LSS STRAIN GAUGE 2 - OUT OF RANGE LOW	MACHINE SETUP → LOAD SYSTEM ≠ NO; Load System is the 1-Cell LSS; Strain Gauge 2 reports an Out of Range Low error	Power Cycled
8226	LSS STRAIN GAUGE 1 - OUT OF RANGE HIGH	MACHINE SETUP → LOAD SYSTEM ≠ NO; Load System is the 1-Cell LSS; Strain Gauge 1 reports an Out of Range High error	Power Cycled
8227	LSS STRAIN GAUGE 2 - OUT OF RANGE HIGH	MACHINE SETUP → LOAD SYSTEM ≠ NO; Load System is the 1-Cell LSS; Strain Gauge 2 reports an Out of Range High error	Power Cycled
8228	LSS STRAIN GAUGE 1 - INITIALIZATION ERROR	MACHINE SETUP → LOAD SYSTEM ≠ NO; Engine State ≠ (ENGINE CRANKING or ENGINE STARTING) > 2 seconds; Load System is the 1-Cell LSS; Strain Gauge 1 reports an Initialization error	Power Cycled
8229	LSS STRAIN GAUGE 2 - INITIALIZATION ERROR	MACHINE SETUP → LOAD SYSTEM ≠ NO; Engine State ≠ (ENGINE CRANKING or ENGINE STARTING) > 2 seconds; Load System is the 1-Cell LSS; Strain Gauge 2 reports an Initialization error	Power Cycled
8230	LSS STRAIN GAUGE 1 - NOT CALIBRATED	MACHINE SETUP → LOAD SYSTEM ≠ NO; Load System is the 1-Cell LSS; Strain Gauge 1 reports a Not Calibrated error	Power Cycled
8231	LSS STRAIN GAUGE 2 - NOT CALIBRATED	MACHINE SETUP → LOAD SYSTEM ≠ NO; Load System is the 1-Cell LSS; Strain Gauge 2 reports a Not Calibrated error	Power Cycled
8232	LSS STRAIN GAUGE 1 - SENSOR DEFECT	MACHINE SETUP → LOAD SYSTEM ≠ NO; Load System is the 1-Cell LSS; Strain Gauge 1 reports a Sensor Defect error	Power Cycled
8233	LSS STRAIN GAUGE 2 - SENSOR DEFECT	MACHINE SETUP → LOAD SYSTEM ≠ NO; Load System is the 1-Cell LSS; Strain Gauge 2 reports a Sensor Defect error	Power Cycled
8234	LSS STRAIN GAUGE 1 - NOT INSTALLED	MACHINE SETUP → LOAD SYSTEM ≠ NO; Load System is the 1-Cell LSS; Strain Gauge 1 reports a Not Installed error	Power Cycled

SECTION 6 - JLG CONTROL SYSTEM

Table 6-14. Diagnostic Trouble Codes

DTC	Help Message	Fault Condition/Trigger (For configurable items, fault applies only if configured. All listed conditions to be met unless stated otherwise)	Conditions Required for Movement and/or to Clear Fault
8235	LSS STRAIN GAUGE 2 - NOT INSTALLED	MACHINE SETUP → LOAD SYSTEM ≠ NO; Load System is the 1-Cell LSS; Strain Gauge 2 reports a Not Installed error	Power Cycled
8236	LSS NOT DETECTING CHANGE	MACHINE SETUP → LOAD SYSTEM ≠ NO; Machine is in Platform Mode; Load System is the 1-Cell LSS; Drive Forward / Reverse or Lift Up output value is ≥ Creep output value; Platform Load does not change (peak to peak) by more than 1 lbs. within the first 5 seconds of the command; Do not report if Platform Load == Unhealthy	Power Cycled
8237	LSS STRAIN GAUGE 1 - A/D DEFECT	MACHINE SETUP → LOAD SYSTEM ≠ NO; Load System is the 1-Cell LSS; Strain Gauge 1 reports a A/D Defect error	Power Cycled
8238	LSS STRAIN GAUGE 2 - A/D DEFECT	MACHINE SETUP → LOAD SYSTEM ≠ NO; Load System is the 1-Cell LSS; Strain Gauge 2 reports a A/D Defect error	Power Cycled
8318	PLATFORM LEVELING SYSTEM TIMEOUT	Electronic Platform Level = Enabled; Auxiliary Power/Emergency Decent Mode is not active {(Electronic Platform Level Up output value is active) and [(Platform Angle < (Platform Angle Max - 1.5 deg))] or [(Electronic Platform Level Down output value is active) and [(Platform Angle < (Platform Angle Max - 1.5 deg))]} [(Platform Angle ≥ Platform Angle Setpoint +5 deg) or (Platform Angle ≤ Platform Angle Setpoint -5 deg)] for longer than 2000ms	Power Cycled
8639	FRONT LEFT STEER VALVE – OPEN CIRCUIT	The UGM detects an open circuit at this output	The UGM no longer detects open circuit
8640	FRONT LEFT STEER VALVE – SHORT TO BATTERY	The UGM detects a short to battery at this output	Power Cycled
8641	FRONT LEFT STEER VALVE – SHORT TO GROUND	The UGM detects a short to ground at this output	Power Cycled
8642	FRONT RIGHT STEER VALVE – OPEN CIRCUIT	The UGM detects an open circuit at this output	The UGM no longer detects open circuit
8643	FRONT RIGHT STEER VALVE – SHORT TO BATTERY	The UGM detects a short to battery at this output	Power Cycled
8644	FRONT RIGHT STEER VALVE – SHORT TO GROUND	The UGM detects a short to ground at this output	Power Cycled
8645	REAR LEFT STEER VALVE - OPEN CIRCUIT	The UGM detects an open circuit at this output	The UGM no longer detects open circuit
8646	REAR LEFT STEER VALVE - SHORT TO BATTERY	The UGM detects a short to battery at this output	Power Cycled

Table 6-14. Diagnostic Trouble Codes

DTC	Help Message	Fault Condition/Trigger (For configurable items, fault applies only if configured. All listed conditions to be met unless stated otherwise)	Conditions Required for Movement and/or to Clear Fault
8647	REAR LEFT STEER VALVE - SHORT TO GROUND	The UGM detects a short to ground at this output	Power Cycled
8648	REAR RIGHT STEER VALVE - OPEN CIRCUIT	The UGM detects an open circuit at this output	The UGM no longer detects open circuit
8649	REAR RIGHT STEER VALVE - SHORT TO BATTERY	The UGM detects a short to battery at this output	Power Cycled
8650	REAR RIGHT STEER VALVE - SHORT TO GROUND	The UGM detects a short to ground at this output	Power Cycled
873	MACHINE SAFETY SYSTEM OVERRIDE OCCURRED	MSSO = Active	Fault shall be retentive through Power Cycled; Can be reset only with an Analyzer via the CALIBRATIONS → MSSO → MSSO RESET menu
876	WIRE ROPE SERVICE REQUIRED	MACHINE SETUP → CABLE SWITCH = YES; Wire Rope Service = Enabled	Power Cycled
991	LSS WATCHDOG RESET	MACHINE SETUP → LOAD SYSTEM ≠ NO; Load System is the 4-Cell LSS; UGM detects LSS report of an anomaly exists that has caused a WatchDog Timer reset.	Power Cycled
992	LSS EEPROM ERROR	MACHINE SETUP → LOAD SYSTEM ≠ NO; Load System is the 4-Cell LSS; UGM detects LSS report of an anomaly that exists in the LSS EEPROM	Power Cycled
993	LSS INTERNAL ERROR – PIN EXCITATION	MACHINE SETUP → LOAD SYSTEM ≠ NO; Load System is the 4-Cell LSS; UGM detects LSS report of improper excitation voltage	Power Cycled
994	LSS INTERNAL ERROR – DRDY MISSING FROM A/D	MACHINE SETUP → LOAD SYSTEM ≠ NO; Load System is the 4-Cell LSS; UGM detects LSS report of an anomaly that exists in the LSS A/D converter operations.	Power Cycled
998	EEPROM FAILURE - CHECK ALL SETTINGS	The UGM has detected an anomaly in EEPROM	Power Cycled
9910	FUNCTIONS LOCKED OUT - PLATFORM MODULE SOFTWARE VERSION IMPROPER	The UGM software version type is 'P' The UGM has received valid version information from the PM The PM software version type is 'P' The UGM software major version number does not match the major version number of the platform software	Not all of the trigger conditions are met
9911	FUNCTION LOCKED OUT - LSS MODULE SOFTWARE VERSION IMPROPER	MACHINE SETUP → LOAD SYSTEM ≠ NO; Load System is the 4-Cell LSS; The UGM determines that the LSS software version is not compatible with existing code	Power Cycled
9915	CHASSIS TILT SENSOR NOT GAIN CALIBRATED	The tilt sensor gain calibration values recorded to flash memory during Phoenix International's manufacturing test are not present	Valid values are present

SECTION 6 - JLG CONTROL SYSTEM

Table 6-14. Diagnostic Trouble Codes

DTC	Help Message	Fault Condition/Trigger (For configurable items, fault applies only if configured. All listed conditions to be met unless stated otherwise)	Conditions Required for Movement and/or to Clear Fault
9920	PLATFORM SENSOR REF VOLTAGE OUT OF RANGE	The PM detects that its reference voltage is out of range and reports the fault to the UGM	Power Cycled
9921	GROUND MODULE FAILURE:HIGH SIDE DRIVER CUTOFF FAULTY	The engine is not running The engine is not cranking The UGM footswitch input J7-15 is LOW The machine is in Platform Mode The Main Dump output J2-13 is detected as HIGH via the analog feedback 300ms after it is attempted to be activated during the one time startup test of the UGM hardware shutoff circuitry	Power Cycled
9922	PLATFORM MODULE FAILURE: HWFS CODE 1	The PM detects that its V(low) FET has failed and reports this fault to the UGM	Power Cycled
9924	FUNCTIONS LOCKED OUT - MACHINE NOT CONFIGURED	The machine is powered up and no model has been selected yet in the MACHINE SETUP menu	Power Cycled
9927	GROUND MODULE CONSTANT DATA UPDATE REQUIRED	The UGM detects one of the following conditions when software type is 'P' or 'B': The Version Verification Word #1 or the Version Verification Word #2 values located in the constant data sector of flash memory (found on constant data spreadsheet tab pstConstantDataVersion) do not match the values located in the code area of flash memory The Version Major value located in the constant data sector of flash memory (found on constant data spreadsheet tab pstConstantDataVersion) does not match the value located in the code area of flash memory	A different application code or constant data version is programmed so that the values match Power Cycled
9944	CURRENT FEEDBACK GAINS OUT OF RANGE	One or more of the current feedback gains that are calculated and written to flash memory during the PIC manufacturing test process are detected as being out of range	Power Cycled
9945	CURRENT FEEDBACK CALIBRATION CHECKSUM INCORRECT	The current feedback gains checksum that is calculated and written to flash memory during the PIC manufacturing test process is detected as being incorrect	Power Cycled
9949	MACHINE CONFIGURATION OUT OF RANGE – CHECK ALL SETTINGS	UGM has detected an anomaly in EEPROM with regard to the Machine Setup configuration.	Power Cycled and EEPROM data in associated area is changed
9977	LSS CORRUPT EEPROM	MACHINE SETUP → LOAD SYSTEM ≠ NO; Load System is the 4-Cell LSS; and one of the following conditions: UGM determines LSS-stored values for Unloaded weight in Indirect 0x100≠ 0x108 or UGM determines LSS-stored values for Accessory weight in Indirect 0x102≠ 0x10A UGM determines LSS-stored checksum1 (0x10F) ≠ checksum 2 (0x107)	Power Cycled
9979	FUNCTIONS LOCKED OUT - GROUND MODULE SOFTWARE VERSION IMPROPER	Ground software has been installed on a UGM with a ST10F274 processor (Hardware Rev < 6), which does not have guaranteed flash storage in the sector where Constant Data is written.	Power Cycled

Table 6-14. Diagnostic Trouble Codes

DTC	Help Message	Fault Condition/Trigger (For configurable items, fault applies only if configured. All listed conditions to be met unless stated otherwise)	Conditions Required for Movement and/or to Clear Fault
9986	GROUND MODULE VLOW FET FAILURE	VLow FET determined to be failed because all Digital Inputs are high; UGM unable to read high-sensing inputs.	Power Cycled
99285	LSS - FACTORY CALIBRATION ERROR	MACHINE SETUP → LOAD SYSTEM ≠ NO; Load System is the 1-Cell LSS; LSS reports an Error Status (other than 0,1,2,8,30,31)	Power Cycled

Go to Discount-Equipment.com to order your parts

PARTS FINDER

**Search Website
by Part Number**



**Search Manual
Library For Parts
Manual & Lookup Part
Numbers – Purchase
or Request Quote**

A screenshot of the "Search Manuals" form. The form has a title "Search Manuals" and a subtitle "Please provide information to help us locate the manual and/or parts you need." It includes fields for "Brand", "Model", "Serial", "Part Number", and "Quantity". There is a "Search" button at the bottom.

**Can't Find Part or
Manual? Request Help
by Manufacturer,
Model & Description**

A screenshot of the "Parts Order Form". The form has a title "Parts Order Form" and a subtitle "Please fill in as much information as possible." It includes fields for "Manufacturer", "Model", "Description", "Part Number", "Quantity", and "Comments". There is a "Submit" button at the bottom.

Discount-Equipment.com is your online resource for quality parts & equipment.

Florida: **561-964-4949** Outside Florida TOLL FREE: **877-690-3101**

Need parts?

Click on this link: <http://www.discount-equipment.com/category/5443-parts/> and choose one of the options to help get the right parts and equipment you are looking for. Please have the machine model and serial number available in order to help us get you the correct parts. If you don't find the part on the website or on one of the online manuals, please fill out the request form and one of our experienced staff members will get back to you with a quote for the right part that your machine needs.

We sell worldwide for the brands: Genie, Terex, JLG, MultiQuip, Mikasa, Essick, Whiteman, Mayco, Toro Stone, Diamond Products, Generac Magnum, Airman, Haulotte, Barreto, Power Blanket, Nifty Lift, Atlas Copco, Chicago Pneumatic, Allmand, Miller Curber, Skyjack, Lull, Skytrak, Tsurumi, Husquvarna Target, , Stow, Wacker, Sakai, Mi-T- M, Sullair, Basic, Dynapac, MBW, Weber, Bartell, Bennar Newman, Haulotte, Ditch Runner, Menegotti, Morrison, Contec, Buddy, Crown, Edco, Wyco, Bomag, Laymor, Barreto, EZ Trench, Bil-Jax, F.S. Curtis, Gehl Pavers, Heli, Honda, ICS/PowerGrit, IHI, Partner, Imer, Clipper, MMD, Koshin, Rice, CH&E, General Equipment, ,AMida, Coleman, NAC, Gradall, Square Shooter, Kent, Stanley, Tamco, Toku, Hatz, Kohler, Robin, Wisconsin, Northrock, Oztec, Toker TK, Rol-Air, Small Line, Wanco, Yanmar

SECTION 7. BASIC ELECTRICAL INFORMATION & ELECTRICAL SCHEMATICS

7.1 GENERAL

This section contains basic electrical information and schematics for locating and correcting most electrical problems. If a problem develops which is not presented in this section or corrected by listed corrective actions, obtain technically qualified guidance before proceeding with any additional maintenance.

NOTE: Some procedures/connectors shown in this section may not apply to all models.

7.2 MULTIMETER BASICS

A wide variety of multimeters or Volt Ohm Meters (VOM) can be used for troubleshooting your equipment. This section shows diagrams of a common, digital VOM configured for several different circuit measurements. Instructions for your VOM may vary. Please consult the meter operator's manual for more information.

Grounding

"Grounding the meter" means to take the black lead (which is connected to the COM (common) or negative port) and touch it to a good path to the negative side of the Voltage source.

Backprobing

To "backprobe" means to take the measurement by accessing a connector's contact on the same side as the wires, the back of the connector. Readings can be done while maintaining circuit continuity this way. If the connector is the sealed type, great care must be taken to avoid damaging the seal around the wire. It is best to use probes or probe tips specifically designed for this technique, especially on sealed connectors. Whenever possible insert probes into the side of the connector such that the test also checks both terminals of the connection. It is possible to inspect a connection within a closed connector by backprobing both sides of a connector terminal and measuring resistance. Do this after giving each wire a gentle pull to ensure the wires are still attached to the contact and contacts are seated in the connector.

Min/Max

Use of the "Min/Max" recording feature of some meters can help when taking measurements of intermittent conditions while alone. For example, you can read voltage applied to a solenoid when it is only operational while a switch, far from the solenoid and meter, is held down.

Polarity

Getting a negative Voltage or current reading when expecting a positive reading frequently means the leads are reversed. Check what reading is expected, location of the signal and leads are correctly connected to the device under test. Also check the lead on the "COM" port goes to the ground or negative side of the signal and lead on the other port goes to the positive side of the signal.

Scale

M = Mega = 1,000,000 * (Displayed Number)

k = kilo = 1,000 * (Displayed Number)

m = milli = (Displayed Number) / 1,000

μ = micro = (Displayed Number) / 1,000,000

Example: 1.2 kW = 1200 W

Example: 50 mA = 0.05 A

Voltage Measurement

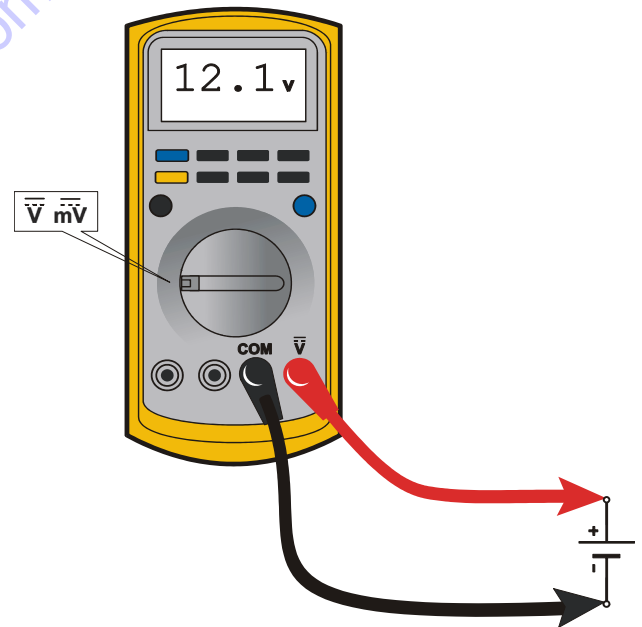

Figure 7-1. Voltage Measurement (DC)

- If meter is not auto ranging, set it to the correct range (See multimeter's operation manual)
- Use firm contact with meter leads

Resistance Measurement

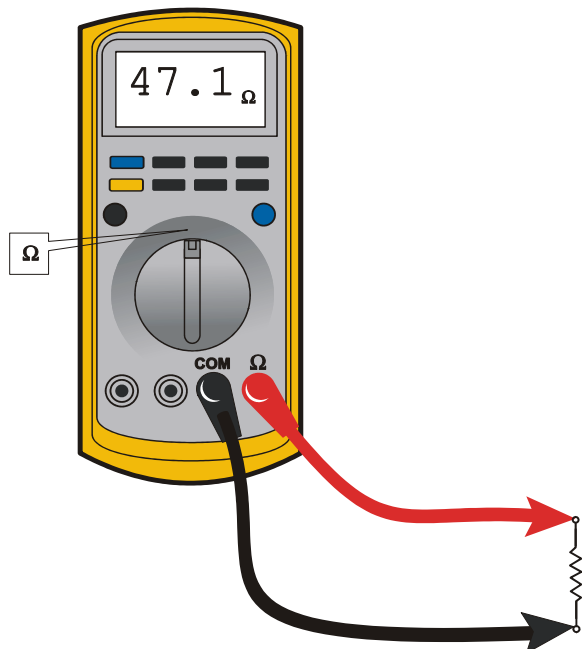

Figure 7-2. Resistance Measurement

- First test meter and leads by touching leads together. Resistance should read a short circuit (very low resistance)
- Circuit power must be turned OFF before testing resistance
- Disconnect component from circuit before testing
- If meter is not auto ranging, set it to the correct range (See multimeter's operation manual)
- Use firm contact with meter leads

Continuity Measurement

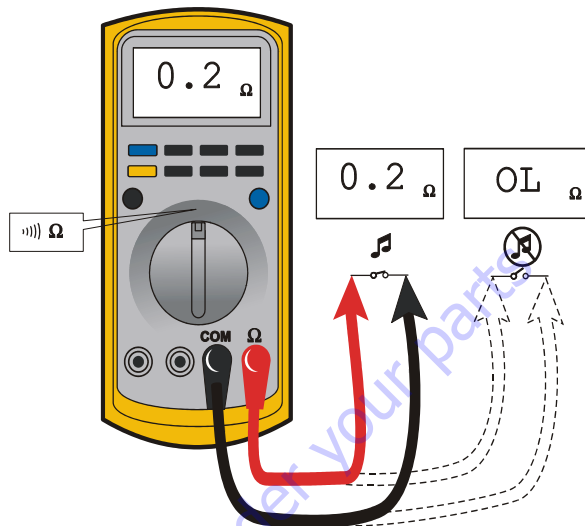

Figure 7-3. Continuity Measurement

- Some meters require a separate button press to enable audible continuity testing
- Circuit power must be turned OFF before testing continuity
- Disconnect component from circuit before testing
- Use firm contact with meter leads
- First test meter and leads by touching leads together. Meter should produce an audible alarm, indicating continuity

Current Measurement

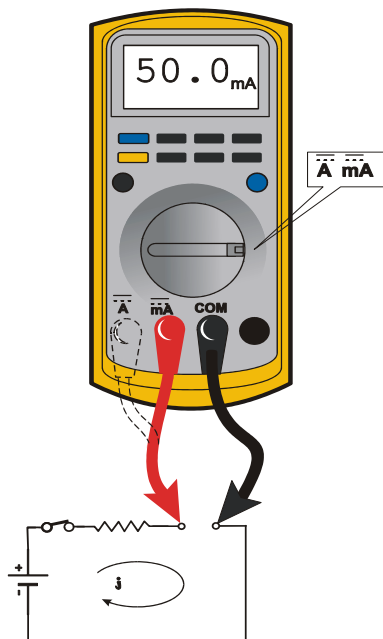

Figure 7-4. Current Measurement (DC)

- Set up meter for expected current range
- Be sure to connect meter leads to correct jacks for selected current range
- If meter is not auto ranging, set it to correct range (See multi meter's operation manual)
- Use firm contact with meter leads

7.3 APPLYING SILICONE DIELECTRIC COMPOUND TO ELECTRICAL CONNECTIONS

NOTE: This section is not applicable for battery terminals.

NOTICE

JLG P/N 0100048 DIELECTRIC GREASE (NOVAGARD G661) IS THE ONLY MATERIAL APPROVED FOR USE AS A DIELECTRIC GREASE.

NOTE: Do NOT apply dielectric grease to the following connections:

- Main Boom Rotary sensor connections (on Celesco Sensor).
- LSS Modules connections,
- Deutz EMR 2 ECM connection.

Silicone Dielectric Compound must be used on all electrical connections except for those mentioned above for the following reasons:

- To prevent oxidation at mechanical joint between male and female pins.
- To prevent electrical malfunction caused by low level conductivity between pins when wet.

Use the following procedure to apply Silicone Dielectric Compound to the electrical connectors. This procedure applies to all plug connections not enclosed in a box. Silicone grease should not be applied to connectors with external seals.

1. To prevent oxidation, silicone grease must be packed completely around male and female pins on the inside of the connector prior to assembly. This is most easily achieved by using a syringe.

NOTE: Over a period of time, oxidation increases electrical resistance at the connection, eventually causing circuit failure.

2. To prevent shorting, silicone grease must be packed around each wire where they enter the outside of the connector housing. Also, silicone grease must be applied at the joint where the male and female connectors come together. Any other joints (around strain reliefs, etc.) where water could enter the connector should also be sealed.

NOTE: This condition is especially common when machines are pressure washed since the washing solution is much more conductive than water.

- Anderson connectors for battery boxes and battery chargers should have silicone grease applied to contacts only.

NOTE: *Curing-type sealants can also be used to prevent shorting and would be less messy, but make future pin removal difficult.*

When applied to electrical connections, dielectric grease helps prevent corrosion of electrical contacts and improper conductivity between contacts from moisture intrusion. Open and sealed connectors benefit from application of dielectric grease.

Dielectric grease shall be applied to all electrical connectors at the time of connection (except those noted under Exclusions).

Installation of Dielectric Grease

Before following these instructions, refer to excluded connector types (See Exclusions below).

- Use dielectric grease in a tube for larger connection points or apply with a syringe for small connectors.
- Apply dielectric grease to plug/male connector housing which typically contains sockets contact/female terminals.
- Leave a thin layer of dielectric grease on the face of the connector.
- Assemble connector system immediately to prevent moisture or dust contamination.
- Pierce one of the unused wire seals before assembly if the connector system tends to trap air (i.e. AMP Seal) and then install a seal plug.

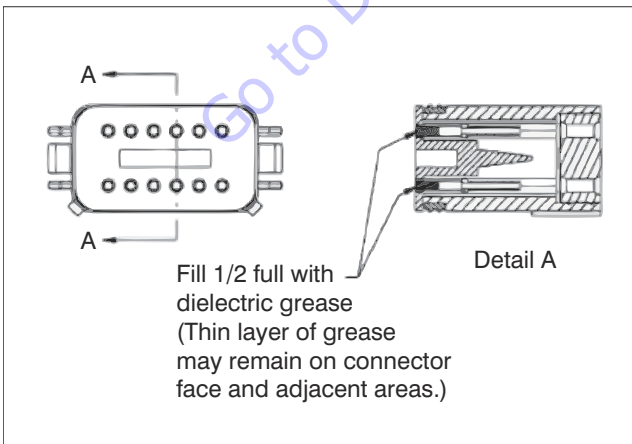

Figure 7-5. Applying Dielectric Grease

Deutsch HD, DT, DTM, DRC Series

The Deutsch connector system is commonly used for harsh environments. Follow installation instructions.

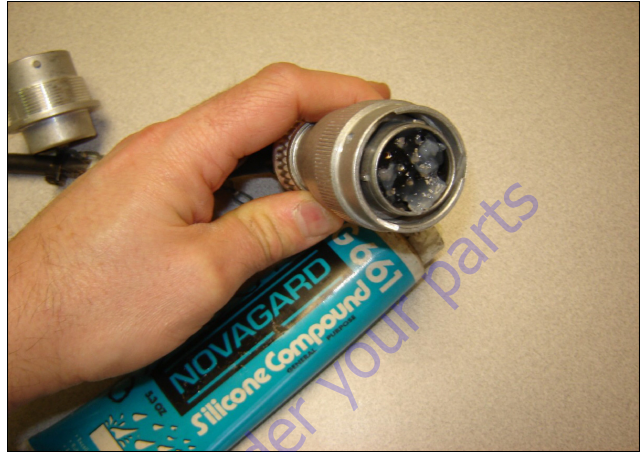

Figure 7-6. Deutsch Connector

AMP Seal

The AMP Seal connector system is used on Control ADE Platform and Ground Modules.

Apply dielectric grease to the plug/male connector housing which typically contains socket contacts/female terminals. If trapped air prevents the connector from latching, pierce one of the unused wire seals. After assembly, install a seal plug (JLG #4460905) in that location to prevent moisture ingress.

Note that seal plugs may be installed by the wire harness manufacturer if an unused wire seal becomes compromised (wire inserted in the wrong cavity during assembly and the corrected).



Figure 7-7. Application to plug/male connector housing

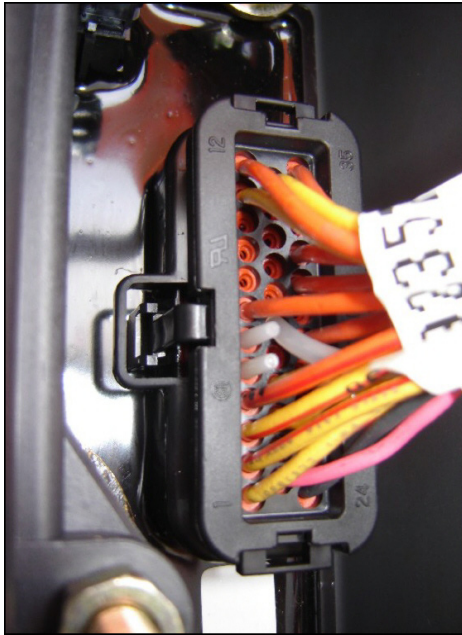

Figure 7-8. Use of Seal Plugs

AMP Mate-N-Lok

Follow manufacturer installation instructions.

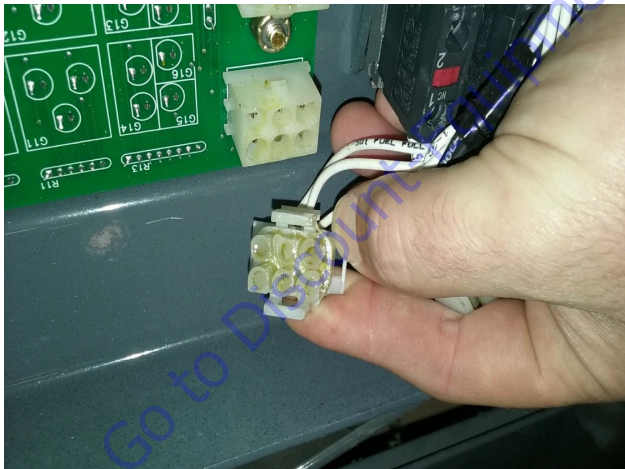

Figure 7-9. AMP Mate-N-Lok Connector

DIN Connectors

This connector is typically used on hydraulic valves. Follow manufacturer installation instructions.



Figure 7-10. DIN Connector

Exclusions

A limited number of connectors do not benefit from dielectric grease, or may be permanently damaged by application. Dielectric grease may not be required in properly sealed enclosures.

BRAD HARRISON/PHOENIX CONTACT M12

The connector uses gold contact material to resist corrosion and an o-ring seal for moisture integrity. If dielectric grease is mistakenly applied to this connector system, the low-force contacts cannot displace the grease to achieve electrical contact. Once contaminated, there is no practical way to remove the dielectric grease (replacement of female contacts required).



ENGINE CONTROL UNIT CONNECTORS

Many times, these types of connectors use back-seals for moisture integrity. However, the low-force contacts cannot displace dielectric grease and create electrical contact. It is possible to use solvents (i.e. contact cleaner or mineral spirits) for the removal of improperly applied dielectric grease. The EMR4 engine control module from Deutz employs this connector system (for example).



7.4 AMP CONNECTOR

Assembly

Check to be sure the wedge lock is in the open, or as-shipped, position (See Figure 7-11.). Proceed as follows:

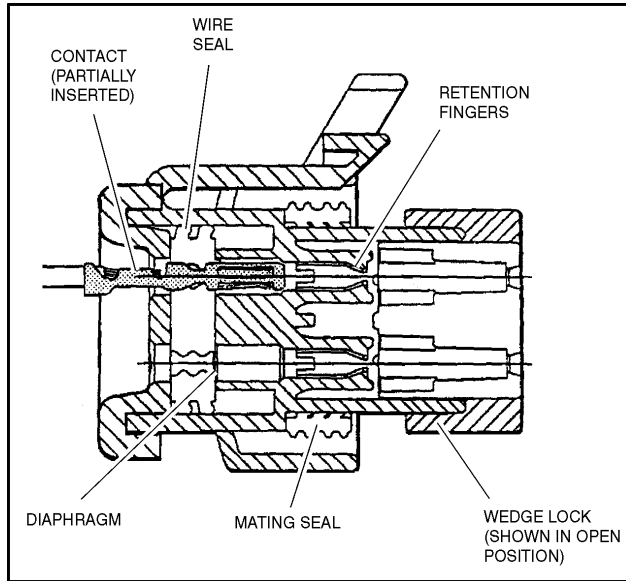

Figure 7-11. Connector Assembly Figure 1

1. To insert a contact, push it straight into the appropriate circuit cavity as far as it will go (See Figure 7-13.).

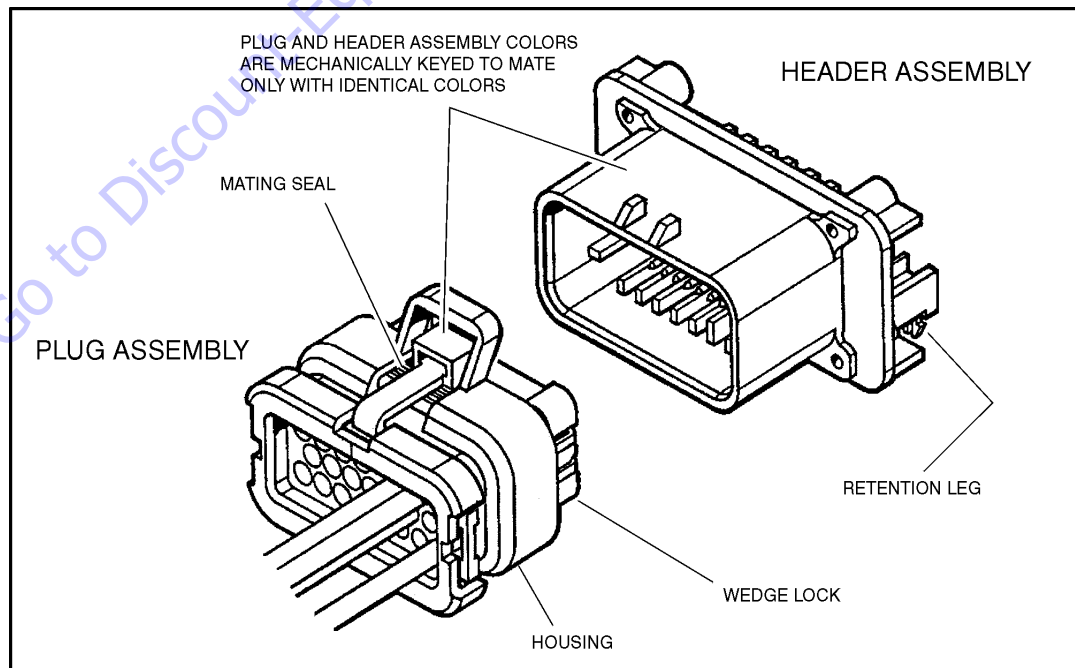

Figure 7-12. AMP Connector

2. Pull back on the contact wire with a force of 1 or 2 lbs. to be sure the retention fingers are holding the contact (See Figure 7-13.).

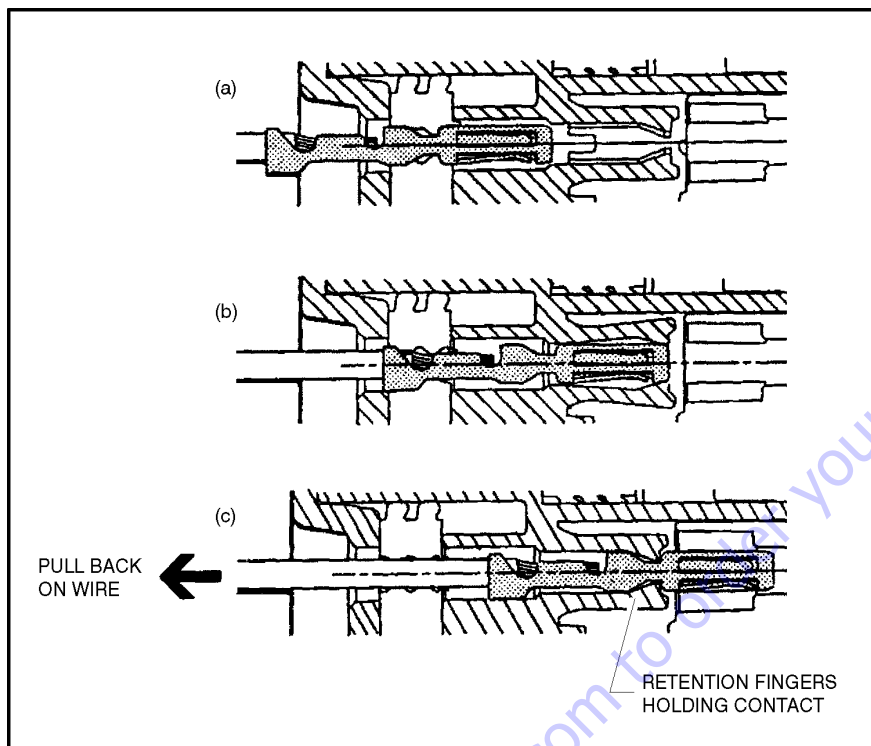

Figure 7-13. Connector Assembly Figure 2

3. After all required contacts have been inserted, the wedge lock must be closed to its locked position. Release the locking latches by squeezing them inward (See Figure 7-14.).
4. Slide the wedge lock into the housing until it is flush with the housing (See Figure 7-15.).

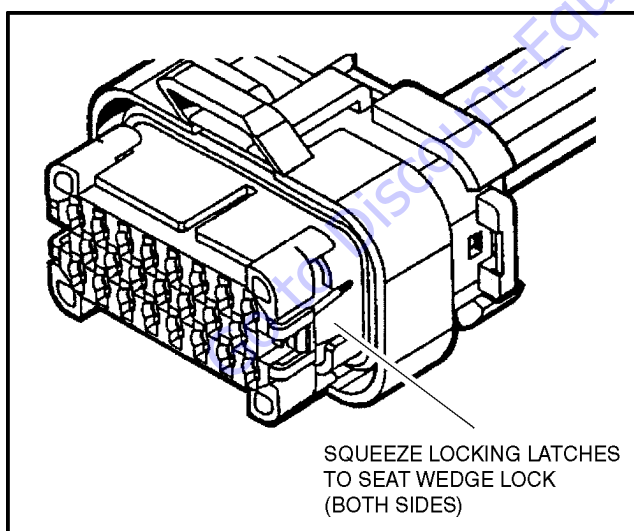

Figure 7-14. Connector Assembly Figure 3

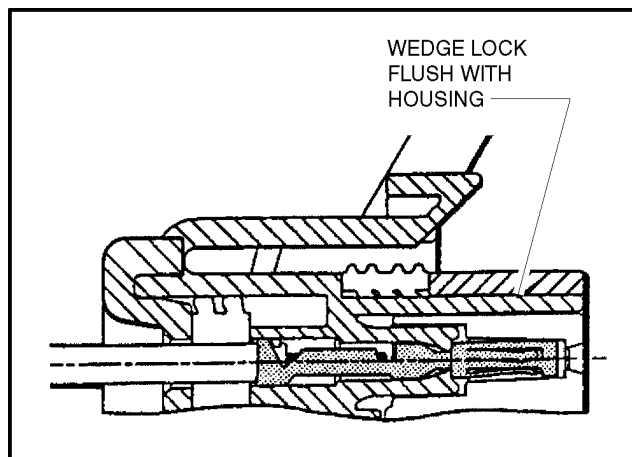

Figure 7-15. Connector Assembly Figure 4

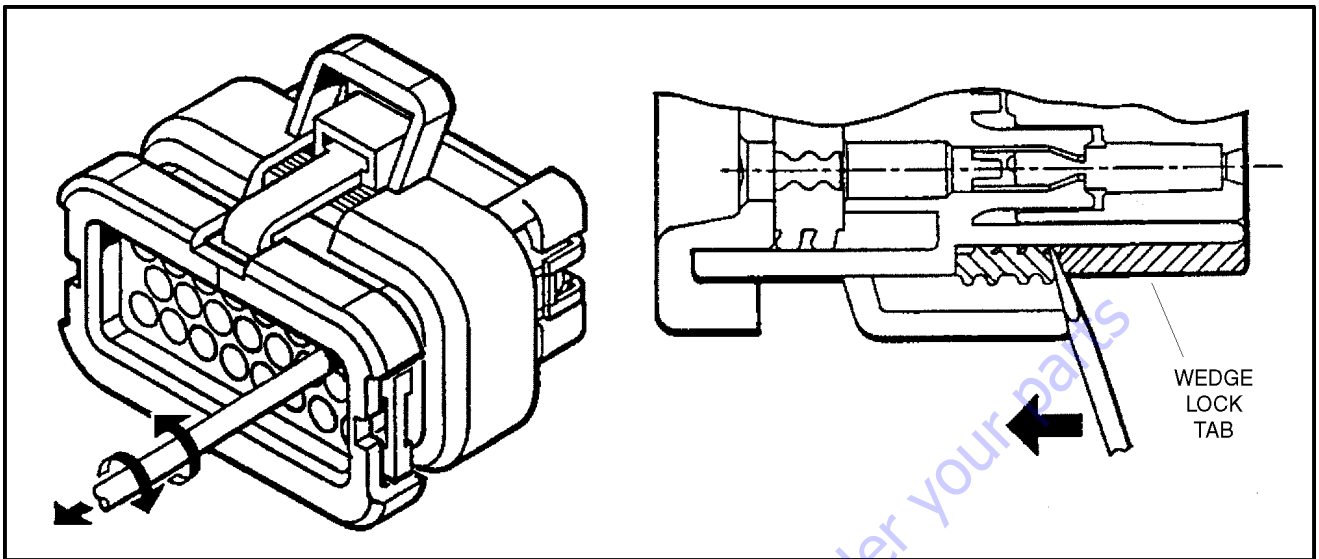

Figure 7-16. Connector Disassembly

Disassembly

5. Insert a 4.8 mm (3/16") wide screwdriver blade between the mating seal and one of the red wedge lock tabs.
6. Pry open the wedge lock to the open position.
7. While rotating the wire back and forth over a half turn (1/4 turn in each direction), gently pull the wire until the contact is removed.

NOTE: The wedge lock should never be removed from the housing for insertion or removal of the contacts.

Wedge Lock

The wedge lock has slotted openings in the forward, or mating end. These slots accommodate circuit testing in the field, by using a flat probe such as a pocket knife. DO NOT use a sharp point such as an ice pick.

Service - Voltage Reading

NOTICE

DO NOT PIERCE WIRE INSULATION TO TAKE VOLTAGE READINGS.

It has been common practice in electrical troubleshooting to probe wires by piercing the insulation with a sharp point. This practice should be discouraged when dealing with the AMPSEAL plug assembly, or any other sealed connector system. The resulting pinholes in the insulation will allow moisture to invade the system by traveling along the wire strands. This nullifies the effectiveness of the connector seals and could result in system failure.

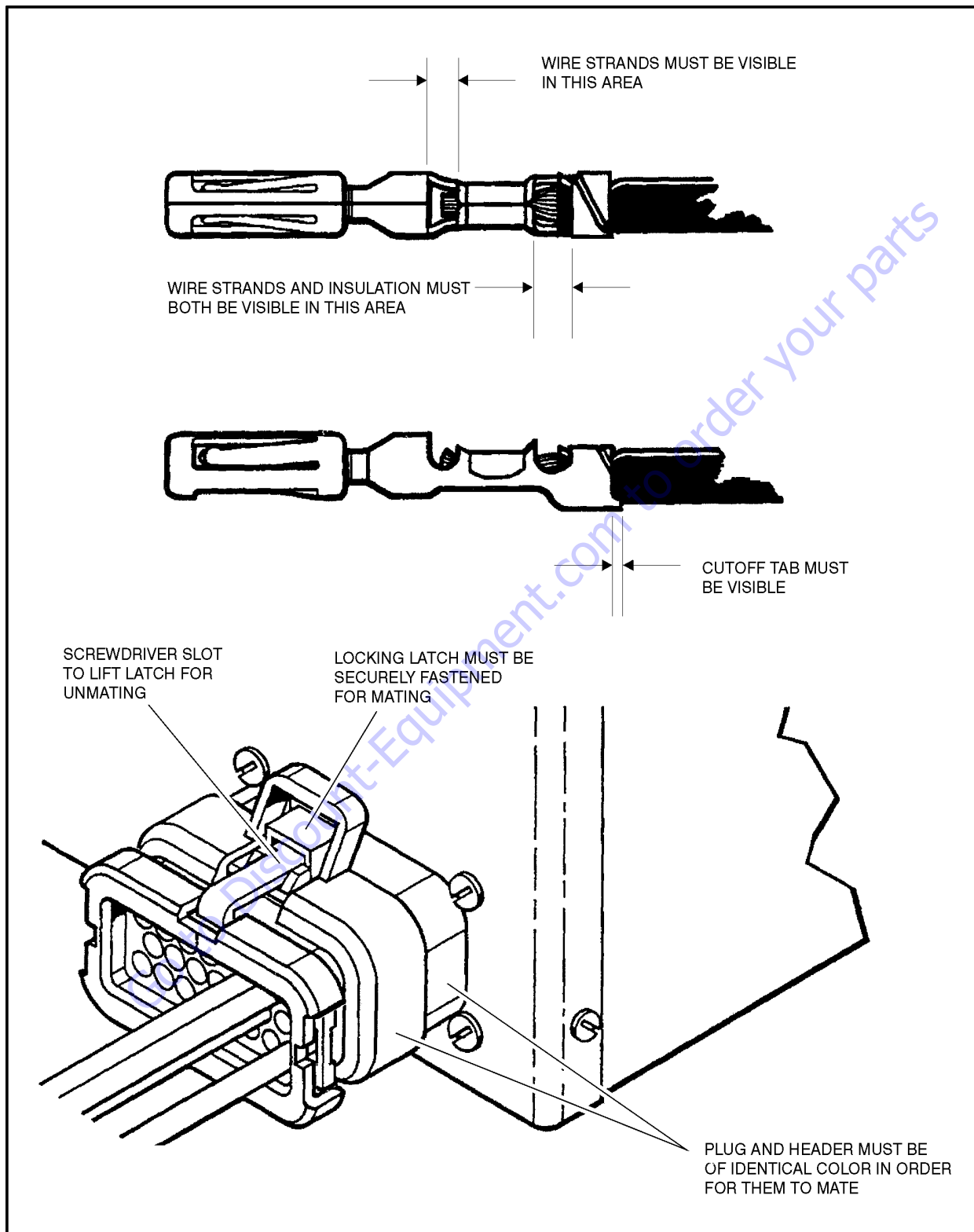

Figure 7-17. Connector Installation

7.5 DEUTSCH CONNECTORS

DT/DTP Series Assembly

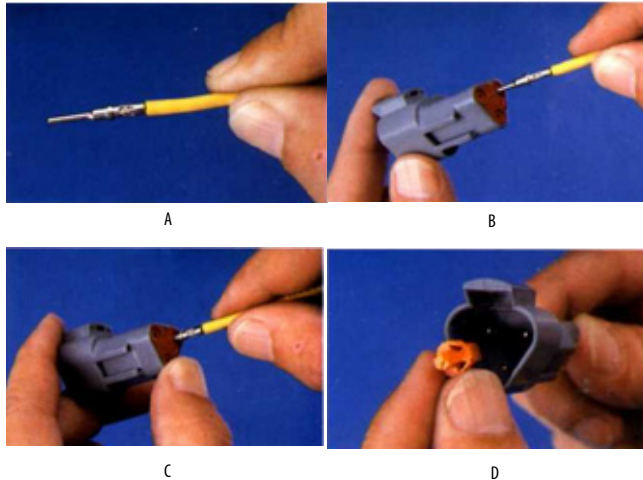

Figure 7-18. DT/DTP Contact Installation

1. Grasp crimped contact about 25mm behind the contact barrel.
2. Hold connector with rear grommet facing you.
3. Push contact straight into connector grommet until a click is felt. A slight tug will confirm that it is properly locked in place.
4. Once all contacts are in place, insert wedgelock with arrow pointing toward exterior locking mechanism. The wedgelock will snap into place. Rectangular wedges are not oriented. They may go in either way.

NOTE: The receptacle is shown - use the same procedure for plug.

DT/DTP Series Disassembly

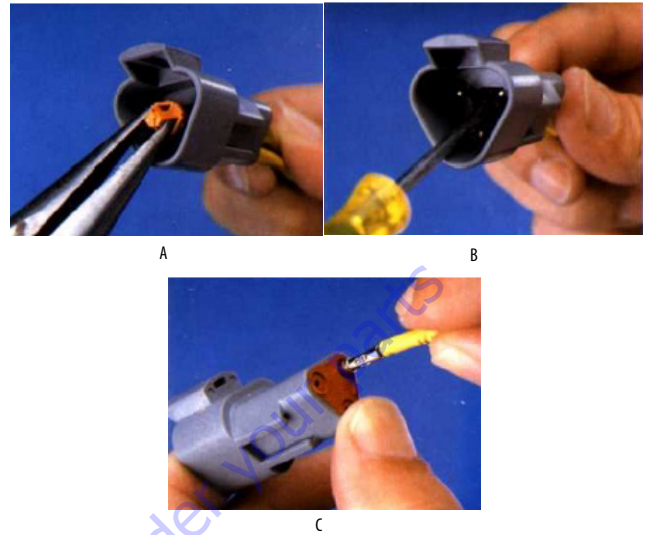

Figure 7-19. DT/DTP Contact Removal

5. Remove wedgelock using needlenose pliers or a hook shaped wire to pull wedge straight out.
6. To remove the contacts, gently pull wire backwards, while at the same time releasing the locking finger by moving it away from the contact with a screwdriver.
7. Hold the rear seal in place, as removing the contact may displace the seal.

HD30/HDP20 Series Assembly

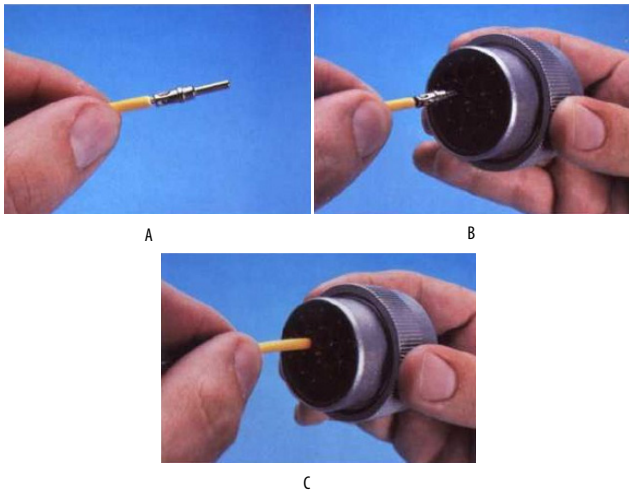

Figure 7-20. HD/HDP Contact Installation

8. Grasp contact about 25mm behind the contact crimp barrel.
9. Hold connector with rear grommet facing you.
10. Push contact straight into connector grommet until a positive stop is felt. A slight tug will confirm that it is properly locked in place.

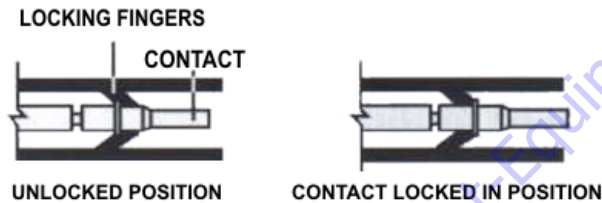

Figure 7-21. HD/HDP Locking Contacts Into Position

NOTE: For unused wire cavities, insert sealing plugs for full environmental sealing.

HD30/HDP20 Series Disassembly

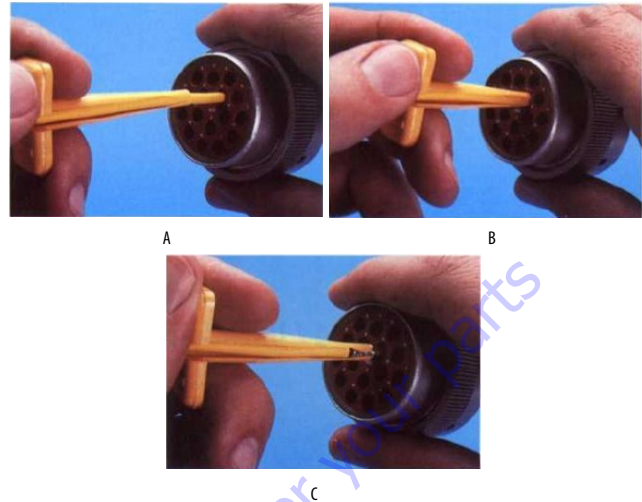

Figure 7-22. HD/HDP Contact Removal

11. With rear insert toward you, snap appropriate size extractor tool over the wire of contact to be removed.
12. Slide tool along into the insert cavity until it engages contact and resistance is felt.
13. Pull contact-wire assembly out of connector.

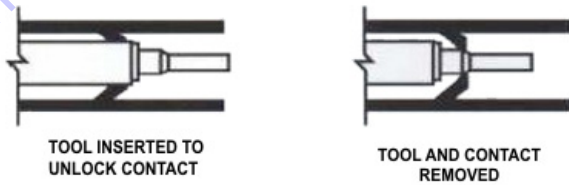

Figure 7-23. HD/HDP Unlocking Contacts

NOTE: Do Not twist or insert tool at an angle.

7.6 TELEMATICS GATEWAY

Personnel using machines equipped with an optional telematics gateway will be able to view the following data through their telematics device:

JLG LABEL	DESCRIPTION	UNIT
EngineSpeed	Actual engine speed.	RPM
DEF Tank Level (If Equipped)	Indicates the level of DEF (diesel exhaust fluid) within the DEF tank if the machine is equipped with DEF tank. <ul style="list-style-type: none"> 0% = Empty 100% = Full 	Percentage (%)
JLG Machine Faults: Active / Not-Active	<ul style="list-style-type: none"> 00 - No Machine Faults 01 - Active Machine Fault 10 - Error 11 - Not available 	Bit
Total Idle Fuel Used	Total amount of fuel used during vehicle operation during idle conditions.	Liters
Total Idle Hours	Total time of engine operation during idle conditions.	Seconds
Total Engine Hours	Total time of engine operation.	Seconds
Total Fuel Used	Total amount of fuel used during vehicle operation.	Liters
Fuel Rate	Amount of fuel consumed by engine per unit of time.	Liters/Hour
Fuel Level	Ratio of fuel volume to the total volume of the fuel storage container. When a low fuel limit switch is present, the fuel level will indicate "full" until the switch opens, which will then indicate 10% fuel remaining. When Fuel Level 2 (SPN38) is not used, Fuel Level 1 represents the total fuel in all fuel storage containers. When Fuel Level 2 is used, Fuel Level 1 represents the fuel level in the primary or left side fuel storage container.	Percentage (%)
DM1 Engine Faults	Shows actual engine fault codes.	N/A

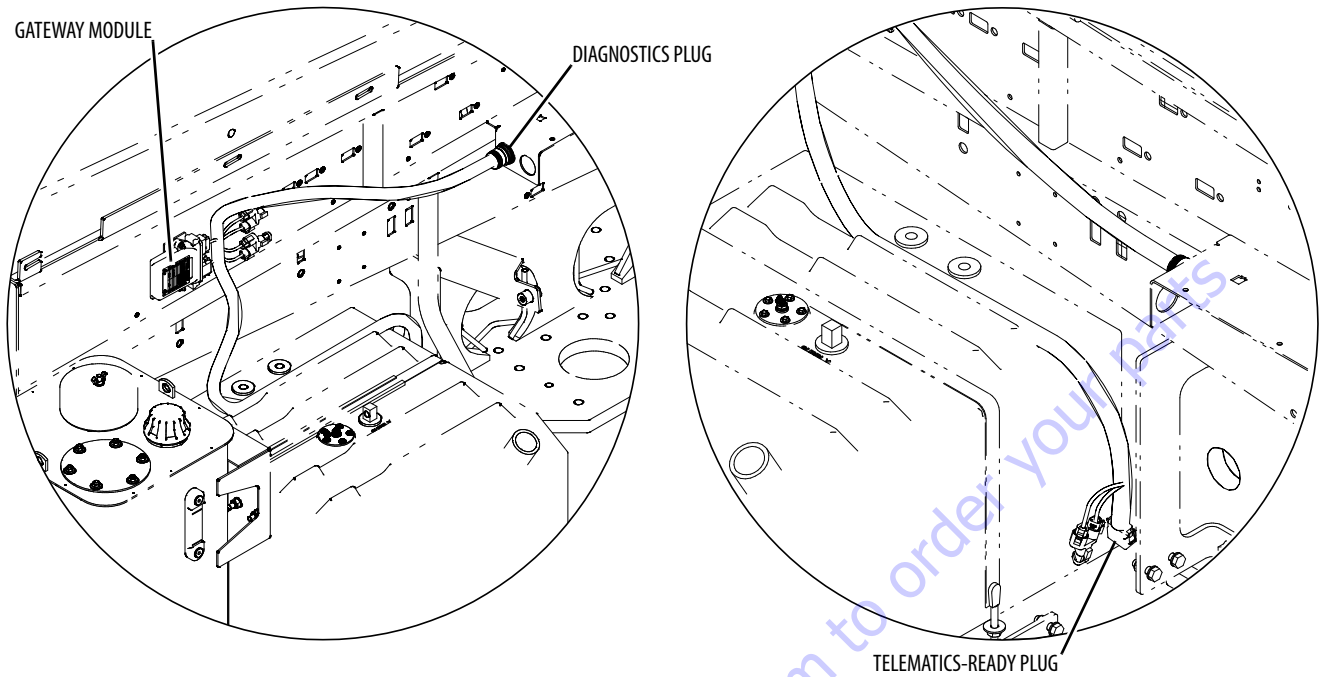

Telematics-Ready (TCU) Plug

The telematics-ready (TCU) plug is a standard 12-pin Deutsch connector. Pin-out locations are shown below:

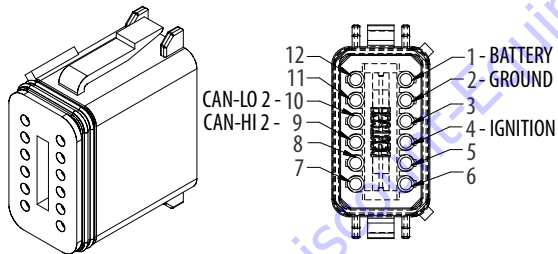

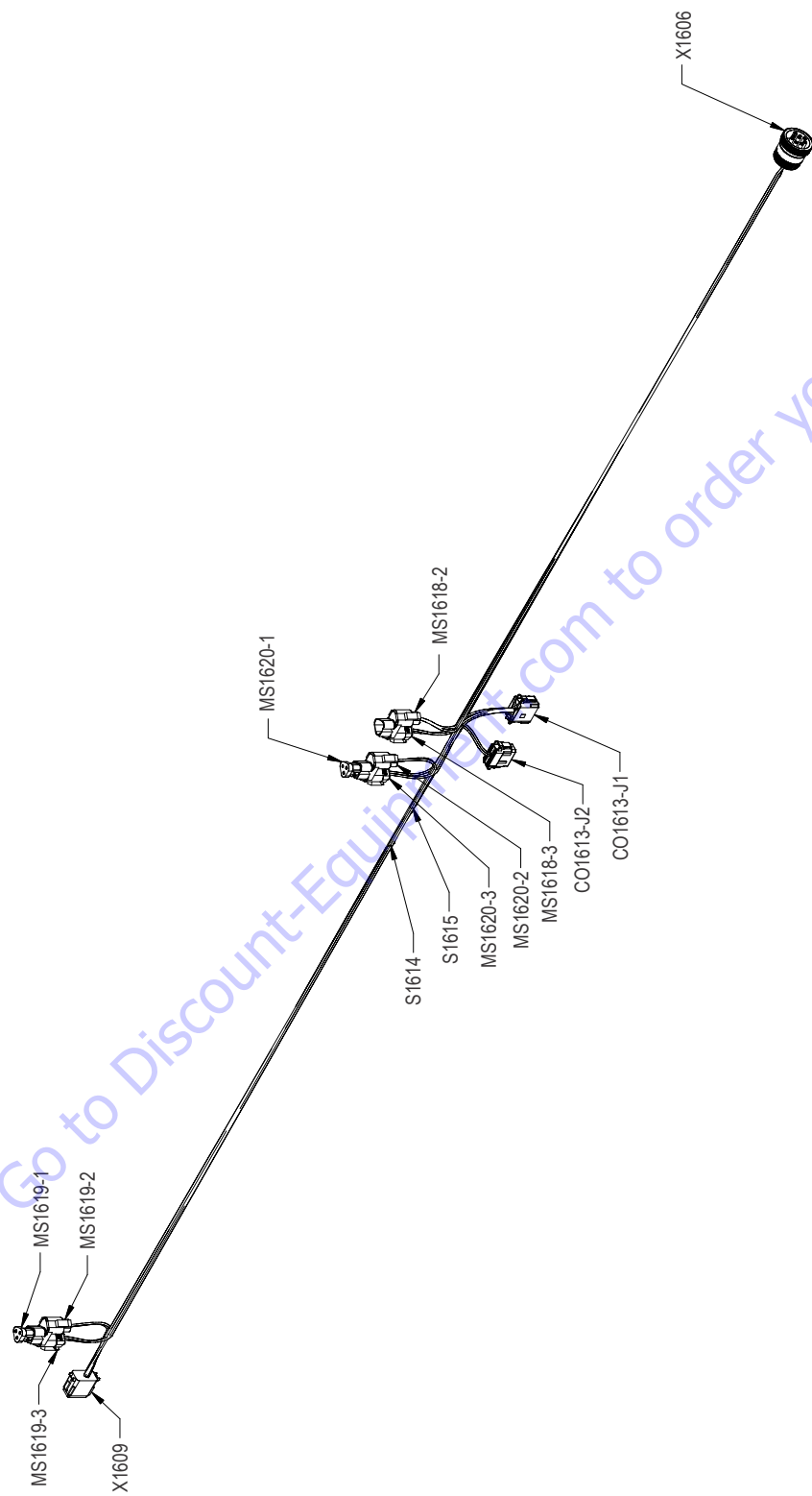

Figure 7-24. Telematics Gateway Harness - Sheet 1 of 3

SECTION 7 - BASIC ELECTRICAL INFORMATION & ELECTRICAL SCHEMATICS

X1609 (TCU)					
CONN POS	WIRE COLOR	WIRE LABEL	GAUGE	JACKET	TO
1	RED	1-0 BAT	16 AWG	GXL	X1606 (B)
2	BLK	0-0 GND	16 AWG	GXL	S1615 (1)
4	ORN	2-0 IGN	16 AWG	GXL	S1614 (1)
9	GRN	CANL2	18 AWG	GXL	MS1619-2 (B)
10	YEL	CANH2	18 AWG	GXL	MS1619-2 (A)

MS1619-2 (CAN-T 2)					
CONN POS	WIRE COLOR	WIRE LABEL	GAUGE	JACKET	TO
A	YEL	CANH2	18 AWG	GXL	X1609 (10)
B	GRN	CANL2	18 AWG	GXL	X1609 (9)

MS1619-3 (CAN-T 2)					
CONN POS	WIRE COLOR	WIRE LABEL	GAUGE	JACKET	TO
A	YEL	CANH2	18 AWG	GXL	MS1620-2 (A)
B	GRN	CANL2	18 AWG	GXL	MS1620-2 (B)

CO1613-J1 (GATEWAY 1)					
CONN POS	WIRE COLOR	WIRE LABEL	GAUGE	JACKET	TO
9	GRN	CAN1	18 AWG	GXL	MS1618-2 (B)
10	YEL	CANH1	18 AWG	GXL	MS1618-2 (A)
11	BLK	0-2 GND	16 AWG	GXL	S1615 (2)
12	ORN	2-2 IGN	16 AWG	GXL	S1614 (2)

CO1613-J2 (GATEWAY 2)					
CONN POS	WIRE COLOR	WIRE LABEL	GAUGE	JACKET	TO
9	GRN	CANL2	18 AWG	GXL	MS1620-3 (B)
10	YEL	CANH2	18 AWG	GXL	MS1620-3 (A)

MS1620-2 (CAN-T 2)					
CONN POS	WIRE COLOR	WIRE LABEL	GAUGE	JACKET	TO
A	YEL	CANH2	18 AWG	GXL	MS1619-3 (A)
B	GRN	CANL2	18 AWG	GXL	MS1619-3 (B)

MS1620-3 (CAN-T 2)					
CONN POS	WIRE COLOR	WIRE LABEL	GAUGE	JACKET	TO
A	YEL	CANH2	18 AWG	GXL	CO1613-J2 (10)
B	GRN	CANL2	18 AWG	GXL	CO1613-J2 (9)

S1614					
CONN POS	WIRE COLOR	WIRE LABEL	GAUGE	JACKET	TO
1	ORN	2-0 IGN	16 AWG	GXL	X1609 (4)
2	ORN	2-1 IGN	16 AWG	GXL	X1606 (H)
2	ORN	2-2 IGN	16 AWG	GXL	CO1613-J1 (12)

S1615					
CONN POS	WIRE COLOR	WIRE LABEL	GAUGE	JACKET	TO
1	BLK	0-0 GND	16 AWG	GXL	X1609 (2)
2	BLK	0-1 GND	16 AWG	GXL	X1606 (A)
2	BLK	0-2 GND	16 AWG	GXL	CO1613-J1 (11)

MS1618-2 (CAN-T 1)					
CONN POS	WIRE COLOR	WIRE LABEL	GAUGE	JACKET	TO
A	YEL	CANH1	18 AWG	GXL	CO1613-J1 (10)
B	GRN	CANL1	18 AWG	GXL	CO1613-J1 (9)

MS1618-3 (CAN-T 1)					
CONN POS	WIRE COLOR	WIRE LABEL	GAUGE	JACKET	TO
A	YEL	CANH1	18 AWG	GXL	X1606 (C)
B	GRN	CANL1	18 AWG	GXL	X1606 (D)

X1606 (DIAG)					
CONN POS	WIRE COLOR	WIRE LABEL	GAUGE	JACKET	TO
A	BLK	0-1 GND	16 AWG	GXL	S1615 (2)
B	RED	1-0 BAT	16 AWG	GXL	X1609 (1)
C	YEL	CANH1	18 AWG	GXL	MS1618-3 (A)
D	GRN	CANL1	18 AWG	GXL	MS1618-3 (B)
H	ORN	2-1 IGN	16 AWG	GXL	S1614 (2)

Figure 7-25. Telematics Gateway Harness - Sheet 2 of 3

SECTION 7 - BASIC ELECTRICAL INFORMATION & ELECTRICAL SCHEMATICS

					FROM		TO	
WIRE NO.	COLOR	WIRE GAUGE	LENGTH (mm)	JACKET	REFERENCE	PIN	REFERENCE	PIN
CAN L2	GRN	18 AWG	1151	GXL	MS1619-3	B	MS1620-2	B
CAN L2	GRN	18 AWG	151	GXL	X1609	9	MS1619-2	B
CAN L1	GRN	18 AWG	157	GXL	MS1618-2	B	CO1613-J1	9
CAN L2	GRN	18 AWG	225	GXL	MS1620-3	B	CO1613-J2	9
CAN L1	GRN	18 AWG	1076	GXL	MS1618-3	B	X1606	D
CAN H2	YEL	18 AWG	155	GXL	X1609	10	MS1619-2	A
CAN H2	YEL	18 AWG	233	GXL	MS1620-3	A	CO1613-J2	10
CAN H1	YEL	18 AWG	157	GXL	MS1618-2	A	CO1613-J1	10
CAN H2	YEL	18 AWG	1150	GXL	MS1619-3	A	MS1620-2	A
CAN H1	YEL	18 AWG	1079	GXL	MS1618-3	A	X1606	C
0-0 GND	BLK	16 AWG	1006	GXL	X1609	2	S1615	1
0-1 GND	BLK	16 AWG	1145	GXL	X1606	A	S1615	2
0-2 GND	BLK	16 AWG	223	GXL	CO1613-J1	11	S1615	2
1-0 BAT	RED	16 AWG	2150	GXL	X1609	1	X1606	B
2-0 IGN	ORN	16 AWG	939	GXL	X1609	4	S1614	1
2-1 IGN	ORN	16 AWG	1212	GXL	S1614	2	X1606	H
2-2 IGN	ORN	16 AWG	287	GXL	CO1613-J1	12	S1614	2

Figure 7-26. Telematics Gateway Harness - Sheet 3 of 3

7.7 WIRING HARNESS

Connector Labels

Connectors between harnesses are identified by the prefix “X” and a sequentially assigned number. An optional suffix (letters & numbers) may be added when multiple terminations occur at one device or when there are optional connections.

Examples:

X25 connects to X25 in another harness.

X65A, X65B connect to different portions of one device

X163 connects to X163A in ANSI and X163B in CE machines

Component Labels

Every component on the vehicle has a unique identification. A standard prefix letter is assigned according to the table below, followed by a unique sequential number. An optional suffix (letters & numbers) may be added when multiple terminations occur at one device.

Terminals that are not loaded into connectors are considered independent components and labeled in the same fashion.

Table 7-1. Wiring Harness Connector Labels

Component	Category	Label
Audible	Alarms	AH
	Horns	
Battery	Batteries	BT
	Battery Terminals	
Control Module	Ground	CO
	LSS	
	Platform	
Engine	Alternator	EC
	Cold Start	
	Controller	
	Coolant Temp	
	Fuel Pump	
	Fuel Solenoid	
	Glow Plugs	
	Oil Pressure	
	Starter	
Fuse & CB Fuse FC	Fuse	FC
	Fusible Link	FC
	Circuit Breaker	CB
Gauge & Display	Board	GD
	Cluster	
	Hour meter	
	LMI	
	Speedometer	
Inline	Resistor	R
	Diode	D
Joystick & Steering	Electronic	JS
	Hydraulic	
Lights	Dome	LB
	Headlights	
	Simple	
	Taillights	
Membrane Panel		MP
Miscellaneous	Radio	MS
	Speakers	
	Splice Blocks	
	T-Connectors	

SECTION 7 - BASIC ELECTRICAL INFORMATION & ELECTRICAL SCHEMATICS

Table 7-1. Wiring Harness Connector Labels

Component	Category	Label
Other Switches	Disconnect	SW
	EMS	
	Foot	
	HVAC	WH
	Key	SW
	Park brake	
	Pump pot	
	Push	
	Shifter	
	Turn signal	
Relay	5 Pin	RL
	4 Pin	
	Contactors	
	Power module	
Rocker Switch		SW
Sensor	Angle	SN
	Fuel	
	Length	
	Limit	
	Load	
	Pressure	
	Proximity	
	Speed	
	Temperature	
	Terminals	
Sockets		
Male Blades		
Female Blades		
Rings		
Forks		
Toggle Switch	DPDT	SW
	DPST	
	SPDT	
	SPST	
	Special	
Valves	Simple	HV
	Suppression	

Examples:

T67 is a ring terminal connected during installation.

C01-J3 is the J3 connector for a UGM control module.

EC9 is a glow plug supplied with the engine

7.8 WIRING HARNESS CONNECTOR LABEL DIAGRAMS

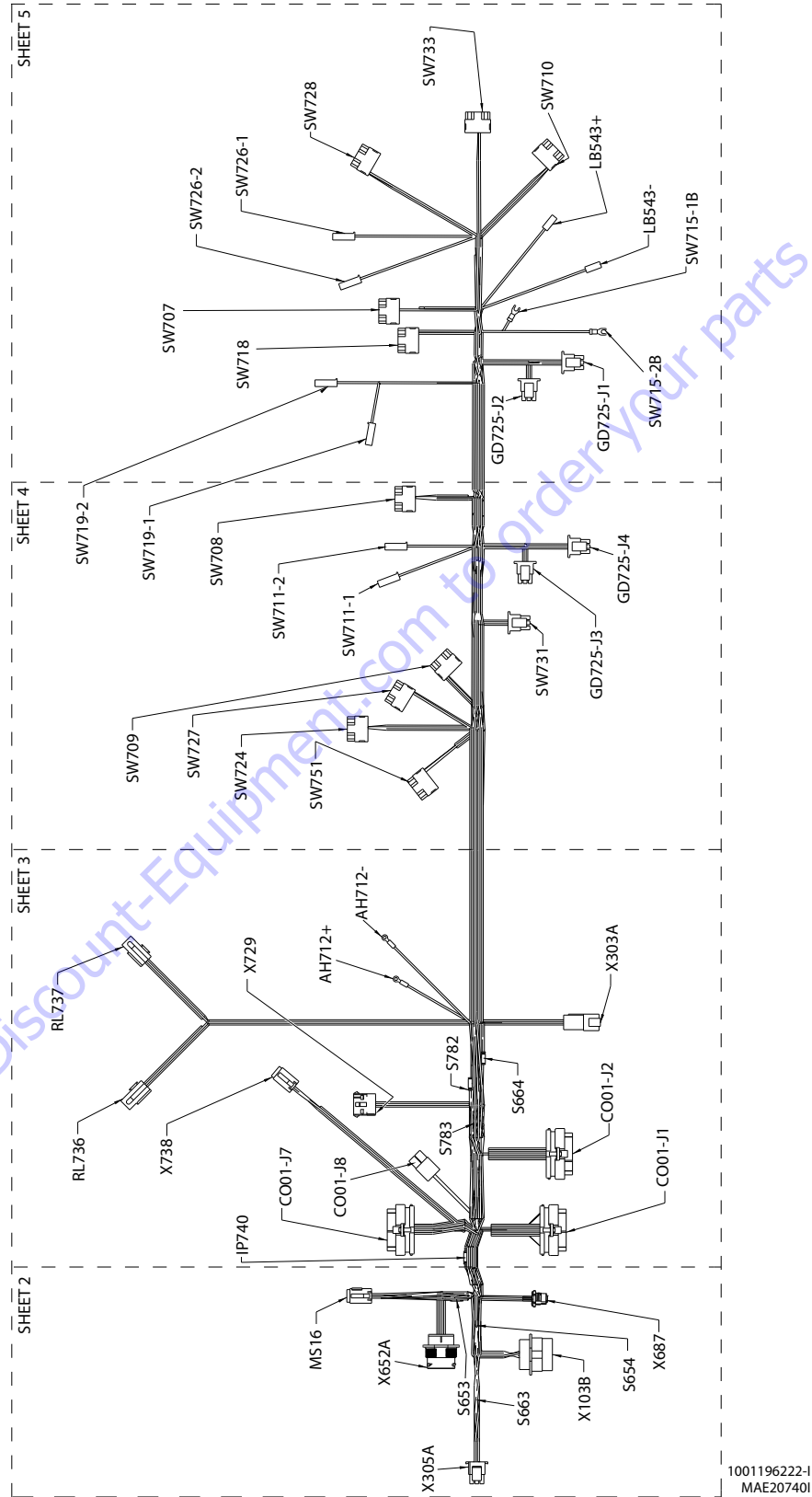

Figure 7-27. Platform Box Harness - Sheet 1 of 6 (SN 0300235168 through 0300259907, SN B30002655 to Present)

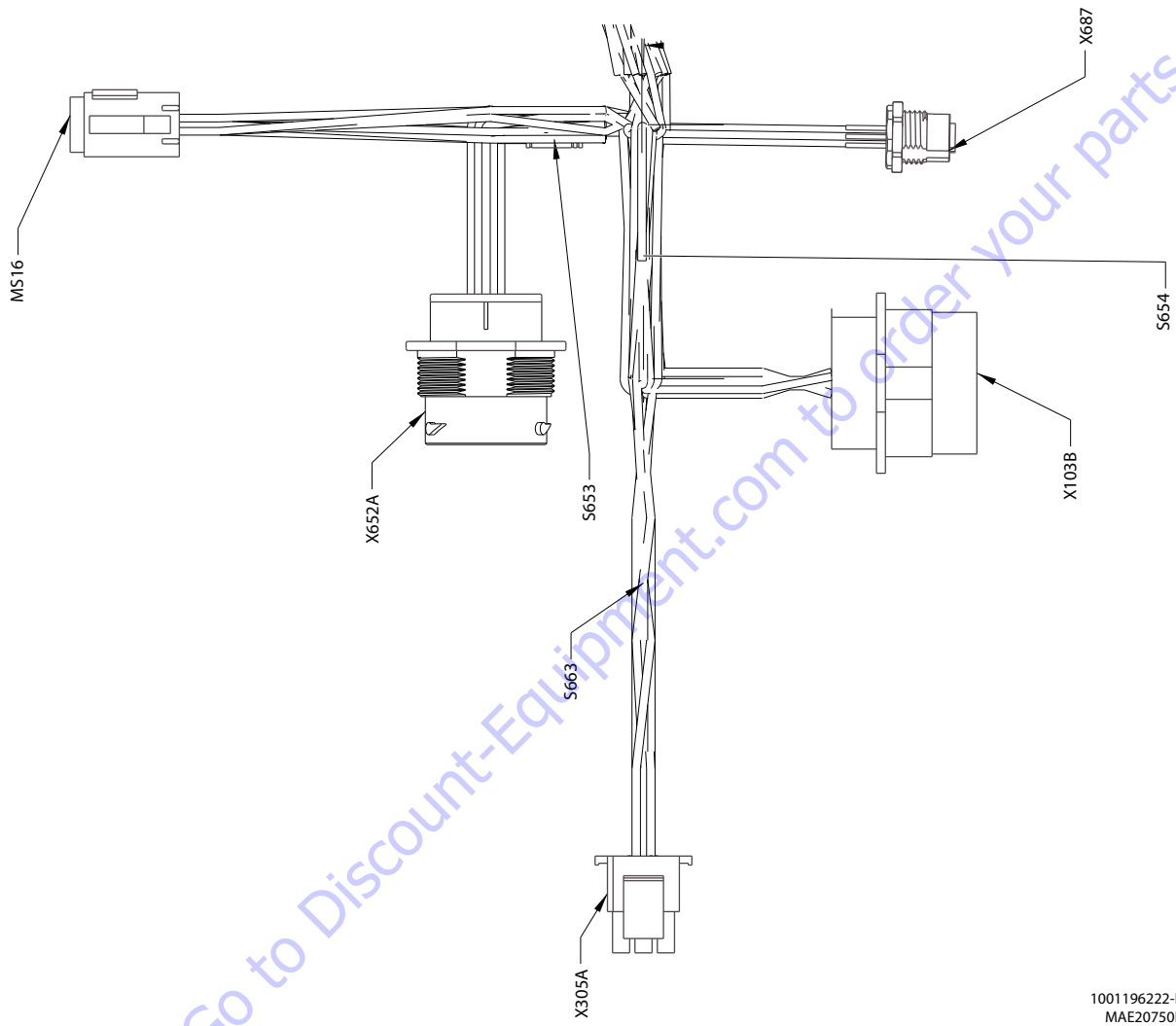

Figure 7-28. Platform Box Harness - Sheet 2 of 6 (SN 03 00235168 through 0300259907, SN B30002655 to Present)

SECTION 7 - BASIC ELECTRICAL INFORMATION & ELECTRICAL SCHEMATICS

X652A					
CONN POS	WIRE COLOR	WIRE LABEL	GAUGE	JACKET	TO
1	BLK	000-10-34 OPTION GND	18 AWG	GXL	S664 (1)
2					
3	WHT	4-15 PLAT DUMP 1	18 AWG	GXL	X103B (13)
4	WHT	4-8 PLAT LEVEL UP	18 AWG	GXL	S653 (1)
5	WHT	4-7 PLAT LEVEL DOWN	18 AWG	GXL	S654 (1)
6					
7					
8	WHT	4-88 PLAT ANGLE SEN 1	18 AWG	GXL	C001-J1 (25)
9	WHT	4-89 PLAT ANGLE SEN 2	18 AWG	GXL	C001-J1 (26)
10	WHT	4-125 PLAT ANGLE SEN 5V	18 AWG	GXL	C001-J7 (11)
11					
12	WHT	4-16 PLAT DUMP 2	18 AWG	GXL	X103B (15)
13	WHT	1-41 PLAT ROTATE LEFT	18 AWG	GXL	C001-J7 (5)
14	WHT	1-42 PLAT ROTATE RIGHT	18 AWG	GXL	C001-J7 (6)
15	WHT	1-36 JIB UP	18 AWG	GXL	C001-J7 (25)
16	WHT	1-43 JIB DOWN	18 AWG	GXL	C001-J7 (26)
17					
18					
19					
20					
21	BLK	000-40-90 PLAT SEN GND	18 AWG	GXL	C001-J7 (14)

MS16					
CONN POS	WIRE COLOR	WIRE LABEL	GAUGE	JACKET	TO
1	YEL	CAN	20 AWG	J1939 CABLE	C001-J7 (31)
2	YEL	CAN	20 AWG	J1939 CABLE	X103B (3)
3	YEL	CAN	20 AWG	J1939 CABLE	X303A (8)
4	GRN	CAN	20 AWG	J1939 CABLE	C001-J7 (30)
5	GRN	CAN	20 AWG	J1939 CABLE	X103B (2)
6	GRN	CAN	20 AWG	J1939 CABLE	X303A (9)
7	GRY	CAN1 LO	20 AWG	CABLE	X687 (5)
8					
9					
10	BLK	CAN1 HI	20 AWG	CABLE	X687 (4)
11					
12					

X305A					
CONN POS	WIRE COLOR	WIRE LABEL	GAUGE	JACKET	TO
1	WHT	1-35 GENERATOR SWITCH	18 AWG	GXL	C001-J7 (9)
2	WHT	1-38 GEN IGN SWITCH	18 AWG	GXL	S663 (2)
3					
4	WHT	1-39 FOOT SW DISENGAGED	18 AWG	GXL	C001-J7 (8)
5	WHT	1-40 FOOT SW	18 AWG	GXL	C001-J7 (4)
6					
7					
8					
9	WHT	1-85 ST POWER	18 AWG	GXL	C001-J2 (34)
10					
11					
12	WHT	1-91 ST SWITCH	18 AWG	GXL	C001-J1 (20)
13					
14	WHT	1-551	18 AWG	GXL	X305A (15)
15	WHT	1-551	18 AWG	GXL	X305A (14)

S653					
CONN POS	WIRE COLOR	WIRE LABEL	GAUGE	JACKET	TO
1	WHT	4-8 PLAT LEVEL UP	18 AWG	GXL	X652A (4)
2	WHT	4-8 PLAT LEVEL UP	18 AWG	GXL	C001-J7 (15)
2	WHT	4-8 PLAT LEVEL UP	18 AWG	GXL	X103B (5)

S654					
CONN POS	WIRE COLOR	WIRE LABEL	GAUGE	JACKET	TO
1	WHT	4-7 PLAT LEVEL DOWN	18 AWG	GXL	X652A (5)
2	WHT	4-7 PLAT LEVEL DOWN	18 AWG	GXL	C001-J7 (16)
2	WHT	4-7 PLAT LEVEL DOWN	18 AWG	GXL	X103B (7)

S663					
CONN POS	WIRE COLOR	WIRE LABEL	GAUGE	JACKET	TO
1	WHT	1-90 SG POWER	18 AWG	GXL	C001-J7 (7)
1	WHT	P2	18 AWG	GXL	IP740 (2)
2	WHT	1-38 GEN IGN SWITCH	18 AWG	GXL	X305A (2)
2	WHT	P9	18 AWG	GXL	RL737 (30)

X687 SINGLE CELL LSS					
CONN POS	WIRE COLOR	WIRE LABEL	GAUGE	JACKET	TO
1					
2	WHT	LSS PWR	20 AWG	CABLE	S782 (2)
3	BLU	LSS GND	20 AWG	CABLE	S783 (2)
4	BLK	CAN1 HI	20 AWG	CABLE	MS16 (10)
5	GRY	CAN1 LO	20 AWG	CABLE	MS16 (7)

X103B					
CONN POS	WIRE COLOR	WIRE LABEL	GAUGE	JACKET	TO
1					
2	GRN	CAN	20 AWG	J1939 CABLE	MS16 (5)
3	YEL	CAN	20 AWG	J1939 CABLE	MS16 (2)
4	WHT	1-44 EMS	18 AWG	GXL	C001-J7 (3)
5	WHT	4-8 PLAT LEVEL UP	18 AWG	GXL	S653 (2)
6					
7	WHT	4-7 PLAT LEVEL DOWN	18 AWG	GXL	S654 (2)
8					
9	WHT	1-62 EMS B+	18 AWG	GXL	SW715-1 (1B)
10					
11	WHT	1-37 GROUND MODE	18 AWG	GXL	C001-J7 (1)
12	WHT	1-1	12 AWG	GXL	C001-J8 (2)
13	WHT	4-15 PLAT DUMP 1	18 AWG	GXL	X652A (3)
14					
15	WHT	4-16 PLAT DUMP 2	18 AWG	GXL	X652A (12)
16	BLK	000-10-14 GND	12 AWG	GXL	C001-J8 (1)
17					
18					
19					

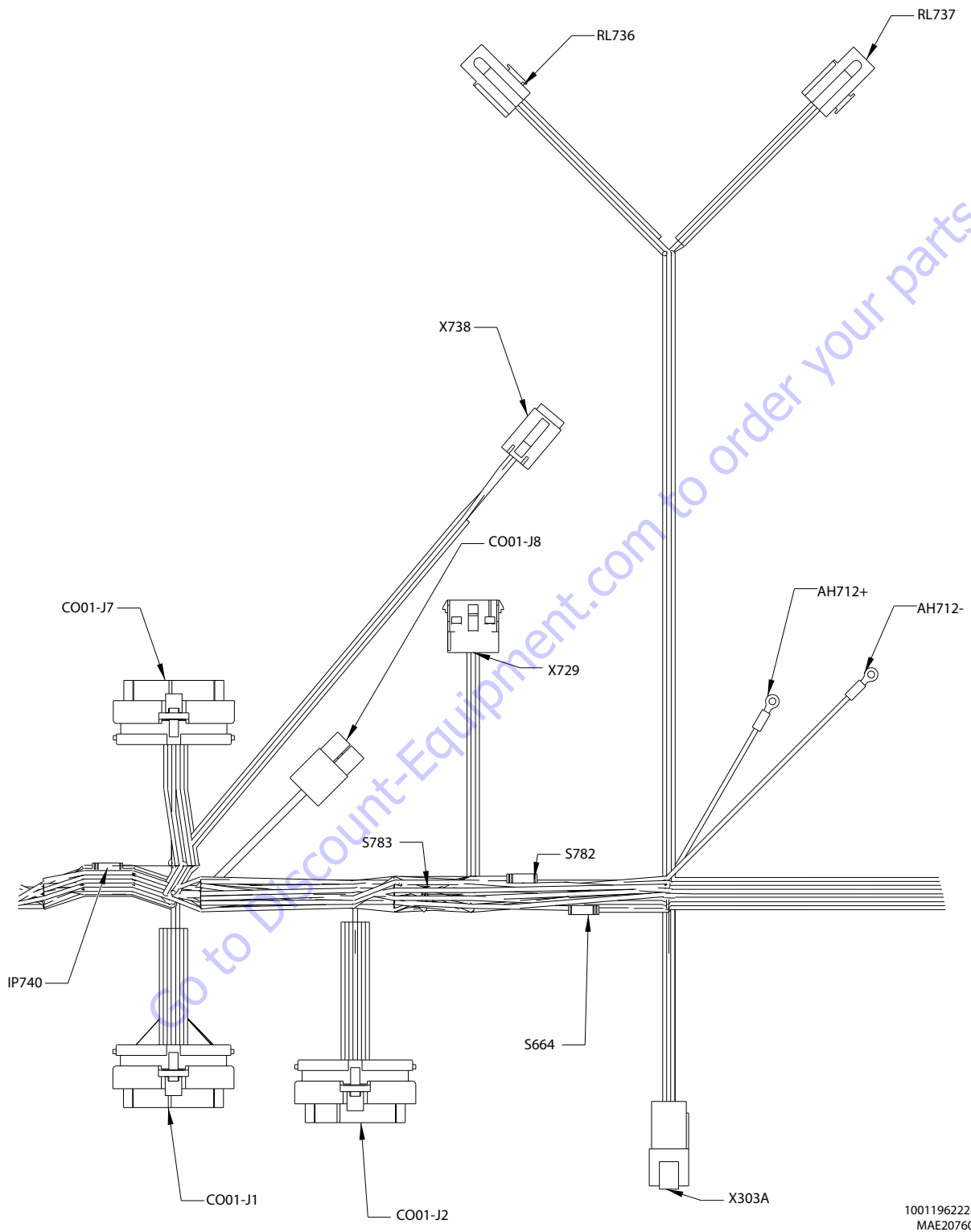

1001196222-1
MAE207601

Figure 7-29. Platform Box Harness - Sheet 3 of 6 (SN 0300235168 through 0300259907, SN B30002655 to Present)

SECTION 7 - BASIC ELECTRICAL INFORMATION & ELECTRICAL SCHEMATICS

X729 ANALYZER					
CONN POS	WIRE COLOR	WIRE LABEL	GAUGE	JACKET	TO
1	WHT	1-66 POWER	18 AWG	GXL	C001-J2 (26)
2	WHT	1-81 RECEIVE	18 AWG	GXL	C001-J2 (28)
3	WHT	1-82 TRANSMIT	18 AWG	GXL	C001-J2 (29)
4	BLK	000-10-12 GND	18 AWG	GXL	C001-J2 (27)

IP740 18 OHM					
CONN POS	WIRE COLOR	WIRE LABEL	GAUGE	JACKET	TO
1	WHT	P10	18 AWG	GXL	X738 (1)
2	WHT	P2	18 AWG	GXL	S663 (1)

X738 5G SNSR					
CONN POS	WIRE COLOR	WIRE LABEL	GAUGE	JACKET	TO
1	WHT	P10	18 AWG	GXL	IP740 (1)
2	BLK	1-86 5G GND	18 AWG	GXL	C001-J7 (21)
3	WHT	P4	18 AWG	GXL	RL736 (86)
4	WHT	P5	18 AWG	GXL	RL736 (85)

S664					
CONN POS	WIRE COLOR	WIRE LABEL	GAUGE	JACKET	TO
1	BLK	000-10-34 OPTION GND	18 AWG	GXL	X652A (1)
1	BLK	000-10-34 OPTION GND	18 AWG	GXL	C001-J7 (29)
2	BLK	000-10-34 OPTION GND	18 AWG	GXL	X303A (6)

RL736 5G RELAY #2					
CONN POS	WIRE COLOR	WIRE LABEL	GAUGE	JACKET	TO
30	WHT	P9-1	18 AWG	GXL	RL737 (30)
85	WHT	P5	18 AWG	GXL	X738 (4)
85	WHT	P5-1	18 AWG	GXL	RL737 (85)
86	WHT	P4	18 AWG	GXL	X738 (3)
86	WHT	P4-1	18 AWG	GXL	RL737 (86)
87	WHT	1-88 ST/SG INPUT 2	18 AWG	GXL	C001-J1 (23)
87a					

RL737 5G RELAY #1					
CONN POS	WIRE COLOR	WIRE LABEL	GAUGE	JACKET	TO
30	WHT	P9	18 AWG	GXL	S663 (2)
30	WHT	P9-1	18 AWG	GXL	RL736 (30)
85	WHT	P5-1	18 AWG	GXL	RL736 (85)
86	WHT	P4-1	18 AWG	GXL	RL736 (86)
87	WHT	P1	18 AWG	GXL	C001-J7 (18)
87a					

C001-J1 NATURAL					
CONN POS	WIRE COLOR	WIRE LABEL	GAUGE	JACKET	TO
1					
2					
3					
4					
5	WHT	1-3 TELE IN	18 AWG	GXL	SW707 (1)
6	WHT	1-5 TELE OUT	18 AWG	GXL	SW707 (3)
7	WHT	1-6 PLTF ROTATE RIGHT	18 AWG	GXL	SW708 (1)
8	WHT	1-7 PLTF ROTATE LEFT	18 AWG	GXL	SW708 (3)
9	WHT	1-8 LEVEL UP	18 AWG	GXL	SW709 (1)
10	WHT	LEVEL DOWN	18 AWG	GXL	SW709 (3)
11	WHT	1-13 JIB UP	18 AWG	GXL	SW718 (1)
12	WHT	1-14 JIB DOWN	18 AWG	GXL	SW718 (3)
13	WHT	1-103 SPD PMP POT GND	18 AWG	GXL	SW731 (5)
14	WHT	1-9 START SWITCH	18 AWG	GXL	SW710 (1)
15	WHT	1-10 AUX POWER	18 AWG	GXL	SW710 (3)
16	WHT	1-110 CRAB STEER	18 AWG	GXL	SW751 (3)
17	WHT	1-111 COORD STEER	18 AWG	GXL	SW751 (1)
18	WHT	1-70 SWITCHES PWR	18 AWG	GXL	SW724 (2)
19					
20	WHT	1-91 ST SWITCH	18 AWG	GXL	X305A (12)
21	WHT	1-50 DUAL CAPACITY	18 AWG	GXL	SW733 (3)
22					
23	WHT	1-88 ST/SG INPUT 2	18 AWG	GXL	RL736 (87)
24					
25	WHT	4-88 PLAT ANGLE SEN 1	18 AWG	GXL	X652A (8)
26	WHT	4-89 PLAT ANGLE SEN 2	18 AWG	GXL	X652A (9)
27	WHT	1-12 MAX SPEED	18 AWG	GXL	SW724 (3)
28	WHT	1-11 MIN SPEED	18 AWG	GXL	SW724 (1)
29	WHT	1-4 SOFT TOUCH	18 AWG	GXL	SW719-1 (1)
30	WHT	1-15 HEAD LIGHTS	18 AWG	GXL	SW726-1 (1)
31	WHT	1-2 HORN	18 AWG	GXL	SW711-1 (1)
32	WHT	1-101 CREEP SW	18 AWG	GXL	SW731 (2)
33	WHT	1-68 FUEL SELECT	18 AWG	GXL	SW727 (3)
34	WHT	1-105 SPD PMP POT PWR	18 AWG	GXL	SW731 (4)
35	WHT	1-104 SPD PMP POT SGL	18 AWG	GXL	SW731 (6)

AH712+ ALARM					
CONN POS	WIRE COLOR	WIRE LABEL	GAUGE	JACKET	TO
1	WHT	1-34 PLAT ALRM	18 AWG	GXL	C001-J7 (19)

X303A					
CONN POS	WIRE COLOR	WIRE LABEL	GAUGE	JACKET	TO
1					
2					
3					
4					
5	BLK	000-10-11 VALVES GND	18 AWG	GXL	C001-J7 (23)
6	BLK	000-10-34 OPTION GND	18 AWG	GXL	S664 (2)
7	WHT	1-89 OPTION POWER	18 AWG	GXL	C001-J2 (33)
8	YEL	CAN	20 AWG	J1939 CABLE	MS16 (3)
9	GRN	CAN	20 AWG	J1939 CABLE	MS16 (6)
10					
11	BLK	000-10-30-2 LSS GND	18 AWG	GXL	S783 (2)
12	WHT	1-33-2 LSS PWR	18 AWG	GXL	S782 (2)

C001-J8					
CONN POS	WIRE COLOR	WIRE LABEL	GAUGE	JACKET	TO
1	BLK	000-10-14 GND	12 AWG	GXL	X103B (16)
2	WHT	1-1	12 AWG	GXL	X103B (12)

SECTION 7 - BASIC ELECTRICAL INFORMATION & ELECTRICAL SCHEMATICS

AH712- ALARM					
CONN POS	WIRE COLOR	WIRE LABEL	GAUGE	JACKET	TO
1	WHT	000-10-16 PLAT ALARM GND	18 AWG	GXL	C001-J7 (20)

S783					
CONN POS	WIRE COLOR	WIRE LABEL	GAUGE	JACKET	TO
1	BLK	000-10-30 LSS GND	18 AWG	GXL	C001-J7 (22)
2	BLK	000-10-30-2 LSS GND	18 AWG	GXL	X303A (11)
2	BLU	LSS GND	20 AWG	CABLE	X687 (3)

S782					
CONN POS	WIRE COLOR	WIRE LABEL	GAUGE	JACKET	TO
1	WHT	1-33 LSS PWR	18 AWG	GXL	C001-J2 (32)
2	WHT	1-33-2 LSS PWR	18 AWG	GXL	X303A (12)
2	WHT	LSS PWR	20 AWG	CABLE	X687 (2)

C001-J2 BLUE					
CONN POS	WIRE COLOR	WIRE LABEL	GAUGE	JACKET	TO
1					
2					
3					
4	WHT	1-67 PLTF ORIENT OVERRIDE	18 AWG	GXL	SW728 (1)
5					
6	WHT	1-20 TILT	18 AWG	GXL	GD725-J4 (5)
7	WHT	1-32 FOOTSWICH ENABLE	18 AWG	GXL	GD725-J2 (2)
8	WHT	1-25 SYSTEM DISTRESS	18 AWG	GXL	GD725-J3 (6)
9	WHT	1-24 CREEP	18 AWG	GXL	GD725-J2 (1)
10	WHT	1-99 SERVICE CABLE	18 AWG	GXL	GD725-J3 (5)
11	WHT	1-22 PLATFORM OVERLOAD	18 AWG	GXL	GD725-J4 (3)
12	WHT	1-21 500#/600# MODE	18 AWG	GXL	GD725-J4 (4)
13	WHT	1-27 1000# MODE	18 AWG	GXL	GD725-J3 (4)
14	WHT	1-28 DRIVE ORIENT SW	18 AWG	GXL	GD725-J3 (3)
15	WHT	1-23 GENERATOR ON	18 AWG	GXL	GD725-J4 (2)
16	WHT	1-31 SOFT TCH/SKY GUARD	18 AWG	GXL	LB732+ (1)
17	WHT	1-29 GLOW PLUG	18 AWG	GXL	GD725-J4 (6)
18	BLK	000-10-27 GND	18 AWG	GXL	GD725-J2 (6)
19	WHT	1-120 PLT LVL	18 AWG	GXL	GD725-J4 (1)
20	WHT	1-121 DRV DISABLE	18 AWG	GXL	GD725-J3 (1)
21	WHT	1-30 LOW FUEL	18 AWG	GXL	GD725-J2 (3)
22	WHT	1-498 1/4 FUEL	18 AWG	GXL	GD725-J1 (1)
23	WHT	1-499 3/4 FUEL	18 AWG	GXL	GD725-J1 (3)
24	WHT	1-500 1/2 FUEL	18 AWG	GXL	GD725-J1 (2)
25	BLK	1-497 FUEL GND	18 AWG	GXL	GD725-J1 (4)
26	WHT	1-66 POWER	18 AWG	GXL	X729 (1)
27	BLK	000-10-12 GND	18 AWG	GXL	X729 (4)
28	WHT	1-81 RECEIVE	18 AWG	GXL	X729 (2)
29	WHT	1-82 TRANSMIT	18 AWG	GXL	X729 (3)
30					
31					
32	WHT	1-33 LSS PWR	18 AWG	GXL	S782 (1)
33	WHT	1-89 OPTION POWER	18 AWG	GXL	X303A (7)
34	WHT	1-85 ST POWER	18 AWG	GXL	X305A (9)
35	WHT	1-501 FUEL FULL	18 AWG	GXL	GD725-J1 (6)

C001-J7 BLACK					
CONN POS	WIRE COLOR	WIRE LABEL	GAUGE	JACKET	TO
1	WHT	1-37 GROUND MODE	18 AWG	GXL	X103B (11)
2	WHT	1-45 PLATF EMS	18 AWG	GXL	SW715-2B (2B)
3	WHT	1-44 EMS	18 AWG	GXL	X103B (4)
4	WHT	1-40 FOOT SW	18 AWG	GXL	X305A (5)
5	WHT	1-41 PLAT ROTATE LEFT	18 AWG	GXL	X652A (13)
6	WHT	1-42 PLAT ROTATE RIGHT	18 AWG	GXL	X652A (14)
7	WHT	1-90 SG POWER	18 AWG	GXL	S663 (1)
8	WHT	1-39 FOOT SW DISENGAGED	18 AWG	GXL	X305A (4)
9	WHT	1-35 GENERATOR SWITCH	18 AWG	GXL	X305A (1)
10					
11	WHT	4-125 PLAT ANGLE SEN 5V	18 AWG	GXL	X652A (10)
12					
13					
14	BLK	000-40-90 PLAT SEN GND	18 AWG	GXL	X652A (21)
15	WHT	4-8 PLAT LEVEL UP	18 AWG	GXL	S653 (2)
16	WHT	4-7 PLAT LEVEL DOWN	18 AWG	GXL	S654 (2)
17					
18	WHT	P1	18 AWG	GXL	RL737 (87)
19	WHT	1-34 PLAT ALRM	18 AWG	GXL	AH712+ (1)
20	WHT	000-10-16 PLAT ALARM GND	18 AWG	GXL	AH712- (1)
21	BLK	1-86 SG GND	18 AWG	GXL	X738 (2)
22	BLK	000-10-30 LSS GND	18 AWG	GXL	S783 (1)
23	BLK	000-10-11 VALVES GND	18 AWG	GXL	X303A (5)
24					
25	WHT	1-36 JIB UP	18 AWG	GXL	X652A (15)
26	WHT	1-43 JIB DOWN	18 AWG	GXL	X652A (16)
27					
28					
29	BLK	000-10-34 OPTION GND	18 AWG	GXL	S664 (1)
30	GRN	CAN	20 AWG	J1939 CABLE	MS16 (4)
31	YEL	CAN	20 AWG	J1939 CABLE	MS16 (1)
32					
33					
34					
35					

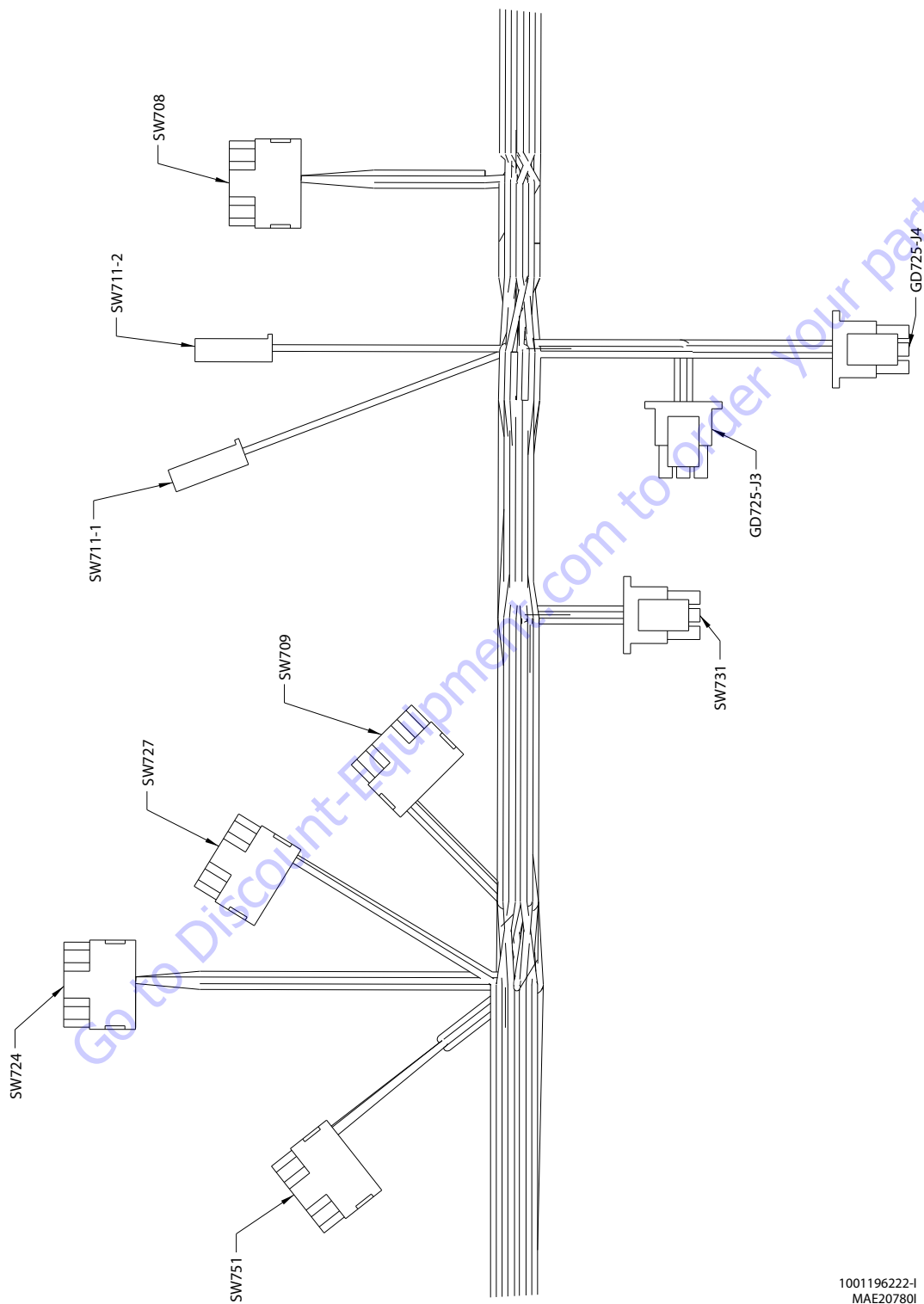

Figure 7-30. Platform Box Harness - Sheet 4 of 6 (SN 0300235168 through 0300259907, SN B30002655 to Present)

1001196222-1
MAE207801

SECTION 7 - BASIC ELECTRICAL INFORMATION & ELECTRICAL SCHEMATICS

SW751 STEER SELECT					
CONN POS	WIRE COLOR	WIRE LABEL	GAUGE	JACKET	TO
1	WHT	1-111 COORD STEER	18 AWG	GXL	C001-J1 (17)
2	WHT	1-69 SWITCHES PWR	18 AWG	GXL	SW724 (2)
2	WHT	1-80 SWITCHES PWR	18 AWG	GXL	SW727 (2)
3	WHT	1-110 CRAB STEER	18 AWG	GXL	C001-J1 (16)
4					
5					
6					

GD725-J4					
CONN POS	WIRE COLOR	WIRE LABEL	GAUGE	JACKET	TO
1	WHT	1 - 120 PLAT LVL	18 AWG	GXL	C001-J2 (19)
2	WHT	1-23 GENERATOR ON	18 AWG	GXL	C001-J2 (15)
3	WHT	1-22 PLATFORM OVERLOAD	18 AWG	GXL	C001-J2 (11)
4	WHT	1-21 500#/600# MODE	18 AWG	GXL	C001-J2 (12)
5	WHT	1-20 TILT	18 AWG	GXL	C001-J2 (6)
6	WHT	1-29 GLOW PLUG	18 AWG	GXL	C001-J2 (17)

SW711-2 HORN					
CONN POS	WIRE COLOR	WIRE LABEL	GAUGE	JACKET	TO
1	WHT	1-102 SW PWR	18 AWG	GXL	SW731 (3)
1	WHT	1-87 SW PWR	18 AWG	GXL	SW719-2 (1)

SW708 PLATFORM ROTATE					
CONN POS	WIRE COLOR	WIRE LABEL	GAUGE	JACKET	TO
1	WHT	1-6 PLTF ROTATE RIGHT	18 AWG	GXL	C001-J1 (7)
2	WHT	1-72 SWITCHES PWR	18 AWG	GXL	SW733 (2)
2	WHT	1-73 SWITCHES PWR	18 AWG	GXL	SW709 (2)
3	WHT	1-7 PLTF ROTATE LEFT	18 AWG	GXL	C001-J1 (8)
4					
5					
6					

SW711-1 HORN					
CONN POS	WIRE COLOR	WIRE LABEL	GAUGE	JACKET	TO
1	WHT	1-2 HORN	18 AWG	GXL	C001-J1 (31)

SW709 LEVEL					
CONN POS	WIRE COLOR	WIRE LABEL	GAUGE	JACKET	TO
1	WHT	1-8 LEVEL UP	18 AWG	GXL	C001-J1 (9)
2	WHT	1-73 SWITCHES PWR	18 AWG	GXL	SW708 (2)
2	WHT	1-74 SWITCHES PWR	18 AWG	GXL	SW710 (2)
3	WHT	LEVEL DOWN	18 AWG	GXL	C001-J1 (10)
4					
5					
6					

SW731 PUMP POT					
CONN POS	WIRE COLOR	WIRE LABEL	GAUGE	JACKET	TO
1					
2	WHT	1-101 CREEP SW	18 AWG	GXL	C001-J1 (32)
3	WHT	1-102 SW PWR	18 AWG	GXL	SW711-2 (1)
3	WHT	1-71 SW PWR	18 AWG	GXL	SW707 (2)
4	WHT	1-105 SPD PMP POT PWR	18 AWG	GXL	C001-J1 (34)
5	WHT	1-103 SPD PMP POT GND	18 AWG	GXL	C001-J1 (13)
6	WHT	1-104 SPD PMP POT SGL	18 AWG	GXL	C001-J1 (35)

SW724 ENGINE SPEED					
CONN POS	WIRE COLOR	WIRE LABEL	GAUGE	JACKET	TO
1	WHT	1-11 MIN SPEED	18 AWG	GXL	C001-J1 (28)
2	WHT	1-69 SWITCHES PWR	18 AWG	GXL	SW751 (2)
2	WHT	1-70 SWITCHES PWR	18 AWG	GXL	C001-J1(18)
3	WHT	1-12 MAX SPEED	18 AWG	GXL	C001-J1(27)
4					
5					
6					

GD725-J3					
CONN POS	WIRE COLOR	WIRE LABEL	GAUGE	JACKET	TO
1	WHT	1 - 121 DRV DISABLE	18 AWG	GXL	C001-J2 (20)
2					
3	WHT	1-28 DRIVE ORIENT SW	18 AWG	GXL	C001-J2 (14)
4	WHT	1-27 1000# MODE	18 AWG	GXL	C001-J2 (13)
5	WHT	1-99 SERVICE CABLE	18 AWG	GXL	C001-J2 (10)
6	WHT	1-25 SYSTEM DISTRESS	18 AWG	GXL	C001-J2 (8)

SW727 FUEL SELECT					
CONN POS	WIRE COLOR	WIRE LABEL	GAUGE	JACKET	TO
1					
2	WHT	1-78 SWITCHES PWR	18 AWG	GXL	SW726-2 (1)
2	WHT	1-80 SWITCHES PWR	18 AWG	GXL	SW751 (2)
3	WHT	1-68 FUEL SELECT	18 AWG	GXL	C001-J1 (33)
4					
5					
6					

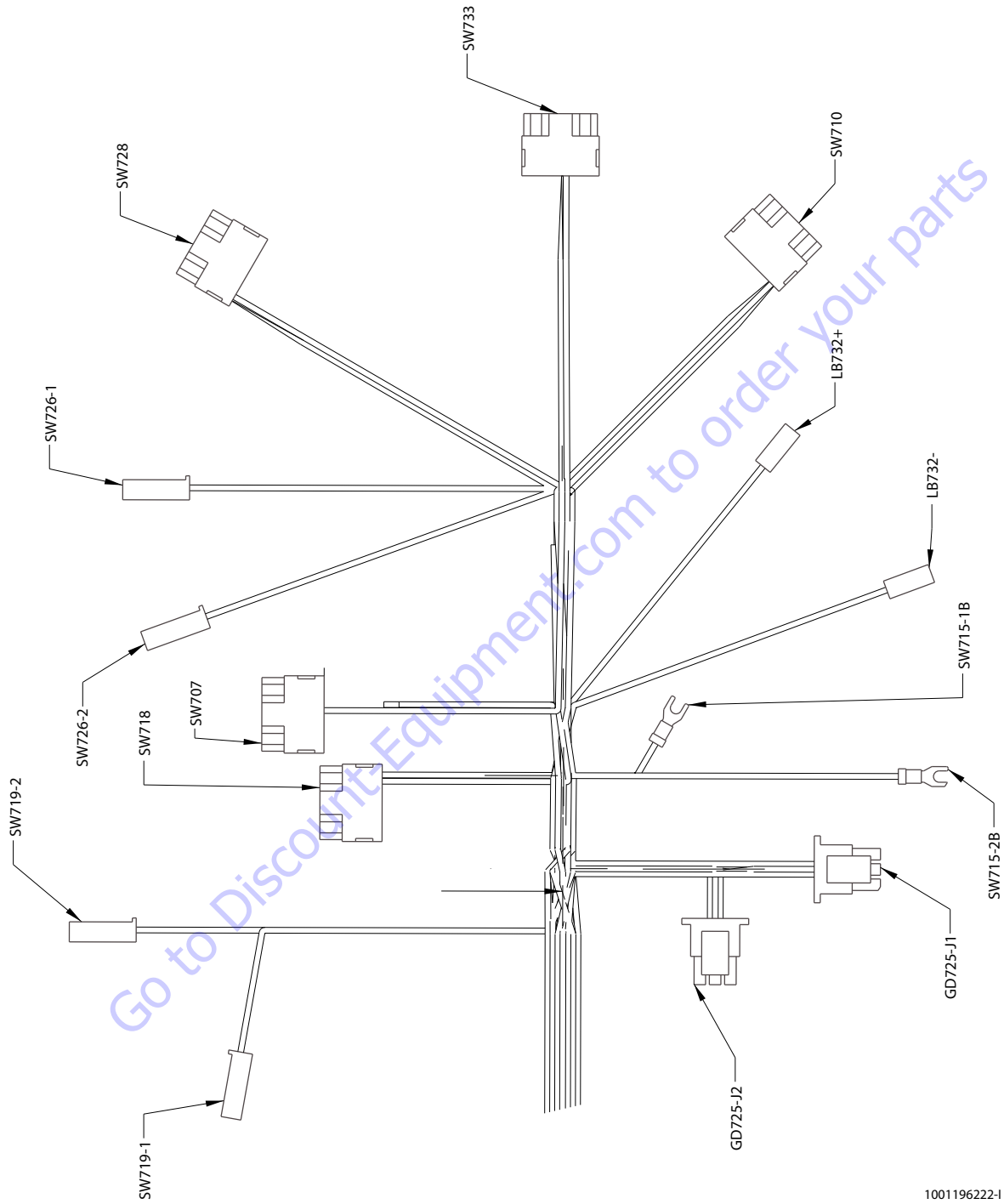

Figure 7-31. Platform Box Harness - Sheet 5 of 6 (SN 0300235168 through 0300259907, SN B30002655 to Present)

1001196222-I
MAE20790I

SECTION 7 - BASIC ELECTRICAL INFORMATION & ELECTRICAL SCHEMATICS

SW715-1BE STOP					
CONN POS	WIRE COLOR	WIRE LABEL	GAUGE	JACKET	TO
1B	WHT	1-62 EMS B+	18 AWG	GXL	X103B (9)

LB732+ SKYGUARD WARNING					
CONN POS	WIRE COLOR	WIRE LABEL	GAUGE	JACKET	TO
1	WHT	1-31 SOFT TCH/SKY GUARD	18 AWG	GXL	C001-J2 (16)

SW715-2B E STOP					
CONN POS	WIRE COLOR	WIRE LABEL	GAUGE	JACKET	TO
2B	WHT	1-45 PLATF EMS	18 AWG	GXL	C001-J7 (2)

LB732- SKYGUARD WARNING					
CONN POS	WIRE COLOR	WIRE LABEL	GAUGE	JACKET	TO
1	BLK	000-10-501 GND	18 AWG	GXL	GD725-J2 (6)

GD725-J2					
CONN POS	WIRE COLOR	WIRE LABEL	GAUGE	JACKET	TO
1	WHT	1-24 CREEP	18 AWG	GXL	C001-J2 (9)
2	WHT	1-32 FOOTSWICH ENABLE	18 AWG	GXL	C001-J2 (7)
3	WHT	1-30 LOW FUEL	18 AWG	GXL	C001-J2 (21)
4					
5					
6	BLK	000-10-27 GND	18 AWG	GXL	C001-J2 (18)
6	BLK	000-10-501 GND	18 AWG	GXL	LB732- (1)

SW726-2 HEAD AND TAIL LIGHTS					
CONN POS	WIRE COLOR	WIRE LABEL	GAUGE	JACKET	TO
1	WHT	1-77 SWITCHES PWR	18 AWG	GXL	SW718 (2)
1	WHT	1-78 SWITCHES PWR	18 AWG	GXL	SW727 (2)

SW710 START AUX					
CONN POS	WIRE COLOR	WIRE LABEL	GAUGE	JACKET	TO
1	WHT	1-9 START SWITCH	18 AWG	GXL	C001-J1 (14)
2	WHT	1-74 SWITCHES PWR	18 AWG	GXL	SW709 (2)
2	WHT	1-75 SWITCHES PWR	18 AWG	GXL	SW728 (2)
3	WHT	1-10 AUX POWER	18 AWG	GXL	C001-J1 (15)
4					
5					
6					

SW726-1 HEAD AND TAIL LIGHTS					
CONN POS	WIRE COLOR	WIRE LABEL	GAUGE	JACKET	TO
1	WHT	1-15 HEAD LIGHTS	18 AWG	GXL	C001-J1 (30)

SW707 MAIN TELE					
CONN POS	WIRE COLOR	WIRE LABEL	GAUGE	JACKET	TO
1	WHT	1-3 TELE IN	18 AWG	GXL	C001-J1 (5)
2	WHT	1-71 SW PWR	18 AWG	GXL	SW731 (3)
2	WHT	1-81 SW PWR	18 AWG	GXL	SW733 (2)
3	WHT	1-5 TELE OUT	18 AWG	GXL	C001-J1 (6)
4					
5					
6					

SW719-1 SOFT TOUCH/SKYGUARD					
CONN POS	WIRE COLOR	WIRE LABEL	GAUGE	JACKET	TO
1	WHT	1-4 SOFT TOUCH	18 AWG	GXL	C001-J1 (29)

SW718J IB LIFT					
CONN POS	WIRE COLOR	WIRE LABEL	GAUGE	JACKET	TO
1	WHT	1-13 JIB UP	18 AWG	GXL	C001-J1 (11)
2	WHT	1-76 SWITCHES PWR	18 AWG	GXL	SW728 (2)
2	WHT	1-77 SWITCHES PWR	18 AWG	GXL	SW726-2 (1)
3	WHT	1-14 JIB DOWN	18 AWG	GXL	C001-J1 (12)
4					
5					
6					

SW719-2 SOFT TOUCH/SKYGUARD					
CONN POS	WIRE COLOR	WIRE LABEL	GAUGE	JACKET	TO
1	WHT	1-87 SW PWR	18 AWG	GXL	SW711-2 (1)

SW733 DUAL CAPACITY					
CONN POS	WIRE COLOR	WIRE LABEL	GAUGE	JACKET	TO
1					
2	WHT	1-72 SWITCHES PWR	18 AWG	GXL	SW708 (2)
2	WHT	1-81 SW PWR	18 AWG	GXL	SW707 (2)
3	WHT	1-50 DUAL CAPACITY	18 AWG	GXL	C001-J1 (21)
4					
5					
6					

GD725-J1					
CONN POS	WIRE COLOR	WIRE LABEL	GAUGE	JACKET	TO
1	WHT	1-498 1/4 FUEL	18 AWG	GXL	C001-J2 (22)
2	WHT	1-500 1/2 FUEL	18 AWG	GXL	C001-J2 (24)
3	WHT	1-499 3/4 FUEL	18 AWG	GXL	C001-J2 (23)
4	BLK	1-497 FUEL GND	18 AWG	GXL	C001-J2 (25)
5					
6	WHT	1-501 FUEL FULL	18 AWG	GXL	C001-J2 (35)

SW728 DRIVE ORIENTATION OVERRIDE					
CONN POS	WIRE COLOR	WIRE LABEL	GAUGE	JACKET	TO
1	WHT	1-67 PLTF ORIENT OVERRIDE	18 AWG	GXL	C001-J2 (4)
2	WHT	1-75 SWITCHES PWR	18 AWG	GXL	SW710 (2)
2	WHT	1-76 SWITCHES PWR	18 AWG	GXL	SW718 (2)
3					
4					
5					
6					

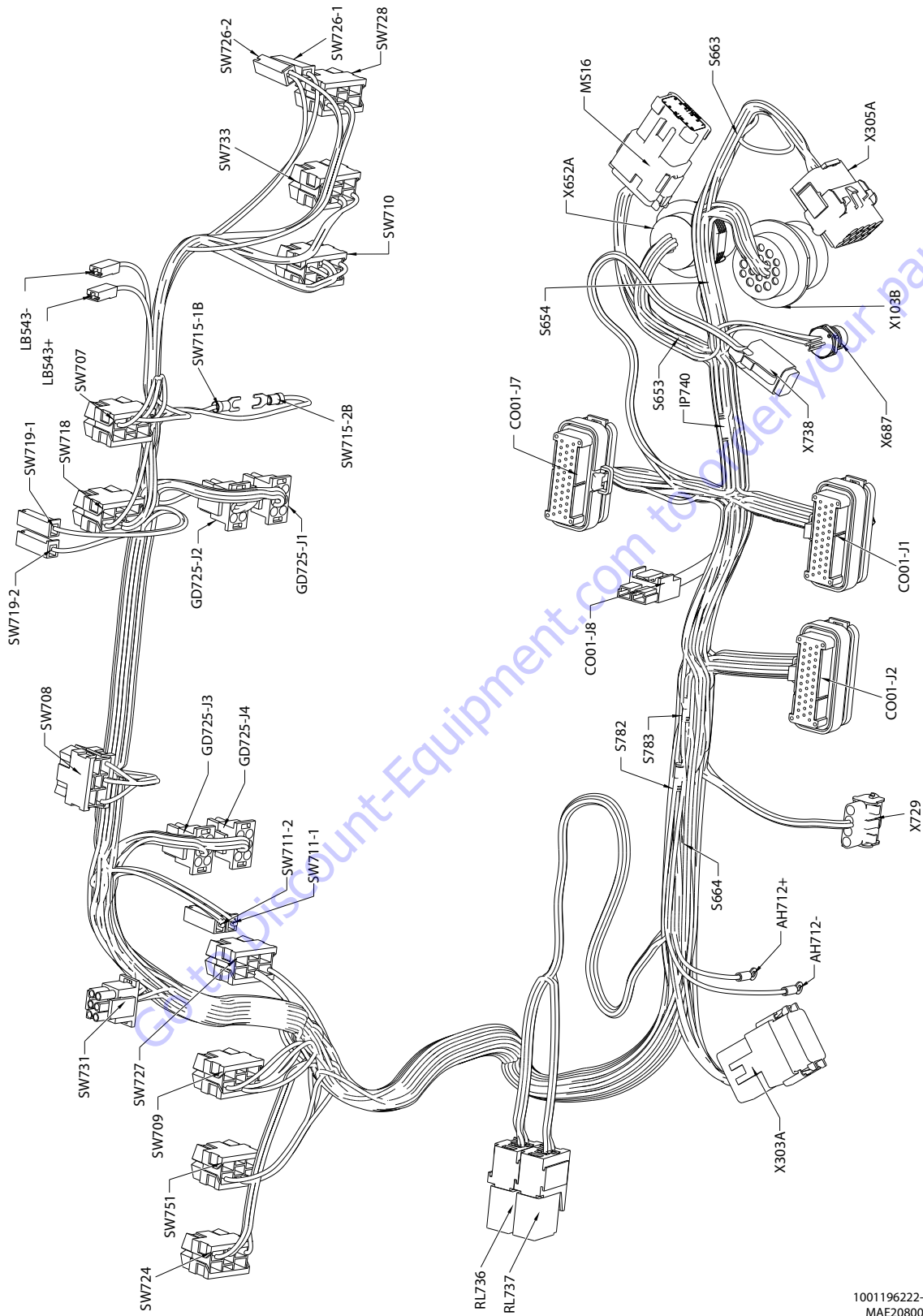

Figure 7-32. Platform Box Harness - Sheet 6 of 6 (SN 0300235168 through 0300259907, SN B30002655 to Present)

1001196222-1
MAE208001

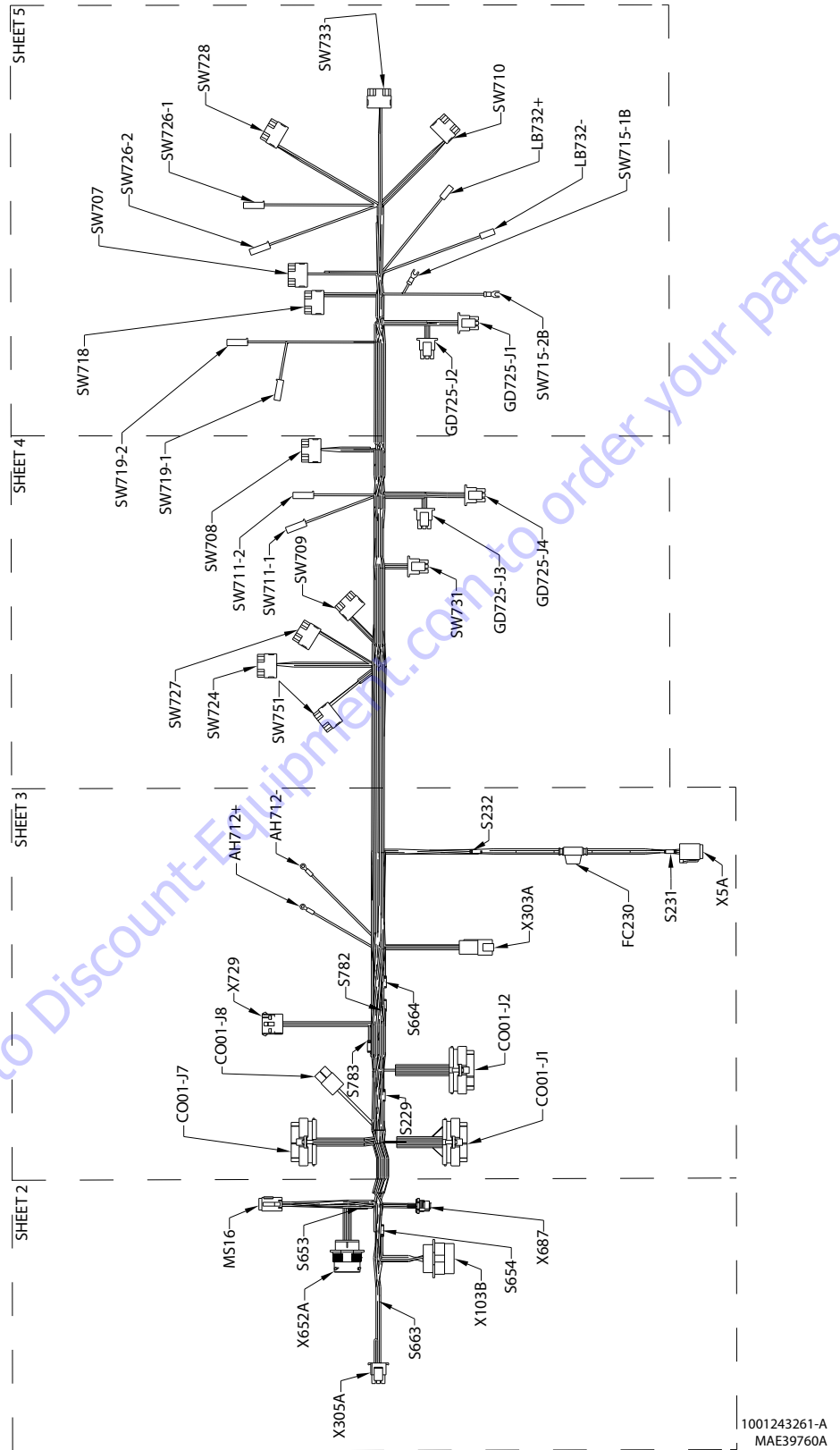

Figure 7-33. Platform Box Harness - Sheet 1 of 6 (SN 0300259908 to Present)

1001243261-A
MAE39760A

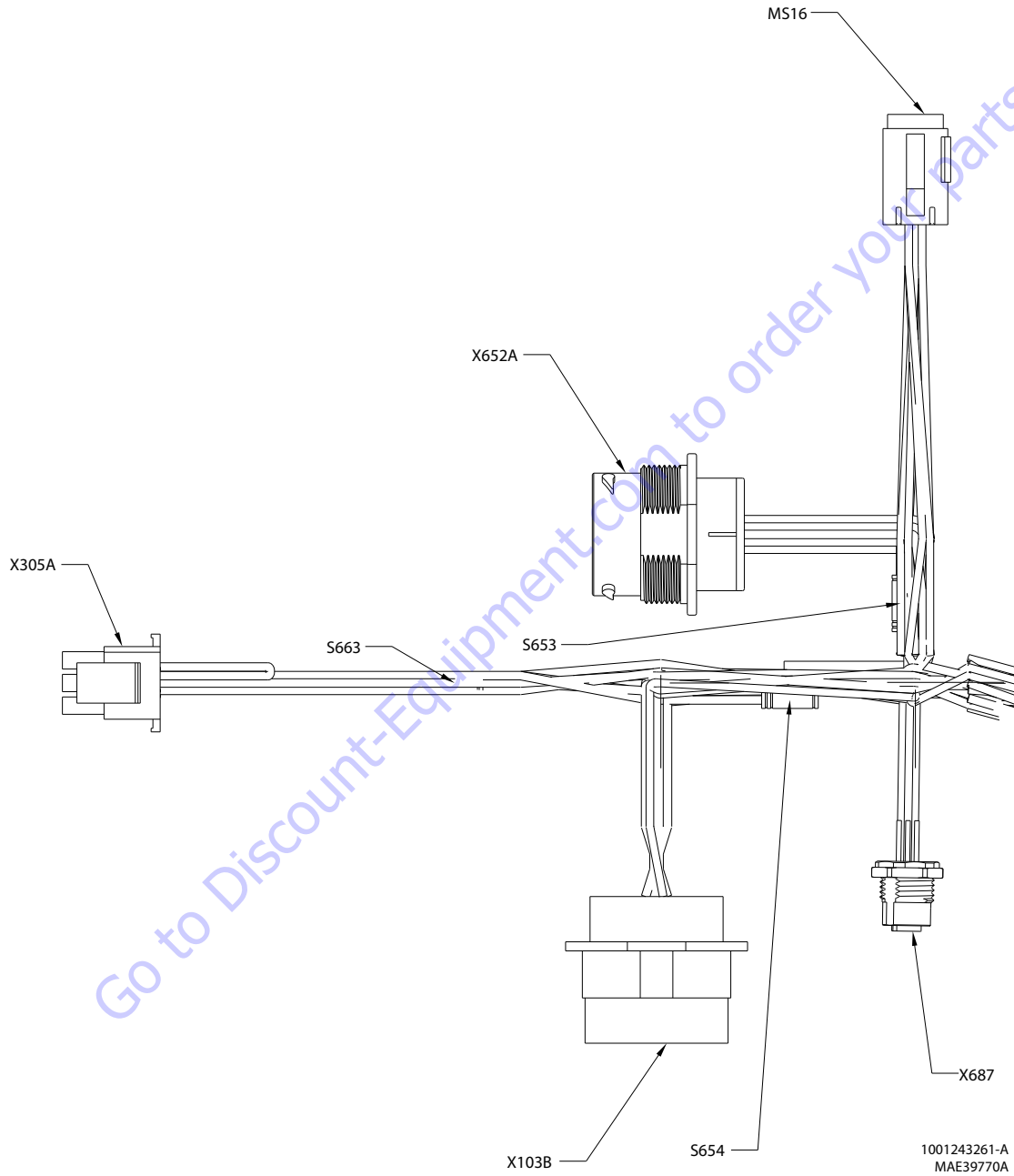

Figure 7-34. Platform Box Harness - Sheet 2 of 6

SECTION 7 - BASIC ELECTRICAL INFORMATION & ELECTRICAL SCHEMATICS

X305A					
CONN POS	WIRE COLOR	WIRE LABEL	GAUGE	JACKET	TO
1	WHT	1-35 GENERATOR SWITCH	18 AWG	GXL	C001-J7 (9)
2	WHT	1-38 GEN IGN SWITCH	18 AWG	GXL	S663 (2)
3					
4	WHT	1-39 FOOT SW DISENGAGED	18 AWG	GXL	C001-J7 (8)
5	WHT	1-40 FOOT SW	18 AWG	GXL	C001-J7 (4)
6					
7					
8					
9	WHT	1-85 ST POWER	18 AWG	GXL	C001-J2 (34)
10					
11					
12	WHT	1-93 ST SWITCH	18 AWG	GXL	S229 (2)
13					
14	WHT	1-551	18 AWG	GXL	X305A (15)
15	WHT	1-551	18 AWG	GXL	X305A (14)

X652A					
CONN POS	WIRE COLOR	WIRE LABEL	GAUGE	JACKET	TO
1	BLK	000-10-34 OPTION GND	18 AWG	GXL	S664 (1)
2					
3	WHT	4-15 PLAT DUMP 1	18 AWG	GXL	X103B (13)
4	WHT	4-8 PLAT LEVEL UP	18 AWG	GXL	S653 (1)
5	WHT	4-7 PLAT LEVEL DOWN	18 AWG	GXL	S654 (1)
6					
7					
8	WHT	4-88 PLAT ANGLE SEN 1	18 AWG	GXL	C001-J1 (25)
9	WHT	4-89 PLAT ANGLE SEN 2	18 AWG	GXL	C001-J1 (26)
10	WHT	4-125 PLAT ANGLE SEN 5V	18 AWG	GXL	C001-J7 (11)
11					
12	WHT	4-16 PLAT DUMP 2	18 AWG	GXL	X103B (15)
13	WHT	1-41 PLAT ROTATE LEFT	18 AWG	GXL	C001-J7 (5)
14	WHT	1-42 PLAT ROTATE RIGHT	18 AWG	GXL	C001-J7 (6)
15	WHT	1-36 JIB UP	18 AWG	GXL	C001-J7 (25)
16	WHT	1-43 JIB DOWN	18 AWG	GXL	C001-J7 (26)
17					
18					
19					
20					
21	BLK	000-40-90 PLAT SEN GND	18 AWG	GXL	C001-J7 (14)

S653					
CONN POS	WIRE COLOR	WIRE LABEL	GAUGE	JACKET	TO
1	WHT	4-8 PLAT LEVEL UP	18 AWG	GXL	X652A (4)
2	WHT	4-8 PLAT LEVEL UP	18 AWG	GXL	C001-J7 (15)
2	WHT	4-8 PLAT LEVEL UP	18 AWG	GXL	X103B (5)

S654					
CONN POS	WIRE COLOR	WIRE LABEL	GAUGE	JACKET	TO
1	WHT	4-7 PLAT LEVEL DOWN	18 AWG	GXL	X652A (5)
2	WHT	4-7 PLAT LEVEL DOWN	18 AWG	GXL	C001-J7 (16)
2	WHT	4-7 PLAT LEVEL DOWN	18 AWG	GXL	X103B (7)

S663					
CONN POS	WIRE COLOR	WIRE LABEL	GAUGE	JACKET	TO
1	WHT	1-90 SG POWER	18 AWG	GXL	C001-J7 (7)
1	WHT	1-90-1 ST/SG PWR	18 AWG	GXL	S232 (2)
2	WHT	1-38 GEN IGN SWITCH	18 AWG	GXL	X305A (2)

X687					
CONN POS	WIRE COLOR	WIRE LABEL	GAUGE	JACKET	TO
1					
2	WHT	LSS PWR	20 AWG	CABLE	S782 (2)
3	BLU	LSS GND	20 AWG	CABLE	S783 (2)
4	BLK	CAN 1 HI	20 AWG	CABLE	MS16 (10)
5	GRY	CAN 1 LO	20 AWG	CABLE	MS16 (7)

SECTION 7 - BASIC ELECTRICAL INFORMATION & ELECTRICAL SCHEMATICS

X103B					
CONN POS	WIRE COLOR	WIRE LABEL	GAUGE	JACKET	TO
1					
2	GRN	CAN LO	20 AWG	J1939 CABLE	MS16 (5)
3	YEL	CAN HI	20 AWGJ	J1939 CABLE	MS16 (2)
4	WHT	1-44 EMS	18 AWG	GXL	C001-J7 (3)
5	WHT	4-8 PLAT LEVEL UP	18 AWG	GXL	S653 (2)
6					
7	WHT	4-7 PLAT LEVEL DOWN	18 AWG	GXL	S654 (2)
8					
9	WHT	1-62 EMSB+	18 AWG	GXL	SW715-1B (1B)
10					
11	WHT	1-37 GROUND MODE	18 AWG	GXL	C001-J7 (1)
12	WHT	1-1 PWR	12 AWG	GXL	C001-J8 (2)
13	WHT	4-15 PLAT DUMP 1	18 AWG	GXL	X652A (3)
14					
15	WHT	4-16 PLAT DUMP 2	18 AWG	GXL	X652A (12)
16	BLK	000-10-14 GND	12 AWG	GXL	C001-J8 (1)
17					
18					
19					

MS16					
CONN POS	WIRE COLOR	WIRE LABEL	GAUGE	JACKET	TO
1	YEL	CAN HI	20 AWG	J1939 CABLE	C001-J7 (31)
2	YEL	CAN HI	20 AWG	J1939 CABLE	X103B (3)
3	YEL	CAN HI	20 AWG	J1939 CABLE	X303A (8)
4	GRN	CAN LO	20 AWG	J1939 CABLE	C001-J7 (30)
5	GRN	CAN LO	20 AWG	J1939 CABLE	X103B (2)
6	GRN	CAN LO	20 AWG	J1939 CABLE	X303A (9)
7	GRY	CAN1 LO	20 AWG	CABLE	X687 (5)
8					
9					
10	BLK	CAN1 HI	20 AWG	CABLE	X687 (4)
11					
12					

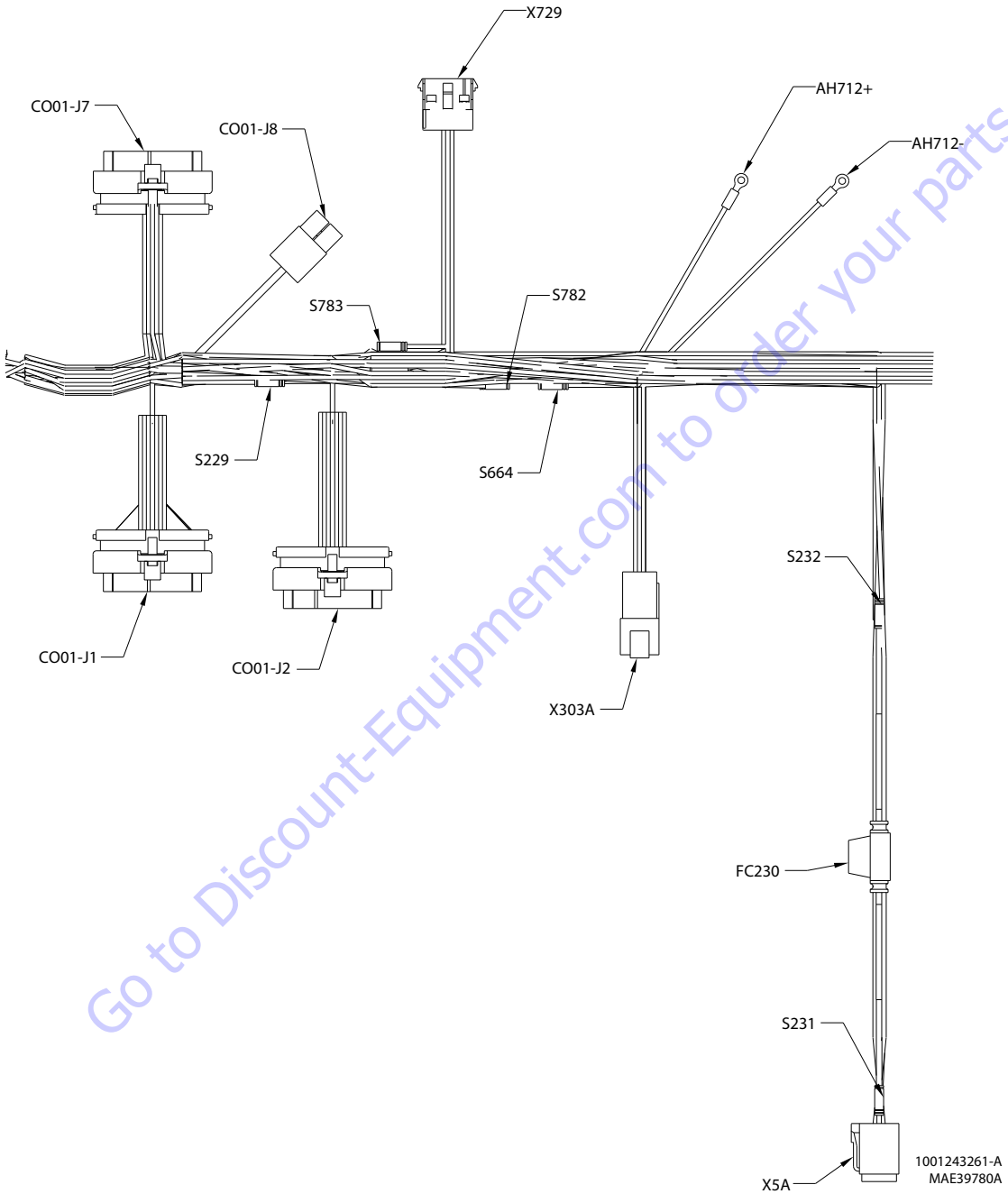

Figure 7-35. Platform Box Harness - Sheet 3 of 6 (SN 0300259908 to Present)

SECTION 7 - BASIC ELECTRICAL INFORMATION & ELECTRICAL SCHEMATICS

CO01-J1-NATURAL					
CONN POS	WIRE COLOR	WIRE LABEL	GAUGE	JACKET	TO
1					
2					
3					
4					
5	WHT	1-3 TELE IN	18 AWG	GXL	SW707 (3)
6	WHT	1-5 TELE OUT	18 AWG	GXL	SW707 (1)
7	WHT	1-6 PLTF ROTATE RIGHT	18 AWG	GXL	SW708 (3)
8	WHT	1-7 PLTF ROTATE LEFT	18 AWG	GXL	SW708 (1)
9	WHT	1-8 LEVEL UP	18 AWG	GXL	SW709 (3)
10	WHT	LEVEL DOWN	18 AWG	GXL	SW709 (1)
11	WHT	1-13 JIB UP	18 AWG	GXL	SW718 (3)
12	WHT	1-14 JIB DOWN	18 AWG	GXL	SW718 (1)
13	WHT	1-103 SPD PMP POT GND	18 AWG	GXL	SW731 (5)
14	WHT	1-9 START SWITCH	18 AWG	GXL	SW710 (3)
15	WHT	1-10 AUX POWER	18 AWG	GXL	SW710 (1)
16	WHT	1-110 CRAB STEER	18 AWG	GXL	SW751 (3)
17	WHT	1-111 COORD STEER	18 AWG	GXL	SW751 (1)
18	WHT	1-70 SWITCHES PWR	18 AWG	GXL	SW724 (2)
19					
20	WHT	1-91 ST SWITCH	18 AWG	GXL	S229 (1)
21	WHT	1-50 DUAL CAPACITY	18 AWG	GXL	SW733 (3)
22					
23	WHT	1-88 ST/SG INPUT 2	18 AWG	GXL	X5A (5)
24					
25	WHT	4-88 PLAT ANGLE SEN 1	18 AWG	GXL	X652A (8)
26	WHT	4-89 PLAT ANGLE SEN 2	18 AWG	GXL	X652A (9)
27	WHT	1-12 MAX SPEED	18 AWG	GXL	SW724 (3)
28	WHT	1-11 MIN SPEED	18 AWG	GXL	SW724 (1)
29	WHT	1-4 SOFT TOUCH	18 AWG	GXL	SW719-1 (1)
30	WHT	1-15 HEAD LIGHTS	18 AWG	GXL	SW726-1 (1)
31	WHT	1-2 HORN	18 AWG	GXL	SW711-1 (1)
32	WHT	1-101 CREEP SW	18 AWG	GXL	SW731 (2)
33	WHT	1-68 FUEL SELECT	18 AWG	GXL	SW727 (3)
34	WHT	1-105 SPD PMP POT PWR	18 AWG	GXL	SW731 (4)
35	WHT	1-104 SPD PMP POT SGL	18 AWG	GXL	SW731 (6)

AH712+-ALARM					
CONN POS	WIRE COLOR	WIRE LABEL	GAUGE	JACKET	TO
1	WHT	1-34 PLAT ALRM	18 AWG	GXL	C001-J7 (19)

S231					
CONN POS	WIRE COLOR	WIRE LABEL	GAUGE	JACKET	TO
1	BLK	FUSIBLE LINK	14 AWG	GXL	FC230 (1)
2	WHT	1-94 SKYG PWR	18 AWG	GXL	X5A (1)
2	WHT	1-95 SOFTT SENSE	18 AWG	GXL	X5A (3)

S229					
CONN POS	WIRE COLOR	WIRE LABEL	GAUGE	JACKET	TO
1	WHT	1-91 ST SWITCH	18 AWG	GXL	C001-J1 (20)
2	WHT	1-91-1 SOFTT OUT	18 AWG	GXL	X5A (6)
2	WHT	1-93 ST SWITCH	18 AWG	GXL	X305A (12)

S664					
CONN POS	WIRE COLOR	WIRE LABEL	GAUGE	JACKET	TO
1	BLK	000-10-34 OPTION GND	18 AWG	GXL	C001-J7 (29)
1	BLK	000-10-34 OPTION GND	18 AWG	GXL	X652A (1)
2	BLK	000-10-34 OPTION GND	18 AWG	GXL	X303A (6)

X5A					
CONN POS	WIRE COLOR	WIRE LABEL	GAUGE	JACKET	TO
1	WHT	1-94 SKYG PWR	18 AWG	GXL	S231 (1)
2	BLK	1-86 SG GND	18 AWG	GXL	C001-J7 (24)
3	WHT	1-95 SOFTT SENSE	18 AWG	GXL	S231 (1)
4	WHT	1-87 SG INPUT 1	18 AWG	GXL	C001-J7 (18)
5	WHT	1-88 ST/SG INPUT 2	18 AWG	GXL	C001-J1 (23)
6	WHT	1-91-1 SOFTT OUT	18 AWG	GXL	S229 (2)

SECTION 7 - BASIC ELECTRICAL INFORMATION & ELECTRICAL SCHEMATICS

C001-J7- BLACK					
CONN POS	WIRE COLOR	WIRE LABEL	GAUGE	JACKET	TO
1	WHT	1-37 GROUND MODE	18 AWG	GXL	X103B (11)
1	BLK	1-86 SG GND	18 AWG	GXL	X5A (2)
2	WHT	1-45 PLATF EMS	18 AWG	GXL	SW715-2B (2B)
3	WHT	1-44 EMS	18 AWG	GXL	X103B (4)
4	WHT	1-40 FOOT SW	18 AWG	GXL	X305A (5)
5	WHT	1-41 PLAT ROTATE LEFT	18 AWG	GXL	X652A (13)
6	WHT	1-42 PLAT ROTATE RIGHT	18 AWG	GXL	X652A (14)
7	WHT	1-90 SG POWER	18 AWG	GXL	S663 (1)
8	WHT	1-39FOOT SW DISENGAGED	18 AWG	GXL	X305A (4)
9	WHT	1-35 GENERATOR SWITCH	18 AWG	GXL	X305A (1)
10					
11	WHT	4-125 PLAT ANGLE SEN 5V	18 AWG	GXL	X652A (10)
12					
13					
14	BLK	000-40-90 PLAT SEN GND	18 AWG	GXL	X652A (21)
15	WHT	4-8 PLAT LEVEL UP	18 AWG	GXL	S653 (2)
16	WHT	4-7 PLAT LEVEL DOWN	18 AWG	GXL	S654 (2)
17					
18	WHT	1-87 SG INPUT 1	18 AWG	GXL	X5A (4)
19	WHT	1-34 PLAT ALRM	18 AWG	GXL	AH712+ (1)
20	WHT	000-10-16 PLAT ALARM GND	18 AWG	GXL	AH712- (1)
21					
22	BLK	000-10-30 LSS GND	18 AWG	GXL	S783 (1)
23	BLK	000-10-11 VALVES GND	18 AWG	GXL	X303A (5)
24	BLK	1-86 SG GND	18 AWG	GXL	X5A (2)
25	WHT	1-36 JIB UP	18 AWG	GXL	X652A (15)
26	WHT	1-43 JIB DOWN	18 AWG	GXL	X652A (16)
27					
28					
29	BLK	000-10-34 OPTION GND	18 AWG	GXL	S664 (1)
30	GRN	CAN LO	20 AWG	J1939 CABLE	MS16 (4)
31	YEL	CAN HI	20 AWG	J1939 CABLE	MS16 (1)
32					
33					
34					
35					

C001-J2-BLUE					
CONN POS	WIRE COLOR	WIRE LABEL	GAUGE	JACKET	TO
1					
2					
3					
4	WHT	1-67 PLTF ORIENT OVERRIDE	18 AWG	GXL	SW728 (1)
5					
6	WHT	1-20 TILT	18 AWG	GXL	GD725-J4 (5)
7	WHT	1-32 FOOT SWITCH ENABLE	18 AWG	GXL	GD725-J2 (2)
8	WHT	1-25 SYSTEM DISTRESS	18 AWG	GXL	GD725-J3 (6)
9	WHT	1-24 CREEP	18 AWG	GXL	GD725-J2 (1)
10	WHT	1-99 BROKEN CABLE	18 AWG	GXL	GD725-J3 (5)
11	WHT	1-22 PLATFORM OVERLOAD	18 AWG	GXL	GD725-J4 (3)
12	WHT	1-21 500#/600# MODE	18 AWG	GXL	GD725-J4 (4)
13	WHT	1-27 1000# MODE	18 AWG	GXL	GD725-J3 (4)
14	WHT	1-28 DRIVE ORIENT SW	18 AWG	GXL	GD725-J3 (3)
15	WHT	1-23 GENERATOR ON	18 AWG	GXL	GD725-J4 (2)
16	WHT	1-31 SOFTTCH/SKY GUARD	18 AWG	GXL	LB732+ (1)
17	WHT	1-29 GLOW PLUG	18 AWG	GXL	GD725-J4 (6)
18	BLK	000-10-27 GND	18 AWG	GXL	GD725-J2 (6)
19	WHT	1-120 PLAT LVL	18 AWG	GXL	GD725-J4 (1)
20	WHT	1-121 DRV DISABLE	18 AWG	GXL	GD725-J3 (1)
21	WHT	1-30 LOW FUEL	18 AWG	GXL	GD725-J2 (3)
22	WHT	1-498 1/4 FUEL	18 AWG	GXL	GD725-J1 (1)
23	WHT	1-499 3/4 FUEL	18 AWG	GXL	GD725-J1 (3)
24	WHT	1-500 1/2 FUEL	18 AWG	GXL	GD725-J1 (2)
25	BLK	1-497 FUEL GND	18 AWG	GXL	GD725-J1 (4)
26	WHT	1-66 POWER	18 AWG	GXL	X729 (1)
27	BLK	000-10-12 GND	18 AWG	GXL	X729 (4)
28	WHT	1-81 RECEIVE	18 AWG	GXL	X729 (2)
29	WHT	1-82 TRANSMIT	18 AWG	GXL	X729 (3)
30					
31					
32	WHT	1-33 LSS PWR	18 AWG	GXL	S782 (1)
33	WHT	1-89 OPTION POWER	18 AWG	GXL	X303A (7)
34	WHT	1-85 ST POWER	18 AWG	GXL	X305A (9)
35	WHT	1-501 FUEL FULL	18 AWG	GXL	GD725-J1 (6)

FC230					
CONN POS	WIRE COLOR	WIRE LABEL	GAUGE	JACKET	TO
1	BLK	FUSIBLE LINK	14 AWG	GXL	S231 (2)
2	BLK	FUSIBLE LINK	14 AWG	GXL	S232 (1)

SECTION 7 - BASIC ELECTRICAL INFORMATION & ELECTRICAL SCHEMATICS

X303A					
CONN POS	WIRE COLOR	WIRE LABEL	GAUGE	JACKET	TO
1					
2					
3					
4					
5	BLK	000-10-11 VALVES GND	18 AWG	GXL	C001-J7 (23)
6	BLK	000-10-34 OPTION GND	18 AWG	GXL	S664 (2)
7	WHT	1-89 OPTION POWER	18 AWG	GXL	C001-J2 (33)
8	YEL	CAN HI	20 AWG	J1939 CABLE	MS16 (3)
9	GRN	CAN LO	20 AWG	J1939 CABLE	MS16 (6)
10					
11	BLK	000-10-30-2 LSS GND	18 AWG	GXL	S783 (2)
12	WHT	1-33-2 LSS PWR	18 AWG	GXL	S782 (2)

X729-ANALYZER					
CONN POS	WIRE COLOR	WIRE LABEL	GAUGE	JACKET	TO
1	WHT	1-66 POWER	18 AWG	GXL	C001-J2 (26)
2	WHT	1-81 RECEIVE	18 AWG	GXL	C001-J2 (28)
3	WHT	1-82 TRANSMIT	18 AWG	GXL	C001-J2 (29)
4	BLK	000-10-12 GND	18 AWG	GXL	C001-J2 (27)

C001-J8					
CONN POS	WIRE COLOR	WIRE LABEL	GAUGE	JACKET	TO
1	BLK	000-10-14 GND	12 AWG	GXL	X103B (16)
2	WHT	1-1 PWR	12 AWG	GXL	X103B (12)

AH712-ALARM					
CONN POS	WIRE COLOR	WIRE LABEL	GAUGE	JACKET	TO
1	WHT	000-10-16 PLAT ALARM GND	18 AWG	GXL	C001-J7 (20)

S783					
CONN POS	WIRE COLOR	WIRE LABEL	GAUGE	JACKET	TO
1	BLK	000-10-30 LSS GND	18 AWG	GXL	C001-J7 (22)
2	BLK	000-10-30-2 LSS GND	18 AWG	GXL	X303A (11)
2	BLU	LSS GND	20 AWG	CABLE	X687 (3)

S782					
CONN POS	WIRE COLOR	WIRE LABEL	GAUGE	JACKET	TO
1	WHT	1-33 LSS PWR	18 AWG	GXL	C001-J2 (32)
2	WHT	1-33-2 LSS PWR	18 AWG	GXL	X303A (12)
2	WHT	LSS PWR	20 AWG	CABLE	X687 (2)

S232					
CONN POS	WIRE COLOR	WIRE LABEL	GAUGE	JACKET	TO
1	BLK	FUSIBLE LINK	14 AWG	GXL	FC230 (2)
2	WHT	1-90-1 ST/SG PWR	18 AWG	GXL	S663 (1)

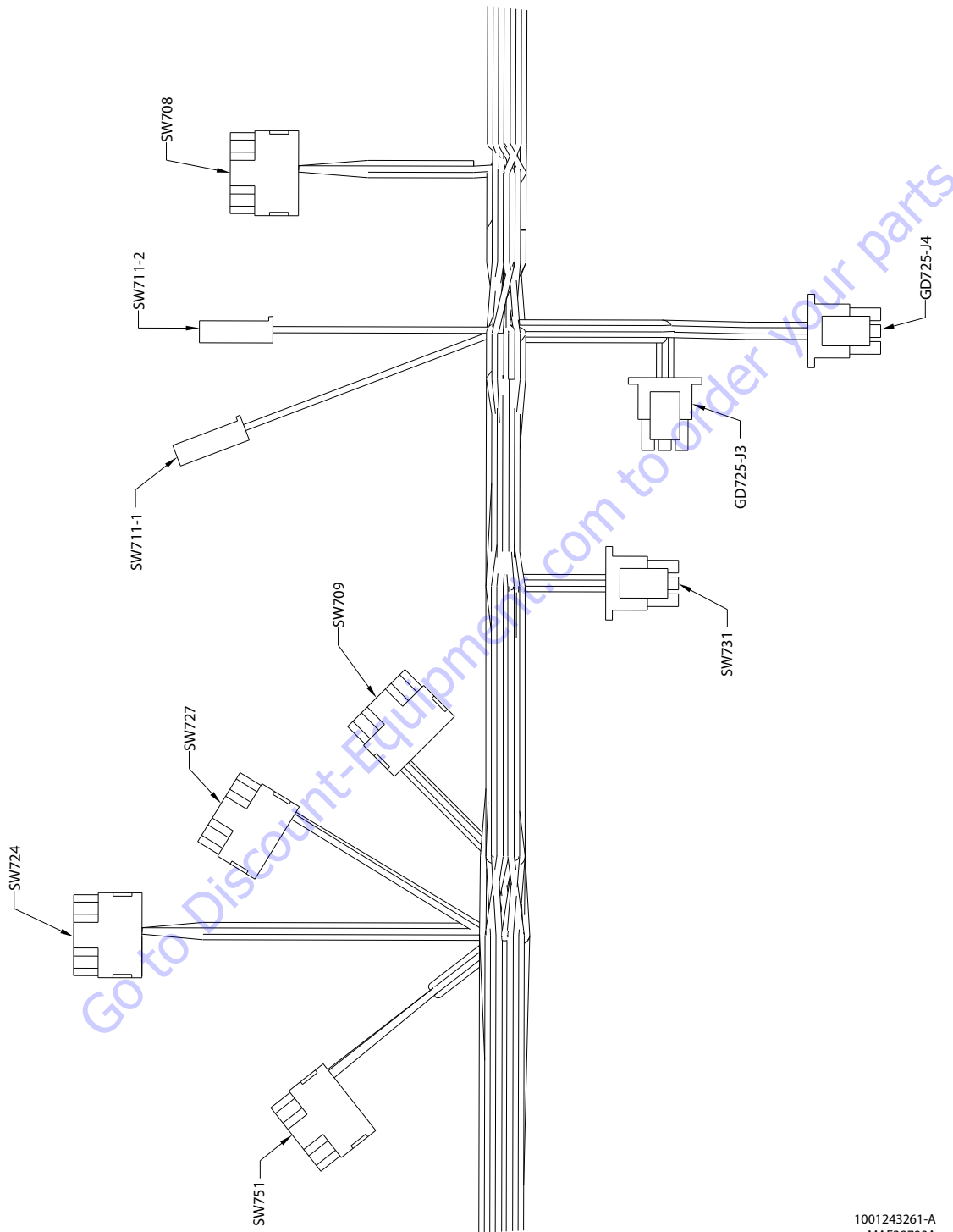

Figure 7-36. Platform Box Harness - Sheet 4 of 6 (SN 0300259908 to Present)

1001243261-A
MAE39790A

SECTION 7 - BASIC ELECTRICAL INFORMATION & ELECTRICAL SCHEMATICS

SW751-STEER SELECT					
CONN POS	WIRE COLOR	WIRE LABEL	GAUGE	JACKET	TO
1	WHT	1-111 COORD STEER	18 AWG	GXL	C001-J1 (17)
2	WHT	1-69 SWITCHES PWR	18 AWG	GXL	SW724 (2)
2	WHT	1-80 SWITCHES PWR	18 AWG	GXL	SW727 (2)
3	WHT	1-110 CRAB STEER	18 AWG	GXL	C001-J1 (16)
4					
5					
6					

SW711-2-HORN					
CONN POS	WIRE COLOR	WIRE LABEL	GAUGE	JACKET	TO
1	WHT	1-102 SW PWR	18 AWG	GXL	SW731 (3)
1	WHT	1-87 SW PWR	18 AWG	GXL	SW719-2 (1)

SW711-1-HORN					
CONN POS	WIRE COLOR	WIRE LABEL	GAUGE	JACKET	TO
1	WHT	1-2 HORN	18 AWG	GXL	C001-J1 (31)

SW727-FUEL SELECT					
CONN POS	WIRE COLOR	WIRE LABEL	GAUGE	JACKET	TO
1					
2	WHT	1-78 SWITCHES PWR	18 AWG	GXL	SW726-2 (1)
2	WHT	1-80 SWITCHES PWR	18 AWG	GXL	SW751 (2)
3	WHT	1-68 FUEL SELECT	18 AWG	GXL	C001-J1 (33)
4					
5					
6					

SW731-PUMP POT					
CONN POS	WIRE COLOR	WIRE LABEL	GAUGE	JACKET	TO
1					
2	WHT	1-101 CREEP SW	18 AWG	GXL	C001-J1 (32)
3	WHT	1-102 SW PWR	18 AWG	GXL	SW711-2 (1)
3	WHT	1-71 SW PWR	18 AWG	GXL	SW707 (2)
4	WHT	1-105 SPD PMP POT PWR	18 AWG	GXL	C001-J1 (34)
5	WHT	1-103 SPD PMP POT GND	18 AWG	GXL	C001-J1 (13)
6	WHT	1-104 SPD PMP POT SGL	18 AWG	GXL	C001-J1 (35)

GD725-J3					
CONN POS	WIRE COLOR	WIRE LABEL	GAUGE	JACKET	TO
1	WHT	1-121 DRV DISABLE	18 AWG	GXL	C001-J2 (20)
2					
3	WHT	1-28 DRIVE ORIENT SW	18 AWG	GXL	C001-J2 (14)
4	WHT	1-27 1000# MODE	18 AWG	GXL	C001-J2 (13)
5	WHT	1-99 BROKEN CABLE	18 AWG	GXL	C001-J2 (10)
6	WHT	1-25 SYSTEM DISTRESS	18 AWG	GXL	C001-J2 (8)

GD725-J4					
CONN POS	WIRE COLOR	WIRE LABEL	GAUGE	JACKET	TO
1	WHT	1-120 PLAT LVL	18 AWG	GXL	C001-J2 (19)
2	WHT	1-23 GENERATOR ON	18 AWG	GXL	C001-J2 (15)
3	WHT	1-22 PLATFORM OVERLOAD	18 AWG	GXL	C001-J2 (11)
4	WHT	1-21 500#/600# MODE	18 AWG	GXL	C001-J2 (12)
5	WHT	1-20 TILT	18 AWG	GXL	C001-J2 (6)
6	WHT	1-29 GLOW PLUG	18 AWG	GXL	C001-J2 (17)

SW708-PLATFORM ROTATE					
CONN POS	WIRE COLOR	WIRE LABEL	GAUGE	JACKET	TO
1	WHT	1-6 PLTF ROTATE RIGHT	18 AWG	GXL	C001-J1 (7)
2	WHT	1-72 SWITCHES PWR	18 AWG	GXL	SW733 (2)
2	WHT	1-73 SWITCHES PWR	18 AWG	GXL	SW709 (2)
3	WHT	1-7 PLTF ROTATE LEFT	18 AWG	GXL	C001-J1 (8)
4					
5					
6					

SW709-LEVEL					
CONN POS	WIRE COLOR	WIRE LABEL	GAUGE	JACKET	TO
1	WHT	1-8 LEVEL UP	18 AWG	GXL	C001-J1 (9)
2	WHT	1-73 SWITCHES PWR	18 AWG	GXL	SW708 (2)
2	WHT	1-74 SWITCHES PWR	18 AWG	GXL	SW710 (2)
3	WHT	LEVEL DOWN	18 AWG	GXL	C001-J1 (10)
4					
5					
6					

SW724-ENGINE SPEED					
CONN POS	WIRE COLOR	WIRE LABEL	GAUGE	JACKET	TO
1	WHT	1-12 MAX SPEED	18 AWG	GXL	C001-J1 (27)
2	WHT	1-69 SWITCHES PWR	18 AWG	GXL	SW751 (2)
2	WHT	1-70 SWITCHES PWR	18 AWG	GXL	C001-J1 (18)
3	WHT	1-11 MIN SPEED	18 AWG	GXL	C001-J1 (28)
4					
5					
6					

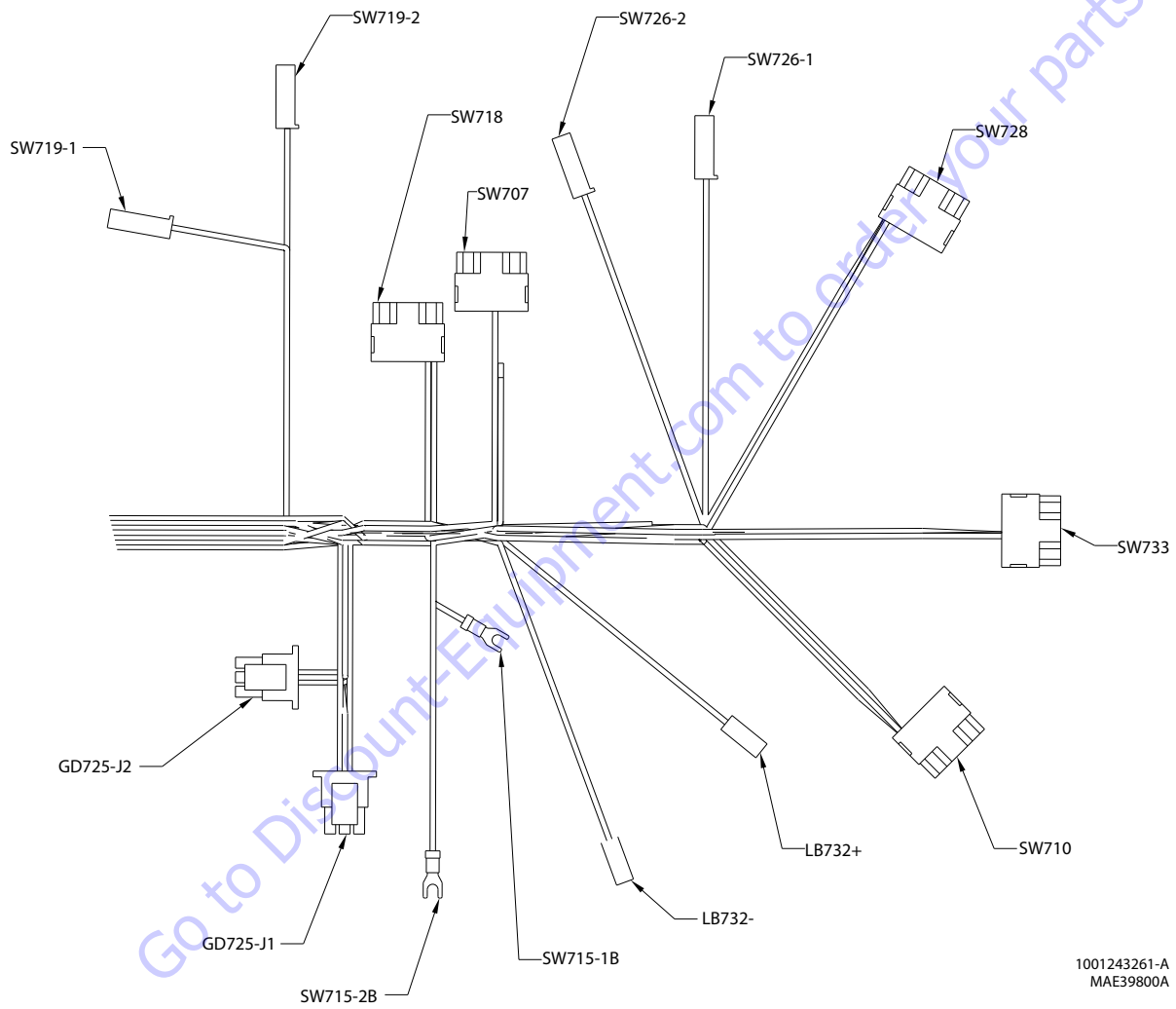

1001243261-A
MAE39800A

Figure 7-37. Platform Box Harness - Sheet 5 of 6 (SN 0300259908 to Present)

SECTION 7 - BASIC ELECTRICAL INFORMATION & ELECTRICAL SCHEMATICS

SW718-JIB LIFT					
CONN POS	WIRE COLOR	WIRE LABEL	GAUGE	JACKET	TO
1	WHT	1-13 JIB UP	18 AWG	GXL	C001-J1 (11)
2	WHT	1-76 SWITCHES PWR	18 AWG	GXL	SW728 (2)
2	WHT	1-77 SWITCHES PWR	18 AWG	GXL	SW726-2 (1)
3	WHT	1-14 JIB DOWN	18 AWG	GXL	C001-J1 (12)
4					
5					
6					

GD725-J2					
CONN POS	WIRE COLOR	WIRE LABEL	GAUGE	JACKET	TO
1	WHT	1-24 CREEP	18 AWG	GXL	C001-J2 (9)
2	WHT	1-32 FOOT SWITCH ENABLE	18 AWG	GXL	C001-J2 (7)
3	WHT	1-30 LOW FUEL	18 AWG	GXL	C001-J2 (21)
4					
5					
6	BLK	000-10-27 GND	18 AWG	GXL	C001-J2 (18)
6	BLK	000-10-501 GND	18 AWG	GXL	LB732- (1)

SW707-MAIN TELE					
CONN POS	WIRE COLOR	WIRE LABEL	GAUGE	JACKET	TO
1	WHT	1-3 TELE IN	18 AWG	GXL	C001-J1 (5)
2	WHT	1-71 SW PWR	18 AWG	GXL	SW731 (3)
2	WHT	1-81 SW PWR	18 AWG	GXL	SW733 (2)
3	WHT	1-5 TELE OUT	18 AWG	GXL	C001-J1 (6)
4					
5					
6					

SW710-START AUX					
CONN POS	WIRE COLOR	WIRE LABEL	GAUGE	JACKET	TO
1	WHT	1-9 START SWITCH	18 AWG	GXL	C001-J1 (14)
2	WHT	1-74 SWITCHES PWR	18 AWG	GXL	SW709 (2)
2	WHT	1-75 SWITCHES PWR	18 AWG	GXL	SW728 (2)
3	WHT	1-10 AUX POWER	18 AWG	GXL	C001-J1 (15)
4					
5					
6					

SW733-DUAL CAPACITY					
CONN POS	WIRE COLOR	WIRE LABEL	GAUGE	JACKET	TO
1					
2	WHT	1-72 SWITCHES PWR	18 AWG	GXL	SW708 (2)
2	WHT	1-81 SW PWR	18 AWG	GXL	SW707 (2)
3	WHT	1-50 DUAL CAPACITY	18 AWG	GXL	C001-J1 (21)
4					
5					
6					

LB732+-SKY GUARD WARNING					
CONN POS	WIRE COLOR	WIRE LABEL	GAUGE	JACKET	TO
1	WHT	1-31 SOFTTCH/SKY GUARD	18 AWG	GXL	C001-J2 (16)

SW715-1B-E STOP					
CONN POS	WIRE COLOR	WIRE LABEL	GAUGE	JACKET	TO
1B	WHT	1-62 EMSB+	18 AWG	GXL	X103B (9)

LB732--SKY GUARD WARNING					
CONN POS	WIRE COLOR	WIRE LABEL	GAUGE	JACKET	TO
1	BLK	000-10-501 GND	18 AWG	GXL	GD725-J2 (6)

SW715-2B-E STOP					
CONN POS	WIRE COLOR	WIRE LABEL	GAUGE	JACKET	TO
2B	WHT	1-45 PLATF EMS	18 AWG	GXL	C001-J7 (2)

SW726-2-HEAD AND TAIL LIGHTS					
CONN POS	WIRE COLOR	WIRE LABEL	GAUGE	JACKET	TO
1	WHT	1-77 SWITCHES PWR	18 AWG	GXL	SW718 (2)
1	WHT	1-78 SWITCHES PWR	18 AWG	GXL	SW727 (2)

SW726-1-HEAD AND TAIL LIGHTS					
CONN POS	WIRE COLOR	WIRE LABEL	GAUGE	JACKET	TO
1	WHT	1-15 HEAD LIGHTS	18 AWG	GXL	C001-J1 (30)

SECTION 7 - BASIC ELECTRICAL INFORMATION & ELECTRICAL SCHEMATICS

SW719-1-SOFTTOUCH/SKY GUARD					
CONN POS	WIRE COLOR	WIRE LABEL	GAUGE	JACKET	TO
1	WHT	1-4 SOFT TOUCH	18 AWG	GXL	C001-J1 (29)

SW719-2-SOFTTOUCH/SKY GUARD					
CONN POS	WIRE COLOR	WIRE LABEL	GAUGE	JACKET	TO
1	WHT	1-87 SW PWR	18 AWG	GXL	SW711-2 (1)

GD725-J1					
CONN POS	WIRE COLOR	WIRE LABEL	GAUGE	JACKET	TO
1	WHT	1-498 1/4 FUEL	18 AWG	GXL	C001-J2 (22)
2	WHT	1-500 1/2 FUEL	18 AWG	GXL	C001-J2 (24)
3	WHT	1-499 3/4 FUEL	18 AWG	GXL	C001-J2 (23)
4	BLK	1-497 FUEL GND	18 AWG	GXL	C001-J2 (25)
5					
6	WHT	1-501 FUEL FULL	18AWG	GXL	C001-J2 (35)

SW728-DRIVE ORIENTATION OVERRIDE					
CONN POS	WIRE COLOR	WIRE LABEL	GAUGE	JACKET	TO
1	WHT	1-67 PLTF ORIENT OVERRIDE	18 AWG	GXL	C001-J2 (4)
2	WHT	1-75 SWITCHES PWR	18 AWG	GXL	SW710 (2)
2	WHT	1-76 SWITCHES PWR	18 AWG	GXL	SW718 (2)
3					
4					
5					
6					

Go to Discount-Equipment.com to order your parts

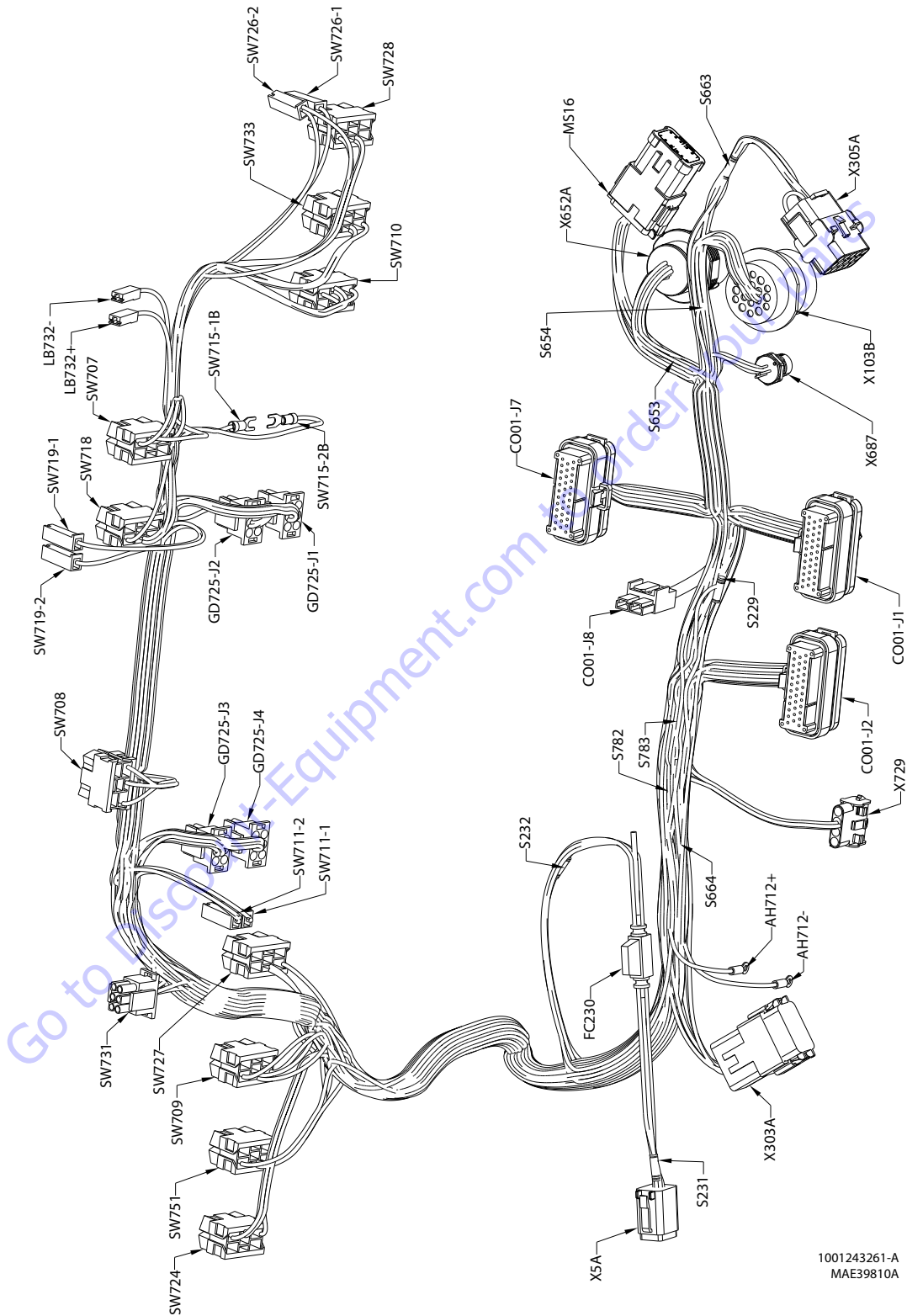

1001243261-A
MAE39810A

Figure 7-38. Platform Box Harness - Sheet 6 of 6 (SN 0300259908 to Present)

BACK VIEW OF CONNECTOR
SAME FOR BOTH ENDS



6 CONTACTS SIZE #12
13 CONTACTS SIZE #16

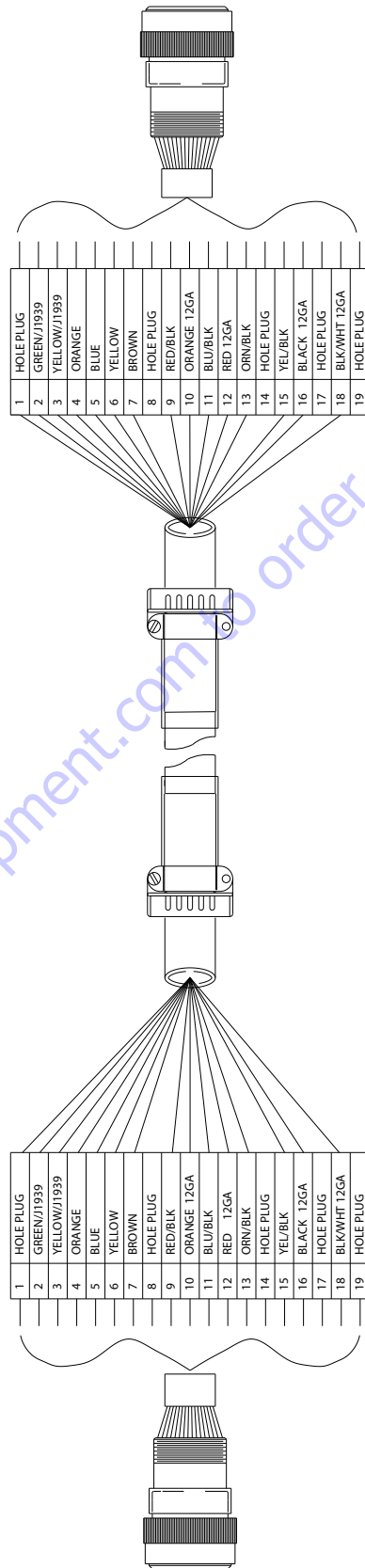

1001188533-C
/MAE20520

Figure 7-39. Main Boom Harness (Without Jib)

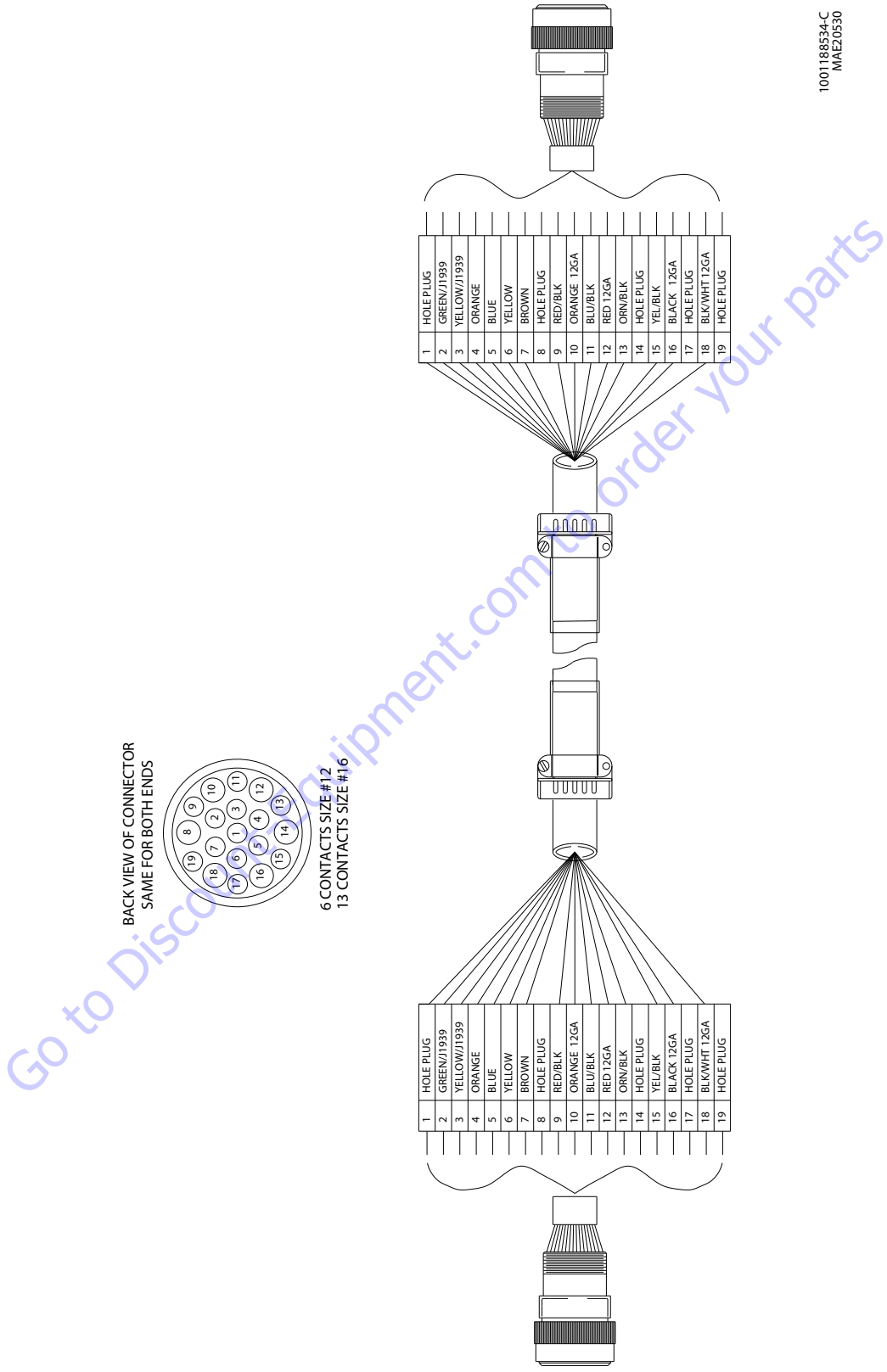
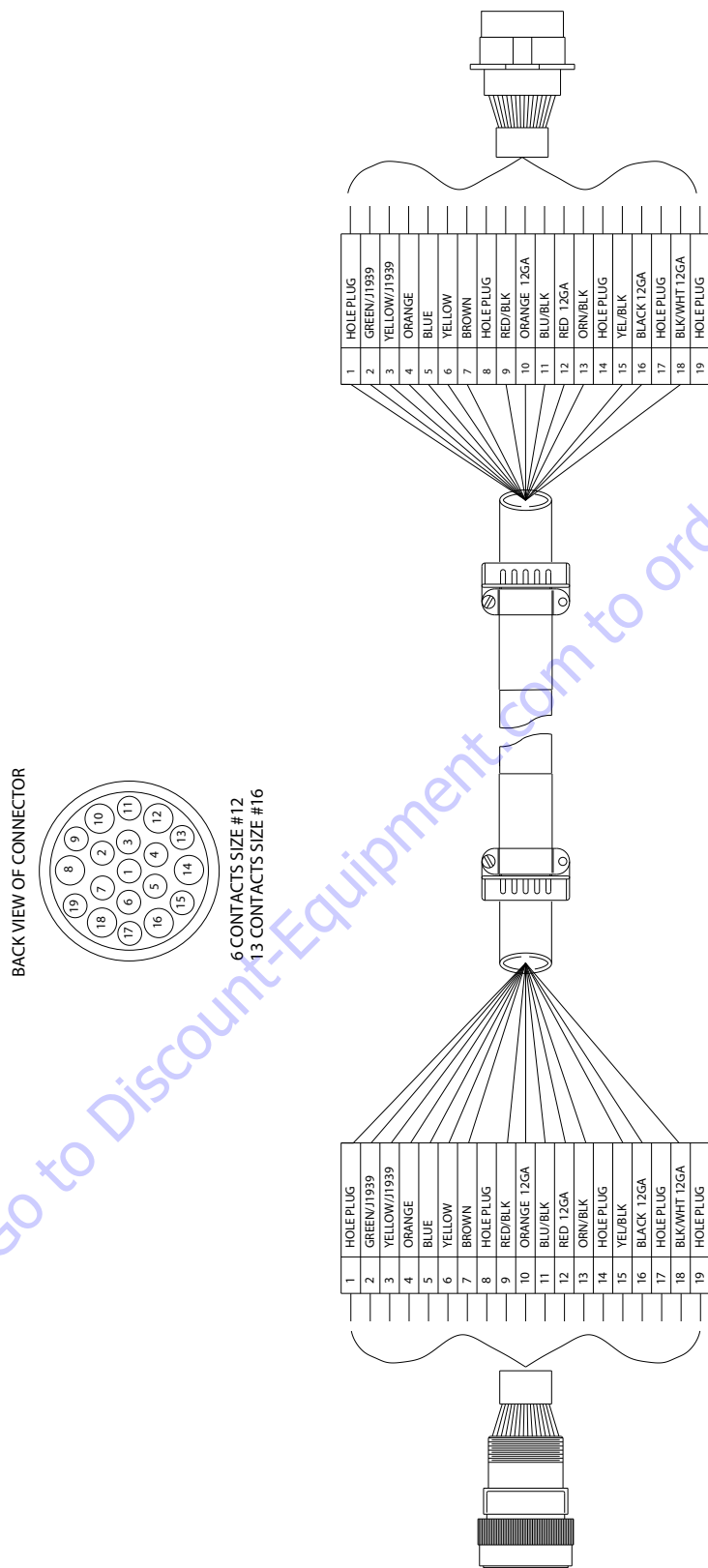

Figure 7-40. Main Boom Harness (With Jib)



1001206082-C
MAE20540

Figure 7-41. Main Boom Harness (TT)

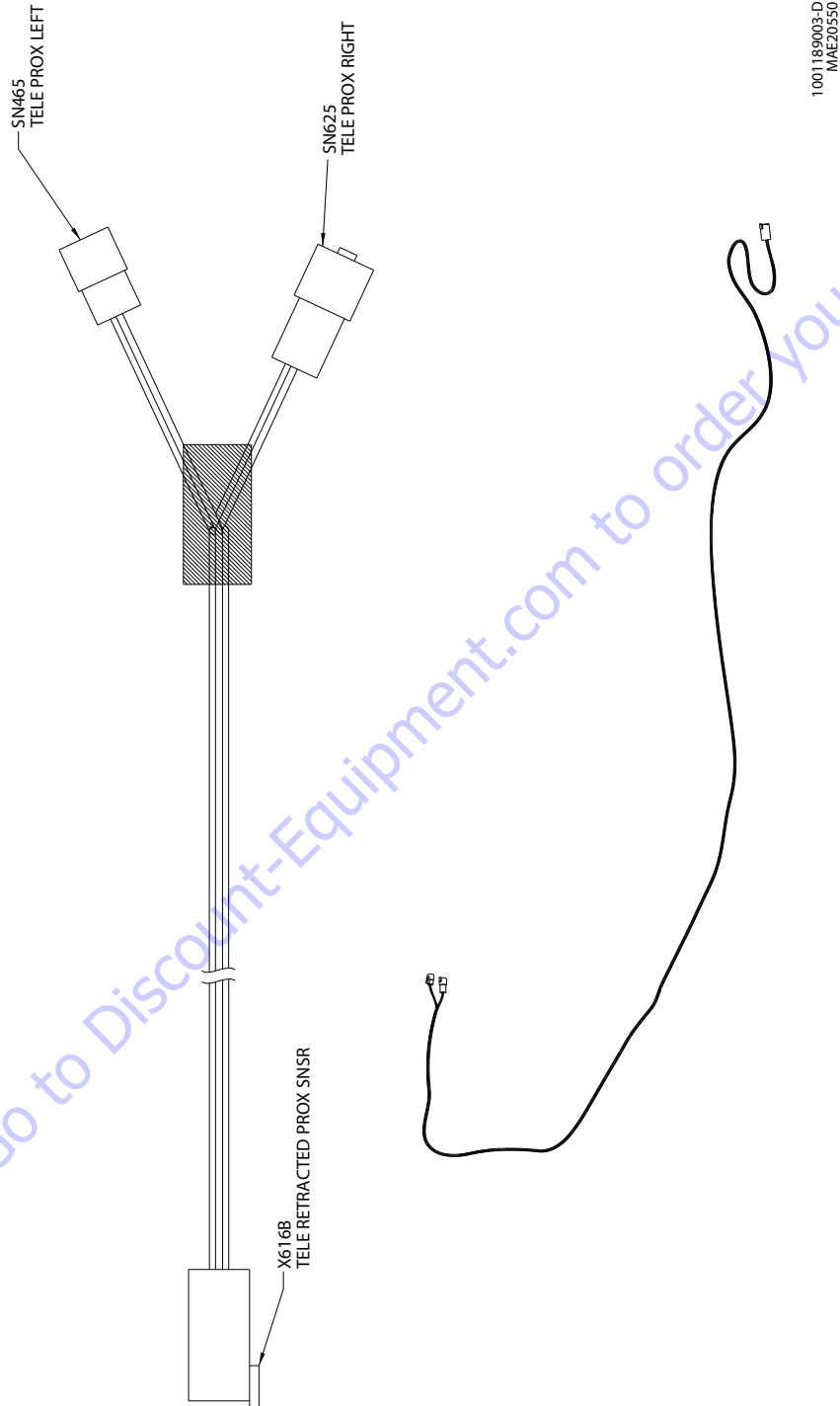

Figure 7-42. Proximity Switch Harness (Telescope In)

SECTION 7 - BASIC ELECTRICAL INFORMATION & ELECTRICAL SCHEMATICS

SN465 TELE PROX LEFT					
CONN POS	WIRE COLOR	WIRE LABEL	GAUGE	JACKET	TO
1	ORN/BLK	CABLE CABLE	18 AWG	TFFN	X616B (1)
2	BLU/RED	CABLE CABLE	18 AWG	TFFN	X616B (3)
3	BLK/RED	CABLE CABLE	18 AWG	TFFN	X616B (2)

X616B TELE RETRACTED PROX SNSR					
CONN POS	WIRE COLOR	WIRE LABEL	GAUGE	JACKET	TO
1	ORN/BLK	CABLE CABLE	18 AWG	TFFN	SN465 (1)
2	BLK/RED	CABLE CABLE	18 AWG	TFFN	SN465 (3)
3	BLU/RED	CABLE CABLE	18 AWG	TFFN	SN465 (2)
4	YEL/BLK	CABLE CABLE	18 AWG	TFFN	SN625 (1)
5	BRN/BLK	CABLE CABLE	18 AWG	TFFN	SN625 (3)
6	BLU/BLK	CABLE CABLE	18 AWG	TFFN	SN625 (2)

SN625 TELE PROX RIGHT					
CONN POS	WIRE COLOR	WIRE LABEL	GAUGE	JACKET	TO
1	YEL/BLK	CABLE CABLE	18 AWG	TFFN	X616B (4)
2	BLU/BLK	CABLE CABLE	18 AWG	TFFN	X616B (6)
3	BRN/BLK	CABLE CABLE	18 AWG	TFFN	X616B (5)

Go to Discount-Equipment.com to order your parts

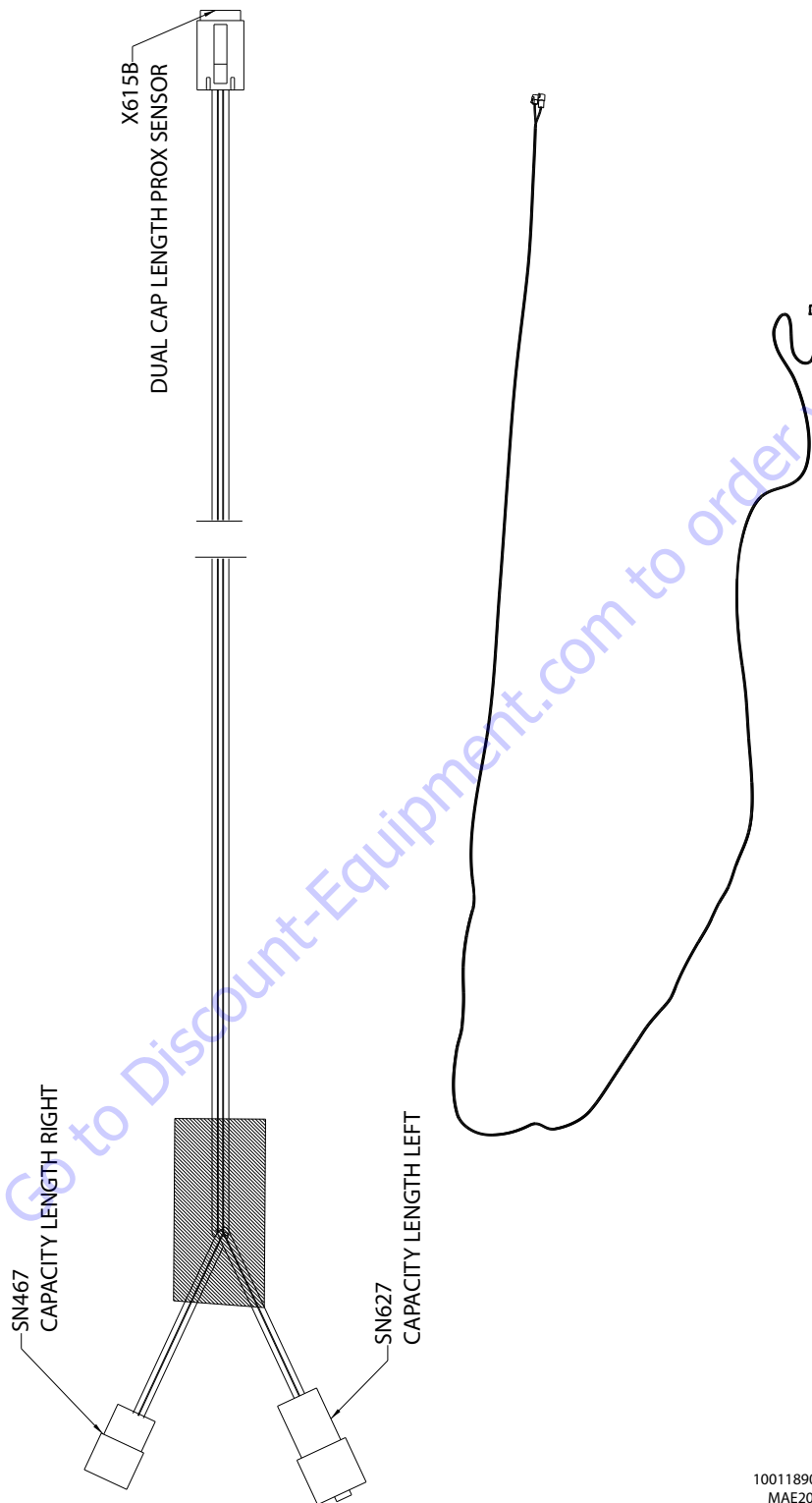

1001189004-E
MAE20590E

Figure 7-43. Proximity Switch Harness (Capacity) - SN 0300235168 through 0300257780, B300002655 to Present

SECTION 7 - BASIC ELECTRICAL INFORMATION & ELECTRICAL SCHEMATICS

SN467 CAPACITY LENGTH RIGHT					
CONN POS	WIRE COLOR	WIRE LABEL	GAUGE	JACKET	TO
1	ORN/BLK	CABLE CABLE	18 AWG	TFFN	X615B (4)
2	BLU/RED	CABLE CABLE	18 AWG	TFFN	X615B (6)
3	BLK/RED	CABLE CABLE	18 AWG	TFFN	X615B (5)

X615B DUAL CAP LENGTH PROX SENSOR					
CONN POS	WIRE COLOR	WIRE LABEL	GAUGE	JACKET	TO
1	YEL/BLK	CABLE CABLE	18 AWG	TFFN	SN627 (1)
2	BRN/BLK	CABLE CABLE	18 AWG	TFFN	SN627 (3)
3	BLU/BLK	CABLE CABLE	18 AWG	TFFN	SN627 (2)
4	ORN/BLK	CABLE CABLE	18 AWG	TFFN	SN467 (1)
5	BLK/RED	CABLE CABLE	18 AWG	TFFN	SN467 (3)
6	BLU/RED	CABLE CABLE	18 AWG	TFFN	SN467 (2)

SN627 CAPACITY LENGTH LEFT					
CONN POS	WIRE COLOR	WIRE LABEL	GAUGE	JACKET	TO
1	YEL/BLK	CABLE CABLE	18 AWG	TFFN	X615B (1)
2	BLU/BLK	CABLE CABLE	18 AWG	TFFN	X615B (3)
3	BRN/BLK	CABLE CABLE	18 AWG	TFFN	X615B (2)

Go to Discount-Equipment.com to order your parts

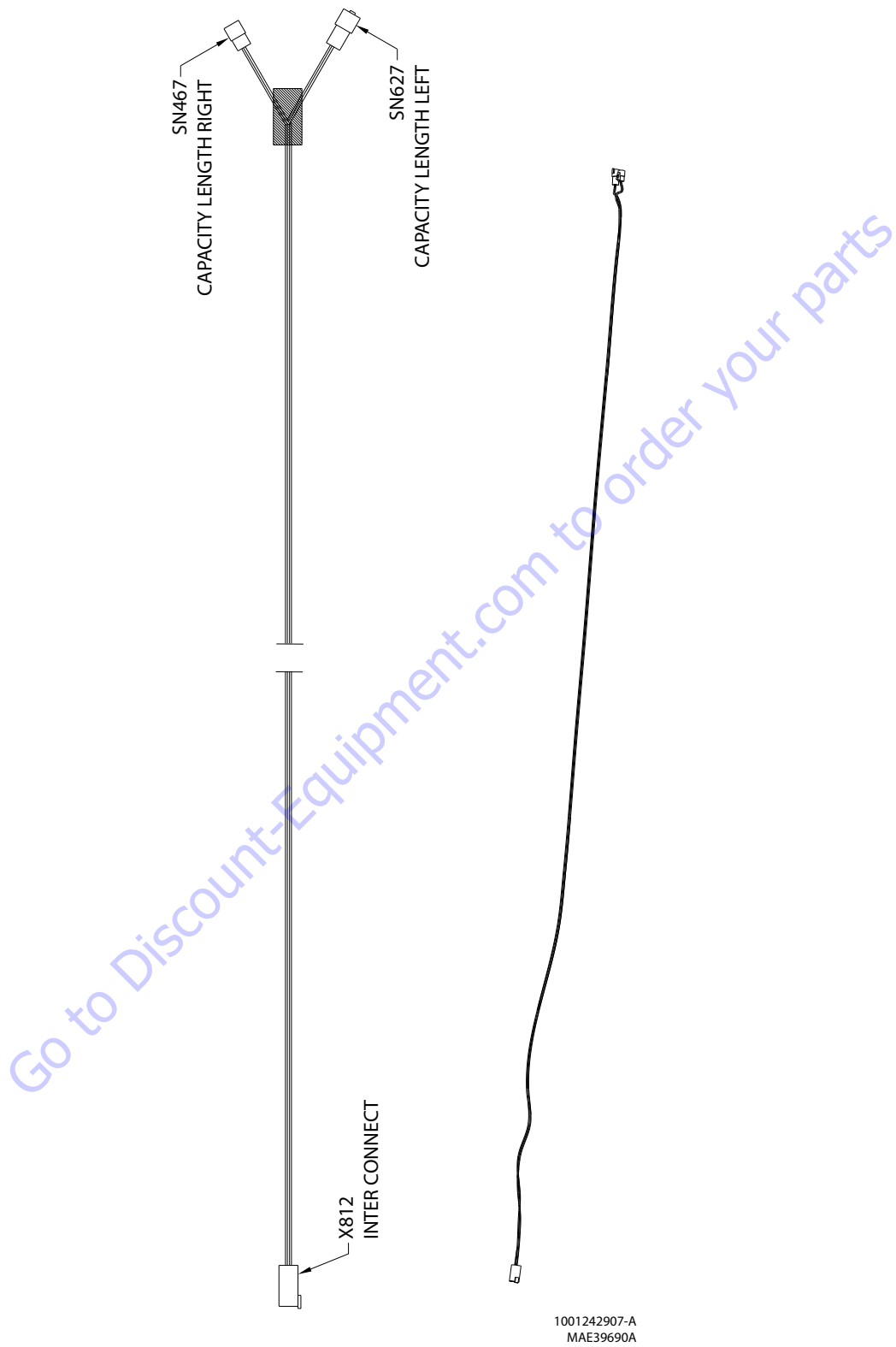

Figure 7-44. Proximity Switch Harness (Capacity) - SN 0300257781 to Present

SECTION 7 - BASIC ELECTRICAL INFORMATION & ELECTRICAL SCHEMATICS

X812 INTER CONNECT					
CONNP OS	WIRE COLOR	WIRE LABEL	GAUGE	JACKET	TO
1	YEL/BLK	CABLE CABLE	18 AWG	TFFN	SN627 (1)
2	BRN/BLK	CABLE CABLE	18 AWG	TFFN	SN627 (3)
3	BLU/BLK	CABLE CABLE	18 AWG	TFFN	SN627 (2)
4	ORN/BLK	CABLE CABLE	18 AWG	TFFN	SN467 (1)
5	BLK/RED	CABLE CABLE	18 AWG	TFFN	SN467 (3)
6	BLU/RED	CABLE CABLE	18 AWG	TFFN	SN467 (2)

SN627 CAPACITY LENGTH LEFT					
CONNP OS	WIRE COLOR	WIRE LABEL	GAUGE	JACKET	TO
1	YEL/BLK	CABLE CABLE	18 AWG	TFFN	X812 (1)
2	BLU/BLK	CABLE CABLE	18 AWG	TFFN	X812 (3)
3	BRN/BLK	CABLE CABLE	18 AWG	TFFN	X812 (2)

SN467 CAPACITY LENGTH RIGHT					
CONNP OS	WIRE COLOR	WIRE LABEL	GAUGE	JACKET	TO
1	ORN/BLK	CABLE CABLE	18 AWG	TFFN	X812 (4)
2	BLU/RED	CABLE CABLE	18 AWG	TFFN	X812 (6)
3	BLK/RED	CABLE CABLE	18 AWG	TFFN	X812 (5)

Go to Discount-Equipment.com to order your parts

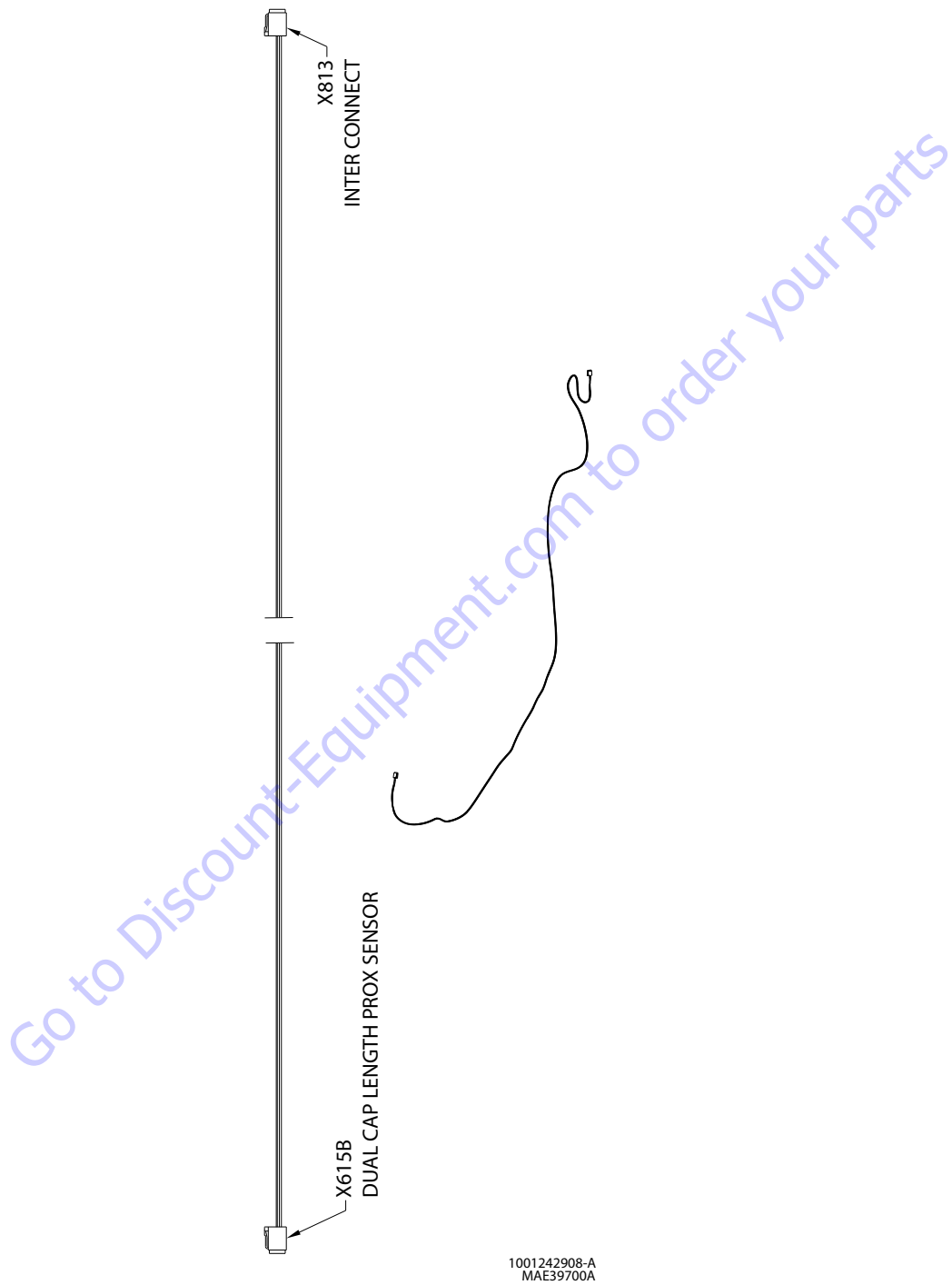

Figure 7-45. Proximity Switch Harness (Capacity) - SN 0300257781 to Present

SECTION 7 - BASIC ELECTRICAL INFORMATION & ELECTRICAL SCHEMATICS

X615B DUAL CAP LENGTH PROX SENSOR					
CONNPOS	WIRE COLOR	WIRE LABEL	GAUGE	JACKET	TO
1	YEL/BLK	CABLE CABLE	18 AWG	TFFN	X813 (1)
2	BRN/BLK	CABLE CABLE	18 AWG	TFFN	X813 (2)
3	BLU/BLK	CABLE CABLE	18 AWG	TFFN	X813 (3)
4	ORN/BLK	CABLE CABLE	18 AWG	TFFN	X813 (4)
5	BLK/RED	CABLE CABLE	18 AWG	TFFN	X813 (5)
6	BLU/RED	CABLE CABLE	18 AWG	TFFN	X813 (6)

X813 INTER CONNECT					
CONNPOS	WIRE COLOR	WIRE LABEL	GAUGE	JACKET	TO
1	YEL/BLK	CABLE CABLE	18 AWG	TFFN	X615B (1)
2	BRN/BLK	CABLE CABLE	18 AWG	TFFN	X615B (2)
3	BLU/BLK	CABLE CABLE	18 AWG	TFFN	X615B (3)
4	ORN/BLK	CABLE CABLE	18 AWG	TFFN	X615B (4)
5	BLK/RED	CABLE CABLE	18 AWG	TFFN	X615B (5)
6	BLU/RED	CABLE CABLE	18 AWG	TFFN	X614B (6)

Go to Discount-Equipment.com to order your parts

SECTION 7 - BASIC ELECTRICAL INFORMATION & ELECTRICAL SCHEMATICS

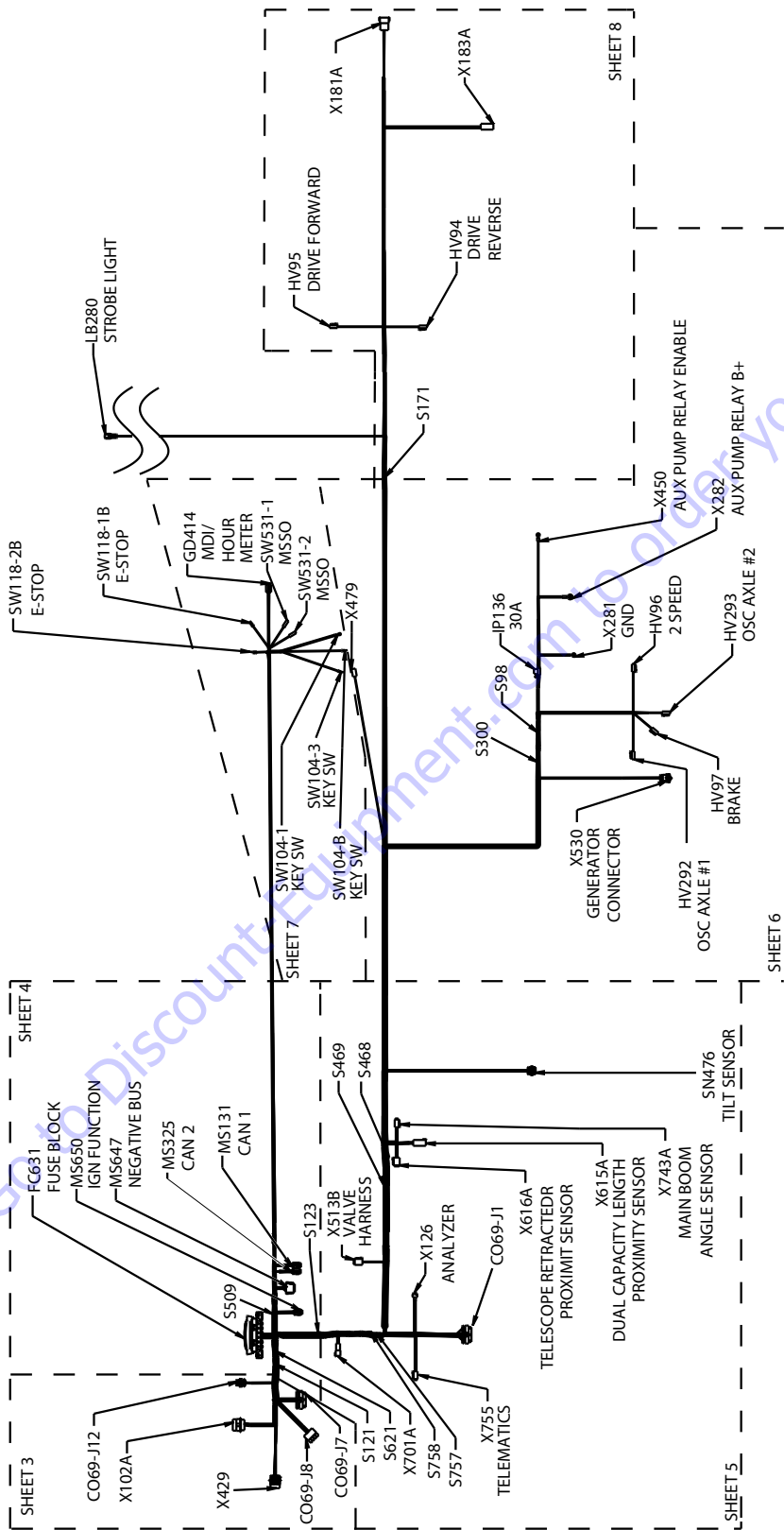

100118642-H
MAE20610

Figure 7-46. Turntable Harness - Sheet 1 of 8

SECTION 7 - BASIC ELECTRICAL INFORMATION & ELECTRICAL SCHEMATICS

LB280 STROBE LIGHT					
CONN POS	WIRE COLOR	WIRE LABEL	GAUGE	JACKET	TO
1	YEL	4-54 STRB LIGHT	18 AWG	GXL	MS650 (3)
2	BLK	000-40-14 STRB GND	18 AWG	GXL	MS647 (3)

Go to Discount-Equipment.com to order your parts

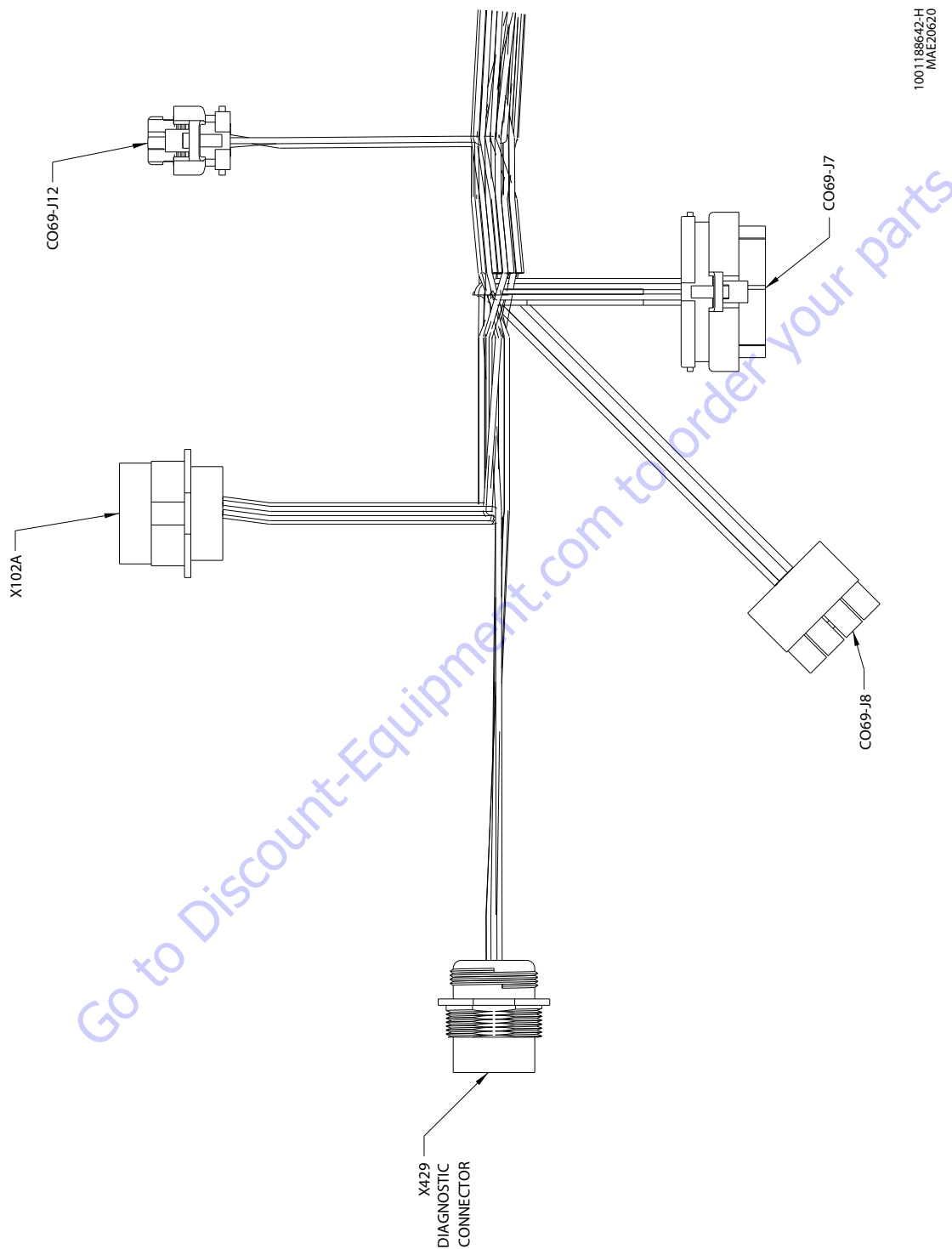

1001188642-H
MAEZ0620

Figure 7-47. Turntable Harness - Sheet 2 of 8

SECTION 7 - BASIC ELECTRICAL INFORMATION & ELECTRICAL SCHEMATICS

C069-J12					
CONN POS	WIRE COLOR	WIRE LABEL	GAUGE	JACKET	TO
1					
2					
3	YEL	CAN2 HI	20 AWG	J1939 CABLE	MS325 (3)
4	GRN	CAN2 LO	20 AWG	J1939 CABLE	MS325 (4)
5					
6	WHT	4-96 CAN2 TERM	18 AWG	GXL	C069-J12 (7)
7	WHT	4-96 CAN2 TERM	18 AWG	GXL	C069-J12 (6)
8	WHT	4-163 MSSO	18 AWG	GXL	SW531-1 (1)

X429					
CONN POS	WIRE COLOR	WIRE LABEL	GAUGE	JACKET	TO
A	BLK	000-40-11 NEGATIVE	18 AWG	GXL	MS647 (4)
B	WHT	4-65-1	18 AWG	GXL	S757 (1)
C	YEL	CAN2 HI	20 AWG	J1939 CABLE	MS325 (2)
D	GRN	CAN2 LO	20 AWG	J1939 CABLE	MS325 (7)
E					
F					
G					
H	WHT	4-66 IGN	18 AWG	GXL	FC631 (40)
J					

X102A					
CONN POS	WIRE COLOR	WIRE LABEL	GAUGE	JACKET	TO
1					
2	GRN	CAN 1 LO	18 AWG	J1939 CABLE	MS131 (4)
3	YEL	CAN 1 HI	18 AWG	J1939 CABLE	MS131 (1)
4	WHT	4-43 PLTF EMS	18 AWG	GXL	S121 (2)
5	WHT	4-8 PLAT LEVEL UP	18 AWG	GXL	X701A (3)
6	WHT	4-52 FOOT SW	18 AWG	GXL	C069-J7 (15)
7	WHT	4-11 PLAT LEVEL DOWN	18 AWG	GXL	X701A (4)
8					
9	RED	4-47 PLTF EMS	18 AWG	GXL	SW104-1 (1)
10					
11	WHT	4-53 GROUND MODE	18 AWG	GXL	C069-J7 (14)
12	RED	4-71	12 AWG	GXL	FC631 (37)
13	WHT	4-15 HIGH PRES DUMP	18 AWG	GXL	X701A (1)
14					
15	WHT	4-16 LOW PRES DUMP	18 AWG	GXL	X701A (2)
16	BLK	000-40-12 PLATF GND	12 AWG	GXL	C069-J8 (3)
17					
18					
19					

C069-J7					
CONN POS	WIRE COLOR	WIRE LABEL	GAUGE	JACKET	TO
1	WHT	4-42 PLTF EMS	18 AWG	GXL	S121 (1)
2	WHT	4-132 PLAT MODE	18 AWG	GXL	S121 (1)
3	RED	4-201	18 AWG	GXL	S766 (1)
4	BLU/BLK	4-86 BM ANGLE SEN 1	18 AWG	TFFN	X743A (3)
5					
6	WHT	4-133 CAN1 TERM	18 AWG	GXL	C069-J7 (17)
7	BLU/RED	4-87 BM ANGLE SEN 2	18 AWG	TFFN	X743A (4)
8					
9	BLK	000-40-76 GND	18 AWG	GXL	X743A (1)
10	WHT	4-123 GND	18 AWG	GXL	SN476 (2)
11					
12					
13	YEL	CAN 1 HI	20 AWG	J1939 CABLE	MS131 (12)
14	WHT	4-53 GROUND MODE	18 AWG	GXL	X102A (11)
15	WHT	4-52 FOOT SW	18 AWG	GXL	X102A (6)
16	WHT	4-118 PWR 5V	18 AWG	GXL	X743A (2)
17	WHT	4-133 CAN1 TERM	18 AWG	GXL	C069-J7 (6)
18					
19	BLK	000-40-13 GND	18 AWG	GXL	FC631 (1)
20					
21	WHT	4-110 PROX 1	18 AWG	GXL	X616A (3)
22					
23	WHT	4-115 CAPACITY	18 AWG	GXL	X615A (6)
24	GRN	CAN 1 LO	20 AWG	J1939 CABLE	MS131 (4)
25	BLK	000-40-51 GND	18 AWG	GXL	GD414 (1)
26					
27					
28	BLK	000-40-75 GND	18 AWG	GXL	S469 (1)
29	RED	4-97 PWR	18 AWG	GXL	S758 (2)
30					
31	WHT	4-203 BROKEN CBL POW	18 AWG	GXL	X513B (4)
32	WHT	4-116 POWER 12V	18 AWG	GXL	X479 (1)
33	WHT	4-119 PWR 12V	18 AWG	GXL	S468 (1)
34	WHT	4-108 VCC	18 AWG	GXL	SN476 (1)
35	WHT	4-92 DOS SW	18 AWG	GXL	X479 (2)

C069-J8					
CONN POS	WIRE COLOR	WIRE LABEL	GAUGE	JACKET	TO
1	BLK	000-40-8 MODL GND	10 AWG	GXL	X281 (1)
2	RED	4-35 IGN	12 AWG	GXL	FC631 (32)
3	BLK	000-40-12 PLATF GND	12 AWG	GXL	X102A (16)
3	BLK	000-40-64 BATT GND	16 AWG	GXL	MS647 (1)
4	YEL	4-36 MODL PWR	14 AWG	GXL	MS650 (1)

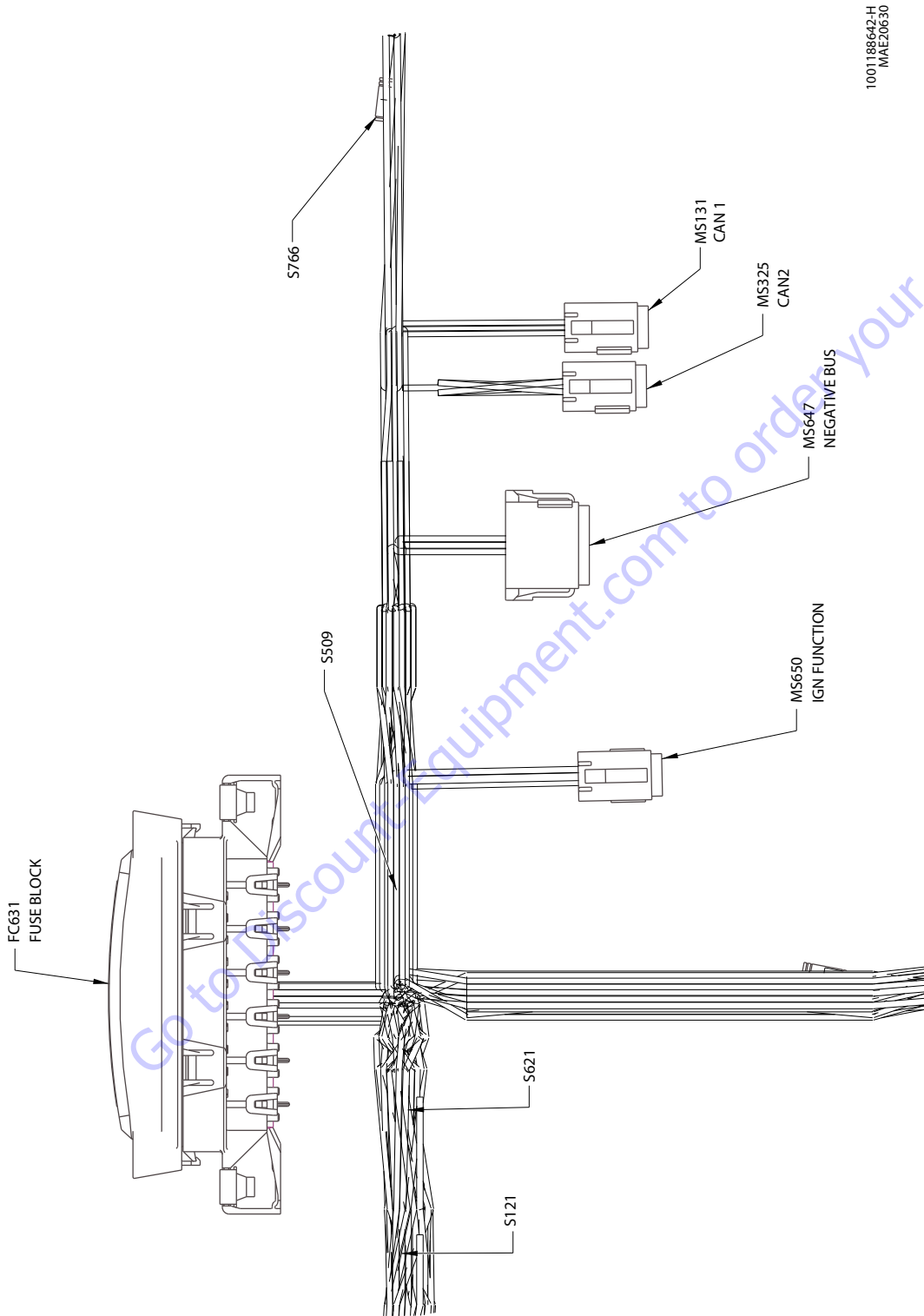

1001188642-H
MIAE20630

Figure 7-48. Turntable Harness - Sheet 3 of 8

SECTION 7 - BASIC ELECTRICAL INFORMATION & ELECTRICAL SCHEMATICS

S121					
CONN POS	WIRE COLOR	WIRE LABEL	GAUGE	JACKET	TO
1	WHT	4-132 PLAT MODE	18 AWG	GXL	C069-J7 (2)
1	WHT	4-42 PLTF EMS	18 AWG	GXL	C069-J7 (1)
2	WHT	4-41	18 AWG	GXL	FC631 (30)
2	WHT	4-43 PLTF EMS	18 AWG	GXL	X102A (4)

S621					
CONN POS	WIRE COLOR	WIRE LABEL	GAUGE	JACKET	TO
1	RED	4-350	12 AWG	GXL	FC631 (28)
1	RED	4-550	12 AWG	GXL	FC631 (33)
2	RED	4-166	12 AWG	GXL	FC631 (2)
2	RED	4-563 LIGHT OPT	18 AWG	GXL	FC631 (47)

S509					
CONN POS	WIRE COLOR	WIRE LABEL	GAUGE	JACKET	TO
1	WHT	4-38	18 AWG	GXL	FC631 (26)
1	RED	4-39	18 AWG	GXL	FC631 (25)
2	WHT	4-170	18 AWG	GXL	FC631 (10)

S766					
CONN POS	WIRE COLOR	WIRE LABEL	GAUGE	JACKET	TO
1	RED	4-201	18 AWG	GXL	C069-J7 (3)
2	RED	4-202	18 AWG	GXL	FC631 (29)
2	RED	4-40	18 AWG	GXL	SW104-1

MS650 IGN FUNCTION					
CONN POS	WIRE COLOR	WIRE LABEL	GAUGE	JACKET	TO
1	YEL	4-36 MODL PWR	14 AWG	GXL	C069-J8 (4)
2	YEL	4-72 IGN	18 AWG	GXL	FC631 (36)
3	YEL	4-54 STRB LIGHT	18 AWG	GXL	LB280 (1)
4	YEL	4-84 IGN	18 AWG	GXL	X183A (1)
5	YEL	4-81 GEN IGN	18 AWG	GXL	FC631 (45)
6					
7					
8					
9					
10					
11					
12					

MS647 NEGATIVE BUS					
CONN POS	WIRE COLOR	WIRE LABEL	GAUGE	JACKET	TO
1	BLK	000-40-64 BATT GND	16 AWG	GXL	C069-J8 (3)
2	BLK	000-40-47 OSC VLS GND	18 AWG	GXL	S300 (1)
3	BLK	000-40-14 STRB GND	18 AWG	GXL	LB280 (2)
4	BLK	000-40-11 NEGATIVE	18 AWG	GXL	X429 (A)
5	BLK	000-40-161 GEN GND	18 AWG	GXL	X530 (3)
6	BLK	000-40-557 GND	18 AWG	GXL	X181A (2)
7	BLK	000-40-558 GND	18 AWG	GXL	X755 (2)
8					
9					
10					
11					
12					

MS325 CAN 2					
CONN POS	WIRE COLOR	WIRE LABEL	GAUGE	JACKET	TO
1	YEL	CAN2 HI	20 AWG	J1939 CABLE	GD414 (3)
2	YEL	CAN2 HI	20 AWG	J1939 CABLE	X429 (C)
3	YEL	CAN2 HI	20 AWG	J1939 CABLE	C069-J12 (3)
4	GRN	CAN2 LO	20 AWG	J1939 CABLE	C069-J12 (4)
5	GRN	CAN2 LO	20 AWG	J1939 CABLE	GD414 (4)
6	GRN	CAN2 LO	20 AWG	J1939 CABLE	X183A (4)
7	GRN	CAN2 LO	20 AWG	J1939 CABLE	X429 (D)
8					
9					
10	YEL	CAN2 HI	20 AWG	J1939 CABLE	X183A (3)
11					
12					

MS131 CAN 1					
CONN POS	WIRE COLOR	WIRE LABEL	GAUGE	JACKET	TO
1	YEL	CAN 1 HI	18 AWG	J1939 CABLE	X102A (3)
2	YEL	CAN 1 HI	20 AWG	J1939 CABLE	C069-J7 (13)
3	YEL	CAN 1 HI	20 AWG	J1939 CABLE	SN476 (3)
4	GRN	CAN 1 LO	18 AWG	J1939 CABLE	X102A (2)
5	GRN	CAN 1 LO	20 AWG	J1939 CABLE	C069-J7 (24)
6	GRN	CAN 1 LO	20 AWG	J1939 CABLE	SN476 (4)
7					
8					
9					
10					
11					
12					

SECTION 7 - BASIC ELECTRICAL INFORMATION & ELECTRICAL SCHEMATICS

FC631					
CONN POS	WIRE COLOR	WIRE LABEL	GAUGE	JACKET	TO
1	BLK	000-40-13 GND	18 AWG	GXL	C069-J7 (19)
2	RED	4-166	12 AWG	GXL	S621 (2)
3					
4					
5					
6					
7					
8					
9	RED	4-37 12AWG	12 AWG	GXL	S123 (1)
10	WHT	4-170	18 AWG	GXL	S509 (2)
11					
12					
13					
14					
15					
16					
17					
18					
19					
20					
21					
22					
23					
24					
25	RED	4-39	18 AWG	GXL	S509 (1)
26	WHT	4-38	18 AWG	GXL	S509 (1)
27					
28	RED	4-350	12 AWG	GXL	S621 (1)
29	RED	4-202	18 AWG	GXL	S766 (2)
30	WHT	4-41	18 AWG	GXL	S121 (2)
31					
32	RED	4-35 IGN	12 AWG	GXL	C069-J8 (2)
33	RED	4-550	12 AWG	GXL	S621 (1)
34	RED	4-552	18 AWG	GXL	SW118-2B (2B)
35	WHT	4-50	18 AWG	GXL	S123 (1)
36	YEL	4-72 IGN	18 AWG	GXL	MS650 (2)
37	RED	4-71	12 AWG	GXL	X102A (12)
38	RED	4-51	12 AWG	GXL	S123 (2)
39	WHT	4-65 -	18 AWG	GXL	S757 (2)
40	WHT	4-66 IGN	18 AWG	GXL	X429 (H)
41	YEL	4-82 GEN IGN	18 AWG	GXL	X530 (1)
42					
43					
44					
45	YEL	4-81 GEN IGN	18 AWG	GXL	MS650 (5)
46					
47	RED	4-563 LIGHT OPT	18 AWG	GXL	S621 (2)
48					

Go to DiscountElectrical.com to order your parts

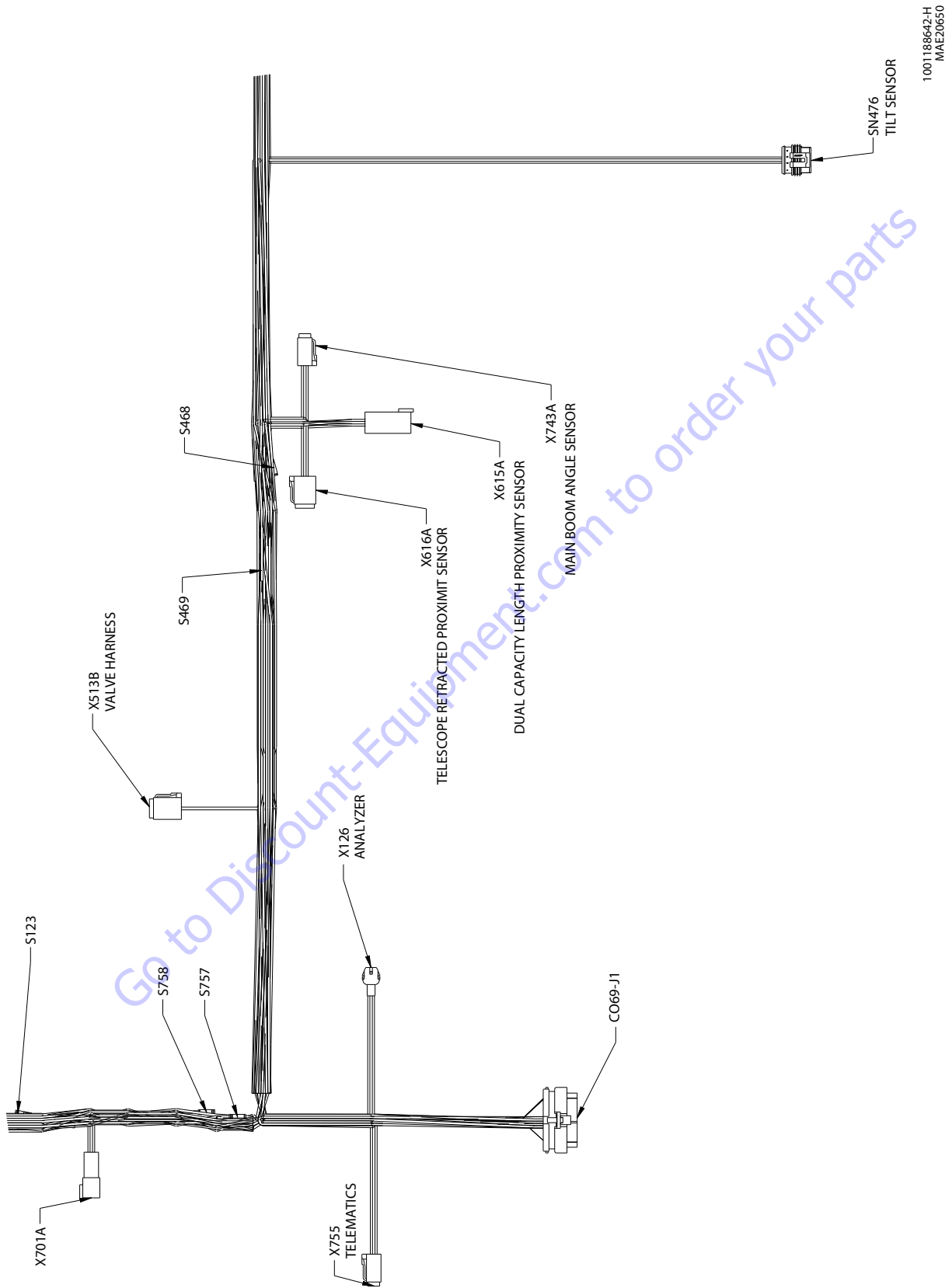

Figure 7-49. Turntable Harness - Sheet 4 of 8

SECTION 7 - BASIC ELECTRICAL INFORMATION & ELECTRICAL SCHEMATICS

X743A					
CONN POS	WIRE COLOR	WIRE LABEL	GAUGE	JACKET	TO
1	BLK	000-40-76 GND	18 AWG	GXL	C069-J7 (9)
2	WHT	4-118 PWR 5V	18 AWG	GXL	C069-J7 (16)
3	BLU/BLK	4-86 BM ANGLE SEN1	18 AWG	TFFN	C069-J7 (4)
4	BLU/RED	4-87 BM ANGLE SEN2	18 AWG	TFFN	C069-J7 (7)

X513B VALVE HARNESS					
CONN POS	WIRE COLOR	WIRE LABEL	GAUGE	JACKET	TO
1	BLK	000-40-43 CF	16 AWG	GXL	S171 (1)
2					
3					
4	WHT	4-203 BROKEN CBL POW	18 AWG	GXL	C069-J7 (31)
5					
6					

S758					
CONN POS	WIRE COLOR	WIRE LABEL	GAUGE	JACKET	TO
1	RED	4-97-1 PWR	18 AWG	GXL	GD414 (2)
2	RED	4-97 PWR	18 AWG	GXL	C069-J7 (29)
2	RED	4-97-2 PWR	18 AWG	GXL	X755 (3)

X701A					
CONN POS	WIRE COLOR	WIRE LABEL	GAUGE	JACKET	TO
1	WHT	4-15 HIGH PRES DUMP	18 AWG	GXL	X102A (13)
2	WHT	4-16 LOW PRES DUMP	18 AWG	GXL	X102A (15)
3	WHT	4-8 PLAT LEVEL UP	18 AWG	GXL	X102A (5)
4	WHT	4-11 PLAT LEVEL DOWN	18 AWG	GXL	X102A (7)

S757					
CONN POS	WIRE COLOR	WIRE LABEL	GAUGE	JACKET	TO
1	WHT	4-65-1	18 AWG	GXL	X429 (8)
2	WHT	4-65	18 AWG	GXL	FC631 (39)
2	WHT	4-65-2	18 AWG	GXL	X755 (1)

SN476 TILT SENSOR					
CONN POS	WIRE COLOR	WIRE LABEL	GAUGE	JACKET	TO
1	WHT	4-108 VCC	18 AWG	GXL	C069-J7 (34)
2	WHT	4-123 GND	18 AWG	GXL	C069-J7 (10)
3	YEL	CAN 1 HI	20 AWG	J1939 CABLE	MS131 (3)
4	GRN	CAN 1 LO	20 AWG	J1939 CABLE	MS131 (6)

S123					
CONN POS	WIRE COLOR	WIRE LABEL	GAUGE	JACKET	TO
1	WHT	4-50	18 AWG	GXL	FC628 (35)
1	RED	4-37 12AWG	12 AWG	GXL	FC628 (9)
2	RED	4-79	12 AWG	GXL	IP136 (1)
2	RED	4-51	12 AWG	GXL	FC628 (38)

S469					
CONN POS	WIRE COLOR	WIRE LABEL	GAUGE	JACKET	TO
1	BLK	000-40-75 GND	18 AWG	GXL	C069-J7 (28)
1	BLK	000-40-98 GND	18 AWG	GXL	X615A (5)
2	BLK	000-40-167 GND	18 AWG	GXL	X615A (2)
2	BLK	000-40-77 GND	18 AWG	GXL	X616A (2)
2	BLK	000-40-80 GND	18 AWG	GXL	X616A (5)

S468					
CONN POS	WIRE COLOR	WIRE LABEL	GAUGE	JACKET	TO
1	WHT	4-114 PWR 12V	18 AWG	GXL	X615A (4)
1	WHT	4-119 PWR 12V	18 AWG	GXL	C069-J7 (33)
2	WHT	4-111 PWR 12V	18 AWG	GXL	X616A (1)
2	WHT	4-113 PWR 12V	18 AWG	GXL	X616A (4)
2	WHT	4-168 PWR 12V	18 AWG	GXL	X615A (1)

X755 TELEMATICS					
CONN POS	WIRE COLOR	WIRE LABEL	GAUGE	JACKET	TO
1	WHT	4-65-2 -	18 AWG	GXL	S757 (2)
2	BLK	000-40-558 GND	18 AWG	GXL	MS647 (8)
3	RED	4-97-2 PWR	18 AWG	GXL	S758 (2)
4	WHT	4-51-1 PLTFM EN	18 AWG	GXL	SW104-3 (1)

X126 ANALYZER					
CONN POS	WIRE COLOR	WIRE LABEL	GAUGE	JACKET	TO
1	WHT	4-5 POWER	18 AWG	GXL	C069-J1 (28)
2	WHT	4-6 RECEIVE	18 AWG	GXL	C069-J1 (29)
3	WHT	4-7 TRANSMIT	18 AWG	GXL	C069-J1 (30)
4	BLK	000-40-4 GND	18 AWG	GXL	C069-J1 (31)

SECTION 7 - BASIC ELECTRICAL INFORMATION & ELECTRICAL SCHEMATICS

X616A TELESCOPE RETRACTED PROXIMIT SENSOR					
CONN POS	WIRE COLOR	WIRE LABEL	GAUGE	JACKET	TO
1	WHT	4-111 PWR 12V	18 AWG	GXL	S468 (2)
2	BLK	000-40-77 GND	18 AWG	GXL	S469 (2)
3	WHT	4-110 PROX 1	18 AWG	GXL	C069-J7 (21)
4	WHT	4-113 PWR 12V	18 AWG	GXL	S468 (2)
5	BLK	000-40-80 GND	18 AWG	GXL	S469 (2)
6	WHT	4-117 PROX 2	18 AWG	GXL	C069-J1 (34)

C069-J1					
CONN POS	WIRE COLOR	WIRE LABEL	GAUGE	JACKET	TO
1					
2	WHT	4-120 OSC AXL V 2	18 AWG	GXL	HV293 (1)
3	WHT	4-3 DRIVE FORWARD	16 AWG	GXL	HV95 (1)
4					
5					
6	WHT	4-4 DRIVE REVERSE	16 AWG	GXL	HV94 (1)
7	WHT	4-121 OSC AXL V 1	18 AWG	GXL	HV292 (1)
8					
9	BLK	000-40-162 GND	18 AWG	GXL	SW531-2 (1)
10	WHT	4-94 EMR4 IGNITION	18 AWG	GXL	X181A (1)
11	WHT	4-67 START	16 AWG	GXL	X183A (2)
12	WHT	4-80 GLOW PLUG	16 AWG	GXL	X181A (4)
13	WHT	4-78 AUX PUMP	16 AWG	GXL	X450 (1)
14					
15					
16					
17					
18					
19					
20	WHT	4-2 TWO SPEED	18 AWG	GXL	HV96 (1)
21					
22	WHT	4-74 GEN ON	18 AWG	GXL	X530 (2)
23	WHT	4-1 BRAKE	18 AWG	GXL	HV97 (1)
24					
25					
26					
27	BLK	000-40-3 GND	18 AWG	GXL	S98 (2)
28	WHT	4-5 POWER	18 AWG	GXL	X126 (1)
29	WHT	4-6 RECEIVE	18 AWG	GXL	X126 (2)
30	WHT	4-7 TRANSMIT	18 AWG	GXL	X126 (3)
31	BLK	000-40-4 GND	18 AWG	GXL	X126 (4)
32	RED	4-76 ALT EXCITE	16 AWG	GXL	X183A (5)
33					
34	WHT	4-117 PROX 2	18 AWG	GXL	X616A (6)
35	WHT	4-167 CAP PROX 2	18 AWG	GXL	X615A (3)

X615ADUAL CAPACITY LENGTH PROXIMITY SENSOR					
CONN POS	WIRE COLOR	WIRE LABEL	GAUGE	JACKET	TO
1	WHT	4-168 PWR 12V	18 AWG	GXL	S468 (2)
2	BLK	000-40-167 GND	18 AWG	GXL	S469 (2)
3	WHT	4-167 CAP PROX 2	18 AWG	GXL	C069-J1 (35)
4	WHT	4-114 PWR 12V	18 AWG	GXL	S468 (1)
5	BLK	000-40-98 GND	18 AWG	GXL	S469 (1)
6	WHT	4-115 CAPACITY	18 AWG	GXL	C069-J7 (23)

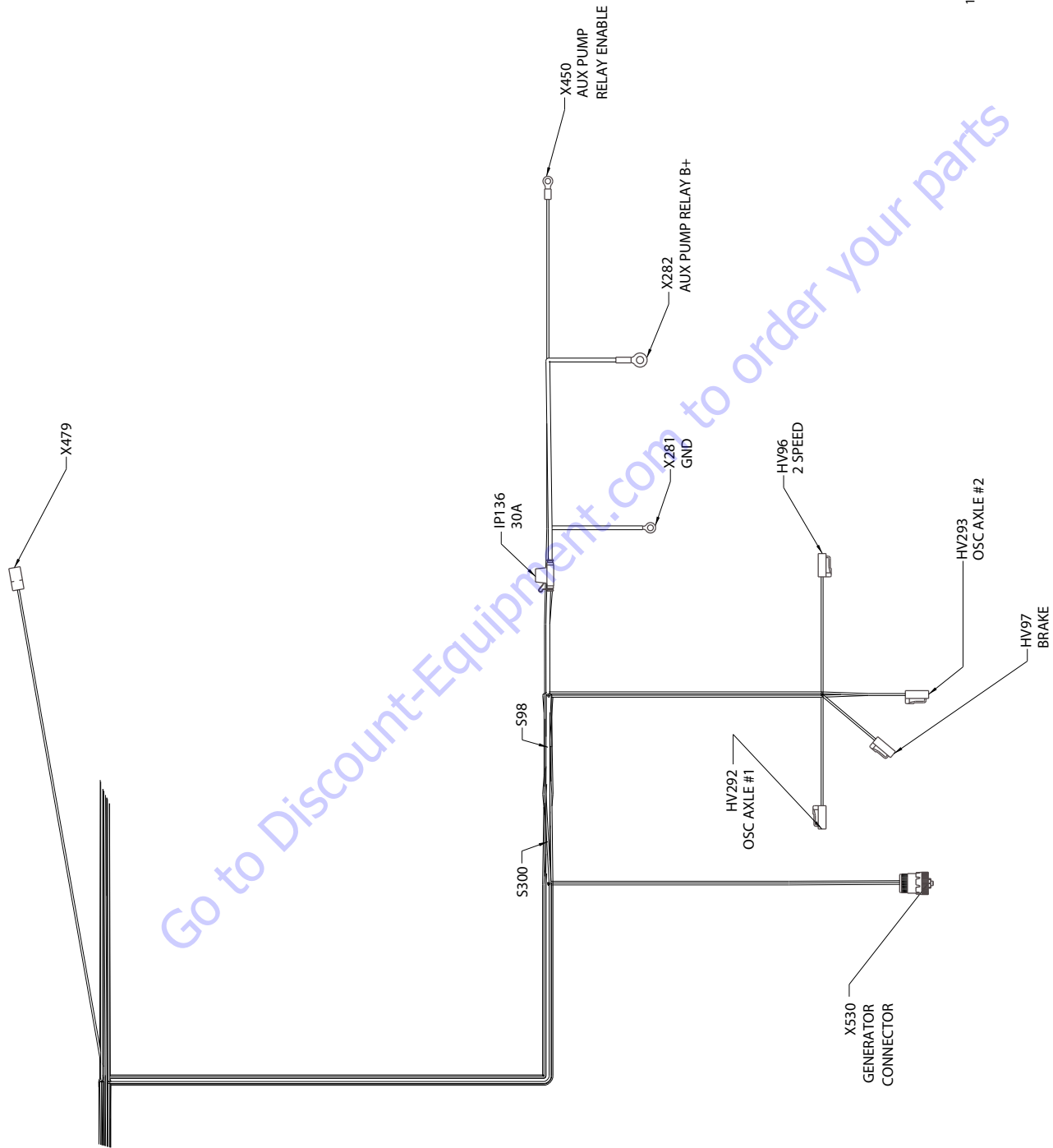

1001188642-H
MAE20660

Figure 7-50. Turntable Harness - Sheet 5 of 8

SECTION 7 - BASIC ELECTRICAL INFORMATION & ELECTRICAL SCHEMATICS

X479					
CONN POS	WIRE COLOR	WIRE LABEL	GAUGE	JACKET	TO
1	WHT	4-116 POWER 12V	18 AWG	GXL	C069-J7 (32)
2	WHT	4-92 DOS SW	18 AWG	GXL	C069-J7 (35)

X281 GND					
CONN POS	WIRE COLOR	WIRE LABEL	GAUGE	JACKET	TO
1	BLK	000-40-8 MODL GND	10 AWG	GXL	C069-J8 (1)

S300					
CONN POS	WIRE COLOR	WIRE LABEL	GAUGE	JACKET	TO
1	BLK	000-40-47 OSC VLV V5 GND	18 AWG	GXL	MS647 (2)
2	BLK	000-40-72	18 AWG	GXL	HV293 (2)
2	BLK	000-40-73	18 AWG	GXL	HV292 (2)

X282 AUX PUMP RELAY B+					
CONN POS	WIRE COLOR	WIRE LABEL	GAUGE	JACKET	TO
1	RED	4-49 B+ AUX PMP	10 AWG	GXL	IP136 (2)

S98					
CONN POS	WIRE COLOR	WIRE LABEL	GAUGE	JACKET	TO
1	BLK	000-40-1 GND	18 AWG	GXL	HV97 (2)
1	BLK	000-40-2 GND	18 AWG	GXL	HV96 (2)
2	BLK	000-40-3 GND	18 AWG	GXL	C069-J1 (27)

X530 GENERATOR CONNECTOR					
CONN POS	WIRE COLOR	WIRE LABEL	GAUGE	JACKET	TO
1	YEL	4-82 GEN IGN	18 AWG	GXL	FC631 (41)
2	WHT	4-74 GEN ON	18 AWG	GXL	C069-J1 (22)
3	BLK	000-40-161 GEN GND	18 AWG	GXL	MS647 (5)

IP136 30A					
CONN POS	WIRE COLOR	WIRE LABEL	GAUGE	JACKET	TO
1	RED	4-79	10 AWG	GXL	S123 (2)
2	RED	4-49 B+ AUX PMP	10 AWG	GXL	X282 (1)

HV292 OSC AXLE #1					
CONN POS	WIRE COLOR	WIRE LABEL	GAUGE	JACKET	TO
1	WHT	4-121 OSC AXL V 1	18 AWG	GXL	C069-J1 (7)
2	BLK	000-40-73	18 AWG	GXL	S300 (2)

HV293 OSC AXLE #2					
CONN POS	WIRE COLOR	WIRE LABEL	GAUGE	JACKET	TO
1	WHT	4-120 OSC AXL V 2	18 AWG	GXL	C069-J1 (2)
2	BLK	000-40-72	18 AWG	GXL	S300 (2)

HV97 BRAKE					
CONN POS	WIRE COLOR	WIRE LABEL	GAUGE	JACKET	TO
1	WHT	4-1 BRAKE	18 AWG	GXL	C069-J1 (23)
2	BLK	000-40-1 GND	18 AWG	GXL	S98 (1)

HV96 2 SPEED					
CONN POS	WIRE COLOR	WIRE LABEL	GAUGE	JACKET	TO
1	WHT	4-2 TWO SPEED	18 AWG	GXL	C069-J1 (20)
2	BLK	000-40-2 GND	18 AWG	GXL	S98 (1)

X450 AUX PUMP RELAY ENABLE					
CONN POS	WIRE COLOR	WIRE LABEL	GAUGE	JACKET	TO
1	WHT	4-78 AUX PUMP	16 AWG	GXL	C069-J1 (13)

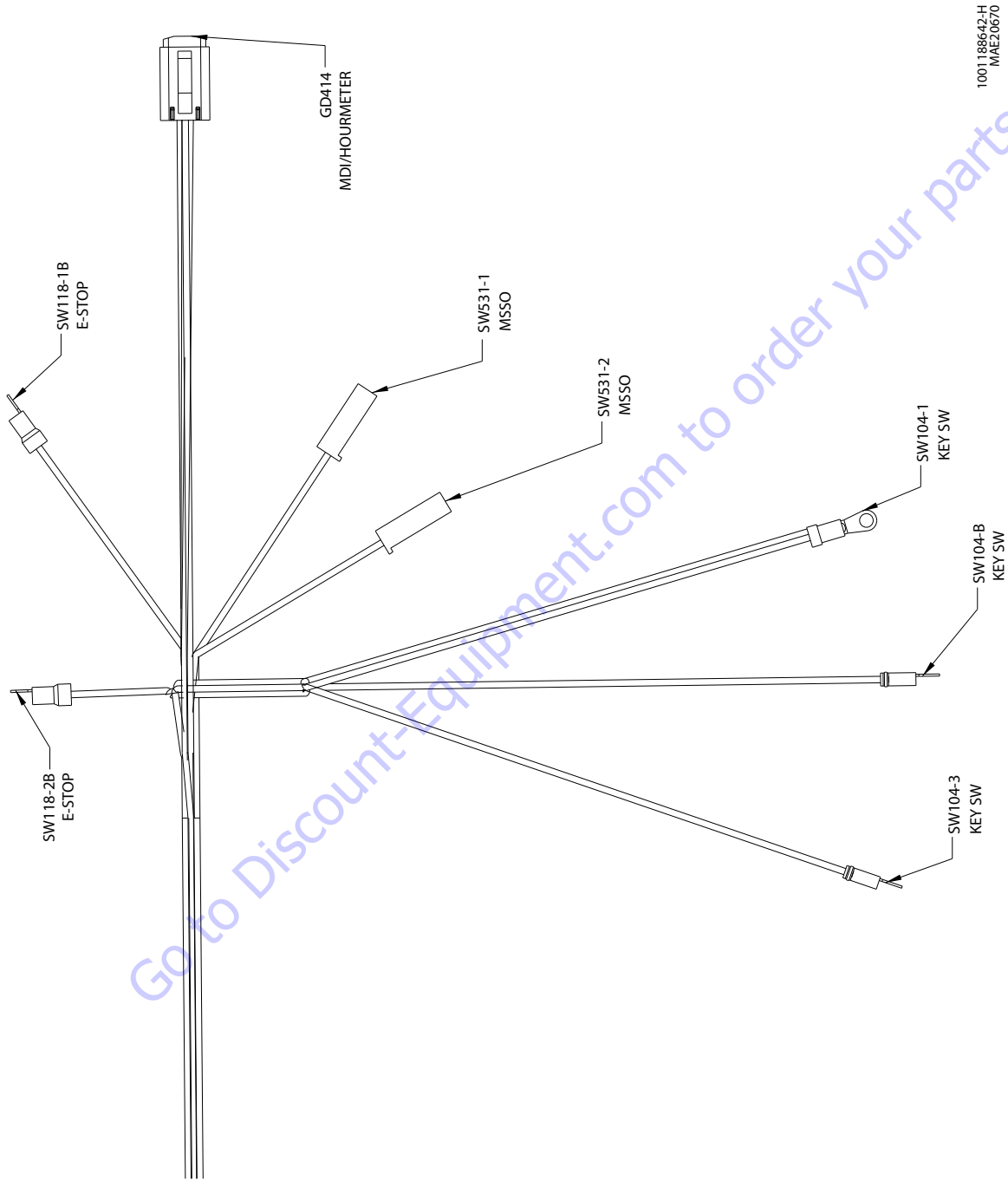

Figure 7-51. Turntable Harness - Sheet 6 of 8

SECTION 7 - BASIC ELECTRICAL INFORMATION & ELECTRICAL SCHEMATICS

SW118-2B E-STOP					
CONN POS	WIRE COLOR	WIRE LABEL	GAUGE	JACKET	TO
2B	RED	4-552	18 AWG	GXL	FC631 (34)

SW118-1B E-STOP					
CONN POS	WIRE COLOR	WIRE LABEL	GAUGE	JACKET	TO
1B	RED	4-46	18 AWG	GXL	SW104-B (1)

GD414 MDI/HOURMETER					
CONN POS	WIRE COLOR	WIRE LABEL	GAUGE	JACKET	TO
1	BLK	000-40-51 GND	18 AWG	GXL	C069-J7 (25)
2	RED	4-97-1 PWR	18 AWG	GXL	S758 (1)
3	YEL	CAN2 HI	20 AWG	J1939 CABLE	MS325 (1)
4	GRN	CAN2 LO	20 AWG	J1939 CABLE	MS325 (5)
5					
6					

SW531-1 MSSO					
CONN POS	WIRE COLOR	WIRE LABEL	GAUGE	JACKET	TO
1	WHT	4-163 MSSO	18 AWG	GXL	C069-J12 (8)

SW531-2 MSSO					
CONN POS	WIRE COLOR	WIRE LABEL	GAUGE	JACKET	TO
1	BLK	000-40-162 GND	18 AWG	GXL	C069-J1 (9)

SW104-3 KEY SW					
CONN POS	WIRE COLOR	WIRE LABEL	GAUGE	JACKET	TO
1	RED	4-40	18 AWG	GXL	S766 (2)

SW104-B KEY SW					
CONN POS	WIRE COLOR	WIRE LABEL	GAUGE	JACKET	TO
1	RED	4-46	18 AWG	GXL	SW118-1B (1B)

SW104-1 KEY SW					
CONN POS	WIRE COLOR	WIRE LABEL	GAUGE	JACKET	TO
1	RED	4-47 PLTF EMS	18 AWG	GXL	X102A (9)
1	WHT	4-51-1 PLTFM EN	18 AWG	GXL	X755 (4)

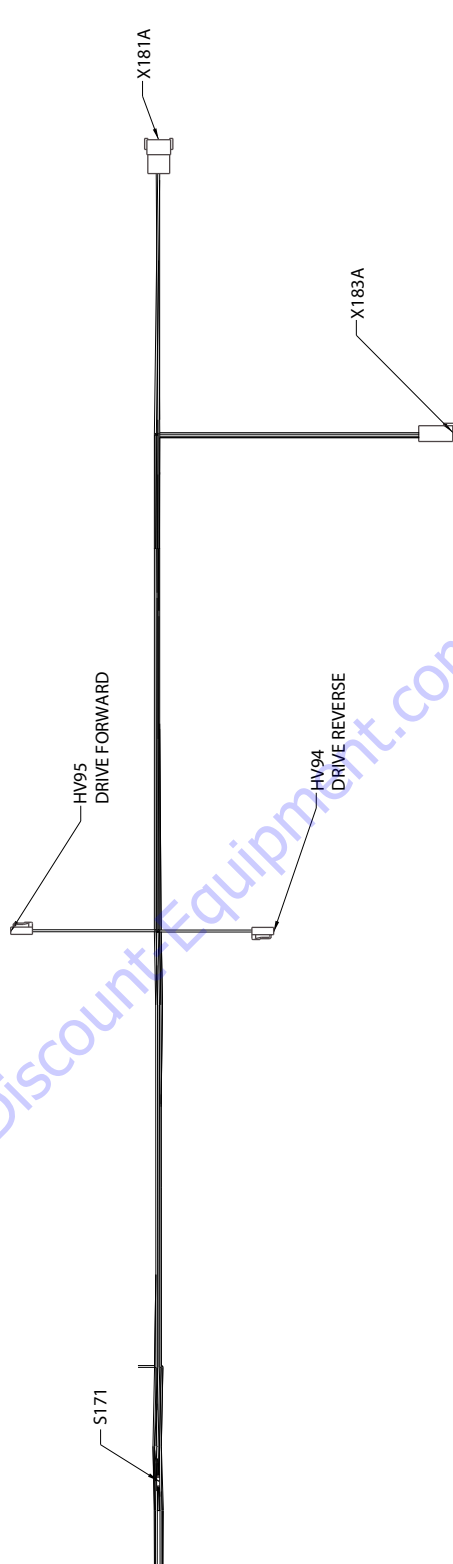

1001188642-H
MAE20680

Go to DiscountEquipment.com to order your parts

Figure 7-52. Turntable Harness - Sheet 7 of 8

SECTION 7 - BASIC ELECTRICAL INFORMATION & ELECTRICAL SCHEMATICS

S171					
CONN POS	WIRE COLOR	WIRE LABEL	GAUGE	JACKET	TO
1	BLK	000-40-43 CF	16 AWG	GXL	X513B (1)
2	BLK	000-40-40 CF	16 AWG	GXL	HV95 (2)
2	BLK	000-40-41 CF	16 AWG	GXL	HV94 (2)

HV94 DRIVE REVERSE					
CONN POS	WIRE COLOR	WIRE LABEL	GAUGE	JACKET	TO
1	WHT	4-4 DRIVE REVERSE	16 AWG	GXL	C069-J1 (6)
2	BLK	000-40-41 CF	16 AWG	GXL	S171 (2)

HV95 DRIVE FORWARD					
CONN POS	WIRE COLOR	WIRE LABEL	GAUGE	JACKET	TO
1	WHT	4-3 DRIVE FORWARD	16 AWG	GXL	C069-J1 (3)
2	BLK	000-40-40 CF	16 AWG	GXL	S171 (2)

X183A					
CONN POS	WIRE COLOR	WIRE LABEL	GAUGE	JACKET	TO
1	YEL	4-84 IGN	18 AWG	GXL	MS650 (4)
2	WHT	4-67 START	16 AWG	GXL	C069-J1 (11)
3	YEL	CAN2 HI	20 AWG	J1939 CABLE	MS325 (10)
4	GRN	CAN2 LO	20 AWG	J1939 CABLE	MS325 (6)
5	RED	4-76 ALT EXCITE	16 AWG	GXL	C069-J1 (32)
6					

X181A					
CONN POS	WIRE COLOR	WIRE LABEL	GAUGE	JACKET	TO
1	WHT	4-94 EMR4 IGNITION	18 AWG	GXL	C069-J1 (10)
2	BLK	000-40-557 GND	18 AWG	GXL	MS647 (7)
3					
4	WHT	4-80 GLOW PLUG	16 AWG	GXL	C069-J1 (12)
5					
6					
7					
8					

SECTION 7 - BASIC ELECTRICAL INFORMATION & ELECTRICAL SCHEMATICS

FUSE BOX LAYOUT
 POPULATE FUSE BOX AS PER CHART.
 USE DIODE KEYS AS REQUIRED.

	DESIGNATION	POSITION	RATING
FUSES	F1	28,32	15A
	F2	33,37	15A
	F3	34,38	3A
	F4	35,39	5A
	F5	36,40	5A
	F6	41,45	5A
	F7	42,46	
	F8	43,47	
	F9	44,48	
DIODES	D1	29 ANODE	
		25 CATHODE	
	D2	30 ANODE	
		26 CATHODE	
	D3	31 ANODE	
		27 CATHODE	
RELAYS	R1	10 (relay post 85)	35A
		1 (relay post 86)	
		2 (relay post 87)	
		9 (relay post 30)	
	R2	6 (relay post 87a)	
		12 (relay post 85)	
		3 (relay post 86)	
		4 (relay post 87)	
		11 (relay post 30)	
		8 (relay post 87a)	
	R3	22 (relay post 85)	
		13 (relay post 86)	
		14 (relay post 87)	
		21 (relay post 30)	
		18 (relay post 87a)	
		24 (relay post 85)	
	R4	15 (relay post 86)	
		16 (relay post 87)	
		23 (relay post 30)	
		20 (relay post 87a)	

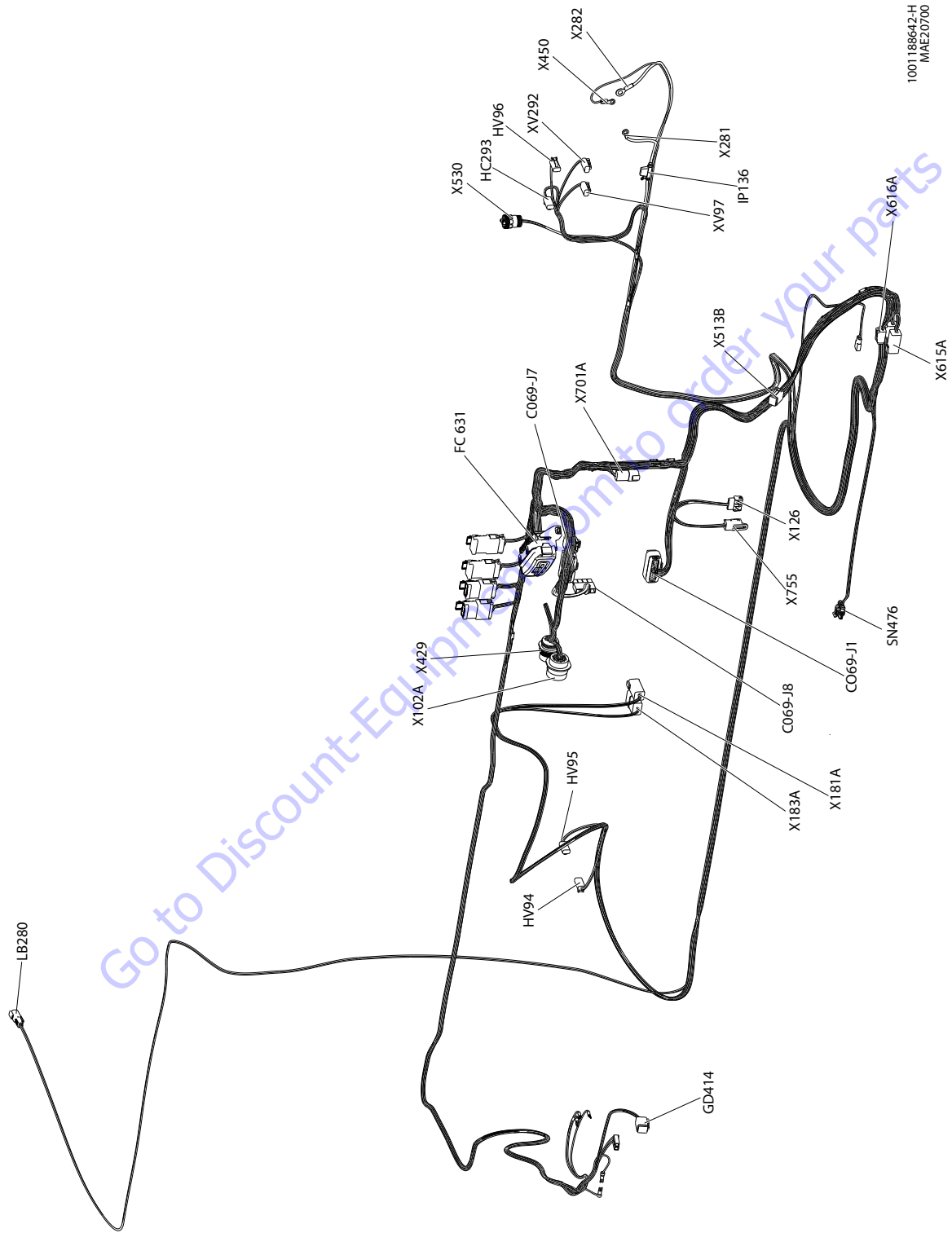

1001186642.H
INAE20700

Figure 7-53. Turntable Harness - Sheet 8 of 8

SECTION 7 - BASIC ELECTRICAL INFORMATION & ELECTRICAL SCHEMATICS

WIRE NO	COLOR	WIRE GAUGE	JACKET	LENGTH (mm)	FROM REFERENCE	PIN	TO REFERENCE	PIN
000-40-11	BLK	18	GXL	755	MS647	4	X429	A
000-40-12	BLK	12	GXL	370	C069-J8	3	X102A	16
000-40-13	BLK	18	GXL	414	FC631	1	C069-J7	19
000-40-14	BLK	18	GXL	6232	LB280	2	MS647	3
000-40-161	BLK	18	GXL	3612	MS647	5	X530	3
000-40-162	BLK	18	GXL	3207	SW531-2	1	C069-J1	9
000-40-167	BLK	18	GXL	271	X615A	2	S469	2
000-40-1	BLK	18	GXL	497	HV97	2	S98	1
000-40-2	BLK	18	GXL	545	HV96	2	S98	1
000-40-3	BLK	18	GXL	3036	C069-J1	27	S98	2
000-40-40	BLK	16	GXL	1009	HV95	2	S171	2
000-40-41	BLK	16	GXL	965	HV94	2	S171	2
000-40-43	BLK	16	GXL	2844	S171	1	X513B	1
000-40-47	BLK	18	GXL	3179	MS647	2	S300	1
000-40-4	BLK	18	GXL	305	X126	4	C069-J1	31
000-40-51	BLK	18	GXL	3022	C069-J7	25	GD414	1
000-40-557	BLK	18	GXL	5769	X181A	2	MS647	6
000-40-558	BLK	18	GXL	878	MS647	7	X755	2
000-40-64	BLK	16	GXL	674	C069-J8	3	MS647	1
000-40-72	BLK	18	GXL	629	S300	2	HV293	2
000-40-73	BLK	18	GXL	653	S300	2	HV292	2
000-40-75	BLK	18	GXL	1305	C069-J7	28	S469	1
000-40-76	BLK	18	GXL	1587	C069-J7	9	X743A	1
000-40-77	BLK	18	GXL	268	S469	2	X616A	2
000-40-80	BLK	18	GXL	254	S469	2	X616A	5
000-40-8	BLK	10	GXL	3923	C069-J8	1	X281	1
000-40-98	BLK	18	GXL	278	S469	1	X615A	5
4-108	WHT	18	GXL	2269	SN476	1	C069-J7	34
4-110	WHT	18	GXL	1584	C069-J7	21	X616A	3
4-111	WHT	18	GXL	166	S468	2	X616A	1
4-113	WHT	18	GXL	150	S468	2	X616A	4
4-114	WHT	18	GXL	171	S468	1	X615A	4
4-115	WHT	18	GXL	1597	C069-J7	23	X615A	6
4-116	WHT	18	GXL	3214	C069-J7	32	X479	1
4-117	WHT	18	GXL	1123	X616A	6	C069-J1	34
4-118	WHT	18	GXL	1571	C069-J7	16	X743A	2
4-119	WHT	18	GXL	1468	C069-J7	33	S468	1
4-11	WHT	18	GXL	740	X102A	7	X701A	4
4-120	WHT	18	GXL	3519	C069-J1	2	HV293	1
4-121	WHT	18	GXL	3552	C069-J1	7	HV292	1
4-123	WHT	18	GXL	2223	SN476	2	C069-J7	10
4-132	WHT	18	GXL	239	S121	1	C069-J7	2
4-133	WHT	18	GXL	67	C069-J7	17	C069-J7	6
4-15	WHT	18	GXL	708	X102A	13	X701A	1
4-163	WHT	18	GXL	2854	SW531-1	1	C069-J12	8
4-166	RED	12	GXL	105	FC631	2	S621	2
4-167	WHT	18	GXL	1132	C069-J1	35	X615A	3
4-168	WHT	18	GXL	163	X615A	1	S468	2

SECTION 7 - BASIC ELECTRICAL INFORMATION & ELECTRICAL SCHEMATICS

WIRE NO	COLOR	WIRE GAUGE	JACKET	LENGTH (mm)	FROM REFERENCE	PIN	TO REFERENCE	PIN
4-169-1	RED	18	GXL	435	C069-J7	3	FC631	46
4-16	WHT	18	GXL	760	X102A	15	X701A	2
4-170	WHT	18	GXL	144	FC631	10	S509	2
4-1	WHT	18	GXL	3497	HV97	1	C069-J1	23
4-201	RED	18	GXL	760	S766	1	C069-J7	3
4-202	RED	18	GXL	489	FC631	29	S766	2
4-203	WHT	18	GXL	1175	C069-J7	31	X513B	1
4-2	WHT	18	GXL	3604	HV96	1	C069-J1	20
4-350	RED	12	GXL	102	S621	1	FC631	28
4-35	RED	12	GXL	490	C069-J8	2	FC631	32
4-36	YEL	14	GXL	599	C069-J8	4	MS650	1
4-37	RED	12	GXL	287	FC631	9	S123	1
4-38	WHT	18	GXL	147	FC631	26	S509	1
4-39	RED	18	GXL	126	FC631	25	S509	1
4-3	WHT	16	GXL	4351	HV95	1	C069-J1	3
4-40	RED	18	GXL	2314	SW104-3	1	S766	2
4-41	WHT	18	GXL	163	S121	2	FC631	30
4-42	WHT	18	GXL	251	C069-J7	1	S121	1
4-43	WHT	18	GXL	351	X102A	4	S121	2
4-46	RED	18	GXL	425	SW104-B	1	SW118-1B	1B
4-47	RED	18	GXL	3107	SW104-1	1	X102A	9
4-49	RED	10	GXL	329	IP136	2	X282	1
4-4	WHT	16	GXL	4306	HV94	1	C069-J1	6
4-50	WHT	18	GXL	282	S123	1	FC631	35
4-51-1	WHT	18	GXL	3271	SW104-1	1	X755	4
4-51-2	WHT	18	GXL	0				
4-51	RED	12	GXL	300	S123	2	FC631	38
4-52	WHT	18	GXL	299	X102A	6	C069-J7	15
4-53	WHT	18	GXL	299	C069-J7	14	X102A	11
4-54	YEL	18	GXL	6144	LB280	1	MS650	3
4-550	RED	12	GXL	109	S621	1	FC631	33
4-552	RED	18	GXL	2511	SW118-2B	2B	FC631	34
4-563	RED	18	GXL	123	FC631	47	S621	2
4-5	WHT	18	GXL	309	X126	1	C069-J1	28
4-65-1	WHT	18	GXL	908	X429	B	S757	1
4-65-2	WHT	18	GXL	282	S757	2	X755	1
4-65	WHT	18	GXL	463	FC631	39	S757	2
4-66	WHT	18	GXL	585	X429	H	FC631	40
4-67	WHT	16	GXL	5428	X183A	2	C069-J1	11
4-6	WHT	18	GXL	297	X126	2	C069-J1	29
4-71	RED	12	GXL	500	FC631	37	X102A	12
4-72	YEL	18	GXL	256	MS650	2	FC631	36
4-74	WHT	18	GXL	3275	C069-J1	22	X530	2
4-76	RED	16	GXL	5445	X183A	5	C069-J1	32
4-78	WHT	16	GXL	3701	C069-J1	13	X450	1
4-79	RED	10	GXL	3111	S123	2	IP136	1
4-7	WHT	18	GXL	305	X126	3	C069-J1	30

SECTION 7 - BASIC ELECTRICAL INFORMATION & ELECTRICAL SCHEMATICS

WIRE NO	COLOR	WIRE GAUGE	JACKET	LENGTH (mm)	FROM REFERENCE	PIN	TO REFERENCE	PIN
4-80	WHT	16	GXL	5439	C069-J1	12	X181A	4
4-81	YEL	18	GXL	267	MS650	5	FC631	45
4-82	YEL	18	GXL	3459	X530	1	FC631	41
4-84	YEL	18	GXL	5687	MS650	4	X183A	1
4-86	BLU/BLK	18	TFFN	1585	X743A	3	C069-J7	4
4-87	BLU/RED	18	TFFN	1559	X743A	4	C069-J7	7
4-8	WHT	18	GXL	738	X102A	5	X701A	3
4-92	WHT	18	GXL	3130	C069-J7	35	X479	2
4-94	WHT	18	GXL	5456	C069-J1	10	X181A	1
4-96	WHT	18	GXL	85	C069-J12	6	C069-J12	7
4-97-1	RED	18	GXL	3000	GD414	2	S758	1
4-97-2	RED	18	GXL	323	S758	2	X755	3
4-97	RED	18	GXL	755	C069-J7	29	S758	2
CAN 1 HI	YEL	20	J1939 CABLE	703	C069-J7	13	MS131	2
CAN 1 HI	YEL	18	J1939 CABLE	793	MS131	1	X102A	3
CAN 1 HI	YEL	20	J1939 CABLE	2215	SN476	3	MS131	3
CAN 1 LO	GRN	20	J1939 CABLE	727	C069-J7	24	MS131	5
CAN 1 LO	GRN	18	J1939 CABLE	825	MS131	4	X102A	2
CAN 1 LO	GRN	20	J1939 CABLE	2183	SN476	4	MS131	6
CAN2 HI	YEL	20	J1939 CABLE	855	MS325	2	X429	C
CAN2 HI	YEL	20	J1939 CABLE	586	C069-J12	3	MS325	3
CAN2 HI	YEL	20	J1939 CABLE	5827	X183A	3	MS325	10
CAN2 HI	YEL	20	J1939 CABLE	2463	GD414	3	MS325	1
CAN2 LO	GRN	20	J1939 CABLE	842	MS325	7	X429	D
CAN2 LO	GRN	20	J1939 CABLE	637	C069-J12	4	MS325	4
CAN2 LO	GRN	20	J1939 CABLE	5893	X183A	4	MS325	6
CAN2 LO	GRN	20	J1939 CABLE	2487	GD414	4	MS325	5

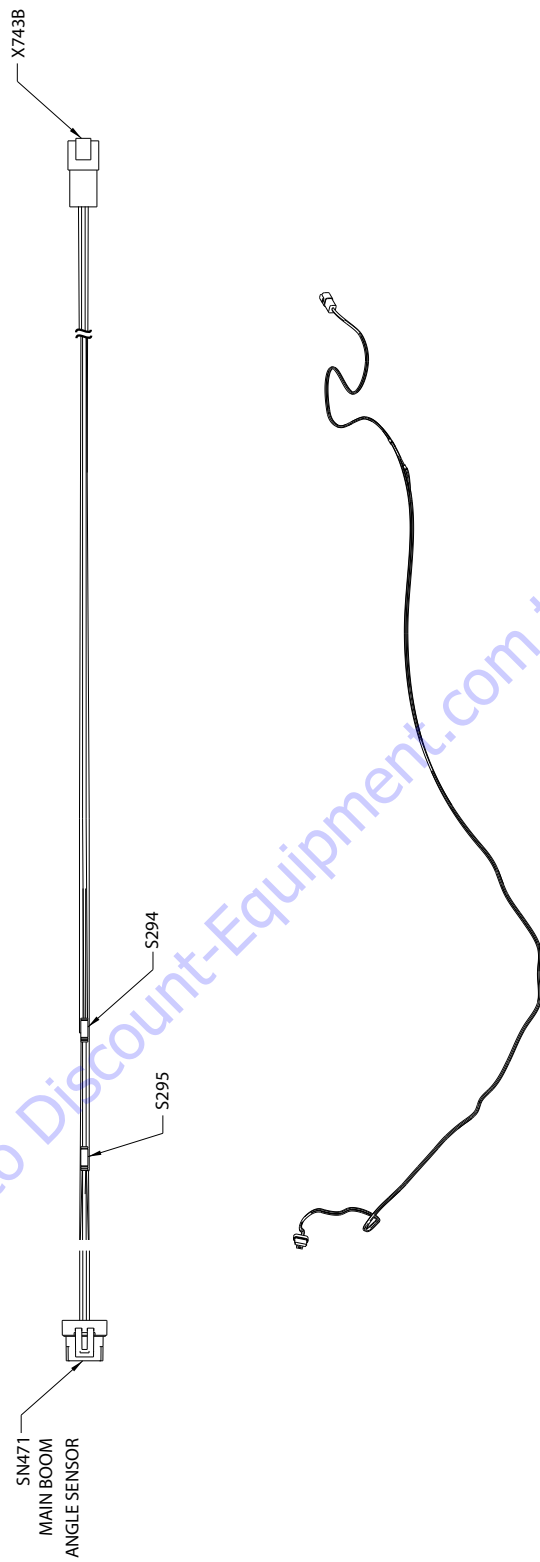

1001189005-B
MAE20810

Go to Discount-Equipment.com to order your parts

Figure 7-54. Boom Angle Sensor Harness

SECTION 7 - BASIC ELECTRICAL INFORMATION & ELECTRICAL SCHEMATICS

S295					
CONN POS	WIRE COLOR	WIRE LABEL	GAUGE	JACKET	TO
1	BLK	000-40-76 GND	18 AWG	GXL	X743B (1)
2	BLK/RED	000-40-78 GND	18 AWG	TFFN	SN471 (A)
2	BRN/BLK	000-40-79 GND	18 AWG	TFFN	SN471 (E)

S294					
CONN POS	WIRE COLOR	WIRE LABEL	GAUGE	JACKET	TO
1	WHT	4-108 PWR 5V	18 AWG	GXL	X743B (2)
2	ORN/BLK	4-106 PWR 5V	18 AWG	TFFN	SN471 (B)
2	YEL/BLK	4-112 PWR 5V	18 AWG	TFFN	SN471 (F)

X743B					
CONN POS	WIRE COLOR	WIRE LABEL	GAUGE	JACKET	TO
1	BLK	000-40-76 GND	18 AWG	GXL	S295 (1)
2	WHT	4-108 PWR 5V	18 AWG	GXL	S294 (1)
3	BLU/BLK	4-86 BM ANGLE SEN 1	18 AWG	TFFN	SN471 (C)
4	BLU/RED	4-87 BM ANGLE SEN 2	18 AWG	TFFN	SN471 (D)

SN471 MAIN BOOM ANGLE SENSOR					
CONN POS	WIRE COLOR	WIRE LABEL	GAUGE	JACKET	TO
A	BLK/RED	000-40-78 GND	18 AWG	TFFN	S295 (2)
B	ORN/BLK	4-106 PWR 5V	18 AWG	TFFN	S294 (2)
C	BLU/BLK	4-86 BM ANGLE SEN 1	18 AWG	TFFN	X743B (3)
D	BLU/RED	4-87 BM ANGLE SEN 2	18 AWG	TFFN	X743B (4)
E	BRN/BLK	000-40-79 GND	18 AWG	TFFN	S295 (2)
F	YEL/BLK	4-112 PWR 5V	18 AWG	TFFN	S294 (2)

SECTION 7 - BASIC ELECTRICAL INFORMATION & ELECTRICAL SCHEMATICS

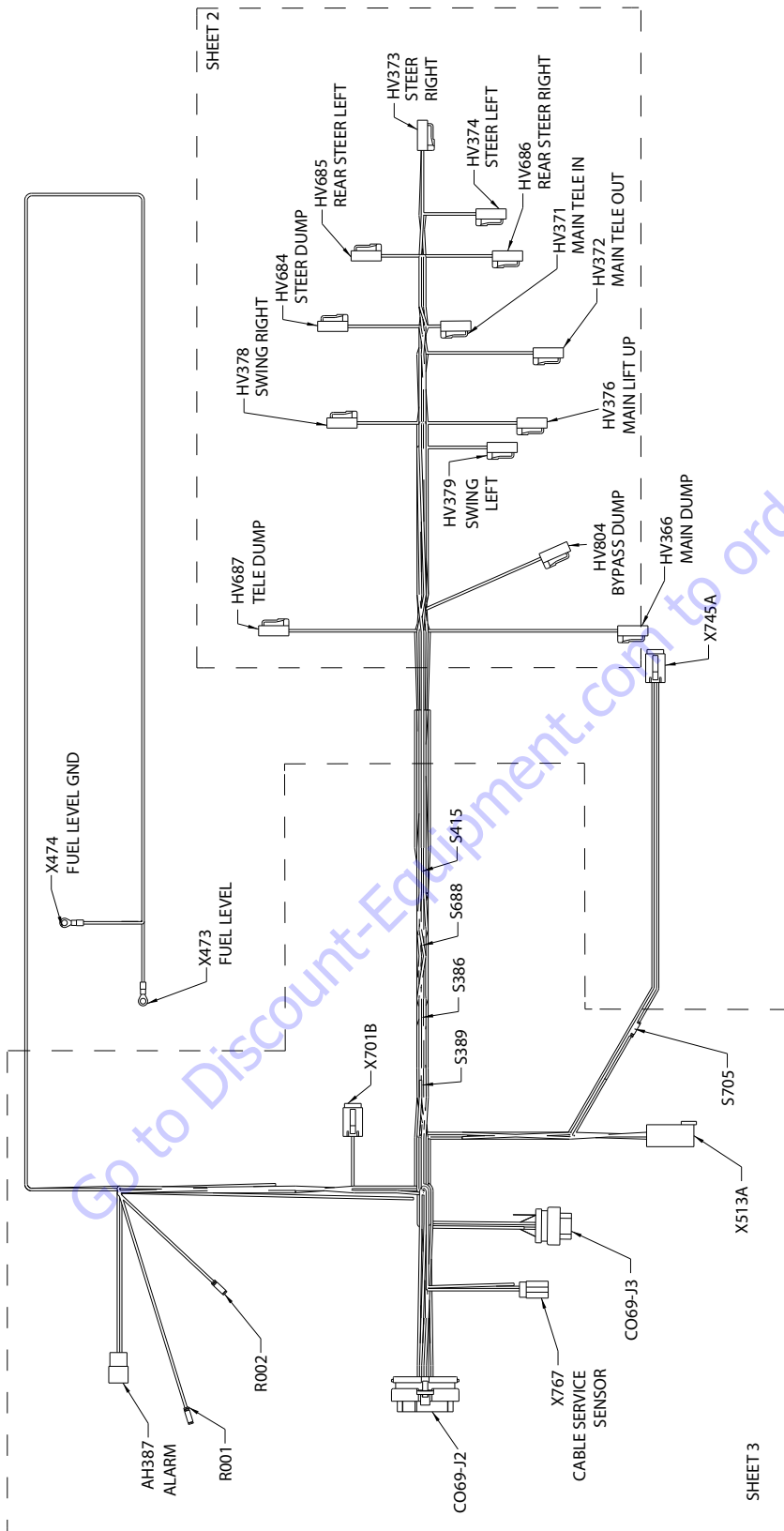

1001186643-G
MAE20820

Figure 7-55. Main valve Harness (4WS) - Sheet 1 of 4

SECTION 7 - BASIC ELECTRICAL INFORMATION & ELECTRICAL SCHEMATICS

X473 FUEL LEVEL					
CONN POS	WIRE COLOR	WIRE LABEL	GAUGE	JACKET	TO
1	WHT	4-75 FUEL SNSR	18 AWG	GXL	C069-J2 (25)

X474 FUEL LEVEL GND					
CONN POS	WIRE COLOR	WIRE LABEL	GAUGE	JACKET	TO
1	BLK	000-40-45	18 AWG	GXL	C069-J2 (6)

X745A					
CONN POS	WIRE COLOR	WIRE LABEL	GAUGE	JACKET	TO
1	WHT	4-25 LIFT DN	18 AWG	GXL	C069-J2 (22)
2	WHT	4-28 AUX DN	18 AWG	GXL	C069-J2 (21)
3	BLK	000-40-36 CF	18 AWG	GXL	S705 (1)
4	BLK	000-40-120 CF	18 AWG	GXL	C069-J3 (2)

Go to Discount-Equipment.com to order your parts

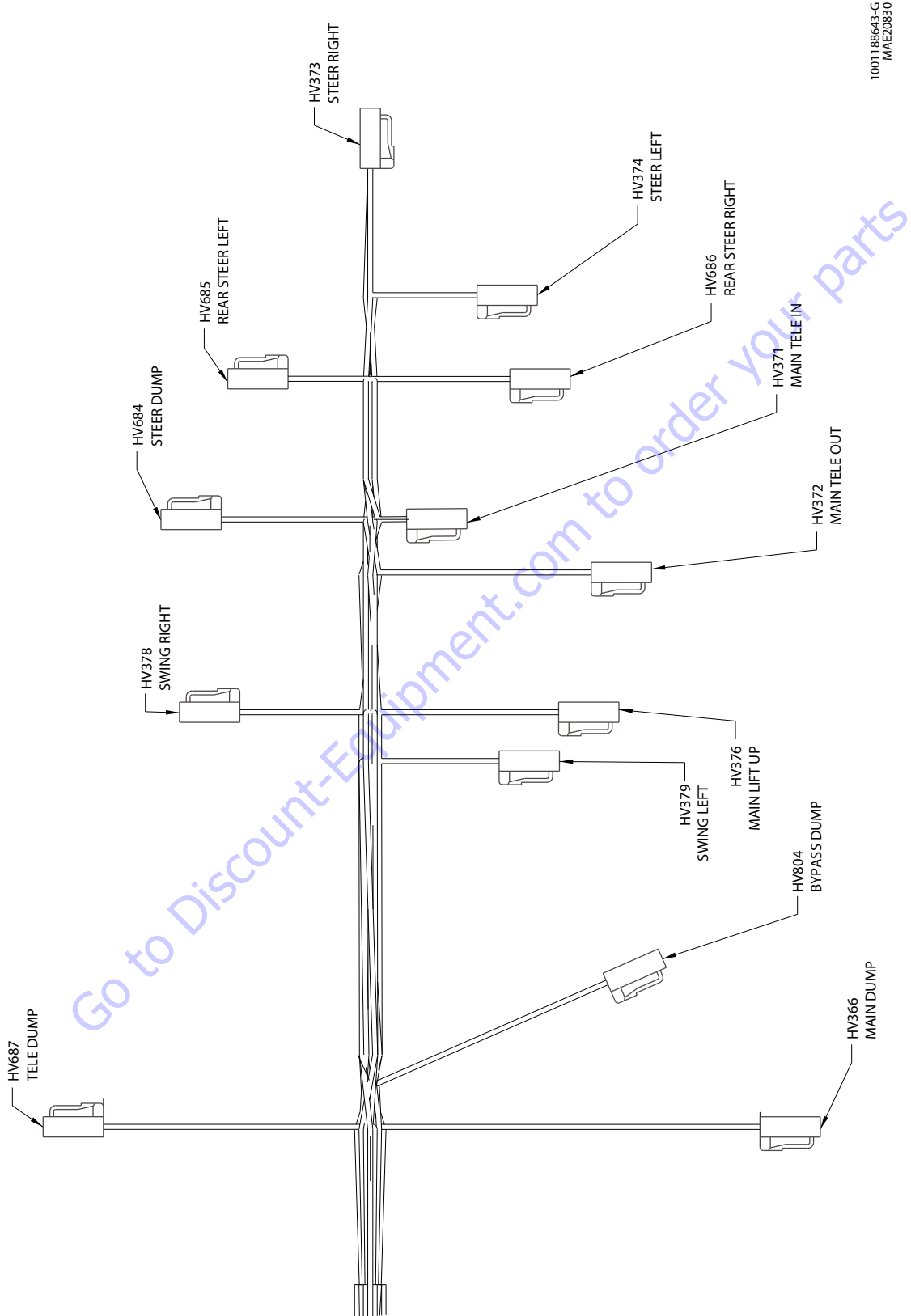

100118643-G
MAE20830

Figure 7-56. Main valve Harness (4WS) - Sheet 2 of 4

SECTION 7 - BASIC ELECTRICAL INFORMATION & ELECTRICAL SCHEMATICS

HV379 SWING LEFT					
CONN POS	WIRE COLOR	WIRE LABEL	GAUGE	JACKET	TO
1	WHT	4-27 SWG LEFT	18 AWG	GXL	C069-J2 (34)
2	BLK	000-40-39 CF	18 AWG	GXL	S389 (1)

HV686 REAR STEER RIGHT					
CONN POS	WIRE COLOR	WIRE LABEL	GAUGE	JACKET	TO
1	WHT	4-104 REAR STR RHT	18 AWG	GXL	C069-J2 (32)
2	BLK	000-40-63 REAR STR RT GND	18 AWG	GXL	S415 (1)

HV366 MAIN DUMP					
CONN POS	WIRE COLOR	WIRE LABEL	GAUGE	JACKET	TO
1	WHT	4-14 MAIN DUMP	18 AWG	GXL	C069-J2 (13)
2	BLK	000-40-25 GND	18 AWG	GXL	S688 (1)

HV371 MAIN TELE IN					
CONN POS	WIRE COLOR	WIRE LABEL	GAUGE	JACKET	TO
1	WHT	4-19 TELE IN	18 AWG	GXL	C069-J2 (9)
2	BLK	000-40-31	18 AWG	GXL	S386 (1)

HV687 TELE DUMP					
CONN POS	WIRE COLOR	WIRE LABEL	GAUGE	JACKET	TO
1	WHT	4-150 TELE DUMP	18 AWG	GXL	C069-J2 (31)
2	BLK	000-40-150 TELE DUMP GROUND	18 AWG	GXL	S688 (1)

HV372 MAIN TELE OUT					
CONN POS	WIRE COLOR	WIRE LABEL	GAUGE	JACKET	TO
1	WHT	4-20 TELE OUT	18 AWG	GXL	C069-J2 (20)
2	BLK	000-40-21	18 AWG	GXL	S386 (1)

HV378 SWING RIGHT					
CONN POS	WIRE COLOR	WIRE LABEL	GAUGE	JACKET	TO
1	WHT	4-26 SWG RHT	18 AWG	GXL	C069-J2 (35)
2	BLK	000-40-37 CF	18 AWG	GXL	S389 (1)

HV804 BYPASS DUMP					
CONN POS	WIRE COLOR	WIRE LABEL	GAUGE	JACKET	TO
1	WHT	4-85 BYPASS DUMP	18 AWG	GXL	C069-J2 (4)
2	BLK	000-4-85 BP DUMP GND	18 AWG	GXL	S688 (2)

HV684 STEER DUMP					
CONN POS	WIRE COLOR	WIRE LABEL	GAUGE	JACKET	TO
1	WHT	4-23 STR DUMP	18 AWG	GXL	C069-J2 (1)
2	BLK	000-40-33 STR DUMP GND	18 AWG	GXL	C069-J2 (18)

HV376 MAIN LIFT UP					
CONN POS	WIRE COLOR	WIRE LABEL	GAUGE	JACKET	TO
1	WHT	4-24 LIFT UP	18 AWG	GXL	C069-J2 (11)
2	BLK	000-40-35 CF	18 AWG	GXL	S705 (1)

HV685 REAR STEER LEFT					
CONN POS	WIRE COLOR	WIRE LABEL	GAUGE	JACKET	TO
1	WHT	4-103 REAR STR LEFT	18 AWG	GXL	C069-J2 (33)
2	BLK	000-40-49 REAR STR LEFT GND	18 AWG	GXL	S415 (2)

HV373 STEER RIGHT					
CONN POS	WIRE COLOR	WIRE LABEL	GAUGE	JACKET	TO
1	WHT	4-21 STR RIGHT	18 AWG	GXL	C069-J2 (8)
2	BLK	000-40-32 GND	18 AWG	GXL	S415 (1)

HV374 STEER LEFT					
CONN POS	WIRE COLOR	WIRE LABEL	GAUGE	JACKET	TO
1	WHT	4-22 STR LEFT	18 AWG	GXL	C069-J2 (19)
2	BLK	000-40-34 GND	18 AWG	GXL	S415 (1)

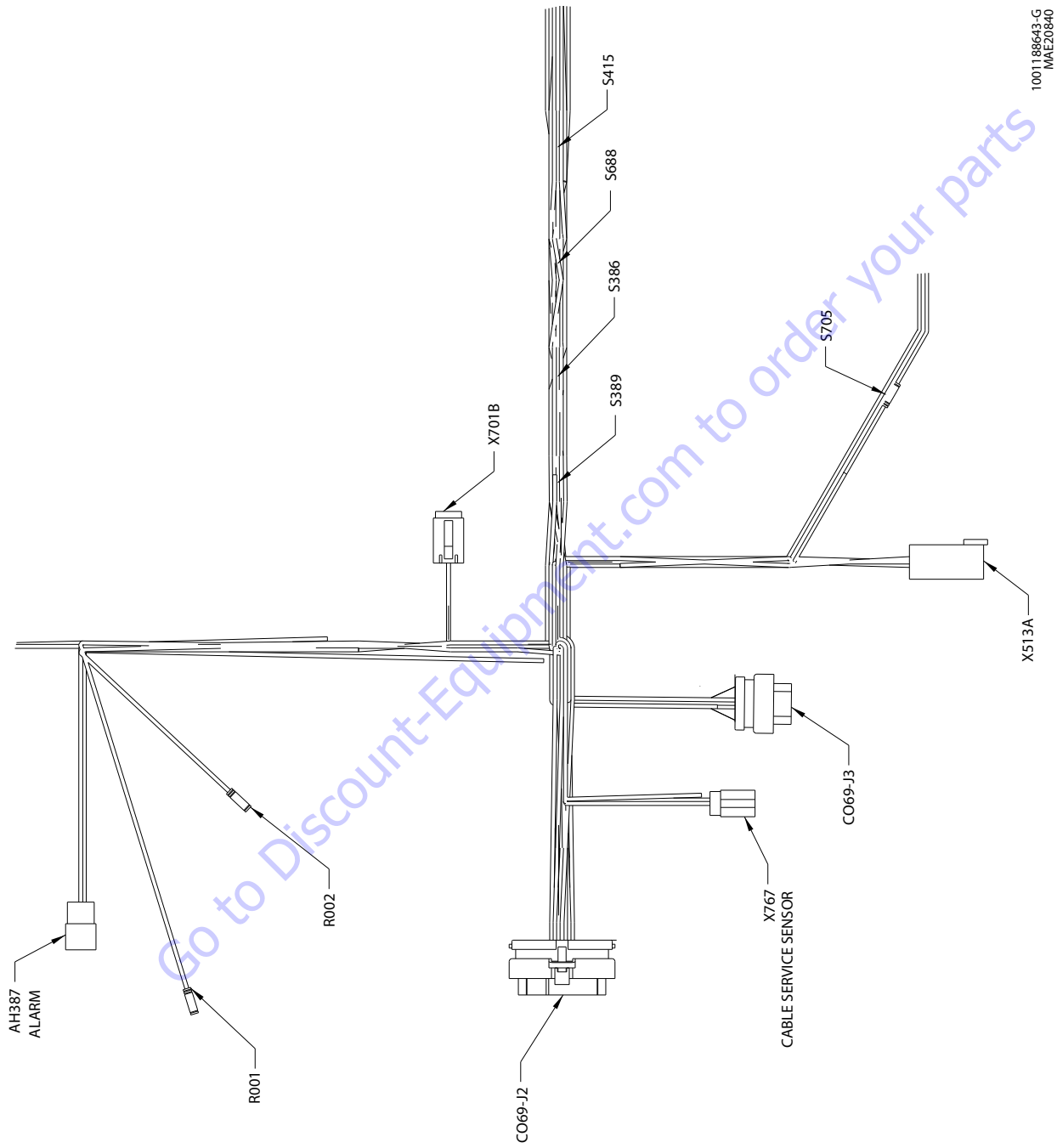

1001186643-G
MAE20840

Figure 7-57. Main valve Harness (AWS) - Sheet 3 of 4

SECTION 7 - BASIC ELECTRICAL INFORMATION & ELECTRICAL SCHEMATICS

C069-J2					
CONN POS	WIRE COLOR	WIRE LABEL	GAUGE	JACKET	TO
1	WHT	4-23 STR DUMP	18 AWG	GXL	HV684 (1)
2					
3	WHT	4-15 HIGH PRES DUMP	18 AWG	GXL	X701B (1)
4	WHT	4-85 BP DUMP	18 AWG	GXL	HV767 (1)
5	WHT	4-8 PLAT LEVEL UP	18 AWG	GXL	R001 (1)
6	BLK	000-40-45	18 AWG	GXL	X474 (1)
7	WHT	4-11 PLAT LEVEL DOWN	18 AWG	GXL	R002 (2)
8	WHT	4-21 STR RIGHT	18 AWG	GXL	HV373 (1)
9	WHT	4-19 TELE IN	18 AWG	GXL	HV371 (1)
10					
11	WHT	4-24 LIFT UP	18 AWG	GXL	HV376 (1)
12					
13	WHT	4-14 MAIN DUMP	18 AWG	GXL	HV366 (1)
14					
15					
16					
17					
18	BLK	000-40-33 STR DUMP GND	18 AWG	GXL	HV684 (2)
19	WHT	4-22 STR LEFT	18 AWG	GXL	HV374 (1)
20	WHT	4-20 TELE OUT	18 AWG	GXL	HV372 (1)
21	WHT	4-28 AUX DN	18 AWG	GXL	X745A (2)
22	WHT	4-25 LIFT DN	18 AWG	GXL	X745A (1)
23	WHT	4-16 LOW PRES DUMP	18 AWG	GXL	X701B (2)
24					
25	WHT	4-75 FUEL SNSR	18 AWG	GXL	X473 (1)
26	WHT	4-102 HEAD & TAIL LIGHTS	18 AWG	GXL	X513A (2)
27	WHT	4-29 ALRM	18 AWG	GXL	AH387 (B)
28	BLK	000-40-53 GND	18 AWG	GXL	S415 (2)
29	BLK	000-40-10 ALRM GND	18 AWG	GXL	AH387 (C)
30	BLK	000-40-151 GND	18 AWG	GXL	S688 (2)
31	WHT	4-150 TELE DUMP	18 AWG	GXL	HV687 (1)
32	WHT	4-104 REAR STR RHT	18 AWG	GXL	HV686 (1)
33	WHT	4-103 REAR STR LEFT	18 AWG	GXL	HV685 (1)
34	WHT	4-27 SWG LEFT	18 AWG	GXL	HV379 (1)
35	WHT	4-26 SWG RHT	18 AWG	GXL	HV378 (1)

AH387 ALARM					
CONN POS	WIRE COLOR	WIRE LABEL	GAUGE	JACKET	TO
A	WHT	4-30 ALRM	18 AWG	GXL	C069-J3 (7)
B	WHT	4-29 ALRM	18 AWG	GXL	C069-J2 (27)
C	BLK	000-40-10 ALRM GND	18 AWG	GXL	C069-J2 (29)

X513A					
CONN POS	WIRE COLOR	WIRE LABEL	GAUGE	JACKET	TO
1	BLK	000-40-44 CF	18 AWG	GXL	C069-J3 (1)
2	WHT	4-102 HEAD & TAIL LIGHTS	18 AWG	GXL	C069-J2 (26)
3	WHT	4-105 CRIBBING	18 AWG	GXL	C069-J3 (9)
4	WHT	4-206 BRKN CBL PWR	18 AWG	GXL	X767 (1)
5					
6					

S386					
CONN POS	WIRE COLOR	WIRE LABEL	GAUGE	JACKET	TO
1	BLK	000-40-21	18 AWG	GXL	HV372 (2)
1	BLK	000-40-31	18 AWG	GXL	HV371 (2)
2	BLK	000-40-7 CF	18 AWG	GXL	C069-J3 (6)

S688					
CONN POS	WIRE COLOR	WIRE LABEL	GAUGE	JACKET	TO
1	BLK	000-40-150 TELE DUMP GROUND	18 AWG	GXL	HV687 (2)
1	BLK	000-40-25 GND	18 AWG	GXL	HV366 (2)
2	BLK	000-4-85 BP DUMP GND	18 AWG	GXL	HV804 (2)
2	BLK	000-40-151 GND	18 AWG	GXL	C069-J2 (30)

C069-J3					
CONN POS	WIRE COLOR	WIRE LABEL	GAUGE	JACKET	TO
1	BLK	000-40-44 CF	18 AWG	GXL	X513A (1)
2	BLK	000-40-120 CF	18 AWG	GXL	X745A (4)
3	WHT	4-204 BRKN CBL GND	18 AWG	GXL	X767 (3)
4	BLK	000-40-38 CF	18 AWG	GXL	S389 (2)
5					
6	BLK	000-40-7 CF	18 AWG	GXL	S386 (2)
7	WHT	4-30 ALRM	18 AWG	GXL	AH387 (A)
8	WHT	4-205 BRKN CBL SIGNAL	18 AWG	GXL	X767 (2)
9	WHT	4-105 CRIBBING	18 AWG	GXL	X513A (3)
10					
11					
12					
13					
14	BLK	000-40-50 CF	18 AWG	GXL	S705 (2)

R002					
CONN POS	WIRE COLOR	WIRE LABEL	GAUGE	JACKET	TO
1	WHT	4-11-2 PLT LVL DN	18 AWG	GXL	X701B (4)
2	WHT	4-11 PLAT LEVEL DOWN	18 AWG	GXL	C069-J2 (7)

SECTION 7 - BASIC ELECTRICAL INFORMATION & ELECTRICAL SCHEMATICS

S415					
CONN POS	WIRE COLOR	WIRE LABEL	GAUGE	JACKET	TO
1	BLK	000-40-32 GND	18 AWG	GXL	HV373 (2)
1	BLK	000-40-34 GND	18 AWG	GXL	HV374 (2)
1	BLK	000-40-63 REAR STR RT GND	18 AWG	GXL	HV686 (2)
2	BLK	000-40-49 REAR STR LEFT GND	18 AWG	GXL	HV685 (2)
2	BLK	000-40-53 GND	18 AWG	GXL	C069-J2 (28)

R001					
CONN POS	WIRE COLOR	WIRE LABEL	GAUGE	JACKET	TO
1	WHT	4-8 PLAT LEVEL UP	18 AWG	GXL	C069-J2 (5)
2	WHT	4-8-2 PLT LVL UP	18 AWG	GXL	X701B (3)

S705					
CONN POS	WIRE COLOR	WIRE LABEL	GAUGE	JACKET	TO
1	BLK	000-40-35 CF	18 AWG	GXL	HV376 (2)
1	BLK	000-40-36 CF	18 AWG	GXL	X745A (3)
2	BLK	000-40-50 CF	18 AWG	GXL	C069-J3 (14)

S389					
CONN POS	WIRE COLOR	WIRE LABEL	GAUGE	JACKET	TO
1	BLK	000-40-37 CF	18 AWG	GXL	HV378 (2)
1	BLK	000-40-39 CF	18 AWG	GXL	HV379 (2)
2	BLK	000-40-38 CF	18 AWG	GXL	C069-J3 (4)

X701B					
CONN POS	WIRE COLOR	WIRE LABEL	GAUGE	JACKET	TO
1	WHT	4-15 HIGH PRES DUMP	18 AWG	GXL	C069-J2 (3)
2	WHT	4-16 LOW PRES DUMP	18 AWG	GXL	C069-J2 (23)
3	WHT	4-8-2002 PLT LVL UP	18 AWG	GXL	R001 (2)
4	WHT	4-11-2002 PLT LVL DN	18 AWG	GXL	R002 (1)

X767 CABLE SERVICE SENSOR					
CONN POS	WIRE COLOR	WIRE LABEL	GAUGE	JACKET	TO
1	WHT	4-206 BRKN CBL PWR	18 AWG	GXL	X513A (4)
2	WHT	4-205 BRKN CBL SIGNAL	18 AWG	GXL	C069-J3 (8)
3	WHT	4-204 BRKN CBL GND	18 AWG	GXL	C069-J3 (3)

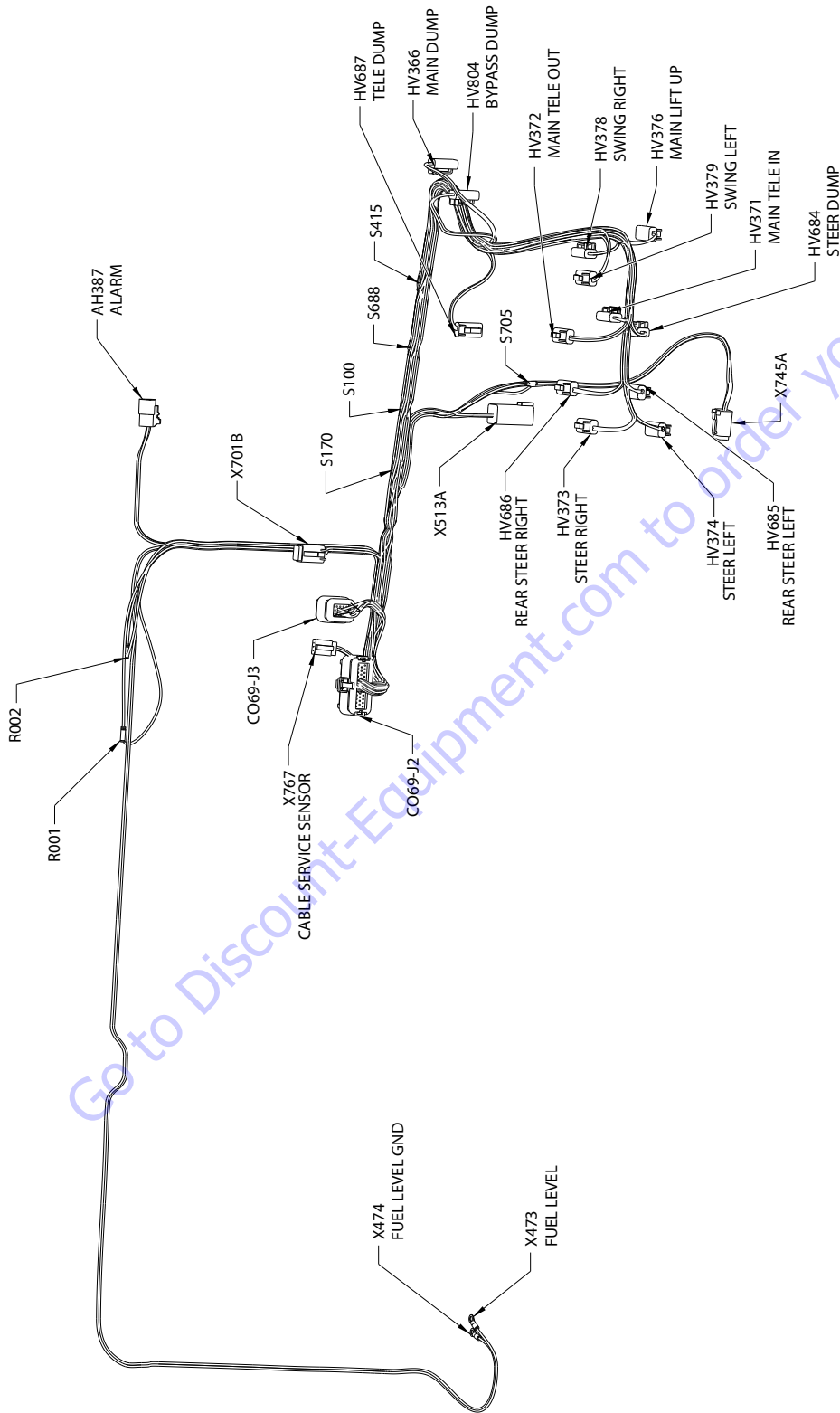

1001188643-G
MAE20860

Figure 7-58. Main valve Harness (4WS) - Sheet 4 of 4

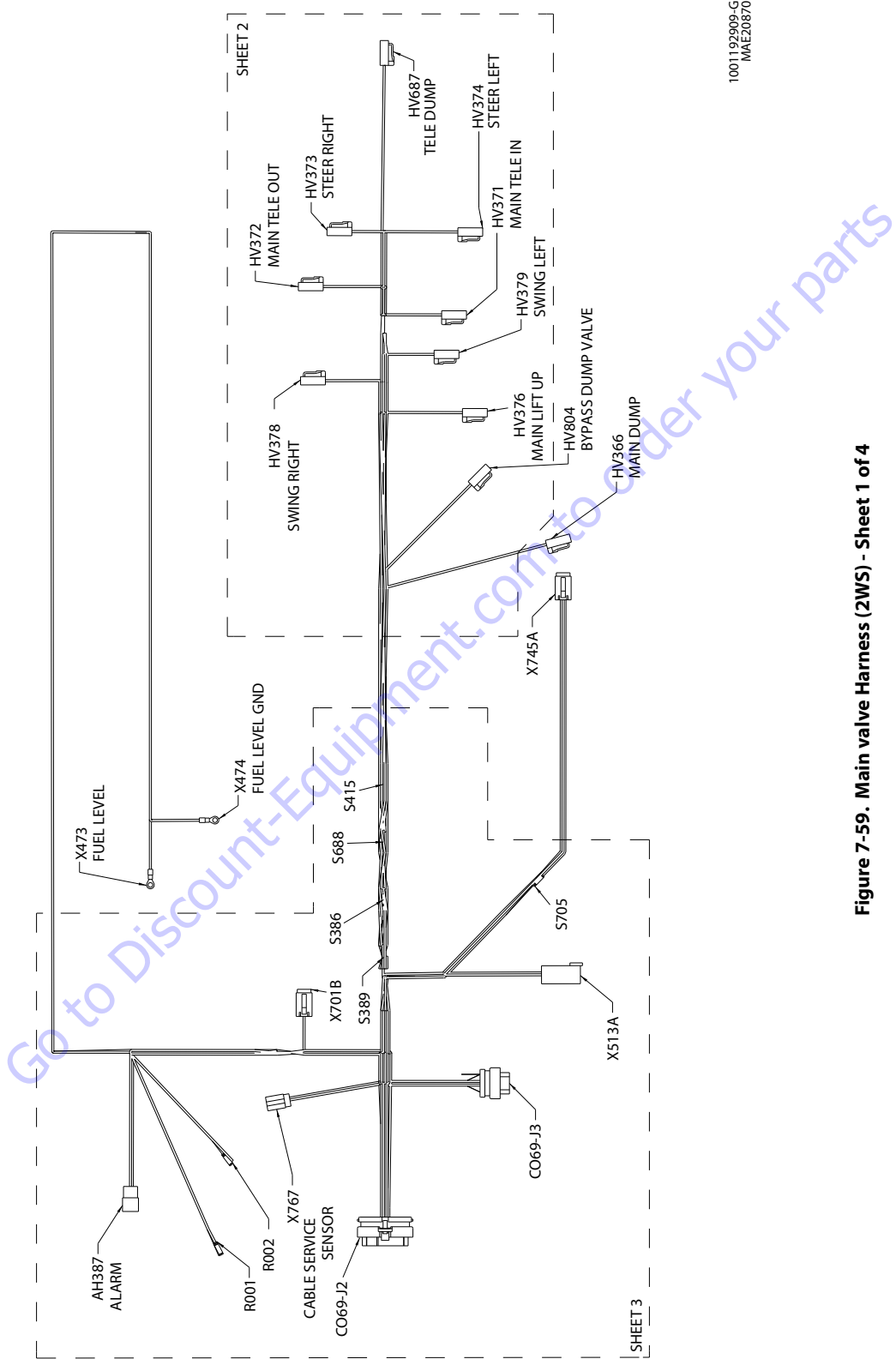

1001192909-G
MAE20870

Figure 7-59. Main valve Harness (2WS) - Sheet 1 of 4

SECTION 7 - BASIC ELECTRICAL INFORMATION & ELECTRICAL SCHEMATICS

X473 FUEL LEVEL					
CONN POS	WIRE COLOR	WIRE LABEL	GAUGE	JACKET	TO
1	WHT	4-75 FUEL SNSR	18 AWG	GXL	C069-J2 (25)

X474 FUEL LEVEL GND					
CONN POS	WIRE COLOR	WIRE LABEL	GAUGE	JACKET	TO
1	BLK	000-40-45	18 AWG	GXL	C069-J2 (6)

X745A					
CONN POS	WIRE COLOR	WIRE LABEL	GAUGE	JACKET	TO
1	WHT	4-25 LIFT DN	18 AWG	GXL	C069-J2 (22)
2	WHT	4-28 AUX DN	18 AWG	GXL	C069-J2 (21)
3	BLK	000-40-36 CF	18 AWG	GXL	S705 (1)
4	BLK	000-40-120 CF	18 AWG	GXL	C069-J3 (2)

Go to Discount-Equipment.com to order your parts

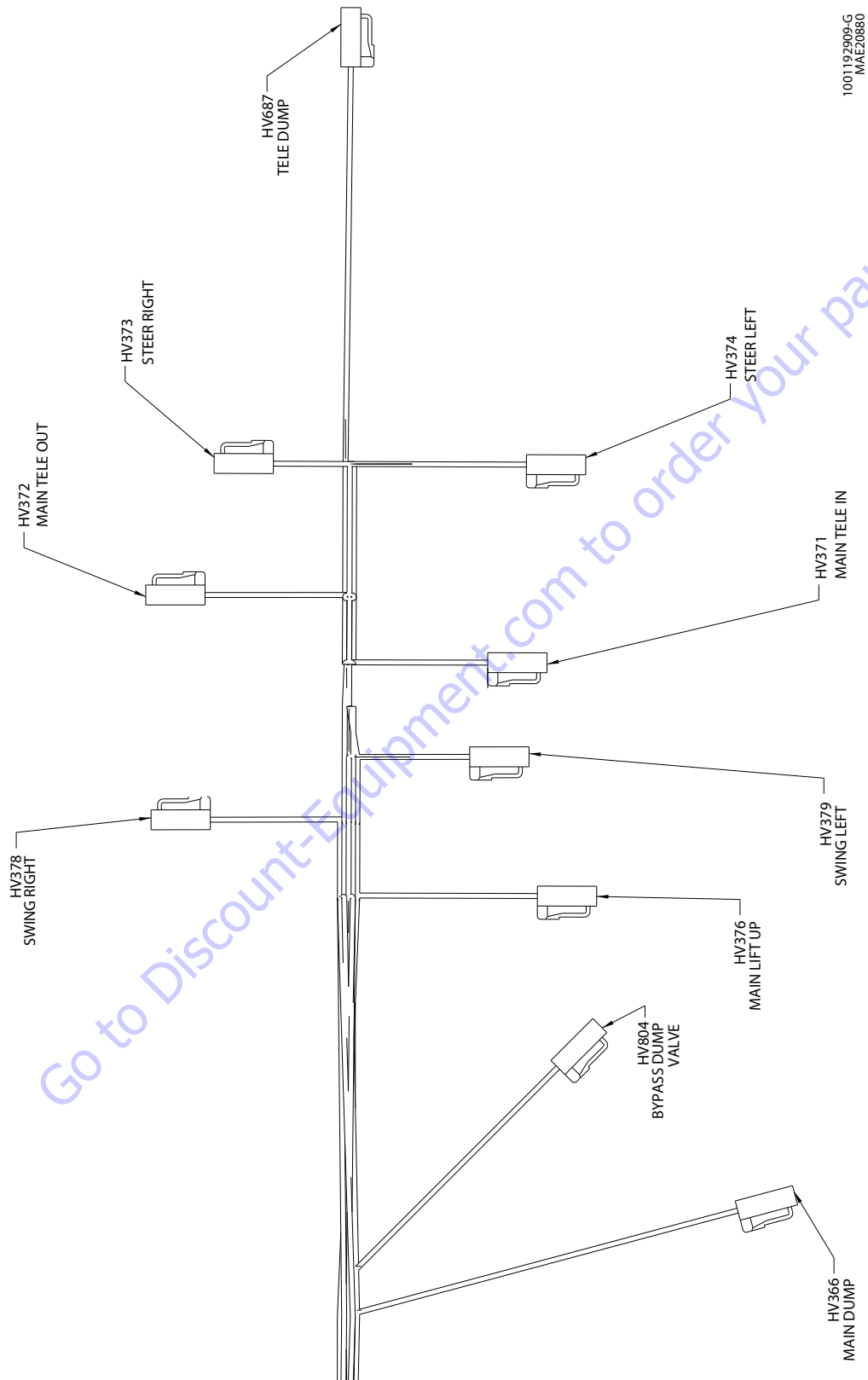

Figure 7-60. Main valve Harness (2WS) - Sheet 2 of 4

SECTION 7 - BASIC ELECTRICAL INFORMATION & ELECTRICAL SCHEMATICS

HV687 TELE DUMP					
CONN POS	WIRE COLOR	WIRE LABEL	GAUGE	JACKET	TO
1	WHT	4-150 TELE DUMP	18 AWG	GXL	C069-J2 (31)
2	BLK	000-40-150 TELE DUMP GROUND	18 AWG	GXL	S688 (1)

HV378 SWING RIGHT					
CONN POS	WIRE COLOR	WIRE LABEL	GAUGE	JACKET	TO
1	WHT	4-26 SWG RHT	18 AWG	GXL	C069-J2 (35)
2	BLK	000-40-37 CF	18 AWG	GXL	S389 (1)

HV379 SWING LEFT					
CONN POS	WIRE COLOR	WIRE LABEL	GAUGE	JACKET	TO
1	WHT	4-27 SWG LEFT	18 AWG	GXL	C069-J2 (34)
2	BLK	000-40-39 CF	18 AWG	GXL	S389 (1)

HV373 STEER RIGHT					
CONN POS	WIRE COLOR	WIRE LABEL	GAUGE	JACKET	TO
1	WHT	4-21 STR RIGHT	18 AWG	GXL	C069-J2 (8)
2	BLK	000-40-32 GND	18 AWG	GXL	S415 (1)

HV374 STEER LEFT					
CONN POS	WIRE COLOR	WIRE LABEL	GAUGE	JACKET	TO
1	WHT	4-22 STR LEFT	18 AWG	GXL	C069-J2 (19)
2	BLK	000-40-34 GND	18 AWG	GXL	S415 (1)

HV372 MAIN TELE OUT					
CONN POS	WIRE COLOR	WIRE LABEL	GAUGE	JACKET	TO
1	WHT	4-20 TELE OUT	18 AWG	GXL	C069-J2 (20)
2	BLK	000-40-21	18 AWG	GXL	S386 (1)

HV371 MAIN TELE IN					
CONN POS	WIRE COLOR	WIRE LABEL	GAUGE	JACKET	TO
1	WHT	4-19 TELE IN	18 AWG	GXL	C069-J2 (9)
2	BLK	000-40-31 CF	18 AWG	GXL	S386 (1)

HV804 BYPASS DUMP VALVE					
CONN POS	WIRE COLOR	WIRE LABEL	GAUGE	JACKET	TO
1	WHT	4-85 BYPASS DUMP	18 AWG	GXL	C069-J2 (4)
2	BLK	000-4-85 BP DUMP GND	18 AWG	GXL	S688 (2)

HV376 MAIN LIFT UP					
CONN POS	WIRE COLOR	WIRE LABEL	GAUGE	JACKET	TO
1	WHT	4-24 LIFT UP	18 AWG	GXL	C069-J2 (11)
2	BLK	000-40-35 CF	18 AWG	GXL	S705 (1)

HV366 MAIN DUMP					
CONN POS	WIRE COLOR	WIRE LABEL	GAUGE	JACKET	TO
1	WHT	4-14 MAIN DUMP	18 AWG	GXL	C069-J2 (13)
2	BLK	000-40-25 GND	18 AWG	GXL	S688 (1)

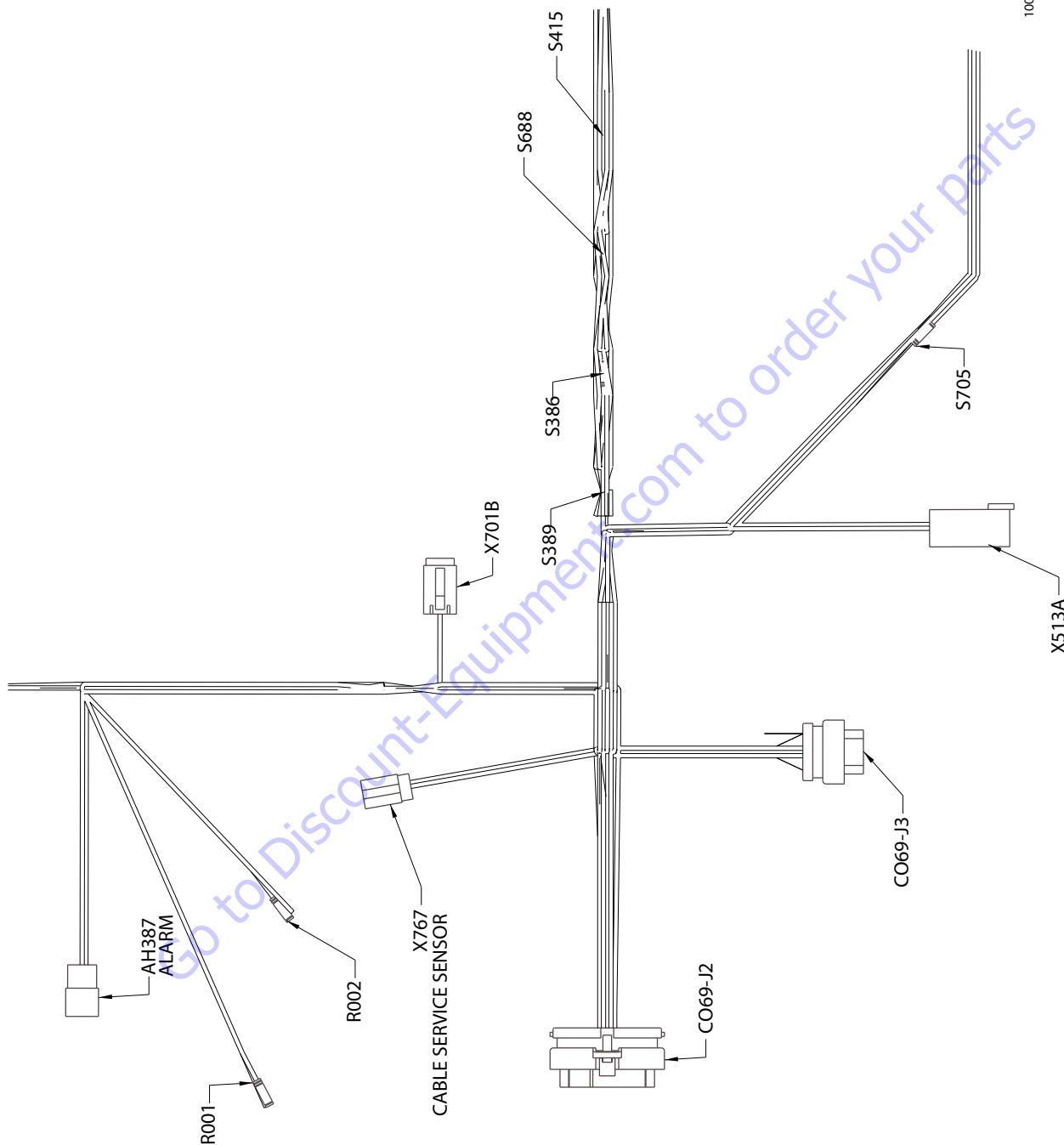

1001192909-G
MAE20890

Figure 7-61. Main valve Harness (2WS) - Sheet 3 of 4

SECTION 7 - BASIC ELECTRICAL INFORMATION & ELECTRICAL SCHEMATICS

C069-J2					
CONN POS	WIRE COLOR	WIRE LABEL	GAUGE	JACKET	TO
1					
2					
3	WHT	4-15 HIGH PRES DUMP	18 AWG	GXL	X701B (1)
4	WHT	4-85 BP DUMP	18 AWG	GXL	HV804 (1)
5	WHT	4-8 PLAT LEVEL UP	18 AWG	GXL	R001 (1)
6	BLK	000-40-45	18 AWG	GXL	X474 (1)
7	WHT	4-11 PLAT LEVEL DOWN	18 AWG	GXL	R002 (2)
8	WHT	4-21 STR RIGHT	18 AWG	GXL	HV373 (1)
9	WHT	4-19 TELE IN	18 AWG	GXL	HV371 (1)
10					
11	WHT	4-24 LIFT UP	18 AWG	GXL	HV376 (1)
12					
13	WHT	4-14 MAIN DUMP	18 AWG	GXL	HV366 (1)
14					
15					
16					
17					
18					
19	WHT	4-22 STR LEFT	18 AWG	GXL	HV374 (1)
20	WHT	4-20 TELE OUT	18 AWG	GXL	HV372 (1)
21	WHT	4-28 AUX DN	18 AWG	GXL	X745A (2)
22	WHT	4-25 LIFT DN	18 AWG	GXL	X745A (1)
23	WHT	4-16 LOW PRES DUMP	18 AWG	GXL	X701B (2)
24					
25	WHT	4-75 FUEL SNSR	18 AWG	GXL	X473 (1)
26	WHT	4-102 HEAD & TAIL LIGHTS	18 AWG	GXL	X513A (2)
27	WHT	4-29 ALRM	18 AWG	GXL	AH387 (B)
28	BLK	000-40-53 GND	18 AWG	GXL	S415 (2)
29	BLK	000-40-10 ALRM GND	18 AWG	GXL	AH387 (C)
30	BLK	000-40-151 GND	18 AWG	GXL	S688 (2)
31	WHT	4-150 TELE DUMP	18 AWG	GXL	HV687 (1)
32					
33					
34	WHT	4-27 SWG LEFT	18 AWG	GXL	HV379 (1)
35	WHT	4-26 SWG RHT	18 AWG	GXL	HV378 (1)

C069-J3					
CONN POS	WIRE COLOR	WIRE LABEL	GAUGE	JACKET	TO
1	BLK	000-40-44 CF	18 AWG	GXL	X513A (1)
2	BLK	000-40-120 CF	18 AWG	GXL	X745A (4)
3	WHT	4-204 BRKN CBL GND	18 AWG	GXL	X767 (3)
4	BLK	000-40-38 CF	18 AWG	GXL	S389 (2)
5					
6	BLK	000-40-7 CF	18 AWG	GXL	S386 (2)
7	WHT	4-30 ALRM	18 AWG	GXL	AH387 (A)
8	WHT	4-205 BRKN CBL SIGNAL	18 AWG	GXL	X767 (2)
9	WHT	4-105 CRIBBING	18 AWG	GXL	X513A (3)
10					
11					
12					
13					
14	BLK	000-40-50 CF	18 AWG	GXL	S705 (2)

X701B					
CONN POS	WIRE COLOR	WIRE LABEL	GAUGE	JACKET	TO
1	WHT	4-15 HIGH PRES DUMP	18 AWG	GXL	C069-J2 (3)
2	WHT	4-16 LOW PRES DUMP	18 AWG	GXL	C069-J2 (23)
3	WHT	4-8-2002 PLT L LVL UP	18 AWG	GXL	R001 (2)
4	WHT	4-11-2002 PLT L LVL UP	18 AWG	GXL	R002 (1)

R001					
CONN POS	WIRE COLOR	WIRE LABEL	GAUGE	JACKET	TO
1	WHT	4-8 PLAT LEVEL UP	18 AWG	GXL	C069-J2 (5)
2	WHT	4-8-2002 PLT LVL UP	18 AWG	GXL	X701B (3)

X767 CABLE SERVICE SENSOR					
CONN POS	WIRE COLOR	WIRE LABEL	GAUGE	JACKET	TO
1	WHT	4-206 BRKN CBL PWR	18 AWG	GXL	X513A (4)
2	WHT	4-205 BRKN CBL SIGNAL	18 AWG	GXL	C069-J3 (8)
3	WHT	4-204 BRKN CBL GND	18 AWG	GXL	C069-J3 (3)

AH387 ALARM					
CONN POS	WIRE COLOR	WIRE LABEL	GAUGE	JACKET	TO
A	WHT	4-30 ALRM	18 AWG	GXL	C069-J3 (7)
B	WHT	4-29 ALRM	18 AWG	GXL	C069-J2 (27)
C	BLK	000-40-10 ALRM GND	18 AWG	GXL	C069-J2 (29)

X513A					
CONN POS	WIRE COLOR	WIRE LABEL	GAUGE	JACKET	TO
1	BLK	000-40-44 CF	18 AWG	GXL	C069-J3 (1)
2	WHT	4-102 HEAD & TAIL LIGHTS	18 AWG	GXL	C069-J2 (26)
3	WHT	4-105 CRIBBING	18 AWG	GXL	C069-J3 (9)
4	WHT	4-206 BRKN CBL PWR	18 AWG	GXL	X767 (1)
5					
6					

S705					
CONN POS	WIRE COLOR	WIRE LABEL	GAUGE	JACKET	TO
1	BLK	000-40-3 CK	18 AWG	GXL	HV376 (2)
1	BLK	000-40-36 CK	18 AWG	GXL	X745A (3)
2	BLK	000-40-50 CK	18 AWG	GXL	C069-J3 (14)

S415					
CONN POS	WIRE COLOR	WIRE LABEL	GAUGE	JACKET	TO
1	BLK	000-40-32 GND	18 AWG	GXL	HV373 (2)
1	BLK	000-40-34 GND	18 AWG	GXL	HV374 (2)
2	BLK	000-40-53 GND	18 AWG	GXL	C069-J2 (28)

S688					
CONN POS	WIRE COLOR	WIRE LABEL	GAUGE	JACKET	TO
1	BLK	000-40-150 TELE DUMP GROUND	18 AWG	GXL	HV687 (2)
1	BLK	000-40-25 GND	18 AWG	GXL	HV366 (2)
2	BLK	000-4-85 BP DUMP GND	18 AWG	GXL	HV804 (2)
2	BLK	000-40-151 GND	18 AWG	GXL	C069-J2 (30)

SECTION 7 - BASIC ELECTRICAL INFORMATION & ELECTRICAL SCHEMATICS

S386					
CONN POS	WIRE COLOR	WIRE LABEL	GAUGE	JACKET	TO
1	BLK	000-40-21	18 AWG	GXL	HV372 (2)
1	BLK	000-40-31	18 AWG	GXL	HV371 (2)
2	BLK	000-40-7 CF	18 AWG	GXL	C069-J3 (6)

S389					
CONN POS	WIRE COLOR	WIRE LABEL	GAUGE	JACKET	TO
1	BLK	000-40-37 CF	18 AWG	GXL	HV378 (2)
1	BLK	000-40-39 CF	18 AWG	GXL	HV379 (2)
2	BLK	000-40-38 CF	18 AWG	GXL	C069-J3 (4)

R002					
CONN POS	WIRE COLOR	WIRE LABEL	GAUGE	JACKET	TO
1	WHT	4-11-2 PLT LVL DN	18 AWG	GXL	X701B (4)
2	WHT	4-11 PLAT LEVEL DOWN	18 AWG	GXL	C069-J2 (7)

Go to Discount-Equipment.com to order your parts

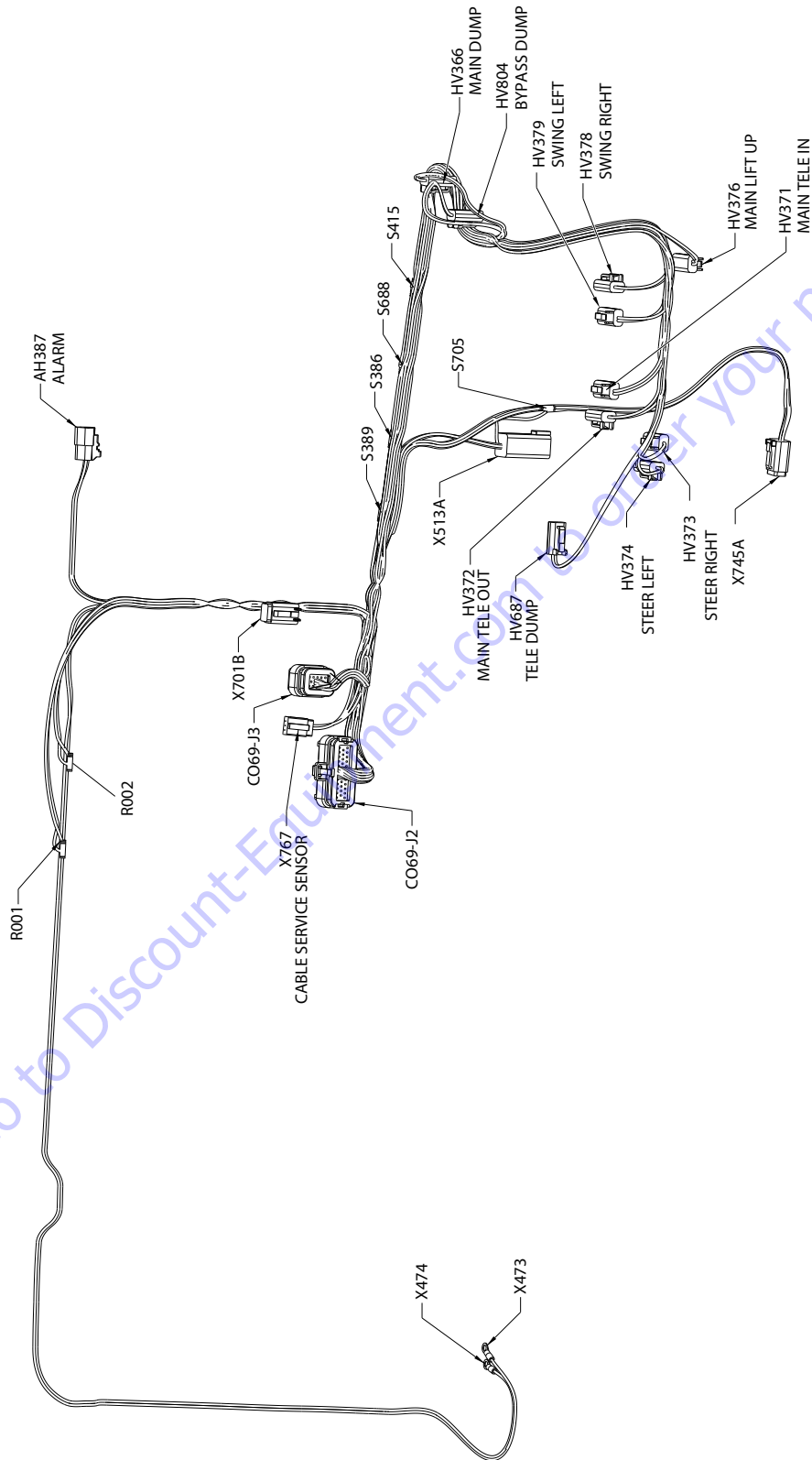

1001192909-G
MAE20910

Go to Discount-Equipment.com to order your parts

Figure 7-62. Main valve Harness (2WS) - Sheet 4 of 4

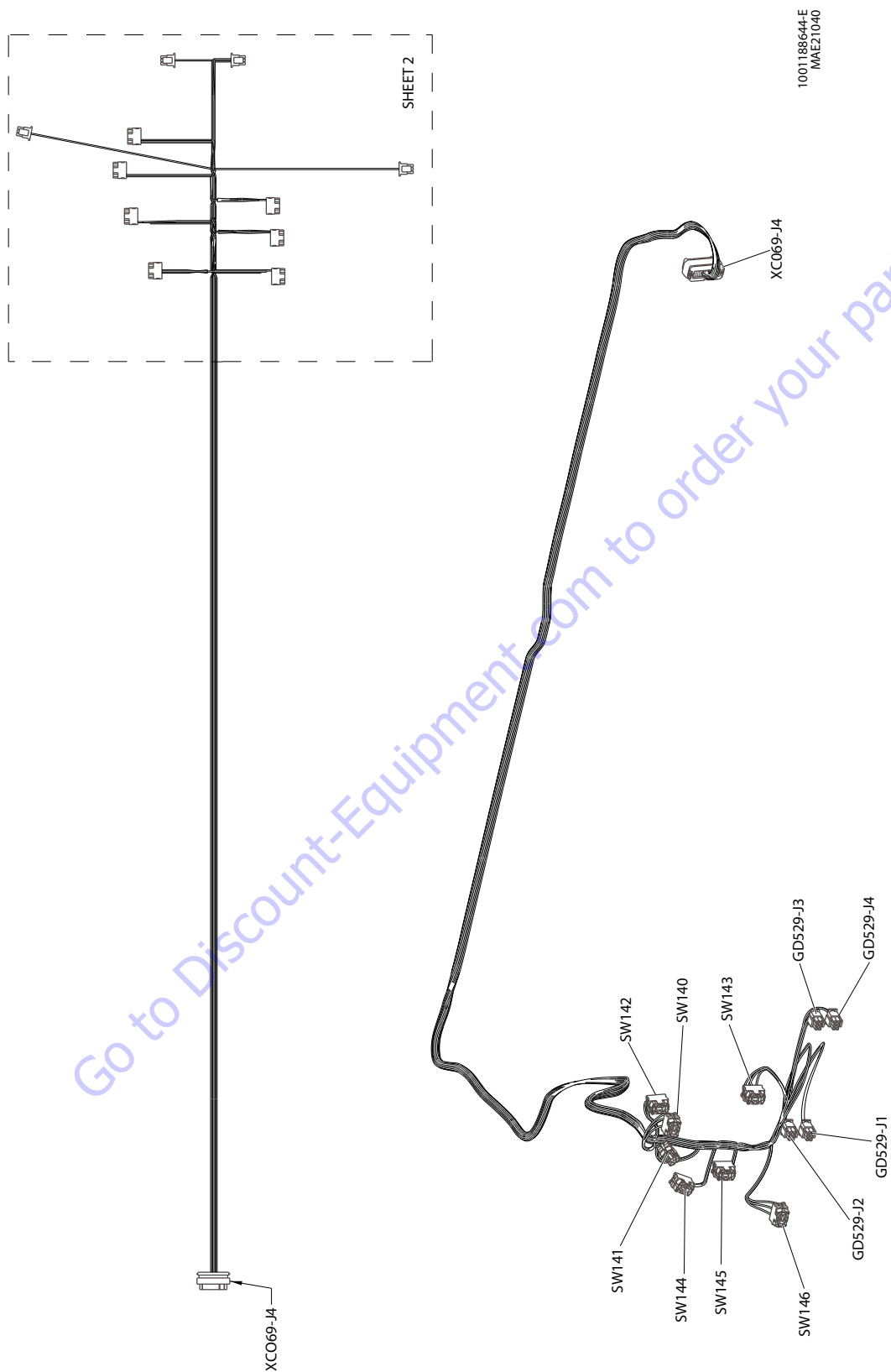
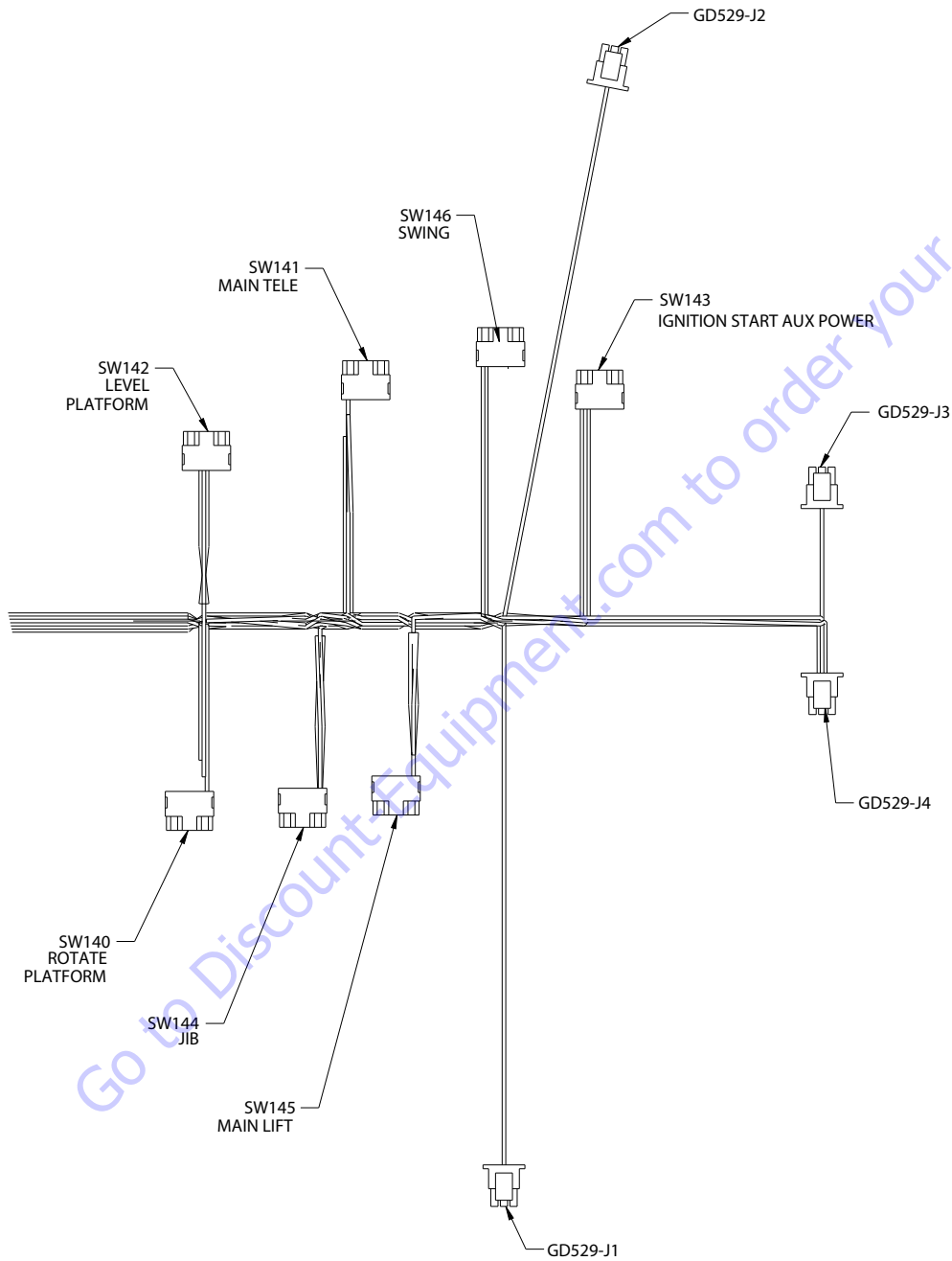

Figure 7-63. Ground Control Harness - Sheet 1 of 2

SECTION 7 - BASIC ELECTRICAL INFORMATION & ELECTRICAL SCHEMATICS

XC069-J4					
CONN POS	WIRE COLOR	WIRE LABEL	GAUGE	JACKET	TO
1	WHT	5-23 CRIBBING ENABLED	18 AWG	GXL	GD529-J3 (1)
2	WHT	5-35 SYSTEM FAULT	18 AWG	GXL	GD529-J4 (5)
3	WHT	5-24 GLOW PLUG	18 AWG	GXL	GD529-J2 (3)
4	WHT	5-9 IGNITION START	18 AWG	GXL	SW143 (1)
5	WHT	5-6 LEVEL DOWN	18 AWG	GXL	SW142 (3)
6	WHT	5-4 ROTATE LEFT	18 AWG	GXL	SW140 (3)
7	WHT	5-1 TELE IN	18 AWG	GXL	SW141 (3)
8	WHT	5-11 JIB DOWN	18 AWG	GXL	SW144 (3)
9					
10					
11					
12					
13	WHT	5-36 LO LVL FUEL	18 AWG	GXL	GD529-J1 (5)
14	WHT	5-25 PLATFORM OVERLOAD	18 AWG	GXL	GD529-J3 (6)
15					
16	WHT	5-8 AUX POWER	18 AWG	GXL	SW143 (3)
17	WHT	5-5 LEVEL UP	18 AWG	GXL	SW142 (1)
18	WHT	5-3 ROTATE RIGHT	18 AWG	GXL	SW140 (1)
19	WHT	5-10 JIB UP	18 AWG	GXL	SW144 (1)
20					
21					
22					
23	WHT	5-12 MAIN LIFT UP	18 AWG	GXL	SW145 (1)
24					
25	WHT	5-26 SWITCH POWER	18 AWG	GXL	SW141 (2)
26	WHT	5-22 NO CHARGE	18 AWG	GXL	GD529-J4 (1)
27					
28	WHT	5-21 ENGINE HIGH TEMP	18 AWG	GXL	GD529-J4 (3)
29	WHT	5-20 ENGINE LOW OIL PRES	18 AWG	GXL	GD529-J4 (2)
30	WHT	5-2 TELE OUT	18 AWG	GXL	SW141 (1)
31	BLK	000-50-1 GND	18 AWG	GXL	GD529-J2 (6)
32	BLK	000-50-2 GND	18 AWG	GXL	GD529-J1 (4)
33	WHT	5-13 MAIN LIFT DOWN	18 AWG	GXL	SW145 (3)
34	WHT	5-15 SWING LEFT	18 AWG	GXL	SW146 (3)
35	WHT	5-14 SWING RIGHT	18 AWG	GXL	SW146 (1)

Go to Discount-Equipment.com to order your parts



1001188644-E
MAE21050

Figure 7-64. Ground Control Harness - Sheet 2 of 2

SECTION 7 - BASIC ELECTRICAL INFORMATION & ELECTRICAL SCHEMATICS

GDS29-J1					
CONN POS	WIRE COLOR	WIRE LABEL	GAUGE	JACKET	TO
1					
2					
3					
4	BLK	000-50-2 GND	18 AWG	GXL	XCO69-J4 (32)
5	WHT	5-36 LO LVL FUEL	18 AWG	GXL	XCO69-J4 (13)
6					

SW140 PLATFORM ROTATE					
CONN POS	WIRE COLOR	WIRE LABEL	GAUGE	JACKET	TO
1	WHT	5-3 ROTATE RIGHT	18 AWG	GXL	XCO69-J4 (18)
2	WHT	5-27	18 AWG	GXL	SW141 (2)
2	WHT	5-28	18 AWG	GXL	SW142 (2)
3	WHT	5-4 ROTATE LEFT	18 AWG	GXL	XCO69-J4 (6)
4					
5					
6					

GDS29-J3					
CONN POS	WIRE COLOR	WIRE LABEL	GAUGE	JACKET	TO
1	WHT	5-23 CRIBBING ENABLED	18 AWG	GXL	XCO69-J4 (1)
2					
3					
4					
5					
6	WHT	5-25 PLATFORM OVERLOAD	18 AWG	GXL	XCO69-J4 (14)

SW141 MAIN TELE					
CONN POS	WIRE COLOR	WIRE LABEL	GAUGE	JACKET	To
1	WHT	5-2 TELE OUT	18 AWG	GXL	XCO69-J4 (30)
2	WHT	5-26 SWITCH POWER	18 AWG	GXL	XCO69-J4 (25)
2	WHT	5-27	18 AWG	GXL	SW140 (2)
3	WHT	5-1 TELE IN	18 AWG	GXL	XCO69-J4 (7)
4					
5					
6					

SW144 JIB					
CONN POS	WIRE COLOR	WIRE LABEL	GAUGE	JACKET	TO
1	WHT	5-10 JIB UP	18 AWG	GXL	XCO69-J4 (19)
2	WHT	5-30	18 AWG	GXL	SW143 (2)
2	WHT	5-31	18 AWG	GXL	SW145 (2)
3	WHT	5-11 JIB DOWN	18 AWG	GXL	XCO69-J4 (8)
4					
5					
6					

SW146 SWING					
CONN POS	WIRE COLOR	WIRE LABEL	GAUGE	JACKET	To
1	WHT	5-14 SWING RIGHT	18 AWG	GXL	XCO69-J4 (35)
2	WHT	5-32	18 AWG	GXL	SW145 (2)
3	WHT	5-15 SWING LEFT	18 AWG	GXL	XCO69-J4 (34)
4					
5					
6					

GDS29-J2					
CONN POS	WIRE COLOR	WIRE LABEL	GAUGE	JACKET	TO
1					
2					
3	WHT	5-24 GLOW PLUG	18 AWG	GXL	XCO69-J4 (3)
4					
5					
6	BLK	000-50-1 GND	18 AWG	GXL	XCO69-J4 (31)

SW143 IGNITION START AUX POWER					
CONN POS	WIRE COLOR	WIRE LABEL	GAUGE	JACKET	TO
1	WHT	5-9 IGNITION START	18 AWG	GXL	XCO69-J4 (4)
2	WHT	5-29	18 AWG	GXL	SW142 (2)
2	WHT	5-30	18 AWG	GXL	SW144 (2)
3	WHT	5-8 AUX POWER	18 AWG	GXL	XCO69-J4 (16)
4					
5					
6					

GDS29-J4					
CONN POS	WIRE COLOR	WIRE LABEL	GAUGE	JACKET	TO
1	WHT	5-22 NO CHARGE	18 AWG	GXL	XCO69-J4 (26)
2	WHT	5-20 ENGINE LOW OIL PRES	18 AWG	GXL	XCO69-J4 (29)
3	WHT	5-21 ENGINE HIGH TEMP	18 AWG	GXL	XCO69-J4 (28)
4					
5	WHT	5-35 SYSTEM FAULT	18 AWG	GXL	XCO69-J4 (2)
6					

SW145 MAIN LIFT					
CONN POS	WIRE COLOR	WIRE LABEL	GAUGE	JACKET	TO
1	WHT	5-12 MAIN LIFT UP	18 AWG	GXL	XCO69-J4 (23)
2	WHT	5-31	18 AWG	GXL	SW144 (2)
2	WHT	5-32	18 AWG	GXL	SW146 (2)
3	WHT	5-13 MAIN LIFT DOWN	18 AWG	GXL	XCO69-J4 (33)
4					
5					
6					

SW142 PLATFORM LEVEL					
CONN POS	WIRE COLOR	WIRE LABEL	GAUGE	JACKET	TO
1	WHT	5-5 LEVEL UP	18 AWG	GXL	XCO69-J4 (17)
2	WHT	5-28	18 AWG	GXL	SW140 (2)
2	WHT	5-29	18 AWG	GXL	SW143 (2)
3	WHT	5-6 LEVEL DOWN	18 AWG	GXL	XCO69-J4 (5)
4					
5					
6					

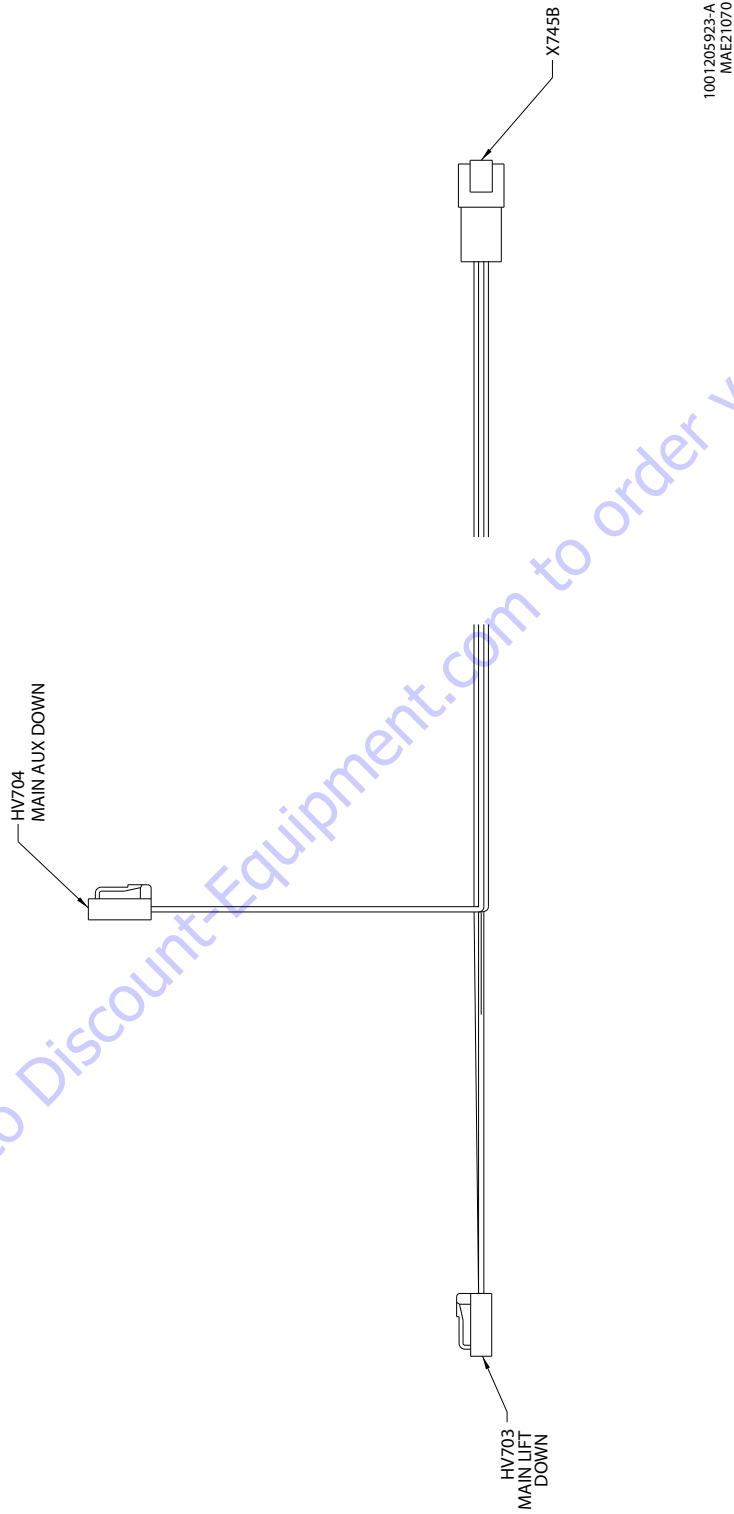

Figure 7-65. Lift Cylinder Harness

SECTION 7 - BASIC ELECTRICAL INFORMATION & ELECTRICAL SCHEMATICS

HV703 MAIN LIFT DOWN					
CONN POS	WIRE COLOR	WIRE LABEL	GAUGE	JACKET	TO
1	WHT	4-25 LIFT DN	18 AWG	GXL	X745B (1)
2	BLK	000-40-36 CF	18 AWG	GXL	X745B (3)

HV704 MAIN AUX DOWN					
CONN POS	WIRE COLOR	WIRE LABEL	GAUGE	JACKET	TO
1	WHT	4-28 AUX DN	18 AWG	GXL	X745B (2)
2	BLK	000-40-120 CF	18 AWG	GXL	X745B (4)

X745B					
CONN POS	WIRE COLOR	WIRE LABEL	GAUGE	JACKET	TO
1	WHT	4-25 LIFT DN	18 AWG	GXL	HV703 (1)
2	WHT	4-28 AUX DN	18 AWG	GXL	HV704 (1)
3	BLK	000-40-36 CF	18 AWG	GXL	HV703 (2)
4	BLK	000-40-120 CF	18 AWG	GXL	HV704 (2)

Go to Discount-Equipment.com to order your parts

SECTION 7 - BASIC ELECTRICAL INFORMATION & ELECTRICAL SCHEMATICS

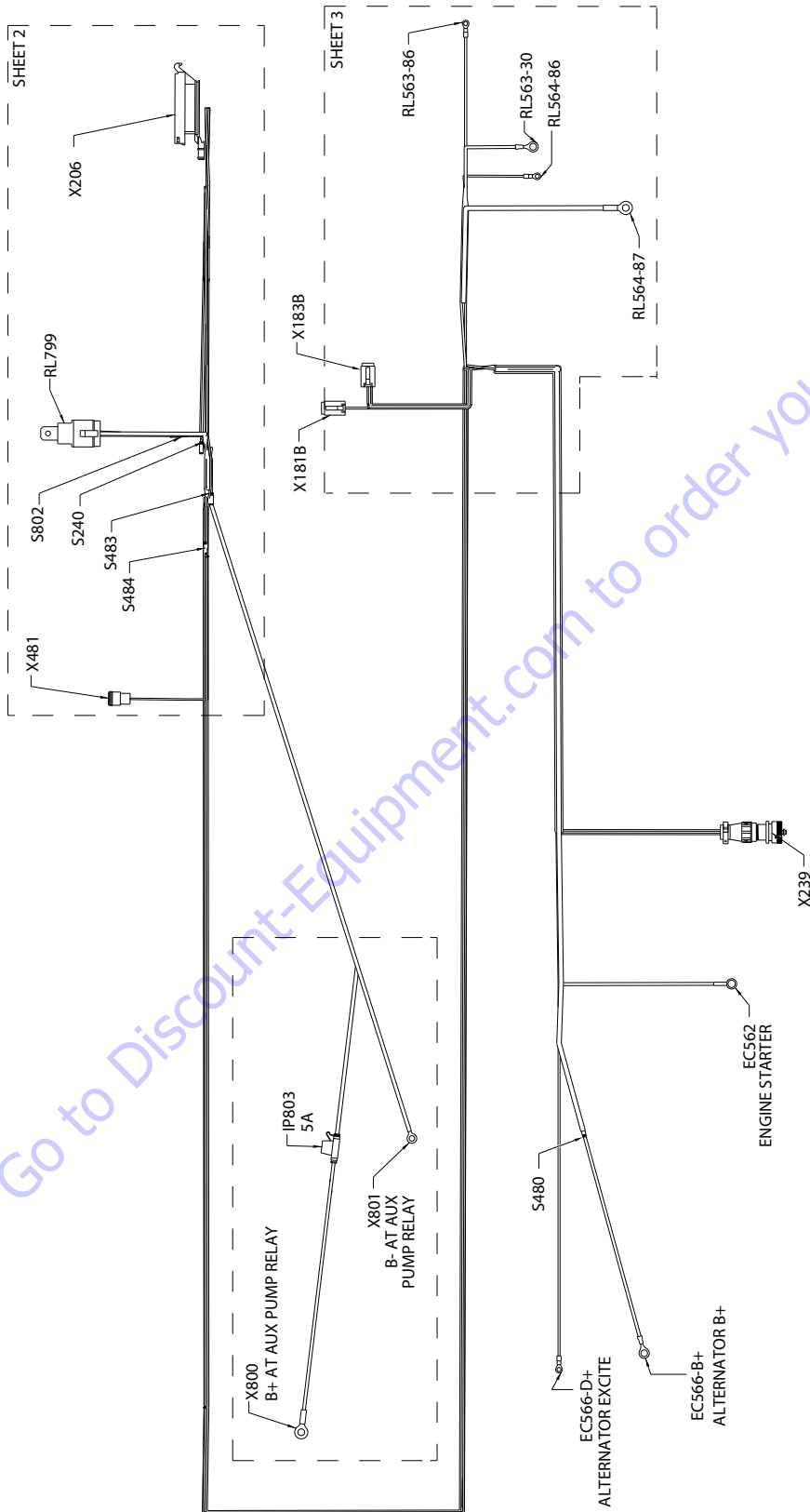

100T188236-F
MAE21110

Figure 7-66. Deutz D2011L04 Engine Harness - Sheet 1 of 3

SECTION 7 - BASIC ELECTRICAL INFORMATION & ELECTRICAL SCHEMATICS

EC566-D+ ALTERNATOR EXCITE					
CONN POS	WIRE COLOR	WIRE LABEL	GAUGE	JACKET	TO
1	RED	6-51 ALT EXCITE	16 AWG	GXL	X183B (5)

EC566-B+ ALTERNATOR B+					
CONN POS	WIRE COLOR	WIRE LABEL	GAUGE	JACKET	TO
1	-	FUSE LINK	12 AWG	FUSIBLE LINK	S480 (2)

EC562 ENGINE STARTER					
CONN POS	WIRE COLOR	WIRE LABEL	GAUGE	JACKET	TO
1	RED	12AWG	12 AWG	GXL	RL563-30 (1)

S480					
CONN POS	WIRE COLOR	WIRE LABEL	GAUGE	JACKET	TO
1	RED	8 AWG	8 AWG	GXL	RL564-87 (1)
2	-	FUSE LINK	12 AWG	FUSIBLE LINK	EC566-B+ (1)

X239					
CONN POS	WIRE COLOR	WIRE LABEL	GAUGE	JACKET	TO
A	WHT	6-17 DIAGNOSTIC	18 AWG	GXL	S240 (2)
B	BLK	000-6-3	18 AWG	GXL	X206 (2)
K	WHT	24-6	18 AWG	GXL	X206 (11)
L	WHT	23-6	18 AWG	GXL	X206 (10)

X800 B+ AT AUX PUMP RELAY					
CONN POS	WIRE COLOR	WIRE LABEL	GAUGE	JACKET	TO
1	RED	FUSE LEAD	12 AWG	GXL	IP803 (2)

IP803 5A					
CONN POS	WIRE COLOR	WIRE LABEL	GAUGE	JACKET	TO
1	RED	6-15-2	16 AWG	GXL	RL799 (1)
2	RED	FUSE LEAD	12 AWG	GXL	X800 (1)

X801 B- AT AUX PUMP RELAY					
CONN POS	WIRE COLOR	WIRE LABEL	GAUGE	JACKET	TO
1	BLK	000-6-1-3	10 AWG	GXL	S802 (2)

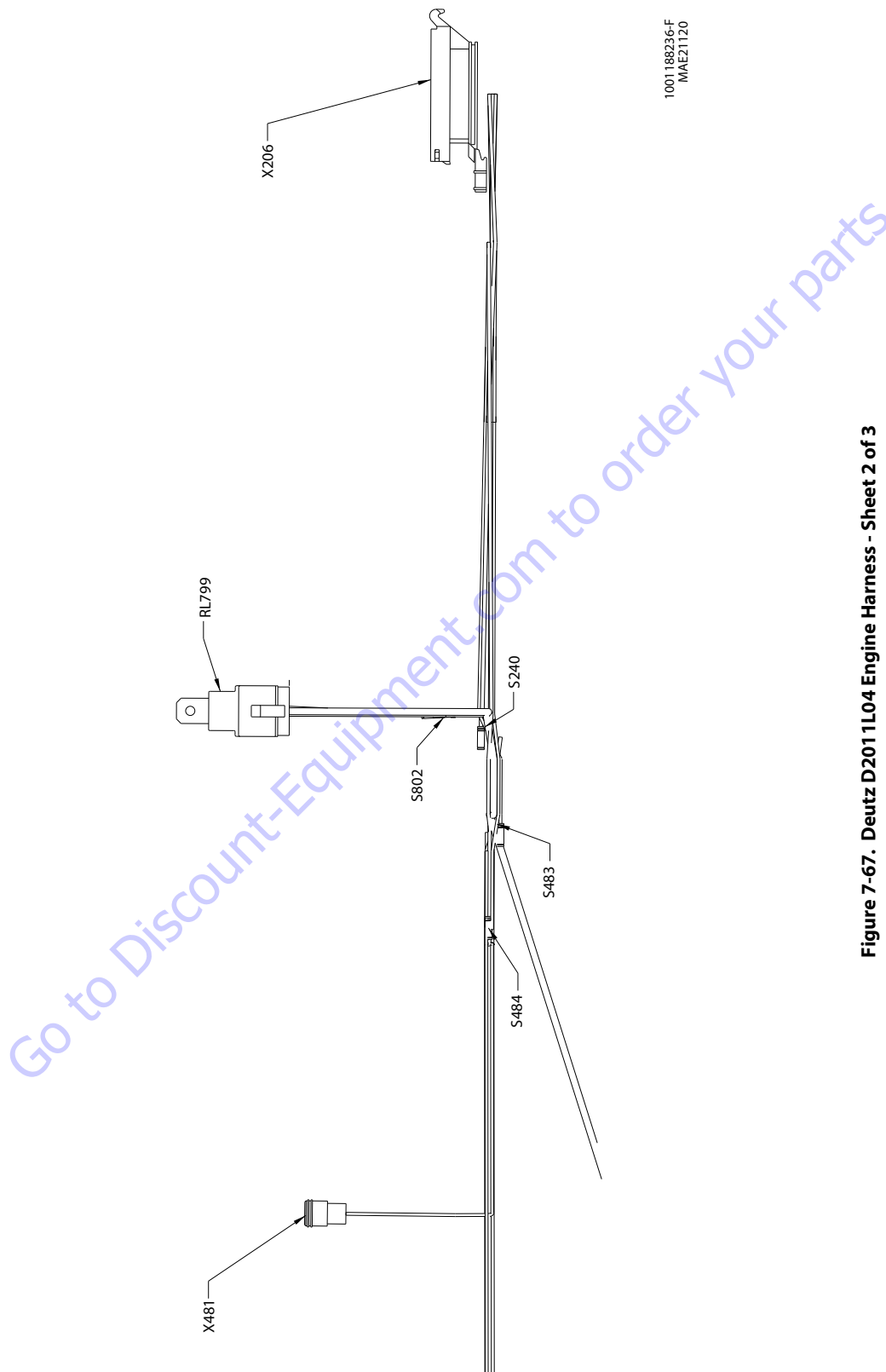

Figure 7-67. Deutz D2011L04 Engine Harness - Sheet 2 of 3

SECTION 7 - BASIC ELECTRICAL INFORMATION & ELECTRICAL SCHEMATICS

X481					
CONN POS	WIRE COLOR	WIRE LABEL	GAUGE	JACKET	TO
A	YEL	CABLE CAN HI	18 AWG	CABLE	S484 (1)
B	GRN	CABLE CAN LO	18 AWG	CABLE	S483 (2)
C					

S484					
CONN POS	WIRE COLOR	WIRE LABEL	GAUGE	JACKET	TO
1	YEL	CABLE CAN HI	18 AWG	CABLE	X183B (3)
1	YEL	CABLE CAN HI	18 AWG	CABLE	X481 (A)
2	YEL	CABLE CAN HI	18 AWG	CABLE	X206 (12)

RL799					
CONN POS	WIRE COLOR	WIRE LABEL	GAUGE	JACKET	TO
1	RED	6-15-2	16 AWG	GXL	IP803 (1)
2	WHT	6-15 DIAGNOSTIC	18 AWG	GXL	S240 (2)
3					
4	WHT	6-15-3	18 AWG	GXL	X206 (14)
5	BLK	000-6-1-2	18 AWG	GXL	S802 (1)

S483					
CONN POS	WIRE COLOR	WIRE LABEL	GAUGE	JACKET	TO
1	GRN	CABLE CAN LO	18 AWG	CABLE	X183B (4)
2	GRN	CABLE CAN LO	18 AWG	CABLE	X481 (B)
2	GRN	CABLE CAN LO	18 AWG	CABLE	X206 (13)

S240					
CONN POS	WIRE COLOR	WIRE LABEL	GAUGE	JACKET	TO
1	WHT	6-16	18 AWG	GXL	X183B (1)
2	WHT	6-15 DIAGNOSTIC	18 AWG	GXL	RL799 (2)
2	WHT	6-17 DIAGNOSTIC	18 AWG	GXL	X239 (A)

S802					
CONN POS	WIRE COLOR	WIRE LABEL	GAUGE	JACKET	TO
1	BLK	000-6-1 GROUND	16 AWG	TFFN	X206 (1)
1	BLK	000-6-1-2	18 AWG	GXL	RL799 (5)
2	BLK	000-6-1-3	10 AWG	GXL	X801 (1)

X206					
CONN POS	WIRE COLOR	WIRE LABEL	GAUGE	JACKET	TO
1	BLK	000-6-1 GROUND	16 AWG	TFFN	S802 (1)
2	BLK	000-6-3	18 AWG	GXL	X239 (B)
3					
4					
5					
6					
7					
8					
9					
10	WHT	6-23	18 AWG	GXL	X239 (L)
11	WHT	6-24	18 AWG	GXL	X239 (K)
12	YEL	CABLE CAN HI	18 AWG	CABLE	S484 (2)
13	GRN	CABLE CAN LO	18 AWG	CABLE	S483 (2)
14	WHT	6-15-3	18 AWG	GXL	RL799 (4)
15					
16					
17					
18					
19					
20					
21					
22					
23					
24					
25					

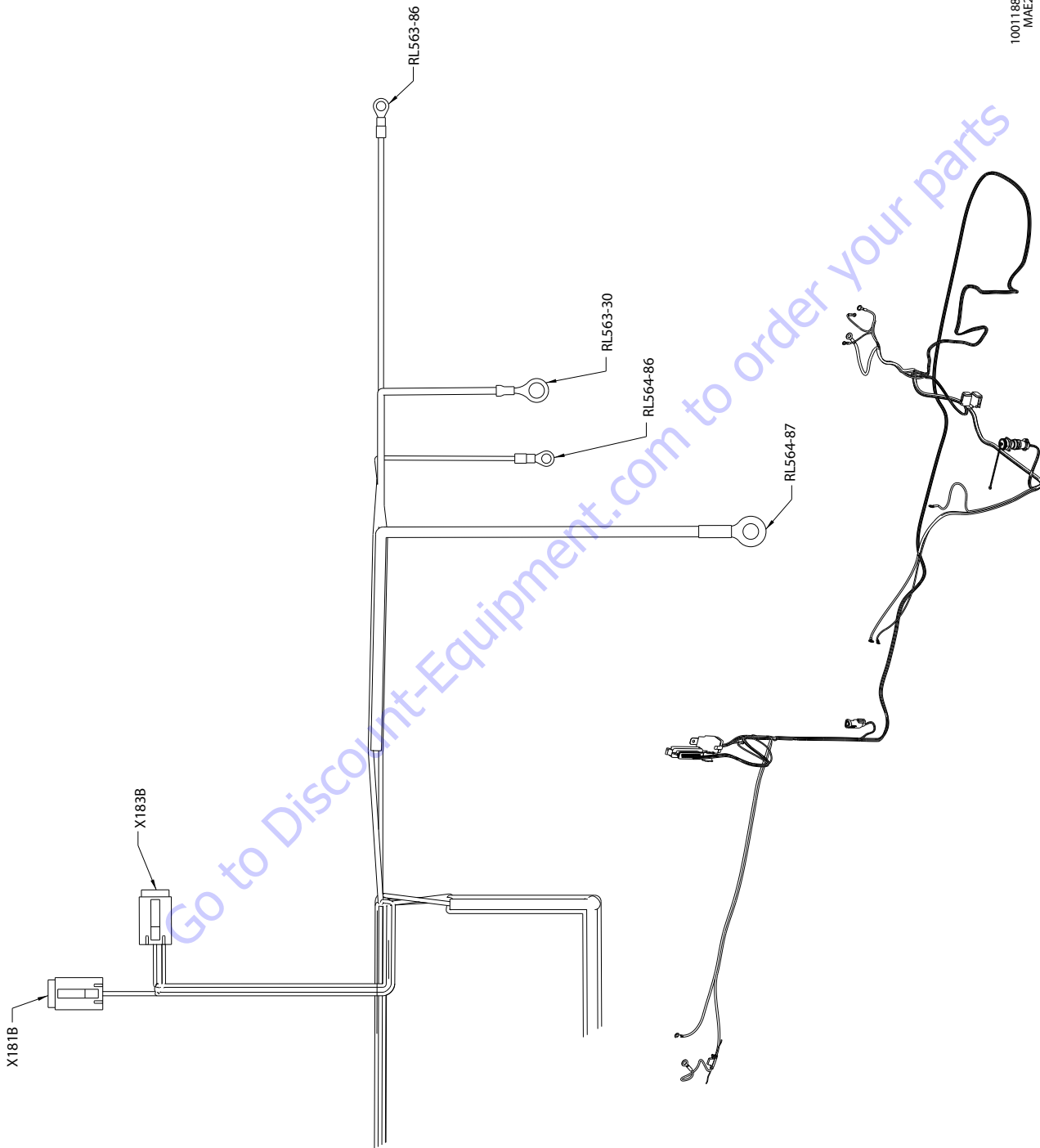

1001188236-F
MAE21130

Figure 7-68. Deutz D2011L04 Engine Harness - Sheet 3 of 3

SECTION 7 - BASIC ELECTRICAL INFORMATION & ELECTRICAL SCHEMATICS

X183B					
CONN POS	WIRE COLOR	WIRE LABEL	GAUGE	JACKET	TO
1	WHT	6-16	18 AWG	GXL	S240 (1)
2	WHT	6-25 ENGINE START	14 AWG	GXL	RL563-86 (1)
3	YEL	CABLE CAN HI	18 AWG	CABLE	S484 (1)
4	GRN	CABLE CAN LO	18 AWG	CABLE	S483 (1)
5	RED	6-51 ALT EXCITE	16 AWG	GXL	EC566-D+ (1)
6					

X181B					
CONN POS	WIRE COLOR	WIRE LABEL	GAUGE	JACKET	TO
1					
2					
3					
4	WHT	6-18 GLOW	18 AWG	GXL	RL564-86 (1)
5					
6					
7					
8					

RL564-86					
CONN POS	WIRE COLOR	WIRE LABEL	GAUGE	JACKET	TO
1	WHT	6-18 GLOW	18 AWG	GXL	X181B (4)

RL564-87					
CONN POS	WIRE COLOR	WIRE LABEL	GAUGE	JACKET	TO
1	RED	8 AWG	8 AWG	GXL	S480 (1)

RL563-86					
CONN POS	WIRE COLOR	WIRE LABEL	GAUGE	JACKET	TO
1	WHT	6-25 ENGINE START	14 AWG	GXL	X183B (2)

RL563-30					
CONN POS	WIRE COLOR	WIRE LABEL	GAUGE	JACKET	TO
1	RED	12AWG	12 AWG	GXL	EC562 (1)

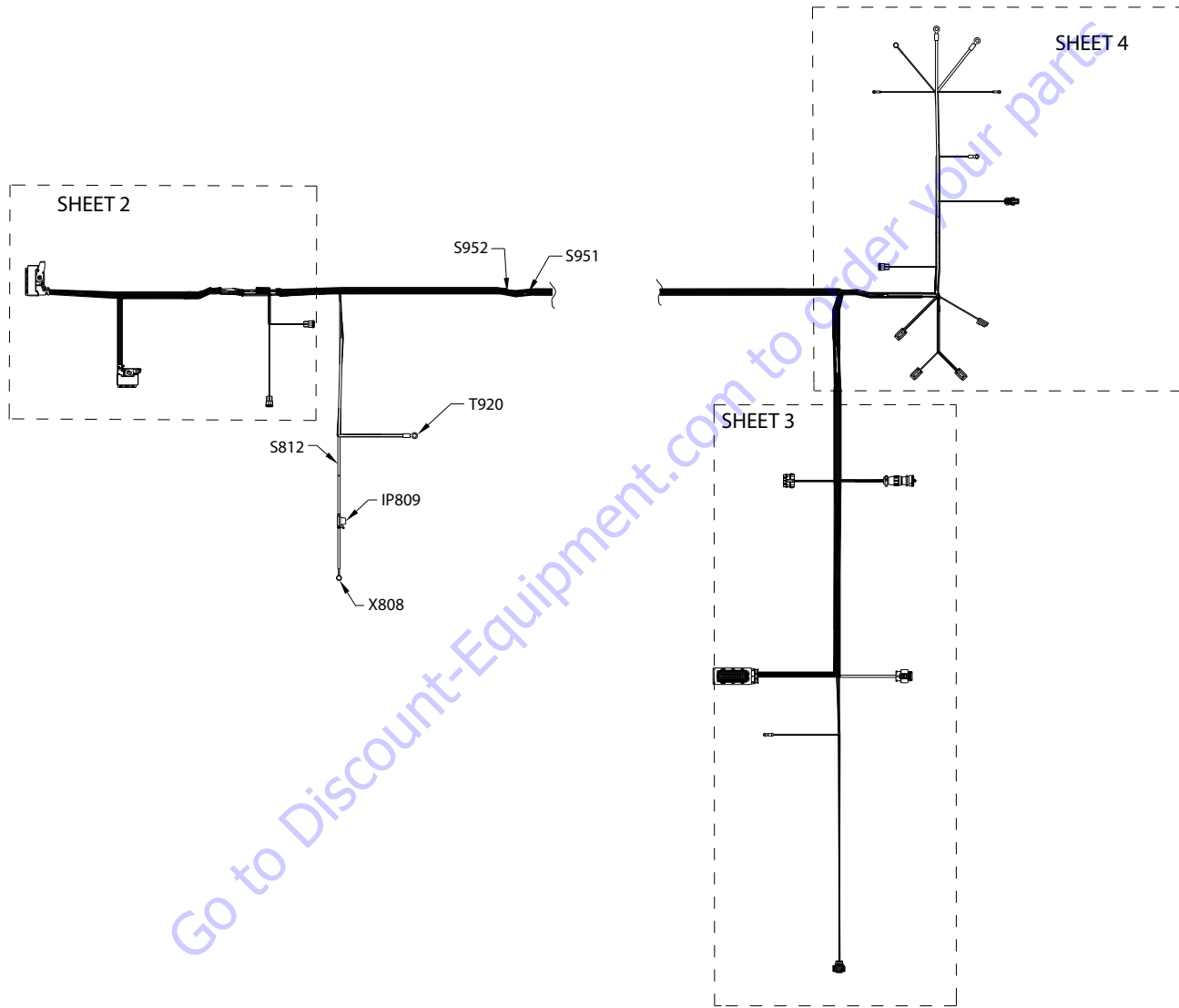

1001233895-F
MAE31340F

Figure 7-69. Deutz T4F Engine Harness - Sheet 1 of 5

SECTION 7 - BASIC ELECTRICAL INFORMATION & ELECTRICAL SCHEMATICS

IP809 ECM PWR 30A					
CONN POS	WIRE COLOR	WIRE LABEL	GAUGE	JACKET	TO
1	RED	1-148-135-2 ECM PWR	12 AWG	GXL	S812 (1)
2	RED	1-148-135-2 ECM PWR	12 AWG	GXL	X808 (1)

T920 ENGINE GROUND					
CONN POS	WIRE COLOR	WIRE LABEL	GAUGE	JACKET	TO
1	BLK	000-148-246 ECM GND	8 AWG	GXL	S945 (1)
1	BLK	000-48-1 ENG GND	14 AWG	GXL	X941 (4)
1	BLK	000-48-2 ENG GND	18 AWG	GXL	X950 (B)
1	BLK	000-48-3 GND	18 AWG	GXL	X999 (2)

X808 BATTERY PWR					
CONN POS	WIRE COLOR	WIRE LABEL	GAUGE	JACKET	TO
1	RED	1-148-135-2 ECM PWR	12 AWG	GXL	IP809 (2)

S951					
CONN POS	WIRE COLOR	WIRE LABEL	GAUGE	JACKET	TO
1	YEL	CAN 1 HI CUSTOMER CAN HIGH	20 AWG	J1939 CABLE	S953 (2)
2	YEL	CAN 1 HI CUSTOMER CAN HIGH	20 AWG	J1939 CABLE	X901 (3)
2	YEL	CAN 1 HI CUSTOMER CAN HIGH	20 AWG	J1939 CABLE	X950 (M)

S952					
CONN POS	WIRE COLOR	WIRE LABEL	GAUGE	JACKET	TO
1	GRN	CAN 1 LO CUSTOMER CAN LOW	20 AWG	J1939 CABLE	S954 (2)
2	GRN	CAN 1 LO CUSTOMER CAN LO	20 AWG	J1939 CABLE	X901 (4)
2	GRN	CAN 1 LO CUSTOMER CAN LO	20 AWG	J1939 CABLE	X950 (F)

S812					
CONN POS	WIRE COLOR	WIRE LABEL	GAUGE	JACKET	TO
1	RED	1-148-135-2 ECM PWR	12 AWG	GXL	IP809 (1)
2	RED	1-148-135 ECM PWR	8 AWG	GXL	S944 (1)

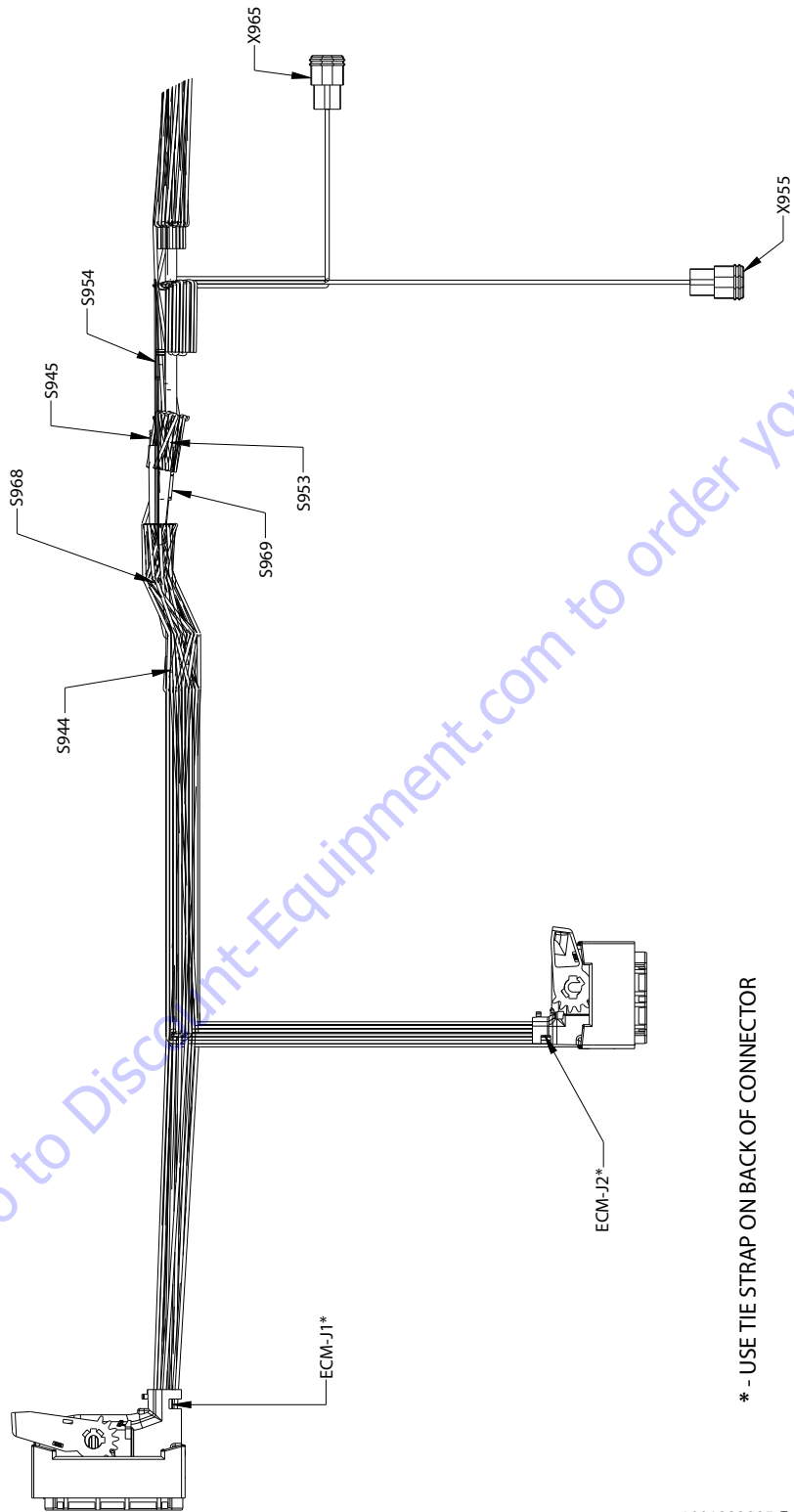

* - USE TIE STRAP ON BACK OF CONNECTOR

1001233895-F
MAE31350F

Figure 7-70. Deutz T4F Engine Harness - Sheet 2 of 5

SECTION 7 - BASIC ELECTRICAL INFORMATION & ELECTRICAL SCHEMATICS

ECM-J1					
CONNPOS	WIRE COLOR	WIRE LABEL	GAUGE	JACKET	TO
1	RED	148-1 ECM PWR	2.5 mm ²	FLRYW	S944 (2)
2	BLK	148-2 ECM GND	2.5 mm ²	FLRYW	S945 (2)
3	RED	148-3 ECM PWR	2.5 mm ²	FLRYW	S944 (2)
4	BLK	148-4 ECM GND	2.5 mm ²	FLRYW	S945 (2)
5	RED	148-5 ECM PWR	2.5 mm ²	FLRYW	S944 (2)
6	BLK	148-6 ECM GND	2.5 mm ²	FLRYW	S945 (2)
7					
8					
9					
10					
11					
12					
13	BLK	148-13 COOLANT LEVEL SIG	0.75 mm ²	FLRYW	SN939 (3)
14					
15	BLK	148-15-68 CLUTCH SWITCH	0.75 mm ²	FLRYW	ECM-J1 (68)
16					
17					
18					
19					
20					
21					
22					
23					
24					
25					
26	BLK	148-26 FUEL PUMP RELAY CTRL GND	0.75 mm ²	FLRYW	RL930 (2)
27					
28	BLK	148-28 START RTN	0.75 mm ²	FLRYW	EIC (2)
29	BLK	148-29 COOLANT LEVEL PWR	0.75 mm ²	FLRYW	SN939 (1)
30					
31					
32					
33					
34					
35	BLK	148-35-2 START	0.75 mm ²	FLRYW	S1001 (1)
36					
37					
38	BLK	148-38 THROTTLE FLAP 4	0.75 mm ²	FLRYW	EIC (52)
39					
40					
41					
42					
43					
44	BLK	148-44 EHXAUST GAS RECIRCULATION	0.75 mm ²	FLRYW	EIC (50)
45					
46					
47					
48					
49					
50					
51					
52					

ECM-J1					
CONNPOS	WIRE COLOR	WIRE LABEL	GAUGE	JACKET	TO
53	GRN	CAN 2 LO DIAG CAN LOW	20 AWG	J1939 CABLE	S968 (1)
54	YEL	CAN 1 HI CUSTOMER CAN HIGH	20 AWG	J1939 CABLE	S953 (1)
55					
56	BLK	148-56 AIR INLET TEMP	0.75 mm ²	FLRYW	EIC (34)
57	BLK	148-57 WATER IN FUEL SW RTN	0.75 mm ²	FLRYW	X941 (2)
58					
59					
60					
61	BLK	148-61 FUEL LOW PRESSURE	0.75 mm ²	FLRYW	EIC (17)
62					
63					
64	BLK	148-64 WATER IN FUEL SW	0.75 mm ²	FLRYW	X941 (1)
65					
66					
67					
68	BLK	148-15-68 CLUTCH SWITCH	0.75 mm ²	FLRYW	ECM-J1 (15)
69					
70					
71					
72	BLK	148-72 THROTTLE FLAP 3	0.75 mm ²	FLRYW	EIC (49)
73	BLK	148-73 START SIGNAL	0.75 mm ²	FLRYW	EIC (3)
74					
75	YEL	CAN 2 HI DIAG CAN HIGH	20 AWG	J1939CABLE	S969 (1)
76	GRN	CAN 1 LO CUSTOMER CAN LOW	20 AWG	J1939 CABLE	S954 (1)
77					
78					
79					
80					
81					
82	BLK	148-82 EHXAUST GAS RECIRCULATION	0.75 mm ²	FLRYW	EIC (51)
83					
84					
85	BLK	148-85 EHXAUST GAS RECIRCULATION	0.75 mm ²	FLRYW	EIC (46)
86					
87	BLK	148-87 COOLANT LEVEL GND	0.75 mm ²	FLRYW	SN939 (2)
88	BLK	148-88 IGNITION	0.75 mm ²	FLRYW	S946 (2)
89					
90					
91					
92					
93					
94					
NC	SHLD	CAN 1 SHLD CUSTOMER CAN SHIELD	18 AWG	J1939 CABLE	X901 (6)

SECTION 7 - BASIC ELECTRICAL INFORMATION & ELECTRICAL SCHEMATICS

ECM-J2					
CONNP OS	WIRE COLOR	WIRE LABEL	GAUGE	JACKET	TO
1					
2	BLK	248-2 INJECTOR 3	1.5 mm ²	FLRYW	EIC (61)
3	BLK	248-3 INJECTOR 2	1.5 mm ²	FLRYW	EIC (41)
4	BLK	248-4 MPROP ACTUATOR	1.5 mm ²	FLRYW	EIC (19)
5	BLK	248-5 MPROP ACTUATOR	1.5 mm ²	FLRYW	EIC (20)
6					
7	BLK	248-7 RAIL PRESSURE FUEL	0.75 mm ²	FLRYW	EIC (32)
8					
9					
10					
11					
12					
13					
14					
15					
16	BLK	248-16 INJECTOR 1	1.5 mm ²	FLRYW	EIC (35)
17					
18	BLK	248-18 INJECTOR 4	1.5 mm ²	FLRYW	EIC (37)
19	BLK	248-19 EXHAUST GAS RECIRCULATION	1.5 mm ²	FLRYW	EIC (47)
20	BLK	248-20 EXHAUST GAS RECIRCULATION	1.5 mm ²	FLRYW	EIC (48)
21					
22					
23	BLK	248-23 GLOW SENSE	0.75 mm ²	FLRYW	MS932 (E)
24	BLK	248-24 BOOST PRESSURE/TEMP	0.75 mm ²	FLRYW	EIC (22)
25	BLK	248-25 RAIL PRESSURE FUEL	0.75 mm ²	FLRYW	EIC (31)
26	BLK	248-26 RAIL PRESSURE FUEL	0.75 mm ²	FLRYW	EIC (25)
27	BLK	248-27 BOOST PRESSURE/TEMP	0.75 mm ²	FLRYW	EIC (29)
28	BLK	248-28 COOLING TEMPERATURE	0.75 mm ²	FLRYW	EIC (24)
29	BLK	248-29 OIL PRESSURE	0.75 mm ²	FLRYW	EIC (27)
30					
31					
32	BLK	248-32 INJECTOR 3	1.5 mm ²	FLRYW	EIC (38)
33	BLK	248-33 INJECTOR 1	1.5 mm ²	FLRYW	EIC (62)
34					
35	BLK	248-35 GLOW RELAY CONTROL GND	0.75 mm ²	FLRYW	RL553-85 (1)
36					
37	BLK	248-37 ENGINE SPEED CAMSHAFT	18 AWG	CABLE	EIC (14)
38	SHLD	248-38 ENGINE SPEED CRANKSHAFT	18 AWG	CABLE	EIC (1)
39	BLK	248-39 ENGINE SPEED CRANKSHAFT	18AWG	CABLE	EIC (15)
40	BLK	248-40 AIR INLET TEMP	0.75 mm ²	FLRYW	EIC (28)
41					
42					
43	BLK	248-43OIL PRESSURE	0.75 mm ²	FLRYW	EIC (23)
44	BLK	248-44 OIL PRESSURE	0.75 mm ²	FLRYW	EIC (26)
45					

ECM-J2					
CONNP OS	WIRE COLOR	WIRE LABEL	GAUGE	JACKET	TO
46	BLK	248-46 INJECTOR 2	1.5 mm ²	FLRYW	EIC (40)
47					
48	BLK	248-48 INJECTOR 4	1.5 mm ²	FLRYW	EIC (42)
49					
50					
51					
52	WHT	248-52 ENGINE SPEED CAMSHAFT	18 AWG	CABLE	EIC (13)
53	SHLD	248-53 ENGINE SPEED CAMSHAFT	18 AWG	CABLE	EIC (9)
54	WHT	248-54 ENGINE SPEED CRANKSHAFT	18 AWG	CABLE	EIC (21)
55					
56					
57					
58					
59					
60					

S954					
CONNP OS	WIRE COLOR	WIRE LABEL	GAUGE	JACKET	TO
1	GRN	CAN 1 LO CUSTOMER CAN LOW	20 AWG	J1939 CABLE	ECM-J1 (76)
2	GRN	CAN 1 LO CUSTOMER CAN LOW	20 AWG	J1939 CABLE	S952 (1)
2	GRN	CAN 1 LO CUSTOMER CAN LOW	20 AWG	J1939 CABLE	X955 (B)

S953					
CONNP OS	WIRE COLOR	WIRE LABEL	GAUGE	JACKET	TO
1	YEL	CAN 1 HI CUSTOMER CAN HIGH	20 AWG	J1939 CABLE	ECM-J1 (54)
2	YEL	CAN 1 HI CUSTOMER CAN HIGH	20 AWG	J1939 CABLE	S951 (1)
2	YEL	CAN 1 HI CUSTOMER CAN HIGH	20 AWG	J1939 CABLE	X955 (A)

S969					
CONNP OS	WIRE COLOR	WIRE LABEL	GAUGE	JACKET	TO
1	YEL	CAN 2 HI DIAG CAN HIGH	20 AWG	J1939 CABLE	ECM-J1 (75)
2	YEL	CAN 2 HI DIAG CAN HIGH	20 AWG	J1939 CABLE	S964 (1)
2	YEL	CAN 2 HI DIAG CAN HIGH	20 AWG	J1939 CABLE	X965 (A)

S968					
CONNP OS	WIRE COLOR	WIRE LABEL	GAUGE	JACKET	TO
1	GRN	CAN 2 LO DIAG CAN LOW	20 AWG	J1939 CABLE	ECM-J1 (53)
2	GRN	CAN 2 LO DIAG CAN LOW	20 AWG	J1939 CABLE	X965 (B)
2	GRN	CAN 2 LO DIAG CAN LOW	20 AWG	J1939 CABLE	S963 (1)

SECTION 7 - BASIC ELECTRICAL INFORMATION & ELECTRICAL SCHEMATICS

X955					
CONNP OS	WIRE COLOR	WIRE LABEL	GAUGE	JACKET	TO
A	YEL	CAN 1 HI CUSTOMER CAN HIGH	20 AWG	J1939 CABLE	S953 (2)
B	GRN	CAN 1 LO CUSTOMER CAN LOW	20 AWG	J1939 CABLE	S954 (2)
C					

X965					
CONNP OS	WIRE COLOR	WIR ELABEL	GAUGE	JACKET	TO
A	YEL	CAN 2 HI DIAG CAN HIGH	20 AWG	J1939 CABLE	S969 (2)
B	GRN	CAN 2 LO DIAG CAN LOW	20 AWG	J1939 CABLE	S968 (2)
C					

S945					
CONNP OS	WIRE COLOR	WIRE LABEL	GAUGE	JACKET	TO
1	BLK	000-148-246 ECM GND	8 AWG	GXL	T920 (1)
2	BLK	148-2 ECM GND	2.5 mm ²	FLRYW	ECM-J1 (2)
2	BLK	148-4 ECM GND	2.5 mm ²	FLRYW	ECM-J1 (4)
2	BLK	148-6 ECM GND	2.5 mm ²	FLRYW	ECM-J1 (6)

S944					
CONNP OS	WIRE COLOR	WIRE LABEL	GAUGE	JACKET	TO
1	RED	1-148-135 ECM PWR	8 AWG	GXL	S812 (2)
2	RED	148-1 ECM PWR	2.5 mm ²	FLRYW	ECM-J1 (1)
2	RED	148-3 ECM PWR	2.5 mm ²	FLRYW	ECM-J1 (3)
2	RED	148-5 ECM PWR	2.5 mm ²	FLRYW	ECM-J1 (5)

Go to Discount-Equipment.com to order your parts

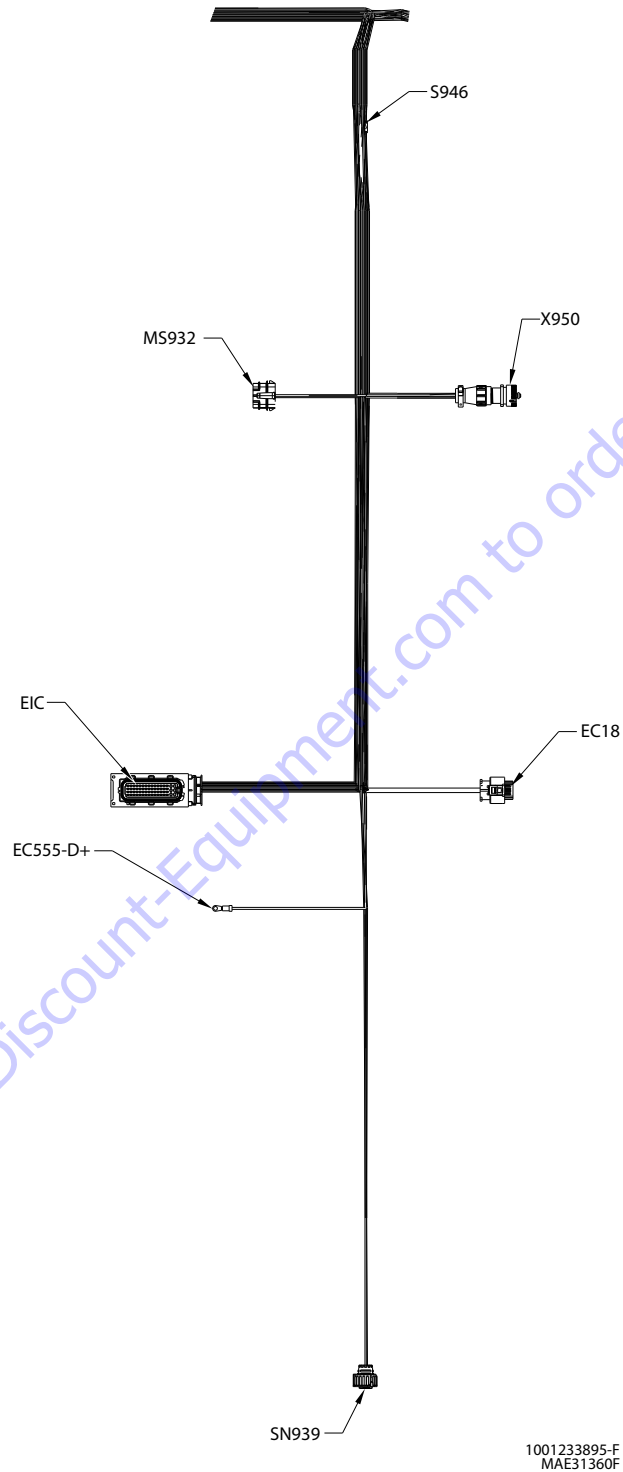

Figure 7-71. Deutz T4F Engine Harness - Sheet 3 of 5

SECTION 7 - BASIC ELECTRICAL INFORMATION & ELECTRICAL SCHEMATICS

EIC					
CONNP OS	WIRE COLOR	WIRE LABEL	GAUGE	JACKET	TO
1	SHLD	248-38 ENGINE SPEED CRANKSHAFT	18 AWG	CABLE	ECM-J2 (38)
2	BLK	148-28 START RTN	0.75 mm ²	FLRYW	ECM-J1 (28)
3	BLK	148-73 START SIGNAL	0.75 mm ²	FLRYW	ECM-J1 (73)
4					
5					
6					
7					
8					
9	SHLD	248-53 ENGINE SPEED CAMSHAFT	18 AWG	CABLE	ECM-J2 (53)
10					
11					
12					
13	WHT	248-52 ENGINE SPEED CAMSHAFT	18 AWG	CABLE	ECM-J2 (52)
14	BLK	248-37 ENGINE SPEED CAMSHAFT	18 AWG	CABLE	ECM-J2 (37)
15	BLK	248-39 ENGINE SPEED CRANKSHAFT	18 AWG	CABLE	ECM-J2 (39)
16					
17	BLK	148-61 FUEL LOW PRESSURE	0.75 mm ²	FLRYW	ECM-J1 (61)
18					
19	BLK	248-4 MPROP ACTUATOR	1.5 mm ²	FLRYW	ECM-J2 (4)
20	BLK	248-5 MPROP ACTUATOR	1.5 mm ²	FLRYW	ECM-J2 (5)
21	WHT	248-54 ENGINE SPEED CRANKSHAFT	18 AWG	CABLE	ECM-J2 (54)
22	BLK	248-24 BOOST PRESSURE/TEMP	0.75 mm ²	FLRYW	ECM-J2 (24)
23	BLK	248-43 OIL PRESSURE	0.75 mm ²	FLRYW	ECM-J2 (43)
24	BLK	248-28 COOLING TEMPERATURE	0.75 mm ²	FLRYW	ECM-J2 (28)
25	BLK	248-26 RAIL PRESSURE FUEL	0.75 mm ²	FLRYW	ECM-J2 (26)
26	BLK	248-44 OIL PRESSURE	0.75 mm ²	FLRYW	ECM-J2 (44)
27	BLK	248-29 OIL PRESSURE	0.75 mm ²	FLRYW	ECM-J2 (29)
28	BLK	248-40 AIR INLET TEMP	0.75 mm ²	FLRYW	ECM-J2 (40)
29	BLK	248-27 BOOST PRESSURE/TEMP	0.75 mm ²	FLRYW	ECM-J2 (27)
30					
31	BLK	248-25 RAIL PRESSURE FUEL	0.75 mm ²	FLRYW	ECM-J2 (25)
32	BLK	248-7 RAIL PRESSURE FUEL	0.75 mm ²	FLRYW	ECM-J2 (7)
33					
34	BLK	148-56 AIR INLET TEMP	0.75 mm ²	FLRYW	ECM-J1 (56)
35	BLK	248-16 INJECTOR 1	1.5 mm ²	FLRYW	ECM-J2 (16)
36					
37	BLK	248-18 INJECTOR 4	1.5 mm ²	FLRYW	ECM-J2 (18)
38	BLK	248-32 INJECTOR 3	1.5 mm ²	FLRYW	ECM-J2 (32)
39					
40	BLK	248-46 INJECTOR 2	1.5 mm ²	FLRYW	ECM-J2 (46)
41	BLK	248-3 INJECTOR 2	1.5 mm ²	FLRYW	ECM-J2 (3)
42	BLK	248-48 INJECTOR 4	1.5 mm ²	FLRYW	ECM-J2 (48)
43					
44					
45					

EIC					
CONNP OS	WIRE COLOR	WIRE LABEL	GAUGE	JACKET	TO
46	BLK	148-85 EHXAUST GAS RECIRCULATION	0.75 mm ²	FLRYW	ECM-J1 (85)
47	BLK	248-19 EHXAUST GAS RECIRCULATION	1.5 mm ²	FLRYW	ECM-J2 (19)
48	BLK	248-20 EHXAUST GAS RECIRCULATION	1.5 mm ²	FLRYW	ECM-J2 (20)
49	BLK	148-72 THROTTLE FLAP 3	0.75 mm ²	FLRYW	ECM-J1 (72)
50	BLK	148-44 EHXAUST GAS RECIRCULATION	0.75 mm ²	FLRYW	ECM-J1 (44)
51	BLK	148-82 EHXAUST GAS RECIRCULATION	0.75 mm ²	FLRYW	ECM-J1 (82)
52	BLK	148-38 THROTTLE FLAP 4	0.75 mm ²	FLRYW	ECM-J1 (38)
53					
54					
55					
56					
57					
58					
59					
60					
61	BLK	248-2 INJECTOR 3	1.5 mm ²	FLRYW	ECM-J2 (2)
62	BLK	248-33 INJECTOR 1	1.5 mm ²	FLRYW	ECM-J2 (33)

SN939					
CONNP OS	WIRE COLOR	WIRE LABEL	GAUGE	JACKET	TO
1	BLK	148-29 COOLANT LEVEL PWR	0.75 mm ²	FLRYW	ECM-J1 (29)
2	BLK	148-87 COOLANT LEVEL GND	0.75mm ²	FLRYW	ECM-J1 (87)
3	BLK	148-13 COOLANT LEVEL SIG	0.75 mm ²	FLRYW	ECM-J1 (13)
4					

EC18					
CONNP OS	WIRE COLOR	WIRE LABEL	GAUGE	JACKET	TO
1	RED	48-14	8 AWG	GXL	RL553-30 (1)
2	RED	48-13 GLOW	8 AWG	GXL	RL553-30-1 (1)

SECTION 7 - BASIC ELECTRICAL INFORMATION & ELECTRICAL SCHEMATICS

X950 DEUTZ DIAGNOSTIC					
CONNP OS	WIRE COLOR	WIRE LABEL	GAUGE	JACKET	TO
A	YEL	2-48-2 IGNITION	18 AWG	GXL	S946 (1)
B	BLK	000-48-2 ENG GND	18 AWG	GXL	T920 (1)
C					
D					
E					
F	GRN	CAN 1 LO CUSTOMER CAN LO	20 AWG	J1939 CABLE	S952 (2)
G	GRN	CAN 2 LO DIAG CAN LOW	20 AWG	J1939 CABLE	S963 (2)
H	YEL	CAN 2 HI DIAG CAN HIGH	20 AWG	J1939 CABLE	S964 (2)
J					
K					
L					
M	YEL	CAN 1 HI CUSTOMER CAN HIGH	20 AWG	J1939 CABLE	S951 (2)

MS932					
CONNP OS	WIRE COLOR	WIRE LABEL	GAUGE	JACKET	TO
A					
B					
C					
D					
E	BLK	248-23 GLOW SENSE	0.75 mm ²	FLRYW	ECM-J2 (23)
F	ORG	248-23-1 GLOW SENSE	18 AWG	GXL	RL553-30-2 (1)
G	YEL	2-1-99 IGNITION	18 AWG	GXL	X902 (1)
H	YEL	2-48-1 IGNITION	16 AWG	GXL	S946 (1)

EC555-D+					
CONNP OS	WIRE COLOR	WIRE LABEL	GAUGE	JACKET	TO
1	RED	47-8 ALT EXCITE	16 AWG	GXL	X901 (5)

SECTION 7 - BASIC ELECTRICAL INFORMATION & ELECTRICAL SCHEMATICS

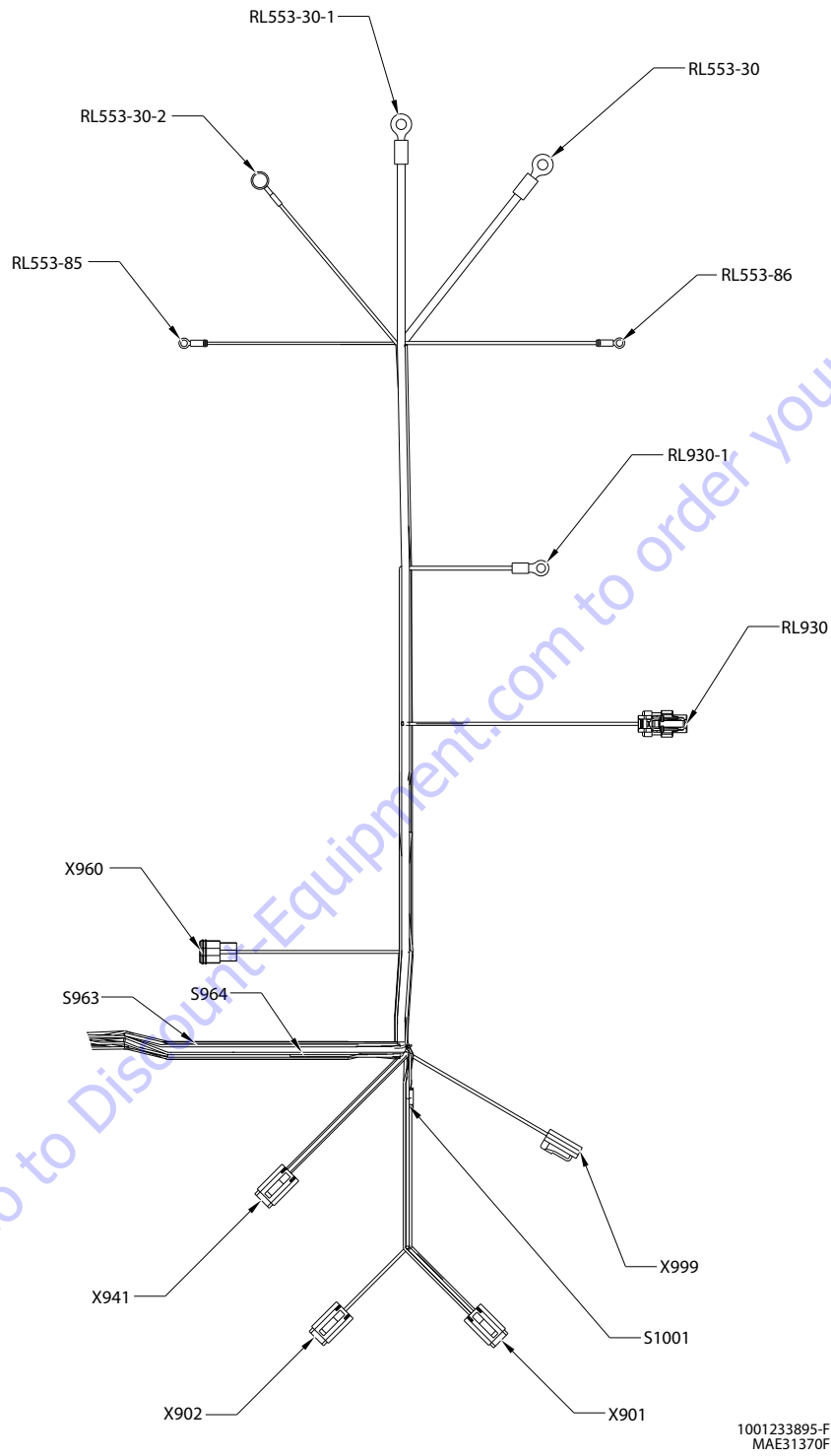

Figure 7-72. Deutz T4F Engine Harness - Sheet 4 of 5

SECTION 7 - BASIC ELECTRICAL INFORMATION & ELECTRICAL SCHEMATICS

X941					
CONNPOS	WIRE COLOR	WIRE LABEL	GAUGE	JACKET	TO
1	BLK	148-64 WATER IN FUEL SW	0.75 mm ²	FLRYW	ECM-J1 (64)
2	BLK	148-57 WATER IN FUEL SW RTN	0.75 mm ²	FLRYW	ECM-J1 (57)
3	WHT	48-96 FUEL PUMP	14 AWG	GXL	RL930-1 (1)
4	BLK	000-48-1 ENG GND	14 AWG	GXL	T920 (1)

S964					
CONNPOS	WIRE COLOR	WIRE LABEL	GAUGE	JACKET	TO
1	YEL	CAN 2 HI DIAG CAN HIGH	20 AWG	J1939 CABLE	S969 (2)
2	YEL	CAN 2 HI DIAG CAN HIGH	20 AWG	J1939 CABLE	X960 (A)
2	YEL	CAN 2 HI DIAG CAN HIGH	20 AWG	J1939 CABLE	X950 (H)

X902					
CONNPOS	WIRE COLOR	WIRE LABEL	GAUGE	JACKET	TO
1	YEL	2-1-99 IGNITION	18 AWG	GXL	MS932 (G)
2					
3					
4					
5					
6					
7					
8					

X999					
CONNPOS	WIRE COLOR	WIRE LABEL	GAUGE	JACKET	TO
1	BLK	148-35-3	18 AWG	GXL	S1001 (1)
2	BLK	000-48-3 GND	18 AWG	GXL	T920 (1)

S1001					
CONNPOS	WIRE COLOR	WIRE LABEL	GAUGE	JACKET	TO
1	BLK	148-35-2 START	0.75 mm ²	FLRYW	ECM-J1 (35)
1	BLK	148-35-3	18 AWG	GXL	X999 (1)
2	BLK	148-35-1 START	18 AWG	GXL	X901 (2)

X901					
CONNPOS	WIRE COLOR	WIRE LABEL	GAUGE	JACKET	TO
1					
2	BLK	148-35-1 START	18 AWG	GXL	S1001 (2)
3	YEL	CAN 1 HI CUSTOMER CAN HIGH	20 AWG	J1939 CABLE	S951 (2)
4	GRN	CAN 1 LO CUSTOMER CAN LO	20 AWG	J1939 CABLE	S952 (2)
5	RED	47-8 ALT EXCITE	16 AWG	GXL	EC555-D+ (1)
6	SHLD	CAN 1 SHLD CUSTOMER CAN SHIELD	20 AWG	J1939 CABLE	ECM-J1 (NC)

RL553-85					
CONNPOS	WIRE COLOR	WIRE LABEL	GAUGE	JACKET	TO
1	BLK	248-35 GLOW RELAY CONTROL GND	0.75mm ²	FLRYW	ECM-J2 (35)

S963					
CONNPOS	WIRE COLOR	WIRE LABEL	GAUGE	JACKET	TO
1	GRN	CAN 2 LO DIAG CAN LOW	20 AWG	J1939 CABLE	S968 (2)
2	GRN	CAN 2 LO DIAG CAN LOW	20 AWG	J1939 CABLE	X950 (G)
2	GRN	CAN 2 LO DIAG CAN LOW	20 AWG	J1939 CABLE	X960 (B)

SECTION 7 - BASIC ELECTRICAL INFORMATION & ELECTRICAL SCHEMATICS

RL553-30-2					
CONN OS	WIRE COLOR	WIRE LABEL	GAUGE	JACKET	TO
1	ORG	248-23-1 GLOW SENSE	18 AWG	GXL	MS932 (F)

RL553-30-1					
CONN OS	WIRE COLOR	WIRE LABEL	GAUGE	JACKET	TO
1	RED	48-13 GLOW	8 AWG	GXL	EC18 (2)

RL553-30					
CONN OS	WIRE COLOR	WIRE LABEL	GAUGE	JACKET	TO
1	RED	48-14	8 AWG	GXL	EC18 (1)

RL553-86					
CONN OS	WIRE COLOR	WIRE LABEL	GAUGE	JACKET	TO
1	YEL	2-48-3	18 AWG	GXL	S946 (2)

RL930-1					
CONN OS	WIRE COLOR	WIRE LABEL	GAUGE	JACKET	TO
1	WHT	48-96 FUEL PUMP	14 AWG	GXL	X941 (3)

RL930					
CONN OS	WIRE COLOR	WIRE LABEL	GAUGE	JACKET	TO
1	YEL	2-48-4 IGNITION	18 AWG	GXL	S946 (2)
2	BLK	148-26 FUEL PUMP RELAY CTRL GND	0.75 mm ²	FLRYW	ECM-J1 (26)

X960					
CONN OS	WIRE COLOR	WIRE LABEL	GAUGE	JACKET	TO
A	YEL	CAN 2 HI DIAG CAN HIGH	20 AWG	J1939 CABLE	S964 (2)
B	GRN	CAN 2 LO DIAG CAN LOW	20 AWG	J1939 CABLE	S963 (2)
C					

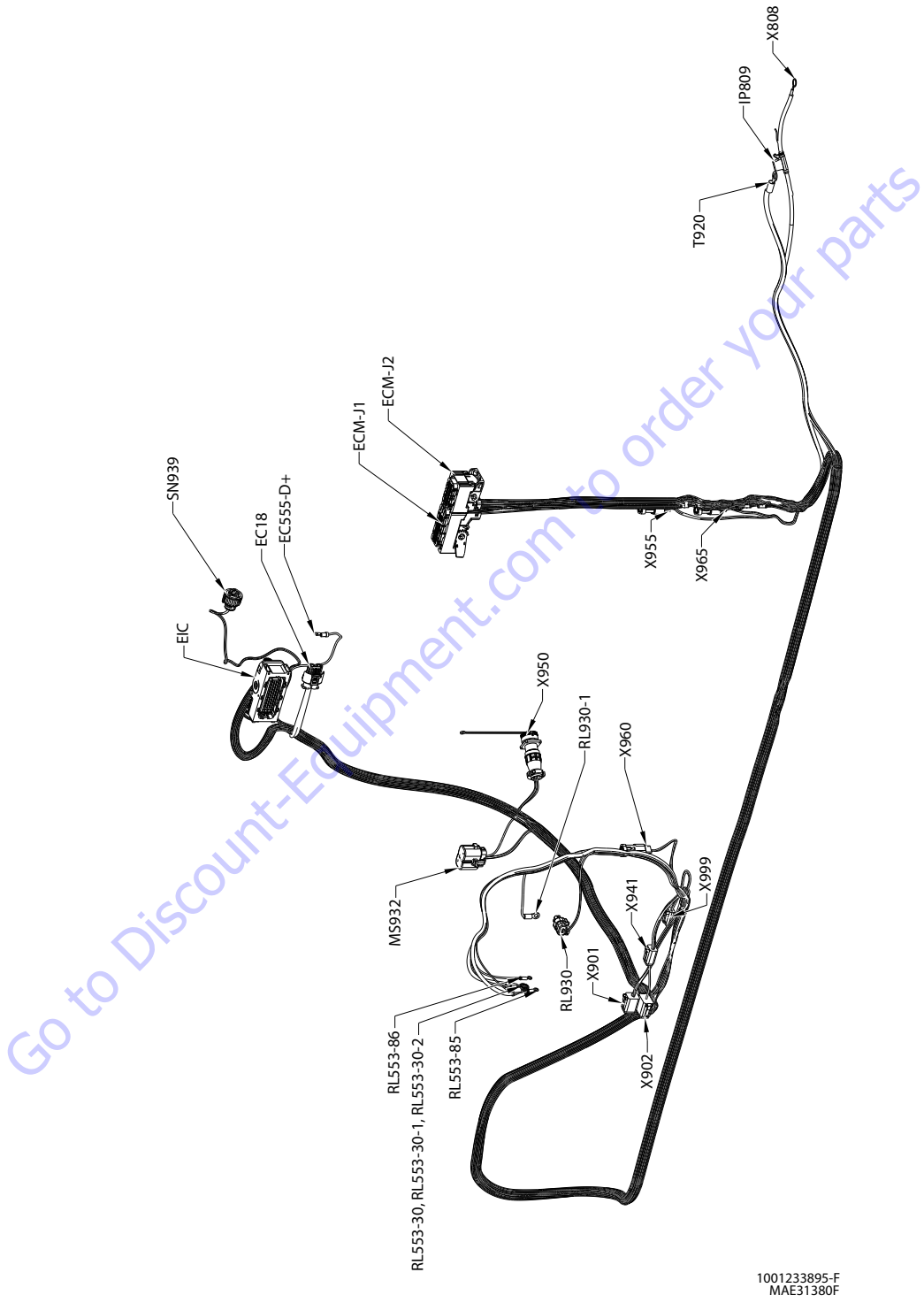

1001233895-F
MAE31380F

Figure 7-73. Deutz T4F Engine Harness - Sheet 5 of 5

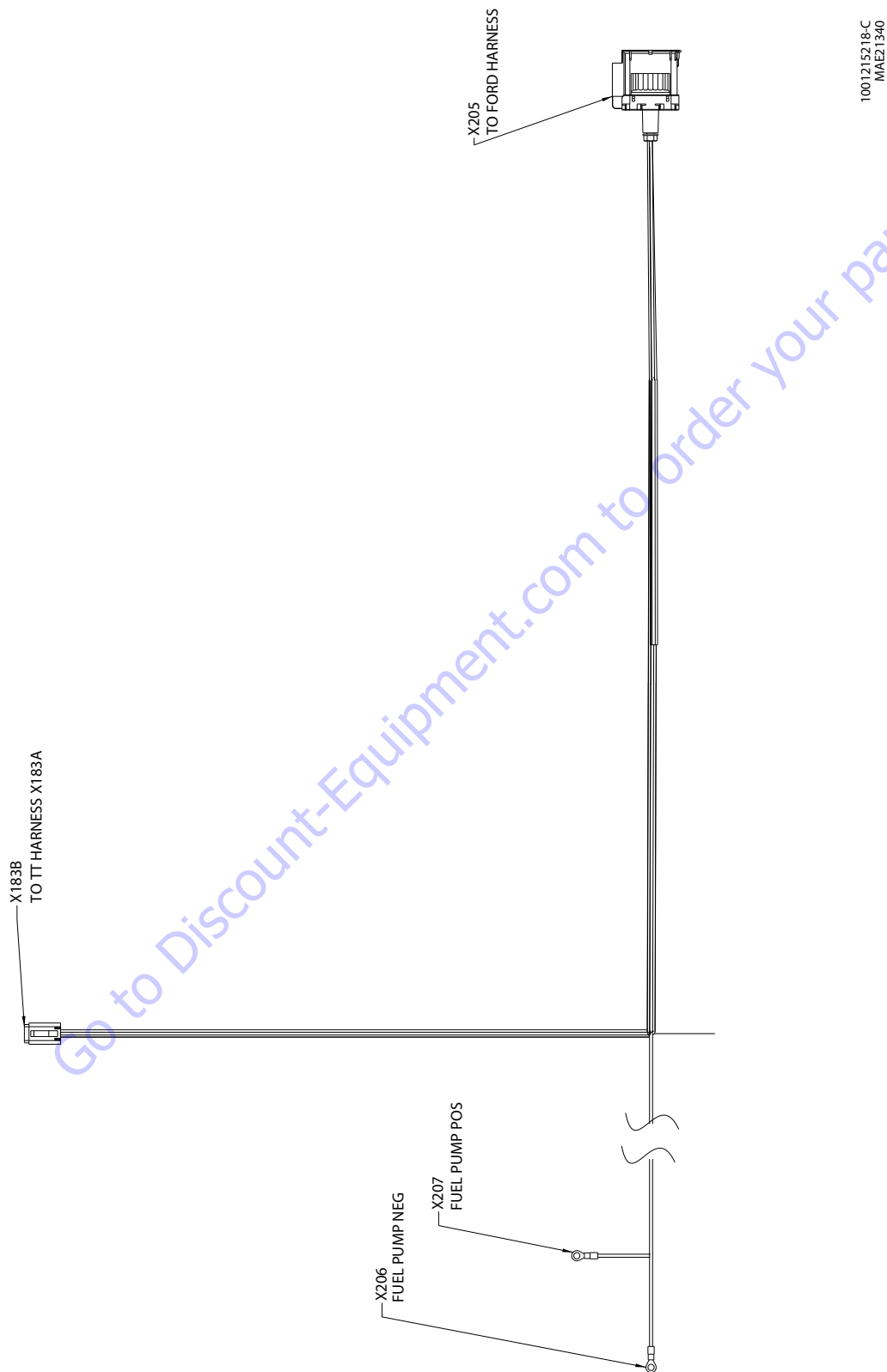

Figure 7-74. Ford Engine Harness

SECTION 7 - BASIC ELECTRICAL INFORMATION & ELECTRICAL SCHEMATICS

X207 FUEL PUMP POS					
CONN POS	WIRE COLOR	WIRE LABEL	GAUGE	JACKET	TO
1	WHT	6-54 FUEL PUMP POS	16 AWG	GXL	X205 (5)

X206 FUEL PUMP NEG					
CONN POS	WIRE COLOR	WIRE LABEL	GAUGE	JACKET	TO
1	BLK	000-60-11 FUEL PUMP NEG	16 AWG	GXL	X205 (18)

X183B TO TT HARNESS X183A					
CONN POS	WIRE COLOR	WIRE LABEL	GAUGE	JACKET	TO
1	WHT	6-14 IGNITION	16 AWG	GXL	X205 (1)
2	WHT	6-12 ENGINE START	18 AWG	GXL	X205 (15)
3	YEL	CAN HI	20 AWG	J1939 CABLE	X205 (28)
4	GRN	CAN LO	20 AWG	J1939 CABLE	X205 (29)
5					
6					

X205 TO FORD HARNESS					
CONN POS	WIRE COLOR	WIRE LABEL	GAUGE	JACKET	TO
1	WHT	6-14 IGNITION	16 AWG	GXL	X181B (1)
2					
3					
4					
5	WHT	6-54 FUEL PUMP POS	16 AWG	GXL	X208 (1)
6					
7					
8					
9					
10					
11					
12					
13					
14					
15	WHT	6-12 ENGINE START	18 AWG	GXL	X181 (2)
16					
17					
18	BLK	000-60-11 FUEL PUMP NEG	16 AWG	GXL	X207 (1)
19					
20					
21					
22					
23					
24					
25					
26					
27					
28	YEL	CAN HI	20 AWG	J1939 CABLE	X181 (3)
29	GRN	CAN LO	20 AWG	J1939 CABLE	X181 (4)
30					
31					
32					
33					
34					
35					
36					
37					
38					
39					
40					
41					
42					

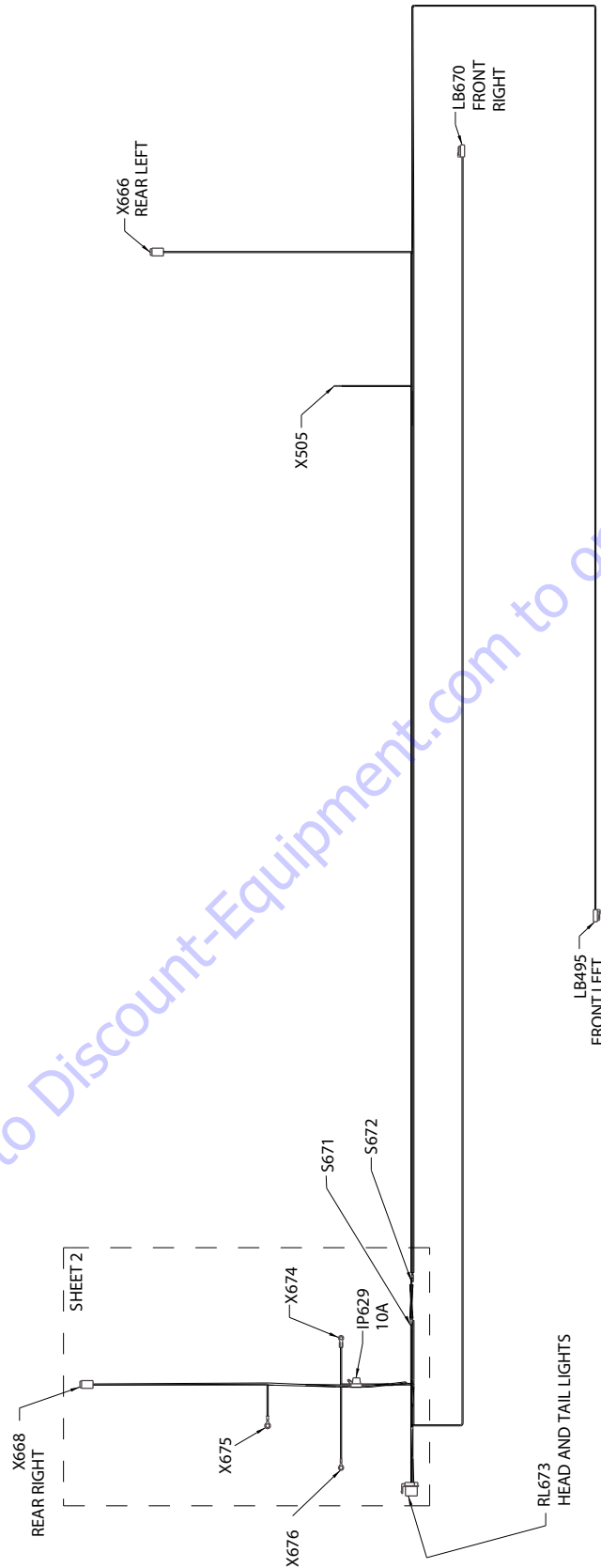

1001193592-C
MAE21350

Figure 7-75. Chassis Head and Tail Lights Harness - Sheet 1 of 2

SECTION 7 - BASIC ELECTRICAL INFORMATION & ELECTRICAL SCHEMATICS

X505					
CONN POS	WIRE COLOR	WIRE LABEL	GAUGE	JACKET	TO
1	WHT	4-145	18 AWG	GXL	RL673 (5)

LB670 FRONT RIGHT					
CONN POS	WIRE COLOR	WIRE LABEL	GAUGE	JACKET	TO
1	WHT	6-29 12V+	16 AWG	GXL	S671 (1)
2	BLK	000-60-29 GND	16 AWG	GXL	S672 (1)

LB495 FRONT LEFT					
CONN POS	WIRE COLOR	WIRE LABEL	GAUGE	JACKET	TO
1	WHT	6-11 12V+	16 AWG	GXL	S671 (1)
2	BLK	000-60-11 GND	16 AWG	GXL	S672 (1)

X666 REAR LEFT					
CONN POS	WIRE COLOR	WIRE LABEL	GAUGE	JACKET	TO
1					
2	BLK	000-60-12 GND	16 AWG	GXL	S672 (2)
3	WHT	6-13 12V+	16 AWG	GXL	S671 (2)
4					

Go to Discount-Equipment.com to order your parts

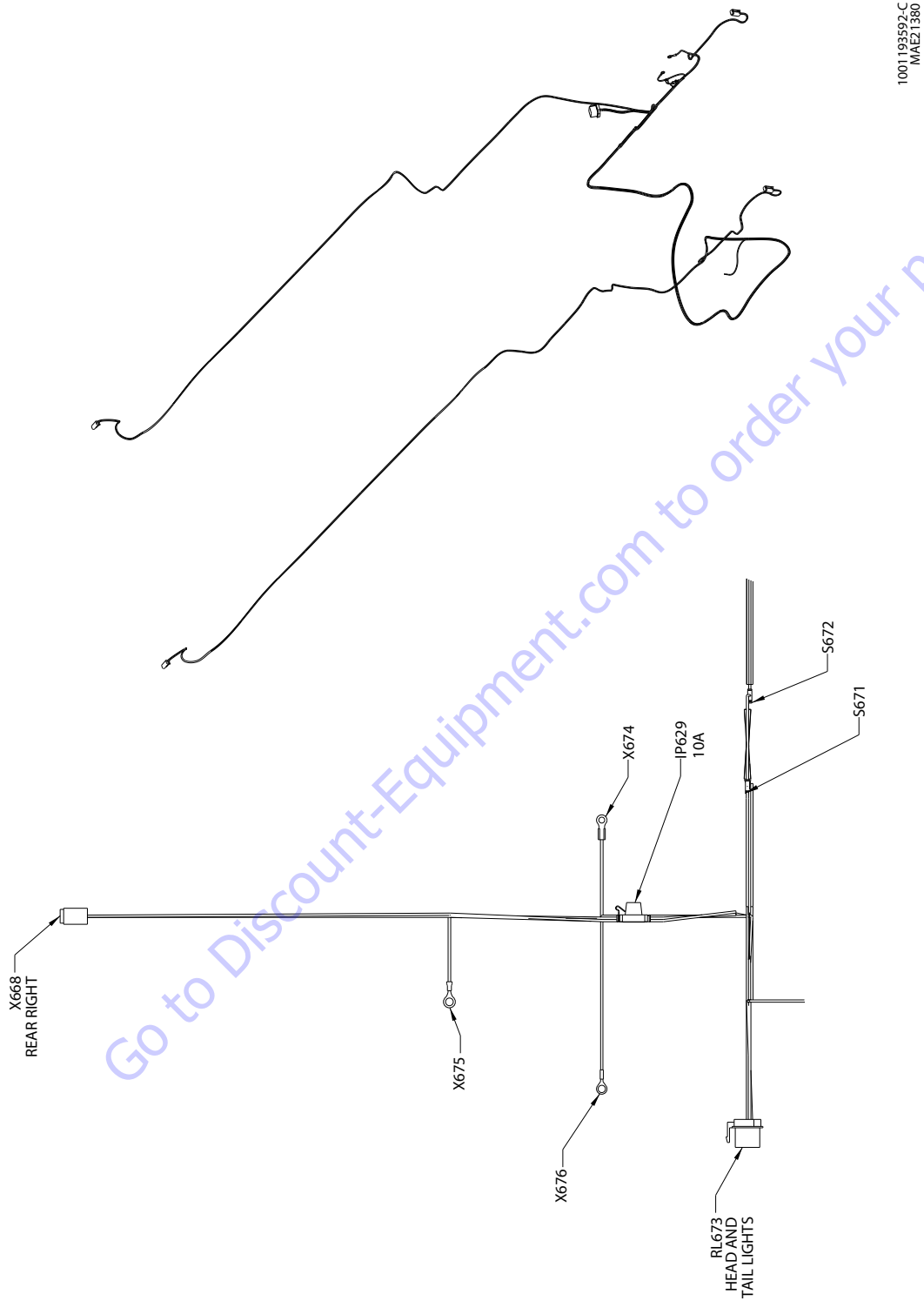

Figure 7-76. Chassis Head and Tail Lights Harness - Sheet 2 of 2

SECTION 7 - BASIC ELECTRICAL INFORMATION & ELECTRICAL SCHEMATICS

IP629 10A					
CONN POS	WIRE COLOR	WIRE LABEL	GAUGE	JACKET	TO
1	WHT	4-146	14 AWG	GXL	X675 (1)
2	WHT	4-146	14 AWG	GXL	RL673 (1)

RL673 HEAD AND TAIL LIGHTS					
CONN POS	WIRE COLOR	WIRE LABEL	GAUGE	JACKET	TO
1	WHT	4-146	14 AWG	GXL	IP629 (2)
2	BLK	000-40-109 GND	16 AWG	GXL	X676 (1)
3					
4	WHT	6-8 12V+	14 AWG	GXL	S671 (2)
5	WHT	4-145	18 AWG	GXL	X505 (1)

X676					
CONN POS	WIRE COLOR	WIRE LABEL	GAUGE	JACKET	TO
1	BLK	000-40-109 GND	16 AWG	GXL	RL673 (2)

X675					
CONN POS	WIRE COLOR	WIRE LABEL	GAUGE	JACKET	TO
1	WHT	4-146	14 AWG	GXL	IP629 (1)

X668 REAR RIGHT					
CONN POS	WIRE COLOR	WIRE LABEL	GAUGE	JACKET	TO
1					
2	BLK	000-60-30 GND	16 AWG	GXL	S672 (2)
3	WHT	6-30 12V+	16 AWG	GXL	S671 (2)
4					

X674					
CONN POS	WIRE COLOR	WIRE LABEL	GAUGE	JACKET	TO
1	BLK	4-122	14 AWG	GXL	S672 (2)

S671					
CONN POS	WIRE COLOR	WIRE LABEL	GAUGE	JACKET	TO
1	WHT	6-11 12V+	16 AWG	GXL	LB495 (1)
2	WHT	6-29 12V+	16 AWG	GXL	LB670 (1)
1	WHT	6-13 12V+	16 AWG	GXL	X666 (2)
2	WHT	6-30 12V+	16 AWG	GXL	X668 (2)
2	WHT	6-8 12V+	14 AWG	GXL	RL673 (4)

S672					
CONN POS	WIRE COLOR	WIRE LABEL	GAUGE	JACKET	TO
1	BLK	000-60-11 GND	16 AWG	GXL	LB495 (2)
2	BLK	000-60-29 GND	16 AWG	GXL	LB670 (2)
1	BLK	000-60-12 GND	16 AWG	GXL	X666 (3)
2	BLK	000-60-30 GND	16 AWG	GXL	X668 (3)
2	BLK	4-122	14 AWG	GXL	X674 (1)

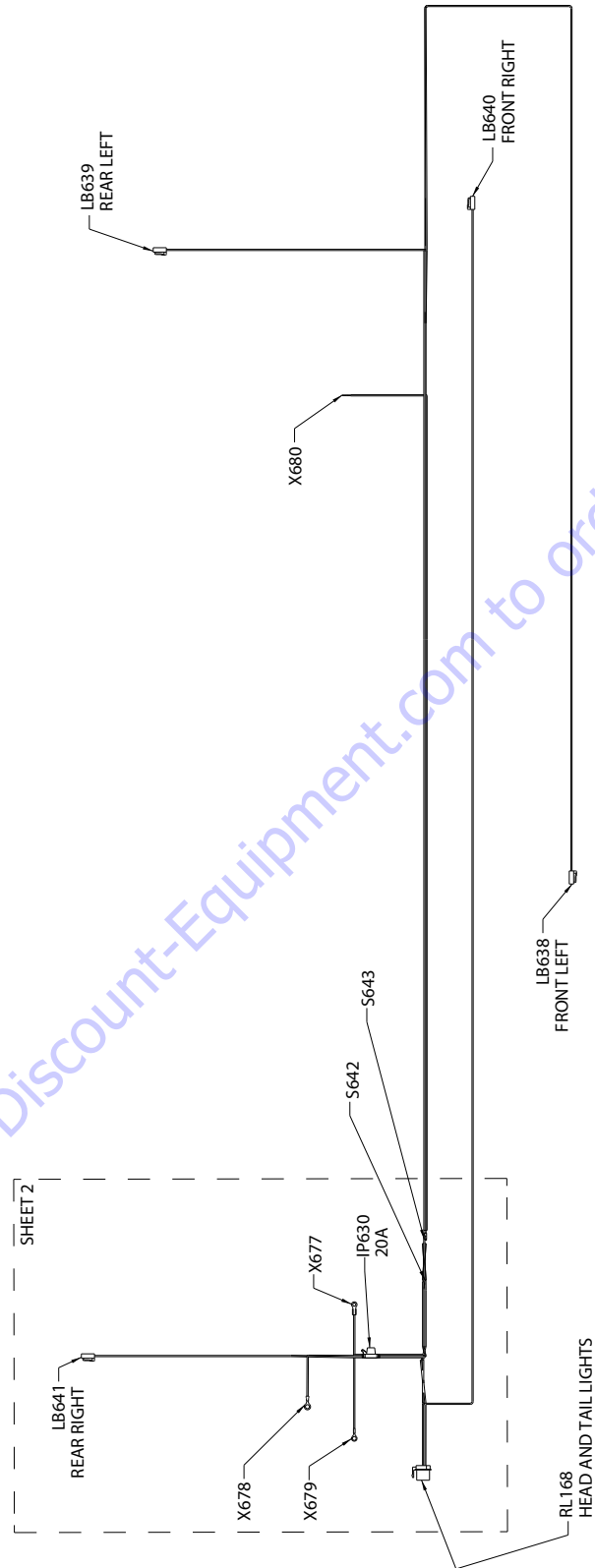

1001103593-C
MAE21360

Go to Discount-Equipment.com to order your parts

Figure 7-77. Chassis Work Lights Harness - Sheet 1 of 2

SECTION 7 - BASIC ELECTRICAL INFORMATION & ELECTRICAL SCHEMATICS

LB638 FRONT LEFT					
CONN POS	WIRE COLOR	WIRE LABEL	GAUGE	JACKET	TO
1	WHT	6-4 12V+	16 AWG	GXL	S642 (1)
2	BLK	000-60-3 GND	16 AWG	GXL	S643 (1)

X680					
CONN POS	WIRE COLOR	WIRE LABEL	GAUGE	JACKET	TO
1	WHT	4-28	16 AWG	GXL	RL168 (5)

LB640 FRONT RIGHT					
CONN POS	WIRE COLOR	WIRE LABEL	GAUGE	JACKET	TO
1	WHT	6-6 12V+	16 AWG	GXL	S642 (1)
2	BLK	000-60-5 GND	16 AWG	GXL	S643 (1)

LB639 REAR LEFT					
CONN POS	WIRE COLOR	WIRE LABEL	GAUGE	JACKET	TO
1	WHT	6-5 12V+	16 AWG	GXL	S642 (2)
2	BLK	000-60-4 GND	16 AWG	GXL	S643 (2)

Go to Discount-Equipment.com to order your parts

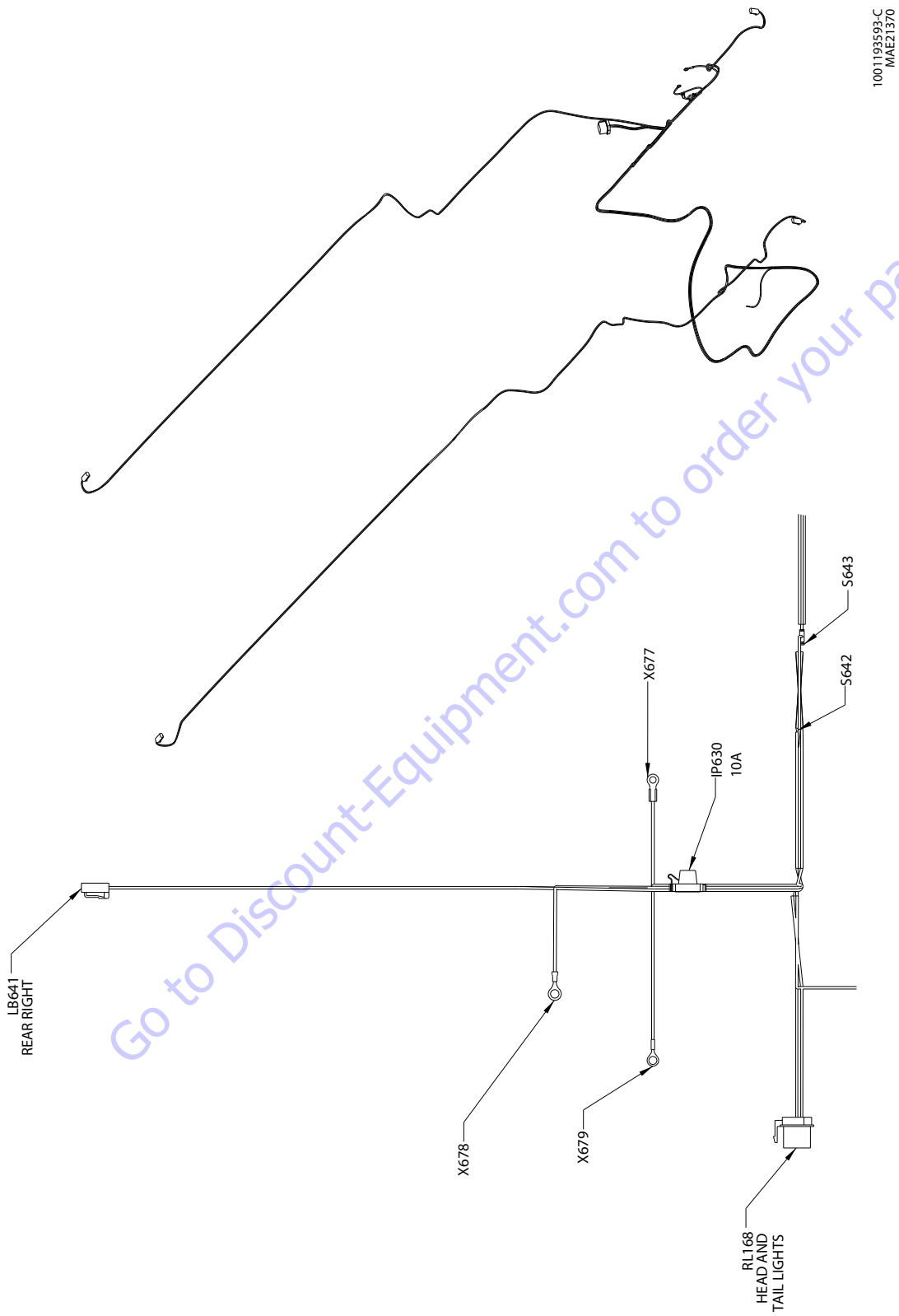

1001193593-C
MAEZ1370

Figure 7-78. Chassis Work Lights Harness - Sheet 2 of 2

SECTION 7 - BASIC ELECTRICAL INFORMATION & ELECTRICAL SCHEMATICS

X678					
CONN POS	WIRE COLOR	WIRE LABEL	GAUGE	JACKET	TO
1	WHT	4-70	14 AWG	GXL	IP630 (1)

X679					
CONN POS	WIRE COLOR	WIRE LABEL	GAUGE	JACKET	TO
1	BLK	000-40-9 GND	16 AWG	GXL	RL168 (2)

RL168 HEAD AND TAIL LIGHTS					
CONN POS	WIRE COLOR	WIRE LABEL	GAUGE	JACKET	TO
1	WHT	4-70	14 AWG	GXL	IP630 (2)
2	BLK	000-40-9 GND	16 AWG	GXL	X679 (1)
3					
4	WHT	6-8 12V+	14 AWG	GXL	S642 (2)
5	WHT	4-28	16 AWG	GXL	X680 (1)

IP630 20A					
CONN POS	WIRE COLOR	WIRE LABEL	GAUGE	JACKET	TO
1	WHT	4-70	14 AWG	GXL	X678 (1)
2	WHT	4-70	14 AWG	GXL	RL168 (1)

X677					
CONN POS	WIRE COLOR	WIRE LABEL	GAUGE	JACKET	TO
1	BLK	000-40-17	14 AWG	GXL	S643 (2)

S642					
CONN POS	WIRE COLOR	WIRE LABEL	GAUGE	JACKET	TO
1	WHT	6-4 12V+	16 AWG	GXL	LB638 (1)
1	WHT	6-6 12V+	16 AWG	GXL	LB640 (1)
2	WHT	6-5 12V+	16 AWG	GXL	LB639 (1)
2	WHT	6-7 12V+	16 AWG	GXL	LB641 (1)
2	WHT	6-8 12V+	14 AWG	GXL	RL168 (4)

LB641 REAR RIGHT					
CONN POS	WIRE COLOR	WIRE LABEL	GAUGE	JACKET	TO
1	WHT	6-7 12V+	16 AWG	GXL	S642 (2)
2	BLK	000-60-6 GND	16 AWG	GXL	S643 (2)

S643					
CONN POS	WIRE COLOR	WIRE LABEL	GAUGE	JACKET	TO
1	BLK	000-60-3 GND	16 AWG	GXL	LB638 (2)
1	BLK	000-60-5 GND	16 AWG	GXL	LB640 (2)
2	BLK	000-40-17	14 AWG	GXL	X677 (1)
2	BLK	000-60-4 GND	16 AWG	GXL	LB639 (2)
2	BLK	000-60-6 GND	16 AWG	GXL	LB641 (2)

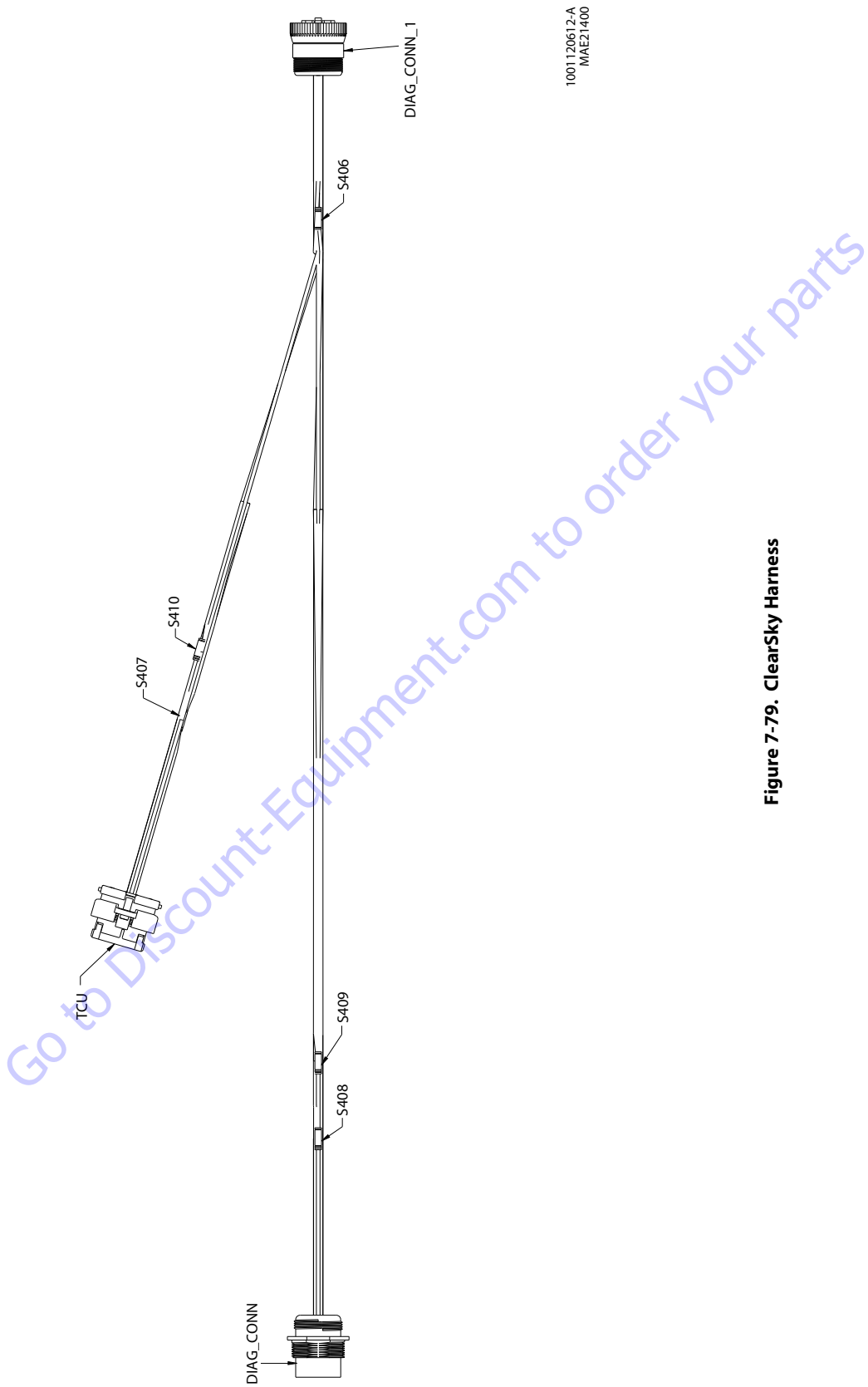

1001120612-A
MAE21400

Figure 7-79. ClearSky Harness

SECTION 7 - BASIC ELECTRICAL INFORMATION & ELECTRICAL SCHEMATICS

S406					
CONN POS	WIRE COLOR	WIRE LABEL	GAUGE	JACKET	TO
1	BLK	0-100-1 GND	16 AWG	GXL	TCU (16)
1	BLK	0-100-2 GND	16 AWG	GXL	DIAG_CONN (A)
2	BLK	0-100-3 GND	16 AWG	GXL	DIAG_CONN_1 (A)

S407					
CONN POS	WIRE COLOR	WIRE LABEL	GAUGE	JACKET	TO
1	RED	1-100-2 B+	16 AWG	GXL	DIAG_CONN (B)
1	RED	1-100-3 B+	16 AWG	GXL	DIAG_CONN_1 (B)
2	RED	1-100-1 B+	16 AWG	GXL	TCU (23)

S408					
CONN POS	WIRE COLOR	WIRE LABEL	GAUGE	JACKET	TO
1	YEL	4-100-1 CAN HI	18 AWG	GXL	TCU (7)
1	YEL	4-100-3 CAN HI	18 AWG	GXL	DIAG_CONN_1 (C)
2	YEL	4-100-2 CAN HI	18 AWG	GXL	DIAG_CONN (C)

S409					
CONN POS	WIRE COLOR	WIRE LABEL	GAUGE	JACKET	TO
1	GRN	3-100-1 CAN LO	18 AWG	GXL	TCU (22)
1	GRN	3-100-3 CAN LO	18 AWG	GXL	DIAG_CONN_1 (D)
2	GRN	3-100-2 CAN LO	18 AWG	GXL	DIAG_CONN (D)

S410					
CONN POS	WIRE COLOR	WIRE LABEL	GAUGE	JACKET	TO
1	YEL/RED	2-100-2 IGN	18 AWG	GXL	DIAG_CONN (H)
2	YEL/RED	2-100-1 IGN	18 AWG	GXL	TCU (15)
2	YEL/RED	2-100-3 IGN	18 AWG	GXL	DIAG_CONN_1 (H)

DIAG_CONN					
CONN POS	WIRE COLOR	WIRE LABEL	GAUGE	JACKET	TO
A	BLK	0-100-2 GND	16 AWG	GXL	S406 (1)
B	RED	1-100-2 B+	16 AWG	GXL	S407 (1)
C	YEL	4-100-2 CAN HI	18 AWG	GXL	S408 (2)
D	GRN	3-100-2 CAN LO	18 AWG	GXL	S409 (2)
E	BLK	5-100-1 SHLD	18 AWG	GXL	DIAG_CONN_1 (E)
F					
G					
H	YEL/RED	2-100-2 IGN	18 AWG	GXL	S410 (1)
J					

TCU					
CONN POS	WIRE COLOR	WIRE LABEL	GAUGE	JACKET	TO
1					
2					
3					
4					
5					
6					
7	YEL	4-100-1 CAN HI	18 AWG	GXL	S408 (1)
8					
9					
10					
11					
12					
13					
14					
15	YEL/RED	2-100-1 IGN	18 AWG	GXL	S410 (2)
16	BLK	0-100-1 GND	16 AWG	GXL	S406 (1)
17					
18					
19					
20					
21					
22	GRN	3-100-1 CAN LO	18 AWG	GXL	S409 (1)
23	RED	1-100-1 B+	16 AWG	GXL	S407 (2)

DIAG_CONN_1					
CONN POS	WIRE COLOR	WIRE LABEL	GAUGE	JACKET	TO
A	BLK	0-100-3 GND	16 AWG	GXL	S406 (2)
B	RED	1-100-3 B+	16 AWG	GXL	S407 (1)
C	YEL	4-100-3 CAN HI	18 AWG	GXL	S408 (1)
D	GRN	3-100-3 CAN LO	18 AWG	GXL	S409 (1)
E	BLK	5-100-1 SHLD	18 AWG	GXL	DIAG_CONN (E)
F					
G					
H	YEL/RED	2-100-3 IGN	18 AWG	GXL	S410 (2)
J					

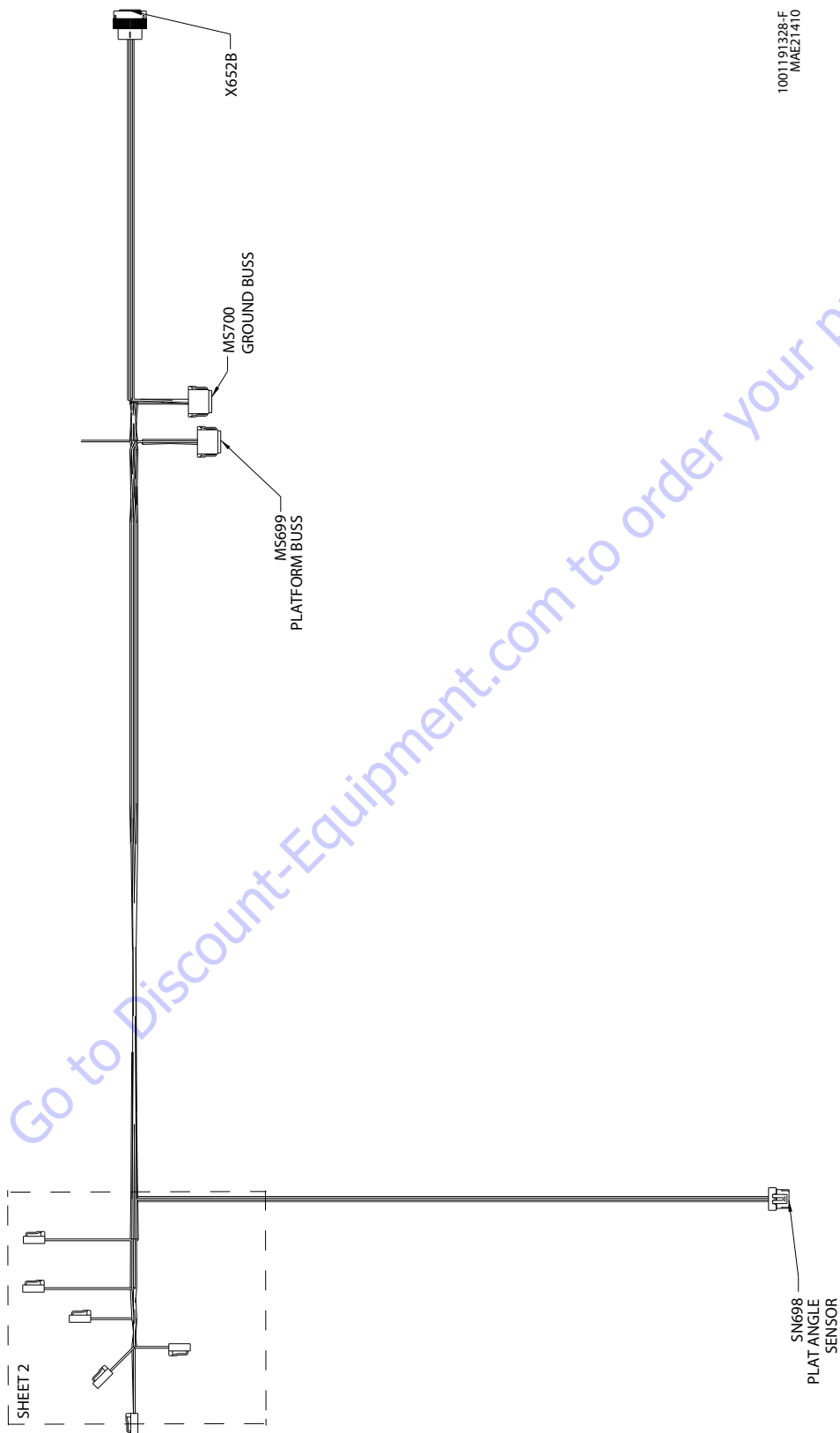

Figure 7-80. Platform Valve W/O Jib Harness - Sheet 1 of 2

SECTION 7 - BASIC ELECTRICAL INFORMATION & ELECTRICAL SCHEMATICS

MS699 PLATFORM BUSS					
CONN POS	WIRE COLOR	WIRE LABEL	GAUGE	JACKET	TO
1					
2					
3					
4					
5					
6	BLK	000-40-91 GND	18 AWG	GXL	SN698 (A)
7	BLK	000-40-92 GND	18 AWG	GXL	SN698 (E)
8	BLK	000-40-90 -	18 AWG	GXL	X652B (21)
9					
10	WHT	4-127 PWR 5V	18 AWG	GXL	SN698 (B)
11	WHT	4-126 PWR 5V	18 AWG	GXL	SN698 (F)
12	WHT	4-125 PLAT ANGLE SEN 5V	18 AWG	GXL	X652B (10)

SN698 PLAT ANGLE SENSOR					
CONN POS	WIRE COLOR	WIRE LABEL	GAUGE	JACKET	TO
A	BLK	000-40-91 GND	18 AWG	GXL	MS699 (6)
B	WHT	4-127 PWR 5V	18 AWG	GXL	MS699 (10)
C	WHT	4-89 PLAT ANGLE SEN 2	18 AWG	GXL	X652B (9)
D	WHT	4-88 PLAT ANGLE SEN 1	18 AWG	GXL	X652B (8)
E	BLK	000-40-92 GND	18 AWG	GXL	MS699 (7)
F	WHT	4-126 PWR 5V	18 AWG	GXL	MS699 (11)

MS700 GROUND BUSS					
CONN POS	WIRE COLOR	WIRE LABEL	GAUGE	JACKET	TO
1					
2	BLK	000-10-34 OPTION GND	18 AWG	GXL	X652B (1)
3	BLK	000-40-27 -	18 AWG	GXL	HV661 (2)
4	BLK	000-40-26	18 AWG	GXL	HV660 (2)
5					
6					
7	BLK	000-40-20	18 AWG	GXL	HV382 (2)
8	BLK	000-40-19	18 AWG	GXL	HV383 (2)
9	BLK	000-40-30	18 AWG	GXL	HV380 (2)
10	BLK	000-40-22	18 AWG	GXL	HV381 (2)
11					
12					

X652B					
CONN POS	WIRE COLOR	WIRE LABEL	GAUGE	JACKET	TO
1	BLK	000-10-34 OPTION GND	18 AWG	GXL	MS700 (2)
2					
3	WHT	4-15 HIGH PRESSURE DUMP	18 AWG	GXL	HV660 (1)
4	WHT	4-8 PLAT LEVEL UP	18 AWG	GXL	HV381 (4)
5	WHT	4-7 PLAT LEVEL DOWN	18 AWG	GXL	HV380 (5)
6					
7					
8	WHT	4-88 PLAT ANGLE SEN 1	18 AWG	GXL	SN698 (D)
9	WHT	4-89 PLAT ANGLE SEN 2	18 AWG	GXL	SN698 (C)
10	WHT	4-125 PLAT ANGLE SEN 5V	18 AWG	GXL	MS699 (12)
11					
12	WHT	4-16 LOW PRESSURE DUMP	18 AWG	GXL	HV661 (1)
13	WHT	4-9 ROTATE LEFT	18 AWG	GXL	HV383 (1)
14	WHT	4-10 ROTATE RIGHT	18 AWG	GXL	HV382 (1)
15					
16					
17					
18					
19					
20					
21	BLK	000-40-90	18 AWG	GXL	MS699 (8)

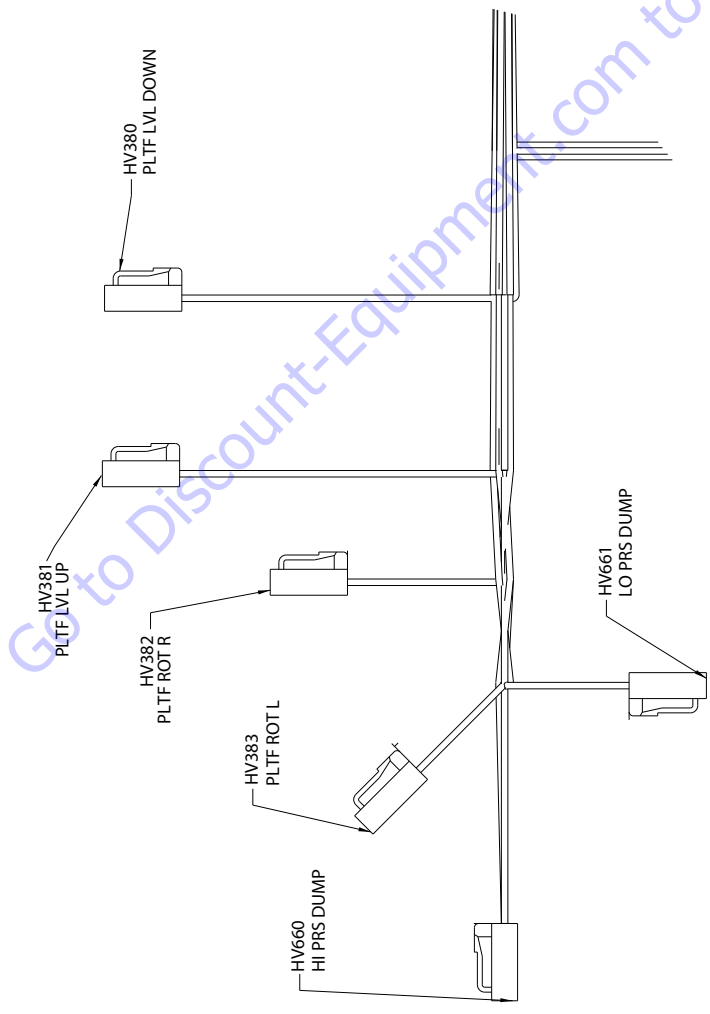
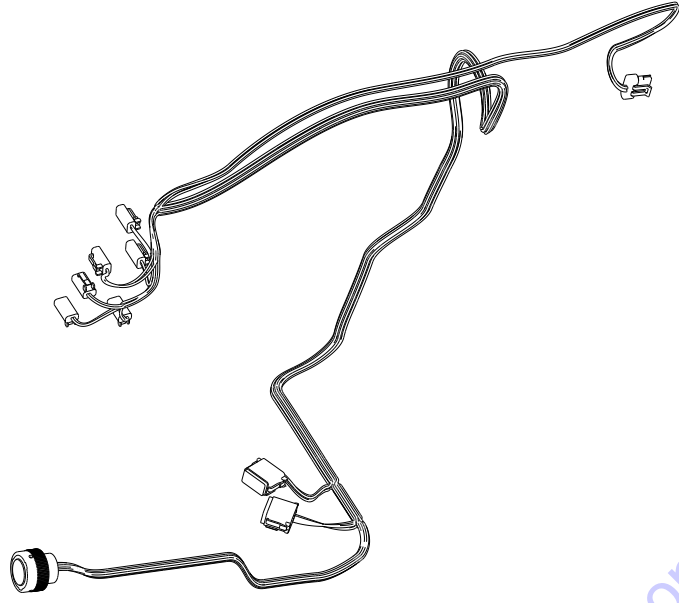

Figure 7-81. Platform Valve W/O Jib Harness - Sheet 2 of 2

SECTION 7 - BASIC ELECTRICAL INFORMATION & ELECTRICAL SCHEMATICS

HV381 PLTF LVL UP					
CONN POS	WIRE COLOR	WIRE LABEL	GAUGE	JACKET	TO
1	WHT	4-8 PLAT LEVEL UP	18 AWG	GXL	X652B (4)
2	BLK	000-40-22	18 AWG	GXL	MS700 (10)

HV380 PLTF LVL DOWN					
CONN POS	WIRE COLOR	WIRE LABEL	GAUGE	JACKET	TO
1	WHT	4-7 PLAT LEVEL DOWN	18 AWG	GXL	X652B (5)
2	BLK	000-40-30	18 AWG	GXL	MS682 (9)

HV383 PLTF ROT L					
CONN POS	WIRE COLOR	WIRE LABEL	GAUGE	JACKET	TO
1	WHT	4-9 ROTATE LEFT	18 AWG	GXL	X652B (13)
2	BLK	000-40-19	18 AWG	GXL	MS700 (8)

HV382 PLTF ROT R					
CONN POS	WIRE COLOR	WIRE LABEL	GAUGE	JACKET	TO
1	WHT	4-10 ROTATE RIGHT	18 AWG	GXL	X652B (14)
2	BLK	000-40-20	18 AWG	GXL	MS700 (7)

HV660HI PRS DUMP					
CONN POS	WIRE COLOR	WIRE LABEL	GAUGE	JACKET	TO
1	WHT	4-15 HIGH PRESSURE DUMP	18 AWG	GXL	X652B (3)
2	BLK	000-40-26	18 AWG	GXL	MS700 (4)

HV661LO PRS DUMP					
CONN POS	WIRE COLOR	WIRE LABEL	GAUGE	JACKET	TO
1	WHT	4-16 LOW PRESSURE DUMP	18 AWG	GXL	X652B (12)
2	BLK	000-40-27	18 AWG	GXL	MS700 (3)

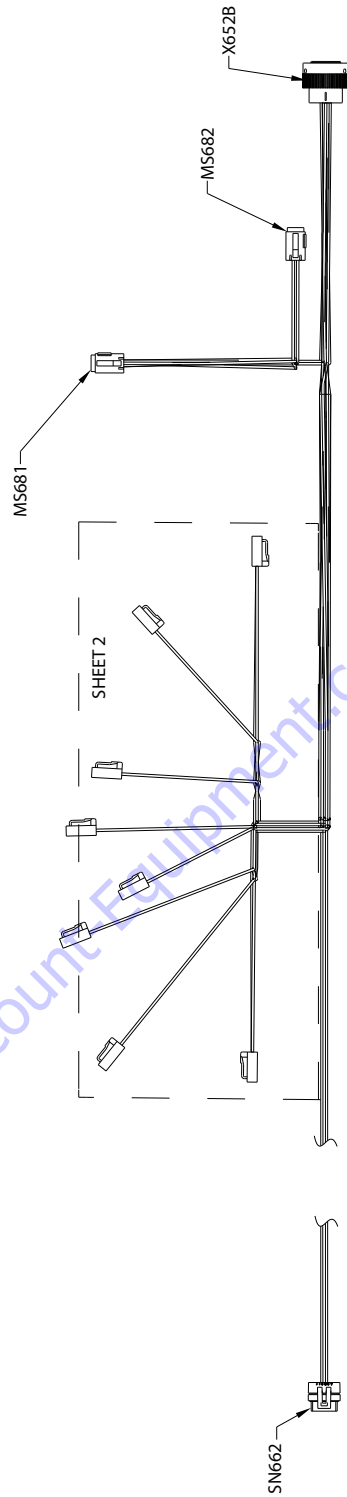

1001189111-J
MAE39640J

Figure 7-82. Platform Valve w/Jib Harness - Sheet 1 of 2

SECTION 7 - BASIC ELECTRICAL INFORMATION & ELECTRICAL SCHEMATICS

SN662 PLATFORM ANGLE SENSOR					
CONN POS	WIRE COLOR	WIRE LABEL	GAUGE	JACKET	TO
A	BLU/BLK	000-40-91 GND	18 AWG	CABLE	MS681 (6)
B	ORN/BLK	4-127 PWR 5V	18 AWG	CABLE	MS681 (10)
C	YEL/BLK	4-88 PLAT ANGLE SEN 1	18 AWG	CABLE	X652B (8)
D	BRN/BLK	4-89 PLAT ANGLE SEN 2	18 AWG	CABLE	X652B (9)
E	BLK/RED	000-40-92 GND	18 AWG	CABLE	MS681 (7)
F	BLU/RED	4-126 PWR 5V	18 AWG	CABLE	MS681 (11)

MS681					
CONN POS	WIRE COLOR	WIRE LABEL	GAUGE	JACKET	TO
1					
2					
3					
4					
5					
6	BLU/BLK	000-40-91 GND	18 AWG	CABLE	SN662 (A)
7	BLK/RED	000-40-92 GND	18 AWG	CABLE	SN662 (E)
8	BLK	000-40-90 GND	18 AWG	GXL	X652B (21)
9					
10	ORN/BLK	4-127 PWR 5V	18 AWG	CABLE	SN662 (B)
11	BLU/RED	4-126 PWR 5V	18 AWG	CABLE	SN662 (F)
12	WHT	4-125 PLAT ANGLE SEN 5V	18 AWG	GXL	X652B (10)

X652B					
CONN POS	WIRE COLOR	WIRE LABEL	GAUGE	JACKET	TO
1	BLK	000-10-34 OPTION GND	18 AWG	GXL	MS682 (2)
2					
3	WHT	4-15 HIGH PRESSURE DUMP	18 AWG	GXL	HV660 (1)
4	WHT	4-8 PLAT LEVEL UP	18 AWG	GXL	HV381 (1)
5	WHT	4-7 PLAT LEVEL DOWN	18 AWG	GXL	HV380 (1)
6					
7					
8	YEL/BLK	4-88 PLAT ANGLE SEN 1	18 AWG	CABLE	SN662 (C)
9	BRN/BLK	4-89 PLAT ANGLE SEN 2	18 AWG	CABLE	SN662 (D)
10	WHT	4-125 PLAT ANGLE SEN 5V	18 AWG	GXL	MS681 (12)
11					
12	WHT	4-16 LOW PRESSURE DUMP	18 AWG	GXL	HV661 (1)
13	WHT	4-9 ROTATE LEFT	18 AWG	GXL	HV383 (1)
14	WHT	4-10 ROTATE RIGHT	18 AWG	GXL	HV382 (1)
15	WHT	4-12 JIB UP	18 AWG	GXL	HV364 (1)
16	WHT	4-13 JIB DOWN	18 AWG	GXL	HV365 (1)
17					
18					
19					
20					
21	BLK	000-40-90 GND	18 AWG	GXL	MS681 (8)

MS682					
CONN POS	WIRE COLOR	WIRE LABEL	GAUGE	JACKET	TO
1					
2	BLK	000-10-34 OPTION GND	18 AWG	GXL	X652B (1)
3	BLK	000-40-27-	18 AWG	GXL	HV661 (2)
4	BLK	000-40-26	18 AWG	GXL	HV660 (2)
5	BLK	000-40-24	18 AWG	GXL	HV365 (2)
6	BLK	000-40-23	18 AWG	GXL	HV364 (2)
7	BLK	000-40-20	18 AWG	GXL	HV382 (2)
8	BLK	000-40-19	18 AWG	GXL	HV383 (2)
9	BLK	000-40-30	18 AWG	GXL	HV380 (2)
10	BLK	000-40-22	18 AWG	GXL	HV381 (2)
11					
12					

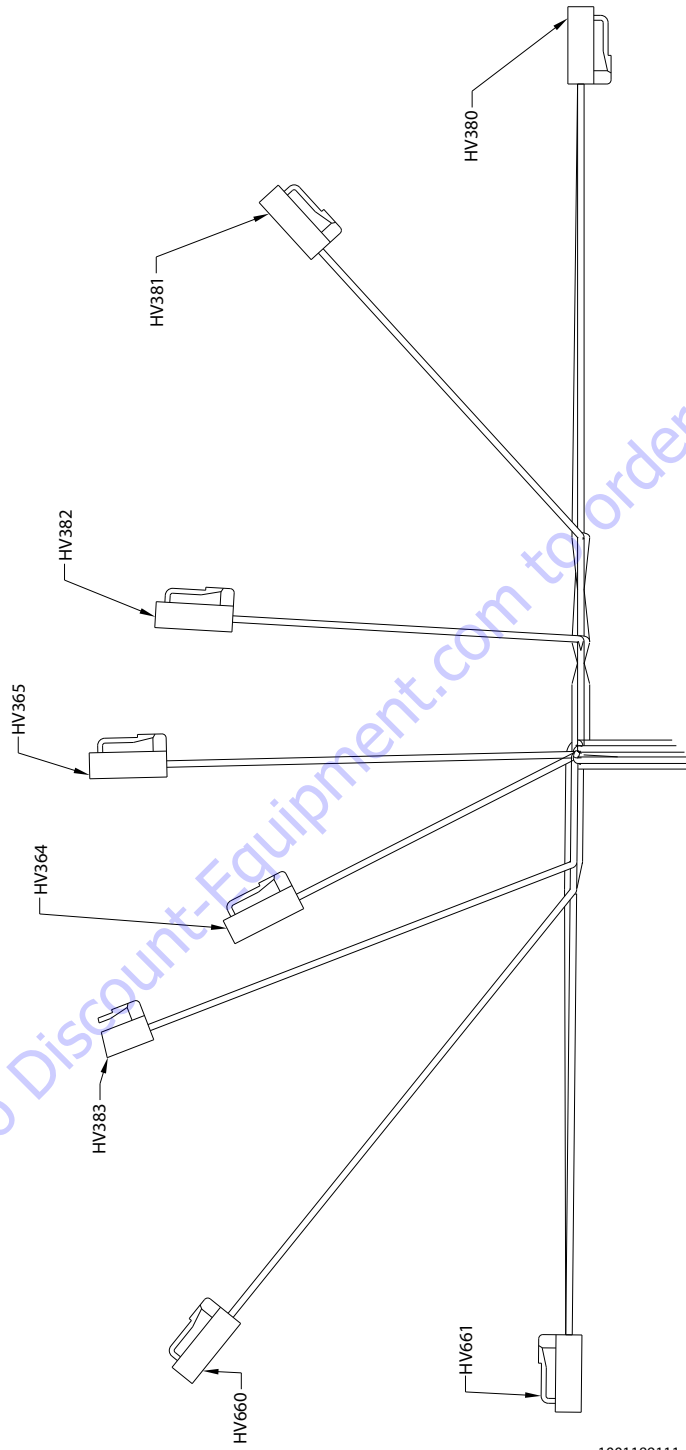

1001189111-J
MAE39650J

Figure 7-83. Platform Valve w/Jib Harness - Sheet 2 of 2

SECTION 7 - BASIC ELECTRICAL INFORMATION & ELECTRICAL SCHEMATICS

HV661 LOW PRES DUMP					
CONN POS	WIRE COLOR	WIRE LABEL	GAUGE	JACKET	TO
1	WHT	4-16 LOW PRESSURE DUMP	18 AWG	GXL	X652B (12)
2	BLK	000-40-27-	18 AWG	GXL	MS682 (3)

HV660 HIGH PRESS DUMP					
CONN POS	WIRE COLOR	WIRE LABEL	GAUGE	JACKET	TO
1	WHT	4-15 HIGH PRESSURE DUMP	18 AWG	GXL	X652B (3)
2	BLK	000-40-26	18 AWG	GXL	MS682 (4)

HV383 PLTF ROT L					
CONN POS	WIRE COLOR	WIRE LABEL	GAUGE	JACKET	TO
1	WHT	4-9 ROTATE LEFT	18 AWG	GXL	X652B (13)
2	BLK	000-40-19	18 AWG	GXL	MS682 (8)

HV364 JIB UP					
CONN POS	WIRE COLOR	WIRE LABEL	GAUGE	JACKET	TO
1	WHT	4-12 JIB UP	18 AWG	GXL	X652B (15)
2	BLK	000-40-23	18 AWG	GXL	MS682 (6)

HV365 JIB DOWN					
CONN POS	WIRE COLOR	WIRE LABEL	GAUGE	JACKET	TO
1	WHT	4-13 JIB DOWN	18 AWG	GXL	X652B (16)
2	BLK	000-40-24	18 AWG	GXL	MS682 (5)

HV382 PLTF ROT R					
CONN POS	WIRE COLOR	WIRE LABEL	GAUGE	JACKET	TO
1	WHT	4-10 ROTATE RIGHT	18 AWG	GXL	X652B (14)
2	BLK	000-40-20	18 AWG	GXL	MS682 (7)

HV381 PLTF LVL UP					
CONN POS	WIRE COLOR	WIRE LABEL	GAUGE	JACKET	TO
1	WHT	4-8 PLAT LEVEL UP	18 AWG	GXL	X652B (4)
2	BLK	000-40-22	18 AWG	GXL	MS682 (10)

HV380 PLTF LVL DOWN					
CONN POS	WIRE COLOR	WIRE LABEL	GAUGE	JACKET	TO
1	WHT	4-7 PLAT LEVEL DOWN	18 AWG	GXL	X652B (5)
2	BLK	000-40-30	18 AWG	GXL	MS682 (9)

Go to Discount-Equipment.com to order your parts

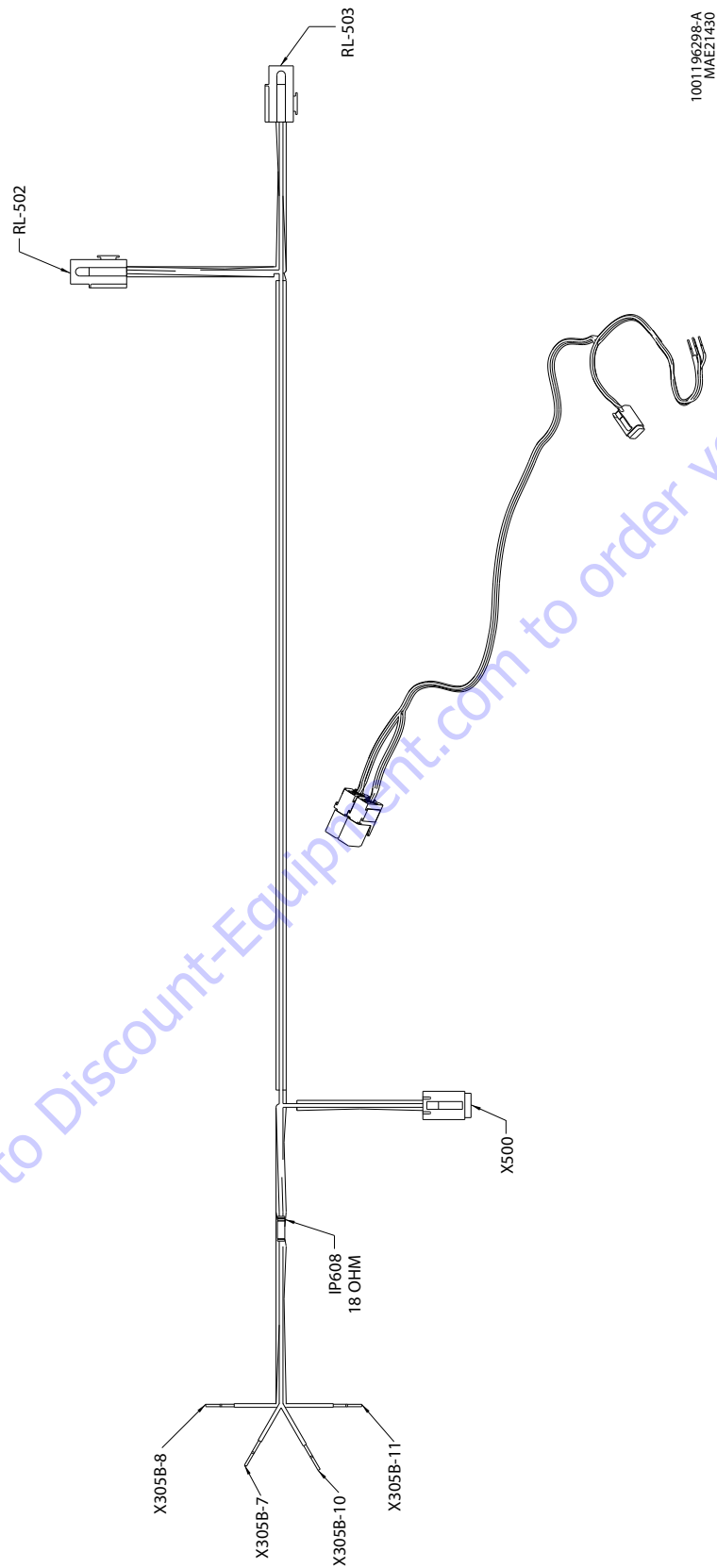

Figure 7-84. Skyguard Harness

SECTION 7 - BASIC ELECTRICAL INFORMATION & ELECTRICAL SCHEMATICS

IP608 18 OHM					
CONN POS	WIRE COLOR	WIRE LABEL	GAUGE	JACKET	TO
1	WHT	P2	18 AWG	GXL	X305B-7 (1)
2	WHT	P10	18 AWG	GXL	X500 (1)

X305B-8					
CONN POS	WIRE COLOR	WIRE LABEL	GAUGE	JACKET	TO
1	BLK	P6	18 AWG	GXL	X500 (2)

X305B-7					
CONN POS	WIRE COLOR	WIRE LABEL	GAUGE	JACKET	TO
1	WHT	P2	18 AWG	GXL	IP608 (1)
1	WHT	P9	18 AWG	GXL	RL-503 (1)

X500					
CONN POS	WIRE COLOR	WIRE LABEL	GAUGE	JACKET	TO
1	WHT	P10	18 AWG	GXL	IP608 (2)
2	BLK	P6	18 AWG	GXL	X305B-8 (1)
3	WHT	P4	18 AWG	GXL	RL-502 (5)
4	WHT	P5	18 AWG	GXL	RL-502 (2)

X305B-10					
CONN POS	WIRE COLOR	WIRE LABEL	GAUGE	JACKET	TO
1	WHT	P1	18 AWG	GXL	RL-503 (4)

X305B-11					
CONN POS	WIRE COLOR	WIRE LABEL	GAUGE	JACKET	TO
1	WHT	P3	18 AWG	GXL	RL-502 (4)

RL-503					
CONN POS	WIRE COLOR	WIRE LABEL	GAUGE	JACKET	TO
1	WHT	P9	18 AWG	GXL	X305B-7 (1)
1	WHT	P9-1	18 AWG	GXL	RL-502 (1)
2	WHT	P5-1	18 AWG	GXL	RL-502 (2)
3					
4	WHT	P1	18 AWG	GXL	X305B-10 (1)
5	WHT	P4-1	18 AWG	GXL	RL-502 (5)

RL-502					
CONN POS	WIRE COLOR	WIRE LABEL	GAUGE	JACKET	TO
1	WHT	P9-1	18 AWG	GXL	RL-503 (1)
2	WHT	P5	18 AWG	GXL	X500 (4)
2	WHT	P5-1	18 AWG	GXL	RL-503 (2)
3					
4	WHT	P3	18 AWG	GXL	X305B-11 (1)
5	WHT	P4	18 AWG	GXL	X500 (3)
5	WHT	P4-1	18 AWG	GXL	RL-503 (5)

Go to Discount-Equipment.com to order your parts

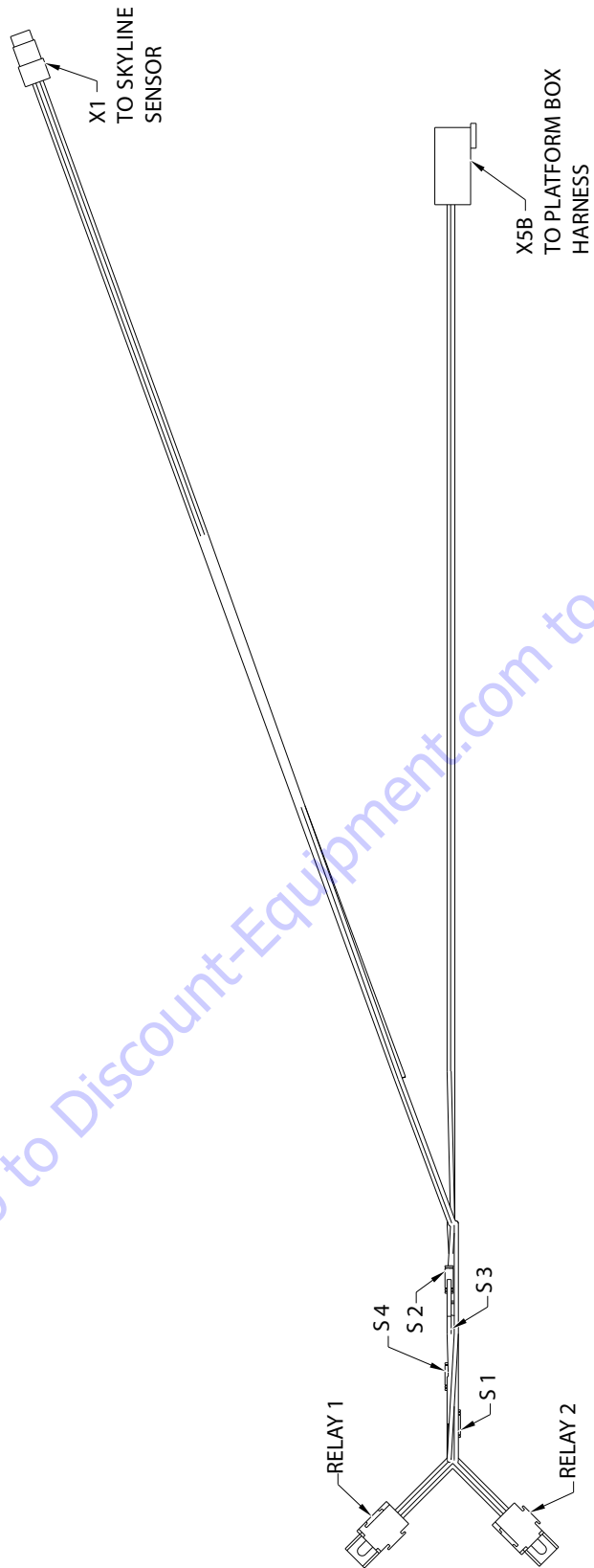

1001238418-A
MAE39660A

Figure 7-85. Sky Line 6 Pin Harness - Sheet 1 of 2

SECTION 7 - BASIC ELECTRICAL INFORMATION & ELECTRICAL SCHEMATICS

RELAY 1					
CONN POS	WIRE COLOR	WIRE LABEL	GAUGE	JACKET	TO
1	WHT	IGN_9	18 AWG	GXL	S3 (1)
2	WHT	SGC_NC	18 AWG	GXL	XT (4)
3	WHT	IGN_3	18 AWG	GXL	S4 (2)
4	WHT	SGC_IN_1	18 AWG	GXL	XSB (4)
5					

S4					
CONN POS	WIRE COLOR	WIRE LABEL	GAUGE	JACKET	TO
1	WHT	IGN_1	18 AWG	GXL	XSB (1)
2	WHT	IGN_3	18 AWG	GXL	RELAY 1 (3)
2	WHT	IGN_4	18 AWG	GXL	S3 (1)

RELAY 2					
CONN POS	WIRE COLOR	WIRE LABEL	GAUGE	JACKET	TO
1	WHT	IGN_8	18 AWG	GXL	S1 (1)
2	WHT	SGC_NO	18 AWG	GXL	XT (2)
3	WHT	IGN_7	18 AWG	GXL	S2 (2)
4					
5	WHT	SGC_IN_2	18 AWG	GXL	XSB (5)

X1					
CONN POS	WIRE COLOR	WIRE LABEL	GAUGE	JACKET	TO
1	WHT	IGN_2	18 AWG	GXL	S1 (2)
2	WHT	SGC_NO	18 AWG	GXL	RELAY 2 (2)
3	WHT	GND	18 AWG	GXL	XSB (2)
4	WHT	SGC_NC	18 AWG	GXL	RELAY 1 (2)

S1					
CONN POS	WIRE COLOR	WIRE LABEL	GAUGE	JACKET	TO
1	WHT	IGN_8	18 AWG	GXL	RELAY 2 (1)
2	WHT	IGN_2	18 AWG	GXL	XT (1)
2	WHT	IGN_6	18 AWG	GXL	S2 (2)

XSB					
CONN POS	WIRE COLOR	WIRE LABEL	GAUGE	JACKET	TO
1	WHT	IGN_1	18 AWG	GXL	S4 (1)
2	WHT	GND	18 AWG	GXL	XT (3)
3					
4	WHT	SGC_IN_1	18 AWG	GXL	RELAY 1 (4)
5	WHT	SGC_IN_2	18 AWG	GXL	RELAY 2 (5)
6					

S2					
CONN POS	WIRE COLOR	WIRE LABEL	GAUGE	JACKET	TO
1	WHT	IGN_5	18 AWG	GXL	S3 (2)
2	WHT	IGN_6	18 AWG	GXL	S1 (1)
2	WHT	IGN_7	18 AWG	GXL	RELAY 2 (3)

S3					
CONN POS	WIRE COLOR	WIRE LABEL	GAUGE	JACKET	TO
1	WHT	IGN_4	18 AWG	GXL	S4 (2)
2	WHT	IGN_5	18 AWG	GXL	S2 (1)
2	WHT	IGN_9	18 AWG	GXL	RELAY 1 (1)

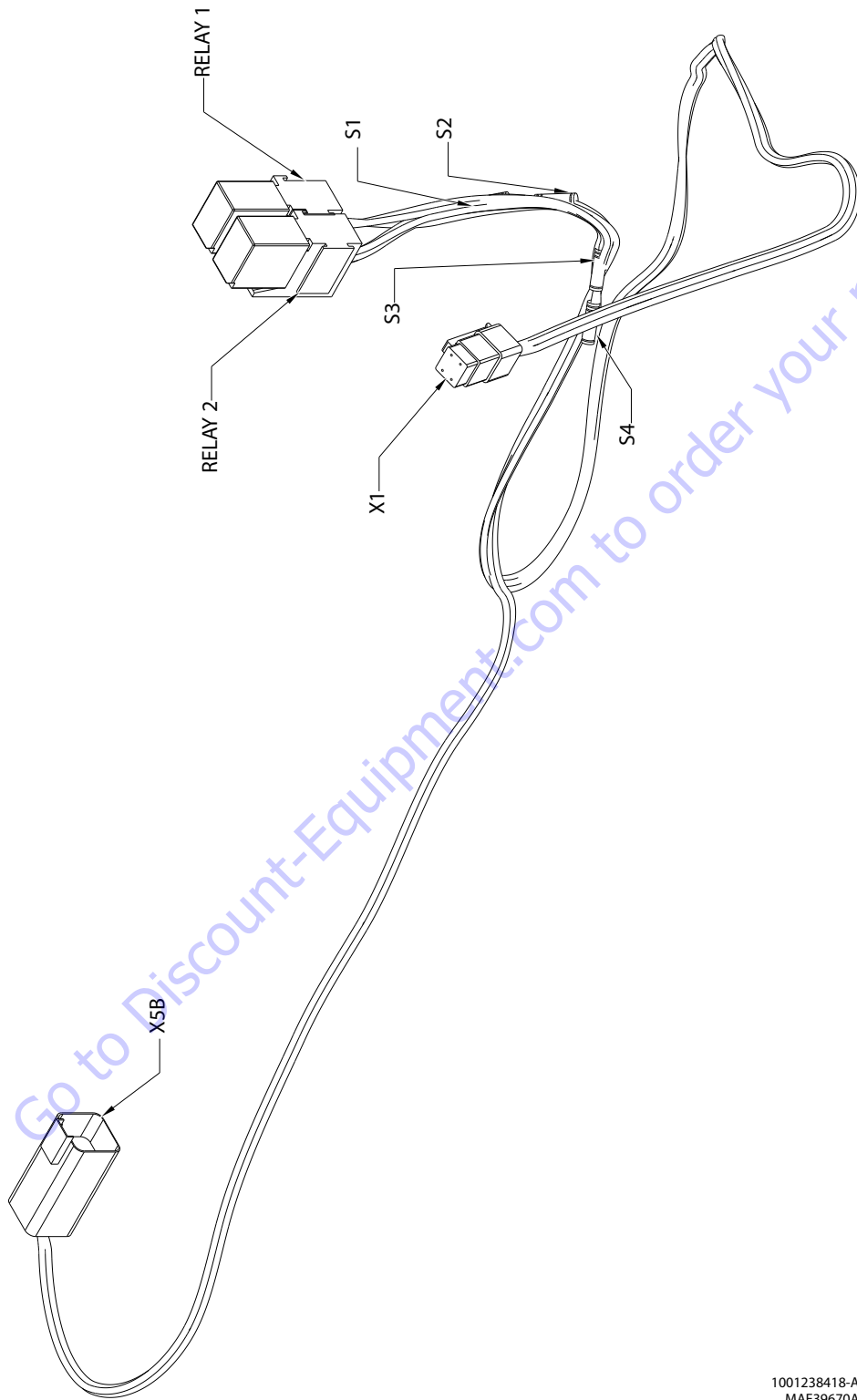

Figure 7-86. Sky Line 6 Pin Harness - Sheet 2 of 2

1001238418-A
MAE39670A

7.9 ELECTRICAL SCHEMATICS

- SHEET 2: PLATFORM
PLATFORM BOX HARNESS SG READY
- SHEET 3: PLATFORM AND BOOM COMPONENTS LSS HARNESS
BOOM CONTROL CABLE - NO JIB , WITH JIB , TT
TELE IN PROX SWITCHES 600/1000# CAPACITY PROX SWITCHES CABLE
- SHEET 4: CHASSIS, TURNTABLE TURNTABLE HARNESS
BOOM ANGLE SENSOR CABLE
- SHEET 5: GROUND USER INTERFACE
4WS MAIN VALVE HARNESS, 2WS MAIN VALVE HARNESS
GROUND CONTROL PANEL HARNESS
LIFT CYLINDER HARNESS
- SHEET 6: ENGINE SCHEMATIC DEUTZ - T4i
DEUTZ T4i ENGINE HARNESS, T4i ENG POS , T4i ENG NEG
POS BATTERY , AUX TO AUX
- SHEET 7: ENGINE SCHEMATIC DEUTZ T4F
DEUTZ T4F ENGINE HARNESS
T4F ENG POS , T4F ENG NEG
- SHEET 8: ENGINE SCHEMATIC FORD
FORD ENGINE HARNESS
FORD ENG POS , FORD ENGINE NEG
- SHEET 9: PLATFORM CHASSIS HEAD AND TAIL PLATF WORKLIGHTS,
CLEARSKY CHASSIS HEAD AND TAIL LIGHTS
CHASSIS WORK LIGHTS CLEAR SKY
- SHEET 10: PLATFORM VALVE HARNESS WITH OUT JIB
- SHEET 11: SKYGUARD
- SHEET 12: SKYEYE/SKYLINE/SKYBAR READY
PLATFORM BOX HARNESS

1001186701-N
MAE20920N

Figure 7-87. Electrical Schematic - Sheet 1 of 21

SECTION 7 - BASIC ELECTRICAL INFORMATION & ELECTRICAL SCHEMATICS

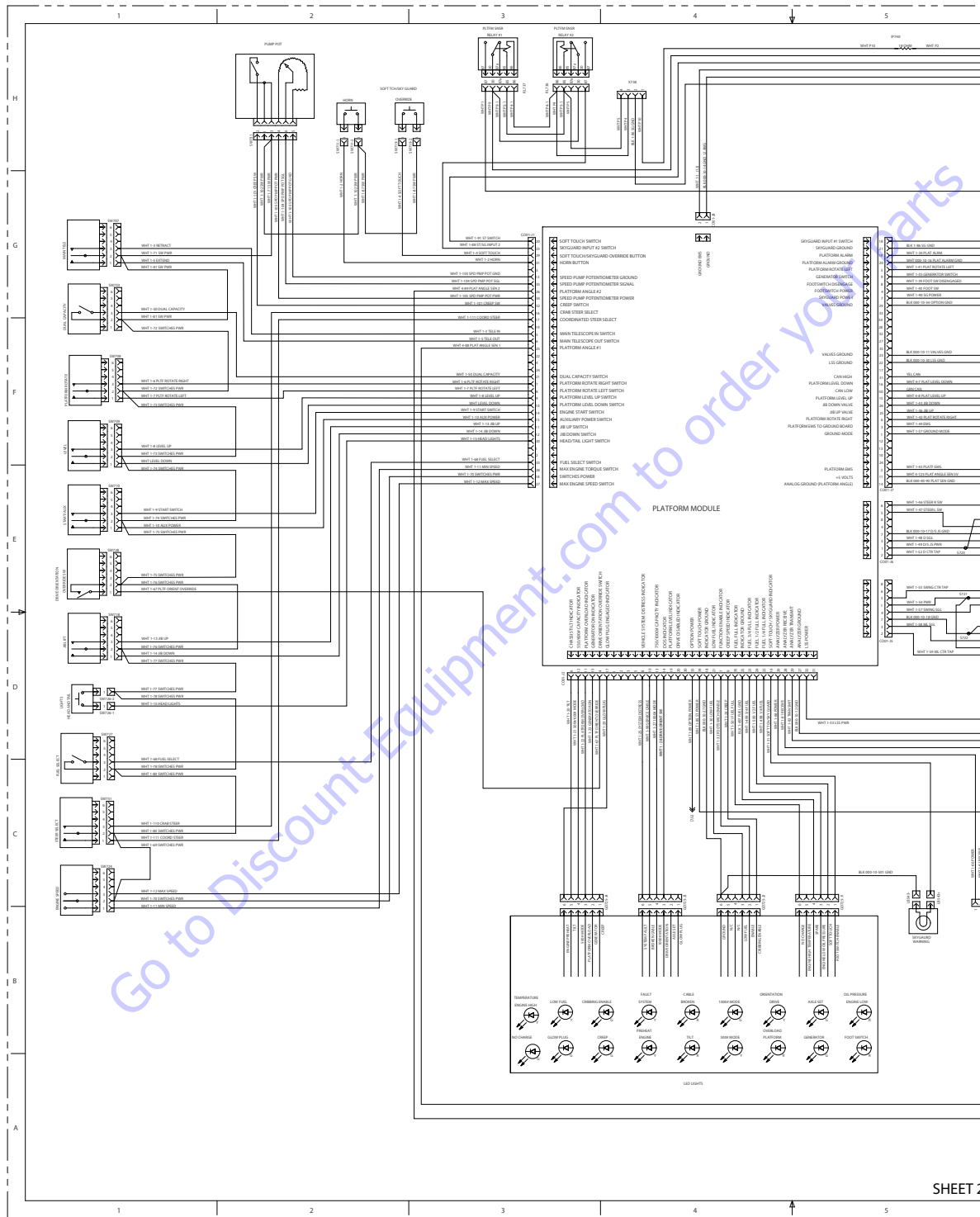

SHEET 2

Figure 7-88. Electrical Schematic - Sheet 2 of 21

SECTION 7 - BASIC ELECTRICAL INFORMATION & ELECTRICAL SCHEMATICS

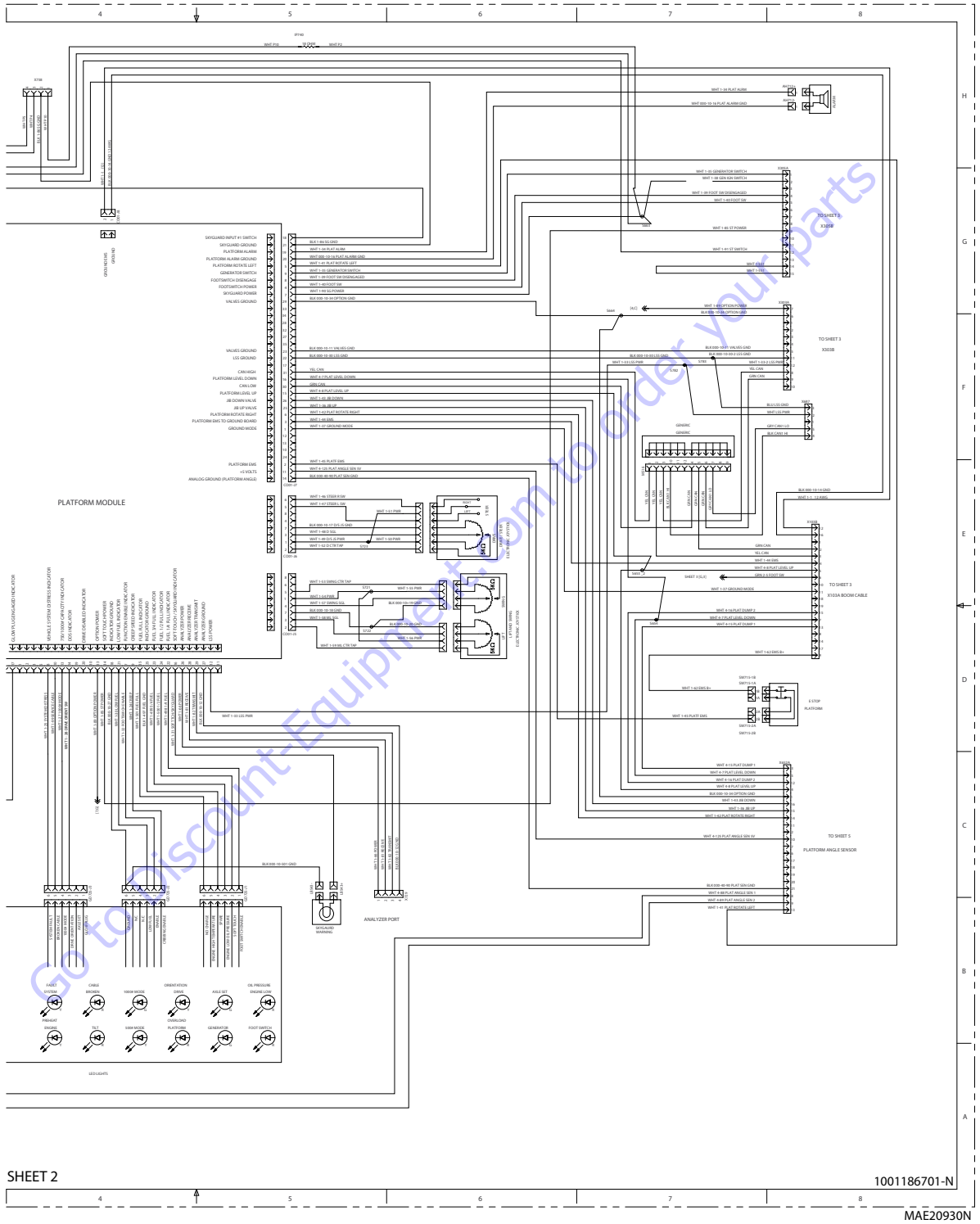

Figure 7-89. Electrical Schematic - Sheet 3 of 21

SECTION 7 - BASIC ELECTRICAL INFORMATION & ELECTRICAL SCHEMATICS

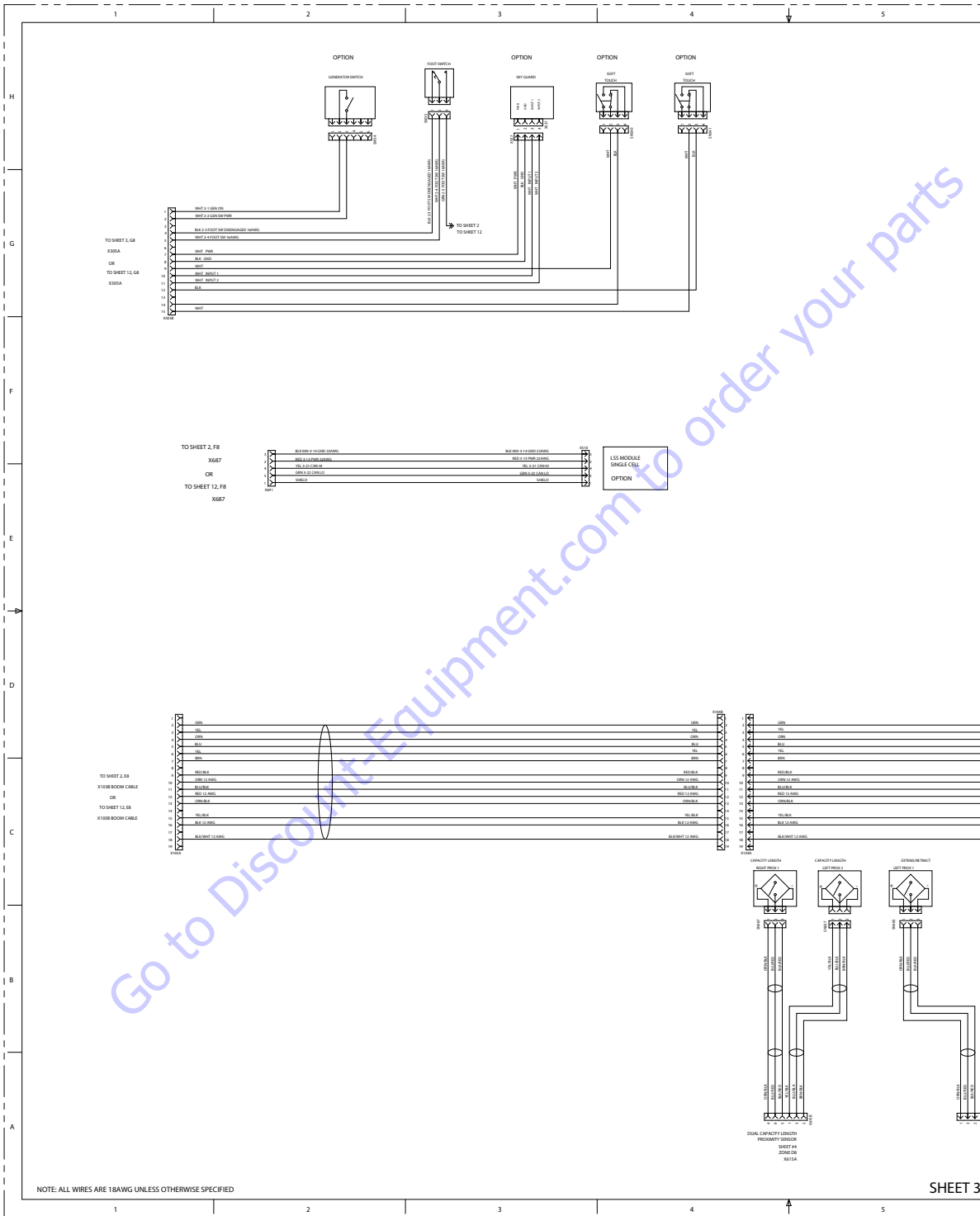

Figure 7-90. Electrical Schematic - Sheet 4 of 21

SECTION 7 - BASIC ELECTRICAL INFORMATION & ELECTRICAL SCHEMATICS

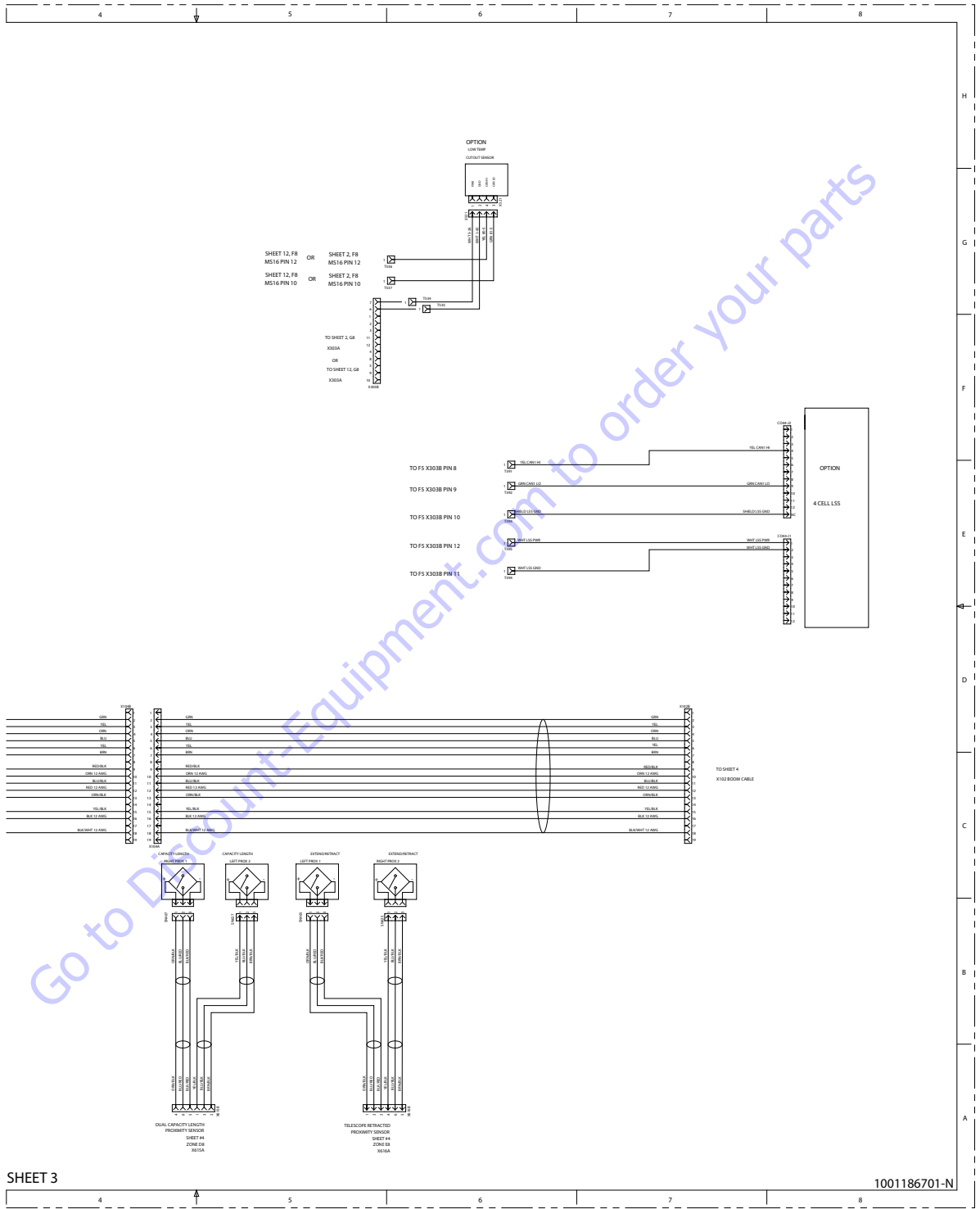

Figure 7-91. Electrical Schematic - Sheet 5 of 21

SECTION 7 - BASIC ELECTRICAL INFORMATION & ELECTRICAL SCHEMATICS

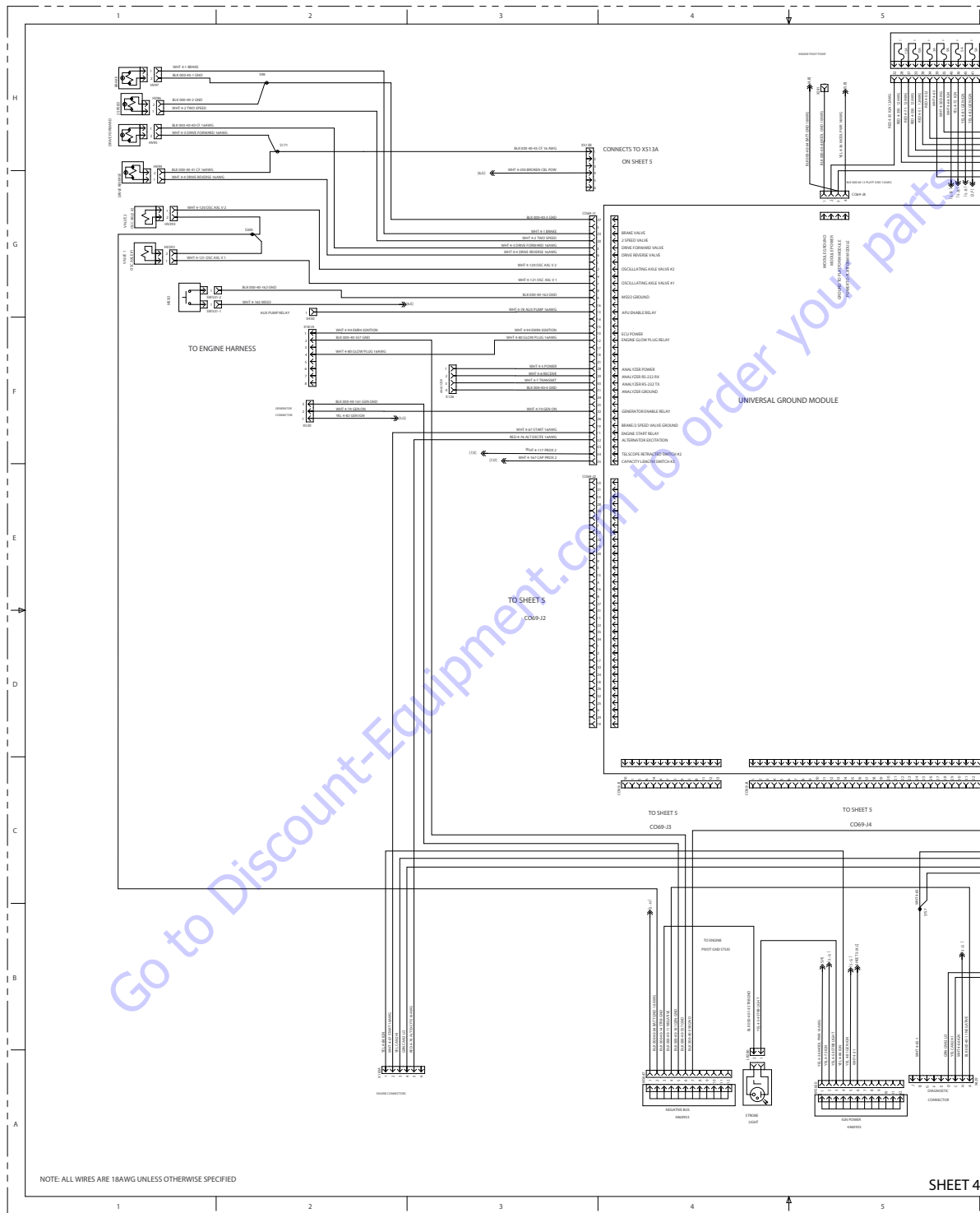

Figure 7-92. Electrical Schematic - Sheet 6 of 21

SECTION 7 - BASIC ELECTRICAL INFORMATION & ELECTRICAL SCHEMATICS

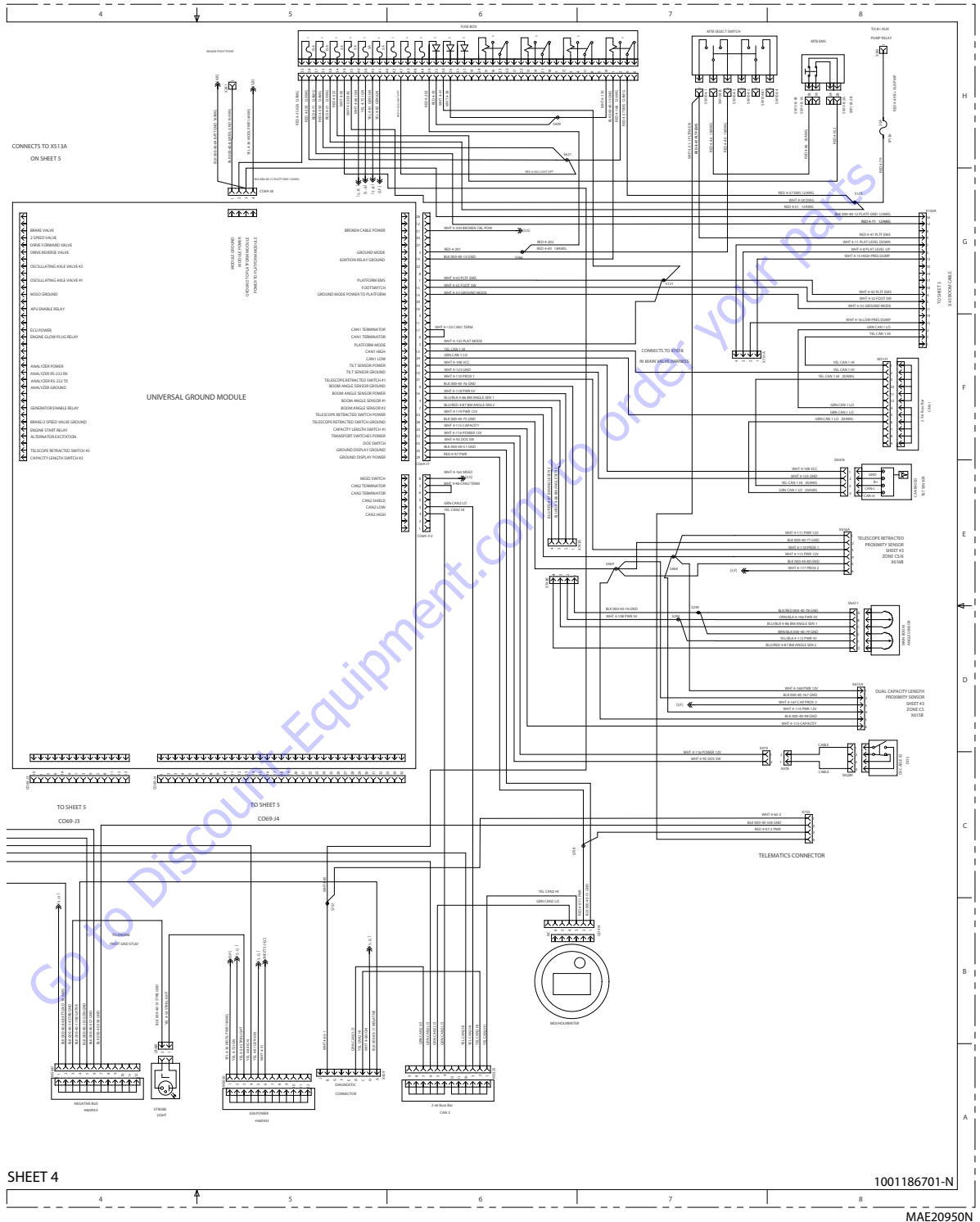

Figure 7-93. Electrical Schematic - Sheet 7 of 21

SECTION 7 - BASIC ELECTRICAL INFORMATION & ELECTRICAL SCHEMATICS

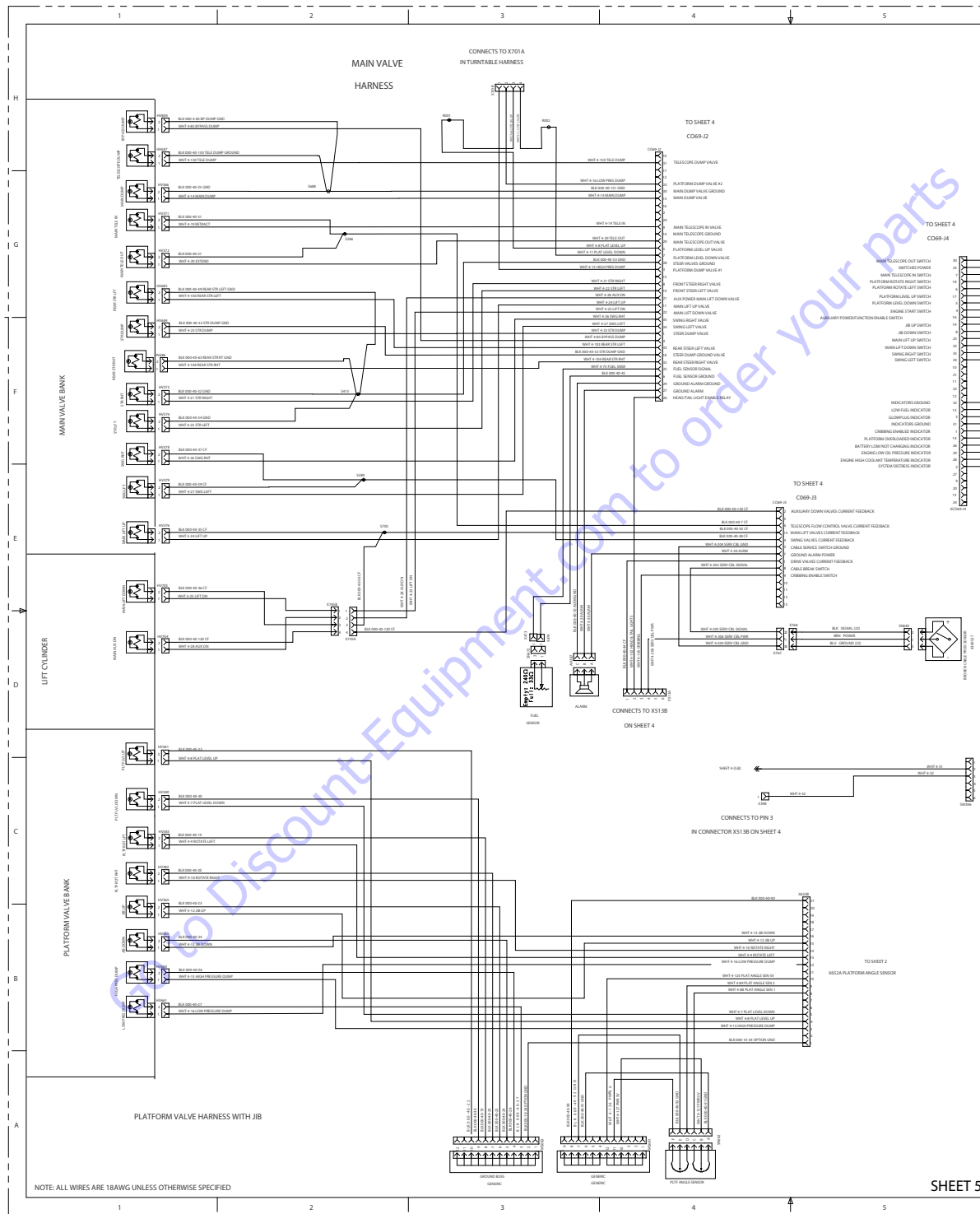

Figure 7-94. Electrical Schematic - Sheet 8 of 21

SECTION 7 - BASIC ELECTRICAL INFORMATION & ELECTRICAL SCHEMATICS

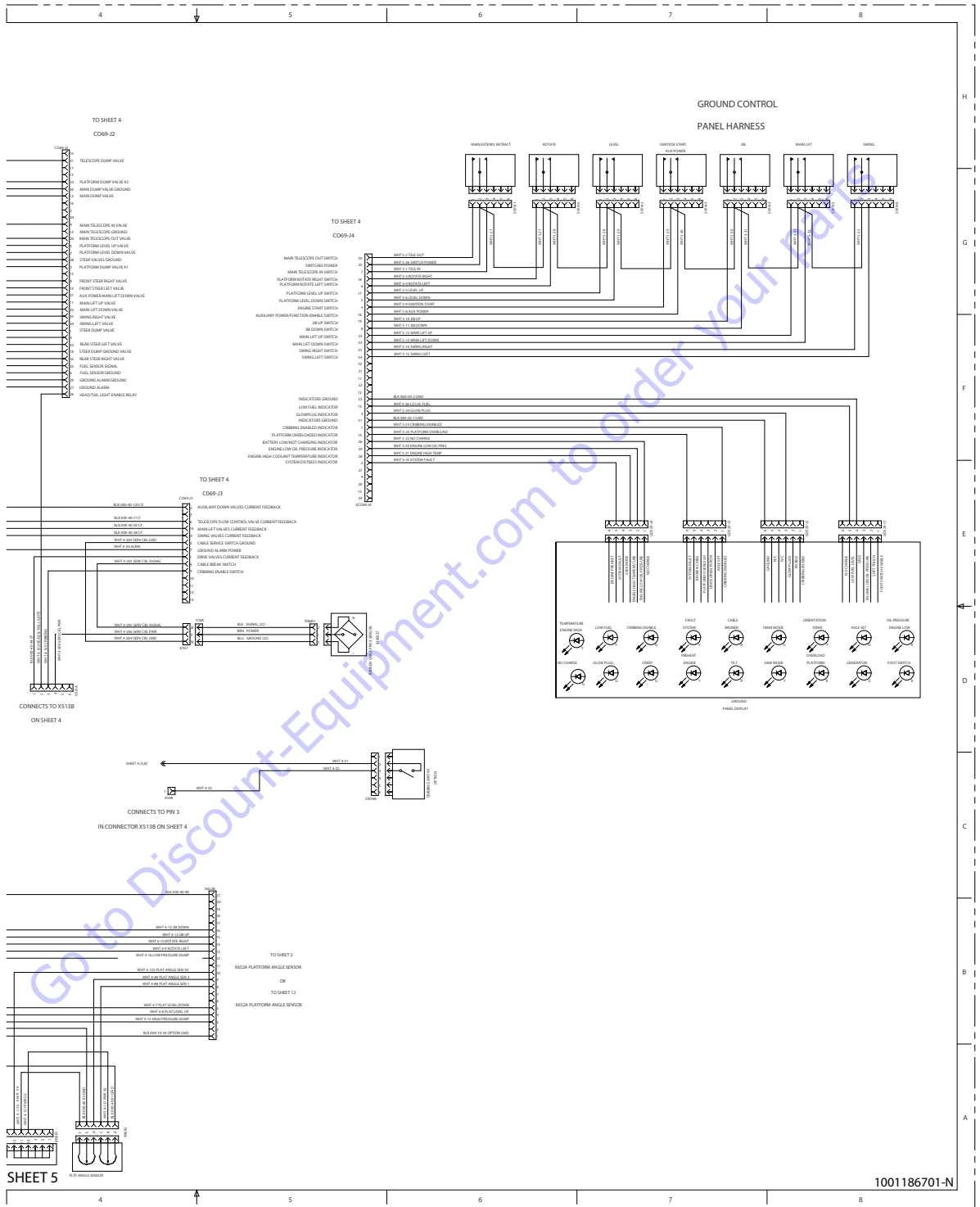

Figure 7-95. Electrical Schematic - Sheet 9 of 21

SECTION 7 - BASIC ELECTRICAL INFORMATION & ELECTRICAL SCHEMATICS

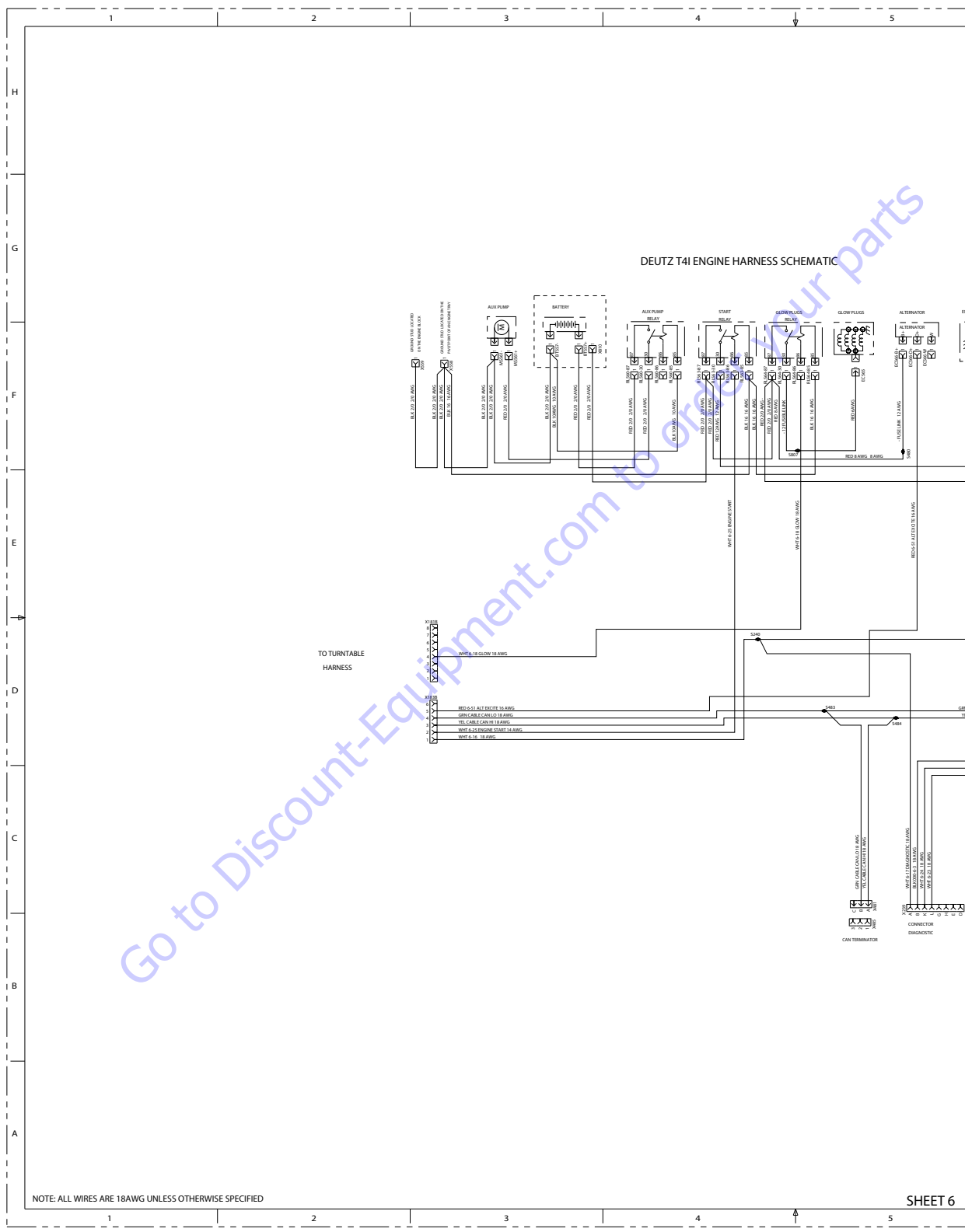
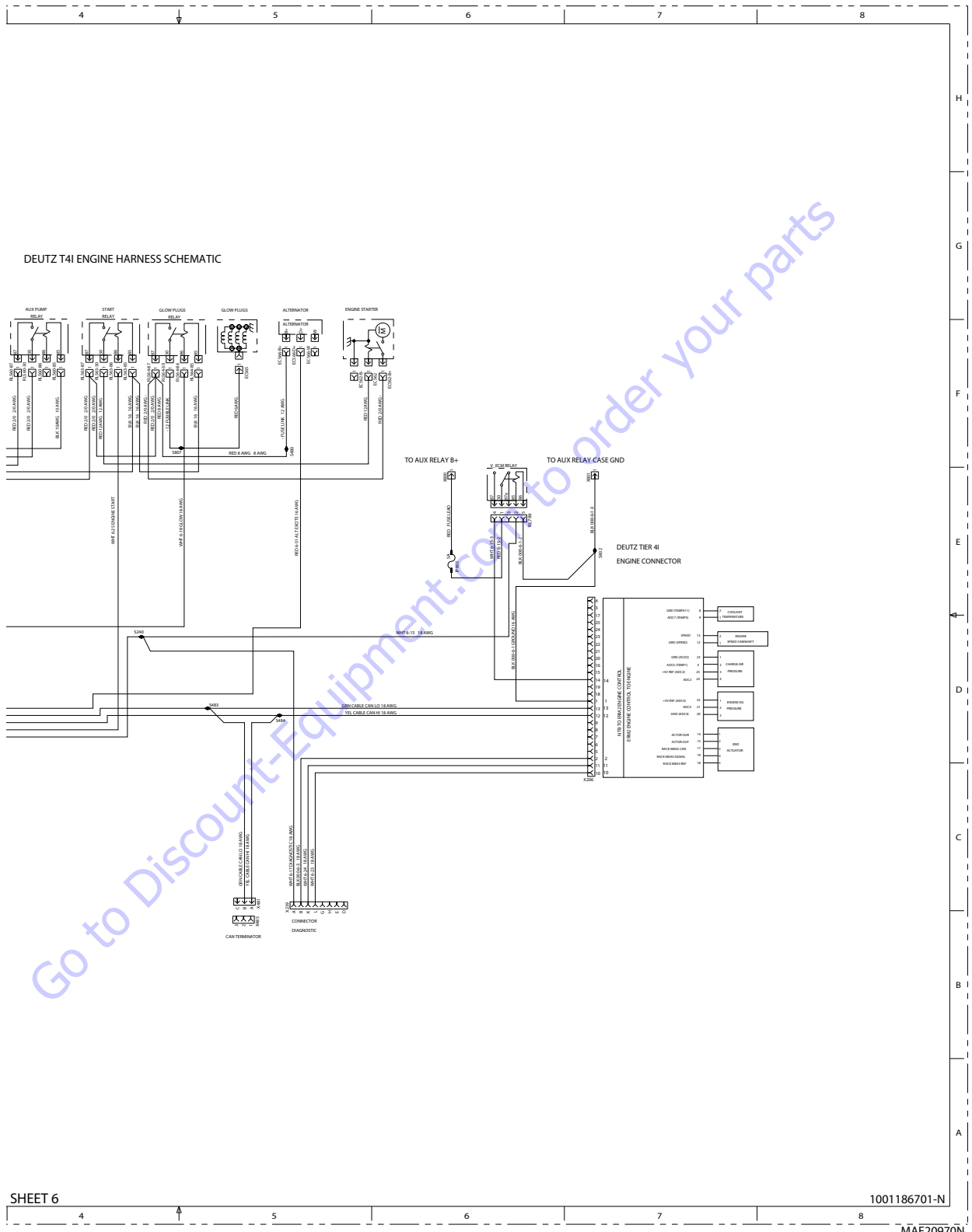

Figure 7-96. Electrical Schematic - Sheet 10 of 21

SECTION 7 - BASIC ELECTRICAL INFORMATION & ELECTRICAL SCHEMATICS



SHEET 6

1001186701-N

MAE20970N

Figure 7-97. Electrical Schematic - Sheet 11 of 21

SECTION 7 - BASIC ELECTRICAL INFORMATION & ELECTRICAL SCHEMATICS

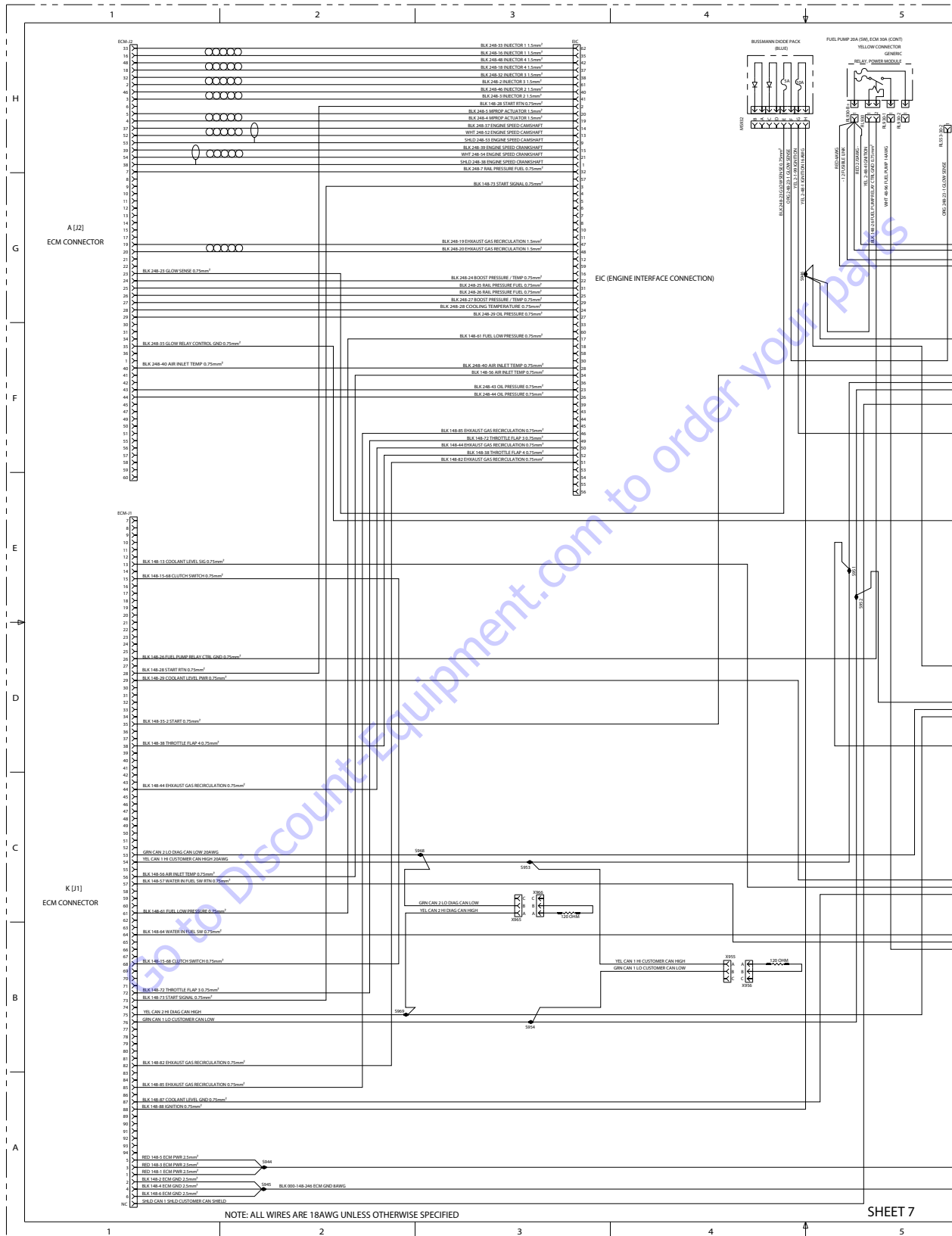

Figure 7-98. Electrical Schematic - Sheet 12 of 21

SECTION 7 - BASIC ELECTRICAL INFORMATION & ELECTRICAL SCHEMATICS

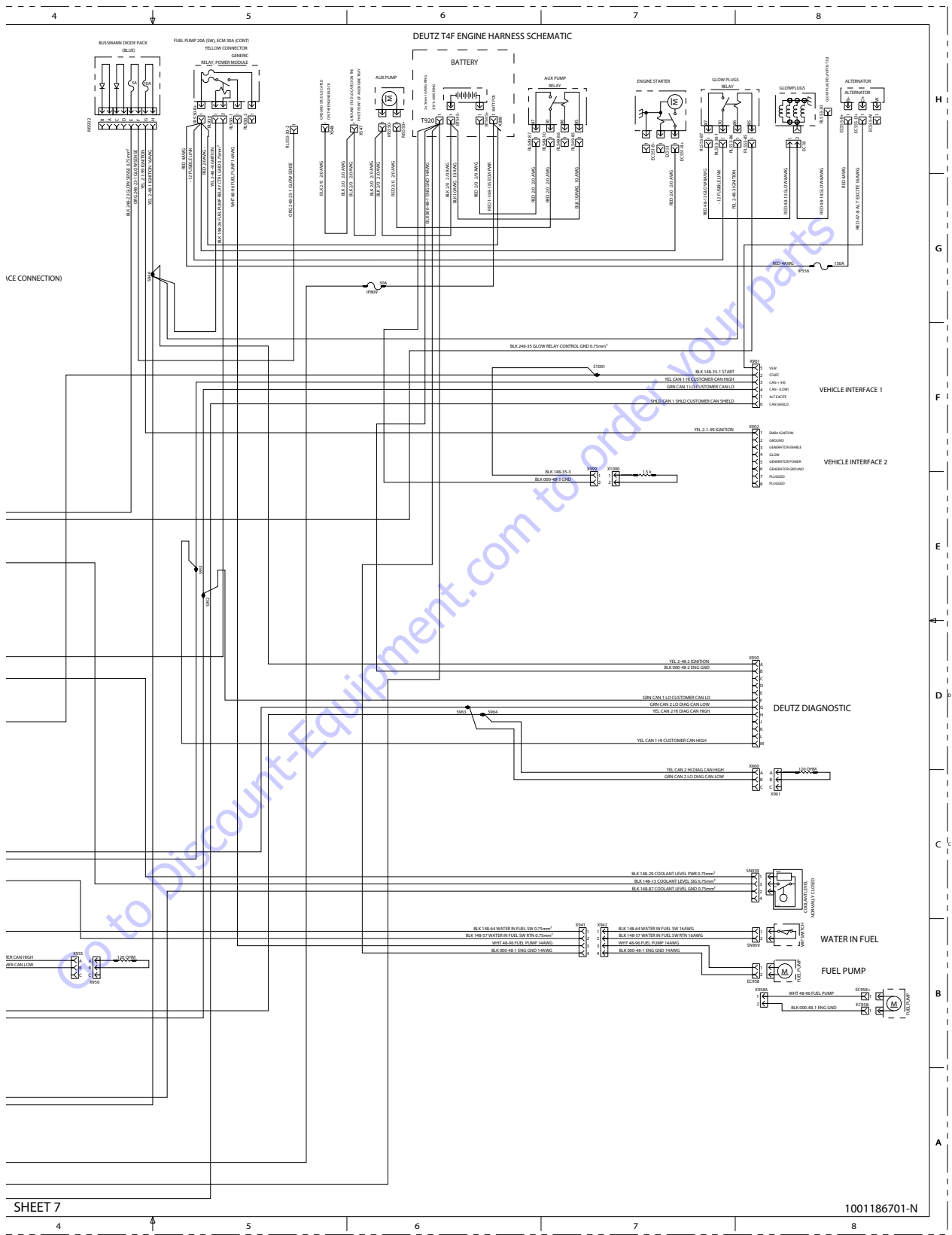

Figure 7-99. Electrical Schematic - Sheet 13 of 21

SECTION 7 - BASIC ELECTRICAL INFORMATION & ELECTRICAL SCHEMATICS

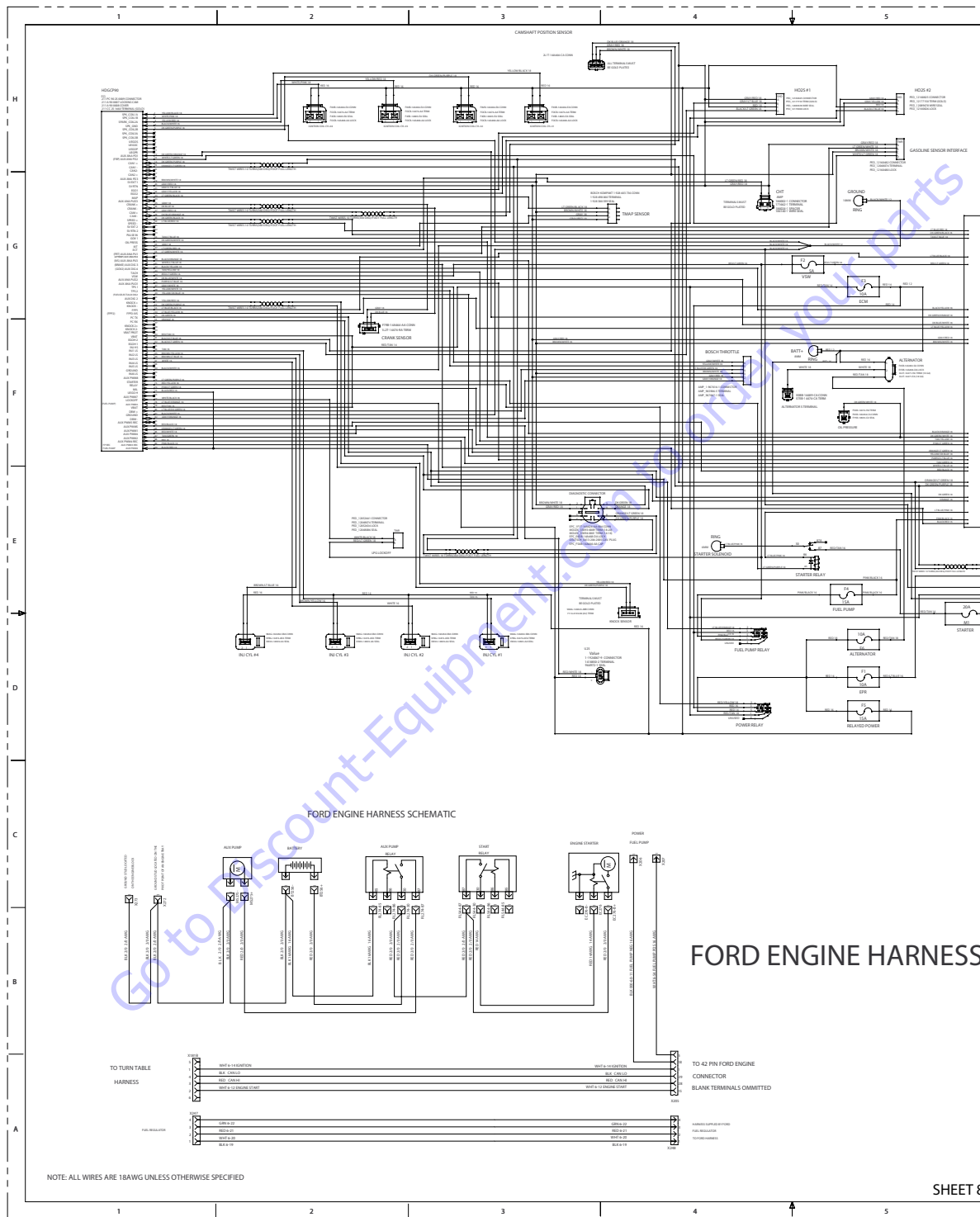

Figure 7-100. Electrical Schematic - Sheet 14 of 21

SECTION 7 - BASIC ELECTRICAL INFORMATION & ELECTRICAL SCHEMATICS

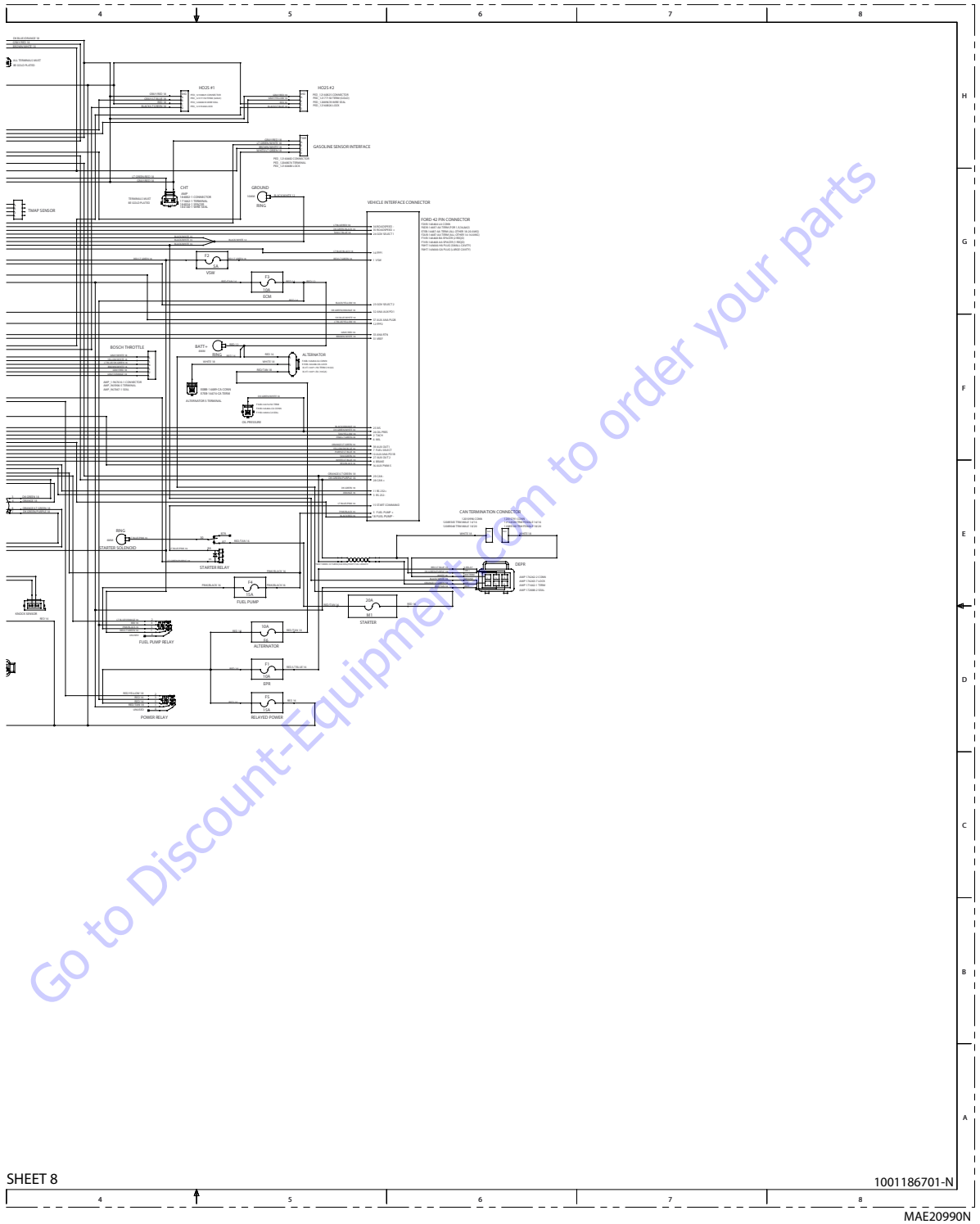

Figure 7-101. Electrical Schematic - Sheet 15 of 21

SECTION 7 - BASIC ELECTRICAL INFORMATION & ELECTRICAL SCHEMATICS

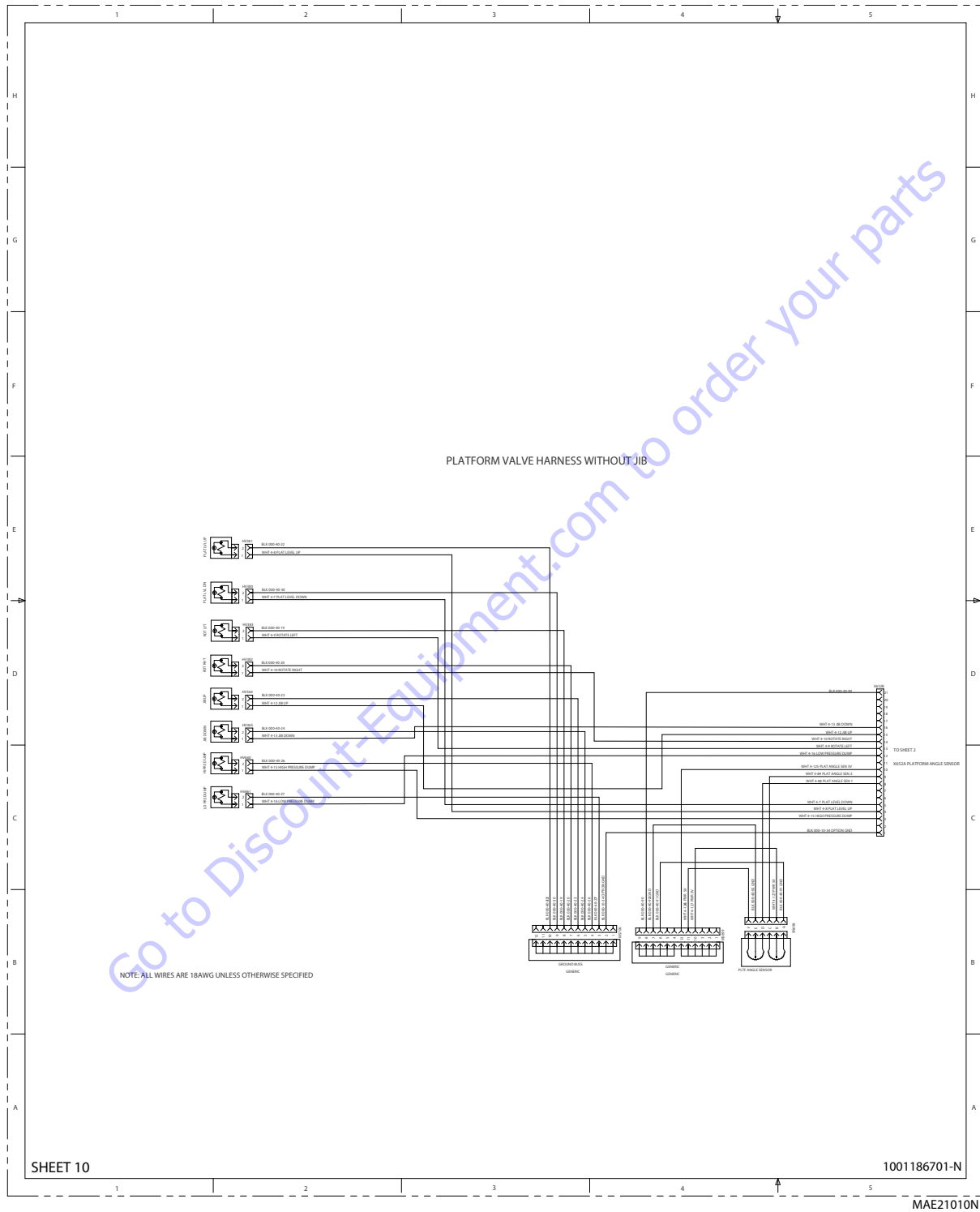

Figure 7-104. Electrical Schematic - Sheet 18 of 21

SECTION 7 - BASIC ELECTRICAL INFORMATION & ELECTRICAL SCHEMATICS

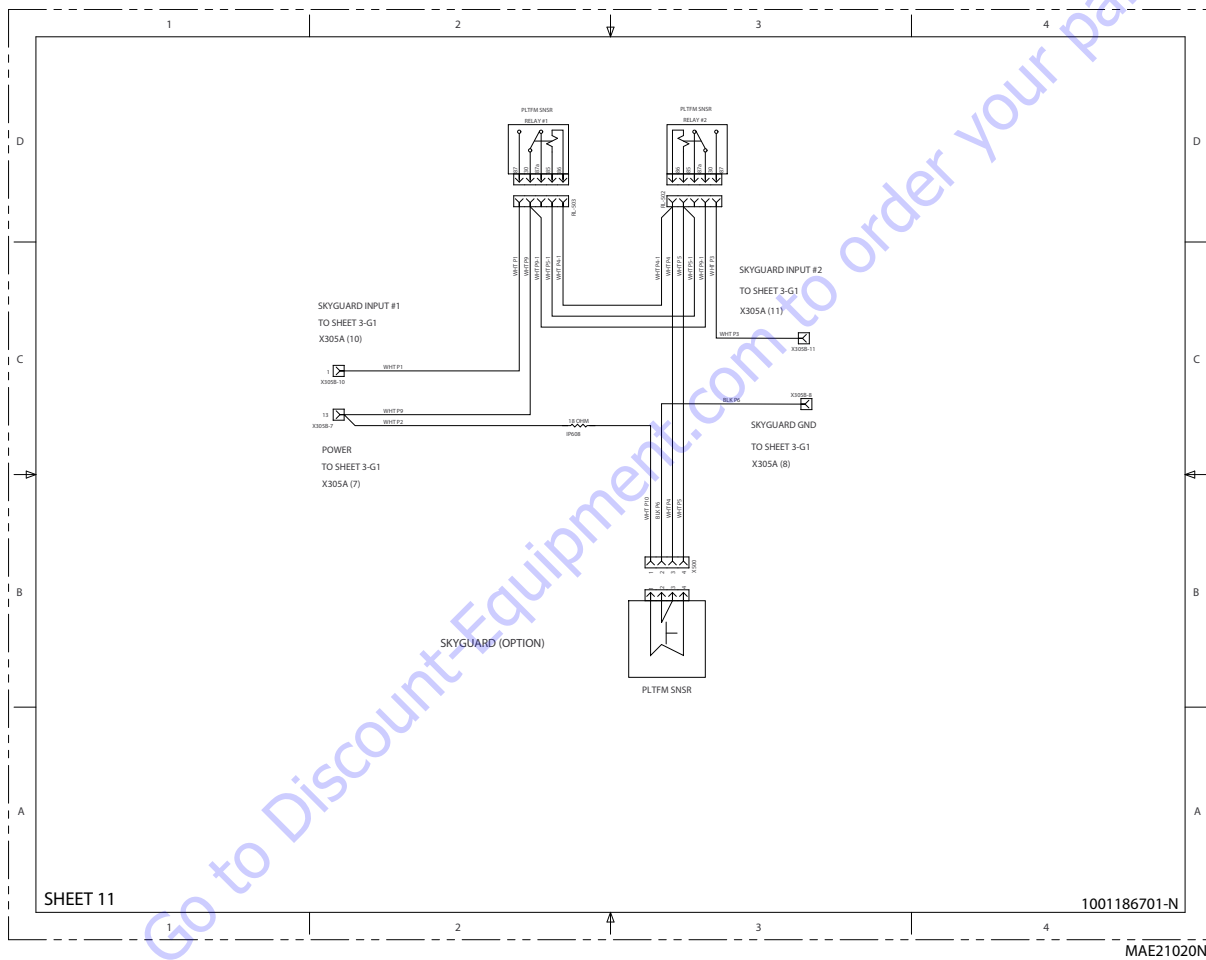

Figure 7-105. Electrical Schematic - Sheet 19 of 21

SECTION 7 - BASIC ELECTRICAL INFORMATION & ELECTRICAL SCHEMATICS

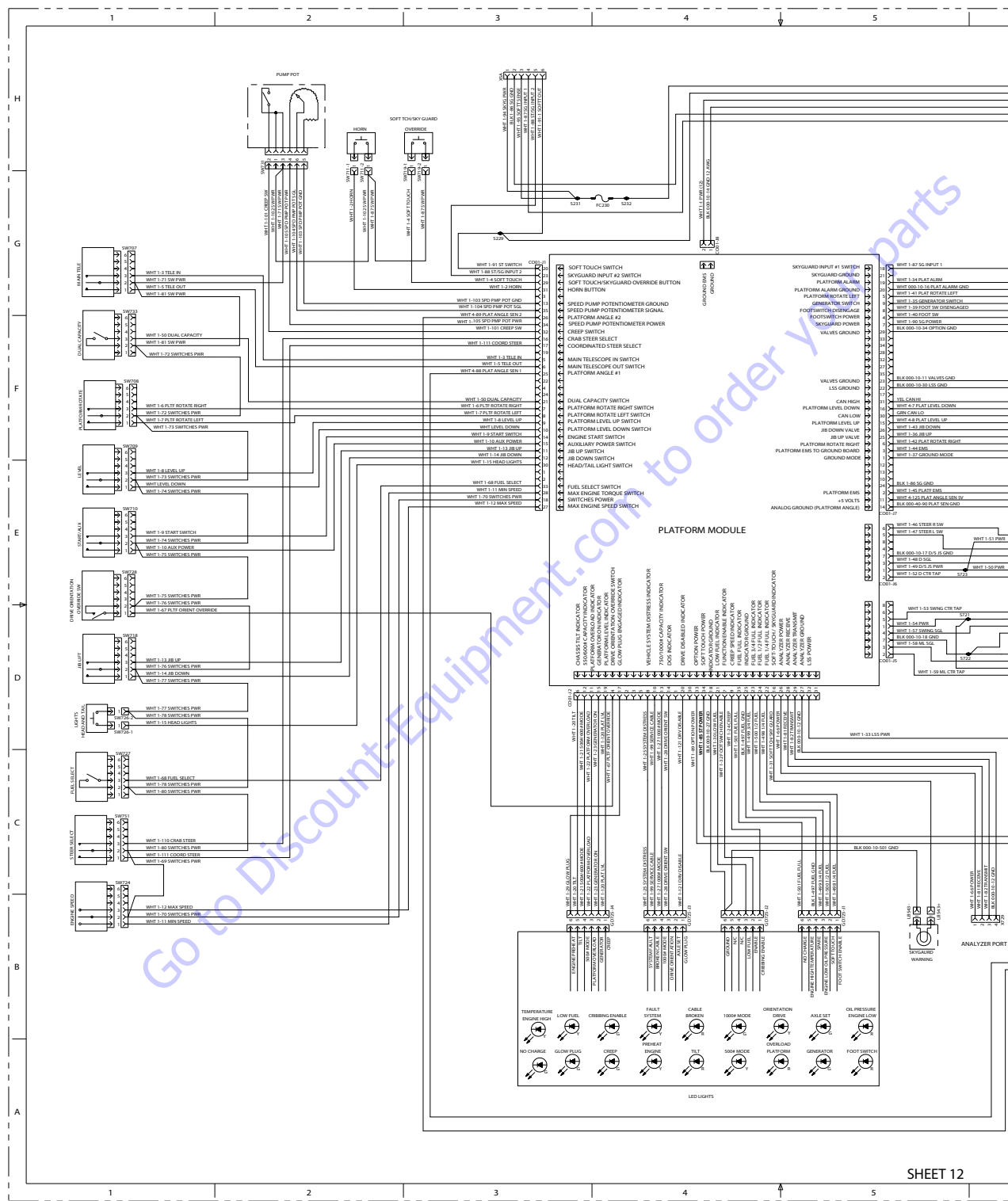
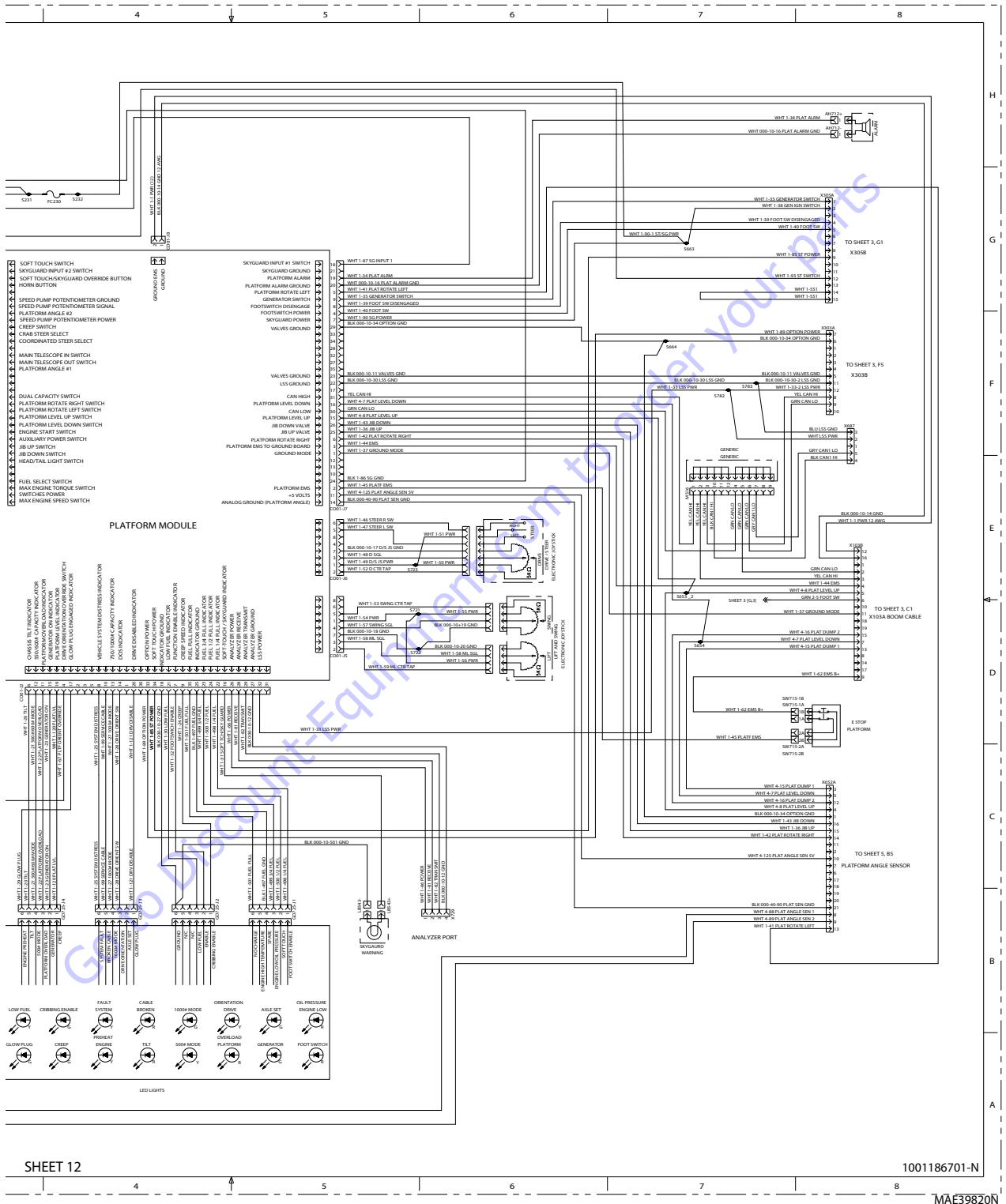

Figure 7-106. Electrical Schematic - Sheet 20 of 21

SECTION 7 - BASIC ELECTRICAL INFORMATION & ELECTRICAL SCHEMATICS



SHEET 12

1001186701-N

MAE39820N

Figure 7-107. Electrical Schematic - Sheet 21 of 21



3121728



An Oshkosh Corporation Company

**Discount
Equipment**

www.Discount-Equipment.com

Go to Discount-Equipment.com to order your parts

PARTS FINDER

**Search Website
by Part Number**



**Search Manual
Library For Parts
Manual & Lookup Part
Numbers – Purchase
or Request Quote**

A screenshot of the "Search Manuals" form. The form has a title "Search Manuals" and a subtitle "Please provide information to help us locate the manual and/or parts you need." It includes fields for "Brand", "Model", "Serial", "Part Number", and "Quantity". There is a "Search" button at the bottom.

**Can't Find Part or
Manual? Request Help
by Manufacturer,
Model & Description**

A screenshot of the "Parts Order Form". The form has a title "Parts Order Form" and a subtitle "Please fill in as much information as possible." It includes fields for "Manufacturer", "Model", "Description", "Part Number", "Quantity", and "Comments". There is a "Submit" button at the bottom.

Discount-Equipment.com is your online resource for quality parts & equipment.

Florida: **561-964-4949** Outside Florida TOLL FREE: **877-690-3101**

Need parts?

Click on this link: <http://www.discount-equipment.com/category/5443-parts/> and choose one of the options to help get the right parts and equipment you are looking for. Please have the machine model and serial number available in order to help us get you the correct parts. If you don't find the part on the website or on once of the online manuals, please fill out the request form and one of our experienced staff members will get back to you with a quote for the right part that your machine needs.

We sell worldwide for the brands: Genie, Terex, JLG, MultiQuip, Mikasa, Essick, Whiteman, Mayco, Toro Stone, Diamond Products, Generac Magnum, Airman, Haulotte, Barreto, Power Blanket, Nifty Lift, Atlas Copco, Chicago Pneumatic, Allmand, Miller Curber, Skyjack, Lull, Skytrak, Tsurumi, Husquvarna Target, , Stow, Wacker, Sakai, Mi-T- M, Sullair, Basic, Dynapac, MBW, Weber, Bartell, Bennar Newman, Haulotte, Ditch Runner, Menegotti, Morrison, Contec, Buddy, Crown, Edco, Wyco, Bomag, Laymor, Barreto, EZ Trench, Bil-Jax, F.S. Curtis, Gehl Pavers, Heli, Honda, ICS/PowerGrit, IHI, Partner, Imer, Clipper, MMD, Koshin, Rice, CH&E, General Equipment, ,AMida, Coleman, NAC, Gradall, Square Shooter, Kent, Stanley, Tamco, Toku, Hatz, Kohler, Robin, Wisconsin, Northrock, Oztec, Toker TK, Rol-Air, Small Line, Wanco, Yanmar