



An Oshkosh Corporation Company



www.Discount-Equipment.com

Service and Maintenance Manual

Models

400S

460SJ

S/N 0300203771*

S/N 1300007289

& S/N E300000100

to Present

** See inside front cover for exceptions*

3121671

November 28, 2018 - Rev E

ANSI

CE



AS/NZS

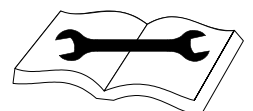

PARTS FINDER

**Search Website
by Part Number**



**Search Manual
Library For Parts
Manual & Lookup Part
Numbers – Purchase
or Request Quote**

Search Manuals

Enter your information to search for manuals and parts.

* Brand:

* Model:

* Serial:

* Part Number:

SEARCH

**Can't Find Part or
Manual? Request Help
by Manufacturer,
Model & Description**

Parts Order Form

Please fill in the following information:

Manufacturer:

Model:

Description:

Quantity:

Part Number:

Part Name:

Part Description:

Part Location:

Part Condition:

Part Status:

Part Color:

Part Material:

Part Weight:

Part Dimensions:

Part Price:

Part Notes:

Submit

Discount-Equipment.com is your online resource for quality parts & equipment.

Florida: **561-964-4949** Outside Florida TOLL FREE: **877-690-3101**

Need parts?

Click on this link: <http://www.discount-equipment.com/category/5443-parts/> and choose one of the options to help get the right parts and equipment you are looking for. Please have the machine model and serial number available in order to help us get you the correct parts. If you don't find the part on the website or on one of the online manuals, please fill out the request form and one of our experienced staff members will get back to you with a quote for the right part that your machine needs.

We sell worldwide for the brands: Genie, Terex, JLG, MultiQuip, Mikasa, Essick, Whiteman, Mayco, Toro Stone, Diamond Products, Generac Magnum, Airman, Haulotte, Barreto, Power Blanket, Nifty Lift, Atlas Copco, Chicago Pneumatic, Allmand, Miller Curber, Skyjack, Lull, Skytrak, Tsurumi, Husquvarna Target, , Stow, Wacker, Sakai, Mi-T- M, Sullair, Basic, Dynapac, MBW, Weber, Bartell, Bennar Newman, Haulotte, Ditch Runner, Menegotti, Morrison, Contec, Buddy, Crown, Edco, Wyco, Bomag, Laymor, Barreto, EZ Trench, Bil-Jax, F.S. Curtis, Gehl Pavers, Heli, Honda, ICS/PowerGrit, IHI, Partner, Imer, Clipper, MMD, Koshin, Rice, CH&E, General Equipment, ,AMida, Coleman, NAC, Gradall, Square Shooter, Kent, Stanley, Tamco, Toku, Hatz, Kohler, Robin, Wisconsin, Northrock, Oztec, Toker TK, Rol-Air, Small Line, Wanco, Yanmar

This manual also covers the following Serial Numbers.

0300184729	0300203261	0300203580	0300203677
0300200144	0300203262	0300203581	0300203678
0300200145	0300203307	0300203582	0300203679
0300200476	0300203308	0300203583	0300203680
0300200477	0300203351	0300203584	0300203681
0300202446	0300203352	0300203628	0300203724
0300202447	0300203394	0300203629	0300203725
0300202448	0300203395	0300203630	0300203727
0300202449	0300203439	0300203631	0300203728
0300202450	0300203440	0300203632	

Go to Discount-Equipment.com to order your parts

SECTION A. INTRODUCTION - MAINTENANCE SAFETY PRECAUTIONS

A GENERAL

This section contains the general safety precautions which must be observed during maintenance of the aerial platform. It is of utmost importance that maintenance personnel pay strict attention to these warnings and precautions to avoid possible injury to themselves or others, or damage to the equipment. A maintenance program must be followed to ensure that the machine is safe to operate.

⚠ WARNING

MODIFICATION OR ALTERATION OF AN AERIAL WORK PLATFORM SHALL BE MADE ONLY WITH WRITTEN PERMISSION FROM THE MANUFACTURER.

The specific precautions to be observed during maintenance are inserted at the appropriate point in the manual. These precautions are, for the most part, those that apply when servicing hydraulic and larger machine component parts.

Your safety, and that of others, is the first consideration when engaging in the maintenance of equipment. Always be conscious of weight. Never attempt to move heavy parts without the aid of a mechanical device. Do not allow heavy objects to rest in an unstable position. When raising a portion of the equipment, ensure that adequate support is provided.

⚠ WARNING

SINCE THE MACHINE MANUFACTURER HAS NO DIRECT CONTROL OVER THE FIELD INSPECTION AND MAINTENANCE, SAFETY IN THIS AREA RESPONSIBILITY OF THE OWNER/OPERATOR.

B HYDRAULIC SYSTEM SAFETY

It should be noted that the machines hydraulic systems operate at extremely high potentially dangerous pressures. Every effort should be made to relieve any system pressure prior to disconnecting or removing any portion of the system.

Do not use your hand to check for leaks. Use a piece of cardboard or paper to search for leaks. Wear gloves to help protect hands from spraying fluid.



C MAINTENANCE

⚠ WARNING

FAILURE TO COMPLY WITH SAFETY PRECAUTIONS LISTED IN THIS SECTION COULD RESULT IN MACHINE DAMAGE, PERSONNEL INJURY OR DEATH AND IS A SAFETY VIOLATION.

- ENSURE REPLACEMENT PARTS OR COMPONENTS ARE IDENTICAL OR EQUIVALENT TO ORIGINAL PARTS OR COMPONENTS.
- NO SMOKING IS MANDATORY. NEVER REFUEL DURING ELECTRICAL STORMS. ENSURE THAT FUEL CAP IS CLOSED AND SECURE AT ALL OTHER TIMES.
- REMOVE ALL RINGS, WATCHES AND JEWELRY WHEN PERFORMING ANY MAINTENANCE.
- DO NOT WEAR LONG HAIR UNRESTRAINED, OR LOOSE-FITTING CLOTHING AND NECKTIES WHICH ARE APT TO BECOME CAUGHT ON OR ENTANGLED IN EQUIPMENT.
- OBSERVE AND OBEY ALL WARNINGS AND CAUTIONS ON MACHINE AND IN SERVICE MANUAL.
- KEEP OIL, GREASE, WATER, ETC. WIPED FROM STANDING SURFACES AND HAND HOLDS.
- USE CAUTION WHEN CHECKING A HOT, PRESSURIZED COOLANT SYSTEM.
- NEVER WORK UNDER AN ELEVATED BOOM UNTIL BOOM HAS BEEN SAFELY RESTRAINED FROM ANY MOVEMENT BY BLOCKING OR OVERHEAD SLING, OR BOOM SAFETY PROP HAS BEEN ENGAGED.
- BEFORE MAKING ADJUSTMENTS, LUBRICATING OR PERFORMING ANY OTHER MAINTENANCE, SHUT OFF ALL POWER CONTROLS.
- BATTERY SHOULD ALWAYS BE DISCONNECTED DURING REPLACEMENT OF ELECTRICAL COMPONENTS.
- KEEP ALL SUPPORT EQUIPMENT AND ATTACHMENTS STOWED IN THEIR PROPER PLACE.
- USE ONLY APPROVED, NONFLAMMABLE CLEANING SOLVENTS.

REVISION LOG

Original Issue	A - July 16, 2015
Revised	B - October 9, 2015
Revised	C - July 26, 2017
Revised	D - June 29, 2018 - Revised Covers
Revised	E - November 28, 2018

Go to Discount-Equipment.com to order your parts

SECTION NO.	TITLE	PAGE NO.
SECTION A - INTRODUCTION - MAINTENANCE SAFETY PRECAUTIONS		
A	General	A-1
B	Hydraulic System Safety	A-1
C	Maintenance	A-1
SECTION 1 - SPECIFICATIONS		
1.1	Operating Specifications	1-1
1.2	Capacities	1-2
1.3	Engine Data	1-2
1.4	Tires	1-3
1.5	Hydraulic Oil	1-3
1.6	Critical Stability Weights	1-5
1.7	Maintenance and Lubrication	1-10
SECTION 2 - GENERAL		
2.1	Machine Preparation, Inspection, and Maintenance	2-1
	General	2-1
	Preparation, Inspection, and Maintenance	2-1
	Pre-Start Inspection	2-1
	Pre-Delivery Inspection and Frequent Inspection	2-1
	Annual Machine Inspection	2-1
	Preventive Maintenance	2-1
2.2	Service and Guidelines	2-2
	General	2-2
	Safety and Workmanship	2-2
	Cleanliness	2-2
	Components Removal and Installation	2-2
	Component Disassembly and Reassembly	2-3
	Pressure-Fit Parts	2-3
	Bearings	2-3
	Gaskets	2-3
	Bolt Usage and Torque Application	2-3
	Hydraulic Lines and Electrical Wiring	2-3
	Hydraulic System	2-3
	Lubrication	2-3
	Battery	2-3
	Lubrication and Servicing	2-3
2.3	Lubrication and Information	2-4
	Hydraulic System	2-4
	Hydraulic Oil	2-4
	Changing Hydraulic Oil	2-4
	Lubrication Specifications	2-4
2.4	Cylinder Drift Test	2-5
	Theory	2-5
	Cylinder Leakage Test	2-5
	Cylinder Thermal Drift	2-5
2.5	Pins and Composite Bearing Repair Guidelines	2-6
2.6	Welding on JLG Equipment	2-6
	Do the Following When Welding on JLG Equipment	2-6
	Do NOT Do the Following When Welding on JLG Equipment	2-6

TABLE OF CONTENTS

SECTION NO.	TITLE	PAGE NO.
SECTION 3 - CHASSIS & TURNTABLE		
3.1	Tires and Wheels	3-1
	Tire Inflation.....	3-1
	Tire Damage	3-1
	Tire Replacement.....	3-1
	Wheel Replacement	3-1
	Wheel Installation	3-1
3.2	Chassis Tilt Indicator System	3-2
3.3	Drive System (4WD & 2WD).....	3-2
3.4	Drive Orientation System	3-2
3.5	Lockout Cylinder Bleeding.....	3-2
3.6	Oscillating Axle System	3-3
3.7	Oscillating Axle Lockout Test	3-3
3.8	Wheel Drive Assembly	3-7
	Removal	3-7
	Installation	3-7
3.9	Torque Hub	3-8
	Roll and Leak Testing	3-8
	Tightening and Torquing Bolts.....	3-8
	Main Disassembly for "B" Drives.....	3-9
	Hub-Spindle Disassembly.....	3-9
	Cover Disassembly	3-15
	Carrier Disassembly.....	3-15
	Assemble Carrier	3-15
	Cover Sub-Assembly.....	3-17
	Hub-Spindle Sub-Assembly.....	3-18
	Main Assembly	3-20
	Tool List.....	3-25
3.10	Re-Align Torque Hub Input Coupling.....	3-26
	Equipment Required	3-26
	Procedure.....	3-26
3.11	Drive Motor	3-26
	Description.....	3-26
	Shaft Seal Replacement.....	3-27
	Loop Flushing Valve	3-27
	Troubleshooting	3-28
	Disassembly.....	3-29
	Inspection.....	3-33
	Assembly	3-35
	Initial Start-Up Procedures	3-39
3.12	Swing Drive Hub	3-41
	Brake Test	3-41
	Spring Checking Procedure	3-42
	Brake Leak Repair Procedure.....	3-42
	Roll and Leak Test	3-42
	Tightening and Torquing Bolts.....	3-43
	Lubrication Information	3-44
	Motor Removal.....	3-44
	Input Brake Disassembly.....	3-46
	Main Disassembly	3-47
	Housing-Shaft Disassembly.....	3-48
	Carrier Disassembly.....	3-49
	Carrier Assembly	3-50
	Housing - Shaft Assembly.....	3-51
	Main Assembly	3-52
	Motor and Brake Assembly	3-54
	Motor Control Valve Installation.....	3-57

SECTION NO.	TITLE	PAGE NO.
3.13	Swing Motor	3-65
	Disassembly and inspection	3-65
	Assembly	3-72
	One Piece Stator Construction	3-79
3.14	Swing Bearing	3-80
	Swing Bearing Wear Tolerance	3-80
	Turntable Bearing Mounting Bolt Condition Check	3-81
	Swing Bearing Removal	3-85
	Swing Bearing Installation	3-85
	Procedure for Setting Swing Gear Backlash	3-86
	Swing Bearing Torque Values	3-87
3.15	Rotary Coupling	3-89
3.16	Generator	3-94
	Maintenance Schedule	3-94
	Overload Protection	3-94
	Inspecting Brushes, Replacing Brushes and Cleaning Slip Rings	3-94
	Generator Disassembly and Assembly	3-96
	Lead Connection List for Generator	3-103
3.17	Deutz Engine	3-104
3.18	GM Engine	3-109
3.19	Kubota Engine	3-111
3.20	Deutz Engine - D2.9L4	3-113
	Glow Plugs	3-113
	Check Oil Level	3-113
	Replacing Engine Oil	3-113
	Replacing the Oil Filter	3-114
	Replacing the Fuel Filters	3-114
3.21	Deutz Engine - D2011	3-115
	Glow Plugs	3-115
	Check Oil Level	3-115
	Replacing Engine Oil	3-116
	Replacing the Oil Filter	3-117
	Replacing the Fuel Filter	3-118
3.22	Deutz EMR 2	3-119
3.23	GM Engine General Maintenance	3-131
	Maintenance of the Drive Belt	3-131
	Engine Electrical System Maintenance	3-131
	Checking/Filling Engine Oil Level	3-131
	Changing the Engine Oil	3-132
	Coolant Fill Procedure - Dual Fuel Engine	3-132
3.24	GM Engine Dual Fuel System	3-133
	Fuel Filter	3-133
	Electric Lock Off	3-134
	EPR Assembly	3-134
	Low Pressure Regulator (LPR)	3-134
	Air Fuel Mixer	3-135
	Electronic Throttle Control (ETC)	3-135
	Engine Control Module	3-136
	Heated Exhaust Gas Oxygen Sensor	3-136
	Gasoline Multi Point Fuel Injection System (MPFI)	3-136
	Gasoline Fuel Pump	3-137
	Gasoline Pressure And Temperature Sensor Manifold	3-137
	Fuel Filter	3-137
	Fuel Injector Rail	3-137
	Fuel Injector	3-137

TABLE OF CONTENTS

SECTION NO.	TITLE	PAGE NO.
3.25	GM Engine Fuel System Repair	3-138
	Propane Fuel System Pressure Relief	3-138
	Propane Fuel System Leak Test	3-138
	Propane Fuel Filter Replacement	3-139
	Electronic Pressure Regulator (EPR) Assembly Replacement	3-140
	Electronic Throttle Control Replacement	3-141
	Mixer Replacement	3-143
	Coolant Hose Replacement	3-143
	Vapor Hose Replacement	3-143
	Engine Control Module Replacement	3-144
	Heated Exhaust Gas Oxygen Sensor Replacement	3-144
3.26	GM Engine LPG Fuel System Diagnosis	3-145
	Fuel System Description	3-145
	Diagnostic Aids	3-145
3.27	Counterweight	3-215
 SECTION 4 - BOOM & PLATFORM		
4.1	Boom Systems	4-1
	Platform Control Enable System	4-1
	Platform Load Sensing System (LSS) (If Equipped)	4-1
	Above Elevation (Above Horizontal) - Drive Speed Cutback System	4-1
	Transport Position Interlock System (CE only)	4-1
	Function Speed Control System	4-1
	Main Boom Lift End of Stroke Dampening	4-2
	Jib Lift End of Stroke Dampening	4-2
	Machine Safety Override (MSSO) (CE Only)	4-2
	Transport Position Sensing System	4-2
4.2	Platform	4-9
	Platform/Support Removal	4-9
	Platform/Support Installation	4-10
4.3	Rotator and Platform Level Cylinder	4-13
	Removal	4-13
	Installation	4-15
4.4	Main Boom Powertrack	4-16
	Removal	4-16
	Installation	4-16
	Powertrack Maintenance	4-18
4.5	boom assembly	4-27
	Removal	4-27
	Disassembly	4-28
	Inspection	4-29
	Assembly	4-29
	Installation	4-31
4.6	Jib (460SJ Only)	4-32
	Removal	4-32
	Disassembly	4-32
	Inspection	4-32
	Assembly	4-32
	Installation	4-33
4.7	Boom Cleanliness Guidelines	4-33
4.8	Boom Shimming Procedure	4-34

SECTION NO.	TITLE	PAGE NO.
4.9	Rotator Assembly	4-35
	Theory of Operation.....	4-35
	Required Tools.....	4-36
	Making a Seal Tool	4-36
	Before Disassembly	4-36
	Disassembly	4-39
	Inspection	4-43
	Assembly	4-43
	Installing Counterbalance Valve	4-49
	Greasing Thrust Washers	4-50
	Testing the Actuator	4-50
	Installation and Bleeding	4-51
4.10	Skyguard	4-52
	Operation.....	4-52
	Function Test	4-52
	Diagnostics & Troubleshooting	4-53
4.11	Platform Rotate Bleed Procedure	4-54
	General Notes & Precautions	4-54
	Procedure	4-54
4.12	Bolt-on External Fall Arrest	4-55
	Inspection Before Use	4-55
	Installation.....	4-55
 SECTION 5 - BASIC HYDRAULICS INFORMATION & SCHEMATICS		
5.1	Lubricating O-Rings in the Hydraulic System	5-1
	Cup and Brush	5-1
	Dip Method.....	5-2
	Spray Method.....	5-2
	Brush-on Method	5-2
5.2	Hydraulic Connection Assembly and Torque Specification.....	5-3
	Tapered Thread Types.....	5-3
	Straight Thread Types, Tube and Hose Connections	5-3
	Straight Thread Types, Port Connections.....	5-4
	Flange Connection Types.....	5-4
	Tightening Methods	5-4
	Assembly And Torque Specifications.....	5-5
	Assembly Instructions for American Standard Pipe Thread Tapered (NPTF) Connections.....	5-6
	Assembly Instructions for British Standard Pipe Thread Tapered (BSPT) Connections	5-7
	Assembly Instructions for 37° (JIC) Flare Fittings	5-8
	Assembly Instructions for 45° SAE Flare Fittings	5-11
	Assembly Instructions for O-ring Face Seal (ORFS) Fittings	5-13
	Assembly Instructions for DIN 24° Flare Bite Type Fittings (MBTL and MBTS).....	5-15
	Assembly Instructions for Bulkhead (BH) Fittings	5-17
	Assembly Instructions for O-ring Boss (ORB) Fittings.....	5-20
	Assembly Instructions for Adjustable Port End Metric (MFF) Fittings	5-27
	Assembly Instructions for Metric ISO 6149 (MPP) Port Assembly Stud Ends	5-34
	Assembly instructions for Adjustable Port End (BSPP) Fittings.....	5-36
	Assembly Instructions for Flange Connections: (FL61 and FL62).....	5-43
	Double Wrench Method.....	5-46
	FFWR and TFFT Methods	5-47
	Adjustable Stud End Assembly	5-47
	O-ring Installation (Replacement).....	5-48

TABLE OF CONTENTS

SECTION NO.	TITLE	PAGE NO.
5.3	Hydraulic Cylinders	5-49
	Axle Lockout Cylinder	5-49
	Platform Level Cylinder	5-51
	Jib Lift Cylinder (460SJ Only)	5-56
	Main Lift Cylinder (SN 0300203771 through 0300243703, SN E300000100 through E300005607)	5-62
	Main Lift Cylinder (SN 0300243704 to Present, SN E300005608 to Present)	5-70
	Master Cylinder	5-75
	Steer Cylinder	5-80
	Telescope Cylinder	5-83
5.4	Pressure Setting Procedure	5-89
	Main System Relief	5-89
	Steer Left Relief	5-89
	Steer Right Relief	5-90
	Swing Relief	5-90
	Jib Lift Down Relief (460SJ only)	5-91
	Platform Level Up Relief	5-91
	Platform Level Down Relief	5-92
5.5	Drive Pump Pre-Fill Procedure	5-99
5.6	Hydraulic Schematics	5-100
SECTION 6 - JLG CONTROL SYSTEM		
6.1	JLG Control System Analyzer Kit Instructions	6-1
	Introduction	6-1
	To Connect the JLG Control System Analyzer	6-2
	Using the Analyzer	6-2
	Changing the Access Level of the Hand Held Analyzer	6-3
	Adjusting Parameters Using the Hand Held Analyzer	6-4
	Machine Setup	6-5
	Tilt Sensor Calibration	6-6
	Ground Control Console Display Gauge	6-9
6.2	LSS System	6-36
	Diagnostic Menu	6-37
	Calibration Procedure	6-38
	Testing & Evaluation	6-43
	Troubleshooting	6-44
6.3	Resetting The MSSO System	6-45
6.4	Machine Model Adjustment	6-47
	Adjustment Notes	6-47
	Machine Orientation When Performing Test	6-47
SECTION 7 - BASIC ELECTRICAL INFORMATION & SCHEMATICS		
7.1	General	7-1
7.2	Multimeter Basics	7-1
	Grounding	7-1
	Backprobing	7-1
	Min/Max	7-1
	Polarity	7-1
	Scale	7-1
	Voltage Measurement	7-1
	Resistance Measurement	7-2
	Continuity Measurement	7-2
	Current Measurement	7-3
7.3	Applying Silicone Dielectric Compound to Electrical Connections	7-3
	Installation of Dielectric Grease	7-4
	Deutsch HD, DT, DTM, DRC Series	7-4
	AMP Seal	7-4
	AMP Mate-N-Lok	7-5
	DIN Connectors	7-5

SECTION NO.	TITLE	PAGE NO.
	Exclusions	7-6
	Brad Harrison / Phoenix Contact M12	7-6
	Engine Control unit connectors.....	7-6
	Sealed Enclosures	7-6
	MIL-C-5015 spec connectors.....	7-7
	MOLEX CMC series connectors.....	7-7
7.4	AMP Connector	7-8
	Assembly	7-8
	Disassembly	7-10
	Wedge Lock	7-10
	Service - Voltage Reading	7-10
7.5	Deutsch Connectors	7-12
	DT/DTP Series Assembly.....	7-12
	DT/DTP Series Disassembly	7-12
	HD30/HDP20 Series Assembly	7-13
	HD30/HDP20 Series Disassembly	7-13
7.6	Telematics Gateway.....	7-14
	Telematics-Ready (TCU) Plug	7-14
7.7	Wiring Harness Connector Labels and Wiring Harnesses	7-23
	Connector Labels	7-23
	Component Labels.....	7-23
7.8	Electrical Schematics	7-103

Go to Discount-Equipment.com to order your parts

FIGURE NO.	TITLE	PAGE NO.
1-1.	Operator Maintenance and Lubrication Diagram - Deutz 2.9L Engine.....	1-6
1-2.	Operator Maintenance and Lubrication Diagram - Deutz 2011L Engine.....	1-7
1-3.	Operator Maintenance and Lubrication Diagram - GM Engine.....	1-8
1-4.	Operator Maintenance and Lubrication Diagram - Kubota Engine.....	1-9
1-5.	Torque Chart - Sheet 1 of 5 - (SAE Fasteners).....	1-17
1-6.	Torque Chart - Sheet 2 of 5 - (SAE Fasteners).....	1-18
1-7.	Torque Chart - Sheet 3 of 5 - (SAE Fasteners).....	1-19
1-8.	Torque Chart - Sheet 4 of 5 - (METRIC Fasteners).....	1-20
1-9.	Torque Chart - Sheet 5 of 5 - (METRIC Fasteners).....	1-21
2-1.	Engine Operating Temperature Specifications - Deutz 2.9.....	2-10
2-2.	Engine Operating Temperature Specifications - GM.....	2-11
2-3.	Engine Oil Operating Temperature Specifications - Deutz 2011.....	2-12
2-4.	Engine Operating Temperature Specifications - Kubota.....	2-13
2-5.	Hydraulic Oil Operating Temperature Specifications.....	2-14
3-1.	Axle Installation.....	3-4
3-2.	Steer Installation (Without Tow Package).....	3-5
3-3.	Steer Installation (With Tow Package).....	3-6
3-4.	Wheel Drive Installation.....	3-7
3-5.	Bolt Tightening Sequence.....	3-8
3-6.	Drive Hub and Brake Assembly (2WD and 4WD) - Sheet 1 of 2.....	3-10
3-7.	Drive Hub and Brake Assembly (2WD and 4WD) - Sheet 2 of 2.....	3-11
3-8.	Drive Hub (4WD Front Only) - Sheet 1 of 2.....	3-12
3-9.	Drive Hub (4WD Front Only) - Sheet 2 of 2.....	3-13
3-10.	Drive Hub (Cross-Section).....	3-14
3-11.	Cluster Gear Punch Marks.....	3-22
3-12.	Drive Motor Cross Section.....	3-26
3-13.	Removing Shaft Seal.....	3-27
3-14.	Loop Flushing Spool.....	3-27
3-15.	Loop Flushing Spool.....	3-29
3-16.	Plugs, Fittings, and Speed Sensor.....	3-29
3-17.	End Cap.....	3-30
3-18.	Valve Plate & Rear Shaft Bearing.....	3-30
3-19.	Cylinder Kit.....	3-31
3-20.	Shaft Seal.....	3-31
3-21.	Shaft & Front Bearing.....	3-31
3-22.	Swash Plate & Servo Piston.....	3-32
3-23.	Cylinder Kit Disassembly.....	3-32
3-24.	Servo Piston.....	3-35
3-25.	Cylinder Kit Assembly.....	3-35
3-26.	Swash Plate and Journal Bearing.....	3-36
3-27.	Shaft and Front Bearing.....	3-36
3-28.	Cylinder Kit Installation.....	3-37
3-29.	Servo Spring and Minimum Angle Stop.....	3-37
3-30.	Valve Plate and Rear Bearing.....	3-37
3-31.	End Cap.....	3-38
3-32.	Shaft Seal.....	3-38
3-33.	Plugs and Fittings Installation.....	3-38
3-34.	Loop Flushing Spool.....	3-39
3-35.	Swing System.....	3-40
3-36.	Bolt Tightening Sequence.....	3-43
3-37.	Swing Motor Valve Removal.....	3-45
3-38.	Swing Motor Removal.....	3-45
3-39.	Input Brake Disassembly.....	3-46
3-40.	Main Disassembly.....	3-47
3-41.	Housing Shaft Disassembly.....	3-48
3-42.	Carrier Disassembly.....	3-49
3-43.	Carrier Assembly.....	3-50

FIGURE NO.	TITLE	PAGE NO.
3-44.	Housing - Shaft Assembly	3-51
3-45.	Main Assembly.....	3-53
3-46.	Brake Port Alignment	3-54
3-47.	Swing Motor Installation	3-55
3-48.	Motor and Brake Assembly	3-56
3-49.	Swing Motor Valve Installation	3-57
3-50.	Bearing Cone Press Tool	3-58
3-51.	Bearing Cone Press Tool.....	3-58
3-52.	Bearing Cup Press Tool	3-59
3-53.	Lockout Wrench Tool.....	3-60
3-54.	Bearing Cup Press Tool	3-61
3-55.	Seal Press Tool	3-62
3-56.	Leak Test Adapter Plate	3-63
3-57.	Swing Drive Test Plate.....	3-64
3-58.	Swing Motor Assembly.....	3-66
3-59.	Swing Bolt Feeler Gauge Check.....	3-81
3-60.	Swing Bearing Wear Tolerance	3-82
3-61.	Swing Bearing Removal (400S).....	3-83
3-62.	Swing Bearing Removal (460SJ).....	3-84
3-63.	Swing Bearing Torque Sequence	3-88
3-64.	Rotary Coupling Cutaway	3-90
3-65.	Rotary Coupling Installation	3-91
3-66.	Rotary Coupling Port Location - (SN 0300203771 through 0300222808).....	3-92
3-67.	Rotary Coupling Port Location - (SN 0300222809 to Present, SN E300000100 to Present, SN 1300007289 through 1300007393)	3-93
3-68.	Inspecting Generator Brushes, Replacing Brushes and Cleaning Slip Rings	3-95
3-69.	Generator Disassembly and Assembly	3-96
3-70.	Generator Troubleshooting Circuit Diagram - Sheet 1 of 2	3-97
3-71.	Generator Troubleshooting Circuit Diagram - Sheet 2 of 2	3-98
3-72.	Generator Electrical Circuit Diagram	3-99
3-73.	Power Board PC1 Electrical Circuit Diagram	3-100
3-74.	Power Board PC2 Electrical Circuit Diagram - Sheet 1 of 2.....	3-101
3-75.	Power Board PC2 Electrical Circuit Diagram - Sheet 2 of 2.....	3-102
3-76.	Deutz D2.9L4 Engine Components - Sheet 1 of 2	3-104
3-77.	Deutz D2.9L4 Engine Components - Sheet 2 of 2	3-105
3-78.	Deutz D2011 Engine Components - Sheet 1 of 3	3-106
3-79.	Deutz D2011 Engine Components - Sheet 2 of 3	3-107
3-80.	Deutz D2011 Engine Components - Sheet 3 of 3	3-108
3-81.	GM Engine Components - Sheet 1 of 2	3-109
3-82.	GM Engine Components - Sheet 2 of 2	3-110
3-83.	Kubota Engine Components - Sheet 1 of 2.....	3-111
3-84.	Kubota Engine Components - Sheet 2 of 2	3-112
3-85.	Engine Oil Viscosity	3-113
3-86.	Location of the Oil Filter	3-114
3-87.	Location of the Fuel Pre-Filter	3-114
3-88.	Location of the Fuel Filter	3-114
3-89.	Deutz Engine Dipstick.....	3-116
3-90.	Engine Oil Viscosity	3-117
3-91.	EMR 2 Engine Side Equipment	3-119
3-92.	Deutz EMR 2 Troubleshooting Flow Chart.....	3-120
3-93.	Deutz EMR 2 Vehicle Side Connection Diagram	3-121
3-94.	Deutz EMR 2 Engine Side Connection Diagram - Sheet 1 of 2	3-122
3-95.	Deutz EMR 2 Engine Side Connection Diagram - Sheet 2 of 2	3-123
3-96.	EMR 2 Engine Plug Pin Identification.....	3-124
3-97.	EMR 2 Vehicle Plug Pin Identification	3-125
3-98.	EMR2 Fault Codes - Sheet 1 of 5	3-126
3-99.	EMR2 Fault Codes - Sheet 2 of 5	3-127

FIGURE NO.	TITLE	PAGE NO.
3-100.	EMR2 Fault Codes - Sheet 3 of 5	3-128
3-101.	EMR2 Fault Codes - Sheet 4 of 5	3-129
3-102.	EMR2 Fault Codes - Sheet 5 of 5	3-130
3-103.	Engine Oil Dip Stick	3-131
3-104.	Electric Fuel Lock Off	3-134
3-105.	EPR Assembly	3-134
3-106.	Low Pressure Regulators	3-134
3-107.	Air Fuel Mixer	3-135
3-108.	ETC throttle control device	3-135
3-109.	LPG Engine Control Unit (ECM)	3-136
3-110.	ECM Assembly	3-136
3-111.	Heated Exhaust Gas Oxygen Sensor (HEGO)	3-136
3-112.	Gasoline Fuel Pressure and Temperature Manifold Assembly	3-137
3-113.	Filter Lock Assembly	3-139
3-114.	EPR Assembly	3-140
3-115.	Pressure Regulator Section	3-140
3-116.	(TMAP) Sensor & Electronic Throttle Control (ETC)	3-141
3-117.	Mixer Assembly	3-142
3-118.	EPR Assembly	3-145
3-119.	Counterweight	3-215
4-1.	Telescope Retracted Sensors	4-3
4-2.	Telescope Retracted Sensors Circuit	4-4
4-3.	Transport Proximity Switch Installation	4-5
4-4.	Dual Capacity Sensors	4-6
4-5.	Dual Capacity Sensors Circuit	4-7
4-6.	Capacity Switch Installation	4-8
4-7.	Location of Components	4-9
4-8.	Platform Support Torque Values (Without LSS)	4-11
4-9.	Platform Support Torque Values (Single Cell LSS)	4-12
4-10.	Removal/Installation of Components - Rotator and Platform Level Cylinder	4-14
4-11.	Location of Components - Powertrack	4-16
4-12.	Powertrack Installation	4-17
4-13.	Main Boom Removal	4-27
4-14.	Main Boom Installation	4-31
4-15.	Fly Boom Wear Pads	4-34
4-16.	Base Boom Wear Pads	4-34
4-17.	Rotator - Exploded View	4-37
4-18.	Rotator - Assembly Drawing	4-38
4-19.	Rotator Counterbalance Valve	4-49
4-20.	Bolt-On External Fall Arrest Cable Tension	4-55
4-21.	Bolt-On External Fall Arrest System	4-57
5-1.	NPTF thread	5-3
5-2.	BSPT thread	5-3
5-3.	JIC Thread	5-3
5-4.	SAE Thread	5-3
5-5.	ORFS Thread	5-3
5-6.	MTBL-MBTS Thread	5-3
5-7.	Bulkhead Thread	5-3
5-8.	MFF-BSPP Thread	5-4
5-9.	ORB-MPP Thread	5-4
5-10.	Torque Wrench Angle	5-5
5-11.	Double Wrench Method	5-46
5-12.	FFWR Method	5-47
5-13.	Adjustable Stud End Assembly	5-48
5-14.	Axle Lockout Cylinder	5-50
5-15.	Cylinder Barrel Support	5-51
5-16.	Cylinder Head Removal	5-51

FIGURE NO.	TITLE	PAGE NO.
5-17.	Cylinder Rod Support	5-51
5-18.	Platform Level Cylinder	5-52
5-19.	Composite Bearing Installation	5-54
5-20.	Rod Seal Installation	5-54
5-21.	Cylinder Head Seal Installation	5-54
5-22.	Wiper Seal Installation	5-55
5-23.	Installation of Head Seal Kit	5-55
5-24.	Piston Seal Kit Installation	5-55
5-25.	Caulking	5-55
5-26.	Cylinder Barrel Support	5-56
5-27.	Capcrew Removal	5-56
5-28.	Cylinder Rod Support	5-56
5-29.	Jib Lift Cylinder (460SJ Only)	5-57
5-30.	Tapered Bushing Removal	5-58
5-31.	Composite Bearing Installation	5-59
5-32.	Rod Seal Installation	5-59
5-33.	Cylinder Head Seal Installation	5-59
5-34.	Wiper Seal Installation	5-60
5-35.	Installation of Head Seal Kit	5-60
5-36.	Tapered Bushing Installation	5-60
5-37.	Seating the Tapered Bearing	5-60
5-38.	Hydrolock Piston Seal Installation	5-61
5-39.	Piston Seal Kit Installation	5-61
5-40.	Rod Assembly Installation	5-61
5-41.	Cylinder Barrel Support	5-62
5-42.	Cylinder Head Removal	5-62
5-43.	Cylinder Rod Support	5-62
5-44.	Main Lift Cylinder (SN 0300203771 through 0300204034)	5-63
5-45.	Main Lift Cylinder (SN 0300204035 through 0300226846, SN E300000100 through E3000004457)	5-64
5-46.	Main Lift Cylinder (SN 0300226847 through 0300243703, SN E3000004458 through E300005607)	5-65
5-47.	Tapered Bushing Removal	5-66
5-48.	Composite Bearing Installation	5-67
5-49.	Rod Seal Installation	5-67
5-50.	Cylinder Head Seal Installation	5-67
5-51.	Wiper Seal Installation	5-68
5-52.	Installation of Head Seal Kit	5-68
5-53.	Tapered Bushing Installation	5-68
5-54.	Seating the Tapered Bearing	5-68
5-55.	Hydrolock Piston Seal Installation	5-69
5-56.	Piston Seal Kit Installation	5-69
5-57.	Cylinder Barrel Support	5-70
5-58.	Cylinder Head Removal	5-70
5-59.	Cylinder Rod Support	5-70
5-60.	Main Lift Cylinder (SN 0300243704 to Present, SN E300005608 to Present)	5-71
5-61.	Composite Bearing Installation	5-73
5-62.	Rod Seal Installation	5-73
5-63.	Cylinder Head Seal Installation	5-73
5-64.	Wiper Seal Installation	5-74
5-65.	Installation of Head Seal Kit	5-74
5-66.	Piston Seal Kit Installation	5-74
5-67.	Caulking	5-74
5-68.	Cylinder Barrel Support	5-75
5-69.	Cylinder Head Removal	5-75
5-70.	Cylinder Barrel Support	5-75
5-71.	Master Cylinder	5-76
5-72.	Composite Bearing Installation	5-78
5-73.	Rod Seal Installation	5-78

FIGURE NO.	TITLE	PAGE NO.
5-74.	Cylinder Head Seal Installation	5-78
5-75.	Wiper Seal Installation	5-79
5-76.	Installation of Head Seal Kit	5-79
5-77.	Installation of Piston Seal Kit	5-79
5-78.	Caulking	5-79
5-79.	Cylinder Barrel Support	5-80
5-80.	Cylinder Head Removal	5-80
5-81.	Cylinder Barrel Support	5-80
5-82.	Steer Cylinder	5-81
5-83.	Rod Seal Installation	5-82
5-84.	Wiper Seal Installation	5-82
5-85.	Cylinder Barrel Support	5-83
5-86.	Cylinder Head Removal	5-83
5-87.	Cylinder Rod Support	5-83
5-88.	Telescope Cylinder	5-84
5-89.	Tapered Bushing Removal	5-85
5-90.	Composite Bearing Installation	5-86
5-91.	Rod Seal Installation	5-86
5-92.	Cylinder Head Seal Installation	5-86
5-93.	Wiper Seal Installation	5-87
5-94.	Installation of Head Seal Kit	5-87
5-95.	Tapered Bushing Installation	5-87
5-96.	Seating the Tapered Bearing	5-87
5-97.	Piston Seal Kit Installation	5-88
5-98.	Main Control Valve Identification (400S) - Sheet 1 of 2	5-93
5-99.	Main Control Valve Identification (400S) - Sheet 2 of 2	5-94
5-100.	Main Control Valve Identification (460SJ) - Sheet 1 of 2	5-95
5-101.	Main Control Valve Identification (460SJ) - Sheet 2 of 2	5-96
5-102.	Main Control Valve Torque Values - Sheet 1 of 2	5-97
5-103.	Main Control Valve Torque Values - Sheet 2 of 2	5-98
5-104.	Hydraulic Schematic - Sheet 1 of 8	5-100
5-105.	Hydraulic Schematic - Sheet 2 of 8	5-101
5-106.	Hydraulic Schematic - Sheet 3 of 8	5-102
5-107.	Hydraulic Schematic - Sheet 4 of 8	5-103
5-108.	Hydraulic Schematic - Sheet 5 of 8	5-104
5-109.	Hydraulic Schematic - Sheet 6 of 8	5-105
5-110.	Hydraulic Schematic - Sheet 7 of 8	5-106
5-111.	Hydraulic Schematic - Sheet 8 of 8	5-107
6-1.	Hand Held Analyzer	6-1
6-2.	Tilt Sensor Location	6-8
6-3.	Splash Screen	6-9
6-4.	Diagnostic Screen	6-9
6-5.	Engine Diagnostic Screen	6-9
6-6.	Ground Control Console Display Gauge	6-10
6-7.	Analyzer Connecting Points	6-13
6-8.	Ground Control Module - Sheet 1 of 3	6-14
6-9.	Ground Control Module - Sheet 2 of 3	6-15
6-10.	Ground Control Module - Sheet 3 of 3	6-16
6-11.	Platform Module - Sheet 1 of 2	6-17
6-12.	Platform Module - Sheet 2 of 2	6-18
6-13.	Analyzer Flow Chart (Software Version P2.10)	6-27
6-14.	Analyzer Flow Chart - Diagnostics (Software Version P2.10) - Sheet 1 of 4	6-28
6-15.	Analyzer Flow Chart - Diagnostics (Software Version P2.10) - Sheet 2 of 4	6-29
6-16.	Analyzer Flow Chart - Diagnostics (Software Version P2.10) - Sheet 3 of 4	6-30
6-17.	Analyzer Flow Chart - Diagnostics (Software Version P2.10) - Sheet 4 of 4	6-31
6-18.	Analyzer Flow Chart - Personalities (Software Version P2.10) - Sheet 1 of 2	6-32
6-19.	Analyzer Flow Chart - Personalities (Software Version P2.10) - Sheet 2 of 2	6-33

FIGURE NO.	TITLE	PAGE NO.
6-20.	Analyzer Flow Chart - Machine setup (Software Version P2.10)	6-34
6-21.	Analyzer Flow Chart - Calibrations (Software Version P2.10)	6-35
7-1.	Voltage Measurement (DC)	7-1
7-2.	Resistance Measurement	7-2
7-3.	Continuity Measurement	7-2
7-4.	Current Measurement (DC)	7-3
7-5.	Application to Male Contacts	7-4
7-6.	Use of Seal Plugs	7-5
7-7.	Brad-Harrison M12	7-6
7-8.	Phoenix Contact M12	7-6
7-9.	Connector Assembly Figure 1	7-8
7-10.	AMP Connector	7-8
7-11.	Connector Assembly Figure 2	7-9
7-12.	Connector Assembly Figure 3	7-9
7-13.	Connector Assembly Figure 4	7-9
7-14.	Connector Disassembly	7-10
7-15.	Connector Installation	7-11
7-16.	DT/DTP Contact Installation	7-12
7-17.	DT/DTP Contact Removal	7-12
7-18.	HD/HDP Contact Installation	7-13
7-19.	HD/HDP Locking Contacts Into Position	7-13
7-20.	HD/HDP Contact Removal	7-13
7-21.	HD/HDP Unlocking Contacts	7-13
7-22.	Telematics Gateway Harness - Sheet 1 of 3	7-15
7-23.	Telematics Gateway Harness - Sheet 2 of 3	7-16
7-24.	Telematics Gateway Harness - Sheet 3 of 3	7-17
7-25.	Electrical Installation - Sheet 1 of 5	7-18
7-26.	Electrical Installation - Sheet 2 of 5	7-19
7-27.	Electrical Installation - Sheet 3 of 5	7-20
7-28.	Electrical Installation - Sheet 4 of 5	7-21
7-29.	Electrical Installation - Sheet 5 of 5	7-22
7-30.	Platform Control Box Harness - Sheet 1 of 12	7-25
7-31.	Platform Control Box Harness - Sheet 2 of 12	7-26
7-32.	Platform Control Box Harness - Sheet 3 of 12	7-27
7-33.	Platform Control Box Harness - Sheet 4 of 12	7-28
7-34.	Platform Control Box Harness - Sheet 5 of 12	7-29
7-35.	Platform Control Box Harness - Sheet 6 of 12	7-30
7-36.	Platform Control Box Harness - Sheet 7 of 12	7-31
7-37.	Platform Control Box Harness - Sheet 8 of 12	7-32
7-38.	Platform Control Box Harness - Sheet 9 of 12	7-34
7-39.	Platform Control Box Harness - Sheet 10 of 12	7-35
7-40.	Platform Control Box Harness - Sheet 11 of 12	7-36
7-41.	Platform Control Box Harness - Sheet 12 of 12	7-37
7-42.	LSS Harness	7-38
7-43.	Main Boom Harness	7-39
7-44.	Main Boom with Jib Harness	7-40
7-45.	Tele In Proximity Switches Harness	7-41
7-46.	Capacity Proximity Switches Harness	7-42
7-47.	Turntable Harness - Sheet 1 of 14	7-43
7-48.	Turntable Harness - Sheet 2 of 14	7-44
7-49.	Turntable Harness - Sheet 3 of 14	7-45
7-50.	Turntable Harness - Sheet 4 of 14	7-46
7-51.	Turntable Harness - Sheet 5 of 14	7-47
7-52.	Turntable Harness - Sheet 6 of 14	7-48
7-53.	Turntable Harness - Sheet 7 of 14	7-49
7-54.	Turntable Harness - Sheet 8 of 14	7-50
7-55.	Turntable Harness - Sheet 9 of 14	7-51

LIST OF FIGURES

FIGURE NO.	TITLE	PAGE NO.
7-56.	Turntable Harness - Sheet 10 of 14	7-52
7-57.	Turntable Harness - Sheet 11 of 14	7-54
7-58.	Turntable Harness - Sheet 12 of 14	7-55
7-59.	Turntable Harness - Sheet 13 of 14	7-56
7-60.	Turntable Harness - Sheet 14 of 14	7-57
7-61.	Main Valve Harness - Sheet 1 of 7	7-58
7-62.	Main Valve Harness - Sheet 2 of 7	7-60
7-63.	Main Valve Harness - Sheet 3 of 7	7-61
7-64.	Main Valve Harness - Sheet 4 of 7	7-62
7-65.	Main Valve Harness - Sheet 5 of 7	7-64
7-66.	Main Valve Harness - Sheet 6 of 7	7-65
7-67.	Main Valve Harness - Sheet 7 of 7	7-66
7-68.	Ground Control Panel Harness - Sheet 1 of 5.....	7-68
7-69.	Ground Control Panel Harness - Sheet 2 of 5.....	7-69
7-70.	Ground Control Panel Harness - Sheet 3 of 5.....	7-70
7-71.	Ground Control Panel Harness - Sheet 4 of 5.....	7-71
7-72.	Ground Control Panel Harness - Sheet 5 of 5.....	7-72
7-73.	Deutz T4i Harness - Sheet 1 of 4.....	7-74
7-74.	Deutz T4i Harness - Sheet 2 of 4.....	7-75
7-75.	Deutz T4i Harness - Sheet 3 of 4.....	7-76
7-76.	Deutz T4i Harness - Sheet 4 of 4.....	7-77
7-77.	Deutz T4F Harness - Sheet 1 of 12	7-78
7-78.	Deutz T4F Harness - Sheet 3 of 11	7-80
7-79.	Deutz T4F Harness - Sheet 2 of 11	7-81
7-80.	Deutz T4F Harness - Sheet 4 of 11	7-82
7-81.	Deutz T4F Harness - Sheet 5 of 11	7-83
7-82.	Deutz T4F Harness - Sheet 6 of 11	7-84
7-83.	Deutz T4F Harness - Sheet 7 of 11	7-85
7-84.	Deutz T4F Harness - Sheet 8 of 11	7-86
7-85.	Deutz T4F Harness - Sheet 9 of 11	7-87
7-86.	Deutz T4F Harness - Sheet 10 of 11.....	7-88
7-87.	Deutz T4F Harness - Sheet 11 of 11.....	7-89
7-88.	GM Engine Harness - Sheet 1 of 2	7-90
7-89.	GM Engine Harness - Sheet 2 of 2	7-91
7-90.	Skyguard Harness - Sheet 1 of 2	7-92
7-91.	Skyguard Harness - Sheet 2 of 2	7-93
7-92.	Cribbing Enable Harness.....	7-94
7-93.	Chassis Head and Tail Lights Harness - Sheet 1 of 3	7-96
7-94.	Chassis Head and Tail Lights Harness - Sheet 2 of 3	7-97
7-95.	Chassis Head and Tail Lights Harness - Sheet 3 of 3	7-98
7-96.	Chassis Work Lights Harness- Sheet 1 of 3	7-100
7-97.	Chassis Work Lights Harness - Sheet 2 of 3.....	7-101
7-98.	Chassis Work Lights Harness - Sheet 3 of 3.....	7-102
7-99.	Electrical Schematic - Sheet 1 of 25.....	7-103
7-100.	Electrical Schematic - Sheet 2 of 25.....	7-104
7-101.	Electrical Schematic - Sheet 3 of 25.....	7-105
7-102.	Electrical Schematic - Sheet 4 of 25.....	7-106
7-103.	Electrical Schematic - Sheet 5 of 25.....	7-107
7-104.	Electrical Schematic - Sheet 6 of 25.....	7-108
7-105.	Electrical Schematic - Sheet 7 of 25.....	7-109
7-106.	Electrical Schematic - Sheet 8 of 25.....	7-110
7-107.	Electrical Schematic - Sheet 9 of 25.....	7-111
7-108.	Electrical Schematic - Sheet 10 of 25	7-112
7-109.	Electrical Schematic - Sheet 11 of 25	7-113
7-110.	Electrical Schematic - Sheet 12 of 25	7-114
7-111.	Electrical Schematic - Sheet 13 of 25	7-115
7-112.	Electrical Schematic - Sheet 14 of 25	7-116

FIGURE NO.	TITLE	PAGE NO.
7-113.	Electrical Schematic - Sheet 15 of 25	7-117
7-114.	Electrical Schematic - Sheet 16 of 25	7-118
7-115.	Electrical Schematic - Sheet 17 of 25	7-120
7-116.	Electrical Schematic - Sheet 18 of 25	7-121
7-117.	Electrical Schematic - Sheet 19 of 25	7-122
7-118.	Electrical Schematic - Sheet 20 of 25	7-123
7-119.	Electrical Schematic - Sheet 21 of 25	7-124
7-120.	Electrical Schematic - Sheet 22 of 25	7-126
7-121.	Electrical Schematic - Sheet 23 of 25	7-127
7-122.	Electrical Schematic - Sheet 24 of 25	7-128
7-123.	Electrical Schematic - Sheet 25 of 25	7-129

Go to Discount-Equipment.com to order your parts

TABLE NO.	TITLE	PAGE NO.
1-1	Operating Specifications - 400S	1-1
1-2	Operating Specifications - 460SJ	1-1
1-3	Capacities	1-2
1-4	Deutz D2011L03	1-2
1-5	Deutz D2.9L4	1-2
1-6	GM 3.0L	1-2
1-7	Kubota WG 2503	1-3
1-8	Tires	1-3
1-9	Hydraulic Oil	1-3
1-10	Mobilfluid 424 Specs	1-3
1-11	Mobil DTE 13M Specs	1-4
1-12	UCon Hydrolube HP-50/46	1-4
1-13	Mobil EAL 224H Specs	1-4
1-14	Mobil EAL Environ H 46 Specs	1-4
1-15	Mobil Hydraulic EAL H 46 Specs	1-4
1-16	Exxon Univis HVI 26 Specs	1-4
1-17	Critical Stability Weights	1-5
1-18	Lubrication Specifications	1-10
2-1	Inspection and Maintenance	2-2
2-2	Cylinder Drift	2-5
2-3	Inspection and Preventive Maintenance Schedule	2-7
3-1	Wheel Torque Chart	3-2
3-2	Excessive Noise and/or Vibration	3-28
3-3	System Operating Hot	3-28
3-4	Won't Shift or Slow to Start	3-28
3-5	Displacement Identifiers	3-31
3-6	Slipper Foot Thickness & End Play	3-33
3-7	Cylinder Block Measurements	3-33
3-8	Brake Chart	3-41
3-9	Recommended Viscosities For Various Ambient Operating Temperatures	3-44
3-10	Coupling Port Information Table - (SN 0300203771 through 0300222808)	3-89
3-11	Coupling Port Information Table - (SN 0300222809 to Present, SN E300000100 to Present, SN 1300007289 through 1300007393)	3-89
3-12	Lead Connection List for Generator	3-103
3-13	GM LPG Fuel System Diagnosis	3-146
3-14	GM Engine Symptom Diagnosis	3-148
3-15	DTC to SPN/FMI Cross Reference Chart	3-156
3-16	Deutz Engine Fault Codes	3-158
4-1	SkyGuard Function Table	4-53
5-1	NPTF Pipe Thread	5-6
5-2	BSPT Pipe Thread	5-7
5-3	37° Flare (JIC)Thread - Steel	5-9
5-4	37° Flare (JIC)Thread - Aluminum/Brass	5-10
5-5	45° Flare (SAE) - Steel	5-12
5-6	45° Flare (SAE) - Aluminum/Brass	5-12
5-7	O-ring Face Seal (ORFS) - Steel	5-13
5-8	O-ring Face Seal (ORFS) - Aluminum/Brass	5-14
5-9	DIN 24° Cone (MBTL & MBTS)	5-16
5-10	Bulkhead Fittings (BH) - INCH	5-18
5-11	Bulkhead Fittings (BH) - METRIC	5-19
5-12	O-ring Boss (ORB) - Table 1 of 6	5-21
5-13	O-ring Boss (ORB) - Table 2 of 6	5-22
5-14	O-ring Boss (ORB) - Table 3 of 6	5-23
5-15	O-ring Boss (ORB) - Table 4 of 6	5-24
5-16	O-ring Boss (ORB) - Table 5 of 6	5-25
5-17	O-ring Boss (ORB) - Table 6 of 6	5-26
5-18	Metric Flat Face Port (MFF) - L Series - Table 1 of 3	5-28

TABLE NO.	TITLE	PAGE NO.
5-19	Metric Flat Face Port (MFF) - L Series - Table 2 of 3	5-29
5-20	Metric Flat Face Port (MFF) - L Series - Table 3 of 3	5-30
5-21	Metric Flat Face Port (MFF) - S Series - Table 1 of 3	5-31
5-22	Metric Flat Face Port (MFF) - S Series - Table 2 of 3	5-32
5-23	Metric Flat Face Port (MFF) - L Series - Table 3 of 3	5-33
5-24	Metric Pipe Parallel O-ring Boss (MPP)	5-35
5-25	British Standard Parallel Pipe Port (BSPP) - L Series - Table 1 of 3	5-37
5-26	British Standard Parallel Pipe Port (BSPP) - L Series - Table 2 of 3	5-38
5-27	British Standard Parallel Pipe Port (BSPP) - L Series - Table 3 of 3	5-39
5-28	British Standard Parallel Pipe Port (BSPP) - S Series - Table 1 of 3	5-40
5-29	British Standard Parallel Pipe Port (BSPP) - S Series - Table 2 of 3	5-41
5-30	British Standard Parallel Pipe Port (BSPP) - S Series - Table 3 of 3	5-42
5-31	Flange Code (FL61 & FL62) -Inch Fasteners	5-44
5-32	Flange Code (FL61 & FL62) - Metric Fasteners	5-45
5-33	Cartridge Torque Values	5-98
5-34	Coil Torque Values	5-98
5-35	Coil Resistance Values	5-98
6-1	Analyzer Abbreviations	6-11
6-2	Machine Configuration Programming Information (Software Version P2.10)	6-19
6-3	Machine Configuration Programming Settings - 400S (Software Version P2.10)	6-25
6-4	Machine Configuration Programming Settings - 460SJ (Software Version P2.10)	6-26
6-5	Diagnostic Menu Descriptions	6-37
6-6	Accessory Weights	6-39
6-7	SkyGlazier Capacity Reductions	6-41
6-8	Pipe Rack Capacity Reductions	6-41
6-9	LSS Troubleshooting Chart	6-44
6-10	Machine Model Adjustment Speeds	6-50
6-11	Diagnostic Trouble Code Chart	6-52
7-1	Wiring Harness Connector Labels	7-23

LIST OF TABLES

TABLE NO.

TITLE

PAGE NO.

This page left blank intentionally.

Go to Discount-Equipment.com to order your parts

SECTION 1. SPECIFICATIONS

1.1 OPERATING SPECIFICATIONS

Table 1-1. Operating Specifications - 400S

Maximum Work Load (Capacity): Unrestricted (CE & Aus) Unrestricted (ANSI) Restricted (CE & Aus) Restricted (ANSI)	600 lb (272 kg) 600 lb (272 kg) 1000 lb (454 kg) 1000 lb (454 kg)
Maximum Travel Grade (Gradeability)*	45%
Maximum Travel Grade (Side Slope)*	5°
Platform Height:	40 ft. 6 in. (12.36 m)
Horizontal Platform Reach:	33 ft. 3 in. (10.13 m)
Turning Radius (Outside)	15 ft. 10 in. (4.8 m)
Turning Radius (Inside)	6 ft. 6 in. (2.0 m)
Overall Width	7 ft. 7 in. (2.3 m)
Stowed Height	8 ft. 1 in. (2.47 m)
Stowed Length	24 ft. 10 in. (7.57 m)
Wheelbase	7 ft. 9.5 in. (2.37 m)
Ground Clearance	12.1 in. (0.3 m)
Tailswing	34 in. (0.86 m)
Max. Tire Load	7200 lbs. (3266 kg)
Ground Bearing Pressure	60 psi (4.19 kg/cm ²)
Travel Speed	4.25 mph (6.84 km/h)
Gross Machine Weight	13,425 (6,090 kg)
Maximum System Voltage	12V
Max. Hydraulic System Operating Pressure	3000 psi (207 Bar)
Manual Force CE ANSI	90 lbs. (400 N) 100 lbs. (445 N)
Maximum Wind Speed	28 mph (12.5 m/s)
* With boom in stowed position	

Table 1-2. Operating Specifications - 460SJ

Maximum Work Load (Capacity): Unrestricted (CE and Aus) Unrestricted (ANSI)	600 lb (272 kg) 600 lb (272 kg)
Maximum Travel Grade (Gradeability)*	45%
Maximum Travel Grade (Side Slope)*	5°
Platform Height:	46 ft. 2.6 in. (14.09 m)
Horizontal Platform Reach:	39 ft. 7 in. (12.07 m)
Turning Radius (Outside)	15 ft. 10 in. (4.8 m)
Turning Radius (Inside)	6 ft. 6 in. (2.0 m)
Overall Width	7 ft. 7 in. (2.3 m)
Stowed Height	8 ft. 1 in. (2.47 m)
Stowed Length	29 ft. 3 in. (8.91 m)
Wheelbase	7 ft. 9.5 in. (2.37 m)
Ground Clearance	12.1 in. (0.3 m)
Tailswing	34 in. (0.86 m)
Max. Tire Load	9000 lbs. (4082 kg)
Ground Bearing Pressure	60 psi (4.19 kg/cm ²)
Travel Speed	4.25 mph (6.84 km/h)
Gross Machine Weight	16,370 lbs. (7,425 kg)
Maximum System Voltage	12V
Max. Hydraulic System Operating Pressure	3000 psi (207 Bar)
Manual Force CE ANSI	90 lbs. (400 N) 100 lbs. (445 N)
Maximum Wind Speed	28 mph (12.5 m/s)
* With boom in stowed position	

1.2 CAPACITIES

Table 1-3. Capacities

Fuel Tank	22 gal. (83.3 L)
Hydraulic Tank	36 gal. (136.3 L)
Hydraulic System (Including Tank)	40 gal. (151.4 L)
Drive Hub	24 oz. (0.7 L)
Drive Brake	27 oz. (0.8 L)
Coolant	
Deutz 2.9L	3 gal. (11.3 L)
Deutz 2011L	2.8 gal. (10.5 L)
GM 3.0L	2.4 gal. (9.1 L)
Kubota	2.2 gal. (8.5 L)

1.3 ENGINE DATA

NOTE: RPM Tolerances are ± 50 .

Table 1-4. Deutz D2011L03

Fuel	Diesel
No. of Cylinders	3
BHP	48.8 hp @ 2800 rpm
Bore	3.7 in (94 mm)
Stroke	4.4 in (112 mm)
Displacement	142 cu. in (2331 cm ³)
Engine Oil Capacity	1.5 gal. (5.5 L)
Starter Rating	12 V. 2.3 kW
Alternator Rating	14 V. 55 Amp.
Glow Plug	12 V. 80 Amp.
Min. Low RPM	1000
Max. High RPM	2800
Max. Rated Torque	101 lb. ft. (137 Nm) @ 1700 rpm
Average Fuel Consumption	0.53 gph (2 Lph)

Table 1-5. Deutz D2.9L4

Type	Liquid Cooled
Number of Cylinders	4
BHP	48.8 hp @ 2600 rpm
Bore	3.6 in (92 mm)
Stroke	4.3 in (110 mm)
Total Displacement	178 cu. in (2925 cm ³)
Firing Order	1-3-4-2
Engine Oil Capacity	2.4 gal. (8.9 L)
Engine Coolant Capacity	0.79 gal. (3 L)
Starter Rating	12 V. 3.2 kW
Alternator Rating	12 V. 95 Amp.
Glow Plug	12 V. 110 Amp
Min. Low RPM	900
Max. High RPM	2600
Max. Rated Torque	108 lb. ft (147 Nm) @ 1600 rpm
Average Fuel Consumption	0.75 gph (2.84 Lph)

Table 1-6. GM 3.0L

Fuel	Gasoline or Gasoline/LP Gas
No. of Cylinders	4
BHP	
Gasoline	80.5 hp @ 3000 rpm
LP	75.1 hp @ 3000 rpm
Bore	4.0 in (101.6 mm)
Stroke	3.6 in (91.44 mm)
Displacement	181 cu. in (3.0 L, 2966 cc)
Engine Oil Capacity	1.14 gal. (4.3 L)
Engine Coolant Capacity	1 gal. (3.8 L)
Starter Rating	12 V. 1.5 kW
Alternator Rating	13.5 V. 70 Amp.
Compression Ratio	9.2:1
Firing Order	1-3-4-2
Max. High RPM	3000
Min. Low RPM	1000
Max. Rated Torque	
Gasoline	149.2 lb. ft (202.2 Nm) @ 2200 rpm
LP	149.6 lb. ft (202.8 Nm) @ 1600 rpm
Average Fuel Consumption	1.10 gph (4.2 Lph)

Table 1-7. Kubota WG 2503

Fuel	Gasoline or Gasoline/LP Gas
No. of Cylinders	4
BHP	
Gasoline	45.5 kW @2700 rpm
LP	46 kW @2700 rpm
Bore	3.46 in (88 mm)
Stroke	4.03 in (102.4 mm)
Displacement	153 cu. in (2.5L)
Engine Oil Capacity	2.5 gal. (9.5L)
Engine Coolant Capacity	1.4 gal. (5.4L)
Starter Rating	12V. 2.0 kW
Alternator Rating	12V. 40 Amp
Min. Low RPM	700
Max. High RPM	2700
Max. Rated Torque	
Gasoline	126 lb. ft (171 Nm) @1800 rpm
LP	131 lb. ft (178 Nm) @1400 rpm
Average Fuel Consumption	0.935 gph (3.544 Lph)

1.4 TIRES

Table 1-8. Tires

Size	Type	Pressure	Weight
12x16.5	Pneumatic	90 psi (6 Bar)	128 lbs. (58 kg)
	Foam-Filled	N/A	328 lbs. (149 kg)
14x17.5	Pneumatic	90 psi (6 Bar)	170 lbs. (77.2 kg)
	Foam-Filled	N/A	440 lbs. (200 kg)
33/16LL x 16.1	Pneumatic	40 psi (3 Bar)	119.5 lbs. (54 kg)
315/55D20	Foam-Filled	N/A	286 lbs. (130 kg)
	Solid	N/A	286 lbs. (130 kg)

1.5 HYDRAULIC OIL

Table 1-9. Hydraulic Oil

Hydraulic System Operating Temperature Range	S.A.E. Viscosity Grade
+0° to +180°F (-18° to +83°C)	10W
+0° to +210°F (-18° to +99°C)	10W-20, 10W-30
+50° to +210°F (+10° to +99°C)	20W-20

NOTE: Hydraulic oils must have anti-wear qualities at least to API Service Classification GL-3, and sufficient chemical stability for mobile hydraulic system service. JLG Ind. recommends Mobilfluid 424 hydraulic oil, which has an SAE viscosity index of 152.

NOTE: When temperatures remain consistently below 20° F (-7° C), JLG Industries recommends the use of Mobil DTE-13.

NOTE: Machines may be equipped with Mobil EAL224H biodegradable and non-toxic hydraulic oil. This is Vegetable oil based and possesses the same antiwear and rust protection characteristics as mineral oils, but will not adversely affect the ground water or the environment when spilled or leaked in small amounts. Mobil EAL224H has a viscosity of 34 cSt at 40° C. and viscosity index of 213. The operating temperature range of this oil is -18° C to +83° C.

Table 1-10. Mobilfluid 424 Specs

SAE Grade	10W30
ISO Viscosity Grade	55
Gravity, API	29.0
Density, Lb/Gal. 60°F	7.35
Pour Point, Max	-46°F (-43°C)
Flash Point, Min.	442°F (228°C)
Viscosity	
Brookfield, cP at -18°C	2700
at 40° C	55 cSt
at 100° C	9.3 cSt
Viscosity Index	152

SECTION 1 - SPECIFICATIONS

Table 1-11. Mobil DTE 13M Specs

ISO Viscosity Grade	#32
Specific Gravity	0.877
Pour Point, Max	-65°F (-54°C)
Flash Point, Min.	482°F (250°C)
Viscosity	
at 40°C	33cSt
at 100°C	6.6 cSt
at 100°F	169SUS
at 210°F	48SUS
cp at -20°F	6,200
Viscosity Index	164

Table 1-12. UCon Hydrolube HP-50/46

Type	Synthetic Biodegradable
Specific Gravity	1.082
Pour Point, Max	-58°F (-50°C)
pH	9.1
Viscosity	
at 0°C (32°F)	340 cSt (1600 SUS)
at 40°C (104°F)	46 cSt (215 SUS)
at 65°C (150°F)	22 cSt (106 SUS)
Viscosity Index	170

Table 1-13. Mobil EAL 224H Specs

Type	Synthetic Biodegradable
ISO Viscosity Grade	32/46
Specific Gravity	0.922
Pour Point, Max	-25°F (-32°C)
Flash Point, Min.	428°F (220°C)
Operating Temp.	0 to 180°F (-17 to 162°C)
Weight	7.64 lb/gal. (0.9 kg/liter)
Viscosity	
at 40°C	37 cSt
at 100°C	8.4 cSt
Viscosity Index	213
NOTE: Must be stored above 32°F (14°C)	

Table 1-14. Mobil EAL Environ H 46 Specs

Type	Synthetic Biodegradable
ISO Viscosity Grade	46
Specific Gravity @ 15° C	0.874
Pour Point	-49°F (-45°C)
Flash Point	500°F (260°C)
Operating Temp.	20 to 200°F (-29 to 93°C)
Weight	7.64 lb/gal. (0.9 kg/L)
Viscosity	
at 40°C	48.8 cSt
at 100°C	7.8 cSt
Viscosity Index	145

Table 1-15. Mobil Hydraulic EAL H 46 Specs

Type	Synthetic Biodegradable
ISO Viscosity Grade	46
Specific Gravity @ 15° C	.874
Pour Point	-27°F (-33°C)
Flash Point	568°F (298°C)
Operating Temp.	20 to 200°F (-29 to 93°C)
Weight	7.64 lb/gal. (0.9 kg/L)
Viscosity	
at 40°C	43.3 cSt
at 100°C	7.7 cSt
Viscosity Index	149

Table 1-16. Exxon Univis HVI 26 Specs

Specific Gravity	32.1
Pour Point	-76°F (-60°C)
Flash Point	217°F (103°C)
Viscosity	
at 40°C	25.8 cSt
at 100°C	9.3 cSt
Viscosity Index	376

NOTE: Mobil/Exxon recommends that this oil be checked on a yearly basis for viscosity.

1.6 CRITICAL STABILITY WEIGHTS

Table 1-17. Critical Stability Weights

Component	lb	kg
Battery	66	30
Counterweight (S)	1060 ± 42.4	481.8 ± 19.3
Counterweight (SJ)	2700 ± 54	1227.3 ± 24.5
Tires	See Table 1-8, Tires	
Platform and Console - 36 x 72	209	95
Platform and Console - 36 x 96	240	109
Platform and Console - Fall Arrest	287	130

Go to Discount-Equipment.com to order your parts

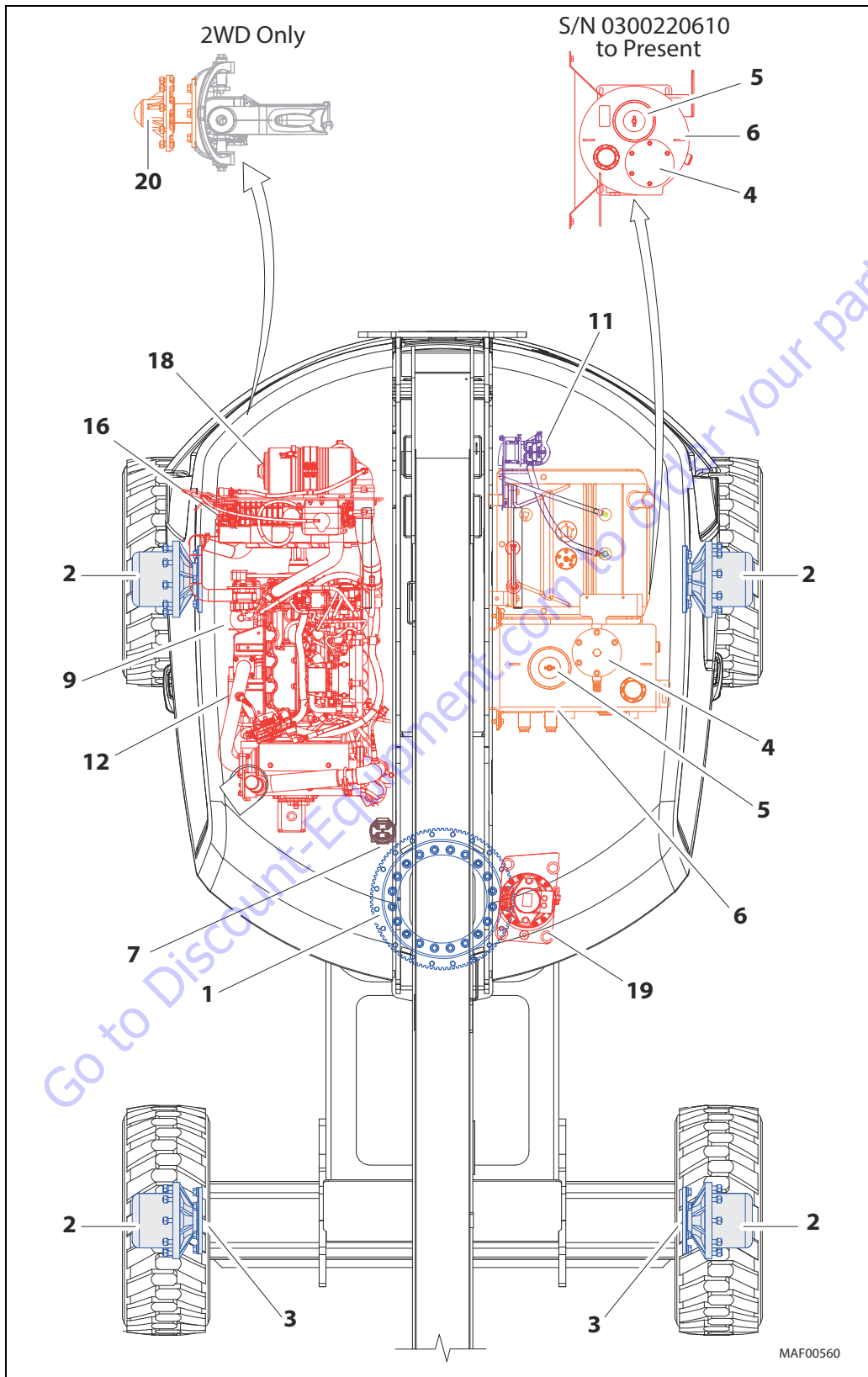

Figure 1-1. Operator Maintenance and Lubrication Diagram - Deutz 2.9L Engine

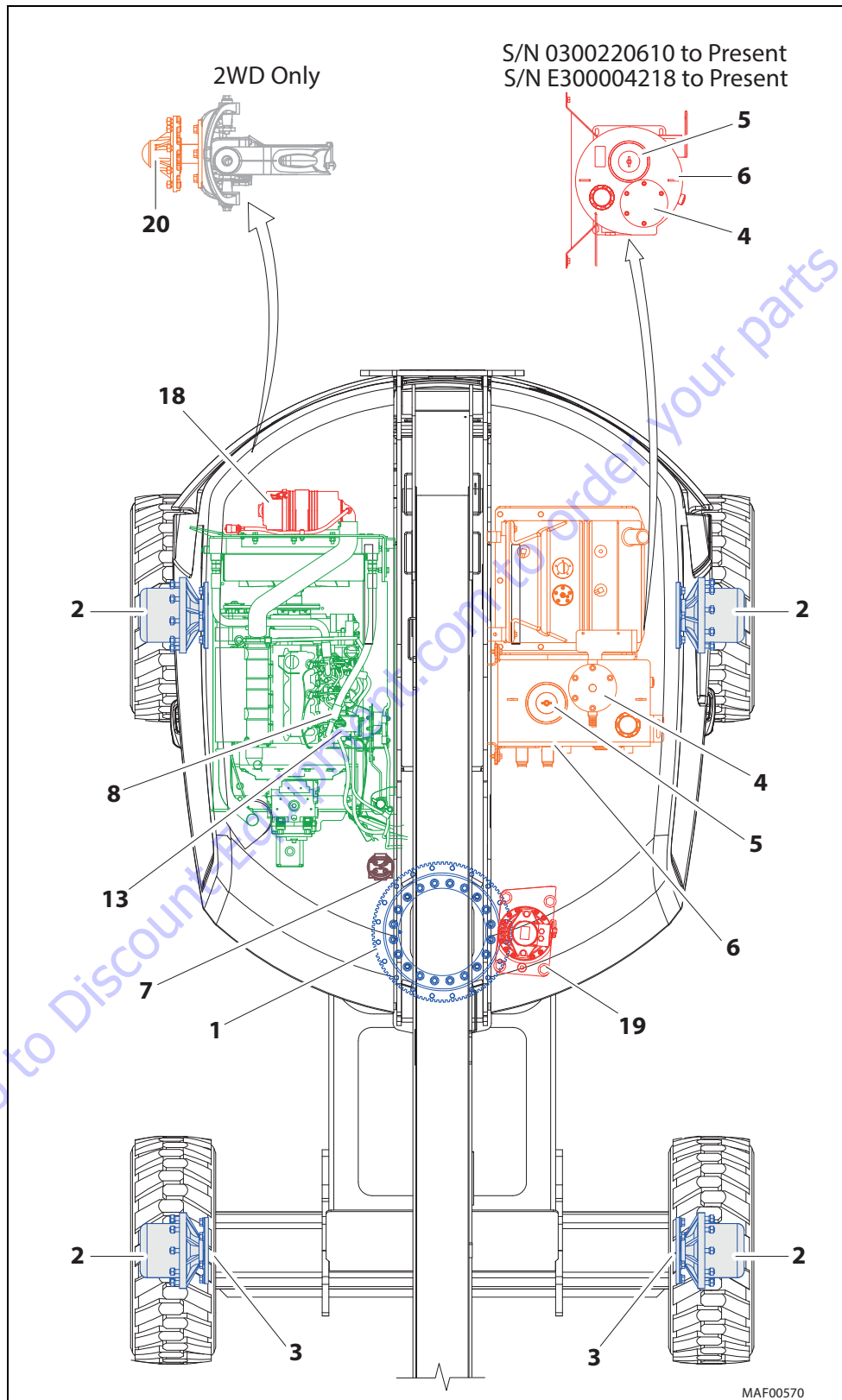

Figure 1-2. Operator Maintenance and Lubrication Diagram - Deutz 2011L Engine

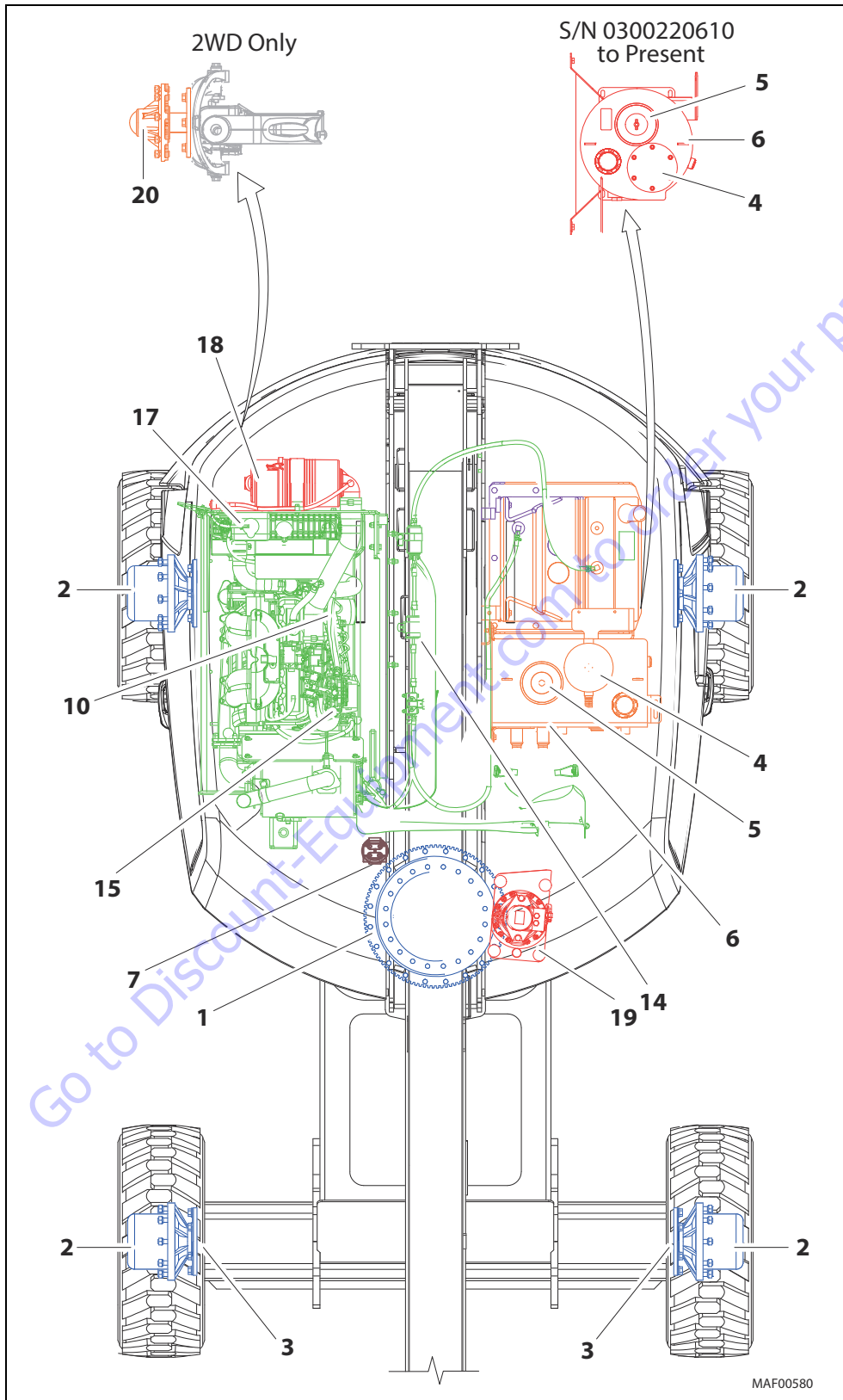

Figure 1-3. Operator Maintenance and Lubrication Diagram - GM Engine

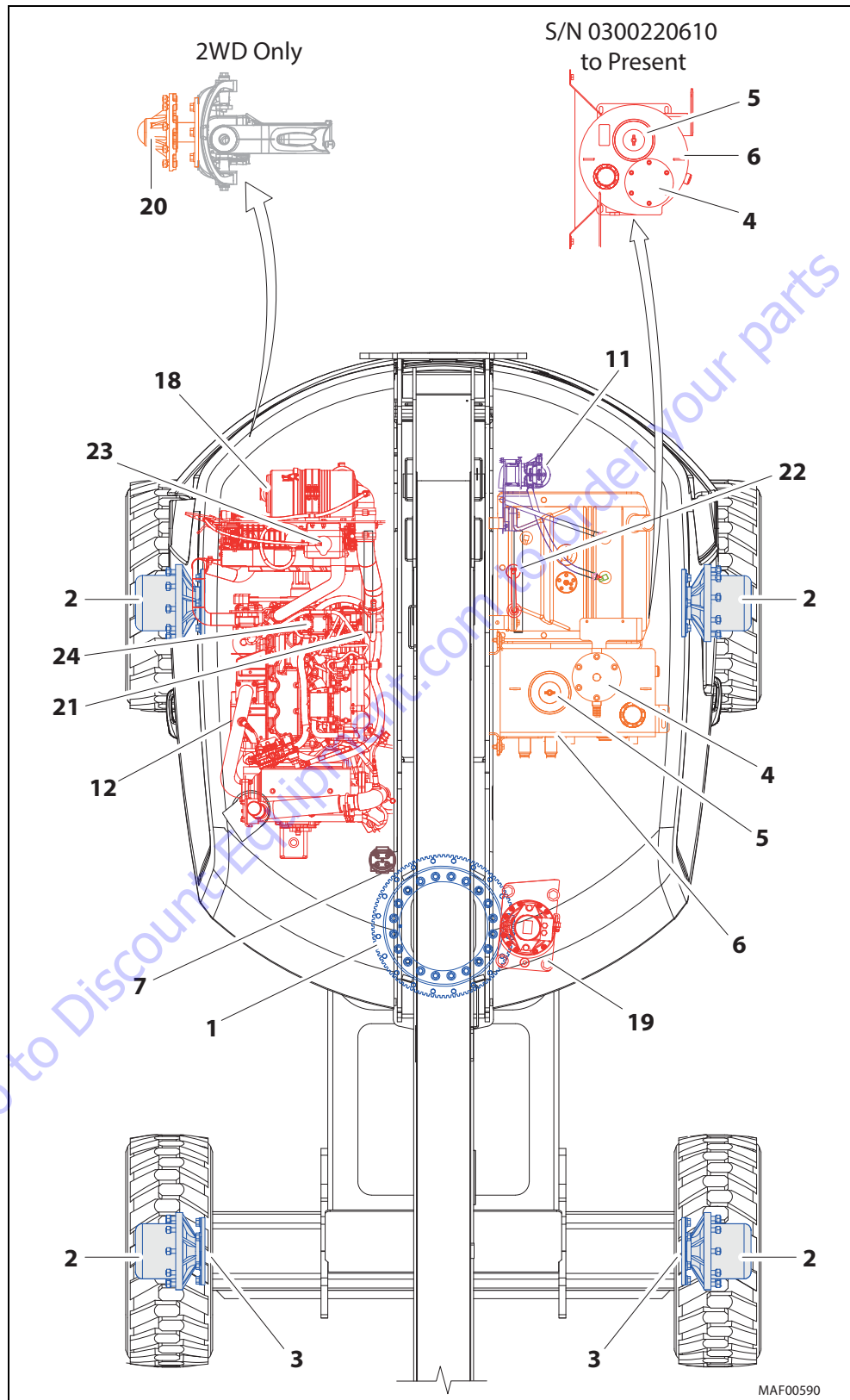

Figure 1-4. Operator Maintenance and Lubrication Diagram - Kubota Engine

1.7 MAINTENANCE AND LUBRICATION

NOTE: The following numbers correspond to those in Figure 1-1., Figure 1-2., Figure 1-3. and Figure 1-4.

Table 1-18. Lubrication Specifications

KEY	SPECIFICATIONS
MPG	Multipurpose Grease having a minimum dripping point of 350°F (177°C). Excellent water resistance and adhesive qualities, and being of extreme pressure type. (Timken OK 40 pounds minimum.)
EPGL	Extreme Pressure Gear Lube (oil) meeting API service classification GL-5 or MIL-Spec MIL-L-2105
HO	Hydraulic Oil. API service classification GL-3, e.g. Mobilfluid 424.
EO	Engine (crankcase). Gas (5W30)-API SN, -Arctic ACEA AI/BI, A5/B5- API SM, SL, SJ, EC, CF, CD- ILSAC GF-4. Diesel (15W40, 5W30 Arctic) - API CJ-4.
OGL	Open Gear Lubricant - Mobiltac375 or equivalent.

NOTICE

LUBRICATION INTERVALS ARE BASED ON MACHINE OPERATION UNDER NORMAL CONDITIONS. FOR MACHINES USED IN MULTI-SHIFT OPERATIONS AND/OR EXPOSED TO HOSTILE ENVIRONMENTS OR CONDITIONS, LUBRICATION FREQUENCIES MUST BE INCREASED ACCORDINGLY.

NOTE: It is recommended as a good practice to replace all filters at the same time.

1. Swing Bearing - Internal Ball Bearing

Lube Point(s) - 2 Grease Fittings
 Capacity - A/R
 Lube - MPG
 Interval - Every 3 months or 150 hours of operation
 Comments - Fittings in center of bearing: Remote Access is optional: Apply grease and rotate in 90 degree intervals until bearing is completely lubricated.

2. Wheel Drive Hub

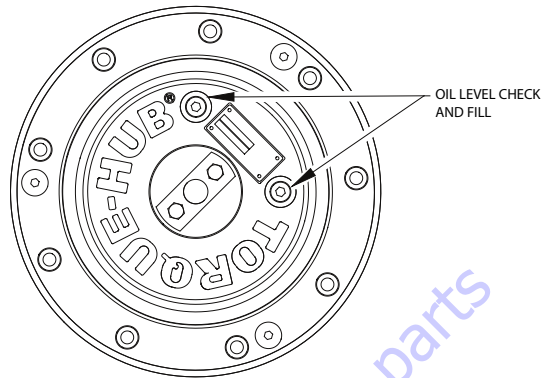

Lube Point(s) - Level/Fill Plug
 Capacity - 24 oz. (0.8 L)(1/2 Full)
 Lube - EPGL

Interval - Check level every 3 months or 150 hrs of operation; change every 2 years or 1200 hours of operation.

3. Drive Brake

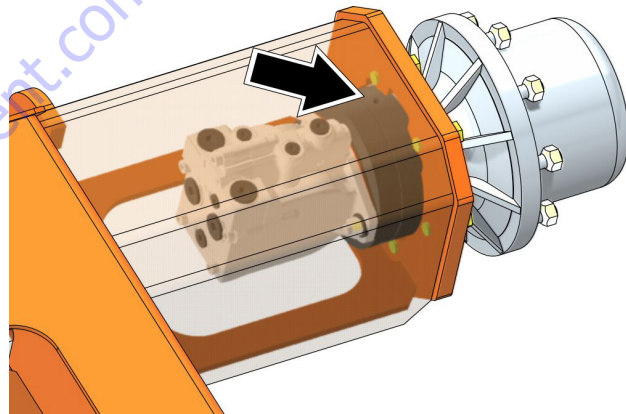

Lube Point(s) - Fill Plug
 Capacity - 27 oz. (0.8 L)
 Lube - DTE-13M
 Interval - Change as necessary.

4. Hydraulic Return Filter

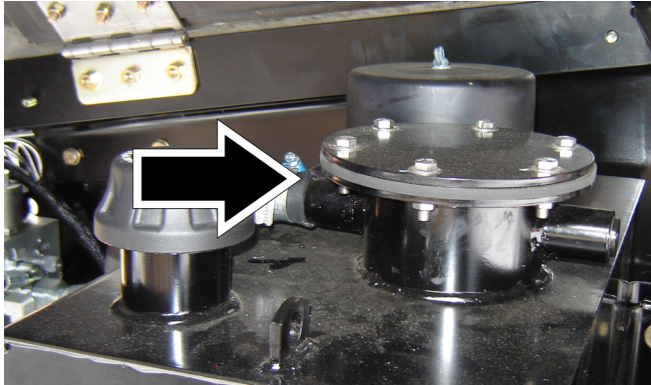

Interval - Change after first 50 hours and every 6 months or 300 hours thereafter or whenever Charge Filter is replaced.

5. Hydraulic Tank Breather

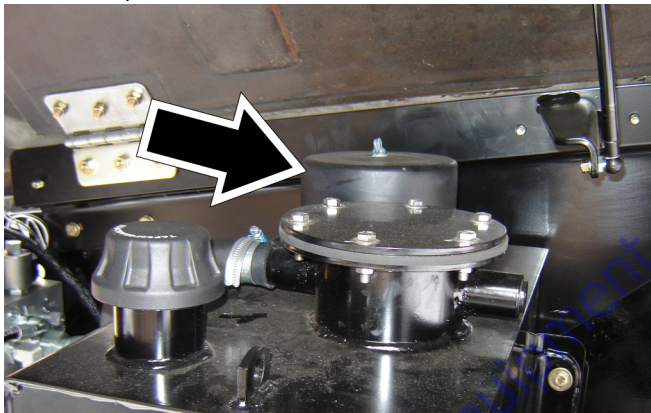

Interval - Change after first 50 hrs. and every 6 months or 300 hrs. thereafter.
 Comments - Remove wing nut and cover to replace. Under certain conditions, it may be necessary to replace on a more frequent basis.

6. Hydraulic Tank

A. Prior to SN 0300220610, Prior to SN E300004218, Prior to SN 1300007394

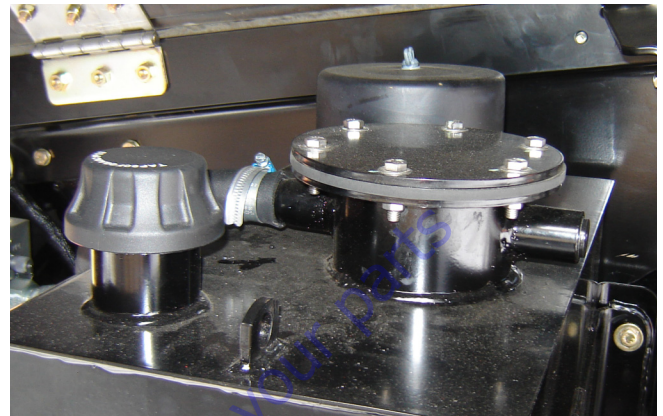

Lube Point(s) - Fill Cap
 Capacity - 32.5 gal tank (123 L) 40.0 gal system (151 L)
 Lube - HO
 Interval - Check Level daily; Change every 2 years or 1200 hours of operation.

B. SN 0300220610 to Present, SN E300004218 to Present

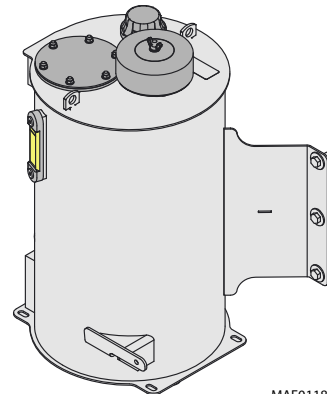

MAF01180

Lube Point(s) - Fill Cap
 Capacity - 15 Gal. (57 L) to Full Level
 Lube - HO
 Interval - Check Level daily; Change every 2 years or 1200 hours of operation.
 Comments - On new machines, those recently overhauled, or after changing hydraulic oil, operate all systems a minimum of two complete cycles and recheck oil level in reservoir.

SECTION 1 - SPECIFICATIONS

7. Hydraulic Charge Filter

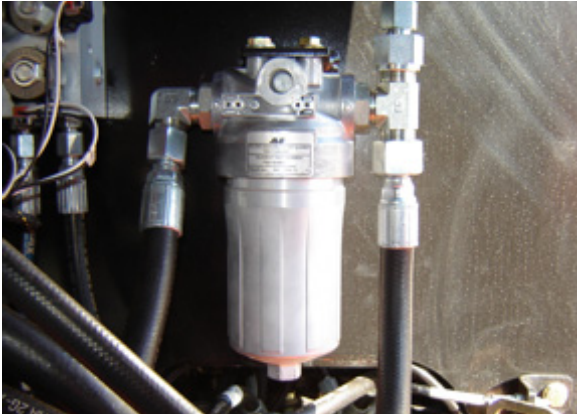

Interval - Change after first 50 hours and every 6 months or 300 hours thereafter or as indicated by Condition Indicator.

8. Oil Change w/Filter - Deutz D2011

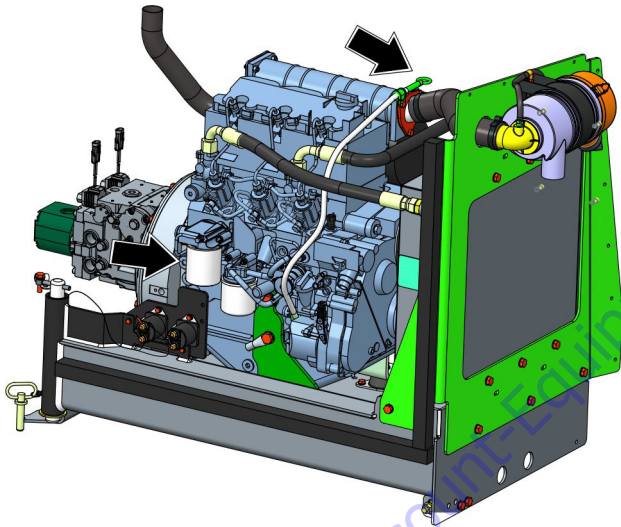

Lube Point(s) - Fill Cap/Spin-on Element
Capacity - 10 Quarts (9.5 L) w/Filter
Lube - EO
Interval - Change every 500 hours or six months, whichever comes first.
Comments - Check level daily/Change in accordance with engine manual. Adjust final oil level by mark on dipstick.

9. Oil Change w/Filter - Deutz 2.9 L4

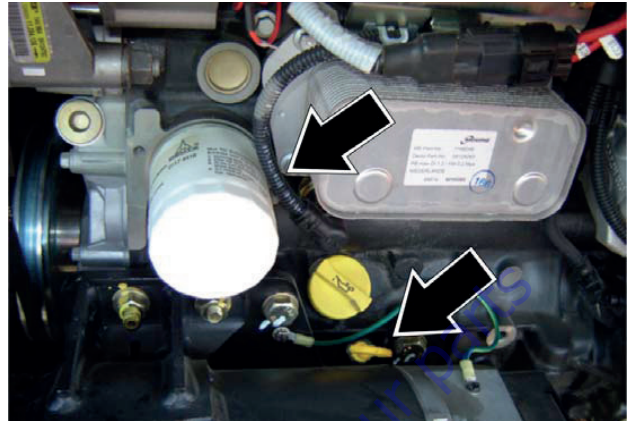

MAF01190

Lube Point(s) - Fill Cap/Spin-on Element
Capacity - 2.4 gal (8.9 L)
Lube - EO
Interval - Every Year or 600 hours of operation
Comments - Check level daily/Change in accordance with engine manual. Adjust final oil level by mark on dipstick.

10. Oil Change w/Filter - GM

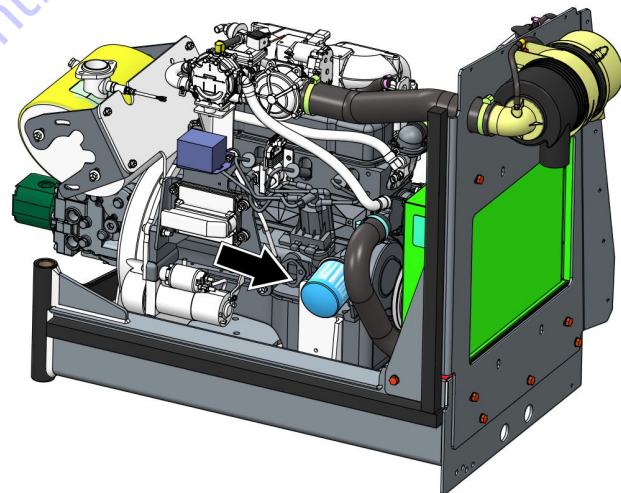

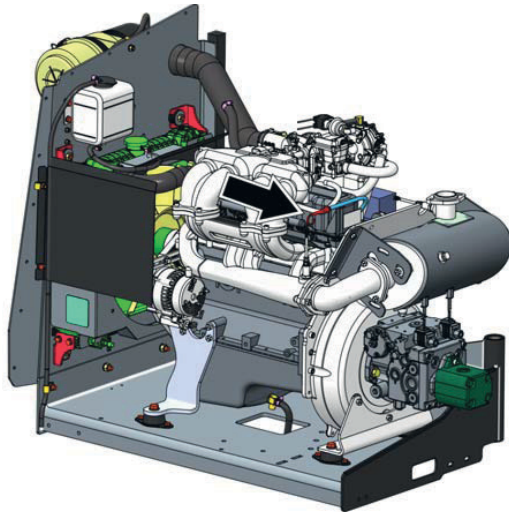

MAF01200

Lube Point(s) - Fill Cap/Spin-on Element
 Capacity - 4.5 qt (4.25 L) w/filter
 Lube - EO
 Interval - 3 Months or 150 hours of operation
 Comments - Check level daily/Change in accordance with engine manual.

11. Fuel Pre-Filter - Deutz D2.9



Lube Point(s) - Replaceable Element
 Interval - Drain water daily; Every year or 600 hours of operation.

12. Fuel Filter - Deutz D2.9



Lube Point(s) - Replaceable Element
 Interval - Every year or 600 hours of operation.

13. Fuel Filter - Deutz D2011

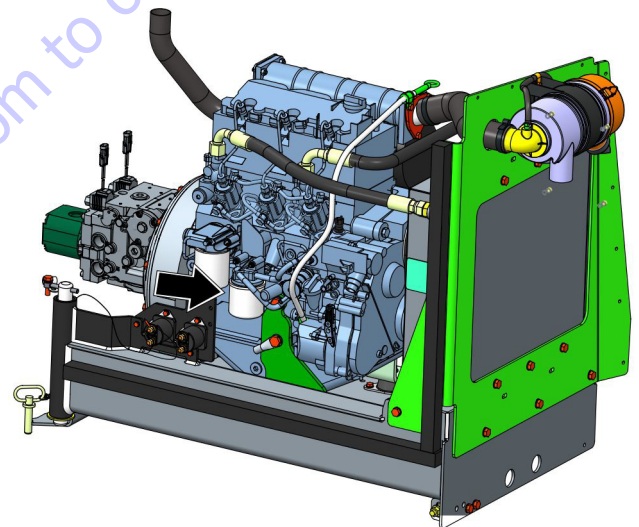

Lube Point(s) - Replaceable Element
 Interval - Every year or 500 hours of operation.

SECTION 1 - SPECIFICATIONS

14. Fuel Filter (Gasoline) - GM

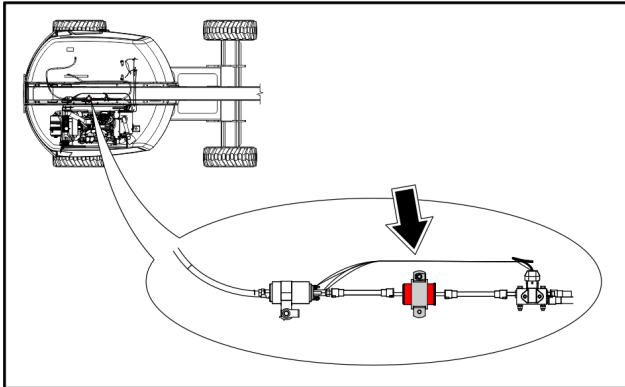

Lube Point(s) - Replaceable Element
Interval - Every 6 months or 300 hours of operation.

15. Fuel Filter (Propane) - GM Engine

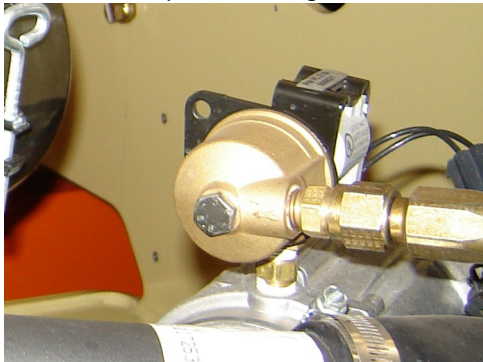

Interval - 3 Months or 150 hours of operation
Comments - Replace filter.

16. Radiator Coolant Deutz 2.9



Lube Point(s) - Fill Cap
Capacity - 2.9 Gallon (11.3 L)
Lube - Anti-Freeze
Interval - Check level daily; change every 1000 hours or 2 years, whichever comes first.

17. Radiator Coolant -GM

Lube Point(s) - Fill Cap
Capacity - 2.4 Gallon (9.1 L)
Lube - Anti-Freeze

Interval - Check level daily; change every 1000 hours or 2 years, whichever comes first.

18. Air Filter



Lube Point(s) - Replaceable Element
Interval - Every 6 months or 300 hours of operation or as indicated by the condition indicator
Comments - Check Dust Valve daily

19. Swing Drive Hub

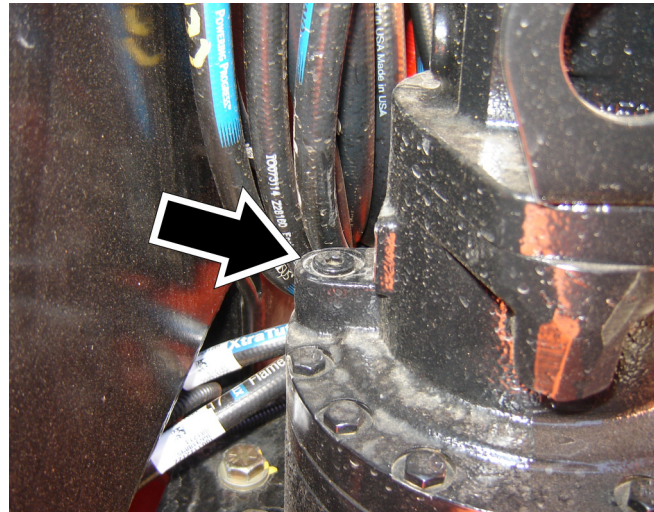

Lube Point - Level/Fill Plug
Capacity - 40 oz. (1.2 L)
Lube - 90w80 Gear Oil
Interval - First change after first 50 hours; Check level every 3 months or 150 hours of operation; change after first 50 hours and every 2 years or 1200 hours of operation thereafter.

20. Wheel Bearings

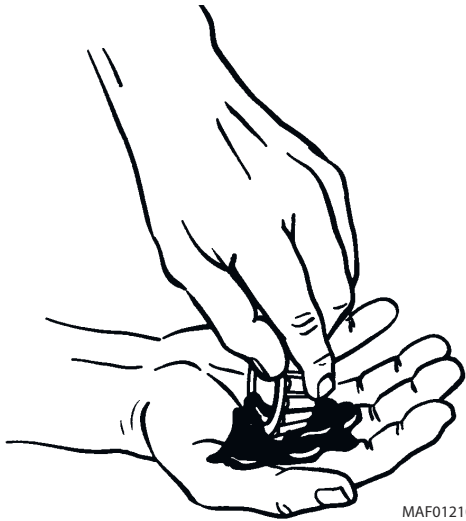

MAF01210

Lube Point(s) - Repack
 Capacity - A/R
 Lube - MPG
 Interval - Every 2 years or 1200 hours of operation.

21. Oil Change w/Filter - Kubota

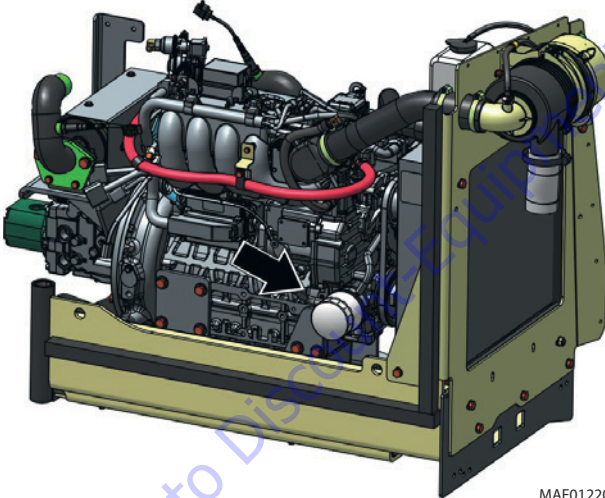

MAF01220

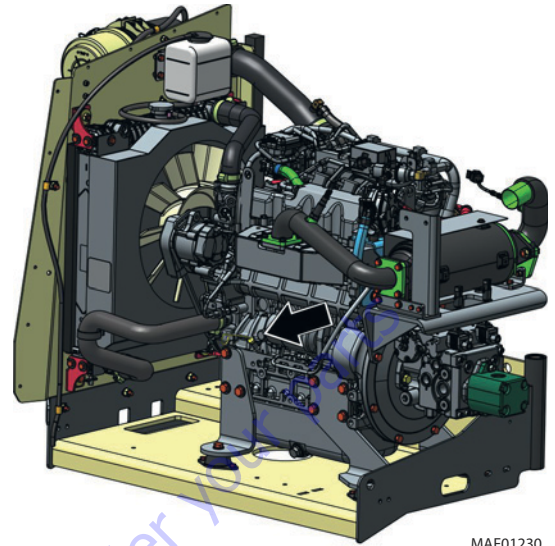

MAF01230

Lube Point(s) - Fill Cap/Spin-on Element
 Capacity - 2.5 gal. (9.5 L) w/filter
 Lube - EO
 Interval - 3 Months or 150 hours of operation
 Comments - Check level daily/Change in accordance with engine manual.

22. Fuel Filter - Kubota

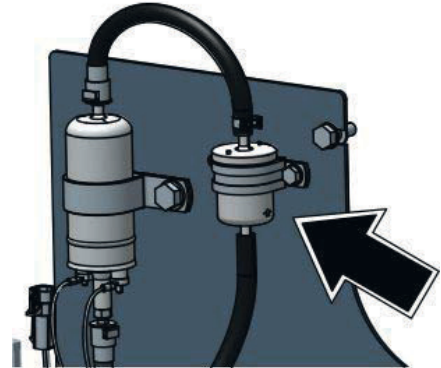

MAF01240

Lube Point(s) - Replaceable Component
 Interval - Every year or 600 hours of operation.

SECTION 1 - SPECIFICATIONS

23. Engine Coolant - Kubota

Lube Point(s) - Fill Cap

Capacity - 2.25 gal. (8.5 L)

Lube - Anti-Freeze

Interval - Check level daily; change every 1000 hours or two years, whichever comes first.

24. Fuel Filter (Propane) - Kubota

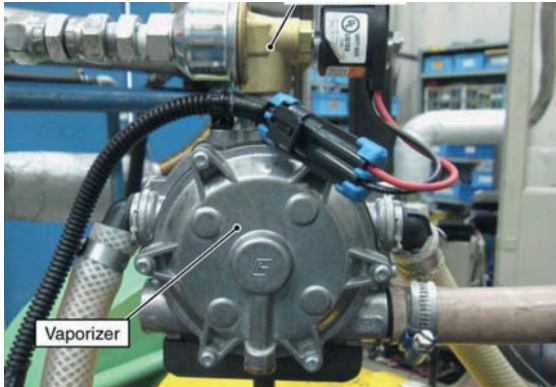

MAF01250

Interval - Every year or 1000 hours of operation

Comments - Replace filter. Refer to Section 7.6, Propane Fuel Filter Replacement (Kubota Engine).

Go to Discount-Equipment.com to order your parts

Values for Zinc Yellow Chromate Fasteners (Ref 4150707)															
SAE GRADE 5 BOLTS & GRADE 2 NUTS							SAE GRADE 8 (HEX HD) BOLTS & GRADE 8 NUTS*								
Size	TPI	Bolt Dia	Tensile Stress Area	Clamp Load	Torque (Dry)	Torque Lubricated		Torque (Loctite® 242™, or 271™ OR Vibra-TITE™ 111 or 140)		Torque (Loctite® 262™, or Vibra-TITE™ 131)		Clamp Load	Torque (Dry or Loctite® 263) K=0.20	Torque (Loctite® 242™, or 271™ OR Vibra-TITE™ 111 or 140)	Torque (Loctite® 262™ or Vibra-TITE™ 131) K=0.15
						IN-LB	FT-LB	IN-LB	FT-LB	IN-LB	FT-LB				
4	40	0.1120	0.00604	380	8	0.9	6	0.7							
4	48	0.1120	0.00661	420	9	1.0	7	0.8							
6	32	0.1380	0.00909	580	16	1.8	12	1.4							
8	40	0.1380	0.01015	610	18	2.0	13	1.5							
8	32	0.1640	0.01400	900	30	3.4	22	2.5							
8	36	0.1640	0.01474	940	31	3.5	23	2.6				1320	43	5	
10	24	0.1900	0.01750	1120	43	4.8	32	3.5				1580	60	7	
10	32	0.1900	0.02000	1285	49	5.5	36	4				1800	68	8	
1/4	20	0.2500	0.0318	2020	96	10.8	75	9	105	12		2860	143	16	
1/4	28	0.2500	0.0364	2320	120	13.5	86	10	135	15		3280	164	19	
5/16	18	0.3125	0.0524	3340	17	23	13	18	19	29		4720	25	35	
5/16	24	0.3125	0.0580	3700	19	26	14	19	21	29		5220	25	35	
3/8	16	0.3750	0.0775	4940	30	41	23	31	35	48		7000	45	60	
3/8	24	0.3750	0.0878	5600	35	47	25	34	40	54		7900	50	70	
7/16	14	0.4375	0.1063	6800	50	68	35	47	55	75		9550	70	95	
1/2	20	0.5000	0.1419	9050	75	102	55	75	85	116		10700	80	110	
1/2	28	0.5000	0.1598	10700	90	122	65	88	100	136		14400	120	165	
9/16	12	0.5625	0.1820	11600	110	149	80	108	120	163		16400	155	210	
9/16	18	0.5625	0.2030	12950	120	163	90	122	135	184		20350	170	230	
5/8	11	0.6250	0.2260	14400	150	203	110	149	165	224		23050	240	325	
5/8	18	0.6250	0.2560	16300	170	230	130	176	190	258		23000	240	325	
3/4	10	0.7500	0.3340	21300	260	353	200	285	388	520		30100	375	510	
3/4	16	0.7500	0.3730	23800	300	407	220	298	330	449		33600	420	570	
7/8	9	0.8750	0.4620	29400	430	583	320	434	475	646		41600	605	825	
1	8	0.8750	0.5090	32400	470	637	350	475	520	707		45800	670	910	
1	14	1.0000	0.6060	38600	640	868	480	651	735	918		51500	860	1170	
1	12	1.0000	0.6630	42200	700	949	530	719	785	1000		59700	985	1355	
1 1/8	7	1.1250	0.7630	42300	800	1085	600	813	840	1142		68700	1290	1755	
1 1/8	12	1.1250	0.8580	47500	880	1193	660	895	925	1258		77000	1445	1965	
1 1/4	7	1.2500	0.9690	53800	1120	1518	840	1139	1175	1598		87200	1815	2470	
1 1/4	12	1.2500	1.0730	59600	1240	1681	920	1247	1300	1768		98600	2015	2740	
1 3/8	6	1.3750	1.1550	64100	1460	1979	1100	1491	1525	2074		104000	2385	3245	
1 3/8	12	1.3750	1.3150	73000	1680	2278	1260	1708	1750	2380		118100	2705	3680	
1 1/2	6	1.5000	1.4050	78000	1940	2630	1460	1979	2025	2754		126500	3165	4305	
1 1/2	12	1.5000	1.5800	87700	2200	2983	1640	2224	2300	3128		142200	3555	4835	

NO. 500059 REV. K

NOTES: 1. THESE TORQUE VALUES DO NOT APPLY TO CADMIUM PLATED FASTENERS
 2. ALL TORQUE VALUES ARE STATIC TORQUE MEASURED PER STANDARD AUDIT METHODS TOLERANCE = ±10%
 3. * ASSEMBLY USES HARDENED WASHER

REFERENCE JLG THREAD LOCKING COMPOUND			
JLG P/N	Loctite® P/N	ND Industries P/N	Description
0100011	242™	Vibra-TITE™ 121	Medium Strength (Blue)
0100019	271™	Vibra-TITE™ 140	High Strength (Red)
0100071	262™	Vibra-TITE™ 131	Medium - High Strength (Red)

Values for Magni Coating Fasteners (Ref 4150701)																	
SAE GRADE 5 BOLTS & GRADE 2 NUTS							SAE GRADE 8 (HEX HD) BOLTS & GRADE 8 NUTS*										
Size	TPI	Bolt Dia	Tensile Stress Area	Clamp Load	Torque (Dry) K=0.17		Torque (Locitite® 242™, or 271™ OR Vibra-TITE™ K=0.16)		Torque (Locitite® 262™, or TITE™, 131) K=0.15		Torque (Dry or Locitite® 263) K=0.17		Torque (Locitite® 242™, or 271™ OR Vibra-TITE™ K=0.16)		Torque (Locitite® 262™, or TITE™, 131) K=0.15		
					IN-LB	[N.m]	IN-LB	[N.m]	IN-LB	[N.m]	IN-LB	[N.m]	IN-LB	[N.m]	IN-LB	[N.m]	IN-LB
4	40	0.1120	0.00604	380	7	0.8											
4.8	48	0.1120	0.00661	420	8	0.9											
6	32	0.1380	0.00909	580	14	1.5											
8	40	0.1380	0.01015	610	14	1.6											
8	32	0.1640	0.01400	900	25	2.8											
10	36	0.1640	0.01474	940	26	2.9											
10	24	0.1900	0.01750	1120	36	4.1											
10	32	0.1900	0.02000	1285	42	4.7											
1/4	20	0.2500	0.0318	2020	86	9.7	80	9						114	13		
1/4	28	0.2500	0.0364	2320	99	11.1	95	11						131	15		
5/16	18	0.3125	0.0524	3340	15	20	14	19									
5/16	24	0.3125	0.0580	3700	15	20	15	21									
3/8	16	0.3750	0.0775	4940	25	35	25	34									
3/8	24	0.3750	0.0878	5600	30	40	28	34									
7/16	14	0.4375	0.1063	6800	40	55	40	54									
7/16	20	0.4375	0.1187	7550	45	60	44	60									
1/2	13	0.5000	0.1419	9050	65	90	60	82									
1/2	20	0.5000	0.1599	10700	75	100	71	97									
9/16	12	0.5625	0.1820	11600	90	120	87	118									
9/16	18	0.5625	0.2030	12950	105	145	97	132									
5/8	11	0.6250	0.2260	14400	130	175	120	163									
5/8	18	0.6250	0.2560	16300	145	195	136	185									
3/4	10	0.7500	0.3340	21300	225	305	213	290									
3/4	16	0.7500	0.3730	23800	255	345	238	324									
7/8	9	0.8750	0.4620	29400	365	495	343	466									
7/8	14	0.8750	0.5090	32400	400	545	378	514									
1	8	1.0000	0.6060	38600	545	740	515	700									
1	12	1.0000	0.6630	42200	600	815	563	765									
1 1/8	7	1.1250	0.7630	42300	675	920	635	863									
1 1/8	12	1.1250	0.8560	47500	755	1025	713	969									
1 1/4	7	1.2500	0.9690	53800	955	1300	897	1219									
1 1/4	12	1.2500	1.0730	59600	1055	1435	993	1351									
1 3/8	6	1.3750	1.1350	64100	1250	1700	1175	1598									
1 3/8	12	1.3750	1.3150	73000	1420	1930	1338	1820									
1 1/2	6	1.5000	1.4050	78000	1660	2260	1560	2122									
1 1/2	12	1.5000	1.5800	87700	1865	2585	1754	2385									

NO. 500059 REV. K

NOTES: 1. THESE TORQUE VALUES DO NOT APPLY TO CADMIUM PLATED FASTENERS
 2. ALL TORQUE VALUES ARE STATIC TORQUE MEASURED PER STANDARD AUDIT METHODS TOLERANCE = ±10%
 3. * ASSEMBLY USES HARDENED WASHER

Figure 1-6. Torque Chart - Sheet 2 of 5 - (SAE Fasteners)

SOCKET HEAD CAP SCREWS												
Magni Coating (Ref 4150701)*						Zinc Yellow Chromate Fasteners (Ref 4150707)*						
Size	TPI	Bolt Dia	Tensile Stress Area	Clamp Load See Note 4	Torque (Dry) K = .17	Torque (Loctite® 242™ or 271™ OR Vibra-TITE™ 111 or TITE™ 131) K=0.16		Clamp Load See Note 4	Torque (Dry) K = .20	Torque (Loctite® 242™ or 271™ OR Vibra-TITE™ 111 or TITE™ 131) K=0.18		Torque (Loctite® 262™ or Vibra-TITE™ 131) K=0.15
						IN-LB [N.m]	FT-LB [N.m]			IN-LB [N.m]	FT-LB [N.m]	
4	40	0.1120	0.00604	LB	IN-LB [N.m]	FT-LB [N.m]	IN-LB [N.m]	FT-LB [N.m]	IN-LB [N.m]	FT-LB [N.m]	IN-LB [N.m]	FT-LB [N.m]
	48	0.1120	0.00661		20	25	20	25	35	20	25	20
6	32	0.1380	0.00903		25	35	25	35	25	35	25	25
8	32	0.1640	0.01015		35	50	35	50	45	60	40	55
	36	0.1640	0.01474		40	55	40	55	50	70	45	60
10	24	0.1900	0.01750		60	80	60	80	70	95	60	80
	32	0.1900	0.02000		65	90	65	90	70	95	60	80
1/4	20	0.2500	0.0318	2860	122	14	114	13	143	16	129	15
	28	0.2500	0.0364	3280	139	16	131	15	164	19	148	17
	18	0.3125	0.0524	4720	20	25	20	25	25	35	20	25
5/16	24	0.3125	0.0580	5220	25	35	25	35	25	35	25	25
	16	0.3750	0.0775	7000	35	50	35	50	45	60	40	55
3/8	24	0.3750	0.0878	7900	40	55	40	55	50	70	45	60
	14	0.4375	0.1063	9550	60	80	60	80	70	95	60	80
7/16	20	0.4375	0.1187	10700	65	90	65	90	80	110	70	95
	13	0.5000	0.1419	12750	90	120	85	115	105	145	95	130
1/2	20	0.5000	0.1599	14400	100	135	95	130	120	165	110	150
	12	0.5625	0.1820	16400	130	175	125	170	155	210	140	190
9/16	18	0.5625	0.2030	18250	145	195	135	185	170	230	155	210
	11	0.6250	0.2260	20350	180	245	170	230	170	285	190	260
5/8	18	0.6250	0.2560	23000	205	280	190	260	240	325	215	290
	10	0.7500	0.3340	30100	320	435	300	380	375	510	340	460
3/4	16	0.7500	0.3730	33600	355	485	335	455	420	570	380	515
	9	0.8750	0.4620	41600	515	700	485	660	605	825	545	740
7/8	14	0.8750	0.5090	45800	570	775	535	730	670	910	600	815
	8	1.0000	0.6060	51500	730	995	685	930	860	1170	775	1055
1	12	1.0000	0.6630	59700	845	1150	795	1080	995	1355	895	1215
1 1/8	7	1.1250	0.7630	68700	1095	1490	1030	1400	1290	1755	1160	1580
	12	1.1250	0.8560	77000	1225	1665	1155	1570	1445	1965	1300	1770
1 1/4	7	1.2500	0.9690	87200	1545	2100	1455	1980	1815	2470	1635	2225
	12	1.2500	1.0730	96600	1710	2325	1610	2190	2015	2740	1810	2460
1 3/8	6	1.3750	1.1550	104000	2025	2755	1905	2590	2385	3245	2145	2915
	12	1.3750	1.3150	118100	2300	3130	2165	2945	2760	3680	2435	3310
1 1/2	6	1.5000	1.4050	126500	2680	3660	2530	3440	3165	4305	2845	3870
	12	1.5000	1.5800	142200	3020	4105	2845	3870	3555	4835	3200	4350

NOTES: 1. THESE TORQUE VALUES DO NOT APPLY TO CADMIUM PLATED FASTENERS
 2. ALL TORQUE VALUES ARE STATIC TORQUE MEASURED PER STANDARD AUDIT METHODS TOLERANCE = +10%
 *3. ASSEMBLY USES HARDENED WASHER OR FASTENER IS PLACED AGAINST PLATED STEEL OR RAW ALUMINUM
 4. CLAMP LOAD LISTED FOR SHCS IS SAME AS GRADE 8 OR CLASS 10.9 AND DOES NOT REPRESENT FULL STRENGTH CAPABILITY OF SHCS. IF HIGHER LOAD IS REQUIRED, ADDITIONAL TESTING IS REQUIRED.

NO. 500059 REV. K

Figure 1-7. Torque Chart - Sheet 3 of 5 - (SAE Fasteners)

Values for Zinc Yellow Chromate Fasteners (Ref 4150707)											
CLASS 8.8 METRIC (HEX/SOCKET HEAD) BOLTS CLASS 8 METRIC NUTS					CLASS 10.9 METRIC (HEX HEAD) BOLTS CLASS 10 METRIC NUTS CLASS 12.9 SOCKET HEAD CAP SCREWS M3 - M5*						
Size	PITCH	Tensile Stress Area	Clamp Load	Torque (Dry or Loctite® 263™)	Torque (Lub)	Torque (Loctite® 262™ OR Vibra-TITE™ 131)	Torque (Loctite® 242™ or 271™ OR Vibra-TITE™ 111 or 140)	Clamp Load	Torque (Dry or Loctite® 263™) K = 0.20	Torque (Lub OR Loctite® 242™ or 271™ OR Vibra-TITE™ 111 or 140) K = 0.18	Torque (Loctite® 262™ OR Vibra-TITE™ 131) K = 0.15
		Sq mm	KN	[N.m]	[N.m]	[N.m]	[N.m]	KN	[N.m]	[N.m]	[N.m]
3	0.5	5.03	2.19	1.3	1.0	1.2	1.4	3.13			
3.5	0.6	6.78	2.95	2.1	1.6	1.9	2.3	4.22			
4	0.7	8.78	3.82	3.1	2.3	2.8	3.4	5.47			
5	0.8	14.20	6.18	6.2	4.6	5.6	6.8	8.85			
6	1	20.10	8.74	11	7.9	9.4	12	12.5			
7	1	28.90	12.6	18	13	16	19	18.0	25	23	19
8	1.25	36.60	15.9	26	19	23	28	22.8	37	33	27
10	1.5	58.00	25.2	50	38	45	55	36.1	70	65	55
12	1.75	84.30	36.7	88	66	79	97	52.5	125	115	95
14	2	115	50.0	140	105	128	154	71.6	200	180	150
16	2	157	68.3	219	164	197	241	97.8	315	280	235
18	2.5	192	89.5	301	226	271	331	119.5	430	385	325
20	2.5	245	106.5	426	320	383	469	152.5	610	550	460
22	2.5	303	132.0	581	436	523	639	189.0	830	750	625
24	3	353	153.5	737	553	663	811	222.0	1065	960	800
27	3	459	199.5	1080	810	970	1130	286.0	1545	1390	1160
30	3.5	561	244.0	1460	1100	1320	1530	349.5	2095	1885	1575
33	3.5	694	302.0	1990	1490	1790	2090	432.5	2855	2570	2140
36	4	817	355.5	2560	1920	2300	2690	509.0	3665	3300	2750
42	4.5	1120	487.0	4090	3070	3680	4290	698.0	5865	5275	4395

NOTES: 1. THESE TORQUE VALUES DO NOT APPLY TO CADMIUM PLATED FASTENERS
 2. ALL TORQUE VALUES ARE STATIC TORQUE MEASURED PER STANDARD AUDIT METHODS TOLERANCE = ±10%
 **3. ASSEMBLY USES HARDENED WASHER OR FASTENER IS PLACED AGAINST PLATED STEEL OR RAW ALUMINUM
 4. CLAMP LOAD LISTED FOR SHCS IS SAME AS GRADE 8 OR CLASS 10.9 AND DOES NOT REPRESENT FULL STRENGTH CAPABILITY OF SHCS. IF HIGHER LOAD IS REQUIRED, ADDITIONAL TESTING IS REQUIRED.

NO. 5000059 REV. K
 your parts

Figure 1-8. Torque Chart - Sheet 4 of 5 - (METRIC Fasteners)

Values for Magni Coated Fasteners (Ref 4150701)										
CLASS 8.8 METRIC (HEX/SOCKET HEAD) BOLTS CLASS 8 METRIC NUTS					CLASS 10.9 METRIC (HEX HEAD) BOLTS CLASS 10 METRIC NUTS CLASS 12.9 SOCKET HEAD CAP SCREWS M6 AND ABOVE*					
Size	PITCH	Tensile Stress Area	Clamp Load	Torque (Dry or Loctite® 263™) K=0.17	Torque (Loctite® 262™ OR Vibra-TITE™ 131) K=0.16	Torque (Loctite® 242™ or 271™ OR Vibra-TITE™ 111 or 140) K=0.15	Clamp Load	Torque (Dry or Loctite® 263™) K=0.17	Torque (Lub OR Loctite® 242™ or 271™ OR Vibra-TITE™ 111 or 140) K=0.16	Torque (Loctite® 262™ OR Vibra-TITE™ 131) K=0.15
		Sq mm	KN	[N.m]	[N.m]	[N.m]	KN	[N.m]	[N.m]	[N.m]
3	0.5	5.03	2.19	1.1	1.1	1.0	3.13			
3.5	0.6	6.78	2.95	1.8	1.7	1.5	4.22			
4	0.7	8.78	3.82	2.6	2.4	2.3	5.47			
5	0.8	14.20	6.18	5.3	4.9	4.6	8.85			
6	1	20.10	8.74	9	8.4	7.9	12.5	13	12	11
7	1	28.90	12.6	15	14	13	18.0	21	20	19
8	1.25	36.60	15.9	22	20	19	22.8	31	29	27
10	1.5	58.00	25.2	43	40	38	36.1	61	58	55
12	1.75	84.30	36.7	75	70	66	52.5	105	100	95
14	2	115	50.0	119	110	105	71.6	170	160	150
16	2	157	68.3	186	175	165	97.8	265	250	235
18	2.5	192	83.5	256	240	225	119.5	365	345	325
20	2.5	245	106.5	362	340	320	152.5	520	490	460
22	2.5	303	132.0	494	465	435	189.0	705	665	625
24	3	353	153.5	627	590	555	222.0	905	850	800
27	3	459	199.5	916	860	810	286.0	1315	1235	1160
30	3.5	561	244.0	1245	1170	1100	349.5	1780	1680	1575
33	3.5	694	302.0	1694	1595	1495	432.5	2425	2285	2140
36	4	817	355.5	2176	2050	1920	509.0	3115	2930	2750
42	4.5	1120	487.0	3477	3275	3070	698.0	4985	4690	4395

NOTES: 1. THESE TORQUE VALUES DO NOT APPLY TO CADMIUM PLATED FASTENERS
 2. ALL TORQUE VALUES ARE STATIC TORQUE MEASURED PER STANDARD AUDIT METHODS TOLERANCE = ±10%
 *3. ASSEMBLY USES HARDENED WASHER OR FASTENER IS PLACED AGAINST PLATED STEEL OR RAW ALUMINUM
 4. CLAMP LOAD LISTED FOR SHCS IS SAME AS GRADE 8 OR CLASS 10.9 AND DOES NOT REPRESENT FULL STRENGTH CAPABILITY OF SHCS. IF HIGHER LOAD IS REQUIRED, ADDITIONAL TESTING IS REQUIRED.

NO. 500059 REV. K

Figure 1-9. Torque Chart - Sheet 5 of 5 - (METRIC Fasteners)

PARTS FINDER

**Search Website
by Part Number**



**Search Manual
Library For Parts
Manual & Lookup Part
Numbers – Purchase
or Request Quote**

Search Manuals

Enter the make and model of the equipment you are looking for to search for parts.

* Brand:

* Model:

* Year:

Serial:

Part Number:

Part Description:

Quantity:

**Can't Find Part or
Manual? Request Help
by Manufacturer,
Model & Description**

Parts Order Form

Please fill in the information below to request help finding a part.

Manufacturer:

Model:

Description:

Quantity:

Part Number:

Part Description:

Quantity:

Year:

Serial:

Customer Name:

Company Name:

Address:

City:

State:

Zip:

Phone:

Fax:

E-mail:

Submit

Discount-Equipment.com is your online resource for quality parts & equipment.

Florida: **561-964-4949** Outside Florida TOLL FREE: **877-690-3101**

Need parts?

Click on this link: <http://www.discount-equipment.com/category/5443-parts/> and choose one of the options to help get the right parts and equipment you are looking for. Please have the machine model and serial number available in order to help us get you the correct parts. If you don't find the part on the website or on one of the online manuals, please fill out the request form and one of our experienced staff members will get back to you with a quote for the right part that your machine needs.

We sell worldwide for the brands: Genie, Terex, JLG, MultiQuip, Mikasa, Essick, Whiteman, Mayco, Toro Stone, Diamond Products, Generac Magnum, Airman, Haulotte, Barreto, Power Blanket, Nifty Lift, Atlas Copco, Chicago Pneumatic, Allmand, Miller Curber, Skyjack, Lull, Skytrak, Tsurumi, Husquvarna Target, , Stow, Wacker, Sakai, Mi-T- M, Sullair, Basic, Dynapac, MBW, Weber, Bartell, Bennar Newman, Haulotte, Ditch Runner, Menegotti, Morrison, Contec, Buddy, Crown, Edco, Wyco, Bomag, Laymor, Barreto, EZ Trench, Bil-Jax, F.S. Curtis, Gehl Pavers, Heli, Honda, ICS/PowerGrit, IHI, Partner, Imer, Clipper, MMD, Koshin, Rice, CH&E, General Equipment, ,AMida, Coleman, NAC, Gradall, Square Shooter, Kent, Stanley, Tamco, Toku, Hatz, Kohler, Robin, Wisconsin, Northrock, Oztec, Toker TK, Rol-Air, Small Line, Wanco, Yanmar

SECTION 2. GENERAL

2.1 MACHINE PREPARATION, INSPECTION, AND MAINTENANCE

General

This section provides the necessary information needed by those personnel that are responsible to place the machine in operation readiness and maintain its safe operating condition. For maximum service life and safe operation, ensure that all the necessary inspections and maintenance have been completed before placing the machine into service. With proper care, maintenance, and inspections performed as per JLG's recommendations, and with any and all discrepancies corrected, this product will be fit for continued use.

Preparation, Inspection, and Maintenance

It is important to establish and conform to a comprehensive inspection and preventive maintenance program. The following table outlines the periodic machine inspections and maintenance recommended by JLG Industries, Inc. Consult your national, regional, or local regulations for further requirements for aerial work platforms. The frequency of inspections and maintenance must be increased as environment, severity and frequency of usage requires.

Pre-Start Inspection

It is the User's or Operator's primary responsibility to perform a Pre-Start Inspection of the machine prior to use daily or at each change of operator. Reference the Operation and Safety Manual for complete procedures for the Pre-Start Inspection. The Operation and Safety Manual must be read in its entirety and understood prior to performing the Pre-Start Inspection.

Pre-Delivery Inspection and Frequent Inspection

The Pre-Delivery Inspection and Frequent Inspection shall be performed by a qualified JLG equipment mechanic. JLG Industries, Inc. recognizes a qualified JLG equipment mechanic as a person who, by possession of a recognized degree, certificate, extensive knowledge, training, or experience, has successfully demonstrated the ability and proficiency to service, repair, and maintain the subject JLG product model.

The Pre-Delivery Inspection and Frequent Inspection procedures are performed in the same manner, but at different times. The Pre-Delivery Inspection shall be performed prior to each sale, lease, or rental delivery. The Frequent Inspection shall be accomplished for each machine in service for 3 months or 150 hours (whichever comes first); out of service for a period of more than 3 months; or when purchased used. The frequency of this inspection must be increased as environment, severity and frequency of usage requires.

Reference the JLG Pre-Delivery and Frequent Inspection Form and the Inspection and Preventive Maintenance Schedule for items requiring inspection during the performance of these inspections. Reference the appropriate areas of this manual for servicing and maintenance procedures.

Annual Machine Inspection

The Annual Machine Inspection must be performed on an annual basis, no later than thirteen (13) months from the date of the prior Annual Machine Inspection. JLG Industries recommends this task be performed by a Factory-Trained Service Technician. JLG Industries, Inc. recognizes a Factory-Trained Service Technician as a person who has successfully completed the JLG Service Training School for the subject JLG product model. Reference the machine Service and Maintenance Manual and appropriate JLG inspection form for performance of this inspection.

Reference the JLG Annual Machine Inspection Form and the Inspection and Preventive Maintenance Schedule for items requiring inspection during the performance of this inspection. Reference the appropriate areas of this manual for servicing and maintenance procedures.

For the purpose of receiving safety-related bulletins, it is important that JLG Industries, Inc. has updated ownership information for each machine. When performing each Annual Machine Inspection, notify JLG Industries, Inc. of the current machine ownership.

Preventive Maintenance

In conjunction with the specified inspections, maintenance shall be performed by a qualified JLG equipment mechanic. JLG Industries, Inc. recognizes a qualified JLG equipment mechanic as a person who, by possession of a recognized degree, certificate, extensive knowledge, training, or experience, has successfully demonstrated the ability and proficiency to service, repair, and maintain the subject JLG product model.

Reference the Preventive Maintenance Schedule and the appropriate areas of this manual for servicing and maintenance procedures. The frequency of service and maintenance must be increased as environment, severity and frequency of usage requires.

Table 2-1. Inspection and Maintenance

Type	Frequency	Primary Responsibility	Service Qualification	Reference
Pre-Start Inspection (See Note)	Prior to use each day; or At each Operator change.	User or Operator	User or Operator	Operation and Safety Manual
Pre-Delivery Inspection (See Note)	Prior to each sale, lease, or rental delivery.	Owner, Dealer, or User	Qualified JLG Mechanic	Service and Maintenance Manual and applicable JLG inspection form.
Frequent Inspection (See Note)	In service for 3 months or 150 hours, whichever comes first; or Out of service for a period of more than 3 months; or purchased used.	Owner, Dealer, or User	Qualified JLG Mechanic	Service and Maintenance Manual and applicable JLG inspection form.
Annual Machine Inspec- tion (See Note)	Annually, no later than 13 months from the date of the prior inspection.	Owner, Dealer, or User	Factory-Trained Service Technician (Recommended)	Service and Maintenance Manual and applicable JLG inspection form.
Preventive Maintenance (See Note)	At intervals as specified in the Service and Mainte- nance Manual.	Owner, Dealer, or User	Qualified JLG Mechanic	Service and Maintenance Manual

NOTE: Inspections forms are available from JLG. Use the Service and Maintenance Manual to perform inspections.

2.2 SERVICE AND GUIDELINES

General

The following information is provided to assist you in the use and application of servicing and maintenance procedures contained in this book.

Safety and Workmanship

Your safety, and that of others, is the first consideration when engaging in the maintenance of equipment. Always be conscious of weight. Never attempt to move heavy parts without the aid of a mechanical device. Do not allow heavy objects to rest in an unstable position. When raising a portion of the equipment, ensure that adequate support is provided.

Cleanliness

1. The most important single item in preserving the long service life of a machine is to keep dirt and foreign materials out of the vital components. Precautions have been taken to safeguard against this. Shields, covers, seals, and filters are provided to keep air, fuel, and oil supplies clean; however, these items must be maintained on a scheduled basis in order to function properly.

2. At any time when air, fuel, or oil lines are disconnected, clear adjacent areas as well as the openings and fittings themselves. As soon as a line or component is disconnected, cap or cover all openings to prevent entry of foreign matter.
3. Clean and inspect all parts during servicing or maintenance, and assure that all passages and openings are unobstructed. Cover all parts to keep them clean. Be sure all parts are clean before they are installed. New parts should remain in their containers until they are ready to be used.

Components Removal and Installation

1. Use adjustable lifting devices, whenever possible, if mechanical assistance is required. All slings (chains, cables, etc.) should be parallel to each other and as near perpendicular as possible to top of part being lifted.
2. Should it be necessary to remove a component on an angle, keep in mind that the capacity of an eyebolt or similar bracket lessens, as the angle between the supporting structure and the component becomes less than 90 degrees.
3. If a part resists removal, check to see whether all nuts, bolts, cables, brackets, wiring, etc., have been removed and that no adjacent parts are interfering.

Component Disassembly and Reassembly

When disassembling or reassembling a component, complete the procedural steps in sequence. Do not partially disassemble or assemble one part, then start on another. Always recheck your work to assure that nothing has been overlooked. Do not make any adjustments, other than those recommended, without obtaining proper approval.

Pressure-Fit Parts

When assembling pressure-fit parts, use a molybdenum disulfide base compound or equivalent to lubricate the mating surface.

Bearings

1. When a bearing is removed, cover it to keep out dirt and abrasives. Clean bearings in nonflammable cleaning solvent and allow to drip dry. Compressed air can be used but do not spin the bearing.
2. Discard bearings if the races and balls (or rollers) are pitted, scored, or burned.
3. If bearing is found to be serviceable, apply a light coat of oil and wrap it in clean (waxed) paper. Do not unwrap reusable or new bearings until they are ready to install.
4. Lubricate new or used serviceable bearings before installation. When pressing a bearing into a retainer or bore, apply pressure to the outer race. If the bearing is to be installed on a shaft, apply pressure to the inner race.

Gaskets

Check that holes in gaskets align with openings in the mating parts. If it becomes necessary to hand-fabricate a gasket, use gasket material or stock of equivalent material and thickness. Be sure to cut holes in the right location, as blank gaskets can cause serious system damage.

Bolt Usage and Torque Application

NOTICE

SELF LOCKING FASTENERS, SUCH AS NYLON INSERT AND THREAD DEFORMING LOCKNUTS, ARE NOT INTENDED TO BE REINSTALLED AFTER REMOVAL.

1. Always use new replacement hardware when installing locking fasteners. Use bolts of proper length. A bolt which is too long will bottom before the head is tight against its related part. If a bolt is too short, there will not be enough thread area to engage and hold the part properly. When replacing bolts, use only those having the same specifications of the original, or one which is equivalent.

2. Unless specific torque requirements are given within the text, standard torque values should be used on heat-treated bolts, studs, and steel nuts, in accordance with recommended shop practices. (See Torque Chart in Section 1.)

Hydraulic Lines and Electrical Wiring

Clearly mark or tag hydraulic lines and electrical wiring, as well as their receptacles, when disconnecting or removing them from the unit. This will assure that they are correctly reinstalled.

Hydraulic System

1. Keep the system clean. If evidence of metal or rubber particles are found in the hydraulic system, drain and flush the entire system.
2. Disassemble and reassemble parts on clean work surface. Clean all metal parts with non-flammable cleaning solvent. Lubricate components, as required, to aid assembly.

Lubrication

Service applicable components with the amount, type, and grade of lubricant recommended in this manual, at the specified intervals. When recommended lubricants are not available, consult your local supplier for an equivalent that meets or exceeds the specifications listed.

Battery

Clean battery using a non-metallic brush and a solution of baking soda and water. Rinse with clean water. After cleaning, thoroughly dry battery and coat terminals with an anti corrosion compound.

Lubrication and Servicing

Components and assemblies requiring lubrication and servicing are shown in the Lubrication Chart in Section 1.

2.3 LUBRICATION AND INFORMATION

Hydraulic System

1. The primary enemy of a hydraulic system is contamination. Contaminants enter the system by various means, e.g., using inadequate hydraulic oil, allowing moisture, grease, filings, sealing components, sand, etc., to enter when performing maintenance, or by permitting the pump to cavitate due to insufficient system warm-up or leaks in the pump supply (suction) lines.
2. The design and manufacturing tolerances of the component working parts are very close, therefore, even the smallest amount of dirt or foreign matter entering a system can cause wear or damage to the components and generally results in faulty operation. Every precaution must be taken to keep hydraulic oil clean, including reserve oil in storage. Hydraulic system filters should be checked, cleaned, and/or replaced as necessary, at the specified intervals required in the Lubrication Chart in Section 1. Always examine filters for evidence of metal particles.
3. Cloudy oils indicate a high moisture content which permits organic growth, resulting in oxidation or corrosion. If this condition occurs, the system must be drained, flushed, and refilled with clean oil.
4. It is not advisable to mix oils of different brands or types, as they may not contain the same required additives or be of comparable viscosities. Good grade mineral oils, with viscosities suited to the ambient temperatures in which the machine is operating, are recommended for use.

NOTE: Metal particles may appear in the oil or filters of new machines due to the wear-in of meshing components.

Hydraulic Oil

1. Refer to Section 1 for recommendations for viscosity ranges.
2. JLG recommends Mobilfluid 424 hydraulic oil, which has an SAE viscosity of 10W-30 and a viscosity index of 152.

NOTE: Start-up of hydraulic system with oil temperatures below -15°F (-26°C) is not recommended. If it is necessary to start the system in a sub-zero environment, it will be necessary to heat the oil with a low density, 100VAC heater to a minimum temperature of -15°F (-26°C).

3. The only exception to the above is to drain and fill the system with Mobil DTE 13 oil or its equivalent. This will allow start up at temperatures down to -20°F (-29°C). However, use of this oil will give poor performance at temperatures above 120°F (49°C). Systems using DTE 13 oil should not be operated at temperatures above 200°F (94°C) under any condition.

Changing Hydraulic Oil

1. Filter elements must be changed after the first 50 hours of operation and every 300 hours (unless specified otherwise) thereafter. If it is necessary to change the oil, use only those oils meeting or exceeding the specifications appearing in this manual. If unable to obtain the same type of oil supplied with the machine, consult local supplier for assistance in selecting the proper equivalent. Avoid mixing petroleum and synthetic base oils.
2. Use every precaution to keep the hydraulic oil clean. If the oil must be poured from the original container into another, be sure to clean all possible contaminants from the service container. Always clean the mesh element of the filter and replace the cartridge any time the system oil is changed.
3. While the unit is shut down, a good preventive maintenance measure is to make a thorough inspection of all hydraulic components, lines, fittings, etc., as well as a functional check of each system, before placing the machine back in service.

Lubrication Specifications

Specified lubricants, as recommended by the component manufacturers, are always the best choice, however, multi-purpose greases usually have the qualities which meet a variety of single purpose grease requirements. Should any question arise, regarding the use of greases in maintenance stock, consult your local supplier for evaluation. Refer to Section 1 for an explanation of the lubricant key designations appearing in the Lubrication Chart.

2.4 CYLINDER DRIFT TEST

Theory

When a hydraulic cylinder is supporting a load, cylinder drift may occur as a result of any of the circumstances below:

- Normal leakage of load holding valves or malfunction of load holding valves. See Cylinder Leakage Test and Table 2-2., Cylinder Drift for evaluation.
- Damaged or worn piston seals.
- Normal thermal expansion or contraction of the hydraulic oil within cylinders (See Cylinder Thermal Drift below).

The first two circumstances may result in cylinder movement due to oil leaking out of the cylinder externally or by leaking back to tank or due to oil leaking internally from one cylinder chamber to the other.

Thermal expansion or contraction of oil in hydraulic cylinders is a normal occurrence and does not result in oil leaking out of the cylinder or leaking internally from one cylinder chamber to the other. Thermal expansion or contraction is the tendency for materials to change size in response to a change in temperature.

Cylinder Leakage Test

Cylinder oil must be at stabilized ambient temperature before beginning this test.

Measure drift at cylinder rod with a calibrated dial indicator.

In an area free of obstructions, cylinder must have load applied and appropriately positioned to detect drift.

Cylinder leakage is acceptable if it passes this test.

Table 2-2. Cylinder Drift

Cylinder Bore Diameter		Max. Acceptable Drift in 10 Minutes	
inches	mm	inches	mm
3	76.2	0.026	0.66
3.5	89	0.019	0.48
4	101.6	0.015	0.38
5	127	0.009	0.22
6	152.4	0.006	0.15
7	177.8	0.005	0.13
8	203.2	0.004	0.10
9	228.6	0.003	0.08

NOTE: The information is based on 6 drops per minute cylinder leakage.

Cylinder Thermal Drift

The oil in all hydraulic cylinders will expand or contract due to thermal effects over time and may result in changes to the boom and/or platform position while the machine is stationary. These effects occur as the cylinder oil changes temperature, usually from a higher oil temperature as it cools and approaches the ambient air temperature. Results of these effects are related to several factors including cylinder length and change in temperature over the time the cylinder remains stationary.

2.5 PINS AND COMPOSITE BEARING REPAIR GUIDELINES

Filament wound bearings.

1. Pinned joints should be disassembled and inspected if the following occurs:
 - a. Excessive sloppiness in joints.
 - b. Noise originating from the joint during operation.
2. Filament wound bearings should be replaced if any of the following is observed:
 - a. Frayed or separated fibers on the liner surface.
 - b. Cracked or damaged liner backing.
 - c. Bearings that have moved or spun in their housing.
 - d. Debris embedded in liner surface.
3. Pins should be replaced if any of the following is observed (pin should be properly cleaned prior to inspection):
 - a. Detectable wear in the bearing area.
 - b. Flaking, peeling, scoring, or scratches on the pin surface.
 - c. Rusting of the pin in the bearing area.
4. Re-assembly of pinned joints using filament wound bearings.
 - a. Housing should be blown out to remove all dirt and debris...bearings and bearing housings must be free of all contamination.
 - b. Bearing/pins should be cleaned with a solvent to remove all grease and oil. Filament wound bearing are a dry joint and should not be lubricated unless otherwise instructed (i.e. sheave pins).
 - c. Pins should be inspected to ensure it is free of burrs, nicks, and scratches which would damage the bearing during installation and operation.

2.6 WELDING ON JLG EQUIPMENT

NOTE: This instruction applies to repairs, or modifications to the machine and to welding performed from the machine on an external structure, or component.

Do the Following When Welding on JLG Equipment

- Disconnect the battery.
- Disconnect the moment pin connection (where fitted).
- Ground only to structure being welded.

Do NOT Do the Following When Welding on JLG Equipment

- Ground on frame and weld on any other area than the chassis.
- Ground on turntable and weld on any other area than the turntable.
- Ground on the platform/support and weld on any other area than the platform/support.
- Ground on a specific boom section and weld on any other area than that specific boom section.
- Allow pins, wear pads, wire ropes, bearings, gearing, seals, valves, electrical wiring, or hoses to be between the grounding position and the welded area.

NOTICE

FAILURE TO COMPLY WITH THE ABOVE REQUIREMENTS MAY RESULT IN COMPONENT DAMAGE (I.E. ELECTRONIC MODULES, SWING BEARING, COLLECTOR RING, BOOM WIRE ROPES ETC.).

NOTE: Refer the Operation and Safety Manual for completion procedures for the Pre-Start Inspection.

Table 2-3. Inspection and Preventive Maintenance Schedule

AREA	Inspections	
	Pre-Delivery ¹ or Frequent ² (Quarterly) Inspection	Annual ³ (Yearly) Inspection
Boom Assembly		
Boom Weldments	1,2	1,2
Hose/Cable Carrier Installations	1,2	1,2
Pivot Pins and Pin Retainers	1,2	1,2
Sheaves, Sheave Pins	1,2	1,2
Bearings	1,2	1,2
Wear Pads	1,2	1,2
Covers or Shields	1,2	1,2
Extend/Retract Chain or Cable Systems ⁴	1,2	1,2
Platform Assembly		
Railing	2	2
Gate	1,2,3	1,2,3
Floor	2	2
Rotator	1,2,3,4	1,2,3,4
Lanyard Anchorage Point	1,2,6	1,2,6
Turntable Assembly		
Swing Bearing or Worm Gear	1 ⁵⁰ ,2	1 ⁵⁰ ,2
Oil Coupling	4	4
Swing Drive System	1,4	1,4
Turntable Lock	1,2,3	1,2,3
Hood, Hood Props, Hood Latches	3	3
Chassis Assembly		
Tires	1,2	1,2
Wheel Nuts/Bolts	1 ⁵⁰	1 ⁵⁰
Wheel Bearings		1,2,4,5
Oscillating Axle/Lockout Cylinder Systems		1,2,4,5
Extendable Axle Systems	3	3
Steer Components		1,2
Spindle Thrust Bearing/Washers		1,2
Drive Hubs	1,4	1,4

SECTION 2 - GENERAL

Table 2-3. Inspection and Preventive Maintenance Schedule

AREA	Inspections	
	Pre-Delivery ¹ or Frequent ² (Quarterly) Inspection	Annual ³ (Yearly) Inspection
Functions/Controls		
Platform Controls return to neutral/off when released	1,3,6,9	1,3,6,9
Ground Controls return to neutral/off when released	1,3,6,9	1,3,6,9
Function Control Locks, Guards, or Detents	1,3,9	1,3,9
Footswitch (shuts off function when released)	1,3,9	1,3,9
Emergency Stop Switches (Ground & Platform) arrest all platform movement	1,3,6	1,3,6
Function Limit or Cutout Switch Systems	1,3,9	1,3,9
Capacity Indicator	1,3,9	1,3,9
Drive Brakes	1,3,9	1,3,9
Swing Brakes	1,3,9	1,3,9
Auxiliary Power	1,3,9	1,3,9
Power System		
Engine Idle, Throttle, and RPM	1,3,7	1,3,7
Engine Fluids: Oil	4	4
Engine Fluids: Coolant	1,4,7	1,4,7
Air Filter	1,4	1,4
Fuel Filter(s)	1,5	1,5
Drain Oil Build Up in 2-Stage Vaporizer (LP Only)	1,4	1,4
Exhaust System	1,4	1,4
Batteries	1,4	1,4
Battery Fluid	4	4
Battery Charger	1,3	1,3
Intake System	1,2	1,2
Glow Plug (Diesel Only)	1,2,3	1,2,3
Serpentine Belt, Tensioner, Pulleys	1,2,3	1,2,3
Fuel Reservoir, Cap, and Breather	1,2,4	1,2,4
Hydraulic/Electric System		
Hydraulic Pumps	1,2,4	1,2,4
Hydraulic Cylinders	1,2,4,5	1,2,4,5
Cylinder Attachment Pins and Pin Retainers	1,2	1,2
Hydraulic Hoses, Lines, and Fittings	1,2,4	1,2,3,4
Hydraulic Reservoir, Cap, and Breather	1,2,3,4,5	1,2,3,4,5
Hydraulic Filter(s)	1,4,5	1,4,5
Hydraulic Fluid	4,5	4,5
Electrical Connections	1,2	1,2
Instruments, Gauges, Switches, Lights, Horn		1,3

Table 2-3. Inspection and Preventive Maintenance Schedule

AREA	Inspections	
	Pre-Delivery ¹ or Frequent ² (Quarterly) Inspection	Annual ³ (Yearly) Inspection
General		
All Decals/Placards Installed, Secure, Legible	9	9
Annual Machine Inspection Due		9
No Unauthorized Modifications or Additions	9	9
All Relevant Safety Publications Incorporated	9	9
General Structural Condition and Welds	2	2
All Fasteners, Pins, Shields, and Covers	1,2	1,2
Grease and Lubricate to Specifications	9	9
Function Test of All Systems	9	9
Paint and Appearance	5	5
Stamp Inspection Date on Frame		9
Notify JLG of Machine Ownership		9
Footnotes:		
¹ Prior to each sale, lease, or delivery		
² In service for 3 months; Out of service for 3 months or more; Purchased used		
³ Annually, no later than 13 months from the date of the prior inspection, Includes all daily and quarterly inspections, mandated by regulating body		
⁴ Replace every 12 years or 7,000 hours		
⁵⁰ Indicates a 50 hour interval required to perform task after initial use of machine. This only occurs once in machine life		
²⁵⁰ Indicates a 250 hour interval required to perform task after initial use of machine. This only occurs once in machine life		
Performance Codes:		
1 - Check for proper and secure: installation, adjustment, or torque		
2 - Visual inspection for damage: (cracks, corrosion, abrasions, distortion, excessive wear, broken welds, gouges, chafing and threads showing)		
3 - Proper operation		
4 - Check for proper sealing, signs of leakage and fluid level		
5 - Clean and free of debris		
6 - Decals installed and legible		
7 - Check for proper tolerances, routing, and lubrication		
8 - Fully Charged		
9 - Verify/Perform		

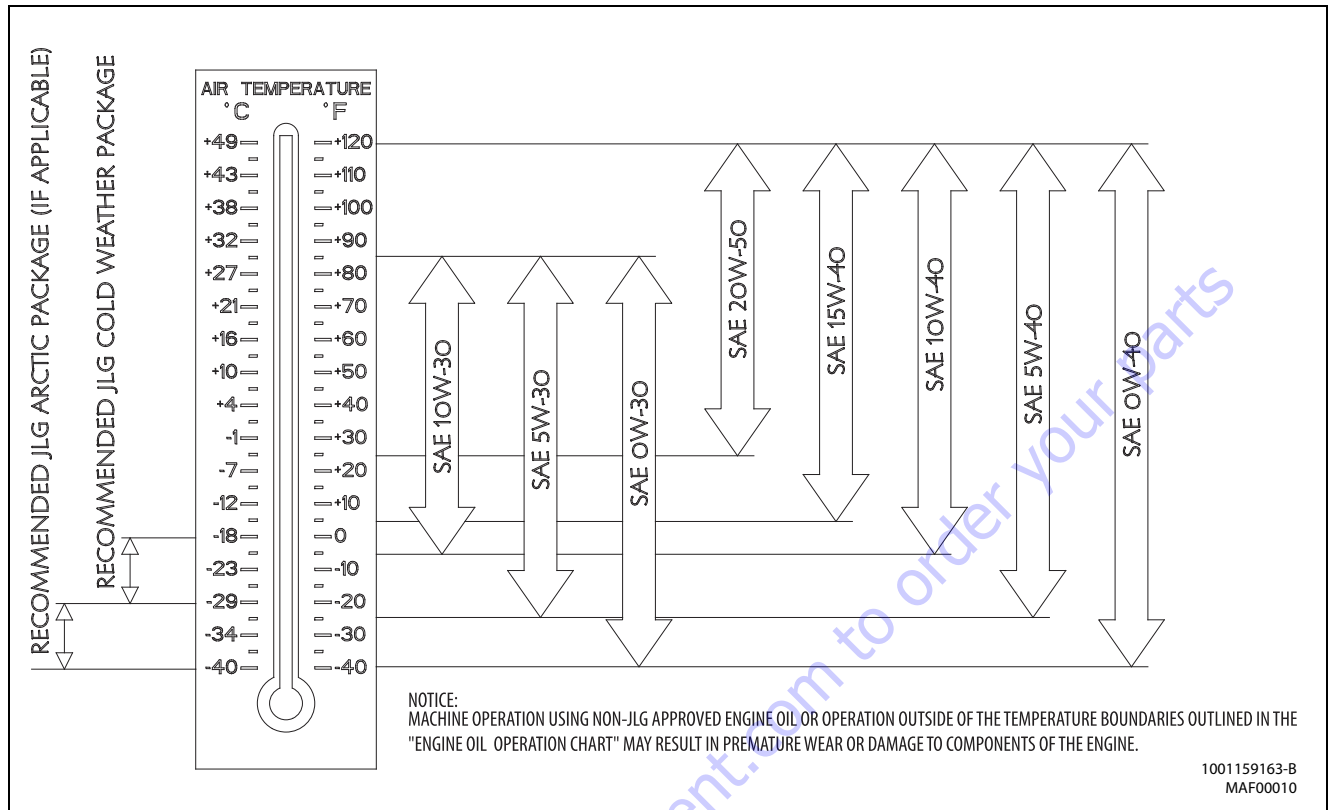

Figure 2-1. Engine Operating Temperature Specifications - Deutz 2.9

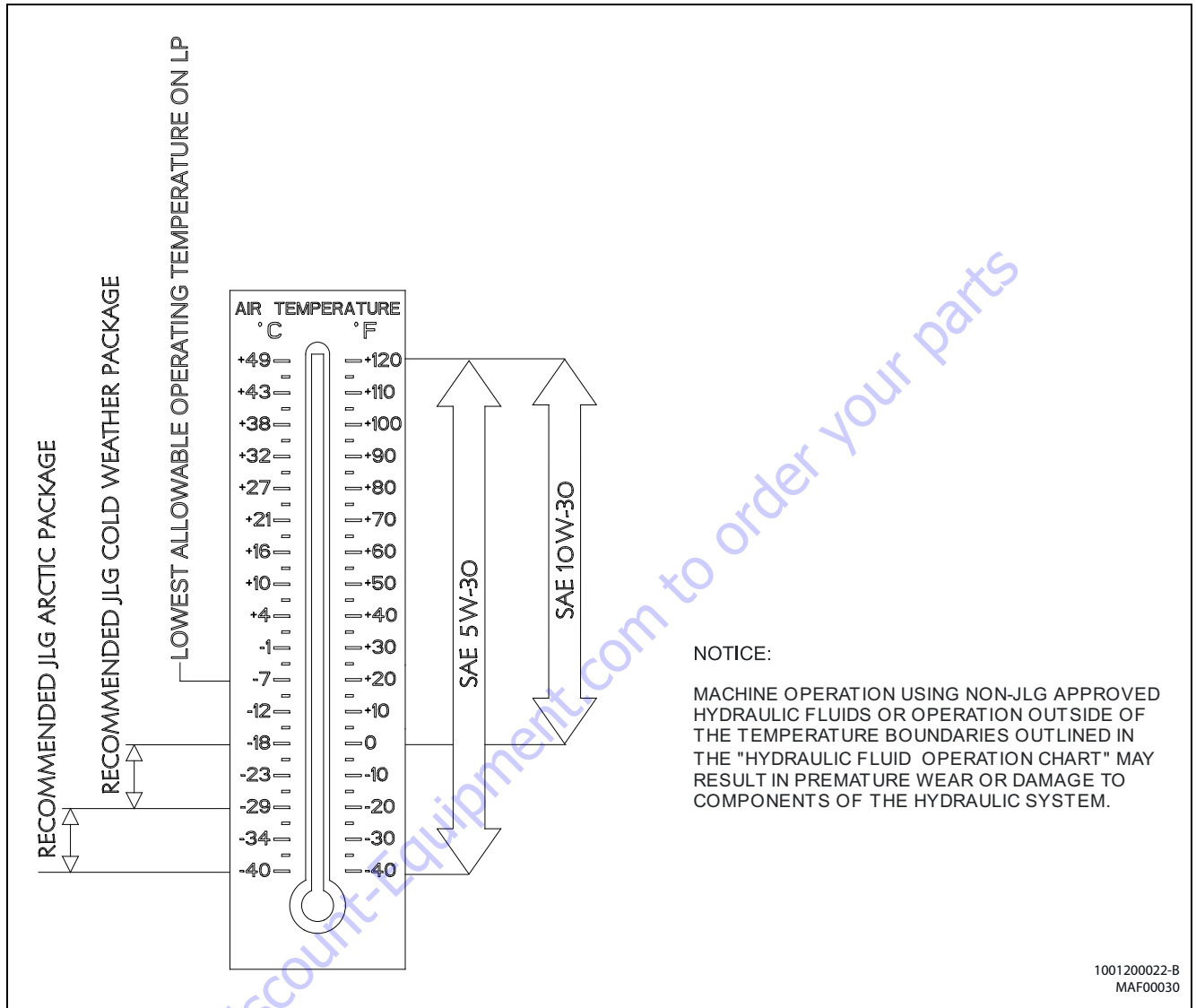

Figure 2-2. Engine Operating Temperature Specifications - GM

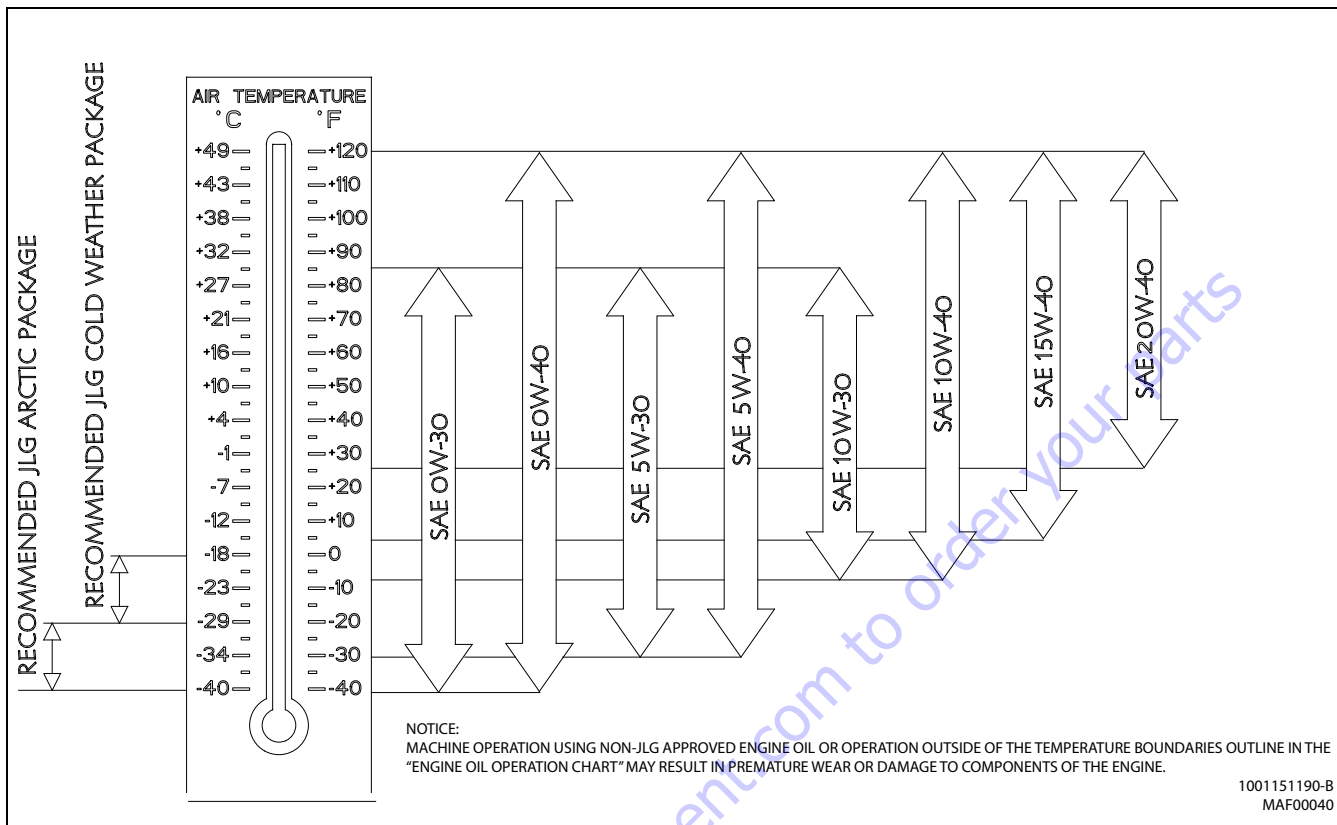

Figure 2-3. Engine Oil Operating Temperature Specifications - Deutz 2011

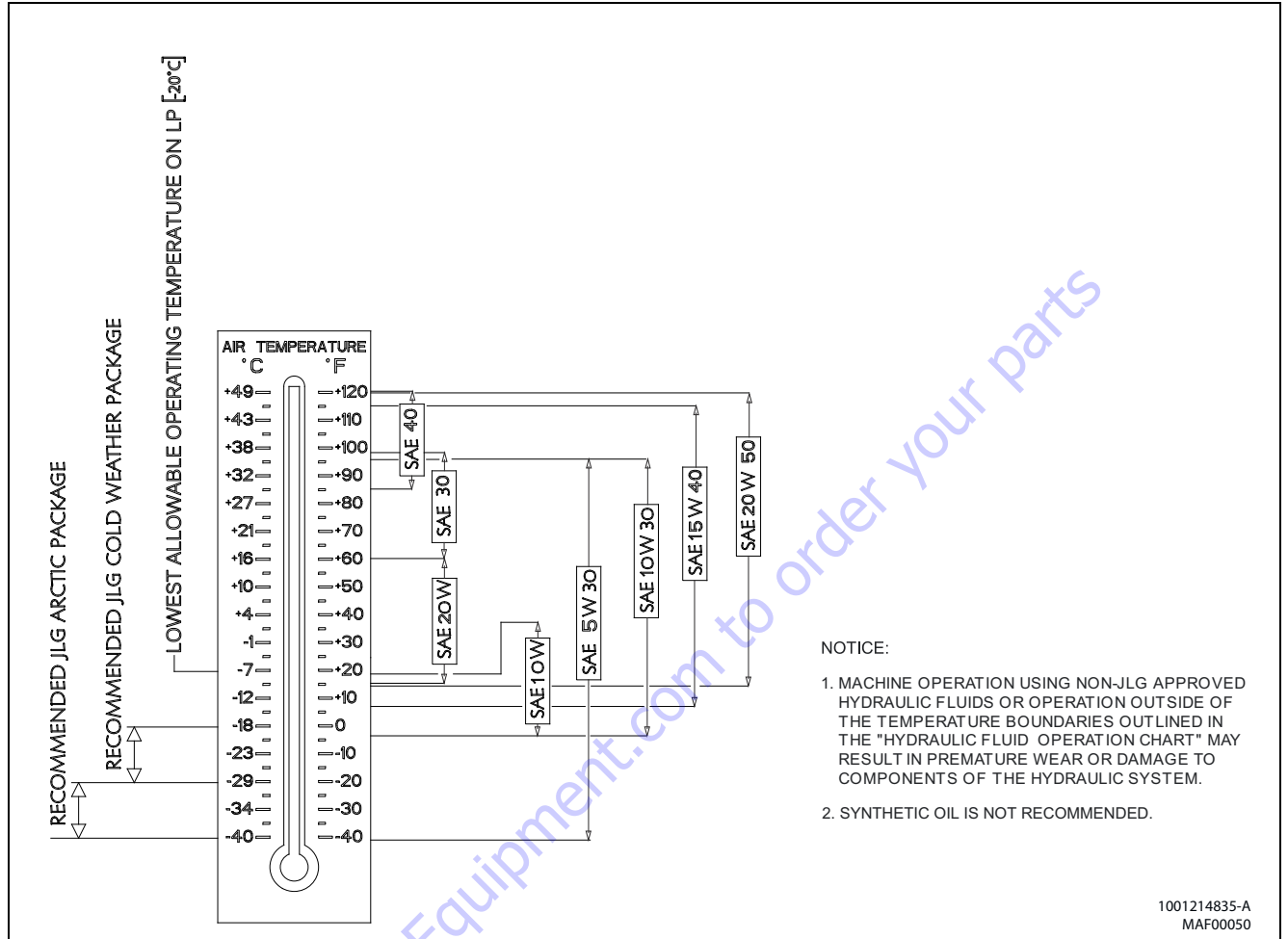

Figure 2-4. Engine Operating Temperature Specifications - Kubota

SECTION 2 - GENERAL

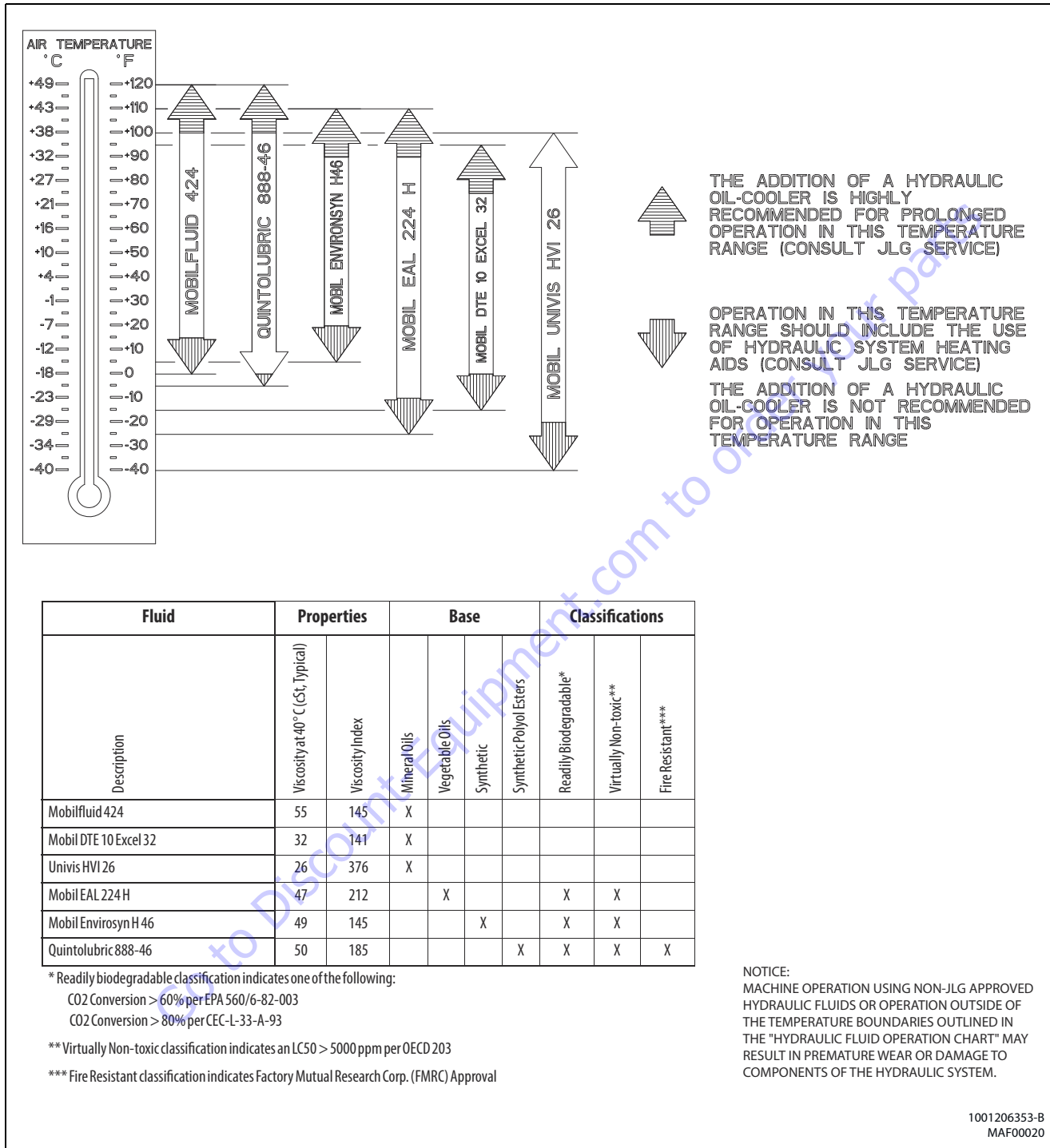

Figure 2-5. Hydraulic Oil Operating Temperature Specifications

PARTS FINDER

**Search Website
by Part Number**



**Search Manual
Library For Parts
Manual & Lookup Part
Numbers – Purchase
or Request Quote**

A screenshot of the "Search Manuals" form. The form has a title "Search Manuals" and a subtitle "Please provide information to help us locate the manual and/or parts you need." It includes fields for "Brand", "Model", "Serial", "Part Number", and "Quantity". There is a "Search" button at the bottom.

**Can't Find Part or
Manual? Request Help
by Manufacturer,
Model & Description**

A screenshot of the "Parts Order Form". The form has a title "Parts Order Form" and a subtitle "Please fill in as much information as possible." It includes fields for "Manufacturer", "Model", "Description", "Part Number", "Quantity", and "Price". There is a "Submit" button at the bottom.

Discount-Equipment.com is your online resource for quality parts & equipment.

Florida: **561-964-4949** Outside Florida TOLL FREE: **877-690-3101**

Need parts?

Click on this link: <http://www.discount-equipment.com/category/5443-parts/> and choose one of the options to help get the right parts and equipment you are looking for. Please have the machine model and serial number available in order to help us get you the correct parts. If you don't find the part on the website or on one of the online manuals, please fill out the request form and one of our experienced staff members will get back to you with a quote for the right part that your machine needs.

We sell worldwide for the brands: Genie, Terex, JLG, MultiQuip, Mikasa, Essick, Whiteman, Mayco, Toro Stone, Diamond Products, Generac Magnum, Airman, Haulotte, Barreto, Power Blanket, Nifty Lift, Atlas Copco, Chicago Pneumatic, Allmand, Miller Curber, Skyjack, Lull, Skytrak, Tsurumi, Husquvarna Target, , Stow, Wacker, Sakai, Mi-T- M, Sullair, Basic, Dynapac, MBW, Weber, Bartell, Bennar Newman, Haulotte, Ditch Runner, Menegotti, Morrison, Contec, Buddy, Crown, Edco, Wyco, Bomag, Laymor, Barreto, EZ Trench, Bil-Jax, F.S. Curtis, Gehl Pavers, Heli, Honda, ICS/PowerGrit, IHI, Partner, Imer, Clipper, MMD, Koshin, Rice, CH&E, General Equipment, ,AMida, Coleman, NAC, Gradall, Square Shooter, Kent, Stanley, Tamco, Toku, Hatz, Kohler, Robin, Wisconsin, Northrock, Oztec, Toker TK, Rol-Air, Small Line, Wanco, Yanmar

SECTION 3. CHASSIS & TURNTABLE

3.1 TIRES AND WHEELS

Tire Inflation

The air pressure for pneumatic tires must be equal to the air pressure that is stenciled on the side of the JLG product or rim decal for safe and proper operational characteristics.

Tire Damage

For pneumatic tires, JLG Industries, Inc. recommends that when any cut, rip, or tear is discovered that exposes sidewall or tread area cords in the tire, measures must be taken to remove the JLG product from service immediately. Arrangements must be made for replacement of the tire or tire assembly.

For polyurethane foam filled tires, JLG Industries, Inc. recommends that when any of the following are discovered, measures must be taken to remove the JLG product from service immediately and arrangements must be made for replacement of the tire or tire assembly.

- A smooth, even cut through the cord plies which exceeds 3 in. (7.5 cm) in total length
- Any tears or rips (ragged edges) in the cord plies which exceeds 1 in. (2.5 cm) in any direction
- Any punctures which exceed 1 in. in diameter
- Any damage to the bead area cords of the tire

If a tire is damaged but is within the above noted criteria, the tire must be inspected on a daily basis to insure the damage hasn't propagated beyond the allowable criteria.

Tire Replacement

JLG recommends a replacement tire be the same size, ply and brand as originally installed on the machine. Please refer to the JLG Parts Manual for the part number of the approved tires for a particular machine model. If not using a JLG approved replacement tire, we recommend that replacement tires have the following characteristics:

- Equal or greater ply/load rating and size of original
- Tire tread contact width equal or greater than original
- Wheel diameter, width, and offset dimensions equal to the original
- Approved for the application by the tire manufacturer (including inflation pressure and maximum tire load)

Unless specifically approved by JLG Industries Inc. do not replace a foam filled or ballast filled tire assembly with a pneumatic tire. When selecting and installing a replacement tire, ensure that all tires are inflated to the pressure recommended by JLG. Due to size variations between tire brands, both tires on the same axle should be the same.

Wheel Replacement

The rims installed on each product model have been designed for stability requirements which consist of track width, tire pressure, and load capacity. Size changes such as rim width, center piece location, larger or smaller diameter, etc., without written factory recommendations, may result in an unsafe condition regarding stability.

Wheel Installation

It is extremely important to apply and maintain proper wheel mounting torque.

⚠ WARNING

WHEEL NUTS MUST BE INSTALLED AND MAINTAINED AT THE PROPER TORQUE TO PREVENT LOOSE WHEELS, BROKEN STUDS, AND POSSIBLE DANGEROUS SEPARATION OF WHEEL FROM THE AXLE. BE SURE TO USE ONLY THE NUTS MATCHED TO THE CONE ANGLE OF THE WHEEL.

Tighten the lug nuts to the proper torque to prevent wheels from coming loose. Use a torque wrench to tighten the fasteners. If you do not have a torque wrench, tighten the fasteners with a lug wrench, then immediately have a service garage or dealer tighten the lug nuts to the proper torque. Over-tightening will result in breaking the studs or permanently deforming the mounting stud holes in the wheels.

The proper procedure for attaching wheels is as follows:

1. Start all nuts by hand to prevent cross threading. DO NOT use a lubricant on threads or nuts.
2. Tighten nuts in the following sequence:

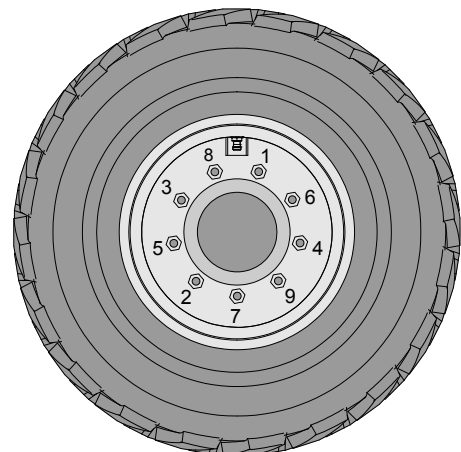

- The tightening of the nuts should be done in stages. Following the recommended sequence, tighten nuts per wheel torque chart.

Table 3-1. Wheel Torque Chart

TORQUE SEQUENCE		
1st Stage	2nd Stage	3rd Stage
40ft. lbs. (55 Nm)	96ft. lbs. (130 Nm)	170ft. lbs. (230 Nm)

- Wheel nuts should be torqued before first road use and after each wheel removal. Check and torque every 3 months or 150 hours of operation.

3.2 CHASSIS TILT INDICATOR SYSTEM

The Chassis Tilt Indicator System measures the turntable angle with respect to level ground. The control system interprets the reading and compares it to turntable tilt angle value set in the JLG Control System.

When the machine is in transport position, it can travel at up to maximum speed until it tilts more than 8.0°, then the system will limit the drive speed to maximum displacement mode (low drive speed).

When the machine is out of transport position and the turntable tilts more than the configured value, the boom functions can only operate in creep speed mode, and the drive function is disabled. The operator has to return the machine to transport mode in order to continue to drive the machine.

Refer Table 6-2, Machine Configuration Programming Information (Software Version P2.10) for details.

3.3 DRIVE SYSTEM (4WD & 2WD)

The four wheel drive system consists of one variable displacement closed loop pump, four variable displacement piston motors, gear reduction hubs, and a traction control manifold that includes three flow dividers/combiners.

The two wheel drive system consists of one variable displacement closed loop pump, two variable displacement piston motors, gear reduction hubs, and a traction control manifold that includes one flow dividers/combiner.

Drive speed is varied by a combination of drive pump displacement, engine speed, and motor displacement. Traction control is full-time and is present in all drive modes. There are three drive modes that can be selected at the platform console. The functionality of the drive system is dependent on the position of the boom.

3.4 DRIVE ORIENTATION SYSTEM

The Drive Orientation System (DOS) is intended to indicate to the operator conditions that could make the direction of movement of the chassis different than the direction of movement of the drive/steer control handle. The system indicates to the operator the need to match the black and white directional arrows on the platform control panel to the arrows on the chassis. The system uses a proximity sensor mounted on the hydraulic oil coupling, an indicator light and an override switch on the platform display panel. The proximity sensor trips when the turntable is swung +/- 42 degrees off center of the normal driving position. This occurs roughly when the boom is swung past a rear tire. When the turntable is in the normal drive position with the boom between the rear tires, no indications or interlocks are made. When the machine is actively driving when the turntable is swung past the switch point, the system is ignored until drive/steer is released. When drive is initiated with the boom swung past the switch point, the DOS indicator will flash and the drive/steer functions will be disabled. The operator must engage the DOS override switch to enable drive/steer (High Speed drive will remain disabled). When the DOS is enabled, the DOS indicator will be illuminated continuously and a 3-second enable timer will be started and will continue for 3 seconds after the end the last drive/steer command. If the timer expires, the DOS override switch must be re-engaged to enable drive/steer.

3.5 LOCKOUT CYLINDER BLEEDING

- Start the engine.
- Position the turntable to the normal stowed position.
- Attach clear tubing to bleeder valve nipple.
- Position a small bucket/bottle in front of the lockout cylinder bleeder valve and insert clear tubing.
- Using a 3/8 in. wrench, loosen the bleeder valve, turning counterclockwise slowly. Bleed air from the top of lockout cylinder. Capture hydraulic oil until a steady unbroken stream of hydraulic oil is viewed. Tighten/close the bleeder valve while stream of hydraulic oil is running.

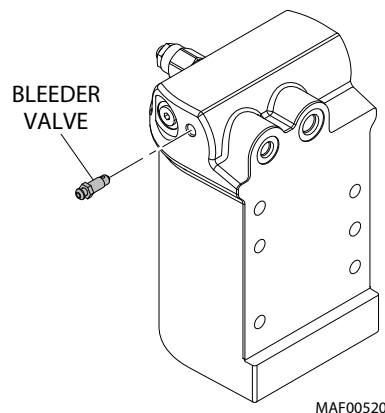

3.6 OSCILLATING AXLE SYSTEM

The oscillating front axle is attached to the frame by a pivot pin, which allows all four wheels to remain on the ground when traveling on rough terrain. There are two lockout cylinders connected between the frame and the axle. The lockout cylinders allow the axle to oscillate when the boom is in Transport Position.

The lockout cylinders will hold down the oscillating axle so to prevent its further movement if:

- Main boom rises above elevation by more than 5°; OR
- Fly boom telescopes out 12 in. (305 mm) or more.

If the boom is telescoped less than 12 in. (305 mm) and boom is no more than 5° greater than horizontal (with respect to the turntable), the turntable can swing 360° continuously without locking up the oscillating axle for better traction.

The boom angle is monitored by the JLG Control System through an angle sensor; the fly boom telescope is monitored by two proximity switches mounted on the main boom side. When the JLG Control System senses the conditions are met, it sends a signal to the 2-speed/lock up valve to supply pressure to lock up the cylinders.

3.7 OSCILLATING AXLE LOCKOUT TEST

NOTICE

LOCKOUT SYSTEM TEST MUST BE PERFORMED QUARTERLY, ANY TIME A SYSTEM COMPONENT IS REPLACED, OR WHEN IMPROPER SYSTEM OPERATION IS SUSPECTED.

NOTE: *Ensure boom is fully retracted, lowered, and centered between rear wheels prior to beginning lockout cylinder test.*

1. Place a 6 in. (15.2 cm) high block with ascension ramp in front of left front wheel.
2. From platform control console, start engine.
3. Place the Drive control lever to the forward position and carefully drive machine up ascension ramp until left front wheel is on top of block.
4. Carefully activate Telescope or Main Boom Lift control and take the boom out of the transport position.
5. Place Drive control lever to Reverse and drive machine off of block and ramp.
6. Have an assistant check to see that left front or right rear wheel remains elevated in position off of ground.
7. Return boom to stowed position. When boom reaches center, stowed position, lockout cylinders should release and allow wheel to rest on ground, it may be necessary to activate Drive to release cylinders.
8. Place the 6 in. (15.2 cm) high block with ascension ramp in front of right front wheel.
9. Place Drive control lever to Forward and carefully drive machine up ascension ramp until right front wheel is on top of block.
10. Repeat steps 4 through 7 to check the opposite side of the oscillating axle.
11. If lockout cylinders do not function properly, have qualified personnel correct the malfunction prior to any further operation.

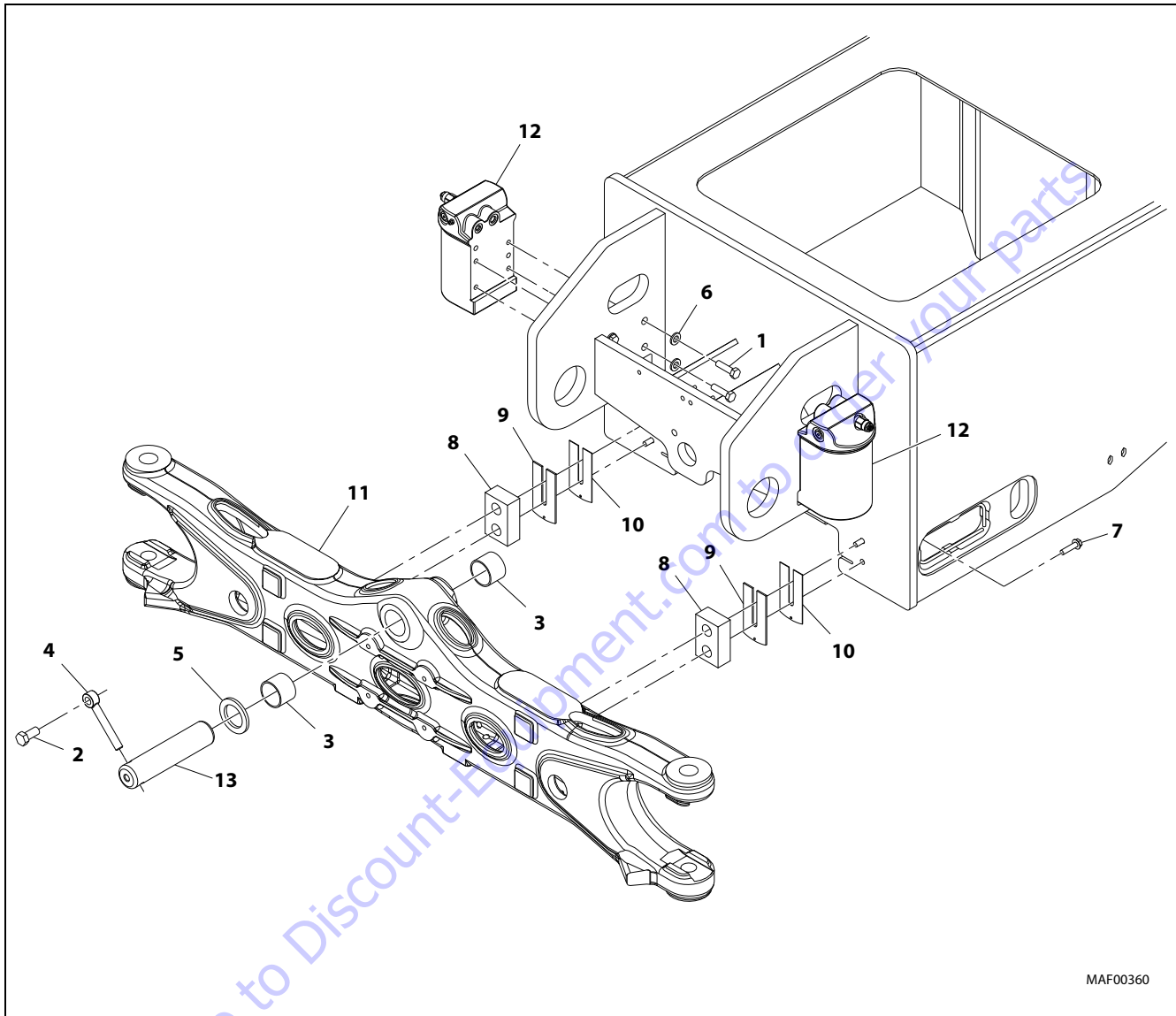

MAF00360

- | | | | |
|---------------|-----------|-------------|---------------------------|
| 1. Bolt | 5. Washer | 8. Wear Pad | 11. Axle |
| 2. Bolt | 6. Washer | 9. Shim | 12. Axle Lockout Cylinder |
| 3. Bearing | 7. Bolt | 10. Shim | 13. Pin |
| 4. Keeper Pin | | | |

Figure 3-1. Axle Installation

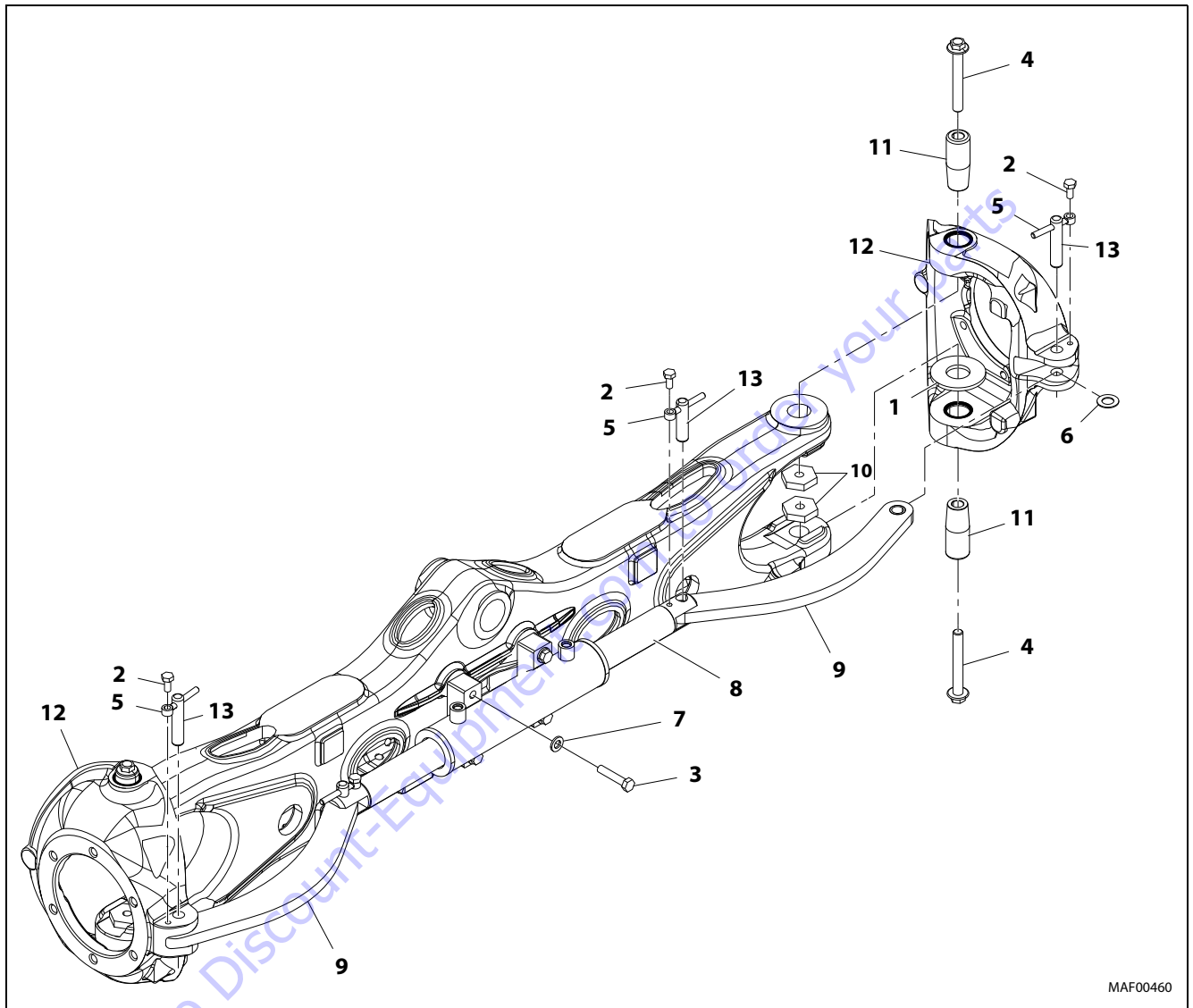

MAF00460

- | | | | |
|-------------------|---------------|-------------------|-------------|
| 1. Thrust Bearing | 5. Keeper Pin | 8. Steer Cylinder | 11. Kingpin |
| 2. Bolt | 6. Washer | 9. Link | 12. Spindle |
| 3. Bolt | 7. Washer | 10. Nut | 13. Pin |
| 4. Bolt | | | |

Figure 3-2. Steer Installation (Without Tow Package)

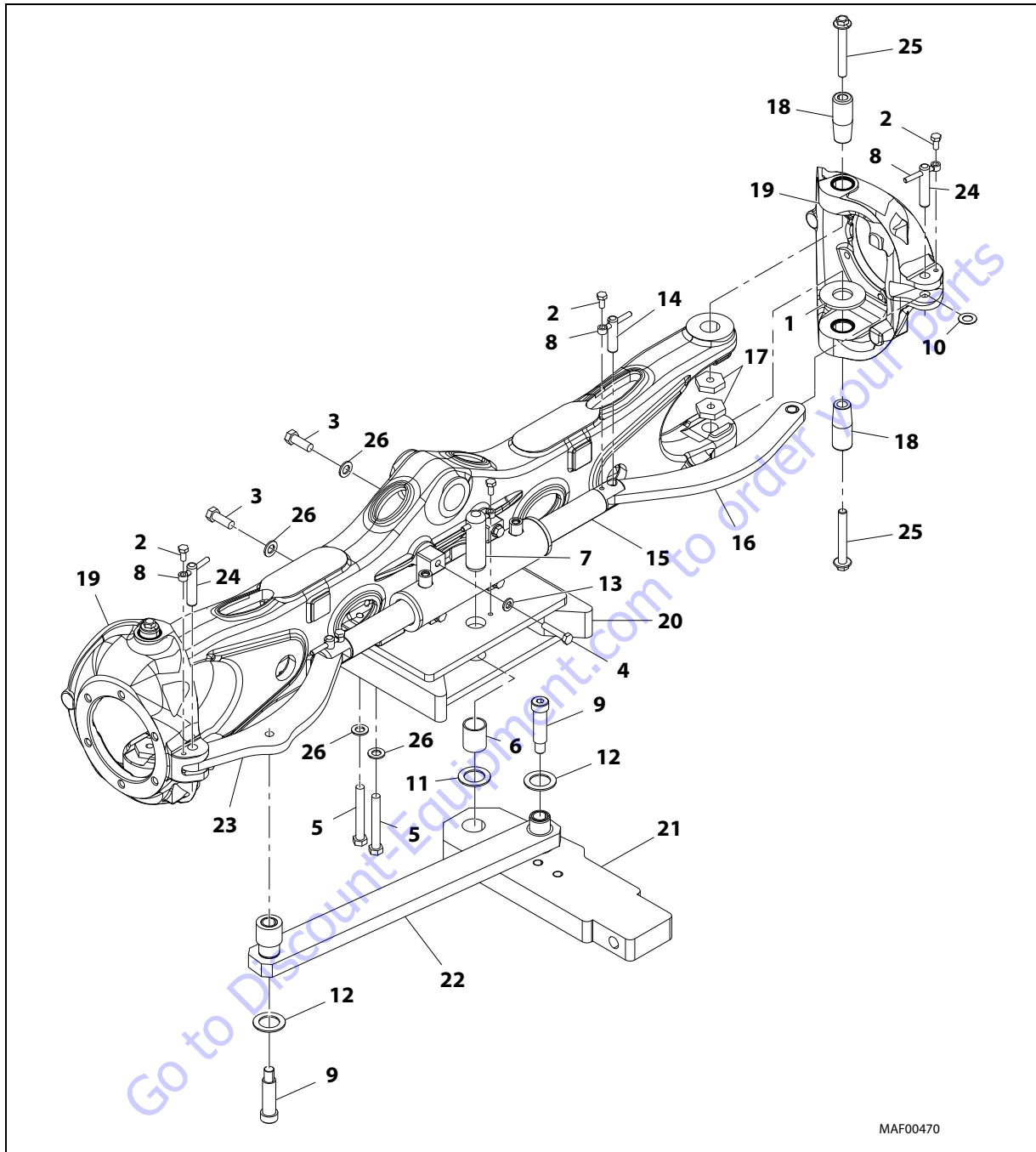

MAF00470

- | | | | | | |
|-------------------|---------------|------------|--------------------|-----------------|------------|
| 1. Thrust Bearing | 6. Bearing | 11. Washer | 15. Steer Cylinder | 19. Spindle | 23. Link |
| 2. Bolt | 7. Pin | 12. Washer | 16. Link | 20. Bracket | 24. Pin |
| 3. Bolt | 8. Keeper Pin | 13. Washer | 17. Nut | 21. Pivot Plate | 25. Bolt |
| 4. Bolt | 9. Bolt | 14. Pin | 18. Kingpin | 22. Link | 26. Washer |
| 5. Bolt | 10. Washer | | | | |

Figure 3-3. Steer Installation (With Tow Package)

3.8 WHEEL DRIVE ASSEMBLY

Removal

NOTE: The drive motor can be removed through the axle flange as part of the wheel drive assembly or they can be removed separately through the bottom of the frame while leaving the drive hub bolted to the axle.

1. Use a jack to lift the frame enough so the tire and wheel assembly is off the ground. Place blocking strong enough to support the weight of the machine under the frame and remove the jack.

NOTE: The pneumatic tire & wheel assembly weighs approximately 170 lbs. (77 kg). The foam-filled tire & wheel assembly weighs approximately 440 lbs. (200 kg). The solid tire & wheel assembly weighs approximately 286 lbs. (130 kg).

2. Remove hardware securing wheel and remove wheel assembly. Using suitable lifting device lift the wheel assembly and place in a suitable area.
3. Tag and disconnect the hydraulic lines running to the drive motor. Cap or plug all openings to ensure no dirt enters the hydraulic system.

NOTE: The drive hub and drive motor assembly weighs approximately 149 lbs. (68 kg).

4. Use a supporting device capable of handling the weight of the drive hub and drive motor, and unbolt the drive hub from the frame. Remove the entire assembly from the machine.
5. Remove the capscrews and washers that secure the drive motor to the drive hub and remove the drive motor. Remove and discard the brake gasket between the drive motor and drive hub.

Installation

1. Install a new brake gasket between the drive motor and drive hub. Apply a coat of JLG Threadlocker P/N 0100011 on capscrews. Install the washers and capscrews to secure the drive hub and drive motor, and torque to 70 ft. lbs. (95 Nm).
2. Place the drive hub flange against the mounting flange on the axle and fasten it in place with the bolts and washers. Torque the bolts to 190 ft. lbs. (258 Nm).
3. Using adequate support, install wheel into wheel assembly and secure with bolts and washers. Torque the lugnuts to 170 ft. lbs. (230 Nm).

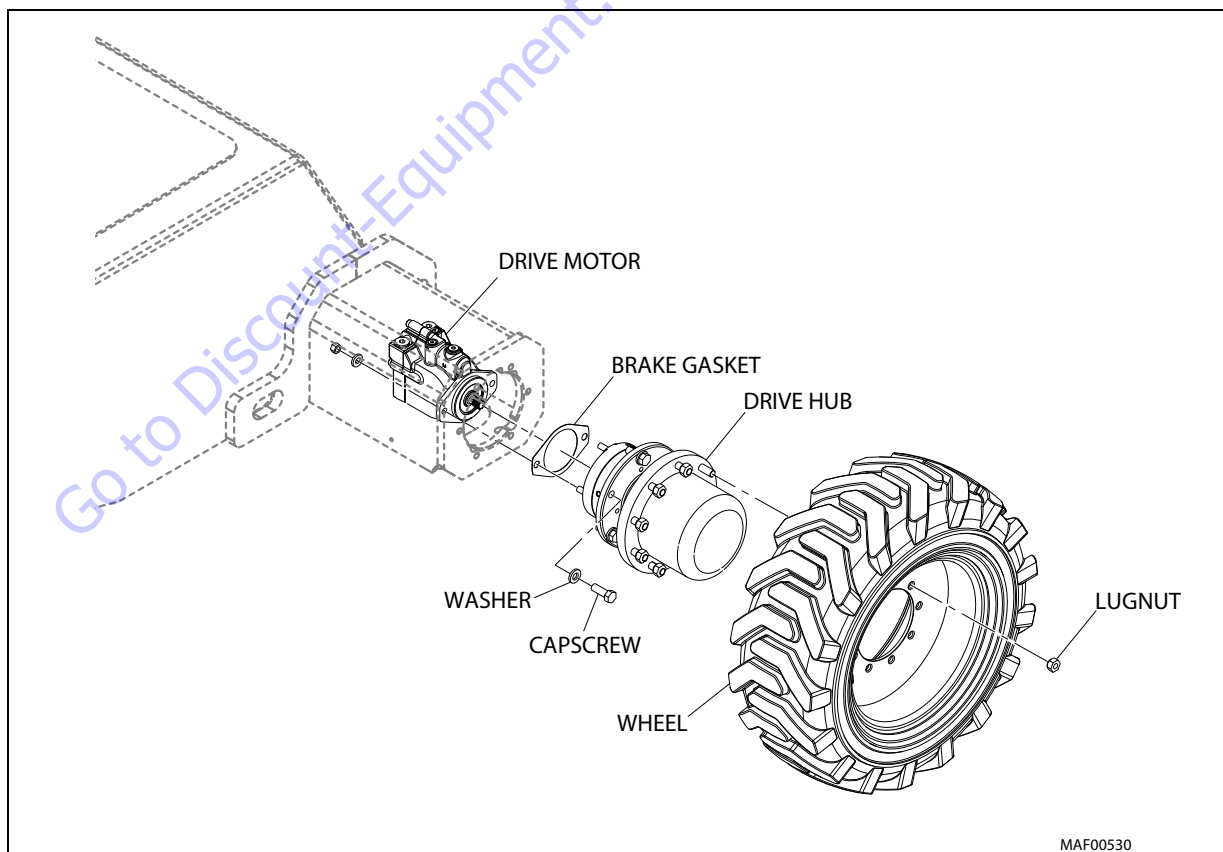

Figure 3-4. Wheel Drive Installation

3.9 TORQUE HUB

Roll and Leak Testing

Always roll and leak test Torque-Hubs after assembly to make sure that the unit's gears and sealants are working properly. The following information briefly outlines what to look for when performing these tests.

ROLL TEST

The roll test determines if the unit's gears rotate freely and properly. You should be able to rotate gears by applying a *constant* force to the roll checker. If you feel *more* drag in gears only at certain points, gears are not rolling freely. Examine them for improper installation or defects.

Some gear packages roll with more difficulty than others. Do not be concerned if gears seem to roll hard as long as they roll with *consistency*.

LEAK TEST

The purpose of a leak test is to make sure unit is air tight. You can tell if your unit has a leak if pressure gauge test reading starts to fall once you have pressurized the unit.

Leaks usually occur at the main seal or wherever O-rings or gaskets are located. You can usually detect location of a leak by brushing a soap and water solution around main seal and where O-rings or gaskets meet unit exterior, then checking for air bubbles. Replace part immediately if you detect a leak in a seal, O-ring, or gasket.

Tightening and Torquing Bolts

NOTICE

USE EXTREME CARE WHEN USING AN AIR IMPACT WRENCH. DO NOT TIGHTEN BOLTS BEYOND THEIR TORQUE SPECIFICATION. NEVER USE AN IMPACT WRENCH TO TIGHTEN SHOULDER BOLTS. TIGHTEN ALL SHOULDER BOLTS BY HAND.

1. Tighten (but do not torque) bolt "A" until snug.
2. Go to opposite side of bolt circle and tighten bolt "B" until equally snug.
3. Continue around bolt circle and tighten remaining bolts.
4. Apply specified torque to bolt "A".
5. Continue around bolt circle and apply equal torque to remaining bolts.

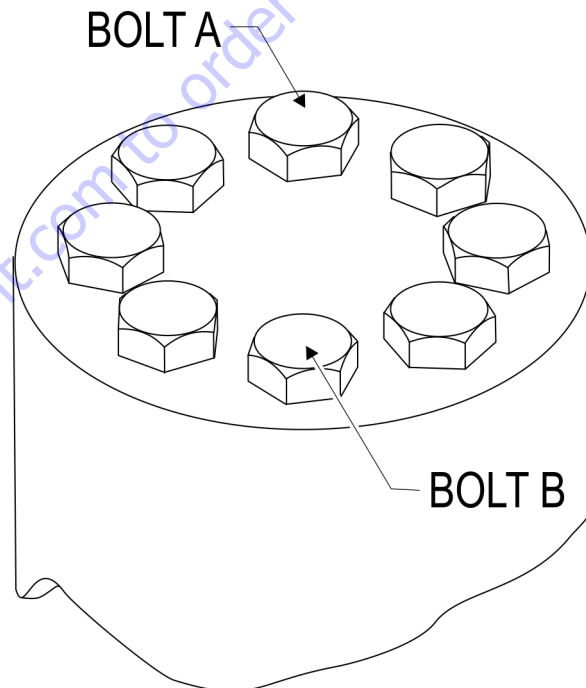

Figure 3-5. Bolt Tightening Sequence

Main Disassembly for "B" Drives

1. Turn hub (1G) on side, Remove coupling (14) from wide end of spindle (1A).
2. Mark location of shoulder bolt holes on outside of ring gear and hub for easy realignment when rebuilding. Remove four shoulder bolts (13) and 12 bolts (12) from cover (6).
3. Remove 16 flat washers (16) from cover (6).
4. Lift cover sub-assembly (6) off ring gear (4). Set cover on table with interior side facing up.

CAUTION

SHARP EDGES CAN CUT AND CAUSE SERIOUS INJURY. BEWARE OF SHARP EDGES IN COUNTERBORE WHEN REMOVING O-RING.

5. Remove O-ring (5) from counterbore around edge of cover (6A). Discard O-ring.

NOTE: *If O-ring is not in cover counterbore, it is in ring gear counterbore. Remove it from hub and discard.*

6. Remove thrust washer (11) from counterbore in top of carrier (3A).
7. Remove input gear (8) from middle of carrier sub-assembly (3).
8. Lift ring gear (4) off hub (1G).
9. Lift carrier sub-assembly (3) out of hub (1G).
10. Remove thrust spacer (9) from input shaft (7) in middle of spindle (1A).
11. Lift input shaft sub-assembly (7) out of middle of spindle (1A). Stand input shaft (7A) on splined end.

CAUTION

UNCONTROLLED OBJECTS CAN CAUSE EYE DAMAGE OR SERIOUS INJURY. ALWAYS WEAR EYE PROTECTION.

12. Using retaining ring pliers, remove retaining ring (7B) from groove on input shaft (7A).
13. Remove one spacer (7D), one spring (7C), and other spacer (7D) from input shaft (7A).
14. Remove thrust washer (11) from around spindle (1A).
15. Lift internal gear (2) out of hub (1G).
16. Remove O-ring (5) from counterbore in hub (1G). Discard O-ring.
17. Main disassembly for "B" drives is complete.

Hub-Spindle Disassembly

NOTE: *Start with large end of hub facing up and large end of spindle facing down.*

CAUTION

UNCONTROLLED OBJECTS CAN CAUSE EYE DAMAGE OR SERIOUS INJURY. ALWAYS WEAR EYE PROTECTION.

1. Remove retaining ring (1I) from around spindle (1A) in hub (1G).
2. Remove spacer (1H) from around spindle (1A) in hub (1G).
3. Set hub (1G), with small end/spindle facing down, on something that will support the hub's flange while it lifts hub up so spindle is not resting on anything. Carefully press or hammer spindle (1A) down and out of hub (1G).

NOTE: *If seal (1B) and bearing cone (1D) come out of hub and rest on spindle, remove these parts from spindle and set them aside. Discard seal.*

4. If seal and bearing cone did not come out of small end of hub (1G) when you pressed spindle out of hub, remove seal (1B) and bearing cone (1D) from small end of hub (1G). Discard seal.
5. Bearing cone (1F) should be lying loose in wide end of hub (1G). Remove bearing cone (1F) from inside hub (1G).

NOTE: *Do not strike counterbore with punch if using a punch and hammer when removing bearing cup.*

6. Remove bearing cup (1C) from counterbore in small end of hub (1G).

NOTE: *Do not strike counterbore with punch if using a punch and hammer when removing bearing cup.*

7. Turn hub (1G) over and lift it out of flange-support. Remove bearing cup (1E) from counterbore in wide end of hub (1G).
8. Turn hub (1G) over onto its small end. Remove two pipe plugs (1J) from side of hub (1G).

NOTE: *If your unit does not have studs, skip this step.*

9. Press nine studs (1N) out of stud holes in hub (1G).
10. Hub-spindle disassembly is complete.

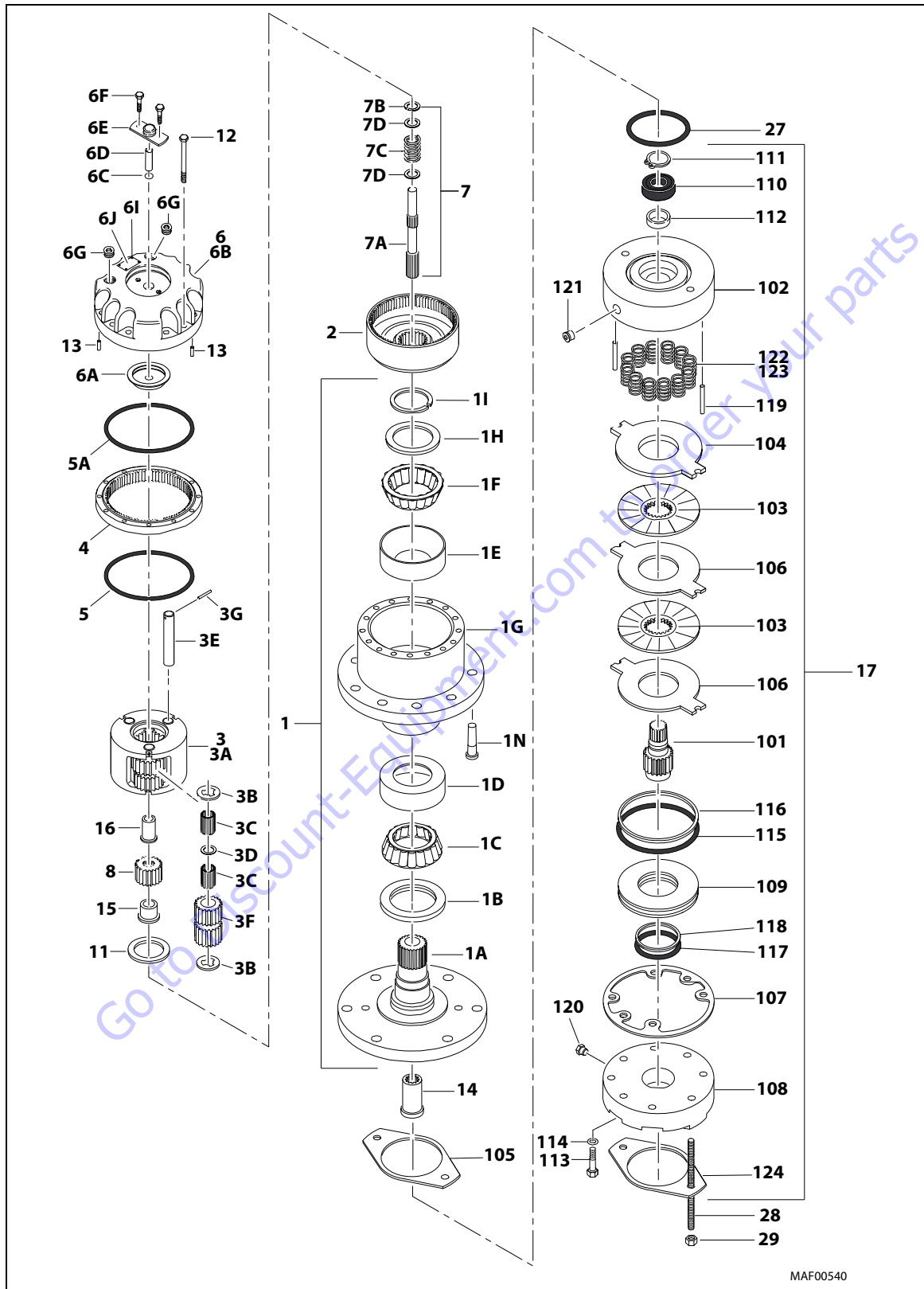
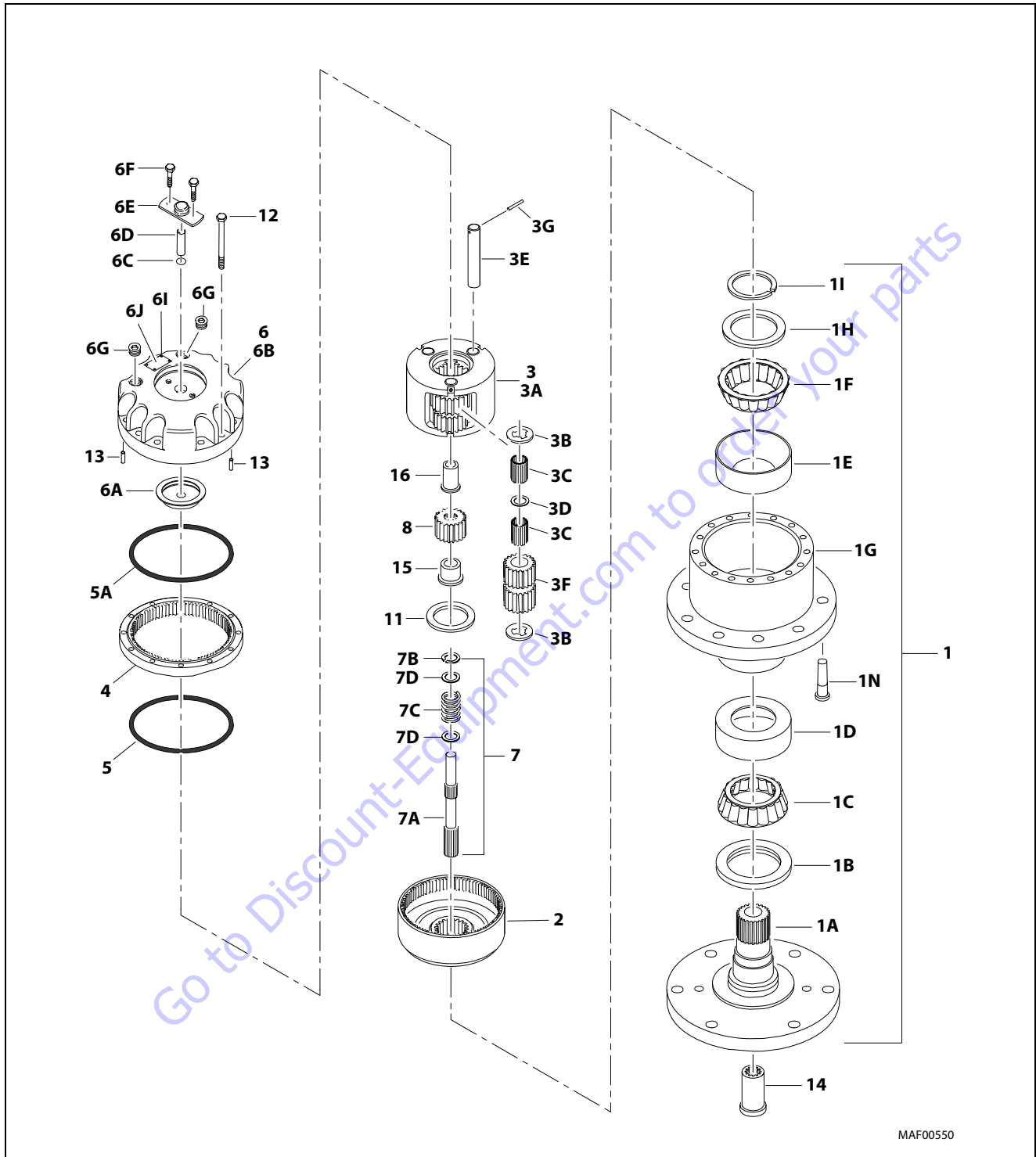

Figure 3-6. Drive Hub and Brake Assembly (2WD and 4WD) - Sheet 1 of 2

1	Spindle/Housing Assembly	3G	Roll Pin	7D	Thrust Spacer	107	Gasket
1A	Spindle	4	Ring Gear	8	Sun Gear	108	Cylinder
1B	Seal	5	O-Ring	11	Thrust Washer	109	Piston
1C	Bearing Cone	5A	O-Ring	12	Bolt	110	Ball Bearing
1D	Bearing Cup	6	Cover Assembly	13	Dowel Pin	111	Retaining Ring
1E	Bearing Cup	6A	Thrust Spacer	14	Coupling	112	Shaft Seal
1F	Bearing Cone	6B	Cover Plate	15	Input Spacer	113	Capscrew
1G	Housing/Ring Gear	6C	O-Ring	16	Input Spacer	114	Lockwasher
1H	Thrust Washer	6D	Disconnect Rod	17	Brake Assembly	115	O-Ring
1I	Retaining Ring	6E	Disengage Cap	27	O-Ring	116	Backup Ring
1N	Wheel Stud	6F	Bolt	28	Threaded Rod	117	O-Ring
2	Internal Gear	6G	Pipe Plug	29	Nut, 1/2in-13NC	118	Backup Ring
3	Carrier Assembly	6I	Rivet	101	Shaft	119	Dowel Pin
3A	Carrier	6J	I.D. Plate	102	Housing	120	Plug
3B	Retaining Ring	7	Input Shaft Assembly	103	Friction Plate	121	Plug
3C	Needle Bearing	7A	Shaft	104	Pressure Plate	122	Spring (Natural)
3D	Thrust Washer	7B	Retaining Ring	105	Gasket	123	Spring (Blue)
3E	Planet Shaft	7C	Spring	106	Outer Plate	124	Gasket
3F	Planet Gear						

Figure 3-7. Drive Hub and Brake Assembly (2WD and 4WD) - Sheet 2 of 2



MAF00550

Figure 3-8. Drive Hub (4WD Front Only) - Sheet 1 of 2

1	Spindle/Housing Assembly	3	Carrier Assembly	6	Cover Assembly	7A	Shaft
1A	Spindle	3A	Carrier	6A	Thrust Spacer	7B	Retaining Ring
1B	Seal	3B	Retaining Ring	6B	Cover Plate	7C	Spring
1C	Bearing Cone	3C	Needle Bearing	6C	O-Ring	7D	Thrust Spacer
1D	Bearing Cup	3D	Thrust Washer	6D	Disconnect Rod	8	Gear, Sun
1E	Bearing Cup	3E	Planet Shaft	6E	Disengage Cap	11	Thrust Washer
1F	Bearing Cone	3F	Planet Gear	6F	Bolt	12	Bolt
1G	Housing/Ring Gear	3G	Roll Pin	6G	Plug, Pipe	13	Pin, Dowel
1H	Thrust Washer	4	Ring Gear	6I	Rivet	14	Coupling
1I	Retaining Ring	5	O-Ring	6J	I.D. Plate	15	Input Spacer
1N	Wheel Stud	5A	O-Ring	7	Input Shaft Assembly	16	Input Spacer
2	Internal Gear						

Figure 3-9. Drive Hub (4WD Front Only) - Sheet 2 of 2

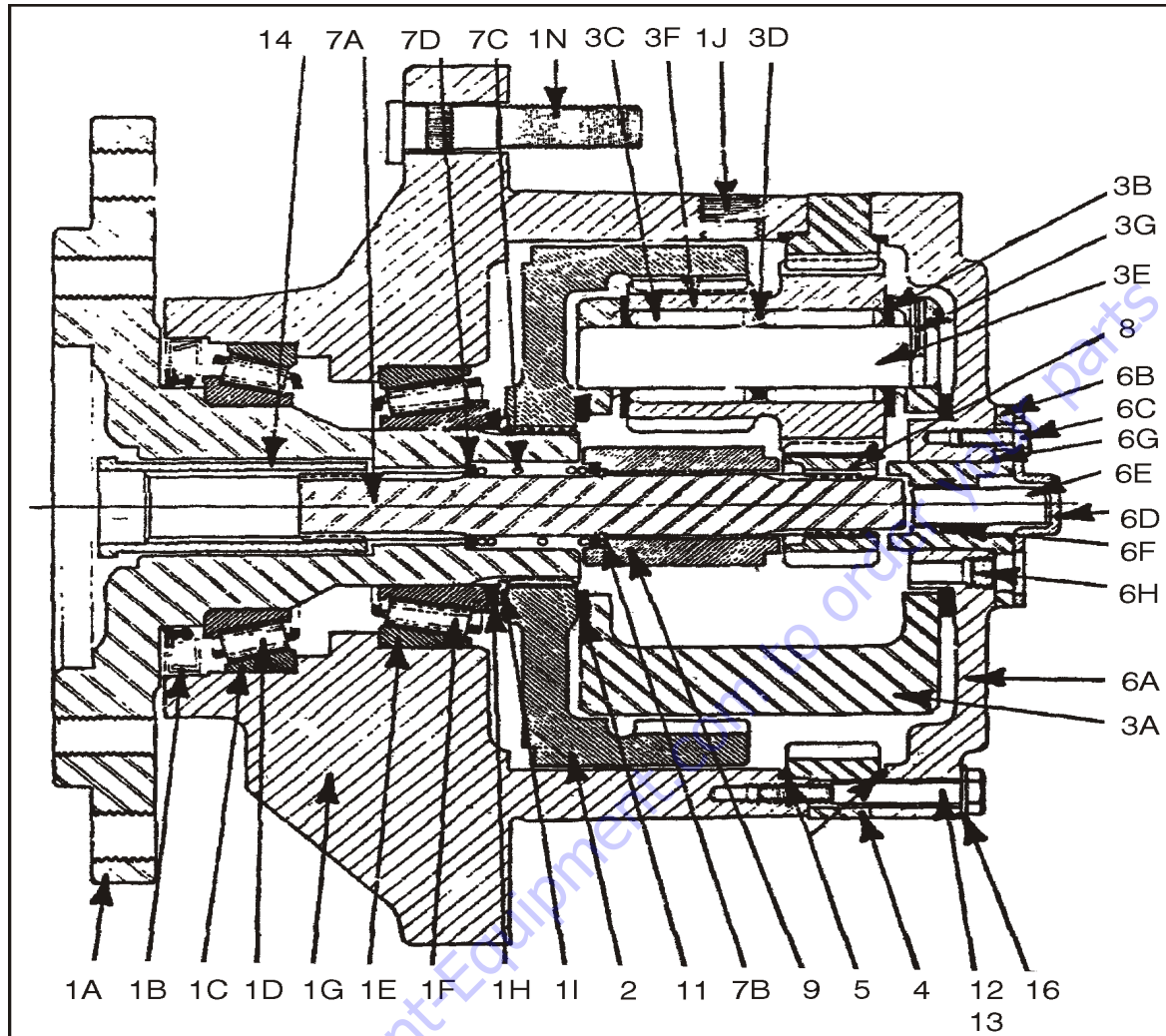

- | | | | |
|-----------------------------|-------------------------|-----------------------------|-------------------|
| 1. Hub-Spindle Sub-Assembly | 2. Internal Gear | A. Cover | C. Spring |
| A. Spindle | 3. Carrier Sub-Assembly | B. Cover Cap | D. Spacer |
| B. Seal | A. Carrier Housing | C. Bolt | 8. Input Gear |
| C. Bearing Cup | B. Thrust Washer | D. Disconnect Cap | 9. Thrust Spacer |
| D. Bearing Cone | C. Needle Roller | E. Disconnect Rod | 11. Thrust Spacer |
| E. Bearing Cup | D. Spacer | F. O Ring | 12. Bolt |
| F. Bearing Cone | E. Planet Shaft | G. O Ring | 13. Shoulder Bolt |
| G. Hub | F. Cluster Gear | H. Pipe Plug | 14. Coupling |
| H. Spacer | G. Roll Pin | I. ID Plate | 16. Flat Washer |
| I. Retaining Ring | 4. Ring Gear | 7. Input Shaft Sub Assembly | |
| J. Pipe Plug | 5. O Ring | A. Seal | |
| N. Stud | 6. Cover Sub-Assembly | B. Retaining Ring | |

Figure 3-10. Drive Hub (Cross-Section)

Cover Disassembly

1. Remove two bolts (6C) holding disconnect cap (6D) to cover (6A).
2. Remove disconnect cap (6D) from on top of cover cap (6B) and cover (6A).
3. Remove two bolts (6C) holding cover cap (6B) to cover (6A).
4. Remove cover cap (6B) from cover (6A).
5. Remove disconnect rod (6E) from cover cap (6B).
6. Pry O-ring (6F) out of groove inside cover cap (6B). Discard O-ring.
7. Remove O-ring (6G) from flange of cover cap (6B). Discard O-ring.
8. Remove pipe plug (6H) from cover (6A).
9. Cover disassembly is complete.

Carrier Disassembly

NOTE: Discard old needle rollers and use new ones during reassembly.

1. Using a punch and hammer, drive roll pin (3G) into planet shaft (3E).

NOTICE

DRIVE ROLL PIN ALL THE WAY INTO PLANET SHAFT OR CARRIER WILL BE DAMAGED WHEN PLANET SHAFT IS REMOVED.

2. Using a punch and hammer, drive planet shaft (3E) out of planet shaft hole in carrier housing (3A).
3. When you remove planet shaft (3E) from carrier housing, one thrust washer (3B), one cluster gear (3F), and one more thrust washer (3B) will come off planet shaft and come to rest inside carrier. Remove these parts from inside carrier.
4. Remove 16 needle rollers (3C) from inside one end of cluster gear (3F). Discard needle rollers.
5. Remove one spacer (3D) from inside cluster gear (3F).
6. Remove remaining 16 needle rollers (3C) from other side of cluster gear (3F). Discard needle rollers.
7. Repeat steps 1-6 to remove and disassemble two remaining cluster gears.
8. At this point carrier disassembly is complete.

Assemble Carrier

1. Apply grease to inside of one cluster gear (3F) and line one half of cluster gear with 16 needle rollers (3C).

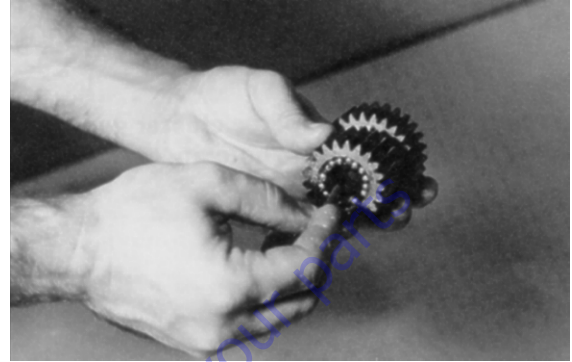

2. Place spacer (3D) inside cluster gear (3F) so it rests on top of needle rollers.



3. Line remaining half of cluster gear (3F) with 16 needle rollers (3C).

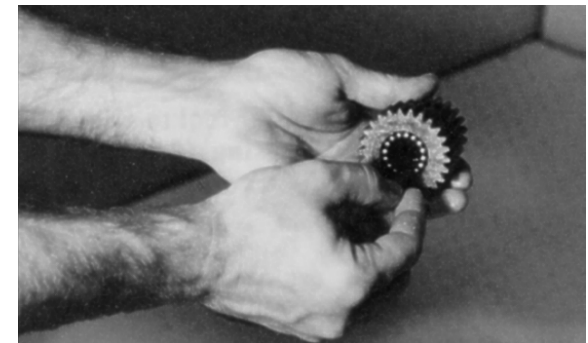

SECTION 3 - CHASSIS & TURNTABLE

4. Set carrier housing (3A) on table, sideways. Insert a planet shaft (3E), roll pin hole last, into one of the planet shaft holes from roll-pin-holed side of carrier housing (3A).

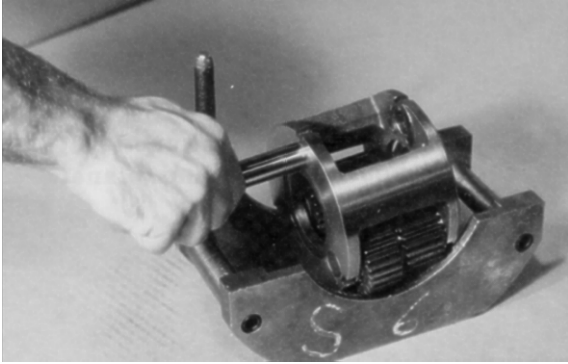

5. Place thrust washer (3B) on end of planet shaft (3E) inside carrier. Fit tang of thrust washer into slot on inside edge of planet shaft hole.

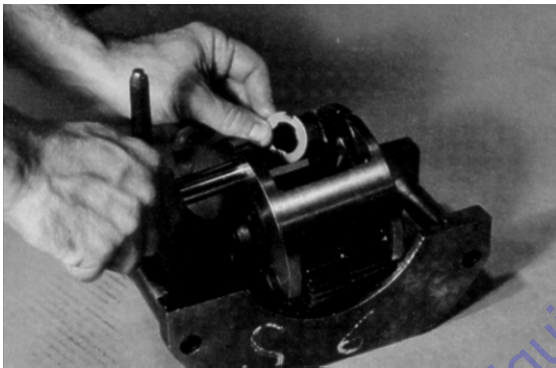

6. Following thrust washer, place cluster gear (3F), large end toward roll pin hole in carrier housing, on planet shaft (3E).



7. Following cluster gear, place one more thrust washer (3B) onto planet shaft (3E) through opposite planet shaft hole in carrier housing (3A).



8. Use an alignment punch or similar tool to align roll pin holes in carrier housing (3A) and planet shaft (3E).

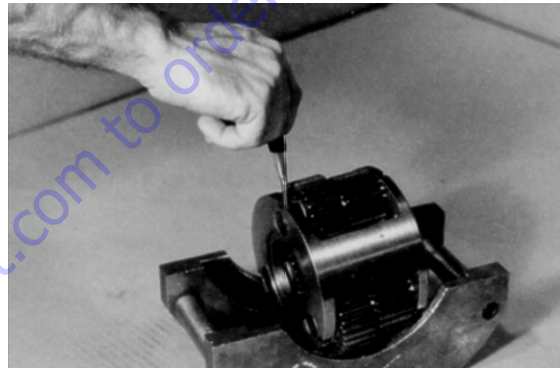

9. Drive roll pin (3G) into aligned roll pin holes in carrier housing (3A) and planet shaft (3E).

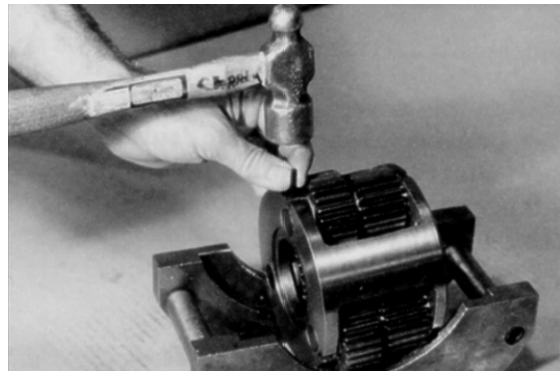

10. Repeat steps 1-9 to assemble and install two remaining cluster gears.
11. At this point carrier sub-assembly is complete.

Cover Sub-Assembly

1. Using disconnect rod, push O-ring (6F) into groove inside cover cap (6B).

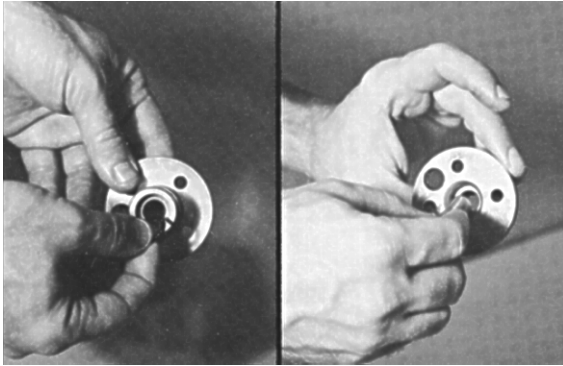

2. Place O-ring (6G) onto cover cap (6B) so it rests against flange of cover cap.

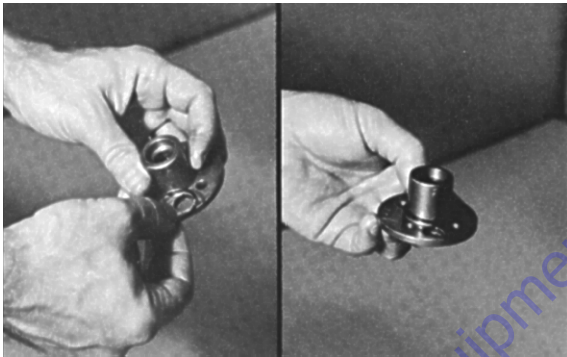

3. Insert disconnect rod (6E) into cover cap (6B).



4. Set cover (6A) on table, exterior side up. Place cover cap (6B) on cover (6A). Align pipe plug hole in cover cap over pipe plug hole in cover.



5. Place two cover cap bolts (6C) in any two bolt holes 180° apart on cover cap (6B) and tighten bolts.



6. Using a torque wrench, apply 36 to 49 in. lbs. (4 to 5 Nm) of torque to both bolts (6C).

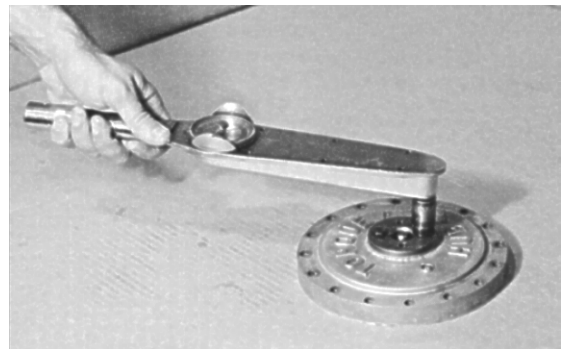

SECTION 3 - CHASSIS & TURNTABLE

7. With large end down, place disconnect cap (6D) on cover cap (6B), aligning pipe plug hole in disconnect cap over pipe plug hole in cover cap.



8. Place two remaining bolts (6C) in bolt holes in disconnect cap (6D) and tighten bolts.



9. Using a torque wrench, apply 36 to 49 in. lbs. (4 to 5 Nm) of torque to both bolts (6C).

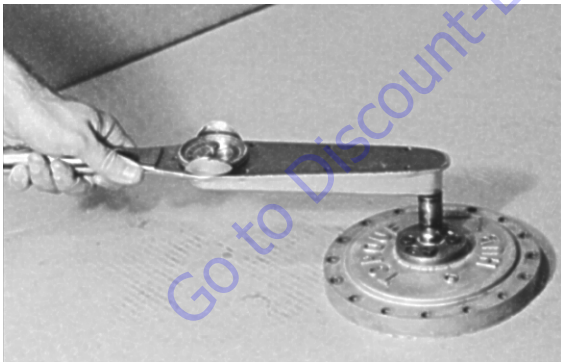

10. Apply a light coat of "Never-Seize" to pipe plug (6H) and tighten it in pipe plug hole in cover (6A).



11. At this point cover sub-assembly is complete.

Hub-Spindle Sub-Assembly

NOTE: Make sure cup sits square with counterbore before pressing.

1. Set hub (1G) on large end. Press bearing cup (1C) into counterbore in small end of hub (1G).

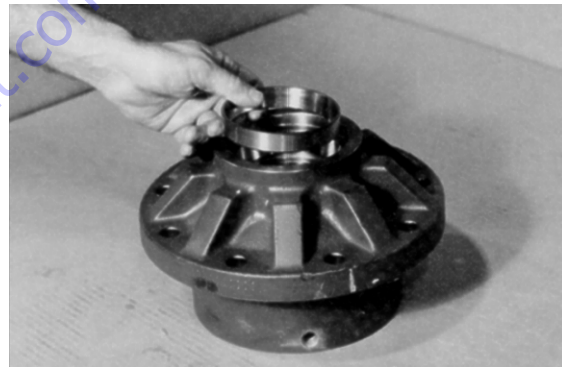

2. Press nine studs (1N) in stud holes in hub (1G).

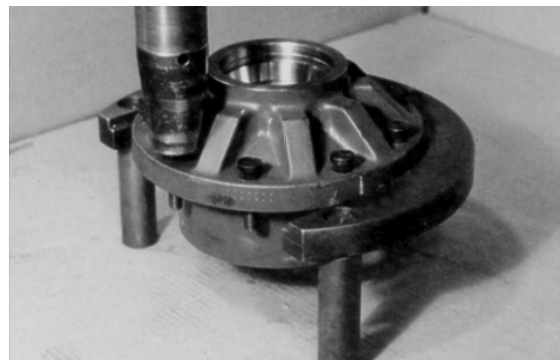

3. Apply a light coat of "Never-Seize" to two pipe plugs (1J) and tighten them in two pipe plug holes in side of hub (1G).

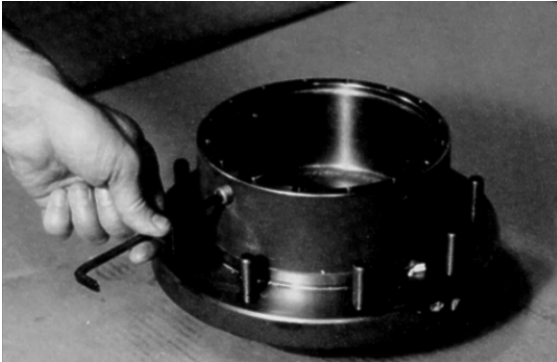

NOTE: Make sure cup sits square with counterbore before pressing.

4. Turn hub (1G) over to small end. Press bearing cup (1E) into counterbore in deep end of hub (1G).

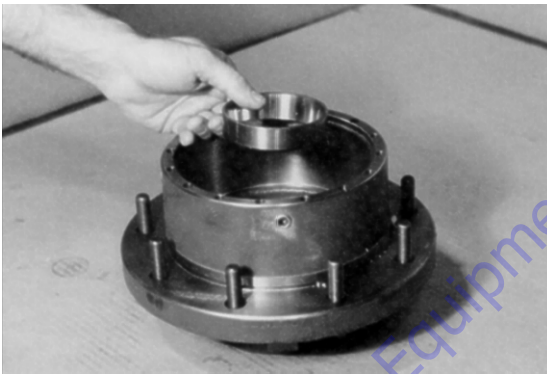

5. Set hub (1G) on large end. Place bearing cone (1D) into bearing cup (1C).



6. Press seal (1B) in small end of hub (1G).



7. Oil spindle, then lower hub (1G) small end down, onto spindle (1A).



8. Press bearing cone (1F) on spindle (1A) in hub (1G).

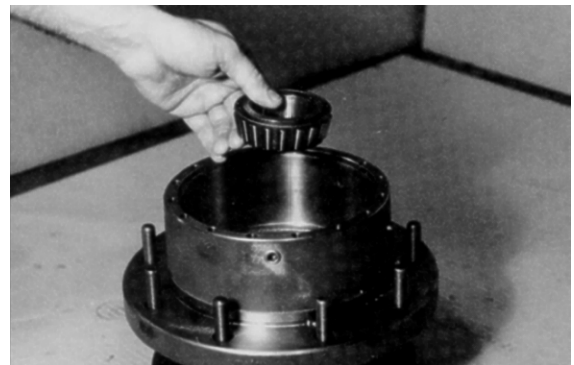

9. Place spacer (1H) on spindle (1A) in hub (1G).



NOTE: Make sure retaining ring is securely seated in groove.

10. Place retaining ring (1I) over spacer onto spindle (1A) in hub (1G).



11. At this point hub-spindle sub-assembly is complete.

Main Assembly

⚠ CAUTION

SHARP EDGES CAN CUT AND CAUSE SERIOUS INJURY. BEWARE OF SHARP EDGES IN COUNTERBORE WHEN REMOVING O-RING.

1. Grease O-ring (5) and place it into counterbore in hub (1G).

NOTE: O-ring may be stretched or pinched together to make it fit into counterbore.

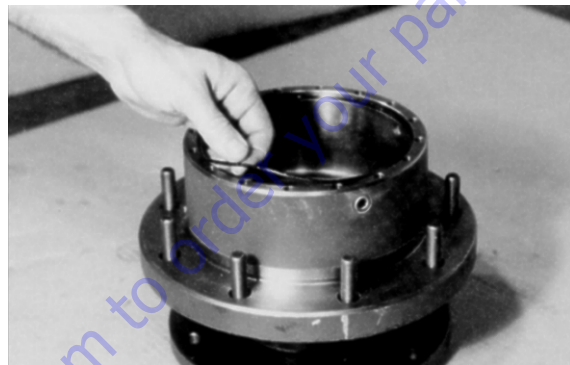

2. Oil exposed surfaces inside hub (1G).

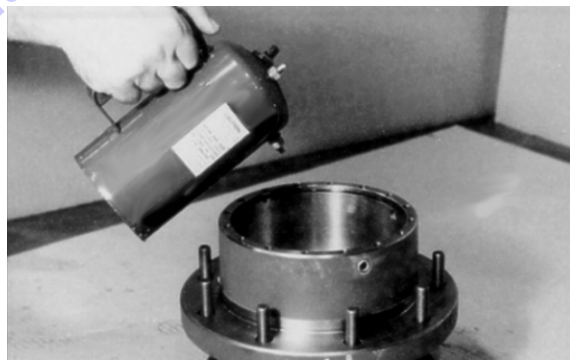

3. Place internal gear (2) in hub (1G) so its internal splines mesh with external splines of spindle (1A). Oil internal gear (2).

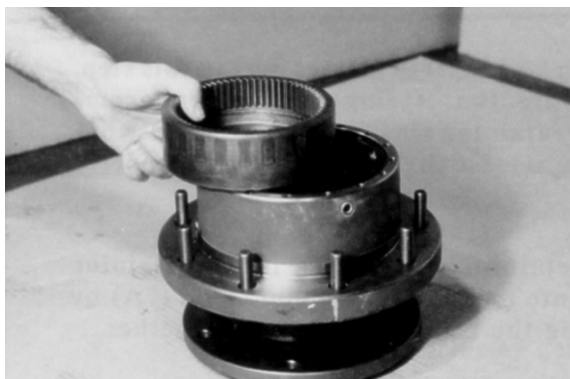

- Place thrust washer (11) around spindle (1A) so it rests on bottom of internal gear (2).



- Place other spacer (7D) on smooth end of input shaft (7A).



- Stand input shaft (7A) on splined end. Place one spacer (7D) on smooth end of input shaft (7A).

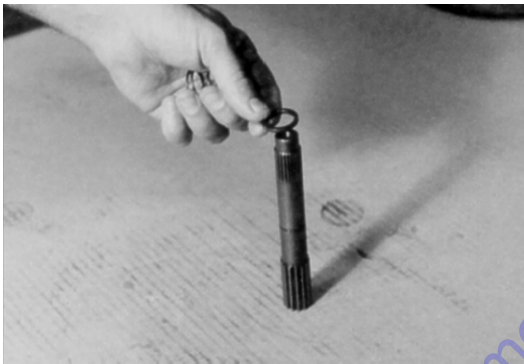

⚠ CAUTION

UNCONTROLLED OBJECTS CAN CAUSE EYE DAMAGE OR SERIOUS INJURY. ALWAYS WEAR EYE PROTECTION.

- Using retaining ring pliers, insert retaining ring (7B) in groove on input shaft (7A) by compressing spring and spacers together.

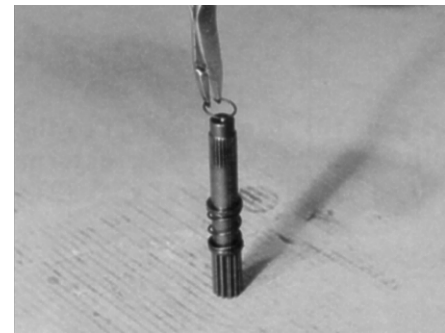

- Place spring (7C) on smooth end of input shaft (7A).



- With large splined end down, place input shaft sub-assembly (7) into spindle (1A).

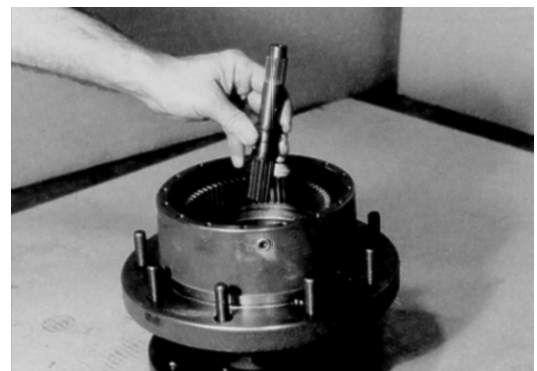

10. Place thrust spacer (9) onto input shaft (7).

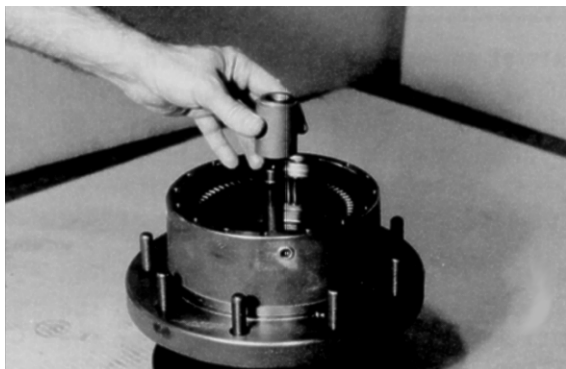

11. Set carrier sub-assembly (3) on a flat work surface so large ends of cluster gears (3F) face up. Locate punch marks on face of each cluster gear (3F) and position them at 12 o'clock.

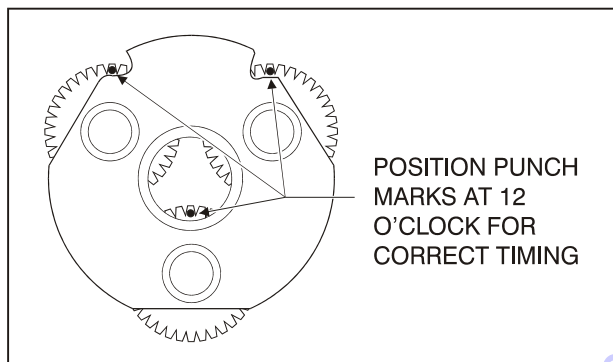
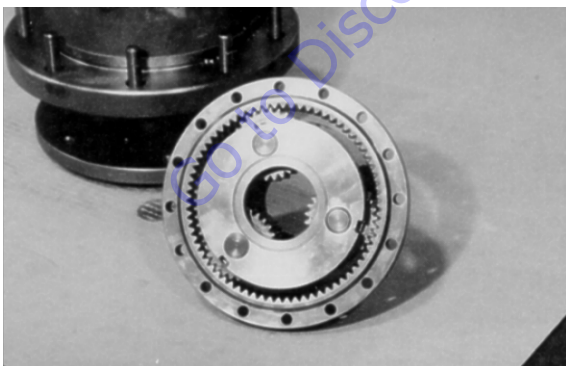

Figure 3-11. Cluster Gear Punch Marks

12. With "X" marked side facing up, place ring gear (4) around cluster gears (3F).

NOTE: This will hold punch marks in position while installing carrier into hub.



13. Place carrier sub assembly (3) and ring gear (4) together into mesh with internal gear (2), aligning "X" marked shoulder bolt hole in ring gear (4) over one of the shoulder bolt holes in hub. Mark location of shoulder bolt holes on outside of ring gear and hub.

NOTE: You may lift ring gear off hub to align shoulder bolt holes. Ring gear and carrier are installed together only to keep punch marks on carrier in place.

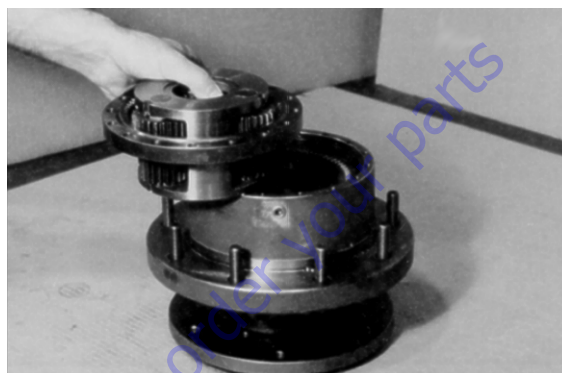

14. With internal splines facing up (counterbore end facing down), place input gear (8) into mesh with carrier sub-assembly (3).

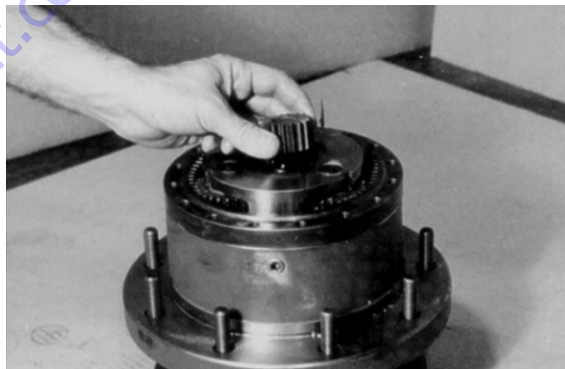

15. Oil all exposed surfaces inside hub (1G). Place thrust washer (11) into counterbore in top of carrier.

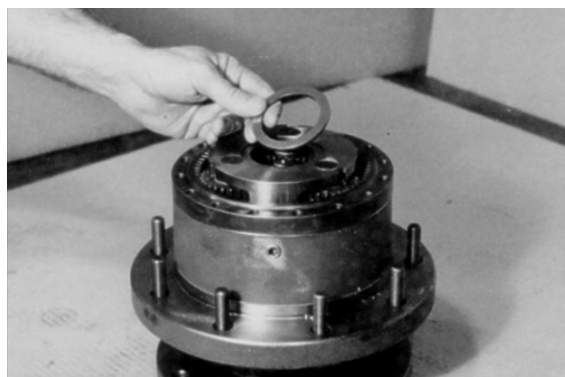

⚠ CAUTION

SHARP EDGES IN COUNTERBORE CAN CUT AND CAUSE INJURY WHEN INSTALLING O-RING.

16. Set cover (6A) on table, interior side up. Grease O-ring (5) and place in counterbore around edge of cover (6A).

NOTE: O-ring may be stretched or pinched together to make it fit counterbore.



17. Place cover sub-assembly (6) on ring gear (4). Align pipe plug holes before disassembly.



18. Place four flat washers (16) on top of bolt holes in cover sub-assembly.



19. Place shoulder bolts (13) in four shoulder bolt holes in cover (6) and hand-tighten.

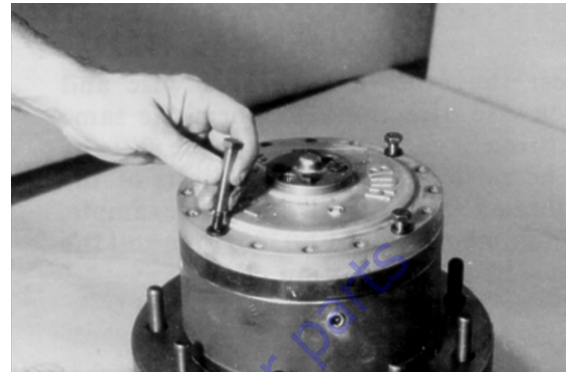

20. Place remaining 12 flat washers (16) on remaining bolt holes in cover (6).

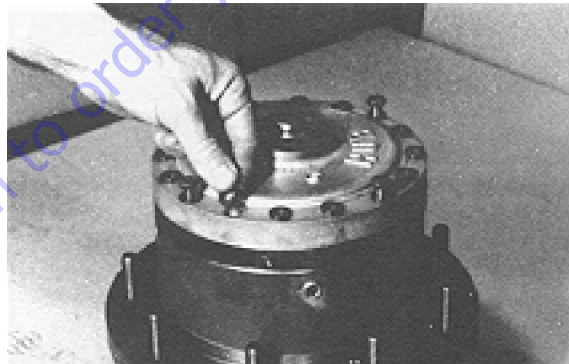

21. Place 12 bolts in remaining bolt holes in cover (6) and tighten.



SECTION 3 - CHASSIS & TURNTABLE

- 22.** Torque shoulder bolts (13) 18 to 25 ft. lbs. (25 to 34 Nm).
Torque bolts (12) 18 to 25 ft. lbs. (25 to 34 Nm).

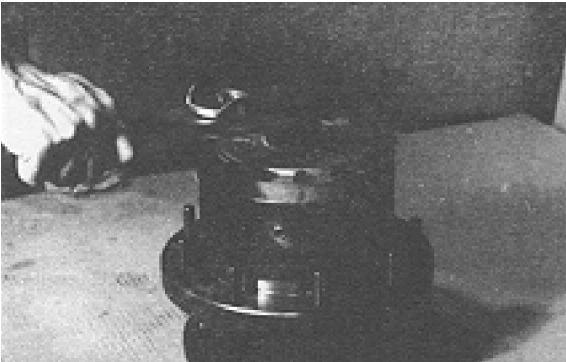

- 23.** Turn hub (1G) on its side. Insert coupling (14) into end of spindle (1A).

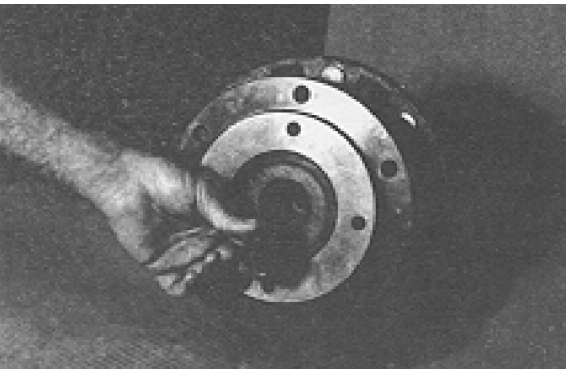

- 24.** Roll test unit in clockwise and counterclockwise directions. Perform same number of turns in each direction as the ratio of the unit. The ratio is the last two digits of the model number on the unit's ID tag.



- 25.** Leak test unit at a pressure of 5 psi (34.47 kPa) for 2 to 3 minutes.



- 26.** At this point main assembly is complete.

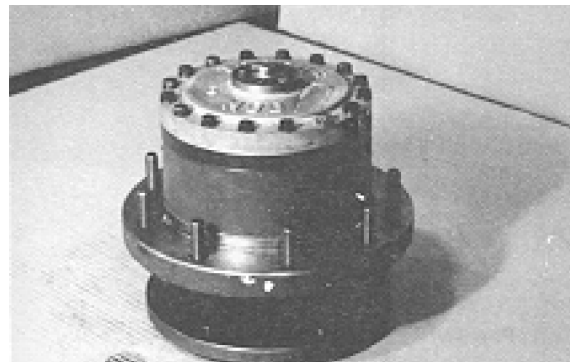

Tool List

The following specialized tools are used to assemble this unit. Tool diagrams in this manual are intended for the customer who may wish to have a tool made. All tools are one piece and must be made from mild steel. All dimensions are in inches.

NOTE: Tools may be carburized and hardened to improve tool life. If this is done, tools must be ground on all surfaces labeled with a "G" on the tool diagram.

1. T-118126 SEAL PRESSING TOOL FOR SEAL (1B).

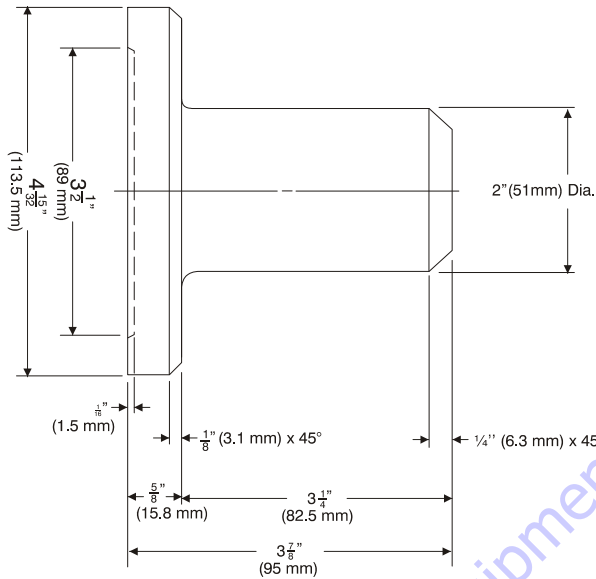

2. T-138903 ASSEMBLY PRESSING TOOL FOR CUP (1C).

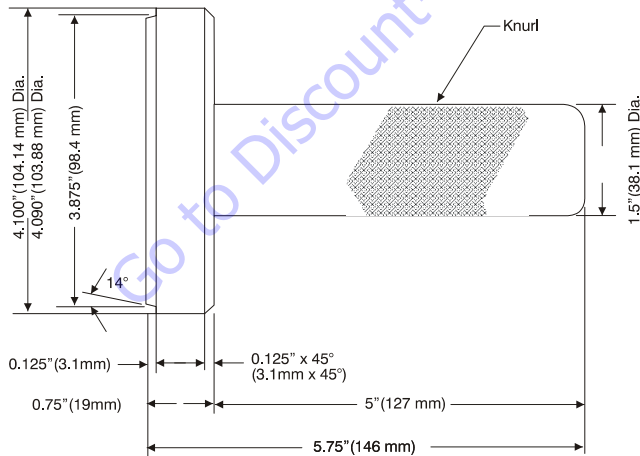

3. T-140433 ASSEMBLY PRESSING TOOL FOR CUP (1E).

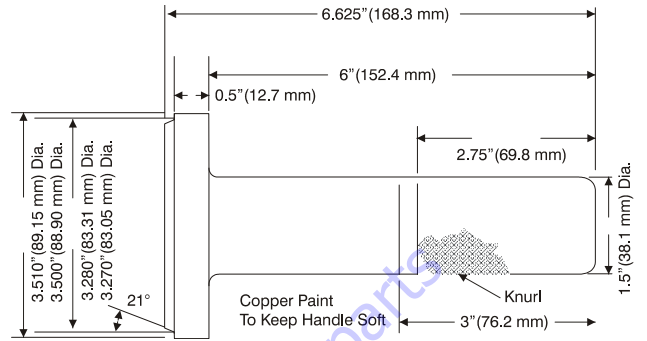

4. T-109691 ASSEMBLY PRESSING TOOL FOR CONE (1F).

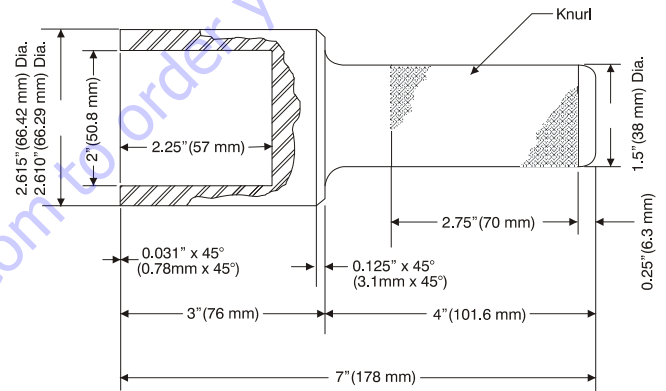

* These tools are for specific seals, cups or cones. There is a specific tool for each cup and cone.

3.10 RE-ALIGN TORQUE HUB INPUT COUPLING

This procedure applies to torque hubs with integral brakes:

Equipment Required

1. Hydraulic power supply (hand pump) capable of producing 200 psi (13.8 bar).
2. Hydraulic fittings to adapt hydraulic supply to brake release port on hub.

Procedure

1. Using appropriate fittings, connect a line from hydraulic power supply to brake port.
2. Pressurize brake release port to 155 - 200 psi (10.6 - 13.8 bar) to release brake.
3. Verify brake is released by rotating input coupling or hub spindle. Once brake is released, input coupling is free to re-align with drive motor.
4. Install drive motor on hub. Release hydraulic pressure at brake release port. Coupling remains in position.
5. Disconnect hydraulic power supply and reconnect line to brake release port.

3.11 DRIVE MOTOR

Description

Drive motors are low to medium power, two-position axial piston motors incorporating an integral servo piston. They are designed for operation in open and closed circuit applications. The standard control is a direct acting single line hydraulic control. The integral servo piston controls motor displacement.

Motors are spring biased to maximum displacement and hydraulically shifted to minimum displacement. Minimum and maximum displacement can be set with fixed internal stops. The large diameter servo piston allows smooth acceleration and deceleration with relatively large circuit orificing.

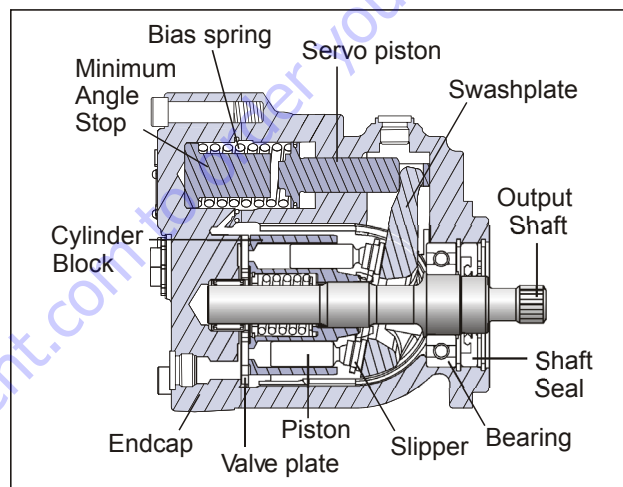
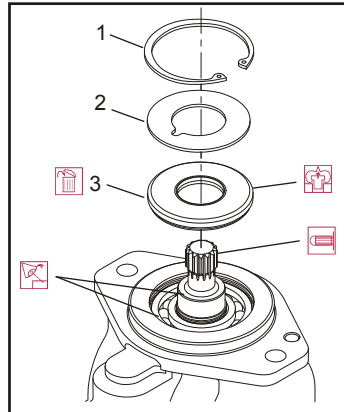

Figure 3-12. Drive Motor Cross Section

Shaft Seal Replacement

REMOVAL

1. Remove snap ring (1) and support washer (2).



1. Snap Ring
2. Support Washer
3. Shaft Seal

Figure 3-13. Removing Shaft Seal

NOTE: To avoid damaging shaft during removal, install a large sheet metal screw into chuck of a slide hammer. Drive screw into seal surface and use slide hammer to pull seal.

2. Carefully pry out and discard shaft seal (3).

INSPECT COMPONENTS

Inspect new seal, motor housing seal bore, and sealing area on shaft for rust, wear, and contamination. Polish shaft and clean housing if necessary.

INSTALLATION

1. Cover shaft splines with an installation sleeve to protect shaft seal during installation.
2. Install a new shaft seal (3) with cupped side facing motor. Press seal into housing until it bottoms out. Press evenly to avoid binding and damaging seal.
3. Install seal support washer (2).
4. Install snap ring (1).
5. Remove installation sleeve.

Loop Flushing Valve

REMOVAL

1. Remove plug (1) and (2) with 11/16 in. internal hex wrench.

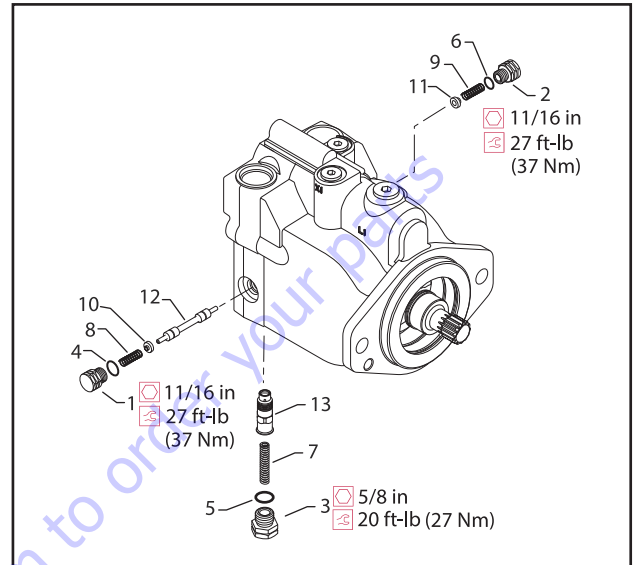

- | | | | |
|-----------|-----------|------------|--------------------|
| 1. Plug | 5. O-ring | 8. Spring | 11. Washer |
| 2. Plug | 6. O-ring | 9. Spring | 12. Shift Spool |
| 3. Plug | 7. Spring | 10. Washer | 13. Orifice Poppet |
| 4. O-ring | | | |

Figure 3-14. Loop Flushing Spool

2. Use 1/4 in. in hex wrench to remove plug (3).
3. Remove O-rings (4, 5, and 6).
4. Use pliers to remove centering springs (7, 8, and 9).
5. Remove spring retaining washers (10 and 11).
6. Remove shift spool (12).
7. Remove orifice poppet (13).
8. Inspect new O-rings and sealing area for rust, wear, or contamination. Check springs and poppet for wear.

INSTALLATION

1. Install orifice poppet (13).
2. Install shift spool (12).
3. Install spring retaining washers on springs (10 and 11).
4. Carefully install centering springs (7, 8, and 9).
5. Install new O-rings (6, 4, and 5).
6. Use 1/4 in. hex wrench to torque plug (3) to 20 ft. lbs. (27 Nm).
7. Use 11/16 in. internal hex and torque plugs (2 and 1) to 27 ft. lbs. (37 Nm).

Troubleshooting

Table 3-2. Excessive Noise and/or Vibration

Item	Description	Action
Check oil level in reservoir and oil supply to motor.	Insufficient hydraulic fluid could lead to cavitation that would cause system noise.	Fill reservoir to proper level and ensure oil supply to motor is adequate and lines are unobstructed.
Check for air in system.	Air trapped in system lines or motor could result in cavitation that would cause system noise.	Ensure system lines and components are purged of air.
Inspect output shaft couplings.	A loose or incorrect shaft coupling will produce vibrations that could result in system noise.	Ensure correct coupling is used and fits properly on shaft.
Inspect output shaft alignment.	Misaligned shafts create excessive frictional vibration that could result in system noise.	Ensure that the shafts are properly aligned.
Hydraulic oil viscosity above limits.	Viscosity above acceptable limits will result in cavitation that would lead to system noise.	Replace hydraulic oil with appropriate fluid for operating conditions.

Table 3-3. System Operating Hot

Item	Description	Action
Check oil level in reservoir and oil supply to pump.	Insufficient amount of hydraulic fluid will not meet system cooling demands.	Fill reservoir to proper level.
Inspect heat exchanger (if equipped).	If heat exchanger fails or becomes obstructed, it may not meet system cooling demands.	Ensure heat exchanger is receiving adequate air flow and is in good operating condition. Repair or replace as necessary.
Check system relief valves.	If a system relief valve becomes unseated for an extended period of time or fails for any other reason, the system could become overheated.	Repair or replace any malfunctioning relief valves and verify loads on machine are not excessive.

Table 3-4. Won't Shift or Slow to Start

Item	Description	Action
Check signal line to servo control port.	Obstructed or restricted flow through the servo control signal lines could result in slow shift or no shift conditions within the motor.	Ensure signal lines are not obstructed or restricted and that signal pressure is adequate to shift the motor.
Check correct supply and drain orifices are properly installed and not obstructed.	Supply and drain orifices determine motor shift rate. The smaller the orifice, the longer time it takes to shift the motor. Obstruction also increases shift times.	Ensure proper control orifices are installed in motor and check they are not obstructed. Clean or replace as needed.

Disassembly

NOTE: Removal of endcap voids warranty.

During assembly, coat all moving parts with a film of clean hydraulic oil. This ensures parts are lubricated during start-up.

Replace all O-Rings and gaskets. Lightly lubricate O-rings with clean petroleum jelly prior to assembly.

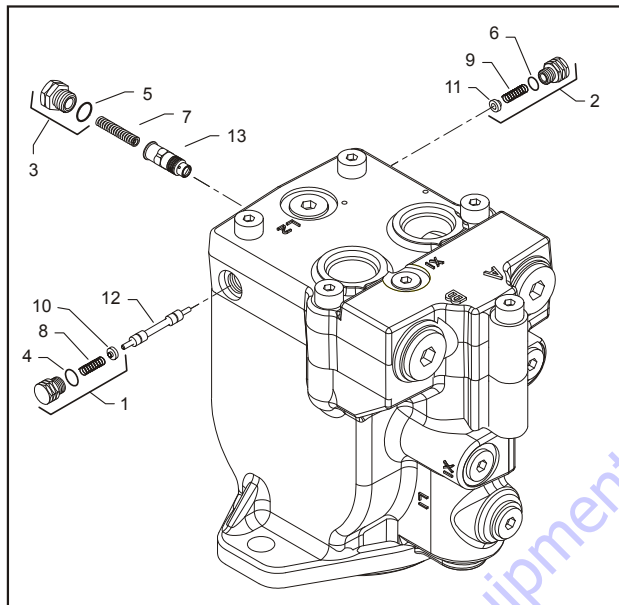

- | | | | |
|-----------|-----------|------------|--------------------|
| 1. Plug | 5. O-ring | 9. Spring | 12. Shift Spool |
| 2. Plug | 6. O-ring | 10. Washer | 13. Orifice Poppet |
| 3. Plug | 7. Spring | 11. Washer | |
| 4. O-ring | 8. Spring | | |

Figure 3-15. Loop Flushing Spool

1. Using a 11/16 in. wrench, remove plug (1) and (2).
2. Using a 5/8 in. hex wrench, remove plug (3).
3. Remove O-rings (4, 5, and 6).
4. Using pliers, remove centering springs (7, 8, and 9).
5. Remove spring retaining washers (10 and 11).
6. Remove shift spool (12).
7. Remove orifice poppet (13).

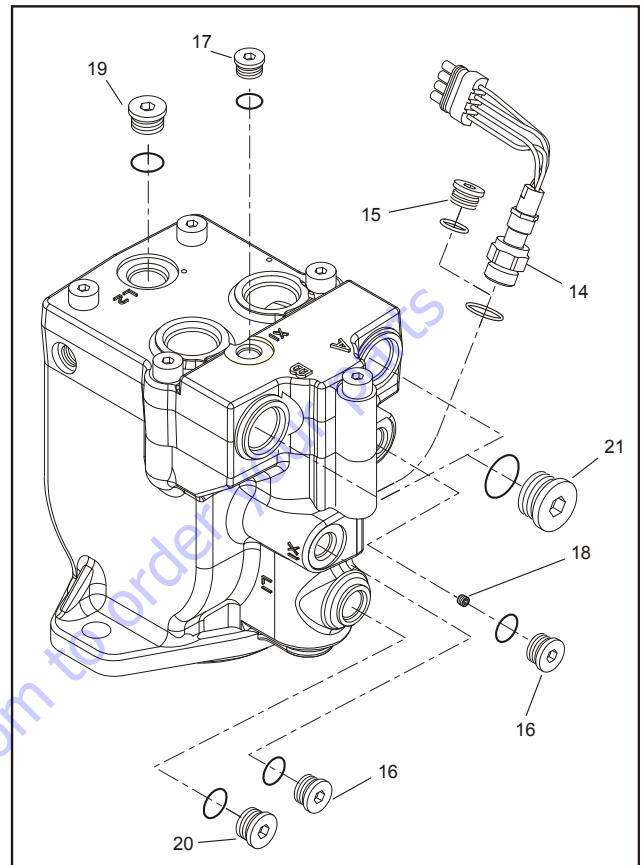

- | | |
|-----------------------|--------------------|
| 14. Lock Nut | 18. Cavity Plug |
| 15. O-ring Plug | 19. Drain Plug |
| 16. Control Line Plug | 20. Drain Plug |
| 17. Control Line Plug | 21. Work Port Plug |

Figure 3-16. Plugs, Fittings, and Speed Sensor

8. Remove all fittings from unit. Discard O-rings.
9. Using an 11/16 in. hex wrench, loosen speed sensor lock nut (14) if equipped and remove speed sensor. Units without speed sensor have an O-ring plug (15) installed in that location; remove it with a 1/4 in. internal hex wrench.
10. Using a 1/4 in. internal hex wrench, remove control line plugs (16, 17). Discard O-rings. Using a 3 mm hex wrench, remove cavity plug (18) (if equipped with two-line control), from X2 cavity.
11. Using a 5/16 in. internal hex wrench, remove drain plugs (19, 20). Discard O-rings.
12. If equipped with axial ports, use a 9/16 in. an internal hex wrench and remove work port plugs (21). Discard O-rings.

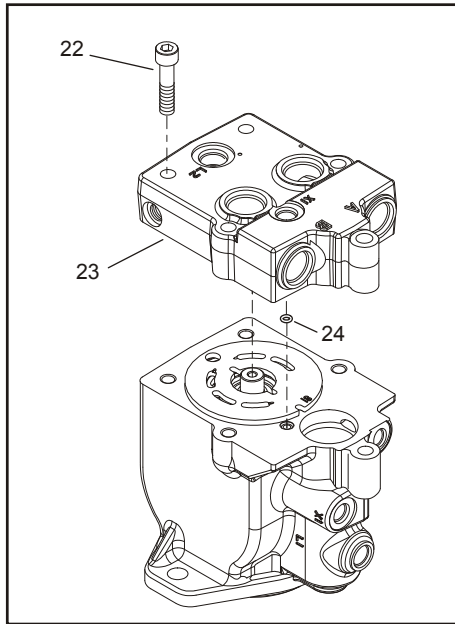

- 22. Screw
- 23. End Cap
- 24. O-ring

Figure 3-17. End Cap

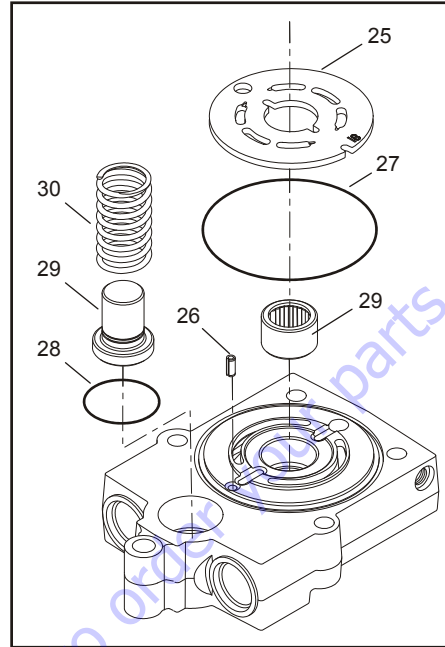

- 25. Valve Plate
- 26. End Cap
- 27. O-ring
- 28. O-ring
- 29. Angle Stop
- 30. Servo Spring

Figure 3-18. Valve Plate & Rear Shaft Bearing

13. Using an 8 mm internal hex wrench, remove endcap screws (22).
14. Remove endcap (23). Remove O-ring (24) from housing or endcap.

NOTE: When endcap screws are removed, pressure from servo spring will cause endcap to bind on shaft. Press down on portion of endcap covering servo piston and hold endcap level while removing.

NOTICE

DO NOT SCRATCH VALVE PLATE SURFACE.

15. Remove valve plate (25) and timing pin (26) from endcap.
- NOTE:** Each displacement has a unique valve plate. The last two digits of the part number are stamped on its surface.
16. Remove and discard O-rings (27, 28).
 17. Remove rear shaft bearing (29) from endcap with a bearing puller.

NOTICE

DO NOT DRIVE BEARING PAST REAR SHAFT JOURNAL. BEARING MAY BECOME TRAPPED ON SHAFT AND DAMAGED.

NOTE: Bearing may be difficult to remove with a puller. Try this as an alternative: Pack bearing cavity with heavy grease. After shaft is removed, insert it into bearing cavity and tap lightly with a soft mallet on the splined end. Grease will force out bearing.

18. Remove minimum angle stop (29) and servo spring (30) from housing.

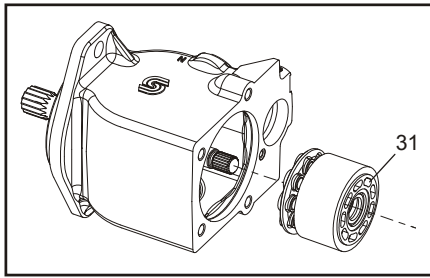

31. Cylinder Kit Assembly

Figure 3-19. Cylinder Kit

19. Turn housing on its side and remove cylinder kit assembly (31). Set assembly aside. Do not scratch running surface.

NOTE: Grooves on surface of cylinder kit identify its displacement:

Table 3-5. Displacement Identifiers

# of Grooves	Frame L	Frame K
1	25	38
2	30	45
3	35	--

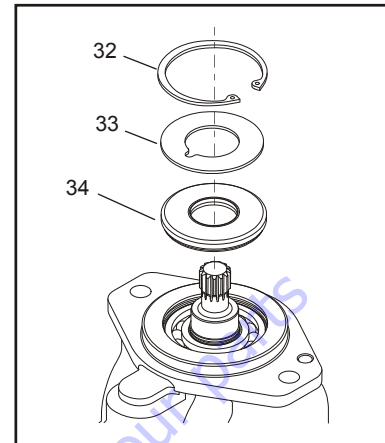

32. Snap Ring
33. Support Washer
34. Shaft Seal

Figure 3-20. Shaft Seal

20. Turn housing over and remove snap ring (32), retaining shaft seal, and support washer. Remove support washer (33). Carefully pry out shaft seal (34). Discard seal.

NOTE: To avoid damaging shaft during seal removal. Install a large sheet metal screw in chuck of a slide hammer. Drive screw into seal surface. Use slide hammer to pull seal.

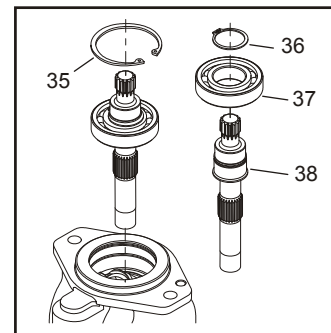

35. Inner Snap Ring
36. Snap Ring
37. Bearing
38. Shaft

Figure 3-21. Shaft & Front Bearing

21. Remove inner snap ring (35) and shaft/bearing assembly.
22. Remove snap ring (36) retaining shaft front bearing. Pull bearing (37) off shaft (38).

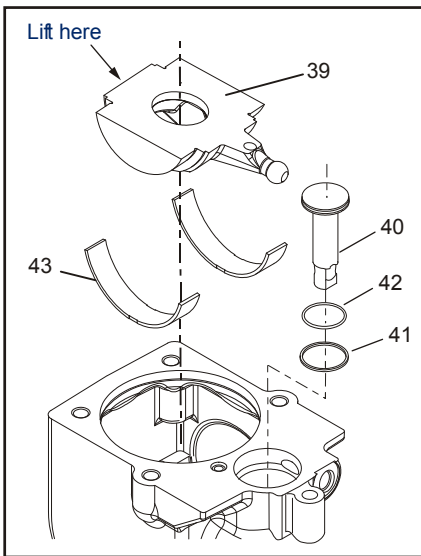

- 39. Swashplate
- 40. Servo Piston
- 41. Piston Seal
- 42. O-ring
- 43. Journal Bearings

Figure 3-22. Swash Plate & Servo Piston

- 23. Turn housing over and remove swashplate (39) by lifting on end opposite servo lever.
- 24. Remove servo piston (40). Remove piston seal (41) and O-ring (42) from servo piston. Discard seal and O-ring.
- 25. Remove journal bearings (43) from housing. If bearings will be reused, note location and orientation of each bearing for reassembly.

- 26. Remove pistons (44) and slipper retainer (45) from cylinder block (46).

NOTE: *Pistons are not selectively fitted. Units with high hourly usage may develop wear patterns. Number pistons and bores for reassembly if they will be reused.*

- 27. Remove ball guide (47), hold-down pins (48), and retaining ring (49) from cylinder block.

NOTE: *Most repairs do not require block spring removal. Perform this procedure only if you suspect problems with the block spring.*

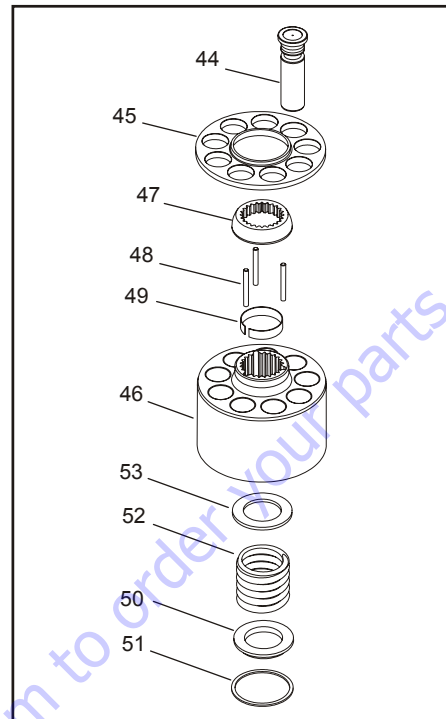

- 44. Piston
- 45. Slipper Retainer
- 46. Cylinder Block
- 47. Ball Guide
- 48. Holddown Pins
- 49. Retaining Ring
- 50. Block Spring Washer
- 51. Spiral Retaining Ring
- 52. Block Spring
- 53. Inner Block Spring Washer

Figure 3-23. Cylinder Kit Disassembly

⚠ WARNING

RISK OF PERSONAL INJURY: COMPRESSING BLOCK SPRING REQUIRES FORCE OF ABOUT 80 TO 90 LBF (350 TO 400 N). USE A PRESS SUFFICIENT TO MAINTAIN THIS FORCE WITH REASONABLE EFFORT. ENSURE SPRING IS SECURE BEFORE ATTEMPTING TO REMOVE SPIRAL RETAINING RING. RELEASE PRESSURE SLOWLY AFTER RETAINING RING IS REMOVED.

- 28. Turn block over. Using a press, apply pressure on block spring washer (50) to compress block spring enough to safely remove spiral retaining ring (51). Maintain pressure and unwind spiral retaining ring (51). Carefully release pressure and remove outer block spring washer (50), block spring (52), and inner block spring washer (53) from cylinder block.

Inspection

Wash all parts after disassembly (including end-cap and housing) thoroughly with clean solvent and allow to air dry. Blow out oil passages in housing and endcap with compressed air. Conduct inspection in a clean area and keep all parts free from contamination. Clean and dry parts again after any rework or resurfacing.

PISTON

Inspect pistons for damage and discoloration. Discolored pistons may indicate excessive heat. Do not reuse.

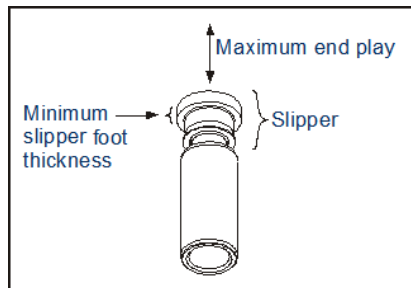

SLIPPERS

Inspect running surface of slippers. Replace piston assemblies with scored or excessively rounded slipper edges. Measure slipper foot thickness. Replace piston assemblies with excessively worn slippers. Check slipper axial end-play. Replace piston assemblies with excessive end-play.

Minimum slipper foot thickness and maximum axial end-play are shown in table 3.6.

Table 3-6. Slipper Foot Thickness & End Play

Measurement		L Frame	K Frame
Slipper Foot Thickness	mm (in.)	2.71 (0.11)	4.07 (0.16)
		0.15 (0.006)	

BALL GUIDE AND SLIPPER RETAINER

Inspect ball guide and slipper retainer for damage, discoloration, or excessive wear. A discolored ball guide or slipper retainer indicates excessive heat. Do not reuse.

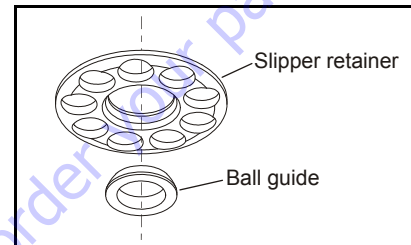

CYLINDER BLOCK

Measure cylinder block height. Replace blocks worn beyond minimum height specification. Inspect running surface of cylinder block. Replace or resurface worn or scratched blocks. Blocks may be resurfaced if resurfacing will not reduce block height below minimum specification shown in Table 3-7, Cylinder Block Measurements.

Table 3-7. Cylinder Block Measurements

Measurement	L25	L30	L35	K38	K45
Minimum Cylinder Block Height (A)	50.8 (2.00)	50.8 (2.00)	50.8 (2.00)	54.4 (2.14)	54.4 (2.14)
Cylinder Block Surface Flatness	0.002 (0.0000079)	0.002 (0.0000079)	0.002 (0.0000079)	0.002 (0.0000079)	0.002 (0.0000079)

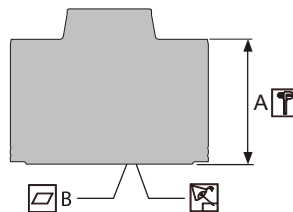

SECTION 3 - CHASSIS & TURNTABLE

VALVE PLATE

Valve plate condition is critical to motor efficiency. Inspect valve plate surfaces for excessive wear, grooves, or scratches.

Replace or resurface grooved or scratched valve plates. Measure valve plate thickness and replace if worn beyond minimum specification.

Valve plate can be resurfaced if finished thickness is not below minimum specification shown in drawing.

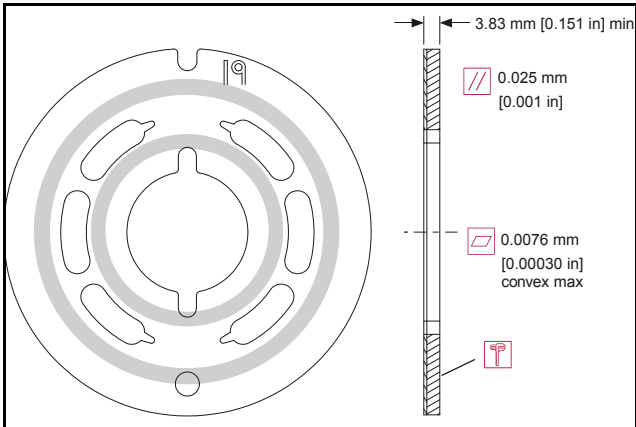

SWASHPLATE AND JOURNAL BEARINGS

Inspect running face, servo ball-joint, and swashplate journal surfaces for damage or excessive wear.

Some material transfer may appear on these surfaces and is acceptable providing surface condition meets specifications shown.

Measure swashplate thickness from journals to running face. Replace swashplate if damaged or worn beyond minimum specification.

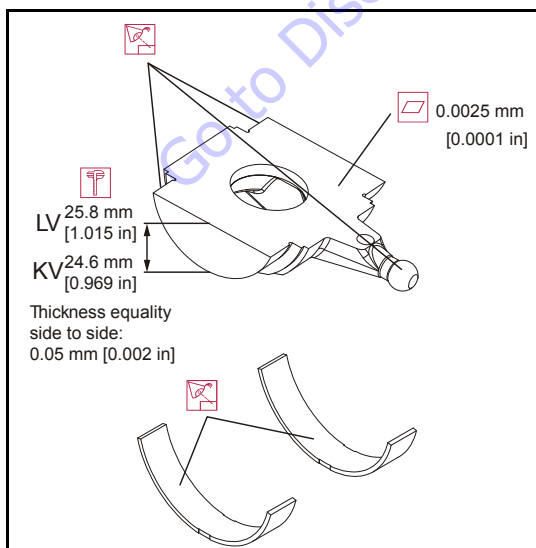

Inspect journal bearings for damage or excessive wear. Replace journal bearings if scratched, warped, or excessively worn. Polymer wear layer must be smooth and intact.

SHAFT BEARINGS

Inspect bearings for excessive wear or contamination. Rotate bearings while feeling for uneven movement. Bearings should spin smoothly and freely. Replace bearings that appear worn or do not rotate smoothly.

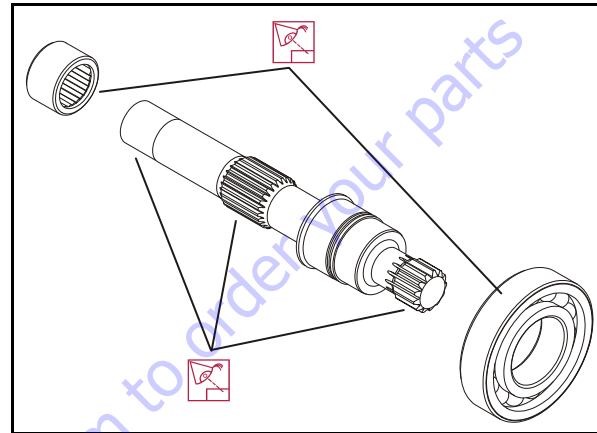

SHAFT

Inspect motor shaft. Look for damage or excessive wear on output and block splines. Inspect bearing surfaces and sealing surface. Replace shafts with damaged or excessively worn splines, bearing surfaces, or sealing surfaces.

SERVO PISTON AND MINIMUM ANGLE STOP

Inspect minimum angle stop, servo piston head, and servo piston ball-socket for damage or excessive wear. Replace as needed.

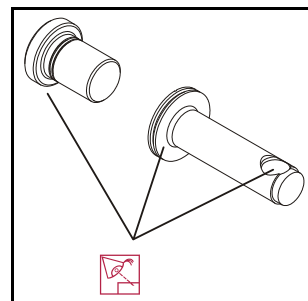

LOOP FLUSHING SPOOL

Inspect loop flushing spool. Check for cracks or damage. Replace as needed.

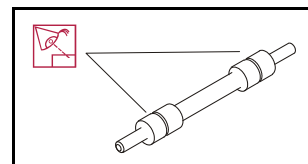

Assembly

1. Install new O-ring (1) and piston seal (2) to servo piston (3). Install piston seal over O-ring.

NOTE: Installing piston seal stretches it, making it difficult to install servo piston in its bore. Allow 30 minutes for seal to relax after installation. To speed up seal relaxation, compress seal by installing piston head in servo cavity in end-cap and let it stand for at least five minutes.

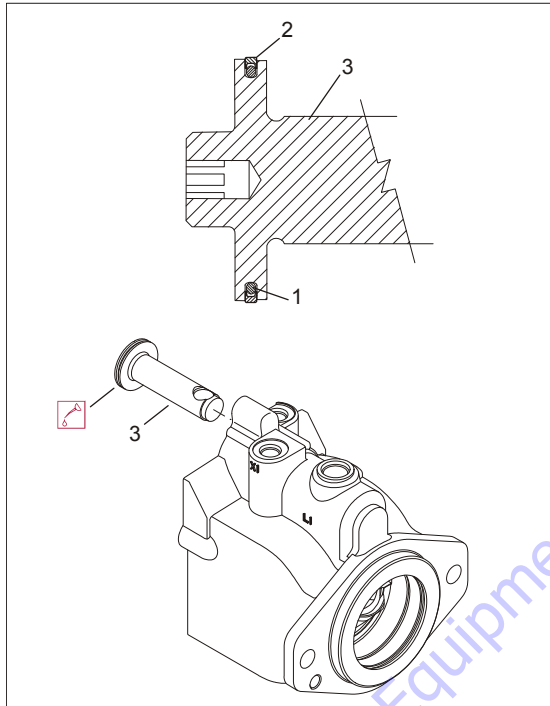

1. O-ring
2. Piston Seal
3. Servo Piston

Figure 3-24. Servo Piston

2. After piston seal has relaxed, lubricate and install servo piston into housing bore. Align piston with ball socket facing inside of housing.

⚠ WARNING

COMPRESSED SPRING MAY FLY OUT AND CAUSE SERIOUS INJURY. COMPRESSING BLOCK SPRING REQUIRES ABOUT 80 TO 90 LBF (350 TO 400 N) OF FORCE. USE A PRESS SUFFICIENT TO MAINTAIN THIS FORCE WITH REASONABLE EFFORT. ENSURE SPRING IS SECURE BEFORE ATTEMPTING TO INSTALL SPIRAL RETAINING RING. RELEASE PRESSURE SLOWLY AFTER RETAINING RING IS INSTALLED.

3. Install inner block spring washer (4), block spring (5), and outer washer (6) in cylinder block. Using a press, compress block spring enough to expose retaining ring groove. Wind spiral retaining ring (7) into cylinder block.

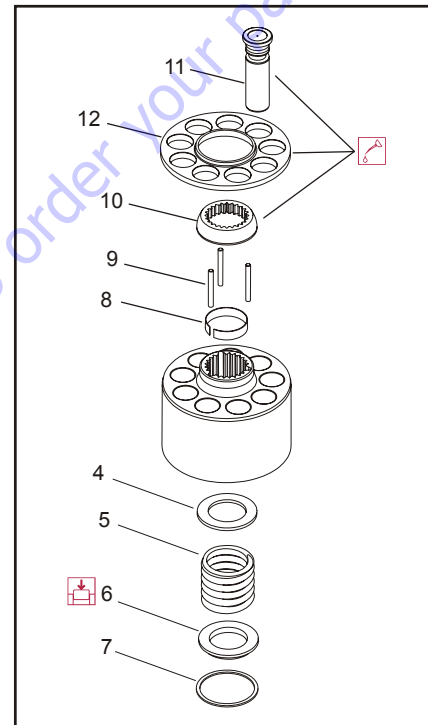

- | | |
|--------------------------|----------------------|
| 4. Block Spring Washer | 9. Holddown Pins |
| 5. Block Spring | 10. Ball Guide |
| 6. Outer Washer | 11. Piston |
| 7. Spiral Retaining Ring | 12. Slipper Retainer |
| 8. Retaining Ring | |

Figure 3-25. Cylinder Kit Assembly

4. Turn block over and install retaining ring (8), hold-down pins (9), and ball guide (10) to cylinder block.

NOTICE

IF REUSING PISTONS, INSTALL THEM IN ORIGINAL BLOCK BORES.

5. Install pistons (11) to slipper retainer (12). Install piston/retainer assembly in cylinder block. Ensure concave surface of retainer seats on the ball guide. Lubricate pistons, slippers, retainer, and ball guide before assembly. Set cylinder kit aside on a clean surface until needed.
6. Install journal bearings (13) into housing seats. Use assembly grease to keep bearings seated during assembly. Ensure locating nubs drop into cavities in seats. If reusing bearings, install them in original location and orientation. Lubricate journal bearings.

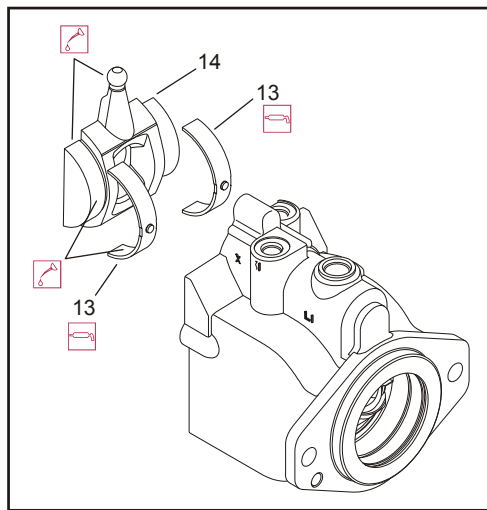

13. Journal Bearings
14. Swash Plate

Figure 3-26. Swash Plate and Journal Bearing

7. Install swashplate (14) in housing. Tilt swashplate and guide servo lever ball into its socket in servo piston rod. Ensure swashplate seats into journal bearings and moves freely. Lubricate swashplate running surface.

8. Press front shaft bearing (15) onto shaft (16). Press bearing onto shaft with lettering facing out. Lubricate bearing rollers. Install snap-ring (17) on shaft.

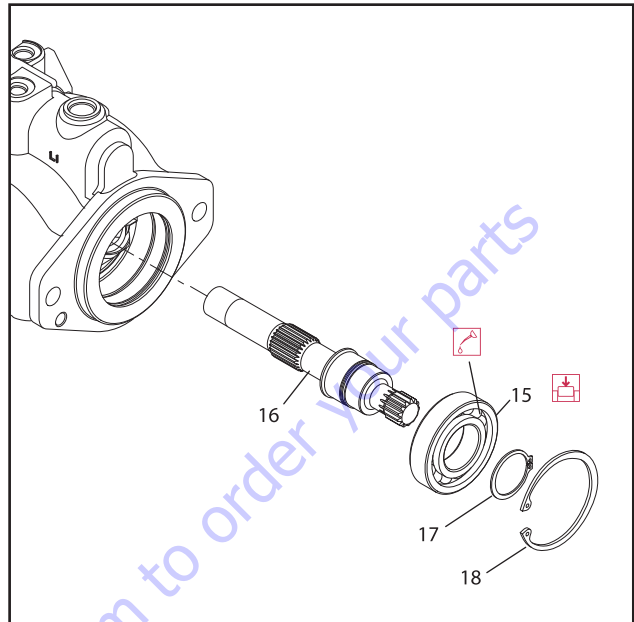

15. Front Shaft Bearing 17. Snap Ring
16. Shaft 18. Snap Ring

Figure 3-27. Shaft and Front Bearing

9. While holding swashplate in place, turn housing on its side. Install shaft/bearing assembly into housing from flange end. Install snap ring (18).

10. Verify swashplate and bearings are properly seated. Install cylinder kit (19) onto shaft. Install with slippers facing swashplate. Rock shaft to align block splines and slide cylinder kit into place. Orient motor with shaft pointing downward and verify cylinder kit, swashplate, journal bearings, and servo piston are all secure and properly installed.

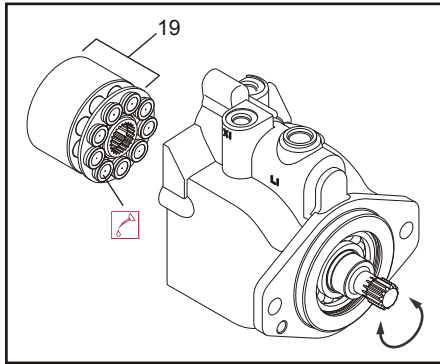

19. Cylinder Kit

Figure 3-28. Cylinder Kit Installation

11. Lubricate and install servo spring (20), and minimum angle stop (21) into housing bore.

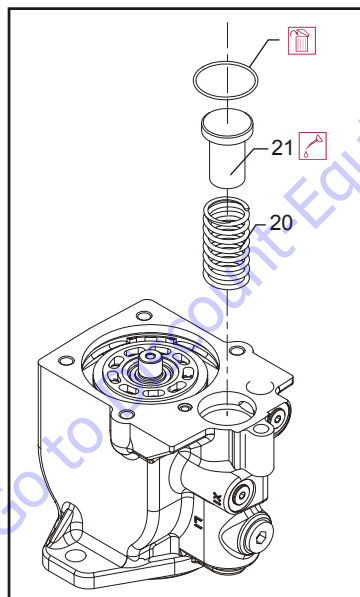

20. Servo Spring
21. Minimum Angle Stop

Figure 3-29. Servo Spring and Minimum Angle Stop

12. Press rear shaft bearing (22) into endcap. Install bearing with letters facing out. Press until bearing surface is 0.08 ± 0.01 in (2 ± 0.25 mm) above endcap surface.

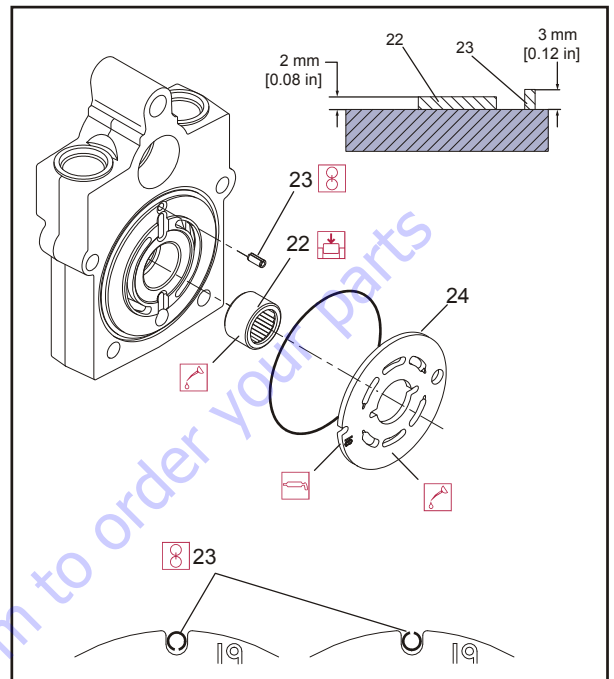

22. Rear Shaft Bearing
23. Timing Pin
24. Valve Plate

Figure 3-30. Valve Plate and Rear Bearing

13. Install timing pin (23) into bore in endcap. Install pin with groove facing toward or away from shaft. Press pin until end protrudes 0.12 ± 0.01 in (3 ± 0.25 mm) above endcap surface.
14. Install valve plate (24) on endcap. Install valve plate with yellow surface toward cylinder block. Align slot in valve plate with timing pin. Apply a liberal coat of assembly grease to endcap side of valve plate to keep it in place during installation.

SECTION 3 - CHASSIS & TURNTABLE

15. Install endcap (25) on housing with endcap screws (26). Check endcap properly seats on housing without interference.

NOTICE

IMPROPER ASSEMBLY OF INTERNAL COMPONENTS MAY PREVENT ENDCAP FROM SEATING PROPERLY. ENSURE O-RINGS SEAT PROPERLY WHEN INSTALLING ENDCAP.

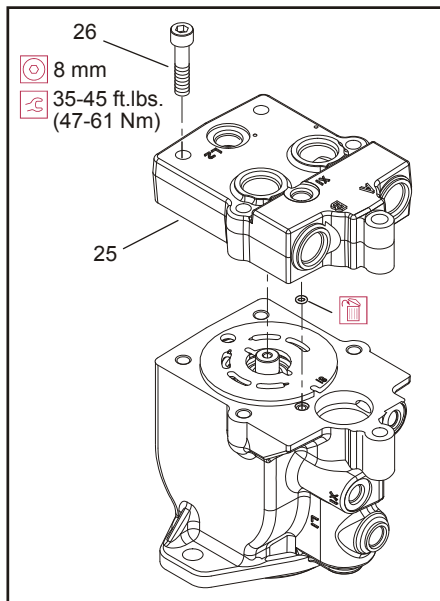

25. End Cap
26. Screw

Figure 3-31. End Cap

16. Using an 8 mm internal hex wrench, tighten endcap screws. Tighten screws in opposite corners slowly and evenly to compress servo spring and properly seat endcap. Torque endcap screws 35 to 45 ft. lbs. (47- 61 Nm).
17. Before installing shaft seal, ensure shaft turns smoothly with less than 120 in. lbs. (13.5 Nm) of force. If shaft does not turn smoothly within specified force, disassemble and check unit.

18. Cover shaft splines with an installation sleeve. Install a new shaft seal (27) with cup side facing motor. Press seal into housing until it bottoms out. Press evenly to avoid binding and damaging seal. Install seal support washer (28) and snap ring (29).

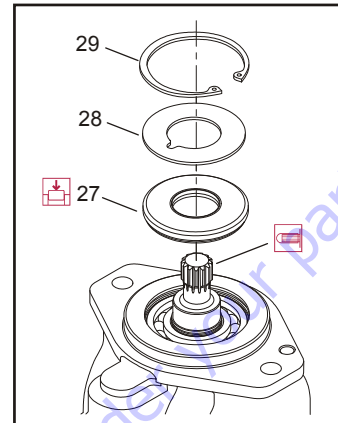

27. Shaft Seal
28. Seal Support Washer
29. Snap Ring

Figure 3-32. Shaft Seal

19. Install remaining plugs and fittings to housing. Refer to drawing below for wrench sizes and torque settings.

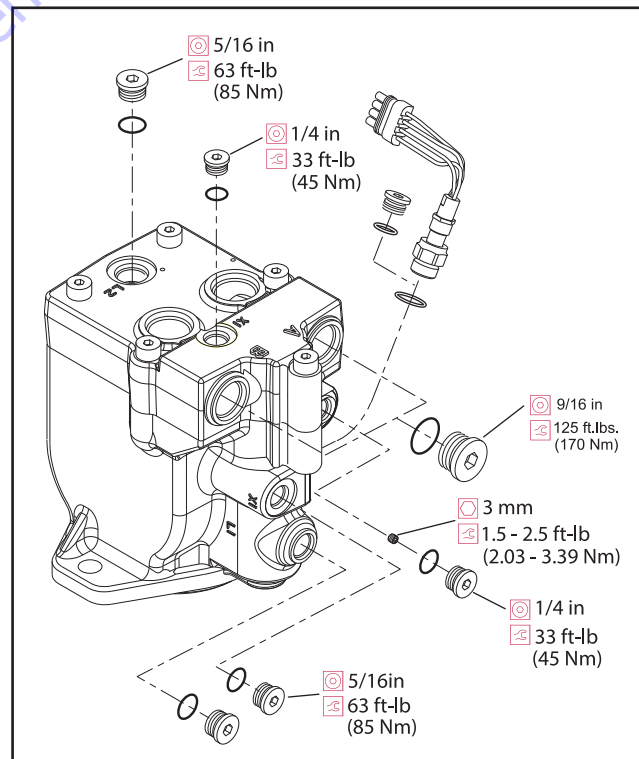
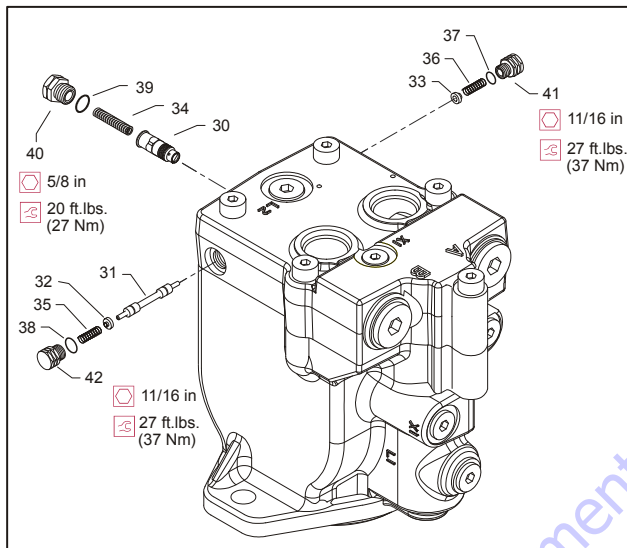

Figure 3-33. Plugs and Fittings Installation

20. Install orifice poppet (30).
21. Install shift spool (31).
22. Install spring retaining washers on springs (32 and 33).
23. Carefully install centering springs (34, 35, and 36).
24. Install new O-rings (37, 38, and 39).
25. Using a 5/8 in. wrench, torque plug (40) to 20 ft. lbs. (27 Nm).
26. Using a 11/16 in. wrench, torque plugs (41 and 42) to 27 ft. lbs. (37 Nm).



30. Orifice Poppet	34. Spring	37. O-ring	40. Plug
31. Shift Spool	35. Spring	38. O-ring	41. Plug
32. Spring	36. Spring	39. O-ring	42. Plug
33. Spring			

Figure 3-34. Loop Flushing Spool

Initial Start-Up Procedures

Follow this procedure when starting up a new motor or after reinstalling a motor.

Prior to installing motor, inspect for damage incurred during shipping or storage. Make certain all system components (reservoir, hoses, valves, fittings, heat exchanger, etc.) are clean before filling with fluid.

1. Fill reservoir with recommended hydraulic fluid. Always filter fluid through a 10 micron filter when pouring into reservoir. Never reuse hydraulic fluid.
2. Fill inlet line leading from pump to reservoir. Check inlet line for properly tightened fittings and be certain it is free of restrictions and air leaks.
3. Fill pump and motor housing with clean hydraulic fluid. Pour filtered oil directly into upper most case drain port.
4. Install case drain lines into upper most case drain ports to ensure pump and motor stay filled with oil.
5. Install a 0 to 500 psi (0 to 35 bar) gauge in charge pressure gauge port of pump to monitor system pressure during start up.
6. Watch pressure gauge and run engine at lowest possible speed until system pressure builds to normal levels (minimum 160 psi (11 bar)). Once system pressure is established, increase to full operating speed. If system pressure is not maintained; shut down engine, determine cause, and take corrective action.
7. Operate hydraulic system at least fifteen minutes under light load conditions.
8. Check and adjust control settings as necessary after installation.
9. Shut down engine and remove pressure gauge. Replace plug at charge pressure gauge port.
10. Check fluid level in reservoir; add clean filtered fluid if necessary. Motor is now ready for operation.

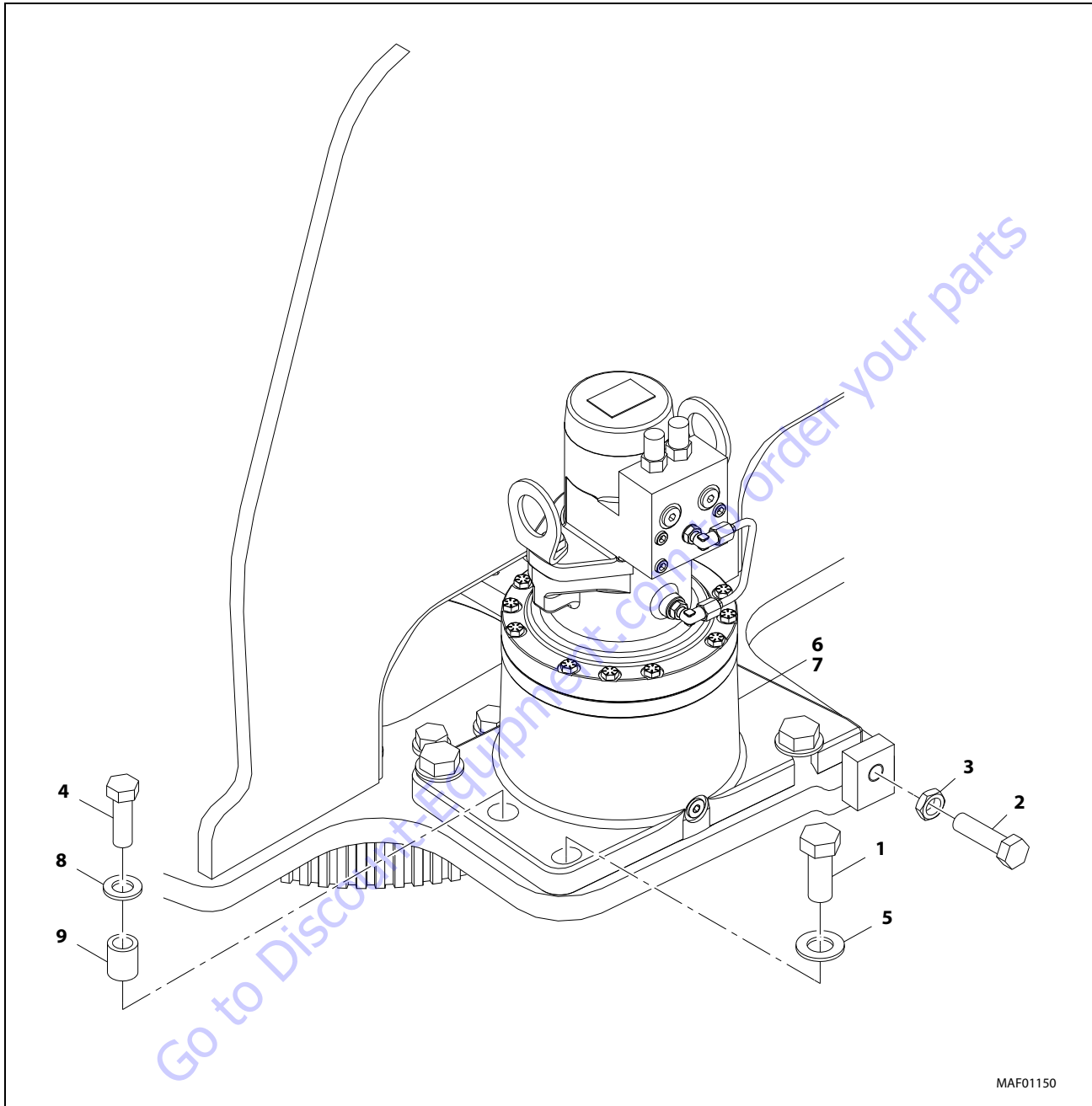

- | | | |
|---------|-----------|---------------------------------|
| 1. Bolt | 4. Bolt | 7. Swing Hub and Motor Assembly |
| 2. Bolt | 5. Washer | 8. Washer |
| 3. Nut | 6. Shim | 9. Spacer Sleeve |

Figure 3-35. Swing System

3.12 SWING DRIVE HUB

Users of this manual should note that each part mentioned is followed by an identification number enclosed in parentheses. These part numbers may be referred to in the Parts List and Assembly Drawing sections of this manual.

Specialized tools used to assemble this unit are noted in the assembly procedures and diagrammed in the Assembly Tools section.

Users should familiarize themselves with the procedures for roll and leak testing, as well as bolt tightening and torquing found on the following pages before starting any repairs.

Standard safety practices should be followed during the disassembly and assembly procedures described. Safety glasses and safety shoes should be worn, and heavy, heat resistant gloves should be used when handling heated components. Be especially alert when you see the word CAUTION. This indicates that a particular operation could cause personal injury if not performed properly or if certain safety procedures are not followed. The word NOTE is used to bring attention to certain procedures or helpful hints that will aid in the disassembly and assembly process.

Brake Test

Prior to brake check remove Motor, Tubing and Elbow as per Motor disassembly instructions in the following subsections. To perform a brake check, use a 7/16-20 thread fitting. Install a hydraulic hand pump with pressure gauge into brake port in Brake Housing using thread fitting.

Place ROLL TEST Tool into Sun gear (8).

Apply 25 in-lbs (29 kgcm) torque. While trying to rotate tool, pump the handle on the hydraulic hand pump and increase the pressure until the brake releases. The brake is released when you are able to rotate the tool.

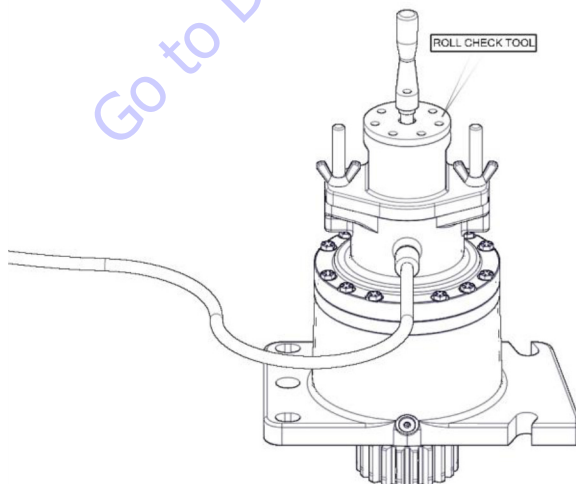

Record the release pressure. If brake does not release within limits shown in Table 3-8, Brake Chart, check to see if it has the proper number of springs using the SPRING CHECKING PROCEDURE.

Increase to maximum pressure (refer to Table 3-8) and hold at that pressure for one minute. If the brake does not leak or lose pressure, the unit has passed the brake test. If brake loses pressure, attempt to repair leak using the leak repair procedure at the end of this procedure.

While brake is still released, roll check the unit for one revolution of the output member by rotating the tool. Bleed off pressure slowly while rotating the ROLL TEST Tool.

Record the pressure at which the brake locks up. Using a clean rag, wipe off excess fluid from around brake port and install the pipe plug.

Table 3-8. Brake Chart

Number Of Springs	Release Pressure Minimum (psi)	Release Pressure Maximum (psi)	Full Release Pressure (psi)	Maximum Release Pressure (psi)	Brake Torque (in-lbs)
7	75	124	140	2000	472

Spring Checking Procedure

Install two Flat Socket Head Cap Screws 0.250-20 UNC, 1/2 in. length into holes in brake piston. Tighten bolts evenly to ensure that brake piston remains straight while being compressed into brake cavity of brake housing.

Carefully remove retaining ring from brake housing. Slowly remove bolts evenly from the input brake. Remove the pressure plate from the end of the input brake and check the number of springs in brake. If incorrect, correct the count.

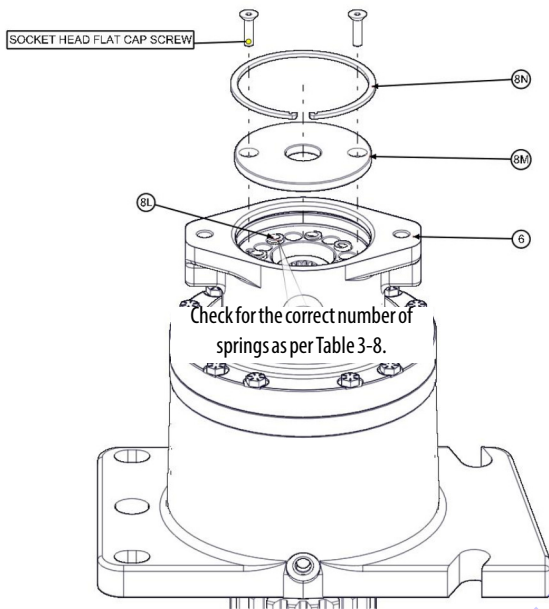

Install the Pressure Plate using two 0.250-20 UNC flat Socket Head Cap Screws. Tighten bolts evenly to ensure that Pressure Plate (8M) does not get wedged to the Brake Cylinder.

Install the large retaining ring into groove in Housing making sure that it is seated properly. Remove all bolts from the brake piston and discard.

NOTE: Use caution when removing bolts as they are subject to spring pressure. Make sure the retaining ring is secured before removing bolts.

Re-test the input brake. If release and/or lockup pressures still do not match the brake chart contact the JLG Service Department.

Grease and install O-ring onto motor pilot. Place motor into brake pilot and line up holes. Check timing marks. Assemble lift lugs onto hex bolts and assemble hex bolts with lugs through the motor and brake against the motor flange. Torque to 80-100 ft. lbs. (108-136 Nm).

Re-test the input brake. If release and/or lockup pressures still do not match the brake chart contact the JLG Service Department.

Brake Leak Repair Procedure

Remove brake piston from housing using the Brake Disassembly Procedure.

Check O-rings, Backup Rings, and brake cavity in Brake Housing for damage. If no damage is found, then reinstall Input Brake according to Input Brake Installation Procedure under Main Assembly procedure and perform pressure test again. If brake still leaks, contact the service department.

NOTE: Failure to perform this test may result in damaged or ineffective brake parts.

Roll and Leak Test

Torque-Hubs should always be roll and leak tested before disassembly (if possible) and after assembly to make sure the gears, bearings, and seals are working properly. The following information briefly outlines what to look for when performing these tests.

THE ROLL TEST

The purpose of the roll test is to determine if the unit gears are rotating consistently, easily and properly. Remove Motor and release the brake by applying 400 psi to the brake port. To perform a roll test, use the recommended tool from table below (or something equivalent) to apply constant rotational force to the input of the gearbox. If more drag is felt in the gears only at certain points, then the gears are not rolling consistently and easily and should be examined for improper installation or defects. Some gear packages roll with more difficulty than others. Do not be concerned if the gears in the unit seem to roll hard as long as they roll with consistency. Rotate the gearbox 36 revolutions both clockwise and counterclockwise.

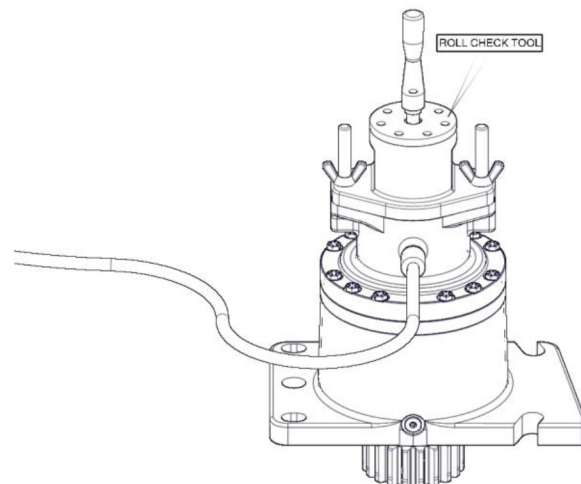

THE LEAK TEST

The purpose of a leak test is to make sure the unit is airtight. To perform a leak test use the leak test fixture from the table below. If the tool is not available, the gearbox must be sealed to perform the test. This can be accomplished by assembling the sealed input device onto the gearbox at the input end and replace one of the oil plugs with an air chuck. **DO NOT EXCEED 10 PSI PRESSURE DURING THE LEAK TEST.** Higher pressure will create a false sealing effect in assemblies with lip-seals. The unit has a leak if the pressure gauge reading on your leak check fitting starts to fall after the gearbox has been pressurized and allowed to equalize. Leaks will most likely occur at the pipe plugs, the main seal or wherever o-rings or gaskets are located. The exact location of a leak can usually be detected by brushing a soap and water solution around the main seal and where the o-rings or gaskets meet on the exterior of the unit and then checking for air bubbles. If a leak is detected in a seal, o-ring, or gasket, the part must be replaced and the unit rechecked. Leak test at 10 psi for 20 minutes.

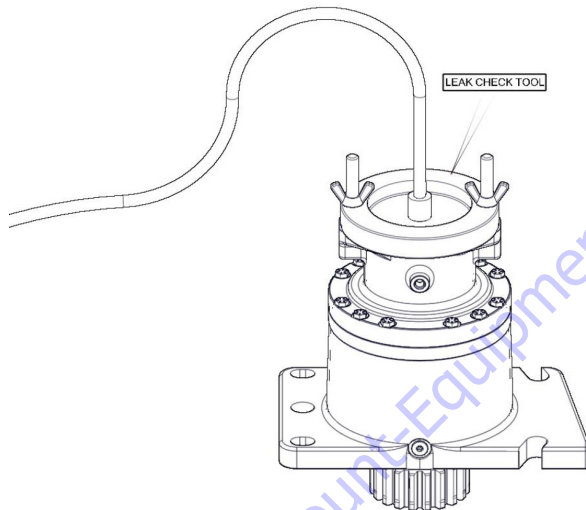
**Tightening and Torquing Bolts**

If an air impact wrench is used to tighten bolts, extreme care should be taken to ensure the bolts are not tightened beyond their specified torque. The following steps describe how to tighten and torque bolts or socket head cap screws in a bolt circle.

1. Tighten (but do not torque) bolt A until snug.

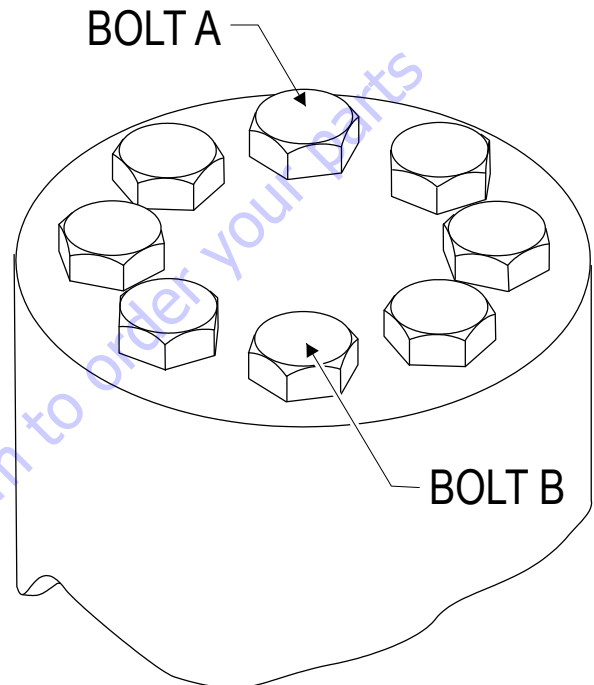

Figure 3-36. Bolt Tightening Sequence

2. Go to the opposite side of the bolt circle and tighten bolt B until equally snug.
3. Crisscross around the bolt circle and tighten the remaining bolts.
4. Use a torque wrench to apply the specified torque to bolt A.
5. Using the same sequence, crisscross around the bolt circle and apply an equal torque to the remaining bolts.

Lubrication Information

GENERAL PROPERTIES

The lubricant used should be petroleum based gear fluid containing anti-oxidation, anti-foaming and extreme pressure additives. The lubricant should have a minimum viscosity index of 95 cst and maintain a minimum viscosity of 40 cst under normal operating conditions. Some applications require special considerations; consult the JLG Service Department for additional information.

The table below lists the recommended viscosities for various ambient operating temperatures. These recommendations are based on temperature rise of 50° to 100°F at normal operating conditions.

Table 3-9. Recommended Viscosities For Various Ambient Operating Temperatures

Ambient Temperature	Differential Planetary		Simple Planetary	
	ISO Index	AGMA Lubricant Number	ISO Index	AGMA Lubricant Number
-40° to -5°F ⁽¹⁾	VG100	3EP	VG100	3EP
-5° to 40°F	VG150	4EP	VG100	3EP
40° to 105°F	VG220/VG320	5EP/6EP	VG150/VG220	4EP/5EP
105° to 150°F ⁽²⁾	VG460	7EP	VG320	6EP

Footnotes
 1. For operation in this ambient temperature range, synthetic oil is recommended with a pour point of 10°F lower than the minimum ambient temperature.
 2. For operation in this ambient temperature range, synthetic oil is recommended for proper lubricant life at elevated temperatures.

MAINTENANCE

Oil amounts for each series of Torque-Hub drives are indicated in the appropriate series literature. An initial oil change should be made after the first 50 hours of operation. Subsequent oil changes should be made at 1,000 hour intervals or annually, whichever comes first.

Oil temperatures should be not higher than 160° to 180°F for continuous operation, and no higher than 200°F for intermittent operation. For special applications, please consult the JLG Service Department.

Motor Removal

Refer to Figure 3-37. and Figure 3-38.

1. Place unit on bench with the motor end up.
2. Remove the magnetic Pipe Plug (1P) and drain the oil out of the gearbox.

NOTE: Record the condition and volume of the oil.

3. Remove Hydraulic Tubing Assembly (35) by loosening fittings on both ends of tube with a wrench.
4. Using a wrench, loosen jam nuts on Elbow Fittings (30) and remove fittings from Brake Housing (6) and Motor Control Valve (32).
5. Remove O-ring Pipe Plugs (23) from Motor Control Valve (32).
6. Remove Motor Control Valve (32) from Motor (31) by removing the four Bolts (21) and washers (22).
7. Remove O-ring (99) between Motor Control Valve (32) and Motor (31). Discard O-ring.
8. With unit resting on bench with Motor (31) end up, loosen Hex Bolts (29) and remove Lift Lugs (28) from the Motor (31).
9. Pull Motor (31) straight up and remove Motor (31) from Brake Housing (6).
10. Remove O-ring (26) from between Motor (31) and Brake Housing (6). Discard O-ring.

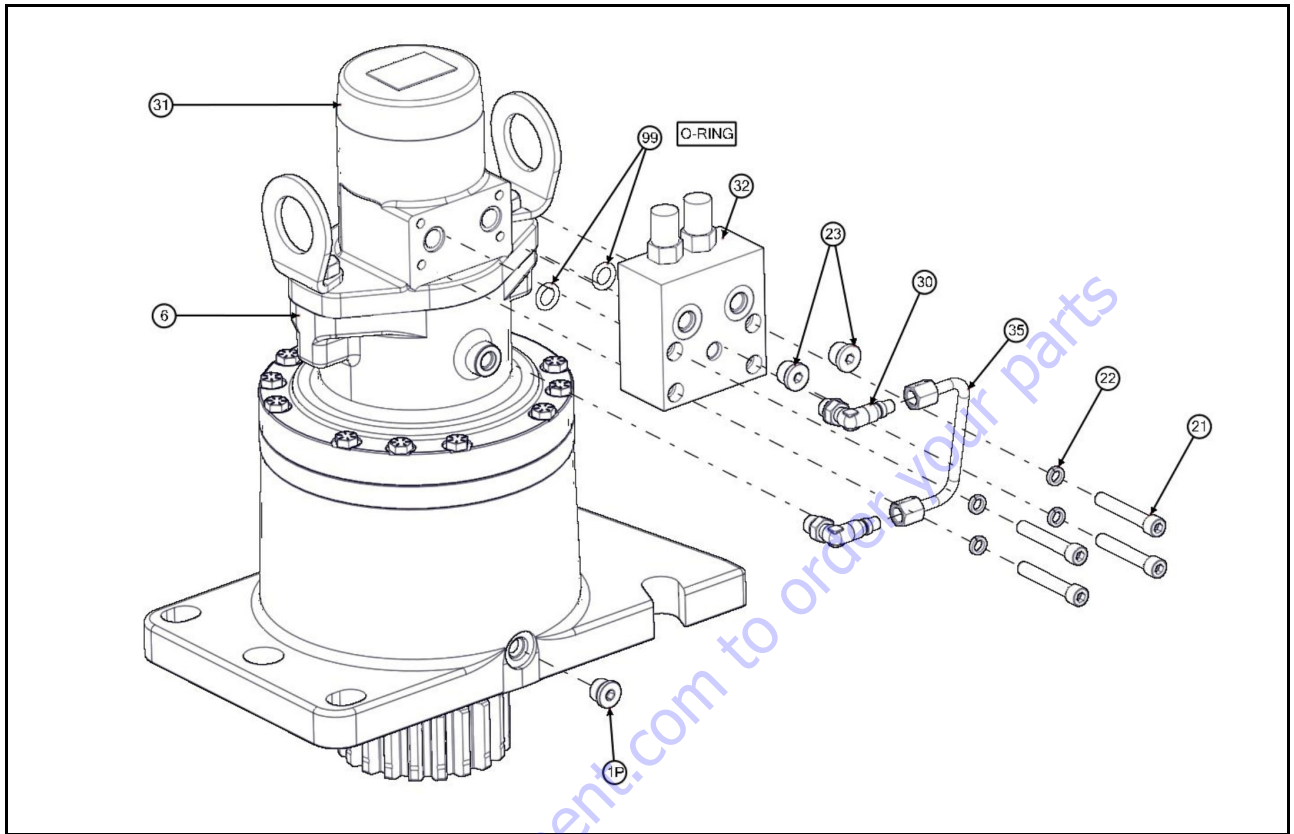

Figure 3-37. Swing Motor Valve Removal

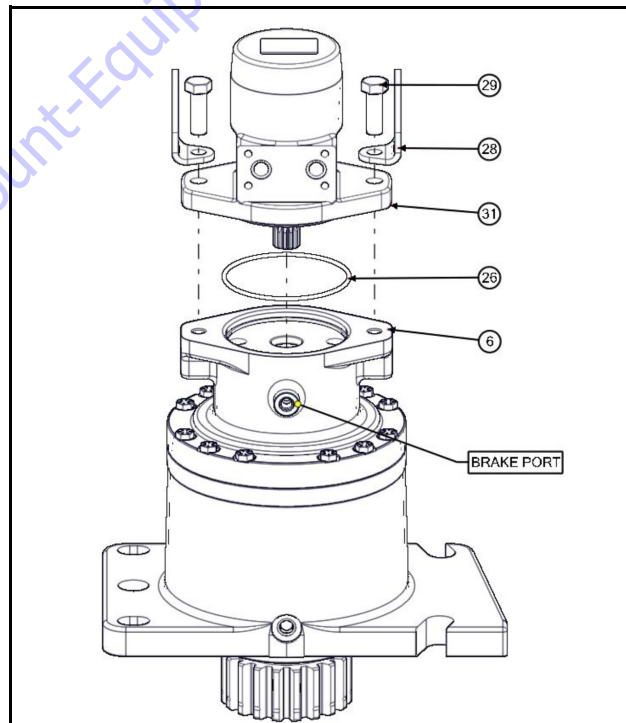

Figure 3-38. Swing Motor Removal

Input Brake Disassembly

Refer to Figure 3-39.

1. Insert and tighten the 0.250-20 UNC flat Socket Head Cap Screws through the Pressure Plate (8M) and into the Brake Piston (8A) to compress the springs and relieve pressure on the Retaining Ring (8N).

⚠ CAUTION

SAFETY GLASSES MUST BE WORN DURING THESE NEXT STEPS.

NOTE: Ensure Step 1 is completed before doing this next step.

2. Using retaining ring pliers, remove Retaining Ring (8N) which holds the Brake Piston assembly in place.

3. Lift Brake Piston Assembly (8A) out of the Brake Housing (6). If the Brake Piston assembly (8A) will not lift out, apply less than 50 psi air to the Brake port to remove Brake Piston (8A). Remove the Inner (Rotor) (8J), Outer (Stator) Plates (8K), from inside Brake Housing (6).

4. Remove O-rings (8D, 8F) and Backup Rings (8E, 8H) from the Brake Housing (6).

Discard O-rings and Backup Rings.

5. Remove 0.250-20 UNC flat Socket Head Cap Screws and lift the Pressure Plate (8M) from the Brake Piston (8A).

NOTE: Record the number of springs and mark their locations before removing them from brake piston.

6. Remove Springs (8L) from the Brake Piston (8A).

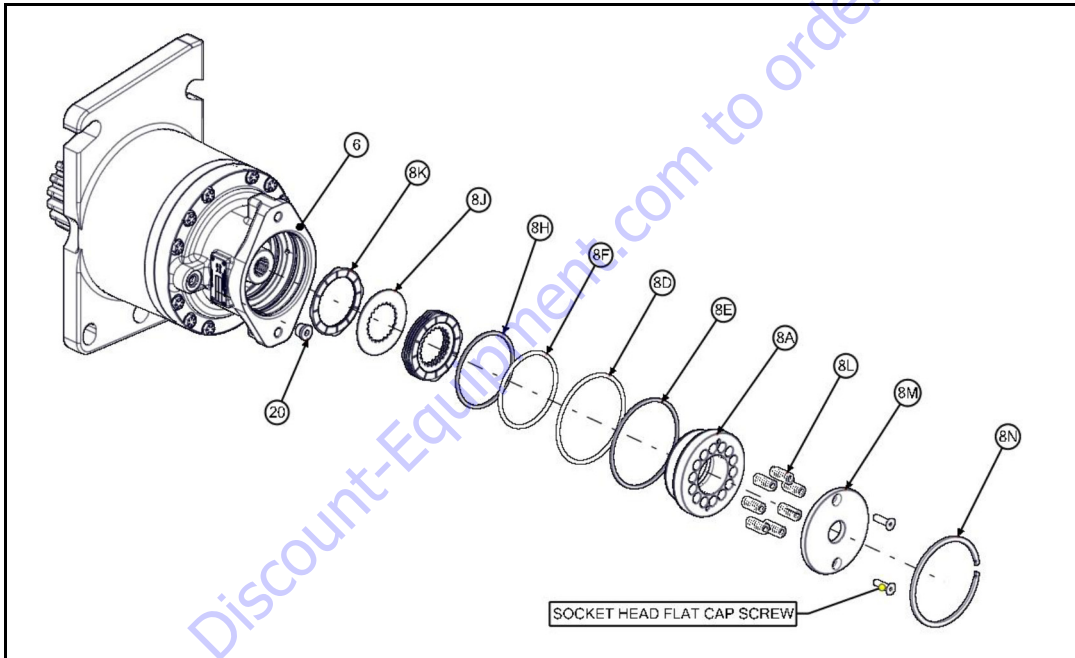

Figure 3-39. Input Brake Disassembly

Main Disassembly

Refer to Figure 3-40.

⚠ CAUTION

SAFETY GLASSES MUST BE WORN DURING THESE NEXT STEPS.

1. Remove Sun Gear (8).
2. With the unit resting on the Output Shaft (Pinion) (1A), remove the Bolts (12) from the Brake Housing (6).
3. Remove the Brake Housing (6) from the main assembly.
4. Remove O-ring (5A) from between Brake Housing (6) and Ring Gear (4). Discard O-Ring.
5. Remove Thrust Washer (11) from between Brake Housing (6) and Carrier Sub-Assembly.
6. Remove Ring Gear (4) from Housing (1G).
7. Remove O-ring (5) from between Ring Gear (4) and Housing (1G), discard O-ring.
8. Remove Carrier Sub-Assembly.
9. Remove Thrust Washer (11) from between Carrier Sub-assembly and Internal Gear (2).
10. Remove Internal Gear (2).

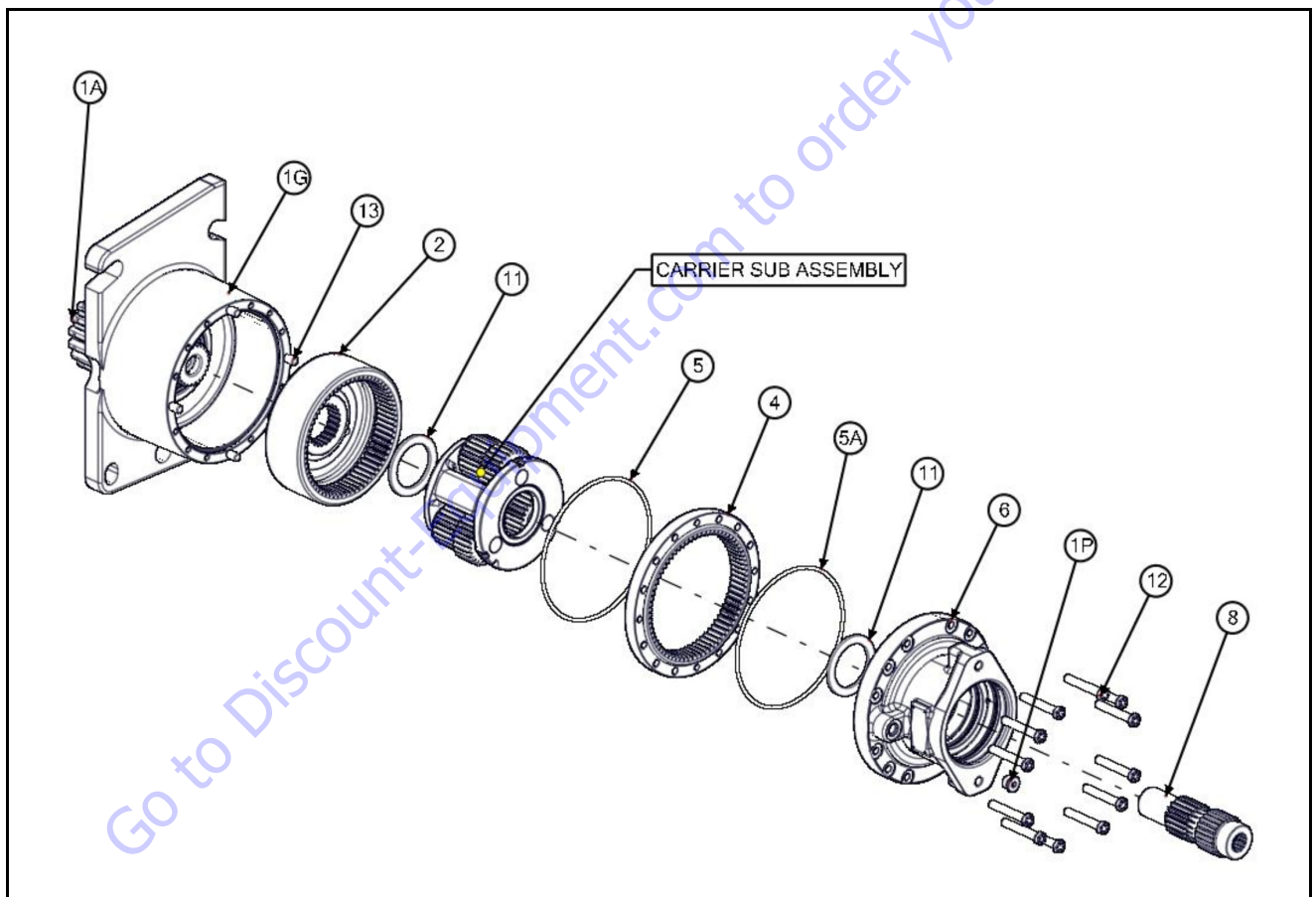

Figure 3-40. Main Disassembly

Housing-Shaft Disassembly

Refer to Figure 3-41.

1. Set the unit on a bench so that the Housing (1G) flange is down.

CAUTION

SAFETY GLASSES MUST BE WORN DURING THESE NEXT STEPS.

2. Using retaining ring pliers remove Retaining Ring (1I) from groove in Output Shaft (1A) and discard.

CAUTION

EYE PROTECTION SHOULD BE WORN DURING THIS PROCEDURE.

3. Remove Thrust Washer (1H).

4. While supporting the Housing (1G) on the Output Shaft (1A) end, press the Output Shaft (1A) out of the Housing (1G).

NOTE: The Lip Seal (1B) will be pressed out of the Housing (1G) by the Bearing Cone (1D) during this step.

5. Remove the Bearing Cone (1E) from the Housing (1G).

6. Use a bearing puller to remove the Bearing Cone (1D) from the Shaft (1A).

7. Bearing Cups (1C & 1F) will remain in Housing (1G).

NOTE: If bearing replacement is necessary, the Bearing Cups (1C & 1F) can be removed with a slide hammer puller or driven out with a punch.

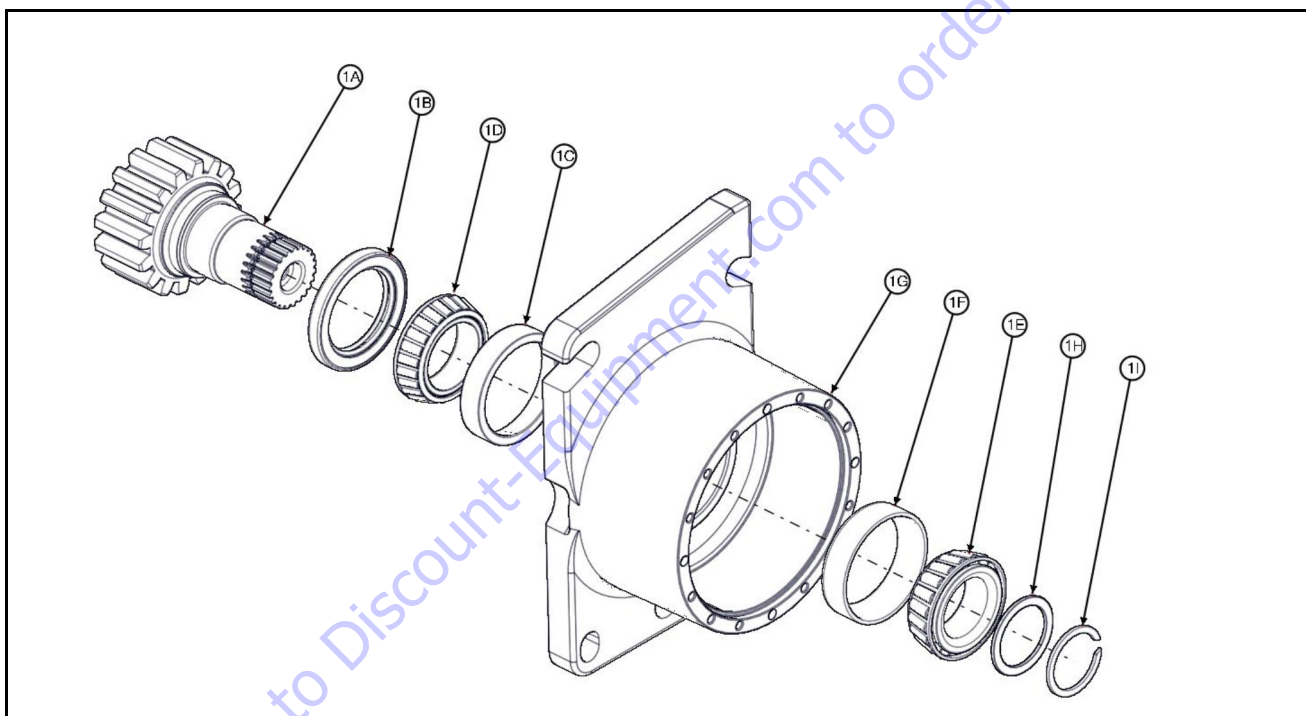

Figure 3-41. Housing Shaft Disassembly

Carrier Disassembly

Refer to Figure 3-42.

1. Drive the Planet Shaft (3E) out of the carrier pin holes; forcing the Roll Pin (3G) to shear off.
2. Hold on to the Planet Gear (3F) and push the Planet Shaft (3E) out of the Carrier (3A). The Thrust Washers (3B) will slide off the shaft as it is removed.
3. Slide the Planet Gear (3F), the two Thrust Washers (3B) out of the Carrier (3A).
4. Using a hammer and punch, drive the pieces of the Roll Pin (3G) out of the Planet Shaft (3E) and Carrier (3A).
5. Remove both rows of Needle Bearings (3C) and the Spacer (3D) from the bore of the Planet Gear (3F).
6. Repeat Steps 1 through 5 for the remaining two Cluster Gears (3F).

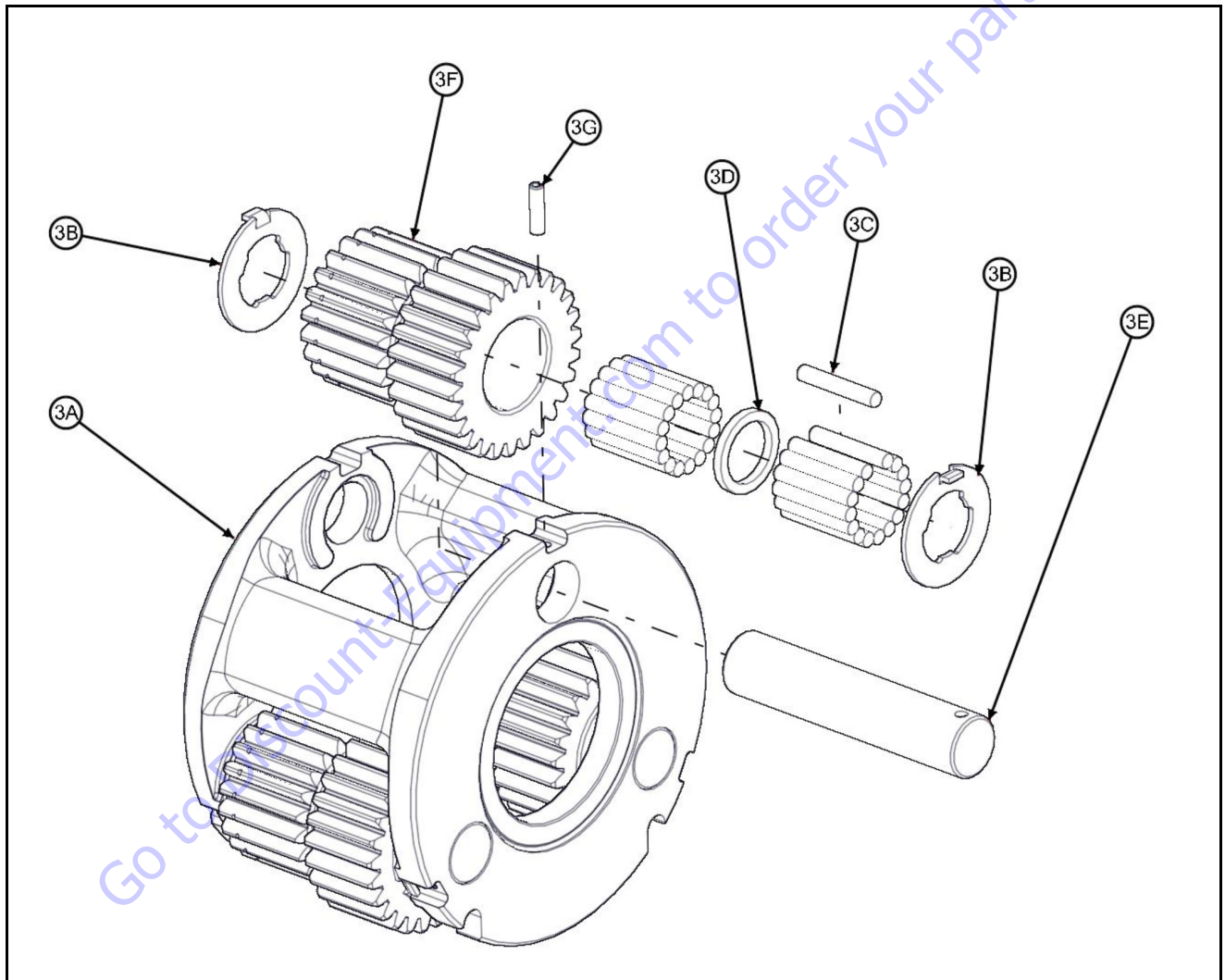

Figure 3-42. Carrier Disassembly

Carrier Assembly

Refer to Figure 3-43.

1. Apply a liberal coat of grease to the bore of Cluster Gear (3F). This will enable the Needle Rollers (3C) to be held in place during assembly.
2. Install one half of the inside of the Cluster Gear (3F) with 16 Needle Rollers (3C).

NOTE: The last roller installed must be installed end wise. That is, the end of the last roller must be placed in between the ends of the two rollers that form the space, and then slid parallel to the other rollers into place.

3. Place one Spacer (3D) on top of the Needle Rollers (3C) inside the Planet Gear (3F).
4. Install the other half of the Cluster Gear (3F) with 16 Needle Rollers (3C).
5. Place Carrier (3A) into tool fixture so that one of the roll pin holes is straight up.
6. Start Planet Shaft (3E), with end opposite roll pin hole first, through the planet shaft hole in carrier (3A), making sure that the roll pin hole with the large chamfer in the planet shaft is straight up.

7. Using ample grease to hold them in position, locate Thrust Washer (3B) onto each side of interior carrier wall with tangs located into slots in Carrier pads.
8. With large end of Cluster Gear (3F) facing the roll pin hole in the Carrier, place the Cluster Gear into position in Carrier (3A) and push Planet Shaft (3E) through the Cluster Gear (3F) without going all the way through the carrier (3A).
9. Finish sliding the Planet Shaft (3E) into the Carrier (3A) until roll pin holes of planet shaft and carrier are aligned. Align roll pin hole using a 1/8 in. diameter punch.

NOTE: The chamfer on the Roll Pin hole should be towards the roll pin hole in the Carrier.

10. Drive the roll pin (3G) through Carrier (3A) and into the Planet Shaft (3E) until the Roll Pin (3G) is flush with the bottom of the cast slot in the Carrier (3A) outside diameter at the Thrust Washer (3B) tang. Use a 1/4" pin punch to make sure the roll pin (3G) is flush in the slot.
11. Repeat Steps 6 through 10 for the remaining two Cluster Gears (3F).

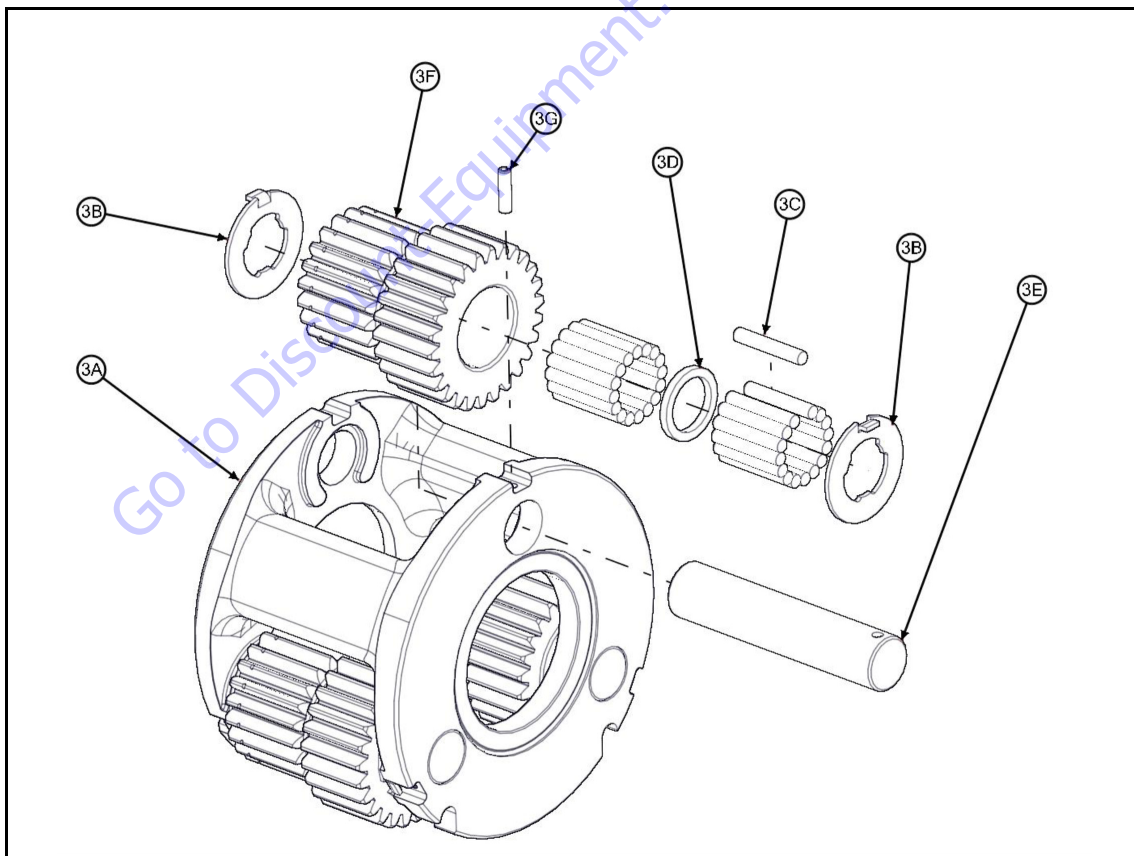

Figure 3-43. Carrier Assembly

Housing - Shaft Assembly

Refer to Figure 3-44.

NOTE: Spray a light film of oil on all component parts during assembly. Spray a generous amount of oil on bearings during installation.

1. Press Bearing Cup (1C) into Housing (1G) taking care to insure cup starts square with the bore of Hub (1G).
2. Place Bearing Cone (1D) in Bearing Cup (1C) in Housing (1G).
3. Press Seal (1B) into the counterbore of Housing (1G) to the point where it becomes flush with the Housing (1G) face. Care should be taken to insure Seal (1B) is being correctly installed (smooth face up). Apply oil to the rubber portion of the seal.
4. Invert Hub (1A) and press Bearing Cup (1F) into counterbore of Housing (1G).
5. Carefully lower Housing (1G) onto the Output Shaft (1A) until Bearing Cone (1D) contacts the Output Shaft (1A).
6. Press on the small end of the Bearing Cone (1D), being careful not to contact the bearing cage, until the Bearing Cone (1D) seats on the shoulder of the Output Shaft (1A).
7. Start the Bearing Cone (1E) onto the Output Shaft (1A).
8. Press or tap the Bearing Cone (1E) onto the Output Shaft (1A) until it is just seated in the Bearing Cup (1F), while rotating the Housing (1G).
9. Install Bearing Spacer (1H) onto Output Shaft (1A) and against Bearing Cone (1F).
10. Install Retaining Ring (1I) into the groove in the Output Shaft (1A). This Retaining Ring (1I) should never be reused in a repair or rebuild.

⚠ CAUTION

EYE PROTECTION SHOULD BE WORN DURING THIS PROCEDURE.

11. Tap the Retaining Ring (1I) with a soft metal punch to ensure that the Retaining Ring (1I) is completely seated in the groove of the Output Shaft (1A).

⚠ CAUTION

EYE PROTECTION SHOULD BE WORN DURING THIS PROCEDURE.

12. Install O-ring Plug (1P) and torque to 23 to 24 ft. lbs. (31 to 32.5 Nm).

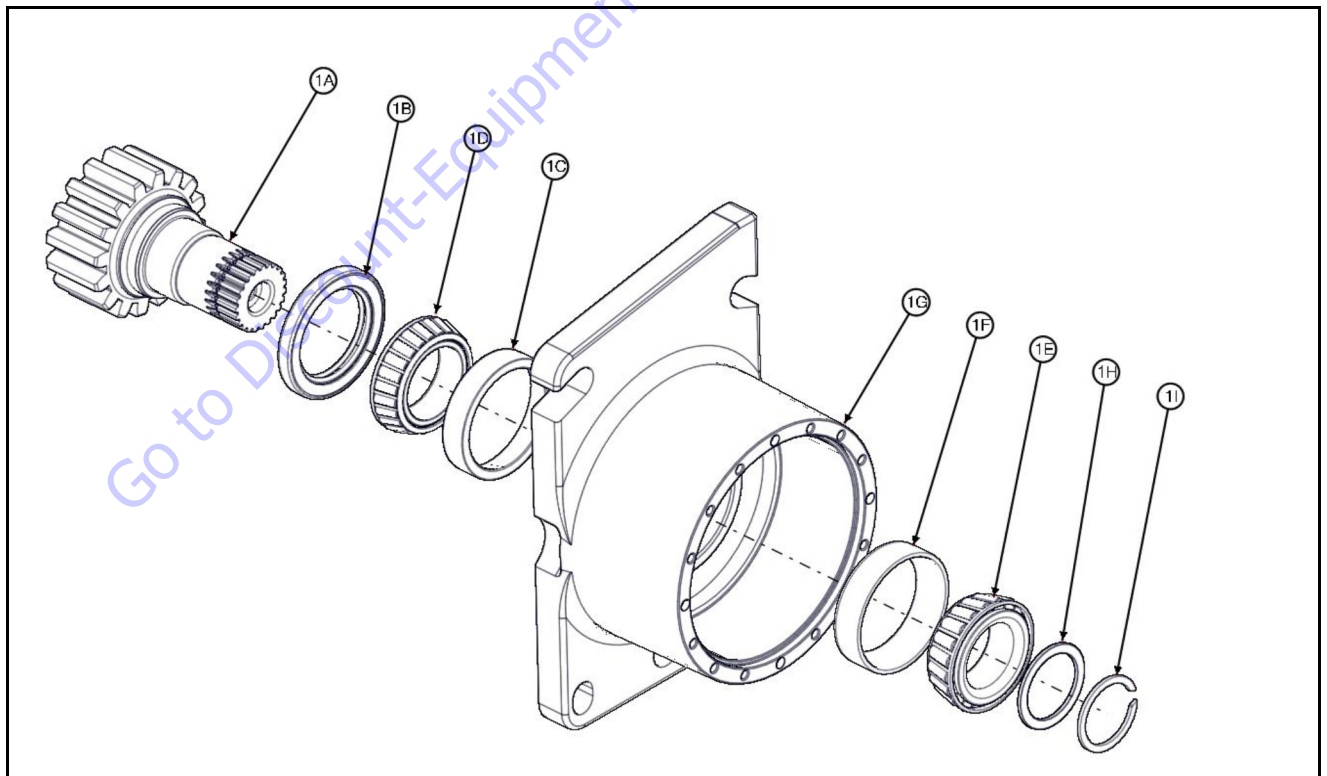
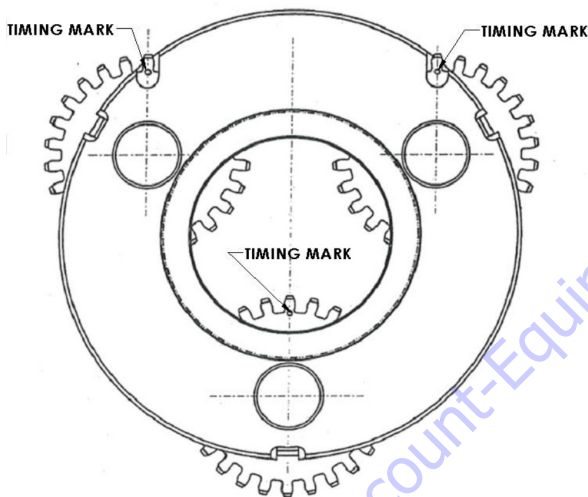

Figure 3-44. Housing - Shaft Assembly

Main Assembly

Refer to Figure 3-45.

1. Slightly tap the Internal Gear (2) with spline side down onto Output Shaft (1A) splines to ensure Internal Gear (2) is properly seated.
2. Grease and install O-ring (5) onto Housing (1G) o-ring groove.
3. Grease and install Thrust Spacer (11) into counterbore of Carrier Sub-assembly on smaller diameter cluster gear side. The grease should hold the Thrust Spacer (11) in place for assembly.
4. Place Carrier Sub-assembly onto table oriented as shown above, with large end of Cluster Gear (3F) facing up. Position all three punch-marks on the face of the large gears at 12 o'clock. Timing marks on the two upper Cluster Gears will be visible through the slots in the Carrier if the Cluster Gears are correctly marked. Secure gear teeth using timing fixture.



5. Place Ring Gear (4) in to large end of Cluster Gear to secure timing.
6. Remove Carrier sub-assembly and Ring Gear (4) from the table and assemble into the Internal gear (2) being careful to keep the ring gear, or sun gear, in mesh with the cluster gears.

7. After engaging internal gear teeth and before rotating carrier, look at the Carrier sub-assembly in the main assembly and insure the timing is correct by locating the timing marks in the slots in the carrier and at 12 o'clock on the gear that the timing mark is visible in the carrier bore.
8. Grease and install O-ring (5A) onto Brake Housing (6) counterbore.
9. Install Brake Housing (6) onto Ring Gear (4) by aligning the bolt holes in brake housing with ring gear holes.
10. Ensure the pipe plugs in Housing (1G) and Brake Housing (6) are timed as shown.
11. Pull one Cover Bolt (12) and place into the bolt hole and repeat for remaining bolts.
12. Torque Bolts (12) in star pattern to 23-27 ft. lbs. (31-36.5 Nm).
13. Install Input Shaft (8) with spline side up into housing bore. Insure the input shaft gear teeth and planet gears are engaged.
14. Install O-ring plugs (1P) into Brake Housing (6) and Housing (1G). Torque 23 to 24 ft. lbs. (31 to 32.5 Nm).
15. The unit should now be leak and roll checked as per instructions in this section.
16. Fill oil through the opening in Brake Housing (6) with 43 oz. (1.3 L) of 80W90 gear oil.

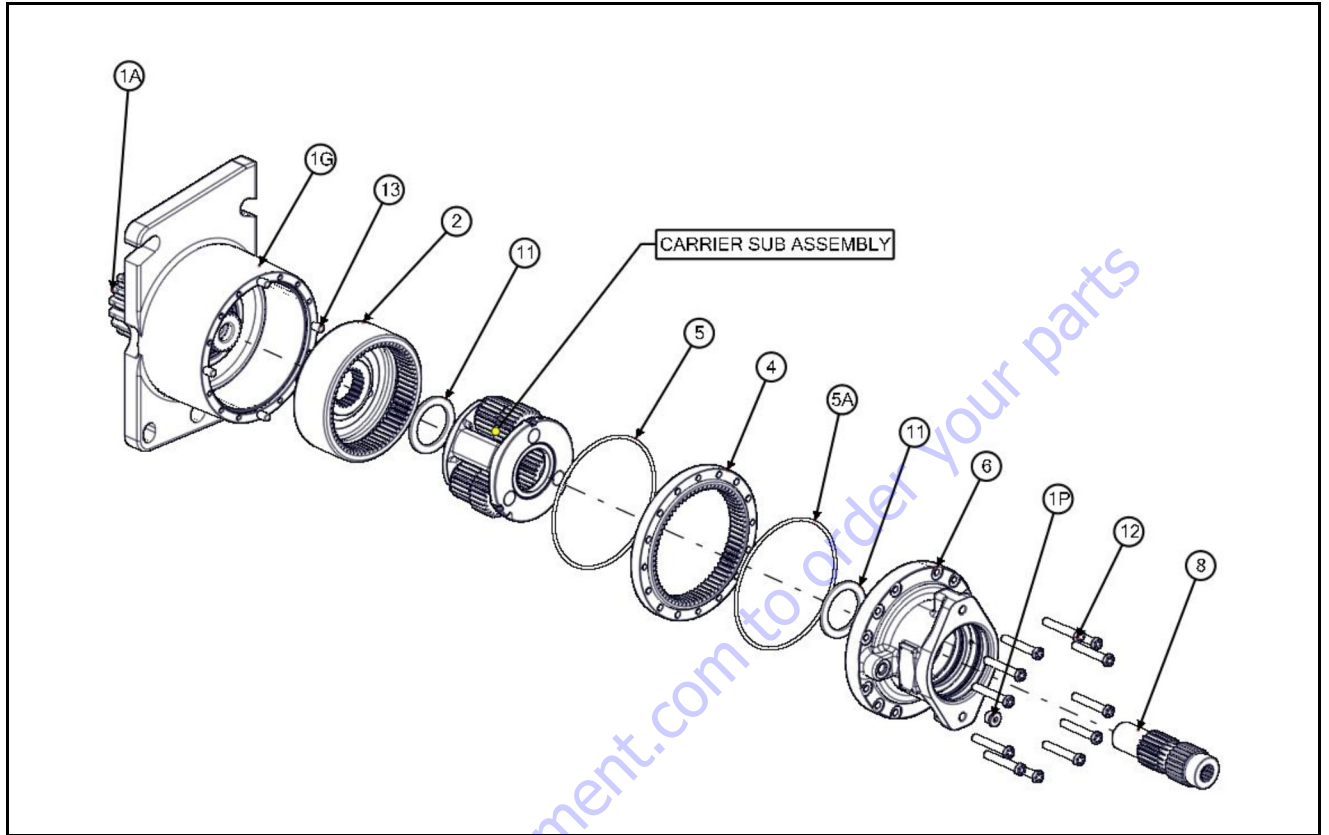

Figure 3-45. Main Assembly

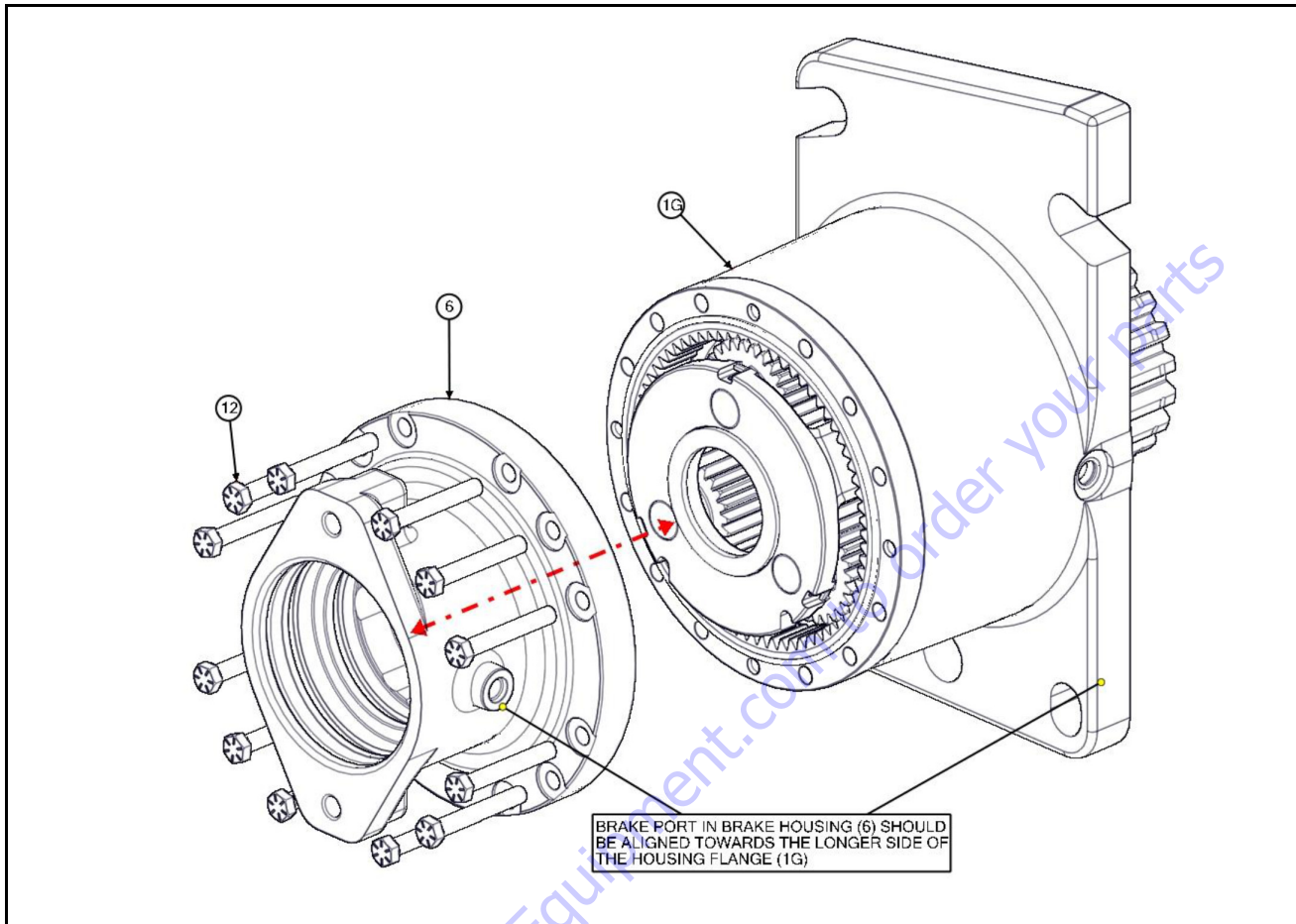

Figure 3-46. Brake Port Alignment

Motor and Brake Assembly

1. Starting with a Stator (8K), alternately stack and install Stators (8K) into Lobes of Brake Housing (6) and Rotors (8J) (internal splines) onto splines of Sun Gear (8).

NOTE: *There should always be a Stator on the top and bottom of the stack.*

2. Insert Brake Piston (8A) completely into Brake Housing (6) without O-rings (8D, 8F) and Backup Rings (8E, 8H) to check fit of brake. The Brake Piston (8A) should slide into Brake Housing (6) without being forced. If Brake Piston (8A) does not fit, check for burrs or size problems before proceeding.

3. Grease O-rings (8D, 8F) and install smaller diameter O-Ring (8F) into smaller diameter O-Ring groove in Brake Housing (6) and install larger diameter O-Ring (8D) into larger diameter O-Ring groove in Brake Housing (6).
4. Insert smaller diameter Solid Backup Ring (8H) into smaller groove in Brake Housing (6) between O-Ring (8F) and side of groove towards Output Shaft (1A).
5. Insert larger diameter Solid Backup Ring (8E) into groove in Brake Housing (6) between O-Ring (8D) and side of groove towards Motor (31).

NOTE: Refer to the figure below for installing O-Rings (8D), (8F) and Backup Rings (8E), (8H).

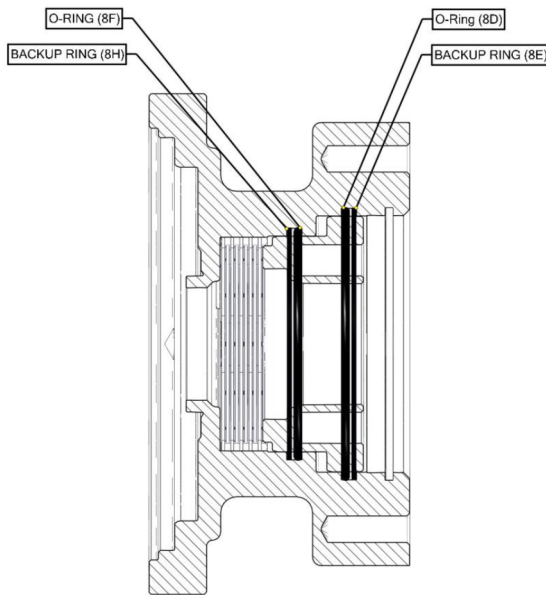

6. Lightly grease cylinder walls of Brake Housing (6) and install Brake Piston (8A) into Brake Housing (6). If necessary, place T-134711 on top of brake and lightly tap until Brake Piston (8A) contacts brake disk stack.
7. Insert 8 Springs (8L) into Brake Piston (8A) spring holes.
8. Install Pressure Plate (8M) into Brake Housing (6) bore and onto top of Springs (8L).
9. Insert and tighten the 0.250-20 UNC Flat Head Cap Screws through the Pressure Plate (8M) and into the Brake Piston (8A) to compress the springs. Tighten Socket Head Cap Screws incrementally to evenly compress the Springs (8L).

⚠ CAUTION

SAFETY GLASSES MUST BE WORN DURING THESE NEXT STEPS.

10. Using retaining ring pliers, install large Retaining Ring (8N) into groove in Brake Housing (6) making sure that it is seated properly.

NOTE: Use caution when installing retaining ring (8N) into Brake Housing (6). It may cause injury if it slips out of retaining ring pliers.

11. Remove the Flat Head Cap Screws from the Brake Piston (8A) incrementally to release the tension of the springs slowly. Discard Flat Head Cap Screws.
12. The Unit should undergo brake test (as per instructions in this section).

13. Grease and install the O-Ring (26) into the Motor (31) pilot.
14. Install Motor (31) into the Brake Housing (6). Insure the motor valve mounting face is aligned with the radial brake release port in the Housing (1G).

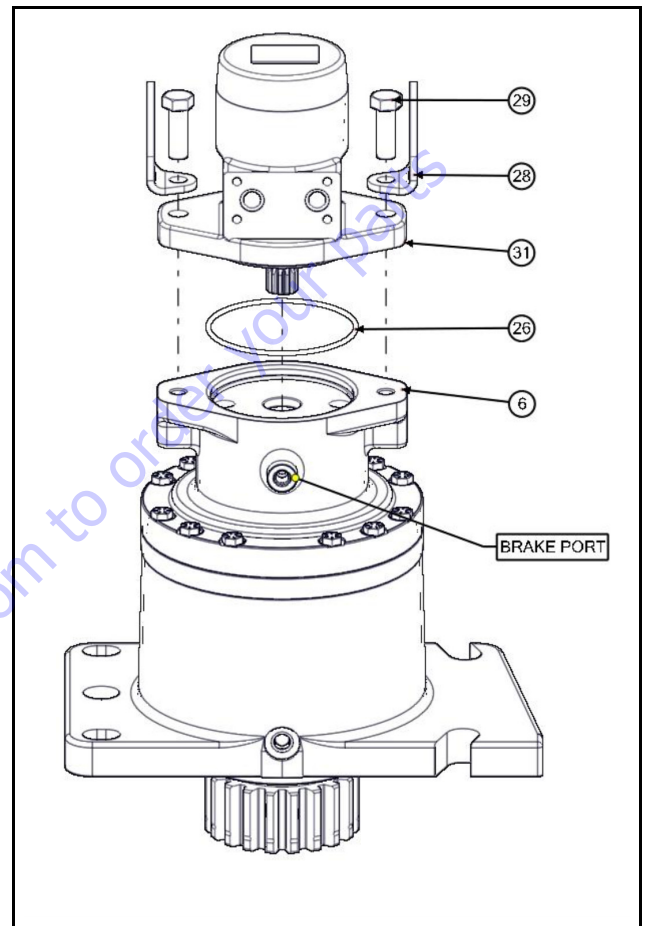

Figure 3-47. Swing Motor Installation

15. Install Bolts (29) into Brake Housing (6) through Lifting Lugs (28) and Motor (31) flange. Torque bolts to 80-100 ft. lbs. (108.5-135.5 Nm).

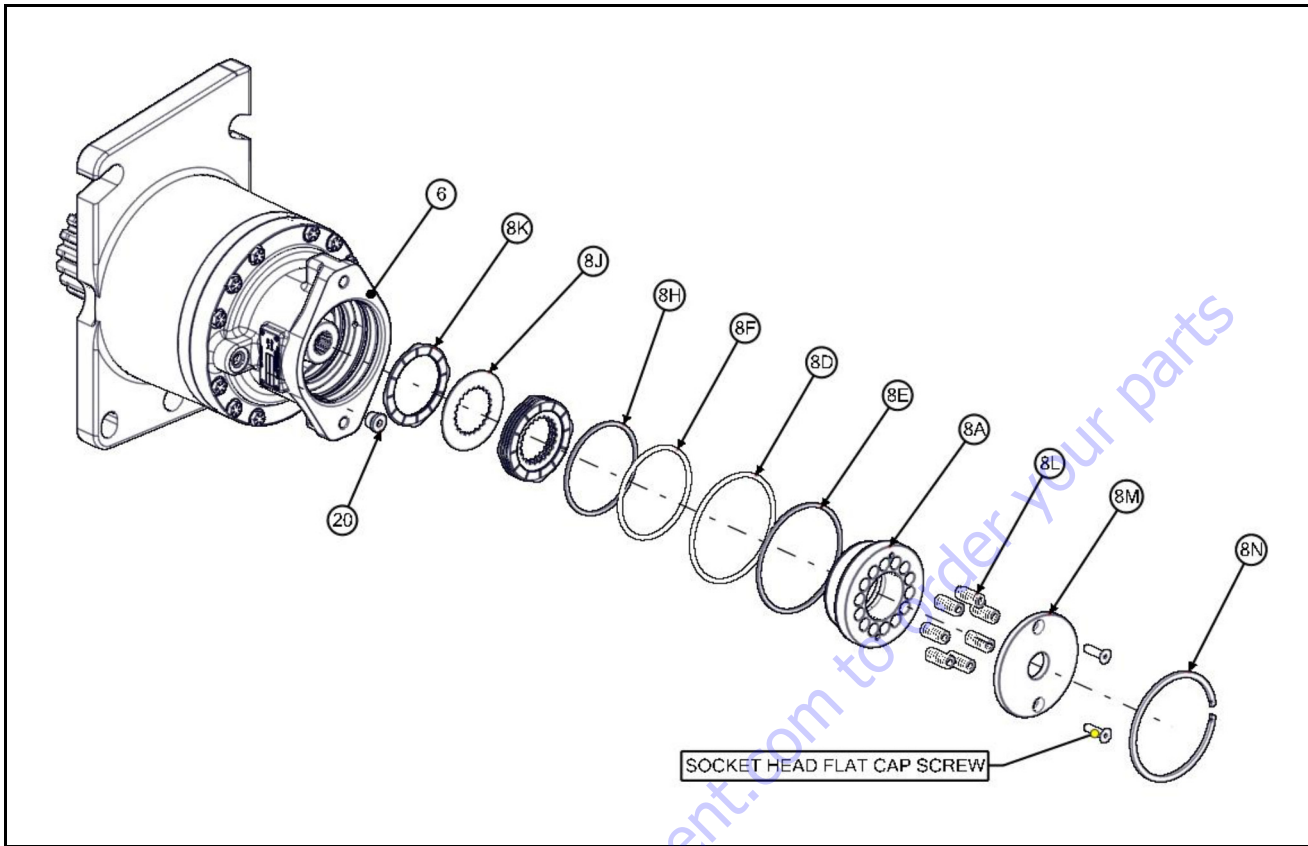

Figure 3-48. Motor and Brake Assembly

Motor Control Valve Installation

NOTE: Verify o-rings are located in between the motor and valve.

1. Install O-Rings (99) into counterbore on Motor Valve face.
2. Install the Motor Control Valve (32) onto the Motor (31) using Bolts (21) and Washers (22). Torque Bolts to 18-20 ft. lbs. (24.5-27 Nm). Insure the holes in Motor Control Valve (32) are aligned with holes in Motor (31).
3. Install Elbow Fitting (30) into Brake Housing (6). Insure the thread fitting o-ring seats onto the Brake Housing (6). Rotate the Elbow Fitting (30) to horizontal position as shown in picture.
4. Install Elbow Fitting (30) into Motor Valve (32). Insure the thread fitting o-ring seats onto the Motor Valve (32). Rotate the Elbow Fitting (30) to horizontal position as shown in picture.
5. Install Tube Assembly (35) to elbow fittings as shown in picture. Torque tube assembly nut to 13-15 ft. lbs. (17.5-20 Nm). Tighten Jam Nut on Elbow Fitting (30) into 13-15 ft. lbs. (17.5-20 Nm). torque.
6. Install one O-Ring Plug (23) onto Motor Control Valve (32). Torque to 18-20 ft. lbs. (24.5-27 Nm).
7. Install hydraulic test fitting into the other control valve O-ring Plug (23) hydraulic port.
8. Perform pressure decay test at "MAXIMUM PRESSURE". Hold pressure for 1 minute. If pressure does decay, remove the pressure and inspect connections and retest.
9. Remove hydraulic test fitting.
10. Install the o-ring plug (23) onto motor control valve (32). Torque to 18-20 ft. lbs. (24.5-27 Nm).

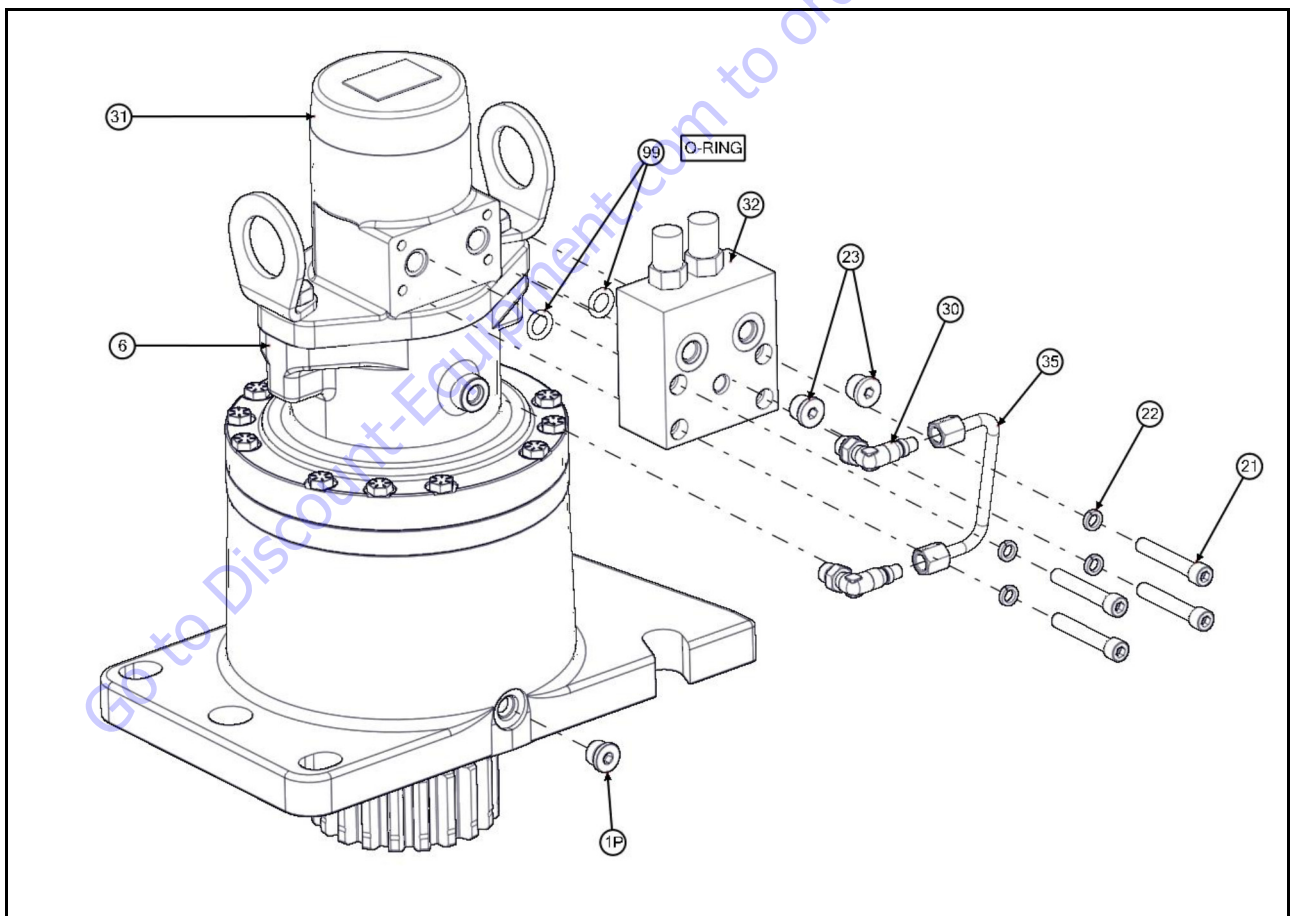

Figure 3-49. Swing Motor Valve Installation

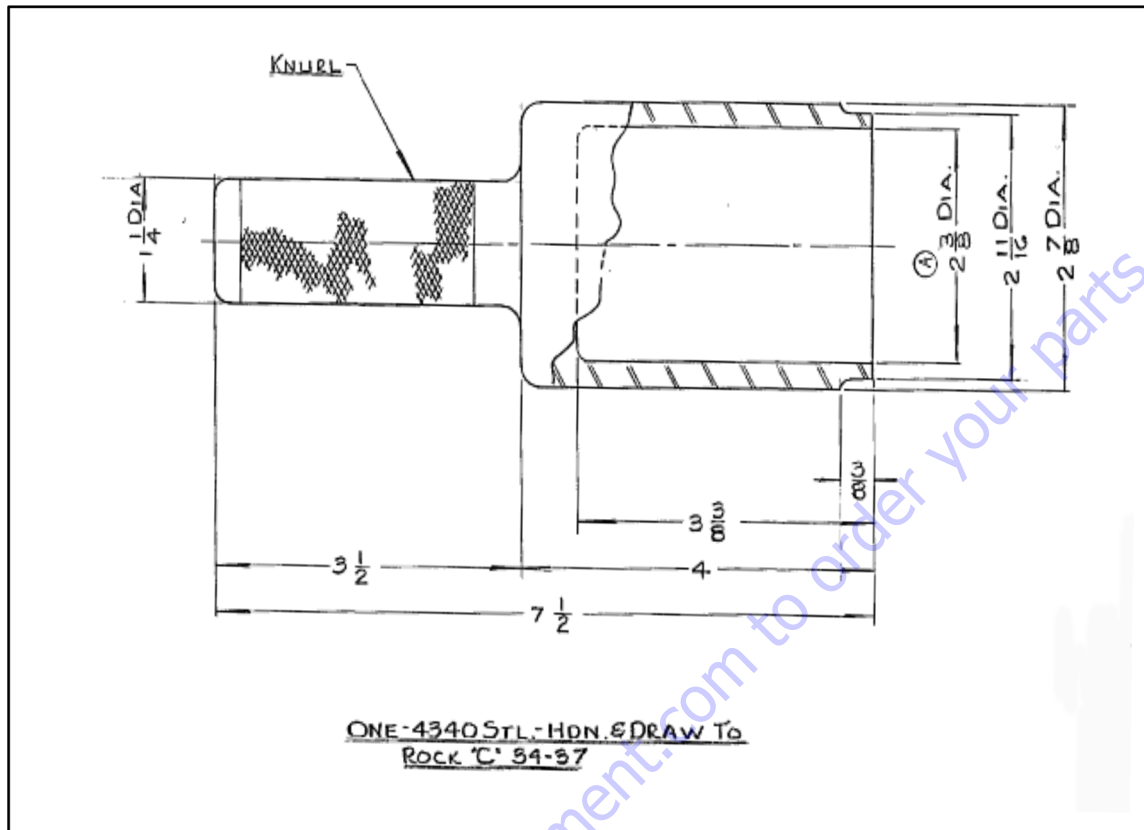

Figure 3-50. Bearing Cone Press Tool

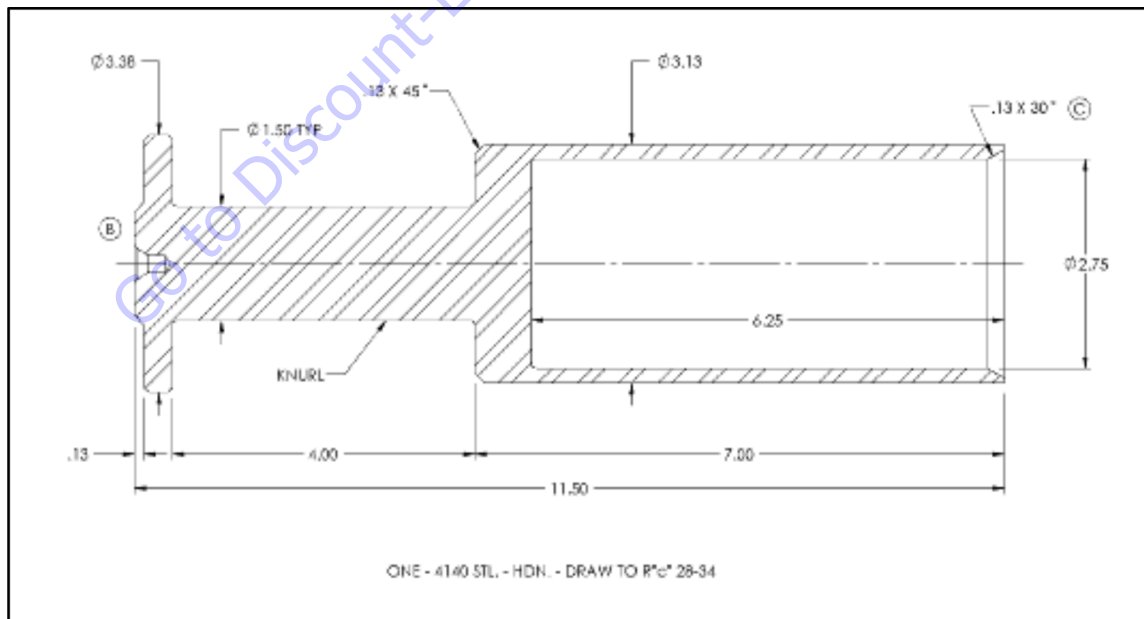

Figure 3-51. Bearing Cone Press Tool

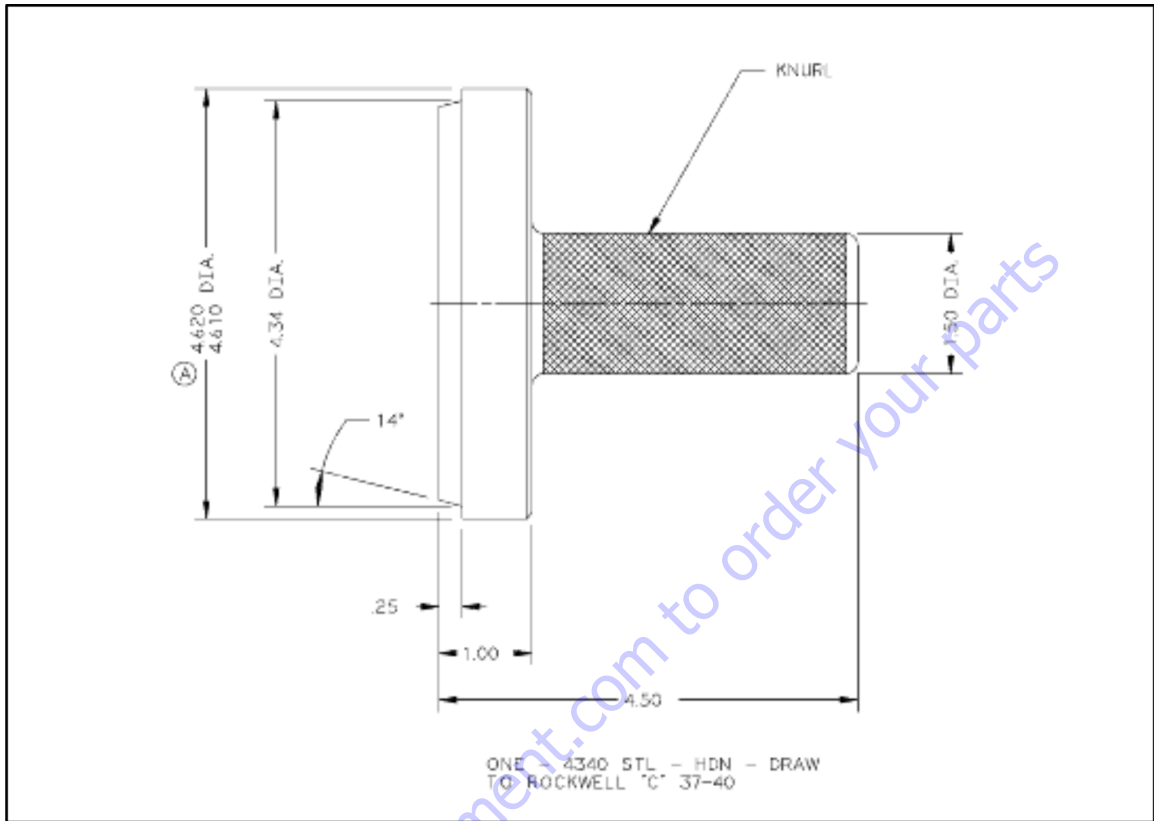

Figure 3-52. Bearing Cup Press Tool

SECTION 3 - CHASSIS & TURNTABLE

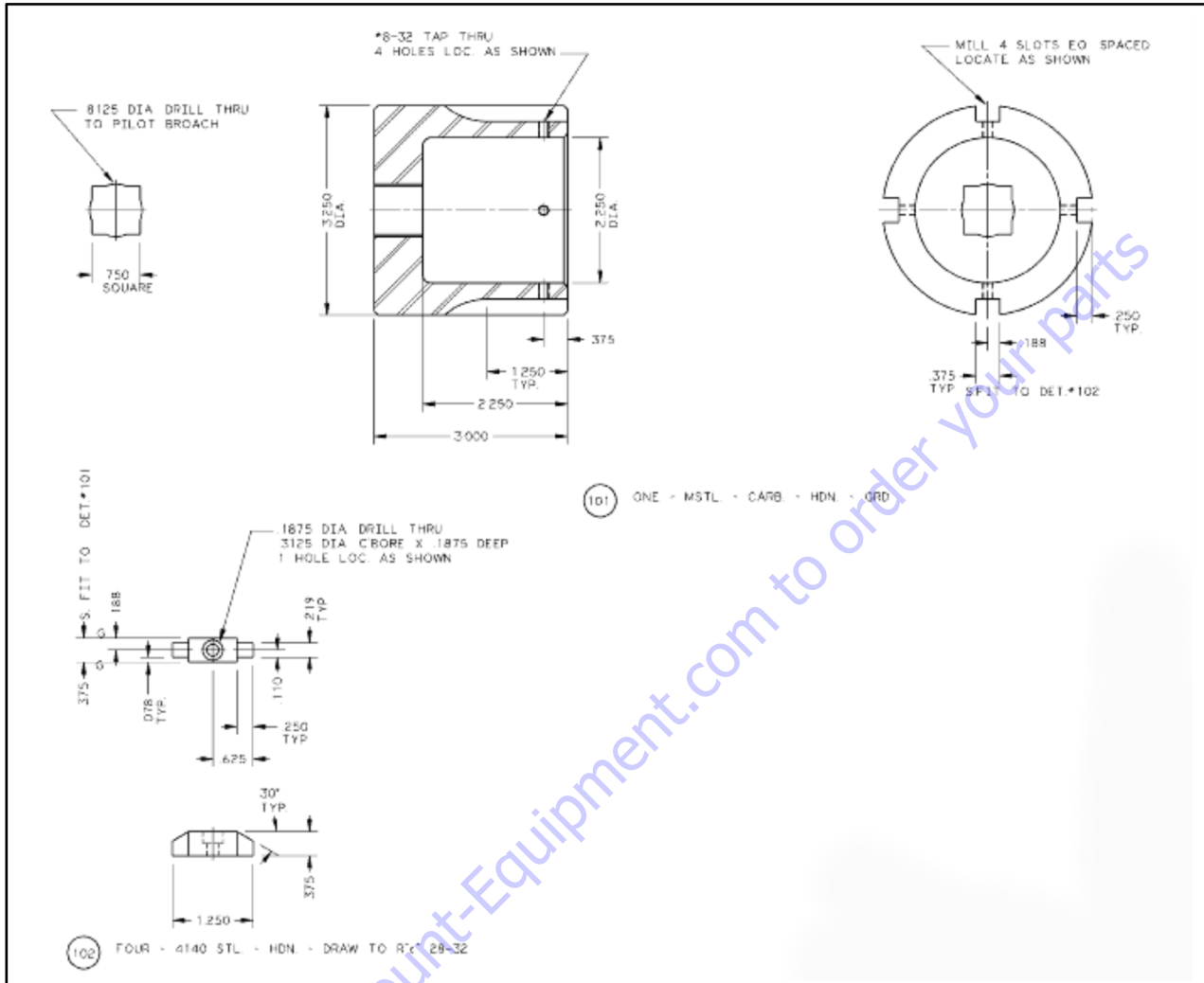

Figure 3-53. Lockout Wrench Tool

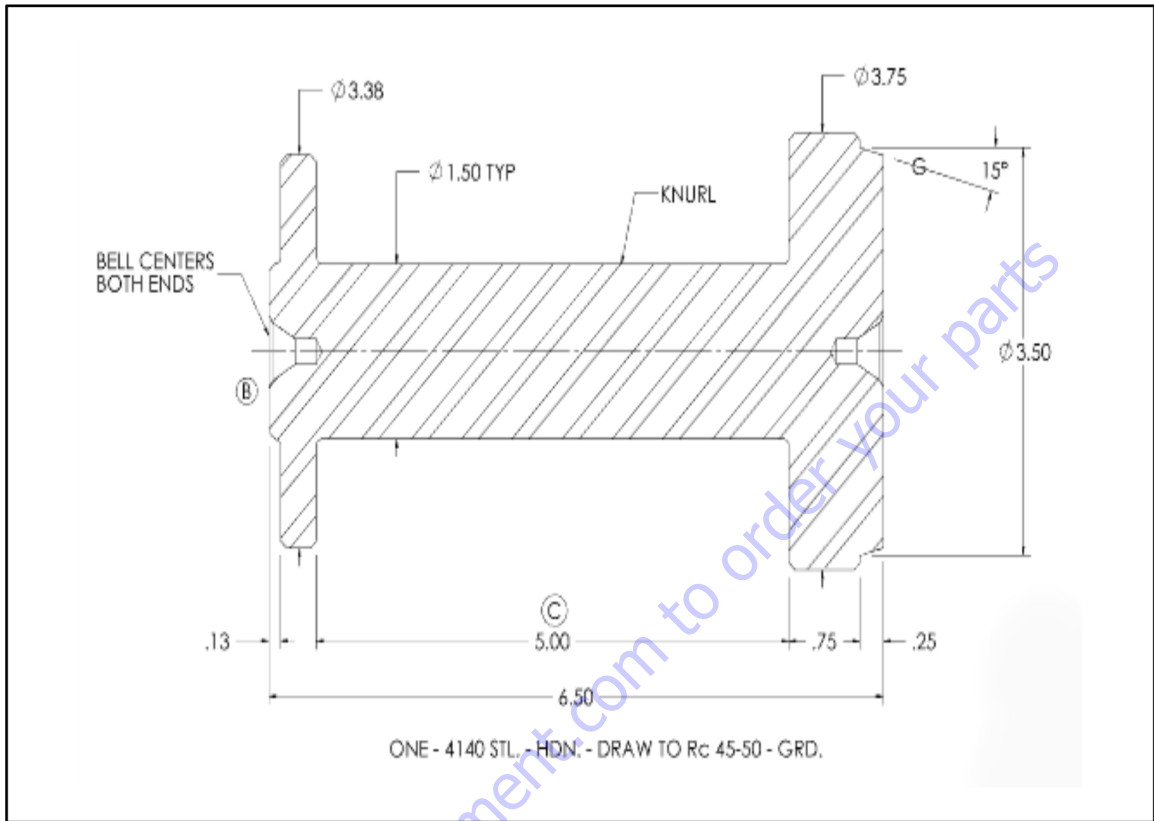

Figure 3-54. Bearing Cup Press Tool

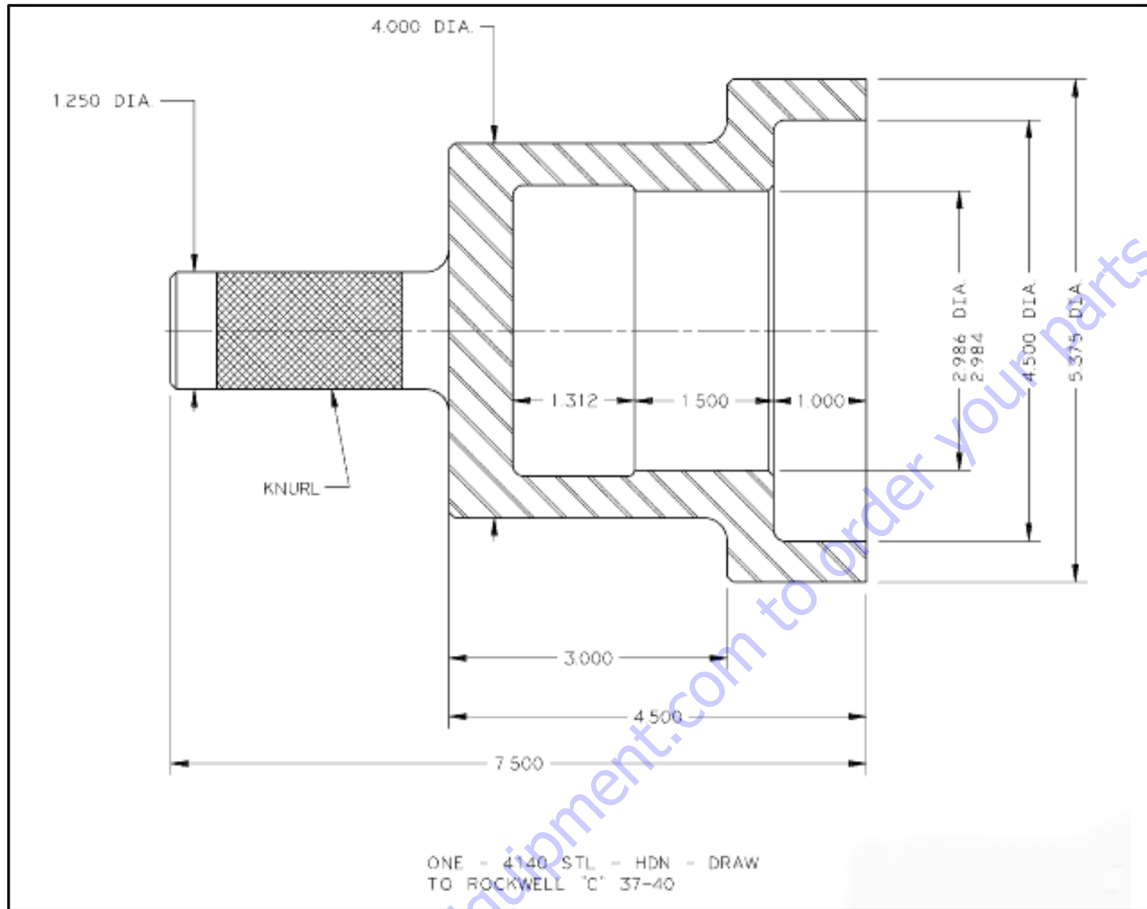
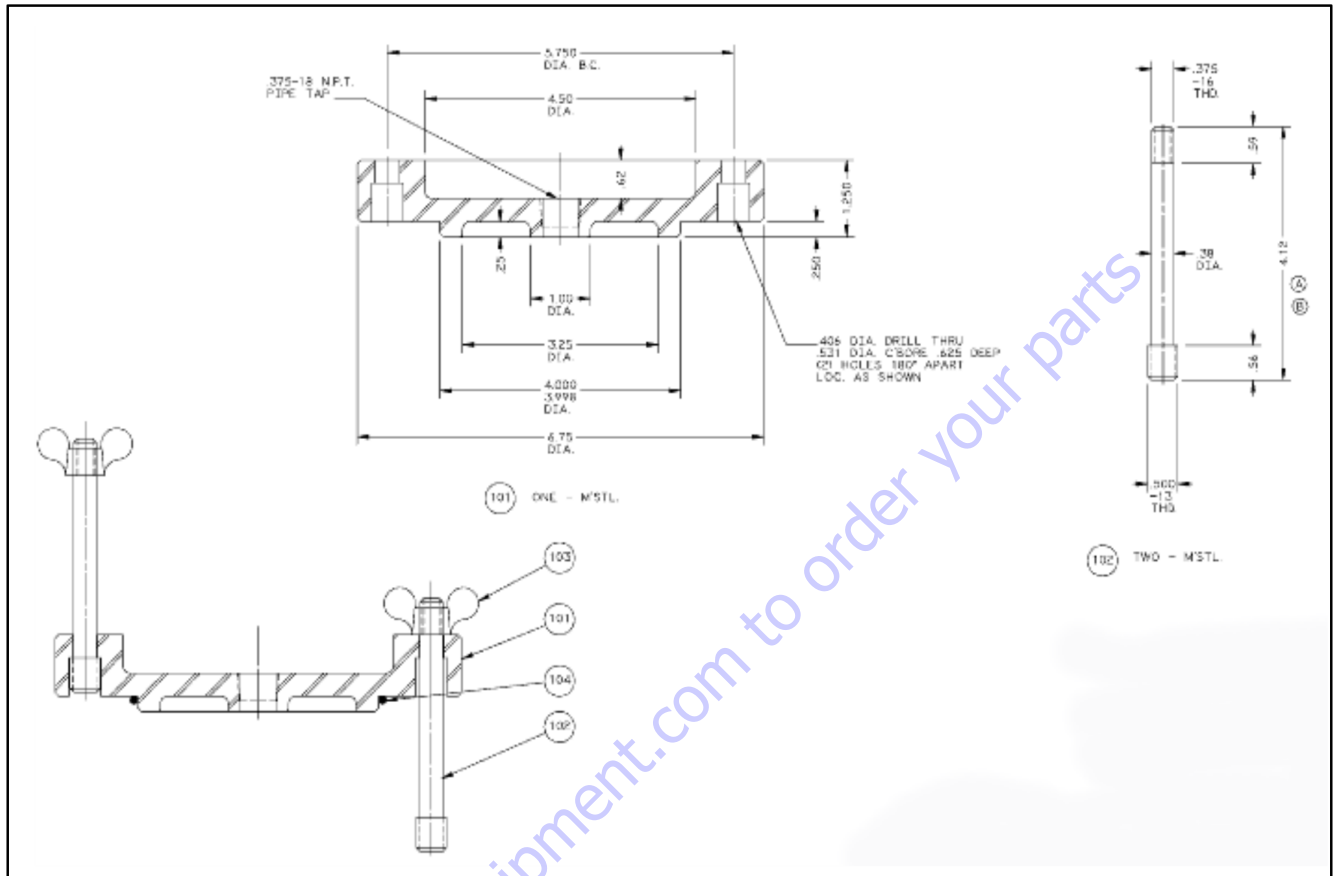

Figure 3-55. Seal Press Tool



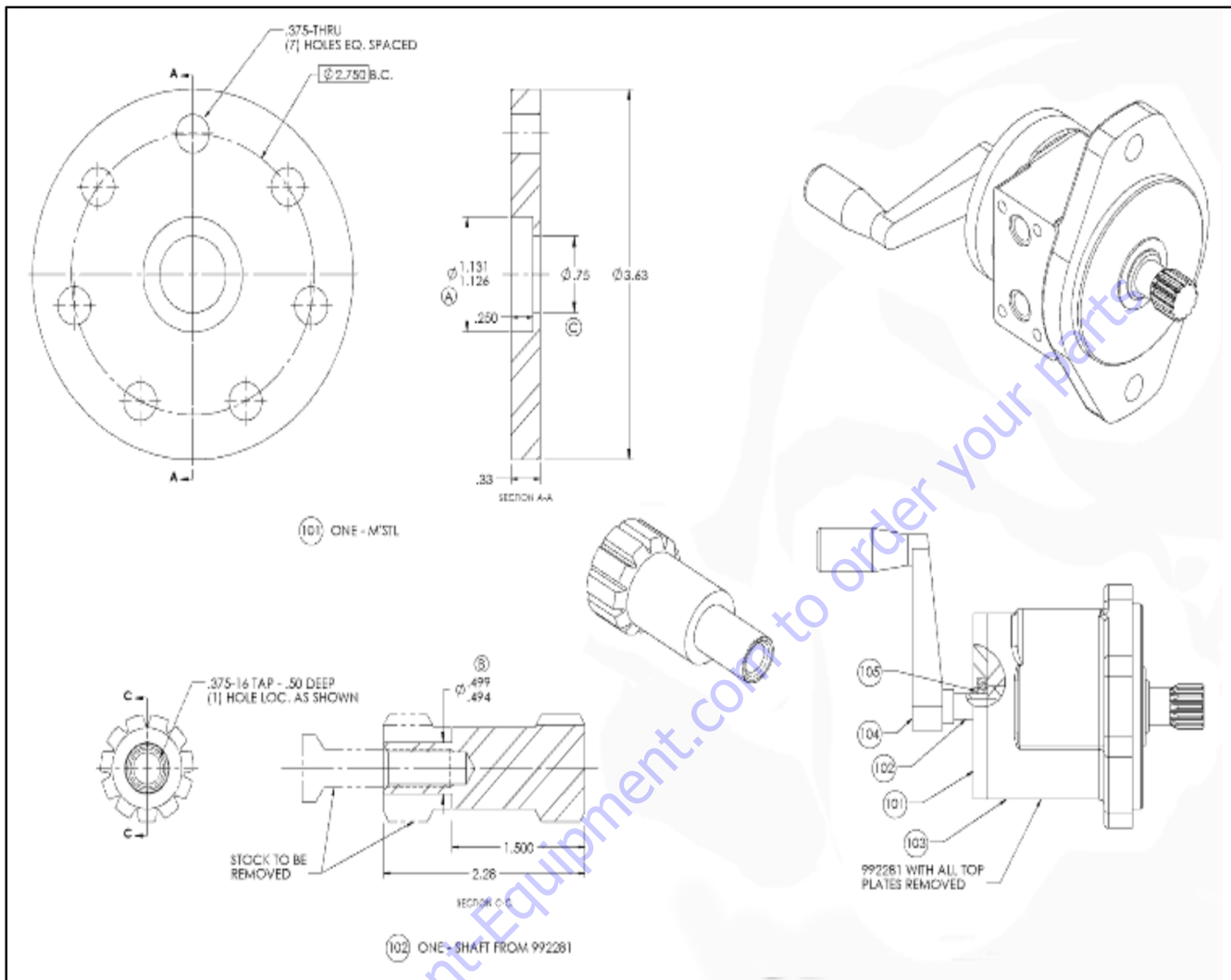
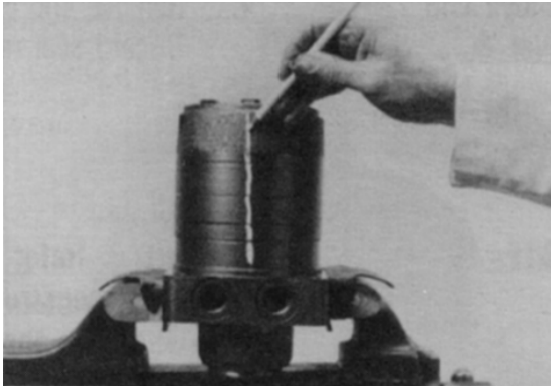

Figure 3-57. Swing Drive Test Plate

3.13 SWING MOTOR

Disassembly and inspection

1. Place the Torqlink™ in a soft jawed vice, with coupling shaft (12) pointed down and the vise jaws clamping firmly on the sides of the housing (18) mounting flange or port bosses. Remove manifold port O-Rings (18A) if applicable.



⚠ WARNING

IF THE TORQLINK™ IS NOT FIRMLY HELD IN THE VISE, IT COULD BE DISLODGED DURING THE SERVICE PROCEDURES, CAUSING INJURY.

2. Scribe an alignment mark down and across the Torqlink™ components from end cover (2) to housing (18) to facilitate reassembly orientation where required. Loosen two shuttle or relief valve plugs (21) for disassembly later if included in end cover. 3/16 or 3/8 in. Allen wrench or 1 in. hex socket required.

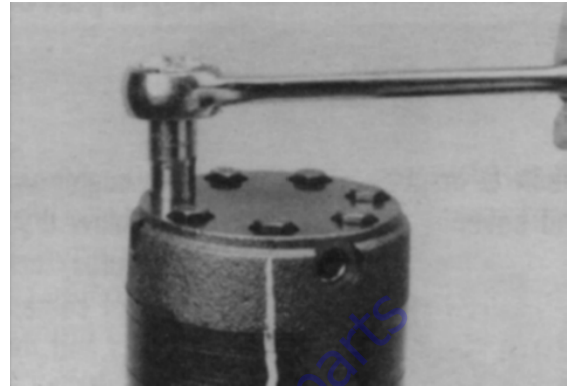

3. Remove the five, six, or seven special ring head bolts (1) using an appropriate 1/2 or 9/16 in. size socket. Inspect bolts for damaged threads, or sealing rings, under the bolt head. Replace damaged bolts.



4. Remove end cover assembly (2) and seal ring (4). Discard seal ring.



NOTE: Refer to the appropriate "alternate cover construction" on the exploded view to determine the end cover construction being serviced.

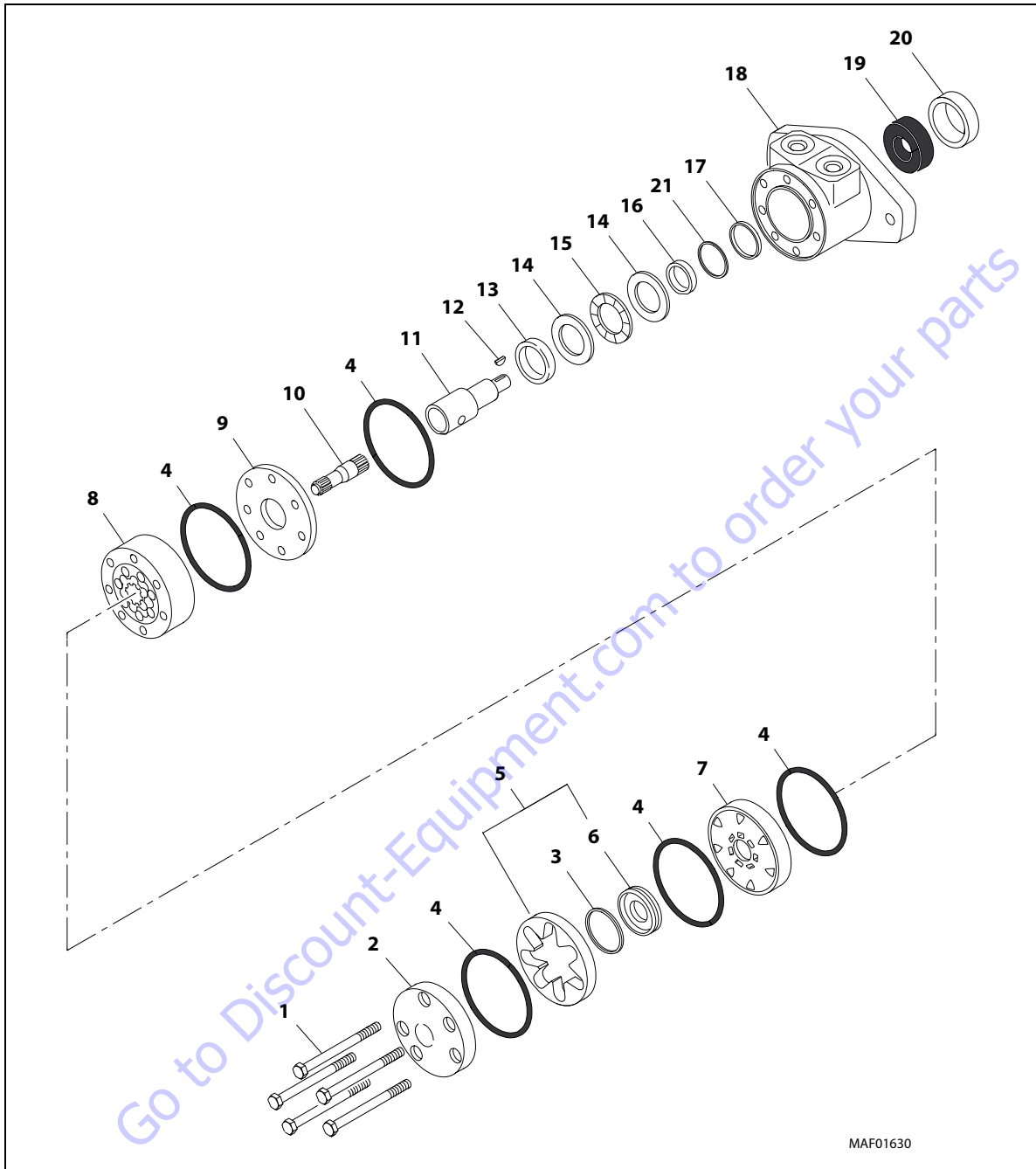

MAF01630

- | | | | | |
|---------------------------------|---------------|--------------------|--------------------|-------------------|
| 1. Bolt | 6. Ring | 10. DriveLink | 14. Thrust Washer | 18. Housing |
| 2. End Cover | 7. Manifold | 11. Coupling Shaft | 15. Thrust Bearing | 19. Bearing |
| 3. Commutator Seal | 8. Rotor Set | 12. Woodruff Key | 16. Inner Seal | 20. Seal |
| 4. Seal Ring | 9. Wear Plate | 13. Bronze Bushing | 17. Backup Washer | 21. Backup Washer |
| 5. Commutator and Ring Assembly | | | | |

Figure 3-58. Swing Motor Assembly

5. If the end cover (2) is equipped with shuttle valve components, remove the two previously loosened plugs (21).

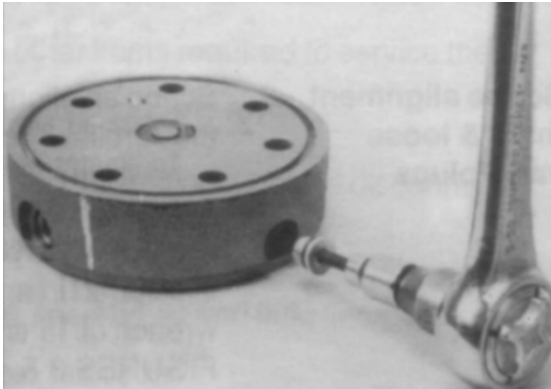

NOTICE

BE READY TO CATCH THE SHUTTLE VALVE OR RELIEF VALVE COMPONENTS THAT WILL FALL OUT OF THE END COVER VALVE CAVITY WHEN THE PLUGS ARE REMOVED.

NOTE: *The insert and if included the orifice plug in the end cover (2) must not be removed as they are serviced as an integral part of the end cover.*

6. Thoroughly wash end cover (2) in proper solvent and blow dry. Be sure the end cover valve apertures, including the internal orifice plug, are free of contamination. Inspect end cover for cracks and the bolt head recesses for good bolt head sealing surfaces. Replace end cover as necessary.

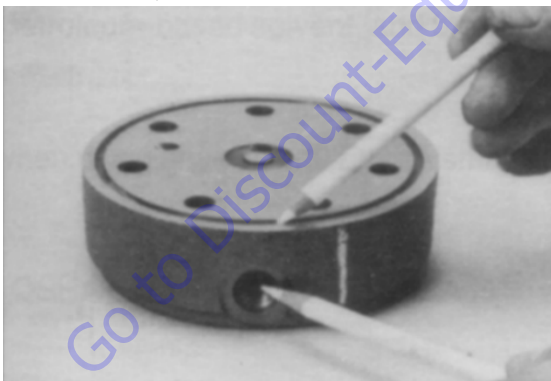

NOTE: *A polished pattern (not scratches) on the cover from rotation of the commutator (5) is normal. Discoloration would indicate excess fluid temperature, thermal shock, or excess speed and require system investigation for cause and close inspection of end cover, commutator, manifold, and rotor set.*

7. Remove commutator ring (6). Inspect commutator ring for cracks, or burrs.



8. Remove commutator (5) and seal ring (3) Remove seal ring from commutator, using an air hose to blow air into ring groove until seal ring is lifted out and discard seal ring. Inspect commutator for cracks or burrs, wear, scoring, spalling or brinelling. If any of these conditions exist, replace commutator and commutator ring as a matched set.



9. Remove manifold (7) and inspect for cracks surface scoring, brinelling or spalling. Replace manifold if any of these conditions exist. A polished pattern on the ground surface from commutator or rotor rotation is normal. Remove and discard the seal rings (4) that are on both sides of the manifold.



NOTE: The manifold is constructed of plates bonded together to form an integral component not subject to further disassembly for service. Compare configuration of both sides of them as if old to ensure that same surface is reassembled against the rotor set.

10. Remove rotor set (8) and warplane (9), together to retain the rotor set in its assembled form, maintaining the same rotor vane (8C) to stator (8B) contact surfaces. The drive link (10) may come away from the coupling shaft (12) with the rotor set, and wearplate. You may have to shift the rotor set on the warplane to work the drive link out of the rotor (8A) and warplane. Inspect the rotor set in its assembled form for nicks, scoring, or spalling on any surface and for broken or worn splines. If the rotor set component requires replacement, the complete rotor set must be replaced as it is a matched set. Inspect the warplane for cracks, brinelling, or scoring. Discard seal ring (4) that is between the rotor set and wearplate.



NOTE: The rotor set (8) components may become disassembled during service procedures. Marking the surface of the rotor and stator that is facing UP, with etching ink or grease pencil before removal from Torqlink™ will ensure correct reassembly of rotor into stator and rotor set into Torqlink™. Marking all rotor components and mating spline components for exact repositioning at assembly will ensure maximum wear life and performance of rotor set and Torqlink™.

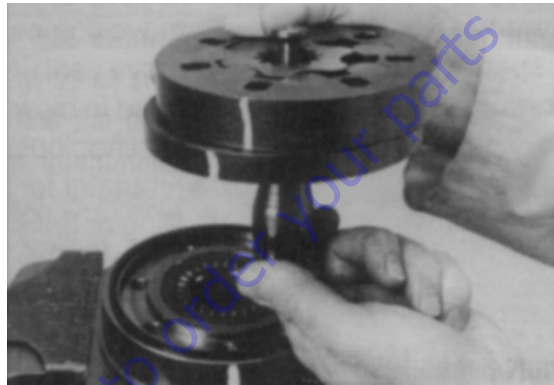

NOTE: Series TG Torqlinks™ may have a rotor set with two stator halves (8B) with a seal ring (4) between them and two sets of seven vanes (8C). Discard seal ring only if stator halves become disassembled during the service procedures.

NOTE: A polished pattern on the wear plate from rotor rotation is normal.

11. Place rotor set (8) and wear plate (9) on a flat surface and center rotor (8A) in stator (8B) such that two rotor lobes (180 degrees apart) and a roller vane (8C) centerline are on the same stator centerline. Check the rotor lobe to roller vane clearance with a feeler gage at this common centerline. If there is more than 0.005 in. (0.13 mm) of clearance, replace rotor set.

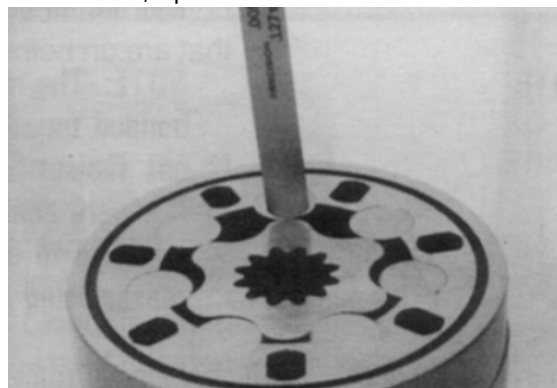

NOTE: If rotor set (8) has two stator halves (8B & 8D) and two sets of seven vanes (8C & 8E) as shown in the alternate construction TG rotor set assembly view, check the rotor lobe to roller vane clearance at both ends of rotor.

- 12.** Remove drive link (10) from coupling shaft (12) if it was not removed with rotor set and wear plate. Inspect drive link for cracks and worn or damaged splines. No perceptible lash (play) should be noted between mating spline parts. Remove and discard seal ring (4) from housing (18).

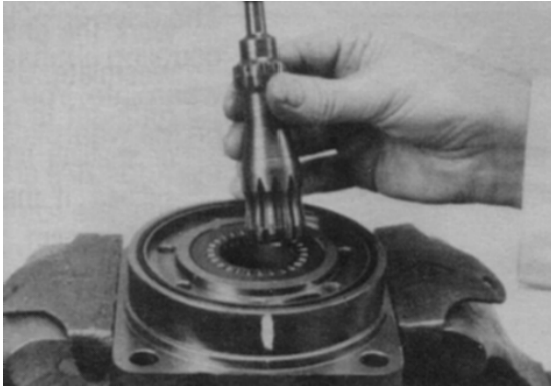

- 13.** Remove thrust bearing (11) from top of coupling shaft (12). Inspect for wear, brinelling, corrosion and a full complement of retained rollers.



- 14.** Check exposed portion of coupling shaft (12) to be sure you have removed all signs of rust and corrosion which might prevent its withdrawal through the seal and bearing. Crocus cloth or fine emery paper may be used.

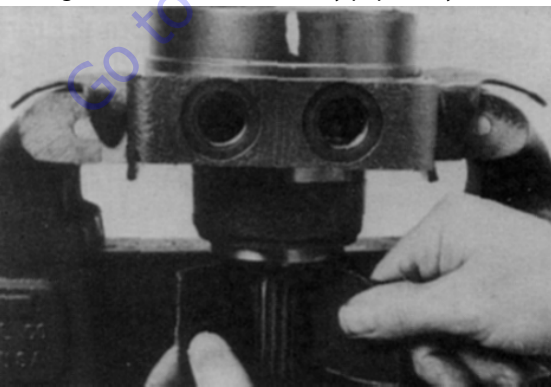

- 15.** Remove coupling shaft (12), by pushing on the output end of shaft. Inspect coupling shaft bearing and seal surfaces for spalling, nicks, grooves, severe wear or corrosion and discoloration. Inspect for damaged or worn internal and external splines or keyway. Replace coupling shaft if any of these conditions exist.

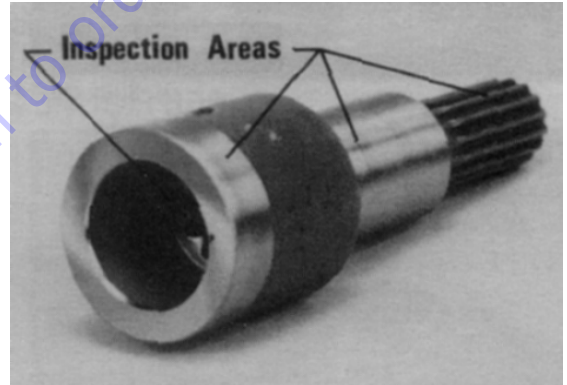
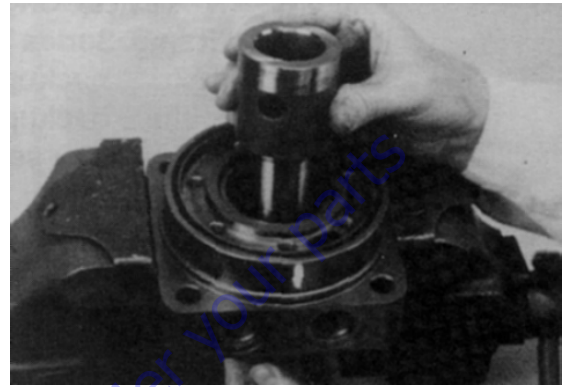

NOTE: Minor shaft wear in seal area is permissible. If wear exceeds 0.020 in. (0.51 mm) diametrically, replace coupling shaft.

NOTE: A slight "polish" is permissible in the shaft bearing areas. Anything more would require coupling shaft replacement.

- 16.** Remove and discard seal ring (4) from housing (18).
17. Remove thrust bearing (15) and thrust washer (14) Inspect for wear, brinelling, corrosion and a full complement of retained rollers.



SECTION 3 - CHASSIS & TURNTABLE

- 18.** Remove seal (16) and back up washer (17) from Small Frame, housing (18). Discard both.

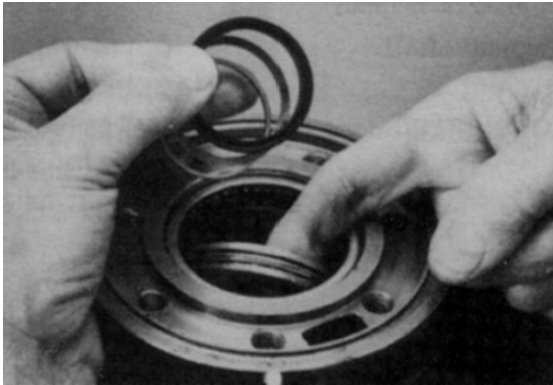

- 19.** Remove housing (18) from vise, invert it and remove and discard seal (20). A blind hole bearing or seal puller is required.



- 20.** Inspect housing (18) assembly for cracks, the machined surfaces for nicks, burrs, brinelling or corrosion. Remove burrs that can be removed without changing dimensional characteristics. Inspect tapped holes for thread damage. If the housing is defective in these areas, discard the housing assembly.

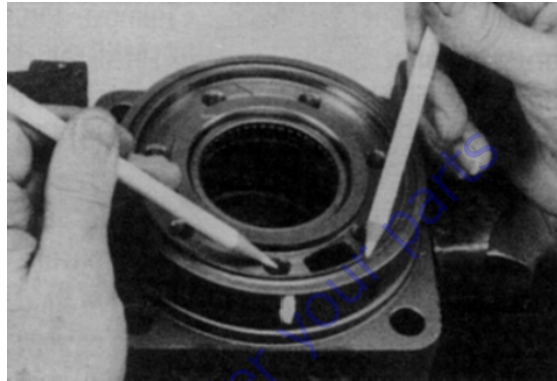

- 21.** If the housing (18) assembly has passed inspection to this point, inspect the housing bearings/bushings (19) and (13) and if they are captured in the housing cavity the two thrust washers (14) and thrust bearing (15). The bearing rollers must be firmly retained in the bearing cages, but must rotate and orbit freely. All rollers and thrust washers must be free of brinelling and corrosion. The bushing (19) or (13) to coupling shaft diameter clearance must not exceed 0.010 in. (0.025 mm). A bearing, bushing, or thrust washer that does not pass inspection must be replaced. If the housing has passed this inspection the disassembly of the Torqlink™ is completed.

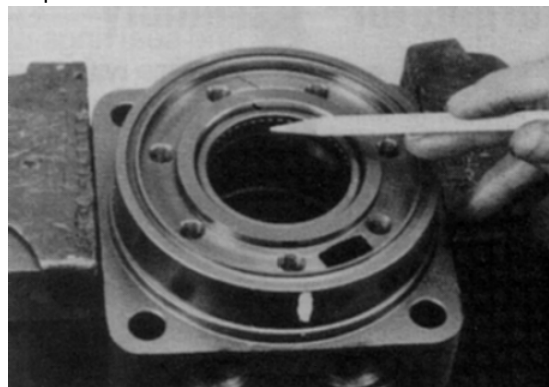

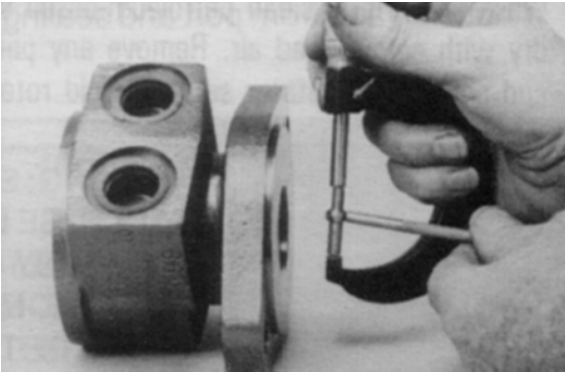

NOTE: The depth or location of bearing/bushing (13) in relation to the housing wear plate surface and the depth or location of bearing/bushing (19) in relation to the beginning of bearing/bushing counterbore should be measured and noted before removing the bearings/ bushings. This will facilitate the correct reassembly of new bearings/bushings.

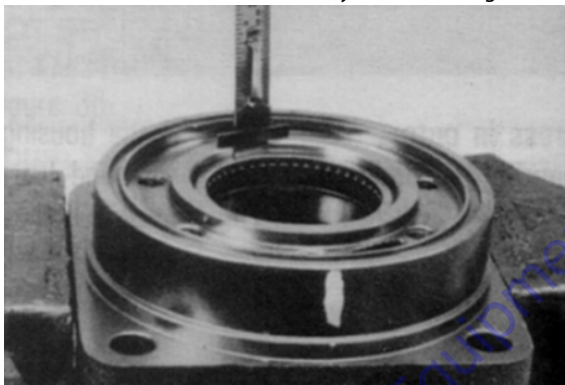

22. If the bearings, bushing or thrust washers must be replaced use a suitable size bearing puller to remove bearing/bushings (19) and (13) from housing (18) without damaging the housing. Remove thrust washers (14) and thrust bearing (15) if they were previously retained in the housing by bearing (13).

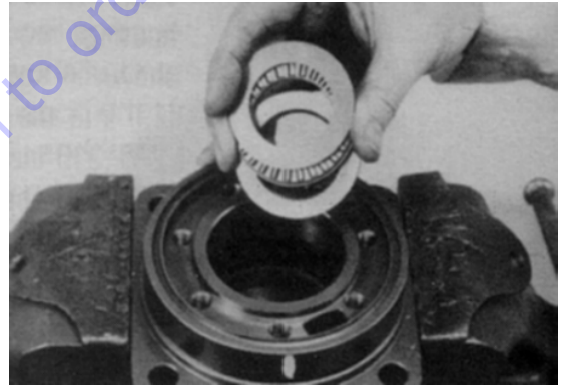
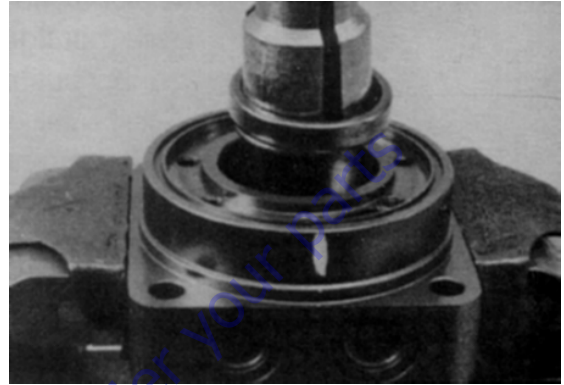

Go to Discount-Equipment.com to order your parts

Assembly

Replace all seals and seal rings with new ones each time you reassemble the Torqlink™ unit. Lubricate all seals and seal rings with SAE 10W40 oil or clean grease before assembly.

NOTE: Individual seals and seal rings as well as a complete seal kit are available. The parts should be available through most OEM parts distributors or Parker approved Torqlink™ distributors. (Contact your local dealer for availability).

NOTE: Unless otherwise indicated, do not oil or grease parts before assembly.

Wash all parts in clean petroleum-based solvents before assembly. Blow them dry with compressed air. Remove any paint chips from mating surfaces of the end cover, commutator set, manifold rotor set, wear plate and housing and from port and sealing areas.

⚠ DANGER

SINCE THEY ARE FLAMMABLE, BE EXTREMELY CAREFUL WHEN USING ANY SOLVENT. EVEN A SMALL EXPLOSION OR FIRE COULD CAUSE INJURY OR DEATH.

⚠ WARNING

WEAR EYE PROTECTION AND BE SURE TO COMPLY WITH OSHA OR OTHER MAXIMUM AIR PRESSURE REQUIREMENTS.

1. If the housing (18) bearing components were removed for replacement, thoroughly coat and pack a new outer bearing/bushing (19) with clean corrosion resistant grease recommended in the material section. Press the new bearing/bushing into the counterbore at the mounting flange end of the housing, using the appropriate sized bearing mandrel, which will control the bearing/ bushing depth.

Torqlink™ housings require the use of bearing mandrel to press bearing/ bushing (19) into the housing to a required depth of 0.151/0.161 in. (3.84/4.09 mm) from the end of the bearing counterbore.



NOTE: Bearing mandrel must be pressed against the lettered end of bearing shell. Take care that the housing bore is square with the press base and the bearing/bushing is not cocked when pressing a bearing/bushing into the housing.

NOTICE

IF THE BEARING MANDREL SPECIFIED IN THE "TOOLS AND MATERIALS REQUIRED FOR SERVICING" SECTION IS NOT AVAILABLE AND ALTERNATE METHODS ARE USED TO PRESS IN BEARING/BUSHING (13) AND (19) THE BEARING/BUSHING DEPTHS SPECIFIED MUST BE ACHIEVED TO INSURE ADEQUATE BEARING SUPPORT AND CORRECT RELATIONSHIP TO ADJACENT COMPONENTS WHEN ASSEMBLED.

NOTICE

BECAUSE THE BEARING/BUSHINGS (13) AND (19) HAVE A PRESS FIT INTO THE HOUSING THEY MUST BE DISCARDED WHEN REMOVED. THEY MUST NOT BE REUSED.

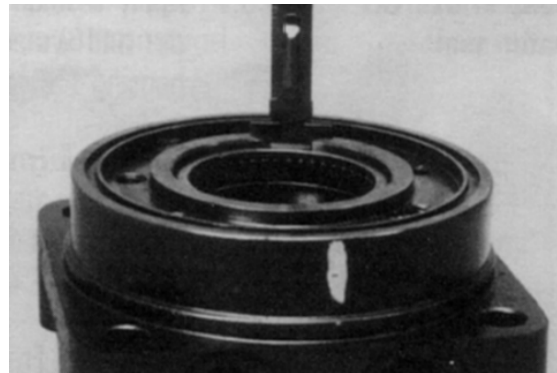

2. The Torqlink™ inner housing bearing/bushing (13) can now be pressed into its counterbore in housing (18) flush to 0.03 in. (0.76 mm) below the housing wear plate contact face. Use the opposite end of the bearing mandrel that was used to press in the outer bearing/bushing (19).

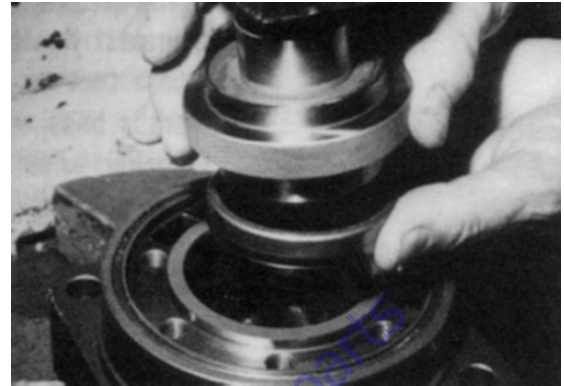
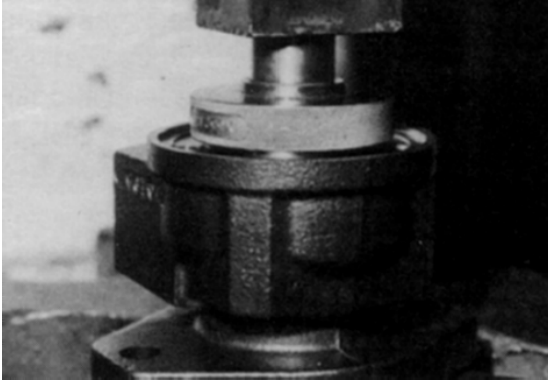

3. Press a new dirt and water seal (20) into the housing (18) outer bearing counterbore.

The Torqlink™ dirt and water seal (20) must be pressed in until its flange is flush against the housing.

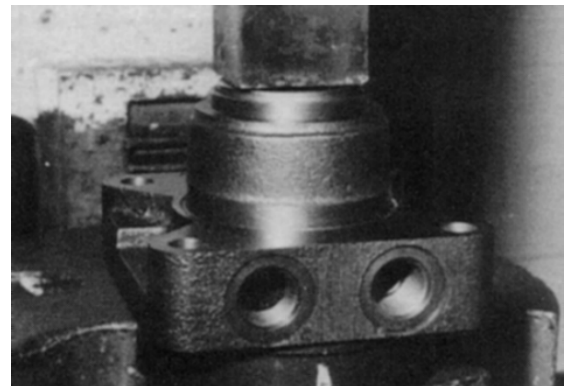
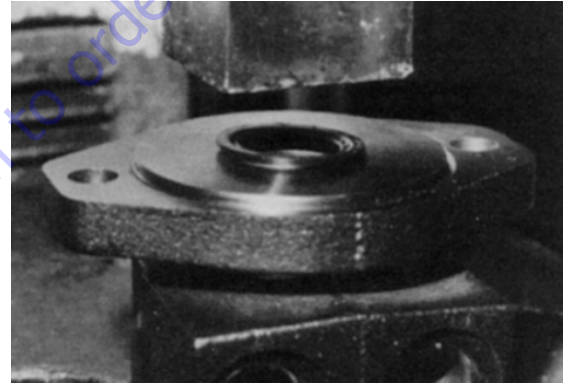

SECTION 3 - CHASSIS & TURNTABLE

- Place housing (18) assembly into a soft jawed vise with the coupling shaft bore down, clamping against the mounting flange.

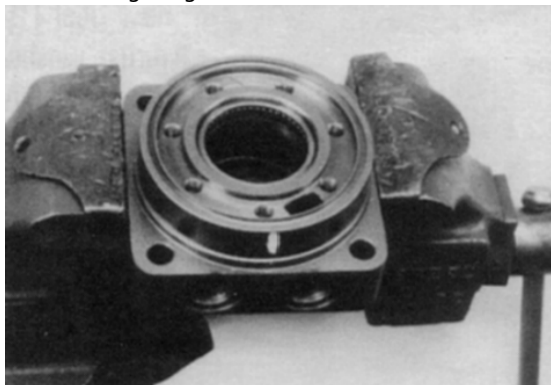

- On the Torqlinks™ assemble a new backup washer (17) and new seal (16) with the seal lip facing toward the inside of Torqlink™, into their respective counterbores in housing (18) if they were not assembled in procedure 2.

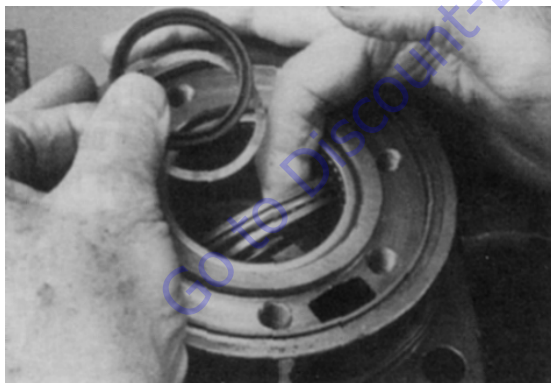
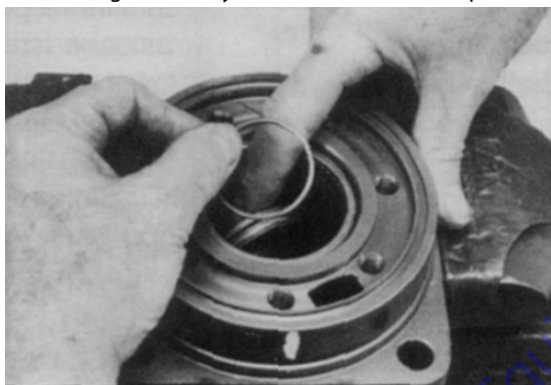

NOTICE

ORIGINAL DESIGN LARGE FRAME, TF & TG TORQLINKS™ THAT DO NOT HAVE BACKUP WASHER (25) WHEN DISASSEMBLED MUST BE ASSEMBLED WITH A NEW BACKUP WASHER (17), NEW BACKUP WASHER (25), AND NEW SEAL (16).

- Assemble thrust washer (14) then thrust bearing (15) that was removed from the Torqlink™.

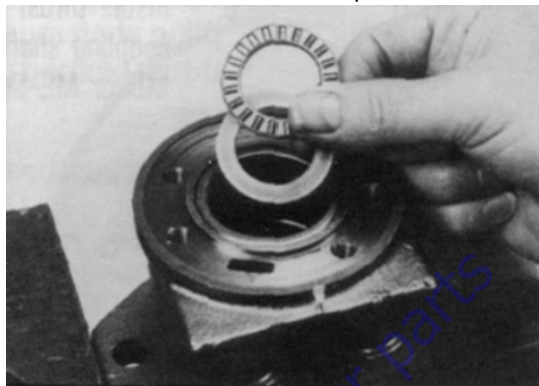

NOTE: Torqlinks™ require one thrust washer (14) with thrust bearing (15). The coupling shaft will be seated directly against the thrust

- Apply masking tape around splines or keyway on shaft (12) to prevent damage to seal.



- Be sure that a generous amount of clean corrosion resistant grease has been applied to the lower (outer) housing bearing/bushing (19). Install the coupling shaft (12) into housing (18), seating it against the thrust bearing (15) in the housings.

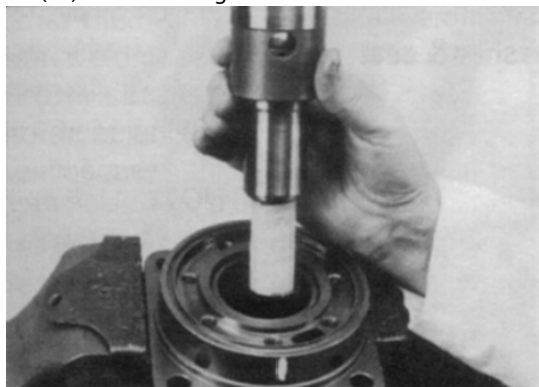

NOTICE

THE OUTER BEARING (19) IS NOT LUBRICATED BY THE SYSTEM'S HYDRAULIC FLUID. BE SURE IT IS THOROUGHLY PACKED WITH THE RECOMMENDED GREASE, PARKER GEAR GREASE SPECIFICATION #045236, E/M LUBRICANT #K-70M.

NOTE: The coupling shaft (12) will be flush or just below the housing wear plate surface on Torqlinks™ when properly seated. The coupling shaft must rotate smoothly on the thrust bearing package.

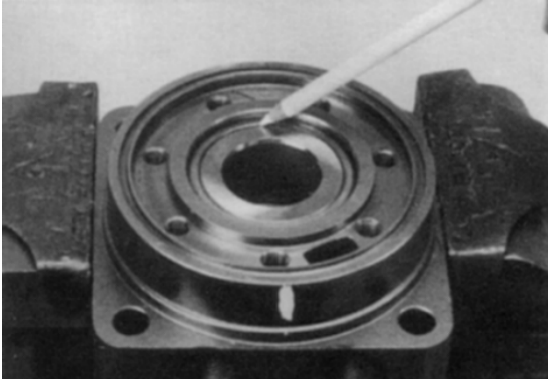

9. Apply a small amount of clean grease to a new seal ring (4) and insert it into the housing (18) seal ring groove.

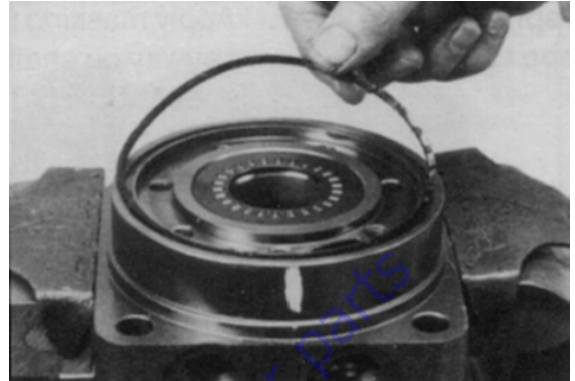

NOTE: One or two alignment studs screwed finger tight into housing (18) bolt holes, approximately 180 degrees apart, will facilitate the assembly and alignment of components as required in the following procedures. The studs can be made by cutting off the heads of either 3/8-24 UNF 2A or 5/16-24 UNF 2A bolts as required that are over 0.5 in. (12.7 mm) longer than the bolts (1) used in the Torqlink™.

10. Install drive link (10) the long splined end down into the coupling shaft (12) and engage the drive link splines into mesh with the coupling shaft splines.



NOTE: Use any alignment marks put on the coupling shaft and drive link before disassembly to assemble the drive link splines in their original position in the mating coupling shaft splines.

SECTION 3 - CHASSIS & TURNTABLE

11. Assemble wear plate (9) over the drive link (10) and alignment studs onto the housing (18).

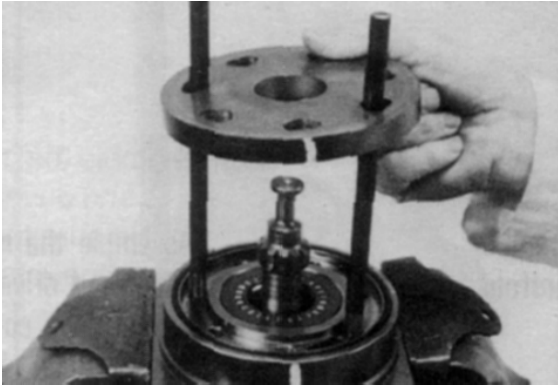

12. Apply a small amount of clean grease to a new seal ring (4) and assemble it into the seal ring groove on the wear plate side of the rotor set stator (8B).

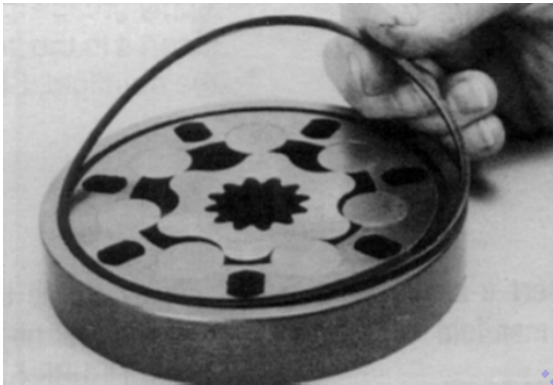

13. Install the assembled rotor set (8) onto wear plate (9) with rotor (8A) counterbore and seal ring side down and the splines into mesh with the drive link splines.

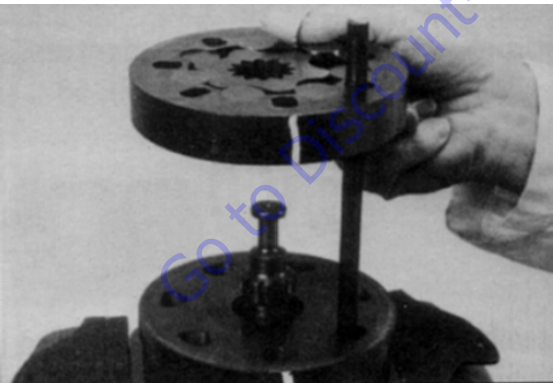

NOTE: It may be necessary to turn one alignment stud out of the housing (18) temporarily to assemble rotor set (8) or manifold (7) over the drive link.

NOTE: If necessary, go to the appropriate, "Rotor Set Component Assembly Procedure."

NOTE: The rotor set rotor counterbore side must be down against wear plate for drive link clearance and to maintain the original rotor-drive link spline contact. A rotor set without a counterbore and that was not etched before disassembly can be reinstalled using the drive link spline pattern on the rotor splines if apparent, to determine which side was down. The rotor set seal ring groove faces toward the wear plate (9).

14. Apply clean grease to a new seal ring (4) and assemble it in the seal ring groove in the rotor set contact side of manifold (7).

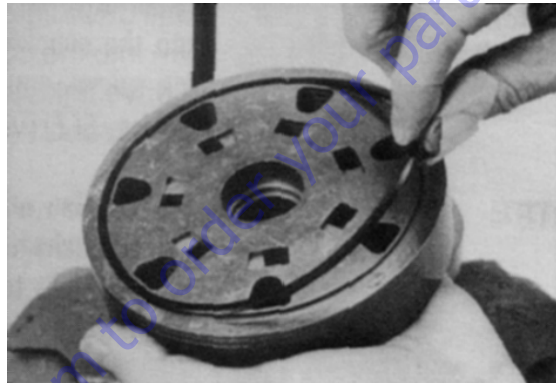

NOTE: The manifold (7) is made up of several plates bonded together permanently to form an integral component. The manifold surface that must contact the rotor set has its series of irregular shaped cavities on the largest circumference or circle around the inside diameter. The polished impression left on the manifold by the rotor set is another indication of which surface must contact the rotor set.

15. Assemble the manifold (7) over the alignment studs and drive link (10) and onto the rotor set. Be sure the correct manifold surface is against the rotor set.

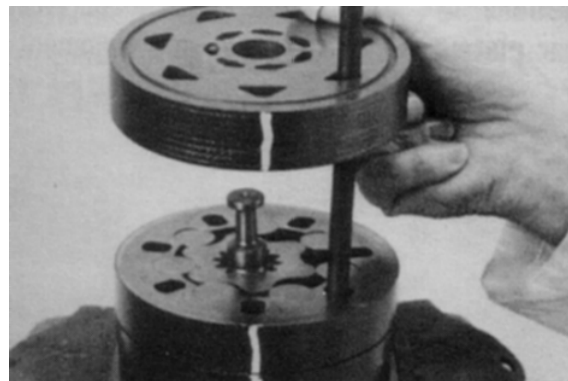

16. Apply grease to a new seal ring (4) and insert it in the seal ring groove exposed on the manifold.

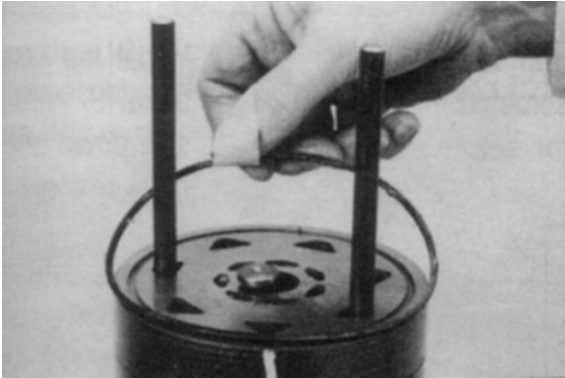

17. Assemble the commutator ring (6) over alignment studs onto the manifold.

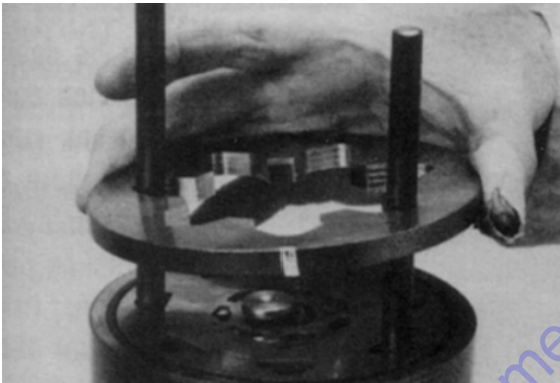

18. Assemble a new seal ring (3) flat side up, into commutator (5) and assemble commutator over the end of drive link (10) onto manifold (7) with seal ring side up.

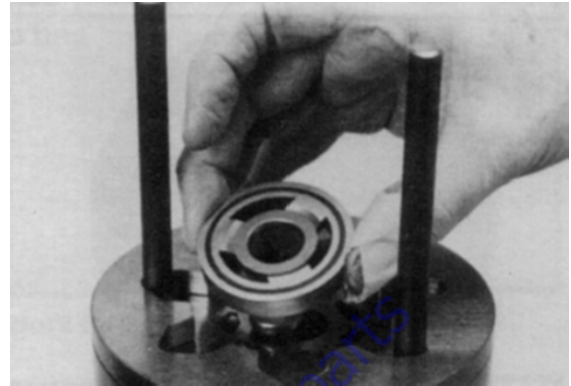

19. If shuttle valve components items #21, were removed from the end cover (2) turn a plug (21), loosely into one end of the valve cavity in the end cover. A 3/16 in. Allen wrench is required.

20. Assemble a new seal ring (4) into end cover (2) and assemble end cover over the alignment studs and onto the commutator set. If the end cover has only 5 bolt holes be sure the cover holes are aligned with the 5 threaded holes in housing (18). The correct 5 bolt end cover bolt hole relationship to housing port bosses.

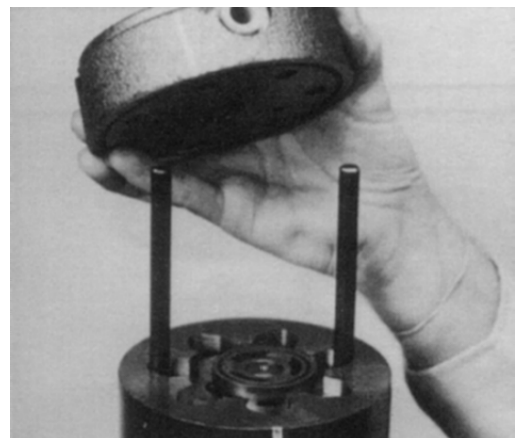
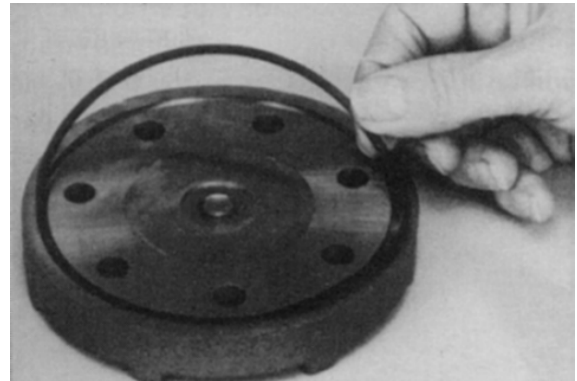

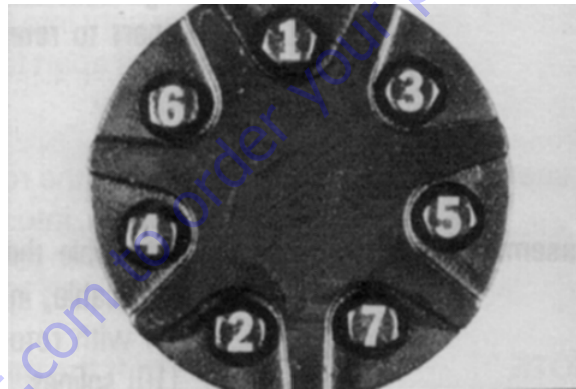
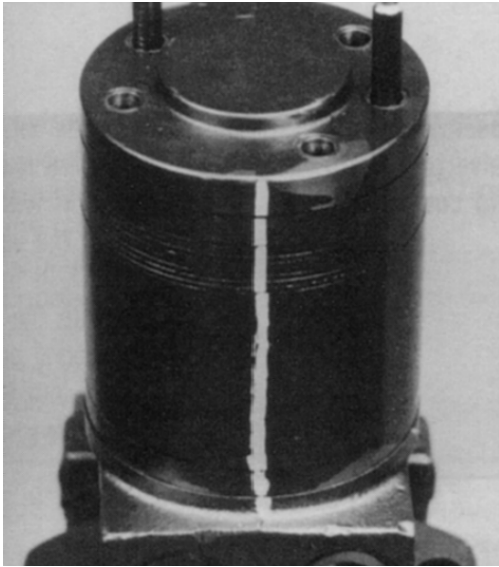

NOTE: If the end cover has a valve (24) or has five bolt holes, use the line you previously scribed on the cover to radially align the end cover into its original position.

21. Assemble the 5 or 7 special bolts (1) and screw in finger tight. Remove and replace the two alignment studs with bolts after the other bolts are in place. Alternately and progressively tighten the bolts to pull the end cover and other components into place with a final torque of 22-26 ft. lbs., (30-35 Nm) 45-55 ft. lbs. (61-75 Nm) for the seven 3/8-24 threaded bolts.



NOTE: The special bolts required for use with the relief or shuttle valve (24) end cover assembly (2) are longer than the bolts required with standard and cover assembly. Refer to the individual service parts lists or parts list charts for correct service part number if replacement is required.

22. Torque the two shuttle valve plug assemblies (21) in end cover assembly to 9-12 ft. lbs. (12-16 Nm) if cover is so equipped.

Torque the two relief valve plug assemblies (21) in end cover assembly to 45-55 ft. lbs. (61-75 Nm) if cover is so equipped.

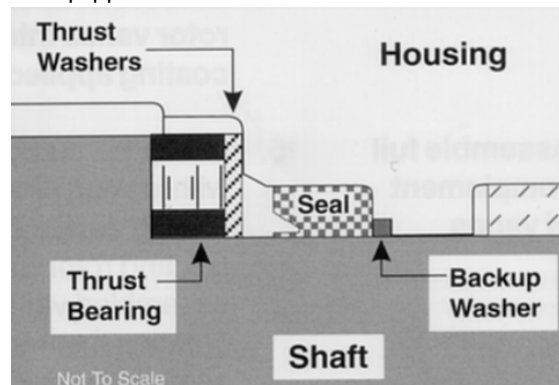

One Piece Stator Construction

A disassembled rotor (8A) stator (8B) and vanes (8C) that cannot be readily assembled by hand can be assembled by the following procedures.

1. Place stator (8B) onto wear plate (9) with seal ring (4) side down, after following Torqlink™ assembly procedures 1 through 13. Be sure the seal ring is in place.

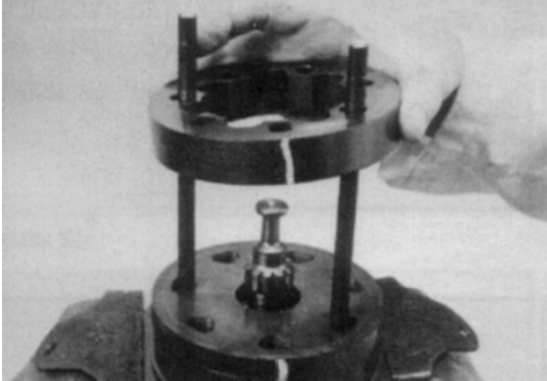

2. If assembly alignment studs are not being utilized, align stator bolt holes with wear plate and housing bolt holes and turn two bolts (1) finger tight into bolt holes approximately 180 degrees apart to retain stator and wear plate stationary.
3. Assemble the rotor (8A), counterbore down if applicable, into stator (8B), and onto wear plate (9) with rotor splines into mesh with drive link (10) splines.

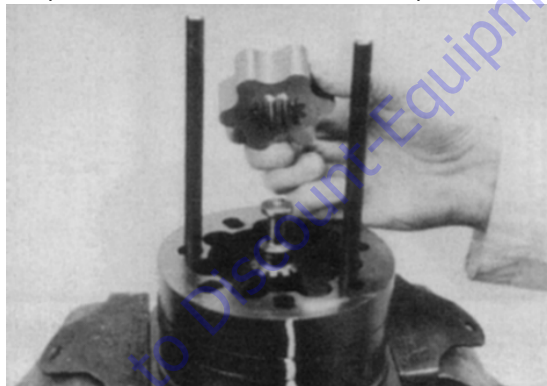

NOTE: *If the manifold side of the rotor was etched during Torqlink disassembly, this side should be up. If the rotor is not etched and does not have a counterbore, use the drive link spline contact pattern apparent on the rotor splines to determine the rotor side that must be against the wear plate.*

4. Assemble six vanes (8C), or as many vanes that will readily assemble into the stator vane pockets.



NOTICE

EXCESSIVE FORCE USED TO PUSH THE ROTOR VANES INTO PLACE COULD SHEAR OFF THE COATING APPLIED TO THE STATOR VANE POCKETS.

5. Grasp the output end of coupling shaft (12) with locking pliers or other appropriate turning device and rotate coupling shaft, drive link and rotor to seat the rotor and the assembled vanes (8C) into stator (8B), creating the necessary clearance to assemble the seventh or full complement of seven vanes. Assemble the seven vanes using minimum force.

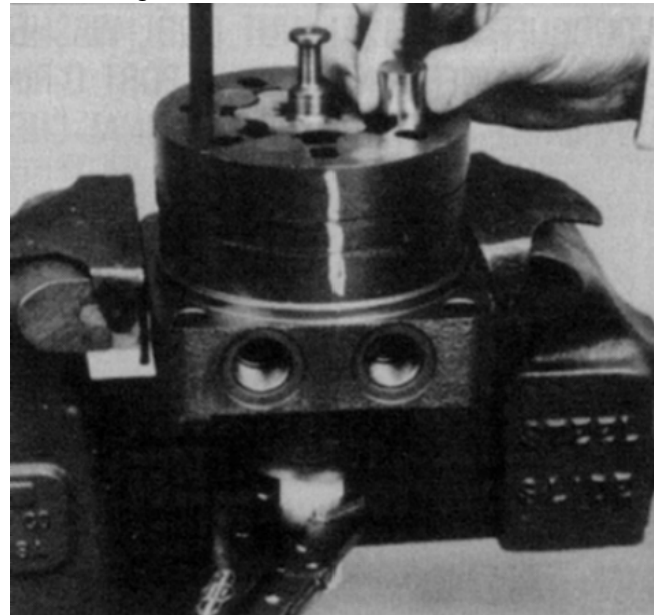

6. Remove the two assembled bolts (1) if used to retain stator and wear plate.

3.14 SWING BEARING

Swing Bearing Wear Tolerance

See Figure 3-60., Swing Bearing Wear Tolerance.

1. Position the machine as follows and as seen in Figure 3-60., Swing Bearing Wear Tolerance, Position 1:
 - a. The turntable needs to be centered between the rear wheels.
 - b. Lift the boom to horizontal and fully extend the main boom
 - c. Lift the jib to be horizontal
 - d. Keep the jib and platform centered and unloaded
2. Set up a dial indicator as follows:
 - a. The dial indicator location is to be at the front center of the machine, next to the bearing, opposite of the tower pivot pin.
 - b. The magnetic base of the indicator should be positioned on the frame



- c. The indicator point needs positioned to measure the turntable base plate 2 in. (51 mm) from the root of the gear tooth. Refer to Figure 3-60., Swing Bearing Wear Tolerance.
3. Zero the dial indicator.
4. Check dial indicator accuracy once positioned, using a feeler gauge and ensure the dial indicator reading, is the same as the feeler gauge thickness.
5. Position the machine as follows and as seen in Figure 3-60., Swing Bearing Wear Tolerance, Position 2:
 - a. Do not rotate the turntable
 - b. Raise the main boom to be fully elevated and retracted
 - c. Raise the jib to be fully elevated and centered
 - d. Center the platform and keep it unloaded

6. Verify the dial indicator has not shifted. Record the value for bearing play.
7. Return the machine to Figure 3-60., Swing Bearing Wear Tolerance, Position 1. The dial indicator should to return to zero. If the dial indicator does not return to zero, take corrective action and repeat the test.
8. If the measurement is more than 0.10 in. (4.2 mm), replace the bearing. If the measurement is less than 0.10 in. (4.2 mm), and any of the following conditions exist, the bearing should be removed, disassembled, and inspected.
 - a. Metal particles in the grease.
 - b. Increased drive power required.
 - c. Noise.
 - d. Rough rotation.
9. If bearing inspection shows no defects, reassemble and return to service.

Turntable Bearing Mounting Bolt Condition Check

NOTICE

THE SWING BEARING IS ONE OF THE MOST CRITICAL POINTS ON AN AERIAL LIFT. IT IS HERE THAT THE STRESSES OF LIFTING ARE CONCENTRATED, AT THE CENTER OF ROTATION. BECAUSE OF THIS, PROPER MAINTENANCE OF THE SWING BEARING BOLTS IS A MUST FOR SAFE OPERATION.

NOTE: This check is designed to replace the existing bearing bolt torque checks on JLG Lifts in service. This check must be performed after the first 50 hours of machine operation and every 600 hours of machine operation thereafter. If during this check any bolts are found to be missing or loose, replace missing or loose bolts with new bolts and torque to the value specified in the torque chart, after lubricating the bolt threads with JLG Threadlocker P/N 0100019. After replacing and retorquing bolt or bolts recheck all existing bolts for looseness.

1. Check the frame to bearing. Attach bolts as follows:
 - a. Elevate the fully extended main boom to horizontal as shown in Figure 3-60.
 - b. At the positions indicated on Figure 3-59, try and insert the 0.0015 in. feeler gauge between the bolt head and hardened washer at the arrow indicated position.
 - c. Assure that the 0.0015 in. feeler gauge will not penetrate under the bolt head to the bolt shank.
 - d. Swing the turntable 90 degrees, and check some selected bolts at the new position.
 - e. Continue rotating the turntable at 90 degree intervals until a sampling of bolts have been checked in all quadrants.

2. Check the turntable to bearing. Attach bolts as follows:
 - a. Elevate the fully retracted main boom to full elevation as shown in Figure 3-60.
 - b. At the positions indicated on Figure 3-59, try and insert the 0.0015 in. feeler gauge between the bolt head and hardened washer at the arrow indicated position.
 - c. Lower the boom to horizontal and fully extend the boom.
 - d. At the position indicated on Figure 3-59, try and insert the 0.0015 in. feeler gauge between the bolt head and hardened washer at the arrow indicated position.

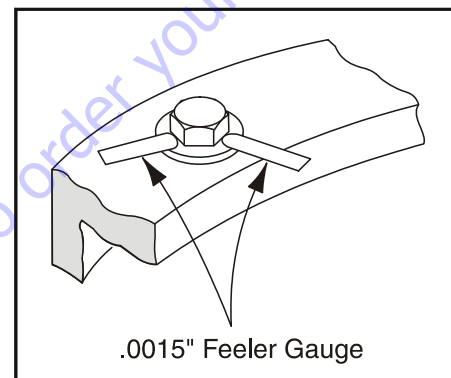

Figure 3-59. Swing Bolt Feeler Gauge Check

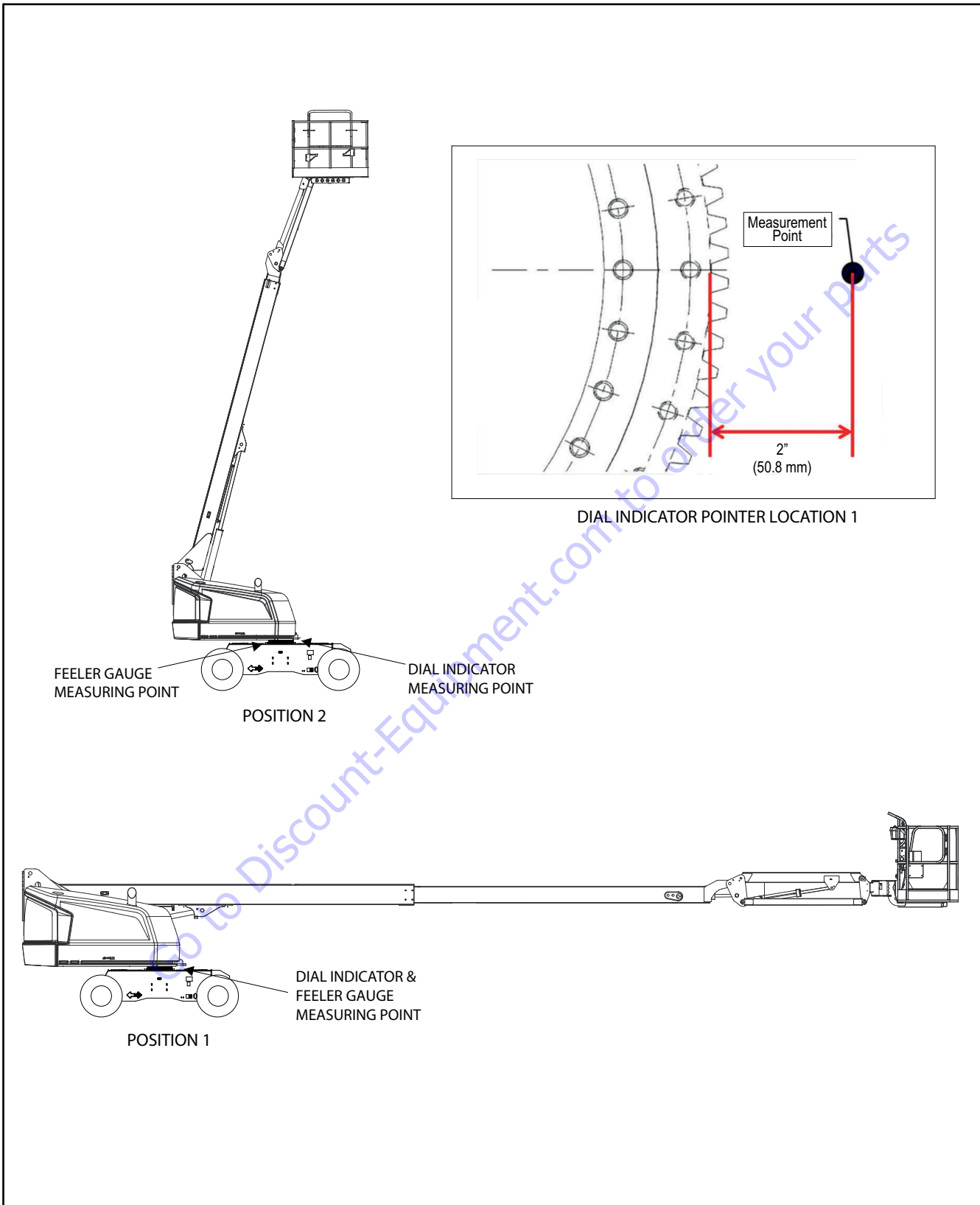

Figure 3-60. Swing Bearing Wear Tolerance

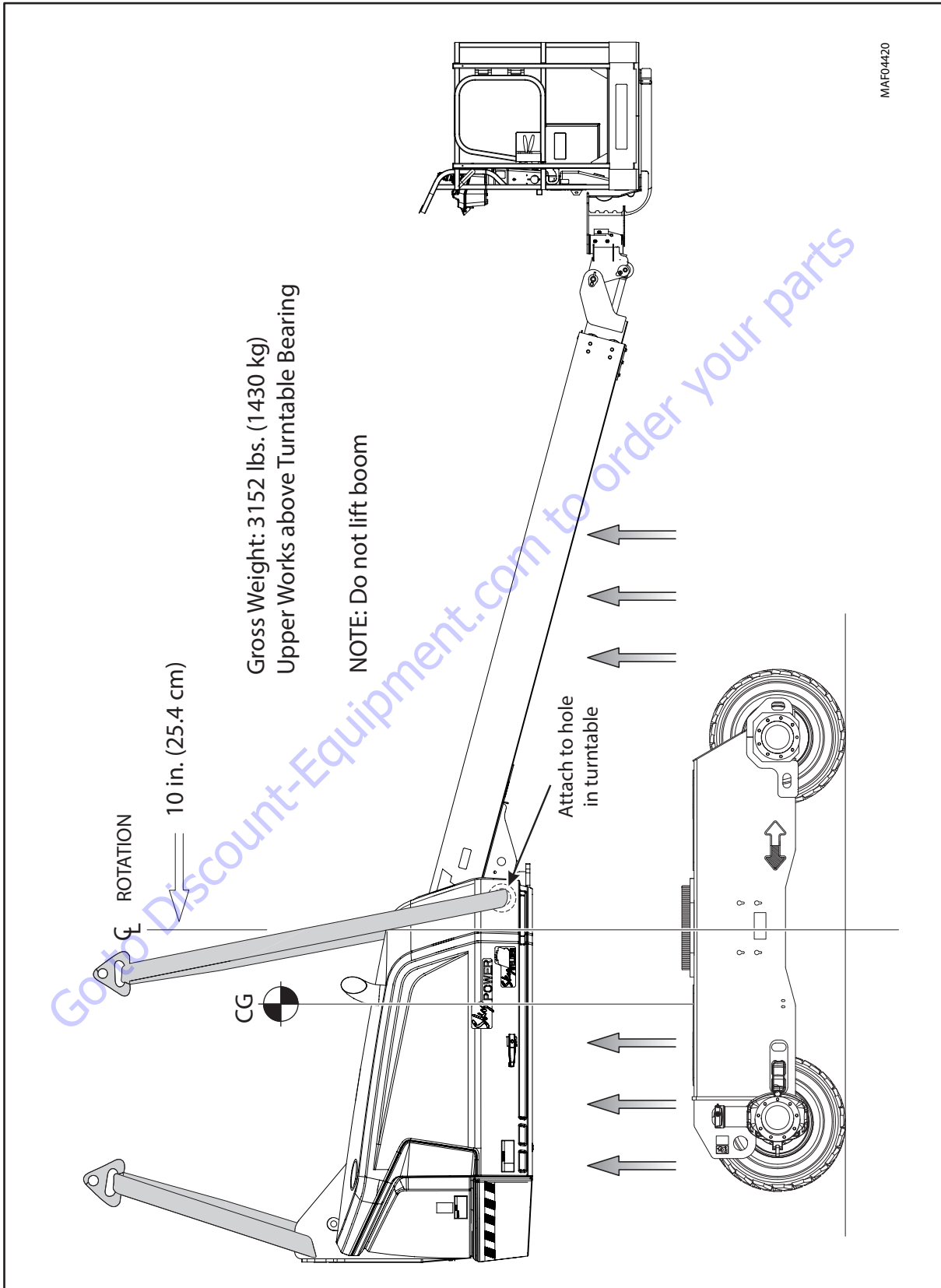

Figure 3-61. Swing Bearing Removal (400S)

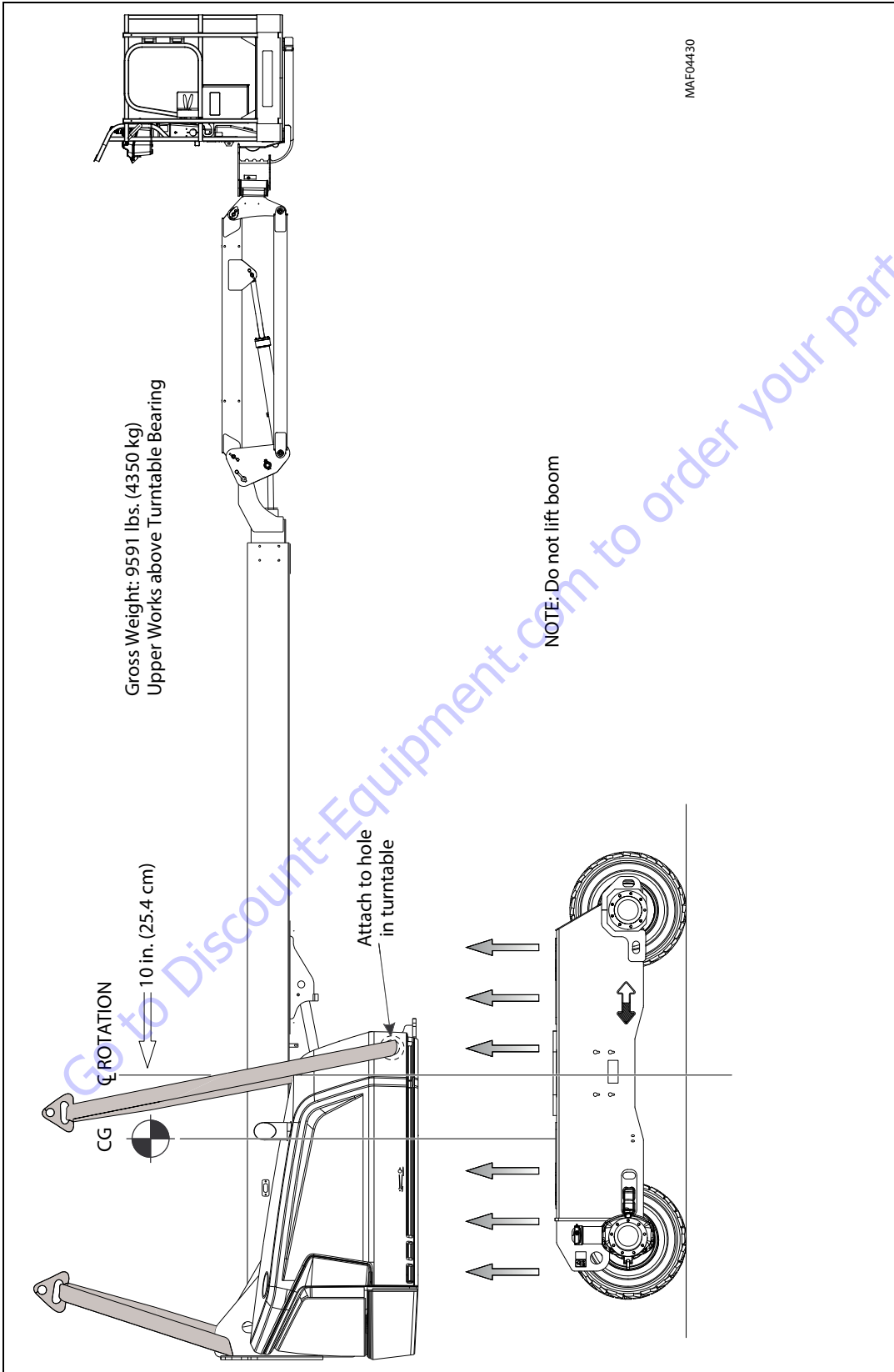

Figure 3-62. Swing Bearing Removal (4605J)

Swing Bearing Removal

1. From ground control station, operate the boom adequately to provide access to frame opening to rotary coupling.

⚠ WARNING

NEVER WORK BENEATH THE BOOM WITHOUT FIRST ENGAGING BOOM SAFETY PROP OR PROVIDING ADEQUATE OVERHEAD SLING SUPPORT AND/OR BLOCKING.

2. Attach an adequate support sling to the boom and draw all slack from sling. Prop or block the boom if feasible.
3. From inside turntable, remove mounting hardware from rotary coupling mount bracket.
4. Tag and disconnect the hydraulic lines from the fittings on the top of the rotary coupling. Use a suitable container to retain any residual hydraulic fluid. Cap or plug all openings of hydraulic lines and port.
5. Disconnect wiring harness connected to the rotary coupling and tag and disconnect remote grease fitting line (if equipped).
6. Attach suitable overhead lifting equipment to the base of the turntable weldment. See "Swing Bearing Removal (400S)"
7. Use a suitable tool to scribe a line on the inner race of the swing bearing and on the underside of the turntable. This will aid in aligning the bearing upon installation. Remove the bolts and washers which attach the turntable to the bearing inner race. Discard the bolts.
8. Use the lifting equipment to carefully lift the complete turntable assembly from the bearing. Ensure that no damage occurs to the turntable, bearing or frame-mounted components.
9. Carefully place the turntable on a suitably supported trestle.

NOTE: *The swing bearing approximately weighs 138 lbs. (55 kg).*

10. Use a suitable tool to scribe a line on the outer race of the swing bearing and the frame. This line will aid in aligning the bearing upon installation. Remove the bolts and washers which attach the outer race of the bearing to the frame. Discard the bolts. Use suitable lifting equipment to remove the bearing from the frame, then move the bearing to a clean, suitably supported work area.

Swing Bearing Installation

NOTE: *The swing bearing approximately weighs 138 lbs. (55 kg).*

1. Using suitable lifting equipment, carefully lower the swing bearing into position on the frame. Ensure the scribed line of the outer race of the bearing aligns with the scribed line on the frame. If a new swing bearing is used, ensure that the filler plug fitting is at 90 degrees from the fore and aft center line of the frame.

⚠ CAUTION

JLG INDUSTRIES RECOMMENDS THAT ALL REMOVED BEARING BOLTS BE DISCARDED AND REPLACED WITH NEW BOLTS. SINCE THE SWING BEARING IS THE ONLY STRUCTURAL LINK BETWEEN THE FRAME AND TURNTABLE, IT IS IMPERATIVE THAT SUCH REPLACEMENT HARDWARE MEETS JLG SPECIFICATIONS. USE OF GENUINE JLG HARDWARE IS HIGHLY RECOMMENDED.

2. Apply a light coating of JLG Threadlocker P/N 0100019 to the new bearing bolts and loosely install the bolts and washers through the frame and outer race of bearing.

NOTICE

IF COMPRESSED AIR OR ELECTRICALLY OPERATED IMPACT WRENCH IS USED FOR TIGHTENING THE BEARING ATTACHMENT BOLTS, THE TORQUE SETTING ACCURACY OF THE TOOL SHOULD BE CHECKED PRIOR TO USE.

3. Refer to the Torque Sequence diagram as shown in Figure 3-63., Swing Bearing Torque Sequence. Clean any residue off the new bearing bolts, then apply a light coating of JLG Threadlocker P/N 0100019 and install the bolts and washers through the frame and outer race of the bearing. Tighten the bolts to an initial torque of 190 ft. lbs. (258 Nm) w/JLG Threadlocker P/N 0100019.
4. Remove the lifting equipment from the bearing.
5. Using suitable lifting equipment, carefully position the turntable assembly above the machine frame.
6. Carefully lower the turntable onto the swing bearing, ensuring that the scribed line of the inner race of the bearing aligns with scribed line on the turntable. If a new swing bearing is used, ensure that the filler plug fitting is at 90 degrees from the fore and aft center line of the turntable.
7. Clean any residue off the new bearing bolts, then apply a light coating of JLG Threadlocker P/N 0100019 and install the bolts and washers through the turntable and inner race of the bearing.
8. Following the Torque Sequence diagram shown in Figure 3-63., Swing Bearing Torque Sequence, tighten the bolts to a torque of 190 ft. lbs. (258 Nm).
9. Remove the lifting equipment.

SECTION 3 - CHASSIS & TURNTABLE

10. Install the rotary coupling mount bracket, apply a light coating of JLG Threadlocker P/N 0100011 to the attaching bolts and secure the mount bracket to the turntable with the mounting hardware.
11. Connect the hydraulic lines, electrical harness and remote grease fitting line (if equipped) to the rotary coupling as tagged prior to removal.
12. At ground control station, use boom lift control to lower boom to stowed position.
13. Using all applicable safety precautions, activate the hydraulic system and check the swing system for proper and safe operation.

Procedure for Setting Swing Gear Backlash

1. Set swing gear backlash to 0.005 - 0.010 in. (0.127 - 0.254 mm) using the following procedure.
2. Place the shim (JLG P/N 1001190964) between the pinion and the bearing on the high spot.

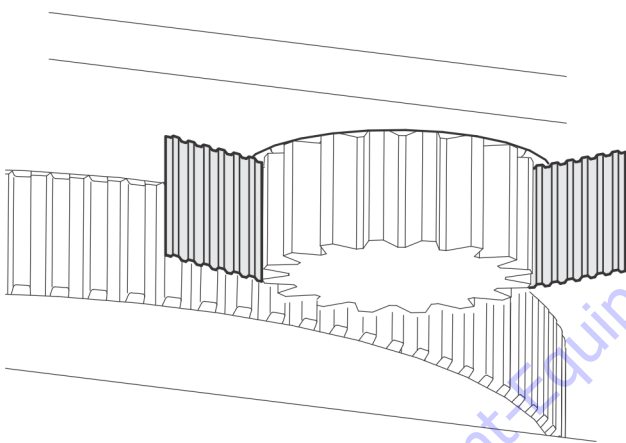

NOTE: The high spot will be marked with yellow paint.

3. Apply JLG Threadlocker (P/N 0100019) to the pivot bolt and torque to 205 ft. lbs. (280 Nm).

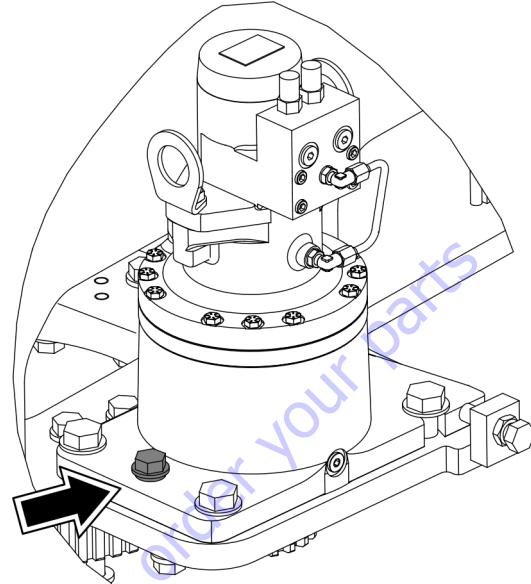

4. Remove the turntable lock pin.

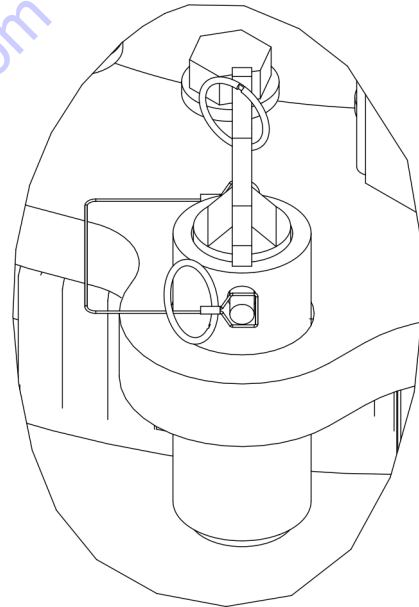

5. Apply JLG Threadlocker (P/N 0100019) to the remaining swing drive mounting bolts and torque them to 30 ft. lbs. (40 Nm).

6. Tighten the jack bolt until the pinion is completely snug against the shim and bearing. After the pinion is snug, loosen the jack bolt.

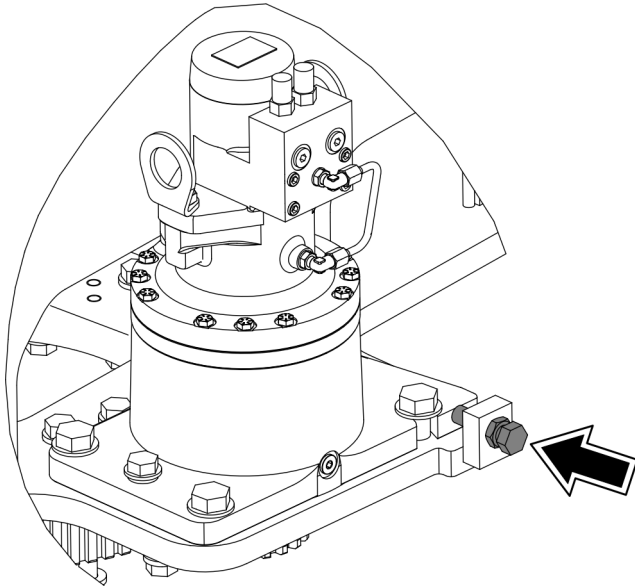

7. Apply JLG Threadlocker (P/N 0100019) to the jack bolt and jam nut and torque the jack bolt to 50 ft. lbs. (68 Nm).
8. Tighten the jam nut.

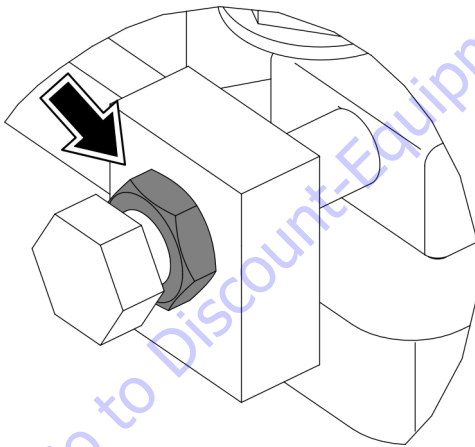

9. Torque the remaining swing drive retaining bolts to 405 ft.lbs. (550 Nm).
10. Remove and discard the shim.

Swing Bearing Torque Values

1. Outer Race - 190 ft. lbs. (258 Nm) with JLG Threadlocker P/N 0100019.
2. Inner Race - 190 ft. lbs. (258 Nm) with JLG Threadlocker P/N 0100019.
3. See Swing Bearing Torquing Sequence.

⚠ WARNING

CHECK THE INNER AND OUTER SWING BEARING BOLTS FOR MISSING OR LOOSENESS AFTER FIRST 50 HOURS OF OPERATION, AND EVERY 600 HOURS THEREAFTER.

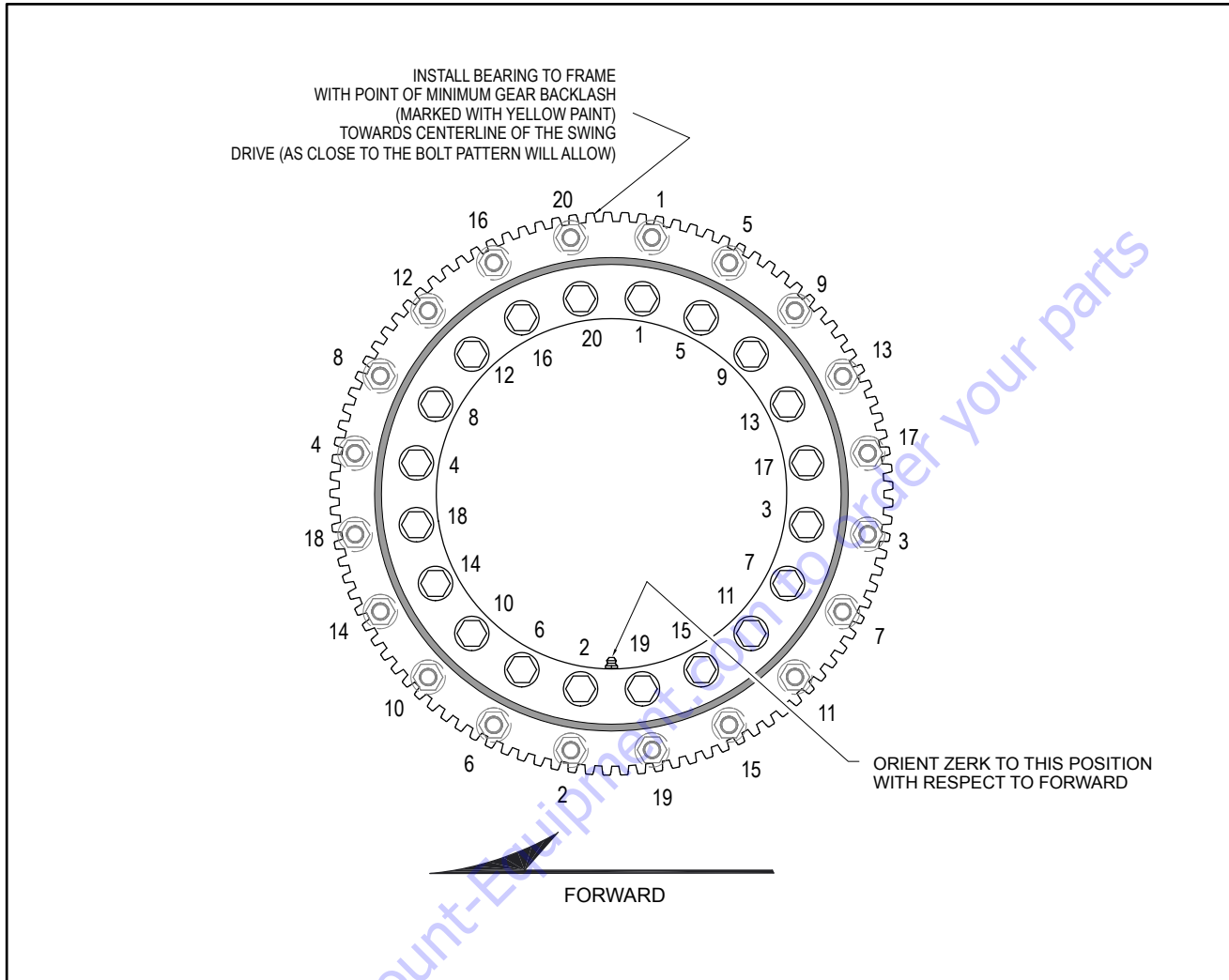

Figure 3-63. Swing Bearing Torque Sequence

3.15 ROTARY COUPLING

Use the following procedure to install the seal kit.

1. If not already removed, remove the axle oscillation valve from the cylinder barrel. The Shaft of the valve protrudes into the barrel and will damage the Shaft and seals if left in place.
2. Remove Retaining ring (5) from end.
3. Remove spacer (4) from the same end.
4. Remove center body (2) from housing (1).
5. Cut off old Seals (11, 12) positioned on the shaft and Seal (13) on the center body .
6. Reassemble O-ring (10).
7. Remove proximity switch.
8. Assemble lip seals (11) in direction shown in Figure 3-64., Rotary Coupling Cutaway.
9. Heat cap seals (12) in hydraulic oil for 5 minutes at 300° F (149° C).
10. Assemble cap seals over O-rings
11. Reinsert center body into housing (lube with hydraulic oil).
12. Replace Spacer and snap ring.

**Table 3-10. Coupling Port Information Table -
(SN 0300203771 through 0300222808)**

Port No.	Outlet	Port Size	Description	Operating Pressure PSI (Bar)	Proof Pressure PSI (Bar)
1	1	-8	Brake	450 (31)	675 (47)
2	1	-6	2 Speed	4500 (310)	675 (47)
3	1	-6	Steer	3000 (207)	3750 (259)
4	1	-6	Steer	3000 (207)	3750 (259)
5	1	-16	Drive Reverse	4500 (310)	6750 (465)
6	1	-16	Drive Forward	4500 (310)	6750 (465)
7	1	-8	Axle Release	450 (31)	675 (47)
8	1	-12	Drain	250 (17)	375 (26)

**Table 3-11. Coupling Port Information Table -
(SN 0300222809 to Present, SN E300000100 to Present, SN
1300007289 through 1300007393)**

Port No.	Outlet	Port Size	Description	Operating Pressure PSI (Bar)	Proof Pressure PSI (Bar)
1	2	-8	Brake	450 (31)	675 (47)
2	2	-6	2 Speed	450 (310)	675 (47)
3	1	-6	Steer	3000 (207)	4500 (310)
4	1	-6	Steer	3000 (207)	4500 (310)
5	1	-16	Drive Reverse	4500 (310)	6750 (465)
6	1	-16	Drive Forward	4500 (310)	6750 (465)
7	1	-8	Axle Release	450 (31)	675 (47)
8	3	-8	Drain	250 (17)	375 (26)

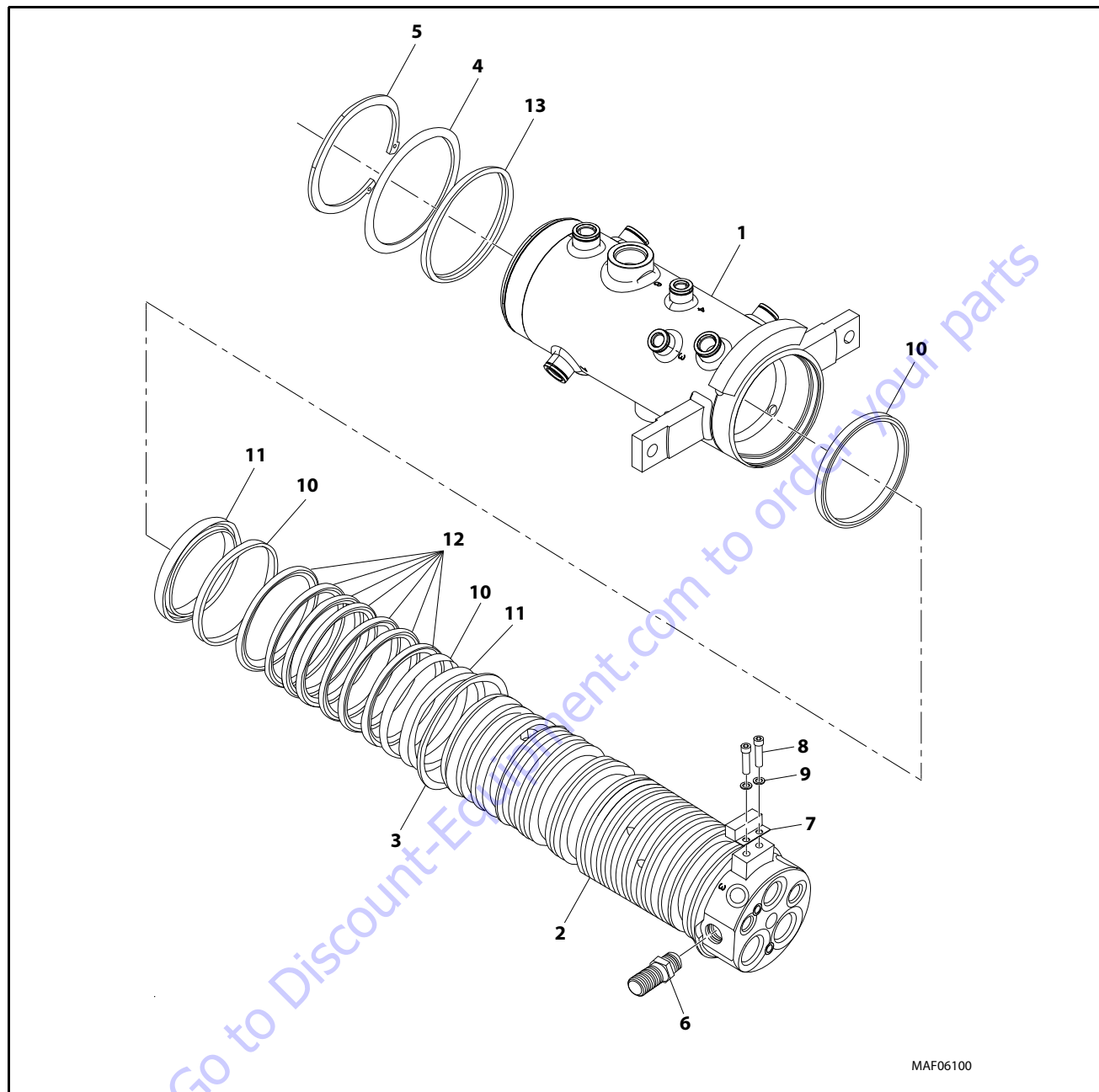

- | | | |
|-------------------|---------------------|----------|
| 1. Housing | 6. Torque Lug | 11. Seal |
| 2. Center Body | 7. Proximity Switch | 12. Seal |
| 3. Ring | 8. Bolt | 13. Seal |
| 4. Spacer | 9. Washer | |
| 5. Retaining Ring | 10. O-ring | |

Figure 3-64. Rotary Coupling Cutaway

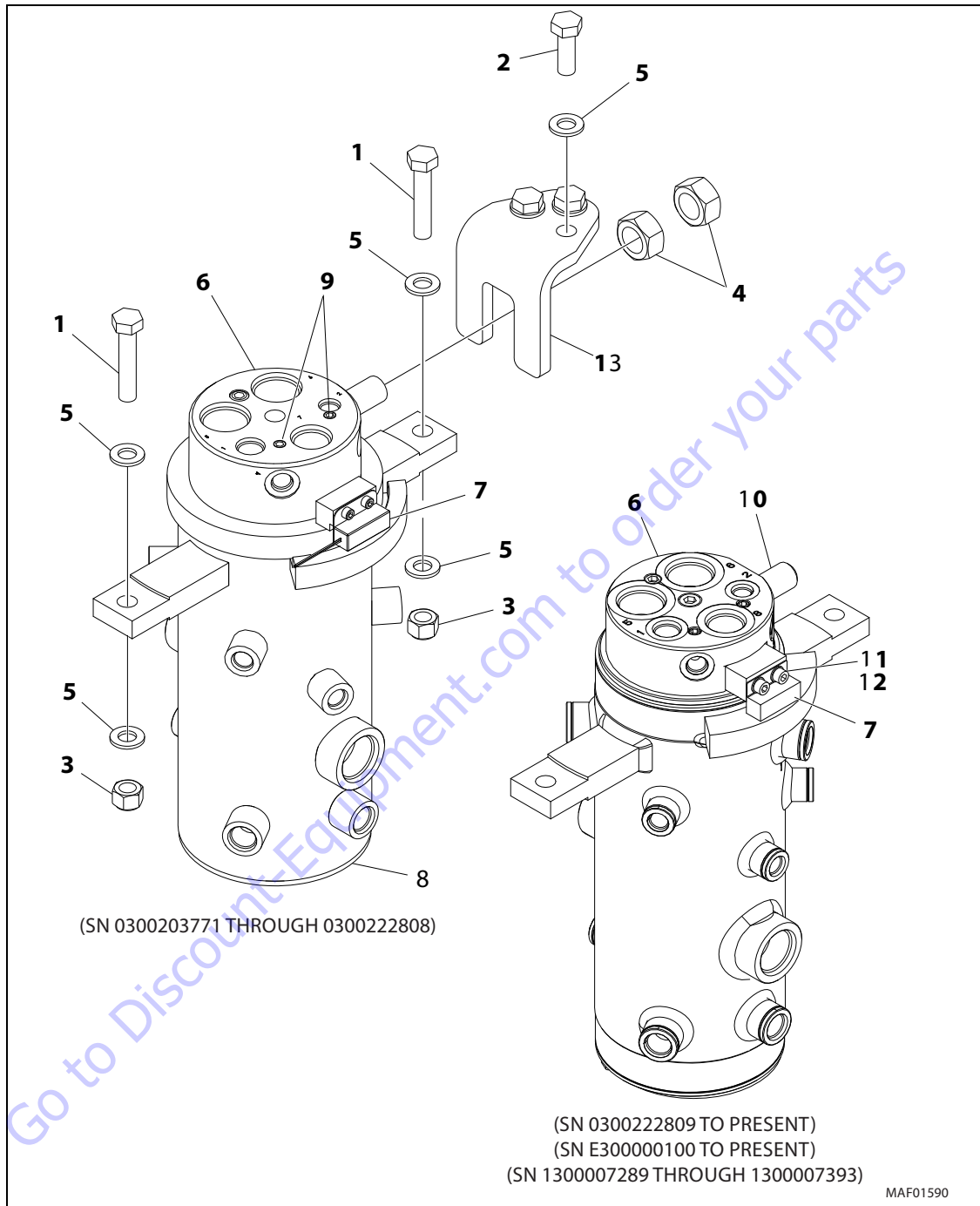

- | | | | |
|---------|-----------------------------|---------------------|------------|
| 1. Bolt | 5. Washer | 8. Thrust Ring | 11. Bolt |
| 2. Bolt | 6. Rotary Coupling Assembly | 9. Plug | 12. Washer |
| 3. Nut | 7. Proximity Switch | 10. Threaded Spigot | 13. Mount |
| 4. Nut | | | |

Figure 3-65. Rotary Coupling Installation

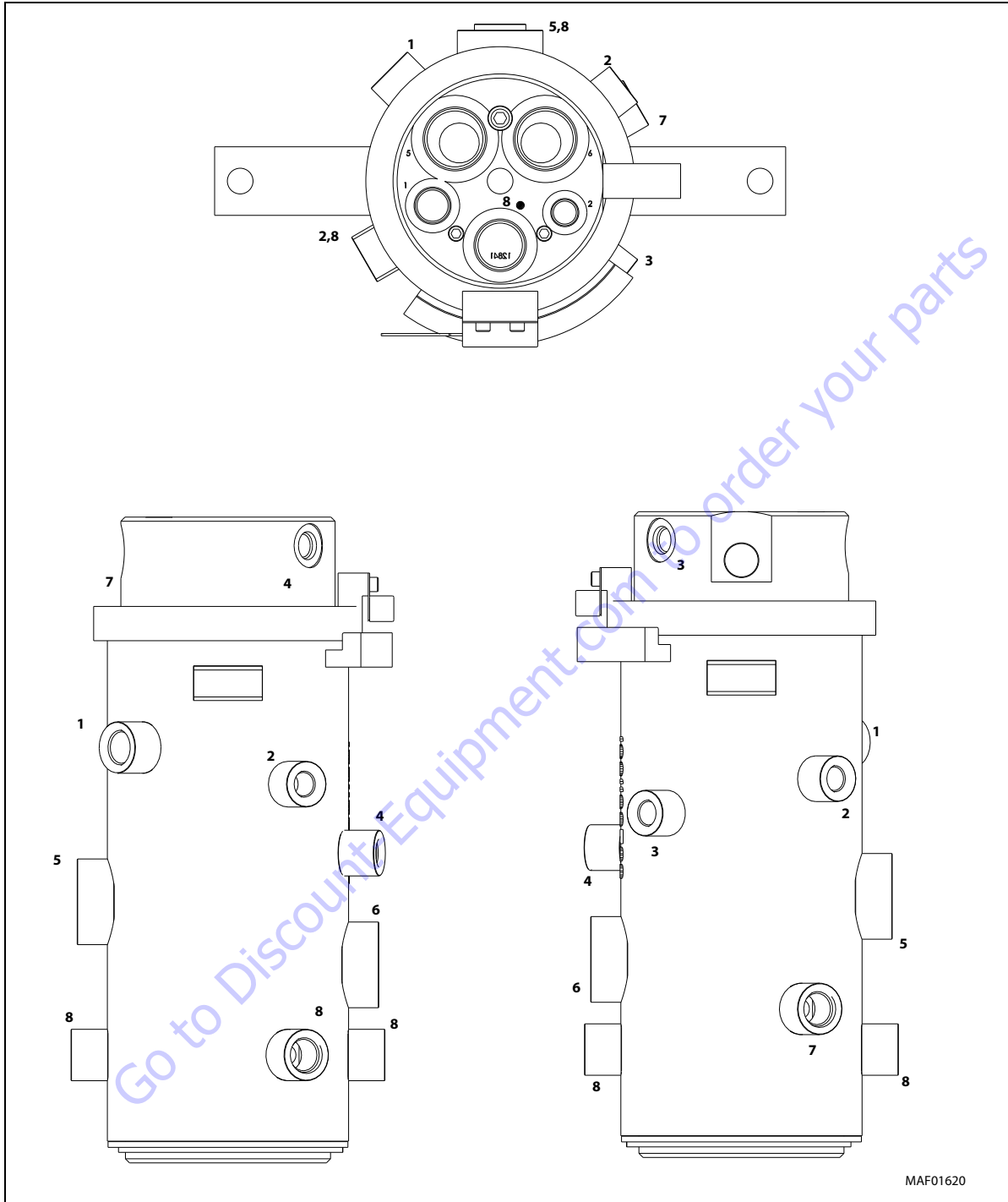
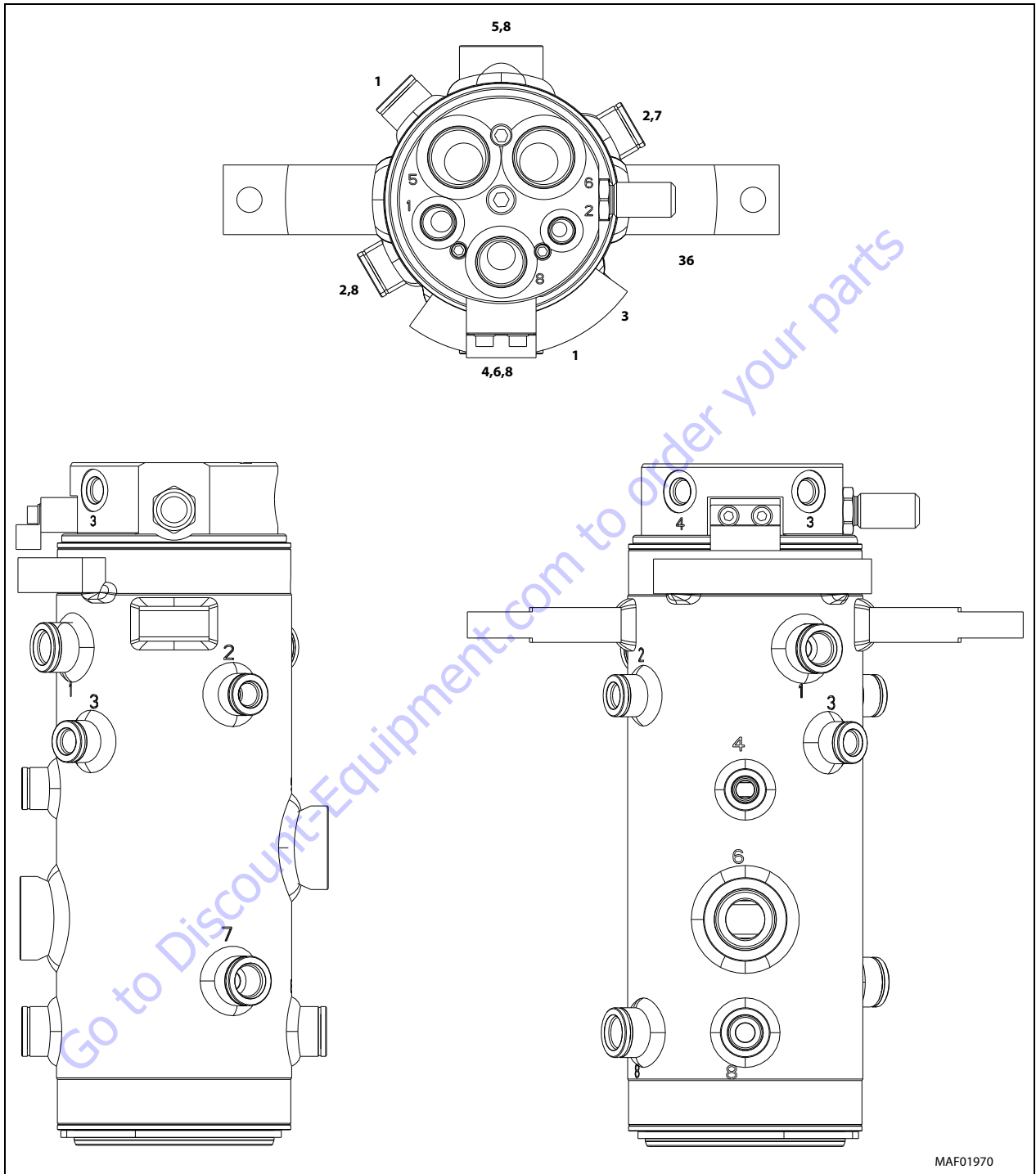

Figure 3-66. Rotary Coupling Port Location - (SN 0300203771 through 0300222808)



MAF01970

Figure 3-67. Rotary Coupling Port Location - (SN 0300222809 to Present, SN E300000100 to Present, SN 1300007289 through 1300007393)

3.16 GENERATOR

⚠ WARNING

STOP ENGINE BEFORE CARRY OUT SCHEDULE MAINTENANCE.

NOTE: Do often service, if operating in hostile environment.

Maintenance Schedule

EVERY 250 HOURS

Every 250 hours of operation, check the drive belt for proper tension.

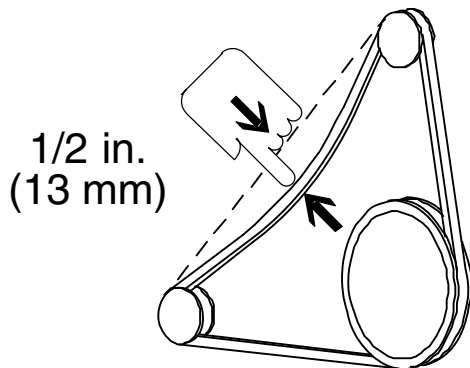

EVERY 500 HOURS

Every 500 hours of operation, service the generator brushes and slip rings. Hostile environments may require more frequent service.

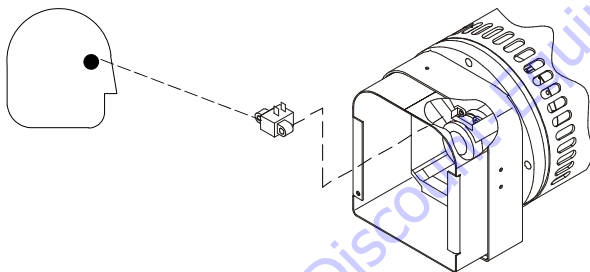

Every 500 hours of service, blow out the inside of the generator. If operating in a hostile environment, clean monthly.

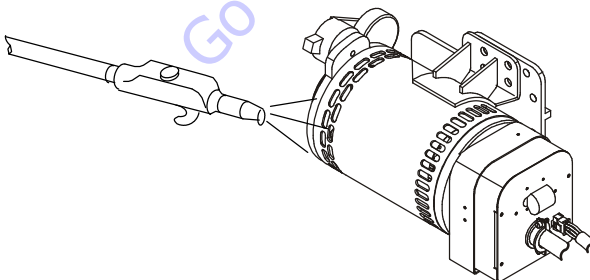

Overload Protection

⚠ WARNING

STOP THE ENGINE WHENEVER CHECKING OR INSPECTING THE CIRCUIT BREAKER.

The circuit breaker protects the generator windings from overload. If the circuit breaker opens, generator output stops. If the circuit breaker continues to open, check for faulty equipment connected to the platform receptacles.

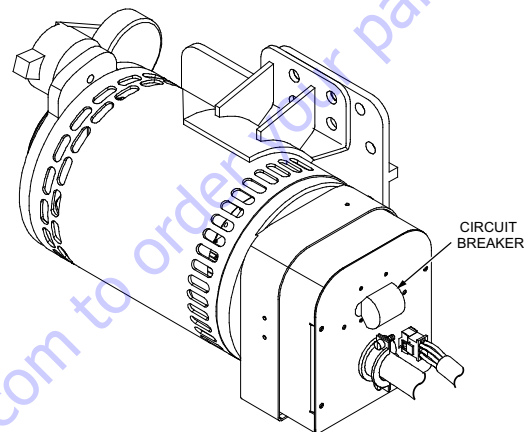

Inspecting Brushes, Replacing Brushes and Cleaning Slip Rings

Refer to Figure 3-68., Inspecting Generator Brushes, Replacing Brushes and Cleaning Slip Rings.

INSPECTING BRUSH POSITION

Inspect brush alignment with slip rings. View alignment through the air vents in the stator barrel. The brushes must ride completely on the slip rings.

INSPECTING BRUSHES

Remove the end panel. Inspect the wires. Remove the brush holder assembly. Pull the brushes from the holders.

Replace the brushes if damaged, or if the brush is at or near minimum length.

CLEANING SLIP RINGS

Visually inspect the slip rings. Under normal use, the rings turn dark brown.

If the slip rings are corroded or their surface is uneven, remove the belt to turn the shaft by hand for cleaning.

Clean the rings with 220 grit emery paper. Remove as little material as possible. If the rings are deeply pitted and do not clean up, consult generator factory service.

Reinstall the belt, brush holder assembly and end panel.

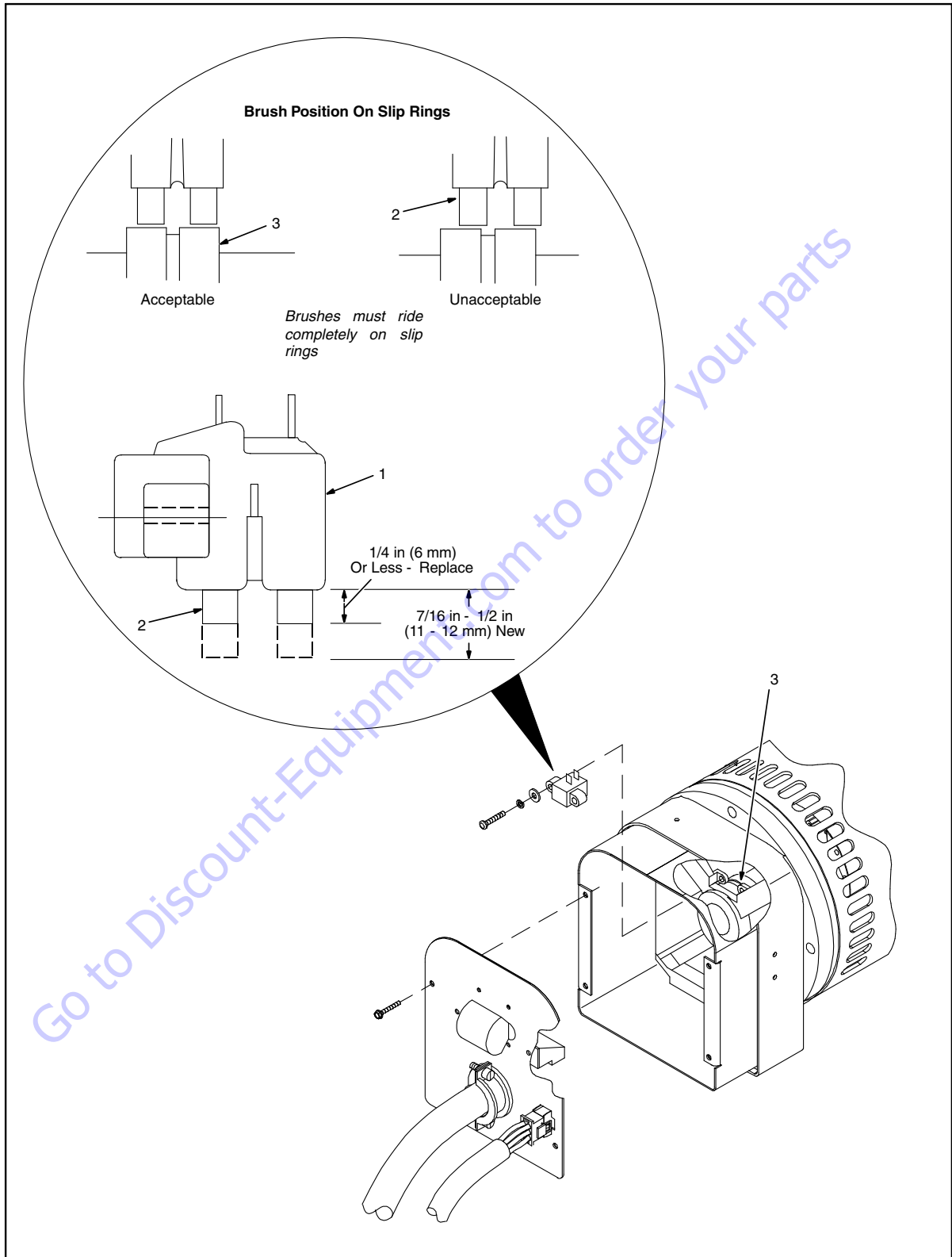

Figure 3-68. Inspecting Generator Brushes, Replacing Brushes and Cleaning Slip Rings

Generator Disassembly and Assembly

Refer to Figure 3-70. and Figure 3-71. to determine if trouble is in stator, rotor, control box, or combination of these components.

1. Rotor
2. Stator Assembly

⚠ CAUTION

DO NOT DAMAGE ROTOR OR STATOR WINDINGS DURING DISASSEMBLY AND ASSEMBLY PROCEDURE.

DISASSEMBLY

1. Mark and disconnect all electrical leads, secure using cable ties.

2. Remove brush holder assembly.
3. Disassemble generator parts shown in Figure 3-69.
4. Clean all parts with approved solvent and dry with compressed air, If applicable.
5. Inspect all part for damage. Replace if necessary.

ASSEMBLY

1. Assemble generator parts using torque values in table.
2. Reconnect all leads. Use cable ties to secure leads away from moving or hot parts.

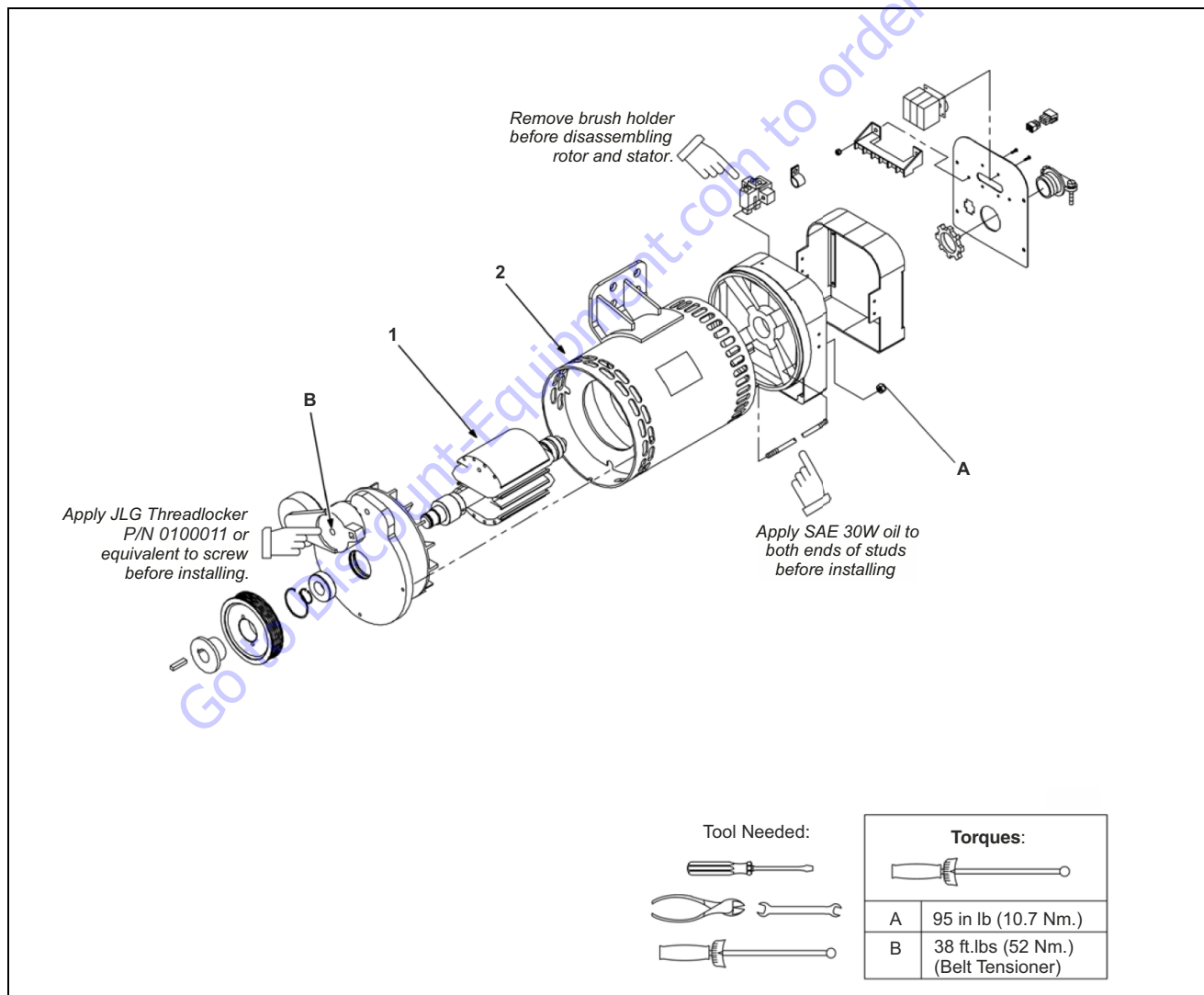

Figure 3-69. Generator Disassembly and Assembly

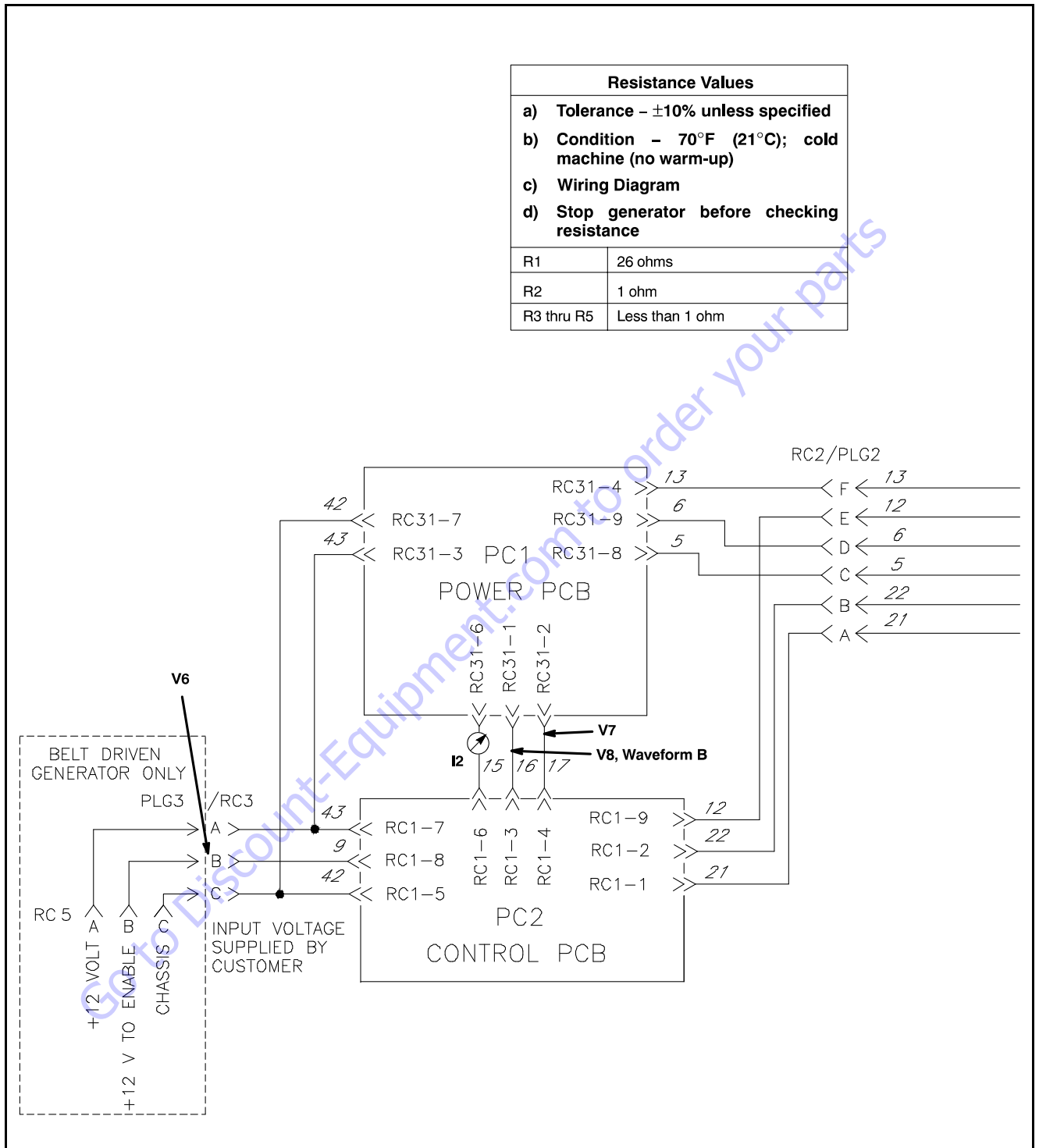

Figure 3-70. Generator Troubleshooting Circuit Diagram - Sheet 1 of 2

SECTION 3 - CHASSIS & TURNTABLE

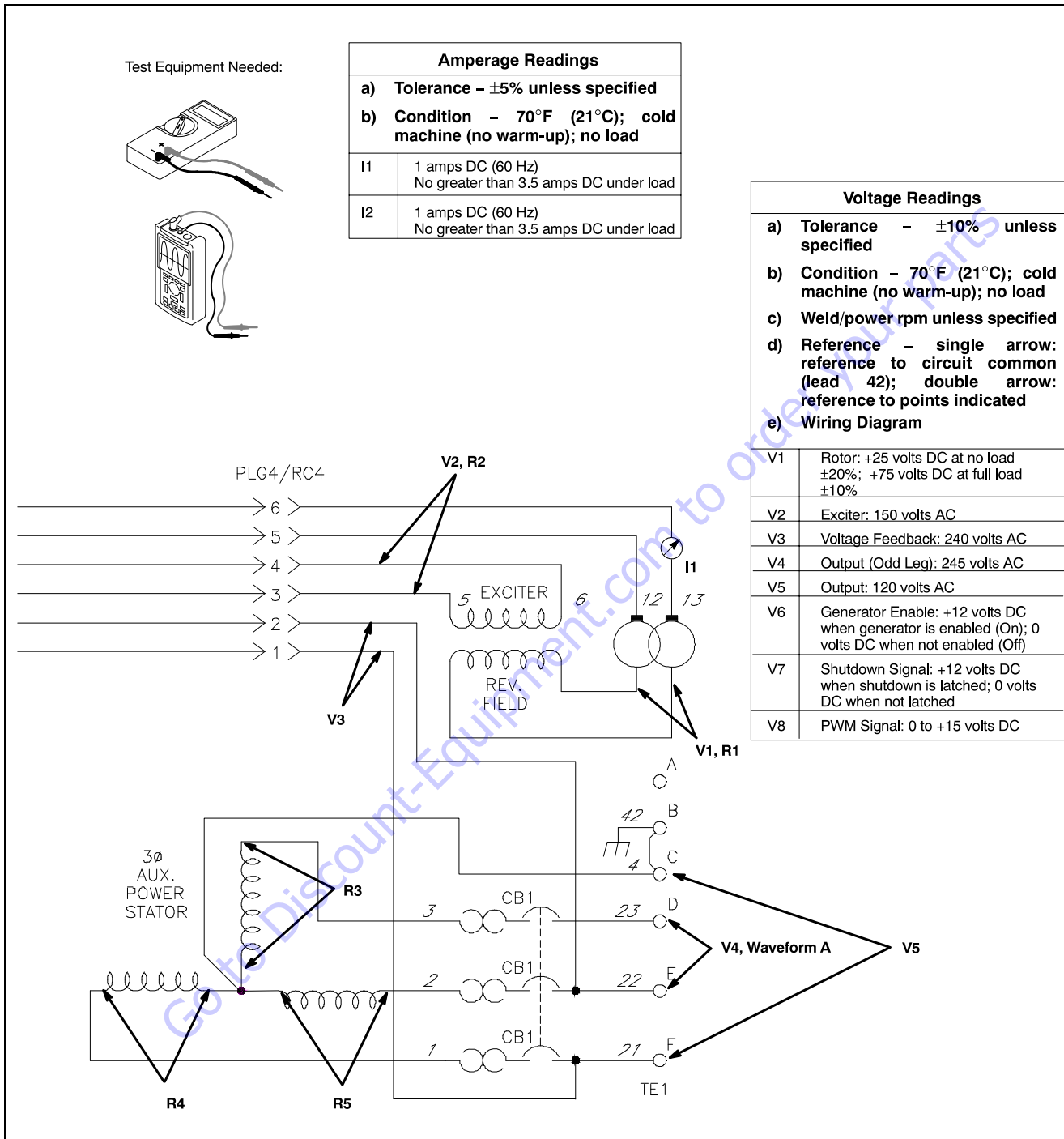

Figure 3-71. Generator Troubleshooting Circuit Diagram - Sheet 2 of 2

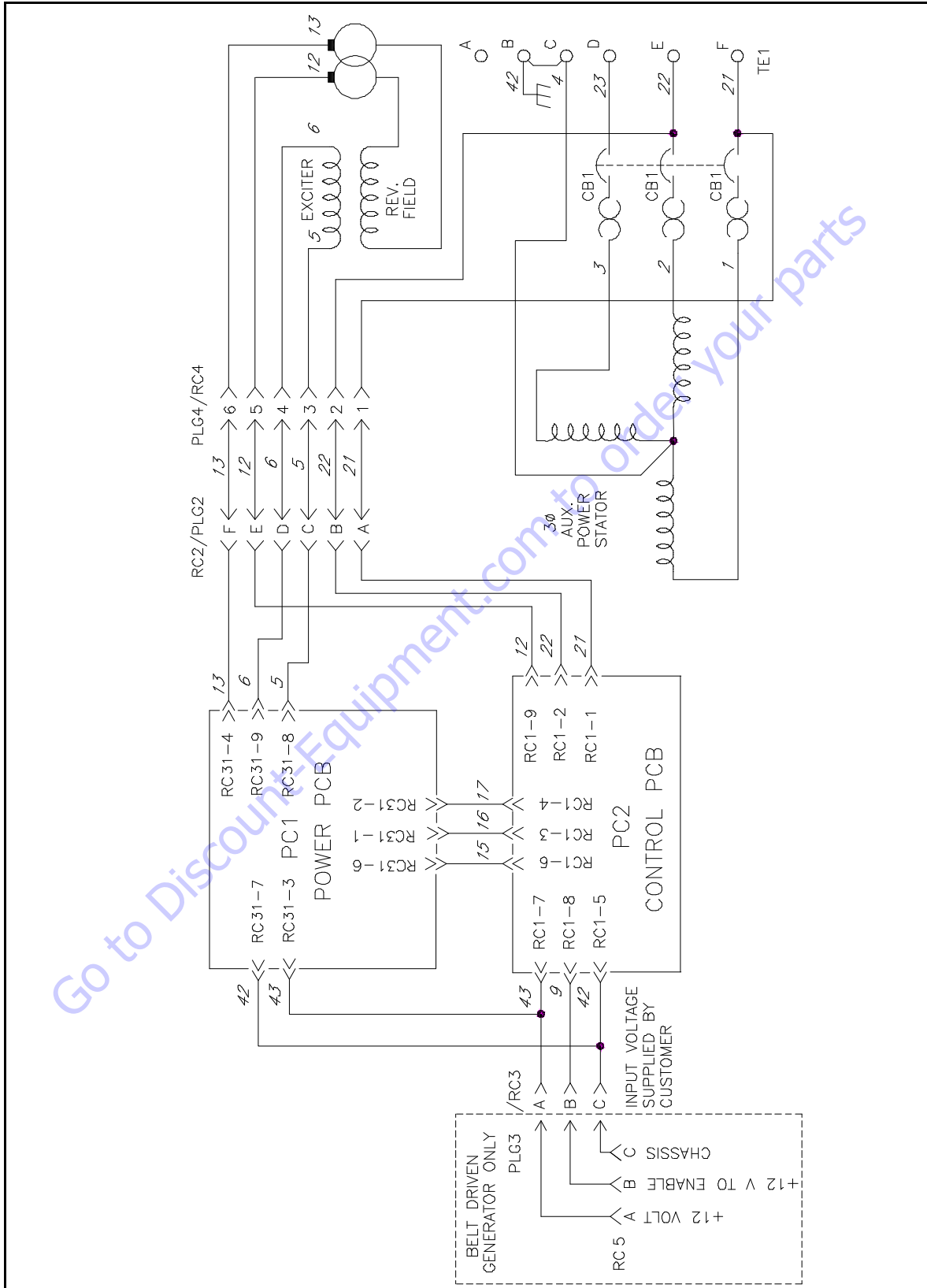

Figure 3-72. Generator Electrical Circuit Diagram

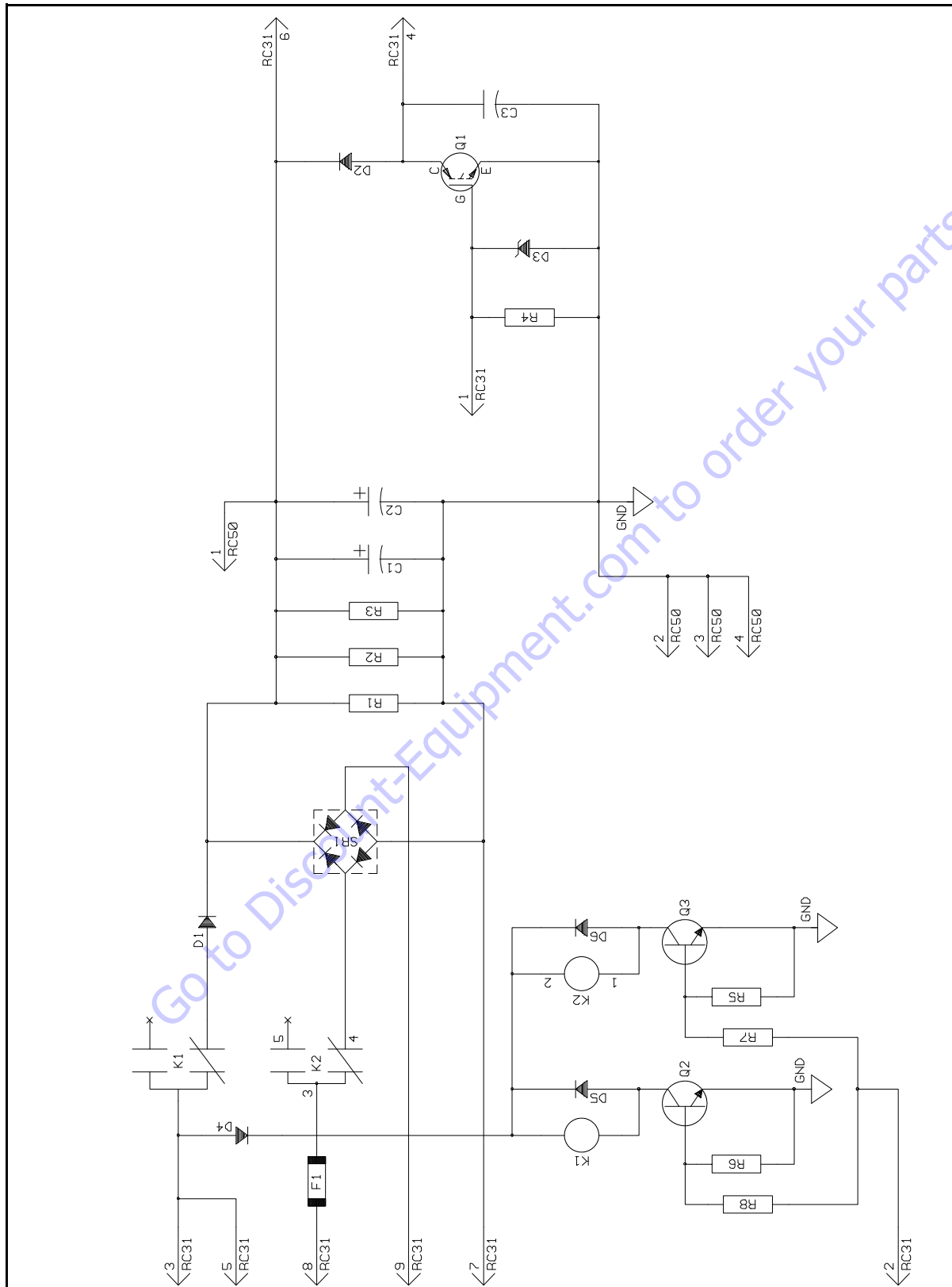

Figure 3-73. Power Board PC1 Electrical Circuit Diagram

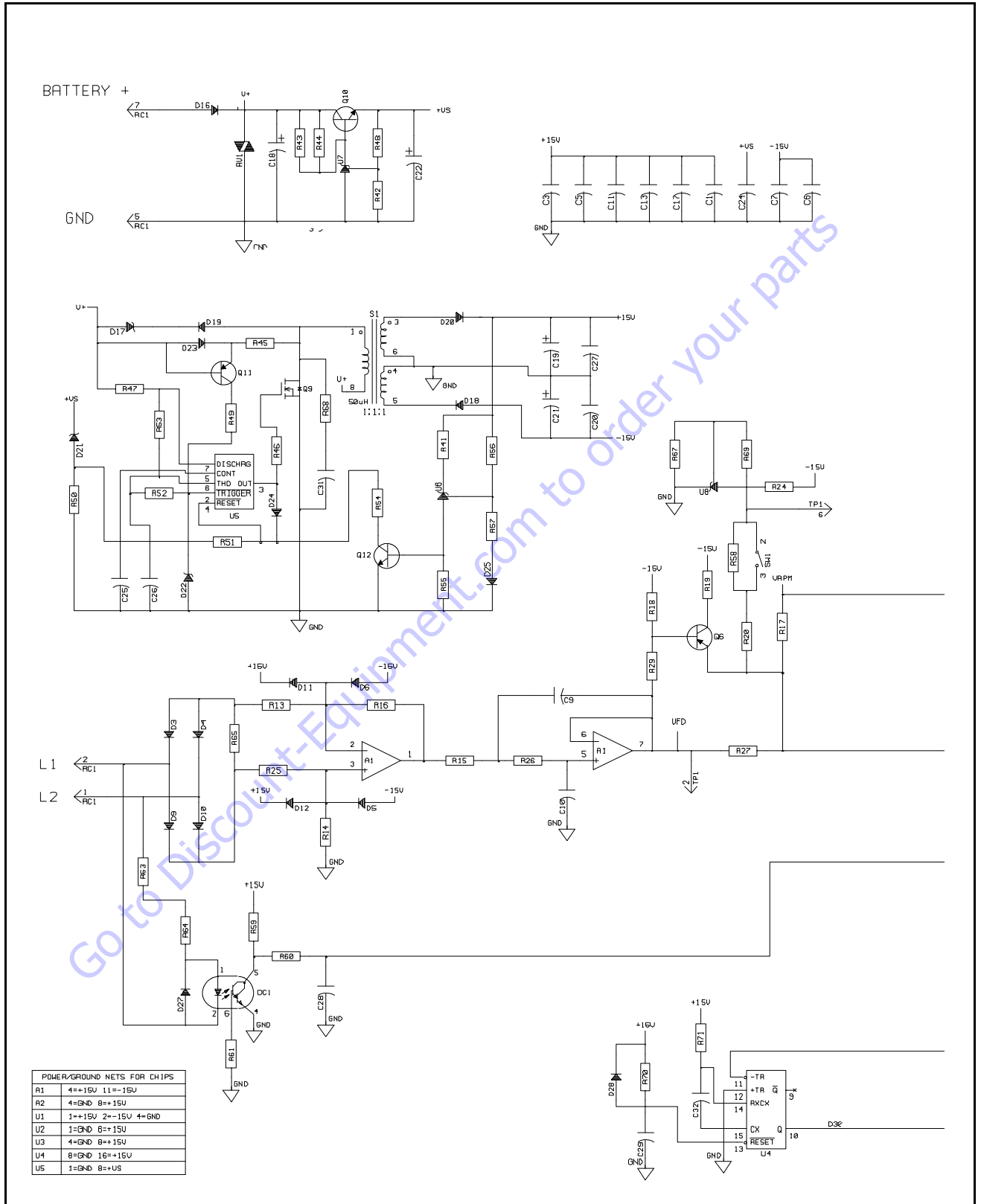

Figure 3-74. Power Board PC2 Electrical Circuit Diagram - Sheet 1 of 2

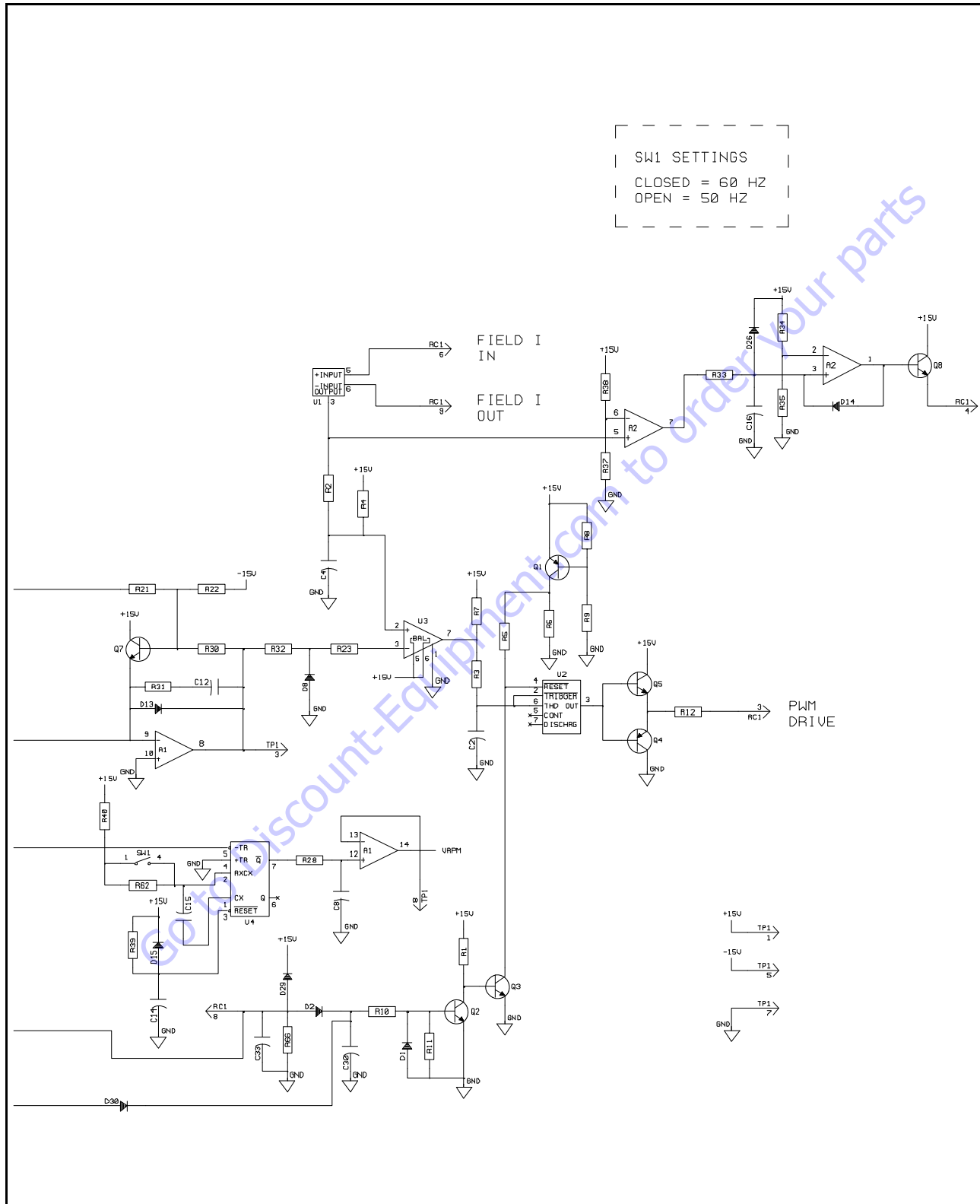

Figure 3-75. Power Board PC2 Electrical Circuit Diagram - Sheet 2 of 2

Lead Connection List for Generator

NOTE: Apply small amount of dielectric grade, nonconductive electric grease to connectors where factory-applied grease had been present.

NOTE: Table shows physical lead connections and should be used with circuit diagram (table replaces wiring diagram).

Table 3-12. Lead Connection List for Generator

Leads	Connections
1A	STATOR TO CB1
2A	STATOR TO CB1
3A	STATOR TO CB1
4A	STATOR TO TE1 (C)
5A	STATOR TO RC4 (3)
5B	PLG2 (C) TO PLG4 (3)
5C	RC2 (C) PLG31 (8)
6A	STATOR TO RC4 (4)
6B	PLG2 (D) TO PLG4 (4)
6C	RC2 (D) PLG31 (9)
9A	RC5 (B) TO PLG3 (B) (Customer Supplied)
9B	RC3 (B) PLG1 (8)
12A	PLG2 (E) TO PLG4 (5)
12B	RC2 (E) PLG1 (9)
12C	RC4 (5) TO BRUSH
13A	PLG2 (F) TO PLG4 (6)
13B	RC2 (F) PLG31 (4)
13C	RC4 (6) TO BRUSH
15A	PLG1 (6) TO PLG31 (6)
16A	PLG1 (3) TO PLG31 (1)
17A	PLG1 (4) TO PLG31 (2)
21A	CB1 TO TE1 (F)
21B	PLG2 (A) TO PLG4 (1)
21C	PLG1 (1) TO RC2 (A)
21D	RC4 (1) TO CB1
22A	CB1 TO TE1 (E)
22B	PLG2 (B) TO PLG4 (2)
22C	PLG1 (2) TO RC2 (B)
22D	RC4 (2) TO CB1
23A	CB1 TO TE1 (D)
42A	RC5 (C) TO PLG3 (C) (Customer Supplied)
42B	RC3 (C) TO CONNECTION POINT 1
42C	PLG31 (7) TO CONNECTION POINT 1
42D	PLG1 (5) TO CONNECTION POINT 1
42F	END BELL SHROUD TO ENGINE MOUNT
42G	CHASSIS TO TE1 (B)
43A	RC5 (A) TO PLG3 (A) (Customer Supplied)
43B	RC3 (A) TO CONNECTION POINT 2
43C	PLG31 (3) TO CONNECTION POINT 2
43D	PLG1 (7) TO CONNECTION POINT 2

3.17 DEUTZ ENGINE

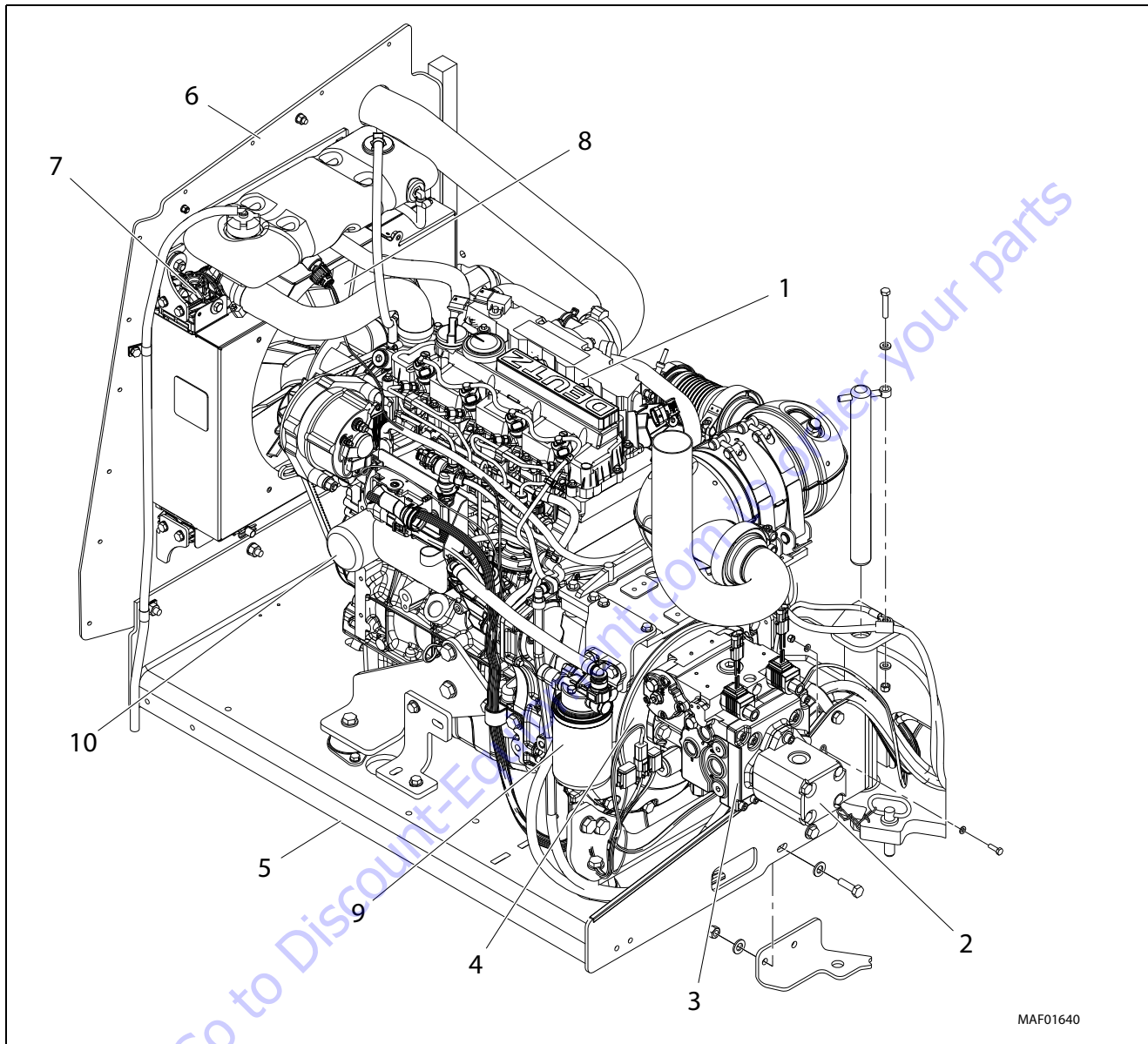

- | | |
|------------------|----------------------|
| 1. Engine | 6. Radiator Mounting |
| 2. Gear Pump | 7. Radiator |
| 3. Piston Pump | 8. Fan |
| 4. Pump Coupling | 9. Fuel Filter |
| 5. Engine Tray | 10. Oil Filter |

Figure 3-76. Deutz D2.9L4 Engine Components - Sheet 1 of 2

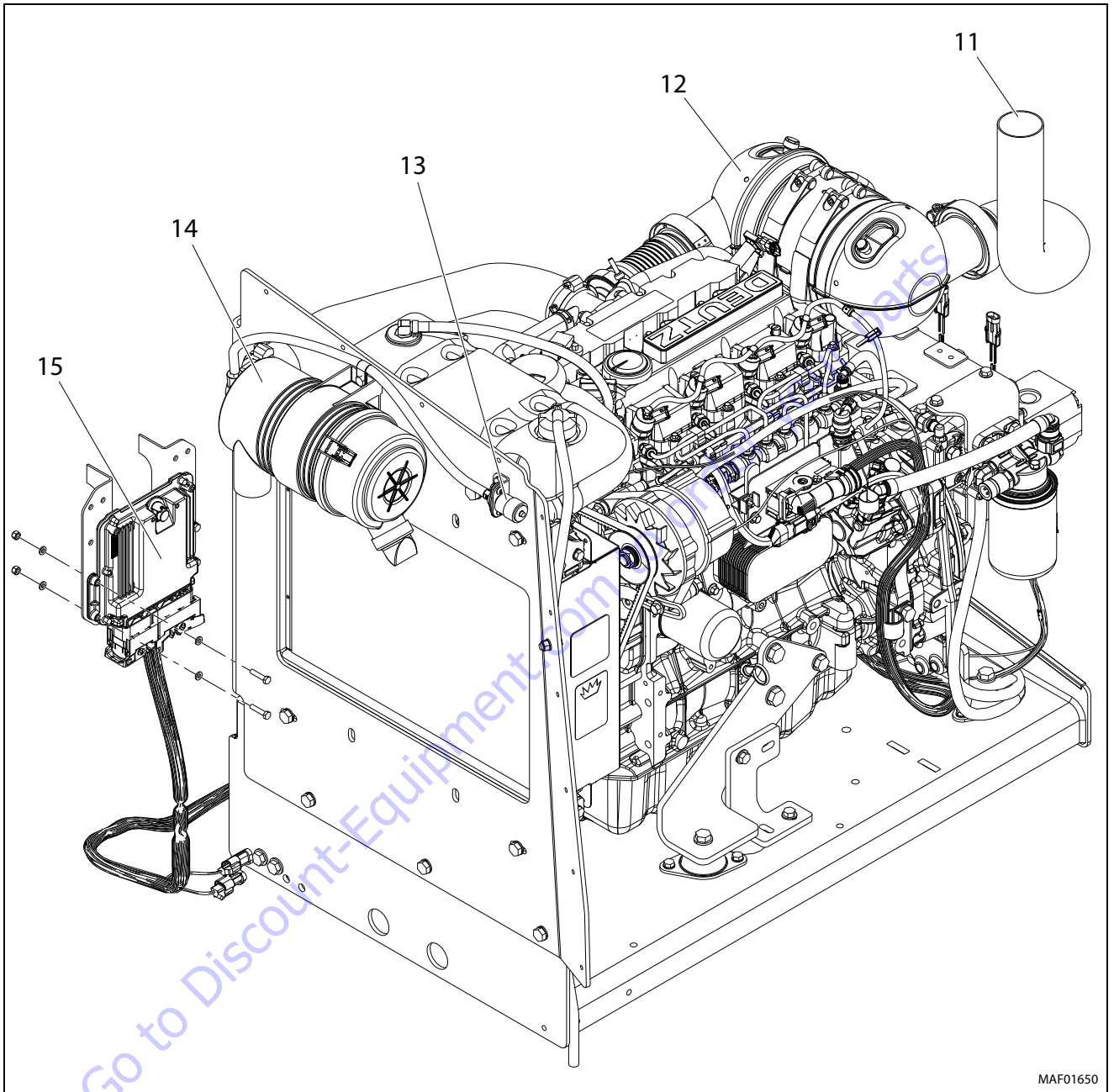

MAF01650

- | | |
|--------------------------|----------------|
| 11. Exhaust Pipe | 14. Air Filter |
| 12. Muffler | 15. ECU module |
| 13. Air Intake Indicator | |

Figure 3-77. Deutz D2.9L4 Engine Components - Sheet 2 of 2

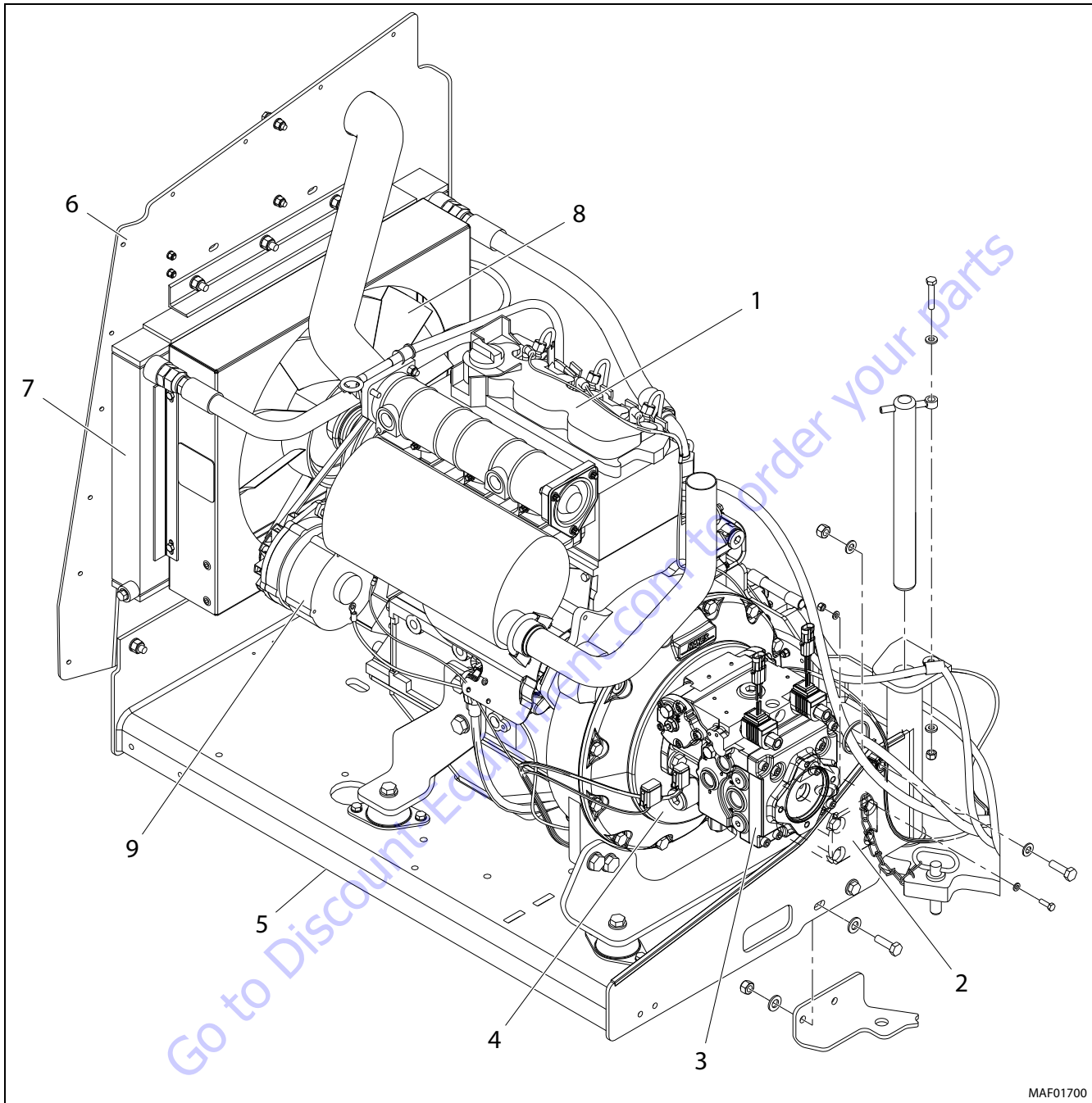

MAF01700

- | | |
|------------------|-------------------------|
| 1. Engine | 6. Radiator Mount Plate |
| 2. Gear Pump | 7. Oil Cooler |
| 3. Piston Pump | 8. Fan |
| 4. Pump Coupling | 9. Alternator |
| 5. Engine Tray | |

Figure 3-78. Deutz D2011 Engine Components - Sheet 1 of 3

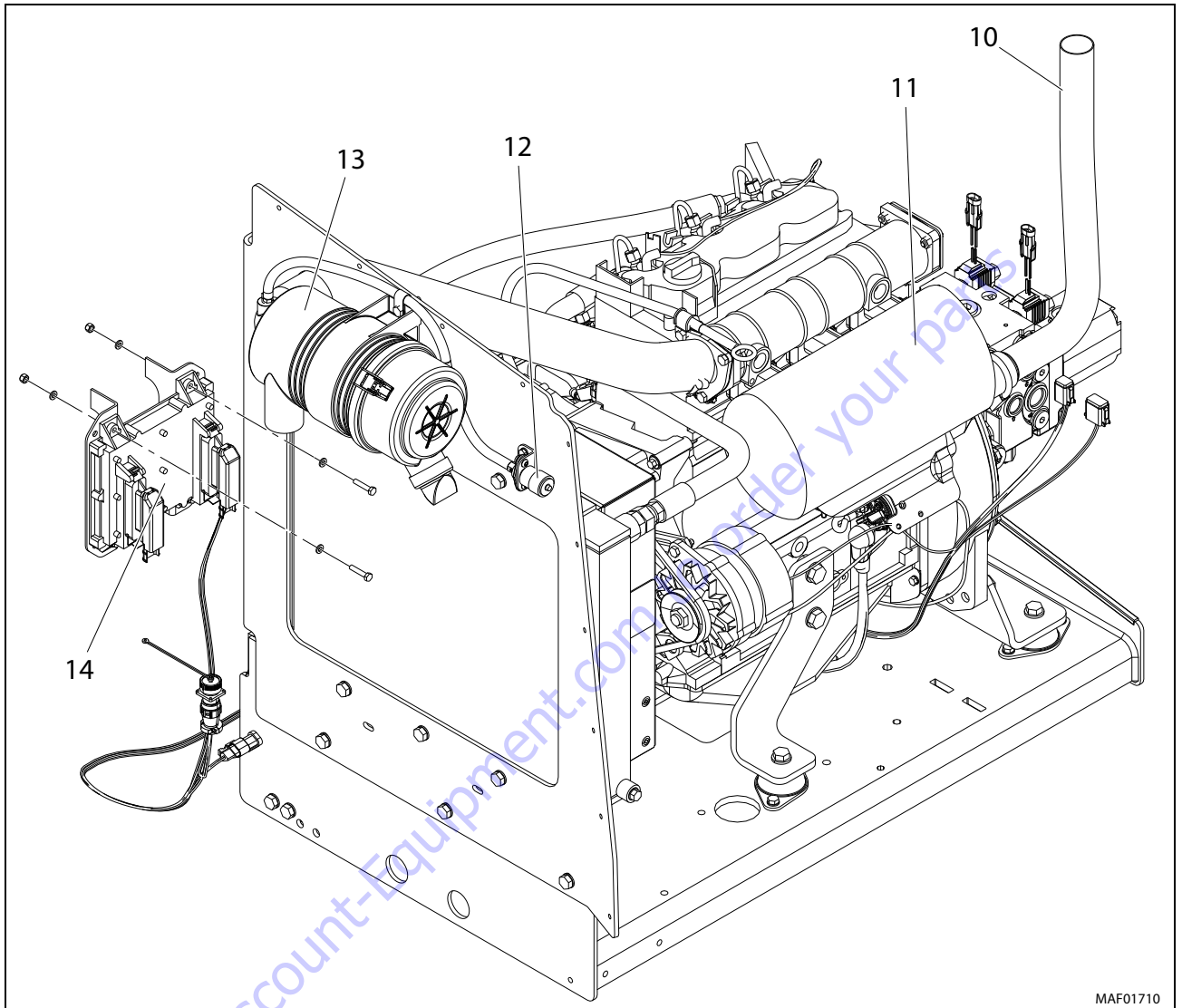

MAF01710

- | | |
|------------------------|---------------|
| 10. ExhaustPipe | 13. AirFilter |
| 11. Muffer | 14. ECUModule |
| 12. AirIntakeIndicator | |

Figure 3-79. Deutz D2011 Engine Components - Sheet 2 of 3

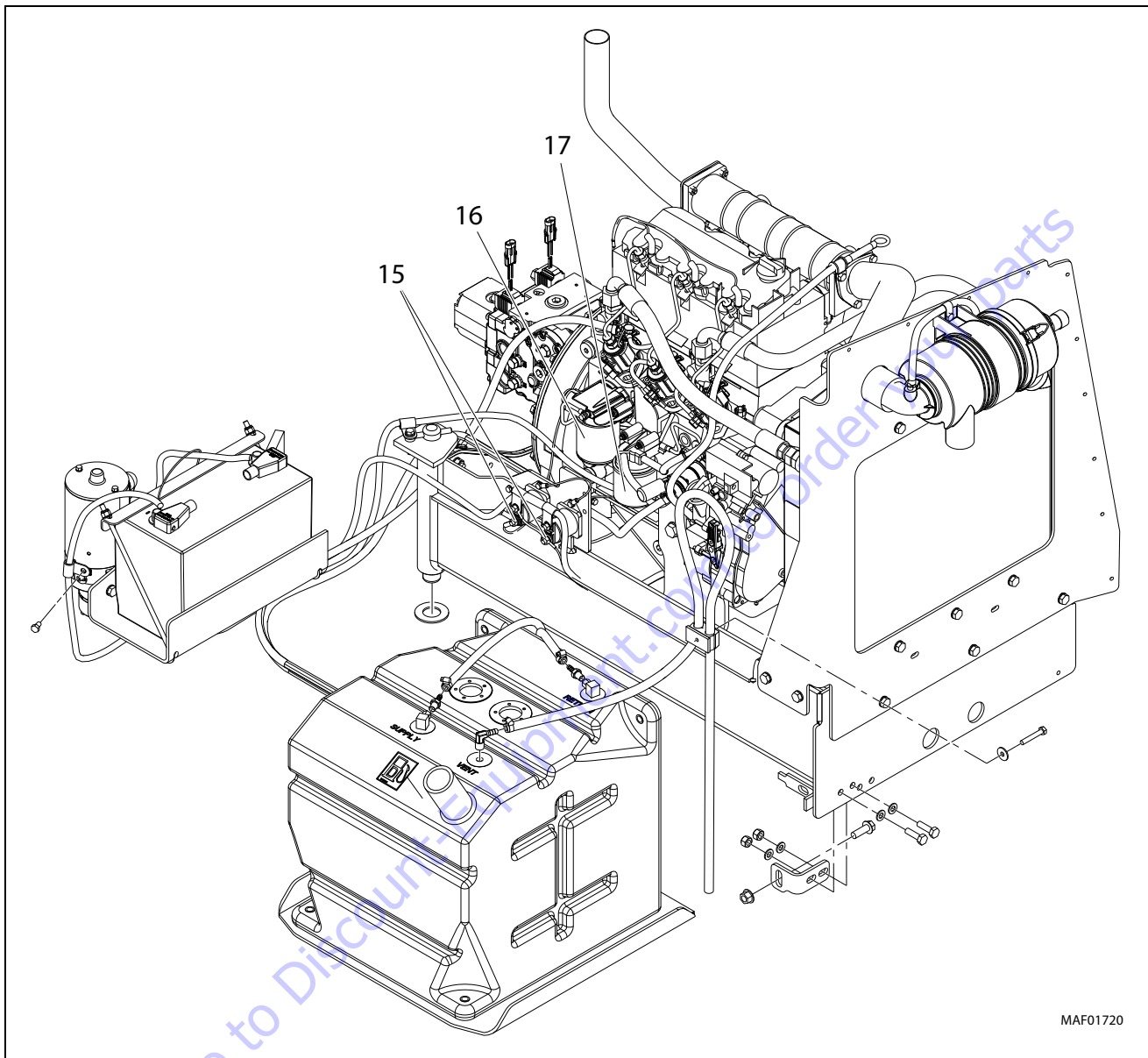

MAF01720

15. RelayAssembly
16. Oil Filter

17. Fuel Filter

Figure 3-80. Deutz D2011 Engine Components - Sheet 3 of 3

3.18 GM ENGINE

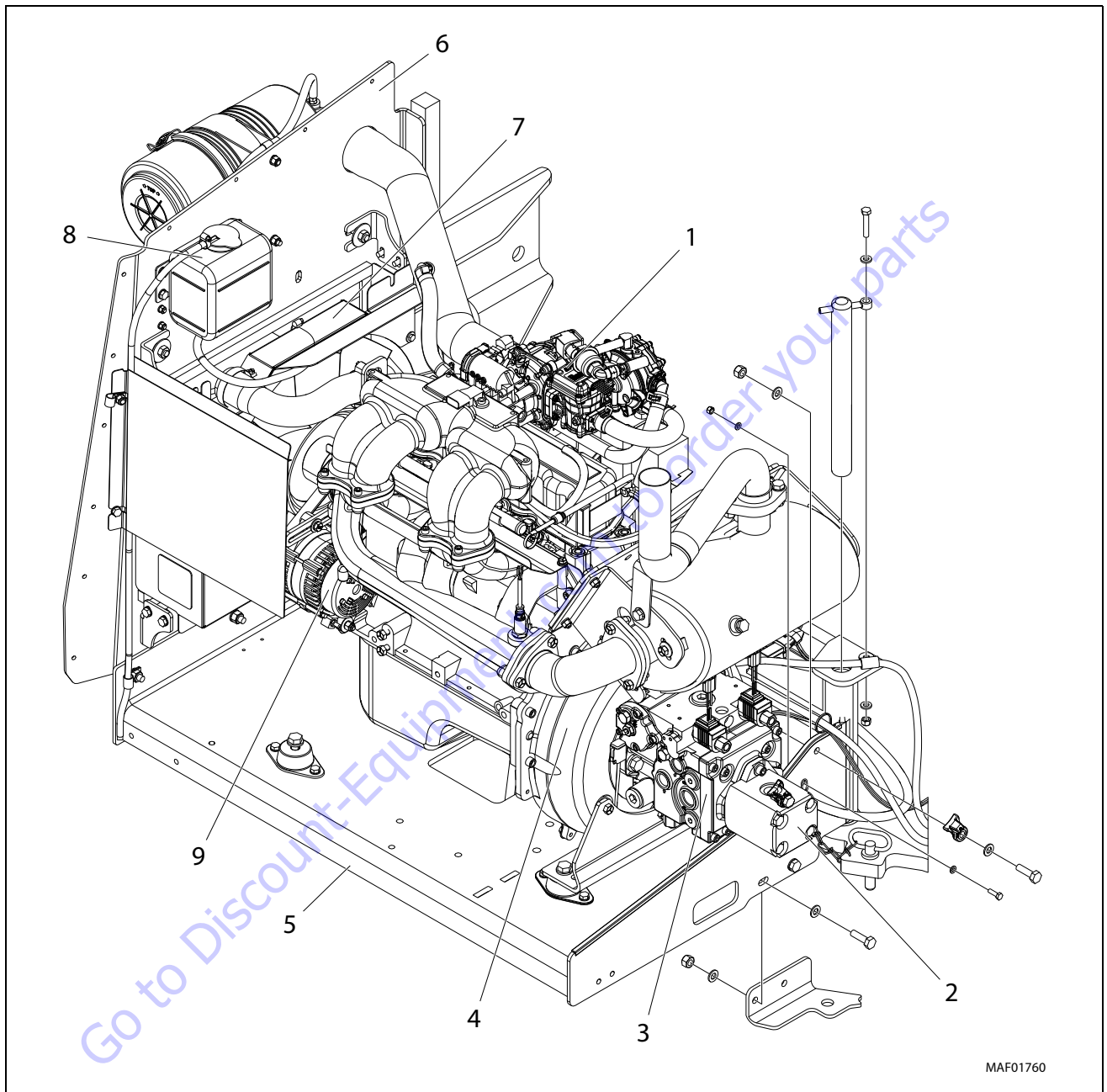

- | | |
|------------------|-------------------------------|
| 1. Engine | 6. Radiator Mounting |
| 2. Gear Pump | 7. Radiator |
| 3. Piston Pump | 8. Coolant Overflow Container |
| 4. Pump Coupling | 9. Alternator |
| 5. Engine Tray | |

Figure 3-81. GM Engine Components - Sheet 1 of 2

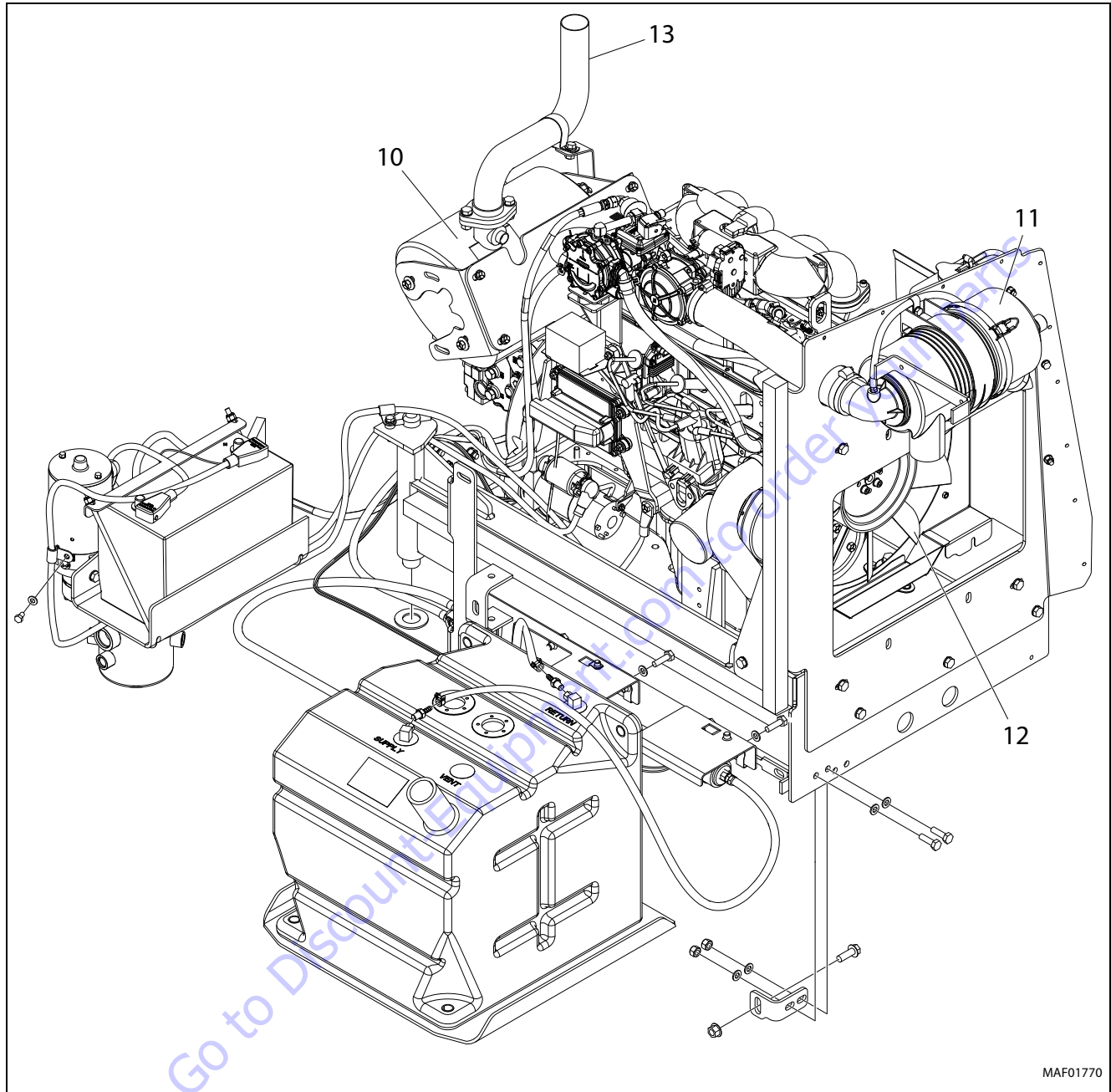

10. Muffler
11. Air Filter

12. Fan
13. Exhaust Pipe

Figure 3-82. GM Engine Components - Sheet 2 of 2

3.19 KUBOTA ENGINE

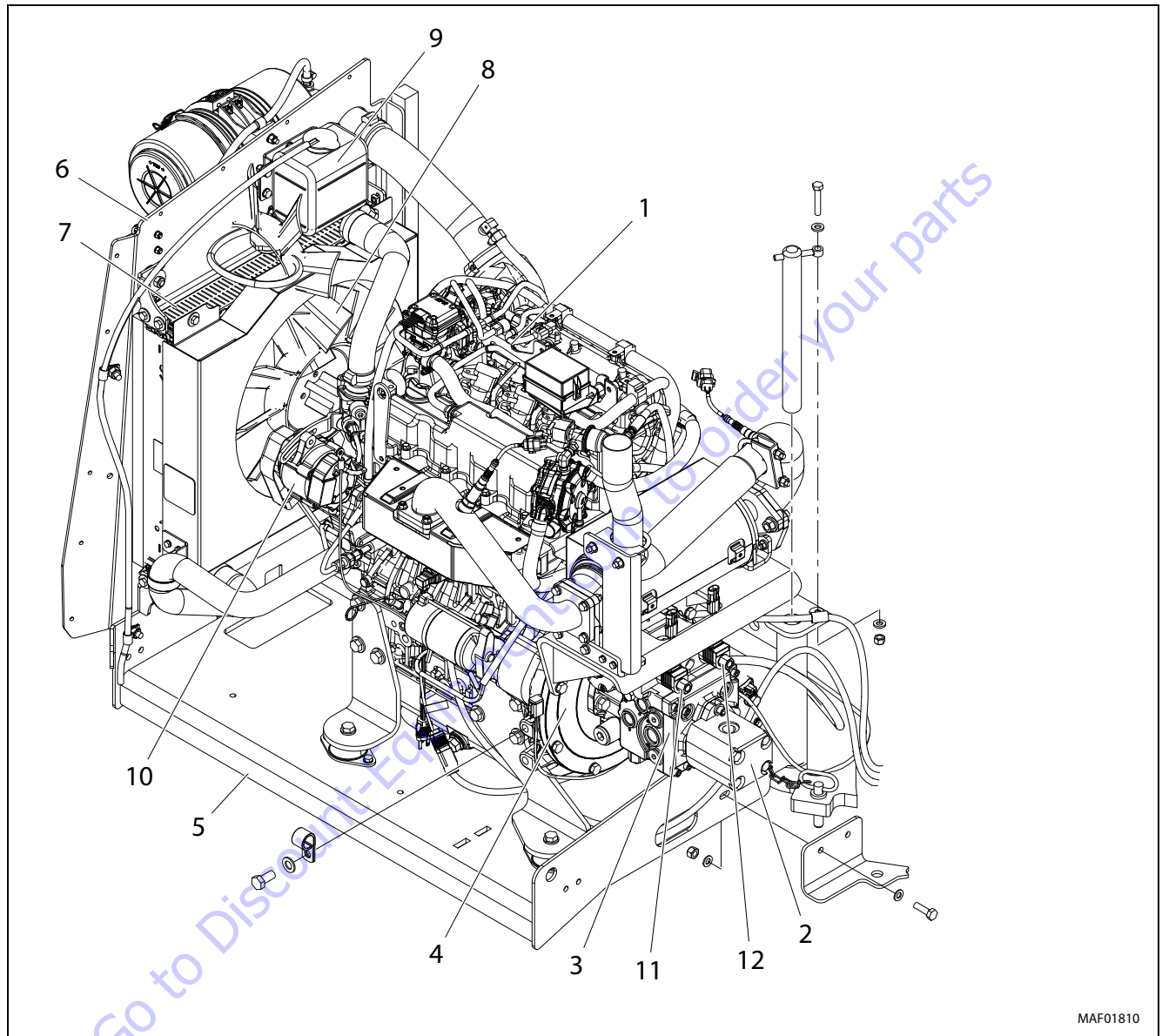

- | | | |
|------------------|----------------------|-------------------------------|
| 1. Engine | 5. Engine Tray | 9. Coolant Overflow Container |
| 2. Gear Pump | 6. Radiator Mounting | 10. Alternator |
| 3. Piston Pump | 7. Radiator | 11. Forward Solenoid |
| 4. Pump Coupling | 8. Fan | 12. Reverse Solenoid |

Figure 3-83. Kubota Engine Components - Sheet 1 of 2

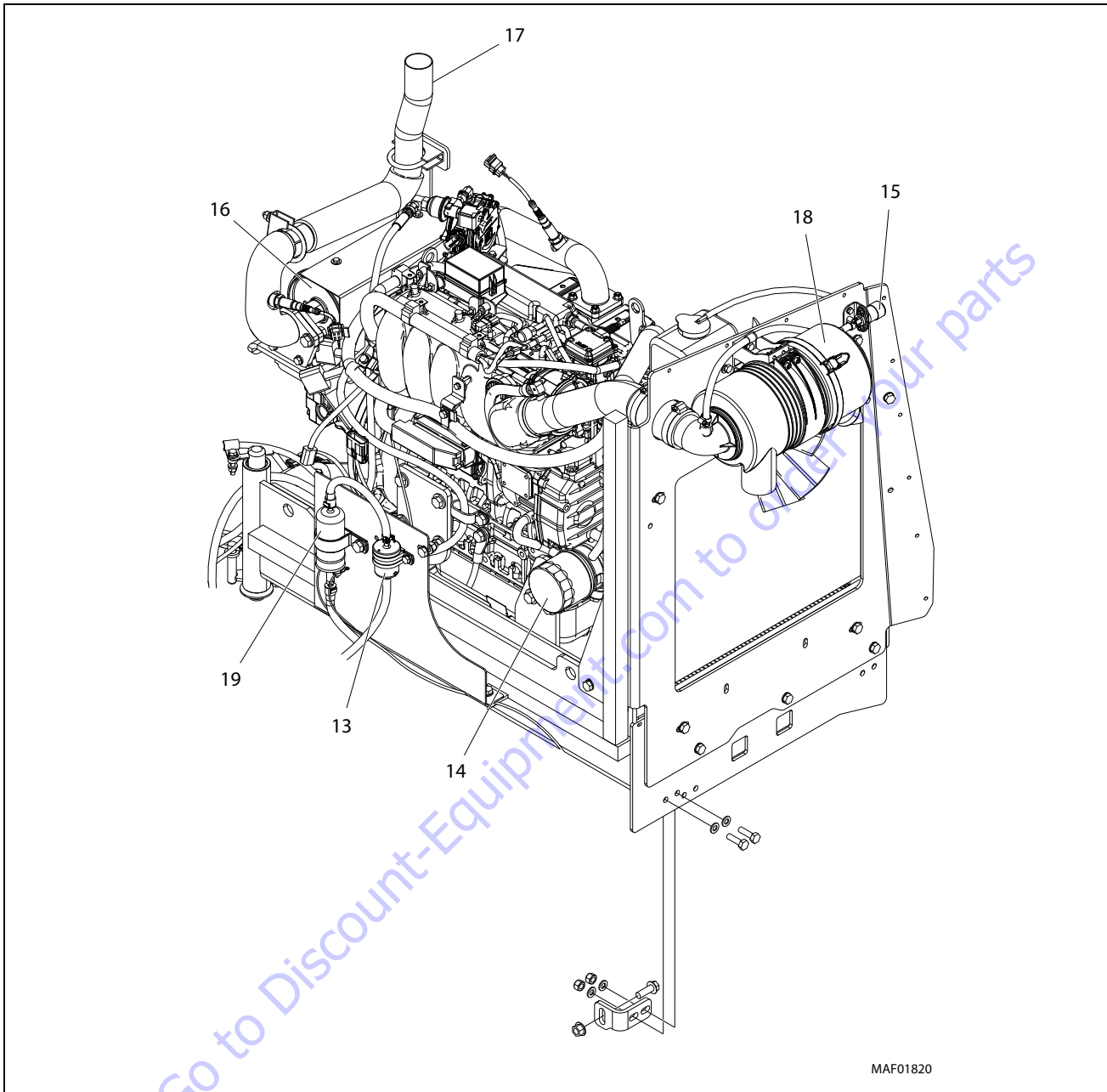

- | | |
|--------------------------|------------------|
| 13. Fuel Filter | 17. Exhaust Pipe |
| 14. Oil Filter | 18. Air Filter |
| 15. Air Intake Indicator | 19. Fuel Pump |
| 16. Muffler | |

Figure 3-84. Kubota Engine Components - Sheet 2 of 2

3.20 DEUTZ ENGINE - D2.9L4

NOTE: Refer to engine manufacturer's manual for detailed operating and maintenance instructions. Limited engine maintenance items are presented here for convenience but detailed engine maintenance items and schedule are included in the engine manufacturer's manual.

Glow Plugs

If the glow plug option is enabled in the JLG Control System, the glow plug and indicator lamp will be energized when the Power/Emergency Stop switch is pulled on if the ambient air temperature is less than 50° F (10° C) and the engine coolant temperature is less than 140° F (60° C). This determination will occur one second after the Power/Emergency Stop switch has been pulled on. The lamp and glow plugs will remain energized for the period of time specified by the setting in the JLG Control System. Engine start shall be disabled during this period. On Deutz engines, the glow plugs will continue (post glow) after the engine has started for three times the machine digit setting.

Check Oil Level

1. Make sure machine and engine are level and switch engine OFF before checking oil level.
2. Remove oil dipstick and wipe with clean cloth.
3. Insert dipstick to the stop and remove again.
4. Check oil level. Top oil level as shown in figure below with an approved grade and type of oil outlined in engine manufacturer's operator's manual.
5. Replace dipstick until fully seated.

Replacing Engine Oil

1. Allow engine to warm up. Engine oil should reach approximately 176° F (80° C).
2. Make sure machine and engine are level.
3. Switch off engine.
4. Place oil tray under engine.

CAUTION

HOT ENGINE OIL CAN CAUSE BURNS. AVOID CONTACT WITH HOT OIL WHEN DRAINING.

NOTICE

COLLECT USED OIL IN A CONTAINER SUITABLE FOR DISPOSAL OR RECYCLING. DISPOSE OF USED ENGINE OIL IN ACCORDANCE WITH ENVIRONMENTAL REGULATIONS.

5. Open oil drain valve and drain oil.
6. Close oil drain valve.
7. Pour in new engine oil. Refer to Section 1 for capacity and Figure 3-85., Engine Oil Viscosity.

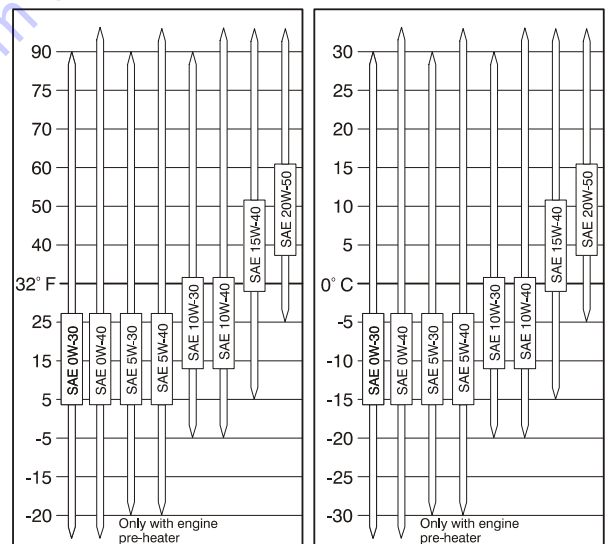
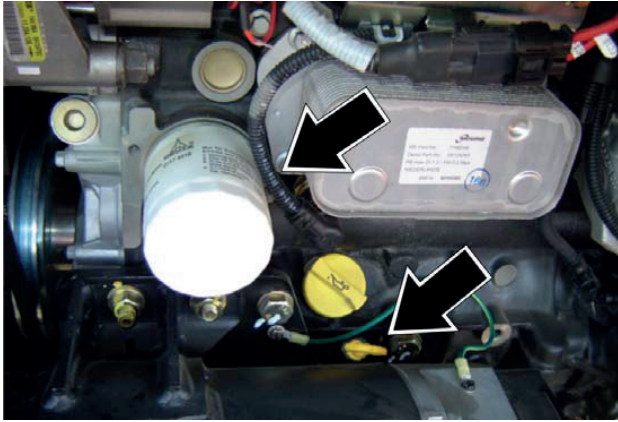

Figure 3-85. Engine Oil Viscosity

Replacing the Oil Filter



MAF01190

Figure 3-86. Location of the Oil Filter

1. Wipe area around filter to clean any dirt from area.
2. Using a suitable oil filter removal tool, loosen lube oil filter element and spin off.

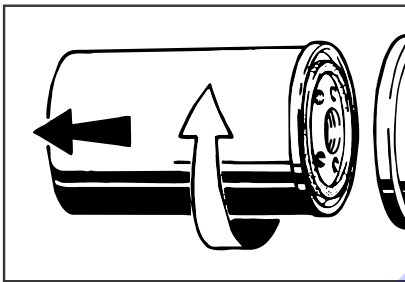

3. Catch any escaping oil.
4. Clean any dirt from filter carrier sealing surface.
5. Lightly coat new oil filter rubber gasket with clean oil.
6. Screw in new filter by hand until gasket is flush.
7. Hand-tighten filter another half-turn.

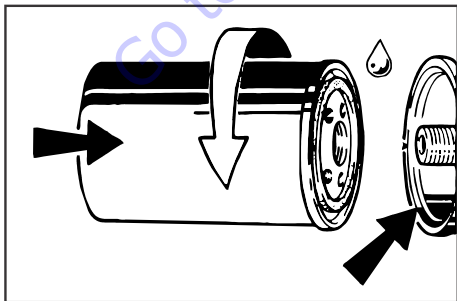

8. Check oil level.
9. Check oil pressure.
10. Check oil filter cartridge for leaks.

Replacing the Fuel Filters

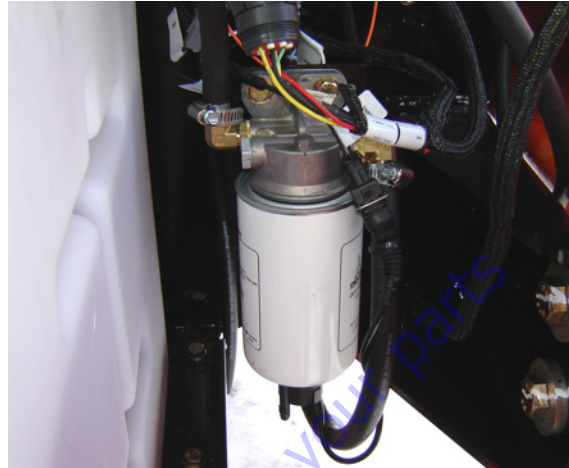

Figure 3-87. Location of the Fuel Pre-Filter



Figure 3-88. Location of the Fuel Filter

⚠ WARNING

FUEL IS FLAMMABLE AND CAN CAUSE DEATH OR SERIOUS INJURY. MAKE SURE NO OPEN FLAMES OR SPARKS ARE IN THE AREA WHEN WORKING ON FUEL SYSTEM. DO NOT SMOKE WHEN WORKING ON THE FUEL SYSTEMS.

1. Wipe area around filter to clean any dirt from area.
2. Fuel supply from the fuel tank may need to be blocked to prevent flow from the fuel tank.
3. Remove fuel filter cartridge.

4. Catch any escaping fuel.

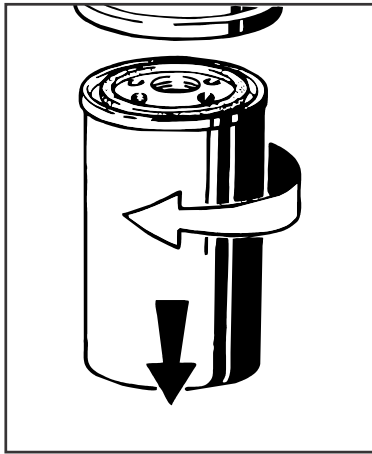

5. Clean dirt from filter carrier sealing surface.
6. Apply light film of oil or diesel fuel to rubber gasket of new filter cartridge.
7. Screw in new filter by hand until gasket is flush. Hand-tighten filter another 3/4 turn.

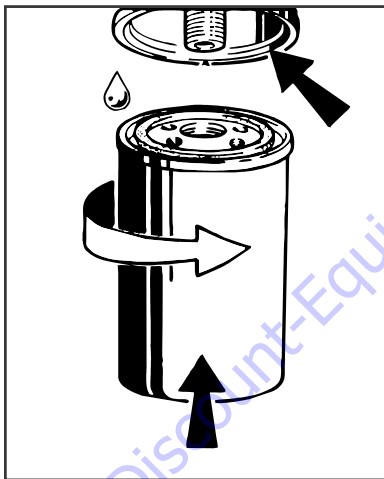

8. Check for leaks.

3.21 DEUTZ ENGINE - D2011

NOTE: Refer to engine manufacturer's manual for detailed operating and maintenance instructions. Limited engine maintenance items are presented here for convenience but detailed engine maintenance items and schedule are included in the engine manufacturer's manual.

Glow Plugs

If the glow plug option is enabled in the JLG Control System, the glow plug and indicator lamp will be energized when the Power/Emergency Stop switch is pulled on if the ambient air temperature is less than 50° F (10° C) and the engine coolant temperature is less than 140° F (60° C). This determination will occur one second after the Power/Emergency Stop switch has been pulled on. The lamp and glow plugs will remain energized for the period of time specified by the setting in the JLG Control System. Engine start shall be disabled during this period. On Deutz engines, the glow plugs will continue (post glow) after the engine has started for three times the machine digit setting.

Check Oil Level

1. Switch the engine off before checking oil level.
2. Make sure the machine and engine are level.
3. Remove the oil dipstick.
4. Wipe the dipstick with non-fibrous, clean cloth.

5. Insert the dipstick to the stop and remove again. Check the oil level, and if necessary, top the oil level up to the MAX mark with an approved grade and type of oil as outlined in the engine manufacturer's operator's manual. Refer to Figure 3-89., Deutz Engine Dipstick.

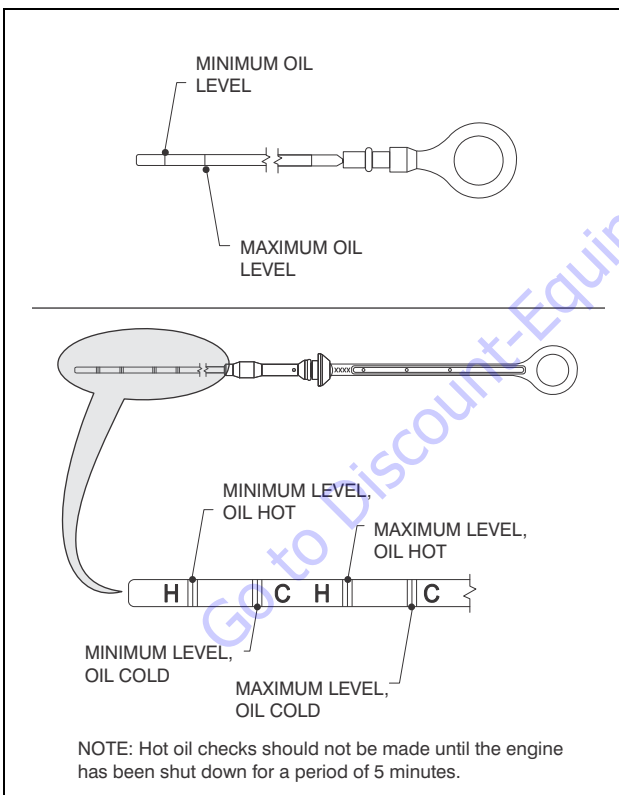

Figure 3-89. Deutz Engine Dipstick

6. Replace the dipstick making sure that it is fully seated in the dipstick tube to seal off the crankcase.

Replacing Engine Oil

1. Allow the engine to warm up. The engine oil should reach approximately 176° F (80° C).
2. Make sure the machine and engine are level.
3. Switch off the engine.
4. Place an oil tray under the engine.

CAUTION

HOT ENGINE OIL CAN CAUSE BURNS, AVOID CONTACT WITH HOT OIL WHEN DRAINING.

NOTICE

COLLECT USED OIL IN A CONTAINER SUITABLE FOR DISPOSAL OR RECYCLING. DISPOSE OF USED ENGINE OIL IN ACCORDANCE WITH ENVIRONMENTAL REGULATIONS.



5. Open the oil drain valve.
6. Drain the oil.
7. Close the oil drain valve.

8. Pour in new engine oil. Refer to Section 1 for capacity and refer to Figure 3-90., Engine Oil Viscosity for the proper grade.

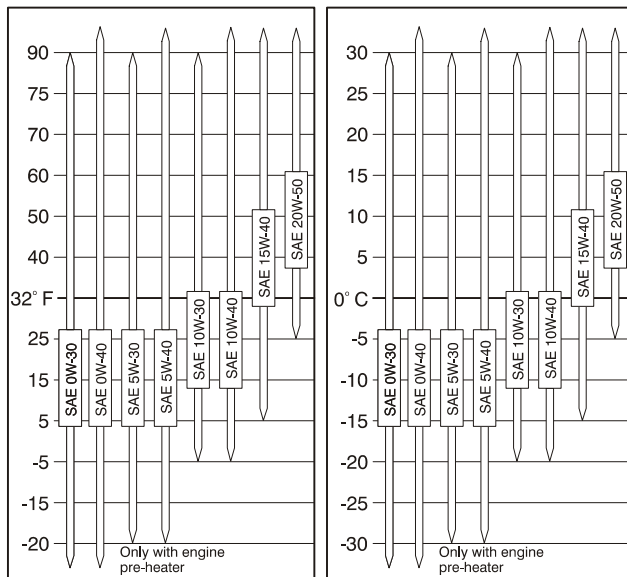
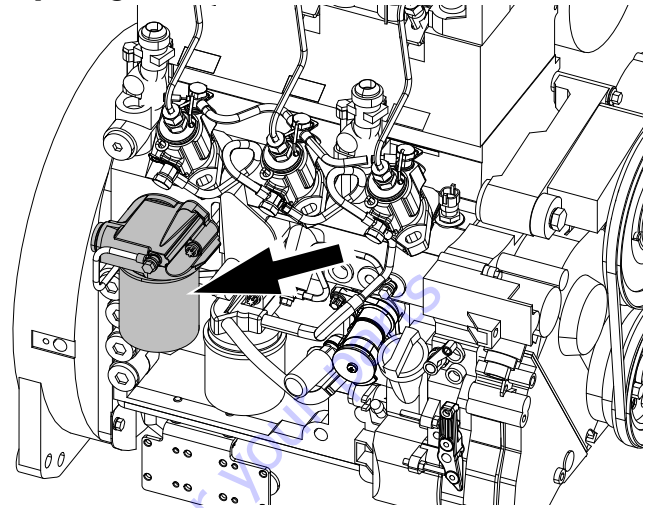
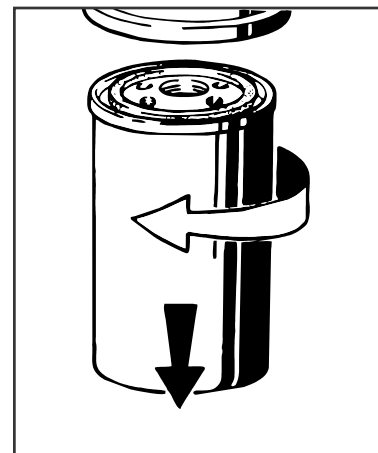

Figure 3-90. Engine Oil Viscosity

Replacing the Oil Filter



1. Wipe the area around the filter to clean any dirt from the area.
2. Using a suitable oil filter removal tool, loosen lube oil filter element and spin off.



3. Catch any escaping oil.
4. Clean any dirt from filter carrier sealing surface.

5. Lightly coat new oil filter rubber gasket with clean oil.

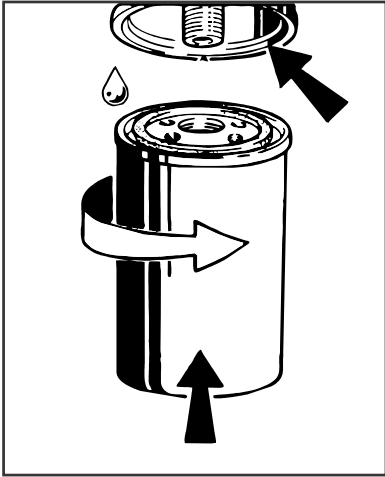

6. Manually screw in the new filter until the gasket is flush.

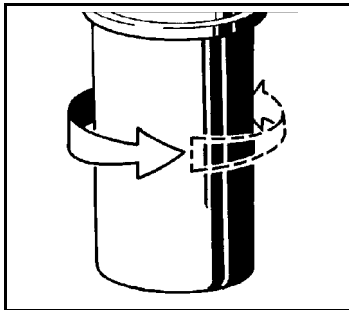

7. Hand-tighten filter another half-turn.
8. Check oil level.
9. Check oil pressure.
10. Check the oil filter cartridge and make sure there are no leaks.

Replacing the Fuel Filter

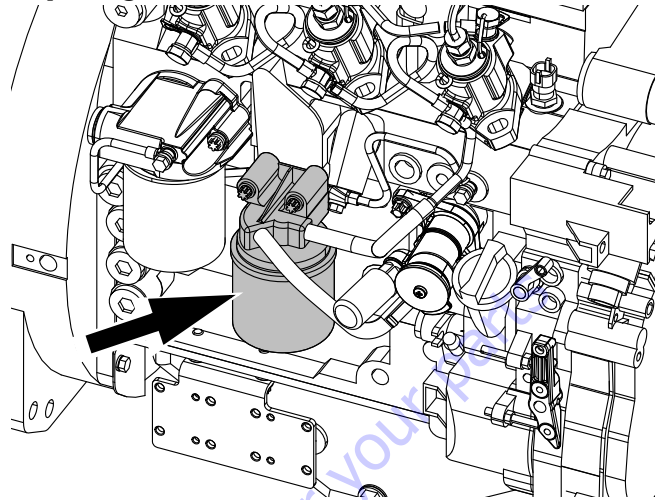

⚠ WARNING

FUEL IS FLAMMABLE AND CAN CAUSE DEATH OR SERIOUS INJURY. MAKE SURE NO OPEN FLAMES OR SPARKS ARE IN THE AREA WHEN WORKING ON FUEL SYSTEM. DO NOT SMOKE WHEN WORKING ON THE FUEL SYSTEMS.

1. Wipe the area around the filter to clean any dirt from the area.
2. Fuel supply from the fuel tank may need to be blocked to prevent fuel flow from the tank.
3. Undo the fuel filter cartridge and spin off.
4. Catch any escaping fuel.
5. Clean any dirt from the filter carrier sealing surface.
6. Apply a light film of oil or diesel fuel to the rubber gasket of the new filter cartridge.
7. Manually screw in the new filter until the gasket is flush.
8. Tighten the fuel filter cartridge with a final half-turn.
9. Check for leaks.

3.22 DEUTZ EMR 2

The EMR2 consists of the sensors, the control unit and the actuator. Engine-side controls as well as the JLG Control System are connected by means of separate cable harnesses to the EMR control unit.

The sensors attached to the engine provide the electronics in the control unit with all the relevant physical parameters. In accordance with the information of the current condition of the engine and the preconditions (throttle position etc.), the EMR2 controls an actuator that operates the control rod of the injection pump and thus doses the fuel quantity in accordance with the performance requirements.

The exact position of the regulating rod is reported back and, if necessary, is corrected, by means of the control rod travel sensor, situated together with the rotation magnets in a housing of the actuator.

The EMR2 is equipped with safety devices and measures in the hardware and software in order to ensure emergency running (Limp home) functions.

In order to switch the engine off, the EMR2 is switched in a de-energized fashion over the ignition switch. A strong spring in the actuator presses the control rod in the de-energized condition into the zero position. As a redundancy measure, an additional solenoid serves for switching off and this, independently of the actuator, also moves the control rod in the de-energized condition into the zero position.

After the programming, that is carried out over the ISO9141 interface, the EMR2 possesses a motor-specific data set and this is then fixedly assigned to the engine. Included in this are the various application cases as well as the customer's wishes regarding a particular scope of function.

Each EMR2 module is matched by serial number to the engine. Modules cannot be swapped between engines.

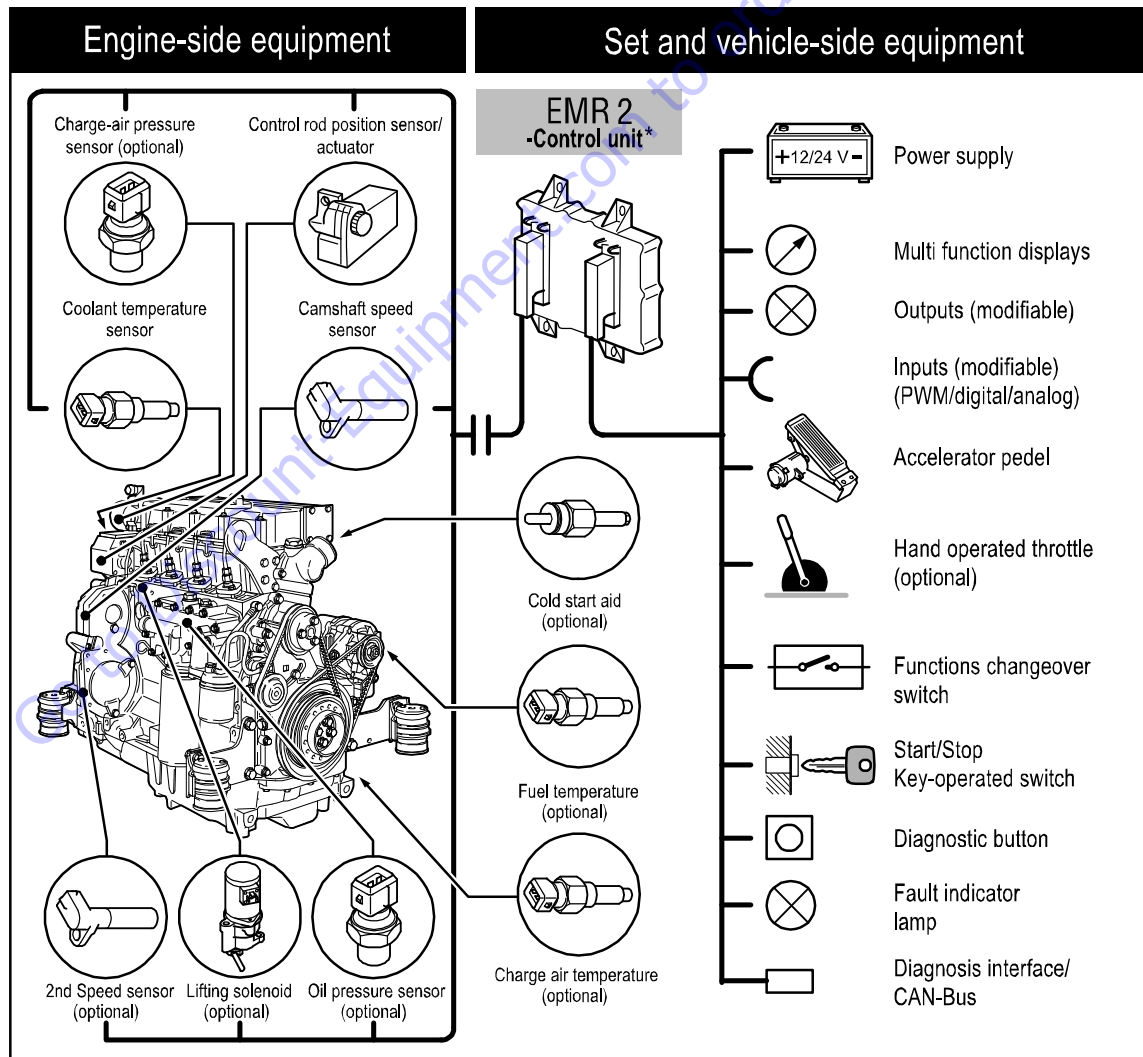

Figure 3-91. EMR 2 Engine Side Equipment

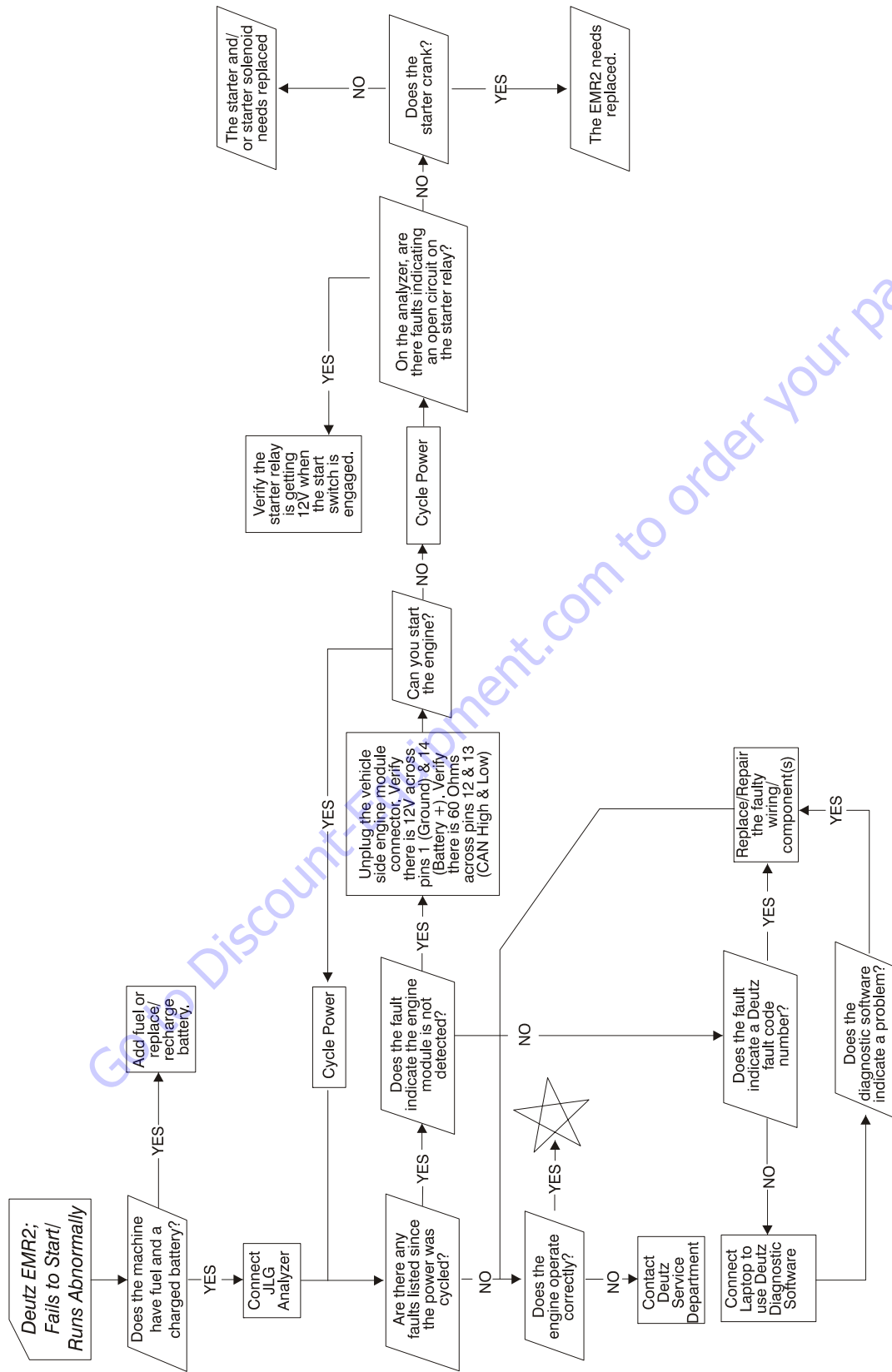

Figure 3-92. Deutz EMR 2 Troubleshooting Flow Chart

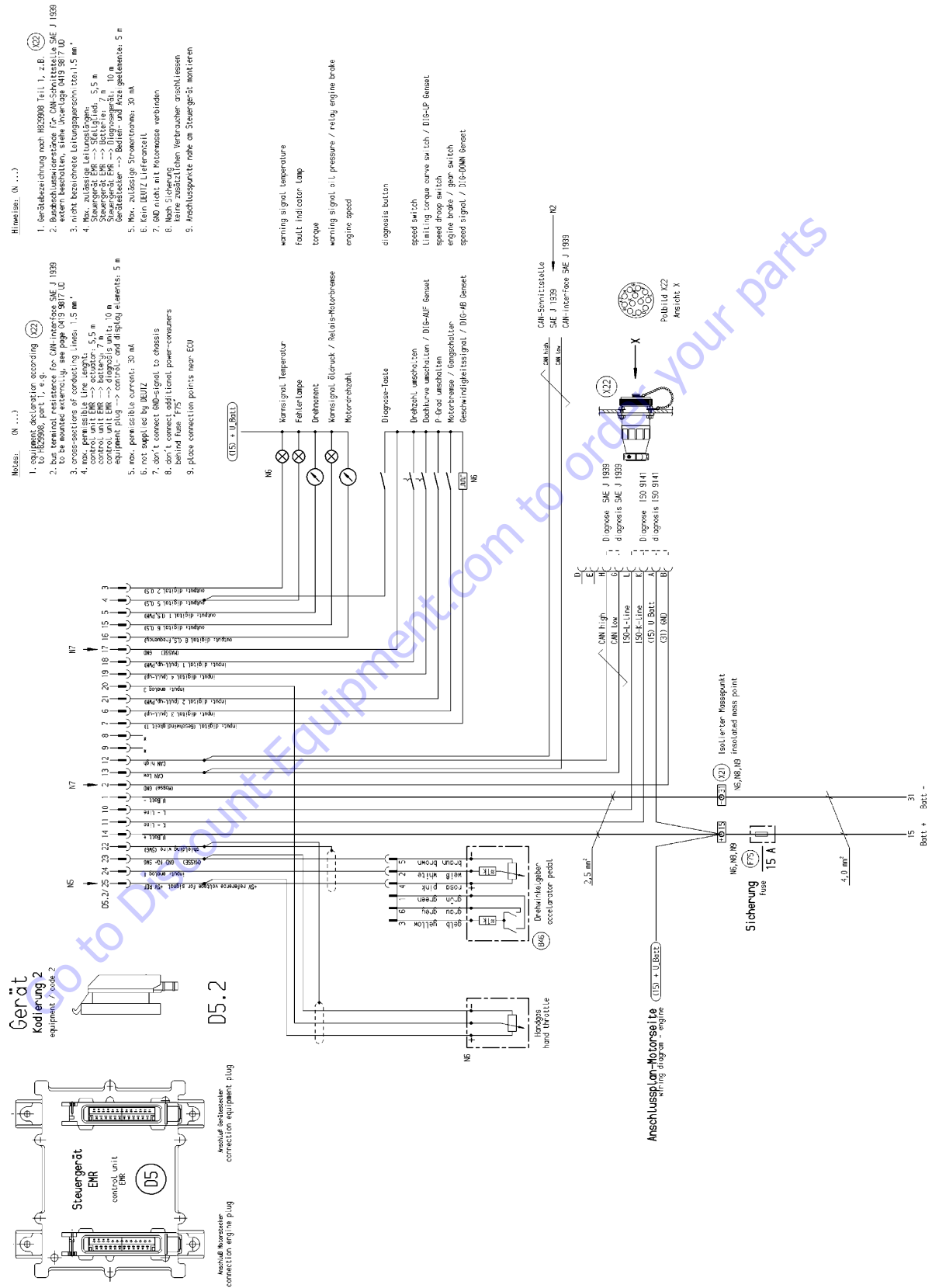

Figure 3-93. Deutz EMR 2 Vehicle Side Connection Diagram

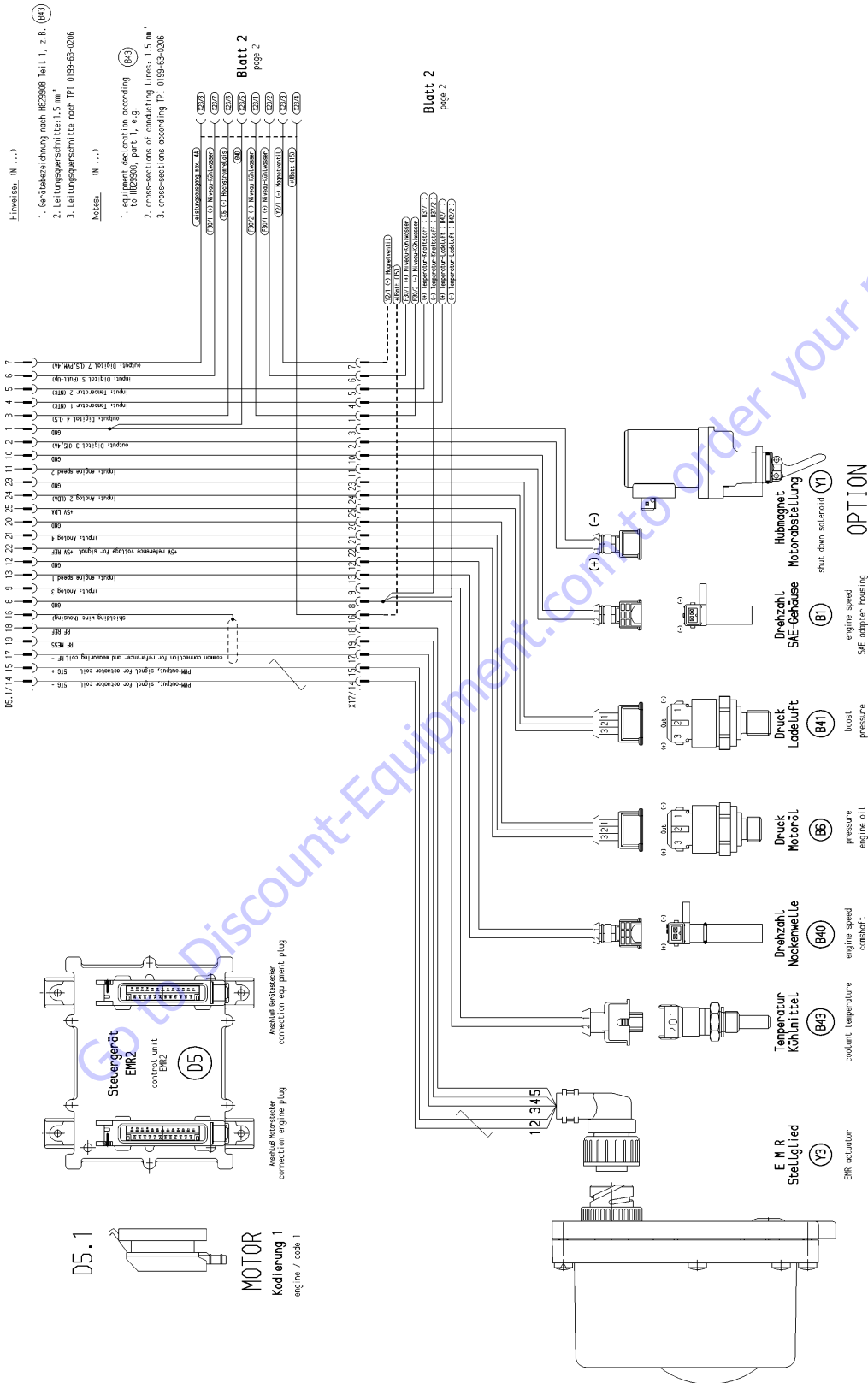

Figure 3-94. Deutz EMR 2 Engine Side Connection Diagram - Sheet 1 of 2

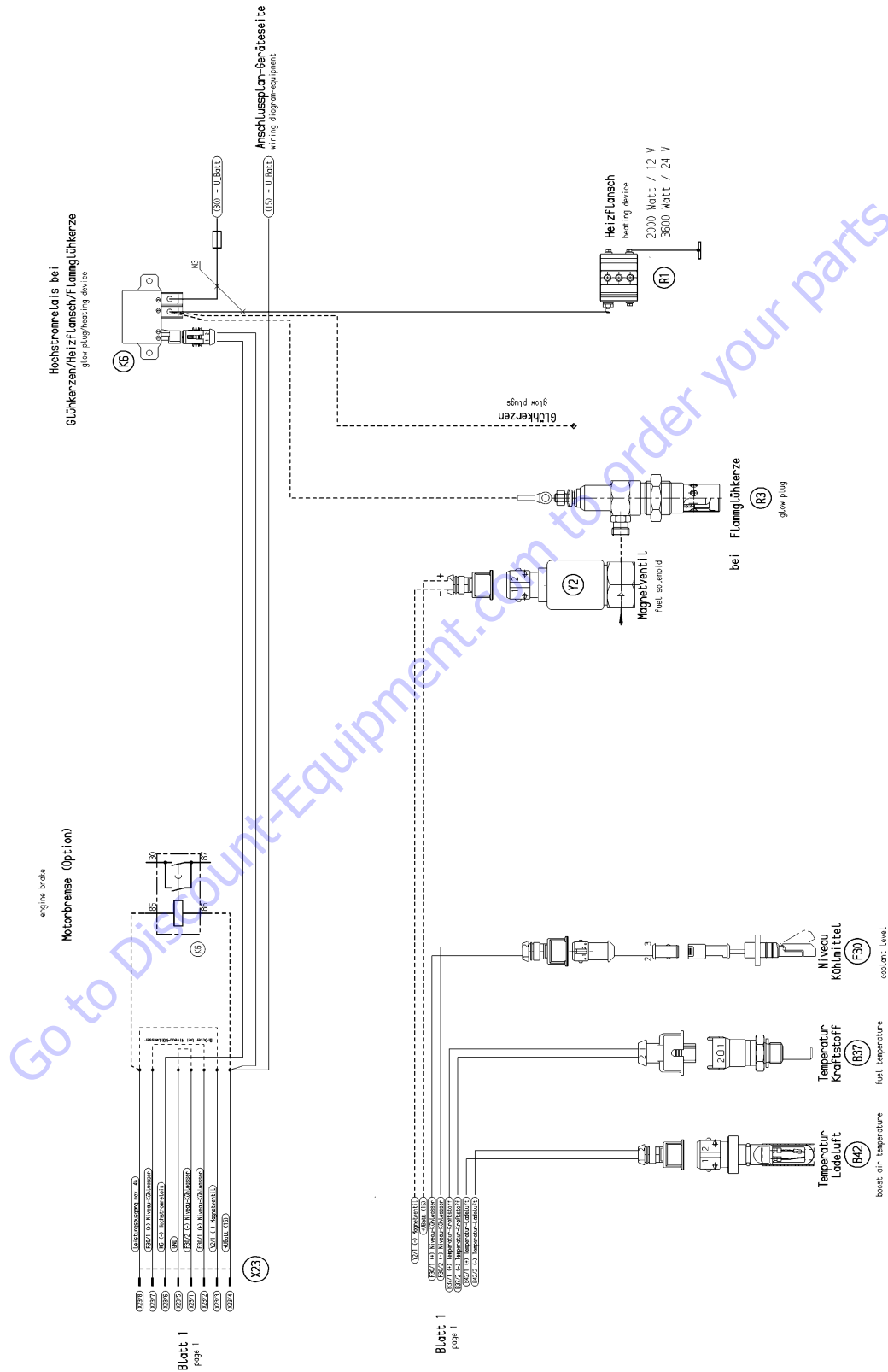
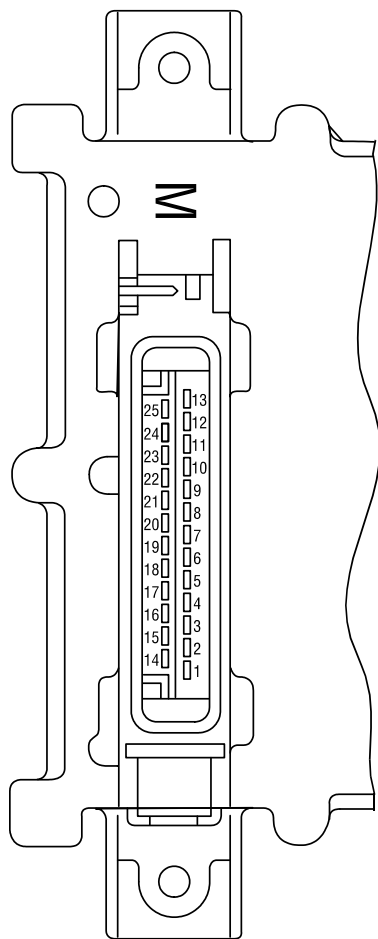

Figure 3-95. Deutz EMR 2 Engine Side Connection Diagram - Sheet 2 of 2



Pin No.	Designation	Description
1	Reserve	Reserve
2	Output: digital 3	Digital output for solenoid ¹⁾
3	Output: digital 4	For heating flange (optional)/ glow plug (optional)
4	Input (optional) Temp 1	Fuel temperature ²⁾
5	Input (optional) Temp 2	Charge air temperature
6	Input (optional) DigIn 5	Coolant level / oil level
7	Output: PWM2/digital 6	
8	GND	Reference potential for analog signal at pin 9
9	Input: analog 7	Analog input for Coolant temperature sensor (NTC)
10	GND	Reference potential for analog signal at pin 11
11	Multi-function input: speed 2/DigIn 2	Digital input second engine speed (crankshaft) (optional) and speed signal (optional)
12	GND	Reference potential for analog signal at pin 13
13	Input: speed 1	Digital input first engine speed (camshaft)
14	STG -	PWM output, signal for actuator coil
15	STG +	PWM output, signal for actuator coil
16	Screen	Screening regulating rod travel sensor (for lines 17, 18, 19)
17	RF -	General connection for reference and measuring coil
18	RF REF	Analog input, reference signal of the reference coil
19	RF MESS	Analog input, measuring signal of the measuring coil
20	GND	Reference potential for signal at pin 21
21	Input: analog 4/digital 9	Analog input 4 (sensor signal oil pressure sensor) or digital input 9
22	+5 V REF	+5 V Reference voltage for signal at pin 21 (max. 15 mA)
23	GND	Reference potential for signal at pin 24
24	Input: analog 2/digital 7	Analog input 2 (sensor signal charge air) or digital input 7
25	+5 V LDA	+5 V Reference potential for signal at pin 24 (max. 15 mA)

1) For continuous power: < 4 A

2) Corresponds to special function "fuel temperature compensation at the EMR (0211 2571)

Figure 3-96. EMR 2 Engine Plug Pin Identification

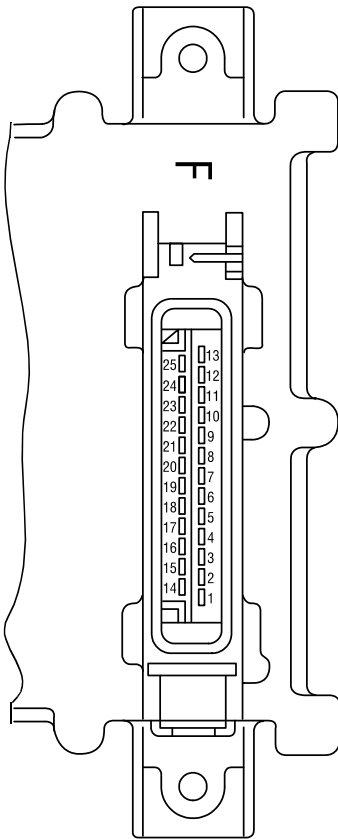

Pin-No.	Designation	Description
1	U Batt -	Negative pole at battery (clamp 31)
2	GND	Reference potential for signal
3	Output: digital 2	PWM or digital output, various functions
4	Input / output: DigInOut	Fault lamp and diagnostic button
5	Output: PWM 1/Dig 1	PWM or digital output, various functions
6	Multi-function input: DigIn 3	Genset applications/gear shift/motor brake
7	Input: digital 10/velocity	Speed signal (tacho input)
8	NC	Not occupied
9	NC	Not occupied
10	L-line	Serial ISO 9141 interface
11	K-line	Serial ISO 9141 interface
12	CAN high	Interface for CAN-Bus
13	CAN low	Interface for CAN-Bus
14	U Batt +	Positive pole for battery (clamp 15)
15	Output: digital 5	Digital output, various functions
16	Output: digital 7/Frequency	Frequency, PWM or digital output, various functions
17	Ground	Reference potential for signal at pins 18, 19 and 21
18	Input: digital 1 / PWM 1	PWM 1 or digital input 1, various functions
19	Multi-function input: DigIn 4	Performance curve switching/genset applications
20	Multi-function input: digital 8 / analog 3	Hand hand throttle/genset applications, Digital (8) or analog input (3)
21	Input: digital 2 / PWM 2	PWM 2 or digital input 2, various functions
22	Screen	Screening (e.g. for lines hand throttle or PWG)
23	GND	Reference potential for signal at pin 24
24	Input: analog 1 / digital 6	Analog input 1 (pedal value sensor, PWG) or digital input 6
25	+5 V REF	+5 V Reference voltage for signal at pin 24

Figure 3-97. EMR 2 Vehicle Plug Pin Identification

SECTION 3 - CHASSIS & TURNTABLE

Fault group	Fault no. (in SERDIA)	Fault locality/ Fault description	SPN	FMI	Cause	Remarks	Help
Zero error display	-	No faults	524287	31	No active faults present		
Revolutions / speed acquisition	01	Speed sensor 1	190	8	Sensor failure. Distance from gear too far. Additional fault impulses. Cable joint interrupted.	Governor in emergency operation (if sensor 2 available). Emergency switch-off (if sensor 2 not available or failed). Governor in emergency operation (with sensor 1) Emergency switch-off (if sensor 1 not available or failed).	Check distance. Check cable connection. Check sensor and replace if required.
	03	Speed sensor	84	8	Tacho failed. Additional fault impulses. Cable connection interrupted.	Governor in emergency operation.	Check cable connection and Tacho. Replace if required.
	04	Excess speed switch-off	190	0	Speed was/is in excess of limit.e. Check PID setting. Check rods. Check actuator and replace if required. Check cable to actuator (impulse on incorrect speed). Check No. of teeth. For vehicles check for possible thrust mode.	Engine stop.	Check parameter (21). Check speed settings.
	07	Charge air pressure	102	2			
Sensors	08	Oil pressure	100	2			
	09	Coolant temperature	110	2	Fault at corresponding sensor entry (e.g. short circuit or cable break).	With failure of the sensor the associated monitoring function is de-activated.	Check sensor cable. Check sensor and replace if required. Check fault limits for sensor.
	10	Charge air temperature	105	2			
	11	Fuel temperature	174	2			

NOTE: SID is equal to 512. To get SPN #, add 512 + number. For example, SID 254 would be 512+254 or an SPN of 766.

Figure 3-98. EMR2 Fault Codes - Sheet 1 of 5

Fault group	Fault no. (in SERDIA)	Fault locality/ Fault description	SPN	FMI	Cause	Remarks	Help
Functional fault warning	30	Oil pressure warning	100	1	Oil pressure below speed-dependent warning line characteristic	Fault message (disappears when oil pressure is again above recovery limit). After a delay time - fill limitation.	Check engine (oil level, oil pump). Check oil pressure sensor and cable. Check oil pressure warning line characteristic.
	31	Coolant temperature warning	110	0	Coolant temperature has exceeded warning level.	Fault message (disappears when coolant temperature again drops below recovery level). After a delay time - fill limitation.	Check coolant. Check coolant temperature sensor and cable.
	32	Charge air temperature warning	105	0	Charge air temperature has exceeded warning level.	Fault message (disappears when charge air temperature gain drops below recovery level). After a delay time - fill limitation.	Check charge air. Check charge air-temperature sensor and cable.
	34	Coolant level warning	111	1	Switch input "Low coolant level" is active.	Fault message.	Check coolant level. Check coolant level sensor and cable.
	35	Speed warning (with thrust mode operation).	SID 190	14	revolutions was/is above (top) revolution speed limit. "Thrust mode" function is active.		Check parameters. Check speed settings.
						Check PID setting. Check rods. Check actuator and replace if required. Check cable to actuator. Check speed sensor (impulses on incorrect speed). Check No. of teeth. For vehicles check for possible thrust mode.	
	36	Fuel temperature warning	174	0	Fuel-temperature has exceeded warning level.	Fault message (disappears when fuel temperature again drops below recovery level)	Check fuel. Check fuel temperature sensor and cable.

NOTE: SID is equal to 512. To get SPN #, add 512 + number. For example, SID 254 would be 512+254 or an SPN of 766.

Figure 3-99. EMR2 Fault Codes - Sheet 2 of 5

Fault group	Fault no. (in SERDIA)	Fault locality/ Fault description	SPN	FMI	Cause	Remarks	Help
Functional fault, switch-off	42	Charge air temperature switch-off	105	0	Charge air temperature has exceeded switch-off limit.	Emergency stop	Check charge air. Check charge air-temperature sensor and cable. Check switch-off limit.
	44	Coolant level switch-off	111	1	Switch input "Low coolant level" is active.	Emergency stop. Start lock.	Check coolant level. Check coolant level sensor and cable.
Actuator	50	Feedback	SID 24	12	Actuator not connected. Fault in actuator confirmation.	Emergency switch-off. Actuator cannot be operated.	Check actuator, replace if required. Check cable, check fault limits for "Confirmation".
	52	Reference feedback	SID 24	13			Check actuator, replace if required. Check cable, check fault limits for "Rifeness confirmation".
	53	Control travel difference	SID 23	7	Injection pump/actuator jammed or not connected. Difference between nominal/actual control travel is > 10 % of the overall control path.	Fault message (disappears when difference is < 10 %).	Check actuator/actuator rods / injection pump. replace if required. Check actuator cable.
	59	Auto calibration BOSCH-EDC pumps faulty operation	SID 23	13	No automatic actuator equalization possible. Incorrect input of the actuator reference values.	Engine stop / start lock. Governor cannot be taken into use. EDC actuator calibration required.	Check actuator and replaced if required. Check feedback cable. Check fault limits and reference values of the feedback. Program the fault limits for feedback, save values. Switch ignition off and on again. Check again. If faulty, inform DEUTZ-Service and carry out automatic equalization again. Set fault limits again.

NOTE: SID is equal to 512. To get SPN #, add 512 + number. For example, SID 254 would be 512+254 or an SPN of 766.

Figure 3-100. EMR2 Fault Codes - Sheet 3 of 5

Fault group	Fault no. (in SERDIA)	Fault locality/ Fault description	SPN	FMI	Cause	Remarks	Help
Hardware inputs/outputs	60	Digital output 3 (Switch-off solenoid, pin M 2)	SID 51	2	Fault (short circuit / cable break) at digital output.	Driver level is switched off.	Check cable of digital output (cable break or short circuit).
	62	Digital output 6, pin M 7	SID 60	2		Fault message.	
	63	Excess voltage switch-off solenoid	SID 51	6			
	67	Error Hand Setp1	91	11			
	68	Error CAN Setp1	898	2			
	Communication	70	CAN-Bus controller	SID 231	12	CAN-controller for CAN-bus is faulty. Fault removal despite re-initialising continuously not possible	Application-dependent.
71		CAN interface SAE J 1939	SID 231	9	Overflow in input buffer or a transmission cannot be placed on the bus.		
74		Cable break, short circuit or bus-error	SID 231	14		Check CAN connection, cable connection. Check sensor and replace if required.	
Memory	76	Parameter programming (write EEPROM)	SID 253	12	Fault in parameter programming in the governor fixed value memory.	Emergency switch-off. engine cannot be started.	Switch ignition off and on again. Check again. If faulty inform DEUTZ Service
	77	Cyclic program test	SID 240	12	Constant monitoring of program memory shows error (so-called "Flash-test").		
	78	Cyclic RAM test	SID 254	2	Constant monitoring of working memory shows error.		

NOTE: SID is equal to 512. To get SPN #, add 512 + number. For example, SID 254 would be 512+254 or an SPN of 766.

Figure 3-101. EMR2 Fault Codes - Sheet 4 of 5

Fault group	Fault no. (in SERDIA)	Fault locality/ Fault description	SPN	FMI	Cause	Remarks	Help
Control unit hardware	80	Power supply (Actuator)	SID 254	2	Power supply for actuator not in the permissible range.	Fault message (disappears when power again in the normal range).	Switch ignition off and on again. Check again. If faulty inform DEUTZ Service.
	83	Reference voltage 1	SID 254	2	Reference voltage for actuator not in the permissible range.	Fault message (disappears when power again in the normal range). Auxiliary value 5 V	Check voltage supply. Switch ignition off and on again. Check again. If faulty inform DEUTZ Service.
	84	Reference voltage 2	SID 254	2			
	85	Reference voltage 4	SID 254	2			
	86	Internal temperature	171	12	Internal temperature for control unit not in permissible range.	Fault message (disappears when power again in the normal range).	Switch ignition off and on again. Check again. If faulty inform DEUTZ Service.
87	Atmospheric pressure	108	12	Atmospheric pressure not in permissible range.	Fault message (disappears when power again in normal range). Atmospheric pressure monitoring function de-activated.	Switch ignition off and on again. Check again. If faulty inform DEUTZ Service.	
Program logic	90	Parameter fault (EEPROM retrieval or checksum faulty).	SID 253	2	No data found or checksum of data is faulty (note: fault only occurs during setting of parameter / saving or reset).	Engine cannot be started.	Check data for correct settings. Save parameters. Switch ignition off and on again. Check again. If faulty inform DEUTZ Service.
	93	Stack overflow	SID 240	2	Internal calculation fault (so-called "Stack overflow" fault).	Emergency switch-off. Engine cannot be started.	Note parameters (3897 and 3898). Switch ignition off and on again. Check again. If faulty inform DEUTZ Service.
	94	Internal fault	SID 254	2			

NOTE: SID is equal to 512. To get SPN #, add 512 + number. For example, SID 254 would be 512+254 or an SPN of 766.

Figure 3-102. EMR2 Fault Codes - Sheet 5 of 5

3.23 GM ENGINE GENERAL MAINTENANCE

Maintenance of the Drive Belt

The serpentine drive belt utilizes a spring loaded tensioner which keeps the belt properly adjusted. The drive belt is an integral part of the cooling and charging systems and should be inspected frequently.

When inspecting the belts check for:

- Cracks or breaks
- Chunking of the belt
- Splits
- Material hanging from the belt
- Glazing and hardening
- Damaged or improperly aligned pulleys
- Improperly performing tensioner

Check the belt tensioner by pressing down on the midway point of the longest stretch between pulleys. The belt should not depress beyond 1/2 in. (13 mm). If the depression is more than allowable adjust the tension.

NOTICE

THE ENGINE MANUFACTURER DOES NOT RECOMMEND THE USE OF "BELT DRESSING" OR "ANTI SLIPPING AGENTS" ON THE DRIVE BELT.

Engine Electrical System Maintenance

The engine electrical system incorporates computers and microprocessors to control the engine ignition, fuel control, and emissions. Due to the sensitivity of the computers to good electrical connections periodic inspection of the electrical wiring is necessary. When inspecting the electrical system use the following:

- Check and clean the battery terminal connections and insure the connections are tight.
- Check the battery for any cracks or damage to the case.
- Check the Positive and Negative battery cables for any corrosion build up, rubbing or chafing, check connection on the chassis to insure they are tight.
- Check the entire engine wire harness for rubbing chafing, cuts or damaged connections, repair if necessary.
- Check all wire harness connectors to insure they are fully seated and locked.

- Check ignition coil and spark plug cables for hardening, cracking, chafing, separation, split boot covers and proper fit.
- Replace spark plugs at the proper intervals as prescribed in the engine manufacturer's manual.
- Check to make sure all electrical components are fitted securely.
- Check the ground and platform control stations to insure all warning indicator lights are functioning.

Checking/Filling Engine Oil Level

NOTICE

AN OVERFILLED CRANKCASE (OIL LEVEL OVER THE SPECIFIED FULL MARK) CAN CAUSE AN OIL LEAK, A FLUCTUATION OR DROP IN THE OIL PRESSURE, AND ROCKER ARM "CLATTER" IN THE ENGINE.

NOTICE

CARE MUST BE TAKEN WHEN CHECKING THE ENGINE OIL LEVEL. OIL LEVEL MUST BE MAINTAINED BETWEEN THE "ADD" MARK AND "FULL" MARK ON THE DIPSTICK.

To ensure that you are not getting a false reading, make sure the following steps are taken to before check the oil level.

1. Stop the engine if in use.
2. Allow sufficient time (approximately 5 minutes) for the oil to drain back into the oil pan.
3. Remove the dipstick. Wipe with a clean cloth or paper towel and reinstall. Push the dipstick all the way into the dipstick tube.
4. Remove the dipstick and note the oil level.
5. Oil level must be between the "FULL" and "ADD" marks.

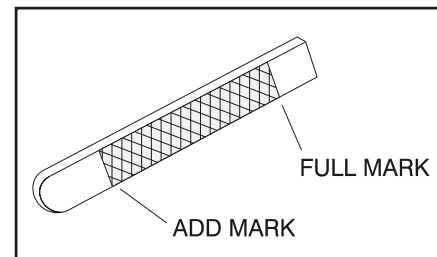

Figure 3-103. Engine Oil Dip Stick

6. If the oil level is below the "ADD" mark, proceed to Step 7 and 8 and reinstall the dipstick into the dipstick tube.
7. Remove the oil filter cap from the valve rocker arm cover.
8. Add the required amount of oil to bring the level up to but not over "FULL" mark on the dipstick.
9. Reinstall the oil fill cap to the valve rocker cover and wipe away any excess oil.

Changing the Engine Oil

NOTICE

WHEN CHANGING THE OIL, ALWAYS CHANGE THE OIL FILTER. CHANGE OIL WHEN THE ENGINE IS WARM FROM OPERATION AS THE OILS WILL FLOW FREELY AND CARRY AWAY MORE IMPURITIES.

To change the oil use the following steps:

1. Start the engine and run until it reaches normal operating temperature.
2. Stop the engine.
3. Remove the drain plug and allow the oil to drain.
4. Remove and discard the oil filter and its sealing ring.
5. Coat the sealing ring on the filter with clean engine oil and wipe the sealing surface on the filter mounting surface to remove any dust, dirt and debris. Tighten the filter securely (follow the filter manufacturers instructions). Do not over tighten.
6. Check the sealing ring on drain plug for any damage, replace if necessary, wipe the plug with a clean rag, and wipe the sealing surface on the pan and reinstall the pan plug. Do not over tighten.
7. Fill the crankcase with oil.
8. Start the engine and check for oil leaks.
9. Stop the engine and check the oil level to insure the oil level is at "FULL".
10. Dispose of the oil and filter in a safe manner.

Coolant Fill Procedure - Dual Fuel Engine

NOTICE

DAMAGE TO THE ENGINE COULD OCCUR IF NOT PROPERLY FILLED WITH COOLANT. LPG FUELED ENGINES ARE MOST PRONE TO CREATING AN AIR LOCK DURING A COOLANT FILL OPERATION DUE TO THE ELECTRONIC PRESSURE REGULATOR (EPR) BEING THE HIGHEST POINT IN THE COOLING SYSTEM. AN EPR THAT APPEARS TO HAVE FROST FORMING ON IT IS A SIGN THAT THE ENGINE COOLING SYSTEM CONTAINS AIR. THE APPEARANCE AND TEMPERATURE OF THE EPR SHOULD BE MONITORED DURING THE COOLANT FILL OPERATION. A WARM EPR IS AN INDICATION THAT THE COOLING SYSTEM IS PROPERLY FILLED AND FUNCTIONING.

CAUTION

MAKE SURE ENGINE IS COOL BEFORE PERFORMING ANY MAINTENANCE WORK.

1. Loosen the worm gear clamp on the coolant line running into the EPR as shown below and remove the hose from the EPR. Place a rag under the hose to prevent coolant from running onto the engine/machine.



2. Remove the radiator cap. Fill the radiator with coolant until coolant starts to appear from the previously removed hose at the EPR. Reinstall the hose back onto the EPR and continue to fill radiator with coolant.



3. With the radiator cap still removed, start the engine and run until the thermostat opens. The thermostat opens at 170° F (77° C), which can be checked using the JLG handheld analyzer.

NOTICE

WHILE ENGINE IS RUNNING, AIR AND/OR STEAM MAY BE PRESENT COMING FROM THE RADIATOR. THIS IS NORMAL.

- After running the engine for 5 minutes after it has reached operating temperature, shut the engine off and continue to step 5.

⚠ CAUTION

WITH THE ENGINE RUNNING OR WHEN SHUTTING OFF THE ENGINE, SOME HEATED COOLANT MAY SPILL OUT DUE TO AIR "BURPING" OUT OF THE SYSTEM WITH THE RADIATOR CAP OFF.

- Next, verify that the 2 coolant hoses on the EPR are warm. If they are not warm repeat step 3 and 4, otherwise continue to step 6.

NOTICE

A PROPERLY PURGED COOLING SYSTEM WILL YIELD A WARM UPPER RADIATOR HOSE AND A WARM EPR HOSE. IF THE UPPER RADIATOR HOSE AND/OR EPR HOSE ARE NOT WARM TO THE TOUCH AFTER THE ENGINE HAS RUN FOR 5-8 MINUTES AFTER REACHING OPERATING TEMPERATURE, THE SYSTEM MAY STILL CONTAIN AIR. IT MAY BE NECESSARY TO REPEAT THE ABOVE STEPS.

- Fill radiator with coolant as needed and install the radiator cap. Next, remove the cap off the coolant recovery bottle and fill just below the HOT FULL line and reinstall the caps.



3.24 GM ENGINE DUAL FUEL SYSTEM

NOTE: +20° F (-6.6° C) is the low temperature limit for LP gas, for both starting and operation. This applies to all LP gas powered engines.

The Dual Fuel system allows the operator to operate the vehicle on either gasoline or LPG by positioning a selector switch in the operator's platform. When the operator places the selector switch in the gasoline mode the gasoline fuel pump is energized. While in the gasoline mode the LPG fuel lock-off is isolated and will not energize. In addition the gasoline injector circuit is enabled and injector pulses are provided to each injector and the ECM calibration for gasoline is also enabled. When the operator selects the LPG mode the Low Pressure LPG lock-off is energized and fuel from the LPG tank flows to the Electronic Pressure Regulator (EPR). The EPR receives an electronic signal to position the secondary lever for the start or run positions and when the engine begins to crank the mixer air valve will rise and fuel will begin flowing to engine. During this mode the gasoline fuel pump is isolated and will not be activated. The primary components of the gasoline dual fuel system are the gasoline tank, electric fuel pump and filter, fuel supply line, injector rail and injectors and the fuel pressure regulator. The primary components of the LPG dual fuel system are the LPG fuel tank, in-fuel filter, LPG Low Pressure lock-off, Electronic Pressure Regulator (EPR) and the fuel mixer module. The LPG fuel system operates at pressures which range from 14.0 in. (355.60 mm) of water column up to 312 psi (21.5 bar).

Components which are shared by both systems include the Electronic Throttle Control and the ECM. The ECM contains a dual calibration; one controls the gasoline fuel system during gasoline operation and one controls the LPG fuel system during LPG operation.

Fuel Filter

Propane fuel like all other motor fuels is subject to contamination from outside sources. Refueling of the equipment's tank and removal of the tank from the equipment can inadvertently introduce dirt and other foreign matter into the fuel system. It is therefore necessary to filter the fuel prior to entering the fuel system components downstream of the tank. An inline fuel filter has been installed in the fuel system to remove the dirt and foreign matter from the fuel. The inline filter is replaceable as a unit only. Maintenance of the filter is critical to proper operation of the fuel system and should be replaced as Section 1. In severe operating condition more frequent replacement of the filter may be necessary.

Electric Lock Off

The Electric Lock Off device is an integrated assembly. When energized the solenoid opens the valve and allows the Propane fuel to flow through the device. The valve opens during cranking and run cycles of the engine. The lock off supply voltage is controlled by the engine control module (ECM).

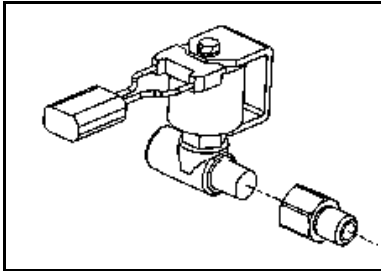
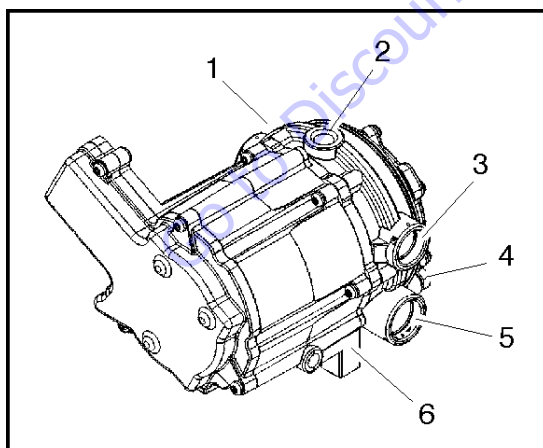

Figure 3-104. Electric Fuel Lock Off

EPR Assembly

The EPR assembly is a combination Low Pressure Regulator and a Voice Coil Assembly. The Voice coil is an electronic actuator which is controlled by an internal microprocessor. The microprocessor provides output data to the ECM and receives input data over a CAN BUS connection. The internal microprocessor receives electrical signals from the Fuel Pressure Sensor FPS and the Fuel Temperature Pressure FTP and communicates the data to the ECM. The ECM uses the FPS and FTP data to calculate the location of the secondary lever in the LPR and sends that data back to the EPR via the CAN BUS. The internal microprocessor in the EPR will then output a signal, which causes the voice coil to move and position the secondary lever to the correct location.



- | | |
|-------------------------------|------------------------|
| 1. Pressure Regulator Section | 4. Primary Test Port |
| 2. Fuel Inlet | 5. Secondary Test Port |
| 3. Coolant Passage | 6. Voice Coil Section |

Figure 3-105. EPR Assembly

Low Pressure Regulator (LPR)

The LPR is a combination vaporizer, pressure regulating device. The LPR is a negative pressure, two stage regulator that is normally closed when the engine is not running. When the engine is cranking or running, a partial vacuum is created in the fuel line which connects the regulator to the mixer. This partial vacuum opens the regulator permitting fuel to flow to the mixer.

Propane fuel enters the primary port of the LPR and passes through the primary jet and into the primary/ exchanger chamber. As the propane passes through the heat exchanger the fuel expands and creates pressure inside the chamber. The pressure rises as the fuel expands when the pressure rises above 1.5 psi (10.34 kpa), sufficient pressure is exerted on the primary diaphragm to cause the diaphragm plate to pivot and press against the primary valve pin thus closing off the flow of fuel. This action causes the flow of fuel into the regulator to be regulated.

When the engine is cranking, sufficient vacuum will be introduced into the secondary chamber from the mixer drawing the secondary diaphragm down onto the spring loaded lever and opening the secondary valve allowing vaporized fuel to pass to the mixer. This mechanical action in conjunction with the EPR reactions causes the downward action on the secondary lever causing it to open wider allowing more fuel to flow to the mixer.

⚠ WARNING

THE VOICE COIL SECTION OF THE EPR ASSEMBLY IS AN EMISSIONS CONTROL DEVICE AND CANNOT BE REBUILT. IF THE COIL ASSEMBLY FAILS TO OPERATE PROPERLY, REPLACE IT WITH AN OEM REPLACEMENT PART ONLY.

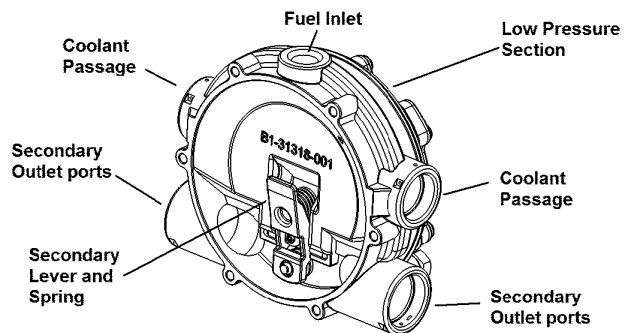

Figure 3-106. Low Pressure Regulators

Air Fuel Mixer

The air valve mixer is an air-fuel metering device and is completely self-contained. The mixer is an air valve design, utilizing a relatively constant pressure drop to draw fuel into the mixer from cranking to full load. The mixer is mounted in the air stream ahead of the throttle control device.

When the engine begins to crank, it draws in air with the air valve covering the inlet, negative pressure begins to build. This negative pressure signal is communicated to the top of the air valve chamber through 4 vacuum ports in the air valve assembly. A pressure/force imbalance begins to build across the air valve diaphragm between the air valve vacuum chamber and the atmospheric pressure below the diaphragm. The air valve vacuum spring is calibrated to generate from 4.0 in. (101.6 mm) of water column at start to as high as 14.0 in. (355.60 mm) of water column at full throttle. The vacuum being created is referred to as Air Valve Vacuum (AVV). As the air valve vacuum reaches 4.0 in. (101.6 mm) of water column, the air valve begins to lift against the air valve spring. The amount of AVV generated is a direct result of the throttle position. At low engine speed the air valve vacuum is low and the air valve position is low thus creating a small venturi for the fuel to flow. As the engine speed increase the AVV increases and the air valve is lifted higher thus creating a much larger venturi. This air valve vacuum is communicated from the mixer venturi to the LPR secondary chamber via the low pressure fuel supply hose. As the AVV increases in the secondary chamber the secondary diaphragm is drawn further down forcing the secondary valve lever to open wider.

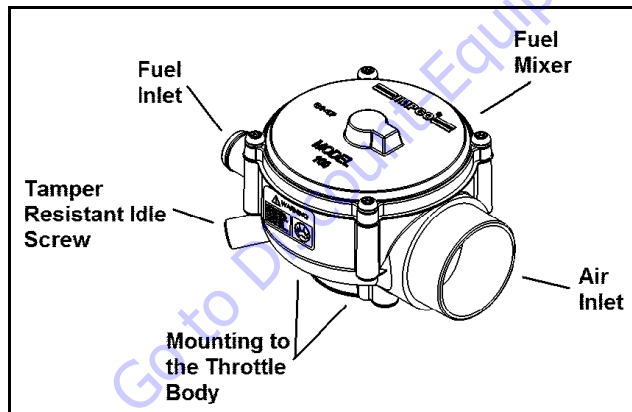

Figure 3-107. Air Fuel Mixer

Electronic Throttle Control (ETC)

Engine speed and load control is maintained by an ETC device. Speed and load control are determined by the ECM. Defaults programmed into the ECM software and throttle position sensors allow the ECM to maintain safe operating control over the engine. The Electronic Throttle Control device or "throttle body assembly" is connected to the intake manifold of the engine. The electronic throttle control device utilizes an electric motor connected to the throttle shaft. When the engine is running electrical signals are sent from the equipment controls to the engine ECM when the operator depresses an equipment function switch. The ECM then sends an electrical signal to the motor on the electronic throttle control to increase or decrease the angle of the throttle blade thus increasing or decreasing the air/fuel flow to the engine.

The electronic throttle control device also incorporates two internal Throttle Position Sensors (TPS) which provide output signals to the ECM as to the location of the throttle shaft and blade. The TPS information is used by the ECM to correct speed and load control as well as emission control.

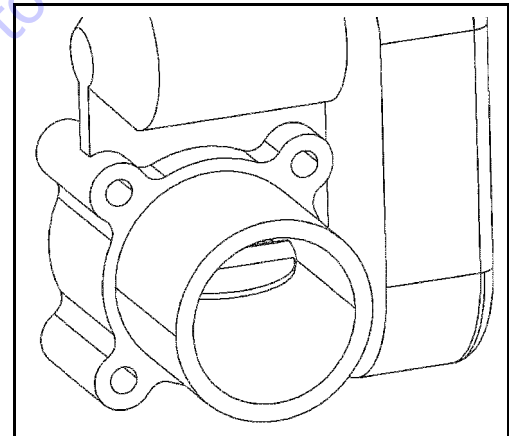

Figure 3-108. ETC throttle control device

Engine Control Module

To obtain maximum effect from the catalyst and accurate control of the air fuel ratio the emission certified engine is equipped with an onboard computer or Engine Control Unit (ECM). The ECM is a 32 bit controller which receives input data from sensors fitted to the engine and fuel system and then outputs various signals to control engine operation.

One specific function of the controller is to maintain "closed loop fuel control". Closed loop fuel control is accomplished when the exhaust gas oxygen sensor (HEGO) mounted in the exhaust system sends a voltage signal to the controller. The controller then calculates any correction that may need to be made to the air fuel ratio. The controller then outputs signals to the EPR to correct the amount of fuel being supplied to the mixer. At the same time the ECM may correct the throttle blade position to correct speed and load of the engine.

The controller also performs diagnostic functions on the fuel system and notifies the operator of malfunctions by turning on a Malfunction Indicator Light (MIL) mounted in the Ground Control Station and the Platform Control Station. Malfunctions in the system are identified by a Diagnostic Code number. In addition to notifying the operator of the malfunction in the system the controller also stores the information about the malfunction in its memory.

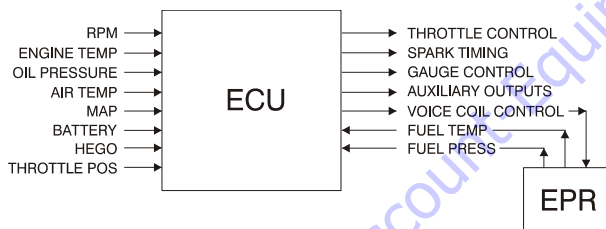

Figure 3-109. LPG Engine Control Unit (ECM)

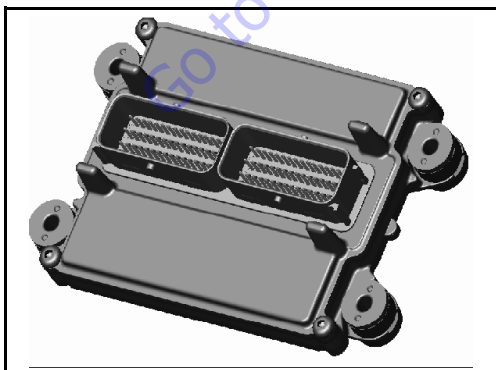

Figure 3-110. ECM Assembly

Heated Exhaust Gas Oxygen Sensor

There are two Heated Exhaust Gas Oxygen Sensors (HEGO). The first HEGO is mounted in the exhaust system downstream of the engine. It is used to measure the amount of oxygen present in the exhaust stream and communicate that to the ECM via an electrical signal. The amount of oxygen present in the exhaust stream indicates whether the fuel/air ratio is too rich or too lean. If the HEGO sensor signal indicates that the exhaust stream is too rich the ECM will decrease or lean the fuel mixture during engine operation, if the mixture is too lean the ECM will richen the mixture. The ECM continuously monitors the HEGO sensor output. If a rich or lean condition is present for an extended period of time, and the ECM cannot correct the condition, the ECM will set a diagnostic code and turn on the MIL light in control box.

The second HEGO is mounted in the exhaust system after the muffler. It measures the amount of oxygen in the exhaust system after the catalyst treatment has been completed in the muffler. If the ECM detects that the catalytic action in the muffler is not sufficient and fuel correction cannot correct the malfunction the MIL light is illuminated in the control box and a DTC code will be stored in the computer.

NOTICE

THE HEATED EXHAUST GAS OXYGEN SENSOR IS AN EMISSION CONTROL DEVICE. IF THE HEGO FAILS TO OPERATE, REPLACE IT WITH AN OEM REPLACEMENT PART. THE HEGO SENSOR IS SENSITIVE TO SILICONE OR SILICONE BASED PRODUCTS AND CAN BECOME CONTAMINATED. AVOID USING SILICONE SEALERS OR HOSES TREATED WITH SILICONE LUBRICANTS IN THE AIR STREAM OR FUEL LINES.



Figure 3-111. Heated Exhaust Gas Oxygen Sensor

Gasoline Multi Point Fuel Injection System (MPFI)

The primary components of the Gasoline Multi Point Fuel Injection (MPFI) fuel system are the fuel tank, electric fuel pump, fuel pressure and temperature sensor manifold, fuel filter and fuel rail.

Gasoline Fuel Pump

The Gasoline is stored as a liquid in the fuel tank and is drawn into the fuel system by an electric fuel pump. The fuel pump will receive a signal from the ECM to prime the fuel system for approximately 2 seconds prior to start. Priming of the fuel system provides for a quicker start, when the engine begins to crank.

Gasoline Pressure And Temperature Sensor Manifold

This engine is equipped with a fuel injector rail that does not have a pressure regulator or a return circuit to the fuel tank. Fuel pressure for this engine is regulated by the engine's ECM. The ECM receives fuel pressure and temperature feedback from the gasoline fuel sensor manifold and uses this information to control the ground side of the fuel pump. Fuel pressure is regulated by the ECM pulse width modulating (PWM) the fuel pump. The fuel pressure and temperature sensor manifold has a return or "bleed" circuit that connects back to the fuel tank. This circuit is used to bleed off any vapor that develops in the line and return a small amount of fuel to the tank. The fuel comes from the fuel tank and passes through the fuel pump. Fuel exits the fuel pump, passes through the filter and then enters the fuel pressure and temperature manifold assembly. Fuel flows through the feed circuit and is delivered to the fuel injector rail. Fuel that enters the bleed circuits through the bypass valve in the manifold is returned to the fuel tank.

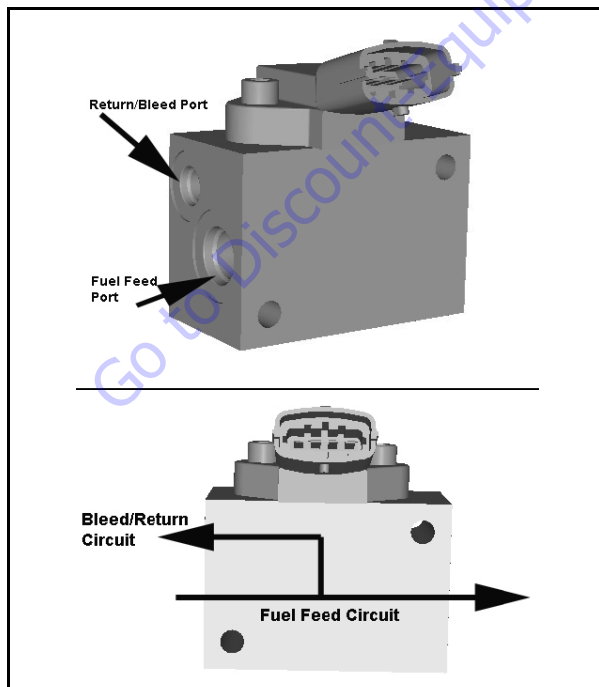

Figure 3-112. Gasoline Fuel Pressure and Temperature Manifold Assembly

Fuel Filter

After the fuel is drawn into the fuel pump, the fuel flows through the gasoline fuel filter. The fuel filter will trap small particles as the fuel passes through the filter to remove debris and prevents the fuel pressure and temperature manifold and fuel injectors from becoming damaged. Maintenance of the fuel filter is required as indicated in Section 1.

Fuel Injector Rail

Fuel flows from the fuel pressure and temperature manifold assembly to the fuel rails where the fuel is delivered to the fuel injectors. The fuel rail also contains a Schrader valve which is utilized to test the regulated pressure of the fuel system.

Fuel Injector

The fuel supply is maintained on the top of the injector from the injector rail. The injector is fed a "pulse" signal through the wire harness which causes the injector to open. During regular operating conditions the ECM controls the opening and duration of opening of the injector. During lower RPM operation the injector signals or "pulses" are less frequent than when the engine is operating at higher RPMs. The engine has been calibrated to deliver the precise amount of fuel for optimum performance and emission control.

3.25 GM ENGINE FUEL SYSTEM REPAIR

Propane Fuel System Pressure Relief

⚠ CAUTION

THE PROPANE FUEL SYSTEM OPERATES AT PRESSURES UP TO 312 PSI (21.5 BAR). TO MINIMIZE THE RISK OF FIRE AND PERSONAL INJURY, RELIEVE THE PROPANE FUEL SYSTEM PRESSURE (WHERE APPLICABLE) BEFORE SERVICING THE PROPANE FUEL SYSTEM COMPONENTS.

To relieve propane fuel system pressure:

1. Close the manual shut-off valve on the propane fuel tank.
2. Start and run the vehicle until the engine stalls.
3. Turn the ignition switch OFF.

NOTICE

RESIDUAL VAPOR PRESSURE WILL BE PRESENT IN THE FUEL SYSTEM. ENSURE THE WORK AREA IS WELL VENTILATED BEFORE DISCONNECTING ANY FUEL LINE.

Propane Fuel System Leak Test

⚠ CAUTION

NEVER USE AN OPEN FLAME OF ANY TYPE TO CHECK FOR PROPANE FUEL SYSTEM LEAKS.

Always inspect the propane fuel system for leaks after performing service. Check for leaks at the fittings of the serviced or replaced component. Use a commercially available liquid leak detector or an electronic leak detector. When using both methods, use the electronic leak detector first to avoid contamination by the liquid leak detector.

Go to Discount-Equipment.com to order your parts

Propane Fuel Filter Replacement

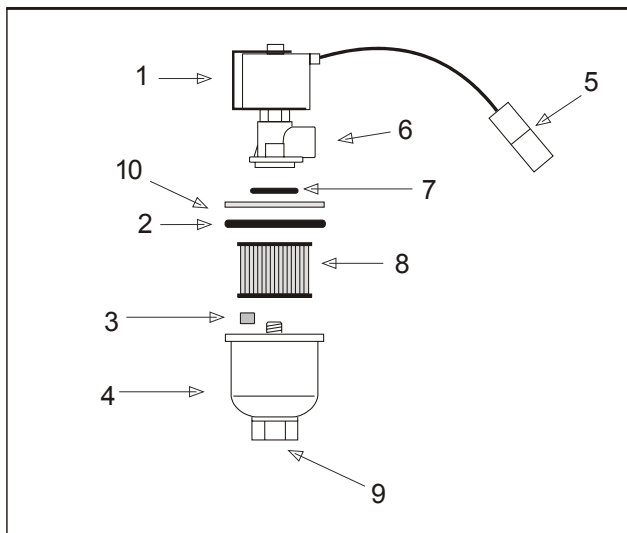

- | | |
|-------------------------------|----------------|
| 1. Electric Lock Off Solenoid | 6. Fuel Outlet |
| 2. Housing Seal | 7. O-ring |
| 3. Filter Magnet | 8. Filter |
| 4. Filter Housing | 9. Fuel Inlet |
| 5. Electrical Connector | 10. Ring |

Figure 3-113. Filter Lock Assembly

INSTALLATION

NOTICE

BE SURE TO REINSTALL THE FILTER MAGNET INTO THE HOUSING BEFORE INSTALLING NEW SEAL

1. Install the mounting plate to lock off o-ring seal.
2. If equipped, install the retaining bolt seal.
3. Install the housing seal.
4. Drop the magnet into the bottom of the filter housing.
5. Install the filter into the housing.
6. If equipped, install the retaining bolt into the filter housing.
7. Install the filter up to the bottom of the electric lock off.
8. Tighten the filter bowl retainer to 106 in. lbs. (12 Nm).
9. Open manual shut-off valve. Start the vehicle and leak check the propane fuel system at each serviced fitting. Refer to Propane Fuel System Leak Test.

REMOVAL

1. Relieve the propane fuel system pressure. Refer to Propane Fuel System Pressure Relief.
2. Disconnect the negative battery cable.
3. Slowly loosen the Filter housing and remove it.
4. Pull the filter housing from the Electric lock off assembly.
5. Remove the filter from the housing.
6. Locate Filter magnet and remove it.
7. Remove and discard the housing seal.
8. If equipped, remove and discard the retaining bolt seal.
9. Remove and discard mounting plate to lock off O-ring seal.

Electronic Pressure Regulator (EPR) Assembly Replacement

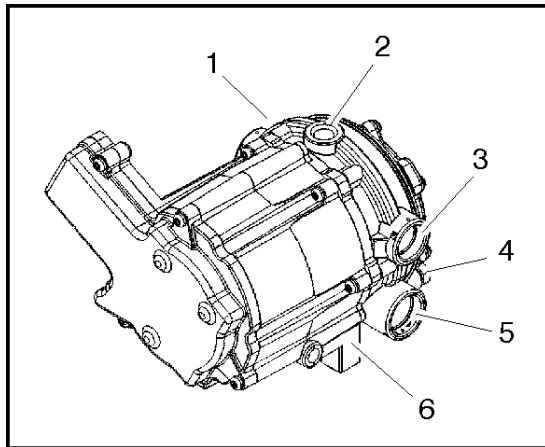

- | | |
|-------------------------------|------------------------|
| 1. Pressure Regulator Section | 4. Primary Test Port |
| 2. Fuel Inlet | 5. Secondary Test Port |
| 3. Coolant Passage | 6. Voice Coil Section |

Figure 3-114. EPR Assembly

The EPR assembly is made up of two separate components. The Voice Coil Section is not serviceable and can only be replaced as an assembly. The pressure regulator section is serviceable and will be detailed in this section.

REMOVAL

1. Relieve the propane fuel system pressure. Refer to Propane Fuel System Pressure Relief.
2. Disconnect the negative battery cable.
3. Slowly remove the fuel inlet fitting at the Electric Lock Off.

NOTE: Residual vapor pressure will be present in the fuel system.

4. Disconnect the electrical connector to the Electric Lock off.
5. Remove the Electric Lock Off from the regulator.
6. Remove the lock pin from the vapor fitting on the regulator housing and remove the fitting and hose and retain the pin.
7. Remove the lock pin from the pressure sensor on the regulator housing and remove the Sensor and retain the pin.
8. Using a clamp pliers pinch off the hoses on the coolant lines to the regulator.
9. Remove the lock pin from both the water fittings on the regulator housing and remove the fittings and hoses and retain the pin.
10. Disconnect the EPR electrical connector.

11. Remove the (3) three nuts from the EPR isolators and the EPR mounting bracket.
12. Remove the EPR from the bracket.
13. Remove the (3) three mounting isolators.

INSTALLATION

NOTICE

DO NOT USE TEFLON TAPE ON ANY FUEL FITTING. USE A LIQUID PIPE THREAD SEALANT WHEN INSTALLING FITTINGS.

CHECK ALL THE O-RINGS ON THE VAPOR AND WATER FITTINGS FOR ANY DAMAGE REPLACE IF NECESSARY.

LUBE ALL THE O-RINGS WITH AN O-RING LUBE BEFORE INSTALLING.

1. Install the three (3) rubber isolators to the bottom of the EPR
2. Install the EPR assembly to the bracket and tighten the retaining nuts.

NOTE: Do not over tighten the isolators and cause a separation of the isolators.

3. Install the fuel temperature sensor into the regulator opening and lock in place with the locking pin, connect the electrical connector.
4. Insert the fuel vapor line and fitting into the regulator port and lock in place with the locking pin.
5. Install both the water hoses and fittings into the regulator and lock in place with the locking pin remove the clamp pliers from the hoses.
6. Install the electric lock off into the regulator inlet and tighten into proper location, connect the electrical connector.
7. Connect the fuel supply line and tighten until fully seated.
8. Connect the EPR electrical connector.
9. Open the manual valve.
10. Start the vehicle and leak check the propane fuel system at each serviced fitting Refer to Propane Fuel System Leak Test.

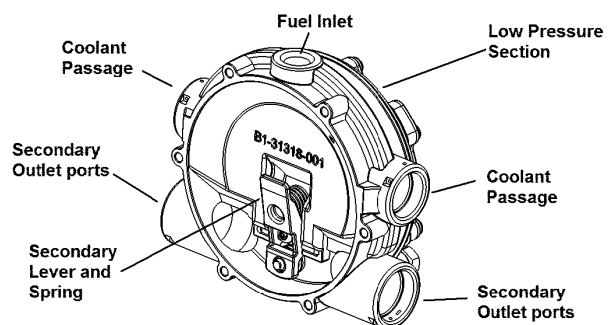

Figure 3-115. Pressure Regulator Section