

OPERATION MANUAL



***WHITEMAN* SERIES**
STX RIDE-ON POWER TROWEL
STX55Y6
(YANMAR DIESEL ENGINE)

Revision #0 (03/15/06)



THIS MANUAL MUST ACCOMPANY THE EQUIPMENT AT ALL TIMES.

P/N 21901

TO PURCHASE THIS PRODUCT PLEASE CONTACT US



**Equipment Financing and
Extended Warranties Available**



**Discount-Equipment.com is your online resource for
commercial and industrial quality parts and equipment sales.**

561-964-4949

visit us on line @ www.discount-equipment.com

Select an option below to find your Equipment

Search by Manufacturer

Search by Product Type

Request a Quote

We sell worldwide for the brands: Genie, Terex, JLG, MultiQuip, Mikasa, Essick, Whiteman, Mayco, Toro Stone, Diamond Products, Generac Magnum, Airman, Haulotte, Barreto, Power Blanket, Nifty Lift, Atlas Copco, Chicago Pneumatic, Allmand, Miller Curber, Skyjack, Lull, Skytrak, Tsurumi, Husquvarna Target, Stow, Wacker, Sakai, Mi-T-M, Sullair, Basic, Dynapac, MBW, Weber, Bartell, Bennar Newman, Haulotte, Ditch Runner, Menegotti, Morrison, Contec, Buddy, Crown, Edco, Wyco, Bomag, Laymor, EZ Trench, Bil-Jax, F.S. Curtis, Gehl Pavers, Heli, Honda, ICS/PowerGrit, IHI, Partner, Imer, Clipper, MMD, Koshin, Rice, CH&E, General Equipment, Amida, Coleman, NAC, Gradall, Square Shooter, Kent, Stanley, Tamco, Toku, Hatz, Kohler, Robin, Wisconsin, Northrock, Oztec, Toker TK, Rol-Air, APT, Wylie, Ingersoll Rand / Doosan, Innovatech, Con X, Ammann, Mecalac, Makinex, Smith Surface Prep, Small Line, Wanco, Yanmar



WARNING



CALIFORNIA — Proposition 65 Warning

Engine exhaust and some of its constituents, and some dust created by power sanding, sawing, grinding, drilling and other construction activities contains chemicals known to the State of California to cause cancer, birth defects and other reproductive harm. Some examples of these chemicals are:

- Lead from lead-based paints.
- Crystalline silica from bricks.
- Cement and other masonry products.
- Arsenic and chromium from chemically treated lumber.

Your risk from these exposures varies, depending on how often you do this type of work. To reduce your exposure to these chemicals: **ALWAYS** work in a well ventilated area, and work with approved safety equipment, such as dust masks that are specially designed to filter out microscopic particles.

WARNING

Grinding/cutting/drilling of masonry, concrete, metal and other materials can generate dust, mists and fumes containing chemicals known to cause serious or fatal injury or illness, such as respiratory disease, cancer, birth defects or other reproductive harm. If you are unfamiliar with the risks associated with the particular process and/or material being cut or the composition of the tool being used, review the material safety data sheet and/or consult your employer, the material manufacturer/supplier, governmental agencies such as OSHA and NIOSH and other sources on hazardous materials. California and some other authorities, for instance, have published lists of substances known to cause cancer, reproductive toxicity, or other harmful effects.

Control dust, mist and fumes at the source where possible. In this regard use good work practices and follow the recommendations of the manufacturers/suppliers, OSHA/NIOSH, and occupational and trade associations. Water should be used for dust suppression when wet cutting is feasible. When the hazards from inhalation of dust, mists and fumes cannot be eliminated, the operator and any bystanders should always wear a respirator approved by NIOSH/MSHA for the materials being used.

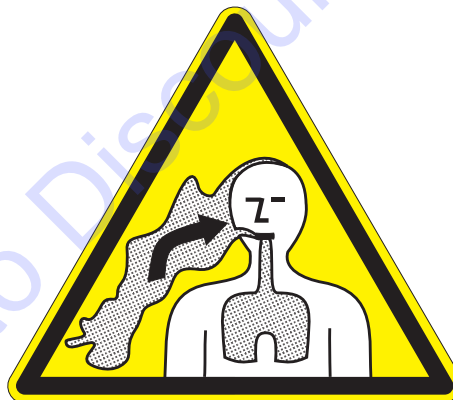

WARNING

Grinding/cutting/drilling of masonry, concrete, metal and other materials with silica in their composition may give off dust or mists containing crystalline silica. Silica is a basic component of sand, quartz, brick clay, granite and numerous other minerals and rocks. Repeated and/or substantial inhalation of airborne crystalline silica can cause serious or fatal respiratory diseases, including silicosis. In addition, California and some other authorities have listed respirable crystalline silica as a substance known to cause cancer. When cutting such materials, always follow the respiratory precautions mentioned above.

STX-SERIES — TABLE OF CONTENTS

Technical Assistance	5
Table of Contents	6
Parts Ordering	7
Dimensions	8
Specifications	9
Training Checklist	10
Daily Pre-Operation Checklist	11
Safety Message Alert Symbols	12-13
Rules For Safe Operation	14-17
Intended Use and General Information	18
Operation And Safety Decals	19

MQ WHITEMAN — STX-SERIES RIDE-ON POWER TROWEL (YANMAR ENGINE)

Controls and Indicators	20-21
Basic Engine Information	22
Trowel Set-Up	23
Pre-Inspection	24
Initial Start-Up	25-26
Operation	27-29
Maintenance	30-43
Troubleshooting	44-45
Terms and Conditions of Sale	47

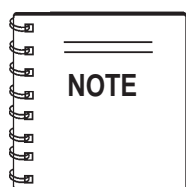

Specifications are subject to
change without notice.

STX-SERIES — DIMENSIONS

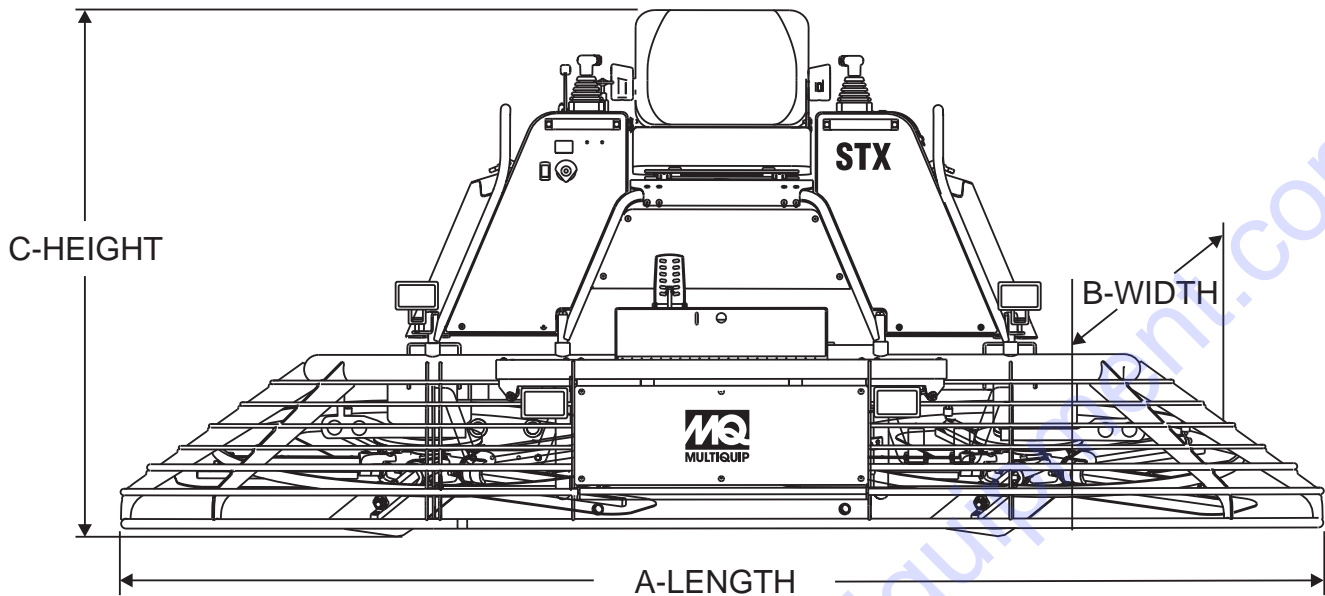

Table 1. STX-Series (STX55Y6) Specifications

A – Length – in. (cm)	125 (318)
B – Width – in. (cm)	65.0 (165)
C – Height – in. (cm) ¹	56.0 (142)
Weight – lbs. (kgs.) Operating	2,000 (909)
Weight – lbs. (kgs.) Shipping	2500 (1137)
Sound Pressure – dBA ²	97
Vibration – ft/s ² (m/ s ²) ³	<8.0 (2.5)
Blade Tip Speed – FPM (m/s)	1924 (9.9)
Engine	4TNV84T Yanmar Diesel Turbocharged
H.P.	55
Fuel Tank – gallons (liters)	11 (42)
Rotor – RPM	0 to 130
Path Width – in. (cm)	117 (297)
Hydraulic Oil ⁴	AW MV 68 ⁴ (10W-40 hot weather) (10W-30 cold weather)

SEE NOTES NEXT PAGE

STX-SERIES — SPECIFICATIONS

Table 2. Specifications (Engine)

Engine	Model	YANMAR 4TNV84T
	Type	Vertical inline water cooled diesel engine - direct injected - turbocharged
	Bore X Stroke	3.3 in. x 3.5 in. (84 mm x 90 mm)
	Displacement	121.7 cu-in. (1.995 L)
	Max Output	55 bhp (41.2 kW/min ⁻¹ , 56PS) @ 3210 min ⁻¹
	Fuel Tank Capacity	Approx. 11 U.S. Gallons (41.64 Liters)
	Fuel	Diesel Fuel Only Cetane fuel number 45 or greater
	Cooling System	Water cooled (Radiator) (Water-antifreeze ratio 50/50)
	Lubricating System	Forced lubrication with trochoid pump
	Lube Oil Capacity	7.82 US qt (7.4 liter) dipstick upper limit
	P.T.O Position	Flywheel side
	Starting Method	Electric Starting
Dimension (L x W x H)	(VM) 25.6 x 19.6 x 28.1 in. (649 x 498.5 x 713 mm)	
Net Weight (Dry With Flywheel Housing)	(CL) 403.5 lbs (183 Kg.) (VM) 375 lbs (170 Kg.)	

NOTE:

- This value includes the seat height.
- Sound pressure is a weighted measure. Measured at the operators ear position while the ride-on trowel is operating at full throttle on concrete in a manner most often experienced in “**normal**” circumstances. Sound pressure may vary depending upon the condition of the concrete. Hearing protection is always recommended.
- The vibration level indicated is the maximum RMS (Root Mean Square) value obtained at the handle grip while operating the ride-on trowel on curing concrete in a manner most often experienced in “**normal**” circumstances. Values were obtained from all three axes of motion. The values shown represent the maximum RMS value from these measurements.
- “AW” stands for **anti-wear** and “MV” stands for **multi-viscosity**. The 68 refers to the general viscosity range and is similar to 10W-30-motor oil. It is recommended that AW MV 68 hydraulic oil be used. If this type of hydraulic oil is not available then use 10W-30 engine oil (cold weather) or 10W-40 engine oil (hot weather).

STX-SERIES — TRAINING CHECKLIST

TRAINING CHECKLIST

This checklist lists the minimum requirements for machine maintenance and operation. Please feel free to detach it and make copies. Use this checklist when training a new operator or use as a review for more experienced operators.

TRAINING CHECKLIST			
NO.	DESCRIPTION	OK?	DATE
1	Read Operator's Manual completely.		
2	Machine layout, location of components, checking of engine and hydraulic oil levels.		
3	Fuel system, refueling procedure.		
4	Operation of spray and lights.		
5	Operation of controls (machine not running).		
6	Safety controls, safety stop switch operation.		
7	Emergency stop procedures.		
8	Startup of machine, pre-heat, engine choke.		
9	Maintaining a hover.		
10	Maneuvering.		
11	Pitching.		
12	Matching blade pitch. Twin-Pitch™		
13	Concrete finishing techniques.		
14	Shutdown of machine.		
15	Lifting of machine (lift loops).		
16	Machine transport and storage.		

Operator _____ Trainee _____

COMMENTS:

STX-SERIES — DAILY PRE-OPERATION CHECKLIST

DAILY PRE-OPERATION CHECKLIST

DAILY PRE-OPERATION CHECKLIST		✓	✓	✓	✓	✓	✓
1	Engine oil level.						
2	Hydraulic oil level.						
3	Radiator coolant level.						
4	Condition of blades.						
5	Blade pitch operation.						
6	Safety Stop Switch operation.						
7	Steering control operation.						

COMMENTS:

To order go to Discount-Equipment.com

STX-SERIES — SAFETY MESSAGE ALERT SYMBOLS

FOR YOUR SAFETY AND THE SAFETY OF OTHERS!

Safety precautions should be followed at all times when operating this equipment. Failure to read, understand and comply with the Safety Messages and Operating Instructions could result in injury to yourself and others.

This Operation Manual has been developed to provide instructions for the safe and efficient operation of the Whiteman Series STX Ride-On Trowel. For engine maintenance information, please refer to the engine manufacturer's instructions for data relative to its safe operation.



Before using this Ride-On Trowel, ensure that the operating individual has read, understands, and complies with all instructions in this manual.

SAFETY MESSAGE ALERT SYMBOLS

The three (3) Safety Messages shown below will inform you about potential hazards that could injure you or others. The Safety Messages specifically address the level of exposure to the operator, and are preceded by one of three words: **DANGER**, **WARNING**, or **CAUTION**.

DANGER

You **WILL** be **KILLED** or **SERIOUSLY INJURED** if you **DO NOT** follow these directions.

WARNING

You **CAN** be **KILLED** or **SERIOUSLY INJURED** if you **DO NOT** follow these directions.

CAUTION

You **CAN** be **INJURED** if you **DO NOT** follow these directions.

Potential hazards associated with trowel operation will be referenced with Hazard Symbols which appear throughout this manual, and will be referenced in conjunction with Safety Message Alert Symbols.

HAZARD SYMBOLS

Lethal Exhaust Gases



Engine exhaust gases contain poisonous carbon monoxide. This gas is colorless and odorless, and can cause death if inhaled. **NEVER** operate this equipment in a confined area or enclosed structure that does not provide ample free flow air.

Explosive Fuel



Diesel fuel is flammable, and its vapors can cause an explosion if ignited. **DO NOT** start the engine near spilled fuel or combustible fluids. **DO NOT** fill the fuel tank while the engine is running or hot. **DO NOT** overfill tank, since spilled fuel could ignite if it comes into contact with hot engine parts or sparks from the ignition system. Store fuel in approved containers, in well-ventilated areas and away from sparks and flames. **NEVER** use fuel as a cleaning agent.

Burn Hazards



Engine components can generate extreme heat. To prevent burns, **DO NOT** touch these areas while the engine is running or immediately after operations. **NEVER** operate the engine with heat shields or heat guards removed.

Rotating Parts



NEVER operate equipment with covers, or guards removed. Keep **fingers, hands, hair** and **clothing** away from all moving parts to prevent injury.

Skin Injection Hazard



NEVER use your hand to find hydraulic leaks. Use a piece of wood or cardboard. Hydraulic fluid injected into the skin must be treated by a knowledgeable physician immediately or severe injury or death can occur.

STX-SERIES — SAFETY MESSAGE ALERT SYMBOLS



Accidental Starting

Accidental starts can cause severe injury or death. **ALWAYS** place the ON/OFF switch in the OFF position. Disconnect and ground spark plug lead and disconnect negative battery cable from battery before servicing.



Over Speed Conditions



NEVER tamper with the factory settings of the engine governor or settings. Personal injury and damage to the engine or equipment can result if operating in speed ranges above maximum allowable.



Respiratory Hazard



ALWAYS wear approved respiratory protection.



Sight and Hearing hazard

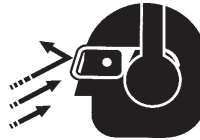

ALWAYS wear approved eye and hearing protection.



Equipment Damage Messages

Other important messages are provided throughout this manual to help prevent damage to your trowel, other property, or the surrounding environment.



CAUTION

This *Ride-On trowel*, other property, or the surrounding environment could be damaged if you do not follow instructions.

STX-SERIES — RULES FOR SAFE OPERATION

RULES FOR SAFE OPERATION

WARNING

Failure to follow instructions in this manual may lead to serious injury or even death! This equipment is to be operated by trained and qualified personnel only! This equipment is for industrial use only.

The following safety guidelines should always be used when operating the STX-SERIES Ride-On Trowel.

SAFETY

- **DO NOT** operate or service this equipment before you read, understand, and comply with all safety messages in this manual. The manual must be kept available and accessible to the operator.



- This equipment should not be operated by persons under the minimum statutory age limit.
- **NEVER** use this machine for any purpose other than those described in this manual.
- **NEVER** operate the trowel without proper protective clothing, shatterproof glasses, steel-toed boots and other protective devices required for the job.



- **NEVER** use accessories or attachments which are not recommended by the manufacturer for this equipment. Damage to the equipment and/or injury to user may result.
- Manufacturer does not assume responsibility for any accident due to equipment modifications. Unauthorized equipment modification will void all warranties. Any modification which could lead to a change in the original characteristics of the machine should be made only by the manufacturer who shall confirm that the machine is in conformity with appropriate safety regulations.

- **NEVER** operate this equipment when not feeling well due to fatigue, illness or taking medicine.
- **NEVER** operate the trowel under the influence of drugs or alcohol.
- Replace nameplate, operation and safety decals when they become difficult to read.
- **ALWAYS** check the trowel for loosened hardware such as nuts and bolts before starting.
- **NEVER** touch the hot exhaust manifold, muffler or cylinder. Allow these parts to cool before servicing the trowel. Contact with **hot!** components can cause serious burns.



- The engine of this trowel requires an adequate free flow of cooling air. **NEVER** operate the trowel in any enclosed or narrow area where free flow of the air is restricted. If the air flow is restricted it will cause serious damage to the engine and may cause injury to people. Remember the engine gives off **DEADLY** carbon monoxide gas.

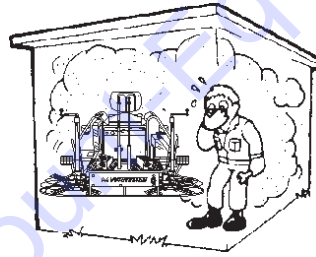

- **ALWAYS** refuel in a well-ventilated area, away from sparks and open flames.
- Topping-off to filler port is dangerous, as it tends to spill fuel.
- **NEVER** use fuel as a cleaning agent.
- **ALWAYS** use extreme caution when working with **flammable** liquids. When refueling, **STOP** the engine. Allow the engine to cool before adding fuel or performing service and maintenance functions.
- **NEVER** operate the trowel in an explosive atmosphere where fumes are present, or near combustible materials. An explosion or fire could result in severe **bodily harm or even death**.
- **NEVER** **smoke** around or near the machine. Fire or explosion could result from **fuel vapors**, or if fuel is spilled on a **hot!** engine.

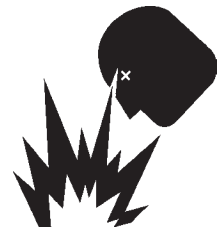

STX-SERIES — RULES FOR SAFE OPERATION

- **NEVER** run engine without air filter. Severe engine damage may occur. Service air filter frequently to prevent carburetor malfunction.
- **NEVER** place your **feet** or **hands** inside the guard rings while starting or operating this equipment.
- **AVOID** wearing jewelry or loose fitting clothing that may snag on the controls or moving parts as this can cause a serious injury.
- **ALWAYS** keep clear of **rotating** or **moving parts** while operating the trowel.
- **Moving Parts** – Shut down the engine before performing service or maintenance functions. Contact with moving parts can cause serious injury.
- **ALWAYS** check to make sure that the operating area is clear before starting the engine.
- **NEVER** leave the machine **unattended** while running.
- **ALWAYS** be sure the operator is familiar with proper safety precautions and operations techniques before using trowel.
- **ALWAYS** keep the work area well organized.
- **ALWAYS** clear the work area of any debris, tools, etc. that would constitute a hazard while the trowel is in operation.

WARNING

ALWAYS check to make sure that the operating area is clear before starting the engine.

- No one other than the operator is to be in the working area when the trowel is in operation.
- **NEVER** allow passengers or riders on the trowel during operation.
- Always observe all applicable compulsory regulations relevant to environmental protection, especially, fuel storage, the handling of hazardous substances, and the wearing of protective clothing and equipment. Instruct the user as necessary, or as the user, request this information and training.
- **ALWAYS** store equipment properly when it is not being used. Equipment should be stored in a clean, dry location out of the reach of children.

DANGER

Pay close attention to ventilation when operating the trowel in confined spaces such as tunnels, buildings or similar areas. The engine exhaust contains harmful elements. Ensure proper air flow to move engine exhaust away from the operator.



Additional Safety Information

A handy safety manual for operating and maintenance personnel of concrete power trowels produced by the Association of Equipment Manufacturers (AEM) can be obtained for a fee by ordering through their website at www.aem.org.

Order FORM PT-160.



Lifting the Ride-On Trowel

CAUTION

This ride-on trowel is very **heavy** and awkward to move around. Use proper heavy lifting procedures and **DO NOT** attempt to lift the ride-on trowel by the guard rings.

The STX-SERIES Ride-On Power Trowel is designed to be moved and handled several ways.

The easiest way to lift the trowel is to utilize the lift loops that are welded to the frame. These lift loops are located to the left and right sides of the operator's seat.

A strap or chain can be attached to these lift loops, allowing a forklift or crane to lift the trowel up onto and off of a slab of concrete. The strap or chain should have a minimum 2,000 pounds (1000-kg) lifting capacity and the lifting gear must be capable of lifting at least this amount.

DANGER

NEVER stand under or allow anyone else to stand under the trowel while it is being lifted.



STX-SERIES — RULES FOR SAFE OPERATION

Transporting

- **ALWAYS** shutdown engine before transporting.
- Tighten fuel tank cap securely and close fuel petcock to prevent fuel from spilling.
- Drain fuel when transporting trowel for long distances or over bad roads.
- When placing the trowel on a truck-bed for transport, **always** tie-down the trowel.
- If the trowel is being transported via a trailer, make sure the trailer complies with all local and state safety transportation laws. Refer to the following "**Towing Safety Precautions**" for basic towing techniques.

Towing Safety Precautions

CAUTION

Conform to **Department of Transportation (DOT) Safety Towing Regulations** before transporting trowel on public roads.

To reduce the possibility of an accident while transporting the trowel on public roads, always make sure the trailer that supports the trowel and the towing vehicle are in good operating condition and both units are mechanically sound.

The following list of suggestions should be used when towing your trowel:

- Make sure the hitch and coupling of the towing vehicle are rated equal to, or greater than the trailer "gross vehicle weight rating" (GVWR) of 6,000 lbs.
- **ALWAYS** inspect the hitch and coupling for wear. **NEVER** tow a trailer with defective hitches, couplings, chains, etc.
- Check the tire air pressure on both towing vehicle and trailer. **Trailer tires should be inflated to 50 psi cold.** Also check the tire tread wear on both vehicles.
- **ALWAYS** make sure the trailer is equipped with "**Safety Chains**".
- **ALWAYS** attach trailer's safety chains to towing vehicle properly.
- **ALWAYS** make sure the vehicle and trailer directional, backup, brake, and trailer lights are connected and working
- **DO NOT** exceed the recommended highway speed when towing. Unless posted otherwise, do not exceed 45 MPH highway, and 10 MPH off-road.

- Use chock-blocks at each wheel when parked to prevent trailer from rolling.
- Use the trailer's swivel jack to adjust the trailer height to a level position while parked.
- Avoid sudden stops and starts. This can cause the trailer to skid or jack-knife. Smooth, gradual starts and stops will improve towing.
- Avoid sharp turns.
- Trailer should be adjusted to a level position at all times when towing.
- Raise and lock trailer wheel stand in the "**UP**" position when transporting.
- DOT requirements include the following:
 - Connect and test electric brake operation.
 - Secure portable power cables in cable tray with tie wraps.

Battery

The battery contains acids that can cause injury to the eyes and skin. To avoid eye irritation, **always** wear safety glasses or face shielding. Use well insulated gloves when picking the battery up. Use the following guidelines when handling the battery.

- **DO NOT** drop the battery. Any impact to the battery may cause it to explode.
- **DO NOT** expose the battery to open flames, sparks, lit cigarettes etc. The battery contains combustible gases and liquids. If these gases and liquids come in contact with a flame or spark an explosion can occur.
- **ALWAYS** keep the battery charged. If the battery is not charged a buildup of combustible gas will occur.
- **ALWAYS** keep battery cables in good working condition. Repair or replace all worn cables.
- **ALWAYS** disconnect the **negative battery terminal** before performing service on the trowel.
- **ALWAYS** recharge the battery in a vented air environment to avoid risk of a dangerous concentration of combustible gases.
- In case the battery liquid, (dilute sulfuric acid), comes in contact with **clothing or skin**, rinse skin or clothing immediately with plenty of water.
- In case the battery liquid, (dilute sulfuric acid), comes in contact with your **eyes**, rinse eyes immediately with plenty of water, then contact the nearest doctor or hospital and seek medical attention.



STX-SERIES — RULES FOR SAFE OPERATION

Maintenance Safety

- **ALWAYS** shut down the engine and disconnect battery before performing service or maintenance functions. Contact with moving parts can cause serious injury.
- Securely support any trowel components that must be raised.
- **NEVER** lubricate components or attempt service on a running trowel.
- **ALWAYS** allow the trowel a proper amount of time to cool before servicing.
- Keep the trowel in proper running condition.
- Make sure that there is no buildup of concrete, grease, oil or debris on the machine.
- Repair damage to the trowel immediately and always replace broken parts.
- Dispose of hazardous waste properly. Examples of potentially hazardous waste are used motor oil, fuel and fuel filters.
- **DO NOT** use plastic food containers to dispose of hazardous waste.
- **DO NOT** pour waste oil or fuel directly onto the ground, down a drain or into any water source.
- **NEVER** store trowel with fuel in the tank for any extended period of time. Always clean up spilled fuel immediately.

Emergencies

- **ALWAYS** know the location of the nearest **fire extinguisher**.



- **ALWAYS** know the location of the nearest **first aid kit**.



- Know the phone numbers of the nearest **ambulance, doctor** and **fire department**. Ensure that a phone or radio is readily available at the jobsite. If this is not possible, know the location of the nearest phone. This information will be invaluable in the event of an emergency.

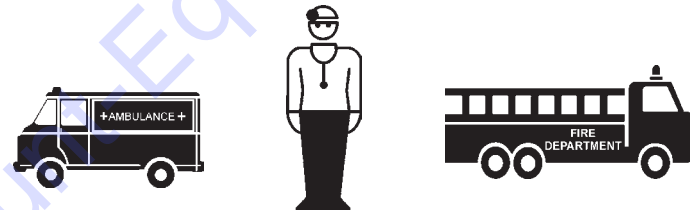

STX-SERIES — INTENDED USE AND GENERAL INFORMATION

Intended Use

Operate the STX-Series Trowel, tools and components in accordance with the manufacturer's instructions. Use of any other tools for stated operation is considered contrary to designated use. The risk of such use lies entirely with the user. The manufacturer cannot be held liable for damages as a result of misuse.

STX- SERIES Ride-On Power Trowel Familiarization

The STX-SERIES Ride-On Power Trowel is designed for the floating and finishing of concrete slabs.

Take a walk around your trowel. Take notice of all the major components (see Figures 2 and 3, pages 20 and 21) like the engine, blades, air cleaner, fuel system, fuel shut-off valve, ignition switch etc. Check that there is always a proper level of oil in the engine and a proper level of hydraulic oil in the hydraulic oil reservoir.

Read all the safety instructions carefully. Safety instructions will be found throughout this manual and on the machine. Keep all safety information in good, readable condition. Operators should be well trained on the operation and maintenance of the trowel.

Before using your trowel, test it on a flat watered down section of finished concrete. This trial test run will increase your confidence in using the trowel and at the same time it will familiarize you with the trowel's controls and indicators. In addition you will understand how the trowel will handle under actual conditions.

Engine

This trowel is equipped with an liquid cooled 55 HP Yanmar diesel engine. Refer to the engine owner's manual for specific instructions regarding engine operation. This manual is included with the trowel at the time of shipping. Please contact Discount-Equipment if a replacement manual is required.

Blades

The blades of the trowel finish the concrete as they are swirled around the surface. Blades are classified as combination (10 or 8 inches wide) and finish (6 inches wide). This trowel is equipped with six blades per rotor equally spaced in a radial pattern and attached to a vertical rotating shaft by means of a **spider assembly**.

Figures 2 and 3 show the location of the controls, indicators and general maintenance parts. Each control may perform more than one function. The functions of the controls or indicators are on pages 20 and 21.

Hydraulic Motor

Independent hydrostatic drive motors are coupled to the engine-powered hydrostatic pumps. Each motor drives a spider assembly.

Hydraulic Steering

Dual palm grip joystick controls located to the left and right of the operator are provided for steering the STX Ride-On Trowel. The joysticks are linked to three hydraulic steering cylinders located within the frame of the machine. Detailed explanation of how the joystick controls affect the steering of the trowel can be found in the Operation section of this manual.

Hydraulic Pump

The hydraulic pump delivers controlled flow of hydraulic fluid to the hydraulic motors.

Training

For training, please use the "TRAINING CHECKLIST" located in the front of this manual (Page 10). This checklist is not intended to be a substitute for proper training but will provide an outline for an experienced operator to provide training to a new operator.

STX-SERIES — OPERATION AND SAFETY DECALS

Machine Safety Decals

The STX-SERIES Ride-On Power Trowel is equipped with a number of operation and safety decals. These decals are provided for operator safety and maintenance information. Should any of these decals become unreadable, replacements can be obtained from your dealer.



P/N 35137



P/N 21589 BLACK 4.76 X 21.87

STX

P/N 21579



P/N 30690



P/N: 13118



P/N: 21455

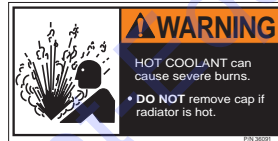

P/N 30691

TURBO

P/N 21590

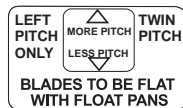

P/N: 21169



P/N 2814 (WHITE)



P/N 30692



CONTACT SERVICE DEPARTMENT



P/N 35168



P/N 36099 (ISO Blue)

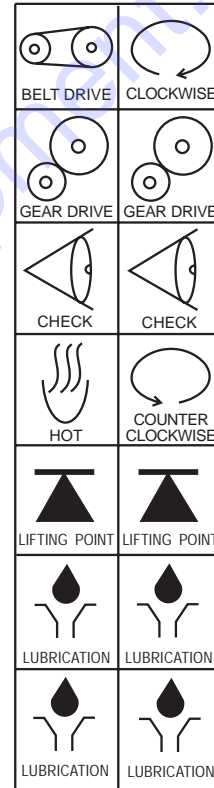

P/N: 11246



P/N 20936



P/N 20953

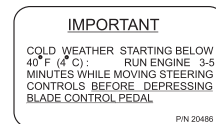

P/N: 20486

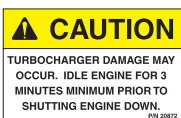

P/N 20872

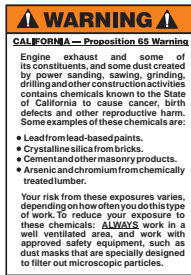

P/N 20525

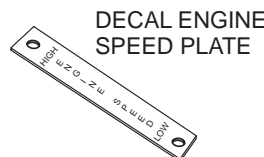

P/N 11712



P/N: 21665



P/N: 11811

Figure 1. STX-SERIES Decals

STX-SERIES — CONTROLS AND INDICATORS

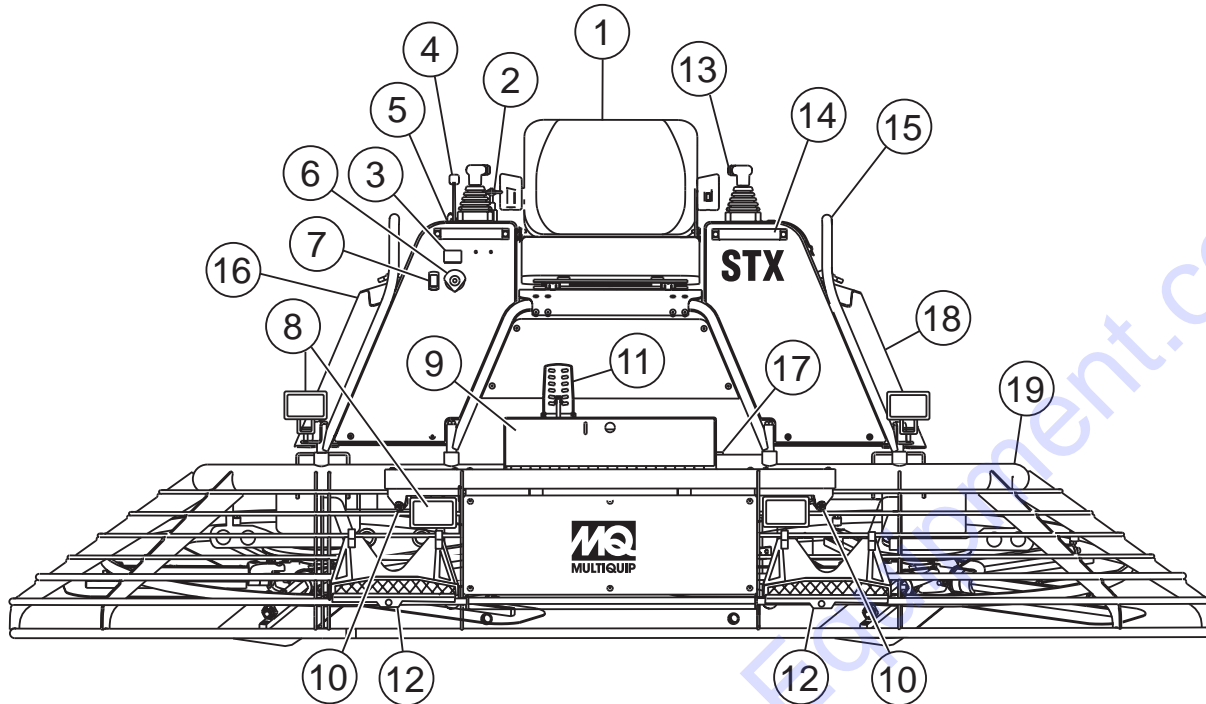

Figure 2. STX-SERIES Controls and Components (Front)

Figures 2 and 3 (pages 20 and 21) show the location of the controls, indicators and general maintenance parts. The function of each control, indicator or maintenance part is explained below:

1. **Seat** – Place for operator to sit. Trowel blades will not rotate unless operator is seated. Seat is adjustable.
2. **Trowel Speed Limiter Control** – Used to adjust the maximum trowel speed that can be obtained when the foot pedal is fully depressed.
3. **Hour Meter** – Indicates number of hours machine has been used.
4. **Throttle Control Lever** – Controls the speed of the engine. Move the hand lever forward to increase engine speed (high), backwards to decrease engine speed (low).
5. **Operator Gauges** – Allows operator to monitor engine, hydraulic and electrical functions.
6. **Ignition Switch** – With key inserted turn clockwise to start engine.
7. **Light Switch** – When activated, turns on six halogen lights. Lights offer better visibility when working indoors.
8. **Lights** – Six low voltage halogen lights are provided with this unit.
9. **Toolbox Compartment** – Storage for tools.
10. **Spray Nozzles** – Spray nozzle for retardant. Two spray nozzles are supplied with this unit.
11. **Foot Pedal** – Controls blade speed. Slow blade speed is accomplished by slightly depressing the foot pedal. Maximum blade speed is accomplished by fully depressing the foot pedal.
12. **Removable Steps (left & right)** – Provides for safe footing for mounting and dismounting trowel. When removed, provides access to spider and blade assemblies.
13. **Retardant Spray Control Buttons (left & right)** – When pressed allows retardant spray to flow through the spray nozzle located at the front of the machine.
14. **Hand Holds** – Use to assist safe mounting and dismounting trowel.
15. **Lift Loops** – Located on both the left and right sides of the main frame. Used when the trowel must be lifted onto a concrete slab.
16. **Pitch Block** – (Behind grill guard.) Measure and adjust pitch pressure at the pitch block.
17. **Fuel Gauge/Filler Cap** – Indicates the amount of fuel in the fuel tank. Remove this cap to add fuel.
18. **Overflow Bottle** – (Behind grill guard.) Supplies water or coolant to the radiator when radiator water or coolant level is low. Fill to indicated level as shown on bottle.
19. **Hydraulic Reservoir** – Part of frame. Holds hydraulic oil necessary for pump operation.

STX-SERIES — CONTROLS AND INDICATORS

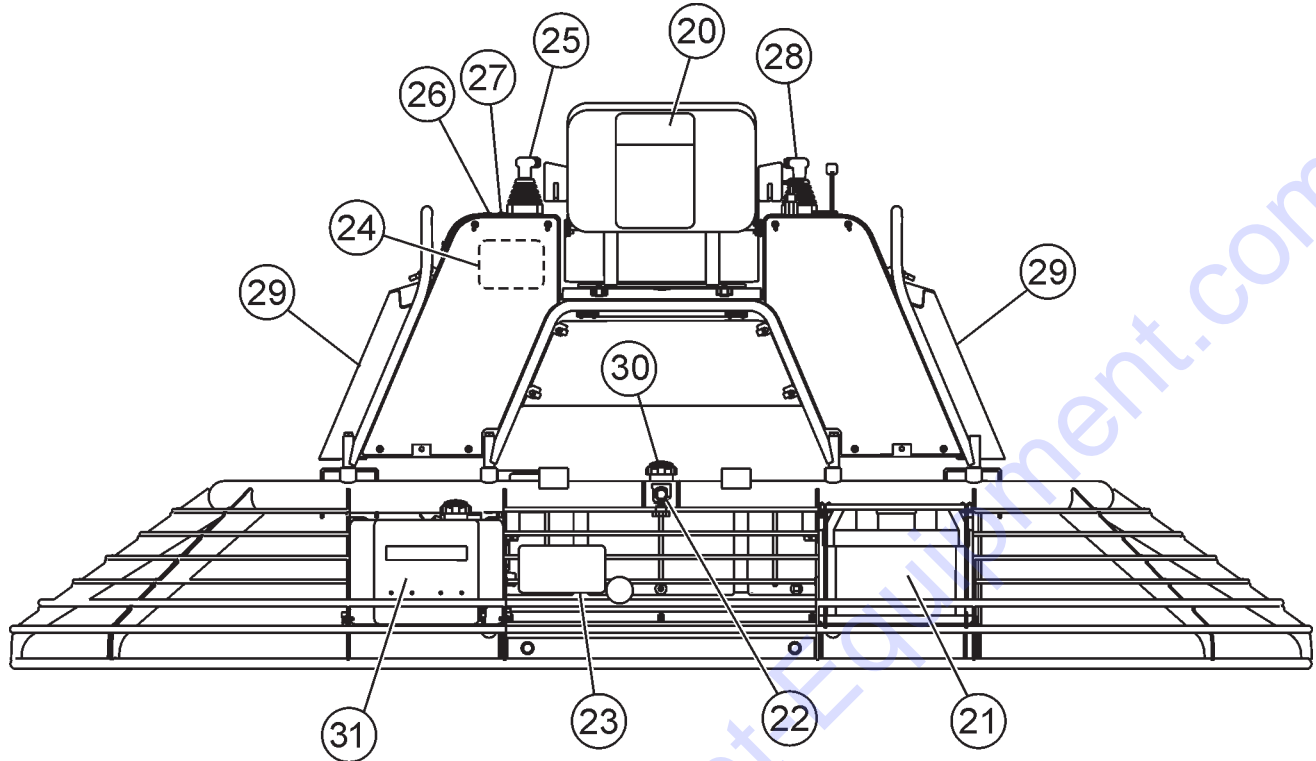

Figure 3. STX-SERIES Controls and Components (Rear)

- 20. **Documentation Box** – Storage for documentation and other information regarding the trowel.
- 21. **Battery** – Provides +12V DC power to the electrical system.
- 22. **Hydraulic Oil Sight Glass** – Indicates the level of the hydraulic oil in the reservoir.
- 23. **Hydraulic Suction Filter** – Filters hydraulic fluid prior to entering the system. (10 Micron absolute synthetic media.)
- 24. **Hydraulic Oil Expansion Tank** – Accommodates expanding hydraulic oil as it gets hot. The oil gravity flows back to the reservoir as it cools down, therefore **NEVER** open the the Hydraulic Oil Filler Cap (Item 30) when the system is warm and the oil has expanded.
- 25. **Steering Control (left side)** – Allows the unit to move in a forward or reverse direction only.
- 26. **Blade Pitch Control Switch (left side)** – Adjusts the left side blade pitch independently of the right side.
- 27. **Blade Pitch Control (Twin Pitch)** – Adjusts the blade pitches simultaneously.
- 28. **Steering Control (right side)** – Allows the unit to move in either a forward, reverse left or right direction.
- 29. **Grill Guards (left & right)** – Protects operator from moving components. Remove for maintenance access.
- 30. **Hydraulic Oil Filler Cap** – Remove this cap to add hydraulic oil. Open **ONLY** when system is cooled down and all expanded oil has returned to the reservoir.
- 31. **Retardant Spray Tank** – Holds 5 gallons of retardant, water, or other liquid.

STX-SERIES — BASIC ENGINE INFORMATION

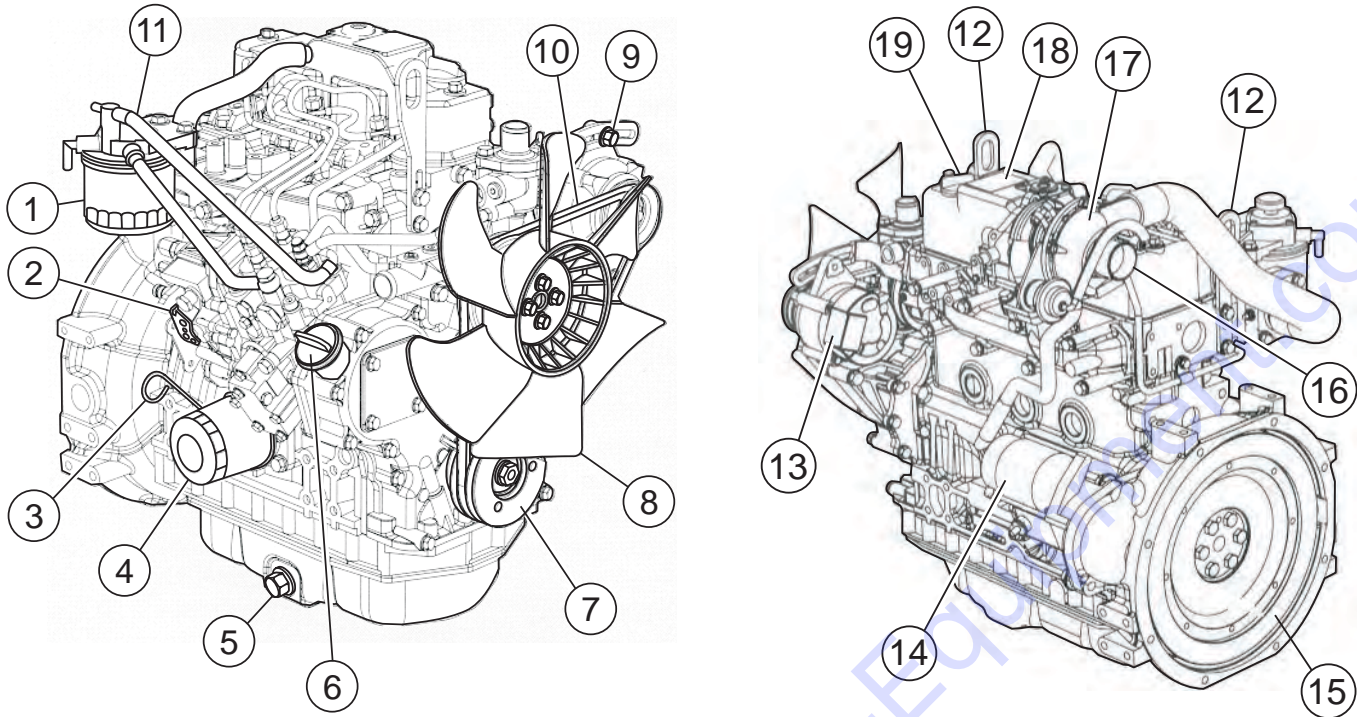

Figure 4. Basic Engine Components

Basic Engine Components

The following refer to basic engine components and their functions that an operator may need to reference. The manufacturer's engine manual provides further instructions and details of operation and servicing. The engine shown in Figure 4 is a **Yanmar** engine.

1. **Fuel Filter** – Removes dirt and water from the engine fuel.
2. **Governor Lever** – This lever restricts engine speed (high idle and low idle) through a speed control device linked to the accelerator system.
3. **Oil Dip Stick** – Remove to check amount and condition of oil in crankcase.
4. **Oil Filter** – Spin-on type, filters oil for contaminants.
5. **Oil Drain Plug** – Remove plug to drain crankcase oil.
6. **Oil Filler Port** – Remove to add fresh crankcase oil.
7. **Crankshaft V-Pulley** – Check fan V-belt between V-Pulley and alternator to determine proper belt tension.
8. **Cooling Fan** – Driven by the V-belt, the cooling fan cools the engine by cooling water/antifreeze mixture that circulates through the engine block and cylinder head.
9. **V-belt Tension Adjustment** – This bolt provides means to adjust the V-belt tension at the alternator bracket.
10. **V-belt (Fan belt)** – Driven by the engine crank during operation, drives the water pump/fan as well as the alternator.
11. **Fuel Return Hose** – Provides fuel to the fuel injection pump.
12. **Lifting Eye** – Two lifting eyes are provided if the removal/installation of the engine becomes necessary.
13. **Alternator** – Provides current to the electrical system and charges the battery. Driven by means of a crankshaft/V-belt pulley system.
14. **Starter** – Starts engine when ignition key is rotated to the "START" position.
15. **Flywheel** – Main power is taken off from the flywheel end.
16. **Air Intake Port** – Provides air from the air cleaner to the turbocharger unit.
17. **Turbocharger** – Provides pressurized intake air to the cylinder by means of a turbine energized by exhaust gas that rotates the blower.

TO PURCHASE THIS PRODUCT PLEASE CONTACT US



**Equipment Financing and
Extended Warranties Available**



**Discount-Equipment.com is your online resource for
commercial and industrial quality parts and equipment sales.**

561-964-4949

visit us on line @ www.discount-equipment.com

Select an option below to find your Equipment

Search by Manufacturer

Search by Product Type

Request a Quote

We sell worldwide for the brands: Genie, Terex, JLG, MultiQuip, Mikasa, Essick, Whiteman, Mayco, Toro Stone, Diamond Products, Generac Magnum, Airman, Haulotte, Barreto, Power Blanket, Nifty Lift, Atlas Copco, Chicago Pneumatic, Allmand, Miller Curber, Skyjack, Lull, Skytrak, Tsurumi, Husquvarna Target, Stow, Wacker, Sakai, Mi-T-M, Sullair, Basic, Dynapac, MBW, Weber, Bartell, Bennar Newman, Haulotte, Ditch Runner, Menegotti, Morrison, Contec, Buddy, Crown, Edco, Wyco, Bomag, Laymor, EZ Trench, Bil-Jax, F.S. Curtis, Gehl Pavers, Heli, Honda, ICS/PowerGrit, IHI, Partner, Imer, Clipper, MMD, Koshin, Rice, CH&E, General Equipment, Amida, Coleman, NAC, Gradall, Square Shooter, Kent, Stanley, Tamco, Toku, Hatz, Kohler, Robin, Wisconsin, Northrock, Oztec, Toker TK, Rol-Air, APT, Wylie, Ingersoll Rand / Doosan, Innovatech, Con X, Ammann, Mecalac, Makinex, Smith Surface Prep, Small Line, Wanco, Yanmar

Trowel Setup

The purpose of this section is to assist the user in setting up a **NEW** trowel. If your trowel is already assembled, (seat, handles, knobs and battery), this section can be skipped.

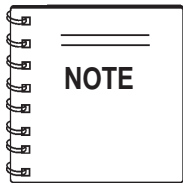

The new trowel cannot be put into service until the pre-setup installation instructions are completed. These pre-setup instructions only need to be performed at the time of unpacking a **NEW** trowel.

Before packaging and shipping, this STX SERIES Ride-On Power Trowel was run and tested at the factory. If there are problems, please let us know.

Seat Assembly

The seat is not installed on the trowel for shipping purposes. To attach the seat perform the following:

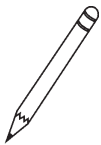

The STX trowels have a seat that is mounted on tracks, similar to an automobile seat. This seat can be adjusted **fore** and **aft** via the control lever under the front of the seat.

1. Remove the seat from the protective wrapping.
2. Remove the bolts on the bottom of the seat, and place seat on the seat mounting plate, then insert the bolts through the holes or slots on the seat mounting plate and tighten.

Battery Setup

CAUTION

Use all safety precautions specified by the battery manufacturer when working with the battery. See further specific safety information on page 16 of this manual.

This trowel was shipped with a wet charged battery. This battery may need to be charged for a brief period of time as per the manufacturer instructions.

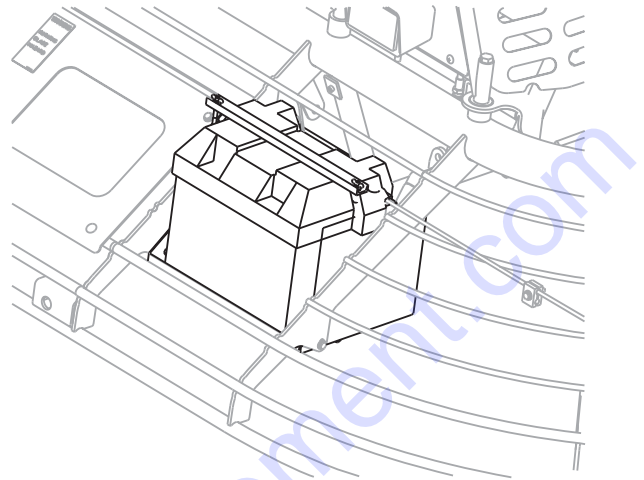
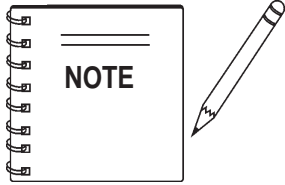

Figure 5. Battery and Battery Box

To install the battery on the trowel, make sure that the battery is well seated in the battery box. Connect the positive cable to the positive terminal on the battery first, then connect the negative cable to the negative terminal. Close the plastic battery box cover and secure the battery box.

STX-SERIES — PRE-INSPECTION

PRE-INSPECTION



The following sections are intended to assist the operator with pre-inspection and the initial start-up of the STX-SERIES Ride-On Power Trowel. It is extremely important that these sections are read carefully before attempting to

use the trowel in the field. **DO NOT** use your Ride-On Power Trowel until these sections are thoroughly understood.

! WARNING

Failure to understand the operation of the STX-SERIES Ride-On Power Trowel could result in severe damage to the trowel or personal injury.

! CAUTION

DO NOT overfill the oil pan with engine oil. Always keep the engine oil level between the upper and lower limit lines on the dipstick.

See Figures 2 and 3 (Pages 20 and 21) for the location of controls and indicators referenced in this manual.

Engine Oil

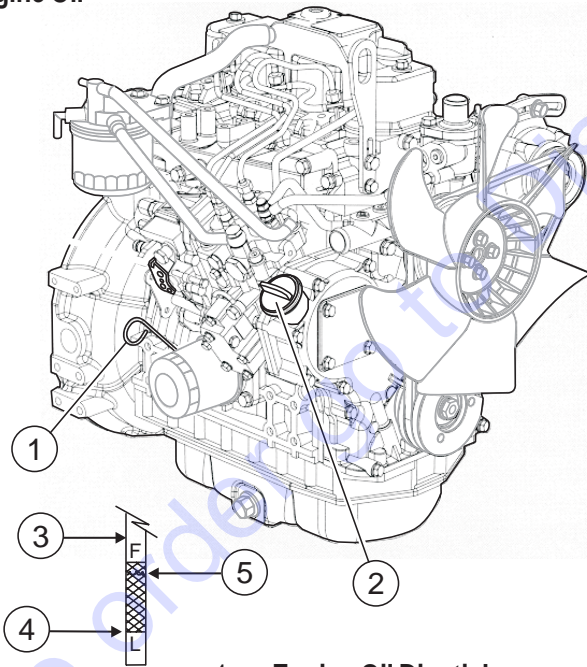

1. Engine Oil Dipstick
2. Engine Oil Filler Cap
3. Dipstick Oil Level Indicator
4. "Add Oil" Line
5. Upper Oil Level Line

Figure 3. Check and Fill Engine Oil

1. When checking or adding oil, place the machine so the engine is level.
2. Pull the engine oil dipstick from its holder (item 1 Fig 6).
3. Determine if engine oil is low (item 4). Oil should be between the upper limit and lower limit (add oil) lines.
4. If oil is below the "Add Engine Oil" line add oil up to upper limit on the dipstick. Allow enough time for any added oil to make its way to the oil pan before rechecking.

Hydraulic Oil

Determine if the hydraulic oil is low by observing the level of oil in the hydraulic Oil Sight Glass (Figure 7). The hydraulic tank has an elevated overflow bottle. **DO NOT** remove the fill cap when the oil is hot or spillage will occur.

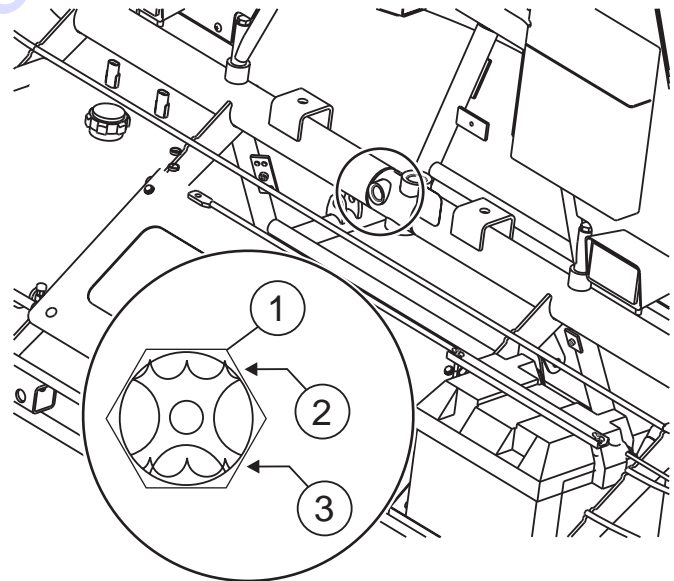

1. Hydraulic Oil Level Sight Glass
2. Normal Level
3. Low Level

Figure 7. Hydraulic Oil Sight Glass

STX-SERIES — INITIAL START-UP

CAUTION

Hydraulic oil can get **HOT!**

ALWAYS allow hydraulic oil to cool before removing fill cap.



CAUTION

Removal of the fill cap when oil fills the sight glass will cause hydraulic oil to spill. Clean up hydraulic oil spills immediately.



To add hydraulic oil, remove fill cap on the hydraulic tank. Fill to overflow with hydraulic system cool. Use Chevron AW / MV ISO 68 or equivalent.

Fuel

Determine if the engine fuel is low (Figure 8). If fuel level is low, remove the fuel filler cap and fill with diesel fuel. Handle fuel safely. Motor fuels are highly flammable and can be dangerous if mishandled. **DO NOT** smoke while refueling. **DO NOT** attempt to refuel the ride-on trowel if the engine is hot or running.



Figure 8. Fuel Gauge

CAUTION

DO NOT store the Ride-On Power Trowel with fuel in the tank for an extended period of time. Completely drain the fuel system (tank, lines, etc.) if the unit is to be put into long term storage. For shorter or intermediate periods of time the tank should be filled to avoid condensation that could cause corrosion or contamination of the fuel.

INITIAL START-UP

WARNING

NEVER operate the trowel in a confined area or enclosed area structure that does not provide ample free flow of air.



ALWAYS wear approved eye and hearing protection before operating the ride-on power trowel.

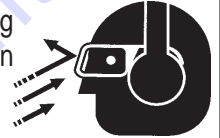

NEVER place hands or feet inside the guard rings while the engine is running. **ALWAYS** shut the engine down before performing any kind of maintenance service on the trowel.



Starting the Engine

1. With one foot on the ground and the other foot placed on the trowel's platform, grasp the grab handles lifting yourself onto the trowel. Then sit down in the operator's seat.

CAUTION

DO NOT grab hold of the joysticks to lift yourself onto the trowel. Pulling on the joysticks repeatedly will weaken the units. **ALWAYS** use the grab handles to lift yourself on the trowel.

2. The STX Ride-On Power Trowel is equipped with a **Safety Stop Switch**. The trowel will not move unless an operator is sitting in the seat. While the engine can be started or continue to run with the operator off the seat, the rotors will not rotate. The weight of an operator activates a switch within the seat allowing the rotors to turn.

STX-SERIES — INITIAL START-UP

WARNING

NEVER disable or disconnect the **Safety Stop Switch**. It is provided for the operators' safety and injury may result if it is disabled, disconnected or improperly maintained.

- It is recommended that the operation of the **Safety Stop Switch** is checked prior to performing any troweling operations. Doing this will verify that the switch is working properly contributing to safe operation of the machine.
- Place the **engine throttle lever** (Figure 9) in the **LOW** position.

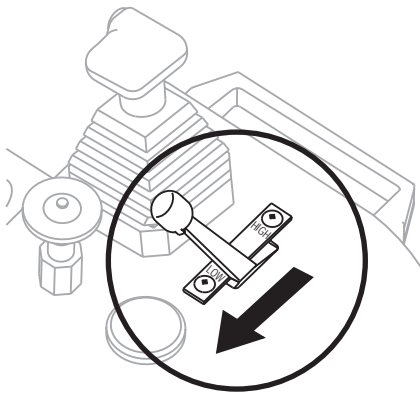

Figure 9. Engine Throttle Control Lever (Low)

- Insert the **ignition key** into the ignition switch (Figure 10).

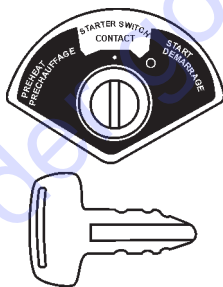

Figure 10. Ignition Switch and Key

- Turn the ignition key clockwise to the (start) position. The **oil** and **charge** indicator lights (Figure 11) should be on.

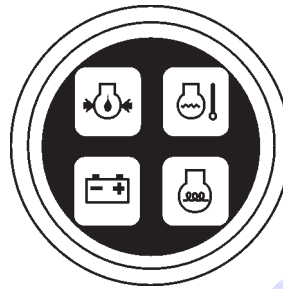
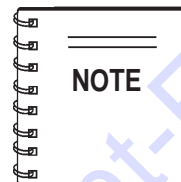

Figure 11. Oil and Charge Indicator Lights



In **cold** weather turn and hold the ignition key counter clockwise to the preheat position, wait until the preheat indicator goes off before turning the ignition key clockwise to the start position. Two or three preheat cycles may be necessary in very cold weather.

- Turn ignition key fully clockwise and listen for engine to start. Once engine has started release ignition key. Let engine warm for a few minutes.
- Place the **engine throttle lever** (Figure 12) in the **HIGH** position.
- The engine should be running at full RPM.
- Repeat this section a few times to get fully acquainted with the engine starting procedure.

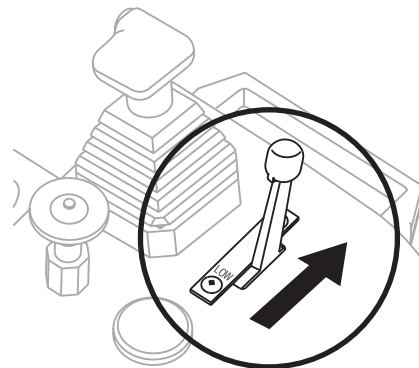
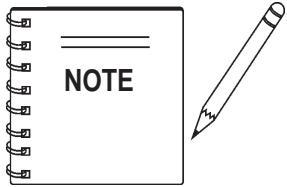

Figure 12. Engine Throttle Control Lever (High)

OPERATION



The following section is intended as a basic guide to the Ride-On Power Trowel operation, and is not to be considered a complete guide to concrete finishing. It is strongly suggested that all operators (experienced and novice) read

“*Slabs on Grade*” published by the American Concrete Institute, Detroit Michigan.

Steering

Two joysticks (Figures 13 and 14) located to the left and right of the operator's seat provide directional control for the STX-SERIES Ride-On Power Trowel. Table 3 illustrates the various directional positions of the joysticks and their effect on the ride-on trowel.

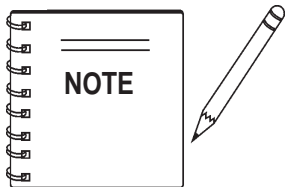

All directional references with respect to the joysticks are from the **operator's** seat position.

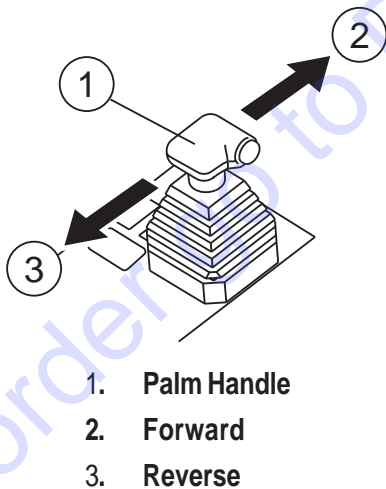
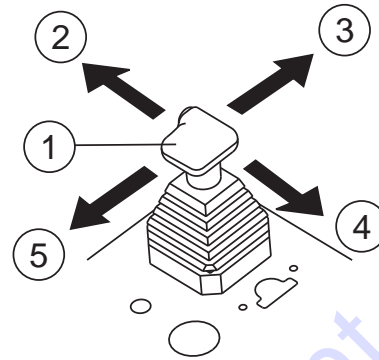

Figure 13. Left Joystick Control



1. Palm Handle
2. Left
3. Forward
4. Right
5. Reverse

Figure 14. Right Joystick Control

See Table 3 for steering and directional relationship to Joystick Control movement.

Table 3. Joystick Directional Positioning	
JOYSTICK & DIRECTION	RESULTS
Move LEFT Joystick Forward ↑	Causes only the left side of the ride-on trowel to move forward.
Move LEFT Joystick Backward ↓	Causes only the left side of the ride-on trowel to move backward.
Move RIGHT Joystick Forward ↑	Causes only the right side of the ride-on trowel to move forward.
Move RIGHT Joystick Backward ↓	Causes only the right side of the ride-on trowel to move backward.
Move BOTH Joysticks Forward ↑ ↑	Causes the ride-on trowel to move forward in a straight line.
Move BOTH Joysticks Backward ↓ ↓	Causes the ride-on trowel to move backward in a straight line.
Move RIGHT Joystick to the Right ⇒⇒⇒	Causes the ride-on trowel to move to the right.
Move RIGHT Joystick to the Left ⇐⇐⇐	Causes the ride-on trowel to move to the left

STX-SERIES — OPERATION

1. The foot pedal (Figure 15) solely controls blade speed. The position of the foot pedal determines the blade speed. Slow blade speed is obtained by slightly depressing the pedal. Maximum blade speed is obtained by fully depressing the pedal.

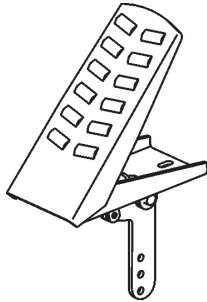
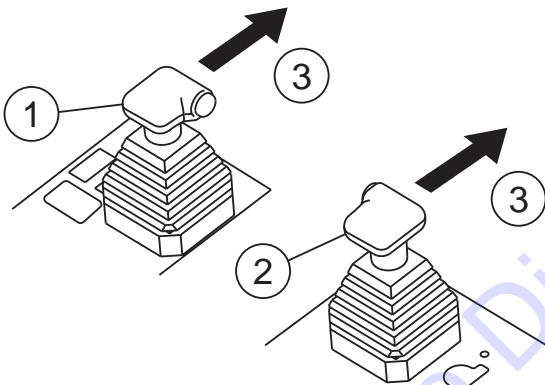

Figure 15. Blade Speed Control Foot Pedal

2. Push both the left and right joysticks forward (Figure 16).



1. **Left Joystick Control**
2. **Right Joystick Control**
3. **Pull Back Forward**

Figure 16. Joystick Control Forward Direction

3. With your right foot, slowly depress the right foot pedal halfway. Notice that the ride-on power trowel begins to move in a forward direction. Release both joystick controls to stop forward movement then remove your right foot from the foot pedal.
4. Practice holding the machine in one place as you increase blade speed. When about 75% of maximum blade speed has been reached, the blade will be moving at proper finishing speed. The machine may be difficult to keep in one place. Trying to keep the ride-on trowel stationary is a good practice for operation.

5. Practice maneuvering the Ride-on Power Trowel using the information listed in Table 3. Try to practice controlled motions as if you were finishing a slab of concrete. Practice edging and covering a large area
6. Try adjusting the pitch of the blades. This can be done with the ride-on trowel stopped or while the trowel is moving, whatever feels comfortable. Test the operation of optional equipment like retardant spray and lights if equipped.
7. Pull both the left and right joysticks backward (Figure 17) and repeat steps 3 through 6 while substituting the word reverse for forward.

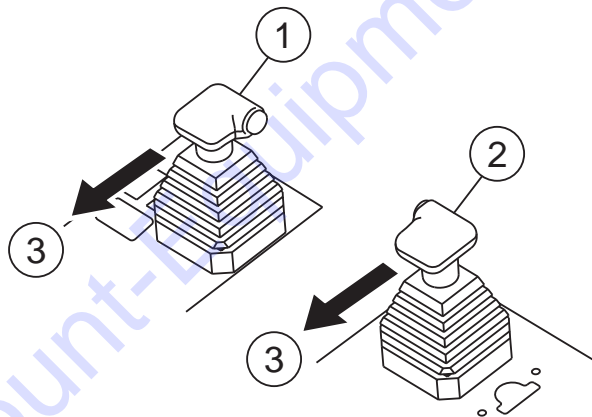

1. **Left Joystick Control**
2. **Right Joystick Control**
3. **Pull Back Reverse**

Figure 17. Joystick Control Reverse Direction

Trowel Speed Limiter Control

The speed limiter control located on the control panel (Figure 18) can be used to adjust the maximum trowel speed that can be obtained when the foot pedal is fully depressed. Pull up to reduce the maximum speed and push down to return to full speed. For fine adjustments, rotate the knob clockwise or counter-clockwise.

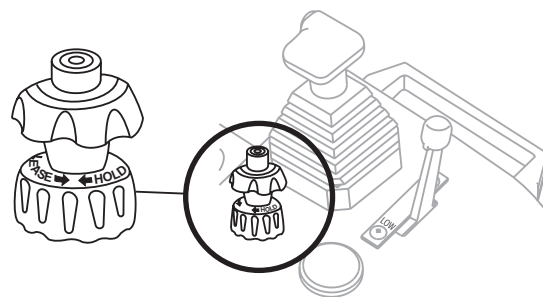

Figure 18. Trowel Speed Limiter Control

Blade Pitch Control

The trowel blades can be pitched for various finishing operations with the two rocker switches located on the left control panel next to the left joystick control (Figure 19).

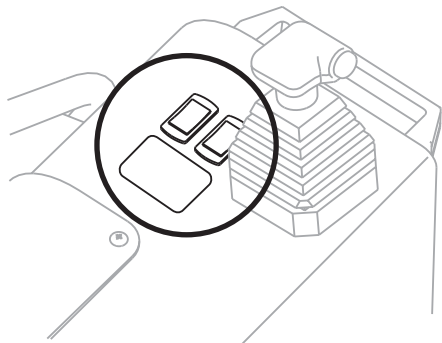

Figure 19. Blade Pitch Control

The right switch pitches both blades at the same time while the left switch will pitch only the left blade. Moving the switches forward increases the pitch while moving them backward decreases the pitch, (Figure 20).

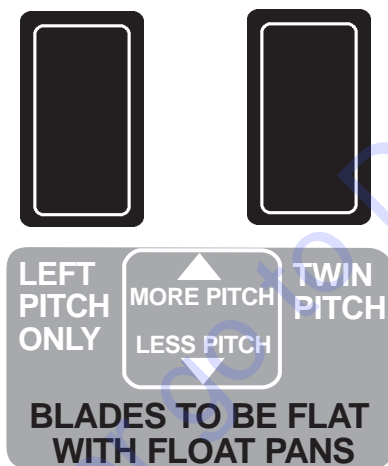

Figure 20. Blade Pitch Rocker Switches

Important! To get the blades absolutely flat for using float pans follow these steps:

1. **TWIN PITCH** all the way **DOWN**.
2. **LEFT PITCH** up a little ways.
3. **TWIN PITCH** all the way **DOWN**, again.
4. **LEFT PITCH** all the way **DOWN**.

Engine Shut-Down

1. Return the speed control lever (Figure 21) to low idle, and allow the engine to idle for 5 minutes .

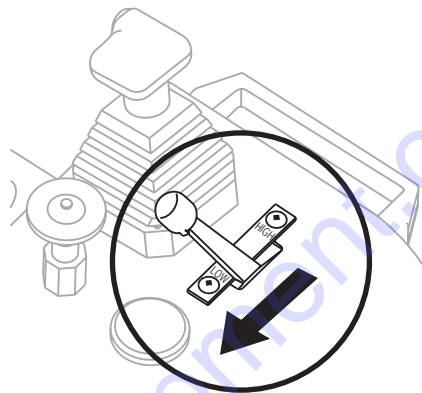
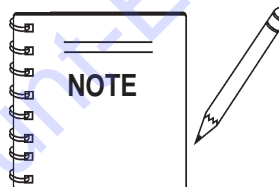

Figure 21. Blade Pitch Control



Failure to allow the engine to idle for 5 minutes before shutting engine **OFF** may lead to turbocharger damage.

2. Turn the ignition key counter-clockwise to the "**starter switch contact**" position, then remove the key.
3. Clean and remove any foreign debris from the trowel.

MAINTENANCE

When performing maintenance on the trowel or engine, follow all safety messages and rules for safe operation stated at the beginning of this manual.

See the engine manual supplied with your machine for appropriate engine maintenance schedule and troubleshooting guide for problems.

WARNING

Accidental starts can cause severe injury or death.

ALWAYS place the ON/OFF switch in the OFF position.

Disconnect and ground spark plug leads and disconnect negative battery cable from battery before servicing.

ALWAYS allow the engine to cool before servicing. **NEVER** attempt any maintenance work on a hot! (muffler, radiator, etc.) trowel.

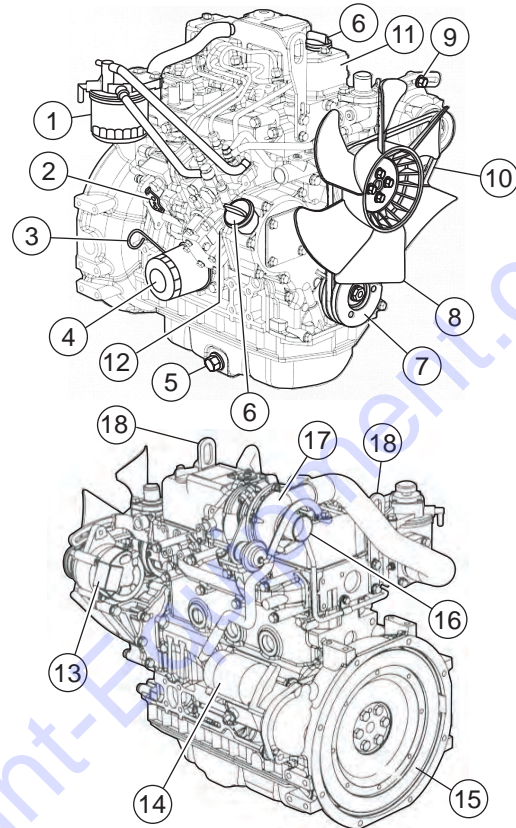

Figure 22. Engine Service Areas

1. Fuel Filter
2. Governor Lever
3. Dipstick (engine oil)
4. Engine Oil Filter
5. Drain Plug (engine oil)
6. Filler Port (engine oil)
7. Crank Shaft V-pulley
8. Cooling Fan
9. Adjustment bolt (V-belt tension)
10. V-belt
11. Rocker Arm Cover
12. Fuel Injection Pump
13. Alternator
14. Starter motor
15. Flywheel
16. Air Intake Port (from air cleaner)
17. Turbocharger
18. Lifting Eyelet

Maintenance Schedule

Change the **hydraulic oil** and **filter** after the first 100 hours of use, then change every 250 hours.

Daily (8-10 Hours)

1. Check fluid levels in engine and reservoir; fill as necessary. Weekly (30-40 Hours)
2. Relube arms, thrust collar and clutch.
3. Replace blades if necessary.
4. Check, clean, or replace the engine air filter as necessary.
5. Replace engine oil and filter as necessary, see engine manual.

Monthly (100-125 Hours)

Remove, clean, reinstall and relube the arms and thrust collar. Adjust the blade arms.

Yearly (500-600 Hours)

1. Check and replace if necessary the arm bushings, and thrust collar bushings.
2. Adjust blade speed.
3. Replace hydraulic fluid and hydraulic filter.

STX-SERIES — MAINTENANCE

! WARNING

Certain maintenance operations or machine adjustments require specialized knowledge and skill. Attempting to perform maintenance operations or adjustments without the proper knowledge, skills or training could result in equipment damage or injury to personnel. If in doubt, consult your dealer.

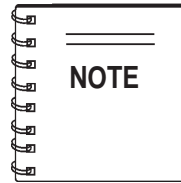

Operating the engine with loose or damaged air cleaner components could allow unfiltered air into the engine causing premature wear and failure.

Air Cleaner (Daily)

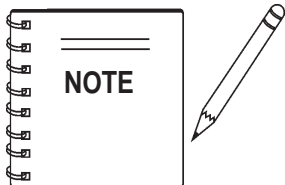

Change the **hydraulic oil** and **filter** after the first 100 hours of use, then change every 250 hours.

The Yanmar 55 hp engine is equipped with a replaceable, high-density paper air cleaner element. Most are also equipped with an oiled-foam precleaner which surrounds the paper element.

Check the air cleaner daily or before starting the engine. Check for and correct heavy buildup of dirt and debris along with loose or damaged components.

! WARNING

Wear protective equipment such as approved safety glasses or face shields and dust masks or respirators when cleaning air filters with compressed air.

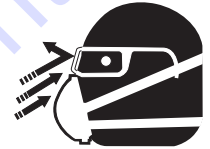

If so equipped, wash and re-oil the precleaner every 25 hours of operation (more often under extremely dusty or dirty conditions).

To service the precleaner perform the following steps, refer to Figure 23:

1. Release the latches located on either side of the air cleaner dust pan (item 6, Figure 23), and remove the dust pan.
2. Remove the air cleaner element.
3. Blow low pressure air from the inside of the element to dislodge the dust and dirt. Do not use excessive air pressure or the element will be damaged and will need to be replaced.
4. Replace the element if it is damaged or excessively dirty.
5. Clean the inside of the dust pan.

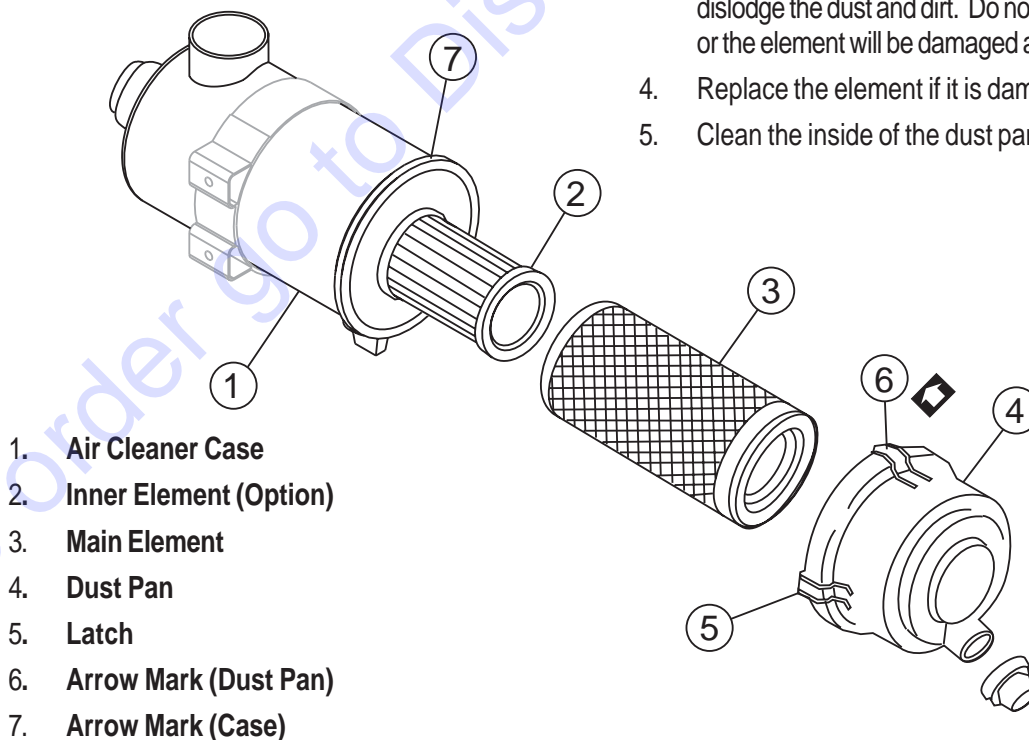
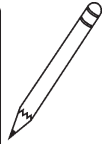

Figure 23. Air Cleaner Components

STX-SERIES — MAINTENANCE

- Reinstall the element or if equipped, the precleaner over the paper air cleaner element.
- Reinstall the air cleaner dust pan and secure the latches.



Make sure the correct depth air cleaner element and rubber seal are used for the engine specification involved.

CAUTION

Do not run the engine with the air cleaner removed or without an element.

Changing Engine Oil And Filter

- Change the engine oil after the first 5 hours of use, then change every 6 months or 100 hours.
- Remove the oil filler cap (Figure 22, Item 6), and fill engine crankcase with recommended type oil as listed in Table 4. Fill to the upper limit of dipstick.
- Crankcase oil capacity with oil filter replacement is 6.72 qts. (7.4 liters).

Oil Filter (100 Hours)

- Replace the engine oil filter (Figure 24) every oil change or 100 hours. Refer to your engine manual for specific details to perform this operation.

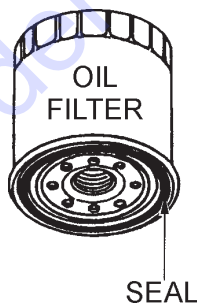

Figure 24. Oil Filter

- Be sure to coat the **seal** of the new oil filter with clean engine oil.

Table 4. Recommended Viscosity Grades

		10W-30, 10W-40							
		5W-20, 5W-30							
°F	-20	0	20	32	40	60	80	100	
°C	-30	-20	-10	0	10	20	30	40	
TEMPERATURE RANGE EXPECTED BEFORE NEXT OIL CHANGE									

Fuel Filter (200 Hours)

- Replace the engine fuel filter (Figure 25) every 500 hours. Refer to your engine manual for specific details to perform this operation.

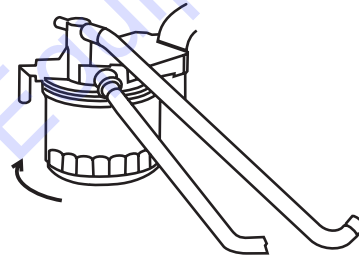

Figure 25. Fuel Filter Removal

Oil/Water Separator

If the Oil/Water Separator has collected a significant amount of water at the bottom of the cup it should be drained off. Refer to your engine manual for specific details to perform this operation.

Oil And Fuel Lines

- Check the oil and fuel lines and connections regularly for leaks or damage. Repair or replace as necessary.
- Replace the oil and fuel lines every two years to maintain the line's performance and flexibility.

Radiator/Cooling System

WARNING

Hot coolant can cause severe burns. **DO NOT** remove cap if radiator is HOT.



1. Check and clean radiator fins.
2. Check cooling water.
3. Check radiator hoses for fatigue or cracking.
4. Check radiator cap seal.

Refer to your engine manual for additional information.

Battery/Charging System

WARNING

Flammable, explosive gas. (produces hydrogen gas while charging or during operation). Keep area around battery well ventilated and keep from any fire source.



Battery electrolyte contains corrosive, toxic chemical. (dilute sulfuric acid). Avoid contact with eyes and skin.



Shock or Fire due to electric short-circuit. Disconnect battery cables before inspecting electrical system and never "spark" battery terminals to test for charge.



1. Check and clean battery terminals for corrosion.
2. Check and keep battery electrolyte between upper and lower limits indicated on the battery. Never operate or recharge without sufficient fluid in the battery.

3. Never attempt to charge a battery that is frozen. The battery can explode unless first allowed to thaw.
4. Disconnect the negative terminal (-) of the battery during storage. If unit will be stored where ambient temperature will drop to -15° C or less, remove and store battery in a warm, dry place.

Long Term Storage

- Remove the battery.
- Drain fuel from fuel tank, fuel line and carburetor.
- Remove spark plug and pour a few drops of motor oil into cylinder. Crank engine 3 to 4 times so that oil reaches all internal parts.
- Clean exterior with a cloth soaked in clean oil.
- Store unit covered with plastic sheet in moisture and dust-free location out of direct sunlight.

CAUTION

Never store the ride-on trowel with fuel in the tank for any extended period of time. Always clean up spilled fuel immediately.

Engine Tune-Up

- See your engine manual for specific information on tuning up your engine.

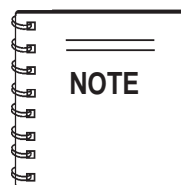

See the engine manual supplied with your machine for appropriate engine maintenance schedule and troubleshooting guide for problems.

At the front of the book (Page 11) there is a "Daily Pre-Operation Checklist". Make copies of this checklist and use it on a daily basis.

ALWAYS disconnect battery cables before attempting any service or maintenance on the ride-on trowel.

MAINTENANCE PROCEDURES

Checking/Adjusting Trowel Speed

Because the two hydraulic drive motors operate independent of each other, the trowel speed between them may vary. If the unit's steering is difficult to control, or if one spider is spinning noticeably faster or slower than the other, the trowel speed may need to be checked. It is also recommended that the trowel speed be checked at least once a year.

Trowel speed adjustment is a two-step process. First, the left side should be checked and/or adjusted. Second, the right side should be adjusted to match the left.

Left Side Trowel Speed Adjustment

The left side trowel speed is adjusted by the set bolt located under the operator's platform (Item A, Figure 26) and accessed by opening the storage panel door. Backing the set screw out decreases the left side trowel speed; screwing it inward increases the speed.

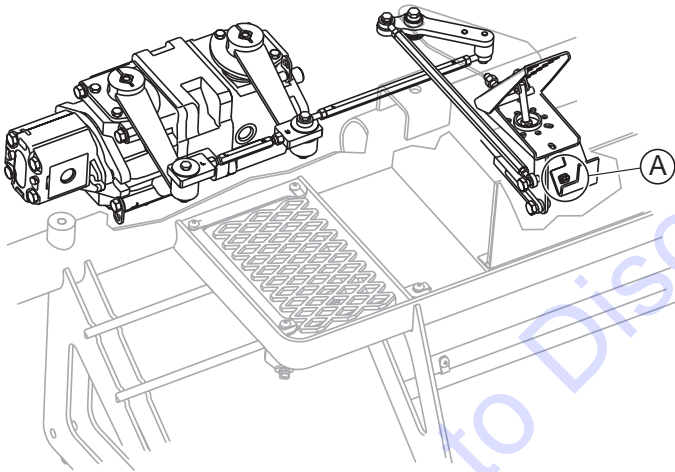
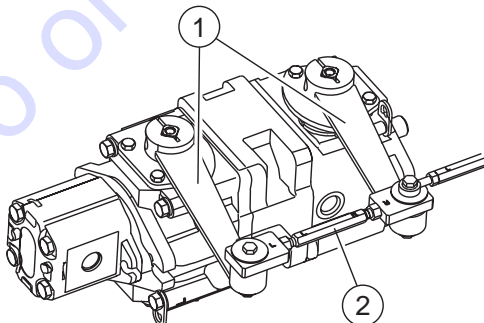

Figure 26. Trowel Speed Control

Right Side Trowel Speed Adjustment

The right side trowel speed is adjusted by changing the length of the connecting rod on the pump actuation levers (Figure 27).



1. Pump Actuation Levers
2. Connecting Rod

Figure 27. Pump Connecting Rod & Levers

This rod is basically a turnbuckle (Figure 28). Rotating it in one direction increases the length and corresponding trowel speed. Rotating it the opposite direction decreases the length and trowel speed. The right side trowel speed should be within 3 rpm of the left.

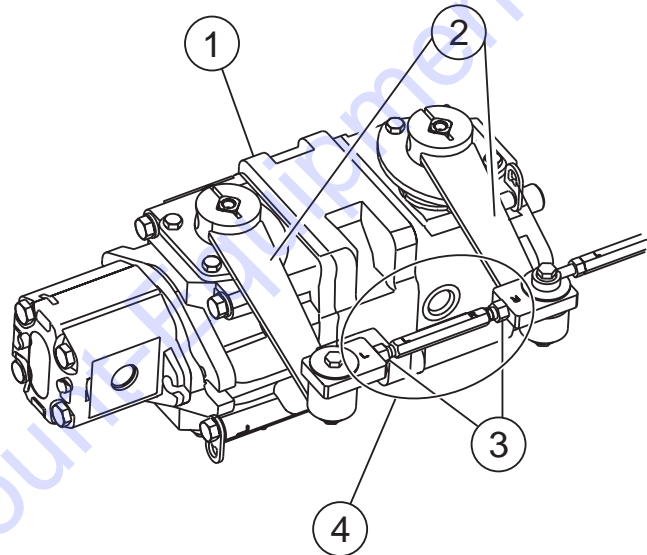

1. Hydraulic Pump (Top View)
2. Pump Actuation Levers
3. Adjustment Nuts
4. Turnbuckle Assembly

Figure 28. Turnbuckle & Adjustment Nuts

A good starting point in the adjustment process is to adjust the rod such that both trowels begin to rotate at the same time when the foot pedal is slowly depressed. This will, generally, get the speeds fairly close; close enough for use if instrumentation is unavailable (i.e. on the job site). From this point on, some form of instrumentation is required to verify that the trowel speeds are within tolerance. A strobe or magnetic pickup type speed indicator is recommended to verify the speeds.

The trowel speeds should be adjusted on a dry concrete floor with the blades pitched flat. Units with the Yanmar turbocharged engine should be set at 130-135 RPM with the engine at full speed.

Matching Blade Pitch for Both Sets of Blades

Sometimes it may be necessary to match blade pitch between the left and right sets of blades. There are some signs that this may be necessary. For example, the differences in pitch can cause a noticeable difference in finish quality between the left and right sets of blades. The difference in blade pitch can also make the machine difficult to control. This is due to the surface area in contact with the concrete (the blade set with the greater contact area tends to stick to the concrete more).

To synchronize pitch on both sides, the left blade assembly can be pitched by itself. By using the electric blade pitch rocker switches, (Figure 29) the pitch can be synchronized on the left and the right sides.

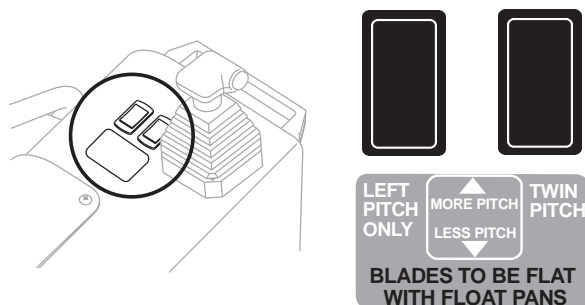

Figure 29. Blade Pitch Rocker Switches

Blade Pitch Adjustment Procedure

The maintenance adjustment of blade pitch is an adjustment that is made by a bolt (Figure 30) on the arm of the trowel blade finger. This bolt is the contact point of the trowel arm to the lower wear plate on the thrust collar. The goal of adjustment is to promote consistent blade pitch and finishing quality.

Watch for the following indications when determining if blade pitch adjustments are necessary:

- Is the machine wearing out blades unevenly (i.e. one blade is completely worn out while the others look new)?
- Does the machine have a perceptible rolling or bouncing motion when in use?
- Look at the machine while it is running, do the guard rings “rock up and down” relative to the ground?

Adjustments are made by tightening or loosening the blade pitch adjustment bolt (Figure 30).

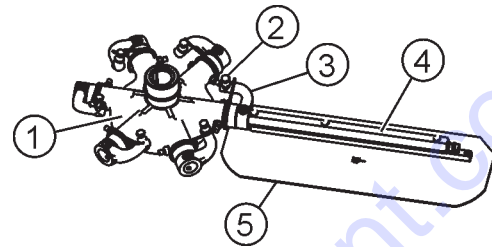

1. Spider Plate
2. Blade Pitch Adjustment Bolt
3. Trowel Lever
4. Trowel Arm
5. Trowel Blade

Figure 30. Blade Pitch Adjustment Bolt

The easiest and most consistent way to make this adjustment is to use the Trowel Arm Adjustment Fixture (P.N. 9177) that is manufactured by Whiteman Industries. This fixture will allow consistent adjustment of the trowel arm fingers. It comes with all the hardware necessary to properly accomplish this maintenance and instructions on how to properly utilize this tool. Adjusting the trowel arm fingers without a fixture requires a special talent.

If a trowel arm adjustment fixture is not available and immediate adjustment is necessary; we suggest the following procedure. If you can see or feel which blade is pulling harder, adjust the bolt that corresponds to that blade. Another way to determine which blades need adjustment is to place the machine on a flat surface and pitch the blades as flat as possible. Now, look at the adjustment bolts. They should all barely make contact with the lower wear plate on the spider. If you can see that one of them is not making contact; some adjustment will be necessary.

It will be possible to adjust the “high” bolts down to the level of the one that is not touching, or adjust the “low” bolt up to the level of the higher ones. If possible, adjust the low bolt up to the level of the rest of the bolts. This is the fastest way, but may not always work. Verify that after adjustment, the blades pitch correctly. Often times, if the blades are incorrectly adjusted, they will not be able to pitch flat. This occurs when the adjusting bolts have been raised too high. Conversely, sometimes the adjusting bolts are too low and the blades cannot be pitched high enough for finishing operations.

Stabilizer Ring Removal

1. To remove the outer stabilizer ring (Figure 31), remove the six bolts at the end of each spider arm.

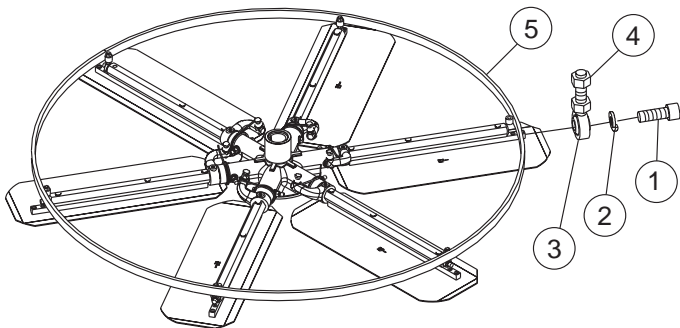

- | | |
|---|-----------------|
| 1 | Hex Cap Screw |
| 2 | Lock Washer |
| 3 | Rod End |
| 4 | Hex Nut |
| 5 | Stabilizer Ring |

Figure 31. Stabilizer Ring

2. Examine stabilizer ring for out of round or bends. If ring is damaged, replace ring. If ring is found to be correct with no damage, set aside.

Changing A Blade

It is recommended that all the blades on the entire machine are changed at the same time. If only one or some of the blades are changed at one time, the machine will not finish concrete consistently and the machine may wobble or bounce.

1. Place the machine on a flat, level surface. Adjust the blade pitch control to make the blades as flat as possible. Note the blade orientation on the trowel arm. This is important for ride-on trowels as the two sets of blades counter-rotate. Lift the machine up, placing blocks under the main guard ring to support it.
2. Remove the bolts and lock washers on the trowel arm, and then remove the blade. (Access is easier if the steps are removed.)
3. Scrape all concrete and debris from the trowel arm. This is important to properly seat the new blade.
4. Install the new blade, maintaining the proper orientation for direction of rotation.
5. Affix the bolts and lock washers.
6. Torque to 9 ft. lbs.
7. Repeat steps 2-6 for all remaining blades.

Trowel Blade Removal

1. Remove the trowel blades from the trowel arm by removing the three hex head bolts (Figure 32) from the trowel arm. Set blades aside.

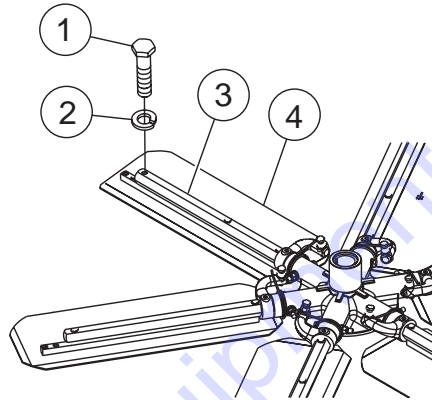

- | | |
|---|---------------|
| 1 | Hex Cap Screw |
| 2 | Lock Washer |
| 3 | Arm |
| 4 | Blade |

Figure 32. Trowel Blade Removal

2. **Wirebrush** any build-up of concrete from all six sides of the trowel arm. Repeat this for the remaining arms.

Trowel Arm Removal

1. Each trowel arm is held in place at the spider plate by a hex head bolt (with zerk grease fitting). Remove the hex head bolt/zerk grease fitting from the spider plate. (Figure 33)
2. Remove the trowel arm from the spider plate.

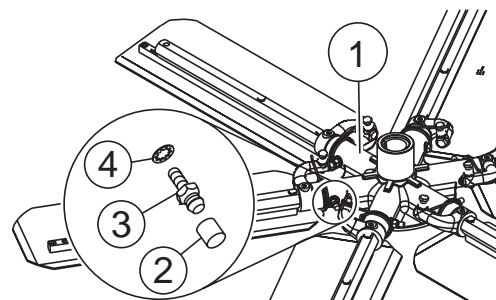

- | | |
|---|------------------------------|
| 1 | Spider Plate |
| 2 | Cap |
| 3 | Hex Head Bolt (Zerk Fitting) |
| 4 | Star Washer |

Figure 33. Removing Zerk Grease Fitting

- Should the trowel arm inserts (bronze bushing) (item 2 Fig. 34) come out with the trowel arm, remove the 2-piece bushing from the trowel arm and set aside in a safe place. If the bushing is retained inside the spider plate, carefully remove the bushing.
- Examine the 2-piece bronze trowel arm bushing insert (Figure 34), clean if necessary. Replace bushing if out-of-round or worn.

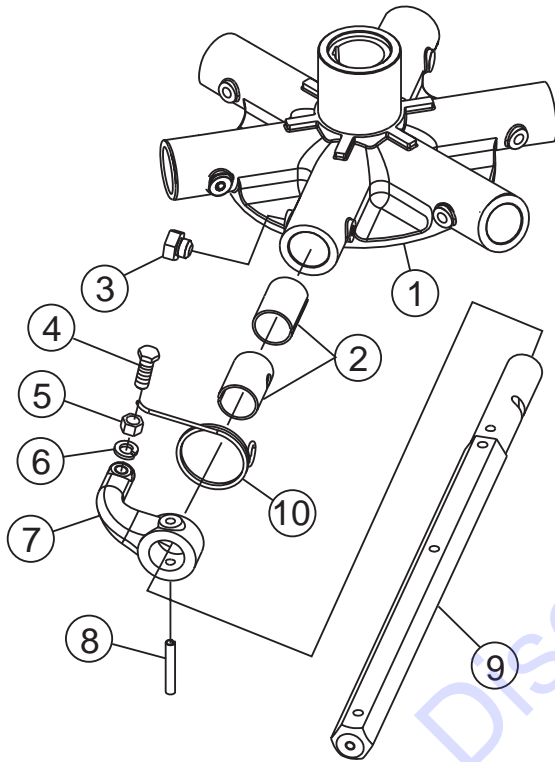

- Spider Plate
- 2-Piece Bushing
- Hex Head Screw
- Hex Head Screw (Rounded)
- Hex Jam Nut
- Lock Washer
- Trowel Arm Lever
- Roll Pin
- Trowel Arm
- Arm Return Spring

Figure 34. Bronze Bushings

Checking Trowel Arm Straightness

Trowel arms can be damaged by rough handling, (such as dropping the trowel on the pad), or by striking exposed plumbing, forms, or rebar while in operation. A bent trowel arm will not allow the trowel to operate in a smooth fluid rotation. If bent trowel arms are suspect, check for flatness as follows, refer to Figures 35 and 36:

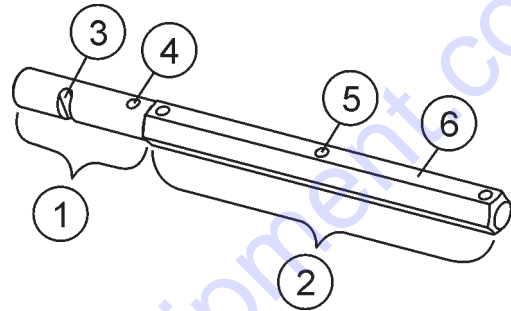

- Trowel Arm Round Shaft Section
- Trowel Arm Hexagonal (Hex) Shaft Section
- Lever Mounting Slot (Left Arm Shown)
- Roll Pin Hole
- Blade Attachment Bolt Hole (One of Three)
- Flat of Hexagonal Shaft (Top of Arm)

Figure 35. Trowel Arm

- Use a thick steel plate, granite slab or any surface which is **true** and **flat**, to check all **six sides** of each trowel arm for flatness.
- Check each of the six sides of the trowel arm (hex section). A feeler gauge of .004" (0.10 mm) should not pass between the flat of the trowel arm and the test surface along its length on the test surface. (Figure 36, Item 3).

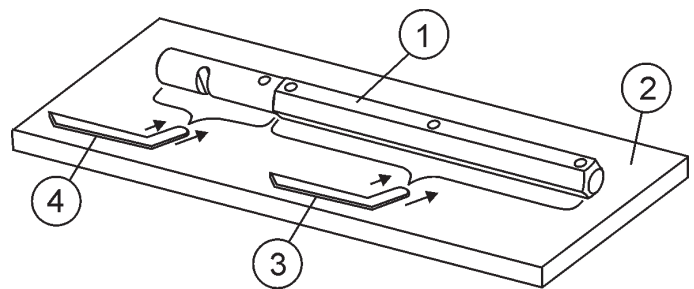

- Trowel Arm
- Flat Test Surface
- Feeler Gauge (.004 in. / 0.10 mm)
- Feeler Gauge (.005 in. / 0.127 mm)

Figure 36. Checking Trowel Arm Flatness

- Next, check the clearance between the round shaft and the test surface as one of the flat hex sections of the arm rests on the test surface. Rotate the arm to each of the flat hex sections and check the clearance of the round shaft. Use a feeler gauge of .005" (0.127 mm). Each section should have the **same clearance** between the round of the trowel arm shaft and the test surface.
- If the trowel arm is found to be **uneven** or **bent**, replace the trowel arm.

Trowel Arm Adjustment

Shown in (Figure 39) is the adjustment fixture with a trowel arm inserted. As each trowel arm is locked into the fixture, the arm bolt is adjusted to where it contacts a stop on the fixture. This will consistently adjust all of the trowel arms, keeping the finisher as flat and evenly pitched as possible.

- Locate the trowel arm adjustment tool P/N 9177.

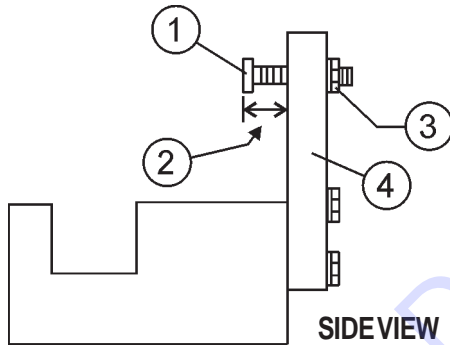

- | | |
|---|-----------------|
| 1 | Adjustment Bolt |
| 2 | "Distance" |
| 3 | Locking Nut |
| 4 | Fixture Arm |

Figure 37. Trowel Arm Adjustment Tool (Side-View)

- Ensure the fixture arm is in the proper setting (up or down) for your trowel arm rotation as shown in Figure 38.

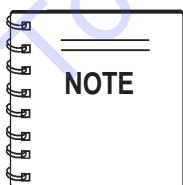

Arms with **CLOCK-WISE** blade rotation use the fixture arm in the **UP** position (A in Figure 38). Arms with **COUNTER CLOCK-WISE** blade rotation use the fixture with the fixture arm in the **DOWN** position. (B in Figure 38).

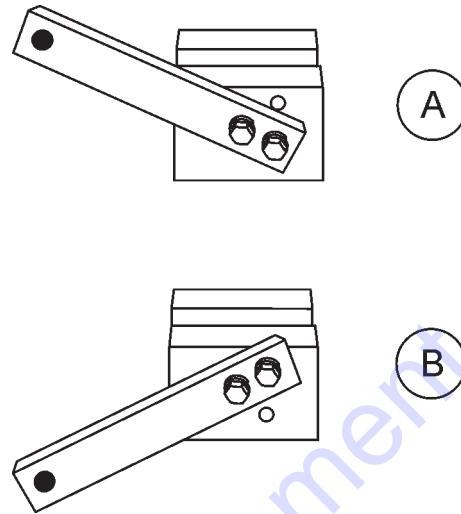
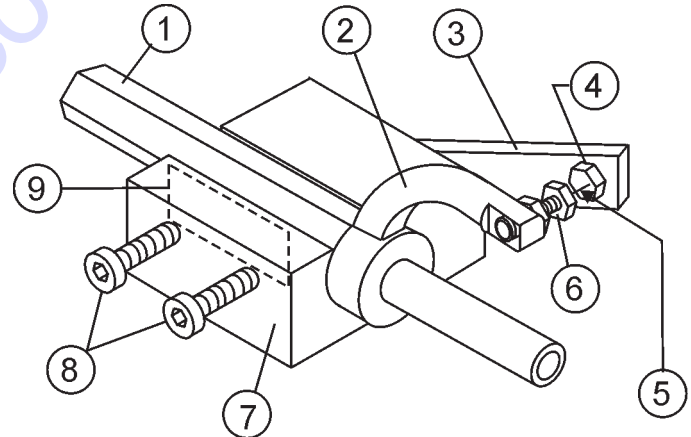

Figure 38. Trowel Arm Adjustment Setup

- Unscrew the locking bolts on the adjustment tool and place the trowel arm into the fixture channel as shown in Figure 39. A **thin shim** may be required to cover the blade holes on the trowel arm. Make sure to align the **trowel** adjustment bolt with the **fixture** adjustment bolt.



- | | |
|---|-------------------------------|
| 1 | Arm |
| 2 | Trowel Arm Lever |
| 3 | Fixture Arm |
| 4 | Adjustment Bolt |
| 5 | Distance = .010 Inch |
| 6 | Adjustment Bolt |
| 7 | Trowel Arm Adjustment Fixture |
| 8 | Locking Bolts |
| 9 | Shim |

Figure 39. Trowel Arm Adjustment Fixture Components

4. Use an allen wrench to tighten the locking bolts securing the trowel arm in place.
5. Adjust the bolt "distance" shown in Figure 37 to match one of the arms. The other arms will be adjusted to match this distance.
6. Loosen the locking nut on the trowel arm lever, then turn the trowel arm adjusting bolt until it barely touches (.010") the fixture adjusting bolt.
7. Once the correct adjustment is made, tighten the lock nut on the trowel arm to lock in place.
8. Loosen locking nuts on the adjustment fixture, and remove trowel arm.
9. Repeat steps for the remaining trowel arms.

Re-Assembly

1. Clean and examine the upper/lower wear plates and thrust collar. Examine the entire spider assembly. Wire brush any concrete or rust build-up. If any of the spider components are found to be damaged or out of round, replace them.
2. Make sure that the bronze trowel arm bushing is not damaged or out of round. Clean the bushing if necessary. If the bronze bushing is damaged or worn, replace it.
3. Reinstall bronze bushing onto trowel arm.
4. Repeat steps 2 -3 for each trowel arm.
5. Make sure that the spring tensioner is in the correct position to exert tension on the trowel arm.
6. Insert all trowel arms with levers into spider plate (with bronze bushing already installed) using care to align grease hole on bronze bushing with grease hole fitting on spider plate.
7. Lock trowel arms in place by tightening the hex head bolt with zerk grease fitting and jam nut.
8. Re-install the blades onto the trowel arms.
9. Install stabilizer ring onto spider assembly.
10. Lubricate all grease points (zerk fittings) with premium "**Lithum 12**" based grease, conforming to NLG1 Grade #2 consistency.

STX-SERIES — MAINTENANCE

Checking Hydraulic Pressure

WARNING

NEVER use your hand to find hydraulic leaks. Use a piece of wood or cardboard. Hydraulic fluid injected into the skin must be treated by a knowledgeable physician immediately or severe injury or death can occur.



Many hydraulic problems are a result of low fluid levels. Before checking any other possibilities, make sure the hydraulic fluid level is up to the top of the sight glass which is located at the back/center of the frame.

Hydrostatic pressure can be checked using a pressure gauge with a range of at least 5,000 psi. Two male diagnostic quick couplers (one for each pump) are located beneath the right grill guard. To access couplers (Figure 41), remove the grill guard. It is best to use two gauges simultaneously (Figure 40), but it is possible to use only one gauge and repeat the procedure for each side.

To fully test the hydrostatic system, the spiders will need to be locked so that they cannot rotate. This can be done by wrapping a chain around an arm on each spider, thus chaining them together in the back of the trowel.

Once the pressure gauges are installed and the spiders chained together, the system can be checked.

With the foot pedal in the idle position and the engine at full speed, the pressure should be 200 to 300 psi. If the pressure is less than 200 psi, the charge system may need to be inspected and/or serviced. In particular, the suction filter and charge pump relief valve should be checked. The suction filter may be plugged, or the relief valve may be stuck. Either condition may cause low charge pressure.

With the engine at 50% to 70% of full speed, and spiders chained together, slowly depress the foot pedal and read the gauges. The pressure should get to at least 4,350 psi (300 bar). If the pressure will not attain 4,350 psi (300 bar), the pump should be inspected and/or serviced by an authorized service representative.

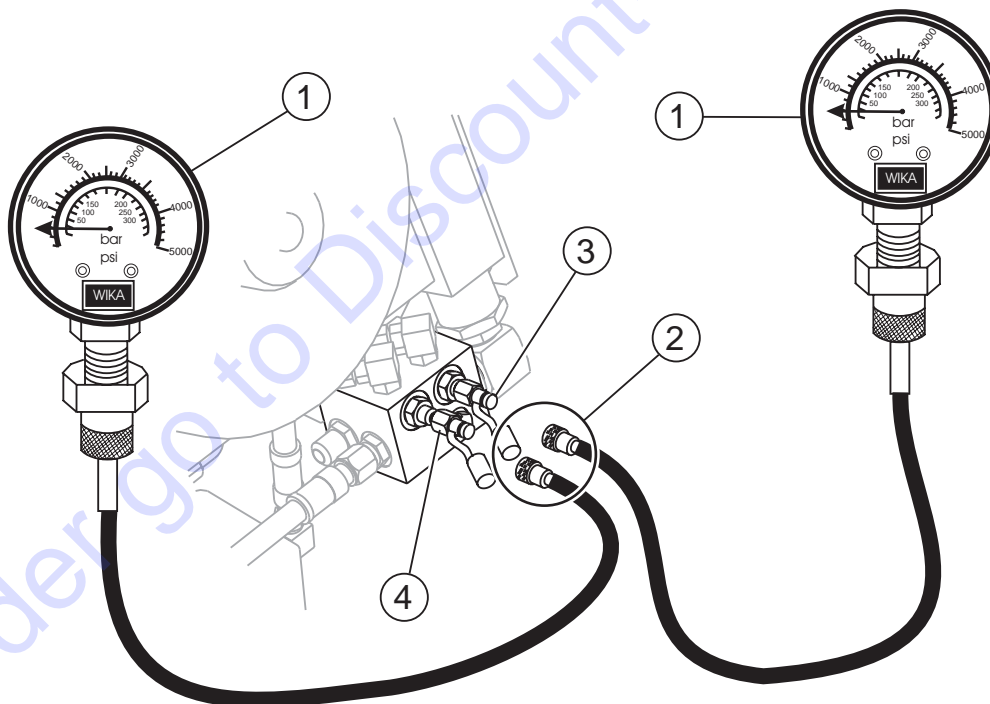

- 1 Pressure Gauge - 5,000 PSI Range
- 2 Parker Hannifin Quick Disconnect PD-Series Diagnostic Female Coupler
- 3 Right Side Hydrostatic Pump Test Port
- 4 Left Side Hydrostatic Pump Test Port

Figure 40. Pressure Gauge (Hydraulic Pump)

STX-SERIES — MAINTENANCE

Checking Steering Pressure

Steering pressure is also checked at either of the high pressure diagnostic couplers under the right grill guard. Check steering pressure at either coupler with a 300-600 PSI gauge.

CAUTION

DO NOT depress the FOOT PEDAL with the 300-600 PSI gauge installed or the gauge will be ruined.

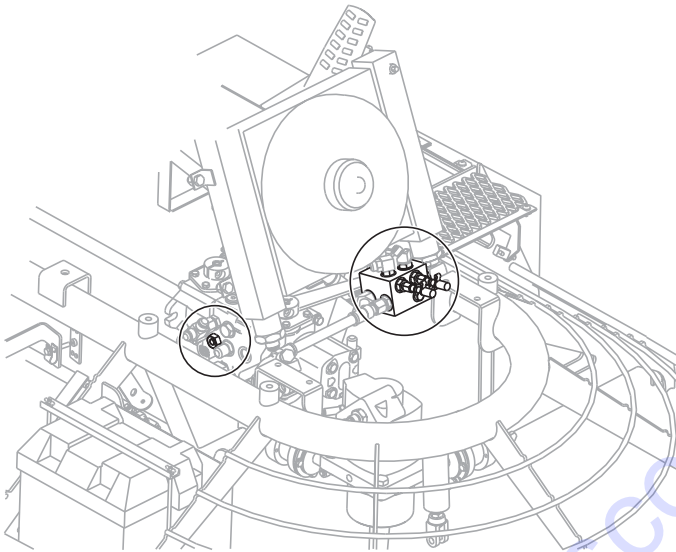
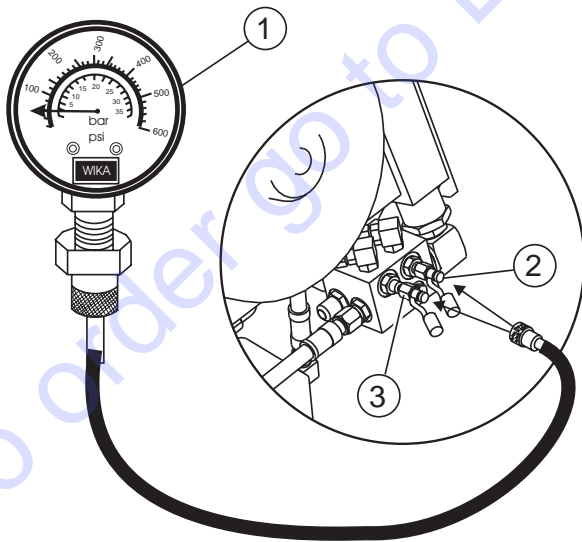

Figure 41. Pressure Check Couplers



- 1 Pressure Gauge - 300 - 600 PSI Range
- 2 Right Side Hydrostatic Pump Test Port
- 3 Left Side Hydrostatic Pump Test Port

Figure 42. Steering Pressure Check

(Table 5) indicates proper steering pressure. Check with engine at Full Speed.

Table 5. Steering Pressure

Checked With Engine at Full Speed	
Cool Oil	200-250 PSI
Hot Oil	180-200 PSI

Run the engine at full RPM. The steering system's factory setting is as shown in Table 5, however some operators may prefer a more responsive steering (higher pressure required) and some operators may prefer a "softer feel" (lower pressure required).

Steering Pressure Adjustment

Remember, **DO NOT** depress the foot pedal with the 300-600 PSI gauge installed. Immediate damage to the gauge will occur.

1. Remove right grill guard.
2. Install 300 or 600 PSI gauge (Figure 42).
3. Loosen 1-1/16" jam nut on charge relief valve (Item A, Figure 43).
4. Use a 1/2" socket to adjust the small hex nut within the larger hex jam nut (Item B, Figure 43).
5. Adjust to proper steering pressure specifications shown in Table 5.
6. Retighten jam nut, remove gauge, and reinstall grill guard.

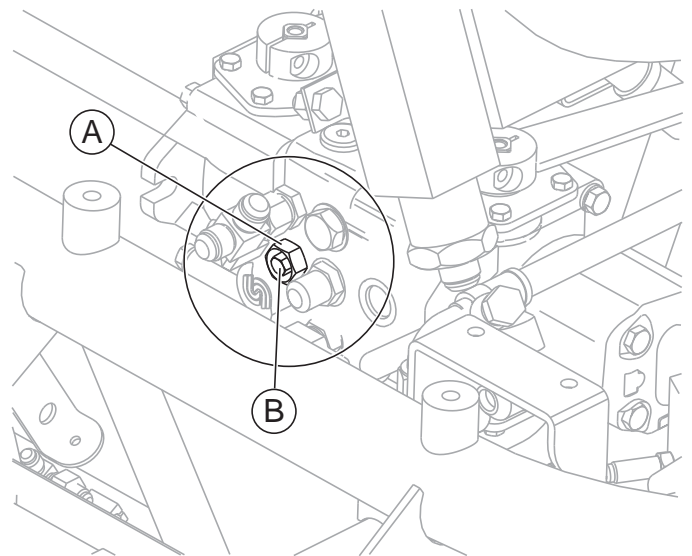

Figure 43. Steering Pressure Adjustment

Pitch Pressure Check

Access the pitch block and pitch pressure test port at the right-rear of the trowel (Figure 44). Removal of the right-rear seat frame panel may be necessary. Pitch pressure must be measured with a pitch switch **activated**. With pitch switches unactivated, the pitch pressure will be the same as the charge/steering pressure. Proper pitch pressure is 2300 PSI (2250 - 2350 PSI).

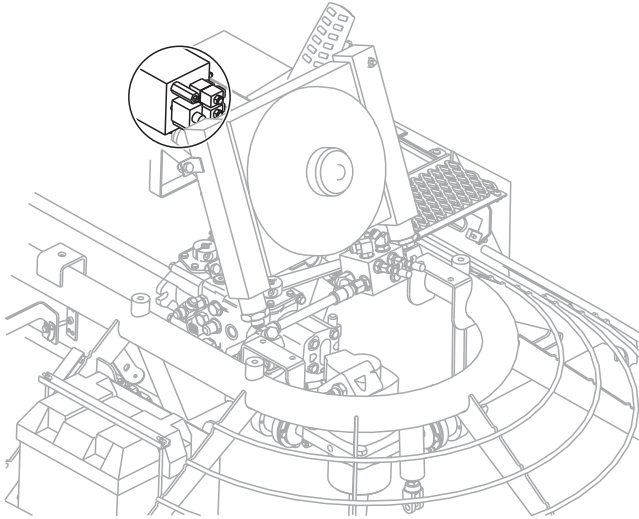
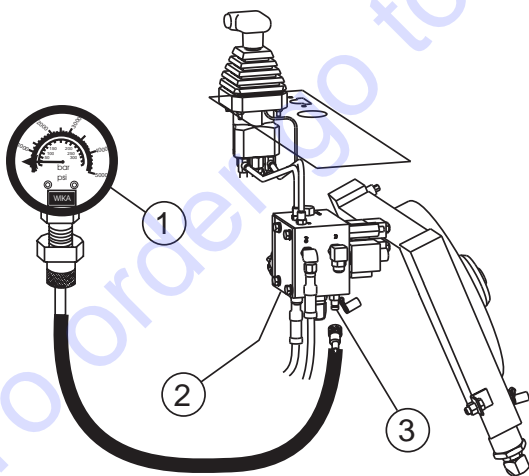

Figure 44. Pitch Block

1. Install 3000 PSI range pressure gauge to pitch pressure test port on pitch block (Figure 45).
2. Activate left pitch switch.
3. Flatten blades (bottom out the pitch cylinders).
4. Continue to hold down pitch switch and record pressure.



- 1 Pressure Gauge - 3,000 PSI Range
- 2 Access Pitch Block at Right-Rear of Trowel
- 3 Pitch Pressure Test Port

Figure 45. Pitch Pressure Check

Pitch Pressure Out of Specification

If the pitch pressure check is out of specification, check for the following:

1. Correct hydraulic fluid level.
2. Plugged hydraulic oil filter
3. Loose or leaking fittings.
4. Ruptured/damaged hydraulic lines.
5. Faulty hydraulic pump.
6. Pitch Pressure Relief Valve no longer at factory setting.

The Pitch Pressure Relief Valve is SET AT THE FACTORY, and normally should not require adjustment. If all other systems are found not to be defective and the pitch relief valve is suspect, the following steps can be used to adjust the valve.

CAUTION

NEVER allow the pitch pressure to exceed 2700 PSI or equipment damage may result.

WARNING

DO NOT attempt to adjust the Pitch Pressure Relief Valve while the engine is running.

1. Remove right grill guard and right rear seat frame panel.
2. With the engine **OFF**, remove the end cover on relief valve (Item A, Figure 46).
3. Adjust the relief valve (Item B, Figure 46) with allen wrench and reinstall the end cover.
4. Start the engine and check the pressure as described earlier. (See Pitch Pressure Check)
5. If pressure requires further adjustment, shut the engine down and repeat steps 2 through 4 until pressure check reads 2300 PSI.

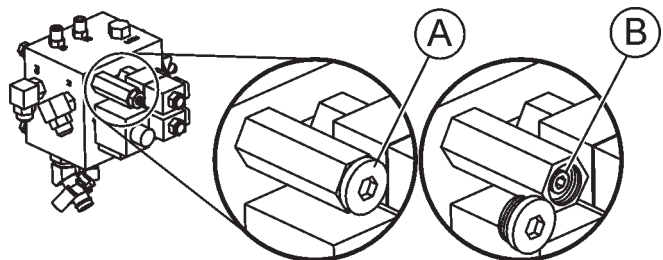

Figure 46. Pitch Pressure Relief Valve

Installing Pans Onto Finisher Blades

These round discs sometimes referred to as "pans" attach to the spiders arms and allow early floating on wet concrete and easy movement from wet to dry areas. They are also very effective in embedding large aggregates and surface hardeners.



Refer to Figure 47 when installing pans onto finisher blades.

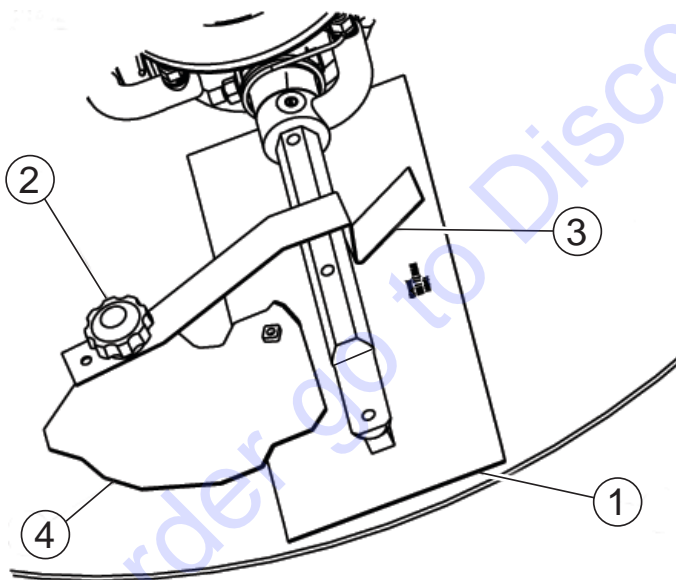

- 1 BLADE ASSEMBLY
- 2 KNOB, TIE-DOWN Z-CLIP PANS
- 3 TIE-DOWN, BLADE
- 4 Z-CLIP, PAN

Figure 47. Z-Clip Finisher Pan Installation

1. Lift trowel just enough to slide pan under blades. Lower finisher onto pan with blades (Item #1) adjacent to Z-Clips (Item #4).
2. Rotate blades into position under Z-Clips. Ensure that the blades are rotated in the direction of travel when the machine is in operation or use the engine to rotate the blades into position.
3. Attach the blade tie-downs (Item #3) to the far side of the Z-Clip brackets (Item #4) with tie-down knobs (Item #2) as shown in Figure 47.
4. Check to make certain that the blade edges are secured under the Z-Clips and the tie-downs are secured completely over the edges of the blade bar before the machine is put back into operation.

Decommissioning Trowel/Components

Decommissioning is a controlled process used to safely retire a piece of equipment that is no longer serviceable. If the equipment poses an unacceptable and unrepairable safety risk due to wear or damage or is no longer cost effective to maintain, (beyond life-cycle reliability) and is to be decommissioned, (demolition and dismantlement), the following procedure must take place:

1. Drain all fluids completely. These may include oil, gasoline, hydraulic oil and antifreeze. Dispose of properly in accordance with local and governmental regulations. Never pour on ground or dump down drains or sewers.
2. Remove battery and bring to appropriate facility for lead reclamation. Use safety precautions when handling batteries that contain sulfuric acid, (See page 16).
3. The remainder can be brought to a salvage yard or metal reclamation facility for further dismantling.

STX-SERIES — TROUBLESHOOTING

TABLE 5. TROUBLESHOOTING

SYMPTOM	POSSIBLE PROBLEM	SOLUTION
Engine running rough or not at all.	Fuel?	Look at the fuel system. Make sure there is fuel being supplied to the engine. Check to ensure that the fuel filter is not clogged.
	Ignition?	Check to ensure that the ignition switch has power and is functioning correctly.
Safety Stop Switch not functioning.	Other problems?	Consult engine manufacturer's manual.
	Loose wire connections?	Check wiring. Replace as necessary.
	Bad contacts?	Replace seat cushion (contains the switch).
If trowel "bounces, rolls concrete, or makes uneven swirls in concrete".	Blades?	Make certain blades are in good condition, not excessively worn. Finish blades should measure no less than 2" (50mm) from the blade bar to the trailing edge, combo blades should measure no less than 3.5" (89mm). Trailing edge of blade should be straight and parallel to the blade bar.
	Spider?	Check that all blades are set at the same pitch angle as measured at the spider. A field adjustment tool is available for height adjustment of the trowel arms (see Optional Equipment).
	Bent trowel arms?	Check the spider assembly for bent trowel arms. If one of the arms is even slightly bent, replace it immediately.
	Trowel arm bushings?	Check the trowel arm bushings for tightness. This can be done by moving the trowel arms up and down. If there is more than 1/8" (3.2 mm) of travel at the tip of the arm, the bushings should be replaced. All bushings should be replaced at the same time.
	Thrust collar?	Check the flatness of the thrust collar by rotating it on the spider. If it varies by more than 0.02" (0.5 mm) replace the thrust collar.
	Thrust collar bushing?	Check the thrust collar by rocking it on the spider. If it can tilt more than 1/16" (1.6 mm) [as measured at the thrust collar O.D.], replace the bushing in the thrust collar.
	Thrust bearing worn?	Check the thrust bearing to see that it is spinning free. Replace if necessary.
	Blade pitch?	Check blades for consistent pitch. Adjust per Maintenance Section instructions if necessary.
Machine has a perceptible rolling motion while running.	Spider Finger Screws?	Adjust per procedure in Maintenance Section.
	Yoke?	Check to make sure that both fingers of the yoke press evenly on the wear cap. Replace yoke as necessary.

STX-SERIES — TROUBLESHOOTING

TABLE 5. TROUBLESHOOTING (CONTINUED)

SYMPTOM	POSSIBLE PROBLEM	SOLUTION
Lights (optional) not working.	Wiring?	Check all electrical connections, including the master on/off switch and check to see if wiring is in good condition with no shorts. Replace as necessary.
	Lights?	Check to see if light bulbs are still good. Replace if broken.
Retardant spray (optional) not working.	Retardant?	Check the tank to make sure retardant is present. Fill tank as necessary.
	Wiring?	Check all electrical connections, including master on/off switch connections. Replace components and wiring as necessary.
	Bad switch?	Check the continuity of master on/off switch. Replace if broken.
	Bad spray pump?	If pump has a voltage present when the switch is turned on, but does not operate and electrical connections to the pump are good, replace the pump.
Steering is unresponsive.	Blade speed out of adjustment?	See section on blade speed adjustment.
	Worn components?	Check for wear of steering bearings and linkage components replace if necessary.
	Pivots?	Check to ensure free movement of hydraulic drive motors.
	Hydraulic pressure?	Check to ensure that hydraulic steering pressure is adequate. See section on checking hydraulic steering pressure.
Operating position is uncomfortable.	Seat adjust for operator?	Adjust seat with lever located on the front of the seat.
Pitch System not working.	Wiring?	Check and repair wiring and connectors as necessary.
	Spool stuck in solenoid valve?	Replace solenoid valve.

TO PURCHASE THIS PRODUCT PLEASE CONTACT US



**Equipment Financing and
Extended Warranties Available**



**Discount-Equipment.com is your online resource for
commercial and industrial quality parts and equipment sales.**

561-964-4949

visit us on line @ www.discount-equipment.com

Select an option below to find your Equipment

Search by Manufacturer

Search by Product Type

Request a Quote

We sell worldwide for the brands: Genie, Terex, JLG, MultiQuip, Mikasa, Essick, Whiteman, Mayco, Toro Stone, Diamond Products, Generac Magnum, Airman, Haulotte, Barreto, Power Blanket, Nifty Lift, Atlas Copco, Chicago Pneumatic, Allmand, Miller Curber, Skyjack, Lull, Skytrak, Tsurumi, Husquvarna Target, Stow, Wacker, Sakai, Mi-T-M, Sullair, Basic, Dynapac, MBW, Weber, Bartell, Bennar Newman, Haulotte, Ditch Runner, Menegotti, Morrison, Contec, Buddy, Crown, Edco, Wyco, Bomag, Laymor, EZ Trench, Bil-Jax, F.S. Curtis, Gehl Pavers, Heli, Honda, ICS/PowerGrit, IHI, Partner, Imer, Clipper, MMD, Koshin, Rice, CH&E, General Equipment, Amida, Coleman, NAC, Gradall, Square Shooter, Kent, Stanley, Tamco, Toku, Hatz, Kohler, Robin, Wisconsin, Northrock, Oztec, Toker TK, Rol-Air, APT, Wylie, Ingersoll Rand / Doosan, Innovatech, Con X, Ammann, Mecalac, Makinex, Smith Surface Prep, Small Line, Wanco, Yanmar