

OPERATION MANUAL



***WHITEMAN* SERIES**
MODEL HHNG5
RIDE-ON TROWEL
(VANGUARD 540000 GASOLINE ENGINE)

Revision #0 (07/16/13)



THIS MANUAL MUST ACCOMPANY THE EQUIPMENT AT ALL TIMES.

PN: 30039

TO PURCHASE THIS PRODUCT PLEASE CONTACT US



**Equipment Financing and
Extended Warranties Available**



**Discount-Equipment.com is your online resource for
commercial and industrial quality parts and equipment sales.**

561-964-4949

visit us on line @ www.discount-equipment.com

Select an option below to find your Equipment

Search by Manufacturer

Search by Product Type

Request a Quote

We sell worldwide for the brands: Genie, Terex, JLG, MultiQuip, Mikasa, Essick, Whiteman, Mayco, Toro Stone, Diamond Products, Generac Magnum, Airman, Haulotte, Barreto, Power Blanket, Nifty Lift, Atlas Copco, Chicago Pneumatic, Allmand, Miller Curber, Skyjack, Lull, Skytrak, Tsurumi, Husquvarna Target, Stow, Wacker, Sakai, Mi-T-M, Sullair, Basic, Dynapac, MBW, Weber, Bartell, Bennar Newman, Haulotte, Ditch Runner, Menegotti, Morrison, Contec, Buddy, Crown, Edco, Wyco, Bomag, Laymor, EZ Trench, Bil-Jax, F.S. Curtis, Gehl Pavers, Heli, Honda, ICS/PowerGrit, IHI, Partner, Imer, Clipper, MMD, Koshin, Rice, CH&E, General Equipment, Amida, Coleman, NAC, Gradall, Square Shooter, Kent, Stanley, Tamco, Toku, Hatz, Kohler, Robin, Wisconsin, Northrock, Oztec, Toker TK, Rol-Air, APT, Wylie, Ingersoll Rand / Doosan, Innovatech, Con X, Ammann, Mecalac, Makinex, Smith Surface Prep, Small Line, Wanco, Yanmar



CALIFORNIA — Proposition 65 Warning

Engine exhaust and some of its constituents, and some dust created by power sanding, sawing, grinding, drilling and other construction activities contains chemicals known to the State of California to cause cancer, birth defects and other reproductive harm.

Some examples of these chemicals are:

- Lead from lead-based paints.
- Crystalline silica from bricks.
- Cement and other masonry products.
- Arsenic and chromium from chemically treated lumber.

Your risk from these exposures varies, depending on how often you do this type of work. To reduce your exposure to these chemicals: **ALWAYS** work in a well ventilated area, and work with approved safety equipment, such as dust masks that are specially designed to filter out microscopic particles.

SILICOSIS/RESPIRATORY WARNINGS

⚠ WARNING



SILICOSIS WARNING

Grinding/cutting/drilling of masonry, concrete, metal and other materials with silica in their composition may give off dust or mists containing crystalline silica. Silica is a basic component of sand, quartz, brick clay, granite and numerous other minerals and rocks. Repeated and/or substantial inhalation of airborne crystalline silica can cause serious or fatal respiratory diseases, including silicosis. In addition, California and some other authorities have listed respirable crystalline silica as a substance known to cause cancer. When cutting such materials, always follow the respiratory precautions mentioned above.

⚠ WARNING

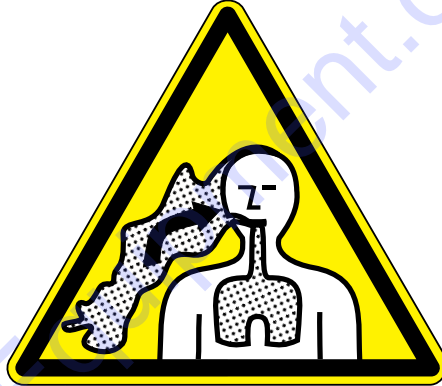

RESPIRATORY HAZARDS

Grinding/cutting/drilling of masonry, concrete, metal and other materials can generate dust, mists and fumes containing chemicals known to cause serious or fatal injury or illness, such as respiratory disease, cancer, birth defects or other reproductive harm. If you are unfamiliar with the risks associated with the particular process and/or material being cut or the composition of the tool being used, review the material safety data sheet and/or consult your employer, the material manufacturer/supplier, governmental agencies such as OSHA and NIOSH and other sources on hazardous materials. California and some other authorities, for instance, have published lists of substances known to cause cancer, reproductive toxicity, or other harmful effects.

Control dust, mist and fumes at the source where possible. In this regard use good work practices and follow the recommendations of the manufacturers or suppliers, OSHA/NIOSH, and occupational and trade associations. Water should be used for dust suppression when wet cutting is feasible. When the hazards from inhalation of dust, mists and fumes cannot be eliminated, the operator and any bystanders should always wear a respirator approved by NIOSH/MSHA for the materials being used.

TABLE OF CONTENTS

HHNG5 RIDE-ON TROWEL

Proposition 65 Warning	2
Silicosis/Respiratory Warnings	3
Table Of Contents	4
Training Checklist	6
Daily Pre-Operation Checklist	7
Safety Information	8-13
Specifications (Trowel).....	14
Specifications (Engine).....	15
General Information.....	16-17
Components (Trowel)	18-19
Components (Engine).....	20
New Machine Setup	21
Inspection	22
Operation.....	23-25
Maintenance.....	26-37
Troubleshooting (Trowel).....	38-39
Troubleshooting (Engine).....	40-41

NOTICE

Specifications are subject to change without notice.

TRAINING CHECKLIST

Training Checklist			
No.	Description	OK?	Date
1	Read operation manual completely.		
2	Machine layout, location of components, checking of engine oil level.		
3	Fuel system, refueling procedure.		
4	Operation of spray and lights.		
5	Operation of controls (machine not running).		
6	Safety controls, safety stop switch operation.		
7	Emergency stop procedures.		
8	Startup of machine, pre-heat, engine choke.		
9	Maintaining a hover.		
10	Maneuvering.		
11	Pitching.		
12	Matching blade pitch. Twin-Pitch™		
13	Concrete finishing techniques.		
14	Shutdown of machine.		
15	Lifting of machine (lift loops).		
16	Machine transport and storage.		

DAILY PRE-OPERATION CHECKLIST

Daily Pre-Operation Checklist		✓	✓	✓	✓	✓	✓
1	Engine oil level						
2	Radiator coolant level						
3	Condition of blades						
4	Blade pitch operation						
5	Safety stop switch operation						
6	Steering control operation						

To order go to Discount-Equipment.com

SAFETY INFORMATION

Do not operate or service the equipment before reading the entire manual. Safety precautions should be followed at all times when operating this equipment. Failure to read and understand the safety messages and operating instructions could result in injury to yourself and others.









SAFETY MESSAGES

The four safety messages shown below will inform you about potential hazards that could injure you or others. The safety messages specifically address the level of exposure to the operator and are preceded by one of four words: **DANGER**, **WARNING**, **CAUTION** or **NOTICE**.

SAFETY SYMBOLS

 DANGER
Indicates a hazardous situation which, if not avoided, WILL result in DEATH or SERIOUS INJURY .
 WARNING
Indicates a hazardous situation which, if not avoided, COULD result in DEATH or SERIOUS INJURY .
 CAUTION
Indicates a hazardous situation which, if not avoided, COULD result in MINOR or MODERATE INJURY .
NOTICE
Addresses practices not related to personal injury.

Potential hazards associated with the operation of this equipment will be referenced with hazard symbols which may appear throughout this manual in conjunction with safety messages.

Symbol	Safety Hazard
	Lethal exhaust gas hazards
	Explosive fuel hazards
	Burn hazards
	Rotating parts hazards
	Pressurized fluid hazards
	Hydraulic fluid hazards

SAFETY INFORMATION

GENERAL SAFETY

CAUTION

- **NEVER** operate this equipment without proper protective clothing, shatterproof glasses, respiratory protection, hearing protection, steel-toed boots and other protective devices required by the job or city and state regulations.





- Avoid wearing jewelry or loose fitting clothes that may snag on the controls or moving parts as this can cause serious injury.
- **NEVER** operate this equipment when not feeling well due to fatigue, illness or when under medication. 
- **NEVER** operate this equipment under the influence of drugs or alcohol.



- **ALWAYS** clear the work area of any debris, tools, etc. that would constitute a hazard while the equipment is in operation.
- No one other than the operator is to be in the working area when the equipment is in operation.
- **DO NOT** use the equipment for any purpose other than its intended purposes or applications.

NOTICE

- This equipment should only be operated by trained and qualified personnel 18 years of age and older.
- Whenever necessary, replace nameplate, operation and safety decals when they become difficult read.
- Manufacturer does not assume responsibility for any accident due to equipment modifications. Unauthorized equipment modification will void all warranties.
- **NEVER** use accessories or attachments that are not recommended by Multiquip for this equipment. Damage to the equipment and/or injury to user may result.
- **ALWAYS** know the location of the nearest fire extinguisher. 
- **ALWAYS** know the location of the nearest first aid kit. 
- **ALWAYS** know the location of the nearest phone or **keep a phone on the job site**. Also, know the phone numbers of the nearest ambulance, doctor and fire department. This information will be invaluable in the case of an emergency.

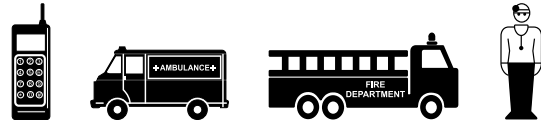

SAFETY INFORMATION

TROWEL SAFETY

DANGER

- Engine fuel exhaust gases contain poisonous carbon monoxide. This gas is colorless and odorless, and can cause death if inhaled.
- The engine of this equipment requires an adequate free flow of cooling air. **NEVER** operate this equipment in any enclosed or narrow area where free flow of the air is restricted. If the air flow is restricted it will cause injury to people and property and serious damage to the equipment or engine.



- **NEVER** operate the equipment in an explosive atmosphere or near combustible materials. An explosion or fire could result causing severe **bodily harm or even death.**



WARNING

- If applicable, **NEVER** use your hand to find hydraulic leaks. Use a piece of wood or cardboard. Hydraulic fluid injected into the skin must be treated by a knowledgeable physician immediately or severe injury or death can occur.
- **ALWAYS** keep clear of rotating or moving parts while operating the trowel.
- **NEVER** disconnect any **emergency or safety devices**. These devices are intended for operator safety. Disconnection of these devices can cause severe injury, bodily harm or even death. Disconnection of any of these devices will void all warranties.



CAUTION

- **NEVER** allow passengers or riders on the trowel during operation.
- **NEVER** lubricate components or attempt service on a running machine.
- **NEVER** place your feet or hands inside the guard rings while starting or operating this equipment.

NOTICE

- **ALWAYS** keep the machine in proper running condition.
- Fix damage to machine and replace any broken parts immediately.
- **ALWAYS** store equipment properly when it is not being used. Equipment should be stored in a clean, dry location out of the reach of children and unauthorized personnel.
- A safety manual for operating and maintenance personnel of concrete power trowels produced by the Association of Equipment Manufacturers (AEM) can be obtained from Discount-Equipment.

ENGINE SAFETY

WARNING

- **DO NOT** place hands or fingers inside engine compartment when engine is running.
- **NEVER** operate the engine with heat shields or guards removed.
- Keep fingers, hands hair and clothing away from all moving parts to prevent injury.
- **DO NOT** remove the radiator cap while the engine is hot. High pressure boiling water will gush out of the radiator and severely scald any persons in the general area of the trowel.
- **DO NOT** remove the coolant drain plug while the engine is hot. Hot coolant will gush out of the coolant tank and severely scald any persons in the general area of the trowel.
- **DO NOT** remove the engine oil drain plug while the engine is hot. Hot oil will gush out of the oil tank and severely scald any persons in the general area of the trowel.



CAUTION

- **NEVER** touch the hot exhaust manifold, muffler or cylinder. Allow these parts to cool before servicing equipment.



SAFETY INFORMATION

NOTICE

- **NEVER** run engine without an air filter or with a dirty air filter. Severe engine damage may occur. Service air filter frequently to prevent engine malfunction.
- **NEVER** tamper with the factory settings of the engine or engine governor. Damage to the engine or equipment can result if operating in speed ranges above the maximum allowable.



FUEL SAFETY

DANGER

- **DO NOT** start the engine near spilled fuel or combustible fluids. Fuel is extremely flammable and its vapors can cause an explosion if ignited.
- **ALWAYS** refuel in a well-ventilated area, away from sparks and open flames.
- **ALWAYS** use extreme caution when working with **flammable** liquids.
- **DO NOT** fill the fuel tank while the engine is running or hot.
- **DO NOT** overfill tank, since spilled fuel could ignite if it comes into contact with hot engine parts or sparks from the ignition system.
- Store fuel in appropriate containers, in well-ventilated areas and away from sparks and flames.
- **NEVER** use fuel as a cleaning agent.
- **DO NOT** smoke around or near the equipment. Fire or explosion could result from fuel vapors or if fuel is spilled on a hot engine.



BATTERY SAFETY

DANGER

- **DO NOT** drop the battery. There is a possibility that the battery will explode.
- **DO NOT** expose the battery to open flames, sparks, cigarettes, etc. The battery contains combustible gases and liquids. If these gases and liquids come into contact with a flame or spark, an explosion could occur.



WARNING

- **ALWAYS** wear safety glasses when handling the battery to avoid eye irritation. The battery contains acids that can cause injury to the eyes and skin.
- Use well-insulated gloves when picking up the battery.
- **ALWAYS** keep the battery charged. If the battery is not charged, combustible gas will build up.
- **DO NOT** charge battery if frozen. Battery can explode. When frozen, warm the battery to at least 61°F (16°C).
- **ALWAYS** recharge the battery in a well-ventilated environment to avoid the risk of a dangerous concentration of combustible gases.
- If the battery liquid (dilute sulfuric acid) comes into contact with **clothing or skin**, rinse skin or clothing immediately with plenty of water.
- If the battery liquid (dilute sulfuric acid) comes into contact with **eyes**, rinse eyes immediately with plenty of water and contact the nearest doctor or hospital to seek medical attention.



CAUTION

- **ALWAYS** disconnect the **NEGATIVE** battery terminal before performing service on the equipment.
- **ALWAYS** keep battery cables in good working condition. Repair or replace all worn cables.

SAFETY INFORMATION

TRANSPORTING SAFETY

CAUTION

- **NEVER** allow any person or animal to stand underneath the equipment while lifting.
- Ride-on trowels are very heavy and awkward to move around. Use proper heavy lifting procedures and **DO NOT** attempt to lift the trowel by the guard rings.



NOTICE

- The easiest way to lift the trowel is to utilize the lift loops that are welded to the frame. These lift loops are located to the left and right sides of the operator's seat.

A strap or chain can be attached to these lift loops, allowing a forklift or crane to lift the trowel up onto and off of a slab of concrete. The strap or chain should have a minimum of 2,000 pounds (1,000 kg) lifting capacity and the lifting gear must be capable of lifting at least this amount.

- **NEVER** transport trowel with float pans attached unless safety catches are used and are specifically cleared for such transport by the manufacturer.
- **NEVER** hoist the trowel more than three feet off the ground with float pans attached.
- Before lifting, make sure that the lift loops are not damaged.
- Always make sure crane or lifting device has been properly secured to the lift loops of the equipment.
- **ALWAYS** shutdown engine before transporting.
- **NEVER** lift the equipment while the engine is running.
- Tighten fuel tank cap securely and close fuel cock to prevent fuel from spilling.
- Use adequate lifting cable (wire or rope) of sufficient strength.
- **DO NOT** lift machine to unnecessary heights.
- **ALWAYS** tie down equipment during transport by securing the equipment with rope.

TOWING SAFETY

CAUTION

- Check with your local county or state safety towing regulations, in addition to meeting **Department of Transportation (DOT) Safety Towing Regulations**, before towing your trowel.
- In order to reduce the possibility of an accident while transporting the trowel on public roads, **ALWAYS** make sure the trailer that supports the trowel and the towing vehicle are mechanically sound and in good operating condition.
- **ALWAYS** shutdown engine before transporting
- Make sure the hitch and coupling of the towing vehicle are rated equal to, or greater than the trailer "gross vehicle weight rating."
- **ALWAYS** inspect the hitch and coupling for wear. **NEVER** tow a trailer with defective hitches, couplings, chains, etc.
- Check the tire air pressure on both towing vehicle and trailer. **Trailer tires should be inflated to 50 psi cold.** Also check the tire tread wear on both vehicles.
- **ALWAYS** make sure the trailer is equipped with a **safety chain**.
- **ALWAYS** properly attach trailer's safety chains to towing vehicle.
- **ALWAYS** make sure the vehicle and trailer directional, backup, brake and trailer lights are connected and working properly.
- DOT Requirements include the following:
 - Connect and test electric brake operation.
 - Secure portable power cables in cable tray with tie wraps.
- The maximum speed for highway towing is 55 MPH unless posted otherwise. Recommended off-road towing is not to exceed 15 MPH or less depending on type of terrain.
- Avoid sudden stops and starts. This can cause skidding, or jack-knifing. Smooth, gradual starts and stops will improve towing.
- Avoid sharp turns to prevent rolling.



- Trailer should be adjusted to a level position at all times when towing.
- Raise and lock trailer wheel stand in up position when towing.
- Place **chock blocks** underneath wheel to prevent rolling while parked.
- Place support blocks underneath the trailer's bumper to prevent tipping while parked.
- Use the trailer's swivel jack to adjust the trailer height to a level position while parked.

ENVIRONMENTAL SAFETY/DECOMMISSIONING

NOTICE

Decommissioning is a controlled process used to safely retire a piece of equipment that is no longer serviceable. If the equipment poses an unacceptable and unreparable safety risk due to wear or damage or is no longer cost effective to maintain (beyond life-cycle reliability) and is to be decommissioned (demolition and dismantlement), be sure to follow rules below.

- **DO NOT** pour waste or oil directly onto the ground, down a drain or into any water source.
- Contact your country's Department of Public Works or recycling agency in your area and arrange for proper disposal of any electrical components, waste or oil associated with this equipment.
- When the life cycle of this equipment is over, remove battery and bring to appropriate facility for lead reclamation. Use safety precautions when handling batteries that contain sulfuric acid.
- When the life cycle of this equipment is over, it is recommended that the trowel frame and all other metal parts be sent to a recycling center.



Metal recycling involves the collection of metal from discarded products and its transformation into raw materials to use in manufacturing a new product.

Recyclers and manufacturers alike promote the process of recycling metal. Using a metal recycling center promotes energy cost savings.

EMISSIONS INFORMATION

NOTICE

The gasoline engine used in this equipment has been designed to reduce harmful levels of carbon monoxide (CO), hydrocarbons (HC) and nitrogen oxides (NOx) contained in diesel exhaust emissions.

This engine has been certified to meet US EPA Evaporative emissions requirements in the installed configuration.

Attempting to modify or make adjustments to the engine emission system by unauthorized personnel without proper training could damage the equipment or create an unsafe condition.

Additionally, modifying the fuel system may adversely affect evaporative emissions, resulting in fines or other penalties.

Emission Control Label

The emission control label is an integral part of the emission system and is strictly controlled by regulations.

The label must remain with the engine for its entire life.

If a replacement emission label is needed, please contact your authorized Yanmar Engine Distributor.

DIMENSIONS/SPECIFICATIONS (TROWEL)

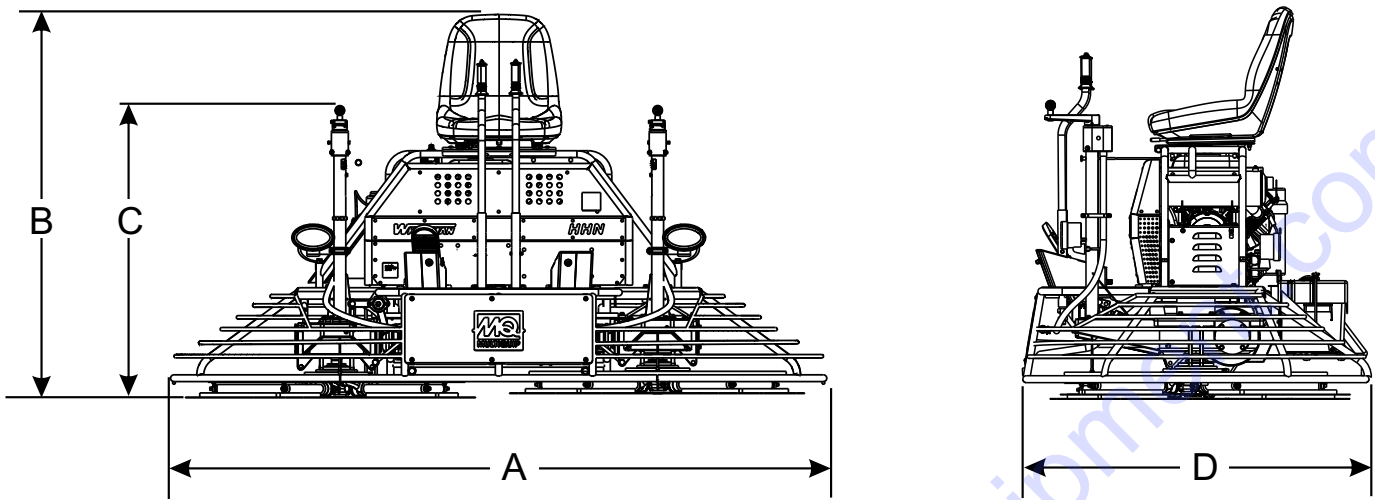

Figure 1. Dimensions

Table 2. HHNG5 Specifications	
A—Length – in. (cm)	97.0 (246.4)
B—Height (Seat) – in. (cm)	50.0 (127)
C—Height (Crank Handle) – in. (cm)	46.0 (117)
D—Width – in. (cm)	46.0 (117)
Weight – lbs. (kgs.) Operating	1,083 (495)
Weight – lbs. (kgs.) Shipping	1,368 (620)
Fuel Tank – gallons (liters)	5 (19)
Rotor – RPM	0 to 180
Path Width – in. (cm)	92 (233)
Gear Box Oil Capacity	144 OZ. (4.26 liters) ISO 220 AGMA GR 5EP

SPECIFICATIONS (ENGINE)

Table 3. Noise and Vibration Emissions	
Model	HHNG5
Guaranteed ISO 11201:2010 Based Sound Pressure Level at Operator Station in dB(A) ^a	91
Guaranteed ISO 3744:2010 Based Sound Power Level in dB(A) ^b	106
Whole Body Vibration Per ISO 2631-1:1997 +A1:2010 in m/s ² $\Sigma A(8)$	0.03
<small>a. With an uncertainty factor K of 2.5 dB (A) included per Note 1 in section 7.2.1 of EN 12649::2008+A1:2011 b. With an uncertainty factor K of 1.5 dB (A) included per Note 1 in section 7.2.1 of EN 12649::2008+A1:2011</small>	

Table 4. Engine Specifications	
Model	540000, Briggs & Stratton, Vanguard
Type	OHV, air cooled gasoline engine
Cylinders	2
Piston Displacement	54.88 cu.in. (896 cc)
Bore and Stroke	3.36 in.x 3.07 in. (85.5 mm x 78 mm)
Max. Output	35 bhp/3600 rpm (26 kW)
Max. Torque	58.3 lbf-ft (26.4 Kg) at 2300 rpm
Engine Oil Type	SAE 30, 10W-30, 5W-30 or SF, SG, SH, SJ or higher
Engine Oil Capacity	2.5 qt. (2.36 liters)
Lubricating System	Pressure feed with spin-on filter
Fuel Type	Gasoline - minimum of 87 octane rating
Starting System	12 VDC Electric Start
Resistor Spark Plug Type	B&S 692051
Spark Plug Gap	.030 in. (0.76 mm)
Dimensions (L x W x H)	20.0 in. x 19 in. x 28 in. (508 mm x 483 mm x 711 mm)
Shipping Weight	149 lbs. (67.5 kg)

GENERAL INFORMATION

HHNG5 RIDE-ON POWER TROWEL FAMILIARIZATION

This Ride-On Power Trowel is designed for the floating and finishing of concrete slabs.

Take a walk around your trowel. Take notice of all the major components (see Figure 2 and Figure 3) like the engine, blades, air cleaner, fuel system, fuel shut-off valve, ignition switch, etc. Ensure engine and gearbox lubricant levels are within proper operating range.

Read all the safety instructions carefully. Safety instructions will be found throughout this manual and on the machine. Keep all safety information in good, readable condition. Operators should be well-trained on the operation and maintenance of the trowel.

Look at the operator control levers. Grasp the control levers and move them around a bit. Observe how moving the control levers cause the gearboxes and frame to move.

Notice the foot pedal which controls the engine and blade speed. Also take a look at the main driveline of the trowel. Take note and reference the drive belt alignment, this is the way the belt should be aligned when adjusted properly.

Before using your trowel, test it on a flat watered down section of finished concrete. This trial test run will increase your confidence in using the trowel, and at the same time, it will familiarize you with the trowel's controls and indicators. In addition, you will understand how the trowel will handle under actual conditions.

Engine

This trowel is equipped with a Briggs and Stratton Vanguard air-cooled, V-twin big block, 35 HP gasoline engine. Refer to the engine owner's manual for specific instructions regarding engine operation. This manual is included with the trowel at the time of shipping. Please contact your nearest Multiquip dealer should a replacement manual be required.

Blades

The blades of the towel finish the concrete as they are swirled around the surface. Blades are classified as combination (10 or 8 inches wide) and finish (6 inches wide). This trowels is equipped with five blades per rotor equally spaced in a radial pattern and attached to a vertical rotating shaft by means of a spider assembly.

Twin Pitch Control™

The Twin Pitch™ control feature allows the operator to simultaneously control the pitch of both rotors with minimal effort yet still allows for individual pitch control.

Helical Gearboxes

This trowel is designed with two separate helical gearbox assemblies that are enclosed in rugged cast aluminum gear cases.

Steering

Dual control levers located in front of the operator's seat are provided for steering this trowel. The control levers are linked to two spring loaded cylinders. In addition a **steering assist** feature has been provided to make controlling of the trowel easier especially when float pans are installed.

Push the left control lever forward and pull the right control lever backward and the trowel will rotate clockwise on approximately a center axis. Pull the left control lever backward and push the right control lever forward and the trowel will rotate counterclockwise. See Table 7 for a complete description of the control levers' directional positioning.

Constant Velocity Joints (CV-Joints)

Constant velocity joints insure the efficient transfer of power to the drive shaft and maintains the timing of the gearboxes without any chance of slippage.

Continuously Variable Transmission (CVT)

A Continuously Variable Transmission (CVT) has been installed to obtain maximum drive torque.

This is accomplished by continually adjusting the drive ratio to obtain optimum torque and speed during all phases of finishing from low speed high torque to high speed burnishing.

HOW IT WORKS

The Multi-Clutch functions much like a standard CVT system. As the engine RPM's increase, the drive or primary clutch closes, forcing the belt to ride outwards on the drive sheaves. The closing of the drive clutch also forces the belt to open the driven or secondary sheaves. The opening and closing of these sheaves creates a ratio variation... hence CVT or Continuously Variable Transmission.

Belt protection is achieved within the Multi-Clutch through the use of a series of centrifugal clutches. While most CVT systems have a loose or slack belt while the engine idles, the sheaves of those systems are constantly rotating and wearing on the belt.

Those systems also require the stationary belt to be pinched by the constantly rotating sheaves during startup. The relative rotation of the sheaves to the belt causes unnecessary wear on the belt. With traditional CVT systems, wear on the belt happens any time the engine is idling and at every start up of the driven equipment. This is where the Multi-Clutch differs from the other CVT's.

The Multi-Clutch utilizes two centrifugal clutches (the starter clutch system) to drive the sheaves of the drive (primary) clutch. What that means is that the belt can remain tight in the sheaves, and that both the sheaves and the belt are stationary while the vehicle is idling. This eliminates the belt wear at an idle, and during start up, while also providing one additional form of belt protection.

The centrifugal clutches (starter clutch) can act as overload protection as well. In cases where too much torque is trying to be transmitted to the belt, the centrifugals can slip before the maximum load on the belt is achieved. What this means is that instead of the belt slipping on the sheaves during an overload, the centrifugals will first slip further protecting the belt from damage.

Training

For training, please use the "TRAINING CHECKLIST" located in the front of this manual. This checklist is not intended to be a substitute for proper training but will provide an outline for an experienced operator to provide training to a new operator.

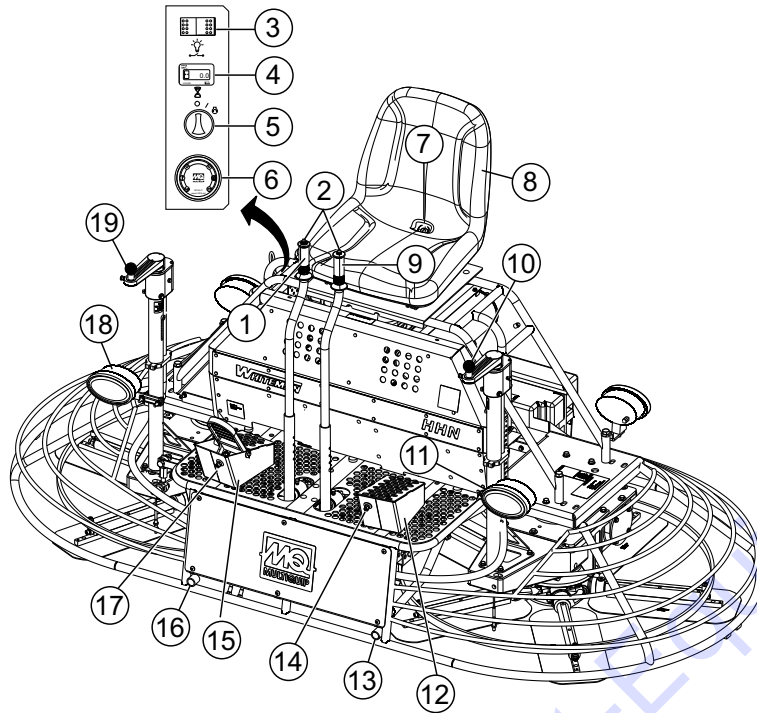

Figure 2. HHNG5 Components (Front)

1. **Steering Control Lever (right-side)** — Allows the unit to move in either a forward, reverse left or right direction
2. **Retardant Spray Control Buttons** — When pressed allows retardant spray to flow through the spray nozzle located at the front of the machine.
3. **Light Switch** — When activated, turns on four halogen lights. Lights offer better visibility when working indoors.
4. **Hour Meter** — Indicates number of hours the key switch is in the "ON" position.
5. **Ignition Switch** — With key inserted turn clockwise to start engine.
6. **Oil, Temperature and Charge Indicator Display** — Will illuminate when oil pressure is low, high water temperature or electrical system is not charging properly
7. **Safety Stop Switch** — Shuts down engine when operator is not sitting in seat.
8. **Seat** — Provides comfortable position for operation of the trowel. Engine will not start unless operator is seated. Seat is adjustable, fore and aft for operator comfort.
9. **Steering Control Lever (left-side)** — Allows the unit to move in either a forward, reverse left or right direction
10. **Twin Pitch Control (Left)** — Adjusts the blade pitch for left side of the trowel. Turn the crank as marked on its top surface to increase or decrease blade pitch.
11. **Left Front Light** — 55 watt, 12 VDC Hella™ halogen light is provided for night time and indoor work.
12. **Left Foot Riser** — Operator foot rest pedal.
13. **EZ- Mover Boss** — Insertion point (left-front) for EZ Mover. Used when the transporting of the trowel is required.
14. **Left-Front Spray Nozzle** — Spray nozzle for retardant.
15. **Right Foot Pedal** — Controls blade speed. Slow blade speed is accomplished by slightly depressing the foot pedal. Maximum blade speed is accomplished by fully depressing the foot pedal.
16. **EZ- Mover Boss** — Insertion point (right-front) for EZ Mover. Used when the transporting of the trowel is required.
17. **Right-Front Spray Nozzle** — Spray nozzle for retardant.
18. **Right Front Light** — 55 watt, 12 VDC Hella™ halogen light is provided for night time and indoor work.
19. **Twin Pitch Control (Right)** — Adjusts the blade pitch for right side of the trowel. Turn the crank as marked on its top surface to increase or decrease blade pitch.

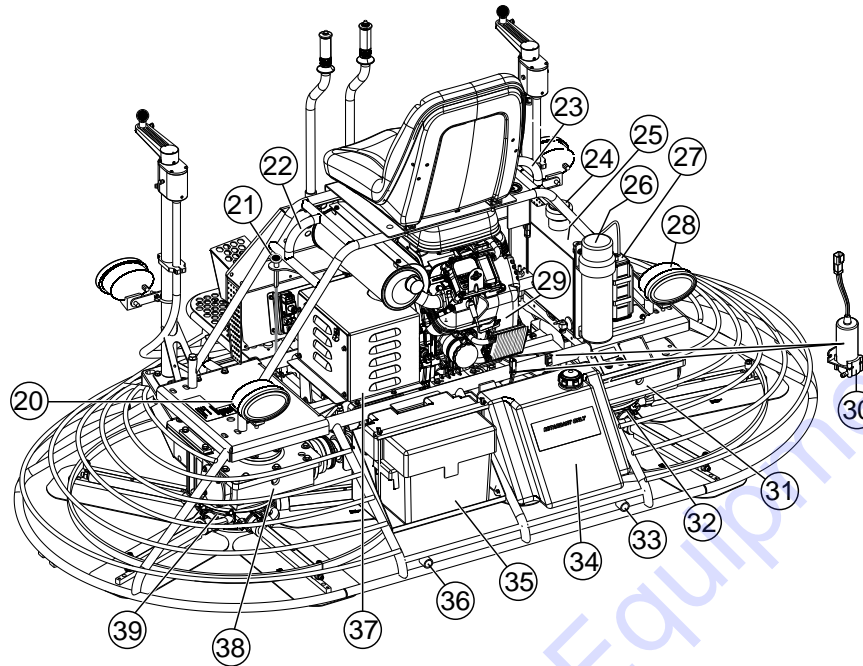

Figure 3. HHNG5 Components (Rear)

- 20. **Left Rear Light** — 55 watt, 12 VDC Hella™ halogen light is provided for night time and indoor work.
- 21. **Choke Knob** — Used in the starting of a cold engine, or in cold weather conditions. The choke enriches the fuel mixture.
- 22. **Left-Side Lift Loop** — Attach a strap of adequate lifting capacity to this loop when the trowel must be lifted.
- 23. **Right-Side Lift Loop** — Attach a strap of adequate lifting capacity to this loop when the trowel must be lifted onto a concrete slab.
- 24. **Fuel Tank** — Holds 5 gallons of fuel. Use unleaded fuel.
- 25. **Fuel Gauge/Filler Cap** — Indicates the amount of fuel in the fuel tank. Remove this cap to add fuel.
- 26. **Documentation Holder** — Contains operation manual and other documents relating to the trowel.
- 27. **Charcoal Canister** — A container filled with activated charcoal that traps gasoline vapors emitted by the fuel system.
- 28. **Left Rear Light** — 55 watt, 12 VDC Hella™ halogen light is provided for night time and indoor work.
- 29. **Engine** — This trowel uses a Briggs and Stratton, Vanguard 35 HP gasoline engine.
- 30. **Right and Left Side Retardant Spray Pumps** — Delivers retardant to the spray nozzles.
- 31. **Right-Side Hydraulic Oil Sight Glass** — Indicates the level of the hydraulic oil in the right-side gear box.
- 32. **Right-Side Spider** — Consists (basic) of trowel arms, blades, wear plate, and thrust collar etc.
- 33. **EZ-Mover Boss** — Insertion point (right-rear) for EZ Mover. Used when the transporting of the trowel is required.
- 34. **Retardant Spray Tank** — Holds 5 gallons of retardant.
- 35. **Battery** — Provides +12V DC power to the electrical system
- 36. **EZ-Mover Boss** — Insertion point (left-rear) for EZ Mover. Used when the transporting of the trowel is required
- 37. **Belt Guard** — Encloses drive belt used in conjunction with clutch. Spare drive belt is also enclosed inside this guard.
- 38. **Left-Side Hydraulic Oil Sight Glass** — Indicates the level of the hydraulic oil in the left-side gear box.
- 39. **Left-Side Spider** — Consists (basic) of trowel arms, blades, wear plate, and thrust collar etc.

TO PURCHASE THIS PRODUCT PLEASE CONTACT US



**Equipment Financing and
Extended Warranties Available**



**Discount-Equipment.com is your online resource for
commercial and industrial quality parts and equipment sales.**

561-964-4949

visit us on line @ www.discount-equipment.com

Select an option below to find your Equipment

Search by Manufacturer

Search by Product Type

Request a Quote

We sell worldwide for the brands: Genie, Terex, JLG, MultiQuip, Mikasa, Essick, Whiteman, Mayco, Toro Stone, Diamond Products, Generac Magnum, Airman, Haulotte, Barreto, Power Blanket, Nifty Lift, Atlas Copco, Chicago Pneumatic, Allmand, Miller Curber, Skyjack, Lull, Skytrak, Tsurumi, Husquvarna Target, Stow, Wacker, Sakai, Mi-T-M, Sullair, Basic, Dynapac, MBW, Weber, Bartell, Bennar Newman, Haulotte, Ditch Runner, Menegotti, Morrison, Contec, Buddy, Crown, Edco, Wyco, Bomag, Laymor, EZ Trench, Bil-Jax, F.S. Curtis, Gehl Pavers, Heli, Honda, ICS/PowerGrit, IHI, Partner, Imer, Clipper, MMD, Koshin, Rice, CH&E, General Equipment, Amida, Coleman, NAC, Gradall, Square Shooter, Kent, Stanley, Tamco, Toku, Hatz, Kohler, Robin, Wisconsin, Northrock, Oztec, Toker TK, Rol-Air, APT, Wylie, Ingersoll Rand / Doosan, Innovatech, Con X, Ammann, Mecalac, Makinex, Smith Surface Prep, Small Line, Wanco, Yanmar

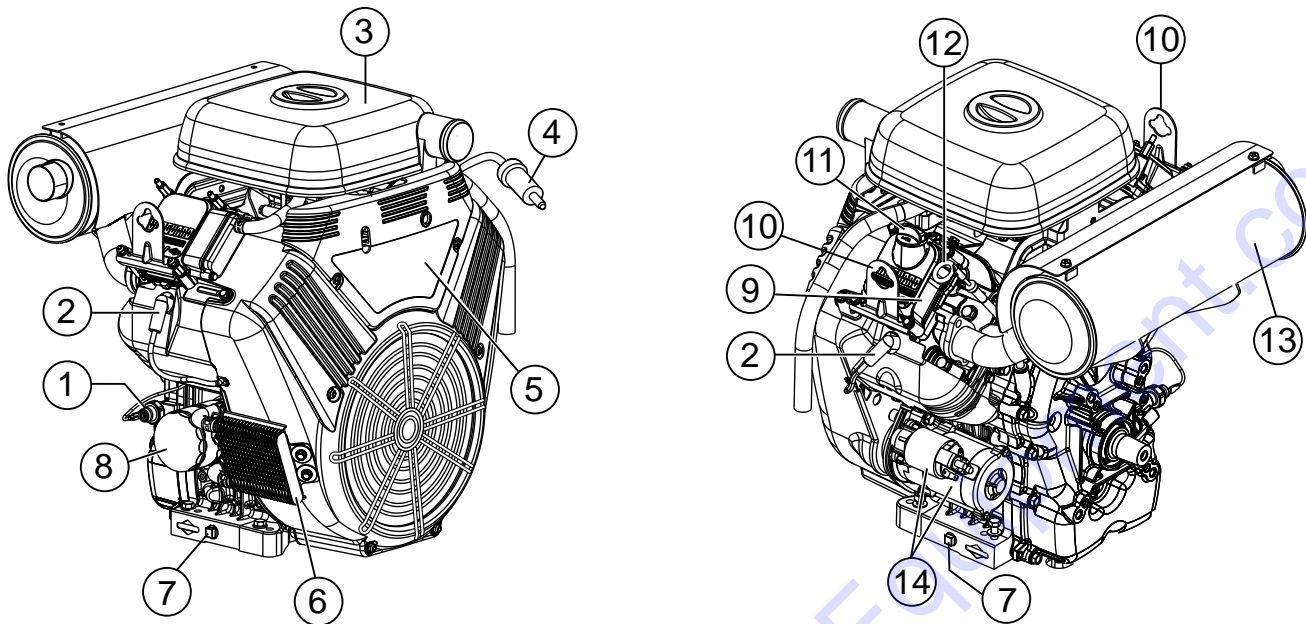

Figure 4. Basic Engine Components

INITIAL SERVICING

The gasoline engine (Figure 4) must be checked for proper lubrication and filled with fuel prior to operation. Refer to the manufacturer's engine manual for instructions and details of operation and servicing.

1. **Oil Pressure Sensor** — Monitors engine oil pressure. In the event of low oil pressure will shut down the engine.
2. **Side Spark Plug (2)** — Provides spark to the ignition system. Set spark plug gap to 0.030 inch (0.7 mm). Clean spark plug once a week.
3. **Air Filter** — Prevents dirt and other debris from entering the fuel system. Unsnap air filter cover to gain access to filter element.
4. **In-Line Fuel Filter** — Filters fuel for contaminants.
5. **Engine** — Briggs and Stratton, Vanguard 35 HP, air cooled, big block gasoline engine.
6. **Engine Oil Cooler** — Continuously provides cool oil for the lubricating system.
7. **Oil Drain Plug (2)** — Remove to drain crankcase oil. Always dispose of used oil and oil filters in an environmentally safe manner. **DO NOT** allow used oil to drain onto the ground or into a water runoff drain.

8. **Oil Filter** — Spin-on type, filters oil for contaminants.
9. **Engine Tag** — Provides engine model identification and information.
10. **Lifting Bail (2)** — When lifting of the engine is required attach a strap or chain of adequate lifting capacity to these lifting points.
11. **Oil Filler Cap** — Remove to add engine oil. Reference Tables 4 and 6 when adding engine oil.
12. **Oil Dip Stick** — Remove to check amount and condition of oil in crankcase.
13. **Muffler** — Used to reduce noise and emissions.

WARNING



Engine components can generate extreme heat. To prevent burns, **DO NOT** touch these areas while the engine is running or immediately after operating. **NEVER** operate the engine with the muffler removed.

14. **Starter** — Starts engine when ignition key is rotated to the "START" position.

NEW MACHINE SETUP

The purpose of this section is to assist the user in setting up a **NEW** trowel. If your trowel is already assembled, (seat, handles, knobs and battery), this section can be skipped.

NOTICE

The new trowel cannot be placed into service until the setup installation instructions are completed.

Before packaging and shipping, the this ride-on power trowel was run and tested at the factory. If there are problems, please let us know.

CONTROL HANDLE ASSEMBLY

The steering control handles are not attached to the trowel's two lower handles at the time of shipment. To attach the steering control handles to the two lower handle assemblies, perform the following:

1. Remove the bolts from the plastic bag tied to the control towers.
2. Remove all protective wrapping and straps from the control handles.
3. Slip the top (loose) piece into the base of the corresponding handle, making sure to line up the holes.
4. Install the bolt through the lined up holes and tighten the acorn nut onto the threaded end.

NOTICE

Some models are equipped with adjustable height handles. Adjust the height by placing the bolt through the set of holes that corresponds to the most comfortable height.

5. Pay close attention to any wires that may be inside the control handles. **DO NOT** pinch or cut any wires during installation.
6. Inside the plastic bag of parts are two knobs for the pitch control tower cranks. Install these two knobs onto the tower crank levers.

SEAT ASSEMBLY

The seat is not installed on the trowel for shipping purposes. To attach the seat perform the following:

1. Remove the seat from the protective wrapping.
2. Insert studs on bottom of seat through holes in the mounting plate.
3. Install and tighten the provided nuts.

4. Connect the "Engine Stop Switch" (seat) cable to the mating plug as shown in Figure 5

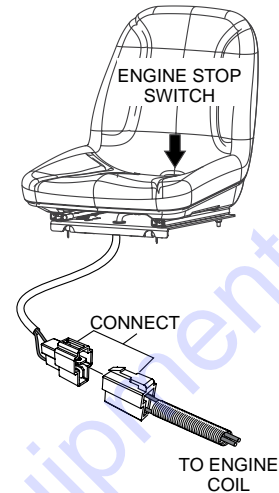

Figure 5. Engine Stop Switch (Seat)

BATTERY SETUP

This trowel was shipped with a wet charged battery. This battery may need to be charged for a brief period of time as per the manufacturer instructions.

CAUTION

Use all safety precautions specified by the battery manufacturer when working with the battery.

To install the battery on the trowel, make sure that the battery is well seated in the battery box. The positive cable, normally red, is associated with the "+" symbol on the battery. The negative cable, normally black, is associated with the "-" symbol on the battery. See Figure 6. Connect the positive cable to the positive terminal on the battery first, then connect the negative cable to the negative terminal. Close the plastic battery box cover and secure the battery box.

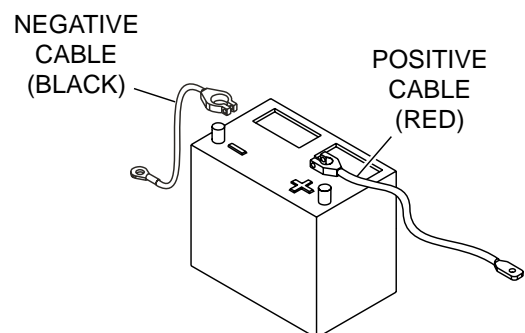

Figure 6. Battery Cable Orientation

This section is intended to assist the operator with the initial inspection of the trowel. It is extremely important that this section be read carefully before attempting to use the trowel in the field.

DO NOT use your trowel until this section is thoroughly understood.

CAUTION

Failure to understand the operation of the trowel could result in severe damage to the trowel or personal injury.

See Figure 2 and Figure 3 for the location of any control or indicator referenced in this manual.

ENGINE OIL LEVEL

1. Pull the engine oil dipstick from its holder.
2. Determine if engine oil is low (Figure 7), add correct amount of engine oil to bring oil level to a normal safe level. (See Table 6).

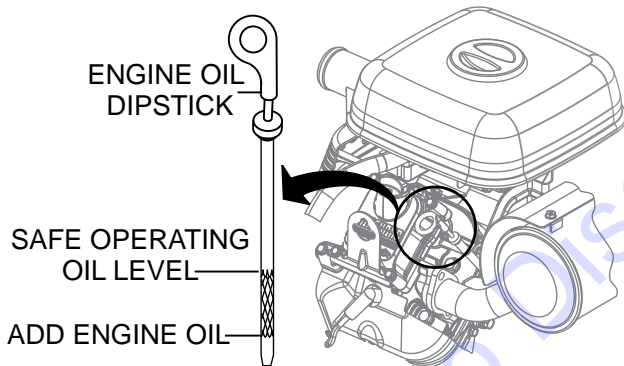
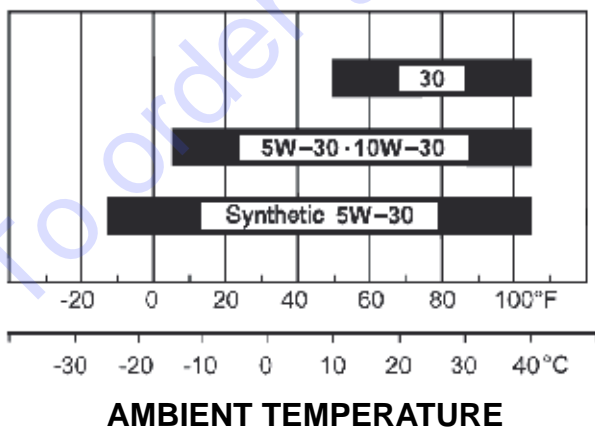

Figure 7. Engine Oil Dipstick

Table 6. Recommended Viscosity Grades



GEARBOX OIL LEVEL

1. Check the gearbox oil level in both gearboxes by viewing the sight glass at the rear of the gearbox. See Figure 8.
2. The oil level of the gear box should be at the half-way point of the sight glass (Figure 8). The gear box oil capacity is 1 U.S. gallon, (3.79 liters). If additional oil is required, unscrew the oil fill plug located on top of the gearbox, and refill with ISO 220 A GMA GR 5 EP oil.

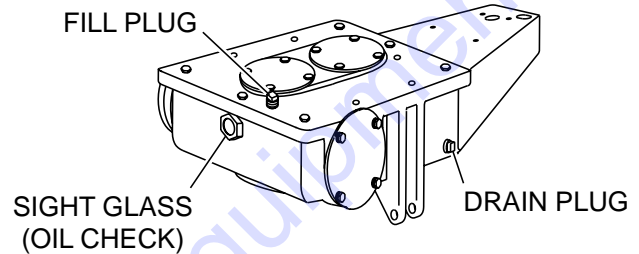

Figure 8. Gearbox Oil Plugs/Sight Glass

FUEL

Determine if the engine fuel is low (Figure 9). If fuel level is low, remove the fuel filler cap and fill with gasoline with an minimum octane rating of 87.

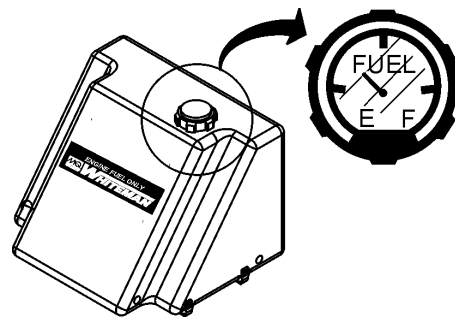

Figure 9. Fuel Gauge

DANGER

Handle fuel safely. Motor fuels are highly flammable and can be dangerous if mishandled. **DO NOT** smoke while refueling. **DO NOT** attempt to refuel the ride-on trowel if the engine is hot or running.

CAUTION

Never store the ride-on trowel with fuel in the tank for any extended period of time. Always clean up spilled fuel immediately.

STARTING THE ENGINE

1. Place one foot on the trowel's platform, grab ahold of any part of the frame, lift yourself onto the trowel, then sit down in the operator's seat.

NOTICE

This trowel is equipped with a safety stop switch that will not allow the engine to start unless an operator is sitting in the operator's seat. The weight of an operator depresses an electrical switch, which allows the engine to start.

WARNING

NEVER disable or disconnect the safety stop switch. It is provided for the operator's safety, and injury may result if it is disabled, disconnected or improperly maintained.

NOTICE

Using the safety stop switch to stop the engine after every use will verify that the switch is working properly. Remember to turn the key to the "OFF" position after stopping the machine. Not doing so may drain the battery.

2. The right foot pedal (Figure 10) controls blade and engine speed. The position of the foot pedal determines the blade speed. Slow blade speed is obtained by slightly depressing the pedal. Maximum blade speed is obtained by fully depressing the pedal.

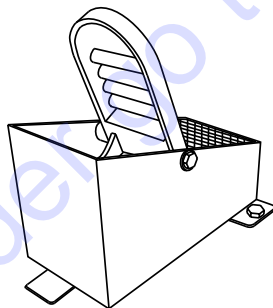

Figure 10. Blade Speed Control Foot Pedal

3. If starting a cold engine, pull the choke knob (Figure 11) upward to the "CLOSED" position.

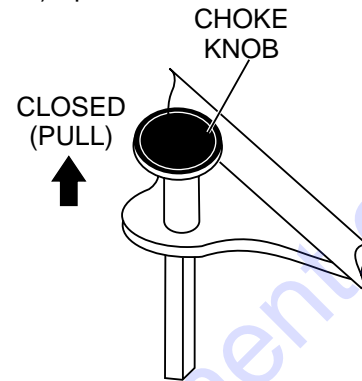

Figure 11. Choke Knob (Closed Position)

4. Insert the ignition key (Figure 12) into the ignition switch.

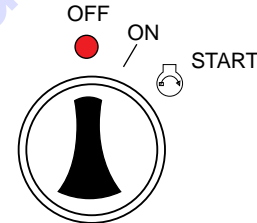

Figure 12. Ignition Switch

5. Turn the ignition key clockwise to the ON position. Aux1, Aux 2, coolant temp and oil indicator lamps will light for 10 seconds (Figure 13). Charge indicator lamp will remain lit until engine starts.

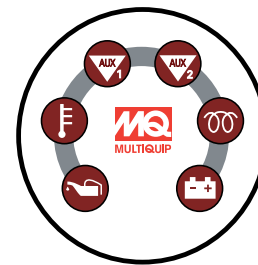

Figure 13. Indicator Lights

NOTICE

The **oil** and **charge**, indicator lights come on when the ignition switch is in the **ON** position, and the engine is **NOT** running.

6. Keeping your foot **OFF** the right foot pedal, turn ignition key fully clockwise and listen for engine to start. Once engine has started release ignition key. The throttle speed defaults to idle. Let the engine warm for a few minutes.

NOTICE

The throttle will default to full speed when the right foot pedal is depressed and operator presence is detected.

7. Once the engine has started and been warmed, return the choke knob (Figure 14) to the **OPEN** position.

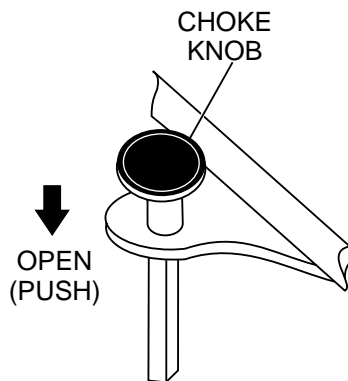

Figure 14. Choke Knob (Open Position)

8. If the engine fails to start in this manner, consult the engine owner's manual supplied with the trowel.
9. Test the safety stop switch by standing up briefly. The switch under the seat should cause the engine to stop. If the switch fails to shut down the engine, turn off the engine with the key switch and fix the safety stop switch. See Troubleshooting tables for possible problems.
10. Repeat this section a few times to get fully acquainted with the engine starting procedure.

STEERING

Two control levers located in front of the operator's seat provide directional control for the trowel. Table 7 illustrates the various directional positions of the joysticks and their effect on the ride-on trowel.

NOTICE

All directional references with respect to the steering control levers are from the operator's seat position.

1. Push both the left and right control levers forward. See Figure 15.

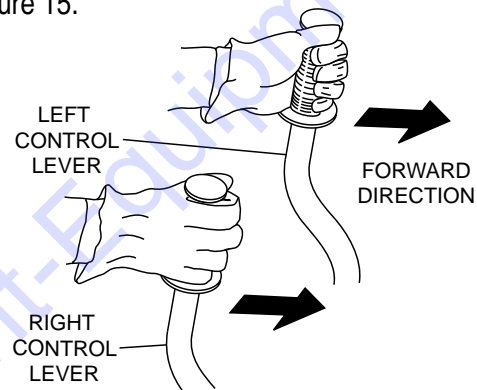

Figure 15. Left and Right Control Levers

2. With your right foot, quickly depress the right foot pedal halfway. Notice that the ride-on power trowel begins to move in a forward direction. Return both joystick controls to their neutral position to stop forward movement, then remove your right foot from the right foot pedal.
3. Practice holding the machine in one place as you increase blade speed. When about 75% of maximum blade speed has been reached, the blade will be moving at proper finishing speed. The machine may be difficult to keep in one place. Trying to keep the ride-on trowel stationary is a good practice for operation.
4. Practice maneuvering the ride-on trowel using the information listed in Table 7. Try to practice controlled motions as if you were finishing a slab of concrete. Practice edging and covering a large area.
5. Try adjusting the pitch of the blades. This can be done with the ride-on trowel stopped or while the trowel is moving, whatever feels comfortable. Test the operation of optional equipment like retardant spray and lights if equipped.

- Push both the left and right joysticks backward and repeat steps 3 through 6 while substituting the word reverse for forward.

Table 7. Control Lever Directional Positioning		
Control Lever	Direction	Results
Left	Move Control Lever Forward	Causes the ride-on trowel to move forward and to the right.
Left	Move Control Lever Backward	Causes the ride-on trowel to move backward and to the left.
Right	Move Control Lever Forward	Causes the ride-on trowel to move forward and to the left.
Right	Move Control Lever Backward	Causes the ride-on trowel to move backward and to the right.
Left and Right	Move Both Control Levers Forward	Causes the ride-on trowel to move forward in a straight line.
Left and Right	Move Both Control Levers Backward	Causes the ride-on trowel to move backward in a straight line.
Left and Right	Move Both Control Levers to the Right	Causes the ride-on trowel to move to the right.
Left and Right	Move Both Control Levers to the Left	Causes the ride-on trowel to move to the left.

CAUTION

Trowel arms can be damaged by rough handling or by striking exposed plumbing or forms while in operation. **ALWAYS** look-out for objects which might cause damage to the trowel arms.

Blade Pitch

Sometimes it may be necessary to match blade pitch between the two sets of blades. There are some signs that this may be necessary. For example, the differences in pitch could cause a noticeable difference in finish quality between the two sets of blades. Or, the difference in blade pitch could make the machine difficult to control. This is due to the surface area in contact with the concrete (the blade set with the greater contact area tends to stick to the concrete more).

Matching Blade Pitch for Both Sets of Blades

Trowels equipped with Twin Pitch™ Controls may need to have blade pitch between the two sets of blades "synchronized". If the blades need to be synchronized this is easily accomplished by performing the following:

- Lift the pitch adjustment handle (Figure 16) on either side. Once lifted, that side is now disconnected from the Twin Pitch™ system.
- Adjust to match the opposite side.
- When adjusted, lower the handle to Twin Pitch™ operating position.

CAUTION

When turning an adjustment handle, **DO NOT** force it to turn or damage to the cable may occur. If the cable starts to noticeably twist this is a good indication that one side is either all ready at full pitch or it is bound up due to concrete, debris, or corrosion.

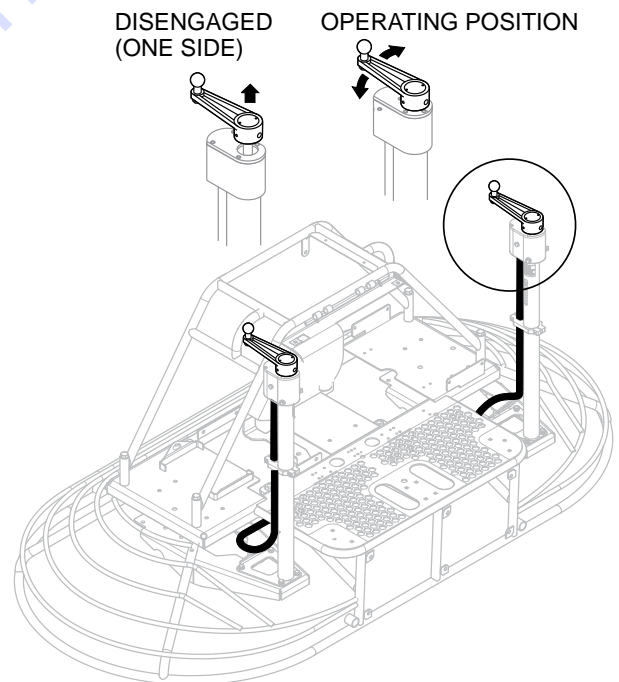

Figure 16. Pitch Towers

MAINTENANCE

Table 8. Engine Maintenance Schedule

DESCRIPTION (3)	OPERATION	BEFORE EACH USE	FIRST MONTH OR 20 HRS.	EVERY 6 MONTHS OR 100 HRS.	EVERY YEAR OR 300 HRS.	EVERY 2 YEARS OR 500 HRS.
Engine Oil	Check	X				
	Change		X	X		
Engine Oil Filter	Replace	Every 200 Hrs.				
Air Cleaner	Check	X				
	Clean			X (1)		
	Change					X (*)
Spark Plugs	Check/Adjust			X		
	Replace				X	
Spark Arrester	Clean			X		
Fuel Filter	Replace				X (2)	
Fuel Tube	Check	Every 2 years (replace if necessary) (2)				

* - Replace the paper filter element only.

(1) Service more frequently when used in **DUSTY** areas.

(2) These items should be serviced by your service dealer, unless you have the proper tools and are mechanically proficient. Refer to the BRIGGS and STRATTON Shop Manual for service procedures.

(3) For commercial use, log hours of operation to determine proper maintenance intervals.

Table 9. Trowel Maintenance Schedule

Check Item	OPERATION	DAILY	Periodic Maintenance Interval			
			Every 25 Hrs	Every 50 Hrs	Every 100-125 Hrs	Every 500 Hrs
Relube arms, thrust collar, steering linkage	Grease			X		
Remove clean, reinstall, and relube arms, and thrust collar	Clean				X	
Check and replace if necessary, arm bushings and thrust collar bushings.	Check			X		
Check blades for excessive wear or damage and replaces if necessary.	Check	X				
Adjust blade speed if necessary.	Check					X
Gearbox lubricant)	Replace				1st time	X
Drive Belt	Check		X			
Fastners	Check	X				

When performing any maintenance on the trowel or engine, follow all safety messages and rules for safe operation stated at the beginning of this manual

At the front of this manual there is a “Daily Pre-Operation Checklist”. Make copies of this checklist and use it on a daily basis.

WARNING

 Accidental starts can cause severe injury or death.

 **ALWAYS** place the ON/OFF switch in the OFF position.

 Disconnect and ground spark plug leads and disconnect negative battery cable from battery before servicing.

WARNING

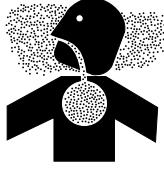
 Some maintenance operations may require the engine to be run. Ensure that the maintenance area is well ventilated. Exhaust contains poisonous carbon monoxide gas that can cause unconsciousness and may result in **DEATH**

CAUTION

 **ALWAYS** allow the engine to cool before servicing. **NEVER** attempt any maintenance work on a hot engine.

Air Cleaner

Thoroughly remove dirt and oil from the engine and control area. Clean or replace the air cleaner elements as necessary. Check and retighten all fasteners as necessary.

1. Unscrew the latch locking knob (Figure 17) located on top of the air cleaner cover, and remove cover.

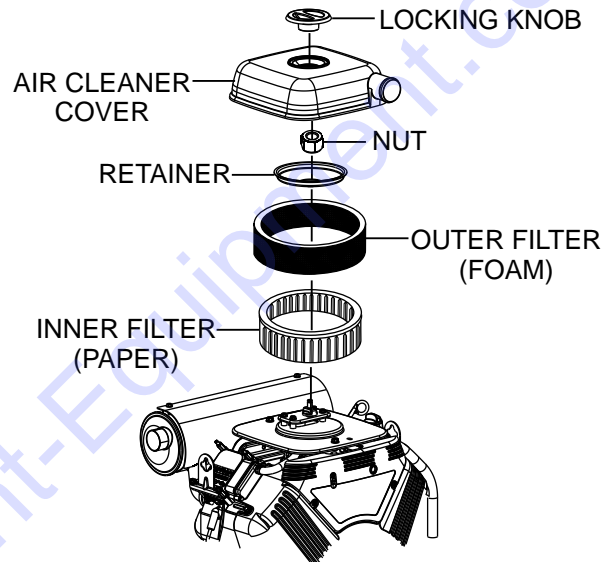

Figure 17. Air Filter Components

2. Next, remove nut, outer (foam) and inner filters (paper).
3. Inspect both air filter elements, replace them if necessary

Air Cleaner Cleaning

CAUTION



Wear protective equipment such as approved safety glasses or face shields and dust masks or respirators when cleaning air filters with compressed air.

1. To clean the paper air filter (Figure 18), tap the filter element several times on a hard surface to remove dirt, or blow compressed air (not to exceed 30 psi (207 kPa, 2.1 kgf/cm²) through the filter element from the inside out.

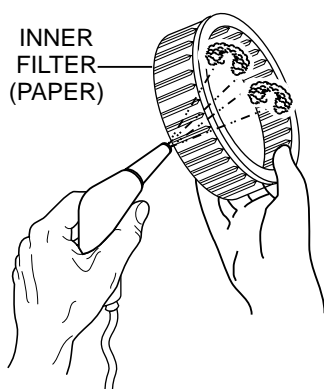

Figure 18. Cleaning Inner Paper Filter

2. **NEVER!** try to brush off dirt; brushing will force dirt into the fibers. If the paper element is excessively dirt, replace element.
3. Clean the foam air filter element in warm soapy water, rinse and allow to dry thoroughly. Or clean with a nonflammable solvent and allow to dry. **DO NOT** pour any type of oil into the foam element.
4. Wipe dirt from the inside of the air cleaner body and cover, using a moist cloth. Be careful not to let any dirt or debris enter the air chamber that leads to the carburetor.
5. Place the foam air filter element back onto the paper air filter element. Reinstall air cleaner and cover. Using the locking knob, securely lock the air cleaner cover.

CAUTION

Operating the engine with a blocked grass screen, dirty or plugged cooling fins, and/or cooling shrouds removed will cause engine damage due to overheating.

Changing Engine Oil (100 Hours)

1. Drain the engine oil when the oil is warm as shown in
2. Remove the oil drain bolt and sealing washer and allow the oil to drain into a suitable container.

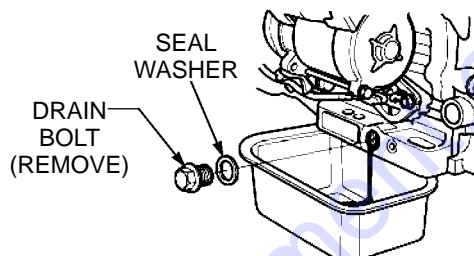

Figure 19. Draining Engine Oil

3. Reinstall drain bolt with sealing washer and tighten securely.
4. Replace engine oil with recommended type oil as listed in Table 4. For engine oil capacity, see Table 4. **DO NOT** over fill.

Oil Filter (200 Hours)

1. Replace the engine oil filter (Figure 20) every 200 hours.

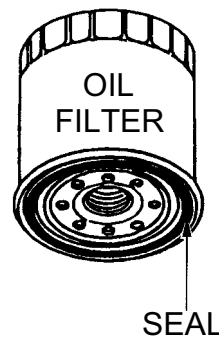

Figure 20. Oil Filter

2. Be sure to coat the seal of the new oil filter with clean engine oil.

Fuel Filter (200 Hours)

1. Replace the fuel filter (Figure 21) every 200 hours.

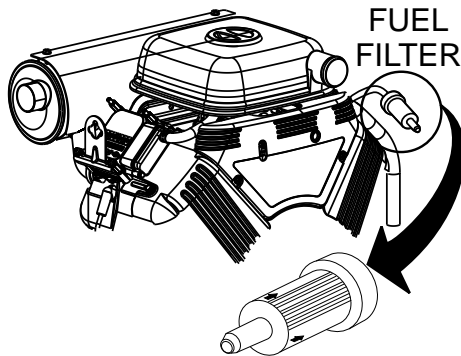

Figure 21. Fuel Filter Location

Spark Plugs

1. Make sure the engine is cool before servicing the spark plugs.
2. Disconnect the spark plug caps. Check for dirt and remove any dirt from around the spark plug area.
3. Remove the spark plugs with a 5/8-inch spark plug wrench.
4. If the spark plugs are damaged, the sealing washer is in poor condition, or if the electrode is worn, replace the spark plugs.
5. Measure the spark plug electrode gap (Figure 22) with a wire-type feeler gauge. If needed, adjust the gap to .030 in. (0.76 mm), by carefully bending the side electrode.

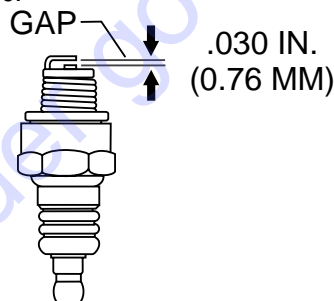

Figure 22. Spark Plug Gap Adjustment

6. Install the spark plug carefully, by hand, to avoid cross threading.
7. After the spark plug is seated, tighten with a 5/8-inch spark plug wrench to compress the sealing washer.

8. When installing a new spark plug, tighten 1/2 turn, after the spark plug seats, to compress the washer.
9. When reinstalling the original spark plug, tighten 1/8 1/4 turn after the spark plug seats to compress the washer.
10. Reattach the spark plug caps

ENGINE TUNE-UP ENGINE

See your engine manual for specific information on tuning up your engine, checking and gapping the spark plugs, etc.

NOTICE

See the engine manual supplied with your machine for appropriate engine maintenance schedule and troubleshooting guide for problems.

LONG TERM STORAGE

- Drain the fuel tank completely, or add STA-BIL to the fuel.
- Remove spark plug and pour a few drops of motor oil into cylinder. Crank engine 3 to 4 times so that oil reaches all internal parts.
- Clean exterior with a cloth soaked in clean oil.
- Remove the battery.
- Store unit covered with plastic sheet in moisture and dust-free location out of direct sunlight.

CAUTION

NEVER store the ride-on trowel with fuel in the tank for any extended period of time. Always clean up spilled fuel immediately.

CHECKING THE DRIVE BELT

The drive belt needs to be changed as soon as it begins to show signs of wear. **DO NOT** reuse a belt under any circumstances. Indications of excessive belt wear are fraying, squealing when in use, belts that emit smoke or a burning rubber smell when in use.

To gain access to the drive belt (Figure 23), remove the drive belt guard cover, then visually inspect the drive belt for signs of damage or excessive wear. If the drive belt is worn or damaged, replace the drive belt.

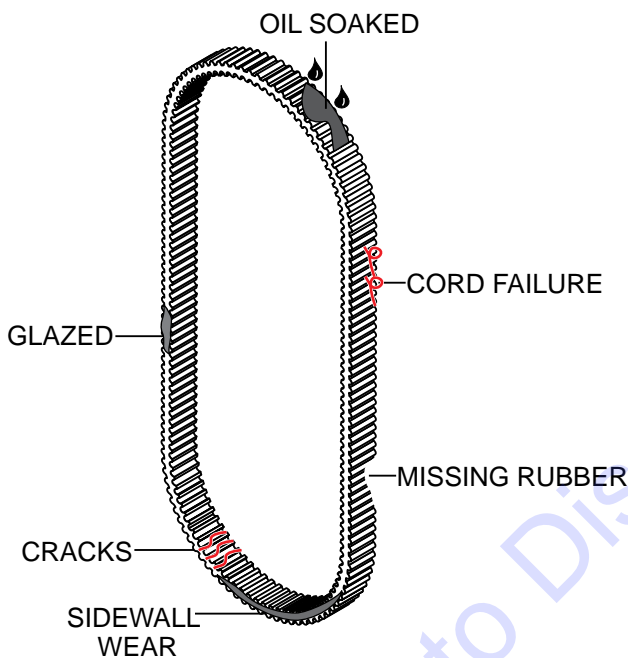

Figure 23. Drive Belt Inspection

BELT MEASUREMENT

Long life can be expected with this drive assembly as long as the drive belt is kept properly aligned.

The clutch will not shift correctly if the drive belt width is below 1.14". Measure the CVT drive belt (Figure 24) every 100 hours of use to make sure it is within the specified tolerance.

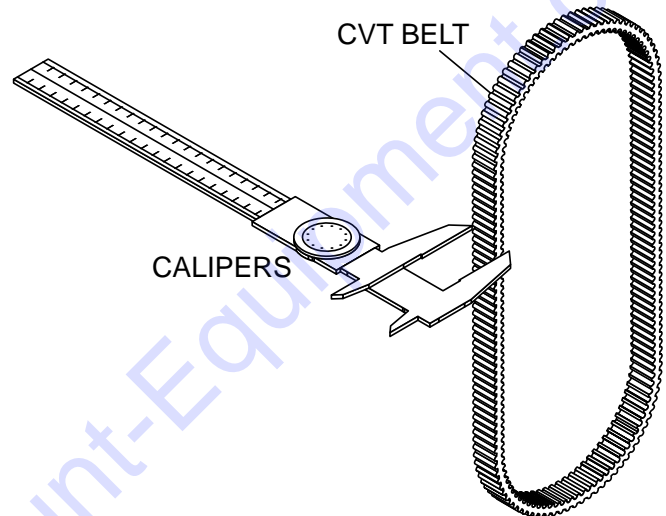

Figure 24. Belt Measurement

REMOVING THE DRIVE BELT

11. Remove the retaining screws (4) that secure the drive belt guard (Figure 25) to the trowel frame.

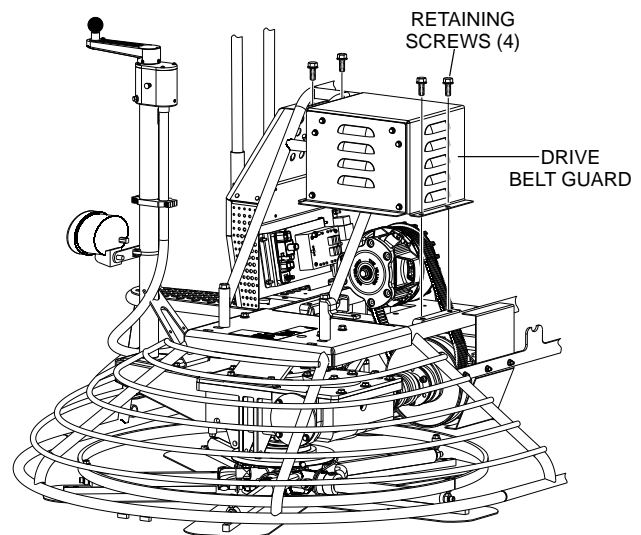

Figure 25. Drive Belt Guard Removal

WARNING

DO NOT attempt to insert hands or tools into the drive belt area while the engine is running and the safety guard has been removed. Keep fingers, hands, hair and clothing away from all moving parts to prevent bodily injury.

WARNING

DO NOT remove the drive belt guard cover until the muffler has cooled. Allow the entire trowel to cool down before performing this procedure.

12. Disconnect the left-side CV Axle from the left-side gearbox and the lower drive pulley coupler. See Figure 26.

NOTICE

Note that the 3 bolts securing the CV axle to the coupler are shorter than those securing the CV axle to the gearbox. Remember bolt orientation for reassembly.

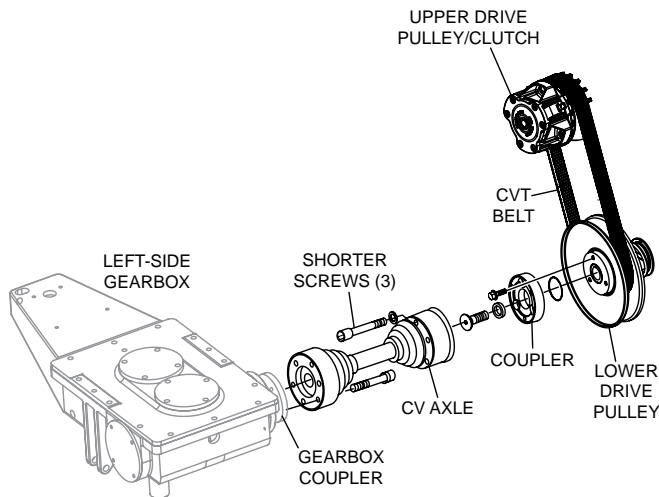

Figure 26. Remove Left-Side CV Axle

13. If the belt is not being reused (recommended), CUT the drive belt. Ensure all belt remnants are removed from the pulleys.

INSTALLING DRIVE BELT

1. Place new CVT belt over the lower pulley. Squeeze the belt (Figure 27) and pull the belt upwards and towards the rear of the trowel. This will spread open the faces of the lower drive pulley.

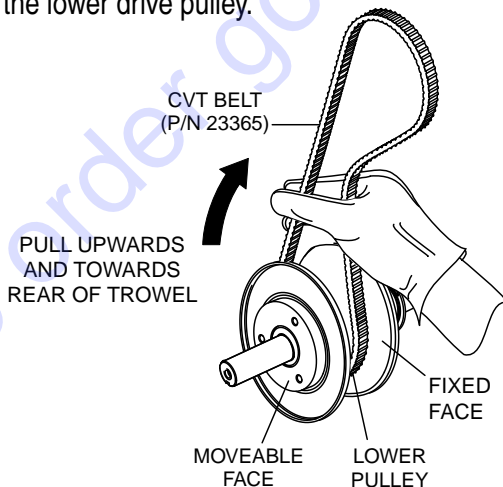

Figure 27. Holding Lower Pulley Open

2. Place free end of CVT belt (Figure 28) into upper pulley grooves.

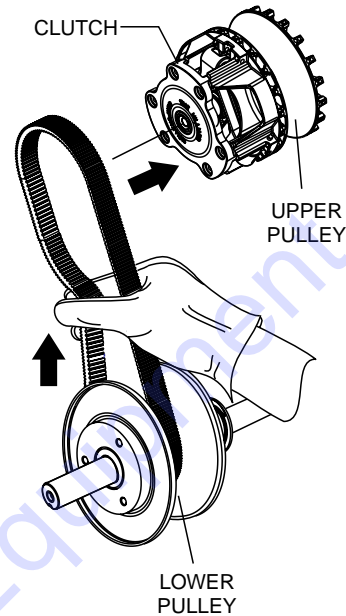

Figure 28. Upper Pulley Belt Installation

3. Apply a thin coat of RVT silicone to mating surfaces of the CV-joint (Figure 29) and left-side gearbox coupler.

APPLY SILICONE
TO CV-JOINT
MATING SURFACES

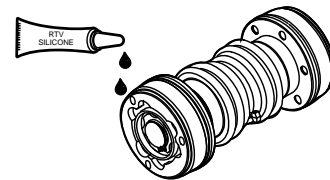

Figure 29. Applying RTF Silicone

4. Reconnect the CV-joint to the left-side gearbox coupler.
5. Re-install drive belt guard onto frame. Secure with retaining screws (4).

Blade Pitch Adjustment Procedure

Maintenance adjustment of blade pitch is made by adjusting a bolt (Figure 30) on the arm of the trowel blade finger. This bolt is the contact point of the trowel arm to the lower wear plate on the thrust collar. The goal of adjustment is to promote consistent blade pitch and finishing quality.

Look for the following indications if blades are wearing unevenly. If so, adjustment may be necessary.

- Is one blade completely worn out while the others look new?
- Does the machine have a perceptible rolling or bouncing motion when in use?
- Look at the machine while it is running, do the guard rings “rock up and down” relative to the ground?
- Do the pitch control towers rock back and forth?

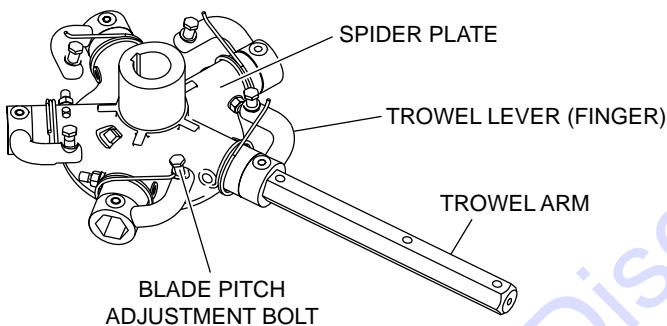

Figure 30. Blade Pitch Adjustment Bolt

The easiest and most consistent way to make adjustments on the trowel arm fingers is to use the Trowel Arm Adjustment Fixture (P/N 9177). It comes with all the hardware necessary to properly accomplish this maintenance and instructions on how to utilize this tool.

If a trowel arm adjustment fixture is not available and immediate adjustment is necessary, temporary field adjustment can be made if you can see or feel which blade is pulling harder by adjusting the bolt that corresponds to that blade.

A better way to determine which blades need adjustment is to place the machine on a known FLAT surface (steel metal plate) and pitch the blades as flat as possible. Look at the adjustment bolts. They should all barely make contact with the lower wear plate on the spider. If you can see that one of them is not making contact, some adjustment will be necessary.

Adjust the “high” bolts down to the level of the one that is not touching, or adjust the “low” bolt up to the level of the higher ones. If possible, adjust the low bolt up to the level of the rest of the bolts. This is the fastest way, but may not always work. Verify after adjustment the blades pitch correctly.

Blades that are incorrectly adjusted often will not be able to pitch flat. This can occur if the adjusting bolts are raised too high. Conversely, adjusting bolts that are too low will not allow the blades to be pitched high enough for finishing operations.

If, after making Blade Pitch adjustments, the machine is still finishing poorly, blades, trowel arms, and trowel arm bushings may be suspect and should be looked at for adjustment, wear, or damage. See the following sections.

Changing Blades

It is recommended that **ALL** the blades on the entire machine are changed at the same time. If only one or some of the blades are changed, the machine will not finish concrete consistently and the machine may wobble or bounce.

1. Place the machine on a flat, level surface. Adjust the blade pitch control to make the blades as flat as possible. Note the blade orientation on the trowel arm. This is important for ride-on trowels as the two sets of blades counter-rotate. Lift the machine up, placing blocks under the main guard ring to support it.
2. Remove the bolts and lock washers on the trowel arm, and then remove the blade.
3. Scrape all concrete and debris from the trowel arm. This is important to properly seat the new blade.
4. Install the new blade, maintaining the proper orientation for direction of rotation.
5. Reinstall the bolts and lock washers.
6. Repeat steps 2-5 for all remaining blades.

Clean-Up

Never allow concrete to harden on the power trowel. Immediately after use wash any concrete off the trowel with water, be careful not to spray a hot engine or muffler. An old paint brush or broom may help loosen any concrete that has started to harden.

Trowel Arm Adjustment

NOTICE

The following procedure should be followed to adjust trowel arms when it becomes apparent that the trowel is finishing poorly or in need of routine maintenance.

A level, clean area to test the trowel prior to and after is essential. Any unlevel spots in the floor or debris under the trowel blades will give an incorrect perception of adjustment. Ideally, a 5' x 5' three-quarters inch thick, flat steel plate should be used for testing.

Some indications of poor concrete finishing is incorrect trowel arm alignment, worn spider bushings or bent trowel arms:

Does your trowel exhibit the following?

- Are blades wearing unevenly? Is one blade completely worn out while the others look new?
- Look at the machine while it is running. Do the guard rings “rock up and down” relative to the ground?
- Does the machine have a perceptible rolling or bouncing motion when in use?

1. To determine which blades need adjustment, place the trowel in the test area (three-quarter inch thick plate) and look for the following conditions:
2. Pitch the blades as flat as possible. The adjustment bolts should all barely make contact with the lower wear plate on the spider. If one is not making contact, adjustment will be necessary (Figure 31).

Figure 31 illustrates “incorrect alignment,” worn spider bushings or bent trowel arms. Check that the adjustment bolt is barely touching (0.10" max. clearance) lower wear plate. All alignment bolts should be spaced the same distance from the lower wear plate.

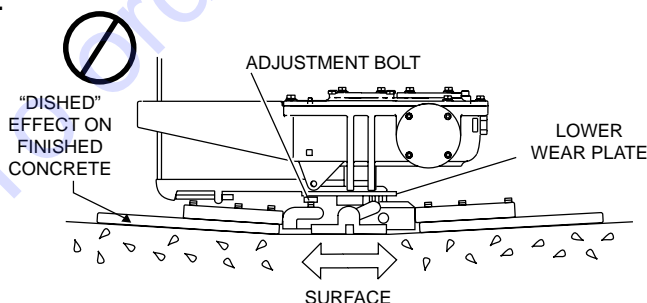

Figure 31. Incorrect Spider Plate Alignment

Figure 32 illustrates the “correct alignment” for a spider plate (as shipped from the factory).

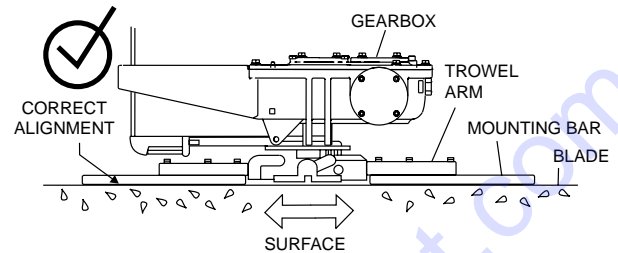

Figure 32. Correct Spider Plate Alignment

SPIDER REMOVAL

Remove the spider assembly from the gearbox shaft as follows:

1. Locate the cone point square head set screw (Figure 33) and attached jam nut found on the side of the spider assembly.
2. Loosen the jam nut and cone point square head set screw.
3. Carefully lift the upper trowel assembly off of the spider assembly. A slight tap with a rubber mallet may be necessary to dislodge the spider from the main shaft of the gearbox.
4. For reassembly apply Blue Loctite #242 to the spider retaining screw and torque to 130 ft.-lbs. (176 N.m)

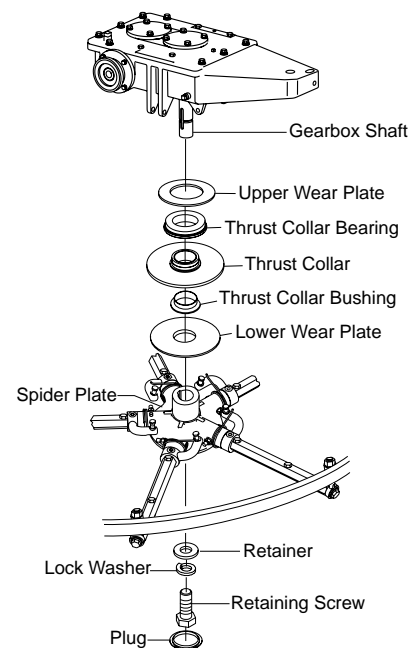

Figure 33. Spider Removal

TROWEL BLADE REMOVAL

Remove the trowel blades by removing the three hex head bolts (Figure 34) from the trowel arm. Set blades aside.

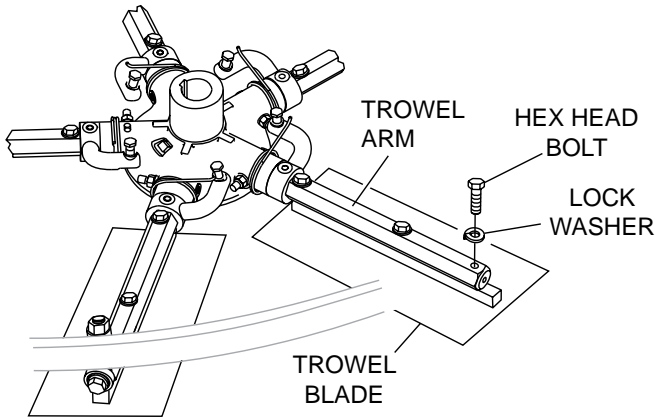

Figure 34. Trowel Blade Removal

TROWEL ARM REMOVAL

1. Remove the hardware securing the stabilizer ring to the trowel arm. (Figure 35)

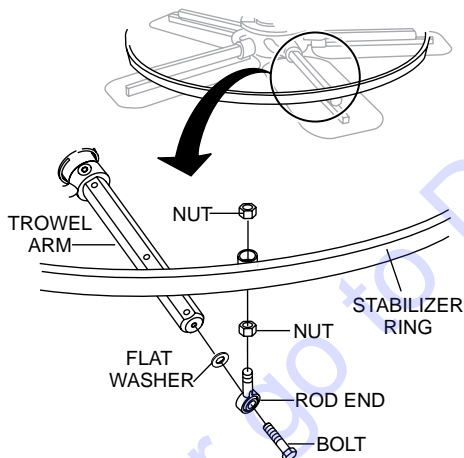

Figure 35. Stabilizer Ring (Stabilizer Ring)

2. Each trowel arm is held in place at the spider plate (Figure 36) by a hex head bolt (zerk grease fitting) and a roll pin. Remove both the hex head bolt and the roll pin from the spider plate.

3. Remove the trowel arm from the spider plate.

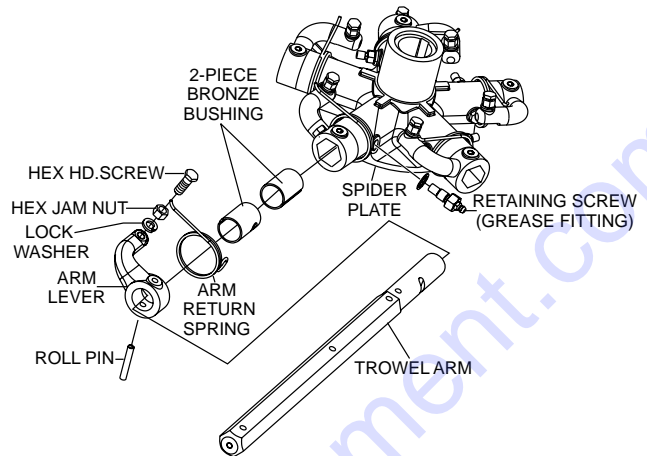

Figure 36. Remove Roll Pin and Zerk Fitting

4. Should the trowel arm inserts (bronze bushing) come out with the trowel arm, remove the bushing from the trowel arm and set aside in a safe place. If the bushing is retained inside the spider plate, carefully remove the bushing.
5. Examine the bronze trowel arm bushings (Figure 37), and clean if necessary. Replace bushing if out-of-round or worn.



Figure 37. Bronze Bushings

6. Wire brush any build-up of concrete from all six sides of the trowel arm. Repeat this for the remaining arms.

CHECKING TROWEL ARM STRAIGHTNESS

Trowel arms can be damaged by rough handling, (such as dropping the trowel on the pad), or by striking exposed plumbing, forms, or rebar while in operation. A bent trowel

arm will not allow the trowel to operate in a smooth fluid rotation. If bent trowel arms are suspect, check for flatness as shown below. Reference Figure 39:

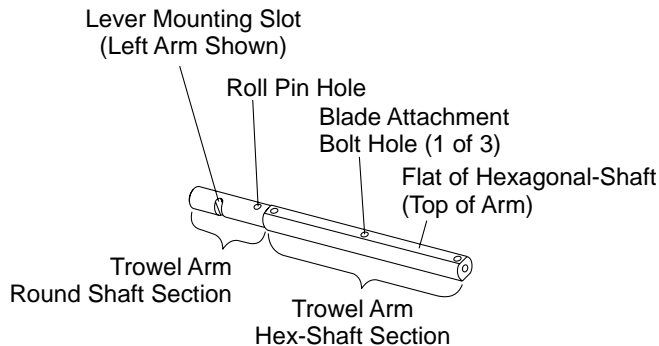

Figure 38. Trowel Arm

1. Use a thick steel plate, granite slab or any surface which is true and flat, to check all six sides of each trowel arm for flatness.
2. Check each of the six sides of the trowel arm (hex section). A feeler gauge of .004" (0.10 mm) should not pass between the flat of the trowel arm and the test surface along its length on the test surface. (Figure 39).

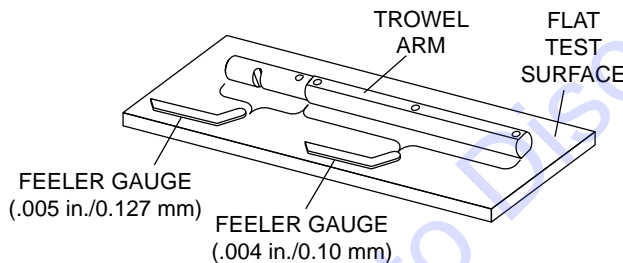

Figure 39. Checking Trowel Arm Flatness

3. Next, check the clearance between the round shaft and the test surface as one of the flat hex sections of the arm rests on the test surface. Rotate the arm to each of the flat hex sections and check the clearance of the round shaft. Use a feeler gauge of .005" (0.127 mm). Each section should have the same clearance between the round of the trowel arm shaft and the test surface.
4. If the trowel arm is found to be uneven or bent, replace the trowel arm.

TROWEL ARM ADJUSTMENT

Shown in (Figure 40) is the adjustment fixture with a trowel arm inserted. As each trowel arm is locked into the fixture, the arm bolt is adjusted to where it contacts a stop on the fixture. This will consistently adjust all of the trowel arms, keeping the finisher as flat and evenly pitched as possible.

1. Locate the trowel arm adjustment tool P/N 9177.

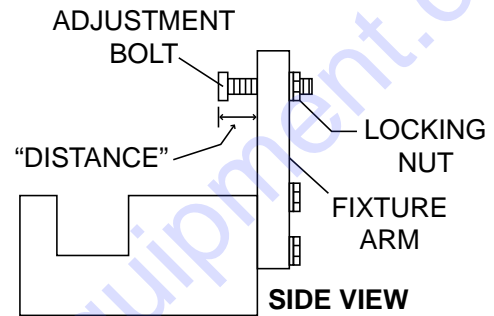

Figure 40. Trowel Arm Adjustment Tool Side View

2. Ensure the fixture arm is in the proper setting (up or down) for your trowel arm rotation as shown in Figure 41.

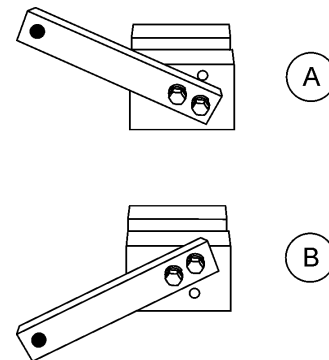

Figure 41. Trowel Arm Adjustment Setup

NOTICE

Arms with CLOCK-WISE blade rotation use the fixture arm in the UP position (Figure 41A). Arms with COUNTER CLOCK-WISE blade rotation use the fixture with the fixture arm in the DOWN position (Figure 41B).

3. Unscrew the locking bolts on the adjustment tool and place the trowel arm into the fixture channel as shown in Figure 42. A thin shim may be required to cover the blade holes on the trowel arm. Make sure to align the trowel adjustment bolt with the fixture adjustment bolt.

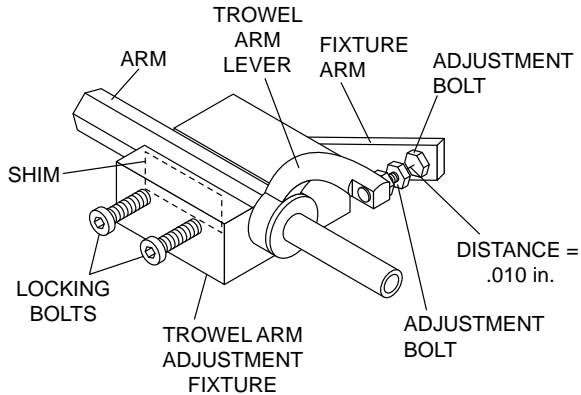

Figure 42. Trowel Arm Adjustment Fixture Components

4. Use an allen wrench to tighten the locking bolts securing the trowel arm in place.
5. Adjust the bolt “distance” shown in Figure 42 to match one of the arms. The other arms will be adjusted to match this distance.
6. Loosen the locking nut on the trowel arm lever, then turn the trowel arm adjusting bolt until it barely touches (.010”) the fixture adjusting bolt.
7. Once the correct adjustment is made, tighten the lock nut on the trowel arm to lock in place.
8. Loosen locking nuts on the adjustment fixture, and remove trowel arm.
9. Repeat steps for the remaining trowel arms.

REASSEMBLY

1. Clean and examine the upper/lower wear plates and thrust collar. Examine the entire spider assembly. Wire brush any concrete or rust build-up. If any of the spider components are found to be damaged or out of round, replace them.
2. Make sure that the bronze trowel arm bushing is not damage or out of round. Clean the bushing if necessary. If the bronze bushing is damaged or worn, replace it.
3. Reinstall bronze bushing onto trowel arm.
4. Repeat steps 2–3 for each trowel arm.
5. Make sure that the spring tensioner is in the correct position to exert tension on the trowel arm.
6. Insert all trowel arms with levers into spider plate (with bronze bushing already installed) using care to align grease hole on bronze bushing with grease hole fitting on spider plate.
7. Lock trowel arms in place by tightening the hex head bolt with zerk grease fitting and jam nut.
8. Re-install the blades onto the trowel arms.
9. Install stabilizer ring onto spider assembly.
10. Lubricate all grease points (zerk fittings) with premium “Lithum 12” based grease, conforming to NLG1 Grade #2 consistency.

INSTALLING PANS ONTO FINISHER BLADES

These round discs sometimes referred to as "pans" attach to the spiders arms and allow early floating on wet concrete and easy movement from wet to dry areas. They are also very effective in embedding large aggregates and surface hardeners.

WARNING

Lifting/Crush Hazard. **DO NOT** lift trowel with pans attached.



WARNING

ALWAYS install pans either on the work area or on an area that is next to and level with the work area. **DO NOT** lift the trowel when the pans are attached.

Refer to Figure 43 when installing pans onto finisher blades.

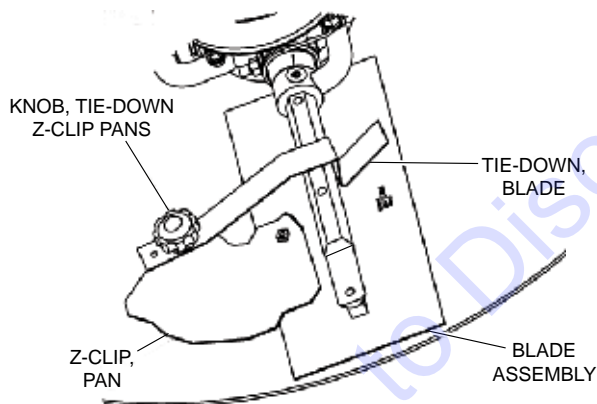

Figure 43. Z-Clip Finisher Pan Installation

1. Lift trowel just enough to slide pan under blades. Lower finisher onto pan with blades adjacent to Z-Clips.
2. Rotate blades into position under Z-Clips. Ensure that the blades are rotated in the direction of travel when the machine is in operation or use the engine to rotate the blades into position.
3. Attach the blade tie-downs to the far side of the Z-Clip brackets with tie-down knobs as shown in Figure 43.
4. Check to make certain that the blade edges are secured under the Z-Clips and the tie-downs are secured completely over the edges of the blade bar before the machine is put back into operation.

DECOMMISSIONING TROWEL/COMPONENTS

Decommissioning is a controlled process used to safely retire a piece of equipment that is no longer serviceable. If the equipment poses an unacceptable and unreparable safety risk due to wear or damage or is no longer cost effective to maintain, (beyond life-cycle reliability) and is to be decommissioned, (demolition and dismantlement), the following procedure must take place:

1. Drain all fluids completely. These may include oil, gasoline, hydraulic oil and antifreeze. Dispose of properly in accordance with local and governmental regulations. Never pour on ground or dump down drains or sewers.
2. Remove battery and bring to appropriate facility for lead reclamation. Use safety precautions when handling batteries that contain sulfuric acid.
3. The remainder can be brought to a salvage yard or metal reclamation facility for further dismantling.

TROUBLESHOOTING (TROWEL)

Troubleshooting (Ride-On Mechanical Trowel)		
Symptom	Possible Problem	Solution
Engine running rough or not at all.	Stop switch malfunction?	Make sure that the stop switch is functioning when the operator is seated. Replace switch if necessary.
	Fuel?	Look at the fuel system. Make sure there is fuel being supplied to the engine. Check to ensure that the fuel filter is not clogged.
	Ignition?	Check to ensure that the ignition switch has power and is functioning correctly.
Safety stop switch not functioning.	Bad contacts?	Replace switch.
	Loose wire connections?	Check wiring. Replace as necessary.
	Other problems?	Consult engine manufacturer's manual.
Trowel bounces, rolls concrete, or makes uneven swirls in concrete.	Blades?	Make sure blades are in good condition, not excessively worn. Finish blades should measure no less than 2 inches (50mm) from the blade bar to the trailing edge, combo blades should measure no less than 3.5 inches (89mm). Trailing edge of blade should be straight and parallel to the blade bar.
	Pitch Adjustment?	Check that all blades are set at the same pitch angle as measured at the spider. A field adjustment tool is available for height adjustment of the trowel arms (contact Parts Department).
	Bent trowel arms?	Check the spider assembly for bent trowel arms. If one of the arms is even slightly bent, replace it immediately.
	Trowel arm bushings?	Check the trowel arm bushings for tightness. This can be done by moving the trowel arms up and down. If there is more than 1/8 inch (3.2 mm) of travel at the tip of the arm, the bushings should be replaced. All bushings should be replaced at the same time.
	Thrust collar?	Check the flatness of the thrust collar by rotating it on the spider. If it varies by more than 0.02 inch (0.5 mm) replace the thrust collar.
	Thrust collar bushing?	Check the thrust collar by rocking it on the spider. If it can tilt more than 1/16 inch (1.6 mm) - as measured at the thrust collar O.D., replace the bushing in the thrust collar.
	Thrust bearing worn?	Check the thrust bearing to see that it is spinning freely. Replace if necessary.
Machine has a perceptible rolling motion while running.	Main shaft?	The main output shaft of the gearbox assembly should be checked for straightness. The main shaft must run straight and cannot be more than 0.003 inch (0.08 mm) out of round at the spider attachment point.
	Yoke?	Check to make sure that both fingers of the yoke press evenly on the wear cap. Replace yoke as necessary.
	Blade Pitch?	Check to ensure that each blade is adjusted to have the same pitch as all other blades. Adjust per maintenance section in manual.

TROUBLESHOOTING (TROWEL)

Troubleshooting (Ride-On Mechanical Trowel) - continued		
Symptom	Possible Problem	Solution
Lights (optional) not working.	Wiring?	Check all electrical connections in the lighting circuit. Verify wiring is in good condition with no shorts. Replace defective wiring or components immediately.
	Lights?	If +12VDC is present at light fixture connector when light switch is activated and light does not turn on, replace light bulb.
	Bad switch?	Check the continuity of light switch. Replace light switch if defective.
	Bad fuse?	Check fuse. Replace fuse if defective.
Retardant spray (optional) not working.	Retardant?	Check retardant level in tank. Fill tank as required.
	Wiring?	Check all electrical connections in the spray pump circuit. Verify wiring is in good condition with no shorts. Replace defective wiring or components immediately.
	Bad switch?	Check the continuity of both left and right spray switches (palm handles). Replace spray switch if defective..
	Bad spray pump?	If +12VDC is present at pump connector when spray switch is activated and pump does not operate, replace spray pump.
	Bad fuse?	Check fuse. Replace fuse if defective.
Steering is unresponsive.	Blade speed out of adjustment?	See section on blade speed adjustment.
	Steering linkage out of adjustment?	Adjust the connecting linkage found at the base of the handle. Contact your MQ field service manager for instructions.
	Worn components?	Check for wear of steering bearings and linkage components. Replace if necessary.
Operating position is uncomfortable.	Seat adjusted for operator?	Adjust seat with lever located on the front of the seat.
Power head on Electric Pitch (optional) not working.	Broken or loose parts?	If the motor runs and the pitch is not affected, parts inside the power head may be loose or broken. Return power head to dealer for service.
	Wiring?	Check all electrical connections and wiring. Check the continuity at the power head unit. Verify that there is voltage present at the power head switch with the key switch in the "on" position.
	Switch?	Check the continuity of the switch. If switch is malfunctioning, replace immediately.
Linkage on Twin Pitch not working.	Crank handles?	Make sure that both crank handles are pushed down as far as possible to ensure that the linkage is engaged.
	Broken part?	Replace all broken parts immediately.
Clutch slipping or sluggish response to engine speed change.	Worn belts?	Replace belt.
	Clutch out of adjustment?	Adjust per instructions in maintenance section of this manual.
	Worn or defective clutch parts?	Replace parts as necessary.
	Worn bearings in gearbox?	Rotate input shaft by hand. If shaft rotates with difficulty, check the input and output shaft bearings. Replace as necessary.
	Worn or broken gears in gearbox?	Verify that the gearbox shaft rotates when the input shaft is rotated. Replace both the worm and worm gear as a

TROUBLESHOOTING (ENGINE)

Troubleshooting (Engine)		
Symptom	Possible Problem	Solution
Engine will not start or start is delayed, although engine can be turned over.	No Fuel reaching injection pump?	Add fuel. Check entire fuel system.
	Defective fuel pump?	Replace fuel pump.
	Fuel filter clogged?	Replace fuel filter and clean tank.
	Faulty fuel supply line?	Replace or repair fuel line.
	Compression too low?	Check piston, cylinder and valves. Adjust or repair per engine repair manual.
	Fuel pump not working correctly?	Repair or replace fuel pump.
	Oil pressure too low?	Check engine oil pressure.
	Low starting temperature limit exceeded?	Comply with cold starting instructions and proper oil viscosity.
	Defective battery?	Charge or replace battery.
	Air or water mixed in fuel system?	Check carefully for loosened fuel line coupling, loose cap nut, etc.
At low temperatures engine will not start.	Engine oil too thick?	Refill engine crankcase with correct type of oil for winter environment.
	Defective battery?	Replace battery.
Engine fires but stops soon as starter is switched off.	Fuel filter blocked?	Replace fuel filter.
	Fuel supply blocked?	Check the entire fuel system.
	Defective fuel pump?	Replace fuel pump.
Engine stops by itself during normal operation.	Fuel tank empty?	Add fuel.
	Fuel filter blocked?	Replace fuel filter.
	Defective fuel pump?	Replace fuel pump.
	Mechanical oil pressure shutdown sensor stops the engine due to low oil?	Add oil. Replace low oil shutdown sensor if necessary.
Low engine power, output and speed.	Fuel tank empty?	Replace fuel filter.
	Fuel filter clogged?	Replace fuel filter.
	Fuel tank venting is inadequate?	Ensure that tank is adequately vented.
	Leaks at pipe unions?	Check threaded pipe unions tape and tighten unions as required.
	Speed control lever does not remain in selected position?	See engine manual for corrective action.
	Engine oil level too full?	Correct engine oil level.
	Injection pump wear?	Use No. 2-D diesel fuel only. Check the fuel injection pump element and delivery valve assembly and replace as necessary.

TROUBLESHOOTING (ENGINE)

Troubleshooting (Engine) - continued		
Symptom	Possible Problem	Solution
Low engine power output and low speed, black exhaust smoke.	Air filter blocked?	Clean or replace air filter.
	Incorrect valve clearances?	Adjust valves per engine specification.
	Malfunction at injector?	See engine manual.
Engine overheats.	Too much oil in engine crankcase?	Drain off engine oil down to uppermark on dipstick.
	Entire cooling air system contaminated/ blocked?	Clean cooling air system and cooling fin areas.
	Fan belt broken or elongated?	Change belt or adjust belt tension.
	Coolant insufficient?	Replenish coolant.
	Radiator net or radiator fin clogged with dust?	Clean net or fin carefully.
	Fan, radiator, or radiator cap defective?	Replace defective part.
	Thermostat defective?	Check thermostat and replace if necessary.
	Head gasket defective or water leakage?	Replace parts.

TO PURCHASE THIS PRODUCT PLEASE CONTACT US



**Equipment Financing and
Extended Warranties Available**



**Discount-Equipment.com is your online resource for
commercial and industrial quality parts and equipment sales.**

561-964-4949

visit us on line @ www.discount-equipment.com

Select an option below to find your Equipment

Search by Manufacturer

Search by Product Type

Request a Quote

We sell worldwide for the brands: Genie, Terex, JLG, MultiQuip, Mikasa, Essick, Whiteman, Mayco, Toro Stone, Diamond Products, Generac Magnum, Airman, Haulotte, Barreto, Power Blanket, Nifty Lift, Atlas Copco, Chicago Pneumatic, Allmand, Miller Curber, Skyjack, Lull, Skytrak, Tsurumi, Husquvarna Target, Stow, Wacker, Sakai, Mi-T-M, Sullair, Basic, Dynapac, MBW, Weber, Bartell, Bennar Newman, Haulotte, Ditch Runner, Menegotti, Morrison, Contec, Buddy, Crown, Edco, Wyco, Bomag, Laymor, EZ Trench, Bil-Jax, F.S. Curtis, Gehl Pavers, Heli, Honda, ICS/PowerGrit, IHI, Partner, Imer, Clipper, MMD, Koshin, Rice, CH&E, General Equipment, Amida, Coleman, NAC, Gradall, Square Shooter, Kent, Stanley, Tamco, Toku, Hatz, Kohler, Robin, Wisconsin, Northrock, Oztec, Toker TK, Rol-Air, APT, Wylie, Ingersoll Rand / Doosan, Innovatech, Con X, Ammann, Mecalac, Makinex, Smith Surface Prep, Small Line, Wanco, Yanmar