



An Oshkosh Corporation Company



[www.Discount-Equipment.com](http://www.Discount-Equipment.com)

---

# ***Operation and Safety Manual***

*Original Instructions - Keep this manual with the machine at all times.*

## **Boom Lift Models**

**800A**

**800AJ**

**Prior to S/N 0300183033**

**ANSI** **CE** 

**3121209**  
August 1, 2016

**TO PURCHASE THIS PRODUCT PLEASE CONTACT US**



**Equipment Financing and  
Extended Warranties Available**



**Discount-Equipment.com is your online resource for  
commercial and industrial quality parts and equipment sales.**

**561-964-4949**

**visit us on line @ [www.discount-equipment.com](http://www.discount-equipment.com)**

Select an option below to find your Equipment

**Search by Manufacturer**

**Search by Product Type**

**Request a Quote**

We sell worldwide for the brands: Genie, Terex, JLG, MultiQuip, Mikasa, Essick, Whiteman, Mayco, Toro Stone, Diamond Products, Generac Magnum, Airman, Haulotte, Barreto, Power Blanket, Nifty Lift, Atlas Copco, Chicago Pneumatic, Allmand, Miller Curber, Skyjack, Lull, Skytrak, Tsurumi, Husquvarna Target, Stow, Wacker, Sakai, Mi-T-M, Sullair, Basic, Dynapac, MBW, Weber, Bartell, Bennar Newman, Haulotte, Ditch Runner, Menegotti, Morrison, Contec, Buddy, Crown, Edco, Wyco, Bomag, Laymor, EZ Trench, Bil-Jax, F.S. Curtis, Gehl Pavers, Heli, Honda, ICS/PowerGrit, IHI, Partner, Imer, Clipper, MMD, Koshin, Rice, CH&E, General Equipment, Amida, Coleman, NAC, Gradall, Square Shooter, Kent, Stanley, Tamco, Toku, Hatz, Kohler, Robin, Wisconsin, Northrock, Oztec, Toker TK, Rol-Air, APT, Wylie, Ingersoll Rand / Doosan, Innovatech, Con X, Ammann, Mecalac, Makinex, Smith Surface Prep, Small Line, Wanco, Yanmar

To order go to [Discount-Equipment.com](http://Discount-Equipment.com)

## **FOREWORD**

This manual is a very important tool! Keep it with the machine at all times.

The purpose of this manual is to provide owners, users, operators, lessors, and lessees with the precautions and operating procedures essential for the safe and proper machine operation for its intended purpose.

Due to continuous product improvements, JLG Industries, Inc. reserves the right to make specification changes without prior notification. Contact JLG Industries, Inc. for updated information.

## SAFETY ALERT SYMBOLS AND SAFETY SIGNAL WORDS



This is the Safety Alert Symbol. It is used to alert you to the potential personal injury hazards. Obey all safety messages that follow this symbol to avoid possible injury or death

### **DANGER**

INDICATES AN IMMINENTLY HAZARDOUS SITUATION. IF NOT AVOIDED, WILL RESULT IN SERIOUS INJURY OR DEATH. THIS DECAL WILL HAVE A RED BACKGROUND.

### **WARNING**

INDICATES A POTENTIALLY HAZARDOUS SITUATION. IF NOT AVOIDED, COULD RESULT IN SERIOUS INJURY OR DEATH. THIS DECAL WILL HAVE AN ORANGE BACKGROUND.

### **CAUTION**

INDICATES A POTENTIALLY HAZARDOUS SITUATION. IF NOT AVOIDED, MAY RESULT IN MINOR OR MODERATE INJURY. IT MAY ALSO ALERT AGAINST UNSAFE PRACTICES. THIS DECAL WILL HAVE A YELLOW BACKGROUND.

### **NOTICE**

INDICATES INFORMATION OR A COMPANY POLICY THAT RELATES DIRECTLY OR INDIRECTLY TO THE SAFETY OF PERSONNEL OR PROTECTION OF PROPERTY.

**⚠ WARNING**

THIS PRODUCT MUST COMPLY WITH ALL SAFETY RELATED BULLETINS. CONTACT JLG INDUSTRIES, INC. OR THE LOCAL AUTHORIZED JLG REPRESENTATIVE FOR INFORMATION REGARDING SAFETY-RELATED BULLETINS WHICH MAY HAVE BEEN ISSUED FOR THIS PRODUCT.

**NOTICE**

JLG INDUSTRIES, INC. SENDS SAFETY RELATED BULLETINS TO THE OWNER OF RECORD OF THIS MACHINE. CONTACT JLG INDUSTRIES, INC. TO ENSURE THAT THE CURRENT OWNER RECORDS ARE UPDATED AND ACCURATE.

**NOTICE**

JLG INDUSTRIES, INC. MUST BE NOTIFIED IMMEDIATELY IN ALL INSTANCES WHERE JLG PRODUCTS HAVE BEEN INVOLVED IN AN ACCIDENT INVOLVING BODILY INJURY OR DEATH OF PERSONNEL OR WHEN SUBSTANTIAL DAMAGE HAS OCCURRED TO PERSONAL PROPERTY OR THE JLG PRODUCT.

**For:**

- Accident Reporting
- Product Safety Publications
- Current Owner Updates
- Questions Regarding Product Safety
- Standards and Regulations Compliance Information
- Questions Regarding Special Product Applications
- Questions Regarding Product Modifications

**Contact:**

Product Safety and Reliability Department  
JLG Industries, Inc.  
13224 Fountainhead Plaza  
Hagerstown, MD 21742  
USA

or Your Local JLG Office  
(See addresses on inside of manual cover)

**In USA:**

Toll Free: 877-JLG-SAFE (877-554-7233)

**Outside USA:**

Phone: 240-420-2661  
Fax: 301-745-3713  
E-mail: ProductSafety@JLG.com

**REVISION LOG**

Original Issue	- May 4, 2005
Revised	- September 1, 2005
Revised	- March 7, 2006
Revised	- July 17, 2006
Revised	- March 12, 2007
Revised	- March 30, 2007
Revised	- January 6, 2009
Revised	- November 6, 2009
Revised	- December 12, 2009
Revised	- July 26, 2010
Revised	- June 21, 2012
Revised	- October 1, 2015
Revised	- August 1, 2016

To order go to Discount-Equipment.com

<b>SECTION - PARAGRAPH, SUBJECT</b>	<b>PAGE</b>	<b>SECTION - PARAGRAPH, SUBJECT</b>	<b>PAGE</b>
<b>SECTION - 1 - SAFETY PRECAUTIONS</b>			
1.1 GENERAL .....	1-1	From the Ground Control Station with No Load in the Platform: .....	2-11
1.2 PRE-OPERATION .....	1-1	SkyGuard Function Test .....	2-13
Operator Training and Knowledge .....	1-1	From the Platform Control Station: .....	2-16
Workplace Inspection .....	1-2	2.4 OSCILLATING AXLE LOCKOUT TEST (IF EQUIPPED)....	2-19
Machine Inspection .....	1-2		
1.3 OPERATION .....	1-3	<b>SECTION - 3 - MACHINE CONTROLS AND INDICATORS</b>	
General .....	1-3	3.1 GENERAL .....	3-1
Trip and Fall Hazards .....	1-3	3.2 CONTROLS AND INDICATORS .....	3-1
Electrocution Hazards .....	1-4	Ground Control Station .....	3-1
Tipping Hazards .....	1-6	Ground Control Indicator Panel .....	3-6
Crushing and Collision Hazards .....	1-7	Platform Station .....	3-9
1.4 TOWING, LIFTING, AND HAULING .....	1-8	Platform Control Indicator Panel .....	3-16
1.5 ADDITIONAL HAZARDS / SAFETY .....	1-9		
		<b>SECTION - 4 - MACHINE OPERATION</b>	
<b>SECTION - 2 - USER RESPONSIBILITIES, MACHINE PREPARATION, AND INSPECTION</b>		4.1 DESCRIPTION .....	4-1
2.1 PERSONNEL TRAINING .....	2-1	4.2 OPERATING CHARACTERISTICS AND LIMITATIONS ....	4-1
Operator Training .....	2-1	Capacities .....	4-1
Training Supervision .....	2-1	Stability .....	4-1
Operator Responsibility .....	2-1	4.3 ENGINE OPERATION .....	4-2
2.2 PREPARATION, INSPECTION, AND MAINTENANCE .....	2-2	Starting Procedure .....	4-2
Pre-Start Inspection .....	2-4	Shutdown Procedure .....	4-6
GENERAL .....	2-8	4.4 TRAVELING (DRIVING) .....	4-6
2.3 FUNCTION CHECK .....	2-11	Traveling Forward and Reverse .....	4-7



## TABLE OF CONTENTS

SECTION - PARAGRAPH, SUBJECT	PAGE	SECTION - PARAGRAPH, SUBJECT	PAGE
4.5 STEERING.....	4-7	4.17 SKYGUARD OPERATION.....	4-21
4.6 PARKING AND STOWING.....	4-7		
4.7 PLATFORM.....	4-8	<b>SECTION - 5 - EMERGENCY PROCEDURES</b>	
Loading From Ground Level.....	4-8	5.1 GENERAL.....	5-1
Loading From Positions Above Ground Level.....	4-8	5.2 INCIDENT NOTIFICATION.....	5-1
Platform Level Adjustment.....	4-8	5.3 EMERGENCY TOWING PROCEDURES.....	5-1
Platform Rotation.....	4-8	5.4 EMERGENCY CONTROLS AND THEIR LOCATIONS.....	5-2
4.8 BOOM.....	4-10	Power/Emergency Stop Switches.....	5-2
Swinging the Boom.....	4-10	Ground Control Station.....	5-2
Raising and Lowering the Tower Boom.....	4-11	Auxiliary Power.....	5-2
Raising and Lowering the Main Boom.....	4-11	5.5 EMERGENCY OPERATION.....	5-3
Telescoping the Main Boom.....	4-11	Use of Ground Controls.....	5-3
Function of Tower Boom.....	4-12	Operator Unable to Control Machine.....	5-4
4.9 SHUT DOWN AND PARK.....	4-13	Platform or Boom Caught Overhead.....	5-4
4.10 LIFTING AND TIE DOWN.....	4-13		
4.11 OSCILLATING AXLE LOCKOUT TEST (IF EQUIPPED).....	4-16	<b>SECTION - 6 - GENERAL SPECIFICATIONS &amp; OPERATOR MAINTENANCE</b>	
4.12 TOWING.....	4-16	6.1 INTRODUCTION.....	6-1
4.13 TOW BAR (IF EQUIPPED).....	4-17	6.2 OPERATING SPECIFICATIONS.....	6-2
4.14 WELDING LEAD (IF EQUIPPED).....	4-17	Tires.....	6-3
4.15 DUAL FUEL SYSTEM (GAS ENGINE ONLY).....	4-19	Capacities.....	6-3
Description.....	4-19	Engine Data.....	6-4
Changing From Gasoline to LP Gas.....	4-19	Hydraulic Oil.....	6-7
Changing From LP Gas to Gasoline.....	4-19	Critical Stability Weights.....	6-10
4.16 RE-SYNCHRONIZE UPRIGHT.....	4-20		
Releveling Valve.....	4-20		

<b>SECTION - PARAGRAPH, SUBJECT</b>	<b>PAGE</b>	<b>SECTION - PARAGRAPH, SUBJECT</b>	<b>PAGE</b>
6.3 OPERATOR MAINTENANCE .....	6-21		
6.4 TIRES & WHEELS .....	6-29		
Tire Inflation .....	6-29		
Tire Damage .....	6-29		
Tire Replacement .....	6-30		
Wheel Replacement .....	6-30		
Wheel Installation .....	6-31		
6.5 DRAINING OIL BUILD UP FROM THE PROPANE REGULATOR (PRIOR TO S/N 0300134626) .....	6-32		
6.6 PROPANE FUEL FILTER REPLACEMENT .....	6-34		
Removal .....	6-34		
Installation .....	6-34		
6.7 PROPANE FUEL SYSTEM PRESSURE RELIEF .....	6-36		
6.8 SUPPLEMENTAL INFORMATION .....	6-36		

**SECTION - 7 - INSPECTION AND REPAIR LOG**

**TABLE OF CONTENTS**

---

**SECTION - PARAGRAPH, SUBJECT**

**PAGE**

**SECTION - PARAGRAPH, SUBJECT**

**PAGE**

**This Page Left Blank Intentionally.**

<b>FIGURE NUMBER - TITLE</b>	<b>PAGE</b>	<b>FIGURE NUMBER - TITLE</b>	<b>PAGE</b>
2-1. Machine Nomenclature - 800A (Sheet 1 of 2) .....	2-5	4-11. Decal Installation - Sheet 3 of 5 .....	4-24
2-2. Machine Nomenclature - 800AJ (Sheet 2 of 2) .....	2-6	4-12. Decal Installation - Sheet 4 of 5 .....	4-25
2-3. Daily Walk-Around Inspection (Sheet 1 of 4) .....	2-7	4-13. Decal Installation - Sheet 5 of 5 .....	4-26
2-4. Daily Walk-Around Inspection (Sheet 2 of 4) .....	2-8	6-1. Engine Operating Temperature Specifications - Deutz - Sheet 1 of 2 .....	6-12
2-5. Daily Walk-Around Inspection (Sheet 3 of 4) .....	2-9	6-2. Engine Operating Temperature Specifications - Deutz - Sheet 2 of 2 .....	6-13
2-6. Daily Walk-Around Inspection (Sheet 4 of 4) .....	2-10	6-3. Engine Operating Temperature Specifications - Ford - Sheet 1 of 2 .....	6-14
2-7. Tower Boom Vertical Limit Switch .....	2-11	6-4. Engine Operating Temperature Specifications - Ford - Sheet 2 of 2 .....	6-15
2-8. Tower Boom Horizontal Limit Switch .....	2-12	6-5. Engine Operating Temperature Specifications - Caterpillar - Sheet 1 of 2 .....	6-16
2-9. Boom Upright Positioning - Correct .....	2-14	6-6. Engine Operating Temperature Specifications - Caterpillar - Sheet 2 of 2 .....	6-17
2-10. Boom Upright Positioning - Incorrect .....	2-15	6-7. Engine Operating Temperature Specifications - GM - Sheet 1 of 2 .....	6-18
3-1. Ground Control Station .....	3-2	6-8. Engine Operating Temperature Specifications - GM - Sheet 2 of 2 .....	6-19
3-2. Ground Control Indicator Panel .....	3-6	6-9. Operator Maintenance and Lubrication Diagram .....	6-20
3-3. Platform Control Console .....	3-10	6-10. Filter Lock Assembly .....	6-35
3-4. Platform Control Console - w/Drive Orientation .....	3-11		
3-5. Platform Light Panel .....	3-18		
3-6. Platform Light Panel w/Drive Orientation .....	3-19		
4-1. Position of Least Forward Stability .....	4-3		
4-2. Positions of Least Backward Stability (Sheet 1 of 2) .....	4-4		
4-3. Positions of Least Backward Stability (Sheet 2 of 2) .....	4-5		
4-4. Grade and Sideslopes .....	4-9		
4-5. Machine Tie Down .....	4-14		
4-6. Lifting Chart .....	4-15		
4-7. Tow Bar .....	4-18		
4-8. Releveling Valve .....	4-20		
4-9. Decal Installation - Sheet 1 of 5 .....	4-22		
4-10. Decal Installation - Sheet 2 of 5 .....	4-23		

***LIST OF FIGURES***

**FIGURE NUMBER - TITLE**

**PAGE**

**FIGURE NUMBER - TITLE**

**PAGE**

**This Page Left Blank Intentionally.**

<b>TABLE NUMBER - TITLE</b>	<b>PAGE</b>	<b>TABLE NUMBER - TITLE</b>	<b>PAGE</b>
1-1	Minimum Approach Distances (M.A.D.) .....	1-5	
1-2	Beaufort Scale (For Reference Only).....	1-10	
2-1	Inspection and Maintenance Table .....	2-3	
4-1	SkyGuard Function Table.....	4-21	
4-2	Decal Legend - 800A - Prior to S/N 0300141330 .....	4-27	
4-3	Decal Legend - 800A - S/N 0300141330 to S/N 0300183033 .....	4-31	
4-4	Decal Legend - 800AJ - Prior to S/N 0300141330 .....	4-35	
4-5	Decal Legend - 800AJ - S/N 0300141330 to S/N 0300183033 .....	4-39	
6-1	Operating Specifications .....	6-2	
6-2	Tire Specifications.....	6-3	
6-3	Capacities .....	6-3	
6-4	Ford LRG-425 Specifications.....	6-4	
6-5	Deutz F4M2011F Specifications.....	6-4	
6-6	Deutz D2011L04 Specifications.....	6-5	
6-7	Caterpillar 3044C/3.4.....	6-5	
6-8	Isuzu 4JB1 .....	6-6	
6-9	GM 3.0L.....	6-6	
6-10	Hydraulic Oil.....	6-7	
6-11	Mobilfluid 424 Specs .....	6-7	
6-12	Mobil DTE 13M Specs .....	6-8	
6-13	Mobil EAL 224H Specs.....	6-8	
6-14	UCon Hydrolube HP-5046.....	6-9	
6-15	Exxon Univis HVI 26 Specs.....	6-9	
6-16	Quintolubric 888-46.....	6-10	
		6-17	Critical Stability Weights - 800A.....
		6-18	Critical Stability Weights - 800AJ.....
		6-19	Lubrication Specifications .....
		6-20	Wheel Torque Chart.....
		7-1	Inspection and Repair Log.....

***LIST OF TABLES***

**TABLE NUMBER - TITLE**

**PAGE**

**TABLE NUMBER - TITLE**

**PAGE**

**This Page Left Blank Intentionally.**

## SECTION 1. SAFETY PRECAUTIONS

### 1.1 GENERAL

This section outlines the necessary precautions for proper and safe machine operation and maintenance. For proper machine use, it is mandatory that a daily routine is established based on the content of this manual. A maintenance program, using the information provided in this manual and the Service and Maintenance Manual, must also be established by a qualified person and followed to ensure the machine is safe to operate.

The owner/user/operator/lessor/lessee of the machine should not operate the machine until this manual has been read, training is accomplished, and operation of the machine has been completed under the supervision of an experienced and qualified operator.

If there are any questions with regard to safety, training, inspection, maintenance, application, and operation, please contact JLG Industries, Inc. ("JLG").

#### **WARNING**

**FAILURE TO COMPLY WITH THE SAFETY PRECAUTIONS LISTED IN THIS MANUAL COULD RESULT IN MACHINE DAMAGE, PROPERTY DAMAGE, PERSONAL INJURY OR DEATH.**

### 1.2 PRE-OPERATION

#### Operator Training and Knowledge

- Read and understand this manual before operating the machine.

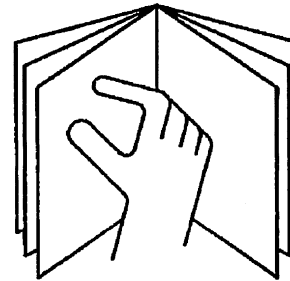

- Do not operate this machine until complete training is performed by authorized persons.
- Only authorized and qualified personnel can operate the machine.



## SECTION 1 - SAFETY PRECAUTIONS

---

- Read, understand, and obey all DANGERS, WARNINGS, CAUTIONS, and operating instructions on the machine and in this manual.
- Use the machine in a manner which is within the scope of its intended application set by JLG.
- All operating personnel must be familiar with the emergency controls and emergency operation of the machine as specified in this manual.
- Read, understand, and obey all applicable employer, local, and governmental regulations as they pertain to operation of the machine.

### Workplace Inspection

- The operator is to take safety measures to avoid all hazards in the work area prior to machine operation.
- Do not operate or raise the platform while on trucks, trailers, railway cars, floating vessels, scaffolds or other equipment unless approved in writing by JLG.
- Do not operate the machine in hazardous environments unless approved for that purpose by JLG.
- Be sure that the ground conditions are able to support the maximum load shown on the decals located on the machine.

### Machine Inspection

- Before machine operation, perform inspections and functional checks. Refer to Section 2 of this manual for detailed instructions.
- Do not operate this machine until it has been serviced and maintained according to requirements specified in the Service and Maintenance Manual.
- Be sure the footswitch and all other safety devices are operating properly. Modification of these devices is a safety violation.

### WARNING

**MODIFICATION OR ALTERATION OF AN AERIAL WORK PLATFORM SHALL BE MADE ONLY WITH WRITTEN PERMISSION FROM THE MANUFACTURER**

- Do not operate any machine on which safety or instruction placards or decals are missing or illegible.
- Avoid any buildup of debris on the platform floor. Keep mud, oil, grease, and other slippery substances from footwear and platform floor.

## 1.3 OPERATION

### General

- Do not use the machine for any purpose other than positioning personnel, their tools, and equipment.
- Never operate a machine that is not working properly. If a malfunction occurs, shut down the machine.
- Never slam a control switch or lever through neutral to an opposite direction. Always return switch to neutral and stop before moving the switch to the next function. Operate controls with slow and even pressure.
- Hydraulic cylinders should never be left fully extended or fully retracted before shutdown or for long periods of time.
- Do not allow personnel to tamper with or operate the machine from the ground with personnel in the platform, except in an emergency.
- Do not carry materials directly on platform railing. Contact JLG for approved material handling accessories.
- When two or more persons are in the platform, the operator shall be responsible for all machine operations.
- Always ensure that power tools are properly stowed and never left hanging by their cord from the platform work area.

- Supplies or tools which extend outside the platform are prohibited unless approved by JLG.
- When driving, always position boom over rear axle in line with the direction of travel. Remember, if boom is over the front axle, steer and drive functions will be reversed.
- Do not assist a stuck or disabled machine by pushing, pulling, or by using boom functions. Only pull the unit from the tie-down lugs on the chassis.
- Do not place boom or platform against any structure to steady the platform or to support the structure.
- Stow boom and shut off all power before leaving machine.

### Trip and Fall Hazards

During operation, occupants in the platform must wear a full body harness with a lanyard attached to an authorized lanyard anchorage point. Attach only one (1) lanyard per lanyard anchorage point.

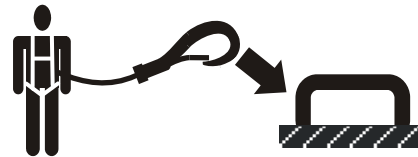

## SECTION 1 - SAFETY PRECAUTIONS

- Before operating the machine, make sure all gates are closed and fastened in their proper position.

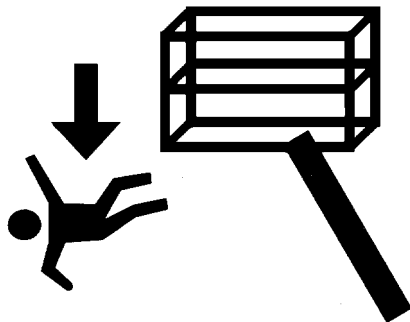

- Keep both feet firmly positioned on the platform floor at all times. Never use ladders, boxes, steps, planks, or similar items on platform to provide additional reach.
- Never use the boom assembly to enter or leave the platform.

- Use extreme caution when entering or leaving platform. Be sure that the boom is fully lowered. It may be necessary to telescope out to position the platform closer to the ground for entry/exit. Face the machine, maintain “three point contact” with the machine, using two hands and one foot or two feet and one hand during entry and exit.

### Electrocution Hazards

- This machine is not insulated and does not provide protection from contact or proximity to electrical current.

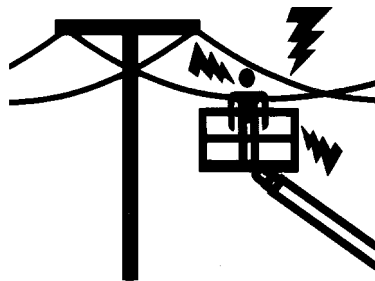

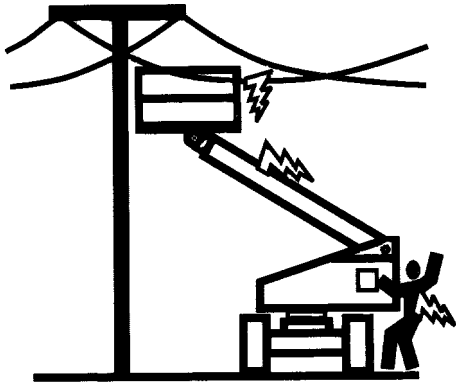

- Maintain distance from electrical lines, apparatus, or any energized (exposed or insulated) parts according to the Minimum Approach Distance (MAD) as shown in Table 1-1.
- Allow for machine movement and electrical line swaying.

**Table 1-1. Minimum Approach Distances (M.A.D.)**

<b>Voltage Range (Phase to Phase)</b>	<b>MINIMUM APPROACH DISTANCE in Feet (Meters)</b>
0 to 50 KV	10 (3)
Over 50KV to 200 KV	15 (5)
Over 200 KV to 350 KV	20 (6)
Over 350 KV to 500 KV	25 (8)
Over 500 KV to 750 KV	35 (11)
Over 750 KV to 1000 KV	45 (14)

**NOTE:** *This requirement shall apply except where employer, local or governmental regulations are more stringent.*

- Maintain a clearance of at least 10 ft. (3m) between any part of the machine and its occupants, their tools, and their equipment from any electrical line or apparatus carrying up to 50,000 volts. One foot additional clearance is required for every additional 30,000 volts or less.

## SECTION 1 - SAFETY PRECAUTIONS

- The minimum approach distance may be reduced if insulating barriers are installed to prevent contact, and the barriers are rated for the voltage of the line being guarded. These barriers shall not be part of (or attached to) the machine. The minimum approach distance shall be reduced to a distance within the designed working dimensions of the insulating barrier. This determination shall be made by a qualified person in accordance with the employer, local, or governmental requirements for work practices near energized equipment

### **⚠ DANGER**

**DO NOT MANEUVER MACHINE OR PERSONNEL INSIDE PROHIBITED ZONE (MAD). ASSUME ALL ELECTRICAL PARTS AND WIRING ARE ENERGIZED UNLESS KNOWN OTHERWISE.**

### **Tipping Hazards**

- The user should be familiar with the surface before driving. Do not exceed the allowable sideslope and grade while driving.

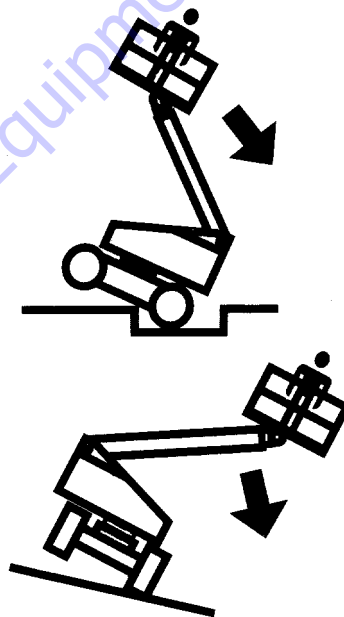

- Do not elevate platform or drive with platform elevated while on a sloping, uneven, or soft surface.

- Before driving on floors, bridges, trucks, and other surfaces, check allowable capacity of the surfaces.
- Never exceed the maximum platform capacity. Distribute loads evenly on platform floor.
- Do not raise the platform or drive from an elevated position unless the machine is on firm, level and smooth surfaces.
- Keep the chassis of the machine at least 2 ft. (0.6m) from holes, bumps, drop-offs, obstructions, debris, concealed holes, and other potential hazards on the floor/surface.
- Do not push or pull any object with the boom.
- Never attempt to use the machine as a crane. Do not tie-off machine to any adjacent structure.
- Do not operate the machine when wind conditions exceed 28 mph (12.5 m/s). Refer to Table 1-2, Beaufort Scale (For Reference Only).
- Do not increase the surface area of the platform or the load. Increase of the area exposed to the wind will decrease stability.
- Do not increase the platform size with unauthorized deck extensions or attachments.
- If boom assembly or platform is in a position that one or more wheels are off the ground, all persons must be removed before attempting to stabilize the machine. Use cranes, forklift trucks, or other appropriate equipment to stabilize machine.

### Crushing and Collision Hazards

- Approved head gear must be worn by all operating and ground personnel.
- Check work area for clearances overhead, on sides, and bottom of platform when lifting or lowering platform, and driving.

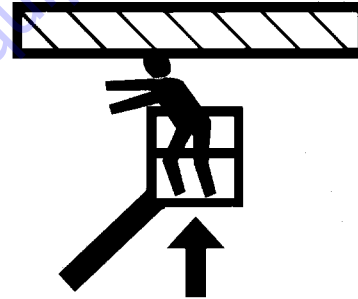

- During operation, keep all body parts inside platform railing.
- Use the boom functions, not the drive function, to position the platform close to obstacles.
- Always post a lookout when driving in areas where vision is obstructed.
- Keep non-operating personnel at least 6 ft. (1.8m) away from machine during all driving and swing operations.

## SECTION 1 - SAFETY PRECAUTIONS

---

- Limit travel speed according to conditions of ground surface, congestion, visibility, slope, location of personnel, and other factors which may cause collision or injury to personnel.
- Be aware of stopping distances in all drive speeds. When driving in high speed, switch to low speed before stopping. Travel grades in low speed only.
- Do not use high speed drive in restricted or close quarters or when driving in reverse.
- Exercise extreme caution at all times to prevent obstacles from striking or interfering with operating controls and persons in the platform.
- Be sure that operators of other overhead and floor level machines are aware of the aerial work platform's presence. Disconnect power to overhead cranes.
- Warn personnel not to work, stand, or walk under a raised boom or platform. Position barricades on floor if necessary.

### 1.4 TOWING, LIFTING, AND HAULING

- Never allow personnel in platform while towing, lifting, or hauling.
- This machine should not be towed, except in the event of emergency, malfunction, power failure, or loading/unloading. Refer to the Emergency Procedures section of this manual for emergency towing procedures.
- Ensure boom is in the stowed position and the turntable locked prior to towing, lifting or hauling. The platform must be completely empty of tools.
- When lifting machine, lift only at designated areas of the machine. Lift the unit with equipment of adequate capacity.
- Refer to the Machine Operation section of this manual for lifting information.

**1.5 ADDITIONAL HAZARDS / SAFETY**

- Do not use machine as a ground for welding.
- When performing welding or metal cutting operations, precautions must be taken to protect the chassis from direct exposure to weld and metal cutting spatter.
- Do not refuel the machine with the engine running.
- Battery fluid is highly corrosive. Avoid contact with skin and clothing at all times.
- Charge batteries only in a well ventilated area.



## SECTION 1 - SAFETY PRECAUTIONS

### NOTICE

DO NOT OPERATE THE MACHINE WHEN WIND CONDITIONS EXCEED 28 MPH (12.5 M/S).

Table 1-2. Beaufort Scale (For Reference Only)

Beaufort Number	Wind Speed		Description	Land Conditions
	mph	m/s		
0	0	0-0.2	Calm	Calm. Smoke rises vertically.
1	1-3	0.3-1.5	Light air	Wind motion visible in smoke.
2	4-7	1.6-3.3	Light breeze	Wind felt on exposed skin. Leaves rustle.
3	8-12	3.4-5.4	Gentle breeze	Leaves and smaller twigs in constant motion.
4	13-18	5.5-7.9	Moderate breeze	Dust and loose paper raised. Small branches begin to move.
5	19-24	8.0-10.7	Fresh breeze	Smaller trees sway.
6	25-31	10.8-13.8	Strong breeze	Large branches in motion. Whistling heard in overhead wires. Umbrella use becomes difficult.
7	32-38	13.9-17.1	Near Gale/Moderate Gale	Whole trees in motion. Effort needed to walk against the wind.
8	39-46	17.2-20.7	Fresh Gale	Twigs broken from trees. Cars veer on road.
9	47-54	20.8-24.4	Strong Gale	Light structure damage.

## **SECTION 2. USER RESPONSIBILITIES, MACHINE PREPARATION, AND INSPECTION**

### **2.1 PERSONNEL TRAINING**

The aerial platform is a personnel handling device; so it is necessary that it be operated and maintained only by trained personnel.

Persons under the influence of drugs or alcohol or who are subject to seizures, dizziness or loss of physical control must not operate this machine.

#### **Operator Training**

Operator training must cover:

1. Use and limitations of the controls in the platform and at the ground, emergency controls and safety systems.
2. Control labels, instructions, and warnings on the machine.
3. Rules of the employer and government regulations.
4. Use of approved fall protection device.
5. Enough knowledge of the mechanical operation of the machine to recognize a malfunction or potential malfunction.

6. The safest means to operate the machine where overhead obstructions, other moving equipment, and obstacles, depressions, holes, drop-offs.
7. Means to avoid the hazards of unprotected electrical conductors.
8. Specific job requirements or machine application.

#### **Training Supervision**

Training must be done under the supervision of a qualified person in an open area free of obstructions until the trainee has developed the ability to safely control and operate the machine.

#### **Operator Responsibility**

The operator must be instructed that he/she has the responsibility and authority to shut down the machine in case of a malfunction or other unsafe condition of either the machine or the job site.

**TO PURCHASE THIS PRODUCT PLEASE CONTACT US**



**Equipment Financing and  
Extended Warranties Available**



**Discount-Equipment.com is your online resource for  
commercial and industrial quality parts and equipment sales.**

**561-964-4949**

**visit us on line @ [www.discount-equipment.com](http://www.discount-equipment.com)**

Select an option below to find your Equipment

**Search by Manufacturer**

**Search by Product Type**

**Request a Quote**

We sell worldwide for the brands: Genie, Terex, JLG, MultiQuip, Mikasa, Essick, Whiteman, Mayco, Toro Stone, Diamond Products, Generac Magnum, Airman, Haulotte, Barreto, Power Blanket, Nifty Lift, Atlas Copco, Chicago Pneumatic, Allmand, Miller Curber, Skyjack, Lull, Skytrak, Tsurumi, Husquvarna Target, Stow, Wacker, Sakai, Mi-T-M, Sullair, Basic, Dynapac, MBW, Weber, Bartell, Bennar Newman, Haulotte, Ditch Runner, Menegotti, Morrison, Contec, Buddy, Crown, Edco, Wyco, Bomag, Laymor, EZ Trench, Bil-Jax, F.S. Curtis, Gehl Pavers, Heli, Honda, ICS/PowerGrit, IHI, Partner, Imer, Clipper, MMD, Koshin, Rice, CH&E, General Equipment, Amida, Coleman, NAC, Gradall, Square Shooter, Kent, Stanley, Tamco, Toku, Hatz, Kohler, Robin, Wisconsin, Northrock, Oztec, Toker TK, Rol-Air, APT, Wylie, Ingersoll Rand / Doosan, Innovatech, Con X, Ammann, Mecalac, Makinex, Smith Surface Prep, Small Line, Wanco, Yanmar

## **2.2 PREPARATION, INSPECTION, AND MAINTENANCE**

The following table covers the periodic machine inspections and maintenance required by JLG Industries, Inc. Consult local regulations for further requirements for aerial work platforms. The frequency of inspections and maintenance must be increased as necessary when the machine is used in a harsh or hostile environment, if the machine is used with increased frequency, or if the machine is used in a severe manner.

### **NOTICE**

**JLG INDUSTRIES, INC. RECOGNIZES A FACTORY-TRAINED SERVICE TECHNICIAN AS A PERSON WHO HAS SUCCESSFULLY COMPLETED THE JLG SERVICE TRAINING SCHOOL FOR THE SPECIFIC JLG PRODUCT MODEL.**

## SECTION 2 - USER RESPONSIBILITIES, MACHINE PREPARATION, AND INSPECTION

**Table 2-1. Inspection and Maintenance Table**

Type	Frequency	Primary Responsibility	Service Qualification	Reference
Pre-Start Inspection	Before using each day; or whenever there's an Operator change.	User or Operator	User or Operator	Operator and Safety Manual
Pre-Delivery Inspection (See Note)	Before each sale, lease, or rental delivery.	Owner, Dealer, or User	Qualified JLG Mechanic	Service and Maintenance Manual and applicable JLG inspection form
Frequent Inspection (See Note)	In service for 3 months or 150 hours, whichever comes first; or Out of service for a period of more than 3 months; or Purchased used.	Owner, Dealer, or User	Qualified JLG Mechanic	Service and Maintenance Manual and applicable JLG inspection form
Annual Machine Inspection (See Note)	Annually, no later than 13 months from the date of prior inspection.	Owner, Dealer, or User	Factory Trained Service Technician (Recommended)	Service and Maintenance Manual and applicable JLG inspection form
Preventative Maintenance	At intervals as specified in the Service and Maintenance Manual.	Owner, Dealer, or User	Qualified JLG Mechanic	Service and Maintenance Manual
<b>NOTE:</b> Inspection forms are available from JLG. Use the Service and Maintenance Manual to perform inspections.				

## SECTION 2 - USER RESPONSIBILITIES, MACHINE PREPARATION, AND INSPECTION

### Pre-Start Inspection

The Pre-Start Inspection should include each of the following:

1. **Cleanliness** – Check all surfaces for leakage (oil, fuel, or battery fluid) or foreign objects. Report any leakage to the proper maintenance personnel.
2. **Structure** - Inspect the machine structure for dents, damage, weld or parent metal cracks or other discrepancies.

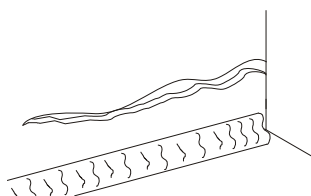

Parent Metal Crack

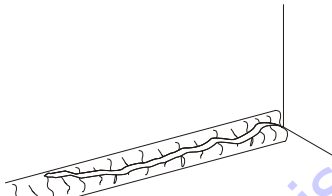

Weld Crack

3. **Decals and Placards** – Check all for cleanliness and legibility. Make sure none of the decals and placards are missing. Make sure all illegible decals and placards are cleaned or replaced.
4. **Operators and Safety Manuals** – Make sure a copy of the Operator and Safety Manual, EMI Safety Manual (Domestic only), and ANSI Manual of Responsibilities (Domestic only) is enclosed in the weather resistant storage container.

5. **“Walk-Around” Inspection** – Refer to Figure 2-3. and Figure 2-4.
6. **Battery** – Charge as required.
7. **Fuel** (Combustion Engine Powered Machines) – Add the proper fuel as necessary.
8. **Engine Oil Supply** - Ensure the engine oil level is at the Full mark on the dipstick and the filler cap is secure.
9. **Hydraulic Oil** – Check the hydraulic oil level. Ensure hydraulic oil is added as required.
10. **Function Check** - Once the "Walk-Around" Inspection is complete, perform a functional check of all systems in accordance with Section 2.3 in an area free of overhead and ground level obstructions. Refer to Sections 3 and 4 for more specific machine operating instructions.

### **⚠ WARNING**

**IF THE MACHINE DOES NOT OPERATE PROPERLY, TURN OFF THE MACHINE IMMEDIATELY! REPORT THE PROBLEM TO THE PROPER MAINTENANCE PERSONNEL. DO NOT OPERATE THE MACHINE UNTIL IT IS DECLARED SAFE FOR OPERATION.**

**SECTION 2 - USER RESPONSIBILITIES, MACHINE PREPARATION, AND INSPECTION**

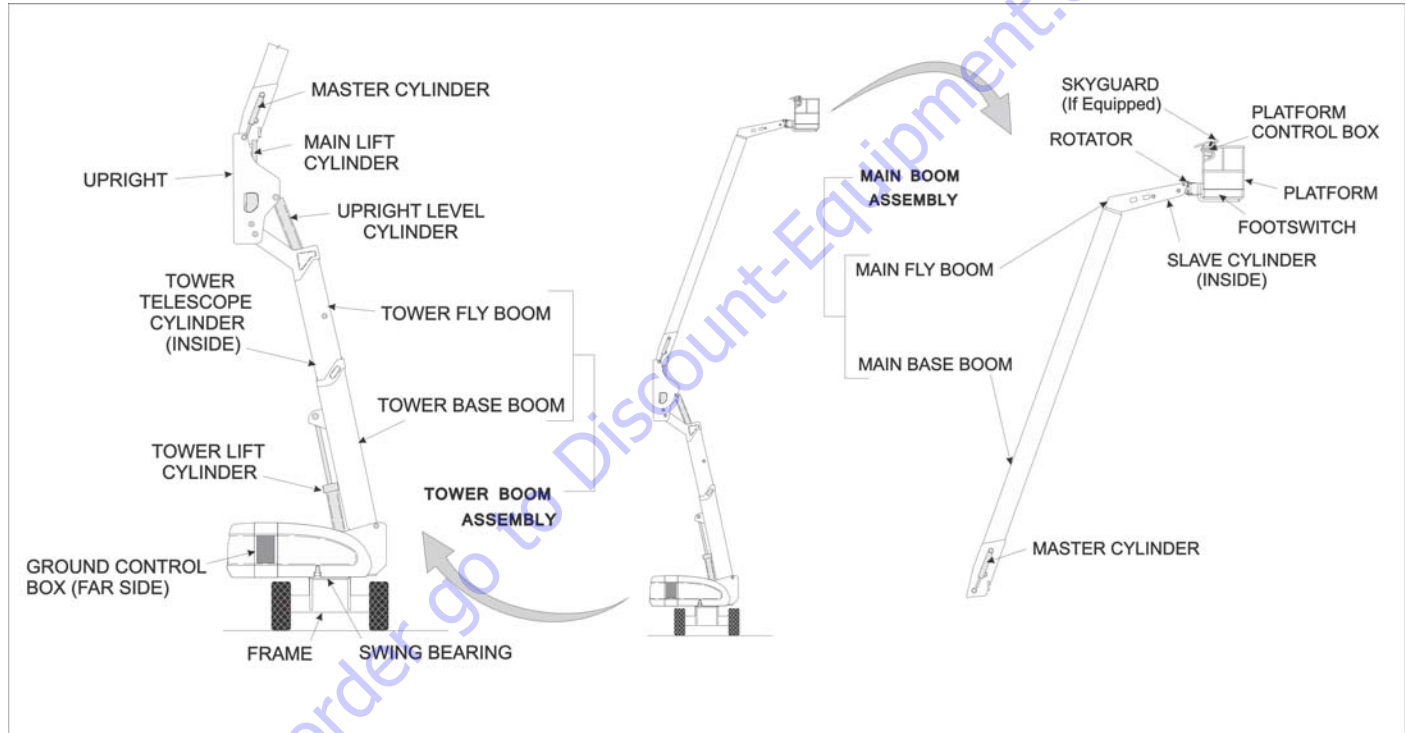

**Figure 2-1. Machine Nomenclature - 800A (Sheet 1 of 2)**

**SECTION 2 - USER RESPONSIBILITIES, MACHINE PREPARATION, AND INSPECTION**

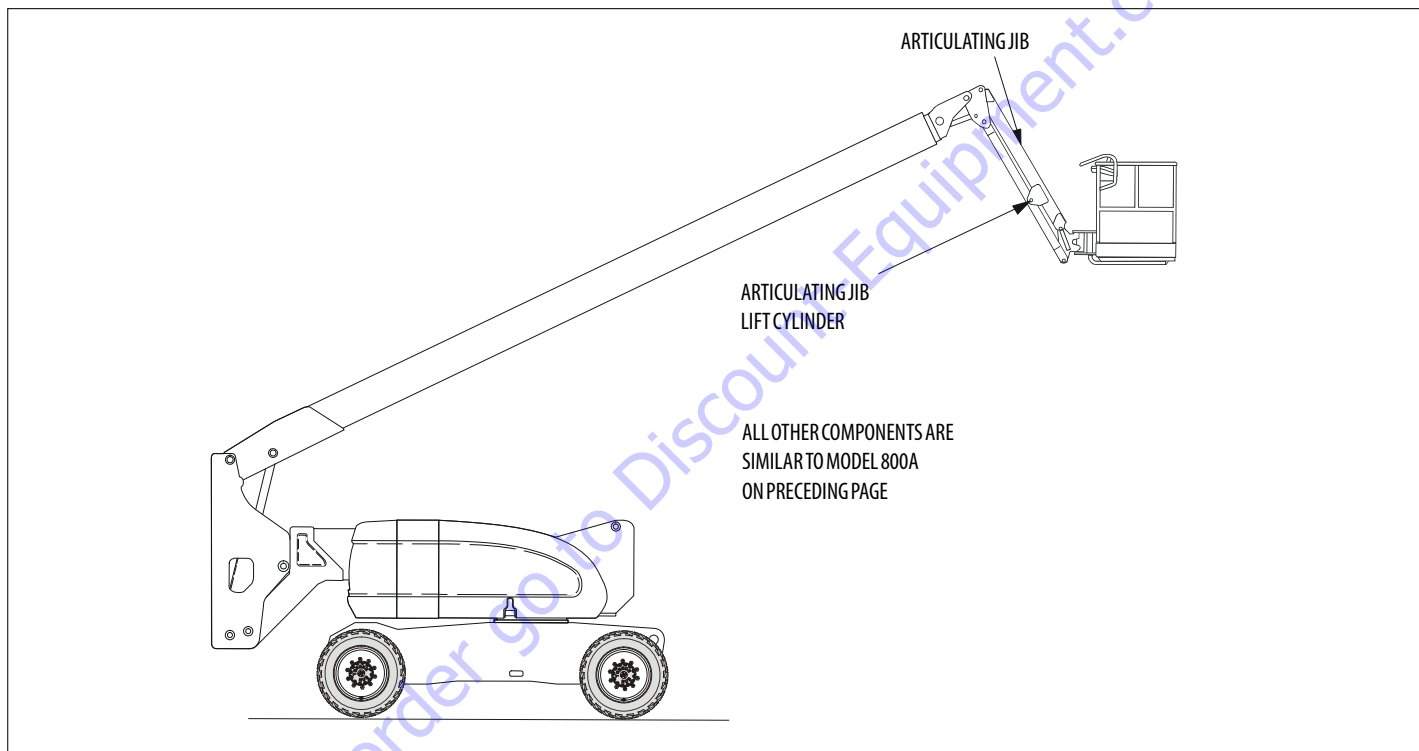

**Figure 2-2. Machine Nomenclature - 800AJ (Sheet 2 of 2)**



**SECTION 2 - USER RESPONSIBILITIES, MACHINE PREPARATION, AND INSPECTION**

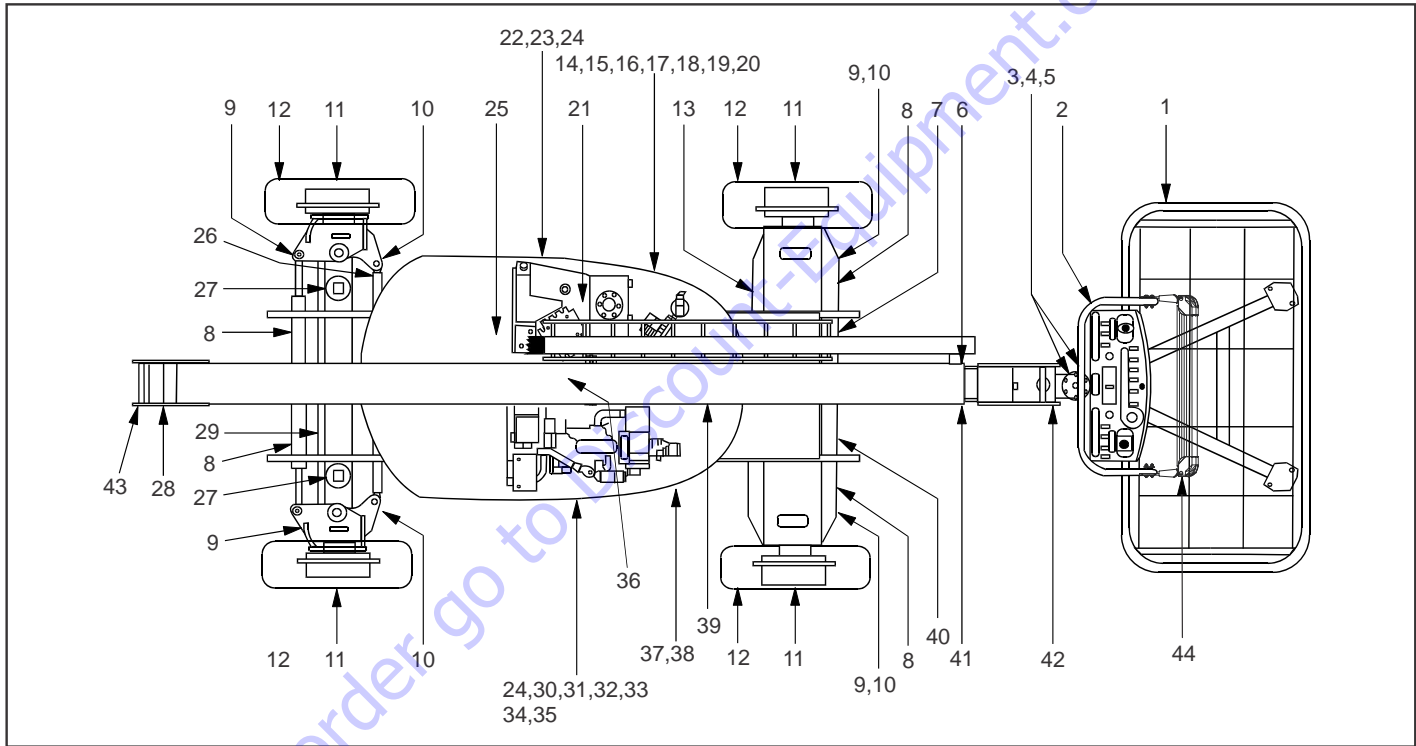

**Figure 2-3. Daily Walk-Around Inspection (Sheet 1 of 4)**

## SECTION 2 - USER RESPONSIBILITIES, MACHINE PREPARATION, AND INSPECTION

---

### GENERAL

Begin the "Walk-Around Inspection" at Item 1, as noted on the diagram. Continue to the right (counterclockwise viewed from top) checking each item in sequence for the conditions listed in the following checklist.

#### **WARNING**

**TO AVOID POSSIBLE INJURY, BE SURE MACHINE POWER IS OFF.**

**DO NOT OPERATE MACHINE UNTIL ALL MALFUNCTIONS HAVE BEEN CORRECTED.**

**INSPECTION NOTE:** *On all components, make sure there are no loose or missing parts, that they are securely fastened, and no visible damage, leaks or excessive wear exists in addition to any other criteria mentioned.*

- 1. Platform Assembly - Platform Assembly and Gate** - Footswitch works properly, not modified, disabled or blocked. Latch, stop, and hinges in working condition.
- 2. Platform Control Console** - Switches and levers return to neutral, decals/placards secure and legible, control markings legible.
- 3. Rotator** - See Inspection Note.

- 4. Rotator Motion Control Valve** - See Inspection Note.
- 5. Articulating Jib Boom** - See Inspection Note.
- 6. Dual Capacity Limit Switch (ANSI, Australia, if equipped); Transport Position Limit Switch (CE)** - Properly secured, no damage to the switch, arm free to move, and free from dirt and grease.
- 7. Power Track** - See Inspection Note.
- 8. Steer Cylinder Assembly** - See Inspection Note. (4 Wheel Steer if equipped)
- 9. Spindle** - See Inspection Note. (4 Wheel Steer if equipped)
- 10. Drive Motor and Brake** - See Inspection Note.
- 11. Drive Hub** - See Inspection Note.
- 12. Wheel/Tire Assembly** - No loose or missing lug nuts, proper inflation (pneumatic). Inspect for worn tread, cuts, tears or other discrepancies. Inspect wheels for damage and corrosion.

**Figure 2-4. Daily Walk-Around Inspection (Sheet 2 of 4)**

## SECTION 2 - USER RESPONSIBILITIES, MACHINE PREPARATION, AND INSPECTION

13. **Control Valve (Tank Compartment)** - No loose or missing lug nuts, proper inflation (pneumatic). Inspect for worn tread, cuts, tears or other discrepancies. Inspect wheels for damage and corrosion.
14. **Turntable Bearing and Pinion** - No loose or missing hardware; no visible damage, evidence of proper lubrication.
15. **Hydraulic Oil Medium Pressure Filter Housing** - See Inspection Note.
16. **Hydraulic Oil Return Filter Housing** - See Inspection Note.
17. **Manual Descent** - See Inspection Note. (if equipped)
18. **LP Gas Tank** - Brackets, hose and fittings secure; no visible damage, no missing parts. (If Equipped)
19. **Hydraulic Oil Supply** - Recommended oil level sight gauge. (Check level with cold oil, systems shut down, machine with booms retracted and lowered) Cap in place and secure.
20. **Hydraulic Oil Breather** - Element in place, not clogged, no sign of overflow.
21. **Ground Controls** - Switches operable, no visible damage, decals secure and legible.
22. **Fuel Supply** - Fuel filler cap secure. Tank - no visible damage; no evidence of leaks.
23. **Swing Drive Motor and Brake** - See Inspection Note.
24. **Door and Latches** - Hood door and latches in working condition, properly secured, no loose or missing parts.
25. **Oscillating Cam Valve** - No visible damage, no evidence of leakage, no unsupported hoses. (If Equipped)
26. **Tie Rod and Steering Linkage** - See Inspection Note.
27. **Oscillating Axle Cylinder** - See Inspection Note. (If Equipped)
28. **Dual Capacity and Horizontal Cutout Limit Switches if equipped** - Properly secured, no damage to the switches, arm free to move, and free from dirt and grease.
29. **Oscillating Axle** - See Inspection Note. (If Equipped)

Figure 2-5. Daily Walk-Around Inspection (Sheet 3 of 4)

## **SECTION 2 - USER RESPONSIBILITIES, MACHINE PREPARATION, AND INSPECTION**

---

- 30. Engine Air Filter** - No loose or missing parts; no visible damage; element clean.
- 31. Battery** - Proper electrolyte levels; cables tight, no visible damage or corrosion.
- 32. Engine Oil Supply** - Full mark on dipstick; filler cap secure.
- 33. Muffler and Exhaust System** - See Inspection Note.
- 34. Hydraulic Pumps** - See Inspection Note.
- 35. Engine Tray Pivot** - See Inspection Note.
- 36. Hydraulic Swivel** - See Inspection Note.
- 37. LP Gas Tank** - Brackets, hose and fittings secure; no visible damage, no missing parts. (If Equipped)
- 38. Flow Valves** - See Inspection Note.
- 39. Tower Boom** - No visible damage; wear pads secure. All cylinders - rod end pins and barrel-end pins properly secured.
- 40. Frame** - See Inspection Note.
- 41. Main Boom Sections** - No visible damage; wear pads secure. All cylinders - rod end shafts and barrel-end shafts properly secured.
- 42. Platform Pivot Pin** - See Inspection Note.
- 43. Upright** - In vertical position, relative to the chassis. Refer to Figure 2-9. and Figure 2-10. If out of alignment, do not use machine until the upright has been synchronized in accordance with Section 4.16.
- 44. SkyGuard (If Equipped)** - See Inspection Note.

**Figure 2-6. Daily Walk-Around Inspection (Sheet 4 of 4)**

## **2.3 FUNCTION CHECK**

Perform a function check of all systems, once the walk-around inspection is complete, in an area free of overhead and ground level obstructions.

### **⚠ WARNING**

**A MACHINE MALFUNCTION COULD CAUSE DEATH OR SERIOUS INJURY. IF ANY MALFUNCTIONS OCCUR DURING THE FUNCTION TEST, DISCONTINUE OPERATION AND CONTACT A QUALIFIED SERVICE TECHNICIAN TO CORRECT THE MALFUNCTION BEFORE OPERATING THE MACHINE.**

### **From the Ground Control Station with No Load in the Platform:**

1. Check that all guards protecting the function switches or locks are in place. Ensure that all function controls and switches return to the "off" or neutral position when released.

### **⚠ WARNING**

**DO NOT OPERATE IF GUARDS OR LOCKS ARE MISSING OR THE SWITCHES DO NOT RETURN TO THE "OFF" OR NEUTRAL POSITION**

2. Test the tower boom assembly sequencing as follows:

- a. Place machine on level ground with the tower boom assembly in the stowed position. Identify the tower boom vertical limit switch adjacent to the tower lift cylinder at the bottom end (rear) of the tower base boom. Open the left side hood and perform a visual check that the plunger on the tower boom vertical limit switch is fully extended. The plunger is shown fully extended in Figure 2-7.

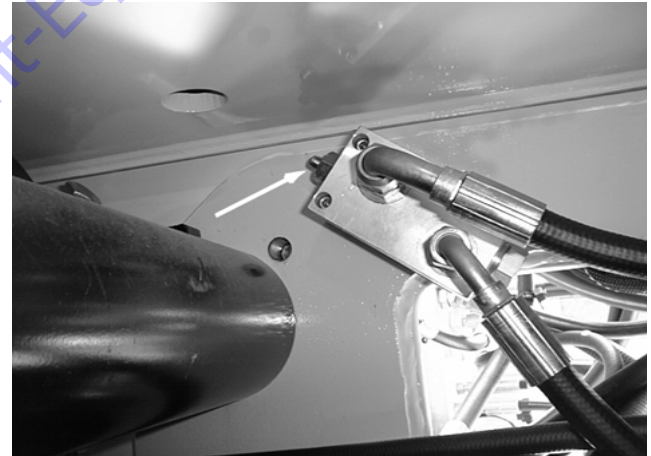

**Figure 2-7. Tower Boom Vertical Limit Switch**

## SECTION 2 - USER RESPONSIBILITIES, MACHINE PREPARATION, AND INSPECTION

### **⚠ WARNING**

**DISCONTINUE OPERATION IF PLUNGER IS NOT FULLY EXTENDED**

- b. Attempt to extend the tower fly boom. The tower fly boom should not extend and the red boom malfunction light in the ground control panel should illuminate when pressing the tower telescope switch.

### **⚠ WARNING**

**DISCONTINUE OPERATION IF THE TOWER FLY BOOM EXTENDS OR THE BOOM MALFUNCTION LIGHT DOES NOT ILLUMINATE.**

- c. Raise the tower base boom to approximately 40 degrees, then lower the tower boom back to the below horizontal position. While raising and lowering the tower boom assembly, observe the position of the upright. Ensure that the upright remains vertical relative to the chassis. Refer to Figure 2-9. and Figure 2-10.

### **⚠ WARNING**

**DISCONTINUE OPERATION IF THE UPRIGHT IS OUT OF ALIGNMENT OR THE BOOM MALFUNCTION LIGHT IS FLASHING OR ON STEADY.**

- d. Raise the tower base boom to full height. Extend the tower fly boom a few feet. Check that the plunger on

the tower boom horizontal limit switch at the end of the tower base boom section is fully extended. The plunger is shown fully extended in Figure 2-8.

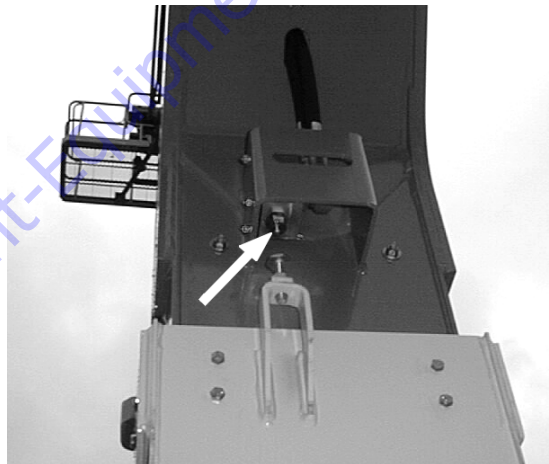

**Figure 2-8. Tower Boom Horizontal Limit Switch**

### **⚠ WARNING**

**DISCONTINUE OPERATION IF PLUNGER IS NOT FULLY EXTENDED**

### SkyGuard Function Test

From the Platform Console:

Test the SkyGuard feature by operating the telescope out functions and then activating the SkyGuard sensor. The telescope out function will stop and the telescope in function will operate for a short duration and the horn will sound until the SkyGuard sensor and foot-switch are disengaged.

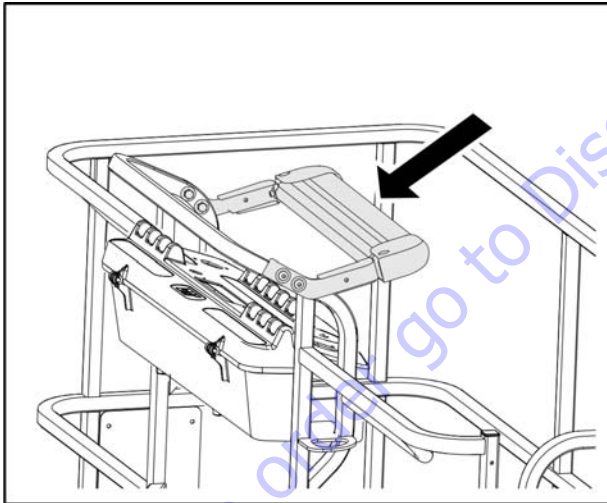

**NOTE:** If the machine is equipped with both SkyGuard and Soft Touch, functions will not reverse, only stop.

**NOTE:** If equipped, ensure the SkyGuard beacon illuminates when SkyGuard is activated.

Disengage the SkyGuard sensor, release controls, recycle the emergency stop button, and make sure normal operation is available.

If SkyGuard remains activated after function reversal or cutout, depress and hold the SkyGuard Override Switch to allow normal use of machine functions until the SkyGuard sensor is disengaged.

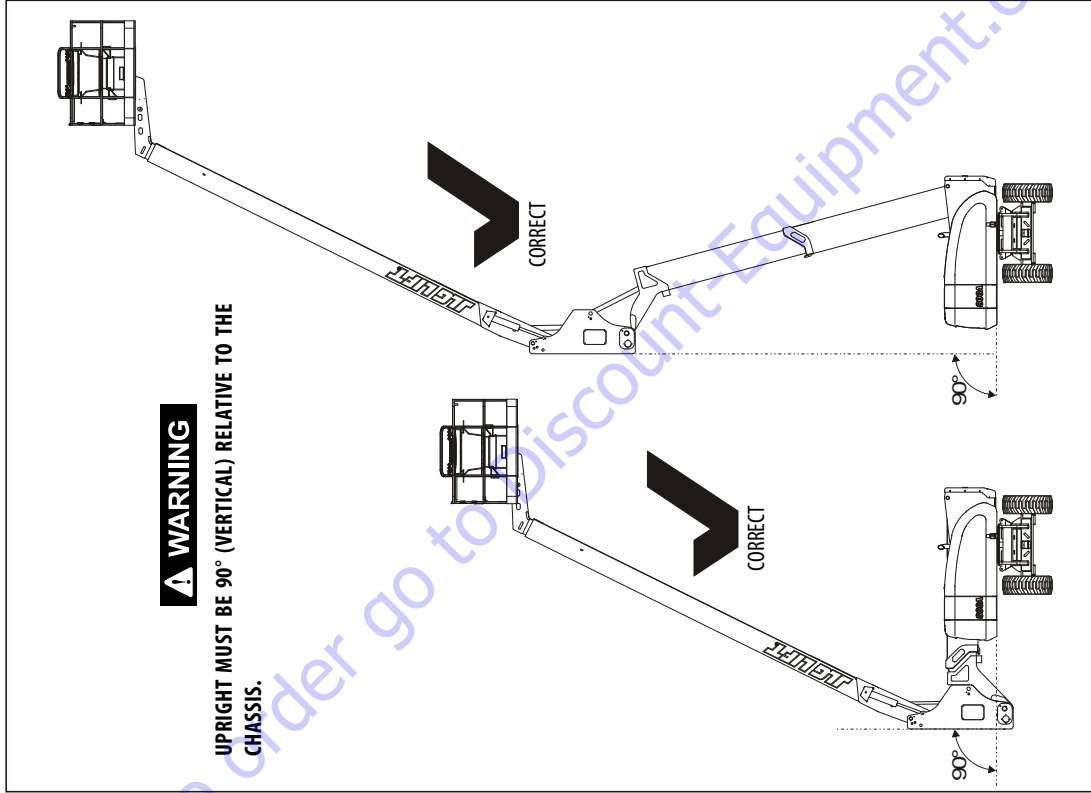

Figure 2-9. Boom Upright Positioning - Correct



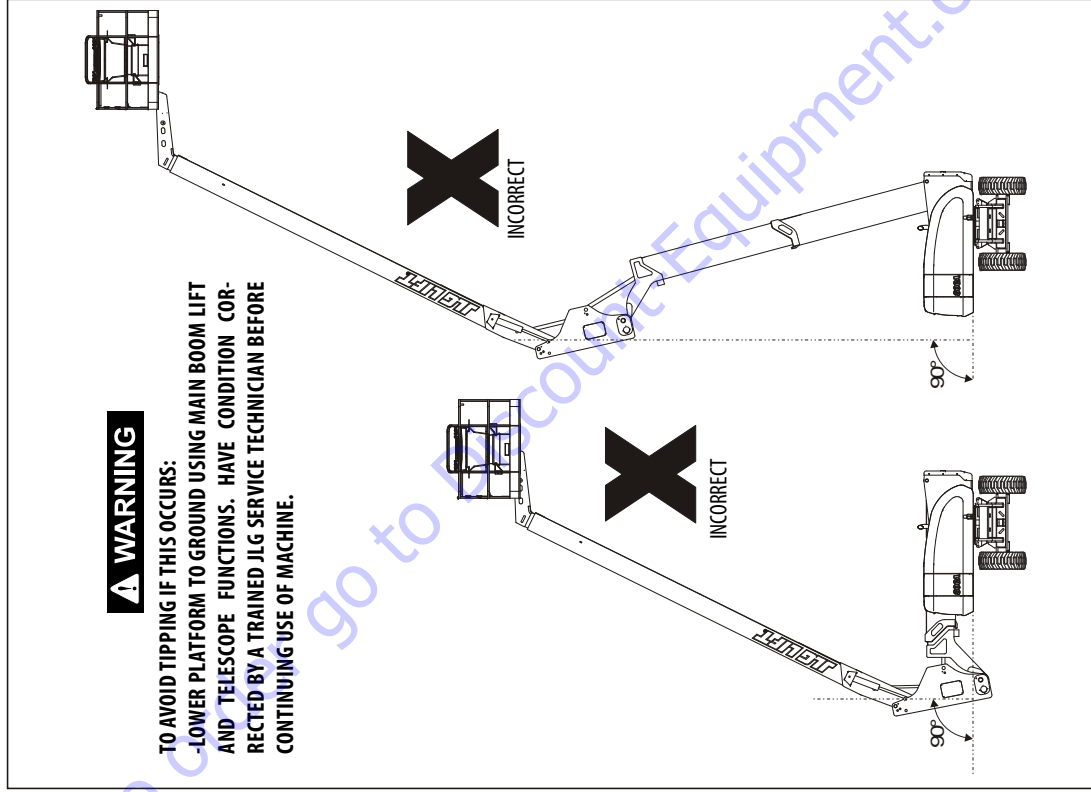

Figure 2-10. Boom Upright Positioning - Incorrect

## SECTION 2 - USER RESPONSIBILITIES, MACHINE PREPARATION, AND INSPECTION

- a. Attempt to lower the tower base boom while the tower fly boom is extended. The tower base boom should not lower and the red boom malfunction light should illuminate when pressing the tower down switch.

### **WARNING**

**DISCONTINUE OPERATION IF THE TOWER BASE BOOM LOWERS OR THE BOOM MALFUNCTION LIGHT DOES NOT ILLUMINATE.**

- b. Check that all machine functions are disabled when the Emergency Stop Button is pushed in.
- c. Check for proper operation of the auxiliary power and manual descent system (if equipped). Operate each function control to ensure proper operation.

### **From the Platform Control Station:**

1. Check that the control console is secure and all guards protecting the function switches or locks are in place. Ensure that all function controls and switches return to the "off" or neutral position when released.

### **WARNING**

**DO NOT OPERATE MACHINE IF GUARDS OR LOCKS ARE MISSING OR THE SWITCHES DO NOT RETURN TO THE "OFF" OR NEUTRAL POSITION**

2. Check the footswitch adjustment and operation as follows:
  - a. With engine power shut down, attempt to start engine. Engine should not attempt to start when footswitch is activated.
  - b. Start engine. Activate hydraulic system by depressing footswitch. Activate a boom function. Continue to activate the function and remove foot from footswitch. The motion should stop.

### **WARNING**

**DISCONTINUE OPERATION IF THE FOOTSWITCH DOES NOT OPERATE PROPERLY.**

- c. Check adjustment of footswitch. Footswitch must be adjusted so that functions will operate when pedal is approximately at its center of travel. If the footswitch operates within last 1/4" of travel, top or bottom, it should be adjusted.

**NOTE:** *Footswitch has a 7 second delay timer. If a function is not activated within 7 seconds after depressing the footswitch, reset the footswitch.*

## SECTION 2 - USER RESPONSIBILITIES, MACHINE PREPARATION, AND INSPECTION

3. Ensure that all machine functions are disabled when the Emergency Stop Button is activated.
4. Check auxiliary power for proper operation. Operate each function control switch to ensure proper operation of the auxiliary power system.
- c. With main boom in this position, raise the main base boom until the capacity indicator lights change back to the 1000 lb. (454 kg) indicator.

### **WARNING**

**DISCONTINUE OPERATION IF THE CAPACITY INDICATOR SYSTEM DOES NOT OPERATE PROPERLY.**

**NOTE:** *Step 5 is only applicable for 800A ANSI market machines.*

5. If equipped with a dual capacity system, check the limit switch as follows:
  - a. On a level surface with less than 500 lb (227 kg) in the platform, raise tower base boom to maximum angle keeping main boom horizontal.
  - b. Extend the main fly boom until the capacity indicator lights change from 1000 lb. (454 kg) to 500 lb. (227 kg).
6. Drive forward and reverse; check for proper operation.
7. Steer left and right; check for proper operation.
8. Check the high-engine cutout for the tower boom assembly as follows:
  - a. Place machine on level surface with booms retracted and lowered.
  - b. From the platform control, position DRIVE SPEED/TORQUE SELECT switch to FAST (Forward Position).
  - c. Using extreme caution, partially position the DRIVE control to FORWARD just enough to obtain high engine but not enough to cause the machine to move.
  - d. Raise the TOWER BASE BOOM until the engine speed shifts from high speed to mid speed. The bottom of the upright should NOT be above the hood level of the machine.

## SECTION 2 - USER RESPONSIBILITIES, MACHINE PREPARATION, AND INSPECTION

---

9. Check the high-engine cutout for the main boom assembly as follows:
  - a. Place machine on level surface with booms retracted and lowered.
  - b. From the platform control, position DRIVE SPEED/TORQUE SELECT switch to FAST (Forward Position).
  - c. Raise the main boom above horizontal.
  - d. Using extreme caution, partially position the DRIVE control to FORWARD just enough to cause the machine to move. The drive speed should be in slow or creep mode.
10. Swing turntable to LEFT and RIGHT a minimum of 45 degrees. Check for smooth motion.

**NOTE:** *Ensure the turntable lock is disengaged. To disengage lock, pull snap pin from lock pin, lift lock pin up to unlock turntable. Return snap pin to lock pin to hold lock pin in the disengaged position. Reverse procedure to engage turntable lock.*

11. Check the Tilt Alarm and Warning System as follows:

### **WARNING**

**IF THE TILT ALARM AND WARNING SYSTEM DOES NOT OPERATE PROPERLY, DISCONTINUE OPERATION. CONTACT A QUALIFIED SERVICE TECHNICIAN TO CORRECT THE MALFUNCTION BEFORE OPERATING THE MACHINE.**

**For Machines prior to serial number 0300062045** - Have an assistant manually activate the tilt indicator light by compressing any one of the three tilt indicator mounting springs. The tilt indicator light on the platform control console should illuminate.

**For Machines from serial number 0300062045 to 0300183033** - With the platform in the transport position (tower base boom lowered, main fly boom retracted, and main base boom below horizontal) drive up a suitable ramp of at least 5° slope. The tilt indicator light on the platform control console should illuminate.

12. Check that the platform automatically levels properly during raising and lowering of the boom.

13. Check that the platform level override operates properly.
14. Check platform rotator for smooth operation and assure platform will rotate 90 degrees in both directions from centerline of boom.
15. If equipped with 4-wheel steer, check rear steer left and right for proper operation.
16. If equipped, raise and lower the articulating jib boom. Check for smooth operation.
17. If equipped with Auxiliary Power, operate each function control switch to assure that they function in both directions using auxiliary power instead of engine power.
18. Ground Controls - Place GROUND/PLATFORM SELECT switch to GROUND. Start engine. Platform controls should not operate.

### 2.4 OSCILLATING AXLE LOCKOUT TEST (IF EQUIPPED)

#### **NOTICE**

**LOCKOUT SYSTEM TEST MUST BE PERFORMED QUARTERLY, ANY TIME A SYSTEM COMPONENT IS REPLACED, OR WHEN IMPROPER SYSTEM OPERATION IS SUSPECTED.**

**NOTE:** *Ensure boom is fully retracted, lowered, and centered between drive wheels prior to beginning lockout cylinder test.*

1. Place a 6 inch (15.2 cm) high block with ascension ramp in front of left front wheel.
2. From platform control station, start engine.
3. Position DRIVE SPEED/TORQUE SELECT SWITCH to SLOW.
4. Place DRIVE control lever to FORWARD position and carefully drive machine up ascension ramp until left front wheel is on top of block.

## **SECTION 2 - USER RESPONSIBILITIES, MACHINE PREPARATION, AND INSPECTION**

---

5. Carefully activate SWING control lever and position boom over RIGHT side of machine.
6. With boom over right side of machine, place DRIVE control lever to REVERSE and drive machine off of block and ramp.
7. Have an assistant check to see that left front or right rear wheel remains elevated in position off of ground.
8. Carefully activate SWING control lever and return boom to stowed position (centered between drive wheels). When boom reaches center, stowed position, lockout cylinders should release and allow wheel to rest on ground, it may be necessary to activate DRIVE to release cylinders.
9. Place the 6 inch (15.2 cm) high block with ascension ramp in front of right front wheel.
10. Place DRIVE control lever to FORWARD and carefully drive machine up ascension ramp until right front wheel is on top of block.
11. Carefully activate SWING control lever and position boom over left side of machine.
12. With boom over left side of machine, place DRIVE control lever to REVERSE and drive machine off of block and ramp.
13. Have an assistant check to see that right front or left rear wheel remains elevated in position off of ground.
14. Carefully activate SWING control lever and return boom to stowed position (centered between drive wheels). When boom reaches center, stowed position, lockout cylinders should release and allow wheel to rest on ground, it may be necessary to activate DRIVE to release cylinders.
15. If lockout cylinders do not function properly, have qualified personnel correct the malfunction prior to any further operation.

**SECTION 2 - USER RESPONSIBILITIES, MACHINE PREPARATION, AND INSPECTION**



**NOTES:**

Blank lined area for notes, consisting of two columns of horizontal lines.

## SECTION 3. MACHINE CONTROLS AND INDICATORS

### 3.1 GENERAL

#### **NOTICE**

**THE MANUFACTURER HAS NO DIRECT CONTROL OVER MACHINE APPLICATION AND OPERATION. THE USER AND OPERATOR ARE RESPONSIBLE FOR CONFORMING WITH GOOD SAFETY PRACTICES.**

This section provides the necessary information needed to understand control functions.

### 3.2 CONTROLS AND INDICATORS

**NOTE:** *This machine is equipped with control panels that use symbols to indicate control functions. Refer to the decal located on the control box guard in front of the control box or by the ground controls for these symbols and the corresponding functions.*

#### Ground Control Station

**NOTE:** *Main Lift, Swing, Platform Level, Main Telescope, Platform Rotor and Auxiliary Power, Tower Telescope, Tower Lift, and jib control switches are spring-loaded and will automatically return to neutral (off) when released.*

**NOTE:** *If equipped, the Function Enable switch must be held down in order to operate Main Boom Telescope, Tower Lift, Swing, Main Lift, Jib Lift, Platform Level Override, and Platform Rotate functions.*



#### 1. Platform Rotate

The platform ROTATE control switch provides rotation of the platform when positioned to LEFT or RIGHT.



## SECTION 3 - MACHINE CONTROLS AND INDICATORS

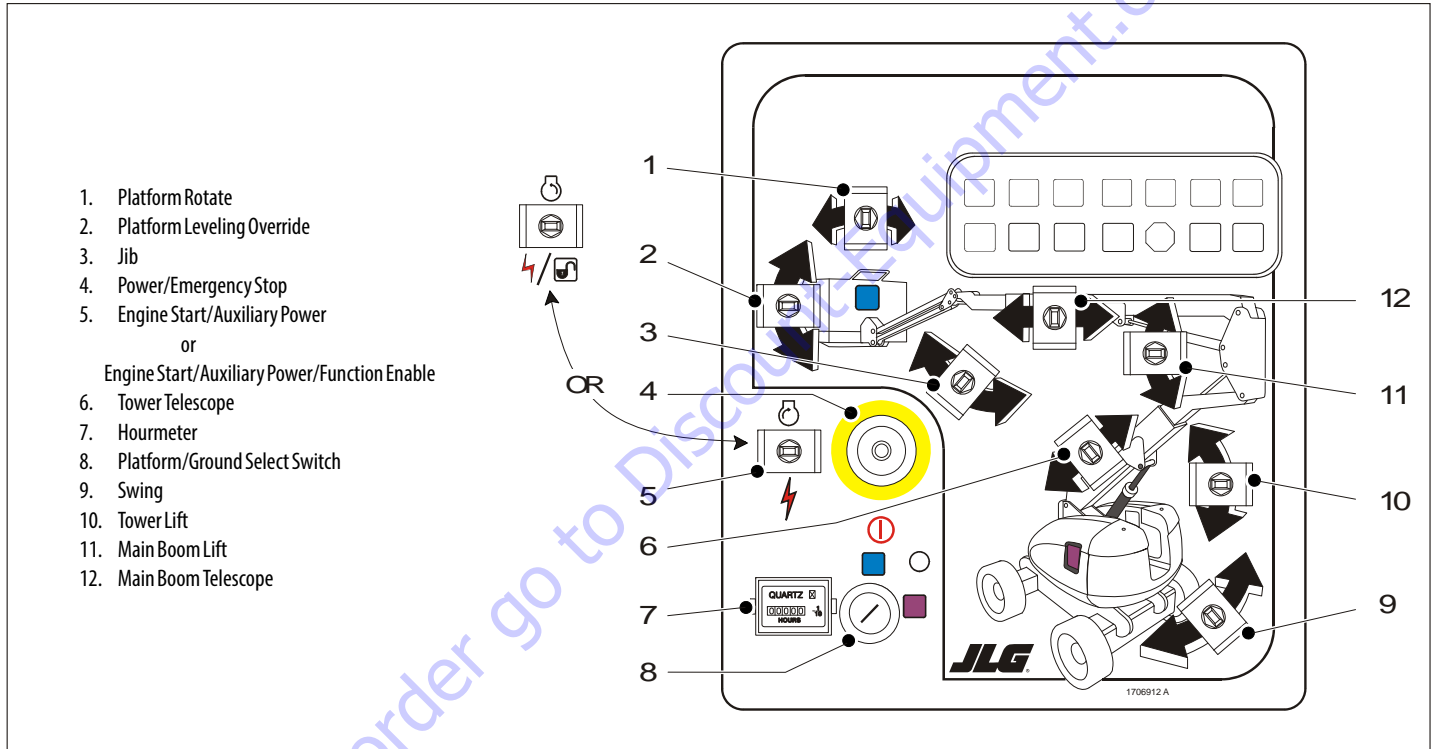

Figure 3-1. Ground Control Station

### **WARNING**

**ONLY USE THE PLATFORM LEVELING OVERRIDE FUNCTION FOR SLIGHT LEVELING OF THE PLATFORM. INCORRECT USE COULD CAUSE THE LOAD/OCCUPANT TO SHIFT OR FALL. FAILURE TO DO SO COULD RESULT IN DEATH OR SERIOUS INJURY.**

#### 2. Platform Leveling Override

A three position switch allows the operator to adjust the automatic self leveling system. This switch is used to adjust platform level in situations such as ascending/descending a grade.

#### 3. Jib (If Equipped)

The jib control switch provides raising and lowering of the jib when positioned to UP or DOWN.

**NOTE:** When Power/Emergency Stop switch is in the "ON" position and engine is not running, an alarm will sound, indicating Ignition is "ON".

### **CAUTION**

**WHEN THE MACHINE IS SHUT DOWN THE MASTER/EMERGENCY STOP SWITCH MUST BE POSITIONED TO THE "OFF" POSITION TO PREVENT DRAINING THE BATTERY.**

#### 4. Power/Emergency Stop Switch

A two-position red mushroom shaped switch furnishes power to PLATFORM/GROUND SELECT switch when pulled out (on). When pushed in (off), power is shut off to the PLATFORM/GROUND SELECT switch.

## SECTION 3 - MACHINE CONTROLS AND INDICATORS

### 5. Engine Start/Auxiliary Power Switch

or

Engine Start/ Auxiliary Power Switch /Function Enable.



To start the engine, the switch must be held "UP" until the engine starts.



To use auxiliary power, the switch must be held "DOWN" for duration of auxiliary pump use. Aux power can only be used if the engine is not running.



If equipped, the enable switch must be held "DOWN" to enable all boom controls when the engine is running.

**NOTE:** Auxiliary power only works if there is no engine oil pressure, and is disabled if engine is running.

**NOTE:** Functions will operate at a slower than normal rate because of the lesser flow of hydraulic fluid delivered.

### **⚠ CAUTION**

**WHEN USING AUXILIARY POWER, DO NOT OPERATE MORE THAN ONE FUNCTION AT A TIME. (SIMULTANEOUS OPERATION CAN OVERLOAD THE AUXILIARY PUMP.)**

### 6. Tower Telescope

The TOWER TELESCOPE control switch provides extending and retracting of the tower boom when positioned to IN or OUT. This function works only when the tower boom is fully elevated (lift up).

### **⚠ WARNING**

**TO AVOID UPSET AND SERIOUS INJURY, DO NOT OPERATE MACHINE IF TOWER LIFT AND TELESCOPE FUNCTIONS DO NOT OPERATE IN THE ABOVE SEQUENCE.**

### 7. Hourmeter

An hour meter, installed in the bottom portion of the Ground Control box, registers the amount of time the machine has been in use, with engine running. By connecting into the oil pressure circuit of the engine, only engine run hours are recorded. The hour meter registers up to 9,999.9 hours and cannot be reset.

8. Platform/Ground Select Switch

A three position, key operated switch supplies power to the platform control console when positioned to PLATFORM. With the switch key held in the GROUND position, power is shut off to platform and only ground controls are operable.

**⚠ CAUTION**

TO AVOID SERIOUS INJURY, DO NOT OPERATE MACHINE IF ANY CONTROL LEVERS OR TOGGLE SWITCHES CONTROLLING PLATFORM MOVEMENT DO NOT RETURN TO THE OFF POSITION WHEN RELEASED.

**NOTE:** With the Platform/Ground Select Switch in the center position, power is shut off to controls at both operating stations.

**⚠ WARNING**

TO AVOID UPSET AND SERIOUS INJURY, DO NOT OPERATE MACHINE IF TOWER LIFT AND TELESCOPE FUNCTIONS DO NOT OPERATE IN THE ABOVE SEQUENCE.

9. Swing Control

The SWING control switch provides 360 degrees continuous turntable rotation when positioned to RIGHT or LEFT.

**⚠ CAUTION**

WHEN OPERATING THE BOOM ENSURE THERE ARE NO PERSONNEL AROUND OR UNDER PLATFORM.

10. Tower Lift

The TOWER LIFT control switch provides raising and lowering of the tower boom when positioned to UP or DOWN. This function works only when the tower boom is fully retracted (telescope in).

## SECTION 3 - MACHINE CONTROLS AND INDICATORS

### 11. Main Lift Control

The MAIN LIFT control switch provides raising and lowering of the main boom when positioned to UP or DOWN.

### 12. Main Telescope Control

The MAIN TELESCOPE control switch provides extension and retraction of the boom, when positioned to IN or OUT.

### Ground Control Indicator Panel

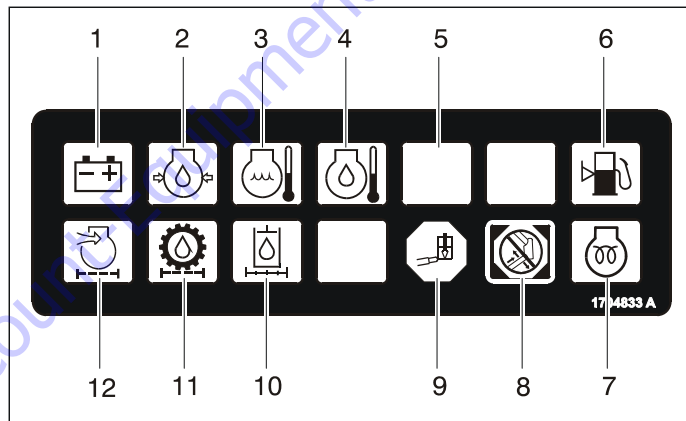

- |                                 |                                 |
|---------------------------------|---------------------------------|
| 1. Battery Charging             | 7. Glow Plug                    |
| 2. Low Engine Oil Pressure      | 8. Boom Malfunction             |
| 3. High Engine Water Temp.      | 9. Platform Overload            |
| 4. High Engine Oil Temp.        | 10. Hyd. Filter Bypass          |
| 5. Engine Malfunction Indicator | 11. Transmission Filter By-Pass |
| 6. Low Fuel                     | 12. Engine Air Filter By-Pass   |

**Figure 3-2. Ground Control Indicator Panel**

## SECTION 3 - MACHINE CONTROLS AND INDICATORS

### 1. Battery Discharging Indicator

When illuminated indicates a problem in the battery or charging circuit, and service is required.

### 2. Engine Oil Pressure Indicator

When illuminated indicates that engine oil pressure is below normal and service is required.

### 3. Engine Coolant Temperature Indicator (Ford)

When illuminated indicates that engine coolant temperature is abnormally high and service is required.

### 4. Engine Oil Temperature Indicator (Deutz)

When illuminated indicates that the temperature of the engine oil, which also serves as engine coolant, is abnormally high and service is required.

### 5. Engine Malfunction Indicator Light (Ford Engines prior to S/N 0300062045)

Indicates that the Engine Control Module has detected a malfunction in the Electronic Fuel Injection System and a Diagnostic Trouble Code has been set in the ECM. Refer to the Service Manual for instructions concerning the trouble codes and trouble code retrieval.

The malfunction indicator light will illuminate for 2-3 seconds when the key is positioned to the on position to act as a self test.

### 6. Low Fuel Level Indicator (N/A for liquid propane)

When illuminated indicates that the fuel level is 1/8 full or less. When the light first turns on, there are approximately four usable gallons of fuel remaining.

### 7. Glow Plug Indicator (If Equipped)

When illuminated the glow plugs are operating. After turning on ignition, wait until light goes out before cranking engine.

## SECTION 3 - MACHINE CONTROLS AND INDICATORS

---

### 8. Boom Malfunction Indicator

If the Boom Malfunction Indicator illuminates when attempting to activate a tower boom function, the function is being cutout by tower boom limit switch. The function is not permitted at the current boom configuration.

If the Boom Malfunction Indicator is flashing or on steady without a boom function attempt, the upright is out of alignment or the monitoring system is in need of calibration.

#### **WARNING**

**DISCONTINUE OPERATION IF THE BOOM MALFUNCTION LIGHT IS FLASHING OR ON STEADY.**

#### **NOTICE**

**IF THE UPRIGHT IS OUT OF ALIGNMENT WITH THE PLATFORM RAISED, LOWER THE MAIN BOOM AND TELESCOPE OUT UNTIL THE PLATFORM REACHES THE GROUND. THE TOWER BOOM DOWN FUNCTION IS CUT OUT IN THIS CONDITION. REPORT THE PROBLEM TO THE PROPER SERVICE PERSONNEL. DO NOT OPERATE THE MACHINE UNTIL THE MALFUNCTION IS CORRECTED.**

### 9. Platform Overload (If equipped)

Indicates the platform has been overloaded.

### 10. Hydraulic Oil Filter Indicator (Prior to S/N 0300085331)

A gauge indicates that the return oil filter is too restrictive and needs to be replaced.

### 11. Transmission Pump Oil Filter Indicator (Prior to S/N 0300085331)

Indicates that the charge pump filter is too restrictive and needs to be replaced.

### 12. Engine Air Filter Indicator (Prior to S/N 0300085331)

When illuminated indicates that the air filter is too restrictive and needs to be replaced.

### Platform Station

#### **WARNING**

**TO AVOID SERIOUS INJURY, DO NOT OPERATE MACHINE IF ANY CONTROL LEVERS OR TOGGLE SWITCHES CONTROLLING PLATFORM MOVEMENT DO NOT RETURN TO THE OFF OR NEUTRAL POSITION WHEN RELEASED.**

#### 1. Power/Emergency Stop

An ON-OFF POWER/EMERGENCY STOP switch and a separate ENGINE START/AUXILIARY POWER toggle switch on the platform console supply electrical power to the starter solenoid, when the ignition switch is placed in the "ON" position and the ENGINE START switch is pushed forward momentarily.

#### 2. Travel Warning Horn

A push-type HORN switch supplies electrical power to an audible warning device when pressed.

#### 3. Main Lift/Swing Controller

A proportional dual axis joystick is provided for main lift and swing. Push forward to lift up, pull backward to lift down. Move right to swing right, move left to swing left.

**NOTE:** *Main boom lift and swing functions may be selected in combination. Maximum speed is reduced when multiple functions are selected.*

#### 4. Main Telescope Control

The MAIN TELESCOPE control switch provides extension and retraction of the main boom when positioned to IN or OUT.

**NOTE:** *MAIN, LIFT, SWING, and DRIVE control levers are spring-loaded and will automatically return to neutral (OFF) position when released.*



## SECTION 3 - MACHINE CONTROLS AND INDICATORS

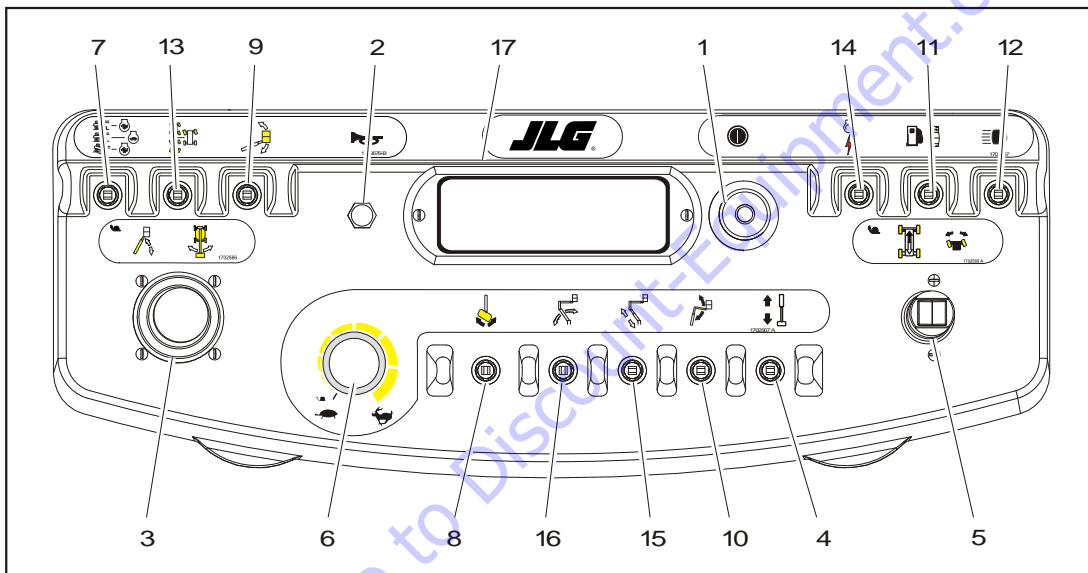

- |                         |                               |                              |                              |
|-------------------------|-------------------------------|------------------------------|------------------------------|
| 1. Power/Emergency Stop | 6. Function Speed Control     | 10. Articulating Jib (800AJ) | 14. Engine Start / Aux Power |
| 2. Horn                 | 7. Drive Speed /Torque Select | 11. Fuel Select              | 15. Tower Telescope          |
| 3. Main Lift / Swing    | 8. Platform Rotate            | 12. Lights                   | 16. Tower Lift               |
| 4. Telescope            | 9. Platform Level Override    | 13. Steer Select             | 17. Light Panel              |
| 5. Drive/Steer          |                               |                              |                              |

**Figure 3-3. Platform Control Console**

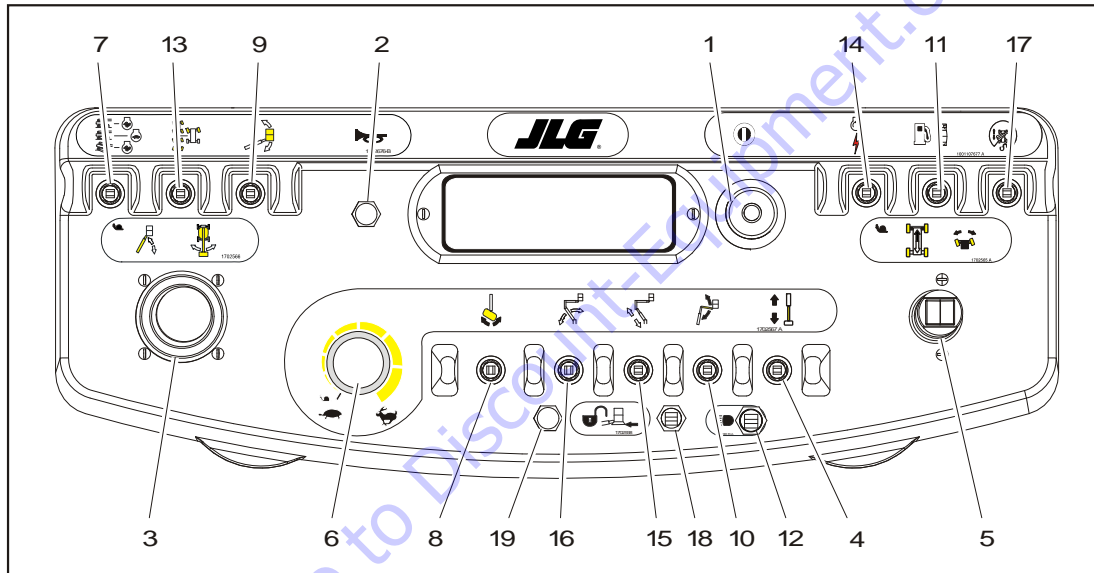

- |                         |                                |                              |                                   |
|-------------------------|--------------------------------|------------------------------|-----------------------------------|
| 1. Power/Emergency Stop | 6. Function Speed Control      | 11. Fuel Select              | 16. Tower Lift                    |
| 2. Horn                 | 7. Drive Speed / Torque Select | 12. Lights                   | 17. Drive Orientation Override    |
| 3. Main Lift / Swing    | 8. Platform Rotate             | 13. Steer Select             | 18. Soft Touch/SkyGuard Override  |
| 4. Telescope            | 9. Platform Level Override     | 14. Engine Start / Aux Power | 19. Soft Touch/SkyGuard Indicator |
| 5. Drive/Steer          | 10. Articulating Jib (800AJ)   | 15. Tower Telescope          |                                   |

**Figure 3-4. Platform Control Console - w/Drive Orientation**

## SECTION 3 - MACHINE CONTROLS AND INDICATORS

---

### 5. Drive/Steer

Proportional single axis joystick is provided to control drive. Push forward to drive forward, pull back to drive in reverse. Steering is accomplished via a thumb-activated rocker switch on the end of the handle. Push on the left side of the switch to steer left, on right side to steer right.

**NOTE:** *Both drive and steer functions work in the opposite direction when the main boom is positioned over front of the chassis.*

**NOTE:** *When main boom is positioned above horizontal and any of the following switches, DRIVE SPEED/TORQUE SELECT or FUNCTION SPEED, are positioned to HIGH, high function speeds are automatically set to creep and the machine continues to operate at a lower speed.*

### 6. Function Speed

Controls the speed of Boom and Swing Functions. Rotate CCW for slower speed and CW for faster speed. To adjust to creep, turn knob fully CCW until it clicks.

### 7. Drive Speed/Torque Select

Drive Speed/Torque Select is a three position switch. The forward position gives maximum drive speed by shifting the drive motors to minimum displacement and giving high engine when drive controller is moved. The back position gives maximum torque for rough terrain and climbing grades by shifting the wheel motors to maximum displacement and giving high engine speed when the drive controller is moved. The center position allows the machine to be driven as quietly as possible by leaving the engine at mid speed and the drive motors in minimum displacement or fastest speed.

### 8. Platform Rotate

This switch allows the operator to rotate the basket to the left or right.

### **WARNING**

**ONLY USE THE PLATFORM LEVELING OVERRIDE FUNCTION FOR SLIGHT LEVELING OF THE PLATFORM. INCORRECT USE COULD CAUSE THE LOAD/OCCUPANT TO SHIFT OR FALL. FAILURE TO DO SO COULD RESULT IN DEATH OR SERIOUS INJURY.**

#### 9. Platform Leveling Override

A three position switch allow the operator to adjust the automatic self leveling system. This switch is used to adjust platform level in situation such as ascending/descending a grade.

#### 10. Articulating Jib Boom (If Equipped)

The ARTICULATING control switch provides raising and lowering of the jib when positioned to UP or DOWN.

#### 11. Fuel Select (Dual Fuel Engine Only) (If Equipped)

Gasoline or liquid propane fuel may be selected by moving the switch to the appropriate position. It is unnecessary to purge the fuel system before switching fuels, so there is no waiting period when switching fuels while the engine is running.

#### 12. Work Lights (If Equipped)

The switch, on the light, operates work lights if the machine is so equipped. The power/emergency stop switch must be on, (mushroom button out) but ignition switch does not have to be on to operate the lights, so care must be taken to avoid draining the battery if left unattended. The master switch and / or the ignition switch at the ground control will turn off power to all lights.

## **SECTION 3 - MACHINE CONTROLS AND INDICATORS**

---

### **13. Steer Select (If Equipped)**

When equipped with four wheel steering, the action of the steering system is operator selectable. The center switch position gives conventional front wheel steering with the rear wheels unaffected. This is the best position for normal driving at maximum speeds. The forward position is for “crab” steering. When in this mode both front and rear axles steer in the same direction, which allows the chassis to move sideways as it goes forward. This can be used for positioning the machine in aisle ways or against buildings. The back switch position is for “coordinated” steering. In this mode the front and rear axles steer in the opposite directions to produce the tightest turning circle for maneuvering in confined areas. A decal located at top of switch, instructs the desired wheel maneuver with the switch position.

To re-synchronize the front and rear axles, activate the steer switch (thumb rocker) until all steer cylinders are at the end of their stroke. This can be done in either crab or coordinated mode.

### **14. Auxiliary Power**

When pushed forward, the switch energizes the starter motor to start the engine.

When pushed back, it energizes the electrically operated hydraulic pump, when actuated. (Switch must be held ON for duration of auxiliary pump use.)

The auxiliary pump functions to provide sufficient oil flow to operate the basic machine functions should the main pump or engine fail. The auxiliary pump will operate tower boom lift, tower telescope, main boom lift, main telescope and swing.

### **15. Tower Lift**

The three position center-off toggle switch provides for raising and lowering of the tower boom when positioned to “UP” or “DOWN”. TOWER LIFT must be fully elevated “UP” before operating TOWER TELESCOPE. (TOWER LIFT should not function when TOWER TELESCOPE is extended).

### 16. Tower Telescope

The three position center-off toggle switch provides for extending and retracting of the tower boom when positioned to IN or OUT. TOWER TELESCOPE must be fully RETRACTED before operating TOWER LIFT. (TOWER TELESCOPE should not function when TOWER LIFT is not fully elevated "UP").

### WARNING

**TO AVOID UPSET AND SERIOUS INJURY, DO NOT OPERATE MACHINE IF TOWER LIFT AND TELESCOPE DO NOT OPERATE IN THE ORDER DESCRIBED ABOVE.**

### 17. Drive Orientation Override

When the boom is swung over the rear tires or further in either direction, the Drive Orientation indicator will illuminate when the drive function is selected. Push and release the switch, and within 3 seconds move the Drive/Steer control to activate drive or steer. Before driving, locate the black/white orientation arrows on both the chassis and the platform controls and match the control direction arrow to the intended chassis direction.

### 18. Soft Touch/SkyGuard Override Switch (If equipped)

The machine can be equipped with one of three options. It may have Soft Touch, SkyGuard, or both Soft Touch and SkyGuard.

If equipped with Soft Touch, the switch enables the functions that were cut out by the Soft Touch system to operate again at creep speed, allowing the operator to move the platform away from the obstacle that caused the shutdown situation.

If equipped with SkyGuard, the switch enables functions cut out by the Skyguard system to be operated again, allowing the operator to resume use of machine functions.

If equipped with both Soft Touch and SkyGuard, the switch operates like described above and allows the operator to override the system that has experienced a cutout situation.

### 19. Soft Touch/SkyGuard Indicator (If Equipped)

Indicates the Soft Touch bumper is against an object or the SkyGuard sensor has been activated. All controls are cut out until the override button is pushed. For Soft Touch, controls are then active in the Creep Mode or for SkyGuard, controls will work normally.

## SECTION 3 - MACHINE CONTROLS AND INDICATORS

### Platform Control Indicator Panel

**NOTE:** The platform control indicator panel uses different shaped symbols to alert the operator to different types of operational situations that could arise. The meaning of those symbols are explained below.



Indicates a potentially hazardous situation, which if not corrected, could result in serious injury or death. This indicator will be red.



Indicates an abnormal operating condition, which if not corrected, may result in machine interruption or damage. This indicator will be yellow.



Indicates important information regarding the operating condition, i.e. procedures essential for safe operation. This indicator will be green with the exception of the capacity indicator which will be green or yellow depending upon platform position.

**NOTE:** For engine starting, the footswitch must be in the released (up) position. Footswitch must be actuated in order for controls to function.

**NOTE:** These machines have a 7 second delay timer. If a function has not been activated within 7 seconds after depressing the footswitch, recycle footswitch.

#### **⚠ WARNING**

**TO AVOID SERIOUS INJURY, DO NOT REMOVE, MODIFY OR DISABLE THE FOOTSWITCH BY BLOCKING OR ANY OTHER MEANS.**

#### **NOTICE**

**FOOTSWITCH MUST BE ADJUSTED SO THAT FUNCTIONS WILL OPERATE WHEN PEDAL IS APPROXIMATELY AT ITS CENTER OF TRAVEL. IF SWITCH OPERATES WITHIN LAST 1/4" OF TRAVEL, TOP OR BOTTOM, IT SHOULD BE ADJUSTED.**

#### 1. Footswitch/Enable Indicator

To operate any function, the footswitch must be depressed and the function selected within seven seconds. The enable indicator shows that the controls are enabled. If a function is not selected within seven seconds, or if a seven second lapse between ending one function and beginning the next function, the enable light will go out and the footswitch must be released and depressed again to enable the controls.

Releasing the footswitch removes power from all controls and applies the drive brakes.

### **WARNING**

**TO AVOID SERIOUS INJURY, DO NOT REMOVE, MODIFY OR DISABLE THE FOOTSWITCH BY BLOCKING OR ANY OTHER MEANS.**

### **WARNING**

**FOOTSWITCH MUST BE ADJUSTED IF FUNCTIONS ACTIVATE WHEN SWITCH ONLY OPERATES WITHIN LAST 1/4" OF TRAVEL, TOP OR BOTTOM.**

### 2. Engine Malfunction Indicator

On machines prior to S/N 0300062045, the light turns on and an alarm sounds when machine's power system requires immediate service. Any of the following conditions will turn on light and alarm: low engine oil pressure, high engine coolant temperature, clogged engine air filter, low alternator output, clogged hydraulic oil return filter, or clogged charge pump filter.

On machines from S/N 0300062045 to 0300183033, the light indicates that the JLG Control System has detected a malfunction and a Diagnostic Trouble Code has been set in the system memory. Refer to the Service Manual for instructions concerning the trouble codes and trouble code retrieval.

The malfunction indicator light will illuminate for 2-3 seconds when the key is positioned to the on position to act as a self test.



## SECTION 3 - MACHINE CONTROLS AND INDICATORS

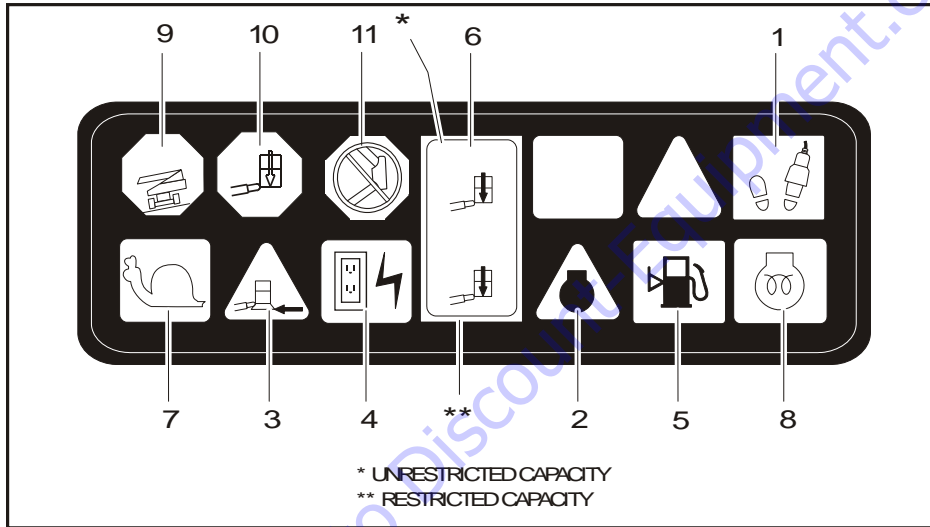

- |                       |                       |
|-----------------------|-----------------------|
| 1. Enable             | 7. Creep Speed        |
| 2. Engine Malfunction | 8. Glow Plug          |
| 3. Soft Touch         | 9. Tilt Alarm Warning |
| 4. AC Generator       | 10. Overload          |
| 5. Fuel Level         | 11. Boom Malfunction  |
| 6. Capacity           |                       |

**Figure 3-5. Platform Light Panel**

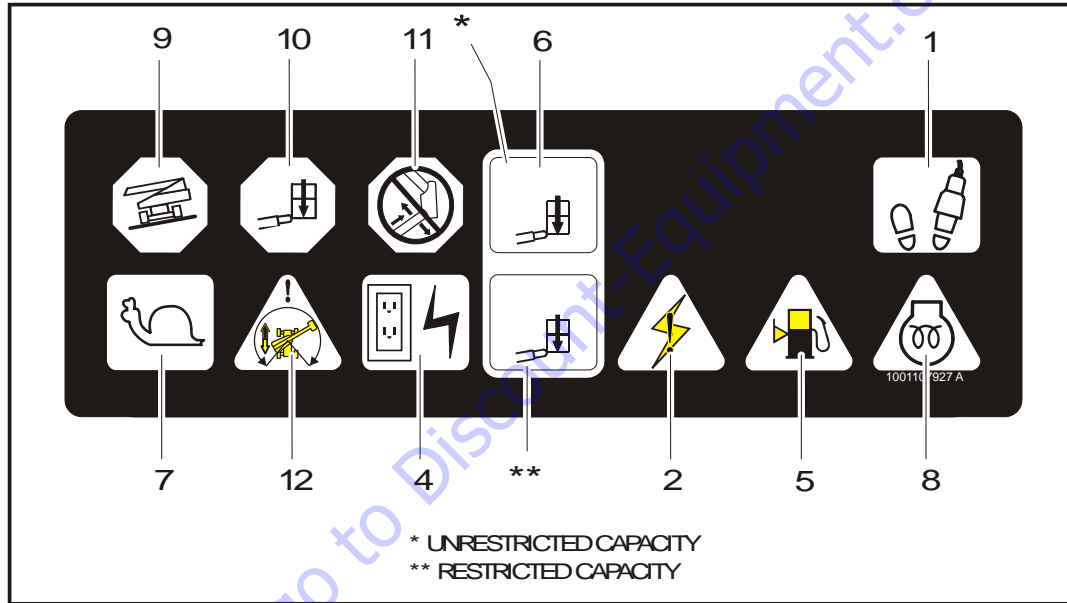

- |                       |                |                       |
|-----------------------|----------------|-----------------------|
| 1. Enable             | 5. Fuel Level  | 9. Tilt Alarm Warning |
| 2. Engine Malfunction | 6. Capacity    | 10. Overload          |
| 3. Not Used           | 7. Creep Speed | 11. Boom Malfunction  |
| 4. AC Generator       | 8. Glow Plug   | 12. Drive Orientation |

**Figure 3-6. Platform Light Panel w/Drive Orientation**

## SECTION 3 - MACHINE CONTROLS AND INDICATORS

---

### 3. Soft Touch Indicator (If Equipped)

When illuminated (Yellow) the Soft Touch bumper is against an object. All controls are disabled until the override button is pushed, at which time controls are active in the Creep mode.

### 4. AC Generator (Green)

When illuminated (Green), the light indicates the generator is in operation.

### 5. Low Fuel Indicator (Yellow) N/A for liquid propane

When illuminated (Yellow), the fuel tank is 1/8 full or less. When the light first turns on, there are approximately four usable gallons of fuel remaining.

### 6. Capacity Indicator

Indicates the maximum platform capacity for the current position of the platform. Restricted capacities are permitted at restricted platform positions (shorter boom lengths and higher boom angles).

**NOTE:** Refer to the capacity decals on the machine for restricted and unrestricted platform capacities.

### 7. Creep Speed Indicator

Illuminated (Green) when the Function Speed Control is turned to the creep position, the indicator acts as a reminder that all functions are set to the slowest speed.

### 8. Glow Plug Indicator (If Equipped)

When illuminated the glow plugs are operating. After turning on ignition, wait until light goes out before cranking engine.

### 9. Tilt Alarm Warning Light and Alarm

This orange illuminator indicates that the chassis is on a slope. An alarm will also sound when the chassis is on a slope and the boom is above horizontal. If lit when boom is raised or extended, retract and lower to below horizontal then reposition machine so that it is level before continuing operation. If the boom is above horizontal and the machine is on a slope, the tilt alarm warning light will illuminate and an alarm will sound and CREEP is automatically activated.

### **WARNING**

**IF TILT WARNING LIGHT IS ILLUMINATED WHEN BOOM IS RAISED OR EXTENDED, RETRACT AND LOWER TO BELOW HORIZONTAL THEN REPOSITION MACHINE SO THAT IT IS LEVEL BEFORE EXTENDING BOOM OR RAISING BOOM ABOVE HORIZONTAL.**

### 10. Overload Indicator (If equipped)

Indicates the platform has been overloaded.

### 11. Boom Malfunction Indicator

When an audible alarm sounds and the Boom Malfunction Indicator illuminates when attempting to activate a tower boom function, the function is being cutout by tower boom limit switch. This function is not permitted at the current boom configuration.

When an audible alarm sounds and the Boom Malfunction Indicator illuminates steady without a boom function attempt, the upright is out of alignment.

### **WARNING**

**DISCONTINUE OPERATION IF THE UPRIGHT IS OUT OF ALIGNMENT OR THE BOOM MALFUNCTION LIGHT REMAINS ILLUMINATED.**

### **NOTICE**

**IF THE UPRIGHT IS OUT OF ALIGNMENT WITH THE PLATFORM RAISED, LOWER THE MAIN BOOM AND TELESCOPE OUT UNTIL THE PLATFORM REACHES THE GROUND. THE TOWER BOOM DOWN FUNCTION IS CUT OUT IN THIS CONDITION. REPORT THE PROBLEM TO THE PROPER SERVICE PERSONNEL. DO NOT OPERATE THE MACHINE UNTIL THE CONDITION IS CORRECTED.**

### 12. Drive Orientation Indicator

When the boom is swung beyond the rear drive tires or further in either direction, the Drive Orientation indicator will illuminate when the drive function is selected. This is a signal for the operator to activate the Drive Orientation Override Switch and verify the drive control direction is correct.



**TO PURCHASE THIS PRODUCT PLEASE CONTACT US**



**Equipment Financing and  
Extended Warranties Available**



**Discount-Equipment.com is your online resource for  
commercial and industrial quality parts and equipment sales.**

**561-964-4949**

**visit us on line @ [www.discount-equipment.com](http://www.discount-equipment.com)**

Select an option below to find your Equipment

**Search by Manufacturer**

**Search by Product Type**

**Request a Quote**

We sell worldwide for the brands: Genie, Terex, JLG, MultiQuip, Mikasa, Essick, Whiteman, Mayco, Toro Stone, Diamond Products, Generac Magnum, Airman, Haulotte, Barreto, Power Blanket, Nifty Lift, Atlas Copco, Chicago Pneumatic, Allmand, Miller Curber, Skyjack, Lull, Skytrak, Tsurumi, Husquvarna Target, Stow, Wacker, Sakai, Mi-T-M, Sullair, Basic, Dynapac, MBW, Weber, Bartell, Bennar Newman, Haulotte, Ditch Runner, Menegotti, Morrison, Contec, Buddy, Crown, Edco, Wyco, Bomag, Laymor, EZ Trench, Bil-Jax, F.S. Curtis, Gehl Pavers, Heli, Honda, ICS/PowerGrit, IHI, Partner, Imer, Clipper, MMD, Koshin, Rice, CH&E, General Equipment, Amida, Coleman, NAC, Gradall, Square Shooter, Kent, Stanley, Tamco, Toku, Hatz, Kohler, Robin, Wisconsin, Northrock, Oztec, Toker TK, Rol-Air, APT, Wylie, Ingersoll Rand / Doosan, Innovatech, Con X, Ammann, Mecalac, Makinex, Smith Surface Prep, Small Line, Wanco, Yanmar

## SECTION 4. MACHINE OPERATION

### 4.1 DESCRIPTION

This machine is a self-propelled hydraulic lift equipped with a work platform on the end of an elevating and rotating boom.

The primary operator control station is in the platform. From this control station, the operator can drive and steer the machine in both forward and reverse directions. The operator can raise or lower the upper or lower boom or swing the boom to the left or right. Standard boom swing is 360 degree continuous left and right of the stowed position. The machine has a Ground Control Station which will override the Platform Control Station. Ground Controls operate Boom Lift and Swing, and are to be used in an emergency to lower the platform to the ground should the operator in the platform be unable to do so. The Ground Control is also to be used in Pre-Start Inspection.

### 4.2 OPERATING CHARACTERISTICS AND LIMITATIONS

#### Capacities

The boom can be raised above horizontal with or without any load in the platform if:

1. Machine is positioned on a smooth, firm and level surface.
2. Load is within manufacturer's rated design capacity.
3. All machine systems are functioning properly.
4. Proper tire pressure exists in the tires.
5. Machine is as originally equipped from JLG.

#### Stability

Machine stability is based on two positions which are called FORWARD STABILITY and BACKWARD STABILITY. The machine position of least forward stability is shown in Figure 4-1. and its positions of least backward stability is shown in Figure 4-2.

#### **WARNING**

**TO AVOID FORWARD OR BACKWARD TIPPING, DO NOT OVERLOAD MACHINE OR OPERATE ON AN OUT-OF-LEVEL SURFACE.**

## SECTION 4 - MACHINE OPERATION

### 4.3 ENGINE OPERATION

**NOTE:** Initial starting should always be performed from the Ground Control station.

#### Starting Procedure

1. Check engine oil. If necessary, add oil in accordance with the Engine Manufacturer's manual.
2. Check fuel level. Add fuel if necessary.
3. Check that air cleaner components are in place and securely fastened.

#### CAUTION

**IF ENGINE FAILS TO START PROMPTLY, DO NOT CRANK FOR AN EXTENDED PERIOD. SHOULD ENGINE FAIL TO START ONCE AGAIN, ALLOW STARTER TO "COOL OFF" FOR 2-3 MINUTES. IF ENGINE FAILS AFTER SEVERAL ATTEMPTS, REFER TO ENGINE MAINTENANCE MANUAL.**

**MACHINES WITH DIESEL ENGINES. AFTER TURNING ON IGNITION, OPERATOR MUST WAIT UNTIL GLOW PLUG INDICATOR LIGHT GOES OUT BEFORE CRANKING ENGINE.(IF EQUIPPED)**

4. Turn key of SELECT switch to GROUND. Position POWER/EMERGENCY STOP switch to ON, then push the ENGINE START switch to the upward position until engine starts.

#### CAUTION

**ALLOW ENGINE TO WARM-UP FOR A FEW MINUTES AT LOW SPEED BEFORE APPLYING ANY LOAD.**

5. After engine has had sufficient time to warm up, shut engine off.
6. Turn key of SELECT switch to PLATFORM.
7. From Platform position POWER/EMERGENCY STOP switch to ON, then push the ENGINE START switch to the forward position until engine starts.

**NOTE:** Footswitch must be in released (up) position before starter will operate. If starter operates with footswitch in the depressed position, DO NOT OPERATE MACHINE.



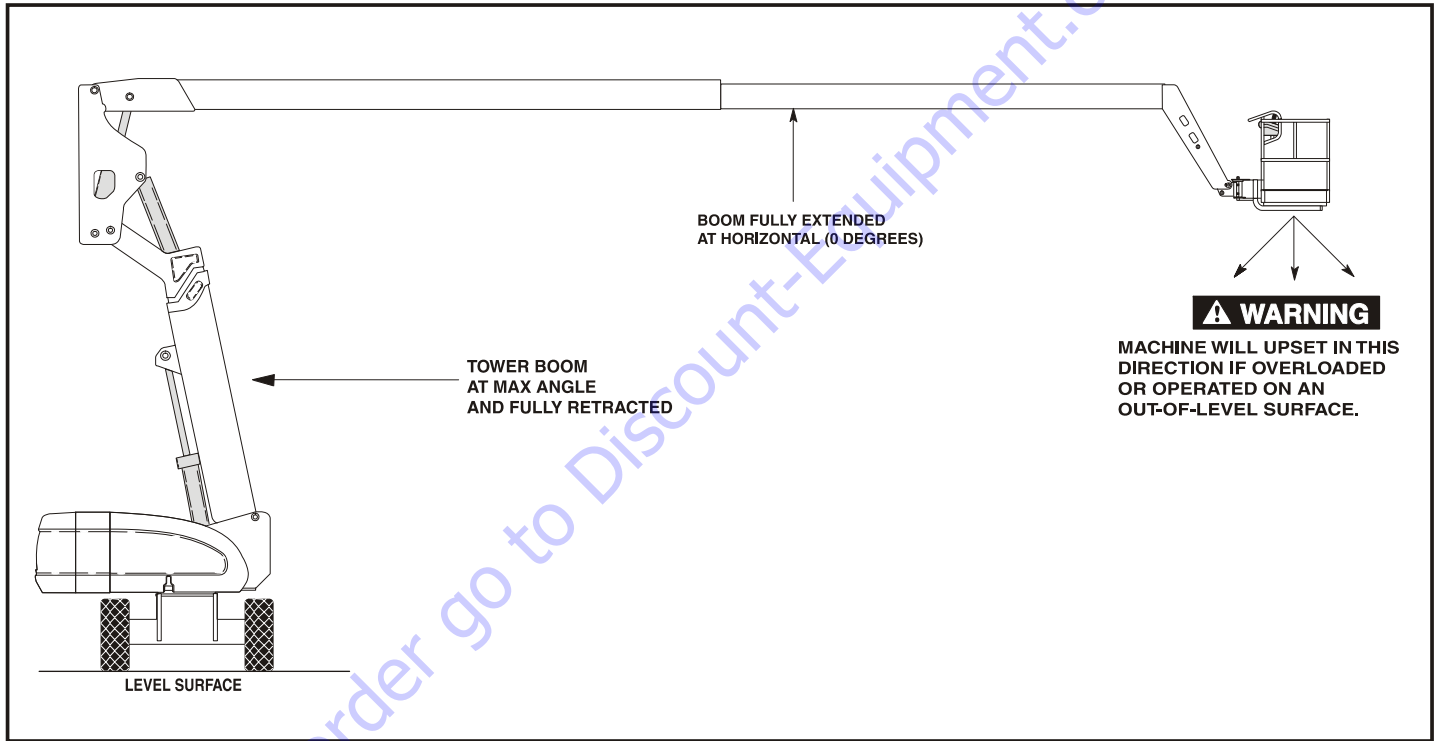

Figure 4-1. Position of Least Forward Stability

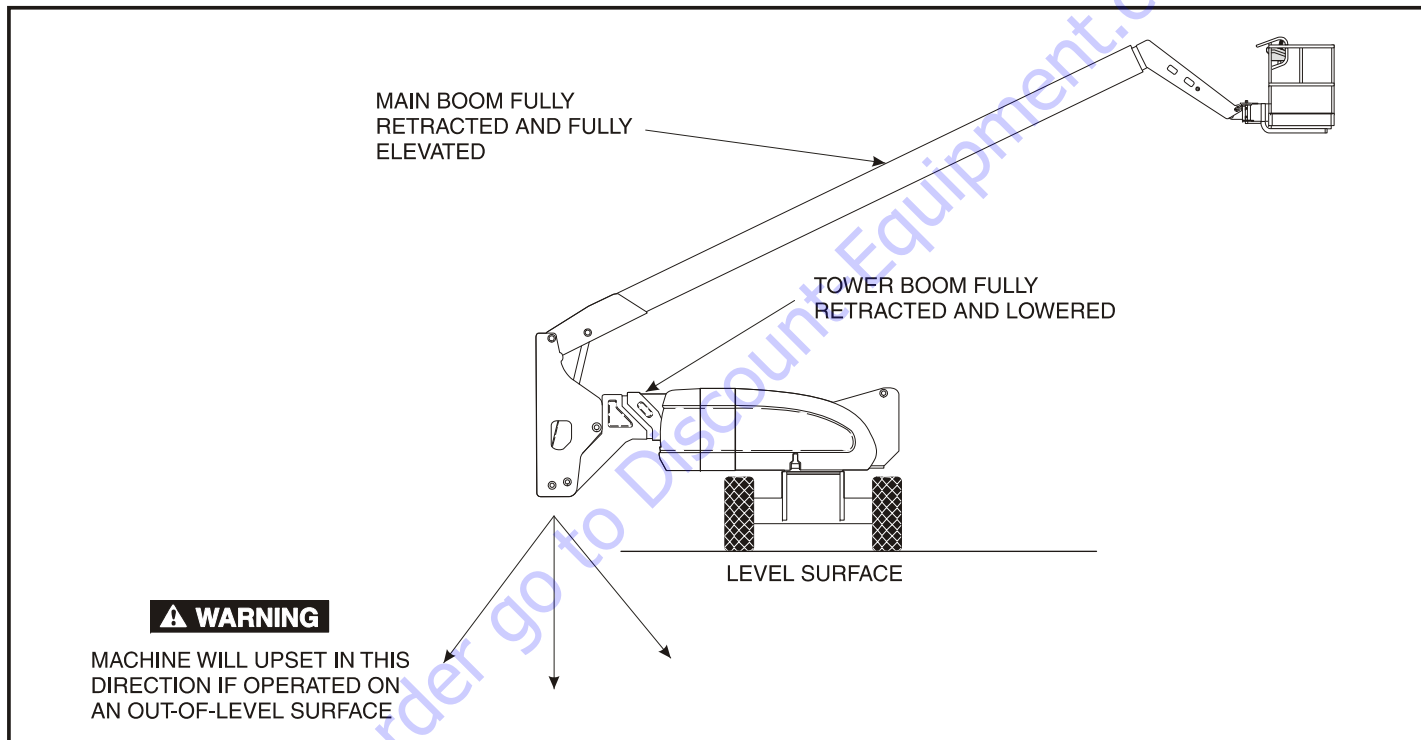

Figure 4-2. Positions of Least Backward Stability (Sheet 1 of 2)

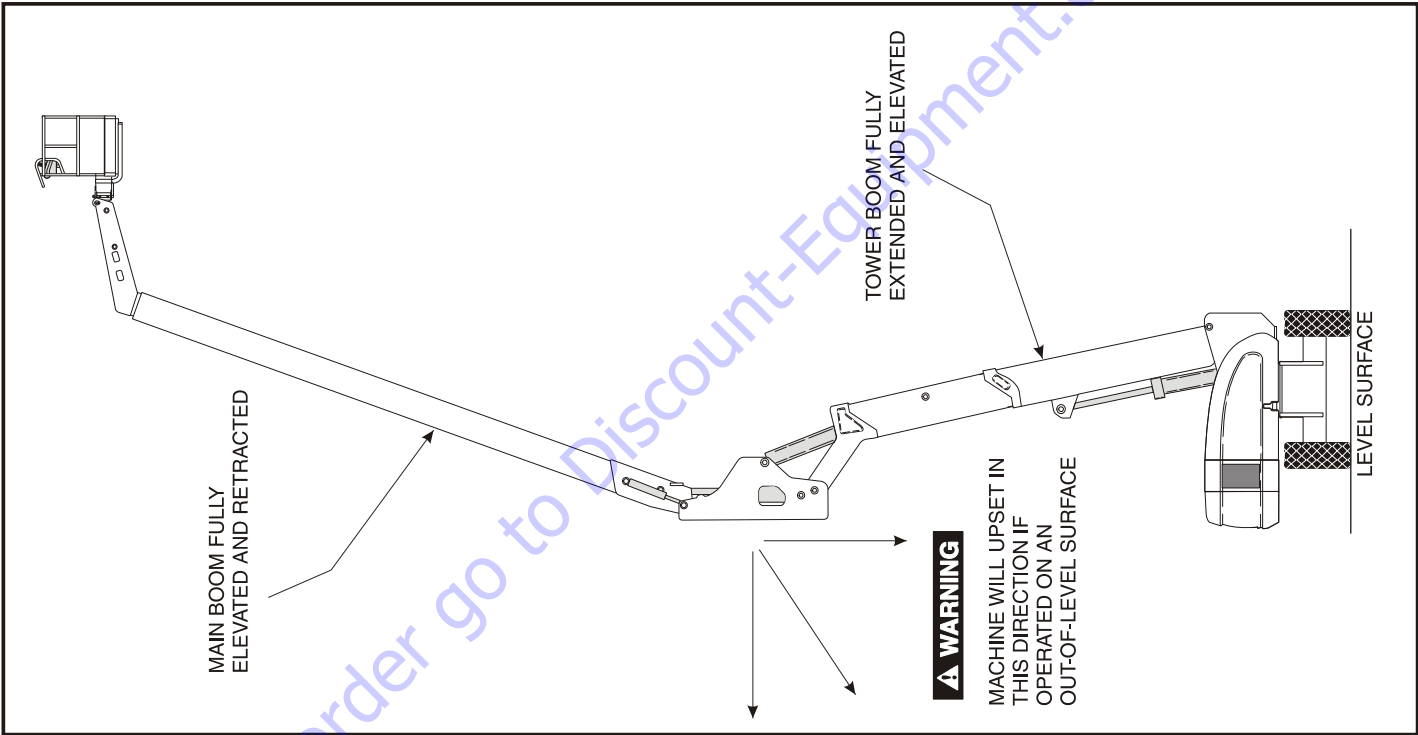

Figure 4-3. Positions of Least Backward Stability (Sheet 2 of 2)

### Shutdown Procedure

#### **⚠ CAUTION**

IF AN ENGINE MALFUNCTION NECESSITATES UNSCHEDULED SHUTDOWN, DETERMINE AND CORRECT CAUSE BEFORE RESUMING ANY OPERATION.

1. Remove all load and allow engine to operate at low speed setting for 3-5 minutes; this allows for further reduction of internal engine temperature.
2. Position POWER/EMERGENCY STOP switch to OFF.
3. Turn key of MASTER switch to OFF position.

**NOTE:** Refer to Engine Manufacturer's manual for detailed information.

### 4.4 TRAVELING (DRIVING)

(See Figure 4-4.)

#### **⚠ WARNING**

DO NOT DRIVE WITH BOOM ABOVE HORIZONTAL EXCEPT ON A SMOOTH, FIRM AND LEVEL SURFACE.

TO AVOID LOSS OF TRAVEL CONTROL OR "TIP OVER," DO NOT DRIVE MACHINE ON GRADES EXCEEDING THOSE SPECIFIED ON THE SERIAL NUMBER PLATE.

DO NOT DRIVE ON SIDESLOPES WHICH EXCEED 5 DEGREES.

USE EXTREME CAUTION WHEN DRIVING IN REVERSE AND AT ALL TIMES WHEN THE PLATFORM IS ELEVATED.

BEFORE DRIVING, LOCATE THE BLACK/WHITE ORIENTATION ARROWS ON BOTH THE CHASSIS AND THE PLATFORM CONTROLS. MOVE THE DRIVE CONTROLS IN A DIRECTION MATCHING THE DIRECTIONAL ARROWS.

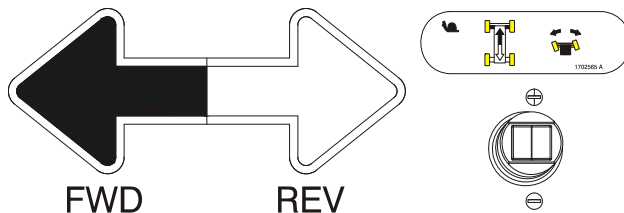

## Traveling Forward and Reverse

1. At Platform Controls, pull out Emergency Stop switch, start engine, and activate footswitch.
2. Position Drive controller to FORWARD or REVERSE as desired.

This machine is equipped with a Drive Orientation Indicator. The yellow light on the platform control console indicates that the boom is swung beyond the rear drive tires and the machine may Drive/Steer in the opposite direction from the movement of the controls. If the indicator is illuminated, operate the Drive function in the following manner:

1. Match the black and white direction arrows on both platform control panel and the chassis to determine the direction the machine will travel.
2. Push and release the Drive Orientation Override switch. Within 3 seconds, slowly move the Drive control toward the arrow matching the intended direction of machine travel. The indicator light will flash during the 3 second interval until the drive function is selected.

## 4.5 STEERING

Depress the footswitch to steer machine, push switch left to steer left, to the right, to steer right.

### **WARNING**

**BEFORE OPERATING MACHINE, MAKE SURE UPPER BOOM IS POSITIONED OVER REAR AXLE. IF BOOM IS OVER FRONT AXLE (STEER WHEELS), STEER AND DRIVE CONTROLS WILL MOVE IN OPPOSITE DIRECTION. THE DIRECTION WILL MATCH THE ARROW DECAL OF THE HAND CONTROLLER WITH THE ARROW DECAL ON THE FRAME.**

## 4.6 PARKING AND STOWING

Park and stow machine as follows:

1. Park machine in travel position; boom lowered over rear, all access panels and doors closed and secured, ignition off, turntable locked.
2. Check that brakes hold machine in position.
3. Chock wheels front and rear.
4. Turn off SELECT switch and remove key.

### 4.7 PLATFORM

#### Loading From Ground Level

1. Position chassis on a smooth, firm and level surface.
2. If total load (personnel, tools and supplies) is less than rated capacity, distribute load uniformly on platform floor and proceed to work position.

#### Loading From Positions Above Ground Level

Before loading weight to platform above ground level:

1. Determine what the total rated capacity weight will be after additional weight is loaded (personnel, tools and supplies).
2. If total weight in platform will be less than rated capacity, proceed with distributing weight uniformly on platform floor.

#### Platform Level Adjustment

1. Leveling UP. Depress footswitch To raise platform, position PLATFORM LEVEL control switch UP and hold until platform is level.
2. Leveling DOWN. Depress footswitch To lower platform, position PLATFORM LEVEL control switch to DOWN and hold until platform is level.

#### **WARNING**

**ONLY USE THE PLATFORM LEVELING OVERRIDE FUNCTION FOR SLIGHT LEVELING OF THE PLATFORM. INCORRECT USE COULD CAUSE THE LOAD/OCCUPANT TO SHIFT OR FALL. FAILURE TO DO SO COULD RESULT IN DEATH OR SERIOUS INJURY.**

#### Platform Rotation

To rotate the platform to the left or right, use the Platform Rotate control switch to select the direction and hold until desired position is reached.

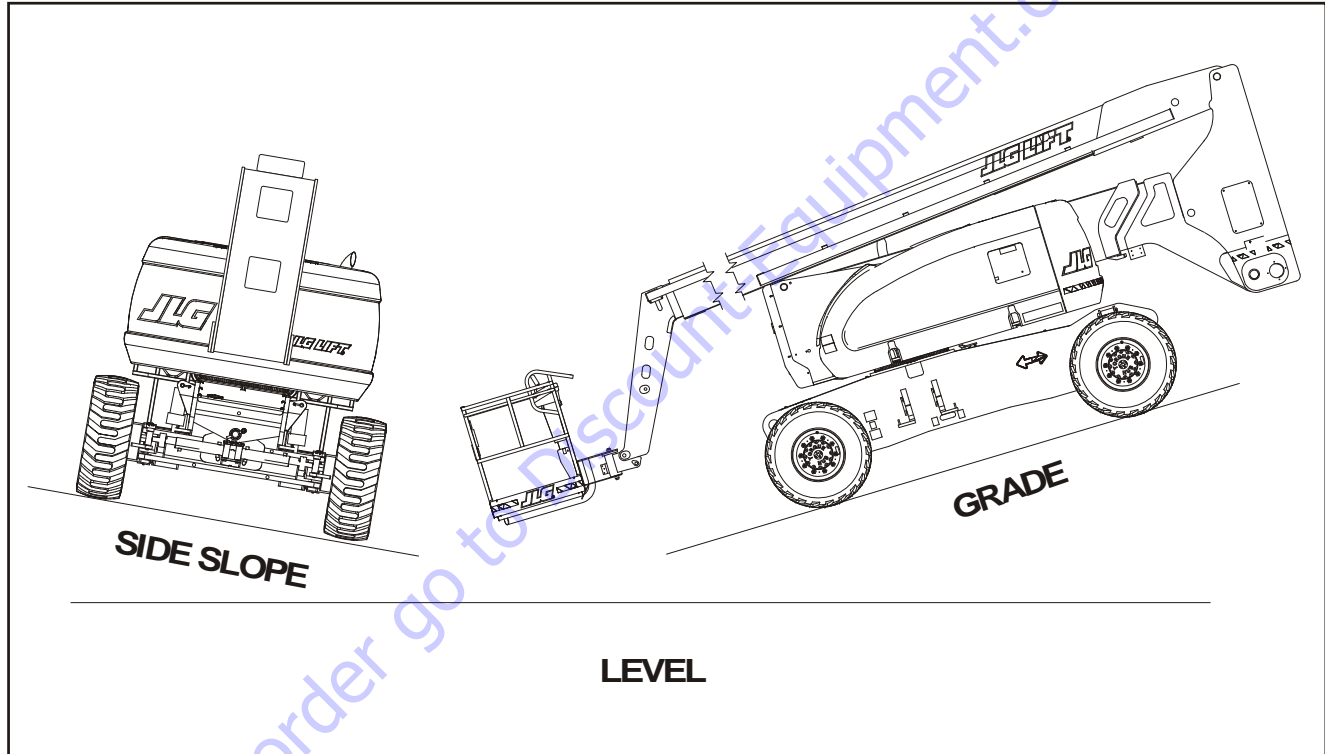

Figure 4-4. Grade and Sideslopes

### 4.8 BOOM

(See Figure 4-2.)

#### **WARNING**

AN ORANGE TILT ALARM WARNING LIGHT, LOCATED ON THE CONTROL CONSOLE, LIGHTS WHEN THE CHASSIS IS ON A SEVERE SLOPE. DO NOT SWING, EXTEND OR RAISE MAIN BOOM ABOVE HORIZONTAL WHEN LIT.

DO NOT DEPEND ON TILT ALARM AS A LEVEL INDICATOR FOR THE CHASSIS. CHASSIS MUST BE LEVEL BEFORE SWINGING, EXTENDING OR RAISING TOWER BOOM ABOVE HORIZONTAL.

TO AVOID UPSET, IF ORANGE TILT ALARM WARNING LIGHT LIGHTS WHEN MAIN BOOM IS EXTENDED OR RAISED ABOVE HORIZONTAL, RETRACT AND LOWER PLATFORM TO NEAR GROUND LEVEL. THEN REPOSITION MACHINE SO THAT CHASSIS IS LEVEL BEFORE EXTENDING OR RAISING MAIN BOOM.

TRAVELING WITH MAIN BOOM RETRACTED AND BELOW HORIZONTAL IS PERMITTED ON GRADES AND SIDE SLOPES SPECIFIED ON THE SERIAL NUMBER PLACARD.

TO AVOID SERIOUS INJURY, DO NOT OPERATE MACHINERY IF ANY CONTROL LEVERS OR TOGGLE SWITCHES CONTROLLING PLATFORM MOVEMENT DO NOT RETURN TO THE OFF OR NEUTRAL POSITION WHEN RELEASED.

TO AVOID A COLLISION AND INJURY IF PLATFORM DOES NOT STOP WHEN A CONTROL SWITCH OR LEVER IS RELEASED, REMOVE FOOT FROM FOOTSWITCH OR USE EMERGENCY STOP TO STOP THE MACHINE.

### Swinging the Boom

#### **NOTICE**

ASSURE THAT TURNABLE LOCK IS DISENGAGED BEFORE STARTING ANY SWING OPERATION.

Depress footswitch. To swing boom, position SWING control switch or controller to RIGHT or LEFT for direction desired.



## **Raising and Lowering the Tower Boom**

This machine will have two controls for the tower boom (two toggle switches), one controls tower lift, the other tower telescope. The switching system will sequence its LIFT and TELESCOPE functions as follows:

- 1.** Depress footswitch and sequence while RAISING the TOWER BOOM from the fully lowered position.
  - a.** The TOWER BOOM must be fully elevated “up” (approximately 12 degrees from vertical) before the TOWER BOOM can be extended from the fully retracted position.
  - b.** The TOWER TELESCOPE “out” will only be operable when the TOWER BOOM is fully elevated “up”.
- 2.** Depress footswitch and sequence while LOWERING the TOWER BOOM from the fully elevated “up” position.
  - a.** TOWER TELESCOPE “in”. The TOWER BOOM must be fully retracted before the TOWER BOOM can be lowered.
  - b.** TOWER BOOM lift “down” will only be operable when the TOWER BOOM is fully retracted.

## **Raising and Lowering the Main Boom**

To raise and lower Main Boom, depress footswitch, position MAIN LIFT controller to UP OR DOWN, and hold until desired height is reached.

## **Telescoping the Main Boom**

To extend or retract Main Boom, depress footswitch, position MAIN TELESCOPE control switch to IN or OUT, and hold until platform reaches desired position.

### Function of Tower Boom

This machine will have two controls for the tower boom (two toggle switches), one controls tower lift, the other tower telescope. The switching system will sequence its LIFT and TELESCOPE functions as follows:

1. Sequence while RAISING the TOWER BOOM from the fully lowered position.
  - a. The TOWER BOOM must be fully elevated “up” (approximately 12 degrees from vertical) before the TOWER BOOM can be extended from the fully retracted position.
  - b. The TOWER TELESCOPE “out” or “in” will only be operable when the TOWER BOOM is fully elevated “up”.

2. Sequence while LOWERING the TOWER BOOM from the fully elevated “up” position.
  - a. TOWER TELESCOPE “in”. The TOWER BOOM must be fully retracted before the TOWER BOOM can be lowered.
  - b. The TOWER BOOM lift “down” will only be operable when the TOWER BOOM is fully retracted.

#### **WARNING**

**DISCONTINUE OPERATION IF THE UPRIGHT IS OUT OF ALIGNMENT OR THE BOOM MALFUNCTION LIGHT REMAINS ILLUMINATED.**

#### **NOTICE**

**IF THE UPRIGHT IS OUT OF ALIGNMENT WITH THE PLATFORM RAISED, LOWER THE MAIN BOOM AND TELESCOPE OUT UNTIL THE PLATFORM REACHES THE GROUND. THE TOWER BOOM DOWN FUNCTION IS CUT OUT IN THIS CONDITION. REPORT THE PROBLEM TO THE PROPER SERVICE PERSONNEL. DO NOT OPERATE THE MACHINE UNTIL THE CONDITION IS CORRECTED.**

## **4.9 SHUT DOWN AND PARK**

1. Drive machine to a protected area.
2. Assure main boom is fully retracted and lowered over rear (Drive) axle; all access panels and doors closed and secured.
3. Remove all load and allow engine to idle 3-5 minutes to permit reduction of engine internal temperatures.
4. At Ground Controls, turn KEY SELECT switch to (center) OFF. Position, POWER/EMERGENCY STOP switch (down) to OFF. Remove key.
5. Cover Platform Control console to protect instruction placards, warning decals and operating controls from hostile environment.

## **4.10 LIFTING AND TIE DOWN**

When transporting machine, boom must be in the stowed position mode, (booms lowered and retracted) with turntable lock pin engaged, and machine securely tied down to truck or trailer deck. Six tie down eyes are provided in the frame slab, one at each corner of the machine and 2 holes at the center of the frame. (See Figure 4-5., Machine Tie Down)

If it becomes necessary to lift the machine using an overhead or mobile crane, it is very important that the turntable lock pin is engaged, lifting devices are attached only to the designated lifting eyes, and spreader bars are to be used to prevent damage to the machine. (See Figure 4-6., Lifting Chart for gross machine weights.)

**NOTE:** *When transporting machine over rough terrain or long distance, the boom needs to be chocked and strapped. This prevents the boom from bouncing up causing possible damage.*

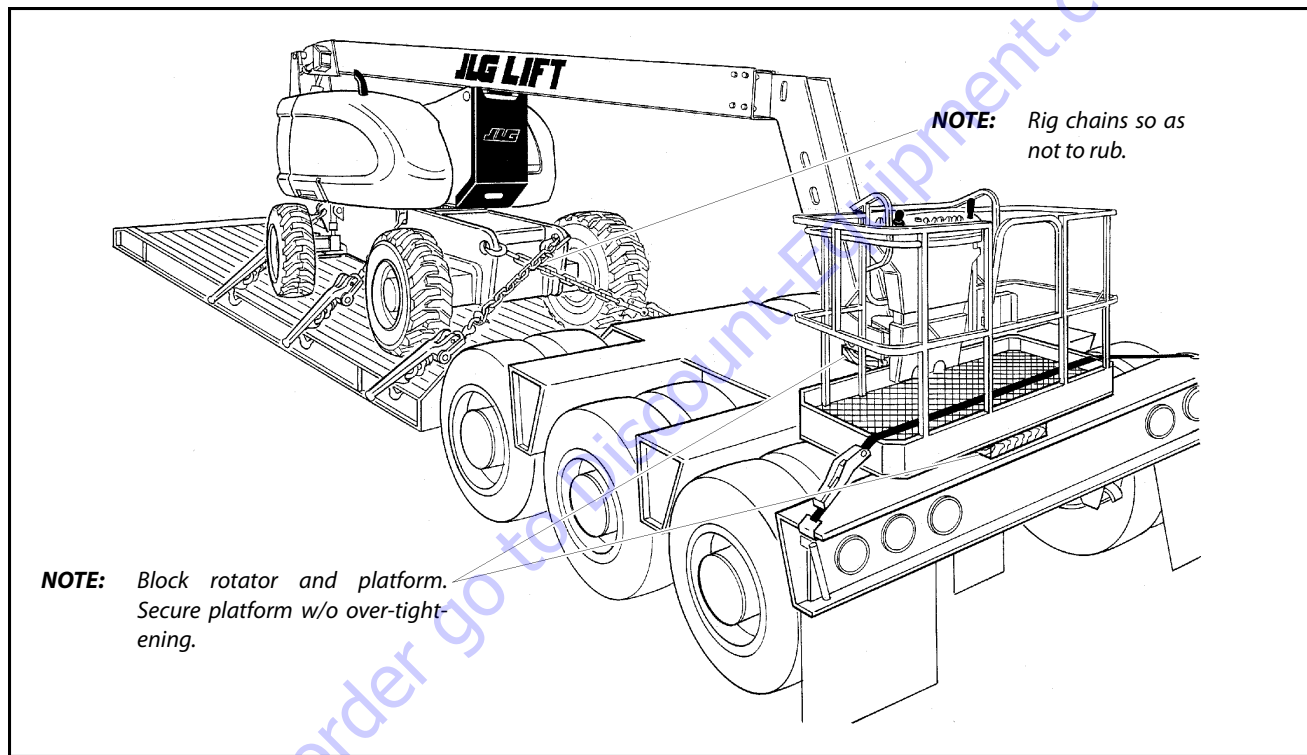

**Figure 4-5. Machine Tie Down**

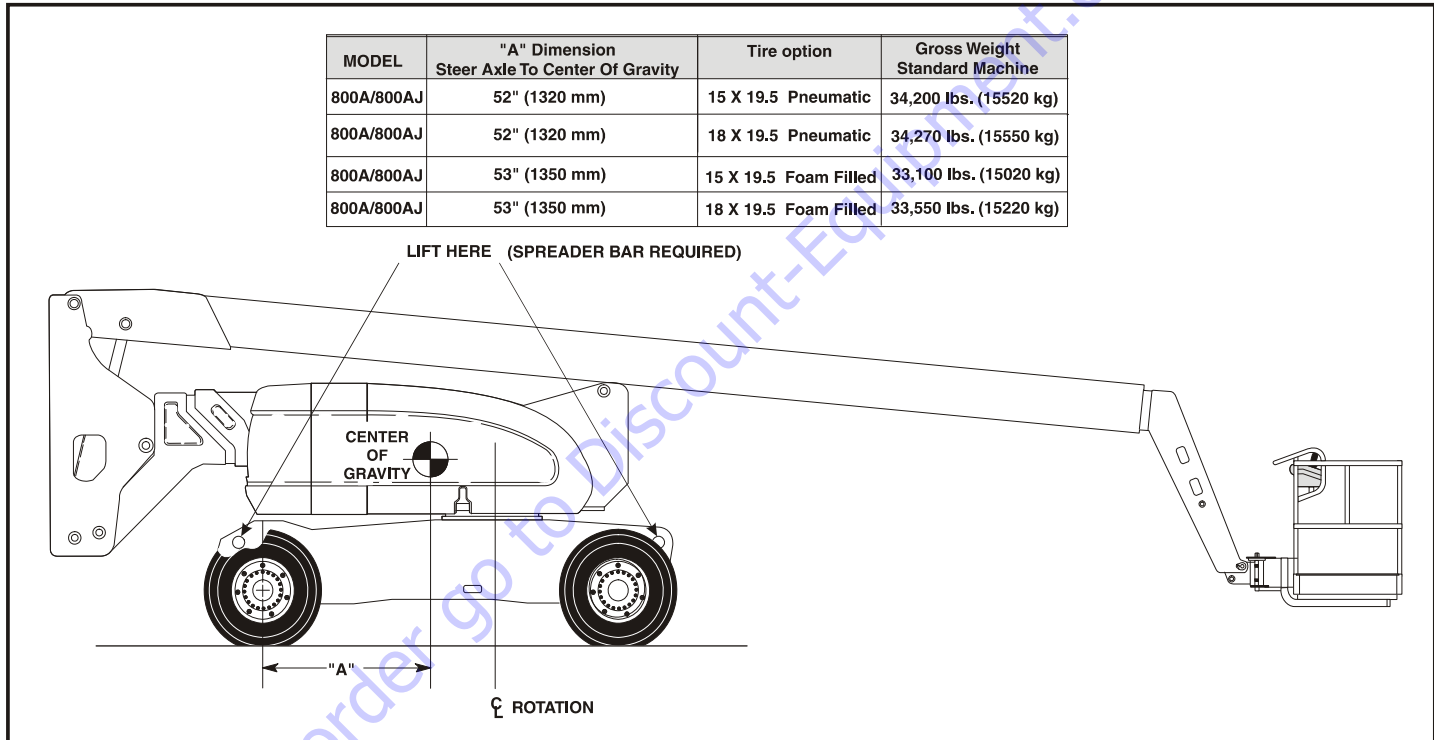

Figure 4-6. Lifting Chart

## SECTION 4 - MACHINE OPERATION

---

**NOTE:** Crane and lifting devices, chains, slings, etc., must be capable of handling the gross machine weight.

### **NOTICE**

**ABOVE IS MINIMUM WEIGHT. CHECK WEIGHT OF UNIT PRIOR TO LIFTING.**

**NOTE:** Lifting eyes are provided at the front and rear in the frame slab. Each of the four chains or slings used for lifting machine must be adjusted individually so machine remains level when elevated.

### **NOTICE**

**SECURE TURNTABLE WITH TURNTABLE LOCK BEFORE TRAVELING LONG DISTANCES OR HAULING MACHINE ON TRUCK/TRAILER.**

## **4.11 OSCILLATING AXLE LOCKOUT TEST (IF EQUIPPED)**

### **NOTICE**

**LOCKOUT SYSTEM TEST MUST BE PERFORMED QUARTERLY, ANY TIME A SYSTEM COMPONENT IS REPLACED, OR WHEN IMPROPER SYSTEM OPERATION IS SUSPECTED.**

Refer to Section 2.4, Oscillating Axle Lockout Test (If Equipped) for procedure.

## **4.12 TOWING**

The machine is not equipped with a tow package. Refer to Section 5 for emergency towing procedures.

### **4.13 TOW BAR (IF EQUIPPED)**

#### **⚠ WARNING**

**RUNAWAY VEHICLE/MACHINE HAZARD. MACHINE HAS NO TOWING BRAKES. TOWING VEHICLE MUST BE ABLE TO CONTROL MACHINE AT ALL TIMES. ON-HIGHWAY TOWING NOT PERMITTED. FAILURE TO FOLLOW INSTRUCTIONS COULD CAUSE SERIOUS INJURY OR DEATH.**

**MAXIMUM TOWING SPEED 5 M.P.H. (8 K.M.H.)**

**MAXIMUM TOWING GRADE 25%.**

**Prior to towing the machine, complete the following:**

#### **⚠ CAUTION**

**DO NOT TOW MACHINE WITH ENGINE OPERATING OR DRIVE HUBS ENGAGED.**

1. Retract, lower and position boom in travel position; lock turntable.
2. Lower tow bar and connect to towing vehicle
3. Disconnect drive hubs by inverting disconnect cap.
4. Position steer/tow selector valve for towing; pull valve knob OUT for towing. The machine is now in the towing mode.

**After towing the machine, complete the following:**

1. Actuate steer/tow selector valve for steering; push valve knob IN to the actuated position.
2. Reconnect drive hubs by inverting disconnect cap.
3. Disconnect tow bar from towing vehicle and place it in the stowed position as shown in Figure 4-7. The machine is now in the driving mode.

### **4.14 WELDING LEAD (IF EQUIPPED)**

This option consists of a single welding cable that is installed in the power track and will allow stick welding from the platform, up to the full elevation of the machine. The single welding cable system differs from the two cable system of previous machines.

#### **NOTICE**

**DO NOT GROUND WELDER TO THE MACHINE. SERIOUS DAMAGE TO THE MACHINE WILL RESULT. THIS SYSTEM IS INTENDED TO BE GROUNDED TO THE MATERIAL BEING WELDED.**

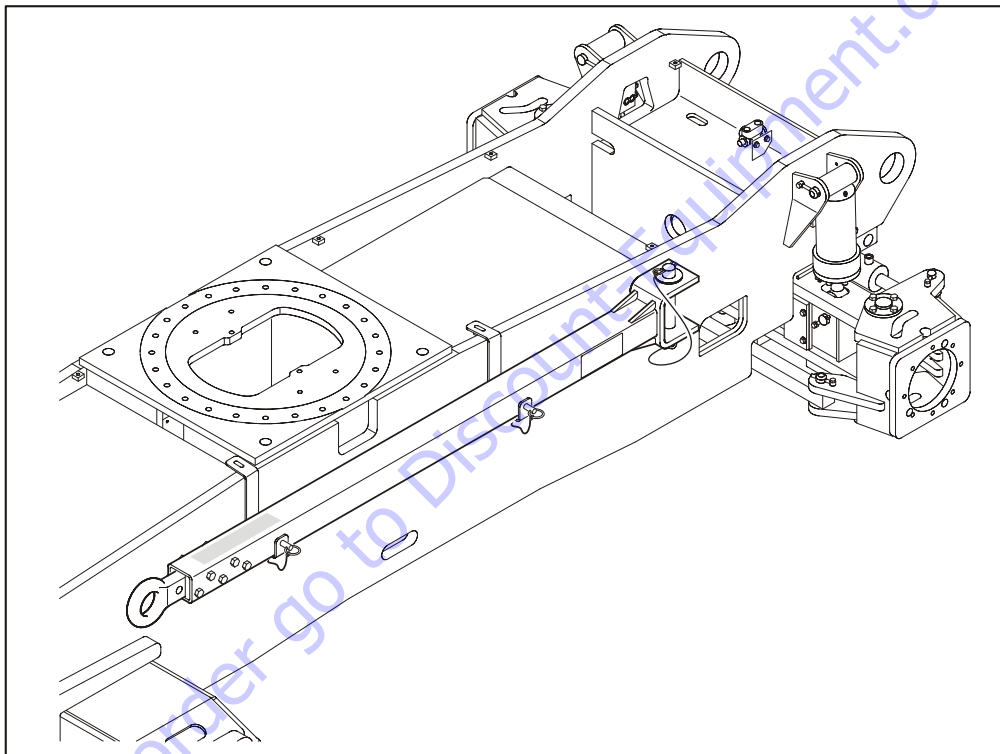

**Figure 4-7. Tow Bar**



## 4.15 DUAL FUEL SYSTEM (GAS ENGINE ONLY)

### Description

The dual fuel system enables the standard gasoline engine to run on either gasoline or LP gas. The system includes pressurized cylinders mounted on the frame, and the valves and switches needed to switch the fuel supply from gasoline to LP gas or from LP gas to gasoline.

A two position, FUEL SELECT toggle switch at the platform control station supplies electrical power to open the gasoline shut-off solenoid and close the LP gas shut off solenoid when positioned to the GASOLINE position. This switch also allows electrical power to open the LP gas shut-off solenoid and close the gasoline shut-off solenoid when positioned to the LP position.

### CAUTION

**IT IS POSSIBLE TO SWITCH FROM ONE FUEL SOURCE TO THE OTHER WITHOUT STOPPING THE ENGINE. EXTREME CARE MUST BE TAKEN AND THE FOLLOWING INSTRUCTIONS MUST BE FOLLOWED.**

### Changing From Gasoline to LP Gas

1. Start engine from Ground Control Station.
2. Open hand valve on LP gas supply tank by turning counter-clockwise.
3. While the engine is operating, place the two position LPG/Gasoline switch at the platform control station to the "LP" position.

### Changing From LP Gas to Gasoline

1. With engine operating on LP under a no-load condition, position FUEL SELECT switch at Platform Control Station to GASOLINE position.
2. Close hand valve on LP gas supply tank by turning clockwise.

### 4.16 RE-SYNCHRONIZE UPRIGHT

#### Releveling Valve

A pull type control valve allows the operator to adjust the upright level cylinder if the upright is not 90° (vertical) relative to the chassis (Refer to Figure 2.9 and Figure 2.10). This valve is located in the tank compartment area.

Perform the following steps with the aid of an assistant:

1. Turn the key switch to the ground control position.
2. Start the engine.
3. Pull and hold the red relevel knob located next to the main control valve. Refer to Figure 4-8.
4. Raise the tower boom 6 feet (1.8 m).
5. Release the red relevel knob.
6. Lower the tower boom fully and continue to hold down the switch to Tower Down for an additional 20 seconds.
7. Repeat steps 3 thru 6 as necessary until the upright is 90° (vertical) relative to the chassis.

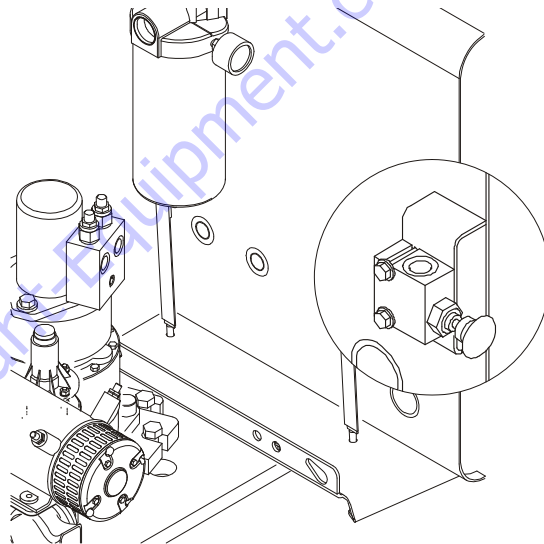

**Figure 4-8. Releveling Valve**

## 4.17 SKYGUARD OPERATION

SkyGuard is used to provide enhanced control panel protection. When the SkyGuard sensor is activated, functions in use at the time of actuation will reverse or cutout. The table below outlines these functions.

**Table 4-1. SkyGuard Function Table**

Main Lift	Main Tele In	Main Tele Out	Swing	Drive Forward		Drive Reverse		Tower Lift Up	Tower Lift Down	Platform Level	Platform Rotate	Jib Lift
				DOS Enabled	DOS Not Enabled	DOS Enabled	DOS Not Enabled					
R	C	R	R	R	C*	R	R	R	C	C	C	C
R=Indicates Reversal is Activated												
C=Indicates Cutout is Activated												
* Disregard when boom is in line and driving forward with or without steering and no other function active												
Note: When Soft Touch is enabled with SkyGuard all functions are cut out only.												

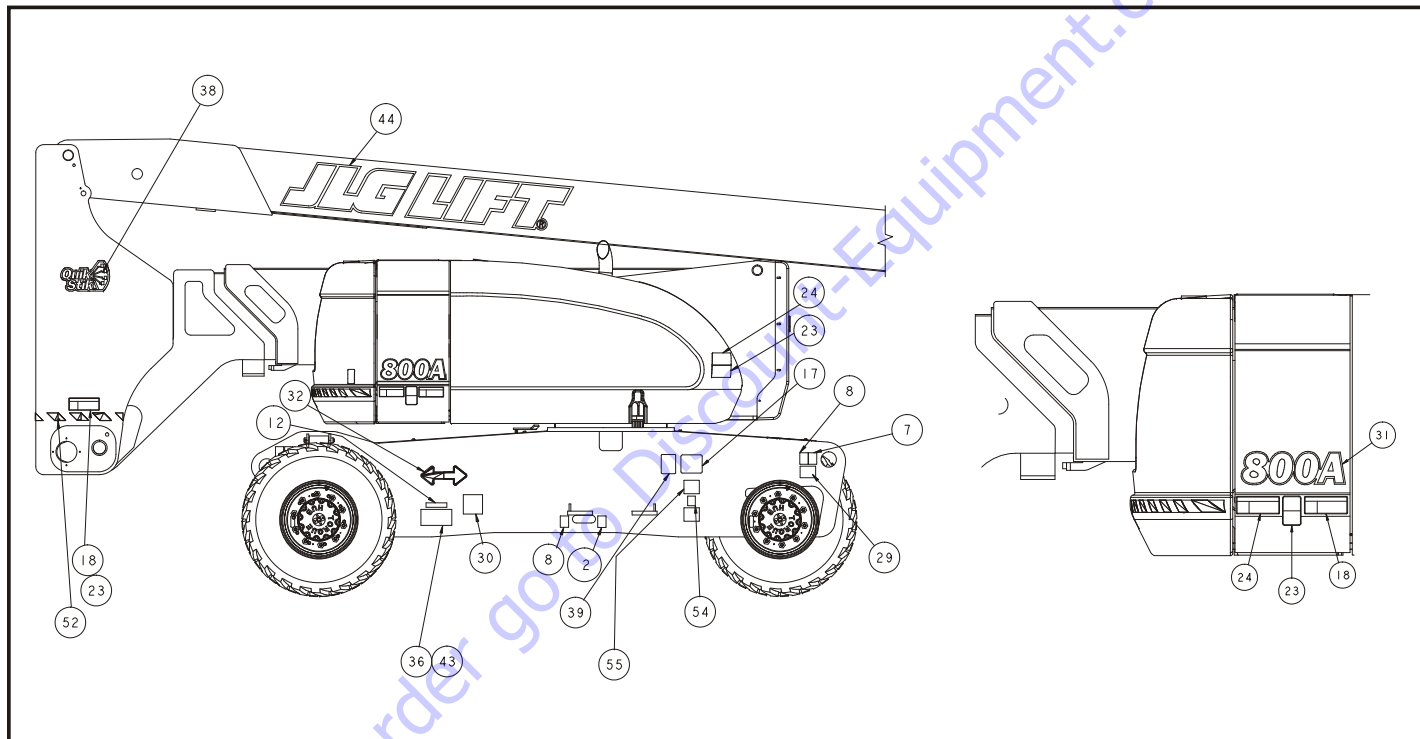

Figure 4-9. Decal Installation - Sheet 1 of 5

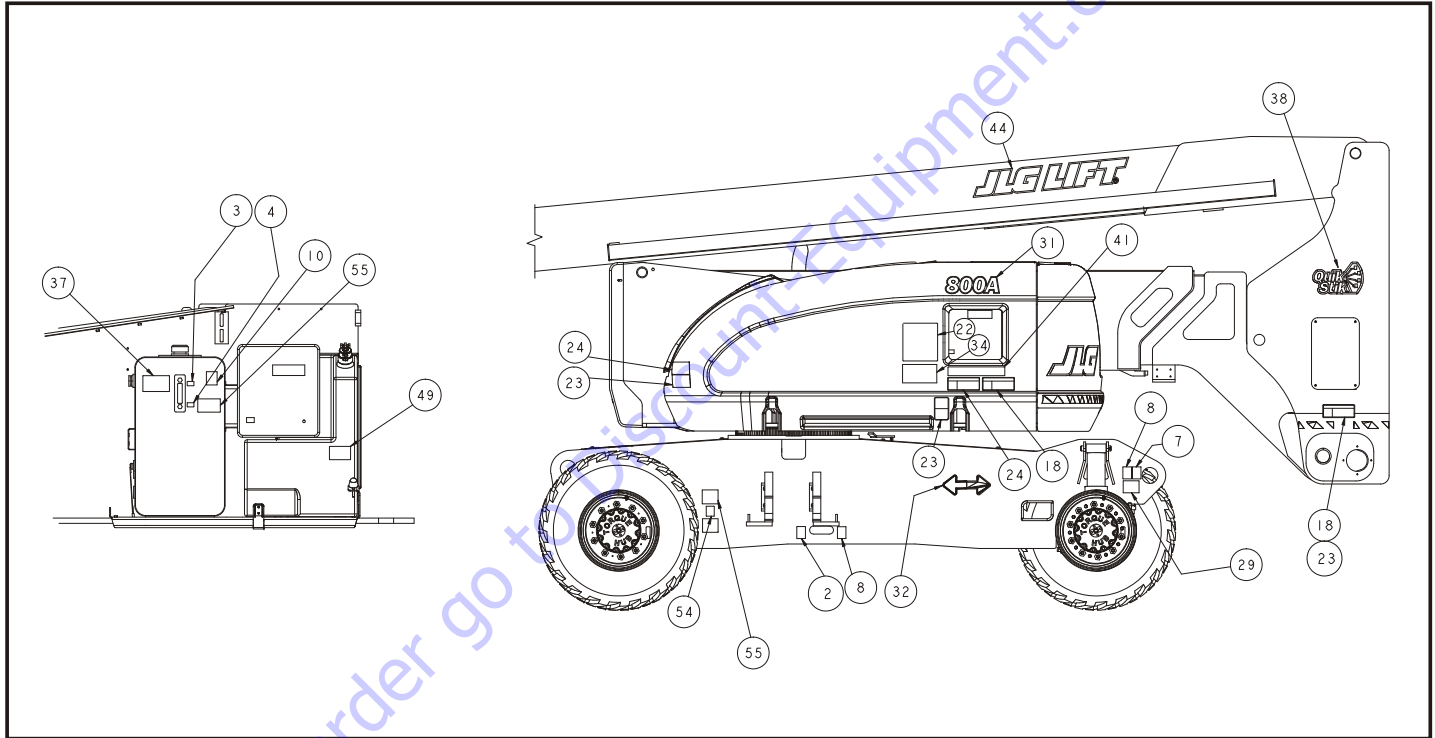

Figure 4-10. Decal Installation - Sheet 2 of 5

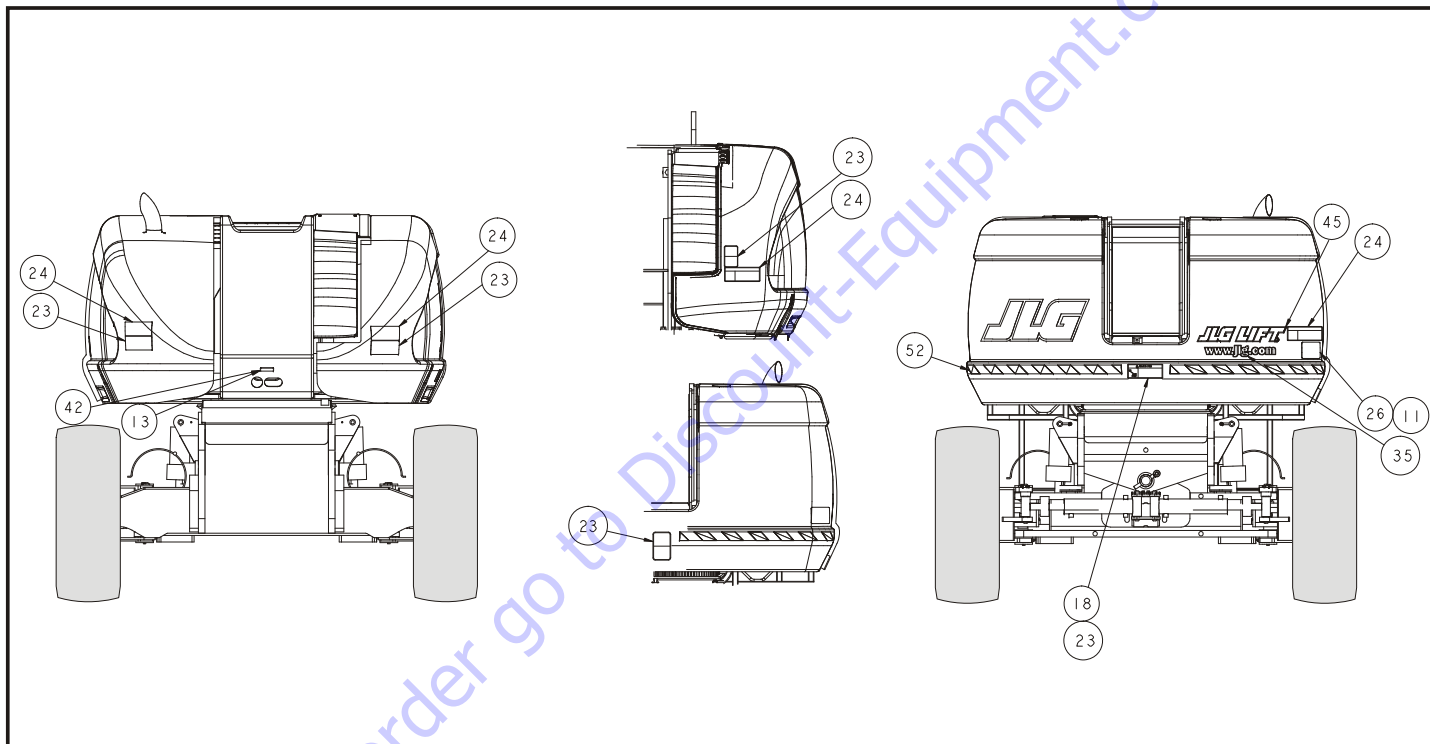

Figure 4-11. Decal Installation - Sheet 3 of 5

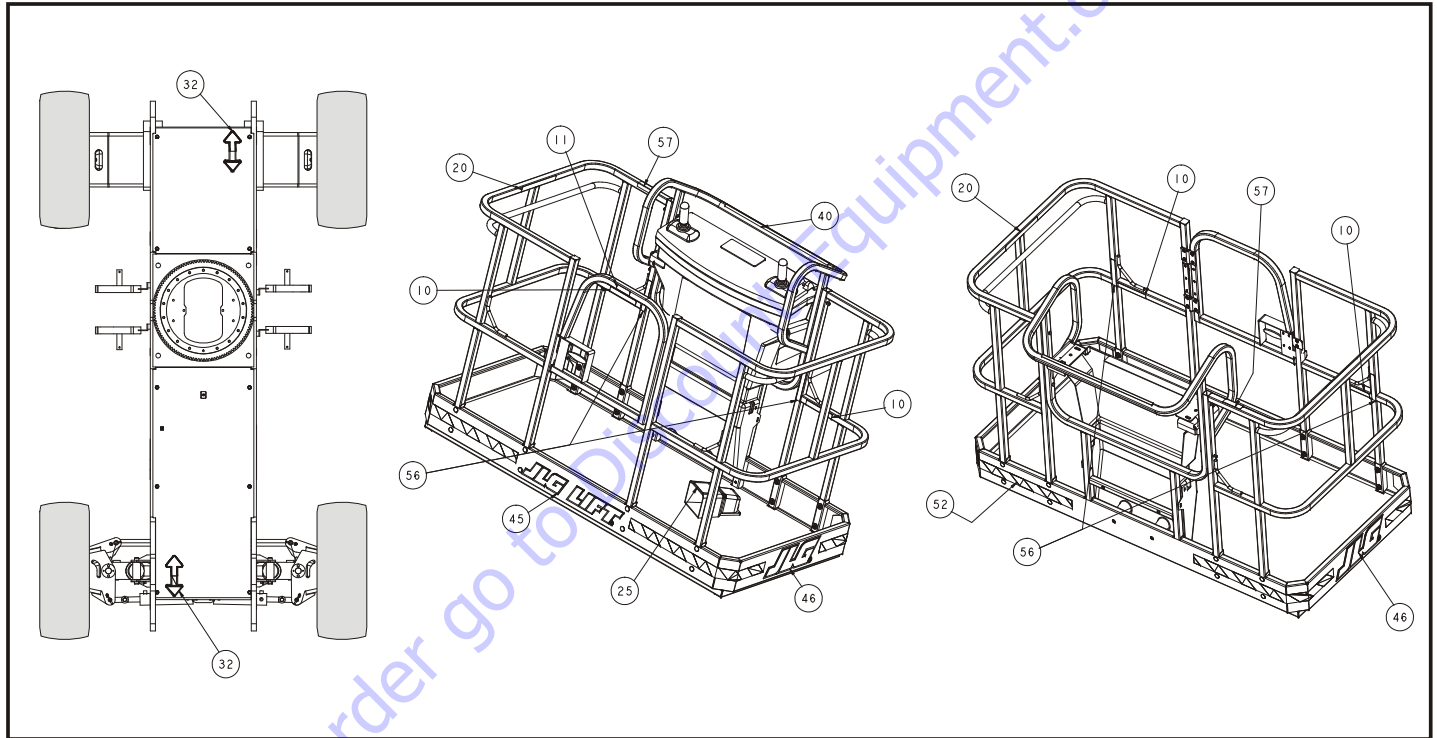

Figure 4-12. Decal Installation - Sheet 4 of 5

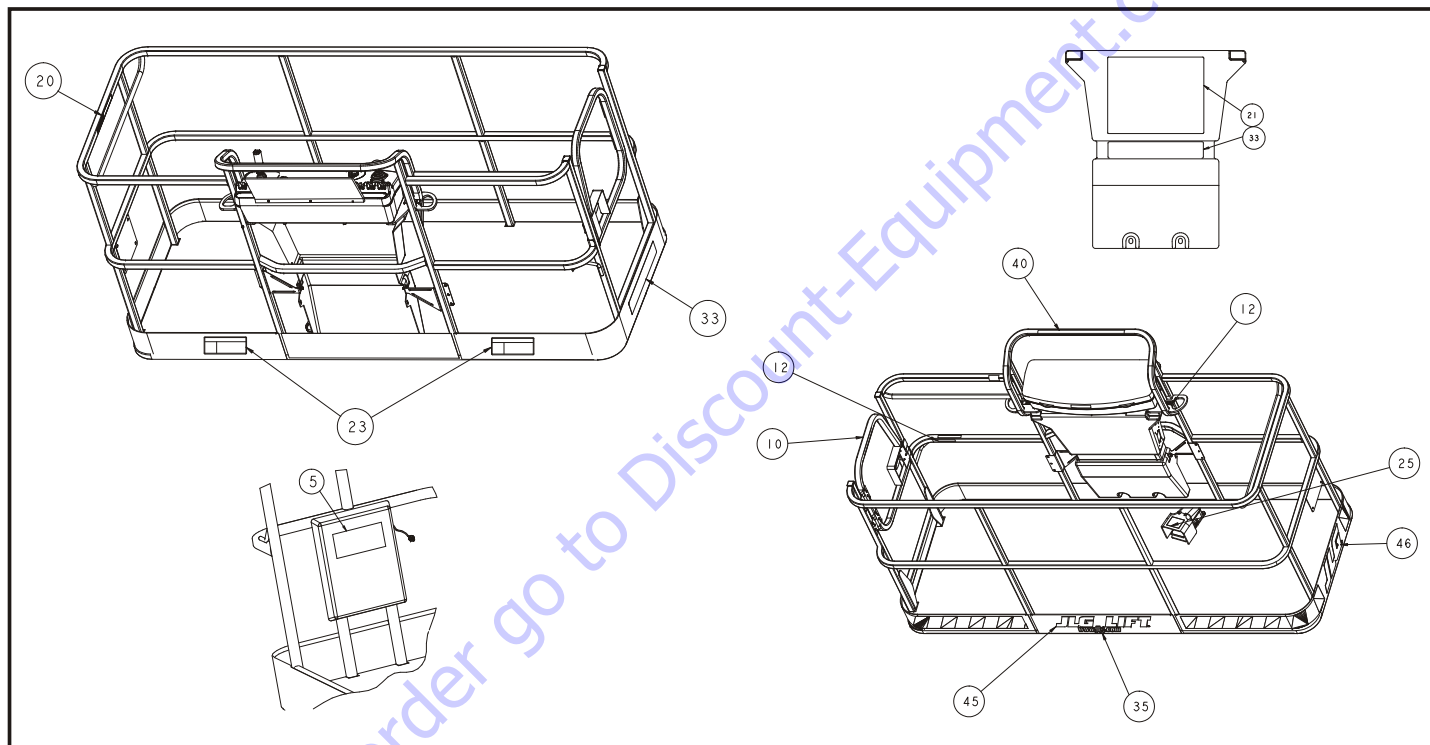

Figure 4-13. Decal Installation - Sheet 5 of 5



Table 4-2. Decal Legend - 800A - Prior to S/N 0300141330

Item #	ANSI 0274460-9	Korean 0274464-7	Chinese 0274470-7	Spanish 0274466-7	Portuguese 0274468-8	French 0274472-7	CE/Aus 0274474-3	Japanese 0274462-7
1	--	--	--	--	--	--	--	--
2	1701499	1701499	1701499	1701499	1701499	1701499	1701499	1701499
3	--	--	--	--	--	--	--	--
4	--	--	--	--	--	--	--	--
5	1701509	1701509	1701509	1701509	1701509	1701509	1701509	1701509
6	--	--	--	--	1701529	--	--	--
7	1703811	1703811	1703811	1703811	1703811	1703811	1703811	1703811
8	1703814	1703814	1703814	1703814	1703814	1703814	1703814	1703814
9	1704277	1704277	1704277	1704277	1704277	1704277	1704277	1704277
10	1704412	1704412	1704412	1704412	1704412	1704412	1704412	1704412
11	--	--	--	--	--	--	1705084	--
12	--	--	--	--	--	1705514	--	--
13	--	--	--	--	--	--	--	--
14	--	--	--	--	--	--	--	--
15	1705337	1705339	1705342	--	--	--	--	--
16	--	--	--	--	--	--	--	--

## SECTION 4 - MACHINE OPERATION

**Table 4-2. Decal Legend - 800A - Prior to S/N 0300141330**

Item #	ANSI 0274460-9	Korean 0274464-7	Chinese 0274470-7	Spanish 0274466-7	Portuguese 0274468-8	French 0274472-7	CE/Aus 0274474-3	Japanese 0274462-7
17	--	--	--	1704007	1705901	1704006	--	--
18	1703953	1703945	1703943	1703941	1705903	1703942	--	1703944
19	--	--	--	--	--	--	--	--
20	1702868	1705969	1705968	1704001	1705967	1704000	--	--
21	1703797	1703927	1703925	1703923	1705895	1703924	1705921	1703926
22	1705336	1705345	1705348	1705917	1705896	1705347	1705822	1705344
23	1703804	1703951	1703949	1703947	1705898	1703948	1701518	1703950
24	1703805	1703939	1703937	1703935	1705897	1703936	1705961	1703938
25	3252347	1703981	1703982	1703983	1705902	1703984	1705828	1703980
26	3251813	--	3251813	3251813	3251813	3251813	--	3251813
27	--	--	--	--	--	--	--	--
28	--	--	--	--	--	--	--	--
29	1703960	1703960	1703960	1703960	1703960	1703960	1703960	1703960
30	1702631	1702631	1702631	1702631	1702631	1702631	1702631	1702631
31	1703772	1703772	1703772	1703772	1703772	1703772	1703772	1703772
32	1701501	1701501	1701501	1701501	1701501	1701501	1701501	1701501
33	1704096	1704103	1704101	1704098	1706380	1704099	1705978	1704102

**Table 4-2. Decal Legend - 800A - Prior to S/N 0300141330**

<b>Item #</b>	<b>ANSI 0274460-9</b>	<b>Korean 0274464-7</b>	<b>Chinese 0274470-7</b>	<b>Spanish 0274466-7</b>	<b>Portuguese 0274468-8</b>	<b>French 0274472-7</b>	<b>CE/Aus 0274474-3</b>	<b>Japanese 0274462-7</b>
34	1707014	1707043	1707045	1707048	1707051	1707046	1705978	1707053
35	--	1704885	1704885	1704885	1704885	1704885	1704885	1704885
36	1706948	1706948	1706948	1706948	1706948	1706948	--	1706948
37	1702265	1703987	1703988	1703989	1706439	1703990	1705977	1703986
38	1703959	1703959	1703959	1703959	1703959	1703959	1703959	1703959
39	1700584	1700584	1700584	1700584	1700584	1700584	1700584	1700584
40	1001108495	1001108495	1001108495	1001108495	1001108495	1001108495	--	1001108495
41	1706941	1706941	1706941	1706941	1706941	1706941	--	1706941
42	--	--	--	--	--	--	--	--
43	--	--	--	--	--	--	--	--
44	--	--	--	--	--	--	--	--
45	--	--	--	--	--	--	--	--
46	--	--	--	--	--	--	--	--
47	--	--	--	--	--	--	--	--
48	--	--	--	--	--	--	--	--
49	--	--	--	--	--	--	--	--
50	--	--	--	--	--	--	--	--

## SECTION 4 - MACHINE OPERATION

---

Table 4-2. Decal Legend - 800A - Prior to S/N 0300141330

Item #	ANSI 0274460-9	Korean 0274464-7	Chinese 0274470-7	Spanish 0274466-7	Portuguese 0274468-8	French 0274472-7	CE/Aus 0274474-3	Japanese 0274462-7
51	--	--	--	--	--	--	--	--
52	--	--	--	--	--	--	--	--
53	--	--	--	--	--	--	--	--
54	--	--	--	--	--	--	--	--
55	--	--	--	--	--	--	--	--
56	1705351	1705427	1705430	1705910	1705905	1705429	--	1705426

**Table 4-3. Decal Legend - 800A - S/N 0300141330 to S/N 0300183033**

<b>Item #</b>	<b>ANSI 0274460-10</b>	<b>Korean 0274464-8</b>	<b>Chinese 0274470-8</b>	<b>Spanish 0274466-8</b>	<b>Portuguese 0274468-9</b>	<b>French 0274472-8</b>	<b>CE/Aus 0274474-3</b>	<b>Japanese 0274462-8</b>
1	--	--	--	--	--	--	--	--
2	1701499	1701499	1701499	1701499	1701499	1701499	1701499	1701499
3	--	--	--	--	--	--	--	--
4	--	--	--	--	--	--	--	--
5	1701509	1701509	1701509	1701509	1701509	1701509	1701509	1701509
6	--	--	--	--	1701529	--	--	--
7	1703811	1703811	1703811	1703811	1703811	1703811	1703811	1703811
8	1703814	1703814	1703814	1703814	1703814	1703814	1703814	1703814
9	1704277	1704277	1704277	1704277	1704277	1704277	1704277	1704277
10	1704412	1704412	1704412	1704412	1704412	1704412	1704412	1704412
11	--	--	--	--	--	--	1705084	--
12	--	--	--	--	--	1705514	--	--
13	--	--	--	--	--	--	--	--
14	--	--	--	--	--	--	--	--
15	1705337	1705339	1705342	--	--	--	--	--
16	--	--	--	--	--	--	--	--

## SECTION 4 - MACHINE OPERATION

Table 4-3. Decal Legend - 800A - S/N 0300141330 to S/N 0300183033

Item #	ANSI 0274460-10	Korean 0274464-8	Chinese 0274470-8	Spanish 0274466-8	Portuguese 0274468-9	French 0274472-8	CE/Aus 0274474-3	Japanese 0274462-8
17	--	--	--	1704007	1705901	1704006	--	--
18	1703953	1703945	1703943	1703941	1705903	1703942	--	1703944
19	--	--	--	--	--	--	--	--
20	1702868	1705969	1705968	1704001	1705967	1704000	--	--
21	1703797	1703927	1703925	1703923	1705895	1703924	1705921	1703926
22	1705336	1705345	1705348	1705917	1705896	1705347	1705822	1705344
23	1703804	1703951	1703949	1703947	1705898	1703948	1701518	1703950
24	1703805	1703939	1703937	1703935	1705897	1703936	1705961	1703938
25	3252347	1703981	1703982	1703983	1705902	1703984	1705828	1703980
26	3251813	--	3251813	3251813	3251813	3251813	--	3251813
27	--	--	--	--	--	--	--	--
28	--	--	--	--	--	--	--	--
29	1703960	1703960	1703960	1703960	1703960	1703960	1703960	1703960
30	1702631	1702631	1702631	1702631	1702631	1702631	1702631	1702631
31	1703772	1703772	1703772	1703772	1703772	1703772	1703772	1703772
32	1701501	1701501	1701501	1701501	1701501	1701501	1701501	1701501
33	1001121800	1001122200	1001121809	1001121804	1001121806	1001121802	1705978	1001121807

**Table 4-3. Decal Legend - 800A - S/N 0300141330 to S/N 0300183033**

<b>Item #</b>	<b>ANSI 0274460-10</b>	<b>Korean 0274464-8</b>	<b>Chinese 0274470-8</b>	<b>Spanish 0274466-8</b>	<b>Portuguese 0274468-9</b>	<b>French 0274472-8</b>	<b>CE/Aus 0274474-3</b>	<b>Japanese 0274462-8</b>
34	1001121813	1001122201	1001121822	1001121817	1001121819	1001121815	1705978	1001121820
35	--	1704885	1704885	1704885	1704885	1704885	1704885	1704885
36	1706948	1706948	1706948	1706948	1706948	1706948	--	1706948
37	1702265	1703987	1703988	1703989	1706439	1703990	1705977	1703986
38	1703959	1703959	1703959	1703959	1703959	1703959	1703959	1703959
39	1700584	1700584	1700584	1700584	1700584	1700584	1700584	1700584
40	1001108495	1001108495	1001108495	1001108495	1001108495	1001108495	--	1001108495
41	1706941	1706941	1706941	1706941	1706941	1706941	--	1706941
42	--	--	--	--	--	--	--	--
43	--	--	--	--	--	--	--	--
44	--	--	--	--	--	--	--	--
45	--	--	--	--	--	--	--	--
46	--	--	--	--	--	--	--	--
47	--	--	--	--	--	--	--	--
48	--	--	--	--	--	--	--	--
49	--	--	--	--	--	--	--	--
50	--	--	--	--	--	--	--	--

## SECTION 4 - MACHINE OPERATION

---

Table 4-3. Decal Legend - 800A - S/N 0300141330 to S/N 0300183033

Item #	ANSI 0274460-10	Korean 0274464-8	Chinese 0274470-8	Spanish 0274466-8	Portuguese 0274468-9	French 0274472-8	CE/Aus 0274474-3	Japanese 0274462-8
51	--	--	--	--	--	--	--	--
52	--	--	--	--	--	--	--	--
53	--	--	--	--	--	--	--	--
54	--	--	--	--	--	--	--	--
55	--	--	--	--	--	--	--	--
56	1705351	1705427	1705430	1705910	1705905	1705429	--	1705426



Table 4-4. Decal Legend - 800AJ - Prior to S/N 0300141330

Item #	ANSI 0274461-9	Korean 0274464-7	Chinese 0274471-7	Spanish 0274467-7	Portuguese 0274469-9	French 0274473-7	CE/Aus 0274475-3	Japanese 0274462-7
1	--	--	--	--	--	--	--	--
2	1701499	1701499	1701499	1701499	1701499	1701499	1701499	1701499
3	--	--	--	--	--	--	--	--
4	--	--	--	--	--	--	--	--
5	1701509	1701509	1701509	1701509	1701509	1701509	1701509	1701509
6	--	--	--	--	--	--	--	--
7	1703811	1703811	1703811	1703811	1703811	1703811	1703811	1703811
8	1703814	1703814	1703814	1703814	1703814	1703814	1703814	1703814
9	1704277	1704277	1704277	1704277	1704277	1704277	1704277	1704277
10	1704412	1704412	1704412	1704412	1704412	1704412	1704412	1704412
11	--	--	--	--	--	--	1705084	--
12	--	--	--	--	--	1705514	--	--
13	--	--	--	--	--	--	--	--
14	--	--	--	--	--	--	--	--
15	1705337	1705339	1705342	--	--	--	--	--
16	--	--	--	--	--	--	--	--
17	1702153	--	--	1704007	1705901	1704006	--	--

## SECTION 4 - MACHINE OPERATION

**Table 4-4. Decal Legend - 800AJ - Prior to S/N 0300141330**

Item #	ANSI 0274461-9	Korean 0274464-7	Chinese 0274471-7	Spanish 0274467-7	Portuguese 0274469-9	French 0274473-7	CE/Aus 0274475-3	Japanese 0274462-7
18	1703953	1703945	1703943	1703941	1705903	1703942	--	1703944
19	--	--	--	--	--	--	--	--
20	1702868	1705969	1705968	1704001	1705967	1704000	--	--
21	1703797	1703927	1703925	1703923	1705895	1703924	1705921	1703926
22	1705336	1705345	1705348	1705917	1705896	1705347	1705822	1705344
23	1703804	1703951	1703949	1703947	1705898	1703948	1701518	1703950
24	1703805	1703939	1703937	1703935	1705897	1703936	1705961	1703938
25	3252347	1703981	1703982	1703983	1705902	1703984	1705828	1703980
26	3241813	--	3251813	3251813	3251813	3251813	--	3251813
27	--	--	--	--	--	--	--	--
28	--	--	--	--	--	--	--	--
29	1703960	1703960	1703960	1703960	1703960	1703960	1703960	1703960
30	1702631	1702631	1702631	1702631	1702631	1702631	1702631	1702631
31	1703773	1703773	1703773	1703773	1703773	1703773	1703773	1703773
32	1701501	1701501	1701501	1701501	1701501	1701501	1701501	1701501
33	1701645	1707058	1707060	1707056	1703996	1707055	1705978	1707059
34	1707013	1707042	1707044	1707049	1704112	1707047	1705978	1707054
35	1704885	1704885	1704885	1704885	1704885	1704885	1704885	1704885

Table 4-4. Decal Legend - 800AJ - Prior to S/N 0300141330

Item #	ANSI 0274461-9	Korean 0274464-7	Chinese 0274471-7	Spanish 0274467-7	Portuguese 0274469-9	French 0274473-7	CE/Aus 0274475-3	Japanese 0274462-7
36	1706948	1706948	1706948	1706948	1706948	1706948	--	1706948
37	1702265	1703987	1703990	1703989	1706439	1703990	1705977	1703986
38	1703959	1703959	1703959	1703959	1703959	1703959	1703959	1703959
39	1700584	1700584	1700584	1700584	1700584	1700584	1700584	1700584
40	1001108495	1001108495	1001108495	1001108495	1001108495	1001108495	--	1001108495
41	1706941	1706941	1706941	1706941	1706941	1706941	--	1706941
42	--	--	--	--	--	--	--	--
43	--	--	--	--	--	--	--	--
44	--	--	--	--	--	--	--	--
45	--	--	--	--	--	--	--	--
46	--	--	--	--	--	--	--	--
47	--	--	--	--	--	--	--	--
48	--	--	--	--	--	--	--	--
49	--	--	--	--	--	--	--	--
50	--	--	--	--	--	--	--	--
51	--	--	--	--	--	--	--	--
52	--	--	--	--	--	--	--	--
53	--	--	--	--	--	--	--	--

## SECTION 4 - MACHINE OPERATION

---

**Table 4-4. Decal Legend - 800AJ - Prior to S/N 0300141330**

<b>Item #</b>	<b>ANSI 0274461-9</b>	<b>Korean 0274464-7</b>	<b>Chinese 0274471-7</b>	<b>Spanish 0274467-7</b>	<b>Portuguese 0274469-9</b>	<b>French 0274473-7</b>	<b>CE/Aus 0274475-3</b>	<b>Japanese 0274462-7</b>
54	--	--	--	--	--	--	--	--
55	--	--	--	--	--	--	--	--
56	1705351	1705427	1705430	1705910	1705905	1705429	--	1705426

Table 4-5. Decal Legend - 800AJ - S/N 0300141330 to S/N 0300183033

Item #	ANSI 0274461-10	Korean 0274465-8	Chinese 0274471-8	Spanish 0274467-8	Portuguese 0274469-10	French 0274473-8	CE/Aus 0274475-3	Japanese 0274463-8
1	--	--	--	--	--	--	--	--
2	1701499	1701499	1701499	1701499	1701499	1701499	1701499	1701499
3	--	--	--	--	--	--	--	--
4	--	--	--	--	--	--	--	--
5	1701509	1701509	1701509	1701509	1701509	1701509	1701509	1701509
6	--	--	--	--	--	--	--	--
7	1703811	1703811	1703811	1703811	1703811	1703811	1703811	1703811
8	1703814	1703814	1703814	1703814	1703814	1703814	1703814	1703814
9	1704277	1704277	1704277	1704277	1704277	1704277	1704277	1704277
10	1704412	1704412	1704412	1704412	1704412	1704412	1704412	1704412
11	--	--	--	--	--	--	1705084	--
12	--	--	--	--	--	1705514	--	--
13	--	--	--	--	--	--	--	--
14	--	--	--	--	--	--	--	--
15	1705337	1705339	1705342	--	--	--	--	--
16	--	--	--	--	--	--	--	--
17	1702153	--	--	1704007	1705901	1704006	--	--

## SECTION 4 - MACHINE OPERATION

**Table 4-5. Decal Legend - 800AJ - S/N 0300141330 to S/N 0300183033**

Item #	ANSI 0274461-10	Korean 0274465-8	Chinese 0274471-8	Spanish 0274467-8	Portuguese 0274469-10	French 0274473-8	CE/Aus 0274475-3	Japanese 0274463-8
18	1703953	1703945	1703943	1703941	1705903	1703942	--	1703944
19	--	--	--	--	--	--	--	--
20	1702868	1705969	1705968	1704001	1705967	1704000	--	--
21	1703797	1703927	1703925	1703923	1705895	1703924	1705921	1703926
22	1705336	1705345	1705348	1705917	1705896	1705347	1705822	1705344
23	1703804	1703951	1703949	1703947	1705898	1703948	1701518	1703950
24	1703805	1703939	1703937	1703935	1705897	1703936	1705961	1703938
25	3252347	1703981	1703982	1703983	1705902	1703984	1705828	1703980
26	3241813	--	3251813	3251813	3251813	3251813	--	3251813
27	--	--	--	--	--	--	--	--
28	--	--	--	--	--	--	--	--
29	1703960	1703960	1703960	1703960	1703960	1703960	1703960	1703960
30	1702631	1702631	1702631	1702631	1702631	1702631	1702631	1702631
31	1703773	1703773	1703773	1703773	1703773	1703773	1703773	1703773
32	1701501	1701501	1701501	1701501	1701501	1701501	1701501	1701501
33	1001121801	1001121918	1001121919	1001121805	1001121656	1001121803	1705978	1001121808
34	1001121814	1001121921	1001121922	1001121818	1001121655	1001121816	1705978	1001121821
35	1704885	1704885	1704885	1704885	1704885	1704885	1704885	1704885

Table 4-5. Decal Legend - 800AJ - S/N 0300141330 to S/N 0300183033

Item #	ANSI 0274461-10	Korean 0274465-8	Chinese 0274471-8	Spanish 0274467-8	Portuguese 0274469-10	French 0274473-8	CE/Aus 0274475-3	Japanese 0274463-8
36	1706948	1706948	1706948	1706948	1706948	1706948	--	1706948
37	1702265	1703987	1703990	1703989	1706439	1703990	1705977	1703986
38	1703959	1703959	1703959	1703959	1703959	1703959	1703959	1703959
39	1700584	1700584	1700584	1700584	1700584	1700584	1700584	1700584
40	1001108495	1001108495	1001108495	1001108495	1001108495	1001108495	--	1001108495
41	1706941	1706941	1706941	1706941	1706941	1706941	--	1706941
42	--	--	--	--	--	--	--	--
43	--	--	--	--	--	--	--	--
44	--	--	--	--	--	--	--	--
45	--	--	--	--	--	--	--	--
46	--	--	--	--	--	--	--	--
47	--	--	--	--	--	--	--	--
48	--	--	--	--	--	--	--	--
49	--	--	--	--	--	--	--	--
50	--	--	--	--	--	--	--	--
51	--	--	--	--	--	--	--	--
52	--	--	--	--	--	--	--	--
53	--	--	--	--	--	--	--	--

## SECTION 4 - MACHINE OPERATION

---

**Table 4-5. Decal Legend - 800AJ - S/N 0300141330 to S/N 0300183033**

Item #	ANSI 0274461-10	Korean 0274465-8	Chinese 0274471-8	Spanish 0274467-8	Portuguese 0274469-10	French 0274473-8	CE/Aus 0274475-3	Japanese 0274463-8
54	--	--	--	--	--	--	--	--
55	--	--	--	--	--	--	--	--
56	1705351	1705427	1705430	1705910	1705905	1705429	--	1705426





NOTES:

Lined area for taking notes, consisting of two columns of horizontal lines.

**TO PURCHASE THIS PRODUCT PLEASE CONTACT US**



**Equipment Financing and  
Extended Warranties Available**



**Discount-Equipment.com is your online resource for  
commercial and industrial quality parts and equipment sales.**

**561-964-4949**

**visit us on line @ [www.discount-equipment.com](http://www.discount-equipment.com)**

Select an option below to find your Equipment

**Search by Manufacturer**

**Search by Product Type**

**Request a Quote**

We sell worldwide for the brands: Genie, Terex, JLG, MultiQuip, Mikasa, Essick, Whiteman, Mayco, Toro Stone, Diamond Products, Generac Magnum, Airman, Haulotte, Barreto, Power Blanket, Nifty Lift, Atlas Copco, Chicago Pneumatic, Allmand, Miller Curber, Skyjack, Lull, Skytrak, Tsurumi, Husquvarna Target, Stow, Wacker, Sakai, Mi-T-M, Sullair, Basic, Dynapac, MBW, Weber, Bartell, Bennar Newman, Haulotte, Ditch Runner, Menegotti, Morrison, Contec, Buddy, Crown, Edco, Wyco, Bomag, Laymor, EZ Trench, Bil-Jax, F.S. Curtis, Gehl Pavers, Heli, Honda, ICS/PowerGrit, IHI, Partner, Imer, Clipper, MMD, Koshin, Rice, CH&E, General Equipment, Amida, Coleman, NAC, Gradall, Square Shooter, Kent, Stanley, Tamco, Toku, Hatz, Kohler, Robin, Wisconsin, Northrock, Oztec, Toker TK, Rol-Air, APT, Wylie, Ingersoll Rand / Doosan, Innovatech, Con X, Ammann, Mecalac, Makinex, Smith Surface Prep, Small Line, Wanco, Yanmar

## SECTION 5. EMERGENCY PROCEDURES

### 5.1 GENERAL

This section explains the steps to be taken in case of an emergency situation while operating.

### 5.2 INCIDENT NOTIFICATION

JLG Industries, Inc. must be notified immediately of any incident involving a JLG product. Even if no injury or property damage is evident, the factory should be contacted by telephone and provided with all necessary details.

In USA:

JLG Phone: 877-JLG-SAFE (554-7233)  
(8am till 4:45pm EST)

Outside USA:

240-420-2661

E-mail:

ProductSafety@JLG.com

Failure to notify the manufacturer of an incident involving a JLG Industries product within 48 hours of such an occurrence may void any warranty consideration on that particular machine.

### **NOTICE**

**FOLLOWING ANY ACCIDENT, THOROUGHLY INSPECT THE MACHINE AND TEST ALL FUNCTIONS FIRST FROM THE GROUND CONTROLS, THEN FROM THE PLATFORM CONTROLS. DO NOT LIFT ABOVE 10 FT. (3 M) UNTIL YOU ARE SURE THAT ALL DAMAGE HAS BEEN REPAIRED, IF REQUIRED, AND THAT ALL CONTROLS ARE OPERATING CORRECTLY.**

### 5.3 EMERGENCY TOWING PROCEDURES

Towing this machine is prohibited, However, provisions for moving the machine, in case of a malfunction or power failure, have been incorporated. The following procedures are to be used ONLY for emergency movement to a suitable maintenance area.

1. Chock wheels securely.
2. Disengage drive hubs by reversing disconnect caps.
3. Connect suitable equipment, remove chocks, and move machine.

## SECTION 5 - EMERGENCY PROCEDURES

---

After moving machine, complete the following procedures:

1. Position machine on a firm and level surface.
2. Chock wheels securely.
3. Engage drive hubs by reversing disconnect caps on hubs.
4. Remove chocks from wheels as needed.

### 5.4 EMERGENCY CONTROLS AND THEIR LOCATIONS

#### Power/Emergency Stop Switches

1. There are red mushroom shaped switches located at the Ground Control box and the platform Control panel. The red switch is pulled up for normal machine operation. In an emergency, push the button down with the palm and the machine will immediately stop.



**CHECK MACHINE DAILY TO MAKE SURE EMERGENCY STOP SWITCH IS OPERATIONAL AND THAT GROUND CONTROL INSTRUCTIONS ARE IN PLACE AND LEGIBLE.**

#### Ground Control Station

The Ground Control Station is located on the right front side of the turntable. The controls on this panel provide the means for overriding the platform controls, and for controlling the platform level, boom and swing functions from the ground. Place the KEY SELECT switch to GROUND position and operate the proper switch to lift, swing, or telescope the boom, or level the platform.

#### Auxiliary Power

A toggle type auxiliary power control switch is located on the platform control station and another is located on the ground control station. Operation of either switch turns on the electrically driven auxiliary hydraulic pump. This should be used in case of failure of the main power plant. The auxiliary pump will operate all functions from the platform control station.

##### To activate auxiliary power:

1. Position PLATFORM/GROUND SELECT KEY SWITCH to PLATFORM.
2. Position POWER/EMERGENCY STOP switch to ON.
3. Depress and hold footswitch.

**NOTE:** On machines S/N 0300065534 to S/N 0300183033, perform step 5 prior to step 4.

4. Operate appropriate control switch, lever or controller for desired function and hold.
5. Position AUXILIARY POWER switch to ON and hold.
6. Release AUXILIARY POWER switch, selected control switch, lever or controller, and footswitch.
7. Position POWER/EMERGENCY STOP switch to OFF.

**To activate auxiliary power from the ground control station:**

1. Position PLATFORM/GROUND SELECT KEY SWITCH to GROUND.
2. Position POWER/EMERGENCY STOP switch to ON.
3. Operate appropriate control switch or controller for desired function and hold.
4. Position AUXILIARY POWER switch to ON and hold.
5. Release AUXILIARY POWER switch followed by the selected control switch or controller.
6. Position POWER/EMERGENCY STOP switch to OFF.

## **5.5 EMERGENCY OPERATION**

### **Use of Ground Controls**

#### **KNOW HOW TO USE THE GROUND CONTROLS IN AN EMERGENCY SITUATION.**

Ground personnel must be thoroughly familiar with the machine operating characteristics and the ground control functions. Training should include operation of the machine, review and understanding of this section and hands-on operation of the controls in simulated emergencies.

### Operator Unable to Control Machine

**IF THE PLATFORM OPERATOR IS PINNED, TRAPPED OR UNABLE TO OPERATE OR CONTROL THE MACHINE:**

** WARNING**

**DO NOT OPERATE WITH PRIMARY POWER SOURCE (ENGINE OR ELECTRIC MOTOR) IF PERSONS ARE PINNED OR TRAPPED. USE AUXILIARY POWER INSTEAD.**

1. Operate the machine from ground controls ONLY with the assistance of other personnel and equipment (cranes, overhead hoists, etc.) as may be required to safely remove the danger or emergency condition.
2. Other qualified personnel on the platform may use the platform controls with regular or auxiliary power. DO NOT CONTINUE OPERATION IF CONTROLS DO NOT FUNCTION NORMALLY.
3. Cranes, forklift trucks or other equipment which may be available are to be used to remove platform occupants and stabilize motion of the machine in case machine controls are inadequate or malfunction when used.

### Platform or Boom Caught Overhead

If the platform or boom becomes jammed or snagged in overhead structures or equipment, do not continue operation of the machine from either the platform or the ground until the operator and all personnel are safely moved to a secure location. Only then should an attempt be made to free the platform using any necessary equipment and personnel. Do not operate controls to cause one or more wheels to leave the ground.

## SECTION 6. GENERAL SPECIFICATIONS & OPERATOR MAINTENANCE

### 6.1 INTRODUCTION

This section of the manual provides additional necessary information to the operator for proper operation and maintenance of this machine.

The maintenance portion of this section is intended as information to assist the machine operator to perform daily maintenance tasks only, and does not replace the more thorough Preventive Maintenance and Inspection Schedule included in the Service and Maintenance Manual.

#### Other Publications Available:

Service and Maintenance Manual - ANSI, CSA Spec Prior to S/N 0300183033 .....	3120740
Service and Maintenance Manual - CE Spec Prior to S/N 0300183033 .....	3120858
Illustrated Parts Manual - ANSI, CSA Spec Prior to S/N 0300069000 .....	3120741
Illustrated Parts Manual - CE Spec Prior to S/N 0300069000 .....	3120859
Illustrated Parts Manual - ANSI, CSA Spec S/N 0300069000 to 0300140000.....	3121176

Illustrated Parts Manual - CE Spec S/N 0300069000 to 0300140000.....	3121854
Illustrated Parts Manual - Global S/N 0300140000 to 0300183033.....	3121276

**6.2 OPERATING SPECIFICATIONS**

**Table 6-1. Operating Specifications**

Travel Speed	
2WD	3.0 MPH (4.83 Km/hr.)
4WD	3.0 MPH (4.83 Km/hr.)
Gradeability	
2WD	30%
4WD	45%
Turning Radius (Outside)	
2WS	22 ft.-6 in. (6.86 m)
4WS	14 ft.-6 in. (4.42 m)
Turning Radius (Inside)	
2WS	12 ft.-0 in. (3.66 m)
4WS	11 ft.-0 in. (2.13 m)
Overall Width	8 ft.-0 in. (2.44 m)
Machine Height Stowed	9 ft. 9.5 in. (2.98 m)
Machine Length (Stowed)	
800A	36 ft.-9 in. (11.25 m)
800AJ	36 ft.-6 in. (11.13 m)
Wheel base	10 ft.-0 in. (3.05 m)
Boom Elevation - 800A	
Above Grade	+80 ft.(24.38 m)
Below Grade	-15 ft.-7 in. (4.75 m)

**Table 6-1. Operating Specifications**

Boom Elevation - 800AJ	
Above Grade	+80 ft.(24.38 m)
Below Grade	-13 ft.-1 in. (3.99 m)
Max. Ground Bearing Pressure	84 psi. (5.9 kg/cm <sup>2</sup> )
Max. Tire Load	17,755 lbs. (8054 kg)
Drive Speed (2WD)	
Forward	42 - 48 Seconds for 200 Ft
Reverse	42 - 48 Seconds for 200 Ft
Drive Speed (4WD)	
Forward	42 - 48 Seconds for 200 Ft
Reverse	42 - 48 Seconds for 200 Ft
Machine Weight approximately	
IN 385/65D 19.5 Pneumatic	34,200 lbs.(15,520 kg)
15X 19.5 Pneumatic	34,200 lbs.(15,520 kg)
IN 445/55D 19.5	34,270 lbs. (15,550 kg)
18X 19.5 Pneumatic Tires	34,270 lbs. (15,550 kg)
IN 385/65D 19.5	33,100 lbs. (15,020 kg)
15X 19.5 Foam Filled Tires	33,100 lbs. (15,020 kg)
IN 445/55D 19.5	33,550 lbs. (15,220 kg)
18X 19.5 Foam Filled Tires	33,550 lbs. (15,220 kg)



**Tires**

**Table 6-2. Tire Specifications**

Size	Type	Ply Rating	Load Range	Pressure
IN385/65D19.5	pneumatic	16	H	95PSI (6.5 Bar)
IN445/55D19.5	pneumatic	16	H	85PSI (6.0 Bar)
15X19.5	pneumatic	16	H	95PSI (6.5 Bar)
18X19.5	pneumatic	16	H	85PSI (6.0 Bar)
IN385/65D19.5	foam-filled	16	H	N/A
IN445/55D19.5	foam-filled	16	H	N/A
15X19.5	foam-filled	16	H	N/A
18X19.5	foam-filled	16	H	N/A

**Capacities**

**Table 6-3. Capacities**

Fuel Tank	Approx. 40 gallons (151.4 liters)
Hydraulic Tank	Approx. 40 gallons (151.4 liters)
Hydraulic System (Including Tank)	77 Gal. (291.4 L)
Drive Hub (Prior to S/N 0300083332)	17 ounces (0.5 L)
Drive Hub (S/N 0300083332 to 0300183033)	44 ounces (1.3 L)
Drive Brake (S/N 0300083332 to 0300183033)	2.7 ounces (80 ml)
Engine Oil Capacity	
Ford	4.5 Quarts (4.25 L) w/Filter
Deutz	
Cooling System	5 Quarts (4.5 L)
Crankcase	11 Quarts (10.5 L) w/Filter
Total Capacity	16 Quarts (15 L)
Caterpillar	10.6 quarts (10 L)
Isuzu	8.5 Quarts (8.0 L)
GM	4.5 Quarts (4.25 L) w/Filter

## SECTION 6 - GENERAL SPECIFICATIONS & OPERATOR MAINTENANCE

### Engine Data

**Table 6-4. Ford LRG-425 Specifications**

Type	Water-cooled
Fuel	Gasoline
Oil Capacity	4.5 Quarts (4.25 L) w/Filter
Idle RPM	1000
Low RPM	1800
High RPM	2800
Alternator	95 Amp, Belt Drive
Fuel Consumption	
Low RPM	3.45 GPH (13.06 lph)
High RPM	4.60 GPH (17.41 lph)
Battery	1000 Cold Cranking Amps, 210 minute reserve Capacity, 12 VDC
Horsepower	74 @ 3000 RPM, full load
Cooling System	16 Quarts (15.14 L)
Spark Plug	AWSF-52-C
Spark Plug Gap	0.044 in. (1.117 mm)

**Table 6-5. Deutz F4M2011F Specifications**

Type	Liquid Cooled (Oil)
Fuel	Diesel
Oil Capacity	
Cooling System	5 Quarts (4.5 L)
Crankcase	11 Quarts (10.5 L) w/Filter
Total Capacity	16 Quarts (15 L)
Idle RPM	1000
Low RPM	1800
High RPM	2800
Alternator	55 Amp, belt drive
Fuel Consumption	
Low RPM	1.90 GPH (7.19 lph)
High RPM	2.50 GPH (9.46 lph)
Battery	1000 Cold Cranking Amps, 210 minutes Reserve Capacity, 12 VDC
Horsepower	65 @ 3000 RPM, full load

## SECTION 6 - GENERAL SPECIFICATIONS & OPERATOR MAINTENANCE

**Table 6-6. Deutz D2011L04 Specifications**

Type	Liquid Cooled (Oil)
Fuel	Diesel
Oil Capacity	5 Quarts (4.5 L)
Cooling System	11 Quarts (10.5 L) w/Filter
Crankcase	16 Quarts (15 L)
Total Capacity	
Idle RPM	1000
Low RPM	1800
High RPM	2600
Alternator	55 Amp, belt drive
Fuel Consumption	
Low RPM	1.90 GPH (7.19 lph)
High RPM	2.50 GPH (9.46 lph)
Battery	1000 Cold Cranking Amps, 210 minutes Reserve Capacity, 12 VDC
Horsepower	64 @ 2600 RPM, full load

**Table 6-7. Caterpillar 3044C/3.4**

Type	Four Stroke Cycle
Cylinders	4 in-line
Bore	3.70 inch (94 mm)
Stroke	4.72 inch (120 mm)
Aspiration	turbocharged
Compression ratio	19:1
Displacement	203 in <sup>3</sup> (3.33 L)
Firing Order	1-3-4-2
Rotation (viewed from flywheel)	Counterclockwise
Oil Capacity (w/filter)	10.6 quarts (10 L)
Cooling System (Engine Only)	5.8 quarts (5.5 L)
Idle RPM - 3044C	1000
Idle RPM - 3.4	1200
Low RPM	1800
High RPM	2600
Alternator	60 Amp, belt drive

## SECTION 6 - GENERAL SPECIFICATIONS & OPERATOR MAINTENANCE

**Table 6-8. Isuzu 4JB1**

Type	Water-cooled
Oil Capacity (w/filter)	8.5 Quarts (8.0L)
Cooling System (Engine Only)	5.8 quarts (5.5 L)
Idle RPM	1000
Low RPM	1800
High RPM	2800
Alternator	55 Amp, belt drive
Battery	1000 Cold Cranking Amps, 210 minutes Reserve Capacity, 12 VDC
Horsepower	66 @ 2800 RPM, full load

**Table 6-9. GM 3.0L**

Fuel	Gasoline or Gasoline/LP Gas
No. of Cylinders	4
BHP	
Gasoline	83 hp @ 3000 rpm
LP	75 hp @ 3000 rpm
Bore	4.0 in. (101.6 mm)
Stroke	3.6 in. (91.44 mm)
Displacement	181 cu.in. (3.0L, 2966 cc)
Oil Capacity w/filter	4.5 qts. (4.25L)
Minimum Oil Pressure	
at idle	6 psi (0.4 Bar) @ 1000 rpm
Hot	18 psi (1.2 Bar) @ 2000 rpm
Compression Ratio	9.2:1
Firing Order	1-3-4-2
Max. RPM	2800

**Hydraulic Oil**

**Table 6-10. Hydraulic Oil**

Hydraulic System Operating Temperature Range	S.A.E. Viscosity Grade
+0° to +180°F (-18° to +83°C)	10W
+0° to +210°F (-18° to +99°C)	10W-20, 10W30
+50° to +210°F (+10° to +99°C)	20W-20

**NOTE:** Hydraulic oils must have anti-wear qualities at least to API Service Classification GL-3, and sufficient chemical stability for mobile hydraulic system service. JLG Industries recommends Mobilfluid 424 hydraulic oil, which has an SAE viscosity index of 152.

**NOTE:** When temperatures remain consistently below 20 degrees F. (-7 degrees C.), JLG Industries recommends the use of Mobil DTE13.

Aside from JLG recommendations, it is not advisable to mix oils of different brands or types, as they may not contain the same required additives or be of comparable viscosities. If use of hydraulic oil other than Mobilfluid 424 is desired, contact JLG Industries for proper recommendations.

**Table 6-11. Mobilfluid 424 Specs**

SAE Grade	10W30
Gravity, API	29.0
Density, Lb/Gal. 60°F	7.35
Pour Point, Max	-46°F (-43°C)
Flash Point, Min.	442°F (228°C)
Viscosity	
Brookfield, cP at -18°C	2700
at 40°C	55 cSt
at 100°C	9.3 cSt
Viscosity Index	152

## SECTION 6 - GENERAL SPECIFICATIONS & OPERATOR MAINTENANCE

**Table 6-12. Mobil DTE 13M Specs**

ISO Viscosity Grade	#32
Specific Gravity	0.877
Pour Point, Max	-40°F (-40°C)
Flash Point, Min.	330°F (166°C)
<b>Viscosity</b>	
at 40°C	33cSt
at 100°C	6.6cSt
at 100°F	169SUS
at 210°F	48SUS
cp at -20°F	6,200
Viscosity Index	140

**Table 6-13. Mobil EAL 224H Specs**

Type	Synthetic Biodegradable
ISO Viscosity Grade	32/46
Specific Gravity	.922
Pour Point, Max	-25°F (-32°C)
Flash Point, Min.	428°F (220°C)
Operating Temp.	0 to 180°F (-17 to 162°C)
Weight	7.64 lb. per gal. (0.9 kg per liter)
<b>Viscosity</b>	
at 40°C	37cSt
at 100°C	8.4cSt
Viscosity Index	213
<b>NOTE:</b> Must be stored above 32°F (14°C)	

## SECTION 6 - GENERAL SPECIFICATIONS & OPERATOR MAINTENANCE

**Table 6-14. UCon Hydrolube HP-5046**

Type	Synthetic Biodegradable
Specific Gravity	1.082
Pour Point, Max	-58°F (-50°C)
pH	9.1
Viscosity	
at 0°C (32°F)	340 cSt (1600 SUS)
at 40°C (104°F)	46 cSt (215 SUS)
at 65°C (150°F)	22 cSt (106 SUS)
Viscosity Index	170

**Table 6-15. Exxon Univil HVI 26 Specs**

Specific Gravity	32.1
Pour Point	-76°F (-60°C)
Flash Point	217°F (103°C)
Viscosity	
at 40°C	25.8 cSt
at 100°C	9.3 cSt
Viscosity Index	376
<b>NOTE:</b>	<i>Mobil/Exxon recommends that this oil be checked on a yearly basis for viscosity.</i>

**Table 6-16. Quintolubric 888-46**

Density	0.91 @ 15°C (59°F)
Pour Point	<-20°C (<-4°F)
Flash Point	275°C (527°F)
Fire Point	325°C (617°F)
Autoignition Temperature	450°C (842°F)
Viscosity	
at 0°C (32°F)	360 cSt
at 20°C (68°F)	102 cSt
at 40°C (104°F)	46 cSt
at 100°C (212°F)	10 cSt
Viscosity Index	220

### Critical Stability Weights

#### **WARNING**

**DO NOT REPLACE ITEMS CRITICAL TO STABILITY WITH ITEMS OF DIFFERENT WEIGHT OR SPECIFICATION (FOR EXAMPLE: BATTERIES, FILLED TIRES, COUNTER WEIGHT, ENGINE, AND PLATFORM) DO NOT MODIFY UNIT IN ANY WAY TO EFFECT STABILITY.**



## SECTION 6 - GENERAL SPECIFICATIONS & OPERATOR MAINTENANCE

**Table 6-17. Critical Stability Weights - 800A**

COMPONENTS		LBS.	KG.
Tire & Wheel Size (Foam Filled Only)	365/65D19.5	565	255
	445/55D19.5	675	305
	15X19.5	565	255
	18X19.5	675	305
Engine	Ford	600	209
	Deutz	534	242
	Isuzu	463	210
	GM w/pumps	1030	468
Counterweight	Turntable	4805	2180
Wheel Hubs	Rear	218	99
	Front 2WD	210	99
	Front 4WD	218	99
Platform	6 FT. (1.83 M)	205	93
	8 FT. (2.44 M)	230	105

**Table 6-18. Critical Stability Weights - 800AJ**

COMPONENTS		LBS.	KG.
Tire & Wheel Size (Foam Filled Only)	365/65D19.5	565	255
	445/55D19.5	675	305
	15X19.5	565	255
	18X19.5	675	305
Engine	Ford	600	209
	Deutz	534	242
	Isuzu	463	210
	GM w/pumps	1030	468
Counterweight	Turntable	4805	2180
Wheel Hubs	Rear	218	99
	Front 2WD	110	99
	Front 4WD	218	99
Platform Size	6 FT. (1.83 M)	205	93
	8 FT. (2.44 M)	230	105

# SECTION 6 - GENERAL SPECIFICATIONS & OPERATOR MAINTENANCE

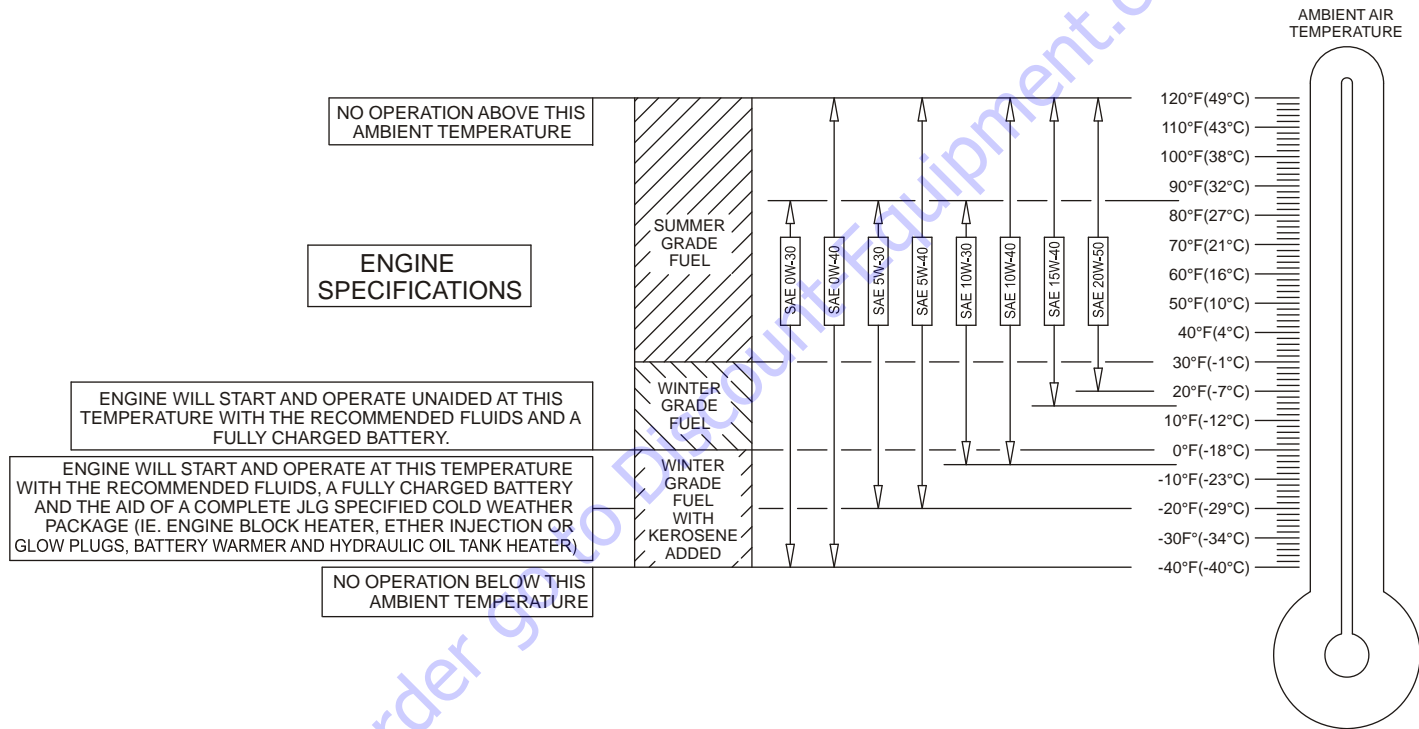

Figure 6-1. Engine Operating Temperature Specifications - Deutz - Sheet 1 of 2

# SECTION 6 - GENERAL SPECIFICATIONS & OPERATOR MAINTENANCE

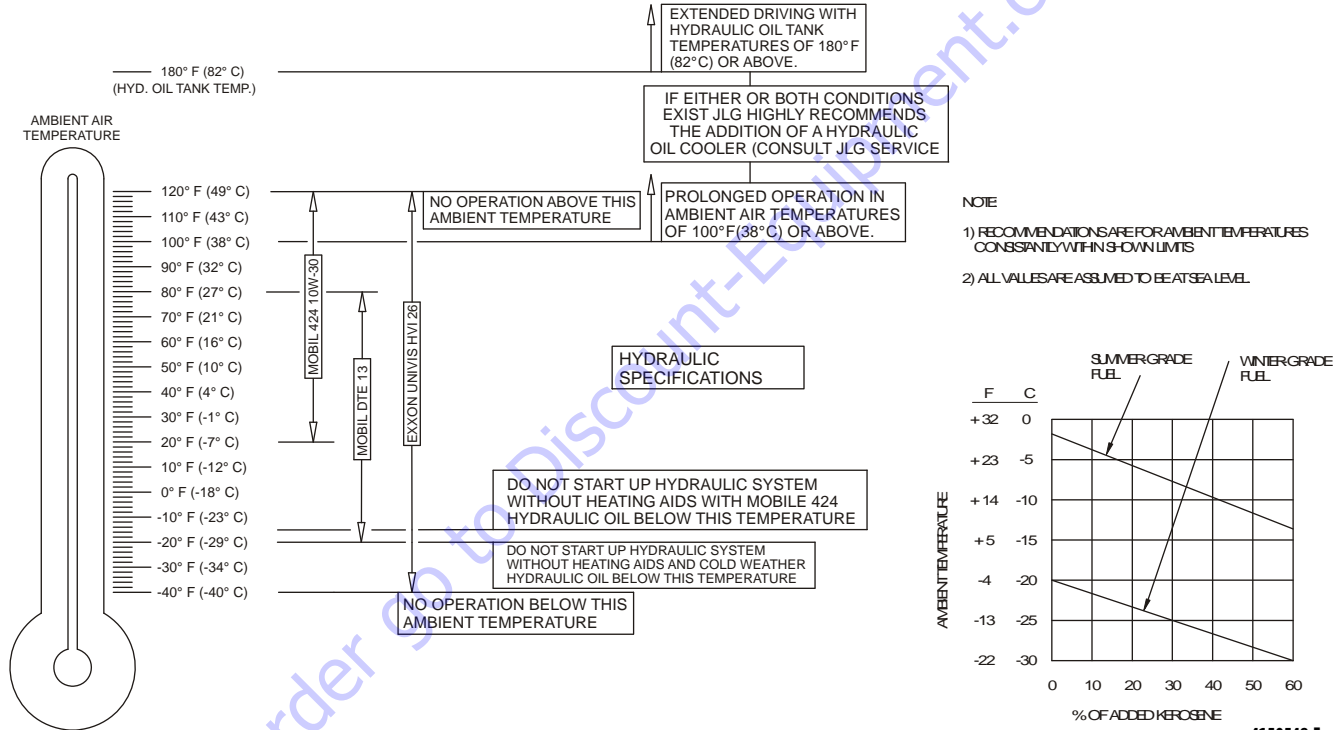

Figure 6-2. Engine Operating Temperature Specifications - Deutz - Sheet 2 of 2

## SECTION 6 - GENERAL SPECIFICATIONS & OPERATOR MAINTENANCE

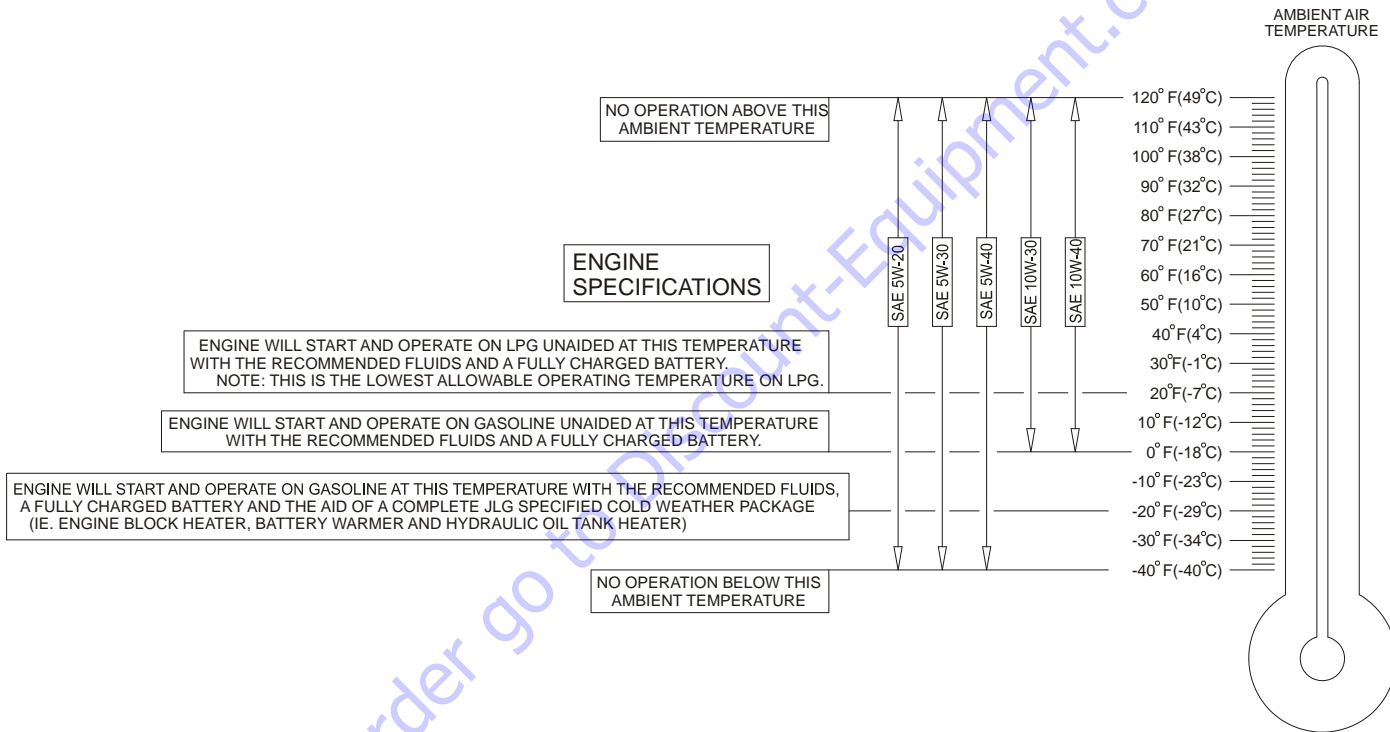
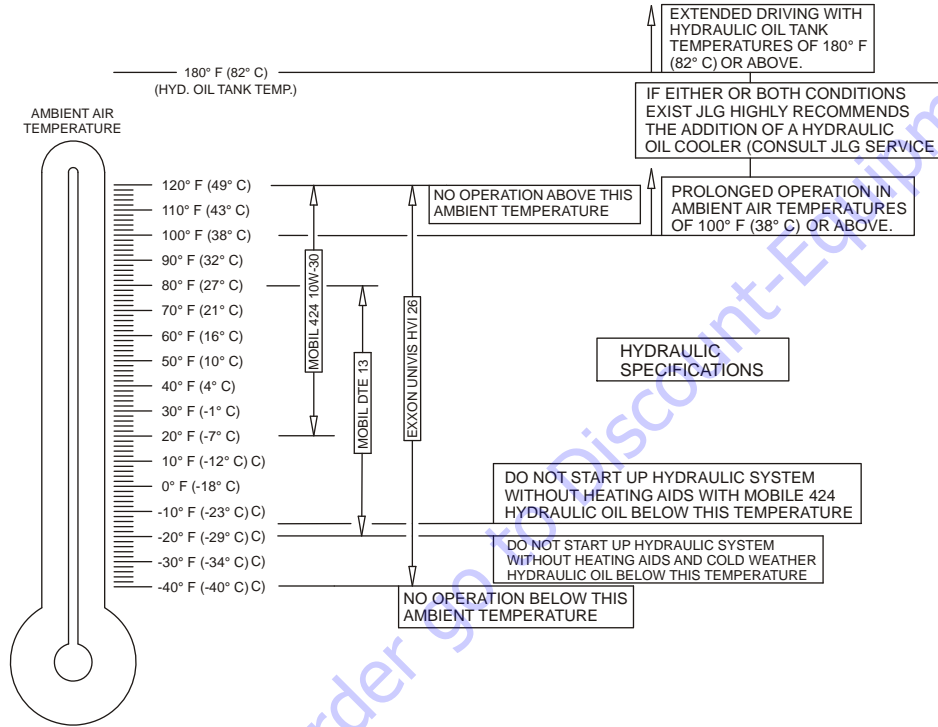

Figure 6-3. Engine Operating Temperature Specifications - Ford - Sheet 1 of 2

## SECTION 6 - GENERAL SPECIFICATIONS & OPERATOR MAINTENANCE



NOTE:

- 1) RECOMMENDATIONS ARE FOR AMBIENT TEMPERATURES CONSISTANTLY WITHIN SHOWN LIMITS
- 2) ALL VALUES ARE ASSUMED TO BE AT SEA LEVEL.

**Figure 6-4. Engine Operating Temperature Specifications - Ford - Sheet 2 of 2**

4150548-E

## SECTION 6 - GENERAL SPECIFICATIONS & OPERATOR MAINTENANCE

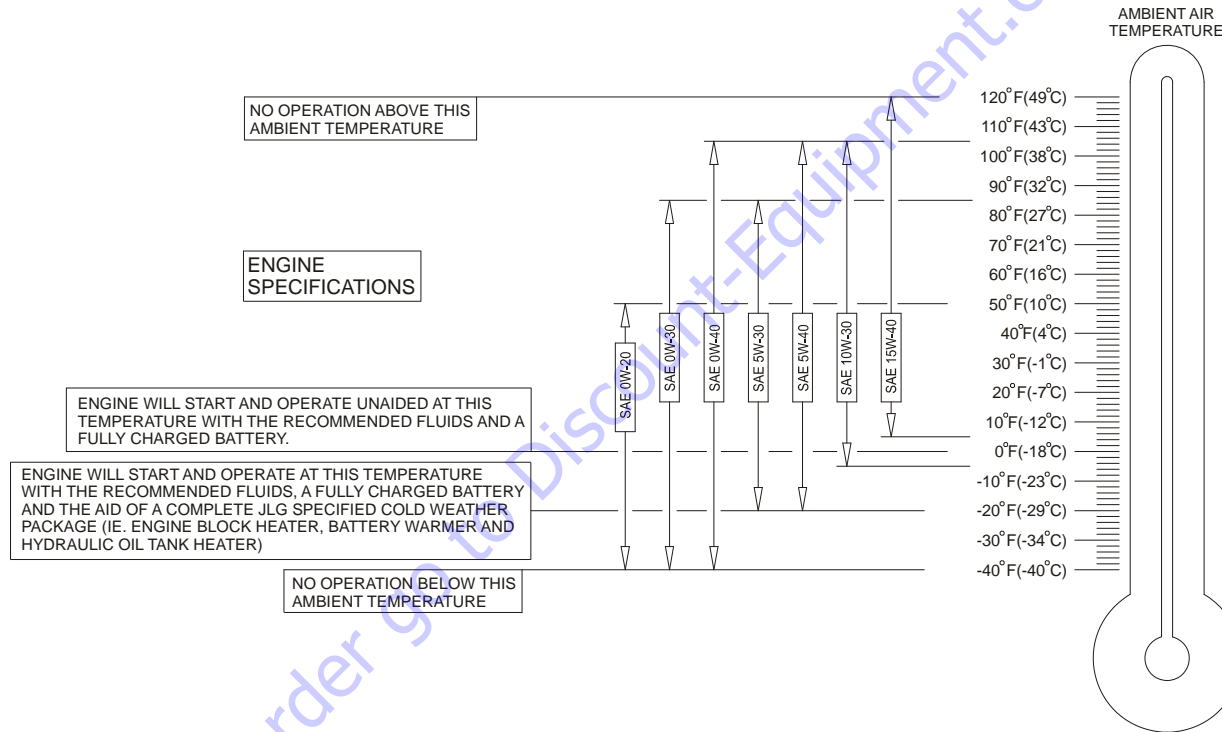

**Figure 6-5. Engine Operating Temperature Specifications - Caterpillar - Sheet 1 of 2**

# SECTION 6 - GENERAL SPECIFICATIONS & OPERATOR MAINTENANCE

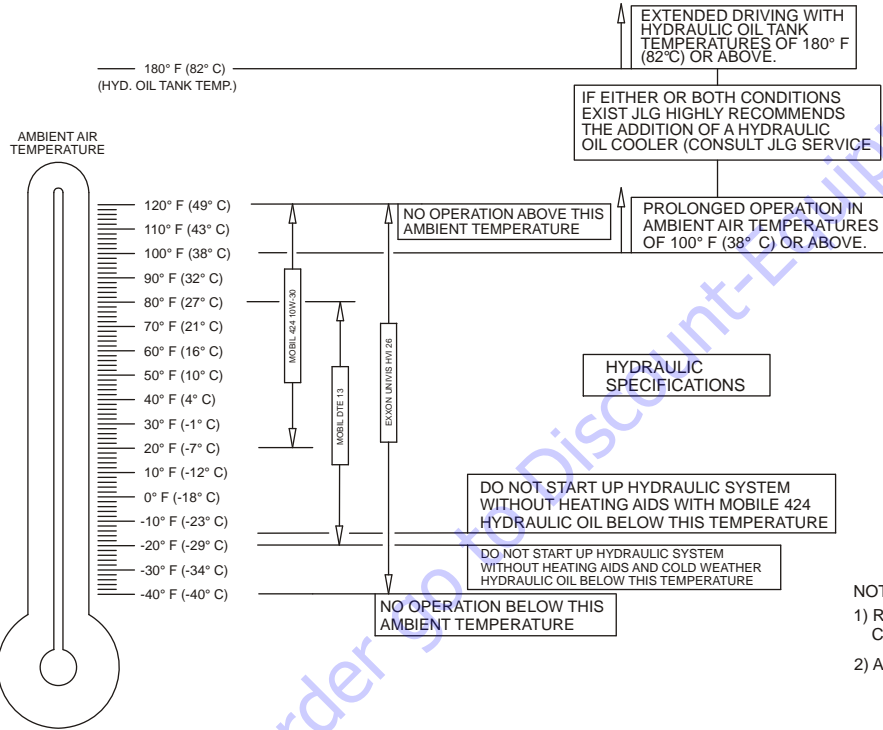

NOTE:

- 1) RECOMMENDATIONS ARE FOR AMBIENT TEMPERATURES CONSISTENTLY WITHIN SHOWN LIMITS
- 2) ALL VALUES ARE ASSUMED TO BE AT SEA LEVEL.

Figure 6-6. Engine Operating Temperature Specifications - Caterpillar - Sheet 2 of 2

4150548-E

## SECTION 6 - GENERAL SPECIFICATIONS & OPERATOR MAINTENANCE

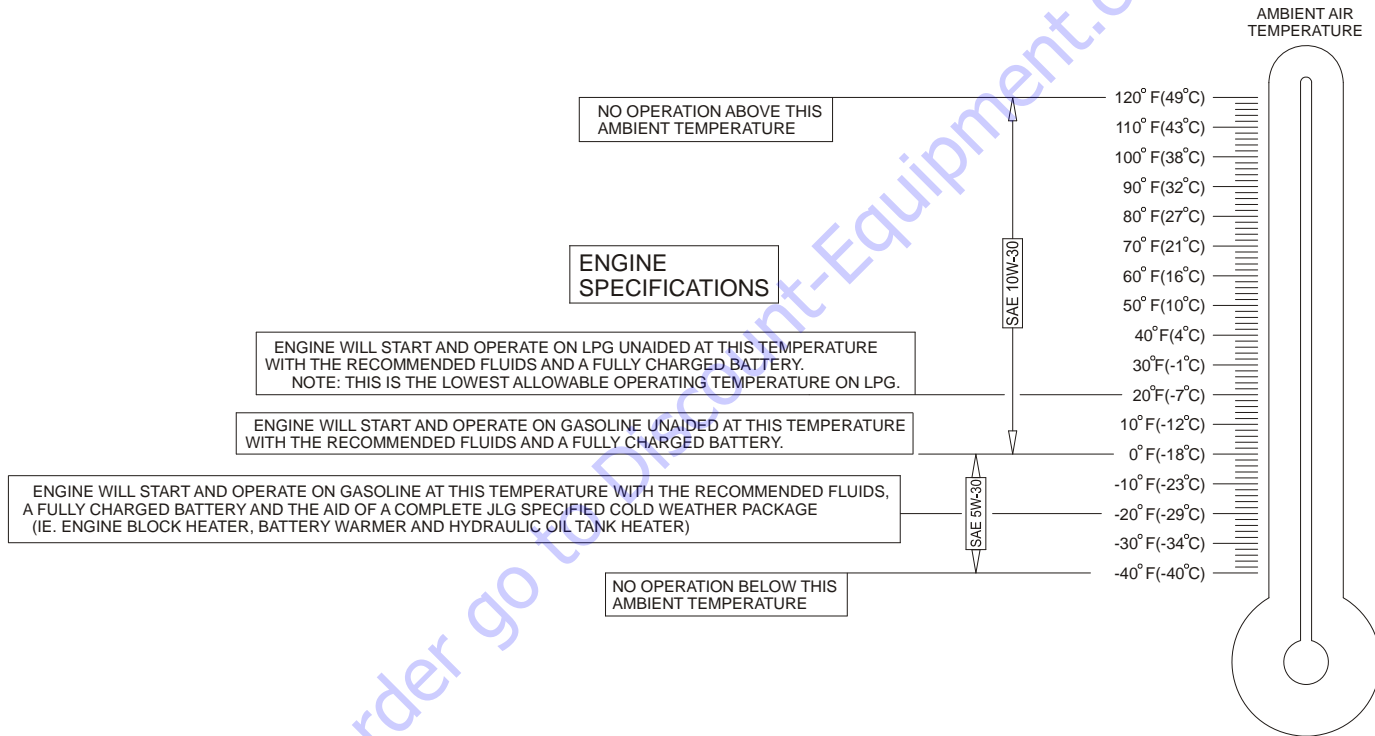
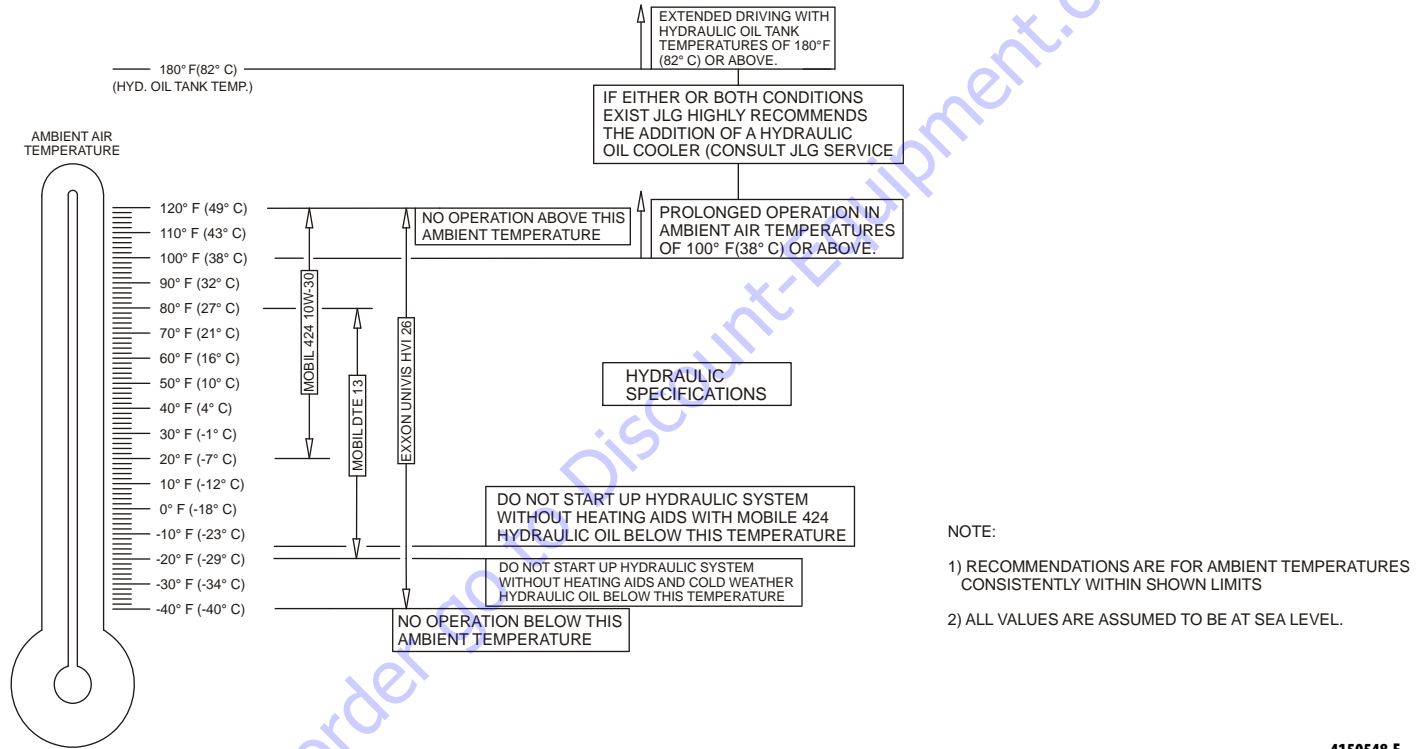

Figure 6-7. Engine Operating Temperature Specifications - GM - Sheet 1 of 2



## SECTION 6 - GENERAL SPECIFICATIONS & OPERATOR MAINTENANCE



**Figure 6-8. Engine Operating Temperature Specifications - GM - Sheet 2 of 2**

**SECTION 6 - GENERAL SPECIFICATIONS & OPERATOR MAINTENANCE**

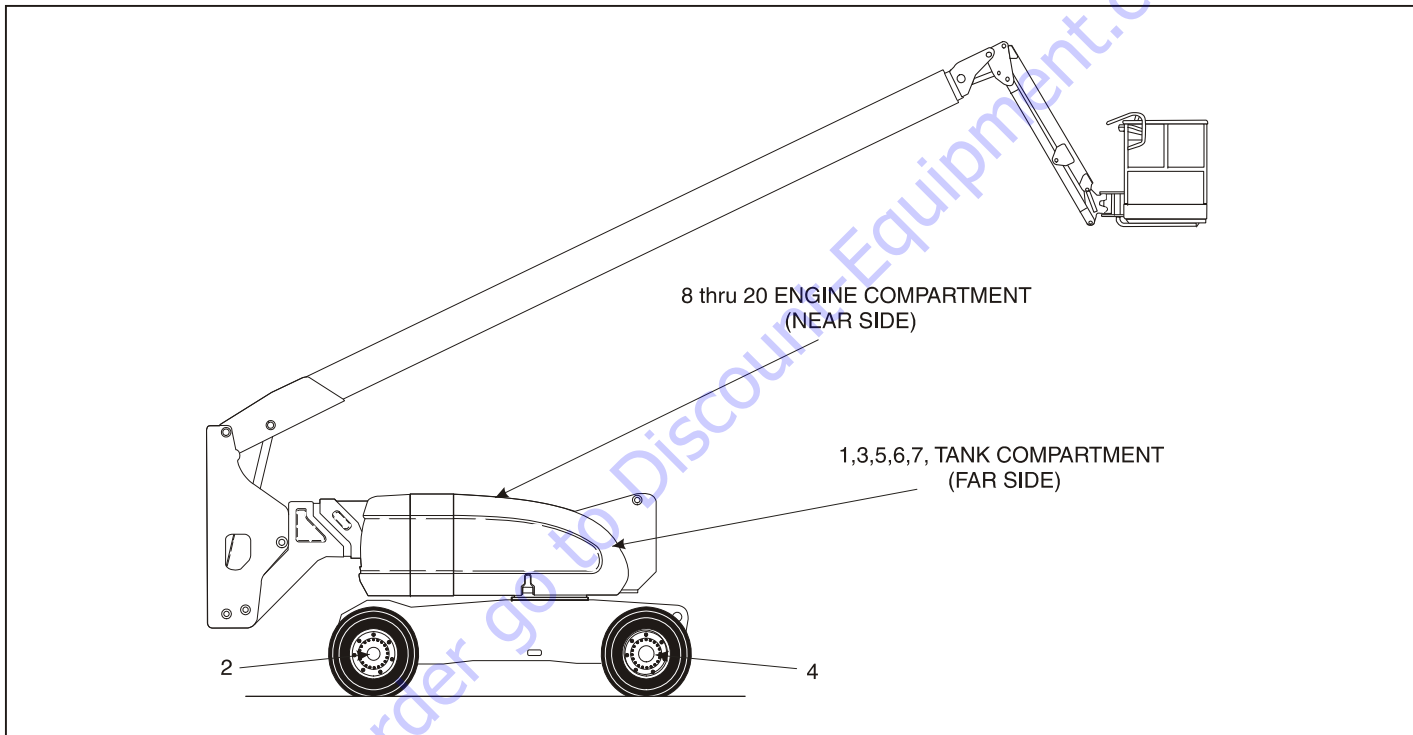

**Figure 6-9. Operator Maintenance and Lubrication Diagram**

**6.3 OPERATOR MAINTENANCE**

**NOTE:** The following numbers correspond to those in Figure 6-9., Operator Maintenance and Lubrication Diagram.

**Table 6-19. Lubrication Specifications**

KEY	SPECIFICATIONS
MPG	Multipurpose Grease having a minimum dripping point of 350°F (177°C). Excellent water resistance and adhesive qualities, and being of extreme pressure type. (Timken OK 40 pounds minimum.)
EPGL	Extreme Pressure Gear Lube (oil) meeting API service classification GL-5 or MIL-Spec MIL-L-2105
HO	Hydraulic Oil. API service classification GL-3, e.g. Mobilfluid 424.
EO	Engine (crankcase) Oil. Gas - API SF, SH, SG class, MIL-L-2104. Diesel - API CC/CD class, MIL-L-2104B/MIL-L-2104C.

**NOTICE**

**LUBRICATION INTERVALS ARE BASED ON MACHINE OPERATION UNDER NORMAL CONDITIONS. FOR MACHINES USED IN MULTI-SHIFT OPERATIONS AND/OR EXPOSED TO HOSTILE ENVIRONMENTS OR CONDITIONS, LUBRICATION FREQUENCIES MUST BE INCREASED ACCORDINGLY.**

**NOTE:** It is recommended as a good practice to replace all filters at the same time.

**1. Swing Bearing - Internal Ball Bearing**



Lube Point(s) - 2 Grease Fittings  
 Capacity - A/R  
 Lube - MPG  
 Interval - Every 3 months or 150 hrs of operation  
 Comments - Remote Access

## SECTION 6 - GENERAL SPECIFICATIONS & OPERATOR MAINTENANCE

### 2. Wheel Bearings

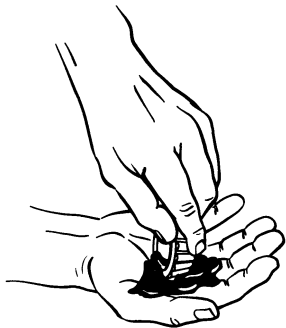

Lube Point(s) - Repack

Capacity - A/R

Lube - MPG

Interval - Every 2 years or 1200 hours of operation

### 3. Wheel Drive Hub

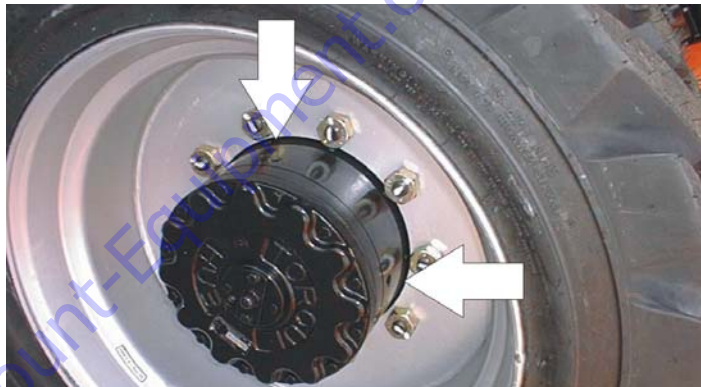

Lube Point(s) - Level/Fill Plug

Capacity - 17 oz. (0.5 L) - 1/2 Full

Lube - EPGL

Interval - Check level every 3 months or 150 hrs of operation;  
change every 2 years or 1200 hours of operation

Comments - Place Fill port at 12 o'clock position and Check  
port at 3 o'clock position. Pour lubricant into fill port until it  
just starts to flow out of check port.

## SECTION 6 - GENERAL SPECIFICATIONS & OPERATOR MAINTENANCE

### 4. Hydraulic Return Filter



Interval - Change after first 50 hrs. and every 6 months or 300 hrs. thereafter or as indicated by Condition Indicator.

### 5. Hydraulic Charge Filter



Interval - Change after first 50 hrs. and every 6 months or 300 hrs. thereafter or as indicated by Condition Indicator.

## SECTION 6 - GENERAL SPECIFICATIONS & OPERATOR MAINTENANCE

### 6. Hydraulic Tank

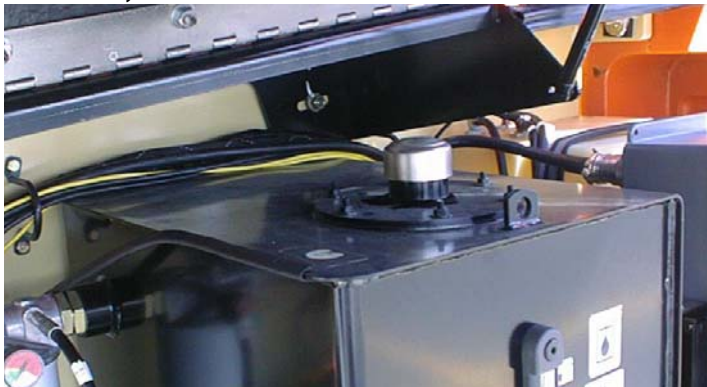

Lube Point(s) - Fill Cap

Capacity - 40 gallons (151 L) Tank; 77 gallons (291.4 L) System

Lube - HO

Interval - Check Level daily; Change every 2 years or 1200 hours of operation.

### 7. Suction Strainers

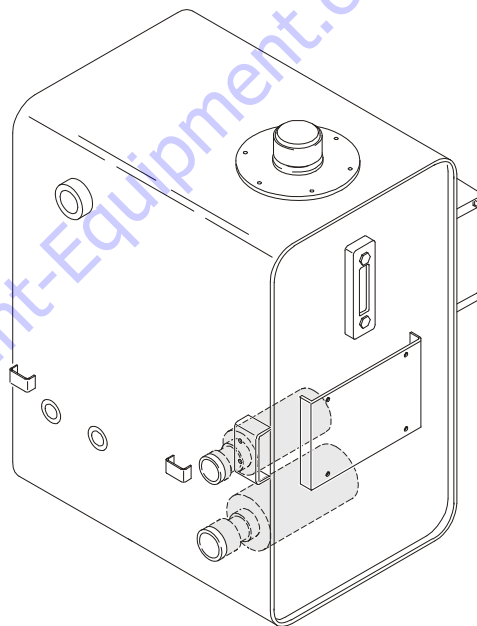

Lube Point(s) - 2

Interval - Every 2 years or 1200 hours of operation, remove and clean at time of hydraulic oil change.

## SECTION 6 - GENERAL SPECIFICATIONS & OPERATOR MAINTENANCE

### 8. Oil Change w/Filter - Ford

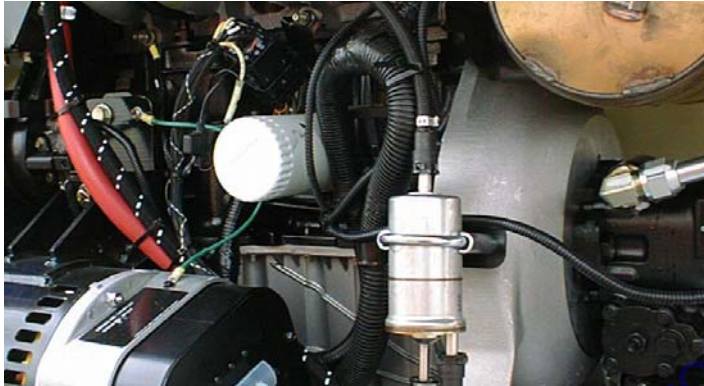

Lube Point(s) - Fill Cap/Spin-on Element  
Capacity - 4.5 Quarts  
Lube - EO  
Interval - 3 Months or 150 hours of operation  
Comments - Check level daily/Change in accordance with engine manual.

### 9. Oil Change w/Filter - Deutz

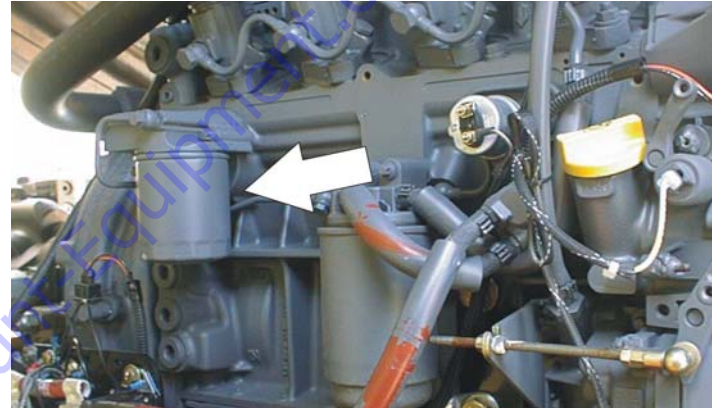

Lube Point(s) - Fill Cap/Spin-on Element  
Capacity - 11 Quarts(10.5 L) Crankcase  
Lube - EO  
Interval - Every Year or 1200 hours of operation  
Comments - Check level daily/Change in accordance with engine manual.

## SECTION 6 - GENERAL SPECIFICATIONS & OPERATOR MAINTENANCE

### 10. Oil Change w/Filter - Isuzu

Lube Point(s) - Fill Cap/Spin-on Element  
Capacity - 8.5 qt. (8.0L) engine; 5.3 qt. (5.L) cooler  
Lube - EO

Interval - Change oil after first 50 and every 200 hrs. there after. Change oil filter after 50hrs. and every 400 hrs. there after.

Comments - Check level daily/Change in accordance with engine manual.

### 11. Oil Change w/Filter - Caterpillar

Lube Point(s) - Fill Cap/Spin-on Element  
Capacity - 10.6 Quarts  
Lube - EO

Interval - 3 Months or 150 hours of operation

Comments - Check level daily/Change in accordance with engine manual.

### 12. Oil Change w/Filter - GM

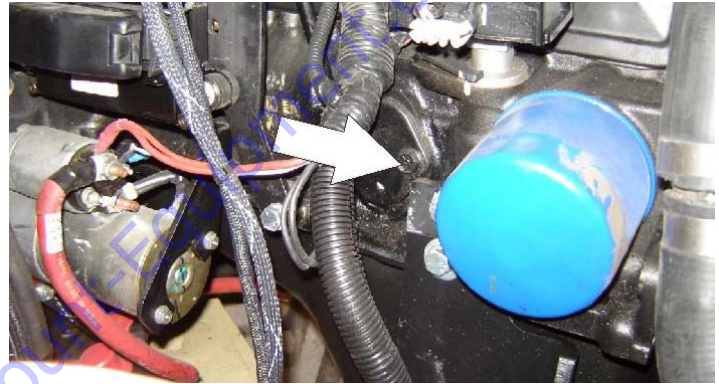

Lube Point(s) - Fill Cap/Spin-on Element  
(JLG P/N 7027965)

Capacity - 4.5 qt. (4.25 L) w/filter

Lube - EO

Interval - 3 Months or 150 hours of operation

Comments - Check level daily/Change in accordance with engine manual.



## SECTION 6 - GENERAL SPECIFICATIONS & OPERATOR MAINTENANCE

### 13. Fuel Filter - Ford

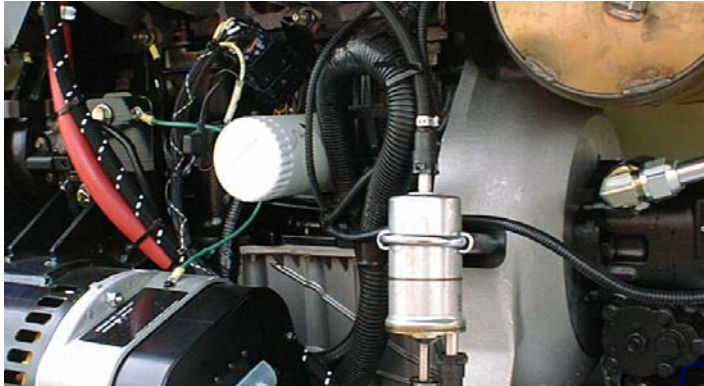

Lube Point(s) - Replaceable Element  
Interval - Every Year or 1200 hours of operation

### 14. Fuel Filter - Deutz

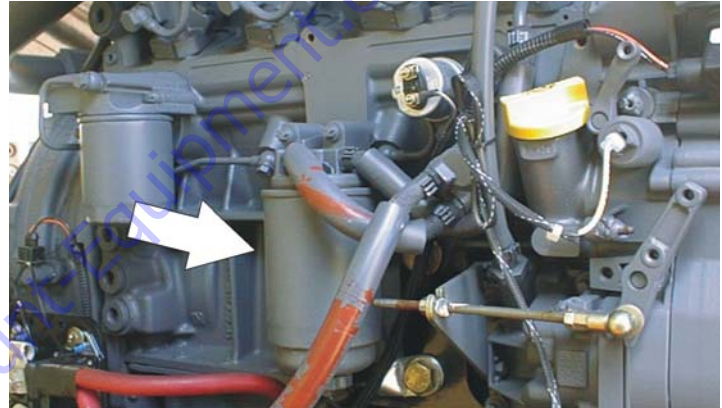

Lube Point(s) - Replaceable Element  
Interval - Every Year or 600 hours of operation

### 15. Fuel Filter - Isuzu

Lube Point(s) - Replaceable Element  
Interval - Every Year or 600 hours of operation

### 16. Fuel Filter - Caterpillar

Lube Point(s) - Replaceable Element  
Interval - Every Year or 600 hours of operation

## SECTION 6 - GENERAL SPECIFICATIONS & OPERATOR MAINTENANCE

### 17. Fuel Filter (Gasoline) - GM

Lube Point(s) - Replaceable Element

Interval - Every 6 months or 300 hours of operation

### 18. Air Filter

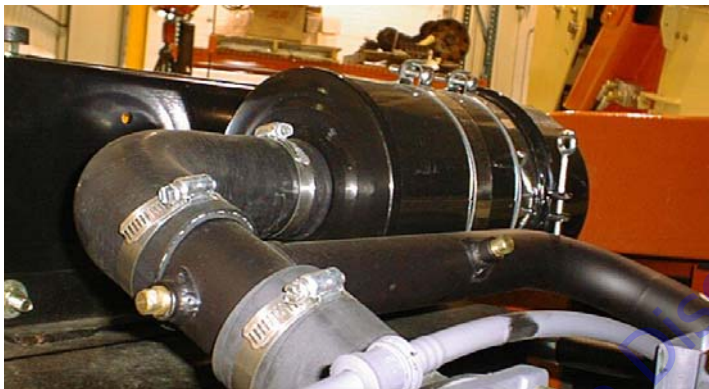

Lube Point(s) - Replaceable Element

Interval - Every 6 months or 300 hours of operation or as indicated by the condition indicator

### 19. Electronic Pressure Regulator (LP only)

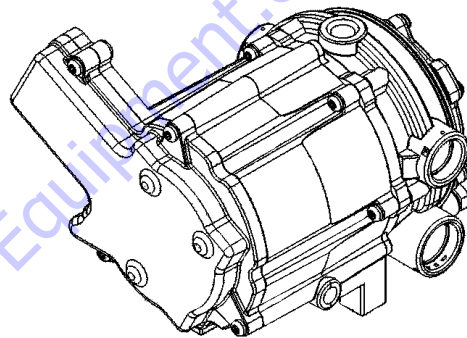

Interval - 3 Months or 150 hours of operation

Comments - Drain oil build up. Refer to Section 6.5, DRAINING OIL BUILD UP FROM THE PROPANE REGULATOR (Prior to S/N 0300134626)

**20. Fuel Filter (Propane) - GM Engine**

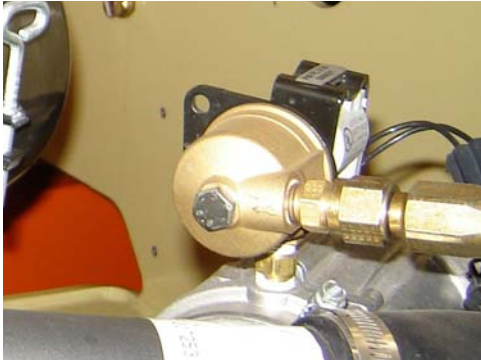

Interval - 3 Months or 150 hours of operation  
Comments - Replace filter. Refer to Section 6.6, Propane Fuel Filter Replacement

**6.4 TIRES & WHEELS**

**Tire Inflation**

The air pressure for pneumatic tires must be equal to the air pressure that is stenciled on the side of the JLG product or rim decal for safe and proper operational characteristics.

**Tire Damage**

For pneumatic tires, JLG Industries, Inc. recommends that when any cut, rip, or tear is discovered that exposes sidewall or tread area cords in the tire, measures must be taken to remove the JLG product from service immediately. Arrangements must be made for replacement of the tire or tire assembly.

For polyurethane foam filled tires, JLG Industries, Inc. recommends that when any of the following are discovered, measures must be taken to remove the JLG product from service immediately and arrangements must be made for replacement of the tire or tire assembly.

- a smooth, even cut through the cord plies which exceeds 3 inches (7.5 cm) in total length
- any tears or rips (ragged edges) in the cord plies which exceeds 1 inch (2.5 cm) in any direction
- any punctures which exceed 1 inch in diameter

- any damage to the bead area cords of the tire

If a tire is damaged but is within the above noted criteria, the tire must be inspected on a daily basis to insure the damage has not propagated beyond the allowable criteria.

### Tire Replacement

JLG recommends a replacement tire be the same size, ply and brand as originally installed on the machine. Please refer to the JLG Parts Manual for the part number of the approved tires for a particular machine model. If not using a JLG approved replacement tire, we recommend that replacement tires have the following characteristics:

- Equal or greater ply/load rating and size of original
- Tire tread contact width equal or greater than original
- Wheel diameter, width, and offset dimensions equal to the original
- Approved for the application by the tire manufacturer (including inflation pressure and maximum tire load)

Unless specifically approved by JLG Industries Inc. do not replace a foam filled or ballast filled tire assembly with a pneumatic tire. When selecting and installing a replacement tire, ensure that all tires are inflated to the pressure recommended by JLG. Due to size variations between tire brands, both tires on the same axle should be the same.

### Wheel Replacement

The rims installed on each product model have been designed for stability requirements which consist of track width, tire pressure, and load capacity. Size changes such as rim width, center piece location, larger or smaller diameter, etc., without written factory recommendations, may result in an unsafe condition regarding stability.

## Wheel Installation

It is extremely important to apply and maintain proper wheel mounting torque.

### **⚠ WARNING**

**WHEEL NUTS MUST BE INSTALLED AND MAINTAINED AT THE PROPER TORQUE TO PREVENT LOOSE WHEELS, BROKEN STUDS, AND POSSIBLE DANGEROUS SEPARATION OF WHEEL FROM THE AXLE. BE SURE TO USE ONLY THE NUTS MATCHED TO THE CONE ANGLE OF THE WHEEL.**

Tighten the lug nuts to the proper torque to prevent wheels from coming loose. Use a torque wrench to tighten the fasteners. If you do not have a torque wrench, tighten the fasteners with a lug wrench, then immediately have a service garage or dealer tighten the lug nuts to the proper torque. Over-tightening will result in breaking the studs or permanently deforming the mounting stud holes in the wheels. The proper procedure for attaching wheels is as follows:

1. Start all nuts by hand to prevent cross threading. DO NOT use a lubricant on threads or nuts.

2. Tighten nuts in the following sequence:

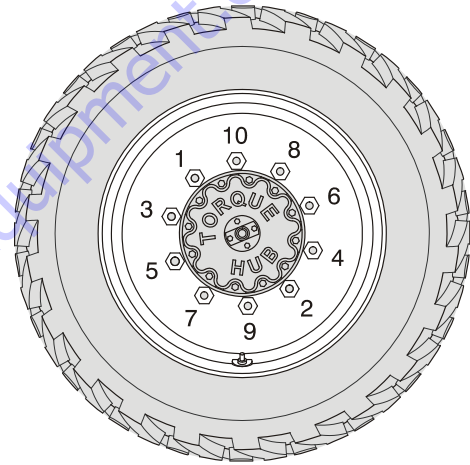

- The tightening of the nuts should be done in stages. Following the recommended sequence, tighten nuts per wheel torque chart.

**Table 6-20. Wheel Torque Chart**

TORQUE SEQUENCE		
1st Stage	2nd Stage	3rd Stage
70 ft. lbs. (95 Nm)	170 ft. lbs. (225 Nm)	300 ft. lbs. (405 Nm)

- Wheel nuts should be torqued after first 50 hours of operation and after each wheel removal. Check torque every 3 months or 150 hours of operation.

### 6.5 DRAINING OIL BUILD UP FROM THE PROPANE REGULATOR (PRIOR TO S/N 0300134626)

During the course of normal operation oils may build inside the primary and secondary chambers of the propane pressure regulator. These oils may be a result of poor fuel quality, contamination of the fuel supply chain, or regional variation in the make up of the fuel. If the build up of the oil is significant this can effect the operation of the fuel control system. Refer to Section 6.3, Operator Maintenance for maintenance intervals. More frequent draining may be required if the fuel supply has been contaminated.

#### **NOTICE**

**FOR BEST RESULTS WARM THE ENGINE TO OPERATING TEMPERATURE BEFORE DRAINING. THIS WILL ALLOW THE OILS TO FLOW FREELY FROM THE REGULATOR.**

- Move the equipment to a well ventilated area. Ensure there are no external ignition sources.
- Start the engine and bring to operating temperature.
- With the engine running, close the manual tank valve and run the engine out of fuel.

## SECTION 6 - GENERAL SPECIFICATIONS & OPERATOR MAINTENANCE

4. Push in the Emergency Switch once the engine stops.
5. Disconnect the electrical connection to the LPG fuel temperature sensor in the auxiliary fuel port of the EPR.



6. Remove the retainer clip for the LPG fuel temperature sensor and remove the sensor from the regulator body.

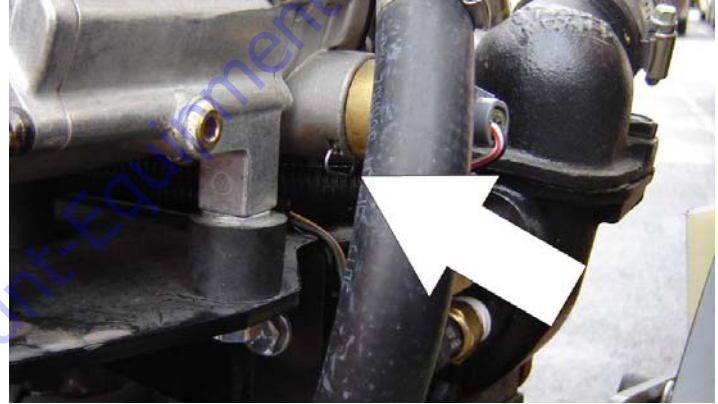

**NOTE:** Have a small container ready to collect oil that will drain freely from the regulator at this point.

7. Once all of the oil has been drained, reinstall the LPG fuel temperature sensor and reconnect the electrical connector.
8. Open the fuel tank manual valve.
9. Start the engine and verify all connections are secure.
10. Dispose of any drained oil per local regulations in a safe and proper fashion.

### 6.6 PROPANE FUEL FILTER REPLACEMENT

#### Installation

#### Removal

1. Relieve the propane fuel system pressure. Refer to Propane Fuel System Pressure Relief.
2. Disconnect the negative battery cable.
3. Slowly loosen the Filter housing and remove it.
4. Pull the filter housing from the Electric lock off assembly.
5. Remove the filter from the housing.
6. Locate Filter magnet and remove it.
7. Remove and discard the housing seal.
8. If equipped, remove and discard the retaining bolt seal.
9. Remove and discard mounting plate to lock off O-ring seal.

#### **NOTICE**

**BE SURE TO REINSTALL THE FILTER MAGNET INTO THE HOUSING BEFORE INSTALLING NEW SEAL**

1. Install the mounting plate to lock off O-ring seal.
2. If equipped, install the retaining bolt seal.
3. Install the housing seal.
4. Drop the magnet into the bottom of the filter housing.
5. Install the filter into the housing.
6. If equipped, install the retaining bolt into the filter housing.
7. Install the filter up to the bottom of the electric lock off.
8. Tighten the filter bowl retainer to 106 in lbs (12 Nm).
9. Open manual shut-off valve. Start the vehicle and leak check the propane fuel system at each serviced fitting. Refer to Propane Fuel System Leak Test.



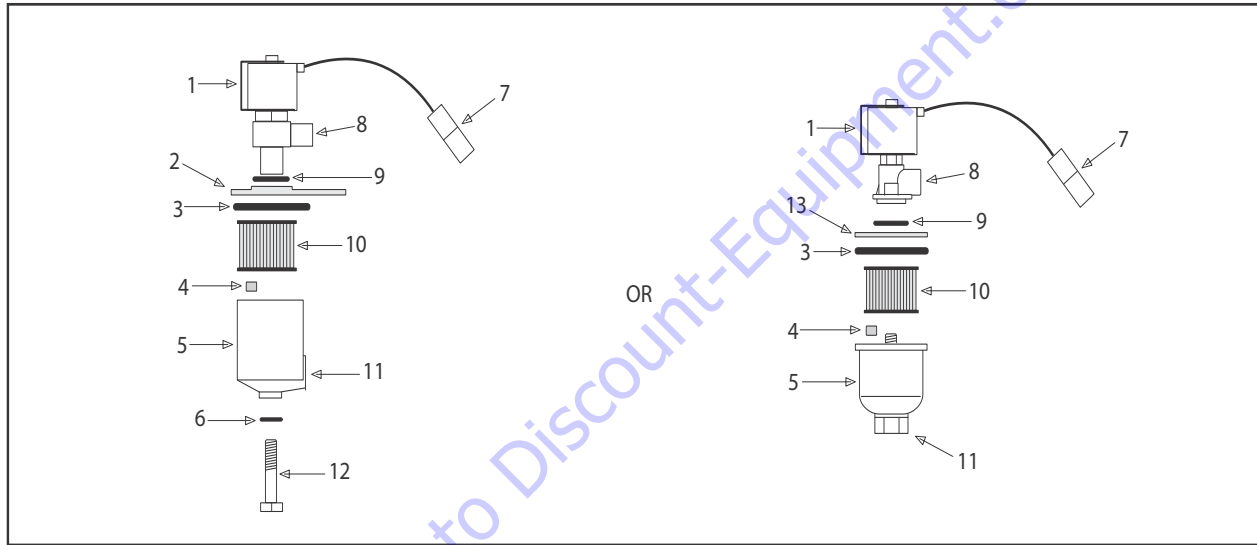

- |                               |                         |                    |
|-------------------------------|-------------------------|--------------------|
| 1. Electric Lock Off Solenoid | 6. Seal                 | 10. Filter         |
| 2. Mounting Plate             | 7. Electrical Connector | 11. Fuel Inlet     |
| 3. Housing Seal               | 8. Fuel Outlet          | 12. Retaining Bolt |
| 4. Filter Magnet              | 9. O-ring               | 13. Ring           |
| 5. Filter Housing             |                         |                    |

**Figure 6-10. Filter Lock Assembly**

### 6.7 PROPANE FUEL SYSTEM PRESSURE RELIEF

#### CAUTION

THE PROPANE FUEL SYSTEM OPERATES AT PRESSURES UP TO 312 PSI (21.5 BAR). TO MINIMIZE THE RISK OF FIRE AND PERSONAL INJURY, RELIEVE THE PROPANE FUEL SYSTEM PRESSURE (WHERE APPLICABLE) BEFORE SERVICING THE PROPANE FUEL SYSTEM COMPONENTS.

To relieve propane fuel system pressure:

1. Close the manual shut-off valve on the propane fuel tank.
2. Start and run the vehicle until the engine stalls.
3. Turn the ignition switch OFF.

#### CAUTION

RESIDUAL VAPOR PRESSURE WILL BE PRESENT IN THE FUEL SYSTEM. ENSURE THE WORK AREA IS WELL VENTILATED BEFORE DISCONNECTING ANY FUEL LINE.

### 6.8 SUPPLEMENTAL INFORMATION

The following information is provided in accordance with the requirements of the European Machinery Directive 2006/42/EC and is only applicable to CE machines.

For electric powered machines, the equivalent continuous A-Weighted sound pressure level at the work platform is less than 70dB(A)

For combustion engine powered machines, guaranteed Sound Power Level (LWA) per European Directive 2000/14/EC (Noise Emission in the Environment by Equipment for Use Outdoors) based on test methods in accordance with Annex III, Part B, Method 1 and 0 of the directive, is 104 dB.

The vibration total value to which the hand-arm system is subjected does not exceed  $2,5 \text{ m/s}^2$ . The highest root mean square value of weighted acceleration to which the whole body is subjected does not exceed  $0,5 \text{ m/s}^2$ .





 **WARNING:** 

**The engine exhaust from this product contains chemicals known to the State of California to cause cancer, birth defects, or other reproductive harm.**

1702961

**PROPOSITION 65  
WARNING**

- **Battery posts, terminals and related accessories contain lead and lead compounds, chemicals known to the State of California to cause cancer and reproductive harm.**
- **Batteries also contain other chemicals known to the State of California to cause cancer.**
- **Wash hands after handling.**



An Oshkosh Corporation Company



[www.Discount-Equipment.com](http://www.Discount-Equipment.com)



3121209

To order go to [Discount-Equipment.com](http://Discount-Equipment.com)

**TO PURCHASE THIS PRODUCT PLEASE CONTACT US**



**Equipment Financing and  
Extended Warranties Available**



**Discount-Equipment.com is your online resource for  
commercial and industrial quality parts and equipment sales.**

**561-964-4949**

**visit us on line @ [www.discount-equipment.com](http://www.discount-equipment.com)**

Select an option below to find your Equipment

**Search by Manufacturer**

**Search by Product Type**

**Request a Quote**

We sell worldwide for the brands: Genie, Terex, JLG, MultiQuip, Mikasa, Essick, Whiteman, Mayco, Toro Stone, Diamond Products, Generac Magnum, Airman, Haulotte, Barreto, Power Blanket, Nifty Lift, Atlas Copco, Chicago Pneumatic, Allmand, Miller Curber, Skyjack, Lull, Skytrak, Tsurumi, Husquvarna Target, Stow, Wacker, Sakai, Mi-T-M, Sullair, Basic, Dynapac, MBW, Weber, Bartell, Bennar Newman, Haulotte, Ditch Runner, Menegotti, Morrison, Contec, Buddy, Crown, Edco, Wyco, Bomag, Laymor, EZ Trench, Bil-Jax, F.S. Curtis, Gehl Pavers, Heli, Honda, ICS/PowerGrit, IHI, Partner, Imer, Clipper, MMD, Koshin, Rice, CH&E, General Equipment, Amida, Coleman, NAC, Gradall, Square Shooter, Kent, Stanley, Tamco, Toku, Hatz, Kohler, Robin, Wisconsin, Northrock, Oztec, Toker TK, Rol-Air, APT, Wylie, Ingersoll Rand / Doosan, Innovatech, Con X, Ammann, Mecalac, Makinex, Smith Surface Prep, Small Line, Wanco, Yanmar